



PIC16C73

PIC16C73 Rev. A Silicon Errata Sheet

The PIC16C73 (Rev. A) parts you have received conform functionally to the Device Data Sheet (DS30390E), except for the anomalies described below.

All the problems listed here will be addressed in future revisions of the PIC16C73 silicon.

1. **Module: USART**

When the USART (SCI) is configured in asynchronous mode with the BRGH bit set, a high number of receive errors may be experienced. For asynchronous receive operations, it is recommended that the USART be configured with the BRGH bit cleared.

Note: As with any windowed EPROM device, please cover the window at all times, except when erasing.

PIC16C73

Clarifications/Corrections to the Data Sheet:

In the Device Data Sheet (DS30390E), the following clarifications and corrections should be noted.

1. Module: I/O Ports

The specification for the High Voltage Open Drain I/O (The RA4 pin on most devices) cannot be met without possible long term reliability issues on that I/O pin. If a high voltage drive is required, use an external transistor that can support the required voltage.

TABLE 1: DC SPECIFICATION CHANGES FROM DATA SHEET

Param No.	Sym.	Characteristic	New Specification			Data Sheet Specification			Units
			Min	Typ	Max	Min	Typ	Max	
D150	VOD	Open-drain High Voltage	—	—	10	—	—	14	V

2. Module: 8-Bit A/D

- a) The minimum A/D reference voltage has been improved to the values shown in Table 2.

TABLE 2: DC SPECIFICATION CHANGES FROM DATA SHEET

Parm No.	Sym.	Characteristic	New Specification			Data Sheet Specification			Units
			Min	Typ	Max	Min	Typ	Max	
A20	VREF	Reference Voltage	2.5 *	—	VDD + 0.3 V	3.0	—	VDD + 0.3 V	V

* This parameter is characterized but not tested

3. Module: SSP (SPI Mode Timing Specifications)

- a) The SPI interface timings have been modified to the values shown in Table 2.

TABLE 3: DC SPECIFICATION CHANGES FROM DATA SHEET

Parm No.	Sym.	Characteristic	New Specification			Data Sheet Specification			Units	
			Min	Typ	Max	Min	Typ	Max		
71	Tsch	SCK input high time (slave mode)	Continuous	1.25 T _{CY} + 30 ns	—	—	T _{CY} + 20 ns	—	—	ns
71A			Single Byte ⁽¹⁾	40	—	—	N.A.			ns
72	TscL	SCK input low time (slave mode)	Continuous	1.25 T _{CY} + 30 ns	—	—	T _{CY} + 20 ns	—	—	ns
72A			Single Byte ⁽¹⁾	40	—	—	N.A.			ns
73A	T _{B2B}	Last clock edge of the Byte1 to 1st clock edge of the Byte2 ⁽¹⁾	1.5 T _{CY} + 40 ns	—	—	N.A.			ns	

* This parameter is characterized but not tested

Note 1: Specification 73A is only required if specifications 71A and 72A are used.

4. Module: Timer1

- a) The operation of Timer1 needs some clarification when the timer registers are written when the TMR1ON bit is set.

The internal clock signal that is the input to the TMR1 prescaler affects the incrementing of Timer1 (TMR1H:TMR1L registers and the Timer1 prescaler). When the Timer1 registers are NOT written, the Timer1 will increment on the rising edge of the TMR1 increment clock.

When the TMR1H and/or TMR1L registers are written while this clock is high, TMR1 will increment on the next rising edge of this clock.

When the TMR1H and/or TMR1L registers are written while this clock is low, TMR1 will not increment on the next rising edge of this clock, but must first have a falling clock and the rising clock for TMR1 to increment.

Figure 1 shows the two cases of writes to the TMR1H and/or TMR1L registers. Due to the V_{IH} and V_{IL} thresholds on the oscillator/clock pins, external Timer1 oscillator components, and external clock frequency, the Timer1 increment clock may not be of a 50% duty cycle.

The TMR1 increment clock is out of phase of the T1OSO/T1CKI pin by a small propagation delay.

FIGURE 1: WRITES TO TIMER1 (EXTERNAL CLOCK / OSCILLATOR MODE)

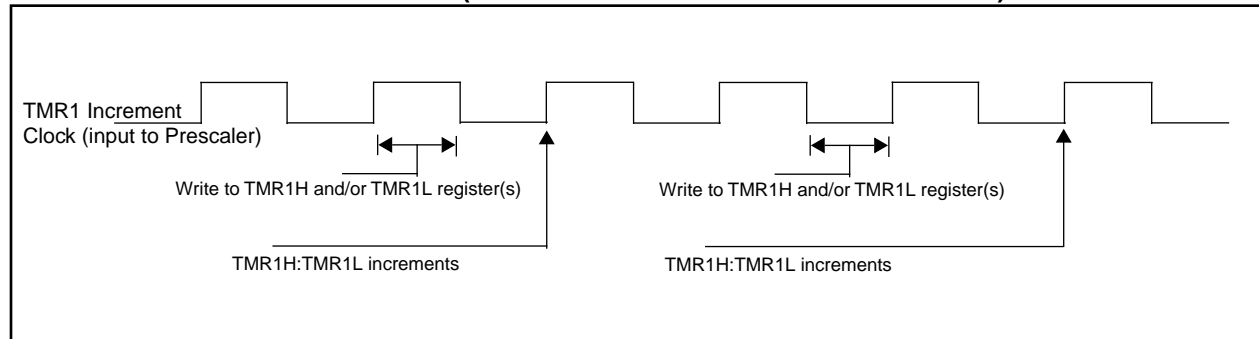

PIC16C73

5. Module: RC Oscillator

The table for RC Oscillator Frequencies in the Device Characterization section of the Data Sheet is incorrect. The correct characterization information is shown in Table 4.

TABLE 4: RC OSCILLATOR FREQUENCIES CHARACTERIZATION CHANGES FROM DATA SHEET

Cext	Rext	Correct Characterization Data		Current Data Sheet Values	
		Average	% Variation	Average	% Variation
22 pF	5.1 K	3.55 MHz	± 9.63%	4.12 MHz	± 1.4%
	10 K	1.99 MHz	± 10.53%	2.35 MHz	± 1.4%
	100 K	221.9 KHz	± 12.10%	268 KHz	± 1.1%
100 pF	3.3 K	1.77 MHz	± 10.67%	1.80 MHz	± 1.0%
	5.1 K	1.22 MHz	± 10.41%	1.27 MHz	± 1.0%
	10 K	669.4 KHz	± 10.92%	688 KHz	± 1.2%
	100 K	71.5 KHz	± 11.21%	77.2 KHz	± 1.0%
330 pF	3.3 K	625.1 KHz	± 10.68%	707 KHz	± 1.4%
	5.1 K	428.5 KHz	± 10.96%	501 KHz	± 1.2%
	10 K	231.9 KHz	± 11.32%	269 KHz	± 1.6%
	100 K	24.4 KHz	± 12.93%	28.3 KHz	± 1.1%

The percentage variation indicated here is part to part variation due to normal process distribution. The variation indicated is ± 3 standard deviation from the average value for $V_{dd} = 5V$



WORLDWIDE SALES AND SERVICE

AMERICAS

Corporate Office

Microchip Technology Inc.
2355 West Chandler Blvd.
Chandler, AZ 85224-6199
Tel: 480-786-7200 Fax: 480-786-7277
Technical Support: 480-786-7627
Web Address: <http://www.microchip.com>

Atlanta

Microchip Technology Inc.
500 Sugar Mill Road, Suite 200B
Atlanta, GA 30350
Tel: 770-640-0034 Fax: 770-640-0307

Boston

Microchip Technology Inc.
5 Mount Royal Avenue
Marlborough, MA 01752
Tel: 508-480-9990 Fax: 508-480-8575

Chicago

Microchip Technology Inc.
333 Pierce Road, Suite 180
Itasca, IL 60143
Tel: 630-285-0071 Fax: 630-285-0075

Dallas

Microchip Technology Inc.
4570 Westgrove Drive, Suite 160
Addison, TX 75248
Tel: 972-818-7423 Fax: 972-818-2924

Dayton

Microchip Technology Inc.
Two Prestige Place, Suite 150
Miamisburg, OH 45342
Tel: 937-291-1654 Fax: 937-291-9175

Detroit

Microchip Technology Inc.
Tri-Atria Office Building
32255 Northwestern Highway, Suite 190
Farmington Hills, MI 48334
Tel: 248-538-2250 Fax: 248-538-2260

Los Angeles

Microchip Technology Inc.
18201 Von Karman, Suite 1090
Irvine, CA 92612
Tel: 949-263-1888 Fax: 949-263-1338

New York

Microchip Technology Inc.
150 Motor Parkway, Suite 202
Hauppauge, NY 11788
Tel: 631-273-5305 Fax: 631-273-5335

San Jose

Microchip Technology Inc.
2107 North First Street, Suite 590
San Jose, CA 95131
Tel: 408-436-7950 Fax: 408-436-7955

AMERICAS (continued)

Toronto

Microchip Technology Inc.
5925 Airport Road, Suite 200
Mississauga, Ontario L4V 1W1, Canada
Tel: 905-405-6279 Fax: 905-405-6253

ASIA/PACIFIC

Hong Kong

Microchip Asia Pacific
Unit 2101, Tower 2
Metroplaza
223 Hing Fong Road
Kwai Fong, N.T., Hong Kong
Tel: 852-2-401-1200 Fax: 852-2-401-3431

Beijing

Microchip Technology, Beijing
Unit 915, 6 Chaoyangmen Bei Dajie
Dong Erhuan Road, Dongcheng District
New China Hong Kong Manhattan Building
Beijing 100027 PRC
Tel: 86-10-85282100 Fax: 86-10-85282104

India

Microchip Technology Inc.
India Liaison Office
No. 6, Legacy, Convent Road
Bangalore 560 025, India
Tel: 91-80-229-0061 Fax: 91-80-229-0062

Japan

Microchip Technology Intl. Inc.
Benex S-1 6F
3-18-20, Shinyokohama
Kohoku-Ku, Yokohama-shi
Kanagawa 222-0033 Japan
Tel: 81-45-471-6166 Fax: 81-45-471-6122

Korea

Microchip Technology Korea
168-1, Youngbo Bldg. 3 Floor
Samsung-Dong, Kangnam-Ku
Seoul, Korea
Tel: 82-2-554-7200 Fax: 82-2-558-5934

Shanghai

Microchip Technology
RM 406 Shanghai Golden Bridge Bldg.
2077 Yan'an Road West, Hong Qiao District
Shanghai, PRC 200335
Tel: 86-21-6275-5700 Fax: 86 21-6275-5060

ASIA/PACIFIC (continued)

Singapore

Microchip Technology Singapore Pte Ltd.
200 Middle Road
#07-02 Prime Centre
Singapore 188980
Tel: 65-334-8870 Fax: 65-334-8850

Taiwan, R.O.C

Microchip Technology Taiwan
10F-1C 207
Tung Hua North Road
Taipei, Taiwan, ROC
Tel: 886-2-2717-7175 Fax: 886-2-2545-0139

EUROPE

United Kingdom

Arizona Microchip Technology Ltd.
505 Eskdale Road
Wokingham
Berkshire, England RG41 5TU
Tel: 44 118 921 5858 Fax: 44-118 921-5835

Denmark

Microchip Technology Denmark ApS
Regus Business Centre
Lautrup hof 1-3
Ballerup DK-2750 Denmark
Tel: 45 4420 9895 Fax: 45 4420 9910

France

Arizona Microchip Technology SARL
Parc d'Activite du Moulin de Massy
43 Rue du Saule Trapu
Batiment A - 1er Etage
91300 Massy, France
Tel: 33-1-69-53-63-20 Fax: 33-1-69-30-90-79

Germany

Arizona Microchip Technology GmbH
Gustav-Heinemann-Ring 125
D-81739 München, Germany
Tel: 49-89-627-144 0 Fax: 49-89-627-144-44

Italy

Arizona Microchip Technology SRL
Centro Direzionale Colleoni
Palazzo Taurus 1 V. Le Colleoni 1
20041 Agrate Brianza
Milan, Italy
Tel: 39-039-65791-1 Fax: 39-039-6899883

11/15/99

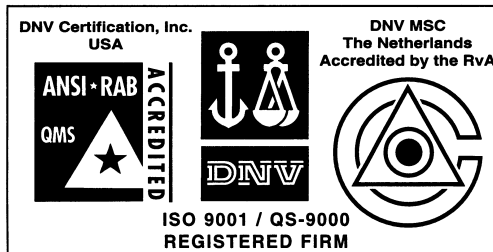

Microchip received QS-9000 quality system certification for its worldwide headquarters, design and water fabrication facilities in Chandler and Tempe, Arizona in July 1999. The Company's quality system processes and procedures are QS-9000 compliant for its PICmicro® 8-bit MCUs, KEELOC® code hopping devices, Serial EEPROMs and microperipheral products. In addition, Microchip's quality system for the design and manufacture of development systems is ISO 9001 certified.

All rights reserved. © 1999 Microchip Technology Incorporated. Printed in the USA. 11/99 Printed on recycled paper.

Information contained in this publication regarding device applications and the like is intended for suggestion only and may be superseded by updates. No representation or warranty is given and no liability is assumed by Microchip Technology Incorporated with respect to the accuracy or use of such information, or infringement of patents or other intellectual property rights arising from such use or otherwise. Use of Microchip's products as critical components in life support systems is not authorized except with express written approval by Microchip. No licenses are conveyed, implicitly or otherwise, under any intellectual property rights. The Microchip logo and name are registered trademarks of Microchip Technology Inc. in the U.S.A. and other countries. All rights reserved. All other trademarks mentioned herein are the property of their respective companies.