

EPROM Memory Programming Specification

This document includes the programming specifications for the following devices:

- PIC16C554
- PIC16C556
- PIC16C558

1.0 PROGRAMMING THE PIC16C55X

The PIC16C55X can be programmed using a serial method. In serial mode the PIC16C55X can be programmed while in the users system. This allows for increased design flexibility.

1.1 Hardware Requirements

The PIC16C55X requires two programmable power supplies, one for VDD (2.0V to 6.5V recommended) and one for VPP (12V to 14V). Both supplies should have a minimum resolution of 0.25V.

1.2 Programming Mode

The programming mode for the PIC16C55X allows programming of user program memory, special locations used for ID, and the configuration word for the PIC16C55X.

Pin Diagrams

PDIP, SOIC, Windowed CERDIP

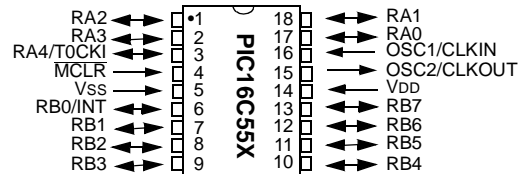

SSOP

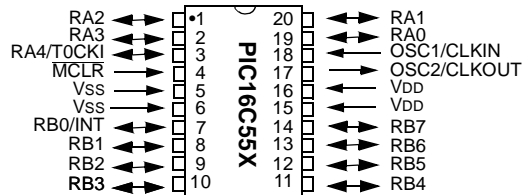

Note: Peripheral pinout functions are not shown (see data sheets for full pinout information).

PIN DESCRIPTIONS (DURING PROGRAMMING): PIC16C554/556/558

Pin Name	During Programming		
	Pin Name	Pin Type	Pin Description
RB6	CLOCK	I	Clock input
RB7	DATA	I/O	Data input/output
MCLR/VPP	VPP	P	Programming Power
VDD	VDD	P	Power Supply
VSS	VSS	P	Ground

Legend: I = Input, O = Output, P = Power

2.0 PROGRAM MODE ENTRY

2.1 User Program Memory Map

The user memory space extends from 0x0000 to 0x1FFF (8K). Table 2-1 shows actual implementation of program memory in the PIC16C55X family.

TABLE 2-1: IMPLEMENTATION OF PROGRAM MEMORY IN THE PIC16C55X

Device	Program Memory Size	Access to Program Memory
PIC16C554	0x000 - 0x1FFF (0.5K)	PC<8:0>
PIC16C556	0x000 - 0x3FFF (1K)	PC<9:0>
PIC16C558	0x000 - 0x7FFF (2K)	PC<10:0>

When the PC reaches the last location of the implemented program memory, it will wrap around and address a location within the physically implemented memory (see Figure 2-1).

In programming mode the program memory space extends from 0x0000 to 0x3FFF, with the first half (0x0000-0x1FFF) being user program memory and the second half (0x2000-0x3FFF) being configuration memory. The PC will increment from 0x0000 to 0x1FFF and wrap to 0x000 or 0x2000 to 0x3FFF and wrap around to 0x2000 (not to 0x0000). Once in configuration memory, the highest bit of the PC stays a '1', thus always pointing to the configuration memory. The only way to point to user program memory is to reset the part and reenter program/verify mode, as described in Section 2.2.

In the configuration memory space, 0x2000-0x20FF are utilized. When in a configuration memory, as in the user memory, the 0x2000-0x2XFF segment is repeatedly accessed as the PC exceeds 0x2XFF (see Figure 2-1).

A user may store identification information (ID) in four ID locations. The ID locations are mapped in [0x2000 : 0x2003]. It is recommended that the user use only the four least significant bits of each ID location. In some devices, the ID locations read-out in a scrambled fashion after code protection is enabled. For these devices, it is recommended that ID location is written as "11 1111 1000 bbbb" where 'bbbb' is ID information.

Note: All other locations are reserved and should not be programmed.

In other devices, the ID locations read out normally, even after code protection. To understand how the devices behave, refer to Table 4-1.

To understand the scrambling mechanism after code protection, refer to Section 4.1.

EPROM Memory Programming Specification

FIGURE 2-1: PROGRAM MEMORY MAPPING

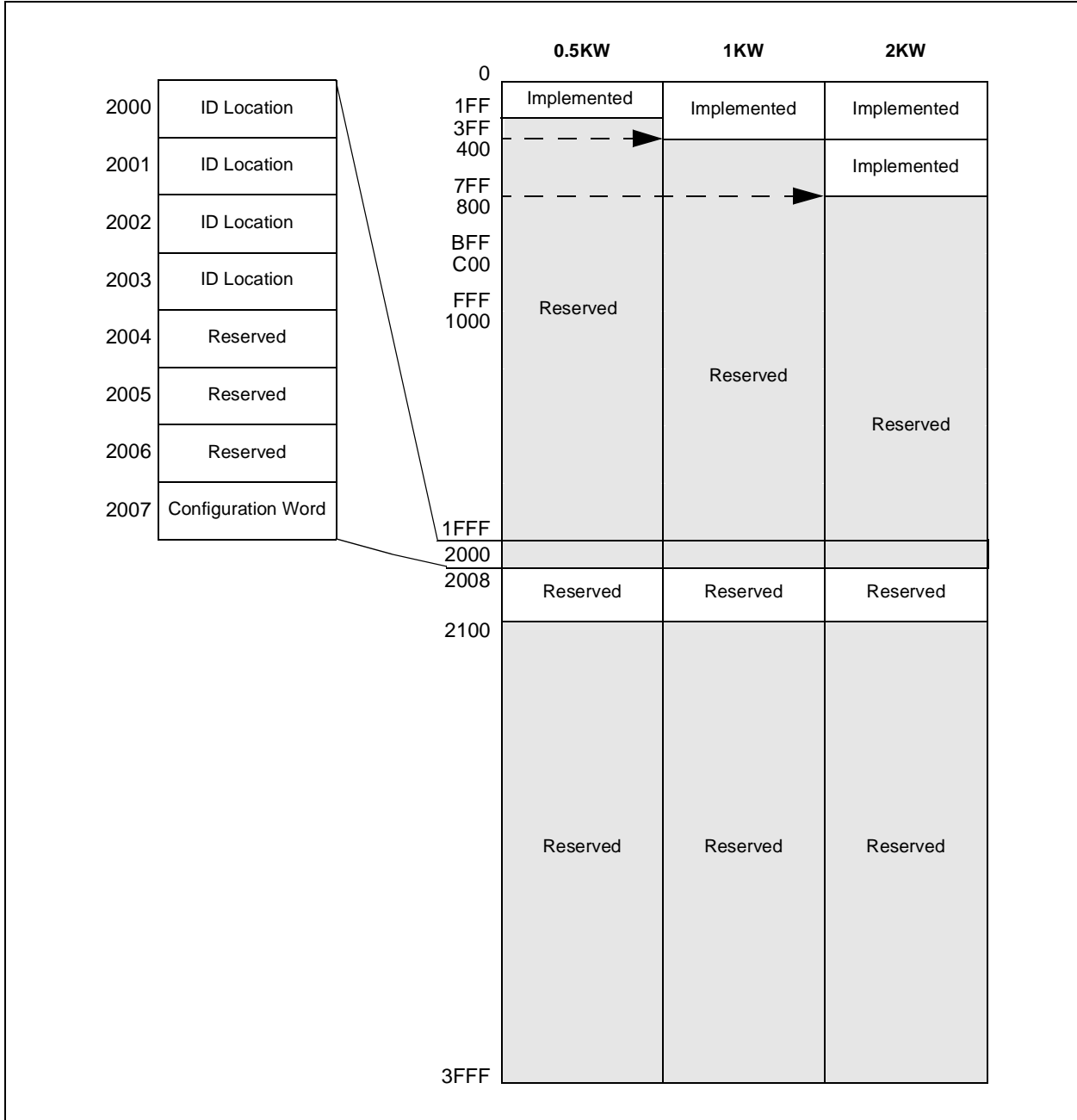

2.2 Program/Verify Mode

The program/verify mode is entered by holding pins RB6 and RB7 low while raising \overline{MCLR} pin from V_{IL} to V_{IH} (high voltage). Once in this mode the user program memory and the configuration memory can be accessed and programmed in serial fashion. The mode of operation is serial, and the memory that is accessed is the user program and configuration memory. RB6 is a Schmitt Trigger input in this mode.

The sequence that enters the device into the programming/verify mode places all other logic into the reset state (the \overline{MCLR} pin was initially at V_{IL}). This means that all I/O are in the reset state (High impedance inputs).

Note: The \overline{MCLR} pin should be raised as quickly as possible from V_{IL} to V_{IH} . This is to ensure that the device does not have the PC incremented while in valid operation range.

2.2.1 PROGRAM/VERIFY OPERATION

The RB6 pin is used as a clock input pin, and the RB7 pin is used for entering command bits and data input/output during serial operation. To input a command, the clock pin (RB6) is cycled six times. Each command bit is latched on the falling edge of the clock with the least significant bit (LSB) of the command being input first. The data on pin RB7 is required to have a minimum setup and hold time (see AC/DC specs) with respect to the falling edge of the clock. Commands that have data associated with them (read

and load) are specified to have a minimum delay of $1\mu s$ between the command and the data. After this delay the clock pin is cycled 16 times with the first cycle being a start bit and the last cycle being a stop bit. Data is also input and output LSB first. Therefore, during a read operation the LSB will be transmitted onto pin RB7 on the rising edge of the second cycle, and during a load operation the LSB will be latched on the falling edge of the second cycle. A minimum $1\mu s$ delay is also specified between consecutive commands.

The commands that are available are listed in Table 2-2.

2.2.1.1 LOAD CONFIGURATION

After receiving this command, the program counter (PC) will be set to $0x2000$. By then applying 16 cycles to the clock pin, the chip will load 14-bits a "data word" as described above, to be programmed into the configuration memory. A description of the memory mapping schemes for normal operation and configuration mode operation is shown in Figure 2-1. After the configuration memory is entered, the only way to get back to the user program memory is to exit the program/verify test mode by taking \overline{MCLR} low (V_{IL}).

TABLE 2-2: COMMAND MAPPING

Command	Mapping (MSB ... LSB)						Data
Load Configuration	0	0	0	0	0	0	0, data(14), 0
Load Data	0	0	0	0	1	0	0, data(14), 0
Read Data	0	0	0	1	0	0	0, data(14), 0
Increment Address	0	0	0	1	1	0	
Begin programming	0	0	1	0	0	0	
End Programming	0	0	1	1	1	0	

Note: The CPU clock must be disabled during in-circuit programming.

EPROM Memory Programming Specification

FIGURE 2-2: PROGRAM FLOW CHART - PIC16C55X PROGRAM MEMORY

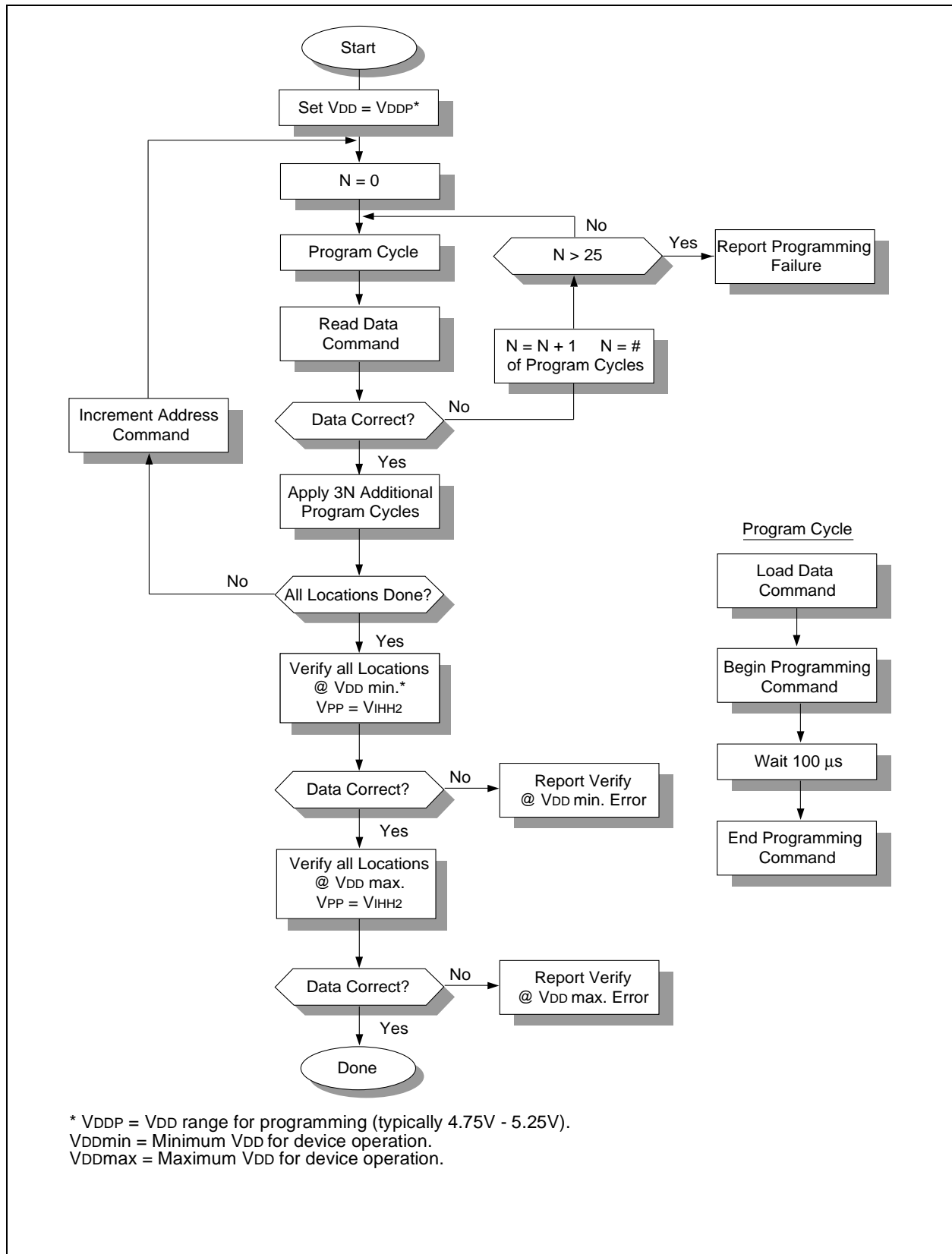

PIC16C55X

FIGURE 2-3: PROGRAM FLOW CHART - PIC16C55X CONFIGURATION WORD & ID LOCATIONS

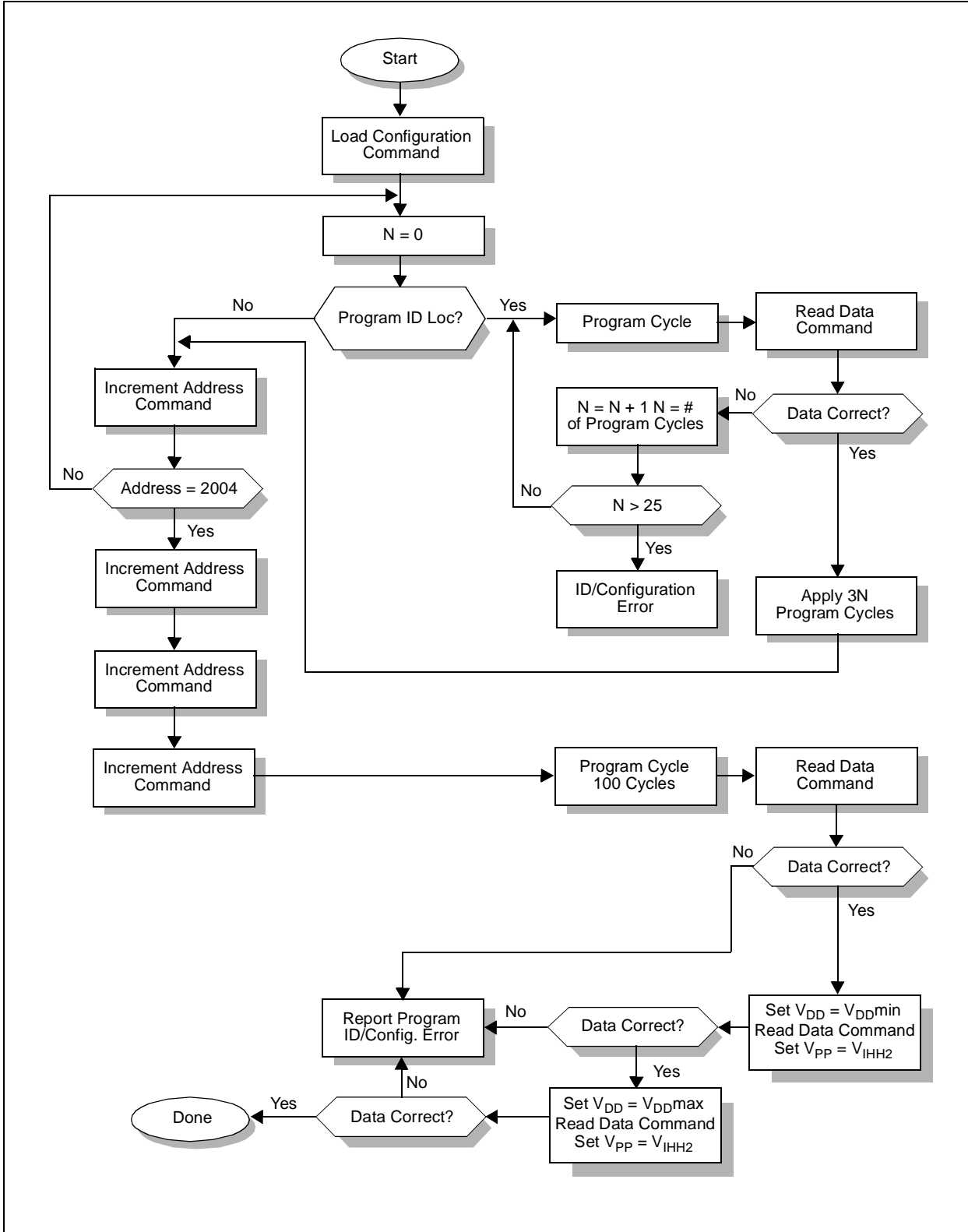

EPROM Memory Programming Specification

2.2.1.2 LOAD DATA

After receiving this command, the chip will load in a 14-bit “data word” when 16 cycles are applied, as described previously. A timing diagram for the load data command is shown in Figure 5-1.

2.2.1.3 READ DATA

After receiving this command, the chip will transmit data bits out of the memory currently accessed starting with the second rising edge of the clock input. The RB7 pin will go into output mode on the second rising clock edge, and it will revert back to input mode (hi-impedance) after the 16th rising edge. A timing diagram of this command is shown in Figure 5-2.

2.2.1.4 INCREMENT ADDRESS

The PC is incremented when this command is received. A timing diagram of this command is shown in Figure 5-3.

2.2.1.5 BEGIN PROGRAMMING

A load command (load configuration or load data) must be given before every begin programming command. Programming of the appropriate memory (test program memory or user program memory) will begin after this command is received and decoded. Programming should be performed with a series of 100 μ s programming pulses. A programming pulse is defined as the time between the begin programming command and the end programming command.

2.2.1.6 END PROGRAMMING

After receiving this command, the chip stops programming the memory (configuration program memory or user program memory) that it was programming at the time.

2.3 Programming Algorithm Requires Variable VDD

The PIC16C55X uses an intelligent algorithm. The algorithm calls for program verification at VDDmin as well as VDDmax. Verification at VDDmin guarantees good “erase margin”. Verification at VDDmax guarantees good “program margin”.

The actual programming must be done with VDD in the VDDP range (4.75 - 5.25V).

VDDP = VCC range required during programming.

VDD min. = minimum operating VDD spec for the part.

VDD max. = maximum operating VDD spec for the part.

Programmers must verify the PIC16C55X at its specified VDDmax and VDDmin levels. Since Microchip may introduce future versions of the PIC16C55X with a broader VDD range, it is best that these levels are user selectable (defaults are ok).

<p>Note: Any programmer not meeting these requirements may only be classified as “prototype” or “development” programmer but not a “production” quality programmer.</p>
--

PIC16C55X

3.0 CONFIGURATION WORD

The PIC16C55X family members have several configuration bits. These bits can be programmed (reads '0') or left unprogrammed (reads '1') to select various device configurations. Figure 3-1 provides an overview of configuration bits.

FIGURE 3-1: CONFIGURATION WORD BIT MAP

Bit Number:	13	12	11	10	9	8	7	6	5	4	3	2	1	0
PIC16C554/556/558	CP1	CP0	CP1	CP0	CP1	CP0	—	0	CP1	CP0	PWRTE	WDTE	FOSC1	FOSC0

bit 7: Reserved for future use
bit 6: Set to 0
bit 5-4: CP1:CP0, Code Protect
bit 8-13

Device	CP1	CP0	Code Protection
PIC16C554	0	0	All memory protected
	0	1	Do not use
	1	0	Do not use
	1	1	Code protection off
PIC16C556	0	0	All memory protected
	0	1	Upper 1/2 memory protected
	1	0	Do not use
	1	1	Code protection off
PIC16C558	0	0	All memory protected
	0	1	Upper 3/4 memory protected
	1	0	Upper 1/2 memory protected
	1	1	Code protection off

bit 3: **PWRTE**, Power Up Timer Enable Bit
PIC16C554/556/558:
0 = Power up timer enabled
1 = Power up timer disabled

bit 2: **WDTE**, WDT Enable Bit
1 = WDT enabled
0 = WDT disabled

bit 1-0:**FOSC<1:0>**, Oscillator Selection Bit
11: RC oscillator
10: HS oscillator
01: XT oscillator
00: LP oscillator

EPROM Memory Programming Specification

4.0 CODE PROTECTION

The program code written into the EPROM can be protected by writing to the CP0 & CP1 bits of the configuration word.

4.1 Programming Locations 0x0000 to 0x03F after Code Protection

For PIC16C55X devices, once code protection is enabled, all protected segments read '0's (or "garbage values") and are prevented from further programming. All unprotected segments, including ID locations and configuration word, read normally. These locations can be programmed.

4.2 Embedding Configuration Word and ID Information in the Hex File

To allow portability of code, the programmer is required to read the configuration word and ID locations from the hex file when loading the hex file. If configuration word information was not present in the hex file then a simple warning message may be issued. Similarly, while saving a hex file, configuration word and ID information must be included. An option to not include this information may be provided.

Microchip Technology Inc. feels strongly that this feature is important for the benefit of the end customer.

TABLE 4-1: CONFIGURATION WORD

PIC16C554

To code protect:

- Protect all memory 0000001000XXXX
- No code protection 1111111011XXXX

Program Memory Segment	R/W in Protected Mode	R/W in Unprotected Mode
Configuration Word (0x2007)	Read Unscrambled, Write Enabled	Read Unscrambled, Write Enabled
Protected memory segment	Read All 0's, Write Disabled	Read Unscrambled, Write Enabled
ID Locations (0x2000 : 0x2003)	Read Unscrambled, Write Enabled	Read Unscrambled, Write Enabled

PIC16C556

To code protect:

- Protect all memory 0000001000XXXX
- Protect upper 1/2 memory 0101011001XXXX
- No code protection 1111111011XXXX

Program Memory Segment	R/W in Protected Mode	R/W in Unprotected Mode
Configuration Word (0x2007)	Read Unscrambled, Write Enabled	Read Unscrambled, Write Enabled
Protected memory segment	Read All 0's, Write Disabled	Read Unscrambled, Write Enabled
ID Locations (0x2000 : 0x2003)	Read Unscrambled, Write Enabled	Read Unscrambled, Write Enabled

PIC16C558

To code protect:

- Protect all memory 0000001000XXXX
- Protect upper 3/4 memory 0101011001XXXX
- Protect upper 1/2 memory 1010101010XXXX
- No code protection 1111111011XXXX

Program Memory Segment	R/W in Protected Mode	R/W in Unprotected Mode
Configuration Word (0x2007)	Read Unscrambled, Write Enabled	Read Unscrambled, Write Enabled
Protected memory segment	Read All 0's, Write Disabled	Read Unscrambled, Write Enabled
ID Locations (0x2000 : 0x2003)	Read Unscrambled, Write Enabled	Read Unscrambled, Write Enabled

PIC16C55X

4.3 Checksum

4.3.1 CHECKSUM CALCULATIONS

Checksum is calculated by reading the contents of the PIC16C55X memory locations and adding up the opcodes up to the maximum user addressable location, e.g., 0x1FF for the PIC16C74. Any carry bits exceeding 16-bits are neglected. Finally, the configuration word (appropriately masked) is added to the checksum. Checksum computation for each member of the PIC16C55X devices is shown in Table 4-2.

The checksum is calculated by summing the following:

- The contents of all program memory locations
- The configuration word, appropriately masked
- Masked ID locations (when applicable)

The least significant 16 bits of this sum is the checksum.

The following table describes how to calculate the checksum for each device. Note that the checksum calculation differs depending on the code protect setting. Since the program memory locations read out differently depending on the code protect setting, the table describes how to manipulate the actual program memory values to simulate the values that would be read from a protected device. When calculating a checksum by reading a device, the entire program memory can simply be read and summed. The configuration word and ID locations can always be read.

Note that some older devices have an additional value added in the checksum. This is to maintain compatibility with older device programmer checksums.

TABLE 4-2: CHECKSUM COMPUTATION

Device	Code Protect	Checksum*	Blank Value	0x25E6 at 0 and max address
PIC16C554	OFF	SUM[0x000:0x1FF] + CFGW & 0x3F3F	3D3F	090D
	ALL	SUM_ID + CFGW & 0x3F3F	3D4E	091C
PIC16C556	OFF	SUM[0x000:0x3FF] + CFGW & 0x3F3F	3B3F	070D
	1/2	SUM[0x000:0x1FF] + CFGW & 0x3F3F + SUM_ID	4E5E	0013
	ALL	CFGW & 0x3F3F + SUM_ID	3B4E	071C
PIC16C558	OFF	SUM[0x000:0x7FF] + CFGW & 0x3F3F	373F	030D
	1/2	SUM[0x000:0x3FF] + CFGW & 0x3F3F + SUM_ID	5D6E	0F23
	3/4	SUM[0x000:0x1FF] + CFGW & 0x3F3F + SUM_ID	4A5E	FC13
	ALL	CFGW & 0x3F3F + SUM_ID	374E	031C

Legend: CFGW = Configuration Word

SUM[a:b] = [Sum of locations a through b inclusive]

SUM_ID = ID locations masked by 0xF then made into a 16-bit value with ID0 as the most significant nibble.

For example,

ID0 = 0x12, ID1 = 0x37, ID2 = 0x4, ID3 = 0x26, then SUM_ID = 0x2746.

*Checksum = [Sum of all the individual expressions] **MODULO** [0xFFFF]

+ = Addition

& = Bitwise AND

EPROM Memory Programming Specification

5.0 PROGRAM/VERIFY MODE ELECTRICAL CHARACTERISTICS

**TABLE 5-1: AC/DC CHARACTERISTICS
TIMING REQUIREMENTS FOR PROGRAM/VERIFY TEST MODE**

Standard Operating Conditions							
Operating Temperature: $+10^{\circ}\text{C} \leq T_A \leq +40^{\circ}\text{C}$, unless otherwise stated, (25°C is recommended)							
Operating Voltage: $4.5\text{V} \leq V_{DD} \leq 5.5\text{V}$, unless otherwise stated.							
Parameter No.	Sym.	Characteristic	Min.	Typ.	Max.	Units	Conditions
General							
PD1	VDDP	Supply voltage during programming	4.75	5.0	5.25	V	
PD2	IDDP	Supply current (from VDD) during programming	-	-	20	mA	
PD3	VDDV	Supply voltage during verify	VDDmin	-	VDDmax	V	Note 1
PD4	VIHH1	Voltage on $\overline{\text{MCLR}}/\text{VPP}$ during programming	12.75	-	13.25	V	Note 2
PD5	VIHH2	Voltage on $\overline{\text{MCLR}}/\text{VPP}$ during verify	VDD + 4.0	-	13.5	-	
PD6	I _{PP}	Programming supply current (from VPP)	-	-	50	mA	
PD9	VIH1	(RB6, RB7) input high level	0.8 VDD	-	-	V	Schmitt Trigger input
PD8	VIL1	(RB6, RB7) input low level	0.2 VDD	-	-	V	Schmitt Trigger input

Serial Program Verify							
P1	T _R	$\overline{\text{MCLR}}/\text{VPP}$ rise time (V _{SS} to V _{HH}) for test mode entry	-	-	8.0	μs	
P2	T _f	$\overline{\text{MCLR}}$ Fall time	-	-	8.0	μs	
P3	T _{set1}	Data in setup time before clock ↓	100	-	-	ns	
P4	T _{hd1}	Data in hold time after clock ↓	100	-	-	ns	
P5	T _{dly1}	Data input not driven to next clock input (delay required between command/data or command/command)	1.0	-	-	μs	
P6	T _{dly2}	Delay between clock ↓ to clock ↑ of next command or data	1.0	-	-	μs	
P7	T _{dly3}	Clock ↑ to data out valid (during read data)	200	-	-	ns	
P8	T _{hd0}	Hold time after $\overline{\text{MCLR}}$ ↑	2	-	-	μs	
-	T _{pw}	Programming Pulse Width	10	100	1000	μs	

Note 1: Program must be verified at the minimum and maximum VDD limits for the part.

Note 2: VIHH must be greater than VDD + 4.5V to stay in programming/verify mode.

PIC16C55X

FIGURE 5-1: LOAD DATA COMMAND (PROGRAM/VERIFY)

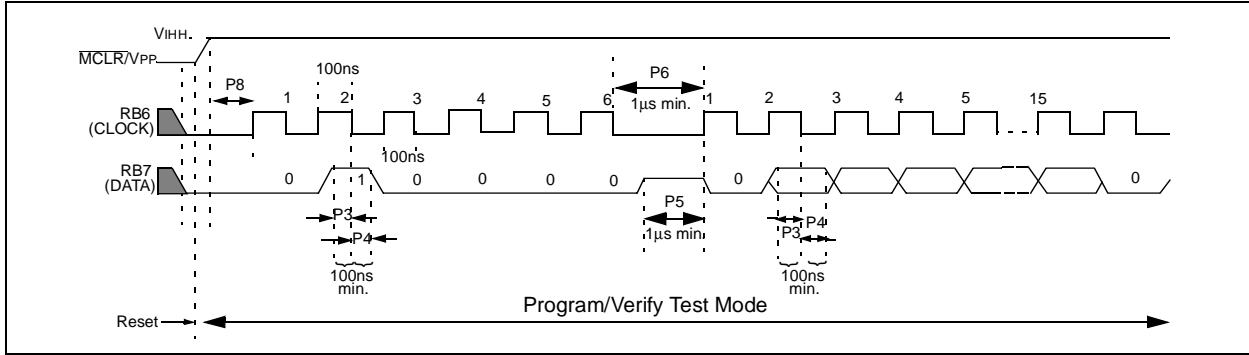

FIGURE 5-2: READ DATA COMMAND (PROGRAM/VERIFY)

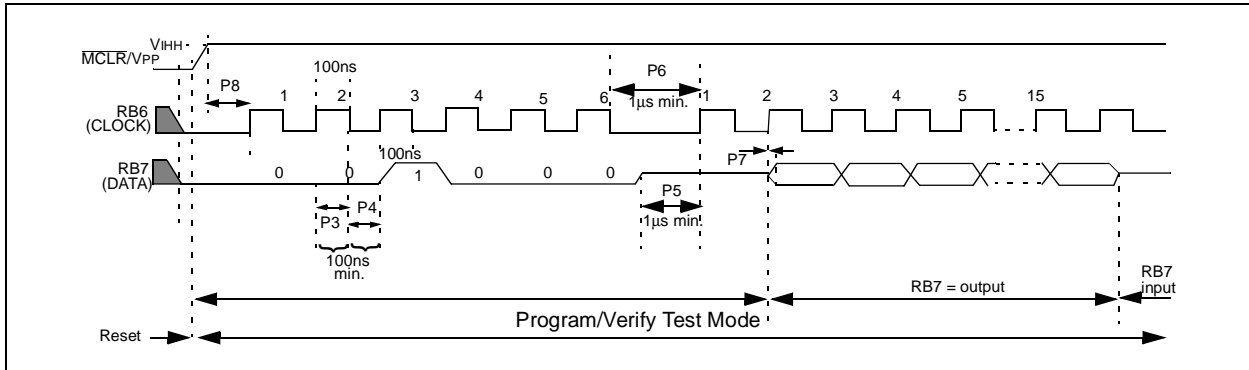
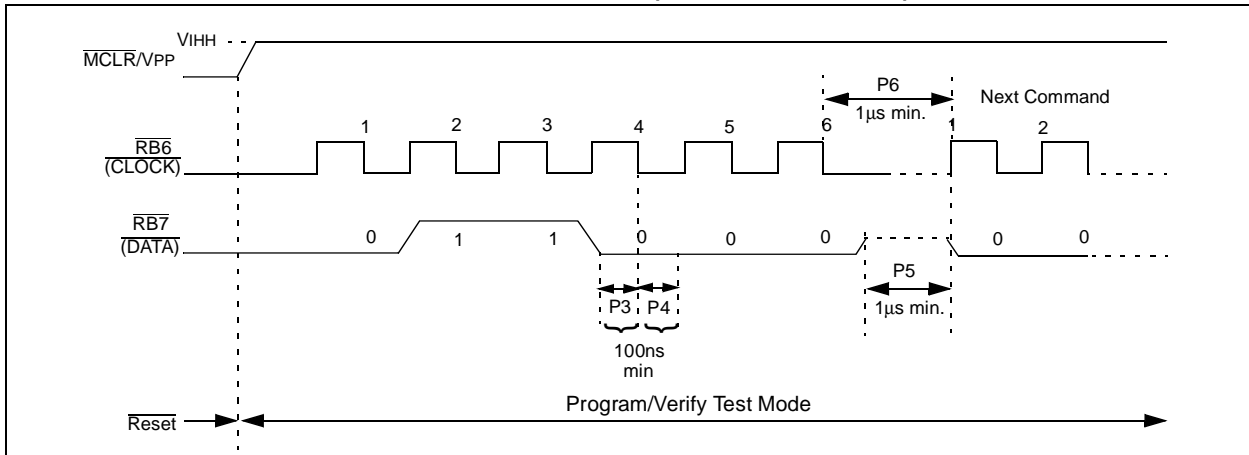

FIGURE 5-3: INCREMENT ADDRESS COMMAND (PROGRAM/VERIFY)



EPROM Memory Programming Specification

NOTES:



WORLDWIDE SALES AND SERVICE

AMERICAS

Corporate Office

Microchip Technology Inc.
2355 West Chandler Blvd.
Chandler, AZ 85224-6199
Tel: 480-786-7200 Fax: 480-786-7277
Technical Support: 480-786-7627
Web Address: <http://www.microchip.com>

Atlanta

Microchip Technology Inc.
500 Sugar Mill Road, Suite 200B
Atlanta, GA 30350
Tel: 770-640-0034 Fax: 770-640-0307

Boston

Microchip Technology Inc.
5 Mount Royal Avenue
Marlborough, MA 01752
Tel: 508-480-9990 Fax: 508-480-8575

Chicago

Microchip Technology Inc.
333 Pierce Road, Suite 180
Itasca, IL 60143
Tel: 630-285-0071 Fax: 630-285-0075

Dallas

Microchip Technology Inc.
4570 Westgrove Drive, Suite 160
Addison, TX 75248
Tel: 972-818-7423 Fax: 972-818-2924

Dayton

Microchip Technology Inc.
Two Prestige Place, Suite 150
Miamisburg, OH 45342
Tel: 937-291-1654 Fax: 937-291-9175

Detroit

Microchip Technology Inc.
Tri-Atria Office Building
32255 Northwestern Highway, Suite 190
Farmington Hills, MI 48334
Tel: 248-538-2250 Fax: 248-538-2260

Los Angeles

Microchip Technology Inc.
18201 Von Karman, Suite 1090
Irvine, CA 92612
Tel: 949-263-1888 Fax: 949-263-1338

New York

Microchip Technology Inc.
150 Motor Parkway, Suite 202
Hauppauge, NY 11788
Tel: 631-273-5305 Fax: 631-273-5335

San Jose

Microchip Technology Inc.
2107 North First Street, Suite 590
San Jose, CA 95131
Tel: 408-436-7950 Fax: 408-436-7955

AMERICAS (continued)

Toronto

Microchip Technology Inc.
5925 Airport Road, Suite 200
Mississauga, Ontario L4V 1W1, Canada
Tel: 905-405-6279 Fax: 905-405-6253

ASIA/PACIFIC

Hong Kong

Microchip Asia Pacific
Unit 2101, Tower 2
Metroplaza
223 Hing Fong Road
Kwai Fong, N.T., Hong Kong
Tel: 852-2-401-1200 Fax: 852-2-401-3431

Beijing

Microchip Technology, Beijing
Unit 915, 6 Chaoyangmen Bei Dajie
Dong Erhuan Road, Dongcheng District
New China Hong Kong Manhattan Building
Beijing 100027 PRC
Tel: 86-10-85282100 Fax: 86-10-85282104

India

Microchip Technology Inc.
India Liaison Office
No. 6, Legacy, Convent Road
Bangalore 560 025, India
Tel: 91-80-229-0061 Fax: 91-80-229-0062

Japan

Microchip Technology Intl. Inc.
Benex S-1 6F
3-18-20, Shinyokohama
Kohoku-Ku, Yokohama-shi
Kanagawa 222-0033 Japan
Tel: 81-45-471-6166 Fax: 81-45-471-6122

Korea

Microchip Technology Korea
168-1, Youngbo Bldg. 3 Floor
Samsung-Dong, Kangnam-Ku
Seoul, Korea
Tel: 82-2-554-7200 Fax: 82-2-558-5934

Shanghai

Microchip Technology
RM 406 Shanghai Golden Bridge Bldg.
2077 Yan'an Road West, Hong Qiao District
Shanghai, PRC 200335
Tel: 86-21-6275-5700 Fax: 86 21-6275-5060

ASIA/PACIFIC (continued)

Singapore

Microchip Technology Singapore Pte Ltd.
200 Middle Road
#07-02 Prime Centre
Singapore 188980
Tel: 65-334-8870 Fax: 65-334-8850

Taiwan, R.O.C

Microchip Technology Taiwan
10F-1C 207
Tung Hua North Road
Taipei, Taiwan, ROC
Tel: 886-2-2717-7175 Fax: 886-2-2545-0139

EUROPE

United Kingdom

Arizona Microchip Technology Ltd.
505 Eskdale Road
Wokingham
Berkshire, England RG41 5TU
Tel: 44 118 921 5858 Fax: 44-118 921-5835

Denmark

Microchip Technology Denmark ApS
Regus Business Centre
Lautrup hof 1-3
Ballerup DK-2750 Denmark
Tel: 45 4420 9895 Fax: 45 4420 9910

France

Arizona Microchip Technology SARL
Parc d'Activite du Moulin de Massy
43 Rue du Saule Trapu
Batiment A - 1er Etage
91300 Massy, France
Tel: 33-1-69-53-63-20 Fax: 33-1-69-30-90-79

Germany

Arizona Microchip Technology GmbH
Gustav-Heinemann-Ring 125
D-81739 München, Germany
Tel: 49-89-627-144 0 Fax: 49-89-627-144-44

Italy

Arizona Microchip Technology SRL
Centro Direzionale Colleoni
Palazzo Taurus 1 V. Le Colleoni 1
20041 Agrate Brianza
Milan, Italy
Tel: 39-039-65791-1 Fax: 39-039-6899883

11/15/99

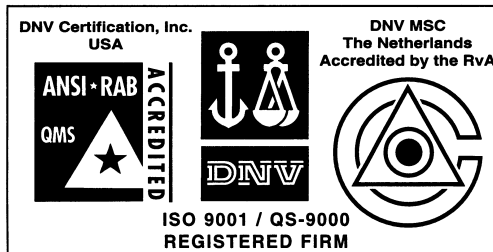

Microchip received QS-9000 quality system certification for its worldwide headquarters, design and water fabrication facilities in Chandler and Tempe, Arizona in July 1999. The Company's quality system processes and procedures are QS-9000 compliant for its PICmicro® 8-bit MCUs, KEELOC® code hopping devices, Serial EEPROMs and microperipheral products. In addition, Microchip's quality system for the design and manufacture of development systems is ISO 9001 certified.

All rights reserved. © 1999 Microchip Technology Incorporated. Printed in the USA. 11/99 Printed on recycled paper.

Information contained in this publication regarding device applications and the like is intended for suggestion only and may be superseded by updates. No representation or warranty is given and no liability is assumed by Microchip Technology Incorporated with respect to the accuracy or use of such information, or infringement of patents or other intellectual property rights arising from such use or otherwise. Use of Microchip's products as critical components in life support systems is not authorized except with express written approval by Microchip. No licenses are conveyed, implicitly or otherwise, under any intellectual property rights. The Microchip logo and name are registered trademarks of Microchip Technology Inc. in the U.S.A. and other countries. All rights reserved. All other trademarks mentioned herein are the property of their respective companies.