

Programming Specifications for PIC16C432 OTP MCUs

This document includes the programming specifications for the following device:

- PIC16C432

1.0 PROGRAMMING THE PIC16C432

The PIC16C432 can be programmed using a serial method. In Serial mode, the PIC16C432 can be programmed while in the users system. This allows for increased design flexibility. This programming specification applies to PIC16C432 devices in all packages.

1.1 Hardware Requirements

The PIC16C432 requires two programmable power supplies, one for VDD (2.0V to 6.5V recommended) and one for VPP (12V to 14V). Both supplies should have a minimum resolution of 0.25V.

1.2 Programming Mode

The Programming mode for the PIC16C432 allows programming of user program memory, special locations used for ID, and the configuration word for the PIC16C432.

Pin Diagram

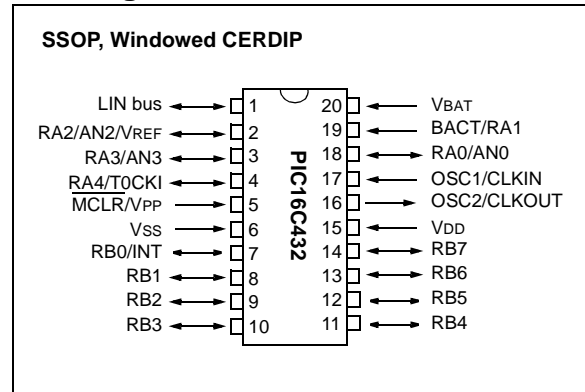

TABLE 1-1: PIN DESCRIPTIONS (DURING PROGRAMMING): PIC16C432

Pin Name	During Programming		
	Pin Name	Pin Type	Pin Description
RB6	CLOCK	I	Clock Input
RB7	DATA	I/O	Data Input/Output
MCLR/VPP	VPP	P	Programming Power
VDD	VDD	P	Power Supply
VSS	VSS	P	Ground

PIC16C432

2.0 PROGRAM MODE ENTRY

2.1 User Program Memory Map

The user memory space extends from 0x0000 to 0x1FFF (8K). Table 2-1 shows actual implementation of program memory in the PIC16C432 family.

TABLE 2-1: IMPLEMENTATION OF PROGRAM MEMORY IN THE PIC16C432

Device	Program Memory Size
PIC16C432	0x000 – 0x7FF (2K)

When the PC reaches the last location of the implemented program memory, it will wrap around and address a location within the physically implemented memory (see Figure 2-1).

Once in configuration memory, the highest bit of the PC stays a '1', thus always pointing to the configuration memory. The only way to point to user program memory is to reset the part and reenter Program/Verify mode, as described in Section 2.2.

A user may store identification information (ID) in four ID locations. The ID locations are mapped in [0x2000 : 0x2003]. It is recommended that the user use only the four least significant bits of each ID location. In some devices, the ID locations read out in a scrambled fashion, after code protection is enabled. For these devices, it is recommended that ID location is written as "11 1111 1bbb bbbb" where 'bbbb' is ID information.

Note: All other locations are reserved and should not be programmed.

In other devices, the ID locations read out normally, even after code protection. To understand how the devices behave, refer to Table 4-1.

To understand the scrambling mechanism after code protection, refer to Section 3.1.

FIGURE 2-1: PROGRAM MEMORY MAPPING

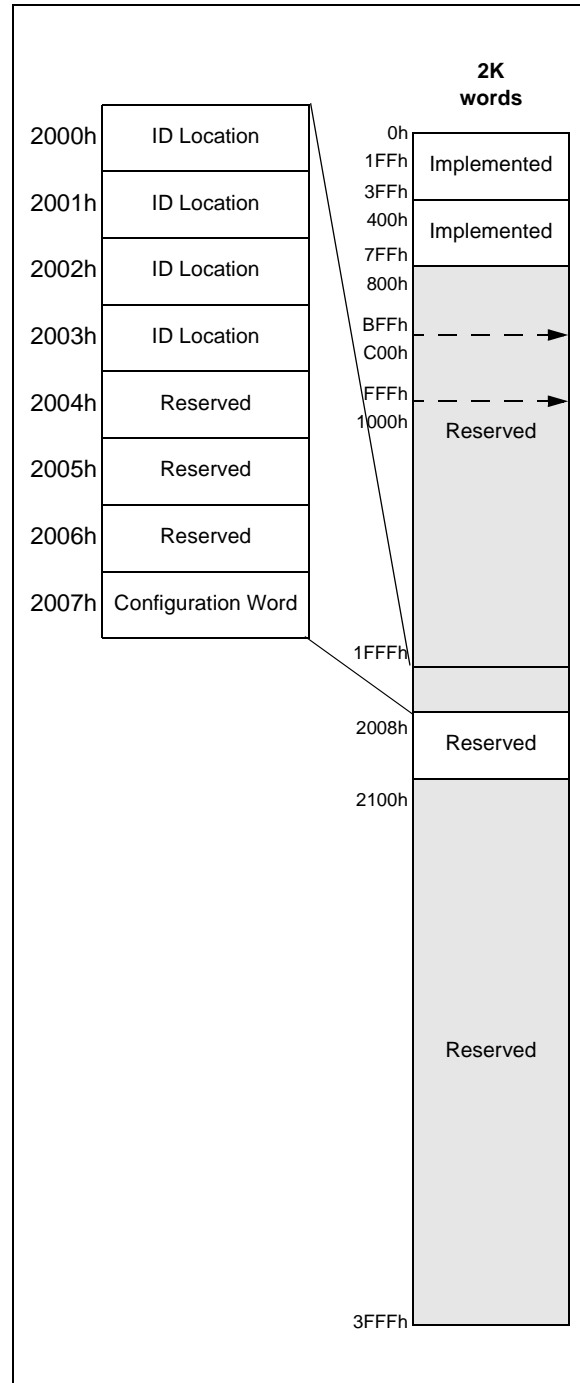

2.2 Program/Verify Mode

The Program/Verify mode is entered by holding pins RB6 and RB7 low, while raising $\overline{\text{MCLR}}$ pin from VSS to the appropriate V_{IH} (high voltage). Once in this mode, the user program memory and the configuration memory can be accessed and programmed in serial fashion. The mode of operation is serial, and the memory that is accessed is the user program memory. RB6 is a Schmitt Trigger input in this mode.

The sequence that enters the device into the Programming/Verify mode places all other logic into the RESET state (the $\overline{\text{MCLR}}$ pin was initially at VSS). This means that all I/O are in the RESET state (hi-impedance inputs).

- Note 1:** The $\overline{\text{MCLR}}$ pin should be raised as quickly as possible from V_{IL} to V_{IH} . This is to ensure that the device does not have the PC incremented while in valid operation range.
- 2:** Do not power any pin before VDD is applied.

2.2.1 PROGRAM/VERIFY OPERATION

The RB6 pin is used as a clock input pin, and the RB7 pin is used for entering command bits and data input/output during serial operation. To input a command, the clock pin (RB6) is cycled six times. Each command bit is latched on the falling edge of the clock with the least significant bit (LSb) of the command being input first. The data on pin RB7 is required to have a minimum setup and hold time (see AC/DC specs), with respect to the falling edge of the clock. Commands that have data

associated with them (read and load) are specified to have a minimum delay of 1 μs between the command and the data. After this delay, the clock pin is cycled 16 times with the first cycle being a START bit and the last cycle being a STOP bit. Data is also input and output LSb first. Therefore, during a read operation, the LSb will be transmitted onto pin RB7 on the rising edge of the second cycle and during a load operation, the LSb will be latched on the falling edge of the second cycle. A minimum 1 μs delay is also specified between consecutive commands.

All commands are transmitted LSb first. Data words are also transmitted LSb first. The data is transmitted on the rising edge and latched on the falling edge of the clock. To allow for decoding of commands and reversal of data pin configuration, a time separation of at least 1 μs is required between a command and a data word (or another command).

The commands that are available are listed in Table 2-2.

2.2.1.1 Load Configuration

After receiving this command, the program counter (PC) will be set to 0x2000. By then applying 16 cycles to the clock pin, the chip will load 14-bits, a "data word" as described above, to be programmed into the configuration memory. A description of the memory mapping schemes for normal operation and Configuration mode operation is shown in Figure 2-1. After the configuration memory is entered, the only way to get back to the user program memory is to exit the Program/Verify Test mode by taking $\overline{\text{MCLR}}$ low (V_{IL}).

TABLE 2-2: COMMAND MAPPING

Command	Mapping (MSb ... LSb)	Data
Load Configuration	0 0 0 0 0 0	0, data(14), 0
Load Data	0 0 0 0 1 0	0, data(14), 0
Read Data	0 0 0 1 0 0	0, data(14), 0
Increment Address	0 0 0 1 1 0	
Begin programming	0 0 1 0 0 0	
End Programming	0 0 1 1 1 0	

Note: The clock must be disabled during In-Circuit Serial Programming (ICSP™).

PIC16C432

FIGURE 2-2: PROGRAM FLOW CHART - PIC16C432 PROGRAM MEMORY

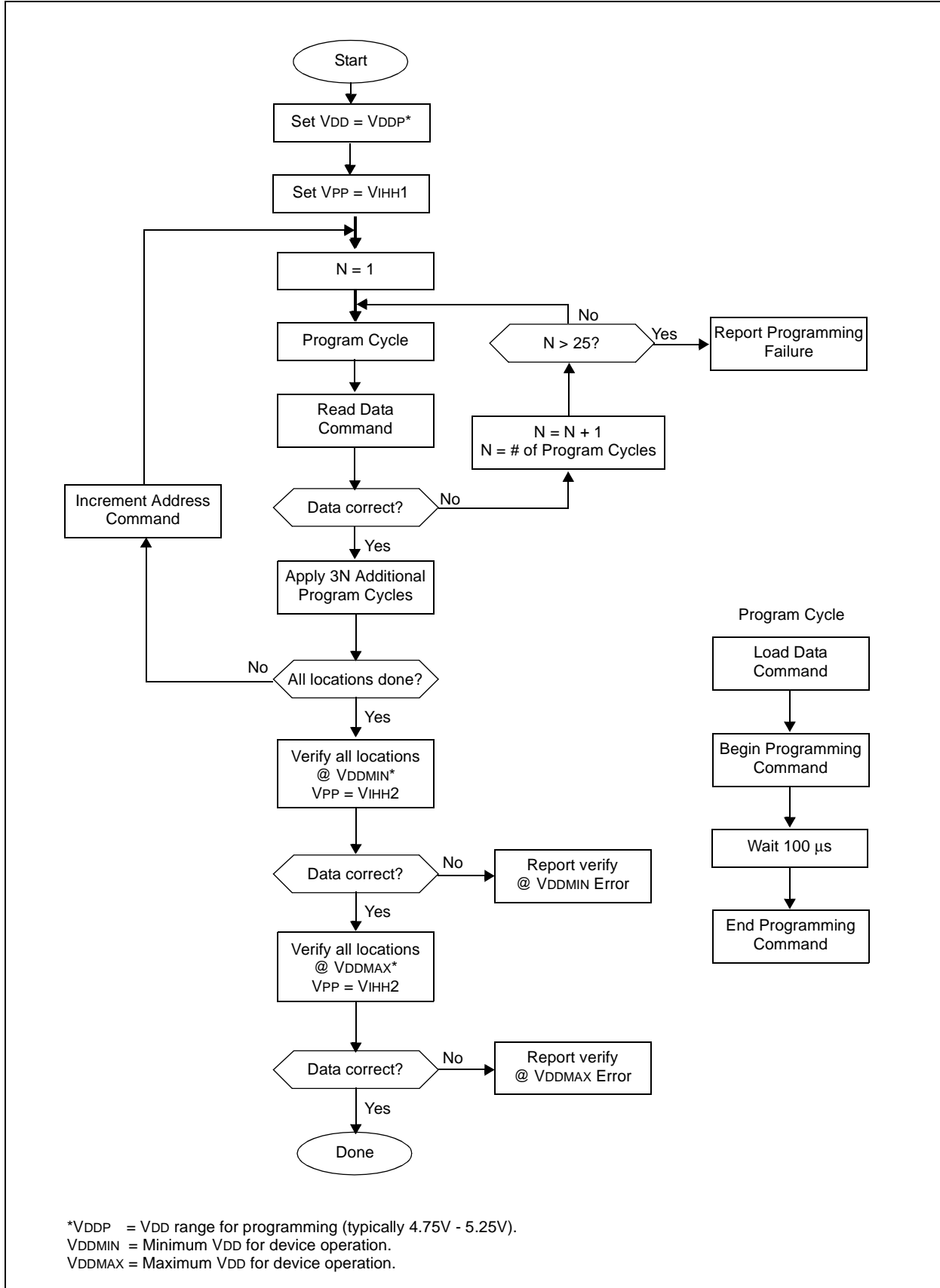
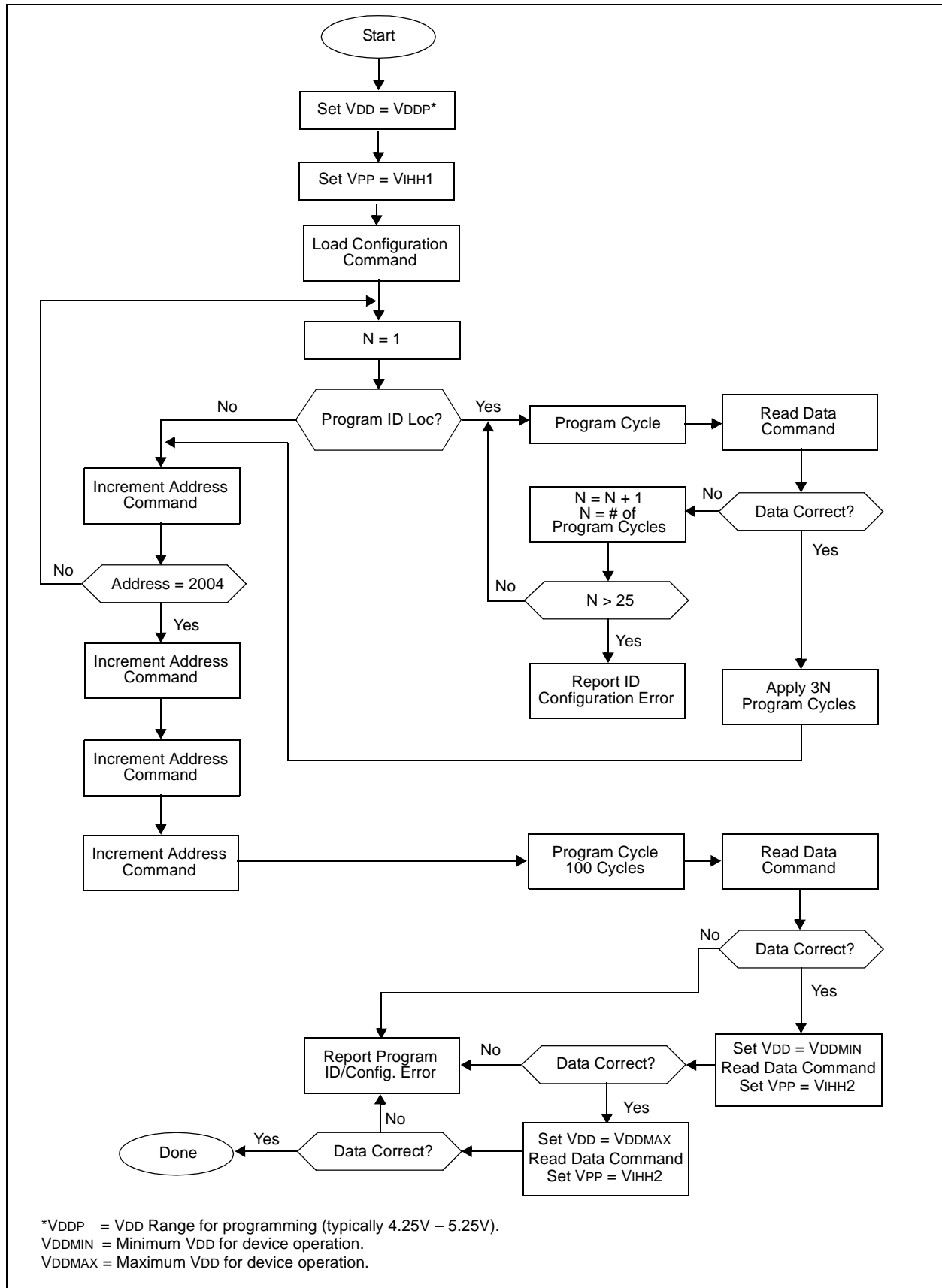

FIGURE 2-3: PROGRAM FLOW CHART - PIC16C432 CONFIGURATION WORD & ID LOCATIONS



PIC16C432

2.2.1.2 Load Data

After receiving this command, the chip will load in a 14-bit “data word” when 16 cycles are applied, as described previously. A timing diagram for the load data command is shown in Figure 4-1.

2.2.1.3 Read Data

After receiving this command, the chip will transmit data bits out of the memory currently accessed, starting with the second rising edge of the clock input. The RB7 pin will go into output mode on the second rising clock edge, and it will revert back to input mode (hi-impedance) after the 16th rising edge. A timing diagram of this command is shown in Figure 4-2.

2.2.1.4 Increment Address

The PC is incremented when this command is received. A timing diagram of this command is shown in Figure 4-3.

2.2.1.5 Begin Programming

A load command (load configuration or load data) must be given before every begin programming command. Programming of the appropriate memory (test program memory or user program memory) will begin after this command is received and decoded. Programming should be performed with a series of 100 μ s programming pulses. A programming pulse is defined as the time between the begin programming command and the end programming command.

2.2.1.6 End Programming

After receiving this command, the chip stops programming the memory (configuration program memory or user program memory) that it was programming at the time.

2.3 Programming Algorithm Requires Variable VDD

The PIC16C432 uses an intelligent algorithm. The algorithm calls for program verification at VDDMIN as well as VDDMAX. Verification at VDDMIN guarantees good “erase margin”. Verification at VDDMAX guarantees good “program margin”.

The actual programming must be done with VDD in the VDDP range (4.75 - 5.25V).

VDDP = VCC range required during programming.

VDDMIN = minimum operating VDD spec for the part.

VDDMAX = maximum operating VDD spec for the part.

Programmers must verify the PIC16C432 at its specified VDDMAX and VDDMIN levels. Since Microchip may introduce future versions of the PIC16C432 with a broader VDD range, it is best that these levels are user selectable (defaults are ok).

<p>Note: Any programmer not meeting these requirements may only be classified as “prototype” or “development” programmer, but not a “production” quality programmer.</p>

3.0 CONFIGURATION WORD

The PIC16C432 family members have several configuration bits. These bits can be programmed (reads '0') or left unprogrammed (reads '1') to select various device configurations. Figure 3-1 provides an overview of configuration bits.

FIGURE 3-1: CONFIGURATION WORD BIT MAP

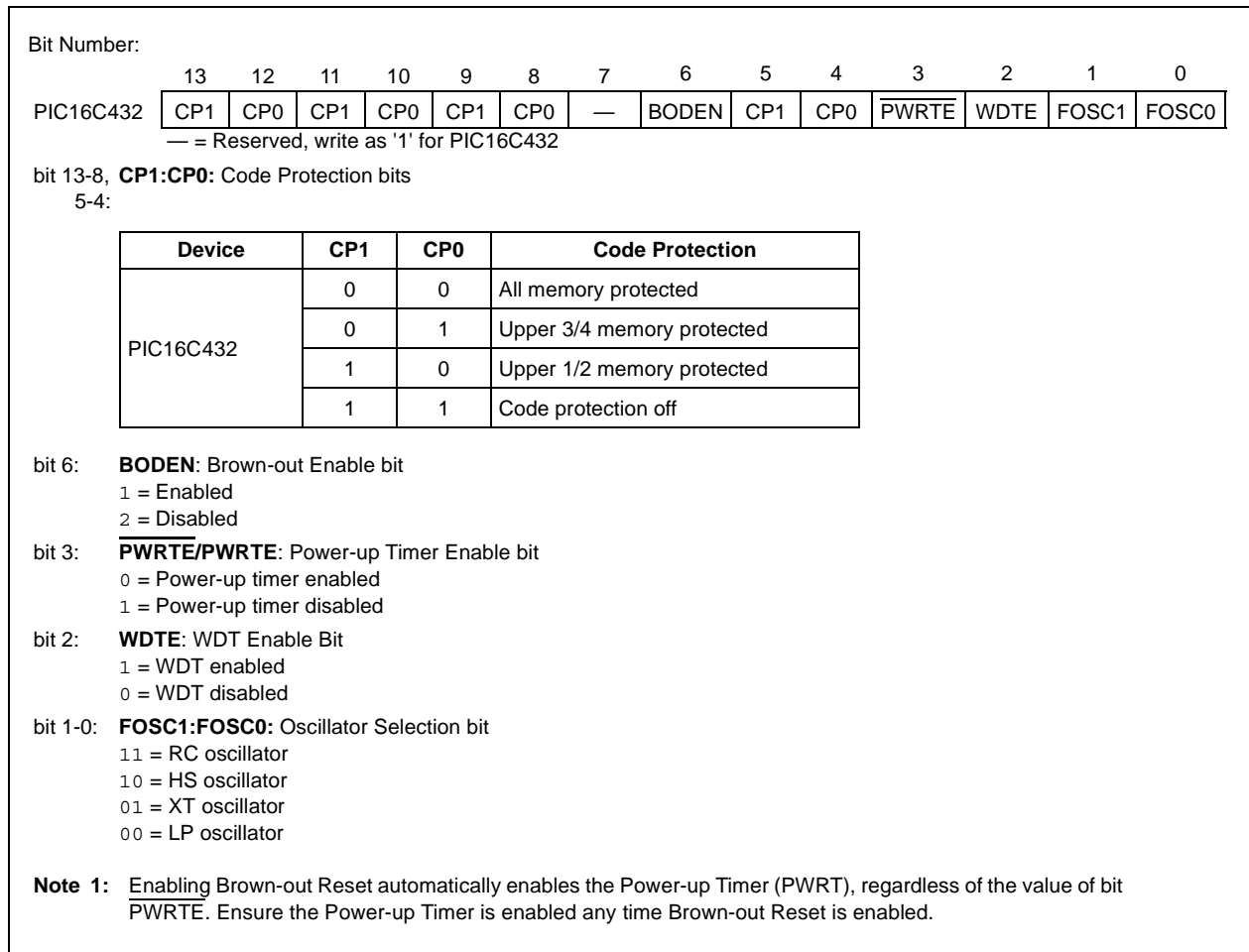

3.1 Embedding Configuration Word and ID Information in the HEX File.

To allow portability of code, the programmer is required to read the configuration word and ID locations from the HEX file when loading the HEX file. If configuration word information was not present in the HEX file, then a simple warning message may be issued. Similarly, while saving a HEX file, configuration word and ID information must be included. An option to not include this information may be provided.

Microchip Technology Inc. feels strongly that this feature is beneficial to the end customer.

PIC16C432

3.2 Checksum

3.2.1 CHECKSUM CALCULATIONS

Checksum is calculated by reading the contents of the PIC16C432 memory locations and adding up the opcodes, up to the maximum user addressable location, e.g., 0x7FF for the PIC16C432. Any carry bits exceeding 16 bits are neglected. Finally, the configuration word (appropriately masked) is added to the checksum. Checksum computation for the PIC16C432 device is shown in Table 3-1.

The checksum is calculated by summing the following:

- The contents of all program memory locations
- The configuration word, appropriately masked
- Masked ID locations (when applicable)

The least significant 16 bits of this sum is the checksum.

The following table describes how to calculate the checksum for the device. Note that the checksum calculation differs depending on the code protect setting. Since the program memory locations read out differently depending on the code protect setting, the table describes how to manipulate the actual program memory values to simulate the values that would be read from a protected device. When calculating a checksum by reading a device, the entire program memory can simply be read and summed. The configuration word and ID locations can always be read.

Note that some older devices have an additional value added in the checksum. This is to maintain compatibility with older device programmer checksums.

TABLE 3-1: CHECKSUM COMPUTATION

Device	Code Protect	Checksum*	Blank Value	0x25E6 at 0 and Max Address
PIC16C432	OFF	SUM[0x000:0x7FF] + CFGW & 0x3F7F	0x377F	0x034D
	1/2	SUM[0x000:0x3FF] + CFGW & 0x3F7F + SUM_ID	0x5DEE	0x0FA3
	3/4	SUM[0x000:0x1FF] + CFGW & 0x3F7F + SUM_ID	0x4ADE	0xFC93
	ALL	CFGW & 0x3F7F + SUM_ID	0x37CE	0x039C

Legend: CFGW = Configuration Word
 SUM[a:b] = [Sum of locations a through b inclusive]
 SUM_XNOR7[a:b] = XNOR of the seven high order bits of memory location with the seven low order bits summed over locations a through b inclusive. For example, XNOR(0x3C31)=0x78 XNOR 0c31 = 0x0036.
 SUM_ID = ID locations masked by 0xF, then made into a 16-bit value with ID0 as the most significant nibble. For example, ID0 = 0x12, ID1 = 0x37, ID2 = 0x4, ID3 = 0x26, then SUM_ID = 0x2746. SUM_ID defaults to the non-code protected checksum.
 *Checksum = [Sum of all the individual expressions] **MODULO** [0xFFFF]
 + = Addition
 & = Bitwise AND
 | = Bitwise OR

4.0 PROGRAM/VERIFY MODE

TABLE 4-1: AC/DC CHARACTERISTICS/TIMING REQUIREMENTS FOR PROGRAM/VERIFY TEST MODE

Standard Operating Conditions							
Operating Temperature: $+10^{\circ}\text{C} \leq T_A \leq +40^{\circ}\text{C}$, unless otherwise stated, (20°C recommended)							
Operating Voltage: $4.5\text{V} \leq V_{DD} \leq 5.5\text{V}$, unless otherwise stated							
Parameter No.	Sym.	Characteristic	Min.	Typ.	Max.	Units	Conditions
General							
PD1	VDDP	Supply voltage during programming	4.75	5.0	5.25	V	
PD2	IDDP	Supply current (from VDD) during programming	–	–	20	mA	
PD3	VDDV	Supply voltage during verify	VDDMIN	–	VDDMAX	V	(Note 1)
PD4	VIHH1	Voltage on $\overline{\text{MCLR}}/\text{VPP}$ during programming	12.75	–	13.25	V	(Note 2)
PD5	VIHH2	Voltage on $\overline{\text{MCLR}}/\text{VPP}$ during verify	$V_{DD} + 4.5$	–	13.25	–	
PD6	I _{PP}	Programming supply current (from VPP)	–	–	50	mA	
PD9	V _{IH}	(RB6, RB7) input high level	0.8 V _{DD}	–	–	V	Schmitt Trigger input
PD8	V _{IL}	(RB6, RB7) input low level	0.2 V _{DD}	–	–	V	Schmitt Trigger input

Serial Program Verify							
P1	T _R	$\overline{\text{MCLR}}/\text{VPP}$ rise time (V _{SS} to V _{IHH}) for Test mode entry	–	–	8.0	μs	
P2	T _f	$\overline{\text{MCLR}}$ fall time	–	–	8.0	μs	
P3	T _{set1}	Data in setup time before clock ↓	100	–	–	ns	
P4	T _{hd1}	Data in hold time after clock ↓	100	–	–	ns	
P5	T _{dly1}	Data input not driven to next clock input (delay required between command/data or command/command)	1.0	–	–	μs	
P6	T _{dly2}	Delay between clock ↓ to clock ↑ of next command or data	1.0	–	–	μs	
P7	T _{dly3}	Clock ↑ to data out valid (during read data)	200	–	–	ns	
P8	T _{hd0}	Hold time after $\overline{\text{MCLR}}$ ↑	2	–	–	μs	

Note 1: Program must be verified at the minimum and maximum V_{DD} limits for the part.

2: V_{IHH} must be greater than V_{DD} + 4.5V to stay in Programming/Verify mode.

NOTES:



WORLDWIDE SALES AND SERVICE

AMERICAS

Corporate Office

2355 West Chandler Blvd.
Chandler, AZ 85224-6199
Tel: 480-792-7200 Fax: 480-792-7277
Technical Support: 480-792-7627
Web Address: <http://www.microchip.com>

Rocky Mountain

2355 West Chandler Blvd.
Chandler, AZ 85224-6199
Tel: 480-792-7966 Fax: 480-792-7456

Atlanta

500 Sugar Mill Road, Suite 200B
Atlanta, GA 30350
Tel: 770-640-0034 Fax: 770-640-0307

Boston

2 Lan Drive, Suite 120
Westford, MA 01886
Tel: 978-692-3848 Fax: 978-692-3821

Chicago

333 Pierce Road, Suite 180
Itasca, IL 60143
Tel: 630-285-0071 Fax: 630-285-0075

Dallas

4570 Westgrove Drive, Suite 160
Addison, TX 75001
Tel: 972-818-7423 Fax: 972-818-2924

Dayton

Two Prestige Place, Suite 130
Miamisburg, OH 45342
Tel: 937-291-1654 Fax: 937-291-9175

Detroit

Tri-Atria Office Building
32255 Northwestern Highway, Suite 190
Farmington Hills, MI 48334
Tel: 248-538-2250 Fax: 248-538-2260

Los Angeles

18201 Von Karman, Suite 1090
Irvine, CA 92612
Tel: 949-263-1888 Fax: 949-263-1338

New York

150 Motor Parkway, Suite 202
Hauppauge, NY 11788
Tel: 631-273-5305 Fax: 631-273-5335

San Jose

Microchip Technology Inc.
2107 North First Street, Suite 590
San Jose, CA 95131
Tel: 408-436-7950 Fax: 408-436-7955

Toronto

6285 Northam Drive, Suite 108
Mississauga, Ontario L4V 1X5, Canada
Tel: 905-673-0699 Fax: 905-673-6509

ASIA/PACIFIC

China - Beijing

Microchip Technology Beijing Office
Unit 915
New China Hong Kong Manhattan Bldg.
No. 6 Chaoyangmen Beidajie
Beijing, 100027, No. China
Tel: 86-10-85282100 Fax: 86-10-85282104

China - Shanghai

Microchip Technology Shanghai Office
Room 701, Bldg. B
Far East International Plaza
No. 317 Xian Xia Road
Shanghai, 200051
Tel: 86-21-6275-5700 Fax: 86-21-6275-5060

Hong Kong

Microchip Asia Pacific
RM 2101, Tower 2, Metroplaza
223 Hing Fong Road
Kwai Fong, N.T., Hong Kong
Tel: 852-2401-1200 Fax: 852-2401-3431

India

Microchip Technology Inc.
India Liaison Office
Divyasree Chambers
1 Floor, Wing A (A3/A4)
No. 11, O'Shaughnessey Road
Bangalore, 560 025, India
Tel: 91-80-2290061 Fax: 91-80-2290062

Japan

Microchip Technology Intl. Inc.
Benex S-1 6F
3-18-20, Shinyokohama
Kohoku-Ku, Yokohama-shi
Kanagawa, 222-0033, Japan
Tel: 81-45-471-6166 Fax: 81-45-471-6122

Korea

Microchip Technology Korea
168-1, Youngbo Bldg. 3 Floor
Samsung-Dong, Kangnam-Ku
Seoul, Korea
Tel: 82-2-554-7200 Fax: 82-2-558-5934

ASIA/PACIFIC (continued)

Singapore

Microchip Technology Singapore Pte Ltd.
200 Middle Road
#07-02 Prime Centre
Singapore, 188980
Tel: 65-334-8870 Fax: 65-334-8850

Taiwan

Microchip Technology Taiwan
11F-3, No. 207
Tung Hua North Road
Taipei, 105, Taiwan
Tel: 886-2-2717-7175 Fax: 886-2-2545-0139

EUROPE

Denmark

Microchip Technology Denmark ApS
Regus Business Centre
Lautrup hoj 1-3
Ballerup DK-2750 Denmark
Tel: 45 4420 9895 Fax: 45 4420 9910

France

Arizona Microchip Technology SARL
Parc d'Activite du Moulin de Massy
43 Rue du Saule Trapu
Batiment A - 1er Etage
91300 Massy, France
Tel: 33-1-69-53-63-20 Fax: 33-1-69-30-90-79

Germany

Arizona Microchip Technology GmbH
Gustav-Heinemann Ring 125
D-81739 Munich, Germany
Tel: 49-89-627-144 0 Fax: 49-89-627-144-44

Italy

Arizona Microchip Technology SRL
Centro Direzionale Colleoni
Palazzo Taurus 1 V. Le Colleoni 1
20041 Agrate Brianza
Milan, Italy
Tel: 39-039-65791-1 Fax: 39-039-6899883

United Kingdom

Arizona Microchip Technology Ltd.
505 Eskdale Road
Winnersh Triangle
Wokingham
Berkshire, England RG41 5TU
Tel: 44 118 921 5869 Fax: 44-118 921-5820

10/01/00

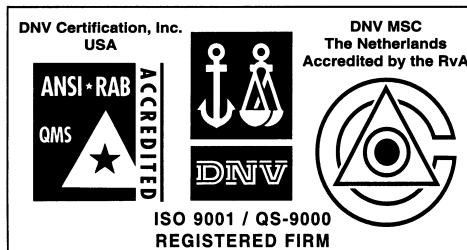

Microchip received QS-9000 quality system certification for its worldwide headquarters, design and wafer fabrication facilities in Chandler and Tempe, Arizona in July 1999. The Company's quality system processes and procedures are QS-9000 compliant for its PICmicro® 8-bit MCUs, KEELoc® code hopping devices, Serial EEPROMs and microperipheral products. In addition, Microchip's quality system for the design and manufacture of development systems is ISO 9001 certified.

All rights reserved. © 2000 Microchip Technology Incorporated. Printed in the USA. 12/00 Printed on recycled paper.

Information contained in this publication regarding device applications and the like is intended through suggestion only and may be superseded by updates. It is your responsibility to ensure that your application meets with your specifications. No representation or warranty is given and no liability is assumed by Microchip Technology Incorporated with respect to the accuracy or use of such information, or infringement of patents or other intellectual property rights arising from such use or otherwise. Use of Microchip's products as critical components in life support systems is not authorized except with express written approval by Microchip. No licenses are conveyed, implicitly or otherwise, except as maybe explicitly expressed herein, under any intellectual property rights. The Microchip logo and name are registered trademarks of Microchip Technology Inc. in the U.S.A. and other countries. All rights reserved. All other trademarks mentioned herein are the property of their respective companies.