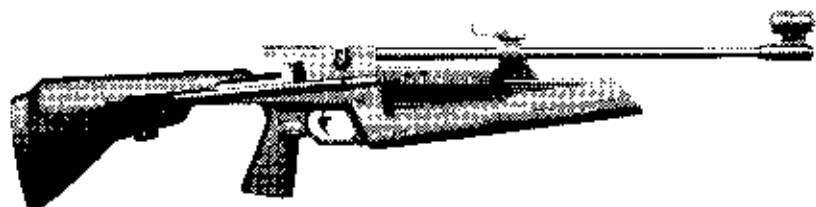


---

# IZH61



## AIR RIFLE INSTRUCTION MANUAL

European American Armory Corp.  
3855 North U.S. Highway One  
Cocoa, Florida 32926  
(321) 639-4842  
[www.eaacorp.com](http://www.eaacorp.com)  
E-mail: [eaacorp@bv.net](mailto:eaacorp@bv.net)

# **EAA MODEL: IZH61**

## **AIR RIFLE INSTRUCTION MANUAL**

### **WARNING AND INSTRUCTION MANUAL**

#### **PLEASE READ THESE INSTRUCTIONS**

**CAUTION:** Air Rifles are not toys. This Air Rifle is recommended for adult use. Misuse or careless use may cause serious injury or death. This Air Rifle is dangerous within 500 yards.

Do **NOT** cock or handle your Air Rifle before you read and understand the instructions and warnings contained in this manual.

**FOR YOUR SAFETY AND THE SAFETY OF OTHERS,** this owner's manual contains important warnings and safety procedures which must be understood **BEFORE** using this Air Rifle. Read the entire manual and if you do not understand any part of it or the operation of your Air Rifle, stop and seek professional instructions. You can get a copy of this manual from European American Armory Corp. on request.

Record the serial number of your firearm:

# \_\_\_\_\_

and a description of it:

\_\_\_\_\_

Make a copy of this manual, proof of purchase/sales record for safekeeping in a secure safe or fireproof container. Such proof is necessary if the Air Rifle is stolen or for warranty repair. Before handling any Air Rifle, make sure you know the safety procedures and most importantly, keep the Air Rifle pointed in a safe direction.

#### **WARNING**

**\*\*YOU RISK INJURY OR DEATH BY HANDLING THIS FIREARM\*\***

Before handling this Air Rifle, read, understand and follow the instructions in this manual. Always keep this manual with the Air Rifle. If you lend, give or sell this Air Rifle, be sure the manual goes with it. If there is anything you do not understand, seek advice from someone qualified in safe handling of Air Rifles.

#### **WARNING**

**\*This Air Rifle should always be transported unloaded in its case.\***

## **10 LIFE SAVING WARNINGS:**

1. Thinking the air rifle is unloaded does not mean it is unloaded. If a pellet is in the chamber and the rifle has been cocked, this rifle can be fired. Always treat your air rifle as if it is loaded.
2. Always point the muzzle of any air rifle in a safe direction whether the rifle is loaded or unloaded...
3. No hands over the muzzle / no way / no time / no how.
4. Only use lead .177 pellets manufactured to industry standards. If the pellet doesn't feed into the chamber, don't force it - there is a reason - determine the reason before continuing.
5. Never alter your air rifle or allow anyone not connected with or authorized to represent the manufacturer to modify, change, or adjust any of the working parts of your air rifle.
6. Learn to regularly clean and inspect your air rifle.
7. Wear eye protection whenever you shoot your rifle or when around others using air rifles. You only get one set of eyes.
8. This air rifle is extremely powerful and is not designed for the beginner. This class of air rifle is intended for use by experienced adult shooters.
9. Your air rifle can not think. You must be alert and thoughtful at all times to insure your safety and the safety of the people and property near you... no drugs...no drinking... no horse play... never shoot a pellet at water or a hard surface...

## **SAFETY WARNING:**

**Do not cock the cocking lever more than once per trigger pull.  
The reason for this warning is so that you do not load  
more than one pellet in the barrel bore at a time.**

Make sure after you have cocked the cocking handle fully that you return it to it's resting position and lock it in place, failure to lock the handle could cause a problem if the trigger was pulled and the cocking handle was not locked in place, the cocking handle could swing rapidly forward when the trigger is pulled.

## **HEALTH WARNING:**

This air rifle fires lead pellets. Lead and lead compounds are known to the State of California to cause cancer, birth defects and reproductive toxicity. Discharging, handling or cleaning an air rifle may result in lead exposure. Have adequate ventilation at all times. Do not put lead pellets in your mouth. Wash hands thoroughly after exposure.

## **GENERAL INFORMATION:**

This is a spring-piston air rifle. It is powered by a powerful spring in the receiver which acts as a piston compressing air in a chamber located behind the breech. The air is not compressed until the air rifle is fired. Cocking the air rifle compresses the spring piston and should only be done prior to firing. Avoid leaving the spring-piston under full compression for extended periods.

## **EXTERNAL CONTROL PARTS:**

1. The **Trigger** is used for discharging the spring tension so as to expel the pellet. Never touch or pull the trigger when the rifle is cocked and the cocking handle is not locked into it's forward position. The trigger mechanism is adjustable, the forward screw adjusts trigger travel length, the back screw adjust trigger pull / weight and the screw in the trigger adjust trigger position. **Warning - Never adjust the trigger pull to less than 32 ounces.**
2. The **Stock** of your air rifle is two pieces and is made from polymer. A loose stock may cause poor accuracy. Do not over tighten the stock screw. Make sure that the stock is tight to the receiver of the air rifle.
4. The **Barrel** of your air rifle is made of steel and has groove rifling. Never put the barrel in a position where it could be bent or damaged. A bent barrel will lead to accuracy problems or could even lead to a pellet being stuck in the barrel. After shooting, always clean the barrel with a light oil.
5. The **Sights** on your air rifle are designed for accuracy. The front sight is an all metal tunnel foresight. The rear sight is all metal with adjustment for windage and elevation and aperture.
6. The **Magazine** is located in the upper portion of the receiver and holds five pellets and is made of plastic
7. The **Magazine Latch** is located on top of the receiver and is spring loaded and holds the magazine in place
8. The **Loading Rod** is located in the back of the receiver and pushes the pellet into the chamber.
9. The **Loading Rod Latch** holds the loading rod in the forward position and if pushed disengages the loading rod.
10. The **Cocking Handle** is located on the right hand side of the rifle and is locked in place by the cocking handle latch.
11. The **Cocking Handle Latch** is located on the right hand side of the rifle in the forward area of the receiver and locks the cocking handle in the forward position.

## **COCKING YOUR AIR RIFLE:**

Grasp the rifle by the pistol grip or middle forearm with your dominate hand. Keep your fingers off the trigger and away from the breech. With the barrel pointing in a safe direction, pull the cocking handle back until you feel a click or hear a click sound. At this point the main spring should be compressed and locked (you can tell that you have fully cocked the rifle when the arm is no longer under spring pressure). Keep your fingers away from the trigger and breach at all times when cocking the air rifle. Do not pull past the click sound and never use excessive force when cocking the air rifle. Once the cocking handle is cocked return it forward and lock it in the cocking handle locking mechanism.

## **LOADING YOUR AIR RIFLE:**

- A) Make sure that the air rifle is pointed in a safe direction  
B) Make sure that the mechanism is not cocked. If the mechanism is cocked, we suggest you a) Make sure the cocking handle is in the forward locked position b) The rifle is pointed in a safe direction c) Fire the air rifle by pulling the trigger. The purpose of this step is to insure that you do have a cocked air rifle and a pellet in the chamber.

With the barrel pointed in a safe direction and the cocking handle in the forward locked position, load the magazine with five pellets (One in each holding position and make sure the pellet skirt is flush with the magazine face. If the pellet is not fully seated, it will be deformed when the handle is cocked and will not be accurate when shot.) Insert the magazine into the breach loading position (left to right with the index teeth up) insert the magazine until it is flush with the right side of the rifle. You may now cock the rifle by unlocking the cocking handle and pulling it toward the rear. As you pull the handle to the rear, the magazine should index to the first position aligning the first pellet with the barrel chamber.

## **FIRING THE AIR RIFLE:**

After completing the above loading step make sure that the rifle is pointed at what you intend to shoot and slowly pull the trigger to the rear. The rifle will discharge and the pellet will be expelled from the barrel. If you wish to fire another pellet unlatch the cocking handle and cock the rifle, see cocking instructions. When you cock the rifle the magazine will index to the next pellet, a pellet will be inserted into the chamber and the piston spring will be compressed. Make sure the rifle is pointed at what you wish to shoot and slowly pull the trigger. Continue this procedure until all five pellets have been fired.

## **REMOVING THE MAGAZINE FROM THE RIFLE:**

With the barrel pointed in a safe direction and the cocking handle in the forward locked position and hands and fingers away from the trigger: A) Press the Loading Rod Latch and move the loading rod to the rear B) Press the Magazine Detent latch with one hand and cover the magazine with the other hand (Warning the magazine is under spring tension and may fly out with force if it is not covered by your hand when the Magazine Detent is pressed) C) Remove the magazine by hand with a right to left hand motion.

## **UN-COCKING YOUR AIR RIFLE:**

**IF YOU HAVE COCKED YOUR AIR RIFLE AND LOADED A PELLET** we suggest you fire the pellet out of the barrel in a safe direction...thus we do not suggest that you un-cock this air rifle.

**Caution:** Unless absolutely necessary do not shoot a spring-piston air rifle without a lead pellet! Firing the air rifle without a pellet allows the piston/cylinder to slam against the front of the air compression chamber. The resistance of the pellet creates a cushion of air for the piston. Never fire damaged or used pellets.

**Caution:** Use only factory new lead air rifle pellets. Use only the correct size pellets (.177 caliber). Do not use steel shot or darts which may damage the rifled bore and which cause greater re-bounce and ricochet.

**Note:** It is a violation of federal law to ship a loaded weapon.

## **-- WARNINGS --**

### **READING THESE SAFETY RULES WILL SAVE YOUR LIFE OR THE LIFE OF SOMEONE ELSE**

Learn how to handle, load, unload, operate, fire and care for your air rifle.

**NEVER PLAY** with your air rifle. It is a potentially dangerous weapon that can cause serious personal injury or death.

**Always keep the air rifle pointed in a safe direction. NEVER point any weapon (loaded or unloaded) at any person or anything you do not intend to shoot. Always keep your air rifle unloaded until ready to fire and make sure that it is unloaded before cleaning.**

**Keep your finger OFF the trigger until you are actually aiming at the target and ready to shoot.**

Never rely on a air rifle's "safety" to protect you from unsafe handling. A safety is only a mechanical device, not a substitute for common sense and good safety procedures.

Never leave a air rifle unattended or where it could fall and fire.

If an air rifle is hit sharply or dropped, damage to the internal precision mechanism may result and consequently an accidental firing.

Store air rifles and pellets separately **beyond the reach of children**. Make sure the air rifle and lead pellets are properly locked and secured so children and un-trained individuals will be denied access.

**Test your air rifle's operation ONLY** at a shooting location while the rifle barrel is pointed in a safe direction.

Know your target and what is beyond. Ask yourself what your pellet will hit if it misses the target or passes through the intended target. Remember, a fired pellet can travel over 400 yards (including a ricochet).

**Never pull an air rifle toward you by the muzzle.** Don't climb a tree, cross a ditch or fence with a loaded air rifle.

Do **NOT** leave your air rifle **COCKED** for long periods of time or store it **COCKED**.

**Always empty** air rifles before entering a house, car, truck, boat, RV, camp or any building.

When receiving a air rifle, always open the action and make sure it is unloaded. **NEVER** accept anyone's word that an air rifle is "unloaded" or "empty". You should also inspect it by passing a cleaning rod through the bore to make sure it is clear.

Avoid exposure to lead by firing where there is adequate ventilation. After cleaning your air rifle and/or handling lead pellets, wash your hands.

Keep air rifles unloaded when not actually in use. Load the air rifle only when preparing to fire.

Never fire a pellet to clear a barrel.

**ALWAYS WEAR** protective shooting glasses when firing air rifles.

Never drop your air rifle. If you do drop it, unload it and check it for proper function before using it again.

Don't alter or modify your air rifle.

Do not remove any internal safety or safety device on the air rifle. Safety mechanisms are designed to protect you from injury or death.

Do maintain and keep your air rifle clean. Keep in a dry place away from other metals and water. If your air rifle shows sign of corrosion or improper operation, have it serviced by a competent gunsmith.

Keep the muzzle pointed in a safe direction when loading and unloading your air rifle. Never point the muzzle at any person or any animal.

Never shoot at hard flat surfaces or water....bullets ricochet.

Never let water, snow, mud or other material enter the barrel. Keep the barrel free of any obstruction.

Use only the correct size lead pellets for your air rifle. Do NOT use steel shot or darts.

Teach children NOT to touch an air rifle or pellets.

Remember an air rifle has the capability of taking your life or the life of someone else. Be careful with your air rifle -- an accident is almost always the result of not following basic safety rules.

WRITE US concerning any items or circumstances which you don't understand and which might relate to your safety and the operation of your air rifle.

## **CARE AND CLEANING:**

**Caution:** make sure the air rifle is unloaded before cleaning (follow un-cocking instructions to insure air rifle is not cocked and loaded)

**Caution:** in lubricating the air compression chamber, use only a special lubricant with a high flash point de- signed specifically for use inside of an air compression chamber

**(A)** To lubricate the air compression chamber and air compression seal, follow cocking instructions and cock the air rifle. Put a few drops of special light oil into the vent hole that leads into the compression chamber. Now cock and un-cock the rifle in several different angles so the oil spreads around the piston chamber. Do not over oil (no more than 3 or 4 drops on each lubrication). The air rifle chamber should be oiled every 500 pellets.

(B) In order to lubricate the mainspring, you must first remove the stock. Turn the action over and apply 6 to 10 drops of a light oil directly onto the spring. Reattach the stock and cock and un-cock in different positions so as to spread the oil around the spring. The main spring should be oiled every 2,000 to 3,000 pellets or every six months. The cocking lever linkage and barrel pivot points should be very lightly oiled every six months.

**Caution:** it is better to under lubricate than to over lubricate. Over lubrication will void your warranty. Do not use firearm cleaners or low flash point oils in the air compression chamber and near the vent and breech seal as this will cause dieseling and damage the seal.

**Caution:** only a competent gun smith should disassemble the rifle for further cleaning or maintenance.

### **LIMITED REPAIR WARRANTY**

European American Armory Corp. air rifles are warranted to the original retail customer for 90 days from date of purchase against factory defects in metal parts. All metal parts and labor or replacement at our option are covered. Mainsprings, seals and stock are warranted to the original retail customer for a period of 30 days from the verified purchase date against defects. Parts and labor to repair mainsprings, seals and stock will be provided for 90 days from the verified purchase date.

Evidence of proof of purchase is necessary for all warranty repair service. Transportation to and from our repair facilities, governmental fees, damage caused by failure to perform normal maintenance, sales outside the United States, damage due to non factory lead pellets, steel shot or darts, or any unauthorized repair, modification, misuse, abuse, or alteration of the product is not covered by this Limited Repair Warranty.

Any implied warranties, including the implied warranties of merchantability and fitness for a particular purpose, are limited to 90 Days from date of original retail purchase. Consequential or incidental damages and/or expenses, or any other expenses are not covered by this warranty.

To obtain warranty performance send your product with proof of retail purchase, freight prepaid to:

European American Armory Corp.  
3855 North U.S. Highway One  
Cocoa, Florida 32926

### **WARNING**

Altering or modifying parts is dangerous and will void the warranty. This air rifle was manufactured to perform properly with the original parts as designed. It is your duty to make sure any parts you buy are made for this air rifle and are installed correctly and that neither the replacements nor originals are altered or changed. Your air rifle is a complex precision tool with many parts that must relate correctly to other parts in order for proper and safe operation. Putting an air rifle together wrong or with incorrect or modified parts can result in a



damaged air rifle, serious injury or death to you and others through malfunction. Always have a qualified gunsmith work on your air rifle or at least check any work not performed by a gunsmith.

**ALL PARTS ORDERS ARE SUBJECT TO A \$10.00 CHARGE FOR SHIPPING AND HANDLING.** For parts and service contact: European American Armory Corp., 3855 N. U.S. Highway One, Cocoa, FL 32926 Phone: (321) 639-4842.

### **STATEMENT OF NON-LIABILITY**

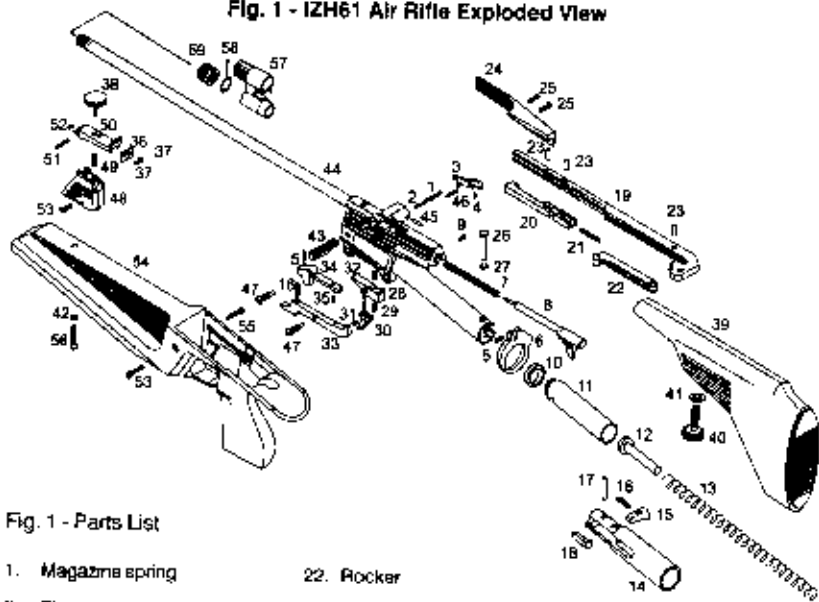
Air Rifles are not classified as firearms by the U.S. Gun Control Act of 1968. Air Rifles are not generally considered to be weapons; however, they can cause serious injury, death and property damage. Thus, they should be handled with great care. Safety is your responsibility. Neither the manufacturer, nor European American Armory Corporation, assume any responsibility for personal injury, death or property damage resulting from either intentional or accidental discharge or for the function of any air rifle subjected to influences beyond our control.

**KEEP THIS BOOKLET AND PROOF OF PURCHASE IN A SECURE LOCATION.**

### **SPECIFICATIONS:**

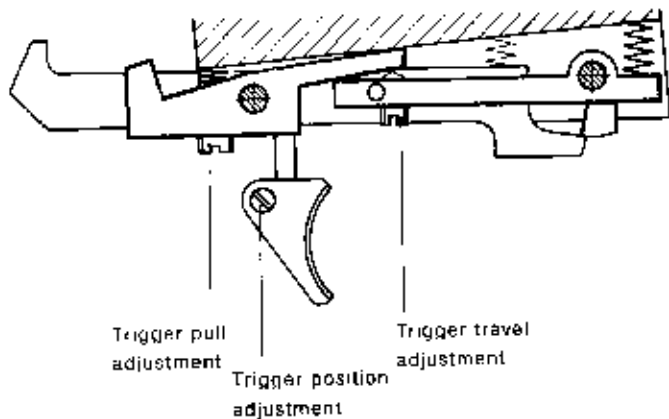
Caliber .....	.177 / 4.5mm
Magazine Capacity .....	5 Pellets
Barrel Length .....	450mm
Overall Dimensions .....	Approx. 787mm x 200mm x 60mm
Weight .....	Approx. 2.7kg

**Fig. 1 - IZH61 Air Rifle Exploded View**

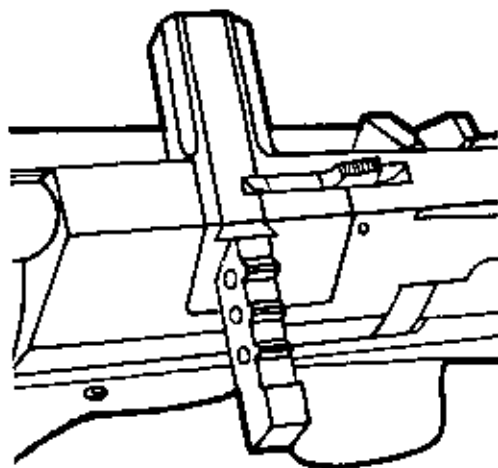


**Fig. 1 - Parts List**

- |                         |                                      |                                   |
|-------------------------|--------------------------------------|-----------------------------------|
| 1. Magazine spring      | 22. Rocker                           | 41. Butt stock washer             |
| 2. Plunger              | 23. Pin                              | 42. Rim                           |
| 3. Magazine catch       | 24. Cocking lever grip               | 43. Magazine                      |
| 4. Catch spring         | 25. Cocking grip screw               | 44. Barrel and receiver assembled |
| 5. Spring               | 26. Cocking lever pivot              | 45. Pin                           |
| 6. Blocking ring        | 27. Collar                           | 46. Magazine catch pivot          |
| 7. Follower spring      | 28. Trigger base                     | 47. Threaded pivot                |
| 8. Follower             | 29. Trigger pull adjusting screw     | 48. Rear sight base               |
| 9. Screw                | 30. Trigger                          | 49. Rear sight spring             |
| 10. Piston seal         | 31. Trigger screw                    | 50. Rear sight lever              |
| 11. Piston              | 32. Trigger spring                   | 51. Rear sight pivot              |
| 12. Mainspring guide    | 33. Sear 2                           | 52. Rear sight stop               |
| 13. Mainspring          | 34. Sear 1                           | 53. Woodscrew                     |
| 14. Cocking lever base  | 35. Trigger travel adjusting screw   | 54. Forend                        |
| 15. Cocking lever catch | 36. Rear sight leaf                  | 55. Woodscrew                     |
| 16. Spring              | 37. Sight leaf screw                 | 56. Woodscrew                     |
| 17. Catch pivot         | 38. Sights elevation adjusting screw | 57. Front sight base              |
| 18. Catch bar           | 39. Butt stock                       | 58. Front sight                   |
| 19. Cocking lever       | 40. Butt stock screw                 | 59. Front sight nut               |
| 20. Cocking lever latch |                                      |                                   |
| 21. Latch spring        |                                      |                                   |



**Fig. 2: IZH61 The Trigger Mechanism**



**Fig. 3: IZH61 Magazine Attachment**

**This owner's manual was  
provided as a service to you  
by:**



[www.airgunsofarizona.com](http://www.airgunsofarizona.com)

[airguns\\_az@yahoo.com](mailto:airguns_az@yahoo.com)

Phone: (480)461-1113

Fax: (480)461-3928