

CHAPTER

06

**DIMENSIONS AND
AREAS**



**737-600/700/800/900
AIRCRAFT MAINTENANCE MANUAL**

**CHAPTER 06
DIMENSIONS AND AREAS**

Subject/Page	Date	COC	Subject/Page	Date	COC	Subject/Page	Date	COC
EFFECTIVE PAGES			06-24-00 (cont)			06-41-00 (cont)		
1 thru 2	Jun 15/2009		202	Oct 10/2003		208	Feb 10/2004	
06-CONTENTS			06-25-00			06-41-00 (cont)		
1	Feb 15/2008		201	Oct 10/2003		209	Feb 10/2007	
2	Feb 15/2008		202	Oct 10/2003		210	Oct 10/2003	
3	Oct 15/2008		06-30-00			211	Oct 10/2003	
4	Feb 15/2008		201	Oct 10/2003		O 212	Jun 15/2009	
06-10-00			202	Oct 10/2003		213	Feb 10/2007	
201	Feb 15/2009		203	Oct 10/2003		214	Feb 15/2009	
202	Feb 15/2009		204	Oct 10/2003		215	Oct 15/2008	
203	Feb 15/2009		205	Jun 15/2008		216	Feb 15/2009	
204	Jun 10/2007		206	Jun 10/2004		O 217	Jun 15/2009	
205	Feb 10/2007		207	Jun 10/2004		218	Oct 15/2008	
206	Feb 15/2009		208	Jun 10/2004		O 219	Jun 15/2009	
207	Feb 10/2007		209	Oct 10/2006		220	Oct 15/2008	
208	BLANK		210	Oct 10/2006		221	Feb 15/2009	
06-21-00			211	Oct 10/2006		222	BLANK	
201	Oct 10/2003		212	Oct 10/2003		06-42-00		
202	Oct 10/2003		213	Oct 10/2003		O 201	Jun 15/2009	
203	Feb 10/2007		214	Oct 10/2003		202	Jun 15/2008	
204	Feb 10/2007		215	Oct 10/2003		R 203	Jun 15/2009	
205	Feb 15/2009		216	Oct 10/2003		O 204	Jun 15/2009	
206	Feb 10/2007		217	Oct 10/2003		O 205	Jun 15/2009	
207	Feb 15/2009		218	Oct 10/2003		O 206	Jun 15/2009	
208	Feb 10/2007		219	Oct 10/2003		O 207	Jun 15/2009	
209	Feb 15/2009		220	Oct 10/2003		O 208	Jun 15/2009	
210	Feb 10/2007		221	Oct 10/2003		O 209	Jun 15/2009	
211	Feb 10/2007		222	Oct 10/2006		O 210	Jun 15/2009	
212	Feb 10/2007		223	Feb 10/2006		O 211	Jun 15/2009	
213	Feb 10/2007		224	Feb 15/2009		212	Jun 15/2008	
214	Feb 15/2009		225	Feb 10/2007		213	Jun 15/2008	
06-22-00			226	Feb 15/2009		214	Jun 15/2008	
201	Oct 10/2003		06-41-00			215	Feb 15/2009	
202	Oct 10/2003		201	Jun 10/2007		216	Jun 15/2008	
06-23-00			202	Jun 10/2006		217	Jun 15/2008	
201	Oct 10/2003		203	Jun 10/2006		218	Jun 15/2008	
202	Oct 10/2003		204	Oct 10/2006		06-43-00		
06-24-00			205	Jun 10/2006		201	Jun 10/2004	
201	Oct 10/2003		206	Feb 10/2004		202	Jun 10/2004	
			207	Feb 10/2004		203	Jun 10/2004	
						204	Jun 10/2004	

A = Added, R = Revised, D = Deleted, O = Overflow, C = Customer Originated Change

06-EFFECTIVE PAGES



**737-600/700/800/900
AIRCRAFT MAINTENANCE MANUAL**

**CHAPTER 06
DIMENSIONS AND AREAS**

Subject/Page	Date	COC	Subject/Page	Date	COC	Subject/Page	Date	COC
06-43-00 (cont)			06-44-00 (cont)					
R 205	Jun 15/2009		233	Oct 10/2004				
R 206	Jun 15/2009		234	Oct 10/2004				
R 207	Jun 15/2009		06-46-00					
208	Jun 10/2004		201	Feb 10/2007				
209	Jun 10/2004		202	Feb 15/2009				
210	BLANK		203	Feb 15/2009				
06-44-00			204	Feb 10/2007				
201	Feb 10/2005		205	Feb 10/2007				
202	Feb 10/2005		206	Feb 15/2009				
203	Jun 10/2004		207	Feb 10/2007				
204	Jun 10/2004		208	BLANK				
205	Jun 10/2004							
206	Jun 10/2004							
207	Jun 10/2005							
208	Jun 10/2005							
209	Jun 10/2007							
210	Oct 10/2004							
211	Oct 10/2004							
212	Oct 10/2004							
213	Oct 10/2004							
214	Jun 10/2005							
215	Jun 10/2005							
216	Jun 10/2005							
217	Oct 10/2004							
218	Oct 10/2004							
219	Oct 10/2004							
220	Oct 10/2004							
221	Oct 10/2004							
222	Oct 10/2004							
223	Oct 10/2004							
224	Oct 10/2004							
225	Oct 10/2004							
226	Oct 10/2004							
227	Oct 10/2004							
228	Oct 10/2004							
229	Feb 15/2009							
230	Oct 10/2004							
231	Oct 10/2004							
232	Oct 10/2004							

A = Added, R = Revised, D = Deleted, O = Overflow, C = Customer Originated Change

06-EFFECTIVE PAGES



737-600/700/800/900
AIRCRAFT MAINTENANCE MANUAL

CHAPTER 06
DIMENSIONS AND AREAS

<u>Subject</u>	<u>Chapter Section Subject</u>	<u>Conf</u>	<u>Page</u>	<u>Effect</u>
<u>PRINCIPAL DIMENSIONS AND AREAS - MAINTENANCE PRACTICES</u>	06-10-00		201	HAP ALL
Principal Dimensions and Areas TASK 06-10-00-800-801			201	HAP ALL
<u>FUSELAGE STATION DIAGRAM - MAINTENANCE PRACTICES</u>	06-21-00		201	HAP ALL
Fuselage Station Diagram TASK 06-21-00-800-801			201	HAP ALL
Fuselage Station Diagram TASK 06-21-00-800-802			203	HAP ALL
Fuselage Station Diagram TASK 06-21-00-800-803			210	HAP ALL
Fuselage Station Diagram TASK 06-21-00-800-804			212	HAP ALL
<u>VERTICAL FIN AND RUDDER STATION DIAGRAM - MAINTENANCE PRACTICES</u>	06-22-00		201	HAP ALL
Vertical Fin and Rudder Station Diagram TASK 06-22-00-800-801			201	HAP ALL
<u>HORIZONTAL STABILIZER AND ELEVATOR STATION DIAGRAM - MAINTENANCE PRACTICES</u>	06-23-00		201	HAP ALL
Horizontal Stabilizer and Elevator Station Diagram TASK 06-23-00-800-801			201	HAP ALL
<u>WING STATION DIAGRAM - MAINTENANCE PRACTICES</u>	06-24-00		201	HAP ALL
Wing Station Diagram TASK 06-24-00-800-801			201	HAP ALL

06-CONTENTS



737-600/700/800/900
AIRCRAFT MAINTENANCE MANUAL

CHAPTER 06
DIMENSIONS AND AREAS

<u>Subject</u>	<u>Chapter Section Subject</u>	<u>Conf</u>	<u>Page</u>	<u>Effect</u>
<u>ENGINE AND NACELLE STATION DIAGRAM - MAINTENANCE PRACTICES</u>	06-25-00		201	HAP ALL
Engine and Nacelle Station Diagram TASK 06-25-00-800-801			201	HAP ALL
<u>ZONE DIAGRAMS - MAINTENANCE PRACTICES</u>	06-30-00		201	HAP ALL
Major Zones TASK 06-30-00-800-801			201	HAP ALL
Lower Half of the Fuselage - Major Zone 100 TASK 06-30-00-800-802			204	HAP ALL
Upper Half of the Fuselage - Major Zone 200 TASK 06-30-00-800-803			207	HAP ALL
Empennage and Body Section 48 - Major Zone 300 TASK 06-30-00-800-804			209	HAP ALL
Power Plants and Nacelle Struts - Major Zone 400 TASK 06-30-00-800-805			213	HAP ALL
Left Wing - Major Zone 500 TASK 06-30-00-800-806			216	HAP ALL
Right Wing - Major Zone 600 TASK 06-30-00-800-807			217	HAP ALL
Landing Gear and Landing Gear Doors - Major Zone 700 TASK 06-30-00-800-808			221	HAP ALL
Passenger and Cargo Compartment Doors - Major Zone 800 TASK 06-30-00-800-809			224	HAP ALL

06-CONTENTS



737-600/700/800/900
AIRCRAFT MAINTENANCE MANUAL

CHAPTER 06
DIMENSIONS AND AREAS

<u>Subject</u>	<u>Chapter Section Subject</u>	<u>Conf</u>	<u>Page</u>	<u>Effect</u>
<u>FUSELAGE (MAJOR ZONES 100 AND 200)</u>	06-41-00		201	HAP ALL
<u>ACCESS DOORS AND PANELS - MAINTENANCE PRACTICES</u>				
Finding an Access Door or Panel on the Lower Half of the Fuselage TASK 06-41-00-800-801			201	HAP ALL
Finding an Access Door or Panel on the Upper Half of the Fuselage TASK 06-41-00-800-802			205	HAP ALL
Passenger and Cargo Compartment Doors - Major Zone 800 TASK 06-41-00-800-803			212	HAP ALL
Passenger and Cargo Compartment Doors - Major Zone 800 TASK 06-41-00-800-804			217	HAP ALL
Passenger and Cargo Compartment Doors - Major Zone 800 TASK 06-41-00-800-805			219	HAP ALL
<u>EMPENNAGE (MAJOR ZONE 300) ACCESS DOORS AND PANELS - MAINTENANCE PRACTICES</u>	06-42-00		201	HAP ALL
Finding an Access Door or Panel in the Empennage TASK 06-42-00-800-801			201	HAP ALL
<u>CFM 56-7 SERIES ENGINE AND NACELLE STRUT (MAJOR ZONE 400) ACCESS DOORS AND PANELS - MAINTENANCE PRACTICES</u>	06-43-00		201	HAP ALL
Engine and Nacelle Strut Access Doors and Panels TASK 06-43-00-800-801			201	HAP ALL

06-CONTENTS



737-600/700/800/900
AIRCRAFT MAINTENANCE MANUAL

CHAPTER 06
DIMENSIONS AND AREAS

<u>Subject</u>	<u>Chapter Section Subject</u>	<u>Conf</u>	<u>Page</u>	<u>Effect</u>
<u>WINGS (MAJOR ZONES 500 AND 600)</u> <u>ACCESS DOORS AND PANELS -</u> <u>MAINTENANCE PRACTICES</u>	06-44-00		201	HAP ALL
Finding an Access Door or Panel on the Wings TASK 06-44-00-800-801			201	HAP ALL
<u>PASSENGER AND CARGO COMPARTMENT</u> <u>DOORS (MAJOR ZONE 800) ACCESS</u> <u>DOORS AND PANELS - MAINTENANCE</u> <u>PRACTICES</u>	06-46-00		201	HAP ALL
Passenger and Cargo Compartment Doors Access Doors and Panels TASK 06-46-00-800-801			201	HAP ALL

06-CONTENTS



737-600/700/800/900

AIRCRAFT MAINTENANCE MANUAL

PRINCIPAL DIMENSIONS AND AREAS - MAINTENANCE PRACTICES

1. General

A. This procedure has these tasks:

- (1) Principal dimensions and areas

TASK 06-10-00-800-801

2. Principal Dimensions and Areas

HAP 101-999

NOTE: See Figure 201.

HAP ALL

NOTE: See Figure 203.

A. General

- (1) This task contains dimensions for the wing, horizontal stabilizer, vertical fin, and fuselage. This task also contains areas for the wing and stabilizer surfaces.
- (2) Some dimensions change with the center of gravity location and the airplane loads. For these dimensions a minimum and maximum are given.

B. Location Zones

Zone	Area
100	Lower Half of Fuselage
200	Upper Half of Fuselage
300	Empennage
400	Powerplant and Nacelle Struts
500	Left Wing
600	Right Wing

C. Dimensions

SUBTASK 06-10-00-220-001

- (1) Airplane:

HAP 101-999

(a) Height

- 1) Minimum -- Not Applicable
- 2) Maximum -- 41 feet and 3 inches (12.57 meters)

HAP 001-013, 015-026, 028-054

(b) Height (Figure 202)

- 1) Minimum -- Not Applicable
- 2) Maximum -- 41 feet and 2 inches (12.54 meters)

HAP 101-999

(c) Length -- 110 feet and 4 inches (33.64 meters)

HAP 001-013, 015-026, 028-054

(d) Length -- 129 feet and 6 inches (39.47 meters)

HAP ALL

EFFECTIVITY
HAP ALL

06-10-00

Page 201
Feb 15/2009

D633A101-HAP



737-600/700/800/900
AIRCRAFT MAINTENANCE MANUAL

SUBTASK 06-10-00-220-002

(2) Engines:

HAP 101-999

- (a) Engine to Ground Distance
 - 1) Minimum -- 18 inches (0.45 meters)
 - 2) Maximum -- 24 inches (0.60 meters)

HAP 001-013, 015-026, 028-054

- (b) Engine to Ground Distance
 - 1) Minimum -- 19 inches (0.48 meters)
 - 2) Maximum -- 25 inches (0.63 meters)

HAP ALL

- (c) Fuselage to Engine Distance (centerline of fuselage to centerline of engine) -- 15 feet and 11 inches (4.85 meters)

SUBTASK 06-10-00-220-003

(3) Fuselage:

HAP 101-999

- (a) Height of Body Reference Plane (WL 208.10) Above Ground at Main Landing Gear
 - 1) Minimum -- 7 Feet and 1 inch (2.15 meters)
 - 2) Maximum -- 8 Feet and 2 inches (2.48 meters)

HAP 001-013, 015-026, 028-054

- (b) Height of Body Reference Plane (WL 208.10) Above Ground at Main Landing Gear
 - 1) Minimum -- 7 Feet and 1 inch (2.15 meters)
 - 2) Maximum -- 8 Feet and 2 inches (2.48 meters)

HAP ALL

- (c) Height (constant cross section)
 - 1) Above Body Reference Plane -- 8 Feet and 2 inches (2.48 meters)
 - 2) Below Body Reference Plane -- 5 Feet and 0 inches (1.52 meters)
- (d) Height to Centerline of Windows Above Body Reference Plane -- 20 Feet and 6 inches (6.24 meters)

HAP 101-999

- (e) Length, Nose to Tail End of Body -- 105 feet and 7 inches (32.1818 meters)

HAP 001-013, 015-026, 028-054

- (f) Length, Nose to Tail End of Body -- 124 feet and 9 inches (38.0238 meters)

HAP ALL

- (g) Width -- 12 feet and 4 inches (3.75 meters)

SUBTASK 06-10-00-220-005

(4) Landing Gear:

- (a) Track -- 18 feet and 9 inches (5.71 meters)

EFFECTIVITY
HAP ALL

D633A101-HAP

06-10-00

Page 202
Feb 15/2009



737-600/700/800/900

AIRCRAFT MAINTENANCE MANUAL

- (b) Nose Landing Gear Offset – 13 feet and 5 inches (4.08 meters)

HAP 101-999

- (c) Wheelbase – 41 feet and 4 inches (12.6 meters)

HAP 001-013, 015-026, 028-054

- (d) Wheelbase – 51 feet and 2 inches (614 inches) (15.5956 meters)

HAP ALL

SUBTASK 06-10-00-220-011

(5) Horizontal Stabilizer:

- (a) Aspect Ratio – 6.161
- (b) Span – 47 feet and 1 inch (14.35 meters)
- (c) Tip Chord – 2 feet and 7 inches (0.78 meters)
- (d) Dihedral (stabilizer reference plane in relation to the body reference plane) – 7 degrees
- (e) Taper Ratio – 0.203
- (f) Sweep (25 percent chord line) – 30 degrees

SUBTASK 06-10-00-220-006

(6) Vertical Stabilizer (Fin):

- (a) Aspect Ratio – 1.941
- (b) Height (root chord, WL 300.50, to top of the fin) – 23 feet 6 inches (7.16 meters)
- (c) Root Chord – 19 feet and 1 inch (5.81 meters)
- (d) Taper Ratio – 0.271
- (e) Sweep (25 percent chord line) – 35 degrees

SUBTASK 06-10-00-220-007

(7) Wing:

- (a) Aspect Ratio – 9.45
- (b) Span – 112 feet and 7 inches (1351 inches) (34.3154 meters)
- (c) Root Chord (at body centerline)
 - 1) Basic Chord – 25 feet and 10 inches (7.87 meters)
 - 2) Trapezoidal Chord – 18 feet and 9 inches (5.71 meters)
- (d) Mean Aerodynamic Chord (basic wing only) – 13 feet and 0 inches (3.96 meters)
- (e) Tip Chord – 4 feet and 1.25 inches (1.25 meters)
- (f) Dihedral (wing reference plane in relation to the body reference plane) – 6.00 degrees
- (g) Taper Ratio
 - 1) Tip Chord/Trapezoidal Root Chord – 0.219
- (h) Sweep (25 percent chord line) – 25.03 degrees

D. Areas

SUBTASK 06-10-00-220-008

- (1) Horizontal Stabilizer Area – 352.8 square feet (32.77 square meters)

SUBTASK 06-10-00-220-009

- (2) Vertical Stabilizer Area – 284.6 square feet (26.44 square meters)

EFFECTIVITY
HAP ALL

D633A101-HAP

06-10-00

Page 203
Feb 15/2009



**737-600/700/800/900
AIRCRAFT MAINTENANCE MANUAL**

SUBTASK 06-10-00-220-010

(3) Wing Basic Area -- 1341.0 square feet (124.6 square meters)

————— **END OF TASK** —————

EFFECTIVITY
HAP ALL

D633A101-HAP

06-10-00

Page 204
Jun 10/2007



737-600/700/800/900

AIRCRAFT MAINTENANCE MANUAL

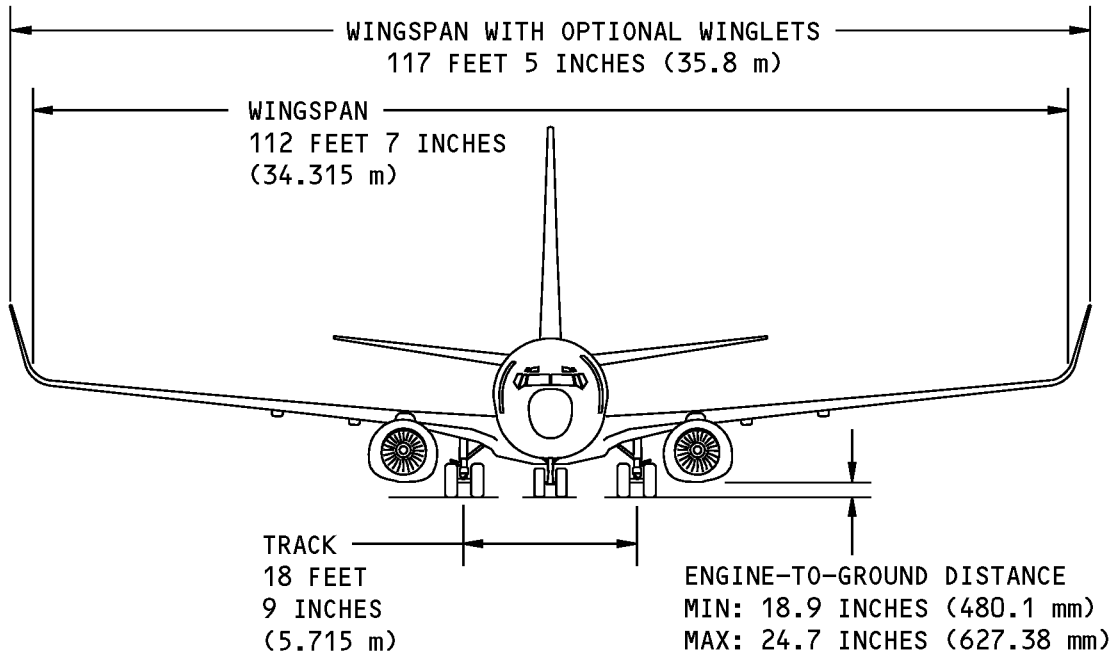
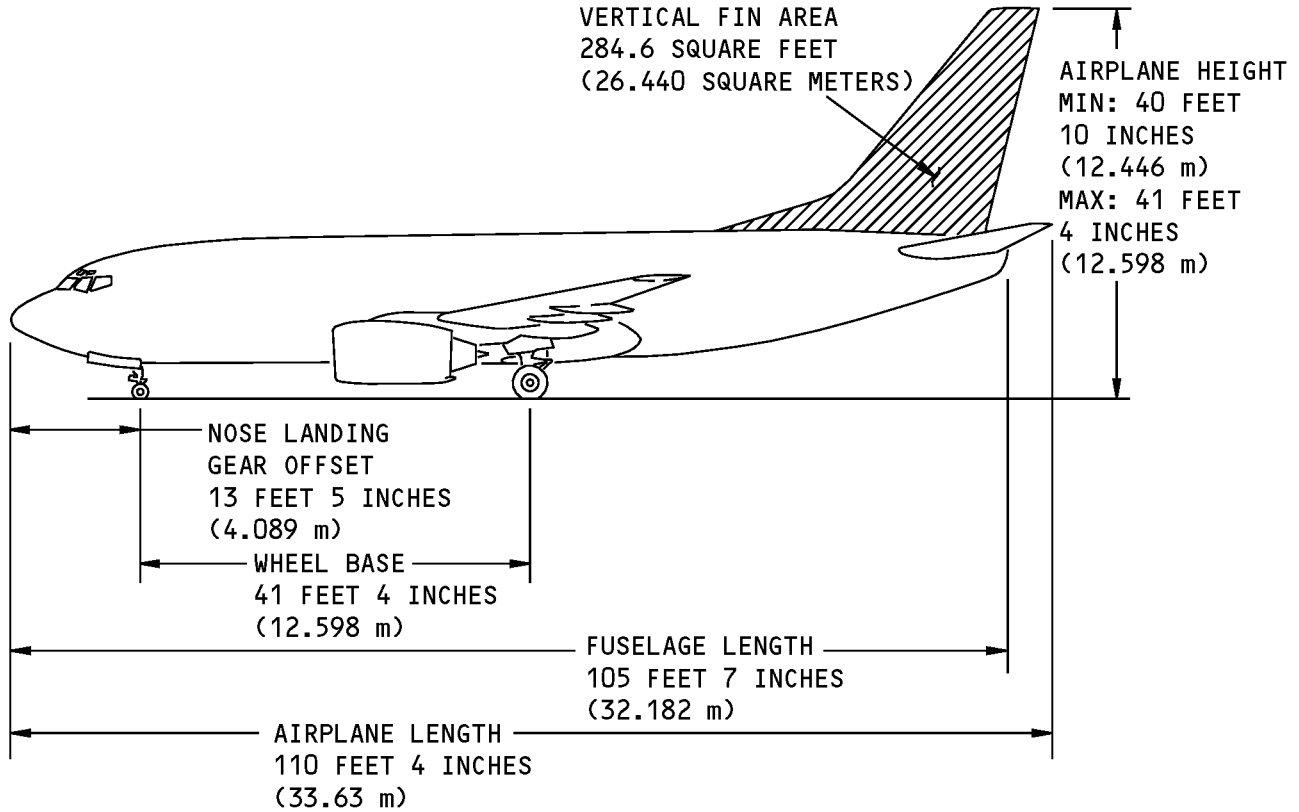

Principal Dimensions and Areas
Figure 201/06-10-00-990-801

EFFECTIVITY
HAP 101-999

06-10-00

Page 205
Feb 10/2007

D633A101-HAP



737-600/700/800/900
AIRCRAFT MAINTENANCE MANUAL

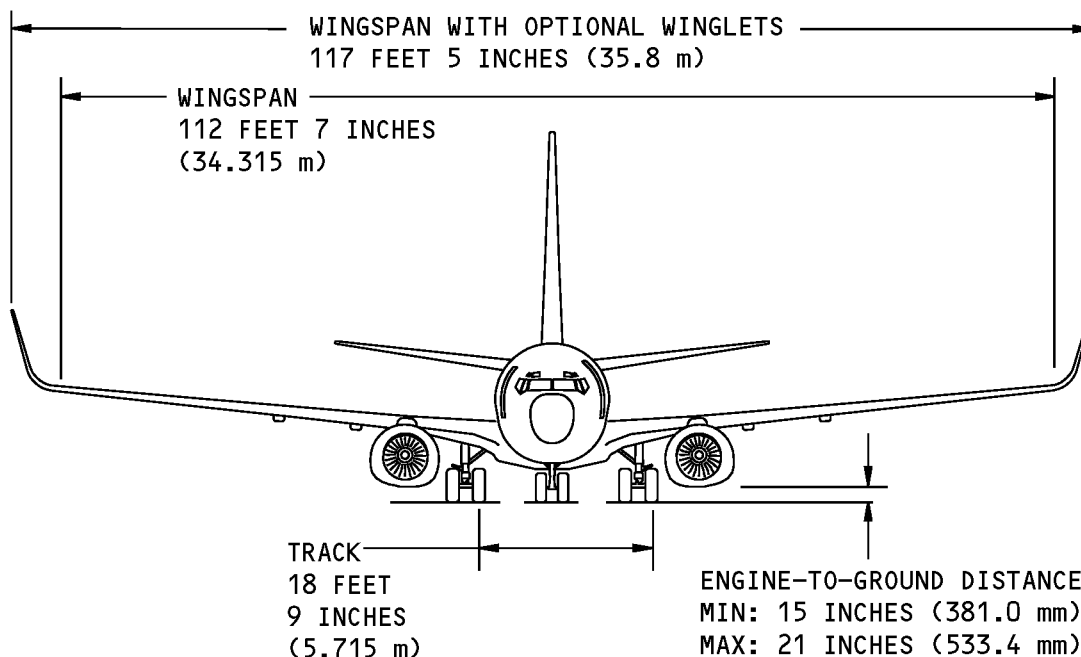
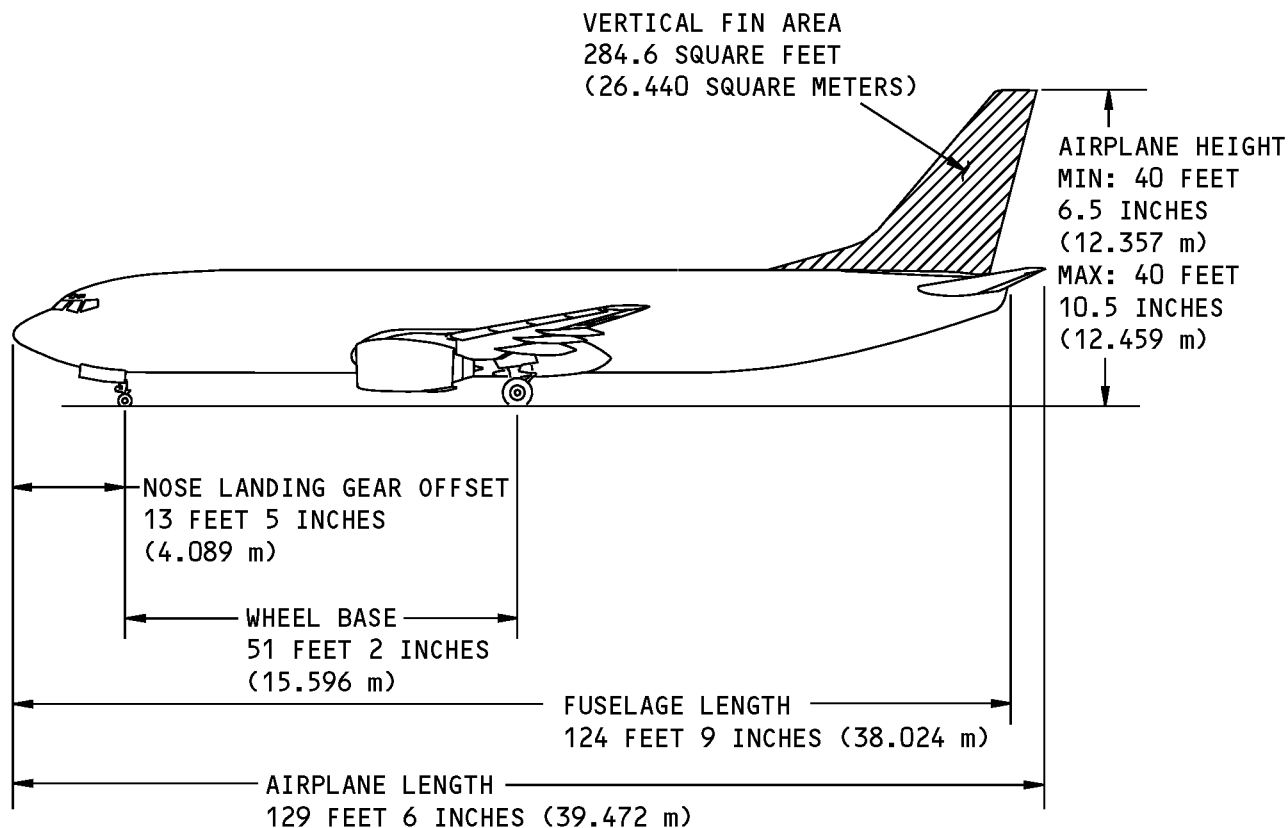

Principal Dimensions and Areas
Figure 202/06-10-00-990-807

EFFECTIVITY
HAP 001-013, 015-026, 028-054

06-10-00

Page 206
Feb 15/2009

D633A101-HAP



737-600/700/800/900
AIRCRAFT MAINTENANCE MANUAL

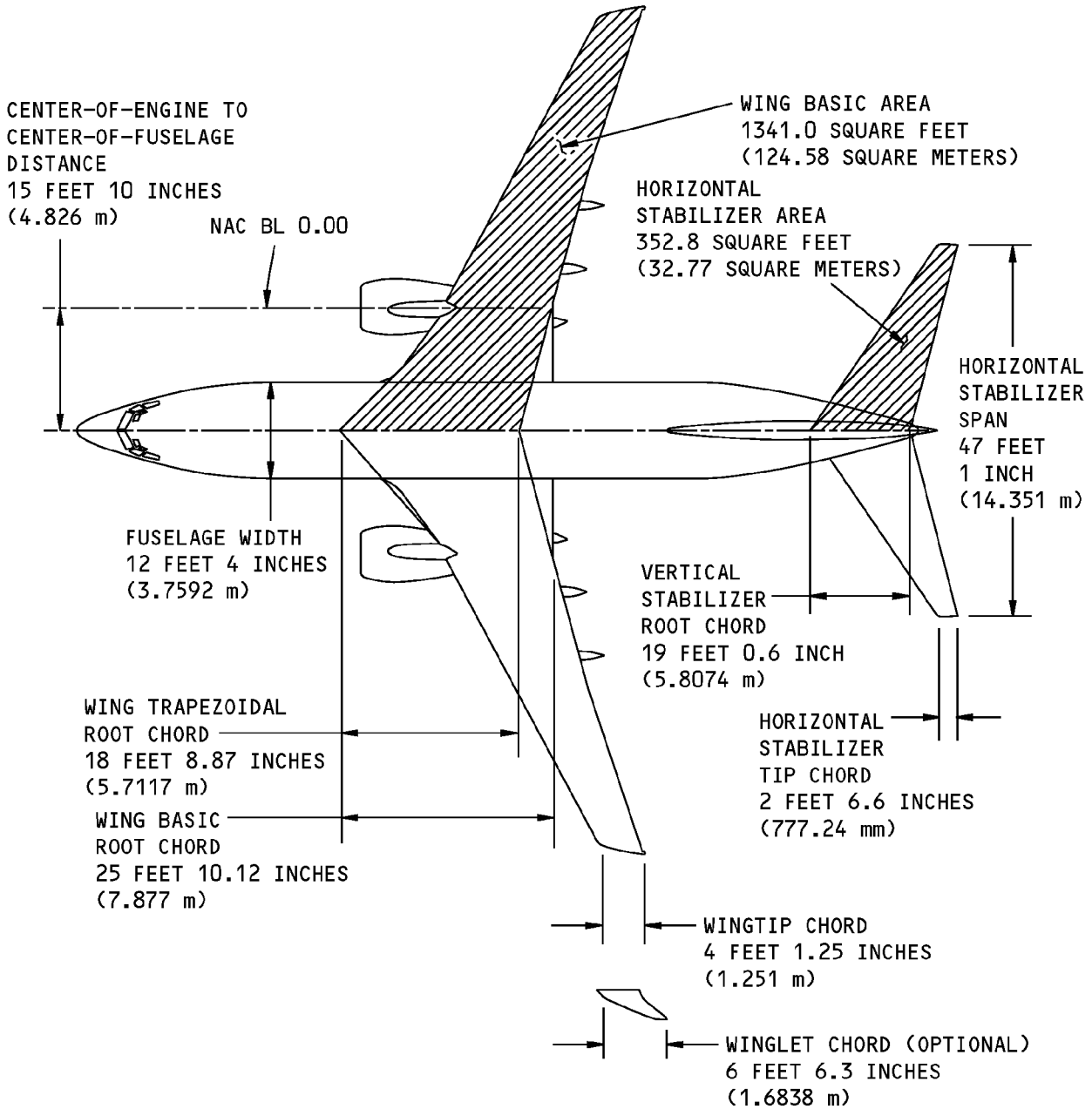

Principal Dimensions and Areas (Plan View)
Figure 203/06-10-00-990-802

EFFECTIVITY
HAP ALL

06-10-00

Page 207
Feb 10/2007

D633A101-HAP



737-600/700/800/900

AIRCRAFT MAINTENANCE MANUAL

FUSELAGE STATION DIAGRAM - MAINTENANCE PRACTICES

1. General

A. This procedure has these tasks:

- (1) Fuselage station diagram for sections 41 only
- (2) Fuselage station diagram for sections 42, 44, and 46 only
- (3) Fuselage station diagram for section 47 only
- (4) Fuselage station diagram for section 48 only

TASK 06-21-00-800-801

2. Fuselage Station Diagram

(Figure 201)

A. General

- (1) The fuselage station diagram gives you a reference system to help you find components, features, and major fuselage structural openings in relation to a datum plane. The datum plane is perpendicular to the fuselage centerline and found 130.0 inches (3.302 meters) forward of the airplane nose.

B. Location Zones

Zone	Area
100	Lower Half of Fuselage
200	Upper Half of Fuselage

————— **END OF TASK** —————

EFFECTIVITY
HAP ALL

D633A101-HAP

06-21-00

Page 201
Oct 10/2003

**737-600/700/800/900
AIRCRAFT MAINTENANCE MANUAL**

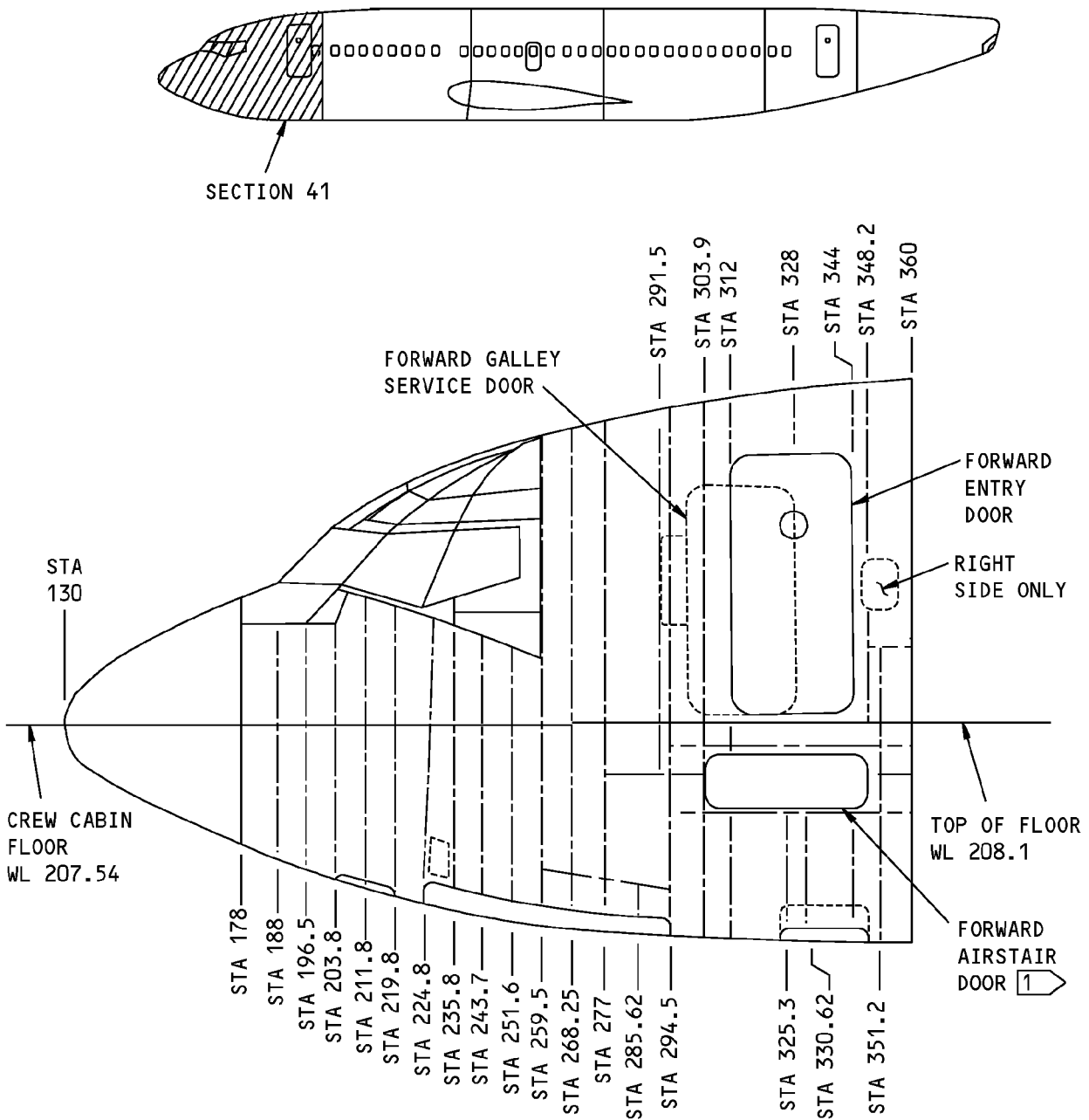

1 NOT ON ALL AIRPLANES

**Fuselage Station Diagram - Section 41
Figure 201/06-21-00-990-801**

EFFECTIVITY
HAP ALL

06-21-00

Page 202
Oct 10/2003

D633A101-HAP



737-600/700/800/900

AIRCRAFT MAINTENANCE MANUAL

TASK 06-21-00-800-802

3. Fuselage Station Diagram

(Figure 202 or Figure 203, Figure 204 or Figure 205, Figure 206 or Figure 207)

A. General

- (1) The fuselage station diagram gives you a reference system to help you find components, features, and major fuselage structural openings in relation to a datum plane. The datum plane is perpendicular to the fuselage centerline and found 130.0 inches (3.302 meters) forward of the airplane nose.

————— **END OF TASK** —————

EFFECTIVITY
HAP ALL

D633A101-HAP

06-21-00

Page 203
Feb 10/2007

**737-600/700/800/900
AIRCRAFT MAINTENANCE MANUAL**

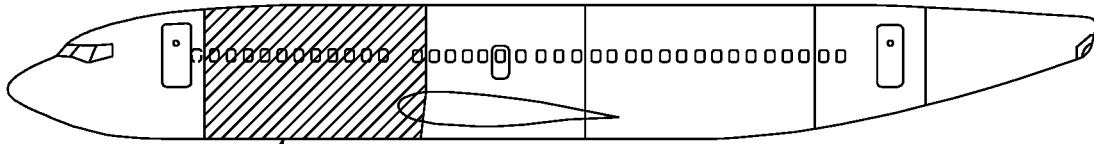

SECTION 43

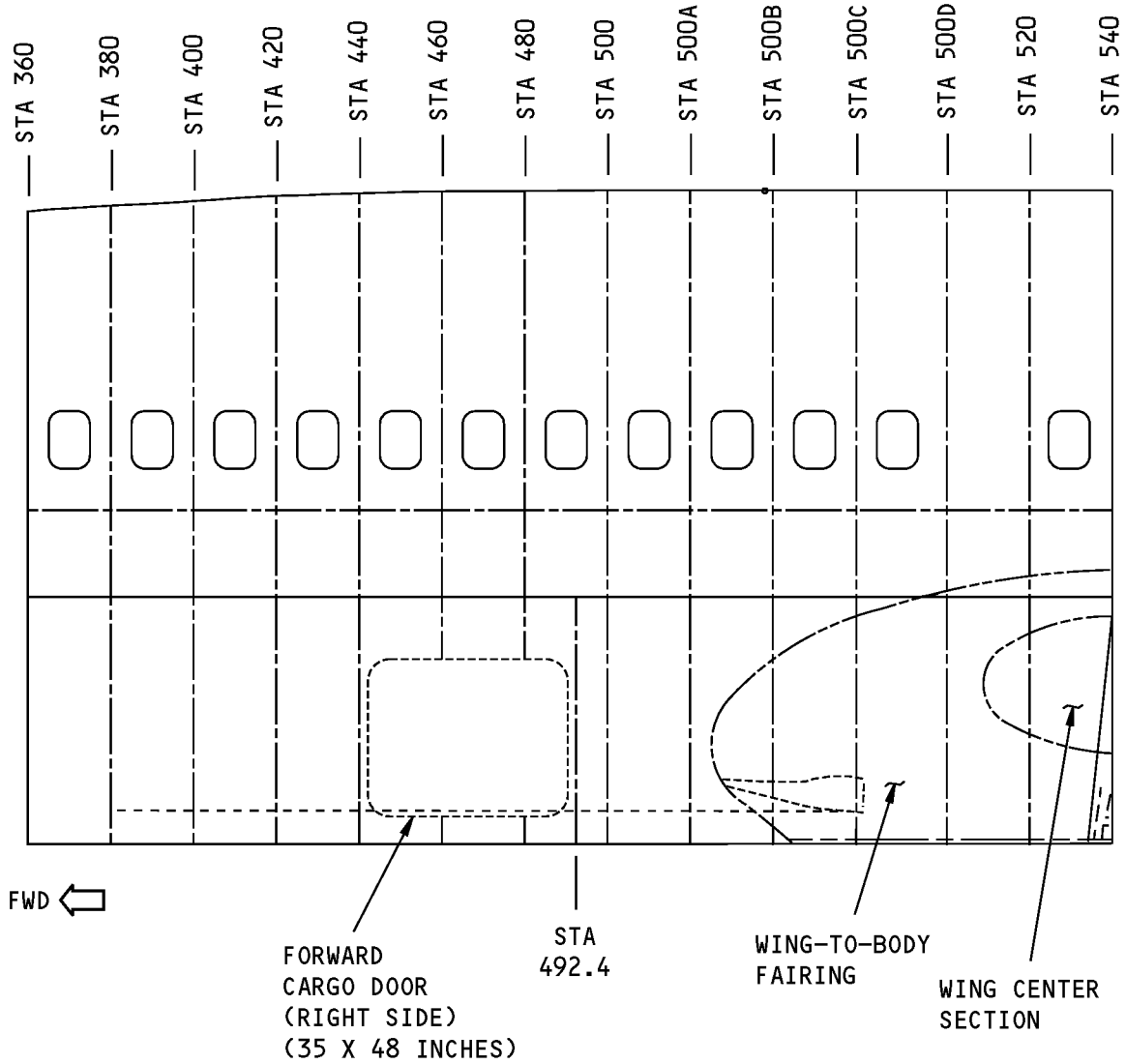

**Fuselage Station Diagram - Section 43
Figure 202/06-21-00-990-802**

EFFECTIVITY
HAP 101-999

06-21-00

**737-600/700/800/900
AIRCRAFT MAINTENANCE MANUAL**

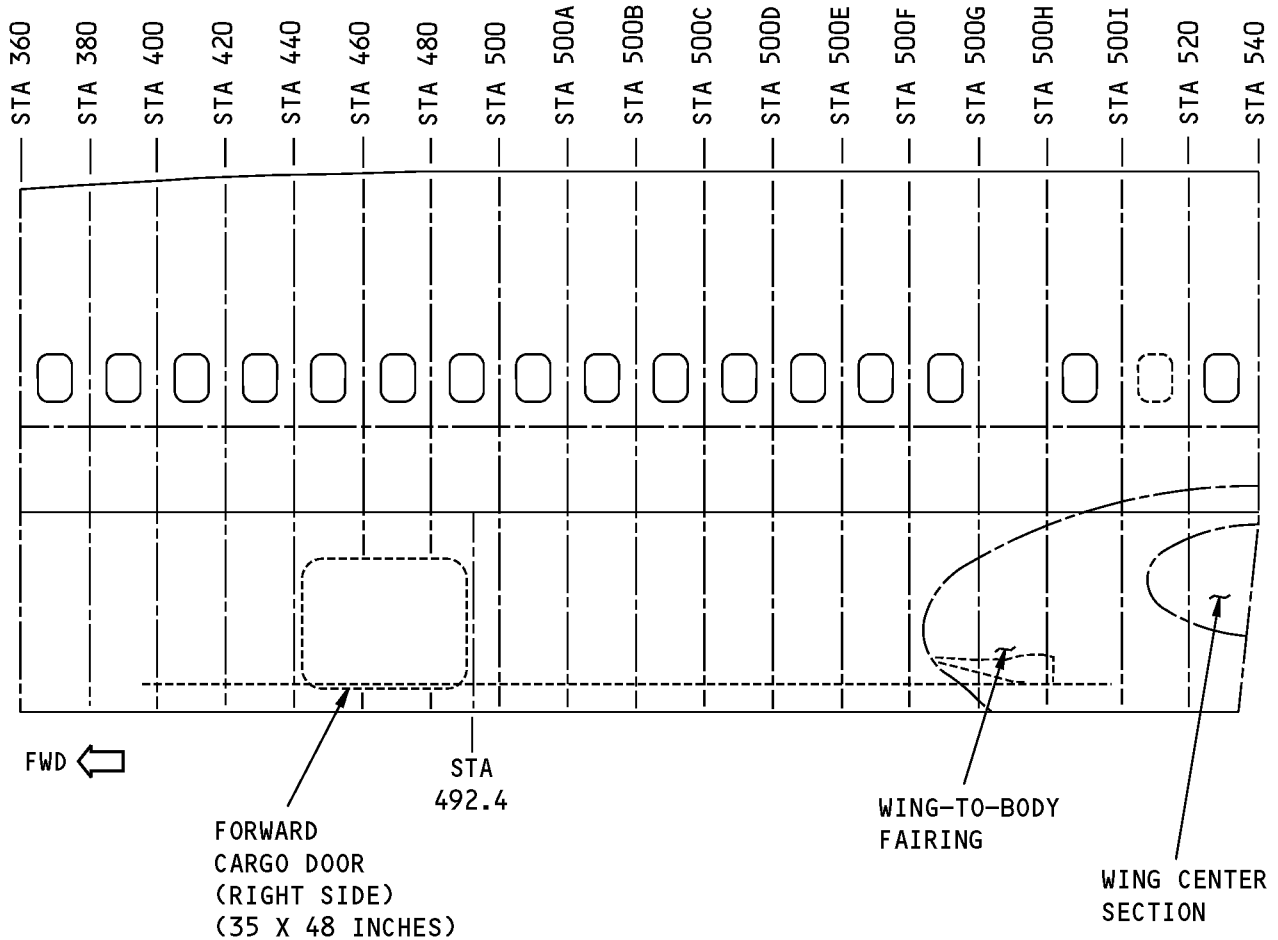
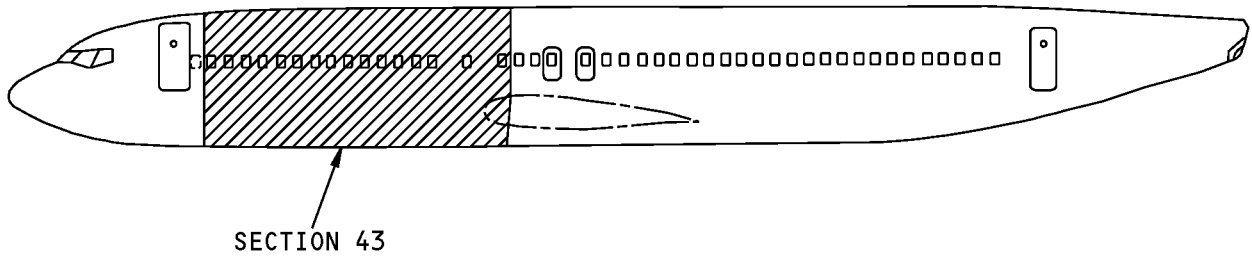

**Fuselage Station Diagram - Section 43
Figure 203/06-21-00-990-815**

EFFECTIVITY
HAP 001-013, 015-026, 028-054

06-21-00

Page 205
Feb 15/2009

D633A101-HAP



737-600/700/800/900
AIRCRAFT MAINTENANCE MANUAL

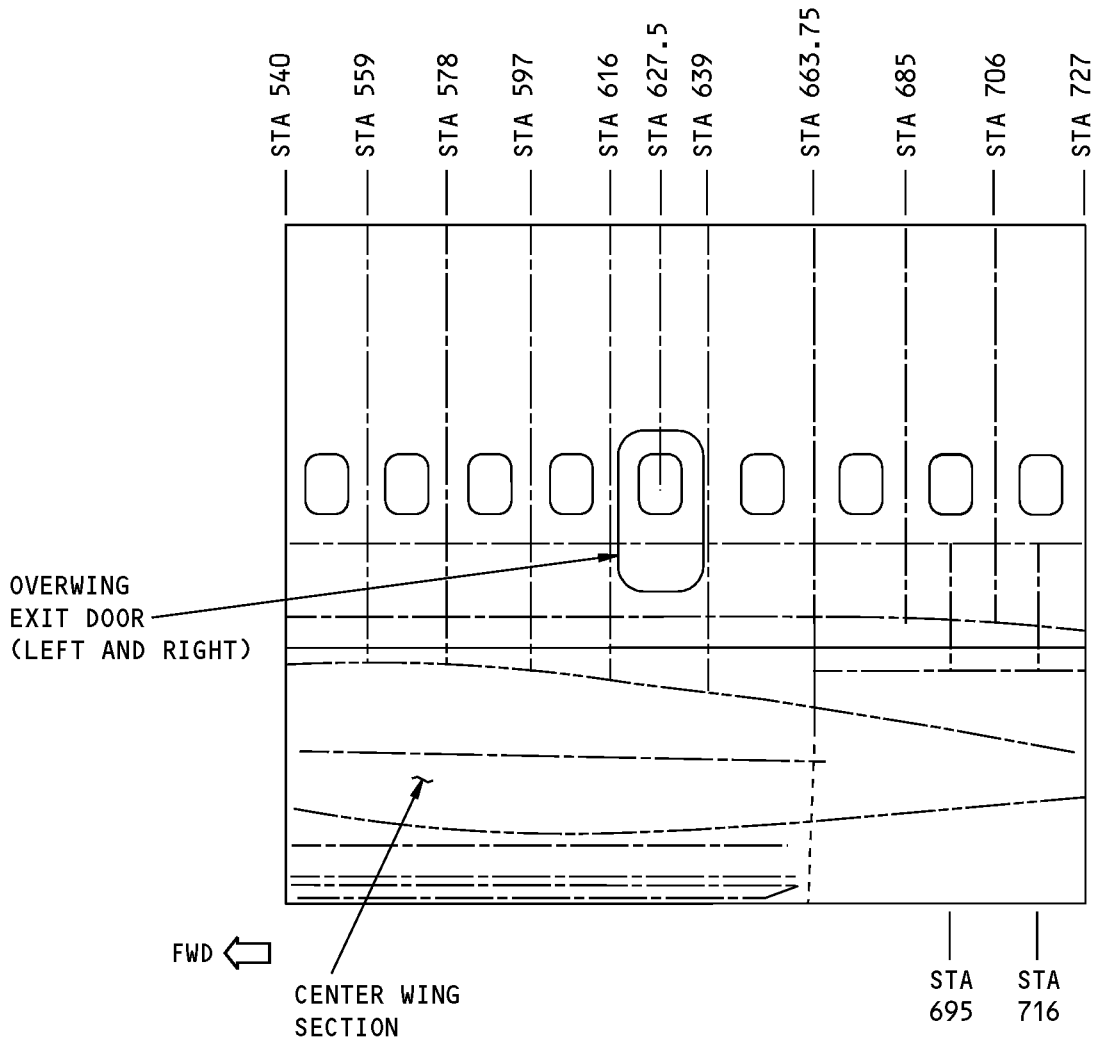
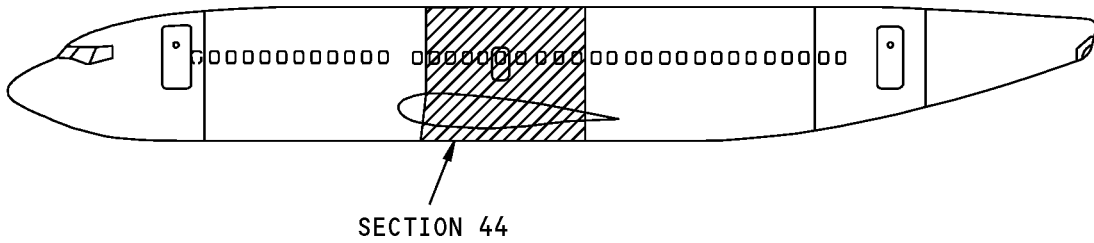

Fuselage Station Diagram - Section 44
Figure 204/06-21-00-990-803

EFFECTIVITY
HAP 101-999

06-21-00



737-600/700/800/900
AIRCRAFT MAINTENANCE MANUAL

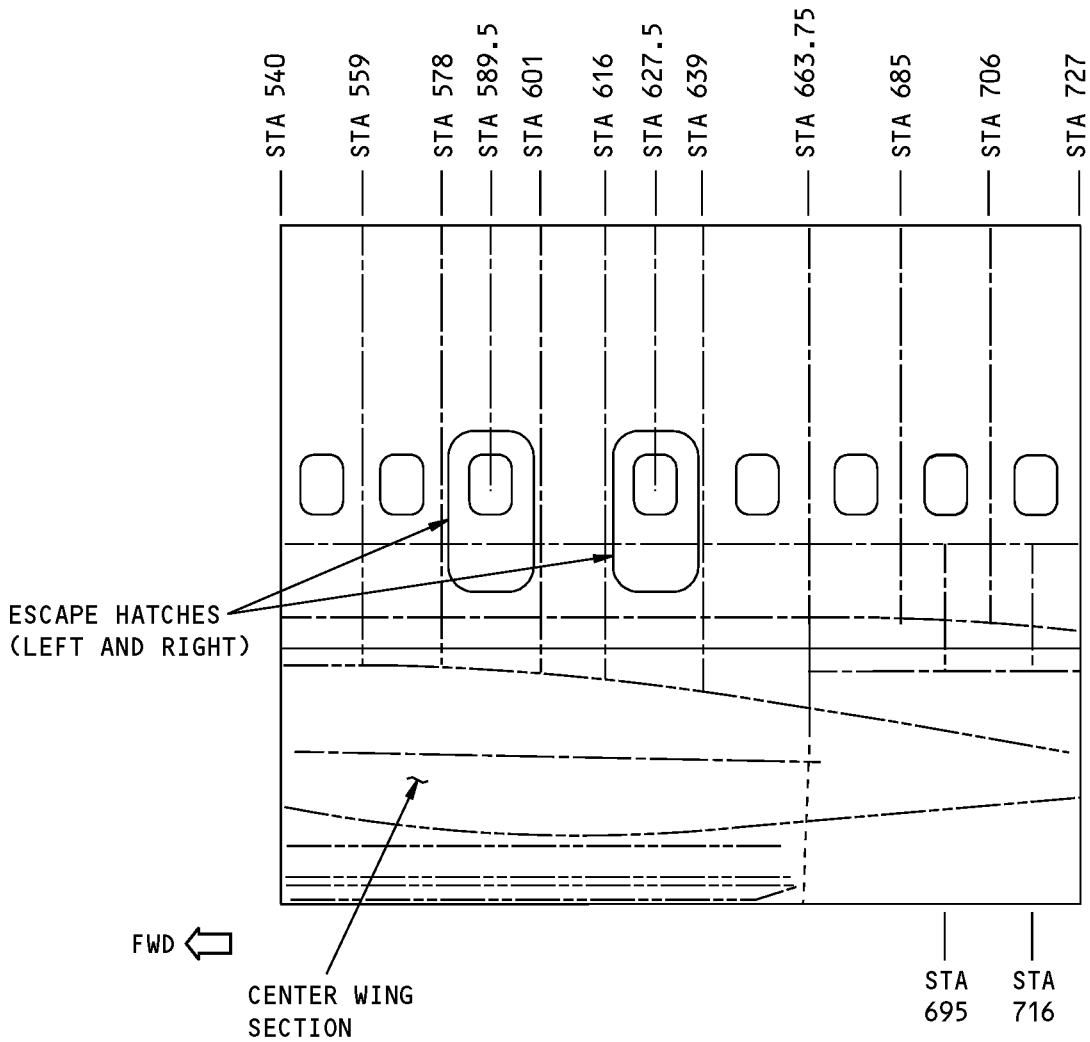
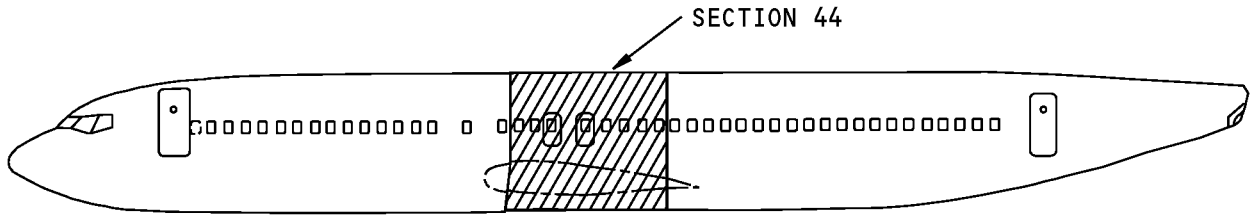

Fuselage Station Diagram - Section 44
Figure 205/06-21-00-990-817

EFFECTIVITY
HAP 001-013, 015-026, 028-054

06-21-00

Page 207
Feb 15/2009

D633A101-HAP



737-600/700/800/900
AIRCRAFT MAINTENANCE MANUAL

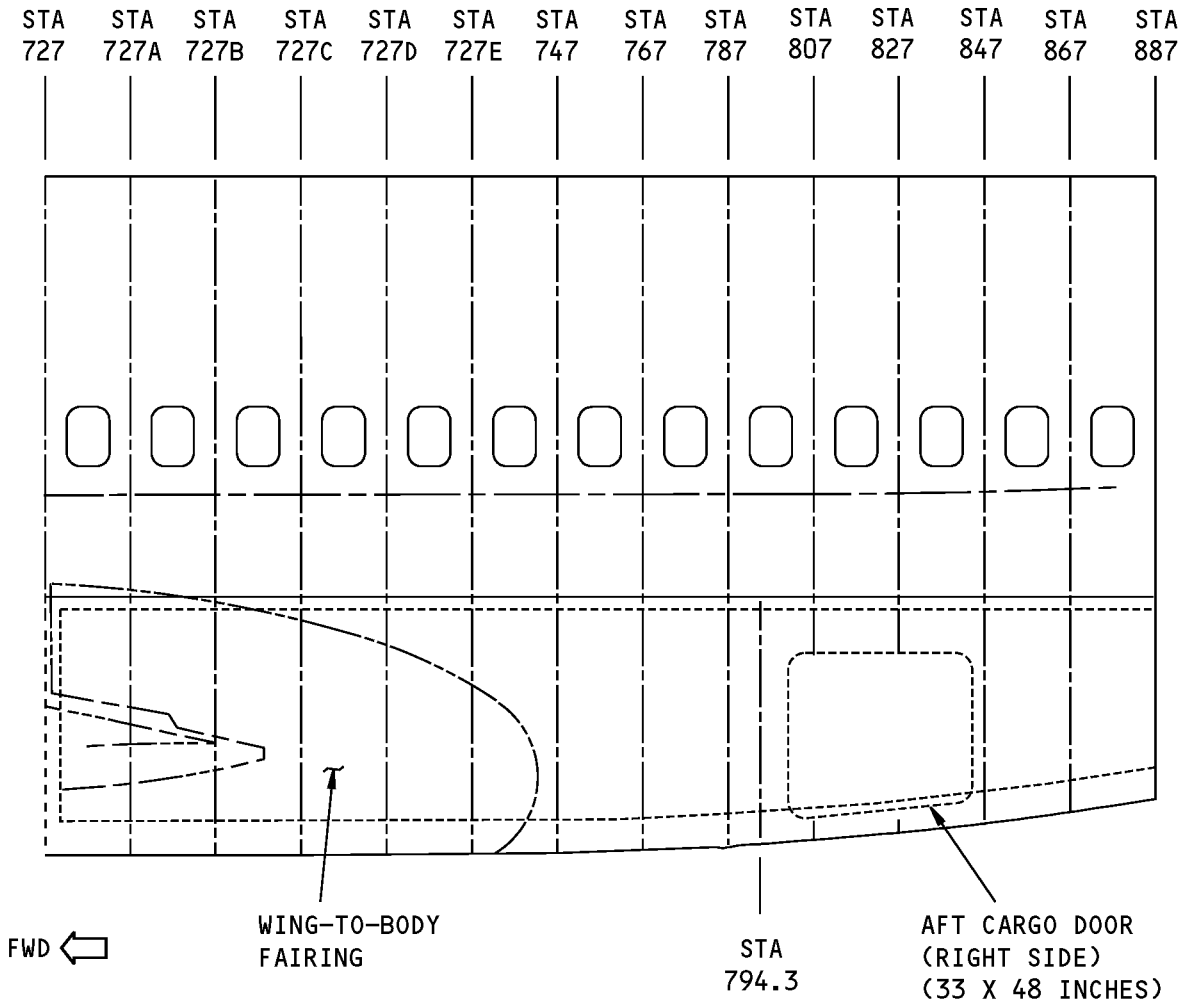
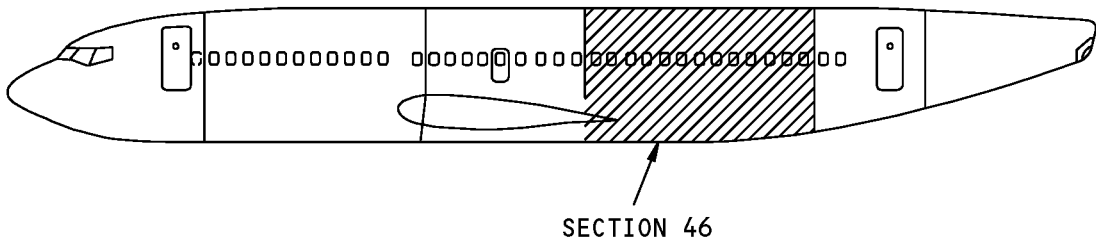

Fuselage Station Diagram - Section 46
Figure 206/06-21-00-990-804

EFFECTIVITY
HAP 101-999

06-21-00



737-600/700/800/900
AIRCRAFT MAINTENANCE MANUAL

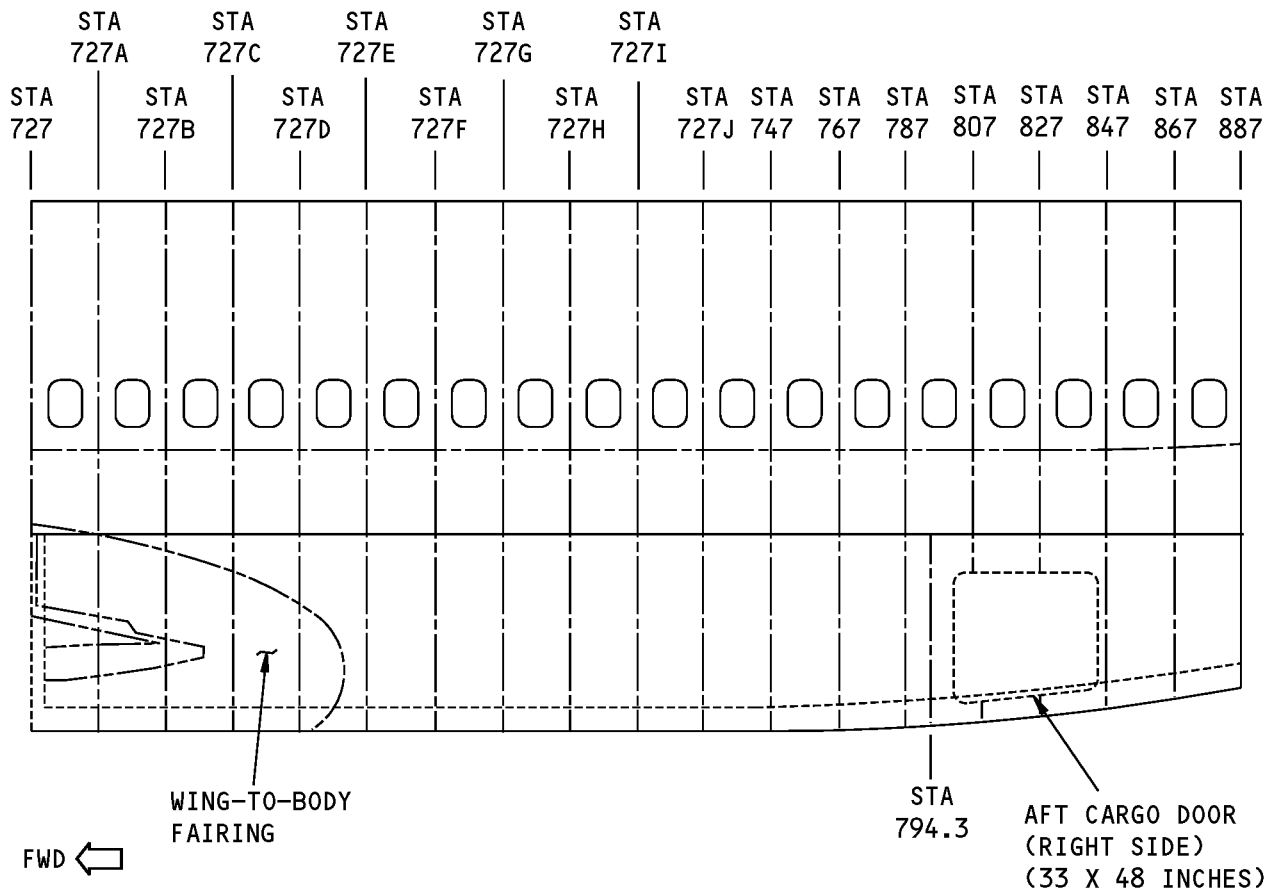
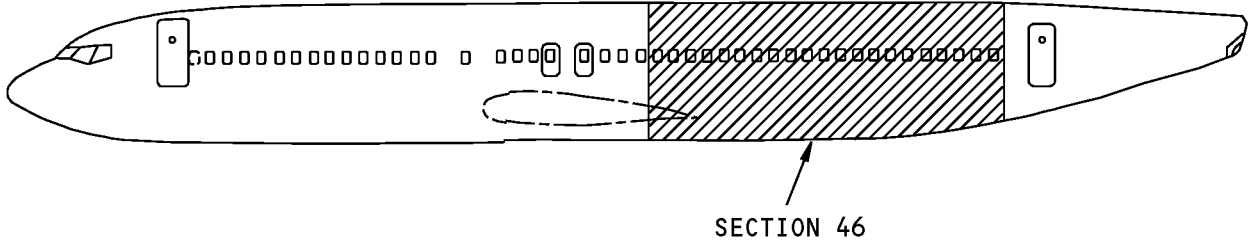

Fuselage Station Diagram - Section 46
Figure 207/06-21-00-990-819

EFFECTIVITY
HAP 001-013, 015-026, 028-054

06-21-00

Page 209
Feb 15/2009

D633A101-HAP



737-600/700/800/900

AIRCRAFT MAINTENANCE MANUAL

TASK 06-21-00-800-803

4. Fuselage Station Diagram

(Figure 208)

A. General

- (1) The fuselage station diagram gives you a reference system to help you find components, features, and major fuselage structural openings in relation to a datum plane. The datum plane is perpendicular to the fuselage centerline and found 130.0 inches (3.302 meters) forward of the airplane nose.

————— END OF TASK —————

EFFECTIVITY
HAP ALL

D633A101-HAP

06-21-00

Page 210
Feb 10/2007



737-600/700/800/900
AIRCRAFT MAINTENANCE MANUAL

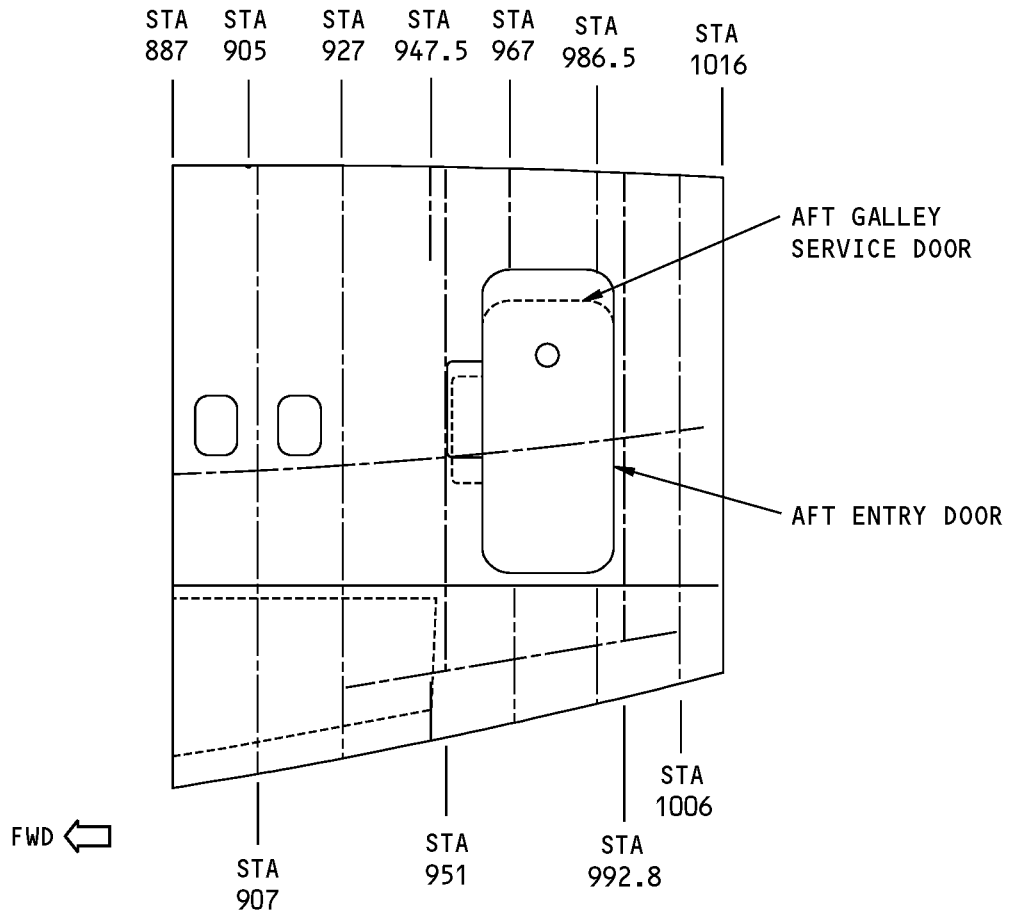
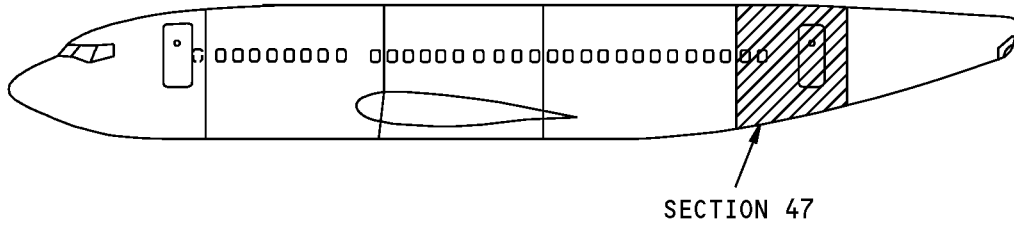

Fuselage Station Diagram - Section 47
Figure 208/06-21-00-990-805

EFFECTIVITY
HAP ALL

06-21-00

Page 211
Feb 10/2007

D633A101-HAP



737-600/700/800/900

AIRCRAFT MAINTENANCE MANUAL

TASK 06-21-00-800-804

5. Fuselage Station Diagram

(Figure 209 or Figure 210)

————— **END OF TASK** —————

EFFECTIVITY
HAP ALL

D633A101-HAP

06-21-00

Page 212
Feb 10/2007

AIRCRAFT MAINTENANCE MANUAL

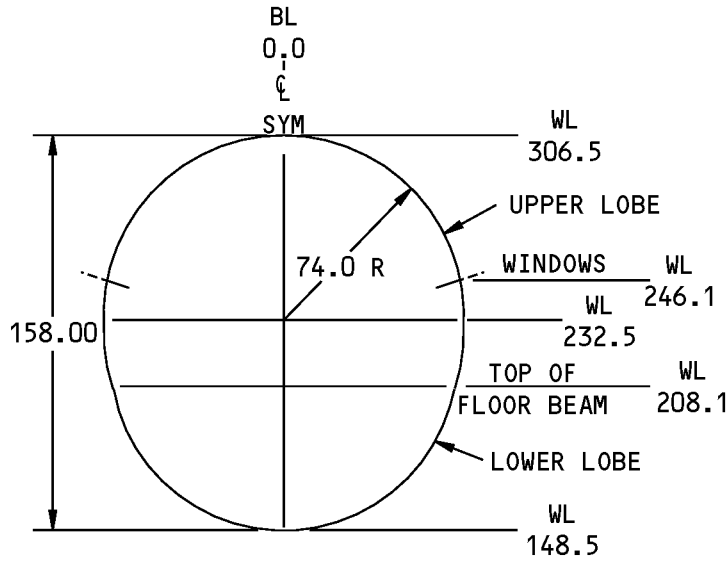
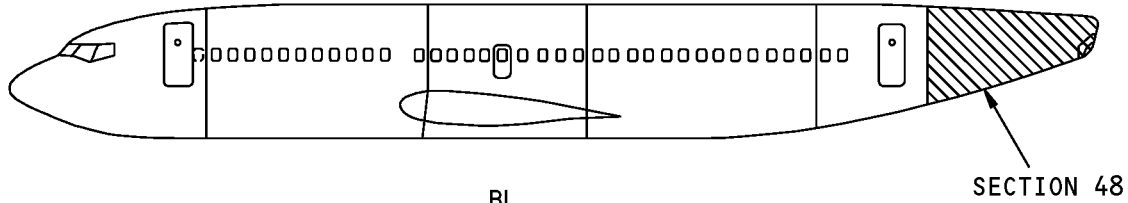

REAR VIEW

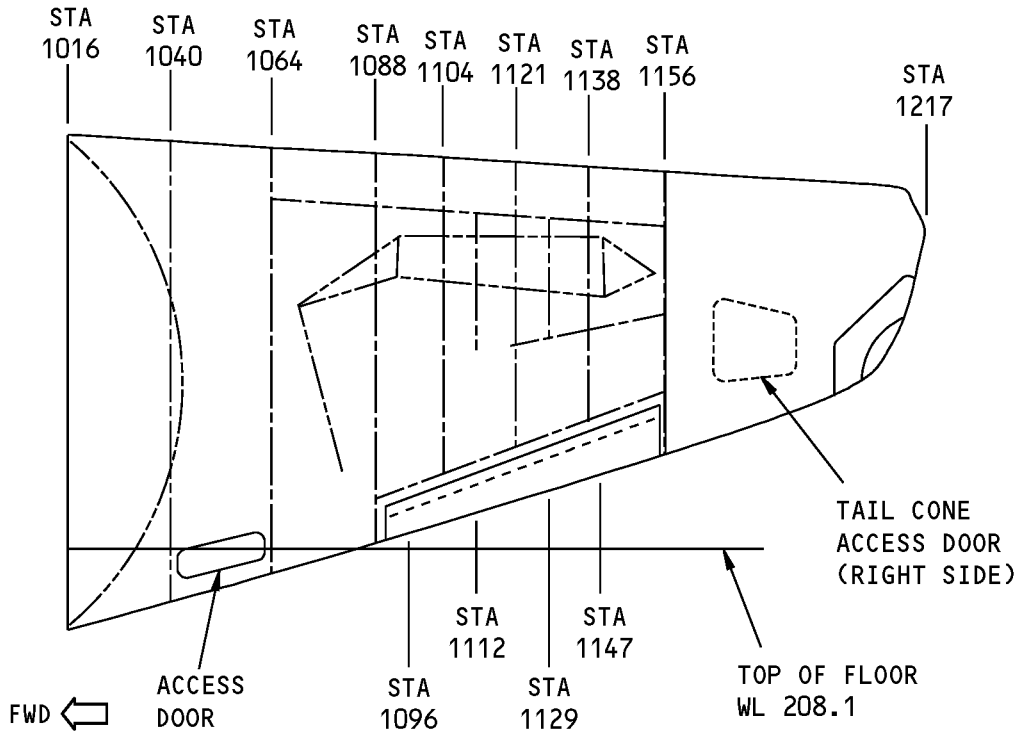

Fuselage Station Diagram - Section 48
Figure 209/06-21-00-990-806

EFFECTIVITY
HAP 101-999

06-21-00

**737-600/700/800/900
AIRCRAFT MAINTENANCE MANUAL**

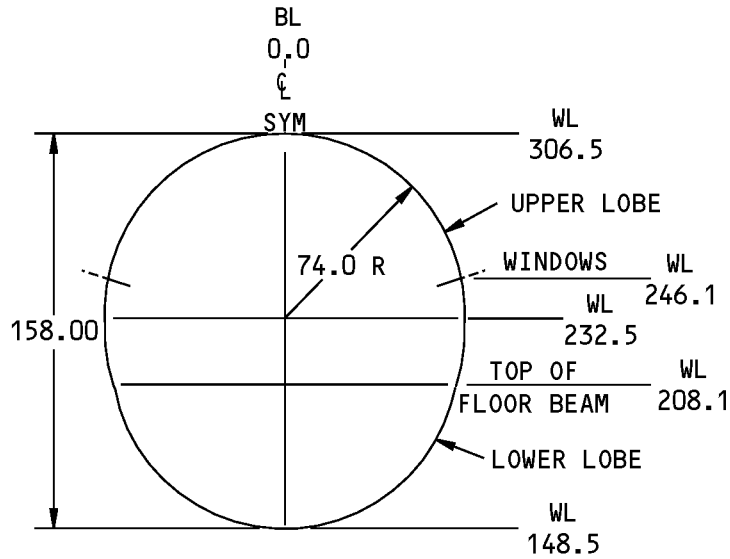
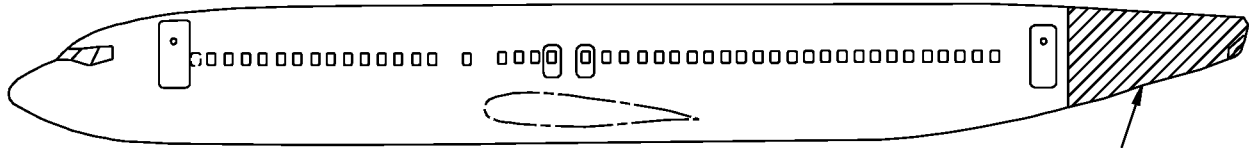

REAR VIEW

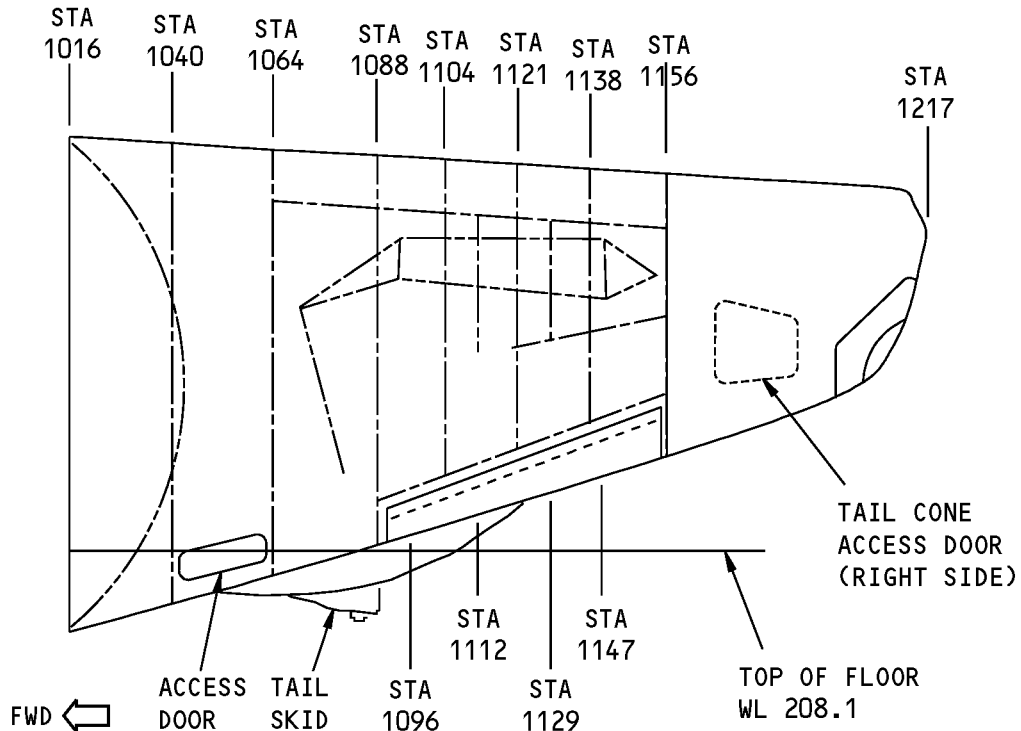

**Fuselage Station Diagram - Section 48
Figure 210/06-21-00-990-836**

EFFECTIVITY
HAP 001-013, 015-026, 028-054

06-21-00



737-600/700/800/900

AIRCRAFT MAINTENANCE MANUAL

VERTICAL FIN AND RUDDER STATION DIAGRAM - MAINTENANCE PRACTICES

1. General

A. This procedure has these tasks:

- (1) Vertical fin and rudder station diagram

TASK 06-22-00-800-801

2. Vertical Fin and Rudder Station Diagram

(Figure 201)

A. General

- (1) The vertical fin and rudder station diagram gives you the locations of the structural components and features on the vertical fin and rudder.
- (2) The following are definitions for the vertical fin and rudder stations:
 - (a) FIN STA is Vertical Fin Station
 - (b) RUD STA is Rudder Station

B. Location Zones

Zone	Area
300	Empennage

————— **END OF TASK** —————

<p>EFFECTIVITY</p> <p>HAP ALL</p>	
-----------------------------------	--

D633A101-HAP

06-22-00

Page 201
Oct 10/2003



**737-600/700/800/900
AIRCRAFT MAINTENANCE MANUAL**

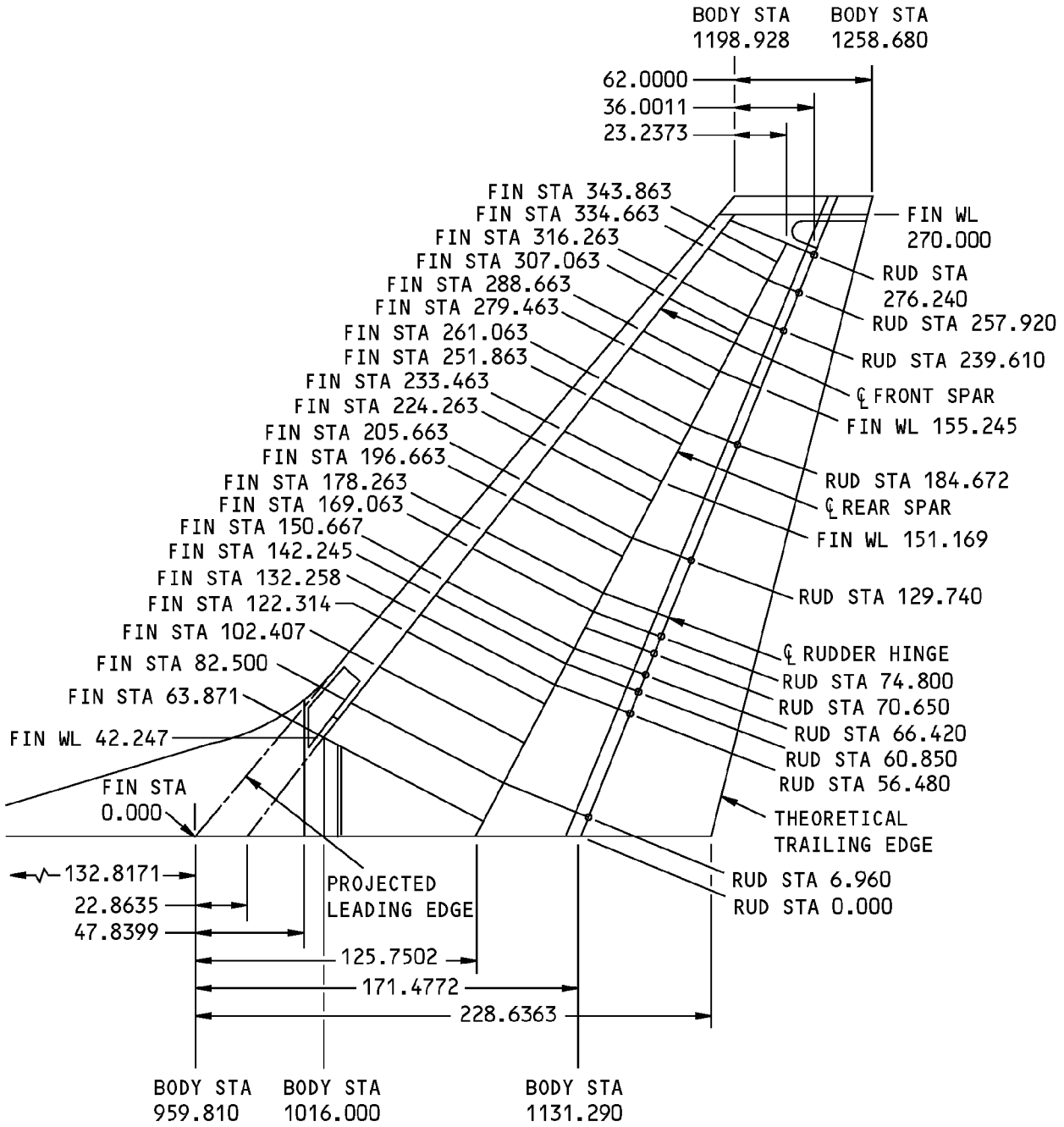

NOTE: ALL DIMENSIONS ARE IN INCHES.

**Vertical Fin and Rudder Station Diagram
Figure 201/06-22-00-990-801**

EFFECTIVITY
HAP ALL

06-22-00

Page 202
Oct 10/2003

D633A101-HAP



737-600/700/800/900

AIRCRAFT MAINTENANCE MANUAL

HORIZONTAL STABILIZER AND ELEVATOR STATION DIAGRAM - MAINTENANCE PRACTICES

1. General

A. This procedure has these tasks:

- (1) Horizontal stabilizer and elevator station diagram

TASK 06-23-00-800-801

2. Horizontal Stabilizer and Elevator Station Diagram

(Figure 201)

A. General

- (1) The horizontal stabilizer and elevator station diagram gives the locations of the structural components and features on the horizontal stabilizer and elevator.
- (2) The following are definitions for the horizontal stabilizer and elevator stations:
 - (a) EL STA is Elevator Station
 - (b) STAB STA is Stabilizer Station

B. Location Zones

Zone	Area
300	Empennage

————— **END OF TASK** —————

EFFECTIVITY
HAP ALL

06-23-00

Page 201
Oct 10/2003

D633A101-HAP

AIRCRAFT MAINTENANCE MANUAL

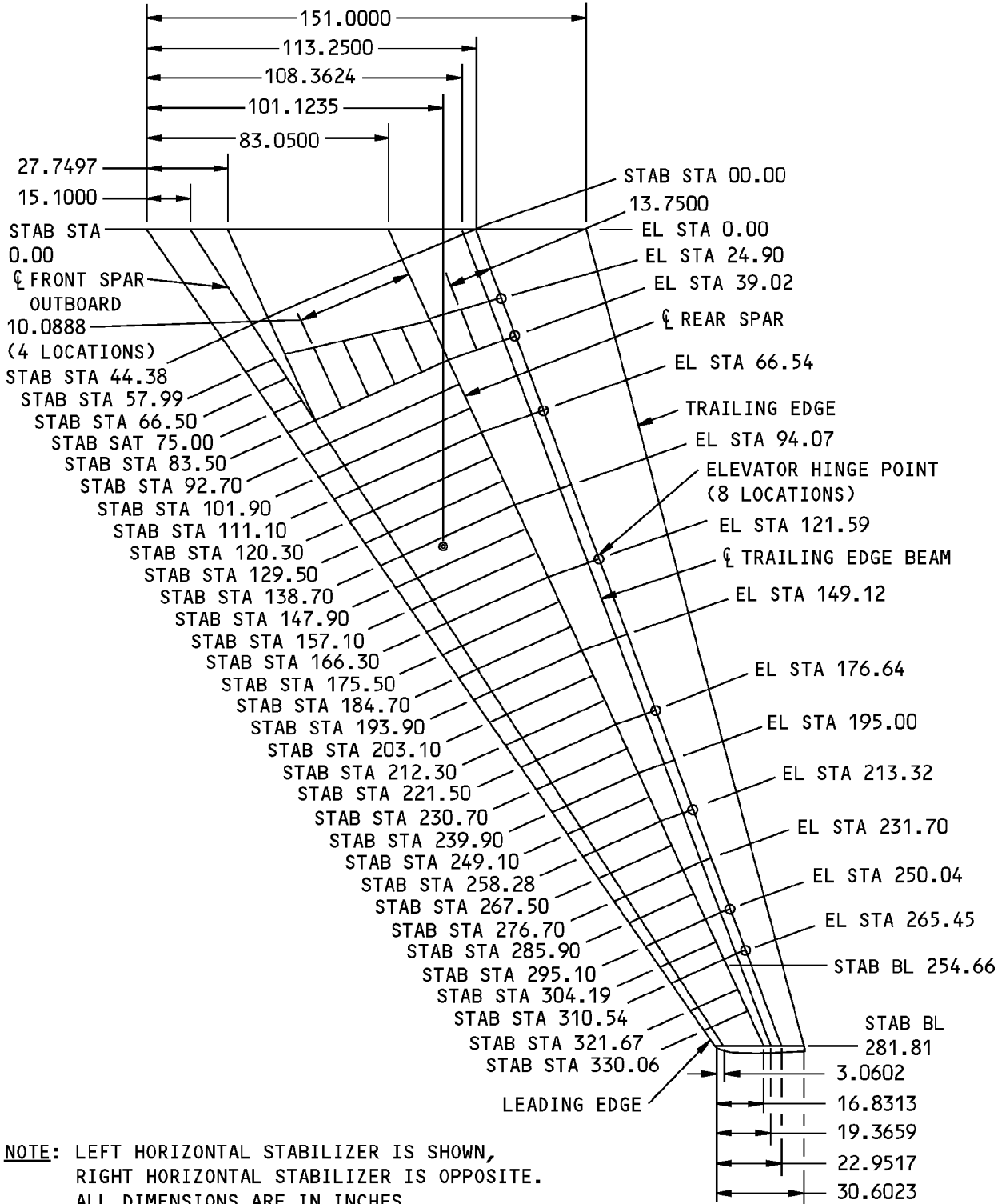

Horizontal Stabilizer and Elevator Station Diagram
Figure 201/06-23-00-990-801

EFFECTIVITY
HAP ALL

06-23-00



737-600/700/800/900

AIRCRAFT MAINTENANCE MANUAL

WING STATION DIAGRAM - MAINTENANCE PRACTICES

1. General

A. This procedure has this task:

- (1) Wing station diagram

TASK 06-24-00-800-801

2. Wing Station Diagram

(Figure 201)

A. General

- (1) The wing station diagram gives the locations of the structural components and features on the wing.

B. Location Zones

<u>Zone</u>	<u>Area</u>
500	Left Wing
600	Right Wing

————— **END OF TASK** —————

EFFECTIVITY
HAP ALL

D633A101-HAP

06-24-00

Page 201
Oct 10/2003

AIRCRAFT MAINTENANCE MANUAL

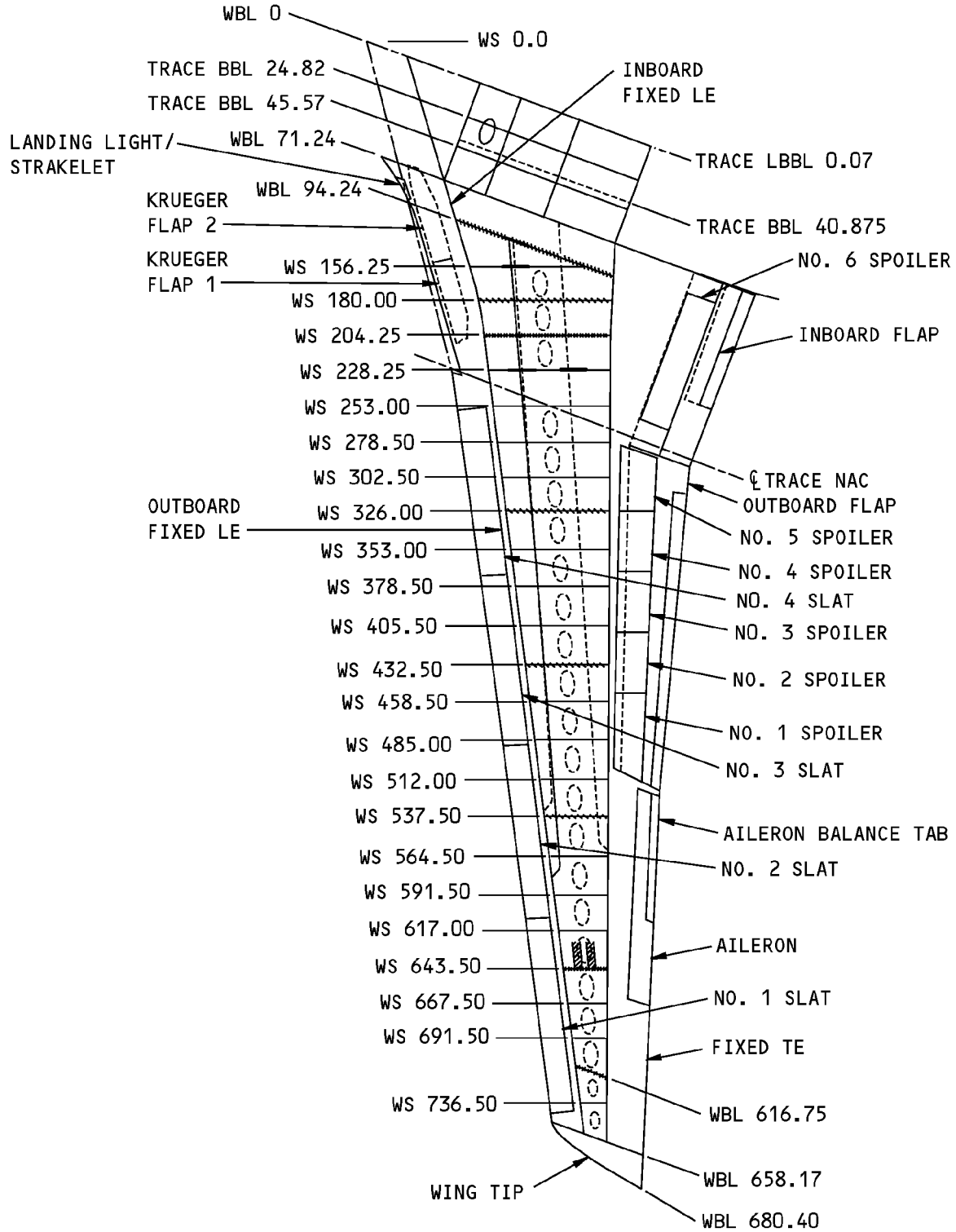

Wing Station Diagram
Figure 201/06-24-00-990-801

EFFECTIVITY
HAP ALL

06-24-00

Page 202
 Oct 10/2003

D633A101-HAP



737-600/700/800/900

AIRCRAFT MAINTENANCE MANUAL

ENGINE AND NACELLE STATION DIAGRAM - MAINTENANCE PRACTICES

1. General

A. This procedure has these tasks:

- (1) Engine and nacelle station diagram

TASK 06-25-00-800-801

2. Engine and Nacelle Station Diagram

(Figure 201)

A. General

- (1) The engine and nacelle station diagram gives you the locations of the structural components and features on the engine and nacelle.

B. Location Zones

Zone	Area
400	Powerplant and Nacelle Struts

————— **END OF TASK** —————

<p>EFFECTIVITY</p> <p>HAP ALL</p>	
---	--

D633A101-HAP

06-25-00

Page 201
Oct 10/2003

**737-600/700/800/900
AIRCRAFT MAINTENANCE MANUAL**

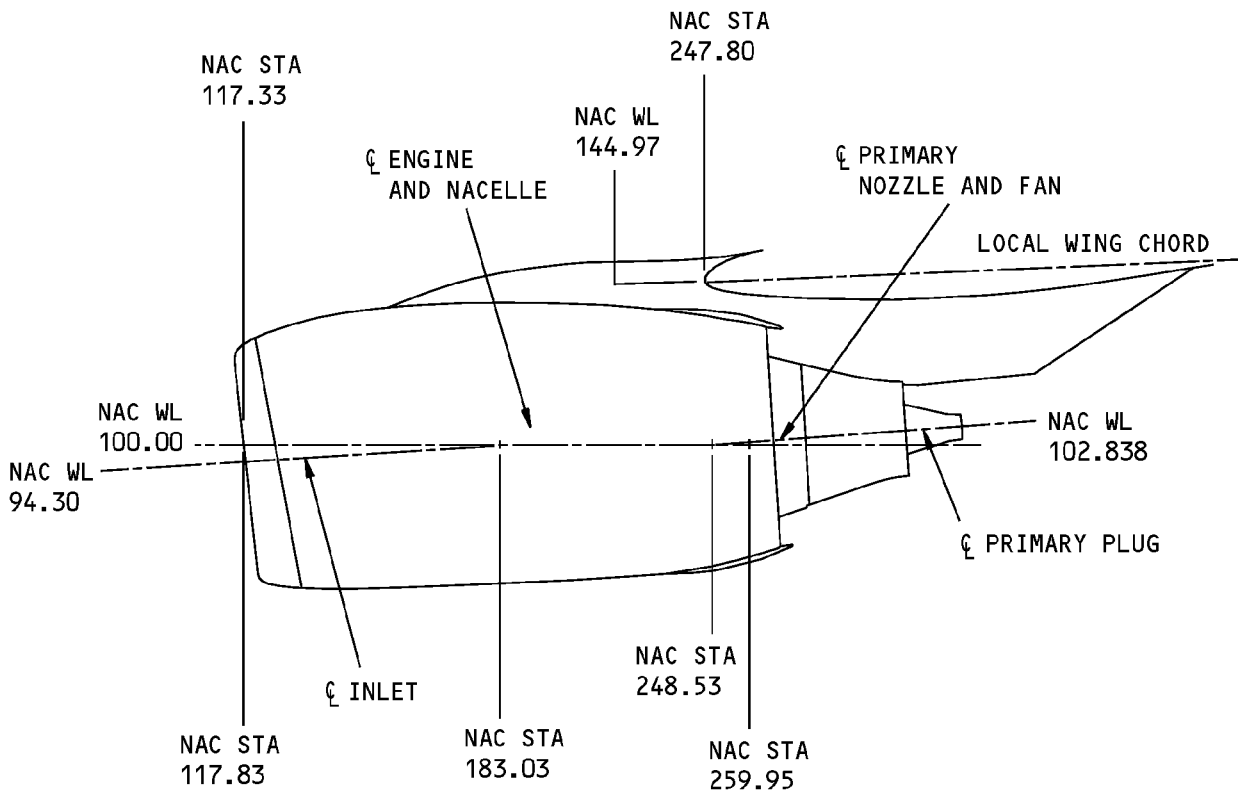

**CMF 56-7 Series Engines - Engine and Nacelle Station Diagram
Figure 201/06-25-00-990-801**

EFFECTIVITY
HAP ALL

D633A101-HAP

06-25-00

Page 202
Oct 10/2003



737-600/700/800/900

AIRCRAFT MAINTENANCE MANUAL

ZONE DIAGRAMS - MAINTENANCE PRACTICES

1. General

A. This procedure has these tasks:

- (1) Major zones
- (2) Lower half of the fuselage - major zone 100
- (3) Upper half of the fuselage - major zone 200
- (4) Empennage and body section 48 - major zone 300
- (5) Power plants and nacelle struts - major zone 400
- (6) Left wing - major zone 500
- (7) Right wing - major zone 600
- (8) landing gear and landing gear doors - major zone 700
- (9) Passenger and cargo compartment doors - major zone 800

TASK 06-30-00-800-801

2. Major Zones

(Figure 201)

A. General

- (1) The 737 airplane is divided into 8 major zones to help you find and identify the airplane components and parts. The major zones are divided into subzones and the subzones into zones.
- (2) The zones are numbered in the sequence that follows:
 - (a) Fuselage - front to back and away from the floorline
 - (b) Wings - inboard to outboard and front to back
 - (c) Horizontal Stabilizer and Elevator - inboard to outboard and front to back
 - (d) Vertical Fin and Rudder - leading edge to the trailing edge of the vertical stabilizer
- (3) Each of the structural components, passenger compartment doors, cargo compartment doors, landing gear doors, rudders, elevators, flaps, ailerons, spoilers, leading edge devices, and equivalent components has a different zone number.
- (4) A three-digit number identifies the major zones, subzones, and zones as follows:
 - (a) Major Zone - the first digit is a number from 1 to 8 followed by two zeroes.
 - (b) Subzone - the first digit represents the major zone, the second digit is a number from 1 to 6 or 9, and the third digit is a zero.
 - (c) Zone - the first two digits represent the subzone number and the third digit shows a component or group of components that are in the subzone.

B. Location Zones

Zone	Area
100	Lower Half of Fuselage
200	Upper Half of Fuselage
300	Empennage
400	Powerplant and Nacelle Struts
500	Left Wing
600	Right Wing
700	Landing Gear and Landing Gear Doors

EFFECTIVITY
HAP ALL

06-30-00

Page 201
Oct 10/2003

D633A101-HAP



**737-600/700/800/900
AIRCRAFT MAINTENANCE MANUAL**

(Continued)

Zone	Area
800	Doors

————— **END OF TASK** —————

EFFECTIVITY
HAP ALL

D633A101-HAP

06-30-00

Page 202
Oct 10/2003



737-600/700/800/900
AIRCRAFT MAINTENANCE MANUAL

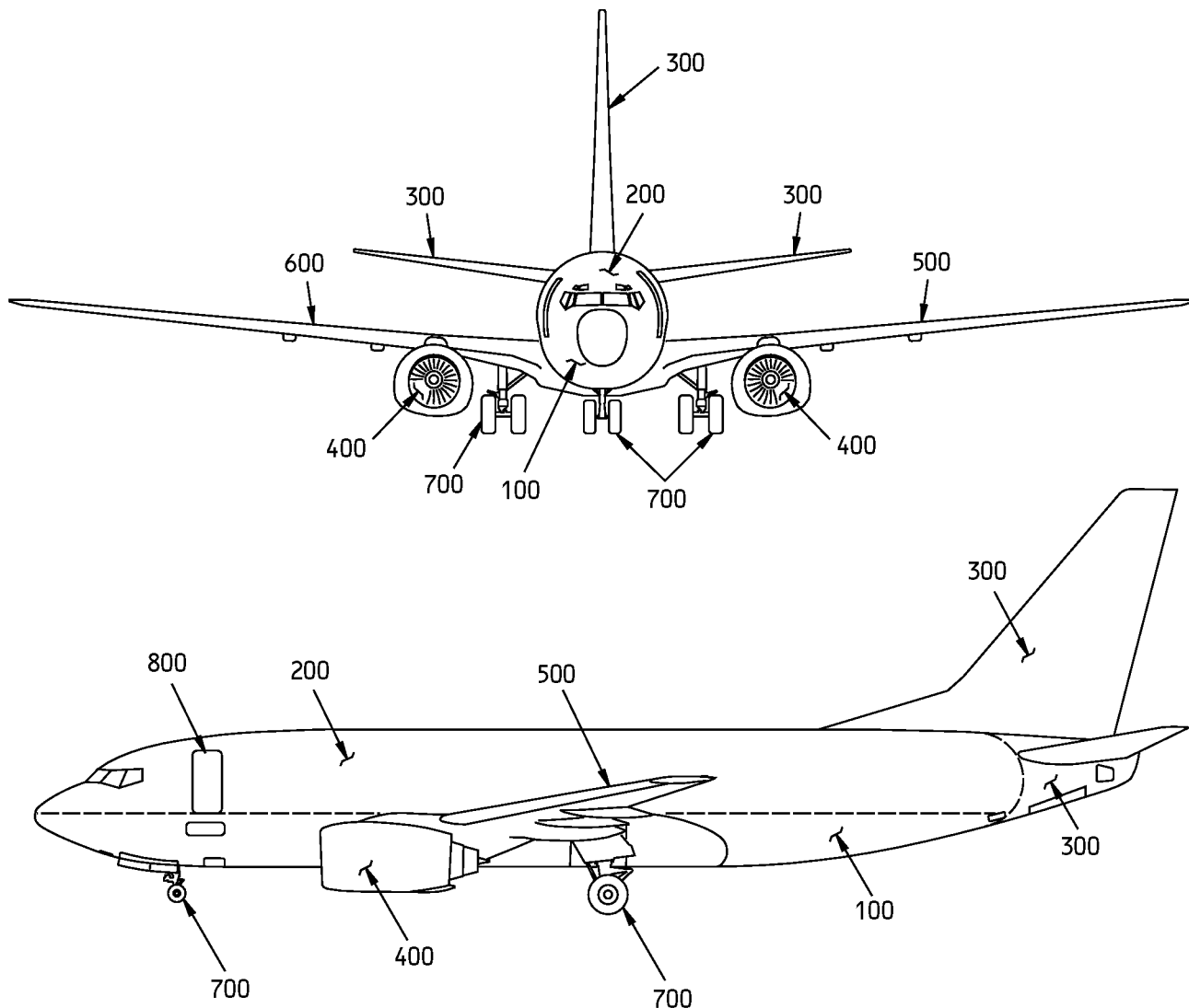

- MAJOR ZONE 100 - LOWER HALF OF FUSELAGE
- MAJOR ZONE 200 - UPPER HALF OF FUSELAGE
- MAJOR ZONE 300 - EMPENNAGE AND BODY SECTION 48
- MAJOR ZONE 400 - POWER PLANTS AND NACELLE STRUTS
- MAJOR ZONE 500 - LEFT WING
- MAJOR ZONE 600 - RIGHT WING
- MAJOR ZONE 700 - LANDING GEAR AND LANDING GEAR DOORS
- MAJOR ZONE 800 - PASSENGER AND CARGO COMPARTMENT DOORS

Airplane Major Zones
Figure 201/06-30-00-990-801

EFFECTIVITY
HAP ALL

06-30-00

Page 203
Oct 10/2003

D633A101-HAP



737-600/700/800/900

AIRCRAFT MAINTENANCE MANUAL

TASK 06-30-00-800-802

3. Lower Half of the Fuselage - Major Zone 100

(Figure 202)

A. Location Zones

Zone	Area
100	Lower Half of Fuselage

B. Procedure

SUBTASK 06-30-00-800-001

(1) The (Table 201) lists the applicable zones for the lower half of the fuselage.

Table 201/06-30-00-993-808 Major Zone 100 - Lower Half of the Fuselage

Subzone	Zone	Zone Name
110		Body Station 130.00 to Body Station 360.00
	111	Radome
	112	Area Forward of Nose Landing Gear Wheel Well
	113	Area Above Nose Landing Gear Wheel Well - Left
	114	Area Above Nose Landing Gear Wheel Well - Right
	115	Nose Landing Gear Wheel Well - Left
	116	Nose Landing Gear Wheel Well - Right
	117	Electrical and Electronics Compartment - Left
	118	Electrical and Electronics Compartment - Right
120		Body Station 360.00 to Body Station 540.00
	121	Forward Cargo Compartment - Left
	122	Forward Cargo Compartment - Right
	123	Area Below Forward Cargo Compartment - Left
	124	Area Below Forward Cargo Compartment - Right
	125	Area Aft of Forward Cargo Compartment - Left
	126	Area Aft of Forward Cargo Compartment - Right
	129	Keel Beam Body Station 501.70 to Body Station 540.00
130		Body Station 540.00 to Body Station 727.00
	131	Center Section Wing Box, Body Station 540.00 to Body Station 663.75 - Left
	132	Center Section Wing Box, Body Station 540.00 to Body Station 663.75 - Right
	133	Main Landing Gear Wheel Well, Body Station 663.75 to Body Station 727.00 - Left
	134	Main Landing Gear Wheel Well, Body Station 663.75 to Body Station 727.00 - Right
	135	Area above Center Section Wing Box, Body Station 540.0 to Body Station 663.75 - Left

EFFECTIVITY
HAP ALL

06-30-00



737-600/700/800/900

AIRCRAFT MAINTENANCE MANUAL

(Continued)

Subzone	Zone	Zone Name
	136	Area above Center Section Wing Box, Body Station 540.0 to Body Station 663.75 - Right
	137	Area above Main Landing Gear Wheel Well, Body Station 663.75 to Body Station 727.00 - Left
	138	Area above Main Landing Gear Wheel Well, Body Station 663-75 to Body Station 727.00 - Right
	139	Keel Beam, Body Station 540.00 to Body Station 727.00
140		Body Station 727.00 to Body Station 1016.00
	141	Aft Cargo Compartment - Left
	142	Aft Cargo Compartment - Right
	143	Area Below Aft Cargo Compartment - Left
	144	Area Below Aft Cargo Compartment - Right
	145	Area Aft of Aft Cargo Compartment - Left
	146	Area Aft of Aft Cargo Compartment - Right
	149	Keel Beam, Body Station 727.00 to Body Station to Body Station 743.95
190		Wing-to-Body Fairings
	191	Lower Wing-to-Body Fairing - Forward of Wing Box
	192	Lower Wing-to-Body Fairing - Under Wing Box
	193	Lower Wing-to-Body Fairing - Wheel Well
	194	Lower Wing-to-Body Fairing - Aft of Wheel Well
	195	Above Wing Wing-to-Body Fairing - Left
	196	Above Wing Wing-to-Body Fairing - Right

————— END OF TASK —————

EFFECTIVITY
HAP ALL

06-30-00

Page 205
Jun 15/2008

D633A101-HAP

**737-600/700/800/900
AIRCRAFT MAINTENANCE MANUAL**

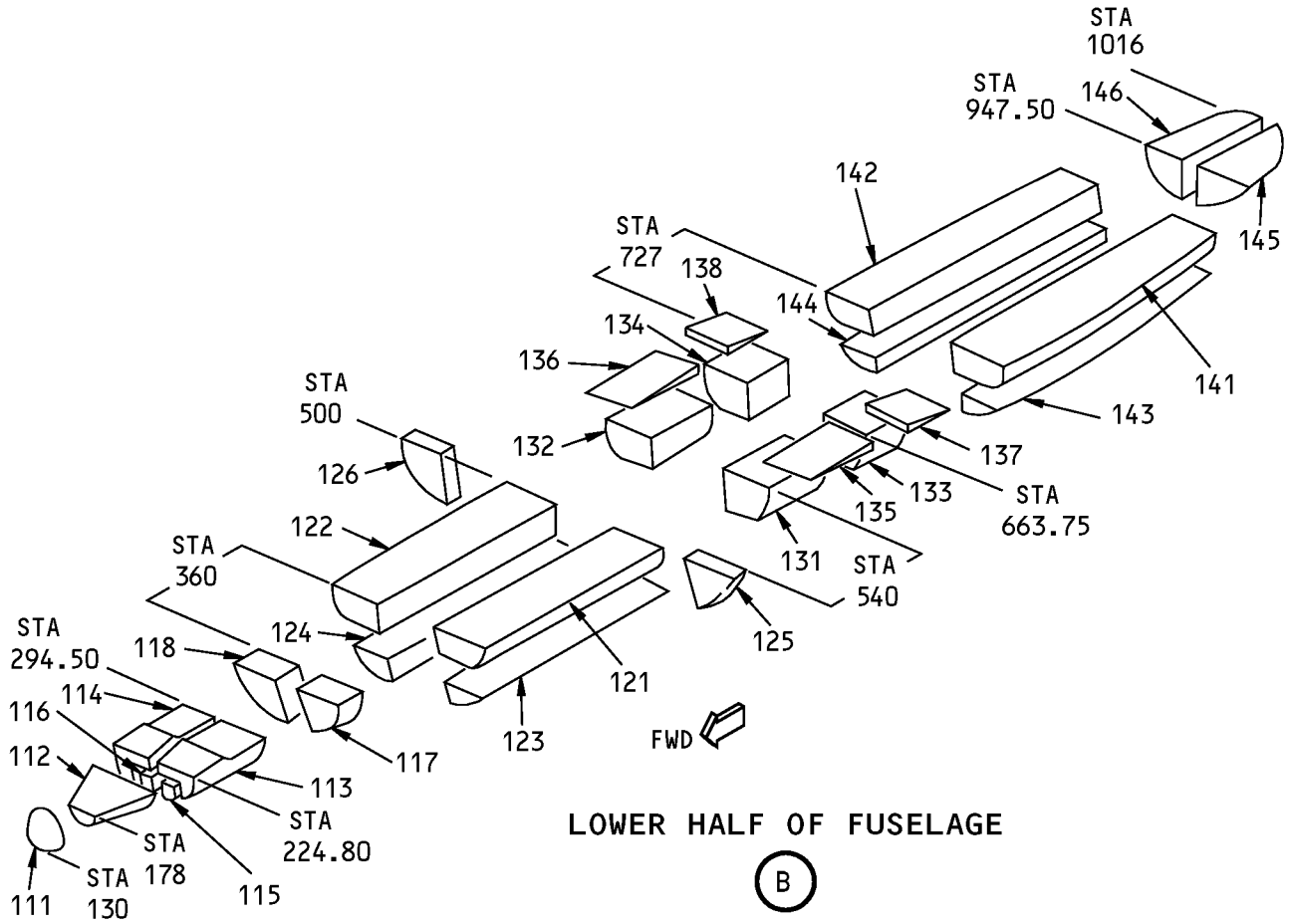

LOWER HALF OF FUSELAGE

(B)

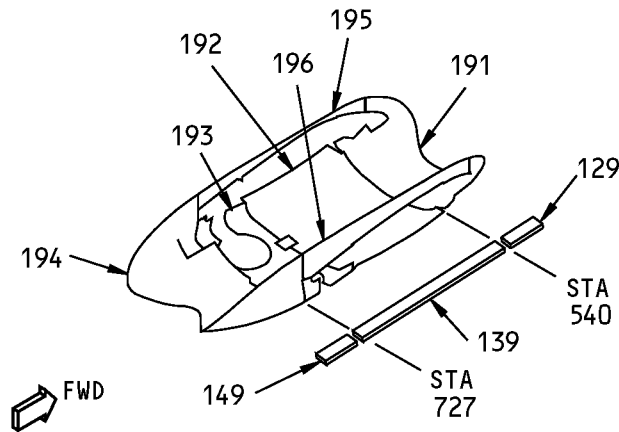

WING-TO-BODY FAIRING

(C)

**Major Zone 100/200 - Lower and Upper Half of Fuselage
Figure 202/06-30-00-990-802**

EFFECTIVITY
HAP ALL

D633A101-HAP

06-30-00



737-600/700/800/900

AIRCRAFT MAINTENANCE MANUAL

TASK 06-30-00-800-803

4. Upper Half of the Fuselage - Major Zone 200

(Figure 202)

A. Location Zones

Zone	Area
200	Upper Half of Fuselage

B. Procedure

SUBTASK 06-30-00-800-002

- (1) The (Table 202) lists the applicable zones for the Upper half of the fuselage.

Table 202/06-30-00-993-809 Major Zone 200 - Upper Half of the Fuselage

Subzone	Zone	Zone Name
210		Control Compartment - Body Station 178.00 to Body Station 259.50
	211	Flight Compartment - Left
	212	Flight Compartment - Right
220		Passenger Compartment - Body Station 259.50 to Body Station 360.00
	221	Passenger Compartment - Aft of Control Compartment to Forward Entry Door, Left
	222	Passenger Compartment - Aft of Control Compartment to Forward Entry Door, Right
230		Passenger Compartment - Body Station 360.00 to Body Station 639.00
	231	Passenger Compartment - Forward Entry Door to Escape Hatch, Left
	232	Passenger Compartment - Forward Entry Door to Escape Hatch, Right
240		Passenger Compartment - Body Station 639.00 to Body Station 1016.00
	241	Passenger Compartment - Escape Hatch to Aft Pressure Bulkhead, Left
	242	Passenger Compartment - Escape Hatch to Aft Pressure Bulkhead, Right

————— END OF TASK —————

EFFECTIVITY
HAP ALL

06-30-00

Page 207
Jun 10/2004

D633A101-HAP

**737-600/700/800/900
AIRCRAFT MAINTENANCE MANUAL**

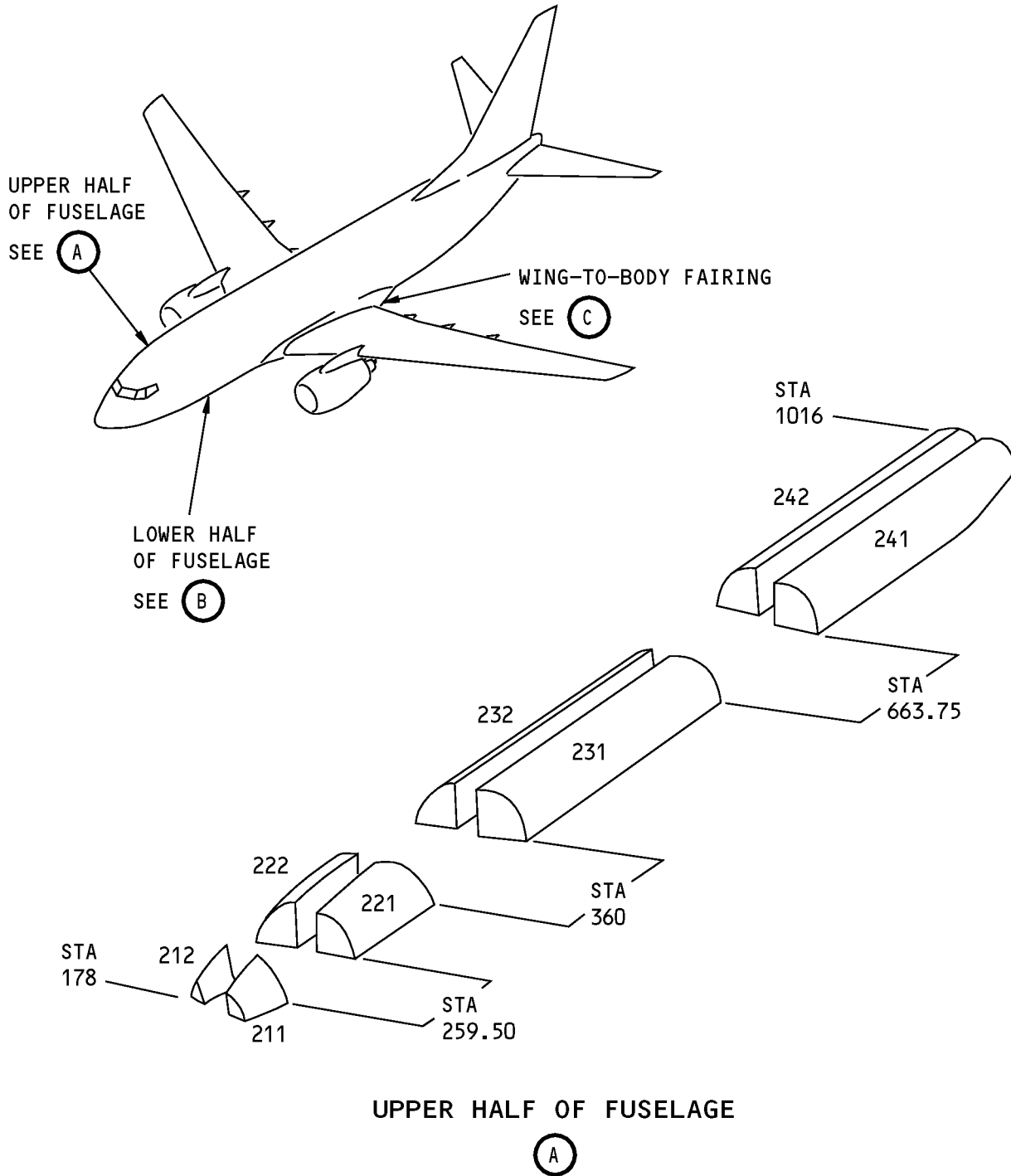

**Major Zone 100/200 - Lower and Upper Half of Fuselage
Figure 203/06-30-00-990-823**

EFFECTIVITY
HAP ALL

06-30-00



737-600/700/800/900

AIRCRAFT MAINTENANCE MANUAL

TASK 06-30-00-800-804

5. Empennage and Body Section 48 - Major Zone 300

(Figure 204)

A. Location Zones

Zone	Area
300	Empennage

B. Procedure

SUBTASK 06-30-00-800-003

- (1) The (Table 203) lists the applicable zones for the empennage and body section 48.

Table 203/06-30-00-993-810 Major Zone 300 - Empennage and Body Section 48

Subzone	Zone	Zone Name
310		Fuselage - Body Station 1016.00 to Body Station 1217.00
	311	Area Aft of Pressure Bulkhead - Left
	312	Area Aft of Pressure Bulkhead - Right
	313	Stabilizer Torsion Box Compartment - Left
	314	Stabilizer Torsion Box Compartment - Right
	315	APU Compartment - Left
	316	APU Compartment - Right
	317	Tail Cone - Left
	318	Tail Cone - Right
320		Vertical Fin and Rudder
	321	Vertical Fin - Dorsal Fin
	322	Vertical Fin - Removable Fin Leading Edge
	323	Vertical Fin - Front Spar to Rear Spar
	324	Vertical Fin - Rear Spar to Trailing Edge
	325	Vertical Fin - Rudder
	326	Vertical Fin - Fin Tip
330		Left Horizontal Stabilizer and Elevator
	331	Left Horizontal Stabilizer - Removable Leading Edge
	332	Left Horizontal Stabilizer - Front Spar to Rear Spar, Stabilizer Station 57.93 to Stabilizer Buttock Line 249.81
	333	Left Horizontal Stabilizer, Rear spar to Trailing Edge
	334	Left Horizontal Stabilizer, Inboard Elevator
	335	Left Horizontal Stabilizer - Tip
340		Right Horizontal Stabilizer and Elevator

EFFECTIVITY
HAP ALL

06-30-00

Page 209
Oct 10/2006

D633A101-HAP



737-600/700/800/900
AIRCRAFT MAINTENANCE MANUAL

(Continued)

Subzone	Zone	Zone Name
	341	Right Horizontal Stabilizer - Leading Edge
	342	Right Horizontal Stabilizer - Front Spar to Rear Spar, Stabilizer Station 57.93 to Stabilizer Buttock Line 249.81
	343	Right Horizontal Stabilizer - Rear Spar to Trailing Edge
	344	Right Horizontal Stabilizer - Inboard Elevator
	345	Right Horizontal Stabilizer - Tip

————— **END OF TASK** —————

EFFECTIVITY
HAP ALL

06-30-00

Page 210
Oct 10/2006

D633A101-HAP

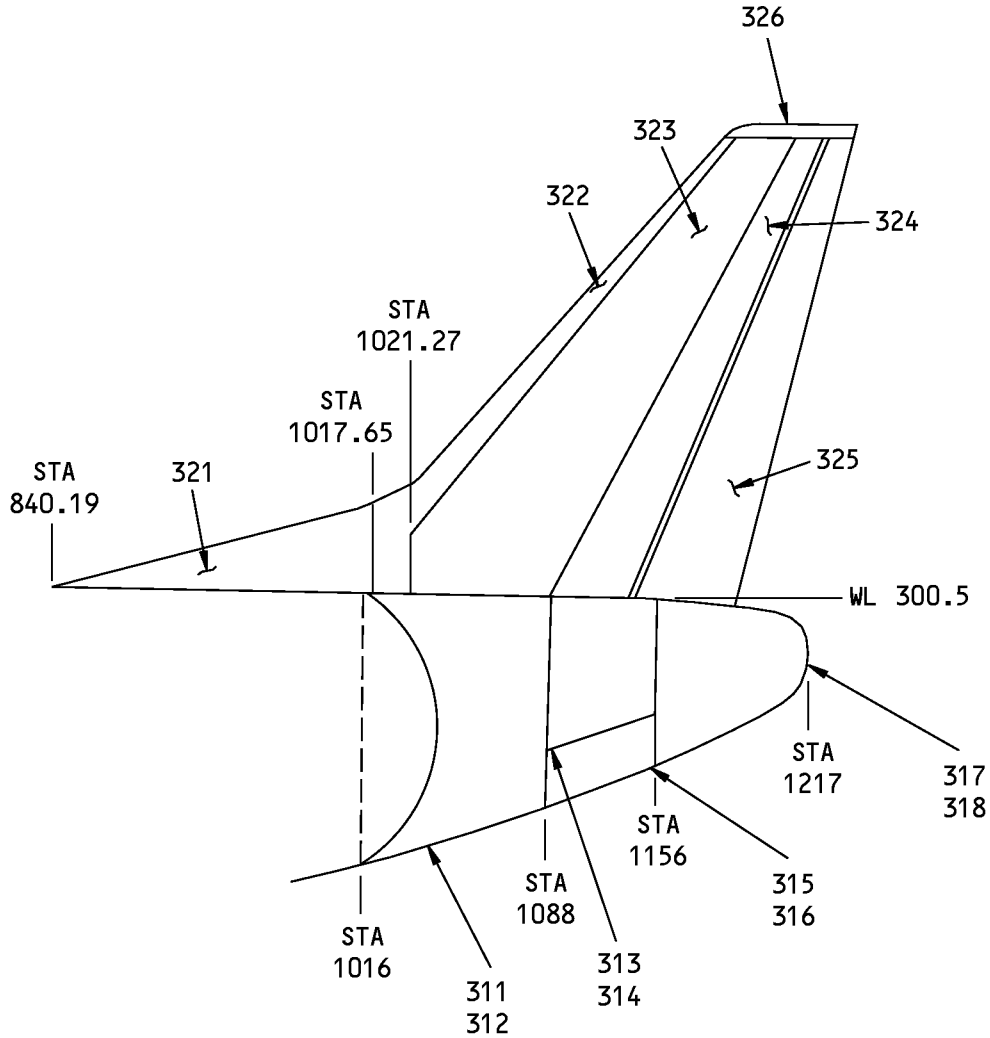

SUBZONE 310 - SECTION 48
SUBZONE 320 - VERTICAL FIN AND RUDDER

**Major Zone 300 - Empennage and Body Section 48
Figure 204 (Sheet 1 of 2)/06-30-00-990-803**

EFFECTIVITY
HAP ALL

06-30-00

Page 211
Oct 10/2006

D633A101-HAP

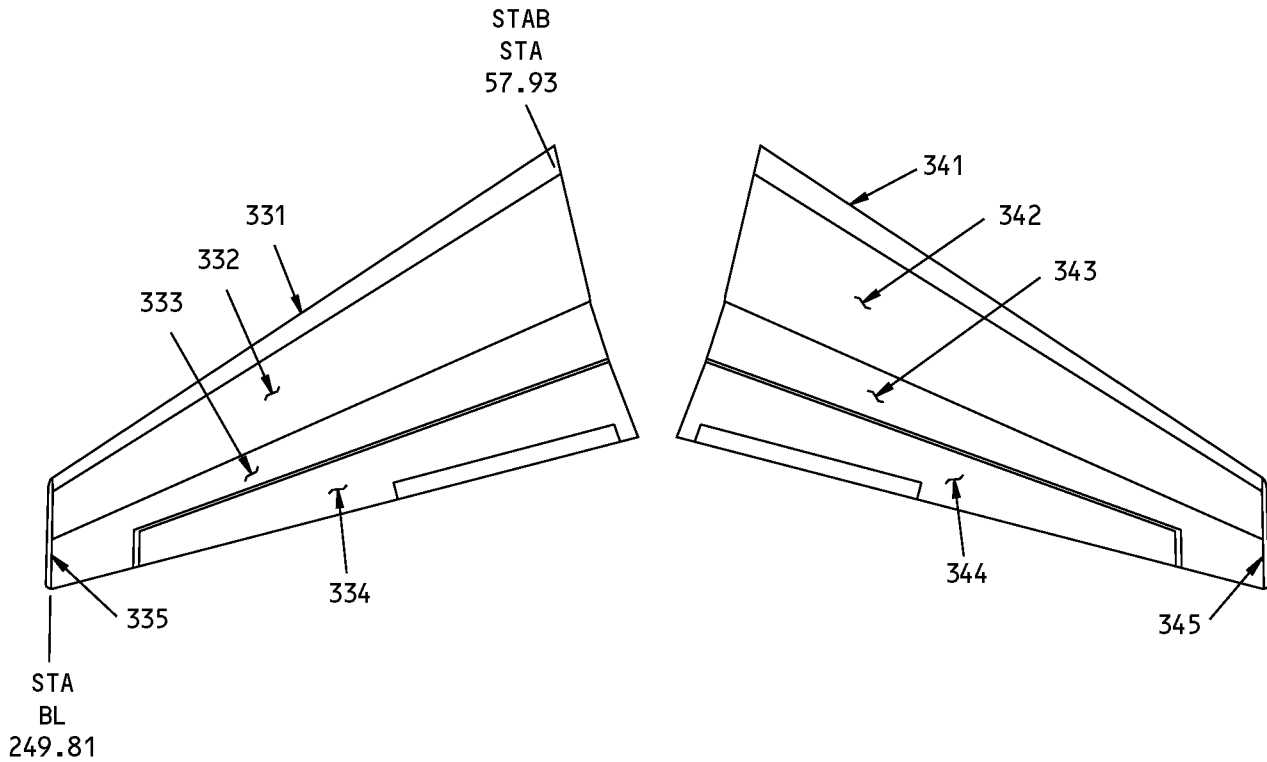

**SUBZONE 330 - LEFT HORIZONTAL STABILIZER AND ELEVATOR
SUBZONE 340 - RIGHT HORIZONTAL STABILIZER AND ELEVATOR**

**Major Zone 300 - Empennage and Body Section 48
Figure 204 (Sheet 2 of 2)/06-30-00-990-803**

EFFECTIVITY
HAP ALL

06-30-00

Page 212
Oct 10/2003

D633A101-HAP



737-600/700/800/900

AIRCRAFT MAINTENANCE MANUAL

TASK 06-30-00-800-805

6. Power Plants and Nacelle Struts - Major Zone 400

(Figure 205)

A. Location Zones

Zone	Area
400	Powerplant and Nacelle Struts

B. Procedure

SUBTASK 06-30-00-800-004

(1) The (Table 204) lists the applicable zones for the power plants and nacelle struts.

Table 204/06-30-00-993-811 Major Zone 400 - Power Plants and Nacelle Struts

SubZone	Zone	Zone Name
410		Left Engine
	411	Left Engine - Engine
	412	Left Engine - Nose Inlet Cowl
	413	Left Engine - Fan Cowl, Left
	414	Left Engine - Fan Cowl, Right
	415	Left Engine - Thrust Reverser, Left
	416	Left Engine - Thrust Reverser, Right
	417	Left Engine - Primary Exhaust Nozzle and Plug
420		Right Engine
	421	Right Engine - Engine
	422	Right Engine - Nose Inlet Cowl
	423	Right Engine - Fan Cowl, Left
	424	Right Engine - Fan Cowl, Right
	425	Right Engine - Thrust Reverser, Left
	426	Right Engine - Thrust Reverser, Right
	427	Right Engine - Primary Exhaust Nozzle and Plug
430		Left Engine - Nacelle Strut
	431	Left Engine - Forward Strut Fairing
	432	Left Engine - Fan Cowl Support Beam
	433	Left Engine - Strut Torque Box
	434	Left Engine - Aft Strut Fairing
440		Right Engine - Nacelle Strut
	441	Right Engine - Forward Strut Fairing
	442	Right Engine - Fan Cowl Support Beam

EFFECTIVITY
HAP ALL

06-30-00

Page 213
Oct 10/2003

D633A101-HAP



**737-600/700/800/900
AIRCRAFT MAINTENANCE MANUAL**

(Continued)

SubZone	Zone	Zone Name
	443	Right Engine - Strut Torque Box
	444	Right Engine - Aft Strut Fairing

————— **END OF TASK** —————

EFFECTIVITY
HAP ALL

D633A101-HAP

06-30-00

Page 214
Oct 10/2003

**737-600/700/800/900
AIRCRAFT MAINTENANCE MANUAL**

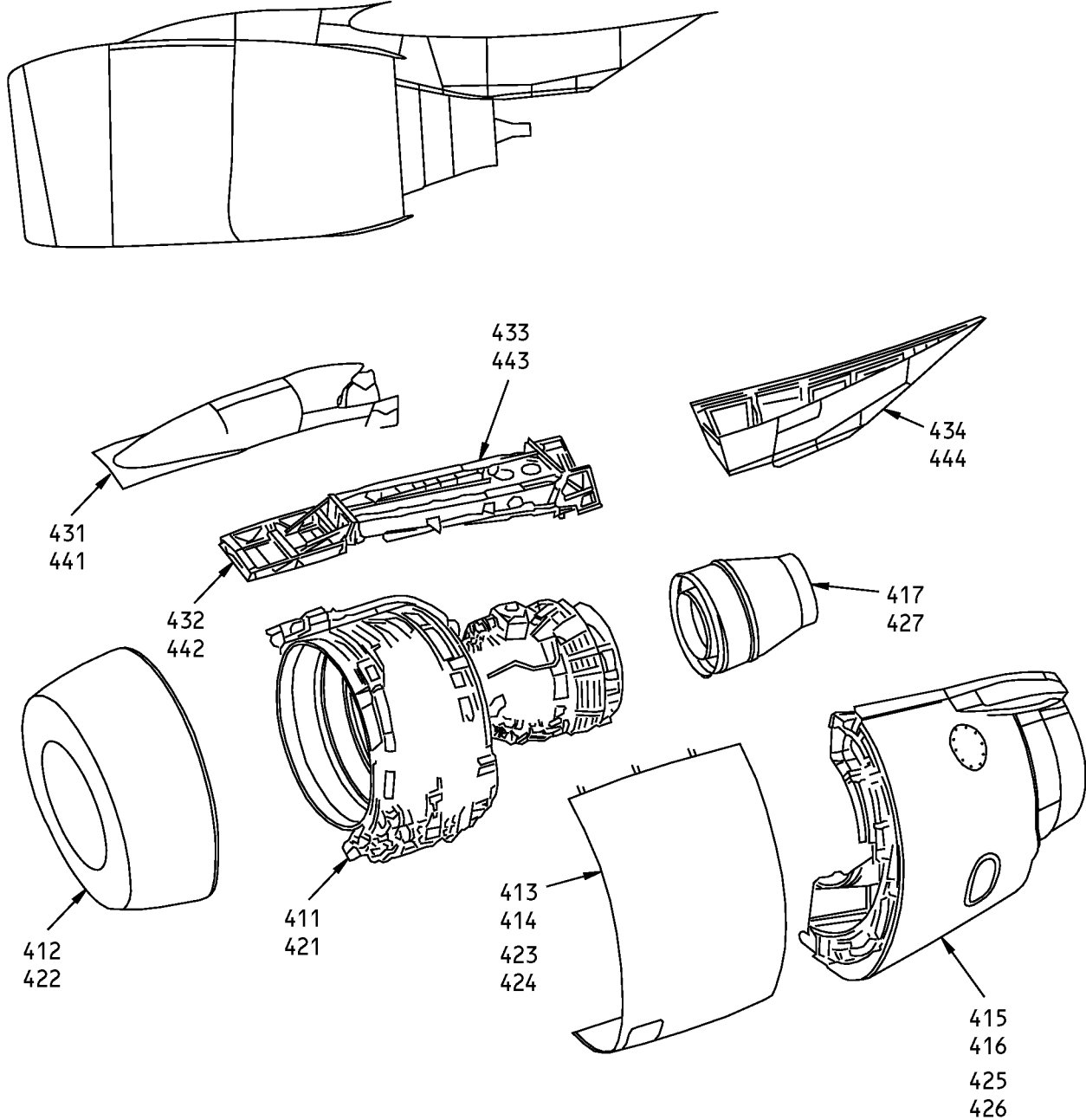

- SUBZONE 410 – LEFT POWERPLANT
- SUBZONE 420 – RIGHT POWERPLANT
- SUBZONE 430 – LEFT NACELLE STRUT
- SUBZONE 440 – RIGHT NACELLE STRUT

**Major Zone 400 CMF 56-7 Series Engines - Power Plants and Nacelle Struts
Figure 205/06-30-00-990-804**

EFFECTIVITY
HAP ALL

06-30-00

Page 215
Oct 10/2003

D633A101-HAP



737-600/700/800/900

AIRCRAFT MAINTENANCE MANUAL

TASK 06-30-00-800-806

7. Left Wing - Major Zone 500

(Figure 206)

A. Location Zones

Zone	Area
500	Left Wing

B. Procedure

SUBTASK 06-30-00-800-005

(1) The (Table 205) lists the applicable zones for the left wing.

Table 205/06-30-00-993-812 Major Zone 500 - Left Wing

Subzone	Zone	Zone Name
510		Left Wing - Wing Leading Edge, Forward of Front Spar, Inboard of Nacelle Strut, Including Nacelle Gap Cover Area
	511	Left Wing - Leading Edge to Front Spar
	512	Left Wing - Krueger Flap No. 2
	513	Left Wing - Krueger Flap No. 1
520		Left Wing Leading Edge - Forward of Front Spar, Outboard of Nacelle Strut
	521	Left Wing - Leading Edge to Front Spar
	522	Left Wing - Slat No. 4
	523	Left Wing - Slat No. 3
	524	Left Wing - Slat No. 2
	525	Left Wing - Slat No. 1
	526	Left Wing - Wing Tip
530		Left Wing - Wing Inspar Area (Fuel Tanks), Inboard of Wing Rib 22, Wing Station 643.50
	531	Left Wing - Center Fuel Tank Rib 1 to Rib 5
	532	Left Wing -Main Tank, Rib 5 to Rib 22, Wing Station 204.25 to Wing Station 643.50
	533	Left Wing - Surge Tank, Rib 22 to Rib 25, Wing Station 616.75 to Wing Buttock Line 643.50
	534	Left Wing - Dry Bay
540		Left Wing - Wing Trailing Edge Flap Track Fairings
	541	Left Wing - Fairing Flap Support No. 4
	542	Left Wing - Fairing Flap Support No. 3
	543	Left Wing - Fairing Flap Support No. 2
	544	Left Wing - Fairing Flap Support No. 1
550		Left Wing - Wing Trailing Edge, Aft of Rear Spar, Inboard of Outboard Trailing Edge Flap

EFFECTIVITY
HAP ALL

06-30-00

Page 216
Oct 10/2003

D633A101-HAP



737-600/700/800/900

AIRCRAFT MAINTENANCE MANUAL

(Continued)

Subzone	Zone	Zone Name
	551	Left Wing - Rear Spar to Landing Gear Support Beam
	552	Left Wing - Spoiler No. 6
	553	Left Wing - Inboard Flap
560		Left Wing - Wing Trailing Edge, Aft of Rear Spar, Outboard of Inboard Trailing Edge Flap, Inboard of Fixed Trailing Edge
	561	Left Wing - Rear Spar to Trailing Edge, Outboard of Inboard Flap, Inboard of Fixed Trailing Edge
	562	Left Wing - Spoiler No. 5
	563	Left Wing - Spoiler No. 4
	564	Left Wing - Spoiler No. 3
	565	Left Wing - Spoiler No. 2
	566	Left Wing - Spoiler No. 1
	567	Left Wing - Outboard Flap
570		Left Wing - Wing Trailing Edge, Outboard of Outboard Flap, Inboard of Wing Tip, Wing Buttock Line 658.17
	571	Left Wing - Fixed Trailing Edge
	572	Left Wing - Aileron

————— **END OF TASK** —————

TASK 06-30-00-800-807

8. Right Wing - Major Zone 600

(Figure 206)

A. Location Zones

Zone	Area
600	Right Wing

B. Procedure

SUBTASK 06-30-00-800-006

(1) The (Table 206) lists the applicable zones for the right wing.

Table 206/06-30-00-993-813 Major Zone 600 - Right Wing

Subzone	Zone	Zone Name
610		Right Wing - Wing Leading Edge, Forward of Front Spar, Inboard of Nacelle Strut, Including Nacelle Gap Cover Area
	611	Right Wing - Leading Edge to Front Spar
	612	Right Wing - Krueger Flap No. 3

<p>EFFECTIVITY</p> <p>HAP ALL</p>

06-30-00

Page 217
Oct 10/2003

D633A101-HAP



737-600/700/800/900

AIRCRAFT MAINTENANCE MANUAL

(Continued)

Subzone	Zone	Zone Name
	613	Right Wing - Krueger Flap No. 4
620		Right Wing - Wing Leading Edge, Forward of Front Spar, Outboard of Nacelle Strut
	621	Right Wing - Leading Edge to Front Spar
	622	Right Wing - Slat No. 5
	623	Right Wing - Slat No. 6
	624	Right Wing - Slat No. 7
	625	Right Wing - Slat No. 8
	626	Right Wing - Wing Tip
630		Right Wing - Wing Inspar Area (Fuel Tanks), Inboard of Wing Rib 22, Wing Station 643.50
	631	Right Wing - Center Fuel Tank, Rib 1 to Rib 5
	632	Right Wing - Main Tank, Rib 5 to Rib 22, Wing Station 204.25 to Wing Station 643.50
	633	Right Wing - Surge Tank, Rib 22 to Rib 25, Wing Station 616.75 to Wing Station 643.50
	634	Right Wing - Dry Bay
640		Right Wing - Wing Trailing Edge, Flap Track Fairings
	641	Right Wing - Fairing Flap Support No. 5
	642	Right Wing - Fairing Flap Support No. 6
	643	Right Wing - Fairing Flap Support No. 7
	644	Right Wing - Fairing Flap Support No. 8
650		Right Wing - Wing Trailing Edge, Aft of Rear Spar, Inboard of Outboard Trailing Edge Flap
	651	Right Wing - Rear Spar to Landing Gear Support Beam
	652	Right Wing - Spoiler No. 7
	653	Right Wing - Inboard Flap
660		Right Wing - Wing Trailing Edge, Aft of Rear Spar, Outboard of Inboard Trailing Edge Flap, Inboard of Fixed Trailing Edge
	661	Right Wing - Rear Spar to Trailing Edge, Outboard of Inboard Flap, Inboard of Fixed Trailing Edge
	662	Right Wing - Spoiler No. 8
	663	Right Wing - Spoiler No. 9
	664	Right Wing - Spoiler No. 10
	665	Right Wing - Spoiler No. 11

EFFECTIVITY
HAP ALL

06-30-00

Page 218
Oct 10/2003

D633A101-HAP



**737-600/700/800/900
AIRCRAFT MAINTENANCE MANUAL**

(Continued)

Subzone	Zone	Zone Name
	666	Right Wing - Spoiler No. 12
	667	Right Wing - Outboard Flap
670		Right Wing - Fixed Trailing Edge, Outboard of of Outboard Flap, Inboard of Wing Tip, Wing Buttock Line 658.17
	671	Right Wing - Fixed Trailing Edge
	672	Right Wing - Aileron

————— **END OF TASK** —————

EFFECTIVITY
HAP ALL

D633A101-HAP

06-30-00

Page 219
Oct 10/2003

**737-600/700/800/900
AIRCRAFT MAINTENANCE MANUAL**

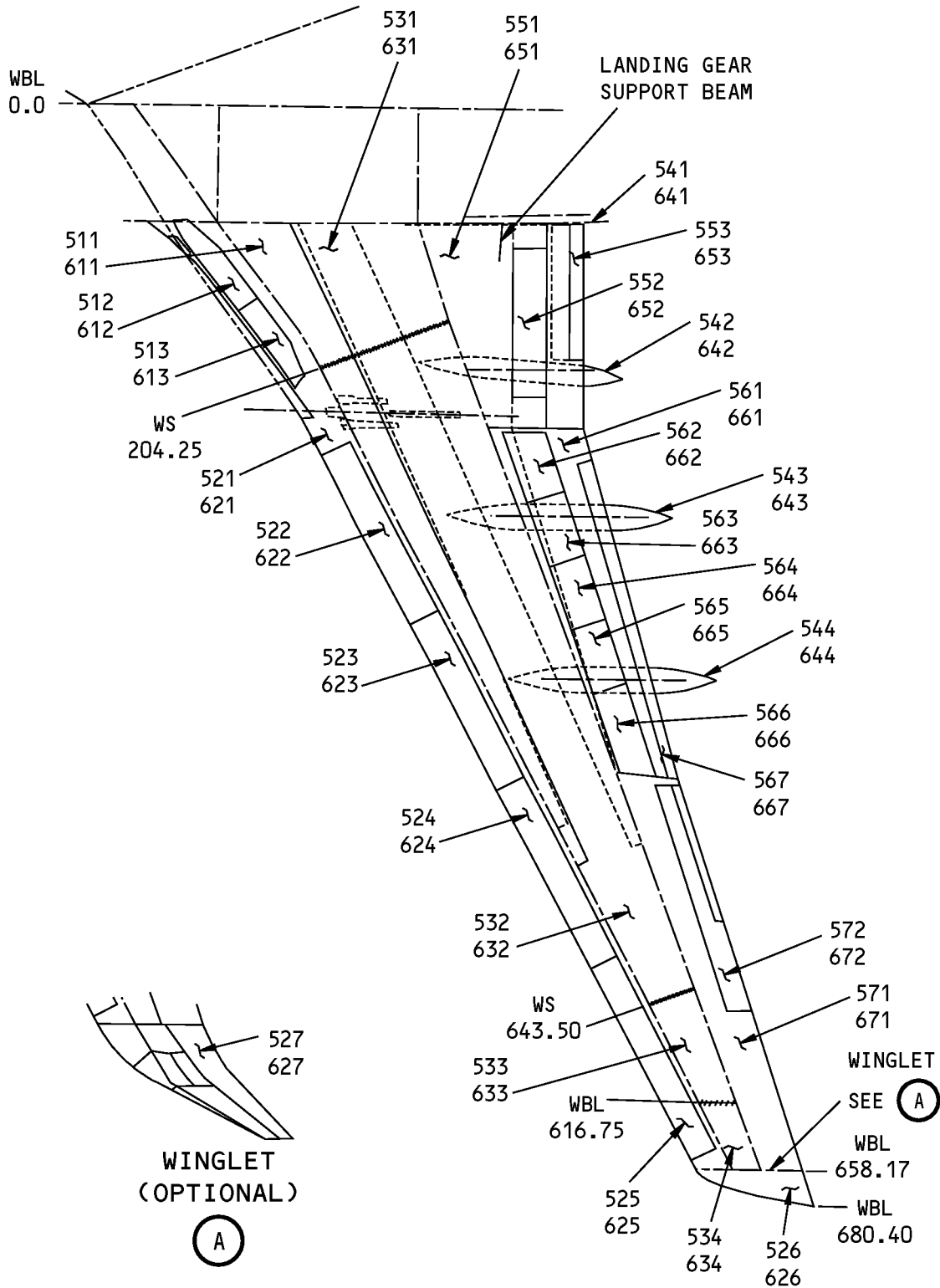

**Major Zone 500/600 - Left and Right Wing
Figure 206/06-30-00-990-805**

EFFECTIVITY
HAP ALL

06-30-00

Page 220
Oct 10/2003

D633A101-HAP



737-600/700/800/900

AIRCRAFT MAINTENANCE MANUAL

TASK 06-30-00-800-808

9. Landing Gear and Landing Gear Doors - Major Zone 700

(Figure 207)

A. Location Zones

Zone	Area
700	Landing Gear and Landing Gear Doors

B. Procedure

SUBTASK 06-30-00-800-007

(1) The (Table 207) lists the applicable zones for the landing gear and landing gear doors.

Table 207/06-30-00-993-814 Major Zone 700 - Landing Gear and Landing Gear Doors

Subzone	Zone	Zone Name
710		Nose Landing Gear and Landing Gear Doors
	711	Nose Landing Gear - Left
	712	Nose Landing Gear - Right
	713	Nose Landing Gear
730		Left Main Landing Gear and Landing Gear Doors
	731	Left Main Landing Gear - Outer Door
	732	Left Main Landing Gear - Middle Door
	733	Left Main Landing Gear - Inner Door
	734	Left Main Landing Gear
740		Right Main Landing Gear and Landing Gear Doors
	741	Right Main Landing Gear - Outer Door
	742	Right Main Landing Gear - Middle Door
	743	Right Main Landing Gear - Inner Door
	744	Right Main Landing Gear

————— END OF TASK —————

EFFECTIVITY
HAP ALL

06-30-00

Page 221
Oct 10/2003

D633A101-HAP



**737-600/700/800/900
AIRCRAFT MAINTENANCE MANUAL**

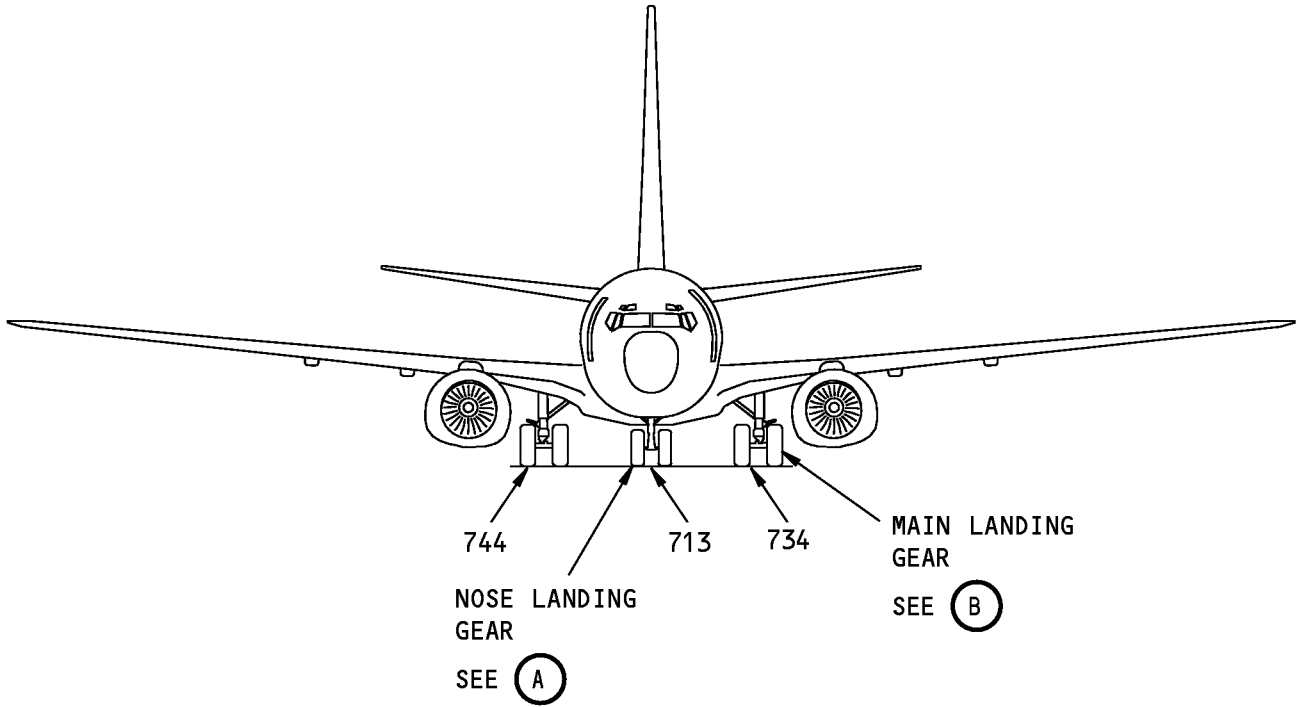

- 710 - NOSE LANDING GEAR AND LANDING GEAR DOORS
- 730 - LEFT MAIN LANDING GEAR AND LANDING GEAR DOORS
- 740 - RIGHT MAIN LANDING GEAR AND LANDING GEAR DOORS

**Major Zone 700 - Landing Gear and Landing Gear Doors
Figure 207 (Sheet 1 of 2)/06-30-00-990-806**

EFFECTIVITY
HAP ALL

D633A101-HAP

06-30-00

Page 222
Oct 10/2006

**737-600/700/800/900
AIRCRAFT MAINTENANCE MANUAL**

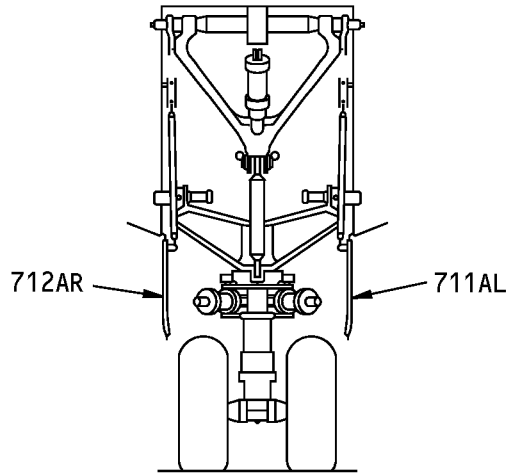

NOSE LANDING GEAR

A

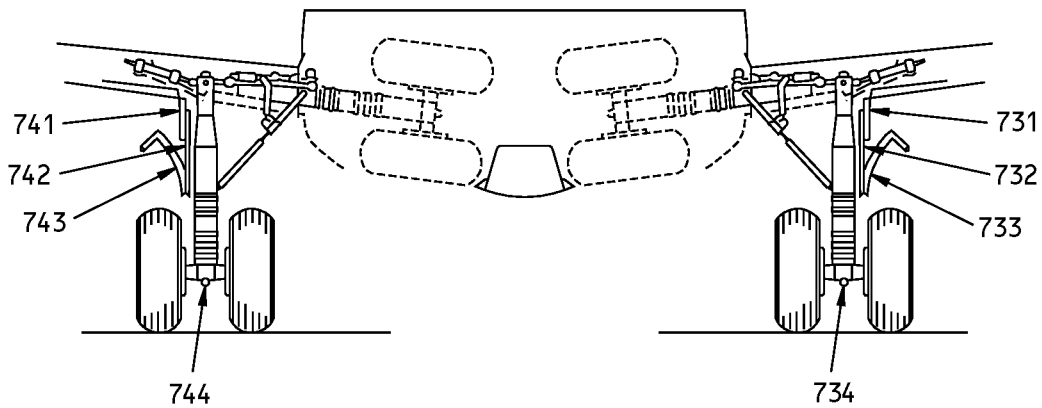

MAIN LANDING GEAR

B

**Major Zone 700 - Landing Gear and Landing Gear Doors
Figure 207 (Sheet 2 of 2)/06-30-00-990-806**

EFFECTIVITY
HAP ALL

06-30-00



737-600/700/800/900

AIRCRAFT MAINTENANCE MANUAL

TASK 06-30-00-800-809

10. Passenger and Cargo Compartment Doors - Major Zone 800

(Figure 208 or Figure 209)

A. Location Zones

Zone	Area
800	Doors

B. Access Panels

Number	Name/Location
821	Forward Cargo Door
822	Aft Cargo Door
831	Forward Entry Door
832	Emergency Exit
833	Emergency Exit
834	Aft Entry Door
841	Forward Galley Service Door
842	Emergency Exit
843	Emergency Exit
844	Aft Galley Service Door

C. Procedure

SUBTASK 06-30-00-800-008

(1) These are the applicable zones for the passenger and cargo compartment doors.

Number	Name/Location
821	Forward Cargo Door
822	Aft Cargo Door
831	Forward Entry Door

HAP 001-013, 015-026, 028-054

832	Emergency Exit
-----	----------------

HAP ALL

833	Emergency Exit
834	Aft Entry Door
841	Forward Galley Service Door

HAP 001-013, 015-026, 028-054

842	Emergency Exit
-----	----------------

HAP ALL

843	Emergency Exit
844	Aft Galley Service Door

————— **END OF TASK** —————

EFFECTIVITY	
HAP ALL	

06-30-00



737-600/700/800/900
AIRCRAFT MAINTENANCE MANUAL

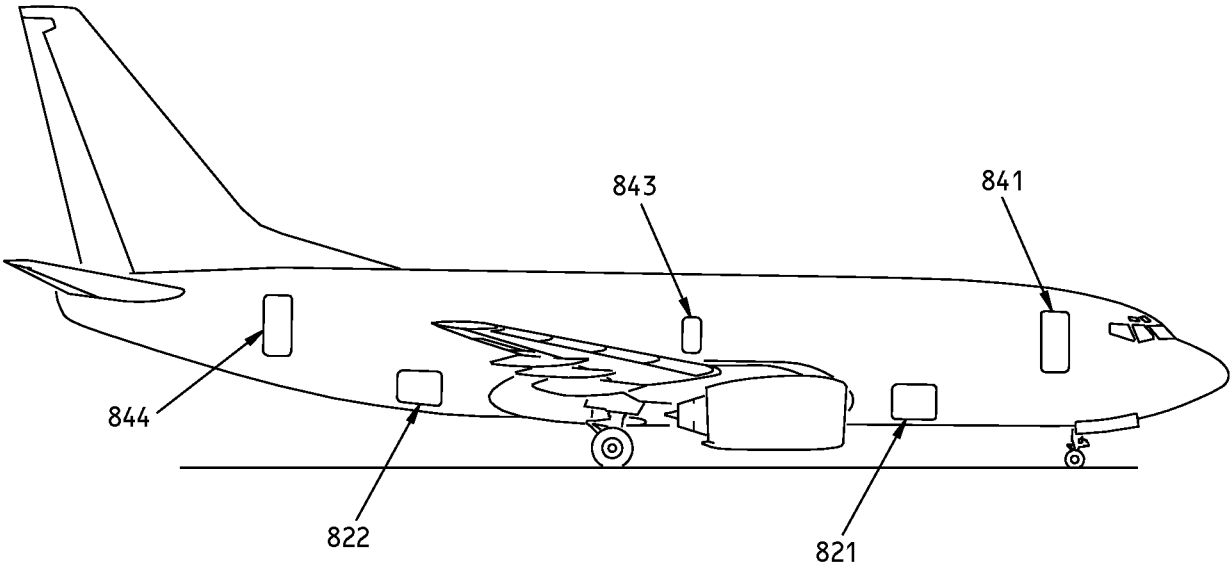
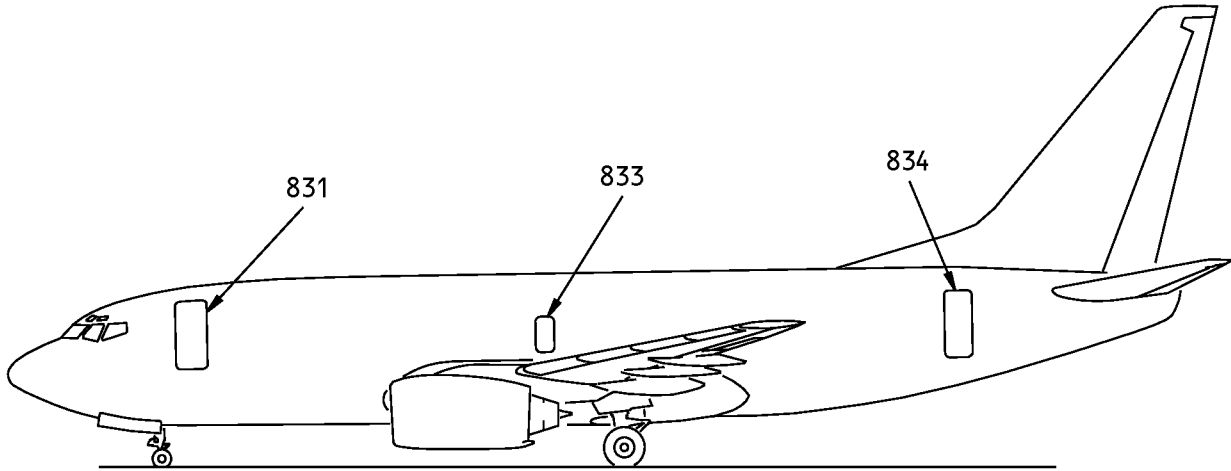

- SUBZONE 820 - CARGO COMPARTMENT DOORS
- SUBZONE 830 - LEFT PASSENGER COMPARTMENT DOORS
- SUBZONE 840 - RIGHT PASSENGER COMPARTMENT DOORS

Major Zone 800 - Passenger and Cargo Compartment Doors
Figure 208/06-30-00-990-807

EFFECTIVITY
HAP 101-999

06-30-00

Page 225
Feb 10/2007

D633A101-HAP

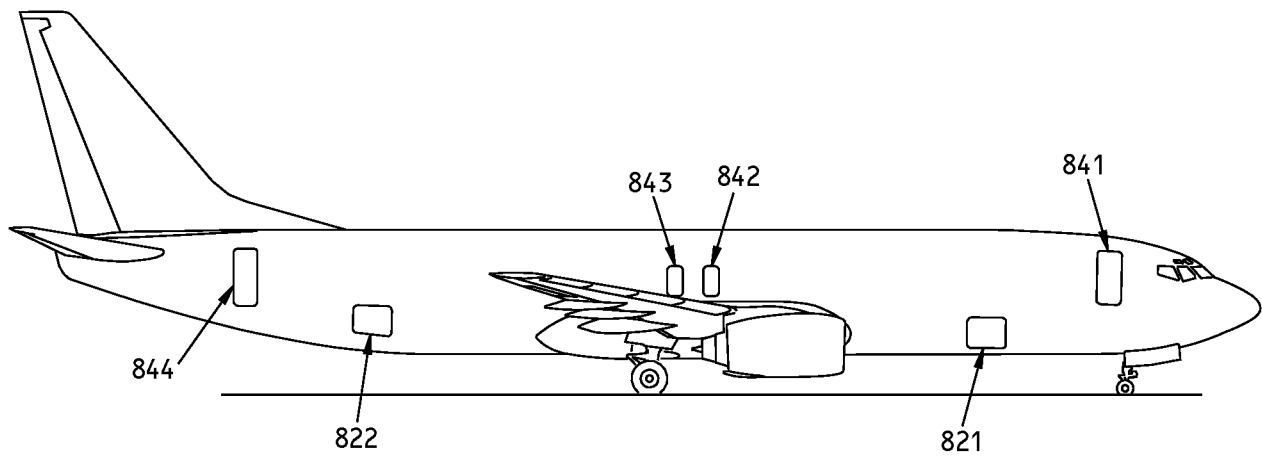
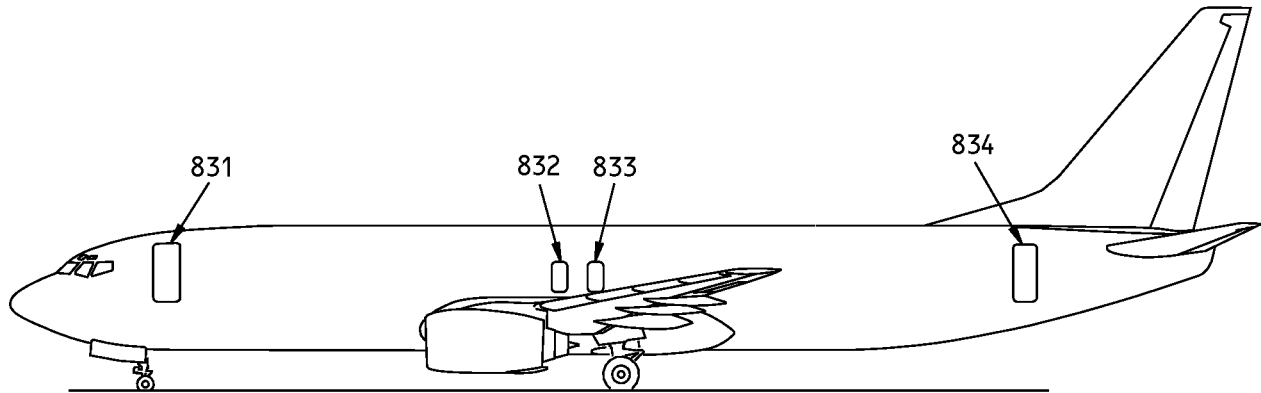

- SUBZONE 820 – CARGO COMPARTMENT DOORS
- SUBZONE 830 – LEFT PASSENGER COMPARTMENT DOORS
- SUBZONE 840 – RIGHT PASSENGER COMPARTMENT DOORS

**Major Zone 800 - Passenger and Cargo Compartment Doors
Figure 209/06-30-00-990-818**

EFFECTIVITY
HAP 001-013, 015-026, 028-054

06-30-00

Page 226
Feb 15/2009

D633A101-HAP



737-600/700/800/900

AIRCRAFT MAINTENANCE MANUAL

FUSELAGE (MAJOR ZONES 100 AND 200) ACCESS DOORS AND PANELS - MAINTENANCE PRACTICES

1. General

- A. Major zone 100 contains the bottom half of the fuselage but does not include Section 48. Major zone 100 includes the subzones shown below, which are identified with two numbers followed by a zero.
 - (1) Subzone 110 - Nose Area
 - (2) Subzone 120 - Forward Cargo Compartment
 - (3) Subzone 130 - Wing Center Section
 - (4) Subzone 130 - Main Landing Gear Wheel Well
 - (5) Subzone 140 - Aft Cargo Compartment
 - (6) Subzone 140 - Bulk Cargo Compartment
 - (7) Subzone 190 - Wing-To-Body Fairings
- B. Major zone 200 contains the top half of the fuselage but does not include section 48. Major zone 200 includes these subzones:
 - (1) Subzone 210 - Flight Compartment
 - (2) Subzone 220 - Section 41
 - (3) Subzone 230 - Section 43
 - (4) Subzone 240 - Section 44
 - (5) Subzone 250 - Section 46
 - (6) Subzone 260 - Section 47
- C. Each subzone is divided into zones that are identified with the first two numbers of the subzone followed by a number that is not zero.
- D. Access doors and panels in a zone are identified by the zone number and a two or three letter suffix. This alphanumeric label is different for each access door or panel.

TASK 06-41-00-800-801

2. Finding an Access Door or Panel on the Lower Half of the Fuselage

(Figure 201, Figure 202, Figure 203, Figure 204, Figure 205)

A. Location Zones

Zone	Area
100	Lower Half of Fuselage

B. Procedure

SUBTASK 06-41-00-800-001

- (1) In the table below, find the number of the applicable access door or panel.

Table 201 Access Door or Panel on the Lower Half of the Fuselage

Number	Name/Location	Provides Access To	Dimensions	Drawing
111	Radome	Bulkhead Structure		284A1801
112A	Forward Access Door			141A6801
113AC	Fwd Nose Wheel Well Upper Access Panel	Top of Nose Wheel Well	16X15	141A7900
113AW	Forward Nose Wheel Well Panel	Side of Nose Wheel Well	16X15	141A7500

EFFECTIVITY

HAP ALL

06-41-00

Page 201
Jun 10/2007

D633A101-HAP



737-600/700/800/900

AIRCRAFT MAINTENANCE MANUAL

(Continued)

Number	Name/Location	Provides Access To	Dimensions	Drawing
113BW	Forward Nose Wheel Well Panel	Side of Nose Wheel Well	16X15	141A7500
114AC	Fwd Nose Wheel Well Upper Access Panel	Top of Nose Wheel Well	16X15	141A7900
114AR	External Power Receptacle Door	External Power Receptacle		141A8701
114AW	Forward Nose Wheel Well Panel	Side of Nose Wheel Well	16X15	141A7500
114BW	Forward Nose Wheel Well Panel	Side of Nose Wheel Well	16X15	141A7500
117A	Electronic Equipment Access Door	Electronic Equipment Bay		141A6700
117AW	Equipment Access Door Cover	Electronic Equipment Bay		141A6710
117BL	Forward Airstair Door	Electronic Equipment Bay		141A6401
146AR	Water Service Door	Water Tank Service		147A7221
191AL	Forward Wing To Body Fairing Panel - Upper	Upper Forward Wing To Body		149A7151
191AR	Forward Wing To Body Fairing Panel - Upper	Upper Forward Wing To Body		149A7151
191BL	Forward Wing To Body Fairing Panel, Ram Air Inlet	Ram Air Inlet		149A7137
191BR	Forward Wing To Body Fairing Panel, Ram Air Inlet	Ram Air Inlet		149A7137
191CL	Forward Wing To Body Fairing Panel - Middle	Forward Lower Wing To Body		149A7156
191CR	Forward Wing To Body Fairing Panel - Middle	Forward Lower Wing To Body		149A7156
191D	Forward Wing To Body Fairing Panel - Lower	Forward Middle Wing To Body		149A7157
191E	Low Pressure ECS Panel - Forward	Forward Low Pressure ECS		149A7148
191FL	Forward Wing To Body Fairing Panel - Mid Fairing, Above Ram Air Inlet	Forward Under Wing		149A7155
191FR	Forward Wing To Body Fairing Panel - Mid Fairing, Above Ram Air Inlet	Forward Under Wing		149A7155
191GL	Ram Air Actuator Panel - Forward	Forward Ram Air Actuator		149A7148
191GR	Ram Air Actuator Panel - Forward	Forward Ram Air Actuator		149A7148

EFFECTIVITY
HAP ALL

06-41-00

Page 202
Jun 10/2006

D633A101-HAP



737-600/700/800/900

AIRCRAFT MAINTENANCE MANUAL

(Continued)

Number	Name/Location	Provides Access To	Dimensions	Drawing
191HL	Ram Air Inlet Lip Panel - Forward	Forward Ram Air Inlet Lip		149A7160
191HR	Ram Air Inlet Lip Panel - Forward	Forward Ram Air Inlet Lip		149A7160
192AL	Underwing Bolt Cover - Forward	Forward Underwing Spar Bolt		149A7257
192AR	Underwing Bolt Cover - Forward	Forward Underwing Spar Bolt		149A7257
192BL	ECS Ram Air Inlet Mixing Duct Panel - Forward	Forward ECS Ram Air Inlet Mixing Duct		149A7259
192BR	ECS Ram Air Inlet Mixing Duct Panel - Forward	Forward ECS Ram Air Inlet Mixing Duct		149A7259
192CL	Air Conditioning Access Door	Air Conditioning Compartment		149A7602
192CR	Air Conditioning Access Door	Air Conditioning Compartment		149A7602
192DR	ECS High Pressure Access Door	Equipment Cooling Sys. High Pressure Connect		149A7602
192E	ECS Under Keel Panel - Forward	Equipment Cooling Sys. Under Keel, Forward		149A7602
192F	ECS Under Keel Panel - Middle	Equipment Cooling Sys. Under Keel, Middle		149A7602
192G	Sump Drain Access Door	Sump Drain Pan Assembly		149A7602
192HL	Underwing Bolt Cover - Aft	Aft Underwing Rear Spar Bolt		149A7602
192HR	Underwing Bolt Cover - Aft	Aft Underwing Rear Spar Bolt		149A7602
192JL	Air Conditioning Panel - Aft	Air Conditioning Compartment		149A7602
192JR	Air Conditioning Panel - Aft	Air Conditioning		149A7602
192K	Air Conditioning Under Keel Panel - Aft	Air Conditioning Under Keel, Aft		149A7602
193AL	Wheel Well Panel - Forward Outboard	Forward Outboard Wheel Well		149A7602
193AR	Wheel Well Panel - Forward Outboard	Forward Outboard Wheel Well		149A7602
193B	Wheel Well Panel - Forward Inboard	Aft Center Wheel Well		149A7602
193CL	Wheel Well Panel - Aft Outboard	Aft Outboard Wheel Well		149A7602
193CR	Wheel Well Panel - Aft Outboard	Aft Outboard Wheel Well		149A7602
193D	Wheel Well Panel - Aft Inboard	Aft Center Wheel Well		149A7602
194AL	Aft Wing To Body Fairing Panel	Upper Flap Track		149A7558
194AR	Aft Wing To Body Fairing Panel	Upper Flap Track		149A7558

EFFECTIVITY
HAP ALL

06-41-00

Page 203
Jun 10/2006

D633A101-HAP



737-600/700/800/900
AIRCRAFT MAINTENANCE MANUAL

(Continued)

Number	Name/Location	Provides Access To	Dimensions	Drawing
194BL	Flap Track Lubrication Panel - Aft	Flap Track Lubrication		149A7558
194BR	Flap Track Lubrication Panel - Aft	Flap Track Lubrication		149A7558
194CL	Aft Wing To Body Fairing Panel	Lower Aft Fairing		149A7552
194CR	Aft Wing To Body Fairing Panel	Lower Aft Fairing		149A7552
194DL	Aft Wing To Body Fairing Panel	Lower Aft Fairing		149A7554
194DR	Aft Wing To Body Fairing Panel	Lower Aft Fairing		149A7554
194E	Aft Wing To Body Fairing Panel	Lower Aft Fairing, Middle		149A7555
194FL	Aft Wing To Body Fairing Panel	Upper Aft Fairing		149A7553
194FR	Aft Wing To Body Fairing Panel	Upper Aft Fairing		149A7553
194GL	Aft Wing To Body Fairing Panel	Upper Aft Fairing		149A7556
194GR	Aft Wing To Body Fairing Panel	Upper Aft Fairing		149A7556
194HL	Aft Wing To Body Fairing Panel	Lower Aft Fairing		149A7557
194HR	Aft Wing To Body Fairing Panel	Lower Aft Fairing		149A7557
195AL	Wing To Body Fairing - Left Side			
195BL	Wing To Body Fairing - Left Side			
195CL	Wing To Body Fairing - Left Side			
196AR	Wing To Body Fairing - Right Side			
196BR	Wing To Body Fairing - Right Side			
196CR	Wing To Body Fairing - Right Side			
711AL	Forward Nose Wheel Door	Nose Wheel Well		141A7900
712AR	Forward Nose Wheel Door	Nose Wheel Well		
822	Aft Cargo Door	Aft Cargo Door		146A6112
822AR	Access Panel on Aft Cargo Door - External	Aft Cargo Door		146A6112
822BR	Access Panel on Aft Cargo Door	Aft Cargo Door		146A6112

————— END OF TASK —————

EFFECTIVITY
HAP ALL

D633A101-HAP

06-41-00

Page 204
Oct 10/2006



**737-600/700/800/900
AIRCRAFT MAINTENANCE MANUAL**

TASK 06-41-00-800-802

3. Finding an Access Door or Panel on the Upper Half of the Fuselage

(Figure 201, Figure 202, Figure 203, Figure 204, Figure 205)

A. Location Zones

Zone	Area
200	Upper Half of Fuselage

B. Procedure

SUBTASK 06-41-00-800-002

(1) In the table below, find the number of the applicable access door or panel.

Table 202 Upper Half of the Fuselage Access Doors and Panels

Number	Name/Location	Provides Access To	Dimensions	Drawing
222AR	Forward Galley Service Door Hinge and Torque Tube Access Panel	Hinge and Torque Tube, Forward Galley Service Door	12X18	147A6104
231AL	Wing Scanning Light	Wing Scanning Lights		284A0111
232AR	Wing Scanning Light	Wing Scanning Lights		284A0111
241AL	Aft Entry Door Hinge and Torque Tube Access Panel	Hinge and Torque Tube, Aft Entry Door	12X18	147A6104
242AR	Aft Galley Service Door Hinge and Torque Tube Access Panel	Hinge and Torque Tube, Aft Galley Service Door	12X18	147A6104

————— **END OF TASK** —————

EFFECTIVITY
HAP ALL

06-41-00

Page 205
Jun 10/2006

D633A101-HAP

**737-600/700/800/900
AIRCRAFT MAINTENANCE MANUAL**

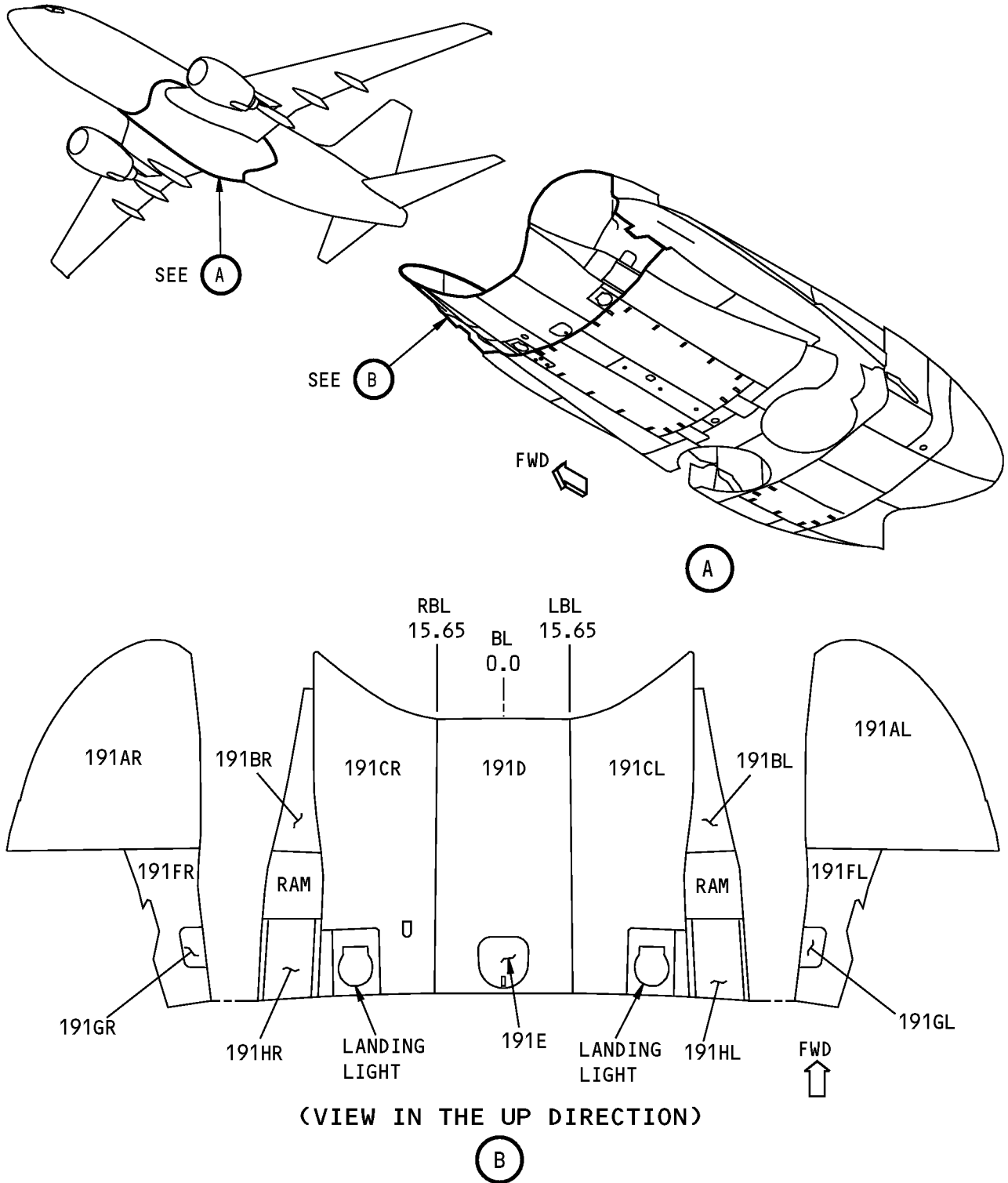

**Zone 191 Wing To Body Fairing Access Doors and Panels
Figure 201/06-41-00-990-801**

EFFECTIVITY
HAP ALL

06-41-00

**737-600/700/800/900
AIRCRAFT MAINTENANCE MANUAL**

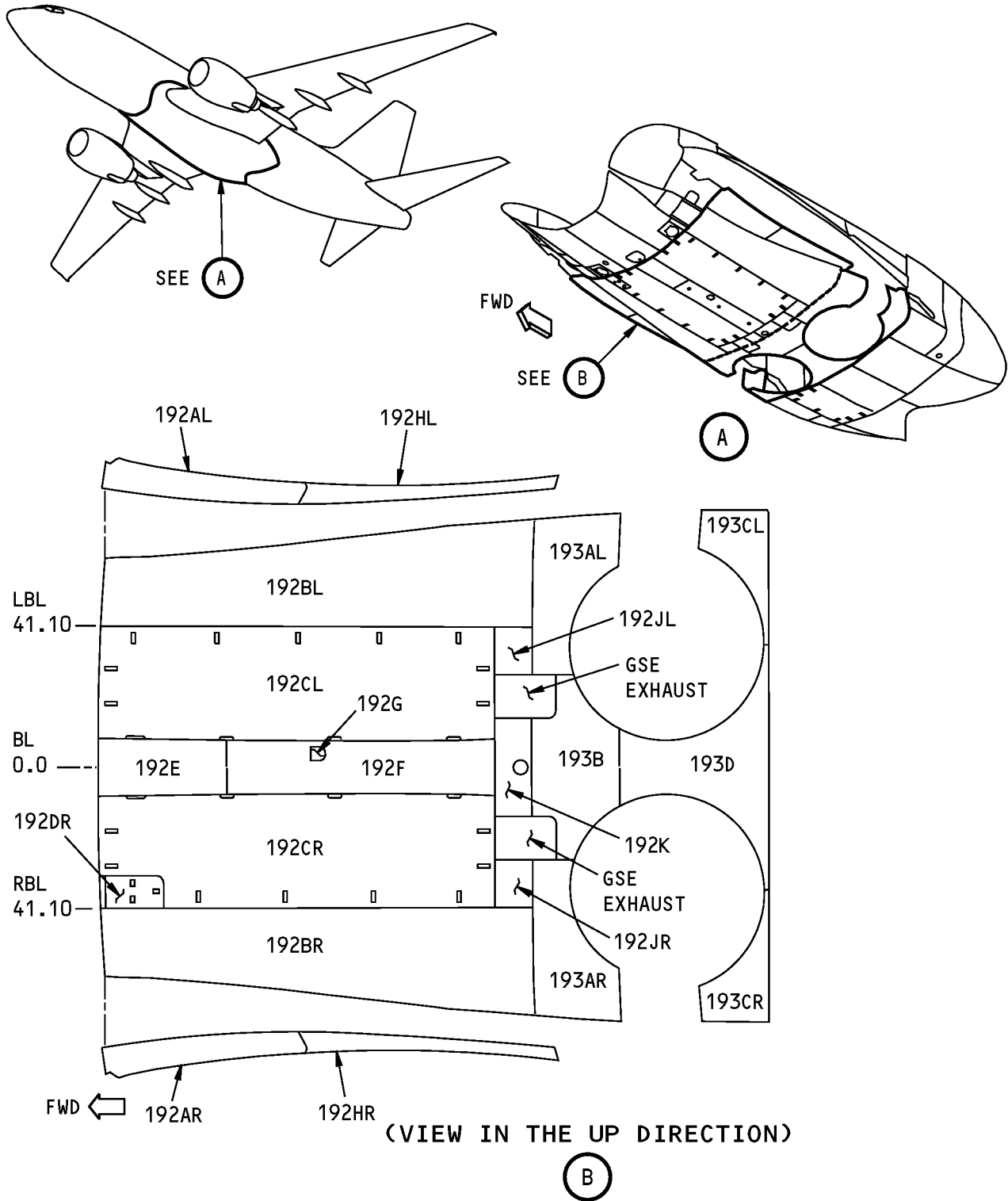

**Zone 192 and 193 Wing To Body Fairing Access Doors and Panels
Figure 202/06-41-00-990-802**

EFFECTIVITY
HAP ALL

06-41-00

Page 207
Feb 10/2004

D633A101-HAP

**737-600/700/800/900
AIRCRAFT MAINTENANCE MANUAL**

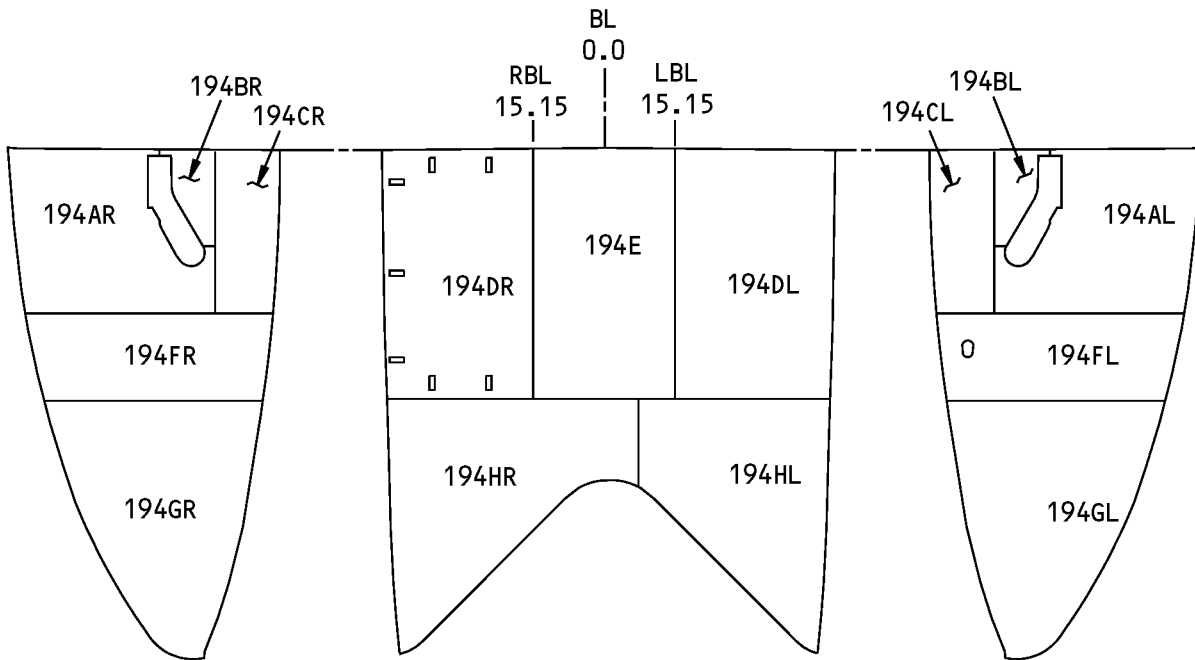
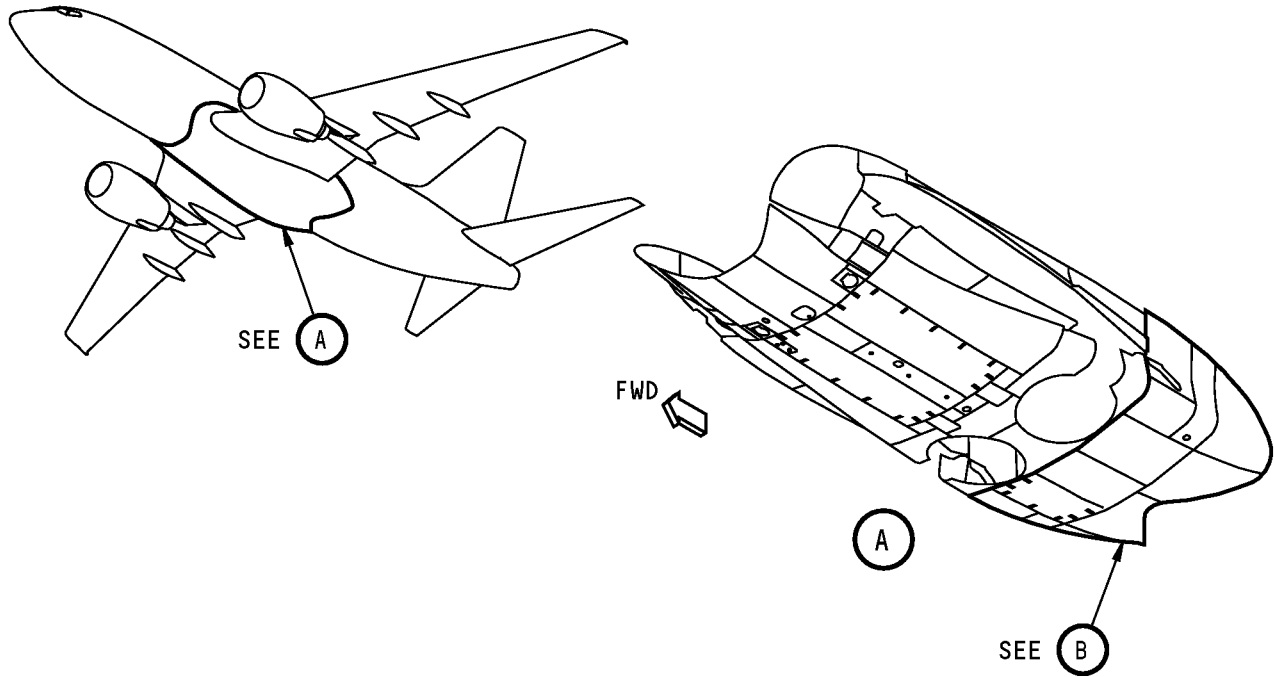

(VIEW IN THE UP DIRECTION)

(B)

**Zone 194 Wing To Body Fairing Access Doors and Panels
Figure 203/06-41-00-990-803**

EFFECTIVITY
HAP ALL

06-41-00

Page 208
Feb 10/2004

D633A101-HAP

**737-600/700/800/900
AIRCRAFT MAINTENANCE MANUAL**

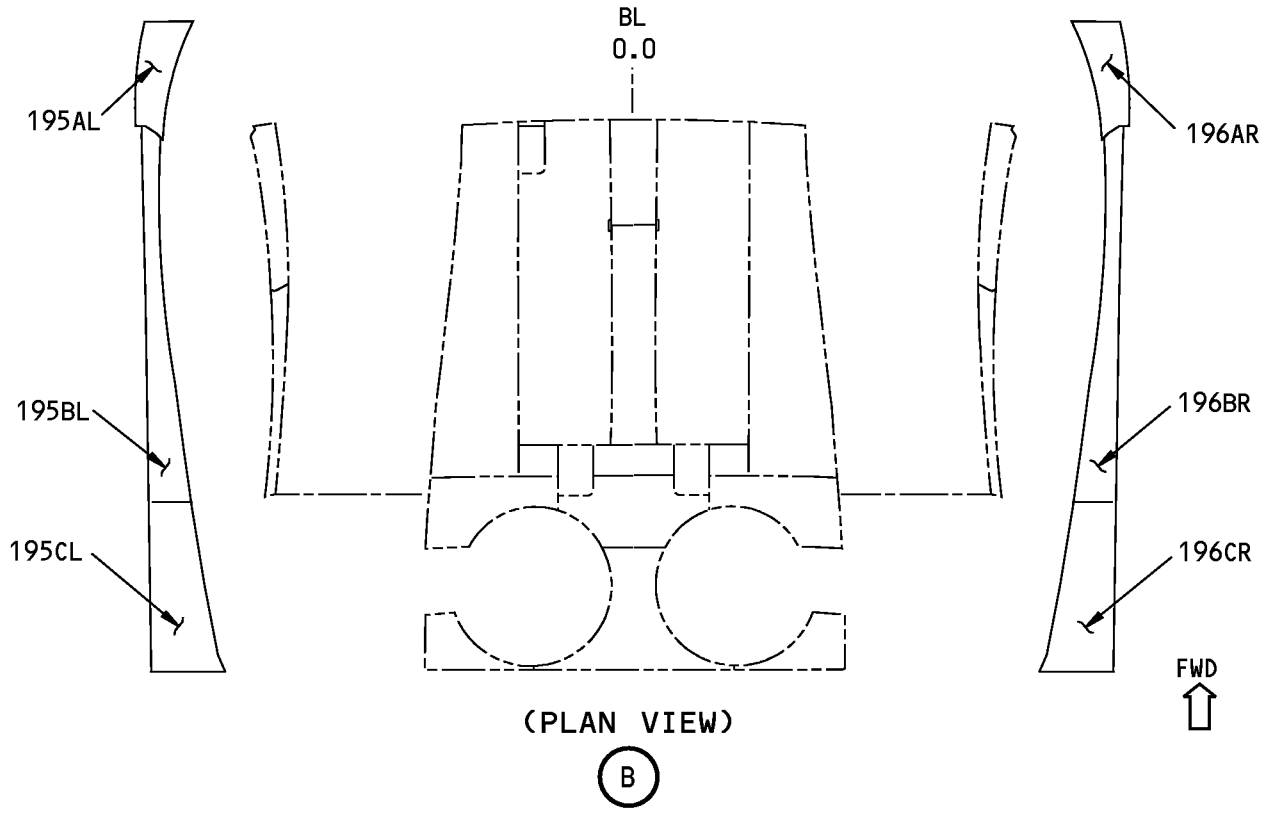
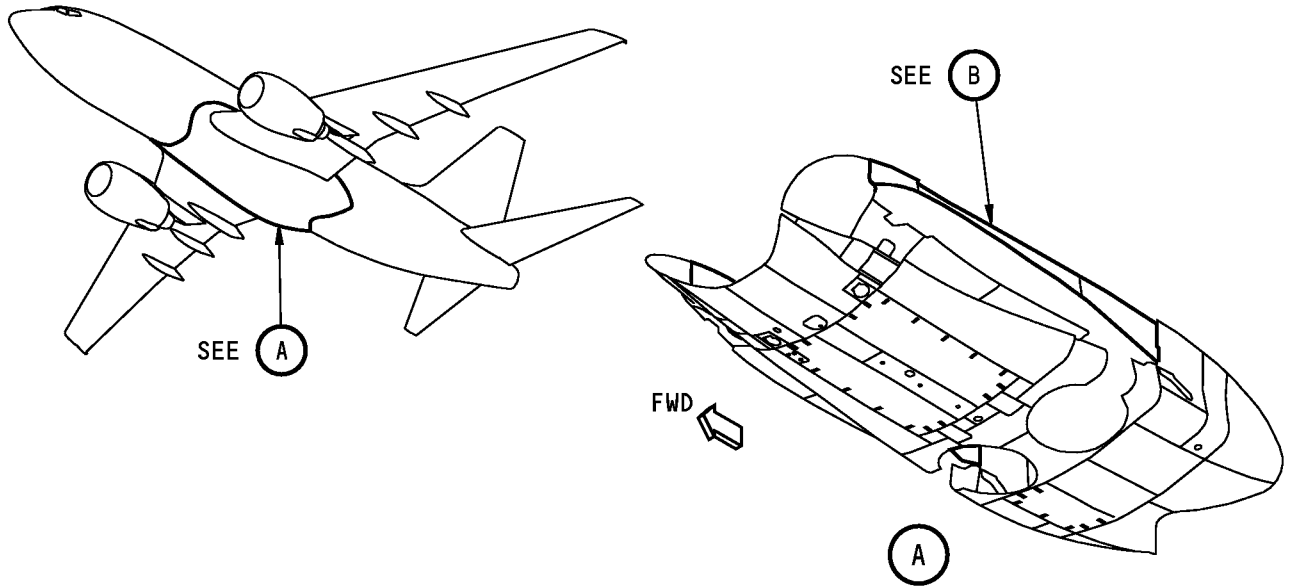

**Zone 195 and 196 Wing To Body Fairing Access Doors and Panels
Figure 204/06-41-00-990-804**

EFFECTIVITY
HAP ALL

06-41-00

**737-600/700/800/900
AIRCRAFT MAINTENANCE MANUAL**

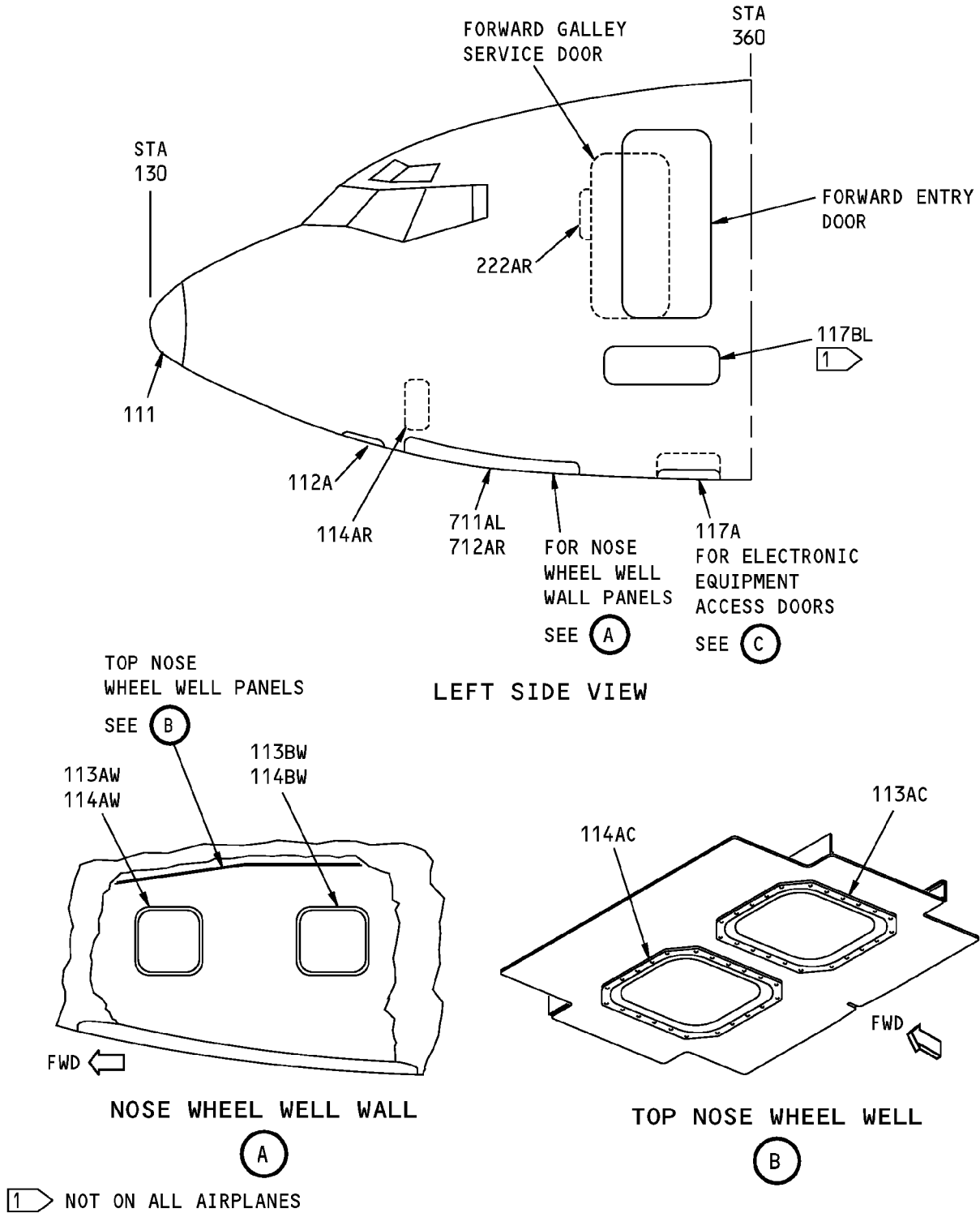

**Fuselage Section 41 Access Door and Panels
Figure 205 (Sheet 1 of 2)/06-41-00-990-807**

EFFECTIVITY
HAP ALL

06-41-00

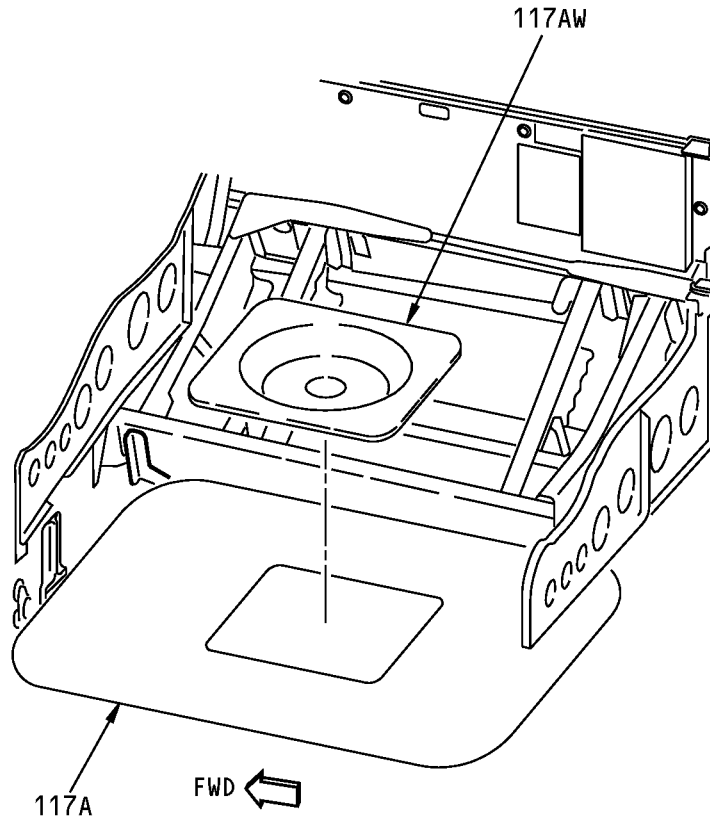

ELECTRONIC EQUIPMENT ACCESS DOOR

(C)

**Fuselage Section 41 Access Door and Panels
Figure 205 (Sheet 2 of 2)/06-41-00-990-807**

EFFECTIVITY
HAP ALL

D633A101-HAP



**737-600/700/800/900
AIRCRAFT MAINTENANCE MANUAL**

TASK 06-41-00-800-803

4. Passenger and Cargo Compartment Doors - Major Zone 800

(Figure 206 or Figure 207)

A. Procedure

SUBTASK 06-41-00-800-003

- (1) This procedure shows the applicable zones for the passenger and cargo compartment doors for sections 43 and 44.

————— **END OF TASK** —————

EFFECTIVITY
HAP ALL

D633A101-HAP

06-41-00

Page 212
Jun 15/2009

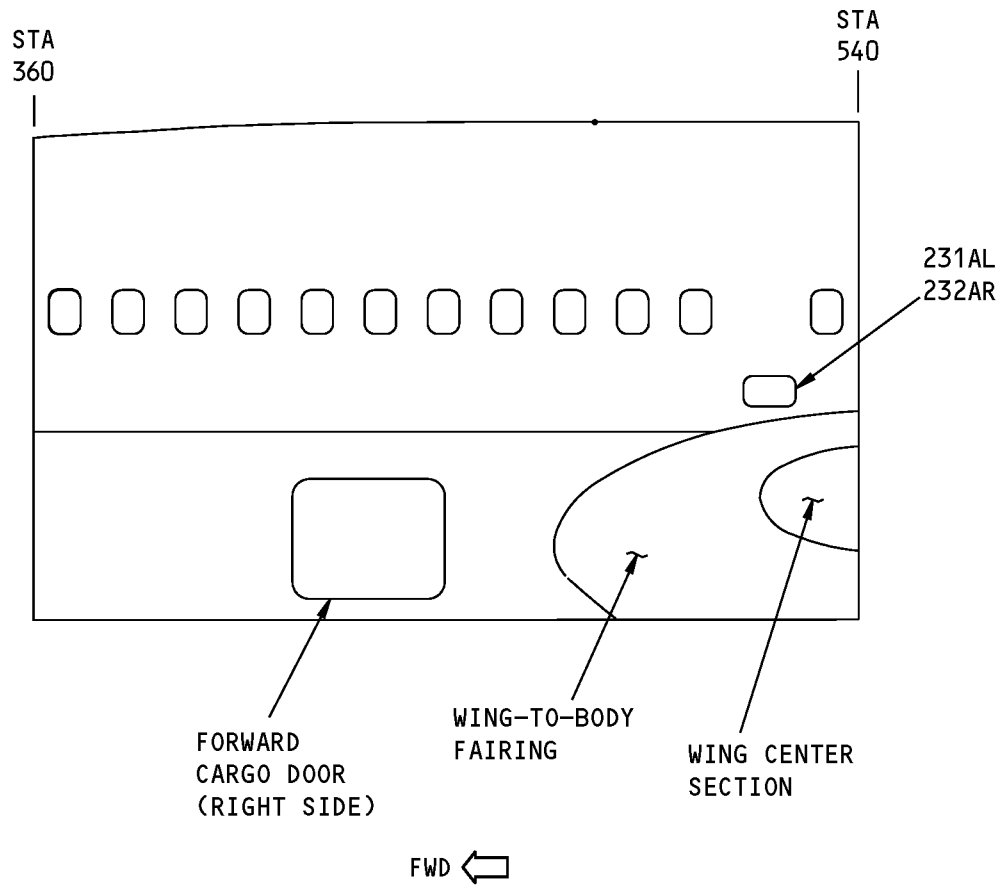

**Fuselage Section 43 Access Doors and Panels
Figure 206/06-41-00-990-808**

EFFECTIVITY
HAP 101-999

D633A101-HAP

06-41-00



737-600/700/800/900
AIRCRAFT MAINTENANCE MANUAL

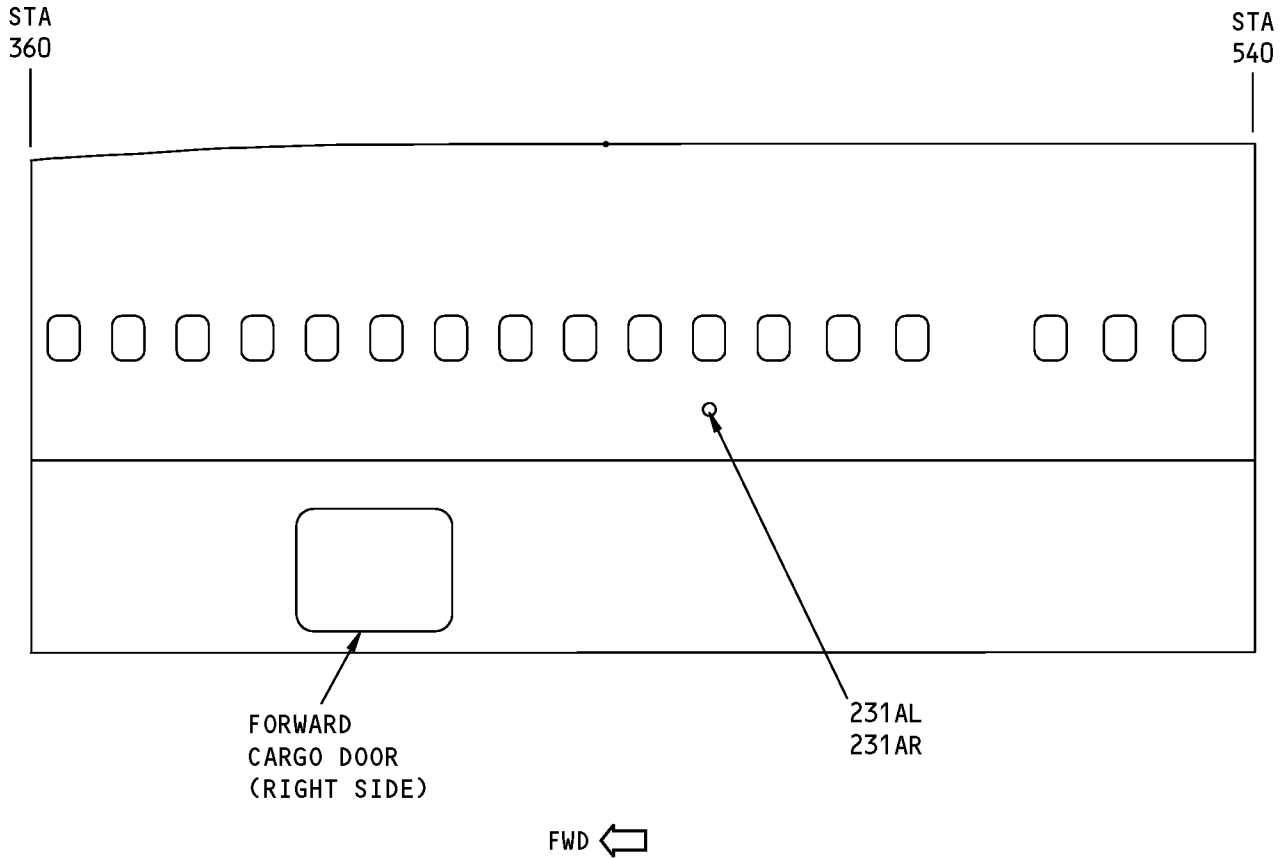

Fuselage Section 43 Access Doors and Panels
Figure 207/06-41-00-990-813

EFFECTIVITY
HAP 001-013, 015-026, 028-054

D633A101-HAP

06-41-00

Page 214
Feb 15/2009

**737-600/700/800/900
AIRCRAFT MAINTENANCE MANUAL**

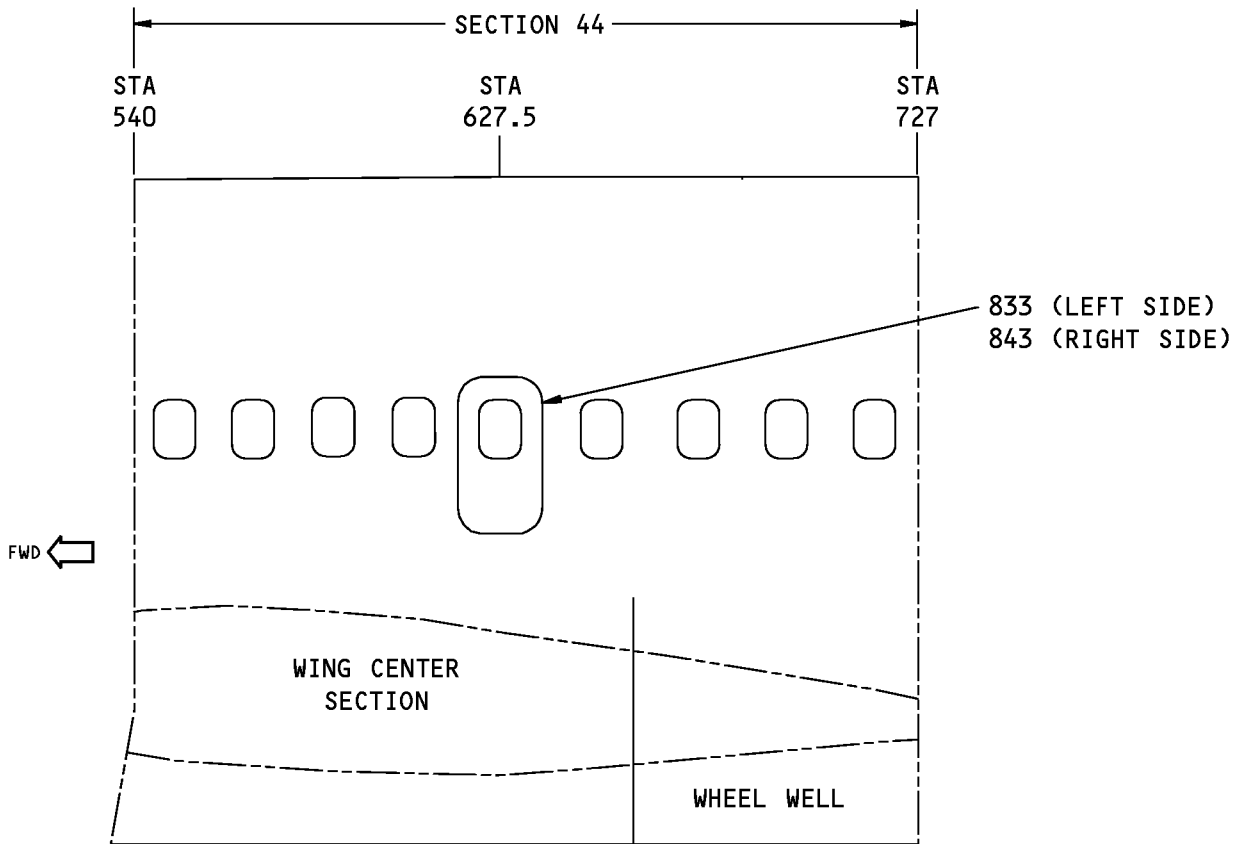
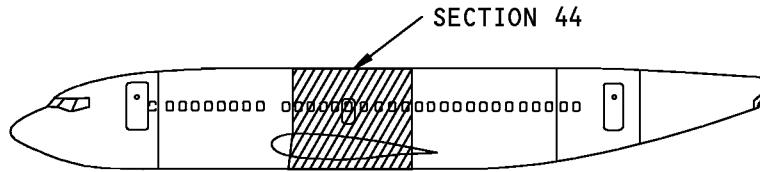

**Fuselage Section 44 Access Doors and Panels
Figure 208 (Sheet 1 of 2)/06-41-00-990-818**

EFFECTIVITY
HAP 101-999

06-41-00

Page 215
Oct 15/2008

D633A101-HAP

**737-600/700/800/900
AIRCRAFT MAINTENANCE MANUAL**

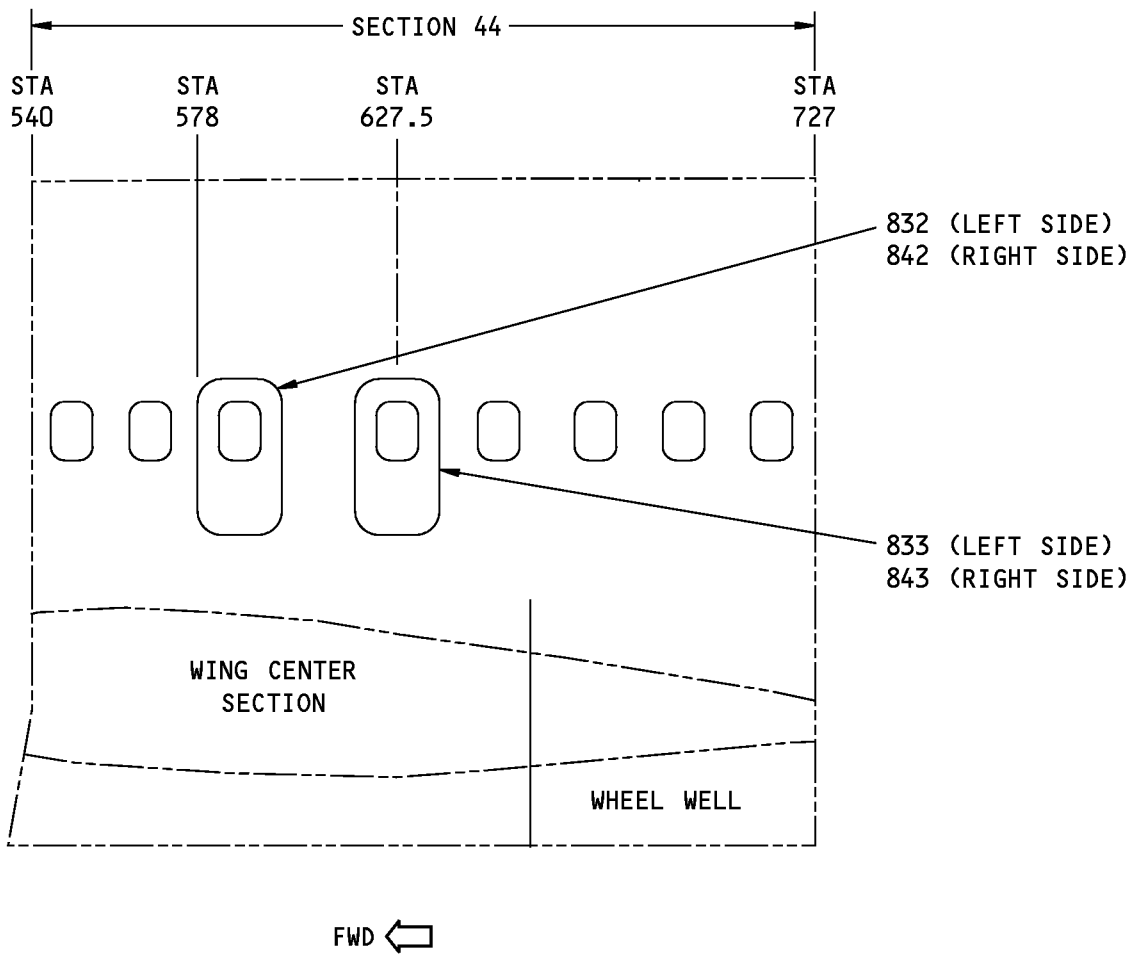
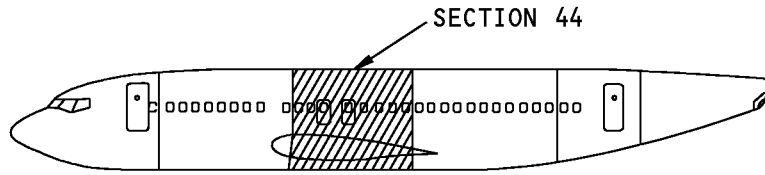

1613854 S0000299574_V1

**Fuselage Section 44 Access Doors and Panels
Figure 208 (Sheet 2 of 2)/06-41-00-990-818**

EFFECTIVITY
HAP 001-013, 015-026, 028-054

06-41-00

Page 216
Feb 15/2009

D633A101-HAP



737-600/700/800/900

AIRCRAFT MAINTENANCE MANUAL

TASK 06-41-00-800-804

5. Passenger and Cargo Compartment Doors - Major Zone 800

(Figure 209)

A. Procedure

SUBTASK 06-41-00-800-004

- (1) This procedure shows the applicable zones for the passenger and cargo compartment doors for section 47.

————— **END OF TASK** —————

EFFECTIVITY
HAP ALL

D633A101-HAP

06-41-00

Page 217
Jun 15/2009



737-600/700/800/900
AIRCRAFT MAINTENANCE MANUAL

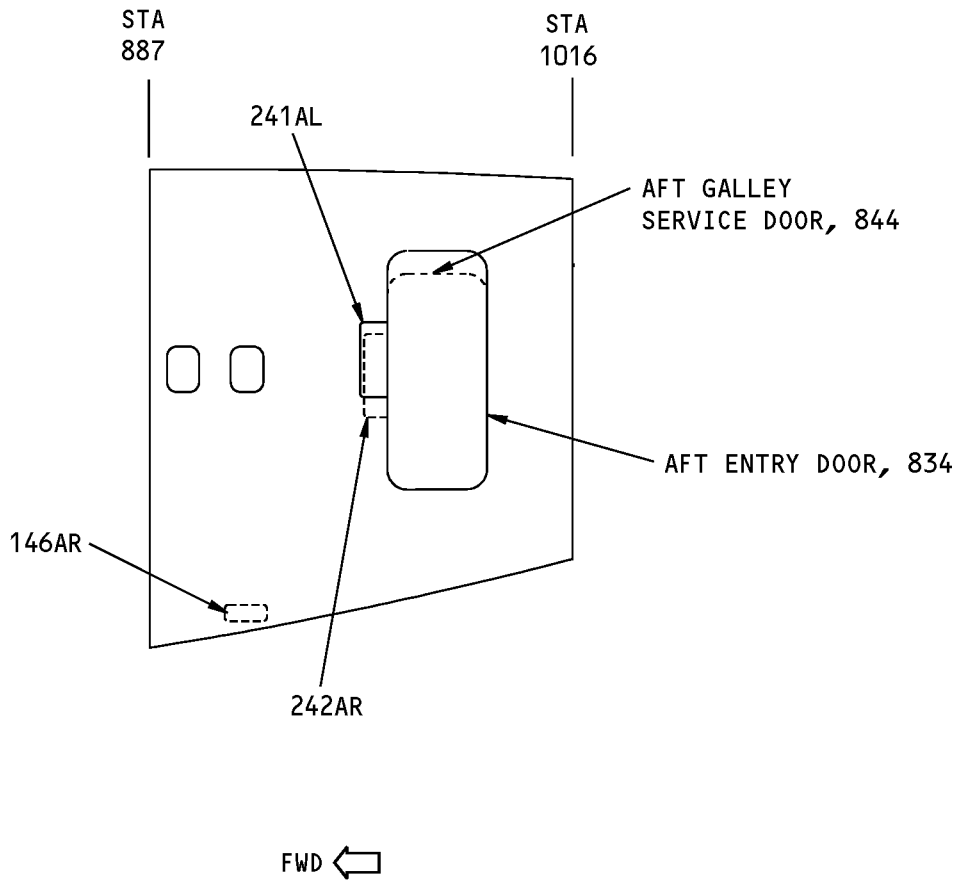

Fuselage Section 47 Access Doors and Panels
Figure 209/06-41-00-990-809

EFFECTIVITY
HAP ALL

D633A101-HAP

06-41-00

Page 218
Oct 15/2008



737-600/700/800/900

AIRCRAFT MAINTENANCE MANUAL

TASK 06-41-00-800-805

6. Passenger and Cargo Compartment Doors - Major Zone 800

(Figure 210)

A. Procedure

SUBTASK 06-41-00-800-005

- (1) This procedure shows the applicable zones for the passenger and cargo compartment doors for section 46.

————— **END OF TASK** —————

EFFECTIVITY
HAP ALL

D633A101-HAP

06-41-00

Page 219
Jun 15/2009



737-600/700/800/900
AIRCRAFT MAINTENANCE MANUAL

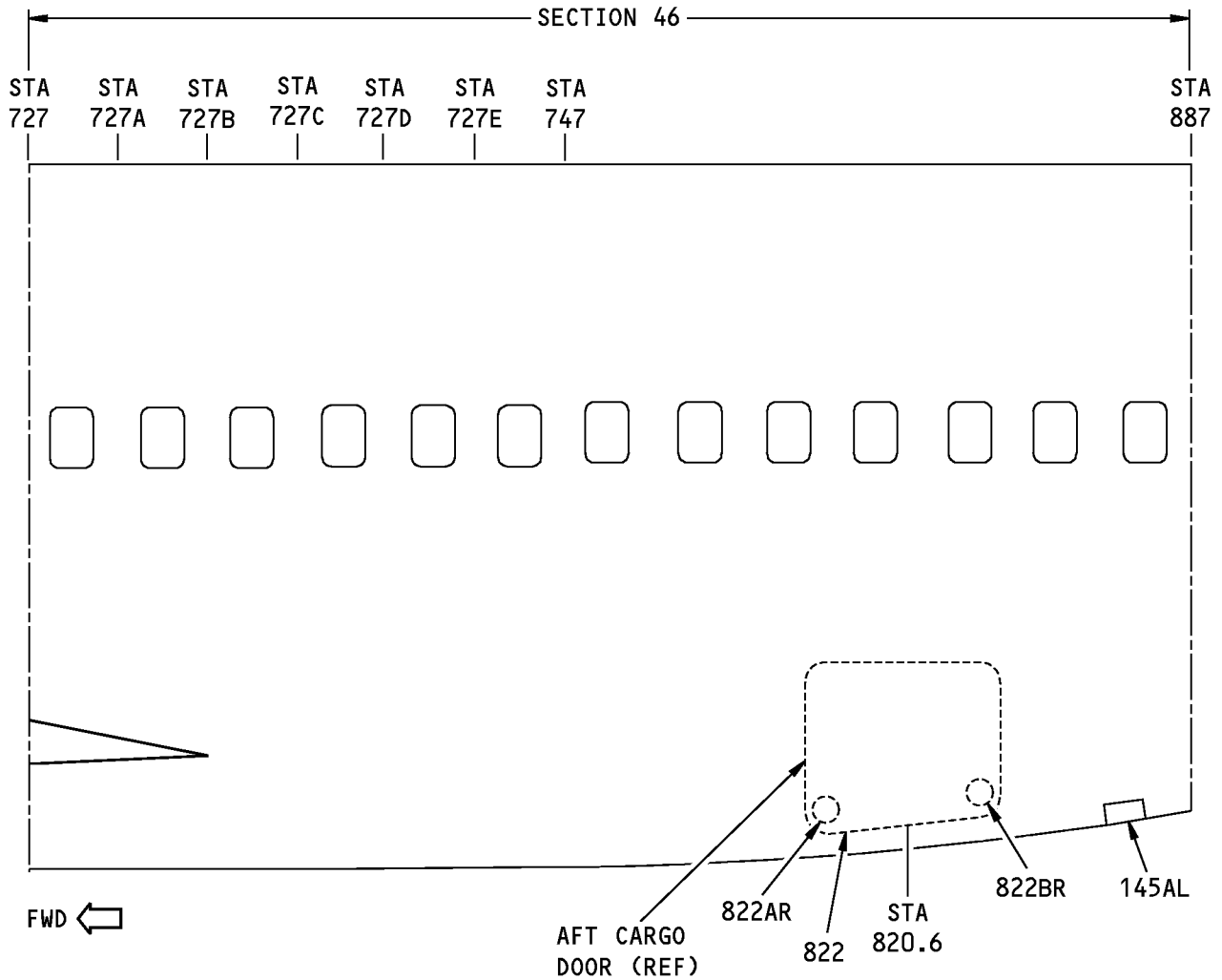
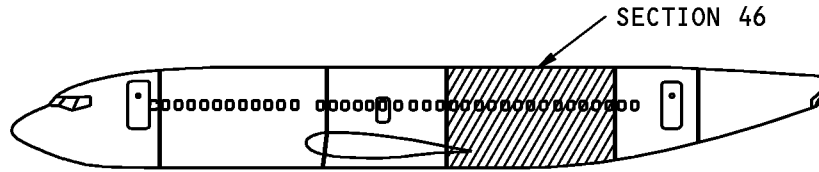

Fuselage Section 46 Access Doors and Panels
Figure 210 (Sheet 1 of 2)/06-41-00-990-812

EFFECTIVITY
HAP 101-999

06-41-00

Page 220
Oct 15/2008

D633A101-HAP



737-600/700/800/900
AIRCRAFT MAINTENANCE MANUAL

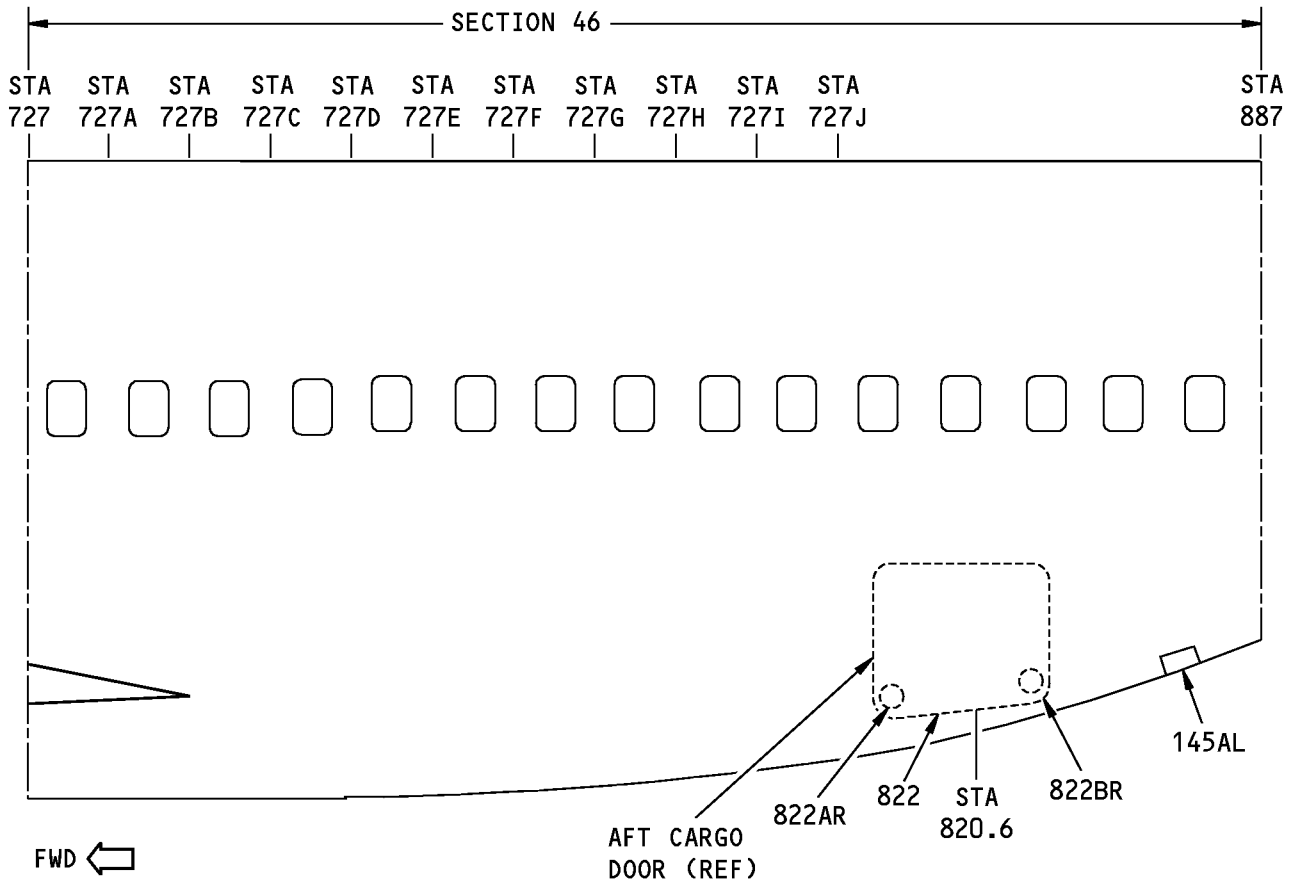
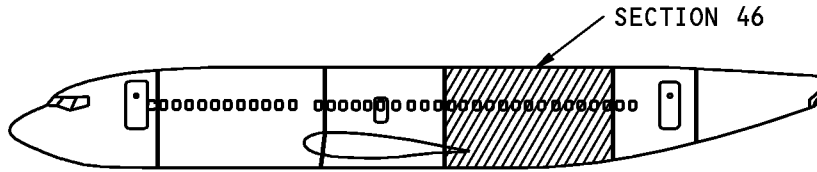

Fuselage Section 46 Access Doors and Panels
Figure 210 (Sheet 2 of 2)/06-41-00-990-812

EFFECTIVITY
HAP 001-013, 015-026, 028-054

06-41-00

Page 221
Feb 15/2009

D633A101-HAP



737-600/700/800/900

AIRCRAFT MAINTENANCE MANUAL

EMPENNAGE (MAJOR ZONE 300) ACCESS DOORS AND PANELS - MAINTENANCE PRACTICES

1. General

- A. Major zone 300 contains fuselage section 48, vertical stabilizer, and horizontal stabilizers. Major zone 300 includes the subzones that follow. The subzones are identified with two numbers followed by a zero.
 - (1) Subzone 310 - Section 48
 - (2) Subzone 320 - Vertical Stabilizer and Rudder
 - (3) Subzone 330 - Left Horizontal Stabilizer and Elevator
 - (4) Subzone 340 - Right Horizontal Stabilizer and Elevator
- B. Each subzone is divided into zones that are identified with the first two numbers of the subzone followed by a number that is not zero.
- C. Access doors and panels in a zone are identified by the zero number and a two or three letter suffix. This alpha-numeric label is different for each access door or panel.

TASK 06-42-00-800-801

2. Finding an Access Door or Panel in the Empennage

(Figure 201, Figure 202, Figure 203, Figure 204, Figure 205, Figure 206, Figure 207)

A. Procedure

SUBTASK 06-42-00-800-001

- (1) In the table below, find the number of the applicable access door or panel.

Table 201

Number	Name/Location	Provides Access To	Dimensions	Drawing
311BL	Stabilizer Trim Access Door	Aft Unpressurized Compartment		148A0042
315A	APU Cowl Door	APU		148A6350
315B	Drain Mast			
317AL	Tail Cone Access Door	Tailcone		148A0042
317CL	Tail Cone Cover Plate	Tailcone		148A0042
317D	APU Exhaust Duct	APU Exhaust		354A4000
317E	APU Enductor Inlet	APU Enductor Inlet		355A1000
317F	Tail Cone Light Access	Tailcone Light Assembly		148A0971
317G	Tail Cone Light			
318BR	Tailcone Access Door	Tailcone		148A7141
321A	Vertical Fin, Dorsal Fin	Vertical Fin		176A0100
322A	Vertical Fin, Fixed Leading Edge	Vertical Fin Leading Edge		176A3009
322AL	Vertical Fin, Fixed Leading Edge	Vertical Fin Leading Edge		176A3009
322AR	Vertical Fin, Fixed Leading Edge	Vertical Fin Leading Edge		176A3010
322B	Vertical Fin, Removable Leading Edge	Removable Vertical Fin Leading Edge		176A1001

EFFECTIVITY

HAP ALL

06-42-00

Page 201
Jun 15/2009

D633A101-HAP



**737-600/700/800/900
AIRCRAFT MAINTENANCE MANUAL**

(Continued)

Number	Name/Location	Provides Access To	Dimensions	Drawing
322C	Vertical Fin, Removable Leading Edge	HF Antenna		176A1510
323AL	Vertical Fin, Front Spar Access Door	Vertical Fin, Front Spar Access at Station 1016		172A6125
323AR	Vertical Fin, Front Spar Access Door	Vertical Fin, Front Spar Access at Station 1016		172A6125
323BL	Vertical Fin, Forward Fin Access Door	Vertical Fin, Forward Fin Access at Station 1050		172A6120
323BR	Vertical Fin, Forward Fin Access Door	Vertical Fin, Forward Fin Access at Station 1050		172A6120
323CL	Vertical Fin, Rear Spar Access Door	Vertical Fin, Rear Spar Access at Station 1090		172A6120
323CR	Vertical Fin, Rear Spar Access Door	Vertical Fin, Rear Spar Access at Station 1090		172A6120
323DL	Vertical Fin, Access	Vertical Fin, Access at Fin Station 78		172A4002
323EL	Vertical Fin, Access	Vertical Fin, Access at Fin Station 97		172A4002
323FL	Vertical Fin, Access	Vertical Fin, Access at Fin Station 122.31 to Fin Station 132.26		172A4002
323GL	Vertical Fin, Access	Vertical Fin, Access at Fin Station 122.31 to Fin Station 132.26		172A4002
324AAL	Panel Assy - Trailing Edge, Beam Seal, Vert Fin	Vertical Fin Trailing Edge Beam and Seal		175A1601
324ABL	Panel Assy - Trailing Edge, Beam Seal, Vertical Fin			175A1601
324ACL	Rudder Nose Cover/Rudder Hinge No. 8 At Rudder Station 276.24			
324ADL	Rudder Nose Cover/Rudder Hinge No. 7 At Rudder Station 257.92			
324AEL	Rudder Nose Cover/Rudder Hinge No. 6 At Rudder Station 239.61			
324AFL	Rudder Nose Cover/Rudder Hinge No. 5 At Rudder Station 184.67			

EFFECTIVITY
HAP ALL

06-42-00

Page 202
Jun 15/2008

D633A101-HAP



737-600/700/800/900

AIRCRAFT MAINTENANCE MANUAL

(Continued)

Number	Name/Location	Provides Access To	Dimensions	Drawing
324AGL	Upper Rudder Gap Cover At Rudder Station 164.90			
324AHL	Rudder Nose Fairing/Rudder Hinge No. 4 At Rudder Station 129.74.			
324AJL	Rudder Nose Fairing/Rudder Hinge No. 3 At Rudder Station 70.65			
324AKL	Rudder Nose Fairing/Rudder Hinge No. 2 At Rudder Station 53.48			
324AL	Vertical Fin, Aft Fin Access Door	Vertical Fin, Aft Fin Access at Station 1115		172A6120
324ALL	Rudder Nose Cover/Rudder Hinge No. 1 At Rudder Station 6.96			
324AR	Vertical Fin, Aft Fin Access Door	Vertical Fin, Aft Fin Access at Station 1115		172A6120
324BL	Vertical Fin, Trailing Edge Access	Vertical Fin, Trailing Edge Access at Rudder Station 6.96 to 56.48		175A1702
324BR	Vertical Fin, Trailing Edge Access	Vertical Fin, Trailing Edge Access at Rudder Station 6.96 to 56.48		175A1702
324CL	Vertical Fin, Access	Vertical Fin, Access at Rudder Station 45		172A6120
324DL	Trailing Edge Access	Vertical Fin, Trailing Edge Access at Rudder Station 56.48 to Rudder Station 74.8		175A1704
324DR	Vertical Fin, Trailing Edge Access	Vertical Fin, Trailing Edge Access at Rudder Station 56.48 to Rudder Station 74.8		175A1704
324EL	Vertical Fin, Access	Vertical Fin, Access At Rudder Station 66.42 to Rudder Station 74.8		175A1704
324ER	Panel Assy - Trailing Edge, Beam Seal, Vert Fin	Vertical Fin Trailing Edge Beam and Seal		175A1601
324FL	Vertical Fin, Access	Vertical Fin, Access at Rudder Station 66.42 to Rudder Station 74.80		175A1704
324FR	Panel Assy - Trailing Edge, Beam Seal, Vert Fin	Vertical Fin Trailing Edge Beam and Seal		175A1601

EFFECTIVITY
HAP ALL

06-42-00

Page 203
Jun 15/2009

D633A101-HAP



737-600/700/800/900

AIRCRAFT MAINTENANCE MANUAL

(Continued)

Number	Name/Location	Provides Access To	Dimensions	Drawing
324GR	Panel Assy - Trailing Edge, Beam Seal, Vert Fin	Vertical Fin Trailing Edge Beam and Seal		175A1601
324HR	Panel Assy - Trailing Edge, Beam Seal, Vert Fin	Vertical Fin Trailing Edge Beam and Seal		175A1601
324JL	Vertical Fin, Access	Vertical Fin, Trailing Edge Access at Rudder Station 74.80 to 164.90		175A1702
324JR	Panel Assy - Trailing Edge, Beam Seal, Vert Fin	Vertical Fin Trailing Edge Beam and Seal		175A1601
324KL	Vertical Fin, Access	Vertical Fin, Access at Fin Water Line 155.25 to Rudder Station 184.67		175A1702
324LL	Vertical Fin, Access	Vertical Fin, Trailing Edge Access at Rudder Station 184.67 to 212.15		175A1702
324ML	Vertical Fin, Access	Vertical Fin, Trailing Edge Access at Rudder Station 212.15 to 239.61		175A1702
324NL	Vertical Fin, Access	Vertical Fin, Trailing Edge Access Below Rudder Station 260.50		175A1702
324PL	Vertical Fin, Access	Vertical Fin Trailing Edge Beam and Seal		175A1601
324QL	Panel Assy - Trailing Edge, Beam Seal, Vert Fin	Vertical Fin Trailing Edge Beam and Seal		175A1601
324RL	Panel Assy - Trailing Edge, Beam Seal, Vert Fin	Vertical Fin Trailing Edge Beam and Seal		175A1601
324SL	Panel Assy - Trailing Edge, Beam Seal, Vert Fin	Vertical Fin Trailing Edge Beam and Seal		175A1601
324TL	Panel Assy - Trailing Edge, Beam Seal, Vert Fin	Vertical Fin Trailing Edge Beam and Seal		175A1601
324UL	Panel Assy - Trailing Edge, Beam Seal, Vert Fin	Vertical Fin Trailing Edge Beam and Seal		175A1601
324VL	Panel Assy - Trailing Edge, Beam Seal, Vert Fin	Vertical Fin Trailing Edge Beam and Seal		175A1601
324WL	Panel Assy - Trailing Edge, Beam Seal, Vert Fin	Vertical Fin Trailing Edge Beam and Seal		175A1601
324XL	Panel Assy - Trailing Edge, Beam Seal, Vert Fin	Vertical Fin Trailing Edge Beam and Seal		175A1601
324YL	Panel Assy - Trailing Edge, Beam Seal, Vert Fin	Vertical Fin Trailing Edge Beam and Seal		175A1601

EFFECTIVITY
HAP ALL

06-42-00

Page 204
Jun 15/2009

D633A101-HAP



737-600/700/800/900

AIRCRAFT MAINTENANCE MANUAL

(Continued)

Number	Name/Location	Provides Access To	Dimensions	Drawing
324ZL	Panel Assy - Trailing Edge, Beam Seal, Vert Fin	Vertical Fin Trailing Edge Beam and Seal		175A1601
326A	Vertical Fin, Vertical Fin Tip	Vertical Fin Tip Assembly		65-73789
331A	Horizontal Stabilizer, Gap Cover	Forward Horizontal Stabilizer to Body		186A3103
331AB	Horizontal Stabilizer, Gap Cover, Horizontal Stabilizer To Body			186A3103
331AZ	Horizontal Stabilizer, Access Panel, Inboard L.E. Closure Rib	Leading Edge, Horizontal Stabilizer Closure Rib		
331B	Horizontal Stabilizer, Removable Leading Edge	Removable Leading Edge, Horizontal Stabilizer		186A1200
331BZ	Horizontal Stabilizer, Front Spar Removable Web	Removable Leading Edge, Horizontal Stabilizer		
331CZ	Horizontal Stabilizer, Front Spar Removable Web	Removable Leading Edge, Horizontal Stabilizer		
331DZ	Horizontal Stabilizer, Front Spar Removable Web	Removable Leading Edge, Horizontal Stabilizer		
332AB	Horizontal Stabilizer, Gap Cover, Horizontal Stabilizer to Body	Mid Lower Horizontal Stabilizer		
332AT	Horizontal Stabilizer, Gap Cover, Horizontal Stabilizer to Body	Mid Top, Horizontal Stabilizer to Body		186A3103
332BB	Horizontal Stabilizer, Access Door	Inspar area between Elevator Station 24.09 and Elevator Station 39.02, Horizontal Stabilizer		182A4002
332CB	Horizontal Stabilizer, Access Door	Inspar area between Elevator Station 24.09 and Elevator Station 39.02, Horizontal Stabilizer		182A4002
332DB	Horizontal Stabilizer, Access Door	Inspar Area between Elevator Station 24.09 and Elevator Station 39.02, Horizontal Stabilizer		182A4002
332EB	Horizontal Stabilizer, Access Door	Inspar Area between Elevator Station 24.09 and Elevator Station 39.02, Horizontal Stabilizer		182A4002

EFFECTIVITY
HAP ALL

06-42-00

Page 205
Jun 15/2009

D633A101-HAP



737-600/700/800/900
AIRCRAFT MAINTENANCE MANUAL

(Continued)

Number	Name/Location	Provides Access To	Dimensions	Drawing
332FB	Horizontal Stabilizer, Access Door	Inspar area between Elevator Station 24.09 and Elevator Station 39.02, Horizontal Stabilizer		182A4002
332GB	Horizontal Stabilizer, Access Door	Inspar area between Elevator Station 24.09 and Elevator Station 39.02, Horizontal Stabilizer		182A4002
332HB	Horizontal Stabilizer, Access Door	Inspar area between Elevator Station 24.09 and Elevator Station 39.02, Horizontal Stabilizer		182A4002
332JB	Horizontal Stabilizer, Access Door	Inspar area between Elevator Station 24.09 and Elevator Station 39.02, Horizontal Stabilizer		182A4002
332KB	Horizontal Stabilizer, Access Door	Inspar area between Elevator Station 24.09 and Elevator Station 39.02, Horizontal Stabilizer		182A4002
332LB	Horizontal Stabilizer, Access Door	Inspar area between Elevator Station 24.09 and Elevator Station 39.02, Horizontal Stabilizer		182A4002
332MB	Horizontal Stabilizer, Access Door	Inspar area between Elevator Station 24.09 and Elevator Station 39.02, Horizontal Stabilizer		182A4002
332NB	Horizontal Stabilizer, Access Door	Inspar area between Elevator Station 24.09 and Elevator Station 39.02, Horizontal Stabilizer		182A4002
332PB	Horizontal Stabilizer, Access Door	Inspar area between Elevator Station 24.09 and Elevator Station 39.02, Horizontal Stabilizer		182A4002
333AB	Horizontal Stabilizer, Gap Cover, Horizontal Stabilizer to Body	Lower Trailing Edge, Horizontal Stabilizer to Body		186A3101
333AT	Horizontal Stabilizer, Gap Cover, Horizontal Stabilizer to Body	Aft Top, Horizontal Stabilizer to Bod		186A3103
333AZ	Horizontal Stabilizer, Access Panel, Inboard T.E. Closure Rib	Inboard Trailing Edge Closure Rib, Horizontal Stabilizer		185A1310

EFFECTIVITY
HAP ALL

D633A101-HAP

06-42-00

Page 206
Jun 15/2009



737-600/700/800/900

AIRCRAFT MAINTENANCE MANUAL

(Continued)

Number	Name/Location	Provides Access To	Dimensions	Drawing
333BB	Horizontal Stabilizer, Access Panel, Trailing Edge	Trailing Edge, Elevator Station 24.90 to 66.54, Horizontal Stabilizer		185A1702
333CB	Horizontal Stabilizer, Access Panel, Trailing Edge	Trailing Edge, Elevator Station 66.54 to 121.59, Horizontal Stabilizer		185A1702
333DB	Horizontal Stabilizer, Access Panel, Trailing Edge	Trailing Edge, Elevator Station 121.59 to 176.64, Horizontal Stabilizer		185A1702
333EB	Horizontal Stabilizer, Access Panel, Trailing Edge	Trailing Edge, Elevator Station 176.64 to 205.53, Horizontal Stabilizer		185A1702
333FB	Horizontal Stabilizer, Access Panel, Trailing Edge	Trailing Edge, Elevator Station 205.53 to 250.04, Horizontal Stabilizer		185A1702
334AB	Horizontal Stabilizer, Seal, Trailing Edge to Elevator	Seal, Lower Trailing Edge to Elevator, Horizontal Stabilizer		185A1621
334AT	Horizontal Stabilizer, Seal, Trailing Edge to Elevator	Seal, Upper Trailing Edge to Elevator, Horizontal Stabilizer		185A1621
334BB	Horizontal Stabilizer, Seal, Trailing Edge to Elevator	Seal, Lower Trailing Edge to Elevator, Horizontal Stabilizer		185A1621
334BT	Horizontal Stabilizer, Seal, Trailing Edge to Elevator	Seal, Upper Trailing Edge to Elevator, Horizontal Stabilizer		185A1621
334CB	Horizontal Stabilizer, Seal, Trailing Edge to Elevator	Seal, Lower Trailing Edge to Elevator, Horizontal Stabilizer		185A1621
334DB	Horizontal Stabilizer, Seal, Trailing Edge to Elevator	Seal, Lower Trailing Edge to Elevator, Horizontal Stabilizer		185A1621
334DT	Horizontal Stabilizer, Seal, Trailing Edge to Elevator	Seal, Upper Trailing Edge to Elevator, Horizontal Stabilizer		185A1621
334GB	Horizontal Stabilizer, Elevator Hinge Cover	Elevator End Fitting, Horizontal Stabilizer		183A3600
334GT	Horizontal Stabilizer, Elevator Hinge Cover	Elevator End Fitting, Horizontal Stabilizer		183A3600
334HB	Horizontal Stabilizer, Elevator Hinge Cover	Elevator End Fitting, Horizontal Stabilizer		183A3500
334JB	Horizontal Stabilizer, Elevator Hinge Cover	Elevator End Fitting, Horizontal Stabilizer		183A3500
334JT	Horizontal Stabilizer, Elevator Hinge Cover	Elevator End Fitting, Horizontal Stabilizer		183A3500
334KB	Horizontal Stabilizer, Elevator Hinge Cover	Elevator End Fitting, Horizontal Stabilizer		183A3500

EFFECTIVITY
HAP ALL

06-42-00

D633A101-HAP

Page 207
Jun 15/2009



737-600/700/800/900

AIRCRAFT MAINTENANCE MANUAL

(Continued)

Number	Name/Location	Provides Access To	Dimensions	Drawing
334LB	Horizontal Stabilizer, Elevator Hinge Cover	Elevator End Fitting, Horizontal Stabilizer		183A3500
334MB	Horizontal Stabilizer, Elevator Hinge Cover	Elevator End Fitting, Horizontal Stabilizer		183A3500
334MT	Horizontal Stabilizer, Elevator Hinge Cover	Elevator End Fitting, Horizontal Stabilizer		183A3500
334NB	Horizontal Stabilizer, Elevator Hinge Cover	Elevator End Fitting, Horizontal Stabilizer		183A3500
334PT	Horizontal Stabilizer, Tab Control Rod Fairing	Control Rod Fairing, Horizontal Stabilizer Trim Tab		183A3300
335A	Horizontal Stabilizer, Removable Stabilizer Tip	Removable Tip Assembly, Horizontal Stabilizer		189A1001
341A	Horizontal Stabilizer, Gap Cover	Forward Horizontal Stabilizer to Body		186A3103
341AB	Horizontal Stabilizer, Gap Cover - H. Stab. To Body			186A3103
341AZ	Horizontal Stabilizer, Access Panel - Inbd L.E. Closure Rib	Leading Edge, Horizontal Stabilizer Closure Rib		
341B	Horizontal Stabilizer, Removable L.E.	Removable Leading Edge, Horizontal Stabilizer		186A1200
341BZ	Horizontal Stabilizer, Front Spar Removable Web	Front Spar Web Assembly, Horizontal Stabilizer		
341CZ	Horizontal Stabilizer, Front Spar Removable Web	Front Spar Web Assembly, Horizontal Stabilizer		
341DZ	Horizontal Stabilizer, Front Spar Removable Web	Front Spar Web Assembly, Horizontal Stabilizer		
342AB	Horizontal Stabilizer, Gap Cover - H. Stab. to Body	Mid Lower Horizontal Stabilizer		
342AT	Gap Cover, Horizontal Stabilizer	Mid Top, Horizontal Stabilizer to Body		186A3103
342BB	Horizontal Stabilizer, Access Door	Inspar area between Elevator Station 24.09 and Elevator Station 39.02, Horizontal Stabilizer		182A4002
342CB	Horizontal Stabilizer, Access Door	Inspar area between Elevator Station 24.09 and Elevator Station 39.02, Horizontal Stabilizer		182A4002

EFFECTIVITY
HAP ALL

D633A101-HAP

06-42-00

Page 208
Jun 15/2009



737-600/700/800/900

AIRCRAFT MAINTENANCE MANUAL

(Continued)

Number	Name/Location	Provides Access To	Dimensions	Drawing
342DB	Horizontal Stabilizer, Access Door	Inspar area between Elevator Station 24.09 and Elevator Station 39.02, Horizontal Stabilizer		182A4002
342EB	Horizontal Stabilizer, Access Door	Inspar area between Elevator Station 24.09 and Elevator Station 39.02, Horizontal Stabilizer		182A4002
342FB	Horizontal Stabilizer, Access Door	Inspar area between Elevator Station 24.09 and Elevator Station 39.02, Horizontal Stabilizer		182A4002
342GB	Horizontal Stabilizer, Access Door	Inspar area between Elevator Station 24.09 and Elevator Station 39.02, Horizontal Stabilizer		182A4002
342HB	Horizontal Stabilizer, Access Door	Inspar area between Elevator Station 24.09 and Elevator Station 39.02, Horizontal Stabilizer		182A4002
342JB	Horizontal Stabilizer, Access Door	Inspar area between Elevator Station 24.09 and Elevator Station 39.02, Horizontal Stabilizer		182A4002
342KB	Horizontal Stabilizer, Access Door	Inspar area between Elevator Station 24.09 and Elevator Station 39.02, Horizontal Stabilizer		182A4002
342LB	Horizontal Stabilizer, Access Door	Inspar area between Elevator Station 24.09 and Elevator Station 39.02, Horizontal Stabilizer		182A4002
342MB	Horizontal Stabilizer, Access Door	Inspar area between Elevator Station 24.09 and Elevator Station 39.02, Horizontal Stabilizer		182A4002
342NB	Horizontal Stabilizer, Access Door	Inspar area between Elevator Station 24.09 and Elevator Station 39.02, Horizontal Stabilizer		182A4002
342PB	Horizontal Stabilizer, Access Door	Inspar area between Elevator Station 24.09 and Elevator Station 39.02, Horizontal Stabilizer		182A4002

EFFECTIVITY
HAP ALL

06-42-00

D633A101-HAP

Page 209
Jun 15/2009



737-600/700/800/900

AIRCRAFT MAINTENANCE MANUAL

(Continued)

Number	Name/Location	Provides Access To	Dimensions	Drawing
343AB	Horizontal Stabilizer, Gap Cover - H. Stab. to Body	Lower Trailing Edge, Horizontal Stabilizer to Body		185A1702
343AT	Horizontal Stabilizer, Gap Cover - H. Stab. to Body	Aft Top, Horizontal Stabilizer to Bod		186A3103
343AZ	Horizontal Stabilizer, Access Panel - Inbd T.E. Closure Rib	Inboard Trailing Edge Closure Rib, Horizontal Stabilizer		185A1702
343BB	Horizontal Stabilizer, Access Panel - T.E. Area	Trailing Edge, Elevator Station 24.90 to 66.54, Horizontal Stabilizer		185A1702
343CB	Horizontal Stabilizer, Access Panel - T.E. Area	Trailing Edge, Elevator Station 66.54 to 121.59, Horizontal Stabilizer		185A1702
343DB	Horizontal Stabilizer, Access Panel - T.E. Area	Trailing Edge, Elevator Station 121.59 to 176.64, Horizontal Stabilizer		185A1702
343EB	Horizontal Stabilizer, Access Panel - T.E. Area	Trailing Edge, Elevator Station 176.64 to 205.53, Horizontal Stabilizer and Logo Light		185A1702
343FB	Horizontal Stabilizer, Access Panel - T.E. Area	Trailing Edge, Elevator Station 205.53 to 250.04, Horizontal Stabilizer		185A1702
344AB	Horizontal Stabilizer, Seal, Trailing Edge to Elevator	Seal, Lower Trailing Edge to Elevator, Horizontal Stabilizer		185A1621
344AT	Horizontal Stabilizer, Seal, Trailing Edge to Elevator	Seal, Upper Trailing Edge to Elevator, Horizontal Stabilizer		185A1621
344BB	Horizontal Stabilizer, Seal, Trailing Edge to Elevator	Seal, Lower Trailing Edge to Elevator, Horizontal Stabilizer		185A1621
344BT	Horizontal Stabilizer, Seal, Trailing Edge to Elevator	Seal, Upper Trailing Edge to Elevator, Horizontal Stabilizer		185A1621
344CB	Horizontal Stabilizer, Seal, Trailing Edge to Elevator	Seal, Lower Trailing Edge to Elevator, Horizontal Stabilizer		185A1621
344DB	Horizontal Stabilizer, Seal, Trailing Edge to Elevator	Seal, Lower Trailing Edge to Elevator, Horizontal Stabilizer		185A1621
344DT	Horizontal Stabilizer, Seal, Trailing Edge to Elevator	Seal, Upper Trailing Edge to Elevator, Horizontal Stabilizer		185A1621
344GB	Horizontal Stabilizer, Hinge Cover, Elevator Station 24.09	Elevator End Fitting, Horizontal Stabilizer		183A3600
344GT	Horizontal Stabilizer, Elevator Hinge Cover, Elevator Sta 39.02	Elevator End Fitting, Horizontal Stabilizer		183A3600
344HB	Horizontal Stabilizer, Elevator Hinge Cover, Elevator Sta 66.54	Elevator End Fitting, Horizontal Stabilizer		183A3500

EFFECTIVITY
HAP ALL

06-42-00

Page 210
Jun 15/2009

D633A101-HAP



737-600/700/800/900

AIRCRAFT MAINTENANCE MANUAL

(Continued)

Number	Name/Location	Provides Access To	Dimensions	Drawing
344JB	Horizontal Stabilizer, Elevator Hinge Cover, Elevator Sta 121.59	Elevator End Fitting, Horizontal Stabilizer		183A3500
344JT	Horizontal Stabilizer, Elevator Hinge Cover, Elevator Sta 121.59	Elevator End Fitting, Horizontal Stabilizer		183A3500
344KB	Horizontal Stabilizer, Elevator Hinge Cover, Elevator Sta 176.64	Elevator End Fitting, Horizontal Stabilizer		183A3500
344LB	Horizontal Stabilizer, Elevator Hinge Cover, Elevator Sta 213.32	Elevator End Fitting, Horizontal Stabilizer		183A3500
344MB	Horizontal Stabilizer, Elevator Hinge Cover, Elevator Sta 250.04	Elevator End Fitting, Horizontal Stabilizer		183A3500
344MT	Horizontal Stabilizer, Elevator Hinge Cover, Elevator Sta 250.04	Elevator End Fitting, Horizontal Stabilizer		183A3500
344NB	Horizontal Stabilizer, Elevator Hinge Cover, Elevator Sta 265.45	Elevator End Fitting, Horizontal Stabilizer		183A3500
344PT	Horizontal Stabilizer, Tab Control Rod Fairing, Elevator Sta 34.0	Control Rod Fairing, Horizontal Stabilizer Trim Tab		183A3300
345A	Horizontal Stabilizer, Removable Stabilizer Tip	Removable Tip Assembly, Horizontal Stabilizer		189A1001

————— END OF TASK —————

EFFECTIVITY
HAP ALL

06-42-00

Page 211
Jun 15/2009

D633A101-HAP

**737-600/700/800/900
AIRCRAFT MAINTENANCE MANUAL**

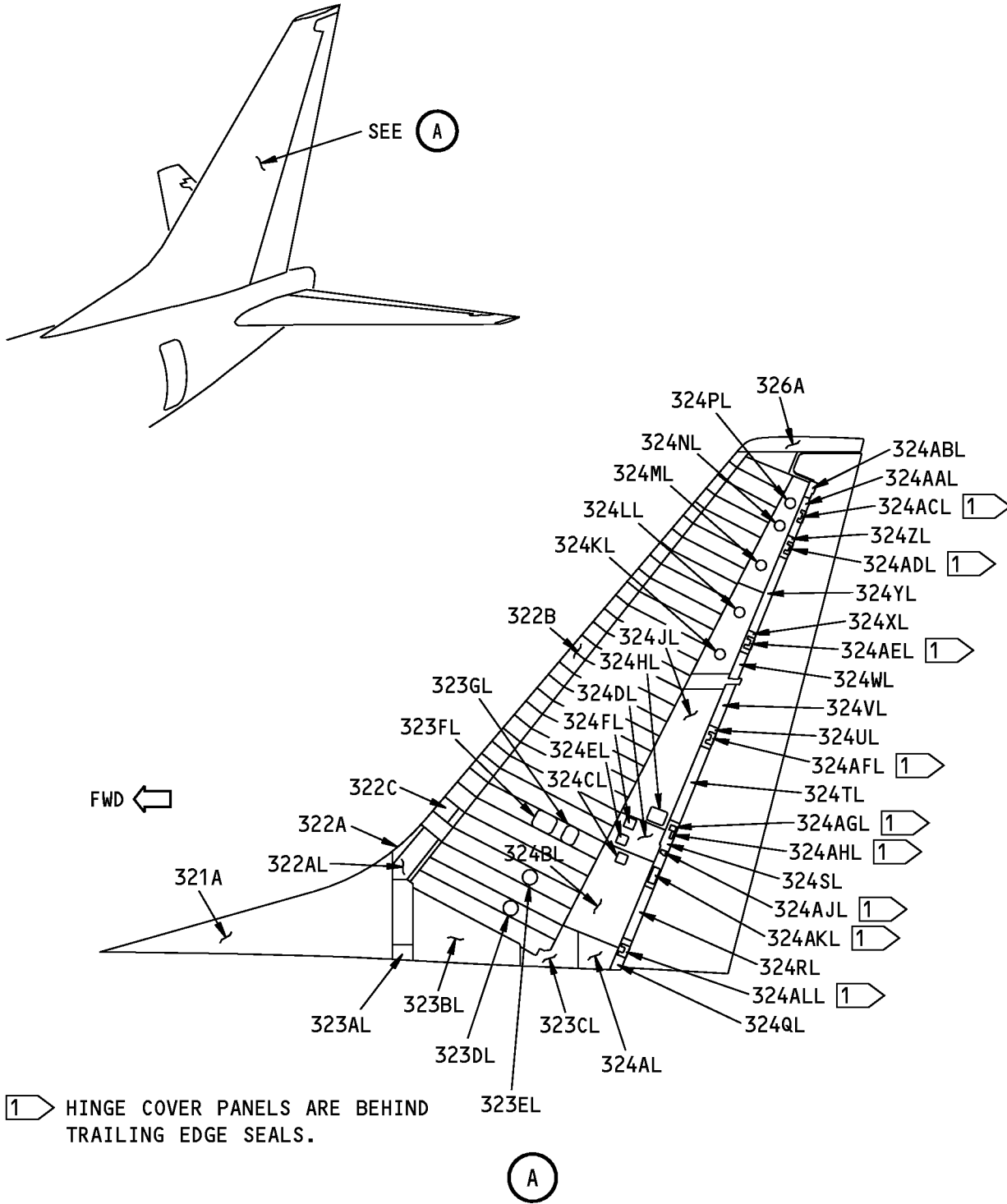

G36560 S0006558377_V6

**Zone 320 Vertical Fin
Figure 201/06-42-00-990-801**

EFFECTIVITY
HAP ALL

06-42-00

Page 212
Jun 15/2008

D633A101-HAP

**737-600/700/800/900
AIRCRAFT MAINTENANCE MANUAL**

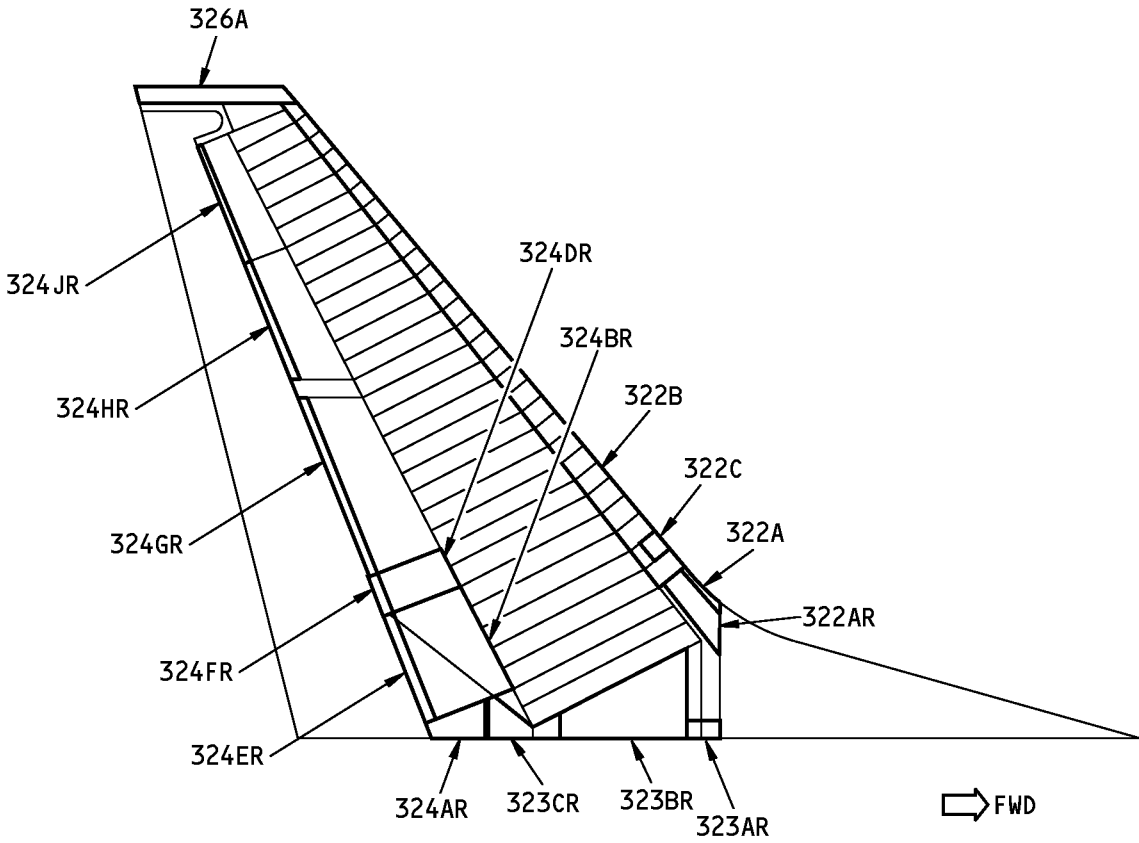
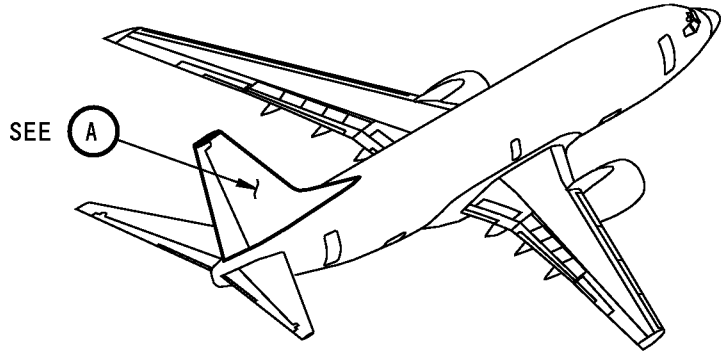

(A)

**Zone 320 Vertical Fin
Figure 202/06-42-00-990-802**

EFFECTIVITY
HAP ALL

06-42-00

Page 213
Jun 15/2008

D633A101-HAP

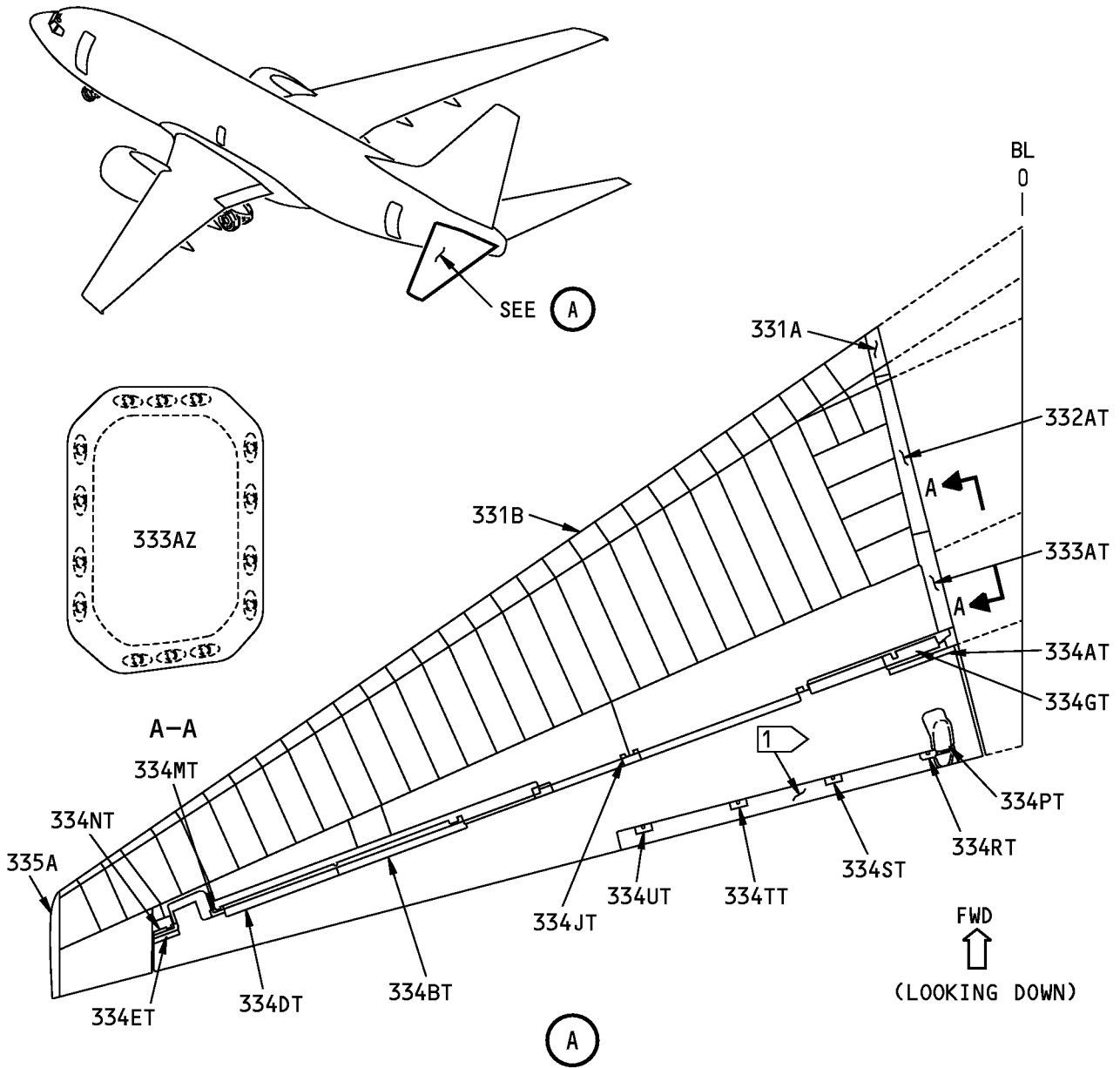

1 THE ELEVATOR TAB CONFIGURATION SHOWN IS FOR AIRCRAFT LINE NUMBERS BEFORE NO. 1175 THAT HAVE NOT INCORPORATED SB 55-1080 AND/OR 1081. THE REVISED CONFIGURATION HAS SIX HINGES AND NO HINGE COVERS. (LINE NO. 1175 AND ON)

**Zone 330 Horizontal Stabilizer Access Doors and Panels
Figure 203/06-42-00-990-803**

EFFECTIVITY
HAP ALL

D633A101-HAP

06-42-00

**737-600/700/800/900
AIRCRAFT MAINTENANCE MANUAL**

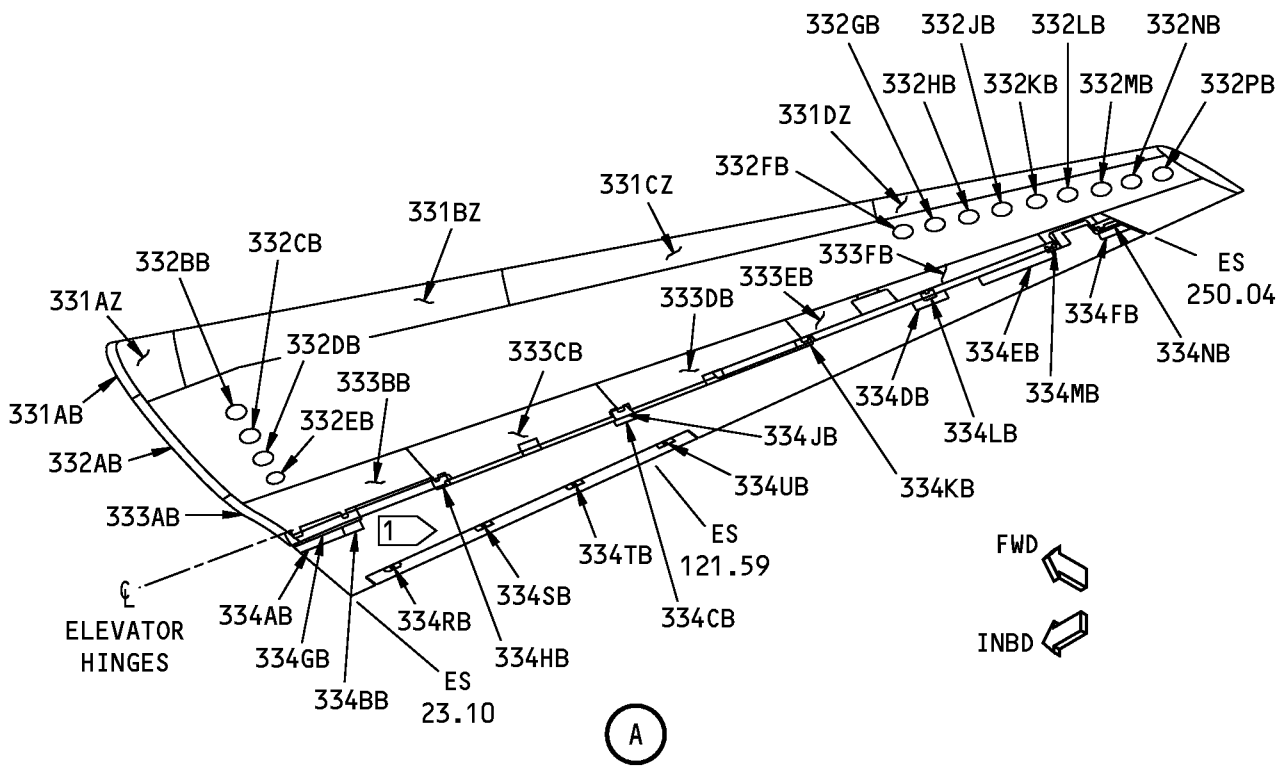
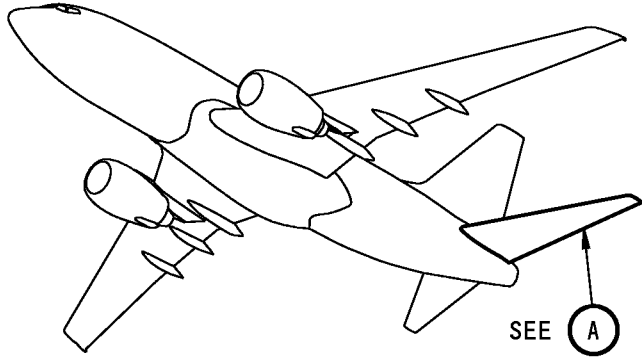

1 THE ELEVATOR TAB CONFIGURATION SHOWN IS FOR AIRCRAFT LINE NUMBERS BEFORE NO. 1175 THAT HAVE NOT INCORPORATED SB 55-1080 AND/OR 1081. THE REVISED CONFIGURATION HAS SIX HINGES AND NO HINGE COVERS. (LINE NO. 1175 AND ON)

G36469 S0006558380_V8

**Zone 330 Horizontal Stabilizer Access Doors and Panels
Figure 204/06-42-00-990-804**

EFFECTIVITY
HAP ALL

06-42-00

Page 215
Feb 15/2009

D633A101-HAP

**737-600/700/800/900
AIRCRAFT MAINTENANCE MANUAL**

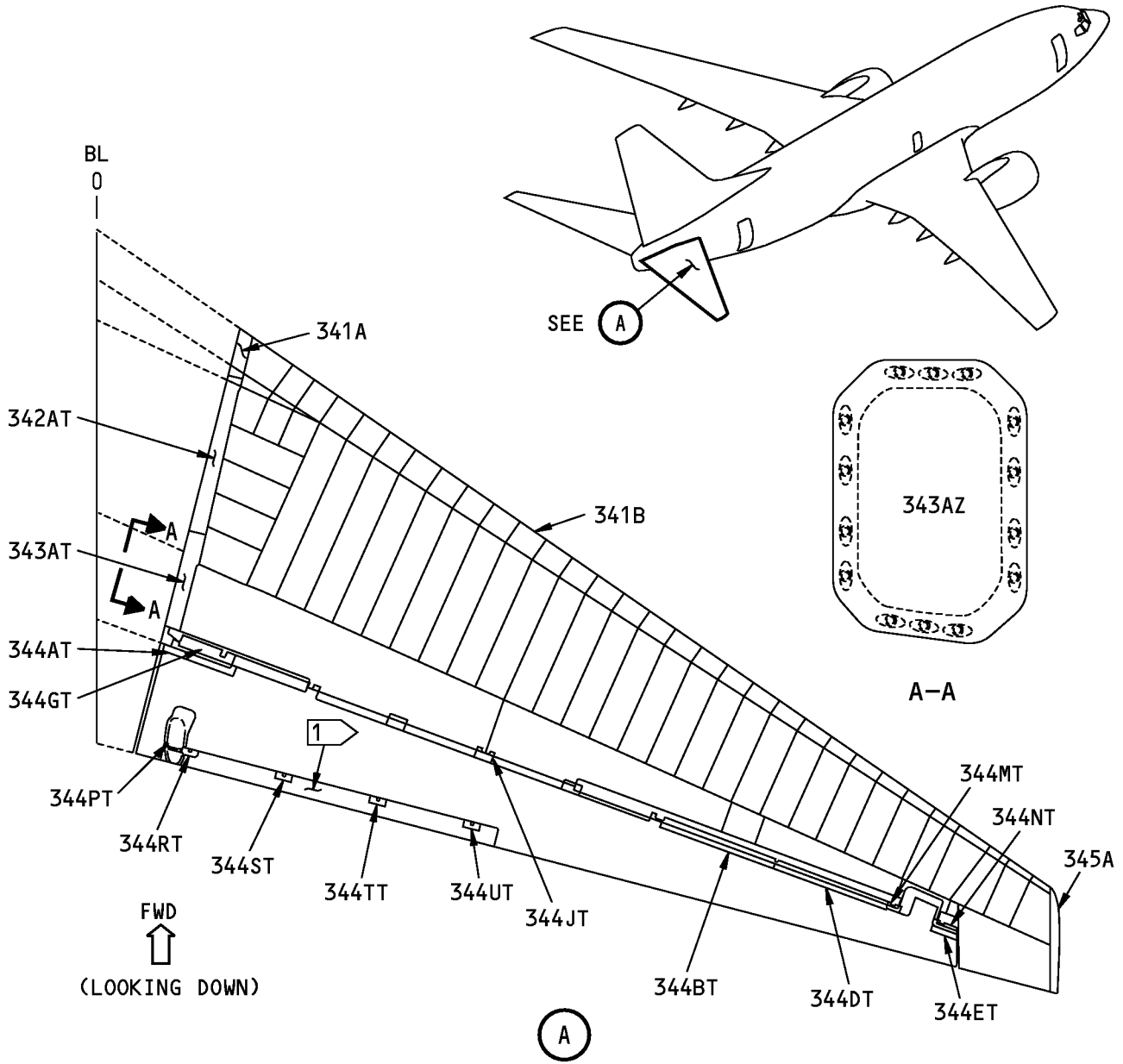

1 THE ELEVATOR TAB CONFIGURATION SHOWN IS FOR AIRCRAFT LINE NUMBERS BEFORE NO. 1175 THAT HAVE NOT INCORPORATED SB 55-1080 AND/OR 1081. THE REVISED CONFIGURATION HAS SIX HINGES AND NO HINGE COVERS. (LINE NO. 1175 AND ON)

**Zone 340 Horizontal Stabilizer Access Doors and Panels
Figure 205/06-42-00-990-805**

EFFECTIVITY
HAP ALL

D633A101-HAP

06-42-00

Page 216
Jun 15/2008

**737-600/700/800/900
AIRCRAFT MAINTENANCE MANUAL**

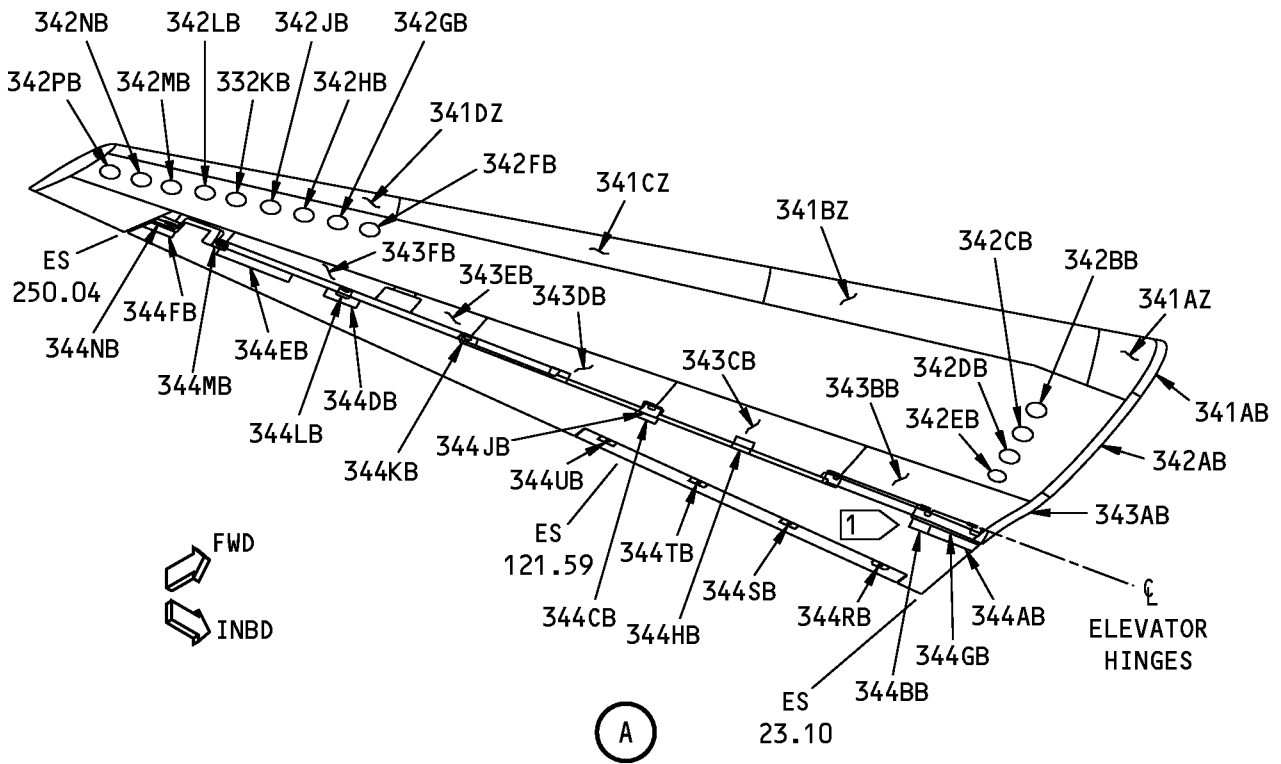
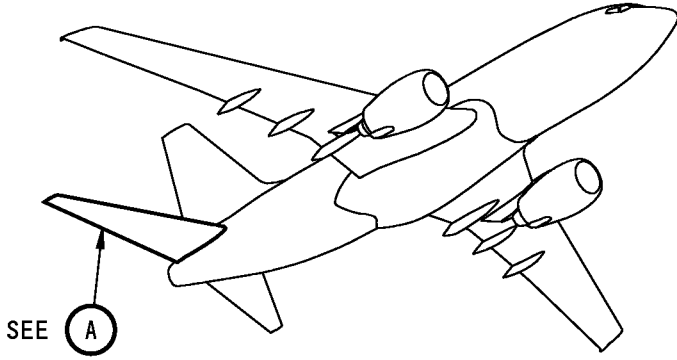

1 THE ELEVATOR TAB CONFIGURATION SHOWN IS FOR AIRCRAFT LINE NUMBERS BEFORE NO. 1175 THAT HAVE NOT INCORPORATED SB 55-1080 AND/OR 1081. THE REVISED CONFIGURATION HAS SIX HINGES AND NO HYNGE COVERS. (LINE NO. 1175 AND ON)

**Zone 340 Horizontal Stabilizer Access Doors and Panels
Figure 206/06-42-00-990-806**

EFFECTIVITY
HAP ALL

06-42-00

Page 217
Jun 15/2008

D633A101-HAP

**737-600/700/800/900
AIRCRAFT MAINTENANCE MANUAL**

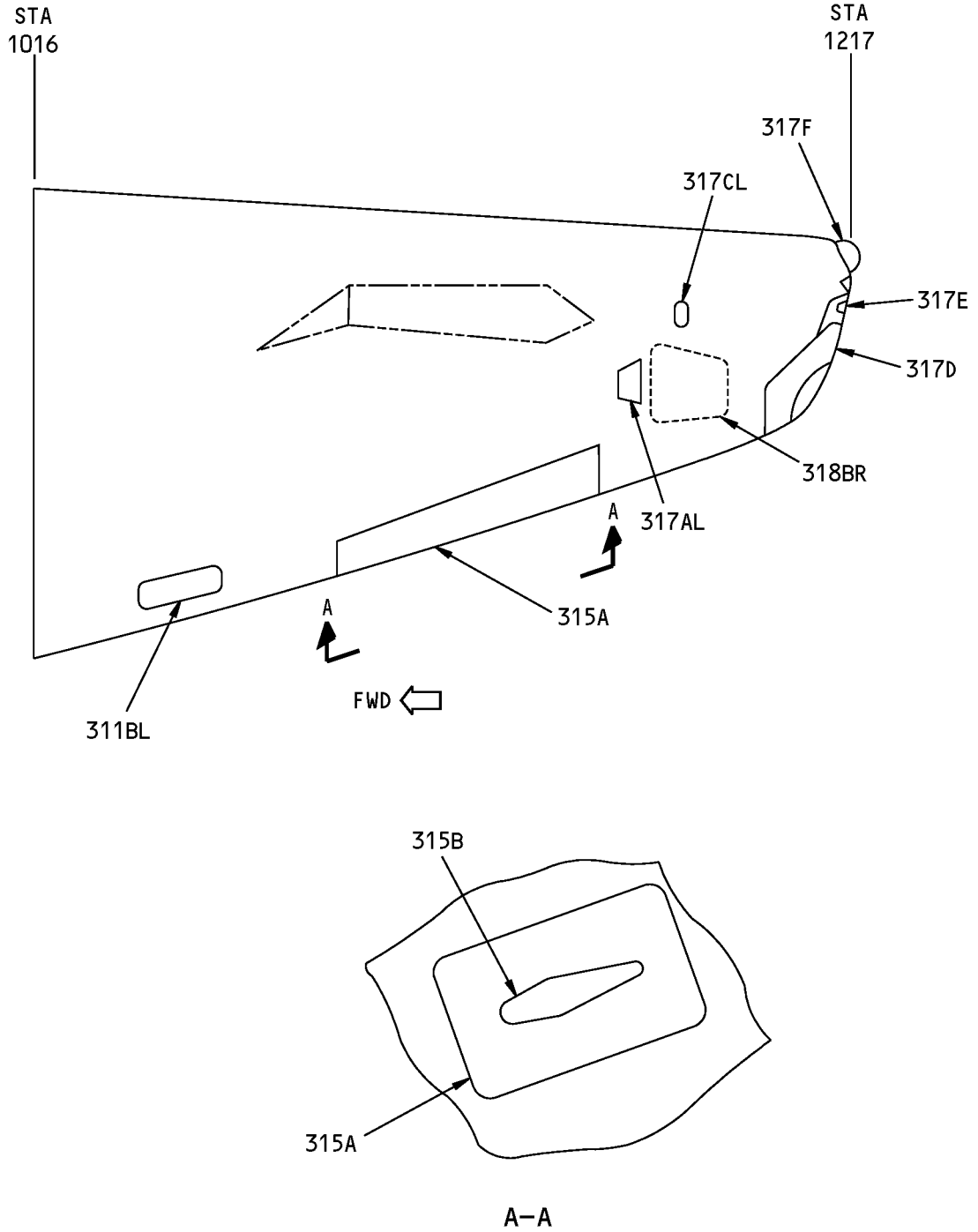

**Zone 310 Fuselage Section 48 Access Doors and Panels
Figure 207/06-42-00-990-808**

EFFECTIVITY
HAP ALL

06-42-00

Page 218
Jun 15/2008

D633A101-HAP



737-600/700/800/900

AIRCRAFT MAINTENANCE MANUAL

CFM 56-7 SERIES ENGINE AND NACELLE STRUT (MAJOR ZONE 400) ACCESS DOORS AND PANELS - MAINTENANCE PRACTICES

1. General

- A. This procedure has these tasks:
(1) Engine and nacelle strut access doors and panels
B. Major zone 400 contains the power plants and nacelle struts. Major zone 400 includes the subzones shown below, which are identified with two numbers followed by a zero.
(1) Subzone 410 - Left Power Plant
(2) Subzone 420 - Right Power Plant
(3) Subzone 430 - Left Nacelle Strut
(4) Subzone 440 - Right Nacelle Strut
C. Each subzone is divided into zones that are identified with the first two numbers of the subzone followed by a number that is not zero.
D. Access doors and panels in a zone are identified by the zone number and a two-letter or three-letter suffix. This alpha-numeric label is different for each access door or panel.

TASK 06-43-00-800-801

2. Engine and Nacelle Strut Access Doors and Panels

(Figure 201)

A. Location Zones

Table with 2 columns: Zone, Area. Row 1: 400, Powerplant and Nacelle Struts

B. Procedure

SUBTASK 06-43-00-800-001

- (1) In the table below, find the number of the applicable access door or panel.

Table 201

Table with 5 columns: Number, Name/Location, Provides Access To, Dimensions, Drawing. Contains 10 rows of access door data.

EFFECTIVITY HAP ALL D633A101-HAP

06-43-00



737-600/700/800/900

AIRCRAFT MAINTENANCE MANUAL

(Continued)

Number	Name/Location	Provides Access To	Dimensions	Drawing
415BL	Left Aft Thrust Reverser Hinge Fairing, Engine 1			315A2321
415DL	Left Thrust Reverser Actuator (Upper), Engine 1			315A2506
415EL	Left Thrust Reverser Actuator (Middle), Engine 1			315A2507
415FL	Left Thrust Reverser Actuator (Lower), Engine 1			315A2506
416	Right Thrust Reverser, Engine 1			315A2295
416AR	Right Forward Thrust Reverser Hinge Fairing, Engine 1			315A2320
416BR	Right Aft Thrust Reverser Hinge Fairing, Engine 1			315A2321
416CR	Right Bump Fairing For Thrust Reverser Hinge Fairing, Engine 1			315A2325
416DR	Right Thrust Reverser Actuator (Upper), Engine 1			315A2506
416ER	Right Thrust Reverser Actuator (Middle), Engine 1			315A2507
416FR	Right Thrust Reverser Actuator (Lower), Engine 1			315A2506
422	Engine No. 2 R. Side, Nose Inlet Cowl			334A2000
422AB	Inlet Access, Engine 2			334A2000
422AR	T12 Access Door, Engine 2			334A2000
423	Left Fan Cowl, Engine 2			314A2000
423AL	IDG Access Door, Engine 2			314A2000
423BL	Chip Detector/Pressure Relief Door, Engine 2			314A2000
424	Right Fan Cowl, Engine 2			314A2000
424AR	Oil Tank Access Door, Engine 2			314A2000
425	Left Thrust Reverser, Engine 2			315A2295
425AL	Left Forward Thrust Reverser Hinge Fairing, Engine 2			315A2320
425BL	Left Aft Thrust Reverser Hinge Fairing, Engine 2			315A2321

EFFECTIVITY
HAP ALL

06-43-00

Page 202
Jun 10/2004

D633A101-HAP



737-600/700/800/900

AIRCRAFT MAINTENANCE MANUAL

(Continued)

Number	Name/Location	Provides Access To	Dimensions	Drawing
425CL	Left Bump Fairing For Thrust Reverser Hinge Fairing, Engine 2			315A2325
425DL	Left Thrust Reverser Actuator (Upper), Engine 2			315A2506
425EL	Left Thrust Reverser Actuator (Middle), Engine 2			315A2507
425FL	Left Thrust Reverser Actuator (Lower), Engine 2			315A2506
426	Right Thrust Reverser, Engine 2			315A2295
426AR	Right Forward Thrust Reverser Hinge Fairing, Engine 2			315A2320
426BR	Right Aft Thrust Reverser Hinge Fairing, Engine 2			315A2321
426DR	Right Thrust Reverser Actuator (Upper), Engine 2			315A2506
426ER	Right Thrust Reverser Actuator (Middle), Engine 2			315A2507
431AL	Forward Strut Fairing, Left Thrust Reverser Disconnect, Strut 1			313A2111
431AR	Forward Strut Fairing, Right Thrust Reverser Disconnect, Strut 1			313A2111
431AT	Forward Strut Fairing, Thumbnail Fairing, Strut 1			313A2110
431BL	Forward Strut Fairing, Left Mid Strut Fairing, Strut 1			313A2121
431BR	Forward Strut Fairing, Right Mid Strut Fairing, Strut 1			313A2121
431BT	Forward Strut Fairing, Pressure Relief Door, Strut 1			311A2071
431CL	Forward Strut Fairing, Left Overwing Fairing, Strut 1			313A2230
431CR	Forward Strut Fairing, Right Overwing Fairing, Strut 1			313A2230
431DL	Forward Strut Fairing, Left Underwing Fairing, Strut 1			313A2210
431DR	Forward Strut Fairing, Right Underwing Fairing, Strut 1			313A2210

EFFECTIVITY
HAP ALL

06-43-00

Page 203
Jun 10/2004

D633A101-HAP



737-600/700/800/900

AIRCRAFT MAINTENANCE MANUAL

(Continued)

Number	Name/Location	Provides Access To	Dimensions	Drawing
431EL	Forward Strut Fairing, Left T.R. Strut Fairing, Strut 1			311A2531
431ER	Forward Strut Fairing, Right T.R. Strut Fairing, Strut 1			311A2531
433AL	Strut, Left Aft Dry Bay, Strut 1			311A2061
433AR	Strut, Right Aft Dry Bay, Strut 1			311A2061
433AT	Strut, Forward Spar Web, Strut 1			311A2060
433BT	Strut, Forward Spar Web, Strut 1			311A2060
433CT	Strut, Upper Spar Web, Strut 1			311A2060
433DT	Strut, Upper Spar Web, Strut 1			311A2060
434AL	Aft Strut Fairing, Left Forward Panel, Strut 1			313A2610
434AR	Aft Strut Fairing, Right Forward Panel, Strut 1			313A2610
434BL	Aft Strut Fairing, Left Aft Panel, Strut 1			313A2620
434CL	Aft Strut Fairing, Left Access To Fuel Door, Strut 1			313A2411
441AL	Forward Strut Fairing, Left Thrust Reverser Disconnect, Strut 2			311A2060
441AR	Forward Strut Fairing, Right Thrust Reverser Disconnect, Strut 2			311A2060
441AT	Forward Strut Fairing, Thumbnail Fairing, Strut 2			313A2110
441BL	Forward Strut Fairing, Left Mid Strut Fairing, Strut 2			313A2121
441BR	Forward Strut Fairing, Right Mid Strut Fairing, Strut 2			313A2121
441BT	Forward Strut Fairing, Pressure Relief Door, Strut 2			311A2071
441CL	Forward Strut Fairing, Left Overwing Fairing, Strut 2			313A2230
441CR	Forward Strut Fairing, Right Overwing Fairing, Strut 2			313A2230
441DL	Forward Strut Fairing, Left Underwing Fairing, Strut 2			313A2210

EFFECTIVITY
HAP ALL

06-43-00

Page 204
Jun 10/2004

D633A101-HAP



737-600/700/800/900

AIRCRAFT MAINTENANCE MANUAL

(Continued)

Number	Name/Location	Provides Access To	Dimensions	Drawing
441DR	Forward Strut Fairing, Right Underwing Fairing, Strut 2			313A2210
441EL	Forward Strut Fairing, Left T.R. Strut Fairing, Strut 2			311A2530
441ER	Forward Strut Fairing, Right T.R. Strut Fairing, Strut 2			311A2530
443AL	Strut, Left Aft Dry Bay, Strut 2			311A2061
443AR	Strut, Right Aft Dry Bay, Strut 2			311A2061
443AT	Strut, Forward Spar Web, Strut 2			311A2060
443BT	Strut, Forward Spar Web, Strut 2			311A2060
443CT	Strut, Upper Spar Web, Strut 2			311A2060
443DT	Strut, Upper Spar Web, Strut 2			311A2060
444AL	Aft Strut Fairing, Left Forward Panel, Strut 2			313A2610
444AR	Aft Strut Fairing, Right Forward Panel, Strut 2			313A2610
444BR	Aft Strut Fairing, Right Aft Panel, Strut 2			313A2620
444CR	Aft Strut Fairing, Right Access To Fuel Door, Strut 2			313A2411

————— END OF TASK —————

EFFECTIVITY
HAP ALL

06-43-00

Page 205
Jun 15/2009

D633A101-HAP

**737-600/700/800/900
AIRCRAFT MAINTENANCE MANUAL**

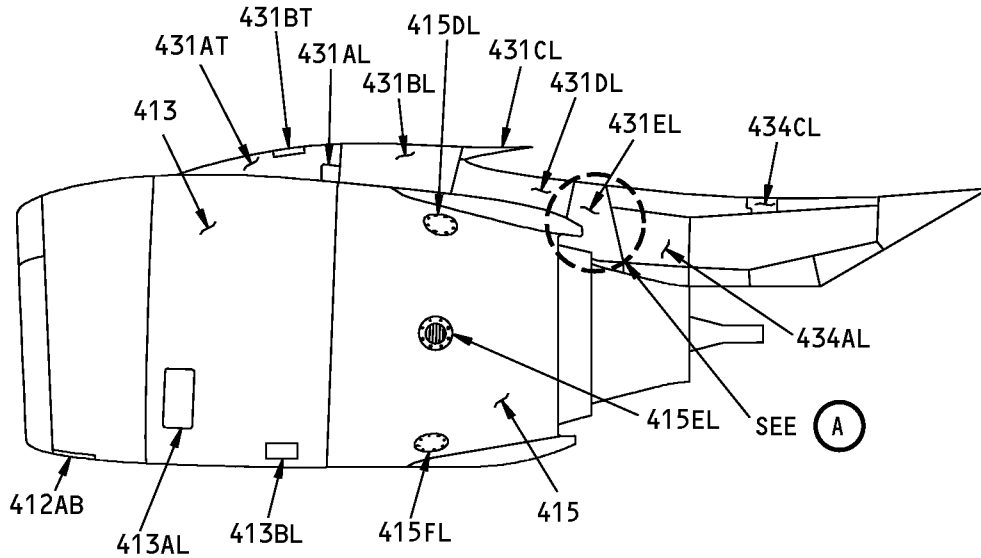

FWD ←

**NO. 1 LEFT ENGINE
(OUTBOARD VIEW)**

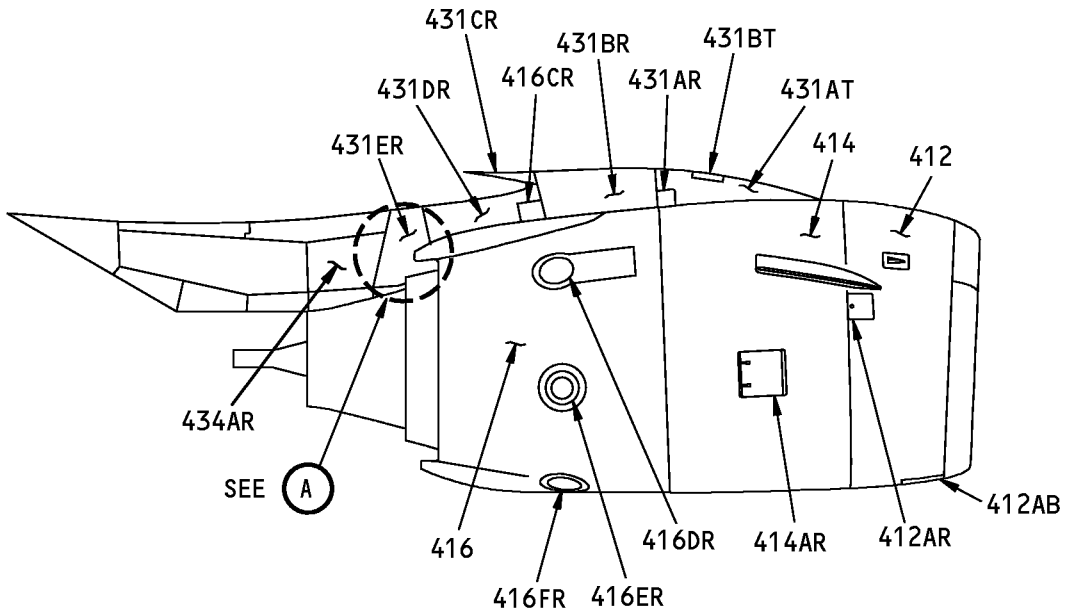

SEE (A)

→ FWD

**NO. 1 LEFT ENGINE
(INBOARD VIEW)**

F86309 S0006558389_V3

**CFM 56-7 Series Engine and Nacelle Strut Access Doors and Panels
Figure 201 (Sheet 1 of 4)/06-43-00-990-801**

EFFECTIVITY
HAP ALL

06-43-00

Page 206
Jun 15/2009

D633A101-HAP

**737-600/700/800/900
AIRCRAFT MAINTENANCE MANUAL**

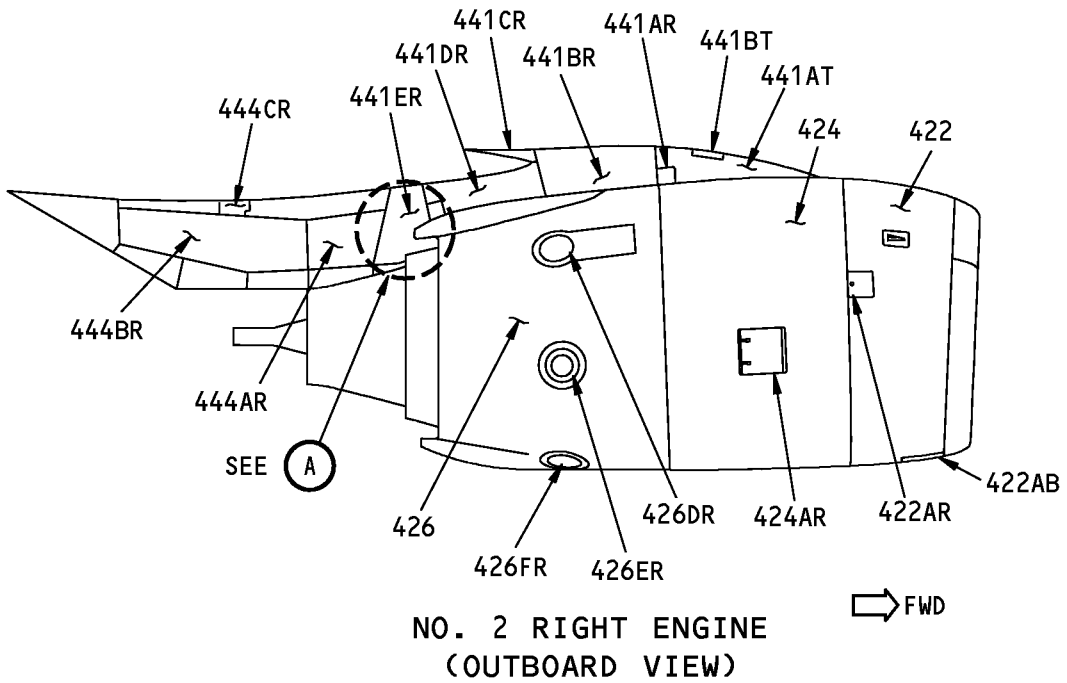
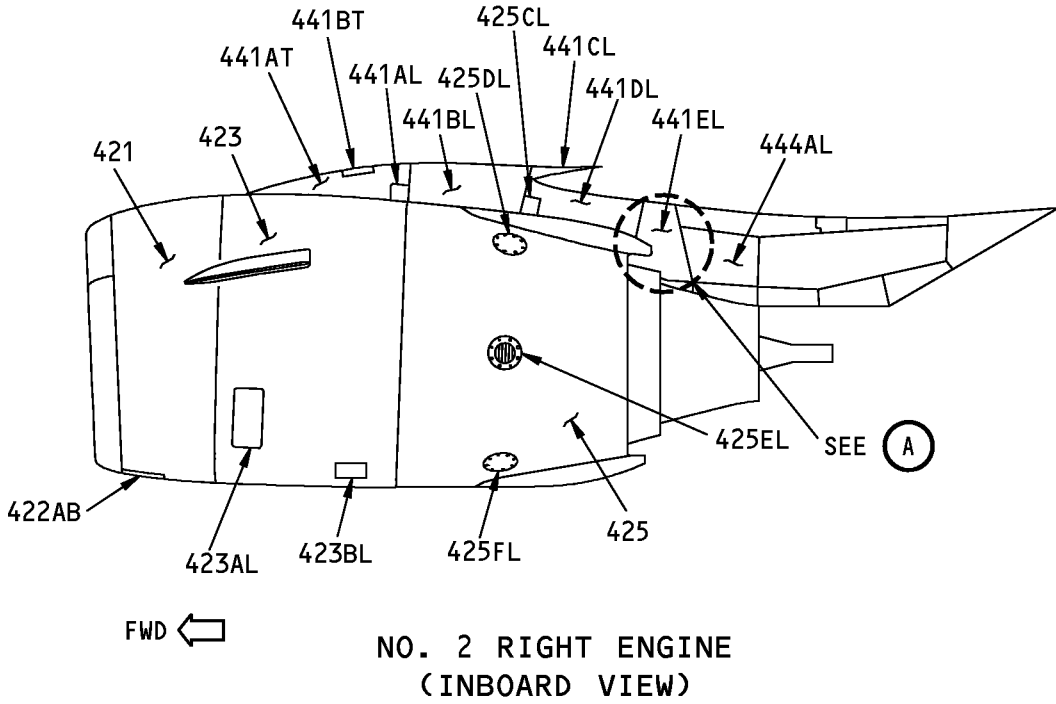

G36570 S0006558390_V5

**CFM 56-7 Series Engine and Nacelle Strut Access Doors and Panels
Figure 201 (Sheet 2 of 4)/06-43-00-990-801**

EFFECTIVITY
HAP ALL

06-43-00

Page 207
Jun 15/2009

D633A101-HAP

**737-600/700/800/900
AIRCRAFT MAINTENANCE MANUAL**

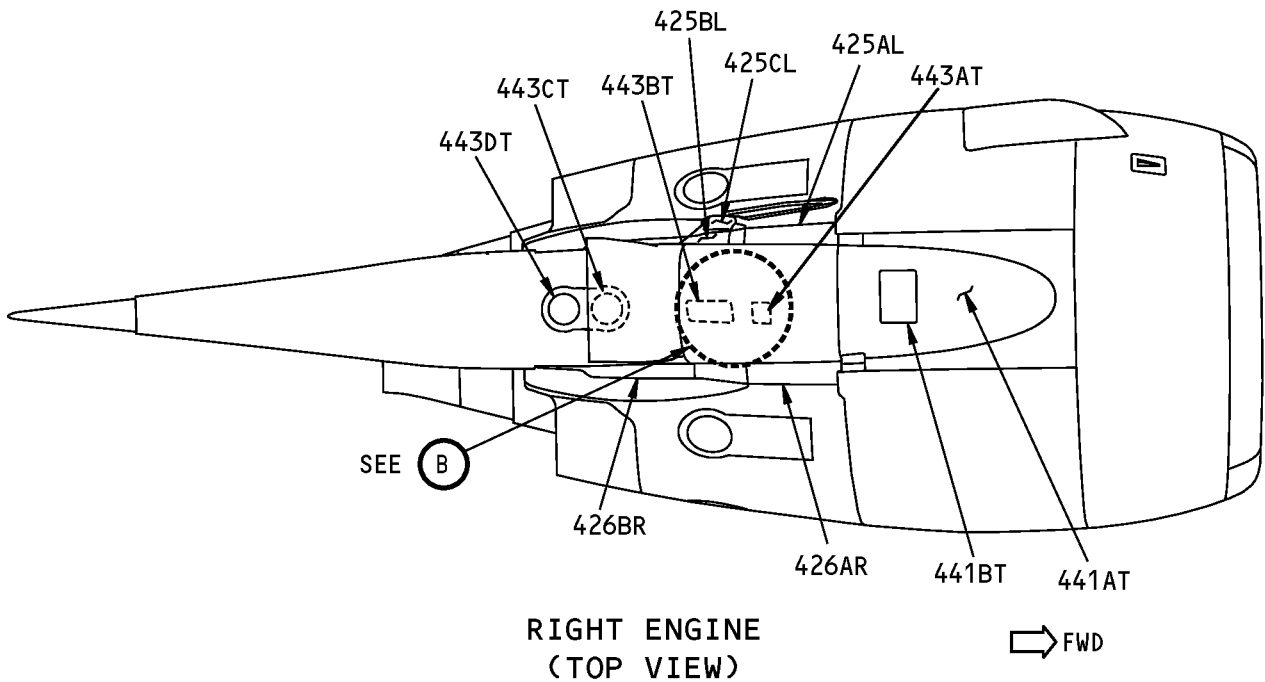
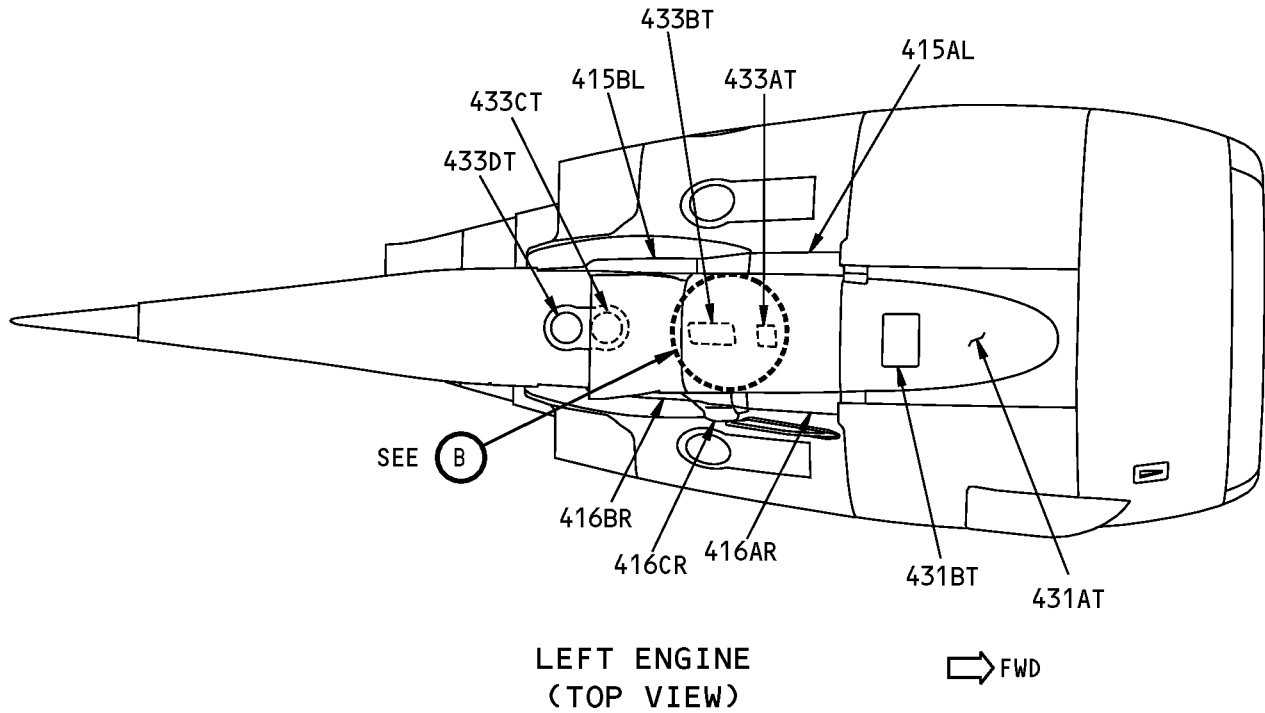

**CFM 56-7 Series Engine and Nacelle Strut Access Doors and Panels
Figure 201 (Sheet 3 of 4)/06-43-00-990-801**

EFFECTIVITY
HAP ALL

06-43-00

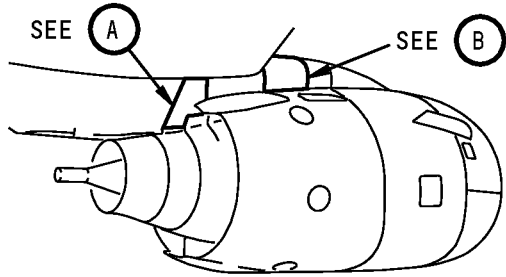

**LEFT STRUT
(RIGHT STRUT IS OPPOSITE)**

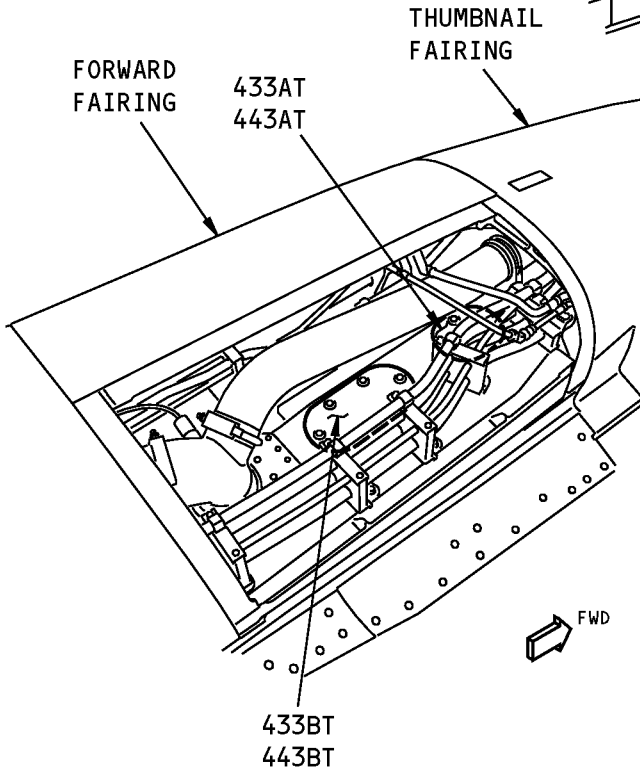
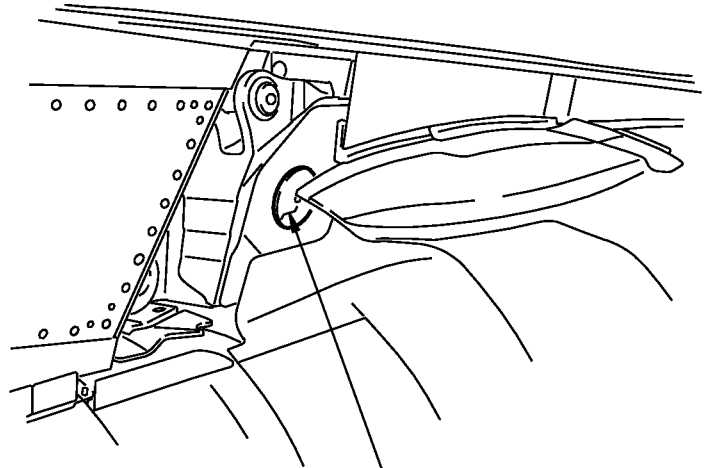

433AL
443AL
433AR
443AR

FWD

(A)

(B)

**CFM 56-7 Series Engine and Nacelle Strut Access Doors and Panels
Figure 201 (Sheet 4 of 4)/06-43-00-990-801**

EFFECTIVITY
HAP ALL

06-43-00

Page 209
Jun 10/2004

D633A101-HAP



737-600/700/800/900

AIRCRAFT MAINTENANCE MANUAL

WINGS (MAJOR ZONES 500 AND 600) ACCESS DOORS AND PANELS - MAINTENANCE PRACTICES

1. General

- A. Major zone 500 contains the left wing and major zone 600 contains the right wing. Major zones 500 and 600 include the subzones that follow. The subzones are identified with two numbers followed by a zero.
 - (1) Subzones 510 and 610 - Wing Leading Edge - Forward of Front Spar - Inboard of Nacelle Strut - Including Nacelle Gap cover Area
 - (2) Subzones 520 and 620 - Wing Leading Edge - Forward of Front Spar - Outboard of Nacelle Strut
 - (3) Subzones 530 and 630 - Wing Inspar Area (Fuel Tanks) - Inboard of Wing Rib 17
 - (4) Subzones 540 and 640 - Wing Inspar Area (Fuel Tanks) - Rib 17 to Wing Tip
 - (5) Subzones 550 and 650 - Wing Trailing Edge - Aft of Rear Spar - Inboard of Outboard Trailing Edge Flap
 - (6) Subzones 560 and 660 - Wing Trailing Edge - Aft of Rear Spar - Outboard of Flaperon
 - (7) Subzones 570 and 670 - Wing Trailing Edge Flap Fairings
- B. Each subzone is divided into zones that are identified with the first two numbers of the subzone followed by a number that is not zero.
- C. Access doors and panels in a zone are identified by the specific zone number and a two or three letter suffix. This alphanumeric label is different for each access door or panel.
 - (1) The third alphanumeric character identifies top or bottom.

TASK 06-44-00-800-801

2. Finding an Access Door or Panel on the Wings

(Figure 201, Figure 202, Figure 203, Figure 204, Figure 205, Figure 206, Figure 207, Figure 208, Figure 209, Figure 210, Figure 211, Figure 212, Figure 213)

A. Location Zones

Zone	Area
500	Left Wing
600	Right Wing

B. Procedure

SUBTASK 06-44-00-800-001

- (1) In the table below, find the number of the applicable access door or panel.

Table 201

Number	Name/Location	Provides Access To	Dimensions	Drawing
511A	Inboard Leading Edge, Skin Assembly			116A4410
511AB	Inboard Leading Edge, Lower Removable Panel			116A0011
511AT	Inboard Leading Edge, Strakelet Upper Panel			116A3311
511BT	Inboard Leading Edge, Upper Removable Access Panel			116A1210

EFFECTIVITY
HAP ALL

06-44-00

Page 201
Feb 10/2005

D633A101-HAP



737-600/700/800/900

AIRCRAFT MAINTENANCE MANUAL

(Continued)

Number	Name/Location	Provides Access To	Dimensions	Drawing
521AAB	Lower Leading Edge Access Panel - Slat Station 508.31			116A9121
521AB	Outboard Leading Edge Blowout Door - Slat Station 20.04			116A5521
521ABB	Lower Leading Edge Access Panel-Slat Station 524.31			
521AT	Outbd Leading Edge - Gap Cover Access			116A6200
521BB	Engine Fuel Valve Shutoff Access Panel - Slat Station 36.02			116A8510
521CB	Lower Leading Edge Access Panel - Slat Station 53.95			116A9110
521DB	Lower Leading Edge Access Panel - Slat Station 71.38			116A9110
521EB	Lower Leading Edge Access Panel - Slat Station 98.95			116A9121
521FB	Lower Leading Edge Access Panel - Slat Station 116.32			116A9110
521GB	Lower Leading Edge Access Panel - Slat Station 125.27			116A9121
521HB	Lower Leading Edge Access Panel - Slat Station 152.81			116A9121
521JB	Lower Leading Edge Access Panel - Slat Station 170.20			116A9110
521KB	Lower Leading Edge Access Panel - Slat Station 188.12			116A9110
521LB	Lower Leading Edge Access Panel - Slat Station 216.76			116A9121
521MB	Lower Leading Edge Access Panel - Slat Station 234.65			116A9110
521NB	Lower Leading Edge Access Panel - Slat Station 252.04			116A9121
521PB	Lower Leading Edge Access Panel - Slat Station 270.42			116A9121
521QB	Lower Leading Edge Access Panel - Slat Station 289.17			116A9110
521RB	Lower Leading Edge Access Panel - Slat Station 307.75			116A9121

EFFECTIVITY
HAP ALL

06-44-00

D633A101-HAP

Page 202
Feb 10/2005



737-600/700/800/900

AIRCRAFT MAINTENANCE MANUAL

(Continued)

Number	Name/Location	Provides Access To	Dimensions	Drawing
521SB	Lower Leading Edge Access Panel - Slat Station 337.62			116A9110
521TB	Lower Leading Edge Access Panel - Slat Station 356.14			116A9121
521UB	Lower Leading Edge Access Panel - Slat Station 374.95			116A9121
521VB	Lower Leading Edge Access Panel - Slat Station 395.64			116A9121
521WB	Lower Leading Edge Access Panel - Slat Station 415.79			116A9110
521XB	Lower Leading Edge Access Panel - Slat Station 435.91			116A9121
521YB	Lower Leading Edge Access Panel - Slat Station 467.98			116A9121
521ZB	Lower Leading Edge Access Panel - Slat Station 488.05			116A9110
522AB	Slat No. 4 - Cove Skin			114A5030
522BB	Slat No. 4 - Cove Skin			114A5030
522CB	Slat No. 4 - Cove Skin			114A5030
522DB	Slat No. 4 - Cove Skin			114A5030
522EB	Slat No. 4 - Cove Skin			114A5030
522FB	Slat No. 4 - Cove Skin			114A5030
522GB	Slat No. 4 - Cove Skin			114A5030
523AB	Slat No. 3 - Cove Skin			114A5030
523BB	Slat No. 3 - Cove Skin			114A5030
523CB	Slat No. 3 - Cove Skin			114A5030
523DB	Slat No. 3 - Cove Skin			114A5030
523EB	Slat No. 3 - Cove Skin			114A5030
523FB	Slat No. 3 - Cove Skin			114A5030
523GB	Slat No. 3 - Cove Skin			114A5030
524AB	Slat No. 2 - Cove Skin			114A5030
524BB	Slat No. 2 - Cove Skin			114A5030
524CB	Slat No. 2 - Cove Skin			114A5030
524DB	Slat No. 2 - Cove Skin			114A5030
524EB	Slat No. 2 - Cove Skin			114A5030

EFFECTIVITY
HAP ALL

06-44-00

Page 203
Jun 10/2004

D633A101-HAP



737-600/700/800/900
AIRCRAFT MAINTENANCE MANUAL

(Continued)

Number	Name/Location	Provides Access To	Dimensions	Drawing
524FB	Slat No. 2 - Cove Skin			114A5030
524GB	Slat No. 2 - Cove Skin			114A5030
525AB	Slat No. 1 - Cove Skin			114A5030
525BB	Slat No. 1 - Cove Skin			114A5030
525CB	Slat No. 1 - Cove Skin			114A5030
525DB	Slat No. 1 - Cove Skin			114A5030
525EB	Slat No. 1 - Cove Skin			114A5030
525FB	Slat No. 1 - Cove Skin			114A5030
525GB	Slat No. 1 - Cove Skin			114A5030
525HB	Slat No. 1 - Cove Skin			114A5030
526AB	Wing Tip Access Door, Light/Strobe			119A1412
526BB	Wing Tip Access Door, Forward Tip			119A1412
526CB	Wing Tip Access Door, Aft Tip			119A1411
527AB	Winglet Access Panel			119A0105
531AB	Center Tank Access Door - Wing Station 168			110A0113
531BB	Center Tank Access Door - Wing Station 192			110A0113
532AB	Main Tank Access Door - Wing Station 216			110A0113
532AZ	Main Tank Inner Access at Rib 6			342A4111
532BB	Main Tank Access Door - Wing Station 265			110A0113
532BZ	Main Tank Inner Access at Rib 6			342A4111
532CB	Main Tank Access Door - Wing Station 290			110A0113
532DB	Main Tank Access Door - Wing Station 313			110A0113
532EB	Main Tank Access Door - Wing Station 337			110A0113
532FB	Main Tank Access Door - Wing Station 367			110A0113
532GB	Main Tank Access Door - Wing Station 390			110A0113

EFFECTIVITY
HAP ALL

06-44-00

D633A101-HAP

Page 204
Jun 10/2004



737-600/700/800/900

AIRCRAFT MAINTENANCE MANUAL

(Continued)

Number	Name/Location	Provides Access To	Dimensions	Drawing
532HB	Main Tank Access Door - Wing Station 417			110A0113
532JB	Main Tank Access Door - Wing Station 443			110A0113
532KB	Main Tank Access Door - Wing Station 470			110A0113
532LB	Main Tank Access Door - Wing Station 496			110A0113
532MB	Main Tank Access Door - Wing Station 523			110A0113
532NB	Main Tank Access Door - Wing Station 549			110A0113
532PB	Main Tank Access Door - Wing Station 576			110A0113
532QB	Main Tank Access Door - Wing Station 602			110A0113
532RB	Main Tank Access Door - Wing Station 629			110A0113
533AB	Surge Tank Access Door - Wing Station 655			110A0113
533BB	Surge Tank Access Door - Wing Station 679			110A0113
533CB	Surge Tank Access Door - Wing Station 703			110A0113
534AB	Main Tank Access Door - Wing Station 727			110A0113
534BB	Main Tank Access Door - Wing Station 748			110A0113
542AB	Flap Support No. 3, Forward Assembly Access Panel			113A9300
542BB	Flap Support No. 3, Aft Assembly Access Panel			113A9300
542CL	Flap Support No. 3, Access Cover			113A9300
542CR	Flap Support No. 3, Access Cover			113A9300
542EB	Flap Support No. 3, Tailcone Access Panel			113A9300

EFFECTIVITY
HAP ALL

06-44-00

Page 205
Jun 10/2004

D633A101-HAP



737-600/700/800/900

AIRCRAFT MAINTENANCE MANUAL

(Continued)

Number	Name/Location	Provides Access To	Dimensions	Drawing
543AB	Flap Support No. 2 Access Panel, Forward Assembly			113A9300
543BB	Flap Support No. 2 Access Panel, Aft Assembly			113A9300
543CL	Flap Support No. 2 Access Cover			113A9300
543CR	Flap Support No. 2 Access Cover			113A9300
543DR	Flap Support No. 2 Access Door			113A9300
543EB	Flap Support No. 2 Access Panel, Tailcone			113A9300
544AB	Flap Support No. 1 Access Panel, Forward Assembly			113A9300
544BB	Flap Support No. 1 Access Panel, Aft Assembly			113A9300
544CL	Flap Support No. 1 Access Cover			113A9300
544CR	Flap Support No. 1 Access Cover			113A9300
544DR	Flap Support No. 1 Access Door			113A9300
544EB	Flap Support No. 1 Access Panel, Tailcone			113A9300
551AB	Lower Inboard Fixed Trailing Edge Access Panel			115A2711
551AT	Upper Inboard Fixed Trailing Edge Access Panel			115A2520
551BB	Lower Inboard Fixed Trailing Edge, Gear Adjustment Door	Panel 551BB		115A2711
551BT	Upper Inboard Fixed Trailing Edge, MLG Actuator Access Panel			115A2521
551CB	Lower Inboard Fixed Trailing Edge, Gear Access Panel			115A2715
551CT	Upper Inboard Fixed Trailing Edge, Structural Pin Access Panel			115A2724
551DB	Lower Inboard Fixed Trailing Edge, Lube Actuator & MLG Beam Outboard Attach Pin Access Panel			115A2712
551DT	Upper Inboard Fixed Trailing Edge, Structural MLG Beam Access Panel			115A2516

EFFECTIVITY
HAP ALL

06-44-00

Page 206
Jun 10/2004

D633A101-HAP



737-600/700/800/900

AIRCRAFT MAINTENANCE MANUAL

(Continued)

Number	Name/Location	Provides Access To	Dimensions	Drawing
551EB	Lower Inboard Fixed Trailing Edge, MLG Attach Fitting Access Panel			115A2713
551ET	Upper Inboard Fixed Trailing Edge, Structural MLG Beam Access Panel			115A2510
551FB	Lower Inboard Fixed Trailing Edge, Landing Gear Access Panel			115A2710
551GB	Lower inboard fixed trailing edge			115A2714
553AT	Inboard Flap - L.E. Skin			113A2149
553BB	Inboard Flap - Lower Skin			113A2146
553CT	Inboard Flap - L.E. Skin			113A2149
553DT	Inboard Flap - Upper Skin			113A2144
553ET	Inboard Flap - Upper Skin			113A2143
561AB	Midspan Fixed Trailing Edge Access Panel - WBL 224			115A3722
561BB	Midspan Ficed Trailing Edge Access Panel - WBL 305			115A3711
561CB	Midspan Ficed Trailing Edge Access Panel Door - WBL 388			115A3711
567AT	Outboard Flap - L.E. Skin			113A3432
567BT	Flap, Forward Carriage Bearing And Fitting			113A3432
567CT	Outboard Flap - L.E. Skin			113A3432
567DT	Outboard Flap - L.E. Skin			113A3432
567ET	Flap, Forward Carriage Bearing And Fitting			113A3432
567FT	Outboard Flap - L.E. Skin			113A3432
567GT	Outboard Flap - Upper Skin			113A3411
567HT	Outboard Flap - Upper Skin			113A3411
571AB	Lower Outboard Fixed Trailing Edge Access Panel at Deflector Rib			115A4724
571AT	Upper Outboard Fixed Trailing Edge, Quadrant Bolt Access Panel			115A4523

EFFECTIVITY
HAP ALL

06-44-00

Page 207
Jun 10/2005

D633A101-HAP



737-600/700/800/900

AIRCRAFT MAINTENANCE MANUAL

(Continued)

Number	Name/Location	Provides Access To	Dimensions	Drawing
571BB	Lower Outboard Fixed Trailing Edge Access Panel			115A4722
571BT	Upper Outboard Fixed Trailing Edge, Pulley Bolt Access Panel			115A4523
571CB	Lower Outboard Fixed Trailing Edge Access Panel			115A4721
571DB	Lower Outboard Fixed Trailing Edge Access Panel			115A4720
571EB	Lower Outboard Fixed Trailing Edge Wedge Access Panel			115A4922
571FB	Lower Outboard Fixed Trailing Edge Wedge Access Panel			115A4921
572AB	Lower Aileron, Hinge Cover - WBL 423.00			113A7100
572BB	Lower Aileron, Actuator Rod Fairing - WBL 472.00			113A7100
572CB	Lower Aileron, Hinge Cover - WBL 447.00			113A7100
572CT	Upper Aileron, Hinge Cover - WBL 447.00			113A7100
572DB	Lower Aileron, Hinge Cover - WBL 469.00			113A7100
572DT	Upper Aileron, Hinge Cover - WBL 474.00			113A7100
572EB	Lower Aileron, Hinge Cover - WBL 481.00			113A7100
572FB	Lower Aileron, Hinge Cover - WBL 502.00			113A7100
572FT	Upper Aileron, Hinge Cover - WBL 502.00			113A7100
572GB	Lower Aileron, Hinge Cover - WBL 528.00			113A7100
572GT	Upper Aileron, Hinge Cover - WBL 528.00			113A7100
572HB	Lower Aileron, Hinge Cover - WBL 553.00			113A7100

SUBTASK 06-44-00-800-002

(2) In the table below, find the number of the applicable access door or panel.

EFFECTIVITY
HAP ALL

D633A101-HAP

06-44-00

Page 208
Jun 10/2005



737-600/700/800/900

AIRCRAFT MAINTENANCE MANUAL

Table 202

Number	Name/Location	Provides Access To	Dimensions	Drawing
611A	Inboard Leading Edge - Skin Assembly			116A4410
611AB	Inboard Leading Edge, Lower Removable Access Panel			116A0011
611AT	Inboard Leading Edge, Strakelet Upper Access Panel			116A3311
611BT	Inboard Leading Edge, Upper Removable Access Panel			116A1210
621AAB	Lower Leading Edge Access Panel - Slat Station 524.31			116A6100
621AB	Outboard Leading Edge Blowout Door - Slat Station 20.04			116A5500
621AT	Outbd Leading Edge - Gap Cover Access			116A1210
621BB	Engine Fuel Spar Valve Access Panel - Slat Station 36.02			116A8500
621CB	Lower Leading Edge Access Panel - Slat Station 53.95			116A9110
621DB	Lower Leading Edge Access Panel - Slat Station 71.38			116A9110
621EB	Defuel Access Panel - Slat Station 95.15			116A8510
621FB	Lower Leading Edge Access Panel - Slat Station 112.52			116A9110
621GB	Refuel Access Panel - Slat Station 143.27			116A8500
621HB	Lower Leading Edge Access Panel - Slat Station 170.21			116A9110
621JB	Lower Leading Edge Access Panel - Slat Station 188.14			116A9110
621KB	Lower Leading Edge Access Panel - Slat Station 216.71			116A9121
621LB	Lower Leading Edge Access Panel - Slat Station 234.59			116A9110
621MB	Lower Leading Edge Access Panel - Slat Station 252.04			116A9121
621NB	Lower Leading Edge Access Panel - Slat Station 270.63			116A9121
621PB	Lower Leading Edge Access Panel - Slat Station 289.18			116A9110

EFFECTIVITY
HAP ALL

06-44-00

Page 209
Jun 10/2007

D633A101-HAP



737-600/700/800/900

AIRCRAFT MAINTENANCE MANUAL

(Continued)

Number	Name/Location	Provides Access To	Dimensions	Drawing
621QB	Lower Leading Edge Access Panel - Slat Station 307.75			116A9110
621RB	Lower Leading Edge Access Panel - Slat Station 337.62			116A9121
621SB	Lower Leading Edge Access Panel - Slat Station 356.15			116A9110
621TB	Lower Leading Edge Access Panel - Slat Station 374.95			116A9121
621UB	Lower Leading Edge Access Panel - Slat Station 395.64			116A9121
621VB	Lower Leading Edge Access Panel - Slat Station 415.79			116A9110
621WB	Lower Leading Edge Access Panel - Slat Station 435.91			116A9121
621XB	Lower Leading Edge Access Panel - Slat Station 467.98			116A9121
621YB	Lower Leading Edge Access Panel - Slat Station 488.04			116A9110
621ZB	Lower Leading Edge Access Panel - Slat Station 508.31			116A9121
622AB	Slat No. 5 - Cove Skin			114A5030
622BB	Slat No. 5 - Cove Skin			114A5030
622CB	Slat No. 5 - Cove Skin			114A5030
622DB	Slat No. 5 - Cove Skin			114A5030
622EB	Slat No. 5 - Cove Skin			114A5030
622FB	Slat No. 5 - Cove Skin			114A5030
622GB	Slat No. 5 - Cove Skin			114A5030
623AB	Slat No. 6 - Cove Skin			114A5030
623BB	Slat No. 6 - Cove Skin			114A5030
623CB	Slat No. 6 - Cove Skin			114A5030
623DB	Slat No. 6 - Cove Skin			114A5030
623EB	Slat No. 6 - Cove Skin			114A5030
623FB	Slat No. 6 - Cove Skin			114A5030
623GB	Slat No. 6 - Cove Skin			114A5030
624AB	Slat No. 7 - Cove Skin			114A5030
624BB	Slat No. 7 - Cove Skin			114A5030

EFFECTIVITY
HAP ALL

06-44-00

Page 210
Oct 10/2004

D633A101-HAP



737-600/700/800/900

AIRCRAFT MAINTENANCE MANUAL

(Continued)

Number	Name/Location	Provides Access To	Dimensions	Drawing
624CB	Slat No. 7 - Cove Skin			114A5030
624DB	Slat No. 7 - Cove Skin			114A5030
624EB	Slat No. 7 - Cove Skin			114A5030
624FB	Slat No. 7 - Cove Skin			114A5030
624GB	Slat No. 7 - Cove Skin			114A5030
625AB	Slat No. 8 - Cove Skin			114A5030
625BB	Slat No. 8 - Cove Skin			114A5030
625CB	Slat No. 8 - Cove Skin			114A5030
625DB	Slat No. 8 - Cove Skin			114A5030
625EB	Slat No. 8 - Cove Skin			114A5030
625FB	Slat No. 8 - Cove Skin			114A5030
625GB	Slat No. 8 - Cove Skin			114A5030
625HB	Slat No. 8 - Cove Skin			114A5030
626AB	Wing Tip Access Door, Light/Strobe			119A1412
626BB	Wing Tip Access Door, Forward Tip			119A1412
626CB	Wing Tip Access Door, Aft Tip			119A1411
627AB	Winglet Access Panel			119A0105
631AB	Center Tank Access Door - Wing Station 168			110A0113
631BB	Center Tank Access Door - Wing Station 192			110A0113
632AB	Main Tank Access Door - Wing Station 216			110A0113
632AZ	Main Tank Inner Access at Rib 6			342A4111
632BB	Main Tank Access Door - Wing Station 265			110A0113
632BZ	Main Tank Inner Access at Rib 6			342A4111
632CB	Main Tank Access Door - Wing Station 290			110A0113
632DB	Main Tank Access Door - Wing Station 313			110A0113
632EB	Main Tank Access Door - Wing Station 337			110A0113

EFFECTIVITY
HAP ALL

06-44-00

Page 211
Oct 10/2004

D633A101-HAP



737-600/700/800/900
AIRCRAFT MAINTENANCE MANUAL

(Continued)

Number	Name/Location	Provides Access To	Dimensions	Drawing
632FB	Main Tank Access Door - Wing Station 367			110A0113
632GB	Main Tank Access Door - Wing Station 390			110A0113
632HB	Main Tank Access Door - Wing Station 417			110A0113
632JB	Main Tank Access Door - Wing Station 443			110A0113
632KB	Main Tank Access Door - Wing Station 470			110A0113
632LB	Main Tank Access Door - Wing Station 496			110A0113
632MB	Main Tank Access Door - Wing Station 523			110A0113
632NB	Main Tank Access Door - Wing Station 549			110A0113
632PB	Main Tank Access Door - Wing Station 576			110A0113
632QB	Main Tank Access Door - Wing Station 602			110A0113
632RB	Main Tank Access Door - Wing Station 629			110A0113
633AB	Surge Tank Access Door - Wing Station 655			110A0113
633BB	Surge Tank Access Door - Wing Station 679			110A0113
633CB	Surge Tank Access Door - Wing Station 703			110A0113
634AB	Main Tank Access Door - Wing Station 727			110A0113
634BB	Main Tank Access Door - Wing Station 748			110A0113
642AB	Flap Support No. 6, Forward Assembly Access Panel			113A9300
642BB	Flap Support No. 6, Aft Assembly Access Panel			113A9300
642CL	Flap Support No. 6, Access Cover			113A9300

EFFECTIVITY
HAP ALL

D633A101-HAP

06-44-00

Page 212
Oct 10/2004



737-600/700/800/900

AIRCRAFT MAINTENANCE MANUAL

(Continued)

Number	Name/Location	Provides Access To	Dimensions	Drawing
642CR	Flap Support No. 6, Access Cover			113A9300
642EB	Flap Support No. 6, Tailcone Access Panel			113A9300
643AB	Flap Support No. 7, Forward Assembly Access Panel			113A9300
643BB	Flap Support No. 7, Aft Assembly Access Panel			113A9300
643CL	Flap Support No. 7, Access Cover			113A9300
643CR	Flap Support No. 7, Access Cover			113A9300
643DL	Flap Support No. 7, Access Door			113A9300
643EB	Flap Support No. 7, Tailcone Access Panel			113A9300
644AB	Flap Support No. 8, Forward Assembly Access Panel			113A9300
644BB	Flap Support No. 8, Aft Assembly Access Panel			113A9300
644CL	Flap Support No. 8, Access Cover			113A9300
644CR	Flap Support No. 8, Access Cover			113A9300
644DL	Flap Support No. 8, Access Door			113A9300
644EB	Flap Support No. 8, Tailcone Access Panel			113A9300
651AB	Lower Inboard Fixed Trailing Edge Access Panel	Panel 651BB		115A2711
651AT	Upper Inboard Fixed Trailing Edge Access Panel			115A2520
651BB	Lower Inboard Fixed Trailing Edge, Gear Door Adjustment			115A2711
651BT	Upper Inboard Fixed Trailing Edge, MLG Actuator Access Panel			115A2521
651CB	Lower Inboard Fixed Trailing Edge, Gear Access Panel			115A2715

EFFECTIVITY
HAP ALL

06-44-00

Page 213
Oct 10/2004

D633A101-HAP



737-600/700/800/900

AIRCRAFT MAINTENANCE MANUAL

(Continued)

Number	Name/Location	Provides Access To	Dimensions	Drawing
651CT	Upper Inboard Fixed Trailing Edge, Structural Pin Access Panel			115A2724
651DB	Lower Inboard Fixed Trailing Edge, Lube Actuator & MLG Beam Outboard Attach Pin Access Panel			115A2712
651DT	Upper Inboard Fixed Trailing Edge, MLG Beam Access Panel			115A2516
651EB	Lower Inboard Fixed Trailing Edge, MLG Attach Fitting Access Panel			115A2713
651ET	Upper Inboard Fixed Trailing Edge, MLG Beam Access Panel			115A2510
651FB	Lower Inboard Fixed Trailing Edge, Landing Gear Access Panel			115A2710
651GB	Lower inboard fixed trailing edge			
653AT	Inboard Flap - L.E. Skin			113A2149
653BB	Inboard Flap - Lower Skin			113A2146
653CT	Inboard Flap - L.E. Skin			113A2149
653DT	Inboard Flap - Upper Skin			113A2144
653ET	Inboard Flap - Upper Skin			113A2143
661AB	Midspan Fixed T.E. Panel			115A3722
661BB	Midspan Fixed T.E. Panel			115A3711
661CB	Midspan Fixed T.E. Panel			115A3711
667AT	Outboard Flap - L.E. Skin			113A3432
667BT	Flap, Forward Carriage Bearing And Fitting			113A3432
667CT	Outboard Flap - L.E. Skin			113A3432
667DT	Outboard Flap - L.E. Skin			113A3432
667ET	Flap, Forward Carriage Bearing And Fitting			113A3432
667FT	Outboard Flap - L.E. Skin			113A3432
667GT	Outboard Flap - Upper Skin			113A3411
667HT	Outboard Flap - Upper Skin			113A3411

EFFECTIVITY
HAP ALL

06-44-00

Page 214
Jun 10/2005

D633A101-HAP



737-600/700/800/900

AIRCRAFT MAINTENANCE MANUAL

(Continued)

Number	Name/Location	Provides Access To	Dimensions	Drawing
671AB	Lower Outboard Fixed Trailing Edge Access Panel			115A4724
671AT	Upper Outboard Fixed Trailing Edge, Quadrant Bolt Access Panel			115A9523
671BB	Lower Outboard Fixed Trailing Edge Access Panel			115A4722
671BT	Upper Outboard Fixed Trailing Edge, Pulley Bolt Access Panel			115A4523
671CB	Lower Outboard Fixed Trailing Edge Access Panel			115A4721
671DB	Lower Outboard Fixed Trailing Edge Access Panel			115A4720
671EB	Lower Outboard Fixed Trailing Edge, Wedge Access Panel			115A4922
671FB	Lower Outboard Fixed Trailing Edge, Wedge Access Panel			115A4921
672AB	Lower Aileron, Hinge Cover - WBL 423.00			113A7100
672BB	Lower Aileron, Actuator Rod Fairing - WBL 472.00			113A7100
672CB	Lower Aileron, Hinge Cover - WBL 447.00			113A7100
672CT	Lower Aileron, Hinge Cover - WBL 447.00			113A7100
672DB	Lower Aileron, Hinge Cover - WBL 469.00			113A7100
672DT	Lower Aileron, Hinge Cover - WBL 474.00			113A7100
672EB	Lower Aileron, Hinge Cover - WBL 481.00			113A7100
672FB	Lower Aileron, Hinge Cover - WBL 502.00			113A7100
672FT	Lower Aileron, Hinge Cover - WBL 502.00			113A7100
672GB	Lower Aileron, Hinge Cover - WBL 528.00			113A7100
672GT	Lower Aileron, Hinge Cover - WBL 528.00			113A7100

EFFECTIVITY
HAP ALL

06-44-00

Page 215
Jun 10/2005

D633A101-HAP



**737-600/700/800/900
AIRCRAFT MAINTENANCE MANUAL**

(Continued)

Number	Name/Location	Provides Access To	Dimensions	Drawing
672HB	Lower Aileron, Hinge Cover - WBL 553.00			113A7100

————— **END OF TASK** —————

EFFECTIVITY
HAP ALL

D633A101-HAP

06-44-00

Page 216
Jun 10/2005

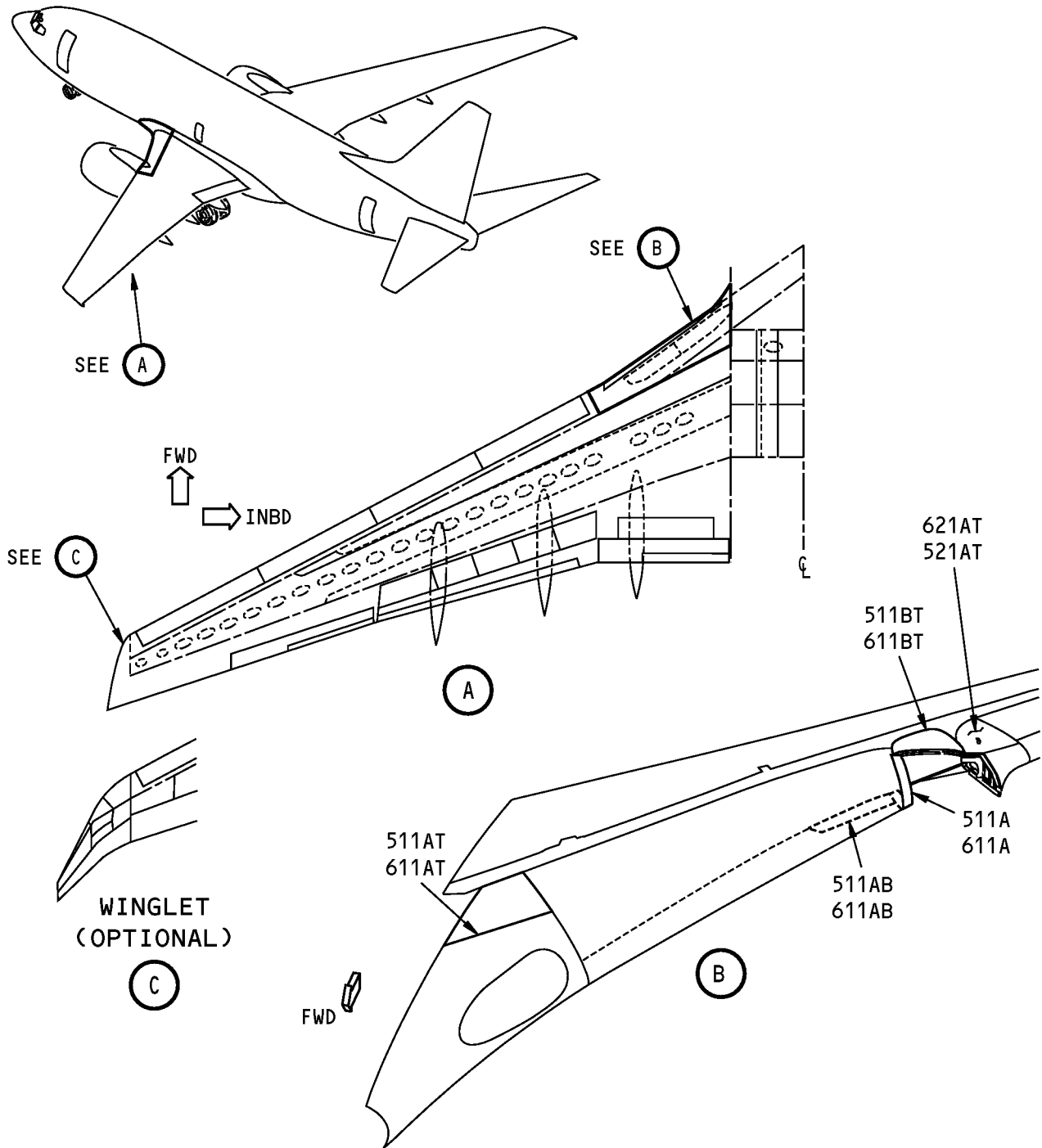

NOTE: MAJOR ZONE 500 - LEFT WING.
 MAJOR ZONE 600 - RIGHT WING.
 LEFT WING IS SHOWN, RIGHT WING IS OPPOSITE.

Subzones 511 and 611 - Leading Edge Inboard of Nacelle Strut
Figure 201/06-44-00-990-801

EFFECTIVITY
 HAP ALL

06-44-00

Page 217
 Oct 10/2004

D633A101-HAP

**737-600/700/800/900
AIRCRAFT MAINTENANCE MANUAL**

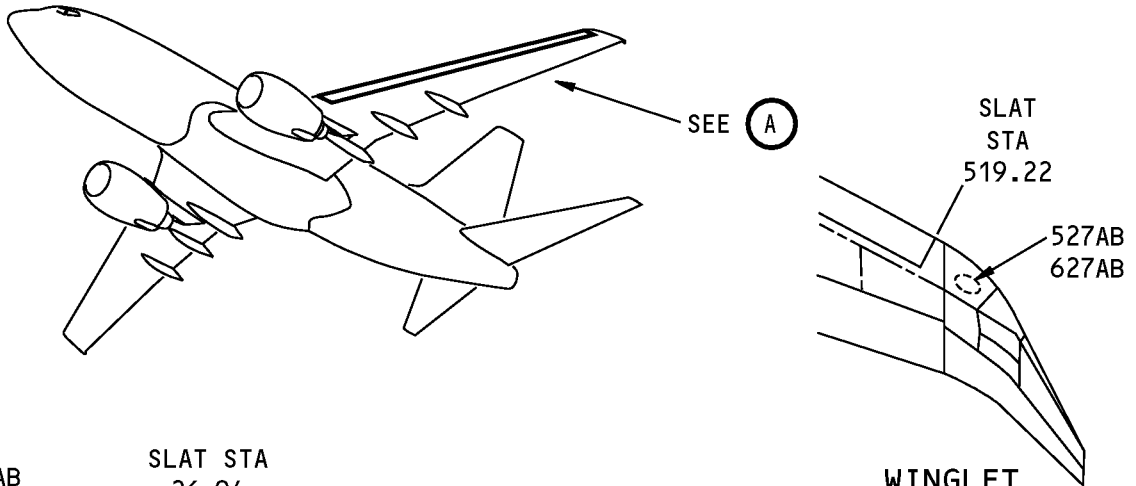

**WINGLET
(OPTIONAL)**

(B)

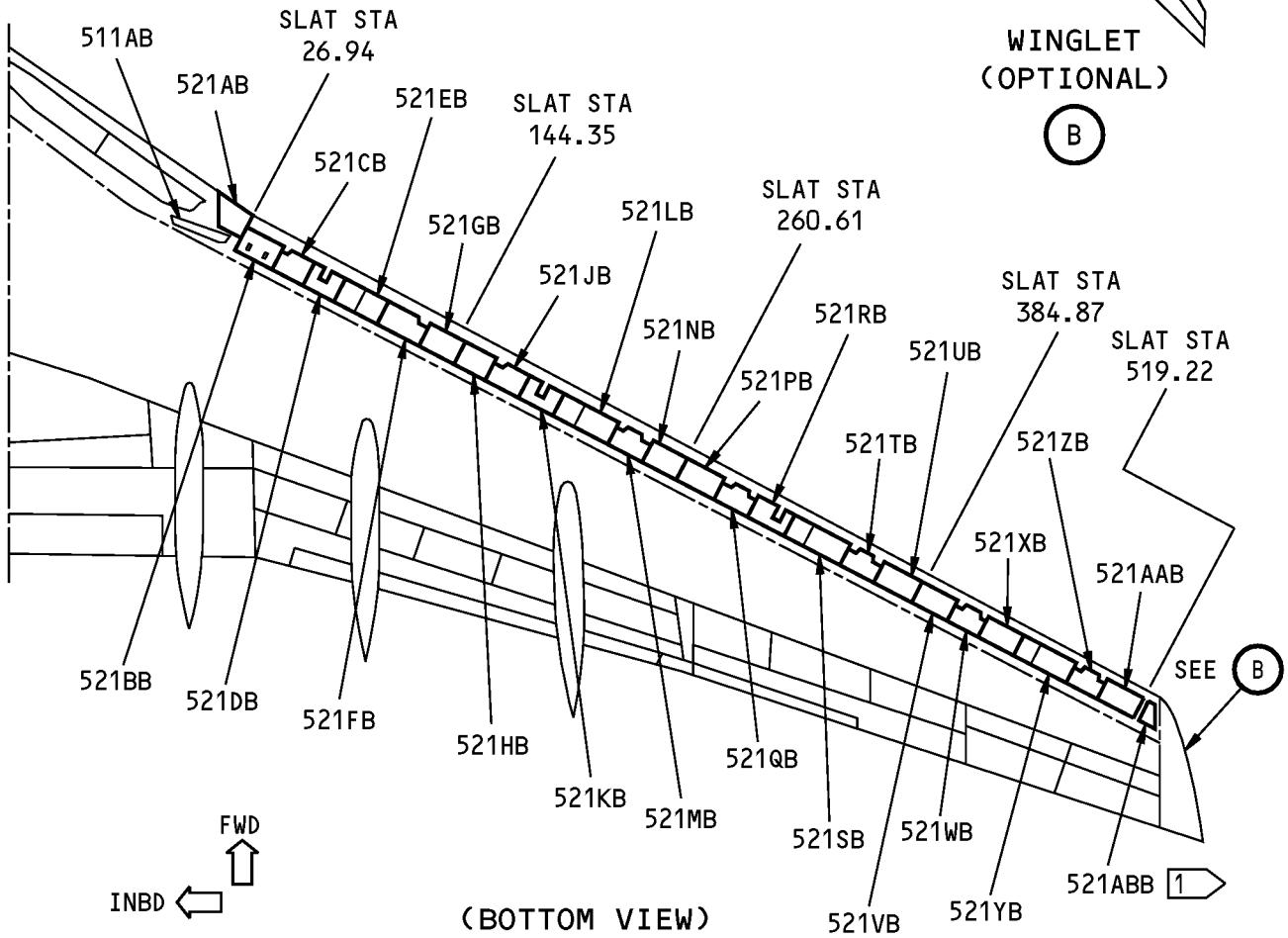

(BOTTOM VIEW)

(A)

NOTE: MAJOR ZONE 500 - LEFT WING.
MAJOR ZONE 600 - RIGHT WING.

1 NOT ON ALL AIRPLANES

**Subzones 521 and 621 - Leading Edge Outboard of Nacelle Strut
Figure 202 (Sheet 1 of 2)/06-44-00-990-802**

EFFECTIVITY
HAP ALL

06-44-00

Page 218
Oct 10/2004

D633A101-HAP

**737-600/700/800/900
AIRCRAFT MAINTENANCE MANUAL**

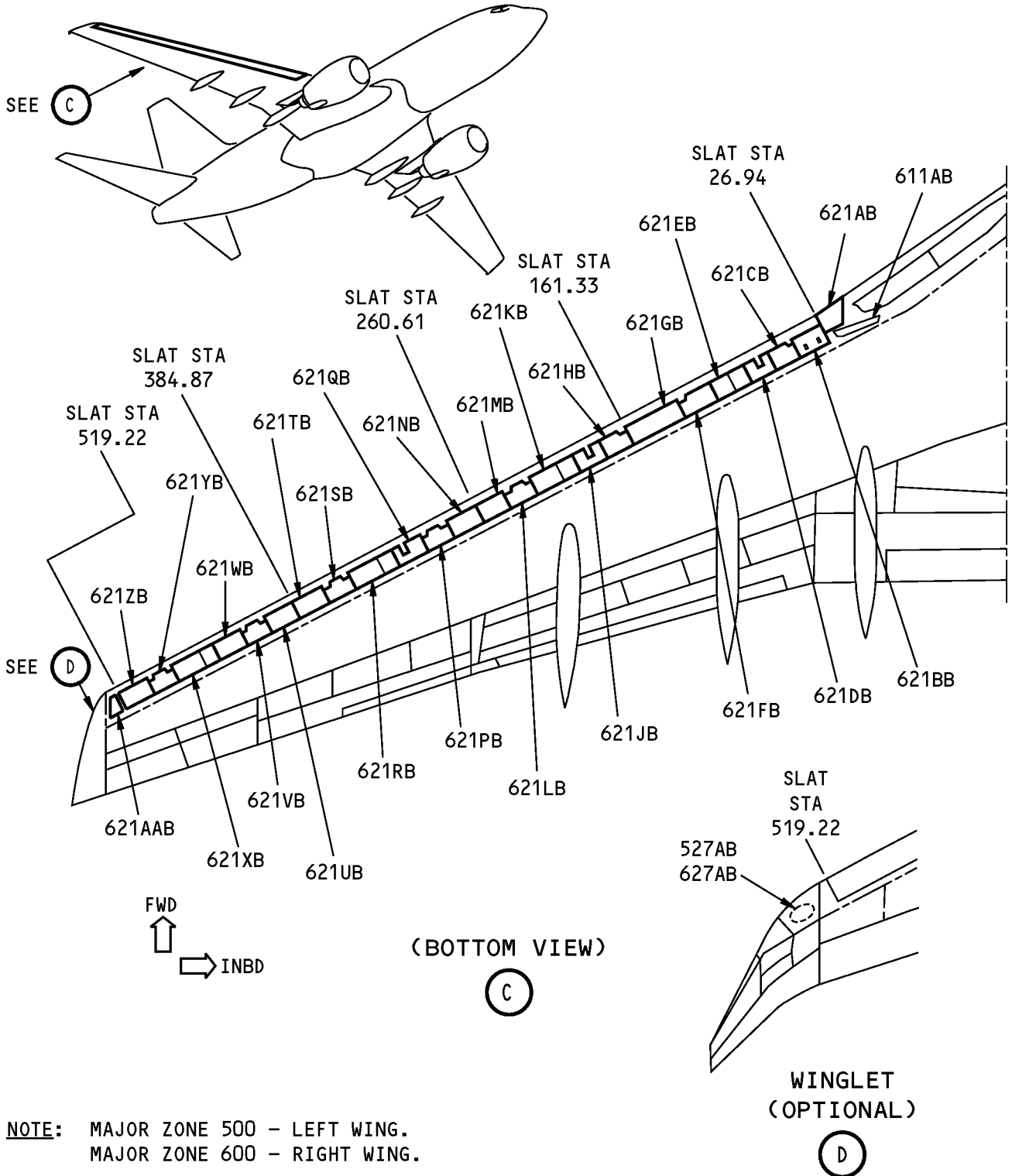

NOTE: MAJOR ZONE 500 - LEFT WING.
MAJOR ZONE 600 - RIGHT WING.

**Subzones 521 and 621 - Leading Edge Outboard of Nacelle Strut
Figure 202 (Sheet 2 of 2)/06-44-00-990-802**

EFFECTIVITY
HAP ALL

06-44-00

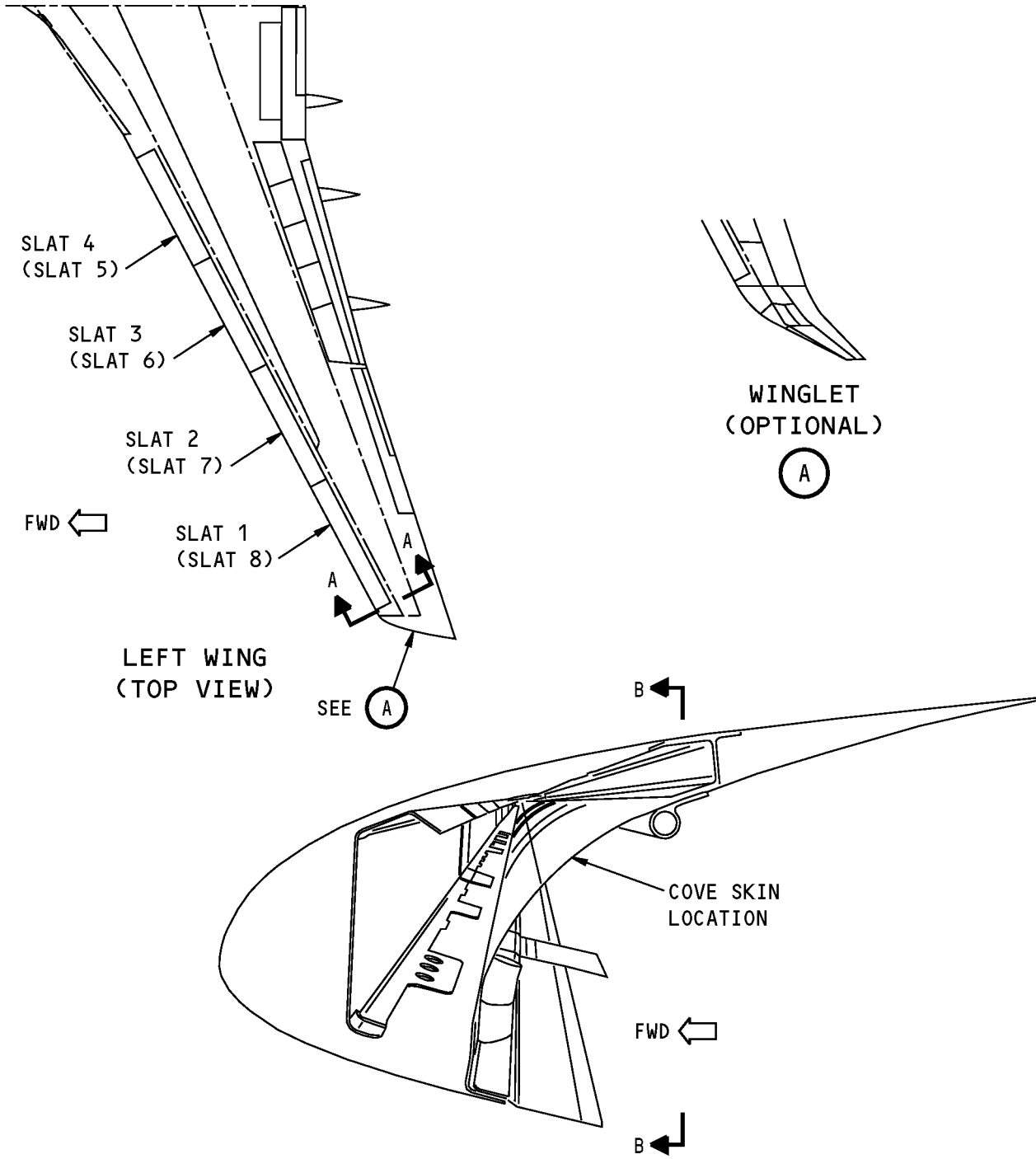

NOTE: MAJOR ZONE 500 - LEFT WING.
MAJOR ZONE 600 - RIGHT WING.
LEFT WING IS SHOWN, RIGHT WING IS OPPOSITE.

A-A

**Subzones 522-525 and 622-625 - Cove Skins
Figure 203 (Sheet 1 of 2)/06-44-00-990-803**

EFFECTIVITY
HAP ALL

06-44-00

Page 220
Oct 10/2004

D633A101-HAP

**737-600/700/800/900
AIRCRAFT MAINTENANCE MANUAL**

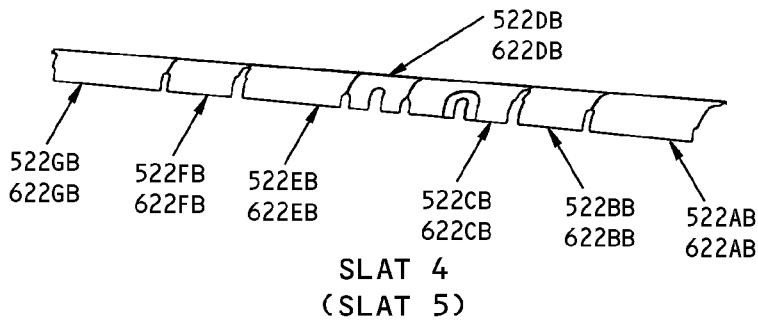
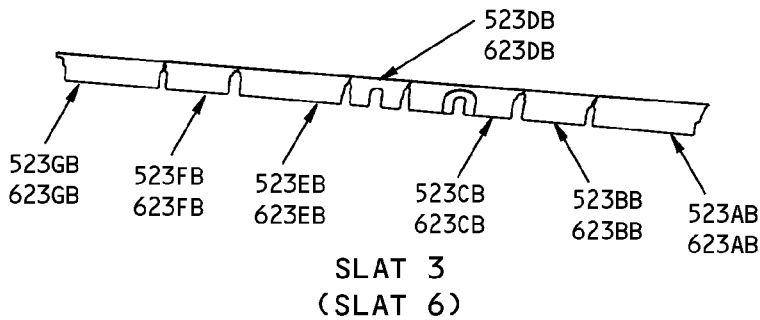
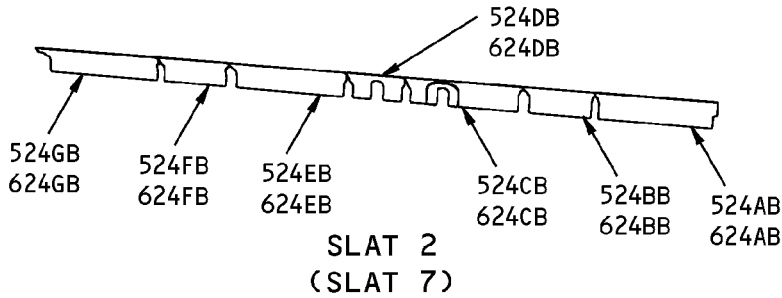
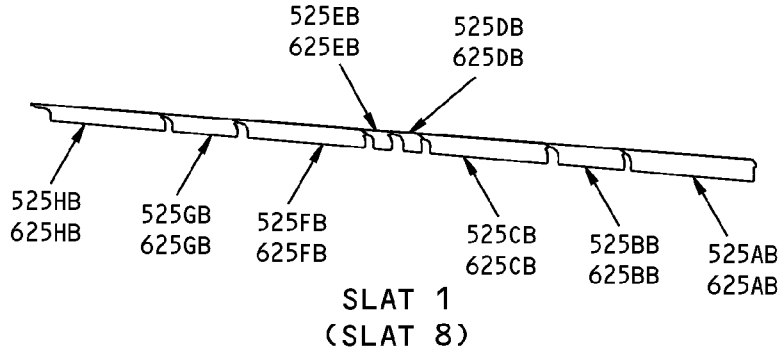

**(VIEW IN THE FORWARD DIRECTION)
B-B**

NOTE: MAJOR ZONE 500 - LEFT WING.
MAJOR ZONE 600 - RIGHT WING.
LEFT WING SHOWN, RIGHT WING OPPOSITE.

**Subzones 522-525 and 622-625 - Cove Skins
Figure 203 (Sheet 2 of 2)/06-44-00-990-803**

EFFECTIVITY
HAP ALL

D633A101-HAP

06-44-00

**737-600/700/800/900
AIRCRAFT MAINTENANCE MANUAL**

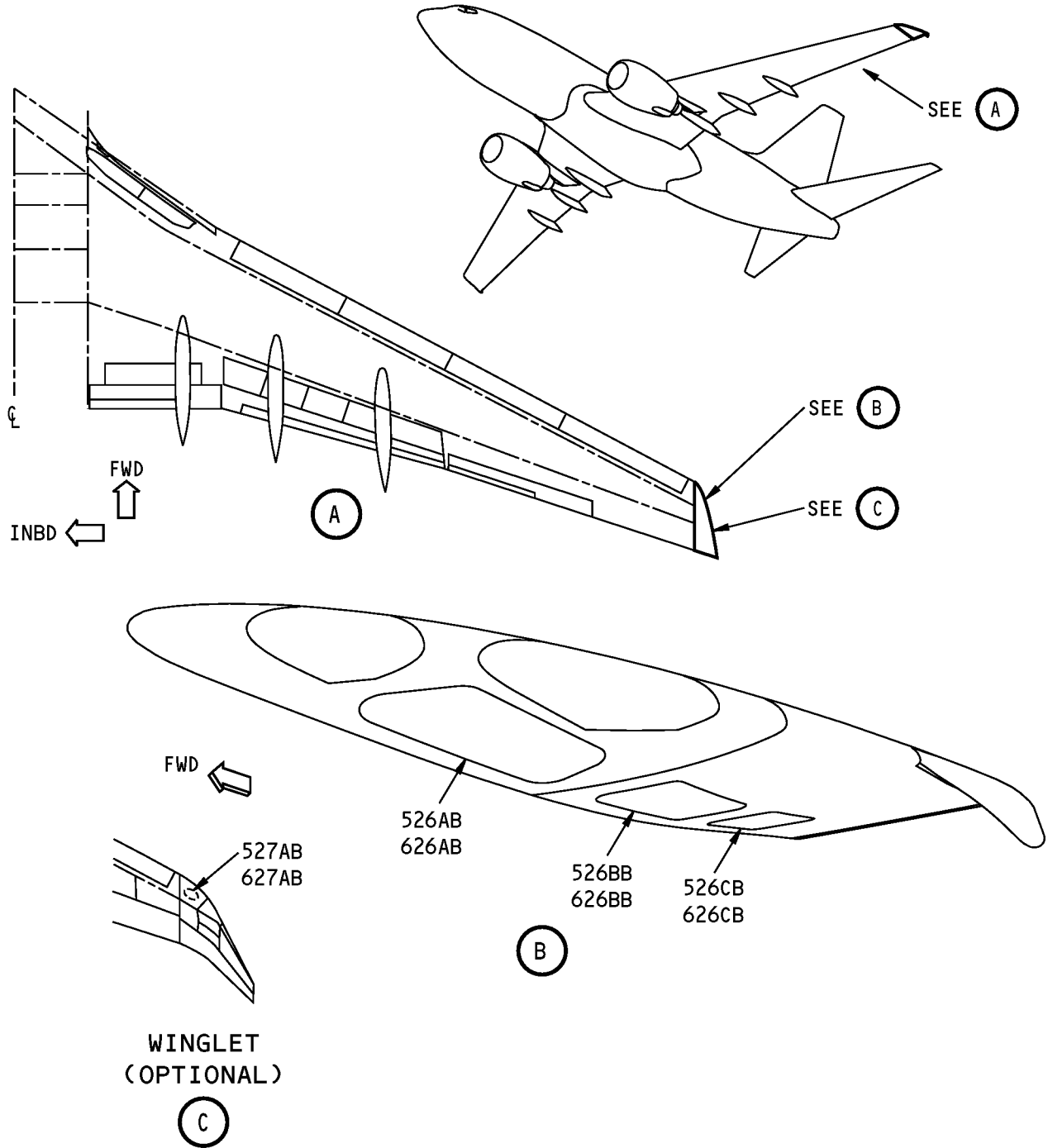

NOTE: MAJOR ZONE 500 - LEFT WING.
 MAJOR ZONE 600 - RIGHT WING.
 LEFT WING IS SHOWN, RIGHT WING IS OPPOSITE.

**Subzones 526 and 626 - Wing Tip
 Figure 204/06-44-00-990-804**

EFFECTIVITY
 HAP ALL

D633A101-HAP

06-44-00

**737-600/700/800/900
AIRCRAFT MAINTENANCE MANUAL**

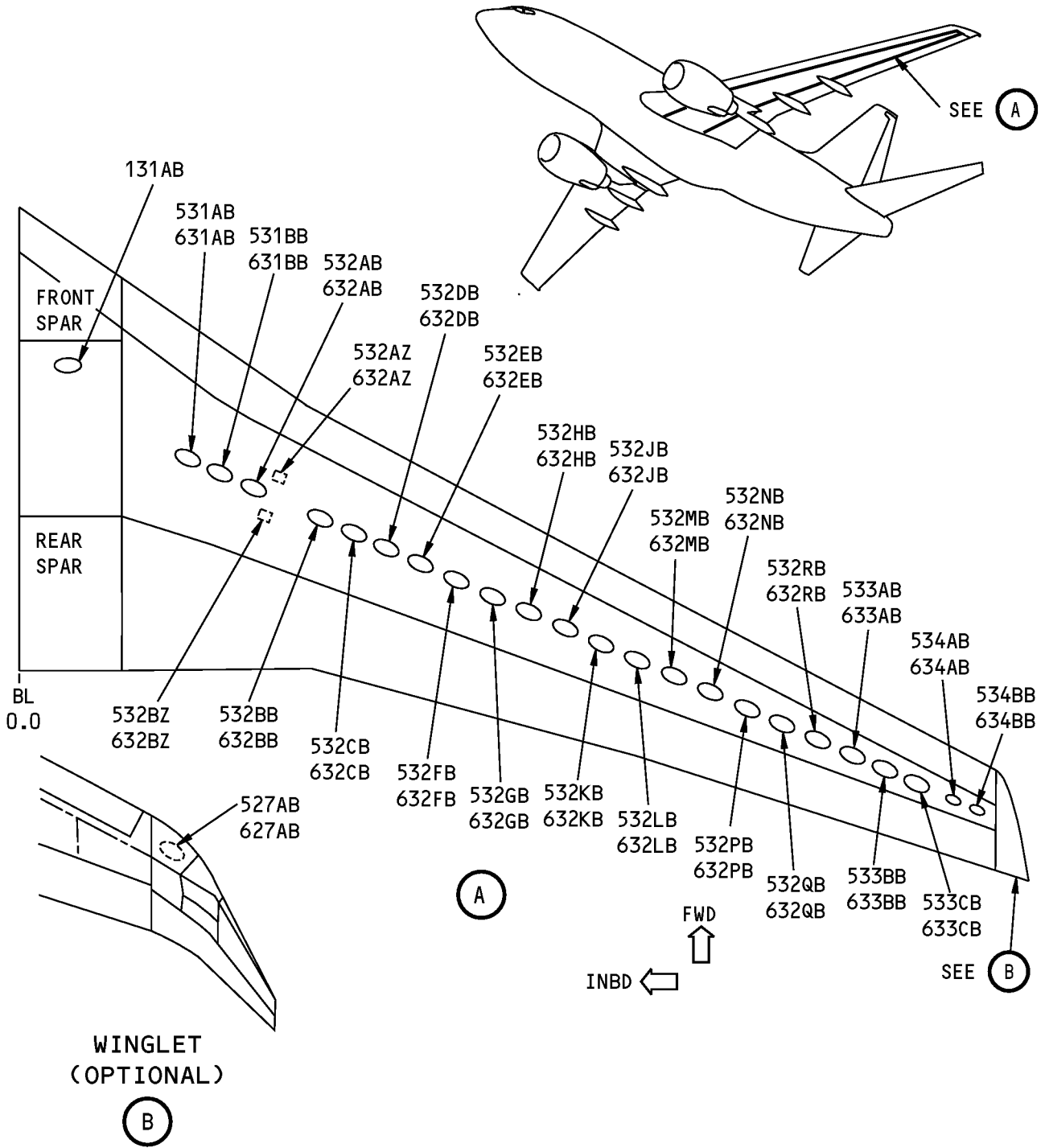

NOTE: MAJOR ZONE 500 - LEFT WING.
MAJOR ZONE 600 - RIGHT WING.
LEFT WING IS SHOWN, RIGHT WING IS OPPOSITE.

**Subzones 530 and 630 Access Doors and Panels
Figure 205/06-44-00-990-805**

EFFECTIVITY
HAP ALL

06-44-00

**737-600/700/800/900
AIRCRAFT MAINTENANCE MANUAL**

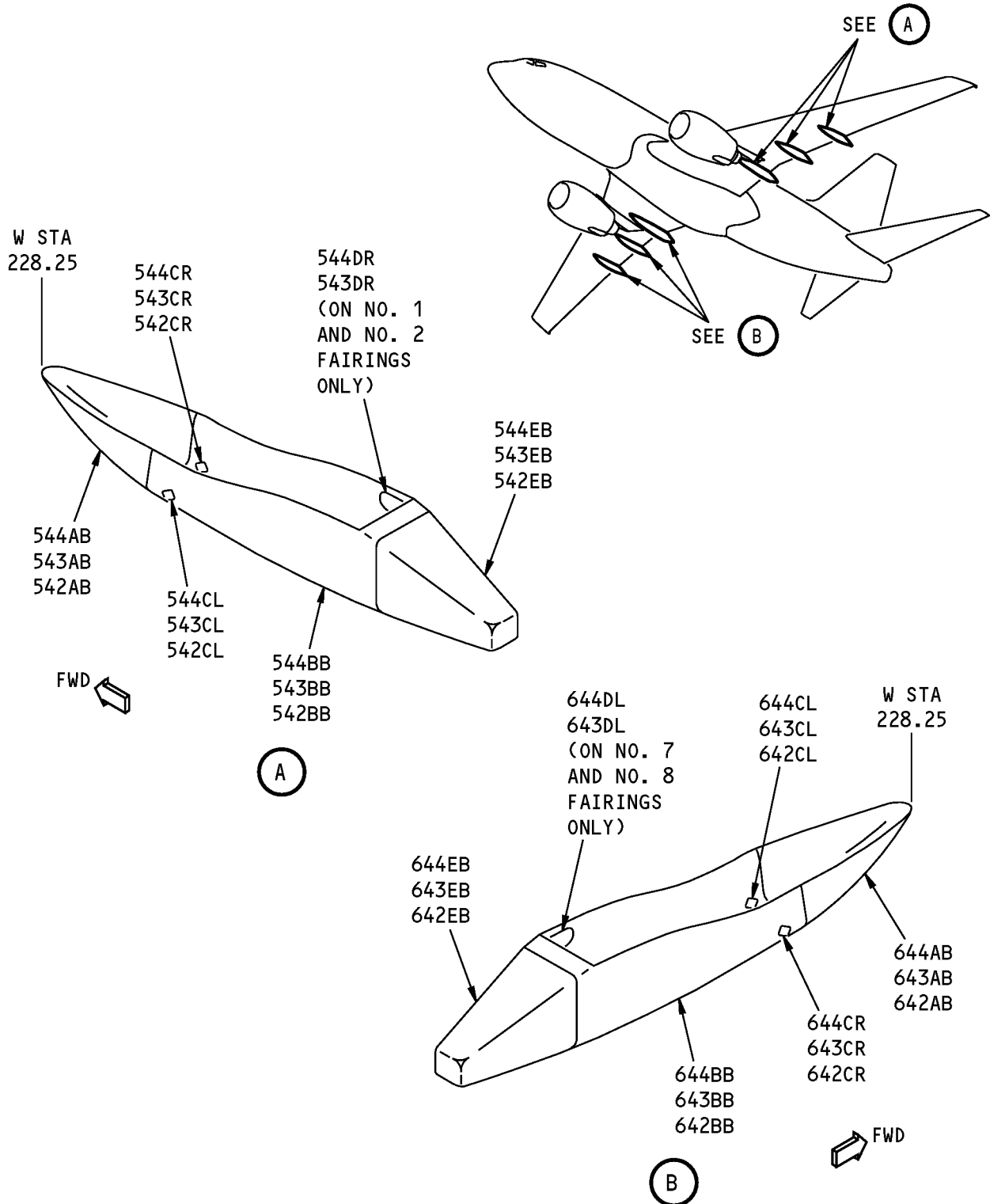

**Subzones 542, 543, 544, 642, 643, 644 - Flap Track Support Fairings
Figure 206/06-44-00-990-806**

EFFECTIVITY
HAP ALL

06-44-00

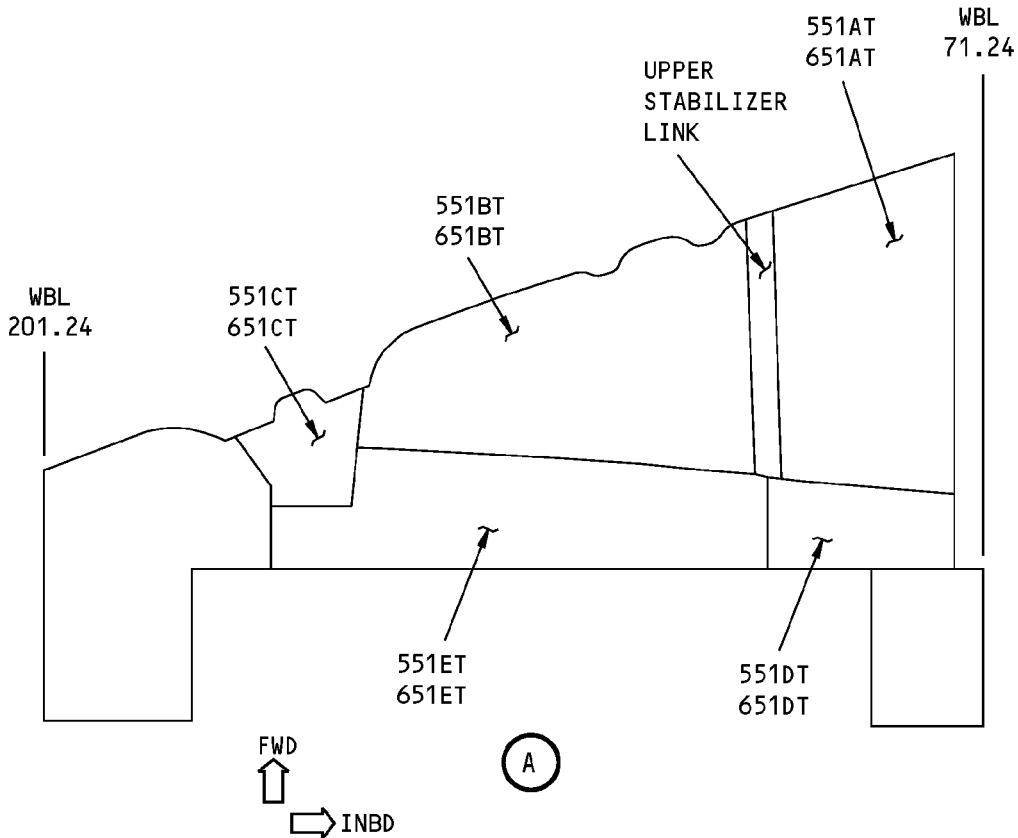
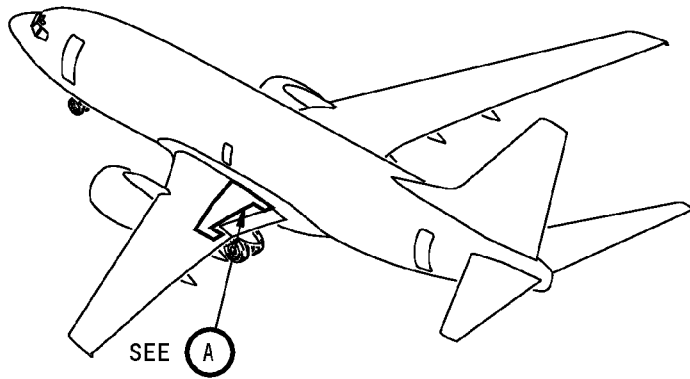

NOTE: MAJOR ZONE 500 - LEFT WING
 MAJOR ZONE 600 - RIGHT WING
 LEFT WING SHOWN, RIGHT WING OPPOSITE

**Subzones 551 and 651 - Inboard Fixed Trailing Edge Panels
 Figure 207 (Sheet 1 of 2)/06-44-00-990-807**

EFFECTIVITY
 HAP ALL

06-44-00

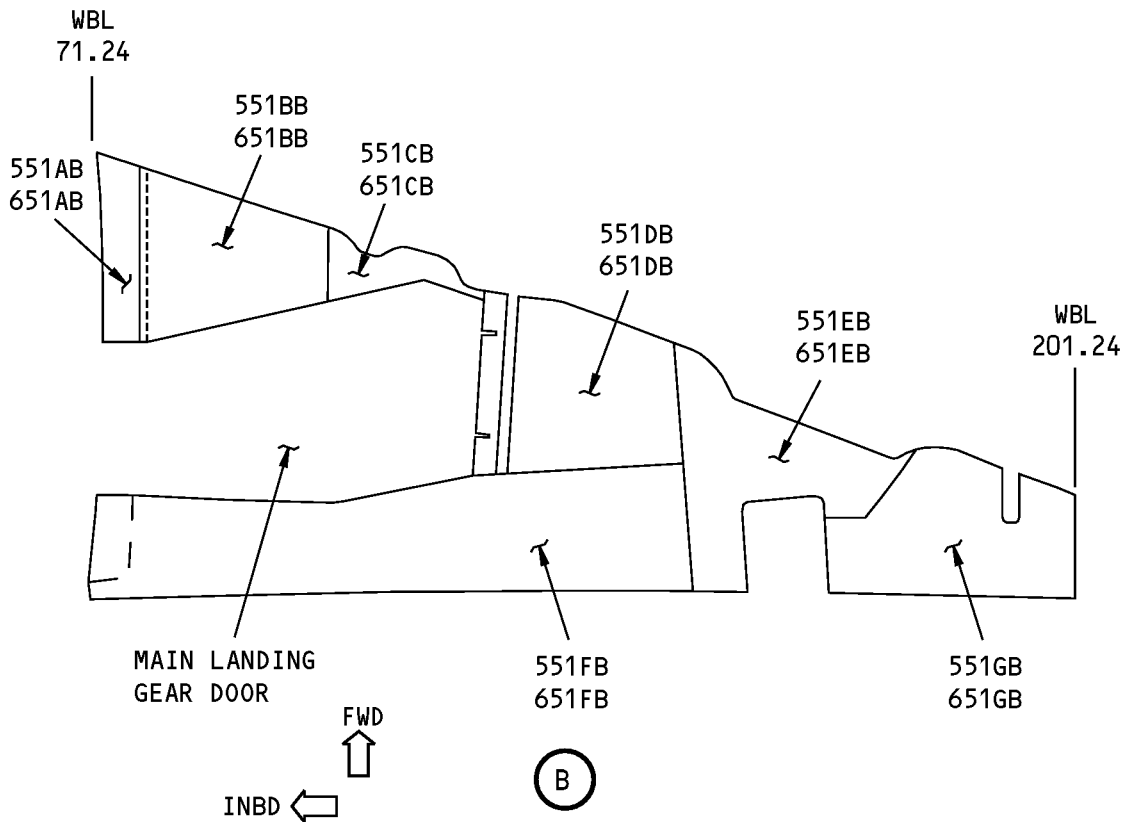
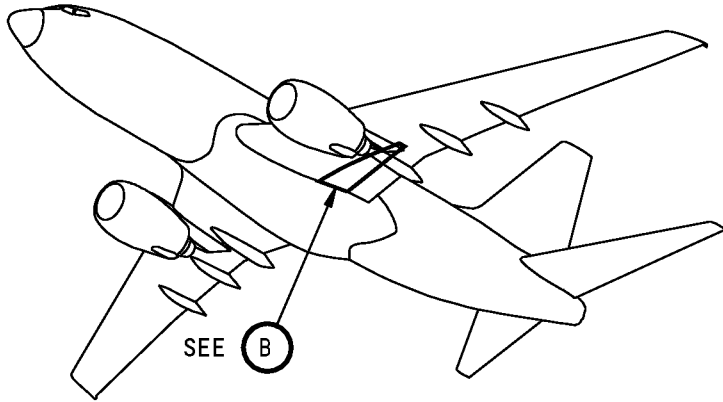

Subzones 551 and 651 - Inboard Fixed Trailing Edge Panels
Figure 207 (Sheet 2 of 2)/06-44-00-990-807

EFFECTIVITY
HAP ALL

06-44-00

Page 226
Oct 10/2004

D633A101-HAP

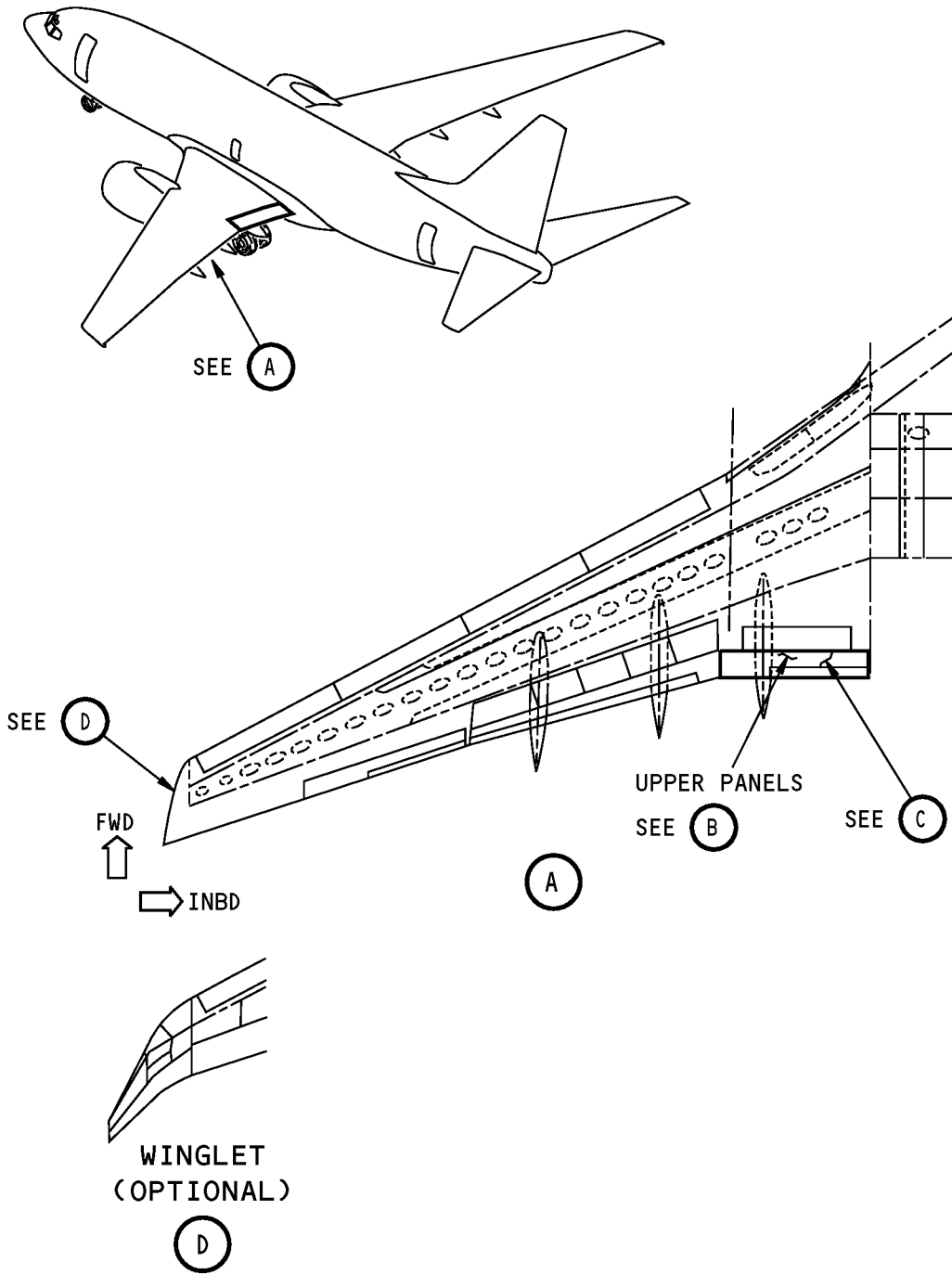

**Subzone 553 - Inboard Trailing Edge Flaps
Figure 208 (Sheet 1 of 2)/06-44-00-990-808**

EFFECTIVITY
HAP ALL

06-44-00

Page 227
Oct 10/2004

D633A101-HAP

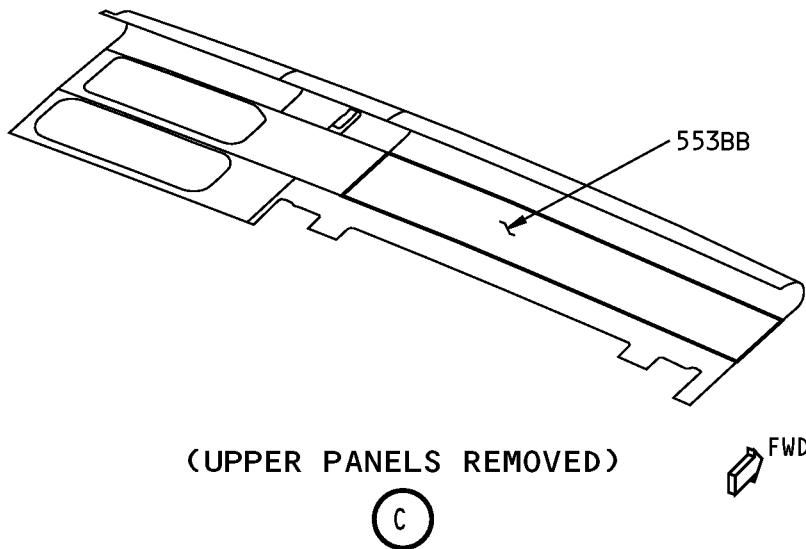
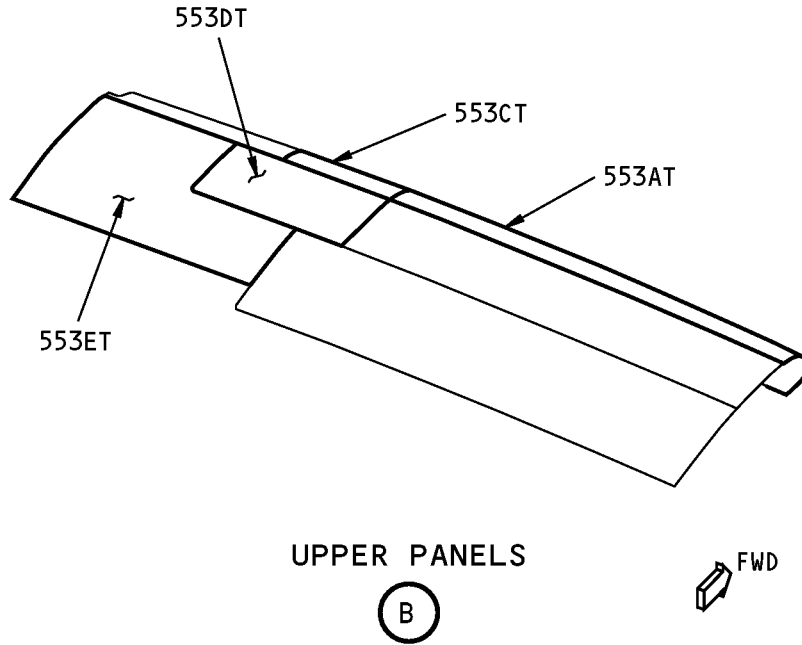

**Subzone 553 - Inboard Trailing Edge Flaps
Figure 208 (Sheet 2 of 2)/06-44-00-990-808**

EFFECTIVITY
HAP ALL

D633A101-HAP

06-44-00



737-600/700/800/900
AIRCRAFT MAINTENANCE MANUAL

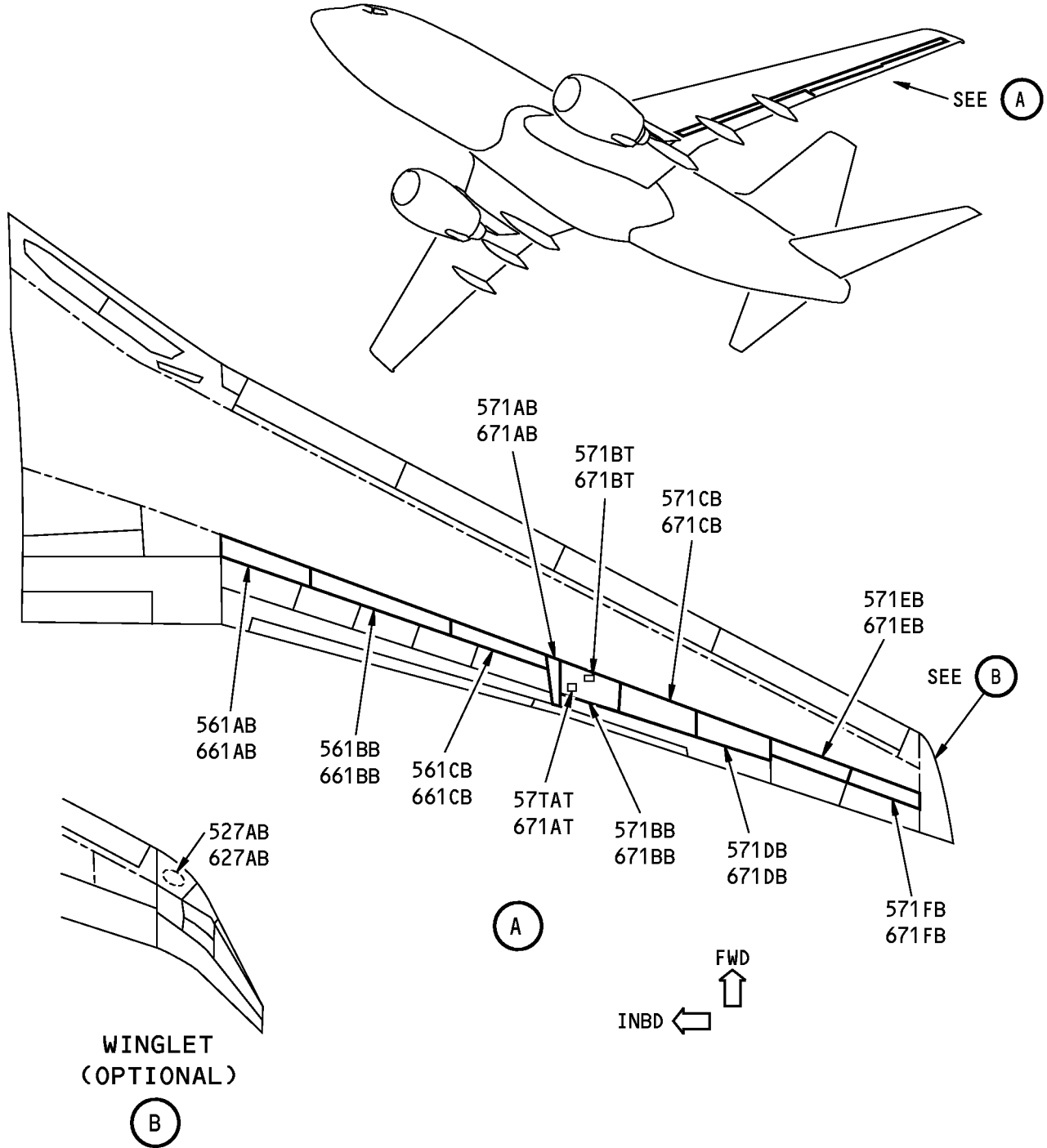

NOTE: MAJOR ZONE 500 - LEFT WING.
MAJOR ZONE 600 - RIGHT WING.
LEFT WING IS SHOWN, RIGHT IS WING OPPOSITE.

K02595 S0006558411_V3

**Subzones 561, 571, 661 and 671 - Lower Surface Trailing Edge
Figure 209/06-44-00-990-809**

EFFECTIVITY
HAP ALL

06-44-00

Page 229
Feb 15/2009

D633A101-HAP

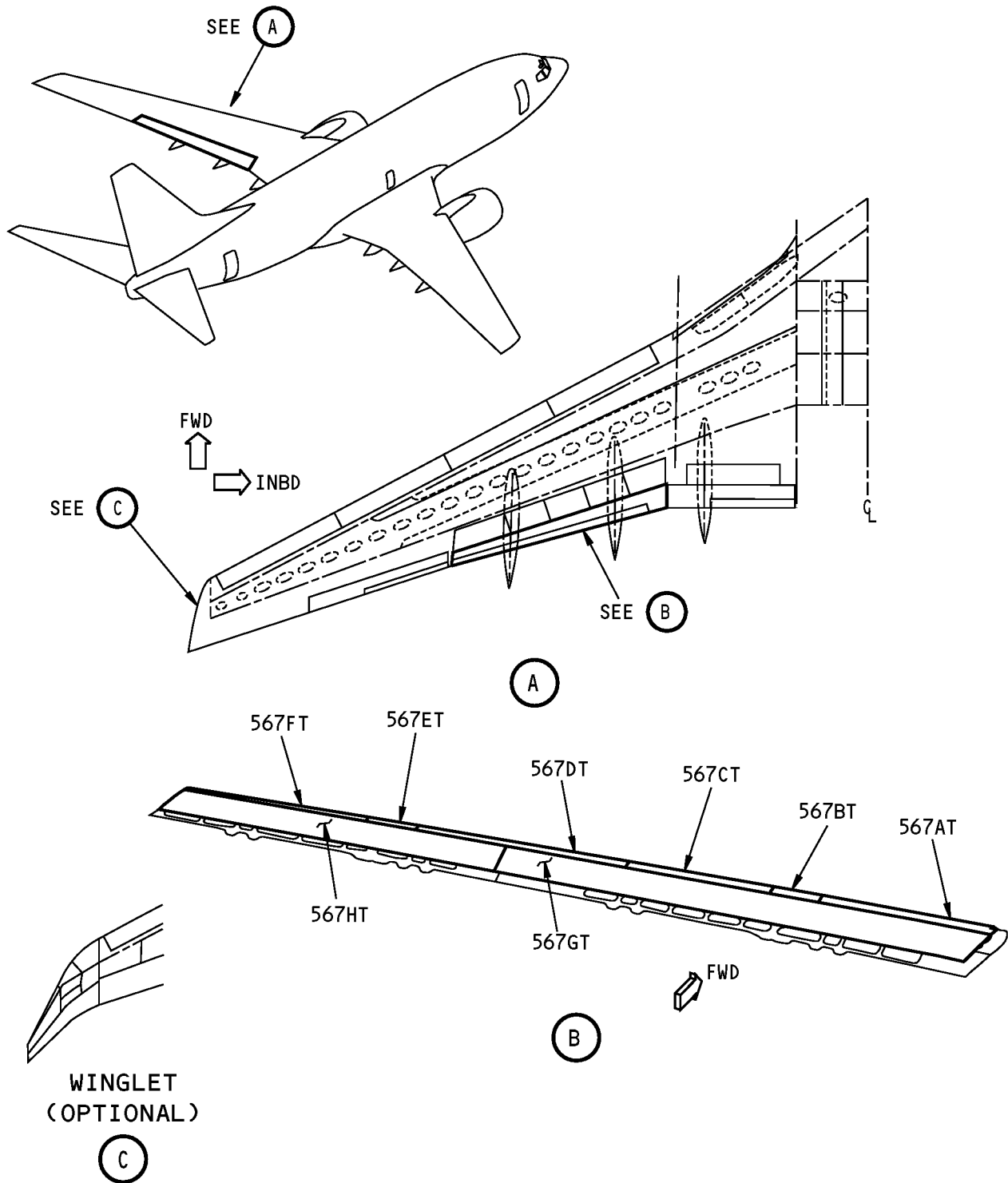

**Subzone 567 - Outboard Trailing Edge Flaps
Figure 210/06-44-00-990-812**

EFFECTIVITY
HAP ALL

06-44-00

**737-600/700/800/900
AIRCRAFT MAINTENANCE MANUAL**

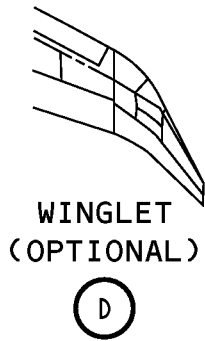
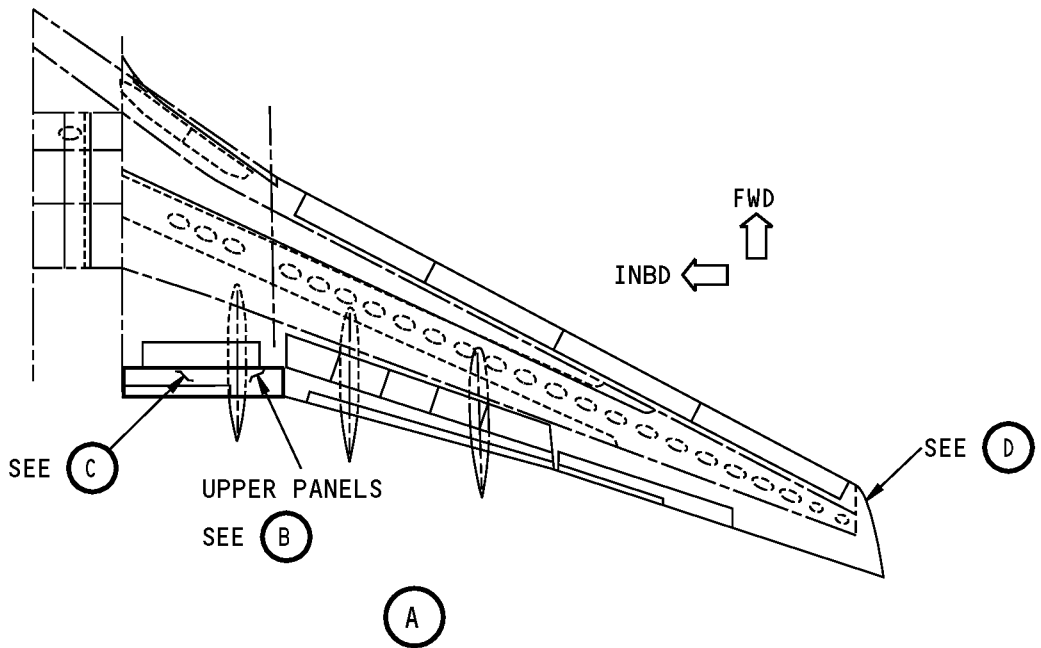
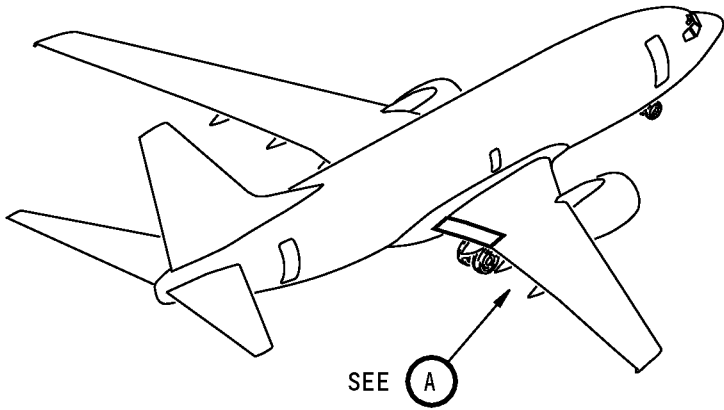

**Subzone 653 - Inboard Trailing Edge Flaps
Figure 211 (Sheet 1 of 2)/06-44-00-990-813**

EFFECTIVITY
HAP ALL

06-44-00

Page 231
Oct 10/2004

D633A101-HAP

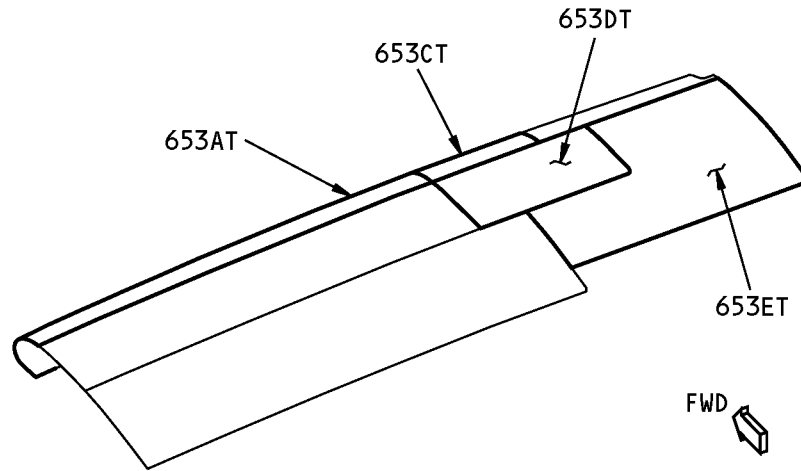

UPPER PANELS

(B)

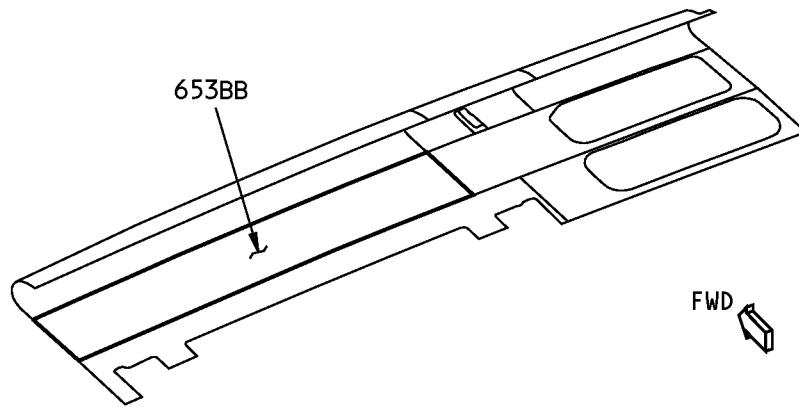

(UPPER PANELS REMOVED)

(C)

**Subzone 653 - Inboard Trailing Edge Flaps
Figure 211 (Sheet 2 of 2)/06-44-00-990-813**

EFFECTIVITY
HAP ALL

D633A101-HAP

06-44-00

**737-600/700/800/900
AIRCRAFT MAINTENANCE MANUAL**

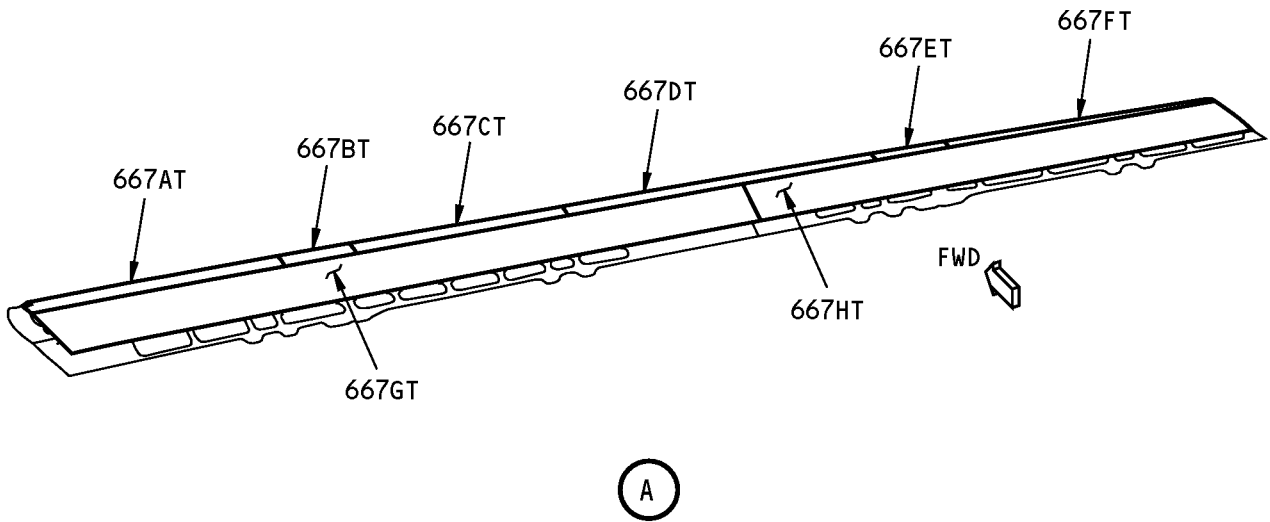
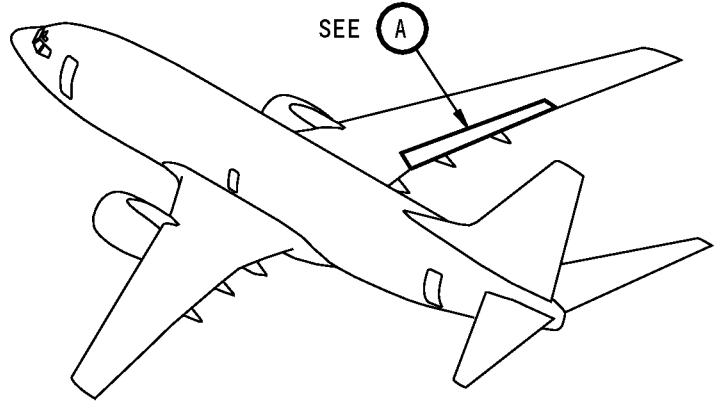

**Subzone 667 - Outboard Trailing Edge Flaps
Figure 212/06-44-00-990-814**

EFFECTIVITY
HAP ALL

06-44-00

Page 233
Oct 10/2004

D633A101-HAP

**737-600/700/800/900
AIRCRAFT MAINTENANCE MANUAL**

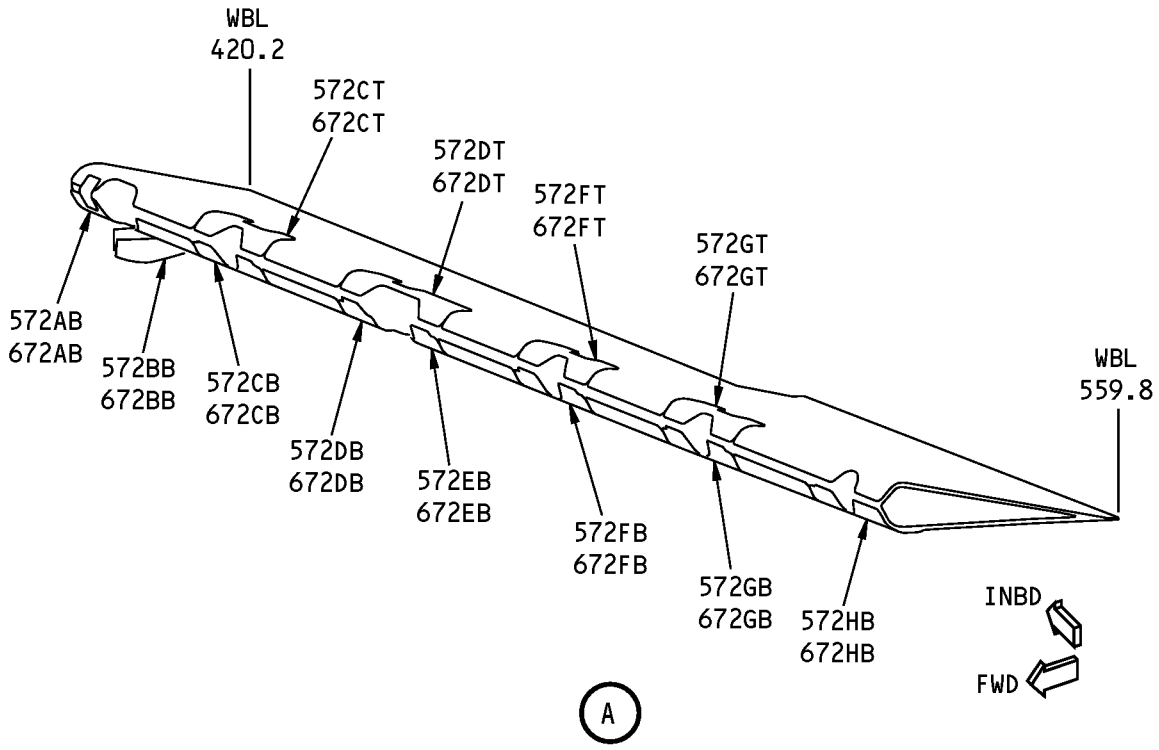
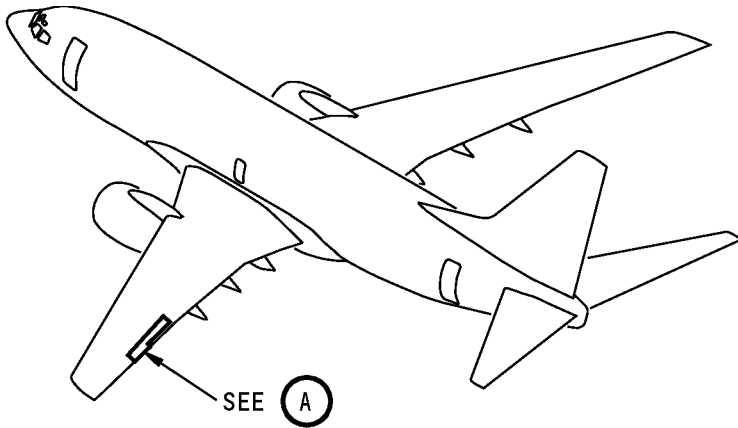

NOTE: MAJOR ZONE 500 - LEFT WING
 MAJOR ZONE 600 - RIGHT WING
 LEFT WING SHOWN, RIGHT WING OPPOSITE

**Subzones 572 and 672 - Fixed Trailing Edge Aileron Hinge Covers
 Figure 213/06-44-00-990-815**

EFFECTIVITY
HAP ALL

06-44-00



737-600/700/800/900

AIRCRAFT MAINTENANCE MANUAL

PASSENGER AND CARGO COMPARTMENT DOORS (MAJOR ZONE 800) ACCESS DOORS AND PANELS - MAINTENANCE PRACTICES

1. General

- A. This procedure has these tasks:
 - (1) Passenger and cargo compartment doors access doors and panels
- B. Major zone 800 contains the doors. The subzones are identified with two numbers followed by a zero.
 - (1) Subzone 820 - Cargo Compartment Doors
 - (2) Subzone 830 - Passenger Compartment Doors, Left
 - (3) Subzone 840 - Passenger Compartment Doors, Right
- C. Each subzone is divided into zones that are identified with the first two numbers of the subzone followed by a number that is not zero.
- D. Access doors and panels in a zone are identified by the zone number and a two or three letter suffix. This alpha-numeric label is different for each access door or panel.

TASK 06-46-00-800-801

2. Passenger and Cargo Compartment Doors Access Doors and Panels

Figure 201 or Figure 202,

A. Location Zones

Zone	Area
800	Doors

B. Procedure

SUBTASK 06-46-00-800-001

- (1) The table below, lists the access doors and panels for the passenger and cargo compartment doors.

Table 201

Number	Name/Location	Provides Access To	Dimensions	Drawing
821	Forward Cargo Door			140A0050
821AR	Access Panel on Forward Cargo Door - External			140A0050
821AZ	Access Panel on Forward Cargo Door - Internal			140A6100
821BR	Access Panel on Forward Cargo Door - External			140A0050
821BZ	Access Panel on Forward Cargo Door - Internal			143A6100
822	Aft Cargo Door	Aft Cargo Door		146A6112
822AR	Access Panel on Aft Cargo Door - External	Aft Cargo Door		146A6112
822AZ	Access Panel - Aft Cargo Door Liner			143A6100
822BR	Access Panel on Aft Cargo Door	Aft Cargo Door		146A6112

EFFECTIVITY
HAP ALL

06-46-00

Page 201
Feb 10/2007

D633A101-HAP



**737-600/700/800/900
AIRCRAFT MAINTENANCE MANUAL**

(Continued)

Number	Name/Location	Provides Access To	Dimensions	Drawing
822BZ	Access Panel - Aft Cargo Door Liner			143A6100
831	Forward Entry Door			141A6100
831AW	Fwd Entry Door - Door Liner (Cosmetic)			
831AZ	Forward Entry Door - Torque Tube Access			141A8205
831BZ	Forward Entry Door - Handle Box and Cam for Handle Box Access			141A6521
831CZ	Forward Entry Door - Handle Box Access			411A2100
831DZ	Forward Entry Door - Gate Hinge Pin Access			411A2100
831EZ	Forward Entry Door - Gate Hinge Pin Access			411A2100
HAP 001-013, 015-026, 028-054				
832	Emergency Exit			
832AZ	Panel Assy - Emergency Escape Hatch - Door Liner			
832BZ	Panel Assy - Emergency Escape Hatch - Cover Plate			
832CZ	Panel Assy - Emergency Escape Hatch - Cover Plate			
HAP ALL				
833	Emergency Exit			144A8801
833AZ	Panel Assy - Emergency Escape Hatch - Door Liner			411A2700
833BZ	Panel Assy - Emergency Escape Hatch - Cover Plate			411A2700
833CZ	Panel Assy - Emergency Escape Hatch - Cover Plate			411A2700
834	Aft Entry Door			147A6100
834AW	Aft Entry Door - Door Liner			
834AZ	Aft Entry Door - Torque Tube Access			411A2100
834BZ	Aft Entry Door - Handle Box and Cam for Handle Box Access			411A2100

EFFECTIVITY
HAP ALL

06-46-00

Page 202
Feb 15/2009

D633A101-HAP



737-600/700/800/900

AIRCRAFT MAINTENANCE MANUAL

(Continued)

Number	Name/Location	Provides Access To	Dimensions	Drawing
834CZ	Aft Entry Door - Handle Box Access			411A2100
834DZ	Aft Entry Door - Lower Hinge Access			411A2100
834EZ	Aft Entry Door - Upper Hinge Access			411A2100
834FZ	Aft Entry Door - Torque Tube Access			
834GZ	AFT Entry Door - Torque Tube Access			
841	Forward Galley Service Door			141A6500
841AW	Fwd Galley Service Door - Door Liner (Cosmetic)			
841AZ	Forward Galley Service Door - Torque Tube Access			411A2100
841BZ	Forward Galley Service Door - Handle Box and Cam for Handle Box Access			411A2100
841CZ	Forward Galley Service Door - Handle Box Access			411A2100
841DZ	Forward Galley Service Door - Lower Hinge Access			411A2100
841EZ	Forward Galley Service Door - Upper Hinge Access			411A2100
841FZ	Forward Galley Service Door - Torque Tube Access			
841GZ	Forward Galley Service Door - Torque Tube Access			
HAP 001-013, 015-026, 028-054				
842	Emergency Exit			144A8801
842AZ	Panel Assy - Emergency Escape Hatch - Door Liner			411A2700
842BZ	Panel Assy - Emergency Escape Hatch - Cover Plate			411A2700
842CZ	Panel Assy - Emergency Escape Hatch - Cover Plate			411A2700
HAP ALL				
843	Emergency Exit			144A8801

EFFECTIVITY
HAP ALL

06-46-00

Page 203
 Feb 15/2009

D633A101-HAP



737-600/700/800/900

AIRCRAFT MAINTENANCE MANUAL

(Continued)

Number	Name/Location	Provides Access To	Dimensions	Drawing
843AZ	Panel Assy - Emergency Escape Hatch - Door Liner			411A2700
843BZ	Panel Assy - Emergency Escape Hatch - Cover Plate			411A2700
843CZ	Panel Assy - Emergency Escape Hatch - Cover Plate			411A2700
844	Aft Galley Service Door			147A6500
844AW	Aft Galley Service Door - Door Liner (Cosmetic)			
844AZ	Aft Galley Service Door - Torque Tube Access			411A2100
844BZ	Aft Galley Service Door - Handle Box and Cam for Handle Box Access			411A2100
844CZ	Aft Galley Service Door - Handle Box Access			411A2100
844DZ	Aft Galley Service Door - Lower Hinge Access			411A2100
844EZ	Aft Galley Service Door - Upper Hinge Access			411A2100
844FZ	Aft Galley Service Door - Torque Tube Access			
844GZ	Aft Galley Service Door - Torque Tube Access			

————— END OF TASK —————

EFFECTIVITY
HAP ALL

06-46-00

Page 204
Feb 10/2007

D633A101-HAP

AIRCRAFT MAINTENANCE MANUAL

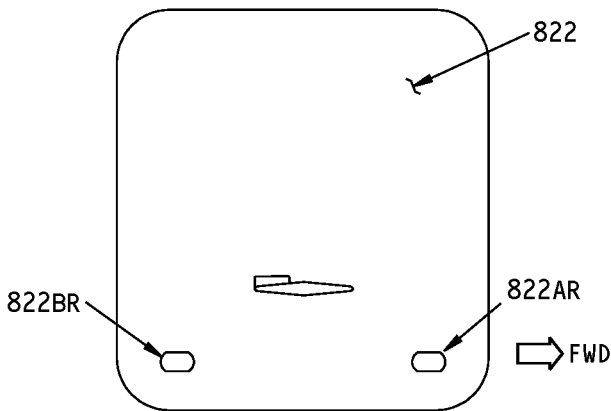
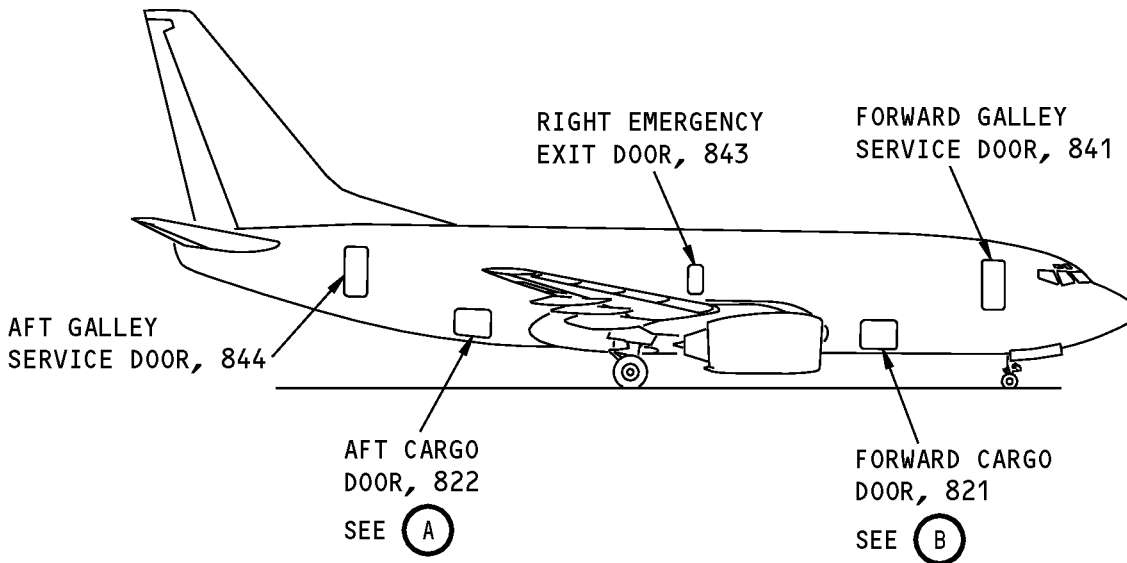
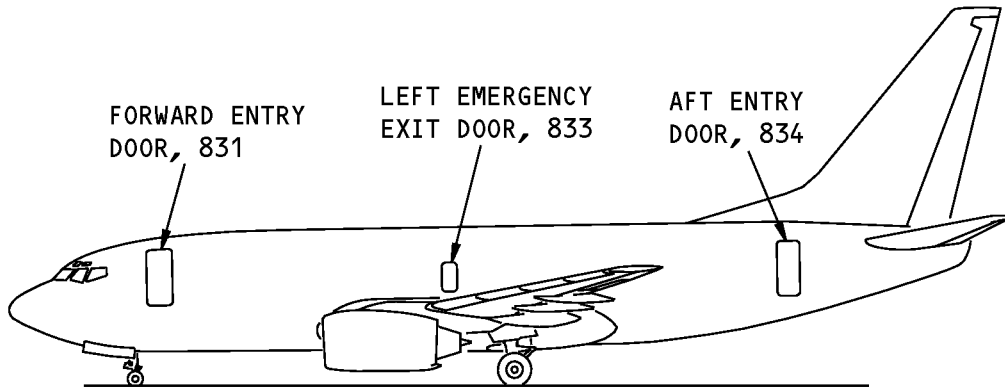

AFT CARGO DOOR

(A)

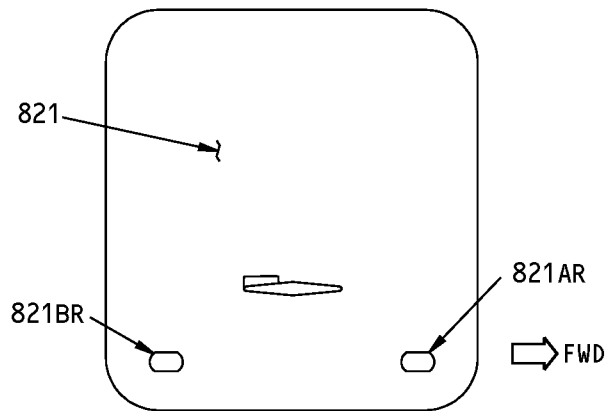

FORWARD CARGO DOOR

(B)

Major Zone 800 - Cargo Compartment Doors Access Doors and Panels
Figure 201/06-46-00-990-801

EFFECTIVITY
HAP 101-999

06-46-00

**737-600/700/800/900
AIRCRAFT MAINTENANCE MANUAL**

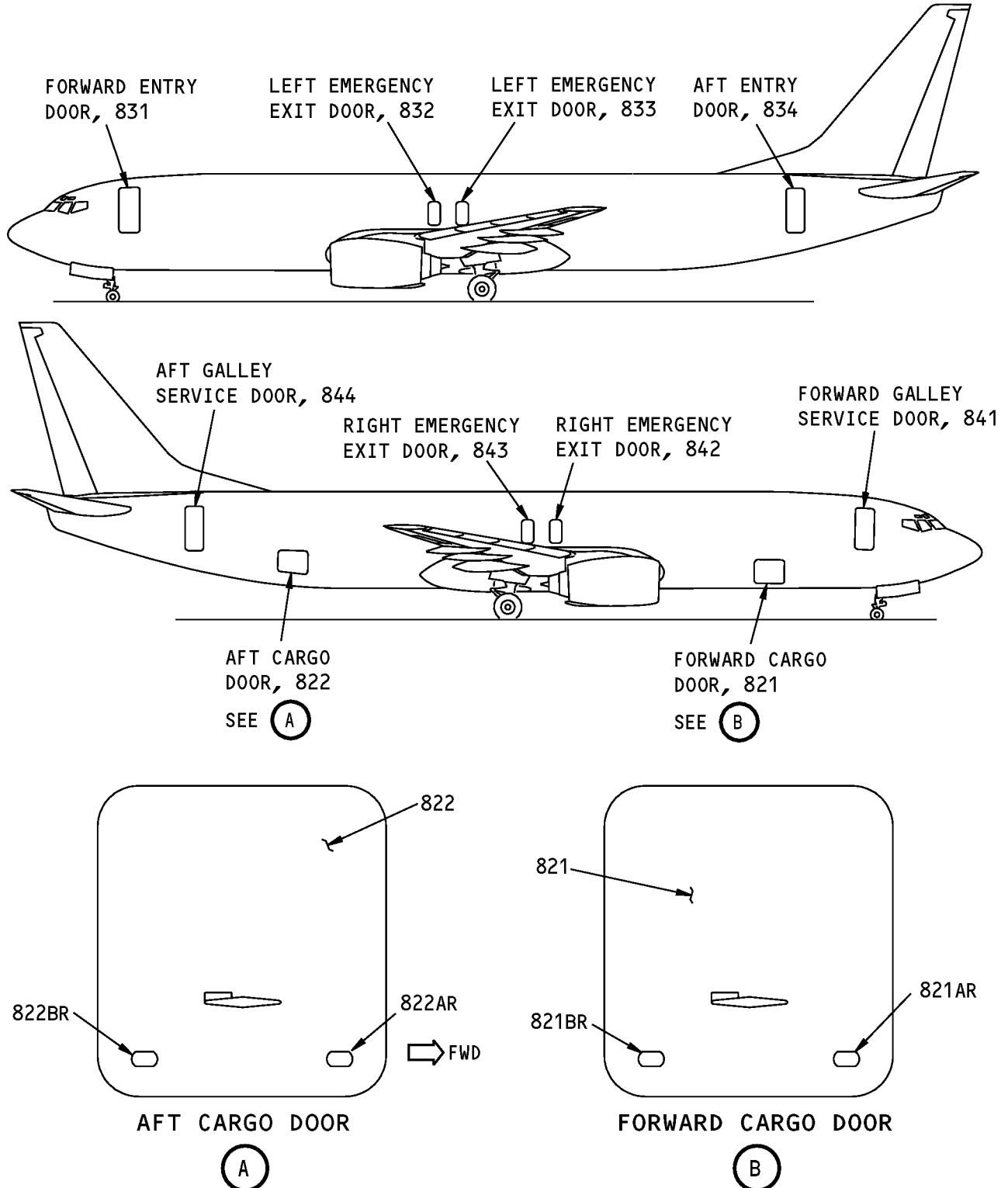

Major Zone 800 - Cargo Compartment Doors Access Doors and Panels
Figure 202/06-46-00-990-809

EFFECTIVITY
HAP 001-013, 015-026, 028-054

06-46-00

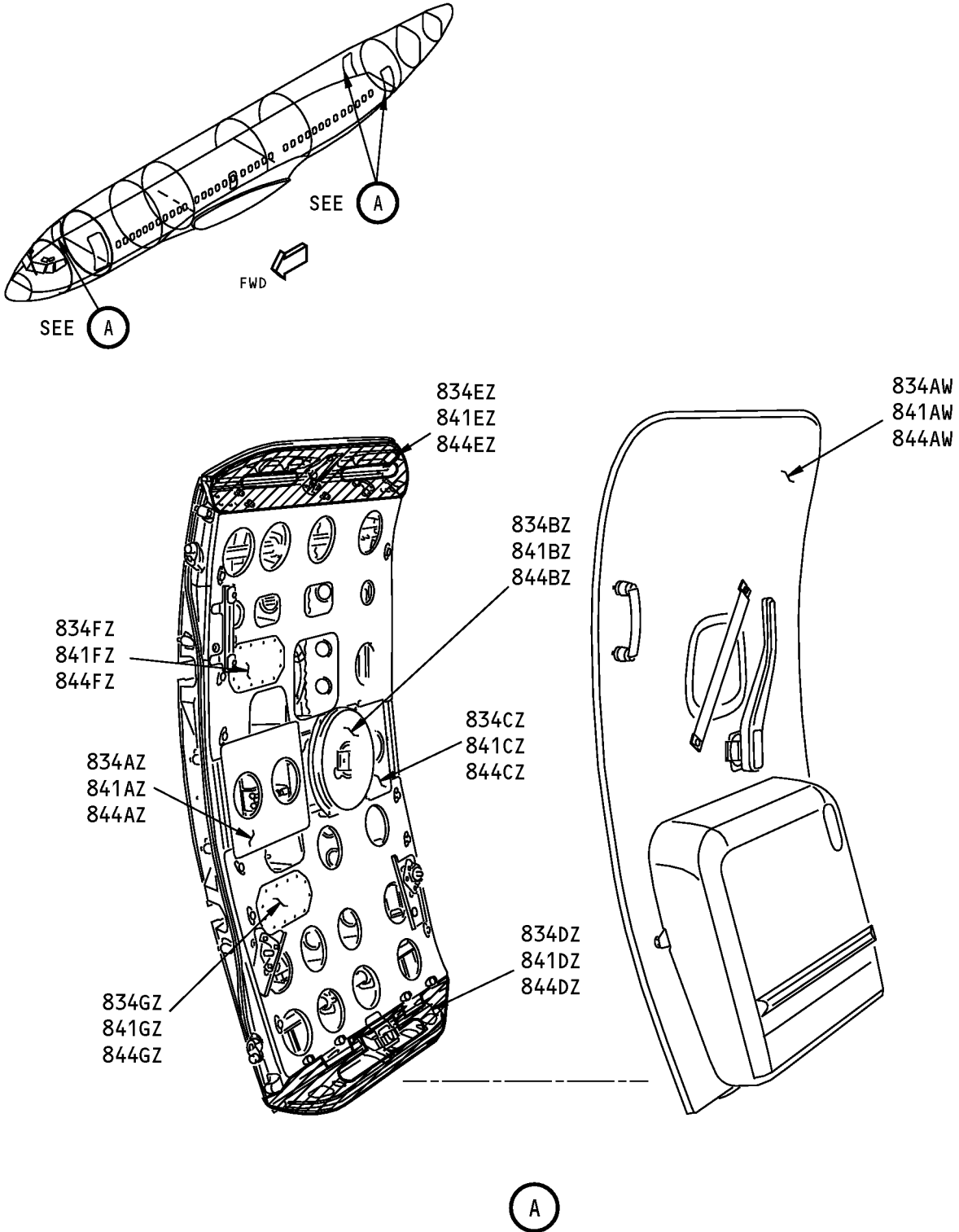

AFT ENTRY/FORWARD AND AFT GALLEY SVC DOOR PANELS
Figure 203/06-46-00-990-810

EFFECTIVITY
HAP ALL

06-46-00