

CHAPTER

08

**LEVELING AND
WEIGHING**



737-600/700/800/900
AIRCRAFT MAINTENANCE MANUAL

CHAPTER 08
LEVELING AND WEIGHING

Subject/Page	Date	COC	Subject/Page	Date	COC	Subject/Page	Date	COC
EFFECTIVE PAGES								
1	Jun 15/2009							
2	BLANK							
08-CONTENTS								
1	Feb 15/2008							
2	BLANK							
08-11-00								
201	Oct 15/2008							
202	BLANK							
08-21-02								
201	Oct 10/2003							
202	Oct 10/2003							
203	Oct 10/2003							
204	BLANK							
08-21-03								
201	Oct 10/2006							
202	Oct 10/2006							
203	Oct 10/2006							
204	Oct 10/2006							
08-21-04								
401	Oct 15/2008							
402	Oct 10/2006							

A = Added, R = Revised, D = Deleted, O = Overflow, C = Customer Originated Change

08-EFFECTIVE PAGES



737-600/700/800/900
AIRCRAFT MAINTENANCE MANUAL

CHAPTER 08
LEVELING AND WEIGHING

<u>Subject</u>	<u>Chapter Section Subject</u>	<u>Conf</u>	<u>Page</u>	<u>Effect</u>
<u>WEIGHING - MAINTENANCE PRACTICES</u>	08-11-00		201	HAP ALL
Procedures to Weigh the Airplane TASK 08-11-00-580-801			201	HAP ALL
<u>LEVEL AIRPLANE WITH A PLUMB BOB - MAINTENANCE PRACTICES</u>	08-21-02		201	HAP ALL
Make the Airplane Level TASK 08-21-02-580-801			201	HAP ALL
<u>LEVEL AIRPLANE WITH THE ATTITUDE GAGE - MAINTENANCE PRACTICES</u>	08-21-03		201	HAP ALL
Make the Airplane Level TASK 08-21-03-580-801			201	HAP ALL
<u>INCLINOMETER - REMOVAL/INSTALLATION</u>	08-21-04		401	HAP ALL
Inclinometer - Removal TASK 08-21-04-000-801			401	HAP ALL
Inclinometer - Installation TASK 08-21-04-400-801			401	HAP ALL

08-CONTENTS



737-600/700/800/900

AIRCRAFT MAINTENANCE MANUAL

WEIGHING - MAINTENANCE PRACTICES

1. General

A. This procedure has a task which gives information on the procedures you use to weigh the airplane.

TASK 08-11-00-580-801

2. Procedures to Weigh the Airplane

A. Procedure

SUBTASK 08-11-00-580-001

(1) Refer to the Weight and Balance Manual for procedures to prepare and weigh the airplane.

NOTE: You can weigh the airplane with the four equally accurate procedures that follow:

- Weigh at the landing gear wheels with a set of floor scales.
- Weigh at the main landing gear and nose landing gear axle jack points.
- Weigh at the main landing gear and forward body jack points.
- Weigh at the wing and aft body jack points.

You can weigh the airplane faster with the first procedure above than with procedures in which jacks are necessary. The second step above is better than the third and fourth step because there is less chance of structural damage to the airplane through failure of a support jack or weigh cell. The second step above is more economical and faster than the third and fourth steps because installation of oleo locks is not necessary.

————— **END OF TASK** —————

EFFECTIVITY
HAP ALL

D633A101-HAP

08-11-00

Page 201
Oct 15/2008



737-600/700/800/900

AIRCRAFT MAINTENANCE MANUAL

LEVEL AIRPLANE WITH A PLUMB BOB - MAINTENANCE PRACTICES

1. General

A. This procedure contains the following task:

- (1) Level the airplane with a plumb bob.

TASK 08-21-02-580-801

2. Make the Airplane Level

A. General

(1) Do this task when you jack the airplane to do any of the procedures that follow:

- (a) Weigh the airplane.
- (b) Do general airplane maintenance.
- (c) Do gear retraction tests.

B. References

Reference	Title
07-11-01-580-815	Lift the Airplane with the Jacks (P/B 201)
07-11-01-580-816	Lower the Airplane Off the Jacks (P/B 201)
10-11-03-580-801	Park the Airplane (P/B 201)
12-15-31-610-802	Main Landing Gear Shock Strut Servicing (P/B 301)

C. Location Zones

Zone	Area
740	Subzone - Right Main Landing Gear and Landing Gear Doors

D. Level the Airplane

SUBTASK 08-21-02-580-001

- (1) Make sure the airplane is parked in the most level position available, do this task (Park the Airplane, TASK 10-11-03-580-801):

SUBTASK 08-21-02-480-001

- (2) Do the steps that follow to level the airplane (Figure 201):

NOTE: It will be easier to Level the airplane laterally (roll direction) first.

WARNING: MAKE SURE THE DOWNLOCK PINS ARE INSTALLED ON ALL THE LANDING GEAR. WITHOUT THE DOWNLOCK PINS, THE LANDING GEAR COULD RETRACT AND CAUSE INJURIES TO PERSONS AND DAMAGE TO EQUIPMENT.

CAUTION: DOWNLOCK PINS INSTALLED WHEN LEVELING THE AIRPLANE MUST BE REMOVED PRIOR TO PERFORMING GEAR RETRACTION TESTS, OTHER WISE DAMAGE TO THE AIRPLANE AND EQUIPMENT CAN OCCUR.

- (a) Install downlock pins for all maintenance requiring the leveling of the airplane.

NOTE: Remove the downlock pins prior to performing gear retraction tests.

- (b) Attach a plumb bob and cord in the right main wheel well to the bracket that shows the words "LEVEL HERE".

- 1) The bracket is directly above the leveling scale.
- 2) The plumb bob cord must be on the outboard side (decal side) of the support bracket.
- 3) The plumb bob must be clear of the target by less than 1/8 inch (3.18 millimeters) .

EFFECTIVITY HAP ALL	
------------------------	--

08-21-02

Page 201
Oct 10/2003

D633A101-HAP



737-600/700/800/900

AIRCRAFT MAINTENANCE MANUAL

- (c) Examine the position of the plumb bob when it is does not move.
- (d) If the plumb bob is not in the zero position on the leveling scale, make the airplane level.

WARNING: DO NOT PRESSURIZE THE SHOCK STRUTS TO MORE THAN USUAL SERVICING PRESSURE. IF YOU DO, INJURY TO PERSONS AND DAMAGE TO SHOCK STRUTS CAN OCCUR.

- 1) For small adjustments, extend or retract the main and nose landing gear shock struts to usual service band limits, do this task (Main Landing Gear Shock Strut Servicing, TASK 12-15-31-610-802):

CAUTION: ALL OF THE JACKS MUST HAVE PRESSURE GAGES. DO NOT USE MORE PRESSURE THAN THE LIMITS PERMIT. IF YOU DO NOT OBEY THESE INSTRUCTIONS, DAMAGE TO EQUIPMENT CAN OCCUR.

- 2) For large adjustments, do these steps:
 - a) Put applicable jack pad adapters and jacks at jacking points A, B, and C, do this task (Lift the Airplane with the Jacks, TASK 07-11-01-580-815):
 - b) Lift or lower the jacks until the plumb bob is at the zero position on the leveling scale.

E. Put the Airplane Back to the Initial Condition

SUBTASK 08-21-02-840-001

- (1) If it is necessary, lower the airplane off of the jacks, do this task (Lower the Airplane Off the Jacks, TASK 07-11-01-580-816):

————— **END OF TASK** —————

EFFECTIVITY
HAP ALL

D633A101-HAP

08-21-02

Page 202
Oct 10/2003

**737-600/700/800/900
AIRCRAFT MAINTENANCE MANUAL**

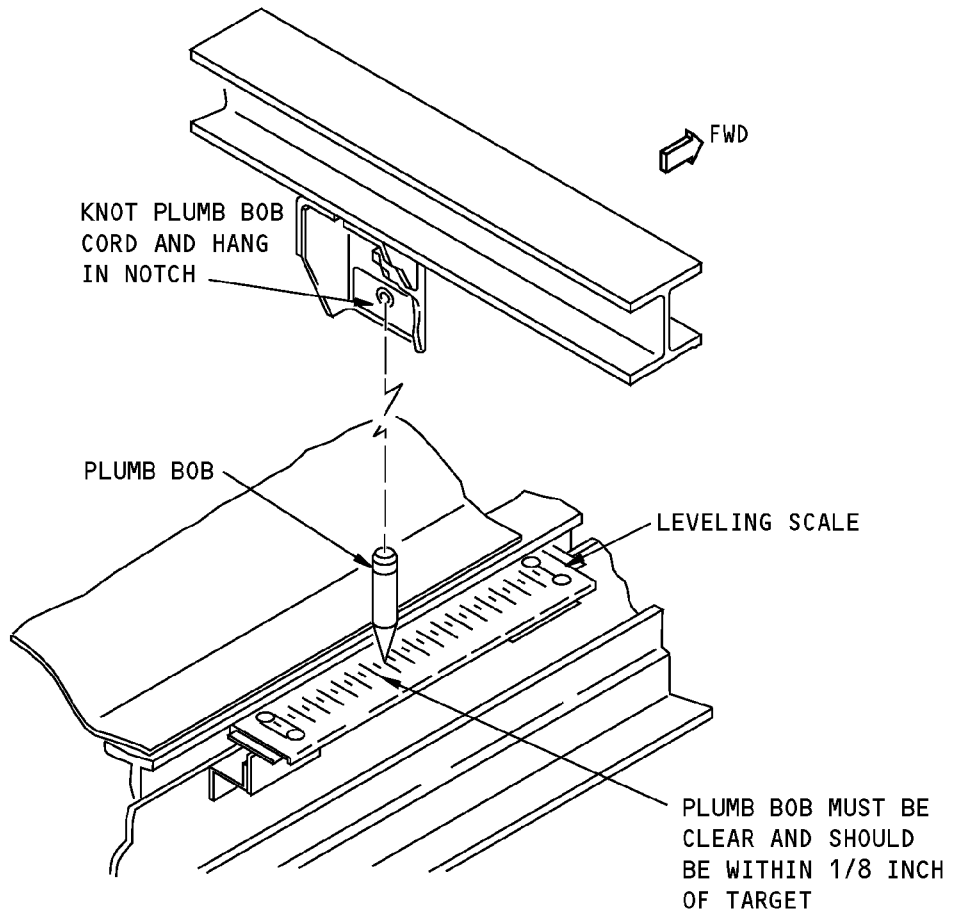
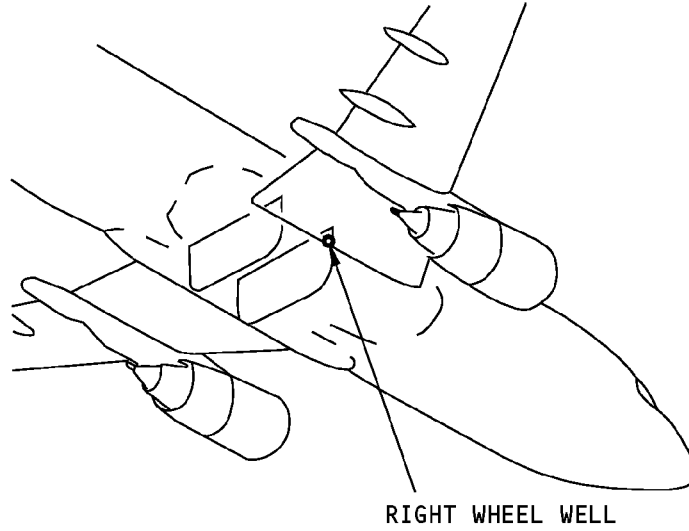

**Airplane Leveling with Plumb Bob
Figure 201/08-21-02-990-801**

EFFECTIVITY
HAP ALL

08-21-02

Page 203
Oct 10/2003

D633A101-HAP



737-600/700/800/900

AIRCRAFT MAINTENANCE MANUAL

LEVEL AIRPLANE WITH THE ATTITUDE GAGE - MAINTENANCE PRACTICES

1. General

- A. This procedure has a task to make the airplane level with an attitude gage.
- B. Do this task when you jack the airplane to do any of the procedures that follow:
 - (1) Weigh the airplane,
 - (2) General airplane maintenance,
 - (3) Gear retraction tests.

TASK 08-21-03-580-801

2. Make the Airplane Level

A. References

Reference	Title
07-11-01-580-815	Lift the Airplane with the Jacks (P/B 201)
07-11-01-580-816	Lower the Airplane Off the Jacks (P/B 201)
10-11-03-580-801	Park the Airplane (P/B 201)
12-15-31-610-802	Main Landing Gear Shock Strut Servicing (P/B 301)

B. Tools/Equipment

NOTE: When more than one tool part number is listed under the same "Reference" number, the tools shown are alternates to each other within the same airplane series. Tool part numbers that are replaced or non-procurable are preceded by "Opt:", which stands for Optional.

Reference	Description
SPL-1497	Gauge - Attitude, Airplane (Part #: F70043, Supplier: 81205, A/P Effectivity: 737-100, -200, -200C, -300, -400, -500, -600, -700, -700C, -700ER, -700QC, -800, -900, -900ER, -BBJ)

C. Location Zones

Zone	Area
740	Subzone - Right Main Landing Gear and Landing Gear Doors

D. Level the Airplane

SUBTASK 08-21-03-580-001

- (1) Do this task: (Park the Airplane, TASK 10-11-03-580-801).
 - (a) Make sure the airplane is parked in the most level position available.

SUBTASK 08-21-03-480-001

- (2) Do the steps that follow to level the airplane (Figure 201), using gauge, SPL-1497.

NOTE: If the airplane is leveled laterally (roll direction) first, it should not need re-leveling after the longitudinal leveling is done.

- (a) Put the gauge, SPL-1497, perpendicular to the airplane centerline to see if the airplane is level in the roll direction.

NOTE: Make sure the alignment tube ends are on a flat surface of the wheel well ceiling.

- (b) Set the screw adjuster on top of the attitude gage until the pointer is on zero.

NOTE: If the bubble is not in the center of the vial, you must lift or lower the sides of the airplane as it is necessary. The bubble will move to the high side of the airplane.

EFFECTIVITY HAP ALL

08-21-03

Page 201
Oct 10/2006

D633A101-HAP



737-600/700/800/900

AIRCRAFT MAINTENANCE MANUAL

- (c) Do these steps to make the airplane level about its roll axis:

WARNING: DO NOT PRESSURIZE THE SHOCK STRUTS TO MORE THAN USUAL SERVICING PRESSURE. IF YOU DO, INJURY TO PERSONS AND DAMAGE TO SHOCK STRUTS CAN OCCUR.

- 1) For small adjustments, do this step:
 - a) Extend or retract the main landing gear shock struts to usual service band limits, do this task: (Main Landing Gear Shock Strut Servicing, TASK 12-15-31-610-802).

CAUTION: ALL OF THE JACKS MUST HAVE PRESSURE GAGES. DO NOT USE MORE PRESSURE THAN THE LIMITS PERMIT. IF YOU DO NOT OBEY THESE INSTRUCTIONS, DAMAGE TO EQUIPMENT CAN OCCUR.

- (d) For large adjustments, do these steps:

- 1) Put the applicable jack pad adapters and jacks at jacking points A and B, do this task: (Lift the Airplane with the Jacks, TASK 07-11-01-580-815).
- 2) Lift or lower the jacks until the bubble is in the center of the vial.

- (e) Put the alignment tube tips of the attitude gage against the ceiling in the main wheel well.

- (f) Put the gage parallel to the airplane centerline to see if the airplane is level about the longitudinal axis.

NOTE: Make sure the alignment tube tips are on a flat surface of the wheel well ceiling.

- (g) Set the screw adjuster on top of the attitude gage until the pointer is on zero.

NOTE: If the bubble is not in the center of the vial, you must lift or lower the airplane as it is necessary. The bubble will move to the high end of the airplane.

- (h) Do these steps to make the airplane level about its longitudinal axis:

WARNING: DO NOT PRESSURIZE THE SHOCK STRUTS TO MORE THAN USUAL SERVICING PRESSURE. IF YOU DO, INJURY TO PERSONS AND DAMAGE TO SHOCK STRUTS CAN OCCUR.

- 1) For small adjustments, do this step:
 - a) Extend or retract the main and nose landing gear shock struts to usual service band limits, do this task: (Main Landing Gear Shock Strut Servicing, TASK 12-15-31-610-802).

CAUTION: ALL OF THE JACKS MUST HAVE PRESSURE GAGES. DO NOT USE MORE PRESSURE THAN THE LIMITS PERMIT. IF YOU DO NOT OBEY THESE INSTRUCTIONS, DAMAGE TO EQUIPMENT CAN OCCUR.

- 2) For large adjustments, do these steps:

- a) Put the applicable jack pad adapter and jack at jacking point C, do this task: (Lift the Airplane with the Jacks, TASK 07-11-01-580-815).
- b) Lift or lower the jack until the bubble is in the center of the vial.

- (i) Do the longitudinal and lateral leveling procedures again until the bubble is in the center in each position.

EFFECTIVITY
HAP ALL

D633A101-HAP

08-21-03

Page 202
Oct 10/2006



737-600/700/800/900

AIRCRAFT MAINTENANCE MANUAL

E. Put the Airplane Back to It's Initial Condition

SUBTASK 08-21-03-820-001

- (1) If it is necessary, lower the airplane off of the jacks, do this task: (Lower the Airplane Off the Jacks, TASK 07-11-01-580-816).

————— **END OF TASK** —————

EFFECTIVITY
HAP ALL

D633A101-HAP

08-21-03

Page 203
Oct 10/2006

**737-600/700/800/900
AIRCRAFT MAINTENANCE MANUAL**

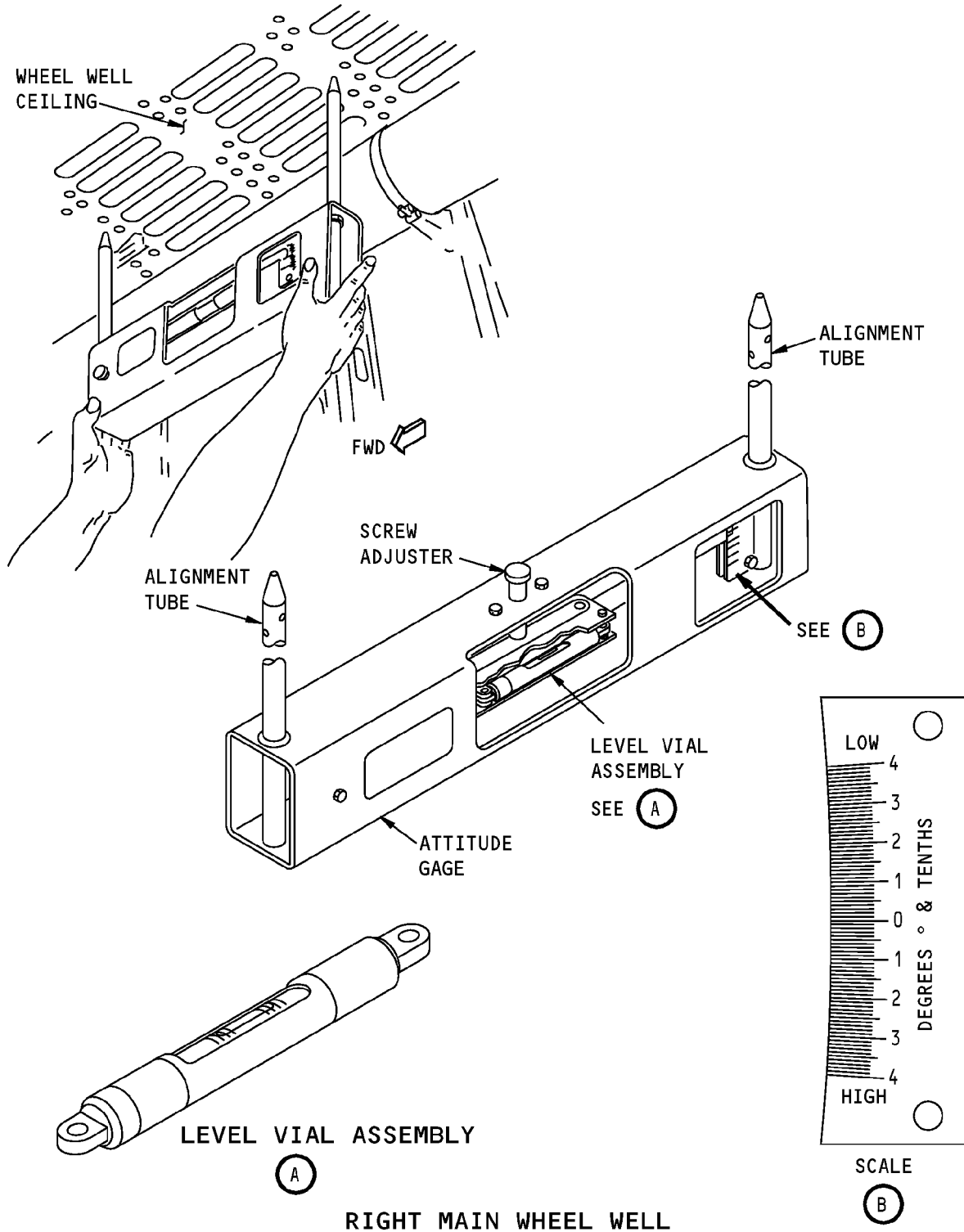

**Airplane Leveling Using Attitude Gage
Figure 201/08-21-03-990-801**

EFFECTIVITY
HAP ALL

D633A101-HAP

08-21-03



737-600/700/800/900

AIRCRAFT MAINTENANCE MANUAL

INCLINOMETER - REMOVAL/INSTALLATION

1. General

- A. The airplane is supplied with one lateral and one longitudinal inclinometer. The inclinometers are located in the main landing gear wheel well.
- B. This procedure contains two tasks. There is one task for removal of lateral/longitudinal inclinometer. There is one task for installation of lateral/longitudinal inclinometer.

TASK 08-21-04-000-801

2. Inclinometer - Removal

A. Procedure

SUBTASK 08-21-04-010-001

- (1) Gain access to the applicable inclinometer in the left main landing gear wheel well.

SUBTASK 08-21-04-020-001

- (2) Remove a screw and washer from each end of the inclinometer.

SUBTASK 08-21-04-020-002

- (3) Remove the inclinometer.

————— **END OF TASK** —————

TASK 08-21-04-400-801

3. Inclinometer - Installation

A. References

Reference	Title
08-21-02-580-801	Make the Airplane Level (P/B 201)
10-11-01-580-801	Airplane Parking (P/B 201)

B. Procedure

SUBTASK 08-21-04-860-001

- (1) Park the airplane in the most level position available, do this task: Airplane Parking, TASK 10-11-01-580-801.

SUBTASK 08-21-04-860-002

- (2) Do this task: Make the Airplane Level, TASK 08-21-02-580-801.

SUBTASK 08-21-04-420-001

- (3) With airplane leveled, install the lateral/longitudinal inclinometer with ball at zero of scale.

NOTE: It may be necessary to lightly tap on the top of the inclinometer to center the ball properly.

SUBTASK 08-21-04-420-002

- (4) Install the washer and screw at each end of the inclinometer.

- (a) Make sure that the leveling bubble in the inclinometer is centered before you tighten the screws.

SUBTASK 08-21-04-840-001

- (5) Restore the airplane to normal.

————— **END OF TASK** —————

EFFECTIVITY
HAP ALL

D633A101-HAP

08-21-04

Page 401
Oct 15/2008

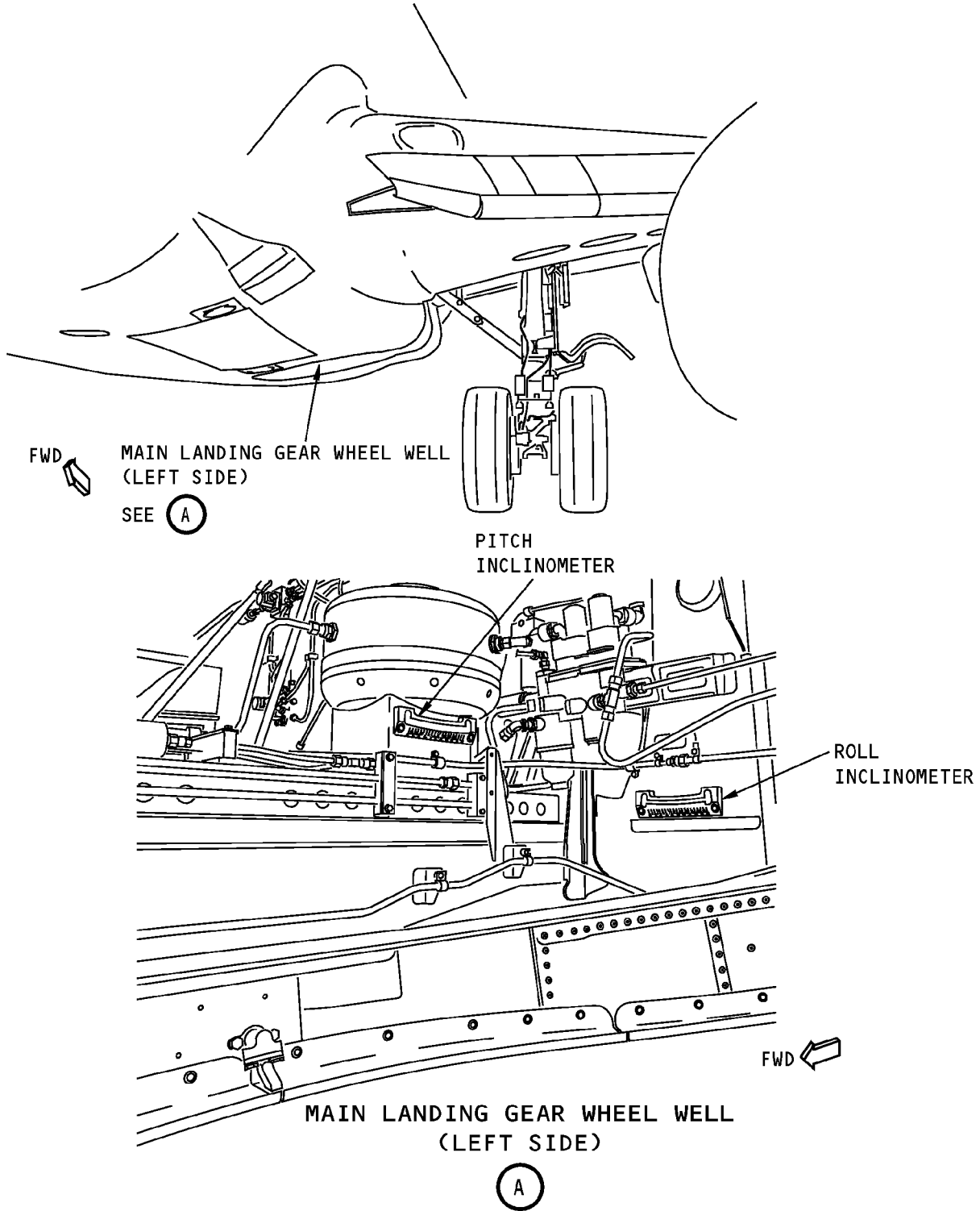

**Inclinometer Installation
Figure 401/08-21-04-990-801**

EFFECTIVITY
HAP ALL

08-21-04

Page 402
Oct 10/2006

D633A101-HAP