

CHAPTER

47

INERT GAS SYSTEM



**737-600/700/800/900
AIRCRAFT MAINTENANCE MANUAL**

**CHAPTER 47
INERT GAS SYSTEM**

Subject/Page	Date	COC	Subject/Page	Date	COC	Subject/Page	Date	COC
EFFECTIVE PAGES			47-00-00 (cont)			47-11-02 (cont)		
1 thru 3	Jun 15/2009		A 507	Jun 15/2009		404	Oct 15/2008	
4	BLANK		A 508	Jun 15/2009		405	Oct 15/2008	
47-CONTENTS			47-00-00			R 406	Jun 15/2009	
O 1	Jun 15/2009		R 601	Jun 15/2009		407	Oct 15/2008	
O 2	Jun 15/2009		602	Feb 15/2009		R 408	Jun 15/2009	
O 3	Jun 15/2009		603	Feb 15/2009		409	Oct 15/2008	
O 4	Jun 15/2009		604	Feb 15/2009		410	BLANK	
O 5	Jun 15/2009		605	Feb 15/2009		47-11-04		
6	Oct 15/2008		R 606	Jun 15/2009		401	Oct 15/2008	
7	Oct 15/2008		O 607	Jun 15/2009		402	Oct 15/2008	
8	BLANK		R 608	Jun 15/2009		403	Oct 15/2008	
47-00-00			R 609	Jun 15/2009		404	Oct 15/2008	
201	Feb 15/2009		R 610	Jun 15/2009		R 405	Jun 15/2009	
202	Feb 15/2009		A 611	Jun 15/2009		R 406	Jun 15/2009	
203	Feb 15/2009		A 612	Jun 15/2009		407	Oct 15/2008	
204	Feb 15/2009		47-00-00			408	BLANK	
205	Feb 15/2009		901	Oct 15/2008		47-21-00		
206	Feb 15/2009		902	Oct 15/2008		201	Feb 15/2009	
207	Oct 15/2008		903	Oct 15/2008		202	BLANK	
208	Oct 15/2008		904	Oct 15/2008		47-21-00		
209	Feb 15/2009		905	Oct 15/2008		601	Feb 15/2009	
210	Feb 15/2009		906	Oct 15/2008		602	Feb 15/2009	
211	Feb 15/2009		47-11-01			47-21-02		
212	Feb 15/2009		401	Feb 15/2009		401	Feb 15/2009	
213	Feb 15/2009		402	Feb 15/2009		402	Feb 15/2009	
214	Feb 15/2009		403	Feb 15/2009		403	Feb 15/2009	
215	Feb 15/2009		404	Oct 15/2008		404	Feb 15/2009	
216	Feb 15/2009		405	Oct 15/2008		R 405	Jun 15/2009	
217	Feb 15/2009		406	Oct 15/2008		406	Feb 15/2009	
218	Oct 15/2008		407	Oct 15/2008		47-21-04		
219	Oct 15/2008		408	Oct 15/2008		401	Feb 15/2009	
220	BLANK		R 409	Jun 15/2009		402	Feb 15/2009	
47-00-00			410	Feb 15/2009		403	Feb 15/2009	
A 501	Jun 15/2009		411	Feb 15/2009		404	Feb 15/2009	
A 502	Jun 15/2009		412	Feb 15/2009		405	Feb 15/2009	
A 503	Jun 15/2009		47-11-02			406	Feb 15/2009	
A 504	Jun 15/2009		401	Oct 15/2008		R 407	Jun 15/2009	
A 505	Jun 15/2009		402	Oct 15/2008		408	Feb 15/2009	
A 506	Jun 15/2009		403	Oct 15/2008		409	Feb 15/2009	

A = Added, R = Revised, D = Deleted, O = Overflow, C = Customer Originated Change

47-EFFECTIVE PAGES



**737-600/700/800/900
AIRCRAFT MAINTENANCE MANUAL**

**CHAPTER 47
INERT GAS SYSTEM**

Subject/Page	Date	COC	Subject/Page	Date	COC	Subject/Page	Date	COC
47-21-04 (cont)			47-21-08 (cont)			47-31-02 (cont)		
410	Feb 15/2009		410	Oct 15/2008		226	Oct 15/2008	
411	Feb 15/2009		47-21-11			227	Oct 15/2008	
412	Feb 15/2009		401	Oct 15/2008		228	Oct 15/2008	
413	Feb 15/2009		402	Oct 15/2008		229	Oct 15/2008	
414	Feb 15/2009		403	Oct 15/2008		230	Oct 15/2008	
415	Feb 15/2009		404	BLANK		231	Oct 15/2008	
R 416	Jun 15/2009		47-31-01			232	Oct 15/2008	
417	Feb 15/2009		401	Oct 15/2008		233	Oct 15/2008	
418	BLANK		402	Oct 15/2008		234	Oct 15/2008	
47-21-05			403	Oct 15/2008		235	Oct 15/2008	
401	Feb 15/2009		404	Oct 15/2008		236	Oct 15/2008	
402	Feb 15/2009		R 405	Jun 15/2009		237	Oct 15/2008	
403	Feb 15/2009		406	Oct 15/2008		238	Oct 15/2008	
404	Feb 15/2009		47-31-02			239	Oct 15/2008	
R 405	Jun 15/2009		201	Oct 15/2008		240	Oct 15/2008	
406	Feb 15/2009		202	Oct 15/2008		241	Oct 15/2008	
407	Feb 15/2009		203	Oct 15/2008		242	Oct 15/2008	
408	BLANK		204	Oct 15/2008		243	Oct 15/2008	
47-21-07			205	Oct 15/2008		244	Oct 15/2008	
401	Oct 15/2008		206	Oct 15/2008		245	Oct 15/2008	
402	Oct 15/2008		207	Oct 15/2008		246	Oct 15/2008	
403	Oct 15/2008		208	Oct 15/2008		247	Oct 15/2008	
404	Oct 15/2008		209	Oct 15/2008		248	Oct 15/2008	
405	Oct 15/2008		210	Oct 15/2008		249	Oct 15/2008	
406	Oct 15/2008		211	Oct 15/2008		250	Oct 15/2008	
R 407	Jun 15/2009		212	Oct 15/2008		251	Oct 15/2008	
408	Oct 15/2008		213	Oct 15/2008		252	Oct 15/2008	
409	Oct 15/2008		214	Oct 15/2008		253	Oct 15/2008	
410	Oct 15/2008		215	Oct 15/2008		254	BLANK	
47-21-08			216	Oct 15/2008		47-31-02		
401	Oct 15/2008		217	Oct 15/2008		401	Oct 15/2008	
402	Oct 15/2008		218	Oct 15/2008		402	Oct 15/2008	
403	Oct 15/2008		219	Oct 15/2008		403	Oct 15/2008	
R 404	Jun 15/2009		220	Oct 15/2008		404	Oct 15/2008	
405	Oct 15/2008		221	Oct 15/2008		R 405	Jun 15/2009	
406	Oct 15/2008		222	Oct 15/2008		406	Feb 15/2009	
407	Oct 15/2008		223	Oct 15/2008		47-31-03		
408	Oct 15/2008		224	Oct 15/2008		401	Feb 15/2009	
R 409	Jun 15/2009		225	Oct 15/2008		402	Feb 15/2009	

A = Added, R = Revised, D = Deleted, O = Overflow, C = Customer Originated Change

47-EFFECTIVE PAGES



**737-600/700/800/900
AIRCRAFT MAINTENANCE MANUAL**

**CHAPTER 47
INERT GAS SYSTEM**

Subject/Page	Date	COC	Subject/Page	Date	COC	Subject/Page	Date	COC
47-31-03 (cont)			47-32-04 (cont)			47-43-01 (cont)		
403	Feb 15/2009		406	Feb 15/2009		404	Oct 15/2008	
R 404	Jun 15/2009		407	Feb 15/2009		405	Oct 15/2008	
405	Feb 15/2009		408	BLANK		406	Feb 15/2009	
406	BLANK		47-32-05			407	Oct 15/2008	
47-32-01			401	Oct 15/2008		408	Oct 15/2008	
401	Feb 15/2009		402	Oct 15/2008		47-43-02		
402	Oct 15/2008		403	Oct 15/2008		401	Oct 15/2008	
403	Oct 15/2008		404	Oct 15/2008		402	Oct 15/2008	
404	Oct 15/2008		405	Oct 15/2008		403	Oct 15/2008	
R 405	Jun 15/2009		R 406	Jun 15/2009		404	Oct 15/2008	
406	Oct 15/2008		407	Feb 15/2009		405	Feb 15/2009	
407	Oct 15/2008		R 408	Jun 15/2009		406	Oct 15/2008	
408	BLANK		47-42-01			47-43-02		
47-32-02			401	Oct 15/2008		501	Feb 15/2009	
401	Feb 15/2009		402	Oct 15/2008		502	BLANK	
402	Feb 15/2009		403	Oct 15/2008		47-43-03		
403	Oct 15/2008		404	Oct 15/2008		401	Oct 15/2008	
404	Oct 15/2008		R 405	Jun 15/2009		402	Oct 15/2008	
R 405	Jun 15/2009		R 406	Jun 15/2009		403	Oct 15/2008	
406	Feb 15/2009		47-42-02			404	Oct 15/2008	
407	Feb 15/2009		401	Oct 15/2008		405	Feb 15/2009	
408	BLANK		402	Oct 15/2008		406	Oct 15/2008	
47-32-03			403	Oct 15/2008		47-43-04		
401	Feb 15/2009		404	Oct 15/2008		401	Oct 15/2008	
402	Feb 15/2009		405	Oct 15/2008		402	Oct 15/2008	
403	Oct 15/2008		406	Oct 15/2008		403	Oct 15/2008	
404	Oct 15/2008		407	Oct 15/2008		404	Oct 15/2008	
405	Oct 15/2008		408	BLANK		405	Oct 15/2008	
406	Oct 15/2008		47-42-03			406	Oct 15/2008	
R 407	Jun 15/2009		401	Oct 15/2008				
408	Feb 15/2009		402	Oct 15/2008				
R 409	Jun 15/2009		403	Oct 15/2008				
410	Feb 15/2009		404	Oct 15/2008				
47-32-04			R 405	Jun 15/2009				
401	Oct 15/2008		406	Oct 15/2008				
402	Oct 15/2008		47-43-01					
403	Oct 15/2008		401	Oct 15/2008				
404	Oct 15/2008		402	Oct 15/2008				
R 405	Jun 15/2009		403	Oct 15/2008				

A = Added, R = Revised, D = Deleted, O = Overflow, C = Customer Originated Change

47-EFFECTIVE PAGES



737-600/700/800/900
AIRCRAFT MAINTENANCE MANUAL

CHAPTER 47
INERT GAS SYSTEM

<u>Subject</u>	<u>Chapter Section Subject</u>	<u>Conf</u>	<u>Page</u>	<u>Effect</u>
<u>NITROGEN GENERATION SYSTEM - MAINTENANCE PRACTICES</u>	47-00-00		201	HAP 036-054, 101-999
Airworthiness Limitation Precautions TASK 47-00-00-910-802			201	HAP 036-054, 101-999
Nitrogen Generation System (NGS) Precautions TASK 47-00-00-010-801			202	HAP 047-053, 106-999
Ground Operation of the Nitrogen Generation System TASK 47-00-00-800-801			209	HAP 047-053, 106-999
<u>NITROGEN GENERATION SYSTEM - ADJUSTMENT/TEST</u>	47-00-00		501	HAP 047-053, 106-999
Functional Test of the Nitrogen Generation System TASK 47-00-00-720-801			501	HAP 047-053, 106-999
<u>NITROGEN GENERATION SYSTEM - INSPECTION/CHECK</u>	47-00-00		601	HAP 047-053, 106-999
Leak Check of the Nitrogen Generation System TASK 47-00-00-790-801			601	HAP 047-053, 106-999
Cross Vent Check Valve - Inspection/ Check TASK 47-00-00-280-801			610	HAP 047-053, 106-999
<u>NITROGEN GENERATION SYSTEM - DDG MAINTENANCE PROCEDURES</u>	47-00-00		901	HAP 047-053, 106-999
MMEL 47-1 (DDPG) Preparation - Nitrogen Generation System Inoperative TASK 47-00-00-040-801			901	HAP 047-053, 106-999
MMEL 47-1 (DDPG) Restoration - Nitrogen Generation System Inoperative TASK 47-00-00-440-801			905	HAP 047-053, 106-999

47-CONTENTS



737-600/700/800/900
AIRCRAFT MAINTENANCE MANUAL

CHAPTER 47
INERT GAS SYSTEM

<u>Subject</u>	<u>Chapter Section Subject</u>	<u>Conf</u>	<u>Page</u>	<u>Effect</u>
<u>AIR SEPARATION MODULE - REMOVAL/ INSTALLATION</u>	47-11-01		401	HAP 047-053, 106-999
Air Separation Module (ASM) Removal TASK 47-11-01-000-801			401	HAP 047-053, 106-999
Air Separation Module (ASM) Installation TASK 47-11-01-420-801			409	HAP 047-053, 106-999
<u>HIGH FLOW VALVE - REMOVAL/ INSTALLATION</u>	47-11-02		401	HAP 047-053, 106-999
High Flow Valve Removal TASK 47-11-02-000-801			401	HAP 047-053, 106-999
High Flow Valve Installation TASK 47-11-02-420-801			406	HAP 047-053, 106-999
<u>OVERTEMPERATURE SHUTOFF VALVE - REMOVAL/INSTALLATION</u>	47-11-04		401	HAP 047-053, 106-999
Overtemperature Shutoff Valve Removal TASK 47-11-04-000-801			401	HAP 047-053, 106-999
Overtemperature Shutoff Valve Installation TASK 47-11-04-400-801			405	HAP 047-053, 106-999
<u>NITROGEN-ENRICHED AIR DISTRIBUTION - MAINTENANCE PRACTICES</u>	47-21-00		201	HAP 036-054, 101-999
<u>NITROGEN-ENRICHED AIR DISTRIBUTION - INSPECTION/CHECK</u>	47-21-00		601	HAP 047-053, 106-999
Drain Cap - Fuel Leak Check TASK 47-21-00-700-802			601	HAP 047-053, 106-999
<u>FLOAT VALVE - REMOVAL/INSTALLATION</u>	47-21-02		401	HAP 036-054, 101-999
Float Valve Removal TASK 47-21-02-000-801			401	HAP 036-054, 101-999
Float Valve Installation TASK 47-21-02-420-801			405	HAP 036-054, 101-999

47-CONTENTS



737-600/700/800/900
AIRCRAFT MAINTENANCE MANUAL

CHAPTER 47
INERT GAS SYSTEM

<u>Subject</u>	<u>Chapter Section Subject</u>	<u>Conf</u>	<u>Page</u>	<u>Effect</u>
<u>BACKFLOW CHECK VALVE - REMOVAL/ INSTALLATION</u>	47-21-04		401	HAP 036-054, 101-999
Primary Backflow Prevention Check Valve Removal TASK 47-21-04-000-801			401	HAP 036-054, 101-999
Primary Backflow Prevention Check Valve Installation TASK 47-21-04-400-801			407	HAP 036-054, 101-999
Secondary Backflow Prevention Check Valve Removal TASK 47-21-04-000-803			409	HAP 036-054, 101-999
Secondary Backflow Prevention Check Valve Installation TASK 47-21-04-400-803			416	HAP 036-054, 101-999
<u>CROSS VENT CHECK VALVE - REMOVAL/ INSTALLATION</u>	47-21-05		401	HAP 036-054, 101-999
Cross Vent Check Valve Removal TASK 47-21-05-000-801			401	HAP 036-054, 101-999
Cross Vent Check Valve Installation TASK 47-21-05-420-801			405	HAP 036-054, 101-999
<u>FLAME ARRESTOR - REMOVAL/ INSTALLATION</u>	47-21-07		401	HAP 047-053, 106-999
Flame Arrestor Removal TASK 47-21-07-000-801			401	HAP 047-053, 106-999
Flame Arrestor Installation TASK 47-21-07-400-801			407	HAP 047-053, 106-999
<u>LIGHTNING SHIELDS - REMOVAL/ INSTALLATION</u>	47-21-08		401	HAP 047-053, 106-999
Upper Lightning Shield Removal TASK 47-21-08-000-801			401	HAP 047-053, 106-999
Upper Lightning Shield Installation TASK 47-21-08-400-801			404	HAP 047-053, 106-999
Lower Lightning Shield Removal TASK 47-21-08-000-802			405	HAP 047-053, 106-999

47-CONTENTS



737-600/700/800/900
AIRCRAFT MAINTENANCE MANUAL

CHAPTER 47
INERT GAS SYSTEM

<u>Subject</u>	<u>Chapter Section Subject</u>	<u>Conf</u>	<u>Page</u>	<u>Effect</u>
Lower Lightning Shield Installation TASK 47-21-08-400-802			409	HAP 047-053, 106-999
<u>DRAIN CAP - REMOVAL/INSTALLATION</u>	47-21-11		401	HAP 047-053, 106-999
Drain Cap Removal TASK 47-21-11-000-801			401	HAP 047-053, 106-999
Drain Cap Installation TASK 47-21-11-400-801			402	HAP 047-053, 106-999
<u>NITROGEN GENERATION SYSTEM CONTROLLER - REMOVAL/ INSTALLATION</u>	47-31-01		401	HAP 047-053, 106-999
Nitrogen Generation System Controller Removal TASK 47-31-01-000-801			401	HAP 047-053, 106-999
Nitrogen Generation System Controller Installation TASK 47-31-01-400-801			405	HAP 047-053, 106-999
<u>BITE DISPLAY UNIT - MAINTENANCE PRACTICES</u>	47-31-02		201	HAP 047-053, 106-999
BDU Main Menu TASK 47-31-02-740-801			201	HAP 047-053, 106-999
BDU Existing Fault Menu TASK 47-31-02-740-802			209	HAP 047-053, 106-999
BDU Fault History Menu TASK 47-31-02-740-803			218	HAP 047-053, 106-999
BDU Ground Test Menu TASK 47-31-02-740-804			230	HAP 047-053, 106-999
Other Function Menu TASK 47-31-02-740-805			243	HAP 047-053, 106-999
<u>BITE DISPLAY UNIT - REMOVAL/ INSTALLATION</u>	47-31-02		401	HAP 047-053, 106-999
BITE Display Unit Removal TASK 47-31-02-000-801			401	HAP 047-053, 106-999

47-CONTENTS



737-600/700/800/900
AIRCRAFT MAINTENANCE MANUAL

CHAPTER 47
INERT GAS SYSTEM

<u>Subject</u>	<u>Chapter Section Subject</u>	<u>Conf</u>	<u>Page</u>	<u>Effect</u>
BITE Display Unit Installation TASK 47-31-02-400-801			405	HAP 047-053, 106-999
<u>OPERABILITY INDICATOR - REMOVAL/ INSTALLATION</u>	47-31-03		401	HAP 036-054, 101-999
Operability Indicator Removal TASK 47-31-03-000-801			401	HAP 036-054, 101-999
Operability Indicator Installation TASK 47-31-03-400-801			404	HAP 036-054, 101-999
<u>NGS SHUTOFF VALVE - REMOVAL/ INSTALLATION</u>	47-32-01		401	HAP 047-053, 106-999
NGS Shutoff Valve Removal TASK 47-32-01-000-801			401	HAP 047-053, 106-999
NGS Shutoff Valve Installation TASK 47-32-01-400-801			405	HAP 047-053, 106-999
<u>OZONE CONVERTER - REMOVAL/ INSTALLATION</u>	47-32-02		401	HAP 047-053, 106-999
Ozone Converter Removal TASK 47-32-02-000-801			401	HAP 047-053, 106-999
Ozone Converter Installation TASK 47-32-02-400-801			405	HAP 047-053, 106-999
<u>HEAT EXCHANGER - REMOVAL/ INSTALLATION</u>	47-32-03		401	HAP 047-053, 106-999
Heat Exchanger Removal TASK 47-32-03-000-801			401	HAP 047-053, 106-999
Heat Exchanger Installation TASK 47-32-03-400-801			407	HAP 047-053, 106-999
<u>FILTER - REMOVAL/INSTALLATION</u>	47-32-04		401	HAP 047-053, 106-999
Filter Removal TASK 47-32-04-000-801			401	HAP 047-053, 106-999
Filter Installation TASK 47-32-04-400-801			405	HAP 047-053, 106-999

47-CONTENTS



737-600/700/800/900
AIRCRAFT MAINTENANCE MANUAL

CHAPTER 47
INERT GAS SYSTEM

<u>Subject</u>	<u>Chapter Section Subject</u>	<u>Conf</u>	<u>Page</u>	<u>Effect</u>
<u>RAM AIR VALVE - REMOVAL/ INSTALLATION</u>	47-32-05		401	HAP 047-053, 106-999
Ram Air Valve Removal TASK 47-32-05-000-801			401	HAP 047-053, 106-999
Ram Air Valve Installation TASK 47-32-05-400-801			406	HAP 047-053, 106-999
<u>ALTITUDE SENSOR - REMOVAL/ INSTALLATION</u>	47-42-01		401	HAP 047-053, 106-999
Altitude Sensor Removal TASK 47-42-01-000-801			401	HAP 047-053, 106-999
Altitude Sensor Installation TASK 47-42-01-400-801			405	HAP 047-053, 106-999
<u>HIGH FLOW VALVE DIFFERENTIAL PRESSURE SENSOR - REMOVAL/ INSTALLATION</u>	47-42-02		401	HAP 047-053, 106-999
High Flow Valve Differential Pressure Sensor Removal TASK 47-42-02-020-801			401	HAP 047-053, 106-999
High Flow Valve Differential Pressure Sensor Installation TASK 47-42-02-400-801			405	HAP 047-053, 106-999
<u>NGS OXYGEN SENSOR - REMOVAL/ INSTALLATION</u>	47-42-03		401	HAP 047-053, 106-999
NGS Oxygen Sensor Removal TASK 47-42-03-020-801			401	HAP 047-053, 106-999
NGS Oxygen Sensor Installation TASK 47-42-03-420-801			405	HAP 047-053, 106-999
<u>FILTER DIFFERENTIAL PRESSURE SWITCH - REMOVAL/INSTALLATION</u>	47-43-01		401	HAP 047-053, 106-999
Filter Differential Pressure Switch Removal TASK 47-43-01-000-801			401	HAP 047-053, 106-999

47-CONTENTS



737-600/700/800/900
AIRCRAFT MAINTENANCE MANUAL

CHAPTER 47
INERT GAS SYSTEM

<u>Subject</u>	<u>Chapter Section Subject</u>	<u>Conf</u>	<u>Page</u>	<u>Effect</u>
Filter Differential Pressure Switch Installation TASK 47-43-01-400-801			406	HAP 047-053, 106-999
<u>THERMAL SWITCH - REMOVAL/ INSTALLATION</u>	47-43-02		401	HAP 047-053, 106-999
Thermal Switch Removal TASK 47-43-02-000-801			401	HAP 047-053, 106-999
Thermal Switch Installation TASK 47-43-02-400-801			405	HAP 047-053, 106-999
<u>THERMAL SWITCH - ADJUSTMENT/TEST</u>	47-43-02		501	HAP 047-053, 106-999
Thermal Switch Functional Test TASK 47-43-02-720-801			501	HAP 047-053, 106-999
<u>TEMPERATURE SENSOR - REMOVAL/ INSTALLATION</u>	47-43-03		401	HAP 047-053, 106-999
Temperature Sensor Removal TASK 47-43-03-000-801			401	HAP 047-053, 106-999
Temperature Sensor Installation TASK 47-43-03-400-801			405	HAP 047-053, 106-999
<u>NGS PRESSURE SENSOR - REMOVAL/ INSTALLATION</u>	47-43-04		401	HAP 047-053, 106-999
NGS Pressure Sensor Removal TASK 47-43-04-000-801			401	HAP 047-053, 106-999
NGS Pressure Sensor Installation TASK 47-43-04-400-801			405	HAP 047-053, 106-999

47-CONTENTS



737-600/700/800/900

AIRCRAFT MAINTENANCE MANUAL

NITROGEN GENERATION SYSTEM - MAINTENANCE PRACTICES

1. General

A. This procedure has these tasks:

- (1) Airworthiness Limitation Precautions

HAP 047-053, 106-999

- (2) Nitrogen Generation System Precautions
- (3) Ground Operation of the Nitrogen Generation System

HAP 036-054, 101-999

TASK 47-00-00-910-802

2. Airworthiness Limitation Precautions

A. General

- (1) Critical Design Configuration Control Limitations (CDCCLs)

(a) All occurrences of CDCCLs found in this chapter of the AMM are identified by this note after each applicable CDCCL design feature:

- 1) NOTE: CDCCL - Refer to the task: Airworthiness Limitation Precautions (NITROGEN GENERATION SYSTEM - MAINTENANCE PRACTICES, 47-00-00/201), for important information on Critical Design Configuration Control Limitations (CDCCLs).

(b) Design features that are CDCCLs are defined and controlled by Special Federal Aviation Regulation (SFAR) 88, and can be found in Section 9 of the Maintenance Planning Data (MPD) document. CDCCLs are a means of identifying certain design configuration features intended to preclude a fuel tank ignition source for the operational life of the airplane. CDCCLs are mandatory and cannot be changed or deleted without the approval of the FAA office that is responsible for the airplane model Type Certificate, or applicable regulatory agency. A critical fuel tank ignition source prevention feature may exist in the fuel system and its related installation or in systems that, if a failure condition were to develop, could interact with the fuel system in such a way that an unsafe condition would develop without this limitation. Strict adherence to configuration, methods, techniques, and practices as prescribed is required to ensure the CDCCL is complied with. Any use of parts, methods, techniques or practices not contained in the applicable CDCCL must be approved by the FAA office that is responsible for the airplane model Type Certificate, or applicable regulatory agency.

- (2) Airworthiness Limitation Instructions (ALIs)

(a) All occurrences of fuel tank system ALIs found in this chapter of the AMM are identified by this step after the General section in the applicable ALI inspection task:

- 1) ALI - Refer to the task: Airworthiness Limitation Precautions (NITROGEN GENERATION SYSTEM - MAINTENANCE PRACTICES, 47-00-00/201), for important information on airworthiness limitation instructions (ALIs).

EFFECTIVITY
HAP 036-054, 101-999

47-00-00

Page 201
Feb 15/2009

D633A101-HAP



737-600/700/800/900

AIRCRAFT MAINTENANCE MANUAL

- (b) Inspection tasks that are ALIs are defined and controlled by Special Federal Aviation Regulation (SFAR) 88, and can be found in Section 9 of the Maintenance Planning Data (MPD) document. These ALIs identify inspection tasks related to fuel tank ignition source prevention which must be done to maintain the design level of safety for the operational life of the airplane. These ALIs are mandatory and cannot be changed or deleted without the approval of the FAA office that is responsible for the airplane model Type Certificate, or applicable regulatory agency. Strict adherence to methods, techniques and practices as prescribed is required to ensure the ALI is complied with. Any use of methods, techniques or practices not contained in these ALIs must be approved by the FAA office that is responsible for the airplane model Type Certificate, or applicable regulatory agency.

B. Location Zones

Zone	Area
100	Lower Half of Fuselage
200	Upper Half of Fuselage
300	Empennage
400	Powerplant and Nacelle Struts
500	Left Wing
600	Right Wing

C. Critical Design Configuration Control Limitations (CDCCLs)

SUBTASK 47-00-00-910-009

WARNING: OBEY THE MANUFACTURER'S PROCEDURES WHEN YOU DO MAINTENANCE THAT HAS AN EFFECT ON A CDCCL. IF YOU DO NOT OBEY THE PROCEDURES, IT CAN INCREASE THE RISK OF A SOURCE OF FUEL TANK IGNITION. INJURIES TO PERSONNEL, AND DAMAGE TO EQUIPMENT CAN OCCUR IF THERE IS A FIRE OR EXPLOSION.

- (1) Make sure you follow the procedures for items identified as CDCCLs.

D. Airworthiness Limitation Instructions (ALIs)

SUBTASK 47-00-00-910-010

WARNING: OBEY THE MANUFACTURER'S PROCEDURES WHEN YOU DO ANY MAINTENANCE THAT MAY AFFECT AN ALI. IF YOU DO NOT FOLLOW THE PROCEDURES, IT CAN INCREASE THE RISK OF A FUEL TANK IGNITION SOURCE.

- (1) Make sure you follow the procedures for the tasks identified as ALIs.

————— **END OF TASK** —————

HAP 047-053, 106-999

TASK 47-00-00-010-801

3. Nitrogen Generation System (NGS) Precautions

(Figure 201)

A. General

- (1) This task has these procedures:
 - (a) Physiological Effects of a Low Oxygen Content Environment
 - (b) Fuel Tank Entry Precautions
 - (c) Air Conditioning Compartment Precautions
 - (d) Main Wheel Well Precautions
 - (e) Nitrogen Generation System Maintenance Precautions

EFFECTIVITY HAP 036-054, 101-999
--

47-00-00

Page 202
Feb 15/2009

D633A101-HAP



737-600/700/800/900

AIRCRAFT MAINTENANCE MANUAL

HAP 047-053, 106-999 (Continued)

(f) Air Separation Module Precautions

- (2) The NGS is an inert gas system that decreases the flammability of the center tank. Fresh air contains approximately 78% nitrogen and 21% oxygen. The NGS separates the nitrogen and oxygen into nitrogen-enriched air (NEA) and oxygen-enriched air (OEA). NEA increases the nitrogen content and decreases the oxygen of the air. If you breathe air that does not have sufficient oxygen, health problems can occur. Obey the precautions in this procedure if you do maintenance in an area where you could breathe air that does not have sufficient oxygen.
- (3) The NGS components are found in the air conditioning compartment on the left side of the airplane. Access to the thermal control unit and air separation module (ASM) is through access door 192BL. The nitrogen enriched air distribution system (NEADS) line is attached to the ASM and is routed to the center tank through the left wheel well. The NEADS line has 1/2 inch aluminum tubing, a dielectric hose, a flame arrestor, check valves, and an ejector nozzle.
- (4) The usual operation of the nitrogen generation system will cause the air inside the fuel tanks to have a decreased oxygen content. Do not breathe the air in a fuel tank unless that tank is fully ventilated. Procedures for fuel tank purging and entry on airplanes equipped with a nitrogen generation system are given in Chapter ATA 28, Fuel Systems. Danger stencils and placards are installed adjacent to fuel tank access doors to warn you of the hazards that can occur if you breathe air with low oxygen content.
- (5) NEA that is generated by the air separation module (ASM) is routed safely to the center tank. The usual operation of the nitrogen generation system outside of the fuel tanks is free from concentrations of NEA. However, a duct leak, or component failure can cause NEA to go into areas outside of the fuel tanks. An NEA leak can cause a condition where the oxygen content of the air is decreased. Caution stencils and placards are installed on access doors adjacent to areas where potential NEA leakage can occur.
- (6) If you make a decision not to do this recommended procedure, you must have an approved alternate procedure. Make sure the conditions during maintenance operations give sufficient protection to the persons and equipment used in this procedure. It is possible that local fire codes, and standards make it necessary to use more restrictive procedures or more procedures than those given in this procedure.

B. References

Reference	Title
28-11-00-910-801	Purging and Fuel Tank Entry Precautions (P/B 201)

C. Location Zones

Zone	Area
134	Main Landing Gear Wheel Well, Body Station 663.75 to Body Station 727.00 - Right
192	Lower Wing-To-Body Fairing - Under Wing Box
531	Left Wing - Center Fuel Tank, Rib 1 to Rib 5
631	Right Wing - Center Fuel Tank, Rib 1 to Rib 5
633	Right Wing - Surge Tank, Rib 22 to Rib 25, Wing Station 643.50 to Wing Buttock Line 616.75

EFFECTIVITY
HAP 036-054, 101-999

47-00-00



737-600/700/800/900

AIRCRAFT MAINTENANCE MANUAL

HAP 047-053, 106-999 (Continued)

D. Physiological Effects of a Low Oxygen Content Environment

SUBTASK 47-00-00-910-001

- (1) NEA increases the nitrogen content and decreases the oxygen of the air. If you breathe air without sufficient oxygen, it can have dangerous and immediate effects. If a person breathes air without sufficient oxygen, these health problems can occur:

Make sure that you read and obey the warning placard in areas where there you can find nitrogen enriched air. Read and obey the warnings in the maintenance instructions. Nitrogen generation equipment is dangerous because you cannot see or smell the gas. The equipment decreases the oxygen in the air to a condition that is not health safe. It can cause hypoxia. Hypoxia can make you dizzy, nauseous, unconscious, and can kill you.

- (a) A person that breathes air with a low oxygen content cannot sense that the oxygen level is too low. The victim can become unconscious before the person is aware of the low oxygen content air.
- (b) An organic vapor filter respirator will not help you breathe in a low oxygen environment.

E. Fuel Tank Entry Precautions

SUBTASK 47-00-00-910-002

WARNING: DO NOT BREATHE THE AIR FROM THE FUEL TANK UNTIL YOU MAKE IT SAFE. THE NITROGEN GENERATION SYSTEM DECREASES THE OXYGEN IN THE AIR. IF YOU BREATHE AIR THAT DOES NOT HAVE SUFFICIENT OXYGEN, DANGEROUS HEALTH CONDITIONS CAN QUICKLY OCCUR. DANGEROUS HEALTH CONDITIONS INCLUDE NAUSEA, UNCONSCIOUSNESS, AND CONVULSIONS. IF THE OXYGEN LEVEL OF THE AIR THAT YOU BREATHE IS VERY LOW, IT CAN KILL YOU.

- (1) For NGS related fuel tank purging and entry precautions obey the steps in this task: Purging and Fuel Tank Entry Precautions, TASK 28-11-00-910-801.

F. Air Conditioning Compartment Precautions

SUBTASK 47-00-00-910-003

WARNING: OBEY THE SUBSEQUENT STEPS FOR ACCESS PANELS IDENTIFIED WITH A NITROGEN GENERATION SYSTEM PLACARD. IF THERE IS A LEAK IN THE NITROGEN GENERATION SYSTEM, IT WILL DECREASE THE OXYGEN IN THE AIR THAT YOU BREATHE. IF YOU BREATHE AIR THAT DOES NOT HAVE SUFFICIENT OXYGEN, DANGEROUS HEALTH CONDITIONS CAN QUICKLY OCCUR.

WARNING: WHEN YOU DO A TEST OF THE SYSTEM, MAKE SURE THAT THERE IS SUFFICIENT AIRFLOW IN THE AREA. USE LIFE SUPPORT EQUIPMENT IF YOU THINK THAT THERE IS A HIGH NITROGEN CONCENTRATION. LOW OXYGEN LEVELS IN THE AIR ARE DANGEROUS TO PERSONNEL.

- (1) Obey these precautions for maintenance tasks in the air conditioning compartment and the left ram air duct bay:
 - (a) Make sure that the L PACK selector switch, on the P5-10 air conditioning panel, is in the OFF position.
 - (b) If the L PACK selector switch is in the AUTO position and the pack is on, do these steps:
 - 1) Make sure that a colleague is present to help you if necessary.
 - 2) Use extreme caution when entering the left air conditioning compartment or the wheel well.

EFFECTIVITY
HAP 036-054, 101-999

47-00-00

Page 204
Feb 15/2009

D633A101-HAP



737-600/700/800/900

AIRCRAFT MAINTENANCE MANUAL

HAP 047-053, 106-999 (Continued)

- 3) If there is an obvious NGS or NEADS leak, get out of the area and shut down the pneumatic air supply.

G. Main Wheel Well Precautions

SUBTASK 47-00-00-910-004

WARNING: OBEY THE SUBSEQUENT STEPS FOR ACCESS PANELS IDENTIFIED WITH A NITROGEN GENERATION SYSTEM PLACARD. IF THERE IS A LEAK IN THE NITROGEN GENERATION SYSTEM, IT WILL DECREASE THE OXYGEN IN THE AIR THAT YOU BREATHE. IF YOU BREATHE AIR THAT DOES NOT HAVE SUFFICIENT OXYGEN, DANGEROUS HEALTH CONDITIONS CAN QUICKLY OCCUR.

WARNING: WHEN YOU DO A TEST OF THE SYSTEM, MAKE SURE THAT THERE IS SUFFICIENT AIRFLOW IN THE AREA. USE LIFE SUPPORT EQUIPMENT IF YOU THINK THAT THERE IS A HIGH NITROGEN CONCENTRATION. LOW OXYGEN LEVELS IN THE AIR ARE DANGEROUS TO PERSONNEL.

- (1) Before you go into the wheel well do these steps:
 - (a) Make sure the L PACK selector switch, on the air conditioning panel, is in the OFF position.
 - (b) If the L PACK selector switch is in the AUTO position and the NGS is operating, do these steps:
 - 1) Make sure that colleague is present to help you if necessary.
 - 2) Do not go into the main wheel well area more than to waist level.
 - 3) If there is an obvious NGS leak, get out of the wheel well and shut off the pneumatic supply.
 - 4) There are no restrictions if the NGS system is locked out.

H. Nitrogen Generation System Maintenance Precautions

SUBTASK 47-00-00-910-005

WARNING: DO NOT TOUCH THE COMPONENTS OF THE NITROGEN GENERATION SYSTEM WHEN THEY ARE HOT. WHEN THE COMPONENTS ARE HOT, THEY CAN CAUSE INJURIES TO PERSONNEL.

- (1) Obey these precautions:
 - (a) Use caution and sufficient protection when you are near the Nitrogen Generation System (NGS) components.

NOTE: The nitrogen generation equipment gets air from the wing bleed crossover duct. The heat exchanger decreases the air temperature from 300°F (149°C) - 400°F (204°C) to 160°F (71.1°C). A temperature of 160°F (71.1°C) will burn you if you touch the components.

NOTE: After the NGS stops, it goes to the cool down mode. The cool down mode prevents damage to the heat exchanger from the thermal shock of a fast cool down. The cool down mode drives the OTSOV and the ram air valve closed, and keeps the NGS shutoff valve open. After approximately 30 minutes, the NGS shutoff valve closes and the ram air valve opens.

EFFECTIVITY
HAP 036-054, 101-999

D633A101-HAP

47-00-00

Page 205
Feb 15/2009



737-600/700/800/900

AIRCRAFT MAINTENANCE MANUAL

HAP 047-053, 106-999 (Continued)

SUBTASK 47-00-00-910-006

WARNING: DO NOT DISCONNECT THE COMPONENTS OF THE NITROGEN GENERATION SYSTEM, OR DUCTS WHEN THE SYSTEM IS PRESSURIZED. THE HOT, HIGH-PRESSURE AIR CAN CAUSE INJURIES TO PERSONNEL, AND DAMAGE TO EQUIPMENT.

- (2) Make sure that you remove the bleed air source and release pressure before you disconnect the system components or ducts.

NOTE: The bleed air source gives high pressure air to the thermal control unit (TCU) components.

I. Air Separation Module Precautions

SUBTASK 47-00-00-910-007

CAUTION: DO NOT LET SOLVENTS, LUBRICANTS, OTHER FLUIDS, OR THEIR FUMES TOUCH THE FIBERS IN THE AIR SEPARATION MODULE (ASM). CONTAMINATION WILL CAUSE DAMAGE TO THE FIBERS, AND DECREASE THE LIFE OF THE ASM.

CAUTION: MAKE SURE THAT THE MAINTENANCE AREA IS FREE OF CONTAMINATION FROM SKYDROL, LUBRICANTS, SOLVENTS, FUEL, FUMES, EXHAUST, OR DUST. DO NOT LET SOLVENTS, LUBRICANTS, OTHER FLUIDS, OR THEIR FUMES GO INTO THE FLOW PATH TO OR FROM THE ASM. CONTAMINATION WILL CAUSE DAMAGE TO THE FIBERS IN THE ASM AND DECREASE THEIR LIFE.

- (1) Make sure the maintenance area is free from solvents, fuel, dust and lubricants that can damage the ASM fibers.

NOTE: The ASM fibers are easily damaged.

SUBTASK 47-00-00-910-008

CAUTION: USE ONLY THE SPECIFIED GREASE WHEN YOU INSTALL THE COMPONENTS FOR THE NITROGEN GENERATION SYSTEM. OTHER LUBRICANTS, OR THEIR FUMES, CAN FLOW THROUGH THE NGS DUCTS AND CAUSE DAMAGE TO THE FIBERS IN THE ASM. DAMAGED FIBERS WILL DECREASE THE LIFE OF THE ASM.

- (2) Use only approved lubricant for the ASM and TCU.

NOTE: Unapproved lubricants can damage the fibers in the ASM.

————— **END OF TASK** —————

EFFECTIVITY
HAP 036-054, 101-999

D633A101-HAP

47-00-00

Page 206
Feb 15/2009

AIRCRAFT MAINTENANCE MANUAL

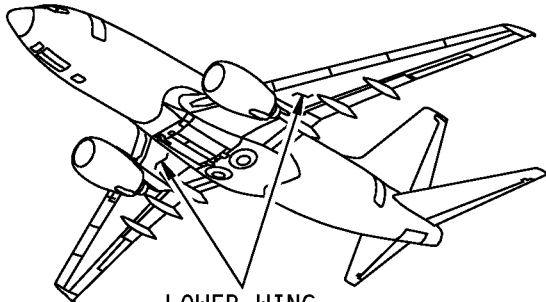

LOWER WING EXTERIOR

SEE (A)

⚠ DANGER

Low Oxygen or Flammable Contents.
Nitrogen Generation System Installed.
Obey Fuel Tank Entry Procedures.
Refer to AMM 28-11-00.
Failure to Obey Will Cause Serious Injury or Death.

BAC27XSTN4045

WING STENCIL (EXAMPLE)

(B)

WING STENCIL (EXAMPLE)

SEE (B)

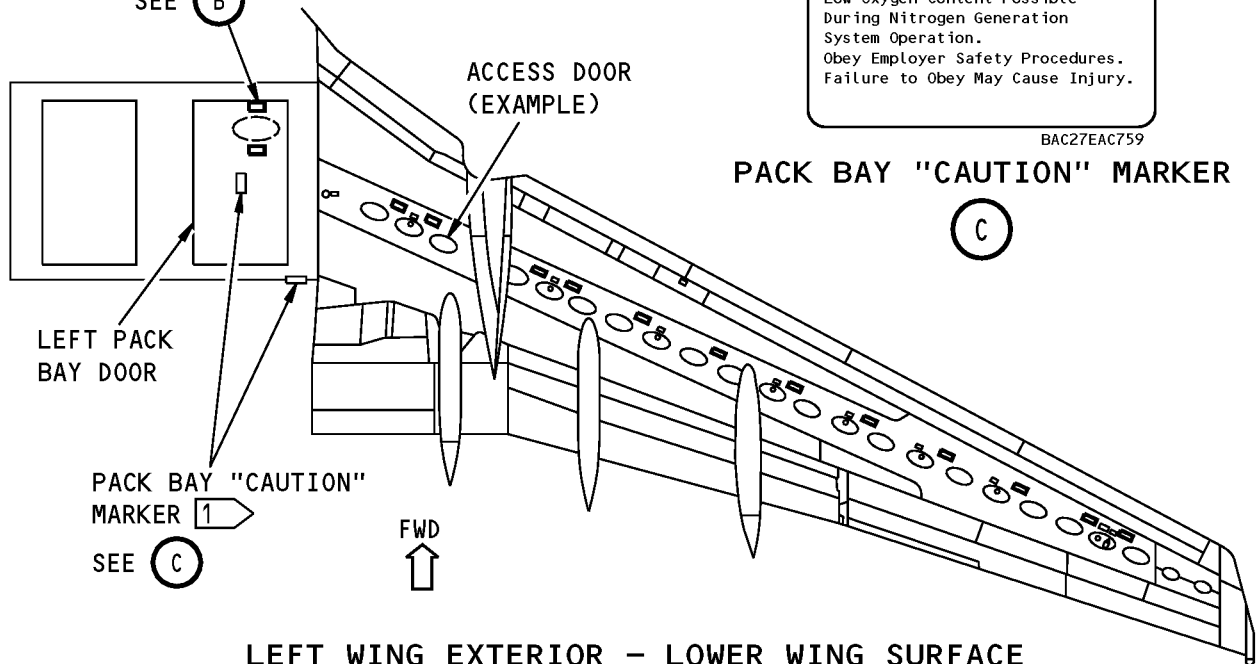

LEFT PACK BAY DOOR

ACCESS DOOR (EXAMPLE)

PACK BAY "CAUTION" MARKER 1

SEE (C)

FWD
↑

⚠ CAUTION

Low Oxygen Content Possible
During Nitrogen Generation
System Operation.
Obey Employer Safety Procedures.
Failure to Obey May Cause Injury.

BAC27EAC759

PACK BAY "CAUTION" MARKER

(C)

**LEFT WING EXTERIOR - LOWER WING SURFACE
(RIGHT WING IS OPPOSITE;
WING STENCILS ARE SYMMETRICAL ONLY)**

(A)

1 MARKERS LOCATE INSIDE THE LEFT PACK BAY DOOR AND THE LEFT SIDE OF THE RAM COMPARTMENT ON VAPOR BARRIER (AFT END, NEAREST WHEEL WELL)

**Nitrogen Generation System Precautions
Figure 201 (Sheet 1 of 2)/47-00-00-990-807**

EFFECTIVITY
HAP 047-053, 106-999

47-00-00

Page 207
Oct 15/2008

D633A101-HAP



737-600/700/800/900
AIRCRAFT MAINTENANCE MANUAL

 **CAUTION**

Low Oxygen Content Possible
During Nitrogen Generation
System Operation.
Obey Employer Safety Procedures.
Failure to Obey May Cause Injury.

BAC27EAC759

A/C BAY PLACARD

 **DANGER**

Low Oxygen or Flammable Contents.
Nitrogen Generation System Installed.
Obey Fuel Tank Entry Procedures.
Refer to AMM 28-11-00.
Failure to Obey Will Cause Serious Injury or Death.

BAC27XSTN4045

WING STENCIL

 **DANGER**

Low Oxygen or Flammable Contents.
Nitrogen Generation System Installed.
Obey Fuel Tank Entry Procedures.
Refer to AMM 28-11-00.
Failure to Obey Will Cause Serious Injury or Death.

BAC27DFS339

TANK ENTRY PLACARD

Nitrogen Generation System Precautions
Figure 201 (Sheet 2 of 2)/47-00-00-990-807

EFFECTIVITY
HAP 047-053, 106-999

D633A101-HAP

47-00-00

Page 208
Oct 15/2008



737-600/700/800/900

AIRCRAFT MAINTENANCE MANUAL

HAP 047-053, 106-999 (Continued)

TASK 47-00-00-800-801

4. Ground Operation of the Nitrogen Generation System

(Figure 202, Figure 203, Figure 204)

A. General

(1) This task contains these procedures:

- (a) Prepare for the Ground Operation of the Nitrogen Generation System
- (b) Electrical Test of the Nitrogen Generation System
- (c) System Test for the Nitrogen Generation System
- (d) Pressurize the ECS Air Supply System
- (e) Ground Operation of the Nitrogen Generation System
- (f) Depressurize the ECS Air Supply System
- (g) Put the Airplane Back to the Usual Condition

B. References

Reference	Title
21-00-00-800-803	Supply Conditioned Air with a Cooling Pack (P/B 201)
21-00-00-800-804	Remove Conditioned Air Supplied by a Cooling Pack (P/B 201)
24-22-00-860-811	Supply Electrical Power (P/B 201)
32-09-00-860-802	Return the Airplane to the Ground Mode (P/B 201)
36-00-00-860-803	Supply Pressure to the Pneumatic System with the APU (P/B 201)
36-00-00-860-804	Supply Pressure to the Pneumatic System with One or Both Engines (P/B 201)
36-00-00-860-806	Remove Pressure from the Pneumatic System (P/B 201)
47-31-02 P/B 201	BITE DISPLAY UNIT - MAINTENANCE PRACTICES
49-11-00-860-802	APU Usual Shutdown (P/B 201)

C. Location Zones

Zone	Area
124	Forward Cargo Compartment - Right
131	Center Section Wing Box, Body Station 540.00 to Body Station 663.75 - Left
133	Main Landing Gear Wheel Well, Body Station 663.75 to Body Station 727.00 - Left
134	Main Landing Gear Wheel Well, Body Station 663.75 to Body Station 727.00 - Right
211	Flight Compartment - Left
212	Flight Compartment - Right

D. Access Panels

Number	Name/Location
192BL	ECS Ram Air Inlet Mixing Duct Panel - Forward
192CL	Air Conditioning Access Door
192CR	Air Conditioning Access Door
621GB	Refuel Access Panel - Slat Station 143.27

EFFECTIVITY HAP 036-054, 101-999

47-00-00

Page 209
Feb 15/2009

D633A101-HAP



737-600/700/800/900

AIRCRAFT MAINTENANCE MANUAL

HAP 047-053, 106-999 (Continued)

E. Prepare for the Ground Operation of the Nitrogen Generation System

SUBTASK 47-00-00-863-001

- (1) On the hydraulic pumps module (P5-8), make sure that these EMDP switches are in the OFF position:
 - (a) ELEC 1
 - (b) ELEC 2

SUBTASK 47-00-00-861-001

- (2) Do this task: Supply Electrical Power, TASK 24-22-00-860-811.

SUBTASK 47-00-00-860-001

- (3) Make sure this access panel is closed:

<u>Number</u>	<u>Name/Location</u>
621GB	Refuel Access Panel - Slat Station 143.27

SUBTASK 47-00-00-860-002

- (4) Make sure that the airplane is in the ground mode.
 - (a) If the airplane is in the air mode, do this task: Return the Airplane to the Ground Mode, TASK 32-09-00-860-802.

SUBTASK 47-00-00-860-003

- (5) Make sure that these circuit breakers are closed:

CAPT Electrical System Panel, P18-3

<u>Row</u>	<u>Col</u>	<u>Number</u>	<u>Name</u>
D	17	C01657	NITROGEN GENERATION CONTROL
E	15	C01680	NGS ALT PWR

SUBTASK 47-00-00-010-001

- (6) Open these access panels:

<u>Number</u>	<u>Name/Location</u>
192BL	ECS Ram Air Inlet Mixing Duct Panel - Forward
192CL	Air Conditioning Access Door
192CR	Air Conditioning Access Door

F. Electrical Test of the Nitrogen Generation System

NOTE: This procedure does a test of the NGS power, IBIT, and Operability indicator.

SUBTASK 47-00-00-010-010

- (1) Go to the NGS BITE display unit (BDU) location.

SUBTASK 47-00-00-740-060

- (2) Use the BDU keys to set up the applicable BITE initiated tests.

SUBTASK 47-00-00-740-061

- (3) Push the ON/OFF button on the BDU to energize the unit.

NOTE: If there is no activity for 5 minutes, the BDU will automatically go into the standby mode. If the BDU goes into the standby mode, push the ON/OFF button to go to the main menu.

EFFECTIVITY HAP 036-054, 101-999
--

47-00-00



737-600/700/800/900

AIRCRAFT MAINTENANCE MANUAL

HAP 047-053, 106-999 (Continued)

SUBTASK 47-00-00-740-062

(4) Make sure that the BDU is in the main menu mode.

SUBTASK 47-00-00-740-063

(5) The BDU will show one of these functions:

NOTE: If the BDU does not show one of these functions, then push the MENU button until one of these functions shows:

- (a) EXISTING FAULTS?
(b) FAULT HISTORY?
(c) GROUND TESTS?
(d) OTHER FUNCTIONS?

SUBTASK 47-00-00-740-064

(6) Push the up or down arrow until the BDU shows GROUND TESTS?

SUBTASK 47-00-00-740-065

(7) Push the YES button on the BDU.

SUBTASK 47-00-00-740-066

(8) Make sure that the BDU shows ELECTRICAL TEST?.

NOTE: If the BDU does not show "ELECTRICAL TEST?", push the up or down arrow until "ELECTRICAL TEST?" shows.

SUBTASK 47-00-00-740-067

(9) Push the YES button on the BDU.

SUBTASK 47-00-00-740-069

(10) The BITE test will start.

NOTE: TEST IN PROGRESS XXX% COMPLETE will show on the display during the test.

NOTE: The electrical test does an IBIT check of the operability indicator lights at 40 to 50 seconds after the test starts. You must make sure that the three colored lights come on in this sequence:

Table with 3 columns: Light Color, System Indication, Time Light is On. Rows include Blue (Degraded Temporarily Serviceable, 12 Seconds), Green (Operational, 15 Seconds), and Amber (Inoperative - Unserviceable, 21Seconds).

SUBTASK 47-00-00-740-070

(11) Make sure that the BITE Display Unit shows ELECTRICAL TEST PASS at the end of the test.

- (a) Make sure that the green OPERATIONAL light on the operability indicator is on.

SUBTASK 47-00-00-740-071

(12) If the test fails, look at the BDU test results for the list of fault messages.

EFFECTIVITY
HAP 036-054, 101-999

47-00-00



737-600/700/800/900

AIRCRAFT MAINTENANCE MANUAL

HAP 047-053, 106-999 (Continued)

G. System Test for the Nitrogen Generation System

NOTE: This procedure does an electrical check of the valves and sensors before the NGS shutoff valve opens and the NGS pressurizes.

SUBTASK 47-00-00-010-002

- (1) Go to the NGS BITE display unit (BDU) location.

SUBTASK 47-00-00-740-001

- (2) Use the BDU keys to set up the applicable BITE initiated tests.

NOTE: Refer to PAGEBLOCK 47-31-02/201 for information on the BDU menus.

SUBTASK 47-00-00-740-002

- (3) Push the ON/OFF button on the BDU to energize the unit.

NOTE: If there is no activity for 5 minutes, the BDU will automatically go into the standby mode. If the BDU goes into the standby mode, push the ON/OFF button to go to the main menu.

SUBTASK 47-00-00-740-003

- (4) Make sure that the BDU is in the MAIN MENU mode.

SUBTASK 47-00-00-740-004

- (5) The BDU will show one of these functions:

NOTE: If the BDU does not show one of these functions, then push the MENU button until one of these functions shows.

- (a) EXISTING FAULTS?
- (b) FAULT HISTORY?
- (c) GROUND TESTS?
- (d) OTHER FUNCTIONS?

SUBTASK 47-00-00-740-005

- (6) Push the up or down arrow until the BDU shows GROUND TESTS?

SUBTASK 47-00-00-740-006

- (7) Push the YES button on the BDU.

SUBTASK 47-00-00-740-007

- (8) Make sure that the BDU shows SYSTEM TEST?.

NOTE: If the BDU does not show SYSTEM TEST?, push the up or down arrow until SYSTEM TEST? shows.

SUBTASK 47-00-00-740-008

- (9) Push the YES button on the BDU.

SUBTASK 47-00-00-740-009

- (10) The BITE test will start.

NOTE: TEST IN PROGRESS XXX% COMPLETE will show during the test.

SUBTASK 47-00-00-740-010

- (11) Wait until the test is complete.

NOTE: The test will take two to three minutes.

EFFECTIVITY
HAP 036-054, 101-999

D633A101-HAP

47-00-00

Page 212
Feb 15/2009



737-600/700/800/900

AIRCRAFT MAINTENANCE MANUAL

HAP 047-053, 106-999 (Continued)

SUBTASK 47-00-00-740-011

(12) If the test is satisfactory, "SYSTEM TEST PASS" shows on the display.

SUBTASK 47-00-00-740-012

(13) If the test fails, look at the BDU test results for the list of fault messages.

H. Pressurize the ECS Air Supply System

SUBTASK 47-00-00-863-005

(1) To supply pressure to the pneumatic system using the APU, do this task:
TASK 36-00-00-860-803.

(a) Make sure that these switches on the P5-10 panel are in the positions shown:

SWITCH	POSITION
APU Bleed	ON
Left Pack	HIGH
Right Pack	OFF
ENG 1 Bleed	OFF
ENG 2 Bleed	OFF
Cabin Temp	AUTO
ISLN Valve	OPEN
RECIRC Fans and Gasper	AUTO

(2) To supply pressure to the pneumatic system using the one or both engines do this task:
TASK 36-00-00-860-804

NOTE: Use of engine(s) air to supply pneumatic pressure for this task is not recommended. All areas around operating engines are dangerous. If you must use the engine(s) to supply pneumatic power, make sure that you obey all applicable WARNINGS.

(a) Make sure that these switches on the P5-10 panel are in the positions shown:

SWITCH	POSITION
APU Bleed	OFF
Left Pack	HIGH
Right Pack	OFF
ENG 1 Bleed	ON (if engine is running) if not, OFF
ENG 2 Bleed	ON (if engine is running) if not, OFF
Cabin Temp	AUTO
ISLN Valve	OPEN
RECIRC Fans and Gasper	AUTO

<p>EFFECTIVITY</p> <p>HAP 036-054, 101-999</p>
--

47-00-00



737-600/700/800/900

AIRCRAFT MAINTENANCE MANUAL

HAP 047-053, 106-999 (Continued)

SUBTASK 47-00-00-863-003

- (3) To supply conditioned air, do this task: Supply Conditioned Air with a Cooling Pack, TASK 21-00-00-800-803.

SUBTASK 47-00-00-700-001

- (4) Do a check of the manifold duct pressure.
 - (a) Look at the dual duct pressure gage on the P5 panel.
 - (b) Make sure that the L and R duct pressure is 15 psig (103.4 kPa) or more.

I. Ground Operation of the Nitrogen Generation System

NOTE: This procedure opens the NGS shutoff valve and pressurizes the NGS and NGS ducts.

SUBTASK 47-00-00-740-013

- (1) Make sure that the BDU initiated SYSTEM TEST? is complete.

SUBTASK 47-00-00-740-014

- (2) Make sure that the BDU is on.

NOTE: If there is no activity for 5 minutes, the BDU will automatically go off. If the BDU goes off, push the ON/OFF button to start the test again.

SUBTASK 47-00-00-740-015

- (3) Make sure that the BDU is in the MAIN MENU mode.

SUBTASK 47-00-00-740-016

- (4) The BDU will show one of these functions:

NOTE: If the BDU does not show one of these functions, push the MENU button until one of these functions shows.

- (a) EXISTING FAULTS?
- (b) FAULT HISTORY?
- (c) GROUND TESTS?
- (d) OTHER FUNCTIONS?

SUBTASK 47-00-00-740-017

- (5) Push the up or down arrow until GROUND TESTS? shows.

SUBTASK 47-00-00-740-026

- (6) Push the YES button on the BDU.

SUBTASK 47-00-00-740-018

- (7) Make sure that the BDU shows the NGS PERF LO FLOW? function.

NOTE: If the BDU does not show NGS PERF LO FLOW?, push the up or down arrow until NGS PERF LO FLOW? shows.

SUBTASK 47-00-00-740-019

- (8) Push the YES button on the BDU.

SUBTASK 47-00-00-740-020

- (9) The NGS shutoff valve will open and the test will start.
 - (a) The display on the BDU will show these messages:

EFFECTIVITY
HAP 036-054, 101-999

47-00-00

Page 214
Feb 15/2009

D633A101-HAP



737-600/700/800/900

AIRCRAFT MAINTENANCE MANUAL

HAP 047-053, 106-999 (Continued)

- 1) GSE O2 SNS: XX.X% (or GSE O2 SNS: WARM during warmup mode)

NOTE: xx.x is the O2% reading from the Oxygen Sensor.

- 2) P: YY PSIA

NOTE: YY = current pressure

- 3) T: SZZZ F

NOTE: ZZZ = current temperature

S = negative sign for negative values of temperature

SUBTASK 47-00-00-740-021

- (10) Look at the manual locking hex bolt [4] on the NGS shutoff valve.

NOTE: The locking pin hole in the manual lock arm of the manual locking hex bolt [4] aligns with the threaded hole in the boss of the valve when the valve is closed. The holes will not align if the valve is not fully closed.

SUBTASK 47-00-00-740-022

- (11) Make sure that the slot goes from the CLOSED position to the OPEN position.

NOTE: The manual lock arm turns 90 degrees counterclockwise when the valve is fully open.

SUBTASK 47-00-00-740-023

- (12) The NGS shutoff valve stays open and the test will continue until you push the MENU button on the BDU.

NOTE: You can go out of the Ground Operation task from the FUNCTIONAL TEST task. Otherwise go to the subsequent step.

SUBTASK 47-00-00-740-025

CAUTION: TO STOP THE GROUND TEST, MAKE SURE YOU PRESS THE MENU BUTTON ON THE NITROGEN GENERATION SYSTEM BDU. IF YOU DO NOT PRESS THE MENU BUTTON, THEN THE NGS SHUTOFF VALVE WILL REMAIN IN THE INCORRECT OPEN POSITION.

- (13) To stop the test, push the MENU button on the BDU.

SUBTASK 47-00-00-212-001

- (14) Make sure that the slot in the manual locking hex bolt [4] aligns with the word CLOSED on the NGS shutoff valve.

J. Depressurize the Pneumatic System

SUBTASK 47-00-00-864-001

- (1) Do the applicable task to remove pressure from the pneumatic system:

- (a) Remove Conditioned Air Supplied by a Cooling Pack, TASK 21-00-00-800-804.

- (b) Remove Pressure from the Pneumatic System, TASK 36-00-00-860-806.

SUBTASK 47-00-00-864-002

- (2) Do a check of the manifold duct pressure:

- (a) Look at the dual duct pressure gage on the Air Conditioning Module, P5 panel.

- (b) Make sure that the L and R duct pressure is 0 psig (0 kPa).

SUBTASK 47-00-00-864-003

- (3) If necessary, do this task: APU Usual Shutdown, TASK 49-11-00-860-802.

EFFECTIVITY
HAP 036-054, 101-999

47-00-00

Page 215
Feb 15/2009

D633A101-HAP



737-600/700/800/900

AIRCRAFT MAINTENANCE MANUAL

HAP 047-053, 106-999 (Continued)

K. Put the Airplane Back to the Usual Condition

SUBTASK 47-00-00-410-001

(1) Close these access panels:

<u>Number</u>	<u>Name/Location</u>
192BL	ECS Ram Air Inlet Mixing Duct Panel - Forward
192CL	Air Conditioning Access Door
192CR	Air Conditioning Access Door

————— **END OF TASK** —————

EFFECTIVITY
HAP 036-054, 101-999

D633A101-HAP

47-00-00

Page 216
Feb 15/2009

AIRCRAFT MAINTENANCE MANUAL

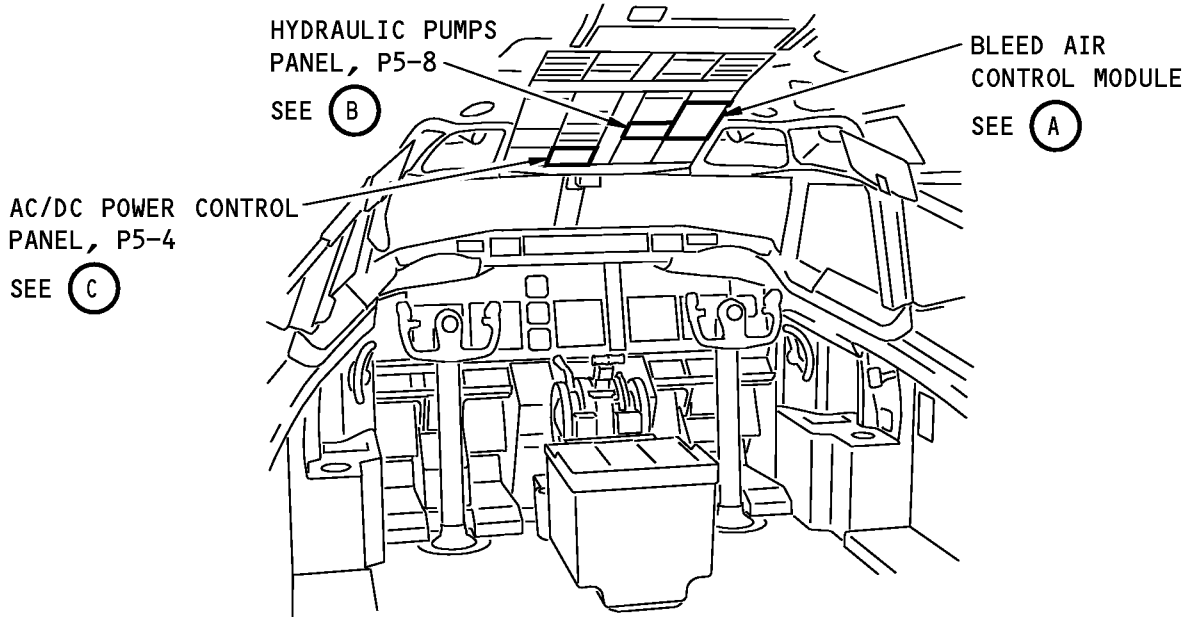

FLIGHT COMPARTMENT

DUAL DUCT PRESSURE GAGE

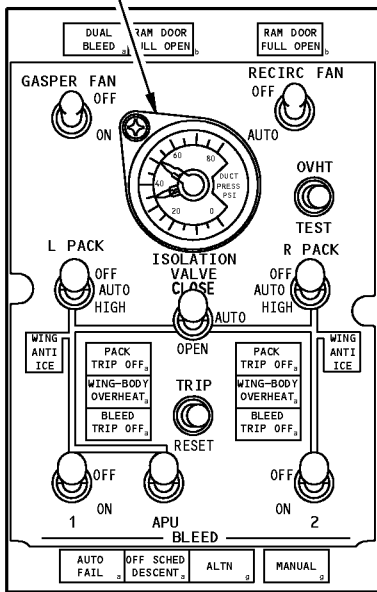

BLEED AIR CONTROL MODULE

(A)

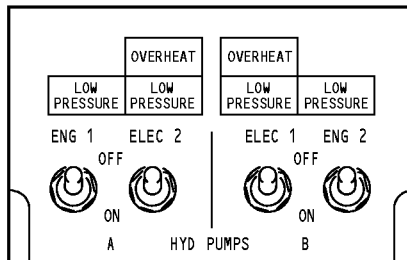

HYDRAULIC PUMPS PANEL, P5-8

(B)

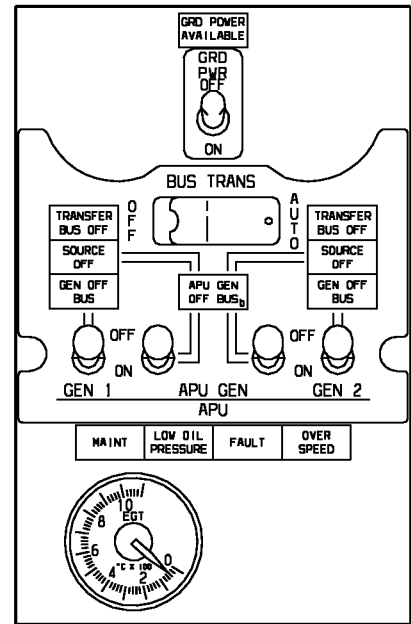

AC/DC POWER CONTROL PANEL, P5-4

(C)

J69684 S0000175422_V3

**NGS - Flight Deck Control Panels
Figure 202/47-00-00-990-801**

EFFECTIVITY
HAP 047-053, 106-999

47-00-00

Page 217
Feb 15/2009

D633A101-HAP

**737-600/700/800/900
AIRCRAFT MAINTENANCE MANUAL**

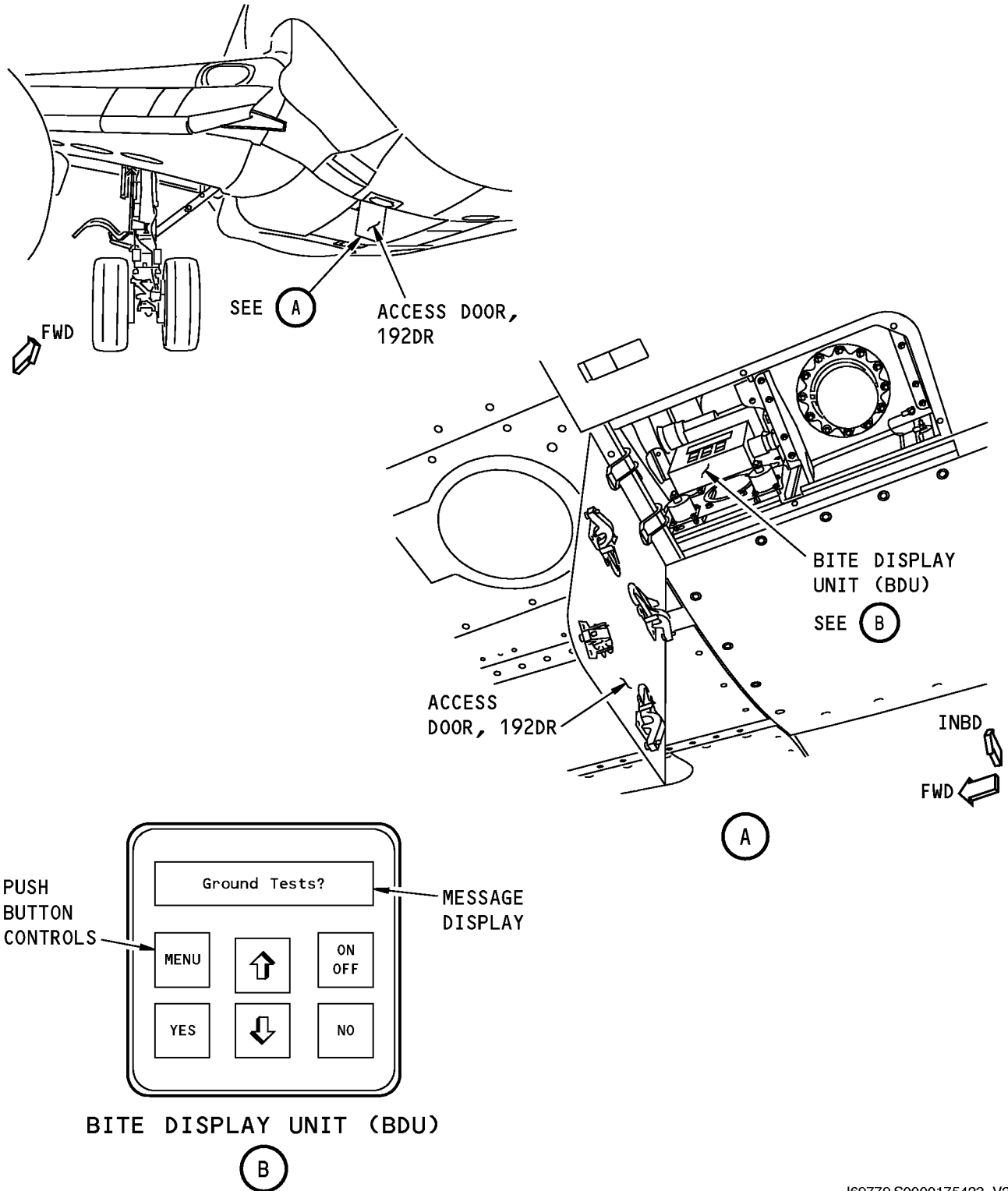

J69779 S0000175423_V2

**NGS - Bite Display Unit (BDU)
Figure 203/47-00-00-990-802**

EFFECTIVITY
HAP 047-053, 106-999

47-00-00

Page 218
Oct 15/2008

D633A101-HAP

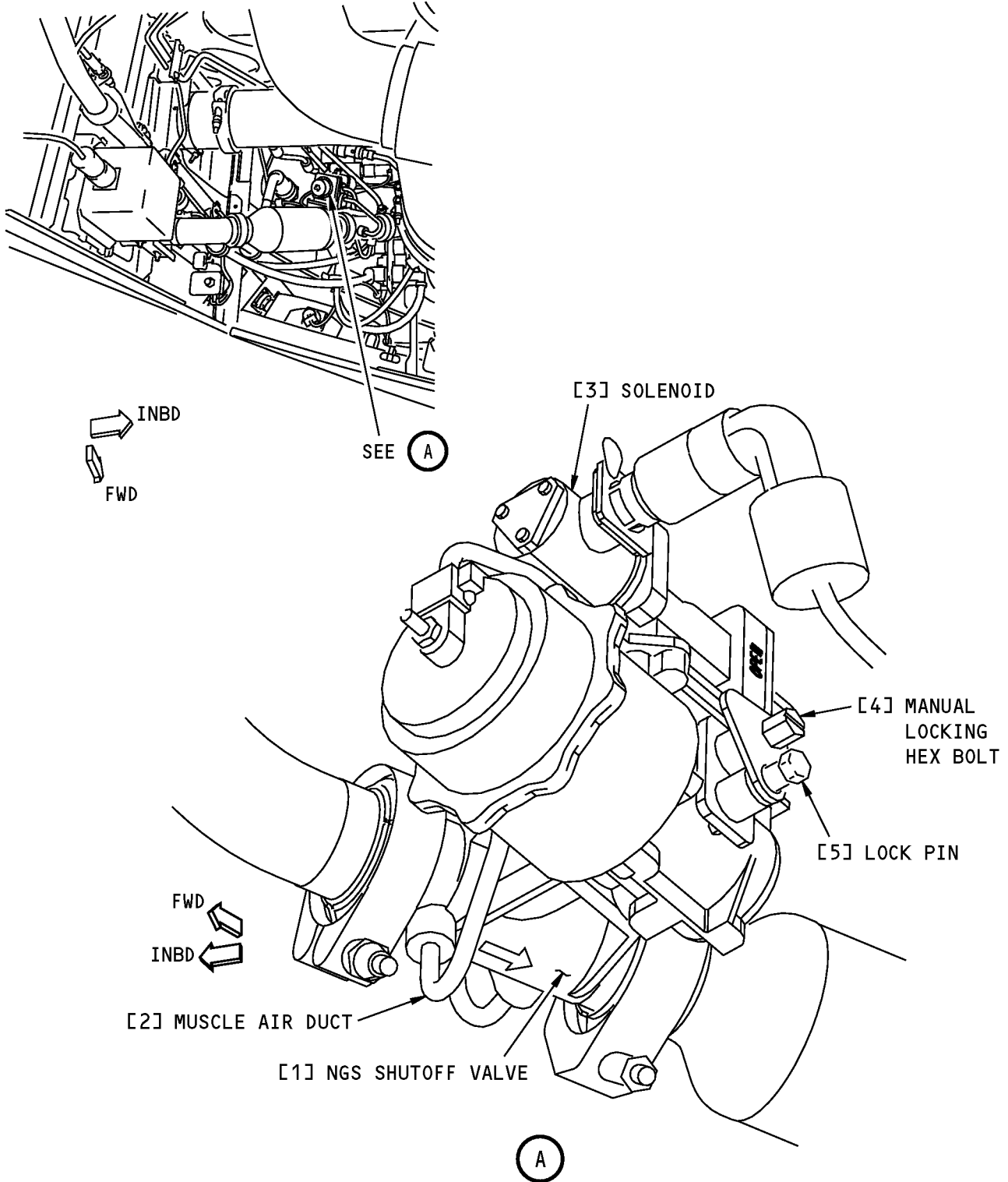

**NGS - Shutoff Valve
Figure 204/47-00-00-990-803**

EFFECTIVITY
HAP 047-053, 106-999

47-00-00

Page 219
Oct 15/2008

D633A101-HAP



737-600/700/800/900

AIRCRAFT MAINTENANCE MANUAL

NITROGEN GENERATION SYSTEM - ADJUSTMENT/TEST

1. General

A. This procedure has this task:

(1) Functional Test of the Nitrogen Generation System.

B. The purpose of the NGS functional test is to do a check of the performance of the air separation module (ASM). ASM performance is measured by the purity of the nitrogen-enriched air (NEA) delivered to the center wing tank.

C. To test the purity of the NEA, it is necessary to check the NGS operational temperature, pressure and the oxygen percentage in the NEA stream. The NGS temperature and pressure measurements are calculated by the NGS controller and shown on the BITE display unit (BDU). To test the oxygen percentage, an oxygen analyzer is connected to the GSE test port on the NEADS line. The percent oxygen (displayed on the oxygen analyzer) and NGS inlet pressure (displayed on the BDU) are plotted on a go-no-go graph. Low flow NEA purity and high flow NEA purity graphs for the ASM are supplied with this procedure.

TASK 47-00-00-720-801

2. Functional Test of the Nitrogen Generation System

(Figure 501)

A. General

(1) ALI - Refer to the task: Airworthiness Limitation Precautions, TASK 47-00-00-910-802, for important information on airworthiness limitation instructions (ALIs).

(2) Do this task to do the requirements of 47-AWL-03.

(3) This task has these functional tests:

(a) Functional Test for the Nitrogen Generation System - NGS PERF LO FLOW

(b) Functional Test for the Nitrogen Generation System - NGS PERF HI FLOW

B. References

Reference	Title
21-00-00-800-804	Remove Conditioned Air Supplied by a Cooling Pack (P/B 201)
36-00-00-860-806	Remove Pressure from the Pneumatic System (P/B 201)
47-00-00-800-801	Ground Operation of the Nitrogen Generation System (P/B 201)
47-00-00-910-802	Airworthiness Limitation Precautions (P/B 201)
47-21-00-700-802	Drain Cap - Fuel Leak Check (P/B 601)
49-11-00-860-802	APU Usual Shutdown (P/B 201)

C. Tools/Equipment

NOTE: When more than one tool part number is listed under the same "Reference" number, the tools shown are alternates to each other within the same airplane series. Tool part numbers that are replaced or non-procurable are preceded by "Opt:", which stands for Optional.

Reference	Description
COM-7456	Analyzer - Oxygen (Part #: MODEL 111B, Supplier: 1UM84, A/P Effectivity: 737-300, -400, -500, -600, -700, -700C, -700ER, -700QC, -800, -900, -900ER, -BBJ)

EFFECTIVITY
HAP 047-053, 106-999

47-00-00

Page 501
Jun 15/2009

D633A101-HAP



737-600/700/800/900

AIRCRAFT MAINTENANCE MANUAL

D. Location Zones

Zone	Area
131	Center Section Wing Box, Body Station 540.00 to Body Station 663.75 - Left
133	Main Landing Gear Wheel Well, Body Station 663.75 to Body Station 727.00 - Left
134	Main Landing Gear Wheel Well, Body Station 663.75 to Body Station 727.00 - Right
211	Flight Compartment - Left
212	Flight Compartment - Right

E. Access Panels

Number	Name/Location
192BL	ECS Ram Air Inlet Mixing Duct Panel - Forward
192CL	Air Conditioning Access Door
192DR	ECS High Pressure Access Door

F. Prepare for the Functional Test of the Nitrogen Generation System

SUBTASK 47-00-00-040-005

(1) Do this task: Ground Operation of the Nitrogen Generation System, TASK 47-00-00-800-801.

SUBTASK 47-00-00-790-012

(2) Do a fuel leak check for the NEADS line (Drain Cap - Fuel Leak Check, TASK 47-21-00-700-802).

G. Prepare the Oxygen Analyzer for the Test

SUBTASK 47-00-00-720-016

(1) Read and obey the procedures supplied with the oxygen analyzer, COM-7456.

SUBTASK 47-00-00-720-017

(2) Make sure the oxygen analyzer, COM-7456, is calibrated and the batteries are charged.

SUBTASK 47-00-00-720-018

(3) Do these steps to connect the oxygen analyzer, COM-7456:

- Connect the sense line to the SAMPLE IN port.
- Make sure that the SAMPLE OUT exhaust port and vent are not blocked.

NOTE: You will get an incorrect oxygen value if the exhaust port or the vent is blocked.

- Set up a platform adjacent to the ECS pack compartment.
- Make sure that the platform is not below the opening for the ECS pack compartment.
- Attach the oxygen analyzer, COM-7456, to the platform.
- Make sure that the oxygen analyzer, COM-7456, is a minimum of 18 in. (0.5 m) above the ground.
- Disconnect the cap on the GSE port adapter.
- Connect the sense line to the GSE port adapter.

SUBTASK 47-00-00-720-019

(4) Do these steps to energize the oxygen analyzer, COM-7456:

- Push the ON/OFF button on the control panel.
- Make sure that the green LED light comes on.

EFFECTIVITY
HAP 047-053, 106-999

D633A101-HAP

47-00-00

Page 502
Jun 15/2009



737-600/700/800/900

AIRCRAFT MAINTENANCE MANUAL

- (c) Let the oxygen analyzer, COM-7456, warm up for two minutes.

NOTE: When the oxygen analyzer, COM-7456, warms up, it will over-shoot the true oxygen content value, and then show the correct % oxygen value.

- (d) Do not push the ON/OFF button again during the test.

- (e) Do not push the SPAN (Calibration) button during the test.

H. Functional Test for the Nitrogen Generation System - NGS PERF LO FLOW

NOTE: This procedure does a check of the NEA purity for the ASM (low flow mode).

SUBTASK 47-00-00-740-073

- (1) Do this task: Ground Operation of the Nitrogen Generation System, TASK 47-00-00-800-801.

- (a) Make sure that you complete and pass the BDU System Test.

- (b) Make sure that the BDU shows the NGS PERF LO FLOW? during the NGS ground operation.

- (c) Let the NGS warm up.

NOTE: The system can take up to 30 minutes to warm up in cold ambient temperatures. Before you begin the function test, make sure the BDU temperature value is $160 \pm 10^{\circ}\text{F}$ ($71.1 \pm 5.6^{\circ}\text{C}$).

SUBTASK 47-00-00-740-074

- (2) When the BDU temperature display is $160 \pm 10^{\circ}\text{F}$ ($71.1 \pm 5.6^{\circ}\text{C}$), push the MENU button on the BDU.

SUBTASK 47-00-00-740-075

- (3) Make sure that the BDU shows the NGS PERF LO FLOW function.

SUBTASK 47-00-00-740-076

- (4) Push the YES button on the BDU.

SUBTASK 47-00-00-740-077

- (5) Make sure the NGS shutoff valve opens and the functional test starts.

- (a) Make sure the display on the BDU shows these messages:

- 1) GSE O2 SNS: XX.X% (or GSE O2 SNS: WARM during warmup mode)

NOTE: xx.x is the O2% reading from the Oxygen Sensor.

- 2) P: YY PSIA

NOTE: YY = current pressure

- 3) T: SZZZ F

NOTE: ZZZ = current temperature

S = negative sign for negative values of temperature

SUBTASK 47-00-00-720-020

- (6) Do a check of the NGS temperature:

- (a) Record the NGS temperature from BDU.

- (b) Make sure that the BDU temperature is approximately 160°F (71°C).

SUBTASK 47-00-00-720-021

- (7) Do a check of the NGS pressure:

- (a) Record the NGS pressure from BDU.

- (b) Record the L and R duct pressure from the dual duct pressure gage on the P5 panel.

EFFECTIVITY
HAP 047-053, 106-999

D633A101-HAP

47-00-00

Page 503
Jun 15/2009



737-600/700/800/900

AIRCRAFT MAINTENANCE MANUAL

- (c) Compare the pressure value on BDU with the pressure value on the dual duct pressure gage.
- (d) Make sure that the BDU pressure is within ± 8 psig (55 kPa) of the dual duct pressure gage values.

SUBTASK 47-00-00-720-022

- (8) Do a check of the NEA purity:
 - (a) Record the PERCENT OXYGEN from the oxygen analyzer, COM-7456.
 - (b) Record the NGS inlet pressure from the BDU.
 - (c) Use the NGS PERF LO FLOW graph to plot the NGS inlet pressure and NEA purity (% O₂) data point.
 - (d) Make sure that the NGS pressure/NEA purity data point is within the go-zone area of the curve.

SUBTASK 47-00-00-740-078

CAUTION: TO STOP THE GROUND TEST, MAKE SURE THAT YOU PUSH THE MENU BUTTON ON THE BDU FOR THE NITROGEN GENERATION SYSTEM. IF YOU DO NOT PUSH THE MENU BUTTON, THEN THE NGS SHUTOFF VALVE WILL STAY IN THE INCORRECT OPEN POSITION.

- (9) To stop the test, push the MENU button on the BDU.
 - (10) Push the ON/OFF button on the oxygen analyzer, COM-7456, to shut off the power.
- I. Functional Test for the Nitrogen Generation System - NGS PERF HI FLOW

NOTE: This procedure does a purity check of the NEA for the ASM (high flow mode).

SUBTASK 47-00-00-720-023

- (1) Do not start the NGS PERF HI FLOW test if the ambient temperature is more than 118°F (48°C).
- NOTE:** Ground operation of the NGS in high flow mode, with high ambient temperatures, can cause the system to get too hot.

SUBTASK 47-00-00-740-079

- (2) If not done previously, do this task: Ground Operation of the Nitrogen Generation System, TASK 47-00-00-800-801.
 - (a) Make sure that you complete and pass the BDU SYSTEM TEST.
 - (b) Make sure that the BDU shows the NGS PERF LO FLOW? during the NGS ground operation.
 - (c) Let the NGS warm up for approximately 30 minutes.
- NOTE:** The system can take up to 30 minutes to warm up in cold ambient temperatures. Before you begin the function test, make sure the temperature value from the BDU display is 160 \pm 10°F (71 \pm 6°C).
- (d) After the NGS is warmed up, push the MENU button on the BDU.

SUBTASK 47-00-00-740-080

- (3) Push the up or down arrow on the BDU until the NGS PERF HI FLOW? function shows.

SUBTASK 47-00-00-740-081

- (4) Push the YES button on the BDU.

SUBTASK 47-00-00-720-024

- (5) Make sure the NGS shutoff valve opens and the functional test starts.
 - (a) Make sure the display on the BDU shows these messages:

EFFECTIVITY
HAP 047-053, 106-999

D633A101-HAP

47-00-00

Page 504
Jun 15/2009



737-600/700/800/900

AIRCRAFT MAINTENANCE MANUAL

- 1) GSE O2 SNS: XX.X% (or GSE O2 SNS: WARM during warmup mode)

NOTE: XX.X is the O2% reading from the oxygen sensor.

- 2) P: YY PSIA

NOTE: YY = current pressure

- 3) T: SZZZ F

NOTE: ZZZ = current temperature

S = negative sign for negative values of temperature

SUBTASK 47-00-00-740-082

- (6) Do a check of the NGS temperature:

- (a) Record the NGS temperature from BDU.

- (b) Make sure that the BDU temperature is $160 \pm 10^{\circ}\text{F}$ ($71 \pm 6^{\circ}\text{C}$).

SUBTASK 47-00-00-740-083

- (7) Do a check of the NGS pressure:

- (a) Record the NGS pressure from BDU.

- (b) Record the L and R manifold duct pressure from the dual duct pressure gage.

- (c) Compare the pressure value on BDU with the pressure on the dual duct pressure gage.

- (d) Make sure that the BDU pressure is within ± 8 psi (55 kPa) of the duct pressure values.

SUBTASK 47-00-00-740-084

- (8) Do a check of the NEA purity:

- (a) Record the percent oxygen from the oxygen analyzer, COM-7456.

- (b) Record the NGS inlet pressure from the BDU.

- (c) Use the NGS PERF HI FLOW graph to plot the NGS inlet pressure and NEA purity (% oxygen) data point.

- (d) Make sure the NGS pressure/NEA purity data point is within the go-zone area of the curve.

SUBTASK 47-00-00-740-085

CAUTION: TO STOP THE GROUND TEST, MAKE SURE THAT YOU PUSH THE MENU BUTTON ON THE BDU FOR THE NITROGEN GENERATION SYSTEM. IF YOU DO NOT PUSH THE MENU BUTTON, THEN THE NGS SHUTOFF VALVE WILL STAY IN THE INCORRECT OPEN POSITION.

- (9) To stop the test, push the MENU button on the BDU.

SUBTASK 47-00-00-720-025

- (10) Make sure that the slot in the manual locking hex bolt aligns with the word CLOSED on the NGS shutoff valve.

J. Put the Airplane Back to the Usual Condition

SUBTASK 47-00-00-720-026

- (1) Do these tasks:

- (a) Remove Conditioned Air Supplied by a Cooling Pack, TASK 21-00-00-800-804.

- (b) Remove Pressure from the Pneumatic System, TASK 36-00-00-860-806.

SUBTASK 47-00-00-080-002

- (2) Remove the oxygen analyzer, COM-7456.

EFFECTIVITY
HAP 047-053, 106-999

D633A101-HAP

47-00-00

Page 505
Jun 15/2009



737-600/700/800/900
AIRCRAFT MAINTENANCE MANUAL

SUBTASK 47-00-00-741-014

- (3) Do a check of the duct pressure on the dual duct pressure gage:
(a) Make sure the L and R duct pressure is 0 psig (0 kPa).

SUBTASK 47-00-00-741-015

- (4) Do this task: APU Usual Shutdown, TASK 49-11-00-860-802, if necessary.

SUBTASK 47-00-00-410-007

- (5) Close these access panels:

<u>Number</u>	<u>Name/Location</u>
192BL	ECS Ram Air Inlet Mixing Duct Panel - Forward
192CL	Air Conditioning Access Door
192DR	ECS High Pressure Access Door

————— **END OF TASK** —————

EFFECTIVITY
HAP 047-053, 106-999

D633A101-HAP

47-00-00

Page 506
Jun 15/2009



737-600/700/800/900
AIRCRAFT MAINTENANCE MANUAL

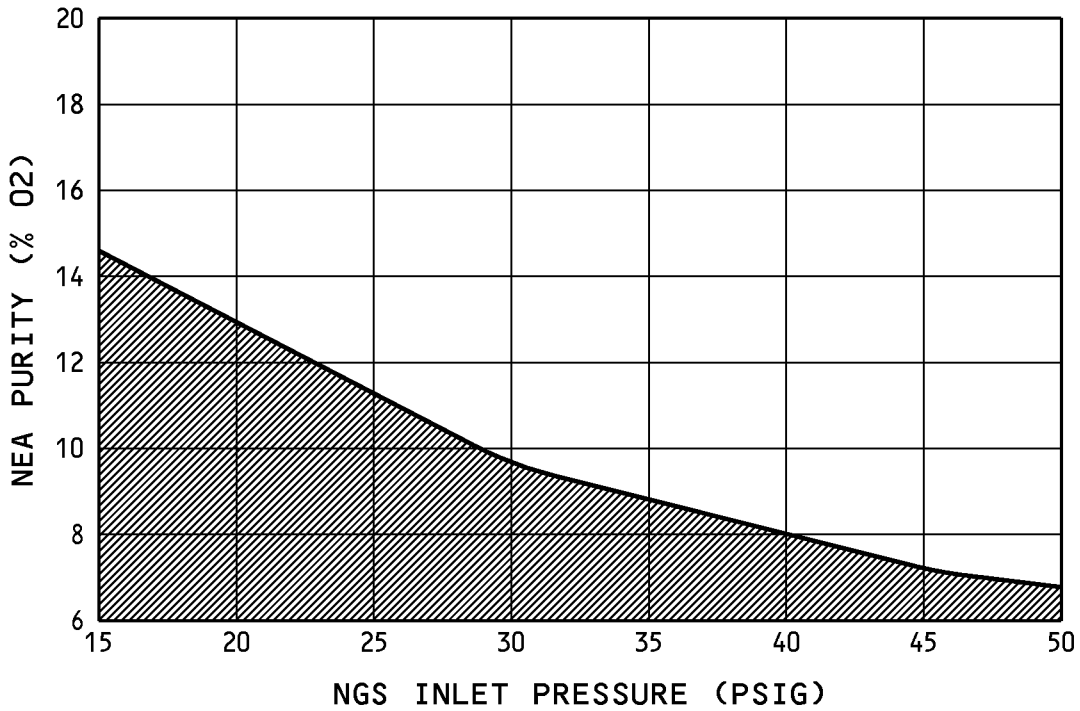

GSE GO-NO-GO CRITERIA AT LOW FLOW

LEGEND:

-  NEA PURITY SATISFACTORY (GO ZONE)
-  NEA PURITY NOT SATISFACTORY (NO-GO ZONE)

1495949 S0000271687_V1

GSE Go-No-Go Criteria
Figure 501 (Sheet 1 of 2)/47-00-00-990-811

EFFECTIVITY
HAP 047-053, 106-999

47-00-00

Page 507
Jun 15/2009

D633A101-HAP



737-600/700/800/900
AIRCRAFT MAINTENANCE MANUAL

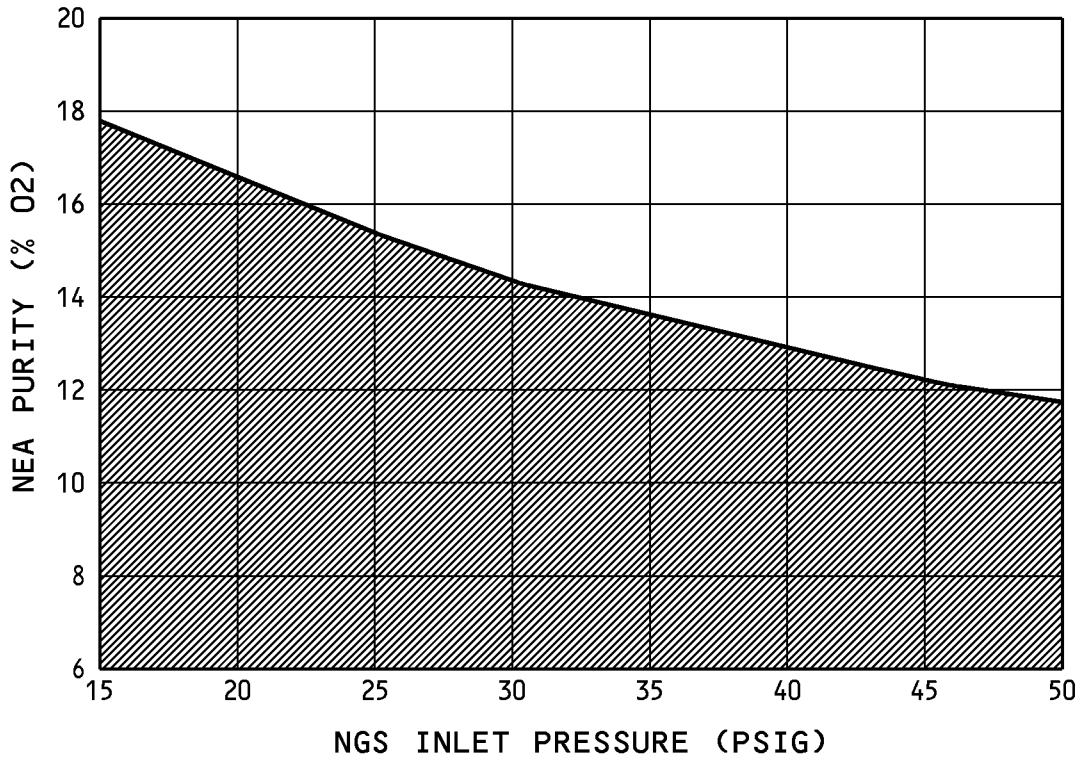

GSE GO-NO-GO CRITERIA AT HIGH FLOW

LEGEND:

- NEA PURITY SATISFACTORY (GO ZONE)
- NEA PURITY NOT SATISFACTORY (NO-GO ZONE)

1495996 S0000271691_V1

GSE Go-No-Go Criteria
Figure 501 (Sheet 2 of 2)/47-00-00-990-811

EFFECTIVITY
HAP 047-053, 106-999

47-00-00

Page 508
Jun 15/2009

D633A101-HAP



737-600/700/800/900

AIRCRAFT MAINTENANCE MANUAL

NITROGEN GENERATION SYSTEM - INSPECTION/CHECK

1. General

- A. This procedure contains scheduled maintenance task data.
- B. This procedure has these tasks:
 - (1) Leak Check of the Nitrogen Generation System
 - (2) Cross Vent Check Valve - Inspection/Check
- C. This procedure will make sure the nitrogen generation system (NGS) is within permitted leak limits. Do this procedure as a general leak check for the nitrogen generation system or as a post-installation leak check after you replace a NGS component or duct.
- D. This procedure pressurizes the nitrogen generation system (NGS) and does a leak check of these components:
 - (1) Thermal Control Unit (TCU)
 - (2) Air Separation Module (ASM)
 - (3) Nitrogen-Enriched Air Distribution System (NEADS) line from the ASM to the rear spar penetration on the center wing tank
 - (4) Tubes and ducts that connect the NGS components

TASK 47-00-00-790-801

2. Leak Check of the Nitrogen Generation System

(Figure 601, Figure 602)

- A. General
 - (1) This procedure is a scheduled maintenance task.
- B. References

Reference	Title
21-00-00-800-804	Remove Conditioned Air Supplied by a Cooling Pack (P/B 201)
36-00-00-860-806	Remove Pressure from the Pneumatic System (P/B 201)
47-00-00-800-801	Ground Operation of the Nitrogen Generation System (P/B 201)
47-21-00-700-802	Drain Cap - Fuel Leak Check (P/B 601)
47-32-01 P/B 401	NGS SHUTOFF VALVE - REMOVAL/INSTALLATION
49-11-00-860-802	APU Usual Shutdown (P/B 201)
71-00-00-700-819-F00	Stop the Engine Procedure (Usual Engine Stop) (P/B 201)

C. Tools/Equipment

Reference	Description
STD-10792	Plug - Flareless Tube, BACP20AU8D

D. Consumable Materials

Reference	Description	Specification
G00034	Cotton Wiper - Process Cleaning Absorbent Wiper (Cheesecloth, Gauze)	BMS15-5
G50135	Leak Detector - Liquid, Non-Corrosive Soap Compound	MIL-PRF-25567

EFFECTIVITY
HAP 047-053, 106-999

47-00-00

Page 601
Jun 15/2009

D633A101-HAP



737-600/700/800/900

AIRCRAFT MAINTENANCE MANUAL

E. Location Zones

Zone	Area
131	Center Section Wing Box, Body Station 540.00 to Body Station 663.75 - Left
133	Main Landing Gear Wheel Well, Body Station 663.75 to Body Station 727.00 - Left
212	Flight Compartment - Right

F. Access Panels

Number	Name/Location
192BL	ECS Ram Air Inlet Mixing Duct Panel - Forward
192CL	Air Conditioning Access Door
192DR	ECS High Pressure Access Door

G. Prepare for the Leak Check

SUBTASK 47-00-00-790-011

- (1) Do this task: Drain Cap - Fuel Leak Check, TASK 47-21-00-700-802.

SUBTASK 47-00-00-881-002

- (2) Do this task: Ground Operation of the Nitrogen Generation System, TASK 47-00-00-800-801.

SUBTASK 47-00-00-740-055

- (3) Push the MENU button on the BITE display unit (BDU).

SUBTASK 47-00-00-740-056

- (4) Push the up or down arrows until the BDU shows the GROUND TESTS? function.

SUBTASK 47-00-00-740-057

- (5) Push the YES button on the BDU.

SUBTASK 47-00-00-740-058

- (6) Push the up or down arrows on the BDU until one of these functions shows:

- (a) NGS PERF LOW FLOW?

NOTE: Use this function to do a leak check of the NGS components in the low flow mode, upstream of the ASM.

- (b) NGS PERF HI FLOW?

NOTE: Use this function to do a leak check between the ASM and the flame arrestor at the left wing rear spar. Do not use the NGS PERF HI FLOW? function if the ambient temperature is above 118°F (48°C). On the ground, the NGS can get too hot when you pressurize the NGS in the high flow mode.

SUBTASK 47-00-00-730-001

- (7) Push the YES button to start the applicable test.

SUBTASK 47-00-00-730-002

- (8) The NGS shutoff valve will open and pressurize the NGS.

- (a) The display on the BDU will show these messages:

- 1) GSE O2 SNS: XX.X% (or GSE O2 SNS: WARM during warmup mode)

NOTE: xx.x is the O2% reading from the Oxygen Sensor.

- 2) P: YY PSIA

NOTE: YY = current pressure

EFFECTIVITY
HAP 047-053, 106-999

D633A101-HAP

47-00-00

Page 602
Feb 15/2009



737-600/700/800/900

AIRCRAFT MAINTENANCE MANUAL

3) T: SZZZ F

NOTE: ZZZ = current temperature

S = negative sign for negative values of temperature

H. Leak Check of the Nitrogen Generation System

SUBTASK 47-00-00-790-003

(1) Do a check for leaks at the joints of these components:

- (a) Thermal Control Unit (TCU)
- (b) Air Separation Module (ASM)
- (c) Oxygen-Enriched Air (OEA) duct

SUBTASK 47-00-00-790-006

(2) If you find a leak, do these steps:

- (a) Position your hand 12 in. (30 cm) above the leak source.
- (b) If you can feel the airflow, then stop the operation of the NGS system and repair the leak immediately.
- (c) If you cannot feel the airflow, then the leak is permitted.
- (d) Several small leaks are permitted, if all the leaks are not concentrated in one area.

SUBTASK 47-00-00-360-001

WARNING: DO NOT DISCONNECT THE COMPONENTS OF THE NITROGEN GENERATION SYSTEM, OR DUCTS WHEN THE SYSTEM IS PRESSURIZED. THE HOT, HIGH-PRESSURE AIR CAN CAUSE INJURIES TO PERSONNEL, AND DAMAGE TO EQUIPMENT.

WARNING: WHEN YOU DO A TEST OF THE SYSTEM, MAKE SURE THAT THERE IS SUFFICIENT AIRFLOW IN THE AREA. USE LIFE SUPPORT EQUIPMENT IF YOU THINK THAT THERE IS A HIGH NITROGEN CONCENTRATION. LOW OXYGEN LEVELS IN THE AIR ARE DANGEROUS TO PERSONNEL.

WARNING: DO NOT BREATHE THE AIR FROM THE FUEL TANK UNTIL YOU MAKE IT SAFE. THE NITROGEN GENERATION SYSTEM DECREASES THE OXYGEN IN THE AIR. IF YOU BREATHE AIR THAT DOES NOT HAVE SUFFICIENT OXYGEN, DANGEROUS HEALTH CONDITIONS CAN QUICKLY OCCUR. DANGEROUS HEALTH CONDITIONS INCLUDE NAUSEA, UNCONSCIOUSNESS, AND CONVULSIONS. IF THE OXYGEN LEVEL OF THE AIR THAT YOU BREATHE IS VERY LOW, IT CAN KILL YOU.

CAUTION: TO STOP THE GROUND TEST, MAKE SURE THAT YOU PUSH THE MENU BUTTON ON THE BDU FOR THE NITROGEN GENERATION SYSTEM. IF YOU DO NOT PUSH THE MENU BUTTON, THEN THE NGS SHUTOFF VALVE WILL STAY IN THE INCORRECT OPEN POSITION.

(3) To repair a leak, do these steps:

- (a) Push the MENU button on the BDU.
- (b) Do the steps in this task to depressurize the ECS air supply system: Remove Pressure from the Pneumatic System, TASK 36-00-00-860-806.

EFFECTIVITY
HAP 047-053, 106-999

D633A101-HAP

47-00-00

Page 603
Feb 15/2009



737-600/700/800/900

AIRCRAFT MAINTENANCE MANUAL

- (c) Examine the manual locking arm on the NGS shutoff valve.

NOTE: When the valve is closed, the hole in the manual locking arm aligns with the hole on the valve body, and you can insert the locking pin. If the valve is not fully closed, the holes will not align, and you cannot fully insert the locking pin.

- (d) Make sure that the valve goes to the CLOSED position.
(e) Examine the connections to do a check for leak(s).
(f) Repair the leaks that you find.
(g) Make sure that the parts align correctly.

SUBTASK 47-00-00-790-007

- (4) Do the steps in this task to pressurize the pneumatic system: Ground Operation of the Nitrogen Generation System, TASK 47-00-00-800-801.

- (a) Do the leak check again to make sure that you repaired the problem.

SUBTASK 47-00-00-790-004

- (5) Push the YES button to start the applicable test.

SUBTASK 47-00-00-790-010

- (6) Do a check for leaks at the NGS switches, sensors, and sense lines:

- (a) Apply a small quantity of leak detector, G50135, to the applicable switch, sensor or sense line connection.
(b) Examine the component or connection for a leak.
(c) No leaks are permitted.
(d) Use a clean cotton wiper, G00034, to remove the leak detector, G50135.

SUBTASK 47-00-00-360-002

WARNING: DO NOT DISCONNECT THE COMPONENTS OF THE NITROGEN GENERATION SYSTEM, OR DUCTS WHEN THE SYSTEM IS PRESSURIZED. THE HOT, HIGH-PRESSURE AIR CAN CAUSE INJURIES TO PERSONNEL, AND DAMAGE TO EQUIPMENT.

WARNING: WHEN YOU DO A TEST OF THE SYSTEM, MAKE SURE THAT THERE IS SUFFICIENT AIRFLOW IN THE AREA. USE LIFE SUPPORT EQUIPMENT IF YOU THINK THAT THERE IS A HIGH NITROGEN CONCENTRATION. LOW OXYGEN LEVELS IN THE AIR ARE DANGEROUS TO PERSONNEL.

CAUTION: TO STOP THE GROUND TEST, MAKE SURE THAT YOU PUSH THE MENU BUTTON ON THE BDU FOR THE NITROGEN GENERATION SYSTEM. IF YOU DO NOT PUSH THE MENU BUTTON, THEN THE NGS SHUTOFF VALVE WILL STAY IN THE INCORRECT OPEN POSITION.

- (7) If you find a leak, do these steps:

- (a) Push the MENU button on the BDU.
(b) Do the steps in this task to depressurize the ECS air supply system: Remove Pressure from the Pneumatic System, TASK 36-00-00-860-806.
(c) Look at the manual locking hex bolt on the NGS shutoff valve.
1) Make sure that the slot goes to the CLOSED position.

EFFECTIVITY
HAP 047-053, 106-999

D633A101-HAP

47-00-00

Page 604
Feb 15/2009



737-600/700/800/900

AIRCRAFT MAINTENANCE MANUAL

(d) Open these circuit breakers and install safety tags:

CAPT Electrical System Panel, P18-3

Row	Col	Number	Name
D	17	C01657	NITROGEN GENERATION CONTROL
E	15	C01680	NGS ALT PWR

(e) Examine the component or sense line to find the cause of the leak.

(f) Repair the problems that you find.

(g) Connect the component or sense line.

(h) Remove the safety tags and close these circuit breakers:

CAPT Electrical System Panel, P18-3

Row	Col	Number	Name
D	17	C01657	NITROGEN GENERATION CONTROL
E	15	C01680	NGS ALT PWR

SUBTASK 47-00-00-790-008

(8) Do the steps in this task to pressurize the pneumatic system: Ground Operation of the Nitrogen Generation System, TASK 47-00-00-800-801.

(a) Do the leak check again to make sure that you repaired the problem.

SUBTASK 47-00-00-790-005

(9) Do these steps to do a check for leaks in the NEADS line between the ASM and the flame arrestor at the rear spar.

(a) Disconnect the dielectric hose from the flame arrestor.

(b) Put a flareless tube plug, STD-10792, (or equivalent) on the dielectric hose.

1) Make sure that the plug is air tight.

(c) Apply a small quantity of leak detector, G50135, to the applicable coupling or drain line connection.

(d) Examine the NEADS coupling or connection for a leak.

(e) No air leaks are permitted.

(f) Use a clean cotton wiper, G00034, to remove the leak detector, G50135.

SUBTASK 47-00-00-360-003

WARNING: DO NOT DISCONNECT THE COMPONENTS OF THE NITROGEN GENERATION SYSTEM, OR DUCTS WHEN THE SYSTEM IS PRESSURIZED. THE HOT, HIGH-PRESSURE AIR CAN CAUSE INJURIES TO PERSONNEL, AND DAMAGE TO EQUIPMENT.

WARNING: WHEN YOU DO A TEST OF THE SYSTEM, MAKE SURE THAT THERE IS SUFFICIENT AIRFLOW IN THE AREA. USE LIFE SUPPORT EQUIPMENT IF YOU THINK THAT THERE IS A HIGH NITROGEN CONCENTRATION. LOW OXYGEN LEVELS IN THE AIR ARE DANGEROUS TO PERSONNEL.

CAUTION: TO STOP THE GROUND TEST, MAKE SURE THAT YOU PUSH THE MENU BUTTON ON THE BDU FOR THE NITROGEN GENERATION SYSTEM. IF YOU DO NOT PUSH THE MENU BUTTON, THEN THE NGS SHUTOFF VALVE WILL STAY IN THE INCORRECT OPEN POSITION.

EFFECTIVITY
HAP 047-053, 106-999

47-00-00

Page 605
Feb 15/2009

D633A101-HAP



737-600/700/800/900

AIRCRAFT MAINTENANCE MANUAL

(CAUTION PRECEDES)

(10) If you find a leak, do these steps:

- (a) Push the MENU button on the BDU.
- (b) Do the steps in this task to depressurize the ECS air supply system: Remove Pressure from the Pneumatic System, TASK 36-00-00-860-806.
- (c) Examine the manual locking arm on the NGS shutoff valve.
 - 1) Make sure that the valve goes from the OPEN position to the CLOSED position.
 - 2) Replace the NGS shutoff valve if the valve fails to close (PAGEBLOCK 47-32-01/401).
- (d) Examine the component to find the cause of the leak(s).
- (e) Repair the problems that you find.
- (f) Remove the flareless tube plug, STD-10792, from the dielectric hose.
- (g) Connect the dielectric hose to the flame arrestor.
- (h) Make sure that the components are aligned.
- (i) Tighten the connections.

SUBTASK 47-00-00-790-009

(11) Do the steps in this task to pressurize the pneumatic system: Ground Operation of the Nitrogen Generation System, TASK 47-00-00-800-801.

- (a) Do the leak check again to make sure that you repaired the problem.

SUBTASK 47-00-00-741-007

CAUTION: TO STOP THE GROUND TEST, MAKE SURE YOU PRESS THE MENU BUTTON ON THE NITROGEN GENERATION SYSTEM BDU. IF YOU DO NOT PRESS THE MENU BUTTON, THEN THE NGS SHUTOFF VALVE WILL REMAIN IN THE INCORRECT OPEN POSITION.

(12) To stop the test, push the MENU button on the BDU.

SUBTASK 47-00-00-741-008

(13) Examine the manual locking arm on the NGS shutoff valve.

- (a) Make sure that the valve goes from the OPEN position to the CLOSED position.

I. Depressurize the Pneumatic System

SUBTASK 47-00-00-741-009

(1) To remove the conditioned air supply, do this task:

- (a) Remove Conditioned Air Supplied by a Cooling Pack, TASK 21-00-00-800-804.

SUBTASK 47-00-00-741-013

(2) Do the steps in this task to depressurize the ECS air supply system: Remove Pressure from the Pneumatic System, TASK 36-00-00-860-806.

SUBTASK 47-00-00-741-010

(3) Do a check of the pneumatic duct pressure:

- (a) Look at the dual duct pressure gage on the air conditioning panel, P5-10.
- (b) Make sure that the L and R duct pressures are 0 psig (0 kPa).

SUBTASK 47-00-00-741-011

(4) To stop the APU, do this task: APU Usual Shutdown, TASK 49-11-00-860-802, if necessary.

SUBTASK 47-00-00-740-072

(5) To stop the engines, do this task: Stop the Engine Procedure (Usual Engine Stop), TASK 71-00-00-700-819-F00, if necessary.

EFFECTIVITY
HAP 047-053, 106-999

D633A101-HAP

47-00-00

Page 606
Jun 15/2009



737-600/700/800/900

AIRCRAFT MAINTENANCE MANUAL

J. Put the Airplane Back to the Usual Condition

SUBTASK 47-00-00-741-012

(1) Close these access panels:

<u>Number</u>	<u>Name/Location</u>
192BL	ECS Ram Air Inlet Mixing Duct Panel - Forward
192CL	Air Conditioning Access Door
192DR	ECS High Pressure Access Door

————— **END OF TASK** —————

EFFECTIVITY
HAP 047-053, 106-999

D633A101-HAP

47-00-00

Page 607
Jun 15/2009

**737-600/700/800/900
AIRCRAFT MAINTENANCE MANUAL**

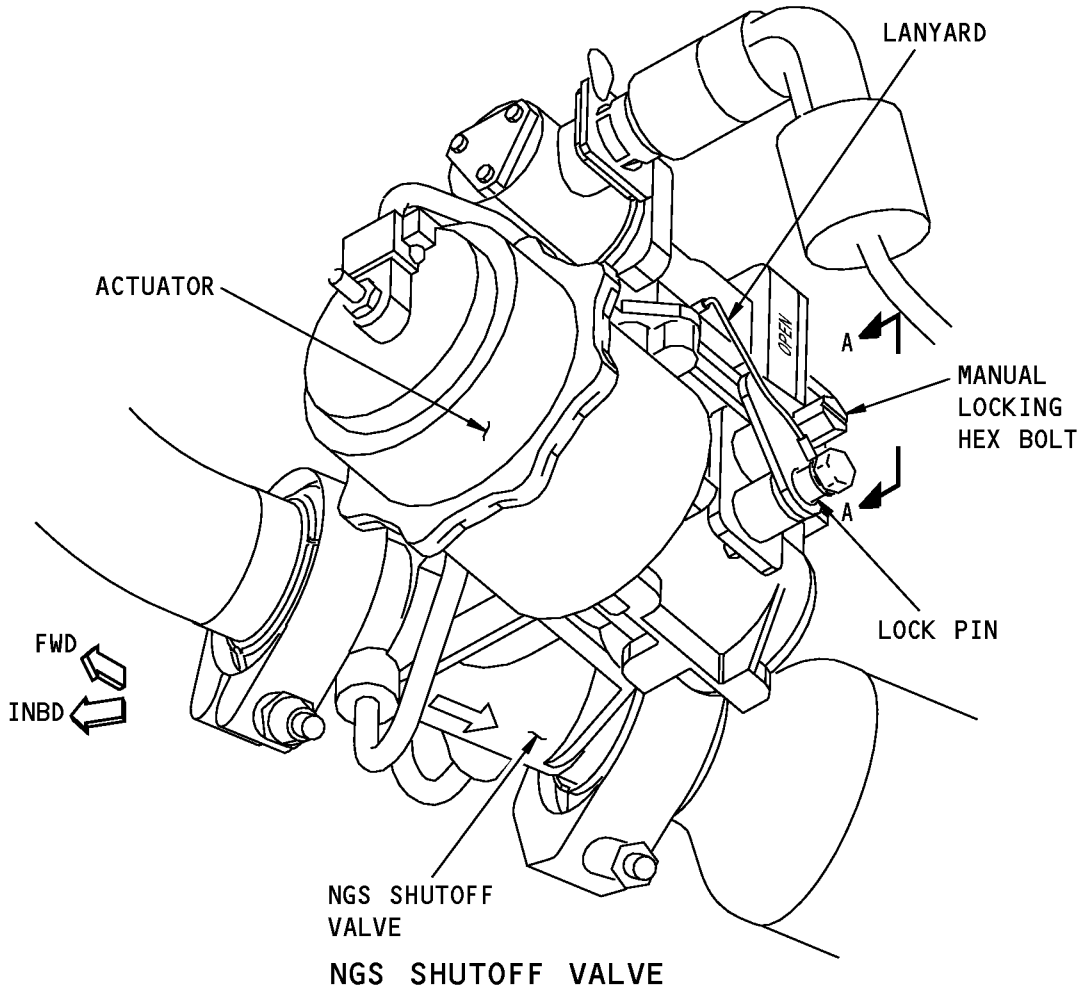

B

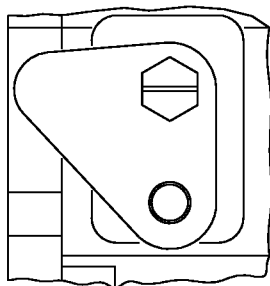

**(ALIGNED)
A-A**

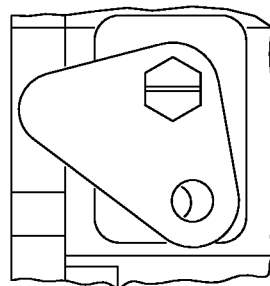

**(MISALIGNED)
A-A**

**NGS - Shutoff Valve
Figure 601/47-00-00-990-812**

EFFECTIVITY
HAP 047-053, 106-999

47-00-00

Page 608
Jun 15/2009

D633A101-HAP

**737-600/700/800/900
AIRCRAFT MAINTENANCE MANUAL**

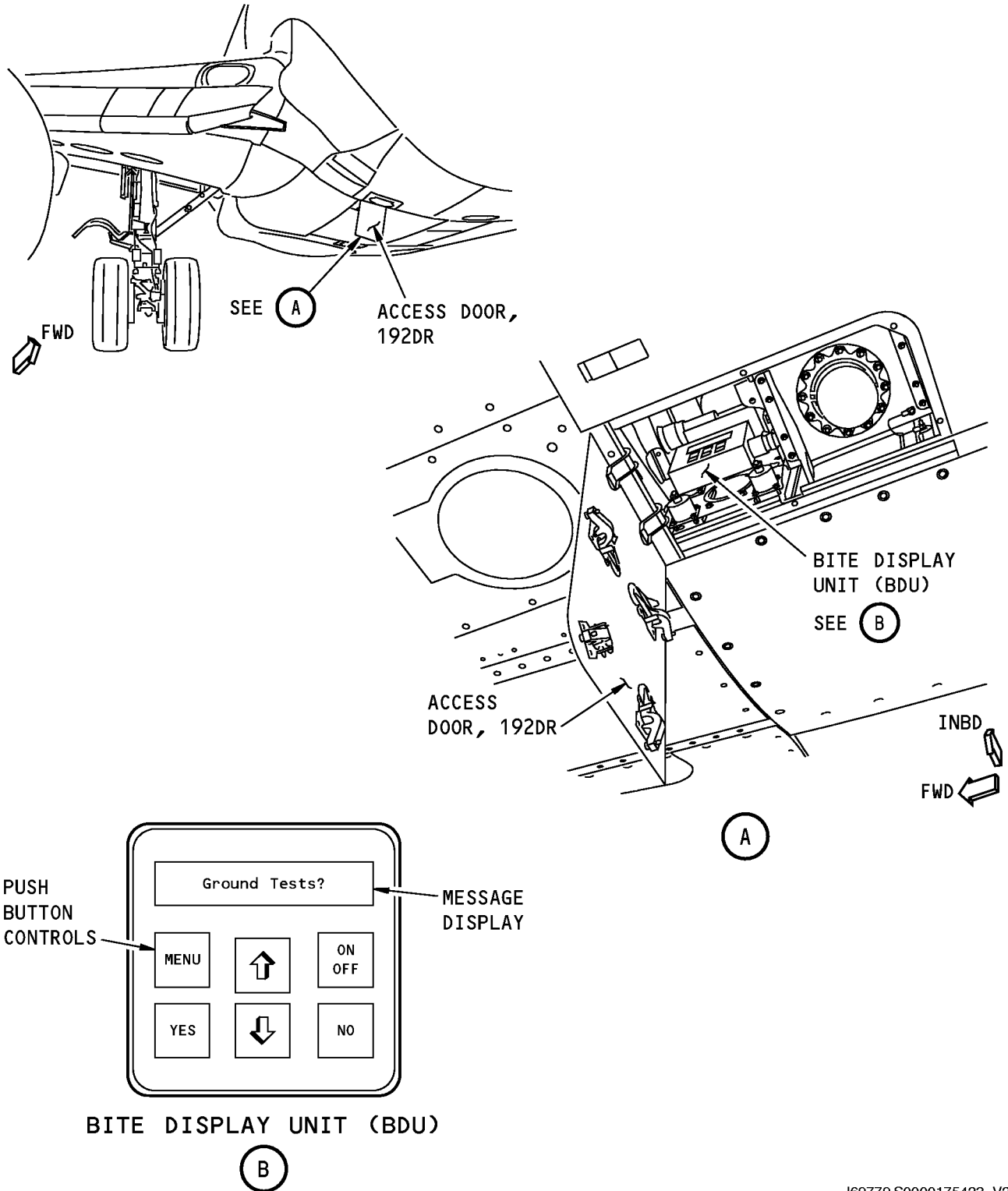

J69779 S0000175423_V2

**NGS - BITE Display Unit (BDU)
Figure 602/47-00-00-990-813**

EFFECTIVITY
HAP 047-053, 106-999

47-00-00



737-600/700/800/900

AIRCRAFT MAINTENANCE MANUAL

TASK 47-00-00-280-801

3. Cross Vent Check Valve - Inspection/Check

(Figure 603)

A. General

- (1) This procedure is a scheduled maintenance task.
- (2) The cross vent check valve opens during overfuel conditions to relieve fuel tank pressure. The valve is normally closed to prevent ambient air from entering the center tank during the descent phase of flight.

B. References

Reference	Title
28-11-11-000-802	Surge Tank Access Door - Removal (P/B 401)
28-11-11-400-802	Surge Tank Access Door - Installation (P/B 401)
47-21-05-000-801	Cross Vent Check Valve Removal (P/B 401)
47-21-05-420-801	Cross Vent Check Valve Installation (P/B 401)

C. Tools/Equipment

Reference	Description
STD-1153	Rod - Stiff Wire, 16 Gauge

D. Location Zones

Zone	Area
633	Right Wing - Surge Tank, Rib 22 to Rib 25, Wing Station 643.50 to Wing Buttock Line 616.75

E. Access Panels

Number	Name/Location
633AB	Surge Tank Access Door - Wing Station 655

F. Prepare for the Test

WARNING: CAREFULLY DO ALL OF THE SAFETY PROCEDURES TO PREPARE TO GO INTO THE FUEL TANK. IF YOU DO NOT OBEY THE SAFETY PROCEDURES, YOU CAN CAUSE AN EXPLOSION. AN EXPLOSION WILL CAUSE INJURIES TO PERSONNEL, AND DAMAGE TO EQUIPMENT.

WARNING: DO NOT BREATHE THE AIR FROM THE FUEL TANK UNTIL YOU MAKE IT SAFE. THE NITROGEN GENERATION SYSTEM DECREASES THE OXYGEN IN THE AIR. IF YOU BREATHE AIR THAT DOES NOT HAVE SUFFICIENT OXYGEN, DANGEROUS HEALTH CONDITIONS CAN QUICKLY OCCUR. DANGEROUS HEALTH CONDITIONS INCLUDE NAUSEA, UNCONSCIOUSNESS, AND CONVULSIONS. IF THE OXYGEN LEVEL OF THE AIR THAT YOU BREATHE IS VERY LOW, IT CAN KILL YOU.

SUBTASK 47-00-00-010-008

- (1) Do this task to open this access door:

Surge Tank Access Door - Removal, TASK 28-11-11-000-802

Number	Name/Location
633AB	Surge Tank Access Door - Wing Station 655

EFFECTIVITY
HAP 047-053, 106-999

47-00-00



**737-600/700/800/900
AIRCRAFT MAINTENANCE MANUAL**

SUBTASK 47-00-00-010-009

(2) Go to the cross vent check valve location.

NOTE: The cross vent check valve is in the right surge tank attached to the number 12 vent stringer.

G. Cross Vent Check Valve Test

SUBTASK 47-00-00-710-001

(1) Make a hook from a piece of 16 guage wire rod, STD-1153, or equivalent.

(a) Insert the hook into the hole in the tang on the lower side of the flapper valve.

NOTE: Do not scratch or mar the surface of the valve flapper.

(b) Gently pull on the wire until the flapper opens.

(c) Release the wire to let the flapper close.

NOTE: The flapper should seat in the valve body.

1) If the cross vent check valve does not open or seat correctly, do these tasks:

a) Cross Vent Check Valve Removal, TASK 47-21-05-000-801.

b) Cross Vent Check Valve Installation, TASK 47-21-05-420-801.

2) If the cross vent check valve operation is satisfactory, remove the wire from the tang on the valve.

3) Make sure that the surface of the cross vent check valve has not been scratched or marred.

H. Put the Airplane Back to Its Usual Condition

SUBTASK 47-00-00-410-006

(1) Do this task: Surge Tank Access Door - Installation, TASK 28-11-11-400-802.

(a) Close this access panel:

<u>Number</u>	<u>Name/Location</u>
633AB	Surge Tank Access Door - Wing Station 655

————— **END OF TASK** —————

EFFECTIVITY
HAP 047-053, 106-999

47-00-00

Page 611
Jun 15/2009

D633A101-HAP

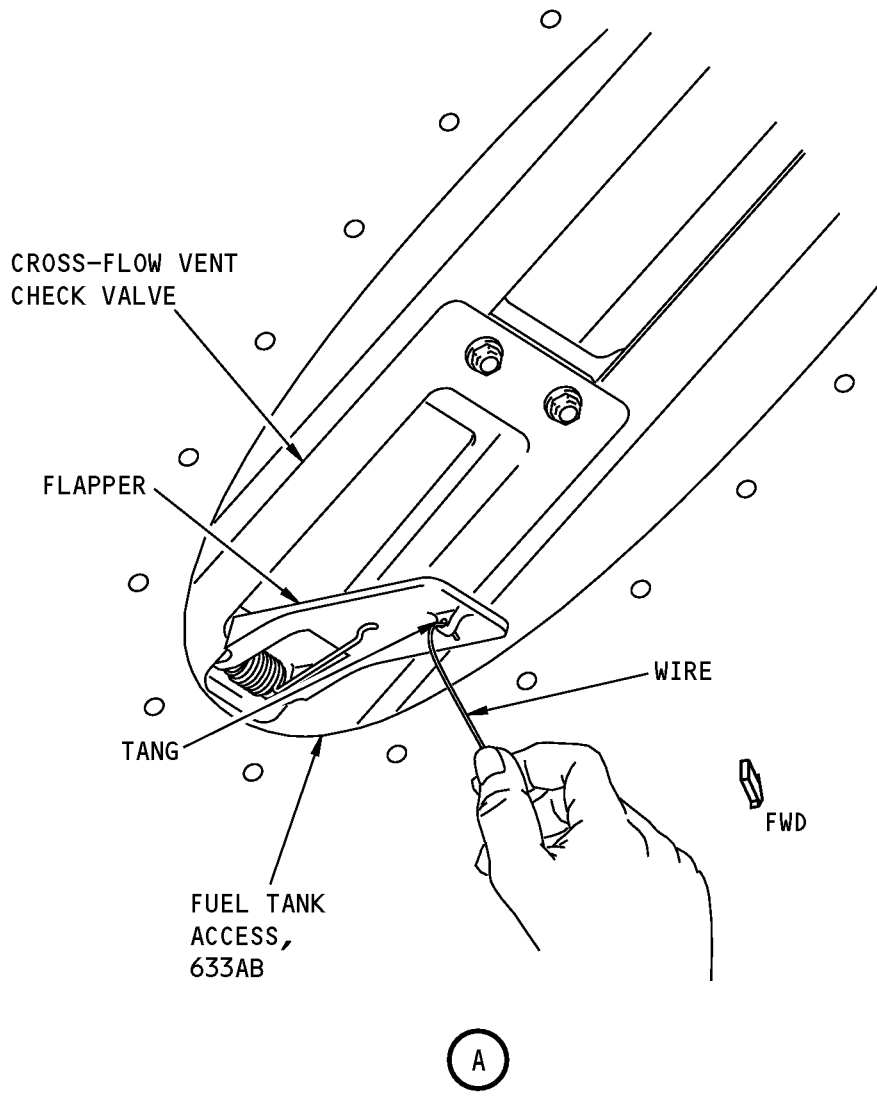
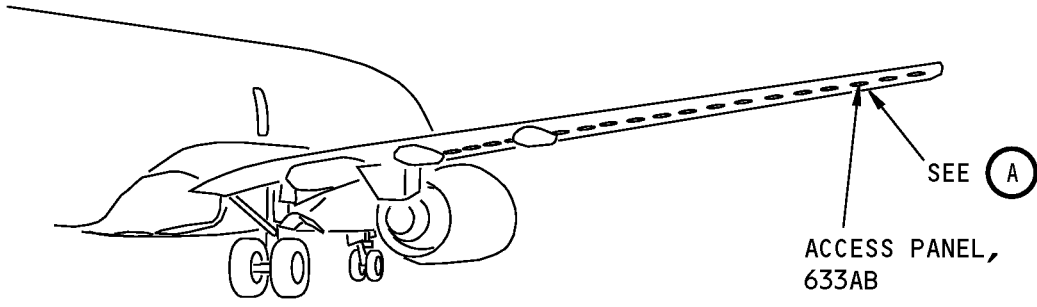

**Cross Vent Check Valve - Test
Figure 603/47-00-00-990-808**

EFFECTIVITY
HAP 047-053, 106-999

47-00-00

Page 612
Jun 15/2009

D633A101-HAP



737-600/700/800/900

AIRCRAFT MAINTENANCE MANUAL

NITROGEN GENERATION SYSTEM - DDG MAINTENANCE PROCEDURES

1. General

- A. This procedure has the maintenance tasks for the Master Minimum Equipment List (MMEL) maintenance requirements as shown in the Dispatch Deviations Procedures Guide (DDPG). These tasks prepare the airplane for flight with systems/components that are inoperative.
- B. The procedure also has tasks to put the airplane back to its usual condition.
- C. These are the tasks for the components in the Nitrogen Generation System (NGS):
 - (1) MEL 47-1 Preparation - Nitrogen Generation System Inoperative
 - (2) MEL 47-1 Restoration - Nitrogen Generation System Inoperative

TASK 47-00-00-040-801

2. MMEL 47-1 (DDPG) Preparation - Nitrogen Generation System Inoperative

(Figure 901)

A. General

- (1) This task is for operation of the airplane with the Nitrogen Generation System (NGS) inoperative.

B. References

Reference	Title
36-00-00-860-806	Remove Pressure from the Pneumatic System (P/B 201)

C. Location Zones

Zone	Area
131	Center Section Wing Box, Body Station 540.00 to Body Station 663.75 - Left
212	Flight Compartment - Right

D. Access Panels

Number	Name/Location
192CL	Air Conditioning Access Door

E. Nitrogen Generation System Deactivation

SUBTASK 47-00-00-040-004

- (1) Open these circuit breakers and install safety locks:

CAPT Electrical System Panel, P18-3

Row	Col	Number	Name
D	17	C01657	NITROGEN GENERATION CONTROL
E	15	C01680	NGS ALT PWR

SUBTASK 47-00-00-864-005

- (2) Do this task: Remove Pressure from the Pneumatic System, TASK 36-00-00-860-806.
 - (a) Make sure that the dual duct pressure gage shows 0.50 psig (3.45 kPa) in the left and right pneumatic ducts.

SUBTASK 47-00-00-860-012

- (3) Put the L PACK and R PACK selector switches, on the P5-10 air conditioning panel, to the OFF position.
 - (a) Put DO-NOT-OPERATE tags on the L PACK and R PACK selector switches.

EFFECTIVITY HAP 047-053, 106-999

47-00-00

Page 901
Oct 15/2008

D633A101-HAP



737-600/700/800/900

AIRCRAFT MAINTENANCE MANUAL

SUBTASK 47-00-00-010-006

WARNING: OBEY THE SUBSEQUENT STEPS FOR ACCESS PANELS IDENTIFIED WITH A NITROGEN GENERATION SYSTEM PLACARD. IF THERE IS A LEAK IN THE NITROGEN GENERATION SYSTEM, IT WILL DECREASE THE OXYGEN IN THE AIR THAT YOU BREATHE. IF YOU BREATHE AIR THAT DOES NOT HAVE SUFFICIENT OXYGEN, DANGEROUS HEALTH CONDITIONS CAN QUICKLY OCCUR.

WARNING: DO NOT TOUCH THE COMPONENTS OF THE NITROGEN GENERATION SYSTEM WHEN THEY ARE HOT. WHEN THE COMPONENTS ARE HOT, THEY CAN CAUSE INJURIES TO PERSONNEL.

(4) Open this access panel:

<u>Number</u>	<u>Name/Location</u>
192CL	Air Conditioning Access Door

(5) Go to the NGS shutoff valve location.

NOTE: The NGS shutoff valve is on the forward bulkhead of the left air conditioning compartment.

SUBTASK 47-00-00-040-003

(6) Do these steps to lock the NGS shutoff valve:

(a) Make sure that the hole in the manual lock arm is aligned with the threaded boss on the NGS shutoff valve body.

1) If the manual lock arm hole is not aligned, use a wrench to turn the manual locking hex bolt clockwise until the hole in the manual lock arm aligns with the threaded boss on the NGS shutoff valve body.

(b) Remove the lock pin from the NGS shutoff valve body.

NOTE: The manual lock pin is attached to the NGS shutoff valve with a lanyard.

(c) Install the lock pin through the hole in the manual lock arm.

(d) Tighten the lock pin to 27 ± 2 in-lb (3 ± 0 N·m).

(7) Make sure that the NGS inoperative condition is recorded.

F. Put the Airplane Back to the Usual Condition.

SUBTASK 47-00-00-860-010

(1) Remove the DO-NOT-OPERATE tags from the L PACK and R PACK selector switches.

(a) Put the L PACK and R PACK selector switches to the AUTO position.

SUBTASK 47-00-00-410-004

(2) Close this access panel:

<u>Number</u>	<u>Name/Location</u>
192CL	Air Conditioning Access Door

————— **END OF TASK** —————

EFFECTIVITY
HAP 047-053, 106-999

D633A101-HAP

47-00-00

Page 902
Oct 15/2008

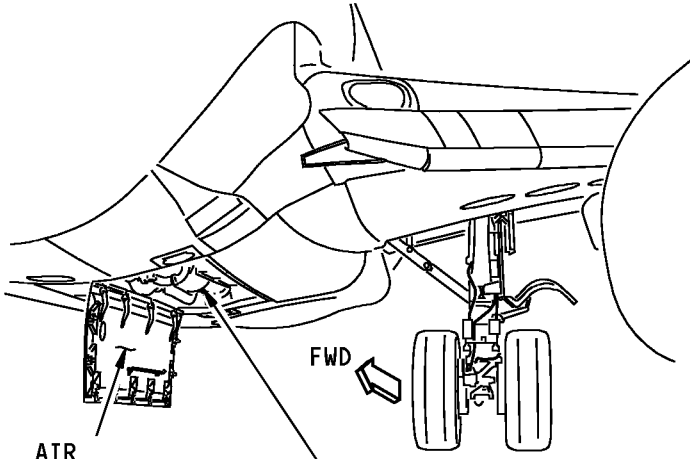

AIR
CONDITIONING
ACCESS DOOR
192CL

NITROGEN
GENERATION
SYSTEM

SEE (A)

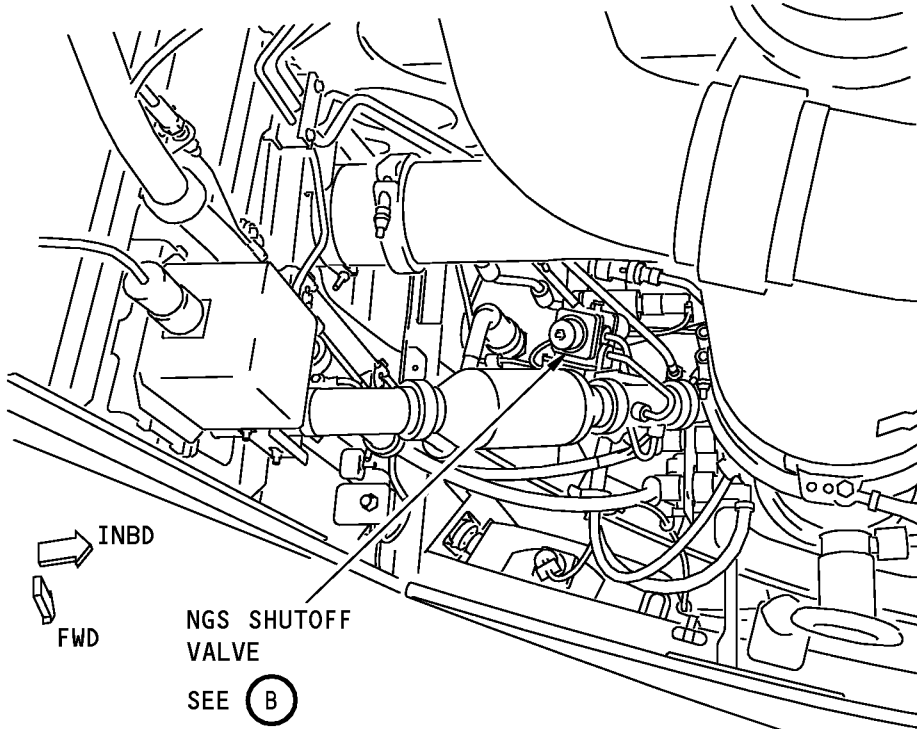

INBD

FWD

NGS SHUTOFF
VALVE

SEE (B)

NITROGEN GENERATION SYSTEM

(A)

J73837 S0000177218_V3

Nitrogen Generation System (NGS) - Shutoff Valve
Figure 901 (Sheet 1 of 2)/47-00-00-990-809

EFFECTIVITY
HAP 047-053, 106-999

47-00-00

Page 903
Oct 15/2008

D633A101-HAP

**737-600/700/800/900
AIRCRAFT MAINTENANCE MANUAL**

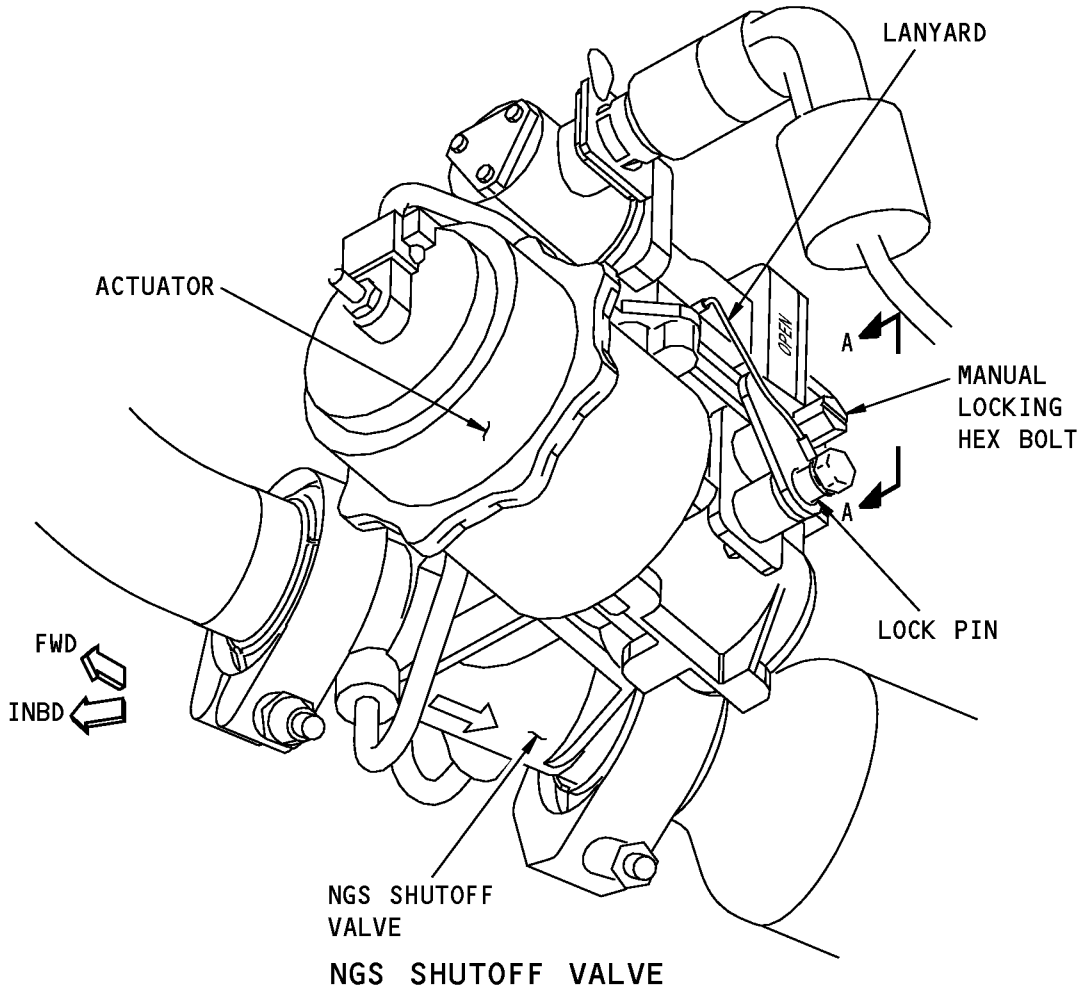

B

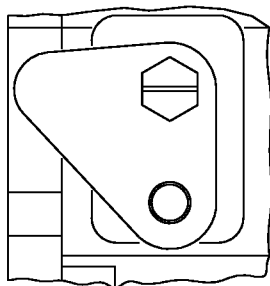

**(ALIGNED)
A-A**

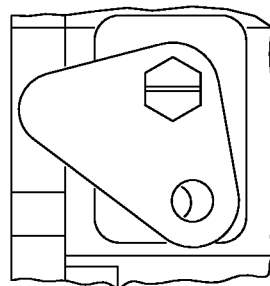

**(MISALIGNED)
A-A**

**Nitrogen Generation System (NGS) - Shutoff Valve
Figure 901 (Sheet 2 of 2)/47-00-00-990-809**

EFFECTIVITY
HAP 047-053, 106-999

D633A101-HAP

BOEING PROPRIETARY - Copyright © Unpublished Work - See title page for details

47-00-00

Page 904
Oct 15/2008



737-600/700/800/900

AIRCRAFT MAINTENANCE MANUAL

TASK 47-00-00-440-801

3. M MEL 47-1 (DDPG) Restoration - Nitrogen Generation System Inoperative

(Figure 901)

A. General

(1) This task restores an airplane with an inoperative Nitrogen Generation System (NGS).

B. References

Reference	Title
36-00-00-860-806	Remove Pressure from the Pneumatic System (P/B 201)

C. Location Zones

Zone	Area
131	Center Section Wing Box, Body Station 540.00 to Body Station 663.75 - Left
212	Flight Compartment - Right

D. Access Panels

Number	Name/Location
192CL	Air Conditioning Access Door

E. Nitrogen Generation System Reactivation

SUBTASK 47-00-00-864-006

- (1) Do this task: Remove Pressure from the Pneumatic System, TASK 36-00-00-860-806.
 - (a) Make sure that the dual duct pressure gage shows 0.50 psi (3.45 kPa) in the left and right pneumatic ducts.

SUBTASK 47-00-00-860-013

- (2) Put the L PACK and R PACK selector switches, found on the P5-10 air conditioning panel, to the OFF position.
 - (a) Put DO-NOT-OPERATE tags on the L PACK and R PACK selector switches.

SUBTASK 47-00-00-010-007

WARNING: OBEY THE SUBSEQUENT STEPS FOR ACCESS PANELS IDENTIFIED WITH A NITROGEN GENERATION SYSTEM PLACARD. IF THERE IS A LEAK IN THE NITROGEN GENERATION SYSTEM, IT WILL DECREASE THE OXYGEN IN THE AIR THAT YOU BREATHE. IF YOU BREATHE AIR THAT DOES NOT HAVE SUFFICIENT OXYGEN, DANGEROUS HEALTH CONDITIONS CAN QUICKLY OCCUR.

WARNING: DO NOT TOUCH THE COMPONENTS OF THE NITROGEN GENERATION SYSTEM WHEN THEY ARE HOT. WHEN THE COMPONENTS ARE HOT, THEY CAN CAUSE INJURIES TO PERSONNEL.

- (3) Open this access panel:

Number	Name/Location
192CL	Air Conditioning Access Door

SUBTASK 47-00-00-440-003

- (4) Go to the NGS shutoff valve location.

NOTE: The NGS shutoff valve is on the forward bulkhead of the left air conditioning compartment.

EFFECTIVITY HAP 047-053, 106-999

47-00-00



**737-600/700/800/900
AIRCRAFT MAINTENANCE MANUAL**

SUBTASK 47-00-00-440-002

(5) Do these steps to reactivate the NGS shutoff valve:

(a) Remove the lock pin from the manual lock arm.

NOTE: The manual lock pin is attached with a lanyard.

NOTE: The NGS shutoff valve is spring loaded to the closed position when the system is not in operation.

(b) Install the lock pin in its storage space in the NGS shutoff valve body.

(c) Tighten the lock pin to 27 ±2 in-lb (3 ±0 N·m).

SUBTASK 47-00-00-860-011

(6) Remove the DO-NOT-OPERATE tags from the L PACK and R PACK selector switches.

(a) Put the L PACK and R PACK selector switches to the AUTO position.

(b) Make sure the NGS operative condition is recorded.

F. Put the Airplane Back to the Usual Condition

SUBTASK 47-00-00-440-004

(1) Remove the safety tags and close these circuit breakers:

CAPT Electrical System Panel, P18-3

<u>Row</u>	<u>Col</u>	<u>Number</u>	<u>Name</u>
D	17	C01657	NITROGEN GENERATION CONTROL
E	15	C01680	NGS ALT PWR

SUBTASK 47-00-00-410-005

(2) Close this access panel:

<u>Number</u>	<u>Name/Location</u>
192CL	Air Conditioning Access Door

————— **END OF TASK** —————

EFFECTIVITY
HAP 047-053, 106-999

47-00-00

Page 906
Oct 15/2008

D633A101-HAP



737-600/700/800/900

AIRCRAFT MAINTENANCE MANUAL

AIR SEPARATION MODULE - REMOVAL/INSTALLATION

1. General

- A. This procedure contains scheduled maintenance task data.
- B. This procedure has these tasks:
 - (1) Air Separation Module Removal
 - (2) Air Separation Module Installation

TASK 47-11-01-000-801

2. Air Separation Module (ASM) Removal

(Figure 401)

A. General

- (1) This procedure is a scheduled maintenance task.

B. References

Reference	Title
36-00-00-860-806	Remove Pressure from the Pneumatic System (P/B 201)

C. Location Zones

Zone	Area
131	Center Section Wing Box, Body Station 540.00 to Body Station 663.75 - Left
211	Flight Compartment - Left
212	Flight Compartment - Right

D. Access Panels

Number	Name/Location
192BL	ECS Ram Air Inlet Mixing Duct Panel - Forward

E. Prepare for the Removal

SUBTASK 47-11-01-864-001

- (1) Do this task: Remove Pressure from the Pneumatic System, TASK 36-00-00-860-806.
 - (a) Make sure that the dual duct pressure gage shows 0.50 psig (3.45 kPa) or less in the L and R pneumatic ducts.

SUBTASK 47-11-01-860-001

- (2) Put the L PACK and R PACK selector switches, on the P5-10 air conditioning panel, to the OFF position.
 - (a) Put DO-NOT-OPERATE tags on the L PACK and R PACK selector switches.

SUBTASK 47-11-01-865-001

- (3) Open these circuit breakers and install safety tags:

CAPT Electrical System Panel, P18-3

Row	Col	Number	Name
D	17	C01657	NITROGEN GENERATION CONTROL
E	15	C01680	NGS ALT PWR

EFFECTIVITY HAP 047-053, 106-999

47-11-01

Page 401
Feb 15/2009

D633A101-HAP



737-600/700/800/900

AIRCRAFT MAINTENANCE MANUAL

SUBTASK 47-11-01-010-001

WARNING: OBEY THE SUBSEQUENT STEPS FOR ACCESS PANELS IDENTIFIED WITH A NITROGEN GENERATION SYSTEM PLACARD. IF THERE IS A LEAK IN THE NITROGEN GENERATION SYSTEM, IT WILL DECREASE THE OXYGEN IN THE AIR THAT YOU BREATHE. IF YOU BREATHE AIR THAT DOES NOT HAVE SUFFICIENT OXYGEN, DANGEROUS HEALTH CONDITIONS CAN QUICKLY OCCUR.

(4) Open this access panel:

<u>Number</u>	<u>Name/Location</u>
192BL	ECS Ram Air Inlet Mixing Duct Panel - Forward

F. Remove the Air Separation Module

SUBTASK 47-11-01-030-001

WARNING: DO NOT TOUCH THE COMPONENTS OF THE NITROGEN GENERATION SYSTEM WHEN THEY ARE HOT. WHEN THE COMPONENTS ARE HOT, THEY CAN CAUSE INJURIES TO PERSONNEL.

WARNING: DO NOT DISCONNECT THE COMPONENTS OF THE NITROGEN GENERATION SYSTEM, OR DUCTS WHEN THE SYSTEM IS PRESSURIZED. THE HOT, HIGH-PRESSURE AIR CAN CAUSE INJURIES TO PERSONNEL, AND DAMAGE TO EQUIPMENT.

CAUTION: MAKE SURE THAT THE MAINTENANCE AREA IS FREE OF CONTAMINATION FROM SKYDROL, LUBRICANTS, SOLVENTS, FUEL, FUMES, EXHAUST, OR DUST. DO NOT LET SOLVENTS, LUBRICANTS, OTHER FLUIDS, OR THEIR FUMES GO INTO THE FLOW PATH TO OR FROM THE ASM. CONTAMINATION WILL CAUSE DAMAGE TO THE FIBERS IN THE ASM AND DECREASE THEIR LIFE.

(1) Obey the Nitrogen Generation System (NGS) precautions.

SUBTASK 47-11-01-010-002

(2) Go to the air separation module (ASM) location.

NOTE: The ASM is in the left ram air duct bay.

SUBTASK 47-11-01-020-003

(3) Do these steps to remove the air separation module [1]:

NOTE: Keep the clamps, sleeves, fasteners, and couplings for installation.

- (a) Remove the clamp [11] between the air separation module [1] and the overtemperature shutoff valve [10].
 - 1) Discard the o-ring [12].
- (b) Disconnect the coupling [15] between the high flow valve [14], and the air separation module [1].
 - 1) Remove the sleeve [13].
 - 2) Discard the two o-rings [16].
- (c) Disconnect the coupling [18] from the OEA outlet port [17] and the OEA exhaust duct [21].
 - 1) Remove the sleeve [19].
 - 2) Discard the two o-rings [20].
- (d) Remove the three bolts [3], washers [4], and nuts [2] from the brackets [5] on the muscle air duct [9].

EFFECTIVITY
HAP 047-053, 106-999

D633A101-HAP

47-11-01

Page 402
Feb 15/2009



737-600/700/800/900

AIRCRAFT MAINTENANCE MANUAL

- (e) Remove the three bolts [24], washers [23], and nuts [25] from the brackets [22] on the NEADS duct [27].
 - (f) Hold the air separation module [1] in its position.
 - (g) Loosen the nut [28] on the strap [8].
 - 1) Separate the strap [8].
 - (h) Loosen the nut [29] on the strap [26].
 - 1) Separate the strap [26]
 - (i) Remove the air separation module [1].
- (4) Place the air separation module [1] on a clean surface.
- (5) Do these steps to remove the insulation from the air separation module [1]:
- (a) Cut the four ties on the surface of the insulation.
 - (b) Slice the tape at the seam line to remove the insulation from the air separation module [1].
NOTE: Be careful not to slice into the insulation, it will be reused for the installation.
 - (c) Remove the insulation.
- (6) Loosen the setscrews [7] on the on the ASM hose clamps [6].
- (a) Remove the brackets [5], brackets [22] and ASM hose clamp [6].
- SUBTASK 47-11-01-490-001
- (7) Install protective covers on the three air separation module [1] ports, overtemperature shutoff valve [10], high flow valve [14] port, and OEA exhaust duct [21].

————— **END OF TASK** —————

EFFECTIVITY
HAP 047-053, 106-999

D633A101-HAP

47-11-01

Page 403
Feb 15/2009

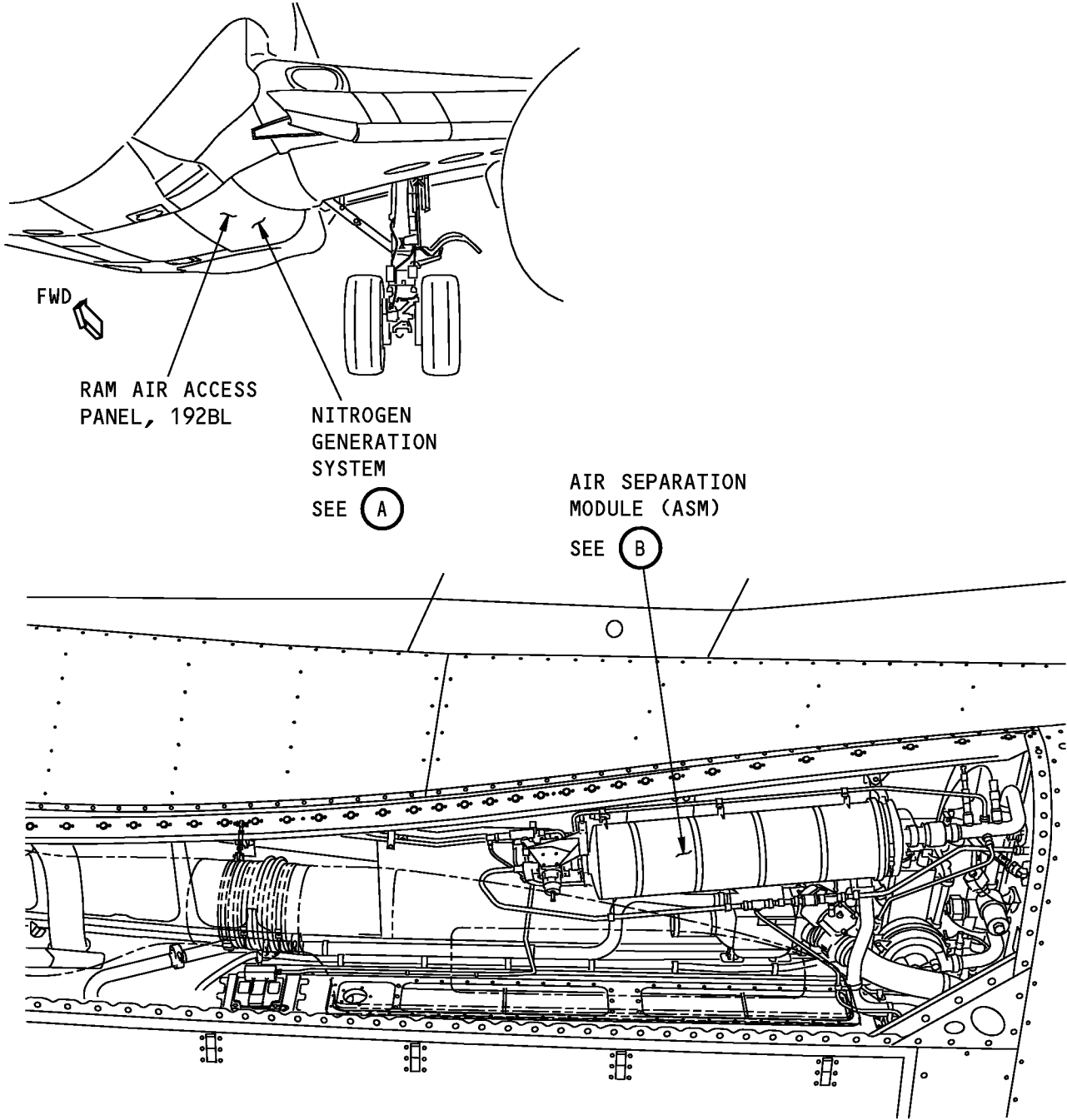

FWD ←

**NITROGEN GENERATION SYSTEM
(VIEW IN THE INBOARD DIRECTION)**

(A)

1484845 S0000268316_V1

**ASM - Removal and Installation
Figure 401 (Sheet 1 of 5)/47-11-01-990-801**

EFFECTIVITY
HAP 047-053, 106-999

47-11-01

Page 404
Oct 15/2008

D633A101-HAP

**737-600/700/800/900
AIRCRAFT MAINTENANCE MANUAL**

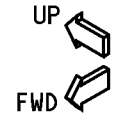
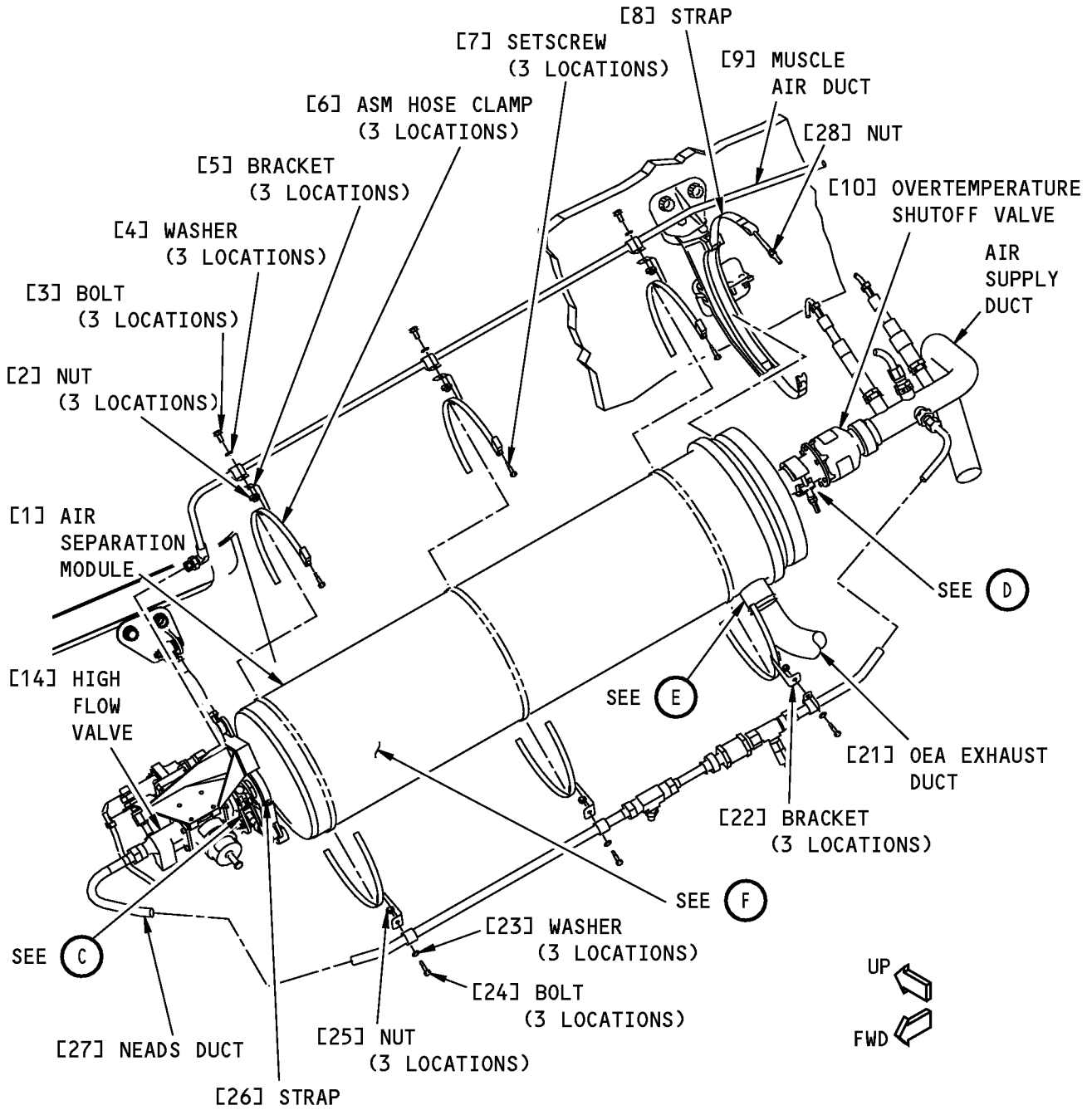

AIR SEPARATION MODULE

NOTE: THE AIR SEPARATION MODULE IS SHOWN WITHOUT THE INSULATION.

(B)

J35668 S0000173705_V4

**ASM - Removal and Installation
Figure 401 (Sheet 2 of 5)/47-11-01-990-801**

EFFECTIVITY
HAP 047-053, 106-999

47-11-01

Page 405
Oct 15/2008

D633A101-HAP

**737-600/700/800/900
AIRCRAFT MAINTENANCE MANUAL**

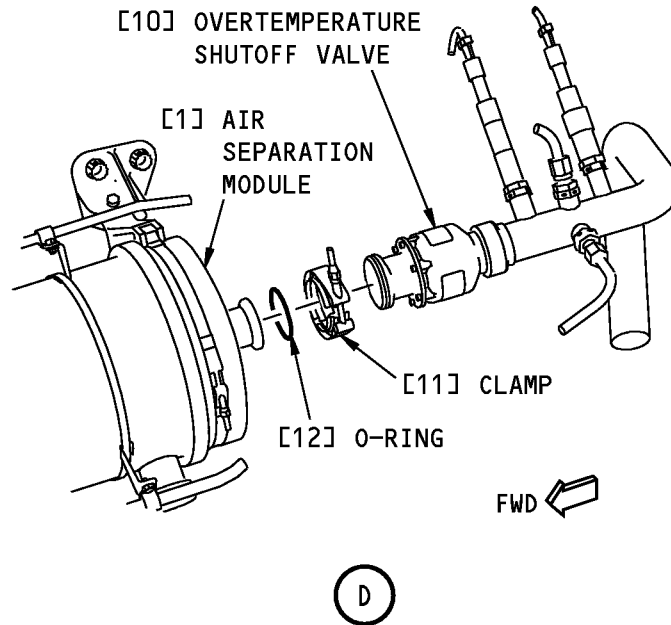
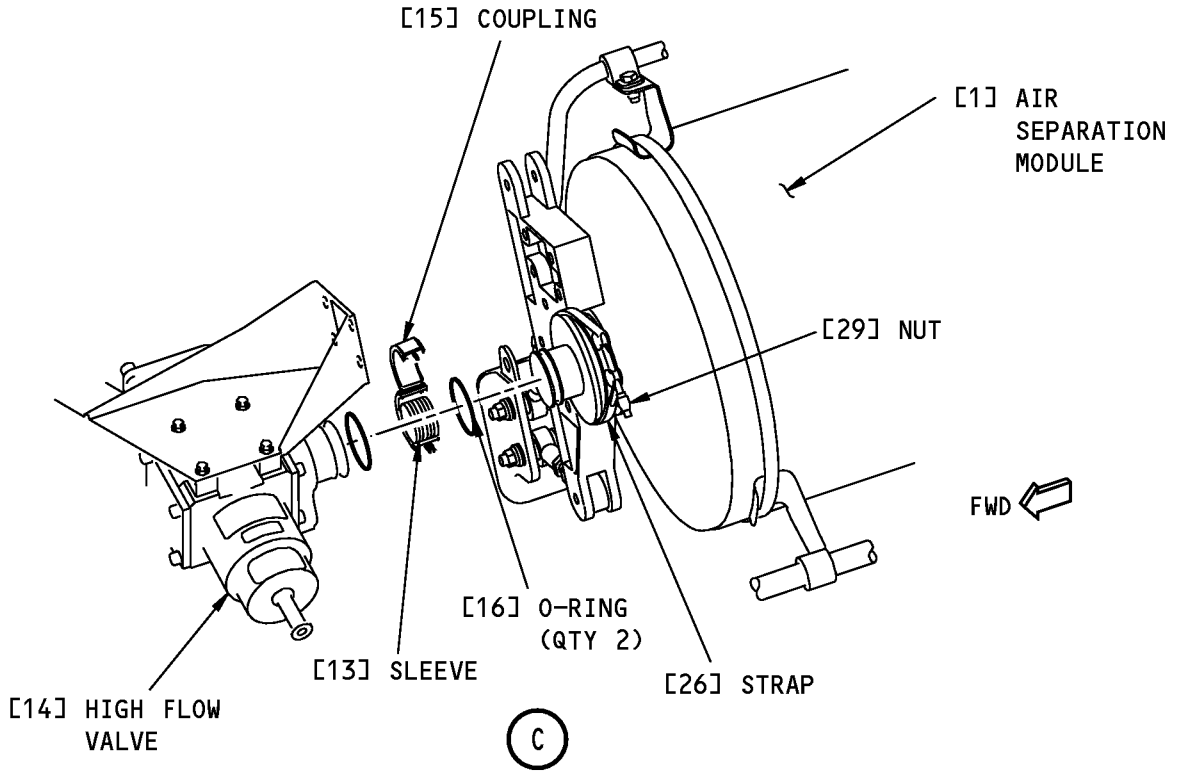

J77848 S0000179124_V3

**ASM - Removal and Installation
Figure 401 (Sheet 3 of 5)/47-11-01-990-801**

EFFECTIVITY
HAP 047-053, 106-999

47-11-01

Page 406
Oct 15/2008

D633A101-HAP

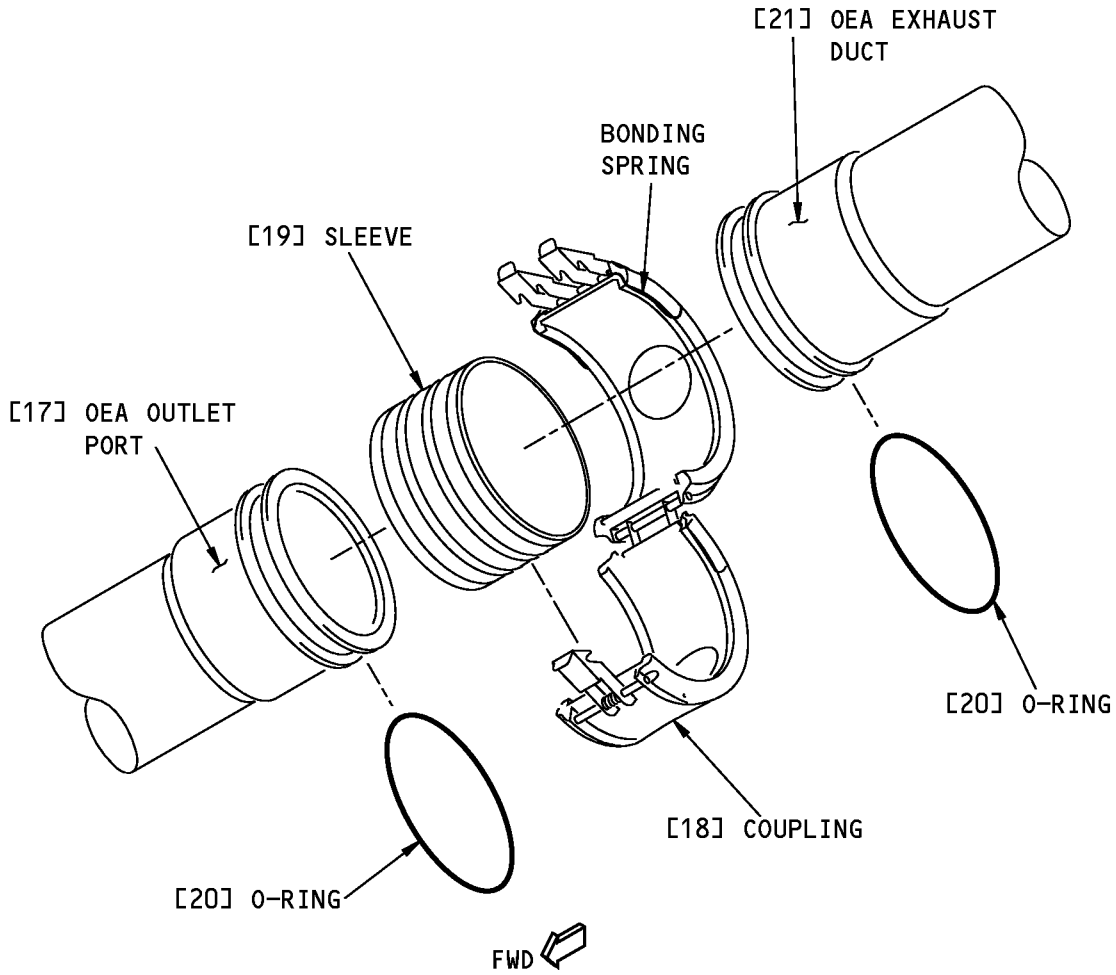

(E)

1483120 S0000268290_V1

**ASM - Removal and Installation
Figure 401 (Sheet 4 of 5)/47-11-01-990-801**

EFFECTIVITY
HAP 047-053, 106-999

47-11-01

Page 407
Oct 15/2008

D633A101-HAP

**737-600/700/800/900
AIRCRAFT MAINTENANCE MANUAL**

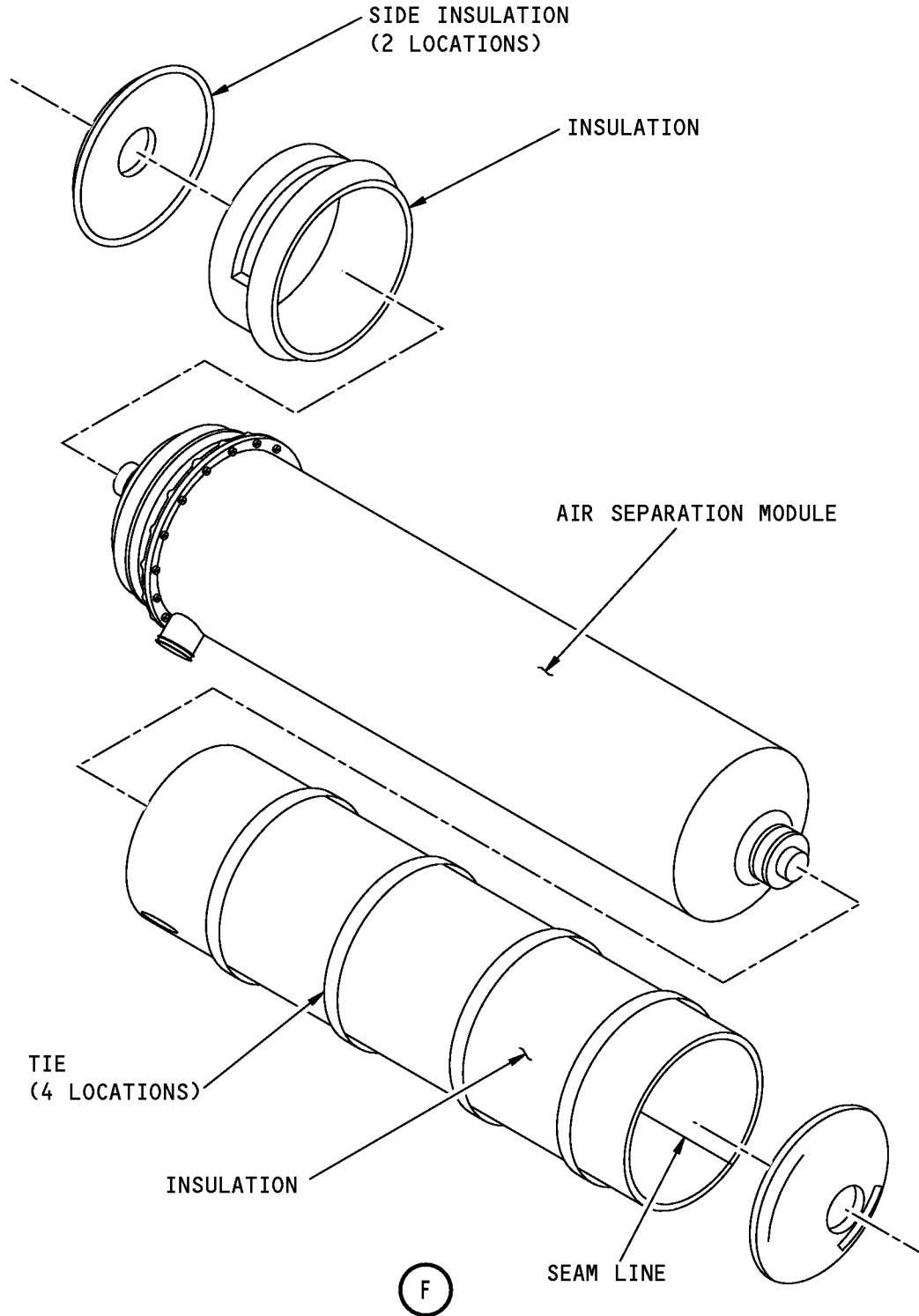

1566194 S0000290687_V1

**ASM - Removal and Installation
Figure 401 (Sheet 5 of 5)/47-11-01-990-801**

EFFECTIVITY
HAP 047-053, 106-999

47-11-01

Page 408
Oct 15/2008

D633A101-HAP



737-600/700/800/900

AIRCRAFT MAINTENANCE MANUAL

TASK 47-11-01-420-801

3. Air Separation Module (ASM) Installation

(Figure 401)

A. General

(1) This procedure is a scheduled maintenance task.

B. References

Reference	Title
47-00-00-790-801	Leak Check of the Nitrogen Generation System (P/B 601)
47-00-00-800-801	Ground Operation of the Nitrogen Generation System (P/B 201)
SWPM 20-20-00	Electrical Bonds and Grounds

C. Tools/Equipment

NOTE: When more than one tool part number is listed under the same "Reference" number, the tools shown are alternates to each other within the same airplane series. Tool part numbers that are replaced or non-procurable are preceded by "Opt:", which stands for Optional.

Reference	Description
COM-1550	Meter - Bonding (Approved Explosion Proof & Intrinsically Safe) (Part #: C15292 (MODEL T477W), Supplier: 01014, A/P Effectivity: 737-ALL) (Part #: M1, Supplier: 3AD17, A/P Effectivity: 737-ALL) (Part #: M1B, Supplier: 3AD17, A/P Effectivity: 737-ALL)

D. Consumable Materials

Reference	Description	Specification
B00130	Alcohol - Isopropyl	TT-I-735
C00346	Primer - Corrosion Inhibiting, Chemical & Solvent Resistant Epoxy, High Solids	MIL-PRF-23377
D50063	Grease - Perfluoropolyether, fuel and oxygen resistant - Krytox 240AC	MIL-PRF-27617, Type III
G00034	Cotton Wiper - Process Cleaning Absorbent Wiper (Cheesecloth, Gauze)	BMS15-5

E. Location Zones

Zone	Area
131	Center Section Wing Box, Body Station 540.00 to Body Station 663.75 - Left
211	Flight Compartment - Left
212	Flight Compartment - Right

F. Access Panels

Number	Name/Location
192BL	ECS Ram Air Inlet Mixing Duct Panel - Forward

G. Prepare the Air Separation Module

SUBTASK 47-11-01-100-001

(1) Do these steps to prepare the air separation module [1] for the installation:

- (a) Remove the protective caps from the overtemperature shutoff valve [10], OEA exhaust duct [21], and high flow valve [14] port.

EFFECTIVITY HAP 047-053, 106-999

47-11-01

Page 409
Jun 15/2009

D633A101-HAP



737-600/700/800/900

AIRCRAFT MAINTENANCE MANUAL

- 1) Make sure that the valve, duct, and port are clean and free from grease, solvents and unwanted material.
- 2) Clean the valve, duct, and port with a clean cotton wiper, G00034, and isopropyl alcohol, B00130.
- (b) Apply a thin layer of Krytox 240AC perfluoropolyether grease, D50063, to the new o-ring [20].
- (c) Install the new o-ring [20] on the OEA exhaust duct [21].
- (d) Apply a thin layer of Krytox 240AC perfluoropolyether grease, D50063, to the new o-ring [16].
- (e) Install the new o-ring [16] on the high flow valve [14] port.
- (f) Place the air separation module [1] on a clean surface.
- (g) Remove the protective caps on the air separation module [1] ports.
 - 1) Make sure that the air separation module [1] ports are free from grease, solvents and unwanted material.
 - 2) Clean the three ports with a clean cotton wiper, G00034, and isopropyl alcohol, B00130.
- (h) Apply a thin layer of Krytox 240AC perfluoropolyether grease, D50063, to the new o-ring [12].
- (i) Install the new o-ring [12] on the inlet port of the air separation module [1].
 - 1) Put a protective cap on the inlet port.
- (j) Apply a thin layer of Krytox 240AC perfluoropolyether grease, D50063, to the new o-ring [20].
- (k) Install the new o-ring [20] on the OEA outlet port [17].
 - 1) Put a protective cap on the OEA outlet port [17].
- (l) Apply a thin layer of Krytox 240AC perfluoropolyether grease, D50063, to the new o-ring [16].
- (m) Install the new o-ring [16] on the NEA outlet port of the air separation module [1].
 - 1) Put a protective cap on the NEA outlet port.
- (2) Do these steps to install the three ASM hose clamps [6] on the air separation module [1]:
 - (a) Apply primer, C00346 to the inside of the ASM hose clamps [6].
 - (b) Slide the three ASM hose clamps [6] on the air separation module [1].
 - (c) Loosen the three setscrews [7] on the ASM hose clamps [6], enough for brackets [5] and brackets [22] to slide between the air separation module [1] and the ASM hose clamps [6].
 - (d) Apply primer, C00346, to the brackets [5] and brackets [22], on the surfaces that will be in contact between the air separation module [1] and ASM hose clamps [6].
 - (e) Install the brackets [5] and brackets [22] between the ASM hose clamps [6] and the air separation module [1].
 - 1) Adjust the brackets [5] and brackets [22] on the ASM hose clamps [6] to their approximate position.
 - 2) Tighten the setscrews [7] enough to hold the brackets [5] and brackets [22] in their positions.
 - (f) Temporarily install the insulation on the air separation module [1] to correctly position the brackets [5] and brackets [22].

EFFECTIVITY
HAP 047-053, 106-999

D633A101-HAP

47-11-01

Page 410
Feb 15/2009



737-600/700/800/900

AIRCRAFT MAINTENANCE MANUAL

- 1) Position the brackets [5] and brackets [22] such that there is a 0.15 ± 0.10 in. (3.81 ± 2.54 mm) clearance between the brackets and insulation cutouts.
- 2) Re-adjust the brackets if necessary.
- (g) Remove the insulation.
- (h) Tighten the three setscrews [7] to 16 ± 2 in-lb (2 ± 0 N-m).
- (3) Do these steps on install the insulation on the air separation module [1]:
 - (a) Install the insulation on the air separation module [1].

NOTE: Install the insulation over the air separation module [1] such that there is a 0.15 ± 0.10 in. (3.81 ± 2.54 mm) clearance between the brackets and insulation cutouts.
 - (b) Use the orientation marks to align the side insulations.
 - (c) Install the side insulations on the air separation module [1].

NOTE: Install the side insulations such that the ASM nameplate is visible.
 - (d) Apply 3 in. (76 mm) wide tape to the seams of the insulation and side insulations.
 - (e) Make sure no insulation foam is exposed.
 - (f) Make sure that the tape is centered between the insulation sections, the tape should extend at least one inch on either side of the seam.

NOTE: Small gaps no larger than 0.25 in. (6.35 mm) are acceptable along the seam, as long as, the gap does not extend through the entire seam and is covered by tape. The ASM surface must not be visible through the gap.
 - (g) Make sure there are no gaps between the foam and the outside diameter of the air separation module [1], except where bunching occurs.

NOTE: If bunching occurs, make sure the gap is not more than 0.25 in. (6.35 mm).
 - (h) Install the ties around the exterior surface of the insulation.

NOTE: Use a square knot on each tie end to prevent fraying. The loose ends of the ties must be tucked under the ties, between the tie and the insulation. A knot shall also be placed on the end of the tie to prevent fraying. The end of the insulation tie must be tucked under itself (between the tie and foam) to prevent the ends from moving around during shipping, installation or service.
 - (i) Make sure that the ties are tightly attached to the insulation.

NOTE: Ties may push down on insulation sufficiently to keep its location, but not to the extent that visible gaps occur.

H. Install the Air Separation Module

SUBTASK 47-11-01-420-001

- (1) Do these steps to install the air separation module [1].
 - (a) Remove the protective caps from the air separation module [1] ports.
 - (b) Position the air separation module [1] into the strap [8] and strap [26].
 - 1) Align all the ports and ducts.
 - 2) Hold the air separation module [1] in this position.
 - (c) Tighten the nut [29] on the strap [26].
 - (d) Tighten the nut [28] on the strap [8].
- (2) Do these steps to connect the ports and ducts:

EFFECTIVITY
HAP 047-053, 106-999

D633A101-HAP

47-11-01

Page 411
Feb 15/2009



737-600/700/800/900

AIRCRAFT MAINTENANCE MANUAL

- (a) Put the sleeve [19] in its position between the OEA outlet port [17] and the OEA exhaust duct [21].
(b) Install the coupling [18].
(c) Put the sleeve [13] in its position between NEA outlet port and high flow valve [14] port.
(d) Install the coupling [15].
(e) Apply primer, C00346 to the clamp [11].
(f) Install the clamp [11] between the inlet port and the overtemperature shutoff valve [10].
(3) Do these steps to attach the muscle air duct [9] and NEADS duct [27] to the air separation module [1]:
(a) Adjust the position of the P-clamps on the muscle air duct [9] and the NEADS duct [27] until they are aligned with the brackets [5] and brackets [22] on the ASM hose clamps [6].
(b) Install the bolts [3], washers [4] and nuts [2], that attach the brackets [5] to the P-clamps on the muscle air duct [9].
(c) Install the bolts [24], washers [23] and nuts [25], that attach the brackets [22] to the P-clamps on the NEADS duct [27].

SUBTASK 47-11-01-765-001

- (4) Use a bonding meter, COM-1550, to measure the electrical resistance between the strap [8] on the air separation module [1] and the airplane structure (SWPM 20-20-00).
(a) Make sure that the electrical resistance between the strap [8] and the structure is 0.010 ohm (10 milliohms) or less (SWPM 20-20-00).

I. Operational Test for the Air Separation Module

SUBTASK 47-11-01-865-002

- (1) Do these steps to prepare for the operational test:
(a) Remove the safety tags and close these circuit breakers:

CAPT Electrical System Panel, P18-3

Table with 4 columns: Row, Col, Number, Name. Rows include D 17 C01657 NITROGEN GENERATION CONTROL and E 15 C01680 NGS ALT PWR.

- (b) Remove the DO-NOT-OPERATE tags from the L PACK and R PACK selector switches.
(c) Put the L PACK and R PACK selector switches in the AUTO position.

SUBTASK 47-11-01-790-001

- (2) Do this task: Ground Operation of the Nitrogen Generation System, TASK 47-00-00-800-801.
(3) Do this task: Leak Check of the Nitrogen Generation System, TASK 47-00-00-790-801.
(a) Repair the leaks that you find.

J. Put the Airplane Back to the Usual Condition

SUBTASK 47-11-01-410-001

- (1) Close this access panel:

Table with 2 columns: Number, Name/Location. Row: 192BL ECS Ram Air Inlet Mixing Duct Panel - Forward

END OF TASK

EFFECTIVITY
HAP 047-053, 106-999

47-11-01

Page 412
Feb 15/2009

D633A101-HAP



737-600/700/800/900

AIRCRAFT MAINTENANCE MANUAL

HIGH FLOW VALVE - REMOVAL/INSTALLATION

1. General

A. This procedure has these tasks:

- (1) High Flow Valve Removal
- (2) High Flow Valve Installation

TASK 47-11-02-000-801

2. High Flow Valve Removal

(Figure 401)

A. General

- (1) This task removes the high flow valve [1] and the differential pressure sensor as one unit.

B. References

Reference	Title
36-00-00-860-806	Remove Pressure from the Pneumatic System (P/B 201)

C. Location Zones

Zone	Area
131	Center Section Wing Box, Body Station 540.00 to Body Station 663.75 - Left
211	Flight Compartment - Left
212	Flight Compartment - Right

D. Access Panels

Number	Name/Location
192BL	ECS Ram Air Inlet Mixing Duct Panel - Forward

E. Prepare for the Removal

SUBTASK 47-11-02-864-001

- (1) Do this task: Remove Pressure from the Pneumatic System, TASK 36-00-00-860-806.
 - (a) Make sure that the dual duct pressure gage shows 0.50 psig (3.45 kPa) or less in the in the L and R pneumatic ducts.

SUBTASK 47-11-02-860-001

- (2) Put the L PACK and R PACK selector switches, found on the P5-10 air conditioning panel, to the OFF position.
 - (a) Put DO-NOT-OPERATE tags on the L PACK and R PACK selector switches.

SUBTASK 47-11-02-865-001

- (3) Open these circuit breakers and install safety tags:

CAPT Electrical System Panel, P18-3

Row	Col	Number	Name
D	17	C01657	NITROGEN GENERATION CONTROL
E	15	C01680	NGS ALT PWR

EFFECTIVITY
HAP 047-053, 106-999

47-11-02

Page 401
Oct 15/2008

D633A101-HAP



737-600/700/800/900

AIRCRAFT MAINTENANCE MANUAL

SUBTASK 47-11-02-010-001

- (4) Open this access panel:

<u>Number</u>	<u>Name/Location</u>
192BL	ECS Ram Air Inlet Mixing Duct Panel - Forward

- F. Remove the High Flow Valve

SUBTASK 47-11-02-030-001

WARNING: DO NOT TOUCH THE COMPONENTS OF THE NITROGEN GENERATION SYSTEM WHEN THEY ARE HOT. WHEN THE COMPONENTS ARE HOT, THEY CAN CAUSE INJURIES TO PERSONNEL.

WARNING: DO NOT DISCONNECT THE COMPONENTS OF THE NITROGEN GENERATION SYSTEM, OR DUCTS WHEN THE SYSTEM IS PRESSURIZED. THE HOT, HIGH-PRESSURE AIR CAN CAUSE INJURIES TO PERSONNEL, AND DAMAGE TO EQUIPMENT.

CAUTION: MAKE SURE THAT THE MAINTENANCE AREA IS FREE OF CONTAMINATION FROM SKYDROL, LUBRICANTS, SOLVENTS, FUEL, FUMES, EXHAUST, OR DUST. DO NOT LET SOLVENTS, LUBRICANTS, OTHER FLUIDS, OR THEIR FUMES GO INTO THE FLOW PATH TO OR FROM THE ASM. CONTAMINATION WILL CAUSE DAMAGE TO THE FIBERS IN THE ASM AND DECREASE THEIR LIFE.

CAUTION: DO NOT LET SOLVENTS, LUBRICANTS, OTHER FLUIDS, OR THEIR FUMES TOUCH THE FIBERS IN THE AIR SEPARATION MODULE (ASM). CONTAMINATION WILL CAUSE DAMAGE TO THE FIBERS, AND DECREASE THE LIFE OF THE ASM.

- (1) Obey the Nitrogen Generation System (NGS) precautions.

SUBTASK 47-11-02-010-002

- (2) Go to the high flow valve [1] location.

NOTE: The high flow valve [1] is on the forward end of the air separation module (ASM [8]) in the left ram air duct bay.

SUBTASK 47-11-02-030-005

- (3) Remove the insulation from the area around the high flow valve [1].

SUBTASK 47-11-02-030-002

- (4) Do these steps to disconnect the electrical connections:
- (a) Disconnect the electrical connector [13] from the high flow valve [1].
 - (b) Disconnect the electrical connector [13] from the high flow differential pressure sensor.

SUBTASK 47-11-02-030-006

- (5) Remove the screw [15], washers [16], and nut [17] to disconnect the bonding jumper [14] from the high flow valve [1].
- (a) Keep the screw [15], washers [16], and nut [17] for the installation.

SUBTASK 47-11-02-030-004

- (6) Do these steps to disconnect the high flow valve [1] from the NGS:
- (a) Disconnect the coupling [5] from the NEA outlet port on the ASM [8].
 - 1) Keep the coupling [5] for the installation.
 - (b) Remove the sleeve [10].

EFFECTIVITY
HAP 047-053, 106-999

D633A101-HAP

47-11-02

Page 402
Oct 15/2008



737-600/700/800/900

AIRCRAFT MAINTENANCE MANUAL

- 1) Keep the sleeve [10] for the installation.
- (c) Discard the two o-rings [9].
- (d) Install identification tags on the ducts and fittings.
NOTE: This will clearly identify the correct connection locations.
- (e) Loosen the nut on the NEA duct [11] at the outlet port on the high flow valve [1].
NOTE: Be careful that you do not bend the NEA duct [11]. It must accurately align with the high flow valve [1] on the installation.
- (f) Loosen the nut on the HFV muscle air duct [7].
NOTE: Be careful that you do not bend the HFV muscle air duct [7]. It must accurately align with the high flow valve [1] on installation.
- (g) Loosen the nut on the oxygen sensor tube [19].
NOTE: Be careful that you do not bend the oxygen sensor tube [19]. It must accurately align with the high flow valve [1] on installation.

SUBTASK 47-11-02-020-001

- (7) Do these steps to remove the high flow valve [1]:
 - (a) Hold the high flow valve [1] in its position.
 - (b) Remove the four bolts [3] and washers [4].
 - 1) Keep the bolts [3] and washers [4] for installation.

SUBTASK 47-11-02-490-001

- (8) Install protective covers on these open ports:
 - (a) ASM [8]
 - (b) HFV muscle air duct [7]
 - (c) NEA duct [11]
 - (d) oxygen sensor tube [19]

SUBTASK 47-11-02-490-002

- (9) Install protective covers on the high flow valve [1].

————— **END OF TASK** —————

EFFECTIVITY
HAP 047-053, 106-999

D633A101-HAP

BOEING PROPRIETARY - Copyright © Unpublished Work - See title page for details

47-11-02

Page 403
Oct 15/2008

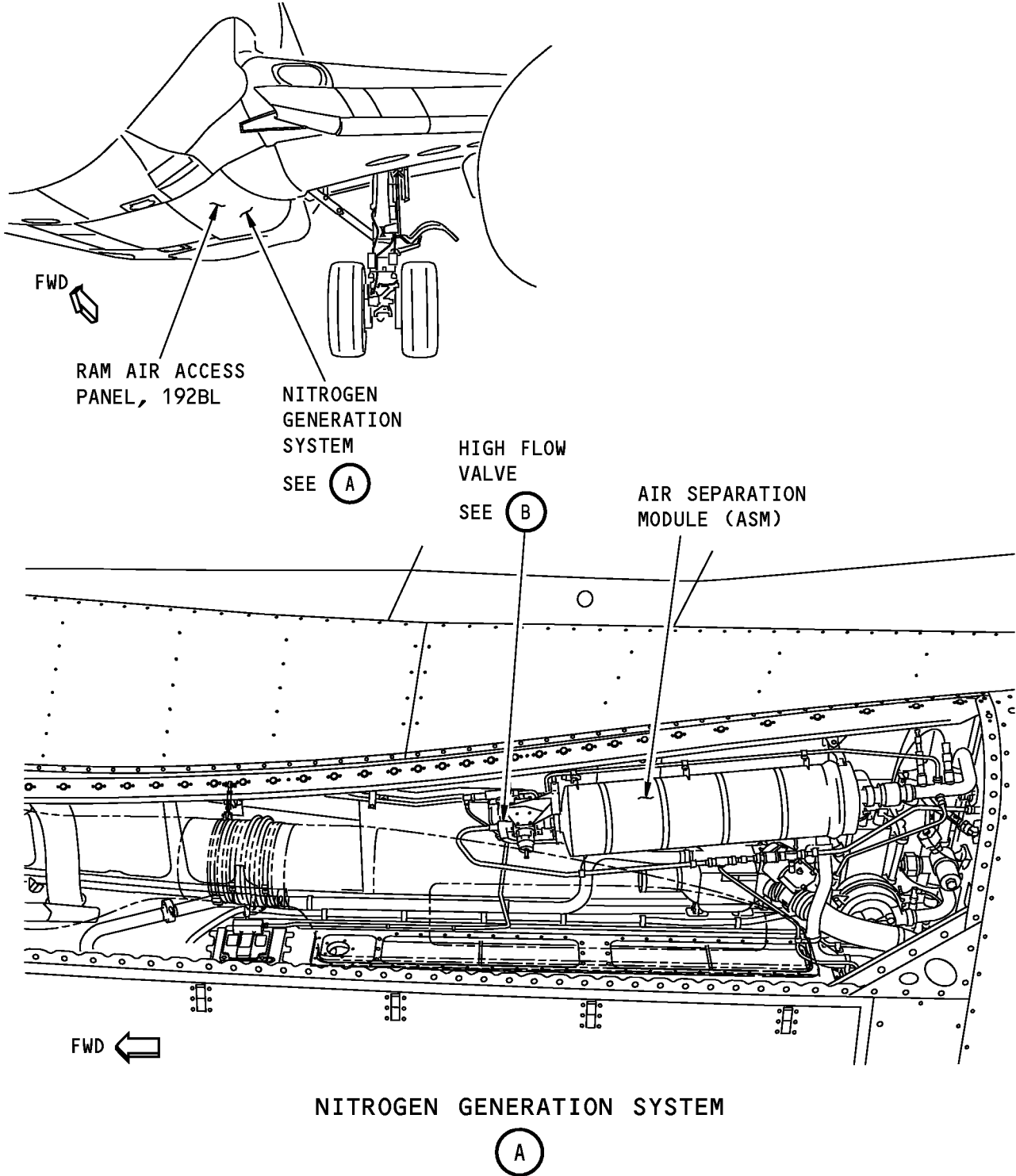

1484715 S0000270481_V1

High Flow Valve
Figure 401 (Sheet 1 of 2)/47-11-02-990-801

EFFECTIVITY
HAP 047-053, 106-999

47-11-02

Page 404
Oct 15/2008

D633A101-HAP

AIRCRAFT MAINTENANCE MANUAL

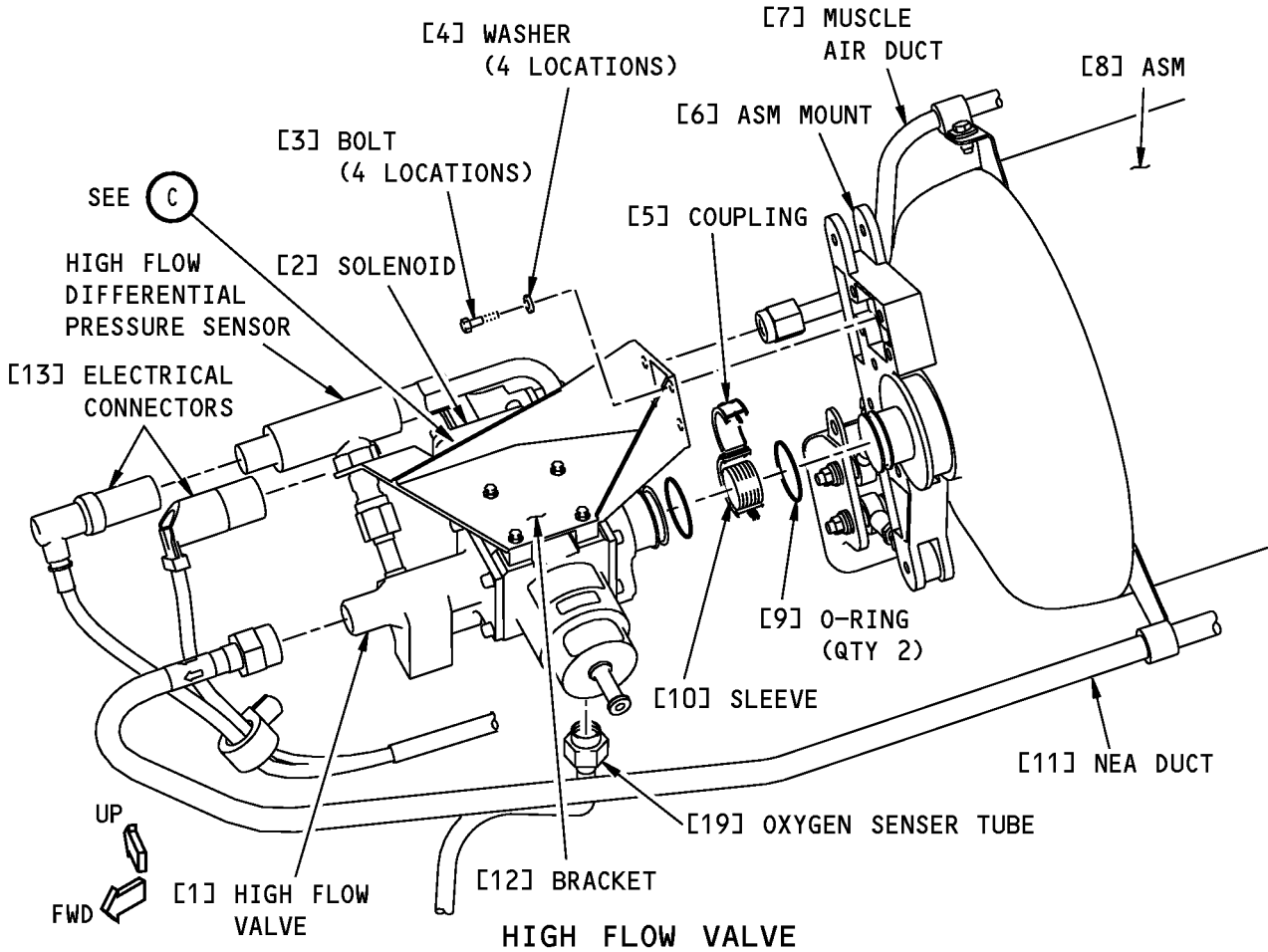

- [15] SCREW
- [16] WASHER
(QTY 2)
- [17] NUT
- [18] JUMPER TAB

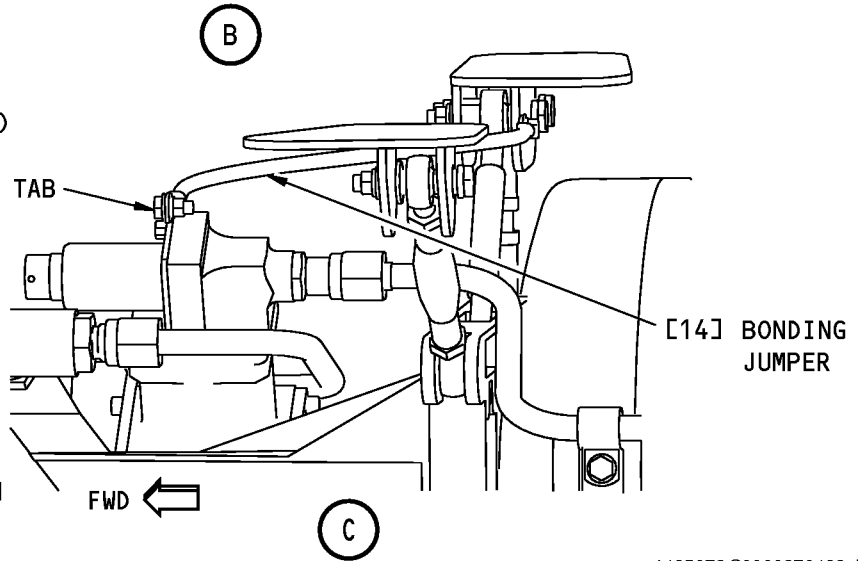

NOTE: INSULATION NOT SHOWN
ON THE HIGH FLOW
VALVE FOR CLARITY

1485072 S0000270482_V1

High Flow Valve
Figure 401 (Sheet 2 of 2)/47-11-02-990-801

EFFECTIVITY
HAP 047-053, 106-999

47-11-02

Page 405
Oct 15/2008

D633A101-HAP



737-600/700/800/900

AIRCRAFT MAINTENANCE MANUAL

TASK 47-11-02-420-801

3. High Flow Valve Installation

(Figure 401)

A. References

Reference	Title
20-30-80-910-801	General Cleaning of Metal (Series 80) (P/B 201)
47-00-00-790-801	Leak Check of the Nitrogen Generation System (P/B 601)
SWPM 20-20-00	Electrical Bonds and Grounds

B. Tools/Equipment

NOTE: When more than one tool part number is listed under the same "Reference" number, the tools shown are alternates to each other within the same airplane series. Tool part numbers that are replaced or non-procurable are preceded by "Opt:", which stands for Optional.

Reference	Description
COM-1550	Meter - Bonding (Approved Explosion Proof & Intrinsically Safe) (Part #: C15292 (MODEL T477W), Supplier: 01014, A/P Effectivity: 737-ALL) (Part #: M1, Supplier: 3AD17, A/P Effectivity: 737-ALL) (Part #: M1B, Supplier: 3AD17, A/P Effectivity: 737-ALL)
COM-2481	Tool - Sealant Removal, BAC5000, PSD 6-184 Approved (Part #: 1-6390-A, Supplier: 63318, A/P Effectivity: 737-ALL) (Part #: 10810, Supplier: \$0855, A/P Effectivity: 737-ALL) (Part #: 234350, Supplier: \$0857, A/P Effectivity: 737-ALL) (Part #: 311, Supplier: KA861, A/P Effectivity: 737-ALL) (Part #: 411B60, Supplier: 3DN12, A/P Effectivity: 737-ALL) (Part #: 411B90, Supplier: 3DN12, A/P Effectivity: 737-ALL) (Part #: DAD5013, Supplier: \$0856, A/P Effectivity: 737-ALL) (Part #: DFD5019, Supplier: \$0856, A/P Effectivity: 737-ALL) (Part #: J5-0275-2010, Supplier: 435R8, A/P Effectivity: 737-ALL) (Part #: SCD5019, Supplier: \$0856, A/P Effectivity: 737-ALL) (Part #: ST982LF, Supplier: 3Z323, A/P Effectivity: 737-ALL) (Part #: TS1275-4, Supplier: 1DWR5, A/P Effectivity: 737-ALL)
SPL-768	Sealant Removal Tool, Hardwood or Plastic (Part #: ST982, Supplier: 81205, A/P Effectivity: 737-ALL)

C. Consumable Materials

Reference	Description	Specification
A50051	Sealant - Temperature Resistant, Integral Fuel Tank Sealant - Pro-Seal 890B	SAE AMS-S-8802, Class B
D50063	Grease - Perfluoropolyether, fuel and oxygen resistant - Krytox 240AC	MIL-PRF- 27617, Type III

D. Location Zones

Zone	Area
131	Center Section Wing Box, Body Station 540.00 to Body Station 663.75 - Left
211	Flight Compartment - Left
212	Flight Compartment - Right

EFFECTIVITY
HAP 047-053, 106-999

47-11-02

Page 406
Jun 15/2009

D633A101-HAP



737-600/700/800/900

AIRCRAFT MAINTENANCE MANUAL

E. Access Panels

Number	Name/Location
192BL	ECS Ram Air Inlet Mixing Duct Panel - Forward

F. Prepare to Install the High Flow Valve

SUBTASK 47-11-02-000-002

- (1) Go to the high flow valve [1] location.

NOTE: The high flow valve [1] is attached to the forward strap bracket [12] that holds the ASM [8] in its position.

SUBTASK 47-11-02-090-001

- (2) Remove the protective covers from these ports:

- (a) HFV muscle air duct [7]
- (b) NEA duct [11]
- (c) ASM [8]
- (d) oxygen sensor tube [19]

SUBTASK 47-11-02-160-001

- (3) Use the sealant removal tool, SPL-768, (sealant removal tool, COM-2481, or equivalent) to remove sealant from the jumper tab [18].

SUBTASK 47-11-02-160-002

- (4) Make sure that the high flow valve [1], ducts, ASM [8], coupling [5], sleeve [10], bolts [3], washers [4], and jumper tab [18] are clean, free from grease and unwanted material.

SUBTASK 47-11-02-100-001

- (5) To clean the components, do this task: General Cleaning of Metal (Series 80), TASK 20-30-80-910-801.

SUBTASK 47-11-02-765-002

- (6) Prepare these components for an electrical mating surface bond (SWPM 20-20-00):

- (a) ASM [8]
- (b) high flow valve [1]
- (c) HFV muscle air duct [7]
- (d) NEA duct [11]
- (e) jumper tab [18]
- (f) oxygen sensor tube [19]

SUBTASK 47-11-02-430-001

- (7) Do these steps to install the two new o-rings [9]:

- (a) Apply a thin layer of Krytox 240AC perfluoropolyether grease, D50063, to the two new o-rings [9].
- (b) Put the o-rings [9] in the cavities on the ASM [8] and the high flow valve [1].

G. Install the High Flow Valve

SUBTASK 47-11-02-430-002

- (1) Do these steps to install the high flow valve [1] to the ASM [8]:

- (a) Use the identification tags to correctly position the high flow valve [1].
- (b) Hold the high flow valve [1] in its position.

EFFECTIVITY
HAP 047-053, 106-999

D633A101-HAP

47-11-02

Page 407
Oct 15/2008



737-600/700/800/900

AIRCRAFT MAINTENANCE MANUAL

- (c) Attach the high flow valve [1] to the ASM mount [6] with the four bolts [3] and washers [4].
 - 1) Do not fully tighten the bolts [3] until you align the high flow valve [1] with the ASM [8], the NEA duct [11], the HFV muscle air duct [7], and the oxygen sensor tube [19].

SUBTASK 47-11-02-430-003

- (2) Do these steps to connect the high flow valve [1] to the Nitrogen Generation System (NGS):
 - (a) Install, but do not tighten, the nut on the HFV muscle air duct [7] to attach to the high flow valve [1].
 - 1) Make sure that the HFV muscle air duct [7] and the high flow valve [1] align.
 - (b) Install, but do not tighten, the nut on the NEA duct [11] to attach to the high flow valve [1].
 - 1) Make sure that the NEA duct [11] and the high flow valve [1] align.
 - (c) Align the high flow valve [1] with the ASM [8].
 - 1) Put the sleeve [10] in its position.
 - 2) Install the coupling [5].
 - (d) Tighten the nut on the HFV muscle air duct [7] to 280 ± 28 in-lb (31.6 ± 3.2 N·m).

NOTE: Use two wrenches to tighten the nuts. This will release torque pressure on the HFV muscle air duct [7] and the NEA duct [11].
 - (e) Tighten the nut on the NEA duct [11] to 280 ± 28 in-lb (31.6 ± 3.2 N·m).

NOTE: Use two wrenches to tighten the nuts. This will release torque pressure on the HFV muscle air duct [7] and the NEA duct [11].
 - (f) Tighten the nut on the oxygen sensor tube [19] to 170 ± 17 in-lb (19.2 ± 1.9 N·m).

NOTE: Use two wrenches to tighten the nuts. This will release torque pressure on the HFV muscle air duct [7] and the oxygen sensor tube [19].

SUBTASK 47-11-02-420-001

- (3) Do these steps to finish the installation:
 - (a) Tighten the four bolts [3] to 109 ± 6 in-lb (12.3 ± 0.7 N·m).
 - (b) Connect the electrical connector [13] to the differential pressure sensor.
 - (c) Connect the electrical connector [13] to the high flow valve [1].
 - (d) Attach the bonding jumper [14] to the jumper tab [18] with the screw [15], washers [16], and nut [17].

SUBTASK 47-11-02-765-001

- (4) Use a bonding meter, COM-1550, to measure the resistance between the high flow valve [1] and the ASM mount [6] (SWPM 20-20-00).
 - (a) Make sure that the resistance between the high flow valve [1] and the ASM mount [6] is 0.010 ohm (10 milliohms) or less.

SUBTASK 47-11-02-390-001

- (5) Apply Pro-Seal 890B sealant, A50051, to fully cover the screw [15], washers [16], nut [17], and jumper tab [18].

H. Operational Test for the High Flow Valve

SUBTASK 47-11-02-865-002

- (1) Do these steps to prepare for the operational test:

EFFECTIVITY
HAP 047-053, 106-999

D633A101-HAP

47-11-02

Page 408
Jun 15/2009



737-600/700/800/900

AIRCRAFT MAINTENANCE MANUAL

- (a) Remove the safety tags and close these circuit breakers:

CAPT Electrical System Panel, P18-3

<u>Row</u>	<u>Col</u>	<u>Number</u>	<u>Name</u>
D	17	C01657	NITROGEN GENERATION CONTROL
E	15	C01680	NGS ALT PWR

- (b) Remove the DO-NOT-OPERATE tags from the L PACK and R PACK selector switches on the P5-10 air conditioning panel.
- (c) Put the L PACK and R PACK selector switches in the AUTO position.

SUBTASK 47-11-02-360-001

- (2) Do this task: Leak Check of the Nitrogen Generation System, TASK 47-00-00-790-801.

- (a) Repair the leaks that you find.

I. Put the Airplane Back to the Usual Condition

SUBTASK 47-11-02-420-002

- (1) Install the insulation around the high flow valve [1].

SUBTASK 47-11-02-410-001

- (2) Close this access panel:

<u>Number</u>	<u>Name/Location</u>
192BL	ECS Ram Air Inlet Mixing Duct Panel - Forward

————— **END OF TASK** —————

EFFECTIVITY HAP 047-053, 106-999

47-11-02

Page 409
Oct 15/2008

D633A101-HAP



737-600/700/800/900

AIRCRAFT MAINTENANCE MANUAL

OVERTEMPERATURE SHUTOFF VALVE - REMOVAL/INSTALLATION

1. General

A. This procedure has these tasks:

- (1) Overtemperature Shutoff Valve Removal
- (2) Overtemperature Shutoff Valve Installation

TASK 47-11-04-000-801

2. Overtemperature Shutoff Valve Removal

(Figure 401)

A. References

Reference	Title
36-00-00-860-806	Remove Pressure from the Pneumatic System (P/B 201)

B. Location Zones

Zone	Area
131	Center Section Wing Box, Body Station 540.00 to Body Station 663.75 - Left
211	Flight Compartment - Left
212	Flight Compartment - Right

C. Access Panels

Number	Name/Location
192BL	ECS Ram Air Inlet Mixing Duct Panel - Forward

D. Prepare for the Removal

SUBTASK 47-11-04-864-001

(1) Do this task: Remove Pressure from the Pneumatic System, TASK 36-00-00-860-806.

- (a) Make sure that the dual duct pressure gage shows 0.50 psig (3.45 kPa) or less in the L and R pneumatic ducts.

SUBTASK 47-11-04-860-001

(2) Turn the L PACK and R PACK selector switches, found on the P5-10 air conditioning panel, to the OFF position.

- (a) Put DO-NOT-OPERATE tags on the L PACK and R PACK selector switches.

SUBTASK 47-11-04-865-001

(3) Open these circuit breakers and install safety tags:

CAPT Electrical System Panel, P18-3

Row	Col	Number	Name
D	17	C01657	NITROGEN GENERATION CONTROL
E	15	C01680	NGS ALT PWR

SUBTASK 47-11-04-010-001

(4) Open this access panel:

Number	Name/Location
192BL	ECS Ram Air Inlet Mixing Duct Panel - Forward

EFFECTIVITY HAP 047-053, 106-999

47-11-04

Page 401
Oct 15/2008

D633A101-HAP



737-600/700/800/900

AIRCRAFT MAINTENANCE MANUAL

E. Remove the Overtemperature Shutoff Valve

SUBTASK 47-11-04-020-002

WARNING: DO NOT TOUCH THE COMPONENTS OF THE NITROGEN GENERATION SYSTEM WHEN THEY ARE HOT. WHEN THE COMPONENTS ARE HOT, THEY CAN CAUSE INJURIES TO PERSONNEL.

WARNING: DO NOT DISCONNECT THE COMPONENTS OF THE NITROGEN GENERATION SYSTEM, OR DUCTS WHEN THE SYSTEM IS PRESSURIZED. THE HOT, HIGH-PRESSURE AIR CAN CAUSE INJURIES TO PERSONNEL, AND DAMAGE TO EQUIPMENT.

CAUTION: MAKE SURE THAT THE MAINTENANCE AREA IS FREE OF CONTAMINATION FROM SKYDROL, LUBRICANTS, SOLVENTS, FUEL, FUMES, EXHAUST, OR DUST. DO NOT LET SOLVENTS, LUBRICANTS, OTHER FLUIDS, OR THEIR FUMES GO INTO THE FLOW PATH TO OR FROM THE ASM. CONTAMINATION WILL CAUSE DAMAGE TO THE FIBERS IN THE ASM AND DECREASE THEIR LIFE.

CAUTION: DO NOT LET SOLVENTS, LUBRICANTS, OTHER FLUIDS, OR THEIR FUMES TOUCH THE FIBERS IN THE AIR SEPARATION MODULE (ASM). CONTAMINATION WILL CAUSE DAMAGE TO THE FIBERS, AND DECREASE THE LIFE OF THE ASM.

- (1) Obey the Nitrogen Generation System (NGS) precautions.

SUBTASK 47-11-04-010-003

- (2) Go to the overtemperature shutoff valve [1] location.

NOTE: The overtemperature shutoff valve [1] is on the aft end of the air separation module [10] in the left ram air duct bay.

SUBTASK 47-11-04-000-001

- (3) Do these steps to remove the overtemperature shutoff valve [1]:

NOTE: Keep the clamp [8], coupling [7], and sleeve [6] for installation.

- (a) Disconnect the electrical connector [3] from the overtemperature shutoff valve [1].
- (b) Remove the screw [12], washer [13], and nut [14] to disconnect the bonding jumper [2].
 - 1) Keep the screw [12], washer [13], and nut [14] for the installation.
- (c) Disconnect the coupling [7] from between the air supply duct [5] and the overtemperature shutoff valve [1].
- (d) Remove the sleeve [6] from between the air supply duct [5] and the overtemperature shutoff valve [1].
 - 1) Discard the two o-rings [4].
- (e) Hold the overtemperature shutoff valve [1] in its position.
- (f) Disconnect the clamp [8] from between the overtemperature shutoff valve [1] and the air separation module [10].
 - 1) Discard the o-ring [9].
- (g) Remove the overtemperature shutoff valve [1].
- (h) Put a protective cover on the inlet port for the air separation module [10], and on the air supply duct [5].

————— END OF TASK —————

EFFECTIVITY
HAP 047-053, 106-999

D633A101-HAP

47-11-04

Page 402
Oct 15/2008

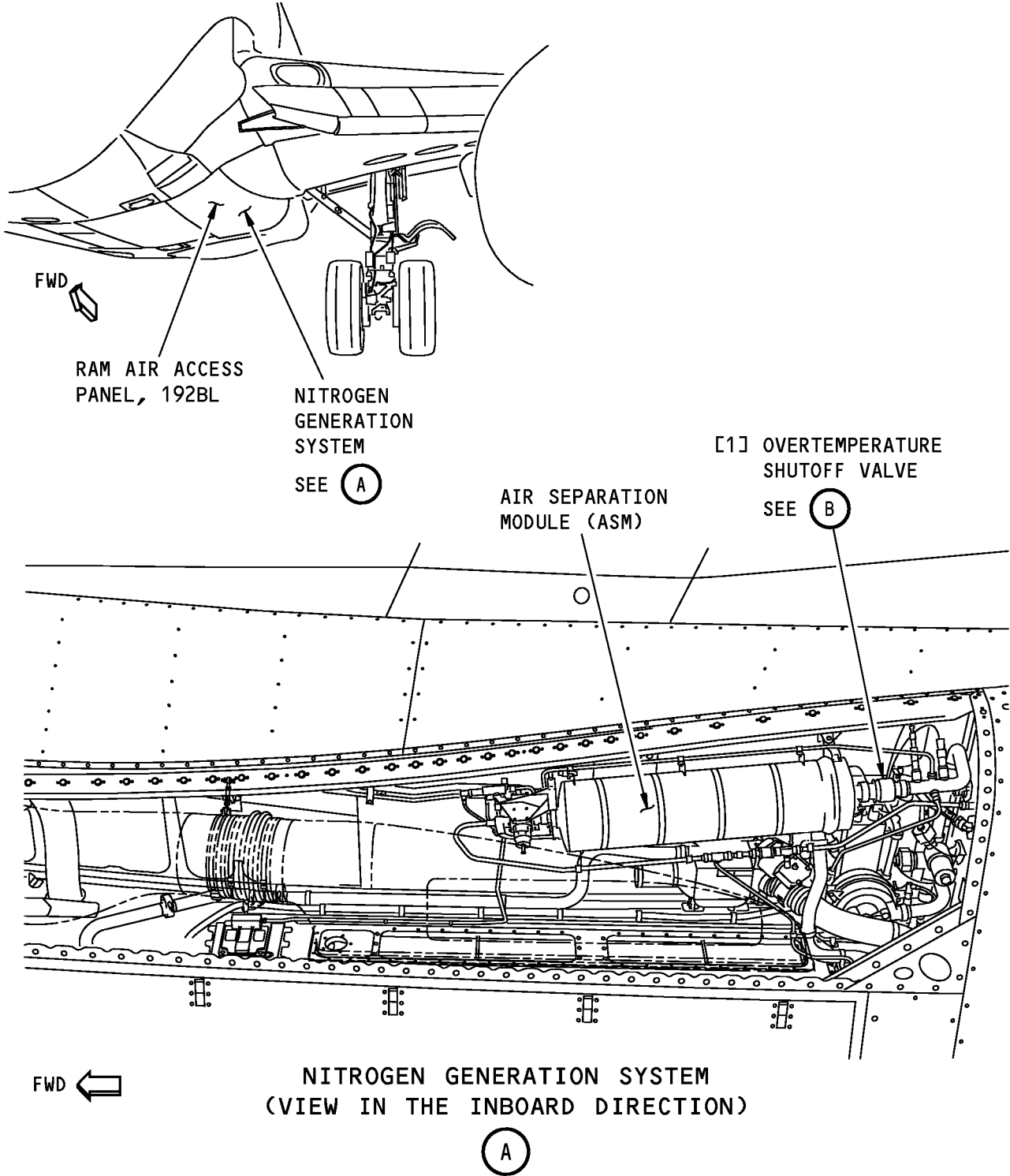

1484774 S0000270502_V2

Overtemperature Shutoff Valve
Figure 401 (Sheet 1 of 2)/47-11-04-990-801

EFFECTIVITY
HAP 047-053, 106-999

47-11-04

Page 403
Oct 15/2008

D633A101-HAP

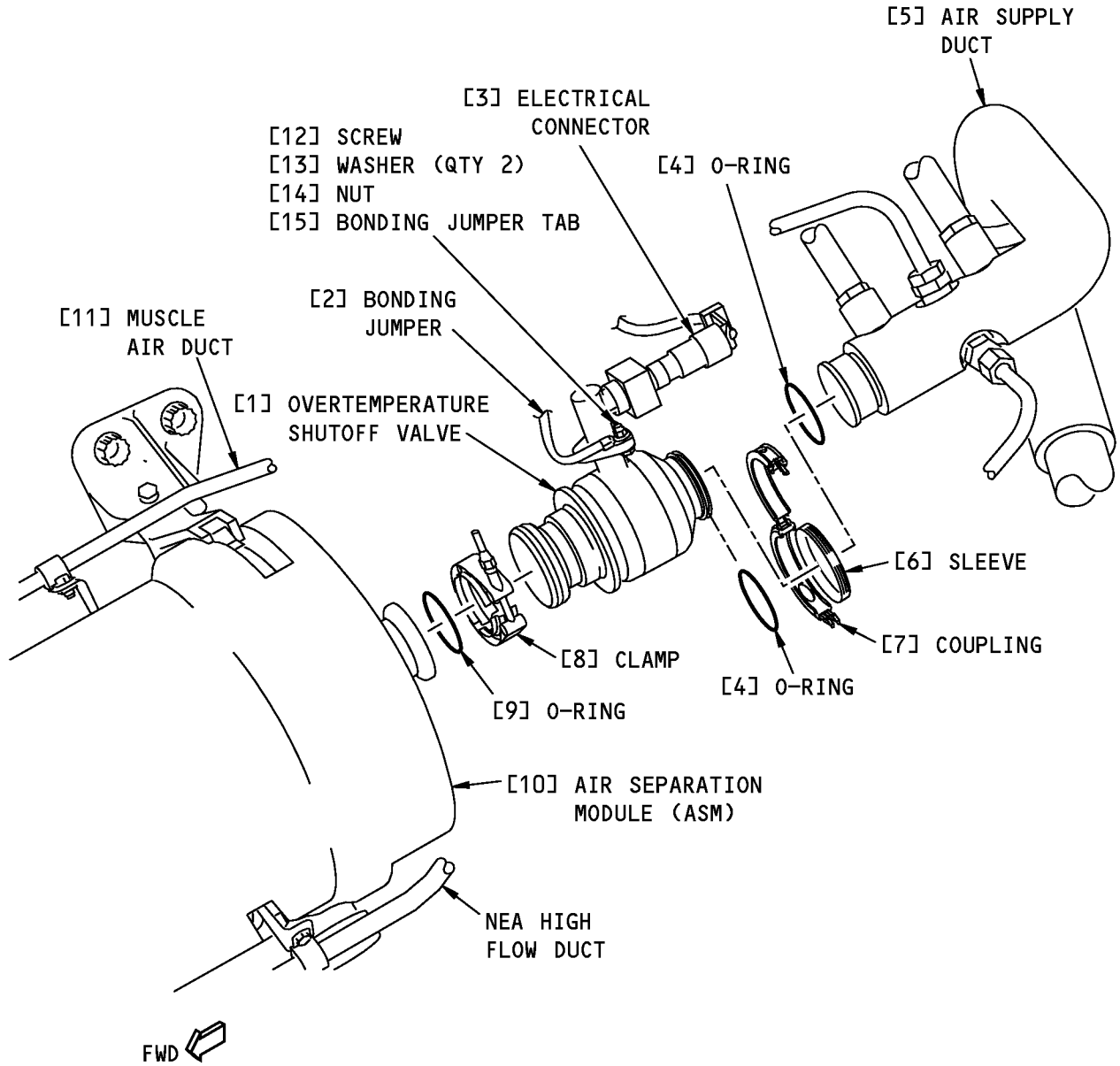

OVERTEMPERATURE SHUTOFF VALVE

(B)

1482905 S0000270503_V2

**Overtemperature Shutoff Valve
Figure 401 (Sheet 2 of 2)/47-11-04-990-801**

EFFECTIVITY
HAP 047-053, 106-999

47-11-04

Page 404
Oct 15/2008

D633A101-HAP



737-600/700/800/900

AIRCRAFT MAINTENANCE MANUAL

TASK 47-11-04-400-801

3. Overtemperature Shutoff Valve Installation

(Figure 401)

A. References

Reference	Title
20-30-80-910-801	General Cleaning of Metal (Series 80) (P/B 201)
47-00-00-790-801	Leak Check of the Nitrogen Generation System (P/B 601)
SWPM 20-20-00	Electrical Bonds and Grounds

B. Tools/Equipment

NOTE: When more than one tool part number is listed under the same "Reference" number, the tools shown are alternates to each other within the same airplane series. Tool part numbers that are replaced or non-procurable are preceded by "Opt:", which stands for Optional.

Reference	Description
COM-1550	Meter - Bonding (Approved Explosion Proof & Intrinsically Safe) (Part #: C15292 (MODEL T477W), Supplier: 01014, A/P Effectivity: 737-ALL) (Part #: M1, Supplier: 3AD17, A/P Effectivity: 737-ALL) (Part #: M1B, Supplier: 3AD17, A/P Effectivity: 737-ALL)

C. Consumable Materials

Reference	Description	Specification
A50051	Sealant - Temperature Resistant, Integral Fuel Tank Sealant - Pro-Seal 890B	SAE AMS-S-8802, Class B
D50063	Grease - Perfluoropolyether, fuel and oxygen resistant - Krytox 240AC	MIL-PRF- 27617, Type III

D. Location Zones

Zone	Area
131	Center Section Wing Box, Body Station 540.00 to Body Station 663.75 - Left
211	Flight Compartment - Left
212	Flight Compartment - Right

E. Access Panels

Number	Name/Location
192BL	ECS Ram Air Inlet Mixing Duct Panel - Forward

F. Prepare for the Installation

SUBTASK 47-11-04-010-002

- (1) Go to the overtemperature shutoff valve [1] location.

NOTE: The overtemperature shutoff valve [1] is on the aft end of the air separation module [10].

SUBTASK 47-11-04-090-001

- (2) Remove the protective covers from the air separation module [10] and the air supply duct [5].

SUBTASK 47-11-04-160-001

- (3) Remove the sealant from the bonding jumper [2] and the bond jumper tab [15].

EFFECTIVITY HAP 047-053, 106-999

47-11-04

Page 405
Jun 15/2009

D633A101-HAP



737-600/700/800/900

AIRCRAFT MAINTENANCE MANUAL

SUBTASK 47-11-04-100-001

- (4) Make sure that the air supply duct [5], bonding jumper [2], coupling [7], clamp [8], and sleeve [6] are clean and free from grease and unwanted material (TASK 20-30-80-910-801).

SUBTASK 47-11-04-765-001

- (5) Prepare the contact surfaces of these components for an electrical mating surface bond (SWPM 20-20-00):
 - (a) bond jumper tab [15]
 - (b) air separation module [10]
 - (c) air supply duct [5]
 - (d) overtemperature shutoff valve [1]

SUBTASK 47-11-04-430-001

- (6) Do these steps to install the two new o-rings [4]:
 - (a) Wet the o-rings [4] with water.
 - (b) Put the two o-rings [4] in the cavities on the overtemperature shutoff valve [1] and the air supply duct [5].
 - (c) Apply a thin layer of Krytox 240AC perfluoropolyether grease, D50063, to the o-ring [9].
 - (d) Put the o-ring [9] in the cavity on the air separation module [10].

SUBTASK 47-11-04-430-002

- (7) Do these steps to install the new o-ring [9]:
 - (a) Apply a thin layer of Krytox 240AC perfluoropolyether grease, D50063, to the o-ring [9].
 - (b) Put the o-ring [9] in the cavity on the air separation module [10].

G. Install the Overtemperature Shutoff Valve

SUBTASK 47-11-04-420-001

- (1) Do these steps to install the overtemperature shutoff valve [1]:
 - (a) Hold the overtemperature shutoff valve [1] in its position.
 - (b) Attach, but do not fully tighten, the overtemperature shutoff valve [1] to the air separation module [10] with the clamp [8].
 - (c) Align the overtemperature shutoff valve [1] with the air supply duct [5].
 - (d) Put the sleeve [6] in its position.
 - (e) Install the coupling [7].
 - (f) Tighten the clamp [8] to 47.5 ± 2.5 in-lb (5.4 ± 0.3 N·m).
 - (g) Connect the bonding jumper [2] to the overtemperature shutoff valve [1] with the screw [12], the two washers [13], and the nut [14].
 - (h) Connect the electrical connector [3] to the overtemperature shutoff valve [1].

SUBTASK 47-11-04-765-002

- (2) Use the bonding meter, COM-1550, to measure the electrical resistance between the overtemperature shutoff valve [1] and the airplane structure (SWPM 20-20-00).
 - (a) Make sure that the electrical resistance between the overtemperature shutoff valve [1] and the airplane structure is 0.008 ohm (8 milliohms) or less.
 - (b) Apply a cap seal of Pro-Seal 890B sealant, A50051, to the terminal, fasteners, and bare conversion coated areas.

EFFECTIVITY
HAP 047-053, 106-999

D633A101-HAP

47-11-04

Page 406
Jun 15/2009



737-600/700/800/900

AIRCRAFT MAINTENANCE MANUAL

H. Operational Test for the Overtemperature Shutoff Valve

SUBTASK 47-11-04-865-002

(1) Do these steps to prepare for the operational test:

(a) Remove the safety tags and close these circuit breakers:

CAPT Electrical System Panel, P18-3

<u>Row</u>	<u>Col</u>	<u>Number</u>	<u>Name</u>
D	17	C01657	NITROGEN GENERATION CONTROL
E	15	C01680	NGS ALT PWR

(b) Remove the DO-NOT-OPERATE tags from the L PACK and R PACK selector switches on the P5-10 air conditioning panel.

(c) Put the L PACK and R PACK selector switches in the AUTO position.

SUBTASK 47-11-04-360-001

(2) Do this task: Leak Check of the Nitrogen Generation System, TASK 47-00-00-790-801.

(a) Repair the leaks that you find.

I. Put the Airplane Back to the Usual Condition

SUBTASK 47-11-04-410-001

(1) Close this access panel:

<u>Number</u>	<u>Name/Location</u>
192BL	ECS Ram Air Inlet Mixing Duct Panel - Forward

————— END OF TASK —————

EFFECTIVITY HAP 047-053, 106-999

47-11-04

Page 407
Oct 15/2008

D633A101-HAP



737-600/700/800/900

AIRCRAFT MAINTENANCE MANUAL

NITROGEN-ENRICHED AIR DISTRIBUTION - MAINTENANCE PRACTICES

1. General

- A. If the nitrogen-enriched air distribution system (NEADS) tubing is damaged and can be repaired, refer to this procedure: FLARELESS TUBING ASSEMBLY - REPAIRS, PAGEBLOCK 20-10-51/801.
- B. If the NEADS tubing must be replaced, refer to this procedure: FLARELESS TUBING ASSEMBLY - REMOVAL/INSTALLATION, PAGEBLOCK 20-10-51/401.

EFFECTIVITY
HAP 036-054, 101-999

D633A101-HAP

47-21-00

Page 201
Feb 15/2009



737-600/700/800/900

AIRCRAFT MAINTENANCE MANUAL

NITROGEN-ENRICHED AIR DISTRIBUTION - INSPECTION/CHECK

1. General

- A. This procedure contains scheduled maintenance task data.
- B. This procedure has a task to do a fuel leak check of the Nitrogen-Enriched Air Distribution System (NEADS) lines.

TASK 47-21-00-700-802

2. Drain Cap - Fuel Leak Check

A. General

- (1) This procedure is a scheduled maintenance task.

B. References

Reference	Title
12-33-01-600-802	Cold Weather Maintenance Procedure (P/B 301)
47-00-00-800-801	Ground Operation of the Nitrogen Generation System (P/B 201)

C. Tools/Equipment

Reference	Description
STD-195	Container - 1 Quart (1 l), Oil/Fuel Resistant

D. Location Zones

Zone	Area
131	Center Section Wing Box, Body Station 540.00 to Body Station 663.75 - Left

E. Access Panels

Number	Name/Location
192BL	ECS Ram Air Inlet Mixing Duct Panel - Forward

F. Prepare for the Procedure

SUBTASK 47-21-00-010-003

- (1) Open this access panel:

Number	Name/Location
192BL	ECS Ram Air Inlet Mixing Duct Panel - Forward

SUBTASK 47-21-00-660-001

- (2) If the ambient temperature is less than 32°F (0°C), do this task: Cold Weather Maintenance Procedure, TASK 12-33-01-600-802.

G. Drain the Fluid from the NEADS Line

SUBTASK 47-21-00-941-001

- (1) Go to the drain cap for the NEA distribution system.

NOTE: The drain cap is found below the air separation module (ASM).

SUBTASK 47-21-00-941-002

- (2) Put the 1 quart (1 l) oil/fuel resistant container, STD-195, below the drain cap.

SUBTASK 47-21-00-010-004

- (3) Remove the drain cap connected to the tee.

EFFECTIVITY
HAP 047-053, 106-999

47-21-00



**737-600/700/800/900
AIRCRAFT MAINTENANCE MANUAL**

SUBTASK 47-21-00-616-002

(4) Collect the fluid from the NEADS line.

SUBTASK 47-21-00-790-011

(5) If there is no fluid in the container, the NEA distribution system is satisfactory.

SUBTASK 47-21-00-790-012

(6) If there was fluid in the NEADS line, do this task: Ground Operation of the Nitrogen Generation System, TASK 47-00-00-800-801.

H. Put the Airplane Back to the Usual Condition

SUBTASK 47-21-00-430-001

(1) Attach the drain cap to the tee.

SUBTASK 47-21-00-410-001

(2) Close this access panel:

<u>Number</u>	<u>Name/Location</u>
192BL	ECS Ram Air Inlet Mixing Duct Panel - Forward

————— **END OF TASK** —————

EFFECTIVITY
HAP 047-053, 106-999

D633A101-HAP

BOEING PROPRIETARY - Copyright © Unpublished Work - See title page for details

47-21-00

Page 602
Feb 15/2009



737-600/700/800/900

AIRCRAFT MAINTENANCE MANUAL

FLOAT VALVE - REMOVAL/INSTALLATION

1. General

A. This procedure contains these tasks:

- (1) Float Valve Removal
- (2) Float Valve Installation

TASK 47-21-02-000-801

2. Float Valve Removal

(Figure 401)

A. References

Reference	Title
28-11-00-300-803	Repair of Sealant Leaks in the Fuel Tank Structure (P/B 801)
28-11-00-910-802	Purging and Fuel Tank Entry (P/B 201)
28-11-31-000-801	Center Tank Access Door - Removal (P/B 401)
28-26-00-650-801	Fuel Tank Defueling (P/B 201)
28-26-00-650-802	Tank to Tank Fuel Transfer (P/B 201)

B. Tools/Equipment

NOTE: When more than one tool part number is listed under the same "Reference" number, the tools shown are alternates to each other within the same airplane series. Tool part numbers that are replaced or non-procurable are preceded by "Opt:", which stands for Optional.

Reference	Description
COM-2481	Tool - Sealant Removal, BAC5000, PSD 6-184 Approved (Part #: 1-6390-A, Supplier: 63318, A/P Effectivity: 737-ALL) (Part #: 10810, Supplier: \$0855, A/P Effectivity: 737-ALL) (Part #: 234350, Supplier: \$0857, A/P Effectivity: 737-ALL) (Part #: 311, Supplier: KA861, A/P Effectivity: 737-ALL) (Part #: 411B60, Supplier: 3DN12, A/P Effectivity: 737-ALL) (Part #: 411B90, Supplier: 3DN12, A/P Effectivity: 737-ALL) (Part #: DAD5013, Supplier: \$0856, A/P Effectivity: 737-ALL) (Part #: DFD5019, Supplier: \$0856, A/P Effectivity: 737-ALL) (Part #: J5-0275-2010, Supplier: 435R8, A/P Effectivity: 737-ALL) (Part #: SCD5019, Supplier: \$0856, A/P Effectivity: 737-ALL) (Part #: ST982LF, Supplier: 3Z323, A/P Effectivity: 737-ALL) (Part #: TS1275-4, Supplier: 1DWR5, A/P Effectivity: 737-ALL)
SPL-768	Sealant Removal Tool, Hardwood or Plastic (Part #: ST982, Supplier: 81205, A/P Effectivity: 737-ALL)

C. Expendables/Parts

AMM Item	Description	AIPC Reference	AIPC Effectivity
6	O-ring	47-21-02-01-025 47-21-02-01A-025	HAP 036 HAP 037-054, 101-999

D. Location Zones

Zone	Area
631	Right Wing - Center Fuel Tank, Rib 1 to Rib 5

E. Access Panels

Number	Name/Location
631AB	Center Tank Access Door - Wing Station 168

EFFECTIVITY HAP 036-054, 101-999

47-21-02

Page 401
Feb 15/2009

D633A101-HAP



737-600/700/800/900

AIRCRAFT MAINTENANCE MANUAL

F. Prepare for the Removal

SUBTASK 47-21-02-650-001

- (1) Defuel or transfer fuel from the center tank (TASK 28-26-00-650-801 or TASK 28-26-00-650-802).

SUBTASK 47-21-02-616-001

WARNING: OBEY THE PRECAUTIONS FOR PURGING, AND FUEL TANK ENTRY. IF YOU DO NOT OBEY THE PRECAUTIONS, INJURIES TO PERSONNEL, AND DAMAGE TO EQUIPMENT CAN OCCUR.

- (2) Do this task: Purging and Fuel Tank Entry, TASK 28-11-00-910-802.

SUBTASK 47-21-02-010-001

- (3) To get access to the center tank, do this task: Center Tank Access Door - Removal, TASK 28-11-31-000-801.

- (a) Open this access panel:

<u>Number</u>	<u>Name/Location</u>
631AB	Center Tank Access Door - Wing Station 168

SUBTASK 47-21-02-010-006

- (4) Go into the center tank.

SUBTASK 47-21-02-010-007

- (5) Go to the float valve assembly [5] location.

NOTE: The float valve assembly [5] is on the forward vent channel of the center wing tank, outboard of body rib #1, and forward of the right vent climb port.

G. Remove the Float Valve

SUBTASK 47-21-02-100-002

- (1) Use the sealant removal tool, SPL-768 (sealant removal tool, COM-2481 or equivalent) to remove the old sealant from around the float valve assembly [5] and the adapter [2].

NOTE: Do not remove the sealant from around the cover plate [1]. Do not remove the cover plate [1] or the adapter [2].

NOTE: The sealant removal/application tools are shown in this task: Repair of Sealant Leaks in the Fuel Tank Structure, TASK 28-11-00-300-803

SUBTASK 47-21-02-020-001

- (2) Do these steps to remove the float valve assembly [5]:

- (a) Hold the float valve assembly [5] in its position.
- (b) Remove the four screws [4] and washers [3].
- (c) Remove the float valve assembly [5] from the adapter [2] and the cover plate [1].
- (d) Discard the used o-ring [6].
- (e) Install a protective cover in the vent tube.

————— **END OF TASK** —————

EFFECTIVITY
HAP 036-054, 101-999

D633A101-HAP

47-21-02

Page 402
Feb 15/2009

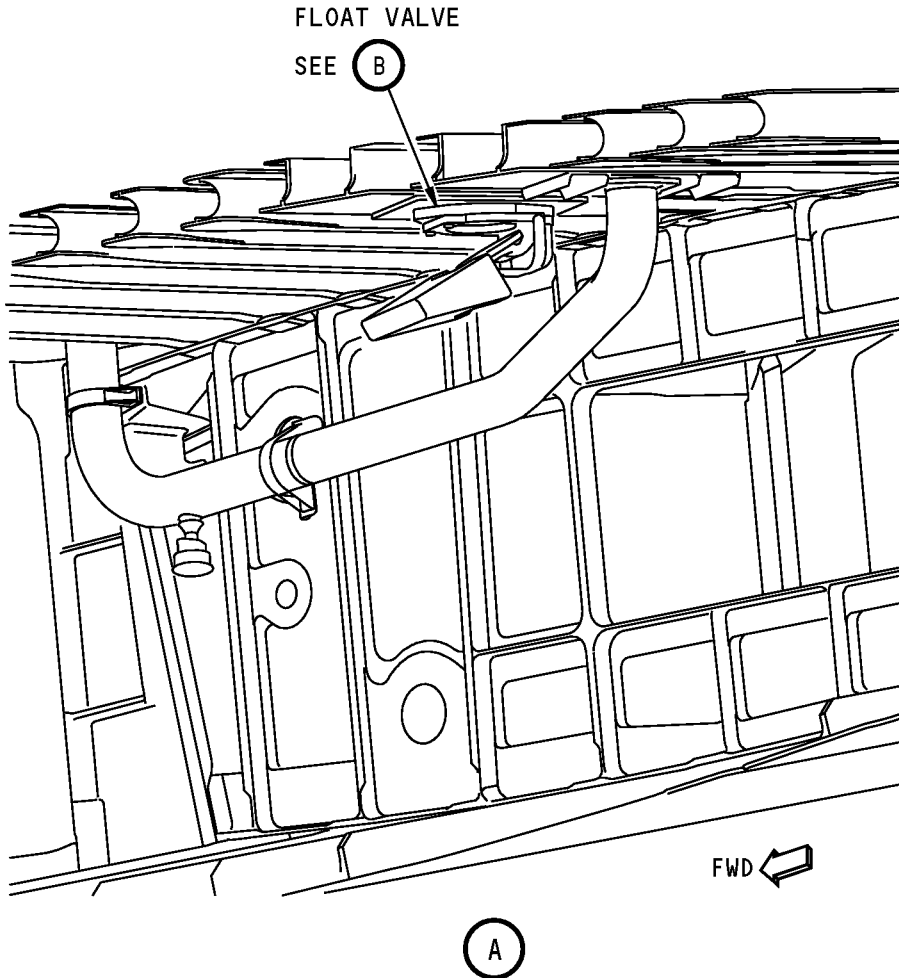
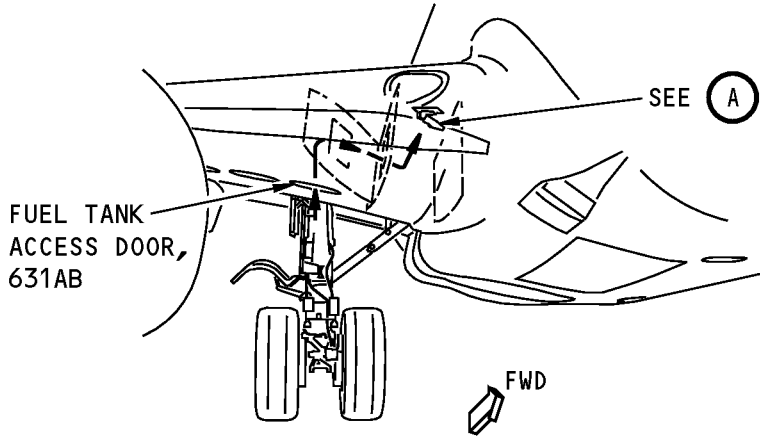

NEADS Vent Float Valve
Figure 401 (Sheet 1 of 2)/47-21-02-990-801

EFFECTIVITY
HAP 036-054, 101-999

D633A101-HAP

47-21-02

Page 403
Feb 15/2009

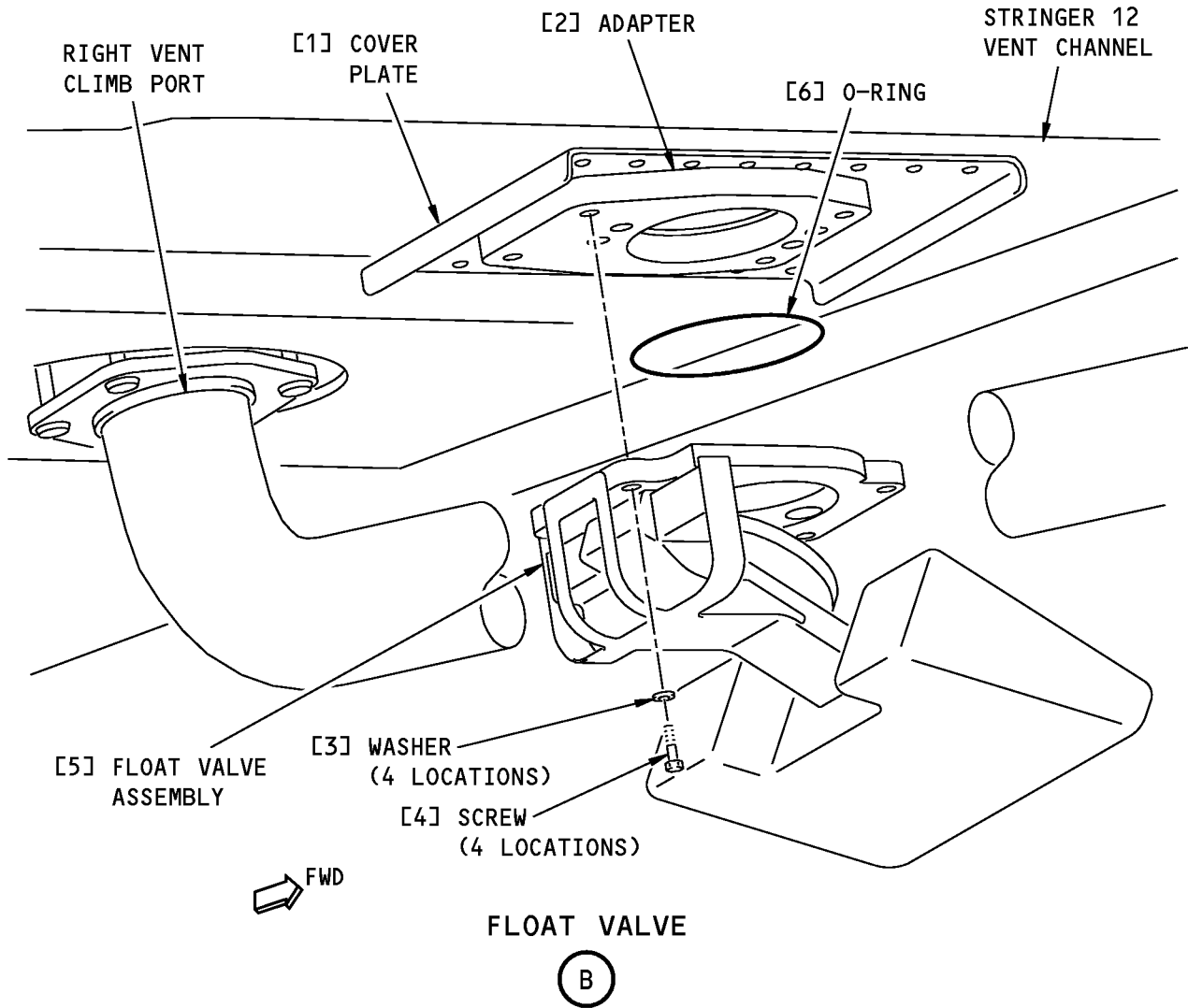

J73712 S0000175622_V4

**NEADS Vent Float Valve
Figure 401 (Sheet 2 of 2)/47-21-02-990-801**

EFFECTIVITY
HAP 036-054, 101-999

47-21-02

Page 404
Feb 15/2009

D633A101-HAP



737-600/700/800/900

AIRCRAFT MAINTENANCE MANUAL

TASK 47-21-02-420-801

3. Float Valve Installation

(Figure 401)

A. References

Reference	Title
20-30-80-910-801	General Cleaning of Metal (Series 80) (P/B 201)
28-11-31-400-801	Center Tank Access Door - Installation (P/B 401)
SWPM 20-20-00	Electrical Bonds and Grounds

B. Tools/Equipment

NOTE: When more than one tool part number is listed under the same "Reference" number, the tools shown are alternates to each other within the same airplane series. Tool part numbers that are replaced or non-procurable are preceded by "Opt:", which stands for Optional.

Reference	Description
COM-1550	Meter - Bonding (Approved Explosion Proof & Intrinsically Safe) (Part #: C15292 (MODEL T477W), Supplier: 01014, A/P Effectivity: 737-ALL) (Part #: M1, Supplier: 3AD17, A/P Effectivity: 737-ALL) (Part #: M1B, Supplier: 3AD17, A/P Effectivity: 737-ALL)

C. Consumable Materials

Reference	Description	Specification
A00767	Sealant - Fuel Tank	BMS5-45
D00128	Grease - Silicone	A-A-59173
G00034	Cotton Wiper - Process Cleaning Absorbent Wiper (Cheesecloth, Gauze)	BMS15-5

D. Expendables/Parts

AMM Item	Description	AIPC Reference	AIPC Effectivity
5	Float valve assembly	47-21-02-01-030	HAP 036
		47-21-02-01A-030	HAP 037-054, 101-999
6	O-ring	47-21-02-01-025	HAP 036
		47-21-02-01A-025	HAP 037-054, 101-999

E. Location Zones

Zone	Area
631	Right Wing - Center Fuel Tank, Rib 1 to Rib 5

F. Access Panels

Number	Name/Location
631AB	Center Tank Access Door - Wing Station 168

G. Prepare for the Installation

SUBTASK 47-21-02-010-002

- (1) Go into the center tank in the right wing.

SUBTASK 47-21-02-010-003

- (2) Remove the protective cap from the vent tube.

EFFECTIVITY HAP 036-054, 101-999

47-21-02

Page 405
Jun 15/2009

D633A101-HAP



737-600/700/800/900

AIRCRAFT MAINTENANCE MANUAL

SUBTASK 47-21-02-100-001

(3) Make sure that the mating surfaces between the float valve assembly [5] and the adapter [2] are free of sealants, grease, and unwanted material.

(a) Make sure that the new o-ring [6] cavity in the float valve assembly [5] is clean and free of sealants and unwanted material.

SUBTASK 47-21-02-110-002

(4) To clean the components, do this task: General Cleaning of Metal (Series 80), TASK 20-30-80-910-801.

SUBTASK 47-21-02-110-001

(5) Prepare the contact surfaces of these components for a faying surface bond (SWPM 20-20-00):

(a) float valve assembly [5]

(b) adapter [2]

H. Install the Float Valve

SUBTASK 47-21-02-640-001

(1) Do these steps to install the new o-ring [6]:

(a) Apply a thin coat of grease, D00128, to the new o-ring [6].

(b) Put the new o-ring [6] in the cavity on the float valve assembly [5].

(c) Remove excess grease, D00128, with a cotton wiper, G00034.

SUBTASK 47-21-02-420-001

(2) Do these steps to install the float valve:

(a) Put the float valve assembly [5] in its position on the adapter [2].

(b) Install the four screws [4] and the washers [3].

SUBTASK 47-21-02-212-001

(3) Do a check of the float valve:

(a) Make sure that the float valve is in the fully open position.

(b) Make sure that the float valve moves freely.

(c) Make sure that the float valve is not limited by the adjacent structure.

SUBTASK 47-21-02-390-001

(4) Apply a fillet seal of sealant, A00767, around the float valve assembly [5] and the adapter [2].

SUBTASK 47-21-02-700-001

(5) Use a bonding meter, COM-1550, to measure the bonding resistance between base of the float valve and the vent channel (SWPM 20-20-00).

(a) Make sure the total resistance is 0.010 ohm (10 milliohms) or less.

I. Put the Airplane Back to the Usual Condition

SUBTASK 47-21-02-410-001

(1) Do this task to go out of and close the fuel tank: Center Tank Access Door - Installation, TASK 28-11-31-400-801.

Close this access panel:

Number	Name/Location
631AB	Center Tank Access Door - Wing Station 168

————— END OF TASK —————

EFFECTIVITY
HAP 036-054, 101-999

47-21-02

Page 406
Feb 15/2009

D633A101-HAP



737-600/700/800/900

AIRCRAFT MAINTENANCE MANUAL

BACKFLOW CHECK VALVE - REMOVAL/INSTALLATION

1. General

A. This procedure has these tasks:

- (1) Primary Backflow Prevention Check Valve Removal
- (2) Primary Backflow Prevention Check Valve Installation
- (3) Secondary Backflow Prevention Check Valve Removal
- (4) Secondary Backflow Prevention Check Valve Installation

B. Access Notes:

- (1) The primary backflow prevention check valve is inside the center tank. You will need to go into the center tank to remove and install the check valve.

TASK 47-21-04-000-801

2. Primary Backflow Prevention Check Valve Removal

(Figure 401)

A. General

- (1) The primary backflow prevention check valve is referred to as the check valve [1] in this task.

B. References

Reference	Title
28-11-00-910-802	Purging and Fuel Tank Entry (P/B 201)
28-11-31-000-801	Center Tank Access Door - Removal (P/B 401)
28-26-00-650-801	Fuel Tank Defueling (P/B 201)
28-26-00-650-802	Tank to Tank Fuel Transfer (P/B 201)

C. Location Zones

Zone	Area
531	Left Wing - Center Fuel Tank, Rib 1 to Rib 5

D. Access Panels

Number	Name/Location
531AB	Center Tank Access Door - Wing Station 168

E. Prepare for the Removal

SUBTASK 47-21-04-650-001

- (1) Defuel or transfer fuel from the center tank (TASK 28-26-00-650-801 or TASK 28-26-00-650-802).

SUBTASK 47-21-04-910-001

WARNING: OBEY THE PRECAUTIONS FOR PURGING, AND FUEL TANK ENTRY. IF YOU DO NOT OBEY THE PRECAUTIONS, INJURIES TO PERSONNEL, AND DAMAGE TO EQUIPMENT CAN OCCUR.

- (2) Do this task: Purging and Fuel Tank Entry, TASK 28-11-00-910-802.

SUBTASK 47-21-04-010-003

WARNING: DO ALL THE SAFETY PROCEDURES TO DEFUEL THE TANK AND TO GO INTO IT. INJURY TO PERSONS AND DAMAGE TO EQUIPMENT CAN OCCUR IF YOU DO NOT FOLLOW THE SAFETY PROCEDURES.

EFFECTIVITY
HAP 036-054, 101-999

47-21-04

Page 401
Feb 15/2009

D633A101-HAP



737-600/700/800/900

AIRCRAFT MAINTENANCE MANUAL

(WARNING PRECEDES)

WARNING: DO NOT BREATHE THE AIR FROM THE FUEL TANK UNTIL YOU MAKE IT SAFE. THE NITROGEN GENERATION SYSTEM DECREASES THE OXYGEN IN THE AIR. IF YOU BREATHE AIR THAT DOES NOT HAVE SUFFICIENT OXYGEN, DANGEROUS HEALTH CONDITIONS CAN QUICKLY OCCUR. DANGEROUS HEALTH CONDITIONS INCLUDE NAUSEA, UNCONSCIOUSNESS, AND CONVULSIONS. IF THE OXYGEN LEVEL OF THE AIR THAT YOU BREATHE IS VERY LOW, IT CAN KILL YOU.

- (3) To get access to the center tank, do this task: Center Tank Access Door - Removal, TASK 28-11-31-000-801.

Open this access panel:

<u>Number</u>	<u>Name/Location</u>
531AB	Center Tank Access Door - Wing Station 168

SUBTASK 47-21-04-010-001

- (4) Go into the center tank (TASK 28-11-00-910-802).

SUBTASK 47-21-04-010-002

- (5) Go to the check valve [1] location.

NOTE: The check valve is installed in the center tank, left side, forward of the vent stringer.

F. Prepare the NEADS Tube

SUBTASK 47-21-04-030-001

- (1) Disconnect the P-clamp [5] from the NEADS tube [6].

(a) Remove the P-clamp [5], screw [31], two washers [30], and nut [29].

SUBTASK 47-21-04-030-005

- (2) Loosen the two clamps [19].

SUBTASK 47-21-04-030-006

- (3) Loosen the nut [32] to disconnect the NEADS tube [6].

SUBTASK 47-21-04-030-007

- (4) Disconnect the bonding jumper [24].

(a) Remove the clamp [28], screw [25], two washers [26], and nut [27].

SUBTASK 47-21-04-560-001

- (5) Swing the NEADS tube [6].

NOTE: The NEADS tube [6] is not flexible. Swing slowly to prevent damage.

(a) Hold the check valve [1].

G. Remove the Check Valve

SUBTASK 47-21-04-030-004

- (1) Disconnect the bonding jumper [2] from the ejector tube [3].

(a) Remove the screw [20], two washers [21] and nut [23] to remove the clamp [22] from the ejector tube [3].

SUBTASK 47-21-04-030-002

- (2) Loosen the nut [7] to disconnect the NEADS tube [6] from the check valve [1].

NOTE: Use a second wrench on the check valve [1] to prevent the NEADS tube [6] from turning.

EFFECTIVITY
HAP 036-054, 101-999

D633A101-HAP

47-21-04

Page 402
Feb 15/2009



**737-600/700/800/900
AIRCRAFT MAINTENANCE MANUAL**

SUBTASK 47-21-04-030-003

- (3) Loosen the nut [8] to disconnect the ejector tube [3] from the check valve [1].

NOTE: Use a second wrench on the check valve [1] to prevent the ejector tube [3] from turning.

- (a) Use a second wrench to hold the check valve [1].

SUBTASK 47-21-04-020-004

- (4) Remove the check valve [1].

- (a) Turn the NEADS tube [6] slowly to remove the check valve [1].

NOTE: The NEADS tube [6] is not flexible.

SUBTASK 47-21-04-420-004

- (5) Install the protective caps on the ejector tube [3], the two ends of the NEADS tube [6], and the flareless fitting [4].

————— **END OF TASK** —————

EFFECTIVITY
HAP 036-054, 101-999

D633A101-HAP

47-21-04

Page 403
Feb 15/2009

**737-600/700/800/900
AIRCRAFT MAINTENANCE MANUAL**

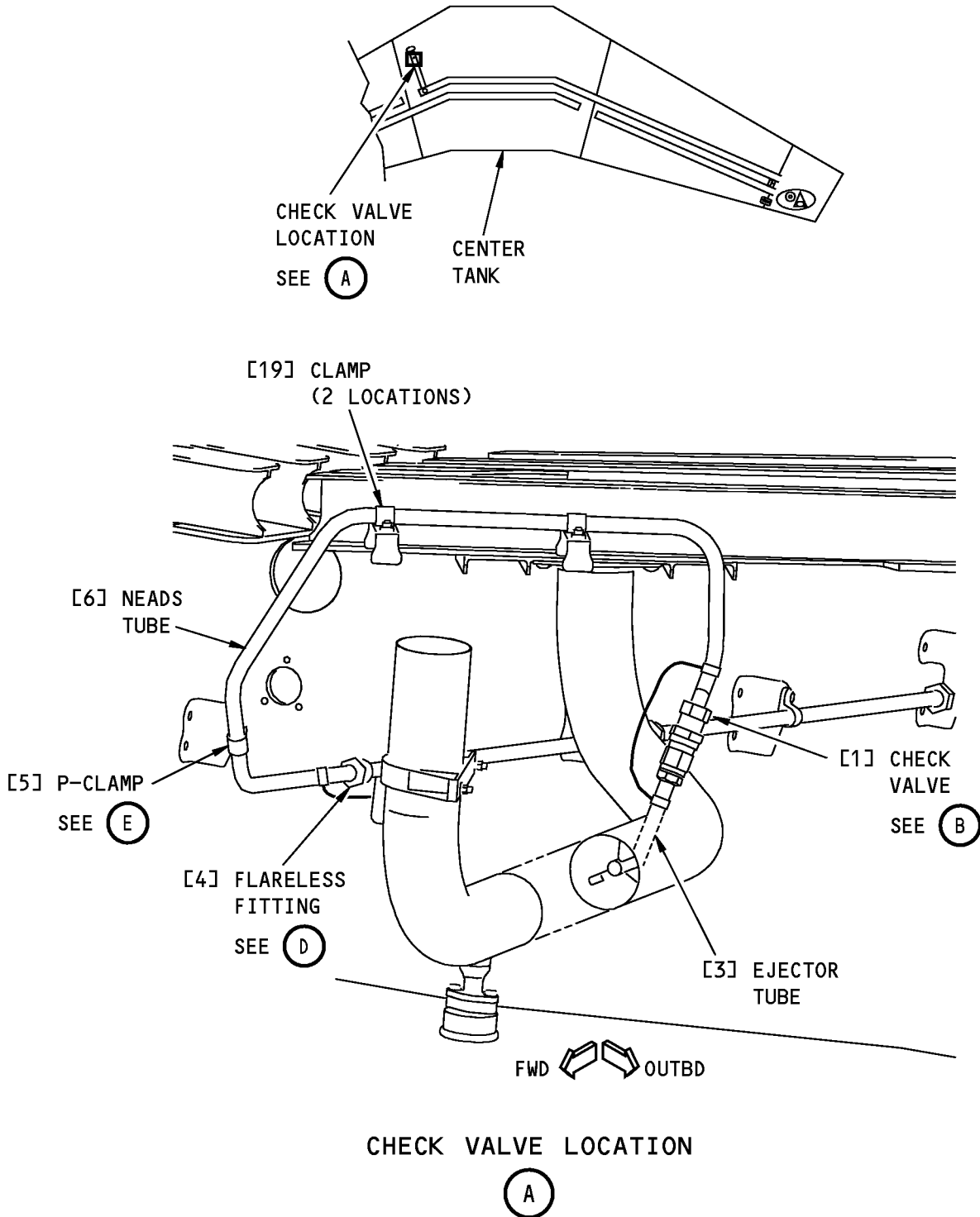

J70265 S0000176624_V5

**Primary Backflow Prevention Check Valve
Figure 401 (Sheet 1 of 3)/47-21-04-990-801**

EFFECTIVITY
HAP 036-054, 101-999

47-21-04

Page 404
Feb 15/2009

D633A101-HAP

**737-600/700/800/900
AIRCRAFT MAINTENANCE MANUAL**

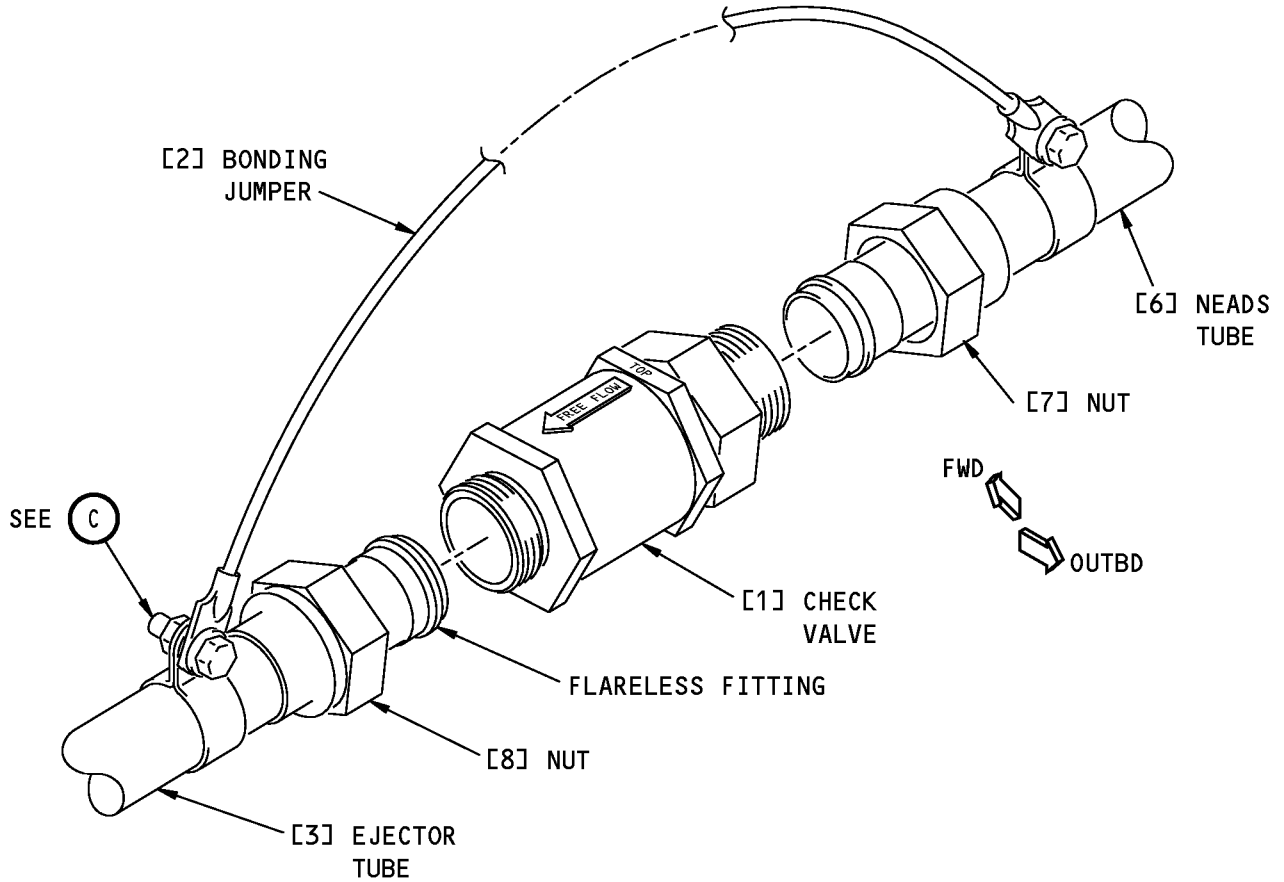

CHECK VALVE

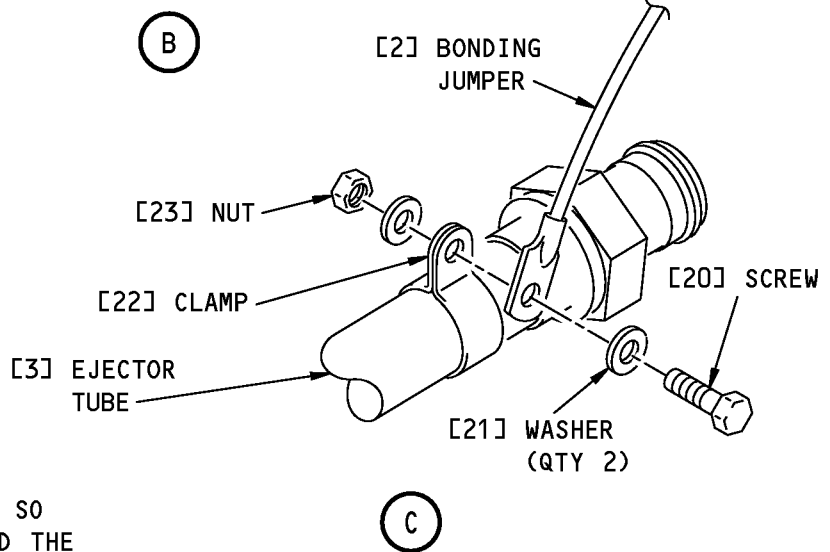

NOTE: ORIENT THE CHECK VALVE SO THAT "TOP" FACES TOWARD THE FRONT OF THE AIRPLANE.

J70269 S0000176625_V4

**Primary Backflow Prevention Check Valve
Figure 401 (Sheet 2 of 3)/47-21-04-990-801**

EFFECTIVITY
HAP 036-054, 101-999

47-21-04

Page 405
Feb 15/2009

D633A101-HAP

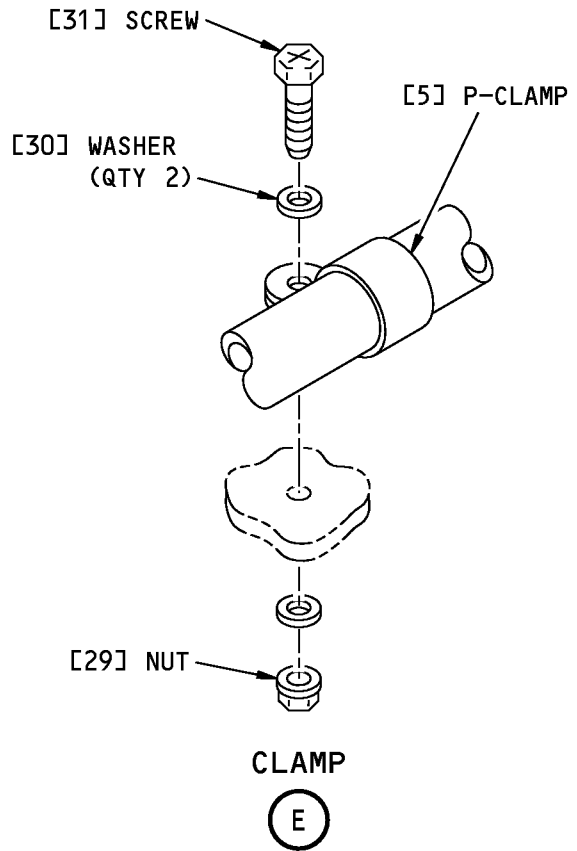
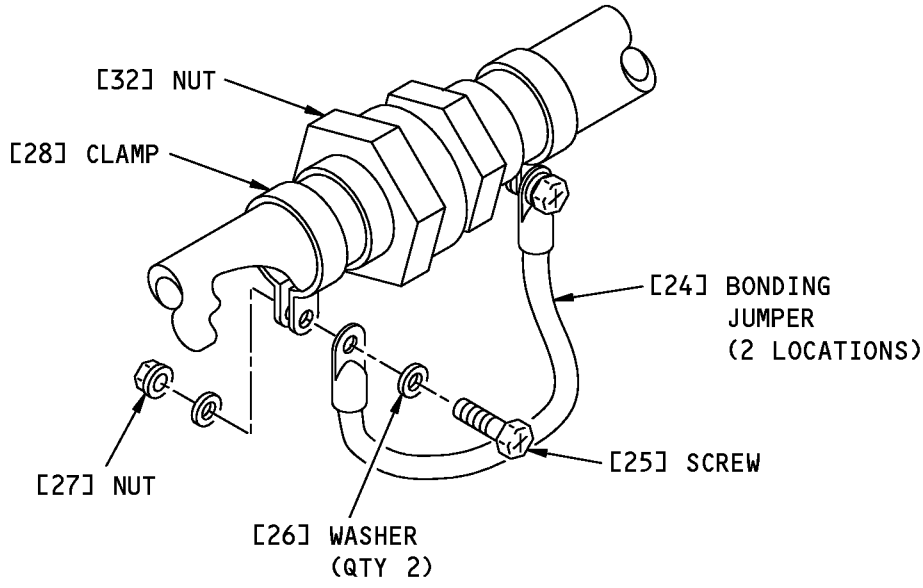

1480043 S0000269709_V1

**Primary Backflow Prevention Check Valve
Figure 401 (Sheet 3 of 3)/47-21-04-990-801**

EFFECTIVITY
HAP 036-054, 101-999

D633A101-HAP

BOEING PROPRIETARY - Copyright © Unpublished Work - See title page for details

47-21-04

Page 406
Feb 15/2009



737-600/700/800/900

AIRCRAFT MAINTENANCE MANUAL

TASK 47-21-04-400-801

3. Primary Backflow Prevention Check Valve Installation

(Figure 401)

A. References

Reference	Title
28-11-00-910-802	Purging and Fuel Tank Entry (P/B 201)
28-11-31-400-801	Center Tank Access Door - Installation (P/B 401)
SWPM 20-20-00	Electrical Bonds and Grounds

B. Tools/Equipment

NOTE: When more than one tool part number is listed under the same "Reference" number, the tools shown are alternates to each other within the same airplane series. Tool part numbers that are replaced or non-procurable are preceded by "Opt:", which stands for Optional.

Reference	Description
COM-1550	Meter - Bonding (Approved Explosion Proof & Intrinsically Safe) (Part #: C15292 (MODEL T477W), Supplier: 01014, A/P Effectivity: 737-ALL) (Part #: M1, Supplier: 3AD17, A/P Effectivity: 737-ALL) (Part #: M1B, Supplier: 3AD17, A/P Effectivity: 737-ALL)

C. Expendables/Parts

AMM Item	Description	AIPC Reference	AIPC Effectivity
1	Check valve	47-21-51-01-070	HAP 036-054, 101-999

D. Location Zones

Zone	Area
531	Left Wing - Center Fuel Tank, Rib 1 to Rib 5

E. Access Panels

Number	Name/Location
531AB	Center Tank Access Door - Wing Station 168

F. Prepare for Installation

SUBTASK 47-21-04-010-004

- (1) Go into the center tank (TASK 28-11-00-910-802).

SUBTASK 47-21-04-010-005

- (2) Remove the protective covers from the NEADS tube [6], the ejector tube [3], and the flareless fitting [4].

SUBTASK 47-21-04-110-001

- (3) Prepare these components for an electrical surface bond (SWPM 20-20-00):
- (a) mating surface of the NEADS tube [6]
 - (b) mating surfaces of the ejector tube [3]
 - (c) mating surfaces of bonding jumper [2] and bonding jumper [24]
 - (d) mating surfaces of the clamp [28]

G. Install the Check Valve

SUBTASK 47-21-04-420-005

- (1) Align the flareless fitting [4] to the nut [32].

EFFECTIVITY HAP 036-054, 101-999

47-21-04

Page 407
Jun 15/2009

D633A101-HAP



737-600/700/800/900

AIRCRAFT MAINTENANCE MANUAL

- (a) Install, but do not fully tighten, the nut [32] on the flareless fitting [4].

SUBTASK 47-21-04-400-001

- (2) Hold the check valve [1] in position.

NOTE: Make sure that you can see the FLOW ARROW and that the arrow direction points down.

NOTE: Make sure that the stamped word HINGE (or TOP) point to the forward direction of the aircraft.

- (a) Install, but do not fully tighten, the NEADS tube [6] on the check valve [1]
(b) Align the check valve [1] to the ejector tube [3].
(c) Install, but do not fully tighten, the ejector tube [3] on the check valve [1].

SUBTASK 47-21-04-430-009

- (3) Tighten the two clamps[19] that hold the NEADS tube [6] to the structure.

SUBTASK 47-21-04-430-010

- (4) Attach the P-clamp [5] and NEADS tube [6] to the structure with the screw [31], washer [30], and nut [29].

SUBTASK 47-21-04-430-011

- (5) Tighten the nut [32] to 280 ± 28 in-lb (31.6 ± 3.2 N·m)

NOTE: Use a second wrench on the nut to stop the NEADS tube [6] from turning.

SUBTASK 47-21-04-430-012

- (6) Attach the bonding jumper [24] to the NEADS tube [6] with a clamp [28], screw [25], washers [26], and nut [27].

SUBTASK 47-21-04-430-013

- (7) Tighten the nut [8] to 280 ± 28 in-lb (31.6 ± 3.2 N·m)

NOTE: Use a second wrench on the check valve [1] adjacent to the nut [8] to hold it.

SUBTASK 47-21-04-430-014

- (8) Tighten the nut [7] to 280 ± 28 in-lb (31.6 ± 3.2 N·m)

NOTE: Use a second wrench on the check valve [1] adjacent to the nut [7] to hold it.

SUBTASK 47-21-04-430-015

- (9) Attach the bonding jumper [2] and clamp [22] to the ejector tube [3] with the screw [20], washers [21], clamp [22], and nut [23].

SUBTASK 47-21-04-700-001

- (10) Use a bonding meter, COM-1550, to measure the electrical resistance between each of these components and the nearest primary structure. (SWPM 20-20-00).

- (a) check valve [1]
(b) ejector tube [3]
(c) NEADS tube [6].

SUBTASK 47-21-04-700-002

- (11) Make sure that the electrical resistance is 0.010 ohm (10 milliohms) or less (SWPM 20-20-00).

H. Put the Airplane Back to Its Usual Condition

SUBTASK 47-21-04-410-001

- (1) Do this task: Center Tank Access Door - Installation, TASK 28-11-31-400-801:

EFFECTIVITY
HAP 036-054, 101-999

D633A101-HAP

47-21-04

Page 408
Feb 15/2009



737-600/700/800/900

AIRCRAFT MAINTENANCE MANUAL

(a) Close this access panel:

<u>Number</u>	<u>Name/Location</u>
531AB	Center Tank Access Door - Wing Station 168

————— END OF TASK —————

TASK 47-21-04-000-803

4. Secondary Backflow Prevention Check Valve Removal

(Figure 402)

A. General

(1) The secondary backflow prevention check valve [16] is referred to as the check valve [16] in this procedure.

B. References

<u>Reference</u>	<u>Title</u>
36-00-00-860-806	Remove Pressure from the Pneumatic System (P/B 201)
47-21-00-700-802	Drain Cap - Fuel Leak Check (P/B 601)

C. Location Zones

<u>Zone</u>	<u>Area</u>
131	Center Section Wing Box, Body Station 540.00 to Body Station 663.75 - Left
211	Flight Compartment - Left
212	Flight Compartment - Right

D. Access Panels

<u>Number</u>	<u>Name/Location</u>
192BL	ECS Ram Air Inlet Mixing Duct Panel - Forward

E. Prepare for Removal

SUBTASK 47-21-04-864-002

(1) Do this task: Remove Pressure from the Pneumatic System, TASK 36-00-00-860-806.

(a) Make sure that the dual duct pressure gage shows 0.50 psig (3.45 kPa) or less in the L and R ducts.

SUBTASK 47-21-04-860-002

(2) Put the L PACK and R PACK selector switches, on the P5-10 air conditioning panel, to the OFF position.

(a) Put a DO-NOT-OPERATE tag on the L PACK and R PACK selector switches.

HAP 047-053, 106-999

SUBTASK 47-21-04-865-003

(3) Open these circuit breakers and install safety tags:

CAPT Electrical System Panel, P18-3

<u>Row</u>	<u>Col</u>	<u>Number</u>	<u>Name</u>
D	17	C01657	NITROGEN GENERATION CONTROL
E	15	C01680	NGS ALT PWR

EFFECTIVITY
HAP 036-054, 101-999

47-21-04

Page 409
Feb 15/2009

D633A101-HAP



737-600/700/800/900

AIRCRAFT MAINTENANCE MANUAL

HAP 047-053, 106-999 (Continued)

HAP 036-054, 101-999

SUBTASK 47-21-04-010-009

WARNING: OBEY THE SUBSEQUENT STEPS FOR ACCESS PANELS IDENTIFIED WITH A NITROGEN GENERATION SYSTEM PLACARD. IF THERE IS A LEAK IN THE NITROGEN GENERATION SYSTEM, IT WILL DECREASE THE OXYGEN IN THE AIR THAT YOU BREATHE. IF YOU BREATHE AIR THAT DOES NOT HAVE SUFFICIENT OXYGEN, DANGEROUS HEALTH CONDITIONS CAN QUICKLY OCCUR.

(4) Open this access panel:

<u>Number</u>	<u>Name/Location</u>
192BL	ECS Ram Air Inlet Mixing Duct Panel - Forward

HAP 047-053, 106-999

SUBTASK 47-21-04-616-002

(5) Drain fuel from the drain cap (TASK 47-21-00-700-802).

HAP 036-054, 101-999

F. Remove the Check Valve

SUBTASK 47-21-04-010-010

WARNING: DO NOT TOUCH THE COMPONENTS OF THE NITROGEN GENERATION SYSTEM WHEN THEY ARE HOT. WHEN THE COMPONENTS ARE HOT, THEY CAN CAUSE INJURIES TO PERSONNEL.

WARNING: DO NOT DISCONNECT THE COMPONENTS OF THE NITROGEN GENERATION SYSTEM, OR DUCTS WHEN THE SYSTEM IS PRESSURIZED. THE HOT, HIGH-PRESSURE AIR CAN CAUSE INJURIES TO PERSONNEL, AND DAMAGE TO EQUIPMENT.

CAUTION: MAKE SURE THAT THE MAINTENANCE AREA IS FREE OF CONTAMINATION FROM SKYDROL, LUBRICANTS, SOLVENTS, FUEL, FUMES, EXHAUST, OR DUST. DO NOT LET SOLVENTS, LUBRICANTS, OTHER FLUIDS, OR THEIR FUMES GO INTO THE FLOW PATH TO OR FROM THE ASM. CONTAMINATION WILL CAUSE DAMAGE TO THE FIBERS IN THE ASM AND DECREASE THEIR LIFE.

(1) Go to the check valve [16] location.

HAP 036-046, 054, 101-105

NOTE: The check valve [16] is on the Air Separation Module (ASM [18]) between the drain cap and the GSE oxygen port tube [14].

HAP 036-054, 101-999

SUBTASK 47-21-04-020-003

- (2) Do these steps to remove the check valve [16]:
- Disconnect the nut [9] from the high flow valve outlet port.
 - Loosen the two screws [11] that attach the NEADS tube [10] to the ASM [18].
 - Disconnect the bonding jumper [12] from the NEADS tube [10].
 - Disconnect the nut [13] from the GSE oxygen port tube [14].

EFFECTIVITY
HAP 036-054, 101-999

D633A101-HAP

47-21-04

Page 410
Feb 15/2009



737-600/700/800/900

AIRCRAFT MAINTENANCE MANUAL

(e) Disconnect the nut [15] from the check valve [16].

NOTE: Attach a second wrench to hold the check valve [16].

(f) Move the NEADS tube [10] forward.

(g) Disconnect the nut [17] from the check valve [16].

NOTE: Attach a second wrench to hold the check valve [16].

(h) Remove the check valve [16].

(i) Install the protective covers on the open ends of the NEADS tube [10].

————— **END OF TASK** —————

EFFECTIVITY
HAP 036-054, 101-999

D633A101-HAP

47-21-04

Page 411
Feb 15/2009

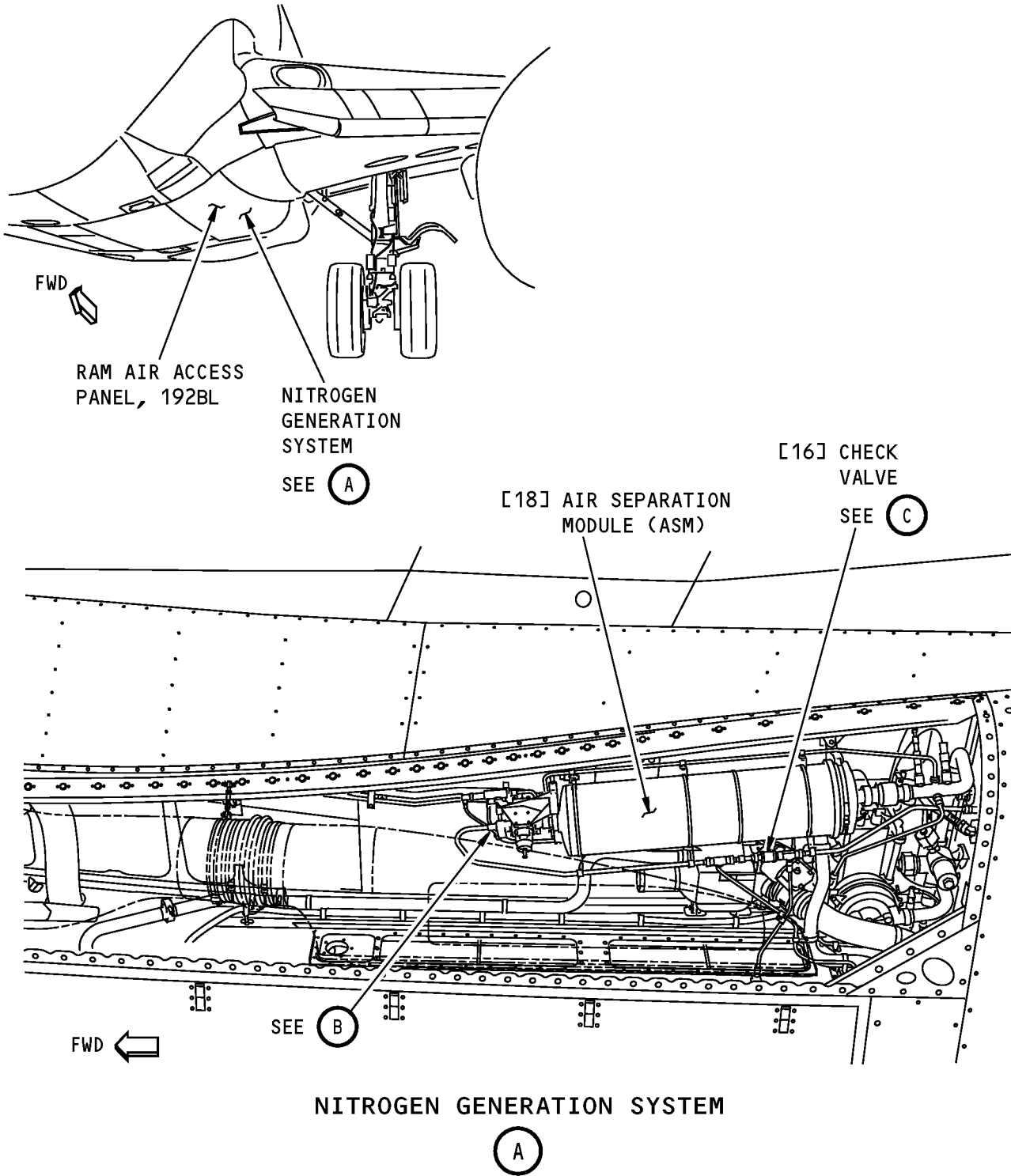

Secondary Backflow Prevention Check Valve
Figure 402 (Sheet 1 of 4)/47-21-04-990-803

EFFECTIVITY
HAP 036-046, 054, 101-105

47-21-04

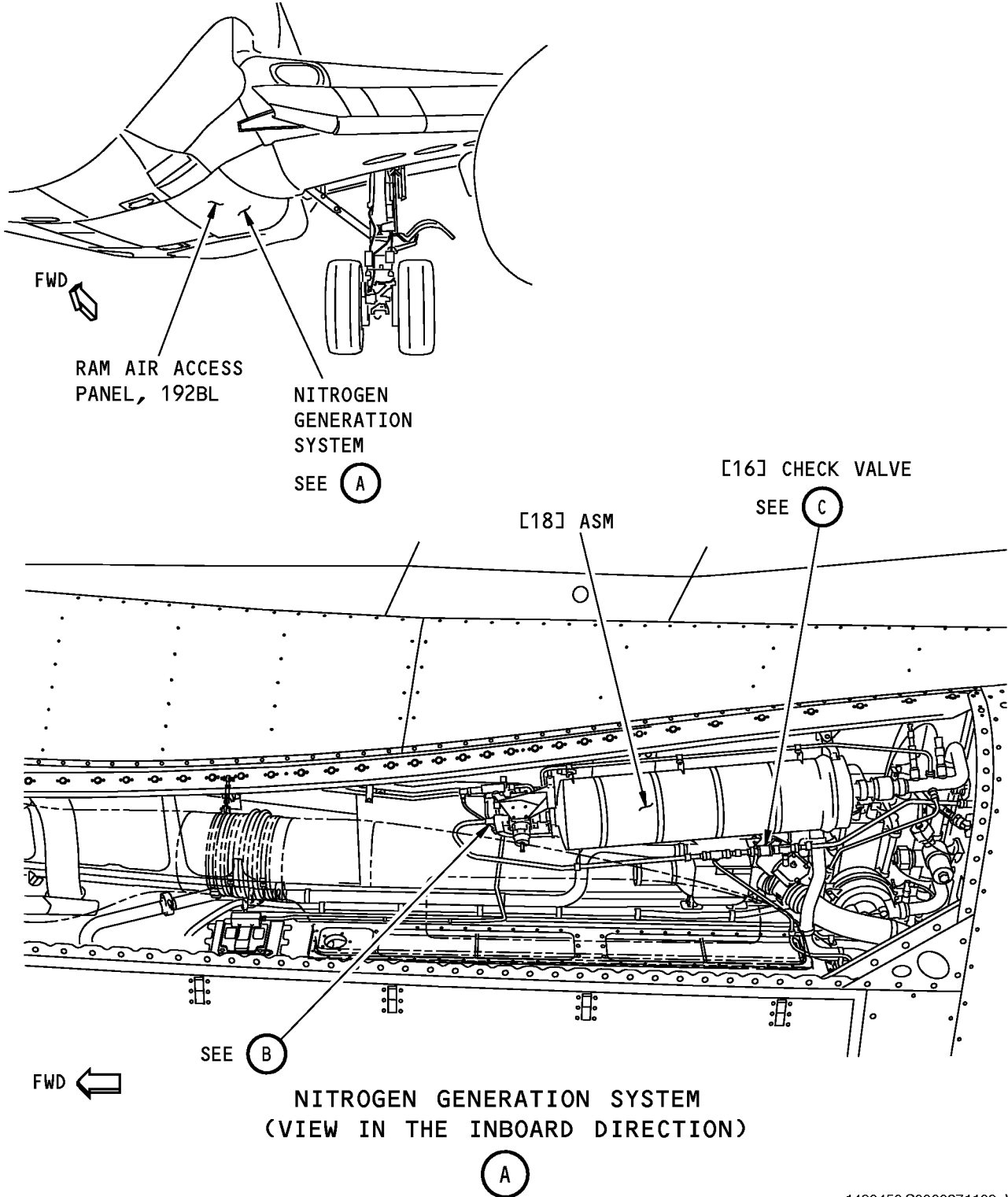

1490450 S0000271109_V1

**Secondary Backflow Prevention Check Valve
Figure 402 (Sheet 2 of 4)/47-21-04-990-803**

EFFECTIVITY
HAP 047-053, 106-999

47-21-04

Page 413
Feb 15/2009

D633A101-HAP

**737-600/700/800/900
AIRCRAFT MAINTENANCE MANUAL**

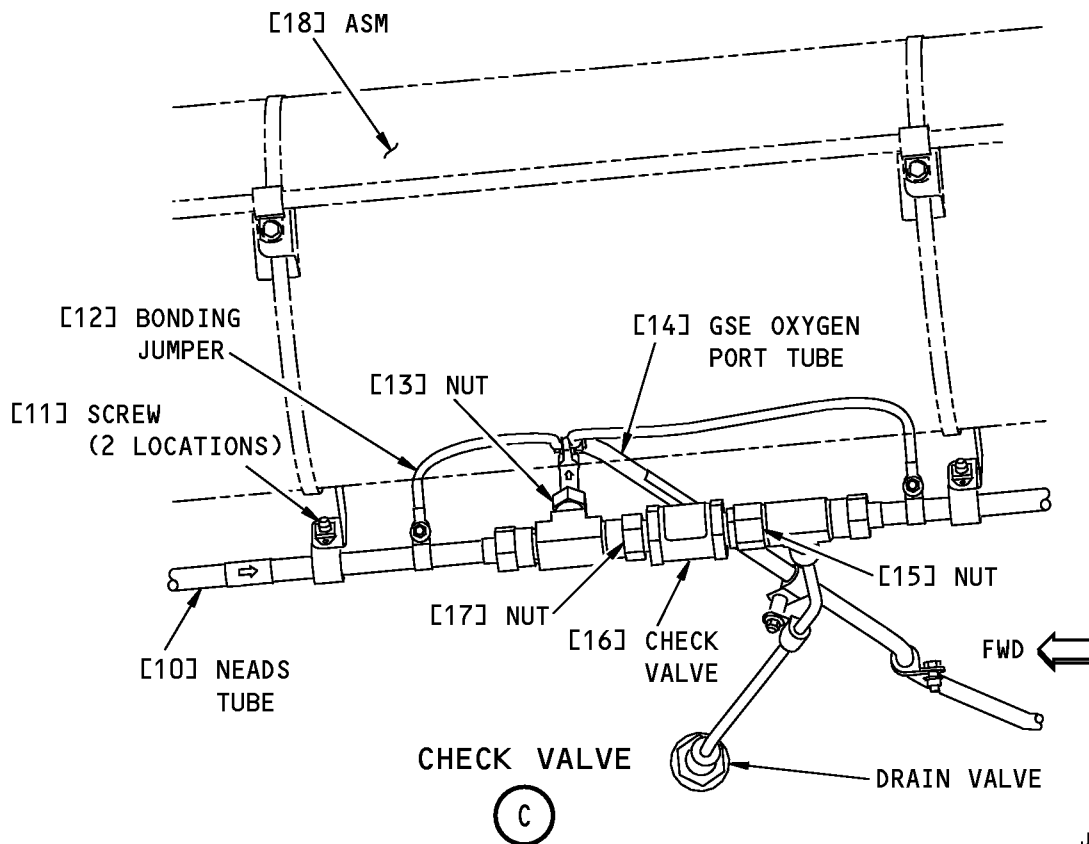
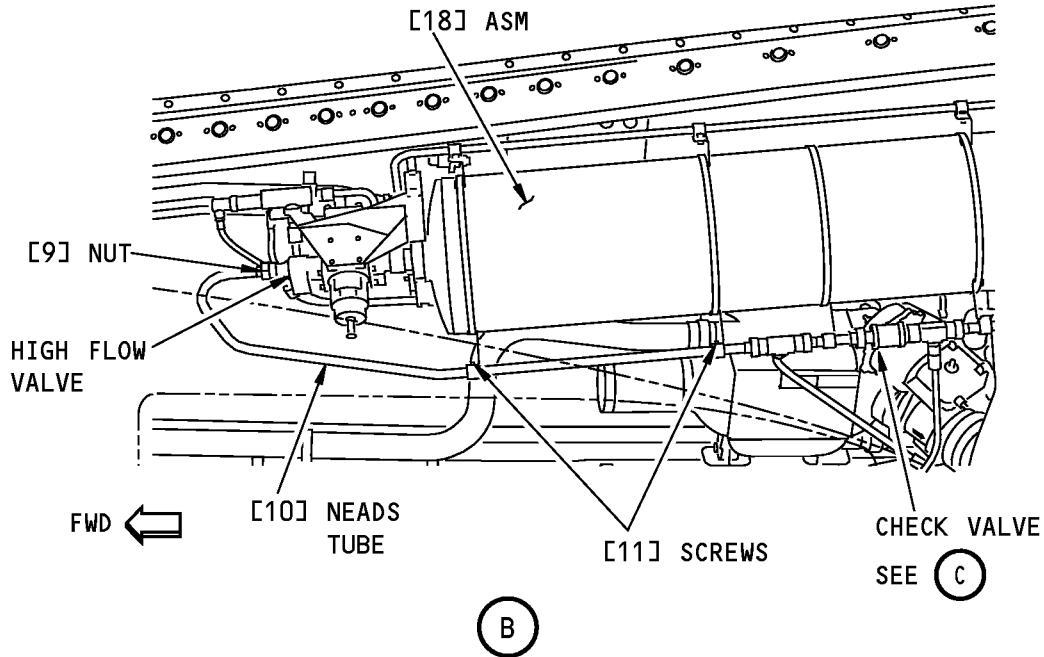

J89437 S0000184129_V3

**Secondary Backflow Prevention Check Valve
Figure 402 (Sheet 3 of 4)/47-21-04-990-803**

EFFECTIVITY
HAP 036-046, 054, 101-105

47-21-04

Page 414
Feb 15/2009

D633A101-HAP

**737-600/700/800/900
AIRCRAFT MAINTENANCE MANUAL**

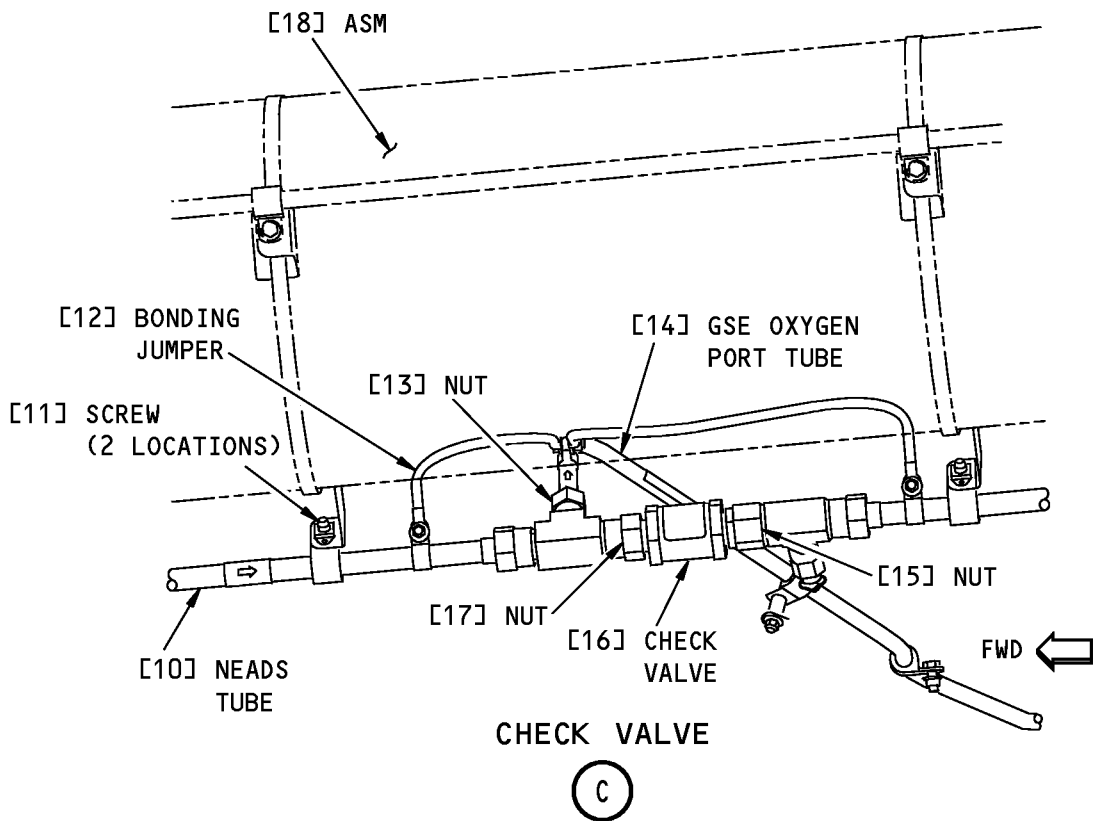
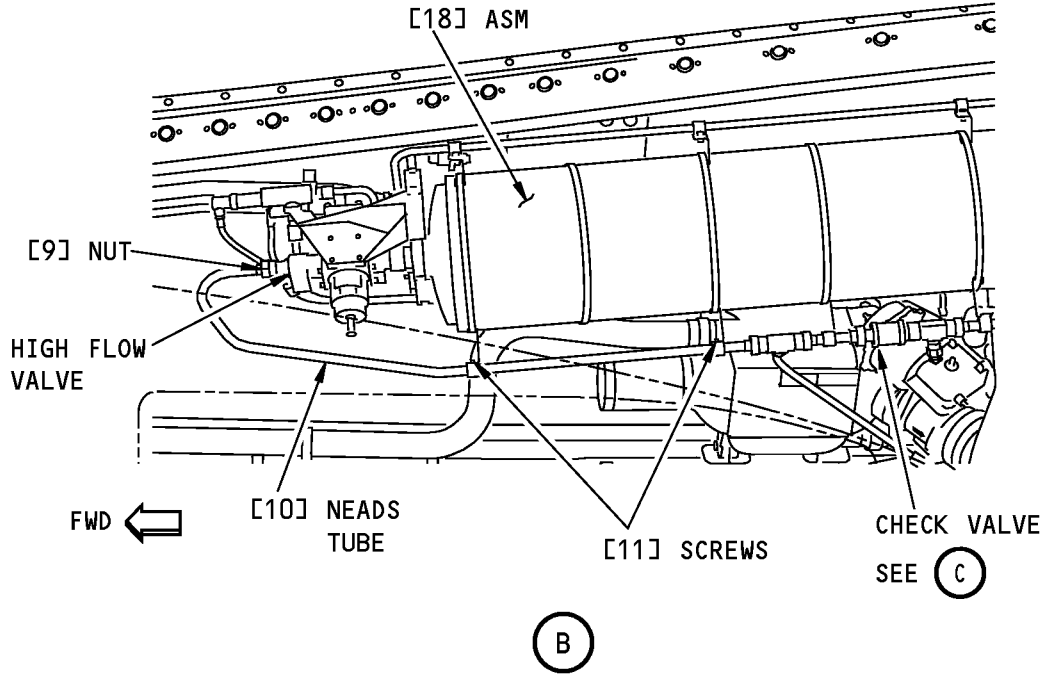

1492170 S0000271110_V1

**Secondary Backflow Prevention Check Valve
Figure 402 (Sheet 4 of 4)/47-21-04-990-803**

EFFECTIVITY
HAP 047-053, 106-999

47-21-04

Page 415
Feb 15/2009

D633A101-HAP



737-600/700/800/900

AIRCRAFT MAINTENANCE MANUAL

TASK 47-21-04-400-803

5. Secondary Backflow Prevention Check Valve Installation

(Figure 402)

A. References

Reference	Title
SWPM 20-20-00	Electrical Bonds and Grounds

B. Tools/Equipment

NOTE: When more than one tool part number is listed under the same "Reference" number, the tools shown are alternates to each other within the same airplane series. Tool part numbers that are replaced or non-procurable are preceded by "Opt:", which stands for Optional.

Reference	Description
COM-1550	Meter - Bonding (Approved Explosion Proof & Intrinsically Safe) (Part #: C15292 (MODEL T477W), Supplier: 01014, A/P Effectivity: 737-ALL) (Part #: M1, Supplier: 3AD17, A/P Effectivity: 737-ALL) (Part #: M1B, Supplier: 3AD17, A/P Effectivity: 737-ALL)

C. Expendables/Parts

AMM Item	Description	AIPC Reference	AIPC Effectivity
16	Check valve	47-21-00-01-070	HAP 047-053, 106-999

D. Location Zones

Zone	Area
131	Center Section Wing Box, Body Station 540.00 to Body Station 663.75 - Left
211	Flight Compartment - Left
212	Flight Compartment - Right

E. Access Panels

Number	Name/Location
192BL	ECS Ram Air Inlet Mixing Duct Panel - Forward

F. Install the Check Valve

SUBTASK 47-21-04-010-011

- (1) Go to the left ram air duct bay.

SUBTASK 47-21-04-090-001

- (2) Remove the protective covers from the NEADS tube [10] ends.

SUBTASK 47-21-04-110-003

- (3) Prepare these components for an electrical surface bond (SWPM 20-20-00):
 - (a) mating surfaces of the NEADS tube [10] ends where the bonding jumper [12] is attached.
 - (b) mating surface of the bonding jumper [12] (if removed).

SUBTASK 47-21-04-420-003

- (4) Do these steps to install check valve [16]:
 - (a) Align the check valve [16] to make sure the FLOW ARROW points aft.
 - (b) Make sure that the word HINGE (or TOP) (stamped into the check valve [16]) is on the top surface of the check valve [16].

EFFECTIVITY HAP 036-054, 101-999

47-21-04



737-600/700/800/900

AIRCRAFT MAINTENANCE MANUAL

- (c) Put the check valve [16] in its position.
- (d) Align the check valve [16] and the NEADS tube [10].
- (e) Install the nut [15] on the check valve [16].
- (f) Install the nut [17] on the check valve [16].
 - 1) Tighten nut [15] and nut [17] to 280 ±28 in-lb (31.6 ±3.2 N·m).

NOTE: Put a second wrench on the check valve [16] to hold it.

SUBTASK 47-21-04-430-007

- (5) Do these steps to complete the installation:
 - (a) Attach the NEADS tube [10] to the high flow valve outlet port.
 - (b) Tighten the nut [9] to 280 ±28 in-lb (31.6 ±3.2 N·m).
 - (c) Attach the GSE oxygen port tube [14] to the O2 GSE fitting.
 - (d) Tighten the nut [13] to 170 ±17 in-lb (19.2 ±1.9 N·m).
 - (e) Install the screw [11] that attach the NEADS tube [10] to the ASM [18].

SUBTASK 47-21-04-430-008

- (6) Install the bonding jumper [12].

SUBTASK 47-21-04-200-003

- (7) Use a bonding meter, COM-1550, to measure the electrical resistance between each of these components and the nearest primary structure (SWPM 20-20-00).
 - (a) check valve [16]
 - (b) NEADS tube [10]

SUBTASK 47-21-04-200-004

- (8) Make sure that the electrical resistance between each of the components and the structure is 0.010 ohm (10 milliohms) or less (SWPM 20-20-00).

G. Put the Airplane Back to the Usual Condition

SUBTASK 47-21-04-410-004

- (1) Close this access panel:

<u>Number</u>	<u>Name/Location</u>
192BL	ECS Ram Air Inlet Mixing Duct Panel - Forward

HAP 047-053, 106-999

SUBTASK 47-21-04-865-005

- (2) Remove the safety tags and close these circuit breakers:

CAPT Electrical System Panel, P18-3

<u>Row</u>	<u>Col</u>	<u>Number</u>	<u>Name</u>
D	17	C01657	NITROGEN GENERATION CONTROL
E	15	C01680	NGS ALT PWR

HAP 036-054, 101-999

SUBTASK 47-21-04-860-003

- (3) Put the L PACK and R PACK selector switches to the AUTO position.
 - (a) Remove the DO-NOT-OPERATE tags on the L PACK and R PACK selector switches.

————— **END OF TASK** —————

EFFECTIVITY HAP 036-054, 101-999
--

47-21-04

Page 417
Feb 15/2009

D633A101-HAP



737-600/700/800/900

AIRCRAFT MAINTENANCE MANUAL

CROSS VENT CHECK VALVE - REMOVAL/INSTALLATION

1. General

A. This procedure has these tasks:

- (1) Cross Vent Check Valve Removal
(2) Cross Vent Check Valve Installation

TASK 47-21-05-000-801

2. Cross Vent Check Valve Removal

(Figure 401)

A. General

- (1) The cross vent check valve [1] is in the right surge tank. The valve is attached to the number 12 vent stringer and fuel dam [2] with a bolt, screws, and a clamping device.

B. References

Table with 2 columns: Reference, Title. Row: 28-11-11-000-802, Surge Tank Access Door - Removal (P/B 401)

C. Tools/Equipment

NOTE: When more than one tool part number is listed under the same "Reference" number, the tools shown are alternates to each other within the same airplane series. Tool part numbers that are replaced or non-procurable are preceded by "Opt:", which stands for Optional.

Table with 2 columns: Reference, Description. Rows: COM-2481 (Tool - Sealant Removal, BAC5000, PSD 6-184 Approved...), SPL-768 (Sealant Removal Tool, Hardwood or Plastic...)

D. Location Zones

Table with 2 columns: Zone, Area. Row: 633, Right Wing - Surge Tank, Rib 22 to Rib 25, Wing Station 643.50 to Wing Buttock Line 616.75

E. Access Panels

Table with 2 columns: Number, Name/Location. Row: 633AB, Surge Tank Access Door - Wing Station 655

EFFECTIVITY HAP 036-054, 101-999 D633A101-HAP

47-21-05



737-600/700/800/900

AIRCRAFT MAINTENANCE MANUAL

F. Prepare for the Removal

SUBTASK 47-21-05-650-001

WARNING: DO ALL THE SAFETY PROCEDURES TO DEFUEL THE TANK AND TO GO INTO IT. INJURY TO PERSONS AND DAMAGE TO EQUIPMENT CAN OCCUR IF YOU DO NOT FOLLOW THE SAFETY PROCEDURES.

WARNING: DO NOT BREATHE THE AIR FROM THE FUEL TANK UNTIL YOU MAKE IT SAFE. THE NITROGEN GENERATION SYSTEM DECREASES THE OXYGEN IN THE AIR. IF YOU BREATHE AIR THAT DOES NOT HAVE SUFFICIENT OXYGEN, DANGEROUS HEALTH CONDITIONS CAN QUICKLY OCCUR. DANGEROUS HEALTH CONDITIONS INCLUDE NAUSEA, UNCONSCIOUSNESS, AND CONVULSIONS. IF THE OXYGEN LEVEL OF THE AIR THAT YOU BREATHE IS VERY LOW, IT CAN KILL YOU.

- (1) Do this task to open this access door:

Surge Tank Access Door - Removal, TASK 28-11-11-000-802.

<u>Number</u>	<u>Name/Location</u>
633AB	Surge Tank Access Door - Wing Station 655

SUBTASK 47-21-05-010-002

- (2) Go into the right surge tank.

G. Remove the Cross Vent Check Valve

SUBTASK 47-21-05-910-001

- (1) Hold the cross vent check valve [1] in its position.

SUBTASK 47-21-05-020-002

- (2) Remove the two screws [5] and washers [3] that attach the cross vent check valve [1] to the fuel dam [2].

SUBTASK 47-21-05-030-001

- (3) Loosen the bolt [7] and washer [8] on the clamping device.

NOTE: Loosen the bolt enough to relieve the spring tension on the clamping device.

SUBTASK 47-21-05-020-003

- (4) Remove the cross vent check valve [1].

SUBTASK 47-21-05-100-001

- (5) Use sealant removal tool, COM-2481, (sealant removal tool, SPL-768 or equivalent) to remove the sealant from the fuel dam [2] and vent channel.

NOTE: Do not remove sealant from the nutplates on the fuel dam.

————— **END OF TASK** —————

<p>EFFECTIVITY HAP 036-054, 101-999</p>

D633A101-HAP

47-21-05

Page 402
Feb 15/2009

**737-600/700/800/900
AIRCRAFT MAINTENANCE MANUAL**

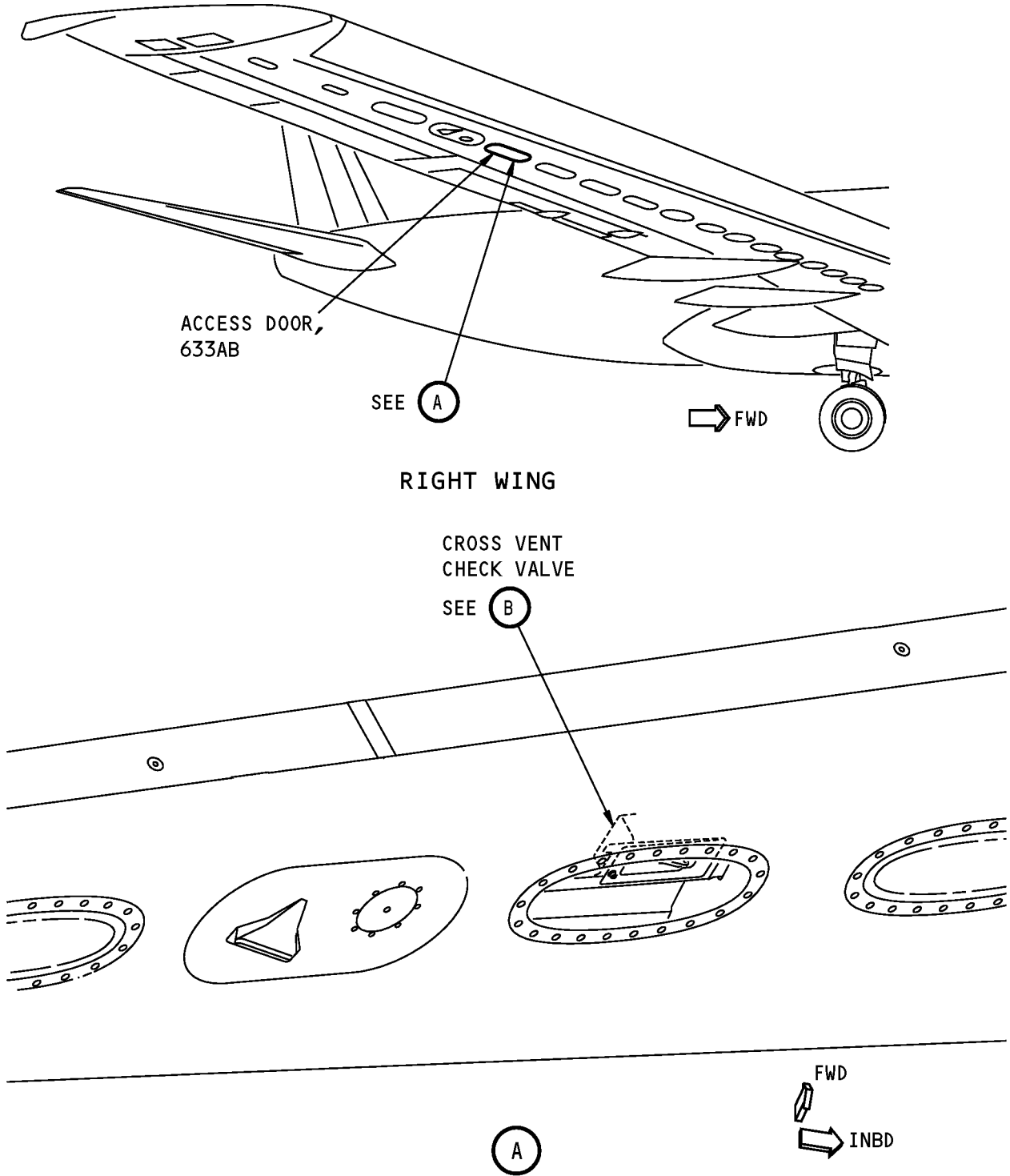

**Cross Vent Check Valve
Figure 401 (Sheet 1 of 2)/47-21-05-990-801**

EFFECTIVITY
HAP 036-054, 101-999

D633A101-HAP

47-21-05

Page 403
Feb 15/2009

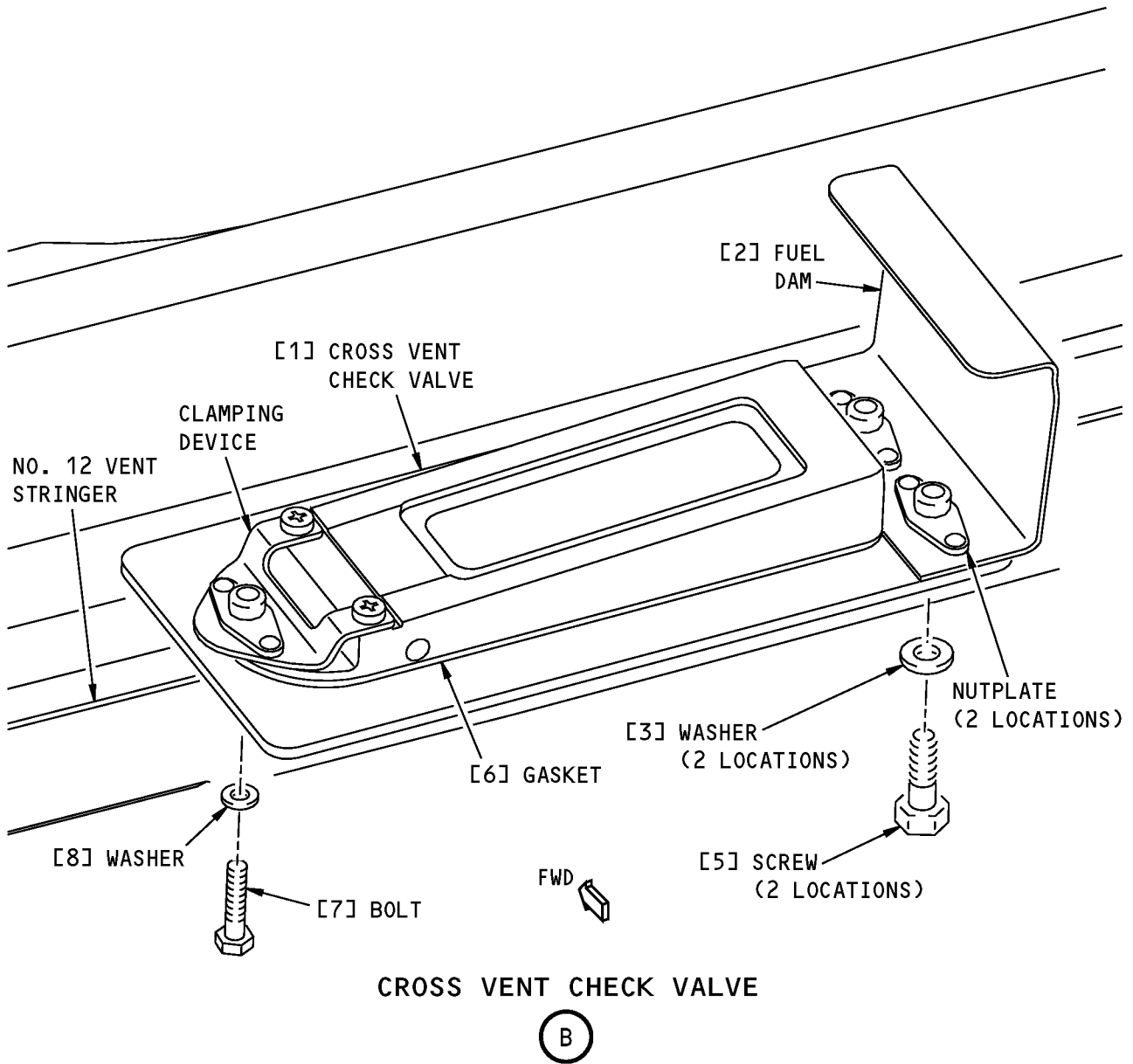

**Cross Vent Check Valve
Figure 401 (Sheet 2 of 2)/47-21-05-990-801**

EFFECTIVITY
HAP 036-054, 101-999

D633A101-HAP

47-21-05

Page 404
Feb 15/2009



737-600/700/800/900

AIRCRAFT MAINTENANCE MANUAL

TASK 47-21-05-420-801

3. Cross Vent Check Valve Installation

(Figure 401)

A. References

Reference	Title
28-11-00-910-802	Purging and Fuel Tank Entry (P/B 201)
28-11-11-400-802	Surge Tank Access Door - Installation (P/B 401)
SWPM 20-20-00	Electrical Bonds and Grounds

B. Tools/Equipment

NOTE: When more than one tool part number is listed under the same "Reference" number, the tools shown are alternates to each other within the same airplane series. Tool part numbers that are replaced or non-procurable are preceded by "Opt:", which stands for Optional.

Reference	Description
COM-1550	Meter - Bonding (Approved Explosion Proof & Intrinsically Safe) (Part #: C15292 (MODEL T477W), Supplier: 01014, A/P Effectivity: 737-ALL) (Part #: M1, Supplier: 3AD17, A/P Effectivity: 737-ALL) (Part #: M1B, Supplier: 3AD17, A/P Effectivity: 737-ALL)

C. Consumable Materials

Reference	Description	Specification
A00767	Sealant - Fuel Tank	BMS5-45

D. Expendables/Parts

AMM Item	Description	AIPC Reference	AIPC Effectivity
1	Cross vent check valve	47-21-05-01-020	HAP 036
		47-21-05-01A-020	HAP 037-054, 101-999

E. Location Zones

Zone	Area
633	Right Wing - Surge Tank, Rib 22 to Rib 25, Wing Station 643.50 to Wing Buttock Line 616.75

F. Access Panels

Number	Name/Location
633AB	Surge Tank Access Door - Wing Station 655

G. Prepare for the Installation

SUBTASK 47-21-05-010-003

WARNING: DO ALL THE SAFETY PROCEDURES TO DEFUEL THE TANK AND TO GO INTO IT. INJURY TO PERSONS AND DAMAGE TO EQUIPMENT CAN OCCUR IF YOU DO NOT FOLLOW THE SAFETY PROCEDURES.

EFFECTIVITY HAP 036-054, 101-999

47-21-05

D633A101-HAP



737-600/700/800/900

AIRCRAFT MAINTENANCE MANUAL

(WARNING PRECEDES)

WARNING: DO NOT BREATHE THE AIR FROM THE FUEL TANK UNTIL YOU MAKE IT SAFE. THE NITROGEN GENERATION SYSTEM DECREASES THE OXYGEN IN THE AIR. IF YOU BREATHE AIR THAT DOES NOT HAVE SUFFICIENT OXYGEN, DANGEROUS HEALTH CONDITIONS CAN QUICKLY OCCUR. DANGEROUS HEALTH CONDITIONS INCLUDE NAUSEA, UNCONSCIOUSNESS, AND CONVULSIONS. IF THE OXYGEN LEVEL OF THE AIR THAT YOU BREATHE IS VERY LOW, IT CAN KILL YOU.

- (1) Go into the right surge tank (TASK 28-11-00-910-802).
 - (a) Go to the cross vent check valve [1] location.

SUBTASK 47-21-05-765-001

- (2) Prepare the faying surfaces of these components for a mating surface bond (SWPM 20-20-00):
 - (a) cross vent check valve [1]
 - (b) vent channel
 - (c) new gasket [6]
 - (d) fuel dam [2]

H. Install the Cross Vent Check Valve

SUBTASK 47-21-05-420-001

- (1) Do these steps to install the cross vent check valve [1]:
 - (a) Put the gasket [6] on the top side of the valve face.
 - (b) Install the cross vent check valve [1] in the vent channel.

NOTE: The valve flange and gasket must be below the No. 12 vent stringer. The clamping device must be in the vent channel.

- 1) Make sure that the clamping device engages the stringer.
- (c) Hold the cross vent check valve [1] in its position.
- (d) Install, but do not fully tighten, the screws [5] and washers [3] into the fuel dam [2] nutplates.
- (e) Make sure that the bolt [7] and washer [8] are attached to the clamping device.
- (f) Make sure that the gasket [6] is between the cross vent check valve [1] and the bottom side of the No. 12 vent stringer.
- (g) Make sure that you align the cross vent check valve [1] with the vent channel and the fuel dam [2].

SUBTASK 47-21-05-420-002

- (2) Fully tighten the two screws [5] and the clamp bolt [7] to 55 ± 4 in-lb (6.2 ± 0.5 N·m).

SUBTASK 47-21-05-280-001

- (3) Use bonding meter, COM-1550, to measure the resistance between the cross vent check valve [1] and the nearest primary structure (SWPM 20-20-00).
 - (a) Make sure that the total resistance is 0.010 ohm (10 milliohm) or less.

SUBTASK 47-21-05-914-001

- (4) Apply sealant, A00767, or to these locations:
 - (a) Apply a cap seal on the bolt [7] and two screws [5].
 - (b) Apply a fillet seal around the periphery of the cross vent check valve [1].

EFFECTIVITY
HAP 036-054, 101-999

D633A101-HAP

47-21-05

Page 406
Feb 15/2009



737-600/700/800/900

AIRCRAFT MAINTENANCE MANUAL

I. Put the Airplane Back to Its Usual Condition

SUBTASK 47-21-05-410-001

(1) Do this task: Surge Tank Access Door - Installation, TASK 28-11-11-400-802.

(a) Close this access panel:

<u>Number</u>	<u>Name/Location</u>
633AB	Surge Tank Access Door - Wing Station 655

————— END OF TASK —————

EFFECTIVITY
HAP 036-054, 101-999

D633A101-HAP

47-21-05

Page 407
Feb 15/2009



737-600/700/800/900

AIRCRAFT MAINTENANCE MANUAL

FLAME ARRESTOR - REMOVAL/INSTALLATION

1. General

A. This procedure has these tasks:

- (1) Flame Arrestor Removal
- (2) Flame Arrestor Installation

B. The flame arrestor is installed on the rear spar of the left side of the center tank. It acts like a bulkhead fitting and requires one person in the center tank and one person in the wheel well to replace it.

TASK 47-21-07-000-801

2. Flame Arrestor Removal

(Figure 401)

A. General

- (1) Two persons are necessary to do this task.

B. References

Reference	Title
20-30-93-910-801	Final Cleaning Prior to Fuel Tank Sealing (Series 93) (P/B 201)
28-11-00-300-803	Repair of Sealant Leaks in the Fuel Tank Structure (P/B 801)
28-11-00-910-802	Purging and Fuel Tank Entry (P/B 201)
28-11-31-000-801	Center Tank Access Door - Removal (P/B 401)
47-00-00-010-801	Nitrogen Generation System (NGS) Precautions (P/B 201)

C. Tools/Equipment

NOTE: When more than one tool part number is listed under the same "Reference" number, the tools shown are alternates to each other within the same airplane series. Tool part numbers that are replaced or non-procurable are preceded by "Opt:", which stands for Optional.

Reference	Description
COM-2481	Tool - Sealant Removal, BAC5000, PSD 6-184 Approved (Part #: 1-6390-A, Supplier: 63318, A/P Effectivity: 737-ALL) (Part #: 10810, Supplier: \$0855, A/P Effectivity: 737-ALL) (Part #: 234350, Supplier: \$0857, A/P Effectivity: 737-ALL) (Part #: 311, Supplier: KA861, A/P Effectivity: 737-ALL) (Part #: 411B60, Supplier: 3DN12, A/P Effectivity: 737-ALL) (Part #: 411B90, Supplier: 3DN12, A/P Effectivity: 737-ALL) (Part #: DAD5013, Supplier: \$0856, A/P Effectivity: 737-ALL) (Part #: DFD5019, Supplier: \$0856, A/P Effectivity: 737-ALL) (Part #: J5-0275-2010, Supplier: 435R8, A/P Effectivity: 737-ALL) (Part #: SCD5019, Supplier: \$0856, A/P Effectivity: 737-ALL) (Part #: ST982LF, Supplier: 3Z323, A/P Effectivity: 737-ALL) (Part #: TS1275-4, Supplier: 1DWR5, A/P Effectivity: 737-ALL)
SPL-768	Sealant Removal Tool, Hardwood or Plastic (Part #: ST982, Supplier: 81205, A/P Effectivity: 737-ALL)
STD-133	Brush - Stiff Bristle, Non-metallic

EFFECTIVITY
HAP 047-053, 106-999

47-21-07

Page 401
Oct 15/2008

D633A101-HAP



737-600/700/800/900

AIRCRAFT MAINTENANCE MANUAL

D. Consumable Materials

Reference	Description	Specification
B01013	Solvent - Final Cleaning Prior To Fuel Tank Sealing (AMM 20-30-93/201) - Series 93	
G00034	Cotton Wiper - Process Cleaning Absorbent Wiper (Cheesecloth, Gauze)	BMS15-5

E. Location Zones

Zone	Area
133	Main Landing Gear Wheel Well, Body Station 663.75 to Body Station 727.00 - Left
212	Flight Compartment - Right
531	Left Wing - Center Fuel Tank, Rib 1 to Rib 5

F. Access Panels

Number	Name/Location
531AB	Center Tank Access Door - Wing Station 168

G. Prepare for the Removal

SUBTASK 47-21-07-860-001

WARNING: DO NOT TOUCH THE COMPONENTS OF THE NITROGEN GENERATION SYSTEM WHEN THEY ARE HOT. WHEN THE COMPONENTS ARE HOT, THEY CAN CAUSE INJURIES TO PERSONNEL.

WARNING: DO NOT DISCONNECT THE COMPONENTS OF THE NITROGEN GENERATION SYSTEM, OR DUCTS WHEN THE SYSTEM IS PRESSURIZED. THE HOT, HIGH-PRESSURE AIR CAN CAUSE INJURIES TO PERSONNEL, AND DAMAGE TO EQUIPMENT.

- (1) Obey the Nitrogen Generation System (NGS) precautions (TASK 47-00-00-010-801).

SUBTASK 47-21-07-860-002

- (2) Open these circuit breakers and install safety tags:

CAPT Electrical System Panel, P18-3

Row	Col	Number	Name
D	17	C01657	NITROGEN GENERATION CONTROL
E	15	C01680	NGS ALT PWR

SUBTASK 47-21-07-860-003

- (3) Put the L PACK and R PACK selector switches, found on the P5-10 air conditioning panel, to the OFF position.
 - (a) Put DO-NOT-OPERATE tags on the L PACK and R PACK selector switches.

SUBTASK 47-21-07-010-001

- (4) Do this task: Center Tank Access Door - Removal, TASK 28-11-31-000-801.

EFFECTIVITY HAP 047-053, 106-999

47-21-07



737-600/700/800/900

AIRCRAFT MAINTENANCE MANUAL

SUBTASK 47-21-07-010-004

WARNING: DO NOT BREATHE THE AIR FROM THE FUEL TANK UNTIL YOU MAKE IT SAFE. THE NITROGEN GENERATION SYSTEM DECREASES THE OXYGEN IN THE AIR. IF YOU BREATHE AIR THAT DOES NOT HAVE SUFFICIENT OXYGEN, DANGEROUS HEALTH CONDITIONS CAN QUICKLY OCCUR. DANGEROUS HEALTH CONDITIONS INCLUDE NAUSEA, UNCONSCIOUSNESS, AND CONVULSIONS. IF THE OXYGEN LEVEL OF THE AIR THAT YOU BREATHE IS VERY LOW, IT CAN KILL YOU.

(5) Open this access panel:

<u>Number</u>	<u>Name/Location</u>
531AB	Center Tank Access Door - Wing Station 168

H. Remove the Flame Arrestor

SUBTASK 47-21-07-030-001

- (1) Go into the left wheel well.
 - (a) Go to the flame arrestor [1] location.

NOTE: The flame arrestor [1] is on the rear spar.

SUBTASK 47-21-07-030-002

- (2) Disconnect the dielectric hose [6] from the flame arrestor [1].
 - (a) Put a protective cover on the dielectric hose [6].

SUBTASK 47-21-07-941-001

- (3) Go into the fuel tank (TASK 28-11-00-910-802).

CAUTION: MAKE SURE THAT YOU DO NOT PUSH OR PULL THE FQIS COMPONENTS IN THE FUEL TANK. DAMAGE TO FQIS COMPONENTS CAN EASILY OCCUR.

- (a) Go to the flame arrestor [1] location.

NOTE: The flame arrestor [1] is on the rear spar adjacent to the fuel boost pump.

SUBTASK 47-21-07-490-001

- (4) Disconnect the NEADS tube [5] from the flame arrestor [1].
 - (a) Put a protective cover on the NEADS tube [5].

SUBTASK 47-21-07-100-001

- (5) Do these steps to remove the flame arrestor [1]:
 - (a) Use the sealant removal tool, SPL-768, (sealant removal tool, COM-2481, or equivalent) to remove the sealant from the nut [3] in the center tank.
 - (b) Use the sealant removal tool, SPL-768, (sealant removal tool, COM-2481, or equivalent) to remove the sealant from the flame arrestor [1] in the wheel well.

NOTE: The sealant removal/application tools are shown in this task: Repair of Sealant Leaks in the Fuel Tank Structure, TASK 28-11-00-300-803.
 - (c) Disconnect the nut [3] and the washer [2] in the center tank.

NOTE: Use a second wrench on the flame arrestor [1] in the wheel well to stop it from turning

 - 1) Keep the nut [3] and the washer [2] for the installation.
 - (d) Remove the flame arrestor [1].
 - (e) Discard the o-ring [7].

EFFECTIVITY
HAP 047-053, 106-999

D633A101-HAP

47-21-07

Page 403
Oct 15/2008



737-600/700/800/900
AIRCRAFT MAINTENANCE MANUAL

SUBTASK 47-21-07-100-002

WARNING: DO NOT GET SOLVENTS IN YOUR MOUTH, YOUR EYES, OR ON YOUR SKIN. DO NOT BREATHE THE FUMES FROM SOLVENTS. SOLVENTS ARE DANGEROUS MATERIALS. SOLVENTS CAN BE FLAMMABLE. OBEY THE MATERIAL SAFETY DATA SHEETS (MSDS) FOR SOLVENTS. OBEY LOCAL REGULATIONS FOR THE CORRECT PROCEDURES TO USE OR DISCARD SOLVENTS. SOLVENTS CAN CAUSE INJURIES TO PERSONNEL AND DAMAGE TO EQUIPMENT.

- (6) Do these steps to remove the remaining sealant:
- (a) Use the sealant removal tool, SPL-768, (or equivalent) to remove the used sealant.
 - (b) Clean the surface with a clean brush, STD-133, a cotton wiper, G00034, and Series 93 solvent, B01013 (TASK 20-30-93-910-801).
 - (c) Rub the area with a clean, dry cotton wiper, G00034.

————— **END OF TASK** —————

EFFECTIVITY
HAP 047-053, 106-999

D633A101-HAP

47-21-07

Page 404
Oct 15/2008

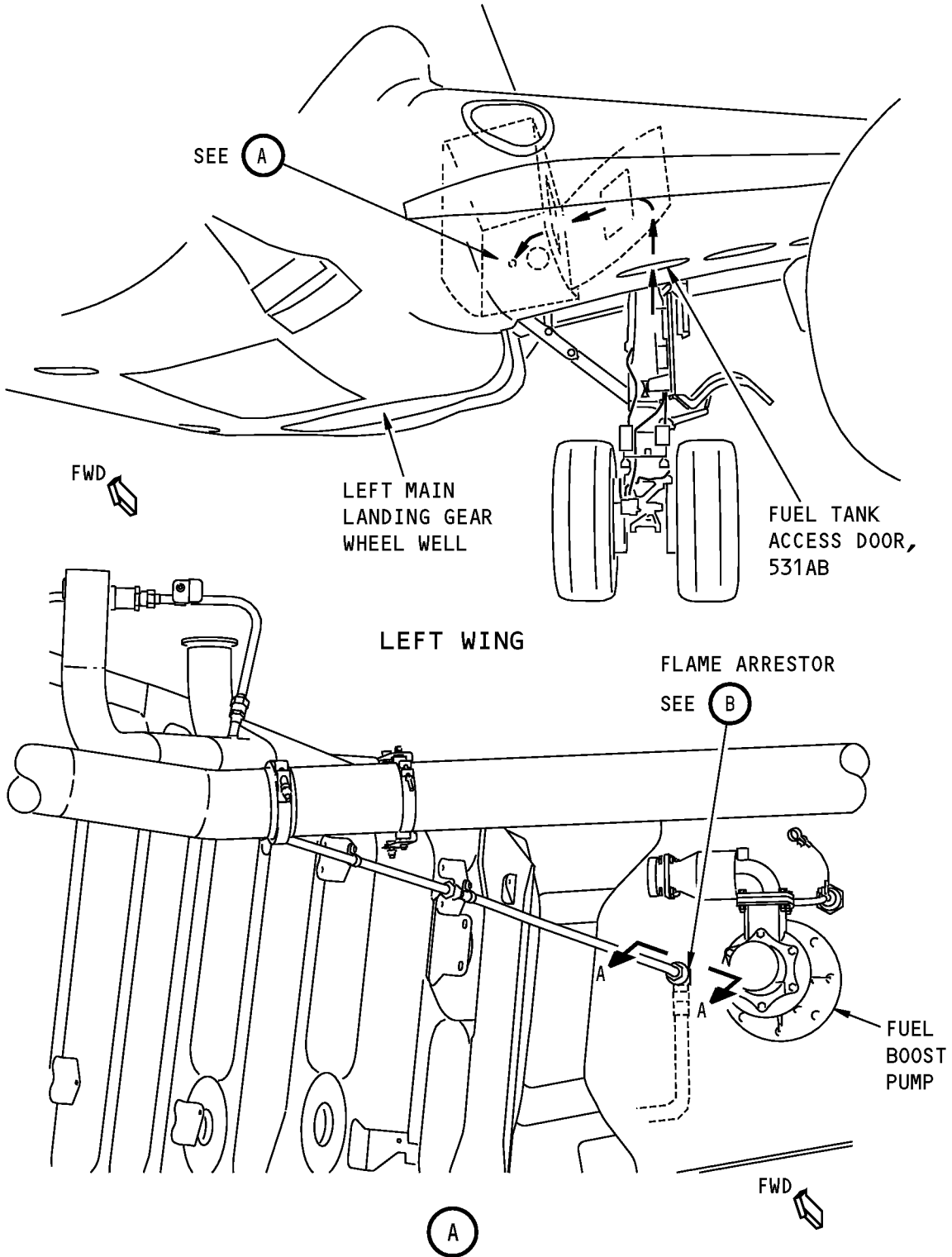

Flame Arrestor
Figure 401 (Sheet 1 of 2)/47-21-07-990-801

EFFECTIVITY
HAP 047-053, 106-999

47-21-07

Page 405
Oct 15/2008

D633A101-HAP

**737-600/700/800/900
AIRCRAFT MAINTENANCE MANUAL**

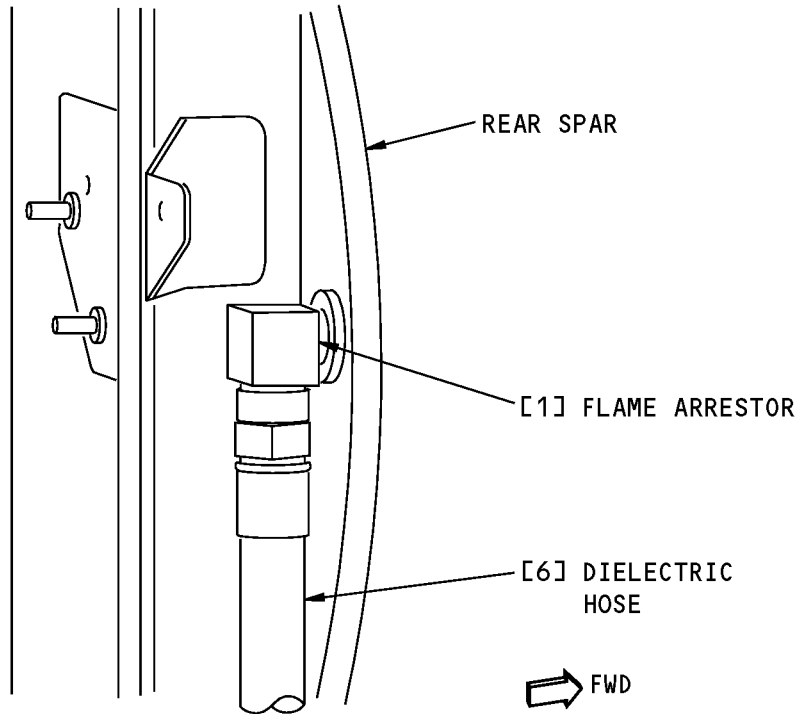
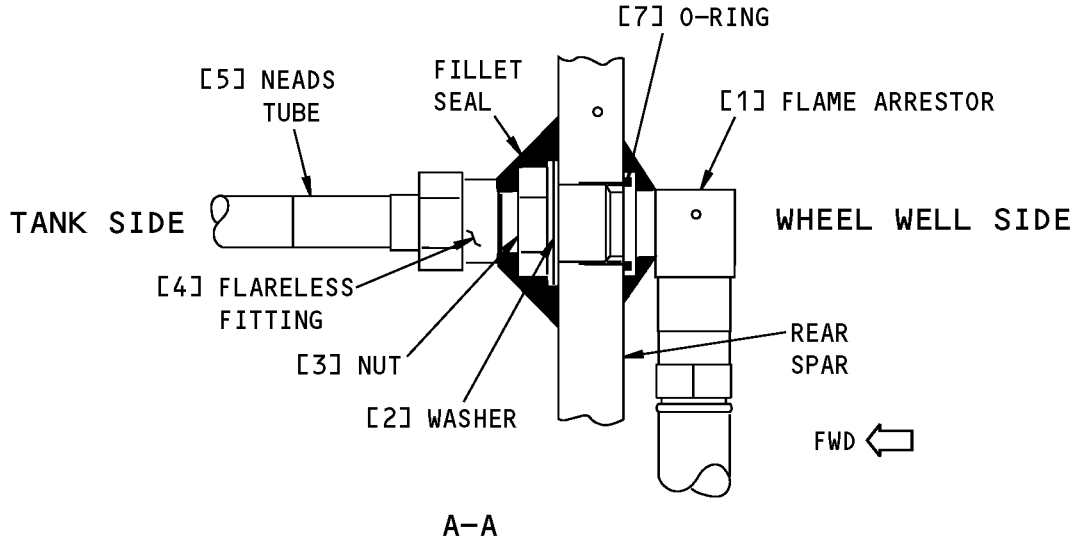

FLAME ARRESTOR

(B)

**Flame Arrestor
Figure 401 (Sheet 2 of 2)/47-21-07-990-801**

EFFECTIVITY
HAP 047-053, 106-999

47-21-07

Page 406
Oct 15/2008

D633A101-HAP



737-600/700/800/900

AIRCRAFT MAINTENANCE MANUAL

TASK 47-21-07-400-801

3. Flame Arrestor Installation

(Figure 401)

A. References

Reference	Title
28-11-00-910-802	Purging and Fuel Tank Entry (P/B 201)
28-11-31-400-801	Center Tank Access Door - Installation (P/B 401)
47-00-00-790-801	Leak Check of the Nitrogen Generation System (P/B 601)
47-00-00-910-802	Airworthiness Limitation Precautions (P/B 201)
SWPM 20-20-00	Electrical Bonds and Grounds

B. Tools/Equipment

NOTE: When more than one tool part number is listed under the same "Reference" number, the tools shown are alternates to each other within the same airplane series. Tool part numbers that are replaced or non-procurable are preceded by "Opt:", which stands for Optional.

Reference	Description
COM-1550	Meter - Bonding (Approved Explosion Proof & Intrinsically Safe) (Part #: C15292 (MODEL T477W), Supplier: 01014, A/P Effectivity: 737-ALL) (Part #: M1, Supplier: 3AD17, A/P Effectivity: 737-ALL) (Part #: M1B, Supplier: 3AD17, A/P Effectivity: 737-ALL)

C. Consumable Materials

Reference	Description	Specification
A00436	Sealant - Fuel Tank	BMS5-45 (Supersedes BMS 5-26)
D00649	Lubricant - O-Ring - Krytox GPL206	

D. Expendables/Parts

AMM Item	Description	AIPC Reference	AIPC Effectivity
1	Flame arrestor	47-21-51-01-075	HAP 047-053, 106-999
7	O-ring	47-21-51-01-065	HAP 047-053, 106-999

E. Location Zones

Zone	Area
133	Main Landing Gear Wheel Well, Body Station 663.75 to Body Station 727.00 - Left
212	Flight Compartment - Right
531	Left Wing - Center Fuel Tank, Rib 1 to Rib 5
551	Left Wing - Rear Spar To Landing Gear Support Beam

F. Access Panels

Number	Name/Location
531AB	Center Tank Access Door - Wing Station 168

EFFECTIVITY
HAP 047-053, 106-999

47-21-07

Page 407
Jun 15/2009

D633A101-HAP



737-600/700/800/900

AIRCRAFT MAINTENANCE MANUAL

G. Prepare for the Installation

SUBTASK 47-21-07-010-003

- (1) Go to the flame arrestor [1] location.

NOTE: One person must be in the center tank location (TASK 28-11-00-910-802). One person must be in the left wheel well.

SUBTASK 47-21-07-090-001

- (2) Remove the protective cover from the NEADS tube [5] in the center tank.

SUBTASK 47-21-07-090-002

- (3) Remove the protective cover from the dielectric hose [6] in the wheel well.

SUBTASK 47-21-07-100-003

- (4) Make sure that the NEADS tube [5], flame arrestor [1], nut [3], and washer [2] are clean, free from grease and unwanted material.

SUBTASK 47-21-07-765-001

- (5) Prepare these components for an electrical mating surface bond (SWPM 20-20-00):
 - (a) flame arrestor [1]
 - (b) rear spar of the center tank where the flame arrestor [1] will attach
 - (c) washer [2]
 - (d) nut [3]

H. Install the Flame Arrestor

SUBTASK 47-21-07-430-001

- (1) Do these steps to install the o-ring [7] in the flame arrestor [1]:
 - (a) Put a thin layer of Krytox GPL206 lubricant, D00649, on a new new o-ring [7].
 - (b) Put the new o-ring [7] in the cavity on the flame arrestor [1].

SUBTASK 47-21-07-420-001

- (2) Install the flame arrestor [1]:
 - (a) Put the flame arrestor [1] in its position on the rear spar in the left wheel well.
 - (b) Put the washer [2] and the nut [3] on the flame arrestor [1] in the center tank.
 - (c) Make sure the flame arrestor [1] correctly aligns.
 - (d) Tighten the nut [3] to 280 ± 28 in-lb (32 ± 4 N-m).

NOTE: Use a second wrench to make sure the flame arrestor [1] does not turn.

SUBTASK 47-21-07-430-002

- (3) Do these steps to connect the flame arrestor [1] to the NEA distribution system:
 - (a) Connect the NEADS tube [5] in the center tank to the flame arrestor [1].
 - (b) Tighten the nut [3] on the flareless fitting [4].

SUBTASK 47-21-07-430-003

- (4) From outside of the center tank, connect the dielectric hose [6] to the flame arrestor [1].
 - (a) Tighten the nut on the dielectric hose [6].

NOTE: Use a second wrench to hold the dielectric hose [6] to make sure that it does not twist.

EFFECTIVITY
HAP 047-053, 106-999

D633A101-HAP

47-21-07

Page 408
Oct 15/2008



737-600/700/800/900

AIRCRAFT MAINTENANCE MANUAL

SUBTASK 47-21-07-430-004

- (5) Apply sealant, A00436, to the inside and outside surface of the rear spar around the perimeter of the flame arrestor [1].

NOTE: CDCCL - Refer to the task: Airworthiness Limitation Precautions, TASK 47-00-00-910-802, for important information on Critical Design Configuration Control Limitations (CDCCLs).

SUBTASK 47-21-07-760-001

- (6) Use a bonding meter, COM-1550, to measure the resistance between the structure inside the tank and the first tube that mates with the flame arrestor (SWPM 20-20-00).

NOTE: CDCCL - Refer to the task: Airworthiness Limitation Precautions, TASK 47-00-00-910-802, for important information on Critical Design Configuration Control Limitations (CDCCLs).

- (a) Make sure that the resistance is 0.01 ohm (10 milliohms) or less.

NOTE: CDCCL - Refer to the task: Airworthiness Limitation Precautions, TASK 47-00-00-910-802, for important information on Critical Design Configuration Control Limitations (CDCCLs).

SUBTASK 47-21-07-765-002

- (7) Use a bonding meter, COM-1550, to measure the resistance between the flame arrestor [1] and the nearest primary structure (SWPM 20-20-00).

NOTE: CDCCL - Refer to the task: Airworthiness Limitation Precautions, TASK 47-00-00-910-802, for important information on Critical Design Configuration Control Limitations (CDCCLs).

- (a) Make sure that the resistance is 0.0005 ohm (0.5 milliohm) or less.

NOTE: CDCCL - Refer to the task: Airworthiness Limitation Precautions, TASK 47-00-00-910-802, for important information on Critical Design Configuration Control Limitations (CDCCLs).

I. Operational Test for the Flame Arrestor

SUBTASK 47-21-07-865-001

- (1) Do these steps to prepare for the operational test:
 - (a) Remove the safety tags and close these circuit breakers:

CAPT Electrical System Panel, P18-3

<u>Row</u>	<u>Col</u>	<u>Number</u>	<u>Name</u>
D	17	C01657	NITROGEN GENERATION CONTROL
E	15	C01680	NGS ALT PWR

- (b) Remove the DO-NOT-OPERATE tags from the L PACK and the R PACK selector switches.
- (c) Put the L PACK and R PACK selector switches in the AUTO position.

SUBTASK 47-21-07-790-001

- (2) Do this task: Leak Check of the Nitrogen Generation System, TASK 47-00-00-790-801.
 - (a) Repair the leaks that you find.

J. Put the Airplane Back to the Usual Condition

SUBTASK 47-21-07-410-001

- (1) Do this task: Center Tank Access Door - Installation, TASK 28-11-31-400-801.

EFFECTIVITY
HAP 047-053, 106-999

47-21-07



737-600/700/800/900

AIRCRAFT MAINTENANCE MANUAL

- (a) Close this access panel:

<u>Number</u>	<u>Name/Location</u>
531AB	Center Tank Access Door - Wing Station 168

SUBTASK 47-21-07-860-004

- (2) Remove the DO-NOT-OPERATE tags from the L PACK and the R PACK selector switches.

- (a) Put the L PACK and R PACK selector switches in the AUTO position.

————— **END OF TASK** —————

EFFECTIVITY
HAP 047-053, 106-999

D633A101-HAP

47-21-07

Page 410
Oct 15/2008



737-600/700/800/900

AIRCRAFT MAINTENANCE MANUAL

LIGHTNING SHIELDS - REMOVAL/INSTALLATION

1. General

A. This procedure has these tasks:

- (1) Upper Lightning Shield Removal
- (2) Upper Lightning Shield Installation
- (3) Lower Lightning Shield Removal
- (4) Lower Lightning Shield Installation

B. The two lightning shields are installed on the rear spar in the left wheel well. They give lightning protection for the Nitrogen Enriched Air Distribution System (NEADS) line.

TASK 47-21-08-000-801

2. Upper Lightning Shield Removal

(Figure 401)

A. References

Reference	Title
47-00-00-010-801	Nitrogen Generation System (NGS) Precautions (P/B 201)

B. Location Zones

Zone	Area
133	Main Landing Gear Wheel Well, Body Station 663.75 to Body Station 727.00 - Left
551	Left Wing - Rear Spar To Landing Gear Support Beam

C. Prepare for the Removal

SUBTASK 47-21-08-860-002

WARNING: DO NOT TOUCH THE COMPONENTS OF THE NITROGEN GENERATION SYSTEM WHEN THEY ARE HOT. WHEN THE COMPONENTS ARE HOT, THEY CAN CAUSE INJURIES TO PERSONNEL.

WARNING: DO NOT DISCONNECT THE COMPONENTS OF THE NITROGEN GENERATION SYSTEM, OR DUCTS WHEN THE SYSTEM IS PRESSURIZED. THE HOT, HIGH-PRESSURE AIR CAN CAUSE INJURIES TO PERSONNEL, AND DAMAGE TO EQUIPMENT.

- (1) Obey the Nitrogen Generation System (NGS) precautions (TASK 47-00-00-010-801).

D. Remove the Upper Lightning Shield

SUBTASK 47-21-08-030-003

- (1) Go into the left wheel well.
 - (a) Go to the upper lightning shield [1] location.

NOTE: The upper lightning shield [1] is on the rear spar, above the flame arrestor.

SUBTASK 47-21-08-030-004

CAUTION: DO NOT CAUSE DAMAGE TO THE RIVET HOLES WHEN YOU REMOVE THE RIVETS. DO NOT MAKE DIAMETER OF THE RIVET HOLES MORE THAN 0.143 IN. (3.363 MM). IF THE RIVET HOLE IS TOO LARGE, YOU CANNOT INSTALL THE RIVET CORRECTLY. THIS CAN CAUSE DAMAGE TO THE ENGINE.

- (2) Do these steps to remove the upper lightning shield [1].

EFFECTIVITY HAP 047-053, 106-999

47-21-08

Page 401
Oct 15/2008

D633A101-HAP



737-600/700/800/900

AIRCRAFT MAINTENANCE MANUAL

- (a) Remove the two rivets [2] that attach the upper lightning shield [1] to the vertical support.

NOTE: Keep the fasteners for installation.

- (b) Remove the cap screw [3] that attaches the upper lightning shield [1] to the wire bundle.

NOTE: Keep the fasteners for installation.

————— **END OF TASK** —————

EFFECTIVITY
HAP 047-053, 106-999

D633A101-HAP

47-21-08

Page 402
Oct 15/2008

**737-600/700/800/900
AIRCRAFT MAINTENANCE MANUAL**

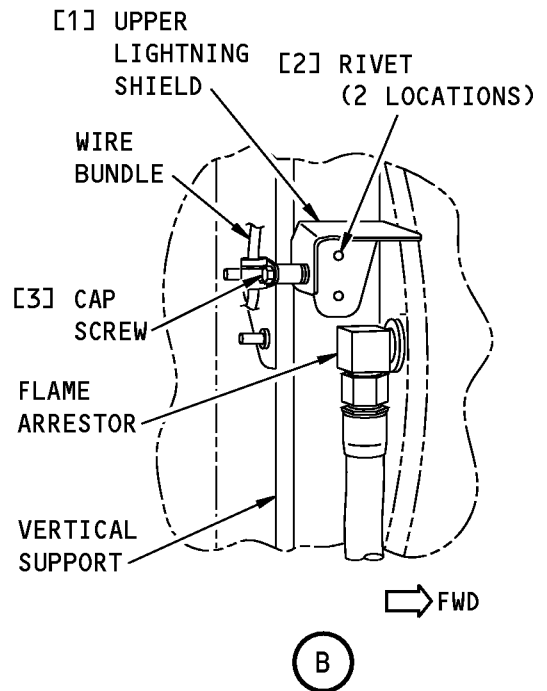
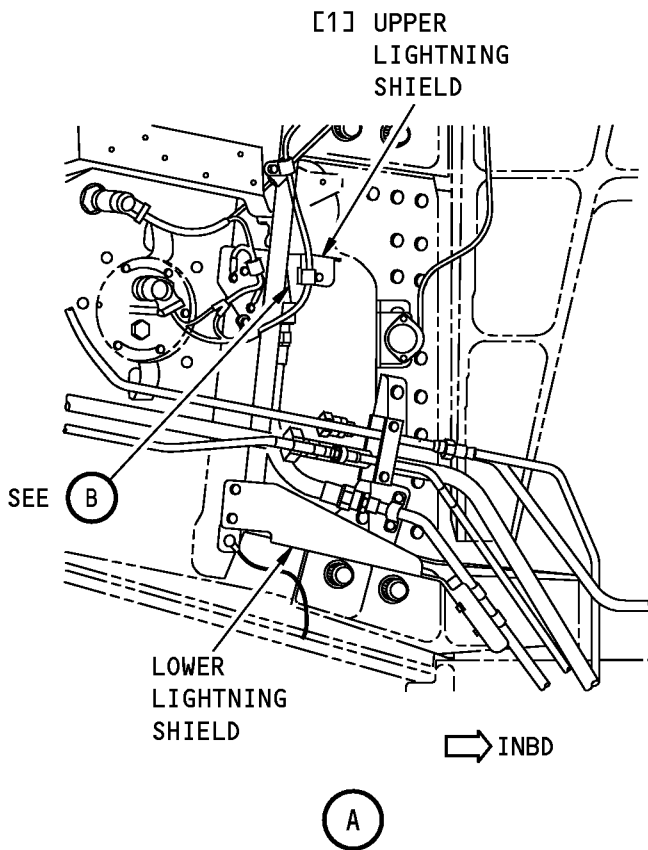
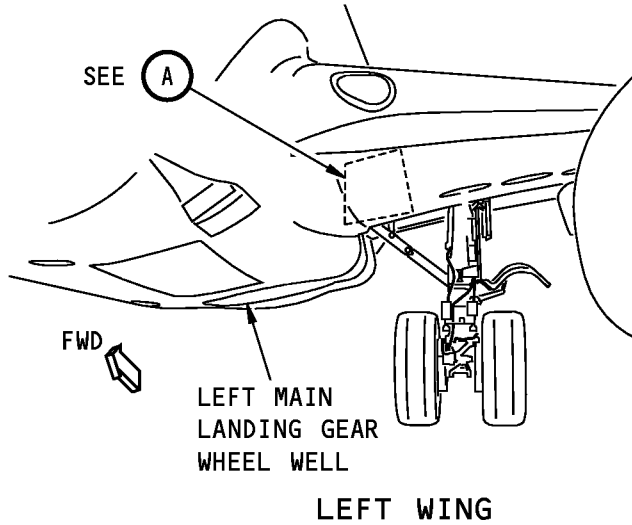

1539975 S0000280494_V1

**Upper Lightning Shield
Figure 401/47-21-08-990-801**

EFFECTIVITY
HAP 047-053, 106-999

47-21-08

Page 403
Oct 15/2008

D633A101-HAP



737-600/700/800/900

AIRCRAFT MAINTENANCE MANUAL

TASK 47-21-08-400-801

3. Upper Lightning Shield Installation

(Figure 401)

A. References

Reference	Title
20-30-80-910-801	General Cleaning of Metal (Series 80) (P/B 201)
47-00-00-910-802	Airworthiness Limitation Precautions (P/B 201)
SWPM 20-20-00	Electrical Bonds and Grounds

B. Tools/Equipment

NOTE: When more than one tool part number is listed under the same "Reference" number, the tools shown are alternates to each other within the same airplane series. Tool part numbers that are replaced or non-procurable are preceded by "Opt:", which stands for Optional.

Reference	Description
COM-1550	Meter - Bonding (Approved Explosion Proof & Intrinsically Safe) (Part #: C15292 (MODEL T477W), Supplier: 01014, A/P Effectivity: 737-ALL) (Part #: M1, Supplier: 3AD17, A/P Effectivity: 737-ALL) (Part #: M1B, Supplier: 3AD17, A/P Effectivity: 737-ALL)

C. Location Zones

Zone	Area
134	Main Landing Gear Wheel Well, Body Station 663.75 to Body Station 727.00 - Right
551	Left Wing - Rear Spar To Landing Gear Support Beam

D. Prepare for Installation

SUBTASK 47-21-08-010-004

- (1) Go into the left wheel well.
 - (a) Go to the upper lightning shield [1] location.

NOTE: The upper lightning shield [1] is on the rear spar, above the flame arrestor.

E. Install the Upper Lightning Shield

SUBTASK 47-21-08-110-003

- (1) To clean the components, do this task: General Cleaning of Metal (Series 80), TASK 20-30-80-910-801.

SUBTASK 47-21-08-110-004

- (2) Prepare these components for an electrical faying surface bond (SWPM 20-20-00):

NOTE: CDCCL - Refer to the task: Airworthiness Limitation Precautions, TASK 47-00-00-910-802, for important information on Critical Design Configuration Control Limitations (CDCCLs).

- (a) Mating surfaces of the vertical support and the upper lightning shield [1].

NOTE: CDCCL - Refer to the task: Airworthiness Limitation Precautions, TASK 47-00-00-910-802, for important information on Critical Design Configuration Control Limitations (CDCCLs).

EFFECTIVITY
HAP 047-053, 106-999

47-21-08

Page 404
Jun 15/2009

D633A101-HAP



737-600/700/800/900

AIRCRAFT MAINTENANCE MANUAL

- (b) Mating surfaces of the spar web and the vertical support (if the vertical support was removed).

NOTE: CDCCL - Refer to the task: Airworthiness Limitation Precautions, TASK 47-00-00-910-802, for important information on Critical Design Configuration Control Limitations (CDCCLs).

SUBTASK 47-21-08-430-002

- (3) Do these steps to install the upper lightning shield [1].
 - (a) Install two rivets [2] that attach the upper lightning shield [1] to the vertical support.
 - (b) Install cap screw [3] that attaches the upper lightning shield [1] to the wire bundle.

SUBTASK 47-21-08-765-002

- (4) Use the bonding meter, COM-1550, to measure the resistance between the upper lightning shield [1] and the rear spar (SWPM 20-20-00).

NOTE: CDCCL - Refer to the task: Airworthiness Limitation Precautions, TASK 47-00-00-910-802, for important information on Critical Design Configuration Control Limitations (CDCCLs).

- (a) Make sure that the resistance is 0.0010 ohm (1.0 milliohm) or less.

NOTE: CDCCL - Refer to the task: Airworthiness Limitation Precautions, TASK 47-00-00-910-802, for important information on Critical Design Configuration Control Limitations (CDCCLs).

————— **END OF TASK** —————

TASK 47-21-08-000-802

4. Lower Lightning Shield Removal

(Figure 402)

A. References

Reference	Title
47-00-00-010-801	Nitrogen Generation System (NGS) Precautions (P/B 201)

B. Location Zones

Zone	Area
133	Main Landing Gear Wheel Well, Body Station 663.75 to Body Station 727.00 - Left
551	Left Wing - Rear Spar To Landing Gear Support Beam

C. Prepare for the Removal

SUBTASK 47-21-08-860-001

WARNING: DO NOT TOUCH THE COMPONENTS OF THE NITROGEN GENERATION SYSTEM WHEN THEY ARE HOT. WHEN THE COMPONENTS ARE HOT, THEY CAN CAUSE INJURIES TO PERSONNEL.

WARNING: DO NOT DISCONNECT THE COMPONENTS OF THE NITROGEN GENERATION SYSTEM, OR DUCTS WHEN THE SYSTEM IS PRESSURIZED. THE HOT, HIGH-PRESSURE AIR CAN CAUSE INJURIES TO PERSONNEL, AND DAMAGE TO EQUIPMENT.

- (1) Obey the Nitrogen Generation System (NGS) precautions (TASK 47-00-00-010-801).

EFFECTIVITY
HAP 047-053, 106-999

47-21-08

Page 405
Oct 15/2008

D633A101-HAP



737-600/700/800/900

AIRCRAFT MAINTENANCE MANUAL

D. Remove the Lower Lightning Shield

SUBTASK 47-21-08-030-001

(1) Go into the left wheel well.

(a) Go to the lower lightning shield [5] location.

NOTE: The lower lightning shield [5] is on the rear spar.

SUBTASK 47-21-08-030-002

(2) Do these steps to remove the lower lightning shield [5].

(a) Remove two cap screws [6], four washers [7], and two nuts [8] that attach the lower lightning shield [5] to the electrical bracket.

NOTE: Keep the fasteners for installation.

(b) Remove the screw [9], two washers [7], and nut [8] that attach the lower lightning shield [5] to the hydraulic bracket.

NOTE: Keep the fasteners for installation.

(c) Remove two cap screws [12], four washers [7], two spacers [10], and two nuts [8] from the two clamps [11] that attach the lower lightning shield [5] to the NEADS tube [13].

NOTE: Keep the fasteners for installation.

————— **END OF TASK** —————

EFFECTIVITY
HAP 047-053, 106-999

D633A101-HAP

BOEING PROPRIETARY - Copyright © Unpublished Work - See title page for details

47-21-08

Page 406
Oct 15/2008

**737-600/700/800/900
AIRCRAFT MAINTENANCE MANUAL**

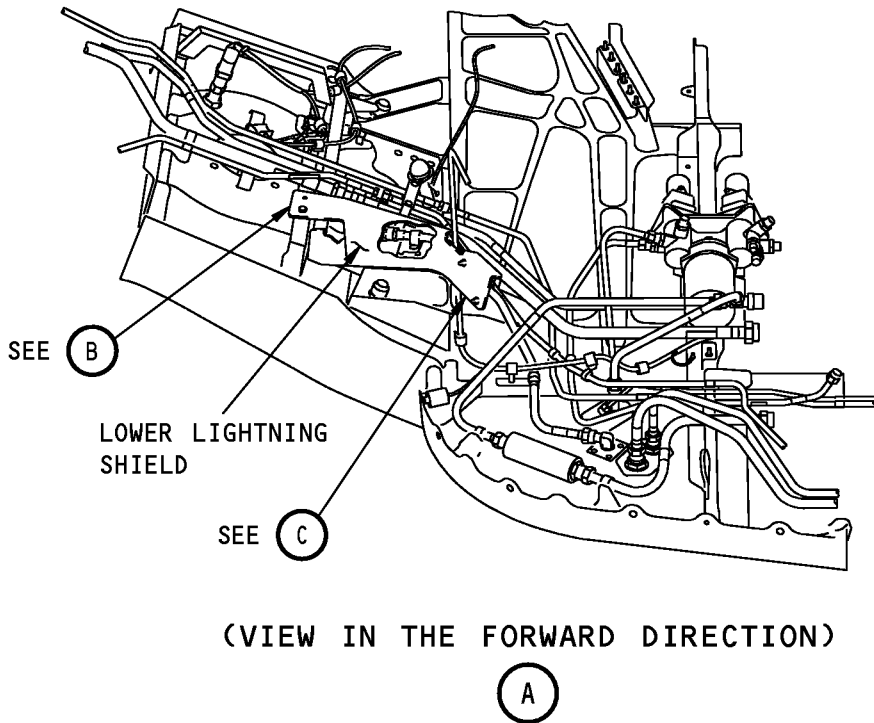
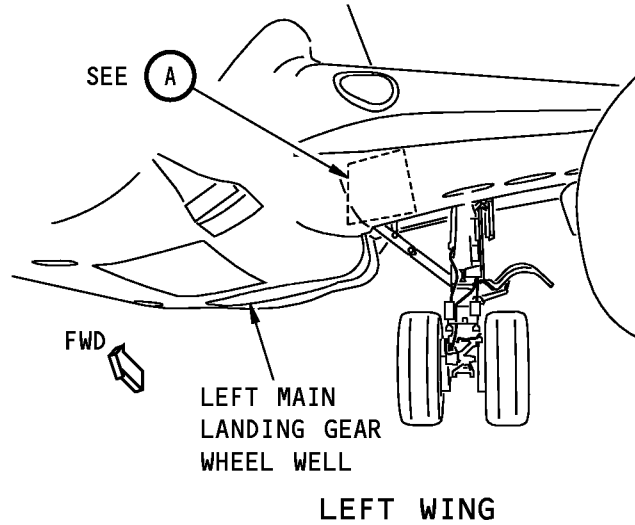

⇨ INBD

1532372 S0000280027_V1

**Lower Lightning Shield
Figure 402 (Sheet 1 of 2)/47-21-08-990-802**

EFFECTIVITY
HAP 047-053, 106-999

D633A101-HAP

BOEING PROPRIETARY - Copyright © Unpublished Work - See title page for details

47-21-08

Page 407
Oct 15/2008

AIRCRAFT MAINTENANCE MANUAL

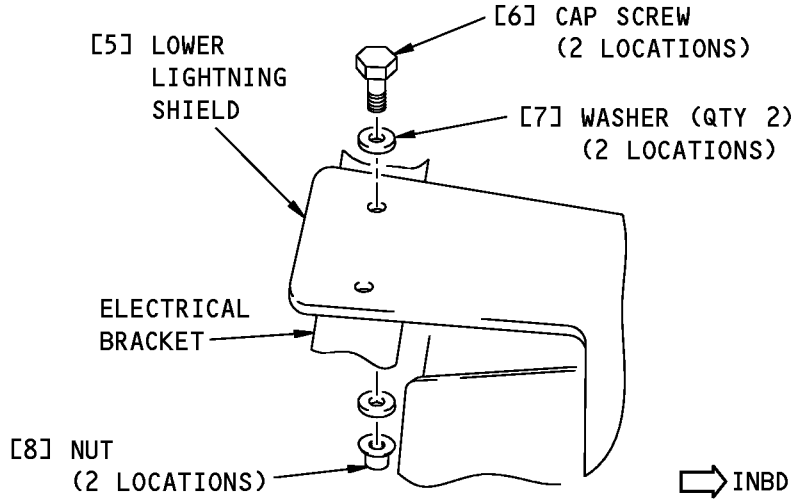

(VIEW IN THE FORWARD DIRECTION)

(B)

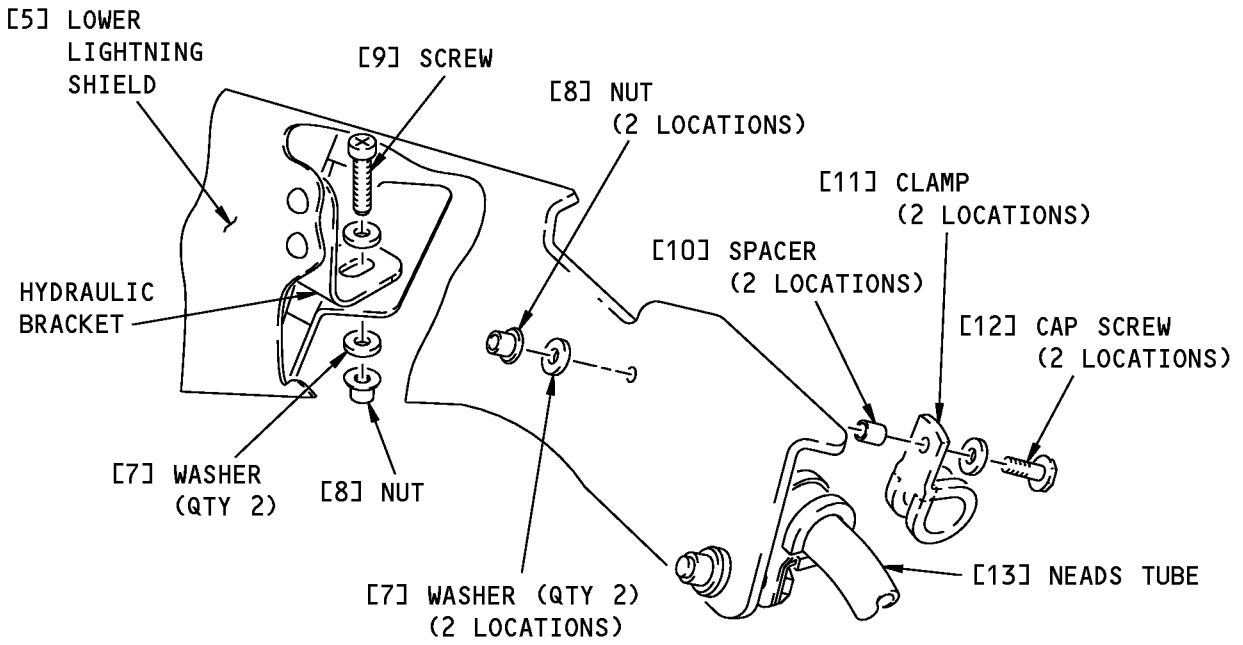

(VIEW IN THE FORWARD DIRECTION)

(C)

1538510 S0000280028_V1

Lower Lightning Shield
Figure 402 (Sheet 2 of 2)/47-21-08-990-802

EFFECTIVITY
HAP 047-053, 106-999

D633A101-HAP

47-21-08

Page 408
Oct 15/2008



737-600/700/800/900

AIRCRAFT MAINTENANCE MANUAL

TASK 47-21-08-400-802

5. Lower Lightning Shield Installation

(Figure 402)

A. References

Reference	Title
20-30-80-910-801	General Cleaning of Metal (Series 80) (P/B 201)
47-00-00-910-802	Airworthiness Limitation Precautions (P/B 201)
SWPM 20-20-00	Electrical Bonds and Grounds

B. Tools/Equipment

NOTE: When more than one tool part number is listed under the same "Reference" number, the tools shown are alternates to each other within the same airplane series. Tool part numbers that are replaced or non-procurable are preceded by "Opt:", which stands for Optional.

Reference	Description
COM-1550	Meter - Bonding (Approved Explosion Proof & Intrinsically Safe) (Part #: C15292 (MODEL T477W), Supplier: 01014, A/P Effectivity: 737-ALL) (Part #: M1, Supplier: 3AD17, A/P Effectivity: 737-ALL) (Part #: M1B, Supplier: 3AD17, A/P Effectivity: 737-ALL)

C. Location Zones

Zone	Area
134	Main Landing Gear Wheel Well, Body Station 663.75 to Body Station 727.00 - Right
551	Left Wing - Rear Spar To Landing Gear Support Beam

D. Prepare for installation

SUBTASK 47-21-08-010-003

- (1) Go into the left wheel well.
 - (a) Go to the lower lightning shield [5] location.

NOTE: The lower lightning shield [5] is on the rear spar.

E. Install the Lower Lightning Shield

SUBTASK 47-21-08-100-001

- (1) Remove the used sealant from the electrical bracket.

SUBTASK 47-21-08-110-002

- (2) To clean the components, do this task: General Cleaning of Metal (Series 80), TASK 20-30-80-910-801.

SUBTASK 47-21-08-110-001

- (3) Prepare these components for an electrical faying surface bond (SWPM 20-20-00):

NOTE: CDCCL - Refer to the task: Airworthiness Limitation Precautions, TASK 47-00-00-910-802, for important information on Critical Design Configuration Control Limitations (CDCCLs).

- (a) Mating surfaces of the electrical bracket and the lower lightning shield [5].

NOTE: CDCCL - Refer to the task: Airworthiness Limitation Precautions, TASK 47-00-00-910-802, for important information on Critical Design Configuration Control Limitations (CDCCLs).

EFFECTIVITY HAP 047-053, 106-999

47-21-08



737-600/700/800/900

AIRCRAFT MAINTENANCE MANUAL

- (b) Mating surfaces of the hydraulic bracket and the lower lightning shield [5].

NOTE: CDCCL - Refer to the task: Airworthiness Limitation Precautions, TASK 47-00-00-910-802, for important information on Critical Design Configuration Control Limitations (CDCCLs).

- (c) Mating surfaces of the stiffener and the electrical bracket (if the electrical bracket was removed).

NOTE: CDCCL - Refer to the task: Airworthiness Limitation Precautions, TASK 47-00-00-910-802, for important information on Critical Design Configuration Control Limitations (CDCCLs).

- (d) Mating surfaces of the stiffener and the hydraulic bracket (if the hydraulic bracket was removed).

NOTE: CDCCL - Refer to the task: Airworthiness Limitation Precautions, TASK 47-00-00-910-802, for important information on Critical Design Configuration Control Limitations (CDCCLs).

- (e) Mating surfaces of the spar web and the stiffener (if the stiffener was removed).

NOTE: CDCCL - Refer to the task: Airworthiness Limitation Precautions, TASK 47-00-00-910-802, for important information on Critical Design Configuration Control Limitations (CDCCLs).

SUBTASK 47-21-08-430-001

- (4) Do these steps to install the lower lightning shield [5].

- (a) Install four washers [7], two cap screws [6], and two nuts [8] that attach the lower lightning shield [5] to the electrical bracket.
- (b) Install the two washers [7], screw [9], and nut [8] that attach the lower lightning shield [5] to the hydraulic bracket.
- (c) Install two spacers [10], four washers [7], two cap screws [12], and nuts [8] to the clamps [11] that attach the lower lightning shield [5] to the NEADS tube [13].

SUBTASK 47-21-08-765-001

- (5) Use the bonding meter, COM-1550, to measure the resistance between the lower lightning shield [5] and the rear spar (SWPM 20-20-00).

NOTE: CDCCL - Refer to the task: Airworthiness Limitation Precautions, TASK 47-00-00-910-802, for important information on Critical Design Configuration Control Limitations (CDCCLs).

- (a) Make sure that the resistance is 0.0015 ohm (1.5 milliohms) or less.

NOTE: CDCCL - Refer to the task: Airworthiness Limitation Precautions, TASK 47-00-00-910-802, for important information on Critical Design Configuration Control Limitations (CDCCLs).

————— END OF TASK —————

EFFECTIVITY
HAP 047-053, 106-999

D633A101-HAP

47-21-08

Page 410
Oct 15/2008



737-600/700/800/900

AIRCRAFT MAINTENANCE MANUAL

DRAIN CAP - REMOVAL/INSTALLATION

1. General

A. This procedure has these tasks:

- (1) Drain Cap Removal
- (2) Drain Cap Installation

B. The drain cap is installed below the air separation module (ASM) inside the 192BL ECS bay door.

TASK 47-21-11-000-801

2. Drain Cap Removal

A. References

Reference	Title
36-00-00-860-806	Remove Pressure from the Pneumatic System (P/B 201)
47-00-00-010-801	Nitrogen Generation System (NGS) Precautions (P/B 201)

B. Access Panels

Number	Name/Location
192CL	Air Conditioning Access Door

C. Prepare for Removal

SUBTASK 47-21-11-922-001

WARNING: DO NOT TOUCH THE COMPONENTS OF THE NITROGEN GENERATION SYSTEM WHEN THEY ARE HOT. WHEN THE COMPONENTS ARE HOT, THEY CAN CAUSE INJURIES TO PERSONNEL.

WARNING: DO NOT DISCONNECT THE COMPONENTS OF THE NITROGEN GENERATION SYSTEM, OR DUCTS WHEN THE SYSTEM IS PRESSURIZED. THE HOT, HIGH-PRESSURE AIR CAN CAUSE INJURIES TO PERSONNEL, AND DAMAGE TO EQUIPMENT.

CAUTION: MAKE SURE THAT THE MAINTENANCE AREA IS FREE OF CONTAMINATION FROM SKYDROL, LUBRICANTS, SOLVENTS, FUEL, FUMES, EXHAUST, OR DUST. DO NOT LET SOLVENTS, LUBRICANTS, OTHER FLUIDS, OR THEIR FUMES GO INTO THE FLOW PATH TO OR FROM THE ASM. CONTAMINATION WILL CAUSE DAMAGE TO THE FIBERS IN THE ASM AND DECREASE THEIR LIFE.

- (1) Obey the Nitrogen Generation System (NGS) precautions (TASK 47-00-00-010-801).

SUBTASK 47-21-11-864-001

- (2) Do this task: Remove Pressure from the Pneumatic System, TASK 36-00-00-860-806.
 - (a) Make sure that the dual duct pressure gage shows 0.50 psig (3.45 kPa) or less in the L and R ducts.

SUBTASK 47-21-11-860-001

- (3) Put the L PACK and R PACK selector switches, found on the P5-10 air conditioning panel, to the OFF position.
 - (a) Put DO-NOT-OPERATE tags on the L PACK and R PACK selector switches.

EFFECTIVITY HAP 047-053, 106-999

47-21-11



**737-600/700/800/900
AIRCRAFT MAINTENANCE MANUAL**

SUBTASK 47-21-11-865-001

(4) Open these circuit breakers and install safety tags:

CAPT Electrical System Panel, P18-3

<u>Row</u>	<u>Col</u>	<u>Number</u>	<u>Name</u>
D	17	C01657	NITROGEN GENERATION CONTROL
E	15	C01680	NGS ALT PWR

SUBTASK 47-21-11-010-001

WARNING: OBEY THE SUBSEQUENT STEPS FOR ACCESS PANELS IDENTIFIED WITH A NITROGEN GENERATION SYSTEM PLACARD. IF THERE IS A LEAK IN THE NITROGEN GENERATION SYSTEM, IT WILL DECREASE THE OXYGEN IN THE AIR THAT YOU BREATHE. IF YOU BREATHE AIR THAT DOES NOT HAVE SUFFICIENT OXYGEN, DANGEROUS HEALTH CONDITIONS CAN QUICKLY OCCUR.

(5) Open this access panel:

<u>Number</u>	<u>Name/Location</u>
192CL	Air Conditioning Access Door

SUBTASK 47-21-11-010-002

(6) Go to the drain cap location.

NOTE: The drain cap is found below the ASM.

D. Remove the Drain Cap

SUBTASK 47-21-11-020-001

(1) Remove the drain cap from the tee.

————— **END OF TASK** —————

TASK 47-21-11-400-801

3. Drain Cap Installation

A. References

<u>Reference</u>	<u>Title</u>
47-00-00-790-801	Leak Check of the Nitrogen Generation System (P/B 601)

B. Location Zones

<u>Zone</u>	<u>Area</u>
131	Center Section Wing Box, Body Station 540.00 to Body Station 663.75 - Left

C. Access Panels

<u>Number</u>	<u>Name/Location</u>
192BL	ECS Ram Air Inlet Mixing Duct Panel - Forward
192CL	Air Conditioning Access Door

D. Install the Drain Cap

SUBTASK 47-21-11-410-001

(1) Go to the drain cap location in the left ECS bay.

<p>EFFECTIVITY</p> <p>HAP 047-053, 106-999</p>
--

47-21-11



**737-600/700/800/900
AIRCRAFT MAINTENANCE MANUAL**

SUBTASK 47-21-11-090-001

- (2) Remove the protective cover from the drain cap.

SUBTASK 47-21-11-430-001

- (3) Connect the drain cap to the tee.
(a) Tighten the drain cap to the tee.

E. Operational Test of the Drain Valve

SUBTASK 47-21-11-865-002

- (1) Remove the safety tags and close these circuit breakers:

CAPT Electrical System Panel, P18-3

<u>Row</u>	<u>Col</u>	<u>Number</u>	<u>Name</u>
D	17	C01657	NITROGEN GENERATION CONTROL
E	15	C01680	NGS ALT PWR

SUBTASK 47-21-11-860-002

- (2) Remove the DO-NOT-OPERATE tags from the L PACK and R PACK selector switches.
(a) Put the L PACK and R PACK selector switches in the AUTO position.

SUBTASK 47-21-11-211-001

- (3) Do this task: Leak Check of the Nitrogen Generation System, TASK 47-00-00-790-801.

F. Put the Airplane Back to Its Usual Condition

SUBTASK 47-21-11-410-002

- (1) Close these access panels:

<u>Number</u>	<u>Name/Location</u>
192BL	ECS Ram Air Inlet Mixing Duct Panel - Forward
192CL	Air Conditioning Access Door

————— **END OF TASK** —————

EFFECTIVITY
HAP 047-053, 106-999

47-21-11



737-600/700/800/900

AIRCRAFT MAINTENANCE MANUAL

NITROGEN GENERATION SYSTEM CONTROLLER - REMOVAL/INSTALLATION

1. General

A. This procedure has these tasks:

- (1) Nitrogen Generation System Controller Removal
- (2) Nitrogen Generation System Controller Installation

TASK 47-31-01-000-801

2. Nitrogen Generation System Controller Removal

(Figure 401)

A. References

Reference	Title
25-52-17-000-801	Forward Cargo Compartment Aft Bulkhead Liner Removal (P/B 401)

B. Location Zones

Zone	Area
122	Forward Cargo Compartment - Right
125	Air Conditioning Distribution Bay - Left
126	Air Conditioning Distribution Bay - Right
212	Flight Compartment - Right

C. Access Panels

Number	Name/Location
821	Forward Cargo Door

D. Prepare for the Removal

SUBTASK 47-31-01-865-001

(1) Open these circuit breakers and install safety tags:

CAPT Electrical System Panel, P18-3

Row	Col	Number	Name
D	17	C01657	NITROGEN GENERATION CONTROL
E	15	C01680	NGS ALT PWR

SUBTASK 47-31-01-010-003

(2) Open this access panel:

Number	Name/Location
821	Forward Cargo Door

SUBTASK 47-31-01-860-001

(3) Make sure that the L PACK and R PACK switches, on the P5-10 air conditioning panel, are in the OFF position.

SUBTASK 47-31-01-010-004

(4) Remove the aft center bulkhead liner in the forward cargo compartment (TASK 25-52-17-000-801).

E. Remove the Controller

SUBTASK 47-31-01-020-001

(1) Do these steps to remove the controller [1]:

EFFECTIVITY HAP 047-053, 106-999

47-31-01

Page 401
Oct 15/2008

D633A101-HAP



737-600/700/800/900

AIRCRAFT MAINTENANCE MANUAL

- (a) Disconnect the two electrical connectors [3] from the controller [1].
 - 1) Move the electrical connectors [3] out of the way.

NOTE: The two electrical connectors [3] have ground wires attached to them. These are for electrical bonding. Use caution to not damage the ground wires or their connections to the airplane structure.

- (b) Remove the four bolts [6] and washers [7].
- (c) Lift the end of the drip shield [2].
- (d) Pull the controller [1] away from the brackets [5] to remove it.

NOTE: The bonding jumpers [9] will stay with the controller [1]. Make sure you do not damage them when you remove the controller [1].

————— **END OF TASK** —————

EFFECTIVITY
HAP 047-053, 106-999

D633A101-HAP

47-31-01

Page 402
Oct 15/2008

AIRCRAFT MAINTENANCE MANUAL

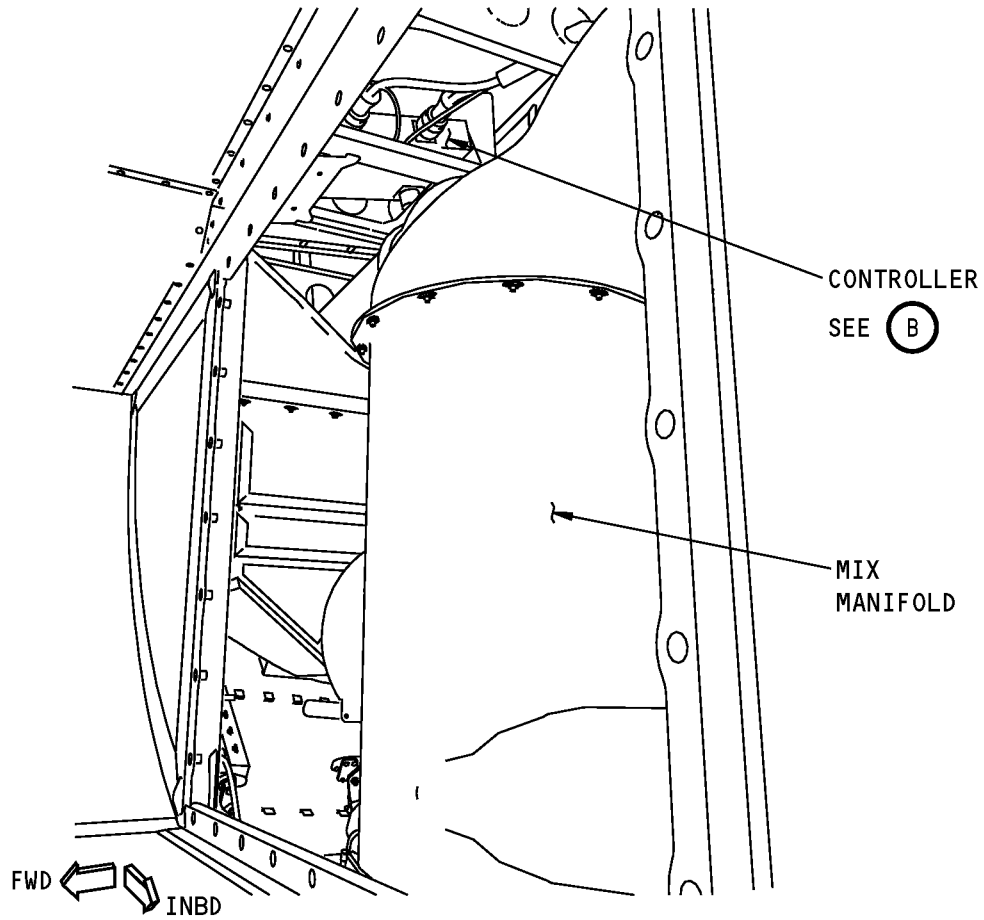
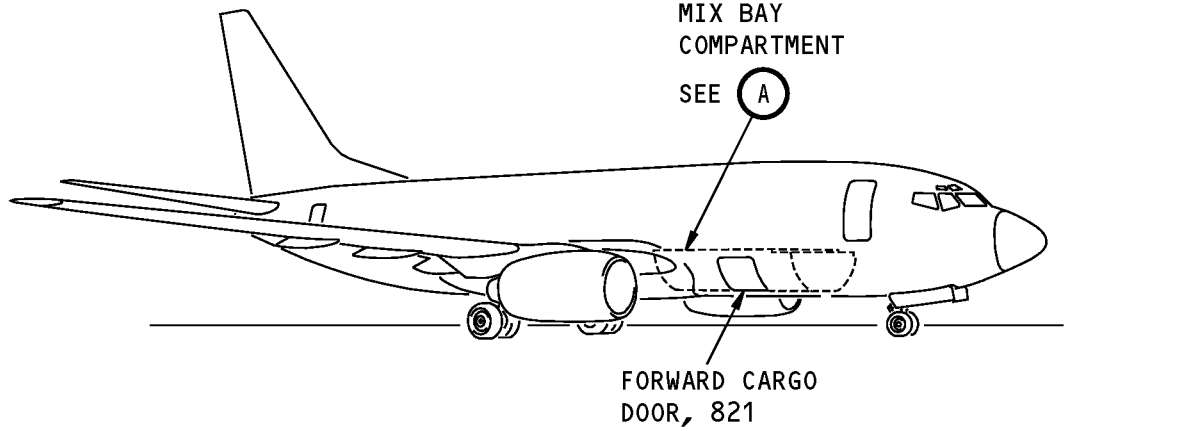

**MIX BAY COMPARTMENT
(CENTER VERTICAL ACCESS LINING REMOVED)**

(A)

**NGS Controller
Figure 401 (Sheet 1 of 2)/47-31-01-990-801**

EFFECTIVITY
HAP 047-053, 106-999

47-31-01

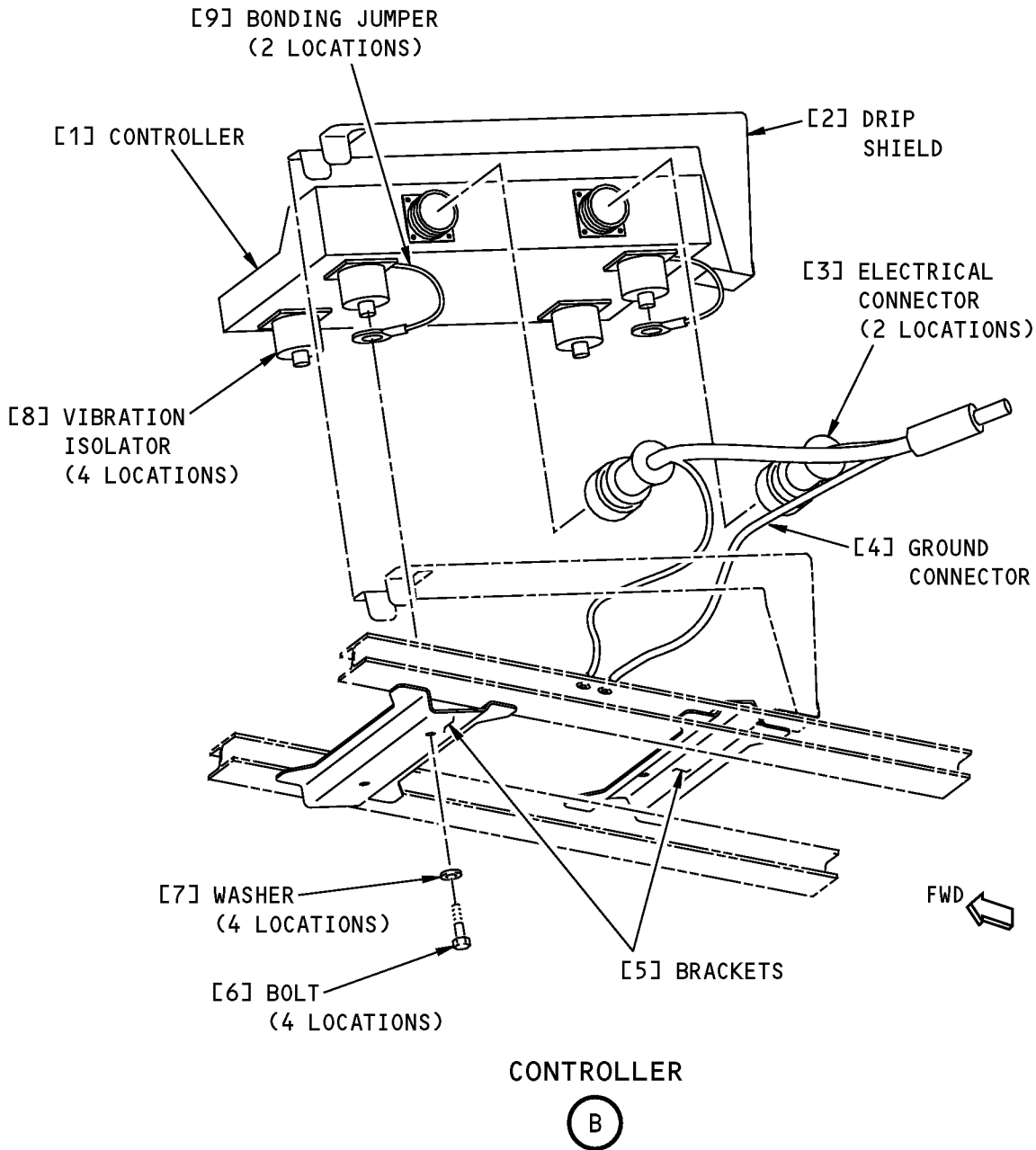

NGS Controller
Figure 401 (Sheet 2 of 2)/47-31-01-990-801

EFFECTIVITY
HAP 047-053, 106-999

D633A101-HAP



737-600/700/800/900

AIRCRAFT MAINTENANCE MANUAL

TASK 47-31-01-400-801

3. Nitrogen Generation System Controller Installation

(Figure 401)

A. References

Reference	Title
25-52-17-400-801	Forward Cargo Compartment Aft Bulkhead Liner Installation (P/B 401)
47-00-00-800-801	Ground Operation of the Nitrogen Generation System (P/B 201)
SWPM 20-20-00	Electrical Bonds and Grounds

B. Consumable Materials

Reference	Description	Specification
A50006	Compound - Sealing, Thread-Locking, Anaerobic, Single-Component (100-200 In-Lbs)	MIL-S-46163, Type II, Grade M

C. Expendables/Parts

AMM Item	Description	AIPC Reference	AIPC Effectivity
1	Controller	47-31-01-01-030	HAP 047-053, 106-999

D. Location Zones

Zone	Area
121	Forward Cargo Compartment - Left
122	Forward Cargo Compartment - Right
125	Air Conditioning Distribution Bay - Left
126	Air Conditioning Distribution Bay - Right
212	Flight Compartment - Right

E. Access Panels

Number	Name/Location
821	Forward Cargo Door

F. Prepare for the Installation

SUBTASK 47-31-01-100-001

- (1) Remove the sealant from the four bolts [6] and the threaded vibration isolators [8] on the brackets [5].

SUBTASK 47-31-01-110-001

- (2) Prepare these components for an electrical faying surface bond (SWPM 20-20-00):
 - (a) contact surface on the brackets [5].
 - (b) contact surface of the vibration isolators [8].
 - (c) contact surface of the bonding jumpers [9].

G. Install the Controller

SUBTASK 47-31-01-390-001

- (1) Apply compound, A50006 to the four bolts [6] and the threaded cavity on the four vibration isolators [8].

SUBTASK 47-31-01-420-003

- (2) Put and hold the controller [1] in its position.

EFFECTIVITY HAP 047-053, 106-999

47-31-01



737-600/700/800/900

AIRCRAFT MAINTENANCE MANUAL

SUBTASK 47-31-01-430-001

- (3) Install the four bolts [6], bonding jumpers [9], and the washers [7] to attach the controller [1] to the brackets [5].

SUBTASK 47-31-01-430-002

- (4) Tighten the four bolts [6] to 13 ± 1 in-lb (1.47 ± 0.11 N·m).

NOTE: Use a second (1/2 inch open-ended) wrench to hold the vibration isolator [8] stem.

SUBTASK 47-31-01-430-003

- (5) If the ground wires were disconnected from the airplane structure during removal, attach the ground wires to the airplane structure.

H. Operational Test for the Controller

SUBTASK 47-31-01-865-002

- (1) Remove the safety tags and close these circuit breakers:

CAPT Electrical System Panel, P18-3

Table with 4 columns: Row, Col, Number, Name. Rows include D 17 C01657 NITROGEN GENERATION CONTROL and E 15 C01680 NGS ALT PWR.

SUBTASK 47-31-01-710-001

- (2) To test the controller, do this task: Ground Operation of the Nitrogen Generation System, TASK 47-00-00-800-801.

I. Put the Airplane Back to the Usual Condition

SUBTASK 47-31-01-410-001

- (1) Do this task: Forward Cargo Compartment Aft Bulkhead Liner Installation, TASK 25-52-17-400-801.

SUBTASK 47-31-01-410-002

- (2) Close this access panel:

Table with 2 columns: Number, Name/Location. Row: 821 Forward Cargo Door

END OF TASK

EFFECTIVITY HAP 047-053, 106-999

47-31-01



737-600/700/800/900

AIRCRAFT MAINTENANCE MANUAL

BITE DISPLAY UNIT - MAINTENANCE PRACTICES

1. General

A. This procedure has these tasks:

- (1) BDU Main Menu
- (2) BDU Existing Fault Menu
- (3) BDU Fault History Menu
- (4) BDU Ground Test Menu
- (5) Other Function Menu

TASK 47-31-02-740-801

2. BDU Main Menu

(BDU Main Menu/Figure 201)

A. General

- (1) This task gives the instructions to operate the main menu for the BDU control panel.
- (2) To help you navigate through the NGS BDU menu structure, refer to BDU Main Menu/Figure 201.
- (3) The NGS BDU control panel has a two line message display and six push button controls. Use the message display and applicable push buttons to navigate through the BDU menu structure. The BDU structure map gives an overview of the available menu item lists and their relationship to other menu items.

B. References

Reference	Title
32-09-00-860-802	Return the Airplane to the Ground Mode (P/B 201)
47-00-00-010-801	Nitrogen Generation System (NGS) Precautions (P/B 201)

C. Location Zones

Zone	Area
131	Center Section Wing Box, Body Station 540.00 to Body Station 663.75 - Left

D. Access Panels

Number	Name/Location
192CR	Air Conditioning Access Door
621GB	Refuel Access Panel - Slat Station 143.27

E. Prepare to Use the BDU

SUBTASK 47-31-02-010-004

WARNING: OBEY THE SUBSEQUENT STEPS FOR ACCESS PANELS IDENTIFIED WITH A NITROGEN GENERATION SYSTEM PLACARD. IF THERE IS A LEAK IN THE NITROGEN GENERATION SYSTEM, IT WILL DECREASE THE OXYGEN IN THE AIR THAT YOU BREATHE. IF YOU BREATHE AIR THAT DOES NOT HAVE SUFFICIENT OXYGEN, DANGEROUS HEALTH CONDITIONS CAN QUICKLY OCCUR.

- (1) Obey the precautions in this task: Nitrogen Generation System (NGS) Precautions, TASK 47-00-00-010-801.

EFFECTIVITY
HAP 047-053, 106-999

47-31-02

Page 201
Oct 15/2008

D633A101-HAP



**737-600/700/800/900
AIRCRAFT MAINTENANCE MANUAL**

SUBTASK 47-31-02-010-005

(2) Make sure this access panel is closed:

<u>Number</u>	<u>Name/Location</u>
621GB	Refuel Access Panel - Slat Station 143.27

SUBTASK 47-31-02-860-002

(3) Make sure that the airplane is in the ground mode (TASK 32-09-00-860-802).

SUBTASK 47-31-02-865-003

(4) Make sure that these circuit breakers are closed:

CAPT Electrical System Panel, P18-3

<u>Row</u>	<u>Col</u>	<u>Number</u>	<u>Name</u>
D	17	C01657	NITROGEN GENERATION CONTROL
E	15	C01680	NGS ALT PWR

SUBTASK 47-31-02-010-006

(5) Open this access panel:

<u>Number</u>	<u>Name/Location</u>
192CR	Air Conditioning Access Door

SUBTASK 47-31-02-010-007

(6) Go to the NGS BDU location.

NOTE: The BDU is in the right air conditioning compartment on the right 41 beam, aft of the forward bulkhead.

F. Standby Mode

SUBTASK 47-31-02-740-002

(1) The BDU is in the standby mode during these conditions:

- (a) NGS controller cold start (approximately 5 minutes)
- (b) No BDU input for 5 minutes.

NOTE: The BDU will not go into the standby mode if a BDU test is in progress.

SUBTASK 47-31-02-740-003

(2) When the BDU is in the standby mode, the message display will not show.

SUBTASK 47-31-02-740-004

(3) Push the ON/OFF button on the control panel to start the operation of the BDU.

SUBTASK 47-31-02-740-005

(4) The main menu item, "Existing Faults?" will show.

SUBTASK 47-31-02-740-006

(5) If the BDU is inhibited, these display messages will show:

- (a) In Air

NOTE: The airplane is in the air mode.

- (b) Switch Inactive

NOTE: You pushed a control button that is not on.

<p>EFFECTIVITY HAP 047-053, 106-999</p>

47-31-02

Page 202
Oct 15/2008

D633A101-HAP



737-600/700/800/900

AIRCRAFT MAINTENANCE MANUAL

(6) Inhibited: CMCS Active

NOTE: The CMCS Active mode is active.

G. Power Off Mode

SUBTASK 47-31-02-740-007

(1) Push the ON/OFF button again to stop the BDU.

NOTE: This puts the BDU in standby.

SUBTASK 47-31-02-740-008

(2) When you push the ON/OFF button, TURN OFF DISPLAY? will show.

NOTE: When you push the ON/OFF button, you stop the display. The BDU will not stop when DISPLAY TEST? shows during a BDU initiated test.

(a) If you push the YES button, the BDU will go to standby, and show no text.

(b) If you push the NO button, the BDU will go to the previous mode.

H. Main Menu Items

SUBTASK 47-31-02-740-009

(1) These are the main menu items:

(a) Existing Faults?

(b) Fault History?

(c) Ground Tests?

(d) Other Functions?

SUBTASK 47-31-02-740-010

(2) Push these buttons to move through the main menu:

(a) up arrow

(b) down arrow

(c) NO

SUBTASK 47-31-02-740-011

(3) You can find more data about the main menu in these tasks:

(a) BDU Existing Fault Menu, TASK 47-31-02-740-802

(b) BDU Fault History Menu, TASK 47-31-02-740-803

(c) BDU Ground Test Menu, TASK 47-31-02-740-804

(d) Other Function Menu, TASK 47-31-02-740-805

SUBTASK 47-31-02-740-012

(4) After you do the necessary maintenance tasks, go to the subsequent procedure.

I. Put the Airplane Back to the Usual Condition

SUBTASK 47-31-02-740-013

(1) Make sure that all the BDU initiated tests are done.

SUBTASK 47-31-02-740-014

(2) Push the ON/OFF button.

EFFECTIVITY
HAP 047-053, 106-999

D633A101-HAP

47-31-02

Page 203
Oct 15/2008



**737-600/700/800/900
AIRCRAFT MAINTENANCE MANUAL**

SUBTASK 47-31-02-410-002

(3) Close this access panel:

<u>Number</u>	<u>Name/Location</u>
192CR	Air Conditioning Access Door

————— **END OF TASK** —————

EFFECTIVITY
HAP 047-053, 106-999

D633A101-HAP

47-31-02

Page 204
Oct 15/2008

**737-600/700/800/900
AIRCRAFT MAINTENANCE MANUAL**

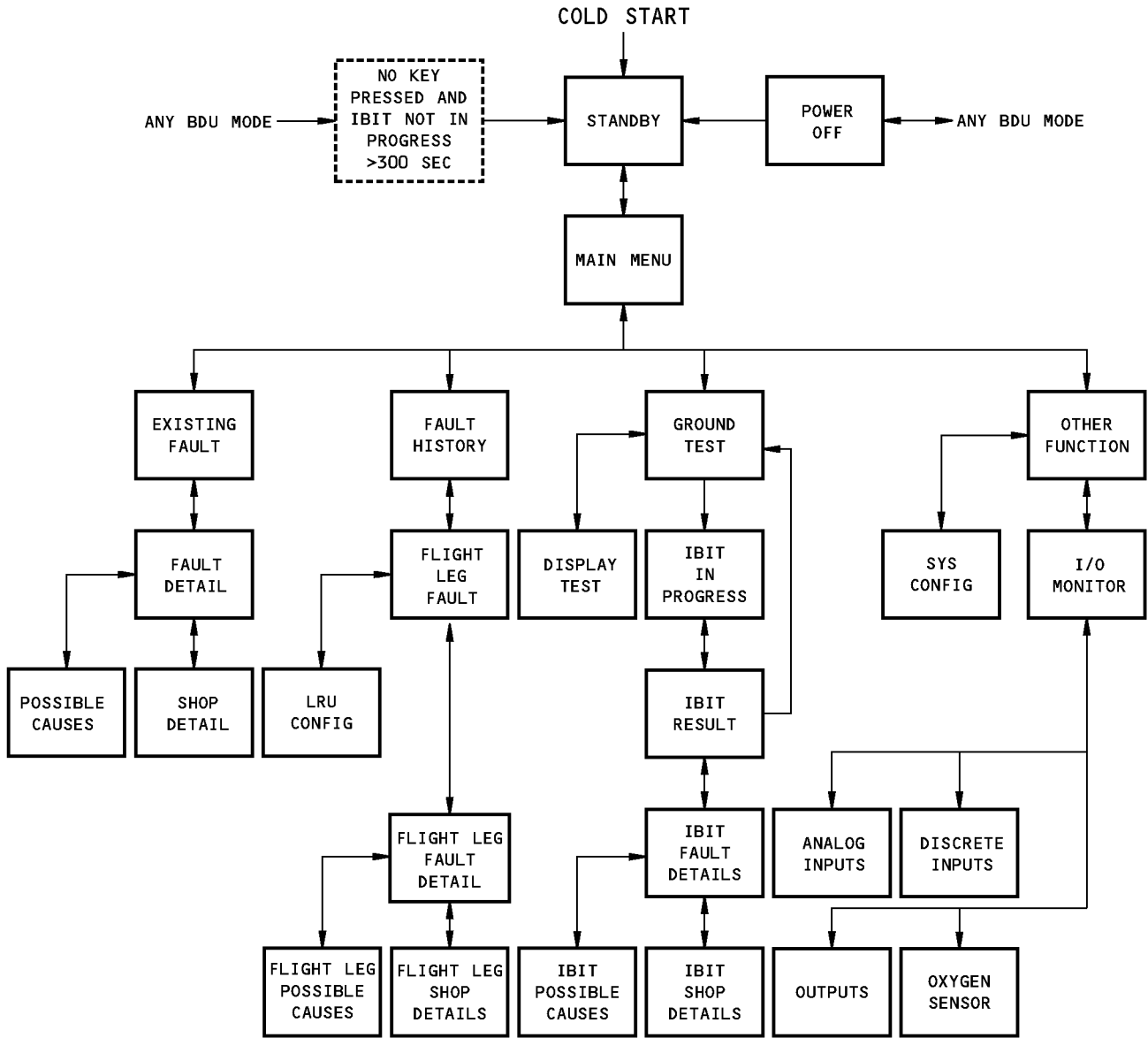

BDU STRUCTURE MAP

1500583 S0000273105_V1

**BDU Main Menu
Figure 201 (Sheet 1 of 4)/47-31-02-990-802**

EFFECTIVITY
HAP 047-053, 106-999

47-31-02

Page 205
Oct 15/2008

D633A101-HAP

**737-600/700/800/900
AIRCRAFT MAINTENANCE MANUAL**

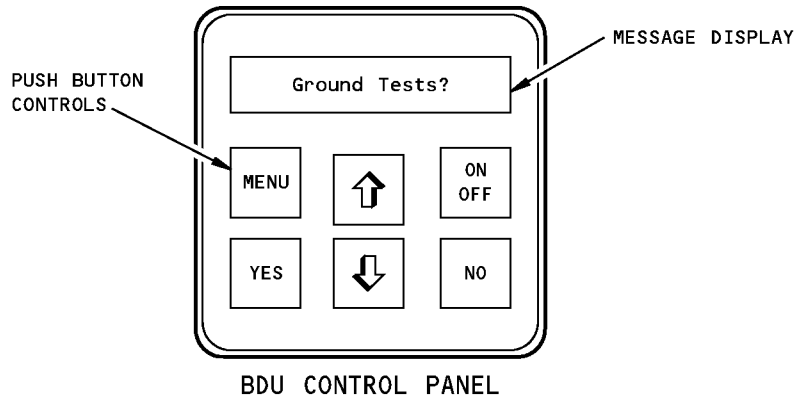

LEGEND:



PRESS THE ON/OFF PUSH BUTTON TO START AND STOP THE BITE DISPLAY. THE ON/OFF BUTTON CAN ALSO BE USED TO IMMEDIATELY STOP THE BDU GROUND TESTS.



PRESS THE MENU PUSH BUTTON TO NAVIGATE THROUGH THE BDU MENUS (REF THE BDU MENU DISPLAY MAP). WHEN YOU PRESS THE MENU BUTTON THE BDU WILL DISPLAY THE PREVIOUS MENU. THE MENU BUTTON IS ALSO USED TO IMMEDIATELY STOP THE BDU GROUND TESTS.



PRESS THE YES PUSH BUTTON TO REPLY TO THE MESSAGE DISPLAY QUESTION (?). THE YES BUTTON IS ALSO USED TO START THE BDU GROUND TEST.



PRESS THE NO PUSH BUTTON TO REPLY TO THE MESSAGE DISPLAY QUESTION (?).



PRESS THE DOWN ARROW TO SCROLL DOWNWARD THROUGH THE LIST OF ITEMS AVAILABLE FOR A SPECIFIC MENU. FOR EXISTING FAULTS, THE FIRST ITEM ON THE LIST IS THE MOST RECENT FAULT. PUSH THE DOWN ARROW AGAIN TO SHOW THE SECOND MOST RECENT FAULT.



PRESS THE UP ARROW TO SCROLL UPWARD THROUGH THE LIST OF ITEMS AVAILABLE FOR A SPECIFIC MENU.

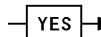

THE PUSH BUTTON CONTROL AND ARROW SHOW THE RESPONSE TO AN EVENT, SUCH AS WHAT HAPPENS WHEN YOU PRESS THE YES BUTTON.

J85771 S0000180481_V2

**BDU Main Menu
Figure 201 (Sheet 2 of 4)/47-31-02-990-802**

EFFECTIVITY
HAP 047-053, 106-999

D633A101-HAP

47-31-02

Page 206
Oct 15/2008

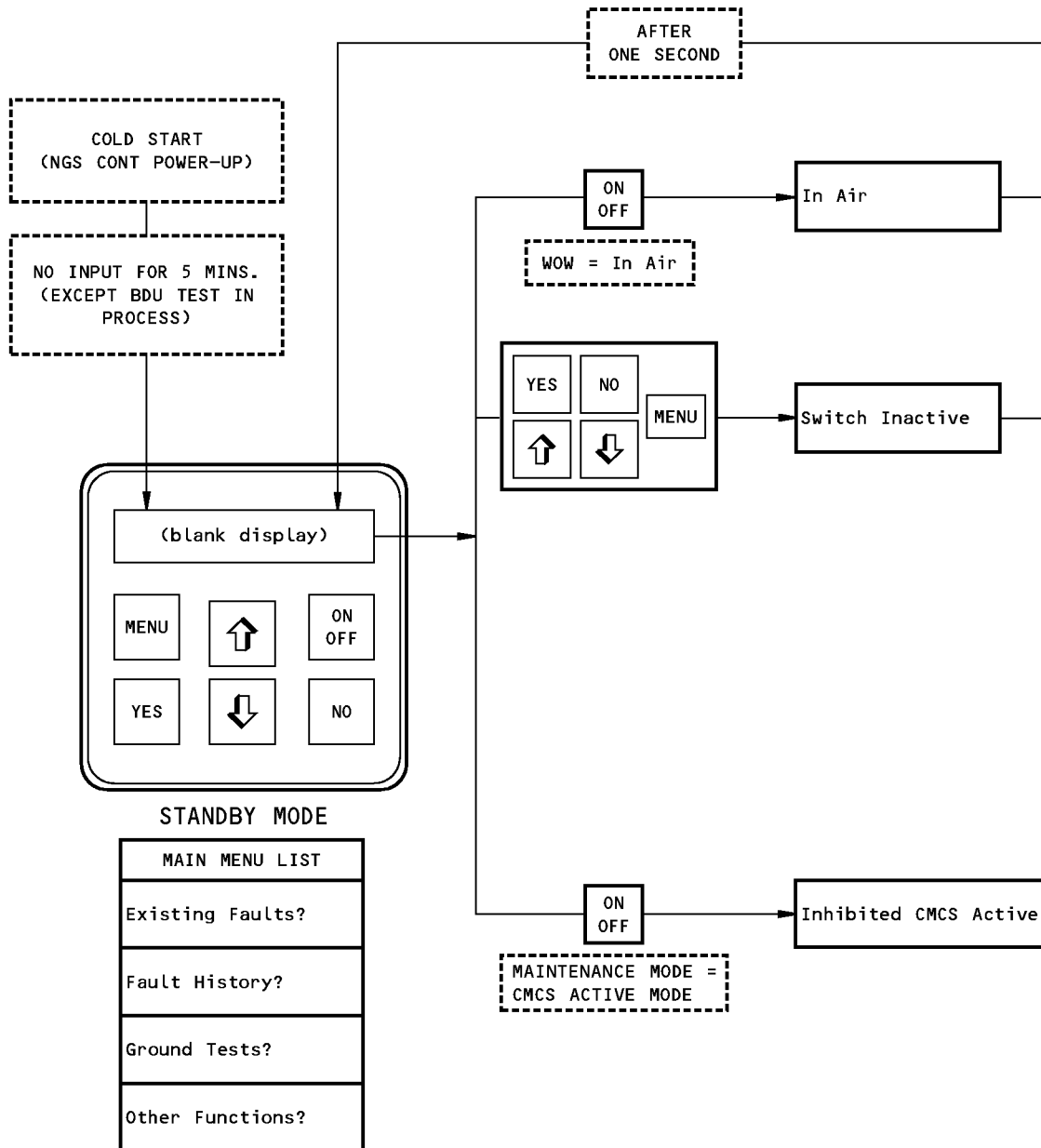

1500580 S0000273106_V1

BDU Main Menu
Figure 201 (Sheet 3 of 4)/47-31-02-990-802

EFFECTIVITY
HAP 047-053, 106-999

47-31-02

Page 207
Oct 15/2008

D633A101-HAP

**737-600/700/800/900
AIRCRAFT MAINTENANCE MANUAL**

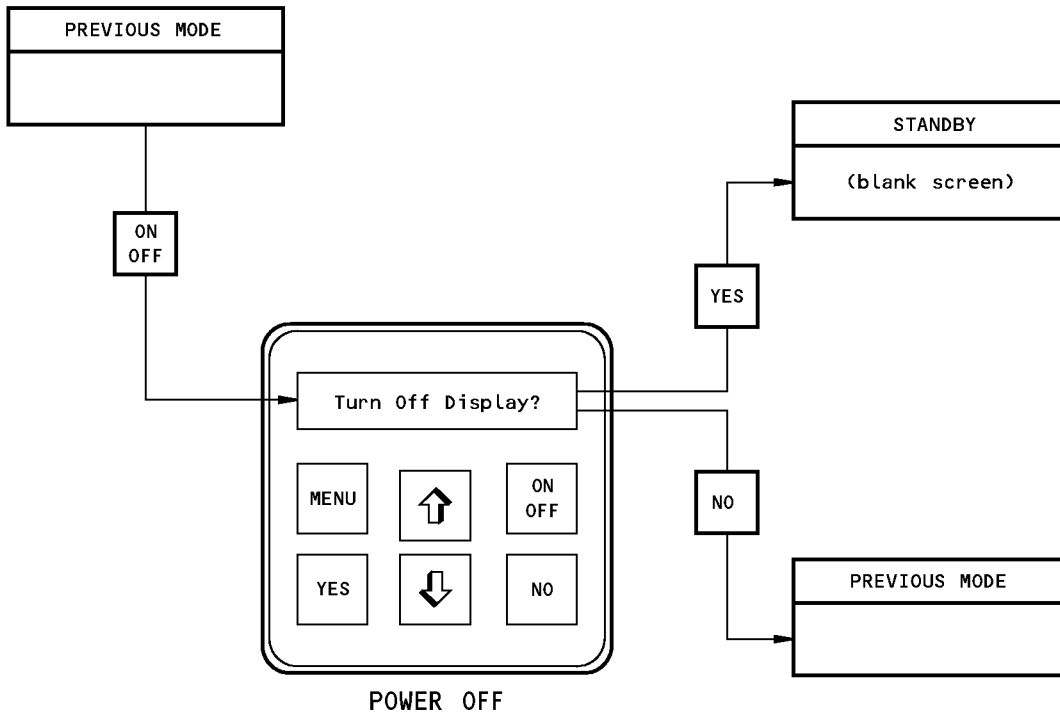

When the ON/OFF button is pressed in any mode, the display goes to Power OFF Mode (except for Display Test.)

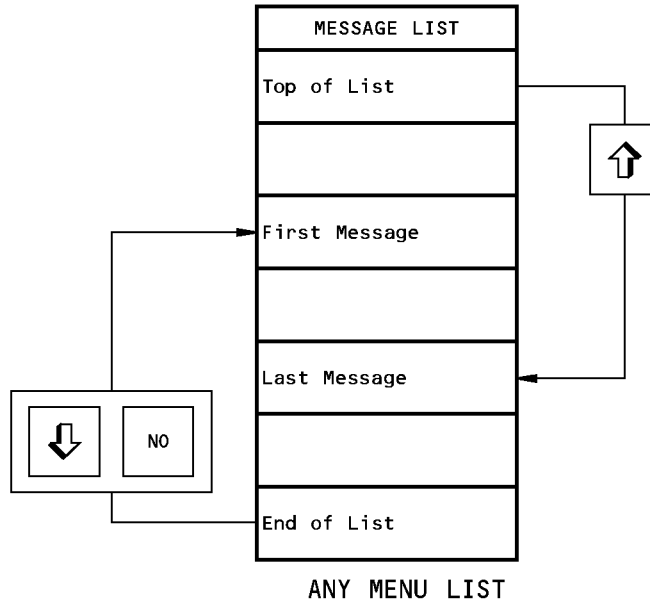

J85819 S0000180483_V2

**BDU Main Menu
Figure 201 (Sheet 4 of 4)/47-31-02-990-802**

EFFECTIVITY
HAP 047-053, 106-999

47-31-02

Page 208
Oct 15/2008

D633A101-HAP



737-600/700/800/900

AIRCRAFT MAINTENANCE MANUAL

TASK 47-31-02-740-802

3. BDU Existing Fault Menu

(Figure 202)

A. General

- (1) This task gives the instructions to operate the BDU control panel for the EXISTING FAULT menu.
- (2) To help you move through the EXISTING FAULT menu, refer to Figure 202.
- (3) The existing faults menu lets you find all NGS faults. Existing faults for all flight phases will show. Existing faults that show might not show the real time fault status. To find out if a fault is currently active, a menu item, ACTIVE: YES/NO, is provided.
- (4) Existing faults show in sequence, with the most recent fault shown first.

B. Location Zones

Zone	Area
132	Center Section Wing Box, Body Station 540.00 to Body Station 663.75 - Right

C. Access Panels

Number	Name/Location
192CR	Air Conditioning Access Door

D. Main Menu

SUBTASK 47-31-02-740-015

- (1) Do this task: BDU Main Menu, TASK 47-31-02-740-801.

SUBTASK 47-31-02-740-016

- (2) Push the BDU control panel up or down arrows or the NO button until EXISTING FAULTS? shows.

E. Existing Fault

SUBTASK 47-31-02-740-017

- (1) Make sure that the display shows EXISTING FAULTS?.
 - (a) Push the YES button.

SUBTASK 47-31-02-740-061

- (2) The display message, "XXX Faults Found" will show.

NOTE: XXX shows the number of existing faults found.

 - (a) If 000 FAULTS FOUND shows, then there are no existing faults recorded.
 - (b) If 001 FAULTS FOUND shows, then push the down arrow to show the existing fault.
 - (c) If 002 FAULTS FOUND (or more) shows, then push the down arrow to show the most recent existing fault.
 - 1) Continue to push the down arrow to see all of the existing faults.

F. Fault Details List

SUBTASK 47-31-02-740-018

- (1) Do these steps to see the fault details:
 - (a) Make sure that the applicable fault shows.
 - (b) Push the down arrow.
 - 1) MORE DETAILS? shows.

EFFECTIVITY
HAP 047-053, 106-999

47-31-02

Page 209
Oct 15/2008

D633A101-HAP



737-600/700/800/900

AIRCRAFT MAINTENANCE MANUAL

- (c) Push the YES button.
 - 1) The FAULT DETAILS list shows.

SUBTASK 47-31-02-740-062

- (2) These are the fault details items:
 - (a) INDICATOR LAMP: < lamp indication > - shows the lamp indication messages
 - (b) POSSIBLE CAUSES? - a list of possible causes, in most probable to least probable sequence
 - (c) LATCHED: YES (NO) - data on the latched status of the existing fault
 - (d) UNLATCH: - the necessary action to be done to unlatch the existing fault

NOTE: Refer to the existing fault menu figure for a list of steps necessary to unlatch the applicable fault.

- (e) ACTIVE: YES (NO) - data on the active status of the existing fault
- (f) SHOP DETAILS? - data on the configuration of the various systems when the existing fault was set.

SUBTASK 47-31-02-740-020

- (3) Push the up and down arrows to see the menu items for the fault details list.

G. Possible Causes

SUBTASK 47-31-02-740-021

- (1) Make sure the applicable existing fault shows.
 - (a) Push the down arrow.
 - 1) More Details? shows.
 - (b) Push the YES button.
 - 1) The fault details list shows.
 - (c) Push the down arrow.
 - 1) POSSIBLE CAUSES? shows.
 - (d) Push the YES button.
 - 1) The most probable cause of the existing fault will show.
 - (e) Push the down arrow.
 - 1) The second most probable cause of the existing fault will show.

NOTE: The list will continue to show possible causes, ranked by probability, until the end of list shows.

H. Shop Details List

SUBTASK 47-31-02-740-022

- (1) Make sure the applicable existing fault shows.
 - (a) Push the down arrow.
 - 1) More Details? shows.
 - (b) Push the YES button.
 - 1) The fault details list items shows.
 - (c) Continue to push the down arrow.
 - 1) SHOP DETAILS? shows.
 - (d) Push the YES button.

EFFECTIVITY
HAP 047-053, 106-999

D633A101-HAP

47-31-02

Page 210
Oct 15/2008



737-600/700/800/900

AIRCRAFT MAINTENANCE MANUAL

1) The shop details list shows.

SUBTASK 47-31-02-740-063

(2) These are the menu items for the shop details list:

- (a) SHOP CODE: XXXX
- (b) NGS STATE: NGS ON (NGS OFF, NGS STARTBIT, NGS IBIT, NGS COOLDOWN)
- (c) IBIT STATE: ELECTRICAL (SYSTEM, NGS PERF LO FLOW, NGS PERF HI FLOW, OFF)
- (d) AIRCRAFT STATE: GROUND (CLIMB, CRUISE, DESCENT, IN AIR)
- (e) ASM STATE: ASM LOW (ASM MID1, ASM MID2, ASM HIGH, ASM IBIT)
- (f) TASMI 1: SXXX F
TASMI 2: SYYYY
- (g) DPHI: SXXX.X psid
DPMID: NA
- (h) PALT: XXXXX ft
PB: SYYY.Y psig
- (i) RAV T/M
I:XXXXmA V:YY.YV
- (j) NGS SOV SOL
I:XXXXmA V:YY.YV
- (k) OTSOV SOL
I:XXXXmA V:YY.YV
- (l) ASM HFV SOL
I:XXXXmA V:YY.YV
- (m) ASM FBV SOL: NA
- (n) NGS FAN REL: NA
- (o) NGS RAD REL: NA

SUBTASK 47-31-02-740-024

(3) Use the up and down arrows to see all the menu items for the shop details list.

SUBTASK 47-31-02-740-025

(4) After you do the necessary maintenance tasks, continue.

I. Put the Airplane Back to the Usual Condition

SUBTASK 47-31-02-740-026

(1) Make sure all BDU initiated tests are complete.

- (a) Push the ON/OFF button.

SUBTASK 47-31-02-410-003

(2) Close this access panel:

<u>Number</u>	<u>Name/Location</u>
192CR	Air Conditioning Access Door

————— END OF TASK —————

EFFECTIVITY HAP 047-053, 106-999

47-31-02

Page 211
Oct 15/2008

D633A101-HAP

**737-600/700/800/900
AIRCRAFT MAINTENANCE MANUAL**

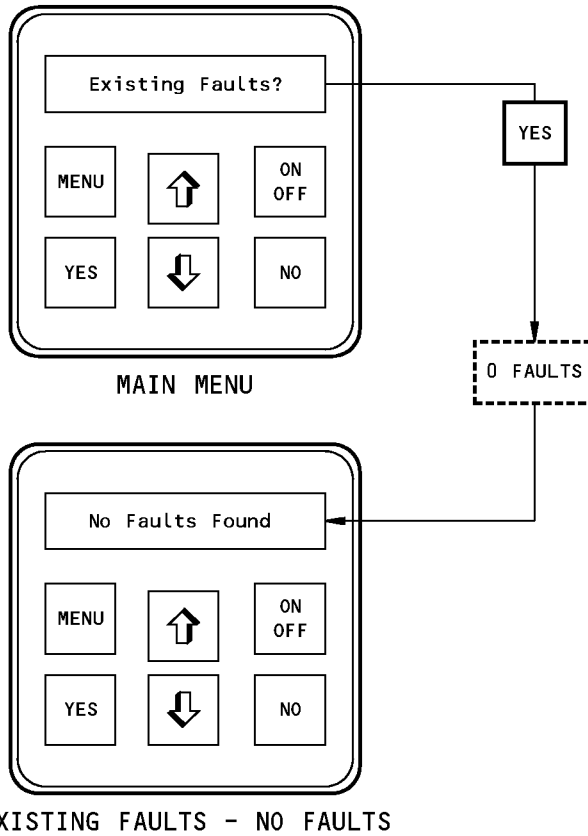
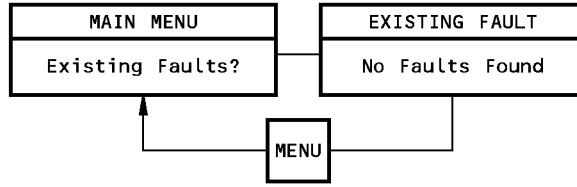

1501058 S0000273469_V1

**Existing Fault Menu
Figure 202 (Sheet 1 of 6)/47-31-02-990-803**

EFFECTIVITY
HAP 047-053, 106-999

D633A101-HAP

47-31-02

Page 212
Oct 15/2008

AIRCRAFT MAINTENANCE MANUAL

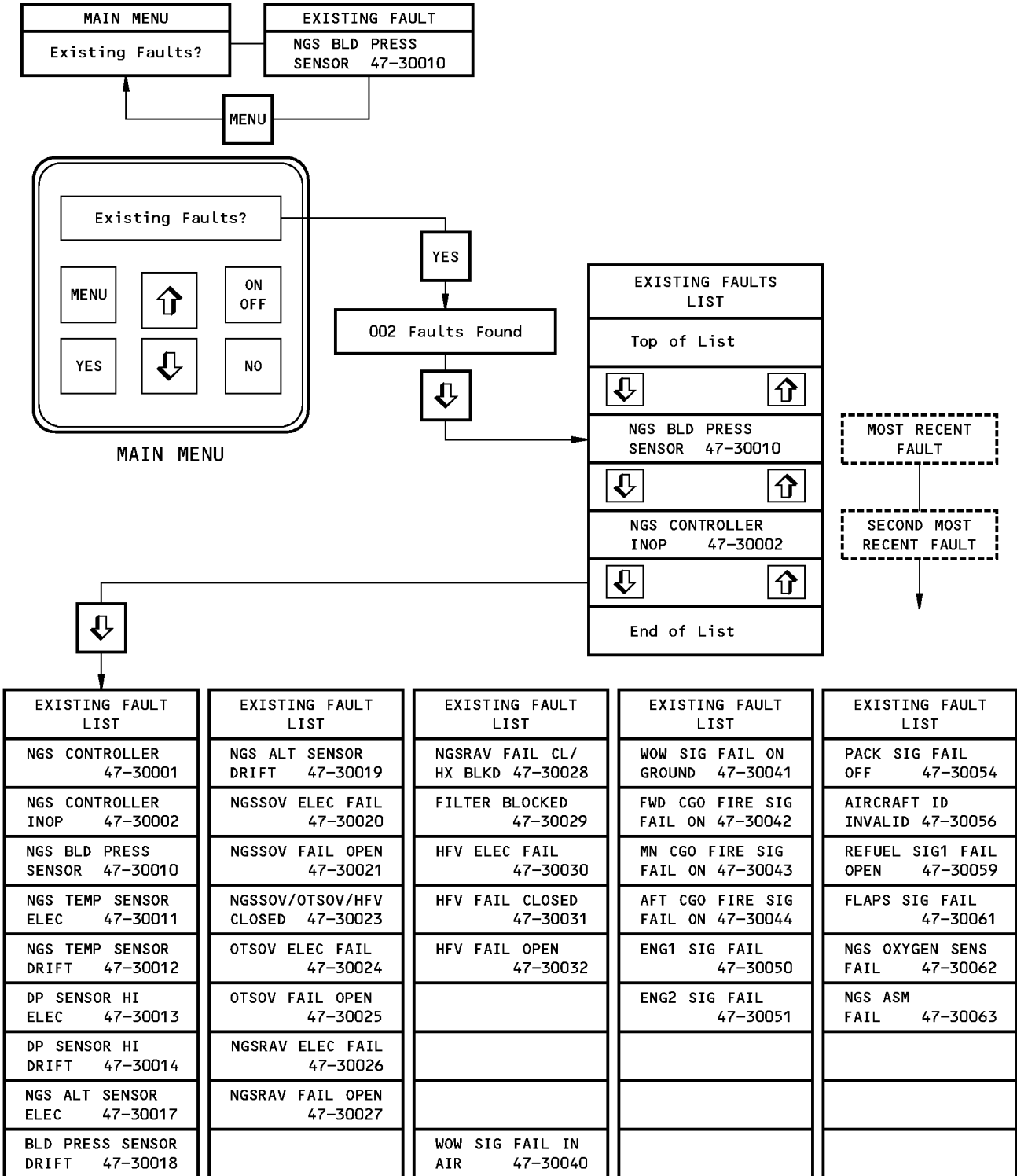

1500682 S0000273147_V1

Existing Fault Menu
Figure 202 (Sheet 2 of 6)/47-31-02-990-803

EFFECTIVITY
HAP 047-053, 106-999

47-31-02

737-600/700/800/900
AIRCRAFT MAINTENANCE MANUAL

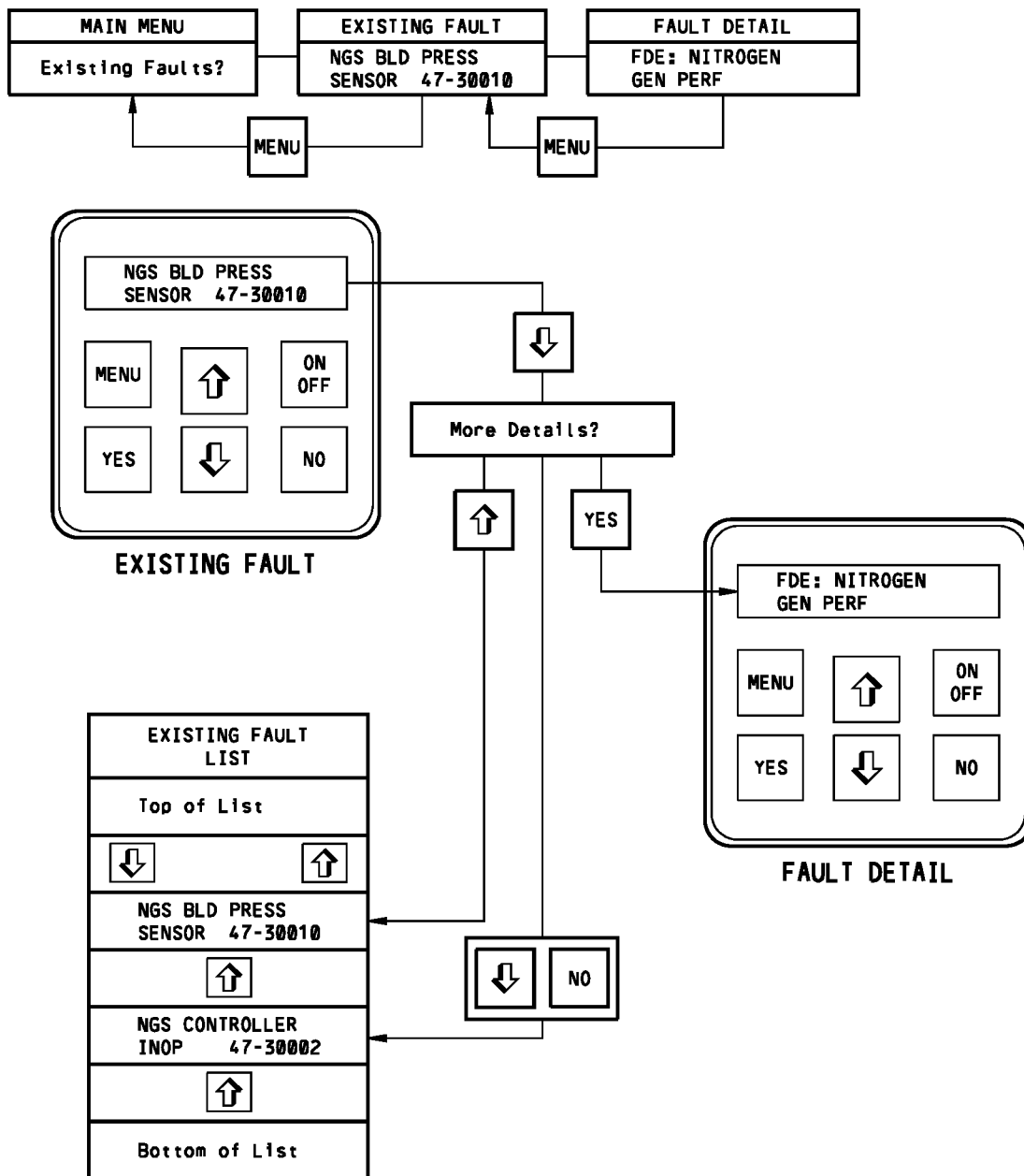

Existing Fault Menu
Figure 202 (Sheet 3 of 6)/47-31-02-990-803

EFFECTIVITY
HAP 047-053, 106-999

47-31-02

**737-600/700/800/900
AIRCRAFT MAINTENANCE MANUAL**

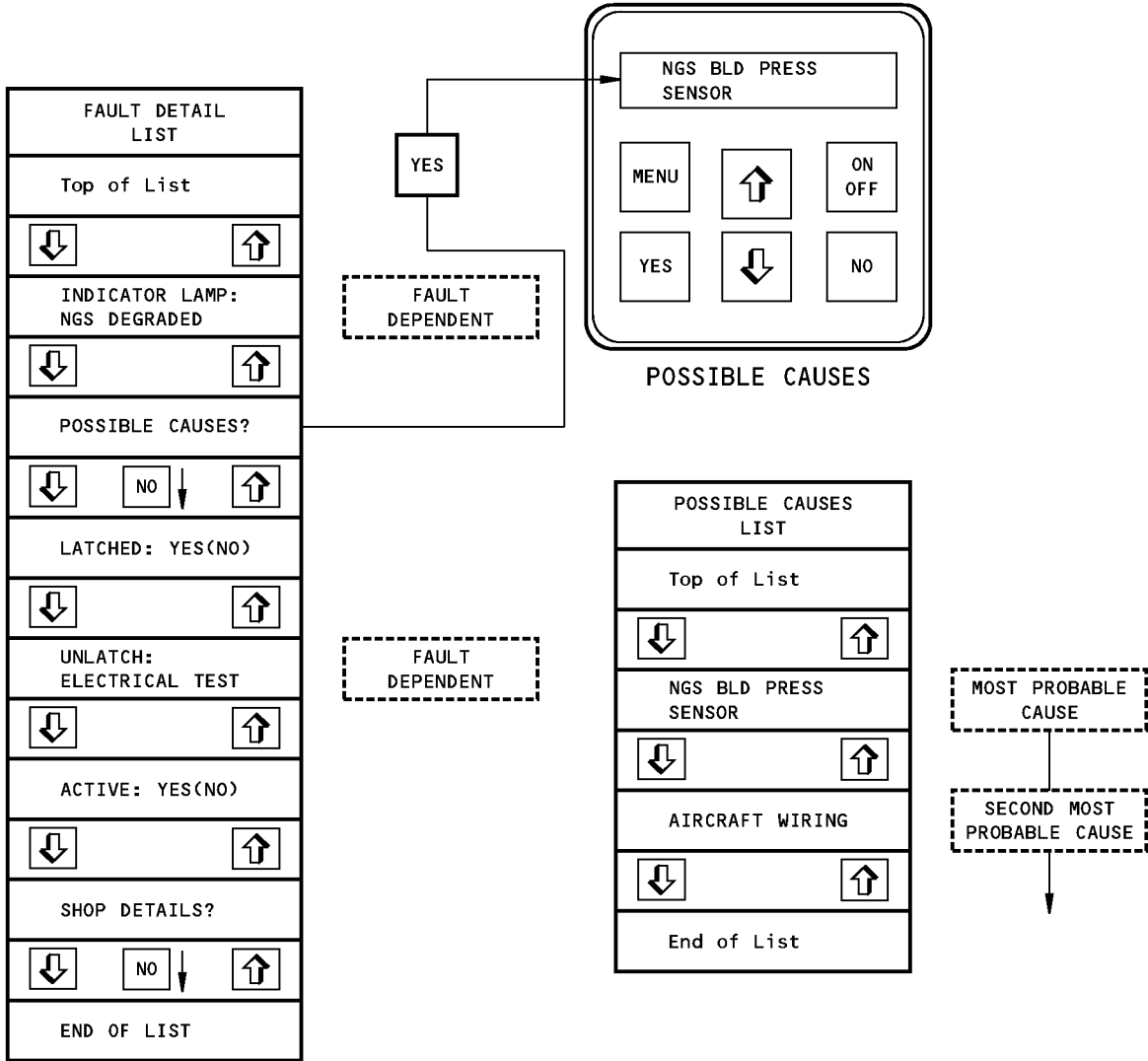
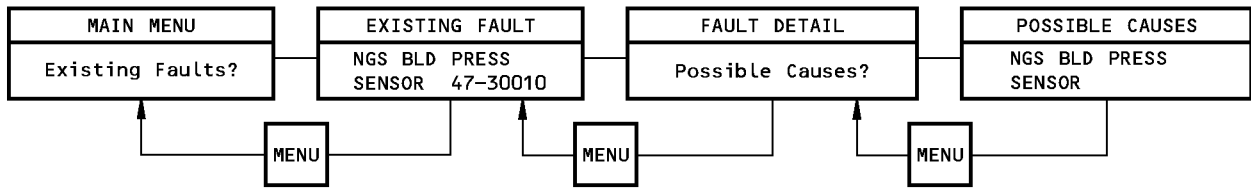

1500650 S0000273148_V1

Existing Fault Menu
Figure 202 (Sheet 4 of 6)/47-31-02-990-803

EFFECTIVITY
HAP 047-053, 106-999

47-31-02

Page 215
Oct 15/2008

D633A101-HAP

**737-600/700/800/900
AIRCRAFT MAINTENANCE MANUAL**

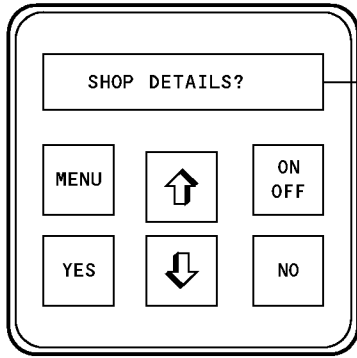
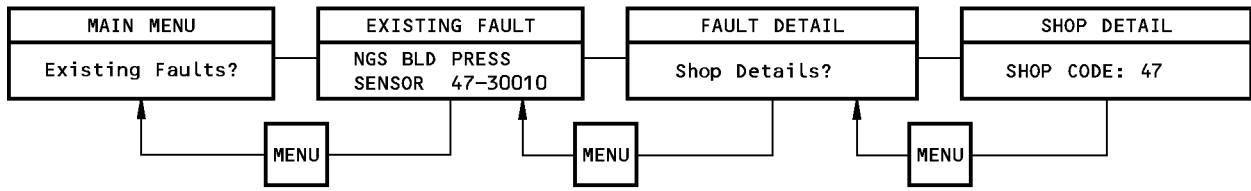

YES

SHOP DETAIL LIST	
Top of List	
↓	↑
SHOP CODE: 47	
↓	↑
NGS STATE: NGS ON	
↓	↑
End of List	

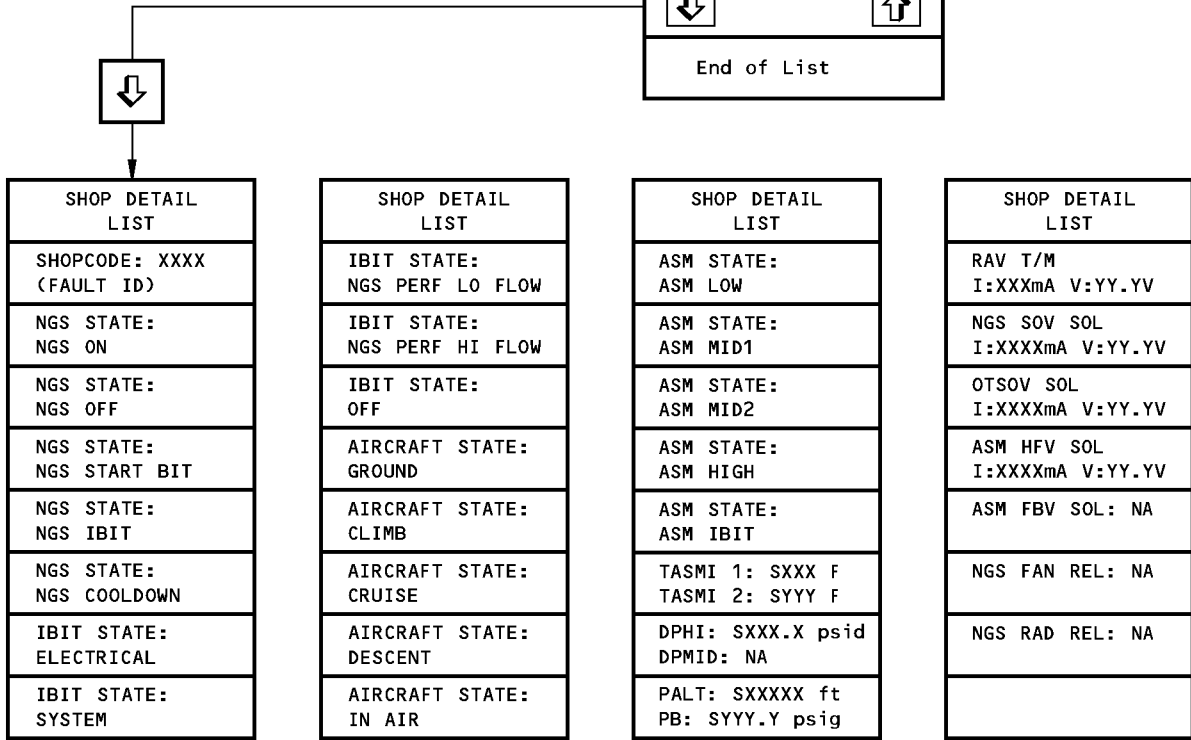

1500540 S0000273149_V1

**Existing Fault Menu
Figure 202 (Sheet 5 of 6)/47-31-02-990-803**

EFFECTIVITY
HAP 047-053, 106-999

47-31-02

Page 216
Oct 15/2008

D633A101-HAP

**737-600/700/800/900
AIRCRAFT MAINTENANCE MANUAL**

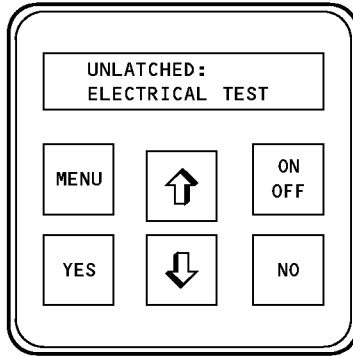
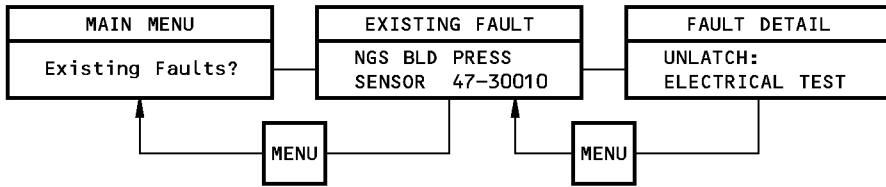

FAULT DETAIL

FAULT DETAIL UNLATCH LIST	FAULT DETAIL UNLATCH LIST
UNLATCH: ELECTRICAL TEST	UNLATCH: SEE FIM
UNLATCH: CYCLE CONTROLLER PWR	UNLATCH: N/A
UNLATCH: SYSTEM TEST	

THE APPLICATION MESSAGE FROM THE UNLATCH LIST WILL SHOW FOR THE FLIGHT LEG FAULT MESSAGE.

1500537 S0000273150_V1

**Existing Fault Menu
Figure 202 (Sheet 6 of 6)/47-31-02-990-803**

EFFECTIVITY
HAP 047-053, 106-999

47-31-02

Page 217
Oct 15/2008

D633A101-HAP



737-600/700/800/900

AIRCRAFT MAINTENANCE MANUAL

TASK 47-31-02-740-803

4. BDU Fault History Menu

(Figure 203)

A. General

- (1) This task gives the instructions to operate the BDU control panel for the Fault History Menu.
- (2) To help you navigate through the NGS BDU fault history structure, refer to Figure 203.
- (3) The fault history menu allows you to look at NGS faults and correlated flight deck effects that occurred during the last 99 flight legs. The flight leg is updated during the ground to air (WOW) transition.
- (4) Fault history can store up to 256 messages. No more than 25% of the fault history can be allocated to a single flight leg. If a single flight leg fault allocation is full, no additional fault records can be recorded for that flight leg. When the total allocation of faults is full, new faults will replace the oldest fault.

B. Location Zones

Zone	Area
132	Center Section Wing Box, Body Station 540.00 to Body Station 663.75 - Right

C. Access Panels

Number	Name/Location
192CR	Air Conditioning Access Door
192DR	ECS High Pressure Access Door

D. Main Menu

SUBTASK 47-31-02-740-027

- (1) Do this task: BDU Main Menu, TASK 47-31-02-740-801
 - (a) Push the BDU control panel up or down arrows or the NO button until FAULT HISTORY? shows.

E. Fault History

SUBTASK 47-31-02-740-028

- (1) Make sure that the display message, FAULT HISTORY? shows on the display.

SUBTASK 47-31-02-740-064

- (2) Push the YES button.
 - (a) If NO FAULT HISTORY? shows on the display, then there are no flight leg faults recorded.
 - (b) If the display message, IN PROGRESS shows on the display, followed by INVALID FAULT HISTORY, then the BDU timed-out or the search was complete with no valid records found.
 - (c) If FLIGHT LEG 0? shows on the display, then the search was successful.

SUBTASK 47-31-02-740-065

- (3) When FLIGHT LEG 0? shows on the display, push the up or down arrows or the NO button.
 - (a) The display moves up or down the fault history list from flight leg 0, to flight leg -99.

SUBTASK 47-31-02-740-029

- (4) Use the push button controls to get to the applicable flight leg.

EFFECTIVITY HAP 047-053, 106-999

D633A101-HAP

47-31-02

Page 218
Oct 15/2008



737-600/700/800/900

AIRCRAFT MAINTENANCE MANUAL

F. Flight Leg Fault List

SUBTASK 47-31-02-740-030

- (1) Make sure FLIGHT LEG 0? or the applicable flight leg shows on the display.

SUBTASK 47-31-02-740-066

- (2) Push the YES button.
 - (a) The most recent flight leg fault for the applicable flight leg will show on the display.

SUBTASK 47-31-02-740-067

- (3) Push the down arrow.
 - (a) MORE DETAILS? shows on the display.

SUBTASK 47-31-02-740-068

- (4) Push the down arrow again or the NO button to show the second most recent flight leg fault.

SUBTASK 47-31-02-740-069

- (5) Continue to push the down arrow or the NO button to see all of the flight leg faults.

SUBTASK 47-31-02-740-070

- (6) After the last flight leg fault, continue to push the down arrow.
 - (a) LRU CONFIG? shows on the display.

SUBTASK 47-31-02-740-071

- (7) Push the YES button.
 - (a) The menu item for the flight leg LRU configuration, "HARDWARE PART NO:" will show on the display.

SUBTASK 47-31-02-740-031

- (8) These are the menu items for the flight leg LRU configuration list:
 - (a) HARDWARE PART NO:
 - (b) BOOT LOADER PART NO:
 - (c) SOFTWARE PART NO:
 - (d) CONFIG DATA PART NO:
 - (e) AIRCRAFT ID:

SUBTASK 47-31-02-740-072

- (9) Push the up and down arrows to see the menu items for the LRU configuration list.

G. Flight Leg Fault Details

SUBTASK 47-31-02-740-032

- (1) Make sure the applicable flight leg fault shows.
 - (a) Push the down arrow.
 - 1) MORE DETAILS? shows on the display.
 - (b) Push the YES button.

SUBTASK 47-31-02-740-033

- (2) The menu item for the flight leg fault details, POSSIBLE CAUSES? will show on the display.
 - (a) Push the up and down arrows to move through the menu items for the flight leg fault details list.

SUBTASK 47-31-02-740-074

- (3) These are the menu items for the flight leg fault details list:

EFFECTIVITY
HAP 047-053, 106-999

D633A101-HAP

47-31-02

Page 219
Oct 15/2008



737-600/700/800/900

AIRCRAFT MAINTENANCE MANUAL

- (a) INDICATOR LAMP: < lamp indication >
 - (b) POSSIBLE CAUSES? - a list of possible causes, in most probable, to least probable sequence
 - (c) TYPE: HARD (INTERMITTENT or MODE DEPENDENT) - type of fault recorded
 - (d) ACTIVE: YES (NO) - data on the active status of the flight leg fault
 - (e) LATCHED?: YES - data on the latched status of the flight leg fault
 - (f) < unlatch method >
 - (g) UNLATCH: NA - the necessary action to be done to unlatch the flight leg fault
- NOTE: Reference the flight leg fault menu figure for a list of actions necessary to unlatch the applicable fault..
- (h) PHASE: GROUND (CLIMB, CRUISE, DESCENT) - flight phase when the fault was recorded
 - (i) DAY:HR:MIN:SEC - The date and time that the fault occurred.
 - (j) SHOP DETAILS? - data on the configuration of the various systems when the flight leg fault was set.

H. Flight Leg Possible Causes

SUBTASK 47-31-02-740-034

- (1) Make sure the applicable flight leg fault shows.
 - (a) Push the down arrow.
 - 1) MORE DETAILS? shows on the display.
 - (b) Push the YES button.
 - 1) The flight leg fault details list will show on the display.
 - (c) Push the down arrow.
 - 1) POSSIBLE CAUSES? shows on the display.
 - (d) Push the YES button.
 - 1) The most probable cause of the flight leg fault will show on the display.
 - (e) Push the down arrow.
 - 1) The second most probable cause of the flight leg fault will show on the display.

NOTE: The list will continue to show possible causes, ranked by probability, until the end of list shows.

I. Flight Leg Shop Details

SUBTASK 47-31-02-740-035

- (1) Make sure the applicable flight leg fault shows.
 - (a) Push the down arrow.
 - 1) MORE DETAILS? shows on the display.
 - (b) Push the YES button.
 - 1) The flight leg fault details list will show.
 - (c) Continue to push the down arrow.
 - 1) SHOP DETAILS? shows on the display.
 - (d) Push the YES button.
 - 1) The flight leg shop details list will show.

EFFECTIVITY
HAP 047-053, 106-999

D633A101-HAP

47-31-02

Page 220
Oct 15/2008



737-600/700/800/900

AIRCRAFT MAINTENANCE MANUAL

SUBTASK 47-31-02-740-036

- (2) Push the up and down arrows to see the menu items for the flight leg shop details list.
- (3) After you complete the necessary maintenance tasks, continue.

SUBTASK 47-31-02-740-076

- (4) These menu items are included for each recorded fault:
 - (a) SHOP CODE: XXXX
 - (b) NGS STATE: NGS ON (NGS OFF, NGS STARTBIT, NGS IBIT, NGS COOLDOWN)
 - (c) IBIT STATE: ELECTRICAL (SYSTEM, NGS PERF LO FLOW, NGS PERF HI FLOW, OFF)
 - (d) AIRCRAFT STATE: GROUND (CLIMB CRUISE, DESCENT, IN AIR)
 - (e) ASM STATE: ASM LOW (ASM MID1, ASM MID2, ASM HIGH, ASM IBIT)
 - (f) TASMI 1: SXXX F
TASMI 2: SYYY F
 - (g) DPHI: SXXX.X psid
DPMID: NA
 - (h) PALT: SXXXXX ft
PB: SYYY.Y psig
 - (i) RAV T/M
I:XXXmA V:YY.YV
 - (j) NGS SOV SOL
I:XXXXmA V:YY.YV
 - (k) OTSOV SOL
I:XXXXmA V:YY.YV
 - (l) ASM HFV SOL
I:XXXXmA V:YY.YV
 - (m) ASM FBV SOL: NA
 - (n) NGS FAN REL: NA
 - (o) NGS RAD REL: NA

J. Put the Airplane Back to the Usual Condition

SUBTASK 47-31-02-740-037

- (1) Make sure all BDU initiated tests are complete.
 - (a) Push the ON/OFF button.

SUBTASK 47-31-02-410-004

- (2) Close these access panels:

<u>Number</u>	<u>Name/Location</u>
192CR	Air Conditioning Access Door
192DR	ECS High Pressure Access Door

————— **END OF TASK** —————

EFFECTIVITY
HAP 047-053, 106-999

47-31-02

Page 221
Oct 15/2008

D633A101-HAP

737-600/700/800/900
AIRCRAFT MAINTENANCE MANUAL

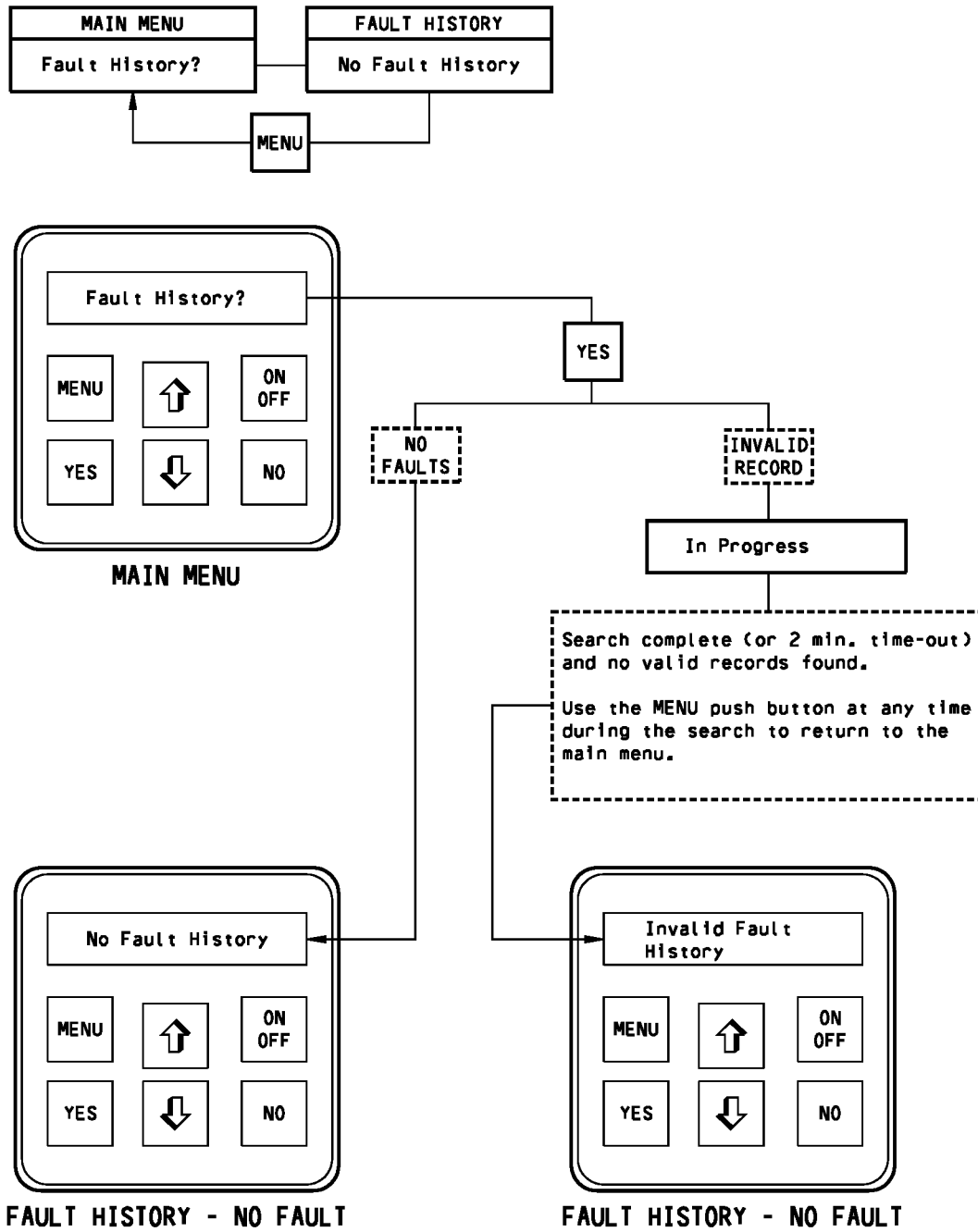

Fault History Menu
 Figure 203 (Sheet 1 of 8)/47-31-02-990-804

EFFECTIVITY
 HAP 047-053, 106-999

47-31-02

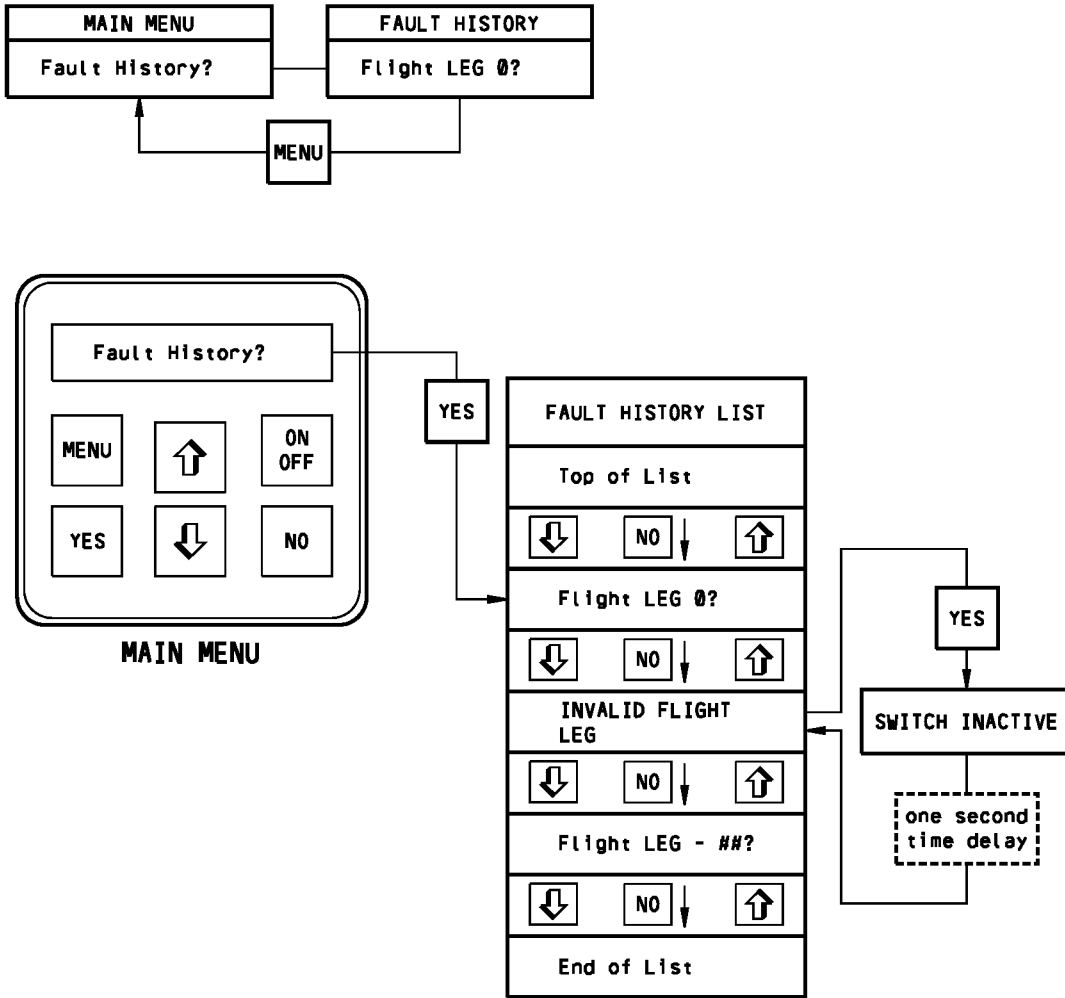

Fault History Menu
Figure 203 (Sheet 2 of 8)/47-31-02-990-804

EFFECTIVITY
HAP 047-053, 106-999

47-31-02

**737-600/700/800/900
AIRCRAFT MAINTENANCE MANUAL**

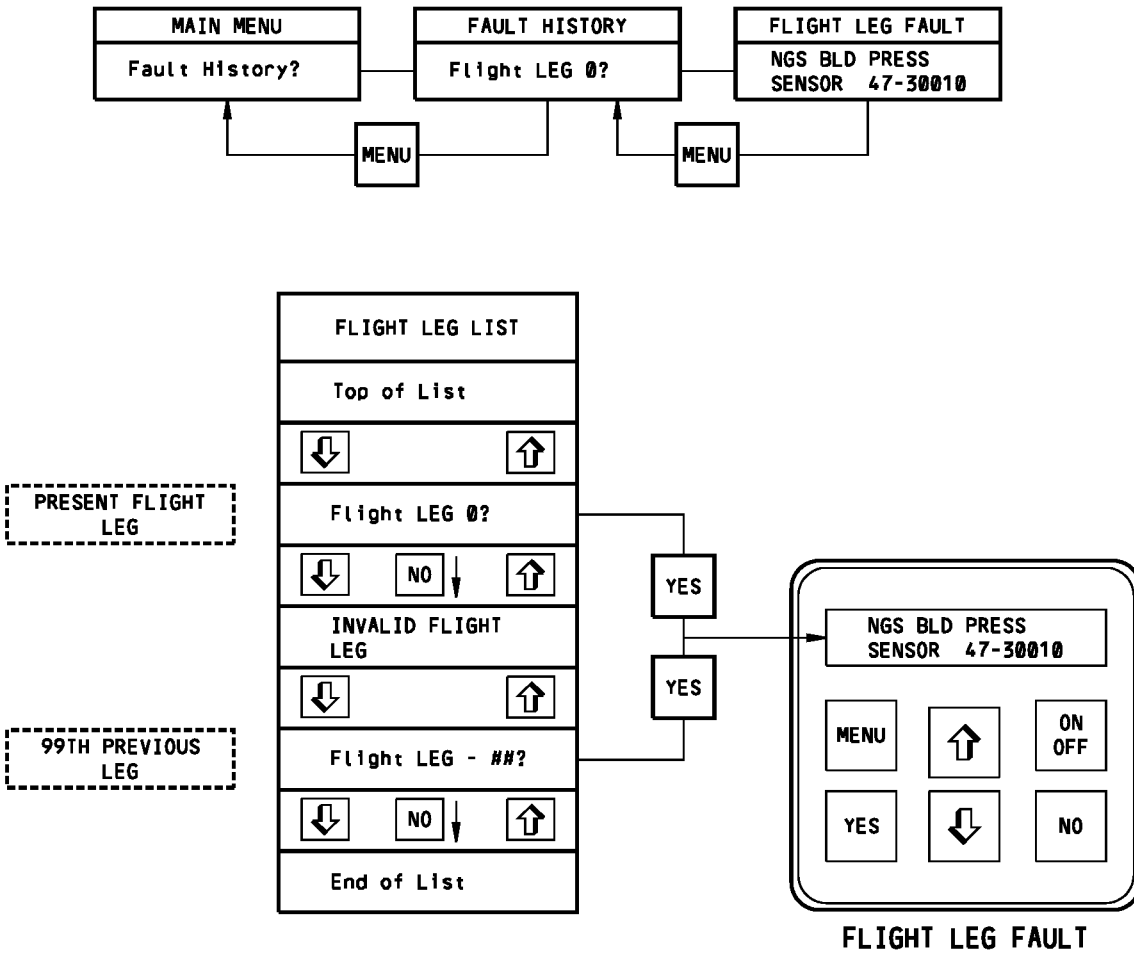

Fault History Menu
Figure 203 (Sheet 3 of 8)/47-31-02-990-804

EFFECTIVITY
HAP 047-053, 106-999

D633A101-HAP

47-31-02

Page 224
Oct 15/2008

**737-600/700/800/900
AIRCRAFT MAINTENANCE MANUAL**

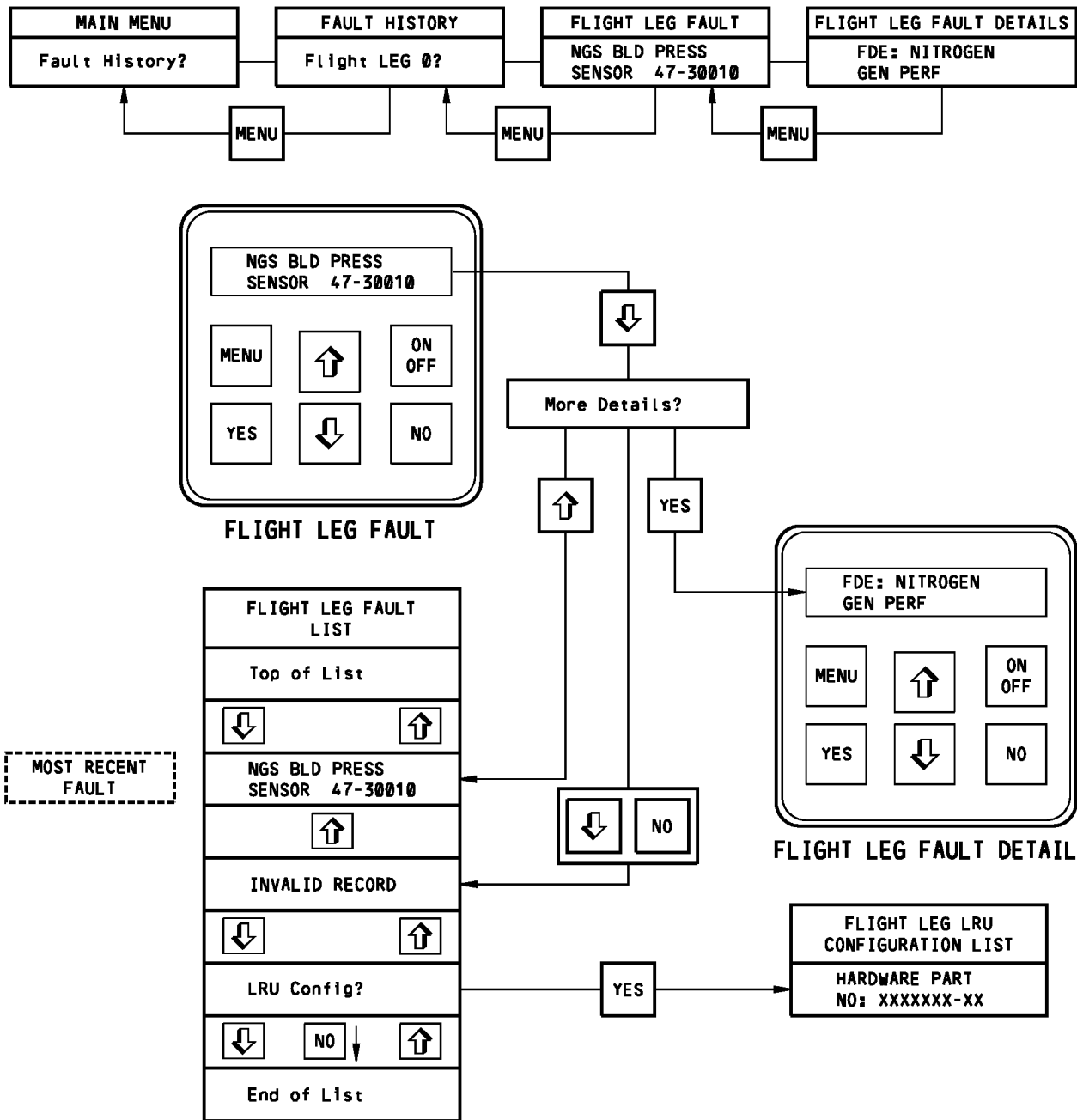

**Fault History Menu
Figure 203 (Sheet 4 of 8)/47-31-02-990-804**

EFFECTIVITY
HAP 047-053, 106-999

47-31-02

Page 225
Oct 15/2008

D633A101-HAP

**737-600/700/800/900
AIRCRAFT MAINTENANCE MANUAL**

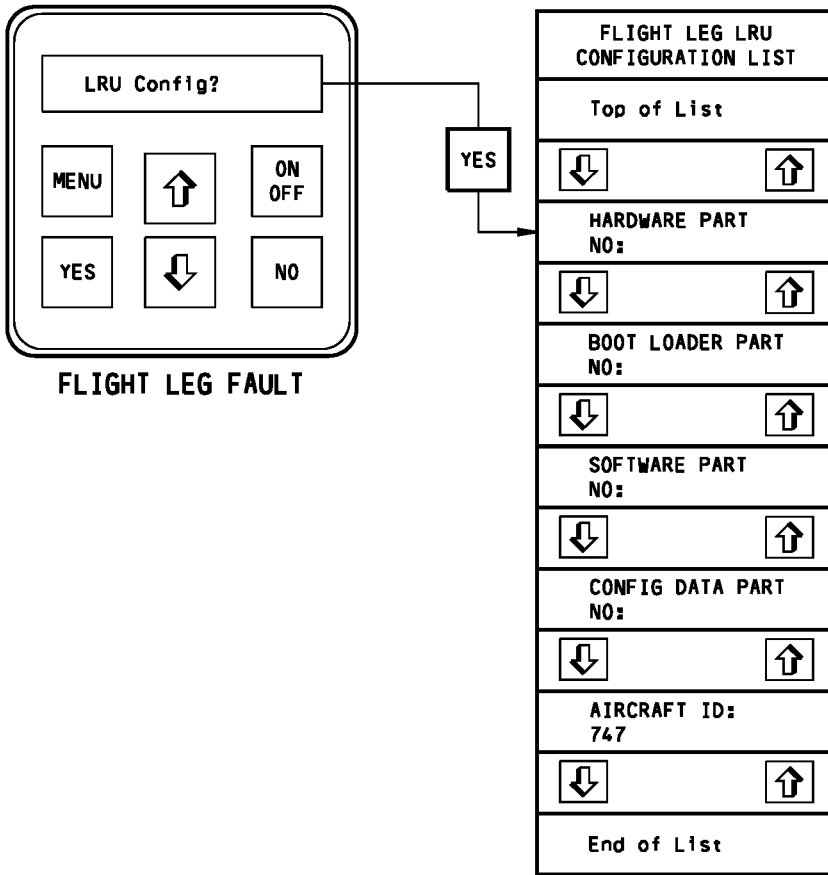
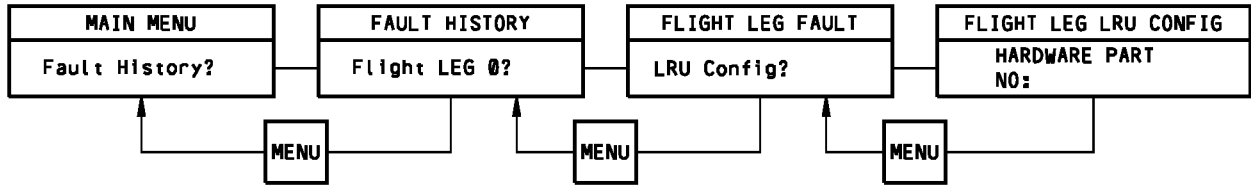

**Fault History Menu
Figure 203 (Sheet 5 of 8)/47-31-02-990-804**

EFFECTIVITY
HAP 047-053, 106-999

47-31-02

AIRCRAFT MAINTENANCE MANUAL

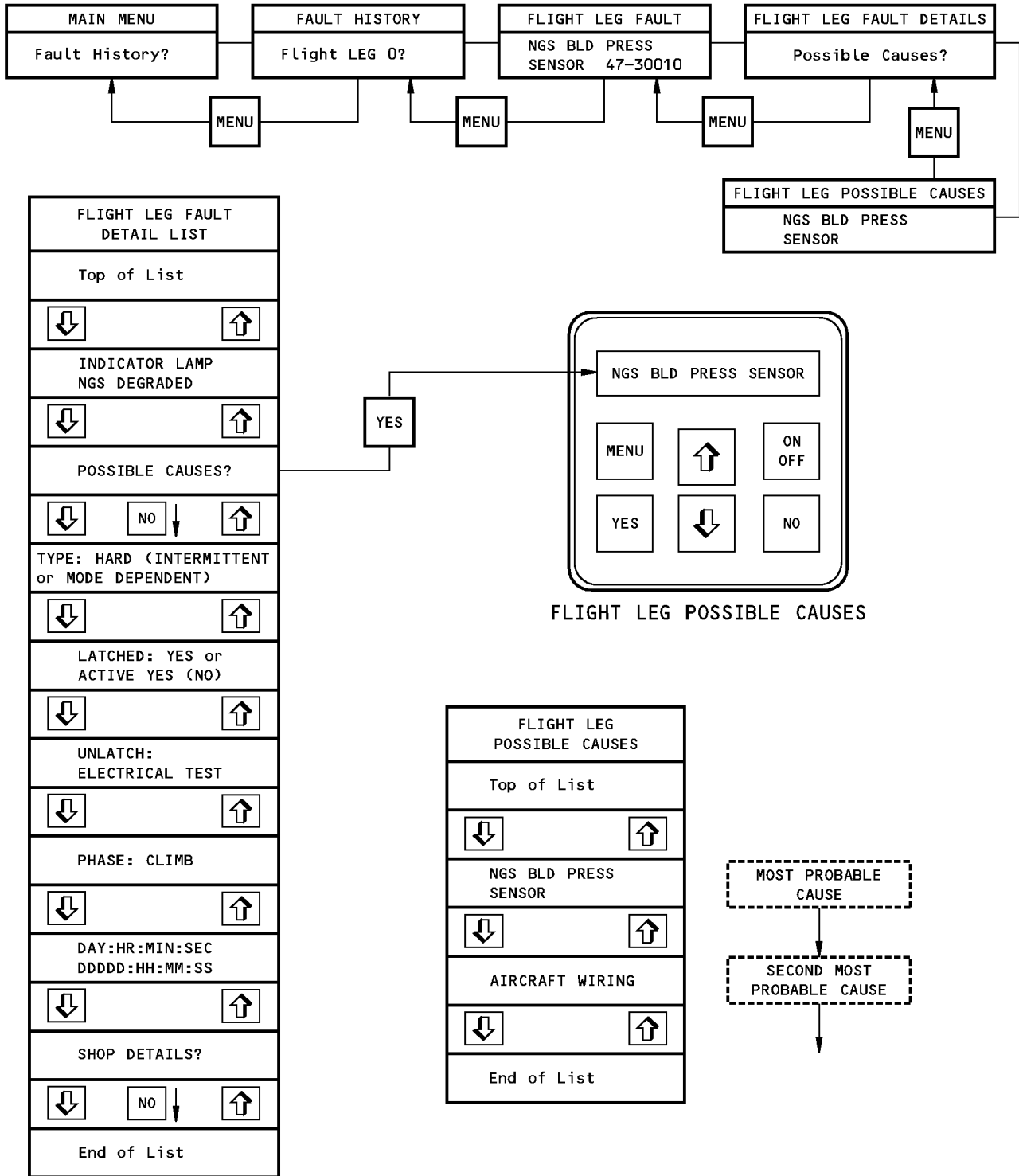

1501035 S0000273404_V1

Fault History Menu
Figure 203 (Sheet 6 of 8)/47-31-02-990-804

EFFECTIVITY
HAP 047-053, 106-999

47-31-02

Page 227
Oct 15/2008

D633A101-HAP

**737-600/700/800/900
AIRCRAFT MAINTENANCE MANUAL**

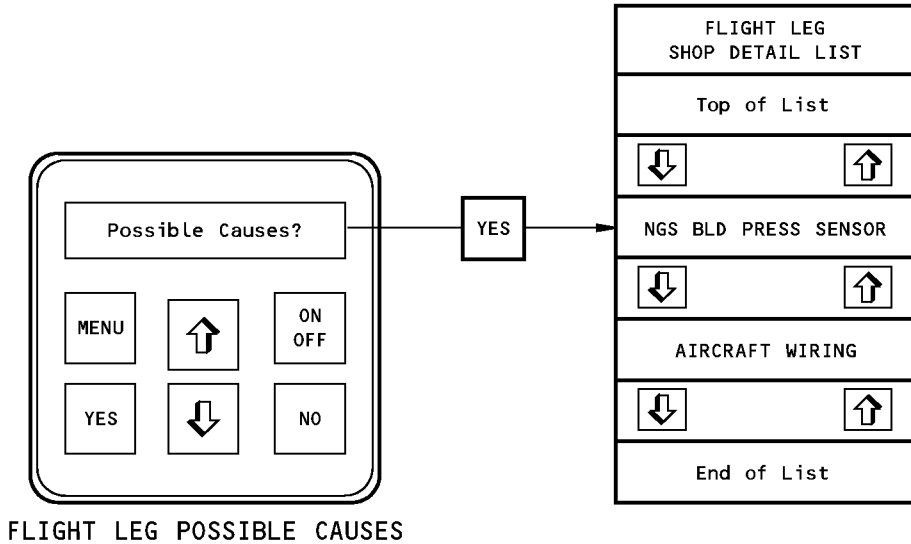
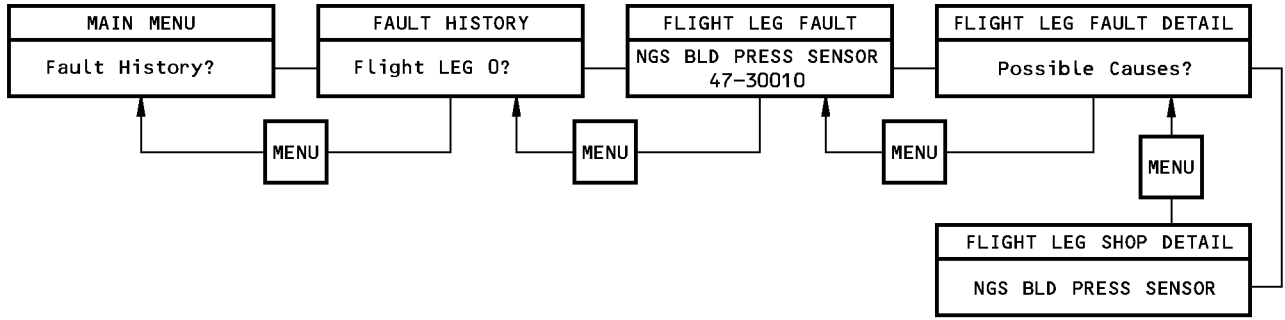

FLIGHT LEG POSSIBLE CAUSES

J84544 S0000180573_V2

**Fault History Menu
Figure 203 (Sheet 7 of 8)/47-31-02-990-804**

EFFECTIVITY
HAP 047-053, 106-999

47-31-02

Page 228
Oct 15/2008

D633A101-HAP

**737-600/700/800/900
AIRCRAFT MAINTENANCE MANUAL**

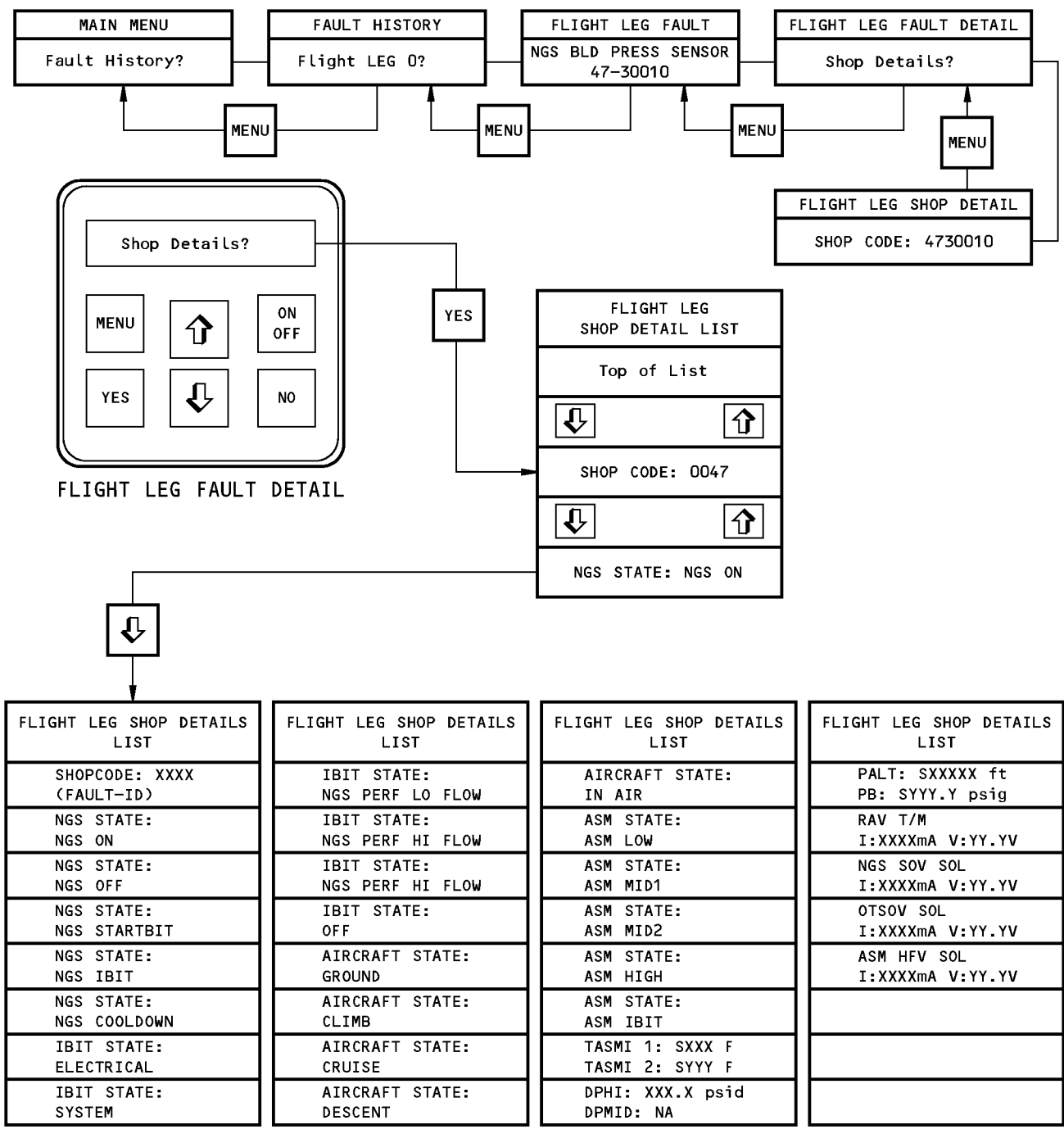

FLIGHT LEG SHOP DETAILS LIST SHOPCODE: XXXX (FAULT-ID) NGS STATE: NGS ON NGS STATE: NGS OFF NGS STATE: NGS STARTBIT NGS STATE: NGS IBIT NGS STATE: NGS COOLDOWN IBIT STATE: ELECTRICAL IBIT STATE: SYSTEM	FLIGHT LEG SHOP DETAILS LIST IBIT STATE: NGS PERF LO FLOW IBIT STATE: NGS PERF HI FLOW IBIT STATE: NGS PERF HI FLOW IBIT STATE: OFF AIRCRAFT STATE: GROUND AIRCRAFT STATE: CLIMB AIRCRAFT STATE: CRUISE AIRCRAFT STATE: DESCENT	FLIGHT LEG SHOP DETAILS LIST AIRCRAFT STATE: IN AIR ASM STATE: ASM LOW ASM STATE: ASM MID1 ASM STATE: ASM MID2 ASM STATE: ASM HIGH ASM STATE: ASM IBIT TASMI 1: SXXX F TASMI 2: SYYY F DPHI: XXX.X psid DPMID: NA	FLIGHT LEG SHOP DETAILS LIST PALT: SXXXXX ft PB: SYYY.Y psig RAV T/M I:XXXXmA V:YY.YV NGS SOV SOL I:XXXXmA V:YY.YV OTSOV SOL I:XXXXmA V:YY.YV ASM HFV SOL I:XXXXmA V:YY.YV
--	--	--	---

FLIGHT LEG SHOP DETAIL

1501108 S0000273405_V1

**Fault History Menu
Figure 203 (Sheet 8 of 8)/47-31-02-990-804**

EFFECTIVITY
HAP 047-053, 106-999

47-31-02

Page 229
Oct 15/2008

D633A101-HAP



737-600/700/800/900

AIRCRAFT MAINTENANCE MANUAL

TASK 47-31-02-740-804

5. BDU Ground Test Menu

(Figure 204)

A. General

- (1) This task gives the instructions to operate the BDU control panel for the BDU Ground Test Menu.
- (2) To help you scroll through the BDU ground test structure, refer to Figure 204.
- (3) The BDU ground test menu supplies the controls to do three types of BDU manually initiated built-in-tests (IBIT). The IBIT tests include these ground tests:
 - (a) System IBIT
 - (b) Electrical IBIT
 - (c) NGS performance IBIT
- (4) BDU System IBIT (System Test?)
 - (a) The BDU system test is manually initiated test done by the NGS controller when the NGS system is pressurized. To do the system test, it is necessary to pressurize the NGS with bleed air pressure and operate the left air conditioning pack. The system test is a timed sequence test that does a check of the open and closed position of all of the electrically controlled valves. This includes the NGS shutoff valve, ram air valve, overtemperature shutoff valve and the ASM high-flow valve. The system test also does a test of the filter pressure switch and a test for sensor drift for the NGS bleed pressure sensor.
 - (b) The NGS controller will not start the test (test inhibited) or once started, stop the test (test aborted), if the airplane configuration is incorrect. This includes: NGS inlet pressure less than 15 psig (103 kPa), the airplane in air mode, the packs are off, the center wing tank refuel valves open, or an invalid aircraft ID.
 - (c) The NGS controller will also not start the test if an NGS sensor that is used to control the open/closed position of a valve is out of limits. The test will not start if there are existing fault messages. The NGS controller will also inhibit the test if a controller valve driver, or valve solenoid/torque motor is inoperative.
 - (d) When the system test is started, the NGS controller monitors the NGS system performance. The NGS controller will stop the test if there is a change in the airplane configuration as noted in the previous step. Other events that will cause the test to stop include an overtemperature condition or an NGS fault is detected by the controller. The test can also be stopped manually if the MENU or ON/OFF push button controls are pushed during the test. If the system test is stopped before the test is fully done, all latched system faults that were present prior to the start of the system test will continue to be recorded as latched faults.
- (5) BDU Electrical IBIT (Electrical Test?)
 - (a) The BDU electrical test is manually initiated test done by the NGS controller to test the controller valve drivers (on and off conditions), sensor interfaces, sensor open/short conditions, solenoid or torque motor open/short conditions and airplane discrete inputs. The electrical test can be done with the NGS system in a pressurized or non-pressurized condition. The electrical test opens and closes the NGS shutoff and overtemperature shutoff valves in a timed sequence to stop the pressurization of the NGS system.
 - (b) The NGS controller will not start the test (test inhibited) or when started, stop the test (test aborted), if the airplane configuration is incorrect. This includes: the airplane in air mode, a different BDU ground test in progress, or an invalid aircraft ID.

EFFECTIVITY
HAP 047-053, 106-999

D633A101-HAP

47-31-02

Page 230
Oct 15/2008



737-600/700/800/900

AIRCRAFT MAINTENANCE MANUAL

- (c) When the electrical test is started, the NGS controller monitors the NGS system performance. The NGS controller will stop the test if there is a change in the airplane configuration as noted previously. The electrical test can also be stopped manually if the MENU or ON/OFF push button controls are pushed during the test. If the electrical test is stopped before the test is fully done, all latched electrical faults that were present prior to the start of the test will continue to be recorded as latched faults.
- (6) NGS Performance IBIT
- (a) There are two manually initiated BDU tests done by the NGS controller to test the NGS performance:
- 1) NGS PERF LO FLOW?
 - 2) NGS PERF HI FLOW?
- (b) The two tests are done when the NGS system is pressurized. The NGS PERF LO FLOW test, does a check of the NGS in the low flow mode. The NGS PERF HI FLOW test, does a check of the NGS in high flow mode. To do the NGS performance tests, it is necessary to pressurize the NGS with bleed air pressure and operate the left air conditioning pack. The left air conditioning pack is also operated to increase the bleed air pressure during the test. It is necessary to warm up the ASM to the operating temperature of $160 \pm 10^{\circ}\text{F}$ ($71 \pm 6^{\circ}\text{C}$). To do a check the performance of the ASM, a GSE Oxygen Analyzer is attached to Nitrogen-Enriched Air Distribution System (NEADS) line. The oxygen analyzer records the % oxygen against the system pressure to check the purity of the Nitrogen-Enriched Air (NEA) produced by the ASMs.
- (c) When the BDU starts the NGS PERF LO FLOW test, the NGS controller commands the NGS shutoff valve and overtemperature valve to ON. The high-flow valve is commanded closed. The NGS ram air valve controls the ASM inlet temperature within the standard temperature range limits. The test continues until the MENU or ON/OFF control push-buttons are pushed.
- (d) When the BDU starts the NGS PERF HI FLOW test, the NGS controller commands the NGS shutoff valve and overtemperature valve to ON. The high-flow valve is commanded open. The NGS ram air valve controls the ASM inlet temperature within the standard temperature range limits. The test continues until the MENU or ON/OFF control push-buttons are pushed.
- (e) The NGS controller will not start the test or stop the test if the airplane configuration is incorrect. This includes NGS inlet pressure less than 15 psig (103 kPa), the airplane is in air mode, the packs are off, the center wing tank refuel valves open, or an invalid aircraft ID is set. The NGS controller will also not start the test if another BDU ground test is in-progress.
- (f) If an existing fault is recorded for one or more of these LRUs', the NGS controller will not start the test:
- 1) NGS controller (drivers and sensor interfaces)
 - 2) NGS shutoff valve
 - 3) Overtemperature shutoff valve
 - 4) NGS ram air valve
 - 5) ASM High-flow valve
 - 6) NGS bleed air pressure sensor
 - 7) NGS Temperature sensor
 - 8) ASM differential pressure sensor.

EFFECTIVITY
HAP 047-053, 106-999

D633A101-HAP

47-31-02

Page 231
Oct 15/2008



737-600/700/800/900

AIRCRAFT MAINTENANCE MANUAL

- (g) When the performance test is started, the NGS controller monitors the NGS system performance. The NGS controller will stop the test if there is a change in the airplane configuration as noted in the previous steps. Other events that will cause the test to stop include an overtemperature condition or an NGS fault is recorded by the controller.
- (h) The test can also be stopped manually if the MENU or ON/OFF push button controls are pushed during the test. If the system test is stopped before the test is fully done, all latched system faults that were present prior to the start of the system test will continue to be recorded as latched faults.
- (i) If the performance test does not start, or the test is stopped by the NGS controller, one of these BDU display messages will show:
 - 1) INHIBITED: SYS PRESS LOW/INVLD
 - 2) INHIBITED: PACK OFF
 - 3) INHIBITED: REFUEL VLV OPEN
 - 4) INHIBITED: A/C ID INVALID
 - 5) INHIBITED: SEE EXISTING FAULTS
 - 6) INHIBITED: WOW = IN AIR

B. References

Reference	Title
47-00-00-800-801	Ground Operation of the Nitrogen Generation System (P/B 201)

C. Location Zones

Zone	Area
131	Center Section Wing Box, Body Station 540.00 to Body Station 663.75 - Left

D. Access Panels

Number	Name/Location
192CR	Air Conditioning Access Door
192DR	ECS High Pressure Access Door

E. Main Menu

SUBTASK 47-31-02-740-038

- (1) Do this task: BDU Main Menu, TASK 47-31-02-740-801.
 - (a) Push the BDU control panel up or down arrows or the NO button until the display message, GROUND TESTS? shows.

F. Ground Test List

SUBTASK 47-31-02-740-039

- (1) Make sure GROUND TESTS? shows on the display.
 - (a) Push the YES button.
 - 1) The menu items for the ground test list will show on the display.
- (2) These are the ground test list items:
 - (a) ELECTRICAL TEST?
 - (b) SYSTEM TEST?
 - (c) NGS PERF LO FLOW?

EFFECTIVITY
 HAP 047-053, 106-999

47-31-02



737-600/700/800/900

AIRCRAFT MAINTENANCE MANUAL

(d) NGS PERF HI FLOW?

(e) DISPLAY TEST?

SUBTASK 47-31-02-740-040

(3) When DISPLAY TEST? shows, push the YES button.

NOTE: The BDU will do a 10 second test display routine. All of the buttons are disabled except for the MENU button.

(a) Push the MENU button to stop the test.

SUBTASK 47-31-02-740-041

(4) Procedures are supplied to do the BDU ground tests. These are the tasks:

(a) Electrical Test: Ground Operation of the Nitrogen Generation System,
TASK 47-00-00-800-801

(b) System Test: Ground Operation of the Nitrogen Generation System,
TASK 47-00-00-800-801

G. BDU Test in Progress

SUBTASK 47-31-02-740-042

(1) Make sure that the applicable ground test item shows.

(a) Push the YES button to start the ground test.

SUBTASK 47-31-02-740-098

(2) TEST IN PROGRESS shows on the first line of the message display.

(a) The second line of the display shows this data:

1) For the electrical test:

XXX% COMPLETE

2) For the system test

XXX% COMPLETE

(3) For the NGS PERF LO FLOW:

• GSE O2 SNS: ZZZZZ

• P: XX PSIA T:SYYYYF

(4) For the NGS PERF HI FLOW:

• GSE O2 SNS: ZZZZZ

• P: XX PSIA T:SYYYYF

SUBTASK 47-31-02-740-099

(5) To stop the test, push the MENU or ON/OFF buttons.

SUBTASK 47-31-02-740-100

(6) The NGS controller will not start the test (inhibited) if there is an incorrect aircraft configuration. If the test is inhibited, one of these inhibited list items will show:

(a) SYS PRESS LOW/INVLD

(b) PACK OFF

(c) REFUEL VLV OPEN

(d) A/C ID INVALID

(e) WOW = IN AIR

EFFECTIVITY
HAP 047-053, 106-999

D633A101-HAP

47-31-02

Page 233
Oct 15/2008



737-600/700/800/900

AIRCRAFT MAINTENANCE MANUAL

(f) SEE EXISTING FAULTS

NOTE: The NGS controller has detected a fault that you must repair before you can do the test.

SUBTASK 47-31-02-740-101

(7) If the ground test is satisfactory, TEST PASS shows on the display when the test is complete.

SUBTASK 47-31-02-740-102

(8) If the ground test is not satisfactory, a BDU test result fault message will show.

NOTE: The fault messages for the BDU test results are shown in sequence. The first fault message is the most recent. The second fault message is the second most recent fault.

H. BDU Test Results

SUBTASK 47-31-02-740-044

(1) Make sure that a BDU test result fault message shows on the display.

(a) Push the down arrow.

1) MORE DETAILS? shows on the display

(b) Push the down arrow.

1) The second most recent fault message will show (if applicable).

(c) Continue to push the down arrow to see all of the fault messages for the applicable BDU ground test.

I. BDU Test Fault Details

SUBTASK 47-31-02-740-045

(1) Push the up or down arrows to get to the applicable fault message that you want to troubleshoot.

(a) Push the down arrow.

1) MORE DETAILS? shows on the display.

(b) Push the YES button.

1) The menu items for the BDU test fault details list shows.

SUBTASK 47-31-02-740-046

(2) These are the menu items for the BDU test fault details list:

(a) POSSIBLE CAUSES?

(b) SHOP DETAILS?

SUBTASK 47-31-02-740-103

(3) Push the up or down arrows to see all of the menu items for the BDU test fault details list.

J. BDU Test Possible Causes

SUBTASK 47-31-02-740-047

(1) Make sure that the applicable fault message for the BDU test result shows.

(a) Push the down arrow.

1) MORE DETAILS? shows on the display.

(b) Push the YES button.

1) The menu items for the BDU test fault details list shows on the display.

(c) Push the down arrow.

1) POSSIBLE CAUSES? shows on the display.

(d) Push the YES button.

EFFECTIVITY
HAP 047-053, 106-999

D633A101-HAP

47-31-02

Page 234
Oct 15/2008



737-600/700/800/900

AIRCRAFT MAINTENANCE MANUAL

- 1) The most probable cause of the fault will show.
- (e) Push the down arrow.
 - 1) The second most probable cause of the fault will show.

NOTE: The list will continue to show possible causes, ranked by probability, until the end of list shows.

K. BDU Test Shop Details List

SUBTASK 47-31-02-740-048

- (1) Make sure that the applicable fault message for the BDU test result shows.
 - (a) Push the down arrow.
 - 1) MORE DETAILS?
 - (b) Push the YES button.
 - 1) The menu items for the BDU test fault details list will show on the display.

SUBTASK 47-31-02-740-104

- (2) Continue to push the down arrow until SHOP DETAILS? shows on the display.
 - (a) Push the YES button.
 - 1) The BDU test shop details list will show on the display.

SUBTASK 47-31-02-740-105

- (3) These are the menu items for the BDU test shop details list:
 - (a) SHOP CODE: XXXX
 - (b) NGS STATE: NGS ON (NGS OFF, NGS STARTBIT, NGS IBIT, NGS COOLDOWN)
 - (c) IBIT STATE: ELECTRICAL (SYSTEM, NGS PERF LO FLOW, NGS PERF HI FLOW, OFF)
 - (d) AIRCRAFT STATE: GROUND (CLIMB, CRUISE, DESCENT, IN AIR)
 - (e) ASM STATE: ASM LOW (ASM MID1, ASM MID2, ASM HIGH, ASM IBIT)
 - (f) TASMI 1: XXX F
TASMI 2: YYY F
 - (g) DPHI: XXX.X psid
DPMID: NA
 - (h) PALT: XXXXXX ft
PB: YYY.Y psig
 - (i) RAV T/M
I: XXXmA V:YY.YV
 - (j) NGS SOV SOL
I:XXXXmA V:YY.YV
 - (k) OTSOV SOL
I:XXXXmA V:YY.YV
 - (l) ASM HFV SOL
I:XXXXmA V:YY.YV
 - (m) ASM FBV SOL: NA
 - (n) NGS FAN REL: NA
 - (o) NGS RAD REL: NA

EFFECTIVITY
HAP 047-053, 106-999

D633A101-HAP

47-31-02

Page 235
Oct 15/2008



737-600/700/800/900

AIRCRAFT MAINTENANCE MANUAL

(4) Push the up and down arrows to see the menu items for the BDU test shop details list.

SUBTASK 47-31-02-740-050

(5) After you do the necessary maintenance tasks, do the subsequent procedure.

L. Put the Airplane Back to the Usual Condition

SUBTASK 47-31-02-740-051

(1) Make sure all BDU initiated tests are complete.

SUBTASK 47-31-02-740-106

(2) Push the ON/OFF button.

SUBTASK 47-31-02-410-005

(3) Close these access panels:

<u>Number</u>	<u>Name/Location</u>
192CR	Air Conditioning Access Door
192DR	ECS High Pressure Access Door

————— **END OF TASK** —————

EFFECTIVITY
HAP 047-053, 106-999

D633A101-HAP

47-31-02

Page 236
Oct 15/2008

**737-600/700/800/900
AIRCRAFT MAINTENANCE MANUAL**

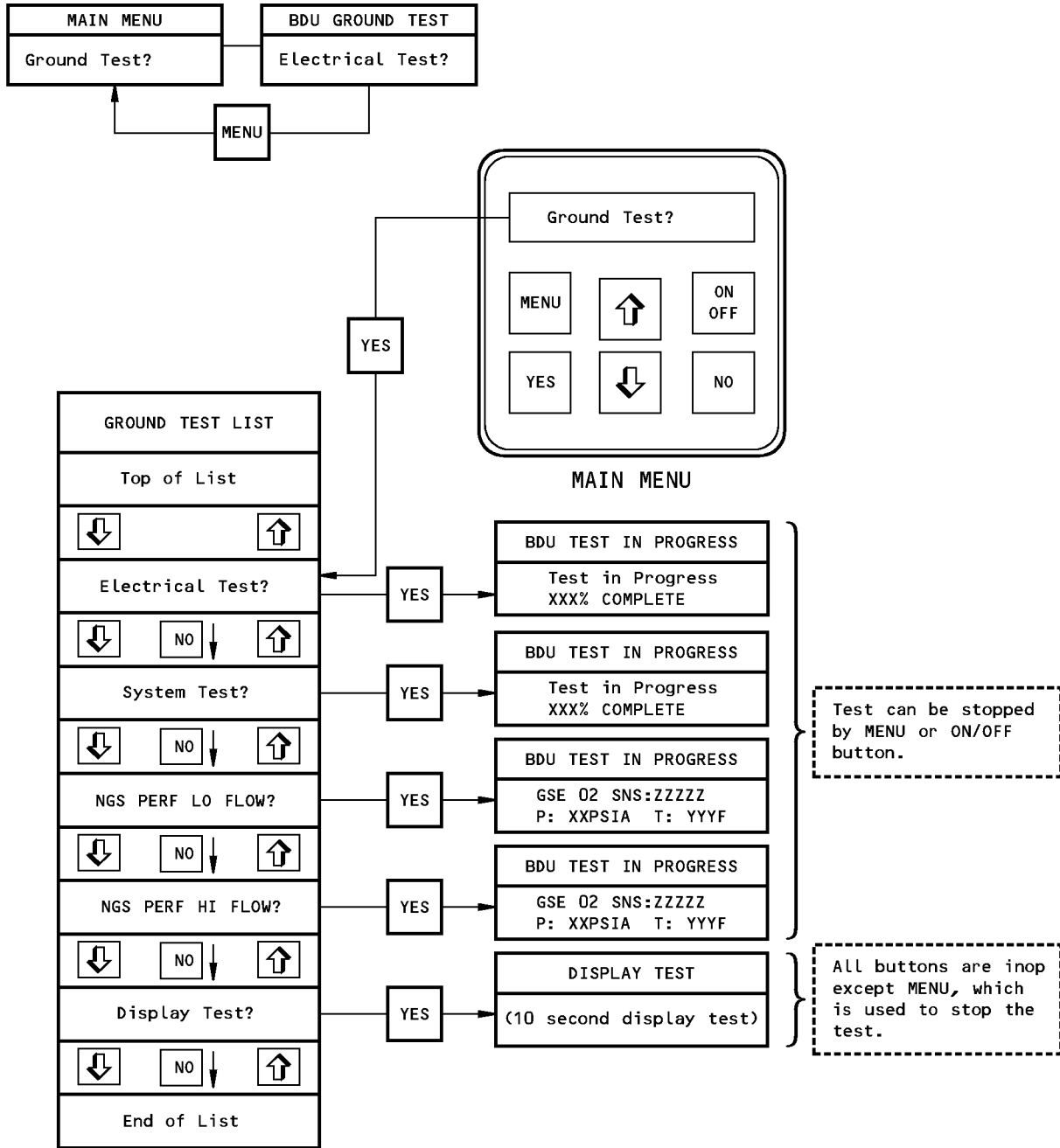

1501308 S0000273555_V1

**Ground Test Menu
Figure 204 (Sheet 1 of 6)/47-31-02-990-805**

EFFECTIVITY
HAP 047-053, 106-999

47-31-02

Page 237
Oct 15/2008

D633A101-HAP

**737-600/700/800/900
AIRCRAFT MAINTENANCE MANUAL**

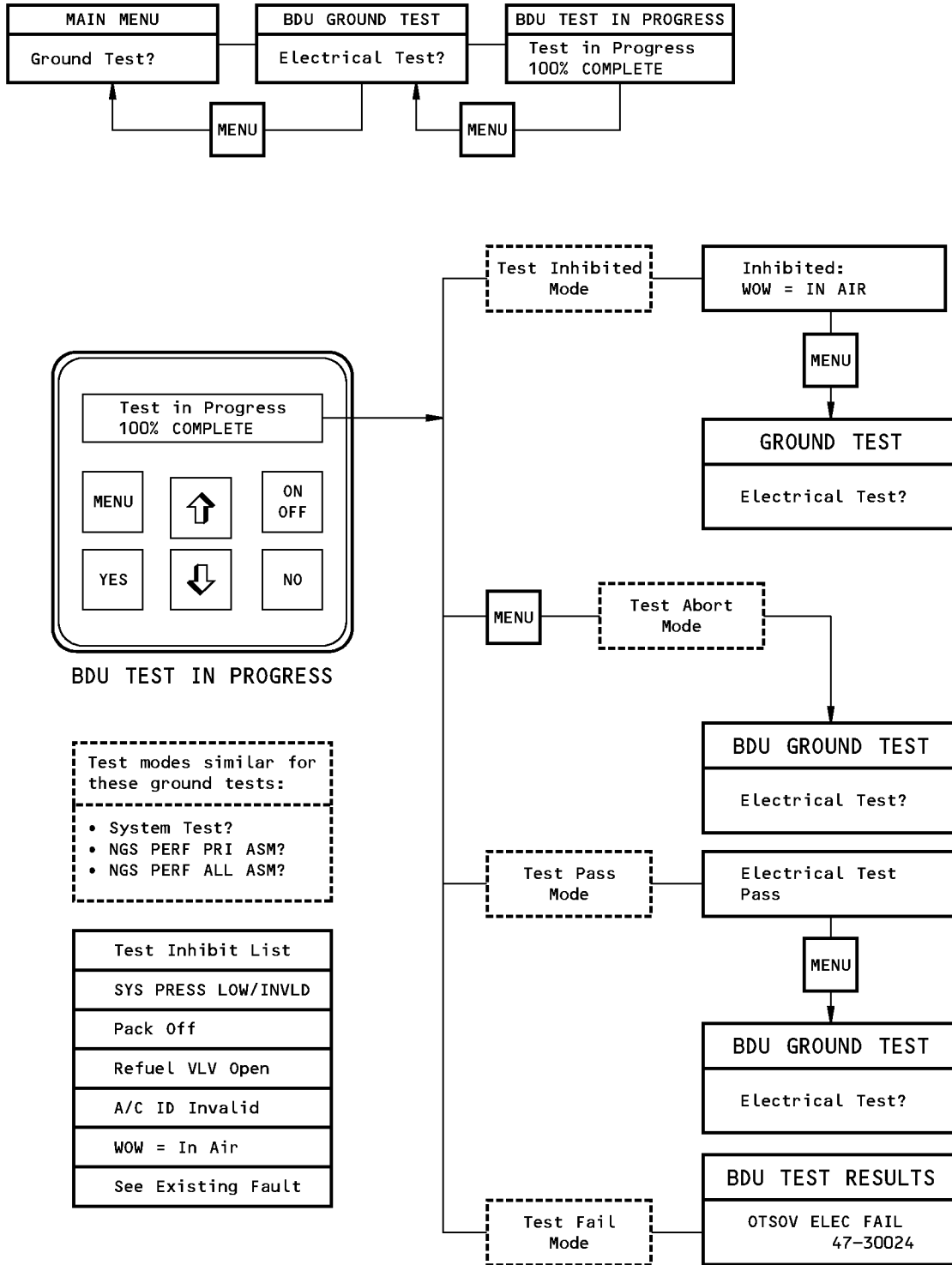

1501313 S0000273556_V1

**Ground Test Menu
Figure 204 (Sheet 2 of 6)/47-31-02-990-805**

EFFECTIVITY
HAP 047-053, 106-999

47-31-02

Page 238
Oct 15/2008

D633A101-HAP

**737-600/700/800/900
AIRCRAFT MAINTENANCE MANUAL**

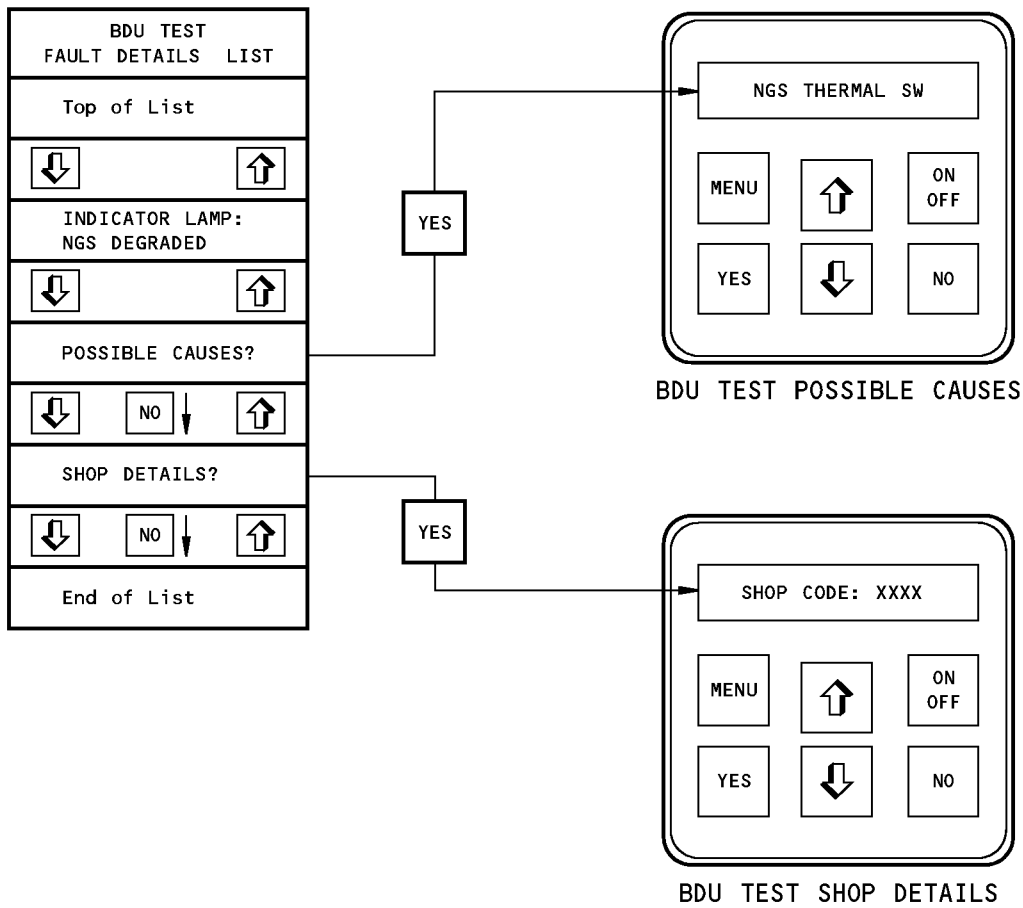
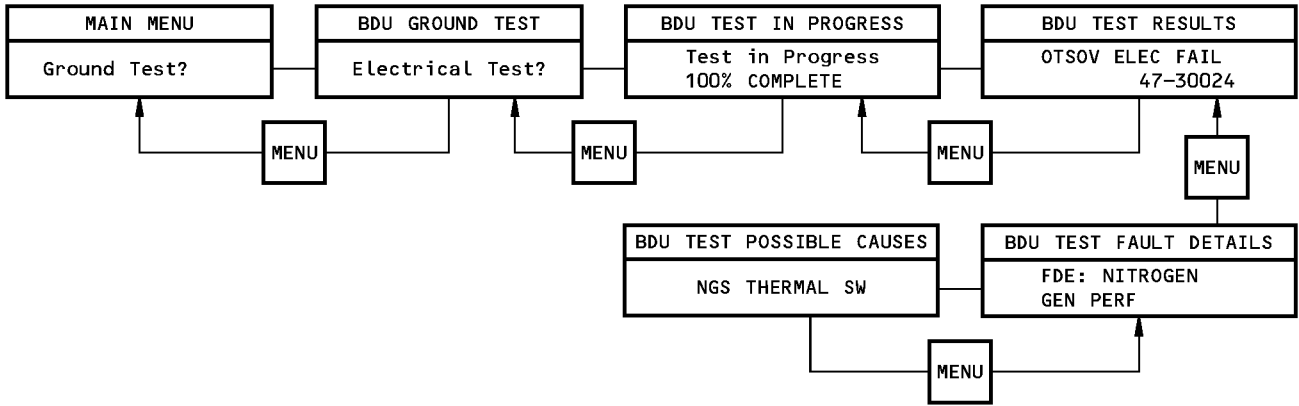

1501316 S0000273557_V1

**Ground Test Menu
Figure 204 (Sheet 4 of 6)/47-31-02-990-805**

EFFECTIVITY
HAP 047-053, 106-999

47-31-02

Page 240
Oct 15/2008

D633A101-HAP

**737-600/700/800/900
AIRCRAFT MAINTENANCE MANUAL**

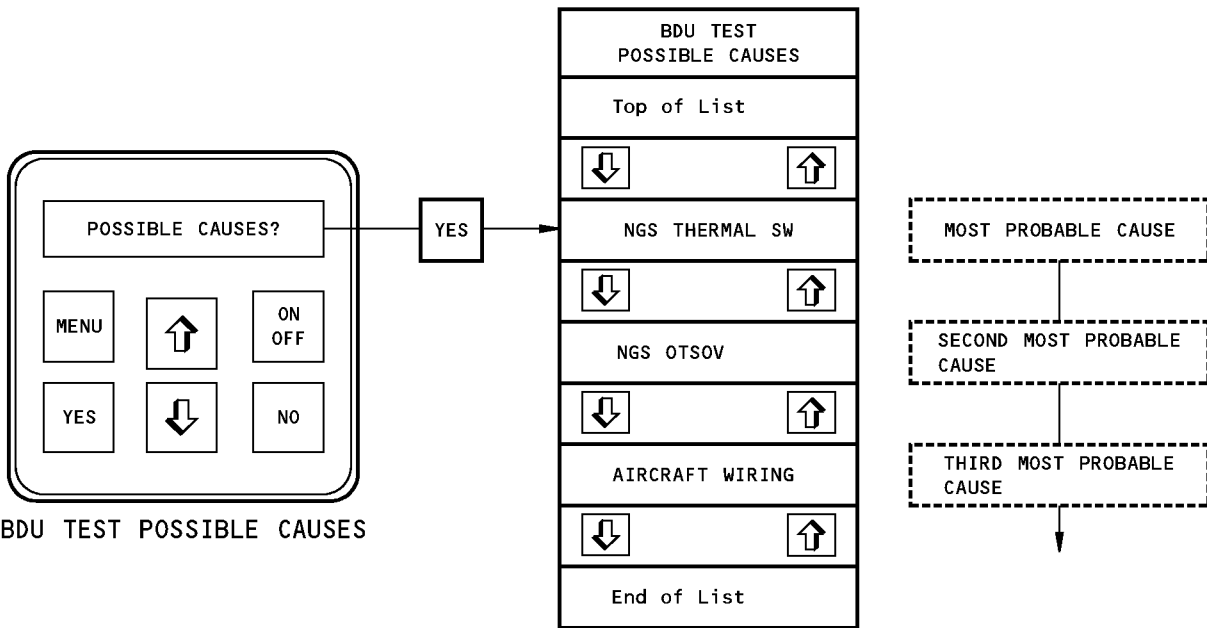
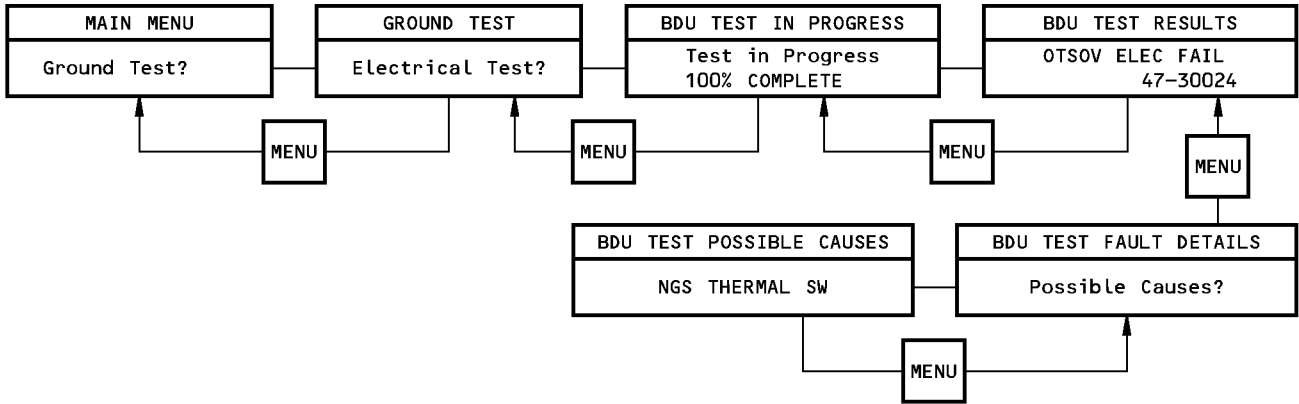

1501317 S0000273558_V1

**Ground Test Menu
Figure 204 (Sheet 5 of 6)/47-31-02-990-805**

EFFECTIVITY
HAP 047-053, 106-999

47-31-02

Page 241
Oct 15/2008

D633A101-HAP

**737-600/700/800/900
AIRCRAFT MAINTENANCE MANUAL**

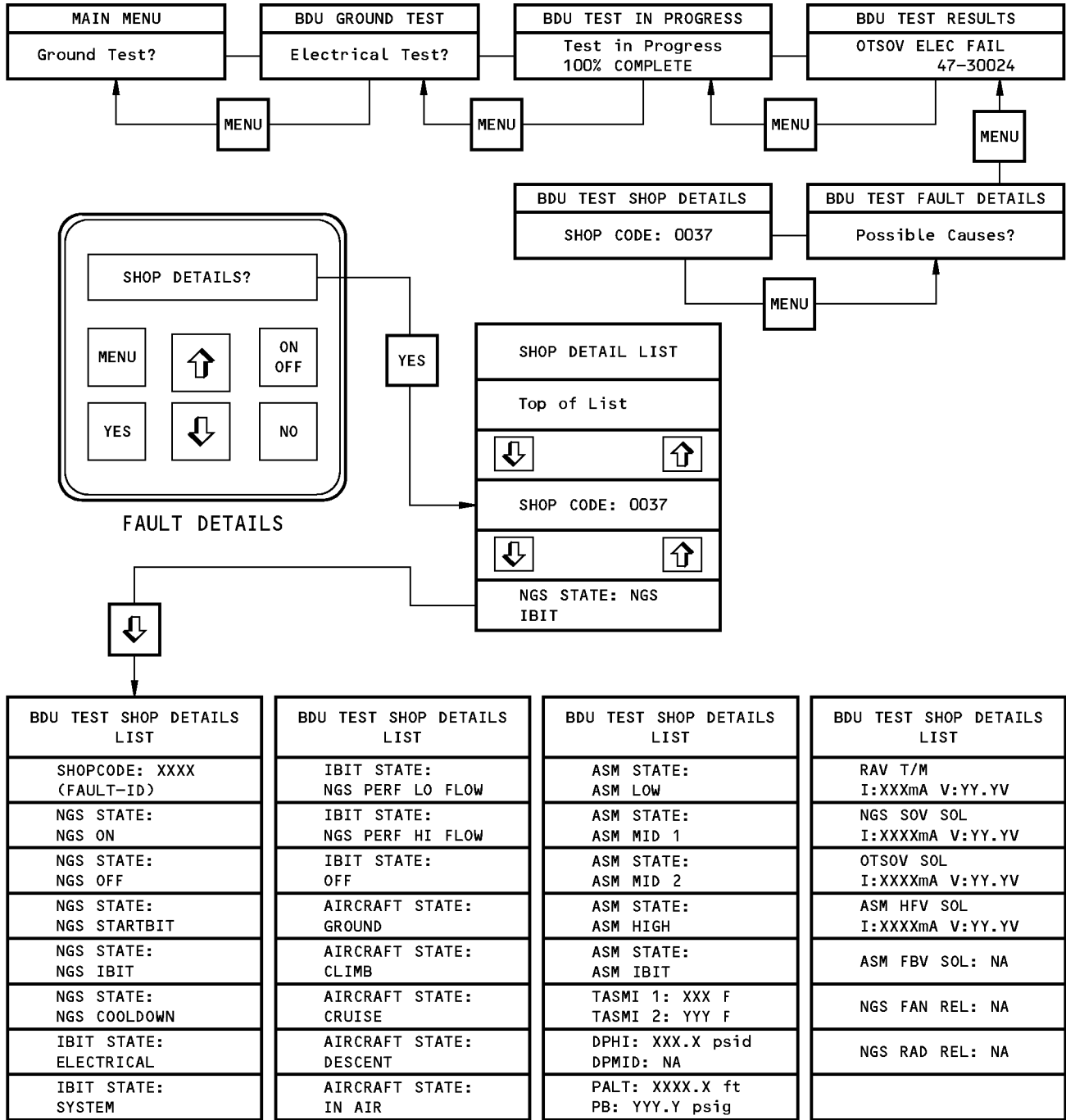

BDU TEST SHOP DETAILS

1501324 S0000273559_V1

**Ground Test Menu
Figure 204 (Sheet 6 of 6)/47-31-02-990-805**

EFFECTIVITY
HAP 047-053, 106-999

47-31-02

Page 242
Oct 15/2008

D633A101-HAP



737-600/700/800/900

AIRCRAFT MAINTENANCE MANUAL

TASK 47-31-02-740-805

6. Other Function Menu

(Figure 205)

A. General

- (1) This task gives the instructions to operate the BDU control panel for the OTHER FUNCTION menu.
- (2) To help you move through the BDU OTHER FUNCTION menu structure, refer to Figure 205.
- (3) The OTHER FUNCTION menu lets you do a check of the NGS system configuration. The OTHER FUNCTION menu also lets you monitor the input signals and the condition of the NGS controller valve drivers.

B. Access Panels

Number	Name/Location
192CR	Air Conditioning Access Door
192DR	ECS High Pressure Access Door

C. Main Menu

SUBTASK 47-31-02-740-052

- (1) Do this task: BDU Main Menu, TASK 47-31-02-740-801.
 - (a) Push the BDU control panel up or down arrows or the NO button until Other Functions? shows on the display.

D. Other Function List

SUBTASK 47-31-02-740-053

- (1) Make sure that Other Functions? shows on the display.
 - (a) Push the YES button.
 - 1) Make sure that System Config? shows on the display.

SUBTASK 47-31-02-740-077

- (2) These are the menu items from the Other Function list:
 - (a) System Config?
 - (b) I/O Monitor?

SUBTASK 47-31-02-740-078

- (3) Push the up and down arrows or NO button to get to the applicable Other Function menu item.

E. System Configuration List

SUBTASK 47-31-02-740-054

- (1) Make sure that SYSTEM CONFIG? shows on the display.
 - (a) Push the YES button.
 - 1) Make sure that HARDWARE PART NO: shows on the display.

SUBTASK 47-31-02-740-079

- (2) These are the menu items from the System Configuration list:
 - (a) HARDWARE PART NO:
 - (b) BOOT LOADER PART NO:
 - (c) SOFTWARE PART NO:
 - (d) CONFIG PART NO:

EFFECTIVITY
HAP 047-053, 106-999

D633A101-HAP

47-31-02

Page 243
Oct 15/2008



737-600/700/800/900

AIRCRAFT MAINTENANCE MANUAL

(e) AIRCRAFT ID: (737)

SUBTASK 47-31-02-740-080

(3) Continue to push the down arrow to see all of the System Configuration items.

F. I/O Monitor List

SUBTASK 47-31-02-740-055

(1) Push the down arrow or NO button on the other function list until I/O Monitor? shows on the display.

(a) Push the YES button.

1) Make sure that the menu item from the I/O monitor list Analog Inputs? shows on the display.

SUBTASK 47-31-02-740-082

(2) These are the menu items for the I/O Monitor list:

(a) Analog Inputs?

(b) Discrete Inputs?

(c) Outputs?

(d) Oxygen Sensor?

SUBTASK 47-31-02-740-083

(3) Continue to push the down arrow to see all of menu items for the I/O Monitor list.

G. Analog Inputs List

SUBTASK 47-31-02-740-084

(1) Make sure that ANALOG INPUTS? from the I/O monitor list shows.

(a) Push the YES button.

1) Make sure that TASMI 1: XXX F from the Analog Input list shows on the display.

SUBTASK 47-31-02-740-086

(2) These are the menu items from the Analog Input list:

(a) TASMI 1: XXX F

TASMI 2: XXX F

(b) DPHI: XXX.Xpsid

DPMID: NA

(c) PALT: XXXXX ft

PB: YYY.Y psig

(d) TOTAL AIR TEMP:

NA

SUBTASK 47-31-02-740-087

(3) Continue to push the down arrow to see all of menu items for the Analog Input list.

H. Discrete Inputs List

SUBTASK 47-31-02-740-057

(1) Push the down/up arrow or the NO button on the I/O Monitor list.

(a) Make sure that Discrete Inputs? shows on the display.

SUBTASK 47-31-02-740-088

(2) Push the YES button.

EFFECTIVITY
HAP 047-053, 106-999

D633A101-HAP

47-31-02

Page 244
Oct 15/2008



737-600/700/800/900

AIRCRAFT MAINTENANCE MANUAL

- (a) Make sure that FLIGHT DECK SMOKE1: NOT EVAC (EVAC) shows on the display.

SUBTASK 47-31-02-740-089

- (3) Continue to push the down arrow to see all of the menu items for Discrete Input list.

NOTE: For the complete list of discrete input items, refer to Figure 205.

I. Outputs List

SUBTASK 47-31-02-740-090

- (1) Push the down/up arrow or the NO button on the I/O Monitor list.

- (a) Make sure that Outputs? shows on the display.

SUBTASK 47-31-02-740-091

- (2) Push the YES button.

- (a) Make sure that RAV Torque Motor CMD: XXX mA shows on the display.

SUBTASK 47-31-02-740-092

- (3) Continue to push the down arrow to see all of the menu items for the Outputs list.

SUBTASK 47-31-02-740-093

- (4) These are the menu items from the Outputs list:

- (a) RAV Torque Motor CMD: XXX mA
- (b) NGS SOV SOL CMD: OPEN (CLOSED)
- (c) OTSOV SOL CMD: OPEN (CLOSED)
- (d) ASM HFV SOL CMD: OPEN (CLOSED)
- (e) ASM FBV SOL CMD: NA
- (f) NGS FAN REL CMD: NA
- (g) NGS RAD REL CMD: NA

SUBTASK 47-31-02-740-094

- (5) After you do the necessary maintenance tasks, continue.

J. Outputs List

SUBTASK 47-31-02-740-095

- (1) Push the down/up arrow or the NO button on the I/O Monitor list.

- (a) Make sure that Oxygen Sensor? shows on the display.
- (b) Push the YES button.

SUBTASK 47-31-02-740-096

- (2) These are the items from the Oxygen Sensor list:

- (a) O2: XX.X%
PO2: YY.YPSIA
- (b) O2: OFF
PO2: OFF
- (c) O2: WARMING
PO2: WARMING
- (d) O2: FAILED
PO2: FAILED

EFFECTIVITY
HAP 047-053, 106-999

D633A101-HAP

47-31-02

Page 245
Oct 15/2008



737-600/700/800/900

AIRCRAFT MAINTENANCE MANUAL

K. Put the Airplane Back to the Usual Condition

SUBTASK 47-31-02-740-060

- (1) Make sure all BDU initiated tests are complete.
- (2) Push the ON/OFF button.

SUBTASK 47-31-02-410-006

- (3) Close these access panels:

<u>Number</u>	<u>Name/Location</u>
192CR	Air Conditioning Access Door
192DR	ECS High Pressure Access Door

————— END OF TASK —————

EFFECTIVITY
HAP 047-053, 106-999

D633A101-HAP

BOEING PROPRIETARY - Copyright © Unpublished Work - See title page for details

47-31-02

Page 246
Oct 15/2008

**737-600/700/800/900
AIRCRAFT MAINTENANCE MANUAL**

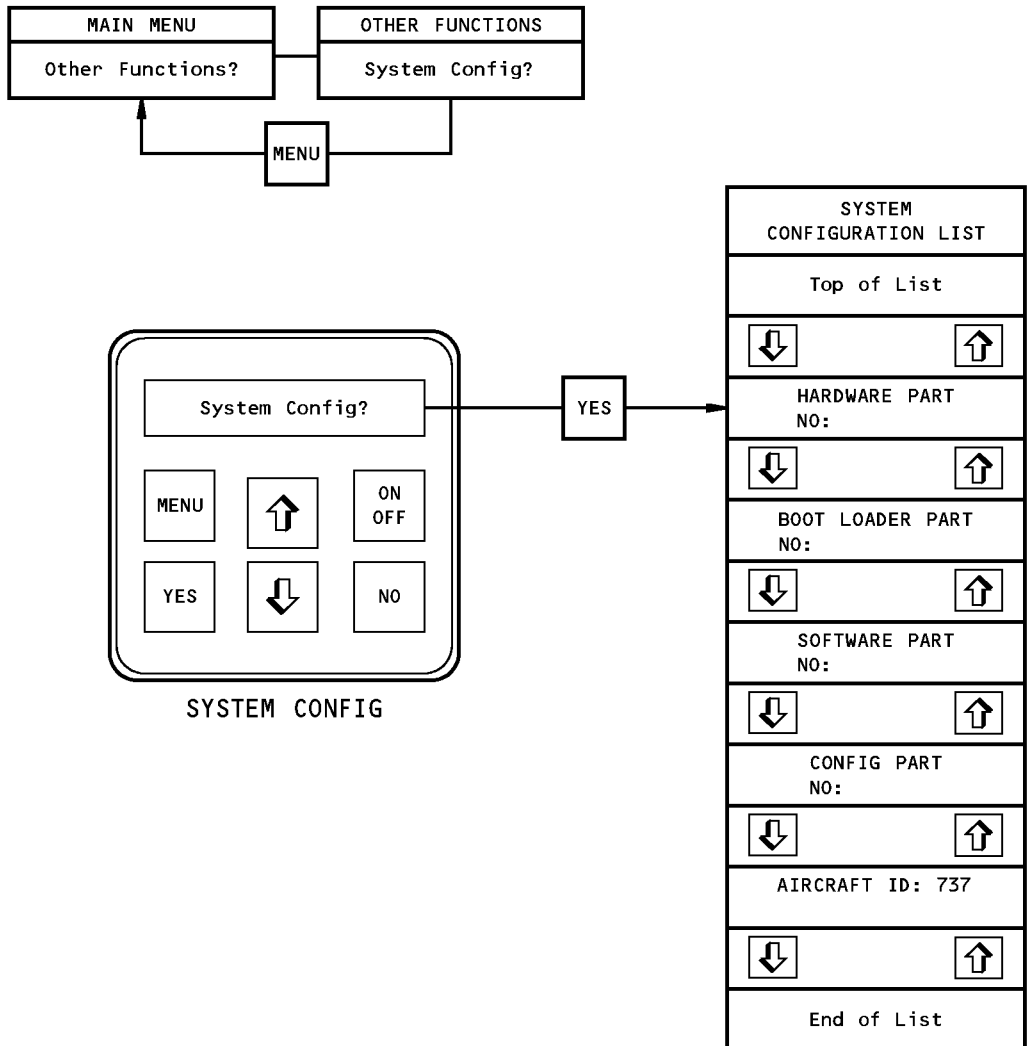

J86054 S0000180643_V2

**Other Functions Menu
Figure 205 (Sheet 2 of 7)/47-31-02-990-806**

EFFECTIVITY
HAP 047-053, 106-999

47-31-02

Page 248
Oct 15/2008

D633A101-HAP

**737-600/700/800/900
AIRCRAFT MAINTENANCE MANUAL**

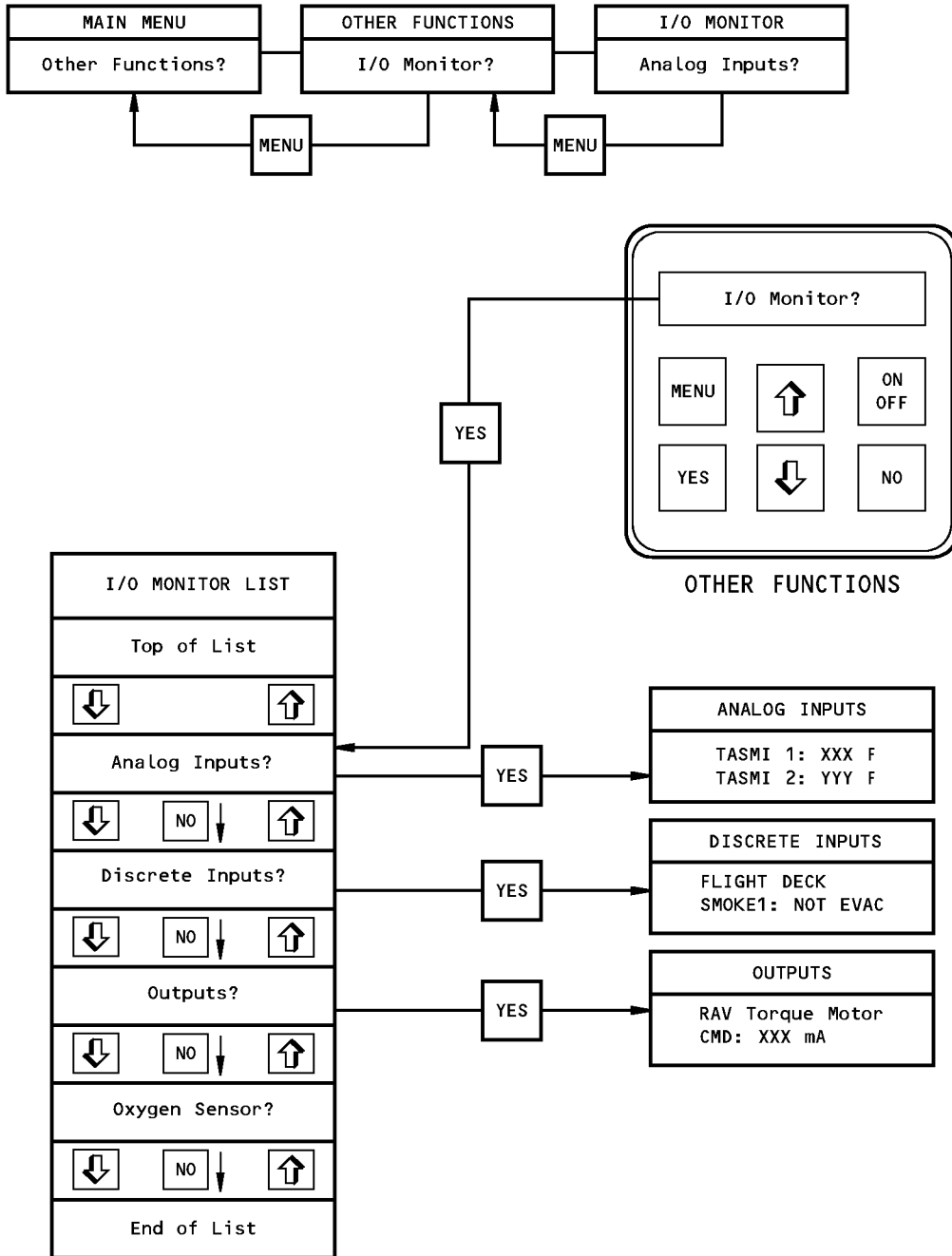

1503679 S0000273985_V1

Other Functions Menu
Figure 205 (Sheet 3 of 7)/47-31-02-990-806

EFFECTIVITY
HAP 047-053, 106-999

47-31-02

Page 249
Oct 15/2008

D633A101-HAP

**737-600/700/800/900
AIRCRAFT MAINTENANCE MANUAL**

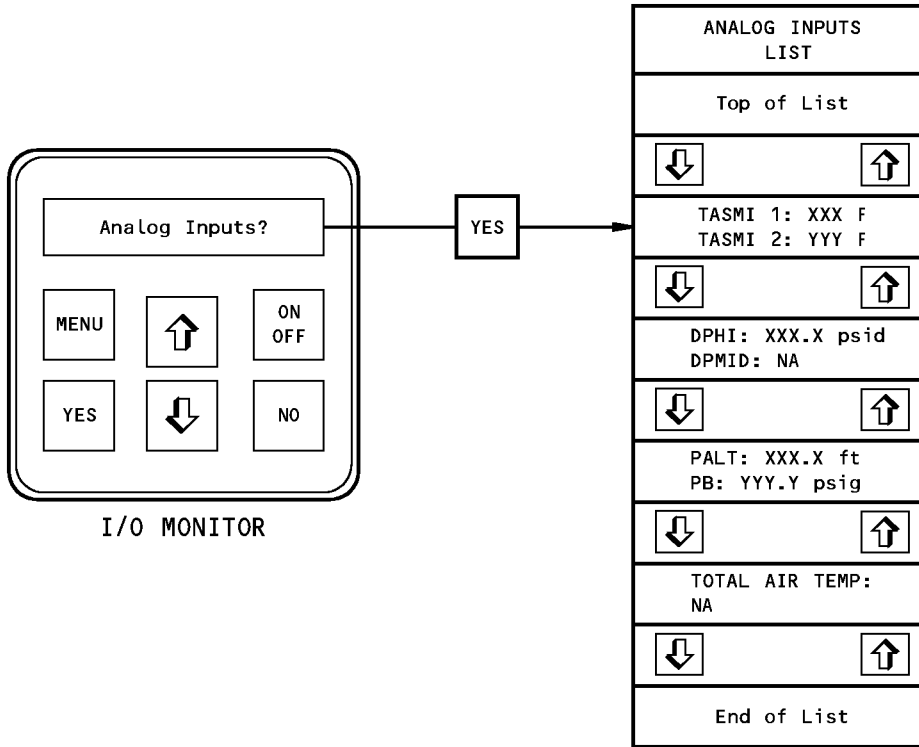
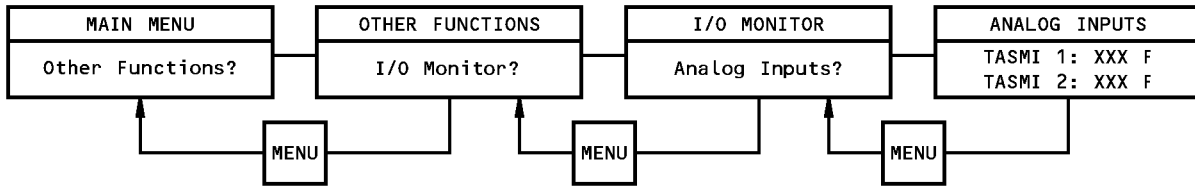

1503721 S0000273987_V1

**Other Functions Menu
Figure 205 (Sheet 4 of 7)/47-31-02-990-806**

EFFECTIVITY
HAP 047-053, 106-999

47-31-02

Page 250
Oct 15/2008

D633A101-HAP

AIRCRAFT MAINTENANCE MANUAL

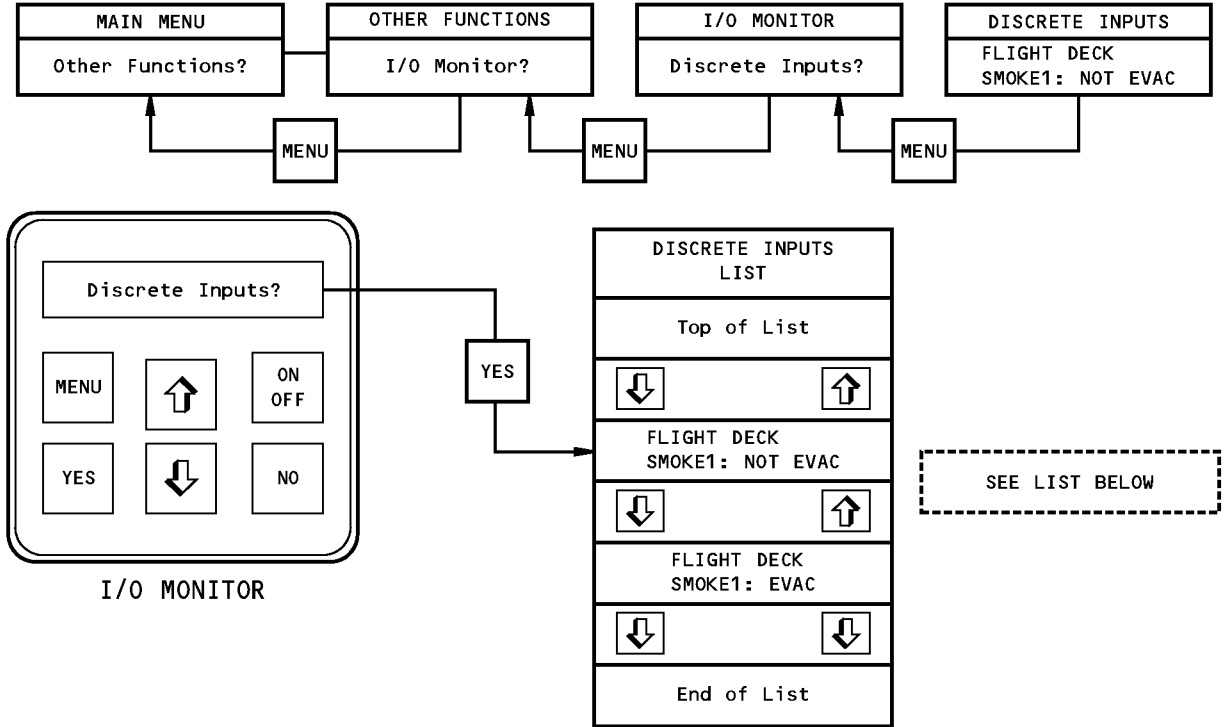

DISCRETE INPUTS LIST	DISCRETE INPUTS LIST	DISCRETE INPUTS LIST	DISCRETE INPUTS LIST	DISCRETE INPUTS LIST	DISCRETE INPUTS LIST
FLIGHT DECK SMOKE1: NOT EVAC	FWD CARGO FIRE: ARMED	ID PIN 1: OPEN	ENGINE 1 SIG: ON	REFUEL VLV SIG2: NA	FLAPS SIG: NA
FLIGHT DECK SMOKE1: EVAC	FWD CARGO FIRE: NOT ARMED	ID PIN 1: GROUND	ENGINE 1 SIG: OFF	FILTER DP SW: High Pressure	CMC ELE IBIT: NA
FLIGHT DECK SMOKE2: NA	TEST MODE 1: OPEN	ID PIN 2: OPEN	ENGINE 2 SIG: ON	FILTER DP SW: Normal	CMC SYS IBIT: NA
	TEST MODE 1: GROUND	ID PIN 2: GROUND	ENGINE 2 SIG: OFF	LAMP DISCRETE: LAMP TEST	FAN ON IND: NA
WOW: ON GROUND	TEST MODE 2: OPEN	ID PIN 3: OPEN	ENGINE 3 SIG: NA	LAMP DISCRETE: NO TEST	RAD OPEN IND: NA
WOW: IN AIR	TEST MODE 2: GROUND	ID PIN 3: GROUND	ENGINE 4 SIG: NA	LAMP DISCRETE: LAMP TEST	RAD CLOSE IND: NA
MAIN CARGO FIRE: ARMED	TEST MODE 3: OPEN	ID PIN 4: OPEN	PACK SIG: OFF	LAMP DISCRETE: NO TEST	RIGHT ENGINE START: NA
MAIN CARGO FIRE: NOT ARMED	TEST MODE 3: GROUND	ID PIN 4: GROUND	PACK SIG: ON	FLAPS SIG: DEPLOYED	LEFT ENGINE START: NA
AFT CARGO FIRE: ARMED	TEST MODE 4: OPEN	ID PIN 5: OPEN	REFUEL VLV SIG1: Valve Open	FLAPS SIG: NOT DEPLOYED	APUSOV ACTUAL POSITION: NA
AFT CARGO FIRE: NOT ARMED	TEST MODE 3: GROUND	ID PIN 5: GROUND	REFUEL VLV SIG1: Valve Closed	FLAPS: DEPLOYED	
				FLAPS: NOT DEPLOYED	

DISCRETE INPUTS

1503864 S0000273988_V1

Other Functions Menu
Figure 205 (Sheet 5 of 7)/47-31-02-990-806

EFFECTIVITY
HAP 047-053, 106-999

47-31-02

AIRCRAFT MAINTENANCE MANUAL

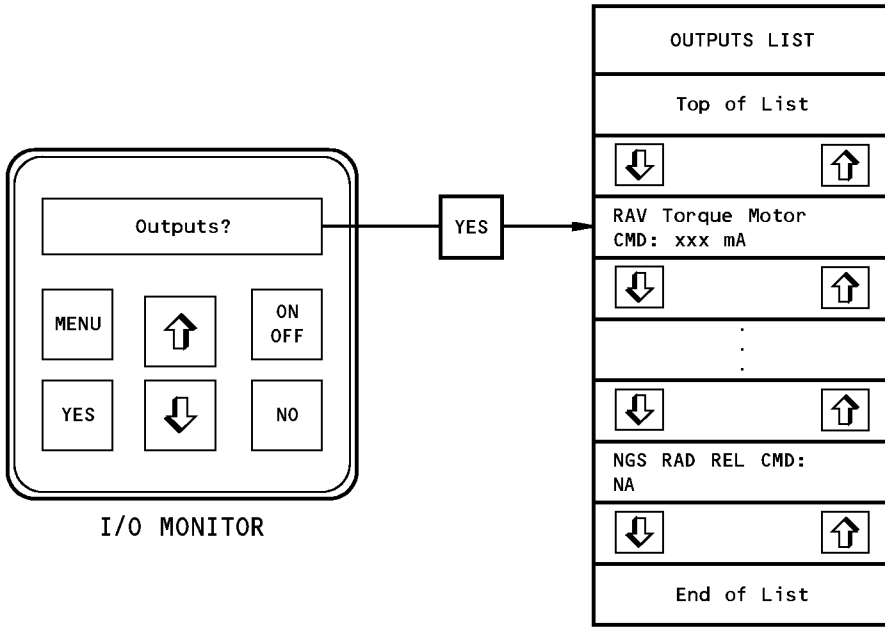
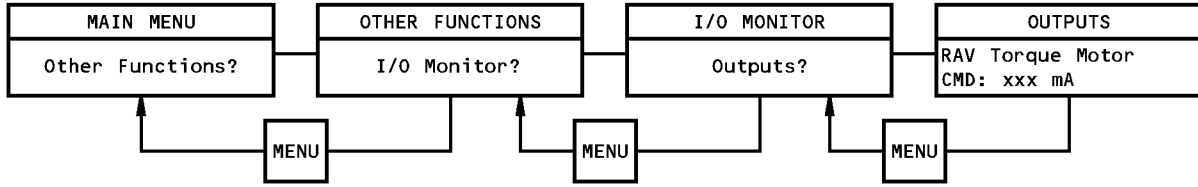

OUTPUTS LIST	OUTPUTS LIST
RAV Torque Motor CMD: XXX mA	ASM HFV SOL CMD: OPEN
NGS SOV SOL CMD: OPEN	ASM HFV SOL CMD: CLOSED
NGS SOV SOL CMD: CLOSED	ASM FBV SOL CMD: NA
OTSOV SOL CMD: OPEN	NGS FAN REL CMD: NA
OTSOV SOL CMD: CLOSED	NGS RAD REL CMD: NA

1503938 S0000273989_V1

Other Functions Menu
Figure 205 (Sheet 6 of 7)/47-31-02-990-806

EFFECTIVITY
 HAP 047-053, 106-999

47-31-02

Page 252
 Oct 15/2008

D633A101-HAP

**737-600/700/800/900
AIRCRAFT MAINTENANCE MANUAL**

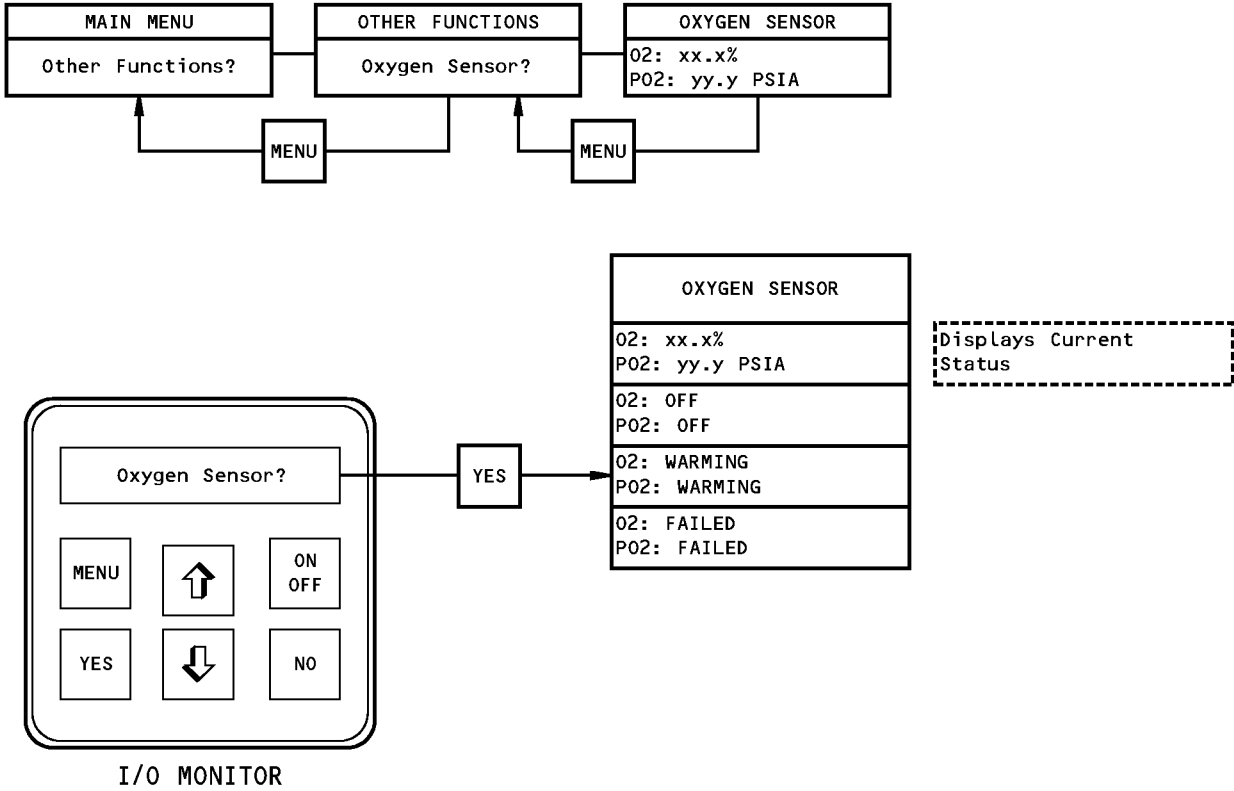

1503967 S0000273990_V1

**Other Functions Menu
Figure 205 (Sheet 7 of 7)/47-31-02-990-806**

**EFFECTIVITY
HAP 047-053, 106-999**

47-31-02

Page 253
Oct 15/2008

D633A101-HAP



737-600/700/800/900

AIRCRAFT MAINTENANCE MANUAL

BITE DISPLAY UNIT - REMOVAL/INSTALLATION

1. General

A. This procedure has these tasks:

- (1) BITE Display Unit Removal
- (2) BITE Display Unit Installation

TASK 47-31-02-000-801

2. BITE Display Unit Removal

(Figure 401)

A. Location Zones

<u>Zone</u>	<u>Area</u>
132	Center Section Wing Box, Body Station 540.00 to Body Station 663.75 - Right
212	Flight Compartment - Right

B. Access Panels

<u>Number</u>	<u>Name/Location</u>
192CR	Air Conditioning Access Door

C. Prepare for Removal

SUBTASK 47-31-02-865-001

(1) Open these circuit breakers and install safety tags:

CAPT Electrical System Panel, P18-3

<u>Row</u>	<u>Col</u>	<u>Number</u>	<u>Name</u>
D	17	C01657	NITROGEN GENERATION CONTROL
E	15	C01680	NGS ALT PWR

SUBTASK 47-31-02-010-001

(2) Open this access panel:

<u>Number</u>	<u>Name/Location</u>
192CR	Air Conditioning Access Door

SUBTASK 47-31-02-860-001

(3) Put the L PACK and R PACK selector switches, on the P5-10 air conditioning panel, to the OFF position.

(a) Attach DO-NOT-OPERATE tags on the L PACK and R PACK selector switches.

SUBTASK 47-31-02-010-002

(4) Go to the BITE Display Unit [1] location.

D. Remove the BITE Display Unit

SUBTASK 47-31-02-020-001

(1) Disconnect the electrical connector [4] from the BITE Display Unit [1].

SUBTASK 47-31-02-030-001

(2) Remove the bolt [2] and washer [3] to disconnect the bonding jumper [5] on the upper left side.

NOTE: Keep the hardware for the installation.

EFFECTIVITY HAP 047-053, 106-999

47-31-02

Page 401
Oct 15/2008

D633A101-HAP



**737-600/700/800/900
AIRCRAFT MAINTENANCE MANUAL**

SUBTASK 47-31-02-020-002

(3) Hold the BITE Display Unit [1] in its position.

SUBTASK 47-31-02-030-002

(4) Remove the remaining three bolts [2] and washers [3].

SUBTASK 47-31-02-020-003

(5) Remove the BITE Display Unit [1] from the vibration isolators [6].

————— **END OF TASK** —————

EFFECTIVITY
HAP 047-053, 106-999

D633A101-HAP

BOEING PROPRIETARY - Copyright © Unpublished Work - See title page for details

47-31-02

Page 402
Oct 15/2008

**737-600/700/800/900
AIRCRAFT MAINTENANCE MANUAL**

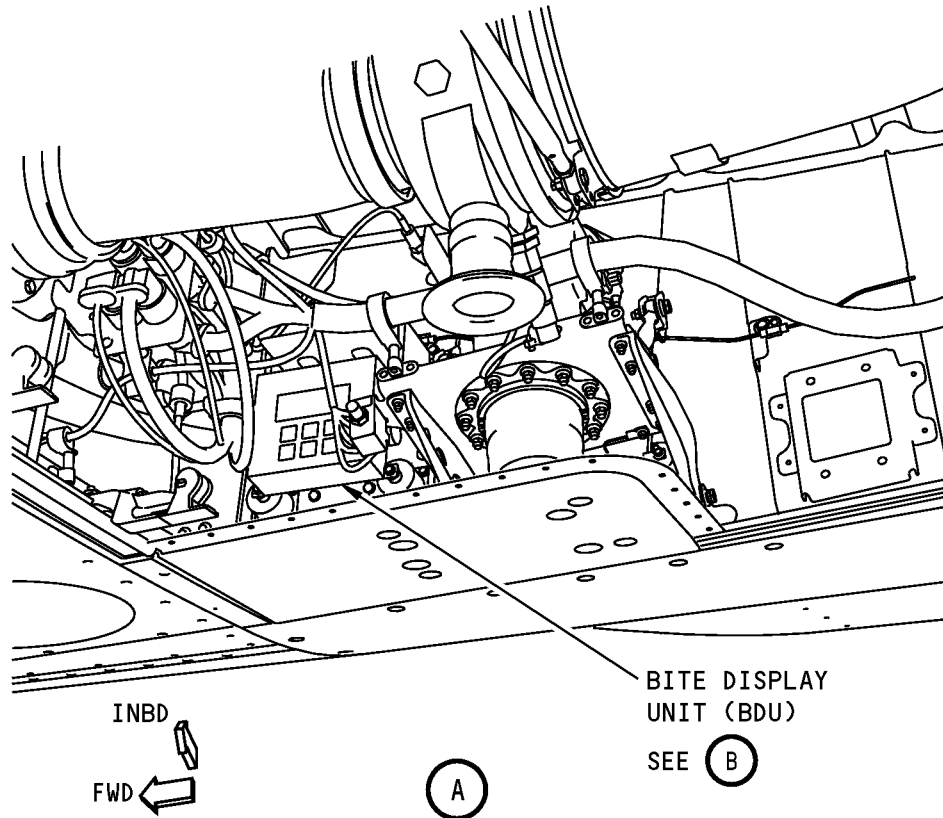
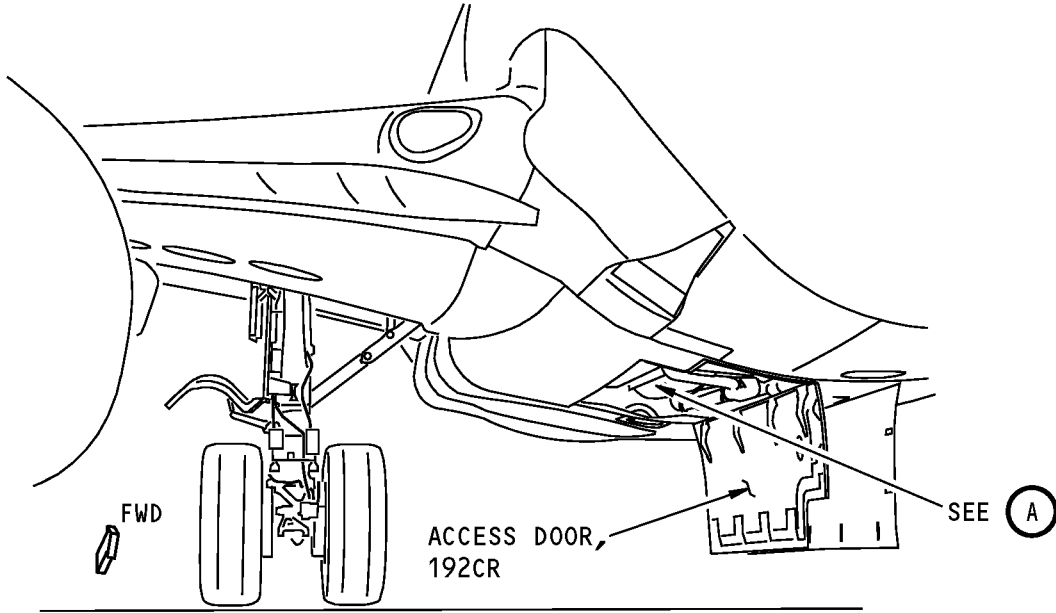

**BITE Display Unit (BDU)
Figure 401 (Sheet 1 of 2)/47-31-02-990-801**

EFFECTIVITY
HAP 047-053, 106-999

47-31-02

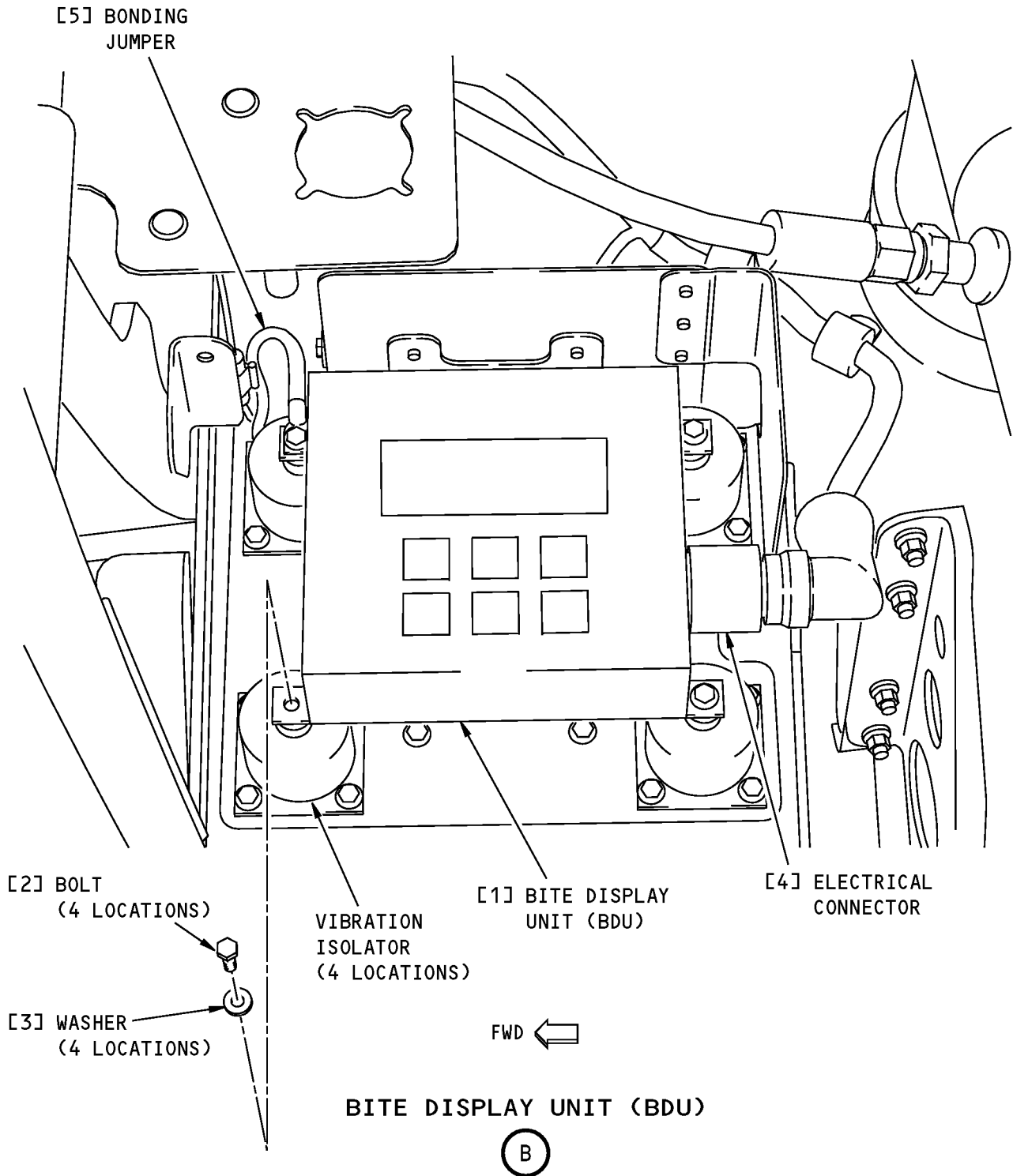

BITE Display Unit (BDU)
Figure 401 (Sheet 2 of 2)/47-31-02-990-801

EFFECTIVITY
HAP 047-053, 106-999

47-31-02



737-600/700/800/900

AIRCRAFT MAINTENANCE MANUAL

TASK 47-31-02-400-801

3. BITE Display Unit Installation

(Figure 401)

A. References

Reference	Title
20-30-80-910-801	General Cleaning of Metal (Series 80) (P/B 201)
47-00-00-800-801	Ground Operation of the Nitrogen Generation System (P/B 201)
51-21-41-370-802	Apply Alodine 600, 1200 or 1200S Solution (P/B 701)
SWPM 20-20-00	Electrical Bonds and Grounds

B. Tools/Equipment

NOTE: When more than one tool part number is listed under the same "Reference" number, the tools shown are alternates to each other within the same airplane series. Tool part numbers that are replaced or non-procurable are preceded by "Opt:", which stands for Optional.

Reference	Description
COM-1550	Meter - Bonding (Approved Explosion Proof & Intrinsically Safe) (Part #: C15292 (MODEL T477W), Supplier: 01014, A/P Effectivity: 737-ALL) (Part #: M1, Supplier: 3AD17, A/P Effectivity: 737-ALL) (Part #: M1B, Supplier: 3AD17, A/P Effectivity: 737-ALL)

C. Consumable Materials

Reference	Description	Specification
C00862	Coating - Chemical Conversion - Alodine 600	

D. Expendables/Parts

AMM Item	Description	AIPC Reference	AIPC Effectivity
1	BITE Display Unit	47-31-02-01A-020	HAP 047-053, 106-999

E. Location Zones

Zone	Area
132	Center Section Wing Box, Body Station 540.00 to Body Station 663.75 - Right
212	Flight Compartment - Right

F. Access Panels

Number	Name/Location
192CR	Air Conditioning Access Door

G. Install the BITE Display Unit

SUBTASK 47-31-02-010-003

(1) Go to the BITE Display Unit [1] location in the air conditioning equipment bay.

SUBTASK 47-31-02-100-001

(2) Make sure that the mating surfaces of the BITE Display Unit [1] and the vibration isolator [6] are clean, free from grease and unwanted material.

(a) To clean the components, do this task: General Cleaning of Metal (Series 80), TASK 20-30-80-910-801.

EFFECTIVITY
HAP 047-053, 106-999

47-31-02



737-600/700/800/900

AIRCRAFT MAINTENANCE MANUAL

SUBTASK 47-31-02-110-001

- (3) Prepare these components for an electrical mating surface bond (SWPM 20-20-00):
 - (a) contact surface of the top forward vibration isolator [6] and the BITE Display Unit [1]
 - (b) bonding jumper [5]
 - (c) bolt [2] and washer [3]

SUBTASK 47-31-02-420-001

- (4) Do these steps to install the BITE Display Unit [1]:
 - (a) Align the BITE Display Unit [1] on the vibration isolator [6].
 - (b) Install, but do not tighten, the three bolts [2] and washers [3].
 - (c) Install the bolts [2] and washers [3] to attach the bonding jumper [5] (SWPM 20-20-00).
 - (d) Tighten the four bolts [2] to 13 ± 1 in-lb (1.47 ± 0.11 N·m).

SUBTASK 47-31-02-760-001

- (5) Use a bonding meter, COM-1550, to measure the electrical resistance across the bonding jumper [5] between the BITE Display Unit [1] and the airplane structure at the vibration isolator [6] (SWPM 20-20-00).
 - (a) Make sure that the electrical resistance between the BITE Display Unit [1] and the airplane structure is 0.008 ohm (8 milliohm) or less (SWPM 20-20-00).

SUBTASK 47-31-02-110-002

- (6) Apply a layer of Alodine 600 coating, C00862, to all bare areas of the BITE Display Unit [1] near the bonding jumper [5] location (TASK 51-21-41-370-802).

SUBTASK 47-31-02-430-001

- (7) Connect the electrical connector [4].

H. Operational Test for the BDU

SUBTASK 47-31-02-865-002

- (1) Remove the safety tags and close these circuit breakers:

CAPT Electrical System Panel, P18-3

<u>Row</u>	<u>Col</u>	<u>Number</u>	<u>Name</u>
D	17	C01657	NITROGEN GENERATION CONTROL
E	15	C01680	NGS ALT PWR

SUBTASK 47-31-02-740-001

- (2) Do this task to do a test of the BITE Display Unit [1]: Ground Operation of the Nitrogen Generation System, TASK 47-00-00-800-801.

I. Put the Airplane Back to its Usual Condition

SUBTASK 47-31-02-410-001

- (1) Close this access panel:

<u>Number</u>	<u>Name/Location</u>
192CR	Air Conditioning Access Door

————— END OF TASK —————

EFFECTIVITY HAP 047-053, 106-999

47-31-02

Page 406
Feb 15/2009

D633A101-HAP



737-600/700/800/900

AIRCRAFT MAINTENANCE MANUAL

OPERABILITY INDICATOR - REMOVAL/INSTALLATION

1. General

A. This procedure has these tasks:

- (1) Operability Indicator Removal
- (2) Operability Indicator Installation

TASK 47-31-03-000-801

2. Operability Indicator Removal

(Figure 401)

A. Location Zones

Zone	Area
134	Main Landing Gear Wheel Well, Body Station 663.75 to Body Station 727.00 - Right

B. Remove the Operability Indicator

HAP 047-053, 106-999

SUBTASK 47-31-03-865-001

(1) Open these circuit breakers and install safety tags:

CAPT Electrical System Panel, P18-3

Row	Col	Number	Name
D	17	C01657	NITROGEN GENERATION CONTROL
E	15	C01680	NGS ALT PWR

HAP 036-054, 101-999

SUBTASK 47-31-03-020-001

(2) Remove the operability indicator [1]:

- (a) Disconnect the electrical connector [8] from the operability indicator [1].
- (b) Remove the nut [3] and washer [4] to disconnect the bonding jumper [2] from the operability indicator [1].

NOTE: Keep the nut [3] and washer [4] for installation.

- (c) Remove the two bolts [5], washers [6] and nuts [7] that hold the operability indicator [1] to the bulkhead.

NOTE: Keep the fasteners for the installation.

- (d) Hold the operability indicator [1] in its position.
- (e) Remove the two screws [9] and washers [10] that attach the operability indicator [1] to the APU fire panel.

NOTE: Keep the fasteners for the installation.

- (f) Remove the operability indicator [1].

————— **END OF TASK** —————

EFFECTIVITY HAP 036-054, 101-999

47-31-03

Page 401
Feb 15/2009

D633A101-HAP

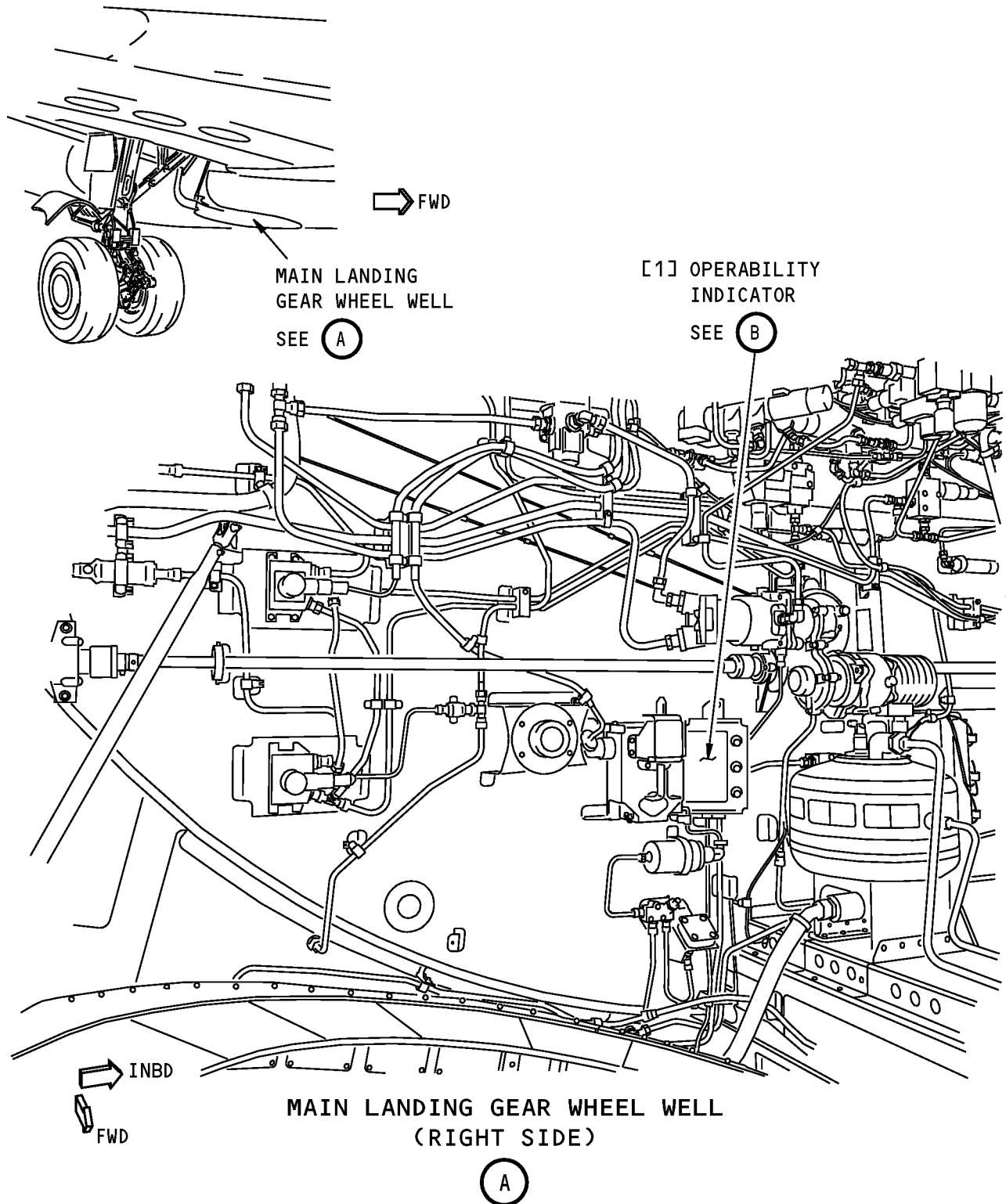

**Operability Indicator
Figure 401 (Sheet 1 of 2)/47-31-03-990-801**

EFFECTIVITY
HAP 036-054, 101-999

47-31-03

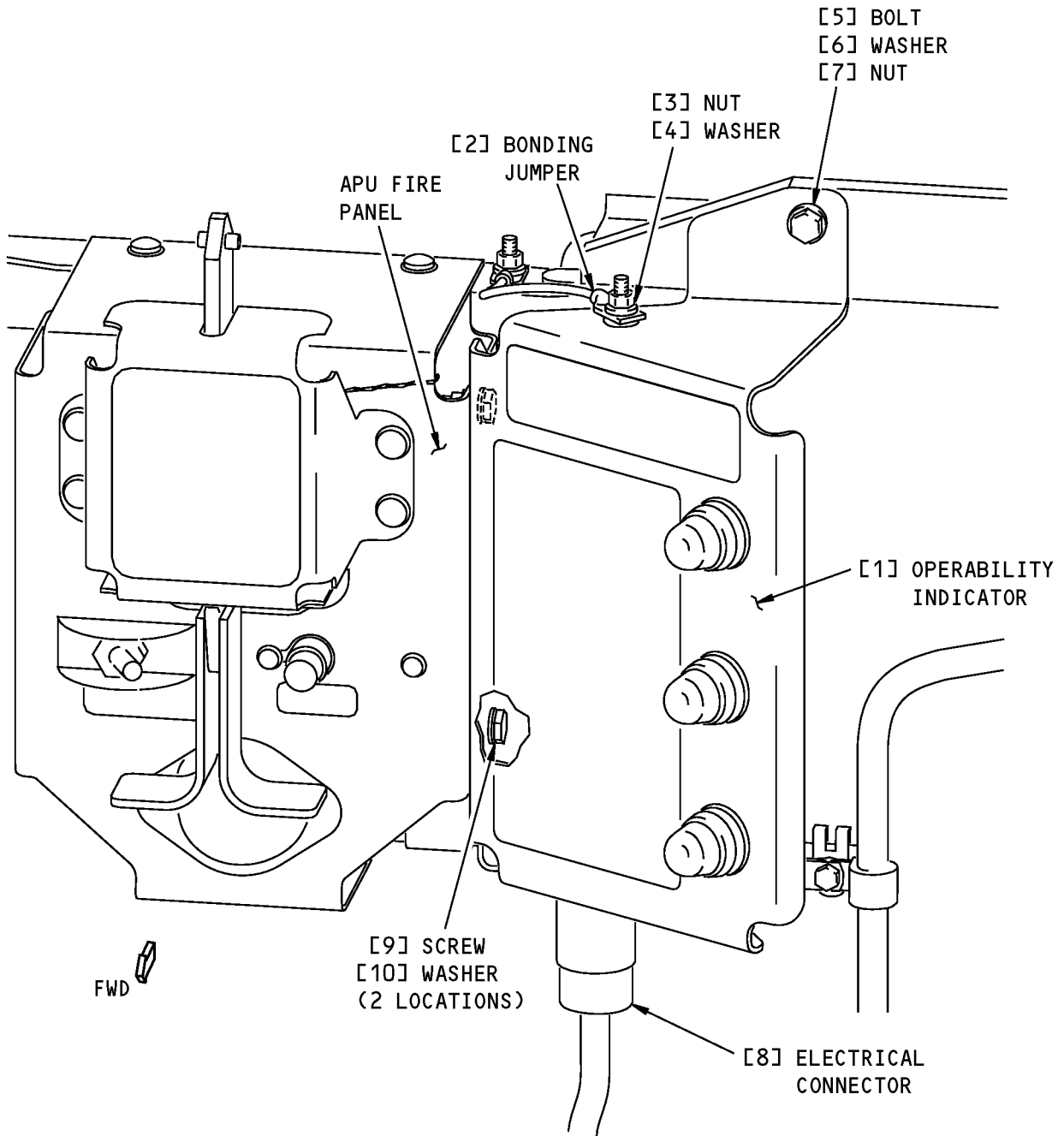

OPERABILITY INDICATOR

(B)

**Operability Indicator
Figure 401 (Sheet 2 of 2)/47-31-03-990-801**

EFFECTIVITY
HAP 036-054, 101-999

47-31-03



737-600/700/800/900

AIRCRAFT MAINTENANCE MANUAL

TASK 47-31-03-400-801

3. Operability Indicator Installation

(Figure 401)

A. References

Reference	Title
20-30-80-910-801	General Cleaning of Metal (Series 80) (P/B 201)
47-00-00-800-801	Ground Operation of the Nitrogen Generation System (P/B 201)
51-21-41-370-802	Apply Alodine 600, 1200 or 1200S Solution (P/B 701)
SWPM 20-20-00	Electrical Bonds and Grounds

B. Tools/Equipment

NOTE: When more than one tool part number is listed under the same "Reference" number, the tools shown are alternates to each other within the same airplane series. Tool part numbers that are replaced or non-procurable are preceded by "Opt:", which stands for Optional.

Reference	Description
COM-1550	Meter - Bonding (Approved Explosion Proof & Intrinsically Safe) (Part #: C15292 (MODEL T477W), Supplier: 01014, A/P Effectivity: 737-ALL) (Part #: M1, Supplier: 3AD17, A/P Effectivity: 737-ALL) (Part #: M1B, Supplier: 3AD17, A/P Effectivity: 737-ALL)

C. Consumable Materials

Reference	Description	Specification
A00247	Sealant - Pressure And Environmental - Chromate Type	BMS 5-95
A50009	Sealant - Low Density, Chromate Type Synthetic Rubber	BMS5-142, Class B-1/2
C00862	Coating - Chemical Conversion - Alodine 600	

D. Location Zones

Zone	Area
134	Main Landing Gear Wheel Well, Body Station 663.75 to Body Station 727.00 - Right

E. Install the Operability Indicator

SUBTASK 47-31-03-010-001

- (1) Go to the operability indicator [1] location in the right main wheel well.

SUBTASK 47-31-03-100-001

- (2) Make sure that the mating surfaces of the operability indicator [1] and the airplane structure are clean, free of grease and unwanted material.
 - (a) To clean the components, do this task: General Cleaning of Metal (Series 80), TASK 20-30-80-910-801.

SUBTASK 47-31-03-110-002

- (3) Prepare these components for the electrical faying surface bond:
 - (a) mating surface of the airplane structure.
 - (b) mating surface of the operability indicator [1].
 - (c) bonding jumper [2].

EFFECTIVITY HAP 036-054, 101-999

47-31-03



737-600/700/800/900
AIRCRAFT MAINTENANCE MANUAL

SUBTASK 47-31-03-420-001

- (4) Do these steps to install the operability indicator [1]:
 - (a) Put the operability indicator [1] in its position.
 - (b) Install the two screws [9] and washers [10] that attach the operability indicator [1] to the APU fire panel.
 - (c) Install the bolt [5], washer [6], and nut [7] that attach the operability indicator [1] to the bulkhead.
 - (d) Install the washer [4] and the nut [3] to connect the bonding jumper [2] to the operability indicator [1].

SUBTASK 47-31-03-700-001

- (5) Use the bonding meter, COM-1550, to measure the electrical resistance between the operability indicator [1] and the airplane structure.
 - (a) Make sure that the electrical resistance between the operability indicator [1] and the airplane structure is 0.010 ohm (10 milliohms) or less (SWPM 20-20-00).

SUBTASK 47-31-03-916-001

- (6) Apply a layer of Alodine 600 coating, C00862, to all bare areas of the operability indicator [1] near the bonding jumper [2] location (TASK 51-21-41-370-802).

SUBTASK 47-31-03-390-001

- (7) Put a cap seal of sealant, A00247, or sealant, A50009, on the bonding jumper [2] terminal.

HAP 047-053, 106-999

F. Operational Test of the Operability Indicator

SUBTASK 47-31-03-840-001

- (1) Remove the safety tags and close these circuit breakers:

CAPT Electrical System Panel, P18-3

<u>Row</u>	<u>Col</u>	<u>Number</u>	<u>Name</u>
D	17	C01657	NITROGEN GENERATION CONTROL
E	15	C01680	NGS ALT PWR

SUBTASK 47-31-03-881-001

- (2) Do this task: Ground Operation of the Nitrogen Generation System, TASK 47-00-00-800-801.

————— **END OF TASK** —————

EFFECTIVITY HAP 036-054, 101-999

47-31-03

Page 405
Feb 15/2009

D633A101-HAP



737-600/700/800/900

AIRCRAFT MAINTENANCE MANUAL

NGS SHUTOFF VALVE - REMOVAL/INSTALLATION

1. General

A. This procedure has these tasks:

- (1) NGS Shutoff Valve Removal
- (2) NGS Shutoff Valve Installation

TASK 47-32-01-000-801

2. NGS Shutoff Valve Removal

(Figure 401)

A. References

Reference	Title
36-00-00-860-806	Remove Pressure from the Pneumatic System (P/B 201)
47-00-00-010-801	Nitrogen Generation System (NGS) Precautions (P/B 201)

B. Expendables/Parts

AMM Item	Description	AIPC Reference	AIPC Effectivity
1	NGS shutoff valve	47-32-01-01-025	HAP 047-053, 106-999

C. Location Zones

Zone	Area
131	Center Section Wing Box, Body Station 540.00 to Body Station 663.75 - Left
212	Flight Compartment - Right

D. Access Panels

Number	Name/Location
192CL	Air Conditioning Access Door

E. Prepare for the Removal

SUBTASK 47-32-01-010-002

(1) Do this task: Remove Pressure from the Pneumatic System, TASK 36-00-00-860-806.

- (a) Make sure that the dual duct pressure gage shows 0.50 psig (3.45 kPa) or less in the left and right pneumatic ducts.

SUBTASK 47-32-01-860-001

(2) Put the L PACK and R PACK selector switches, found on the P5-10 air conditioning panel, to the OFF position.

- (a) Put DO-NOT-OPERATE tags on the L PACK and R PACK selector switches.

SUBTASK 47-32-01-865-002

(3) Open these circuit breakers and install safety tags:

CAPT Electrical System Panel, P18-3

Row	Col	Number	Name
D	17	C01657	NITROGEN GENERATION CONTROL
E	15	C01680	NGS ALT PWR

EFFECTIVITY HAP 047-053, 106-999

47-32-01

Page 401
Feb 15/2009

D633A101-HAP



737-600/700/800/900

AIRCRAFT MAINTENANCE MANUAL

SUBTASK 47-32-01-010-003

(4) Open this access panel:

<u>Number</u>	<u>Name/Location</u>
192CL	Air Conditioning Access Door

F. Remove the NGS Shutoff Valve

SUBTASK 47-32-01-869-001

WARNING: DO NOT TOUCH THE COMPONENTS OF THE NITROGEN GENERATION SYSTEM WHEN THEY ARE HOT. WHEN THE COMPONENTS ARE HOT, THEY CAN CAUSE INJURIES TO PERSONNEL.

WARNING: DO NOT DISCONNECT THE COMPONENTS OF THE NITROGEN GENERATION SYSTEM, OR DUCTS WHEN THE SYSTEM IS PRESSURIZED. THE HOT, HIGH-PRESSURE AIR CAN CAUSE INJURIES TO PERSONNEL, AND DAMAGE TO EQUIPMENT.

CAUTION: MAKE SURE THAT THE MAINTENANCE AREA IS FREE OF CONTAMINATION FROM SKYDROL, LUBRICANTS, SOLVENTS, FUEL, FUMES, EXHAUST, OR DUST. DO NOT LET SOLVENTS, LUBRICANTS, OTHER FLUIDS, OR THEIR FUMES GO INTO THE FLOW PATH TO OR FROM THE ASM. CONTAMINATION WILL CAUSE DAMAGE TO THE FIBERS IN THE ASM AND DECREASE THEIR LIFE.

(1) Obey the Nitrogen Generation System (NGS) precautions (TASK 47-00-00-010-801).

SUBTASK 47-32-01-010-004

(2) Go to the NGS shutoff valve [1] location.

NOTE: The NGS shutoff valve [1] is in the forward part of the left air conditioning bay between the bleed air inlet duct [2] and the ozone converter [6].

SUBTASK 47-32-01-030-001

(3) Disconnect the electrical connector [7].

SUBTASK 47-32-01-030-002

(4) Disconnect the bonding jumper [12].

SUBTASK 47-32-01-020-001

(5) Do these steps to disconnect the NGS shutoff valve [1] from the bleed air inlet duct [2].

(a) Disconnect the coupling [4].

1) Keep the coupling [4] for the installation.

SUBTASK 47-32-01-020-002

(6) Do these steps to disconnect the NGS shutoff valve [1] from the ozone converter [6]:

(a) Hold the NGS shutoff valve [1] in its position.

(b) Disconnect the coupling [5].

1) Keep the coupling [5] for the installation.

(c) Remove the NGS shutoff valve [1].

(d) Keep the two seals [3].

SUBTASK 47-32-01-490-001

(7) Install protective covers on the open bleed air inlet duct [2] and ozone converter [6].

————— **END OF TASK** —————

EFFECTIVITY
HAP 047-053, 106-999

D633A101-HAP

47-32-01

Page 402
Oct 15/2008

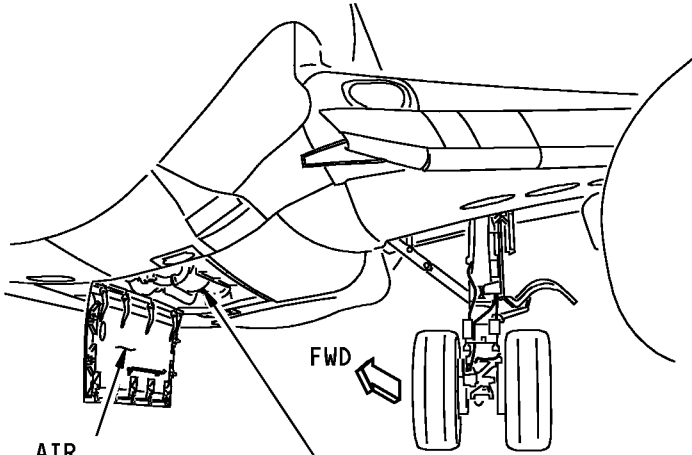

AIR
CONDITIONING
ACCESS DOOR
192CL

NITROGEN
GENERATION
SYSTEM

SEE (A)

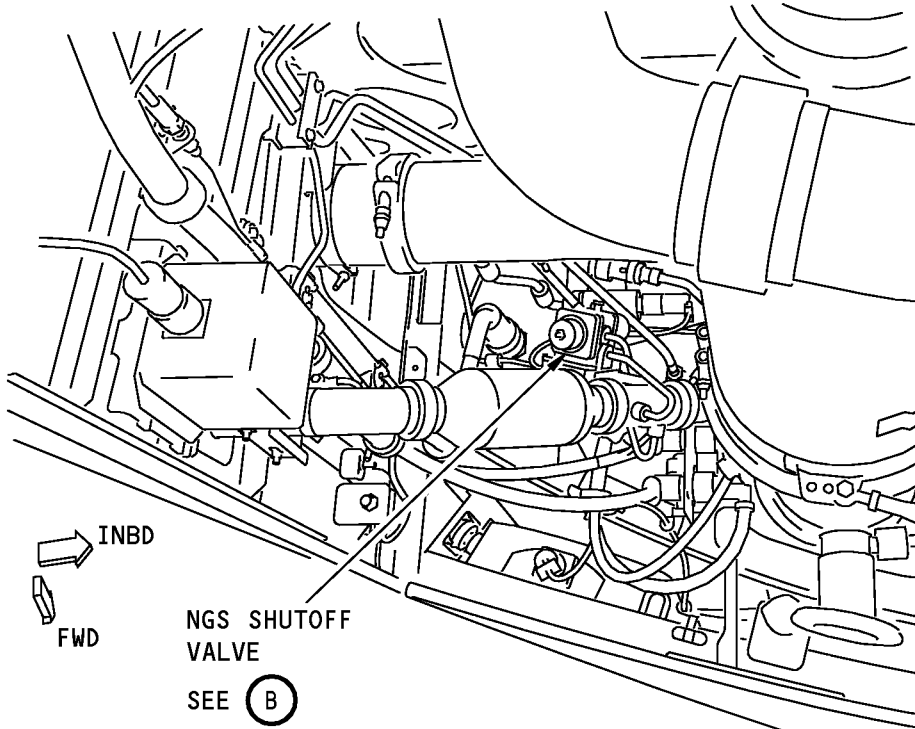

INBD
FWD

NGS SHUTOFF
VALVE

SEE (B)

NITROGEN GENERATION SYSTEM

(A)

J73837 S0000177218_V3

**NGS Shutoff Valve
Figure 401 (Sheet 1 of 2)/47-32-01-990-801**

EFFECTIVITY
HAP 047-053, 106-999

47-32-01

Page 403
Oct 15/2008

D633A101-HAP

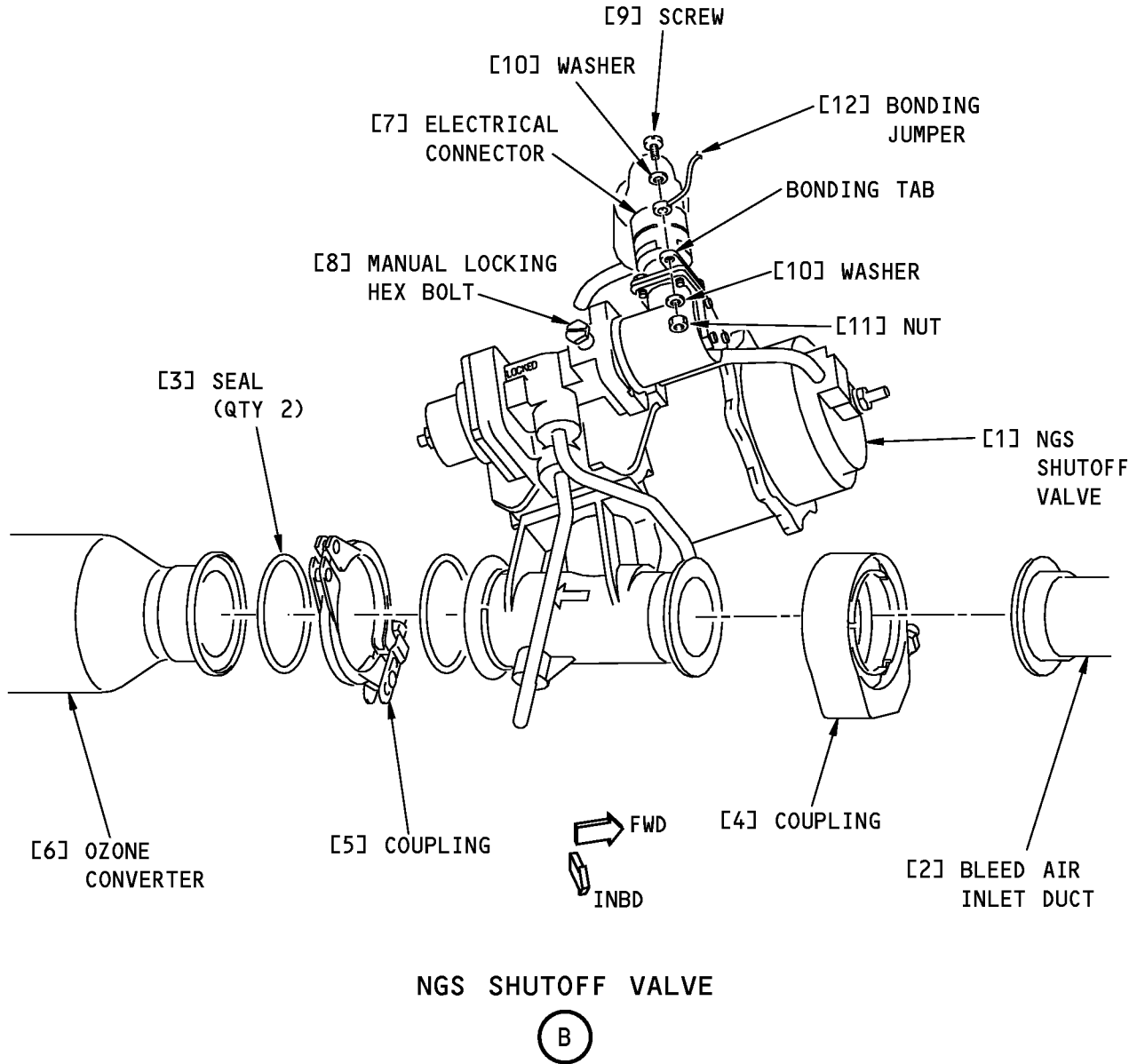

J73923 S0000177219_V4

**NGS Shutoff Valve
Figure 401 (Sheet 2 of 2)/47-32-01-990-801**

EFFECTIVITY
HAP 047-053, 106-999

47-32-01

Page 404
Oct 15/2008

D633A101-HAP



737-600/700/800/900

AIRCRAFT MAINTENANCE MANUAL

TASK 47-32-01-400-801

3. NGS Shutoff Valve Installation

(Figure 401)

A. References

Reference	Title
20-30-80-910-801	General Cleaning of Metal (Series 80) (P/B 201)
47-00-00-790-801	Leak Check of the Nitrogen Generation System (P/B 601)
47-00-00-800-801	Ground Operation of the Nitrogen Generation System (P/B 201)
SWPM 20-20-00	Electrical Bonds and Grounds

B. Tools/Equipment

NOTE: When more than one tool part number is listed under the same "Reference" number, the tools shown are alternates to each other within the same airplane series. Tool part numbers that are replaced or non-procurable are preceded by "Opt:", which stands for Optional.

Reference	Description
COM-1550	Meter - Bonding (Approved Explosion Proof & Intrinsically Safe) (Part #: C15292 (MODEL T477W), Supplier: 01014, A/P Effectivity: 737-ALL) (Part #: M1, Supplier: 3AD17, A/P Effectivity: 737-ALL) (Part #: M1B, Supplier: 3AD17, A/P Effectivity: 737-ALL)

C. Expendables/Parts

AMM Item	Description	AIPC Reference	AIPC Effectivity
1	NGS shutoff valve	47-32-01-01-025	HAP 047-053, 106-999

D. Location Zones

Zone	Area
131	Center Section Wing Box, Body Station 540.00 to Body Station 663.75 - Left
212	Flight Compartment - Right

E. Access Panels

Number	Name/Location
192CL	Air Conditioning Access Door

F. Prepare for the Installation

SUBTASK 47-32-01-430-001

- (1) Do these steps to prepare the NGS shutoff valve [1] for the installation:
 - (a) Make sure that the manual locking hex bolt [8] is installed in the NGS shutoff valve [1], and fully tightened.
 - (b) Make sure that the slot in the manual locking hex bolt [8] points to the CLOSED position.

SUBTASK 47-32-01-010-001

- (2) Go to the NGS shutoff valve [1] location in the left air conditioning bay.

SUBTASK 47-32-01-090-001

- (3) Remove the protective covers from the ozone converter [6] and the bleed air inlet duct [2].

SUBTASK 47-32-01-100-001

- (4) Make sure that the NGS shutoff valve [1], ozone converter [6], seals [3], coupling [4], and coupling [5] are clean, free from grease and unwanted materials.

EFFECTIVITY HAP 047-053, 106-999

47-32-01



737-600/700/800/900

AIRCRAFT MAINTENANCE MANUAL

SUBTASK 47-32-01-110-001

- (5) To clean the components, do this task: General Cleaning of Metal (Series 80), TASK 20-30-80-910-801.

SUBTASK 47-32-01-110-002

- (6) Prepare these components for an electrical faying surface bond (SWPM 20-20-00):
 - (a) mating surfaces of the NGS shutoff valve [1]
 - (b) mating surfaces of the coupling [4]
 - (c) mating surfaces of the coupling [5]
 - (d) mating surfaces of the ozone converter [6]
 - (e) mating surfaces of the bleed air inlet duct [2].

SUBTASK 47-32-01-430-002

- (7) Install the seal [3] in the cavity of the NGS shutoff valve [1] and the ozone converter [6].

G. Install the NGS Shutoff Valve

SUBTASK 47-32-01-420-001

- (1) Do these steps to install the NGS shutoff valve [1]:
 - (a) Align the NGS shutoff valve [1] with the bleed air inlet duct [2].
 - (b) Move the coupling [4] for the bleed air inlet duct [2] to its position on the NGS shutoff valve [1].
 - 1) Close, but do not fully tighten, the coupling [4].
 - (c) Make sure that the NGS shutoff valve [1] aligns with the ozone converter [6].
 - (d) Put the coupling [5] in its position on the ozone converter [6] and NGS shutoff valve [1].
 - (e) Tighten the coupling [4] to 52.5 ± 2.5 in-lb (5.9 ± 0.3 N·m).
 - (f) Tighten the coupling [5] to 63 ± 7 in-lb (7 ± 1 N·m).
 - (g) Connect the electrical connector [7].

SUBTASK 47-32-01-430-003

- (2) Connect the bonding jumper [12] to the NGS shutoff valve [1] with the screw [9], washers [10] and nut [11].

SUBTASK 47-32-01-200-001

- (3) Use a bonding meter, COM-1550, to measure the electrical resistance between the structure and the NGS shutoff valve [1] (SWPM 20-20-00).
 - (a) Make sure that the resistance between the electrical connector [7] shell and the valve body is 0.008 ohm (8 milliohms) or less.

H. Operational Test of the NGS Shutoff Valve

SUBTASK 47-32-01-865-001

- (1) Prepare the airplane for the operational test:
 - (a) Remove the safety tags and close these circuit breakers:

CAPT Electrical System Panel, P18-3

<u>Row</u>	<u>Col</u>	<u>Number</u>	<u>Name</u>
D	17	C01657	NITROGEN GENERATION CONTROL
E	15	C01680	NGS ALT PWR

- (b) Remove the DO-NOT-OPERATE tags from the L PACK and R PACK selector switches.

EFFECTIVITY HAP 047-053, 106-999

47-32-01

Page 406
Oct 15/2008

D633A101-HAP



737-600/700/800/900

AIRCRAFT MAINTENANCE MANUAL

1) Put the L PACK and R PACK selector switches to the AUTO position.

SUBTASK 47-32-01-881-001

(2) Do this task: Ground Operation of the Nitrogen Generation System, TASK 47-00-00-800-801.

SUBTASK 47-32-01-720-001

(3) Do this task: Leak Check of the Nitrogen Generation System, TASK 47-00-00-790-801.

(a) With the NGS pressurized, do a check for leaks around the NGS shutoff valve [1].

(b) Repair leaks that you find.

I. Put the Airplane Back to the Usual Condition

SUBTASK 47-32-01-410-001

(1) Close this access panel:

<u>Number</u>	<u>Name/Location</u>
192CL	Air Conditioning Access Door

————— **END OF TASK** —————

EFFECTIVITY
HAP 047-053, 106-999

D633A101-HAP

BOEING PROPRIETARY - Copyright © Unpublished Work - See title page for details

47-32-01

Page 407
Oct 15/2008



737-600/700/800/900

AIRCRAFT MAINTENANCE MANUAL

OZONE CONVERTER - REMOVAL/INSTALLATION

1. General

- A. This procedure contains scheduled maintenance task data.
- B. This procedure has these tasks:
 - (1) Ozone Converter Removal
 - (2) Ozone Converter Installation

TASK 47-32-02-000-801

2. Ozone Converter Removal

(Figure 401)

A. General

- (1) This procedure is a scheduled maintenance task.

B. References

Reference	Title
36-00-00-860-806	Remove Pressure from the Pneumatic System (P/B 201)

C. Location Zones

Zone	Area
131	Center Section Wing Box, Body Station 540.00 to Body Station 663.75 - Left
212	Flight Compartment - Right

D. Access Panels

Number	Name/Location
192CL	Air Conditioning Access Door

E. Prepare for the Removal

SUBTASK 47-32-02-864-001

- (1) Do this task to remove pressure from the pneumatic system: Remove Pressure from the Pneumatic System, TASK 36-00-00-860-806.
 - (a) Make sure that the dual duct pressure gage shows 0.50 psig (3.45 kPa) or less in the left and right ducts.

SUBTASK 47-32-02-860-001

- (2) Put the L PACK and R PACK selector switches, found on the P5-10 air conditioning panel, to the OFF position.
 - (a) Put DO-NOT-OPERATE tags on the L PACK and R PACK selector switches.

SUBTASK 47-32-02-865-001

- (3) Open these circuit breakers and install safety tags:

CAPT Electrical System Panel, P18-3

Row	Col	Number	Name
D	17	C01657	NITROGEN GENERATION CONTROL
E	15	C01680	NGS ALT PWR

EFFECTIVITY
HAP 047-053, 106-999

47-32-02

Page 401
Feb 15/2009

D633A101-HAP



737-600/700/800/900

AIRCRAFT MAINTENANCE MANUAL

SUBTASK 47-32-02-010-001

(4) Open this access panel:

<u>Number</u>	<u>Name/Location</u>
192CL	Air Conditioning Access Door

F. Remove the Ozone Converter

SUBTASK 47-32-02-020-002

WARNING: DO NOT TOUCH THE COMPONENTS OF THE NITROGEN GENERATION SYSTEM WHEN THEY ARE HOT. WHEN THE COMPONENTS ARE HOT, THEY CAN CAUSE INJURIES TO PERSONNEL.

WARNING: DO NOT DISCONNECT THE COMPONENTS OF THE NITROGEN GENERATION SYSTEM, OR DUCTS WHEN THE SYSTEM IS PRESSURIZED. THE HOT, HIGH-PRESSURE AIR CAN CAUSE INJURIES TO PERSONNEL, AND DAMAGE TO EQUIPMENT.

CAUTION: MAKE SURE THAT THE MAINTENANCE AREA IS FREE OF CONTAMINATION FROM SKYDROL, LUBRICANTS, SOLVENTS, FUEL, FUMES, EXHAUST, OR DUST. DO NOT LET SOLVENTS, LUBRICANTS, OTHER FLUIDS, OR THEIR FUMES GO INTO THE FLOW PATH TO OR FROM THE ASM. CONTAMINATION WILL CAUSE DAMAGE TO THE FIBERS IN THE ASM AND DECREASE THEIR LIFE.

(1) Obey the nitrogen generation system precautions.

SUBTASK 47-32-02-010-002

(2) Go to the ozone converter [5] location.

NOTE: The ozone converter [5] is in the left Air Conditioning bay between the NGS shutoff valve [2] and the left 41 beam.

SUBTASK 47-32-02-020-001

(3) Do these tasks to disconnect the ozone converter [5]:

- (a) Disconnect the first coupling [4] between the ozone converter [5] and the NGS shutoff valve [2].
- (b) Hold the ozone converter [5] in its position.
- (c) Disconnect the second coupling [4] between the ozone converter [5] and the air duct [6], inboard of the 41 beam.
- (d) Remove the ozone converter [5].
 - 1) Keep the four seals [3].

SUBTASK 47-32-02-913-001

(4) Put protective covers on the air duct [6] and the NGS shutoff valve [2] to keep out unwanted material.

————— END OF TASK —————

EFFECTIVITY
HAP 047-053, 106-999

D633A101-HAP

47-32-02

Page 402
Feb 15/2009

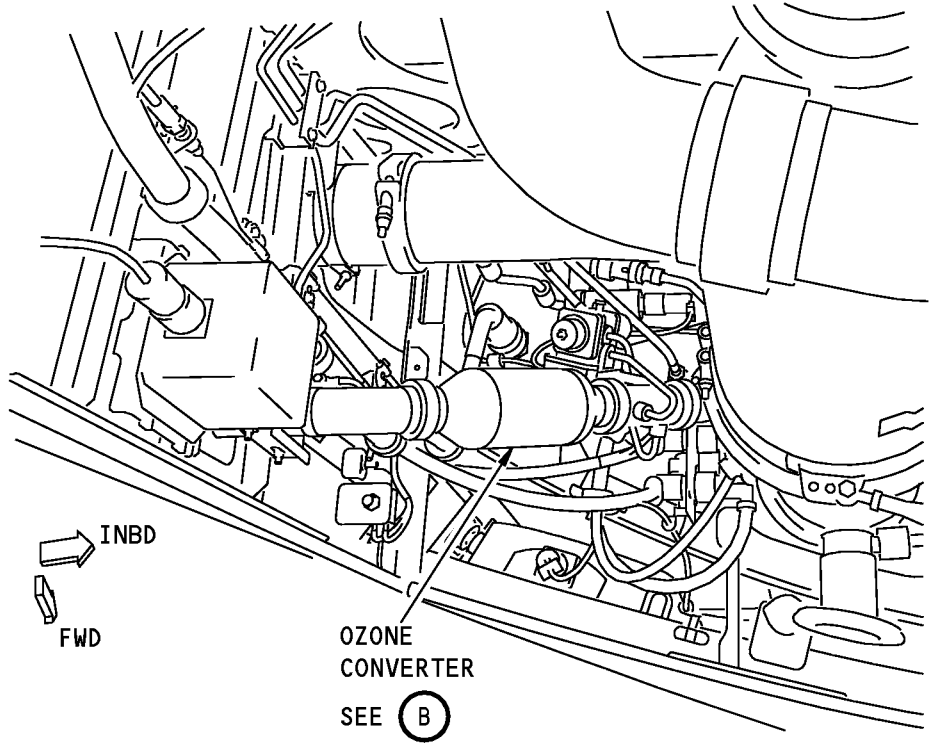
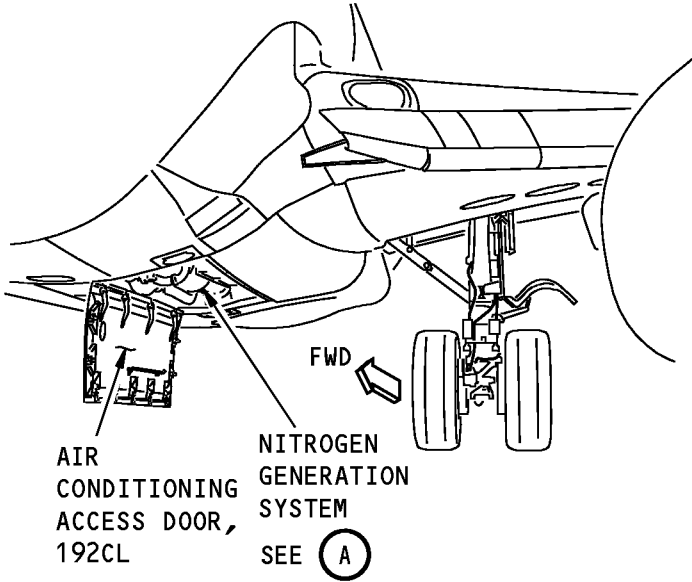

NITROGEN GENERATION SYSTEM

(A)

J73794 S0000177525_V3

**Ozone Converter
Figure 401 (Sheet 1 of 2)/47-32-02-990-801**

EFFECTIVITY
HAP 047-053, 106-999

47-32-02

Page 403
Oct 15/2008

D633A101-HAP

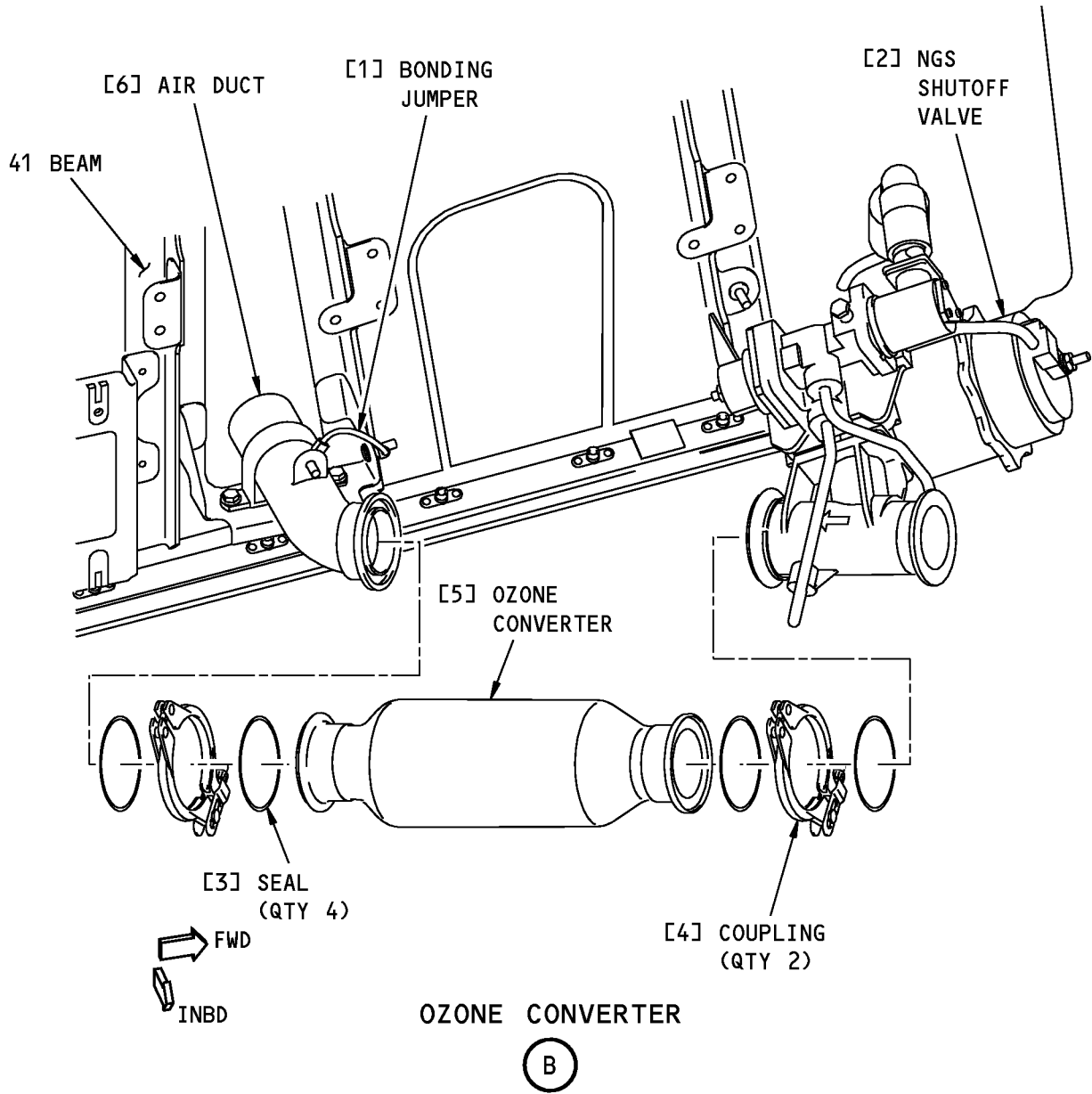

J74216 S0000177526_V4

Ozone Converter
Figure 401 (Sheet 2 of 2)/47-32-02-990-801

EFFECTIVITY
HAP 047-053, 106-999

47-32-02

Page 404
Oct 15/2008

D633A101-HAP



737-600/700/800/900

AIRCRAFT MAINTENANCE MANUAL

TASK 47-32-02-400-801

3. Ozone Converter Installation

(Figure 401)

A. General

(1) This procedure is a scheduled maintenance task.

B. References

Reference	Title
20-30-80-910-801	General Cleaning of Metal (Series 80) (P/B 201)
47-00-00-790-801	Leak Check of the Nitrogen Generation System (P/B 601)
SWPM 20-20-00	Electrical Bonds and Grounds

C. Tools/Equipment

NOTE: When more than one tool part number is listed under the same "Reference" number, the tools shown are alternates to each other within the same airplane series. Tool part numbers that are replaced or non-procurable are preceded by "Opt:", which stands for Optional.

Reference	Description
COM-1550	Meter - Bonding (Approved Explosion Proof & Intrinsically Safe) (Part #: C15292 (MODEL T477W), Supplier: 01014, A/P Effectivity: 737-ALL) (Part #: M1, Supplier: 3AD17, A/P Effectivity: 737-ALL) (Part #: M1B, Supplier: 3AD17, A/P Effectivity: 737-ALL)

D. Expendables/Parts

AMM Item	Description	AIPC Reference	AIPC Effectivity
5	Ozone converter	47-32-02-01-005	HAP 047-053, 106-999

E. Location Zones

Zone	Area
131	Center Section Wing Box, Body Station 540.00 to Body Station 663.75 - Left
212	Flight Compartment - Right

F. Access Panels

Number	Name/Location
192CL	Air Conditioning Access Door

G. Install the Ozone Converter

SUBTASK 47-32-02-010-003

(1) Go to the ozone converter [5] location in the left air conditioning bay.

SUBTASK 47-32-02-030-001

(2) Remove the protective covers from the NGS shutoff valve [2] and the air duct [6].

SUBTASK 47-32-02-100-001

(3) Make sure that the ozone converter [5], air duct [6], NGS shutoff valve [2], seals [3], and couplings [4] are clean, free from grease and unwanted material.

SUBTASK 47-32-02-110-001

(4) To clean the components, do this task: General Cleaning of Metal (Series 80), TASK 20-30-80-910-801.

EFFECTIVITY
HAP 047-053, 106-999

47-32-02

Page 405
Jun 15/2009

D633A101-HAP



737-600/700/800/900

AIRCRAFT MAINTENANCE MANUAL

SUBTASK 47-32-02-110-002

- (5) Prepare these components for an electrical faying surface bond (SWPM 20-20-00):
 - (a) Mating surfaces of the ozone converter [5].
 - (b) Mating surface of the NGS shutoff valve [2].
 - (c) Mating surface of the couplings [4].

SUBTASK 47-32-02-430-001

- (6) Do these steps to install the seals [3]:
 - (a) Install a seal [3] in the cavity of the ozone converter [5].
 - (b) Install two seals [3] on each side of the NGS shutoff valve [2].
 - (c) Install a seal [3] in the cavity of the air duct [6].

SUBTASK 47-32-02-420-001

- (7) Do these steps to install the ozone converter [5]:
 - (a) Put one coupling [4] on each end of the ozone converter [5].
 - (b) Put the ozone converter [5] in its position
 - (c) Connect, but do not tighten, the coupling [4] to the ozone converter [5] and the NGS shutoff valve [2].
 - (d) Connect, but do not tighten, the coupling [4] on the ozone converter [5] and the air duct [6].
 - (e) Make sure the ozone converter [5] is aligned with the NGS shutoff valve [2] and the air duct [6].
 - (f) Tighten the two couplings [4] to 60 ± 10 in-lb (6.8 ± 1.2 N·m).

SUBTASK 47-32-02-765-001

- (8) Use the bonding meter, COM-1550, to measure the resistance between the bonding jumper at the 41 beam and the NGS shutoff valve [2] (SWPM 20-20-00).
 - (a) Make sure the resistance is 0.010 ohm (10 milliohms) or less.

H. Operational Test of the Ozone Converter

SUBTASK 47-32-02-710-001

- (1) Remove the safety tags and close these circuit breakers:

CAPT Electrical System Panel, P18-3

<u>Row</u>	<u>Col</u>	<u>Number</u>	<u>Name</u>
D	17	C01657	NITROGEN GENERATION CONTROL
E	15	C01680	NGS ALT PWR

SUBTASK 47-32-02-860-002

- (2) Remove the DO-NOT-OPERATE tags from the L PACK and R PACK selector switches, on the P5-10 air conditioning panel.
 - (a) Put the L PACK and R PACK selector switches to the AUTO position.

SUBTASK 47-32-02-790-001

- (3) Do this task: Leak Check of the Nitrogen Generation System, TASK 47-00-00-790-801.
 - (a) Repair the leaks that you find.

EFFECTIVITY HAP 047-053, 106-999

47-32-02

Page 406
Feb 15/2009

D633A101-HAP



737-600/700/800/900

AIRCRAFT MAINTENANCE MANUAL

I. Put the Airplane Back to the Usual Condition

SUBTASK 47-32-02-410-001

(1) Close this access panel:

<u>Number</u>	<u>Name/Location</u>
192CL	Air Conditioning Access Door

————— **END OF TASK** —————

EFFECTIVITY
HAP 047-053, 106-999

D633A101-HAP

47-32-02

Page 407
Feb 15/2009



737-600/700/800/900

AIRCRAFT MAINTENANCE MANUAL

HEAT EXCHANGER - REMOVAL/INSTALLATION

1. General

- A. This procedure contains scheduled maintenance task data.
- B. This procedure has these tasks:
 - (1) Heat Exchanger Removal
 - (2) Heat Exchanger Installation.
- C. There is insulation installed on the heat exchanger, but it is not shown on Figure 401 in this procedure.

TASK 47-32-03-000-801

2. Heat Exchanger Removal

(Figure 401)

A. General

- (1) This procedure is a scheduled maintenance task.

B. References

Reference	Title
21-51-24-000-801	Ram Air Ducts Removal (P/B 401)
36-00-00-860-806	Remove Pressure from the Pneumatic System (P/B 201)

C. Location Zones

Zone	Area
131	Center Section Wing Box, Body Station 540.00 to Body Station 663.75 - Left
212	Flight Compartment - Right

D. Access Panels

Number	Name/Location
192BL	ECS Ram Air Inlet Mixing Duct Panel - Forward

E. Prepare for the Removal

SUBTASK 47-32-03-864-001

- (1) Do this task: Remove Pressure from the Pneumatic System, TASK 36-00-00-860-806.
 - (a) Make sure that the dual duct pressure gage shows 0.50 psig (3.45 kPa) or less in the L and R pneumatic ducts.

SUBTASK 47-32-03-860-001

- (2) Put the L PACK and R PACK selector switches, on the P5-10 air conditioning panel, to the OFF position.
 - (a) Put DO-NOT-OPERATE tags on the L PACK and R PACK selector switches.

SUBTASK 47-32-03-865-002

- (3) Open these circuit breakers and install safety tags:

CAPT Electrical System Panel, P18-3

Row	Col	Number	Name
D	17	C01657	NITROGEN GENERATION CONTROL
E	15	C01680	NGS ALT PWR

EFFECTIVITY
HAP 047-053, 106-999

47-32-03

Page 401
Feb 15/2009

D633A101-HAP



737-600/700/800/900

AIRCRAFT MAINTENANCE MANUAL

SUBTASK 47-32-03-010-001

- (4) Open this access panel:

<u>Number</u>	<u>Name/Location</u>
192BL	ECS Ram Air Inlet Mixing Duct Panel - Forward

SUBTASK 47-32-03-010-003

WARNING: DO NOT TOUCH THE COMPONENTS OF THE NITROGEN GENERATION SYSTEM WHEN THEY ARE HOT. WHEN THE COMPONENTS ARE HOT, THEY CAN CAUSE INJURIES TO PERSONNEL.

WARNING: DO NOT DISCONNECT THE COMPONENTS OF THE NITROGEN GENERATION SYSTEM, OR DUCTS WHEN THE SYSTEM IS PRESSURIZED. THE HOT, HIGH-PRESSURE AIR CAN CAUSE INJURIES TO PERSONNEL, AND DAMAGE TO EQUIPMENT.

CAUTION: MAKE SURE THAT THE MAINTENANCE AREA IS FREE OF CONTAMINATION FROM SKYDROL, LUBRICANTS, SOLVENTS, FUEL, FUMES, EXHAUST, OR DUST. DO NOT LET SOLVENTS, LUBRICANTS, OTHER FLUIDS, OR THEIR FUMES GO INTO THE FLOW PATH TO OR FROM THE ASM. CONTAMINATION WILL CAUSE DAMAGE TO THE FIBERS IN THE ASM AND DECREASE THEIR LIFE.

- (5) Obey the nitrogen generation system precautions.

SUBTASK 47-32-03-030-001

- (6) Loosen the hose clamp [16] that connects the heat exchanger [1] to the flex hose [17].

NOTE: The hose clamp [16] is above the ram air inlet duct on the forward end of the heat exchanger [1]. If you can not see the hose clamp [16], you can feel it with your hand.

SUBTASK 47-32-03-010-002

- (7) Do this task to get access to the heat exchanger [1]: Ram Air Ducts Removal, TASK 21-51-24-000-801.

NOTE: When you remove the ram air duct, the flex hose [17] will stay attached to the ram air inlet duct. You must pull the flex hose [17] off the ram air inlet duct.

F. Remove the Heat Exchanger

SUBTASK 47-32-03-030-002

- (1) Remove the coupling [10] between the bleed air inlet duct and the heat exchanger [1]
- Keep the coupling [10] for the installation.
 - Discard the two o-rings [9].

SUBTASK 47-32-03-030-003

- (2) Remove the coupling [10] between the bleed air outlet duct and the heat exchanger [1].
- Keep the coupling [10] for the installation.
 - Discard the two o-rings [9].

SUBTASK 47-32-03-030-004

- (3) Remove the coupling [8] between the ram air valve and the heat exchanger [1].
- Keep the coupling [8] and seal [7] for the installation.

SUBTASK 47-32-03-030-005

- (4) Remove the flex hose [17] between the ram air inlet duct and the heat exchanger [1].
- Keep the two hose clamps [16] and flex hose [17] for installation.

EFFECTIVITY
HAP 047-053, 106-999

D633A101-HAP

47-32-03

Page 402
Feb 15/2009



737-600/700/800/900

AIRCRAFT MAINTENANCE MANUAL

SUBTASK 47-32-03-030-006

- (5) Do these steps to disconnect the attached bracket (View C, View E).
- (a) Remove the bolt [2], washer [3], two bushings [4], washer [18], and nut [5].
 - (b) Keep the fasteners for the installation.

SUBTASK 47-32-03-030-007

- (6) Do these steps to disconnect the extension rod [6] (View D)
- (a) Remove the bolt [21], washer [3], bushing [20], washer [19], and nut [5].
 - (b) Keep the fasteners for the installation.

SUBTASK 47-32-03-020-001

- (7) Do these steps to remove the heat exchanger [1] from the attached bracket (View F):
- (a) Hold the heat exchanger [1] in its position.
 - (b) Remove the bolt [21], washer [3], bonding jumper [22], washer [19], bushing [20], washer [18], and nut [15].
 - (c) Keep the fasteners for the installation.

SUBTASK 47-32-03-913-001

- (8) Install protective covers on the duct openings to keep out unwanted material.

————— **END OF TASK** —————

EFFECTIVITY
HAP 047-053, 106-999

D633A101-HAP

BOEING PROPRIETARY - Copyright © Unpublished Work - See title page for details

47-32-03

Page 403
Oct 15/2008

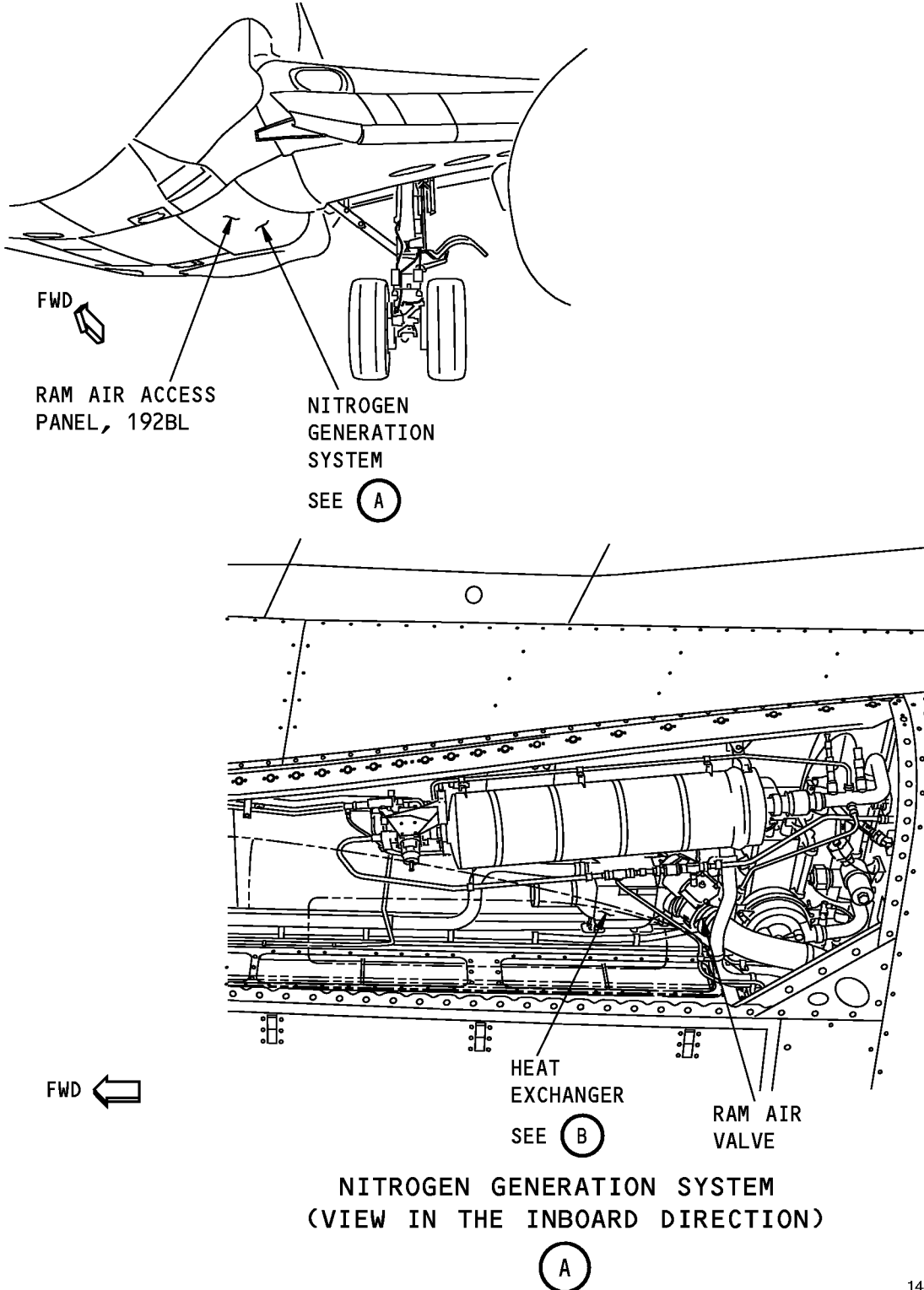

1497022 S0000272089_V1

Heat Exchanger
Figure 401 (Sheet 1 of 3)/47-32-03-990-801

EFFECTIVITY
HAP 047-053, 106-999

47-32-03

Page 404
Oct 15/2008

D633A101-HAP

AIRCRAFT MAINTENANCE MANUAL

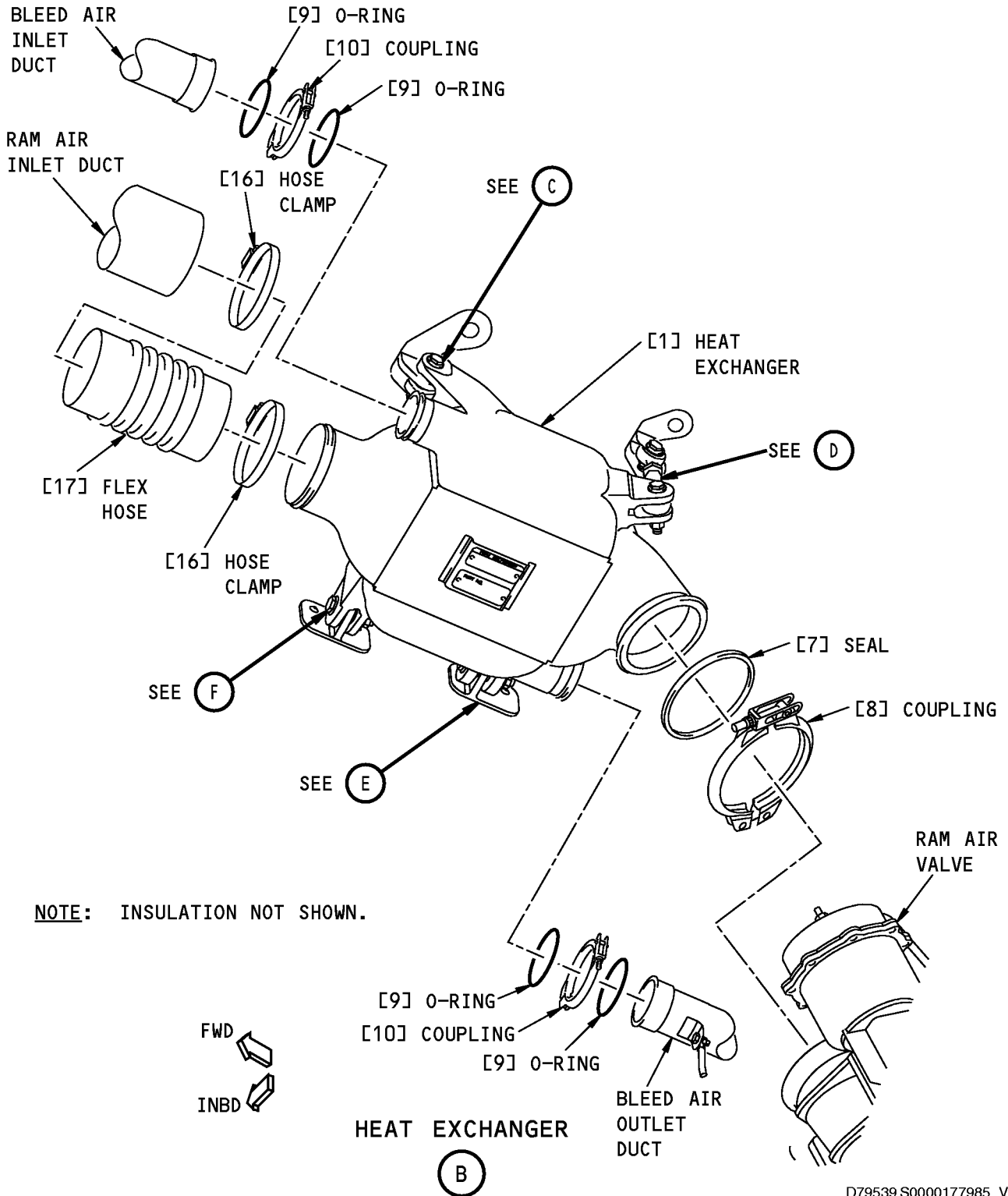

D79539 S0000177985_V3

Heat Exchanger
Figure 401 (Sheet 2 of 3)/47-32-03-990-801

EFFECTIVITY
HAP 047-053, 106-999

47-32-03

Page 405
Oct 15/2008

D633A101-HAP

AIRCRAFT MAINTENANCE MANUAL

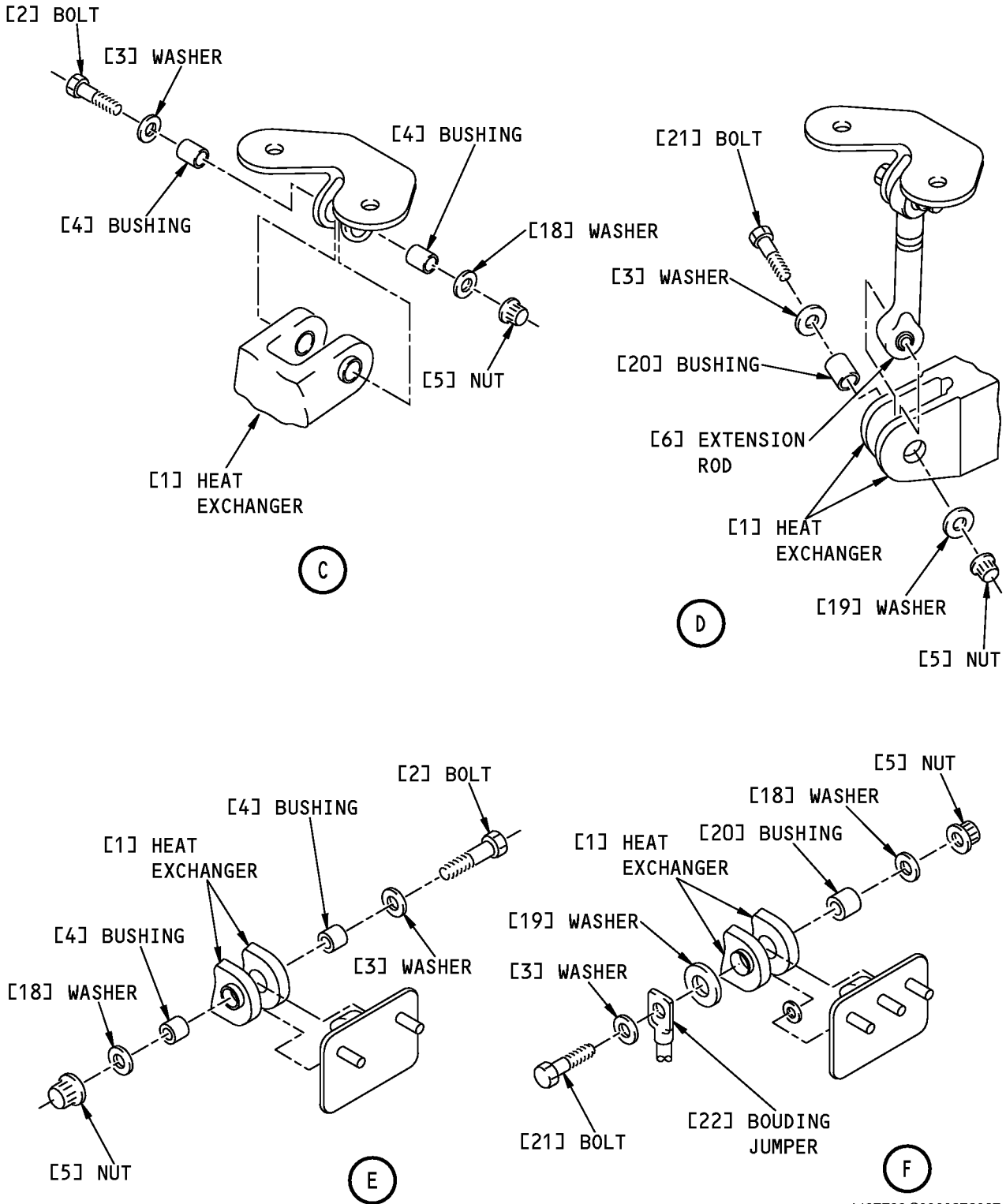

1497799 S0000272087_V1

Heat Exchanger
Figure 401 (Sheet 3 of 3)/47-32-03-990-801

EFFECTIVITY
HAP 047-053, 106-999

47-32-03

Page 406
Oct 15/2008

D633A101-HAP



737-600/700/800/900

AIRCRAFT MAINTENANCE MANUAL

TASK 47-32-03-400-801

3. Heat Exchanger Installation

(Figure 401)

A. General

(1) This procedure is a scheduled maintenance task.

B. References

Reference	Title
20-30-80-910-801	General Cleaning of Metal (Series 80) (P/B 201)
21-51-24-400-801	Ram Air Ducts Installation (P/B 401)
47-00-00-790-801	Leak Check of the Nitrogen Generation System (P/B 601)
SWPM 20-20-00	Electrical Bonds and Grounds

C. Tools/Equipment

NOTE: When more than one tool part number is listed under the same "Reference" number, the tools shown are alternates to each other within the same airplane series. Tool part numbers that are replaced or non-procurable are preceded by "Opt:", which stands for Optional.

Reference	Description
COM-1550	Meter - Bonding (Approved Explosion Proof & Intrinsically Safe) (Part #: C15292 (MODEL T477W), Supplier: 01014, A/P Effectivity: 737-ALL) (Part #: M1, Supplier: 3AD17, A/P Effectivity: 737-ALL) (Part #: M1B, Supplier: 3AD17, A/P Effectivity: 737-ALL)

D. Consumable Materials

Reference	Description	Specification
A50051	Sealant - Temperature Resistant, Integral Fuel Tank Sealant - Pro-Seal 890B	SAE AMS-S-8802, Class B
C00852	Compound - Antiseize, Molybdenum Disulfide-Petrolatum	MIL-PRF-83483
D50063	Grease - Perfluoropolyether, fuel and oxygen resistant - Krytox 240AC	MIL-PRF- 27617, Type III

E. Expendables/Parts

AMM Item	Description	AIPC Reference	AIPC Effectivity
1	Heat exchanger	47-32-03-01-090	HAP 047-053, 106-999
9	O-ring	47-21-01-01-025	HAP 047-053, 106-999

F. Location Zones

Zone	Area
131	Center Section Wing Box, Body Station 540.00 to Body Station 663.75 - Left
212	Flight Compartment - Right

G. Access Panels

Number	Name/Location
192CL	Air Conditioning Access Door

EFFECTIVITY HAP 047-053, 106-999

47-32-03



737-600/700/800/900

AIRCRAFT MAINTENANCE MANUAL

H. Prepare to Install the Heat Exchanger

SUBTASK 47-32-03-010-004

- (1) Go to the heat exchanger [1] location in the left ram air bay.

SUBTASK 47-32-03-100-001

- (2) Remove the sealant from these components:
 - (a) attach brackets on the structure
 - (b) attach brackets on the heat exchanger [1].

SUBTASK 47-32-03-020-002

- (3) Remove the protective covers from the ducts.

SUBTASK 47-32-03-100-002

- (4) Make sure that the ducts, couplings, clamps, and fasteners are clean, free from grease and unwanted material.

SUBTASK 47-32-03-110-001

- (5) To clean the components, do this task: General Cleaning of Metal (Series 80), TASK 20-30-80-910-801.

SUBTASK 47-32-03-100-003

- (6) Prepare these components for an electrical faying surface bond (SWPM 20-20-00):
 - (a) mating surfaces of the attach brackets.
 - (b) mating surfaces of the heat exchanger [1] attach brackets.
 - (c) mating surfaces of the ram air valve and the heat exchanger [1].

I. Install the Heat Exchanger

SUBTASK 47-32-03-430-002

- (1) Do these steps to attach the heat exchanger [1] to the bracket (View C).
 - (a) Make sure the bushings [4] are installed in the attached bracket.
 - (b) Apply a thin layer of compound, C00852, to the bolt [2]
 - (c) Put the heat exchanger [1] in its position.
 - (d) Install, but do not fully tighten, the bolt [2], washer [3], two bushings [4], washer [18] and nut [5].

SUBTASK 47-32-03-430-003

- (2) Do these steps to attach the heat exchanger [1] to the extension rod [6] (View D).
 - (a) Make sure the bushing [20] is installed.
 - (b) Apply a thin layer of compound, C00852, to the bolt [21]
 - (c) Put the heat exchanger [1] in its position.
 - (d) Install, but do not fully tighten, the bolt [21], washer [3], bushing [20], washer [19] and nut [5].

SUBTASK 47-32-03-430-004

- (3) Do these steps to attach the heat exchanger [1] to the bracket (View E).
 - (a) Make sure the bushings [4] are installed in the attached bracket.
 - (b) Put the heat exchanger [1] in its position.
 - (c) Install, but do not fully tighten, the bolt [2], washer [3], two bushings [4], washer [18] and nut [5].

SUBTASK 47-32-03-430-005

- (4) Do these steps to attach the heat exchanger [1] to the bracket (View F).

EFFECTIVITY
HAP 047-053, 106-999

D633A101-HAP

47-32-03

Page 408
Feb 15/2009



737-600/700/800/900

AIRCRAFT MAINTENANCE MANUAL

- (a) Make sure the bushing [4] is installed in the attached bracket.
- (b) Install, but do not fully tighten, the bolt [21], washer [3], bonding jumper [22], washer [19], bushing [20], washer [18] and nut [5].

NOTE: Use a shim if needed.

SUBTASK 47-32-03-430-006

- (5) Do these steps to connect to the bleed air inlet duct.
 - (a) Apply a thin layer of Krytox 240AC perfluoropolyether grease, D50063, to the two new o-rings [9].
 - (b) Install the o-rings [9] on the bleed air inlet duct and the heat exchanger inlet.
 - (c) Install the coupling [10] to the bleed air inlet.
 - 1) Tighten the coupling [10] to 60 ± 5 in-lb (7 ± 1 N·m).

SUBTASK 47-32-03-430-007

- (6) Do these steps to connect to the bleed air outlet duct.
 - (a) Apply a thin layer of Krytox 240AC perfluoropolyether grease, D50063, to the two o-rings [9].
 - (b) Install the o-rings [9] on the bleed air outlet duct and the heat exchanger outlet.
 - (c) Install the coupling [10] to the bleed air outlet.
 - 1) Tighten the coupling [10] to 60 ± 5 in-lb (7 ± 1 N·m).

SUBTASK 47-32-03-430-008

- (7) Do these steps to connect to the ram air valve.
 - (a) Apply a thin layer of Krytox 240AC perfluoropolyether grease, D50063, to the seal [7].
 - (b) Install the seal [7] to the bleed ram air valve.
 - (c) Install the coupling [10] to the bleed air outlet.
 - 1) Tighten the coupling [10]coupling [10] to 60 ± 5 in-lb (7 ± 1 N·m).

SUBTASK 47-32-03-420-001

- (8) Tighten the bolts [2] and bolt [21] to 65 ± 15 in-lb (7.3 ± 1.7 N·m).

SUBTASK 47-32-03-280-001

- (9) Use bonding meter, COM-1550, to measure the electrical resistance between the bleed air inlet coupling [10] and the airplane structure (SWPM 20-20-00).
 - (a) Make sure that the electrical resistance is 0.010 ohm (10 milliohms) or less (SWPM 20-20-00).

SUBTASK 47-32-03-390-001

- I (10) Apply Pro-Seal 890B sealant, A50051, to cover the attached bolt [21], washer [3], bonding jumper [22], washer [19],and nut [5] on the forward 41 beam attach bracket.

NOTE: The Pro-Seal 890B sealant, A50051, must cover the exposed conversion coating on the electrically bonded mounting components.

J. Install the Left Ram Air Duct

SUBTASK 47-32-03-210-001

- (1) Prepare to install the left ram air duct:
 - (a) Examine the flex hose [17] and the hose clamp [16] that remained on the ram air duct.
 - 1) Replace the flex hose [17] and hose clamp [16] if it is necessary.
 - (b) Install, but do not tighten, the remaining hose clamp [16] on the flex hose.

EFFECTIVITY
HAP 047-053, 106-999

D633A101-HAP

47-32-03

Page 409
Jun 15/2009



737-600/700/800/900

AIRCRAFT MAINTENANCE MANUAL

SUBTASK 47-32-03-410-002

(2) Do this task to install the left ram air duct: Ram Air Ducts Installation, TASK 21-51-24-400-801.

SUBTASK 47-32-03-430-001

(3) Do these steps to complete the installation:

- (a) Put the flex hose [17] on the heat exchanger [1] ram air inlet port.
(b) Align the clamp in its position on the heat exchanger [1].
(c) Tighten the hose clamp [16].

K. Operational Test for the Heat Exchanger

SUBTASK 47-32-03-710-001

(1) Prepare the airplane for the operational test:

(a) Remove the safety tags and close these circuit breakers:

CAPT Electrical System Panel, P18-3

Table with 4 columns: Row, Col, Number, Name. Rows include D 17 C01657 NITROGEN GENERATION CONTROL and E 15 C01680 NGS ALT PWR.

(b) Remove the DO-NOT-OPERATE tags from these switches on the P5 panel.

- 1) L PACK
2) R PACK
3) BLEED 1
4) BLEED APU

(c) Put the L PACK and R PACK selector switches to the AUTO position.

(d) Put the BLEED 1, BLEED APU, and BLEED 2 switches to the ON position.

SUBTASK 47-32-03-790-001

(2) Do this task: Leak Check of the Nitrogen Generation System, TASK 47-00-00-790-801.

- (a) With the NGS pressurized, do a check for leaks around the heat exchanger [1].
(b) Repair the leaks that you find.

L. Put the Airplane Back to the Usual Condition

SUBTASK 47-32-03-410-001

(1) Close this access panel:

Table with 2 columns: Number, Name/Location. Row: 192CL Air Conditioning Access Door

END OF TASK

EFFECTIVITY
HAP 047-053, 106-999

47-32-03

Page 410
Feb 15/2009

D633A101-HAP



**737-600/700/800/900
AIRCRAFT MAINTENANCE MANUAL**

FILTER - REMOVAL/INSTALLATION

1. General

A. This procedure has these tasks:

- (1) Filter Removal
- (2) Filter Installation

TASK 47-32-04-000-801

2. Filter Removal

(Figure 401)

A. References

<u>Reference</u>	<u>Title</u>
36-00-00-860-806	Remove Pressure from the Pneumatic System (P/B 201)
47-00-00-010-801	Nitrogen Generation System (NGS) Precautions (P/B 201)
47-32-05-000-801	Ram Air Valve Removal (P/B 401)

B. Location Zones

<u>Zone</u>	<u>Area</u>
131	Center Section Wing Box, Body Station 540.00 to Body Station 663.75 - Left
212	Flight Compartment - Right

C. Access Panels

<u>Number</u>	<u>Name/Location</u>
192BL	ECS Ram Air Inlet Mixing Duct Panel - Forward

D. Prepare for the Removal

SUBTASK 47-32-04-864-001

- (1) Do this task: Remove Pressure from the Pneumatic System, TASK 36-00-00-860-806.
 - (a) Make sure that the dual duct pressure gage shows 0.50 psig (3.45 kPa) in the L and R pneumatic ducts.

SUBTASK 47-32-04-860-001

- (2) Put the L PACK and R PACK selector switches, found on the P5-10 air conditioning panel, to the OFF position.
 - (a) Put DO-NOT-OPERATE tags on the L PACK and R PACK selector switches.

SUBTASK 47-32-04-865-001

- (3) Open these circuit breakers and install safety tags:

CAPT Electrical System Panel, P18-3

<u>Row</u>	<u>Col</u>	<u>Number</u>	<u>Name</u>
D	17	C01657	NITROGEN GENERATION CONTROL
E	15	C01680	NGS ALT PWR

SUBTASK 47-32-04-010-001

- (4) Open this access panel:

<u>Number</u>	<u>Name/Location</u>
192BL	ECS Ram Air Inlet Mixing Duct Panel - Forward

EFFECTIVITY HAP 047-053, 106-999

47-32-04



737-600/700/800/900

AIRCRAFT MAINTENANCE MANUAL

E. Remove the Filter

SUBTASK 47-32-04-910-001

WARNING: DO NOT TOUCH THE COMPONENTS OF THE NITROGEN GENERATION SYSTEM WHEN THEY ARE HOT. WHEN THE COMPONENTS ARE HOT, THEY CAN CAUSE INJURIES TO PERSONNEL.

WARNING: DO NOT DISCONNECT THE COMPONENTS OF THE NITROGEN GENERATION SYSTEM, OR DUCTS WHEN THE SYSTEM IS PRESSURIZED. THE HOT, HIGH-PRESSURE AIR CAN CAUSE INJURIES TO PERSONNEL, AND DAMAGE TO EQUIPMENT.

CAUTION: MAKE SURE THAT THE MAINTENANCE AREA IS FREE OF CONTAMINATION FROM SKYDROL, LUBRICANTS, SOLVENTS, FUEL, FUMES, EXHAUST, OR DUST. DO NOT LET SOLVENTS, LUBRICANTS, OTHER FLUIDS, OR THEIR FUMES GO INTO THE FLOW PATH TO OR FROM THE ASM. CONTAMINATION WILL CAUSE DAMAGE TO THE FIBERS IN THE ASM AND DECREASE THEIR LIFE.

(1) Obey the nitrogen generation system (NGS) precautions (TASK 47-00-00-010-801).

SUBTASK 47-32-04-010-002

(2) Go to the filter [1] location.

NOTE: The filter [1] is aft of the Air Separation Module (ASM). The filter bracket [2] is attached to the 41 beam.

SUBTASK 47-32-04-010-005

(3) To remove the ram air exhaust hose, do the steps to disconnect the flexible exhaust hose in this task: Ram Air Valve Removal, TASK 47-32-05-000-801.

NOTE: You can remove the ram air exhaust duct to help remove the filter [1].

SUBTASK 47-32-04-020-001

(4) Do these steps to remove the filter [1].

- (a) Remove the coupling [5] from between the filter [1] and the outlet duct [3].
 - 1) Keep the coupling [5] for the installation.
 - 2) Discard the two o-rings [4].
- (b) Remove the coupling [8] from between the filter [1] and the inlet duct [9].
 - 1) Keep the coupling [8] for the installation.
 - 2) Discard the two o-rings [4].
- (c) Hold the filter [1] in its position.
- (d) Remove the three bolts [6], three washers [7] and three washers [10].
 - 1) Keep the bolts [6], washers [7] and washers [10] for the installation.
- (e) Remove the filter [1].
- (f) Put protective covers on the ends of the outlet duct [3] and inlet duct [9].

————— END OF TASK —————

EFFECTIVITY
HAP 047-053, 106-999

D633A101-HAP

47-32-04

Page 402
Oct 15/2008

AIRCRAFT MAINTENANCE MANUAL

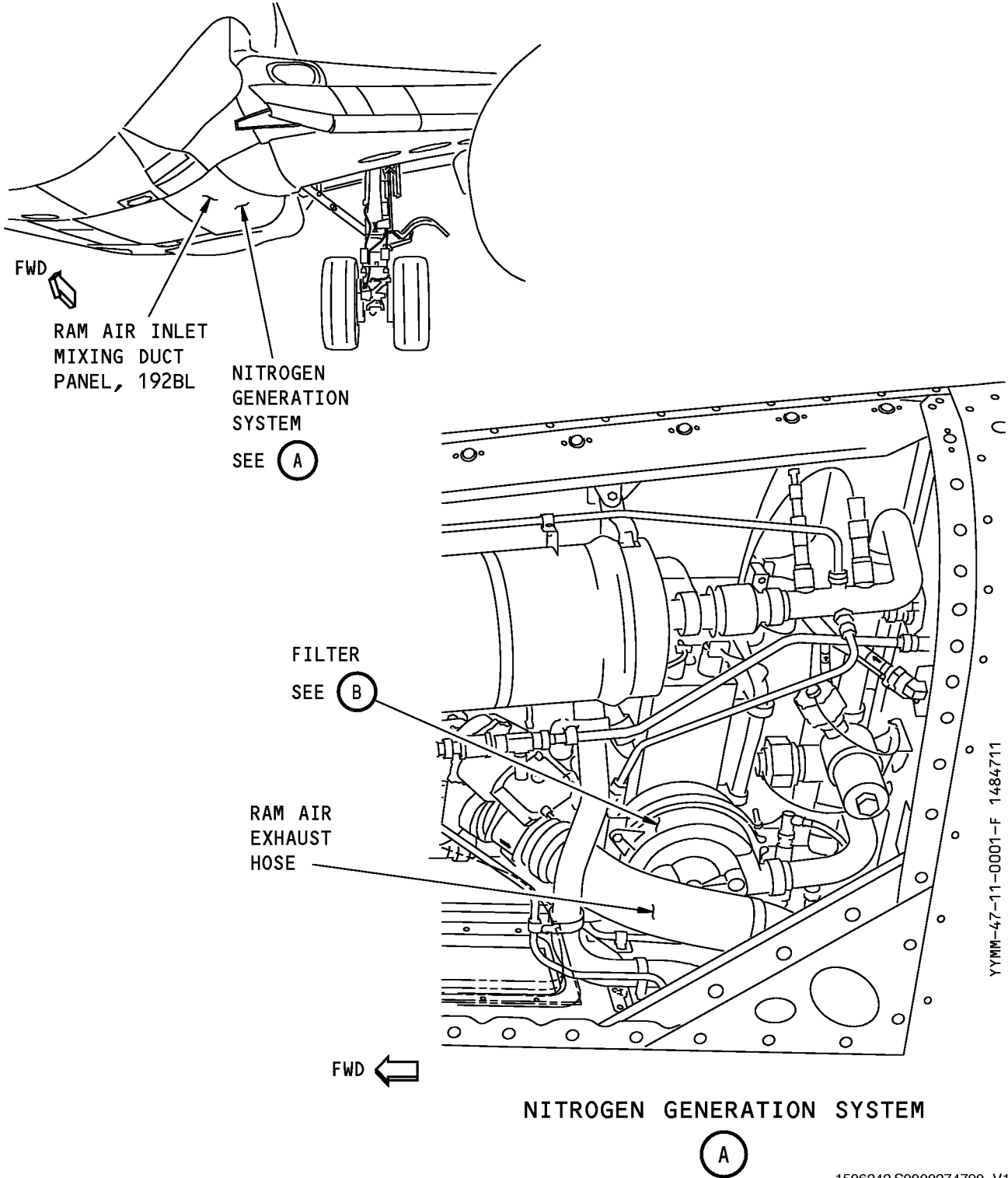

1506242 S0000274790_V1

Filter

Figure 401 (Sheet 1 of 2)/47-32-04-990-801

EFFECTIVITY
HAP 047-053, 106-999

47-32-04

Page 403
Oct 15/2008

D633A101-HAP

**737-600/700/800/900
AIRCRAFT MAINTENANCE MANUAL**

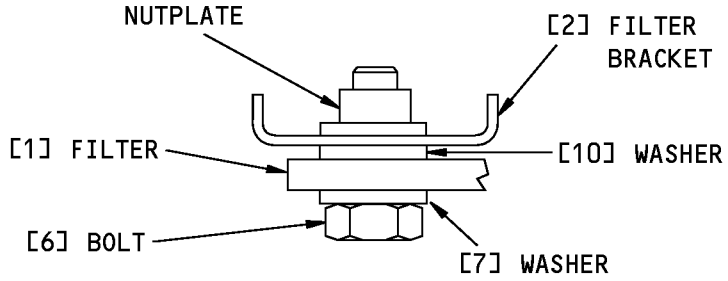

(EXAMPLE, 3 LOCATIONS)

(C)

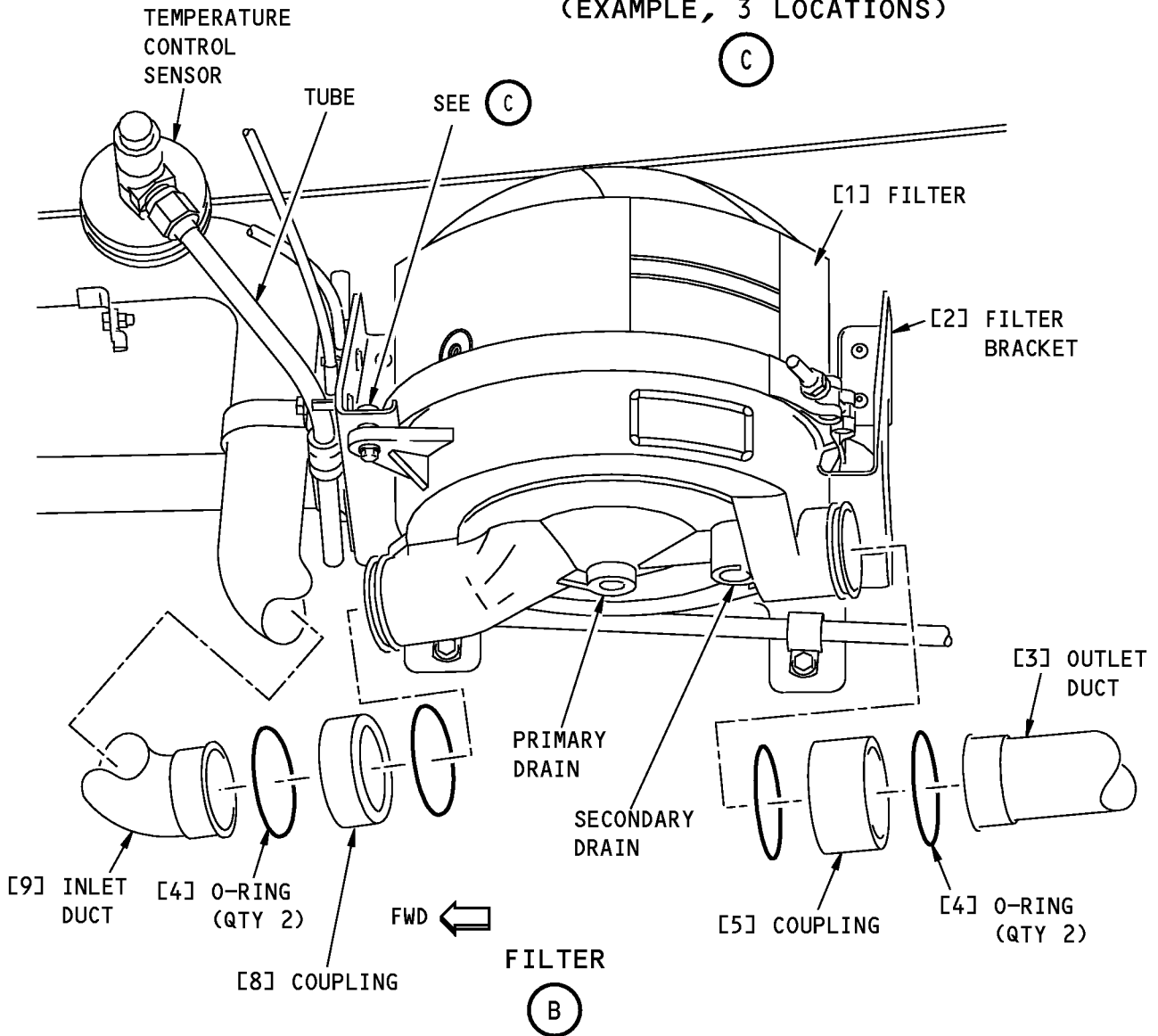

1506293 S0000274791_V1

Filter

Figure 401 (Sheet 2 of 2)/47-32-04-990-801

EFFECTIVITY
HAP 047-053, 106-999

47-32-04

Page 404
Oct 15/2008

D633A101-HAP



737-600/700/800/900

AIRCRAFT MAINTENANCE MANUAL

TASK 47-32-04-400-801

3. Filter Installation

(Figure 401)

A. References

Reference	Title
20-30-80-910-801	General Cleaning of Metal (Series 80) (P/B 201)
47-00-00-790-801	Leak Check of the Nitrogen Generation System (P/B 601)
SWPM 20-20-00	Electrical Bonds and Grounds

B. Tools/Equipment

NOTE: When more than one tool part number is listed under the same "Reference" number, the tools shown are alternates to each other within the same airplane series. Tool part numbers that are replaced or non-procurable are preceded by "Opt:", which stands for Optional.

Reference	Description
COM-1550	Meter - Bonding (Approved Explosion Proof & Intrinsically Safe) (Part #: C15292 (MODEL T477W), Supplier: 01014, A/P Effectivity: 737-ALL) (Part #: M1, Supplier: 3AD17, A/P Effectivity: 737-ALL) (Part #: M1B, Supplier: 3AD17, A/P Effectivity: 737-ALL)

C. Consumable Materials

Reference	Description	Specification
C00852	Compound - Antiseize, Molybdenum Disulfide-Petrolatum	MIL-PRF-83483
G50136	Paste - Corrosion Inhibiting, Non-drying	BMS 3-38

D. Expendables/Parts

AMM Item	Description	AIPC Reference	AIPC Effectivity
1	Filter	47-32-04-01-010	HAP 047-053, 106-999
4	O-ring	47-21-01-01-025	HAP 047-053, 106-999

E. Location Zones

Zone	Area
131	Center Section Wing Box, Body Station 540.00 to Body Station 663.75 - Left
212	Flight Compartment - Right

F. Access Panels

Number	Name/Location
192BL	ECS Ram Air Inlet Mixing Duct Panel - Forward

G. Install the Filter

SUBTASK 47-32-04-010-003

(1) Go to the filter [1] location.

SUBTASK 47-32-04-010-004

(2) Remove the protective covers from the outlet duct [3] and the inlet duct [9].

EFFECTIVITY HAP 047-053, 106-999

47-32-04



737-600/700/800/900
AIRCRAFT MAINTENANCE MANUAL

SUBTASK 47-32-04-100-001

- (3) Make sure that these components are clean, free from grease, solvents, and unwanted material:
- (a) filter [1]
 - (b) outlet duct [3]
 - (c) inlet duct [9]
 - (d) coupling [8] and coupling [5]
 - (e) bolt [6]
 - (f) washer [7] and washer [10]

SUBTASK 47-32-04-110-001

- (4) To clean the components, do this task: General Cleaning of Metal (Series 80), TASK 20-30-80-910-801.

SUBTASK 47-32-04-110-002

- (5) Prepare these components for an electrical faying surface bond (SWPM 20-20-00):
- NOTE: The filter [1] is electrically bonded to the filter bracket [2] at the three attach points.
- (a) mating surfaces on the filter [1]
 - (b) mating surfaces on the filter bracket [2].

SUBTASK 47-32-04-430-001

- (6) Do these steps to install four new o-rings [4] on the inlet duct [9] and outlet duct [3]:
- (a) Use water to lubricate the four o-rings [4].
 - (b) Install the o-rings [4] to the o-ring cavities on the filter [1] and the ends of the outlet duct [3] and the inlet duct [9].

SUBTASK 47-32-04-420-001

- (7) Do these steps to install the filter [1]:
- (a) Apply a thin layer of compound, C00852, to the three bolts [6].
 - (b) Apply a thin layer of corrosion inhibiting non-drying paste, G50136, to each washer [10].
 - 1) Remove all excess corrosion inhibiting non-drying paste, G50136.
 - (c) Hold the filter [1] in its position at the filter bracket [2].
 - (d) Install, but do not tighten, the three bolts [6], washers [7], and washers [10].
 - 1) Make sure that each washer [10] is installed between the filter [1] and filter bracket [2].

NOTE: The filter [1] and the filter bracket [2] are made from dissimilar materials. The washer [10] and washer [7] are installed between them to prevent electrical arcing and corrosion.

 - 2) Make sure that the filter [1] is aligned with the outlet duct [3] and the inlet duct [9].
 - (e) Move the coupling [5] and the coupling [8] into their positions.
 - 1) Latch the coupling [5] between the outlet duct [3] and filter [1].
 - 2) Latch the coupling [8] between the inlet duct [9] and filter [1].
 - (f) Tighten the three bolts [6] to 80 ± 2 in-lb (9 ± 0 N·m).

SUBTASK 47-32-04-760-001

- (8) Use a bonding meter, COM-1550, to measure the electrical resistance between the outlet duct [3] on the filter [1] and the filter bracket (SWPM 20-20-00).

EFFECTIVITY
HAP 047-053, 106-999

D633A101-HAP

47-32-04

Page 406
Feb 15/2009



737-600/700/800/900

AIRCRAFT MAINTENANCE MANUAL

- (a) Make sure that the resistance is 0.010 ohm (10 milliohms) or less (SWPM 20-20-00).

SUBTASK 47-32-04-410-002

- (9) Install the flexible ram air exhaust hose.

- (a) Tighten the hose clamps.

H. Operational Test for the Filter

SUBTASK 47-32-04-865-002

- (1) Prepare the airplane for the operational test.

- (a) Remove the safety tags and close these circuit breakers:

CAPT Electrical System Panel, P18-3

<u>Row</u>	<u>Col</u>	<u>Number</u>	<u>Name</u>
D	17	C01657	NITROGEN GENERATION CONTROL
E	15	C01680	NGS ALT PWR

- (b) Remove the DO-NOT-OPERATE tags from the L PACK and R PACK selector switches.

- (c) Put the L PACK and R PACK selector switches to the AUTO position.

SUBTASK 47-32-04-790-001

- (2) Do this task: Leak Check of the Nitrogen Generation System, TASK 47-00-00-790-801.

- (a) With the NGS pressurized, do a leak check of the filter [1].

- (b) Repair the leaks that you find.

I. Put the Airplane Back to the Usual Condition

SUBTASK 47-32-04-410-001

- (1) Close this access panel:

<u>Number</u>	<u>Name/Location</u>
192BL	ECS Ram Air Inlet Mixing Duct Panel - Forward

END OF TASK

EFFECTIVITY
HAP 047-053, 106-999

47-32-04



737-600/700/800/900

AIRCRAFT MAINTENANCE MANUAL

RAM AIR VALVE - REMOVAL/INSTALLATION

1. General

A. This procedure has these tasks:

- (1) Ram Air Valve Removal
- (2) Ram Air Valve Installation

TASK 47-32-05-000-801

2. Ram Air Valve Removal

(Figure 401)

A. References

<u>Reference</u>	<u>Title</u>
36-00-00-860-806	Remove Pressure from the Pneumatic System (P/B 201)
47-00-00-010-801	Nitrogen Generation System (NGS) Precautions (P/B 201)
47-11-01-000-801	Air Separation Module (ASM) Removal (P/B 401)

B. Location Zones

<u>Zone</u>	<u>Area</u>
131	Center Section Wing Box, Body Station 540.00 to Body Station 663.75 - Left
212	Flight Compartment - Right

C. Access Panels

<u>Number</u>	<u>Name/Location</u>
192BL	ECS Ram Air Inlet Mixing Duct Panel - Forward

D. Prepare for the Removal

SUBTASK 47-32-05-864-001

- (1) Do this task: Remove Pressure from the Pneumatic System, TASK 36-00-00-860-806.
 - (a) Make sure that the dual duct pressure gage shows 0.50 psig (3.45 kPa) or less in the L and R pneumatic ducts.

SUBTASK 47-32-05-860-001

- (2) Put the L PACK and R PACK selector switches, on the P5-10 air conditioning panel, to the OFF position.
 - (a) Put DO-NOT-OPERATE tags on the L PACK and R PACK selector switches.

SUBTASK 47-32-05-865-001

- (3) Open these circuit breakers and install safety tags:

CAPT Electrical System Panel, P18-3

<u>Row</u>	<u>Col</u>	<u>Number</u>	<u>Name</u>
D	17	C01657	NITROGEN GENERATION CONTROL
E	15	C01680	NGS ALT PWR

SUBTASK 47-32-05-010-001

- (4) Open this access panel:

<u>Number</u>	<u>Name/Location</u>
192BL	ECS Ram Air Inlet Mixing Duct Panel - Forward

EFFECTIVITY HAP 047-053, 106-999

47-32-05

Page 401
Oct 15/2008

D633A101-HAP



737-600/700/800/900

AIRCRAFT MAINTENANCE MANUAL

E. Remove the Ram Air Valve

SUBTASK 47-32-05-910-001

WARNING: DO NOT TOUCH THE COMPONENTS OF THE NITROGEN GENERATION SYSTEM WHEN THEY ARE HOT. WHEN THE COMPONENTS ARE HOT, THEY CAN CAUSE INJURIES TO PERSONNEL.

WARNING: DO NOT DISCONNECT THE COMPONENTS OF THE NITROGEN GENERATION SYSTEM, OR DUCTS WHEN THE SYSTEM IS PRESSURIZED. THE HOT, HIGH-PRESSURE AIR CAN CAUSE INJURIES TO PERSONNEL, AND DAMAGE TO EQUIPMENT.

CAUTION: MAKE SURE THAT THE MAINTENANCE AREA IS FREE OF CONTAMINATION FROM SKYDROL, LUBRICANTS, SOLVENTS, FUEL, FUMES, EXHAUST, OR DUST. DO NOT LET SOLVENTS, LUBRICANTS, OTHER FLUIDS, OR THEIR FUMES GO INTO THE FLOW PATH TO OR FROM THE ASM. CONTAMINATION WILL CAUSE DAMAGE TO THE FIBERS IN THE ASM AND DECREASE THEIR LIFE.

(1) Obey the nitrogen generation system (NGS) precautions (TASK 47-00-00-010-801).

SUBTASK 47-32-05-010-002

(2) Go to the ram air valve [1] location.

NOTE: The ram air valve [1] is in the left ram air bay between the heat exchanger and the exhaust duct [5].

SUBTASK 47-32-05-410-002

(3) To remove the OEA duct, do the steps to disconnect the OEA duct in this task: Air Separation Module (ASM) Removal, TASK 47-11-01-000-801.

NOTE: To improve access to the ram air valve, you can remove the OEA duct.

SUBTASK 47-32-05-030-001

(4) Disconnect the electrical connector [3] from the ram air valve [1].

SUBTASK 47-32-05-020-002

(5) Do these steps to remove the bonding jumper [2]:

(a) Remove the sealant from the ram air valve [1] at the bonding tab location.

(b) Remove the bolt [11], washer [12], bonding jumper [2] and nut [14].

1) Keep the bolt [11], washer [12], bonding jumper [2] and nut [14] for the installation.

SUBTASK 47-32-05-020-001

(6) Do these steps to disconnect the ram air valve [1]:

(a) Disconnect the muscle air line [4] from the ram air valve [1].

(b) Disconnect the coupling [8] on the flexible hose [7] side.

1) Keep the coupling [8] for the installation.

2) Remove and discard the two O-rings [9]

(c) Loosen the hose clamp [6].

(d) Disconnect the flexible flexible hose [7] from the exhaust duct [5].

1) Keep the flexible hose [7] and the hose clamp [6] for the installation.

(e) Hold the ram air valve [1] in its position.

(f) Disconnect the coupling [13] from the heat exchanger.

EFFECTIVITY
HAP 047-053, 106-999

D633A101-HAP

47-32-05

Page 402
Oct 15/2008



737-600/700/800/900

AIRCRAFT MAINTENANCE MANUAL

- 1) Keep the coupling [13] for installation.
- (g) Remove the ram air valve [1].
- (h) Remove the seal [15].

SUBTASK 47-32-05-490-001

- (7) Install protective covers on the heat exchanger and the exhaust duct [5].

————— **END OF TASK** —————

EFFECTIVITY
HAP 047-053, 106-999

D633A101-HAP

47-32-05

Page 403
Oct 15/2008

**737-600/700/800/900
AIRCRAFT MAINTENANCE MANUAL**

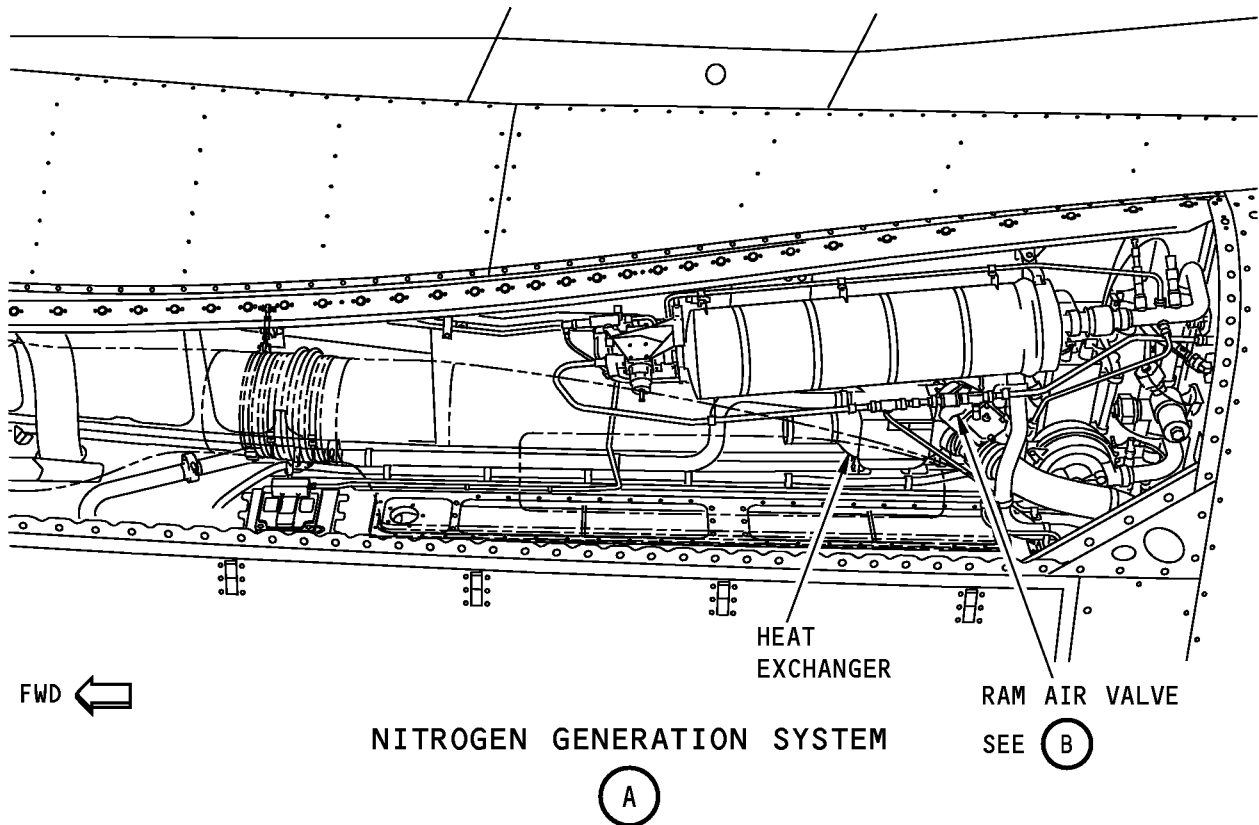
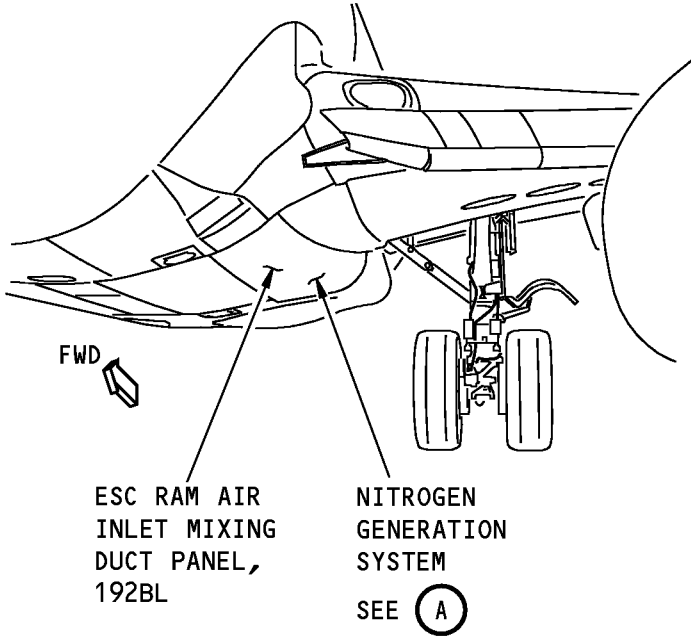

1506137 S0000274812_V2

**Ram Air Valve
Figure 401 (Sheet 1 of 2)/47-32-05-990-801**

EFFECTIVITY
HAP 047-053, 106-999

47-32-05

Page 404
Oct 15/2008

D633A101-HAP

**737-600/700/800/900
AIRCRAFT MAINTENANCE MANUAL**

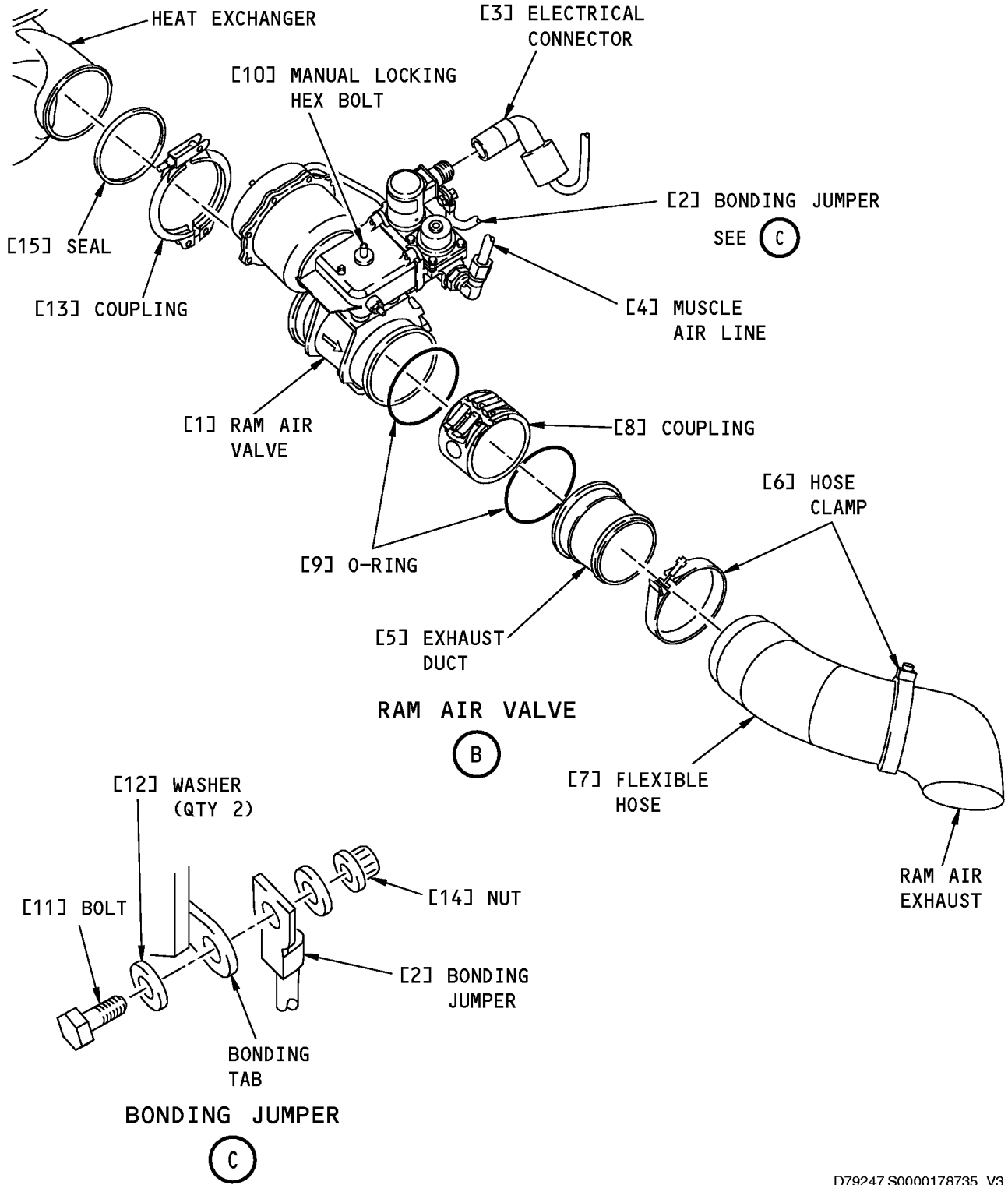

**Ram Air Valve
Figure 401 (Sheet 2 of 2)/47-32-05-990-801**

D79247 S0000178735_V3

EFFECTIVITY
HAP 047-053, 106-999

47-32-05

Page 405
Oct 15/2008

D633A101-HAP



737-600/700/800/900

AIRCRAFT MAINTENANCE MANUAL

TASK 47-32-05-400-801

3. Ram Air Valve Installation

(Figure 401)

A. References

Reference	Title
20-30-80-910-801	General Cleaning of Metal (Series 80) (P/B 201)
47-00-00-790-801	Leak Check of the Nitrogen Generation System (P/B 601)
47-00-00-800-801	Ground Operation of the Nitrogen Generation System (P/B 201)
47-11-01-420-801	Air Separation Module (ASM) Installation (P/B 401)
SWPM 20-20-00	Electrical Bonds and Grounds

B. Tools/Equipment

NOTE: When more than one tool part number is listed under the same "Reference" number, the tools shown are alternates to each other within the same airplane series. Tool part numbers that are replaced or non-procurable are preceded by "Opt:", which stands for Optional.

Reference	Description
COM-1550	Meter - Bonding (Approved Explosion Proof & Intrinsically Safe) (Part #: C15292 (MODEL T477W), Supplier: 01014, A/P Effectivity: 737-ALL) (Part #: M1, Supplier: 3AD17, A/P Effectivity: 737-ALL) (Part #: M1B, Supplier: 3AD17, A/P Effectivity: 737-ALL)

C. Consumable Materials

Reference	Description	Specification
A50051	Sealant - Temperature Resistant, Integral Fuel Tank Sealant - Pro-Seal 890B	SAE AMS-S-8802, Class B
C00852	Compound - Antiseize, Molybdenum Disulfide-Petrolatum	MIL-PRF-83483
D50063	Grease - Perfluoropolyether, fuel and oxygen resistant - Krytox 240AC	MIL-PRF- 27617, Type III

D. Location Zones

Zone	Area
131	Center Section Wing Box, Body Station 540.00 to Body Station 663.75 - Left
212	Flight Compartment - Right

E. Access Panels

Number	Name/Location
192BL	ECS Ram Air Inlet Mixing Duct Panel - Forward
192CL	Air Conditioning Access Door
192CR	Air Conditioning Access Door

F. Install the Ram Air Valve

SUBTASK 47-32-05-840-001

(1) Use the manual locking hex bolt [10] to close the ram air valve [1].

EFFECTIVITY
HAP 047-053, 106-999

47-32-05

Page 406
Jun 15/2009

D633A101-HAP



737-600/700/800/900

AIRCRAFT MAINTENANCE MANUAL

SUBTASK 47-32-05-100-001

- (2) Remove the sealant from the bonding jumper [2], bolt [11], washers [12], nut [14], and the bonding tab.

SUBTASK 47-32-05-110-001

- (3) Make sure that the ram air valve [1], the heat exchanger, couplings [8], coupling [13], hose clamps [6], and the flexible hose [7] are clean, free from grease and unwanted material.

SUBTASK 47-32-05-110-002

- (4) To clean the components, do this task: General Cleaning of Metal (Series 80), TASK 20-30-80-910-801.

SUBTASK 47-32-05-110-003

- (5) Prepare these components for an electrical faying surface bond (SWPM 20-20-00):
 - (a) Contact surfaces of the bonding tab on the ram air valve [1].
 - (b) Contact surfaces of the bonding jumper [2].

SUBTASK 47-32-05-430-001

WARNING: KRYTOX 240AC IS AN AGENT THAT IS POISONOUS AND AN IRRITANT. MAKE SURE ALL PERSONS OBEY THE PRECAUTIONS WHEN KRYTOX 240AC IS USED.

- DO NOT USE IN AREAS WHERE THERE IS HIGH HEAT, SPARKS, OR FLAMES.
- CLOSE THE CONTAINER WHEN NOT USED.
- DO NOT GET KRYTOX 240AC IN THE EYES, ON THE SKIN, OR ON YOUR CLOTHES.
- DO NOT BREATHE THE GAS.
- DO NOT EAT KRYTOX 240AC.

- (6) Do these steps to install the O-rings [9]:
 - (a) Apply a thin layer of Krytox 240AC perfluoropolyether grease, D50063, to the two O-rings [9].
 - (b) Install one O-ring [9] in the in the cavity on the ram air valve [1].
 - (c) Install one O-ring [9] in the in the cavity on the exhaust duct [5].

SUBTASK 47-32-05-420-001

- (7) Do these steps to install the ram air valve [1]:
 - (a) Put the ram air valve [1] in its position.
 - (b) Install the seal [15] in the cavity between the heat exchanger and the ram air valve [1].
 - (c) Install the coupling [8] on the ram air valve [1] and the heat exchanger.
 - (d) Install the flexible hose [7] on the ram air exhaust duct in the lower fairing.
 - (e) Install the flexible hose [7] to the exhaust duct [5].
 - (f) Tighten the hose clamp [6] on the ram air exhaust duct in the lower fairing.
 - (g) Connect the muscle air line [4] to the ram air valve [1].

SUBTASK 47-32-05-430-002

- (8) Do these steps to connect the bonding jumper [2] to the ram air valve [1]:
 - (a) Apply a thin layer of compound, C00852, to the bolt [11].
 - (b) Install the bolt [11], washers [12], bonding jumper [2], and nut [14] to the bonding tab.
 - (c) Tighten the bolt [11] to 48 ± 3 in-lb (5 ± 1 N·m).

NOTE: This torque value is in addition to the torque necessary to overcome the self-locking devices.

EFFECTIVITY
HAP 047-053, 106-999

47-32-05

Page 407
Feb 15/2009

D633A101-HAP



737-600/700/800/900

AIRCRAFT MAINTENANCE MANUAL

SUBTASK 47-32-05-765-001

(9) Use the bonding meter, COM-1550, to measure the electrical resistance between the electrical connector [3] shell and the airplane structure.

(a) Make sure the electrical resistance between the electrical connector [3] shell and the airplane structure is 0.010 ohm (10 milliohms) or less (SWPM 20-20-00).

SUBTASK 47-32-05-390-001

(10) Apply the Pro-Seal 890B sealant, A50051, to fully cover the terminal on the bonding jumper [2], bolt [11], washers [12], nut [14], and the exposed conversion coating on the bonding tab.

SUBTASK 47-32-05-410-003

(11) To install the OEA duct, do the steps to connect the OEA duct in this task: Air Separation Module (ASM) Installation, TASK 47-11-01-420-801.

G. Operational Test for the Ram Air Valve

SUBTASK 47-32-05-860-002

(1) Prepare the airplane for the operational test:

(a) Remove the safety tags and close these circuit breakers:

CAPT Electrical System Panel, P18-3

<u>Row</u>	<u>Col</u>	<u>Number</u>	<u>Name</u>
D	17	C01657	NITROGEN GENERATION CONTROL
E	15	C01680	NGS ALT PWR

(b) Remove the DO-NOT-OPERATE tags from the L PACK and R PACK selector switches on the P5 panel.

(c) Put the L PACK and R PACK selector switches in the AUTO position.

SUBTASK 47-32-05-710-002

(2) Do this task: Ground Operation of the Nitrogen Generation System, TASK 47-00-00-800-801.

SUBTASK 47-32-05-790-001

(3) Do this task: Leak Check of the Nitrogen Generation System, TASK 47-00-00-790-801.

(a) Repair the leaks that you find.

H. Put the Airplane Back to the Usual Condition

SUBTASK 47-32-05-410-001

(1) Close these access panels:

<u>Number</u>	<u>Name/Location</u>
192BL	ECS Ram Air Inlet Mixing Duct Panel - Forward
192CL	Air Conditioning Access Door
192CR	Air Conditioning Access Door

————— END OF TASK —————

EFFECTIVITY
HAP 047-053, 106-999

47-32-05

Page 408
Jun 15/2009

D633A101-HAP



737-600/700/800/900

AIRCRAFT MAINTENANCE MANUAL

ALTITUDE SENSOR - REMOVAL/INSTALLATION

1. General

A. This procedure has these tasks:

- (1) Altitude Sensor Removal
- (2) Altitude Sensor Installation

TASK 47-42-01-000-801

2. Altitude Sensor Removal

(Figure 401)

A. References

Reference	Title
36-00-00-860-806	Remove Pressure from the Pneumatic System (P/B 201)
47-00-00-010-801	Nitrogen Generation System (NGS) Precautions (P/B 201)

B. Location Zones

Zone	Area
131	Center Section Wing Box, Body Station 540.00 to Body Station 663.75 - Left
212	Flight Compartment - Right

C. Access Panels

Number	Name/Location
192BL	ECS Ram Air Inlet Mixing Duct Panel - Forward
192CR	Air Conditioning Access Door

D. Prepare for Removal

SUBTASK 47-42-01-864-001

- (1) Do this task: Remove Pressure from the Pneumatic System, TASK 36-00-00-860-806.
 - (a) Make sure that the dual duct pressure shows less than 0.50 psig (3.45 kPa) in the left and right duct.

SUBTASK 47-42-01-860-001

- (2) Put the L PACK and R PACK selector switches, found on the P5-10 air conditioning panel, to the OFF position.
 - (a) Put DO-NOT-OPERATE tags on the L PACK and R PACK selector switches.

SUBTASK 47-42-01-865-001

- (3) Open these circuit breakers and install safety tags:

CAPT Electrical System Panel, P18-3

Row	Col	Number	Name
D	17	C01657	NITROGEN GENERATION CONTROL
E	15	C01680	NGS ALT PWR

EFFECTIVITY HAP 047-053, 106-999

47-42-01

Page 401
Oct 15/2008

D633A101-HAP



737-600/700/800/900

AIRCRAFT MAINTENANCE MANUAL

SUBTASK 47-42-01-010-001

(4) Open these access panels:

<u>Number</u>	<u>Name/Location</u>
192BL	ECS Ram Air Inlet Mixing Duct Panel - Forward
192CR	Air Conditioning Access Door

E. Remove the Altitude Sensor

WARNING: DO NOT TOUCH THE COMPONENTS OF THE NITROGEN GENERATION SYSTEM WHEN THEY ARE HOT. WHEN THE COMPONENTS ARE HOT, THEY CAN CAUSE INJURIES TO PERSONNEL.

SUBTASK 47-42-01-869-001

(1) Obey the nitrogen generation system (NGS) precautions (TASK 47-00-00-010-801).

SUBTASK 47-42-01-010-002

(2) Go to the altitude sensor [1] location.

NOTE: The altitude sensor is attached to the filter mounting bracket. It is attached to the aft side of the mounting bracket with two clamps [8].

SUBTASK 47-42-01-030-001

(3) Disconnect the electrical connector [2].

SUBTASK 47-42-01-020-001

(4) Do these steps to remove the altitude sensor [1]:

- (a) Remove the sealant from the nut [6], washers [5], and bonding jumper [7] where it attaches to the ground clamp [3].
- (b) Hold the altitude sensor [1] in its position.
- (c) Remove the altitude sensor [1] from the clamps [8].
 - 1) Remove the two screws [9] and washers [10] that attach the clamps [8] to the mounting bracket.
- (d) Disconnect the bonding jumper [7].
 - 1) Remove the nut [6], washers [5], and screw [4] that attach the bonding jumper [7] to the ground clamp [3].
- (e) Keep the clamps and fasteners for the installation.

————— **END OF TASK** —————

EFFECTIVITY
HAP 047-053, 106-999

D633A101-HAP

47-42-01

Page 402
Oct 15/2008

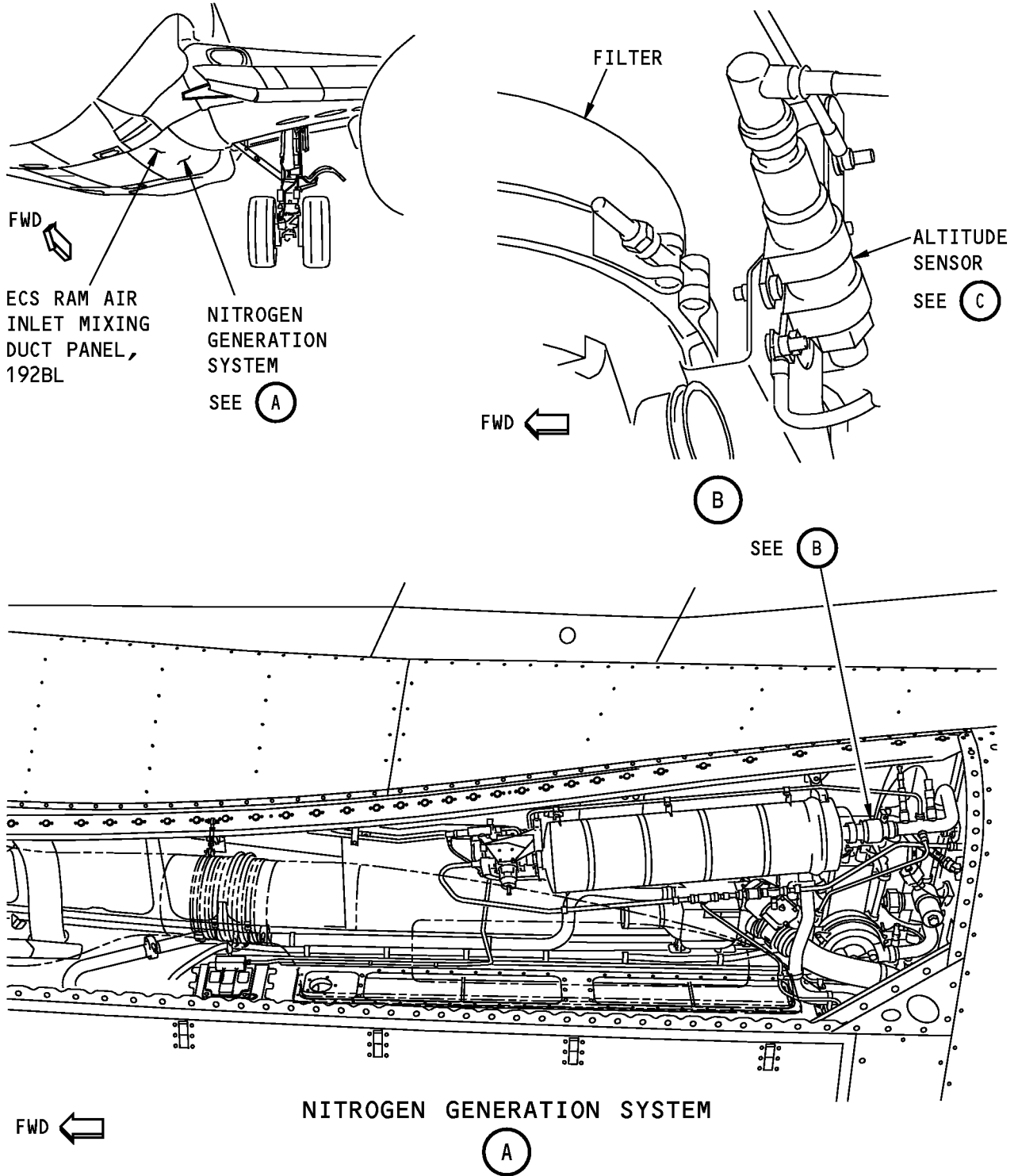

1505166 S0000274819_V1

Altitude Sensor
Figure 401 (Sheet 1 of 2)/47-42-01-990-801

EFFECTIVITY
HAP 047-053, 106-999

47-42-01

Page 403
Oct 15/2008

D633A101-HAP

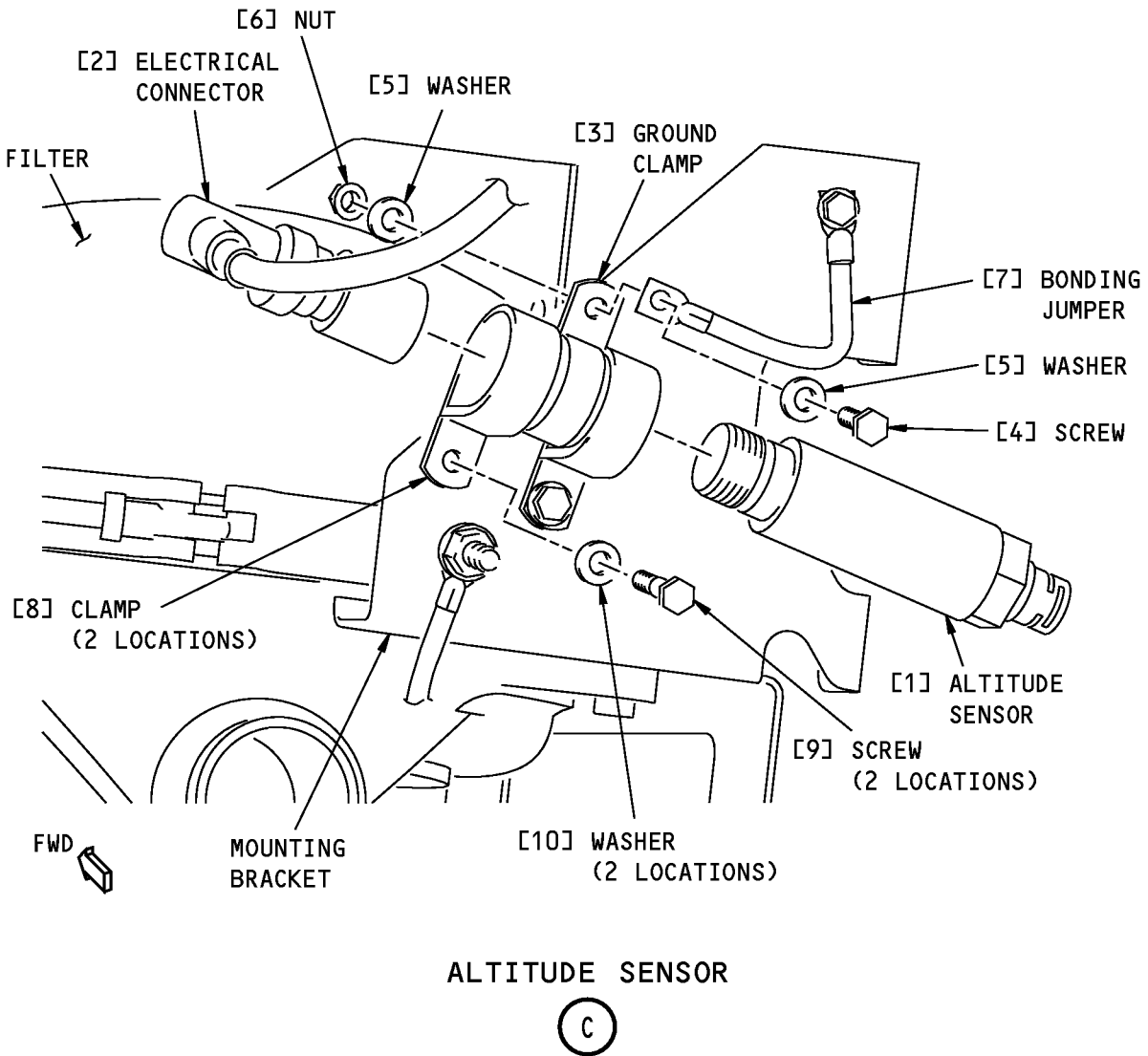

J74326 S0000177474_V2

Altitude Sensor
Figure 401 (Sheet 2 of 2)/47-42-01-990-801

EFFECTIVITY
HAP 047-053, 106-999

47-42-01

Page 404
Oct 15/2008

D633A101-HAP



737-600/700/800/900

AIRCRAFT MAINTENANCE MANUAL

TASK 47-42-01-400-801

3. Altitude Sensor Installation

(Figure 401)

A. References

Reference	Title
47-00-00-800-801	Ground Operation of the Nitrogen Generation System (P/B 201)
SWPM 20-20-00	Electrical Bonds and Grounds

B. Tools/Equipment

NOTE: When more than one tool part number is listed under the same "Reference" number, the tools shown are alternates to each other within the same airplane series. Tool part numbers that are replaced or non-procurable are preceded by "Opt:", which stands for Optional.

Reference	Description
COM-1550	Meter - Bonding (Approved Explosion Proof & Intrinsically Safe) (Part #: C15292 (MODEL T477W), Supplier: 01014, A/P Effectivity: 737-ALL) (Part #: M1, Supplier: 3AD17, A/P Effectivity: 737-ALL) (Part #: M1B, Supplier: 3AD17, A/P Effectivity: 737-ALL)

C. Consumable Materials

Reference	Description	Specification
A50051	Sealant - Temperature Resistant, Integral Fuel Tank Sealant - Pro-Seal 890B	SAE AMS-S-8802, Class B

D. Expendables/Parts

AMM Item	Description	AIPC Reference	AIPC Effectivity
1	Altitude sensor	47-40-51-01-045	HAP 047-053, 106-999

E. Location Zones

Zone	Area
131	Center Section Wing Box, Body Station 540.00 to Body Station 663.75 - Left
211	Flight Compartment - Left
212	Flight Compartment - Right

F. Access Panels

Number	Name/Location
192BL	ECS Ram Air Inlet Mixing Duct Panel - Forward

G. Install the Altitude Sensor

SUBTASK 47-42-01-100-001

- (1) Remove the used sealant from the ground clamp [3], fasteners, and bonding jumper [7].

SUBTASK 47-42-01-110-001

- (2) Prepare these components for an electrical faying surface bond (SWPM 20-20-00):
 - (a) Mating surface of the altitude sensor [1].
 - (b) Mating surface of the ground clamp [3].

EFFECTIVITY HAP 047-053, 106-999

47-42-01



**737-600/700/800/900
AIRCRAFT MAINTENANCE MANUAL**

SUBTASK 47-42-01-420-001

(3) Do these steps to install the altitude sensor [1]:

NOTE: The altitude sensor [1] is oriented with the keyway clocked at the 9 o'clock position.

- (a) Install the ground clamp [3] on the altitude sensor [1].
 - 1) Install the screw [4], washers [5], and nut [6] to attach the bonding jumper [7].
 - 2) Tighten the screw [4] to 31 ± 3 in-lb (3.5 ± 0.3 N·m)
- (b) Put the two clamps [8] on each end of the altitude sensor [1].
- (c) Align the clamps [8] with the mounting holes on the mounting bracket.
- (d) Install the two screws [9] and washers [10] to attach the clamps [8] to the mounting bracket.
 - 1) Tighten the screws [9] to 25 in-lb (2.8 N·m).

SUBTASK 47-42-01-765-001

- (4) Use the bonding meter, COM-1550, to measure the electrical resistance between the altitude sensor [1] and the mounting bracket (SWPM 20-20-00).
 - (a) Make sure that the resistance between the altitude sensor [1] and the mounting bracket is 0.008 ohm (8 milliohms) or less (SWPM 20-20-00).

SUBTASK 47-42-01-390-001

- (5) Apply a cap seal of Pro-Seal 890B sealant, A50051, to the bonding jumper [7] terminal, fasteners and bare conversion coated areas.

SUBTASK 47-42-01-430-001

- (6) Connect the electrical connector [2].

H. Operational Test of the Altitude Sensor

SUBTASK 47-42-01-865-002

- (1) Remove the safety tags and close these circuit breakers:

CAPT Electrical System Panel, P18-3

<u>Row</u>	<u>Col</u>	<u>Number</u>	<u>Name</u>
D	17	C01657	NITROGEN GENERATION CONTROL
E	15	C01680	NGS ALT PWR

SUBTASK 47-42-01-860-002

- (2) Remove the DO-NOT-OPERATE tags from the L PACK and R PACK selector switches.
 - (a) Put the L PACK and R PACK selector switches to the AUTO position.

SUBTASK 47-42-01-710-001

- (3) Do this task: Ground Operation of the Nitrogen Generation System, TASK 47-00-00-800-801.
 - (a) Make sure that the electrical test is good and the ALTITUDE SENSOR message does not show on the BDU.

I. Put the Airplane Back to the Usual Condition

SUBTASK 47-42-01-410-001

- (1) Close this access panel:

<u>Number</u>	<u>Name/Location</u>
192BL	ECS Ram Air Inlet Mixing Duct Panel - Forward

————— **END OF TASK** —————

<p>EFFECTIVITY HAP 047-053, 106-999</p>
--

47-42-01



737-600/700/800/900

AIRCRAFT MAINTENANCE MANUAL

HIGH FLOW VALVE DIFFERENTIAL PRESSURE SENSOR - REMOVAL/INSTALLATION

1. General

A. This procedure has these tasks:

- (1) High Flow Valve Differential Pressure Sensor Removal
- (2) High Flow Valve Differential Pressure Sensor Installation

TASK 47-42-02-020-801

2. High Flow Valve Differential Pressure Sensor Removal

(Figure 401)

A. General

- (1) The high flow valve differential pressure sensor is referred to as the pressure sensor [1] in this procedure.

B. References

Reference	Title
36-00-00-860-806	Remove Pressure from the Pneumatic System (P/B 201)
47-11-02-000-801	High Flow Valve Removal (P/B 401)

C. Location Zones

Zone	Area
211	Flight Compartment - Left
212	Flight Compartment - Right

D. Access Panels

Number	Name/Location
192BL	ECS Ram Air Inlet Mixing Duct Panel - Forward
192CR	Air Conditioning Access Door

E. Prepare for Removal

SUBTASK 47-42-02-864-002

- (1) Do this task: Remove Pressure from the Pneumatic System, TASK 36-00-00-860-806.
 - (a) Make sure that the dual duct pressure shows less than 0.50 psig (3.45 kPa) in the left and right duct.

SUBTASK 47-42-02-860-002

- (2) Put the L PACK and R PACK selector switches, found on the P5-10 air conditioning panel, to the OFF position.
 - (a) Put DO-NOT-OPERATE tags on the L PACK and R PACK selector switches.

SUBTASK 47-42-02-865-002

- (3) Open these circuit breakers and install safety tags:

CAPT Electrical System Panel, P18-3

Row	Col	Number	Name
D	17	C01657	NITROGEN GENERATION CONTROL
E	15	C01680	NGS ALT PWR

EFFECTIVITY
HAP 047-053, 106-999

47-42-02

Page 401
Oct 15/2008

D633A101-HAP



737-600/700/800/900

AIRCRAFT MAINTENANCE MANUAL

SUBTASK 47-42-02-010-004

WARNING: OBEY THE SUBSEQUENT STEPS FOR ACCESS PANELS IDENTIFIED WITH A NITROGEN GENERATION SYSTEM PLACARD. IF THERE IS A LEAK IN THE NITROGEN GENERATION SYSTEM, IT WILL DECREASE THE OXYGEN IN THE AIR THAT YOU BREATHE. IF YOU BREATHE AIR THAT DOES NOT HAVE SUFFICIENT OXYGEN, DANGEROUS HEALTH CONDITIONS CAN QUICKLY OCCUR.

(4) Open these access panels:

<u>Number</u>	<u>Name/Location</u>
192BL	ECS Ram Air Inlet Mixing Duct Panel - Forward
192CR	Air Conditioning Access Door

SUBTASK 47-42-02-020-001

(5) Remove the high flow valve (TASK 47-11-02-000-801).

F. Remove the Pressure Sensor

SUBTASK 47-42-02-941-001

(1) Put the high flow valve on a clean surface.

SUBTASK 47-42-02-030-003

(2) Loosen the sense line nut to disconnect the sense line [2] from the pressure sensor [1].

NOTE: The nut will stay with the sense line [2].

NOTE: Make sure you support the sense line [2] when you disconnect the nut.

SUBTASK 47-42-02-030-004

(3) Disconnect the nut [5] on the tube assembly [4].

NOTE: The nut will stay with the tube assembly [4].

NOTE: Use a second wrench on the pressure sensor [1] when you disconnect the nut [5].

SUBTASK 47-42-02-020-002

(4) Remove the jamnut [6] that holds the pressure sensor [1] to the bracket.

(a) Keep the jamnut [6] for the installation.

SUBTASK 47-42-02-020-003

(5) Remove the pressure sensor [1].

SUBTASK 47-42-02-030-002

(6) Disconnect the tube assembly [4] from the high flow valve.

(a) Keep the tube assembly [4] for the installation.

(b) Discard the o-ring [3].

SUBTASK 47-42-02-490-001

(7) Install protective covers on the high flow valve.

————— **END OF TASK** —————

EFFECTIVITY
HAP 047-053, 106-999

D633A101-HAP

47-42-02

Page 402
Oct 15/2008

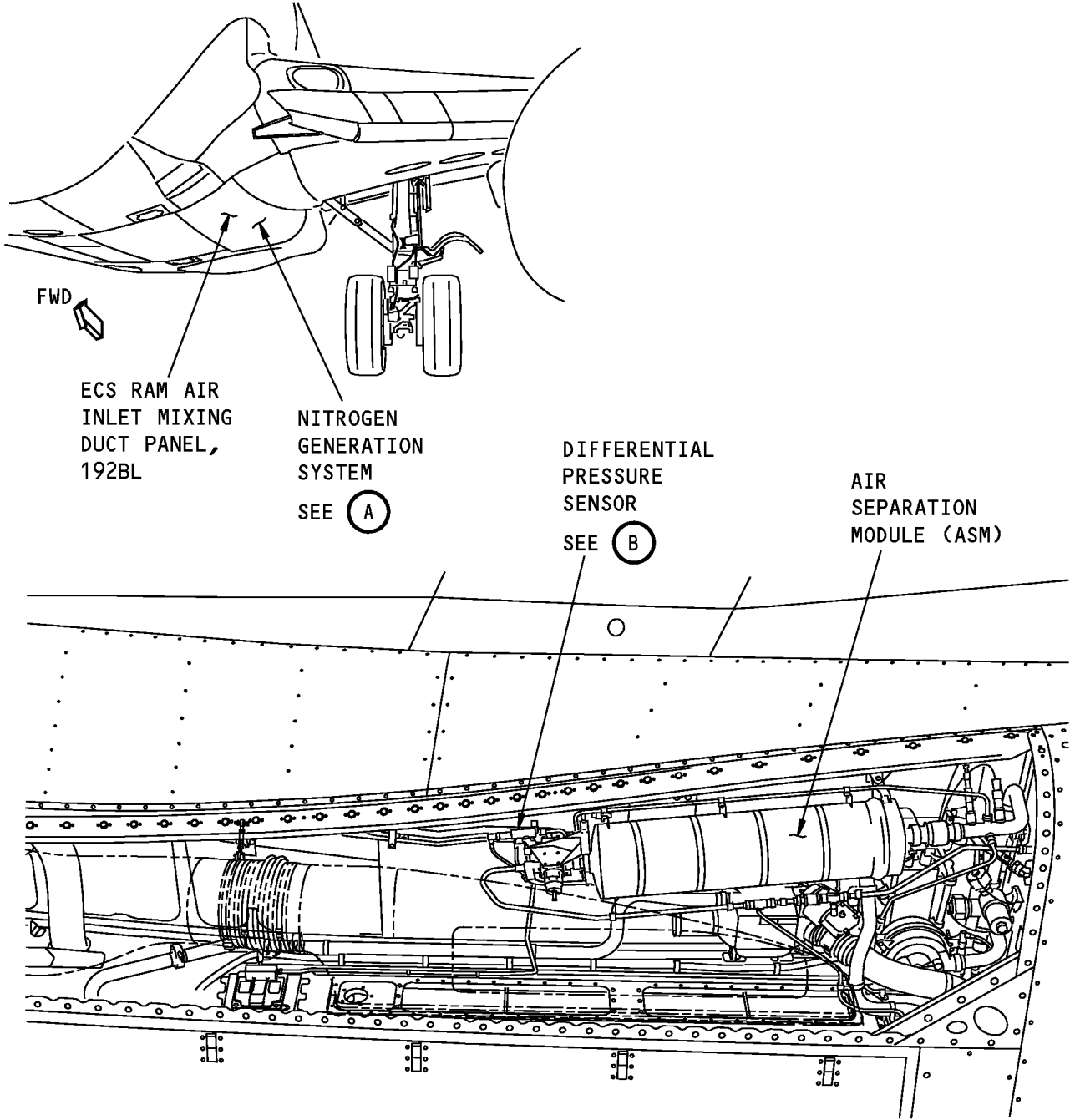

FWD ←

NITROGEN GENERATION SYSTEM

(A)

1505067 S0000274963_V1

**High Flow Valve Differential Pressure Sensor
Figure 401 (Sheet 1 of 2)/47-42-02-990-801**

EFFECTIVITY
HAP 047-053, 106-999

47-42-02

Page 403
Oct 15/2008

D633A101-HAP

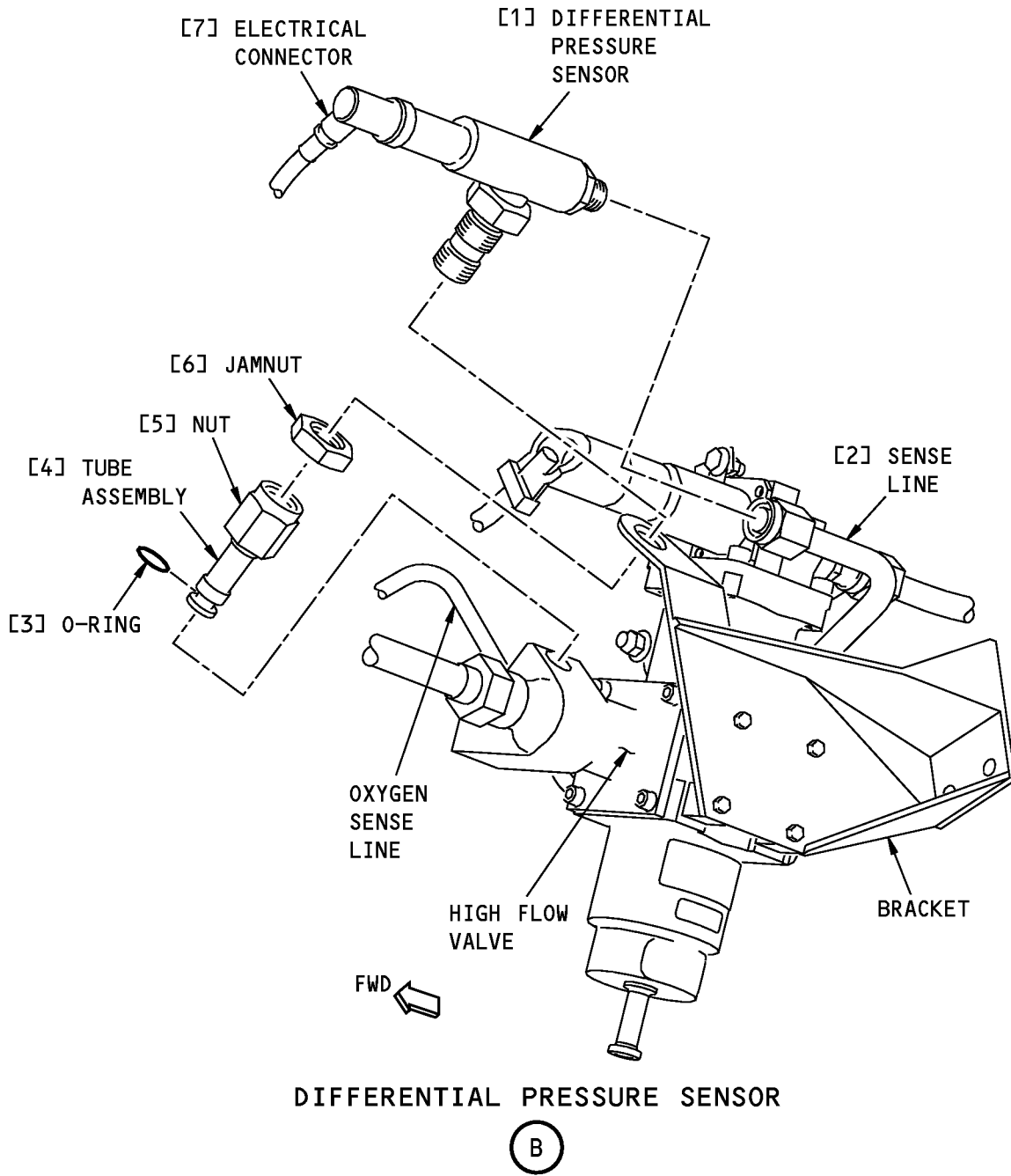

NOTE: INSULATION NOT SHOWN FOR CLARITY

1505149 S0000274964_V1

**High Flow Valve Differential Pressure Sensor
Figure 401 (Sheet 2 of 2)/47-42-02-990-801**

EFFECTIVITY
HAP 047-053, 106-999

47-42-02

Page 404
Oct 15/2008

D633A101-HAP



737-600/700/800/900

AIRCRAFT MAINTENANCE MANUAL

TASK 47-42-02-400-801

3. High Flow Valve Differential Pressure Sensor Installation

(Figure 401)

A. General

- (1) The high flow valve differential pressure sensor is referred to as the pressure sensor [1] in this procedure

B. References

Reference	Title
20-30-80-910-801	General Cleaning of Metal (Series 80) (P/B 201)
47-00-00-800-801	Ground Operation of the Nitrogen Generation System (P/B 201)
47-11-02-420-801	High Flow Valve Installation (P/B 401)

C. Tools/Equipment

Reference	Description
STD-4373	Vise

D. Consumable Materials

Reference	Description	Specification
C00852	Compound - Antiseize, Molybdenum Disulfide-Petrolatum	MIL-PRF-83483
D50063	Grease - Perfluoropolyether, fuel and oxygen resistant - Krytox 240AC	MIL-PRF-27617, Type III
G00034	Cotton Wiper - Process Cleaning Absorbent Wiper (Cheesecloth, Gauze)	BMS15-5

E. Location Zones

Zone	Area
131	Center Section Wing Box, Body Station 540.00 to Body Station 663.75 - Left
211	Flight Compartment - Left
212	Flight Compartment - Right

F. Access Panels

Number	Name/Location
192BL	ECS Ram Air Inlet Mixing Duct Panel - Forward

G. Prepare to Install the Pressure Sensor

SUBTASK 47-42-02-100-001

- (1) Do these steps to prepare the components for the installation:

- (a) Put the high flow valve on a clean surface.

NOTE: Use a vise, STD-4373, to fasten the high flow valve to the surface, if it is necessary.

- (b) Remove the protective covers from the high flow valve.
- (c) Make sure that the threaded flanges, nuts, tubes, and the high flow valve are clean and free from grease, solvents and unwanted material.
- (d) To clean the components, do this task: General Cleaning of Metal (Series 80), TASK 20-30-80-910-801.

EFFECTIVITY HAP 047-053, 106-999

47-42-02



737-600/700/800/900

AIRCRAFT MAINTENANCE MANUAL

- (e) Remove the protective shipping caps from the new pressure sensor [1].
- (f) Use a clean, solvent free, cotton wiper, G00034, to clean the mating surfaces of the pressure sensor [1].

H. Install the Pressure Sensor

SUBTASK 47-42-02-430-001

- (1) Do these steps to install the pressure sensor [1]:
 - (a) Apply a thin layer of Krytox 240AC perfluoropolyether grease, D50063, to the new o-ring [3].
 - (b) Install the new o-ring [3] on the tube assembly [4].
 - (c) Insert the tube assembly [4] and the o-ring [3] into the high flow valve.
 - (d) Apply a thin layer of compound, C00852, to the pressure sensor [1] threads.
 - (e) Install the new pressure sensor [1] in its position on the bracket:

- 1) Put the jamnut [6] on the pressure sensor [1].

NOTE: You must connect the tube assembly [4] to the pressure sensor [1] when you install the pressure sensor [1] on the high flow valve.

- 2) Install, but do not tighten, the nut [5].
- 3) Install, but do not tighten, the nut on the sense line [2].
- 4) Tighten the jamnut [6] to 135 ± 15 in-lb (15 ± 2 N·m).
- 5) Tighten the nut on the sense line [2] to 230 ± 15 in-lb (26 ± 2 N·m).
- 6) Tighten the nut [5] on the tube assembly [4] to 230 ± 15 in-lb (26 ± 2 N·m).

I. Install the High Flow Valve (If Removed)

SUBTASK 47-42-02-420-001

- (1) Install the high flow valve (TASK 47-11-02-420-801).

J. Operational Test of the Altitude Sensor

SUBTASK 47-42-02-865-003

- (1) Remove the safety tags and close these circuit breakers:

CAPT Electrical System Panel, P18-3

<u>Row</u>	<u>Col</u>	<u>Number</u>	<u>Name</u>
D	17	C01657	NITROGEN GENERATION CONTROL
E	15	C01680	NGS ALT PWR

SUBTASK 47-42-02-942-001

- (2) Remove the DO-NOT-OPERATE tags from the L PACK and R PACK selector switches.
 - (a) Put the L PACK and R PACK selector switches to the AUTO position.

SUBTASK 47-42-02-710-001

- (3) Do this task: Ground Operation of the Nitrogen Generation System, TASK 47-00-00-800-801.
 - (a) Make sure that the electrical test is good.

K. Put the Airplane Back to the Usual Condition

SUBTASK 47-42-02-410-001

- (1) Close this access panel:

<u>Number</u>	<u>Name/Location</u>

EFFECTIVITY
HAP 047-053, 106-999

47-42-02



737-600/700/800/900

AIRCRAFT MAINTENANCE MANUAL

(Continued)

<u>Number</u>	<u>Name/Location</u>
192BL	ECS Ram Air Inlet Mixing Duct Panel - Forward

————— **END OF TASK** —————

EFFECTIVITY
HAP 047-053, 106-999

D633A101-HAP

47-42-02

Page 407
Oct 15/2008



737-600/700/800/900

AIRCRAFT MAINTENANCE MANUAL

NGS OXYGEN SENSOR - REMOVAL/INSTALLATION

1. General

- A. This procedure has these tasks:
 - (1) NGS Oxygen Sensor Removal
 - (2) NGS Oxygen Sensor Installation

TASK 47-42-03-020-801

2. NGS Oxygen Sensor Removal

(Figure 401)

A. General

- (1) This task removes the NGS oxygen sensor.
- (2) Put the parts in a container (or equivalent) to prevent loss, contamination, or damage.

B. References

Reference	Title
47-00-00-010-801	Nitrogen Generation System (NGS) Precautions (P/B 201)

C. Location Zones

Zone	Area
131	Center Section Wing Box, Body Station 540.00 to Body Station 663.75 - Left
211	Flight Compartment - Left
212	Flight Compartment - Right

D. Access Panels

Number	Name/Location
192BL	ECS Ram Air Inlet Mixing Duct Panel - Forward

E. Oxygen Sensor Preparation

SUBTASK 47-42-03-010-001

WARNING: OBEY THE SUBSEQUENT STEPS FOR ACCESS PANELS IDENTIFIED WITH A NITROGEN GENERATION SYSTEM PLACARD. IF THERE IS A LEAK IN THE NITROGEN GENERATION SYSTEM, IT WILL DECREASE THE OXYGEN IN THE AIR THAT YOU BREATHE. IF YOU BREATHE AIR THAT DOES NOT HAVE SUFFICIENT OXYGEN, DANGEROUS HEALTH CONDITIONS CAN QUICKLY OCCUR.

- (1) Open this access panel:

Number	Name/Location
192BL	ECS Ram Air Inlet Mixing Duct Panel - Forward

F. Oxygen Sensor Removal Procedure

SUBTASK 47-42-03-923-001

WARNING: DO NOT TOUCH THE COMPONENTS OF THE NITROGEN GENERATION SYSTEM WHEN THEY ARE HOT. WHEN THE COMPONENTS ARE HOT, THEY CAN CAUSE INJURIES TO PERSONNEL.

- (1) Obey the Nitrogen Generation System (NGS) precautions (TASK 47-00-00-010-801).

EFFECTIVITY HAP 047-053, 106-999

47-42-03

Page 401
Oct 15/2008

D633A101-HAP



**737-600/700/800/900
AIRCRAFT MAINTENANCE MANUAL**

SUBTASK 47-42-03-171-001

(2) Go to the oxygen sensor.

SUBTASK 47-42-03-030-001

(3) Disconnect the electrical connector from the oxygen sensor.

SUBTASK 47-42-03-030-003

(4) Loosen the coupling nut [3] that attaches the oxygen sensor inlet tube.

SUBTASK 47-42-03-030-004

(5) Disconnect the oxygen sensor inlet tube from the sensor board assembly.

SUBTASK 47-42-03-030-005

(6) Remove the three screws [1] that attach the sensor plate with the mounting frame

SUBTASK 47-42-03-030-008

(7) Remove the screw [4] that connects the bonding jumper [2].

SUBTASK 47-42-03-030-006

(8) Disconnect the bonding jumper [2].

SUBTASK 47-42-03-030-007

(9) Remove the oxygen sensor from the mounting frame.

————— **END OF TASK** —————

EFFECTIVITY
HAP 047-053, 106-999

D633A101-HAP

BOEING PROPRIETARY - Copyright © Unpublished Work - See title page for details

47-42-03

Page 402
Oct 15/2008

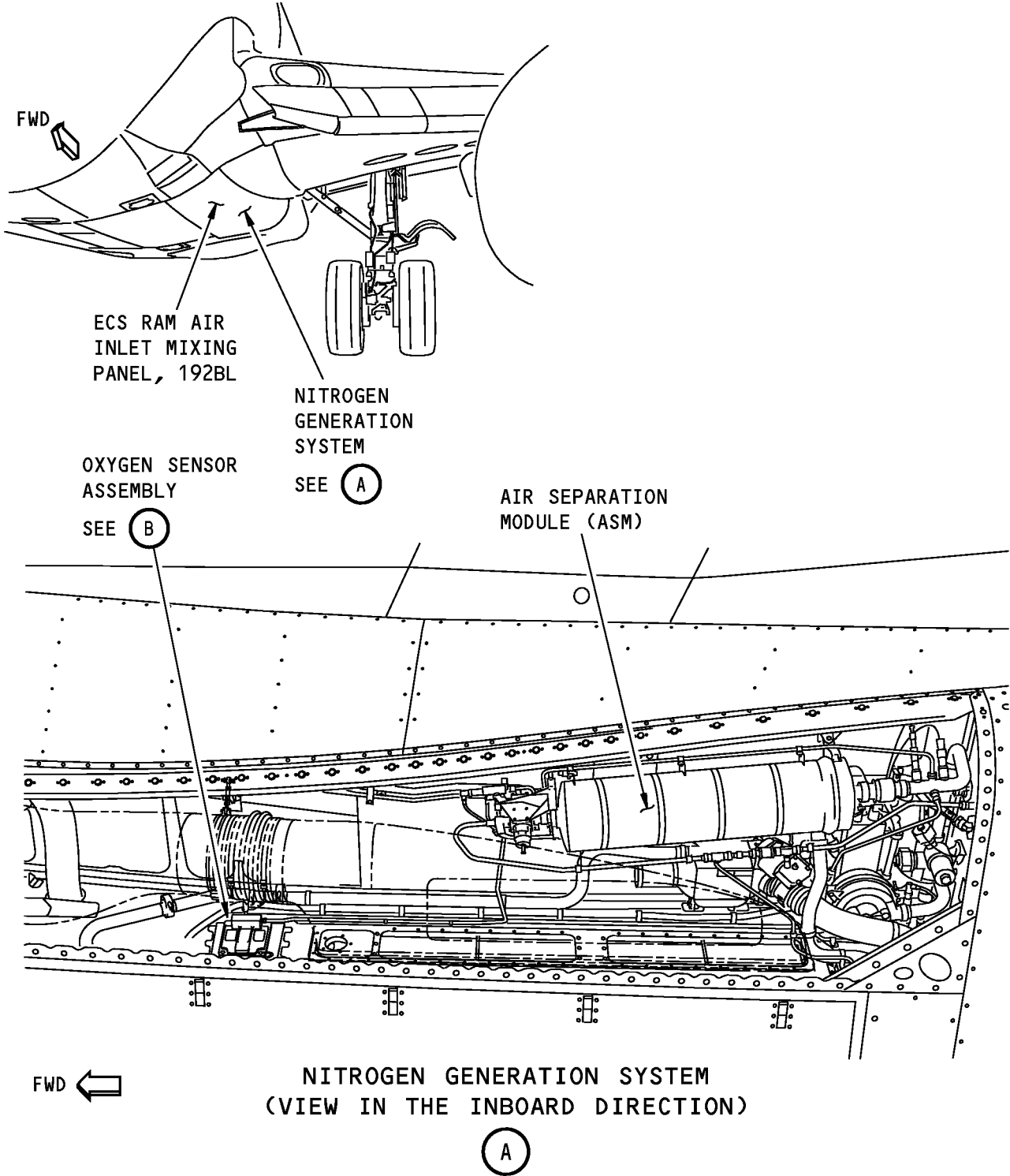

**NITROGEN GENERATION SYSTEM
(VIEW IN THE INBOARD DIRECTION)**

A

1506203 S0000275281_V1

**NGS Oxygen Sensor
Figure 401 (Sheet 1 of 2)/47-42-03-990-801**

EFFECTIVITY
HAP 047-053, 106-999

47-42-03

Page 403
Oct 15/2008

D633A101-HAP

**737-600/700/800/900
AIRCRAFT MAINTENANCE MANUAL**

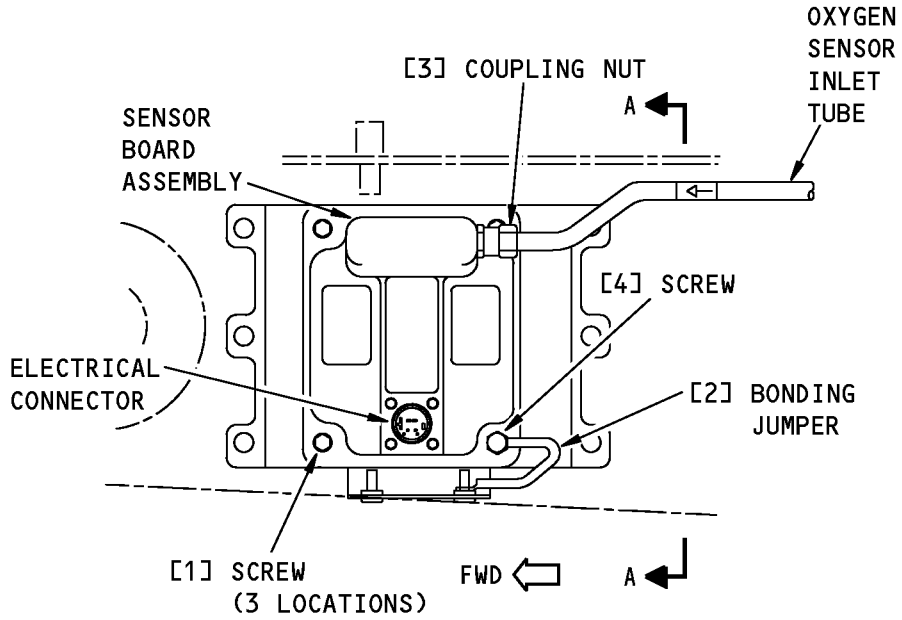

**OXYGEN SENSOR ASSEMBLY
(VIEW IN THE INBOARD DIRECTION)**

(B)

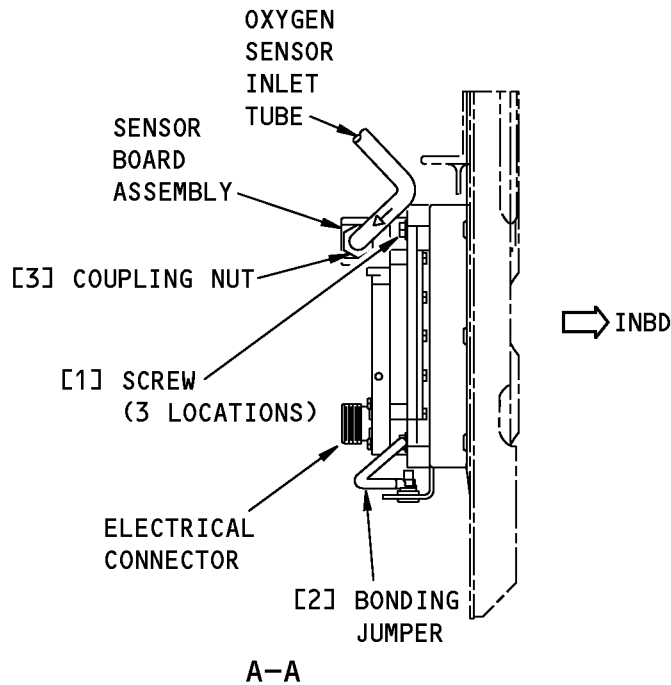

1506201 S0000275285_V1

**NGS Oxygen Sensor
Figure 401 (Sheet 2 of 2)/47-42-03-990-801**

EFFECTIVITY
HAP 047-053, 106-999

47-42-03

Page 404
Oct 15/2008

D633A101-HAP



737-600/700/800/900

AIRCRAFT MAINTENANCE MANUAL

TASK 47-42-03-420-801

3. NGS Oxygen Sensor Installation

(Figure 401)

A. General

- (1) This task installs the NGS oxygen sensor.

B. References

Reference	Title
47-00-00-800-801	Ground Operation of the Nitrogen Generation System (P/B 201)
SWPM 20-20-00	Electrical Bonds and Grounds

C. Tools/Equipment

NOTE: When more than one tool part number is listed under the same "Reference" number, the tools shown are alternates to each other within the same airplane series. Tool part numbers that are replaced or non-procurable are preceded by "Opt:", which stands for Optional.

Reference	Description
COM-1550	Meter - Bonding (Approved Explosion Proof & Intrinsically Safe) (Part #: C15292 (MODEL T477W), Supplier: 01014, A/P Effectivity: 737-ALL) (Part #: M1, Supplier: 3AD17, A/P Effectivity: 737-ALL) (Part #: M1B, Supplier: 3AD17, A/P Effectivity: 737-ALL)

D. Location Zones

Zone	Area
131	Center Section Wing Box, Body Station 540.00 to Body Station 663.75 - Left
211	Flight Compartment - Left
212	Flight Compartment - Right

E. Access Panels

Number	Name/Location
192BL	ECS Ram Air Inlet Mixing Duct Panel - Forward

F. Oxygen Sensor Installation Procedure

SUBTASK 47-42-03-430-001

- (1) Put the oxygen sensor on the mounting frame and install the three screws [1].

SUBTASK 47-42-03-430-004

- (2) Connect the oxygen sensor inlet tube to the sensor board assembly and tighten the coupling nut [3].

SUBTASK 47-42-03-430-002

- (3) Install the screw [4] to attach the bonding jumper [2].

SUBTASK 47-42-03-030-009

- (4) Connect the electrical connector.

SUBTASK 47-42-03-765-001

- (5) Do a check of the electrical bond between the oxygen sensor and the structure with a bonding meter, COM-1550 (SWPM 20-20-00).

- (a) Make sure the resistance is 0.010 ohm (10 milliohms) or less.

EFFECTIVITY
HAP 047-053, 106-999

47-42-03

Page 405
Jun 15/2009

D633A101-HAP



737-600/700/800/900

AIRCRAFT MAINTENANCE MANUAL

G. Operational Test of the Oxygen Sensor

SUBTASK 47-42-03-700-001

- (1) Remove the safety tags and close these circuit breakers:

CAPT Electrical System Panel, P18-3

<u>Row</u>	<u>Col</u>	<u>Number</u>	<u>Name</u>
D	17	C01657	NITROGEN GENERATION CONTROL
E	15	C01680	NGS ALT PWR

SUBTASK 47-42-03-700-002

- (2) Do this task: Ground Operation of the Nitrogen Generation System, TASK 47-00-00-800-801.

SUBTASK 47-42-03-700-003

- (3) Make sure the oxygen sensor operates correctly.

H. Put the Airplane Back to the Usual Condition

SUBTASK 47-42-03-410-002

- (1) Close this access panel:

<u>Number</u>	<u>Name/Location</u>
192BL	ECS Ram Air Inlet Mixing Duct Panel - Forward

————— END OF TASK —————

EFFECTIVITY HAP 047-053, 106-999

47-42-03



737-600/700/800/900

AIRCRAFT MAINTENANCE MANUAL

FILTER DIFFERENTIAL PRESSURE SWITCH - REMOVAL/INSTALLATION

1. General

A. This procedure has these tasks:

- (1) Filter Differential Pressure Switch Removal
- (2) Filter Differential Pressure Switch Installation

TASK 47-43-01-000-801

2. Filter Differential Pressure Switch Removal

(Figure 401)

A. General

- (1) The filter differential pressure switch is referred to as the pressure switch [1] in this procedure.

B. References

Reference	Title
36-00-00-860-806	Remove Pressure from the Pneumatic System (P/B 201)
47-00-00-010-801	Nitrogen Generation System (NGS) Precautions (P/B 201)

C. Location Zones

Zone	Area
131	Center Section Wing Box, Body Station 540.00 to Body Station 663.75 - Left
211	Flight Compartment - Left
212	Flight Compartment - Right

D. Access Panels

Number	Name/Location
192BL	ECS Ram Air Inlet Mixing Duct Panel - Forward

E. Prepare for the Removal

SUBTASK 47-43-01-864-001

- (1) Do this task: Remove Pressure from the Pneumatic System, TASK 36-00-00-860-806.
 - (a) Make sure that the dual duct pressure gage shows 0.50 psig (3.45 kPa) or less in the L and R pneumatic ducts.

SUBTASK 47-43-01-860-001

- (2) Put the L PACK and R PACK selector switches, found on the P5-10 air conditioning panel, to the OFF position.
 - (a) Put DO-NOT-OPERATE tags on the L PACK and R PACK selector switches.

SUBTASK 47-43-01-865-001

- (3) Open these circuit breakers and install safety tags:

CAPT Electrical System Panel, P18-3

Row	Col	Number	Name
D	17	C01657	NITROGEN GENERATION CONTROL
E	15	C01680	NGS ALT PWR

EFFECTIVITY
HAP 047-053, 106-999

47-43-01

Page 401
Oct 15/2008

D633A101-HAP



737-600/700/800/900

AIRCRAFT MAINTENANCE MANUAL

SUBTASK 47-43-01-010-001

(4) Open this access panel:

<u>Number</u>	<u>Name/Location</u>
192BL	ECS Ram Air Inlet Mixing Duct Panel - Forward

SUBTASK 47-43-01-922-001

WARNING: DO NOT TOUCH THE COMPONENTS OF THE NITROGEN GENERATION SYSTEM WHEN THEY ARE HOT. WHEN THE COMPONENTS ARE HOT, THEY CAN CAUSE INJURIES TO PERSONNEL.

WARNING: DO NOT DISCONNECT THE COMPONENTS OF THE NITROGEN GENERATION SYSTEM, OR DUCTS WHEN THE SYSTEM IS PRESSURIZED. THE HOT, HIGH-PRESSURE AIR CAN CAUSE INJURIES TO PERSONNEL, AND DAMAGE TO EQUIPMENT.

CAUTION: MAKE SURE THAT THE MAINTENANCE AREA IS FREE OF CONTAMINATION FROM SKYDROL, LUBRICANTS, SOLVENTS, FUEL, FUMES, EXHAUST, OR DUST. DO NOT LET SOLVENTS, LUBRICANTS, OTHER FLUIDS, OR THEIR FUMES GO INTO THE FLOW PATH TO OR FROM THE ASM. CONTAMINATION WILL CAUSE DAMAGE TO THE FIBERS IN THE ASM AND DECREASE THEIR LIFE.

(5) Obey the nitrogen generation system (NGS) precautions (TASK 47-00-00-010-801).

SUBTASK 47-43-01-020-002

(6) Do these steps to disconnect the ram air valve exhaust duct at the front and aft ends.

NOTE: These steps are make it easier to get access to the pressure switch [1].

- (a) Loosen the hose clamps at the front and rear of the exhaust hose.
- (b) Remove the hose.
 - 1) Keep the hose and the two clamps for the installation.

F. Remove the Pressure Switch

SUBTASK 47-43-01-010-002

(1) Go to the pressure switch [1] location.

NOTE: The pressure switch [1] is attached to the air filter inlet duct [6].

SUBTASK 47-43-01-020-003

(2) Disconnect the electrical connector [2].

SUBTASK 47-43-01-030-002

(3) Disconnect the sense line [3].

NOTE: Use a second wrench to hold the pressure switch [1] when you disconnect the sense line [3].

SUBTASK 47-43-01-030-003

(4) Loosen the nut [4].

NOTE: Use a second wrench to hold the boss [7] when you loosen the nut [4].

NOTE: The sense line [3] is rigid. Do not bend the sense line [3] when you remove the pressure switch [1].

EFFECTIVITY
HAP 047-053, 106-999

D633A101-HAP

47-43-01

Page 402
Oct 15/2008



**737-600/700/800/900
AIRCRAFT MAINTENANCE MANUAL**

SUBTASK 47-43-01-020-001

(5) Remove the pressure switch [1].

NOTE: Keep the nut [4] for the installation.

(a) Discard the o-ring [5].

(b) Keep the washer [8]

SUBTASK 47-43-01-800-001

(6) Put protective caps on the sense line [3] and the duct [6] to keep out unwanted material.

————— **END OF TASK** —————

EFFECTIVITY
HAP 047-053, 106-999

D633A101-HAP

47-43-01

Page 403
Oct 15/2008

AIRCRAFT MAINTENANCE MANUAL

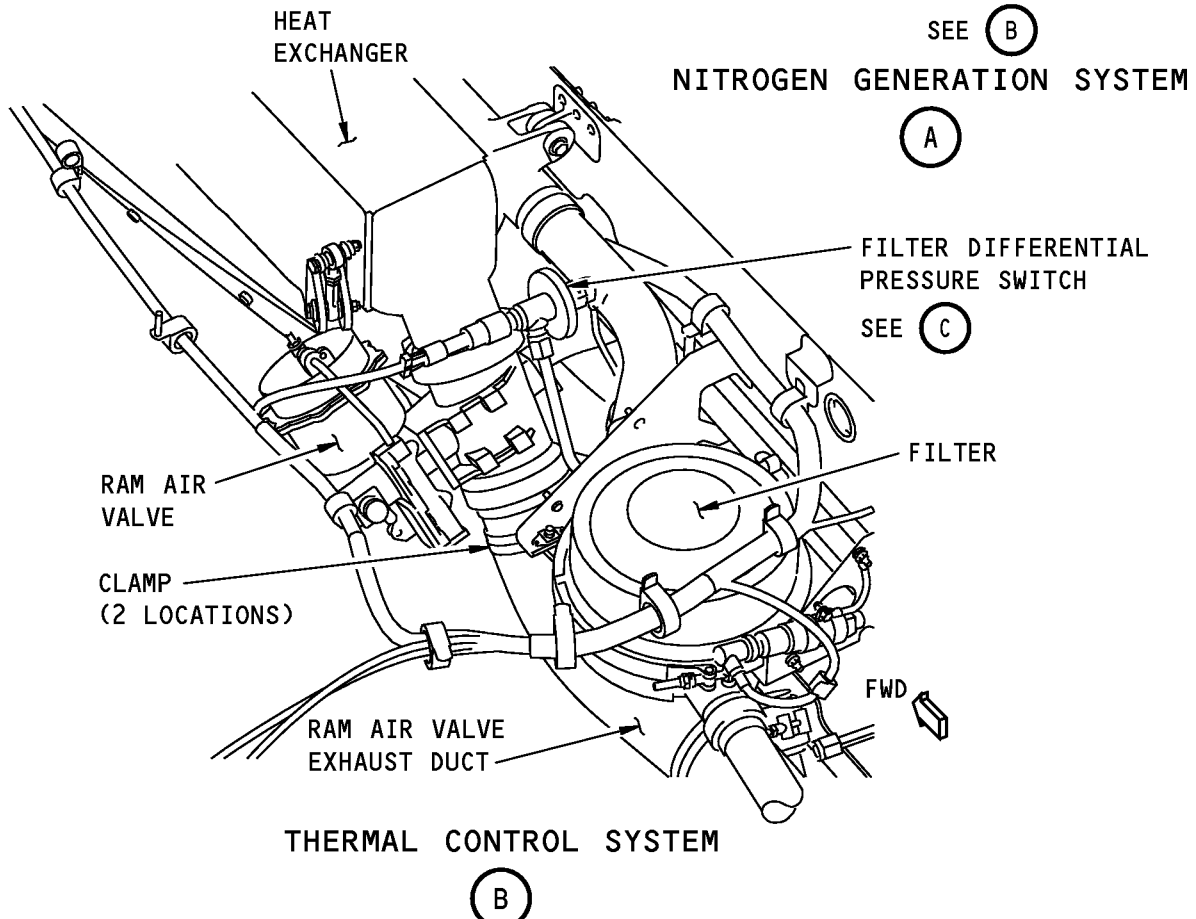
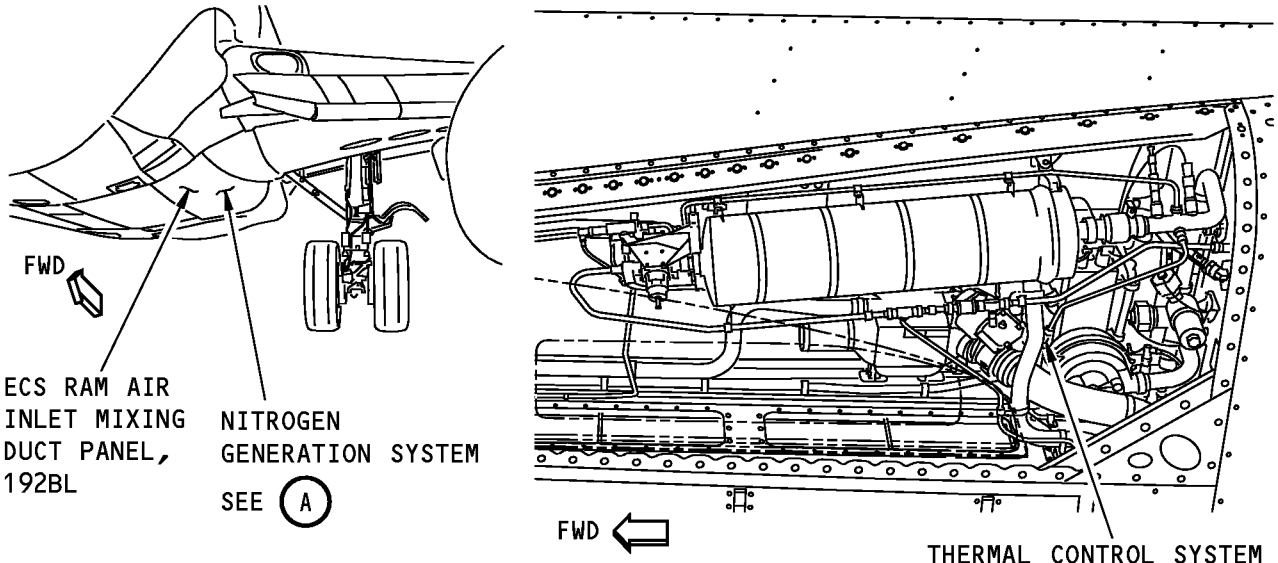

1505956 S0000275062_V1

**Filter Differential Pressure Switch
Figure 401 (Sheet 1 of 2)/47-43-01-990-801**

EFFECTIVITY
HAP 047-053, 106-999

47-43-01

Page 404
Oct 15/2008

D633A101-HAP

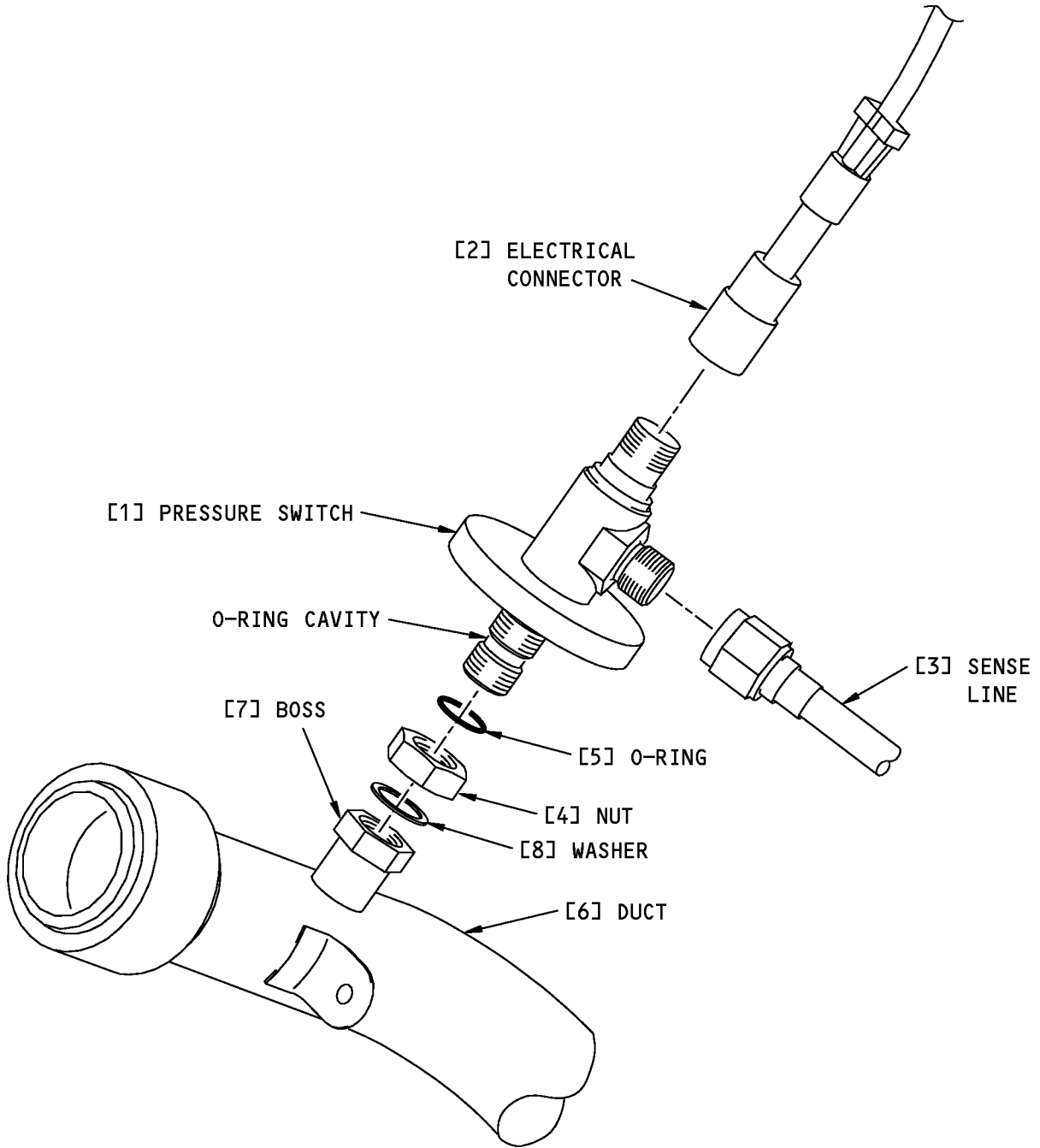

FILTER DIFFERENTIAL PRESSURE SWITCH

(C)

J17378 S0000176396_V3

**Filter Differential Pressure Switch
Figure 401 (Sheet 2 of 2)/47-43-01-990-801**

EFFECTIVITY
HAP 047-053, 106-999

47-43-01

Page 405
Oct 15/2008

D633A101-HAP



737-600/700/800/900

AIRCRAFT MAINTENANCE MANUAL

TASK 47-43-01-400-801

3. Filter Differential Pressure Switch Installation

(Figure 401)

A. General

(1) The filter differential pressure switch is referred to as the pressure switch [1] in this procedure.

B. References

Reference	Title
47-00-00-800-801	Ground Operation of the Nitrogen Generation System (P/B 201)

C. Consumable Materials

Reference	Description	Specification
G00034	Cotton Wiper - Process Cleaning Absorbent Wiper (Cheesecloth, Gauze)	BMS15-5
G50135	Leak Detector - Liquid, Non-Corrosive Soap Compound	MIL-PRF-25567

D. Expendables/Parts

AMM Item	Description	AIPC Reference	AIPC Effectivity
1	Pressure switch	47-43-01-01-065	HAP 047-053, 106-999
5	O-ring	47-43-01-01-060	HAP 047-053, 106-999

E. Location Zones

Zone	Area
131	Center Section Wing Box, Body Station 540.00 to Body Station 663.75 - Left
212	Flight Compartment - Right

F. Access Panels

Number	Name/Location
192BL	ECS Ram Air Inlet Mixing Duct Panel - Forward

G. Install the Pressure Switch

SUBTASK 47-43-01-090-001

(1) Remove the protective cap from the duct [6] and sense line [3].

SUBTASK 47-43-01-430-001

(2) Install the nut [4] on the pressure switch [1].

(a) Continue to turn until the nut [4] is on the pressure switch [1] side of the o-ring [5] cavity.

SUBTASK 47-43-01-640-001

(3) Lubricate the new o-ring [5] with water.

SUBTASK 47-43-01-430-002

(4) Install the new o-ring [5] in the cavity of the pressure switch [1]

SUBTASK 47-43-01-430-003

(5) Install the washer [8] on the pressure switch [1]

SUBTASK 47-43-01-420-002

(6) Install the pressure switch [1] into the boss [7] on the duct [6].

EFFECTIVITY HAP 047-053, 106-999

47-43-01

Page 406
Feb 15/2009

D633A101-HAP



737-600/700/800/900

AIRCRAFT MAINTENANCE MANUAL

- (a) Continue to turn the pressure switch [1] until the o-ring [5] is in its position in the top of the boss [7].

SUBTASK 47-43-01-430-004

- (7) Tighten the nut [4] to 90 ±3 in-lb (10.2 ±0.4 N·m).

NOTE: Use a second wrench on the boss [7] when you tighten the pressure switch [1].

NOTE: This torque value is in addition to the torque necessary to overcome the self-locking devices.

SUBTASK 47-43-01-420-001

- (8) Align the pressure switch [1] with the sense line [3].

- (a) Connect the sense line [3] to the pressure switch [1].

NOTE: Use a second wrench on the pressure switch [1] when you tighten the sense line [3].

SUBTASK 47-43-01-420-003

- (9) Connect the electrical connector [2].

SUBTASK 47-43-01-410-002

- (10) Do these steps to install the ram air valve exhaust hose:

- (a) Put the clamps on the hose.
 - 1) Make sure you can get access to the clamp screws.
- (b) Install the hose on the ram air exhaust duct.
 - 1) Tighten the clamp.
- (c) Install the hose on the ram air valve exhaust port.
 - 1) Tighten the hose clamp.

H. Operational Test for the Pressure Switch

SUBTASK 47-43-01-865-002

- (1) Remove the safety tags and close these circuit breakers:

CAPT Electrical System Panel, P18-3

<u>Row</u>	<u>Col</u>	<u>Number</u>	<u>Name</u>
D	17	C01657	NITROGEN GENERATION CONTROL
E	15	C01680	NGS ALT PWR

SUBTASK 47-43-01-860-002

- (2) Remove the DO-NOT-OPERATE tags from the L PACK and R PACK selector switches.

- (a) Put the L PACK and R PACK selector switches to the AUTO position.

SUBTASK 47-43-01-740-001

- (3) Do this task: Ground Operation of the Nitrogen Generation System, TASK 47-00-00-800-801.

- (a) Make sure that the test is good and the BITE message for the pressure switch [1] does not show.
- (b) With the NGS pressurized, use the leak detector, G50135, to do a check for leaks around the pressure switch [1].
- (c) Use a clean cotton wiper, G00034, to remove the leak detector, G50135.
- (d) Repair the leaks that you find.

EFFECTIVITY
HAP 047-053, 106-999

47-43-01



737-600/700/800/900

AIRCRAFT MAINTENANCE MANUAL

I. Put the Airplane Back to the Usual Condition

SUBTASK 47-43-01-410-001

(1) Close this access panel:

<u>Number</u>	<u>Name/Location</u>
192BL	ECS Ram Air Inlet Mixing Duct Panel - Forward

————— **END OF TASK** —————

EFFECTIVITY
HAP 047-053, 106-999

D633A101-HAP

47-43-01

Page 408
Oct 15/2008



737-600/700/800/900

AIRCRAFT MAINTENANCE MANUAL

THERMAL SWITCH - REMOVAL/INSTALLATION

1. General

A. This procedure has these tasks:

- (1) Thermal Switch Removal
- (2) Thermal Switch Installation

TASK 47-43-02-000-801

2. Thermal Switch Removal

(Figure 401)

A. References

Reference	Title
20-10-44-000-801	Lockwires Removal (P/B 401)
36-00-00-860-806	Remove Pressure from the Pneumatic System (P/B 201)
47-00-00-010-801	Nitrogen Generation System (NGS) Precautions (P/B 201)

B. Location Zones

Zone	Area
131	Center Section Wing Box, Body Station 540.00 to Body Station 663.75 - Left
132	Center Section Wing Box, Body Station 540.00 to Body Station 663.75 - Right
212	Flight Compartment - Right

C. Access Panels

Number	Name/Location
192BL	ECS Ram Air Inlet Mixing Duct Panel - Forward
192CR	Air Conditioning Access Door

D. Prepare for the Removal

SUBTASK 47-43-02-864-001

- (1) Do this task to prepare for the removal: Remove Pressure from the Pneumatic System, TASK 36-00-00-860-806.
 - (a) Make sure that the dual duct pressure gage shows less than 0.50 psig (3.45 kPa) in the L and R pneumatic ducts.

SUBTASK 47-43-02-860-002

- (2) Put the L PACK and R PACK selector switches, found on the P5-10 air conditioning panel, to the OFF position.
 - (a) Put DO-NOT-OPERATE tags on the L PACK and R PACK selector switches.

SUBTASK 47-43-02-865-002

- (3) Open these circuit breakers and install safety tags:

CAPT Electrical System Panel, P18-3

Row	Col	Number	Name
D	17	C01657	NITROGEN GENERATION CONTROL
E	15	C01680	NGS ALT PWR

EFFECTIVITY
HAP 047-053, 106-999

47-43-02

Page 401
Oct 15/2008

D633A101-HAP



737-600/700/800/900

AIRCRAFT MAINTENANCE MANUAL

SUBTASK 47-43-02-010-001

(4) Open these access panels:

<u>Number</u>	<u>Name/Location</u>
192BL	ECS Ram Air Inlet Mixing Duct Panel - Forward
192CR	Air Conditioning Access Door

E. Remove the Thermal Switch

SUBTASK 47-43-02-910-001

WARNING: DO NOT TOUCH THE COMPONENTS OF THE NITROGEN GENERATION SYSTEM WHEN THEY ARE HOT. WHEN THE COMPONENTS ARE HOT, THEY CAN CAUSE INJURIES TO PERSONNEL.

WARNING: DO NOT DISCONNECT THE COMPONENTS OF THE NITROGEN GENERATION SYSTEM, OR DUCTS WHEN THE SYSTEM IS PRESSURIZED. THE HOT, HIGH-PRESSURE AIR CAN CAUSE INJURIES TO PERSONNEL, AND DAMAGE TO EQUIPMENT.

CAUTION: MAKE SURE THAT THE MAINTENANCE AREA IS FREE OF CONTAMINATION FROM SKYDROL, LUBRICANTS, SOLVENTS, FUEL, FUMES, EXHAUST, OR DUST. DO NOT LET SOLVENTS, LUBRICANTS, OTHER FLUIDS, OR THEIR FUMES GO INTO THE FLOW PATH TO OR FROM THE ASM. CONTAMINATION WILL CAUSE DAMAGE TO THE FIBERS IN THE ASM AND DECREASE THEIR LIFE.

(1) Obey the nitrogen generation system (NGS) precautions (TASK 47-00-00-010-801).

SUBTASK 47-43-02-010-002

(2) Go to the thermal switch [2] location.

NOTE: The thermal switch [2] is on the inlet duct [4] to the air separation module upstream of and adjacent to the overtemperature shutoff valve.

SUBTASK 47-43-02-020-001

(3) Disconnect the electrical connector [1].

SUBTASK 47-43-02-020-002

(4) Do these steps to remove the thermal switch [2]:

(a) Remove the lockwire (TASK 20-10-44-000-801)

(b) Remove the thermal switch [2] from the duct [4].

NOTE: Use a second wrench on the duct [4] when you disconnect the thermal switch [2].

(c) Discard the O-ring [3].

(d) Put a protective cap on the thermal switch port of the duct [4].

————— **END OF TASK** —————

EFFECTIVITY
HAP 047-053, 106-999

D633A101-HAP

47-43-02

Page 402
Oct 15/2008

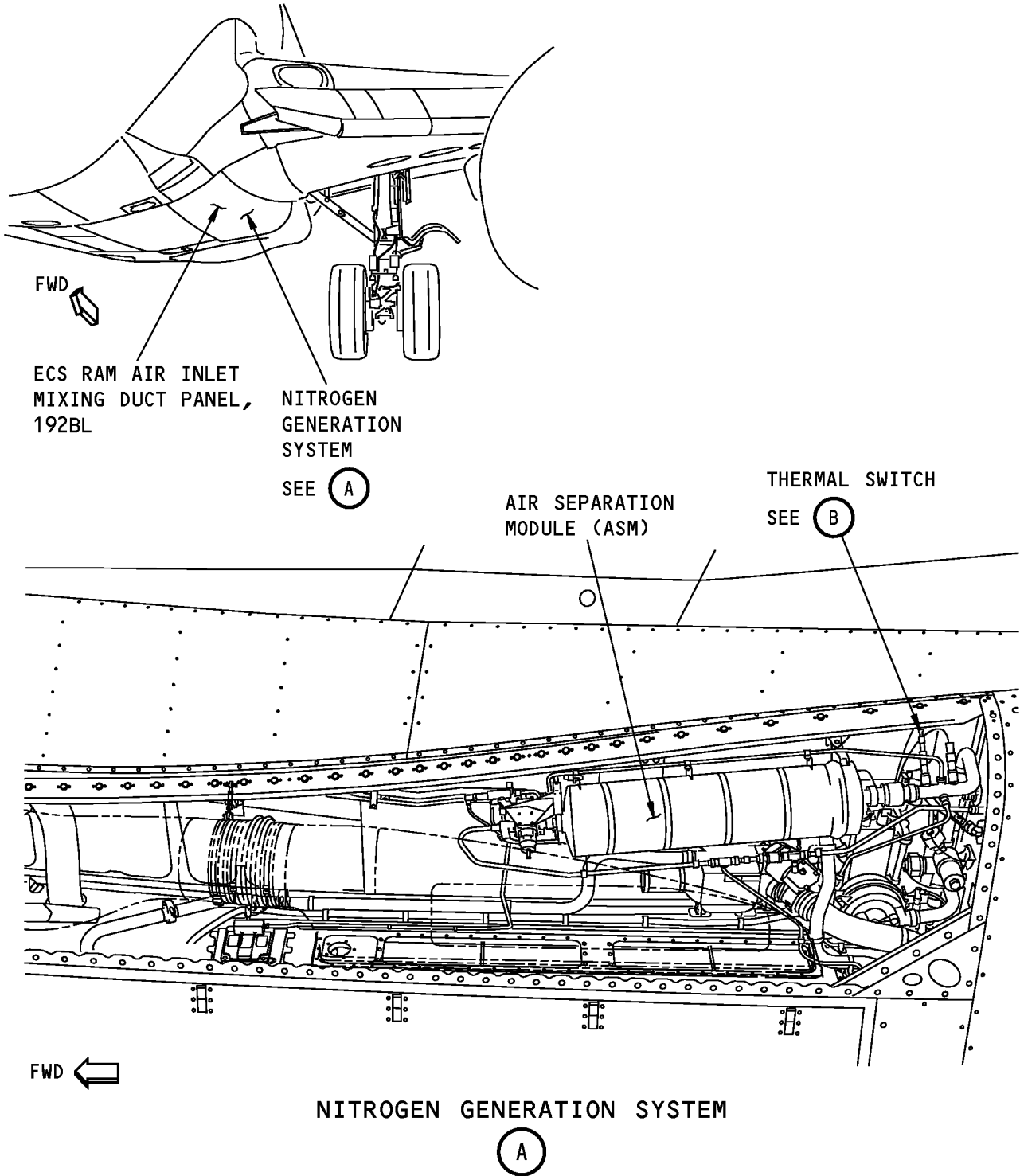

1505407 S0000275202_V1

Thermal Switch
Figure 401 (Sheet 1 of 2)/47-43-02-990-801

EFFECTIVITY
HAP 047-053, 106-999

47-43-02

Page 403
Oct 15/2008

D633A101-HAP

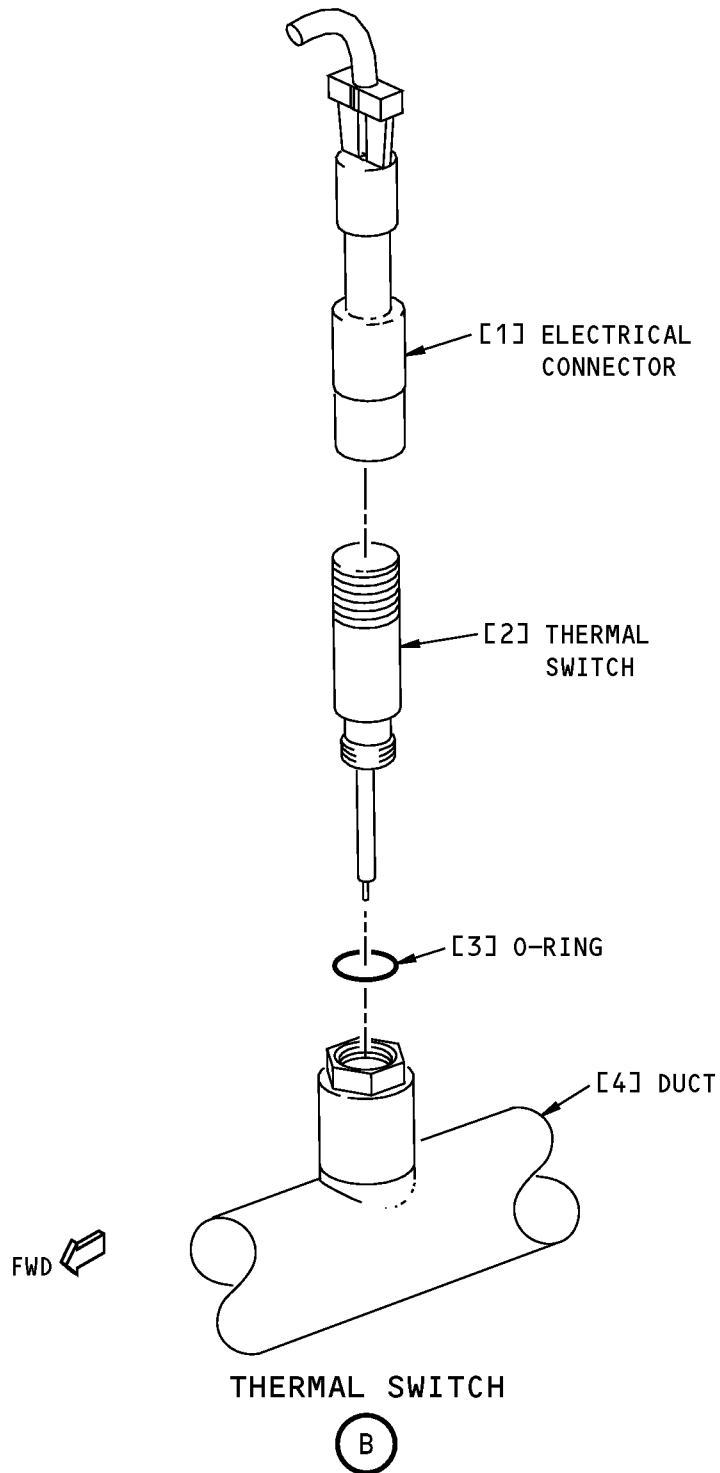

Thermal Switch
Figure 401 (Sheet 2 of 2)/47-43-02-990-801

EFFECTIVITY
HAP 047-053, 106-999

D633A101-HAP



737-600/700/800/900

AIRCRAFT MAINTENANCE MANUAL

TASK 47-43-02-400-801

3. Thermal Switch Installation

(Figure 401)

A. References

Reference	Title
20-10-44-400-801	Lockwires Installation (P/B 401)
47-00-00-800-801	Ground Operation of the Nitrogen Generation System (P/B 201)

B. Consumable Materials

Reference	Description	Specification
G00034	Cotton Wiper - Process Cleaning Absorbent Wiper (Cheesecloth, Gauze)	BMS15-5
G50135	Leak Detector - Liquid, Non-Corrosive Soap Compound	MIL-PRF-25567

C. Expendables/Parts

AMM Item	Description	AIPC Reference	AIPC Effectivity
2	Thermal switch	47-43-02-01-010	HAP 047-053, 106-999
3	O-ring	47-43-02-01-005	HAP 047-053, 106-999

D. Location Zones

Zone	Area
131	Center Section Wing Box, Body Station 540.00 to Body Station 663.75 - Left
212	Flight Compartment - Right

E. Access Panels

Number	Name/Location
192BL	ECS Ram Air Inlet Mixing Duct Panel - Forward
192CR	Air Conditioning Access Door

F. Install the Thermal Switch

SUBTASK 47-43-02-020-004

(1) Remove the protective cap.

SUBTASK 47-43-02-640-001

(2) Lubricate the new O-ring [3] with water.

SUBTASK 47-43-02-420-003

(3) Install the new O-ring [3] on the thermal switch [2].

SUBTASK 47-43-02-420-004

(4) Carefully install the thermal switch [2] into the thermal switch port.

NOTE: Use a second wrench on the nut attached to the duct [4] when you tighten the thermal switch [2].

SUBTASK 47-43-02-420-001

(5) Tighten the thermal switch [2] to 100 ± 10 in-lb (11 ± 1 N·m).

(a) Put a lockwire on the thermal switch [2] and the duct [4] (TASK 20-10-44-400-801).

EFFECTIVITY
HAP 047-053, 106-999

47-43-02

Page 405
Feb 15/2009

D633A101-HAP



**737-600/700/800/900
AIRCRAFT MAINTENANCE MANUAL**

SUBTASK 47-43-02-430-001

- (6) Connect the electrical connector [1] to the thermal switch [2].

G. Operational Test of the Thermal Switch

SUBTASK 47-43-02-865-001

- (1) Remove the safety tags and close these circuit breakers:

CAPT Electrical System Panel, P18-3

<u>Row</u>	<u>Col</u>	<u>Number</u>	<u>Name</u>
D	17	C01657	NITROGEN GENERATION CONTROL
E	15	C01680	NGS ALT PWR

SUBTASK 47-43-02-860-001

- (2) Remove the DO-NOT-OPERATE tags from the L PACK and R PACK selector switches on the P5 panel.
 - (a) Put the L PACK and R PACK selector switches to the AUTO position.

SUBTASK 47-43-02-740-001

- (3) Do this task to do a check of the thermal switch: Ground Operation of the Nitrogen Generation System, TASK 47-00-00-800-801.
 - (a) Make sure the test is good and the BITE message for the thermal switch [2] does not show.
 - (b) With the NGS pressurized, use the leak detector, G50135, to do a check for leaks around the thermal switch [2].
 - (c) Use a clean cotton wiper, G00034, to remove the leak detector, G50135.
 - (d) Repair the leaks that you find.

H. Put the Airplane Back to the Usual Condition

SUBTASK 47-43-02-410-001

- (1) Close these access panels:

<u>Number</u>	<u>Name/Location</u>
192BL	ECS Ram Air Inlet Mixing Duct Panel - Forward
192CR	Air Conditioning Access Door

————— **END OF TASK** —————

EFFECTIVITY
HAP 047-053, 106-999

47-43-02

Page 406
Oct 15/2008

D633A101-HAP



737-600/700/800/900

AIRCRAFT MAINTENANCE MANUAL

THERMAL SWITCH - ADJUSTMENT/TEST

1. General

A. This procedure contains scheduled maintenance task data.

TASK 47-43-02-720-801

2. Thermal Switch Functional Test

A. General

- (1) This procedure is a scheduled maintenance task.
- (2) ALI - Refer to the task: Airworthiness Limitation Precautions, TASK 47-00-00-910-802, for important information on airworthiness limitation instructions (ALIs).
- (3) This task removes and bench tests the NGS thermal switch.
- (4) The thermal switch (S01129), is on the air duct that connects the air filter to the air separation module (ASM).
- (5) You get access to the thermal switch through the underwing fairing access panel for the ram air duct, 192BL.

B. References

Reference	Title
47-00-00-910-802	Airworthiness Limitation Precautions (P/B 201)
47-43-02-000-801	Thermal Switch Removal (P/B 401)
47-43-02-400-801	Thermal Switch Installation (P/B 401)

C. Location Zones

Zone	Area
131	Center Section Wing Box, Body Station 540.00 to Body Station 663.75 - Left

D. Functional Test

SUBTASK 47-43-02-020-003

- (1) Do this task: Thermal Switch Removal, TASK 47-43-02-000-801.

SUBTASK 47-43-02-720-001

- (2) Test the thermal switch (S01129) per the manufacturer's instructions.

SUBTASK 47-43-02-420-002

- (3) Do this task to install a new or servicable thermal switch: Thermal Switch Installation, TASK 47-43-02-400-801.

————— **END OF TASK** —————

EFFECTIVITY HAP 047-053, 106-999

47-43-02

Page 501
Feb 15/2009

D633A101-HAP



737-600/700/800/900

AIRCRAFT MAINTENANCE MANUAL

TEMPERATURE SENSOR - REMOVAL/INSTALLATION

1. General

A. This procedure has these tasks:

- (1) Temperature Sensor Removal
- (2) Temperature Sensor Installation

TASK 47-43-03-000-801

2. Temperature Sensor Removal

(Figure 401)

A. References

Reference	Title
36-00-00-860-806	Remove Pressure from the Pneumatic System (P/B 201)
47-00-00-010-801	Nitrogen Generation System (NGS) Precautions (P/B 201)

B. Location Zones

Zone	Area
131	Center Section Wing Box, Body Station 540.00 to Body Station 663.75 - Left
132	Center Section Wing Box, Body Station 540.00 to Body Station 663.75 - Right
212	Flight Compartment - Right

C. Access Panels

Number	Name/Location
192BL	ECS Ram Air Inlet Mixing Duct Panel - Forward
192CR	Air Conditioning Access Door

D. Prepare for the Removal

SUBTASK 47-43-03-864-001

(1) Do this task: Remove Pressure from the Pneumatic System, TASK 36-00-00-860-806.

- (a) Make sure that the dual duct pressure gage shows less than 0.50 psig (3.45 kPa) on the L and R pneumatic ducts.

SUBTASK 47-43-03-860-001

(2) Put the L PACK and R PACK selector switches, found on the P5-10 air conditioning panel, to the OFF position.

- (a) Put DO-NOT-OPERATE tags on the L PACK and R PACK selector switches.

SUBTASK 47-43-03-865-001

(3) Open these circuit breakers and install safety tags:

CAPT Electrical System Panel, P18-3

Row	Col	Number	Name
D	17	C01657	NITROGEN GENERATION CONTROL
E	15	C01680	NGS ALT PWR

EFFECTIVITY
HAP 047-053, 106-999

47-43-03

Page 401
Oct 15/2008

D633A101-HAP



737-600/700/800/900

AIRCRAFT MAINTENANCE MANUAL

SUBTASK 47-43-03-010-001

(4) Open these access panels:

<u>Number</u>	<u>Name/Location</u>
192BL	ECS Ram Air Inlet Mixing Duct Panel - Forward
192CR	Air Conditioning Access Door

E. Remove the Temperature Sensor

SUBTASK 47-43-03-800-001

WARNING: DO NOT TOUCH THE COMPONENTS OF THE NITROGEN GENERATION SYSTEM WHEN THEY ARE HOT. WHEN THE COMPONENTS ARE HOT, THEY CAN CAUSE INJURIES TO PERSONNEL.

WARNING: DO NOT DISCONNECT THE COMPONENTS OF THE NITROGEN GENERATION SYSTEM, OR DUCTS WHEN THE SYSTEM IS PRESSURIZED. THE HOT, HIGH-PRESSURE AIR CAN CAUSE INJURIES TO PERSONNEL, AND DAMAGE TO EQUIPMENT.

CAUTION: MAKE SURE THAT THE MAINTENANCE AREA IS FREE OF CONTAMINATION FROM SKYDROL, LUBRICANTS, SOLVENTS, FUEL, FUMES, EXHAUST, OR DUST. DO NOT LET SOLVENTS, LUBRICANTS, OTHER FLUIDS, OR THEIR FUMES GO INTO THE FLOW PATH TO OR FROM THE ASM. CONTAMINATION WILL CAUSE DAMAGE TO THE FIBERS IN THE ASM AND DECREASE THEIR LIFE.

(1) Obey the nitrogen generation system (NGS) precautions (TASK 47-00-00-010-801).

SUBTASK 47-43-03-010-002

(2) Go to the temperature sensor [2] location.

NOTE: The temperature sensor [2] is on the inlet duct aft of the air separation module, upstream of and adjacent to the overtemperature shutoff valve.

SUBTASK 47-43-03-030-001

(3) Disconnect the electrical connector [1].

SUBTASK 47-43-03-030-002

(4) Do these steps to remove the temperature sensor [2]:

- (a) Remove the lockwire.
- (b) Remove the temperature sensor [2] from the duct [4].

NOTE: Use a second wrench on the duct [4] when you disconnect the temperature sensor [2]

- (c) Discard the o-ring [3].
- (d) Put a protective cap on the port for the duct [4].

————— **END OF TASK** —————

EFFECTIVITY
HAP 047-053, 106-999

D633A101-HAP

47-43-03

Page 402
Oct 15/2008

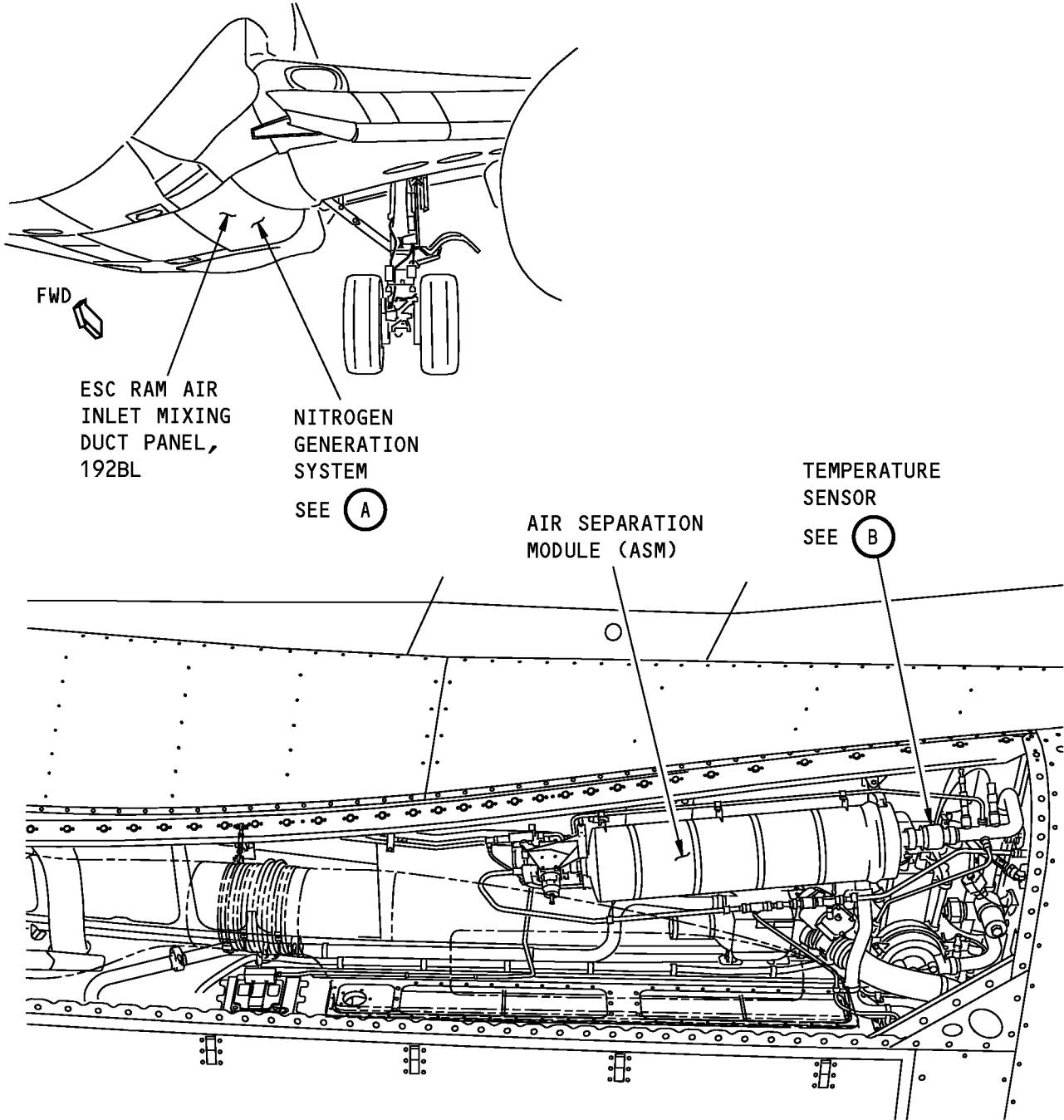

FWD ←

**NITROGEN GENERATION SYSTEM
(VIEW IN THE INBOARD DIRECTION)**

(A)

1506300 S0000275081_V1

**Temperature Sensor
Figure 401 (Sheet 1 of 2)/47-43-03-990-801**

EFFECTIVITY
HAP 047-053, 106-999

47-43-03

Page 403
Oct 15/2008

D633A101-HAP

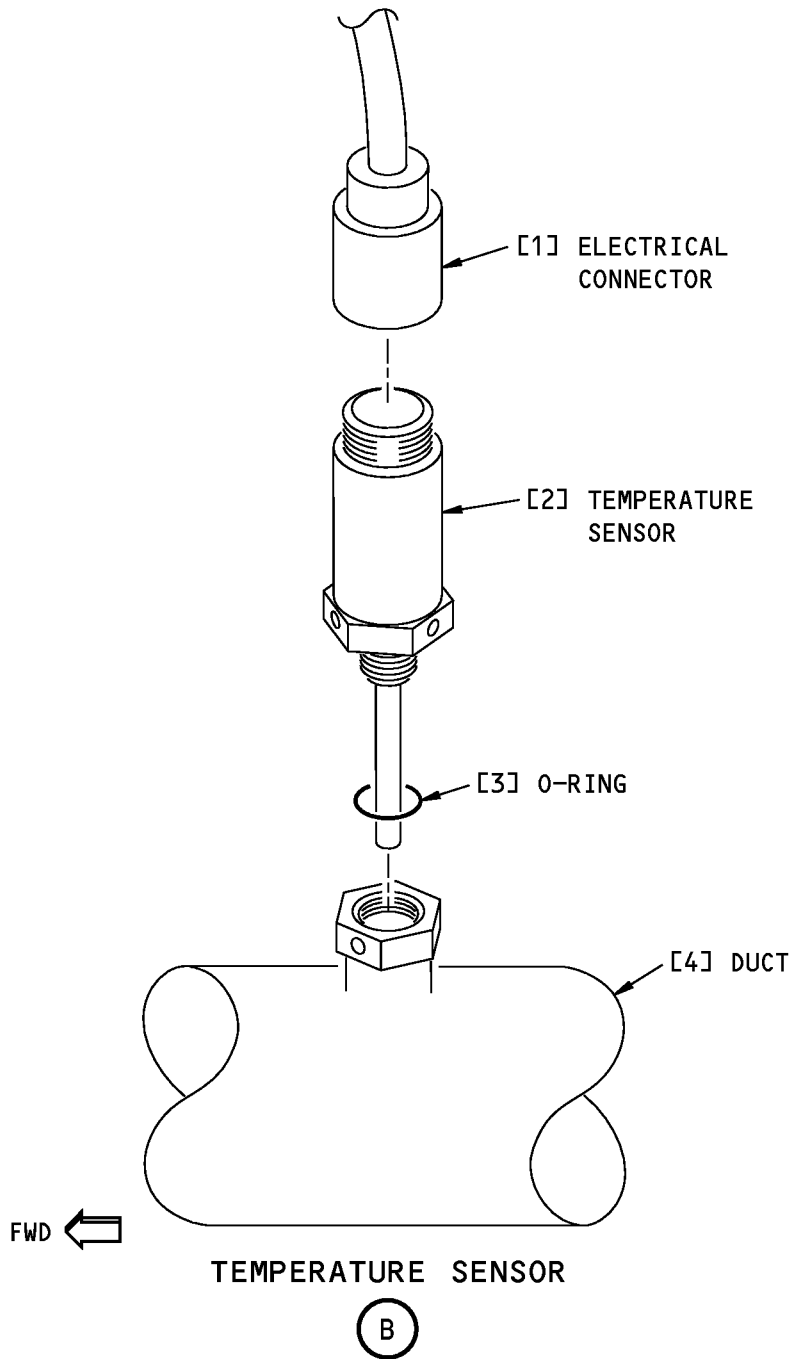

J22089 S0000176447_V2

Temperature Sensor
Figure 401 (Sheet 2 of 2)/47-43-03-990-801

EFFECTIVITY
HAP 047-053, 106-999

D633A101-HAP



737-600/700/800/900

AIRCRAFT MAINTENANCE MANUAL

TASK 47-43-03-400-801

3. Temperature Sensor Installation

(Figure 401)

A. References

Reference	Title
20-10-44-400-801	Lockwires Installation (P/B 401)
47-00-00-800-801	Ground Operation of the Nitrogen Generation System (P/B 201)

B. Consumable Materials

Reference	Description	Specification
G00034	Cotton Wiper - Process Cleaning Absorbent Wiper (Cheesecloth, Gauze)	BMS15-5
G50135	Leak Detector - Liquid, Non-Corrosive Soap Compound	MIL-PRF-25567

C. Expendables/Parts

AMM Item	Description	AIPC Reference	AIPC Effectivity
2	Temperature sensor	47-43-03-01-010	HAP 047-053, 106-999
3	O-ring	47-43-03-01-005	HAP 047-053, 106-999

D. Location Zones

Zone	Area
131	Center Section Wing Box, Body Station 540.00 to Body Station 663.75 - Left
132	Center Section Wing Box, Body Station 540.00 to Body Station 663.75 - Right
212	Flight Compartment - Right

E. Access Panels

Number	Name/Location
192BL	ECS Ram Air Inlet Mixing Duct Panel - Forward
192CR	Air Conditioning Access Door

F. Install the Temperature Sensor

SUBTASK 47-43-03-090-001

(1) Remove the protective cap.

SUBTASK 47-43-03-640-001

(2) Lubricate the new o-ring [3] with water.

SUBTASK 47-43-03-430-003

(3) Install the o-ring [3] on the temperature sensor [2].

SUBTASK 47-43-03-420-001

(4) Install the temperature sensor [2] in its position.

NOTE: Use a second wrench on the nut attached to the duct [4] when you tighten the temperature sensor [2].

(a) Tighten the temperature sensor [2] to 80 ± 8 in-lb (9.0 ± 0.9 N-m).

SUBTASK 47-43-03-430-001

(5) Put a lockwire on the temperature sensor [2] and the duct [4] (TASK 20-10-44-400-801).

EFFECTIVITY HAP 047-053, 106-999

47-43-03

Page 405
Feb 15/2009

D633A101-HAP



**737-600/700/800/900
AIRCRAFT MAINTENANCE MANUAL**

SUBTASK 47-43-03-430-002

- (6) Connect the electrical connector [1] to the temperature sensor [2].

G. Operational Test of the Temperature Sensor

SUBTASK 47-43-03-865-002

- (1) Remove the safety tags and close these circuit breakers:

CAPT Electrical System Panel, P18-3

<u>Row</u>	<u>Col</u>	<u>Number</u>	<u>Name</u>
D	17	C01657	NITROGEN GENERATION CONTROL
E	15	C01680	NGS ALT PWR

SUBTASK 47-43-03-440-001

- (2) Remove the DO-NOT-OPERATE tags from the L PACK and R PACK selector switches on the P5 panel.
 - (a) Put the L PACK and R PACK selector switches to the AUTO position.

SUBTASK 47-43-03-740-001

- (3) Do this task to do a check of the temperature sensor [2]: Ground Operation of the Nitrogen Generation System, TASK 47-00-00-800-801.
 - (a) Make sure that the test is good and the BITE message for the temperature sensor [2] does not show.
 - (b) With the NGS pressurized, use the leak detector, G50135, to do a check for leaks around the temperature sensor [2].
 - (c) Use a clean cotton wiper, G00034, to remove the leak detector, G50135.
 - (d) Repair the leaks that you find.

H. Put the Airplane Back to the Usual Condition

SUBTASK 47-43-03-410-001

- (1) Close these access panels:

<u>Number</u>	<u>Name/Location</u>
192BL	ECS Ram Air Inlet Mixing Duct Panel - Forward
192CR	Air Conditioning Access Door

————— **END OF TASK** —————

EFFECTIVITY
HAP 047-053, 106-999

47-43-03

Page 406
Oct 15/2008

D633A101-HAP



737-600/700/800/900

AIRCRAFT MAINTENANCE MANUAL

NGS PRESSURE SENSOR - REMOVAL/INSTALLATION

1. General

A. This procedure has these tasks:

- (1) NGS Pressure Sensor Removal
- (2) NGS Pressure Sensor Installation

TASK 47-43-04-000-801

2. NGS Pressure Sensor Removal

A. References

Reference	Title
20-10-51-000-801	Flareless Tubing Assembly Removal (P/B 401)
36-00-00-860-806	Remove Pressure from the Pneumatic System (P/B 201)

B. Location Zones

Zone	Area
131	Center Section Wing Box, Body Station 540.00 to Body Station 663.75 - Left
132	Center Section Wing Box, Body Station 540.00 to Body Station 663.75 - Right
212	Flight Compartment - Right

C. Access Panels

Number	Name/Location
192CL	Air Conditioning Access Door
192CR	Air Conditioning Access Door

D. Prepare for the Removal

SUBTASK 47-43-04-864-001

- (1) Do this task to prepare for removal: Remove Pressure from the Pneumatic System, TASK 36-00-00-860-806.
 - (a) Make sure that the dual duct pressure gage shows left and right duct pressure at less than 0.50 psig (3.45 kPa).

SUBTASK 47-43-04-860-001

- (2) Turn the L PACK and R PACK selector switches, found on the P5-10 air conditioning panel, to the OFF position
 - (a) Put DO-NOT-OPERATE tags on the L PACK and R PACK selector switches.

SUBTASK 47-43-04-865-001

- (3) Open these circuit breakers and install safety tags:

CAPT Electrical System Panel, P18-3

Row	Col	Number	Name
D	17	C01657	NITROGEN GENERATION CONTROL
E	15	C01680	NGS ALT PWR

EFFECTIVITY
HAP 047-053, 106-999

47-43-04



737-600/700/800/900

AIRCRAFT MAINTENANCE MANUAL

SUBTASK 47-43-04-010-001

(4) Open these access panels:

<u>Number</u>	<u>Name/Location</u>
192CL	Air Conditioning Access Door
192CR	Air Conditioning Access Door

E. Remove the Pressure Sensor

SUBTASK 47-43-04-860-002

WARNING: DO NOT TOUCH THE COMPONENTS OF THE NITROGEN GENERATION SYSTEM WHEN THEY ARE HOT. WHEN THE COMPONENTS ARE HOT, THEY CAN CAUSE INJURIES TO PERSONNEL.

WARNING: DO NOT DISCONNECT THE COMPONENTS OF THE NITROGEN GENERATION SYSTEM, OR DUCTS WHEN THE SYSTEM IS PRESSURIZED. THE HOT, HIGH-PRESSURE AIR CAN CAUSE INJURIES TO PERSONNEL, AND DAMAGE TO EQUIPMENT.

CAUTION: MAKE SURE THAT THE MAINTENANCE AREA IS FREE OF CONTAMINATION FROM SKYDROL, LUBRICANTS, SOLVENTS, FUEL, FUMES, EXHAUST, OR DUST. DO NOT LET SOLVENTS, LUBRICANTS, OTHER FLUIDS, OR THEIR FUMES GO INTO THE FLOW PATH TO OR FROM THE ASM. CONTAMINATION WILL CAUSE DAMAGE TO THE FIBERS IN THE ASM AND DECREASE THEIR LIFE.

(1) Obey the nitrogen generation system (NGS) precautions when you do maintenance on the pressure sensor [1].

SUBTASK 47-43-04-010-002

(2) Go to the pressure sensor [1] location.

NOTE: The NGS pressure sensor [1] is attached to a bracket assembly [3] on the left side front spar in the left air conditioning pack bay. The sense line is upstream from the NGS shutoff valve.

SUBTASK 47-43-04-030-001

(3) Disconnect the electrical connector [6].

SUBTASK 47-43-04-020-001

(4) Do these steps to remove the pressure sensor [1]:

(a) Do this task to disconnect the sense line: Flareless Tubing Assembly Removal, TASK 20-10-51-000-801.

NOTE: Use a second wrench on the pressure sensor [1] when you disconnect the pressure sense line.

(b) Hold the pressure sensor [1] in its position.

(c) Remove the washers [4], screws [5], and the clamps [2].

(d) Remove the pressure sensor [1].

(e) Keep the washers [4], screws [5], and the clamps [2] for the installation.

————— **END OF TASK** —————

EFFECTIVITY
HAP 047-053, 106-999

D633A101-HAP

47-43-04

Page 402
Oct 15/2008

**737-600/700/800/900
AIRCRAFT MAINTENANCE MANUAL**

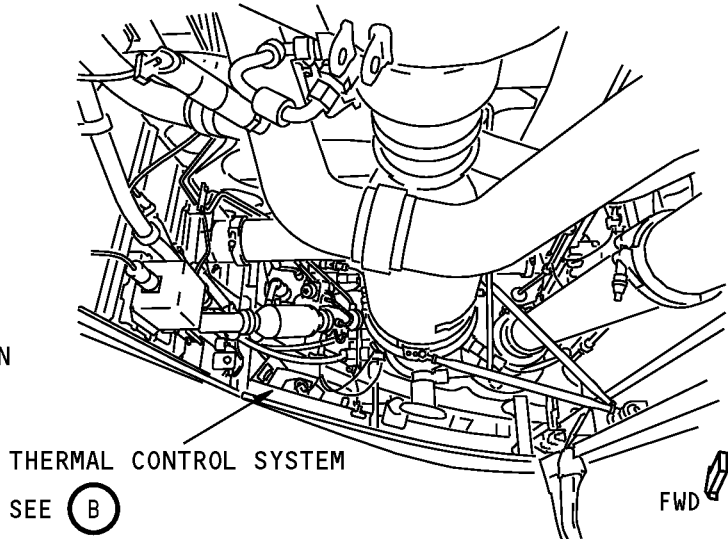
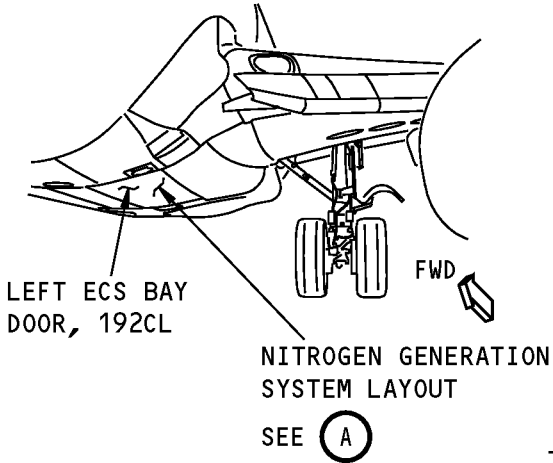

NITROGEN GENERATION SYSTEM LAYOUT

(A)

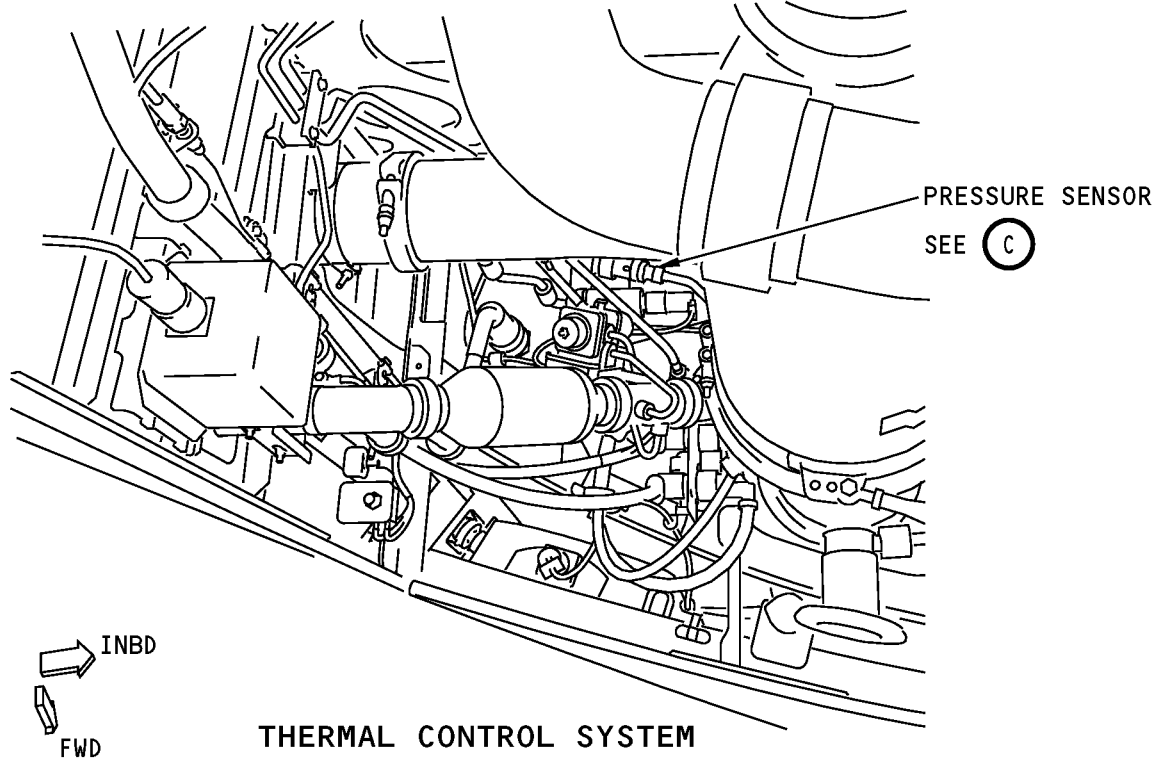

**Pressure Sensor
Figure 401 (Sheet 1 of 2)/47-43-04-990-801**

EFFECTIVITY
HAP 047-053, 106-999

47-43-04

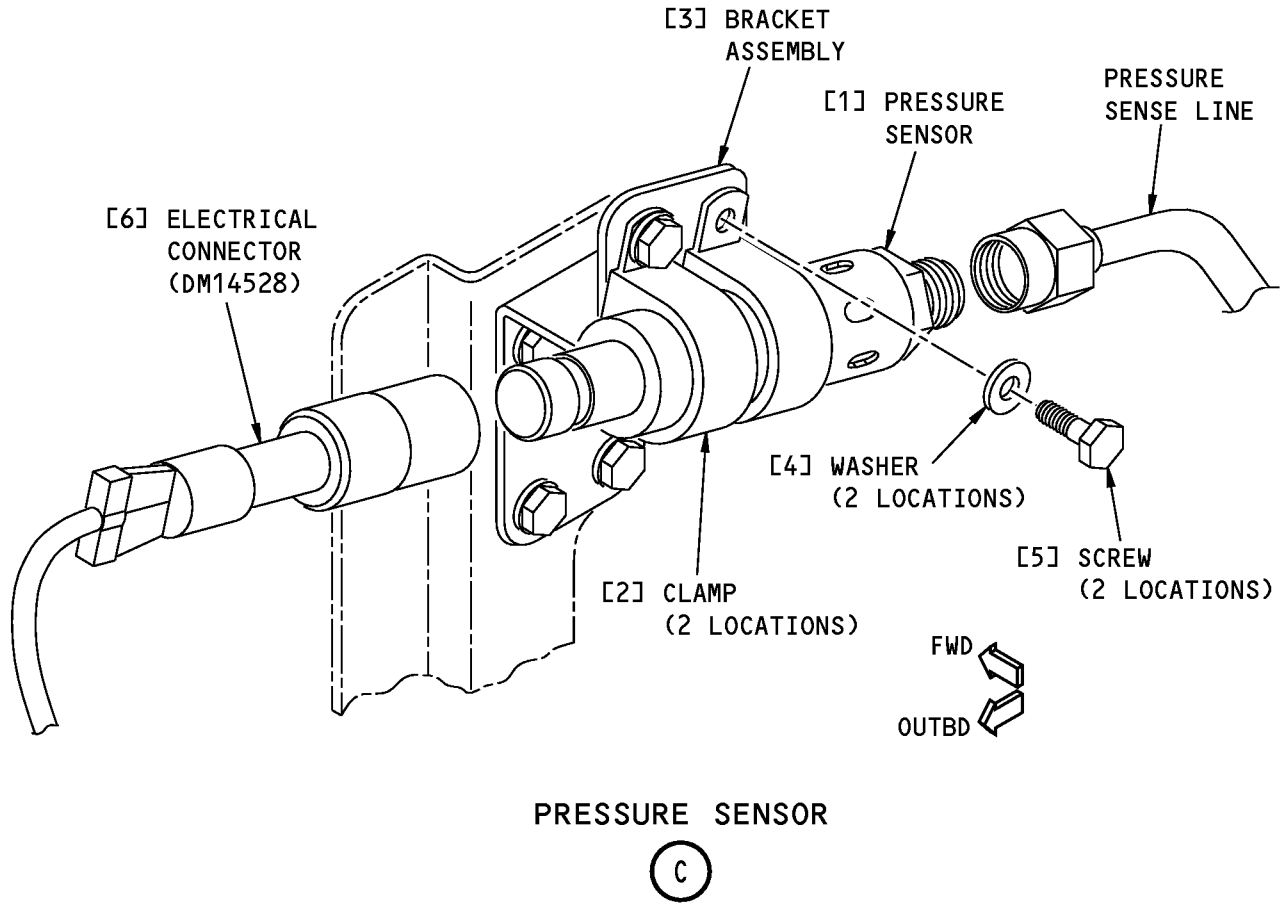

J22304 S0000176253_V2

Pressure Sensor
Figure 401 (Sheet 2 of 2)/47-43-04-990-801

EFFECTIVITY
HAP 047-053, 106-999

47-43-04

Page 404
Oct 15/2008

D633A101-HAP



737-600/700/800/900

AIRCRAFT MAINTENANCE MANUAL

TASK 47-43-04-400-801

3. NGS Pressure Sensor Installation

(Figure 401)

A. References

Reference	Title
20-10-51-400-804	Flareless Tubing Assembly Installation (P/B 401)
47-00-00-800-801	Ground Operation of the Nitrogen Generation System (P/B 201)

B. Consumable Materials

Reference	Description	Specification
G00034	Cotton Wiper - Process Cleaning Absorbent Wiper (Cheesecloth, Gauze)	BMS15-5
G50135	Leak Detector - Liquid, Non-Corrosive Soap Compound	MIL-PRF-25567

C. Location Zones

Zone	Area
131	Center Section Wing Box, Body Station 540.00 to Body Station 663.75 - Left
132	Center Section Wing Box, Body Station 540.00 to Body Station 663.75 - Right
212	Flight Compartment - Right

D. Access Panels

Number	Name/Location
192CL	Air Conditioning Access Door
192CR	Air Conditioning Access Door

E. Install the Pressure Sensor

SUBTASK 47-43-04-420-001

WARNING: DO NOT TOUCH THE COMPONENTS OF THE NITROGEN GENERATION SYSTEM WHEN THEY ARE HOT. WHEN THE COMPONENTS ARE HOT, THEY CAN CAUSE INJURIES TO PERSONNEL.

- (1) Do these steps to install the pressure sensor [1]:
 - (a) Put the clamps [2] and the pressure sensor [1] into their position on the bracket assembly [3].
 - (b) Install the clamps and pressure sensor with the two washers [4] and two screws [5].

NOTE: Do not tighten the screws until the pressure sense line is attached to the pressure sensor [1].
 - (c) Do this task to attach the pressure sense line to the pressure sensor [1]: Flareless Tubing Assembly Installation, TASK 20-10-51-400-804.

NOTE: Use a second wrench on the pressure sensor when you connect the pressure sense line.
 - (d) Tighten the bolts [7] and screws [5].
 - (e) Connect the electrical connector [6].

EFFECTIVITY HAP 047-053, 106-999

47-43-04

Page 405
Oct 15/2008

D633A101-HAP



737-600/700/800/900

AIRCRAFT MAINTENANCE MANUAL

F. Operational Test of the Pressure Sensor

SUBTASK 47-43-04-090-001

- (1) Remove the safety tags and close these circuit breakers:

CAPT Electrical System Panel, P18-3

<u>Row</u>	<u>Col</u>	<u>Number</u>	<u>Name</u>
D	17	C01657	NITROGEN GENERATION CONTROL
E	15	C01680	NGS ALT PWR

SUBTASK 47-43-04-865-002

- (2) Remove the DO-NOT-OPERATE tags from the L PACK and R PACK selector switches on the P5 panel.

- (a) Put the L PACK and R PACK selector switches to the AUTO position.

SUBTASK 47-43-04-710-001

- (3) Do this task to do a check of the pressure sensor [1]: Ground Operation of the Nitrogen Generation System, TASK 47-00-00-800-801.

- (a) Make sure that the test is good and the BITE message for the pressure sensor [1] does not show.

- (b) With the NGS pressurized, use the leak detector, G50135, to do a check for leaks around the pressure sensor [1].

- (c) Use a clean cotton wiper, G00034, to remove the leak detector, G50135.

- (d) Repair the leaks that you find.

G. Put the Airplane Back to its Usual Condition

SUBTASK 47-43-04-410-001

- (1) Close these access panels:

<u>Number</u>	<u>Name/Location</u>
192CL	Air Conditioning Access Door
192CR	Air Conditioning Access Door

————— END OF TASK —————

EFFECTIVITY
HAP 047-053, 106-999

D633A101-HAP

47-43-04

Page 406
Oct 15/2008