

CHAPTER

75

AIR

**737-600/700/800/900
AIRCRAFT MAINTENANCE MANUAL**

**CHAPTER 75
AIR**

Subject/Page	Date	COC	Subject/Page	Date	COC	Subject/Page	Date	COC
EFFECTIVE PAGES			75-23-01 (cont)			75-32-00		
1 thru 2	Jun 15/2009		408	Feb 15/2009		501	Feb 15/2009	
			409	Jun 15/2008		502	Feb 15/2009	
75-CONTENTS			410	BLANK		503	Feb 15/2009	
1	Feb 15/2008		75-31-00			504	Oct 10/2003	
2	Feb 15/2009		201	Oct 15/2008		505	Oct 10/2003	
3	Feb 15/2008		202	Oct 15/2008		506	Feb 15/2009	
4	BLANK		203	Oct 15/2008		507	Feb 15/2009	
75-21-01			204	Oct 15/2008		508	Feb 15/2009	
401	Oct 15/2008		205	Oct 10/2003		75-32-00		
402	Feb 15/2009		206	Oct 10/2003		601	Feb 15/2009	
403	Feb 15/2009		75-31-01			602	Feb 15/2009	
404	Oct 10/2003		401	Oct 15/2008		603	Feb 15/2009	
405	Feb 15/2009		402	Jun 15/2008		604	Feb 15/2009	
406	Oct 10/2003		403	Oct 10/2003		605	Feb 15/2009	
R 407	Jun 15/2009		404	Jun 15/2008		606	BLANK	
408	Feb 15/2009		405	Oct 10/2003		75-32-02		
409	Feb 15/2009		406	Oct 10/2003		401	Oct 10/2003	
410	BLANK		R 407	Jun 15/2009		402	Oct 15/2008	
75-22-04			408	Feb 15/2009		403	Jun 10/2005	
401	Oct 15/2008		409	Feb 15/2009		404	Oct 10/2004	
402	Oct 15/2008		410	Feb 15/2009		R 405	Jun 15/2009	
403	Oct 10/2007		411	Feb 15/2009		406	Feb 15/2009	
404	Oct 15/2008		412	Oct 10/2003		407	Jun 15/2008	
405	Oct 10/2003		413	Oct 10/2003		408	Oct 15/2008	
406	Oct 10/2003		R 414	Jun 15/2009		409	Jun 15/2008	
407	Oct 10/2003		415	Feb 15/2009		410	Oct 10/2004	
R 408	Jun 15/2009		416	Feb 15/2009		R 411	Jun 15/2009	
409	Feb 15/2009		417	Feb 15/2009		412	Feb 15/2009	
410	Jun 15/2008		418	Feb 15/2009		413	Oct 15/2008	
411	Jun 15/2008		419	Oct 10/2007		414	BLANK	
412	BLANK		420	BLANK		75-32-03		
75-23-01			75-32-00			401	Oct 15/2008	
401	Oct 15/2008		201	Oct 15/2008		402	Jun 10/2004	
402	Jun 10/2005		202	Oct 15/2008		403	Jun 10/2005	
403	Oct 10/2004		203	Jun 10/2005		404	Oct 10/2003	
404	Oct 10/2003		204	Jun 10/2004		405	Oct 10/2003	
405	Oct 10/2003		205	Oct 10/2003		406	Oct 10/2003	
406	Oct 10/2003		206	Oct 10/2003		R 407	Jun 15/2009	
R 407	Jun 15/2009					408	Jun 15/2008	

A = Added, R = Revised, D = Deleted, O = Overflow, C = Customer Originated Change

75-EFFECTIVE PAGES

**737-600/700/800/900
AIRCRAFT MAINTENANCE MANUAL**

**CHAPTER 75
AIR**

Subject/Page	Date	COC	Subject/Page	Date	COC	Subject/Page	Date	COC
75-32-03 (cont)								
409	Oct 15/2008							
410	Oct 15/2008							
411	Oct 15/2008							
412	Oct 10/2003							
413	Oct 10/2003							
R 414	Jun 15/2009							
415	Jun 15/2008							
416	Jun 15/2008							
75-32-03								
601	Jun 10/2005							
602	Oct 10/2007							
603	Oct 10/2003							
604	Oct 10/2003							
605	Oct 10/2003							
606	BLANK							

A = Added, R = Revised, D = Deleted, O = Overflow, C = Customer Originated Change

75-EFFECTIVE PAGES

AIRCRAFT MAINTENANCE MANUAL

CHAPTER 75
AIR

<u>Subject</u>	<u>Chapter Section Subject</u>	<u>Conf</u>	<u>Page</u>	<u>Effect</u>
<u>HIGH PRESSURE TURBINE ACTIVE CLEARANCE CONTROL VALVE - REMOVAL/INSTALLATION</u>	75-21-01		401	HAP ALL
HPTACC Valve Removal TASK 75-21-01-000-801-F00			401	HAP ALL
HPTACC Valve Installation TASK 75-21-01-400-801-F00			407	HAP ALL
<u>LOW PRESSURE TURBINE ACTIVE CLEARANCE CONTROL VALVE - REMOVAL/INSTALLATION</u>	75-22-04		401	HAP ALL
LPTACC Valve Removal TASK 75-22-04-000-802-F00			401	HAP ALL
LPTACC Valve Installation TASK 75-22-04-400-802-F00			408	HAP ALL
<u>TRANSIENT BLEED VALVE - REMOVAL/ INSTALLATION</u>	75-23-01		401	HAP ALL
Transient Bleed Valve Removal TASK 75-23-01-000-801-F00			401	HAP ALL
Transient Bleed Valve Installation TASK 75-23-01-400-801-F00			407	HAP ALL
<u>VARIABLE STATOR VANE (VSV) ACTUATION SYSTEM - MAINTENANCE PRACTICES</u>	75-31-00		201	HAP ALL
VSV Actuation System - Manual Operation TASK 75-31-00-790-801-F00			201	HAP ALL
<u>VARIABLE STATOR VANE ACTUATOR - REMOVAL/INSTALLATION</u>	75-31-01		401	HAP ALL
Prepare the Airplane for the Removal TASK 75-31-01-840-801-F00			401	HAP ALL
Left VSV Actuator Removal TASK 75-31-01-000-801-F00			402	HAP ALL

75-CONTENTS

AIRCRAFT MAINTENANCE MANUAL

CHAPTER 75
AIR

<u>Subject</u>	<u>Chapter Section Subject</u>	<u>Conf</u>	<u>Page</u>	<u>Effect</u>
Left VSV Actuator Installation TASK 75-31-01-400-801-F00			407	HAP ALL
Right VSV Actuator Removal TASK 75-31-01-000-802-F00			409	HAP ALL
Right VSV Actuator Installation TASK 75-31-01-400-802-F00			414	HAP ALL
VSV Actuator Leak Test TASK 75-31-01-790-801-F00			416	HAP ALL
<u>VARIABLE BLEED VALVE (VBV) ACTUATION SYSTEM - MAINTENANCE PRACTICES</u>	75-32-00		201	HAP ALL
VBV Actuation System - Manual Operation TASK 75-32-00-730-801-F00			201	HAP ALL
<u>VARIABLE BLEED VALVE (VBV) ACTUATION SYSTEM - ADJUSTMENT/TEST</u>	75-32-00		501	HAP ALL
Unison Ring-Operated Variable Bleed Valve (VBV) Door - Adjustment TASK 75-32-00-700-802-F00			501	HAP ALL
Actuator-Operated Variable Bleed Valve (VBV) Door - Adjustment TASK 75-32-00-710-801-F00			506	HAP ALL
<u>VARIABLE BLEED VALVE (VBV) ACTUATION SYSTEM - INSPECTION/CHECK</u>	75-32-00		601	HAP ALL
VBV Ring Guide Pads Inspection TASK 75-32-00-200-801-F00			601	HAP ALL
VBV System Inspection TASK 75-32-00-200-802-F00			605	HAP ALL
<u>VARIABLE BLEED VALVE ACTUATOR - REMOVAL/INSTALLATION</u>	75-32-02		401	HAP ALL
Left VBV Actuator Removal TASK 75-32-02-000-801-F00			401	HAP ALL
Left VBV Actuator Installation TASK 75-32-02-400-801-F00			405	HAP ALL

75-CONTENTS

AIRCRAFT MAINTENANCE MANUAL

CHAPTER 75
AIR

<u>Subject</u>	<u>Chapter Section Subject</u>	<u>Conf</u>	<u>Page</u>	<u>Effect</u>
Right VBV Actuator Removal TASK 75-32-02-000-802-F00			407	HAP ALL
Right VBV Actuator Installation TASK 75-32-02-400-802-F00			411	HAP ALL
<u>VARIABLE BLEED VALVE DOORS - REMOVAL/INSTALLATION</u>	75-32-03		401	HAP ALL
Unison Ring-Operated VBV Door Removal TASK 75-32-03-000-801-F00			401	HAP ALL
Unison Ring-Operated VBV Door Installation TASK 75-32-03-400-801-F00			407	HAP ALL
Actuator-Operated VBV Door Removal TASK 75-32-03-000-802-F00			409	HAP ALL
Actuator-Operated VBV Door Installation TASK 75-32-03-400-802-F00			414	HAP ALL
<u>VARIABLE BLEED VALVE DOORS - INSPECTION/CHECK</u>	75-32-03		601	HAP ALL
Variable Bleed Valve Doors Inspection TASK 75-32-03-200-801-F00			601	HAP ALL

75-CONTENTS

AIRCRAFT MAINTENANCE MANUAL

HIGH PRESSURE TURBINE ACTIVE CLEARANCE CONTROL VALVE - REMOVAL/INSTALLATION**1. General**

A. This procedure has two tasks:

- (1) The removal of the HPTACC valve
- (2) The installation of the HPTACC valve.

TASK 75-21-01-000-801-F00**2. HPTACC Valve Removal**

(Figure 401)

A. General

- (1) This task is the removal procedure for the High Pressure Turbine Active Clearance Control valve (referred to as the HPTACC valve).
- (2) The HPTACC valve is found on the aft side of the fan frame hub at the 3:00 o'clock position.

B. References

Reference	Title
24-22-00-860-811	Supply Electrical Power (P/B 201)
24-22-00-860-812	Remove Electrical Power (P/B 201)
70-10-02-910-801-F00	General Precautions During the Removal and Installation of Engine Components (P/B 201)
70-30-01-910-802-F00	Seals (Preformed Packings and O-Rings) and Gaskets (P/B 201)
78-31-00-010-801-F00	Open the Thrust Reverser (Selection) (P/B 201)

C. Tools/Equipment

Reference	Description
STD-4049	Container - Fuel Resistant, 1 Gallon (4 Liters)

D. Consumable Materials

Reference	Description	Specification
G00270	Tape - Scotch Flatback Masking 250	ASTM D6123 (Supersedes A-A-883)

E. Location Zones

Zone	Area
411	Engine 1 - Engine
421	Engine 2 - Engine

F. Prepare for the Removal

SUBTASK 75-21-01-840-001-F00

- (1) Do these steps to isolate the fuel from the fuel pump:
 - (a) Do this task: Supply Electrical Power, TASK 24-22-00-860-811.
 - (b) Make sure the engine start lever is in the CUTOFF position.
 - 1) Install a DO-NOT-OPERATE tag on the applicable engine start lever.

EFFECTIVITY
HAP ALL

D633A101-HAP

75-21-01

Page 401
Oct 15/2008

AIRCRAFT MAINTENANCE MANUAL

- (c) Make sure the ENG VALVE CLOSED and the SPAR VALVE CLOSED lights on the fuel control panel (P5 overhead panel) are dim.

NOTE: The lights for the fuel shutoff valves identify three positions: 1) bright when the valves are in transition or when the valves do not agree with the commanded position; or 2) dim when the valves are closed; or 3) off when the valves are opened.

- (d) Do this task: Remove Electrical Power, TASK 24-22-00-860-812.
- 1) Set the BAT switch on the Electrical Meters Battery and Galley Power Module (P5-13) to the OFF position and install a DO-NOT-OPERATE tag.

SUBTASK 75-21-01-010-001-F00

WARNING: DO THESE SPECIFIED TASKS IN THE CORRECT SEQUENCE BEFORE YOU OPEN THE THRUST REVERSER: RETRACT THE LEADING EDGE, DO THE DEACTIVATION OF THE LEADING EDGE AND THE THRUST REVERSER (FOR GROUND MAINTENANCE), AND OPEN THE FAN COWL PANELS. IF YOU DO NOT OBEY THE ABOVE SEQUENCE, INJURIES TO PERSONS AND DAMAGE TO EQUIPMENT CAN OCCUR.

- (2) For the right thrust reverser, do this task: Open the Thrust Reverser (Selection), TASK 78-31-00-010-801-F00.

G. HPTACC Valve Removal

SUBTASK 75-21-01-020-002-F00

- (1) Do these steps to remove the fuel manifold [26] from the HPTACC valve [22]:
- Disconnect the electrical connectors, DP0903 (CH A) [24] and DP1003 (CH B) [25] from the HPTACC valve receptacles.
 - Put a 1 gallon (4 l) fuel resistant container, STD-4049, below the fuel manifold [26].
 - Remove the four bolts [32] that attach the fuel manifold [26] to the HPTACC valve [22].
 - Remove the four bolts [35] that attach the fuel manifold [26] to the fuel distribution manifold [36].
 - Let the fuel drain in the container.
 - Remove and examine the gasket [31] and gasket [34] (TASK 70-30-01-910-802-F00).

NOTE: Use the gaskets if they are in a good condition.

- 1) Discard the gasket [31] or [34], if it is in unsatisfactory condition.

SUBTASK 75-21-01-020-003-F00

- (2) Do these steps to disconnect the stage 9 inlet tube [23] from the HPTACC valve [22]:
- Remove the clamp [30] that attaches the stage 9 inlet tube [23] to the HPTACC valve [22].
 - Loosen the three bolts [49] that attach the stage 9 inlet tube [23] to the combustor case.

SUBTASK 75-21-01-020-004-F00

- (3) Do these steps to disconnect the TCC air manifold [21] from the HPTACC valve [22]:
- Remove the clamp [27] that attaches the stage 9 end of the TCC air manifold [21] to the HPTACC valve [22].
 - Remove the clamp [45] that attaches the stage 4 end of the TCC air manifold [21] to the HPTACC valve [22].

SUBTASK 75-21-01-020-005-F00

- (4) Do these steps to remove the harness bracket [41]:
- Remove the bolt [43] from the hinged clamp [42].

EFFECTIVITY
HAP ALL

D633A101-HAP

75-21-01

Page 402
Feb 15/2009

AIRCRAFT MAINTENANCE MANUAL

- 1) Open the hinged clamp [42].
- (b) Remove the J10 harness from the hinged clamp [42] and the electrical clip [44].
- (c) Remove the two bolts [40] that attach the harness bracket [41] to the stage 4 inlet tube [39].
- (d) Remove the harness bracket [41].

SUBTASK 75-21-01-020-006-F00

- (5) Remove the two bolts [38] to disconnect the stage 4 inlet tube [39] from the stage 4 port.

SUBTASK 75-21-01-020-007-F00

- (6) Do these steps to remove the HPTACC valve [22]:
 - (a) Remove the three bolts [47] that attach the HPTACC valve [22] to the aft mounting bracket (View D).
 - (b) Remove the three bolts [48] that attach the HPTACC valve [22] to the forward mounting bracket (Views E and F).
 - (c) Remove the HPTACC valve [22].
 - (d) Remove and examine the metal gasket [37] and the seal [28], seal [29] and seal [46] (View C).

NOTE: Use the gaskets and the seals if they are in a good condition.

- 1) Discard the metal gasket [37] or the seal [28], [29] or [46], if it is in unsatisfactory condition.
 - a) Look for cracks, dents or other damage in the seal.

SUBTASK 75-21-01-020-008-F00

- (7) Do these steps to give protection to the HPTACC valve [22] and other components (TASK 70-10-02-910-801-F00):
 - (a) Put a protective cover on the fuel manifold [26].
 - (b) Put protective covers on all the openings of the HPTACC valve [22].
 - (c) Put protective covers on all the inlet and the outlet tubes.
 - (d) Put a protective cover or Scotch Flatback Masking Tape 250, G00270, (metal tape) on the stage 4 port.

————— **END OF TASK** —————

EFFECTIVITY
HAP ALL

D633A101-HAP

75-21-01Page 403
Feb 15/2009

737-600/700/800/900
AIRCRAFT MAINTENANCE MANUAL

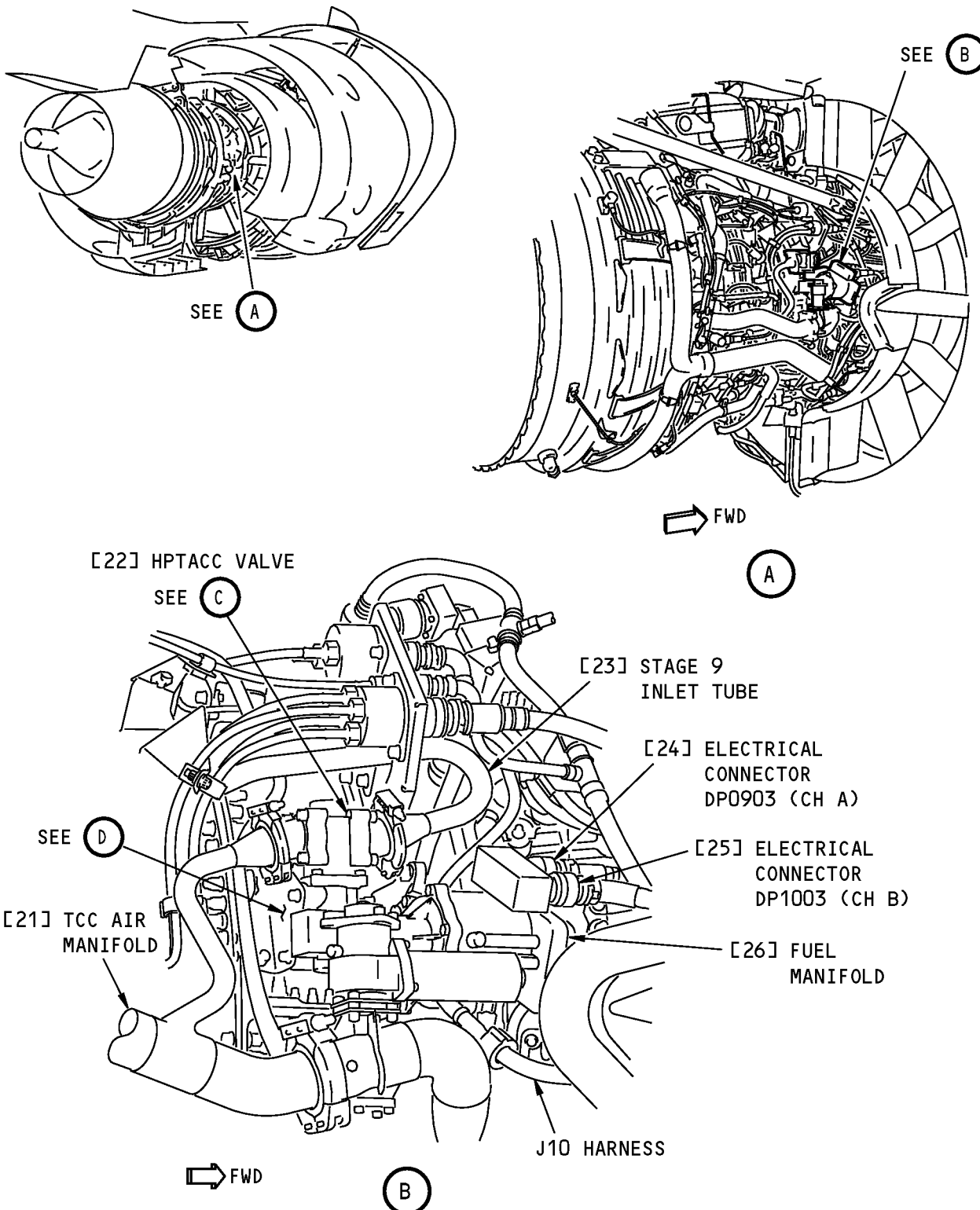

High Pressure Turbine Active Clearance Control Valve Installation
Figure 401 (Sheet 1 of 3)/75-21-01-990-801-F00

EFFECTIVITY
HAP ALL

75-21-01

737-600/700/800/900
AIRCRAFT MAINTENANCE MANUAL

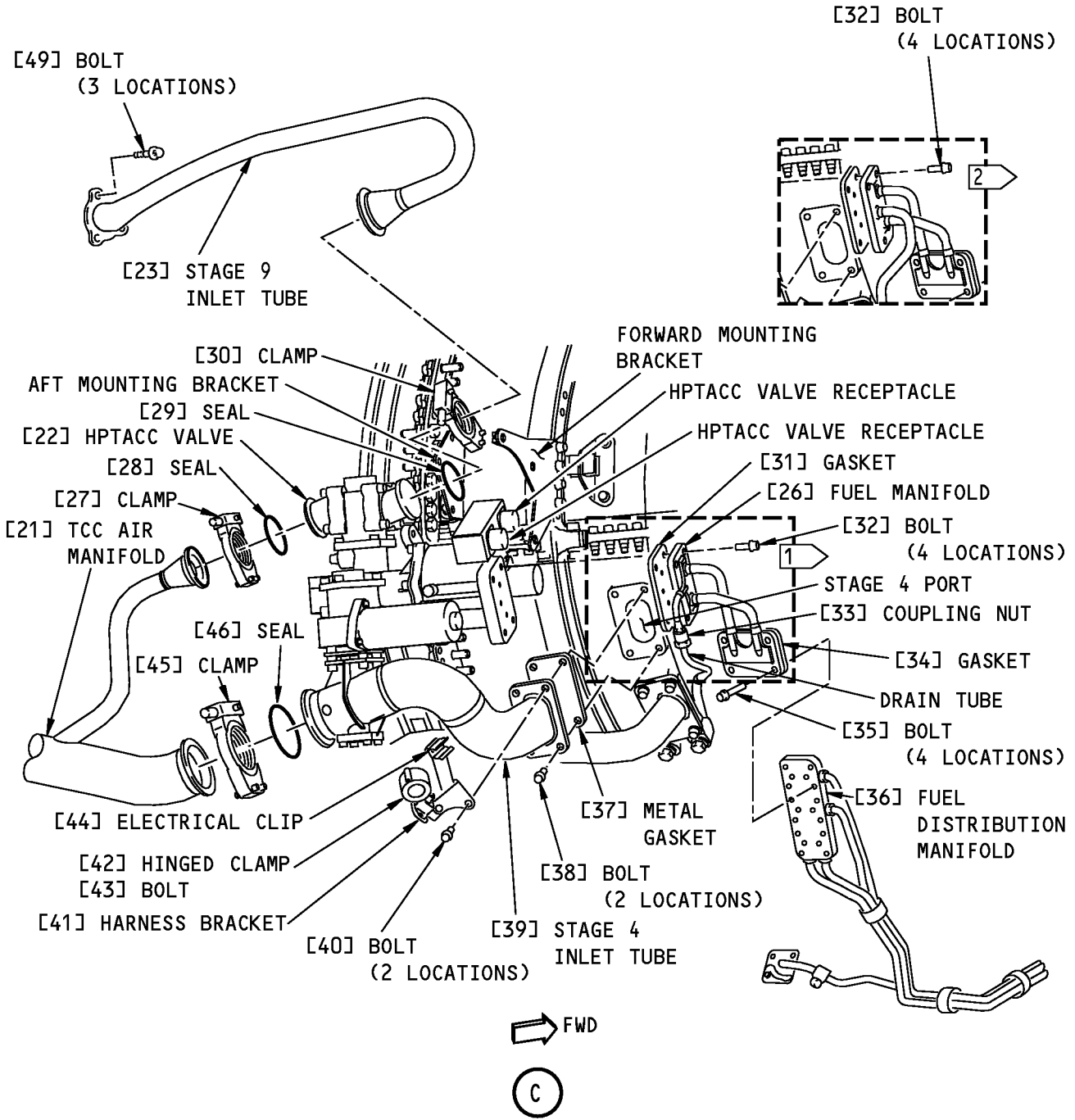

- [1] PRE-CFM-SB 73-045
- [2] POST-CFM-SB 73-045

GMM-T186526-00-A
F03389 S0006582953_V3

High Pressure Turbine Active Clearance Control Valve Installation
Figure 401 (Sheet 2 of 3)/75-21-01-990-801-F00

EFFECTIVITY
HAP ALL

75-21-01

AIRCRAFT MAINTENANCE MANUAL

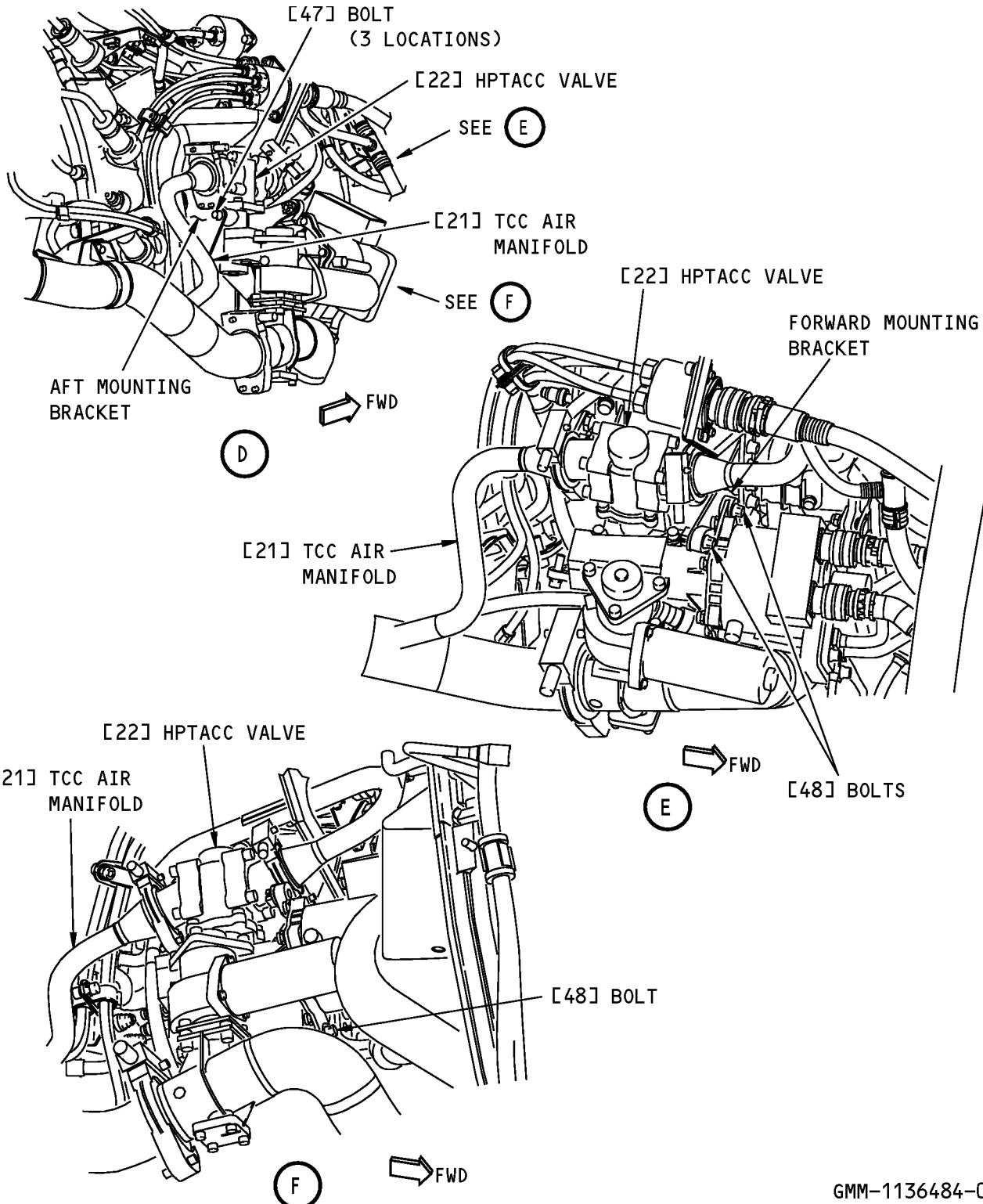

GMM-1136484-00

**High Pressure Turbine Active Clearance Control Valve Installation
Figure 401 (Sheet 3 of 3)/75-21-01-990-801-F00**

EFFECTIVITY
HAP ALL

75-21-01

AIRCRAFT MAINTENANCE MANUAL

TASK 75-21-01-400-801-F00

3. HPTACC Valve Installation

(Figure 401)

A. General

- (1) This task is the installation procedure for the High Pressure Turbine Active Clearance Control valve (referred to as the HPTACC valve).

B. References

Reference	Title
70-10-02-910-801-F00	General Precautions During the Removal and Installation of Engine Components (P/B 201)
71-00-00-800-811-F00	Power Plant Test Reference Table (P/B 501)
78-31-00-010-804-F00	Close the Thrust Reverser (Selection) (P/B 201)

C. Consumable Materials

Reference	Description	Specification
D00601 [CP2101]	Grease - Graphite, High Temperature	SAE AMS 2518
G02345 [CP8001]	Lockwire - Inconel (0.032 inch Dia.)	NASM20995~ N32
G50065 [CP8006]	Cable, Safety, Stainless Steel, 0.8mm (0.032inch) Diameter	

D. Expendables/Parts

AMM Item	Description	AIPC Reference	AIPC Effectivity
22	Valve	75-21-01-01-040	HAP ALL
28	Seal	75-20-00-04-040	HAP ALL
29	Seal	75-20-00-04-130	HAP ALL
31	Gasket	75-20-00-04-260	HAP ALL
34	Gasket	75-20-00-04-260	HAP ALL
37	Gasket	75-21-01-01-035	HAP ALL
46	Seal	75-20-00-04-030	HAP ALL

E. Location Zones

Zone	Area
411	Engine 1 - Engine
421	Engine 2 - Engine

F. HPTACC Valve Installation

SUBTASK 75-21-01-210-001-F00

- (1) Do these steps to prepare to install the HPTACC valve [22] (TASK 70-10-02-910-801-F00):
- Remove the tape from the stage 4 port.
 - Remove protective covers from all the inlet and the outlet tubes (TASK 70-10-02-910-801-F00).
 - Remove protective covers from all the openings on the HPTACC valve [22].
 - Remove the protective cover from the fuel distribution manifold [36].
 - Remove the protective cover from the fuel manifold [26].
 - Make sure that all the mating interfaces of the fuel manifold [26] are clean and in good condition.

EFFECTIVITY
HAP ALL

75-21-01

D633A101-HAP

Page 407
Jun 15/2009

AIRCRAFT MAINTENANCE MANUAL

- (g) Make sure that all the mating interfaces of the HPTACC valve [22] are clean and in good condition.

SUBTASK 75-21-01-420-001-F00

- (2) Do these steps to install the HPTACC valve [22] (View C):
- (a) Do these steps to install the seals [28], [29] and [46]:
 - 1) Put the seal [29] on the end of the stage 9 inlet tube [23].
 - 2) Put the seal [28] on the end of the HPTACC valve [22].
 - 3) Put the seal [46] on the end of the TCC air manifold [21].
 - (b) Put the HPTACC valve [22] between the forward and the aft mounting brackets.
 - (c) Loosely install the clamp [27] to hold the HPTACC valve [22] in its position.

SUBTASK 75-21-01-420-002-F00

- (3) Do these steps to attach the stage 4 inlet tube [39] to the stage 4 port:
- (a) Lubricate the threads of the two bolts [38] and the two bolts [40] with grease, D00601 [CP2101].
 - (b) Put the metal gasket [37] between the stage 4 inlet tube [39] and the stage 4 port.
 - (c) Loosely install the two lower bolts [38].
 - (d) Put the harness bracket [41] on the two top bolt holes.
 - (e) Loosely install the two top bolts [40].

SUBTASK 75-21-01-020-009-F00

- (4) Do these steps to attach the HPTACC valve [22] to the forward mounting bracket and the aft mounting bracket:
- (a) Lubricate the threads of the three bolts [47] and the three bolts [48] with grease, D00601 [CP2101].
 - (b) Loosely install the three bolts [47] to attach the HPTACC valve [22] to the aft mounting bracket (View D).
 - (c) Loosely install the three bolts [48] to attach the HPTACC valve [22] to the forward mounting bracket (Views E and F).

SUBTASK 75-21-01-420-003-F00

- (5) Do these steps to attach the TCC air manifold [21] to the HPTACC valve [22] (View C):
- (a) Install the clamp [45] to attach the stage 4 end of the TCC air manifold [21] to the HPTACC valve [22].
 - (b) Tighten the clamps [45] and [27] to 62-68 pound-inches (7-8 Newton meters).

SUBTASK 75-21-01-420-004-F00

- (6) Do these steps to attach the stage 9 inlet tube [23] to the HPTACC valve [22]:
- (a) Put the stage 9 inlet tube [23] in its position on the HPTACC valve [22].
 - (b) Install the clamp [30] to attach the stage 9 inlet tube [23] to the HPTACC valve [22].
 - 1) Tighten the clamp to 62-68 pound-inches (7-8 Newton meters).

SUBTASK 75-21-01-020-010-F00

- (7) Do these steps to tighten the bolts [38], [40], [47], [48] and [49] to 62-68 pound-inches (7-8 Newton meters).
- (a) Install lockwire, G02345 [CP8001] or cable, G50065 [CP8006] to the bolts [38], [40] and [49].

EFFECTIVITY
HAP ALL

D633A101-HAP

75-21-01

Page 408
Feb 15/2009

AIRCRAFT MAINTENANCE MANUAL

SUBTASK 75-21-01-420-005-F00

- (8) Do these steps to install the fuel manifold [26]:
- Lubricate the threads of the four bolts [32] and [35] with grease, D00601 [CP2101].
 - Put the fuel manifold [26] on the fuel distribution manifold [36].
 - Install the gasket [34] between the fuel manifold [26] and the fuel distribution manifold [36].
 - Loosely install the four bolts [35].
 - Install the gasket [31] between the fuel manifold [26] and the HPTACC valve [22].
 - Install the four bolts [32].
 - Tighten the bolts [32] and [35] to 62-68 pound-inches (7-8 Newton meters).

SUBTASK 75-21-01-410-001-F00

- (9) Connect the electrical connectors, DP0903 (CH A) [24] and DP1003 (CH B) [25] to the applicable HPTACC valve receptacles, CH A and CH B.

G. Put the Airplane Back to Its Usual Condition

SUBTASK 75-21-01-010-002-F00

WARNING: OBEY THE INSTRUCTIONS IN THE PROCEDURE TO CLOSE THE THRUST REVERSER. IF YOU DO NOT OBEY THE INSTRUCTIONS, INJURIES TO PERSONS AND DAMAGE TO EQUIPMENT CAN OCCUR.

- (1) Do this task: Close the Thrust Reverser (Selection), TASK 78-31-00-010-804-F00.

SUBTASK 75-21-01-860-005-F00

- (2) Remove the DO-NOT-OPERATE tags from the start lever.

SUBTASK 75-21-01-860-008-F00

- (3) Remove the DO-NOT-OPERATE tag from the BAT switch.

H. HPTACC Valve Installation Test

SUBTASK 75-21-01-800-001-F00

- (1) Do the tests that are listed in the Power Plant Test Reference Table (TASK 71-00-00-800-811-F00).

————— **END OF TASK** —————

EFFECTIVITY
HAP ALL

D633A101-HAP

75-21-01

Page 409
Feb 15/2009

AIRCRAFT MAINTENANCE MANUAL

LOW PRESSURE TURBINE ACTIVE CLEARANCE CONTROL VALVE - REMOVAL/INSTALLATION**1. General**

A. This procedure has two tasks:

- (1) The removal of the LPTACC valve
- (2) The installation of the LPTACC valve.

TASK 75-22-04-000-802-F00**2. LPTACC Valve Removal**

(Figure 401)

A. General

- (1) This task is the removal procedure for the Low Pressure Turbine Active Clearance Control valve (referred to as the LPTACC valve).
- (2) The LPTACC valve is found on the aft side of the fan frame hub at the 4:30 o'clock position.
- (3) This procedure refers to the LPT cooling air duct as the LPT duct.
- (4) This procedure refers to the LPT cooling air manifold as the LPT manifold.

B. References

Reference	Title
24-22-00-860-811	Supply Electrical Power (P/B 201)
24-22-00-860-812	Remove Electrical Power (P/B 201)
70-10-02-910-801-F00	General Precautions During the Removal and Installation of Engine Components (P/B 201)
70-30-01-910-802-F00	Seals (Preformed Packings and O-Rings) and Gaskets (P/B 201)
72-23-03-000-802-F00	Shroud Segments Removal (P/B 401)
78-31-00-010-801-F00	Open the Thrust Reverser (Selection) (P/B 201)

C. Tools/Equipment

Reference	Description
STD-4049	Container - Fuel Resistant, 1 Gallon (4 Liters)

D. Consumable Materials

Reference	Description	Specification
G00270	Tape - Scotch Flatback Masking 250	ASTM D6123 (Supersedes A-A-883)

E. Location Zones

Zone	Area
411	Engine 1 - Engine
421	Engine 2 - Engine

F. Prepare for the Removal

SUBTASK 75-22-04-840-002-F00

- (1) Do these steps to isolate the fuel from the fuel pump:
 - (a) Do this task: Supply Electrical Power, TASK 24-22-00-860-811.
 - (b) Make sure the engine start lever is in the CUTOFF position.
 - 1) Install a DO-NOT-OPERATE tag on the applicable engine start lever.

EFFECTIVITY
HAP ALL

D633A101-HAP

75-22-04

Page 401
Oct 15/2008

AIRCRAFT MAINTENANCE MANUAL

- (c) Make sure the ENG VALVE CLOSED and the SPAR VALVE CLOSED lights on the fuel control panel (P5 overhead panel) are dim.

NOTE: The lights for the fuel shutoff valves identify three positions: 1) bright when the valves are in transition or when the valves do not agree with the commanded position; or 2) dim when the valves are closed; or 3) off when the valves are opened.

- (d) Do this task: Remove Electrical Power, TASK 24-22-00-860-812.
- 1) Set the BAT switch on the Electrical Meters Battery and Galley Power Module (P5-13) to the OFF position and install a DO-NOT-OPERATE tag.

SUBTASK 75-22-04-010-004-F00

WARNING: DO THESE SPECIFIED TASKS IN THE CORRECT SEQUENCE BEFORE YOU OPEN THE THRUST REVERSER: RETRACT THE LEADING EDGE, DO THE DEACTIVATION OF THE LEADING EDGE AND THE THRUST REVERSER (FOR GROUND MAINTENANCE), AND OPEN THE FAN COWL PANELS. IF YOU DO NOT OBEY THE ABOVE SEQUENCE, INJURIES TO PERSONS AND DAMAGE TO EQUIPMENT CAN OCCUR.

- (2) For the right thrust reverser, do this task: Open the Thrust Reverser (Selection), TASK 78-31-00-010-801-F00.

SUBTASK 75-22-04-010-005-F00

- (3) For the bottom right shroud segment, do this task: Shroud Segments Removal, TASK 72-23-03-000-802-F00.

G. LPTACC Valve Removal

SUBTASK 75-22-04-020-007-F00

- (1) Disconnect these electrical connectors:
- (a) Disconnect the electrical connectors, DP1004 (CH B) [6] and DP0904 (CH A) [7] from the LPTACC valve receptacles.
- (b) Disconnect the electrical connectors, DP1006 (CH B) [1] and DP0906 (CH A) [14] from the receptacles.
- (c) Install protective caps on the electrical connectors and related components.
- (d) Remove the engine harness cables from the spring clips.
- (e) Use lockwire or tape to tie the electrical harness out of the way.

SUBTASK 75-22-04-020-011-F00

- (2) Do these steps to remove the fuel drain tube [9] to the LPTACC valve [3] and the fuel drain tube [8] to the VBV actuator:
- (a) Remove the two bolts [4] and nuts [5] that attach the fuel drain tubes [8] and [9] to the engine.

HAP ALL POST SB CFM56-7B-72-073

- (b) Remove the bolt [23] that attach the two clamps [24] of the fuel drain tubes [8] and [9] to the LPT duct [2].

HAP ALL

CAUTION: USE TWO WRENCHES TO LOOSEN THE COUPLING NUT. USE ONE TO HOLD THE FITTING, AND THE OTHER TO LOOSEN THE COUPLING NUT. IF YOU DO NOT USE TWO WRENCHES, DAMAGE TO THE EQUIPMENT CAN OCCUR.

- (c) Disconnect the fuel drain tube [9] from the LPTACC valve nipple and from the nipple on the LPTACC drain tube.

EFFECTIVITY
HAP ALL

75-22-04

Page 402
Oct 15/2008

D633A101-HAP

AIRCRAFT MAINTENANCE MANUAL

- (d) Disconnect the fuel drain tube [8] from the VBV actuator nipple and from the nipple on the upper drain manifold.
- (e) Remove the fuel drain tubes [8] and [9] and the clamp assembly.

SUBTASK 75-22-04-020-008-F00

- (3) Do these steps to remove the LPT duct [2] from the LPTACC valve [3]:
 - (a) Use chalk to make alignment marks on the adjacent LPT manifold [13] and the LPT duct [2] to show the duct position for the installation (View D).
 - (b) Remove the nut [15], washer [17] and bolt [16] that attach the LPT duct [2] to the engine bracket at the 4:00 o'clock position on flange B11.
 - (c) Do these steps to remove the V-band clamp [10] that attaches the LPT duct [2] to the LPTACC valve [3]:
 - 1) Loosen the nut [11] on the V-band clamp [10].
 - 2) Remove the V-band clamp [10].

CAUTION: MAKE SURE THAT YOU DO NOT PUSH THE LPT DUCT TOO FAR. IF YOU DO, DAMAGE TO THE LPT DUCT CAN OCCUR.

- (d) Carefully, push the LPT duct [2] rearward into the LPT manifold [13].

NOTE: Make sure that you keep the axial alignment.

- (e) Turn the LPT duct [2] slightly in the clockwise direction (view in the forward direction).

NOTE: The LPT duct turns in the LPT manifold.

- (f) Pull the LPT duct [2] forward.
- (g) Remove the LPT duct [2] from the engine.
- (h) Remove and keep the metallic seal [12].

NOTE: Make sure that you do not lose the metallic seal found between the LPTACC valve and the LPT duct.

- 1) Examine the metallic seal [12] for damage, and discard the metallic seal if it is in unsatisfactory condition.
- (i) Put protective covers on the ends of the LPT duct [2] (TASK 70-10-02-910-801-F00).
- (j) Put a protective cover on the LPT manifold [13].

SUBTASK 75-22-04-020-009-F00

- (4) Do these steps to remove the fuel tube manifold [20]:
 - (a) Put a 1 gallon (4 l) fuel resistant container, STD-4049, below the fuel tube manifold [20].

HAP ALL PRE SB CFM56-7B-75-001

- (b) Remove the eight bolts [18] that attach the fuel tube manifold [20] to the two engine fuel pads.
 - 1) Let the fuel drain into the container.

HAP ALL POST SB CFM56-7B-75-001

- (c) Remove the eight bolts [18] and the four washers [25] that attach the fuel tube manifold [20] to the two engine fuel pads.
 - 1) Let the fuel drain into the container.

HAP ALL

- (d) Remove the fuel tube manifold [20].

EFFECTIVITY
HAP ALL

75-22-04

Page 403
Oct 10/2007

D633A101-HAP

AIRCRAFT MAINTENANCE MANUAL

- (e) Remove and examine the two gaskets [19] below the fuel tube manifold [20] (TASK 70-30-01-910-802-F00).

NOTE: Use the gaskets if they are in a good condition.

- 1) Discard the gaskets [19], if it is in unsatisfactory condition.
- (f) Put protective covers on the ends of the fuel tube manifold [20].
- (g) Put protective covers on the two engine fuel pads.

SUBTASK 75-22-04-020-010-F00

- (5) Do these steps to remove the LPTACC valve [3] from the fan frame:
- (a) Loosen the four captive bolts [22].
- (b) Carefully remove the LPTACC valve [3].
- (c) Put protective covers on all the openings of the LPTACC valve [3].
- (d) Put a protective cover or Scotch Flatback Masking Tape 250, G00270 (metal tape) on the fan frame recess.

————— **END OF TASK** —————

EFFECTIVITY
HAP ALL

D633A101-HAP

75-22-04

Page 404
Oct 15/2008

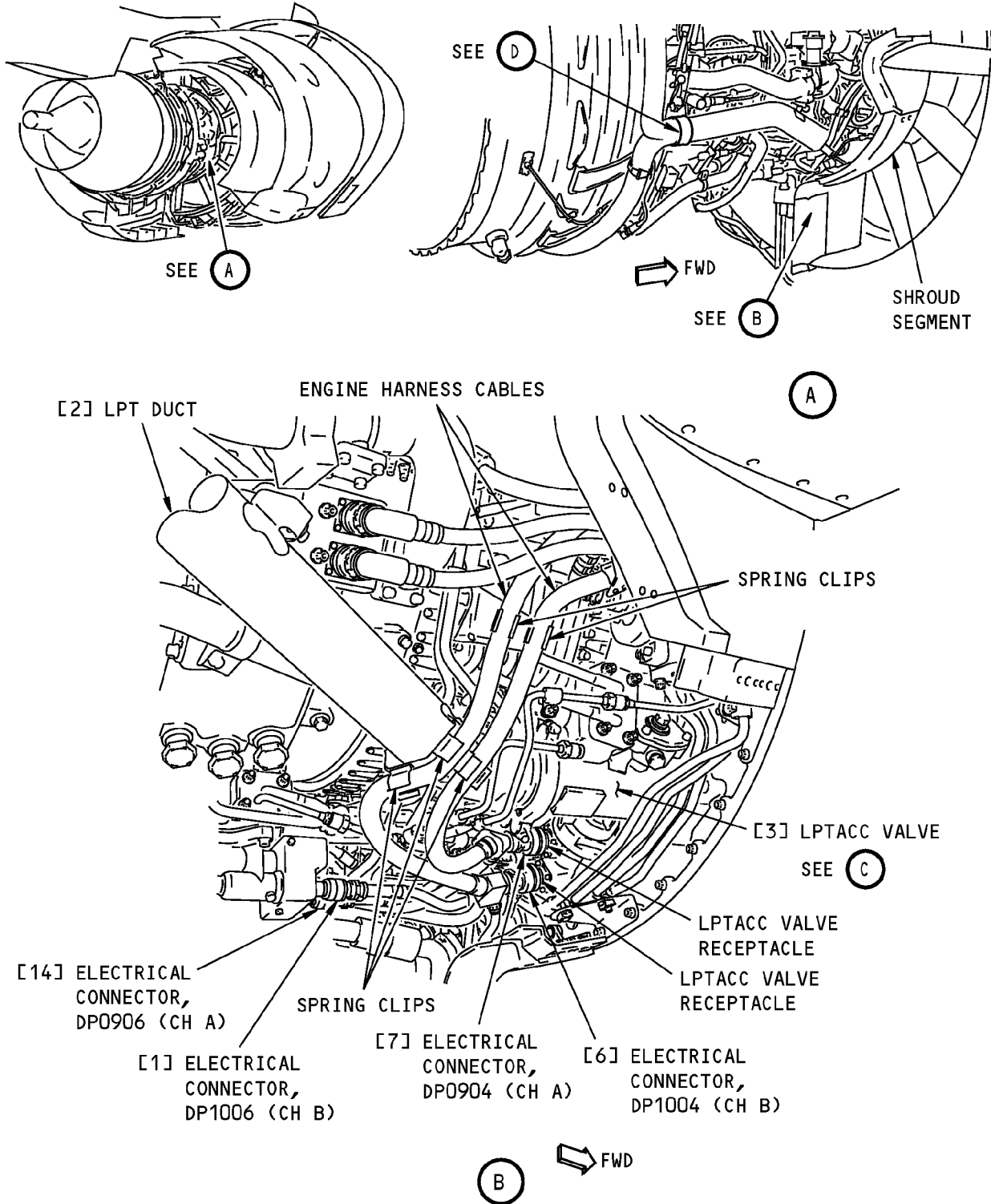

**Low Pressure Turbine Active Clearance Control Valve Installation
Figure 401 (Sheet 1 of 3)/75-22-04-990-801-F00**

EFFECTIVITY
HAP ALL

75-22-04

737-600/700/800/900
AIRCRAFT MAINTENANCE MANUAL

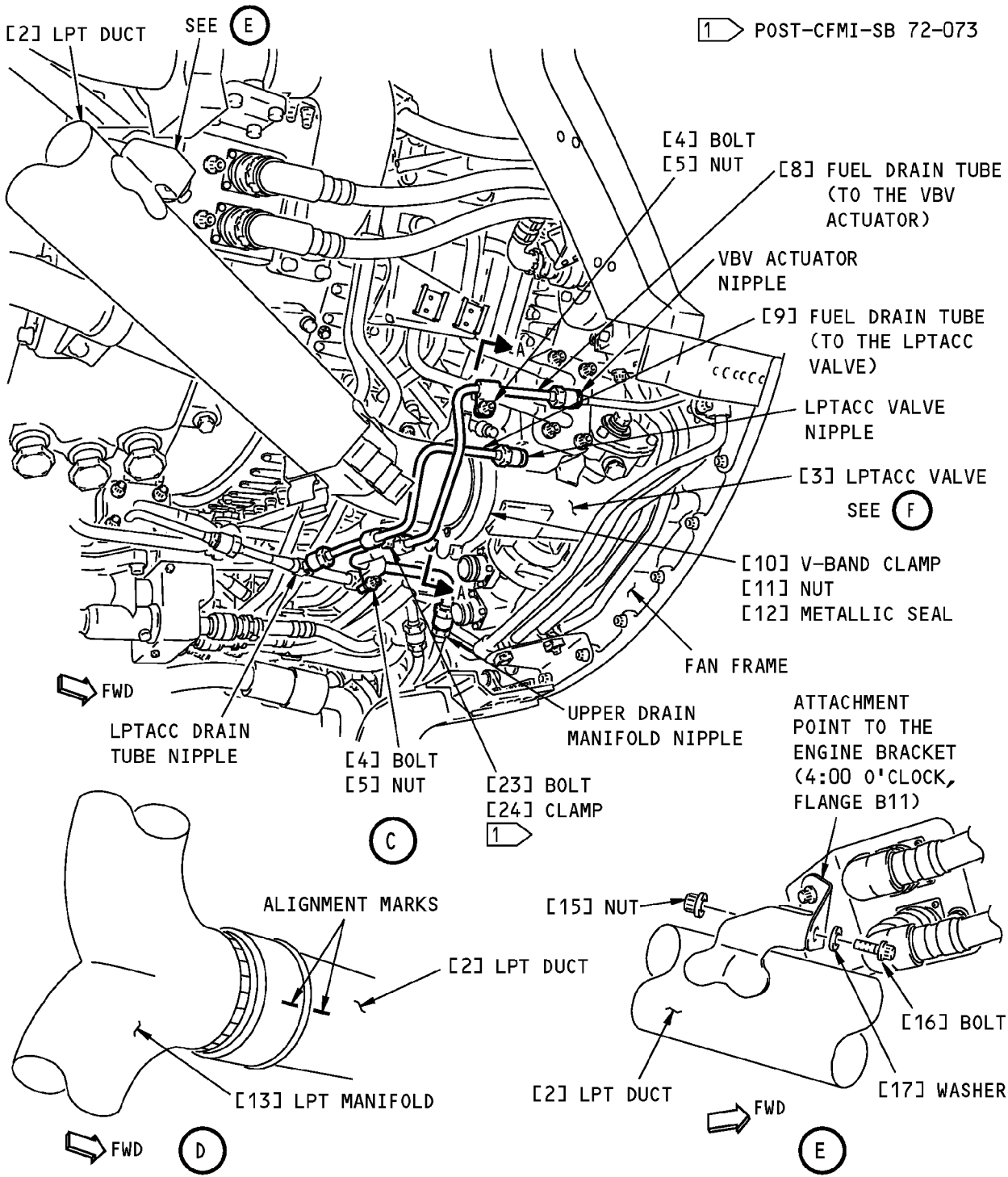

Low Pressure Turbine Active Clearance Control Valve Installation
Figure 401 (Sheet 2 of 3)/75-22-04-990-801-F00

EFFECTIVITY
HAP ALL

75-22-04

Page 406
Oct 10/2003

D633A101-HAP

AIRCRAFT MAINTENANCE MANUAL

[25] WASHER
(4 LOCATIONS) [18] BOLT
(4 LOCATIONS)

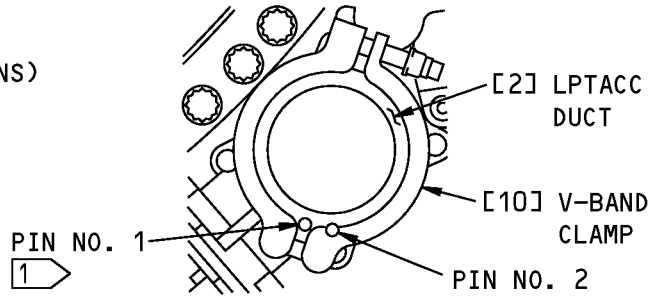
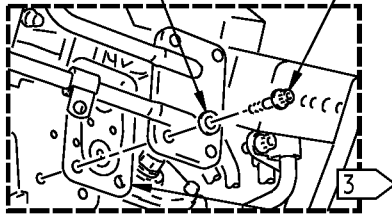

A-A

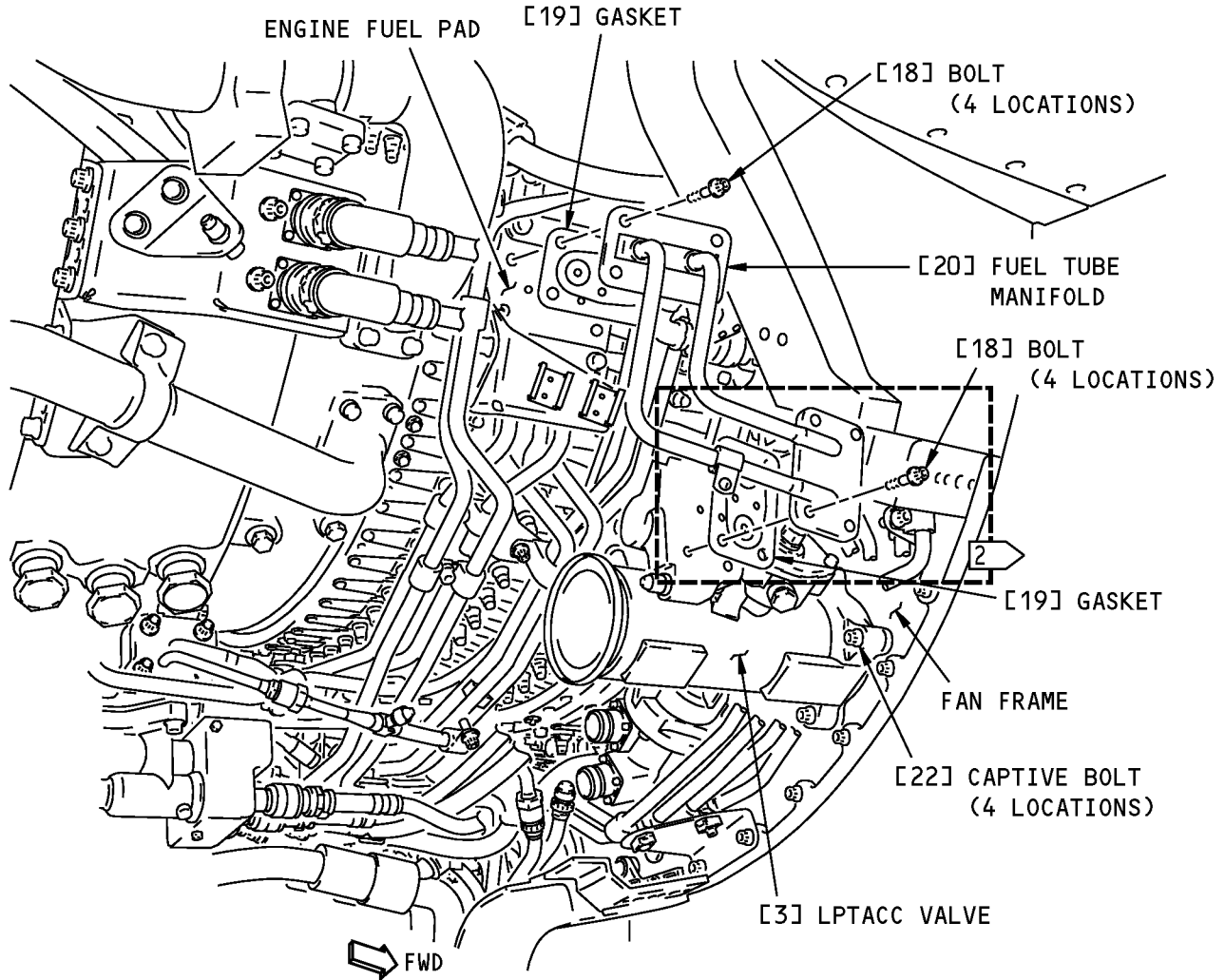

- 1 POST-CFMI-SB 72-141
- 2 PRE-CFMI-SB 75-001
- 3 POST-CFMI-SB 75-001

F

Low Pressure Turbine Active Clearance Control Valve Installation
Figure 401 (Sheet 3 of 3)/75-22-04-990-801-F00

EFFECTIVITY
HAP ALL

75-22-04

AIRCRAFT MAINTENANCE MANUAL

TASK 75-22-04-400-802-F00

3. LPTACC Valve Installation

(Figure 401)

A. References

Reference	Title
70-10-02-910-801-F00	General Precautions During the Removal and Installation of Engine Components (P/B 201)
71-00-00-800-811-F00	Power Plant Test Reference Table (P/B 501)
72-23-03-400-802-F00	Shroud Segments Installation (P/B 401)
78-31-00-010-804-F00	Close the Thrust Reverser (Selection) (P/B 201)

B. Tools/Equipment

Reference	Description
STD-3906	Mallet - Rubber

C. Consumable Materials

Reference	Description	Specification
D00599 [CP2442]	Oil - Engine (CFMI SB 79-001)	
D00601 [CP2101]	Grease - Graphite, High Temperature	SAE AMS 2518

D. Expendables/Parts

AMM Item	Description	AIPC Reference	AIPC Effectivity
3	Valve	75-22-04-01-020	HAP ALL
12	Seal	75-20-00-01-060	HAP ALL
19	Gasket	75-20-00-04-315	HAP ALL

E. Location Zones

Zone	Area
411	Engine 1 - Engine
421	Engine 2 - Engine

F. Prepare for the LPTACC Valve Installation

SUBTASK 75-22-04-420-006-F00

- (1) Do these steps to prepare the LPTACC valve [3] for the installation (TASK 70-10-02-910-801-F00):
 - (a) Remove the protective cover or tape from the fan frame recess.
 - (b) Remove protective covers from the LPTACC valve [3].
 - (c) Make sure that all the mating interfaces of the LPTACC valve [3], LPT duct [2] and the fuel tube manifold [20] are clean and in a good condition.

G. LPTACC Valve Installation

SUBTASK 75-22-04-420-007-F00

- (1) Do these steps to install the LPTACC valve [3] to the fan frame:
 - (a) Lubricate the threads of the four bolts [22] with grease, D00601 [CP2101].
 - (b) Carefully put the LPTACC valve [3] on the fan frame.
 - (c) Make sure that the LPTACC valve [3] alignment is correct.
 - (d) Tighten the bolts [22] to 98-110 pound-inches (11-12.5 Newton meters).

EFFECTIVITY
HAP ALL

75-22-04

D633A101-HAP

Page 408
Jun 15/2009

AIRCRAFT MAINTENANCE MANUAL

SUBTASK 75-22-04-420-008-F00

- (2) Do these steps to install the fuel tube manifold [20]:
- (a) Remove protective covers from the two engine fuel pads.
 - (b) Remove protective covers from the fuel tube manifold [20].
 - (c) Lubricate the two gaskets [19] with oil, D00599 [CP2442].
 - (d) Lubricate the threads of the eight bolts [18] with grease, D00601 [CP2101].
 - (e) Put the two gaskets [19] on the two engine fuel pads.
 - (f) Carefully put the fuel tube manifold [20] in its position on the two engine fuel pads.

HAP ALL PRE SB CFM56-7B-75-001

- (g) Install the eight bolts [18] that attach the fuel tube manifold [20] to the two engine fuel pads.
- 1) Tighten the bolts [18] to 62-68 pound-inches (7-8 Newton meters).

HAP ALL POST SB CFM56-7B-75-001

- (h) Install the eight bolts [18] and the four washers [25] that attach the fuel tube manifold [20] to the two engine fuel pads.
- 1) Tighten the bolts [18] to 62-68 pound-inches (7-8 Newton meters).

HAP ALL

SUBTASK 75-22-04-420-009-F00

- (3) Do these steps to install the LPT duct [2] to the LPTACC valve [3]:
- (a) Remove the protective covers from the LPT duct [2] and the LPT manifold [13].
 - (b) Align the LPT duct [2] in the axial direction with the LPT manifold [13].

CAUTION: MAKE SURE THAT YOU DO NOT PUSH THE LPT DUCT TOO FAR. IF YOU DO, DAMAGE TO THE LPT DUCT CAN OCCUR.

- (c) Fully engage the aft end of the LPT duct [2] into the LPT manifold [13].
- NOTE: Make sure that you keep the axial alignment.
- (d) Install the metallic seal [12] between the LPT duct [2] and the LPTACC valve [3].
- (e) Push the engine harness cables forward of the LPTACC valve orifice.
- NOTE: This permits the lateral movement of the LPT duct.
- (f) Turn the LPT duct [2] in the counterclockwise direction for alignment with the LPTACC valve orifice.
- NOTE: Make sure that the metallic seal on the LPT duct (LPTACC valve side) is in its position.
- (g) Move the LPT duct [2] slightly forward to engage in the LPTACC valve [3].
- NOTE: Make sure that the alignment marks are aligned (View D).
- (h) Lubricate the threads of the bolt [16] with grease, D00601 [CP2101].
- (i) Install the bolt [16], washer [17] and nut [15] hand tight to attach the LPT duct [2] to the engine bracket.
- (j) Do these steps to install the V-band clamp [10] to the LPT duct [2] and LPTACC valve [3]:
- 1) Install the V-band clamp [10] around the LPT duct [2] and the LPTACC valve flanges.

EFFECTIVITY
HAP ALL

75-22-04

Page 409
Feb 15/2009

D633A101-HAP

AIRCRAFT MAINTENANCE MANUAL

- 2) Turn the V-band clamp [10] around until the pin no. 2 is in the slot machined in the V-band clamp [10] (View A-A).
- 3) Make sure that the V-band clamp [10] does not touch other engine parts.
- 4) Lubricate the threads of the locking device on the V-band clamp [10] with grease, D00601 [CP2101].

CAUTION: MAKE SURE THAT YOU INSTALL THE LOCKING DEVICE OF THE CLAMP CORRECTLY. IF YOU DO NOT INSTALL THE CLAMP FINGERS IN THE LOCKING DEVICE, THE CLAMP CAN LOOSEN AND CAUSE DAMAGE TO EQUIPMENT.

- 5) Install the nut [11] that attach the LPT duct [2] to the LPTACC valve [3].
 - a) Tighten the nut [11] to 110-120 pound-inches (12.5-13.5 Newton meters).
- 6) Use a rubber mallet, STD-3906 to lightly hit around the V-band clamp [10].
 - a) Tighten the nut [11] to 110-120 pound-inches (12.5-13.5 Newton meters) again.
- (k) Tighten the nut [15] at the engine bracket to 98-110 pound-inches (11-12.5 Newton meters).

SUBTASK 75-22-04-420-010-F00

- (4) Do these steps to connect the fuel drain tube [8] and the fuel drain tube [9]:
 - (a) Lubricate the threads of the LPTACC valve nipple, the VBV actuator nipple and the two nipples to the LPTACC drain tube and the upper drain manifold with oil, D00599 [CP2442].

CAUTION: USE TWO WRENCHES TO TIGHTEN THE COUPLING NUT. USE ONE TO HOLD THE FITTING, AND THE OTHER TO TIGHTEN THE COUPLING NUT. IF YOU DO NOT USE TWO WRENCHES, DAMAGE TO THE EQUIPMENT CAN OCCUR.

- (b) Loosely connect the coupling nuts of the fuel drain tube [9] to the nipples of the LPTACC valve and the LPTACC drain tube.
- (c) Loosely connect the coupling nuts of the fuel drain tube [8] to the nipples of the VBV actuator and the upper drain manifold.
- (d) Lubricate the threads of the two bolts [4] and the bolt [23] with oil, D00599 [CP2442].
- (e) Loosely install the two bolts [4] and nuts [5] that attach the fuel drain tubes [8] and [9] and the clamp assembly on the engine brackets.

HAP ALL POST SB CFM56-7B-72-073

- (f) Loosely install the bolt [23] that attach the two clamps [24] of the fuel drain tubes [8] and [9] to the LPT duct [2].

HAP ALL

- (g) Tighten the coupling nuts of the two drain tubes to 135-150 pound-inches (15-16 Newton meters).
- (h) Tighten the bolts [4] to 62-68 pound-inches (7-8 Newton meters).

HAP ALL POST SB CFM56-7B-72-073

- (i) Tighten the bolts [23] to 62-68 pound-inches (7-8 Newton meters).

HAP ALL

SUBTASK 75-22-04-420-011-F00

- (5) Do these steps to connect the electrical connectors:
 - (a) Connect the electrical connectors, DP0906 (CH A) [14] and DP1006 (CH B) [1] to the applicable receptacles CH A and CH B.

EFFECTIVITY
HAP ALL

75-22-04

Page 410
Jun 15/2008

D633A101-HAP

AIRCRAFT MAINTENANCE MANUAL

- (b) Connect the electrical connectors, DP0904 (CH A) [7] and DP1004 (CH B) [6] to the applicable LPTACC valve receptacles CH A and CH B.
- (c) Install the engine harness cables into the spring clips.

H. Put the Airplane Back to Its Usual Condition

SUBTASK 75-22-04-410-002-F00

- (1) For the bottom right shroud segment, do this task: Shroud Segments Installation, TASK 72-23-03-400-802-F00.

SUBTASK 75-22-04-010-006-F00

WARNING: OBEY THE INSTRUCTIONS IN THE PROCEDURE TO CLOSE THE THRUST REVERSER. IF YOU DO NOT OBEY THE INSTRUCTIONS, INJURIES TO PERSONS AND DAMAGE TO EQUIPMENT CAN OCCUR.

- (2) For the right thrust reverser, do this task: Close the Thrust Reverser (Selection), TASK 78-31-00-010-804-F00.

SUBTASK 75-22-04-860-008-F00

- (3) Remove the DO-NOT-OPERATE tags from the start lever.

SUBTASK 75-22-04-860-009-F00

- (4) Remove the DO-NOT-OPERATE tag from the BAT switch.

I. LPTACC Valve Installation Test

SUBTASK 75-22-04-800-001-F00

- (1) Do the tests that are listed in the Power Plant Test Reference Table (TASK 71-00-00-800-811-F00).

————— **END OF TASK** —————

EFFECTIVITY
HAP ALL

D633A101-HAP

75-22-04Page 411
Jun 15/2008

AIRCRAFT MAINTENANCE MANUAL

TRANSIENT BLEED VALVE - REMOVAL/INSTALLATION**1. General**

A. This procedure has two tasks:

- (1) The removal of the transient bleed valve.
- (2) The installation of the transient bleed valve.

TASK 75-23-01-000-801-F00**2. Transient Bleed Valve Removal**

(Figure 401, Figure 402)

A. General

- (1) This task is the removal procedure for the transient bleed valve (referred to as the TB valve).

B. References

Reference	Title
24-22-00-860-811	Supply Electrical Power (P/B 201)
24-22-00-860-812	Remove Electrical Power (P/B 201)
70-10-02-910-801-F00	General Precautions During the Removal and Installation of Engine Components (P/B 201)
70-30-01-910-802-F00	Seals (Preformed Packings and O-Rings) and Gaskets (P/B 201)
78-31-00-010-801-F00	Open the Thrust Reverser (Selection) (P/B 201)

C. Tools/Equipment

Reference	Description
STD-4049	Container - Fuel Resistant, 1 Gallon (4 Liters)

D. Location Zones

Zone	Area
411	Engine 1 - Engine
421	Engine 2 - Engine

E. Prepare for the TB Valve Removal

SUBTASK 75-23-01-840-001-F00

- (1) Do these steps to isolate the fuel from the fuel pump:
 - (a) Do this task: Supply Electrical Power, TASK 24-22-00-860-811.
 - (b) Make sure the engine start lever is in the CUTOFF position.
 - 1) Install a DO-NOT-OPERATE tag on the applicable engine start lever.
 - (c) Make sure the ENG VALVE CLOSED and the SPAR VALVE CLOSED lights on the fuel control panel (P5 overhead panel) is dim.

NOTE: The lights for the fuel shutoff valves identify three positions: 1) bright when the valves are in transition or when the valves do not agree with the commanded position; or 2) dim when the valves are closed; or 3) off when the valves are opened.
 - (d) Do this task: Remove Electrical Power, TASK 24-22-00-860-812.
 - 1) Set the BAT switch on the Electrical Meters Battery and Galley Power Module (P5-13) to the OFF position and install a DO-NOT-OPERATE tag.

EFFECTIVITY
HAP ALL

75-23-01

Page 401
Oct 15/2008

D633A101-HAP

737-600/700/800/900
AIRCRAFT MAINTENANCE MANUAL

SUBTASK 75-23-01-010-003-F00

WARNING: DO THESE SPECIFIED TASKS IN THE CORRECT SEQUENCE BEFORE YOU OPEN THE THRUST REVERSER: RETRACT THE LEADING EDGE, DO THE DEACTIVATION OF THE LEADING EDGE AND THE THRUST REVERSER (FOR GROUND MAINTENANCE), AND OPEN THE FAN COWL PANELS. IF YOU DO NOT OBEY THE ABOVE SEQUENCE, INJURIES TO PERSONS AND DAMAGE TO EQUIPMENT CAN OCCUR.

(2) Do this task: Open the Thrust Reverser (Selection), TASK 78-31-00-010-801-F00.

F. TB Valve Removal

HAP ALL; AIRPLANES WITH SINGLE ANNULAR COMBUSTOR (SAC) ENGINES

SUBTASK 75-23-01-020-008-F00

- (1) Do these steps to remove the ignition leads [1] (Figure 401):
- (a) Remove the two bolts [3] that attaches the two clamps [4] to the ignition leads [1].
 - (b) Remove the ignition leads [1] from the spring clips on bracket [2].

HAP ALL

SUBTASK 75-23-01-860-005-F00

- (2) Disconnect the electrical connectors, DP1007 (CH B) [29] and DP0907 (CH A) [30] from the TB valve receptacles (Figure 402).

SUBTASK 75-23-01-020-002-F00

- (3) Do these steps to disconnect the fuel manifold [23] from the TB valve [26] (Figure 402):
- (a) Put a 1 gallon (4 l) fuel resistant container, STD-4049, below the fuel manifold [23].
 - (b) Remove the four bolts [28] that attaches the fuel manifold [23] to the TB valve [26].
 - 1) Let the fuel drain in the container.
 - (c) Remove and examine the gasket [27] (TASK 70-30-01-910-802-F00).

NOTE: Use the gasket if it is in good condition.

- 1) Discard the gasket [27], if it is in unsatisfactory condition.

SUBTASK 75-23-01-020-005-F00

- (4) Do these steps to remove the TB valve [26] (Figure 402):
- (a) Loosen and remove the couplings [32] and [39].
 - (b) Remove the two bolts [34] that attaches the manifold bracket [35] to the flange bracket [36].
 - (c) Remove the three bolts [25] that attach the TB valve [26] to the flange extension bracket [22].
 - (d) Remove the TB valve [26].
 - (e) Remove and examine the seal [38] from the end of the air manifold [21].

NOTE: Use the seal if it is in good condition.

- 1) Discard the seal [38], if it is in unsatisfactory condition.

- (f) Remove and examine the seal [33] from the end of the TB valve [26].

NOTE: Use the seal if it is in good condition.

- 1) Discard the seal [33], if it is in unsatisfactory condition.

- (g) Put protective covers on the end of the air tube [40] and the air manifold [21] (TASK 70-10-02-910-801-F00).

EFFECTIVITY
HAP ALL

D633A101-HAP

75-23-01

Page 402
 Jun 10/2005

AIRCRAFT MAINTENANCE MANUAL

- (h) Put a protective cover on the fuel manifold [23].
- (i) Put protective covers on all the openings of the TB valve [26].

HAP ALL; AIRPLANES WITH SINGLE ANNULAR COMBUSTOR (SAC) ENGINES

SUBTASK 75-23-01-020-006-F00

- (5) Do these steps to remove the bracket [31] and manifold bracket [35] from the TB valve [26] (Figure 402):
 - (a) Remove the two bolts [24].
 - (b) Remove the bracket [31].
 - (c) Remove the two bolts [37].
 - (d) Remove the manifold bracket [35].

HAP ALL

————— **END OF TASK** —————

EFFECTIVITY
HAP ALL

D633A101-HAP

75-23-01Page 403
Oct 10/2004

737-600/700/800/900
AIRCRAFT MAINTENANCE MANUAL

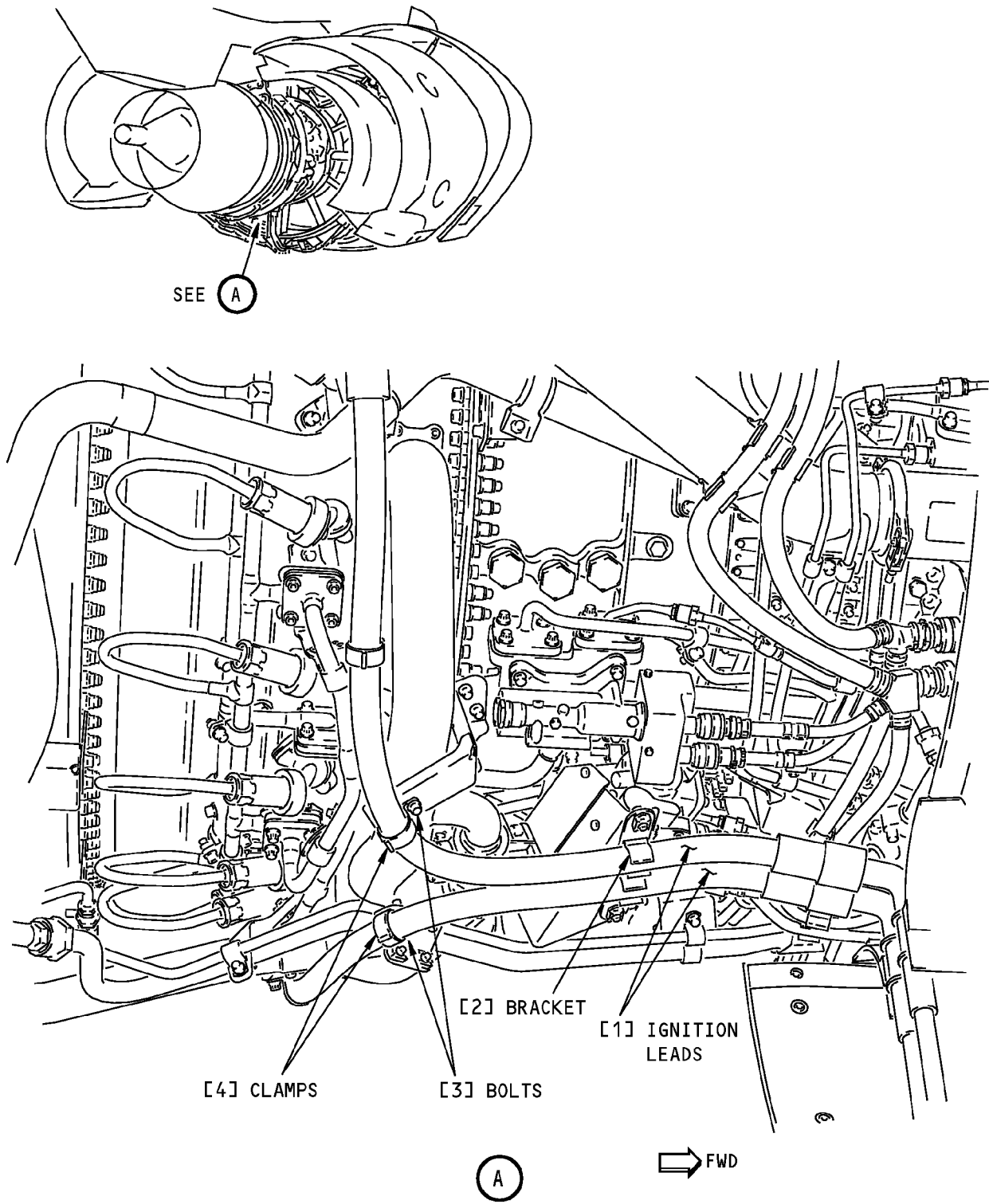

Ignition Lead Installation
Figure 401/75-23-01-990-801-F00

<p>EFFECTIVITY</p> <p>HAP ALL; AIRPLANES WITH SINGLE ANNULAR COMBUSTOR (SAC) ENGINES</p>
--

75-23-01

737-600/700/800/900
AIRCRAFT MAINTENANCE MANUAL

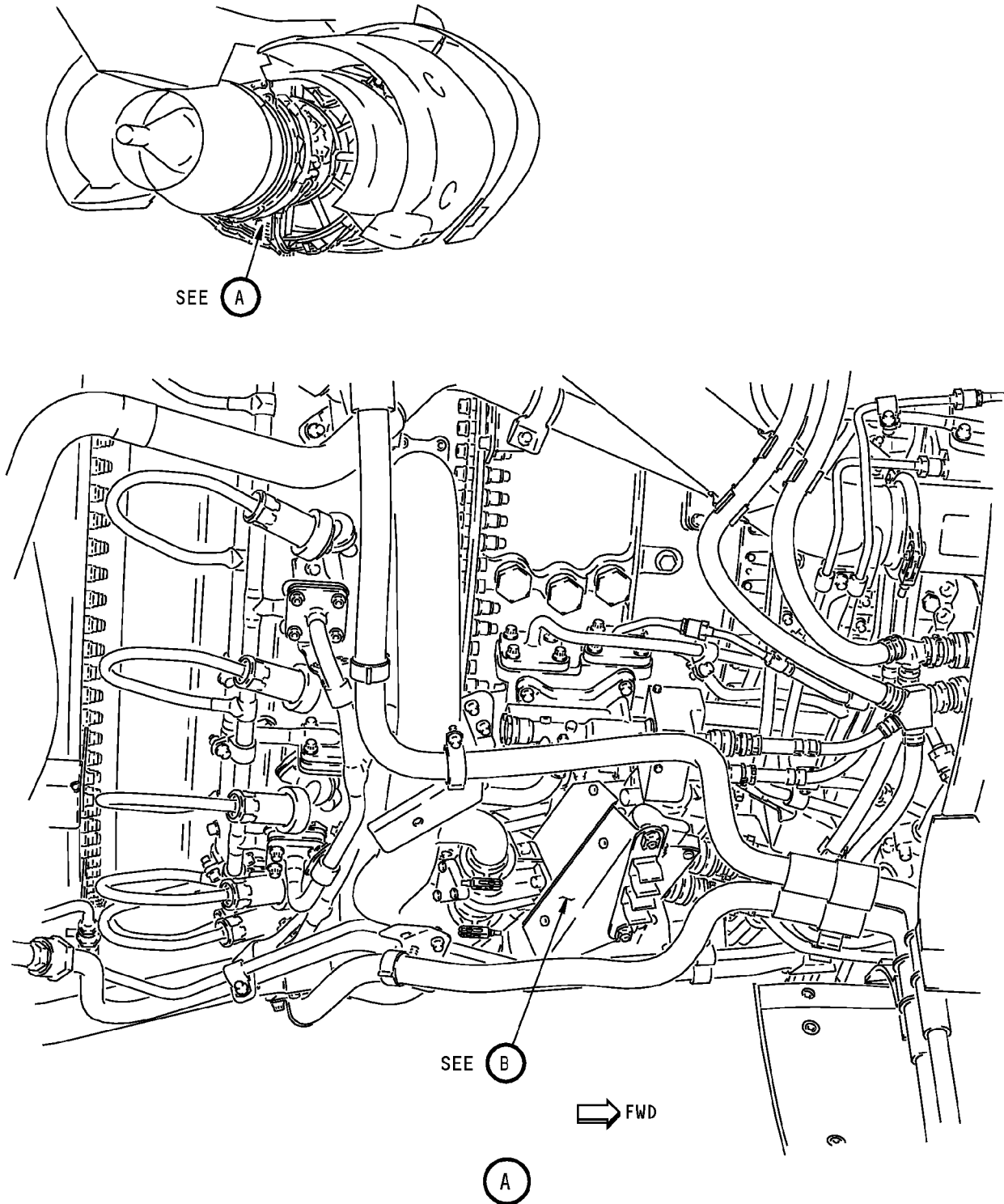

Transient Bleed Valve Installation
Figure 402 (Sheet 1 of 2)/75-23-01-990-802-F00

<p>EFFECTIVITY</p> <p>HAP ALL; AIRPLANES WITH SINGLE ANNULAR COMBUSTOR (SAC) ENGINES</p>
--

75-23-01

Page 405
Oct 10/2003

D633A101-HAP

AIRCRAFT MAINTENANCE MANUAL

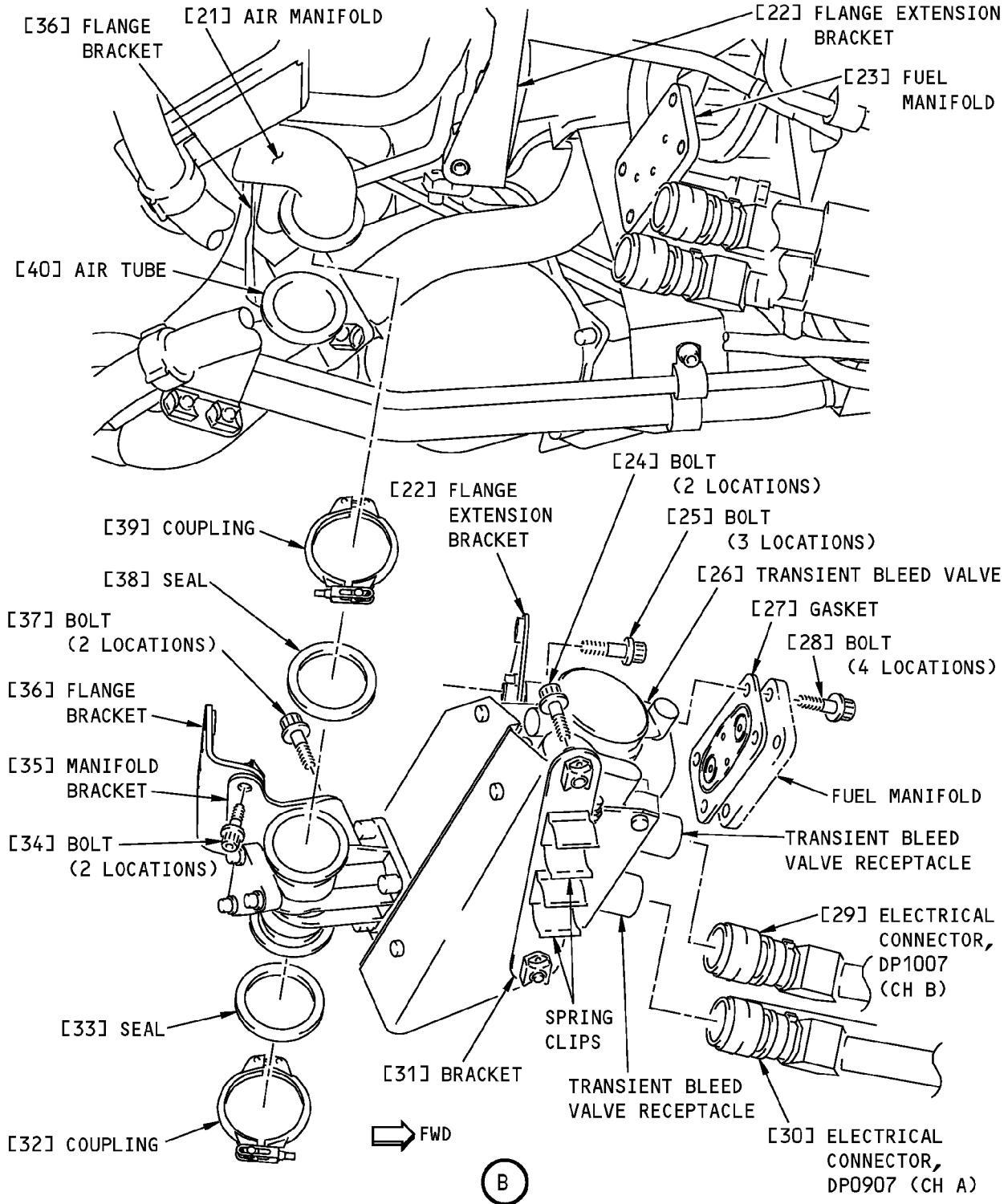

Transient Bleed Valve Installation
Figure 402 (Sheet 2 of 2)/75-23-01-990-802-F00

EFFECTIVITY
 HAP ALL; AIRPLANES WITH SINGLE ANNULAR COM-
 BUSTOR (SAC) ENGINES

D633A101-HAP

BOEING PROPRIETARY - Copyright © Unpublished Work - See title page for details

75-23-01

Page 406
 Oct 10/2003

AIRCRAFT MAINTENANCE MANUAL

TASK 75-23-01-400-801-F00

3. Transient Bleed Valve Installation

(Figure 401, Figure 402)

A. References

Reference	Title
70-10-02-910-801-F00	General Precautions During the Removal and Installation of Engine Components (P/B 201)
71-00-00-800-811-F00	Power Plant Test Reference Table (P/B 501)
78-31-00-010-804-F00	Close the Thrust Reverser (Selection) (P/B 201)

B. Consumable Materials

Reference	Description	Specification
D00601 [CP2101]	Grease - Graphite, High Temperature	SAE AMS 2518

C. Expendables/Parts

AMM Item	Description	AIPC Reference	AIPC Effectivity
26	Valve	75-23-01-01-020	HAP ALL
27	Gasket	75-20-00-04-315	HAP ALL
33	Seal	75-20-00-04-165	HAP ALL
38	Seal	75-20-00-04-195	HAP ALL

D. Location Zones

Zone	Area
411	Engine 1 - Engine
421	Engine 2 - Engine

E. TB Valve Installation

SUBTASK 75-23-01-420-001-F00

- (1) Do these steps to prepare the TB valve [26] for the installation (TASK 70-10-02-910-801-F00):
- Remove protective covers on all the openings of the TB valve [26].
 - Remove the protective cover on the fuel manifold [23].
 - Remove protective covers on the end of the air tube [40] and the air manifold [21].

HAP ALL; AIRPLANES WITH SINGLE ANNULAR COMBUSTOR (SAC) ENGINES

SUBTASK 75-23-01-420-007-F00

- (2) Do these steps to install the bracket [31] to the TB valve [26] (Figure 402):
- Lubricate the threads of the two bolts [24] with grease, D00601 [CP2101].
 - Put the bracket [31] in its position.
 - Install the two bolts [24].
 - Tighten the bolts [24] to 62-68 pound-inches (7-8 Newton meters).

HAP ALL

SUBTASK 75-23-01-420-012-F00

- (3) Do these steps to install the manifold bracket [35] to the TB valve [26] (Figure 402):
- Lubricate the threads of the two bolts [37] with grease, D00601 [CP2101].
 - Put the manifold bracket [35] in its position.

EFFECTIVITY
HAP ALL

75-23-01

D633A101-HAP

Page 407
Jun 15/2009

AIRCRAFT MAINTENANCE MANUAL

- (c) Install the two bolts [37].
- 1) Tighten the bolts [37] to 62-68 pound-inches (7-8 Newton meters).

SUBTASK 75-23-01-420-002-F00

- (4) Do these steps to install the seals [33] and [38] (Figure 402):
- (a) Put the seal [33] in the end of the TB valve [26].
 - (b) Put the seal [38] in the end of the air manifold [21].

SUBTASK 75-23-01-420-003-F00

- (5) Do these steps to install the TB valve [26] (Figure 402):
- (a) Lubricate the threads of the nine bolts [25], [28] and [34] with grease, D00601 [CP2101].
 - (b) Put the TB valve [26] between the air manifold [21] and the air tube [40].
 - (c) Loosely install the three bolts [25] that attaches the TB valve [26] to the flange extension bracket [22].
 - (d) Put the gasket [27] between the TB valve [26] and the fuel manifold [23].
 - (e) Loosely install the four bolts [28] that attaches the fuel manifold [23] to the TB valve [26].
 - (f) Loosely install the two bolts [34] that attaches the manifold bracket [35] to the flange bracket [36].
 - (g) Tighten the bolts [25], [28] and [34] to 62-68 pound-inches (7-8 Newton meters).

SUBTASK 75-23-01-420-004-F00

- (6) Do these steps to attach the TB valve [26] to the air manifold [21] and the air tube [40] (Figure 402):
- (a) Loosely install the coupling [32] that attaches the air tube [40] to the TB valve [26].
 - (b) Install the coupling [39] that attaches the air manifold [21] to the TB valve [26].
 - 1) Tighten the two couplings [32] and [39] to 62-68 pound-inches (7-8 Newton meters).

SUBTASK 75-23-01-860-006-F00

- (7) Connect the electrical connectors, DP0907 (CH A) [30] and DP1007 (CH B) [29] to the applicable TB valve receptacles, CH A and CH B (Figure 402).

HAP ALL; AIRPLANES WITH SINGLE ANNULAR COMBUSTOR (SAC) ENGINES

SUBTASK 75-23-01-420-010-F00

- (8) Do these steps to install the ignition leads [1] (Figure 401):
- (a) Install the ignition leads [1] into the spring clips on the bracket [2].
 - (b) Lubricate the two bolts [3] with grease, D00601 [CP2101].
 - (c) Install the two bolts [3] to attach the clamps [4] to the ignition leads [1].
 - 1) Tighten the bolts [3] to 62-68 pound-inches (7-8 Newton meters).

HAP ALL

F. Put the Airplane Back to Its Usual Condition

SUBTASK 75-23-01-010-004-F00

WARNING: OBEY THE INSTRUCTIONS IN THE PROCEDURE TO CLOSE THE THRUST REVERSER. IF YOU DO NOT OBEY THE INSTRUCTIONS, INJURIES TO PERSONS AND DAMAGE TO EQUIPMENT CAN OCCUR.

- (1) Do this task: Close the Thrust Reverser (Selection), TASK 78-31-00-010-804-F00.

EFFECTIVITY
HAP ALL

D633A101-HAP

75-23-01

Page 408
Feb 15/2009

AIRCRAFT MAINTENANCE MANUAL

SUBTASK 75-23-01-860-009-F00

(2) Remove the DO-NOT-OPERATE tags from the start lever.

SUBTASK 75-23-01-860-010-F00

(3) Remove the DO-NOT-OPERATE tag from the BAT switch.

G. TB Valve Installation Test

SUBTASK 75-23-01-800-001-F00

(1) Do the tests that are listed in the Power Plant Test Reference Table (TASK 71-00-00-800-811-F00).

————— **END OF TASK** —————

EFFECTIVITY
HAP ALL

D633A101-HAP

75-23-01

Page 409
Jun 15/2008

AIRCRAFT MAINTENANCE MANUAL

VARIABLE STATOR VANE (VSV) ACTUATION SYSTEM - MAINTENANCE PRACTICES**1. General**

A. This procedure contains one task, the manual operation of the variable stator vane actuation system.

TASK 75-31-00-790-801-F00**2. VSV Actuation System - Manual Operation**

(Figure 201)

A. General

- (1) This task is the manual operation of the variable stator vane actuation system (referred to as the VSV actuation system).
- (2) This procedure can be used as follows:
 - (a) To manually operate the VSV actuation system to the full-open position for the borescope inspection or full-closed position.
 - (b) To examine the actuation system after the VSV actuator replacement.
 - (c) To do fault isolation.

B. References

Reference	Title
24-22-00-860-811	Supply Electrical Power (P/B 201)
24-22-00-860-812	Remove Electrical Power (P/B 201)
71-00-00-800-811-F00	Power Plant Test Reference Table (P/B 501)
72-23-03-000-802-F00	Shroud Segments Removal (P/B 401)
72-23-03-400-802-F00	Shroud Segments Installation (P/B 401)
78-31-00-010-801-F00	Open the Thrust Reverser (Selection) (P/B 201)
78-31-00-010-804-F00	Close the Thrust Reverser (Selection) (P/B 201)

C. Tools/Equipment

NOTE: When more than one tool part number is listed under the same "Reference" number, the tools shown are alternates to each other within the same airplane series. Tool part numbers that are replaced or non-procurable are preceded by "Opt:", which stands for Optional.

Reference	Description
SPL-2187	Actuator - Hydraulic, Portable, VSV Stator - CFM56-7/CFM56-3 (Part #: 856A1084G04, Supplier: 58828, A/P Effectivity: 737-300, -400, -500, -600, -700, -700C, -700ER, -700QC, -800, -900, -900ER, -BBJ)
STD-1054	Container - Fuel Resistant, 5 Gallon (19 Liters)

D. Consumable Materials

Reference	Description	Specification
D00599 [CP2442]	Oil - Engine (CFMI SB 79-001)	

E. Location Zones

Zone	Area
411	Engine 1 - Engine
421	Engine 2 - Engine

F. Prepare for the VSV Actuation System - Manual Operation

SUBTASK 75-31-00-840-001-F00

- (1) Do these steps to isolate the fuel from the fuel pump:

EFFECTIVITY
HAP ALL

D633A101-HAP

75-31-00

Page 201
Oct 15/2008

AIRCRAFT MAINTENANCE MANUAL

- (a) Do this task: Supply Electrical Power, TASK 24-22-00-860-811.
- (b) Make sure the engine start lever is in the CUTOFF position.
 - 1) Install a DO-NOT-OPERATE tag on the applicable engine start lever.
- (c) Make sure the ENG VALVE CLOSED and the SPAR VALVE CLOSED lights on the fuel control panel (P5 overhead panel) are dim.

NOTE: The lights for the fuel shutoff valves identify three positions: 1) bright when the valves are in transition or when the valves do not agree with the commanded position; or 2) dim when the valves are closed; or 3) off when the valves are opened.

- (d) Do this task: Remove Electrical Power, TASK 24-22-00-860-812.
 - 1) Set the BAT switch on the Electrical Meters Battery and Galley Power Module (P5-13) to the OFF position and install a DO-NOT-OPERATE tag.

SUBTASK 75-31-00-010-001-F00

WARNING: DO THESE SPECIFIED TASKS IN THE CORRECT SEQUENCE BEFORE YOU OPEN THE THRUST REVERSER: RETRACT THE LEADING EDGE, DO THE DEACTIVATION OF THE LEADING EDGE AND THE THRUST REVERSER (FOR GROUND MAINTENANCE), AND OPEN THE FAN COWL PANELS. IF YOU DO NOT OBEY THE ABOVE SEQUENCE, INJURIES TO PERSONS AND DAMAGE TO EQUIPMENT CAN OCCUR.

- (2) Do this task: Open the Thrust Reverser (Selection), TASK 78-31-00-010-801-F00.

SUBTASK 75-31-00-010-002-F00

- (3) If it is necessary to see the VSV actuators, remove the applicable shroud segments (TASK 72-23-03-000-802-F00).

G. VSV Actuation System - Manual Operation

SUBTASK 75-31-00-020-001-F00

CAUTION: USE TWO WRENCHES TO LOOSEN OR TIGHTEN THE COUPLING NUT. USE ONE TO HOLD THE FITTING, AND THE OTHER TO LOOSEN OR TIGHTEN THE COUPLING NUT. IF YOU DO NOT USE TWO WRENCHES, DAMAGE TO THE EQUIPMENT CAN OCCUR.

- (1) Obey this caution when you loosen or tighten all coupling nuts.

SUBTASK 75-31-00-020-002-F00

- (2) Do these steps to connect the VSV flexhoses to the supply hose [6] and return hose [5]:
 - (a) Put a 5 gallon (19 liters) fuel resistant container, STD-1054, below the VSV HEAD-END flexhose [4] and VSV ROD-END flexhose [3].

WARNING: DO NOT GET FUEL IN YOUR MOUTH OR EYES, OR ON YOUR SKIN. DO NOT BREATHE THE FUMES FROM FUEL. KEEP THE FUEL AWAY FROM SPARKS, FLAME AND HEAT. FUEL IS A POISONOUS AND FLAMMABLE, WHICH CAN CAUSE INJURIES TO PERSONS AND DAMAGE TO EQUIPMENT.

- (b) Disconnect the VSV HEAD-END flexhose [4] from the VSV HEAD-END nipple [2].
 - 1) Let the fuel drain in the container.
- (c) Put a protective cover on the VSV HEAD-END nipple [2].
- (d) Disconnect the VSV ROD-END flexhose [3] from the VSV ROD-END nipple [1].
 - 1) Let the fuel drain in the container.
- (e) Put a protective cover on the VSV ROD-END nipple [1].

EFFECTIVITY
HAP ALL

75-31-00

Page 202
Oct 15/2008

D633A101-HAP

AIRCRAFT MAINTENANCE MANUAL

- (f) Connect the supply hose [6] from the actuator, SPL-2187, to the VSV HEAD-END flexhose [4].
- (g) Connect the return hose [5] from the actuator, SPL-2187, to the VSV ROD-END flexhose [3].

SUBTASK 75-31-00-860-001-F00

CAUTION: DO NOT APPLY MORE THAN 300 PSI (2100 KPA) TO THE VSV SYSTEM. IF YOU APPLY TOO MUCH PRESSURE, DAMAGE TO THE ENGINE CAN OCCUR.

- (3) Operate the VSV system to the full-closed position as follows (Figure 201):

NOTE: An extended actuator rod is the full-closed position.

- (a) Set the pressure to 0 psi.
- (b) Apply and hold a pressure of 200-300 psi (1400-2100 kPa) to the VSV HEAD-END flexhose [4].

NOTE: When the VSV actuator closes, movement must be smooth, that does not bind or jump. The VSV actuator must start to close at 100 psi (700 kPa) and must continue until it gets to the stop position. An indication that the actuator is at the stop position is a rapid increase in gage pressure. If the stator vanes do not move, examine the VSV actuators for leakage.

- (c) Set the pressure to 0 psi.

SUBTASK 75-31-00-860-002-F00

- (4) Operate the VSV system to the full-open position as follows (Figure 201):

NOTE: A retracted actuator rod is the full-open position.

- (a) Apply and hold a pressure of 200-300 psi (1400-2100 kPa) to the VSV ROD-END flexhose [3].

NOTE: When the VSV actuator opens, movement must be smooth, that does not bind or jump. The VSV actuator must start to open at 100 psi (700 kPa) and must continue until it gets to the stop position. An indication that the actuator is at the stop position is a rapid increase in gage pressure. If the stator vanes do not move, examine the VSV actuators for leakage.

- (b) Set the pressure to 0 psi.

SUBTASK 75-31-00-420-001-F00

- (5) Do these steps to disconnect the VSV flexhoses from the supply hose [6] and return hose [5] (Figure 201):

- (a) Release the hydraulic pressure.
- (b) Put a 5 gallon (19 liters) fuel resistant container, STD-1054, below the VSV HEAD-END flexhose [4] and VSV ROD-END flexhose [3].
- (c) Disconnect the supply hose [6] from the VSV HEAD-END flexhose [4].
- (d) Remove the protective cover from the VSV HEAD-END nipple [2].
- (e) Disconnect the return hose [5] from the VSV ROD-END flexhose [3].
- (f) Remove the protective cover from the VSV ROD-END nipple [1].
- (g) Lubricate the threads of the VSV HEAD-END and ROD-END nipples [2] and [1], respectively with oil, D00599 [CP2442].
- (h) Connect the VSV HEAD-END flexhose [4] to the VSV HEAD-END nipple [2].
 - 1) Tighten the coupling nut to 450-550 pound-inches (50-60 Newton meters).
- (i) Connect the VSV ROD-END flexhose [3] to the VSV ROD-END nipple [1].

EFFECTIVITY
HAP ALL

D633A101-HAP

75-31-00

Page 203
Oct 15/2008

AIRCRAFT MAINTENANCE MANUAL

1) Tighten the coupling nut to 270-300 pound-inches (30-35 Newton meters).

H. Put the Airplane Back to Its Usual Condition

SUBTASK 75-31-00-410-001-F00

(1) If you removed a shroud segment, do this task: Shroud Segments Installation, TASK 72-23-03-400-802-F00.

SUBTASK 75-31-00-410-002-F00

WARNING: OBEY THE INSTRUCTIONS IN THE PROCEDURE TO CLOSE THE THRUST REVERSERS. IF YOU DO NOT OBEY THE INSTRUCTIONS, INJURIES TO PERSONS AND DAMAGE TO EQUIPMENT CAN OCCUR.

(2) Do this task: Close the Thrust Reverser (Selection), TASK 78-31-00-010-804-F00.

SUBTASK 75-31-00-860-004-F00

(3) Remove the DO-NOT-OPERATE tags from the start lever.

SUBTASK 75-31-00-860-005-F00

(4) Remove the DO-NOT-OPERATE tag from the BAT switch.

I. VSV Actuation System Installation Test

SUBTASK 75-31-00-800-001-F00

(1) Do the test that are listed in the Power Plant Test Reference Table (TASK 71-00-00-800-811-F00).

————— **END OF TASK** —————

EFFECTIVITY
HAP ALL

D633A101-HAP

75-31-00

Page 204
Oct 15/2008

737-600/700/800/900
AIRCRAFT MAINTENANCE MANUAL

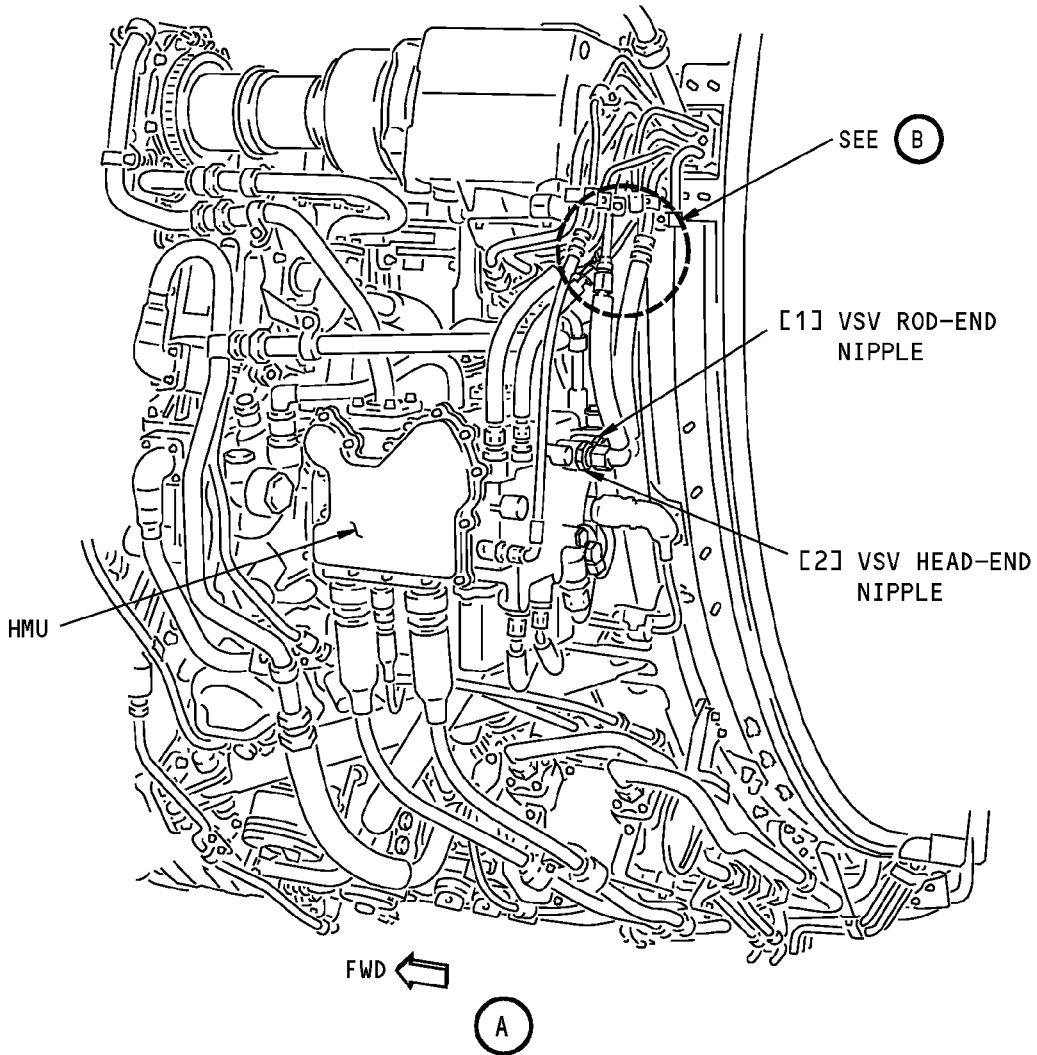
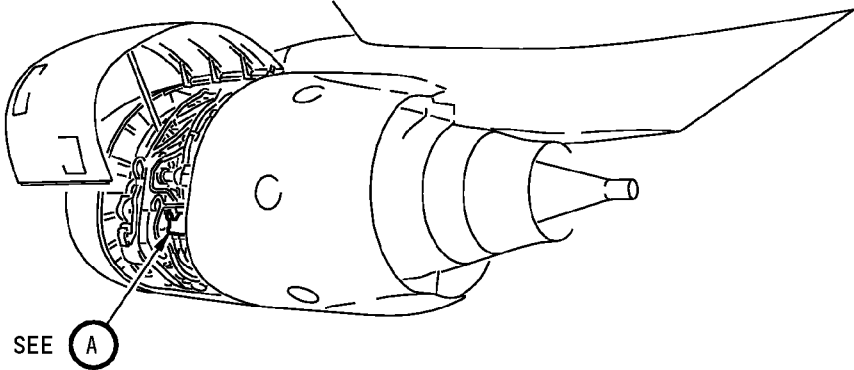

VSV Actuation System - Manual Operation
Figure 201 (Sheet 1 of 2)/75-31-00-990-801-F00

EFFECTIVITY
HAP ALL

75-31-00

Page 205
Oct 10/2003

D633A101-HAP

737-600/700/800/900
AIRCRAFT MAINTENANCE MANUAL

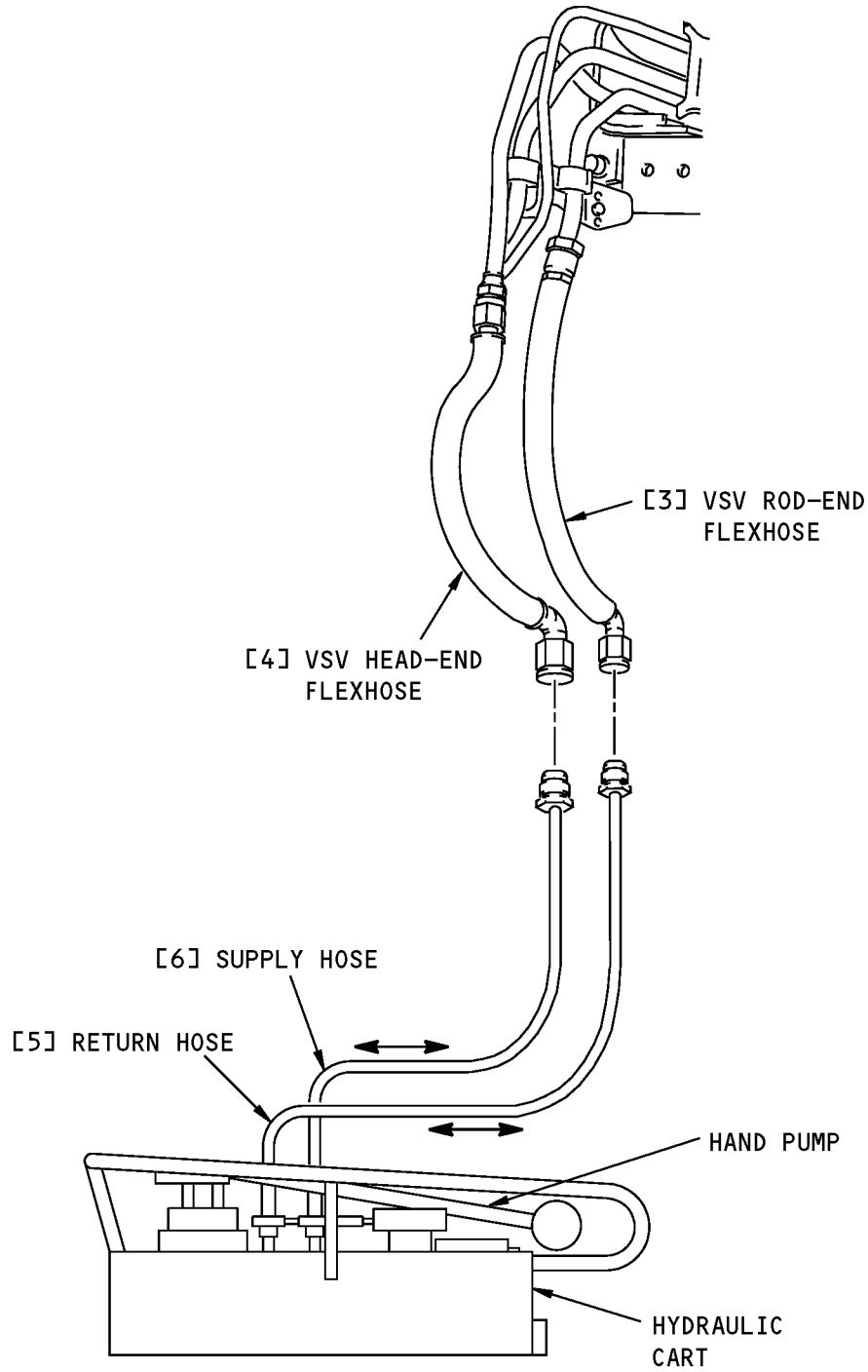

(B)

VSV Actuation System - Manual Operation
Figure 201 (Sheet 2 of 2)/75-31-00-990-801-F00

EFFECTIVITY
HAP ALL

D633A101-HAP

75-31-00

AIRCRAFT MAINTENANCE MANUAL

VARIABLE STATOR VANE ACTUATOR - REMOVAL/INSTALLATION**1. General**

A. This procedure has these tasks:

- (1) Prepare the airplane for the removal.
- (2) The removal of the left VSV actuator.
- (3) The installation of the left VSV actuator.
- (4) The removal of the right VSV actuator.
- (5) The installation of the right VSV actuator.
- (6) The leak test of the VSV actuator.

TASK 75-31-01-840-801-F00**2. Prepare the Airplane for the Removal**

A. References

Reference	Title
24-22-00-860-811	Supply Electrical Power (P/B 201)
24-22-00-860-812	Remove Electrical Power (P/B 201)
36-11-06-000-801	High Stage Valve Removal (P/B 401)
72-23-03-000-802-F00	Shroud Segments Removal (P/B 401)
78-31-00-010-801-F00	Open the Thrust Reverser (Selection) (P/B 201)

B. Location Zones

Zone	Area
411	Engine 1 - Engine
421	Engine 2 - Engine

C. Prepare for the Removal

SUBTASK 75-31-01-840-002-F00

- (1) Do these steps to isolate the fuel from the fuel pump:
 - (a) Do this task: Supply Electrical Power, TASK 24-22-00-860-811.
 - (b) Make sure the engine start lever is in the CUTOFF position.
 - 1) Install a DO-NOT-OPERATE tag on the applicable engine start lever.
 - (c) Make sure the ENG VALVE CLOSED and the SPAR VALVE CLOSED lights on the fuel control panel (P5 overhead panel) are dim.

NOTE: The lights for the fuel shutoff valves identify three positions: 1) bright when the valves are in transition or when the valves do not agree with the commanded position; or 2) dim when the valves are closed; or 3) off when the valves are opened.
- (d) Do this task: Remove Electrical Power, TASK 24-22-00-860-812.
 - 1) Set the BAT switch on the Electrical Meters Battery and Galley Power Module (P5-13) to the OFF position and install a DO-NOT-OPERATE tag.

EFFECTIVITY
HAP ALL

D633A101-HAP

75-31-01

Page 401
Oct 15/2008

AIRCRAFT MAINTENANCE MANUAL

SUBTASK 75-31-01-010-003-F00

WARNING: DO THESE SPECIFIED TASKS IN THE CORRECT SEQUENCE BEFORE YOU OPEN THE THRUST REVERSER: RETRACT THE LEADING EDGE, DEACTIVATE THE LEADING EDGE, DEACTIVATE THE THRUST REVERSER (FOR GROUND MAINTENANCE), AND OPEN THE FAN COWL PANELS. IF YOU DO NOT OBEY THE ABOVE SEQUENCE, INJURIES TO PERSONS AND DAMAGE TO EQUIPMENT CAN OCCUR.

(2) Do this task: Open the Thrust Reverser (Selection), TASK 78-31-00-010-801-F00.

SUBTASK 75-31-01-410-004-F00

(3) Remove bottom left shroud segment for the left VSV actuator, do this task: Shroud Segments Removal, TASK 72-23-03-000-802-F00.

SUBTASK 75-31-01-410-005-F00

(4) Remove top right shroud segment for the right VSV actuator, do this task: Shroud Segments Removal, TASK 72-23-03-000-802-F00.

SUBTASK 75-31-01-010-004-F00

(5) To get access to the left VSV actuator, do this task: High Stage Valve Removal, TASK 36-11-06-000-801.

————— **END OF TASK** —————

TASK 75-31-01-000-801-F00**3. Left VSV Actuator Removal**

(Figure 401)

A. General

- (1) This task is the removal procedure for the variable stator vane actuator (referred to as the actuator).
- (2) There are two VSV actuators on each engine.
 - (a) The left VSV actuator is found at the 8:00 o'clock position.
- (3) This procedure refers to the rod-end fuel manifold and head-end fuel manifold as the rod-end manifold and head-end manifold.

B. References

Reference	Title
70-10-02-910-801-F00	General Precautions During the Removal and Installation of Engine Components (P/B 201)
75-31-00-790-801-F00	VSV Actuation System - Manual Operation (P/B 201)

C. Tools/Equipment

Reference	Description
STD-4049	Container - Fuel Resistant, 1 Gallon (4 Liters)

D. Consumable Materials

Reference	Description	Specification
D00623 [CP5066]	Oil - Fuel System, Corrosion Preventive	MIL-PRF-6081, Grade 1010
D50186 [CP2691]	Fluid - Penetrating - Aerokroil	

EFFECTIVITY
HAP ALL

75-31-01

Page 402
Jun 15/2008

D633A101-HAP

AIRCRAFT MAINTENANCE MANUAL

E. Location Zones

Zone	Area
411	Engine 1 - Engine
421	Engine 2 - Engine

F. Left Actuator Removal

SUBTASK 75-31-01-840-003-F00

- (1) If it is not done, do this task: Prepare the Airplane for the Removal, TASK 75-31-01-840-801-F00.

SUBTASK 75-31-01-730-003-F00

- (2) Operate the VSV actuator to the full-closed position (TASK 75-31-00-790-801-F00).

NOTE: An extended actuator rod is the full-closed position.

SUBTASK 75-31-01-860-005-F00

- (3) Disconnect the electrical connector, DP1002 (CH B) [27] from the actuator receptacle.

SUBTASK 75-31-01-020-002-F00

- (4) Do these steps to disconnect the two VSV drain manifolds [19]:

CAUTION: USE TWO WRENCHES TO LOOSEN THE COUPLING NUT. USE ONE TO HOLD THE FITTING, AND THE OTHER TO LOOSEN THE COUPLING NUT. IF YOU DO NOT USE TWO WRENCHES, DAMAGE TO THE EQUIPMENT CAN OCCUR.

- Disconnect the two VSV drain manifolds [19].
- Put protective caps on the two VSV drain manifolds [19] (TASK 70-10-02-910-801-F00).
- Put protective caps on the head-end shroud nipple [22] and rod-end shroud nipple [18].

SUBTASK 75-31-01-020-003-F00

- (5) Do these steps to disconnect the head-end coupling nut [24] and rod-end coupling nut [21]:

- Put a 1 gallon (4 l) fuel resistant container, STD-4049, under the actuator [28].
- Disconnect the head-end shroud [23] and rod-end shroud [16].

NOTE: This will get access to the head-end coupling nut and rod-end coupling nut.

- Move the head-end shroud [23] and rod-end shroud [16] out of the way.
- Disconnect the head-end coupling nut [24] and rod-end coupling nut [21] from the head-end nipple [25] and rod-end nipple [13].
 - Let the fuel drain in the container.

SUBTASK 75-31-01-020-009-F00

- (6) Do these steps to disconnect the bellcrank assembly [3] from the actuator clevis:

- Remove the nut [7], washer [8] and bolt [11] from the actuator clevis.
 - Remove the bushing [9].
- Remove the nut [6] and bolt [10] from the actuator clevis.
- Use your hand to fully retract the actuator rod.
- Remove the bushing [31] from the link [4] and bellcrank assembly [3].
 - Remove the link [4] and washer [5].

SUBTASK 75-31-01-020-005-F00

- (7) Do these steps to remove the actuator [28]:

EFFECTIVITY
HAP ALL

75-31-01

Page 403
Oct 10/2003

D633A101-HAP

AIRCRAFT MAINTENANCE MANUAL

(a) Apply penetrating fluid, D50186 [CP2691] to bolt [33] at both the inboard and outboard bellcrank assembly clevis locations [3].

1) Allow the penetrant to soak for a minimum of 5 minutes.

(b) Remove bolt [1] and nut [34] that attach the actuator [28] to the bellcrank assembly [3].

CAUTION: ROTATING BOLT (33) WILL RESULT IN SEIZURE BETWEEN THE BOLT AND BELLCRANK ASSEMBLY.

(c) Hold bolt [33] stationary and remove nut [2].

1) Remove bolt [33] that attaches the actuator [28] to the bellcrank assembly [3].

a) Do not rotate bolt [33].

NOTE: Once nut [2] has been rotated 2 or 3 turns, carefully pry bolt [33] outboard in order to verify the bolt is not seized to the bellcrank assembly [3].

(d) Remove the actuator [28].

(e) Remove the sleeve [29] from the actuator boss.

SUBTASK 75-31-01-020-006-F00

(8) Do these steps to remove the drain plug [30]:

(a) Remove the drain plug [30].

(b) Remove and discard the packing [32].

SUBTASK 75-31-01-020-010-F00

(9) Remove and discard the two packings [14] and two packings [15] (2 packings each on the rod-end and head-end).

(a) Put protective covers on the head-end coupling nut [24] and rod-end coupling nut [21].

SUBTASK 75-31-01-800-009-F00

(10) Do these steps to remove the head-end nipple [25] and rod-end nipple [13] from the actuator [28]:

(a) Remove the head-end nipple [25] and rod-end nipple [13].

(b) Remove and discard the two packings [12].

SUBTASK 75-31-01-020-007-F00

(11) Do these steps to flush the actuator [28]:

(a) Drain the fuel into the 1 gallon (4 l) fuel resistant container, STD-4049, from the actuator [28].

(b) Flush the actuator [28] with oil, D00623 [CP5066].

(c) Install protective caps in the three actuator ports.

————— **END OF TASK** —————

EFFECTIVITY
HAP ALL

D633A101-HAP

75-31-01

Page 404
Jun 15/2008

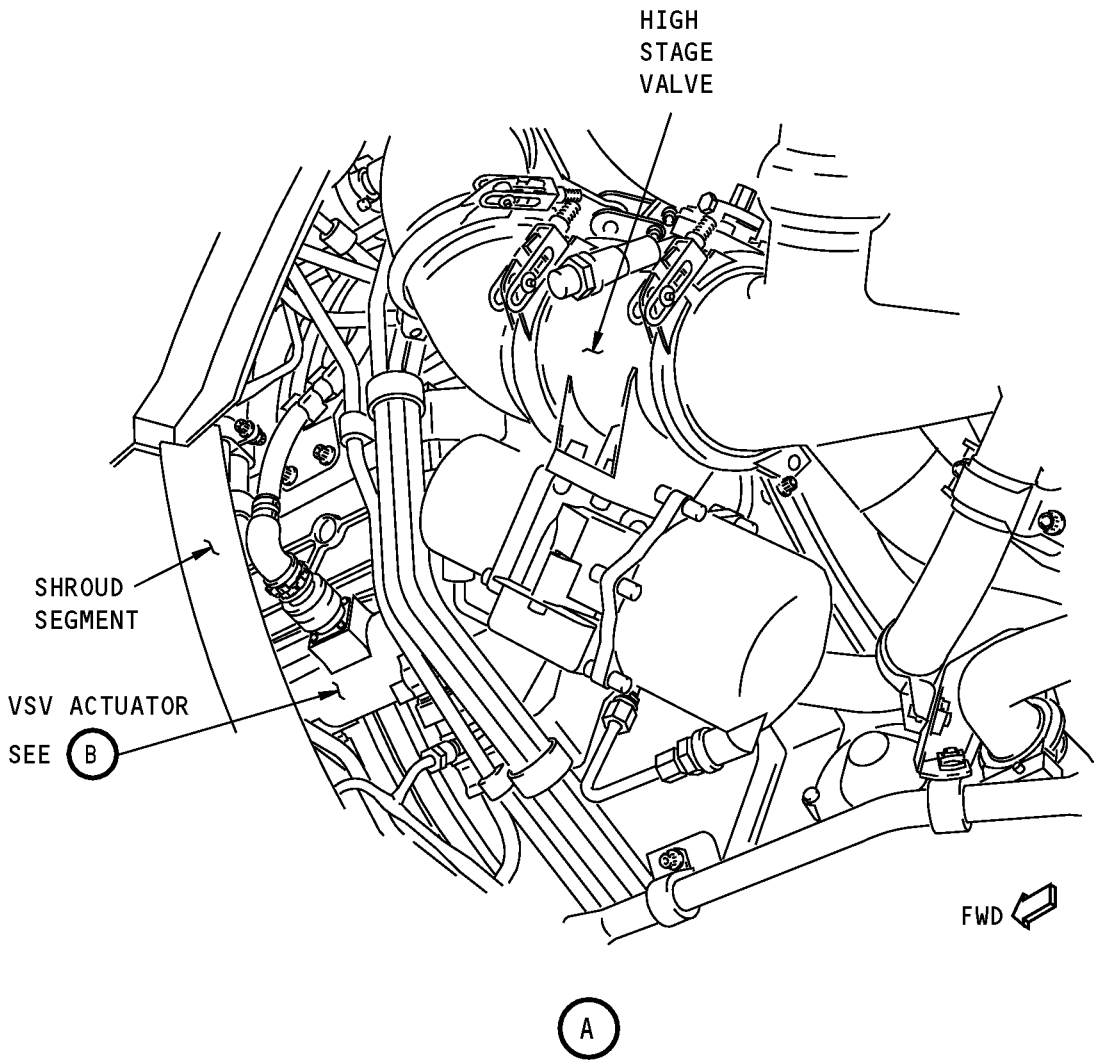
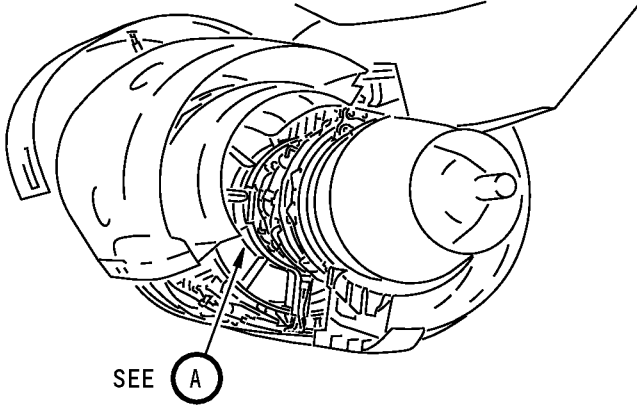

**Left Variable Stator Vane Actuator Installation
Figure 401 (Sheet 1 of 2)/75-31-01-990-801-F00**

EFFECTIVITY
HAP ALL

75-31-01

Page 405
Oct 10/2003

D633A101-HAP

AIRCRAFT MAINTENANCE MANUAL

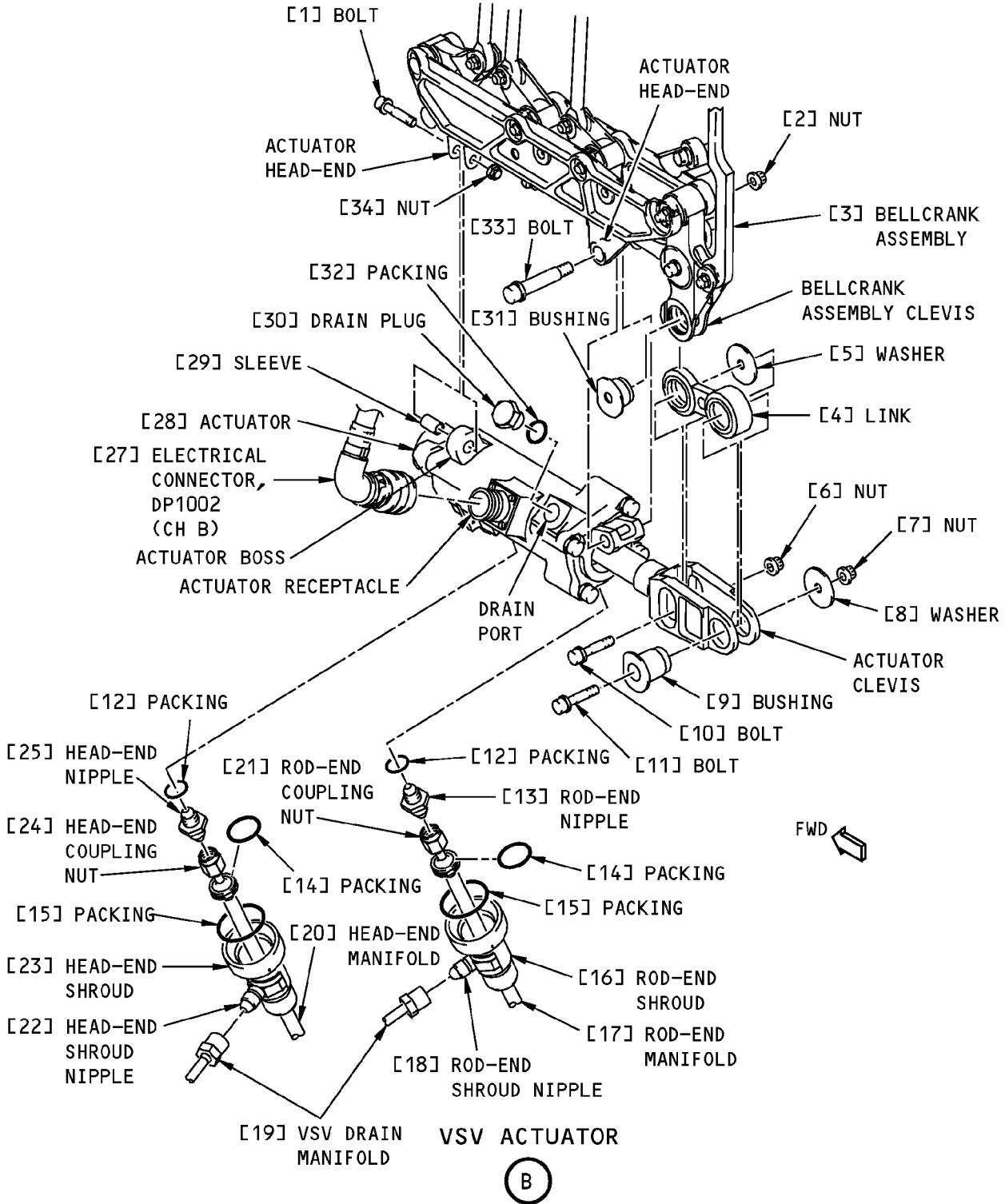

**Left Variable Stator Vane Actuator Installation
Figure 401 (Sheet 2 of 2)/75-31-01-990-801-F00**

EFFECTIVITY
HAP ALL

75-31-01

Page 406
Oct 10/2003

D633A101-HAP

AIRCRAFT MAINTENANCE MANUAL

TASK 75-31-01-400-801-F00

4. Left VSV Actuator Installation

(Figure 401)

A. General

- (1) This task is the installation procedure for the variable stator vane actuator (referred to as the actuator).
- (2) This procedure refers to the rod-end fuel manifold and head-end fuel manifold as the rod-end manifold and head-end manifold.

B. References

Reference	Title
70-10-02-910-801-F00	General Precautions During the Removal and Installation of Engine Components (P/B 201)

C. Consumable Materials

Reference	Description	Specification
D00599 [CP2442]	Oil - Engine (CFMI SB 79-001)	
D00601 [CP2101]	Grease - Graphite, High Temperature	SAE AMS 2518
G02345 [CP8001]	Lockwire - Inconel (0.032 inch Dia.)	NASM20995~ N32
G50065 [CP8006]	Cable, Safety, Stainless Steel, 0.8mm (0.032inch) Diameter	

D. Expendables/Parts

AMM Item	Description	AIPC Reference	AIPC Effectivity
12	Packing	73-11-00-03-465	HAP ALL
		73-11-00-03-495	HAP ALL
		75-31-00-02-062	HAP ALL
		75-31-00-02-060	HAP ALL
14	Packing	75-31-00-02-055	HAP ALL
15	Packing	75-31-01-01-045	HAP ALL
28	Actuator	75-31-00-01-095	HAP ALL
32	Packing		

E. Location Zones

Zone	Area
411	Engine 1 - Engine
421	Engine 2 - Engine

F. Left Actuator Installation

SUBTASK 75-31-01-800-010-F00

- (1) Do these steps to install the head-end nipple [25] and rod-end nipple [13] (TASK 70-10-02-910-801-F00):
 - (a) Remove the protective caps from the actuator [28].
 - (b) Lubricate the two new packings [12] with oil, D00599 [CP2442].
 - (c) Install the two packings [12] on the head-end nipple [25] and rod-end nipple [13].
 - (d) Lubricate the threads of the head-end nipple [25] and rod-end nipple [13] with grease, D00601 [CP2101] on the actuator side.

NOTE: Lubricate only the threads that are installed into the actuator.

EFFECTIVITY
HAP ALL

75-31-01

D633A101-HAP

Page 407
Jun 15/2009

AIRCRAFT MAINTENANCE MANUAL

CAUTION: USE TWO WRENCHES TO TIGHTEN THE COUPLING NUT. USE ONE TO HOLD THE FITTING, AND THE OTHER TO TIGHTEN THE COUPLING NUT. IF YOU DO NOT USE TWO WRENCHES, DAMAGE TO THE EQUIPMENT CAN OCCUR.

- (e) Install the head-end nipple [25] and rod-end nipple [13] in the actuator [28].
 1) Tighten the nipples to 135-150 pound-inches (15.5-17.0 Newton meters).

SUBTASK 75-31-01-800-011-F00

- (2) Do these steps to install the drain plug [30]:
- (a) Remove the protective cap from the actuator [28].
 - (b) Lubricate the new packing [32] with oil, D00599 [CP2442].
 - (c) Install the packing [32] on the drain plug [30].
 - (d) Lubricate the threads of the drain plug [30] with grease, D00601 [CP2101] on the actuator side.
 - (e) Install the drain plug [30] in the actuator [28].
 1) Tighten the drain plug to 135-150 pound-inches (15.5-17.0 Newton meters).
 - (f) Install the lockwire, G02345 [CP8001] or cable, G50065 [CP8006], from the drain plug [30] to the actuator [28].

SUBTASK 75-31-01-420-002-F00

- (3) Do these steps to attach the actuator [28]:
- (a) Lubricate the threads of the bolts [1] and [33] with grease, D00601 [CP2101].
 - (b) Make sure that the actuator rod is fully retracted into the actuator [28].
 - (c) Install the sleeve [29] in the actuator boss.
 - (d) Put the actuator [28] into its position on the bellcrank assembly [3].
 - (e) Install the bolt [1] and nut [34] and the bolt [33] and nut [2].
- NOTE:** The bolt head [1] for the head-end points forward and the bolt head [33] for the rod-end points outboard.
- 1) Tighten the nut [34] at the head-end to 62-68 pound-inches (7-8 Newton meters).
 - 2) Tighten the nut [2] at the rod-end to 100-120 pound-inches (11.5-13.5 Newton meters).

SUBTASK 75-31-01-800-005-F00

- (4) Do these steps to connect the bellcrank assembly [3]:
- (a) Lubricate the threads of the nuts [6] and [7] with grease, D00601 [CP2101].
 - (b) Put the link [4] in the bellcrank assembly clevis.
 - (c) Install the bushing [31] in the bellcrank assembly clevis.
 - (d) Extend the actuator rod to align the bushing [31] with the actuator clevis.
 - (e) Put the washer [5] between the bellcrank assembly clevis and the actuator clevis.
 - (f) Install the bolt [10] and nut [6].
 1) Tighten the nut [6] to 62-68 pound-inches (7-8 Newton meters).
 - (g) Align the end of the link [4] with the actuator clevis.
 - (h) Install the bushing [9].
 - (i) Install the bolt [11], washer [8] and nut [7].

NOTE: The washer is below the nut.

- 1) Tighten the nut [7] to 62-68 pound-inches (7-8 Newton meters).

EFFECTIVITY
HAP ALL

D633A101-HAP

75-31-01

Page 408
Feb 15/2009

AIRCRAFT MAINTENANCE MANUAL

SUBTASK 75-31-01-420-004-F00

- (5) Do these steps to install the head-end manifold [20] and rod-end manifold [17]:
- (a) Lubricate the four new packings [14] and [15] with oil, D00599 [CP2442].
 - (b) Install the two packings [14] on the head-end manifold [20] and rod-end manifold [17].
 - (c) Install the two packings [15] on the head-end shroud [23] and rod-end shroud [16].
 - (d) Lubricate the threads of the head-end nipple [25] and rod-end nipple [13] with oil, D00599 [CP2442].
 - (e) Connect the head-end coupling nut [24] and rod-end coupling nut [21] to the head-end nipple [25] and rod-end nipple [13].
 - 1) Tighten the coupling nuts to 135-150 pound-inches (15.5-17.0 Newton meters).

SUBTASK 75-31-01-860-006-F00

- (6) Connect the electrical connector, DP1002 (CH B) [27] to the actuator receptacle, CH B.

SUBTASK 75-31-01-790-001-F00

- (7) Do this task: VSV Actuator Leak Test, TASK 75-31-01-790-801-F00.

NOTE: The steps to connect the head-end and rod-end shroud and two VSV drain manifolds are included in this task. Steps to put the airplane back to its usual condition and do an installation test are also included.

————— END OF TASK —————

TASK 75-31-01-000-802-F00**5. Right VSV Actuator Removal**

(Figure 402)

A. General

- (1) This task is the removal procedure for the variable stator vane actuator (referred to as the actuator).
- (2) There are two VSV actuators on each engine.
 - (a) The right VSV actuator is found at the 2:00 o'clock position.
- (3) This procedure refers the rod-end fuel manifold and head-end fuel manifold as the rod-end manifold and head-end manifold.

B. References

Reference	Title
70-10-02-910-801-F00	General Precautions During the Removal and Installation of Engine Components (P/B 201)
75-31-00-790-801-F00	VSV Actuation System - Manual Operation (P/B 201)

C. Tools/Equipment

Reference	Description
STD-4049	Container - Fuel Resistant, 1 Gallon (4 Liters)

D. Consumable Materials

Reference	Description	Specification
D00623 [CP5066]	Oil - Fuel System, Corrosion Preventive	MIL-PRF-6081, Grade 1010
D50186 [CP2691]	Fluid - Penetrating - Aerokroil	

EFFECTIVITY
HAP ALL

75-31-01

D633A101-HAP

Page 409
Feb 15/2009

AIRCRAFT MAINTENANCE MANUAL

E. Location Zones

Zone	Area
411	Engine 1 - Engine
421	Engine 2 - Engine

F. Right Actuator Removal

SUBTASK 75-31-01-840-005-F00

- (1) If it is not done, do this task: Prepare the Airplane for the Removal, TASK 75-31-01-840-801-F00.

SUBTASK 75-31-01-730-004-F00

- (2) Operate the VSV actuator to the full-closed position (TASK 75-31-00-790-801-F00).

NOTE: An extended actuator rod is the full-closed position.

SUBTASK 75-31-01-860-007-F00

- (3) Disconnect the electrical connectors, DP0902 (CH A) [64], DP0911 [51] and DP1011 [52] from the connector plate receptacles.

SUBTASK 75-31-01-020-011-F00

- (4) Do these steps to disconnect the two VSV drain manifolds [53]:

CAUTION: USE TWO WRENCHES TO LOOSEN THE COUPLING NUT. USE ONE TO HOLD THE FITTING, AND THE OTHER TO LOOSEN THE COUPLING NUT. IF YOU DO NOT USE TWO WRENCHES, DAMAGE TO THE EQUIPMENT CAN OCCUR.

- Disconnect the two VSV drain manifolds [53] (TASK 70-10-02-910-801-F00).
- Put protective caps on the two VSV drain manifolds [53].
- Put protective caps on the head-end shroud nipple [54] and rod-end shroud nipple [86].

SUBTASK 75-31-01-020-012-F00

- (5) Do these steps to disconnect the head-end coupling nut [58] and rod-end coupling nut [84]:

- Put a 1 gallon (4 l) fuel resistant container, STD-4049, under the actuator [65].
- Disconnect the head-end shroud [56] and rod-end shroud [85].

NOTE: This will get access to the head-end coupling nut and rod-end coupling nut.

- Move the head-end shroud [56] and rod-end shroud [85] out of the way.
- Disconnect the head-end coupling nut [58] and rod-end coupling nut [84] from the head-end nipple [59] and rod-end nipple [61].
 - Let the fuel drain into the container.

SUBTASK 75-31-01-020-013-F00

- (6) Disconnect the drain tube [67] from the drain port nipple [68].

- Put a protective cover on the drain tube [67].

SUBTASK 75-31-01-020-014-F00

- (7) Do these steps to disconnect the bellcrank assembly [74] from the actuator clevis:

- Remove the nut [79], washer [80] and bolt [82] from the actuator clevis.
 - Remove the bushing [81].
- Remove the nut [78] and bolt [83] from the actuator clevis.
- Use your hand to fully retract the actuator rod.
- Remove the bushing [75] from the link [77] and bellcrank assembly [74].

EFFECTIVITY
HAP ALL

D633A101-HAP

75-31-01

Page 410
Feb 15/2009

AIRCRAFT MAINTENANCE MANUAL

- 1) Remove the link [77] and the washer [76].

SUBTASK 75-31-01-020-015-F00

- (8) Do these steps to remove the actuator [65]:

- (a) Apply penetrating fluid, D50186 [CP2691] to bolt [69] at both the inboard and outboard bellcrank assembly clevis locations [74].

- 1) Allow the penetrant to soak for a minimum of 5 minutes.

- (b) Remove bolt [70] and nut [71] that attach the actuator [65] to the bellcrank assembly [74].

CAUTION: ROTATING BOLT (69) WILL RESULT IN SEIZURE BETWEEN THE BOLT AND BELLCRANK ASSEMBLY.

- (c) Hold bolt [69] stationary and remove nut [73].

- 1) Remove bolt [69] that attaches the actuator [65] to the bellcrank assembly [74].

- a) Do not rotate bolt [69].

NOTE: Once nut [73] has been rotated 2 or 3 turns, carefully pry bolt [69] outboard in order to verify the bolt is not seized to the bellcrank assembly [74].

- (d) Remove the actuator [65].

- (e) Remove the sleeve [66] from the actuator boss.

SUBTASK 75-31-01-020-016-F00

- (9) Remove and discard the two packings [62] and two packings [57] (2 packings each on the rod-end and head-end) from the manifolds.

- (a) Put protective covers on the head-end coupling nut [58] and rod-end coupling nut [84].

SUBTASK 75-31-01-800-012-F00

- (10) Do these steps to remove the head-end nipple [59] and rod-end nipple [61]:

- (a) Remove the head-end nipple [59] and rod-end nipple [61] from the actuator [65].

- (b) Remove and discard the two packings [60].

SUBTASK 75-31-01-800-013-F00

- (11) Do these steps to remove the drain port nipple [68] from the actuator [65]:

- (a) Remove the drain port nipple [68].

- (b) Remove and discard the packing [72].

SUBTASK 75-31-01-020-017-F00

- (12) Do these steps to flush the actuator [65]:

- (a) Drain the fuel into the 1 gallon (4 l) fuel resistant container, STD-4049, from the actuator [65].

- (b) Flush the actuator [65] with oil, D00623 [CP5066].

- (c) Install protective caps in the three actuator ports.

————— END OF TASK —————

EFFECTIVITY
HAP ALL

D633A101-HAP

75-31-01

Page 411
Feb 15/2009

737-600/700/800/900
AIRCRAFT MAINTENANCE MANUAL

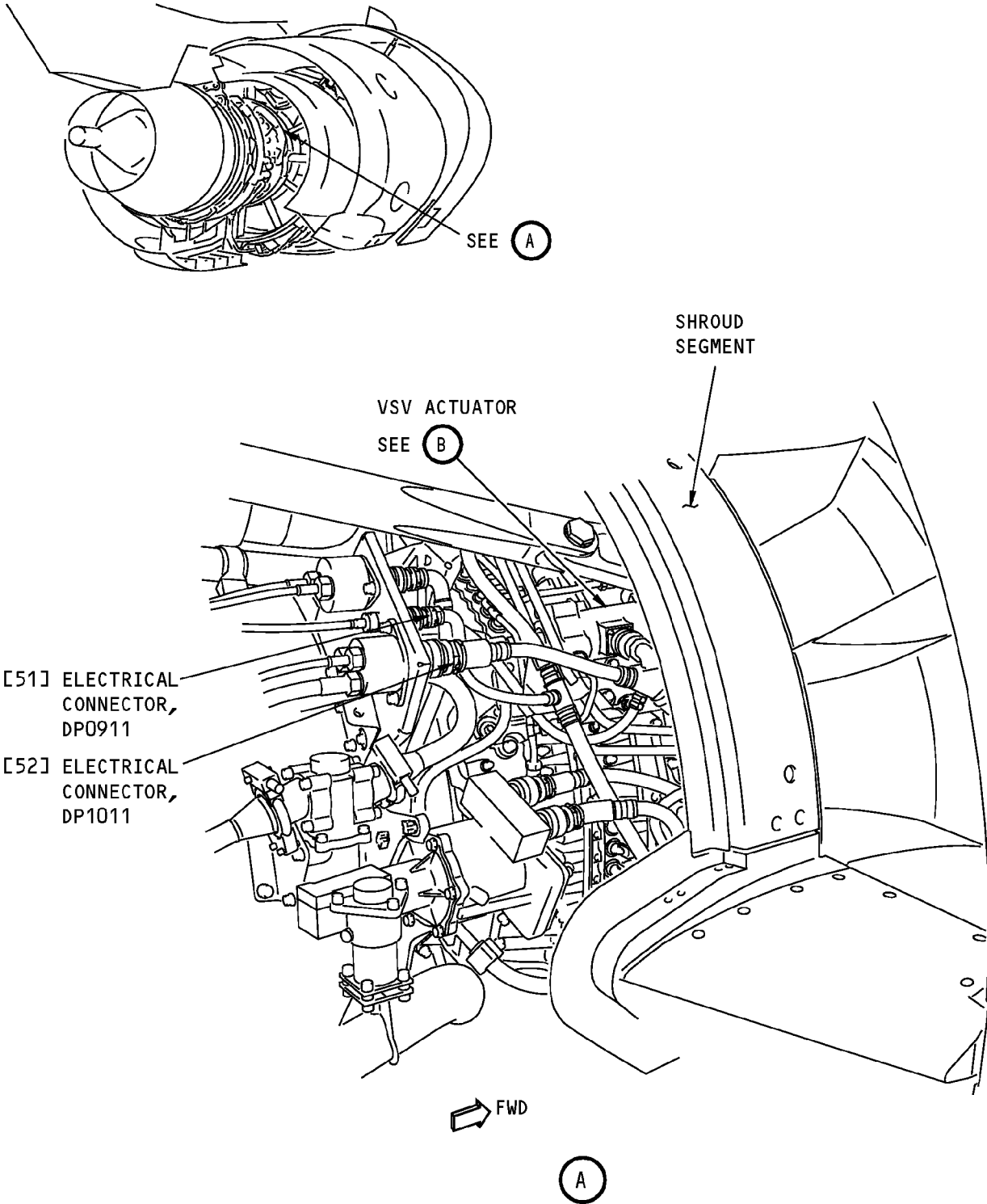

Right Variable Stator Vane Actuator Installation
Figure 402 (Sheet 1 of 2)/75-31-01-990-802-F00

EFFECTIVITY
HAP ALL

75-31-01

Page 412
Oct 10/2003

D633A101-HAP

AIRCRAFT MAINTENANCE MANUAL

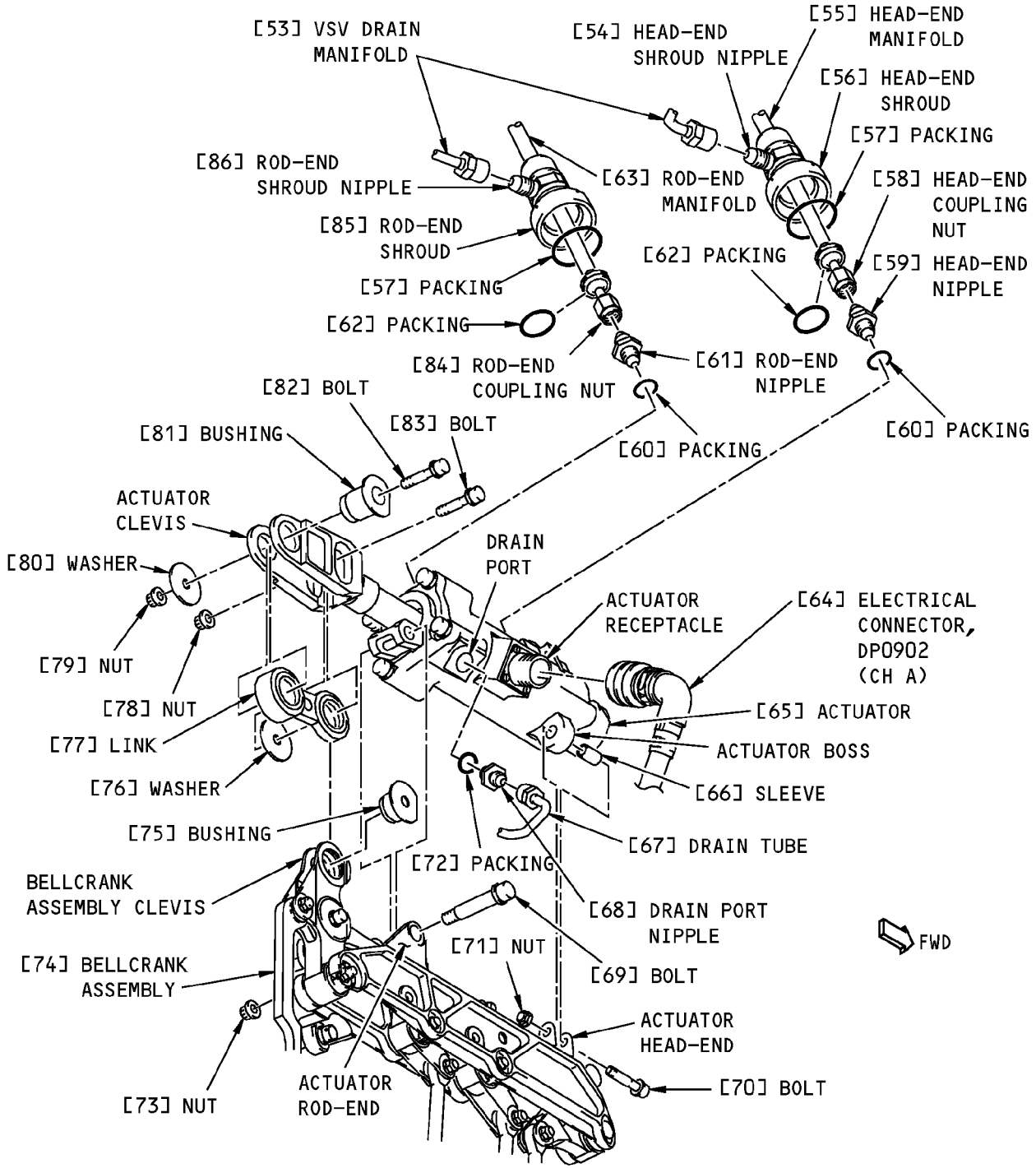

VSV ACTUATOR



Right Variable Stator Vane Actuator Installation
Figure 402 (Sheet 2 of 2)/75-31-01-990-802-F00

EFFECTIVITY
HAP ALL

75-31-01

AIRCRAFT MAINTENANCE MANUAL

TASK 75-31-01-400-802-F00

6. Right VSV Actuator Installation

(Figure 402)

A. General

- (1) This task is the installation procedure for the variable stator vane actuator (referred to as the actuator).
- (2) This procedure refers the rod-end fuel manifold and the head-end fuel manifold as the rod-end manifold and the head-end manifold.

B. References

Reference	Title
70-10-02-910-801-F00	General Precautions During the Removal and Installation of Engine Components (P/B 201)

C. Consumable Materials

Reference	Description	Specification
D00599 [CP2442]	Oil - Engine (CFMI SB 79-001)	
D00601 [CP2101]	Grease - Graphite, High Temperature	SAE AMS 2518

D. Expendables/Parts

AMM Item	Description	AIPC Reference	AIPC Effectivity
57	Packing	75-31-00-02-055	HAP ALL
60	Packing	75-31-00-01-095	HAP ALL
62	Packing	75-31-00-02-060	HAP ALL
65	Actuator	75-31-01-01-045	HAP ALL
72	Packing	73-11-00-03-465	HAP ALL
		75-31-00-01-095	HAP ALL

E. Location Zones

Zone	Area
411	Engine 1 - Engine
421	Engine 2 - Engine

F. Right Actuator Installation

SUBTASK 75-31-01-800-014-F00

- (1) Do these steps to install the head-end nipple [59] and rod-end nipple [61] (TASK 70-10-02-910-801-F00):
 - (a) Remove the protective caps from the actuator [65].
 - (b) Lubricate the two new packings [60] with oil, D00599 [CP2442].
 - (c) Install the two packings [60] on the head-end nipple [59] and rod-end nipple [61].
 - (d) Lubricate the threads of the head-end nipple [59] and rod-end nipple [61] with grease, D00601 [CP2101] on the actuator side.

NOTE: Lubricate only the threads that are installed into the actuator.

CAUTION: USE TWO WRENCHES TO TIGHTEN THE COUPLING NUT. USE ONE TO HOLD THE FITTING, AND THE OTHER TO TIGHTEN THE COUPLING NUT. IF YOU DO NOT USE TWO WRENCHES, DAMAGE TO THE EQUIPMENT CAN OCCUR.

- (e) Install the head-end nipple [59] and rod-end nipple [61] in the actuator [65].

EFFECTIVITY
HAP ALL

75-31-01

D633A101-HAP

Page 414
Jun 15/2009

AIRCRAFT MAINTENANCE MANUAL

1) Tighten the nipples to 135-150 pound-inches (15.5-17.0 Newton meters).

SUBTASK 75-31-01-420-009-F00

(2) Do these steps to install the drain port nipple [68] in the actuator [28]:

- (a) Remove the protective cap from the actuator [65].
- (b) Lubricate the new packing [72] with oil, D00599 [CP2442].
- (c) Install the packing [72] on the drain port nipple [68].
- (d) Lubricate the threads of the drain port nipple [68] with grease, D00601 [CP2101] on the actuator side.
- (e) Install the drain port nipple [68] in the actuator [65].

1) Tighten the nipple to 135-150 pound-inches (15.5-17.0 Newton meters).

SUBTASK 75-31-01-420-010-F00

(3) Do these steps to attach the actuator [65] to the bellcrank assembly [74]:

- (a) Lubricate the threads of the bolts [70] and [69] with grease, D00601 [CP2101].
- (b) Make sure that the actuator rod is fully retracted into the actuator [65].
- (c) Install the sleeve [66] in the actuator boss.
- (d) Put the actuator [65] into its position on the bellcrank assembly [74].
- (e) Install the bolt [70] and nut [71], and the bolt [69] and nut [73].

NOTE: The bolt head [70] for the head-end points forward and the bolt head [69] for the rod-end points outboard.

1) Tighten the nut [71] at the head-end to 62-68 pound-inches (7-8 Newton meters).

2) Tighten the nut [73] at the rod-end to 100-120 pound-inches (11.5-13.5 Newton meters).

SUBTASK 75-31-01-800-015-F00

(4) Do these steps to connect the bellcrank assembly [74]:

- (a) Lubricate the threads of the nuts [78] and [79] with grease, D00601 [CP2101].
- (b) Put the link [77] in the bellcrank assembly clevis.
- (c) Install the bushing [75] in the bellcrank assembly clevis.
- (d) Extend the actuator rod to align the bushing [75] with the actuator clevis.
- (e) Put the washer [76] between the bellcrank assembly clevis and the actuator clevis.
- (f) Install the bolt [83] and nut [78].

1) Tighten the nut [78] to 62-68 pound-inches (7-8 Newton meters).

(g) Align the end of the link [77] with the actuator clevis.

(h) Install the bushing [81].

(i) Install the bolt [82], washer [80] and nut [79].

NOTE: The washer is below the nut.

1) Tighten the nut [79] to 62-68 pound-inches (7-8 Newton meters).

SUBTASK 75-31-01-420-011-F00

(5) Do these steps to install the head-end manifold [55] and rod-end manifold [63]:

- (a) Lubricate the four new packings [62] and [57] with oil, D00599 [CP2442].
- (b) Install the two packings [62] on the head-end manifold [55] and rod-end manifold [63].
- (c) Install the two packings [57] on the head-end shroud [56] and rod-end shroud [85].

EFFECTIVITY
HAP ALL

75-31-01

Page 415
Feb 15/2009

D633A101-HAP

AIRCRAFT MAINTENANCE MANUAL

- (d) Lubricate the threads of the head-end nipple [59] and rod-end nipple [61] with oil, D00599 [CP2442].
- (e) Connect the head-end coupling nut [58] and rod-end coupling nut [84] to the head-end nipple [59] and rod-end nipple [61].
- 1) Tighten the coupling nuts to 135-150 pound-inches (15.5-17.0 Newton meters).

SUBTASK 75-31-01-420-012-F00

- (6) Do these steps to install the drain tube [67]:
- (a) Lubricate the threads of the drain port nipple [68] with oil, D00599 [CP2442].
 - (b) Connect the coupling nut on the drain tube [67] to the drain port nipple [68].
 - 1) Tighten the coupling nut to 135-150 pound-inches (15.5-17 Newton meters).

SUBTASK 75-31-01-860-008-F00

- (7) Connect the electrical connector, DP0902 (CH A) [64] to the actuator receptacle, CH A and the electrical connectors, DP1011 [52] and DP0911 [51] to the connector plate receptacles.

SUBTASK 75-31-01-790-002-F00

- (8) Do this task: VSV Actuator Leak Test, TASK 75-31-01-790-801-F00.

NOTE: The steps to connect the head-end and rod-end shroud and two VSV drain manifolds are included in this task. Steps to put the airplane back to its usual condition and do an installation test are also included.

————— **END OF TASK** —————

TASK 75-31-01-790-801-F00**7. VSV Actuator Leak Test**

(Figure 401, Figure 402, Figure 403)

A. References

Reference	Title
36-11-06-400-801	High Stage Valve Installation (P/B 401)
71-00-00-800-811-F00	Power Plant Test Reference Table (P/B 501)
72-23-03-400-802-F00	Shroud Segments Installation (P/B 401)
78-31-00-010-804-F00	Close the Thrust Reverser (Selection) (P/B 201)

B. Tools/Equipment

NOTE: When more than one tool part number is listed under the same "Reference" number, the tools shown are alternates to each other within the same airplane series. Tool part numbers that are replaced or non-procurable are preceded by "Opt:", which stands for Optional.

Reference	Description
SPL-2187	Actuator - Hydraulic, Portable, VSV Stator - CFM56-7/CFM56-3 (Part #: 856A1084G04, Supplier: 58828, A/P Effectivity: 737-300, -400, -500, -600, -700, -700C, -700ER, -700QC, -800, -900, -900ER, -BBJ)

C. Consumable Materials

Reference	Description	Specification
G02345 [CP8001]	Lockwire - Inconel (0.032 inch Dia.)	NASM20995~ N32
G50065 [CP8006]	Cable, Safety, Stainless Steel, 0.8mm (0.032inch) Diameter	

EFFECTIVITY
HAP ALL

D633A101-HAP

75-31-01

Page 416
Feb 15/2009

AIRCRAFT MAINTENANCE MANUAL

D. Location Zones

Zone	Area
411	Engine 1 - Engine
421	Engine 2 - Engine

E. VSV Actuator Leak Test

SUBTASK 75-31-01-790-003-F00

- (1) Do these steps to do a leak test of the head-end coupling nut and the rod-end coupling nut at the actuator:

CAUTION: USE TWO WRENCHES TO LOOSEN THE COUPLING NUT. USE ONE TO HOLD THE FITTING, AND THE OTHER TO LOOSEN THE COUPLING NUT. IF YOU DO NOT USE TWO WRENCHES, DAMAGE TO THE EQUIPMENT CAN OCCUR.

- (a) Disconnect the head-end flexhose [102] and rod-end flexhose [101] from the HMU [103].
- (b) Put protective caps in the HMU ports.

CAUTION: USE TWO WRENCHES TO TIGHTEN THE COUPLING NUT. USE ONE TO HOLD THE FITTING, AND THE OTHER TO TIGHTEN THE COUPLING NUT. IF YOU DO NOT USE TWO WRENCHES, DAMAGE TO THE EQUIPMENT CAN OCCUR.

- (c) Connect the actuator, SPL-2187, to the head-end flexhose [102] and rod-end flexhose [101].
- (d) Set the pressure to 0 psi.
 - 1) Open the valve to the rod-end side of the actuator, then increase the pressure to 200-300 psi.
 - 2) Do a leak check for fuel at the rod-end coupling nut at the actuator.
 - 3) If you find a leak, loosen and then tighten the rod-end coupling nut at the actuator again.
 - a) Tighten the rod-end coupling nut to 135-150 pound-inches (15.5-17.0 Newton meters).
- (e) Set the pressure to 0 psi.
- (f) Change the valve to the head-end side of the actuator.
 - 1) Open the valve to the head-end side, then increase the pressure to 200-300 psi.
 - 2) Do a leak check for fuel at the head-end coupling nut at the actuator.
 - 3) If you find a leak, loosen and then tighten the head-end coupling nut.
 - a) Tighten the head-end coupling nut to 135-150 pound-inches (15.5-17.0 Newton meters).
- (g) Set the pressure to 0 psi.
- (h) Disconnect the cart from the head-end flexhose [102] and rod-end flexhose [101].
- (i) Connect the rod-end flexhose [101] and head-end flexhose [102] to the HMU [103].
 - 1) Tighten the rod-end flexhose [101] to 270-300 pound-inches (30-35 Newton meters).
 - 2) Tighten the head-end flexhose [102] to 450-550 pound-inches (50-60 Newton meters).

SUBTASK 75-31-01-420-013-F00

- (2) Do these steps to connect the head-end shroud and rod-end shroud at the actuator:
- (a) Connect the head-end shroud and rod-end shroud to the bottom of the actuator.
 - 1) Tighten the knurled nuts until a maximum of two full threads of the knurled nuts are exposed.

EFFECTIVITY
HAP ALL

D633A101-HAP

75-31-01

Page 417
Feb 15/2009

AIRCRAFT MAINTENANCE MANUAL

- (b) Align the nipples with the VSV drain manifold.
- (c) Connect the two VSV drain manifolds to the head-end shroud nipple and rod-end shroud nipple.
 - 1) Tighten the coupling nuts to 135-150 pound-inches (15.5-17.0 Newton meters).
- (d) Install a lockwire, G02345 [CP8001] or cable, G50065 [CP8006] from the head-end shroud and rod-end shroud at the actuator.

F. Put the Airplane Back to Its Usual Condition

SUBTASK 75-31-01-410-009-F00

- (1) If it was removed, do this task: High Stage Valve Installation, TASK 36-11-06-400-801.

SUBTASK 75-31-01-410-010-F00

- (2) For the applicable shroud segment, do this task: Shroud Segments Installation, TASK 72-23-03-400-802-F00.

SUBTASK 75-31-01-410-011-F00

WARNING: OBEY THE INSTRUCTIONS IN THE PROCEDURE TO CLOSE THE THRUST REVERSER. IF YOU DO NOT OBEY THE INSTRUCTIONS, INJURIES TO PERSONS AND DAMAGE TO EQUIPMENT CAN OCCUR.

- (3) Do this task: Close the Thrust Reverser (Selection), TASK 78-31-00-010-804-F00.

SUBTASK 75-31-01-860-014-F00

- (4) Remove the DO-NOT-OPERATE tags from the start lever.

SUBTASK 75-31-01-860-015-F00

- (5) Remove the DO-NOT-OPERATE tag from the BAT switch.

G. Actuator Installation Test

SUBTASK 75-31-01-800-016-F00

- (1) Do the tests that are listed in the Power Plant Test Reference Table (TASK 71-00-00-800-811-F00).
 - (a) If you removed the high stage valve, do a check for leaks at the connection to the high stage valve.
 - (b) Do a check for leaks at the HMU connections.

————— END OF TASK —————

EFFECTIVITY
HAP ALL

D633A101-HAP

75-31-01

Page 418
Feb 15/2009

737-600/700/800/900
AIRCRAFT MAINTENANCE MANUAL

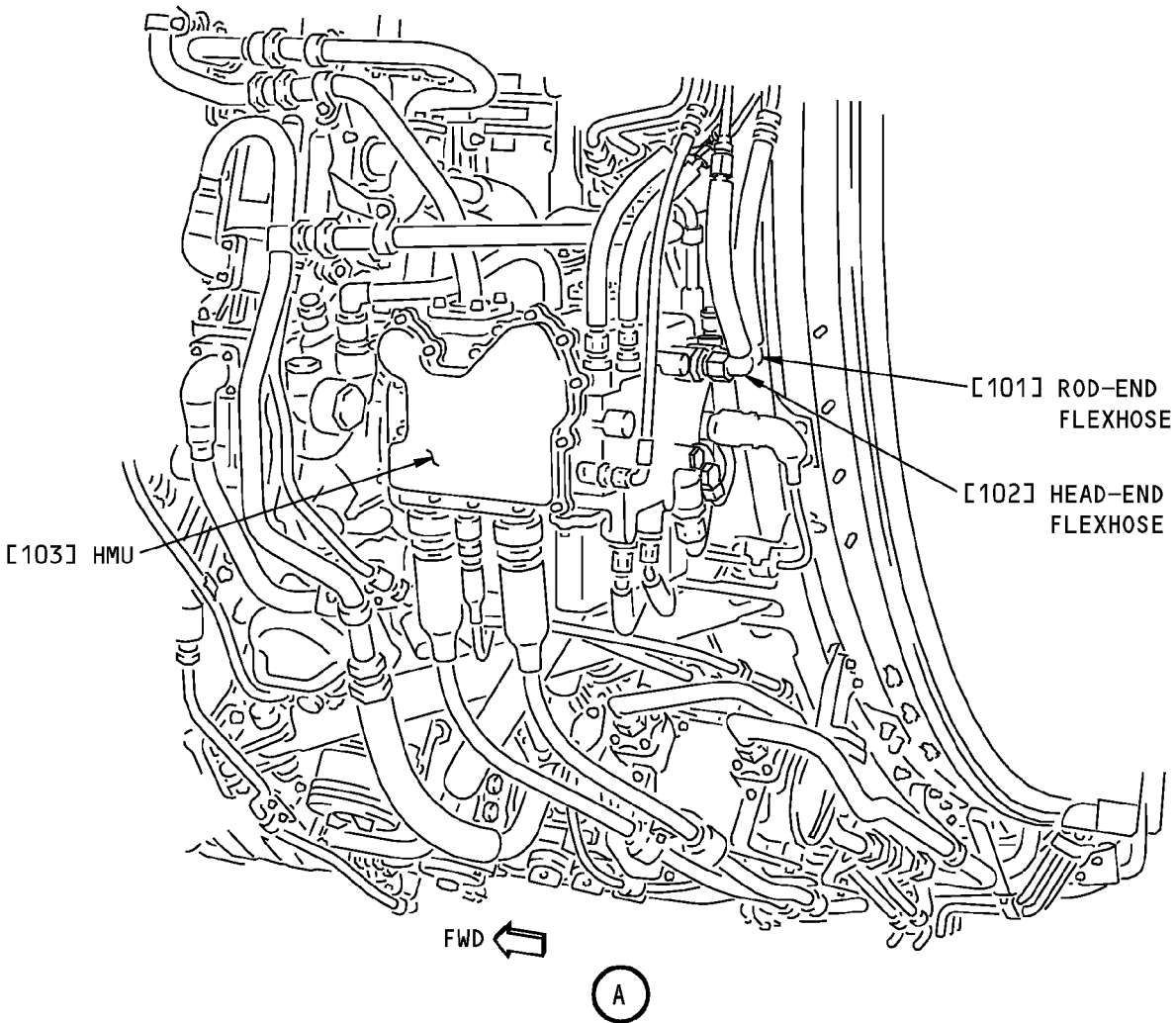
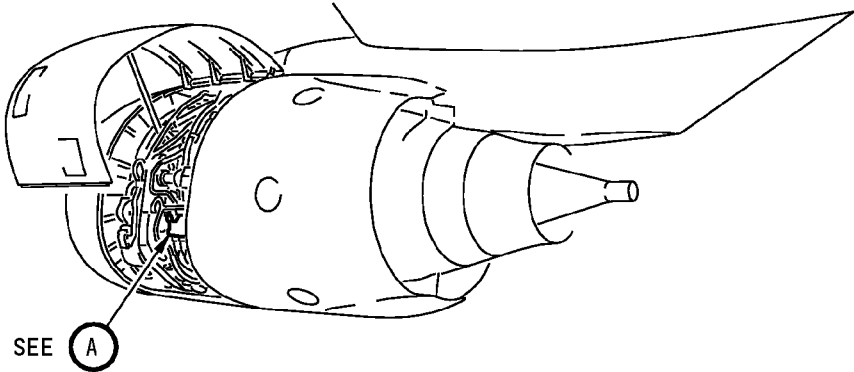

Variable Stator Vane Actuator Leak Test
Figure 403/75-31-01-990-803-F00

EFFECTIVITY
HAP ALL

75-31-01

Page 419
Oct 10/2007

D633A101-HAP

AIRCRAFT MAINTENANCE MANUAL

VARIABLE BLEED VALVE (VBV) ACTUATION SYSTEM - MAINTENANCE PRACTICES**1. General**

A. This procedure contains one task, the manual operation of the variable bleed valve actuation system.

TASK 75-32-00-730-801-F00**2. VBV Actuation System - Manual Operation**

(Figure 201)

A. General

- (1) This task is the manual operation of the variable bleed valve actuation system (referred to as the VBV actuation system).
- (2) This procedure can be used as follows:
 - (a) To manually operate the VBV actuation system to the open or closed position
 - (b) To examine the actuation system after the VBV actuator replacement
 - (c) To do fault isolation.

B. References

Reference	Title
24-22-00-860-811	Supply Electrical Power (P/B 201)
24-22-00-860-812	Remove Electrical Power (P/B 201)
71-00-00-800-811-F00	Power Plant Test Reference Table (P/B 501)
78-31-00-010-801-F00	Open the Thrust Reverser (Selection) (P/B 201)
78-31-00-010-804-F00	Close the Thrust Reverser (Selection) (P/B 201)

C. Tools/Equipment

NOTE: When more than one tool part number is listed under the same "Reference" number, the tools shown are alternates to each other within the same airplane series. Tool part numbers that are replaced or non-procurable are preceded by "Opt:", which stands for Optional.

Reference	Description
SPL-2187	Actuator - Hydraulic, Portable, VSV Stator - CFM56-7/CFM56-3 (Part #: 856A1084G04, Supplier: 58828, A/P Effectivity: 737-300, -400, -500, -600, -700, -700C, -700ER, -700QC, -800, -900, -900ER, -BBJ)
STD-1054	Container - Fuel Resistant, 5 Gallon (19 Liters)

D. Consumable Materials

Reference	Description	Specification
D00599 [CP2442]	Oil - Engine (CFMI SB 79-001)	

E. Location Zones

Zone	Area
411	Engine 1 - Engine
421	Engine 2 - Engine

F. Prepare for the VBV Actuation System - Manual Operation

SUBTASK 75-32-00-840-002-F00

- (1) Do these steps to isolate the fuel from the fuel pump:
 - (a) Do this task: Supply Electrical Power, TASK 24-22-00-860-811.
 - (b) Make sure the engine start lever is in the CUTOFF position.

EFFECTIVITY
HAP ALL

D633A101-HAP

75-32-00

Page 201
Oct 15/2008

AIRCRAFT MAINTENANCE MANUAL

- 1) Install a DO-NOT-OPERATE tag on the applicable engine start lever.
- (c) Make sure the ENG VALVE CLOSED and the SPAR VALVE CLOSED lights on the fuel control panel (P5 overhead panel) are dim.

NOTE: The lights for the fuel shutoff valves identify three positions: 1) bright when the valves are in transition or when the valves do not agree with the commanded position; or 2) dim when the valves are closed; or 3) off when the valves are opened.

- (d) Do this task: Remove Electrical Power, TASK 24-22-00-860-812.
 - 1) Set the BAT switch on the Electrical Meters Battery and Galley Power Module (P5-13) to the OFF position and install a DO-NOT-OPERATE tag.

SUBTASK 75-32-00-010-002-F00

WARNING: DO THESE SPECIFIED TASKS IN THE CORRECT SEQUENCE BEFORE YOU OPEN THE THRUST REVERSER: RETRACT THE LEADING EDGE, DO THE DEACTIVATION OF THE LEADING EDGE AND THE THRUST REVERSER (FOR GROUND MAINTENANCE), AND OPEN THE FAN COWL PANELS. IF YOU DO NOT OBEY THE ABOVE SEQUENCE, INJURIES TO PERSONS AND DAMAGE TO EQUIPMENT CAN OCCUR.

- (2) Do this task: Open the Thrust Reverser (Selection), TASK 78-31-00-010-801-F00.

G. VBV Actuation System - Manual Operation

SUBTASK 75-32-00-020-002-F00

CAUTION: USE TWO WRENCHES TO LOOSEN OR TIGHTEN THE COUPLING NUT. USE ONE TO HOLD THE FITTING, AND THE OTHER TO LOOSEN OR TIGHTEN THE COUPLING NUT. IF YOU DO NOT USE TWO WRENCHES, DAMAGE TO THE EQUIPMENT CAN OCCUR.

- (1) Obey this caution when you loosen or tighten all coupling nuts.

SUBTASK 75-32-00-020-001-F00

- (2) Do these steps to connect the supply hose [6] and the return hose [5] to the VBV hoses:
 - (a) Put a 5 gallon (19 liters) fuel resistant container, STD-1054, below the VBV OPEN hose [3] and VBV CLOSED hose [4].

WARNING: DO NOT GET FUEL IN YOUR MOUTH OR EYES, OR ON YOUR SKIN. DO NOT BREATHE THE FUMES FROM FUEL. KEEP THE FUEL AWAY FROM SPARKS, FLAME AND HEAT. FUEL IS A POISONOUS AND FLAMMABLE, WHICH CAN CAUSE INJURIES TO PERSONS AND DAMAGE TO EQUIPMENT.

- (b) Disconnect the VBV OPEN hose [3] from the PSF OPEN nipple [2].
 - 1) Let the fuel drain in the container.
- (c) Put a protective cover on the PSF OPEN nipple [2].
- (d) Disconnect the VBV CLOSED hose [4] from the PCB CLOSED nipple [1].
 - 1) Let the fuel drain in the container.
- (e) Put a protective cover on the PCB CLOSED nipple [1].
- (f) Connect the supply hose [6] from the actuator, SPL-2187, to the VBV OPEN hose [3].
- (g) Connect the return hose [5] from the actuator, SPL-2187, to the VBV CLOSED hose [4].

EFFECTIVITY
HAP ALL

D633A101-HAP

75-32-00

Page 202
Oct 15/2008

AIRCRAFT MAINTENANCE MANUAL

SUBTASK 75-32-00-860-002-F00

CAUTION: DO NOT APPLY MORE THAN 150 PSI (1000 KPA) TO THE SYSTEM. IF YOU APPLY TOO MUCH PRESSURE, DAMAGE TO THE SYSTEM CAN OCCUR.

(3) Operate the VBV system to the full-closed position as follows:

NOTE: A retracted actuator rod is the full-closed position.

- (a) Set the pressure to 0 psi.
- (b) Apply and hold a pressure of 30-60 psi (200-400 kPa) to the VBV CLOSED hose [4].

NOTE: When the VBV system closes, movement must be smooth, and does not bind or jump. The VBV system must start to close at 30 psi (200 kPa) and must continue until it gets to the stop position. An indication the system is at the stop position is a rapid increase in gage pressure. If the VBV system does not move, examine the VBV actuators for leakage.

- (c) Set the pressure to 0 psi.

SUBTASK 75-32-00-860-003-F00

(4) Operate the VBV system to the full-open position as follows:

NOTE: An extended actuator rod is the full-open position.

- (a) Apply and hold a pressure of 30-60 psi (200-400 kPa) to the VBV OPEN hose [3].

NOTE: When the VBV system opens, movement must be smooth, and does not bind or jump. The VBV system must start to open at 30 psi (200 kPa) and must continue until it gets to the stop position. An indication the system is at the stop position is a rapid increase in gage pressure. If the VBV system does not move, examine the VBV actuators for leakage.

- (b) Set the pressure to 0 psi.

SUBTASK 75-32-00-420-001-F00

(5) Do these steps to disconnect the VBV hoses from the supply hose [6] and return hose [5]:

- (a) Release the hydraulic pressure.
- (b) Disconnect the supply hose [6] from the VBV OPEN hose [3].
- (c) Remove the protective cover from the PSF OPEN nipple [2].
- (d) Disconnect the return hose [5] from the VBV CLOSED hose [4].
- (e) Remove the protective cover from the PCB CLOSED nipple [1].
- (f) Lubricate the threads of the PSF OPEN nipple [2] with oil, D00599 [CP2442].
- (g) Lubricate the threads of the PCB CLOSED nipple [1] with oil, D00599 [CP2442].
- (h) Connect the VBV OPEN hose [3] to the PSF OPEN nipple [2].
 - 1) Tighten the coupling nut on the VBV OPEN hose to 450-550 pound-inches (50-60 Newton meters).
- (i) Connect the VBV CLOSED hose [4] to the PCB CLOSED nipple [1].
 - 1) Tighten the coupling nut on the VBV CLOSED hose to 270-300 pound-inches (30-35 Newton meters).

EFFECTIVITY
HAP ALL

D633A101-HAP

75-32-00

Page 203
Jun 10/2005

AIRCRAFT MAINTENANCE MANUAL

H. Put the Airplane Back to Its Usual Condition

SUBTASK 75-32-00-410-002-F00

WARNING: OBEY THE INSTRUCTIONS IN THE PROCEDURE TO CLOSE THE THRUST REVERSERS. IF YOU DO NOT OBEY THE INSTRUCTIONS, INJURIES TO PERSONS AND DAMAGE TO EQUIPMENT CAN OCCUR.

(1) Do this task: Close the Thrust Reverser (Selection), TASK 78-31-00-010-804-F00.

SUBTASK 75-32-00-860-007-F00

(2) Remove the DO-NOT-OPERATE tags from the start lever.

SUBTASK 75-32-00-860-014-F00

(3) Remove the DO-NOT-OPERATE tag from the BAT switch.

I. VBV Actuation System Installation Test

SUBTASK 75-32-00-800-001-F00

(1) Do the test listed in the Power Plant Test Reference Table (TASK 71-00-00-800-811-F00).

————— **END OF TASK** —————

EFFECTIVITY
HAP ALL

D633A101-HAP

75-32-00

Page 204
Jun 10/2004

737-600/700/800/900
AIRCRAFT MAINTENANCE MANUAL

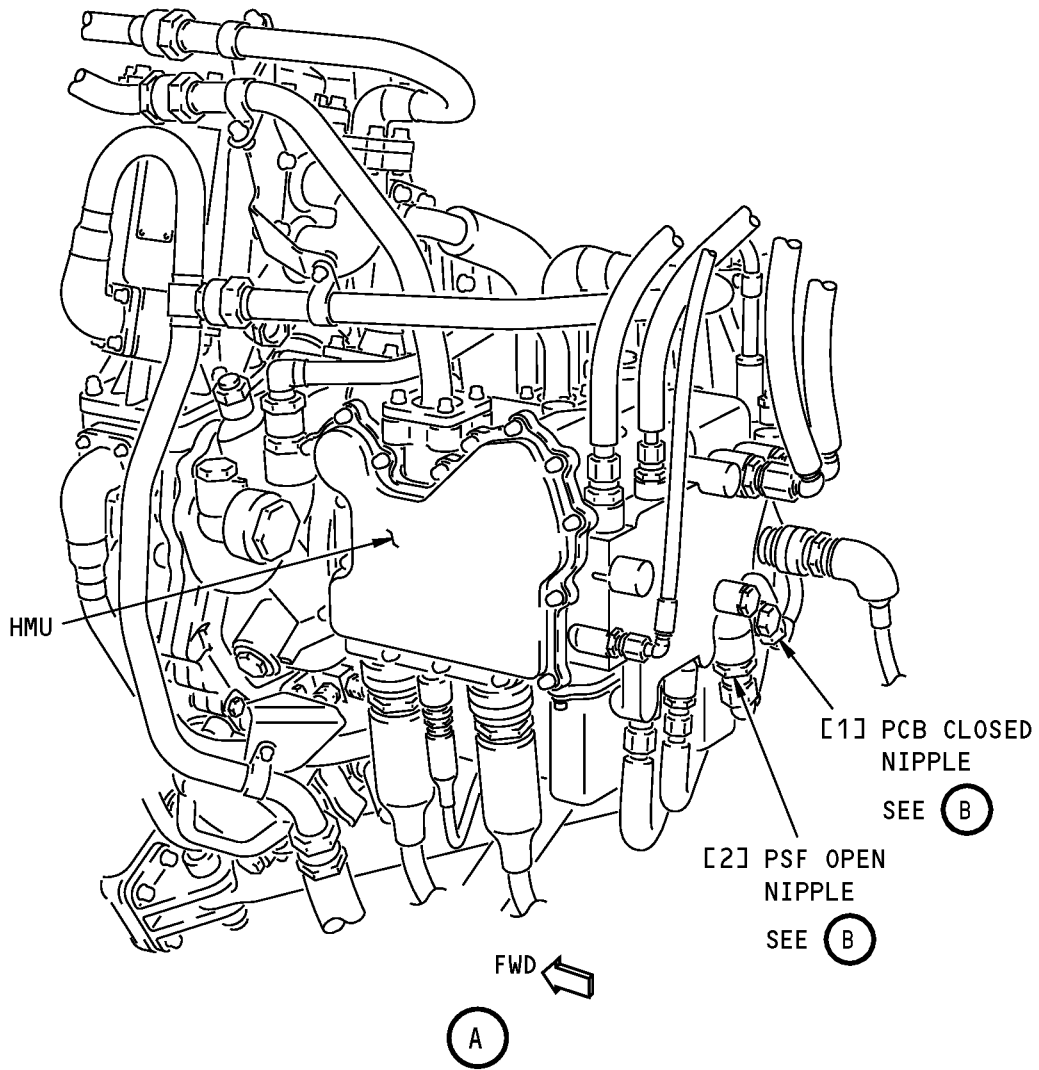
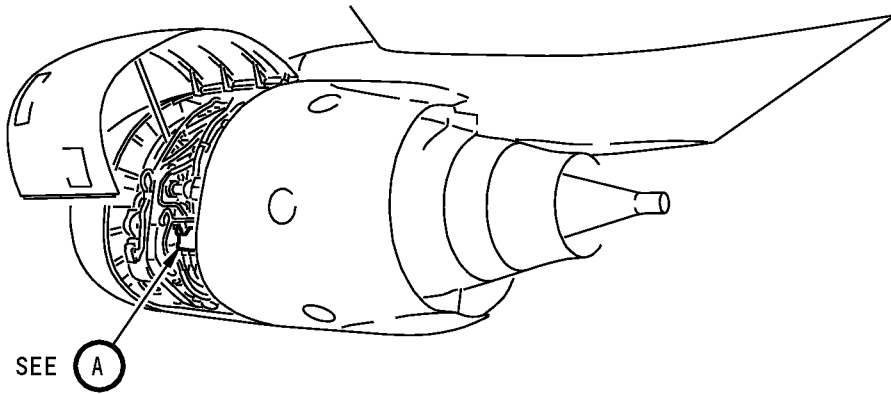

VBV Actuation System - Manual Operation
Figure 201 (Sheet 1 of 2)/75-32-00-990-801-F00

EFFECTIVITY
HAP ALL

75-32-00

Page 205
Oct 10/2003

D633A101-HAP

737-600/700/800/900
AIRCRAFT MAINTENANCE MANUAL

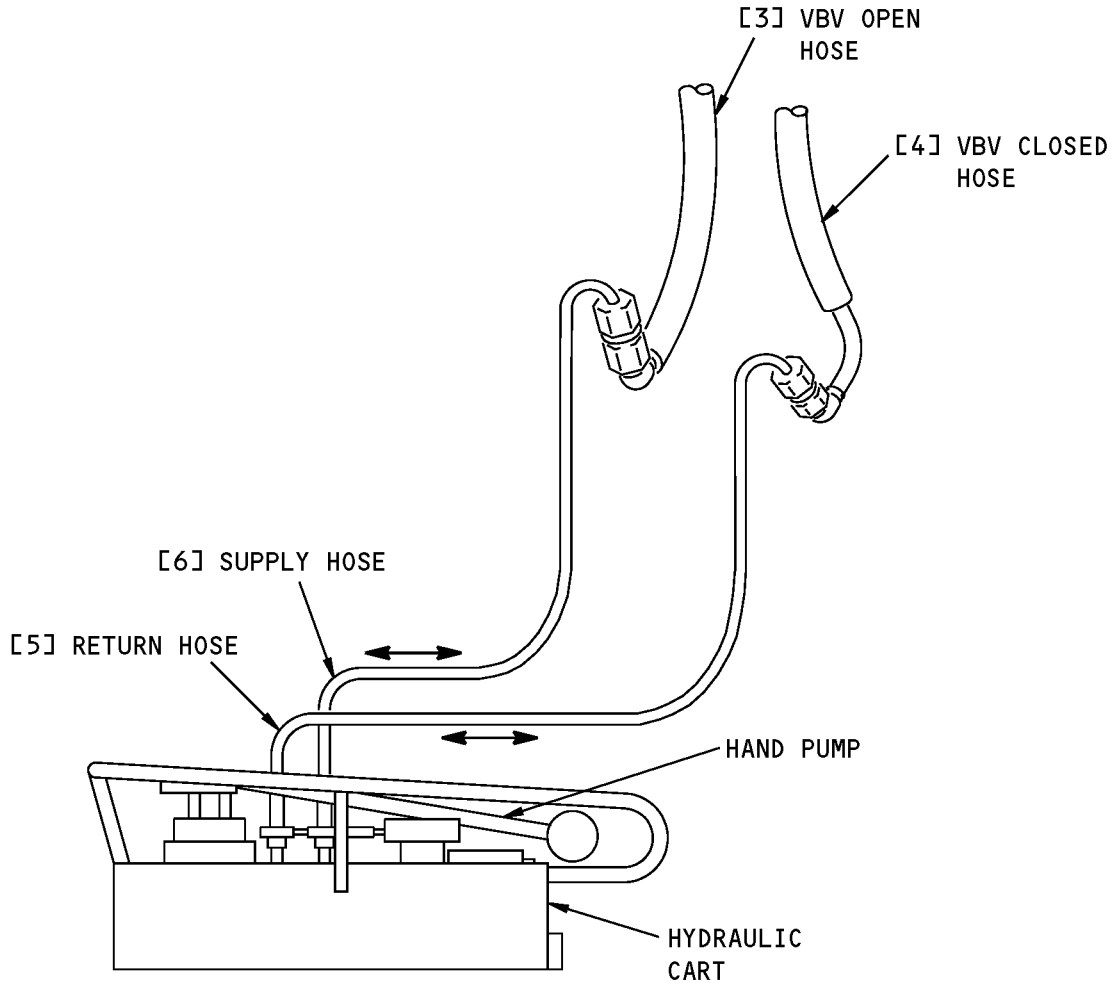

VBV Actuation System - Manual Operation
Figure 201 (Sheet 2 of 2)/75-32-00-990-801-F00

EFFECTIVITY
HAP ALL

D633A101-HAP

75-32-00

AIRCRAFT MAINTENANCE MANUAL

VARIABLE BLEED VALVE (VBV) ACTUATION SYSTEM - ADJUSTMENT/TEST**1. General**

A. This procedure has two tasks:

- (1) The adjustment of the unison ring-operated variable bleed valve door.
- (2) The adjustment of the actuator-operated variable bleed valve door.

TASK 75-32-00-700-802-F00**2. Unison Ring-Operated Variable Bleed Valve (VBV) Door - Adjustment**

(Figure 501)

A. General

- (1) This task is the adjustment procedure for the unison ring-operated variable bleed valve door (referred to as the VBV door).
- (2) If the lockwire was not removed and if you think the VBV system was not mis-adjusted, it is not necessary to do this task.

NOTE: The VBV door must be removed to adjust the VBV door turnbuckle.

B. References

Reference	Title
75-32-00-730-801-F00	VBV Actuation System - Manual Operation (P/B 201)
75-32-03-000-801-F00	Unison Ring-Operated VBV Door Removal (P/B 401)
75-32-03-400-801-F00	Unison Ring-Operated VBV Door Installation (P/B 401)

C. Tools/Equipment

NOTE: When more than one tool part number is listed under the same "Reference" number, the tools shown are alternates to each other within the same airplane series. Tool part numbers that are replaced or non-procurable are preceded by "Opt:", which stands for Optional.

Reference	Description
COM-2405	Fixture - Adjustment, VBV Door (Opt Part #: 856A3781G01, Supplier: 58828, A/P Effectivity: 737-600, -700, -700C, -700ER, -700QC, -800, -900, -900ER, -BBJ)

D. Consumable Materials

Reference	Description	Specification
G02345 [CP8001]	Lockwire - Inconel (0.032 inch Dia.)	NASM20995~ N32
G50065 [CP8006]	Cable, Safety, Stainless Steel, 0.8mm (0.032inch) Diameter	

E. Location Zones

Zone	Area
411	Engine 1 - Engine
421	Engine 2 - Engine

F. VBV Door Adjustment

SUBTASK 75-32-00-020-003-F00

- (1) If not done already, remove the applicable VBV door to adjust the turnbuckle; do this task: Unison Ring-Operated VBV Door Removal, TASK 75-32-03-000-801-F00.

EFFECTIVITY
HAP ALL

75-32-00

Page 501
Feb 15/2009

D633A101-HAP

AIRCRAFT MAINTENANCE MANUAL

SUBTASK 75-32-00-860-008-F00

WARNING: DO NOT OPERATE THE VBV SYSTEM WHILE YOU HAVE YOUR HANDS ON IT. IF YOU OPERATE THE VBV SYSTEM WHILE YOU HAVE YOUR HANDS ON IT, INJURIES TO PERSONS CAN OCCUR.

(2) Operate the VBV system to the full-closed position, do this task: VBV Actuation System - Manual Operation, TASK 75-32-00-730-801-F00.

(a) Release the pressure to 0 psi.

SUBTASK 75-32-00-480-001-F00

CAUTION: DO NOT OPERATE THE VBV SYSTEM WITH THE TOOL INSTALLED ON THE TURNBUCKLE. IF YOU OPERATE THE VBV SYSTEM WITH THE TOOL INSTALLED ON THE TURNBUCKLE, DAMAGE TO THE VBV SYSTEM, FAN FRAME AND TOOL CAN OCCUR.

(3) Do these steps to install the VBV door adjustment tool (Figure 501):

NOTE: The VBV door adjustment tool consists of these captive items, checking pin, tool lever, tool lever yoke, and safety cable.

(a) Install the fixture, COM-2405 (preferred) or fixture, COM-2405 (alternate), on the fan frame at the location of the VBV door.

NOTE: For USA tool suppliers, you can use fixture, COM-2405 (preferred) or fixture, COM-2405 (alternate).

- 1) Put the safety cable around the fan frame strut.
- 2) Tighten the two captive bolts [1] with your hand.

(b) Make sure that the tool lever end touches the inner wall of the fan frame in the air flow path.

(c) Make sure that the rod-end bearing correctly engages in the tool lever yoke.

CAUTION: WHEN YOU DO A CHECK OF THE ADJUSTMENT, MAKE SURE THAT THE INNER PART OF THE TOOL LEVER TOUCHES THE INNER WALL OF THE FAN FRAME. IF THE TOOL LEVER DOES NOT TOUCH THE INNER WALL OF THE FAN FRAME, THE VBV SYSTEM CAN BE ADJUSTED CLOSED TOO MUCH AND ENGINE DAMAGE CAN OCCUR.

(d) Keep and firmly maintain the tool lever in its position.

(e) Use the checking pin to make sure that the rod-end bearing aligns correctly with the tool lever yoke.

SUBTASK 75-32-00-820-001-F00

(4) Do these steps to adjust the rod-end bearing, if rod-end bearing does not correctly align with the tool lever yoke:

CAUTION: BE CAREFUL WHEN YOU REMOVE OR INSTALL PARTS THAT ARE AROUND AN OPEN VBV DOOR. PARTS THAT FALL INTO AN OPEN VBV DOOR CAN FALL IN THE HIGH PRESSURE COMPRESSOR OF THE ENGINE. PARTS WHICH FALL INTO THE ENGINE CAN CAUSE SERIOUS ENGINE DAMAGE AT THE FIRST ENGINE OPERATION.

(a) If installed, remove the jamnut lockwire.

(b) Loosen the jamnut.

(c) Pull the locking washer backward.

(d) Pull and remove the tool lever yoke from the rod-end bearing.

EFFECTIVITY
HAP ALL

75-32-00

Page 502
Feb 15/2009

D633A101-HAP

AIRCRAFT MAINTENANCE MANUAL

- (e) Turn the rod-end bearing clockwise or counterclockwise to get the correct alignment.

SUBTASK 75-32-00-820-002-F00

- (5) Do these steps again to make sure that rod-end bearing is correctly aligned with the tool lever yoke:
- Make sure that the tool lever end touches the inner wall of the fan frame in the air flow path.
 - Make sure that the rod-end bearing correctly engages in the tool lever yoke.

CAUTION: WHEN YOU DO A CHECK OF THE ADJUSTMENT, MAKE SURE THAT THE INNER PART OF THE TOOL LEVER TOUCHES THE INNER WALL OF THE FAN FRAME. IF THE TOOL LEVER DOES NOT TOUCH THE INNER WALL OF THE FAN FRAME, THE VBV SYSTEM CAN BE ADJUSTED CLOSED TOO MUCH AND ENGINE DAMAGE CAN OCCUR.

- Keep and firmly maintain the tool lever in its position.
- Use the checking pin to make sure that the pin keeps the rod-end bearing aligned correctly with the tool lever yoke.

SUBTASK 75-32-00-820-003-F00

- (6) Repeat the adjustment and check steps until the alignment is correct.

SUBTASK 75-32-00-860-009-F00

- (7) Do these steps to keep the rod-end bearing in position:
- When correctly adjusted, loosen the rod-end bearing by 1/2 turn.
 - Push the locking washer forward.
 - Tighten the jamnut by hand.
 - Make sure that the rod-end bearing stays in the adjusted position.
 - Remove the fixture, COM-2405 (preferred) or fixture, COM-2405 (alternate).

SUBTASK 75-32-00-860-010-F00

WARNING: DO NOT OPERATE THE VBV SYSTEM WHILE YOU HAVE YOUR HANDS ON IT. IF YOU OPERATE THE VBV SYSTEM WHILE YOU HAVE YOUR HANDS ON IT, INJURIES TO PERSONS CAN OCCUR.

- (8) Operate the VBV system to the full-open position, do this task: VBV Actuation System - Manual Operation, TASK 75-32-00-730-801-F00.
- Release the pressure to 0 psi.

SUBTASK 75-32-00-420-002-F00

- (9) Do this task: Unison Ring-Operated VBV Door Installation, TASK 75-32-03-400-801-F00.
- Install the lockwire, G02345 [CP8001] or cable, G50065 [CP8006] between the turnbuckle and the jamnut.

————— END OF TASK —————

EFFECTIVITY
HAP ALL

D633A101-HAP

75-32-00

Page 503
Feb 15/2009

**737-600/700/800/900
AIRCRAFT MAINTENANCE MANUAL**

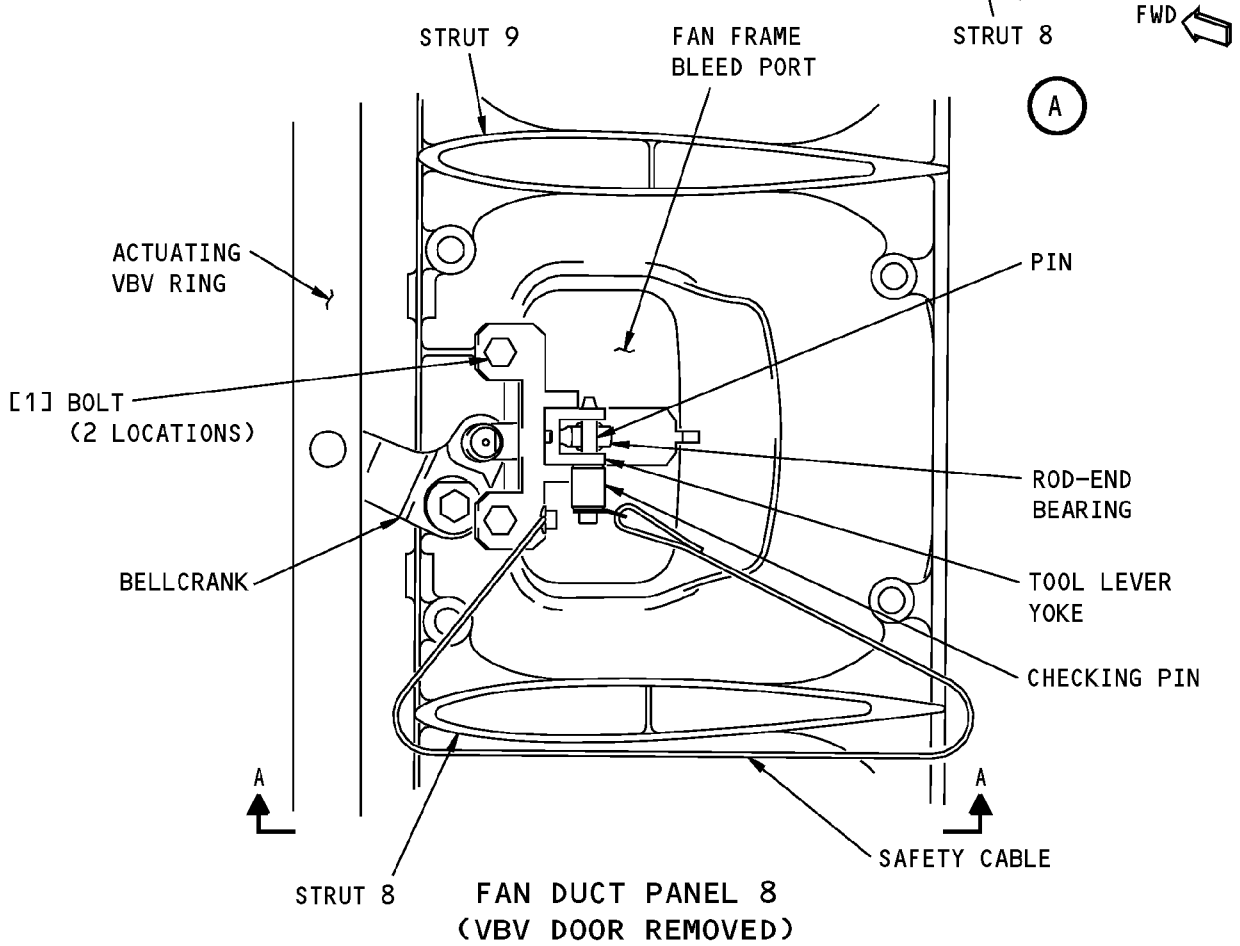
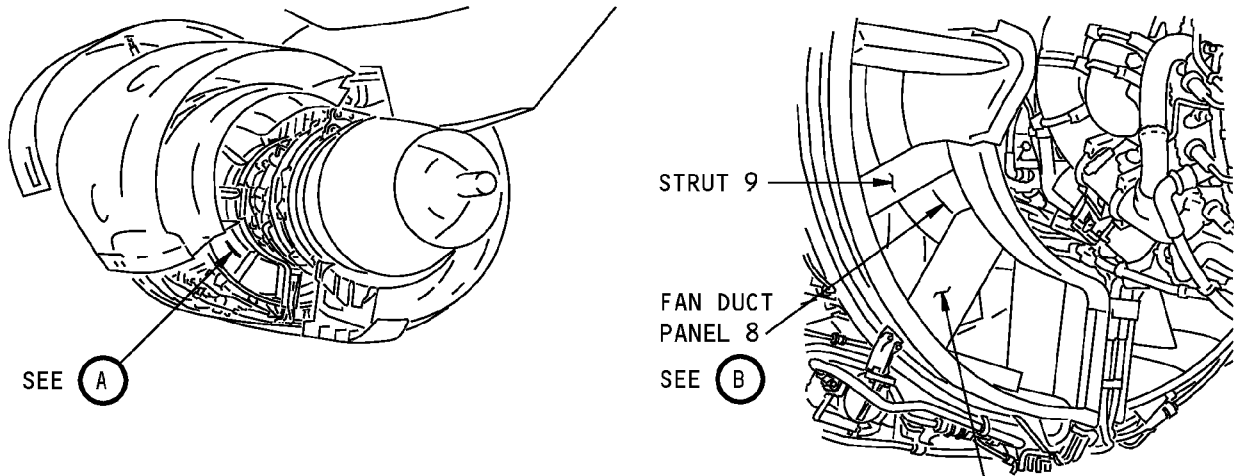

NOTE: VIEW OF UNISON RING-OPERATED VBV DOOR.

(B)

S-M56-MM-03927-00-B

**VBV Actuation System - Adjustment/Test
Figure 501 (Sheet 1 of 2)/75-32-00-990-802-F00**

EFFECTIVITY
HAP ALL

75-32-00

Page 504
Oct 10/2003

D633A101-HAP

737-600/700/800/900
AIRCRAFT MAINTENANCE MANUAL

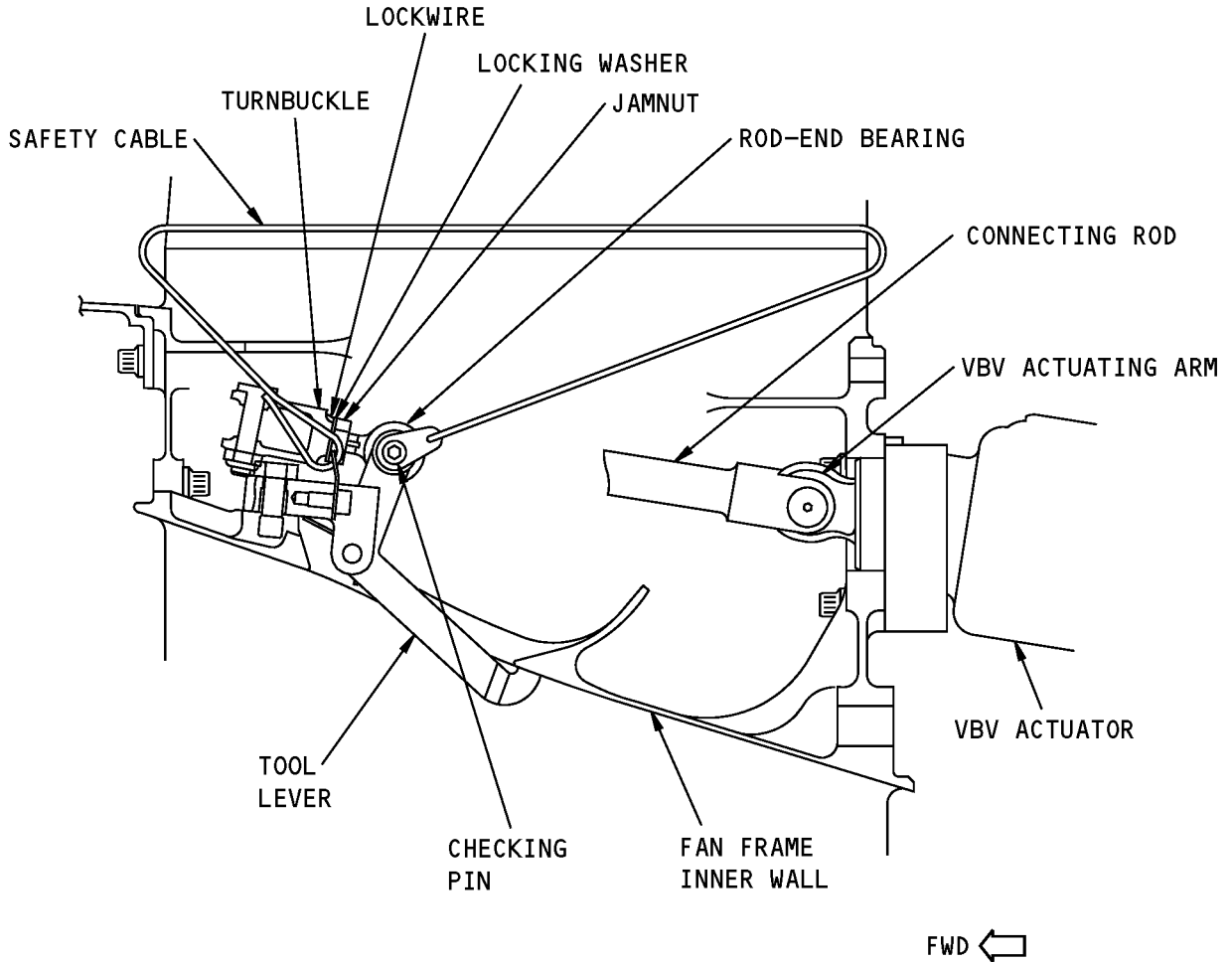

(VBV DOOR REMOVED)
A-A

NOTE: VIEW OF ACTUATOR-OPERATED
VBV DOOR.

S-M56-MM-03926-00-B

VBV Actuation System - Adjustment/Test
Figure 501 (Sheet 2 of 2)/75-32-00-990-802-F00

EFFECTIVITY
HAP ALL

75-32-00

Page 505
Oct 10/2003

D633A101-HAP

AIRCRAFT MAINTENANCE MANUAL

TASK 75-32-00-710-801-F00

3. Actuator-Operated Variable Bleed Valve (VBV) Door - Adjustment

(Figure 501)

A. General

- (1) This task is the adjustment procedure for the actuator-operated variable bleed valve door (referred to as the VBV door).
- (2) If the lockwire was not removed and if you think the VBV system was not mis-adjusted, it is not necessary to do this task.

NOTE: The VBV door must be removed to adjust the VBV door turnbuckle.

B. References

Reference	Title
75-32-00-730-801-F00	VBV Actuation System - Manual Operation (P/B 201)
75-32-03-000-802-F00	Actuator-Operated VBV Door Removal (P/B 401)
75-32-03-400-802-F00	Actuator-Operated VBV Door Installation (P/B 401)

C. Tools/Equipment

NOTE: When more than one tool part number is listed under the same "Reference" number, the tools shown are alternates to each other within the same airplane series. Tool part numbers that are replaced or non-procurable are preceded by "Opt:", which stands for Optional.

Reference	Description
COM-2405	Fixture - Adjustment, VBV Door (Opt Part #: 856A3781G01, Supplier: 58828, A/P Effectivity: 737-600, -700, -700C, -700ER, -700QC, -800, -900, -900ER, -BBJ)

D. Consumable Materials

Reference	Description	Specification
G02345 [CP8001]	Lockwire - Inconel (0.032 inch Dia.)	NASM20995~ N32
G50065 [CP8006]	Cable, Safety, Stainless Steel, 0.8mm (0.032inch) Diameter	

E. Location Zones

Zone	Area
411	Engine 1 - Engine
421	Engine 2 - Engine

F. VBV Door Adjustment

SUBTASK 75-32-00-020-004-F00

- (1) Do these steps to prepare for the actuation of the VBV door:
 - (a) If not done already, do this task: Actuator-Operated VBV Door Removal, TASK 75-32-03-000-802-F00.
 - (b) Re-install the connecting rod to the VBV actuator arm.
 - (c) Re-install the bellcrank to the actuating VBV ring with the bolt.

WARNING: DO NOT OPERATE THE VBV SYSTEM WHILE YOU HAVE YOUR HANDS ON IT. IF YOU OPERATE THE VBV SYSTEM WHILE YOU HAVE YOUR HANDS ON IT, INJURIES TO PERSONS CAN OCCUR.

EFFECTIVITY
HAP ALL

D633A101-HAP

75-32-00

Page 506
Feb 15/2009

AIRCRAFT MAINTENANCE MANUAL

(WARNING PRECEDES)

CAUTION: DO NOT OPERATE THE VBV SYSTEM IF ALL THE PARTS BETWEEN THE ACTUATORS AND THE UNISON RING ARE NOT INSTALLED. IF ALL THE PARTS BETWEEN THE ACTUATORS AND THE UNISON RING ARE NOT INSTALLED, DAMAGE TO THE VBV SYSTEM CAN OCCUR.

- (d) Make sure that all the parts from the VBV actuator to the actuating VBV ring are installed and tight.

SUBTASK 75-32-00-860-011-F00

- (2) Operate the VBV system to the full-closed position, do this task: VBV Actuation System - Manual Operation, TASK 75-32-00-730-801-F00.

- (a) Release the pressure to 0 psi.

SUBTASK 75-32-00-480-002-F00

- (3) Do these steps to install the VBV door adjustment tool (Figure 501):

CAUTION: DO NOT OPERATE THE VBV SYSTEM WITH THE TOOL INSTALLED ON THE TURNBUCKLE. IF YOU OPERATE THE VBV SYSTEM WITH THE TOOL INSTALLED ON THE TURNBUCKLE, DAMAGE TO THE VBV SYSTEM, FAN FRAME AND TOOL CAN OCCUR.

- (a) Install the fixture, COM-2405 (preferred) or fixture, COM-2405 (alternate), on the fan frame at the location of the VBV door.

NOTE: For USA tool suppliers, you can use fixture, COM-2405 (preferred) or fixture, COM-2405 (alternate).

- 1) Put the safety cable around the fan frame strut.
- 2) Tighten the two captive bolts [1] with your hand.

- (b) Make sure that the tool lever end touches the inner wall of the fan frame in the air flow path.
 (c) Make sure that the rod-end bearing correctly engages in the tool lever yoke.

CAUTION: WHEN YOU DO A CHECK OF THE ADJUSTMENT, MAKE SURE THAT THE INNER PART OF THE TOOL LEVER TOUCHES THE INNER WALL OF THE FAN FRAME. IF THE TOOL LEVER DOES NOT TOUCH THE INNER WALL OF THE FAN FRAME, THE VBV SYSTEM CAN BE ADJUSTED CLOSED TOO MUCH AND ENGINE DAMAGE CAN OCCUR.

- (d) Keep and firmly maintain lever in its position.
 (e) Use the checking pin to make sure that the rod-end bearing aligns correctly with the tool lever yoke.

SUBTASK 75-32-00-820-004-F00

CAUTION: BE CAREFUL WHEN YOU REMOVE OR INSTALL PARTS THAT ARE AROUND AN OPEN VBV DOOR. PARTS THAT FALL INTO AN OPEN VBV DOOR CAN FALL IN THE HIGH PRESSURE COMPRESSOR OF THE ENGINE. PARTS WHICH FALL INTO THE ENGINE CAN CAUSE SERIOUS ENGINE DAMAGE AT THE FIRST ENGINE OPERATION.

- (4) Do these steps to adjust the rod-end bearing, if rod-end bearing does not correctly align with the tool lever yoke:
- (a) If installed, remove the jamnut lockwire.
 - (b) Loosen the jamnut.
 - (c) Pull the locking washer backward.

EFFECTIVITY
 HAP ALL

75-32-00

Page 507
 Feb 15/2009

D633A101-HAP

AIRCRAFT MAINTENANCE MANUAL

- (d) Pull and remove the tool lever yoke from the rod-end bearing.
- (e) Turn the rod-end bearing clockwise or counterclockwise to get the correct the alignment.

SUBTASK 75-32-00-820-005-F00

- (5) Do these steps again to make sure that rod-end bearing is correctly aligned with the tool lever yoke:
 - (a) Make sure that the tool lever end touches the inner wall of the fan frame in the air flow path.
 - (b) Make sure that the rod-end bearing correctly engages in the tool lever yoke.

CAUTION: WHEN YOU DO A CHECK OF THE ADJUSTMENT, MAKE SURE THAT THE INNER PART OF THE TOOL LEVER TOUCHES THE INNER WALL OF THE FAN FRAME. IF THE TOOL LEVER DOES NOT TOUCH THE INNER WALL OF THE FAN FRAME, THE VBV SYSTEM CAN BE ADJUSTED CLOSED TOO MUCH AND ENGINE DAMAGE CAN OCCUR.

- (c) Keep and firmly maintain the tool lever in its position.
- (d) Use the checking pin to make sure that the pin keeps the rod-end bearing aligned correctly with the tool lever yoke.

SUBTASK 75-32-00-820-006-F00

- (6) Repeat the adjustment and check steps until the alignment is correct.

SUBTASK 75-32-00-860-012-F00

- (7) Do these steps to keep the rod-end bearing in its position:
 - (a) When correctly adjusted, loosen the rod-end bearing by 1/2 turn.
 - (b) Push the locking washer forward.
 - (c) Tighten the jamnut by hand.
 - (d) Make sure that the rod-end bearing stays in the adjusted position.
 - (e) Remove the fixture, COM-2405 (preferred) or fixture, COM-2405 (alternate).

SUBTASK 75-32-00-860-013-F00

WARNING: DO NOT OPERATE THE VBV SYSTEM WHILE YOU HAVE YOUR HANDS ON IT. IF YOU OPERATE THE VBV SYSTEM WHILE YOU HAVE YOUR HANDS ON IT, INJURIES TO PERSONS CAN OCCUR.

- (8) Operate the VBV system to the full-open position, do this task: VBV Actuation System - Manual Operation, TASK 75-32-00-730-801-F00.
 - (a) Release the pressure to 0 psi.

SUBTASK 75-32-00-420-003-F00

- (9) Do these steps to install the VBV door:
 - (a) Disconnect the connecting rod from the VBV actuator arm.
 - (b) Remove the bolt to disconnect the bellcrank from the actuating VBV ring with the bolt.
 - (c) Do this task: Actuator-Operated VBV Door Installation, TASK 75-32-03-400-802-F00.
 - 1) Install the lockwire, G02345 [CP8001] or cable, G50065 [CP8006] between the turnbuckle and jamnut.

————— END OF TASK —————

EFFECTIVITY
HAP ALL

D633A101-HAP

75-32-00

Page 508
Feb 15/2009

AIRCRAFT MAINTENANCE MANUAL

VARIABLE BLEED VALVE (VBV) ACTUATION SYSTEM - INSPECTION/CHECK**1. General**

- A. This procedure contains scheduled maintenance task data.
- B. This procedure has these tasks: .
 - (1) The inspection of the VBV Ring Guide Pads
 - (2) The inspection of the VBV System.

TASK 75-32-00-200-801-F00**2. VBV Ring Guide Pads Inspection**

A. General

- (1) This task contains the instructions for a visual examination of the four VBV Ring Guide Pads.
- (2) The inspection makes sure that the pads are not missing or loose.

B. References

Reference	Title
72-23-07-000-801-F00	Fan Duct Panel Removal (P/B 401)
72-23-07-400-801-F00	Fan Duct Panel Installation (P/B 401)

C. Location Zones

Zone	Area
411	Engine 1 - Engine
421	Engine 2 - Engine

D. Prepare for the Inspection

(Figure 601)

SUBTASK 75-32-00-840-003-F00

- (1) Remove the Fan Duct Panels 2, 3, 8, and 9 to get access to the VBV Ring Guide Pads.

NOTE: Panels 2 and 3 are located between struts 2 to 4. Panels 8 and 9 are located between struts 8 to 10.

- (a) Do this task: Fan Duct Panel Removal, TASK 72-23-07-000-801-F00.

E. VBV Ring Guide Pads Inspection

SUBTASK 75-32-00-210-001-F00

- (1) Visually examine the VBV Ring Guide Pads (pads) to look for missing or loose pads.

NOTE: There are two pads on each actuator that are located 120 degrees apart.

- (a) Any amount of missing pad is serviceable until the next shop visit, if there is no other damage to the VBV system.
- (b) If you find a pad that is loose, totally or partially disbonded, then remove it from the engine.
- (c) If you find pads that are totally or partially missing, then do these steps:
 - 1) Remove all of the Fan Duct Panels. To remove them, do this task: Fan Duct Panel Removal, TASK 72-23-07-000-801-F00.
 - 2) Remove the pads, or pieces of pads from the engine.

EFFECTIVITY
HAP ALL

D633A101-HAP

75-32-00

Page 601
Feb 15/2009

AIRCRAFT MAINTENANCE MANUAL

F. Put the Airplane Back to the Usual Condition

SUBTASK 75-32-00-840-004-F00

(1) Do this task: Fan Duct Panel Installation, TASK 72-23-07-400-801-F00.

————— **END OF TASK** —————

EFFECTIVITY
HAP ALL

D633A101-HAP

75-32-00

Page 602
Feb 15/2009

AIRCRAFT MAINTENANCE MANUAL

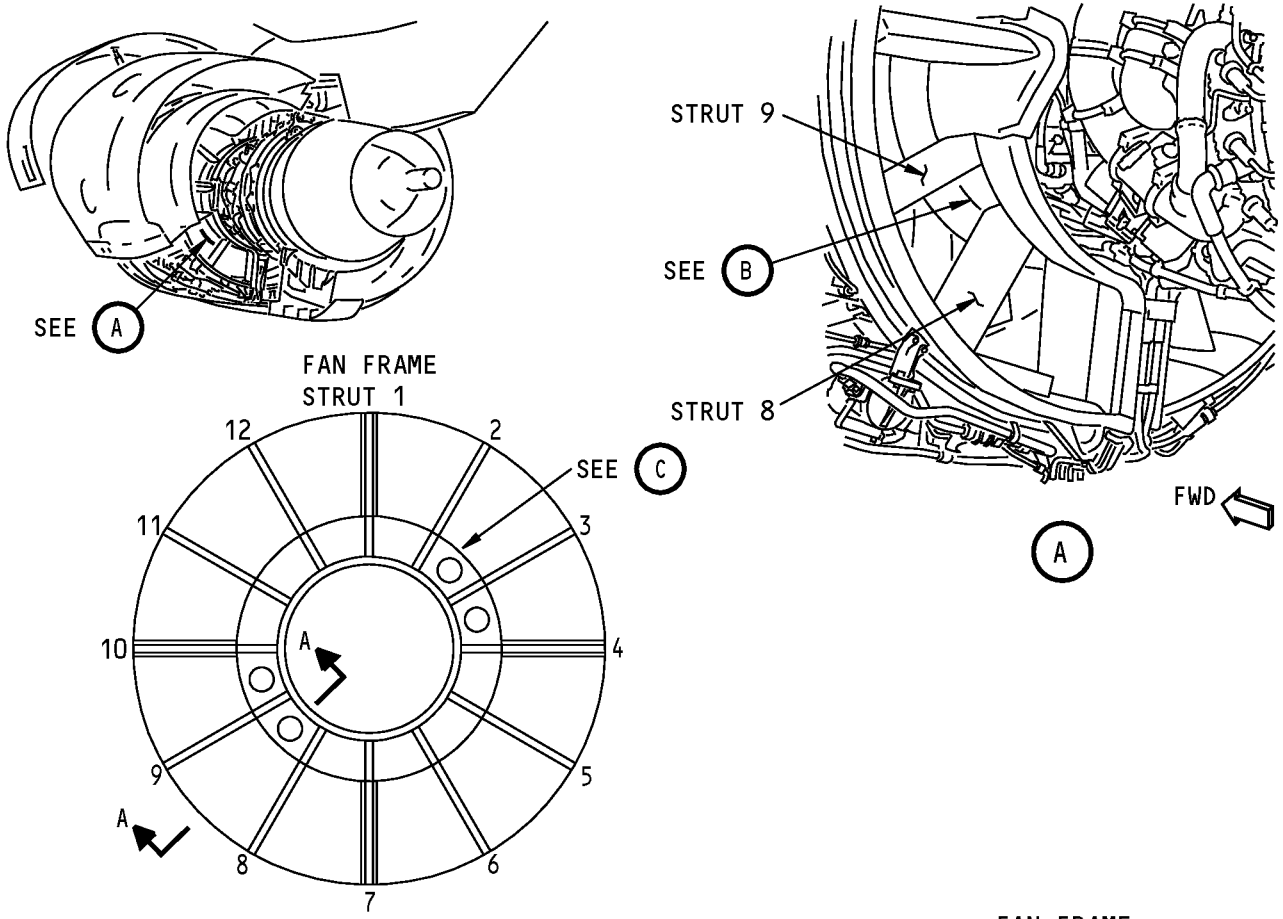

(VIEW IN THE FORWARD DIRECTION)

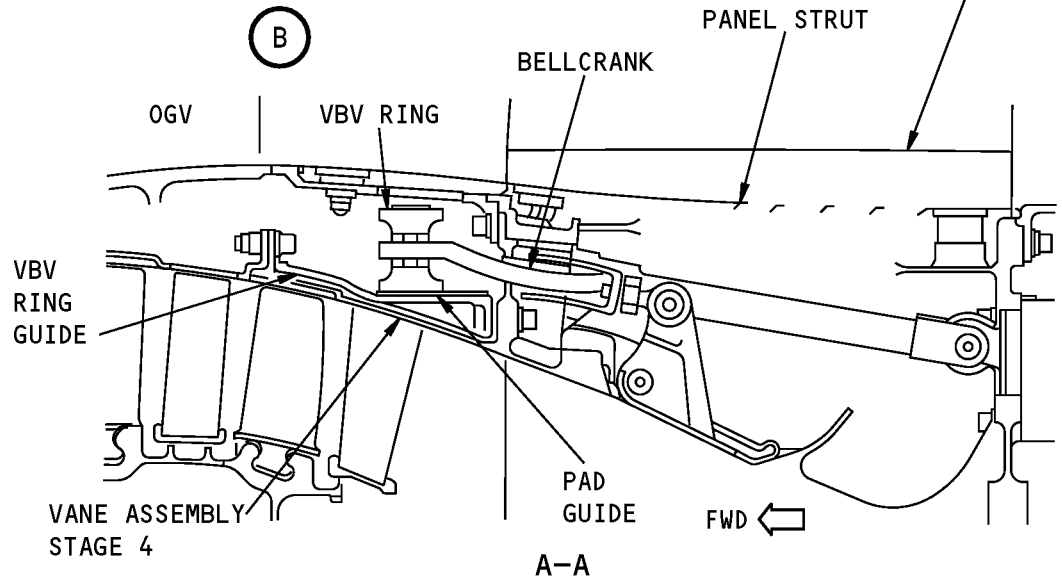

VBV Actuation System Guide Pads
Figure 601 (Sheet 1 of 2)/75-32-00-990-803-F00

EFFECTIVITY
HAP ALL

75-32-00

737-600/700/800/900
AIRCRAFT MAINTENANCE MANUAL

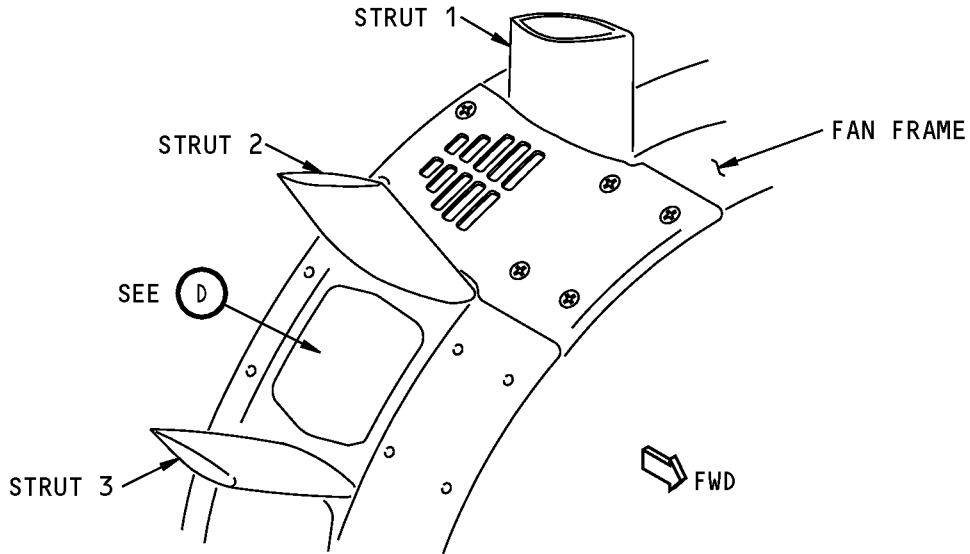

(PANEL STRUT REMOVED FOR CLARITY)

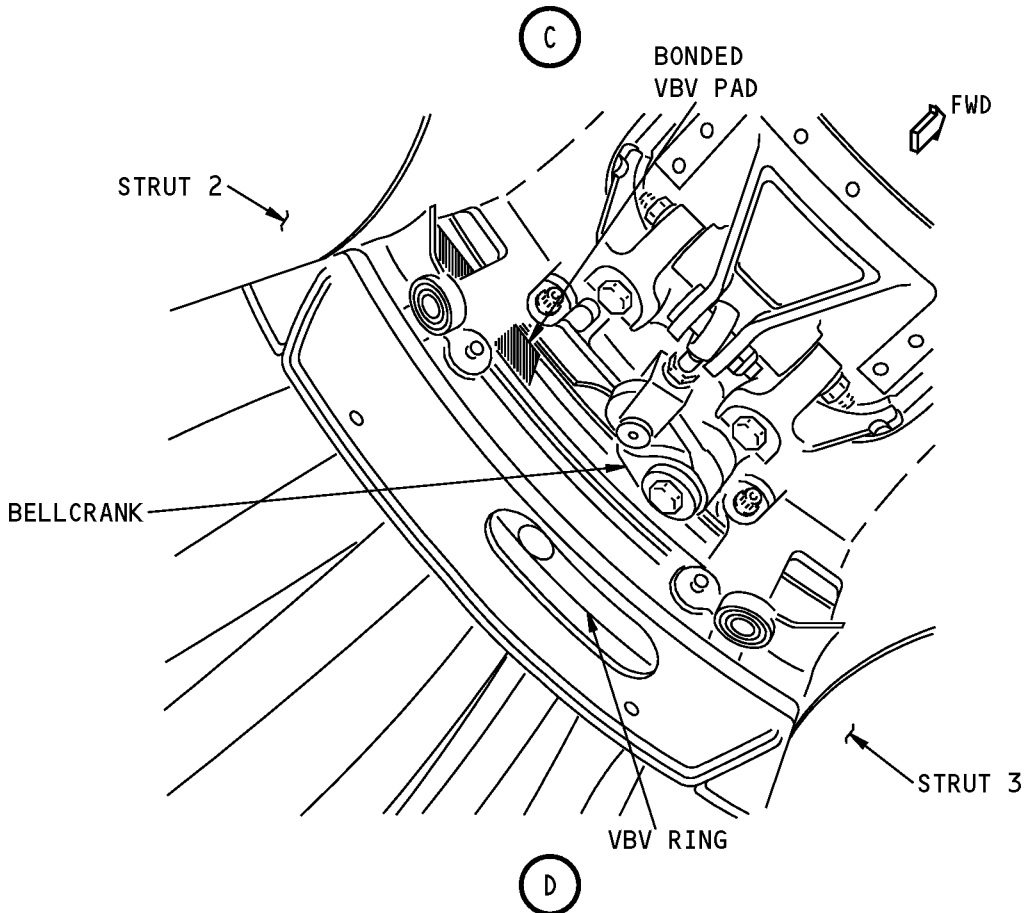

VBV Actuation System Guide Pads
Figure 601 (Sheet 2 of 2)/75-32-00-990-803-F00

EFFECTIVITY
HAP ALL

75-32-00

Page 604
Feb 15/2009

D633A101-HAP

AIRCRAFT MAINTENANCE MANUAL

TASK 75-32-00-200-802-F00

3. VBV System Inspection

A. General

(1) This task contains the instructions for a visual examination of the steel parts in the VBV system.

B. References

Reference	Title
72-23-07-000-801-F00	Fan Duct Panel Removal (P/B 401)
72-23-07-400-801-F00	Fan Duct Panel Installation (P/B 401)

C. Location Zones

Zone	Area
411	Engine 1 - Engine
421	Engine 2 - Engine

D. Prepare for the Inspection

(Figure 601)

SUBTASK 75-32-00-840-005-F00

(1) Remove the Fan Duct Panels 2, 3, 8, and 9 to get access to the VBV system.

NOTE: Panels 2 and 3 are located between struts 2 to 4. Panels 8 and 9 are located between struts 8 to 10.

(a) Do this task: Fan Duct Panel Removal, TASK 72-23-07-000-801-F00.

E. VBV System (Steel Parts) Inspection

SUBTASK 75-32-00-212-001-F00

(1) Visually examine the steel parts of the VBV system for signs of corrosion.

(a) Any amount of surface oxidation, pitting or corrosion marks is permitted.

F. Put the Airplane Back to the Usual Condition

SUBTASK 75-32-00-840-006-F00

(1) Do this task: Fan Duct Panel Installation, TASK 72-23-07-400-801-F00.

————— **END OF TASK** —————

EFFECTIVITY
HAP ALL

D633A101-HAP

75-32-00

Page 605
Feb 15/2009

AIRCRAFT MAINTENANCE MANUAL

VARIABLE BLEED VALVE ACTUATOR - REMOVAL/INSTALLATION**1. General**

- A. This procedure has four tasks:
- (1) The removal of the left VBV actuator
 - (2) The installation of the left VBV actuator
 - (3) The removal of the right VBV actuator
 - (4) The installation of the right VBV actuator.

TASK 75-32-02-000-801-F00**2. Left VBV Actuator Removal**

(Figure 401)

A. General

- (1) This task is the removal procedure for the variable bleed valve actuator (referred to as the actuator).
- (2) There are two VBV actuators (referred to as the left and the right actuators).
 - (a) They are attached to the aft side of the fan frame hub.

NOTE: They have the same design.

- (b) The left actuator is found at the 9:30 o'clock position.

B. References

Reference	Title
24-22-00-860-811	Supply Electrical Power (P/B 201)
24-22-00-860-812	Remove Electrical Power (P/B 201)
70-10-02-910-801-F00	General Precautions During the Removal and Installation of Engine Components (P/B 201)
70-30-01-910-802-F00	Seals (Preformed Packings and O-Rings) and Gaskets (P/B 201)
72-23-03-000-802-F00	Shroud Segments Removal (P/B 401)
72-23-07-000-801-F00	Fan Duct Panel Removal (P/B 401)
75-32-00-730-801-F00	VBV Actuation System - Manual Operation (P/B 201)
78-31-00-010-801-F00	Open the Thrust Reverser (Selection) (P/B 201)

C. Tools/Equipment

Reference	Description
STD-195	Container - 1 Quart (1 l), Oil/Fuel Resistant

D. Location Zones

Zone	Area
411	Engine 1 - Engine
421	Engine 2 - Engine

E. Prepare for the Removal

SUBTASK 75-32-02-840-001-F00

- (1) Do these steps to isolate the fuel from the fuel pump:
 - (a) Do this task: Supply Electrical Power, TASK 24-22-00-860-811.
 - (b) Make sure the engine start lever is in the CUTOFF position.
 - 1) Install a DO-NOT-OPERATE tag on the applicable engine start lever.

EFFECTIVITY
HAP ALL

75-32-02

Page 401
Oct 10/2003

D633A101-HAP

AIRCRAFT MAINTENANCE MANUAL

- (c) Make sure the ENG VALVE CLOSED and the SPAR VALVE CLOSED lights on the fuel control panel (P5 overhead panel) are dim.

NOTE: The lights for the fuel shutoff valves identify three positions: 1) bright when the valves are in transition or when the valves do not agree with the commanded position; or 2) dim when the valves are closed; or 3) off when the valves are opened.

- (d) Do this task: Remove Electrical Power, TASK 24-22-00-860-812.

- 1) Set the BAT switch on the Electrical Meters Battery and Galley Power Module (P5-13) to the OFF position and install a DO-NOT-OPERATE tag.

SUBTASK 75-32-02-010-001-F00

WARNING: DO THESE SPECIFIED TASKS IN THE CORRECT SEQUENCE BEFORE YOU OPEN THE THRUST REVERSER: RETRACT THE LEADING EDGE, DO THE DEACTIVATION OF THE LEADING EDGE AND THE THRUST REVERSER (FOR GROUND MAINTENANCE), AND OPEN THE FAN COWL PANELS. IF YOU DO NOT OBEY THE ABOVE SEQUENCE, INJURIES TO PERSONS AND DAMAGE TO EQUIPMENT CAN OCCUR.

- (2) Do this task: Open the Thrust Reverser (Selection), TASK 78-31-00-010-801-F00.

SUBTASK 75-32-02-010-002-F00

- (3) To get better access to the VBV actuator, do this task: Shroud Segments Removal, TASK 72-23-03-000-802-F00

for the top left shroud segment.

SUBTASK 75-32-02-010-003-F00

- (4) At position 10, do this task: Fan Duct Panel Removal, TASK 72-23-07-000-801-F00.

SUBTASK 75-32-02-980-001-F00

- (5) Move the VBV system to the fully closed position; do this task: VBV Actuation System - Manual Operation, TASK 75-32-00-730-801-F00.

F. Left Actuator Removal

SUBTASK 75-32-02-860-007-F00

- (1) Disconnect the electrical connector, DP1008 [5] from the actuator receptacle.

- (a) Put a protective cover on the electrical connector and actuator receptacle.

SUBTASK 75-32-02-020-002-F00

- (2) Do these steps to disconnect the fuel plate manifold [1] from the actuator [4]:

- (a) Put a 1 quart (1 l) oil/fuel resistant container, STD-195, below the fuel plate manifold [1].

- (b) Remove the four bolts [2] to disconnect the fuel plate manifold [1].

- 1) Let the fuel drain in the container.

- (c) Remove and examine the gasket [3] (TASK 70-30-01-910-802-F00).

NOTE: Use the gasket if it is in good condition.

- 1) Discard the gasket [3], if it is in unsatisfactory condition.

SUBTASK 75-32-02-020-003-F00

- (3) Do these steps to disconnect the actuator arm from the actuator rod clevis:

- (a) Use an allen wrench in the bolthead for counter torque, remove and discard the self-locking nut [9] from the (special) bolt [8].

- (b) Remove the (special) bolt [8] as follows:

EFFECTIVITY
HAP ALL

D633A101-HAP

75-32-02

Page 402
Oct 15/2008

AIRCRAFT MAINTENANCE MANUAL

- 1) Push the threaded end of the (special) bolt [8] while you turn it to engage the bolt threads in the actuator rod clevis thread.
- 2) Loosen and remove the (special) bolt [8].

SUBTASK 75-32-02-020-004-F00

- (4) Do these steps to remove the actuator [4] from the fan frame hub:
 - (a) Remove the four bolts [7] that attach the actuator [4] to the aft side of the fan frame hub.
 - (b) Move the actuator [4] rearward.
 - (c) Remove the actuator [4] from the fan frame hub.
 - (d) Drain the fuel into the container from the actuator.

SUBTASK 75-32-02-020-005-F00

- (5) Do these steps to give protection to the actuator [4] (TASK 70-10-02-910-801-F00):
 - (a) Put a protective cover or tie through the spherical bearing on the end of the actuator arm.
 - (b) Put a protective cover on the fuel plate manifold [1].
 - (c) Put a protective cover on the mounting flange.

————— **END OF TASK** —————

EFFECTIVITY
HAP ALL

D633A101-HAP

75-32-02Page 403
Jun 10/2005

AIRCRAFT MAINTENANCE MANUAL

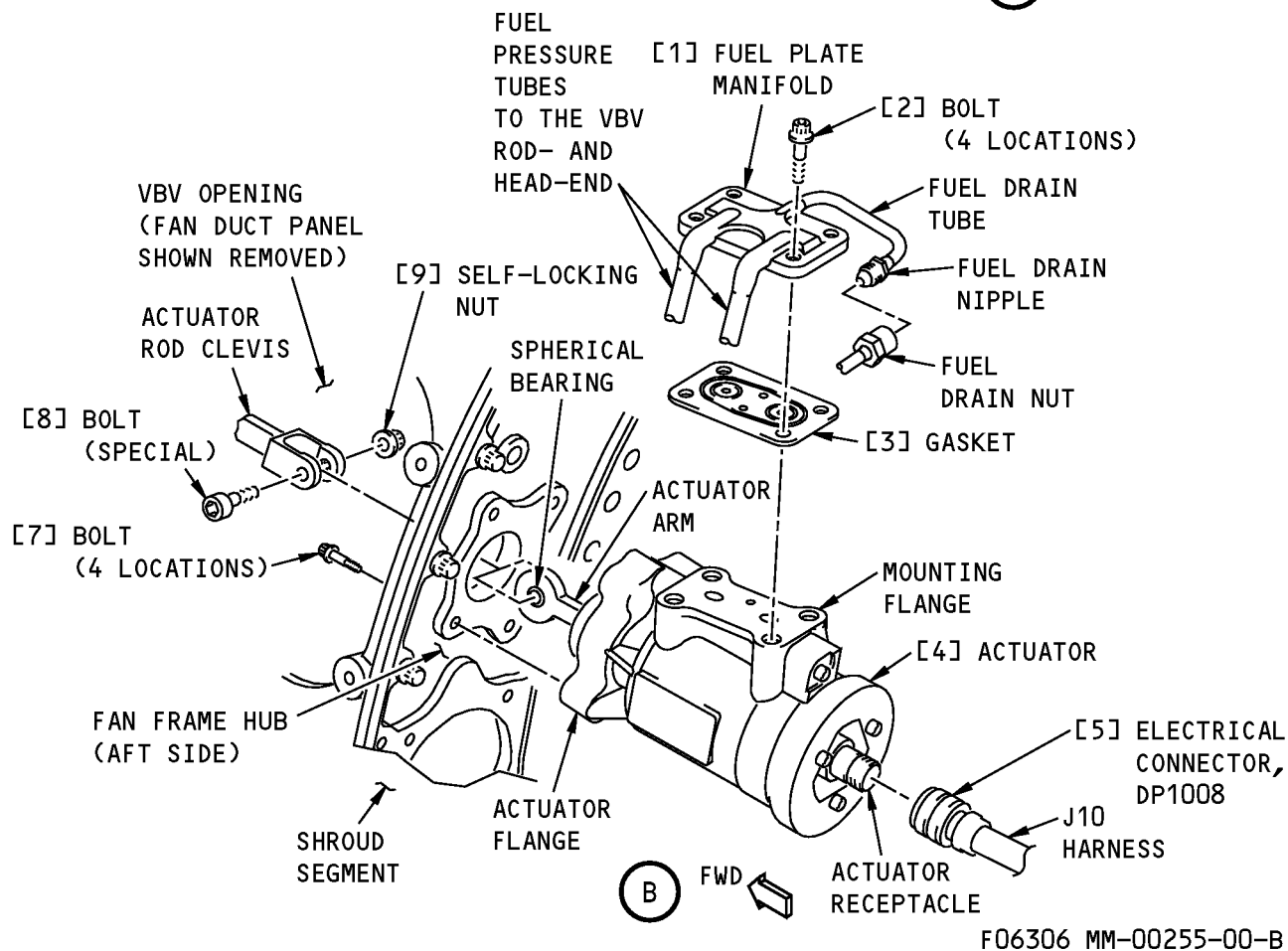
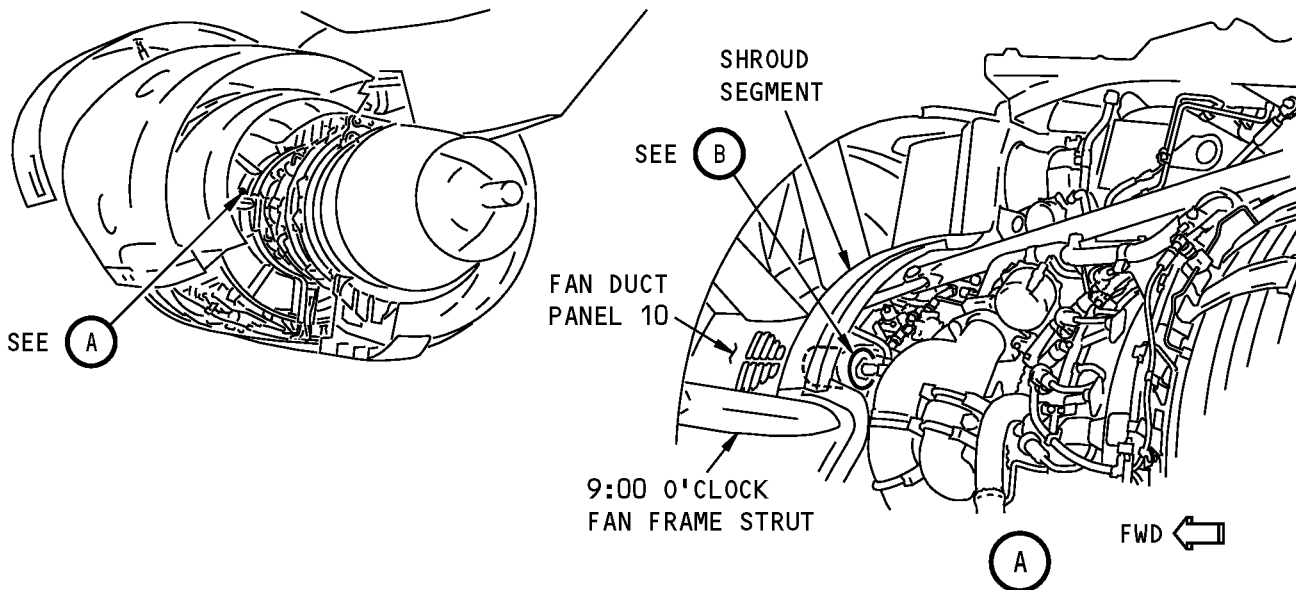

Left VBV Actuator Installation
Figure 401/75-32-02-990-801-F00

EFFECTIVITY
HAP ALL

75-32-02

AIRCRAFT MAINTENANCE MANUAL

TASK 75-32-02-400-801-F00

3. Left VBV Actuator Installation

(Figure 401)

A. General

- (1) This task is the installation procedure for the left variable bleed valve actuator (referred to as the actuator).

B. References

Reference	Title
70-10-02-910-801-F00	General Precautions During the Removal and Installation of Engine Components (P/B 201)
71-00-00-800-811-F00	Power Plant Test Reference Table (P/B 501)
72-23-03-400-802-F00	Shroud Segments Installation (P/B 401)
72-23-07-400-801-F00	Fan Duct Panel Installation (P/B 401)
75-32-00-730-801-F00	VBV Actuation System - Manual Operation (P/B 201)
78-31-00-010-804-F00	Close the Thrust Reverser (Selection) (P/B 201)

C. Tools/Equipment

NOTE: When more than one tool part number is listed under the same "Reference" number, the tools shown are alternates to each other within the same airplane series. Tool part numbers that are replaced or non-procurable are preceded by "Opt:", which stands for Optional.

Reference	Description
SPL-2187	Actuator - Hydraulic, Portable, VSV Stator - CFM56-7/CFM56-3 (Part #: 856A1084G04, Supplier: 58828, A/P Effectivity: 737-300, -400, -500, -600, -700, -700C, -700ER, -700QC, -800, -900, -900ER, -BBJ)

D. Consumable Materials

Reference	Description	Specification
D00601 [CP2101]	Grease - Graphite, High Temperature	SAE AMS 2518

E. Expendables/Parts

AMM Item	Description	AIPC Reference	AIPC Effectivity
3	Gasket	75-32-00-02-015	HAP ALL
4	Actuator	75-32-02-01-010	HAP ALL

F. Location Zones

Zone	Area
411	Engine 1 - Engine
421	Engine 2 - Engine

G. Left Actuator Installation

SUBTASK 75-32-02-420-001-F00

- (1) Do these steps to prepare for the actuator installation (TASK 70-10-02-910-801-F00):
- Remove the protective cover on the mounting flange.
 - Remove the protective cover on the fuel plate manifold [1].
 - Make sure that all the mating surfaces of the actuator [4] are clean and in good condition.
 - Make sure that all the mating surfaces of the fuel plate manifold [1] are clean and in good condition.

EFFECTIVITY
HAP ALL

75-32-02

D633A101-HAP

Page 405
Jun 15/2009

**737-600/700/800/900
AIRCRAFT MAINTENANCE MANUAL**

SUBTASK 75-32-02-420-002-F00

(2) Do these steps to install the actuator [4] to the aft side of the fan frame hub:

- (a) Lubricate the four bolts [7] with grease, D00601 [CP2101].
- (b) If not already done, fully retract the actuator arm.
- (c) Manually align the actuator [4] in its correct position.
- (d) Put the actuator arm through the opening in the fan frame hub.

NOTE: Hold the actuator rod clevis in its axis.

- (e) Carefully, align the actuator flange on the fan frame hub.
- (f) Align the bolt holes in the actuator flange with the bolt holes in the fan frame hub.
- (g) Install and tighten the four bolts [7] with your hand.

NOTE: Do not tighten the bolts at this time.

SUBTASK 75-32-02-020-008-F00

(3) Do these steps to install the fuel plate manifold [1] to the mounting flange:

- (a) Lubricate the four bolts [2] with grease, D00601 [CP2101].
- (b) Install the gasket [3] between the fuel plate manifold [1] and the mounting flange.
- (c) Install and tighten the four bolts [2] with your hand to attach the fuel plate manifold [1] to the mounting flange.
- (d) Tighten the four bolts [7] on the fan frame hub to 126-140 pound-inches (14-16 Newton meters).
- (e) Tighten the four bolts [2] to 60-65 pound-inches (7-8 Newton meters).

SUBTASK 75-32-02-420-006-F00

(4) Do these steps to connect the actuator rod clevis to the actuator arm:

- (a) Remove the protective cover or tie through the spherical bearing on the end of the actuator arm.
- (b) Make sure that the spherical bearing engages into the actuator rod clevis end.
- (c) Engage the (special) bolt [8] through the fork of the actuator rod clevis and the spherical bearing on the actuator arm.
 - 1) Tighten the (special) bolt [8] until the bolt threads are free of the actuator rod clevis threads.

NOTE: The bolt thread comes out of the actuator rod clevis thread.

- (d) Install a new self-locking nut [9] on the (special) bolt [8].
 - 1) Use an allen wrench in the bolthead for counter torque, tighten the self-locking nut to 68-74 pound-inches (7.5-8.5 Newton meters).

SUBTASK 75-32-02-860-008-F00

(5) Connect the electrical connector, DP1008 [5] to the actuator receptacle.

H. Put the Airplane Back to Its Usual Condition

SUBTASK 75-32-02-790-001-F00

(1) Move the VBV system to the fully open position and do a check for leaks (TASK 75-32-00-730-801-F00).

EFFECTIVITY
HAP ALL

D633A101-HAP

75-32-02Page 406
Feb 15/2009

AIRCRAFT MAINTENANCE MANUAL

SUBTASK 75-32-02-080-001-F00

- (2) Disconnect the VBV hoses from the actuator, SPL-2187, and connect the hoses to the HMU (TASK 75-32-00-730-801-F00).

SUBTASK 75-32-02-410-005-F00

- (3) At position 10, do this task: Fan Duct Panel Installation, TASK 72-23-07-400-801-F00.

SUBTASK 75-32-02-410-006-F00

- (4) If you removed the shroud segment, do this task: Shroud Segments Installation, TASK 72-23-03-400-802-F00.

SUBTASK 75-32-02-010-009-F00

WARNING: OBEY THE INSTRUCTIONS IN THE PROCEDURE TO CLOSE THE THRUST REVERSER. IF YOU DO NOT OBEY THE INSTRUCTIONS, INJURIES TO PERSONS AND DAMAGE TO EQUIPMENT CAN OCCUR.

- (5) Do this task: Close the Thrust Reverser (Selection), TASK 78-31-00-010-804-F00.

SUBTASK 75-32-02-860-011-F00

- (6) Remove the DO-NOT-OPERATE tags from the start lever.

SUBTASK 75-32-02-860-017-F00

- (7) Remove the DO-NOT-OPERATE tag from the BAT switch.

I. Left Actuator Installation Test

SUBTASK 75-32-02-800-001-F00

- (1) Do the tests that are listed in the Power Plant Test Reference Table (TASK 71-00-00-800-811-F00).

————— END OF TASK —————

TASK 75-32-02-000-802-F00**4. Right VBV Actuator Removal**

(Figure 402)

A. General

- (1) This task is the removal procedure for the variable bleed valve actuator (referred to as the actuator).
- (2) There are two actuators (referred to as the left and the right actuators).
- (a) They are attached to the aft side of the fan frame hub.

NOTE: They have the same design.

- (b) The right actuator is found at the 3:30 o'clock position.

B. References

Reference	Title
24-22-00-860-811	Supply Electrical Power (P/B 201)
24-22-00-860-812	Remove Electrical Power (P/B 201)
70-10-02-910-801-F00	General Precautions During the Removal and Installation of Engine Components (P/B 201)
70-30-01-910-802-F00	Seals (Preformed Packings and O-Rings) and Gaskets (P/B 201)
72-23-03-000-802-F00	Shroud Segments Removal (P/B 401)
72-23-07-000-801-F00	Fan Duct Panel Removal (P/B 401)
75-32-00-730-801-F00	VBV Actuation System - Manual Operation (P/B 201)

EFFECTIVITY
HAP ALL

D633A101-HAP

75-32-02

Page 407
Jun 15/2008

AIRCRAFT MAINTENANCE MANUAL

(Continued)

Reference	Title
78-31-00-010-801-F00	Open the Thrust Reverser (Selection) (P/B 201)

C. Tools/Equipment

Reference	Description
STD-195	Container - 1 Quart (1 l), Oil/Fuel Resistant

D. Location Zones

Zone	Area
411	Engine 1 - Engine
421	Engine 2 - Engine

E. Prepare for the Removal

SUBTASK 75-32-02-840-003-F00

- (1) Do these steps to isolate the fuel from the fuel pump:
 - (a) Do this task: Supply Electrical Power, TASK 24-22-00-860-811.
 - (b) Make sure the engine start lever is in the CUTOFF position.
 - 1) Install a DO-NOT-OPERATE tag on the applicable engine start lever.
 - (c) Make sure the ENG VALVE CLOSED and the SPAR VALVE CLOSED lights on the fuel control panel (P5 overhead panel) are dim.

NOTE: The lights for the fuel shutoff valves identify three positions: 1) bright when the valves are in transition or when the valves do not agree with the commanded position; or 2) dim when the valves are closed; or 3) off when the valves are opened.
 - (d) Do this task: Remove Electrical Power, TASK 24-22-00-860-812.
 - 1) Set the BAT switch on the Electrical Meters Battery and Galley Power Module (P5-13) to the OFF position and install a DO-NOT-OPERATE tag.

SUBTASK 75-32-02-010-005-F00

WARNING: DO THESE SPECIFIED TASKS IN THE CORRECT SEQUENCE BEFORE YOU OPEN THE THRUST REVERSER: RETRACT THE LEADING EDGE, DO THE DEACTIVATION OF THE LEADING EDGE AND THE THRUST REVERSER (FOR GROUND MAINTENANCE), AND OPEN THE FAN COWL PANELS. IF YOU DO NOT OBEY THE ABOVE SEQUENCE, INJURIES TO PERSONS AND DAMAGE TO EQUIPMENT CAN OCCUR.

- (2) Do this task: Open the Thrust Reverser (Selection), TASK 78-31-00-010-801-F00.

SUBTASK 75-32-02-010-006-F00

- (3) To get better access to the VBV actuator, do this task: Shroud Segments Removal, TASK 72-23-03-000-802-F00
for the bottom right shroud segment.

SUBTASK 75-32-02-010-007-F00

- (4) At position 4, do this task: Fan Duct Panel Removal, TASK 72-23-07-000-801-F00.

SUBTASK 75-32-02-980-002-F00

- (5) Move the VBV system to the fully closed position; do this task: VBV Actuation System - Manual Operation, TASK 75-32-00-730-801-F00.

EFFECTIVITY
HAP ALL

75-32-02

Page 408
Oct 15/2008

D633A101-HAP

AIRCRAFT MAINTENANCE MANUAL

F. Right Actuator Removal

SUBTASK 75-32-02-860-012-F00

- (1) Disconnect the electrical connector, DP0908 [29] from the actuator receptacle.
- (a) Put a protective cover on the electrical connector and actuator receptacle.

SUBTASK 75-32-02-020-019-F00

- (2) Do these steps to disconnect the fuel plate manifold [26] from the actuator [22]:
- (a) Put a 1 quart (1 l) oil/fuel resistant container, STD-195, below the fuel plate manifold [26].
- (b) Remove the four bolts [27] to disconnect the fuel plate manifold [26].
- 1) Let the fuel drain in the container.
- (c) Remove and examine the gasket [28] (TASK 70-30-01-910-802-F00).

NOTE: Use the gasket if it is in good condition.

- 1) Discard the gasket [28], if it is in unsatisfactory condition.

SUBTASK 75-32-02-020-012-F00

- (3) Do these steps to disconnect the actuator arm from the actuator rod clevis:
- (a) Use an allen wrench in the bolt head for counter torque, remove and discard the self-locking nut [25] from the (special) bolt [24].
- (b) Remove the (special) bolt [24] as follows:
- 1) Push the threaded end of the (special) bolt [24] while you turn it to engage the bolt threads in the actuator rod clevis thread.
- 2) Loosen and remove the (special) bolt [24].

SUBTASK 75-32-02-020-013-F00

- (4) Do these steps to remove the actuator [22] from the fan frame hub:
- (a) Remove the four bolts [23] that attach the actuator [22] to the aft side of the fan frame hub.
- (b) Move the actuator [22] rearward.
- (c) Turn the mounting flange of the actuator [22] inboard.
- (d) Remove the actuator [22] from the fan frame hub.
- (e) Drain the fuel into the container from the actuator.

SUBTASK 75-32-02-020-014-F00

- (5) Do these steps to give protection to the actuator [22] (TASK 70-10-02-910-801-F00):
- (a) Put a protective cover or tie through the spherical bearing on the end of the actuator arm.
- (b) Put a protective cover on the fuel plate manifold [26].
- (c) Put a protective cover on the mounting flange.

————— END OF TASK —————

EFFECTIVITY
HAP ALL

D633A101-HAP

75-32-02

Page 409
Jun 15/2008

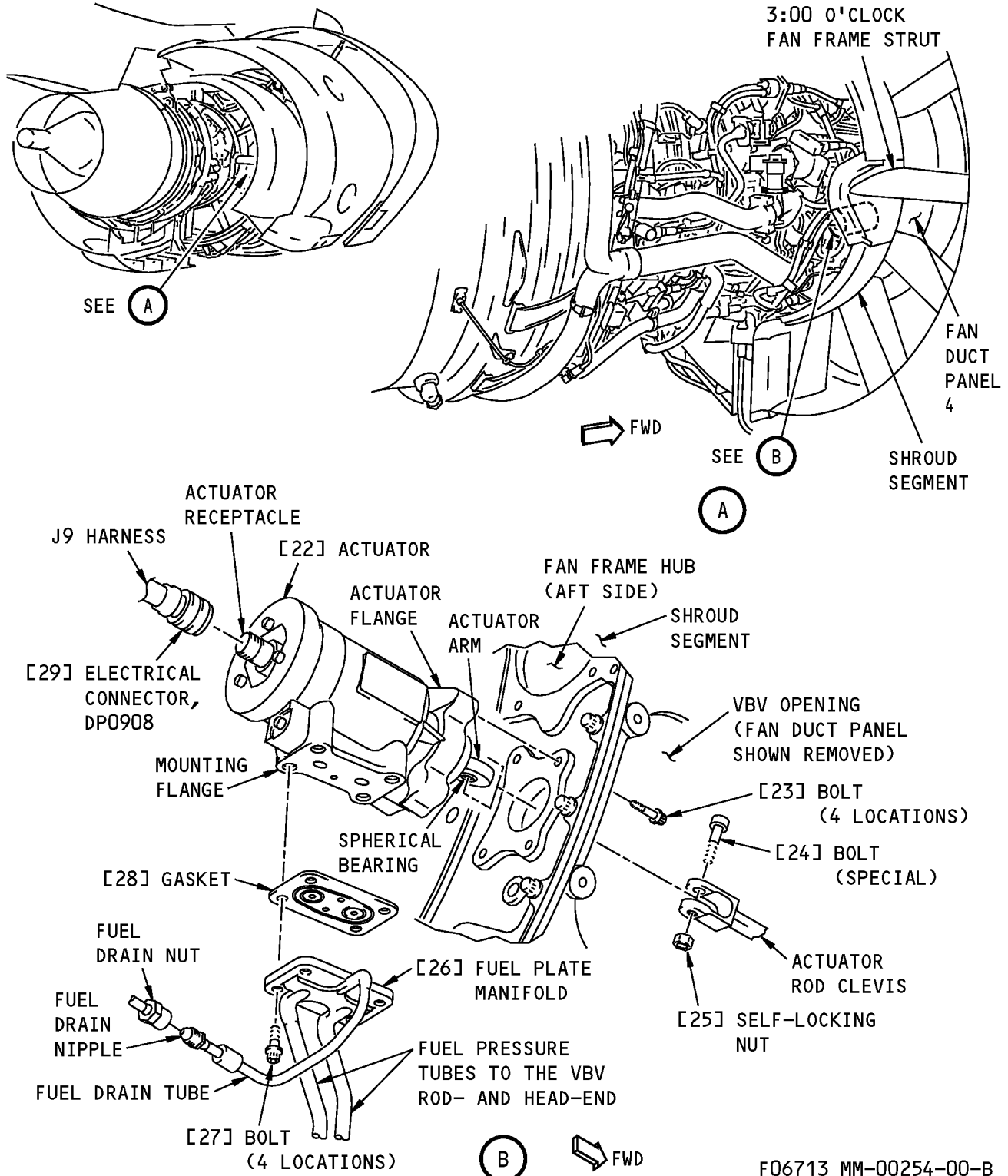

Right VBV Actuator Installation
Figure 402/75-32-02-990-802-F00

F06713 MM-00254-00-B

EFFECTIVITY
HAP ALL

75-32-02

Page 410
Oct 10/2004

D633A101-HAP

AIRCRAFT MAINTENANCE MANUAL

TASK 75-32-02-400-802-F00

5. Right VBV Actuator Installation

(Figure 402)

A. General

- (1) This task is the installation procedure for the right variable bleed valve actuator (referred to as the actuator).

B. References

Reference	Title
70-10-02-910-801-F00	General Precautions During the Removal and Installation of Engine Components (P/B 201)
71-00-00-800-811-F00	Power Plant Test Reference Table (P/B 501)
72-23-03-400-802-F00	Shroud Segments Installation (P/B 401)
72-23-07-400-801-F00	Fan Duct Panel Installation (P/B 401)
75-32-00-730-801-F00	VBV Actuation System - Manual Operation (P/B 201)
78-31-00-010-804-F00	Close the Thrust Reverser (Selection) (P/B 201)

C. Tools/Equipment

NOTE: When more than one tool part number is listed under the same "Reference" number, the tools shown are alternates to each other within the same airplane series. Tool part numbers that are replaced or non-procurable are preceded by "Opt:", which stands for Optional.

Reference	Description
SPL-2187	Actuator - Hydraulic, Portable, VSV Stator - CFM56-7/CFM56-3 (Part #: 856A1084G04, Supplier: 58828, A/P Effectivity: 737-300, -400, -500, -600, -700, -700C, -700ER, -700QC, -800, -900, -900ER, -BBJ)

D. Consumable Materials

Reference	Description	Specification
D00601 [CP2101]	Grease - Graphite, High Temperature	SAE AMS 2518

E. Expendables/Parts

AMM Item	Description	AIPC Reference	AIPC Effectivity
22	Actuator	75-32-02-01-010 75-32-02-01-015	HAP ALL HAP ALL
28	Gasket	75-32-00-02-015	HAP ALL

F. Location Zones

Zone	Area
411	Engine 1 - Engine
421	Engine 2 - Engine

G. Right Actuator Installation

SUBTASK 75-32-02-210-001-F00

- (1) Do these steps to prepare for the actuator installation (TASK 70-10-02-910-801-F00):
- Remove the protective cover on the mounting flange.
 - Remove the protective cover on the fuel plate manifold [26].
 - Make sure that all the mating surfaces of the actuator [22] are clean and in good condition.

EFFECTIVITY
HAP ALL

75-32-02

Page 411
Jun 15/2009

D633A101-HAP

AIRCRAFT MAINTENANCE MANUAL

- (d) Make sure that all the mating surfaces of the fuel plate manifold [22] are clean and in good condition.

SUBTASK 75-32-02-420-004-F00

- (2) Do these steps to install the actuator [22] to the aft side of the fan frame hub:

- (a) Lubricate the four bolts [23] with grease, D00601 [CP2101].
- (b) If not already done, fully retract the actuator arm.
- (c) Manually align the actuator [22] in its correct position.
- (d) Put the actuator arm through the opening in the fan frame hub.

NOTE: Hold the actuator rod clevis in its axis.

- (e) Carefully, align the actuator flange on the fan frame hub.
- (f) Align the bolt holes in the actuator flange with the bolt holes in the fan frame hub.
- (g) Install and tighten the four bolts [23] with your hand.

NOTE: Do not tighten the bolts [23] at this time.

SUBTASK 75-32-02-020-017-F00

- (3) Do these steps to install the fuel plate manifold [26] to the mounting flange:

- (a) Lubricate the four bolts [27] with grease, D00601 [CP2101].
- (b) Install the gasket [28] between the fuel plate manifold [26] and the mounting flange.
- (c) Install and tighten the four bolts [27] with your hand to attach the fuel plate manifold [26] to the mounting flange.
- (d) Tighten the four bolts [23] on the fan frame hub to 126-140 pound-inches (14-16 Newton meters).
- (e) Tighten the four bolts [27] to 60-65 pound-inches (7-8 Newton meters).

SUBTASK 75-32-02-420-007-F00

- (4) Do these steps to connect the actuator rod clevis to the actuator arm:

- (a) Remove the protective cover or tie through the spherical bearing on the end of the actuator arm.
- (b) Make sure that the spherical bearing engages into the actuator rod clevis end.
- (c) Engage the (special) bolt [24] through the fork of the actuator rod clevis and the spherical bearing on the VBV actuator arm.
 - 1) Tighten the (special) bolt [24] until the bolt threads are free of the actuator rod clevis threads.

NOTE: The bolt thread comes out of the actuator rod clevis thread.

- (d) Install a new self-locking nut [25] on the (special) bolt [24].
 - 1) Use an allen wrench in the bolt head for counter torque, tighten the self-locking nut to 68-74 pound-inches (7.5-8.5 Newton meters).

SUBTASK 75-32-02-860-013-F00

- (5) Connect the electrical connector, DP0908 [29] to the actuator receptacle.

H. Put the Airplane Back to Its Usual Condition

SUBTASK 75-32-02-790-002-F00

- (1) Move the VBV system to the fully open position and check for leaks (TASK 75-32-00-730-801-F00).

EFFECTIVITY
HAP ALL

D633A101-HAP

75-32-02

Page 412
Feb 15/2009

AIRCRAFT MAINTENANCE MANUAL

SUBTASK 75-32-02-080-002-F00

- (2) Disconnect the VBV hoses from the actuator, SPL-2187, and connect the hoses to the HMU (TASK 75-32-00-730-801-F00).

SUBTASK 75-32-02-410-007-F00

- (3) At position 4, do this task: Fan Duct Panel Installation, TASK 72-23-07-400-801-F00.

SUBTASK 75-32-02-410-008-F00

- (4) If you removed the shroud segment, do this task: Shroud Segments Installation, TASK 72-23-03-400-802-F00.

SUBTASK 75-32-02-010-010-F00

WARNING: OBEY THE INSTRUCTIONS IN THE PROCEDURE TO CLOSE THE THRUST REVERSER. IF YOU DO NOT OBEY THE INSTRUCTIONS, INJURIES TO PERSONS AND DAMAGE TO EQUIPMENT CAN OCCUR.

- (5) Do this task: Close the Thrust Reverser (Selection), TASK 78-31-00-010-804-F00.

SUBTASK 75-32-02-860-016-F00

- (6) Remove the DO-NOT-OPERATE tags from the start lever.

SUBTASK 75-32-02-860-018-F00

- (7) Remove the DO-NOT-OPERATE tag from the BAT switch.

I. Right VBV Actuator Installation Test

SUBTASK 75-32-02-800-002-F00

- (1) Do the tests that are listed in the Power Plant Test Reference Table (TASK 71-00-00-800-811-F00).

————— **END OF TASK** —————

EFFECTIVITY
HAP ALL

D633A101-HAP

75-32-02Page 413
Oct 15/2008

AIRCRAFT MAINTENANCE MANUAL

VARIABLE BLEED VALVE DOORS - REMOVAL/INSTALLATION**1. General**

A. This procedure has four tasks:

- (1) The removal of the unison ring-operated VBV door
- (2) The installation of the unison ring-operated VBV door
- (3) The removal of the actuator-operated VBV door
- (4) The installation of the actuator-operated VBV door.

TASK 75-32-03-000-801-F00**2. Unison Ring-Operated VBV Door Removal**

(Figure 401, Figure 402)

A. General

- (1) This task is the removal procedure for the unison ring-operated VBV door (referred to as the VBV door).
- (2) In this procedure, the 12 VBV doors are given positions 1 through 12 in the clockwise direction (view in the forward direction). VBV Door 1 is at the 1:00 o'clock position. The fan frame strut 1 is at the 12:00 o'clock position.
- (3) Each engine has ten unison ring-operated VBV doors and two actuator-operated VBV doors 9 (positions 4 and 10).
- (4) All VBV doors are found on the fan frame.

B. References

Reference	Title
70-10-02-910-801-F00	General Precautions During the Removal and Installation of Engine Components (P/B 201)
72-23-07-000-801-F00	Fan Duct Panel Removal (P/B 401)
75-32-00-700-802-F00	Unison Ring-Operated Variable Bleed Valve (VBV) Door - Adjustment (P/B 501)
75-32-00-730-801-F00	VBV Actuation System - Manual Operation (P/B 201)
78-31-00-010-801-F00	Open the Thrust Reverser (Selection) (P/B 201)

C. Tools/Equipment

NOTE: When more than one tool part number is listed under the same "Reference" number, the tools shown are alternates to each other within the same airplane series. Tool part numbers that are replaced or non-procurable are preceded by "Opt:", which stands for Optional.

Reference	Description
SPL-2187	Actuator - Hydraulic, Portable, VSV Stator - CFM56-7/CFM56-3 (Part #: 856A1084G04, Supplier: 58828, A/P Effectivity: 737-300, -400, -500, -600, -700, -700C, -700ER, -700QC, -800, -900, -900ER, -BBJ)

D. Location Zones

Zone	Area
411	Engine 1 - Engine
421	Engine 2 - Engine

EFFECTIVITY
HAP ALL

D633A101-HAP

75-32-03

Page 401
Oct 15/2008

AIRCRAFT MAINTENANCE MANUAL

E. Prepare for the Removal

SUBTASK 75-32-03-860-001-F00

- (1) For engine 1, do this step:

Open these circuit breakers and install safety tags:

CAPT Electrical System Panel, P18-2

<u>Row</u>	<u>Col</u>	<u>Number</u>	<u>Name</u>
A	4	C01390	ENGINE 1 ALTN PWR CHAN B
A	5	C01314	ENGINE 1 ALTN PWR CHAN A

SUBTASK 75-32-03-860-002-F00

- (2) For engine 2, do this step:

Open these circuit breakers and install safety tags:

F/O Electrical System Panel, P6-2

<u>Row</u>	<u>Col</u>	<u>Number</u>	<u>Name</u>
D	7	C01391	ENGINE 2 ALTN PWR CHAN B
D	8	C01315	ENGINE 2 ALTN PWR CHAN A

SUBTASK 75-32-03-010-007-F00

WARNING: DO THESE SPECIFIED TASKS IN THE CORRECT SEQUENCE BEFORE YOU OPEN THE THRUST REVERSER: RETRACT THE LEADING EDGE, DO THE DEACTIVATION OF THE LEADING EDGE AND THE THRUST REVERSER (FOR GROUND MAINTENANCE), AND OPEN THE FAN COWL PANELS. IF YOU DO NOT OBEY THE ABOVE SEQUENCE, INJURIES TO PERSONS AND DAMAGE TO EQUIPMENT CAN OCCUR.

- (3) Do this task: Open the Thrust Reverser (Selection), TASK 78-31-00-010-801-F00.

SUBTASK 75-32-03-010-002-F00

- (4) For the applicable door, do this task: Fan Duct Panel Removal, TASK 72-23-07-000-801-F00.

SUBTASK 75-32-03-860-015-F00

- (5) Do these steps if the VBV door is fully closed:

- (a) Use the actuator, SPL-2187, to slightly open the VBV door and release pressure of the seal [28] from the fan frame; do this task: VBV Actuation System - Manual Operation, TASK 75-32-00-730-801-F00.
- 1) Release the hydraulic pressure on the cart.
 - 2) Disconnect the pressure source to prevent the actuation of the VBV system (TASK 75-32-00-730-801-F00).

F. Unison Ring-Operated VBV Door Removal

NOTE: There are 10 unison ring-operated doors on each engine. The VBV doors operate by the unison ring and are found at positions 1, 2, 3, 5, 6, 7, 8, 9, 11 and 12.

SUBTASK 75-32-03-820-001-F00

CAUTION: DO NOT REMOVE THE JAMNUT LOCKWIRE, LOOSEN THE JAMNUT OR TURN THE ROD-END BEARING. IF YOU DO NOT OBEY THIS INSTRUCTION, ENGINE DAMAGE CAN OCCUR.

- (1) If the jamnut lockwire is removed or missing, and if it is possible that the rod-end bearing [24] was turned, do this task: Unison Ring-Operated Variable Bleed Valve (VBV) Door - Adjustment, TASK 75-32-00-700-802-F00

EFFECTIVITY
HAP ALL

D633A101-HAP

75-32-03

Page 402
Jun 10/2004

AIRCRAFT MAINTENANCE MANUAL

after you replace or re-install the VBV door [27].

SUBTASK 75-32-03-020-001-F00

CAUTION: BE CAREFUL WHEN YOU REMOVE PARTS THAT ARE AROUND AN OPEN VBV DOOR. PARTS THAT FALL INTO AN OPEN VBV DOOR CAN FALL IN THE HIGH PRESSURE COMPRESSOR OF THE ENGINE. PARTS WHICH FALL INTO THE ENGINE CAN CAUSE ENGINE DAMAGE AT THE FIRST ENGINE OPERATION.

- (2) Do these steps to disconnect the rod-end bearing [24] from the VBV door yoke [23]:
- (a) Remove and discard the self-locking nut [26] from the bolt [22] which connects the rod-end bearing [24] to the VBV door yoke [23].
 - (b) Remove the bolt [22].

SUBTASK 75-32-03-020-002-F00

- (3) Remove the two bolts [29] that attach the VBV hinge [21] to the fan frame.

SUBTASK 75-32-03-020-003-F00

- (4) Do these steps to remove the VBV door [27] from the fan frame:
- (a) While you keep the axial alignment, lift and turn the VBV door [27] slightly forward about its hinge axis.
 - (b) Move the VBV door [27] rearward.
 - (c) Remove the VBV door [27].
 - (d) Install a protective cover on the fan frame bleed port, if it is necessary (TASK 70-10-02-910-801-F00).

SUBTASK 75-32-03-020-009-F00

- (5) If a VBV hinge [21] is not installed on the replacement VBV door [27], then do these steps to remove the VBV hinge [21] from the VBV door [27] and retain for the subsequent installation:
- (a) Remove the two pins [31] and the two nuts [30] that attach the VBV hinge [21] to the VBV door [27].
 - (b) Remove the VBV hinge [21] from the VBV door [27].

————— **END OF TASK** —————

EFFECTIVITY
HAP ALL

D633A101-HAP

75-32-03

Page 403
Jun 10/2005

737-600/700/800/900
AIRCRAFT MAINTENANCE MANUAL

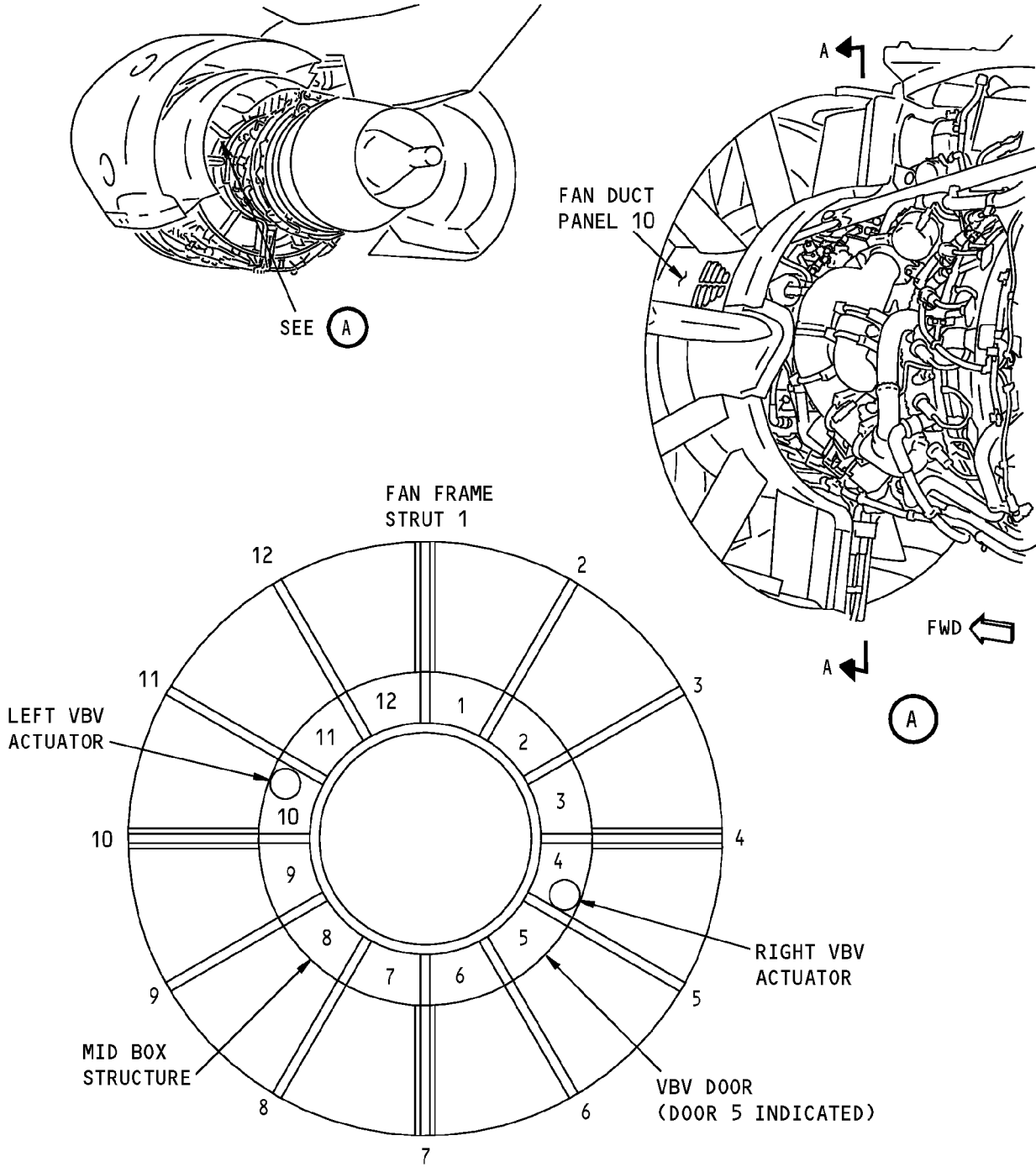

NUMBERING OF FAN FRAME STRUTS AND VBV DOORS
 (VIEW IN THE FORWARD DIRECTION)
 A-A

Location and Positions of VBV Doors
 Figure 401/75-32-03-990-801-F00

EFFECTIVITY
HAP ALL

75-32-03

AIRCRAFT MAINTENANCE MANUAL

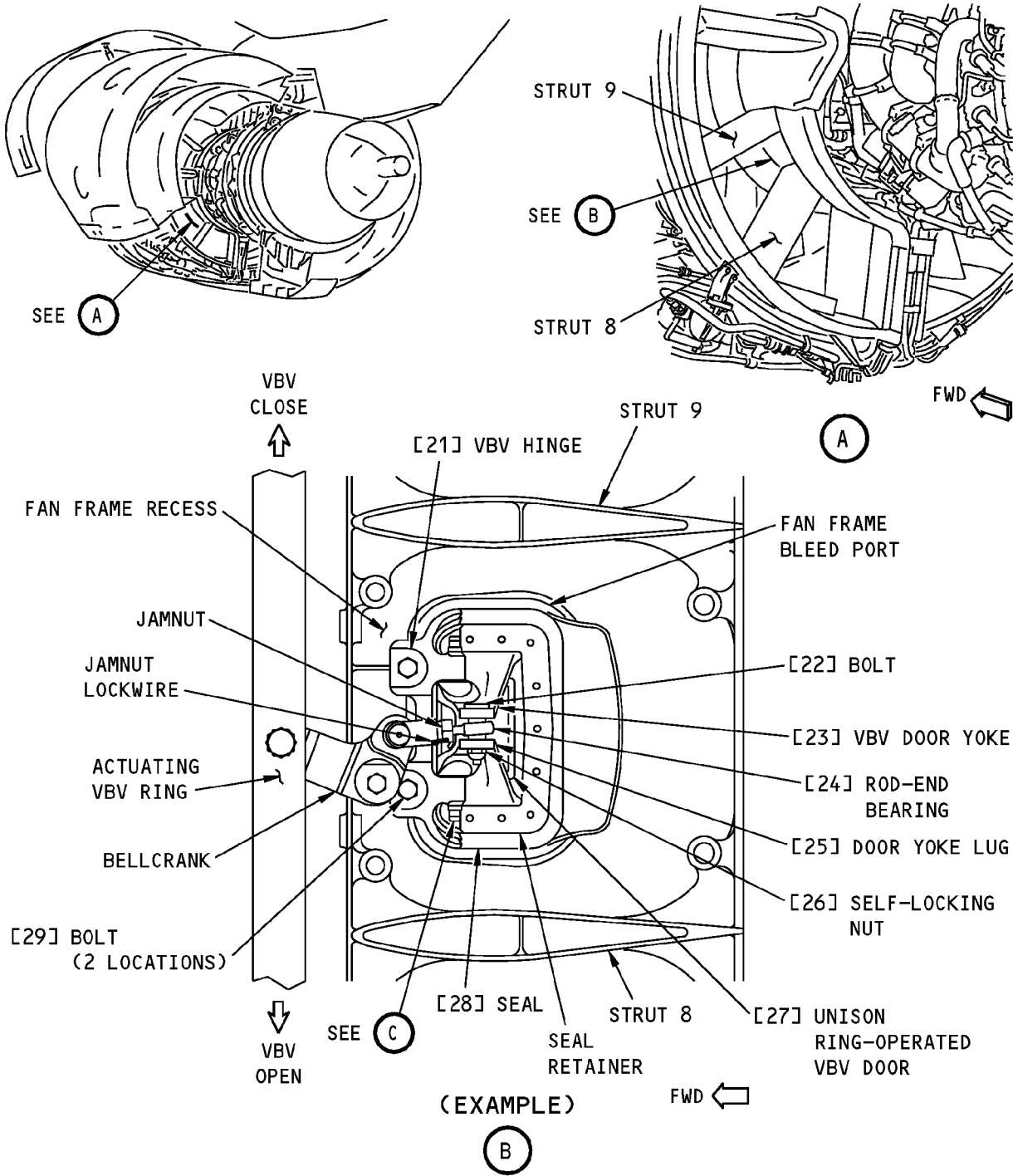

NOTE: THE ABOVE ARRANGEMENT IS IDENTICAL AT VBV DOOR POSITIONS 1, 2, 3, 5, 6, 7, 8, 9, 11 AND 12 (FIG. 401).

S-M56-MM-03418-00-B

**Unison Ring-Operated VBV Door Installation
Figure 402 (Sheet 1 of 2)/75-32-03-990-802-F00**

EFFECTIVITY
HAP ALL

D633A101-HAP

75-32-03

Page 405
Oct 10/2003

737-600/700/800/900
AIRCRAFT MAINTENANCE MANUAL

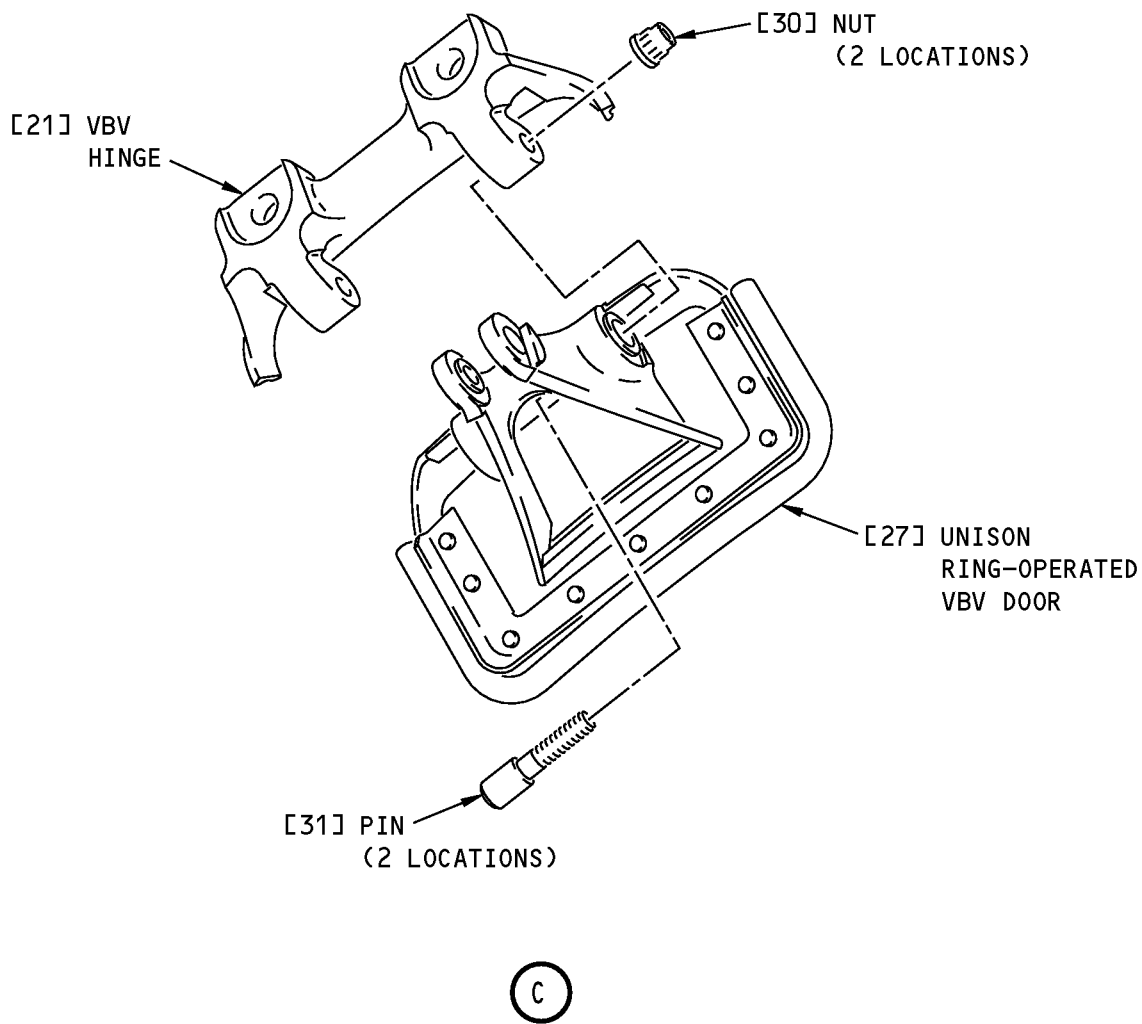

MM-00028-00-B

Unison Ring-Operated VBV Door Installation
Figure 402 (Sheet 2 of 2)/75-32-03-990-802-F00

EFFECTIVITY
HAP ALL

75-32-03

Page 406
Oct 10/2003

D633A101-HAP

AIRCRAFT MAINTENANCE MANUAL

TASK 75-32-03-400-801-F00

3. Unison Ring-Operated VBV Door Installation

(Figure 401, Figure 402)

A. General

- (1) This task is the installation procedure for the unison ring-operated VBV door (referred to as the VBV door).

B. References

Reference	Title
70-10-02-910-801-F00	General Precautions During the Removal and Installation of Engine Components (P/B 201)
71-00-00-800-811-F00	Power Plant Test Reference Table (P/B 501)
72-23-07-400-801-F00	Fan Duct Panel Installation (P/B 401)
75-32-00-700-802-F00	Unison Ring-Operated Variable Bleed Valve (VBV) Door - Adjustment (P/B 501)
78-31-00-010-804-F00	Close the Thrust Reverser (Selection) (P/B 201)

C. Consumable Materials

Reference	Description	Specification
D00601 [CP2101]	Grease - Graphite, High Temperature	SAE AMS 2518

D. Expendables/Parts

AMM Item	Description	AIPC Reference	AIPC Effectivity
27	Door	75-32-03-01-030	HAP ALL

E. Location Zones

Zone	Area
411	Engine 1 - Engine
421	Engine 2 - Engine

F. Prepare for the VBV Door Installation

SUBTASK 75-32-03-420-011-F00

- (1) If not already installed, do these steps to assemble the VBV hinge on the VBV door [27] (Figure 402):
- (a) Put the VBV hinge on the VBV door [27].
 - (b) Install the two pins [31] and the two nuts [30].
 - 1) Tighten the nuts [30] to 125-140 pound-inches (14-16 Newton-meters).

G. Unison Ring-Operated VBV Door Installation

SUBTASK 75-32-03-820-002-F00

CAUTION: DO NOT REMOVE THE JAMNUT LOCKWIRE, LOOSEN THE JAMNUT OR TURN THE ROD-END BEARING. IF YOU DO NOT OBEY THIS INSTRUCTION, ENGINE DAMAGE CAN OCCUR.

- (1) If the jamnut lockwire is removed or missing, and if it is possible that the rod-end bearing [24] was turned, do this task: Unison Ring-Operated Variable Bleed Valve (VBV) Door - Adjustment, TASK 75-32-00-700-802-F00 after you replace or re-install the VBV door [27].

EFFECTIVITY
HAP ALL

75-32-03Page 407
Jun 15/2009

D633A101-HAP

AIRCRAFT MAINTENANCE MANUAL

SUBTASK 75-32-03-420-001-F00

CAUTION: BE CAREFUL WHEN YOU INSTALL PARTS THAT ARE AROUND AN OPEN VBV DOOR. PARTS THAT FALL INTO AN OPEN VBV DOOR CAN FALL IN THE HIGH PRESSURE COMPRESSOR OF THE ENGINE. PARTS WHICH FALL INTO THE ENGINE CAN CAUSE ENGINE DAMAGE AT THE FIRST ENGINE OPERATION.

- (2) Do these steps to install the VBV door [27] on the fan frame:
- Remove the protective cover from the fan frame bleed port (TASK 70-10-02-910-801-F00).
 - Engage the VBV door [27], hinge first, on the fan frame.
 - Put the rod-end bearing [24] between the door yoke lugs [25].
 - Move the VBV door [27] slightly forward, then lower and center it against the fan frame.

SUBTASK 75-32-03-420-002-F00

- (3) Do these steps to attach the VBV hinge [21] to the fan frame:
- Lubricate the threads of the two bolts [29] with grease, D00601 [CP2101].
 - Loosely install the two bolts [29].
 - Push the VBV hinge [21] forward against the fan frame.

NOTE: Hold the VBV hinge in this position.

- Tighten the bolts [29] to 230-250 pound-inches (25.7-28.3 Newton meters).

SUBTASK 75-32-03-420-003-F00

- (4) Do these steps to connect the rod-end bearing [24] to the VBV door yoke [23]:
- Engage the bolt [22] through the VBV door yoke [23] and the eye of the rod-end bearing [24].
 - Install a new self-locking nut [26] on the bolt [22].
 - Tighten the self-locking nut [26] to 68-74 pound-inches (7.6-8.4 Newton meters).

H. Put the Airplane Back to Its Usual Condition

SUBTASK 75-32-03-410-003-F00

- (1) Do this task: Fan Duct Panel Installation, TASK 72-23-07-400-801-F00.

SUBTASK 75-32-03-010-008-F00

WARNING: OBEY THE INSTRUCTIONS IN THE PROCEDURE TO CLOSE THE THRUST REVERSER. IF YOU DO NOT OBEY THE INSTRUCTIONS, INJURIES TO PERSONS AND DAMAGE TO EQUIPMENT CAN OCCUR.

- (2) Do this task: Close the Thrust Reverser (Selection), TASK 78-31-00-010-804-F00.

SUBTASK 75-32-03-860-011-F00

- (3) For engine 1, do this step:

Remove the safety tags and close these circuit breakers:

CAPT Electrical System Panel, P18-2

<u>Row</u>	<u>Col</u>	<u>Number</u>	<u>Name</u>
A	4	C01390	ENGINE 1 ALTN PWR CHAN B
A	5	C01314	ENGINE 1 ALTN PWR CHAN A

SUBTASK 75-32-03-860-012-F00

- (4) For engine 2, do this step:

EFFECTIVITY
HAP ALL

D633A101-HAP

75-32-03

Page 408
Jun 15/2008

AIRCRAFT MAINTENANCE MANUAL

Remove the safety tags and close these circuit breakers:

F/O Electrical System Panel, P6-2

<u>Row</u>	<u>Col</u>	<u>Number</u>	<u>Name</u>
D	7	C01391	ENGINE 2 ALTN PWR CHAN B
D	8	C01315	ENGINE 2 ALTN PWR CHAN A

I. Unison Ring-Operated VBV Door Installation Test

SUBTASK 75-32-03-800-001-F00

- (1) Do the tests that are listed in the Power Plant Test Reference Table (TASK 71-00-00-800-811-F00).

————— END OF TASK —————

TASK 75-32-03-000-802-F00**4. Actuator-Operated VBV Door Removal**

(Figure 401, Figure 403)

A. General

- (1) This task is the removal procedure for the actuator-operated VBV door (referred to as the VBV door).
- (2) In this procedure, the 12 VBV doors are given positions 1 through 12 in the clockwise direction (view in the forward direction). VBV Door 1 is at the 1:00 o'clock position. The fan frame strut 1 is at the 12:00 o'clock position.
- (3) Each engine has ten unison ring-operated VBV doors and two actuator-operated VBV doors (positions 4 and 10).
- (4) All VBV doors are found on the fan frame.

B. References

<u>Reference</u>	<u>Title</u>
70-10-02-910-801-F00	General Precautions During the Removal and Installation of Engine Components (P/B 201)
72-23-07-000-801-F00	Fan Duct Panel Removal (P/B 401)
75-32-00-710-801-F00	Actuator-Operated Variable Bleed Valve (VBV) Door - Adjustment (P/B 501)
75-32-00-730-801-F00	VBV Actuation System - Manual Operation (P/B 201)
78-31-00-010-801-F00	Open the Thrust Reverser (Selection) (P/B 201)

C. Tools/Equipment

NOTE: When more than one tool part number is listed under the same "Reference" number, the tools shown are alternates to each other within the same airplane series. Tool part numbers that are replaced or non-procurable are preceded by "Opt:", which stands for Optional.

<u>Reference</u>	<u>Description</u>
SPL-2187	Actuator - Hydraulic, Portable, VSV Stator - CFM56-7/CFM56-3 (Part #: 856A1084G04, Supplier: 58828, A/P Effectivity: 737-300, -400, -500, -600, -700, -700C, -700ER, -700QC, -800, -900, -900ER, -BBJ)

D. Location Zones

<u>Zone</u>	<u>Area</u>
411	Engine 1 - Engine
421	Engine 2 - Engine

EFFECTIVITY
HAP ALL

D633A101-HAP

75-32-03

Page 409
Oct 15/2008

AIRCRAFT MAINTENANCE MANUAL

E. Prepare for the Removal

SUBTASK 75-32-03-860-005-F00

(1) For engine 1, do this step:

Open these circuit breakers and install safety tags:

CAPT Electrical System Panel, P18-2

<u>Row</u>	<u>Col</u>	<u>Number</u>	<u>Name</u>
A	4	C01390	ENGINE 1 ALTN PWR CHAN B
A	5	C01314	ENGINE 1 ALTN PWR CHAN A

SUBTASK 75-32-03-860-006-F00

(2) For engine 2, do this step:

Open these circuit breakers and install safety tags:

F/O Electrical System Panel, P6-2

<u>Row</u>	<u>Col</u>	<u>Number</u>	<u>Name</u>
D	7	C01391	ENGINE 2 ALTN PWR CHAN B
D	8	C01315	ENGINE 2 ALTN PWR CHAN A

SUBTASK 75-32-03-010-004-F00

WARNING: DO THESE SPECIFIED TASKS IN THE CORRECT SEQUENCE BEFORE YOU OPEN THE THRUST REVERSER: RETRACT THE LEADING EDGE, DEACTIVATE THE LEADING EDGE, DEACTIVATE THE THRUST REVERSER (FOR GROUND MAINTENANCE), AND OPEN THE FAN COWL PANEL. IF YOU DO NOT OBEY THE ABOVE SEQUENCE, INJURIES TO PERSONS AND DAMAGE TO EQUIPMENT CAN OCCUR.

(3) Do this task: Open the Thrust Reverser (Selection), TASK 78-31-00-010-801-F00.

SUBTASK 75-32-03-010-005-F00

(4) For position 4 or 10, do this task: Fan Duct Panel Removal, TASK 72-23-07-000-801-F00.

SUBTASK 75-32-03-860-016-F00

(5) Do these steps if the VBV door is fully closed:

(a) Use the actuator, SPL-2187, to slightly open the VBV door and release pressure of the seal [42] from the fan frame; do this task: VBV Actuation System - Manual Operation, TASK 75-32-00-730-801-F00.

1) Release the hydraulic pressure on the cart.

2) Disconnect the pressure source to prevent the actuation of the VBV system (TASK 75-32-00-730-801-F00).

F. Actuator-Operated VBV Door Removal

NOTE: There are 2 actuator-operated VBV doors on each engine. The VBV doors are operated by the actuators and are found at positions 4 and 10.

SUBTASK 75-32-03-020-004-F00

CAUTION: BE CAREFUL WHEN YOU REMOVE PARTS THAT ARE AROUND AN OPEN VBV DOOR. PARTS THAT FALL INTO AN OPEN VBV DOOR CAN FALL IN THE HIGH PRESSURE COMPRESSOR OF THE ENGINE. PARTS WHICH FALL INTO THE ENGINE CAN CAUSE ENGINE DAMAGE AT THE FIRST ENGINE OPERATION.

(1) Do these steps to disconnect the connecting rod [54] from the VBV actuator arm [52]:

(a) Remove and discard the self-locking nut [53] from the bolt [51].

EFFECTIVITY
HAP ALL

D633A101-HAP

75-32-03

Page 410
Oct 15/2008

AIRCRAFT MAINTENANCE MANUAL

(b) Remove the bolt [51] as follows:

- 1) Push the threaded-end of the bolt [51] to engage the bolt thread in the thread of the connecting rod [54].
- 2) Loosen and remove the bolt [51].

SUBTASK 75-32-03-020-005-F00

(2) Remove and discard the (double hex head) bolt [45] that attaches the bellcrank to the actuating VBV ring.

SUBTASK 75-32-03-020-006-F00

(3) Move the connecting rod [54] away from the VBV actuator arm [52].

SUBTASK 75-32-03-820-003-F00

CAUTION: DO NOT REMOVE THE JAMNUT LOCKWIRE, LOOSEN THE JAMNUT OR TURN THE ROD-END BEARING. IF YOU DO NOT OBEY THIS INSTRUCTION, ENGINE DAMAGE CAN OCCUR.

(4) If the jamnut lockwire is removed or missing, and if it is possible that the rod-end bearing [50] was turned, do this task: Actuator-Operated Variable Bleed Valve (VBV) Door - Adjustment, TASK 75-32-00-710-801-F00

after you replace or re-install the VBV door [48].

SUBTASK 75-32-03-020-007-F00

(5) Do these steps to disconnect the rod-end bearing [50] from the VBV door yoke [49]:

- (a) Remove and discard the self-locking nut [47] from the bolt [43].
- (b) Remove the bolt [43].

SUBTASK 75-32-03-020-008-F00

(6) Do these steps to remove the VBV hinge [44] from the fan frame:

- (a) Remove the two bolts [46] which attach the VBV hinge [44] to the fan frame.
- (b) Remove the VBV door [48] and the VBV hinge [44].
- (c) Install a protective cover on the fan frame bleed port (TASK 70-10-02-910-801-F00).

SUBTASK 75-32-03-020-010-F00

(7) If a VBV hinge [44] is not installed on the replacement VBV door [48], then do these steps to remove the VBV hinge [44] from the VBV door [48] and retain for the subsequent installation:

- (a) Remove the two pins [56] and the two nuts [55] that attach the VBV hinge [44] to the VBV door [48].
- (b) Remove the VBV hinge [44] from the VBV door [48].

————— END OF TASK —————

EFFECTIVITY
HAP ALL

D633A101-HAP

75-32-03

Page 411
Oct 15/2008

AIRCRAFT MAINTENANCE MANUAL

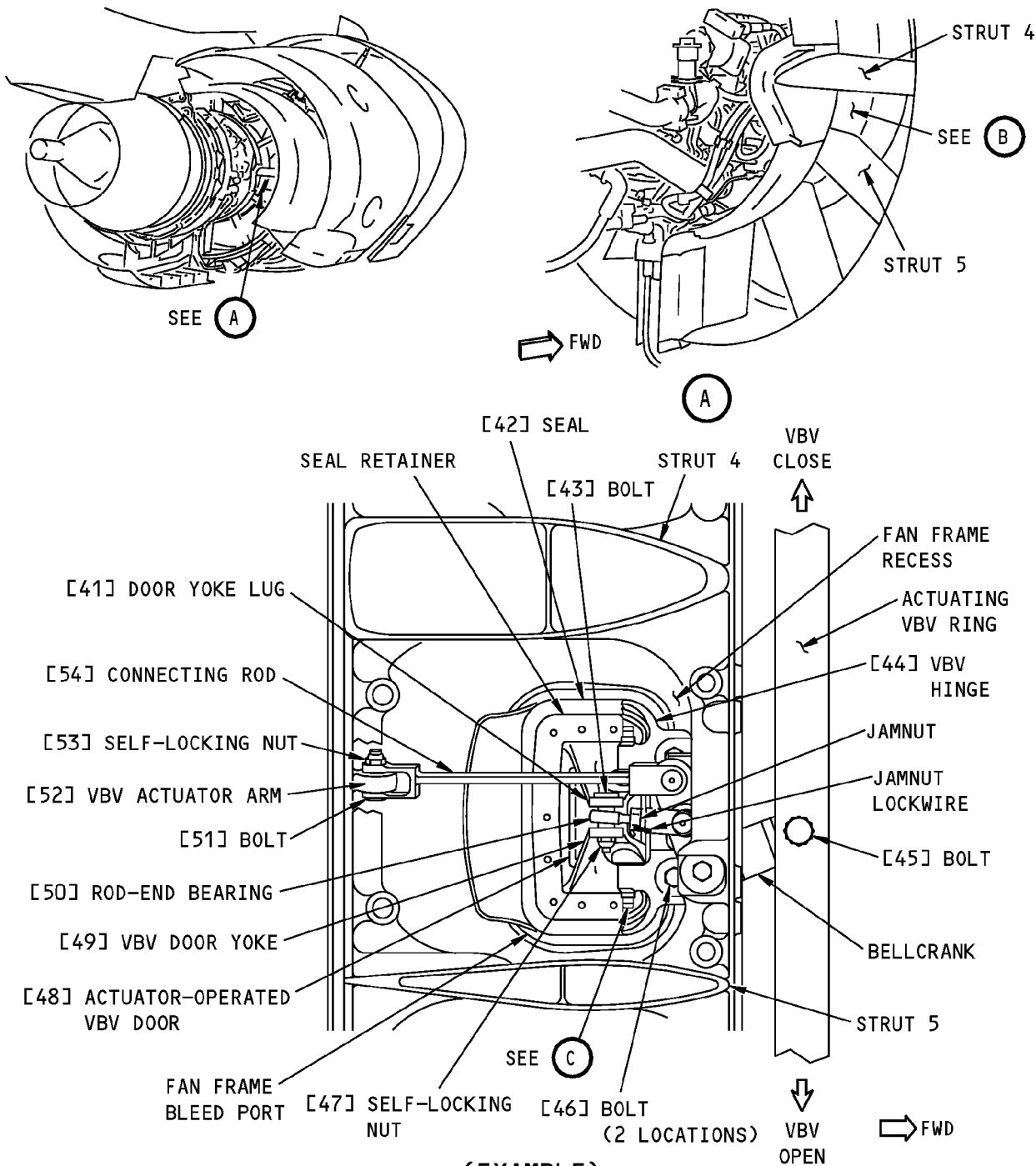

NOTE: THE ABOVE ARRANGEMENT IS IDENTICAL AT VBV DOOR POSITIONS 4 AND 10 (FIG. 401)

**Actuator-Operated VBV Door Installation
Figure 403 (Sheet 1 of 2)/75-32-03-990-803-F00**

EFFECTIVITY
HAP ALL

75-32-03

Page 412
Oct 10/2003

D633A101-HAP

737-600/700/800/900
AIRCRAFT MAINTENANCE MANUAL

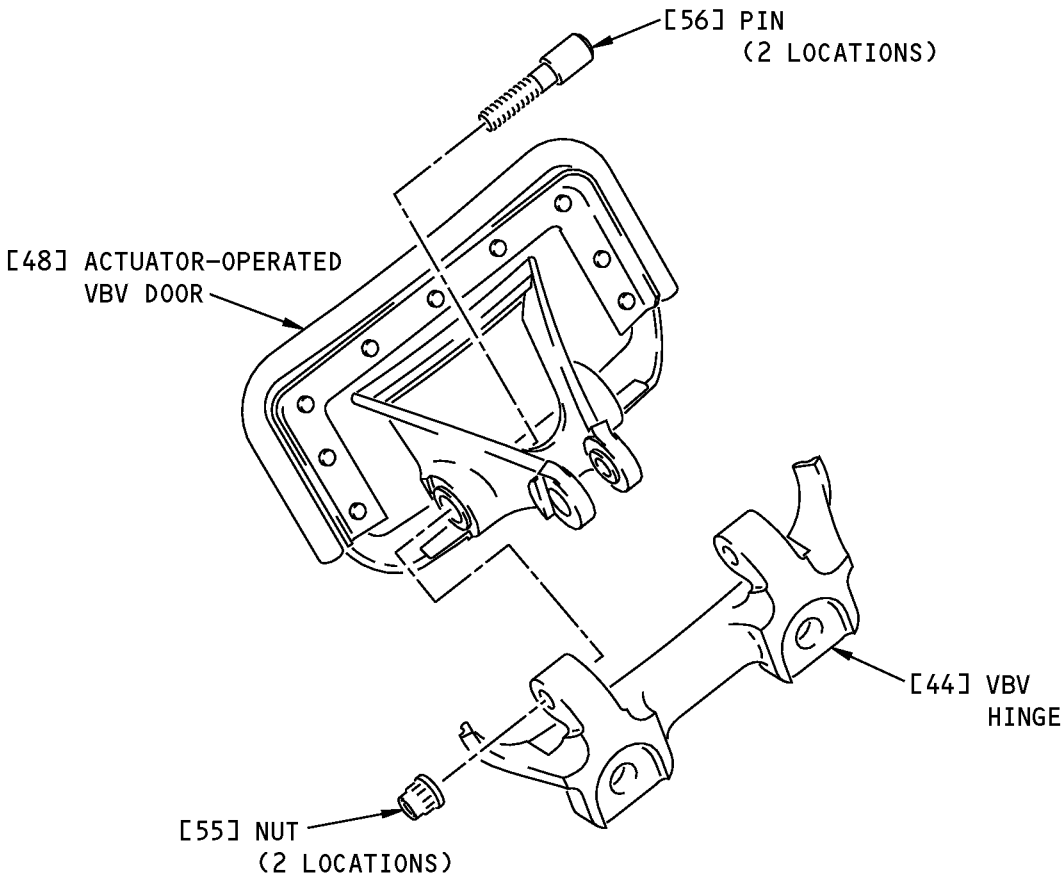

(C)

MM-00028-00-B

Actuator-Operated VBV Door Installation
Figure 403 (Sheet 2 of 2)/75-32-03-990-803-F00

EFFECTIVITY
HAP ALL

75-32-03

Page 413
Oct 10/2003

D633A101-HAP

AIRCRAFT MAINTENANCE MANUAL

TASK 75-32-03-400-802-F00

5. Actuator-Operated VBV Door Installation

(Figure 401, Figure 403)

A. General

- (1) This task is the installation procedure for the actuator-operated VBV door (referred to as the VBV door).

B. References

Reference	Title
70-10-02-910-801-F00	General Precautions During the Removal and Installation of Engine Components (P/B 201)
71-00-00-800-811-F00	Power Plant Test Reference Table (P/B 501)
72-23-07-400-801-F00	Fan Duct Panel Installation (P/B 401)
75-32-00-710-801-F00	Actuator-Operated Variable Bleed Valve (VBV) Door - Adjustment (P/B 501)
78-31-00-010-804-F00	Close the Thrust Reverser (Selection) (P/B 201)

C. Consumable Materials

Reference	Description	Specification
D00601 [CP2101]	Grease - Graphite, High Temperature	SAE AMS 2518

D. Expendables/Parts

AMM Item	Description	AIPC Reference	AIPC Effectivity
48	Door	75-32-03-01-030	HAP ALL

E. Location Zones

Zone	Area
411	Engine 1 - Engine
421	Engine 2 - Engine

F. Prepare for the VBV Door Installation

SUBTASK 75-32-03-420-012-F00

- (1) If not already installed, do these steps to assemble the VBV hinge on the VBV door [48] for each door (Figure 403):
- (a) Put the VBV hinge on the VBV door [48].
 - (b) Install the two pins [56] and the two nuts [55].
 - 1) Tighten the nuts [55] to 125-140 pound-inches (14-16 Newton meters).

G. Actuator-Operated VBV Door Installation

SUBTASK 75-32-03-820-005-F00

CAUTION: DO NOT REMOVE THE JAMNUT LOCKWIRE, LOOSEN THE JAMNUT OR TURN THE ROD-END BEARING. IF YOU DO NOT OBEY THIS INSTRUCTION, ENGINE DAMAGE CAN OCCUR.

- (1) If the jamnut lockwire is removed or missing, and if it is possible that the rod-end bearing [50] was turned, do this task: Actuator-Operated Variable Bleed Valve (VBV) Door - Adjustment, TASK 75-32-00-710-801-F00 after you replace or re-install the VBV door [48].

EFFECTIVITY
HAP ALL

75-32-03

Page 414
Jun 15/2009

D633A101-HAP

AIRCRAFT MAINTENANCE MANUAL

SUBTASK 75-32-03-420-005-F00

CAUTION: BE CAREFUL WHEN YOU INSTALL PARTS THAT ARE AROUND AN OPEN VBV DOOR. PARTS THAT FALL INTO AN OPEN VBV DOOR CAN FALL IN THE HIGH PRESSURE COMPRESSOR OF THE ENGINE. PARTS WHICH FALL INTO THE ENGINE CAN CAUSE ENGINE DAMAGE AT THE FIRST ENGINE OPERATION.

- (2) Do these steps to install the VBV door [48] on the fan frame:
- Remove the protective cover from the fan frame bleed port (TASK 70-10-02-910-801-F00).
 - Install the VBV door [48] on the fan frame bleed port.
 - Put the rod-end bearing [50] between the door yoke lugs [41] correctly.
 - Lubricate the threads of the two bolts [46] with grease, D00601 [CP2101].
 - Loosely install the two bolts [46].
 - Push the VBV hinge [44] forward against the fan frame.

NOTE: Hold the VBV hinge in this position.

- Tighten the bolts [46] to 230-250 pound-inches (25.5-28.0 Newton meters).

SUBTASK 75-32-03-420-006-F00

- (3) Do these steps to connect the rod-end bearing [50] to the VBV door [48]:
- Install the bolt [43] through the door yoke lug [41] and the eye of the rod-end bearing [50].
 - Install a new self-locking nut [47] on the bolt [43].
 - Tighten the self-locking nut [47] to 68-74 pound-inches (7.5-8.5 Newton meters).

SUBTASK 75-32-03-420-010-F00

- (4) Do these steps to connect the connecting rod [54] to the VBV actuator arm [52]:
- Carefully engage the bolt [51] through the fork of the connecting rod [54] and the eye of VBV actuator arm [52].
 - Tighten the bolt [51] until the bolt threads come out of the connecting rod threads.

NOTE: The bolt must be loose.
 - Install a new self-locking nut [53] on the bolt [51].
 - Tighten the self-locking nut [53] to 68-74 pound-inches (7.5-8.5 Newton meters).

SUBTASK 75-32-03-420-007-F00

- (5) Do these steps to connect the bellcrank to the actuating VBV ring:
- NOTE:** Move the connecting rod back and forth with your hand to engage the bolt through the actuating VBV ring and the bellcrank.
- Install a (double hex head) bolt [45].
 - Tighten the bolt [45] to 200-220 pound-inches (23.0-25.0 Newton meters).

H. Put the Airplane Back to Its Usual Condition

SUBTASK 75-32-03-410-004-F00

- Do this task: Fan Duct Panel Installation, TASK 72-23-07-400-801-F00.

SUBTASK 75-32-03-010-009-F00

WARNING: OBEY THE INSTRUCTIONS IN THE PROCEDURE TO CLOSE THE THRUST REVERSER. IF YOU DO NOT OBEY THE INSTRUCTIONS, INJURIES TO PERSONS AND DAMAGE TO EQUIPMENT CAN OCCUR.

- Do this task: Close the Thrust Reverser (Selection), TASK 78-31-00-010-804-F00.

EFFECTIVITY
HAP ALL

D633A101-HAP

75-32-03

Page 415
Jun 15/2008

737-600/700/800/900
AIRCRAFT MAINTENANCE MANUAL

SUBTASK 75-32-03-860-013-F00

(3) For engine 1, do this step:

Remove the safety tags and close these circuit breakers:

CAPT Electrical System Panel, P18-2

<u>Row</u>	<u>Col</u>	<u>Number</u>	<u>Name</u>
A	4	C01390	ENGINE 1 ALTN PWR CHAN B
A	5	C01314	ENGINE 1 ALTN PWR CHAN A

SUBTASK 75-32-03-860-014-F00

(4) For engine 2, do this step:

Remove the safety tags and close these circuit breakers:

F/O Electrical System Panel, P6-2

<u>Row</u>	<u>Col</u>	<u>Number</u>	<u>Name</u>
D	7	C01391	ENGINE 2 ALTN PWR CHAN B
D	8	C01315	ENGINE 2 ALTN PWR CHAN A

I. Actuator-Operated VBV Door Installation Test

SUBTASK 75-32-03-800-002-F00

(1) Do the tests that are listed in the Power Plant Test Reference Table (TASK 71-00-00-800-811-F00).

————— **END OF TASK** —————

EFFECTIVITY
HAP ALL

D633A101-HAP

75-32-03

Page 416
Jun 15/2008

AIRCRAFT MAINTENANCE MANUAL

VARIABLE BLEED VALVE DOORS - INSPECTION/CHECK1. General

A. This procedure contains one task, the visual inspection of the variable bleed valve doors for damage.

TASK 75-32-03-200-801-F002. Variable Bleed Valve Doors Inspection

(Figure 601, Figure 602)

A. General

(1) This task is the visual inspection procedure for the variable bleed valve doors (referred to as the VBV doors).

B. References

Reference	Title
72-23-07-000-801-F00	Fan Duct Panel Removal (P/B 401)
72-23-07-400-801-F00	Fan Duct Panel Installation (P/B 401)
75-32-03-000-801-F00	Unison Ring-Operated VBV Door Removal (P/B 401)
75-32-03-000-802-F00	Actuator-Operated VBV Door Removal (P/B 401)
75-32-03-400-801-F00	Unison Ring-Operated VBV Door Installation (P/B 401)
75-32-03-400-802-F00	Actuator-Operated VBV Door Installation (P/B 401)
78-31-00-010-801-F00	Open the Thrust Reverser (Selection) (P/B 201)
78-31-00-010-804-F00	Close the Thrust Reverser (Selection) (P/B 201)

C. Tools/Equipment

Reference	Description
STD-1081	Flashlight - Explosion Proof
STD-3907	Mirror - Dental

D. Consumable Materials

Reference	Description	Specification
G02345 [CP8001]	Lockwire - Inconel (0.032 inch Dia.)	NASM20995~ N32
G50065 [CP8006]	Cable, Safety, Stainless Steel, 0.8mm (0.032inch) Diameter	

E. Location Zones

Zone	Area
411	Engine 1 - Engine
421	Engine 2 - Engine

F. Prepare for the Variable Bleed Valve Door Inspection

SUBTASK 75-32-03-010-010-F00

WARNING: DO THESE SPECIFIED TASKS IN THE CORRECT SEQUENCE BEFORE YOU OPEN THE THRUST REVERSER: RETRACT THE LEADING EDGE, DO THE DEACTIVATION OF THE LEADING EDGE AND THE THRUST REVERSER (FOR GROUND MAINTENANCE), AND OPEN THE FAN COWL PANELS. IF YOU DO NOT OBEY THE ABOVE SEQUENCE, INJURIES TO PERSONS AND DAMAGE TO EQUIPMENT CAN OCCUR.

(1) Do this task: Open the Thrust Reverser (Selection), TASK 78-31-00-010-801-F00.

EFFECTIVITY
HAP ALL

D633A101-HAP

75-32-03

Page 601
Jun 10/2005

AIRCRAFT MAINTENANCE MANUAL

SUBTASK 75-32-03-010-011-F00

- (2) For the applicable VBV door, do this task: Fan Duct Panel Removal, TASK 72-23-07-000-801-F00.

SUBTASK 75-32-03-100-001-F00

- (3) Clean the VBV door of all dirt or unwanted material.

G. Variable Bleed Valve Door Inspection

SUBTASK 75-32-03-960-001-F00

- (1) If you find damage which are not in the limits, do the steps that follow unless you are given other instructions:

- (a) For VBV doors at positions 4 and 10, replace the applicable VBV door.

These are the tasks:

Unison Ring-Operated VBV Door Removal, TASK 75-32-03-000-801-F00,

Unison Ring-Operated VBV Door Installation, TASK 75-32-03-400-801-F00.

- (b) For VBV doors at positions 1, 2, 3, 5, 6, 7, 8, 9, 11 and 12, replace the applicable VBV door.

These are the tasks:

Actuator-Operated VBV Door Removal, TASK 75-32-03-000-802-F00,

Actuator-Operated VBV Door Installation, TASK 75-32-03-400-802-F00.

SUBTASK 75-32-03-210-001-F00

- (2) Examine the VBV doors for cracks:

NOTE: Use a explosion proof flashlight, STD-1081 and a dental mirror, STD-3907 to examine the areas of the VBV doors that are not easy to see.

- (a) Cracks are not permitted.

SUBTASK 75-32-03-210-002-F00

- (3) Examine the VBV doors for loose or missing rivets:

- (a) Loose or missing rivets are not permitted.

SUBTASK 75-32-03-210-003-F00

- (4) Examine the seal retainer for cracks:

- (a) Cracks are not permitted.

SUBTASK 75-32-03-210-004-F00

- (5) Examine the seal for tears or cuts:

- (a) Tears or cuts are not permitted.

SUBTASK 75-32-03-210-005-F00

- (6) Examine the seal for torn edges:

- (a) Torn edges of 0.05 inch (1.27 mm) in length on the outer surface are permitted.

SUBTASK 75-32-03-210-006-F00

- (7) Examine the lockwire:

- (a) Broken or missing lockwire is not permitted.

- (b) If the lockwire or safety cable is broken or missing, then install lockwire, G02345 [CP8001] or cable, G50065 [CP8006]

EFFECTIVITY
HAP ALL

D633A101-HAP

75-32-03

Page 602
Oct 10/2007

AIRCRAFT MAINTENANCE MANUAL

H. Put the Airplane Back to Its Usual Condition

SUBTASK 75-32-03-410-005-F00

(1) Do this task: Fan Duct Panel Installation, TASK 72-23-07-400-801-F00.

SUBTASK 75-32-03-010-012-F00

WARNING: OBEY THE INSTRUCTIONS IN THE PROCEDURE TO CLOSE THE THRUST REVERSER. IF YOU DO NOT OBEY THE INSTRUCTIONS, INJURIES TO PERSONS AND DAMAGE TO EQUIPMENT CAN OCCUR.

(2) Do this task: Close the Thrust Reverser (Selection), TASK 78-31-00-010-804-F00.

————— **END OF TASK** —————

EFFECTIVITY
HAP ALL

D633A101-HAP

75-32-03Page 603
Oct 10/2003

737-600/700/800/900
AIRCRAFT MAINTENANCE MANUAL

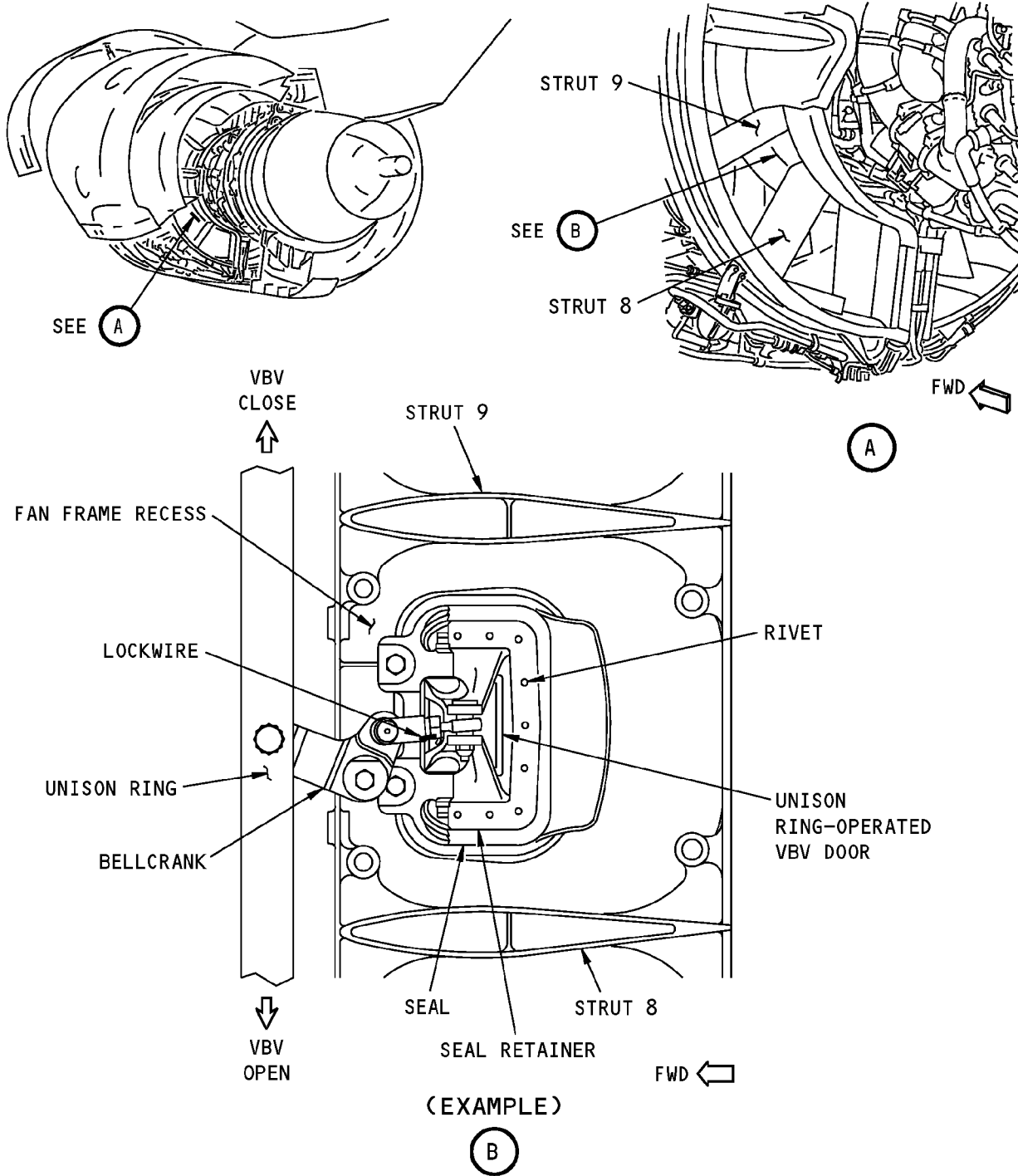

NOTE: THE ABOVE ARRANGEMENT IS IDENTICAL AT VBV DOOR POSITIONS 1, 2, 3, 5, 6, 7, 8, 9, 11 AND 12.

S-M56-MM-03712-00-B

Unison Ring-Operated VBV Door Adjustment
Figure 601/75-32-03-990-804-F00

EFFECTIVITY
HAP ALL

75-32-03

AIRCRAFT MAINTENANCE MANUAL

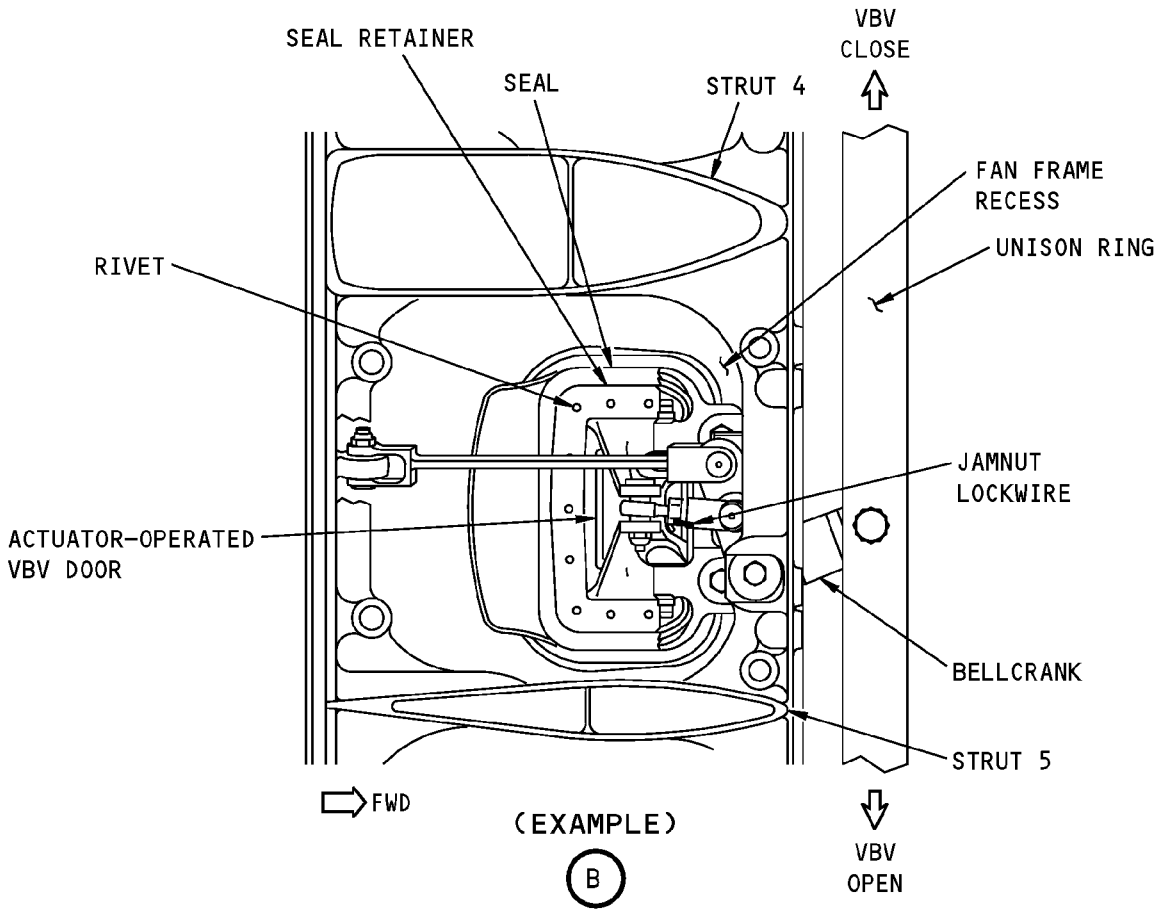
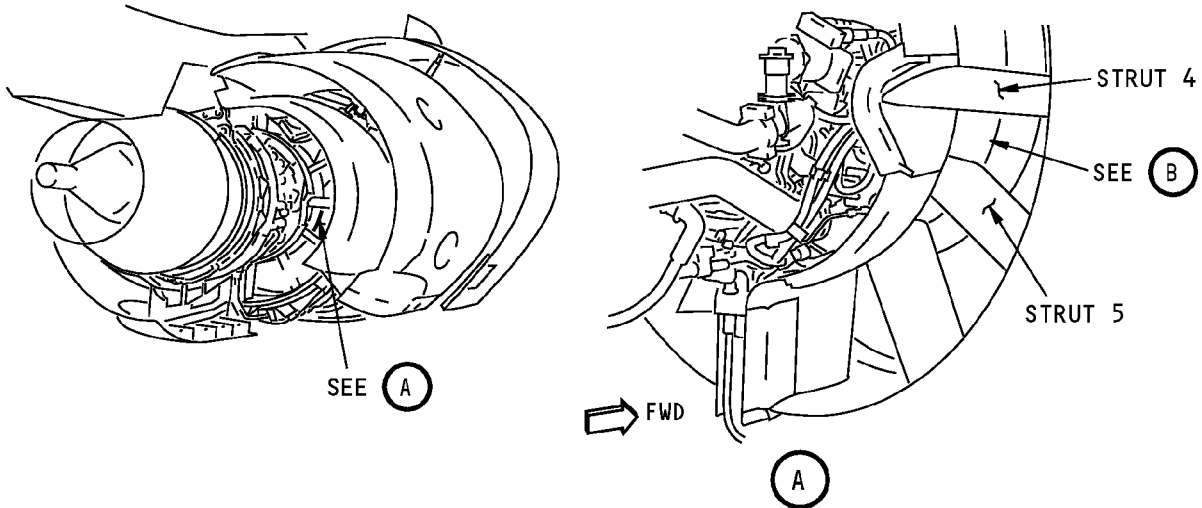

NOTE: THE ABOVE ARRANGEMENT IS IDENTICAL AT VBV DOOR POSITIONS 4 AND 10.

**Actuator-Operated VBV Door Inspection
Figure 602/75-32-03-990-805-F00**

EFFECTIVITY
HAP ALL

75-32-03