

CHAPTER

79

OIL

**737-600/700/800/900
AIRCRAFT MAINTENANCE MANUAL**

**CHAPTER 79
OIL**

Subject/Page	Date	COC	Subject/Page	Date	COC	Subject/Page	Date	COC
EFFECTIVE PAGES			79-00-00 (cont)			79-11-01 (cont)		
1 thru 2	Jun 15/2009		630	Jun 10/2007		812	Jun 15/2008	
79-CONTENTS			79-00-00			813		
1	Feb 15/2008		901	Oct 10/2003		814	BLANK	
2	Jun 15/2008		902	Oct 10/2003		79-21-00		
3	Oct 15/2008		79-11-01			201	Feb 10/2007	
O 4	Jun 15/2009		401	Oct 10/2003		202	Feb 10/2007	
O 5	Jun 15/2009		402	Oct 10/2003		203	Feb 10/2005	
6	BLANK		403	Jun 10/2005		204	Oct 10/2003	
79-00-00			404	Oct 10/2003		205	Oct 10/2003	
601	Feb 15/2009		405	Oct 10/2003		206	Feb 10/2007	
602	Feb 15/2009		R 406	Jun 15/2009		207	Feb 10/2007	
603	Oct 10/2003		407	Feb 15/2009		208	Jun 10/2004	
604	Oct 10/2003		408	Feb 15/2009		209	Jun 10/2004	
605	Oct 10/2003		409	Feb 15/2009		210	Jun 10/2004	
606	Oct 10/2003		410	BLANK		211	Jun 10/2004	
607	Oct 10/2003		79-11-01			212	Jun 10/2004	
608	Feb 15/2009		601	Feb 15/2009		213	Jun 10/2004	
609	Oct 10/2007		602	Feb 15/2009		214	Jun 10/2004	
610	Oct 10/2007		603	Oct 10/2003		215	Jun 10/2004	
611	Jun 10/2004		604	Oct 10/2003		216	BLANK	
612	Jun 10/2004		605	Oct 10/2003		79-21-01		
613	Feb 15/2009		606	BLANK		401	Oct 15/2008	
R 614	Jun 15/2009		79-11-01			402	Jun 10/2004	
615	Jun 10/2006		R 701	Jun 15/2009		403	Jun 10/2004	
616	Jun 10/2007		702	Jun 10/2006		404	Jun 10/2005	
617	Feb 15/2009		703	Oct 10/2003		405	Oct 10/2003	
618	Feb 15/2009		704	Oct 10/2003		406	Oct 10/2003	
619	Feb 15/2009		79-11-01			407	Oct 10/2003	
620	Feb 15/2009		801	Feb 15/2009		408	Oct 10/2003	
621	Feb 15/2008		802	Feb 15/2009		R 409	Jun 15/2009	
622	Feb 15/2008		803	Oct 10/2003		410	Feb 15/2009	
623	Feb 15/2008		804	Jun 15/2008		411	Feb 15/2009	
624	Jun 10/2007		805	Jun 15/2008		412	BLANK	
625	Jun 10/2007		806	Jun 10/2006		79-21-01		
626	Jun 10/2007		807	Jun 15/2008		801	Oct 15/2008	
627	Jun 10/2007		808	Jun 15/2008		802	Oct 15/2008	
628	Feb 15/2009		809	Jun 10/2006		803	Oct 10/2003	
629	Jun 10/2007		810	Jun 10/2006		804	Oct 10/2003	
			811	Jun 15/2008		805	Feb 15/2009	

A = Added, R = Revised, D = Deleted, O = Overflow, C = Customer Originated Change

79-EFFECTIVE PAGES

**737-600/700/800/900
AIRCRAFT MAINTENANCE MANUAL**

**CHAPTER 79
OIL**

Subject/Page	Date	COC	Subject/Page	Date	COC	Subject/Page	Date	COC
79-21-01 (cont)			79-21-05 (cont)			79-31-01		
806	Oct 15/2008		403	Oct 10/2003		401	Oct 10/2003	
807	Oct 15/2008		404	Oct 10/2007		402	Jun 10/2005	
808	Oct 15/2008		405	Feb 10/2007		403	Oct 10/2003	
809	Oct 15/2008		406	BLANK		R 404	Jun 15/2009	
810	Oct 15/2008		79-21-06			405	Feb 15/2009	
811	Oct 15/2008		401	Feb 15/2009		406	Feb 15/2009	
812	Oct 15/2008		402	Feb 15/2009		79-32-01		
813	Oct 15/2008		403	Feb 15/2009		401	Oct 10/2004	
814	Oct 15/2008		404	Feb 15/2009		402	Jun 10/2005	
79-21-02			405	Feb 10/2004		403	Oct 10/2003	
401	Oct 10/2007		406	Feb 15/2009		R 404	Jun 15/2009	
402	Oct 10/2005		407	Oct 15/2008		405	Jun 10/2005	
403	Oct 10/2005		408	Oct 15/2008		406	BLANK	
404	Oct 10/2005		79-21-07			79-34-02		
405	Oct 10/2005		R 401	Jun 15/2009		401	Oct 10/2004	
406	Oct 10/2005		402	Jun 10/2005		402	Jun 10/2005	
407	Oct 10/2005		403	Jun 10/2005		403	Oct 10/2003	
R 408	Jun 15/2009		R 404	Jun 15/2009		404	Oct 10/2003	
409	Feb 15/2009		405	Jun 15/2008		405	Feb 15/2009	
410	Feb 15/2009		406	BLANK		406	Jun 10/2005	
411	Feb 15/2009		79-21-09					
412	BLANK		401	Oct 10/2003				
79-21-03			402	Oct 10/2003				
401	Feb 15/2009		403	Jun 10/2005				
R 402	Jun 15/2009		404	Oct 10/2003				
403	Oct 10/2003		405	Oct 10/2003				
R 404	Jun 15/2009		R 406	Jun 15/2009				
405	Feb 15/2009		407	Feb 15/2009				
406	Feb 15/2009		408	Oct 10/2003				
79-21-04			79-21-10					
401	Oct 10/2003		A 401	Jun 15/2009				
402	Oct 10/2003		A 402	Jun 15/2009				
403	Oct 10/2003		A 403	Jun 15/2009				
R 404	Jun 15/2009		A 404	Jun 15/2009				
405	Oct 10/2007		A 405	Jun 15/2009				
406	Oct 10/2003		A 406	BLANK				
79-21-05			79-31-00					
401	Feb 10/2007		501	Oct 10/2003				
402	Feb 10/2007		502	Oct 10/2003				

A = Added, R = Revised, D = Deleted, O = Overflow, C = Customer Originated Change

79-EFFECTIVE PAGES

AIRCRAFT MAINTENANCE MANUAL

CHAPTER 79
OIL

<u>Subject</u>	<u>Chapter Section Subject</u>	<u>Conf</u>	<u>Page</u>	<u>Effect</u>
<u>OIL - INSPECTION/CHECK</u>	79-00-00		601	HAP ALL
External Oil System Inspection TASK 79-00-00-200-802-F00			601	HAP ALL
Internal Oil System Inspection TASK 79-00-00-200-803-F00			608	HAP ALL
Aft Sump Oil System Inspection TASK 79-00-00-200-806-F01			609	HAP ALL
Chip Detectors and Scavenge Screens Inspection TASK 79-00-00-200-804-F00			613	HAP ALL
Oil Supply Filter Pop-Out Indicator Inspection (Visual Check) TASK 79-00-00-200-805-F00			628	HAP ALL
<u>OIL - DDG MAINTENANCE PROCEDURES</u>	79-00-00		901	HAP ALL
MMEL 79-1 (DDPG) Preparation - Oil Quantity Indication Inoperative TASK 79-00-00-040-801-F00			901	HAP ALL
MMEL 79-1 (DDPG) Restoration - Oil Quantity Indication Inoperative TASK 79-00-00-440-801-F00			901	HAP ALL
MMEL 79-2 (DDPG) Preparation - Oil Filter Bypass Warning Systems Inoperative TASK 79-00-00-040-802-F00			902	HAP ALL
MMEL 79-2 (DDPG) Restoration - Oil Filter Bypass Warning Systems Inoperative TASK 79-00-00-440-802-F00			902	HAP ALL
<u>OIL TANK - REMOVAL/INSTALLATION</u>	79-11-01		401	HAP ALL
Oil Tank Removal TASK 79-11-01-000-801-F00			401	HAP ALL
Oil Tank Installation TASK 79-11-01-400-801-F00			406	HAP ALL

79-CONTENTS

AIRCRAFT MAINTENANCE MANUAL

CHAPTER 79
OIL

<u>Subject</u>	<u>Chapter Section Subject</u>	<u>Conf</u>	<u>Page</u>	<u>Effect</u>
<u>OIL TANK - INSPECTION/CHECK</u>	79-11-01		601	HAP ALL
Oil Tank Inspection TASK 79-11-01-200-801-F00			601	HAP ALL
<u>OIL TANK - CLEANING/PAINTING</u>	79-11-01		701	HAP ALL
Oil Tank Cleaning TASK 79-11-01-100-801-F00			701	HAP ALL
<u>OIL TANK - REPAIRS</u>	79-11-01		801	HAP ALL
Replacement of the Filler Cap Packing or Filler Cap TASK 79-11-01-300-801-F00			801	HAP ALL
Replacement of the Oil Cap Assembly Packings TASK 79-11-01-300-802-F00			804	HAP ALL
Replacement of the Plugs by the Remote Filling Kit TASK 79-11-01-300-803-F00			807	HAP ALL
Replacement of the Sight Glass TASK 79-11-01-800-801-F00			811	HAP ALL
<u>OIL DISTRIBUTION - MAINTENANCE PRACTICES</u>	79-21-00		201	HAP ALL
Calibration of the Air Flow Test Rig TASK 79-21-00-280-801-F00			201	HAP ALL
Air Flow Test of the Engine Oil Circuit TASK 79-21-00-700-801-F00			206	HAP ALL
<u>LUBRICATION UNIT - REMOVAL/ INSTALLATION</u>	79-21-01		401	HAP ALL
Lubrication Unit Removal TASK 79-21-01-000-801-F00			401	HAP ALL
Lubrication Unit Installation TASK 79-21-01-400-801-F00			409	HAP ALL

79-CONTENTS

AIRCRAFT MAINTENANCE MANUAL

CHAPTER 79
OIL

<u>Subject</u>	<u>Chapter Section Subject</u>	<u>Conf</u>	<u>Page</u>	<u>Effect</u>
<u>LUBRICATION UNIT - REPAIRS</u>	79-21-01		801	HAP ALL
Packing Replacement On The Inner Sealing Spool (Lubrication Unit Installed) TASK 79-21-01-400-802-F00			801	HAP ALL
Packing Replacement On The Inner and Outer Sealing Spools (Lubrication Unit Removed) TASK 79-21-01-400-803-F00			805	HAP ALL
Packing Replacement On The Inner and Outer Sealing Spools (Lubrication Unit Installed) TASK 79-21-01-400-804-F00			812	HAP ALL
<u>MAIN OIL/FUEL HEAT EXCHANGER - REMOVAL/INSTALLATION</u>	79-21-02		401	HAP ALL
Main Oil/Fuel Heat Exchanger Removal TASK 79-21-02-000-801-F00			401	HAP ALL
Main Oil/Fuel Heat Exchanger Installation TASK 79-21-02-400-801-F00			408	HAP ALL
<u>OIL SUPPLY FILTER - REMOVAL/ INSTALLATION</u>	79-21-03		401	HAP ALL
Oil Supply Filter Removal TASK 79-21-03-000-802-F00			401	HAP ALL
Oil Supply Filter Installation TASK 79-21-03-400-801-F00			404	HAP ALL
<u>SCAVENGE OIL FILTER ASSEMBLY - REMOVAL/INSTALLATION</u>	79-21-04		401	HAP ALL
Scavenge Oil Filter Assembly Removal TASK 79-21-04-000-801-F00			401	HAP ALL
Scavenge Oil Filter Assembly Installation TASK 79-21-04-400-801-F00			404	HAP ALL

79-CONTENTS

AIRCRAFT MAINTENANCE MANUAL

CHAPTER 79
OIL

<u>Subject</u>	<u>Chapter Section Subject</u>	<u>Conf</u>	<u>Page</u>	<u>Effect</u>
<u>CHIP DETECTOR REMOVAL/INSTALLATION</u>	79-21-05		401	HAP ALL
Magnetic Chip Detector (MCD) Removal TASK 79-21-05-000-806-F00			401	HAP ALL
Magnetic Chip Detector (MCD) Installation TASK 79-21-05-400-804-F00			404	HAP ALL
<u>SCAVENGE OIL FILTER ELEMENT - REMOVAL/INSTALLATION</u>	79-21-06		401	HAP ALL
Scavenge Oil Filter Element Removal TASK 79-21-06-000-801-F00			401	HAP ALL
Scavenge Oil Filter Element Installation TASK 79-21-06-400-801-F00			406	HAP ALL
<u>SCAVENGE OIL FILTER CLOGGING TRANSMITTER - REMOVAL/ INSTALLATION</u>	79-21-07		401	HAP ALL
Scavenge Oil Filter Clogging Transmitter Removal TASK 79-21-07-000-801-F00			401	HAP ALL
Scavenge Oil Filter Clogging Transmitter Installation TASK 79-21-07-400-801-F00			404	HAP ALL
<u>OIL ANTI-LEAK VALVE - REMOVAL/ INSTALLATION</u>	79-21-09		401	HAP ALL
Oil Anti-Leak Valve Removal TASK 79-21-09-000-801-F00			401	HAP ALL
Oil Anti-Leak Valve - Installation TASK 79-21-09-400-801-F00			406	HAP ALL
<u>CLOGGING INDICATOR - REMOVAL/ INSTALLATION</u>	79-21-10		401	HAP ALL
Clogging Indicator Removal TASK 79-21-10-000-801-F00			401	HAP ALL
Clogging Indicator Installation TASK 79-21-10-400-801-F00			404	HAP ALL

79-CONTENTS

AIRCRAFT MAINTENANCE MANUAL

CHAPTER 79
OIL

<u>Subject</u>	<u>Chapter Section Subject</u>	<u>Conf</u>	<u>Page</u>	<u>Effect</u>
<u>OIL QUANTITY INDICATING SYSTEM - ADJUSTMENT/TEST</u>	79-31-00		501	HAP ALL
System Test - Oil Quantity Indicating System TASK 79-31-00-730-801-F00			501	HAP ALL
<u>OIL QUANTITY TRANSMITTER - REMOVAL/ INSTALLATION</u>	79-31-01		401	HAP ALL
Oil Quantity Transmitter Removal TASK 79-31-01-000-801-F00			401	HAP ALL
Oil Quantity Transmitter Installation TASK 79-31-01-400-801-F00			404	HAP ALL
<u>OIL PRESSURE SENSOR - REMOVAL/ INSTALLATION</u>	79-32-01		401	HAP ALL
Oil Pressure Sensor Removal TASK 79-32-01-000-801-F00			401	HAP ALL
Oil Pressure Sensor Installation TASK 79-32-01-400-801-F00			404	HAP ALL
<u>OIL TEMPERATURE SENSOR - REMOVAL/ INSTALLATION</u>	79-34-02		401	HAP ALL
Oil Temperature Sensor Removal TASK 79-34-02-000-801-F00			401	HAP ALL
Oil Temperature Sensor Installation TASK 79-34-02-400-801-F00			405	HAP ALL

79-CONTENTS

AIRCRAFT MAINTENANCE MANUAL

OIL - INSPECTION/CHECK**1. General**

- A. This procedure contains scheduled maintenance task data.
- B. This procedure has these tasks:
 - (1) The inspection of the external oil system
 - (2) The inspection of the internal oil system
 - (3) Chip Detector Inspection for Bearing and Gearbox Deterioration
 - (4) The inspection of the chip detectors and scavenge screens
 - (5) The inspection of the oil supply filter pop-out indicator.

TASK 79-00-00-200-802-F00**2. External Oil System Inspection**

(Figure 601), (Figure 602), (Figure 603), (Figure 604)

A. General

- (1) This task is a visual check of the engine and nacelle for evidence of oil leakage.

B. References

Reference	Title
71-00-02-000-801-F00	Power Plant Removal (P/B 401)
71-00-02-400-801-F00	Power Plant Installation (P/B 401)
71-11-02-010-801-F00	Open the Fan Cowl Panels (P/B 201)
71-71-00-200-801-F00	Engine Vents and Drains Inspection (P/B 601)
78-31-00-010-801-F00	Open the Thrust Reverser (Selection) (P/B 201)
78-31-00-010-804-F00	Close the Thrust Reverser (Selection) (P/B 201)

C. Location Zones

Zone	Area
411	Engine 1 - Engine
421	Engine 2 - Engine

D. Do a Check for the External Oil Leakage

SUBTASK 79-00-00-210-001-F00

- (1) With the engine stopped, do a check of the bottom of the fan cowls for oil leakage at these locations (Figure 601):
 - (a) The starter air discharge duct.
 - (b) The forward drain holes.
 - (c) The aft drain holes.

SUBTASK 79-00-00-010-001-F00

- (2) If you find oil leakage, do this task: Engine Vents and Drains Inspection, TASK 71-71-00-200-801-F00.

SUBTASK 79-00-00-210-005-F00

- (3) Do a check of the inner side of the primary nozzle on the turbine frame struts and the stage 4 LPT blades for oil leakage (Figure 602).
 - (a) If they are wet with oil and the oil consumption is above serviceable limits, replace the engine.

EFFECTIVITY
HAP ALL

79-00-00Page 601
Feb 15/2009

D633A101-HAP

AIRCRAFT MAINTENANCE MANUAL

These are the tasks:

- Power Plant Removal, TASK 71-00-02-000-801-F00
- Power Plant Installation, TASK 71-00-02-400-801-F00.

SUBTASK 79-00-00-210-006-F00

- (4) Do a check of the fan blades and the stage 1 vanes at the 6:00 o'clock position for oil leakage (Figure 603).
- (a) If they are wet with oil, replace the engine.

These are the tasks:

- Power Plant Removal, TASK 71-00-02-000-801-F00
- Power Plant Installation, TASK 71-00-02-400-801-F00.

SUBTASK 79-00-00-010-002-F00

- (5) If the fan cowl panels are not open, do this task: Open the Fan Cowl Panels, TASK 71-11-02-010-801-F00.

SUBTASK 79-00-00-210-007-F00

- (6) Do a check of these components to see if they are wet with oil:
- (a) The fan cowl panels.
 - (b) The engine surfaces.
 - (c) The oil system components.
 - (d) The fan frame interface points with the transfer gearbox.
 - (e) If they are wet with oil, replace the applicable engine component.

SUBTASK 79-00-00-010-008-F00

WARNING: DO THESE SPECIFIED TASKS IN THE CORRECT SEQUENCE BEFORE YOU OPEN THE THRUST REVERSER: RETRACT THE LEADING EDGE, DO THE DEACTIVATION PROCEDURES FOR THE LEADING EDGE AND THE THRUST REVERSER (FOR GROUND MAINTENANCE), AND OPEN THE FAN COWL PANELS. IF YOU DO NOT OBEY THE ABOVE SEQUENCE, INJURIES TO PERSONS AND DAMAGE TO EQUIPMENT CAN OCCUR.

- (7) Do this task: Open the Thrust Reverser (Selection), TASK 78-31-00-010-801-F00.

SUBTASK 79-00-00-210-008-F00

- (8) Do a check of the oil scavenge and the oil supply tubes for damage or for loose connections (Figure 604):

NOTE: Look for oil stripes and drops of oil.

- (a) Tubes and tube coupling nuts with cracks are not serviceable.
- (b) There is no limit to the number of nicks and scratches that are permitted if the depth is less than 0.01 inch (0.25 mm) (after you remove the high metal).
- (c) Two dents for each tube is permitted if they have a smooth contour and the depth is less than 0.05 inch (1.30 mm).
- (d) Replace or tighten the nuts and bolts which are loose or missing.
- (e) Replace or repair the tube clamps which are loose or worn.

EFFECTIVITY
HAP ALL

D633A101-HAP

79-00-00

Page 602
Feb 15/2009

AIRCRAFT MAINTENANCE MANUAL

SUBTASK 79-00-00-410-009-F00

WARNING: OBEY THE INSTRUCTIONS IN THE PROCEDURE TO CLOSE THE THRUST REVERSERS. IF YOU DO NOT OBEY THE INSTRUCTIONS, INJURIES TO PERSONS AND DAMAGE TO EQUIPMENT CAN OCCUR.

(9) Do this task: Close the Thrust Reverser (Selection), TASK 78-31-00-010-804-F00.

————— **END OF TASK** —————

EFFECTIVITY
HAP ALL

D633A101-HAP

79-00-00

Page 603
Oct 10/2003

737-600/700/800/900
AIRCRAFT MAINTENANCE MANUAL

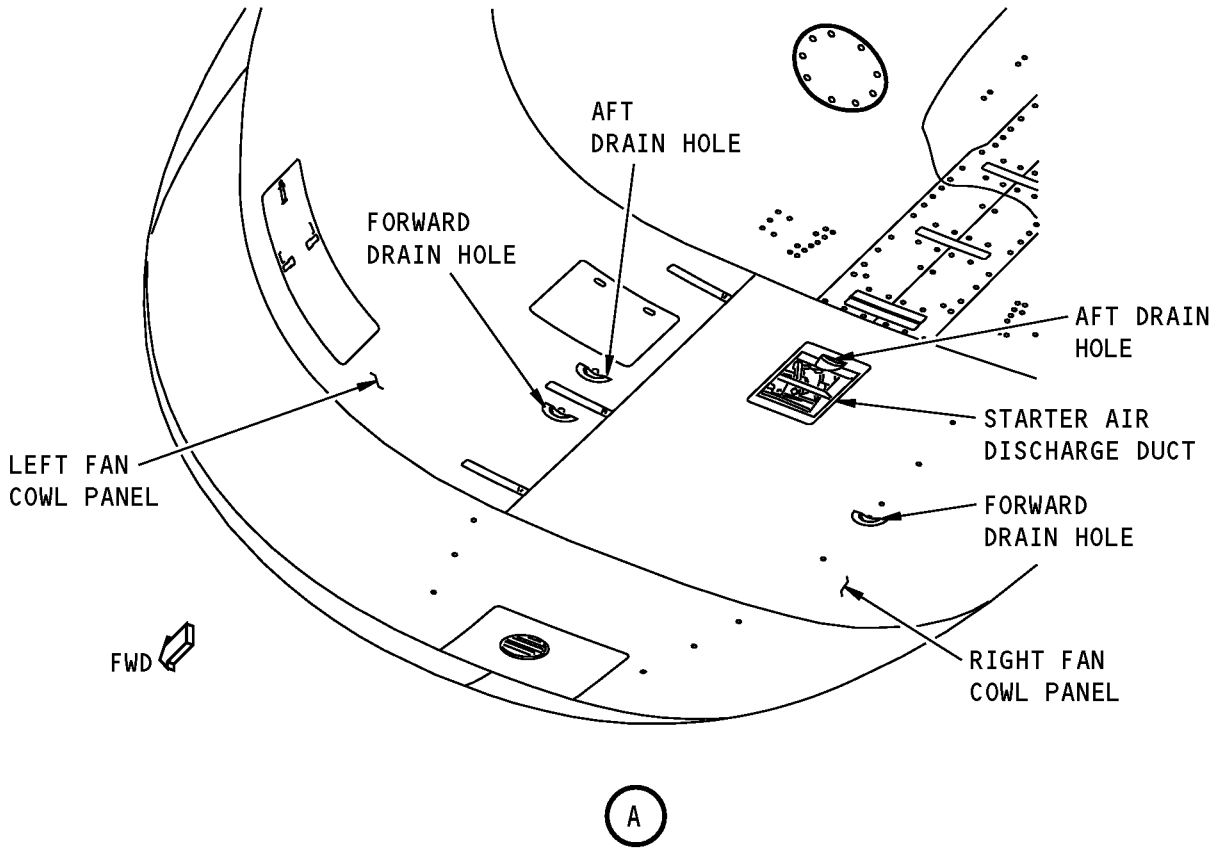
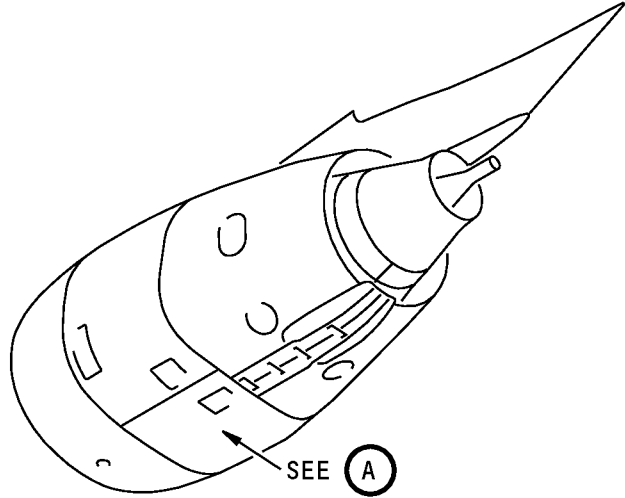

Fan Cowl Inspection
Figure 601/79-00-00-990-801-F00

EFFECTIVITY
HAP ALL

79-00-00

737-600/700/800/900
AIRCRAFT MAINTENANCE MANUAL

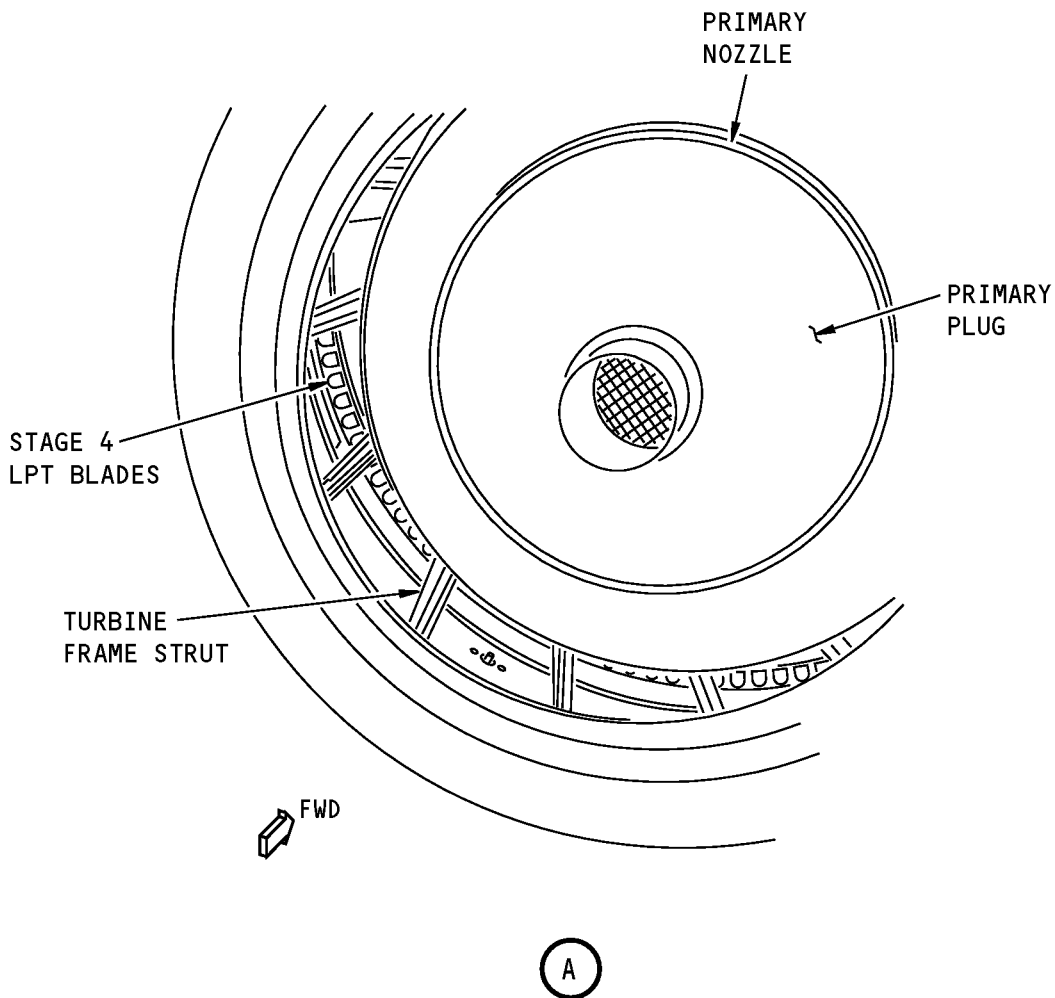
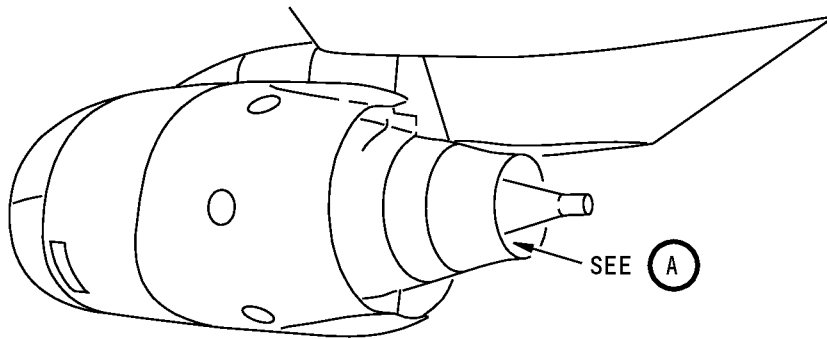

Primary Nozzle Assembly Inspection
Figure 602/79-00-00-990-802-F00

EFFECTIVITY
HAP ALL

79-00-00

Page 605
Oct 10/2003

D633A101-HAP

**737-600/700/800/900
AIRCRAFT MAINTENANCE MANUAL**

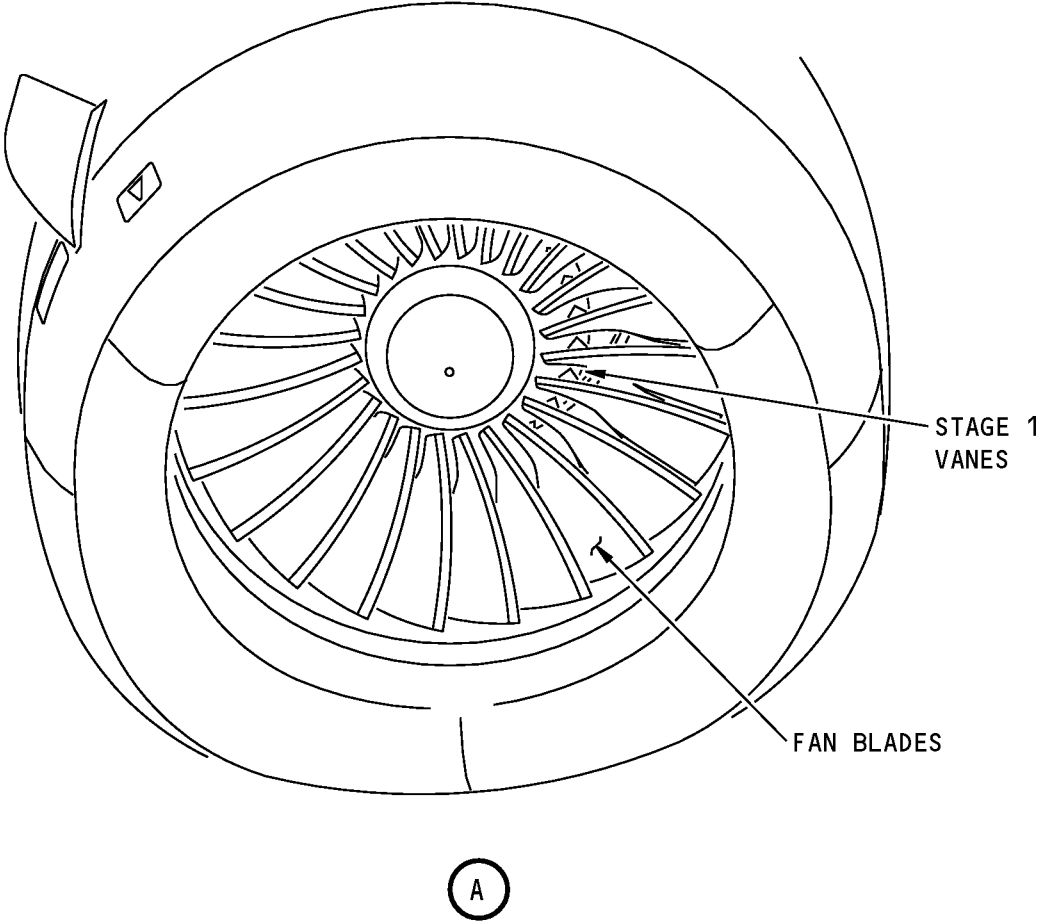
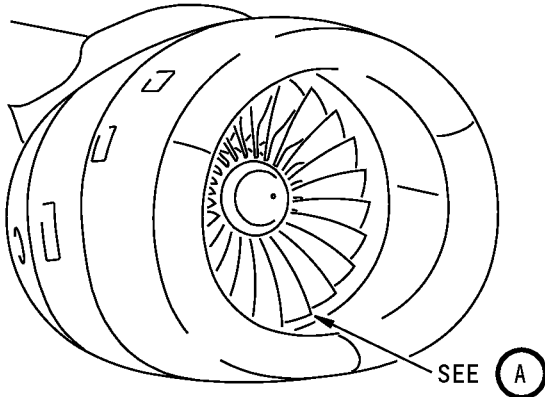

**Fan Blades and Stage 1 Vanes Inspection
Figure 603/79-00-00-990-803-F00**

EFFECTIVITY
HAP ALL

79-00-00

Page 606
Oct 10/2003

D633A101-HAP

737-600/700/800/900
AIRCRAFT MAINTENANCE MANUAL

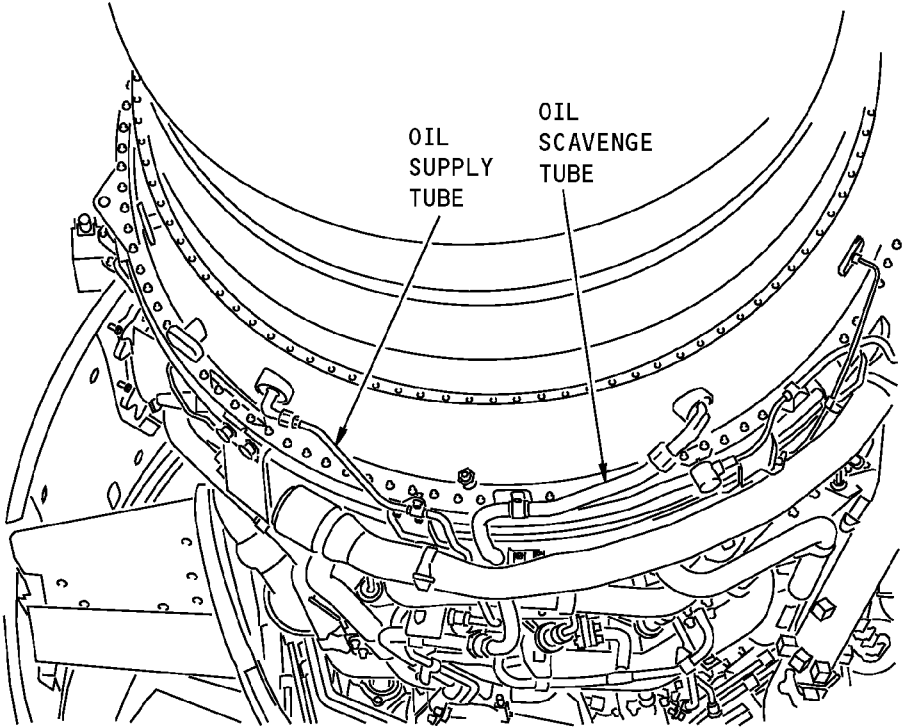
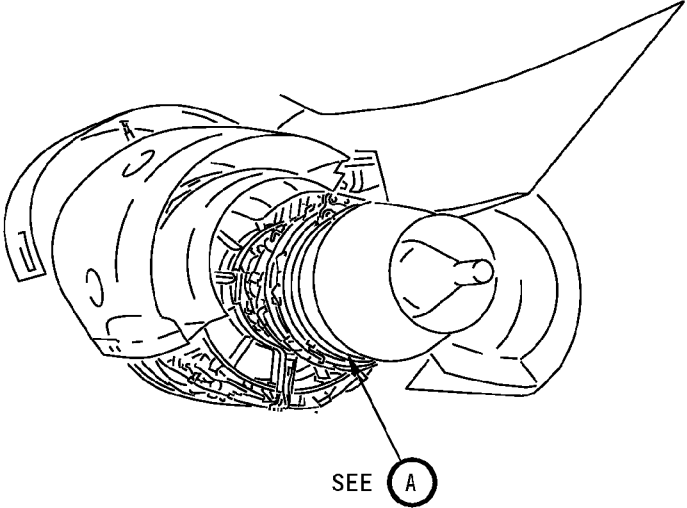

A

Oil Supply and Oil Scavenge Tubes Inspection
Figure 604/79-00-00-990-804-F00

EFFECTIVITY
HAP ALL

79-00-00

Page 607
Oct 10/2003

D633A101-HAP

AIRCRAFT MAINTENANCE MANUAL

TASK 79-00-00-200-803-F00

3. Internal Oil System Inspection

A. General

- (1) This task is a borescope inspection of areas of the internal engine where oil leakage could occur. When you do the fault isolation for an oil consumption problem, an inspection for an internal oil leak could be necessary.
- (2) This task includes a borescope inspection of the High Pressure Compressor (HPC).

B. References

Reference	Title
71-00-02-000-801-F00	Power Plant Removal (P/B 401)
71-00-02-400-801-F00	Power Plant Installation (P/B 401)
71-71-00-200-801-F00	Engine Vents and Drains Inspection (P/B 601)
72-00-00-200-804-F00	Borecope Inspection of the HP Compressor Blades (P/B 601)
78-31-00-010-801-F00	Open the Thrust Reverser (Selection) (P/B 201)
78-31-00-010-804-F00	Close the Thrust Reverser (Selection) (P/B 201)

C. Location Zones

Zone	Area
411	Engine 1 - Engine
421	Engine 2 - Engine

D. Procedure

SUBTASK 79-00-00-010-003-F00

WARNING: DO THESE SPECIFIED TASKS IN THE CORRECT SEQUENCE BEFORE YOU OPEN THE THRUST REVERSER: RETRACT THE LEADING EDGE, DO THE DEACTIVATION PROCEDURES FOR THE LEADING EDGE AND THE THRUST REVERSER (FOR GROUND MAINTENANCE), AND OPEN THE FAN COWL PANELS. IF YOU DO NOT OBEY THE ABOVE SEQUENCE, INJURIES TO PERSONS AND DAMAGE TO EQUIPMENT CAN OCCUR.

- (1) Do this task: Open the Thrust Reverser (Selection), TASK 78-31-00-010-801-F00.

SUBTASK 79-00-00-290-001-F00

- (2) To do a check of the stage 1 and 2 blades on the HPC, do this task: Borecope Inspection of the HP Compressor Blades, TASK 72-00-00-200-804-F00.

NOTE: Look for signs of oil on the blades.

- (a) If the stage 1 and 2 blades on the HPC are wet with oil and the engine oil consumption is above serviceable limits Engine Vents and Drains Inspection, TASK 71-71-00-200-801-F00, replace the engine.

These are the tasks:

- Power Plant Removal, TASK 71-00-02-000-801-F00
- Power Plant Installation, TASK 71-00-02-400-801-F00.

EFFECTIVITY
HAP ALL

D633A101-HAP

79-00-00

Page 608
Feb 15/2009

737-600/700/800/900
AIRCRAFT MAINTENANCE MANUAL

SUBTASK 79-00-00-410-002-F00

WARNING: OBEY THE INSTRUCTIONS IN THE PROCEDURE TO CLOSE THE THRUST REVERSERS. IF YOU DO NOT OBEY THE INSTRUCTIONS, INJURIES TO PERSONS AND DAMAGE TO EQUIPMENT CAN OCCUR.

(3) Do this task: Close the Thrust Reverser (Selection), TASK 78-31-00-010-804-F00.

————— **END OF TASK** —————

TASK 79-00-00-200-806-F01**4. Aft Sump Oil System Inspection**

Figure 605

A. General

(1) This task is a visual check of the aft sump oil system for oil leakage.

B. References

Reference	Title
71-00-02-000-801-F00	Power Plant Removal (P/B 401)
71-00-02-400-801-F00	Power Plant Installation (P/B 401)
72-56-00-000-802-F00	Oil Inlet Cover Removal (P/B 401)
72-56-00-300-801-F00	Oil Supply Tube Replacement (P/B 801)
72-56-00-400-801-F00	Oil Inlet Cover Installation (P/B 401)
78-11-01-000-801-F00	Primary Nozzle Assembly Removal (P/B 401)
78-11-01-400-801-F00	Primary Nozzle Assembly Installation (P/B 401)
78-11-02-000-801-F00	Primary Plug Assembly Removal (P/B 401)
78-11-02-400-801-F00	Primary Plug Assembly Installation (P/B 401)

C. Location Zones

Zone	Area
411	Engine 1 - Engine
421	Engine 2 - Engine

D. Procedure

SUBTASK 79-00-00-210-015-F01

(1) With the engine stopped, do a visual check of the oil tubes at the turbine rear frame (TRF) interface for oil leakage and coking.

SUBTASK 79-00-00-360-001-F01

(2) If there is oil leakage or large amount of coking at the TRF interface, do these steps:

- (a) Do this task: Primary Nozzle Assembly Removal, TASK 78-11-01-000-801-F00.
- (b) Do this task: Primary Plug Assembly Removal, TASK 78-11-02-000-801-F00.
- (c) Remove the flame arrestor, refer to this task TASK 72-56-00-000-802-F00.
- (d) Remove the flange assembly, refer to this task TASK 72-56-00-000-802-F00.
- (e) Examine the oil supply coupling nuts for loose connections.

NOTE: Do not touch, disconnect, or tighten the scavenge tube coupling nut to the TRF scavenge nipple unless you have the CFM tool, 856A3492G01 or 856A3492G02. Damage to the equipment can occur which can lead to oil loss.

- 1) If it is necessary, tighten the loose coupling nuts.

EFFECTIVITY
HAP ALL

D633A101-HAP

79-00-00

Page 609
Oct 10/2007

AIRCRAFT MAINTENANCE MANUAL

- (f) Examine the oil scavenge tube and connection for cracks.
 - 1) If there is a crack on the scavenge tube or connection, replace the engine. These are the tasks: Power Plant Removal, TASK 71-00-02-000-801-F00 and Power Plant Installation, TASK 71-00-02-400-801-F00.
- (g) Examine the oil supply tube assembly for cracks.
 - 1) If there is a crack on the oil supply tube that goes through the No.10 TRF strut, do this step:
 - a) ENGINES PRE-CFMI-SB 72-0339;
Do this bulletin to install a replaceable oil supply tube.
 - b) ENGINES POST-CFMI-SB 72-0339;
Replace the oil supply tube. Do this task: Oil Supply Tube Replacement, TASK 72-56-00-300-801-F00.
- (h) If there are no cracks on the oil supply tube or loose coupling nuts, replace the oil inlet cover o-ring and gasket.
 - 1) To replace the o-ring and seal, do these tasks: Oil Inlet Cover Removal, TASK 72-56-00-000-802-F00 and Oil Inlet Cover Installation, TASK 72-56-00-400-801-F00.
- (i) Install the flange assembly, refer to this task TASK 72-56-00-400-801-F00
- (j) Install the flame arrestor, refer to this task TASK 72-56-00-400-801-F00
- (k) Do this task: Primary Plug Assembly Installation, TASK 78-11-02-400-801-F00.
- (l) Do this task: Primary Nozzle Assembly Installation, TASK 78-11-01-400-801-F00.

————— **END OF TASK** —————

EFFECTIVITY
HAP ALL

D633A101-HAP

79-00-00

Page 610
Oct 10/2007

AIRCRAFT MAINTENANCE MANUAL

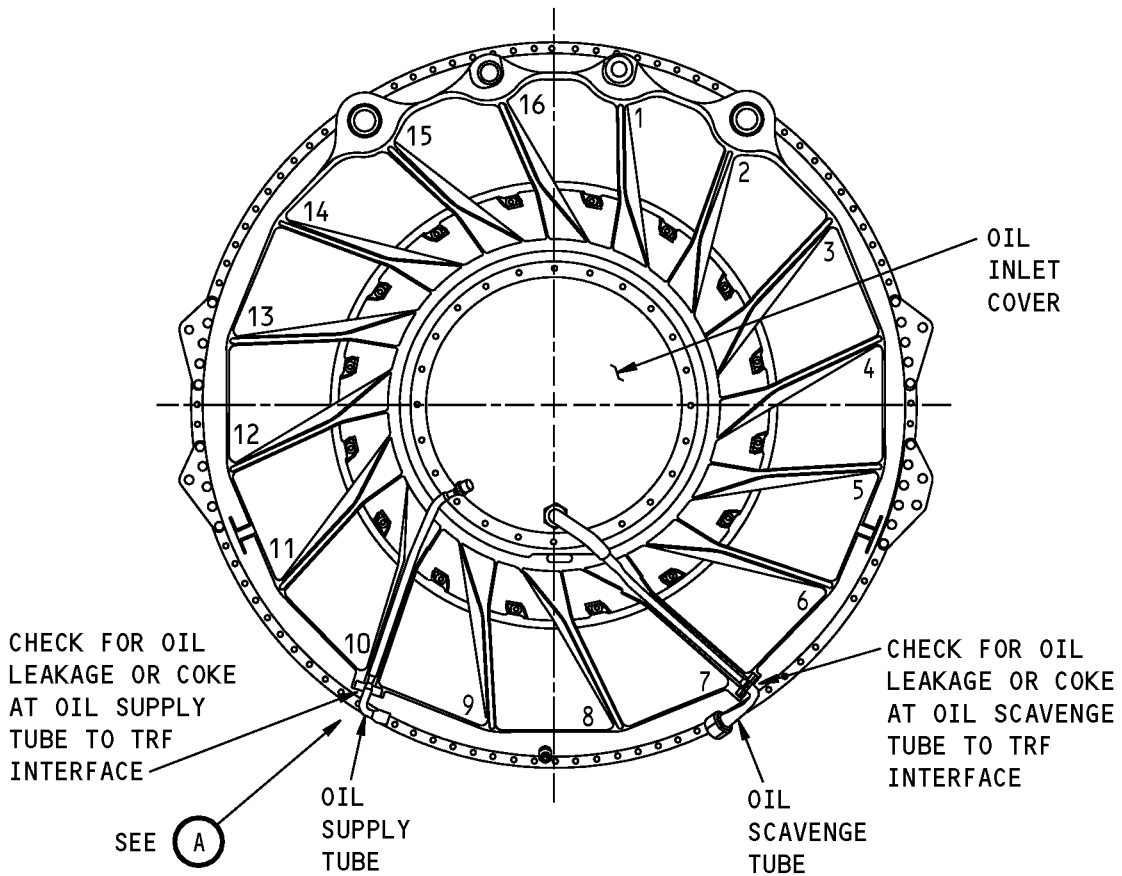
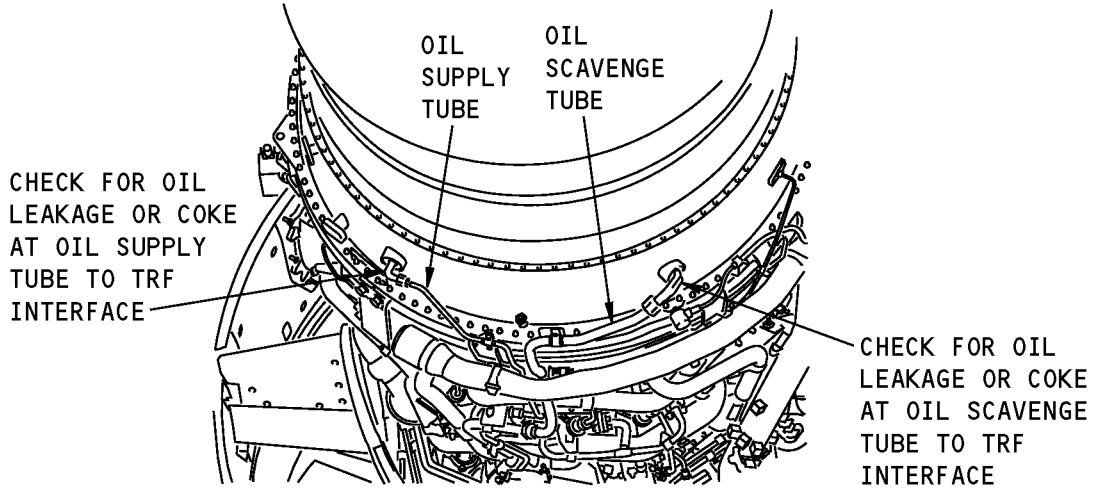

(VIEW IN THE FORWARD DIRECTION)

Aft Sump Oil System Inspection
Figure 605 (Sheet 1 of 2)/79-00-00-990-808-F01

EFFECTIVITY
HAP ALL

79-00-00

Page 611
Jun 10/2004

D633A101-HAP

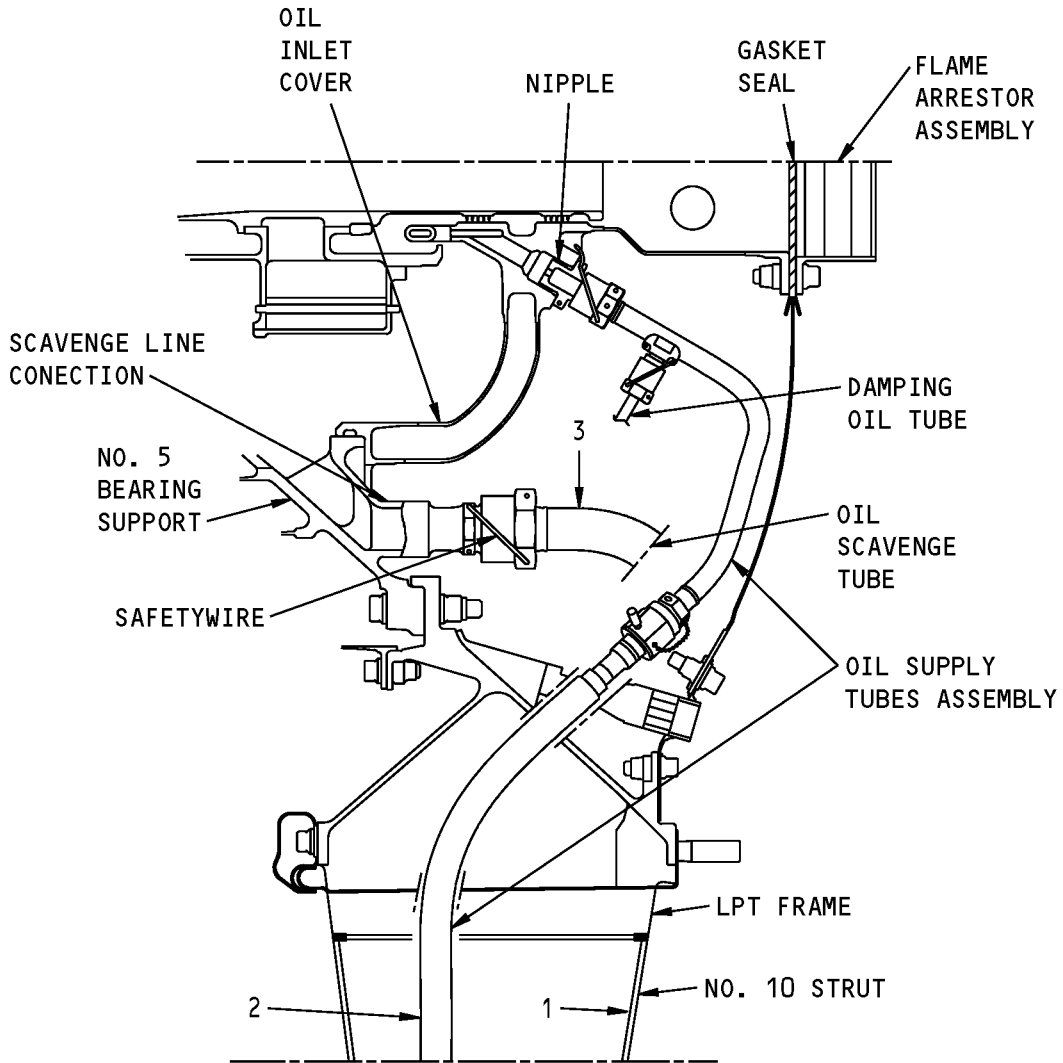

(A)

MATERIAL:

- 1: INCONEL 718 (NC19FeNB)
- 2: AISI 321 (Z10CNT18)
- 3: AISI 321 (Z10CNT18)

Aft Sump Oil System Inspection
Figure 605 (Sheet 2 of 2)/79-00-00-990-808-F01

EFFECTIVITY
HAP ALL

79-00-00

AIRCRAFT MAINTENANCE MANUAL

TASK 79-00-00-200-804-F00

5. Chip Detectors and Scavenge Screens Inspection

(Figure 606), (Figure 607)

A. General

- (1) This procedure is a scheduled maintenance task.
- (2) For identification of a bearing failure and other failures of the oil system components, examine the chip detectors and scavenge screens.

B. References

Reference	Title
12-13-11-100-801	Flush The Engine Oil System (P/B 301)
71-00-00-800-806-F00	Engine Operation Limits (P/B 201)
71-00-00-800-807-F00	Start the Engine Procedure (Selection) (P/B 201)
71-00-02-000-801-F00	Power Plant Removal (P/B 401)
71-00-02-400-801-F00	Power Plant Installation (P/B 401)
71-11-02-010-801-F00	Open the Fan Cowl Panels (P/B 201)
71-11-02-410-801-F00	Close the Fan Cowl Panels (P/B 201)
72-56-00-000-801-F00	Oil Supply Line Cleaning (P/B 701)
72-56-00-100-802-F00	Oil Scavenge Line Cleaning (P/B 701)
72-56-00-300-801-F00	Oil Supply Tube Replacement (P/B 801)
72-60-00-000-802-F00	Sealol Seal Removal (P/B 201)
72-60-00-400-802-F00	Sealol Seal Installation (P/B 201)
72-62-00-000-801-F00	Transfer Gearbox Assembly Removal (P/B 401)
72-62-00-200-802-F00	Transfer Gearbox Internal Inspection (P/B 601)
72-62-00-400-801-F00	Transfer Gearbox Assembly Installation (P/B 401)
73-21-08-000-801-F00	EEC Alternator and Alternator Rotor Removal (P/B 401)
73-21-08-400-801-F00	EEC Alternator and Alternator Rotor Installation (P/B 401)
79-21-01-400-802-F00	Packing Replacement On The Inner Sealing Spool (Lubrication Unit Installed) (P/B 801)
79-21-01-400-803-F00	Packing Replacement On The Inner and Outer Sealing Spools (Lubrication Unit Removed) (P/B 801)
79-21-05-000-806-F00	Magnetic Chip Detector (MCD) Removal (P/B 401)
79-21-05-400-804-F00	Magnetic Chip Detector (MCD) Installation (P/B 401)
79-21-06-000-801-F00	Scavenge Oil Filter Element Removal (P/B 401)
79-21-06-400-801-F00	Scavenge Oil Filter Element Installation (P/B 401)
80-11-01-200-801-F00	Starter Magnetic Plug Inspection (P/B 601)

C. Tools/Equipment

NOTE: When more than one tool part number is listed under the same "Reference" number, the tools shown are alternates to each other within the same airplane series. Tool part numbers that are replaced or non-procurable are preceded by "Opt:", which stands for Optional.

Reference	Description
SPL-2450	Set - Print, Identification, Magnetic Chip Detector Debris (Part #: 856A2683G01, Supplier: 58828, A/P Effectivity: 737-300, -400, -500, -600, -700, -700C, -700ER, -700QC, -800, -900, -900ER, -BBJ) (Opt Part #: 856A1364G02, Supplier: 58828, A/P Effectivity: 737-300, -400, -500, -600, -700, -700C, -700ER, -700QC, -800, -900, -900ER, -BBJ)
STD-1070	Lens - Magnifying, 10X, Hand Held
STD-1280	Source - Air, Regulated, Dry Filtered, 0-30 PSIG

EFFECTIVITY
HAP ALL

79-00-00

Page 613
Feb 15/2009

D633A101-HAP

AIRCRAFT MAINTENANCE MANUAL

D. Consumable Materials

Reference	Description	Specification
B00682 [CP2011]	Solvent - Stoddard	P-D-680, Type I, II or III
G00034	Cotton Wiper - Process Cleaning Absorbent Wiper (Cheesecloth, Gauze)	BMS15-5
G01659	Swab - Disposable, Cotton Or Rayon Applicator	GG-A-616

E. Location Zones

Zone	Area
411	Engine 1 - Engine
421	Engine 2 - Engine

F. Examine the Particles From the Chip Detectors and Scavenge Screens

NOTE: Accumulation, of a specific volume, of particles over a series of regularly scheduled chip detector inspections is not used as a method to identify any specific engine failure. However, based on initial chip detector findings, reduced interval chip detector inspections may be necessary to determine the amount, type and source of collected particles. Particle identification is based on visual or laboratory analysis. Corrective action is taken after you have identified the collected particles.

SUBTASK 79-00-00-010-007-F00

(1) Do this task: Open the Fan Cowl Panels, TASK 71-11-02-010-801-F00.

SUBTASK 79-00-00-020-001-F00

CAUTION: REMOVE AND TAG ONE CHIP DETECTOR AT A TIME. THIS CAN PREVENT AN ERROR IN IDENTIFICATION OF THE SOURCE OF THE MATERIAL ON THE CHIP DETECTORS.

(2) Do this task: Magnetic Chip Detector (MCD) Removal, TASK 79-21-05-000-806-F00.

(a) Place without dripping, the chip detector or scavenge screen with particles in a new polyethylene bag.

(b) Attach a tag to identify each chip detector location.

1) The tag identifies the plug location for each sump scavenge circuit (AGB/TGB Scavenge, Front FWD Sump Scavenge, AFT Sump Scavenge).

SUBTASK 79-00-00-020-002-F00

CAUTION: REMOVE THE SCREEN FROM THE CHIP DETECTORS TO EXAMINE THE CHIP DETECTOR MAGNET FOR THE PRESENCE OF PARTICLES. IF YOU DO NOT REMOVE THE SCREEN FROM THE CHIP DETECTOR, IT IS POSSIBLE THAT YOU WILL NOT BE ABLE TO SEE THE PARTICLES THAT ARE CAUGHT BY THE CHIP DETECTOR MAGNET.

EFFECTIVITY
HAP ALL

D633A101-HAP

79-00-00

Page 614
Jun 15/2009

AIRCRAFT MAINTENANCE MANUAL

(CAUTION PRECEDES)

CAUTION: CFM DOES NOT RECOMMEND THE USE OF ADHESIVE TAPE. HOWEVER, IF A PIECE OF ADHESIVE TAPE IS USED TO COLLECT THE PARTICLES, MAKE SURE THE ADHESIVE IS NOT TOO STRONG. IF THE ADHESIVE ON THE TAPE IS TOO STRONG THE PARTICLES MAY BE DAMAGED WHEN THEY ARE REMOVED AND/OR IT WILL AFFECT THE LABORATORY ANALYSIS OF THE MATERIAL.

- (3) If not already done, do these steps to remove the scavenge screen from the chip detector and clean the scavenge screen (Figure 606):

NOTE: Make sure you do not remove the particles from the chip detector magnet. Make sure you collect all the particles in the scavenge screen while you remove the scavenge screen from the chip detector.

- (a) Place the chip detector on a clean surface, keep the plastic bag and identification tag.
- (b) Push the spring-loaded pin that attaches the scavenge screen to the chip detector with a swab, G01659.
- (c) Carefully remove the scavenge screen from the chip detector.
- (d) Carefully remove and keep the particles from the scavenge screen.

WARNING: DO NOT GET THE SOLVENT IN YOUR MOUTH OR EYES, OR ON YOUR SKIN. DO NOT BREATHE THE FUMES FROM THE SOLVENT. PUT ON PROTECTIVE SPLASH GOGGLES AND GLOVES WHEN YOU USE THE SOLVENT. KEEP THE SOLVENT AWAY FROM SPARKS, FLAME AND HEAT. THE SOLVENT IS POISONOUS AND FLAMMABLE WHICH CAN CAUSE INJURIES TO PERSONS AND DAMAGE TO EQUIPMENT.

- (e) After you remove all the particles, clean the scavenge screen with solvent, B00682 [CP2011].
 - 1) Dry the scavenge screen with an 0-30 psig dry filtered regulated air source, STD-1280.
 - 2) Make sure that the scavenge screen is free of all particles.

SUBTASK 79-00-00-170-001-F00

CAUTION: REMOVE THE SCREEN FROM THE CHIP DETECTORS TO EXAMINE THE CHIP DETECTOR MAGNET FOR THE PRESENCE OF PARTICLES. IF YOU DO NOT REMOVE THE SCREEN FROM THE CHIP DETECTOR, IT IS POSSIBLE THAT YOU WILL NOT BE ABLE TO SEE THE PARTICLES THAT ARE CAUGHT BY THE CHIP DETECTOR MAGNET.

CAUTION: DO NOT USE A MAGNET TO REMOVE THE PARTICLES FROM THE CHIP DETECTOR MAGNET. IF YOU USE A MAGNET, IT CAN DECREASE THE MAGNETIC PERFORMANCE OF THE CHIP DETECTOR.

CAUTION: CFM DOES NOT RECOMMEND THE USE OF ADHESIVE TAPE. HOWEVER, IF A PIECE OF ADHESIVE TAPE IS USED TO COLLECT THE PARTICLES, MAKE SURE THE ADHESIVE IS NOT TOO STRONG. IF THE ADHESIVE ON THE TAPE IS TOO STRONG THE PARTICLES MAY BE DAMAGED WHEN THEY ARE REMOVED AND/OR IT WILL AFFECT THE LABORATORY ANALYSIS OF THE MATERIAL.

- (4) Do these steps to remove the particles from the chip detector magnet and clean the chip detector (Figure 607):
- (a) Carefully remove and keep the particles from the chip detector magnet with a cotton wiper, G00034 on a thin sheet of paper.

EFFECTIVITY
HAP ALL

79-00-00

Page 615
Jun 10/2006

D633A101-HAP

AIRCRAFT MAINTENANCE MANUAL

WARNING: DO NOT GET THE SOLVENT IN YOUR MOUTH OR EYES, OR ON YOUR SKIN. DO NOT BREATHE THE FUMES FROM THE SOLVENT. PUT ON PROTECTIVE SPLASH GOGGLES AND GLOVES WHEN YOU USE THE SOLVENT. KEEP THE SOLVENT AWAY FROM SPARKS, FLAME AND HEAT. THE SOLVENT IS POISONOUS AND FLAMMABLE WHICH CAN CAUSE INJURIES TO PERSONS AND DAMAGE TO EQUIPMENT.

(b) After you remove all the particles, clean the chip detector magnet with solvent, B00682 [CP2011].

1) Dry the chip detector magnet with an 0-30 psig dry filtered regulated air source, STD-1280.

a) Make sure that the chip detector is free of all particles.

2) Do this task: Magnetic Chip Detector (MCD) Installation, TASK 79-21-05-400-804-F00.

SUBTASK 79-00-00-160-002-F00

(5) Prepare all particles collected from the chip detector and scavenge screen to examine them:

WARNING: DO NOT GET THE SOLVENT IN YOUR MOUTH OR EYES, OR ON YOUR SKIN. DO NOT BREATHE THE FUMES FROM THE SOLVENT. PUT ON PROTECTIVE SPLASH GOGGLES AND GLOVES WHEN YOU USE THE SOLVENT. KEEP THE SOLVENT AWAY FROM SPARKS, FLAME AND HEAT. THE SOLVENT IS POISONOUS AND FLAMMABLE WHICH CAN CAUSE INJURIES TO PERSONS AND DAMAGE TO EQUIPMENT.

(a) Remove the oil from the particles that are not metallic with solvent, B00682 [CP2011].

(b) Use a magnet to isolate the metallic particles.

SUBTASK 79-00-00-212-001-F01

(6) Examine the particles from the chip detector and scavenge screen to identify the physical properties of the material (shape, size, quantity, magnetic properties, color) to be used in (SUBTASK 79-00-00-240-001-F00).

(a) Any quantity of material that is less than or equal to 0.004 inch (0.10 mm) in all dimension is satisfactory.

NOTE: Material that is greater than 0.004 inch (0.10 mm) in any dimension is not normal fuzz.

(b) Use a 10x hand held magnifying lens, STD-1070 and a magnetic bar to examine the magnetic particles from the chip detectors if more than 0.004 inch (0.10 mm) in any dimension:

1) Refer to CFM NDT manual Part 10 "CFMI-TP.NT.11" and/or set, SPL-2450, CD-ROM 856A2683G01 to identify possible source and/or refer to Figure 608 for examples of shapes that may be seen on a chip detector.

(c) Use a 10x hand held magnifying lens, STD-1070 to examine the non-magnetic particles from the chip detectors if more than 0.004 inch (0.10 mm) in any dimension:

1) Refer to CFM NDT manual Part 10 "CFMI-TP.NT.11" and/or set, SPL-2450, CD-ROM 856A2683G01 to identify possible source and/or refer to Figure 608 for examples of shapes that may be seen on a chip detector.

SUBTASK 79-00-00-240-001-F00

(7) If you have identified the collected particles, do these steps:

(a) If you find magnetic rectangular tang [approximate size 0.12 X 0.16 X 0.06 inch (3 X 4 X 1.5 mm)] from the AGB/TGB detector, it can be an AGB sealol seal anti-rotation tab. Do these steps:

EFFECTIVITY
HAP ALL

79-00-00

Page 616
Jun 10/2007

D633A101-HAP

AIRCRAFT MAINTENANCE MANUAL

- 1) Continue the engine in service provided that the oil consumption is in the limit. Refer to this task: Engine Operation Limits, TASK 71-00-00-800-806-F00.
 - 2) If there is an AGB pad oil leakage, replace the affected sealol seal. These are the tasks:
 - Sealol Seal Removal, TASK 72-60-00-000-802-F00
 - Sealol Seal Installation, TASK 72-60-00-400-802-F00.
- (b) If you find magnetic material on the AGB/TGB scavenge screen or chip detector, examine the starter magnetic plug for contamination. To examine it, do this task: Starter Magnetic Plug Inspection, TASK 80-11-01-200-801-F00.
- 1) If the starter magnetic plug has contamination or if there was a recent starter failure, do these steps:
 - a) Replace the scavenge oil filter element.
These are the tasks:
 - Scavenge Oil Filter Element Removal, TASK 79-21-06-000-801-F00
 - Scavenge Oil Filter Element Installation, TASK 79-21-06-400-801-F00.
 - b) Re-examine the AGB/TGB chip detector each 10 to 20 cycles until the chip detector is found to be clean. Replace the scavenge oil filter element each time you find contamination on the AGB/TGB chip detector.
 - 2) If you find that the material is not from the starter or from a recent starter removal, do these steps:
 - a) Do this task: Transfer Gearbox Internal Inspection, TASK 72-62-00-200-802-F00.
 - b) Do this task: EEC Alternator and Alternator Rotor Removal, TASK 73-21-08-000-801-F00.
 - c) Do a visual check of EEC alternator and rotor and look for debris and obvious damage.
 - d) If damage or debris is found, do these steps:
 - < 1 > Remove the debris from the alternator pad area and clean as necessary.
 - < 2 > Install a new EEC alternator and rotor. Do this task: EEC Alternator and Alternator Rotor Installation, TASK 73-21-08-400-801-F00.
 - < 3 > Do this task: Flush The Engine Oil System, TASK 12-13-11-100-801.
 - < 4 > Re-examine the AGB/TGB chip detector every 10 to 20 cycles until it is found to be clean. Replace the scavenge oil filter element each time you find contamination.
 - e) If no damage or debris is found, do this task: EEC Alternator and Alternator Rotor Installation, TASK 73-21-08-400-801-F00.
 - f) Remove the TGB. Do this task: Transfer Gearbox Assembly Removal, TASK 72-62-00-000-801-F00.
 - g) Do a visual check of the TGB input and output area and look for debris and obvious damage.
 - h) If damage or debris is found, replace the TGB. Do this task: Transfer Gearbox Assembly Installation, TASK 72-62-00-400-801-F00.

EFFECTIVITY
HAP ALL

79-00-00

Page 617
Feb 15/2009

D633A101-HAP

AIRCRAFT MAINTENANCE MANUAL

- i) If no damage or debris is found, and bearing material (M50 material from either the inner/outer race and/or rolling elements) has been identified on the AGB/TGB chip detector, replace the engine. These are the tasks:

NOTE: M50 material has the appearance as thin shiny bright laminated magnetic flakes.

- Power Plant Removal, TASK 71-00-02-000-801-F00
- Power Plant Installation, TASK 71-00-02-400-801-F00.

- (c) If you find non-magnetic flat piece with castellated portion in the AGB/TGB scavenge screen, it can be a key lock, AGB stud or insert. Do this step:

1) Continue the engine in service provided there is no other metallic debris.

- (d) If you find aluminum debris in the AGB/TGB sump scavenge screen, do these steps:

NOTE: Aluminum on the AGB/TGB detector can indicate either a failed alternator or AGB.

1) Do this task: EEC Alternator and Alternator Rotor Removal, TASK 73-21-08-000-801-F00.

2) Do a visual check of the EEC alternator and rotor and the AGB pad, look for debris and obvious damage.

a) If there was no damage in the AGB, but debris was found, remove the debris from the alternator pad area and clean as necessary.

b) Install a new EEC alternator and rotor. Do this task: EEC Alternator and Alternator Rotor Installation, TASK 73-21-08-400-801-F00.

c) Do this task: Flush The Engine Oil System, TASK 12-13-11-100-801.

d) Re-examine the AGB/TGB chip detector and the scavenge oil filter element every 10 to 20 cycles until they are found to be clean.

3) If the damage is in the AGB alternator pad, replace the engine. These are the tasks:

- Power Plant Removal, TASK 71-00-02-000-801-F00
- Power Plant Installation, TASK 71-00-02-400-801-F00.

- (e) If you find coke particles in some of the AGB/TGB, AFT and/or FWD screens, do these steps:

1) Replace the scavenge oil filter element.

These are the tasks:

- Scavenge Oil Filter Element Removal, TASK 79-21-06-000-801-F00
- Scavenge Oil Filter Element Installation, TASK 79-21-06-400-801-F00.

- (f) If you find coke particles in the AGB/TGB screen only, do these steps:

1) Do this task: EEC Alternator and Alternator Rotor Removal, TASK 73-21-08-000-801-F00.

2) Do a visual check of the EEC alternator and alternator rotor for coke particles. If it is necessary, clean the coke particles.

3) Do this task: EEC Alternator and Alternator Rotor Installation, TASK 73-21-08-400-801-F00.

AIRCRAFT MAINTENANCE MANUAL

- (g) If you find bearing material (material from either the inner/outer race and/or rolling elements) on the Aft sump or Fwd sump scavenge screen or chip detector, replace the engine. These are the tasks:

NOTE: Material from the inner/outer race and/or rolling elements has the appearance as thin shiny bright laminated magnetic flakes. Refer to CFM NDT manual Part 10 "CFMI-TP.NT.11" and/or set, SPL-2450, CD-ROM 856A2683G01 to identify possible source.

- Power Plant Removal, TASK 71-00-02-000-801-F00
- Power Plant Installation, TASK 71-00-02-400-801-F00.

- (h) If you find plastic or organic material in the Fwd sump scavenge screen, do these steps:

NOTE: The plastic or organic material is an indication of a deterioration of the forward air/oil abrasible seal or the forward air/oil separator ducts and can include one or more of these:

- 1) Glass fiber with polyamide material with grooves (reddish-brown color)
- 2) Phenolic or plastic material (greenish-white color)
- 3) Resin polyamide material (green or brown color).

- 1) Continue the engine in service provided that the oil consumption is in the limits. Refer to this task: Engine Operation Limits, TASK 71-00-00-800-806-F00.

- (i) If you find one or more 0.25 inch (6.4 mm) hex base nuts in the Fwd Sump, replace the engine. These are the tasks:

NOTE: This nut came from the Inlet gearbox (IGB).

- Power Plant Removal, TASK 71-00-02-000-801-F00
- Power Plant Installation, TASK 71-00-02-400-801-F00.

- (j) If you find hastelloy X material looks same as honeycomb or AS7G06 material in the aft sump scavenge screen, it can be from the air/oil separator, replace the engine. These are the tasks:

- 1) Do this task: Power Plant Removal, TASK 71-00-02-000-801-F00
- 2) Do this task: Power Plant Installation, TASK 71-00-02-400-801-F00.

- (k) If you find one of the following materials in the Aft Sump scavenge screen, continue the engine in service provided that the oil consumption is in the limit. Refer to this task: Engine Operation Limits, TASK 71-00-00-800-806-F00.

- 1) Non-magnetic, gray and granular debris - can be abrasible material
- 2) Non-magnetic or metallic hair-like debris - can be rotating air/oil seal material
- 3) Non-magnetic, silver sheath - can be air/oil seal coating material.

- (l) If you find organic material from packings (O-rings), that has black broken pieces from any sump, do these steps:

- 1) Make sure that the oil pressure and the oil consumption are in the limits that are listed in this task: Engine Operation Limits, TASK 71-00-00-800-806-F00.
- 2) Examine the scavenge oil filter element for similar packing material. Do this task: Scavenge Oil Filter Element Removal, TASK 79-21-06-000-801-F00.

EFFECTIVITY
HAP ALL

D633A101-HAP

79-00-00

Page 619
Feb 15/2009

AIRCRAFT MAINTENANCE MANUAL

CAUTION: THE OUTER SPOOL VALVE O-RING WILL BE CAPTURED IN THE SCAVENGE FILTER. THE INNER SPOOL VALVE O-RING WILL BE CAPTURED IN THE CHIP DETECTOR SCAVENGE SCREEN. IF EITHER OF THE ABOVE O-RINGS ARE MISSING OR DAMAGED, THE ENGINE OIL CAN LEAK OUT IF THE CHIP DETECTOR IS NOT INSTALLED CORRECTLY.

- 3) If black packing debris is found in the scavenge screen, it is probably from the inner sealing spool valve on the lubrication unit, do these steps.
 - a) Replace the packing for the inner and outer spool of the lubrication unit. These are the tasks:
 - Packing Replacement On The Inner Sealing Spool (Lubrication Unit Installed), TASK 79-21-01-400-802-F00
 - Packing Replacement On The Inner and Outer Sealing Spools (Lubrication Unit Removed), TASK 79-21-01-400-803-F00.
 - b) If you do not replace these packings, a Continue-In-Service limit of 250 cycles is permitted with these conditions.
 - < 1 > All chip detectors are examined for correct installation [locked] by two different persons prior to the close of the fan cowls (TASK 79-21-05-400-804-F00).
 - < 2 > Do the chip detector installation check again each time the fan cowls are opened.
- 4) Do the chip detector installation check (by two people) again anytime the chip detectors are removed and installed.
- (m) If you find granular carbon material in the Aft Sump scavenge screen, it can be from a cracked scavenge line in the TRF or coke buildup in the aft sump oil system. Do these steps:
 - 1) Do this task: Aft Sump Oil System Inspection, TASK 79-00-00-200-806-F01.
 - 2) If the engine oil pressure trend does not show a gradual increase, do these tasks at the next convenient opportunity.
 - a) Do this task: Oil Scavenge Line Cleaning, TASK 72-56-00-100-802-F00.
 - b) Do this task: Oil Supply Line Cleaning, TASK 72-56-00-000-801-F00 or Oil Supply Tube Replacement, TASK 72-56-00-300-801-F00.
 - 3) If the engine oil pressure trend shows a gradual increase, do these tasks in less than 25 cycles.
 - a) Do this task: Oil Scavenge Line Cleaning, TASK 72-56-00-100-802-F00.
 - b) Do this task: Oil Supply Line Cleaning, TASK 72-56-00-000-801-F00 or Oil Supply Tube Replacement, TASK 72-56-00-300-801-F00.
 - 4) Replace the scavenge oil filter element.

These are the tasks:

 - Scavenge Oil Filter Element Removal, TASK 79-21-06-000-801-F00
 - Scavenge Oil Filter Element Installation, TASK 79-21-06-400-801-F00.
 - 5) Monitor the engine oil pressure during the next 20 to 50 hours of operation.
- (n) If you find the materials that follow from any sump, continue the engine in service:
 - 1) Machined chips that are shiny curls of metal or that have parallel marks from machine tools when you see them with a 10x hand held magnifying lens, STD-1070.

EFFECTIVITY
HAP ALL

79-00-00

Page 620
Feb 15/2009

D633A101-HAP

AIRCRAFT MAINTENANCE MANUAL

- 2) Rub strips from the labyrinth seal that are made of stainless steel that look like silver shavings.
- (o) If the material identified per the laboratory analysis was not identified in one of the above categories, continue the engine operation for one month but reduce the chip detector inspection interval at 50-75 hours. Return to normal inspection interval when the chip detector is found to be clean.

SUBTASK 79-00-00-210-009-F00

- (8) If you find magnetic particles that you cannot identify, do these steps:
 - (a) SATISFACTORY CONDITION - If you find less than four particles with the condition below, continue the engine in service.
 - 1) The largest particle is more than 0.004 inch (0.10 mm) and less than 0.01 inch (0.25 mm) in any dimension.
 - (b) MARGINAL CONDITION - Do these steps for the limits, which are given below (Table 601):

Table 601/79-00-00-993-809-F00

PARTICLES FOUND	LARGEST PARTICLE DIMENSION
4 or More	More than 0.004 inch (0.10 mm) and less than 0.01 inch (0.25 mm)
Less than 4	More than or equal to 0.01 inch (0.25 mm), But less than 0.02 inch (0.50 mm)

- 1) Send the particles to the laboratory for analysis.
- 2) Do the inspection of the chip detectors for particles after each flight until you get the analysis from the laboratory.
- 3) If you find magnetic particles during the post flight inspections that you cannot identify limit the engine operation to 5 cycles or 25 hours which ever comes first.
- 4) After you get the analysis from the laboratory, then do the applicable corrective action for the type of material that you found as defined in SUBTASK 79-00-00-240-001-F00.

NOTE: For more information on particle analysis, refer to the CFMI Non-Destructive Test Manual, Part 9 and Part 10 or CD-ROM 856A2683G01.

- (c) UNSATISFACTORY CONDITION - Do these steps for the limits, which are given below (Table 602):

Table 602/79-00-00-993-810-F00

PARTICLES FOUND	LARGEST PARTICLE DIMENSION
Any amount	More than or equal to 0.02 inch (0.50 mm)
4 or more	More than or equal to 0.01 inch (0.25 mm), But less than 0.02 inch (0.50 mm)

- 1) Send the particles to the laboratory for analysis.

CAUTION: DO NOT INSTALL THE CHIP DETECTOR WITHOUT THE PACKING. INSTALLATION OF THE CHIP DETECTOR WITHOUT THE PACKING CAN CAUSE OIL LEAKAGE DURING ENGINE OPERATION AND A POSSIBLE ENGINE FAILURE.

- 2) Do this task: Magnetic Chip Detector (MCD) Installation, TASK 79-21-05-400-804-F00.

EFFECTIVITY
HAP ALL

79-00-00

Page 621
Feb 15/2008

D633A101-HAP

AIRCRAFT MAINTENANCE MANUAL

- 3) Operate the engine at a minimum of 70 percent N1 for 10 minutes. Do this task: Start the Engine Procedure (Selection), TASK 71-00-00-800-807-F00.
- 4) Do a check of the chip detectors where magnetic particles were identified.
 - a) If you do not find magnetic particles, do these steps:
 - < 1 > If you cannot get the analysis from the laboratory, do a check of the chip detectors after each flight until you get the analysis from the laboratory.
 - < 2 > If you find magnetic particles larger than 0.004 inch (0.10 mm) in any dimension during any chip detector inspection, do not operate the engine until the first sample of magnetic particles have been identified.
 - b) If you find magnetic particles larger than 0.004 inch (0.10 mm) in any dimension during any chip detector inspection, do not operate the engine until the first sample of magnetic particles have been identified.
- 5) After you get the analysis from the laboratory, then do the applicable corrective action for the type of material that you found as defined in SUBTASK 79-00-00-240-001-F00.

NOTE: For more information on particle analysis, refer to the CFMI Non-Destructive Test Manual, Part 9 and Part 10, or set, SPL-2450, CD-ROM 856A2683G01.

SUBTASK 79-00-00-210-010-F00

- (9) If you find non-magnetic particles that you cannot identify in the Fwd or Aft Sump scavenge screen or in the AGB/TGB chip detector which are not aluminum-like, do these steps:
 - (a) SATISFACTORY CONDITION - If you find less than four particles with the condition below, continue the engine in service.
 - 1) The largest particle is less than 0.4 inch (10 mm) in all dimensions.
 - (b) UNSATISFACTORY CONDITION - Do these steps for the limits, which are given below (Table 603):

Table 603/79-00-00-993-811-F00

PARTICLES FOUND	LARGEST PARTICLE DIMENSION
Any amount	More than or equal to 0.4 inch (10 mm)
4 or more	Less than 0.4 inch (10 mm)

- 1) Send the particles to the laboratory for analysis.

CAUTION: DO NOT INSTALL THE CHIP DETECTOR WITHOUT A PACKING. INSTALLATION OF THE CHIP DETECTOR WITHOUT A PACKING CAN CAUSE OIL LEAKAGE DURING ENGINE OPERATION AND A POSSIBLE ENGINE FAILURE.

- 2) Do this task: Magnetic Chip Detector (MCD) Installation, TASK 79-21-05-400-804-F00.
- 3) Operate the engine at a minimum of 70 percent N1 for 10 minutes. Do this task: Start the Engine Procedure (Selection), TASK 71-00-00-800-807-F00.
- 4) Do a check of the scavenge screens where the particles were found.
 - a) If you do not find particles, continue the engine in operation until you get the analysis from the laboratory.
 - b) If you find particles which are less than 0.2 inch (5 mm), do these steps:
 - < 1 > Do a check of the scavenge screens after each flight until you get the analysis from the laboratory.

EFFECTIVITY
HAP ALL

D633A101-HAP

79-00-00

Page 622
Feb 15/2008

737-600/700/800/900**AIRCRAFT MAINTENANCE MANUAL**

- <2> If you find non-magnetic particles which are more than 0.4 inch (10 mm) during post flight chip detector inspections, limit the engine operation to 10 cycles.
- c) If you find non-magnetic particles which are more than 0.2 inch (5 mm), limit the engine operation to 10 cycles.
- <1> Do a post flight check of the chip detector and scavenge screens until you get the analysis from the laboratory.
- 5) After you get the analysis from the laboratory, then do the applicable corrective action for the type of material that you found as defined in SUBTASK 79-00-00-240-001-F00.

NOTE: For more information on particle analysis, refer to the CFMI Non-Destructive Test Manual, Part 9 and Part 10, or set, SPL-2450, CD-ROM 856A2683G01.

SUBTASK 79-00-00-420-001-F00

CAUTION: DO NOT INSTALL THE CHIP DETECTOR WITHOUT A PACKING. INSTALLATION OF THE CHIP DETECTOR WITHOUT A PACKING CAN CAUSE OIL LEAKAGE DURING ENGINE OPERATION AND A POSSIBLE ENGINE FAILURE.

- (10) If not already done, do this task: Magnetic Chip Detector (MCD) Installation, TASK 79-21-05-400-804-F00.

SUBTASK 79-00-00-410-008-F00

- (11) Do this task: Close the Fan Cowl Panels, TASK 71-11-02-410-801-F00.

————— **END OF TASK** —————

EFFECTIVITY
HAP ALL

D633A101-HAP

79-00-00

Page 623
Feb 15/2008

737-600/700/800/900
AIRCRAFT MAINTENANCE MANUAL

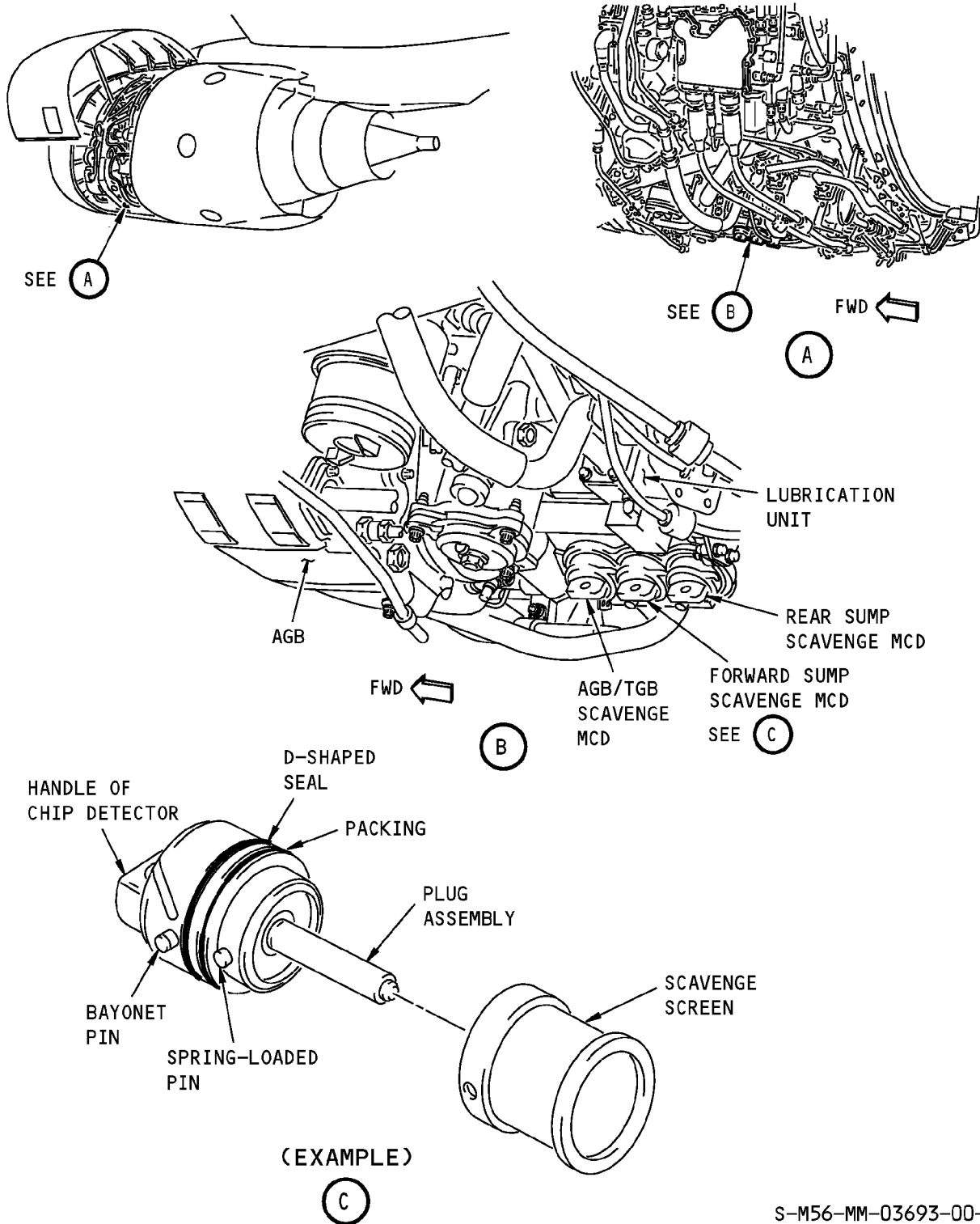

Scavenge Screen Inspection
Figure 606/79-00-00-990-805-F00

S-M56-MM-03693-00-B

EFFECTIVITY
HAP ALL

79-00-00

737-600/700/800/900
AIRCRAFT MAINTENANCE MANUAL

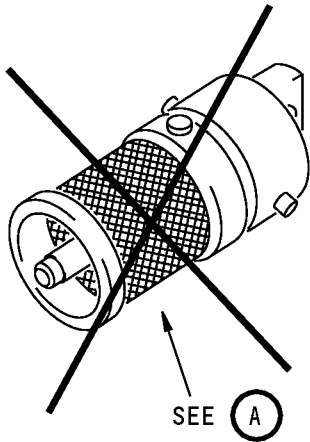

NOTE: DO NOT INSPECT WITH SCREEN INSTALLED.

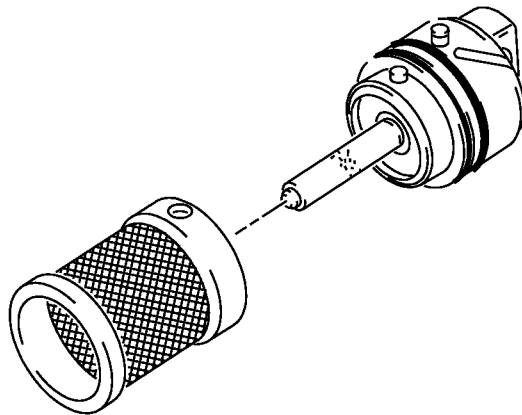

NOTE: REMOVE SCREEN TO CLOSELY INSPECT DETECTOR
CLEANING REQUIRED AFTER INSPECTION.

MM-00051-00-B

Chip Detector Inspection
Figure 607/79-00-00-990-806-F00

EFFECTIVITY
HAP ALL

79-00-00

Page 625
Jun 10/2007

D633A101-HAP

737-600/700/800/900
AIRCRAFT MAINTENANCE MANUAL

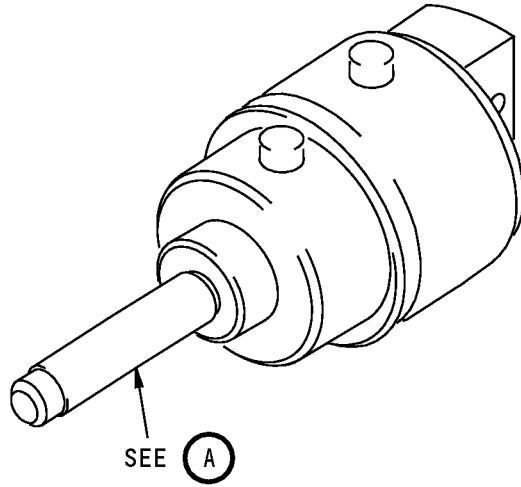

MAGNETIC CHIP DETECTOR

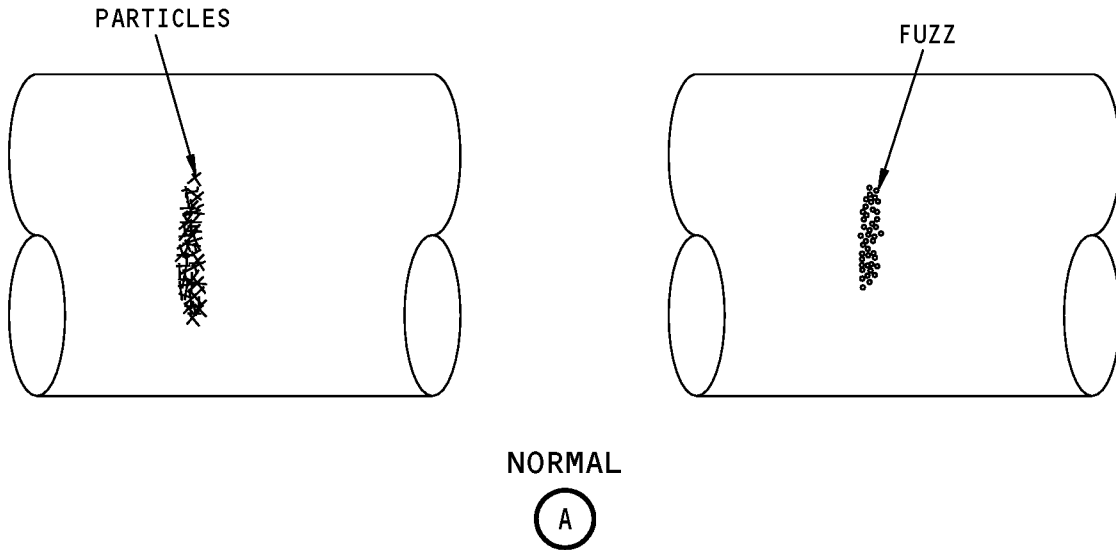

Chip Detector Particles
Figure 608 (Sheet 1 of 2)/79-00-00-990-809-F00

EFFECTIVITY
HAP ALL

79-00-00

Page 626
Jun 10/2007

D633A101-HAP

737-600/700/800/900
AIRCRAFT MAINTENANCE MANUAL



FLAKE

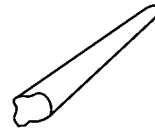

SLIVER

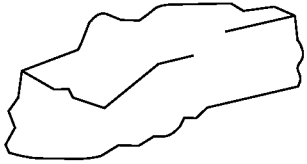

CHUNK

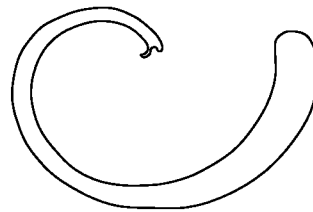

MACHINING CHIPS

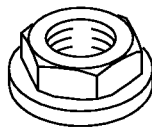

HEXAGONAL NUT 1/4 in.



Chip Detector Particles
Figure 608 (Sheet 2 of 2)/79-00-00-990-809-F00

EFFECTIVITY
HAP ALL

79-00-00

Page 627
Jun 10/2007

D633A101-HAP

AIRCRAFT MAINTENANCE MANUAL

TASK 79-00-00-200-805-F00

6. Oil Supply Filter Pop-Out Indicator Inspection (Visual Check)

(Figure 609)

A. General

- (1) This procedure is a scheduled maintenance task.
- (2) This procedure is a visual check of the oil supply filter pop-out indicator (referred to as the pop-out indicator).

B. References

Reference	Title
12-13-11-100-801	Flush The Engine Oil System (P/B 301)
12-13-11-600-801	Replenish the Engine Oil (P/B 301)
12-13-11-600-803	Drain the Engine Oil (P/B 301)
79-21-03-000-802-F00	Oil Supply Filter Removal (P/B 401)
79-21-03-400-801-F00	Oil Supply Filter Installation (P/B 401)
FIM 79-05 TASK 817	OIL FILTER BYP Message Shows - Fault Isolation

C. Location Zones

Zone	Area
411	Engine 1 - Engine
421	Engine 2 - Engine

D. Access Panels

Number	Name/Location
413BL	Chip Detector/Pressure Relief Door, Engine 1
423BL	Chip Detector/Pressure Relief Door, Engine 2

E. Pop-Out Indicator Visual Check

SUBTASK 79-00-00-010-006-F00

- (1) Open the applicable access doors on the left fan cowl panel.

Number	Name/Location
413BL	Chip Detector/Pressure Relief Door, Engine 1
423BL	Chip Detector/Pressure Relief Door, Engine 2

SUBTASK 79-00-00-210-011-F00

- (2) Do a visual check of the pop-out indicator.
 - (a) If you see that the pop-out indicator is not extended, no additional work is necessary.
 - 1) Close the applicable access doors on the left fan cowl panel.

Number	Name/Location
413BL	Chip Detector/Pressure Relief Door, Engine 1
423BL	Chip Detector/Pressure Relief Door, Engine 2

- (b) If you see that the pop-out indicator is extended, continue.

SUBTASK 79-00-00-810-003-F00

- (3) Do these steps if you can see the pop-out indicator:
 - (a) If the OIL FILTER BYP warning light was illuminated on the last flight, do this task: OIL FILTER BYP Message Shows - Fault Isolation, FIM 79-05 TASK 817.

EFFECTIVITY
HAP ALL

79-00-00

Page 628
Feb 15/2009

D633A101-HAP

AIRCRAFT MAINTENANCE MANUAL

(b) If the OIL FILTER BYP warning light was not illuminated on the last flight, then do these steps:

- 1) Examine the oil supply filter. Do this task: Oil Supply Filter Removal, TASK 79-21-03-000-802-F00.
- 2) If the filter has obvious contamination, do this task: Drain the Engine Oil, TASK 12-13-11-600-803.

NOTE: Do this for the oil tank only.

- 3) Install a new oil supply filter. Do this task: Oil Supply Filter Installation, TASK 79-21-03-400-801-F00.

a) For the filter installation, make sure to reset the pop-out indicator.

- 4) Do this task: Replenish the Engine Oil, TASK 12-13-11-600-801.

(c) Identify the type and source of material on the oil supply filter.

- 1) If it has contamination, then do these steps:
 - a) Send the oil filter to the laboratory for analysis of the contamination.
 - b) Correct the cause of the contamination.
 - c) Do this task: Flush The Engine Oil System, TASK 12-13-11-100-801.

F. Put the Airplane Back to Its Usual Condition

SUBTASK 79-00-00-410-006-F00

(1) Close the applicable access doors on the left fan cowl panel.

<u>Number</u>	<u>Name/Location</u>
413BL	Chip Detector/Pressure Relief Door, Engine 1
423BL	Chip Detector/Pressure Relief Door, Engine 2

————— **END OF TASK** —————

EFFECTIVITY
HAP ALL

79-00-00

Page 629
Jun 10/2007

D633A101-HAP

AIRCRAFT MAINTENANCE MANUAL

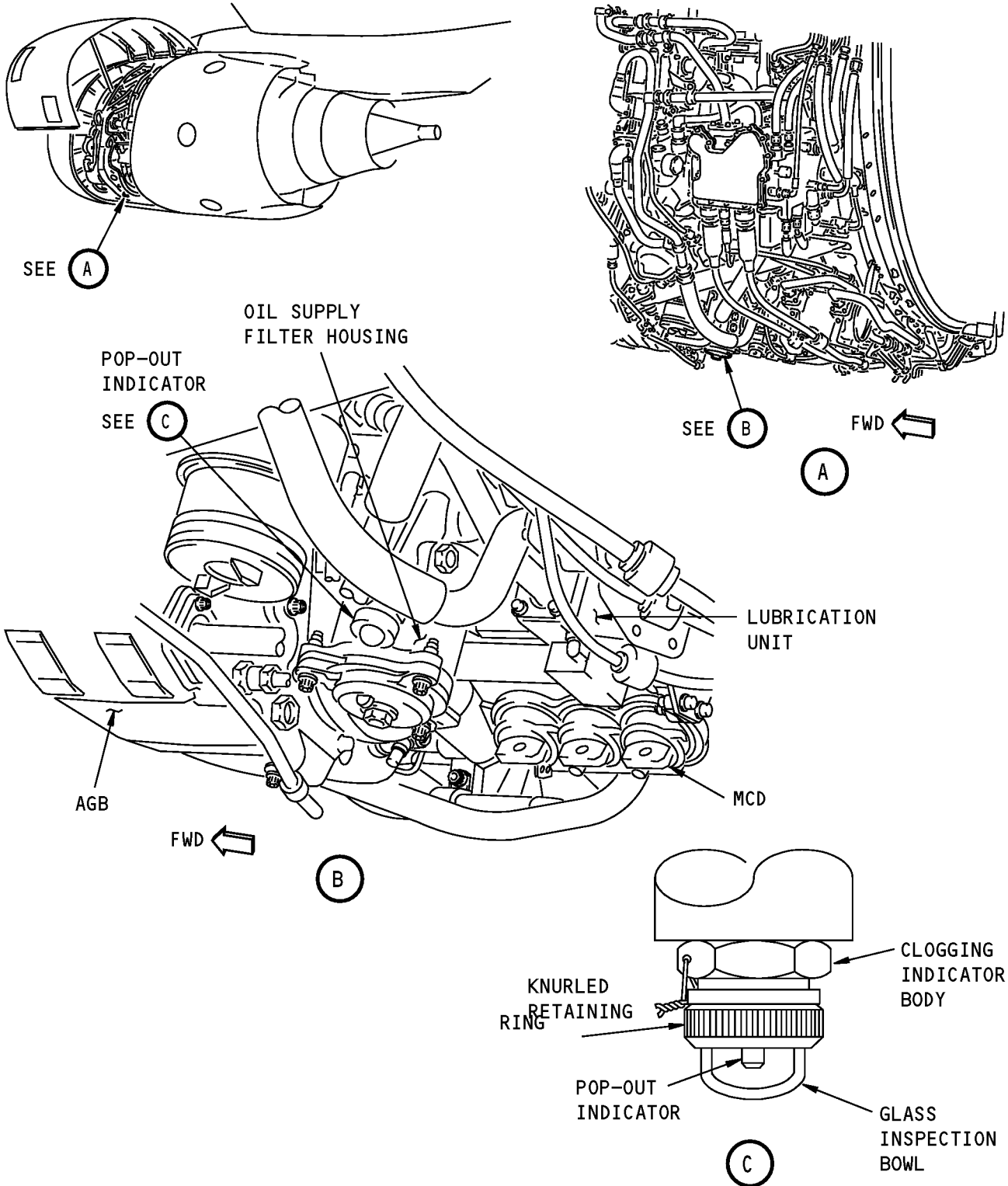

Oil Supply Filter Pop-Out Indicator Inspection
Figure 609/79-00-00-990-807-F00

EFFECTIVITY
HAP ALL

79-00-00

AIRCRAFT MAINTENANCE MANUAL

OIL - DDG MAINTENANCE PROCEDURES**1. General**

- A. This procedure has the maintenance tasks for the Master Minimum Equipment List (MMEL) maintenance requirements as shown in the Dispatch Deviations Procedures Guide (DDPG). These tasks prepare the airplane for flight with systems/components that are inoperative.
- B. This procedure also has the tasks that put the airplane back to its usual condition.
- C. These are the tasks for the components in the oil system:
- (1) MMEL 79-1 (DDPG) Preparation - Oil Quantity Indication Inoperative.
 - (2) MMEL 79-1 (DDPG) Restoration - Oil Quantity Indication Inoperative.
 - (3) MMEL 79-2 (DDPG) Preparation - Oil Filter Bypass Warning Systems Inoperative.
 - (4) MMEL 79-2 (DDPG) Restoration - Oil Filter Bypass Warning Systems Inoperative.

TASK 79-00-00-040-801-F00**2. MMEL 79-1 (DDPG) Preparation - Oil Quantity Indication Inoperative**

A. General

- (1) This task gives the maintenance steps which prepare the airplane for flight with the Oil Quantity Indication Inoperative.

B. References

Reference	Title
12-13-11-600-801	Replenish the Engine Oil (P/B 301)
71-00-00-800-806-F00	Engine Operation Limits (P/B 201)

C. Procedure

SUBTASK 79-00-00-220-001-F00

- (1) If the oil level is low, do this task: Replenish the Engine Oil, TASK 12-13-11-600-801.

SUBTASK 79-00-00-210-012-F00

- (2) Make sure that the oil consumption is in the limits Engine Operation Limits, TASK 71-00-00-800-806-F00.

SUBTASK 79-00-00-210-013-F00

- (3) Do a check of the aircraft flight log to make sure that no faults were recorded which relate to the oil pressure and oil temperature indications and that indications were in limits Engine Operation Limits, TASK 71-00-00-800-806-F00.

————— END OF TASK —————

TASK 79-00-00-440-801-F00**3. MMEL 79-1 (DDPG) Restoration - Oil Quantity Indication Inoperative**

A. General

- (1) This task puts the airplane back to its usual condition after operation with the Oil Quantity Indication Inoperative.

B. Procedure

SUBTASK 79-00-00-810-001-F00

- (1) Do the applicable fault isolation task in the Fault Isolation Manual (FIM) to correct the problem.

————— END OF TASK —————

EFFECTIVITY
HAP ALL

79-00-00

Page 901
Oct 10/2003

D633A101-HAP

AIRCRAFT MAINTENANCE MANUAL

TASK 79-00-00-040-802-F00**4. M MEL 79-2 (DDPG) Preparation - Oil Filter Bypass Warning Systems Inoperative**

A. General

- (1) This task gives the maintenance steps which prepare the airplane for flight with the Oil Filter Bypass Warning Systems Inoperative.

B. References

Reference	Title
79-21-06-000-801-F00	Scavenge Oil Filter Element Removal (P/B 401)
79-21-06-400-801-F00	Scavenge Oil Filter Element Installation (P/B 401)

C. Procedure

SUBTASK 79-00-00-020-004-F00

- (1) Do this task: Scavenge Oil Filter Element Removal, TASK 79-21-06-000-801-F00.

SUBTASK 79-00-00-210-014-F00

- (2) Do a visual inspection of the scavenge oil filter element for unwanted material once daily.

SUBTASK 79-00-00-420-002-F00

- (3) Do this task: Scavenge Oil Filter Element Installation, TASK 79-21-06-400-801-F00.

————— **END OF TASK** —————

TASK 79-00-00-440-802-F00**5. M MEL 79-2 (DDPG) Restoration - Oil Filter Bypass Warning Systems Inoperative**

A. General

- (1) This task puts the airplane back to its usual condition after operation with the Oil Filter Bypass Warning Systems Inoperative.

B. Procedure

SUBTASK 79-00-00-810-002-F00

- (1) Do the applicable fault isolation task in the Fault Isolation Manual (FIM) to correct the problem.

————— **END OF TASK** —————

EFFECTIVITY
HAP ALL

79-00-00

Page 902
Oct 10/2003

D633A101-HAP

AIRCRAFT MAINTENANCE MANUAL

OIL TANK - REMOVAL/INSTALLATION**1. General**

A. This procedure has two tasks:

- (1) The removal of the oil tank.
- (2) The installation of the oil tank.

TASK 79-11-01-000-801-F00**2. Oil Tank Removal**

(Figure 401)

A. General

- (1) This task is the removal procedure for the oil tank.
- (2) The oil tank is installed on the right side of the fan case on three brackets at the B4, B5, B6 and B7 flanges.
- (3) This procedure refers to the oil quantity transmitter as the transmitter.

B. References

Reference	Title
12-13-11-600-803	Drain the Engine Oil (P/B 301)
70-10-02-910-801-F00	General Precautions During the Removal and Installation of Engine Components (P/B 201)
70-30-01-910-802-F00	Seals (Preformed Packings and O-Rings) and Gaskets (P/B 201)
71-11-02-010-801-F00	Open the Fan Cowl Panels (P/B 201)
79-31-01-000-801-F00	Oil Quantity Transmitter Removal (P/B 401)

C. Location Zones

Zone	Area
411	Engine 1 - Engine
421	Engine 2 - Engine

D. Prepare for the Removal

SUBTASK 79-11-01-860-001-F00

- (1) For Engine 1, open these circuit breakers and install safety tags:

CAPT Electrical System Panel, P18-2

Row	Col	Number	Name
D	5	C01359	DISPLAY DEU 1 PRI

F/O Electrical System Panel, P6-1

Row	Col	Number	Name
D	10	C01361	DISPLAY DEU 1 HOLDUP

SUBTASK 79-11-01-860-002-F00

- (2) For Engine 2, open these circuit breakers and install safety tags:

F/O Electrical System Panel, P6-1

Row	Col	Number	Name
D	9	C01362	DISPLAY DEU 2 HOLDUP
D	11	C01360	DISPLAY DEU 2 PRI

EFFECTIVITY
HAP ALL

D633A101-HAP

79-11-01

Page 401
Oct 10/2003

AIRCRAFT MAINTENANCE MANUAL

SUBTASK 79-11-01-010-005-F00

- (3) Do this task: Open the Fan Cowl Panels, TASK 71-11-02-010-801-F00.

E. Oil Tank Removal

SUBTASK 79-11-01-610-009-F00

- (1) If the new oil tank does not come with a new oil quantity transmitter, do this step:
- (a) Do this task: Oil Quantity Transmitter Removal, TASK 79-31-01-000-801-F00.

SUBTASK 79-11-01-020-008-F00

- (2) If the new oil tank does come with a new oil quantity transmitter, do this step:
- (a) Disconnect the electrical connector, DP1301 [25] from the transmitter receptacle.

SUBTASK 79-11-01-610-001-F00

- (3) Do this task: Drain the Engine Oil, TASK 12-13-11-600-803.

SUBTASK 79-11-01-020-002-F00

- (4) Do these steps to remove the vent [9], oil-in [11] and oil-out [7] hoses from the oil tank [5] (Figure 401):
- (a) Remove the four bolts [4] from vent hose [9].
- (b) Disconnect the vent hose [9].
- (c) Remove and examine the gasket [3] Seals (Preformed Packings and O-Rings) and Gaskets, TASK 70-30-01-910-802-F00.

NOTE: Use the gasket if it is in good condition.

- 1) Discard the gasket [3], if it is in unsatisfactory condition.
- (d) Remove the four bolts [10] from oil-in hose [11].
- (e) Disconnect the oil-in hose [11].
- (f) Remove and examine the gasket [12].

NOTE: Use the gasket if it is in good condition.

- 1) Discard the gasket [12], if it is in unsatisfactory condition.
- (g) Loosen the oil-in coupling nut to the oil-in hose [11].
- (h) Turn the oil-in hose [11] counterclockwise.
- (i) Remove the four bolts [6] from the oil-out hose [7].
- (j) Disconnect the oil-out hose [7].
- (k) Remove and examine the gasket [8].

NOTE: Use the gasket if it is in good condition.

- 1) Discard the gasket [8], if it is in unsatisfactory condition.

SUBTASK 79-11-01-020-003-F00

- (5) Do these steps to remove the drain hose [2] from the oil tank [5] (Figure 401):

CAUTION: USE TWO WRENCHES TO LOOSEN THE COUPLING NUT. USE ONE TO HOLD THE FITTING, AND THE OTHER TO LOOSEN THE COUPLING NUT. IF YOU DO NOT USE TWO WRENCHES, DAMAGE TO THE EQUIPMENT CAN OCCUR.

- (a) Disconnect the drain hose [2] from the oil scupper nipple [1].
- (b) Install protective caps in the open ends of the hoses, the tubes and the oil tank General Precautions During the Removal and Installation of Engine Components, TASK 70-10-02-910-801-F00.

EFFECTIVITY
HAP ALL

D633A101-HAP

79-11-01

Page 402
Oct 10/2003

AIRCRAFT MAINTENANCE MANUAL

SUBTASK 79-11-01-020-004-F00

(6) Do these steps to disconnect the bonding strip [15] from the fan frame on flange B6 (Figure 401) (View B):

- (a) Remove the nut [17], spacer [16], washer [14] and bolt [13] to remove the bonding strip [15].

NOTE: The bonding strip stays with the oil tank.

SUBTASK 79-11-01-020-005-F00

(7) Do these steps to disconnect the forward and the aft bottom mounts from the brackets on flanges B4, B5 and B7 (Figure 401) (View D and E):

- (a) Remove the two shoulder-headed pins [24].

SUBTASK 79-11-01-020-006-F00

(8) Do these steps to disconnect the top mount from the bracket on flange B6 (Figure 401) (View C):

NOTE: The oil tank weighs 24 pounds (11 Kg) empty.

- (a) Remove and discard the cotter pin [18].
(b) Remove the castellated nut [21] and the washer [22].

CAUTION: HOLD THE OIL TANK DURING THE REMOVAL OF THE SHOULDER-HEADED PIN. THIS WILL PREVENT DAMAGE TO THE OIL TANK.

- (c) Remove the shoulder-headed pin [20] from the top mount.
(d) Disengage the oil tank [5] from the forward and the aft bottom mounts.
(e) Disengage the oil tank [5] from the top mount and remove the oil tank [5].
(f) Remove the four dampers [23] from the bottom mounts and brackets on flanges B4, B5 and B7.

————— **END OF TASK** —————

EFFECTIVITY
HAP ALL

D633A101-HAP

79-11-01Page 403
Jun 10/2005

737-600/700/800/900
AIRCRAFT MAINTENANCE MANUAL

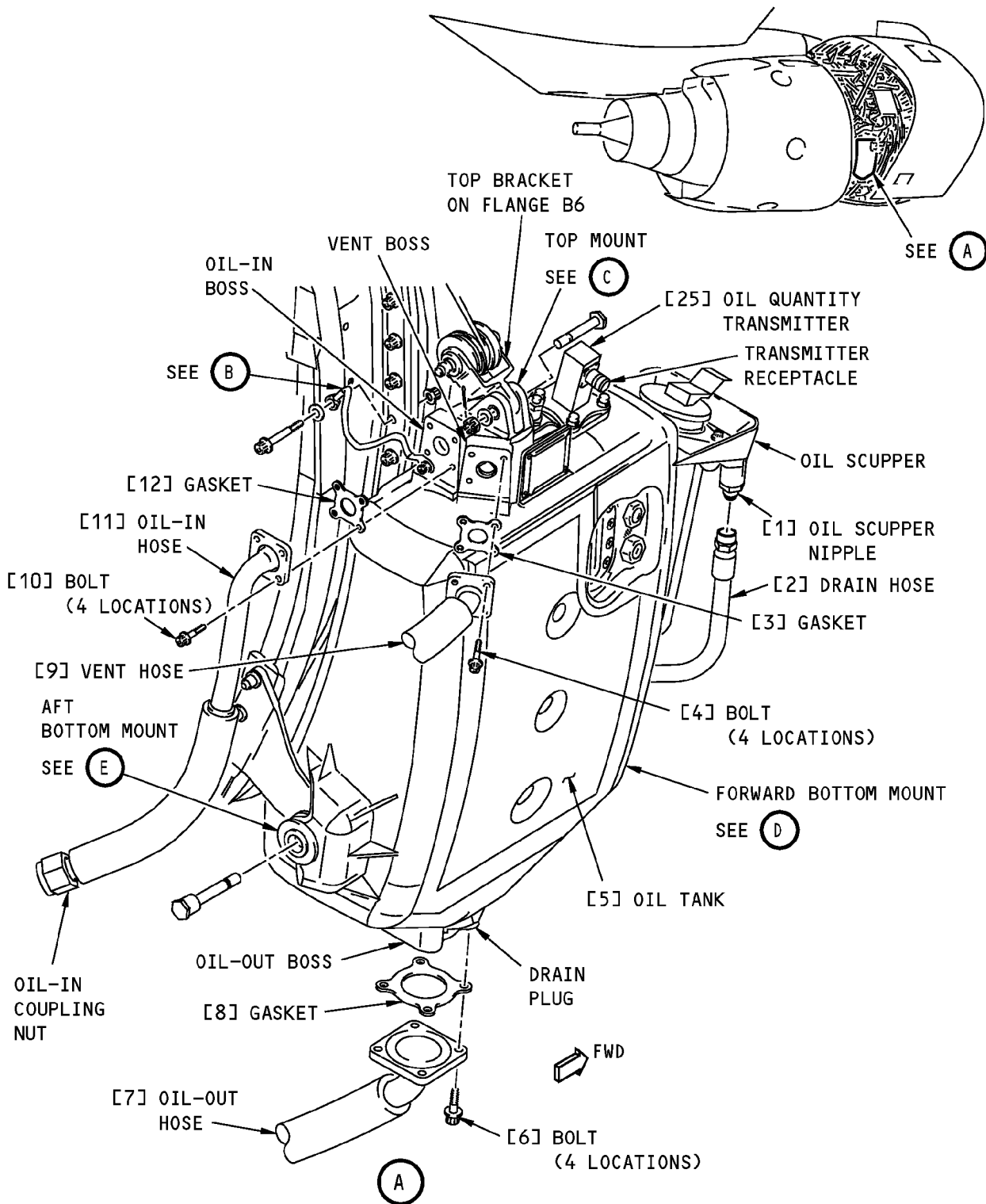

Oil Tank Installation
Figure 401 (Sheet 1 of 2)/79-11-01-990-801-F00

EFFECTIVITY
HAP ALL

79-11-01

Page 404
Oct 10/2003

D633A101-HAP

AIRCRAFT MAINTENANCE MANUAL

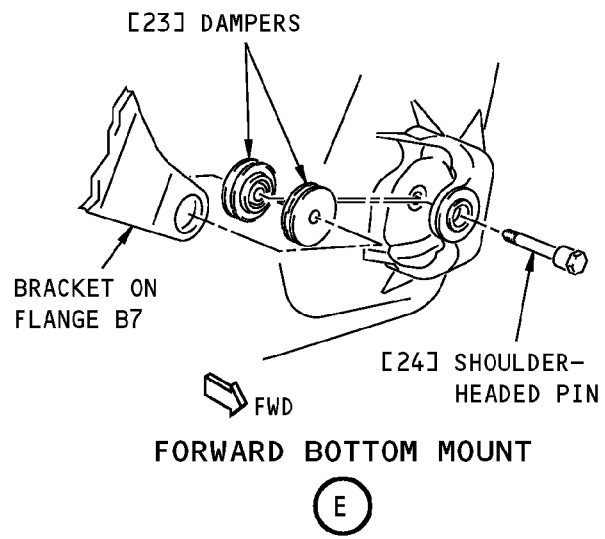
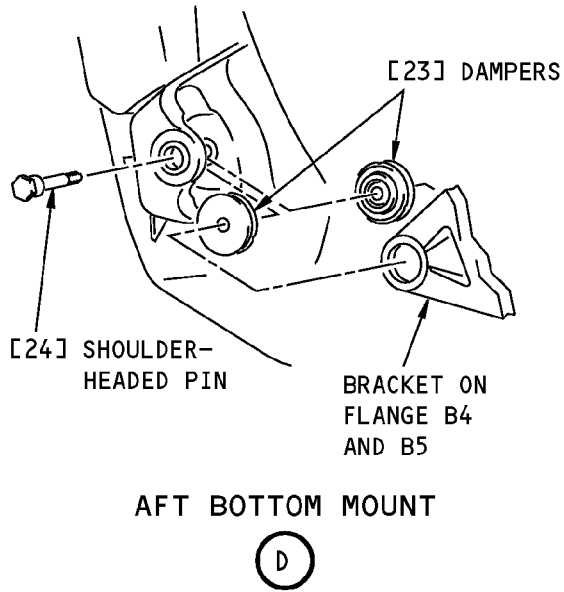
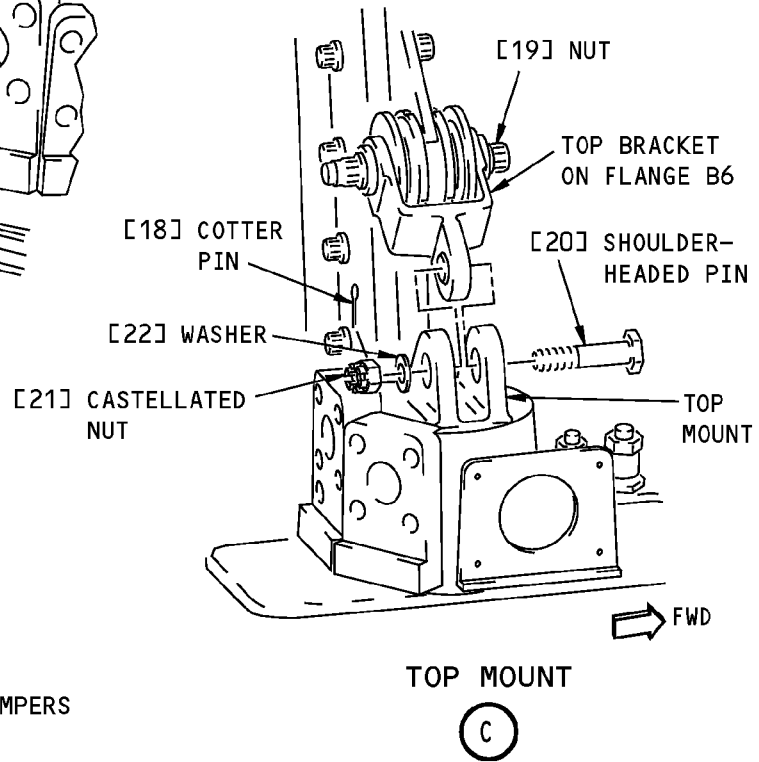
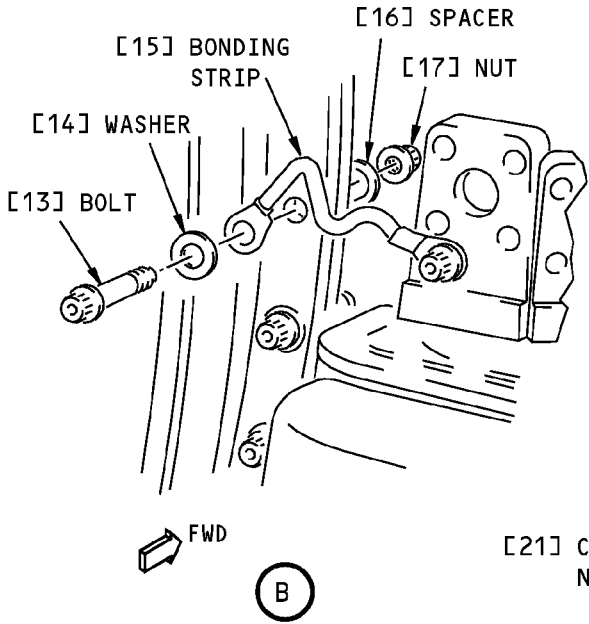

Oil Tank Installation
Figure 401 (Sheet 2 of 2)/79-11-01-990-801-F00

EFFECTIVITY
HAP ALL

79-11-01

AIRCRAFT MAINTENANCE MANUAL

TASK 79-11-01-400-801-F00

3. Oil Tank Installation

(Figure 401)

A. General

- (1) This task is the installation procedure for the oil tank.
- (2) This procedure refers to the oil quantity transmitter as the transmitter.

B. References

Reference	Title
12-13-11-600-801	Replenish the Engine Oil (P/B 301)
70-10-02-910-801-F00	General Precautions During the Removal and Installation of Engine Components (P/B 201)
71-00-00-800-811-F00	Power Plant Test Reference Table (P/B 501)
71-11-02-410-801-F00	Close the Fan Cowl Panels (P/B 201)
79-31-01-400-801-F00	Oil Quantity Transmitter Installation (P/B 401)

C. Consumable Materials

Reference	Description	Specification
B00676 [CP1041]	Alcohol - Isopropyl	TT-I-735
D00599 [CP2442]	Oil - Engine (CFMI SB 79-001)	
D00601 [CP2101]	Grease - Graphite, High Temperature	SAE AMS 2518
D00625 [CP2338]	Grease - Conductive - Brisal OX	
G00034	Cotton Wiper - Process Cleaning Absorbent Wiper (Cheesecloth, Gauze)	BMS15-5

D. Expendables/Parts

AMM Item	Description	AIPC Reference	AIPC Effectivity
3	Gasket	79-21-00-03-025	HAP ALL
5	Tank	79-11-01-01-085	HAP ALL
8	Gasket	79-21-00-03-030	HAP ALL
12	Gasket	79-21-00-03-025	HAP ALL
15	Strip	79-11-01-01-027	HAP ALL
18	Pin	79-11-01-01-040	HAP ALL

E. Location Zones

Zone	Area
411	Engine 1 - Engine
421	Engine 2 - Engine

F. Oil Tank Installation

SUBTASK 79-11-01-210-001-F00

- (1) Do these steps to prepare for the installation of the oil tank [5] General Precautions During the Removal and Installation of Engine Components, TASK 70-10-02-910-801-F00 (Figure 401):
 - (a) Make sure that the mating interfaces of the three square hose flanges and the oil-out, oil-in and vent bosses are clean and in a good condition.

SUBTASK 79-11-01-420-001-F00

- (2) Do these steps to attach the top mount to the top bracket on flange B6 (Figure 401) (View C):

EFFECTIVITY
HAP ALL

79-11-01

D633A101-HAP

Page 406
Jun 15/2009

AIRCRAFT MAINTENANCE MANUAL

- (a) Lubricate the threads and the shank of the shoulder-headed pin [20] with grease, D00601 [CP2101].
- (b) Loosen the nut [19].
- (c) Put the top mount of the oil tank [5] in its position on flange B6.
- (d) Install the shoulder-headed pin [20], washer [22] and castellated nut [21].

NOTE: Install the shoulder-headed pin with the head in the forward position.

- 1) Tighten the castellated nut [21] with your fingers.

SUBTASK 79-11-01-420-002-F00

- (3) Do these steps to attach the forward and aft bottom mounts to the brackets on flanges B4, B5 and B7 (Figure 401) (View D and E):
 - (a) Lubricate the threads and the shank of the two shoulder-headed pins [24] and mating faces of the two dampers [23] with grease, D00601 [CP2101].
 - (b) Install the dampers [23] to the brackets on flanges B4, B5 and B7.
 - (c) Put the forward and aft bottom mounts on the four dampers [23].
 - (d) Install the two shoulder-headed pins [24] to attach the oil tank [5].
 - 1) Tighten the shoulder-headed pins [24] and nut [19] at the same time, to 314-346 pound-inches (35-39 Newton meters).
 - 2) Tighten the castellated nut [21] to 110-120 pound-inches (12.5-13.5 Newton meters).
 - (e) Install a new cotter pin [18] in the castellated nut [21].

NOTE: Loosen the castellated nut slightly to be clear of the first slot and help with the installation of the cotter pin, if it is necessary.

SUBTASK 79-11-01-420-003-F00

- (4) Do these steps to install the bonding strip [15] to the fan frame on flange B6 (Figure 401) (View B):
 - (a) Clean the bolt [13], washer [14], terminal lug of the bonding strip [15] and area around the terminal lug with alcohol, B00676 [CP1041].
 - (b) Carefully clean the fasteners and the area around the terminal lug with a dry cotton wiper, G00034.
 - (c) Lubricate the mating faces of the bolt [13], washer [14], terminal lug of the bonding strip [15] and area around of the terminal lug with a thin layer of Brisal OX grease, D00625 [CP2338].
 - (d) Install the washer [14] and bolt [13] to attach the terminal lug of the bonding strip [15] to the fan frame flange with the spacer [16] and nut [17].
 - 1) Tighten the nut [17] to 228-252 pound-inches (25.5-28 Newton meters).

SUBTASK 79-11-01-420-004-F00

- (5) Do these steps to attach the oil-out [7], oil-in [11] and vent [9] hoses to the oil tank [5] (Figure 401):
 - (a) Remove the protective caps from the hoses, tubes and oil tank openings.
 - (b) Lubricate the gaskets [8], [12] and [3] with oil, D00599 [CP2442].
 - (c) Lubricate the threads of the bolts [6], [10] and [4] with grease, D00601 [CP2101].
 - (d) Install the gasket [8] between the oil-out boss and oil-out hose [7].
 - (e) Install the four bolts [6] to attach the oil-out hose [7].
 - 1) Tighten the bolts [6] to 98-110 pound-inches (11-12.5 Newton meters).

EFFECTIVITY
HAP ALL

D633A101-HAP

79-11-01

Page 407
Feb 15/2009

AIRCRAFT MAINTENANCE MANUAL

- (f) Install the gasket [12] between the oil-in boss and oil-in hose [11].
- (g) Install the four bolts [10] to attach the oil-in hose [11].
- (h) Install the gasket [3] between the vent boss and vent hose [9].
- (i) Install the four bolts [4] to attach the vent hose [9].
 - 1) Tighten the bolts [10] and [4] to 45-55 pound-inches (5-6.2 Newton meters).
 - 2) Tighten the oil-in coupling nut to 900-1100 pound-inches (100-125 Newton meters).

SUBTASK 79-11-01-420-005-F00

- (6) Do these steps to connect the drain hose [2] to the oil tank [5] (Figure 401):
 - (a) Lubricate the threads of the oil scupper nipple [1] with oil, D00599 [CP2442].
 - (b) Connect the drain hose [2] to the bottom of the oil scupper nipple [1].

CAUTION: USE TWO WRENCHES TO TIGHTEN THE COUPLING NUT. USE ONE TO HOLD THE FITTING, AND THE OTHER TO TIGHTEN THE COUPLING NUT. IF YOU DO NOT USE TWO WRENCHES, DAMAGE TO THE EQUIPMENT CAN OCCUR.

- 1) Tighten the drain hose [2] to 135-150 pound-inches (15.2-17.0 Newton meters).

SUBTASK 79-11-01-610-008-F00

- (7) If the new oil tank did not come with a new oil quantity transmitter, do this step:
 - (a) Do this task: Oil Quantity Transmitter Installation, TASK 79-31-01-400-801-F00.

SUBTASK 79-11-01-020-009-F00

- (8) If the new oil tank did come with a new oil quantity transmitter, do this step:
 - (a) Connect the electrical connector, DP1301 [25] to the transmitter receptacle.

SUBTASK 79-11-01-610-006-F00

- (9) Do this task: Replenish the Engine Oil, TASK 12-13-11-600-801.

G. Put the Airplane Back to Its Usual Condition

SUBTASK 79-11-01-410-004-F00

- (1) Do this task: Close the Fan Cowl Panels, TASK 71-11-02-410-801-F00.

SUBTASK 79-11-01-860-015-F00

- (2) For Engine 1, remove the safety tags and close these circuit breakers:

CAPT Electrical System Panel, P18-2

<u>Row</u>	<u>Col</u>	<u>Number</u>	<u>Name</u>
D	5	C01359	DISPLAY DEU 1 PRI

F/O Electrical System Panel, P6-1

<u>Row</u>	<u>Col</u>	<u>Number</u>	<u>Name</u>
D	10	C01361	DISPLAY DEU 1 HOLDUP

SUBTASK 79-11-01-860-016-F00

- (3) For Engine 2, remove the safety tags and close these circuit breakers:

F/O Electrical System Panel, P6-1

<u>Row</u>	<u>Col</u>	<u>Number</u>	<u>Name</u>
D	9	C01362	DISPLAY DEU 2 HOLDUP
D	11	C01360	DISPLAY DEU 2 PRI

EFFECTIVITY
HAP ALL

D633A101-HAP

79-11-01

Page 408
Feb 15/2009

AIRCRAFT MAINTENANCE MANUAL

H. Oil Tank Installation Test

SUBTASK 79-11-01-800-001-F00

- (1) Do the tests that are listed in the Power Plant Test Reference Table, TASK 71-00-00-800-811-F00.

SUBTASK 79-11-01-610-007-F00

- (2) If the oil level is low, do this task: Replenish the Engine Oil, TASK 12-13-11-600-801.

————— **END OF TASK** —————

EFFECTIVITY
HAP ALL

D633A101-HAP

79-11-01

Page 409
Feb 15/2009

737-600/700/800/900
AIRCRAFT MAINTENANCE MANUAL

OIL TANK - INSPECTION/CHECK

1. General

A. This procedure contains one task, the visual inspection of the oil tank for damage and leaks.

TASK 79-11-01-200-801-F00

2. Oil Tank Inspection

(Figure 601)

A. General

(1) This task is the inspection procedure for the oil tank envelope (referred to as the envelope).

B. References

Reference	Title
12-13-11-600-803	Drain the Engine Oil (P/B 301)
71-11-02-010-801-F00	Open the Fan Cowl Panels (P/B 201)
71-11-02-410-801-F00	Close the Fan Cowl Panels (P/B 201)
79-11-01-000-801-F00	Oil Tank Removal (P/B 401)
79-11-01-300-801-F00	Replacement of the Filler Cap Packing or Filler Cap (P/B 801)
79-11-01-400-801-F00	Oil Tank Installation (P/B 401)

C. Tools/Equipment

Reference	Description
STD-1238	Indicator - Dial

D. Location Zones

Zone	Area
411	Engine 1 - Engine
421	Engine 2 - Engine

E. Prepare for the Oil Tank Inspection

SUBTASK 79-11-01-010-006-F00

(1) Do this task: Open the Fan Cowl Panels, TASK 71-11-02-010-801-F00.

F. Oil Tank Inspection

SUBTASK 79-11-01-900-001-F00

(1) If you find damage that is more than the limits, replace the oil tank, unless you are given other instructions.

These are the tasks:

- Oil Tank Removal, TASK 79-11-01-000-801-F00
- Oil Tank Installation, TASK 79-11-01-400-801-F00.

SUBTASK 79-11-01-210-002-F00

(2) Examine the envelope for damage:

(a) Cracks

- 1) Cracks in the envelope are not permitted.
- 2) Cracks in the forward bottom mount are not permitted.
- 3) Cracks in the aft bottom mount are not permitted.

(b) Nicks or scratches

EFFECTIVITY
HAP ALL

D633A101-HAP

79-11-01

Page 601
Feb 15/2009

AIRCRAFT MAINTENANCE MANUAL

- 1) No more than three nicks or scratches are permitted, with these conditions:
 - a) The depth of the nicks or scratches is no more than 0.015 inches (0.38 mm).
 - b) The length of the nicks or scratches is no more than 0.375 inches (9.52 mm).
 - c) Damage does not connect.
 - d) You can not feel the nicks or scratches with a 0.030 inch (0.760 mm) dial indicator, STD-1238.
- (c) Cracks or a cloudy glass window
 - 1) Cracks or a cloudy glass window in the sight gage is not permitted.
- (d) Small dents or bumps
 - 1) No more than three small dents or bumps are permitted, with these conditions:
 - a) The contour is smooth.
 - b) The damage is not connected or aligned.
 - c) The capacity of the oil tank does not change.
 - d) The damage does not cause distortion of adjacent items that you can see.

SUBTASK 79-11-01-210-003-F00

- (3) Examine the sealing interfaces between the areas that follow for leaks:
 - (a) The sight gage and the envelope
 - 1) Leaks between the sight gage and the envelope are not permitted.
 - (b) The drain plug and the envelope boss recess
 - 1) Leaks between the drain plug and the envelope boss recess are not serviceable.
 - 2) If you find leaks, do these steps:
 - a) Tighten the drain plug to 135-150 pound-inches (15.2-16.9 Newton meters).
 - b) If it still leaks, do this task: Drain the Engine Oil, TASK 12-13-11-600-803 and, replace the packing.
 - (c) The flanges of the oil-in, the vent and the oil-out hoses and the envelope boss
 - 1) Leaks between the flanges are not serviceable.
 - 2) If you find leaks, do these steps:
 - a) Tighten the flange bolts.
 - b) If it still leaks, replace the gaskets; and, if it still leaks, then replace the oil tank.
These are the tasks:
 - Oil Tank Removal, TASK 79-11-01-000-801-F00
 - Oil Tank Installation, TASK 79-11-01-400-801-F00.
 - (d) The filler cap and the oil cap assembly
 - 1) Leaks between the filler cap and the oil cap assembly are not serviceable.
 - 2) If you find leaks, do these steps:
 - a) Make sure that the filler cap is correctly locked.
 - b) If the filler cap is correctly locked, replace the filler cap packing Replacement of the Filler Cap Packing or Filler Cap, TASK 79-11-01-300-801-F00.

EFFECTIVITY	
HAP ALL	

D633A101-HAP

79-11-01Page 602
Feb 15/2009

AIRCRAFT MAINTENANCE MANUAL

G. Put the Airplane Back to Its Usual Condition

SUBTASK 79-11-01-410-002-F00

- (1) Do this task: Close the Fan Cowl Panels, TASK 71-11-02-410-801-F00.

————— **END OF TASK** —————

EFFECTIVITY
HAP ALL

D633A101-HAP

79-11-01

Page 603
Oct 10/2003

AIRCRAFT MAINTENANCE MANUAL

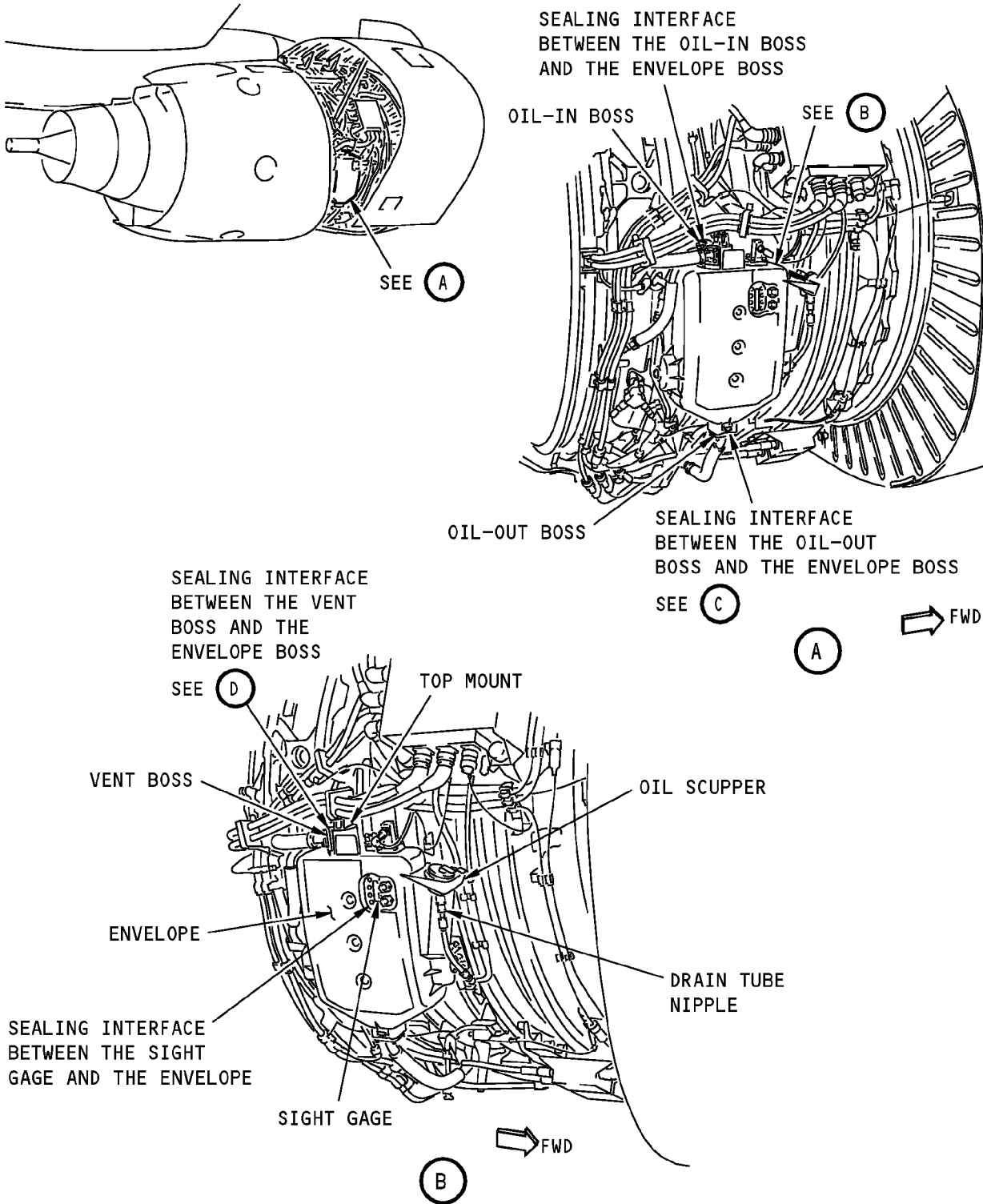

Oil Tank Inspection
Figure 601 (Sheet 1 of 2)/79-11-01-990-802-F00

EFFECTIVITY
HAP ALL

79-11-01

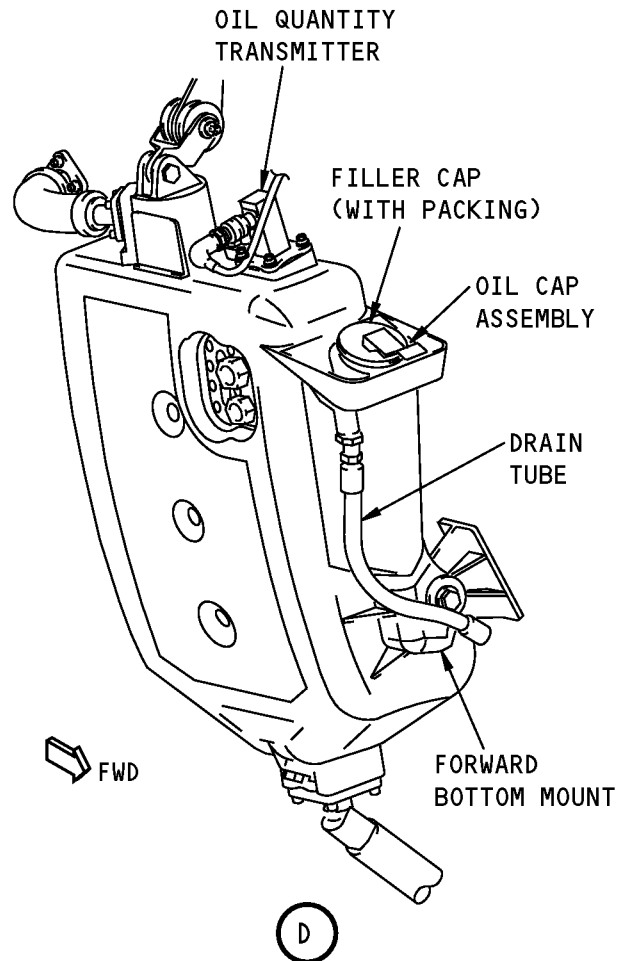
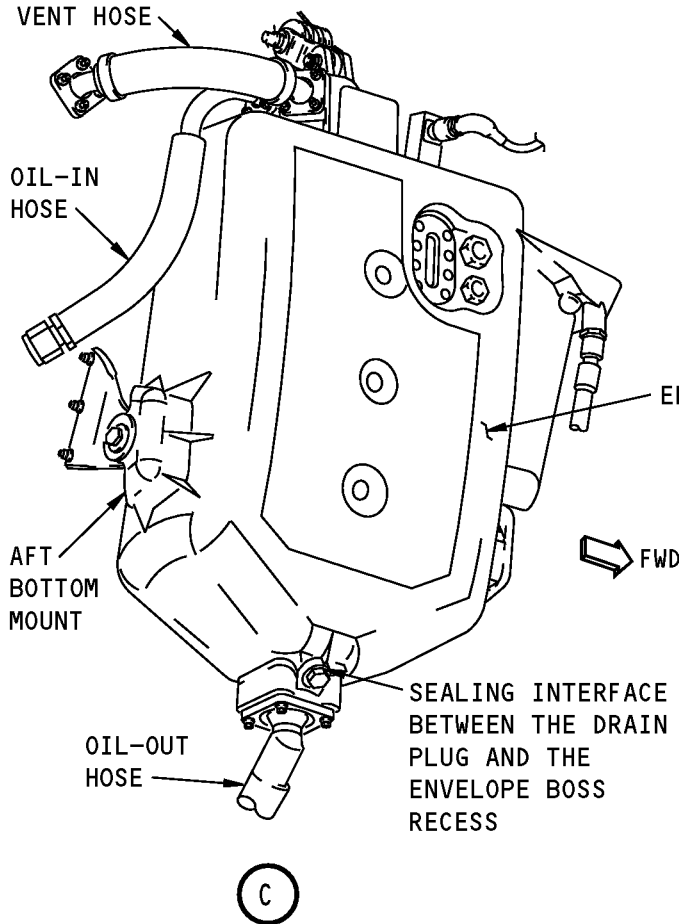

Oil Tank Inspection
Figure 601 (Sheet 2 of 2)/79-11-01-990-802-F00

EFFECTIVITY
HAP ALL

79-11-01

AIRCRAFT MAINTENANCE MANUAL

OIL TANK - CLEANING/PAINTING**1. General**

A. This procedure has one task:

- (1) The oil tank cleaning (external and internal).

TASK 79-11-01-100-801-F00**2. Oil Tank Cleaning**

(Figure 701)

A. General

- (1) This task is the cleaning procedure for the external and internal surfaces of the oil tank.
 (2) You must remove the oil tank to clean the internal surfaces.

B. References

Reference	Title
70-10-02-910-801-F00	General Precautions During the Removal and Installation of Engine Components (P/B 201)
71-11-02-010-801-F00	Open the Fan Cowl Panels (P/B 201)
71-11-02-410-801-F00	Close the Fan Cowl Panels (P/B 201)
79-11-01-000-801-F00	Oil Tank Removal (P/B 401)
79-11-01-400-801-F00	Oil Tank Installation (P/B 401)

C. Tools/Equipment

Reference	Description
STD-1271	Screen - 300 Micron, for Oil Tank Contaminate Inspection
STD-1280	Source - Air, Regulated, Dry Filtered, 0-30 PSIG
STD-3911	Brush - Bristle, Medium Nylon

D. Consumable Materials

Reference	Description	Specification
B00682 [CP2011]	Solvent - Stoddard	P-D-680, Type I, II or III
B00683 [CP1008]	Solvent - Stabilized Trichloroethylene	
B01028 [CP1010]	Solvent - Perchloroethylene	ASTM D4081

E. Location Zones

Zone	Area
411	Engine 1 - Engine
421	Engine 2 - Engine

F. Prepare for the Oil Tank Cleaning

SUBTASK 79-11-01-860-011-F00

- (1) For Engine 1, open these circuit breakers and install safety tags:

CAPT Electrical System Panel, P18-2

Row	Col	Number	Name
D	5	C01359	DISPLAY DEU 1 PRI

EFFECTIVITY
HAP ALL

D633A101-HAP

79-11-01

Page 701
Jun 15/2009

AIRCRAFT MAINTENANCE MANUAL

F/O Electrical System Panel, P6-1

<u>Row</u>	<u>Col</u>	<u>Number</u>	<u>Name</u>
D	10	C01361	DISPLAY DEU 1 HOLDUP

SUBTASK 79-11-01-860-012-F00

- (2) For Engine 2, open these circuit breakers and install safety tags:

F/O Electrical System Panel, P6-1

<u>Row</u>	<u>Col</u>	<u>Number</u>	<u>Name</u>
D	9	C01362	DISPLAY DEU 2 HOLDUP
D	11	C01360	DISPLAY DEU 2 PRI

SUBTASK 79-11-01-010-002-F00

- (3) Do this task: Open the Fan Cowl Panels, TASK 71-11-02-010-801-F00.

SUBTASK 79-11-01-020-007-F00

- (4) If you clean the oil tank internally, do this task: Oil Tank Removal, TASK 79-11-01-000-801-F00.

G. Oil Tank Cleaning (External)

SUBTASK 79-11-01-110-001-F00

- (1) Do these steps to clean the external surface of the oil tank:

WARNING: DO NOT GET THE SOLVENT IN YOUR MOUTH OR EYES, OR ON YOUR SKIN. DO NOT BREATHE THE FUMES FROM THE SOLVENT. PUT ON PROTECTIVE SPLASH GOGGLES AND GLOVES WHEN YOU USE THE SOLVENT. KEEP THE SOLVENT AWAY FROM SPARKS, FLAME AND HEAT. THE SOLVENT IS POISONOUS AND FLAMMABLE WHICH CAN CAUSE INJURIES TO PERSONS AND DAMAGE TO EQUIPMENT.

CAUTION: ALL OIL TANK OPENINGS MUST BE SEALED BEFORE YOU START TO CLEAN. IF YOU DO NOT SEAL THE OIL TANK OPENINGS, THEN CONTAMINATION OF THE OIL CIRCUIT CAN CAUSE DAMAGE TO THE ENGINE.

- (a) Clean the outer wall of the oil tank with solvent, B00683 [CP1008], or solvent, B01028 [CP1010], or solvent, B00682 [CP2011], and a medium nylon bristle brush, STD-3911.
- (b) Dry the outer wall with an 0-30 psig dry filtered regulated air source, STD-1280 (200 kPa).

H. Oil Tank Cleaning (Internal)

SUBTASK 79-11-01-110-002-F00

- (1) Do these steps to clean the internal surface of the oil tank:

- (a) Fill the oil tank about 1/3 full with solvent, B00683 [CP1008], or solvent, B01028 [CP1010], or solvent, B00682 [CP2011], through the fill port.
- (b) Shake the oil tank to loosen all the contamination from the inner wall.
- (c) Drain the oil tank through the drain port with a screen, STD-1271.
- (d) Examine the screen for all particles of 300 microns or more.
- (e) If you find particles, clean the oil tank again until there are no particles.
- (f) Dry the inner wall with 0-30 psig dry filtered regulated air source, STD-1280 (200 kPa).
- (g) Put protective covers on all the oil tank orifices General Precautions During the Removal and Installation of Engine Components, TASK 70-10-02-910-801-F00.

EFFECTIVITY
HAP ALL

D633A101-HAP

79-11-01

Page 702
Jun 10/2006

AIRCRAFT MAINTENANCE MANUAL

I. Put the Airplane Back to Its Usual Condition

SUBTASK 79-11-01-420-007-F00

(1) If you removed the oil tank, then, do this task: Oil Tank Installation, TASK 79-11-01-400-801-F00.

SUBTASK 79-11-01-410-003-F00

(2) Do this task: Close the Fan Cowl Panels, TASK 71-11-02-410-801-F00.

SUBTASK 79-11-01-860-017-F00

(3) For Engine 1, remove the safety tags and close these circuit breakers:

CAPT Electrical System Panel, P18-2

<u>Row</u>	<u>Col</u>	<u>Number</u>	<u>Name</u>
D	5	C01359	DISPLAY DEU 1 PRI

F/O Electrical System Panel, P6-1

<u>Row</u>	<u>Col</u>	<u>Number</u>	<u>Name</u>
D	10	C01361	DISPLAY DEU 1 HOLDUP

SUBTASK 79-11-01-860-018-F00

(4) For Engine 2, remove the safety tags and close these circuit breakers:

F/O Electrical System Panel, P6-1

<u>Row</u>	<u>Col</u>	<u>Number</u>	<u>Name</u>
D	9	C01362	DISPLAY DEU 2 HOLDUP
D	11	C01360	DISPLAY DEU 2 PRI

————— END OF TASK —————

EFFECTIVITY
HAP ALL

D633A101-HAP

79-11-01

Page 703
Oct 10/2003

737-600/700/800/900
AIRCRAFT MAINTENANCE MANUAL

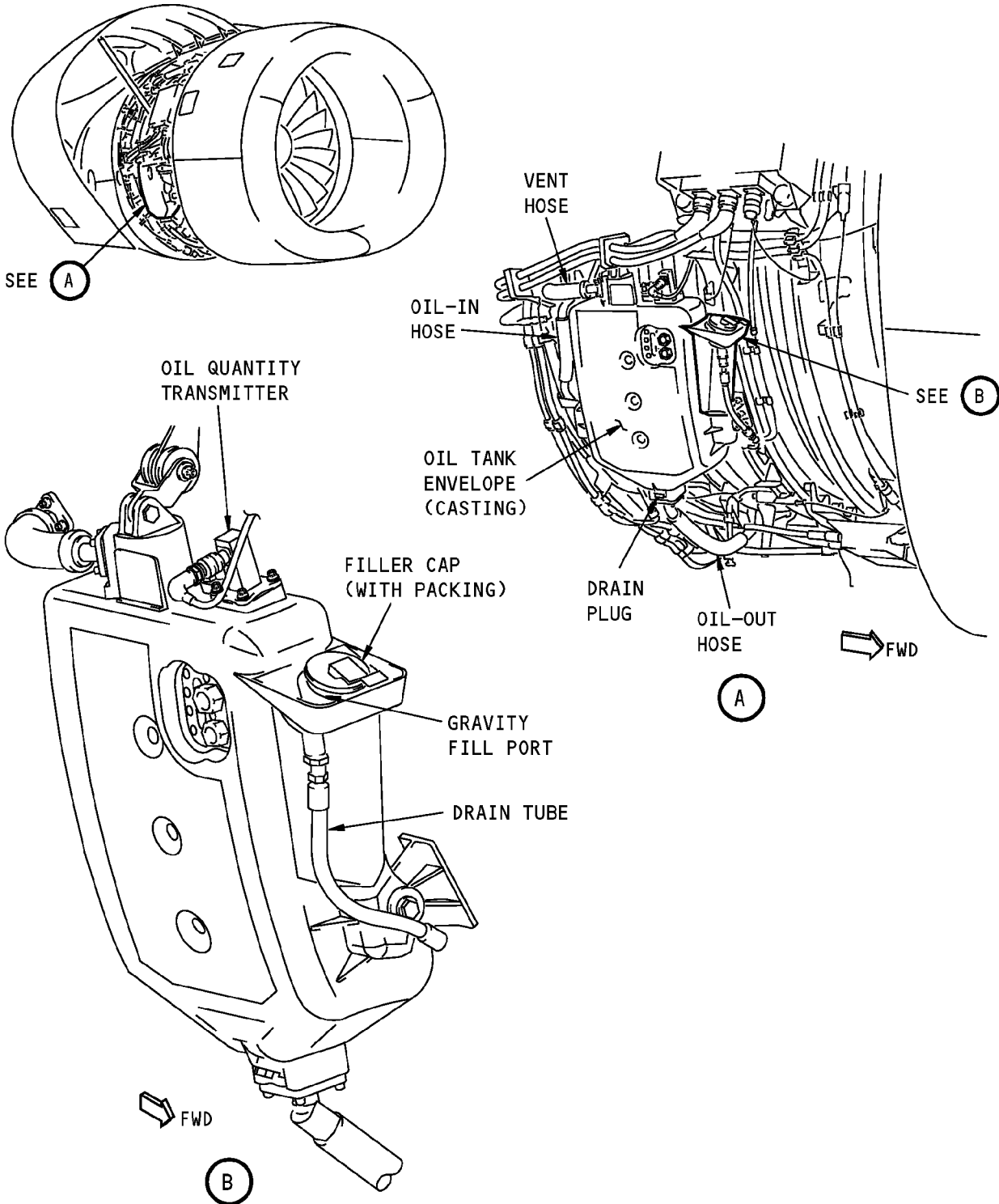

Oil Tank Cleaning
Figure 701/79-11-01-990-803-F00

EFFECTIVITY
HAP ALL

79-11-01

AIRCRAFT MAINTENANCE MANUAL

OIL TANK - REPAIRS**1. General**

A. This procedure contains these tasks:

- (1) The replacement of the filler cap packing or the filler cap.
- (2) The replacement of the oil cap assembly packings.
- (3) The replacement of the plugs by the remote filling kit.
- (4) The replacement of the sight glass.

TASK 79-11-01-300-801-F00**2. Replacement of the Filler Cap Packing or Filler Cap**

(Figure 801)

A. General

- (1) Replace the filler cap packing if you find an oil leak between the oil tank and the filler cap.
- (2) Replace the filler cap if you find it damaged.
- (3) The oil tank is installed on the right side of the fan case.
- (4) This procedure refers to the oil tank filler cap as the filler cap.

B. References

Reference	Title
71-11-02-010-801-F00	Open the Fan Cowl Panels (P/B 201)
71-11-02-410-801-F00	Close the Fan Cowl Panels (P/B 201)

C. Consumable Materials

Reference	Description	Specification
D00599 [CP2442]	Oil - Engine (CFMI SB 79-001)	
G00034	Cotton Wiper - Process Cleaning Absorbent Wiper (Cheesecloth, Gauze)	BMS15-5

D. Expendables/Parts

AMM Item	Description	AIPC Reference	AIPC Effectivity
1	Filler cap packing	79-11-01-01-095	HAP ALL

E. Location Zones

Zone	Area
411	Engine 1 - Engine
421	Engine 2 - Engine

F. Procedure

SUBTASK 79-11-01-010-004-F00

- (1) Do this task: Open the Fan Cowl Panels, TASK 71-11-02-010-801-F00.

SUBTASK 79-11-01-960-001-F00

- (2) Do these steps to replace the filler cap packing [1] or the filler cap [2]:

CAUTION: MAKE SURE THAT THE OIL SCUPPER IS CLEAN. IF THE OIL SCUPPER IS NOT CLEAN, CONTAMINATION OF THE OIL TANK CAN OCCUR DURING THE SAMPLING OPERATION.

- (a) Use a cotton wiper, G00034, to clean the oil scupper.

EFFECTIVITY
HAP ALL

79-11-01

Page 801
Feb 15/2009

D633A101-HAP

AIRCRAFT MAINTENANCE MANUAL

- (b) Lift the filler cap handle.
- (c) Turn the filler cap handle counterclockwise to open it.
- (d) Pull the filler cap [2] from the gravity fill port.
- (e) Disconnect the chain [3] from the split ring [4] on the filler cap.
- (f) Remove and discard the filler cap packing [1] from the groove of the filler cap [2].

NOTE: If you find the filler cap [2] is damaged, replace it.

- (g) Lubricate a new filler cap packing [1] with oil, D00599 [CP2442].

CAUTION: MAKE SURE YOU INSTALL THE PACKING CORRECTLY ON THE FILLER CAP. IF YOU DO NOT INSTALL THE PACKING CORRECTLY, OIL LOSS CAN OCCUR DURING ENGINE OPERATION AND CAN CAUSE DAMAGE TO THE ENGINE.

- (h) Install the filler cap packing [1] in the groove of the filler cap [2].
- (i) Connect the chain [3] to the split ring [4] on the filler cap [2].
- (j) Put the filler cap [2] in its position in the gravity fill port.
- (k) Push the filler cap [2] in and turn the handle clockwise to lock it.
- (l) Push the filler cap handle down to the closed position.

G. Put the Airplane Back to Its Usual Condition

SUBTASK 79-11-01-410-005-F00

- (1) Do this task: Close the Fan Cowl Panels, TASK 71-11-02-410-801-F00.

————— **END OF TASK** —————

EFFECTIVITY
HAP ALL

D633A101-HAP

BOEING PROPRIETARY - Copyright © Unpublished Work - See title page for details

79-11-01

Page 802
Feb 15/2009

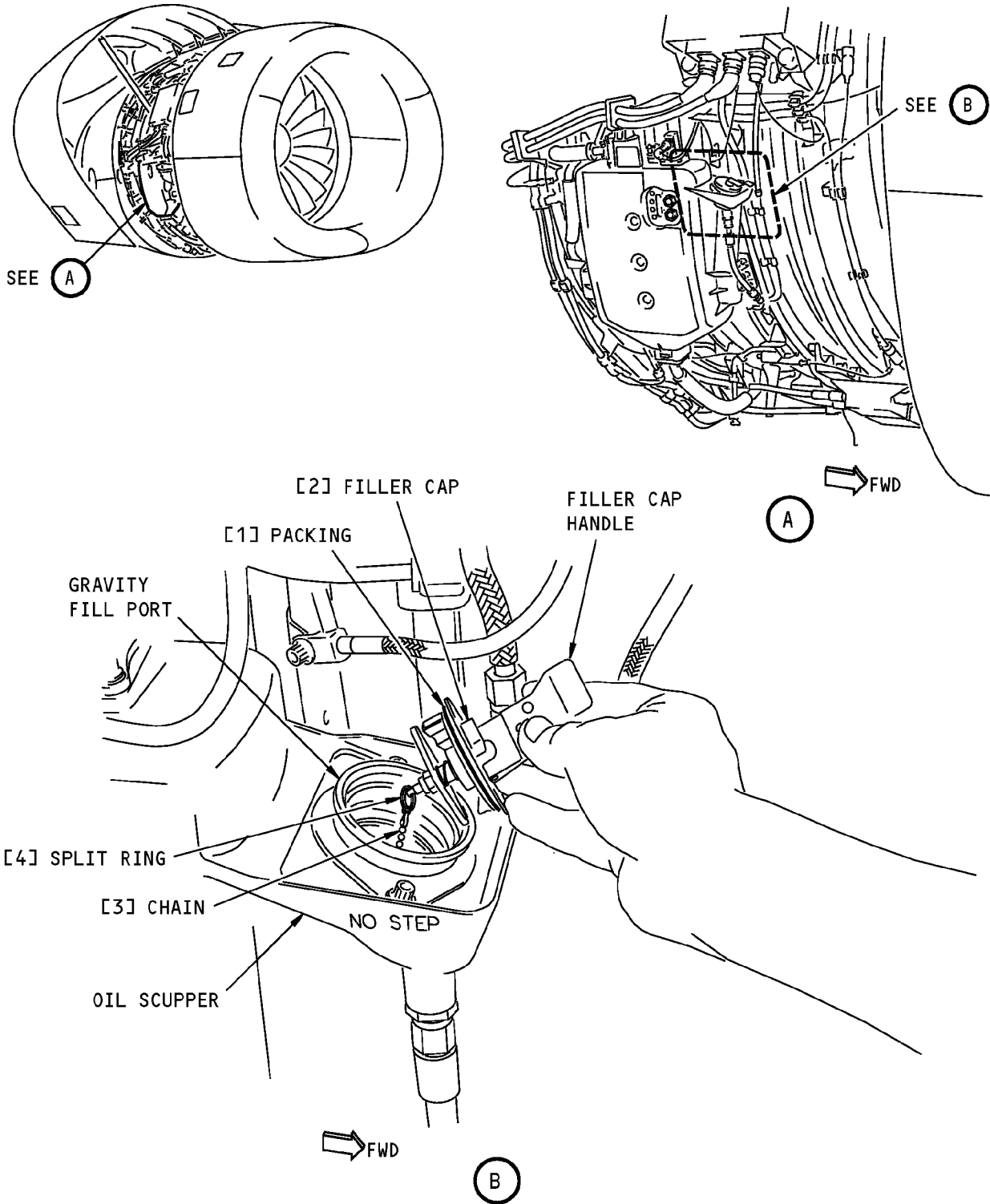

Replacement of the Filler Cap Packing
Figure 801/79-11-01-990-804-F00

EFFECTIVITY
HAP ALL

79-11-01

AIRCRAFT MAINTENANCE MANUAL

TASK 79-11-01-300-802-F00

3. Replacement of the Oil Cap Assembly Packings

A. General

- (1) Replace the oil cap assembly packings if you find them damaged.
- (2) The oil tank is installed on the right side of the fan case.
- (3) This procedure refers the oil tank cap assembly as the oil cap assembly.

B. References

Reference	Title
71-11-02-010-801-F00	Open the Fan Cowl Panels (P/B 201)
71-11-02-410-801-F00	Close the Fan Cowl Panels (P/B 201)

C. Consumable Materials

Reference	Description	Specification
D00599 [CP2442]	Oil - Engine (CFMI SB 79-001)	
G00034	Cotton Wiper - Process Cleaning Absorbent Wiper (Cheesecloth, Gauze)	BMS15-5

D. Expendables/Parts

AMM Item	Description	AIPC Reference	AIPC Effectivity
24	Oil cap assembly packing	79-11-01-01-088	HAP ALL
26	Oil cap assembly packing	79-11-01-01-099	HAP ALL

E. Procedure

SUBTASK 79-11-01-010-007-F00

- (1) Do this task: Open the Fan Cowl Panels, TASK 71-11-02-010-801-F00.

SUBTASK 79-11-01-960-003-F00

- (2) Do these steps to replace the oil cap assembly packing [24] and oil cap assembly packing [26].

CAUTION: MAKE SURE THAT THE OIL SCUPPER IS CLEAN. A DIRTY SCUPPER CAN CAUSE THE CONTAMINATION OF THE OIL TANK.

- (a) Use a cotton wiper, G00034, to clean the oil scupper.
- (b) Put the oil tank filler cap handle to the (unlocked) vertical position and turn the filler cap [2] counterclockwise to open it.
- (c) Remove the two bolts [22] and washers [21].
- (d) Remove the oil cap assembly [23] from the oil scupper [25].
- (e) Put the oil cap assembly [23] in a clean container to collect oil drippings.
- (f) Remove and discard the oil cap assembly packing [24] and the oil cap assembly packing [26] from the grooves of the oil cap assembly.

WARNING: DO NOT LET THE ENGINE OIL STAY ON YOUR SKIN. ENGINE OIL IS POISONOUS. DO NOT BREATHE THE FUMES. USE ENGINE OIL IN AN AREA WITH GOOD AIRFLOW. DO NOT GET ENGINE OIL ON YOUR CLOTHES OR ON THE AIRPLANE. ENGINE OIL CAN CAUSE INJURIES.

- (g) Lubricate the new oil cap assembly packing [24] and the new oil cap assembly packing [26] with oil, D00599 [CP2442].
- (h) Install a new oil cap assembly packing [24] in the groove of the oil cap assembly [23].

EFFECTIVITY
HAP ALL

79-11-01

Page 804
Jun 15/2008

D633A101-HAP

AIRCRAFT MAINTENANCE MANUAL

- (i) Open up the flapper of the oil cap assembly [23]. Install a new oil cap assembly packing [26] in the groove.

NOTE: Make sure that the surfaces are clean before you install the parts.

- (j) Install the oil cap assembly [23] on the oil scupper [25]. Make sure that you do not damage the new oil cap assembly packing [24].

NOTE: Make sure that the oil cap assembly [23] and the oil scupper [25] are installed in the correct position.

- (k) Install the two bolts [22] and washers [21] to attach the oil cap assembly [23] to the oil tank.
(l) Tighten the bolts [22] to between 75 in-lb (8.5 N·m) and 85 in-lb (9.6 N·m).
(m) Push the filler cap [2] in and turn the filler cap handle clockwise to lock it. Push the filler cap handle down to the closed position.

F. Put the Airplane Back to Its Usual Condition

SUBTASK 79-11-01-410-006-F00

- (1) Do this task: Close the Fan Cowl Panels, TASK 71-11-02-410-801-F00.

————— **END OF TASK** —————

EFFECTIVITY
HAP ALL

D633A101-HAP

79-11-01

Page 805
Jun 15/2008

737-600/700/800/900
AIRCRAFT MAINTENANCE MANUAL

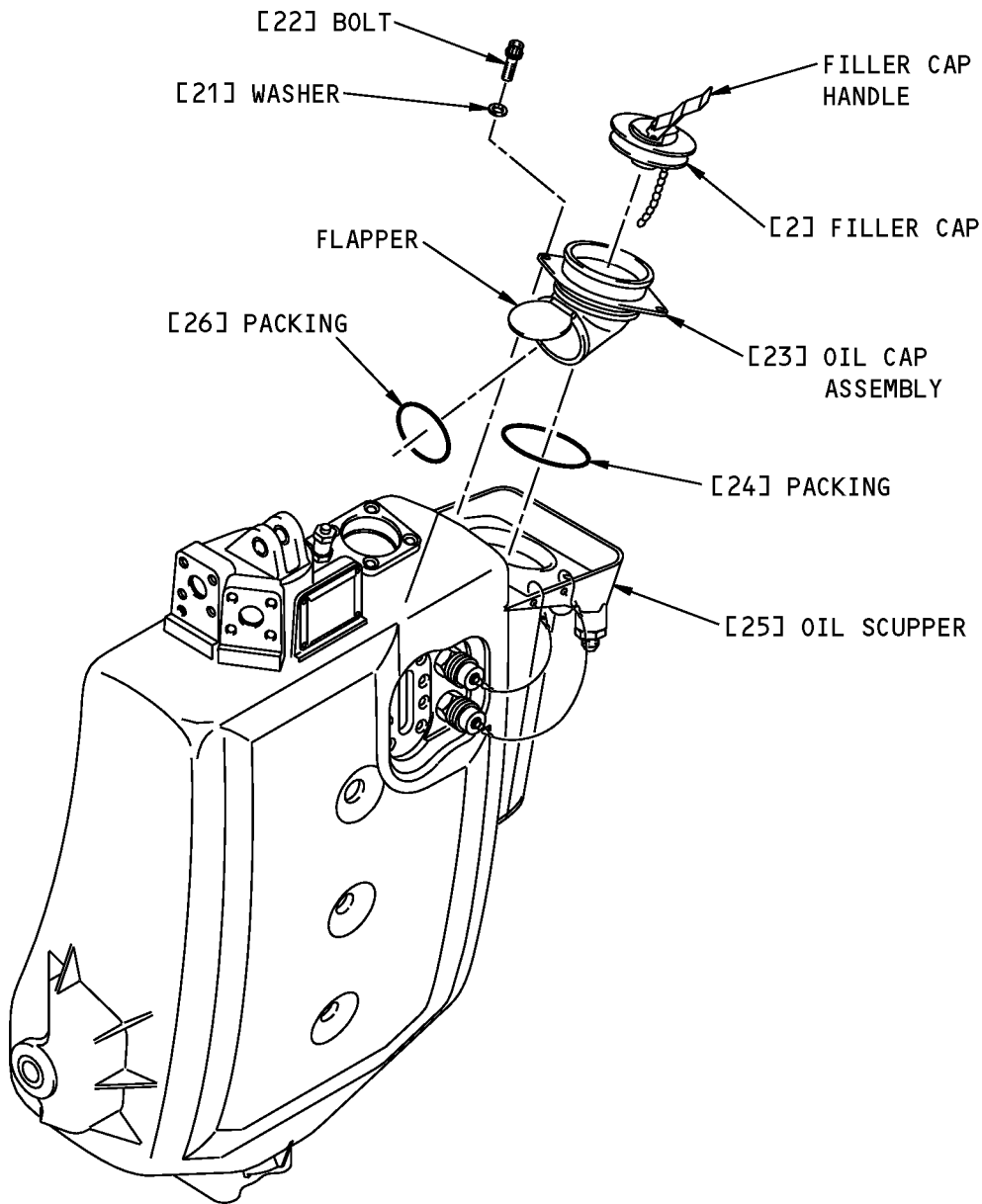

Replacement of the Cap Assembly Packings
Figure 802/79-11-01-990-805-F00

EFFECTIVITY
HAP ALL

79-11-01

AIRCRAFT MAINTENANCE MANUAL

TASK 79-11-01-300-803-F00

4. Replacement of the Plugs by the Remote Filling Kit

A. General

- (1) The oil tank is installed on the right side of the fan case.
- (2) This procedure gives the instructions to replace the plugs by the remote filling kit.
- (3) The procedure must be done after you drain the oil tank to prevent oil leakage and contamination (TASK 12-13-11-600-803).

B. References

Reference	Title
12-13-11-600-801	Replenish the Engine Oil (P/B 301)
12-13-11-600-803	Drain the Engine Oil (P/B 301)
12-13-11-600-806	Replenish the Engine Oil (Remote Fill Procedure) (P/B 301)
71-11-02-010-801-F00	Open the Fan Cowl Panels (P/B 201)
71-11-02-410-801-F00	Close the Fan Cowl Panels (P/B 201)

C. Consumable Materials

Reference	Description	Specification
D00599 [CP2442]	Oil - Engine (CFMI SB 79-001)	
G00034	Cotton Wiper - Process Cleaning Absorbent Wiper (Cheesecloth, Gauze)	BMS15-5

D. Procedure

SUBTASK 79-11-01-010-008-F00

- (1) Do this task: Open the Fan Cowl Panels, TASK 71-11-02-010-801-F00.

SUBTASK 79-11-01-960-004-F00

- (2) Do these steps to replace the plug [42] and plug [43] by the remote filling kit.

CAUTION: MAKE SURE THAT THE OIL SCUPPER IS CLEAN. A DIRTY SCUPPER CAN CAUSE THE CONTAMINATION OF THE OIL TANK.

- (a) Use a cotton wiper, G00034, to clean the oil scupper.
- (b) Put the oil tank filler cap handle to the (unlocked) vertical position. Turn the filler cap [2] counterclockwise to open it.
- (c) Remove the plug [42] and the plug [43] and discard the packing [41] and the packing [44].

WARNING: DO NOT LET THE ENGINE OIL STAY ON YOUR SKIN. ENGINE OIL IS POISONOUS. DO NOT BREATHE THE FUMES. USE ENGINE OIL IN AN AREA WITH GOOD AIRFLOW. DO NOT GET ENGINE OIL ON YOUR CLOTHES OR ON THE AIRPLANE. ENGINE OIL CAN CAUSE INJURIES.

- (d) Lubricate the new packing [41] and the new packing [44] with oil, D00599 [CP2442].
- (e) Install a new packing [41] in the groove on the over flow block head coupling [61] with the toolkit 9970-957-740.

NOTE: Make sure that the surfaces are clean before you install the parts.

- (f) Install a new packing [44] in the groove on the remote filling block head coupling [62] with the tool kit 9970-957-740.

NOTE: Make sure that the surfaces are clean before you install the parts.

EFFECTIVITY
HAP ALL

79-11-01

Page 807
Jun 15/2008

D633A101-HAP

AIRCRAFT MAINTENANCE MANUAL

- (g) Install the remote filling block head coupling [62] in the remote filling port (lower opening). Tighten the coupling by hand.

NOTE: Make sure that the surfaces are clean before you install the parts.

- (h) Tighten the remote filling block head coupling [62] to between 181.5 in-lb (20.5 N·m) and 203.0 in-lb (22.9 N·m).
- (i) Install the over flow block head coupling [61] in the over flow port (upper opening). Tighten the coupling by hand.

NOTE: Make sure that the surfaces are clean before you install the parts.

- (j) Tighten the over flow block head coupling [61] to between 270 in-lb (30.5 N·m) and 300 in-lb (33.9 N·m).

WARNING: DO NOT LET THE ENGINE OIL STAY ON YOUR SKIN. ENGINE OIL IS POISONOUS. DO NOT BREATHE THE FUMES. USE ENGINE OIL IN AN AREA WITH GOOD AIRFLOW. DO NOT GET ENGINE OIL ON YOUR CLOTHES OR ON THE AIRPLANE. ENGINE OIL CAN CAUSE INJURIES.

- (k) Lubricate the new plug [42] with oil, D00599 [CP2442].
- (l) Lubricate the new plug [43] with oil, D00599 [CP2442].
- (m) Attach the new plug [42] with its chain to the scupper hole and install it on the remote filling block head coupling [62].
- (n) Push the plug [42] to lock it.
- (o) Attach the new plug [43] with its chain to the scupper hole and install it on the remote filling block head coupling [62].
- (p) Push the plug [43] to lock it.
- (q) Push the filler cap [2] in and turn the filler cap handle clockwise to lock it. Push the filler cap handle down to its closed position.

SUBTASK 79-11-01-612-001-F00

- (3) Do this task: Replenish the Engine Oil, TASK 12-13-11-600-801 or Replenish the Engine Oil (Remote Fill Procedure), TASK 12-13-11-600-806.

E. Put the Airplane Back to Its Usual Condition

SUBTASK 79-11-01-410-007-F00

- (1) Do this task: Close the Fan Cowl Panels, TASK 71-11-02-410-801-F00.

————— **END OF TASK** —————

EFFECTIVITY
HAP ALL

D633A101-HAP

79-11-01

Page 808
Jun 15/2008

737-600/700/800/900
AIRCRAFT MAINTENANCE MANUAL

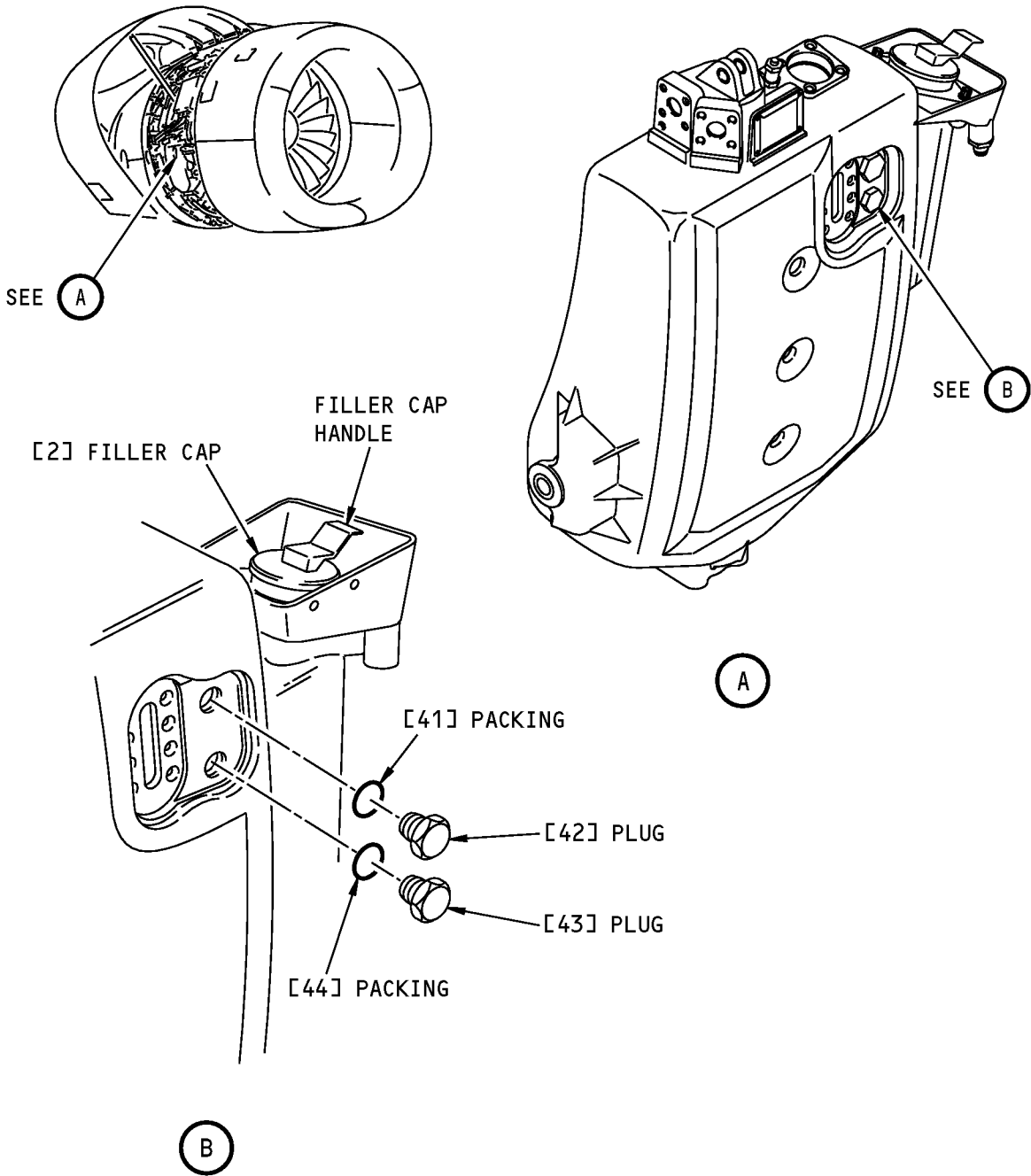

Remote Filling Kit
Figure 803 (Sheet 1 of 2)/79-11-01-990-806-F00

EFFECTIVITY
HAP ALL

79-11-01

Page 809
Jun 10/2006

D633A101-HAP

737-600/700/800/900
AIRCRAFT MAINTENANCE MANUAL

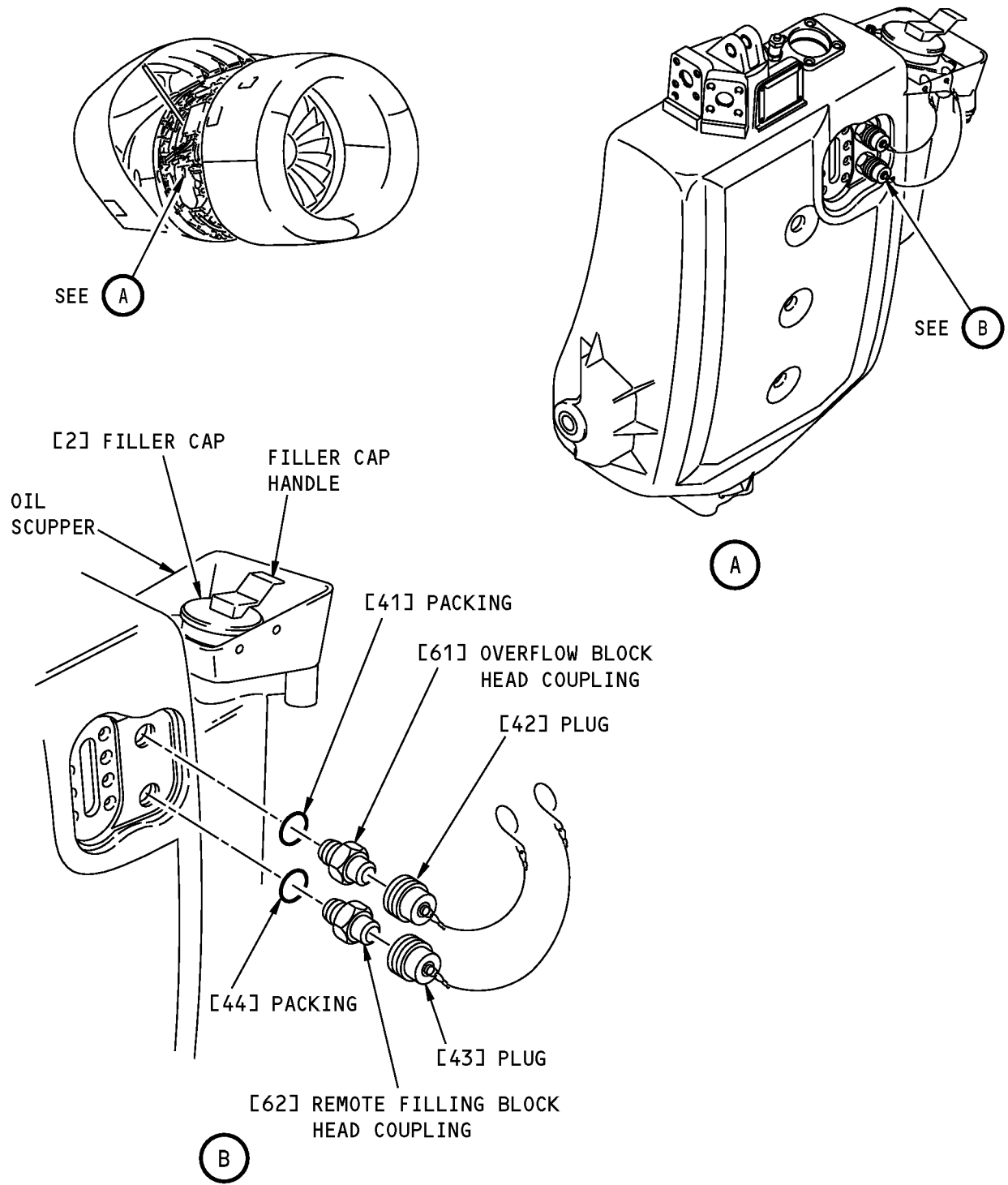

Remote Filling Kit
Figure 803 (Sheet 2 of 2)/79-11-01-990-806-F00

EFFECTIVITY
HAP ALL

79-11-01

Page 810
Jun 10/2006

D633A101-HAP

AIRCRAFT MAINTENANCE MANUAL

TASK 79-11-01-800-801-F00

5. Replacement of the Sight Glass

(Figure 804)

A. General

- (1) Replace the sight glass if you find it damaged.
- (2) The oil tank is installed on the right side of the fan case.
- (3) This procedure refers to the oil tank sight glass as the sight glass.

B. References

Reference	Title
12-13-11-600-801	Replenish the Engine Oil (P/B 301)
71-00-00-700-801-F00	Test 3A - Idle-Power Leak Check (P/B 501)
71-00-00-700-823-F00	Test 3B - Part-Power Leak Check (P/B 501)
71-11-02-010-801-F00	Open the Fan Cowl Panels (P/B 201)
71-11-02-410-801-F00	Close the Fan Cowl Panels (P/B 201)

C. Consumable Materials

Reference	Description	Specification
G00034	Cotton Wiper - Process Cleaning Absorbent Wiper (Cheesecloth, Gauze)	BMS15-5
G50135	Leak Detector - Liquid, Non-Corrosive Soap Compound	MIL-PRF-25567
G50464	Talcum Powder (White)	

D. Location Zones

Zone	Area
411	Engine 1 - Engine
421	Engine 2 - Engine

E. Procedure

SUBTASK 79-11-01-010-009-F00

- (1) Do this task: Open the Fan Cowl Panels, TASK 71-11-02-010-801-F00.

SUBTASK 79-11-01-960-005-F00

- (2) Do these steps to replace the sight glass [84]:
 - (a) Remove the eight flat head screws [83].
 - (b) Remove the plate [82].
 - (c) Remove the gasket [81].
 - (d) Remove the sight glass [84].
 - (e) Remove and discard the packing [85].
 - (f) Examine and clean the area below the sight glass with a cotton wiper, G00034.
 - (g) Install a new packing [85].
 - (h) Install a new sight glass [84].
 - (i) Install the gasket [81].
 - (j) Install the plate [82].
 - (k) Install the eight flat head screws [83].

EFFECTIVITY
HAP ALL

D633A101-HAP

79-11-01

Page 811
Jun 15/2008

AIRCRAFT MAINTENANCE MANUAL

- (l) Tighten the screws [3] to 24.8-30.1 pound-inches (2.8-3.4 Newton meters).

SUBTASK 79-11-01-790-001-F00

- (3) Do the idle-power leak test:

- (a) Fill the oil tank with engine oil below the sight glass. Do this task, Replenish the Engine Oil, TASK 12-13-11-600-801.
- (b) Apply a leak detector, G50135 solution on the sight glass level.
- (c) Do this task, Test 3A - Idle-Power Leak Check, TASK 71-00-00-700-801-F00
- 1) Do a visual check for the bubbles. No bubbles are permitted.
- (d) Clean the sight glass with a cotton wiper, G00034.

SUBTASK 79-11-01-790-002-F00

- (4) Do the part-power leak test:

- (a) Fill the oil tank with engine oil to the maximum level. Do this task, Replenish the Engine Oil, TASK 12-13-11-600-801.
- (b) Apply a Powder - Talc, G50464 on the sight glass.
- (c) Do this task Test 3B - Part-Power Leak Check, TASK 71-00-00-700-823-F00
- 1) Do a visual check for oil seepage. No oil leaks are permitted.

- F. Put the Airplane Back to its Usual Condition

SUBTASK 79-11-01-410-008-F00

- (1) Do this task: Close the Fan Cowl Panels, TASK 71-11-02-410-801-F00

————— **END OF TASK** —————

EFFECTIVITY
HAP ALL

D633A101-HAP

79-11-01

Page 812
Jun 15/2008

737-600/700/800/900
AIRCRAFT MAINTENANCE MANUAL

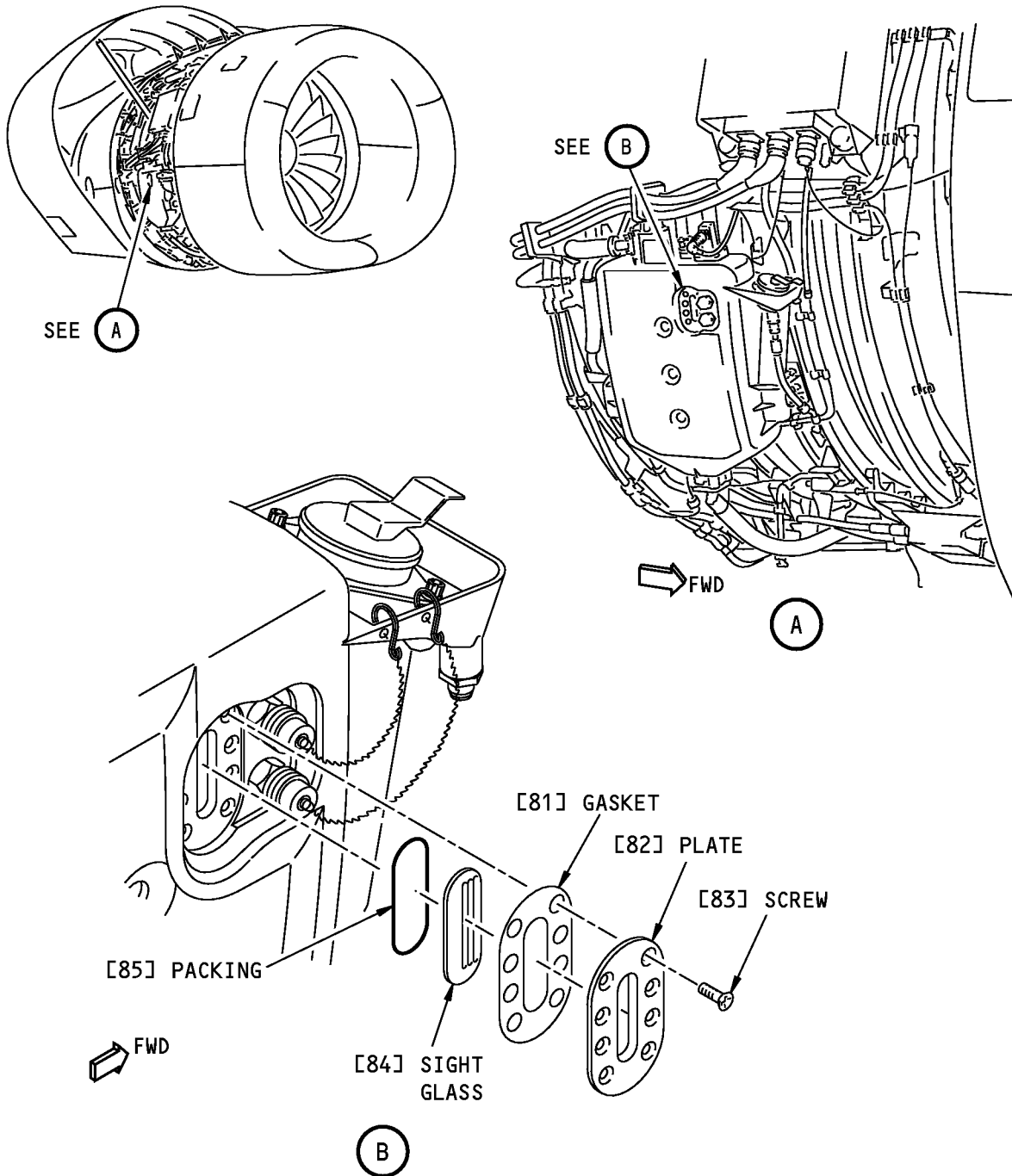

1554734 S0000285650_V1

Replacement of the Sight Glass
Figure 804/79-11-01-990-807-F00

EFFECTIVITY
HAP ALL

79-11-01

Page 813
Jun 15/2008

D633A101-HAP

AIRCRAFT MAINTENANCE MANUAL

OIL DISTRIBUTION - MAINTENANCE PRACTICES**1. General**

A. This procedure has these tasks:

- (1) Calibration of the Air Flow Test Rig used for the Air Flow Test of the Engine Oil Circuit.
- (2) Air Flow Test of the Engine Oil Circuit.

TASK 79-21-00-280-801-F00**2. Calibration of the Air Flow Test Rig**

(Figure 201)

A. General

- (1) This task is for the calibration of the air flow test rig used in the Air Flow Test of the Engine Oil Circuit.
- (2) Read the procedure to know the instructions before you try to do this procedure.

B. Tools/Equipment

NOTE: When more than one tool part number is listed under the same "Reference" number, the tools shown are alternates to each other within the same airplane series. Tool part numbers that are replaced or non-procurable are preceded by "Opt:", which stands for Optional.

Reference	Description
SPL-2458	Kit - Tool, Masters Air Nozzle (Part #: 856A2662G01, Supplier: 58828, A/P Effectivity: 737-300, -400, -500, -600, -700, -700C, -700ER, -700QC, -800, -900, -900ER, -BBJ)
SPL-3933	Adapter - Test Rig, No. 1 and No. 2 Bearing Support, Air Flow Check (Part #: 856A3267G02, Supplier: 58828, A/P Effectivity: 737-300, -400, -500, -600, -700, -700C, -700ER, -700QC, -800, -900, -900ER, -BBJ)
STD-3940	Air Source - Regulated, Dry Filtered, 0 to 150 psig

C. Air Flow Parameters, Formula and References

SUBTASK 79-21-00-480-001-F00

- (1) 0 to 150 psig dry filtered regulated air source, STD-3940 for the calibration of the test rig and air flow test.
 - (a) Clean and dry
 - (b) Pressure 34.5 Psia (237.5 KPa)
 - (c) Hose with maximum length 13 feet (4 meters) and with minimum section 0.1 square inches (.64 sq.cm)

SUBTASK 79-21-00-970-001-F00

- (2) Use this air flow formula to correct the measured air flow (in pph or kg/h only) for the calibration of the test rig and the air flow test (Table 201).

Table 201/79-21-00-993-806-F00 Air Flow Correction Formula

$W_{corrected} = W_{measured} \times \text{sq.root} (T_{measured}/293.15) \times 34.5/P_{measured}$	
Parameter	Definition
W _{measured}	Air flow measured (pph or kg/h only)
293.15 Deg K	Reference temperature for air flow, = 528 Deg Rankin (for info only, not to correct W _{measured} , = 20 Deg C = 68 Deg F)
T _{measured}	Air temperature supplied for calibration or sent into engine tube for test in Deg K or Deg R

EFFECTIVITY
HAP ALL

79-21-00

Page 201
Feb 10/2007

D633A101-HAP

737-600/700/800/900
AIRCRAFT MAINTENANCE MANUAL

(Continued)

$W_{corrected} = W_{measured} \times \text{sq.root} (T_{measured}/293.15) \times 34.5/P_{measured}$	
Parameter	Definition
34.5	Reference pressure in PSIA
P _{measured}	Air pressure supplied for calibration or sent into engine tube for test in PSIA, If air pressure supplied is measured in PSIG, then sum up P _{ambient} and P _{measured} , P _{ambient} + P _{measured} to correct W _{measured}

SUBTASK 79-21-00-970-002-F00

(3) Air flow reference for the test rig (3 and 5 mm restrictors)

(a) The air flow check varies with the restrictor criteria, so no reference is provided and is left to the user's monitoring.

SUBTASK 79-21-00-970-003-F00

(4) Air flow reference (Table 202) for the test rig used with the kit, SPL-2458.

Table 202/79-21-00-993-807-F00 Air Flow References

Air Nozzle Diam.		Necessary Air Flow Rate			
inch	mm	pph	kgh	scfm	m3/h
0.06	1.5	7.3/7.9	3.3/3.6	1.6/1.8	2.7/3.0
0.13	3.4	37.3/41.3	16.9/18.7	8.2/9.2	14.0/15.5
0.18	4.5	67.4/74.6	30.5/33.8	14.9/16.5	25.3/28.0

D. Calibration of the Air Test Rig (3 and 5 mm restrictors)

SUBTASK 79-21-00-970-004-F00

(1) For each restrictor (Figure 201), (Sheet 1) measure and record the air flows.

SUBTASK 79-21-00-970-005-F00

(2) Correct the air flows with the formula (in pph or kg/hr only) (Table 201).

(a) The corrected air flows is left to the user's monitoring.

E. Calibration of the Air Test Rig with the Master Air Nozzle

SUBTASK 79-21-00-480-002-F00

(1) Connect the supply hose (Figure 201), (Sheets 2 and 3) with the test rig adapter, SPL-3933 to the kit, SPL-2458.

SUBTASK 79-21-00-970-006-F00

(2) Do these steps to measure the air flow of each of the three calibrated nozzles:

(a) Firmly hold the body of the master air nozzle.

(b) Put the nozzle, calibrated hole first, inside the body of the tool.

(c) Measure and record the air flow.

1) Do the steps again, to measure and record the air flow for each nozzle.

SUBTASK 79-21-00-970-007-F00

(3) Correct the air flows with the formula (in pph or kg/hr only) (Table 201).

(a) The corrected air flows must be in the reference limits (Table 202).

————— **END OF TASK** —————

EFFECTIVITY HAP ALL

D633A101-HAP

79-21-00

Page 202
Feb 10/2007

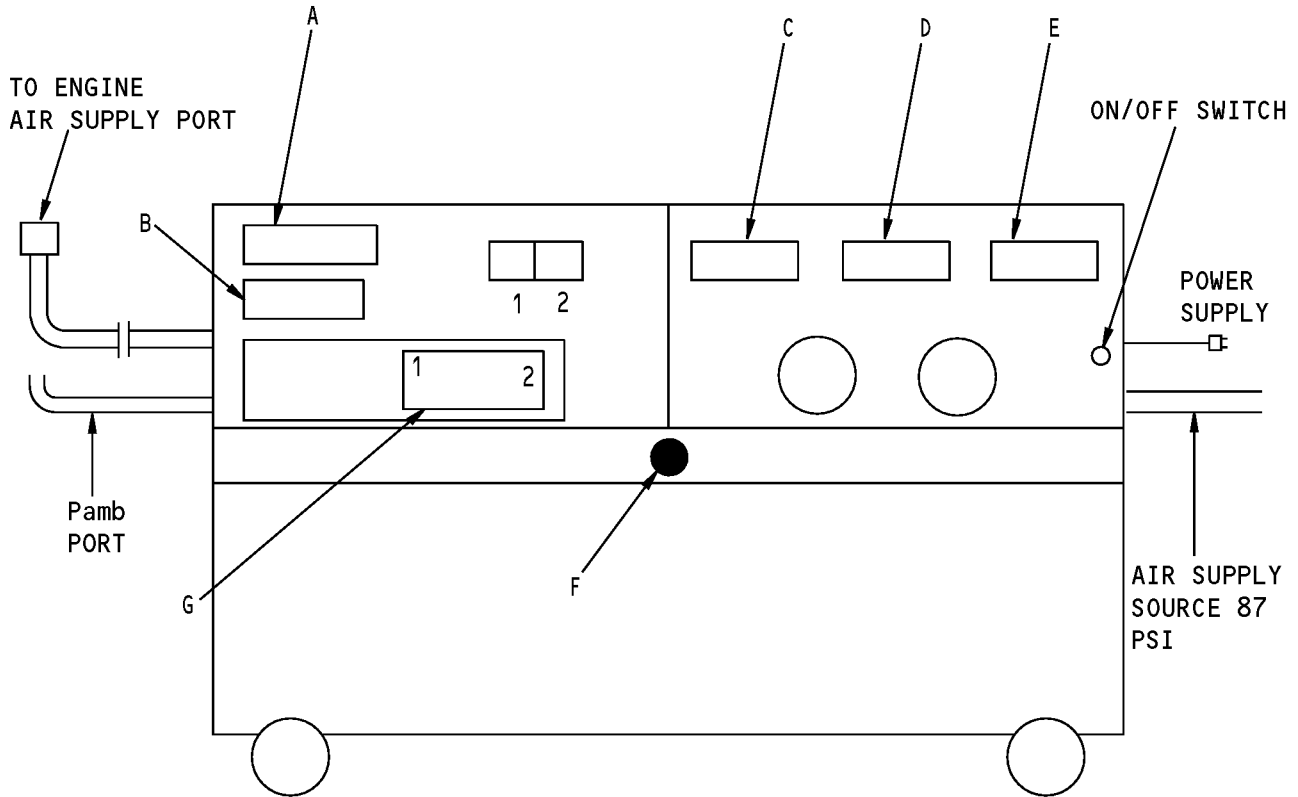

AIR TEST RIG

- A. Pamb INDICATOR
- B. Tamb INDICATOR
- C. P1 PRESSURE INDICATOR
- D. P2 PRESSURE INDICATOR
- E. AIR SUPPLY PRESSURE INDICATOR
- F. AIR SUPPLY CONTROL
- G. AIR MEASURING CIRCUIT SYNOPTIC
 - 1 SMALL SIZE PORT SELECTOR (3 mm DIA RESTRICTOR)
 - 2 MEDIUM SIZE PORT SELECTOR (5 mm DIA RESTRICTOR)

MM-00099-00-B

Oil Circuit Air Flow Check - Test Equipment
Figure 201 (Sheet 1 of 3)/79-21-00-990-801-F00

EFFECTIVITY
HAP ALL

D633A101-HAP

BOEING PROPRIETARY - Copyright © Unpublished Work - See title page for details

79-21-00

Page 203
Feb 10/2005

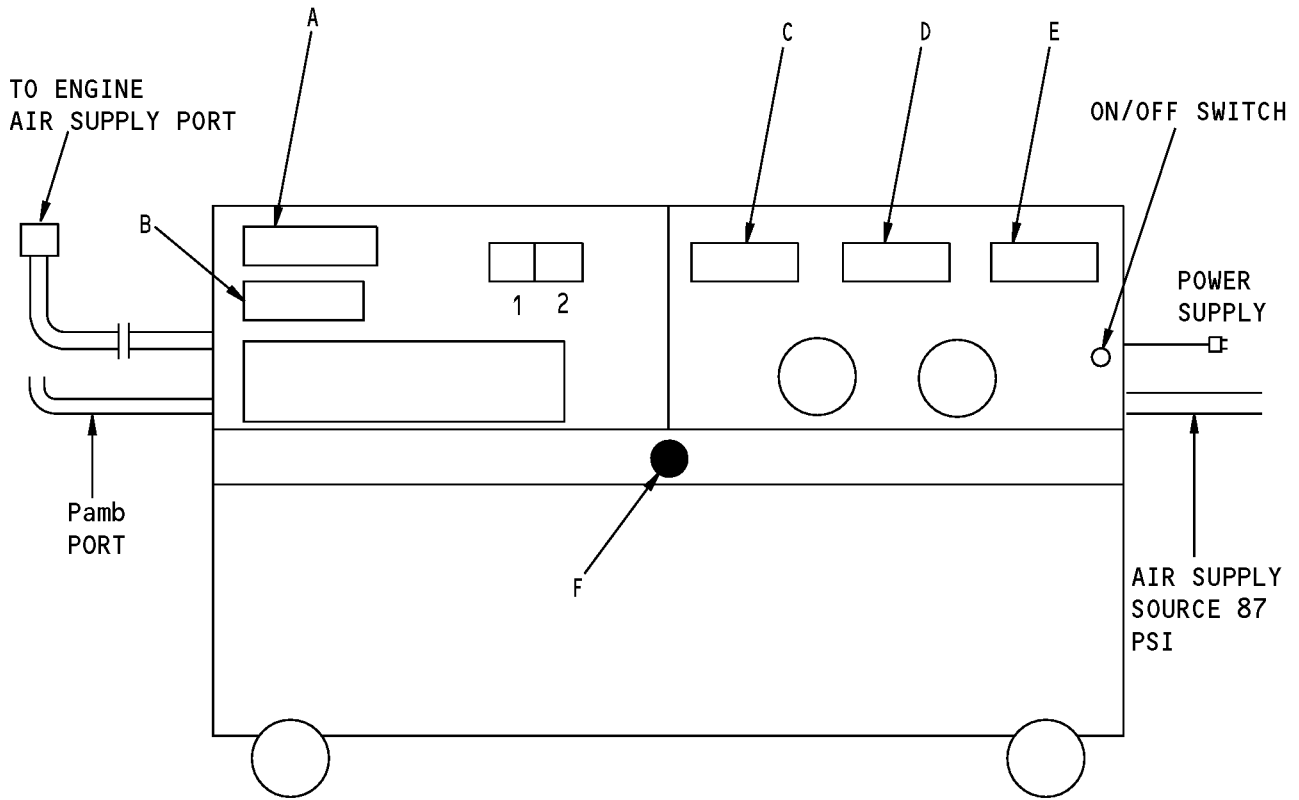

AIR TEST RIG

- A. Pamb INDICATOR
- B. Tamb INDICATOR
- C. P1 PRESSURE INDICATOR
- D. P2 PRESSURE INDICATOR
- E. AIR SUPPLY PRESSURE INDICATOR
- F. AIR SUPPLY CONTROL

MM-00-109-00-B

Oil Circuit Air Flow Check - Test Equipment
Figure 201 (Sheet 2 of 3)/79-21-00-990-801-F00

EFFECTIVITY
 HAP ALL

79-21-00

Page 204
Oct 10/2003

D633A101-HAP

737-600/700/800/900
AIRCRAFT MAINTENANCE MANUAL

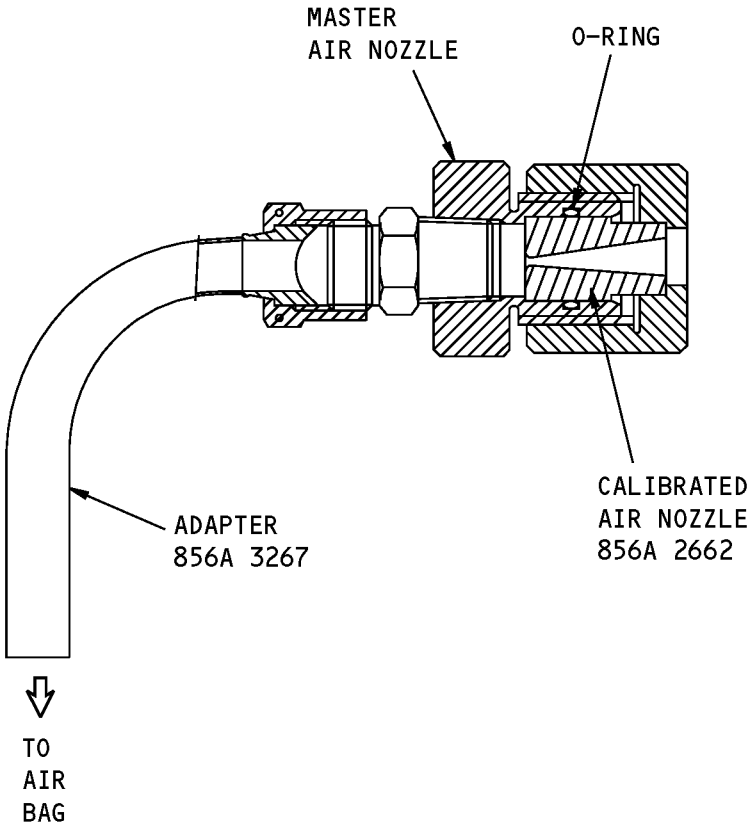

MM-00-110-00-B

Oil Circuit Air Flow Check - Test Equipment
Figure 201 (Sheet 3 of 3)/79-21-00-990-801-F00

EFFECTIVITY
HAP ALL

79-21-00

Page 205
Oct 10/2003

D633A101-HAP

AIRCRAFT MAINTENANCE MANUAL

TASK 79-21-00-700-801-F00

3. Air Flow Test of the Engine Oil Circuit

(Figure 202), (Figure 203), (Figure 204), (Figure 205)

A. General

- (1) The air flow test is for these parts of the engine oil circuit:
 - (a) Forward sump.
 - (b) Transfer gearbox (TGB).
 - (c) Accessory gearbox (AGB).
 - (d) Rear sump.
- (2) Read the procedure to know the instructions before you try to do this procedure.
- (3) The air flow test rig must be calibrated before you do this procedure.
- (4) This test can be done without flushing the engine, when the engine is off the oil supply goes back to the oil tank.
- (5) Some oil can leak when the oil supply tubes are disconnected, it is necessary to clean these areas before the engine continued in service.
- (6) Plug or cover any connections not used to prevent objects from entering the engine.

B. References

Reference	Title
12-13-11-600-801	Replenish the Engine Oil (P/B 301)
71-00-00-800-811-F00	Power Plant Test Reference Table (P/B 501)
78-31-00-010-801-F00	Open the Thrust Reverser (Selection) (P/B 201)
78-31-00-010-804-F00	Close the Thrust Reverser (Selection) (P/B 201)

C. Tools/Equipment

NOTE: When more than one tool part number is listed under the same "Reference" number, the tools shown are alternates to each other within the same airplane series. Tool part numbers that are replaced or non-procurable are preceded by "Opt:", which stands for Optional.

Reference	Description
SPL-3933	Adapter - Test Rig, No. 1 and No. 2 Bearing Support, Air Flow Check (Part #: 856A3267G02, Supplier: 58828, A/P Effectivity: 737-300, -400, -500, -600, -700, -700C, -700ER, -700QC, -800, -900, -900ER, -BBJ)

D. Location Zones

Zone	Area
411	Engine 1 - Engine
421	Engine 2 - Engine

EFFECTIVITY
HAP ALL

D633A101-HAP

79-21-00

Page 206
Feb 10/2007

AIRCRAFT MAINTENANCE MANUAL

E. Prepare for the Test

SUBTASK 79-21-00-010-001-F00

WARNING: DO THESE SPECIFIED TASKS IN THE CORRECT SEQUENCE BEFORE YOU OPEN THE THRUST REVERSERS: RETRACT THE LEADING EDGE, DO THE DEACTIVATION PROCEDURES FOR THE LEADING EDGE AND THE THRUST REVERSERS (FOR GROUND MAINTENANCE), AND OPEN THE FAN COWL PANELS. IF YOU DO NOT OBEY THE ABOVE SEQUENCE, INJURIES TO PERSONS AND DAMAGE TO EQUIPMENT CAN OCCUR.

(1) Do this task: Open the Thrust Reverser (Selection), TASK 78-31-00-010-801-F00.

SUBTASK 79-21-00-700-001-F00

CAUTION: IF THE AIR FLOW TEST RIG IS NOT CALIBRATED, THE AIR FLOW TEST RESULTS WILL NO BE ACCURATE.

(2) Make sure that the air flow test rig is calibrated, do this task: Calibration of the Air Flow Test Rig, TASK 79-21-00-280-801-F00

F. Forward Sump Air Flow Check

SUBTASK 79-21-00-480-003-F00

(1) if you use the Air Test Rig (3 and 5 mm restrictors), use the 5 mm restrictor.

SUBTASK 79-21-00-480-004-F00

(2) Do these steps to connect the air supply hose of the test rig to the forward sump (Figure 202):

- (a) Disconnect the coupling nut [1] of the fwd sump oil supply external tube.
- (b) Remove the bolt, nut [2] and clamp [3].
- (c) Disconnect the coupling nut [4].
- (d) If the tube at the fwd sump elbow connection cannot be disconnected, disconnect or loosen the coupling nut [5].
- (e) Connect the supply hose with the test rig adapter, SPL-3933 to the fwd sump elbow connection.

1) Tighten the adapter to 225-275 pound-inches (25-31 Newton meters).

SUBTASK 79-21-00-970-008-F00

(3) Measure and record the air flow.

SUBTASK 79-21-00-970-009-F00

(4) Correct the air flow with the Air Flow Correction Formula (in pph or kg/hr only) (Table 201) Calibration of the Air Flow Test Rig, TASK 79-21-00-280-801-F00.

(a) The corrected air flow (Fwd Sump) must be in these limits:

NOTE: The reference temperature of the air flows is 293.15 degrees K.

- 1) 53.2/61.9 pph.
- 2) 24.12/28.08 kg/hr.
- 3) 11.6/13.5 scfm.
- 4) 19.7/22.98 m3/h.

SUBTASK 79-21-00-080-001-F00

(5) Do these steps to disconnect the test rig (Figure 202):

- (a) Disconnect the air supply hose of the test rig from the fwd sump.

EFFECTIVITY
HAP ALL

D633A101-HAP

79-21-00

Page 207
Feb 10/2007

AIRCRAFT MAINTENANCE MANUAL

- (b) Install the fwd sump external oil supply tube at the elbow and connect the coupling nuts [1 and 5].
- (c) Connect the coupling nut [4].
- (d) Install the clamp [3], bolt and nut [2].
- (e) Before you tighten the connections, make sure the fwd sump external oil supply tube is unrestrained.
 - 1) Tighten the nut [2] to 98-110 pound-inches (11.0-12.5 Newton meters).
 - 2) Tighten the coupling nut [2] to 450-550 pound-inches (50.0-60.0 Newton meters).
 - 3) Tighten the coupling nut [4] to 270-300 pound-inches (30.0-35.0 Newton meters).

G. TGB Air Flow Check

SUBTASK 79-21-00-480-005-F00

- (1) If you use the Air Test Rig (3 and 5 mm restrictors), use the 3 mm restrictor.

SUBTASK 79-21-00-480-006-F00

- (2) Use the part identification to make a hose to connect at the TGB oil supply tube and to the supply hose of the air flow test rig:
 - (a) Dash number - 06.
 - (b) Coupling nut - 649-676-146-0.
 - (c) Ferrule tube coupling - 649-688-806-0.

SUBTASK 79-21-00-480-007-F00

- (3) Do these steps to connect the air supply hose of the test rig to the TGB connection (Figure 203):
 - (a) Disconnect the two coupling nuts [1] and remove the TGB oil supply tube.
 - (b) Install the hose (you made) at the TGB connection.
 - (c) Connect the hose with the air supply hose of the test rig.

SUBTASK 79-21-00-970-010-F00

- (4) Measure and record the air flow.

SUBTASK 79-21-00-970-011-F00

- (5) Correct the air flow with the Air Flow Correction Formula (in pph or kg/hr only) (Table 201) Calibration of the Air Flow Test Rig, TASK 79-21-00-280-801-F00.
 - (a) The corrected air flow (TGB) must be in these limits:

NOTE: The reference temperature of the air flows is 293.15 degrees K.

- 1) 8.3/10.2 pph.
- 2) 3.78/4.68 kg/hr.
- 3) 1.8/2.2 scfm.
- 4) 3.05/3.75 m³/h.

SUBTASK 79-21-00-080-002-F00

- (6) Do these steps to disconnect the test rig (Figure 203):
 - (a) Disconnect the hose at the TGB connection.
 - (b) Install the TGB oil supply tube with the two coupling nuts [1].
 - (c) Before you tighten the coupling nuts [1], make sure the TGB oil supply tube is unrestrained.
 - 1) Tighten the two coupling nuts [1] to 270-300 pound-inches (30.0-35.0 Newton meters).

AIRCRAFT MAINTENANCE MANUAL

H. AGB Air Flow Check

SUBTASK 79-21-00-480-008-F00

- (1) if you use the Air Test Rig (3 and 5 mm restrictors), use the 3 mm restrictor.

SUBTASK 79-21-00-480-009-F00

- (2) Use the part identification to make a hose to connect between the AGB connection and the supply hose of the air flow test rig:
- Dash number - 06.
 - Coupling nut - 649-676-146-0.
 - Ferrule tube coupling - 649-688-806-0.

SUBTASK 79-21-00-480-010-F00

- (3) Do these steps to connect the air supply hose of the test rig to the AGB connection (Figure 204):
- Disconnect the two coupling nuts [1] and remove the AGB oil supply tube.
 - Install the hose (you made) at the AGB connection.
 - Connect the hose with the air supply hose of the test rig.

SUBTASK 79-21-00-970-012-F00

- (4) Measure and record the air flow.

SUBTASK 79-21-00-970-013-F00

- (5) Correct the air flow with the Air Flow Correction Formula (in pph or kg/hr only) (Table 201) Calibration of the Air Flow Test Rig, TASK 79-21-00-280-801-F00.

- (a) The corrected air flow (AGB) must be in these limits:

NOTE: The reference temperature of the air flows is 293.15 degrees K.

- 21.9/27.4 pph.
- 9.9/12.42 kg/hr.
- 4.75/6.0 scfm.
- 8.1/10.1 m³/h.

SUBTASK 79-21-00-080-003-F00

- (6) Do these steps to disconnect the test rig (Figure 204):
- Disconnect the hose at the AGB connection.
 - Install the AGB oil supply tube with the two coupling nuts [1].
 - Before you tighten the coupling nuts [1], make sure the AGB oil supply tube is unrestrained.
 - Tighten the two coupling nuts [1] to 270-300 pound-inches (30.0-35.0 Newton meters).

I. Rear Sump Air Flow Check

SUBTASK 79-21-00-480-011-F00

- (1) If you use the Air Test Rig (3 and 5 mm restrictors), use the 3 mm restrictor.

SUBTASK 79-21-00-480-012-F00

- (2) Use the part identification to make a hose to connect between the rear sump connection and the supply hose of the air flow test rig:
- Dash number - 06.
 - Coupling tube - J1328P06B.

EFFECTIVITY
HAP ALL

D633A101-HAP

79-21-00

Page 209
Jun 10/2004

AIRCRAFT MAINTENANCE MANUAL

SUBTASK 79-21-00-480-013-F00

- (3) Do these steps to connect the air supply hose of the test rig to the rear sump connection at the turbine rear frame (Figure 205):
- Remove the bolt, nut [1], clamp [2] and the heat shield [3].
 - Remove the coupling nut [4].
 - Loosen the bolt [5] and disconnect the rear sump oil supply tube.
 - Install the hose (you made) at the rear sump connection.
 - Connect the hose with the air supply hose of the test rig.

SUBTASK 79-21-00-970-014-F00

- (4) Measure and record the air flow.

SUBTASK 79-21-00-970-015-F00

- (5) Correct the air flow with the Air Flow Correction Formula (in pph or kg/hr only) (Table 201) Calibration of the Air Flow Test Rig, TASK 79-21-00-280-801-F00.
- The corrected air flow (Rear Sump) must be in these limits:

NOTE: The reference temperature of the air flows is 293.15 degrees K.

- 22.2/26.6 pph.
- 10.08/12.06 kg/hr.
- 4.8/5.75 scfm.
- 8.2/9.8 m³/h.

SUBTASK 79-21-00-080-004-F00

- (6) Do these steps to disconnect the test rig (Figure 205):
- Disconnect the hose at the rear sump connection.
 - Install the rear sump oil supply tube with the coupling nut [4].
 - Before you tighten the connections, make sure the rear sump oil supply tube is unrestrained.
 - Tighten the bolt [5] to 62-71 pound-inches (7.0-8.0 Newton meters).
 - Tighten the coupling nut [4] to 270-300 pound-inches (30.0-35.0 Newton meters).
 - Install the clamp [2], heat shield [3], bolt and nut [1].
 - Tighten the nut [1] to 62-71 pound-inches (7.0-8.0 Newton meters).

J. Put the Airplane Back To Its Usual Condition

SUBTASK 79-21-00-100-001-F00

- (1) Do a check for signs of oil leakage at the test connections and clean those areas.

SUBTASK 79-21-00-410-001-F00

WARNING: OBEY THE INSTRUCTIONS IN THE PROCEDURE TO CLOSE THE THRUST REVERSERS. IF YOU DO NOT OBEY THE INSTRUCTIONS, INJURIES TO PERSONS AND DAMAGE TO EQUIPMENT CAN OCCUR.

- (2) Do this task: Close the Thrust Reverser (Selection), TASK 78-31-00-010-804-F00.

SUBTASK 79-21-00-700-002-F00

- (3) Do the tests that are listed for the oil system pipes and manifold in the Power Plant Test Reference Table, TASK 71-00-00-800-811-F00.
- Examine the test connections for signs of oil leakage.

EFFECTIVITY
HAP ALL

79-21-00

Page 210
Jun 10/2004

D633A101-HAP

AIRCRAFT MAINTENANCE MANUAL

SUBTASK 79-21-00-610-001-F00

- (4) Do a check of the engine oil quantity, do this task: Replenish the Engine Oil,
TASK 12-13-11-600-801

————— **END OF TASK** —————

EFFECTIVITY
HAP ALL

D633A101-HAP

79-21-00

Page 211
Jun 10/2004

737-600/700/800/900
AIRCRAFT MAINTENANCE MANUAL

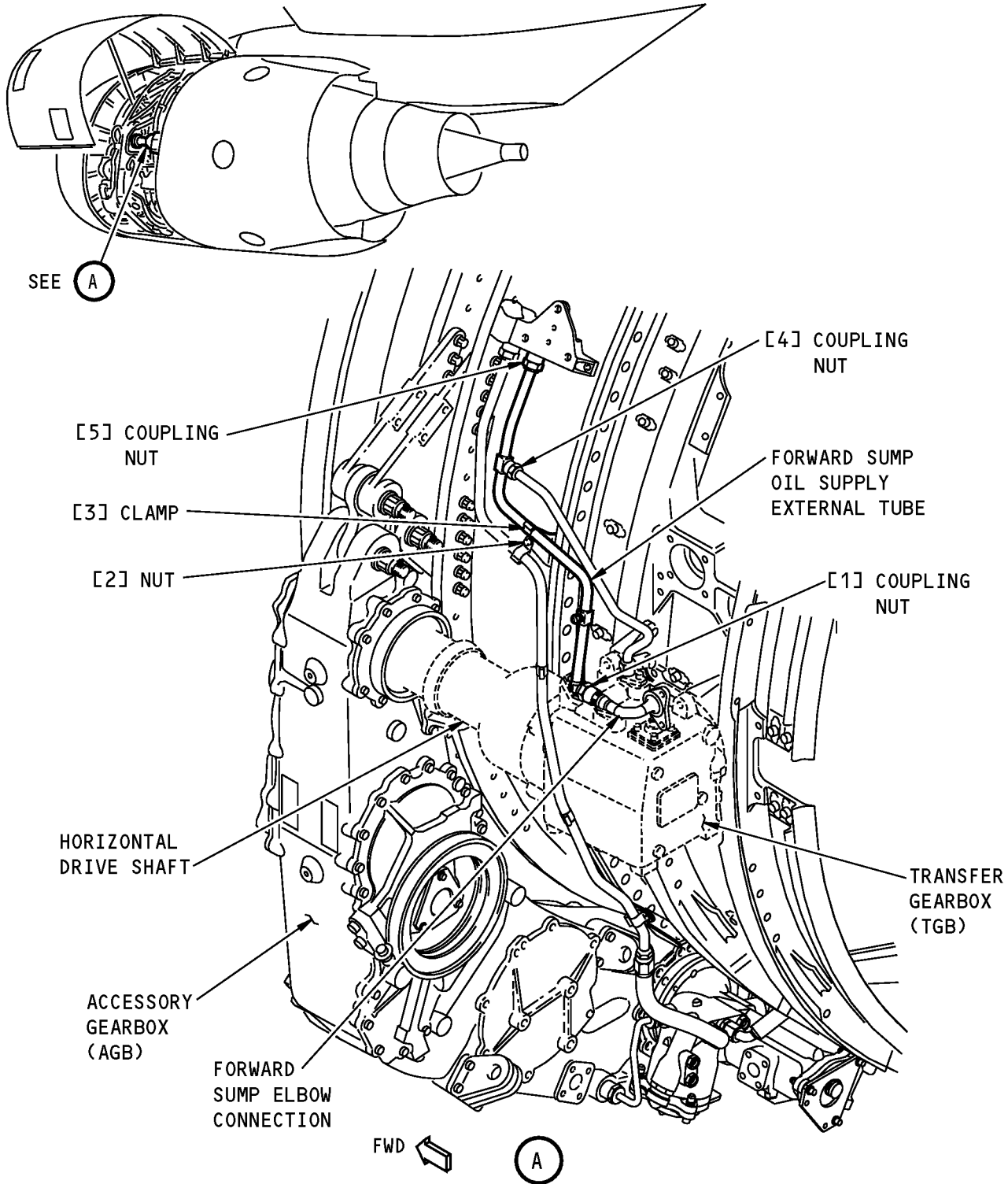

MM-00-100-00-B

Forward Sump Air Flow Check
Figure 202/79-21-00-990-802-F00

EFFECTIVITY
HAP ALL

79-21-00

Page 212
Jun 10/2004

D633A101-HAP

737-600/700/800/900
AIRCRAFT MAINTENANCE MANUAL

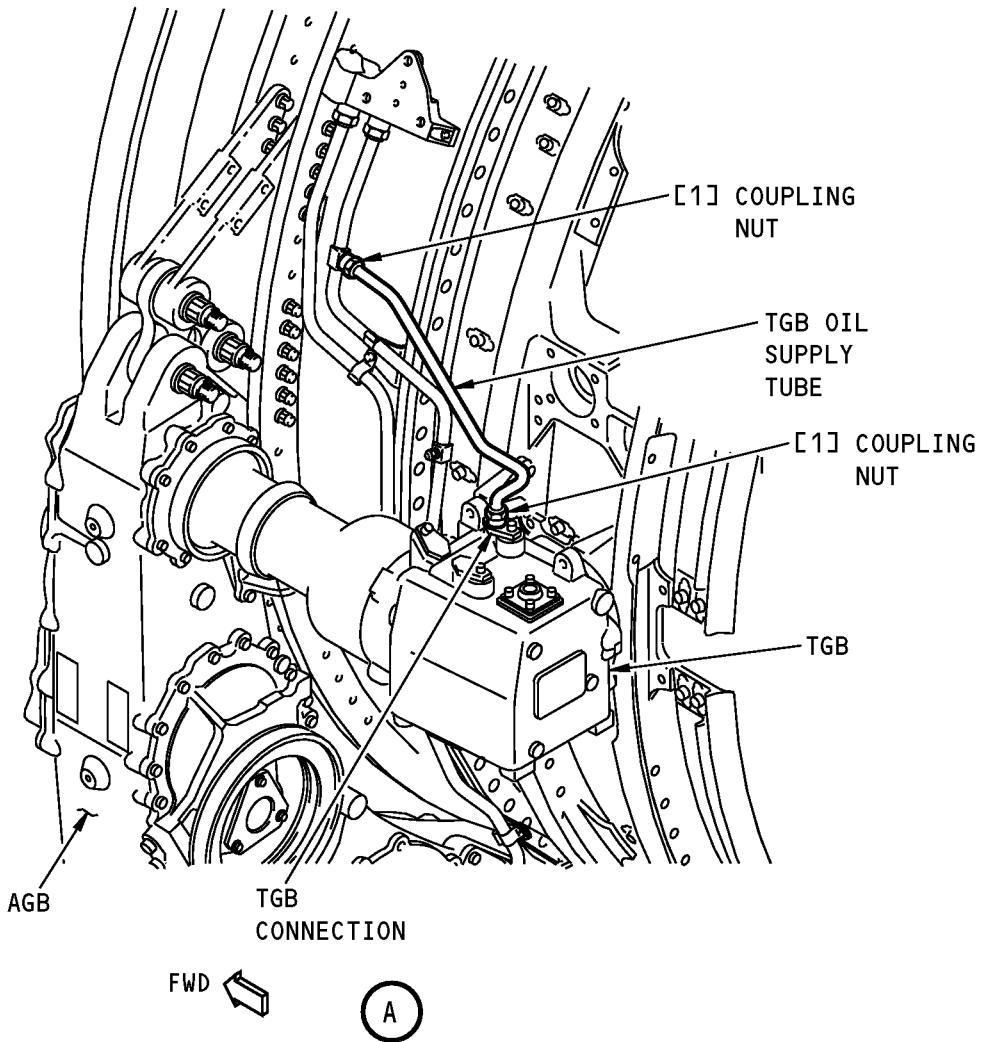
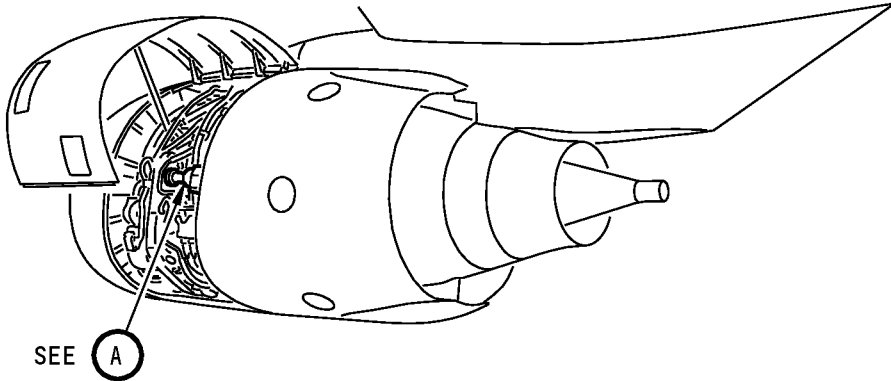

MM-00-101-00-B

TGB Air Flow Check
Figure 203/79-21-00-990-803-F00

EFFECTIVITY
HAP ALL

79-21-00

Page 213
Jun 10/2004

D633A101-HAP

737-600/700/800/900
AIRCRAFT MAINTENANCE MANUAL

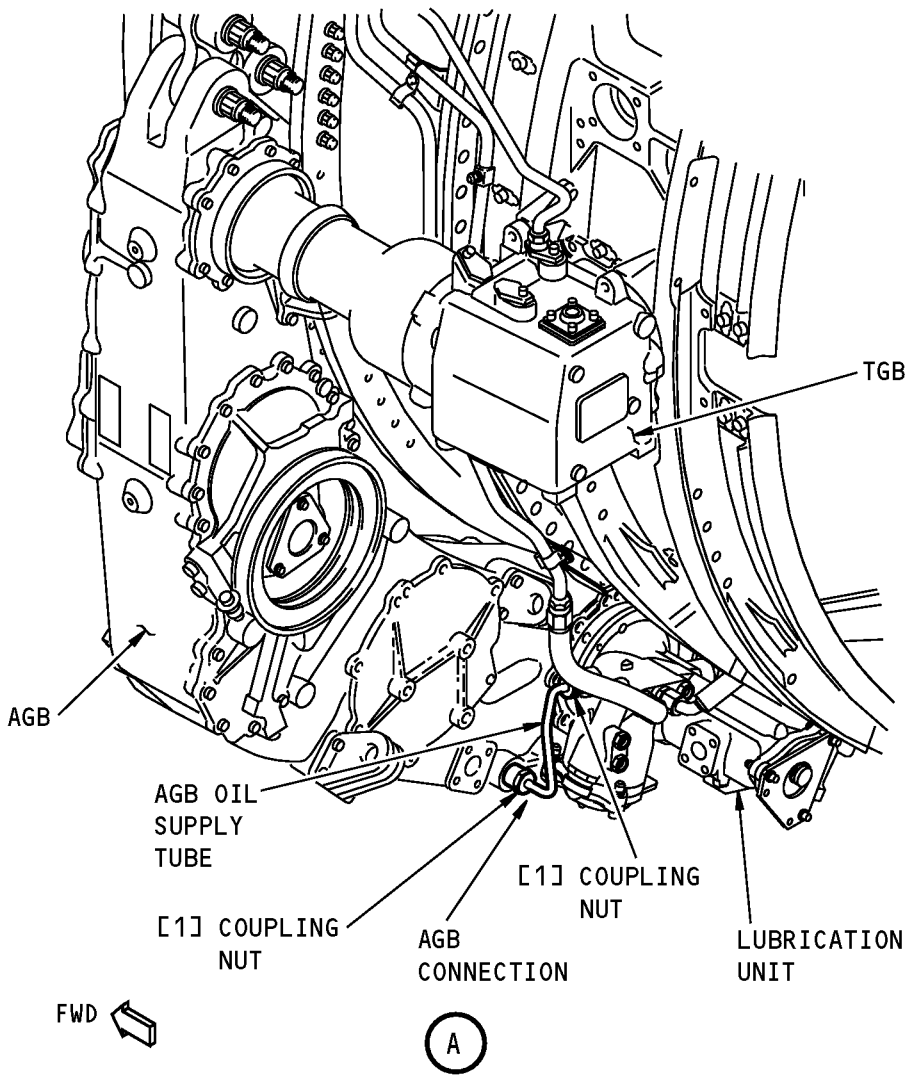
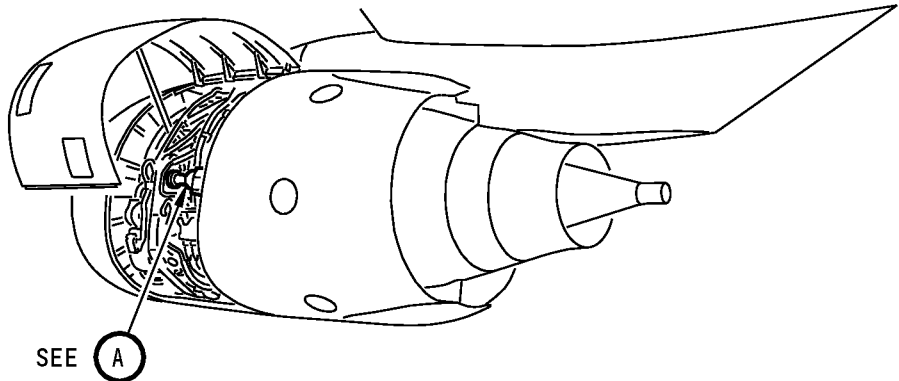

MM-00-102-00-B

AGB Air Flow Check
Figure 204/79-21-00-990-804-F00

EFFECTIVITY
HAP ALL

79-21-00

AIRCRAFT MAINTENANCE MANUAL

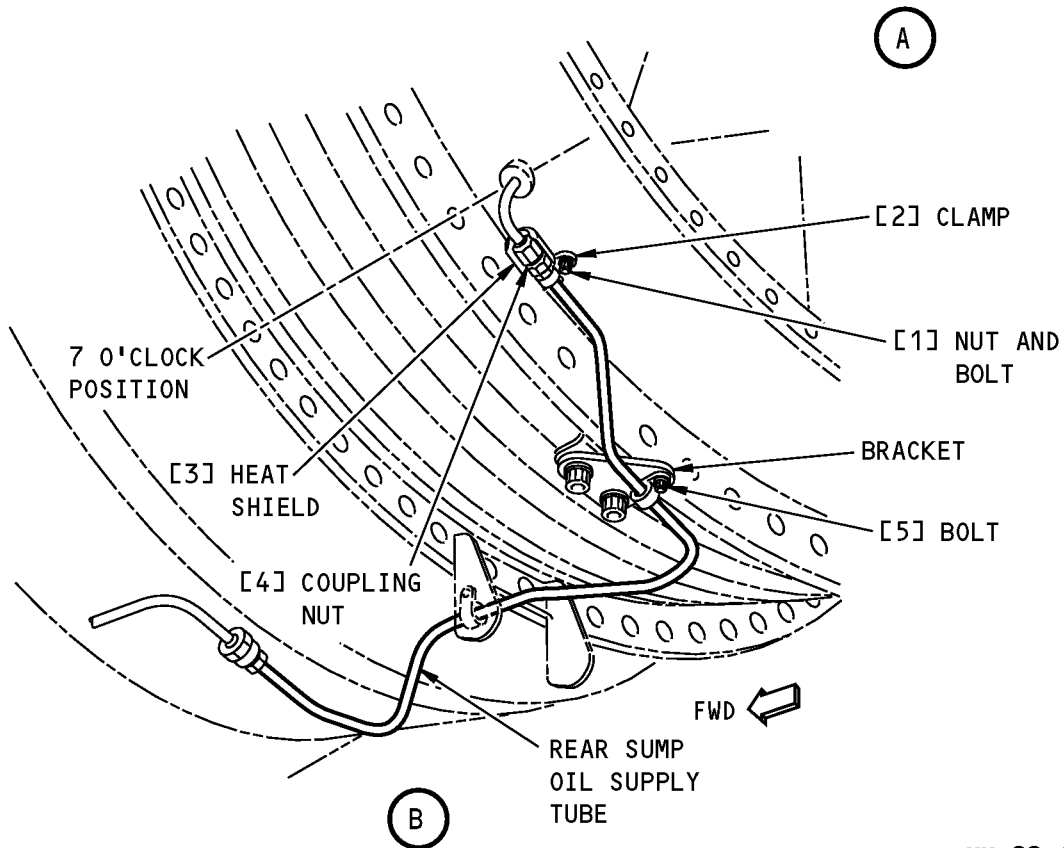
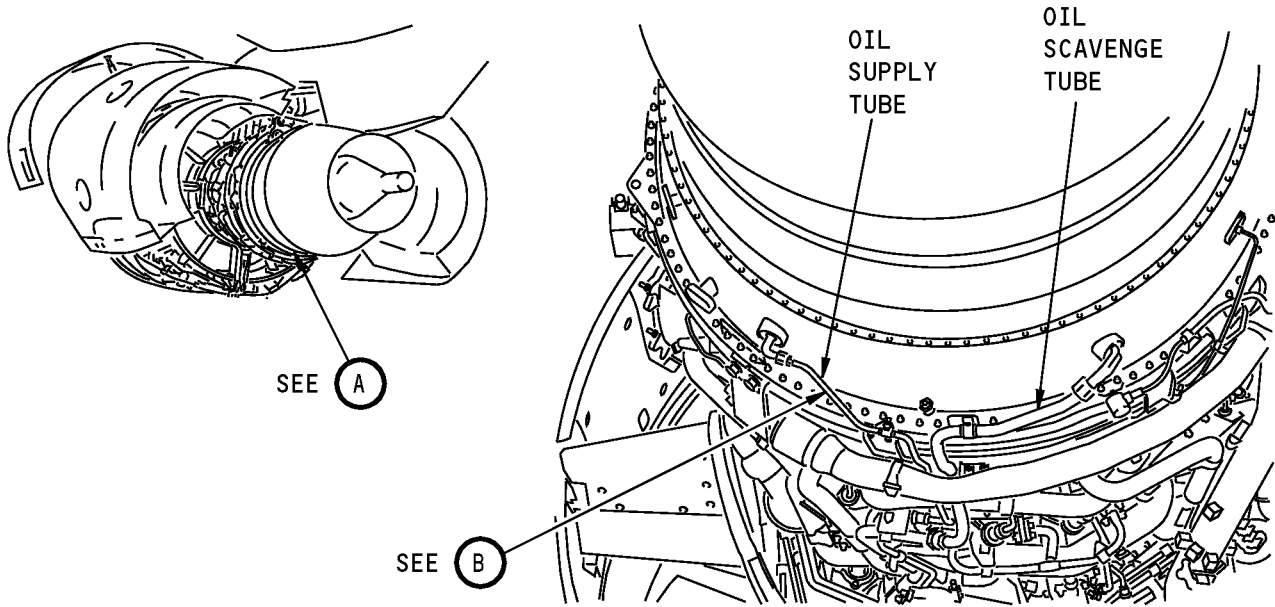

MM-00-104-00-B

Rear Sump Air Flow Check
Figure 205/79-21-00-990-805-F00

EFFECTIVITY
HAP ALL

79-21-00

Page 215
Jun 10/2004

D633A101-HAP

AIRCRAFT MAINTENANCE MANUAL

LUBRICATION UNIT - REMOVAL/INSTALLATION**1. General**

A. This procedure has two tasks:

- (1) The removal of the lubrication unit.
- (2) The installation of the lubrication unit.

TASK 79-21-01-000-801-F00**2. Lubrication Unit Removal**

(Figure 401), (Figure 402), (Figure 403), (Figure 404),

A. General

- (1) This task is the removal procedure for the lubrication unit.
- (2) The lubrication unit is found on the accessory gearbox (AGB) at the 6:00 o'clock position.

B. References

Reference	Title
70-10-02-910-801-F00	General Precautions During the Removal and Installation of Engine Components (P/B 201)
70-30-01-910-802-F00	Seals (Preformed Packings and O-Rings) and Gaskets (P/B 201)
71-11-02-010-801-F00	Open the Fan Cowl Panels (P/B 201)
79-21-05-000-806-F00	Magnetic Chip Detector (MCD) Removal (P/B 401)
79-21-05-400-804-F00	Magnetic Chip Detector (MCD) Installation (P/B 401)

C. Tools/Equipment

NOTE: When more than one tool part number is listed under the same "Reference" number, the tools shown are alternates to each other within the same airplane series. Tool part numbers that are replaced or non-procurable are preceded by "Opt:", which stands for Optional.

Reference	Description
SPL-2446	Adapter - Drain, Lubrication Unit (Part #: 856A3601G01, Supplier: 58828, A/P Effectivity: 737-300, -400, -500, -600, -700, -700C, -700ER, -700QC, -800, -900, -900ER, -BBJ)
STD-203	Container - Oil Resistant, 1 U.S.-Gal (3.8 l)

D. Consumable Materials

Reference	Description	Specification
D00599 [CP2442]	Oil - Engine (CFMI SB 79-001)	

E. Expendables/Parts

AMM Item	Description	AIPC Reference	AIPC Effectivity
22	Packing	79-21-01-01-235	HAP ALL

F. Location Zones

Zone	Area
411	Engine 1 - Engine
421	Engine 2 - Engine

EFFECTIVITY
HAP ALL

79-21-01

Page 401
Oct 15/2008

D633A101-HAP

AIRCRAFT MAINTENANCE MANUAL

G. Prepare for the Removal

SUBTASK 79-21-01-860-001-F00

- (1) For Engine 1, open these circuit breakers and install safety tags:

CAPT Electrical System Panel, P18-2

<u>Row</u>	<u>Col</u>	<u>Number</u>	<u>Name</u>
A	4	C01390	ENGINE 1 ALTN PWR CHAN B
A	5	C01314	ENGINE 1 ALTN PWR CHAN A

SUBTASK 79-21-01-860-002-F00

- (2) For Engine 2, open these circuit breakers and install safety tags:

F/O Electrical System Panel, P6-2

<u>Row</u>	<u>Col</u>	<u>Number</u>	<u>Name</u>
D	7	C01391	ENGINE 2 ALTN PWR CHAN B
D	8	C01315	ENGINE 2 ALTN PWR CHAN A

SUBTASK 79-21-01-010-001-F00

- (3) Do this task: Open the Fan Cowl Panels, TASK 71-11-02-010-801-F00.

H. Lubrication Unit Removal

SUBTASK 79-21-01-020-001-F00

- (1) Do these steps to prepare the lubrication unit [1] for removal (Figure 401):
- Put a 1 U.S.-gal (3.81 l) oil resistant container, STD-203, below the lubrication unit [1].
 - Put protective caps on the connection interfaces while you disconnect them (General Precautions During the Removal and Installation of Engine Components, TASK 70-10-02-910-801-F00).

SUBTASK 79-21-01-020-002-F00

WARNING: DO NOT TOUCH THE COMPONENTS OF THE OIL SYSTEM IF THE ENGINE IS HOT. THESE COMPONENTS STAY HOTTER THAN OTHER COMPONENTS. HOT COMPONENTS CAN BURN YOU.

WARNING: DO NOT OPEN THE OIL SYSTEM UNTIL THE PRESSURE GOES TO ZERO. THE PRESSURE GOES TO ZERO APPROXIMATELY 5 MINUTES AFTER AN ENGINE SHUTDOWN. A PRESSURIZED ENGINE CAN RELEASE A SPRAY OF HOT OIL THAT CAN BURN YOU.

WARNING: DO NOT LET HOT OIL GET ON YOU. PUT ON GOGGLES AND OTHER EQUIPMENT FOR PROTECTION OR LET THE ENGINE BECOME COOL. HOT OIL CAN BURN YOU.

CAUTION: DO NOT LET HOT OIL GET ON THE ENGINE OR OTHER COMPONENTS. IMMEDIATELY CLEAN THE COMPONENT IF OIL FALLS ON IT. OIL CAN CAUSE DAMAGE TO PAINT AND RUBBER.

- (2) Do these steps to drain the oil from the lubrication unit [1] (Figure 401):
- Do this task: Magnetic Chip Detector (MCD) Removal, TASK 79-21-05-000-806-F00.
 - Put the adapter, SPL-2446, in the lubrication unit [1] at a chip detector location.
 - At the same time, push and turn the drain adapter 1/4 turn clockwise.
 - Let the oil drain in the container.

EFFECTIVITY
HAP ALL

D633A101-HAP

79-21-01

Page 402
Jun 10/2004

AIRCRAFT MAINTENANCE MANUAL

- (d) At the same time, push and turn the drain adapter 1/4 turn counterclockwise.
- (e) Pull the drain adapter down.
- (f) Remove the drain adapter from the lubrication unit [1].
- (g) Drain the oil from all of the other chip detector locations.

CAUTION: DO NOT INSTALL THE CHIP DETECTOR WITHOUT AN O-RING. INSTALLATION OF THE CHIP DETECTOR WITHOUT AN O-RING CAN CAUSE OIL LEAKAGE DURING ENGINE OPERATION AND A POSSIBLE ENGINE FAILURE.

- (h) Do this task: Magnetic Chip Detector (MCD) Installation, TASK 79-21-05-400-804-F00.

SUBTASK 79-21-01-020-003-F00

- (3) Do these steps to disconnect the oil supply tube [10] from the lubrication unit [1] (Figure 401):
 - (a) Remove the four bolts [12].
 - (b) Disconnect the oil supply tube [10].
 - (c) Remove and examine the gasket [11] Seals (Preformed Packings and O-Rings) and Gaskets, TASK 70-30-01-910-802-F00.

NOTE: Use the gaskets if it is in good condition.

- 1) Discard the gasket [11], if it is in unsatisfactory condition.

SUBTASK 79-21-01-020-004-F00

- (4) Do these steps to disconnect the oil scavenge tubes from the lubrication unit [1] (Figure 401):
 - (a) Remove the four bolts [13].
 - (b) Disconnect the AGB tube [8].
 - (c) Remove and examine the gasket [9].

NOTE: Use the gaskets if it is in good condition.

- 1) Discard the gasket [9], if it is in unsatisfactory condition.

- (d) Remove the four bolts [5].
- (e) Disconnect the forward sump tube [6].
- (f) Remove and examine the gasket [7].

NOTE: Use the gaskets if it is in good condition.

- 1) Discard the gasket [7], if it is in unsatisfactory condition.

- (g) Remove the four bolts [2].
- (h) Disconnect the aft sump tube [3].
- (i) Remove and examine the gasket [4].

NOTE: Use the gaskets if it is in good condition.

- 1) Discard the gasket [4], if it is in unsatisfactory condition.

SUBTASK 79-21-01-020-005-F00

- (5) Do these steps to disconnect the oil inlet tube [15] to the scavenge filter from the lubrication unit [1] (Figure 402):
 - (a) Remove the four bolts [18].
 - (b) Disconnect the oil inlet tube [15].
 - (c) Remove and examine the gasket [16].

NOTE: Use the gaskets if it is in good condition.

EFFECTIVITY
HAP ALL

79-21-01

Page 403
Jun 10/2004

D633A101-HAP

AIRCRAFT MAINTENANCE MANUAL

- 1) Discard the gasket [16], if it is in unsatisfactory condition.

SUBTASK 79-21-01-020-006-F00

CAUTION: USE TWO WRENCHES TO LOOSEN THE COUPLING NUT. USE ONE TO HOLD THE FITTING, AND THE OTHER TO LOOSEN THE COUPLING NUT. IF YOU DO NOT USE TWO WRENCHES, DAMAGE TO THE EQUIPMENT CAN OCCUR.

- (6) Do these steps to disconnect the three oil supply tubes from the lubrication unit [1] (Figure 402):
 - (a) Disconnect the AGB tube [14] from the AGB.
 - (b) Disconnect the aft sump tube [19] and forward sump tube [17].

SUBTASK 79-21-01-020-007-F00

- (7) Do these steps to remove the lubrication unit [1] from the AGB (Figure 402):

CAUTION: HOLD THE LUBRICATION UNIT WHEN YOU REMOVE THE V-CLAMP. DO THIS TO PREVENT DAMAGE TO THE DRIVE SHAFT AND SPLINES.

- (a) Loosen the V-clamp nut [20].
- (b) Open the V-clamp [21].
- (c) Remove the V-clamp [21].
- (d) Remove the lubrication unit [1].

NOTE: You must be careful not to cause damage to the tubes and hoses.

- 1) Remove and discard the packing [25] and packing [24].

SUBTASK 79-21-01-020-008-F00

- (8) Do these steps if the hollow drive shaft [23] moves from the pad drive shaft to the AGB (Figure 402):
 - (a) Remove the hollow drive shaft [23].
 - (b) Remove and discard the packing [22].
 - (c) Lubricate a new packing [22] with oil, D00599 [CP2442].

CAUTION: MAKE SURE YOU INSTALL THE PACKING CORRECTLY ON THE HOLLOW DRIVE SHAFT. IF YOU DO NOT INSTALL THE PACKING CORRECTLY, OIL LOSS CAN OCCUR DURING ENGINE OPERATION AND CAN CAUSE DAMAGE TO THE ENGINE.

- (d) Install the packing [22] in the groove of the hollow drive shaft [23].
- (e) Install the hollow drive shaft [23] in the pad drive shaft.
- (f) Install protective covers on all the open hoses and the AGB.

————— **END OF TASK** —————

EFFECTIVITY
HAP ALL

D633A101-HAP

79-21-01Page 404
Jun 10/2005

737-600/700/800/900
AIRCRAFT MAINTENANCE MANUAL

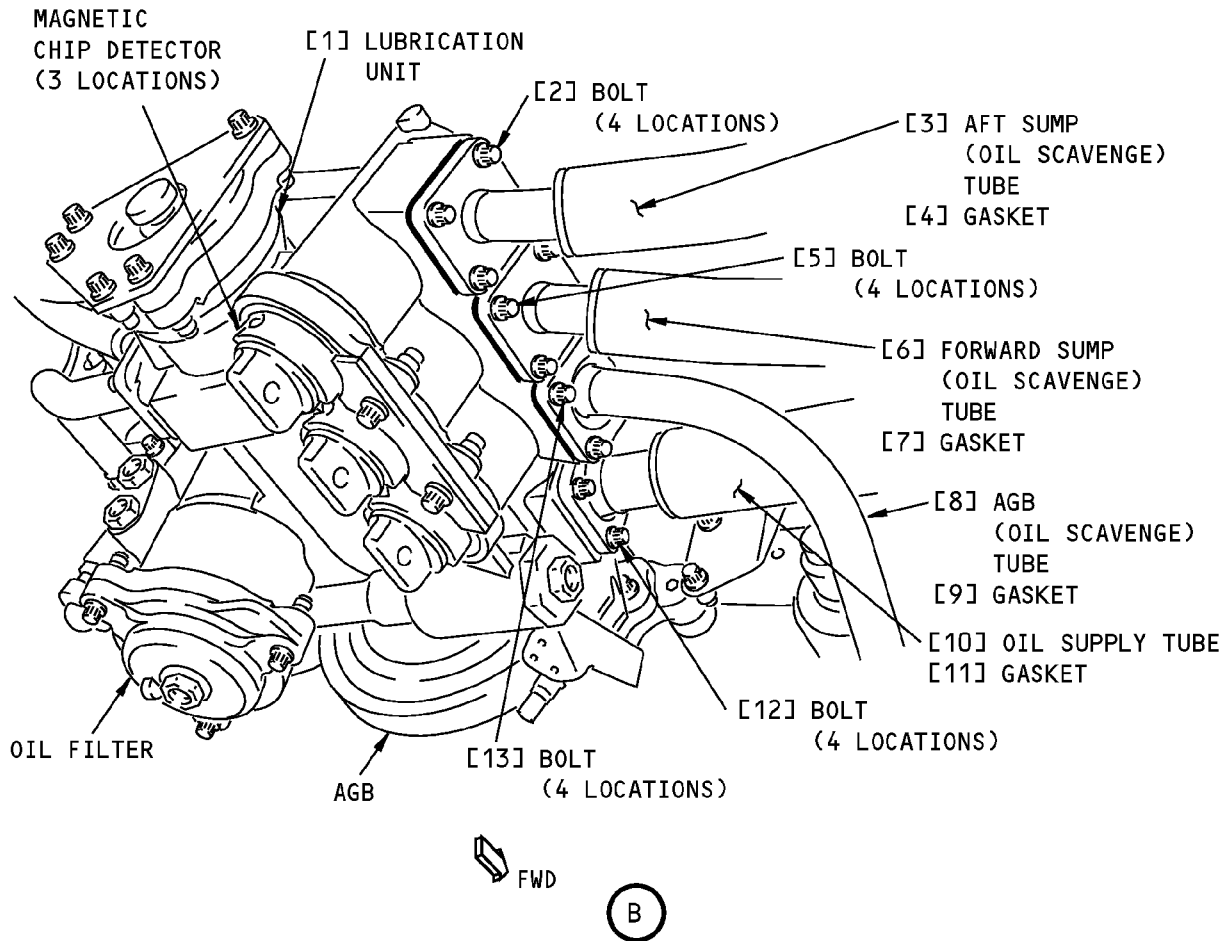
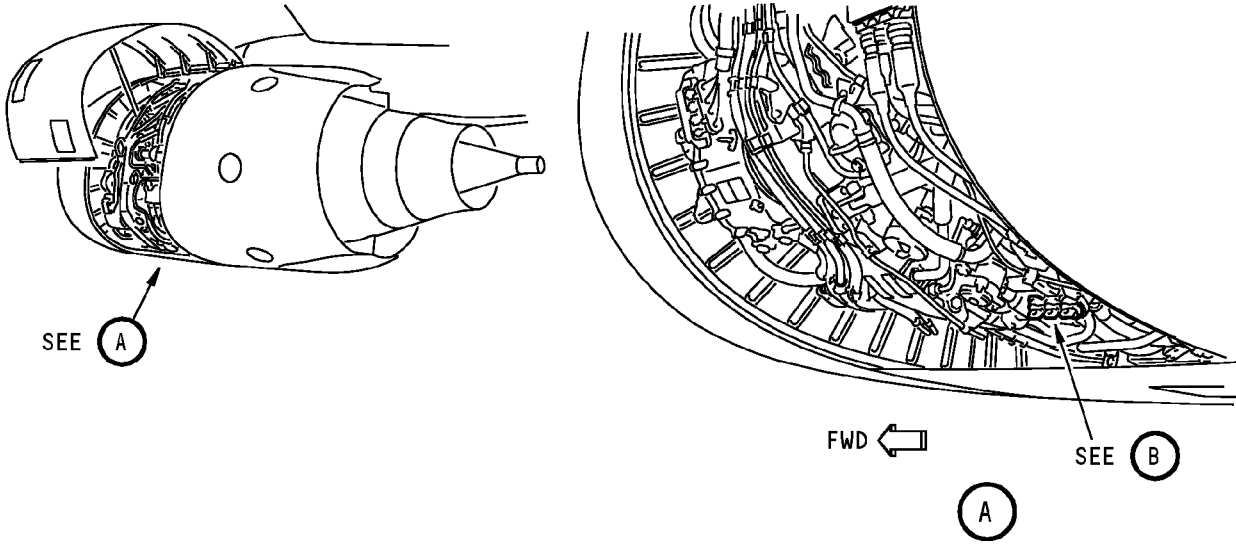

Oil Return Tube Installation
Figure 401/79-21-01-990-801-F00

EFFECTIVITY
HAP ALL

79-21-01

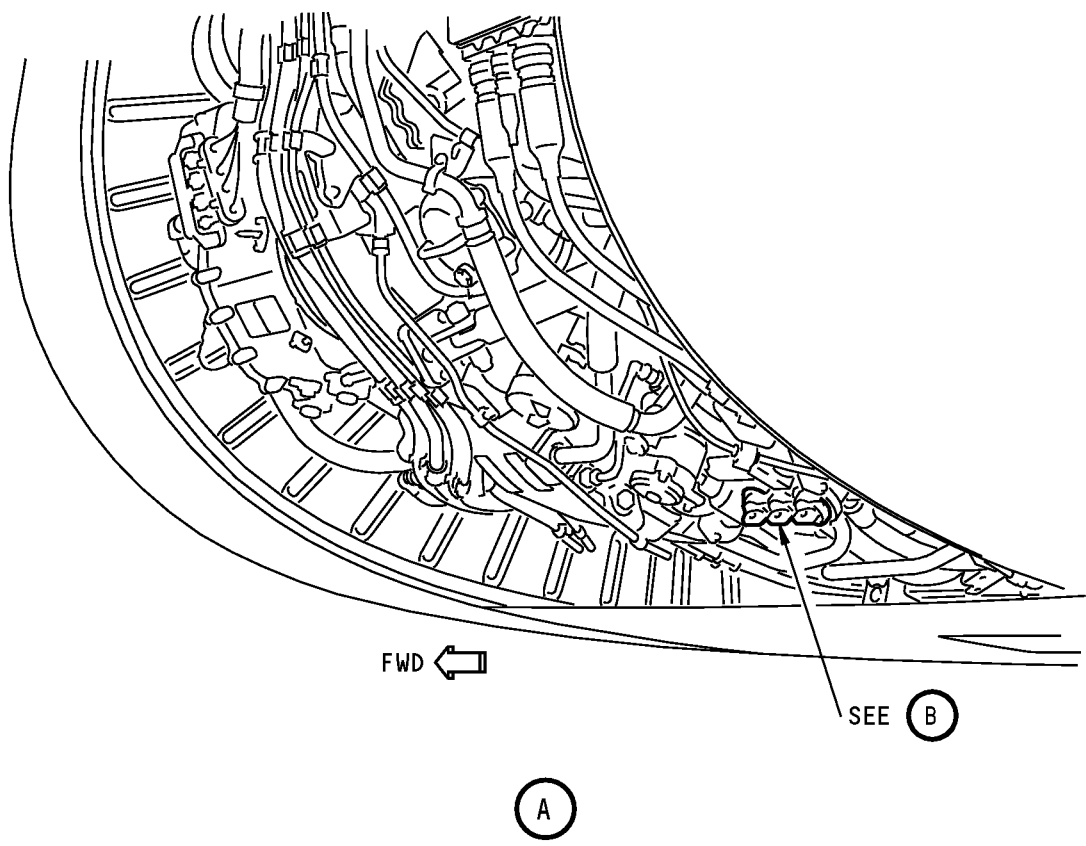
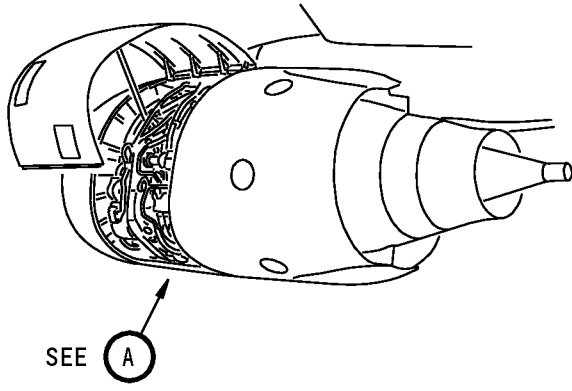

Oil Supply Tube Installation
Figure 402/79-21-01-990-802-F00

EFFECTIVITY
HAP ALL

79-21-01

AIRCRAFT MAINTENANCE MANUAL

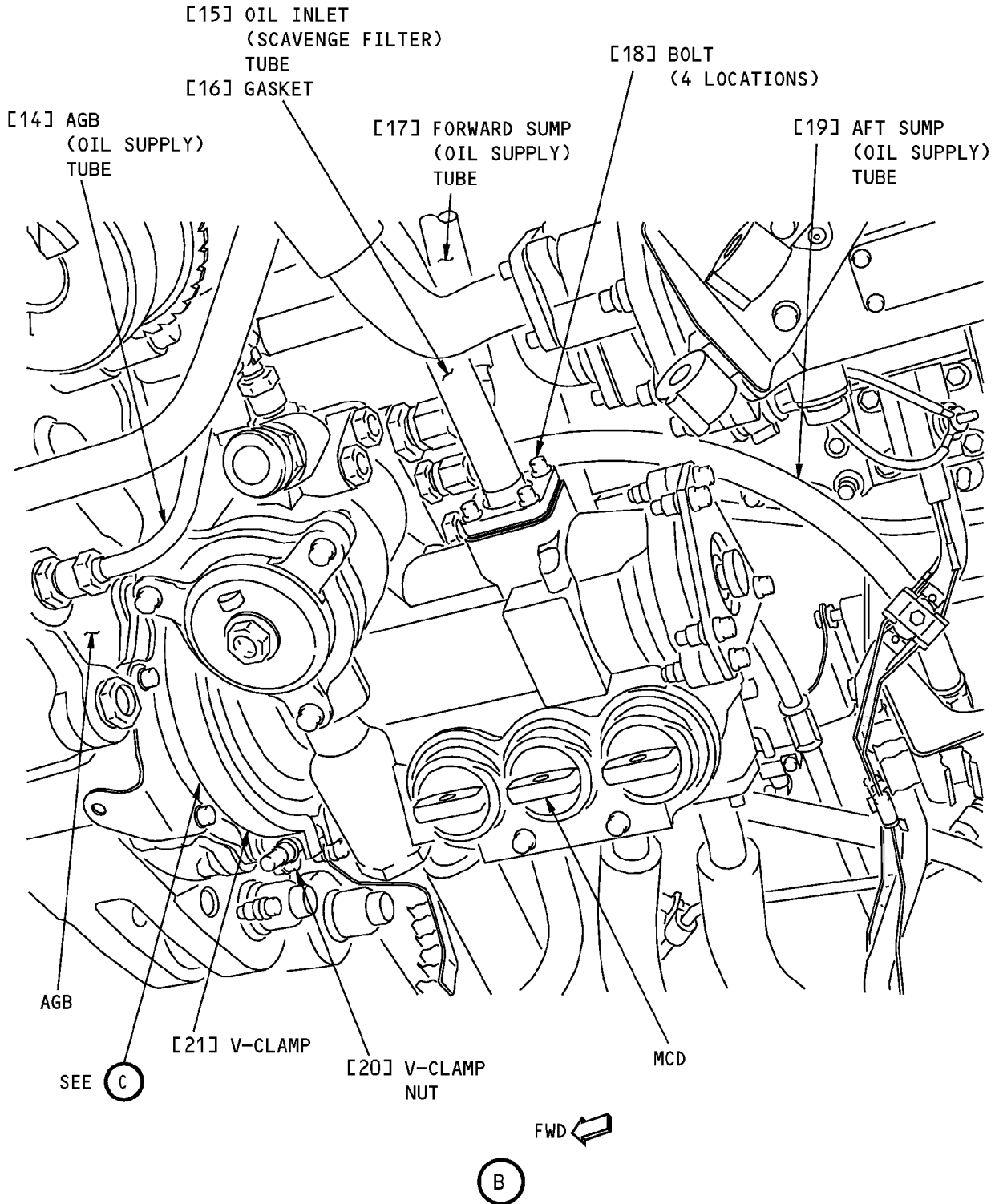

Oil Supply Tube Installation
Figure 403/79-21-01-990-808-F00

EFFECTIVITY
HAP ALL

79-21-01

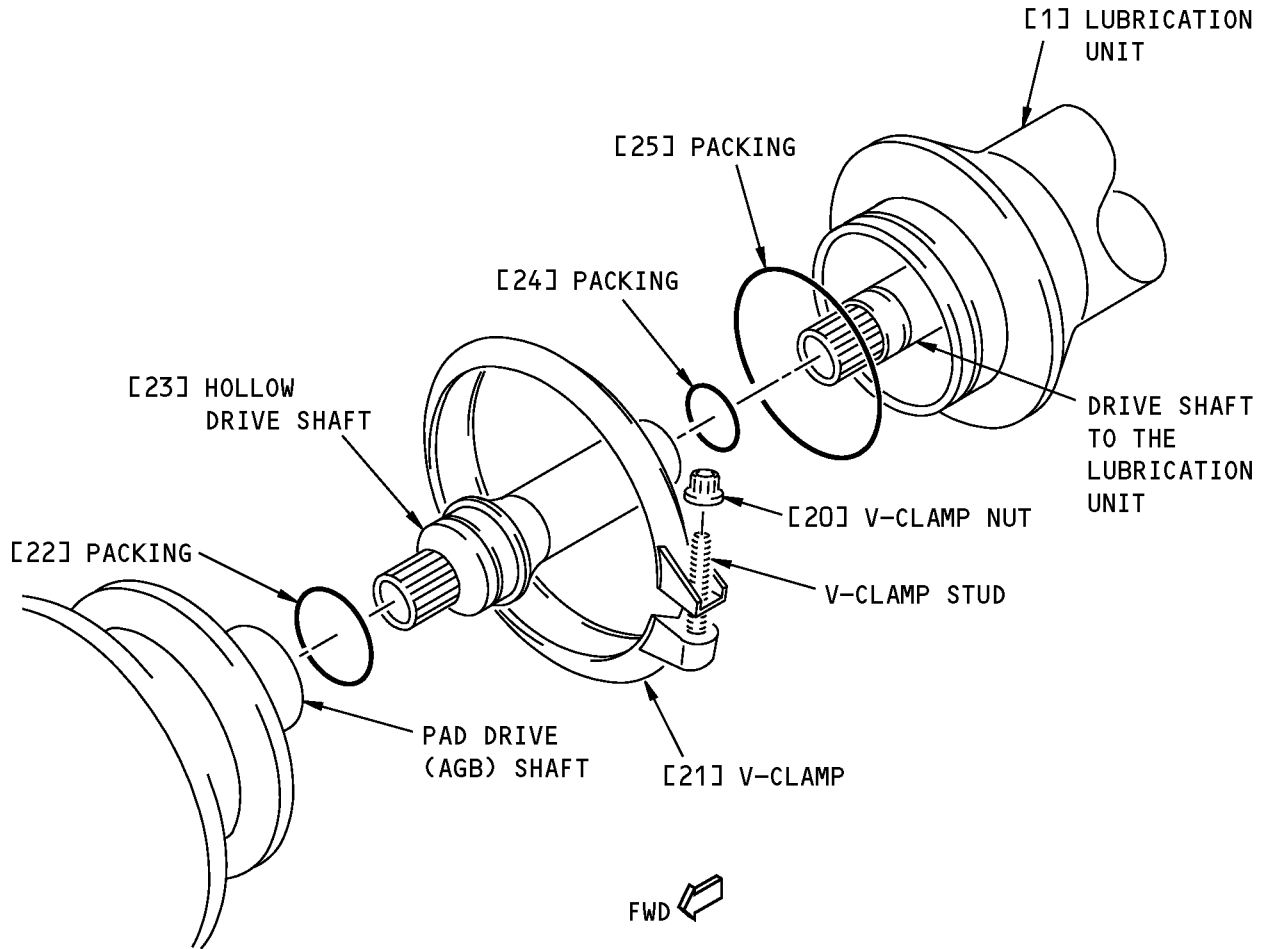

(C)

Drive Shaft Installation
Figure 404/79-21-01-990-809-F00

EFFECTIVITY
HAP ALL

79-21-01

Page 408
Oct 10/2003

D633A101-HAP

AIRCRAFT MAINTENANCE MANUAL

TASK 79-21-01-400-801-F00

3. Lubrication Unit Installation

(Figure 401), (Figure 402), (Figure 403), (Figure 404),

A. General

(1) This task is the installation procedure for the lubrication unit.

B. References

Reference	Title
12-13-11-600-801	Replenish the Engine Oil (P/B 301)
70-10-02-910-801-F00	General Precautions During the Removal and Installation of Engine Components (P/B 201)
71-00-00-800-811-F00	Power Plant Test Reference Table (P/B 501)
71-11-02-410-801-F00	Close the Fan Cowl Panels (P/B 201)

C. Consumable Materials

Reference	Description	Specification
D00599 [CP2442]	Oil - Engine (CFMI SB 79-001)	
D00601 [CP2101]	Grease - Graphite, High Temperature	SAE AMS 2518

D. Expendables/Parts

AMM Item	Description	AIPC Reference	AIPC Effectivity
1	Unit	79-21-01-01-021	HAP ALL
4	Gasket	79-21-00-01-140	HAP ALL
7	Gasket	79-21-00-01-160	HAP ALL
9	Gasket	79-21-00-01-180	HAP ALL
11	Gasket	79-21-00-01-200	HAP ALL
16	Gasket	79-21-00-01-120	HAP ALL
24	Packing	79-21-01-01-015	HAP ALL
25	Packing	79-21-01-01-020	HAP ALL

E. Location Zones

Zone	Area
411	Engine 1 - Engine
421	Engine 2 - Engine

F. Prepare for the Installation

SUBTASK 79-21-01-840-001-F00

- (1) Do these steps to prepare the lubrication unit [1] for the installation (General Precautions During the Removal and Installation of Engine Components, TASK 70-10-02-910-801-F00):
- Remove all the protective caps from the connection interfaces.
 - Make sure that all the mating interfaces to the lubrication unit [1] are clean and in good condition.
 - Lubricate all the gaskets with oil, D00599 [CP2442].
 - Lubricate the threads of all the bolts with grease, D00601 [CP2101].
 - Lubricate the threads of all the nipples with oil, D00599 [CP2442].

EFFECTIVITY
HAP ALL

79-21-01

Page 409
Jun 15/2009

D633A101-HAP

AIRCRAFT MAINTENANCE MANUAL

G. Lubrication Unit Installation

SUBTASK 79-21-01-420-001-F00

- (1) Do these steps to install the lubrication unit [1] (Figure 402):
- (a) Lubricate the new packings [24] and [25] with oil, D00599 [CP2442].

CAUTION: MAKE SURE YOU INSTALL THE PACKING CORRECTLY ON THE DRIVE SHAFT. IF YOU DO NOT INSTALL THE PACKING CORRECTLY, OIL LOSS CAN OCCUR DURING ENGINE OPERATION AND CAN CAUSE DAMAGE TO THE ENGINE.

- (b) Install the packing [24] in the drive shaft groove of the lubrication unit [1].
- (c) Install the packing [25] in the groove of the lubrication unit [1].
- (d) Put the V-clamp [21] around the lubrication unit housing.

NOTE: The V-clamp nut must be on the side of the lubrication unit by the identification plate.

- (e) Put the lubrication unit [1] in its position on the AGB.
- (f) Attach the lubrication unit [1] with the V-clamp [21].
- (g) Lubricate the threads of the V-clamp stud with grease, D00601 [CP2101].
- 1) Tighten the V-clamp nut [20] to 115-133 pound-inches (13-15 Newton meters).

SUBTASK 79-21-01-420-002-F00

CAUTION: USE TWO WRENCHES TO TIGHTEN THE COUPLING NUT. USE ONE TO HOLD THE FITTING, AND THE OTHER TO TIGHTEN THE COUPLING NUT. IF YOU DO NOT USE TWO WRENCHES, DAMAGE TO THE EQUIPMENT CAN OCCUR.

- (2) Do these steps to connect the three oil supply tubes to the lubrication unit [1] (Figure 402):
- (a) Connect the aft sump tube [19].
- 1) Tighten the coupling nut to 270-300 pound-inches (30-35 Newton meters).
- (b) Connect the forward sump tube [17].
- 1) Tighten the coupling nut to 450-550 pound-inches (50-60 Newton meters).
- (c) Connect the AGB tube [14].
- 1) Tighten the coupling nut to 270-300 pound-inches (30-35 Newton meters).

SUBTASK 79-21-01-420-003-F00

- (3) Do these steps to connect the oil inlet tube [15] to the scavenge filter to the lubrication unit [1] (Figure 402):
- (a) Install the gasket [16].
- (b) Install the four bolts [18] to attach the oil inlet tube [15].
- 1) Tighten the bolts [18] to 49-53 pound-inches (5.5-6.0 Newton meters).

SUBTASK 79-21-01-420-006-F00

- (4) Do these steps to connect the oil supply tube [10] to the lubrication unit [1] (Figure 401):
- (a) Install the gasket [11].
- (b) Install the four bolts [12] to attach the oil supply tube [10].
- 1) Tighten the bolts [12] to 49-53 pound-inches (5.5-6.0 Newton meters).

SUBTASK 79-21-01-420-004-F00

- (5) Do these steps to connect the oil scavenge tubes to the lubrication unit [1] (Figure 401):
- (a) Install the gasket [9].

EFFECTIVITY
HAP ALL

D633A101-HAP

79-21-01

Page 410
Feb 15/2009

AIRCRAFT MAINTENANCE MANUAL

- (b) Install the four bolts [13] to attach the AGB tube [8].
- (c) Install the gasket [7].
- (d) Install the four bolts [5] to attach the forward sump tube [6].
- (e) Install the gasket [4].
- (f) Install the four bolts [2] to attach the aft sump tube [3].
 - 1) Tighten the bolts [13], [5] and [2] to 49-53 pound-inches (5.5-6.0 Newton meters).

SUBTASK 79-21-01-610-002-F00

- (6) Do this task: Replenish the Engine Oil, TASK 12-13-11-600-801.

H. Put the Airplane Back to Its Usual Condition

SUBTASK 79-21-01-410-002-F00

- (1) Do this task: Close the Fan Cowl Panels, TASK 71-11-02-410-801-F00.

SUBTASK 79-21-01-860-005-F00

- (2) For Engine 1, remove the safety tags and close these circuit breakers:

CAPT Electrical System Panel, P18-2

<u>Row</u>	<u>Col</u>	<u>Number</u>	<u>Name</u>
A	4	C01390	ENGINE 1 ALTN PWR CHAN B
A	5	C01314	ENGINE 1 ALTN PWR CHAN A

SUBTASK 79-21-01-860-006-F00

- (3) For Engine 2, remove the safety tags and close these circuit breakers:

F/O Electrical System Panel, P6-2

<u>Row</u>	<u>Col</u>	<u>Number</u>	<u>Name</u>
D	7	C01391	ENGINE 2 ALTN PWR CHAN B
D	8	C01315	ENGINE 2 ALTN PWR CHAN A

I. Lubrication Unit Installation Test

SUBTASK 79-21-01-800-001-F00

- (1) Do the tests that are listed in the Power Plant Test Reference Table, TASK 71-00-00-800-811-F00.

SUBTASK 79-21-01-610-001-F00

- (2) If the oil level is low, do this task: Replenish the Engine Oil, TASK 12-13-11-600-801.

————— END OF TASK —————

EFFECTIVITY
HAP ALL

D633A101-HAP

79-21-01

Page 411
Feb 15/2009

AIRCRAFT MAINTENANCE MANUAL

LUBRICATION UNIT - REPAIRS**1. General**

A. This procedure has the tasks to replace the packing in these areas of the lubrication unit:

- (1) Inner sealing spool (lubrication unit installed)
- (2) Inner and outer sealing spools (lubrication unit removed)
- (3) Inner and outer sealing spools (lubrication unit installed).

TASK 79-21-01-400-802-F00**2. Packing Replacement On The Inner Sealing Spool (Lubrication Unit Installed)**

(Figure 801)

A. General

- (1) Replace this packing if you find debris from the packing on the applicable detector of the lubrication unit.

NOTE: It is recommended to replace the packing from the three inner sealing spools at the same time.

- (2) The lubrication unit is found on the accessory gearbox at the 6:00 o'clock position.

B. References

Reference	Title
12-13-11-600-801	Replenish the Engine Oil (P/B 301)
71-00-00-700-801-F00	Test 3A - Idle-Power Leak Check (P/B 501)
71-11-02-010-801-F00	Open the Fan Cowl Panels (P/B 201)
71-11-02-410-801-F00	Close the Fan Cowl Panels (P/B 201)
79-21-05-000-806-F00	Magnetic Chip Detector (MCD) Removal (P/B 401)
79-21-05-400-804-F00	Magnetic Chip Detector (MCD) Installation (P/B 401)

C. Tools/Equipment

NOTE: When more than one tool part number is listed under the same "Reference" number, the tools shown are alternates to each other within the same airplane series. Tool part numbers that are replaced or non-procurable are preceded by "Opt:", which stands for Optional.

Reference	Description
SPL-2199	Adapter - Inner Seal, Lubrication Unit (Part #: 856A3625G01, Supplier: 58828, A/P Effectivity: 737-300, -400, -500, -600, -700, -700C, -700ER, -700QC, -800, -900, -900ER, -BBJ)

D. Consumable Materials

Reference	Description	Specification
D00599 [CP2442]	Oil - Engine (CFMI SB 79-001)	

E. Location Zones

Zone	Area
411	Engine 1 - Engine
421	Engine 2 - Engine

F. Procedure

SUBTASK 79-21-01-010-002-F00

- (1) Do this task: Open the Fan Cowl Panels, TASK 71-11-02-010-801-F00.

EFFECTIVITY
HAP ALL

D633A101-HAP

79-21-01

Page 801
Oct 15/2008

AIRCRAFT MAINTENANCE MANUAL

SUBTASK 79-21-01-020-009-F00

- (2) Remove the applicable detector from the lubrication unit. To remove the detector, do this task: Magnetic Chip Detector (MCD) Removal, TASK 79-21-05-000-806-F00.

SUBTASK 79-21-01-400-001-F00

- (3) Do these steps to install a new packing [1] on the inner sealing spool:

CAUTION: MAKE SURE THE DETECTOR LOCATION IS CLEAN. IF THE LOCATION IS NOT CLEAN, IT CAN CAUSE AN INCORRECT INSTALLATION OF THE PACKING IN THE GROOVE OF THE INNER SEALING SPOOL.

- (a) Make sure the detector location in the lubrication unit is clean.
- (b) Lightly apply a layer of oil, D00599 [CP2442] on a new packing [1].
- (c) Put the sliding handle of the adapter, SPL-2199 in the down position.
- (d) Put the packing around the top end of the tool, so that it touches the packing stops.
- (e) Put the tool in the spool sleeve with the centering pin engaged through the hole in the inner sealing spool.
- (f) Turn the tool and engage it farther in the sleeve until the stops of the handle touch the edge of the sleeve.
- (g) Keep the handle stops against the sleeve while you move the handle to the up position.
- (h) While you keep the handle stops against the sleeve, move the handle to the down position.

CAUTION: BEFORE THE REMOVAL OF THE INSTALLATION TOOL, LET THE SLIDING HANDLE AND THE HANDLE COME BACK TO THEIR DOWN POSITIONS UNDER THE UNBENDING SPRINGS. THIS WILL PREVENT DAMAGE TO THE EQUIPMENT.

- (i) Remove the installation tool from the lubrication unit.

SUBTASK 79-21-01-210-001-F00

- (4) Do a check that the inner and outer sealing spools move freely in the lubrication unit housing.

SUBTASK 79-21-01-410-004-F00

- (5) Do this task: Close the Fan Cowl Panels, TASK 71-11-02-410-801-F00.

SUBTASK 79-21-01-790-001-F00

- (6) Do this task: Test 3A - Idle-Power Leak Check, TASK 71-00-00-700-801-F00.

NOTE: The detector is not yet installed in the lubrication unit.

SUBTASK 79-21-01-020-010-F00

- (7) Install the applicable detector in the lubrication unit. To install the detector, do this task: Magnetic Chip Detector (MCD) Installation, TASK 79-21-05-400-804-F00.

SUBTASK 79-21-01-610-003-F00

- (8) If the oil level is low, do this task: Replenish the Engine Oil, TASK 12-13-11-600-801.

————— **END OF TASK** —————

EFFECTIVITY
HAP ALL

D633A101-HAP

79-21-01

Page 802
Oct 15/2008

737-600/700/800/900
AIRCRAFT MAINTENANCE MANUAL

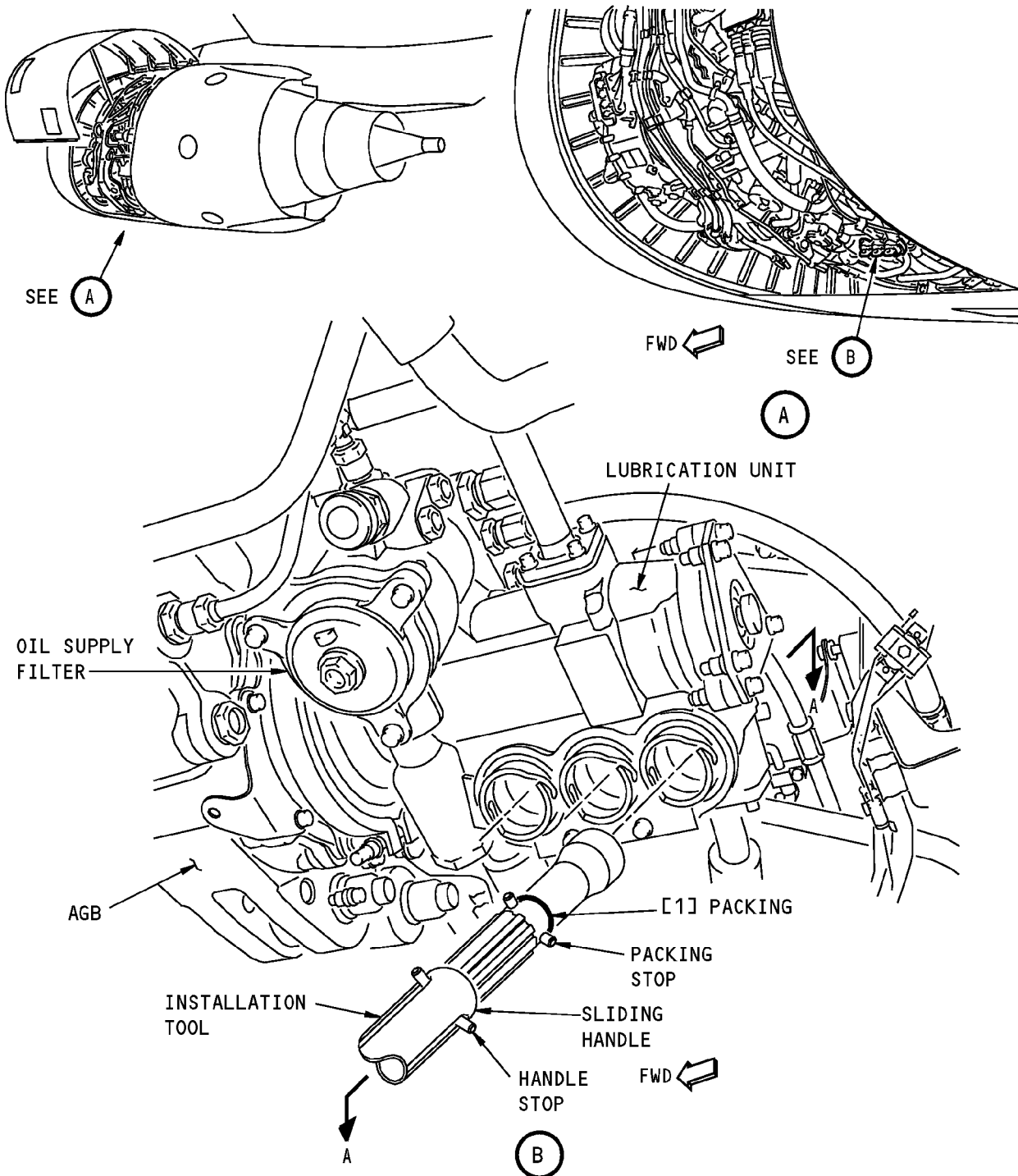

NOTE: DETECTORS NOT INSTALLED.

**Packing Replacement on the Inner Sealing Spool
Figure 801 (Sheet 1 of 2)/79-21-01-990-804-F00**

EFFECTIVITY
HAP ALL

79-21-01

Page 803
Oct 10/2003

D633A101-HAP

737-600/700/800/900
AIRCRAFT MAINTENANCE MANUAL

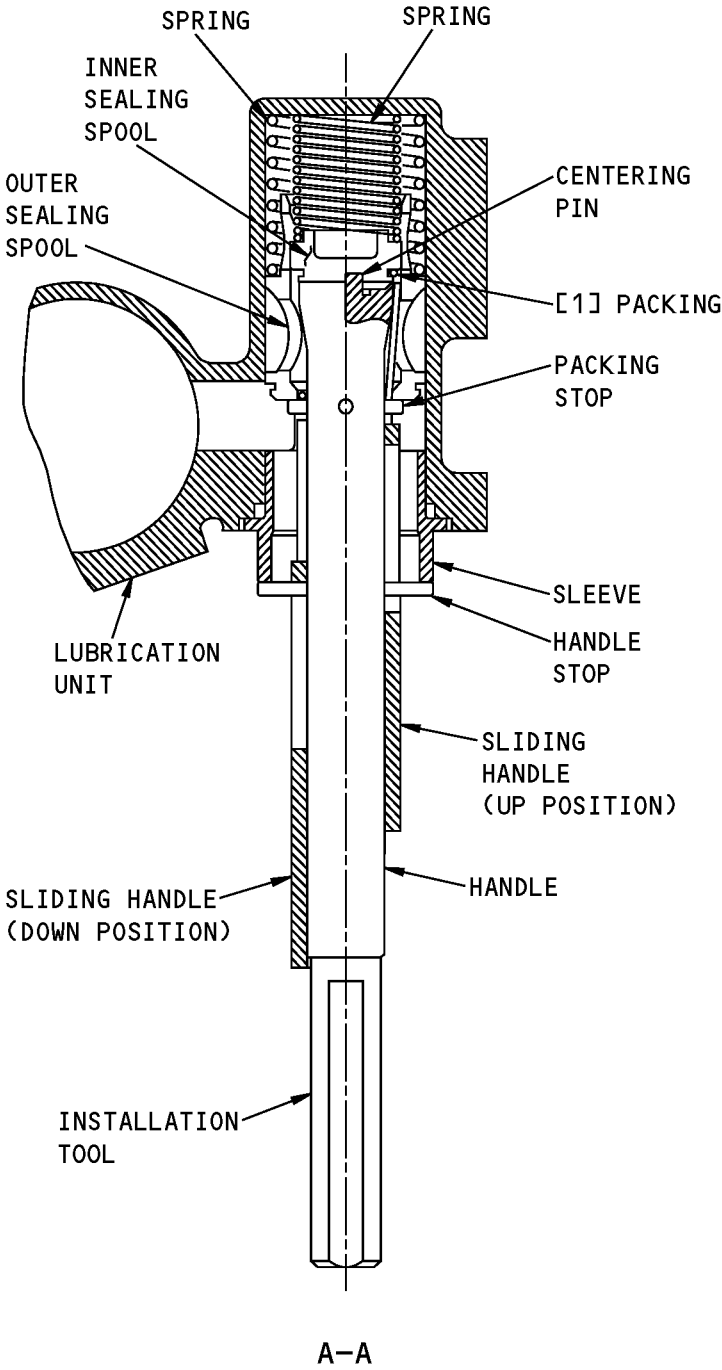

Packing Replacement on the Inner Sealing Spool
Figure 801 (Sheet 2 of 2)/79-21-01-990-804-F00

EFFECTIVITY
HAP ALL

79-21-01

Page 804
Oct 10/2003

D633A101-HAP

AIRCRAFT MAINTENANCE MANUAL

TASK 79-21-01-400-803-F00

3. Packing Replacement On The Inner and Outer Sealing Spools (Lubrication Unit Removed)

(, Figure 802, Figure 803, Figure 804, Figure 805)

A. General

- (1) Replace this packing if you find debris from this packing in the scavenge filter cartridge.

NOTE: It is recommended to replace the packing from the three outer sealing spools at the same time.

- (2) It is necessary to remove the lubrication unit to do this task.
- (3) This task has two procedures to remove and two procedures to install the outer and inner sealing spools. The sealing spools are installed in the lubrication unit and are called check valves in procedure.

B. References

Reference	Title
12-13-11-600-801	Replenish the Engine Oil (P/B 301)
71-00-00-700-801-F00	Test 3A - Idle-Power Leak Check (P/B 501)
71-11-02-010-801-F00	Open the Fan Cowl Panels (P/B 201)
71-11-02-410-801-F00	Close the Fan Cowl Panels (P/B 201)
79-21-01-000-801-F00	Lubrication Unit Removal (P/B 401)
79-21-01-400-801-F00	Lubrication Unit Installation (P/B 401)
79-21-05-000-806-F00	Magnetic Chip Detector (MCD) Removal (P/B 401)
79-21-05-400-804-F00	Magnetic Chip Detector (MCD) Installation (P/B 401)

C. Consumable Materials

Reference	Description	Specification
D00599 [CP2442]	Oil - Engine (CFMI SB 79-001)	

D. Expendables/Parts

AMM Item	Description	AIPC Reference	AIPC Effectivity
21	Packing	Not Specified	
28	Packing	79-21-01-01-210	HAP ALL
30	Packing	79-21-01-01-215	HAP 001-013, 015-026, 028-030

E. Location Zones

Zone	Area
411	Engine 1 - Engine
421	Engine 2 - Engine

F. Procedure

SUBTASK 79-21-01-010-003-F00

- (1) Do this task: Open the Fan Cowl Panels, TASK 71-11-02-010-801-F00.

SUBTASK 79-21-01-020-011-F00

- (2) Remove the detectors from the lubrication unit (TASK 79-21-05-000-806-F00).

EFFECTIVITY
HAP ALL

79-21-01

D633A101-HAP

Page 805
Feb 15/2009

AIRCRAFT MAINTENANCE MANUAL

SUBTASK 79-21-01-020-012-F00

CAUTION: AFTER THE REMOVAL OF THE LUBRICATION UNIT, MAKE SURE TO PUT LUBRICATION UNIT ON A CLEAN TABLE. UNWANTED DEBRIS CAN CAUSE AN INCORRECT INSTALLATION OF THE PACKING.

(3) Do this task: Lubrication Unit Removal, TASK 79-21-01-000-801-F00.

- (a) Make sure that you do not remove the nipples installed on the ports of the lubrication unit.

SUBTASK 79-21-01-400-002-F00

(4) Do these steps to remove each check valve with the locally manufactured tool (Figure 802):

- (a) Make the pusher tool and the locking tools (Figure 803).
 (b) Put the pusher tool into the scavenge screen hole in the lubrication unit housing (Figure 804).
 (c) Push back the outer sealing spool [31] and at the same time put the locking tool into the oil inlet to block the valve assembly in the upper position.
 (d) Remove the pusher.
 (e) Do the above steps again, to install a locking tool at the other scavenge screen holes.

WARNING: LOCK THE SPOOL VALVES BEFORE YOU REMOVE THE FASTENERS FOR THE RETAINING PLATE. SPOOL VALVE EXTENSIONS CAN CAUSE INJURIES TO PERSONNEL AND DAMAGE TO EQUIPMENT.

- (f) Remove the two nuts [24], washers [25] and bolts [27] which attach the retaining plate [26] on the lubrication unit housing.
 (g) Remove the retaining plate [26].
 (h) Remove the sleeves [29].
 (i) Remove and discard the packings [28].
 (j) Put the pusher into the scavenge screen hole in the lubrication unit housing.

WARNING: MAKE SURE YOU HOLD THE OUTER SEALING SPOOL TIGHTLY WHEN YOU REMOVE THE LOCKING TOOL. UNCONTROLLED RELEASE OF THE SPRING CAN CAUSE INJURY. THE SPRING LOAD IS 30.24 POUND FORCE (134.5 NEWTONS).

- (k) Push the outer sealing spool [31] and remove the locking tool from the lubrication unit housing.
 (l) Remove the outer sealing spool [31], inner sealing spool [22] and the two springs [32] and [23].
 (m) Remove and discard the packing [30] from the outer sealing spool [31] and the packing [21] from the inner sealing spool [22].
 (n) Examine the inner diameter of the outer sealing spool for the presence of wear:
 1) If the wear is less than 0.024 in. (0.61 mm), the part is serviceable.
 2) If the wear is 0.024 in. (0.61 mm) to 0.028 in. (0.71 mm), a continue-in-service extension of 500 hours is permitted.
 3) If the wear is more than 0.028 in. (0.71 mm), discard the outer sealing spool.

SUBTASK 79-21-01-400-003-F00

(5) Do these steps to install each check valve with the locally manufactured tool:

EFFECTIVITY
HAP ALL

79-21-01

Page 806
Oct 15/2008

D633A101-HAP

AIRCRAFT MAINTENANCE MANUAL

- (a) Make sure that the check valve location in the lubrication unit is clean.
- NOTE: If the location is not clean, it can cause an incorrect installation of the packings in the groove of the outer and inner sealing spool.
- (b) Lightly apply a layer of oil, D00599 [CP2442] on the new packings [30], packings [21] and packings [28].
- (c) Install the new packing [30] on the outer sealing spool groove [31].
- (d) Install the new packing [21] on the inner sealing spool groove [22].
- (e) Install the two springs [32] and [23] in the scavenge screen hole.
- (f) Install the inner sealing spool [22] on the spring [23].
- 1) Note the orientation of the inner sealing spool [22] (Figure 802).
- (g) Install the outer sealing spool [31] on the spring [32] so that the inner sealing spool [22] and spring [23] are fully engaged in the inner diameter of the outer sealing spool.
- 1) Note the orientation of the parts (Figure 802).
- (h) Push the outer sealing spool [31] with the pusher and hold until you can install the locking tool to hold the valve assembly in place.
- (i) Remove the pusher.
- (j) Install the new packing [28] on the sleeve [29].
- (k) Install the sleeve [29] in the scavenge screen hole in the lubrication unit housing.
- 1) Make sure the packing [28] is fully engaged in the housing.
- (l) Do these steps to install the retaining plate [26]:
- 1) Hold the retaining plate [26] on the housing and install two bolts [27], washers [25] and nuts [24].
- 2) Tighten the nuts [24] to 39.9-48.6 pound-inches (4.5-5.5 Newton meters).
- (m) Do these steps to release the outer sealing spool [31]:
- 1) Push the outer sealing spool [31] with the pusher.
- 2) Remove the locking tool.
- 3) Release the outer sealing spool [31] and remove the pusher.

SUBTASK 79-21-01-210-002-F00

- (6) Make sure that the inner and outer sealing spools move freely in the lubrication unit housing.

SUBTASK 79-21-01-400-004-F00

- (7) Do this task: Lubrication Unit Installation, TASK 79-21-01-400-801-F00.

SUBTASK 79-21-01-410-005-F00

- (8) Do this task: Close the Fan Cowl Panels, TASK 71-11-02-410-801-F00.

SUBTASK 79-21-01-790-002-F00

- (9) Do this task: Test 3A - Idle-Power Leak Check, TASK 71-00-00-700-801-F00.

NOTE: The detector is not yet installed in the lubrication unit.

SUBTASK 79-21-01-020-013-F00

- (10) Install the applicable detector in the lubrication unit (TASK 79-21-05-400-804-F00).

SUBTASK 79-21-01-610-004-F00

- (11) If the oil level is low, do this task: Replenish the Engine Oil, TASK 12-13-11-600-801.

————— **END OF TASK** —————

EFFECTIVITY
HAP ALL

79-21-01

Page 807
Oct 15/2008

D633A101-HAP

737-600/700/800/900
AIRCRAFT MAINTENANCE MANUAL

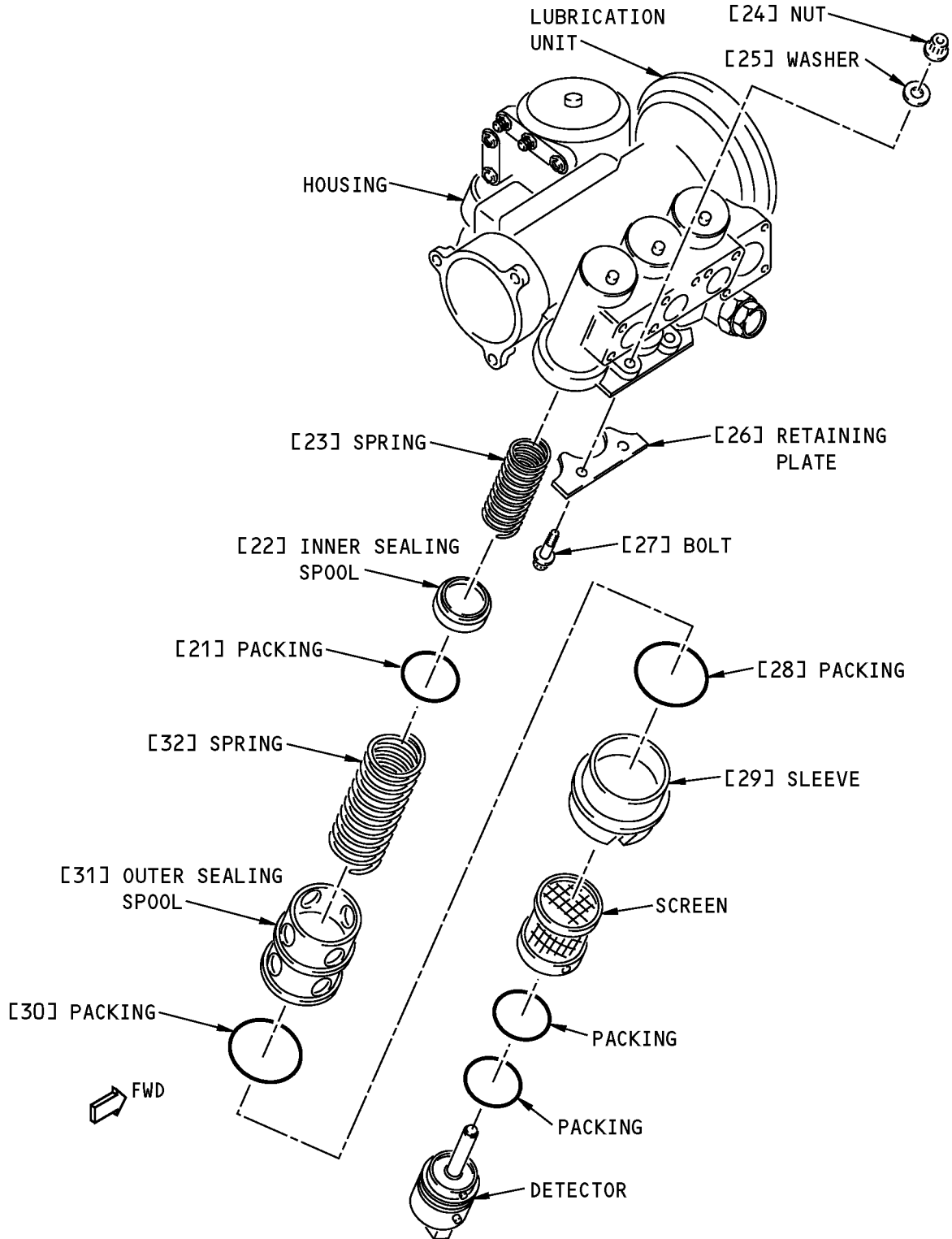

Packing Replacement on the Outer Sealing Spool and Inner Sealing Spool
Figure 802/79-21-01-990-805-F00

EFFECTIVITY
HAP ALL

79-21-01

737-600/700/800/900
AIRCRAFT MAINTENANCE MANUAL

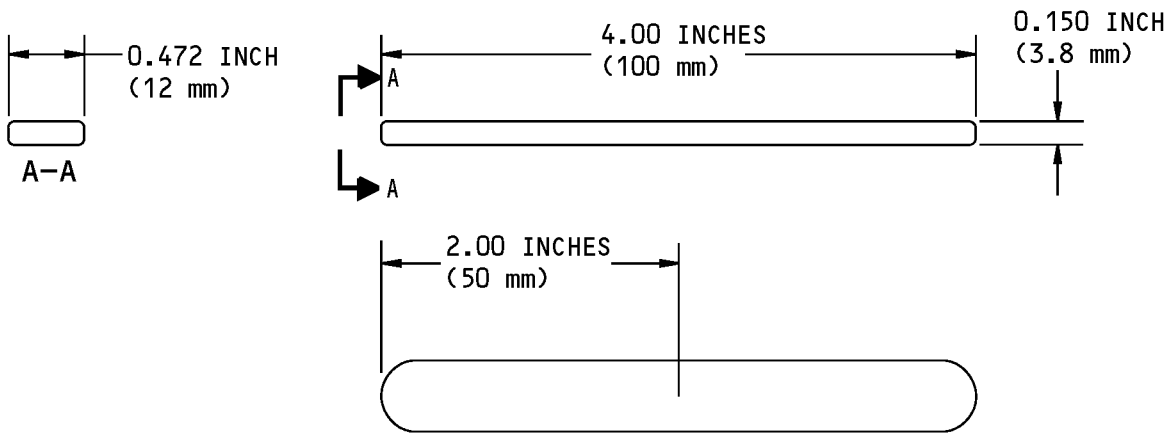

MATERIAL: AA2024T3 STK THK
OR 2017AT4

LOCKING TOOL

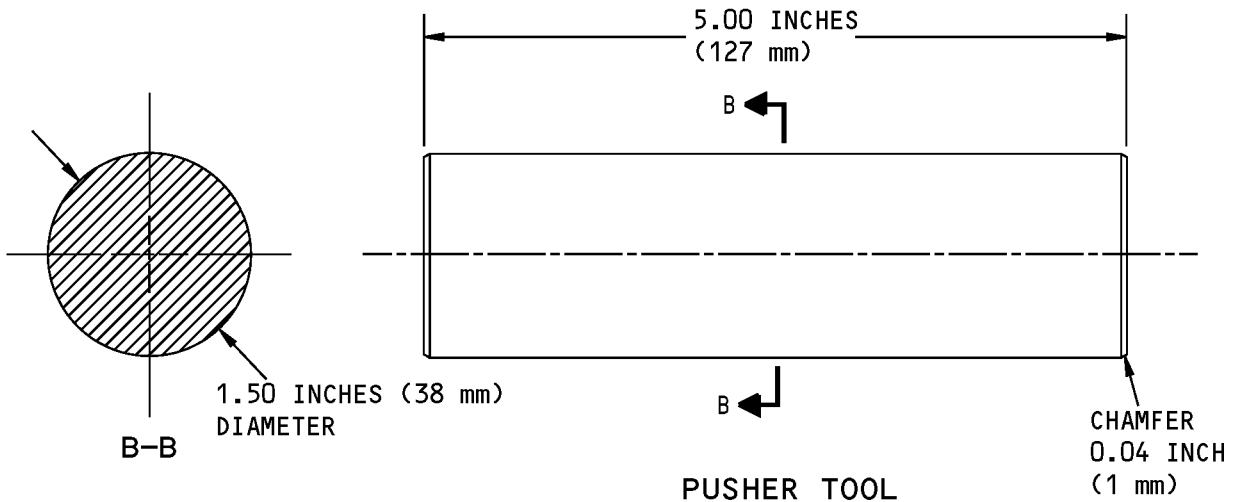

MATERIAL: ERTALON OR NYLON TYP6

PUSHER TOOL

Tool Fabrication
Figure 803/79-21-01-990-806-F00

EFFECTIVITY
HAP ALL

79-21-01

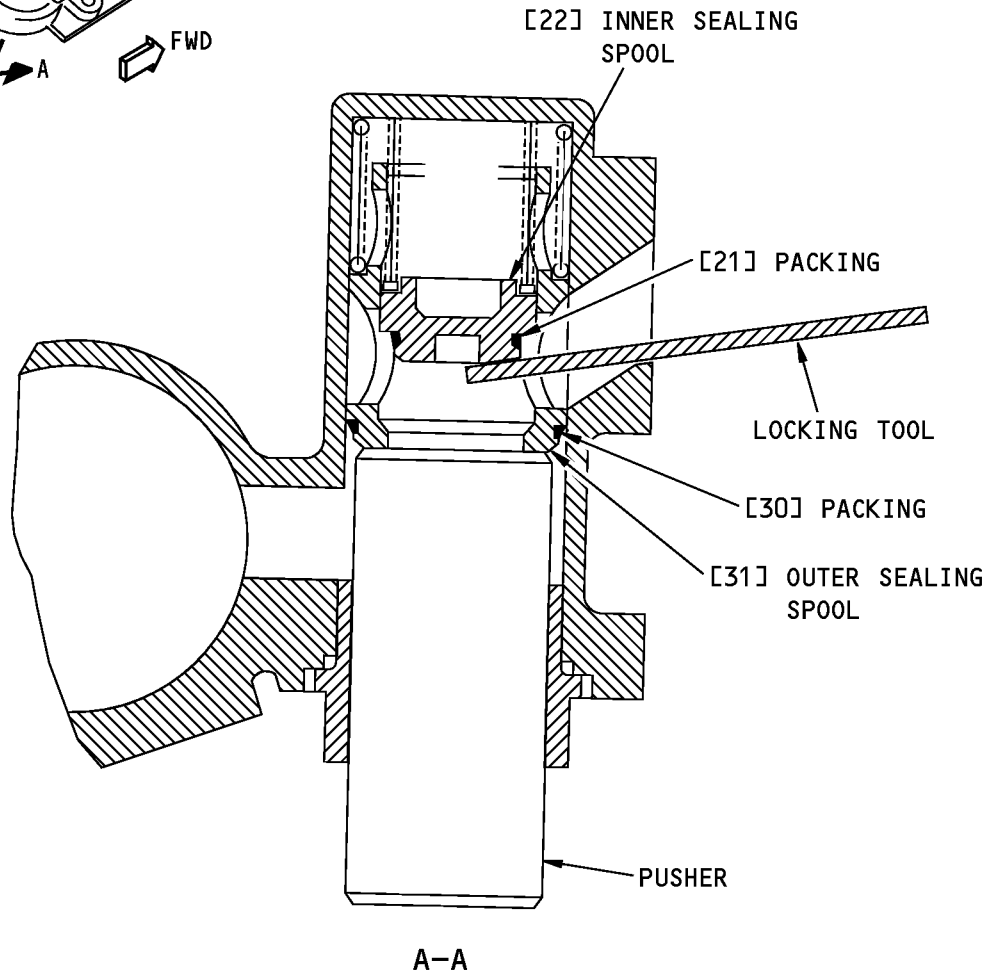
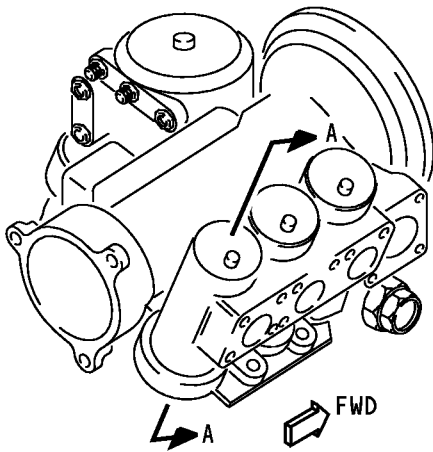

M45465 S0006583671_V2

Locking Tool Installation
Figure 804/79-21-01-990-807-F00

EFFECTIVITY
HAP ALL

79-21-01

Page 810
Oct 15/2008

D633A101-HAP

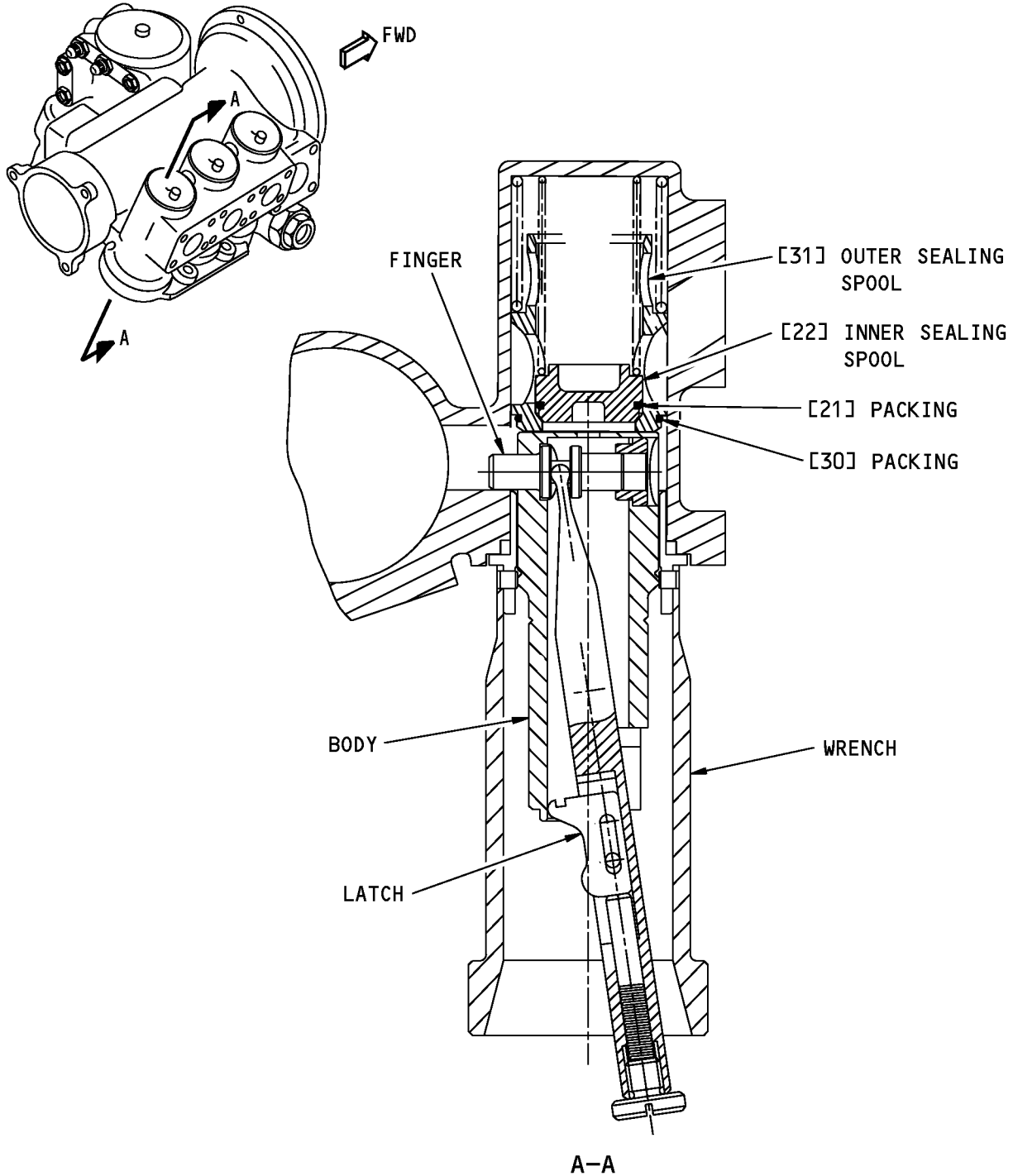

1558395 S0000287839_V2

Scavenge Filter Housing Tool Set Installation
Figure 805/79-21-01-990-812-F00

EFFECTIVITY
HAP ALL

79-21-01

Page 811
Oct 15/2008

D633A101-HAP

AIRCRAFT MAINTENANCE MANUAL

TASK 79-21-01-400-804-F00

4. Packing Replacement On The Inner and Outer Sealing Spools (Lubrication Unit Installed)

(Figure 802, Figure 805)

A. General

- (1) Replace this packing if you find debris from this packing in the scavenge filter cartridge.

NOTE: It is recommended to replace the packing from the three outer sealing spools at the same time.

- (2) The sealing spools are installed in the lubrication unit and are called check valves in procedure.

B. References

Reference	Title
12-13-11-600-801	Replenish the Engine Oil (P/B 301)
71-00-00-700-801-F00	Test 3A - Idle-Power Leak Check (P/B 501)
71-11-02-010-801-F00	Open the Fan Cowl Panels (P/B 201)
71-11-02-410-801-F00	Close the Fan Cowl Panels (P/B 201)
79-21-05-000-806-F00	Magnetic Chip Detector (MCD) Removal (P/B 401)
79-21-05-400-804-F00	Magnetic Chip Detector (MCD) Installation (P/B 401)

C. Tools/Equipment

NOTE: When more than one tool part number is listed under the same "Reference" number, the tools shown are alternates to each other within the same airplane series. Tool part numbers that are replaced or non-procurable are preceded by "Opt:", which stands for Optional.

Reference	Description
SPL-9649	Tool Set - A/D Lubrication Unit Scavenge Filter Housing (Part #: 856A2957G01, Supplier: 58828, A/P Effectivity: 737-600, -700, -700C, -700ER, -700QC, -800, -900, -900ER, -BBJ)

D. Consumable Materials

Reference	Description	Specification
D00599 [CP2442]	Oil - Engine (CFMI SB 79-001)	

E. Location Zones

Zone	Area
411	Engine 1 - Engine
412	Engine 1 - Nose Inlet Cowl

F. Procedure

SUBTASK 79-21-01-010-004-F00

- (1) Do this task: Open the Fan Cowl Panels, TASK 71-11-02-010-801-F00.

SUBTASK 79-21-01-020-015-F00

- (2) Remove the detectors from the lubrication unit (Magnetic Chip Detector (MCD) Removal, TASK 79-21-05-000-806-F00).

SUBTASK 79-21-01-020-016-F00

- (3) Remove each check valve with tool set, SPL-9649 as follows (Figure 805):
- Retract the finger and lock in position with the latch.
 - Install the tool through the lubrication unit sleeve [29] in the scavenge.

EFFECTIVITY
HAP ALL

79-21-01

Page 812
Oct 15/2008

D633A101-HAP

AIRCRAFT MAINTENANCE MANUAL

- (c) Push the lubrication unit outer sealing spool [31] and release the latch.
- (d) Engage the finger in the oil port to the pump.
- (e) Engage the latch into the body of the tool to lock the finger in extended position.

WARNING: LOCK THE SPOOL VALVES BEFORE YOU REMOVE THE FASTENERS FOR THE RETAINING PLATE. SPOOL VALVE EXTENSIONS CAN CAUSE INJURIES TO PERSONNEL AND DAMAGE TO EQUIPMENT.

- (f) Remove the bolts [27], washers [25] and nuts [24] and the retaining plate [26].
- (g) Use the wrench to remove the lubrication unit sleeve [29].
- (h) Remove and discard the packings [28].
- (i) Hold the body, release the latch and carefully retract the finger to release the lubrication unit outer sealing spool assembly springs.
- (j) Remove the lubrication unit sealing spool assembly.
- (k) Remove and discard the packing [30] from the outer sealing spool [31] and the packing [21] from the inner sealing spool [22].
- (l) Examine the inner diameter of the outer sealing spool [31] for the presence of wear as follows:
 - 1) If the wear is less than 0.024 in. (0.61 mm), the part is serviceable.
 - 2) If the wear is less than 0.024 in. (0.61 mm) to 0.028 in. (0.71 mm), a continue-in-service extension of 500 hours is permitted.
 - 3) If the wear is less than 0.028 in. (0.71 mm), discard the outer sealing spool.

SUBTASK 79-21-01-420-008-F00

- (4) Install each check valve with tool set, SPL-9649 as follows:
 - (a) Make sure that the check valve location in the lubrication unit is clean.

NOTE: If the location is not clean, it can cause an incorrect installation of the packings in the groove of the outer and inner sealing spool.
 - (b) Apply a light layer of oil, D00599 [CP2442] on the packings [30], packings [21] and packings [28].
 - (c) Install the new packing [30] on the outer sealing spool groove [31].
 - (d) Install the new packing [21] on the inner sealing spool groove [22].
 - (e) Install the two springs [32] and [23] in the scavenge screen hole.
 - (f) Install the lubrication unit sealing spool assembly in the scavenge cavity.
 - (g) Retract the finger and lock in position with the latch.
 - (h) Install the tool in the scavenge.
 - (i) Push the lubrication unit outer sealing spool and release the latch.
 - (j) Engage the finger in the oil port to the pump.
 - (k) Engage the latch into the body of the tool to lock the finger in the extended position.
 - (l) Install the packing [28] on the lubrication unit sleeve [29].
 - (m) Install the lubrication unit sleeve [29].
 - (n) Do these steps to install the retaining plate [26]:
 - 1) Hold the retaining plate [26] on the housing and install two bolts [27], washers [25] and nuts [24].

EFFECTIVITY
HAP ALL

D633A101-HAP

79-21-01

Page 813
Oct 15/2008

AIRCRAFT MAINTENANCE MANUAL

- 2) Tighten the nuts [24] to 39.9-48.6 pound-inches (4.5-5.5 Newton meters).
- (o) Hold the body, release the latch and retract the finger and remove the body from the lubrication unit.

SUBTASK 79-21-01-212-002-F00

- (5) Make sure that the inner and outer sealing spools move freely in the lubrication unit housing.

SUBTASK 79-21-01-410-006-F00

- (6) Do this task: Close the Fan Cowl Panels, TASK 71-11-02-410-801-F00.

SUBTASK 79-21-01-790-003-F00

- (7) Do this task: Test 3A - Idle-Power Leak Check, TASK 71-00-00-700-801-F00.

NOTE: You do the idle power leak check before you install the detectors.

SUBTASK 79-21-01-420-009-F00

- (8) Install the applicable detectors in the lubrication unit (TASK 79-21-05-400-804-F00).

SUBTASK 79-21-01-612-001-F00

- (9) If the oil level is low, replenish the engine oil (TASK 12-13-11-600-801).

————— **END OF TASK** —————

EFFECTIVITY
HAP ALL

D633A101-HAP

79-21-01Page 814
Oct 15/2008

AIRCRAFT MAINTENANCE MANUAL

MAIN OIL/FUEL HEAT EXCHANGER - REMOVAL/INSTALLATION**1. General**

A. This procedure has two tasks:

- (1) The removal of the main oil/fuel heat exchanger.
- (2) The installation of the main oil/fuel heat exchanger.

TASK 79-21-02-000-801-F00**2. Main Oil/Fuel Heat Exchanger Removal**

(Figure 401)

A. General

- (1) This task is the removal procedure for the main oil/fuel heat exchanger (referred to as the heat exchanger).
- (2) The main oil/fuel heat exchanger is found on the fuel pump package.

B. References

Reference	Title
24-22-00-860-811	Supply Electrical Power (P/B 201)
24-22-00-860-812	Remove Electrical Power (P/B 201)
70-10-02-910-801-F00	General Precautions During the Removal and Installation of Engine Components (P/B 201)
70-30-01-910-802-F00	Seals (Preformed Packings and O-Rings) and Gaskets (P/B 201)
71-11-02-010-801-F00	Open the Fan Cowl Panels (P/B 201)
73-11-07-000-801-F00	Servo Fuel Heater Removal (P/B 401)

C. Consumable Materials

Reference	Description	Specification
D00599 [CP2442]	Oil - Engine (CFMI SB 79-001)	

D. Location Zones

Zone	Area
411	Engine 1 - Engine
421	Engine 2 - Engine

E. Prepare for the Removal

SUBTASK 79-21-02-840-001-F00

- (1) Do these steps to isolate the fuel from the fuel pump:
 - (a) Do this task: Supply Electrical Power, TASK 24-22-00-860-811.
 - (b) Make sure the engine start lever is in the CUTOFF position.
 - 1) Install a DO-NOT-OPERATE tag on the applicable engine start lever.
 - (c) Make sure the ENG VALVE CLOSED and the SPAR VALVE CLOSED lights on the fuel control panel (P5 overhead panel) are dim.

NOTE: The lights for the fuel shutoff valves have three positions: 1) bright when the valves are in transition or when the valves do not agree with the commanded position; or 2) dim when the valves are closed; or 3) off when the valves are opened.

- (d) Do this task: Remove Electrical Power, TASK 24-22-00-860-812.

EFFECTIVITY
HAP ALL

79-21-02

Page 401
Oct 10/2007

D633A101-HAP

AIRCRAFT MAINTENANCE MANUAL

- 1) Set the BAT switch on the Electrical Meters Battery and Galley Power Module (P5-13) to the OFF position and install a DO-NOT-OPERATE tag.

SUBTASK 79-21-02-010-001-F00

- (2) Do this task: Open the Fan Cowl Panels, TASK 71-11-02-010-801-F00.

SUBTASK 79-21-02-010-002-F00

- (3) Do this task: Servo Fuel Heater Removal, TASK 73-11-07-000-801-F00.

F. Main Oil/Fuel Heat Exchanger Removal

SUBTASK 79-21-02-020-002-F00

WARNING: DO NOT TOUCH THE COMPONENTS OF THE OIL SYSTEM IF THE ENGINE IS HOT. THESE COMPONENTS STAY HOTTER THAN OTHER COMPONENTS. HOT COMPONENTS CAN BURN YOU.

WARNING: DO NOT OPEN THE OIL SYSTEM UNTIL THE PRESSURE GOES TO ZERO. THE PRESSURE GOES TO ZERO APPROXIMATELY 5 MINUTES AFTER AN ENGINE SHUTDOWN. A PRESSURIZED ENGINE CAN RELEASE A SPRAY OF HOT OIL THAT CAN BURN YOU.

WARNING: DO NOT LET HOT OIL GET ON YOU. PUT ON GOGGLES AND OTHER EQUIPMENT FOR PROTECTION OR LET THE ENGINE BECOME COOL. HOT OIL CAN BURN YOU.

CAUTION: DO NOT LET HOT OIL GET ON THE ENGINE OR OTHER COMPONENTS. IMMEDIATELY CLEAN THE COMPONENT IF OIL FALLS ON IT. OIL CAN CAUSE DAMAGE TO PAINT AND RUBBER.

- (1) Do these steps to disconnect the fuel tubes [7] and [3]:
 - (a) Disconnect the fuel tube [3] from the fuel tube [7].
 - 1) Let the fuel drain from the fuel tubes [3] and [7].
 - (b) Remove the nut [15], bolt [14] and clamp [16] that attach the fuel tube [7] to the bracket [9].

HAP ALL PRE CFM56-7B-79-0023 OR PRE CFM56-7B-72-0468

- (c) Remove the four bolts [6] and washers [20] that attach the fuel tube [7] to the heat exchanger [1].

HAP ALL POST CFM56-7B-79-0023 AND POST CFM56-7B-72-0468

- (d) Remove the four bolts [21] that attach the fuel tube [7] to the heat exchanger [1].

HAP ALL

- (e) Disconnect the fuel tube [7] from the heat exchanger [1].
 - 1) Let the fuel drain from the fuel tube [7] and the heat exchanger [1].
- (f) Remove and examine the gasket [8] Seals (Preformed Packings and O-Rings) and Gaskets, TASK 70-30-01-910-802-F00.

NOTE: Use the gasket if it is in good condition.

- 1) Discard the gasket [8], if it is in unsatisfactory condition.

- (g) Push the fuel tube [7] forward of the heat exchanger [1].

NOTE: Move the fuel tube to get access to the fasteners and to remove the heat exchanger. You can temporarily attach or put the fuel tube behind a different tube.

- (h) Remove the four bolts [2] that attach the fuel tube [3] to the Hydromechanical Unit.

EFFECTIVITY
HAP ALL

79-21-02

Page 402
Oct 10/2005

D633A101-HAP

AIRCRAFT MAINTENANCE MANUAL

- (i) Remove the fuel tube [3].
- (j) Remove and examine the gasket [4].
 - NOTE: Use the gasket if it is in good condition.
 - 1) Discard the gasket [4], if it is in unsatisfactory condition.
- (k) Install protective covers on the fuel tubes General Precautions During the Removal and Installation of Engine Components, TASK 70-10-02-910-801-F00.

SUBTASK 79-21-02-020-005-F00

- (2) Do these steps to remove the drain tube [5]:
 - (a) Remove the nut [12], bolt [10], washer [11] and clamp [13] that attach the drain tube [5] to the bracket [9].
 - (b) Disconnect the drain tube [5] from the heat exchanger [1].
 - 1) Let the fluid drain from the drain tube [5] and the heat exchanger [1].
 - (c) Disconnect the drain tube [5] from the drain manifold.
 - 1) Let the fluid drain from the drain tube [5] and the drain manifold.
 - (d) Remove the drain tube [5].
 - 1) Install protective covers on the drain tube [5].

SUBTASK 79-21-02-020-006-F00

- (3) Do these steps to remove the heat exchanger [1]:
 - (a) Remove the six nuts [19] and washers [18] that attach the heat exchanger [1] to the fuel pump.
 - (b) Remove the heat exchanger [1] from the fuel pump.
 - (c) Remove and examine the gasket [17].
 - NOTE: Use the gasket if it is in good condition.
 - 1) Discard the gasket [17], if it is in unsatisfactory condition.
 - 2) Install protective covers on the fuel pump and the heat exchanger General Precautions During the Removal and Installation of Engine Components, TASK 70-10-02-910-801-F00.

SUBTASK 79-21-02-620-001-F00

- (4) If it is necessary, do these steps to preserve the heat exchanger:
 - (a) Remove protective plugs and caps from all the orifices.
 - (b) Put oil, D00599 [CP2442], in the oil and fuel circuits of the heat exchanger.
 - (c) Put protective plugs and caps in all the open orifices.

————— END OF TASK —————

EFFECTIVITY
HAP ALL

D633A101-HAP

79-21-02

Page 403
Oct 10/2005

737-600/700/800/900
AIRCRAFT MAINTENANCE MANUAL

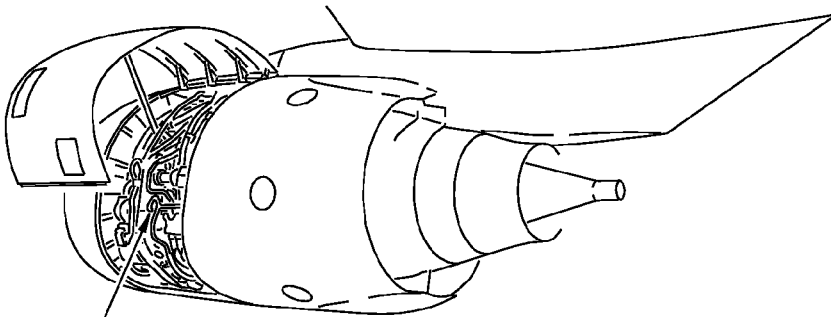

SEE (A) (B)

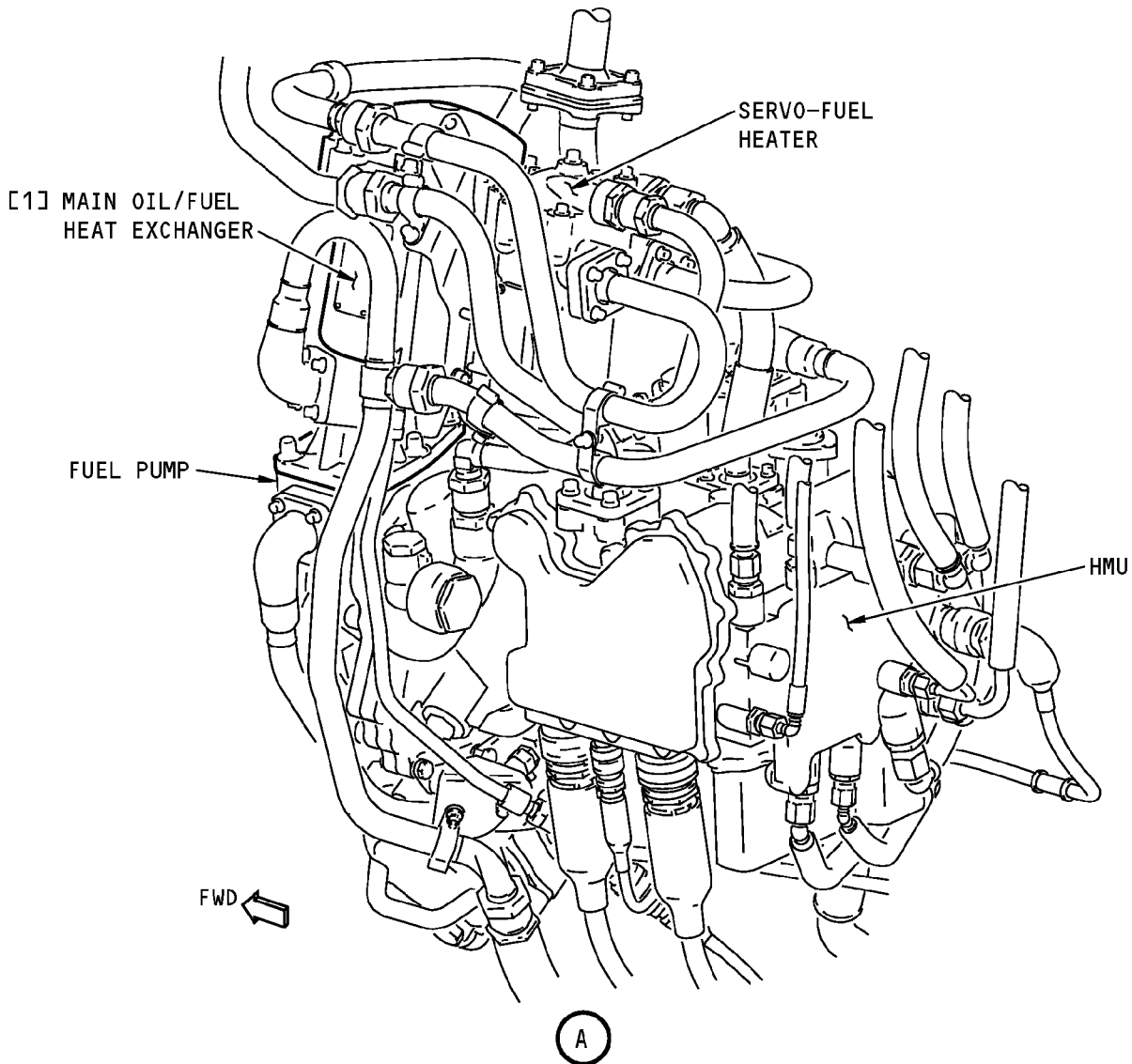

Main Oil/Fuel Heat Exchanger Installation
Figure 401 (Sheet 1 of 4)/79-21-02-990-801-F00

EFFECTIVITY
HAP ALL

79-21-02

Page 404
Oct 10/2005

D633A101-HAP

737-600/700/800/900
AIRCRAFT MAINTENANCE MANUAL

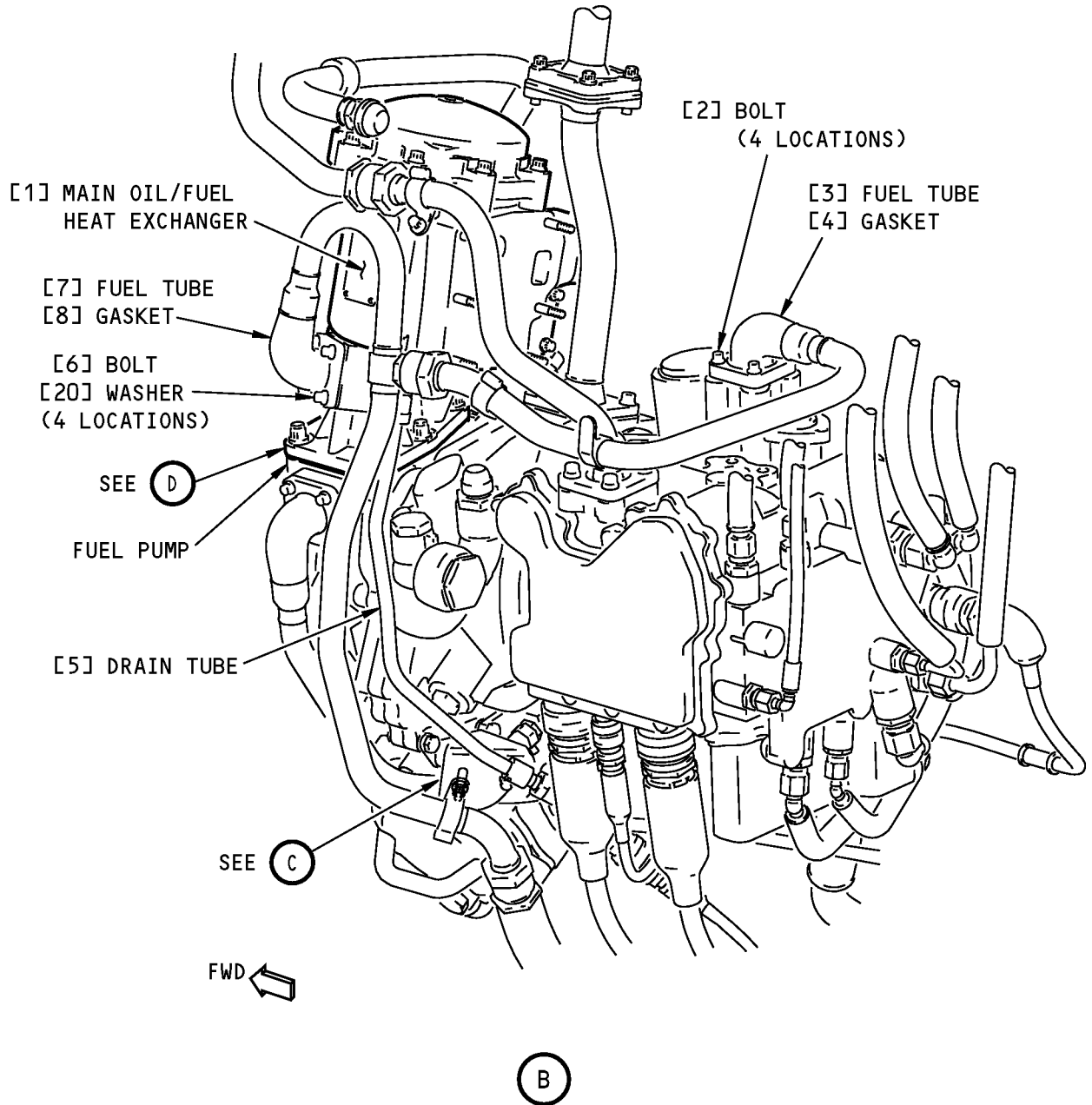

Main Oil/Fuel Heat Exchanger Installation
Figure 401 (Sheet 2 of 4)/79-21-02-990-801-F00

<p>EFFECTIVITY</p> <p>HAP ALL PRE CFM56-7B-79-0023 OR PRE CFM56-7B-72-0468</p>
--

79-21-02

737-600/700/800/900
AIRCRAFT MAINTENANCE MANUAL

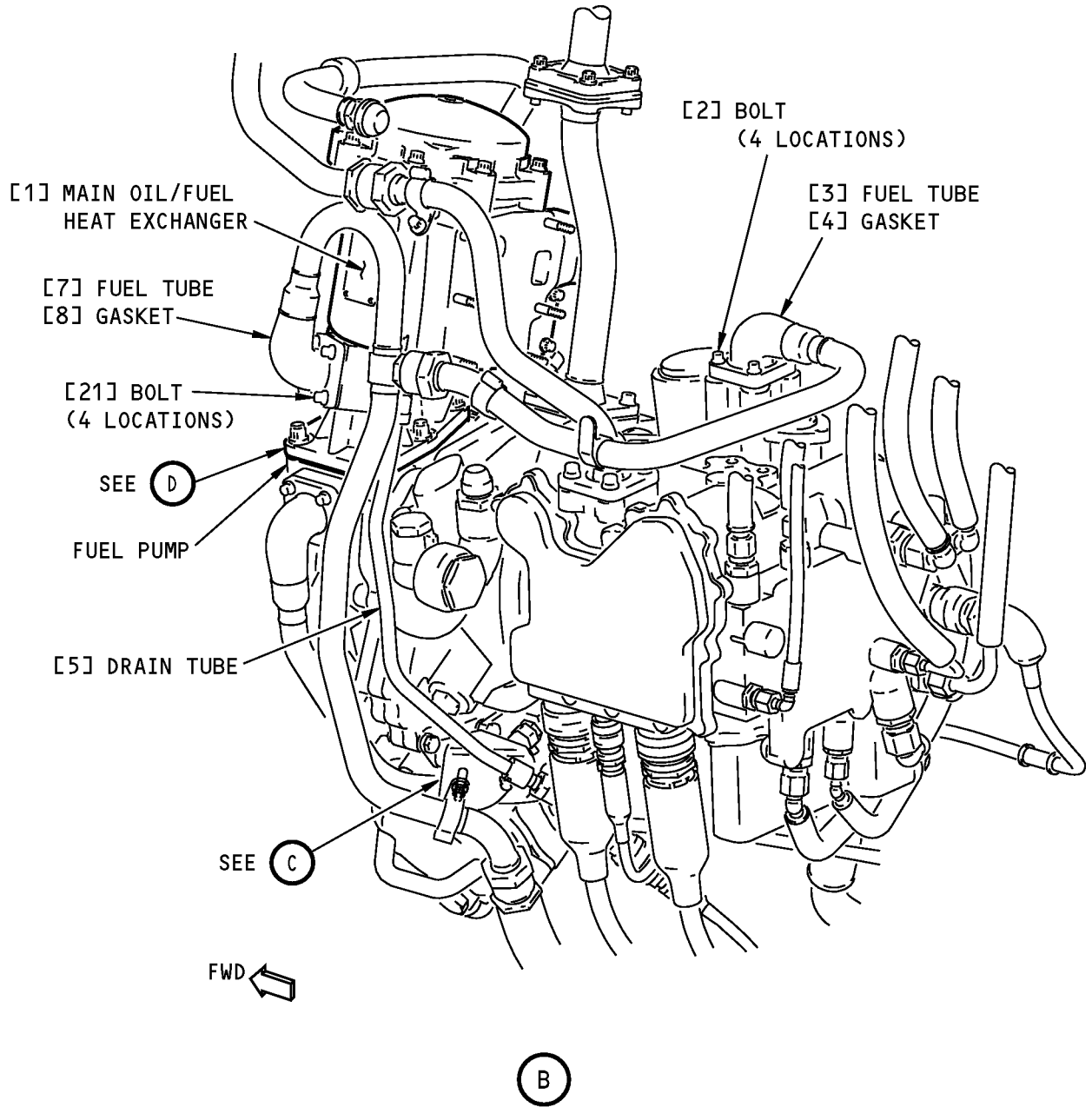

Main Oil/Fuel Heat Exchanger Installation
Figure 401 (Sheet 3 of 4)/79-21-02-990-801-F00

<p>EFFECTIVITY</p> <p>HAP ALL POST CFM56-7B-79-0023 AND POST CFM56-7B-72-0468</p>

79-21-02

AIRCRAFT MAINTENANCE MANUAL

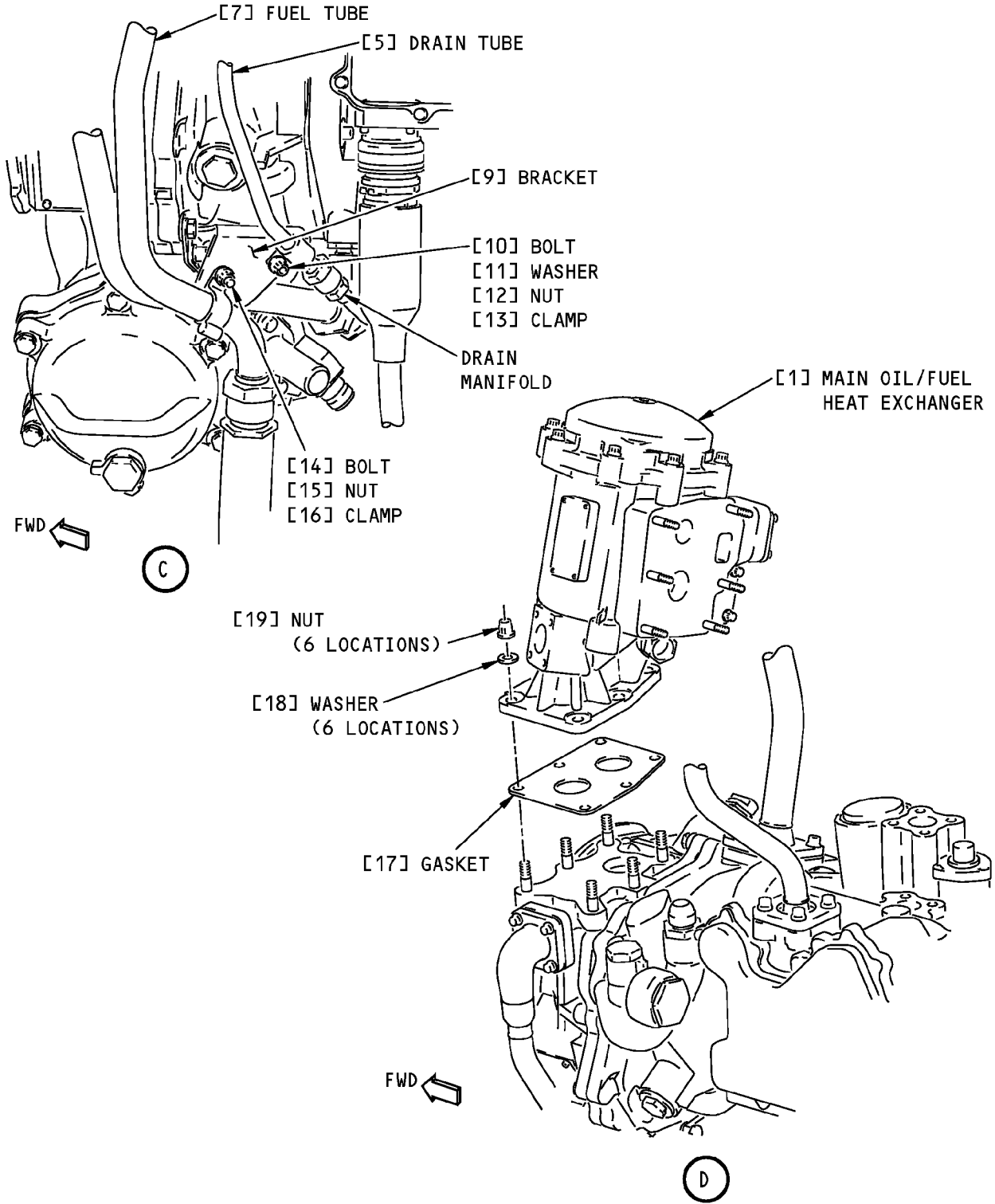

**Main Oil/Fuel Heat Exchanger Installation
Figure 401 (Sheet 4 of 4)/79-21-02-990-801-F00**

EFFECTIVITY
HAP ALL

79-21-02

Page 407
Oct 10/2005

D633A101-HAP

AIRCRAFT MAINTENANCE MANUAL

TASK 79-21-02-400-801-F00

3. Main Oil/Fuel Heat Exchanger Installation

(Figure 401)

A. General

- (1) This task is the installation procedure for the main oil/fuel heat exchanger (referred to as the heat exchanger).

B. References

Reference	Title
70-10-02-910-801-F00	General Precautions During the Removal and Installation of Engine Components (P/B 201)
71-00-00-800-811-F00	Power Plant Test Reference Table (P/B 501)
71-11-02-410-801-F00	Close the Fan Cowl Panels (P/B 201)
73-11-07-400-801-F00	Servo Fuel Heater Installation (P/B 401)

C. Consumable Materials

Reference	Description	Specification
D00599 [CP2442]	Oil - Engine (CFMI SB 79-001)	
D00601 [CP2101]	Grease - Graphite, High Temperature	SAE AMS 2518
G00034	Cotton Wiper - Process Cleaning Absorbent Wiper (Cheesecloth, Gauze)	BMS15-5

D. Expendables/Parts

AMM Item	Description	AIPC Reference	AIPC Effectivity
1	Heat exchanger	79-21-02-01-060	HAP ALL
4	Gasket	73-11-00-02-260	HAP ALL
8	Gasket	73-11-00-02-260	HAP ALL
17	Gasket	79-21-02-01-055	HAP ALL

E. Location Zones

Zone	Area
411	Engine 1 - Engine
421	Engine 2 - Engine

F. Prepare for the Installation

SUBTASK 79-21-02-630-001-F00

- (1) If you did a preservation of the heat exchanger, drain the oil from the oil circuits and the fuel circuits.

SUBTASK 79-21-02-840-002-F00

- (2) Do these steps to prepare the heat exchanger for the installation General Precautions During the Removal and Installation of Engine Components, TASK 70-10-02-910-801-F00:
- Remove all the protective covers and caps.
 - Clean the mating interfaces of the heat exchanger flanges, adapter, fuel pump and adjacent areas with a cotton wiper, G00034.
 - Make sure that the heat exchanger flanges, adapter, fuel pump and adjacent areas are clean and in a good condition.
 - Lubricate the gaskets with oil, D00599 [CP2442].

EFFECTIVITY
HAP ALL

79-21-02

Page 408
Jun 15/2009

D633A101-HAP

AIRCRAFT MAINTENANCE MANUAL

- (e) Lubricate the threads of the bolts and the studs with grease, D00601 [CP2101], before the installation.
- (f) Lubricate the threads of the nipples with oil, D00599 [CP2442], before the connection.

G. Main Oil/Fuel Heat Exchanger Installation

SUBTASK 79-21-02-420-002-F00

- (1) Do these steps to install the heat exchanger [1] on the fuel pump:
 - (a) Install the gasket [17].
 - (b) Put the heat exchanger [1] in its position on the fuel pump.
 - (c) Attach the heat exchanger [1] to the fuel pump with the six washers [18] and nuts [19].
 - 1) Tighten the nuts [19] to 120-140 pound-inches (14-15.5 Newton meters).

SUBTASK 79-21-02-420-003-F00

- (2) Do these steps to install the drain tube [5]:

CAUTION: USE TWO WRENCHES TO TIGHTEN THE COUPLING NUT. USE ONE TO HOLD THE FITTING, AND THE OTHER TO TIGHTEN THE COUPLING NUT. IF YOU DO NOT USE TWO WRENCHES, DAMAGE TO THE EQUIPMENT CAN OCCUR.

- (a) Connect the drain tube [5] to the drain manifold.
 - 1) Tighten the tube coupling nut to 257-284 pound-inches (29-32 Newton meters).
- (b) Connect the drain tube [5] to the heat exchanger [1].
 - 1) Tighten the tube coupling nut to 257-284 pound-inches (29-32 Newton meters).
- (c) Attach the drain tube [5] to the bracket [9] with the clamp [13], bolt [10], washer [11] and nut [12].
 - 1) Tighten the nut [12] to 50-80 pound-inches (5.6-9.0 Newton meters).

HAP ALL PRE CFM56-7B-79-0023 OR PRE CFM56-7B-72-0468

SUBTASK 79-21-02-420-006-F00

- (3) Do these steps to connect the fuel tube [7] and [3]:
 - (a) Install the gasket [8].
 - (b) Connect the fuel tube [7] to the heat exchanger [1] with the four bolts [6] and washers [20].
 - (c) Install the gasket [4].
 - (d) Put the fuel tube [3] in its position.
 - (e) Install the four bolts [2].
 - (f) Connect the fuel tube [3] to the fuel tube [7].
 - (g) Attach the fuel tube [7] to the bracket [9] with the clamp [16], bolt [14] and nut [15].
 - (h) Tighten the four bolts [6] as follows:

NOTE: You must apply the following steps at each of the four bolts [6] to cross-tighten them.

Start with the first bolt at the top left side of the port.

The second bolt is at the diagonal opposite location of the first bolt.

The third bolt is at the bottom left side of the port.

The fourth bolt is at the diagonal opposite location of the third bolt.

- 1) Tighten the bolts [6] to 40-45 pound-inches (4.52-5.08 Newton meters).

EFFECTIVITY
HAP ALL

79-21-02

Page 409
Feb 15/2009

D633A101-HAP

AIRCRAFT MAINTENANCE MANUAL

HAP ALL PRE CFM56-7B-79-0023 OR PRE CFM56-7B-72-0468 (Continued)

- 2) Loosen the bolts [6] but do not remove them
- 3) Measure the locking torque of each bolt [6]. This value must be 2.2-15 pound-inches (0.24-1.69 Newton meters); if not, replace the bolt.
- 4) Tighten again the bolts [6] to 40-45 pound-inches (4.52-5.08 Newton meters)
- 5) Add the locking torque value of the bolts [6] recorded before.
- 6) Tighten the bolts [6] to a final torque between 42.2-60 pound-inches (4.77-6.78 Newton meters).
 - (i) Tighten the four bolts [2] to 49-53 pound-inches (5.5-6 Newton meters).
 - (j) Tighten the tube coupling nut to 900-1100 pound-inches (100-125 Newton meters).
 - (k) Tighten the nut [15] to 98-110 pound-inches (11-12.5 Newton meters).

HAP ALL POST CFM56-7B-79-0023 AND POST CFM56-7B-72-0468

SUBTASK 79-21-02-430-001-F00

- (4) Do these steps to connect the fuel tube [7] and [3]:
 - (a) Install the gasket [8].
 - (b) Connect the fuel tube [7] to the heat exchanger [1] with the four bolts [21].
 - (c) Install the gasket [4].
 - (d) Put the fuel tube [3] in its position.
 - (e) Install the four bolts [2].
 - (f) Connect the fuel tube [3] to the fuel tube [7].
 - (g) Attach the fuel tube [7] to the bracket [9] with the clamp [16], bolt [14] and nut [15].
 - (h) Tighten the four bolts [21] as follows:

NOTE: You must apply the following steps at each of the four bolts [21] to cross-tighten them.

Start with the first bolt at the top left side of the port.

The second bolt is at the diagonal opposite location of the first bolt.

The third bolt is at the bottom left side of the port.

The fourth bolt is at the diagonal opposite location of the third bolt.

- 1) Tighten the bolts [21] to 40-45 inch-pounds (4.52-5.08 newton-meters).
- 2) Loosen the bolts [21] but do not remove them
- 3) Measure the locking torque of each bolt [21]. This value must be 2.2-15 inch-pounds (0.248-1.69 newton-meters); if not, replace the bolt.
- 4) Tighten again the bolts [21] to 40-45 inch-pounds (4.5-5.08 newton-meters)
- 5) Add the locking torque value of the bolts [6] recorded before.
- 6) Tighten the bolts [21] to a final torque between 42.2-60 inch-pounds (4.77-6.78 newton-meters).
 - (i) Tighten the four bolts [2] to 49-53 inch-pounds (5.5-6 newton-meters).
 - (j) Tighten the tube coupling nut to 900-1100 inch-pounds(100-125 newton-meters).

EFFECTIVITY
HAP ALL

79-21-02

Page 410
Feb 15/2009

D633A101-HAP

AIRCRAFT MAINTENANCE MANUAL**HAP ALL POST CFM56-7B-79-0023 AND POST CFM56-7B-72-0468 (Continued)**

(k) Tighten the nut [15] to 98-110 inch-pounds (11-12.5 newton-meters).

HAP ALL**H. Put the Airplane Back to Its Usual Condition**

SUBTASK 79-21-02-410-003-F00

(1) Do this task: Servo Fuel Heater Installation, TASK 73-11-07-400-801-F00.

SUBTASK 79-21-02-410-002-F00

(2) Do this task: Close the Fan Cowl Panels, TASK 71-11-02-410-801-F00.

SUBTASK 79-21-02-860-006-F00

(3) Remove the DO-NOT-OPERATE tags from the start levers.

SUBTASK 79-21-02-860-007-F00

(4) Remove the DO-NOT-OPERATE tag from the BAT switch.

I. Main Oil/Fuel Heat Exchanger Installation Test

SUBTASK 79-21-02-800-001-F00

(1) Do the test listed in the Power Plant Test Reference Table, TASK 71-00-00-800-811-F00.

————— **END OF TASK** —————

EFFECTIVITY
HAP ALL

D633A101-HAP

79-21-02

Page 411
Feb 15/2009

AIRCRAFT MAINTENANCE MANUAL

OIL SUPPLY FILTER - REMOVAL/INSTALLATION**1. General**

- A. This procedure contains scheduled maintenance task data.
- B. This procedure contains these tasks:
- (1) The removal of the oil supply filter
 - (2) The installation of the oil supply filter.

TASK 79-21-03-000-802-F00**2. Oil Supply Filter Removal**

(Figure 401)

A. General

- (1) This procedure is a scheduled maintenance task.
- (2) This task is the removal procedure for the oil supply filter (referred to as the filter).
- (3) The lubrication unit is found on the aft side of the accessory gearbox (AGB) at approximately the 7:00 o'clock position.
- (4) The engine has one oil supply filter installed in a cavity of the lubrication unit housing.
- (5) This procedure refers to the oil supply filter housing as the filter housing.

B. References

Reference	Title
70-10-02-910-801-F00	General Precautions During the Removal and Installation of Engine Components (P/B 201)
71-11-02-010-801-F00	Open the Fan Cowl Panels (P/B 201)

C. Tools/Equipment

Reference	Description
STD-195	Container - 1 Quart (1 l), Oil/Fuel Resistant

D. Location Zones

Zone	Area
411	Engine 1 - Engine
421	Engine 2 - Engine

E. Prepare for the Removal

SUBTASK 79-21-03-860-005-F00

- (1) For Engine 1, open these circuit breakers and install safety tags:

CAPT Electrical System Panel, P18-2

Row	Col	Number	Name
A	4	C01390	ENGINE 1 ALTN PWR CHAN B
A	5	C01314	ENGINE 1 ALTN PWR CHAN A

EFFECTIVITY
HAP ALL

79-21-03

Page 401
Feb 15/2009

D633A101-HAP

AIRCRAFT MAINTENANCE MANUAL

SUBTASK 79-21-03-860-006-F00

- (2) For Engine 2, open these circuit breakers and install safety tags:

F/O Electrical System Panel, P6-2

<u>Row</u>	<u>Col</u>	<u>Number</u>	<u>Name</u>
D	7	C01391	ENGINE 2 ALTN PWR CHAN B
D	8	C01315	ENGINE 2 ALTN PWR CHAN A

SUBTASK 79-21-03-010-002-F00

- (3) Do this task: Open the Fan Cowl Panels, TASK 71-11-02-010-801-F00.

F. Oil Supply Filter Removal

SUBTASK 79-21-03-680-002-F00

- (1) Do these steps to drain the filter housing (Figure 401):

- (a) Put a 1 quart (1 l) oil/fuel resistant container, STD-195, below the filter.

WARNING: DO NOT TOUCH THE COMPONENTS OF THE OIL SYSTEM IF THE ENGINE IS HOT. THESE COMPONENTS STAY HOTTER THAN OTHER COMPONENTS. HOT COMPONENTS CAN BURN YOU.

WARNING: DO NOT OPEN THE OIL SYSTEM UNTIL THE PRESSURE GOES TO ZERO. THE PRESSURE GOES TO ZERO APPROXIMATELY 5 MINUTES AFTER AN ENGINE SHUTDOWN. A PRESSURIZED ENGINE CAN RELEASE A SPRAY OF HOT OIL THAT CAN BURN YOU.

WARNING: DO NOT LET HOT OIL GET ON YOU. PUT ON GOGGLES AND OTHER EQUIPMENT FOR PROTECTION OR LET THE ENGINE BECOME COOL. HOT OIL CAN BURN YOU.

CAUTION: DO NOT LET HOT OIL GET ON THE ENGINE OR OTHER COMPONENTS. IMMEDIATELY CLEAN THE COMPONENT IF OIL FALLS ON IT. OIL CAN CAUSE DAMAGE TO PAINT AND RUBBER.

- (b) Remove the drain plug [9] from the bottom of the cover [7].

- 1) Let the oil drain from the filter housing.

- (c) Remove and discard the packing [8].

SUBTASK 79-21-03-020-002-F00

- (2) Do these steps to remove the filter element [4] (Figure 401):

- (a) Remove the three bolts [10], washers [1] and nuts [2] that attach the cover [7] to the filter housing.

- (b) Remove the cover [7] from the filter housing with your hands.

- (c) Remove and discard the packing [6] from the cover [7].

- (d) Remove and discard the filter element [4], packing [3] and packing [5].

- (e) Install a protective cover on the filter housing General Precautions During the Removal and Installation of Engine Components, TASK 70-10-02-910-801-F00.

————— **END OF TASK** —————

EFFECTIVITY
HAP ALL

D633A101-HAP

79-21-03

Page 402
Jun 15/2009

737-600/700/800/900
AIRCRAFT MAINTENANCE MANUAL

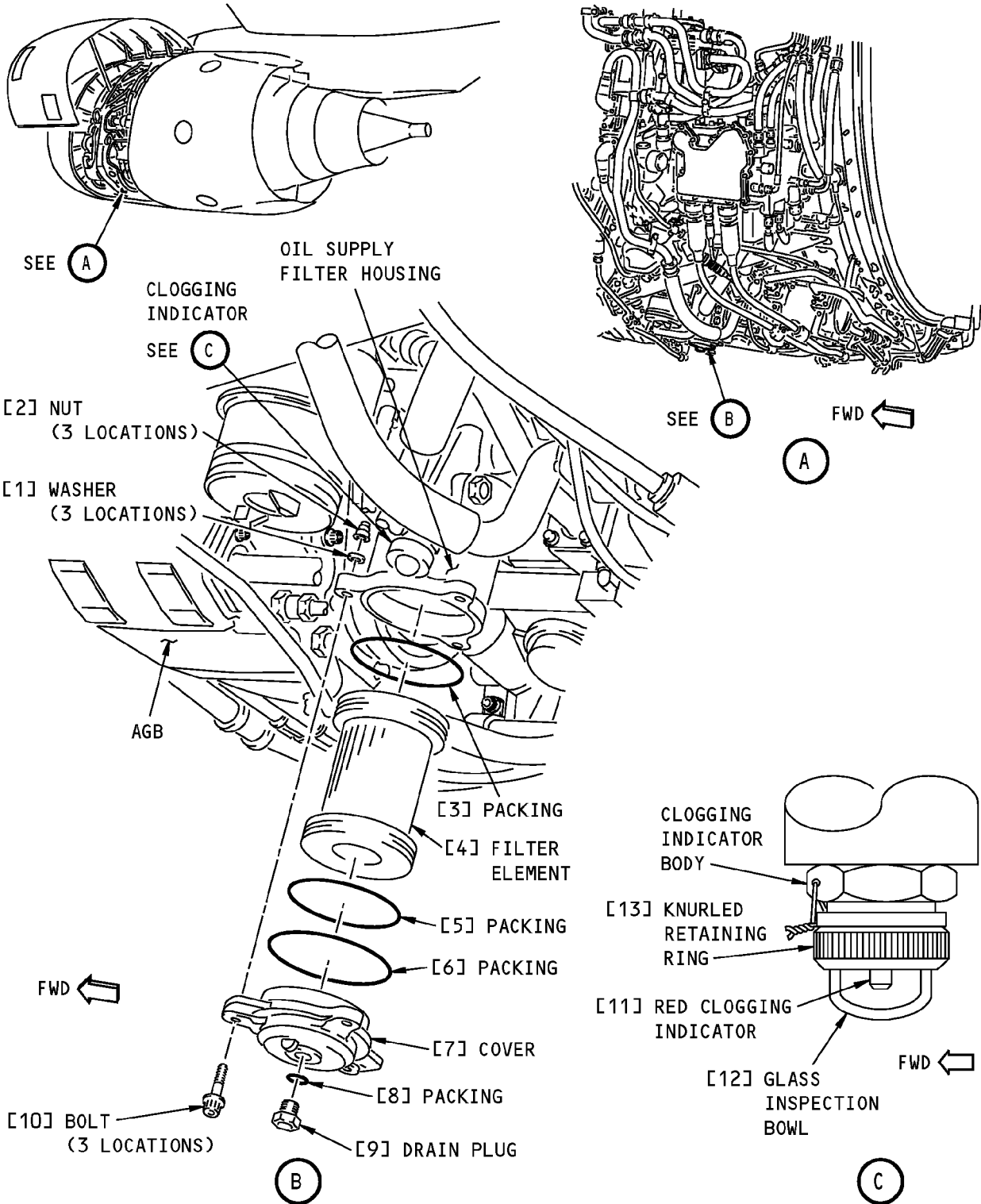

Oil Supply Filter Installation
Figure 401/79-21-03-990-801-F00

EFFECTIVITY
HAP ALL

79-21-03

AIRCRAFT MAINTENANCE MANUAL

TASK 79-21-03-400-801-F00

3. Oil Supply Filter Installation

(Figure 401)

A. General

- (1) This procedure is a scheduled maintenance task.
- (2) This task is the installation procedure for the oil supply filter (referred to as the filter).
- (3) This procedure refers to the oil supply filter housing as the filter housing.

B. References

Reference	Title
12-13-11-600-801	Replenish the Engine Oil (P/B 301)
70-10-02-910-801-F00	General Precautions During the Removal and Installation of Engine Components (P/B 201)
71-00-00-800-811-F00	Power Plant Test Reference Table (P/B 501)
71-11-02-410-801-F00	Close the Fan Cowl Panels (P/B 201)
79-00-00-200-805-F00	Oil Supply Filter Pop-Out Indicator Inspection (Visual Check) (P/B 601)

C. Consumable Materials

Reference	Description	Specification
D00599 [CP2442]	Oil - Engine (CFMI SB 79-001)	
D00601 [CP2101]	Grease - Graphite, High Temperature	SAE AMS 2518
G02345 [CP8001]	Lockwire - Inconel (0.032 inch Dia.)	NASM20995~ N32
G50065 [CP8006]	Cable, Safety, Stainless Steel, 0.8mm (0.032inch) Diameter	

D. Expendables/Parts

AMM Item	Description	AIPC Reference	AIPC Effectivity
3	Packing	79-21-01-01-060	HAP ALL
4	Filter element	79-21-01-01-065	HAP ALL
5	Packing	79-21-01-01-060	HAP ALL
6	Packing	79-21-01-01-055	HAP ALL
8	Packing	79-21-01-01-030	HAP ALL

E. Location Zones

Zone	Area
411	Engine 1 - Engine
421	Engine 2 - Engine

F. Prepare for the Installation

SUBTASK 79-21-03-100-001-F00

- (1) Do these steps to prepare the filter housing for the installation General Precautions During the Removal and Installation of Engine Components, TASK 70-10-02-910-801-F00:
 - (a) Make sure that the mating flanges to the cover [7] and the filter housing are clean and in good condition.
 - (b) Make sure that the grooves of the new filter element [4] are clean and in good condition.
 - (c) Remove the protective cover from the filter housing.

EFFECTIVITY
HAP ALL

79-21-03Page 404
Jun 15/2009

D633A101-HAP

AIRCRAFT MAINTENANCE MANUAL

G. Oil Supply Filter Installation

SUBTASK 79-21-03-420-001-F00

(1) Do these steps to install the filter element [4] (Figure 401):

(a) Lubricate the new packing [3], [5], [6] and [8] with oil, D00599 [CP2442].

CAUTION: MAKE SURE THAT YOU INSTALL THE PACKINGS CORRECTLY DURING THE INSTALLATION OF THE FILTER ELEMENT. IF YOU DO NOT INSTALL THE PACKINGS CORRECTLY, OIL LOSS CAN OCCUR DURING ENGINE OPERATION AND CAN CAUSE DAMAGE TO THE ENGINE.

(b) Install the packing [3] and packing [5] on the filter element [4].

(c) Install the packing [6] on the cover [7].

(d) Carefully, engage the new filter element [4], with its packings [3] and [5], in the filter housing.

(e) Install the cover [7] on the filter housing.

(f) Lubricate the bolts [10] with grease, D00601 [CP2101].

(g) Install the three bolts [10], washers [1] and nuts [2] that attach the cover [7] to the filter housing.

1) Tighten the bolts [10] to 45-50 pound-inches (5.0-5.5 Newton meters).

(h) Install the packing [8] on the drain plug [9].

(i) Install the drain plug [9] on the cover [7].

1) Tighten the drain plug [9] to 45-50 pound-inches (5.0-5.5 Newton meters).

2) Install lockwire, G02345 [CP8001] or cable, G50065 [CP8006] on the drain plug [9].

SUBTASK 79-21-03-210-001-F00

(2) Do a visual check of the red clogging indicator [11].

(a) If you can see the red clogging indicator [11], then do these steps:

1) Do the steps below to set the red clogging indicator [11].

2) Do this task: Oil Supply Filter Pop-Out Indicator Inspection (Visual Check), TASK 79-00-00-200-805-F00.

(b) If you can not see the red clogging indicator [11], then do the steps below to put the airplane back to its usual condition.

SUBTASK 79-21-03-820-001-F00

(3) Do these steps to set the red clogging indicator [11] (Figure 401):

(a) Manually remove the knurled retaining ring [13].

(b) Remove the glass inspection bowl [12].

(c) Push the button on the red clogging indicator [11] to the retracted position.

NOTE: The button must stay in the retracted position.

(d) Install the glass inspection bowl [12].

(e) Lubricate the knurled retaining ring [13] with oil, D00599 [CP2442].

(f) Install the knurled retaining ring [13] with your hand.

(g) Make sure that the red clogging indicator [11] stays in its retracted position.

(h) Install lockwire, G02345 [CP8001] or cable, G50065 [CP8006] to the knurled retaining ring [13] and the clogging indicator body.

EFFECTIVITY
HAP ALL

D633A101-HAP

79-21-03

Page 405
Feb 15/2009

AIRCRAFT MAINTENANCE MANUAL

H. Put the Airplane Back to Its Usual Condition

SUBTASK 79-21-03-410-002-F00

- (1) Do this task: Close the Fan Cowl Panels, TASK 71-11-02-410-801-F00.

SUBTASK 79-21-03-860-007-F00

- (2) For Engine 1, remove the safety tags and close these circuit breakers:

CAPT Electrical System Panel, P18-2

<u>Row</u>	<u>Col</u>	<u>Number</u>	<u>Name</u>
A	4	C01390	ENGINE 1 ALTN PWR CHAN B
A	5	C01314	ENGINE 1 ALTN PWR CHAN A

SUBTASK 79-21-03-860-008-F00

- (3) For Engine 2, remove the safety tags and close these circuit breakers:

F/O Electrical System Panel, P6-2

<u>Row</u>	<u>Col</u>	<u>Number</u>	<u>Name</u>
D	7	C01391	ENGINE 2 ALTN PWR CHAN B
D	8	C01315	ENGINE 2 ALTN PWR CHAN A

I. Oil Supply Filter Installation Test

SUBTASK 79-21-03-800-001-F00

- (1) Do the tests that are listed in the Power Plant Test Reference Table, TASK 71-00-00-800-811-F00.

SUBTASK 79-21-03-610-002-F00

- (2) If the oil level is low, do this task: Replenish the Engine Oil, TASK 12-13-11-600-801.

————— END OF TASK —————

EFFECTIVITY
HAP ALL

D633A101-HAP

79-21-03

Page 406
Feb 15/2009

AIRCRAFT MAINTENANCE MANUAL

SCAVENGE OIL FILTER ASSEMBLY - REMOVAL/INSTALLATION**1. General**

A. This procedure has two tasks:

- (1) The removal of the scavenge oil filter assembly.
- (2) The installation of the scavenge oil filter assembly.

TASK 79-21-04-000-801-F00**2. Scavenge Oil Filter Assembly Removal**

(Figure 401)

A. General

- (1) This task is the removal procedure for the scavenge oil filter assembly (referred to as the filter assembly).
- (2) The scavenge oil filter assembly is found on the aft face of the accessory gearbox (AGB) at the 7:00 o'clock position.

B. References

Reference	Title
70-10-02-910-801-F00	General Precautions During the Removal and Installation of Engine Components (P/B 201)
70-30-01-910-802-F00	Seals (Preformed Packings and O-Rings) and Gaskets (P/B 201)
71-11-02-010-801-F00	Open the Fan Cowl Panels (P/B 201)

C. Tools/Equipment

Reference	Description
STD-195	Container - 1 Quart (1 l), Oil/Fuel Resistant

D. Location Zones

Zone	Area
411	Engine 1 - Engine
421	Engine 2 - Engine

E. Prepare for the Removal

SUBTASK 79-21-04-860-001-F00

- (1) For Engine 1, open these circuit breakers and install safety tags:

CAPT Electrical System Panel, P18-2

Row	Col	Number	Name
A	4	C01390	ENGINE 1 ALTN PWR CHAN B
A	5	C01314	ENGINE 1 ALTN PWR CHAN A

SUBTASK 79-21-04-860-002-F00

- (2) For Engine 2, open these circuit breakers and install safety tags:

F/O Electrical System Panel, P6-2

Row	Col	Number	Name
D	7	C01391	ENGINE 2 ALTN PWR CHAN B
D	8	C01315	ENGINE 2 ALTN PWR CHAN A

EFFECTIVITY
HAP ALL

D633A101-HAP

79-21-04

Page 401
Oct 10/2003

AIRCRAFT MAINTENANCE MANUAL

SUBTASK 79-21-04-010-001-F00

(3) Do this task: Open the Fan Cowl Panels, TASK 71-11-02-010-801-F00.

F. Scavenge Oil Filter Assembly Removal

SUBTASK 79-21-04-020-002-F00

(1) Do these steps to remove the filter assembly [9]:

- (a) Disconnect the electrical connector, DP0703 [4] from the clogging transmitter receptacle.
- (b) Put a 1 quart (1 l) oil/fuel resistant container, STD-195, below the filter assembly [9].
- (c) Remove the four bolts [5] to disconnect the inlet hose [6] from the filter assembly [9].
- (d) Loosen the four bolts [8] that attach the inlet tube [6] to the lubrication unit.

NOTE: This will give sufficient clearance between the inlet tube and the filter to remove and install the gasket.

- (e) Remove and examine the gasket [7] Seals (Preformed Packings and O-Rings) and Gaskets, TASK 70-30-01-910-802-F00.

NOTE: Use the gasket if it is in good condition.

- 1) Discard the gasket [7], if it is in unsatisfactory condition.

- (f) Remove the four bolts [1] to disconnect the outlet hose [2] from the filter assembly [9].
- (g) Remove and examine the gasket [12].

NOTE: Use the gasket if it is in good condition.

- 1) Discard the gasket [12], if it is in unsatisfactory condition.

- (h) Remove the three bolts [10] and the three washers [11] that attach the filter assembly [9] to the AGB.
- (i) Remove the filter assembly [9].
 - 1) Let the oil drain in the container.
- (j) Install protective covers on the filter assembly [9] and the hose flanges General Precautions During the Removal and Installation of Engine Components, TASK 70-10-02-910-801-F00.

————— **END OF TASK** —————

EFFECTIVITY
HAP ALL

D633A101-HAP

79-21-04Page 402
Oct 10/2003

AIRCRAFT MAINTENANCE MANUAL

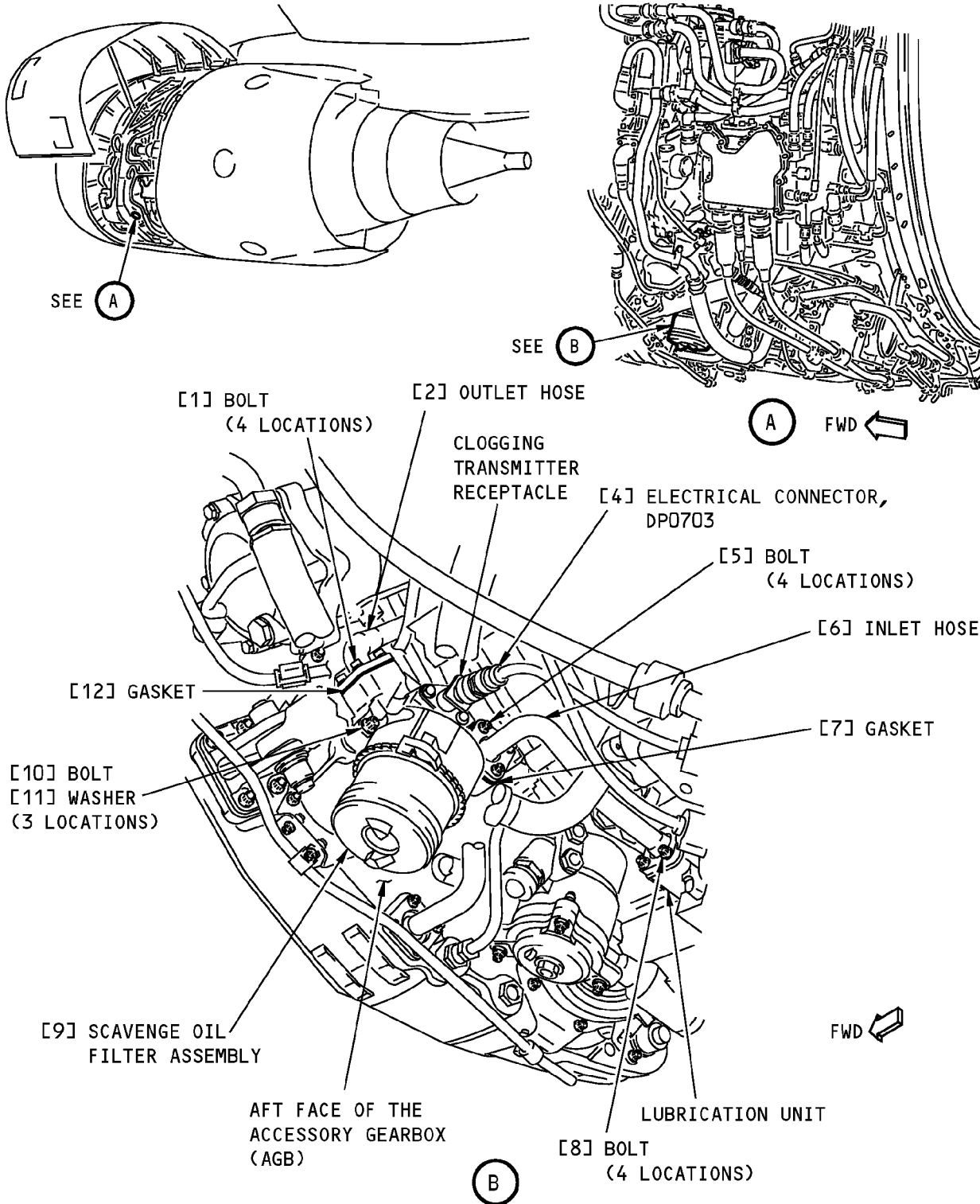

Scavenge Oil Filter Assembly Installation
Figure 401/79-21-04-990-801-F00

EFFECTIVITY
HAP ALL

79-21-04

AIRCRAFT MAINTENANCE MANUAL

TASK 79-21-04-400-801-F00

3. Scavenge Oil Filter Assembly Installation

(Figure 401)

A. General

- (1) This task is the installation procedure for the scavenge oil filter assembly (referred to as the filter assembly).

B. References

Reference	Title
12-13-11-600-801	Replenish the Engine Oil (P/B 301)
70-10-02-910-801-F00	General Precautions During the Removal and Installation of Engine Components (P/B 201)
71-00-00-800-811-F00	Power Plant Test Reference Table (P/B 501)
71-11-02-410-801-F00	Close the Fan Cowl Panels (P/B 201)

C. Consumable Materials

Reference	Description	Specification
B00130	Alcohol - Isopropyl	TT-I-735
D00599 [CP2442]	Oil - Engine (CFMI SB 79-001)	
D00601 [CP2101]	Grease - Graphite, High Temperature	SAE AMS 2518
G00034	Cotton Wiper - Process Cleaning Absorbent Wiper (Cheesecloth, Gauze)	BMS15-5

D. Expendables/Parts

AMM Item	Description	AIPC Reference	AIPC Effectivity
7	Gasket	79-21-00-01-115	HAP ALL
12	Gasket	79-21-00-01-090	HAP ALL

E. Location Zones

Zone	Area
411	Engine 1 - Engine
421	Engine 2 - Engine

F. Prepare for the Installation

SUBTASK 79-21-04-840-001-F00

- (1) Do these steps to prepare the filter assembly [9] for the installation General Precautions During the Removal and Installation of Engine Components, TASK 70-10-02-910-801-F00:
- Remove the protective covers from the filter assembly [9] and the hose flanges.
 - Clean the flanges on the filter and the hose flanges with alcohol, B00130 and a cotton wiper, G00034.
 - Make sure that all the flanges on the filter and the hoses are clean and in good condition.

G. Scavenge Oil Filter Assembly Installation

SUBTASK 79-21-04-420-001-F00

- (1) Do these steps to install the filter assembly [9]:
- Lubricate the threads of the three bolts [10] with grease, D00601 [CP2101].
 - Put the filter assembly [9] in its position.

EFFECTIVITY
HAP ALL

79-21-04Page 404
Jun 15/2009

D633A101-HAP

AIRCRAFT MAINTENANCE MANUAL

- (c) Install the three bolts [10] and the three washers [11] to attach the filter assembly [9] to the AGB.

1) Tighten the bolts [10] to 370-400 pound-inches (42-45 Newton meters).

SUBTASK 79-21-04-420-002-F00

- (2) Do these steps to install the outlet hose [2]:

(a) Lubricate the four bolts [1] with grease, D00601 [CP2101].

(b) Lubricate the gasket [12] with oil, D00599 [CP2442].

(c) Install the gasket [12] between the outlet hose [2] and the filter assembly [9].

(d) Install the four bolts [1] to attach the outlet hose [2] to the filter assembly [9].

1) Tighten the bolts [1] to 98-110 pound-inches (11.0-12.5 Newton meters).

SUBTASK 79-21-04-420-003-F00

- (3) Do these steps to install the inlet hose [6]:

(a) Lubricate the four bolts [5] with grease, D00601 [CP2101].

(b) Lubricate the gasket [7] with oil, D00599 [CP2442].

(c) Install the gasket [7] between the inlet hose [6] and the filter assembly [9].

(d) Install the four bolts [5] to attach the inlet hose [6] to the filter assembly [9].

1) Tighten the bolts [5] to 98-110 pound-inches (11-12.5 Newton meters).

(e) Tighten the bolts [8] at the lubrication unit to 49-53 pound-inches (5.5-6 Newton meters).

SUBTASK 79-21-04-420-004-F00

- (4) Connect the electrical connector, DP0703 [4] to the clogging transmitter receptacle.

H. Put the Airplane Back to Its Usual Condition

SUBTASK 79-21-04-410-002-F00

- (1) Do this task: Close the Fan Cowl Panels, TASK 71-11-02-410-801-F00.

SUBTASK 79-21-04-860-005-F00

- (2) For Engine 1, remove the safety tags and close these circuit breakers:

CAPT Electrical System Panel, P18-2

<u>Row</u>	<u>Col</u>	<u>Number</u>	<u>Name</u>
A	4	C01390	ENGINE 1 ALTN PWR CHAN B
A	5	C01314	ENGINE 1 ALTN PWR CHAN A

SUBTASK 79-21-04-860-006-F00

- (3) For Engine 2, remove the safety tags and close these circuit breakers:

F/O Electrical System Panel, P6-2

<u>Row</u>	<u>Col</u>	<u>Number</u>	<u>Name</u>
D	7	C01391	ENGINE 2 ALTN PWR CHAN B
D	8	C01315	ENGINE 2 ALTN PWR CHAN A

I. Filter Assembly Installation Test

SUBTASK 79-21-04-800-001-F00

- (1) Do the tests that are listed in the Power Plant Test Reference Table, TASK 71-00-00-800-811-F00.

EFFECTIVITY
HAP ALL

D633A101-HAP

79-21-04

Page 405
Oct 10/2007

AIRCRAFT MAINTENANCE MANUAL

SUBTASK 79-21-04-610-002-F00

(2) If the oil level is low, do this task: Replenish the Engine Oil, TASK 12-13-11-600-801.

————— **END OF TASK** —————

EFFECTIVITY
HAP ALL

D633A101-HAP

79-21-04

Page 406
Oct 10/2003

AIRCRAFT MAINTENANCE MANUAL

CHIP DETECTOR REMOVAL/INSTALLATION**1. General**

A. This procedure has these tasks:

- (1) The removal of the magnetic chip detector.
- (2) The installation of the magnetic chip detector.

TASK 79-21-05-000-806-F00**2. Magnetic Chip Detector (MCD) Removal**

(Figure 401)

A. General

- (1) The magnetic chip detectors are found on the lubrication unit at the 6:00 o'clock position.
- (2) The engine has three magnetic chip detectors in the lubrication unit.

B. References

Reference	Title
71-11-02-010-801-F00	Open the Fan Cowl Panels (P/B 201)
79-00-00-200-804-F00	Chip Detectors and Scavenge Screens Inspection (P/B 601)

C. Tools/Equipment

NOTE: When more than one tool part number is listed under the same "Reference" number, the tools shown are alternates to each other within the same airplane series. Tool part numbers that are replaced or non-procurable are preceded by "Opt:", which stands for Optional.

Reference	Description
SPL-2447	Puller - Magnetic Plug, Lubrication Unit (Part #: 856A3617G01, Supplier: 58828, A/P Effectivity: 737-300, -400, -500, -600, -700, -700C, -700ER, -700QC, -800, -900, -900ER, -BBJ)

D. Location Zones

Zone	Area
411	Engine 1 - Engine
421	Engine 2 - Engine

E. Prepare for the Removal

SUBTASK 79-21-05-010-004-F00

- (1) Do this task: Open the Fan Cowl Panels, TASK 71-11-02-010-801-F00.

SUBTASK 79-21-05-100-005-F00

- (2) Make sure that the area around each magnetic chip detector [6] is clean before you remove it.

F. Magnetic Chip Detector Removal

SUBTASK 79-21-05-020-005-F00

- (1) Do these steps to remove a magnetic chip detector [6]:

WARNING: DO NOT TOUCH THE COMPONENTS OF THE OIL SYSTEM IF THE ENGINE IS HOT. THESE COMPONENTS STAY HOTTER THAN OTHER COMPONENTS. HOT COMPONENTS CAN BURN YOU.

- (a) Install the puller, SPL-2447, on the magnetic chip detector [6].

EFFECTIVITY
HAP ALL

79-21-05

Page 401
Feb 10/2007

D633A101-HAP

AIRCRAFT MAINTENANCE MANUAL

CAUTION: REMOVE AND TAG ONE MAGNETIC CHIP DETECTOR AT A TIME. THIS CAN PREVENT AN ERROR IN IDENTIFICATION OF THE SOURCE OF THE MATERIAL ON THE MAGNETIC CHIP DETECTORS.

- (b) When you remove each magnetic chip detector [6], attach a tag to identify it.
 - 1) The tags identify the plug location to each scavenge circuit (AGB/TGB Sump Scavenge, FWD Sump Scavenge, or AFT Sump Scavenge).
- (c) Push and turn the magnetic chip detector [6] 1/4 turn counterclockwise.
- (d) Pull the magnetic chip detector [6] and the tool assembly from the lubrication unit.

NOTE: Make sure that you do not lose the debris from the scavenge screen and the chip detector, to bring them for analysis if it is necessary.

NOTE: Make sure that you do not move the particles from the chip detector or scavenge screen.

- (e) Remove the puller, SPL-2447, from the magnetic chip detector [6].
- (f) Push the spring-loaded pin [2].
- (g) Remove the scavenge screen [1].
- (h) Immediately, examine the magnetic plug and the scavenge screen [1] very carefully for unusual or unwanted material Chip Detectors and Scavenge Screens Inspection, TASK 79-00-00-200-804-F00.

NOTE: Be careful not to remove the debris on the scavenge screen.

- (i) Remove and discard the packing [3].

————— **END OF TASK** —————

EFFECTIVITY
HAP ALL

D633A101-HAP

79-21-05

Page 402
Feb 10/2007

737-600/700/800/900
AIRCRAFT MAINTENANCE MANUAL

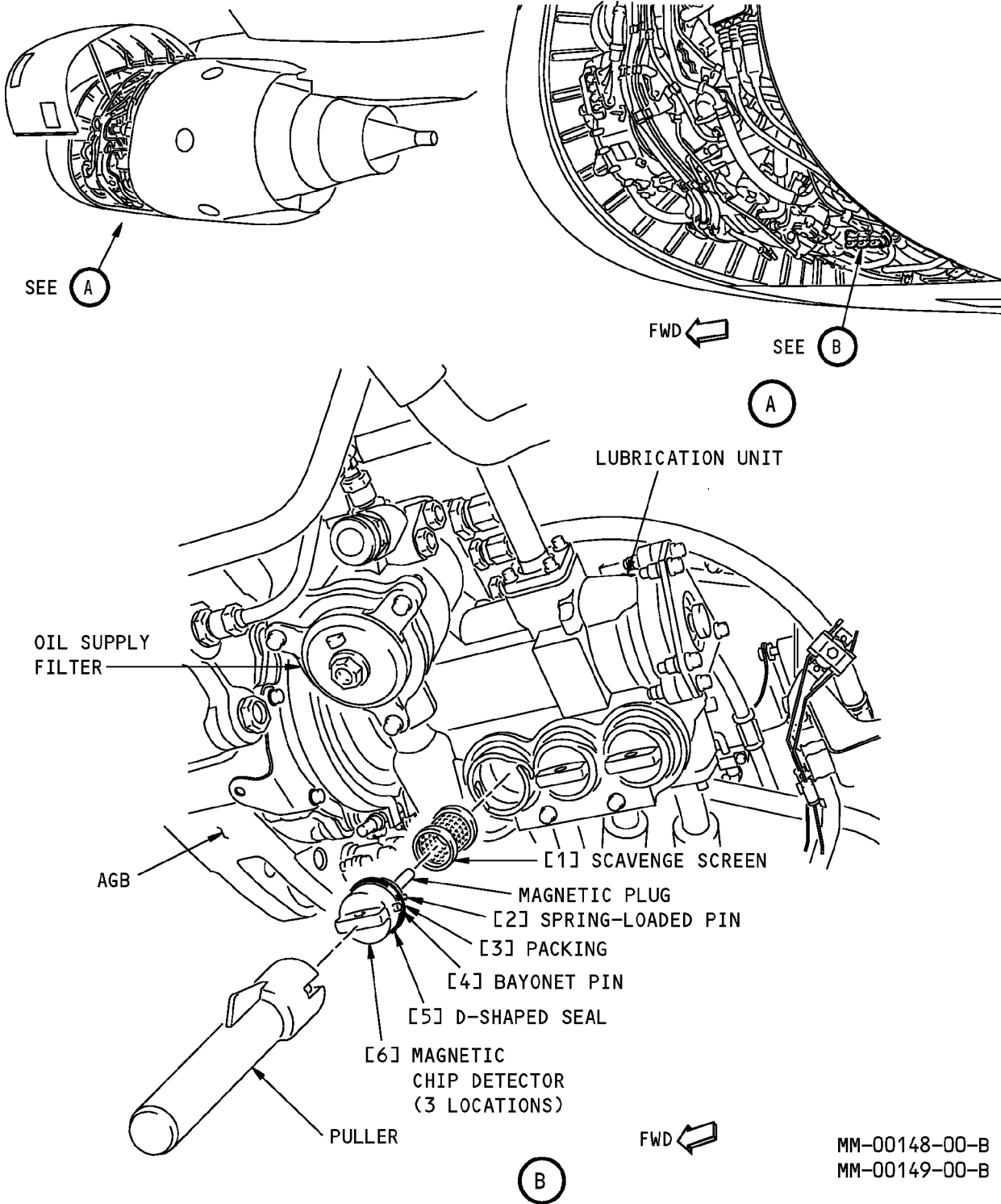

MM-00148-00-B
MM-00149-00-B

Chip Detector Installation
Figure 401/79-21-05-990-804-F00

EFFECTIVITY
HAP ALL

79-21-05

AIRCRAFT MAINTENANCE MANUAL

TASK 79-21-05-400-804-F00

3. Magnetic Chip Detector (MCD) Installation

(Figure 401)

A. References

Reference	Title
12-13-11-600-801	Replenish the Engine Oil (P/B 301)
70-30-01-910-802-F00	Seals (Preformed Packings and O-Rings) and Gaskets (P/B 201)
71-11-02-410-801-F00	Close the Fan Cowl Panels (P/B 201)

B. Tools/Equipment

NOTE: When more than one tool part number is listed under the same "Reference" number, the tools shown are alternates to each other within the same airplane series. Tool part numbers that are replaced or non-procurable are preceded by "Opt:", which stands for Optional.

Reference	Description
SPL-2447	Puller - Magnetic Plug, Lubrication Unit (Part #: 856A3617G01, Supplier: 58828, A/P Effectivity: 737-300, -400, -500, -600, -700, -700C, -700ER, -700QC, -800, -900, -900ER, -BBJ)
SPL-2449	Tool - Seal Fitting, D-Shape (Part #: 856A3557G01, Supplier: 58828, A/P Effectivity: 737-300, -400, -500, -600, -700, -700C, -700ER, -700QC, -800, -900, -900ER, -BBJ)

C. Consumable Materials

Reference	Description	Specification
D00599 [CP2442]	Oil - Engine (CFMI SB 79-001)	

D. Location Zones

Zone	Area
411	Engine 1 - Engine
421	Engine 2 - Engine

E. Prepare for the Installation

SUBTASK 79-21-05-210-004-F00

(1) Do these steps to prepare the magnetic chip detector [6] for the installation:

CAUTION: THE D-SHAPED SEAL IS NOT AN EXPENDABLE ITEM. YOU CAN USE IT AGAIN UNLESS IT IS TORN, CUT OR HAS OTHER DAMAGE. THE SEAL MUST BE DAMAGED TO REMOVE IT AND A FITTING TOOL IS NECESSARY TO INSTALL A NEW SEAL.

- (a) Examine the D-shaped seal [5] for tears, cuts or other damage. Seals (Preformed Packings and O-Rings) and Gaskets, TASK 70-30-01-910-802-F00.
 - 1) Use the D-shaped seal [5] again, if it is in good condition.
- (b) If there is damage to the D-shaped seal [5], replace the seal as follows:
 - 1) Break the D-shaped seal [5].
 - 2) Remove and discard the D-shaped seal [5] from the groove.
 - 3) Lubricate a new D-shaped seal [5] with oil, D00599 [CP2442].

EFFECTIVITY
HAP ALL

D633A101-HAP

79-21-05

Page 404
Oct 10/2007

AIRCRAFT MAINTENANCE MANUAL

- 4) Install a D-shaped seal [5] in the groove nearest the handle of the magnetic chip detector [6], with the tool, SPL-2449.

NOTE: The D-shaped seal does not replace the packing. You must install the two seals for a correct sealing of the magnetic chip detector.

CAUTION: MAKE SURE THAT YOU INSTALL A PACKING. THE INSTALLATION OF THE MAGNETIC CHIP DETECTOR WITHOUT A PACKING CAN CAUSE OIL LOSS DURING ENGINE OPERATION AND A POSSIBLE ENGINE FAILURE.

- (c) Lubricate a new packing [3] with oil, D00599 [CP2442].
- 1) Install the packing [3] in the magnetic chip detector [6] groove.
- (d) Install the scavenge screen [1] on the magnetic chip detector [6].

F. Magnetic Chip Detector Installation

SUBTASK 79-21-05-420-005-F00

- (1) Do these steps to install the magnetic chip detector [6]:
- (a) Install the puller, SPL-2447, on the magnetic chip detector [6].
- (b) Carefully, engage the magnetic chip detector [6] in the lubrication unit.
- (c) Align the bayonet pins [4] with the slots of the bayonet housing on the lubrication unit.
- (d) At the same time, push and turn the magnetic chip detector [6] and tool assembly 1/4 turn clockwise.

CAUTION: MAKE SURE THAT THE MAGNETIC CHIP DETECTORS ARE CORRECTLY INSTALLED WITH THE TWO BAYONET PINS ENGAGED. MAKE SURE THAT YOU CAN SEE THE RED STRIPES CLEARLY THROUGH THE LUBRICATION UNIT SLOTS. THE INCORRECT INSTALLATION CAN CAUSE OIL LOSS DURING ENGINE OPERATION AND A POSSIBLE ENGINE FAILURE.

- (e) Make sure that the magnetic chip detector [6] is correctly installed.

NOTE: The three plug handles must be aligned and in the locked position.

- (f) Remove the puller, SPL-2447, from the magnetic chip detector [6].

G. Put the Airplane Back to Its Usual Condition

SUBTASK 79-21-05-610-005-F00

- (1) If the oil level is low, do this task: Replenish the Engine Oil, TASK 12-13-11-600-801.

SUBTASK 79-21-05-410-005-F00

- (2) Do this task: Close the Fan Cowl Panels, TASK 71-11-02-410-801-F00.

————— END OF TASK —————

EFFECTIVITY
HAP ALL

D633A101-HAP

79-21-05

Page 405
Feb 10/2007

AIRCRAFT MAINTENANCE MANUAL

SCAVENGE OIL FILTER ELEMENT - REMOVAL/INSTALLATION**1. General**

- A. This procedure contains scheduled maintenance task data.
- B. This procedure has two tasks:
- (1) The removal of the scavenge oil filter element.
 - (2) The installation of the scavenge oil filter element.

TASK 79-21-06-000-801-F00**2. Scavenge Oil Filter Element Removal**

(Figure 401)

A. General

- (1) This procedure is a scheduled maintenance task.
- (2) This task is the removal procedure for the scavenge oil filter element (referred to as the filter element).
- (3) The scavenge oil filter assembly is attached to the aft face of the accessory gearbox (AGB) at the 7:00 o'clock position.
- (4) Each scavenge oil filter assembly has a scavenge oil filter element and a filter bowl.
- (5) The scavenge oil filter element is in the filter bowl of the scavenge oil filter assembly.
- (6) This procedure refers to the scavenge oil filter assembly as the filter assembly.

B. References

Reference	Title
12-13-11-100-801	Flush The Engine Oil System (P/B 301)
71-00-02-000-801-F00	Power Plant Removal (P/B 401)
71-00-02-400-801-F00	Power Plant Installation (P/B 401)
71-11-02-010-801-F00	Open the Fan Cowl Panels (P/B 201)
72-56-00-000-801-F00	Oil Supply Line Cleaning (P/B 701)
72-56-00-100-802-F00	Oil Scavenge Line Cleaning (P/B 701)
72-56-00-300-801-F00	Oil Supply Tube Replacement (P/B 801)
73-21-08-000-801-F00	EEC Alternator and Alternator Rotor Removal (P/B 401)
73-21-08-400-801-F00	EEC Alternator and Alternator Rotor Installation (P/B 401)
79-00-00-200-804-F00	Chip Detectors and Scavenge Screens Inspection (P/B 601)
79-00-00-200-806-F01	Aft Sump Oil System Inspection (P/B 601)
79-21-01-400-802-F00	Packing Replacement On The Inner Sealing Spool (Lubrication Unit Installed) (P/B 801)
79-21-01-400-803-F00	Packing Replacement On The Inner and Outer Sealing Spools (Lubrication Unit Removed) (P/B 801)
79-21-05-400-804-F00	Magnetic Chip Detector (MCD) Installation (P/B 401)

C. Tools/Equipment

Reference	Description
STD-195	Container - 1 Quart (1 l), Oil/Fuel Resistant

EFFECTIVITY
HAP ALL

79-21-06

Page 401
Feb 15/2009

D633A101-HAP

AIRCRAFT MAINTENANCE MANUAL

D. Location Zones

Zone	Area
411	Engine 1 - Engine
421	Engine 2 - Engine

E. Prepare for the Removal

SUBTASK 79-21-06-860-001-F00

- (1) For Engine 1, open these circuit breakers and install safety tags:

CAPT Electrical System Panel, P18-2

Row	Col	Number	Name
A	4	C01390	ENGINE 1 ALTN PWR CHAN B
A	5	C01314	ENGINE 1 ALTN PWR CHAN A

SUBTASK 79-21-06-860-002-F00

- (2) For Engine 2, open these circuit breakers and install safety tags:

F/O Electrical System Panel, P6-2

Row	Col	Number	Name
D	7	C01391	ENGINE 2 ALTN PWR CHAN B
D	8	C01315	ENGINE 2 ALTN PWR CHAN A

SUBTASK 79-21-06-010-001-F00

- (3) Do this task: Open the Fan Cowl Panels, TASK 71-11-02-010-801-F00.

F. Filter Element Removal

SUBTASK 79-21-06-420-004-F00

WARNING: DO NOT TOUCH THE COMPONENTS OF THE OIL SYSTEM IF THE ENGINE IS HOT. THESE COMPONENTS STAY HOTTER THAN OTHER COMPONENTS. HOT COMPONENTS CAN BURN YOU.

WARNING: DO NOT OPEN THE OIL SYSTEM UNTIL THE PRESSURE GOES TO ZERO. THE PRESSURE GOES TO ZERO APPROXIMATELY 5 MINUTES AFTER AN ENGINE SHUTDOWN. A PRESSURIZED ENGINE CAN RELEASE A SPRAY OF HOT OIL THAT CAN BURN YOU.

WARNING: DO NOT LET HOT OIL GET ON YOU. PUT ON GOGGLES AND OTHER EQUIPMENT FOR PROTECTION OR LET THE ENGINE BECOME COOL. HOT OIL CAN BURN YOU.

CAUTION: DO NOT LET HOT OIL GET ON THE ENGINE OR OTHER COMPONENTS. IMMEDIATELY CLEAN THE COMPONENT IF OIL FALLS ON IT. OIL CAN CAUSE DAMAGE TO PAINT AND RUBBER.

- (1) Do these steps to remove the filter bowl [4]:
- Put a 1 quart (1 l) oil/fuel resistant container, STD-195, below the filter assembly.
 - Push the ratchet lever with one hand.

NOTE: This releases the filter bowl.

EFFECTIVITY
HAP ALL

D633A101-HAP

79-21-06

Page 402
Feb 15/2009

AIRCRAFT MAINTENANCE MANUAL

- (c) While you push on the ratchet lever, loosen the filter bowl [4] counterclockwise with the other hand.

NOTE: If the filter bowl is too tight, put the blade of a large screwdriver between the lugs at the bottom of the filter bowl. Use the screwdriver only as a lever to "break" the tightening force of the filter bowl and to loosen it.

- (d) Remove the filter bowl [4].
- 1) Let the oil in the filter bowl [4] drain into the container.
 - 2) Examine the oil for unusual color or grit content.
- (e) Remove and discard the packing [3] from the filter bowl [4].

SUBTASK 79-21-06-020-001-F00

- (2) Pull the filter element [2] from the filter housing.
- (a) Examine the filter element and the inside of the filter bowl [4] for unusual debris.
 - (b) If unusual debris is found, do this task: Chip Detectors and Scavenge Screens Inspection, TASK 79-00-00-200-804-F00.
 - 1) Do the corrective action for the unusual contamination.
 - (c) If black packing debris is found, it is probably from the inner and outer sealing spool valves on the lubrication unit, do these steps:
 - 1) Replace the packing on the inner and outer spool of the lubrication unit. Do these tasks: Packing Replacement On The Inner Sealing Spool (Lubrication Unit Installed), TASK 79-21-01-400-802-F00 and Packing Replacement On The Inner and Outer Sealing Spools (Lubrication Unit Removed), TASK 79-21-01-400-803-F00.
 - 2) If you do not replace these packings, a continue-in-service limit of 250 cycles is permitted with these conditions:
 - a) All three detectors are examined for correct installation [locked] by two different persons prior to the close of the fan cowls (TASK 79-21-05-400-804-F00).
 - b) Do the detector installation check again each time the fan cowls are opened.
 - (d) If aluminum debris is found, do these steps:
 - 1) Do this task: EEC Alternator and Alternator Rotor Removal, TASK 73-21-08-000-801-F00.
 - 2) Do a visual check of the EEC alternator and rotor for debris and obvious damage.
 - 3) Examine the alternator rotor area in the AGB for damage.
 - a) If there is damage in the AGB, replace the engine. These are the tasks: Power Plant Removal, TASK 71-00-02-000-801-F00 and Power Plant Installation, TASK 71-00-02-400-801-F00.
 - b) If there is no damage in the AGB but debris was found, remove the debris in the AGB pad and clean as necessary.
 - c) Install a new EEC alternator and rotor, do this task: EEC Alternator and Alternator Rotor Installation, TASK 73-21-08-400-801-F00.
 - d) Do this task: Flush The Engine Oil System, TASK 12-13-11-100-801.
 - 4) Re-examine the AGB/TGB chip detector and scavenge oil filter element every 10 to 20 cycles until they are found to be clean.
 - (e) If coke/carbon debris is found in the filter or if oil drained from bowl is unusually heavy dark or has grit in it, do these steps:

EFFECTIVITY
HAP ALL

D633A101-HAP

79-21-06

Page 403
Feb 15/2009

AIRCRAFT MAINTENANCE MANUAL

- 1) Do a Check of the AFT sump oil system for Oil Leakage Aft Sump Oil System Inspection, TASK 79-00-00-200-806-F01.
 - 2) If engine oil pressure trend does not show a gradual increase, do these tasks at the next convenient opportunity.
 - a) Do this task: Oil Scavenge Line Cleaning, TASK 72-56-00-100-802-F00.
 - b) Do this task: Oil Supply Line Cleaning, TASK 72-56-00-000-801-F00 or do this task: Oil Supply Tube Replacement, TASK 72-56-00-300-801-F00.
 - 3) If the engine oil pressure trend show a gradual increase but is still in the limits, do these tasks in less than 25 cycles:
 - a) Do this task: Oil Scavenge Line Cleaning, TASK 72-56-00-100-802-F00.
 - b) Do this task: Oil Supply Line Cleaning, TASK 72-56-00-000-801-F00 or do this task: Oil Supply Tube Replacement, TASK 72-56-00-300-801-F00.
 - 4) Monitor the engine oil pressure during the next 20-50 hours of operation.
- (f) Discard the filter element [2] and the packing [1].

————— **END OF TASK** —————

EFFECTIVITY
HAP ALL

D633A101-HAP

79-21-06

Page 404
Feb 15/2009

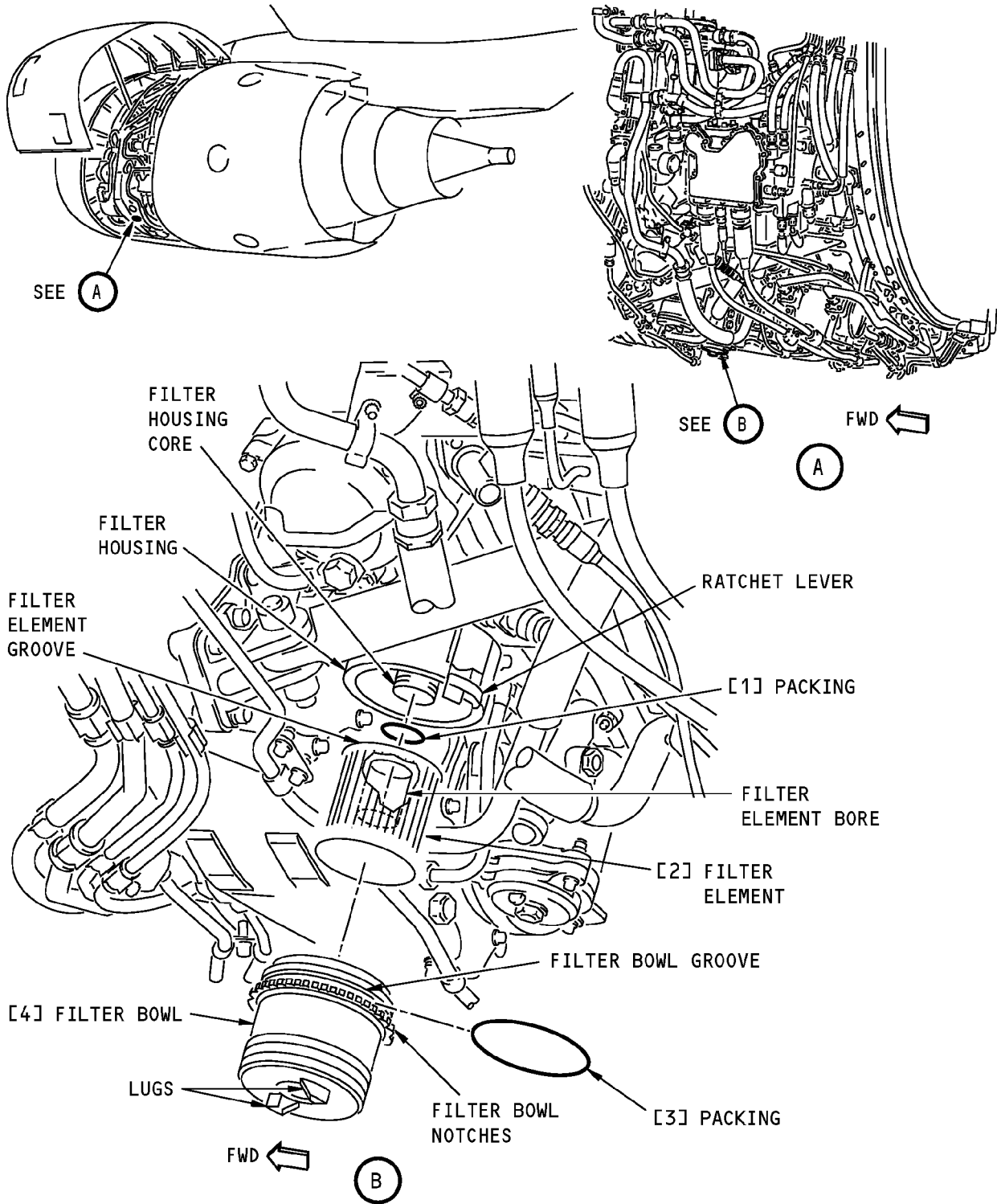

Scavenge Oil Filter Element Installation
Figure 401/79-21-06-990-801-F00

EFFECTIVITY
HAP ALL

79-21-06

AIRCRAFT MAINTENANCE MANUAL

TASK 79-21-06-400-801-F00

3. Scavenge Oil Filter Element Installation

(Figure 401)

A. General

- (1) This procedure is a scheduled maintenance task.
- (2) This task is the installation procedure for the scavenge oil filter element (referred to as the filter element).
- (3) This procedure refers to the scavenge oil filter assembly as the filter assembly.

B. References

Reference	Title
12-13-11-600-801	Replenish the Engine Oil (P/B 301)
70-10-02-910-801-F00	General Precautions During the Removal and Installation of Engine Components (P/B 201)
71-00-00-800-811-F00	Power Plant Test Reference Table (P/B 501)
71-11-02-410-801-F00	Close the Fan Cowl Panels (P/B 201)

C. Tools/Equipment

Reference	Description
STD-3911	Brush - Bristle, Medium Nylon

D. Consumable Materials

Reference	Description	Specification
D00599 [CP2442]	Oil - Engine (CFMI SB 79-001)	
D00640 [CP2104]	Lubricant - Molybdenum Disulfide, Solid - Molykote G	
D00673 [CP2569]	Lubricant - Molybdenum Disulfide, Solid - Dow Corning G-n Metal Assembly	
D50019 [CP2444]	Lubricant - Molydisulfide Solid Film, Paste - Molykote G-n Plus	
G00034	Cotton Wiper - Process Cleaning Absorbent Wiper (Cheesecloth, Gauze)	BMS15-5

E. Expendables/Parts

AMM Item	Description	AIPC Reference	AIPC Effectivity
1	Packing	79-21-04-01-035	HAP ALL
2	Filter element	79-21-04-01-030	HAP ALL
3	Packing	79-21-04-01-040	HAP ALL

F. Location Zones

Zone	Area
411	Engine 1 - Engine
421	Engine 2 - Engine

G. Filter Element Installation

SUBTASK 79-21-06-840-001-F00

- (1) Do these steps to prepare for the installation General Precautions During the Removal and Installation of Engine Components, TASK 70-10-02-910-801-F00:

EFFECTIVITY
HAP ALL

79-21-06Page 406
Feb 15/2009

D633A101-HAP

AIRCRAFT MAINTENANCE MANUAL

- (a) Clean the mating interfaces of the filter housing and the filter bowl [4] with a cotton wiper, G00034.
- (b) Make sure that the filter housing flanges and the filter bowl [4] are clean and in good condition.

SUBTASK 79-21-06-420-001-F00

- (2) Do these steps to install the new filter element [2]:

- (a) Lubricate a new packing [1] and a new packing [3] with oil, D00599 [CP2442].

CAUTION: MAKE SURE THAT YOU INSTALL THE PACKING ON THE NEW FILTER ELEMENT CORRECTLY DURING THE INSTALLATION OF THE FILTER ELEMENT. IF YOU DO NOT INSTALL THE PACKING CORRECTLY, OIL LOSS CAN OCCUR DURING ENGINE OPERATION AND CAN CAUSE DAMAGE TO THE ENGINE.

- (b) Install the packing [1] in the filter element groove.
- (c) Put the filter element bore below the filter housing core.
- (d) Push the filter element [2] on the filter housing core.

SUBTASK 79-21-06-420-002-F00

CAUTION: USE YOUR HANDS ONLY, DO NOT USE A TOOL, TO TIGHTEN THE FILTER BOWL. IF YOU DO USE TOOLS TO TIGHTEN THE FILTER BOWL, DAMAGE TO THE FILTER ASSEMBLY CAN OCCUR.

- (3) Do these steps to install the filter bowl [4]:

CAUTION: MAKE SURE THAT YOU INSTALL THE PACKING IN THE FILTER BOWL GROOVE CORRECTLY DURING THE INSTALLATION OF THE FILTER BOWL. IF YOU DO NOT INSTALL THE PACKING CORRECTLY, OIL LOSS CAN OCCUR DURING ENGINE OPERATION AND CAN CAUSE DAMAGE TO THE ENGINE.

- (a) Install the packing [3] in the filter bowl groove.

CAUTION: MAKE SURE THAT THERE IS NO EXCESS LUBRICANT. MAKE SURE THAT THE LUBRICANT DOES NOT OVER FLOW AS THE FILTER BOWL IS TIGHTENED. IF THERE IS TOO MUCH LUBRICANT, IT CAN CAUSE DAMAGE TO THE EQUIPMENT.

- (b) Use a medium nylon bristle brush, STD-3911 to lubricate the threads and the mating surfaces of the filter bowl [4] with Molykote G lubricant, D00640 [CP2104], Dow Corning G-n Metal Assembly lubricant, D00673 [CP2569], or Molykote G-n Plus lubricant, D50019 [CP2444].

- 1) Make sure that there is no excess lubricant on the filter bowl.

- a) If it is necessary, use a cotton wiper, G00034 to remove the excess lubricant.

- (c) Align the filter bowl [4] with the filter housing.
- (d) Engage the filter bowl [4] in the filter housing.
- (e) Use one hand to press the ratchet lever to release it from the notches in the filter bowl [4]
- (f) Use your other hand to turn the filter bowl [4] clockwise into the filter housing until the filter bowl [4] does not turn.
- (g) Make sure that the ratchet lever fully engages a notch on the filter bowl [4] to hold the filter assembly in its position.

NOTE: This locks the filter bowl to the filter housing.

EFFECTIVITY
HAP ALL

D633A101-HAP

79-21-06

Page 407
Oct 15/2008

AIRCRAFT MAINTENANCE MANUAL

H. Put the Airplane Back to Its Usual Condition

SUBTASK 79-21-06-410-002-F00

- (1) Do this task: Close the Fan Cowl Panels, TASK 71-11-02-410-801-F00.

SUBTASK 79-21-06-860-005-F00

- (2) For Engine 1, remove the safety tags and close these circuit breakers:

CAPT Electrical System Panel, P18-2

<u>Row</u>	<u>Col</u>	<u>Number</u>	<u>Name</u>
A	4	C01390	ENGINE 1 ALTN PWR CHAN B
A	5	C01314	ENGINE 1 ALTN PWR CHAN A

SUBTASK 79-21-06-860-006-F00

- (3) For Engine 2, remove the safety tags and close these circuit breakers:

F/O Electrical System Panel, P6-2

<u>Row</u>	<u>Col</u>	<u>Number</u>	<u>Name</u>
D	7	C01391	ENGINE 2 ALTN PWR CHAN B
D	8	C01315	ENGINE 2 ALTN PWR CHAN A

I. Filter Element Installation Test

SUBTASK 79-21-06-800-001-F00

- (1) Do the tests that are listed in the Power Plant Test Reference Table, TASK 71-00-00-800-811-F00.

SUBTASK 79-21-06-610-003-F00

- (2) If the oil level is low, do this task: Replenish the Engine Oil, TASK 12-13-11-600-801.

————— END OF TASK —————

EFFECTIVITY
HAP ALL

D633A101-HAP

79-21-06

Page 408
Oct 15/2008

AIRCRAFT MAINTENANCE MANUAL

SCAVENGE OIL FILTER CLOGGING TRANSMITTER - REMOVAL/INSTALLATION**1. General**

A. This procedure has two tasks:

- (1) The removal of the scavenge oil filter clogging transmitter.
- (2) The installation of the scavenge oil filter clogging transmitter.

TASK 79-21-07-000-801-F00**2. Scavenge Oil Filter Clogging Transmitter Removal**

(Figure 401)

A. General

- (1) This task is the removal procedure for the scavenge oil filter clogging transmitter (referred to as the clogging transmitter).
- (2) The clogging transmitter is found on the aft face of the scavenge oil filter assembly.
- (3) This procedure refers to the scavenge oil filter assembly as the filter assembly.

B. References

Reference	Title
70-10-02-910-801-F00	General Precautions During the Removal and Installation of Engine Components (P/B 201)
71-11-02-010-801-F00	Open the Fan Cowl Panels (P/B 201)

C. Tools/Equipment

Reference	Description
STD-123	Brush - Soft Bristle
STD-203	Container - Oil Resistant, 1 U.S.-Gal (3.8 l)

D. Consumable Materials

Reference	Description	Specification
B00682 [CP2011]	Solvent - Stoddard	P-D-680, Type I, II or III

E. Location Zones

Zone	Area
411	Engine 1 - Engine
421	Engine 2 - Engine

F. Prepare for the Removal

SUBTASK 79-21-07-860-001-F00

- (1) For Engine 1, open these circuit breakers and install safety tags:

CAPT Electrical System Panel, P18-2

Row	Col	Number	Name
A	4	C01390	ENGINE 1 ALTN PWR CHAN B
A	5	C01314	ENGINE 1 ALTN PWR CHAN A

EFFECTIVITY
HAP ALL

79-21-07

Page 401
Jun 15/2009

D633A101-HAP

AIRCRAFT MAINTENANCE MANUAL

SUBTASK 79-21-07-860-002-F00

- (2) For Engine 2, open these circuit breakers and install safety tags:

F/O Electrical System Panel, P6-2

<u>Row</u>	<u>Col</u>	<u>Number</u>	<u>Name</u>
D	7	C01391	ENGINE 2 ALTN PWR CHAN B
D	8	C01315	ENGINE 2 ALTN PWR CHAN A

SUBTASK 79-21-07-010-001-F00

- (3) Do this task: Open the Fan Cowl Panels, TASK 71-11-02-010-801-F00.

G. Clogging Transmitter Removal

SUBTASK 79-21-07-020-001-F00

WARNING: DO NOT TOUCH THE COMPONENTS OF THE OIL SYSTEM IF THE ENGINE IS HOT. THESE COMPONENTS STAY HOTTER THAN OTHER COMPONENTS. HOT COMPONENTS CAN BURN YOU.

WARNING: DO NOT OPEN THE OIL SYSTEM UNTIL THE PRESSURE GOES TO ZERO. THE PRESSURE GOES TO ZERO APPROXIMATELY 5 MINUTES AFTER AN ENGINE SHUTDOWN. A PRESSURIZED ENGINE CAN RELEASE A SPRAY OF HOT OIL THAT CAN BURN YOU.

WARNING: DO NOT LET HOT OIL GET ON YOU. PUT ON GOGGLES AND OTHER EQUIPMENT FOR PROTECTION OR LET THE ENGINE BECOME COOL. HOT OIL CAN BURN YOU.

CAUTION: DO NOT LET HOT OIL GET ON THE ENGINE OR OTHER COMPONENTS. IMMEDIATELY CLEAN THE COMPONENT IF OIL FALLS ON IT. OIL CAN CAUSE DAMAGE TO PAINT AND RUBBER.

- (1) Do these steps to remove the clogging transmitter [1]:
- Clean the clogging transmitter [1] and clogging transmitter housing area with a soft bristle brush, STD-123 and solvent, B00682 [CP2011].
 - Disconnect the electrical connector, DP0703 [4] from the clogging transmitter receptacle.
 - Put a 1 U.S.-gal (3.81 l) oil resistant container, STD-203, below the filter assembly.

CAUTION: THE CLOGGING TRANSMITTER CONTAINS MAGNETIZED COMPONENTS. DO NOT LET FOREIGN PARTICLES TOUCH THE CLOGGING TRANSMITTER. CONTAMINATION IN THE CLOGGING TRANSMITTER PORTS CAN CAUSE DAMAGE TO EQUIPMENT.

- Remove the two bolts [3].
- Remove the clogging transmitter [1] from the clogging transmitter housing.
 - Let the oil drain in the container.
- Remove and discard the packing [2] and the packing [5].
- Install a protective cover on the clogging transmitter [1] General Precautions During the Removal and Installation of Engine Components, TASK 70-10-02-910-801-F00.

————— **END OF TASK** —————

EFFECTIVITY
HAP ALL

D633A101-HAP

79-21-07

Page 402
Jun 10/2005

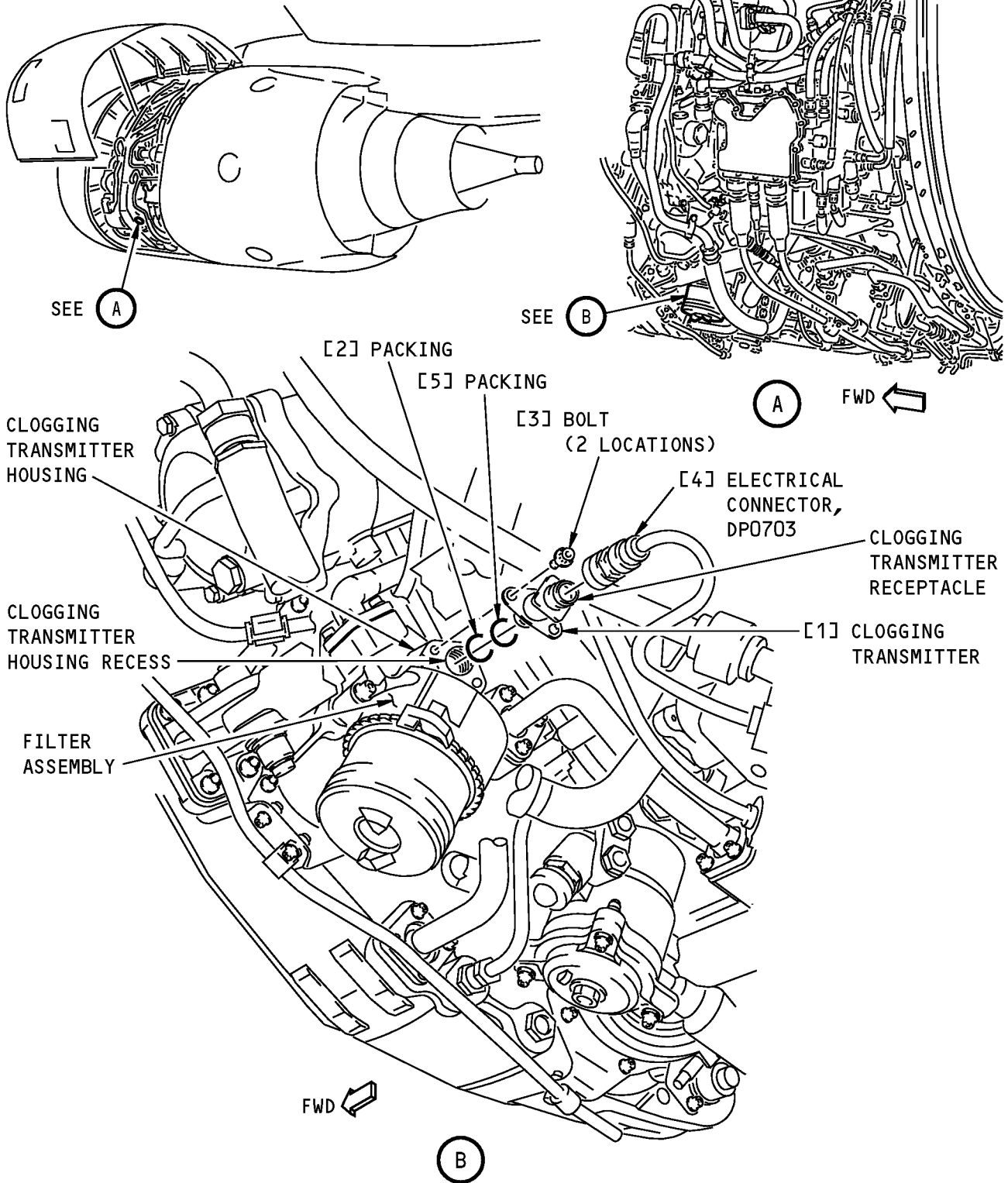

Scavenge Oil Filter Clogging Transmitter Installation
Figure 401/79-21-07-990-801-F00

EFFECTIVITY
HAP ALL

79-21-07

AIRCRAFT MAINTENANCE MANUAL

TASK 79-21-07-400-801-F00

3. Scavenge Oil Filter Clogging Transmitter Installation

(Figure 401)

A. General

- (1) This task is the installation procedure for the scavenge oil filter clogging transmitter (referred to as the clogging transmitter).

B. References

Reference	Title
70-10-02-910-801-F00	General Precautions During the Removal and Installation of Engine Components (P/B 201)
71-00-00-800-811-F00	Power Plant Test Reference Table (P/B 501)
71-11-02-410-801-F00	Close the Fan Cowl Panels (P/B 201)

C. Consumable Materials

Reference	Description	Specification
D00599 [CP2442]	Oil - Engine (CFMI SB 79-001)	
D00601 [CP2101]	Grease - Graphite, High Temperature	SAE AMS 2518

D. Expendables/Parts

AMM Item	Description	AIPC Reference	AIPC Effectivity
1	Transmitter	79-21-07-01-025	HAP ALL
2	Packing	79-21-07-01-015	HAP ALL
5	Packing	79-21-07-01-020	HAP ALL

E. Location Zones

Zone	Area
411	Engine 1 - Engine
421	Engine 2 - Engine

F. Prepare for the Installation

SUBTASK 79-21-07-840-001-F00

- (1) Do these steps to prepare the clogging transmitter [1] for the installation General Precautions During the Removal and Installation of Engine Components, TASK 70-10-02-910-801-F00:
- (a) Remove the protective cover from the clogging transmitter [1].

WARNING: DO NOT TOUCH THE COMPONENTS OF THE OIL SYSTEM IF THE ENGINE IS HOT. THESE COMPONENTS STAY HOTTER THAN OTHER COMPONENTS. HOT COMPONENTS CAN BURN YOU.

- (b) Make sure that all the flanges on the clogging transmitter switch [1] and the clogging transmitter housing are clean and in good condition.

G. Pressure Switch Installation

SUBTASK 79-21-07-420-001-F00

CAUTION: THE CLOGGING TRANSMITTER CONTAINS MAGNETIZED COMPONENTS. DO NOT LET FOREIGN PARTICLES TOUCH THE CLOGGING TRANSMITTER. CONTAMINATION IN THE CLOGGING TRANSMITTER PORTS CAN CAUSE DAMAGE OF THE ENGINE COMPONENT.

- (1) Do these steps to install the clogging transmitter [1]:

EFFECTIVITY
HAP ALL

79-21-07

Page 404
Jun 15/2009

D633A101-HAP

AIRCRAFT MAINTENANCE MANUAL

(a) Lubricate the new packings [2] and [5] with oil, D00599 [CP2442].

CAUTION: MAKE SURE YOU INSTALL THE PACKING CORRECTLY ON THE CLOGGING TRANSMITTER. IF YOU DO NOT INSTALL THE PACKING CORRECTLY, OIL LOSS CAN OCCUR DURING ENGINE OPERATION AND CAN CAUSE DAMAGE TO THE ENGINE.

(b) Install the new packing [5] on the clogging transmitter [1].

(c) Install the new packing [2] on the clogging transmitter [1].

CAUTION: KEEP THE CLOGGING TRANSMITTER ALIGNED WITH THE CLOGGING TRANSMITTER HOUSING RECESS. YOU MUST BE CAREFUL WHEN YOU INSTALL THE CLOGGING TRANSMITTER OR DAMAGE CAN OCCUR.

(d) Install the clogging transmitter [1] in the clogging transmitter housing.

(e) Lubricate the two bolts [3] with grease, D00601 [CP2101].

(f) Install the two bolts [3].

1) Tighten the bolts [3] to 35-53 pound-inches (4-6 Newton meters).

SUBTASK 79-21-07-420-002-F00

(2) Connect the electrical connector, DP0703 [4] to the clogging transmitter receptacle.

H. Put the Airplane Back to Its Usual Condition

SUBTASK 79-21-07-410-001-F00

(1) Do this task: Close the Fan Cowl Panels, TASK 71-11-02-410-801-F00.

SUBTASK 79-21-07-860-003-F00

(2) For Engine 1, remove the safety tags and close these circuit breakers:

CAPT Electrical System Panel, P18-2

<u>Row</u>	<u>Col</u>	<u>Number</u>	<u>Name</u>
A	4	C01390	ENGINE 1 ALTN PWR CHAN B
A	5	C01314	ENGINE 1 ALTN PWR CHAN A

SUBTASK 79-21-07-860-004-F00

(3) For Engine 2, remove the safety tags and close these circuit breakers:

F/O Electrical System Panel, P6-2

<u>Row</u>	<u>Col</u>	<u>Number</u>	<u>Name</u>
D	7	C01391	ENGINE 2 ALTN PWR CHAN B
D	8	C01315	ENGINE 2 ALTN PWR CHAN A

I. Clogging Transmitter Installation Test

SUBTASK 79-21-07-800-001-F00

(1) Do the tests that are listed in the Power Plant Test Reference Table, TASK 71-00-00-800-811-F00.

————— **END OF TASK** —————

EFFECTIVITY
HAP ALL

D633A101-HAP

79-21-07

Page 405
Jun 15/2008

AIRCRAFT MAINTENANCE MANUAL

OIL ANTI-LEAK VALVE - REMOVAL/INSTALLATION**1. General**

A. This procedure has two tasks:

- (1) The removal of the oil anti-leak valve.
- (2) The installation of the oil anti-leak valve.

TASK 79-21-09-000-801-F00**2. Oil Anti-Leak Valve Removal**

(Figure 401)

A. General

- (1) This task is the removal procedure for the oil anti-leak valve (referred to as the valve).
- (2) The oil anti-leak valve is installed at the 6:00 o'clock position on the fan case.

B. References

Reference	Title
12-13-11-600-803	Drain the Engine Oil (P/B 301)
70-10-02-910-801-F00	General Precautions During the Removal and Installation of Engine Components (P/B 201)
70-30-01-910-802-F00	Seals (Preformed Packings and O-Rings) and Gaskets (P/B 201)
71-11-02-010-801-F00	Open the Fan Cowl Panels (P/B 201)

C. Tools/Equipment

Reference	Description
STD-203	Container - Oil Resistant, 1 U.S.-Gal (3.8 l)

D. Location Zones

Zone	Area
411	Engine 1 - Engine
421	Engine 2 - Engine

E. Prepare for the Removal

SUBTASK 79-21-09-860-001-F00

- (1) For Engine 1, open these circuit breakers and install safety tags:

CAPT Electrical System Panel, P18-2

Row	Col	Number	Name
D	5	C01359	DISPLAY DEU 1 PRI

F/O Electrical System Panel, P6-1

Row	Col	Number	Name
D	10	C01361	DISPLAY DEU 1 HOLDUP

SUBTASK 79-21-09-860-002-F00

- (2) For Engine 2, open these circuit breakers and install safety tags:

F/O Electrical System Panel, P6-1

Row	Col	Number	Name
D	9	C01362	DISPLAY DEU 2 HOLDUP
D	11	C01360	DISPLAY DEU 2 PRI

EFFECTIVITY
HAP ALL

79-21-09

Page 401
Oct 10/2003

D633A101-HAP

AIRCRAFT MAINTENANCE MANUAL

SUBTASK 79-21-09-010-001-F00

(3) Do this task: Open the Fan Cowl Panels, TASK 71-11-02-010-801-F00.

SUBTASK 79-21-09-680-001-F00

(4) Drain the oil from the oil tank Drain the Engine Oil, TASK 12-13-11-600-803.

F. Oil Anti-Leak Valve Removal

SUBTASK 79-21-09-020-001-F00

(1) Do these steps to prepare the valve [1] for removal:

- (a) Put a 1 U.S.-gal (3.81 l) oil resistant container, STD-203, below the valve [1].
- (b) Put protective caps on the connection interfaces after you disconnect them General Precautions During the Removal and Installation of Engine Components, TASK 70-10-02-910-801-F00.

SUBTASK 79-21-09-020-002-F00

WARNING: DO NOT TOUCH THE COMPONENTS OF THE OIL SYSTEM IF THE ENGINE IS HOT. THESE COMPONENTS STAY HOTTER THAN OTHER COMPONENTS. HOT COMPONENTS CAN BURN YOU.

WARNING: DO NOT OPEN THE OIL SYSTEM UNTIL THE PRESSURE GOES TO ZERO. THE PRESSURE GOES TO ZERO APPROXIMATELY 5 MINUTES AFTER AN ENGINE SHUTDOWN. A PRESSURIZED ENGINE CAN RELEASE A SPRAY OF HOT OIL THAT CAN BURN YOU.

WARNING: DO NOT LET HOT OIL GET ON YOU. PUT ON GOGGLES AND OTHER EQUIPMENT FOR PROTECTION OR LET THE ENGINE BECOME COOL. HOT OIL CAN BURN YOU.

CAUTION: DO NOT LET HOT OIL GET ON THE ENGINE OR OTHER COMPONENTS. IMMEDIATELY CLEAN THE COMPONENT IF OIL FALLS ON IT. OIL CAN CAUSE DAMAGE TO PAINT AND RUBBER.

- (2) Do these steps to disconnect the oil supply tube from the valve [1]:
 - (a) Remove the bolt [2], nut [4] and clamp [3] that attach the oil supply tube to the engine bracket.
 - (b) Remove the four bolts [9] that attach the oil supply tube to the valve [1].
 - 1) Let the oil drain in the container.
 - (c) Remove and examine the gasket [5] Seals (Preformed Packings and O-Rings) and Gaskets, TASK 70-30-01-910-802-F00.

NOTE: Use the gasket if it is in good condition.

- 1) Discard the gasket [5], if it is in unsatisfactory condition.

SUBTASK 79-21-09-020-003-F00

(3) Do these steps to disconnect the oil pressure tube from the valve [1]:

- (a) Disconnect the oil pressure tube from the valve [1].
 - 1) Let the oil drain into the container.

SUBTASK 79-21-09-020-004-F00

(4) Do these steps to disconnect the oil outlet tube from the valve [1]:

- (a) Remove the four bolts [6] that attach the oil outlet tube to the valve [1].
- (b) Remove and discard the packing [7].

EFFECTIVITY
HAP ALL

D633A101-HAP

79-21-09

Page 402
Oct 10/2003

AIRCRAFT MAINTENANCE MANUAL

SUBTASK 79-21-09-020-005-F00

- (5) Do these steps to remove the valve [1]:
- (a) Remove the four bolts [8] that attach the valve [1] to the fan case bracket.
 - (b) Remove the valve [1].

————— **END OF TASK** —————

EFFECTIVITY
HAP ALL

D633A101-HAP

79-21-09

Page 403
Jun 10/2005

737-600/700/800/900
AIRCRAFT MAINTENANCE MANUAL

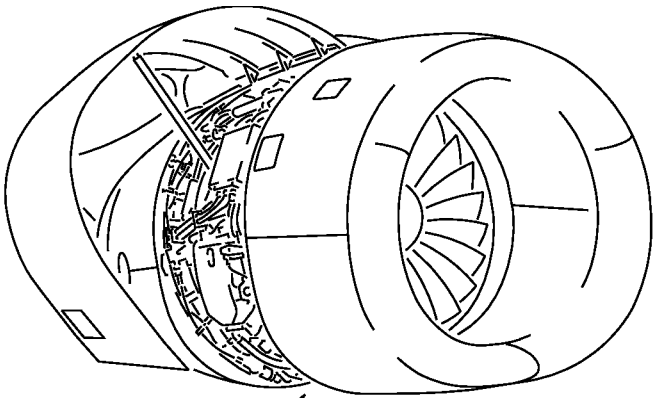

SEE (A)

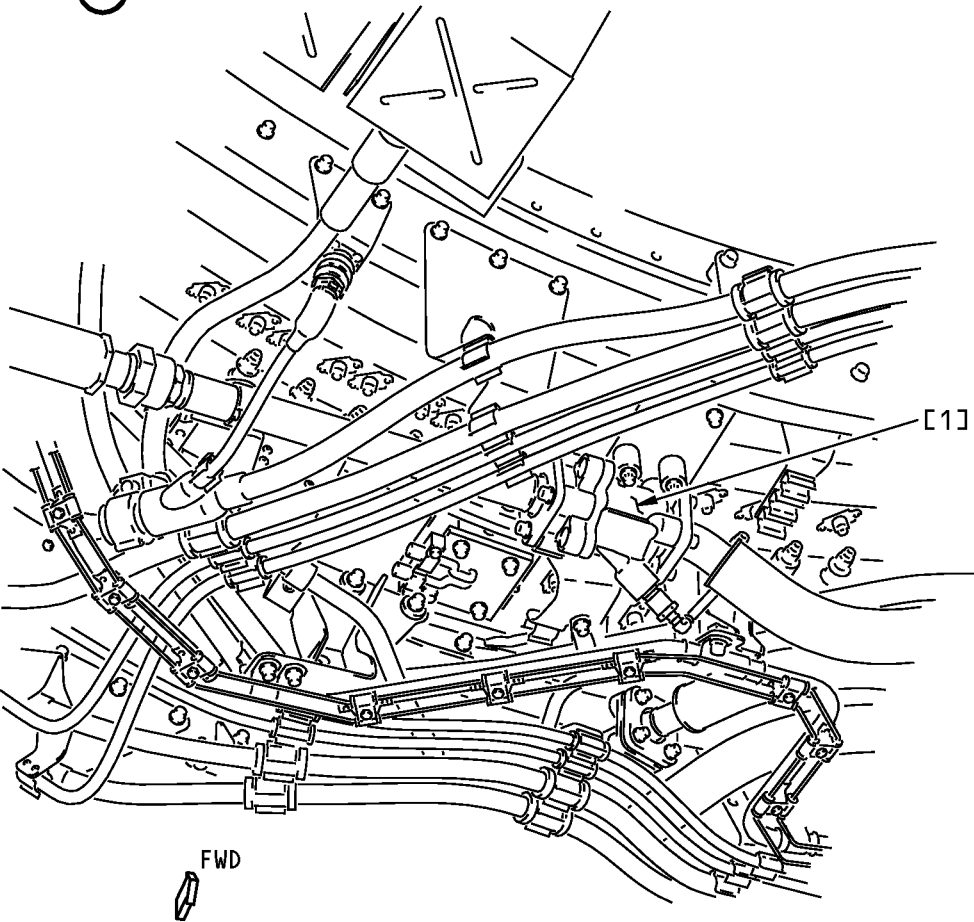

[1] OIL ANTI-LEAK VALVE
SEE (B)

(A)

Oil Anti-Leak Valve Installation
Figure 401 (Sheet 1 of 2)/79-21-09-990-801-F00

EFFECTIVITY
HAP ALL

79-21-09

Page 404
Oct 10/2003

D633A101-HAP

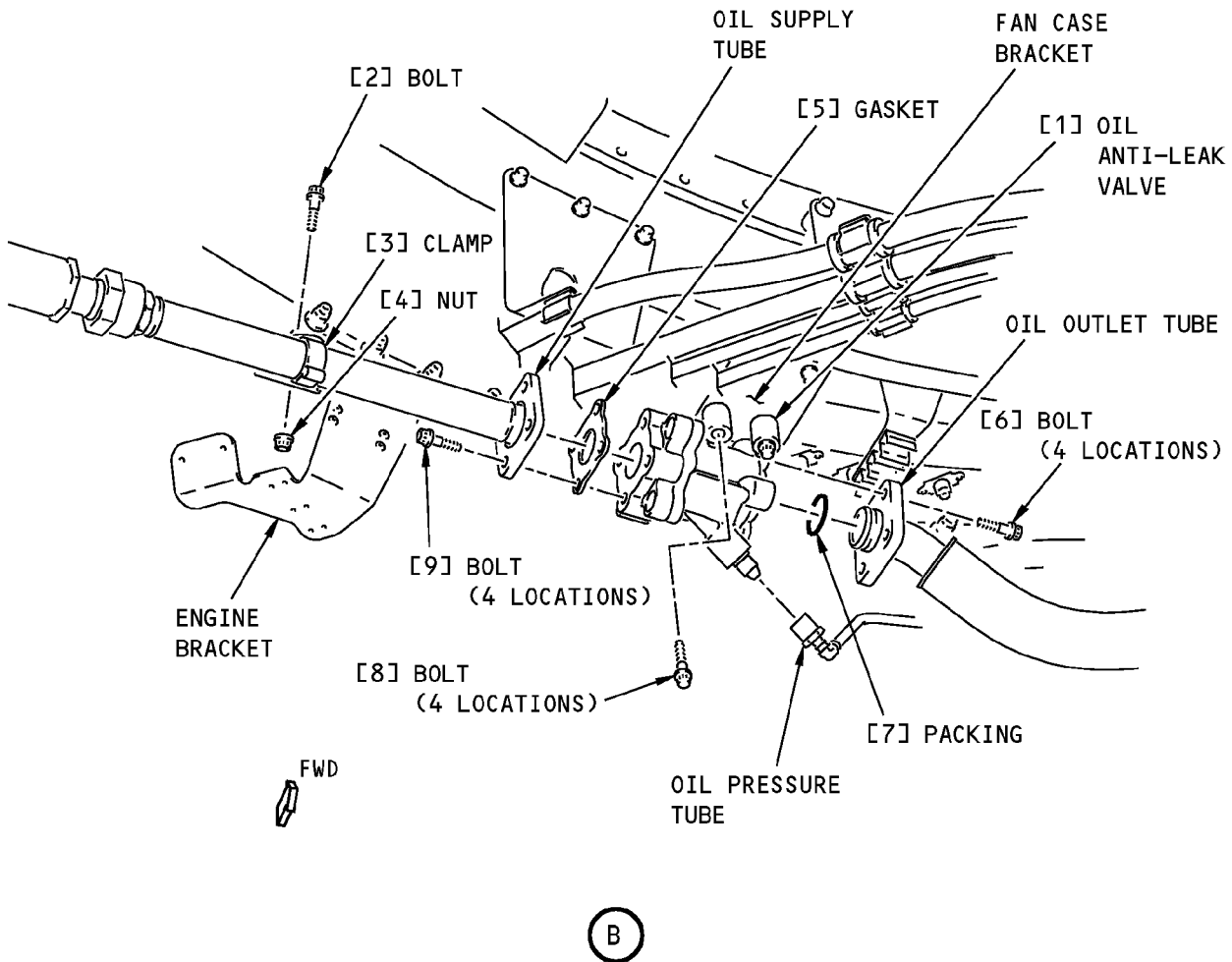

Oil Anti-Leak Valve Installation
Figure 401 (Sheet 2 of 2)/79-21-09-990-801-F00

EFFECTIVITY
HAP ALL

79-21-09

Page 405
Oct 10/2003

D633A101-HAP

AIRCRAFT MAINTENANCE MANUAL

TASK 79-21-09-400-801-F00

3. Oil Anti-Leak Valve - Installation

(Figure 401)

A. General

(1) This task is the installation procedure for the oil anti-leak valve (referred to as the valve).

B. References

Reference	Title
12-13-11-600-801	Replenish the Engine Oil (P/B 301)
70-10-02-910-801-F00	General Precautions During the Removal and Installation of Engine Components (P/B 201)
71-00-00-800-811-F00	Power Plant Test Reference Table (P/B 501)
71-11-02-410-801-F00	Close the Fan Cowl Panels (P/B 201)

C. Consumable Materials

Reference	Description	Specification
D00599 [CP2442]	Oil - Engine (CFMI SB 79-001)	
D00601 [CP2101]	Grease - Graphite, High Temperature	SAE AMS 2518

D. Expendables/Parts

AMM Item	Description	AIPC Reference	AIPC Effectivity
1	Valve	79-21-00-03-090	HAP ALL
5	Gasket	79-21-00-03-080	HAP ALL
7	Packing	79-21-00-01-205	HAP ALL

E. Location Zones

Zone	Area
411	Engine 1 - Engine
421	Engine 2 - Engine

F. Prepare for the Installation

SUBTASK 79-21-09-840-001-F00

(1) Do these steps to prepare the valve [1] for the installation General Precautions During the Removal and Installation of Engine Components, TASK 70-10-02-910-801-F00:

- (a) Remove all the protective caps from the connection interfaces.
- (b) Make sure that all the mating interfaces to the valve [1] are clean and in good condition.

CAUTION: EXAMINE THE USED GASKET FOR DAMAGE BEFORE YOU USE IT AGAIN.
REPLACE THE GASKET AS NECESSARY. OIL LEAKAGE COULD OCCUR.

- (c) Lubricate the gasket with oil, D00599 [CP2442].
- (d) Lubricate the packing with grease, D00601 [CP2101].
- (e) Lubricate the threads of all the bolts with grease, D00601 [CP2101].
- (f) Lubricate the threads of the valve nipple with oil, D00599 [CP2442].

G. Oil Anti-Leak Valve Installation

SUBTASK 79-21-09-420-001-F00

(1) Do these steps to install the valve [1]:

- (a) Put the valve [1] in its position on the fan case bracket.

EFFECTIVITY
HAP ALL

79-21-09

Page 406
Jun 15/2009

D633A101-HAP

AIRCRAFT MAINTENANCE MANUAL

- (b) Attach the valve [1] to the fan case bracket with the four bolts [8].
- 1) Tighten the bolts [8] to 98-110 pound-inches (11-12.5 Newton meters).

SUBTASK 79-21-09-420-002-F00

- (2) Do these steps to connect the oil outlet tube to the valve [1]:

CAUTION: MAKE SURE YOU INSTALL THE PACKING CORRECTLY ON THE VALVE. IF YOU DO NOT INSTALL THE PACKING CORRECTLY, OIL LOSS CAN OCCUR DURING ENGINE OPERATION AND CAN CAUSE DAMAGE TO THE ENGINE.

- (a) Install the packing [7].
- (b) Install the four bolts [6] to attach the oil outlet tube to the valve [1].
 - 1) Tighten the bolts [6] to 98-110 pound-inches (11-12.5 Newton meters).

SUBTASK 79-21-09-420-003-F00

- (3) Do these steps to connect the oil pressure tube to the valve [1]:

CAUTION: USE TWO WRENCHES TO TIGHTEN THE COUPLING NUT. USE ONE TO HOLD THE FITTING, AND THE OTHER TO TIGHTEN THE COUPLING NUT. IF YOU DO NOT USE TWO WRENCHES, DAMAGE TO THE EQUIPMENT CAN OCCUR.

- (a) Connect the oil pressure tube to the valve [1].
- (b) Tighten the tube coupling nut to 135-150 pound-inches (15.3-17 Newton meters).

SUBTASK 79-21-09-420-004-F00

- (4) Do these steps to connect the oil supply tube to the valve [1]:

- (a) Install the gasket [5].
- (b) Install the four bolts [9] to attach the oil supply tube to the valve [1].
 - 1) Tighten the bolts [9] to 98-110 pound-inches (11-12.5 Newton meters).
- (c) Attach the supply tube to the engine bracket with the clamp [3], bolt [2] and nut [4].
 - 1) Tighten the bolt [2] to 98-110 pound-inches (11-12.5 Newton meters).

H. Put the Airplane Back to Its Usual Condition

SUBTASK 79-21-09-610-001-F00

- (1) Do this task: Replenish the Engine Oil, TASK 12-13-11-600-801.

SUBTASK 79-21-09-410-001-F00

- (2) Do this task: Close the Fan Cowl Panels, TASK 71-11-02-410-801-F00.

SUBTASK 79-21-09-860-003-F00

- (3) For Engine 1, remove the safety tags and close these circuit breakers:

CAPT Electrical System Panel, P18-2

<u>Row</u>	<u>Col</u>	<u>Number</u>	<u>Name</u>
D	5	C01359	DISPLAY DEU 1 PRI

F/O Electrical System Panel, P6-1

<u>Row</u>	<u>Col</u>	<u>Number</u>	<u>Name</u>
D	10	C01361	DISPLAY DEU 1 HOLDUP

EFFECTIVITY
HAP ALL

D633A101-HAP

79-21-09

Page 407
Feb 15/2009

AIRCRAFT MAINTENANCE MANUAL

SUBTASK 79-21-09-860-004-F00

- (4) For Engine 2, remove the safety tags and close these circuit breakers:

F/O Electrical System Panel, P6-1

<u>Row</u>	<u>Col</u>	<u>Number</u>	<u>Name</u>
D	9	C01362	DISPLAY DEU 2 HOLDUP
D	11	C01360	DISPLAY DEU 2 PRI

I. Oil Anti-Leak Valve Installation Test

SUBTASK 79-21-09-800-001-F00

- (1) Do the tests that are listed in the Power Plant Test Reference Table, TASK 71-00-00-800-811-F00.

————— END OF TASK —————

EFFECTIVITY
HAP ALL

D633A101-HAP

79-21-09

Page 408
Oct 10/2003

AIRCRAFT MAINTENANCE MANUAL

CLOGGING INDICATOR - REMOVAL/INSTALLATION**1. General**

A. This procedure has two tasks:

- (1) The removal of the clogging indicator
- (2) The installation of the clogging indicator.

TASK 79-21-10-000-801-F00**2. Clogging Indicator Removal**

(Figure 401)

A. General

- (1) This task is the removal procedure for the clogging indicator.
- (2) The clogging indicator is installed in a cavity of the lubrication unit housing.

B. References

Reference	Title
71-11-02-010-801-F00	Open the Fan Cowl Panels (P/B 201)

C. Tools/Equipment

Reference	Description
STD-3941	Container - Calibrated, 1 quart (1 l), oil resistant

D. Location Zones

Zone	Area
411	Engine 1 - Engine
421	Engine 2 - Engine

E. Prepare for the Removal

SUBTASK 79-21-10-865-001-F00

- (1) For Engine 1, open these circuit breakers and install safety tags:

CAPT Electrical System Panel, P18-2

Row	Col	Number	Name
A	4	C01390	ENGINE 1 ALTN PWR CHAN B
A	5	C01314	ENGINE 1 ALTN PWR CHAN A

SUBTASK 79-21-10-865-002-F00

- (2) For Engine 2, open these circuit breakers and install safety tags:

F/O Electrical System Panel, P6-2

Row	Col	Number	Name
D	7	C01391	ENGINE 2 ALTN PWR CHAN B
D	8	C01315	ENGINE 2 ALTN PWR CHAN A

SUBTASK 79-21-10-010-001-F00

- (3) Do this task: Open the Fan Cowl Panels, TASK 71-11-02-010-801-F00.

EFFECTIVITY
HAP ALL

D633A101-HAP

79-21-10

Page 401
Jun 15/2009

AIRCRAFT MAINTENANCE MANUAL

F. Procedure

SUBTASK 79-21-10-490-001-F00

WARNING: DO NOT TOUCH THE COMPONENTS OF THE OIL SYSTEM IF THE ENGINE IS HOT. THESE COMPONENTS STAY HOTTER THAN OTHER COMPONENTS. HOT COMPONENTS CAN BURN YOU.

WARNING: DO NOT OPEN THE OIL SYSTEM UNTIL THE PRESSURE GOES TO ZERO. THE PRESSURE GOES TO ZERO APPROXIMATELY 5 MINUTES AFTER AN ENGINE STOPS. A PRESSURIZED OIL SYSTEM CAN RELEASE A SPRAY OF HOT OIL THAT CAN BURN YOU.

WARNING: DO NOT LET HOT OIL GET ON YOU. PUT ON CLOTHES, GOGGLES, AND OTHER EQUIPMENT FOR PROTECTION, OR LET THE ENGINE BECOME COOL. HOT OIL CAN BURN YOU.

CAUTION: IMMEDIATELY CLEAN OFF ALL ENGINE OIL THAT FALLS ON THE PAINTED SURFACES AND RUBBER PARTS OF THE AIRPLANE. THE SPECIFIED OIL FOR THIS OIL SYSTEM WILL CAUSE DAMAGE TO THE PAINTED SURFACES AND SOME TYPES OF RUBBER AND MUST NOT BE PERMITTED TO TOUCH THESE PARTS OF THE ENGINE.

USE VERY CLEAN CONTAINERS AND EQUIPMENT. OIL CONTAMINATION BY SMALL QUANTITIES OF SOME ALKALINE CLEANERS CAN CAUSE A FAILURE OF THE SYNTHETIC OIL.

DO NOT PUT THE OIL THAT IS DRAINED FROM THE ENGINE BACK INTO THE ENGINE.

- (1) Put the 1 quart (1 l) oil resistant calibrated container, STD-3941 below the clogging indicator [1] to catch the oil.

SUBTASK 79-21-10-030-001-F00

- (2) Remove the safety wire.

SUBTASK 79-21-10-616-001-F00

- (3) Remove the clogging indicator [1].
 - (a) Let the oil drain in the container.

SUBTASK 79-21-10-030-002-F00

- (4) Remove and discard the packing [2] and the packing [3].

SUBTASK 79-21-10-490-002-F00

- (5) Install a cap in clogging indicator housing in the lubrication unit.

————— **END OF TASK** —————

EFFECTIVITY
HAP ALL

D633A101-HAP

79-21-10

Page 402
Jun 15/2009

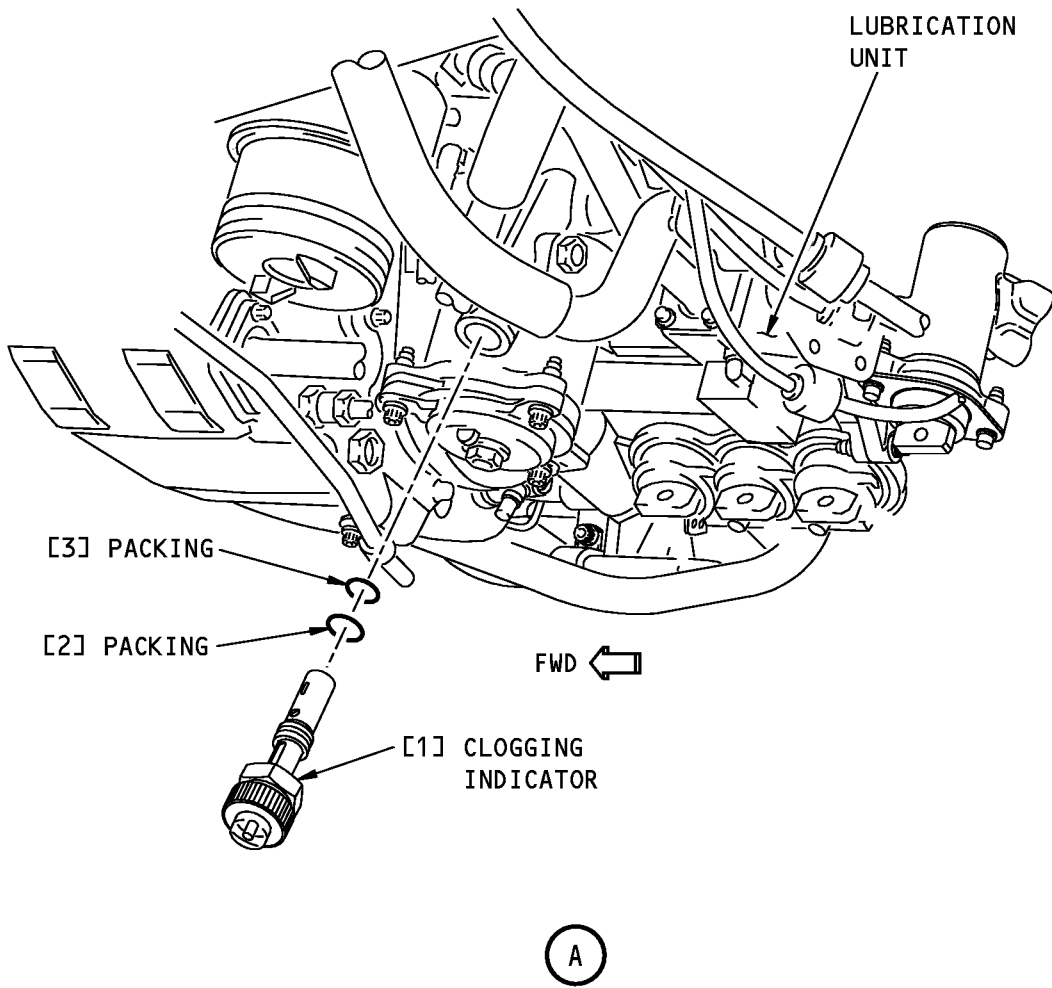
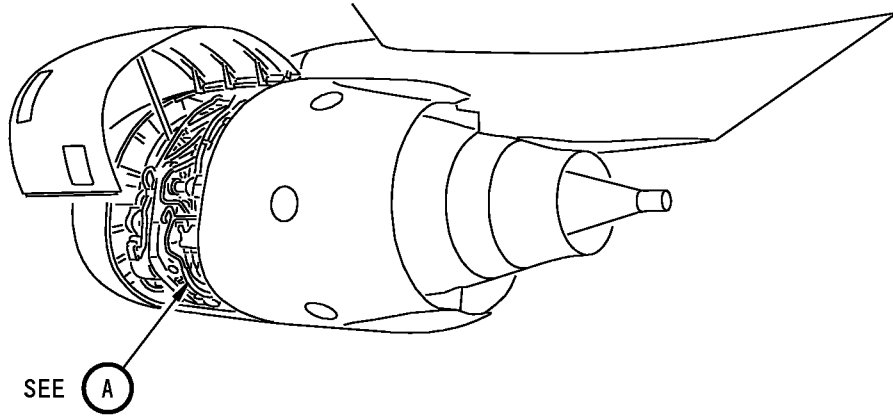

1844498 S0000327509_V1

Clogging Indicator Installation
Figure 401/79-21-10-990-801-F00

EFFECTIVITY
HAP ALL

79-21-10

Page 403
Jun 15/2009

D633A101-HAP

AIRCRAFT MAINTENANCE MANUAL

TASK 79-21-10-400-801-F00

3. Clogging Indicator Installation

(Figure 401)

A. References

Reference	Title
12-13-11-600-801	Replenish the Engine Oil (P/B 301)
71-00-00-800-811-F00	Power Plant Test Reference Table (P/B 501)
71-11-02-410-801-F00	Close the Fan Cowl Panels (P/B 201)

B. Consumable Materials

Reference	Description	Specification
D00599 [CP2442]	Oil - Engine (CFMI SB 79-001)	
G02345 [CP8001]	Lockwire - Inconel (0.032 inch Dia.)	NASM20995~ N32
G02495 [CP8002]	Lockwire - 0.032 inch Dia., AMS 5689	NASM20995~ C32

C. Location Zones

Zone	Area
411	Engine 1 - Engine
421	Engine 2 - Engine

D. Prepare for the Installation

SUBTASK 79-21-10-030-003-F00

(1) Remove the protective cover from the clogging indicator [1].

SUBTASK 79-21-10-212-001-F00

WARNING: DO NOT TOUCH THE COMPONENTS OF THE OIL SYSTEM IF THE ENGINE IS HOT. THESE COMPONENTS STAY HOTTER THAN OTHER COMPONENTS. HOT COMPONENTS CAN BURN YOU.

(2) Make sure that all the flanges on the clogging indicator [1] and the lubrication unit housing are clean and in good condition.

E. Procedure

SUBTASK 79-21-10-640-001-F00

WARNING: DO NOT LET OIL STAY ON YOUR SKIN. THE SYNTHETIC OIL CONTAINS ADDITIVES THAT CAN BE POISONOUS IF THEY ARE ABSORBED THROUGH THE SKIN. CLEAN AWAY ALL OIL THAT GETS ON THE SKIN.

(1) Lubricate the new packing [2] and the new packing [3] with oil, D00599 [CP2442].

SUBTASK 79-21-10-420-001-F00

CAUTION: DO NOT CAUSE DAMAGE TO THE PREFORMED PACKING. OIL LEAKS WILL OCCUR. THIS CAN CAUSE DAMAGE TO THE ENGINE.

(2) Install the packing [2] and the packing [3] on the clogging indicator [1].

SUBTASK 79-21-10-090-001-F00

(3) Remove the cap from the lubrication unit.

SUBTASK 79-21-10-430-001-F00

(4) Engage the clogging indicator [1] in the lubrication unit housing and fully install by hand.

EFFECTIVITY
HAP ALL

D633A101-HAP

79-21-10

Page 404
Jun 15/2009

AIRCRAFT MAINTENANCE MANUAL

SUBTASK 79-21-10-430-002-F00

(5) Tighten the clogging indicator [1] to 127-139 pound-inches (14.25-15.75 Newton meters).

SUBTASK 79-21-10-420-002-F00

(6) Install lockwire, G02345 [CP8001] or lockwire, G02495 [CP8002] on the clogging indicator [1].

F. Put the Airplane Back to its Usual Condition

SUBTASK 79-21-10-612-001-F00

(1) Do this task: Replenish the Engine Oil, TASK 12-13-11-600-801.

SUBTASK 79-21-10-865-003-F00

(2) For Engine 1, close these circuit breakers and remove the safety tags:

CAPT Electrical System Panel, P18-2

<u>Row</u>	<u>Col</u>	<u>Number</u>	<u>Name</u>
A	4	C01390	ENGINE 1 ALTN PWR CHAN B
A	5	C01314	ENGINE 1 ALTN PWR CHAN A

SUBTASK 79-21-10-865-004-F00

(3) For Engine 2, close these circuit breakers and remove the safety tags:

F/O Electrical System Panel, P6-2

<u>Row</u>	<u>Col</u>	<u>Number</u>	<u>Name</u>
D	7	C01391	ENGINE 2 ALTN PWR CHAN B
D	8	C01315	ENGINE 2 ALTN PWR CHAN A

SUBTASK 79-21-10-410-001-F00

(4) Do this task: Close the Fan Cowl Panels, TASK 71-11-02-410-801-F00.

G. Clogging Indicator Installation Test

SUBTASK 79-21-10-790-001-F00

(1) Do the tests that are listed in the Power Plant Test Reference Table, TASK 71-00-00-800-811-F00.

————— **END OF TASK** —————

EFFECTIVITY
HAP ALL

D633A101-HAP

79-21-10

Page 405
Jun 15/2009

AIRCRAFT MAINTENANCE MANUAL

OIL QUANTITY INDICATING SYSTEM - ADJUSTMENT/TEST**1. General**

A. This procedure contains one task, the system test procedure for the oil quantity indication system.

TASK 79-31-00-730-801-F00**2. System Test - Oil Quantity Indicating System**

A. General

- (1) The system test drains the oil tank and adds known quantities of oil to the oil tank.
- (2) Approximately 2.2-2.76 quarts (2.1-2.6 liters) of oil are in the engine sumps.
 - (a) This oil is not usable by the engine and is not measured by the indicator system.

B. References

Reference	Title
12-13-11-600-801	Replenish the Engine Oil (P/B 301)
12-13-11-600-803	Drain the Engine Oil (P/B 301)
71-00-00-800-811-F00	Power Plant Test Reference Table (P/B 501)
71-11-02-010-801-F00	Open the Fan Cowl Panels (P/B 201)
71-11-02-410-801-F00	Close the Fan Cowl Panels (P/B 201)

C. Location Zones

Zone	Area
211	Flight Compartment - Left
212	Flight Compartment - Right
411	Engine 1 - Engine
421	Engine 2 - Engine

D. Prepare to Do the System Test for the Oil Quantity Indicating System

SUBTASK 79-31-00-860-001-F00

- (1) For Engine 1, make sure that these circuit breakers are closed:

CAPT Electrical System Panel, P18-2

Row	Col	Number	Name
D	5	C01359	DISPLAY DEU 1 PRI

F/O Electrical System Panel, P6-1

Row	Col	Number	Name
D	10	C01361	DISPLAY DEU 1 HOLDUP

SUBTASK 79-31-00-860-002-F00

- (2) For Engine 2, make sure that these circuit breakers are closed:

F/O Electrical System Panel, P6-1

Row	Col	Number	Name
D	9	C01362	DISPLAY DEU 2 HOLDUP
D	11	C01360	DISPLAY DEU 2 PRI

SUBTASK 79-31-00-010-001-F00

- (3) Do this task: Open the Fan Cowl Panels, TASK 71-11-02-010-801-F00.

EFFECTIVITY
HAP ALL

D633A101-HAP

79-31-00

Page 501
Oct 10/2003

AIRCRAFT MAINTENANCE MANUAL**E. Do the System Test for the Oil Quantity Indicating System**

SUBTASK 79-31-00-680-001-F00

(1) Drain the oil from the oil tank Drain the Engine Oil, TASK 12-13-11-600-803.

SUBTASK 79-31-00-730-001-F00

(2) Do these steps to do a check of the oil quantity indicating system:

- (a) Add 2 U.S. quarts (1.90 liters) of oil to the oil tank.
- (b) Make sure that the OIL QTY display reads zero to 6% or zero to one quart or zero to one liter.
- (c) Add 10 U.S. quarts (9.50 liters) of oil to the oil tank.
- (d) Make sure that the OIL QTY display reads $53 \pm 6\%$ or 9 to 11 quarts or 8 to 11 liters.
- (e) Add 9 U.S. quarts (8.50 liters) of oil to the oil tank.
- (f) Make sure that the OIL QTY display reads $97 \pm 3\%$ or 18 to 20 quarts or 17 to 19 liters.

SUBTASK 79-31-00-610-002-F00

(3) Do this task: Replenish the Engine Oil, TASK 12-13-11-600-801.

SUBTASK 79-31-00-410-001-F00

(4) Do this task: Close the Fan Cowl Panels, TASK 71-11-02-410-801-F00.

SUBTASK 79-31-00-800-001-F00

(5) Do the tests that are listed in the Power Plant Test Reference Table, TASK 71-00-00-800-811-F00.

END OF TASK**EFFECTIVITY**
HAP ALL

D633A101-HAP

79-31-00Page 502
Oct 10/2003

AIRCRAFT MAINTENANCE MANUAL

OIL QUANTITY TRANSMITTER - REMOVAL/INSTALLATION**1. General**

A. This procedure has two tasks:

- (1) The removal of the oil quantity transmitter.
- (2) The installation of the oil quantity transmitter.

TASK 79-31-01-000-801-F00**2. Oil Quantity Transmitter Removal**

(Figure 401)

A. General

- (1) This task is the removal procedure for the oil quantity transmitter (referred to as the transmitter).
- (2) The oil quantity transmitter is installed on top of the oil tank cover.
- (3) The engine has one oil quantity transmitter.

B. References

Reference	Title
70-30-01-910-802-F00	Seals (Preformed Packings and O-Rings) and Gaskets (P/B 201)
71-11-02-010-801-F00	Open the Fan Cowl Panels (P/B 201)

C. Location Zones

Zone	Area
411	Engine 1 - Engine
421	Engine 2 - Engine

D. Prepare for the Removal

SUBTASK 79-31-01-860-001-F00

- (1) For Engine 1, open these circuit breakers and install safety tags:

CAPT Electrical System Panel, P18-2

Row	Col	Number	Name
D	5	C01359	DISPLAY DEU 1 PRI

F/O Electrical System Panel, P6-1

Row	Col	Number	Name
D	10	C01361	DISPLAY DEU 1 HOLDUP

SUBTASK 79-31-01-860-002-F00

- (2) For Engine 2, open these circuit breakers and install safety tags:

F/O Electrical System Panel, P6-1

Row	Col	Number	Name
D	9	C01362	DISPLAY DEU 2 HOLDUP
D	11	C01360	DISPLAY DEU 2 PRI

SUBTASK 79-31-01-010-001-F00

- (3) Do this task: Open the Fan Cowl Panels, TASK 71-11-02-010-801-F00.

EFFECTIVITY
HAP ALL

D633A101-HAP

79-31-01

Page 401
Oct 10/2003

AIRCRAFT MAINTENANCE MANUAL

E. Oil Quantity Transmitter Removal

SUBTASK 79-31-01-020-002-F00

WARNING: DO NOT TOUCH THE COMPONENTS OF THE OIL SYSTEM IF THE ENGINE IS HOT. THESE COMPONENTS STAY HOTTER THAN OTHER COMPONENTS. HOT COMPONENTS CAN BURN YOU.

WARNING: DO NOT OPEN THE OIL SYSTEM UNTIL THE PRESSURE GOES TO ZERO. THE PRESSURE GOES TO ZERO APPROXIMATELY 5 MINUTES AFTER AN ENGINE SHUTDOWN. A PRESSURIZED ENGINE CAN RELEASE A SPRAY OF HOT OIL THAT CAN BURN YOU.

WARNING: DO NOT LET HOT OIL GET ON YOU. PUT ON GOGGLES AND OTHER EQUIPMENT FOR PROTECTION OR LET THE ENGINE BECOME COOL. HOT OIL CAN BURN YOU.

CAUTION: DO NOT LET HOT OIL GET ON THE ENGINE OR OTHER COMPONENTS. IMMEDIATELY CLEAN THE COMPONENT IF OIL FALLS ON IT. OIL CAN CAUSE DAMAGE TO PAINT AND RUBBER.

- (1) Do these steps to remove the transmitter:
 - (a) Disconnect the electrical connector, DP1301 [6] from the transmitter receptacle.
 - (b) Remove the four bolts [2] and washers [3].
 - (c) Remove the transmitter [4] from the oil tank recess.
 - (d) Put a protective cover on the oil tank recess Seals (Preformed Packings and O-Rings) and Gaskets, TASK 70-30-01-910-802-F00.
 - (e) Remove and discard the packing [5] from the transmitter [4].

————— **END OF TASK** —————

EFFECTIVITY
HAP ALL

D633A101-HAP

79-31-01Page 402
Jun 10/2005

737-600/700/800/900
AIRCRAFT MAINTENANCE MANUAL

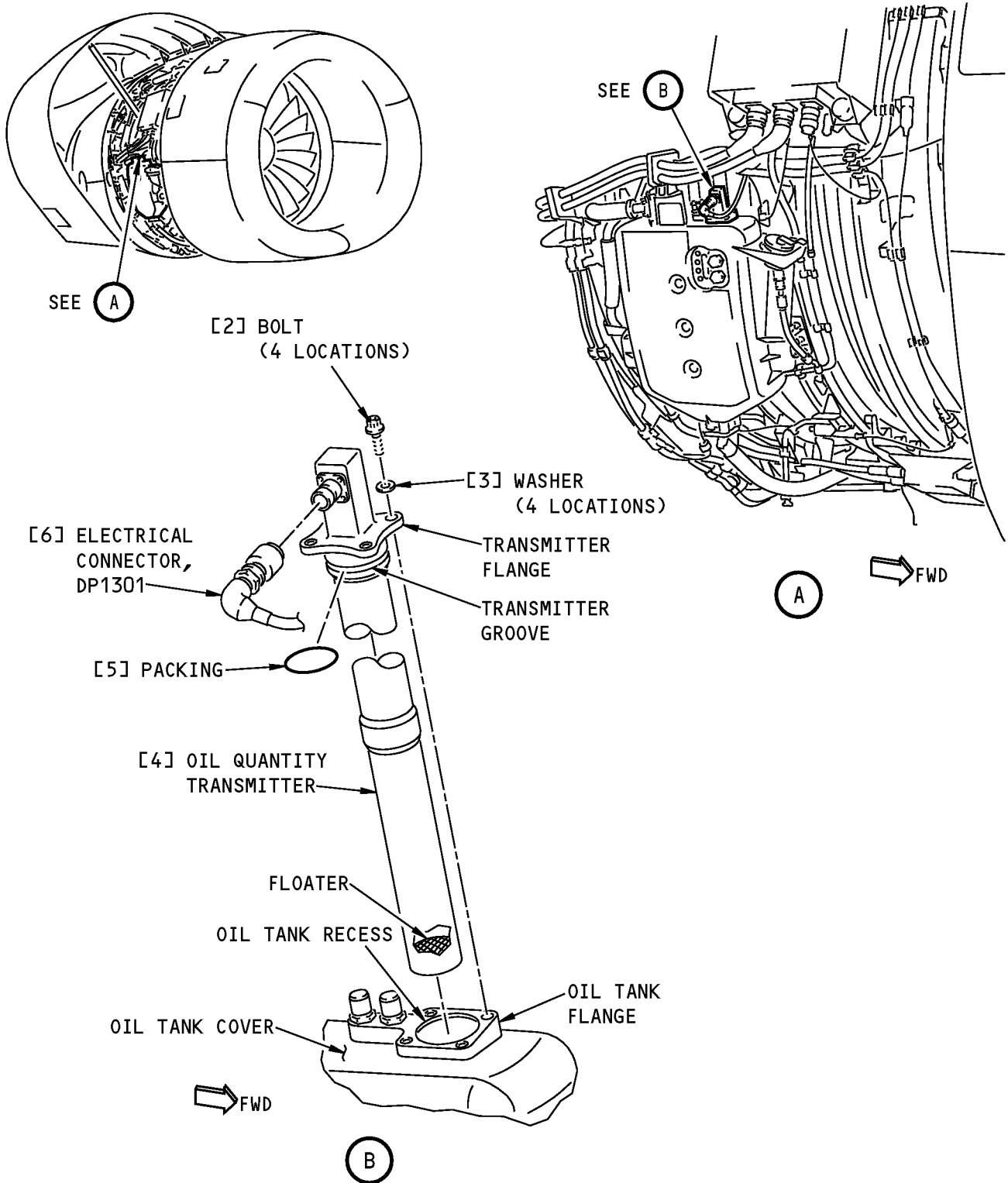

Oil Quantity Transmitter Installation
Figure 401/79-31-01-990-801-F00

EFFECTIVITY
HAP ALL

79-31-01

Page 403
Oct 10/2003

D633A101-HAP

AIRCRAFT MAINTENANCE MANUAL

TASK 79-31-01-400-801-F00

3. Oil Quantity Transmitter Installation

(Figure 401)

A. References

Reference	Title
12-13-11-600-801	Replenish the Engine Oil (P/B 301)
70-10-02-910-801-F00	General Precautions During the Removal and Installation of Engine Components (P/B 201)
70-30-01-910-802-F00	Seals (Preformed Packings and O-Rings) and Gaskets (P/B 201)
71-00-00-800-811-F00	Power Plant Test Reference Table (P/B 501)
71-11-02-410-801-F00	Close the Fan Cowl Panels (P/B 201)

B. Consumable Materials

Reference	Description	Specification
B00130	Alcohol - Isopropyl	TT-I-735
D00599 [CP2442]	Oil - Engine (CFMI SB 79-001)	
D00601 [CP2101]	Grease - Graphite, High Temperature	SAE AMS 2518
G00034	Cotton Wiper - Process Cleaning Absorbent Wiper (Cheesecloth, Gauze)	BMS15-5

C. Expendables/Parts

AMM Item	Description	AIPC Reference	AIPC Effectivity
4	Transmitter	79-31-01-01-025	HAP ALL
5	Packing	79-31-01-01-020	HAP ALL

D. Location Zones

Zone	Area
411	Engine 1 - Engine
421	Engine 2 - Engine

E. Prepare for the Installation

SUBTASK 79-31-01-210-001-F00

- (1) Do a visual check through the bottom of the oil quantity transmitter to make sure you can see the floater.

NOTE: If the floater is not at the bottom of the transmitter before installation, an incorrect indication (always full) in the flight compartment will occur.

- (a) If you do not see the floater, shake the oil quantity transmitter upwards to release the floater.
- (b) Make sure the floater is at the bottom of the transmitter.

SUBTASK 79-31-01-840-001-F00

- (2) Do these steps to prepare for the installation:

- (a) Clean the transmitter flange and oil tank flange with alcohol, B00130 and a cotton wiper, G00034.
- (b) Make sure that the mating interfaces of the transmitter are clean and in a good condition General Precautions During the Removal and Installation of Engine Components, TASK 70-10-02-910-801-F00.

EFFECTIVITY
HAP ALL

79-31-01

Page 404
Jun 15/2009

D633A101-HAP

AIRCRAFT MAINTENANCE MANUAL

- (c) Remove the protective cover from the oil tank recess Seals (Preformed Packings and O-Rings) and Gaskets, TASK 70-30-01-910-802-F00.

F. Transmitter Installation

SUBTASK 79-31-01-420-001-F00

- (1) Do these steps to install the transmitter [4]:

CAUTION: DO NOT LET HOT OIL GET ON THE ENGINE OR OTHER COMPONENTS. IMMEDIATELY CLEAN THE COMPONENT IF OIL FALLS ON IT. OIL CAN CAUSE DAMAGE TO PAINT AND RUBBER.

- (a) Lubricate a new packing [5] with oil, D00599 [CP2442].
 (b) Lubricate the threads of the four bolts [2] with grease, D00601 [CP2101].

CAUTION: MAKE SURE THAT YOU INSTALL THE PACKING ON THE TRANSMITTER CORRECTLY DURING THE INSTALLATION OF THE TRANSMITTER. IF YOU DO NOT INSTALL THE PACKING CORRECTLY, OIL LOSS CAN OCCUR DURING ENGINE OPERATION AND CAN CAUSE DAMAGE TO THE ENGINE.

- (c) Install the packing [5] in the transmitter groove.
 (d) Put the transmitter [4] in the oil tank recess.
 (e) Install the four bolts [2] and washers [3] to attach the transmitter [4] to the oil tank cover.
 1) Tighten the bolts [2] to 98-110 pound-inches (11-12.5 Newton meters).
 (f) Connect the electrical connector, DP1301 [6] to the transmitter receptacle.

G. Put the Airplane Back to Its Usual Condition

SUBTASK 79-31-01-610-002-F00

- (1) Make sure that the level in the oil tank is full Replenish the Engine Oil, TASK 12-13-11-600-801.

SUBTASK 79-31-01-410-002-F00

- (2) Do this task: Close the Fan Cowl Panels, TASK 71-11-02-410-801-F00.

SUBTASK 79-31-01-860-005-F00

- (3) For Engine 1, remove the safety tags and close these circuit breakers:

CAPT Electrical System Panel, P18-2

Row	Col	Number	Name
D	5	C01359	DISPLAY DEU 1 PRI

F/O Electrical System Panel, P6-1

Row	Col	Number	Name
D	10	C01361	DISPLAY DEU 1 HOLDUP

SUBTASK 79-31-01-860-006-F00

- (4) For Engine 2, remove the safety tags and close these circuit breakers:

F/O Electrical System Panel, P6-1

Row	Col	Number	Name
D	9	C01362	DISPLAY DEU 2 HOLDUP
D	11	C01360	DISPLAY DEU 2 PRI

H. Oil Quantity Transmitter Installation Test

SUBTASK 79-31-01-710-001-F00

- (1) Make sure that the oil quantity indication reads full on the display in the flight compartment.

EFFECTIVITY
HAP ALL

79-31-01

D633A101-HAP

Page 405
Feb 15/2009

AIRCRAFT MAINTENANCE MANUAL

SUBTASK 79-31-01-800-001-F00

- (2) Do the tests that are listed in the Power Plant Test Reference Table, TASK 71-00-00-800-811-F00.

————— **END OF TASK** —————

EFFECTIVITY
HAP ALL

D633A101-HAP

79-31-01

Page 406
Feb 15/2009

AIRCRAFT MAINTENANCE MANUAL

OIL PRESSURE SENSOR - REMOVAL/INSTALLATION**1. General**

A. This procedure has two tasks:

- (1) The removal of the oil pressure sensor.
- (2) The installation of the oil pressure sensor.

TASK 79-32-01-000-801-F00**2. Oil Pressure Sensor Removal**

(Figure 401)

A. General

- (1) This task is the removal procedure for the oil pressure sensor (referred to as the sensor).
- (2) The oil pressure sensor is installed on the fan inlet case at the 10:00 o'clock position, adjacent to the oil temperature sensor.

B. References

Reference	Title
70-10-02-910-801-F00	General Precautions During the Removal and Installation of Engine Components (P/B 201)
70-30-01-910-802-F00	Seals (Preformed Packings and O-Rings) and Gaskets (P/B 201)
71-11-02-010-801-F00	Open the Fan Cowl Panels (P/B 201)

C. Consumable Materials

Reference	Description	Specification
G00034	Cotton Wiper - Process Cleaning Absorbent Wiper (Cheesecloth, Gauze)	BMS15-5

D. Location Zones

Zone	Area
411	Engine 1 - Engine
421	Engine 2 - Engine

E. Prepare for the Removal

SUBTASK 79-32-01-860-001-F00

- (1) For Engine 1, open these circuit breakers and install safety tags:

CAPT Electrical System Panel, P18-2

Row	Col	Number	Name
A	4	C01390	ENGINE 1 ALTN PWR CHAN B
A	5	C01314	ENGINE 1 ALTN PWR CHAN A

SUBTASK 79-32-01-860-002-F00

- (2) For Engine 2, open these circuit breakers and install safety tags:

F/O Electrical System Panel, P6-2

Row	Col	Number	Name
D	7	C01391	ENGINE 2 ALTN PWR CHAN B
D	8	C01315	ENGINE 2 ALTN PWR CHAN A

EFFECTIVITY
HAP ALL

D633A101-HAP

79-32-01

Page 401
Oct 10/2004

AIRCRAFT MAINTENANCE MANUAL

SUBTASK 79-32-01-010-001-F00

(3) Do this task: Open the Fan Cowl Panels, TASK 71-11-02-010-801-F00.

F. Oil Pressure Sensor Removal

SUBTASK 79-32-01-020-002-F00

WARNING: DO NOT TOUCH THE COMPONENTS OF THE OIL SYSTEM IF THE ENGINE IS HOT. THESE COMPONENTS STAY HOTTER THAN OTHER COMPONENTS. HOT COMPONENTS CAN BURN YOU.

WARNING: DO NOT OPEN THE OIL SYSTEM UNTIL THE PRESSURE GOES TO ZERO. THE PRESSURE GOES TO ZERO APPROXIMATELY 5 MINUTES AFTER AN ENGINE SHUTDOWN. A PRESSURIZED ENGINE CAN RELEASE A SPRAY OF HOT OIL THAT CAN BURN YOU.

WARNING: DO NOT LET HOT OIL GET ON YOU. PUT ON GOGGLES AND OTHER EQUIPMENT FOR PROTECTION OR LET THE ENGINE BECOME COOL. HOT OIL CAN BURN YOU.

CAUTION: DO NOT LET HOT OIL GET ON THE ENGINE OR OTHER COMPONENTS. IMMEDIATELY CLEAN THE COMPONENT IF OIL FALLS ON IT. OIL CAN CAUSE DAMAGE TO PAINT AND RUBBER.

(1) Do these steps to remove the sensor [2] from the oil pressure manifold (Figure 401):

- (a) Disconnect the electrical connectors, DP0705 (CH A) [5] and DP0805 (CH B) [6] from the sensor receptacles.
- (b) Put a cotton wiper, G00034, below the sensor [2].
- (c) Remove the three bolts [1] and the three washers [3] from the sensor [2].

NOTE: Move the bonding strip out of the way.

- (d) Remove the sensor [2].
 - 1) Clean the oil off with a cloth.
- (e) Remove the vespel plate [7] and the four packings [8] Seals (Preformed Packings and O-Rings) and Gaskets, TASK 70-30-01-910-802-F00.

NOTE: Use the vespel plate again if it is in good condition.

- 1) Discard the four packings [8].
- (f) Put protective covers in the opening of the oil pressure manifold and the sensor flange General Precautions During the Removal and Installation of Engine Components, TASK 70-10-02-910-801-F00.

————— **END OF TASK** —————

EFFECTIVITY
HAP ALL

D633A101-HAP

79-32-01Page 402
Jun 10/2005

737-600/700/800/900
AIRCRAFT MAINTENANCE MANUAL

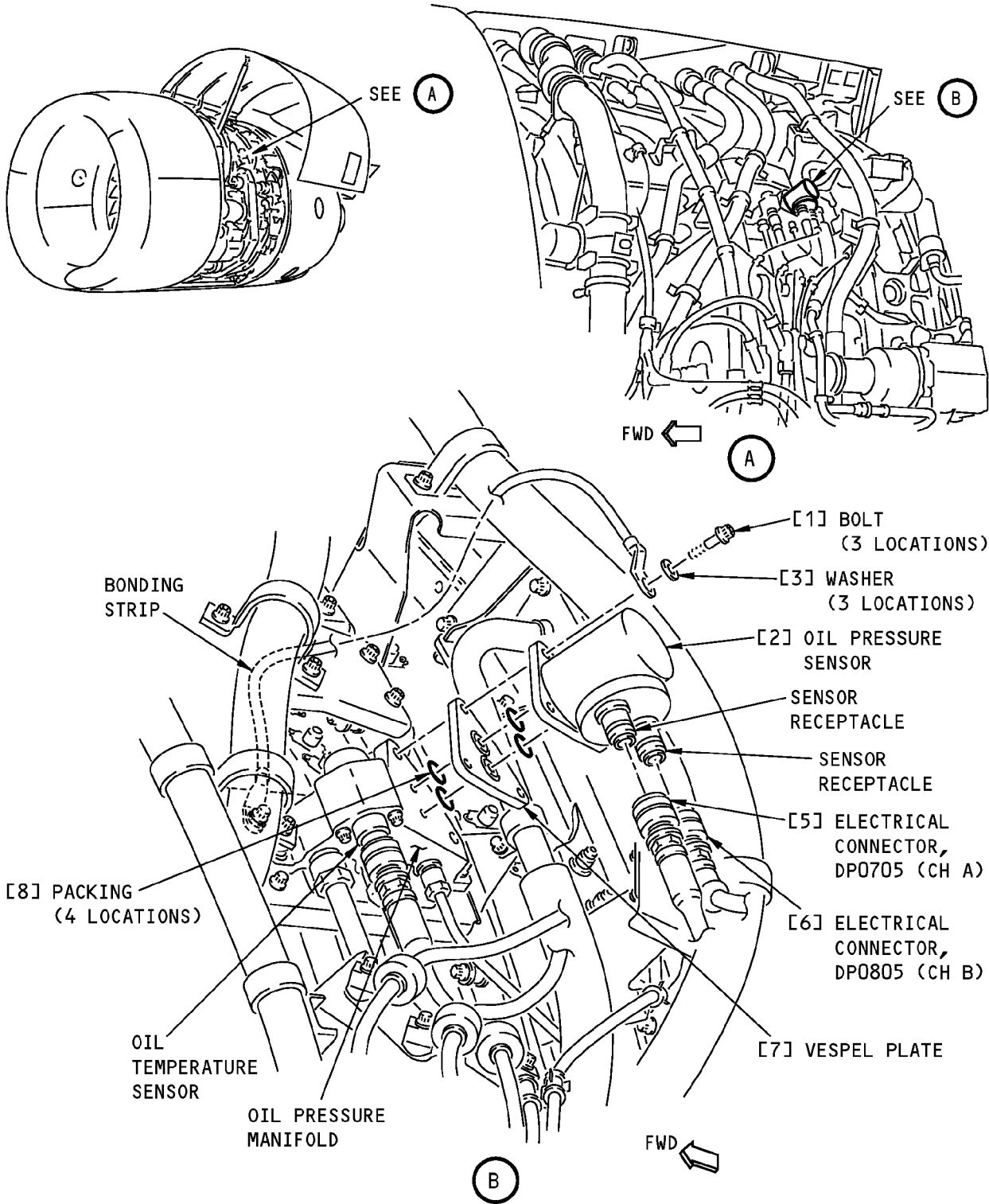

Oil Pressure Sensor Installation
Figure 401/79-32-01-990-801-F00

EFFECTIVITY
HAP ALL

79-32-01

AIRCRAFT MAINTENANCE MANUAL

TASK 79-32-01-400-801-F00

3. Oil Pressure Sensor Installation

(Figure 401)

A. General

(1) This task is the installation procedure for the oil pressure sensor (referred to as the sensor).

B. References

Reference	Title
12-13-11-600-801	Replenish the Engine Oil (P/B 301)
70-10-02-910-801-F00	General Precautions During the Removal and Installation of Engine Components (P/B 201)
71-00-00-800-811-F00	Power Plant Test Reference Table (P/B 501)
71-11-02-410-801-F00	Close the Fan Cowl Panels (P/B 201)

C. Consumable Materials

Reference	Description	Specification
D00599 [CP2442]	Oil - Engine (CFMI SB 79-001)	
D00601 [CP2101]	Grease - Graphite, High Temperature	SAE AMS 2518

D. Expendables/Parts

AMM Item	Description	AIPC Reference	AIPC Effectivity
2	Sensor	79-32-01-01-020	HAP ALL
8	Packing	79-32-01-01-030	HAP ALL

E. Location Zones

Zone	Area
411	Engine 1 - Engine
421	Engine 2 - Engine

F. Prepare for the Installation

SUBTASK 79-32-01-840-001-F00

- (1) Do these steps to prepare the sensor [2] for the installation General Precautions During the Removal and Installation of Engine Components, TASK 70-10-02-910-801-F00:
- Make sure that the mating flanges to the sensor [2] and the oil pressure manifold are clean and in a good condition.
 - Remove protective covers from the opening in the oil pressure manifold and on the sensor flange.

G. Oil Pressure Sensor Installation

SUBTASK 79-32-01-420-003-F00

- (1) Do these steps to install the sensor [2] (Figure 401):
- Lubricate the four new packings [8] with oil, D00599 [CP2442].
 - Install the three washers [3] on the three bolts [1].
 - Lubricate the threads of the three bolts [1] with grease, D00601 [CP2101].

EFFECTIVITY
HAP ALL

79-32-01Page 404
Jun 15/2009

D633A101-HAP

AIRCRAFT MAINTENANCE MANUAL

WARNING: DO NOT TOUCH THE COMPONENTS OF THE OIL SYSTEM IF THE ENGINE IS HOT. THESE COMPONENTS STAY HOTTER THAN OTHER COMPONENTS. HOT COMPONENTS CAN BURN YOU.

(d) Install the four packings [8] in the grooves of the vespel plate [7].

CAUTION: MAKE SURE THAT THE PACKINGS STAY IN THE GROOVES OF THE VESPEL PLATE. IF THE PACKINGS ARE NOT INSTALLED ON THE VESPEL PLATE CORRECTLY, OIL LOSS CAN OCCUR DURING ENGINE OPERATION.

(e) Install the vespel plate [7] on the mating face of the oil pressure manifold.

(f) Install the sensor [2] on the mating face of the oil pressure manifold.

(g) Loosely install the two lower bolts [1] that attach the sensor [2] to the oil pressure manifold.

(h) Install the top bolt [1] to attach the bonding strip.

1) Tighten the bolts [1] to 98-110 pound-inches (11-12.5 Newton meters).

(i) Connect the electrical connectors, DP0705 (CH A) [5] and DP0805 (CH B) [6] to the applicable sensor receptacles, CH A and CH B.

H. Put the Airplane Back to Its Usual Condition

SUBTASK 79-32-01-410-001-F00

(1) Do this task: Close the Fan Cowl Panels, TASK 71-11-02-410-801-F00.

SUBTASK 79-32-01-860-006-F00

(2) For Engine 1, remove the safety tags and close these circuit breakers:

CAPT Electrical System Panel, P18-2

<u>Row</u>	<u>Col</u>	<u>Number</u>	<u>Name</u>
A	4	C01390	ENGINE 1 ALTN PWR CHAN B
A	5	C01314	ENGINE 1 ALTN PWR CHAN A

SUBTASK 79-32-01-860-007-F00

(3) For Engine 2, remove the safety tags and close these circuit breakers:

F/O Electrical System Panel, P6-2

<u>Row</u>	<u>Col</u>	<u>Number</u>	<u>Name</u>
D	7	C01391	ENGINE 2 ALTN PWR CHAN B
D	8	C01315	ENGINE 2 ALTN PWR CHAN A

I. Sensor Installation Test

SUBTASK 79-32-01-800-001-F00

(1) Do the tests that are listed in the Power Plant Test Reference Table, TASK 71-00-00-800-811-F00.

SUBTASK 79-32-01-610-003-F00

(2) If the oil level is low, do this task: Replenish the Engine Oil, TASK 12-13-11-600-801.

————— **END OF TASK** —————

EFFECTIVITY
HAP ALL

D633A101-HAP

79-32-01

Page 405
Jun 10/2005

AIRCRAFT MAINTENANCE MANUAL

OIL TEMPERATURE SENSOR - REMOVAL/INSTALLATION**1. General**

A. This procedure has two tasks:

- (1) The removal of the oil temperature sensor.
- (2) The installation of the oil temperature sensor.

TASK 79-34-02-000-801-F00**2. Oil Temperature Sensor Removal**

(Figure 401), (Figure 402)

A. General

- (1) The oil temperature sensor is installed on the fan inlet case at the 10:00 o'clock position, adjacent to the oil pressure sensor.
- (2) This task is the removal procedure for the oil temperature sensor (referred to as the sensor).

B. References

Reference	Title
70-10-02-910-801-F00	General Precautions During the Removal and Installation of Engine Components (P/B 201)
71-11-02-010-801-F00	Open the Fan Cowl Panels (P/B 201)

C. Consumable Materials

Reference	Description	Specification
G00034	Cotton Wiper - Process Cleaning Absorbent Wiper (Cheesecloth, Gauze)	BMS15-5

D. Location Zones

Zone	Area
411	Engine 1 - Engine
421	Engine 2 - Engine

E. Prepare for the Removal

SUBTASK 79-34-02-860-001-F00

- (1) For Engine 1, open these circuit breakers and install safety tags:

CAPT Electrical System Panel, P18-2

Row	Col	Number	Name
A	4	C01390	ENGINE 1 ALTN PWR CHAN B
A	5	C01314	ENGINE 1 ALTN PWR CHAN A

SUBTASK 79-34-02-860-002-F00

- (2) For Engine 2, open these circuit breakers and install safety tags:

F/O Electrical System Panel, P6-2

Row	Col	Number	Name
D	7	C01391	ENGINE 2 ALTN PWR CHAN B
D	8	C01315	ENGINE 2 ALTN PWR CHAN A

SUBTASK 79-34-02-010-001-F00

- (3) Do this task: Open the Fan Cowl Panels, TASK 71-11-02-010-801-F00.

EFFECTIVITY
HAP ALL

D633A101-HAP

79-34-02

Page 401
Oct 10/2004

AIRCRAFT MAINTENANCE MANUAL

F. Oil Temperature Sensor Removal

SUBTASK 79-34-02-020-002-F00

WARNING: DO NOT TOUCH THE COMPONENTS OF THE OIL SYSTEM IF THE ENGINE IS HOT. THESE COMPONENTS STAY HOTTER THAN OTHER COMPONENTS. HOT COMPONENTS CAN BURN YOU.

WARNING: DO NOT OPEN THE OIL SYSTEM UNTIL THE PRESSURE GOES TO ZERO. THE PRESSURE GOES TO ZERO APPROXIMATELY 5 MINUTES AFTER AN ENGINE SHUTDOWN. A PRESSURIZED ENGINE CAN RELEASE A SPRAY OF HOT OIL THAT CAN BURN YOU.

WARNING: DO NOT LET HOT OIL GET ON YOU. PUT ON GOGGLES AND OTHER EQUIPMENT FOR PROTECTION OR LET THE ENGINE BECOME COOL. HOT OIL CAN BURN YOU.

CAUTION: DO NOT LET HOT OIL GET ON THE ENGINE OR OTHER COMPONENTS. IMMEDIATELY CLEAN THE COMPONENT IF OIL FALLS ON IT. OIL CAN CAUSE DAMAGE TO PAINT AND RUBBER.

- (1) Do these steps to remove the sensor [2]:
 - (a) Disconnect the electrical connector, DP0602 [4] from the sensor receptacle.
 - (b) Put a cotton wiper, G00034, below the sensor [2].
 - (c) Remove the two bolts [5] that attach the sensor [2] to the sensor probe housing.
 - (d) Carefully, pull the sensor [2] down.
 - 1) Clean the oil off with the cloth.
 - (e) Remove the sensor [2] from the sensor probe housing.
 - (f) Remove and discard the packing [7] from the sensor probe groove.
 - (g) Put protective covers in the openings of the sensor probe housing and the sensor General Precautions During the Removal and Installation of Engine Components, TASK 70-10-02-910-801-F00.

————— **END OF TASK** —————

EFFECTIVITY
HAP ALL

D633A101-HAP

BOEING PROPRIETARY - Copyright © Unpublished Work - See title page for details

79-34-02Page 402
Jun 10/2005

737-600/700/800/900
AIRCRAFT MAINTENANCE MANUAL

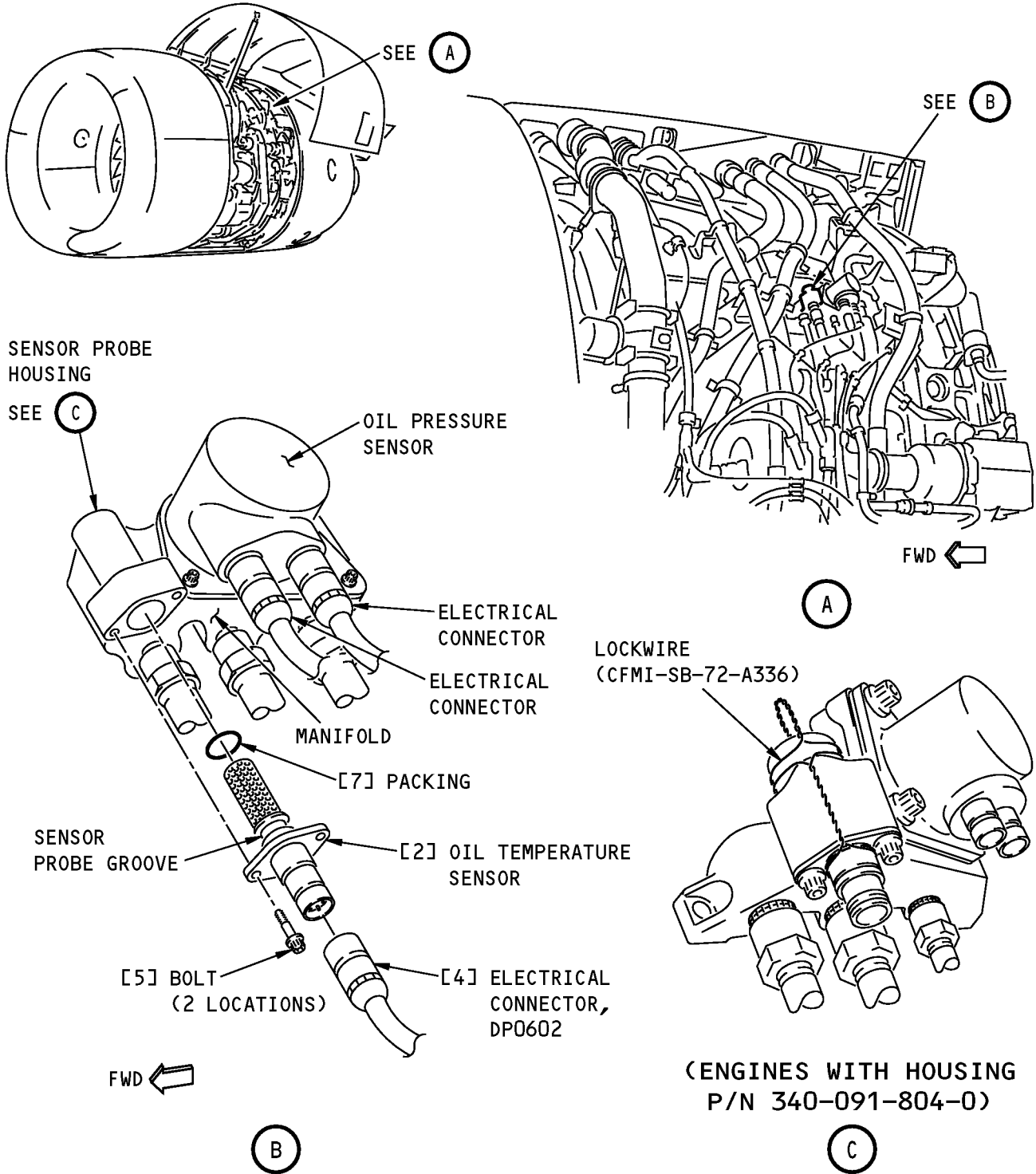

S-M56-MM-03196-00-B

Oil Temperature Sensor Installation
Figure 401/79-34-02-990-801-F00

EFFECTIVITY
HAP ALL

79-34-02

Page 403
Oct 10/2003

D633A101-HAP

AIRCRAFT MAINTENANCE MANUAL

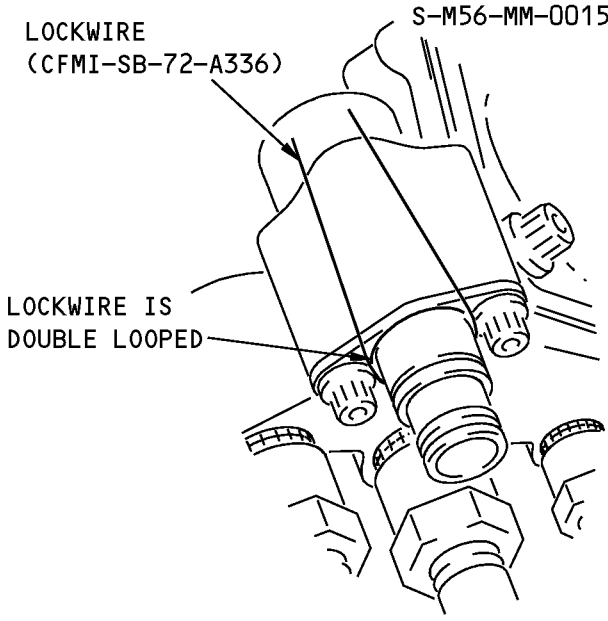

STEP 1

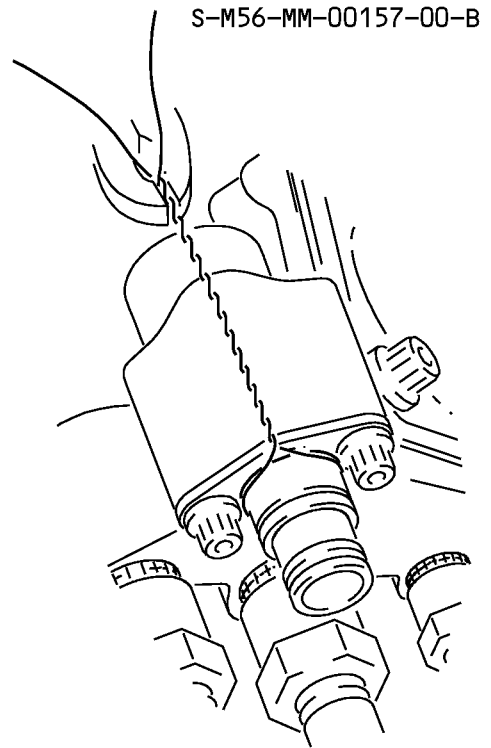

STEP 2

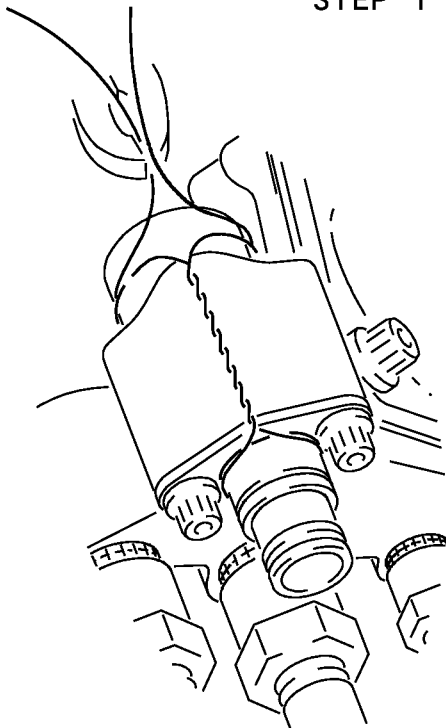

STEP 3

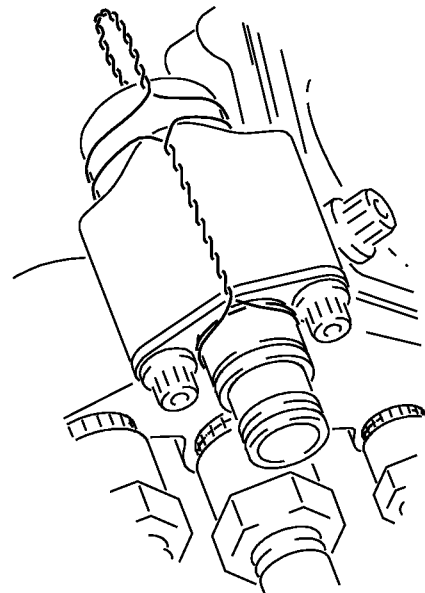

STEP 4

Oil Temperature Sensor Lockwire (ENGINES WITH SENSOR HOUSING P/N 340-091-804-0) Installation
Figure 402/79-34-02-990-802-F00

EFFECTIVITY
HAP ALL

79-34-02

AIRCRAFT MAINTENANCE MANUAL

TASK 79-34-02-400-801-F00

3. Oil Temperature Sensor Installation

(Figure 401), (Figure 402)

A. General

(1) This task is the installation procedure for the oil temperature sensor (referred to as the sensor).

B. References

Reference	Title
12-13-11-600-801	Replenish the Engine Oil (P/B 301)
70-10-02-910-801-F00	General Precautions During the Removal and Installation of Engine Components (P/B 201)
71-00-00-800-811-F00	Power Plant Test Reference Table (P/B 501)
71-11-02-410-801-F00	Close the Fan Cowl Panels (P/B 201)

C. Consumable Materials

Reference	Description	Specification
D00599 [CP2442]	Oil - Engine (CFMI SB 79-001)	
G00034	Cotton Wiper - Process Cleaning Absorbent Wiper (Cheesecloth, Gauze)	BMS15-5

D. Expendables/Parts

AMM Item	Description	AIPC Reference	AIPC Effectivity
2	Sensor	79-34-02-01-020	HAP ALL
7	Packing	79-34-02-01-015	HAP ALL

E. Location Zones

Zone	Area
411	Engine 1 - Engine
421	Engine 2 - Engine

F. Oil Temperature Sensor Installation

SUBTASK 79-34-02-840-001-F00

- (1) Do these steps to prepare the sensor for the installation General Precautions During the Removal and Installation of Engine Components, TASK 70-10-02-910-801-F00:
 - (a) Remove protective covers from the openings in the sensor probe housing and the sensor [2].
 - (b) Clean the mating interfaces of the sensor [2] and the sensor probe housing with a cotton wiper, G00034.
 - (c) Make sure that the mating interfaces of the sensor [2] and the sensor probe housing are clean and in a good condition.

SUBTASK 79-34-02-420-002-F00

- (2) Do these steps to install the sensor [2] in the sensor probe housing:
 - (a) Lubricate a new packing [7] with oil, D00599 [CP2442].
 - (b) Lubricate the threads of the two bolts [5] with oil, D00599 [CP2442].

EFFECTIVITY
HAP ALL

79-34-02Page 405
Feb 15/2009

D633A101-HAP

AIRCRAFT MAINTENANCE MANUAL

CAUTION: MAKE SURE YOU INSTALL THE PACKING CORRECTLY ON THE SENSOR. IF YOU DO NOT INSTALL THE PACKING CORRECTLY, OIL LOSS CAN OCCUR DURING ENGINE OPERATION AND CAN CAUSE DAMAGE TO THE ENGINE.

- (c) Install the packing [7] in the sensor probe groove.
- (d) Engage the sensor [2] in the sensor probe housing.
- (e) Install the two bolts [5].

CAUTION: DO NOT TIGHTEN THE BOLTS TOO MUCH. IF YOU OVER-TIGHTEN THE BOLTS, THEN DAMAGE TO THE SENSOR HOUSING CAN OCCUR. IF THE SENSOR HOUSING IS DAMAGED, THEN ENGINE OIL LOSS CAN OCCUR.

- 1) Tighten the bolts [5] to 38-42 pound-inches (4.3-4.7 Newton meters).
- (f) Connect the electrical connector, DP0602 [4] to the sensor receptacle.

HAP ALL; AIRPLANES WITH SENSOR PROBE HOUSING P/N 340-091-804-0

SUBTASK 79-34-02-410-002-F00

- (3) It is necessary to install lockwire on the oil temperature sensor and housing to prevent possible loss of engine oil.

NOTE: The part number is found on the outside of the housing.

- (a) Refer to CFMI-SB-72-A336 for the details to install the lockwire (Figure 402).

HAP ALL

G. Put the Airplane Back to Its Usual Condition

SUBTASK 79-34-02-410-001-F00

- (1) Do this task: Close the Fan Cowl Panels, TASK 71-11-02-410-801-F00.

SUBTASK 79-34-02-860-005-F00

- (2) For Engine 1, remove the safety tags and close these circuit breakers:

CAPT Electrical System Panel, P18-2

<u>Row</u>	<u>Col</u>	<u>Number</u>	<u>Name</u>
A	4	C01390	ENGINE 1 ALTN PWR CHAN B
A	5	C01314	ENGINE 1 ALTN PWR CHAN A

SUBTASK 79-34-02-860-006-F00

- (3) For Engine 2, remove the safety tags and close these circuit breakers:

F/O Electrical System Panel, P6-2

<u>Row</u>	<u>Col</u>	<u>Number</u>	<u>Name</u>
D	7	C01391	ENGINE 2 ALTN PWR CHAN B
D	8	C01315	ENGINE 2 ALTN PWR CHAN A

H. Oil Temperature Sensor Installation Test

SUBTASK 79-34-02-800-001-F00

- (1) Do the test listed in the Power Plant Test Reference Table, TASK 71-00-00-800-811-F00.

SUBTASK 79-34-02-610-001-F00

- (2) If the oil level is low, do this task: Replenish the Engine Oil, TASK 12-13-11-600-801.

————— **END OF TASK** —————

EFFECTIVITY
HAP ALL

D633A101-HAP

79-34-02

Page 406
Jun 10/2005