

CHAPTER

34

Navigation



CHAPTER 34
Navigation

Subject/Page	Date	COC	Subject/Page	Date	COC
EFFECTIVE PAGES			34-CONTENTS (cont.)		
1 thru 34	Jun 15/2009		O 21	Jun 15/2009	
			O 22	Jun 15/2009	
34-CONTENTS			O 23	Jun 15/2009	
O 1	Jun 15/2009		O 24	Jun 15/2009	
O 2	Jun 15/2009		O 25	Jun 15/2009	
O 3	Jun 15/2009		O 26	BLANK	
O 4	Jun 15/2009		D 27	Jun 15/2009	
O 5	Jun 15/2009		D 28	BLANK	
O 6	Jun 15/2009		34-11-00		
O 7	Jun 15/2009		1	Oct 10/2002	
O 8	Jun 15/2009		2	Feb 15/2009	
O 9	Jun 15/2009		3	Oct 10/2004	
O 10	Jun 15/2009		4	Feb 15/2009	
O 11	Jun 15/2009		5	Jun 10/2007	
O 12	Jun 15/2009		6	Feb 15/2009	
O 13	Jun 15/2009		7	Feb 10/2006	
O 14	Jun 15/2009		8	Feb 10/2006	
O 15	Jun 15/2009		9	Feb 10/2006	
O 16	Jun 15/2009		10	Feb 10/2006	
O 17	Jun 15/2009		11	Feb 10/2006	
O 18	Jun 15/2009		12	Feb 10/2006	
O 19	Jun 15/2009		13	Feb 10/2006	
O 20	Jun 15/2009		14	Feb 10/2006	

A = Added, R = Revised, D = Deleted, O = Overflow, C = Customer Originated Change

34-EFFECTIVE PAGES



CHAPTER 34
Navigation

Subject/Page	Date	COC	Subject/Page	Date	COC
34-11-00 (cont.)			34-13-00 (cont.)		
15	Feb 10/2006		11	Oct 10/2007	
16	Feb 15/2009		12	Oct 10/2007	
17	Jun 10/2007		13	Oct 10/2007	
18	Feb 15/2009		14	BLANK	
19	Feb 10/2006		34-16-00		
20	Feb 10/2006		1	Oct 10/2002	
21	Feb 10/2006		2	Oct 10/2002	
22	Feb 15/2009		3	Oct 10/2004	
23	Feb 10/2006		4	Feb 15/2009	
24	Feb 10/2006		5	Oct 10/2004	
25	Feb 10/2006		6	Oct 10/2004	
26	BLANK		7	Oct 10/2004	
34-13-00			8	Oct 10/2004	
1	Oct 10/2002		9	Oct 10/2004	
2	Oct 10/2007		10	Oct 10/2004	
3	Oct 10/2007		11	Oct 10/2004	
4	Oct 10/2007		12	BLANK	
5	Oct 10/2007		34-21-00		
6	Oct 10/2007		1	Feb 15/2009	
7	Oct 10/2007		2	Feb 15/2009	
8	Oct 10/2007		3	Oct 10/2004	
9	Oct 10/2007		4	Oct 10/2004	
10	Oct 10/2007		5	Feb 15/2009	

A = Added, R = Revised, D = Deleted, O = Overflow, C = Customer Originated Change

34-EFFECTIVE PAGES



CHAPTER 34
Navigation

Subject/Page	Date	COC	Subject/Page	Date	COC
34-21-00 (cont.)			34-21-00 (cont.)		
6	Feb 15/2009		29	Feb 10/2007	
7	Jun 10/2007		30	Feb 10/2007	
8	Feb 15/2009		31	Feb 10/2007	
9	Feb 10/2007		32	Feb 10/2007	
10	Feb 15/2009		33	Feb 10/2007	
11	Jun 10/2007		34	Feb 10/2007	
12	Feb 15/2009		35	Feb 15/2009	
13	Oct 10/2006		R 36	Jun 15/2009	
14	Oct 10/2006		37	Jun 10/2007	
15	Oct 10/2006		38	Jun 10/2007	
16	Feb 15/2009		39	Feb 15/2009	
17	Jun 10/2007		40	Feb 15/2009	
18	Feb 15/2009		41	Feb 15/2009	
19	Feb 10/2007		R 42	Jun 15/2009	C
20	Feb 10/2007		O 43	Jun 15/2009	
21	Feb 10/2007		O 44	Jun 15/2009	
22	Feb 10/2007		45	Jun 10/2007	
23	Feb 10/2007		46	Feb 15/2008	
24	Feb 10/2007		47	Jun 10/2007	
25	Feb 10/2007		48	Feb 15/2009	
26	Feb 10/2007		49	Feb 15/2009	
27	Feb 10/2007		50	Jun 10/2007	
28	Feb 10/2007		51	Feb 15/2009	

A = Added, R = Revised, D = Deleted, O = Overflow, C = Customer Originated Change

34-EFFECTIVE PAGES

**CHAPTER 34
Navigation**

Subject/Page	Date	COC	Subject/Page	Date	COC
34-21-00 (cont.)			34-21-00 (cont.)		
52	Feb 15/2009		75	Jun 10/2007	
53	Feb 15/2009		76	Jun 10/2007	
54	Jun 10/2007		77	Jun 10/2007	
55	Feb 15/2009		78	Feb 15/2009	
56	Jun 10/2007		79	Feb 15/2009	
57	Jun 10/2007		80	Jun 10/2007	
58	Feb 15/2009		81	Jun 10/2007	
59	Jun 10/2007		82	Jun 10/2007	
60	Feb 15/2009		83	Jun 10/2007	
61	Feb 15/2008		84	Jun 10/2007	
62	Feb 15/2009		85	Jun 10/2007	
63	Jun 10/2007		86	Feb 15/2009	
64	Jun 10/2007		87	Jun 10/2007	
65	Jun 10/2007		88	Jun 10/2007	
66	Feb 15/2009		89	Jun 10/2007	
67	Feb 15/2009		90	Jun 10/2007	
68	Jun 10/2007		91	Jun 10/2007	
69	Jun 10/2007		O 92	Jun 15/2009	
70	Feb 15/2009		93	Feb 15/2009	
71	Jun 10/2007		94	Jun 10/2007	
72	Jun 10/2007		95	Jun 10/2007	
73	Jun 10/2007		96	Jun 10/2007	
74	Jun 10/2007		97	Jun 10/2007	

A = Added, R = Revised, D = Deleted, O = Overflow, C = Customer Originated Change

34-EFFECTIVE PAGES

CHAPTER 34
Navigation

Subject/Page	Date	COC	Subject/Page	Date	COC
34-21-00 (cont.)			34-21-00 (cont.)		
98	Jun 10/2007		98.23	Jun 10/2007	
98.1	Jun 10/2007		98.24	Jun 10/2007	
98.2	Jun 10/2007		98.25	Jun 10/2007	
98.3	Jun 10/2007		98.26	Jun 10/2007	
98.4	Jun 10/2007		98.27	Jun 10/2007	
98.5	Jun 10/2007		98.28	Feb 15/2009	
98.6	Jun 10/2007		98.29	Feb 15/2009	
98.7	Jun 10/2007		98.30	Jun 10/2007	
98.8	Jun 10/2007		98.31	Jun 10/2007	
98.9	Jun 10/2007		98.32	Jun 10/2007	
98.10	Jun 10/2007		98.33	Feb 15/2009	
98.11	Jun 10/2007		98.34	Oct 15/2008	
98.12	Jun 10/2007		98.35	Jun 15/2008	
98.13	Feb 15/2009		98.36	Jun 15/2008	
98.14	Oct 15/2008		98.37	Jun 15/2008	
98.15	Feb 15/2009		98.38	Jun 15/2008	
98.16	Feb 15/2009		98.39	Jun 15/2008	
98.17	Feb 15/2009		98.40	Jun 15/2008	
98.18	Jun 10/2007		98.41	Jun 15/2008	
98.19	Feb 15/2009		98.42	Jun 15/2008	
98.20	Feb 15/2009		98.43	Jun 15/2008	
98.21	Feb 15/2009		98.44	Jun 15/2008	
98.22	Feb 15/2009		98.45	Jun 15/2008	

A = Added, R = Revised, D = Deleted, O = Overflow, C = Customer Originated Change

34-EFFECTIVE PAGES

**CHAPTER 34
Navigation**

Subject/Page	Date	COC	Subject/Page	Date	COC
34-21-00 (cont.)			34-21-00 (cont.)		
98.46	Jun 15/2008		98.69	Feb 15/2009	
98.47	Jun 15/2008		98.70	Oct 15/2008	
98.48	Jun 15/2008		98.71	Jun 15/2008	
98.49	Feb 15/2009		98.72	Jun 15/2008	
98.50	Oct 15/2008		98.73	Feb 15/2009	
98.51	Jun 15/2008		98.74	Oct 15/2008	
98.52	Jun 15/2008		98.75	Jun 15/2008	
98.53	Feb 15/2009		98.76	Jun 15/2008	
98.54	Oct 15/2008		98.77	Jun 15/2008	
98.55	Jun 15/2008		98.78	Jun 15/2008	
98.56	Jun 15/2008		98.79	Jun 15/2008	
98.57	Feb 15/2009		98.80	Jun 15/2008	
98.58	Oct 15/2008		98.81	Jun 15/2008	
98.59	Jun 15/2008		98.82	Jun 15/2008	
98.60	Jun 15/2008		98.83	Jun 15/2008	
98.61	Feb 15/2009		98.84	Jun 15/2008	
98.62	Oct 15/2008		98.85	Jun 15/2008	
98.63	Jun 15/2008		98.86	Jun 15/2008	
98.64	Jun 15/2008		98.87	Jun 15/2008	
98.65	Feb 15/2009		98.88	Jun 15/2008	
98.66	Oct 15/2008		98.89	Jun 15/2008	
98.67	Jun 15/2008		98.90	Jun 15/2008	
98.68	Jun 15/2008		98.91	Feb 15/2009	

A = Added, R = Revised, D = Deleted, O = Overflow, C = Customer Originated Change

34-EFFECTIVE PAGES

CHAPTER 34
Navigation

Subject/Page	Date	COC	Subject/Page	Date	COC
34-21-00 (cont.)			34-22-00 (cont.)		
98.92	Jun 15/2008		2	Oct 10/2002	
98.93	Feb 15/2009		3	Oct 10/2004	
98.94	Jun 15/2008		4	Oct 10/2004	
98.95	Jun 15/2008		5	Jun 10/2007	
98.96	Jun 15/2008		6	Oct 10/2004	
98.97	Jun 15/2008		7	Oct 10/2004	
98.98	Jun 15/2008		8	Oct 10/2004	
98.99	Jun 15/2008		9	Oct 10/2004	
98.100	Jun 15/2008		10	Jun 10/2007	
98.101	Jun 15/2008		11	Jun 10/2007	
98.102	Jun 15/2008		12	BLANK	
98.103	Jun 15/2008		34-23-00		
98.104	Jun 15/2008		1	Oct 10/2002	
98.105	Jun 15/2008		2	Feb 10/2003	
98.106	Jun 15/2008		3	Jun 10/2004	
98.107	Jun 15/2008		4	BLANK	
98.108	Feb 15/2009		34-24-00		
98.109	Jun 15/2008		1	Oct 10/2002	
98.110	Jun 15/2008		2	Oct 15/2008	
98.111	Jun 15/2008		3	Jun 10/2007	
98.112	BLANK		4	Jun 10/2007	
34-22-00			5	Jun 10/2007	
1	Oct 10/2002		6	Jun 10/2007	

A = Added, R = Revised, D = Deleted, O = Overflow, C = Customer Originated Change

34-EFFECTIVE PAGES

**CHAPTER 34
Navigation**

Subject/Page	Date	COC	Subject/Page	Date	COC
34-24-00 (cont.)			34-24-00 (cont.)		
7	Jun 10/2007		30	Feb 15/2009	
8	Jun 10/2007		31	Feb 15/2009	
9	Jun 10/2007		32	Feb 15/2009	
10	Jun 10/2007		33	Feb 15/2009	
11	Jun 10/2007		34	Feb 15/2009	
12	Oct 10/2004		35	Feb 15/2009	
13	Jun 10/2007		36	Feb 15/2009	
14	Jun 10/2007		37	Feb 15/2009	
15	Jun 10/2007		38	Feb 15/2009	
16	Oct 10/2005		39	Feb 15/2009	
17	Feb 15/2009		40	Feb 15/2009	
18	Feb 15/2009		41	Feb 15/2009	
19	Feb 15/2009		42	Feb 15/2009	
20	Oct 10/2005		43	Feb 15/2009	
21	Feb 15/2009		44	Feb 15/2009	
22	Feb 15/2009		45	Feb 15/2009	
23	Feb 15/2009		46	Feb 15/2009	
24	Feb 15/2009		47	Feb 15/2009	
25	Jun 15/2008		48	Feb 15/2009	
26	Feb 15/2009		49	Feb 15/2009	
27	Oct 10/2006		50	Feb 15/2009	
28	Feb 15/2009		51	Oct 10/2006	
29	Feb 15/2009		52	Feb 15/2009	

A = Added, R = Revised, D = Deleted, O = Overflow, C = Customer Originated Change

34-EFFECTIVE PAGES

CHAPTER 34
Navigation

Subject/Page	Date	COC	Subject/Page	Date	COC
34-24-00 (cont.)			34-31-00 (cont.)		
53	Feb 15/2009		7	Jun 10/2007	
54	Oct 10/2006		8	Feb 15/2009	
55	Feb 15/2009		R 9	Jun 15/2009	
56	Feb 15/2009		R 10	Jun 15/2009	
57	Feb 15/2009		11	Feb 15/2009	
58	Feb 15/2009		12	Feb 15/2009	
59	Feb 15/2009		13	Feb 15/2009	
60	Feb 15/2009		14	Feb 15/2009	
61	Feb 15/2009		15	Feb 15/2009	
62	Feb 15/2009		16	Feb 15/2009	
63	Feb 15/2009		17	Feb 15/2009	
64	Feb 15/2009		18	Feb 15/2009	
65	Feb 15/2009		19	Feb 15/2009	
66	Feb 15/2009		20	Feb 15/2009	
67	Feb 15/2009		21	Feb 15/2009	
68	BLANK		22	Feb 15/2009	
34-31-00			23	Feb 15/2009	
1	Feb 15/2009		24	Feb 15/2009	
2	Feb 15/2009		25	Feb 15/2009	
3	Oct 10/2004		26	Feb 15/2009	
4	Jun 10/2007		27	Feb 15/2009	
5	Jun 10/2007		28	Feb 15/2009	
6	Jun 10/2007		29	Feb 15/2009	

A = Added, R = Revised, D = Deleted, O = Overflow, C = Customer Originated Change

34-EFFECTIVE PAGES

**CHAPTER 34
Navigation**

Subject/Page	Date	COC	Subject/Page	Date	COC
34-31-00 (cont.)			34-31-00 (cont.)		
30	Feb 15/2009		R 53	Jun 15/2009	
31	Feb 15/2009		R 54	Jun 15/2009	
32	Feb 15/2009		55	Feb 15/2009	
33	Feb 15/2009		56	Feb 15/2009	
34	Feb 15/2009		57	Feb 15/2009	
35	Feb 15/2009		58	Feb 15/2009	
36	Feb 15/2009		59	Feb 15/2009	
37	Feb 15/2009		60	Feb 15/2009	
38	Feb 15/2009		61	Feb 15/2009	
39	Feb 15/2009		62	Feb 15/2009	
40	Feb 15/2009		63	Feb 15/2009	
41	Feb 15/2009		64	Feb 15/2009	
42	Feb 15/2009		65	Feb 15/2009	
43	Feb 15/2009		66	Feb 15/2009	
44	Feb 15/2009		67	Feb 15/2009	
45	Feb 15/2009		68	Feb 15/2009	
46	Feb 15/2009		69	Feb 15/2009	
47	Feb 15/2009		70	Feb 15/2009	
48	Feb 15/2009		71	Feb 15/2009	
49	Feb 15/2009		72	Feb 15/2009	
50	Feb 15/2009		73	Feb 15/2009	
51	Feb 15/2009		74	Feb 15/2009	
52	Feb 15/2009		75	Feb 15/2009	

A = Added, R = Revised, D = Deleted, O = Overflow, C = Customer Originated Change

34-EFFECTIVE PAGES



CHAPTER 34
Navigation

Subject/Page	Date	COC	Subject/Page	Date	COC
34-31-00 (cont.)			34-32-00		
76	Feb 15/2009		1	Oct 10/2002	
77	Feb 15/2009		2	Oct 10/2002	
78	Feb 15/2009		3	Oct 10/2004	
79	Feb 15/2009		4	Oct 10/2004	
80	Feb 15/2009		5	Oct 10/2004	
81	Feb 15/2009		6	Oct 10/2004	
82	Feb 15/2009		7	Oct 10/2004	
83	Feb 15/2009		8	Oct 10/2004	
84	Feb 15/2009		9	Oct 10/2004	
85	Feb 15/2009		10	Oct 10/2004	
86	Feb 15/2009		11	Oct 10/2004	
87	Jun 15/2008		12	Oct 10/2004	
88	Feb 15/2009		13	Oct 10/2004	
89	Feb 15/2009		14	Oct 10/2004	
90	Feb 15/2009		15	Oct 10/2004	
91	Feb 15/2009		16	Oct 10/2004	
92	Feb 15/2009		17	Oct 10/2004	
93	Feb 15/2009		18	Oct 10/2004	
94	Feb 15/2009		19	Oct 10/2004	
95	Feb 15/2009		20	Oct 10/2004	
96	Feb 15/2009		21	Oct 10/2004	
97	Feb 15/2009		22	BLANK	
98	BLANK				

A = Added, R = Revised, D = Deleted, O = Overflow, C = Customer Originated Change

34-EFFECTIVE PAGES



CHAPTER 34
Navigation

Subject/Page	Date	COC	Subject/Page	Date	COC
34-33-00			34-33-00 (cont.)		
1	Oct 10/2002		R 24	Jun 15/2009	
2	Oct 10/2002		25	Feb 15/2009	
3	Oct 10/2004		R 26	Jun 15/2009	
4	Oct 10/2004		27	Jun 10/2006	
5	Oct 10/2004		28	Jun 10/2006	
6	Oct 10/2004		29	Jun 10/2006	
7	Oct 10/2004		30	Jun 10/2006	
8	Oct 10/2004		31	Jun 10/2006	
9	Oct 10/2004		32	Jun 10/2006	
10	Oct 10/2004		33	Jun 10/2006	
11	Oct 10/2004		34	Jun 10/2006	
12	Oct 10/2004		R 35	Jun 15/2009	
13	Oct 10/2004		R 36	Jun 15/2009	
14	Oct 10/2004		37	Feb 15/2009	
15	Oct 10/2004		38	Feb 15/2009	
16	Oct 10/2004		39	Feb 15/2009	
17	Oct 10/2004		40	BLANK	
R 18	Jun 15/2009		34-43-00		
R 19	Jun 15/2009		1	Feb 15/2009	
R 20	Jun 15/2009		2	Feb 15/2009	
21	Feb 15/2009		3	Oct 10/2004	
R 22	Jun 15/2009		4	Oct 10/2004	
23	Jun 10/2006		5	Feb 15/2009	

A = Added, R = Revised, D = Deleted, O = Overflow, C = Customer Originated Change

34-EFFECTIVE PAGES

CHAPTER 34
Navigation

Subject/Page	Date	COC	Subject/Page	Date	COC
34-43-00 (cont.)			34-43-00 (cont.)		
6	Feb 15/2009		29	Feb 15/2008	
7	Feb 15/2008		30	Feb 15/2009	
8	Feb 15/2009		31	Feb 15/2008	
9	Jun 10/2007		32	Feb 15/2009	
10	Feb 15/2008		33	Feb 15/2008	
11	Feb 15/2008		34	Feb 15/2008	
12	Feb 15/2008		35	Feb 15/2008	
13	Feb 15/2008		36	Feb 15/2008	
14	Oct 15/2008		37	Feb 15/2008	
15	Feb 15/2008		38	Feb 15/2008	
16	Feb 15/2008		39	Oct 15/2008	
17	Feb 15/2009		40	Feb 15/2008	
18	Feb 15/2009		41	Feb 15/2008	
19	Feb 15/2008		42	Feb 15/2008	
20	Feb 15/2009		43	Feb 15/2008	
21	Feb 15/2009		44	Feb 15/2009	
22	Feb 15/2009		45	Feb 15/2009	
23	Feb 15/2008		46	Feb 15/2008	
24	Feb 15/2009		47	Feb 15/2008	
25	Feb 15/2009		48	Feb 15/2008	
26	Feb 15/2009		49	Feb 15/2008	
27	Feb 15/2009		50	Feb 15/2008	
28	Feb 15/2008		51	Feb 15/2009	

A = Added, R = Revised, D = Deleted, O = Overflow, C = Customer Originated Change

34-EFFECTIVE PAGES



CHAPTER 34
Navigation

Subject/Page	Date	COC	Subject/Page	Date	COC
34-43-00 (cont.)			34-43-00 (cont.)		
52	Feb 15/2009		75	Feb 15/2008	
53	Feb 15/2009		76	Feb 15/2008	
54	Feb 15/2009		77	Feb 15/2008	
55	Feb 15/2009		78	Feb 15/2009	
56	Feb 15/2009		79	Feb 15/2009	
57	Feb 15/2009		80	Feb 15/2009	
58	Feb 15/2009		81	Feb 15/2008	
59	Feb 15/2009		82	Feb 15/2009	
60	Feb 15/2008		83	Feb 15/2008	
61	Feb 15/2008		84	Feb 15/2008	
62	Oct 15/2008		85	Feb 15/2008	
63	Feb 15/2008		86	Feb 15/2008	
64	Feb 15/2008		87	Feb 15/2008	
65	Feb 15/2009		88	Feb 15/2008	
66	Feb 15/2009		89	Feb 15/2008	
67	Feb 15/2009		90	Feb 15/2009	
68	Feb 15/2008		34-45-00		
69	Feb 15/2008		1	Oct 10/2002	
70	Feb 15/2009		2	Oct 10/2002	
71	Feb 15/2008		3	Oct 10/2004	
72	Feb 15/2008		4	Feb 15/2009	
73	Feb 15/2008		5	Feb 15/2009	
74	Feb 15/2008		6	Jun 10/2007	

A = Added, R = Revised, D = Deleted, O = Overflow, C = Customer Originated Change

34-EFFECTIVE PAGES

CHAPTER 34
Navigation

Subject/Page	Date	COC	Subject/Page	Date	COC
34-45-00 (cont.)			34-45-00 (cont.)		
7	Jun 10/2007		30	Oct 10/2006	
8	Oct 10/2004		31	Oct 10/2006	
9	Oct 10/2004		32	Feb 15/2009	
10	Oct 10/2004		33	Feb 15/2009	
11	Oct 10/2004		34	Feb 15/2009	
O 12	Jun 15/2009		R 35	Jun 15/2009	C
R 13	Jun 15/2009	C	36	Feb 15/2009	
O 14	Jun 15/2009		37	Jun 10/2007	
R 15	Jun 15/2009		38	Jun 10/2007	
16	Jun 10/2007		39	Feb 15/2009	
17	Feb 15/2009		40	Oct 10/2006	
18	Oct 10/2005		41	Oct 10/2006	
19	Feb 15/2009		42	Oct 10/2006	
20	Oct 10/2005		43	Oct 10/2006	
21	Oct 10/2005		44	Oct 10/2006	
22	Oct 10/2006		45	Feb 15/2009	
23	Feb 15/2009		46	Feb 15/2009	
24	Feb 15/2009		47	Oct 10/2006	
25	Jun 10/2007		48	Oct 10/2006	
26	Feb 15/2009		49	Jun 10/2007	
27	Jun 10/2007		50	Jun 10/2007	
28	Oct 10/2006		51	Jun 10/2007	
29	Oct 10/2006		52	Jun 10/2007	

A = Added, R = Revised, D = Deleted, O = Overflow, C = Customer Originated Change

34-EFFECTIVE PAGES



CHAPTER 34
Navigation

Subject/Page	Date	COC	Subject/Page	Date	COC
34-45-00 (cont.)			34-46-00 (cont.)		
53	Jun 10/2007		3	Oct 10/2004	
54	Jun 10/2007		R 4	Jun 15/2009	C
55	Jun 10/2007		R 5	Jun 15/2009	
56	Feb 15/2009		R 6	Jun 15/2009	
57	Feb 15/2009		O 7	Jun 15/2009	
58	Feb 15/2009		O 8	Jun 15/2009	C
59	Feb 15/2009		R 9	Jun 15/2009	
60	Jun 10/2007		R 10	Jun 15/2009	C
61	Feb 15/2009		R 11	Jun 15/2009	
62	Jun 10/2007		O 12	Jun 15/2009	
63	Feb 15/2009		R 13	Jun 15/2009	C
64	Jun 10/2007		O 14	Jun 15/2009	C
65	Feb 15/2009		R 15	Jun 15/2009	
66	Feb 15/2009		O 16	Jun 15/2009	
67	Jun 10/2007		R 17	Jun 15/2009	C
68	Feb 15/2009		R 18	Jun 15/2009	C
69	Feb 15/2009		R 19	Jun 15/2009	C
70	Jun 10/2007		R 20	Jun 15/2009	C
71	Jun 10/2007		R 21	Jun 15/2009	
72	Feb 15/2009		O 22	Jun 15/2009	
34-46-00			O 23	Jun 15/2009	
R 1	Jun 15/2009	C	O 24	Jun 15/2009	
R 2	Jun 15/2009	C	O 25	Jun 15/2009	

A = Added, R = Revised, D = Deleted, O = Overflow, C = Customer Originated Change

34-EFFECTIVE PAGES

CHAPTER 34
Navigation

Subject/Page	Date	COC	Subject/Page	Date	COC
34-46-00 (cont.)			34-46-00 (cont.)		
R 26	Jun 15/2009	C	O 49	Jun 15/2009	
R 27	Jun 15/2009	C	O 50	Jun 15/2009	
O 28	Jun 15/2009	C	O 51	Jun 15/2009	
O 29	Jun 15/2009	C	O 52	Jun 15/2009	C
O 30	Jun 15/2009	C	R 53	Jun 15/2009	
R 31	Jun 15/2009		O 54	Jun 15/2009	
R 32	Jun 15/2009	C	O 55	Jun 15/2009	
R 33	Jun 15/2009	C	O 56	Jun 15/2009	
R 34	Jun 15/2009	C	R 57	Jun 15/2009	
R 35	Jun 15/2009	C	O 58	Jun 15/2009	
R 36	Jun 15/2009	C	O 59	Jun 15/2009	
R 37	Jun 15/2009		O 60	Jun 15/2009	
O 38	Jun 15/2009		O 61	Jun 15/2009	
O 39	Jun 15/2009		O 62	Jun 15/2009	C
O 40	Jun 15/2009	C	O 63	Jun 15/2009	
R 41	Jun 15/2009		O 64	Jun 15/2009	
O 42	Jun 15/2009		O 65	Jun 15/2009	
O 43	Jun 15/2009		O 66	Jun 15/2009	C
O 44	Jun 15/2009		R 67	Jun 15/2009	
O 45	Jun 15/2009		O 68	Jun 15/2009	
O 46	Jun 15/2009	C	R 69	Jun 15/2009	C
R 47	Jun 15/2009		R 70	Jun 15/2009	C
O 48	Jun 15/2009		R 71	Jun 15/2009	

A = Added, R = Revised, D = Deleted, O = Overflow, C = Customer Originated Change

34-EFFECTIVE PAGES

**CHAPTER 34
Navigation**

Subject/Page	Date	COC	Subject/Page	Date	COC
34-46-00 (cont.)			34-46-00 (cont.)		
R 72	Jun 15/2009		R 95	Jun 15/2009	
R 73	Jun 15/2009	C	R 96	Jun 15/2009	C
R 74	Jun 15/2009	C	R 97	Jun 15/2009	C
R 75	Jun 15/2009		R 98	Jun 15/2009	C
R 76	Jun 15/2009		R 98.1	Jun 15/2009	C
R 77	Jun 15/2009	C	R 98.2	Jun 15/2009	C
R 78	Jun 15/2009	C	R 98.3	Jun 15/2009	
R 79	Jun 15/2009		R 98.4	Jun 15/2009	
O 80	Jun 15/2009		R 98.5	Jun 15/2009	C
O 81	Jun 15/2009		R 98.6	Jun 15/2009	
O 82	Jun 15/2009		R 98.7	Jun 15/2009	
O 83	Jun 15/2009		R 98.8	Jun 15/2009	C
R 84	Jun 15/2009	C	R 98.9	Jun 15/2009	C
R 85	Jun 15/2009		R 98.10	Jun 15/2009	C
O 86	Jun 15/2009		R 98.11	Jun 15/2009	C
O 87	Jun 15/2009		R 98.12	Jun 15/2009	C
O 88	Jun 15/2009		R 98.13	Jun 15/2009	
O 89	Jun 15/2009		O 98.14	Jun 15/2009	
R 90	Jun 15/2009		O 98.15	Jun 15/2009	
R 91	Jun 15/2009		O 98.16	Jun 15/2009	
O 92	Jun 15/2009		R 98.17	Jun 15/2009	
R 93	Jun 15/2009	C	O 98.18	BLANK	
R 94	Jun 15/2009	C	D 98.19	Jun 15/2009	

A = Added, R = Revised, D = Deleted, O = Overflow, C = Customer Originated Change

34-EFFECTIVE PAGES

CHAPTER 34
Navigation

Subject/Page	Date	COC	Subject/Page	Date	COC
34-46-00 (cont.)			34-46-00 (cont.)		
D 98.20	Jun 15/2009		D 98.43	Jun 15/2009	
D 98.21	Jun 15/2009		D 98.44	Jun 15/2009	
D 98.22	Jun 15/2009		D 98.45	Jun 15/2009	
D 98.23	Jun 15/2009		D 98.46	Jun 15/2009	
D 98.24	Jun 15/2009		D 98.47	Jun 15/2009	
D 98.25	Jun 15/2009		D 98.48	BLANK	
D 98.26	Jun 15/2009		34-51-00		
D 98.27	Jun 15/2009		1	Oct 10/2002	
D 98.28	Jun 15/2009		2	Jun 10/2007	
D 98.29	Jun 15/2009		3	Oct 10/2004	
D 98.30	Jun 15/2009		4	Oct 10/2004	
D 98.31	Jun 15/2009		R 5	Jun 15/2009	
D 98.32	Jun 15/2009		R 6	Jun 15/2009	
D 98.33	Jun 15/2009		7	Feb 15/2009	
D 98.34	Jun 15/2009		8	Jun 10/2007	
D 98.35	Jun 15/2009		9	Jun 10/2007	
D 98.36	Jun 15/2009		10	Jun 10/2007	
D 98.37	Jun 15/2009		11	Jun 10/2007	
D 98.38	Jun 15/2009		12	Jun 10/2007	
D 98.39	Jun 15/2009		13	Feb 15/2009	
D 98.40	Jun 15/2009		14	Jun 10/2007	
D 98.41	Jun 15/2009		15	Feb 15/2009	
D 98.42	Jun 15/2009		16	Jun 10/2007	

A = Added, R = Revised, D = Deleted, O = Overflow, C = Customer Originated Change

34-EFFECTIVE PAGES



CHAPTER 34
Navigation

Subject/Page	Date	COC	Subject/Page	Date	COC
34-51-00 (cont.)			34-51-00 (cont.)		
17	Jun 10/2007		40	Feb 15/2009	
18	Feb 15/2009		41	Feb 15/2009	
19	Jun 10/2007		42	Feb 15/2009	
20	Feb 15/2009		43	Feb 15/2009	
21	Jun 10/2007		44	Feb 15/2009	
22	Jun 10/2007		45	Feb 15/2009	
23	Jun 10/2007		46	Feb 15/2009	
24	Oct 10/2007		47	Feb 15/2009	
25	Jun 10/2007		48	Feb 15/2009	
26	Jun 10/2007		49	Feb 15/2009	
27	Feb 15/2009		50	Feb 15/2009	
28	Feb 15/2009		51	Feb 15/2009	
R 29	Jun 15/2009		52	Feb 15/2009	
R 30	Jun 15/2009		53	Feb 15/2009	
31	Feb 15/2009		54	Feb 15/2009	
32	Feb 15/2009		55	Feb 15/2009	
33	Feb 15/2009		56	Feb 15/2009	
34	Feb 15/2009		57	Feb 15/2009	
35	Feb 15/2009		58	Feb 15/2009	
36	Feb 15/2009		59	Feb 15/2009	
37	Feb 15/2009		60	BLANK	
38	Feb 15/2009		34-53-00		
39	Feb 15/2009		1	Feb 10/2005	

A = Added, R = Revised, D = Deleted, O = Overflow, C = Customer Originated Change

34-EFFECTIVE PAGES



CHAPTER 34
Navigation

Subject/Page	Date	COC	Subject/Page	Date	COC
34-53-00 (cont.)			34-53-00 (cont.)		
2	Feb 10/2005		25	Feb 15/2008	
3	Oct 10/2004		26	Feb 15/2008	
R 4	Jun 15/2009		27	Feb 15/2008	
5	Feb 10/2006		28	Feb 15/2008	
6	Oct 10/2004		29	Feb 15/2008	
7	Oct 10/2004		30	Feb 15/2008	
8	Oct 10/2004		31	Feb 15/2008	
9	Oct 10/2004		32	Feb 15/2008	
10	Oct 10/2004		33	Feb 15/2008	
11	Oct 10/2004		34	Feb 15/2008	
12	Feb 15/2009		35	Feb 15/2008	
13	Feb 15/2009		36	Feb 15/2008	
14	Feb 15/2008		37	Feb 15/2008	
15	Feb 15/2008		38	Feb 15/2008	
16	Feb 15/2008		39	Feb 15/2008	
17	Feb 15/2008		40	Feb 15/2008	
18	Feb 15/2008		41	Feb 15/2008	
19	Feb 15/2008		42	Feb 15/2008	
20	Feb 15/2008		43	Feb 15/2008	
21	Feb 15/2008		44	BLANK	
22	Feb 15/2008		34-55-00		
23	Feb 15/2008		1	Jun 10/2007	
24	Feb 15/2008		2	Jun 10/2007	

A = Added, R = Revised, D = Deleted, O = Overflow, C = Customer Originated Change

34-EFFECTIVE PAGES



CHAPTER 34
Navigation

Subject/Page	Date	COC	Subject/Page	Date	COC
34-55-00 (cont.)			34-55-00 (cont.)		
3	Oct 10/2004		26	Feb 15/2009	
4	Oct 10/2004		27	Feb 15/2009	
5	Jun 10/2007		28	Jun 10/2007	
6	Jun 10/2007		29	Jun 10/2007	
7	Jun 10/2007		30	Jun 10/2007	
8	Feb 15/2009		31	Jun 10/2007	
9	Feb 15/2009		32	Jun 10/2007	
10	Jun 10/2007		33	Jun 10/2007	
11	Jun 10/2007		34	Jun 10/2007	
12	Jun 10/2007		35	Jun 10/2007	
13	Jun 10/2007		36	Jun 10/2007	
14	Jun 10/2007		37	Jun 10/2007	
15	Feb 15/2009		38	Jun 10/2007	
16	Jun 10/2007		39	Jun 10/2007	
17	Jun 10/2007		40	Jun 10/2007	
18	Jun 10/2007		41	Jun 10/2007	
19	Jun 10/2007		42	Jun 10/2007	
20	Jun 10/2007		43	Feb 15/2009	
21	Jun 10/2007		44	Jun 10/2007	
22	Jun 10/2007		45	Jun 10/2007	
23	Jun 10/2007		46	BLANK	
24	Jun 10/2007		34-57-00		
25	Feb 15/2009		1	Oct 10/2002	

A = Added, R = Revised, D = Deleted, O = Overflow, C = Customer Originated Change

34-EFFECTIVE PAGES



CHAPTER 34
Navigation

Subject/Page	Date	COC	Subject/Page	Date	COC
34-57-00 (cont.)			34-57-00 (cont.)		
2	Oct 10/2002		25	Jun 10/2007	
3	Oct 10/2004		26	Jun 10/2007	
4	Jun 10/2007		27	Jun 10/2007	
5	Oct 10/2004		28	Jun 10/2007	
6	Feb 15/2009		29	Jun 10/2007	
7	Jun 10/2007		30	Jun 10/2007	
8	Oct 10/2004		31	Jun 10/2007	
9	Oct 10/2004		32	Jun 10/2007	
10	Jun 10/2007		33	Jun 10/2007	
11	Jun 10/2007		34	Jun 10/2007	
12	Jun 10/2007		35	Jun 10/2007	
13	Jun 10/2007		36	Jun 10/2007	
14	Jun 10/2007		37	Jun 10/2007	
15	Jun 10/2007		38	BLANK	
16	Oct 10/2004		34-58-00		
17	Oct 10/2004		1	Oct 10/2002	
18	Oct 10/2004		2	Oct 10/2002	
19	Oct 10/2004		3	Oct 10/2004	
20	Oct 10/2004		O 4	Jun 15/2009	C
21	Feb 15/2009		5	Jun 10/2007	
22	Feb 15/2009		R 6	Jun 15/2009	
23	Oct 10/2004		O 7	Jun 15/2009	
24	Feb 15/2009		O 8	Jun 15/2009	

A = Added, R = Revised, D = Deleted, O = Overflow, C = Customer Originated Change

34-EFFECTIVE PAGES

**CHAPTER 34
Navigation**

Subject/Page	Date	COC	Subject/Page	Date	COC
34-58-00 (cont.)			34-58-00 (cont.)		
O 9	Jun 15/2009		O 32	Jun 15/2009	
O 10	Jun 15/2009		O 33	Jun 15/2009	
O 11	Jun 15/2009		O 34	Jun 15/2009	
O 12	Jun 15/2009		O 35	Jun 15/2009	
O 13	Jun 15/2009		O 36	Jun 15/2009	C
O 14	Jun 15/2009		R 37	Jun 15/2009	
R 15	Jun 15/2009	C	O 38	Jun 15/2009	
R 16	Jun 15/2009	C	O 39	Jun 15/2009	
O 17	Jun 15/2009		O 40	Jun 15/2009	
R 18	Jun 15/2009		O 41	Jun 15/2009	
O 19	Jun 15/2009		O 42	Jun 15/2009	
O 20	Jun 15/2009		O 43	Jun 15/2009	
O 21	Jun 15/2009		O 44	Jun 15/2009	
O 22	Jun 15/2009		45	Jun 10/2007	
23	Jun 10/2007		O 46	Jun 15/2009	
O 24	Jun 15/2009		O 47	Jun 15/2009	
O 25	Jun 15/2009		O 48	Jun 15/2009	
O 26	Jun 15/2009		O 49	Jun 15/2009	
O 27	Jun 15/2009		O 50	Jun 15/2009	
O 28	Jun 15/2009		O 51	Jun 15/2009	
O 29	Jun 15/2009		O 52	Jun 15/2009	
O 30	Jun 15/2009		O 53	Jun 15/2009	
O 31	Jun 15/2009		O 54	Jun 15/2009	

A = Added, R = Revised, D = Deleted, O = Overflow, C = Customer Originated Change

34-EFFECTIVE PAGES

CHAPTER 34
Navigation

Subject/Page	Date	COC	Subject/Page	Date	COC
34-58-00 (cont.)			34-61-00 (cont.)		
D 55	Jun 15/2009		17	Jun 10/2007	
D 56	Jun 15/2009		18	Feb 15/2009	
D 57	Jun 15/2009		19	Feb 15/2009	
D 58	Jun 15/2009		20	Jun 10/2007	
D 59	Jun 15/2009		21	Jun 10/2006	
D 60	Jun 15/2009		22	Jun 10/2007	
34-61-00			23	Jun 10/2007	
1	Oct 10/2002		24	Feb 15/2009	
2	Oct 10/2002		25	Feb 15/2009	
3	Oct 15/2008	C	26	Feb 15/2009	
4	Feb 15/2009		27	Jun 10/2007	
5	Oct 10/2007		28	Feb 15/2009	
6	Oct 10/2007		29	Feb 15/2009	
7	Feb 10/2003		30	Feb 15/2009	
8	Feb 15/2009		31	Feb 15/2009	
9	Oct 10/2006		32	Feb 15/2008	
10	Feb 15/2009		33	Feb 15/2008	
11	Jun 10/2007		34	Feb 15/2009	
12	Jun 10/2007		35	Feb 15/2009	
13	Jun 10/2007		36	Feb 15/2009	
14	Feb 15/2009		37	Jun 10/2007	
15	Jun 10/2007		38	Jun 10/2007	
16	Feb 15/2009		39	Feb 15/2009	

A = Added, R = Revised, D = Deleted, O = Overflow, C = Customer Originated Change

34-EFFECTIVE PAGES

**CHAPTER 34
Navigation**

Subject/Page	Date	COC	Subject/Page	Date	COC
34-61-00 (cont.)			34-61-00 (cont.)		
40	Jun 10/2007		O 63	Jun 15/2009	
41	Jun 10/2007		O 64	Jun 15/2009	
42	Feb 15/2009		O 65	Jun 15/2009	
43	Feb 15/2009		O 66	Jun 15/2009	
44	Feb 15/2009		O 67	Jun 15/2009	
45	Feb 15/2009		O 68	Jun 15/2009	
46	Feb 15/2009		O 69	Jun 15/2009	
47	Feb 15/2009		O 70	Jun 15/2009	
48	Feb 15/2009		O 71	Jun 15/2009	
49	Feb 15/2008		O 72	Jun 15/2009	
R 50	Jun 15/2009		O 73	Jun 15/2009	
O 51	Jun 15/2009		O 74	Jun 15/2009	
O 52	Jun 15/2009		O 75	Jun 15/2009	
O 53	Jun 15/2009		O 76	Jun 15/2009	
O 54	Jun 15/2009		O 77	Jun 15/2009	
O 55	Jun 15/2009		O 78	Jun 15/2009	
O 56	Jun 15/2009		O 79	Jun 15/2009	C
O 57	Jun 15/2009		O 80	Jun 15/2009	C
O 58	Jun 15/2009		O 81	Jun 15/2009	
O 59	Jun 15/2009		O 82	Jun 15/2009	
O 60	Jun 15/2009		O 83	Jun 15/2009	
O 61	Jun 15/2009		O 84	Jun 15/2009	
O 62	Jun 15/2009		O 85	Jun 15/2009	

A = Added, R = Revised, D = Deleted, O = Overflow, C = Customer Originated Change

34-EFFECTIVE PAGES

CHAPTER 34
Navigation

Subject/Page	Date	COC	Subject/Page	Date	COC
34-61-00 (cont.)			34-61-00 (cont.)		
O 86	Jun 15/2009		O 98.11	Jun 15/2009	
O 87	Jun 15/2009		O 98.12	Jun 15/2009	
O 88	Jun 15/2009		O 98.13	Jun 15/2009	
O 89	Jun 15/2009		O 98.14	Jun 15/2009	
R 90	Jun 15/2009		O 98.15	Jun 15/2009	
O 91	Jun 15/2009		O 98.16	Jun 15/2009	
O 92	Jun 15/2009		O 98.17	Jun 15/2009	
O 93	Jun 15/2009		O 98.18	Jun 15/2009	
O 94	Jun 15/2009		O 98.19	Jun 15/2009	
O 95	Jun 15/2009		O 98.20	Jun 15/2009	
O 96	Jun 15/2009		O 98.21	Jun 15/2009	
O 97	Jun 15/2009		O 98.22	Jun 15/2009	
O 98	Jun 15/2009		O 98.23	Jun 15/2009	
O 98.1	Jun 15/2009		O 98.24	Jun 15/2009	
O 98.2	Jun 15/2009		O 98.25	Jun 15/2009	
O 98.3	Jun 15/2009		O 98.26	Jun 15/2009	
O 98.4	Jun 15/2009		O 98.27	Jun 15/2009	
O 98.5	Jun 15/2009		O 98.28	Jun 15/2009	
O 98.6	Jun 15/2009		O 98.29	Jun 15/2009	
O 98.7	Jun 15/2009		R 98.30	Jun 15/2009	
O 98.8	Jun 15/2009		O 98.31	Jun 15/2009	
O 98.9	Jun 15/2009		O 98.32	Jun 15/2009	
O 98.10	Jun 15/2009		O 98.33	Jun 15/2009	

A = Added, R = Revised, D = Deleted, O = Overflow, C = Customer Originated Change

34-EFFECTIVE PAGES



CHAPTER 34
Navigation

Subject/Page	Date	COC	Subject/Page	Date	COC
34-61-00 (cont.)			34-61-00 (cont.)		
O 98.34	Jun 15/2009		O 98.57	Jun 15/2009	
O 98.35	Jun 15/2009		O 98.58	Jun 15/2009	
O 98.36	Jun 15/2009		O 98.59	Jun 15/2009	
O 98.37	Jun 15/2009		O 98.60	Jun 15/2009	
O 98.38	Jun 15/2009		O 98.61	Jun 15/2009	
O 98.39	Jun 15/2009		O 98.62	Jun 15/2009	
O 98.40	Jun 15/2009		O 98.63	Jun 15/2009	
O 98.41	Jun 15/2009		O 98.64	Jun 15/2009	
O 98.42	Jun 15/2009		O 98.65	Jun 15/2009	
O 98.43	Jun 15/2009		O 98.66	Jun 15/2009	
O 98.44	Jun 15/2009		O 98.67	Jun 15/2009	
O 98.45	Jun 15/2009		O 98.68	Jun 15/2009	
O 98.46	Jun 15/2009		O 98.69	Jun 15/2009	
O 98.47	Jun 15/2009		O 98.70	Jun 15/2009	
O 98.48	Jun 15/2009		O 98.71	Jun 15/2009	
O 98.49	Jun 15/2009		O 98.72	Jun 15/2009	
O 98.50	Jun 15/2009		O 98.73	Jun 15/2009	
O 98.51	Jun 15/2009		O 98.74	Jun 15/2009	
O 98.52	Jun 15/2009		O 98.75	Jun 15/2009	
O 98.53	Jun 15/2009		O 98.76	Jun 15/2009	
O 98.54	Jun 15/2009		O 98.77	Jun 15/2009	
O 98.55	Jun 15/2009		O 98.78	Jun 15/2009	
O 98.56	Jun 15/2009		O 98.79	Jun 15/2009	

A = Added, R = Revised, D = Deleted, O = Overflow, C = Customer Originated Change

34-EFFECTIVE PAGES

CHAPTER 34
Navigation

Subject/Page	Date	COC	Subject/Page	Date	COC
34-61-00 (cont.)			34-61-00 (cont.)		
O 98.80	Jun 15/2009		O 98.103	Jun 15/2009	
O 98.81	Jun 15/2009		O 98.104	Jun 15/2009	
O 98.82	Jun 15/2009		O 98.105	Jun 15/2009	
O 98.83	Jun 15/2009		O 98.106	Jun 15/2009	
O 98.84	Jun 15/2009		O 98.107	Jun 15/2009	
O 98.85	Jun 15/2009		O 98.108	Jun 15/2009	
O 98.86	Jun 15/2009		O 98.109	Jun 15/2009	
O 98.87	Jun 15/2009		O 98.110	Jun 15/2009	
O 98.88	Jun 15/2009		O 98.111	Jun 15/2009	
O 98.89	Jun 15/2009		O 98.112	Jun 15/2009	
O 98.90	Jun 15/2009		O 98.113	Jun 15/2009	
O 98.91	Jun 15/2009		O 98.114	Jun 15/2009	
O 98.92	Jun 15/2009		O 98.115	Jun 15/2009	
O 98.93	Jun 15/2009		O 98.116	Jun 15/2009	
O 98.94	Jun 15/2009		O 98.117	Jun 15/2009	
O 98.95	Jun 15/2009		O 98.118	Jun 15/2009	
O 98.96	Jun 15/2009		O 98.119	Jun 15/2009	
R 98.97	Jun 15/2009		O 98.120	Jun 15/2009	
O 98.98	Jun 15/2009		O 98.121	Jun 15/2009	
O 98.99	Jun 15/2009		O 98.122	Jun 15/2009	
O 98.100	Jun 15/2009		O 98.123	Jun 15/2009	
O 98.101	Jun 15/2009		O 98.124	Jun 15/2009	
O 98.102	Jun 15/2009		O 98.125	Jun 15/2009	

A = Added, R = Revised, D = Deleted, O = Overflow, C = Customer Originated Change

34-EFFECTIVE PAGES

**CHAPTER 34
Navigation**

Subject/Page	Date	COC	Subject/Page	Date	COC
34-61-00 (cont.)			34-61-00 (cont.)		
O 98.126	Jun 15/2009		O 98.149	Jun 15/2009	
O 98.127	Jun 15/2009		O 98.150	Jun 15/2009	
O 98.128	Jun 15/2009		O 98.151	Jun 15/2009	
O 98.129	Jun 15/2009		O 98.152	Jun 15/2009	
O 98.130	Jun 15/2009		O 98.153	Jun 15/2009	
O 98.131	Jun 15/2009		O 98.154	Jun 15/2009	
O 98.132	Jun 15/2009		O 98.155	Jun 15/2009	
R 98.133	Jun 15/2009		O 98.156	Jun 15/2009	
R 98.134	Jun 15/2009		O 98.157	Jun 15/2009	
O 98.135	Jun 15/2009		O 98.158	Jun 15/2009	
O 98.136	Jun 15/2009		O 98.159	Jun 15/2009	
R 98.137	Jun 15/2009		O 98.160	Jun 15/2009	
O 98.138	Jun 15/2009		O 98.161	Jun 15/2009	
O 98.139	Jun 15/2009		O 98.162	Jun 15/2009	
O 98.140	Jun 15/2009		O 98.163	Jun 15/2009	
O 98.141	Jun 15/2009		O 98.164	Jun 15/2009	
O 98.142	Jun 15/2009	C	O 98.165	Jun 15/2009	
O 98.143	Jun 15/2009	C	O 98.166	Jun 15/2009	
O 98.144	Jun 15/2009	C	O 98.167	Jun 15/2009	
R 98.145	Jun 15/2009	C	O 98.168	Jun 15/2009	
R 98.146	Jun 15/2009		O 98.169	Jun 15/2009	
R 98.147	Jun 15/2009		O 98.170	Jun 15/2009	
R 98.148	Jun 15/2009		O 98.171	Jun 15/2009	

A = Added, R = Revised, D = Deleted, O = Overflow, C = Customer Originated Change

34-EFFECTIVE PAGES

**CHAPTER 34
Navigation**

Subject/Page	Date	COC	Subject/Page	Date	COC
34-61-00 (cont.)			34-61-00 (cont.)		
O 98.172	Jun 15/2009		O 98.195	Jun 15/2009	
O 98.173	Jun 15/2009		O 98.196	Jun 15/2009	
O 98.174	Jun 15/2009		O 98.197	Jun 15/2009	
O 98.175	Jun 15/2009		O 98.198	Jun 15/2009	
O 98.176	Jun 15/2009		O 98.199	Jun 15/2009	
O 98.177	Jun 15/2009		O 98.200	Jun 15/2009	
O 98.178	Jun 15/2009		O 98.201	Jun 15/2009	
O 98.179	Jun 15/2009		O 98.202	Jun 15/2009	
O 98.180	Jun 15/2009		O 98.203	Jun 15/2009	
O 98.181	Jun 15/2009		O 98.204	Jun 15/2009	
O 98.182	Jun 15/2009		O 98.205	Jun 15/2009	
O 98.183	Jun 15/2009		O 98.206	Jun 15/2009	
O 98.184	Jun 15/2009		O 98.207	Jun 15/2009	
O 98.185	Jun 15/2009		O 98.208	Jun 15/2009	
O 98.186	Jun 15/2009		O 98.209	Jun 15/2009	
O 98.187	Jun 15/2009		O 98.210	Jun 15/2009	
O 98.188	Jun 15/2009		O 98.211	Jun 15/2009	
O 98.189	Jun 15/2009		O 98.212	Jun 15/2009	
O 98.190	Jun 15/2009		O 98.213	Jun 15/2009	
O 98.191	Jun 15/2009		O 98.214	Jun 15/2009	
O 98.192	Jun 15/2009		O 98.215	Jun 15/2009	
O 98.193	Jun 15/2009		O 98.216	Jun 15/2009	
O 98.194	Jun 15/2009		O 98.217	Jun 15/2009	

A = Added, R = Revised, D = Deleted, O = Overflow, C = Customer Originated Change

34-EFFECTIVE PAGES

**CHAPTER 34
Navigation**

Subject/Page	Date	COC	Subject/Page	Date	COC
34-61-00 (cont.)			34-61-00 (cont.)		
O 98.218	Jun 15/2009		O 98.241	Jun 15/2009	
O 98.219	Jun 15/2009		O 98.242	Jun 15/2009	
O 98.220	Jun 15/2009		O 98.243	Jun 15/2009	
O 98.221	Jun 15/2009		O 98.244	Jun 15/2009	
O 98.222	Jun 15/2009		O 98.245	Jun 15/2009	
O 98.223	Jun 15/2009		O 98.246	Jun 15/2009	
O 98.224	Jun 15/2009		O 98.247	Jun 15/2009	
O 98.225	Jun 15/2009		O 98.248	Jun 15/2009	
O 98.226	Jun 15/2009		O 98.249	Jun 15/2009	
O 98.227	Jun 15/2009		R 98.250	Jun 15/2009	
O 98.228	Jun 15/2009		O 98.251	Jun 15/2009	
O 98.229	Jun 15/2009		R 98.252	Jun 15/2009	
O 98.230	Jun 15/2009		O 98.253	Jun 15/2009	
O 98.231	Jun 15/2009		R 98.254	Jun 15/2009	
O 98.232	Jun 15/2009		O 98.255	Jun 15/2009	
O 98.233	Jun 15/2009		O 98.256	Jun 15/2009	
O 98.234	Jun 15/2009		R 98.257	Jun 15/2009	
O 98.235	Jun 15/2009		O 98.258	Jun 15/2009	
O 98.236	Jun 15/2009		O 98.259	Jun 15/2009	
O 98.237	Jun 15/2009		O 98.260	Jun 15/2009	
O 98.238	Jun 15/2009		R 98.261	Jun 15/2009	
O 98.239	Jun 15/2009		O 98.262	Jun 15/2009	
O 98.240	Jun 15/2009		O 98.263	Jun 15/2009	

A = Added, R = Revised, D = Deleted, O = Overflow, C = Customer Originated Change

34-EFFECTIVE PAGES

**CHAPTER 34
Navigation**

Subject/Page	Date	COC	Subject/Page	Date	COC
34-61-00 (cont.)			34-61-00 (cont.)		
O 98.264	Jun 15/2009		O 98.287	Jun 15/2009	
R 98.265	Jun 15/2009		O 98.288	Jun 15/2009	
O 98.266	Jun 15/2009		O 98.289	Jun 15/2009	
O 98.267	Jun 15/2009		O 98.290	Jun 15/2009	
R 98.268	Jun 15/2009		O 98.291	Jun 15/2009	
R 98.269	Jun 15/2009		O 98.292	Jun 15/2009	
O 98.270	Jun 15/2009		O 98.293	Jun 15/2009	
O 98.271	Jun 15/2009		O 98.294	Jun 15/2009	
O 98.272	Jun 15/2009		O 98.295	Jun 15/2009	
O 98.273	Jun 15/2009		O 98.296	Jun 15/2009	
O 98.274	Jun 15/2009		O 98.297	Jun 15/2009	
O 98.275	Jun 15/2009		O 98.298	Jun 15/2009	
O 98.276	Jun 15/2009		O 98.299	Jun 15/2009	
O 98.277	Jun 15/2009		O 98.300	Jun 15/2009	
O 98.278	Jun 15/2009		O 98.301	Jun 15/2009	
O 98.279	Jun 15/2009		O 98.302	Jun 15/2009	
O 98.280	Jun 15/2009		O 98.303	Jun 15/2009	
O 98.281	Jun 15/2009		O 98.304	Jun 15/2009	
O 98.282	Jun 15/2009		O 98.305	Jun 15/2009	
O 98.283	Jun 15/2009		O 98.306	Jun 15/2009	
O 98.284	Jun 15/2009		O 98.307	Jun 15/2009	
O 98.285	Jun 15/2009		O 98.308	Jun 15/2009	
O 98.286	Jun 15/2009		O 98.309	Jun 15/2009	

A = Added, R = Revised, D = Deleted, O = Overflow, C = Customer Originated Change

34-EFFECTIVE PAGES

CHAPTER 34
Navigation

Subject/Page	Date	COC	Subject/Page	Date	COC
34-61-00 (cont.)					
O 98.310	Jun 15/2009				
O 98.311	Jun 15/2009				
O 98.312	Jun 15/2009				
O 98.313	Jun 15/2009				
O 98.314	Jun 15/2009				
O 98.315	Jun 15/2009				
O 98.316	BLANK				
D 98.317	Jun 15/2009				
D 98.318	BLANK				

A = Added, R = Revised, D = Deleted, O = Overflow, C = Customer Originated Change

34-EFFECTIVE PAGES



737-600/700/800/900 AIRCRAFT MAINTENANCE MANUAL

CHAPTER 34 Navigation

<u>CH-SC-SU</u>	<u>Subject</u>	<u>Page</u>	<u>Effectivity</u>
34-11-00	STATIC AND TOTAL AIR PRESSURE SYSTEM - INTRODUCTION	2	HAP ALL
34-11-00	STATIC AND TOTAL AIR PRESSURE SYSTEM - GENERAL DESCRIPTION	4	HAP ALL
34-11-00	STATIC AND TOTAL AIR PRESSURE SYSTEM - COMPONENT LOCATION - FORWARD EQUIPMENT COMPARTMENT	8	HAP ALL
34-11-00	STATIC AND TOTAL AIR PRESSURE SYSTEM - COMPONENT LOCATION - ELECTRONIC EQUIPMENT COMPARTMENT	10	HAP ALL
34-11-00	STATIC AND TOTAL AIR PRESSURE SYSTEM - COMPONENT LOCATION - FORWARD CARGO COMPARTMENT	12	HAP ALL
34-11-00	STATIC AND TOTAL AIR PRESSURE SYSTEM - COMPONENT LOCATION - EXTERNAL	14	HAP ALL
34-11-00	STATIC AND TOTAL AIR PRESSURE SYSTEM - INTERFACE AND FUNCTIONAL DESCRIPTION	16	HAP ALL
34-11-00	STATIC AND TOTAL AIR PRESSURE SYSTEM - PITOT PROBE	20	HAP ALL
34-11-00	STATIC AND TOTAL AIR PRESSURE SYSTEM - STATIC PORT	22	HAP ALL
34-11-00	STATIC AND TOTAL AIR PRESSURE SYSTEM - DRAIN FITTING	24	HAP ALL
34-13-00	AIR DATA INSTRUMENTS - INTRODUCTION	2	HAP 001-013, 015-026, 028-030
34-13-00	AIR DATA INSTRUMENTS - GENERAL DESCRIPTION	4	HAP 001-013, 015-026, 028-030
34-13-00	AIR DATA INSTRUMENTS - COMPONENT LOCATION	6	HAP 001-013, 015-026, 028-030
34-13-00	AIR DATA INSTRUMENTS - INTERFACE	8	HAP 001-013, 015-026, 028-030
34-13-00	AIR DATA INSTRUMENTS - STANDBY ALTIMETER/AIRSPEED INDICATOR	10	HAP 001-013, 015-026, 028-030

34-CONTENTS

D633A101-HAP

BOEING PROPRIETARY - Copyright © - Unpublished Work - See title page for details.

Page 1
Jun 15/2009



CHAPTER 34
Navigation

<u>CH-SC-SU</u>	<u>Subject</u>	<u>Page</u>	<u>Effectivity</u>
34-13-00	AIR DATA INSTRUMENTS - FUNCTIONAL DESCRIPTION	12	HAP 001-013, 015-026, 028-030
34-16-00	OVERSPEED WARNING - INTRODUCTION	2	HAP ALL
34-16-00	OVERSPEED WARNING - GENERAL DESCRIPTION	4	HAP ALL
34-16-00	OVERSPEED WARNING - COMPONENT LOCATION	6	HAP ALL
34-16-00	OVERSPEED WARNING - INTERFACE	8	HAP ALL
34-16-00	OVERSPEED WARNING - MACH AIRSPEED WARNING TEST SWITCH	10	HAP ALL
34-21-00	AIR DATA INERTIAL REFERENCE SYSTEM - INTRODUCTION	1	HAP ALL
34-21-00	ADIRS - GENERAL DESCRIPTION	5	HAP ALL
34-21-00	ADIRS - COMPONENT LOCATION - FLIGHT COMPARTMENT	10	HAP ALL
34-21-00	ADIRS - COMPONENT LOCATION - IRS MASTER CAUTION UNIT	14	HAP ALL
34-21-00	ADIRS - COMPONENT LOCATION - EE COMPARTMENT	16	HAP ALL
34-21-00	ADIRS - COMPONENT LOCATION - PITOT AIR DATA MODULES	20	HAP ALL
34-21-00	ADIRS - COMPONENT LOCATION - STATIC AIR DATA MODULES	22	HAP ALL
34-21-00	ADIRS - COMPONENT LOCATION - AOA SENSORS AND TAT PROBE	24	HAP ALL
34-21-00	ADIRS - POWER	26	HAP ALL
34-21-00	ADIRS - DC POWER OPERATION	28	HAP ALL
34-21-00	ADIRS - NO COOLING AND ON DC WARNING	30	HAP ALL
34-21-00	ADIRS - CONTROL AND WARNING	32	HAP ALL
34-21-00	ADIRS - SYSTEM INPUTS	35	HAP ALL
34-21-00	ADIRS - LEFT INERTIAL REFERENCE DIGITAL OUTPUTS	40	HAP ALL

34-CONTENTS



CHAPTER 34
Navigation

<u>CH-SC-SU</u>	<u>Subject</u>	<u>Page</u>	<u>Effectivity</u>
34-21-00	ADIRS - RIGHT INERTIAL REFERENCE DIGITAL OUTPUTS	51	HAP ALL
34-21-00	ADIRS - LEFT AIR DATA OUTPUTS	58	HAP ALL
34-21-00	ADIRS - RIGHT AIR DATA OUTPUTS	66	HAP ALL
34-21-00	ADIRS - IR SIGNAL SWITCHING	72	HAP ALL
34-21-00	ADIRS - AIR DATA INERTIAL REFERENCE UNIT	74	HAP ALL
34-21-00	ADIRS - INERTIAL SYSTEM DISPLAY UNIT	76	HAP ALL
34-21-00	ADIRS - MODE SELECT UNIT	78	HAP ALL
34-21-00	ADIRS - IRS MASTER CAUTION UNIT	82	HAP ALL
34-21-00	ADIRS - AIR DATA MODULE	84	HAP ALL
34-21-00	ADIRS - ANGLE OF ATTACK SENSOR	86	HAP ALL
34-21-00	ADIRS - TOTAL AIR TEMPERATURE PROBE	88	HAP ALL
34-21-00	ADIRS - ALTERNATE VMO/MMO SWITCH	92	HAP 031-054, 101-999
34-21-00	ADIRS - IR GENERAL THEORY 1	94	HAP ALL
34-21-00	ADIRS - IR GENERAL THEORY 2	96	HAP ALL
34-21-00	ADIRS - IR GENERAL THEORY 3	98	HAP ALL
34-21-00	ADIRS - IR GENERAL THEORY 4	98.2	HAP ALL
34-21-00	ADIRS - IR GENERAL THEORY 5	98.4	HAP ALL
34-21-00	ADIRS - ADIRU FUNCTIONAL DESCRIPTION	98.7	HAP ALL
34-21-00	ADIRS - PFD AND ND INDICATIONS DURING ALIGNMENT	98.10	HAP ALL
34-21-00	ADIRS - PFD AND ND INDICATIONS AFTER ALIGNMENT	98.13	HAP ALL

34-CONTENTS

**CHAPTER 34
Navigation**

<u>CH-SC-SU</u>	<u>Subject</u>	<u>Page</u>	<u>Effectivity</u>
34-21-00	ADIRS - PFD AND ND INVALID ADIRS DATA	98.19	HAP ALL
34-21-00	ADIRS - BAROMETRIC CORRECTION INDICATION	98.24	HAP ALL
34-21-00	ADIRS - TAT INDICATION	98.26	HAP ALL
34-21-00	ADIRS - ANGLE OF ATTACK INDICATION	98.28	HAP 031-054, 101-999
34-21-00	ADIRS - ALIGNMENT PROCEDURE 1	98.30	HAP ALL
34-21-00	ADIRS - ALIGNMENT PROCEDURE 2	98.32	HAP ALL
34-21-00	ADIRS - ALIGNMENT PROCEDURE 3	98.36	HAP ALL
34-21-00	ADIRS - LAST POSITION PRESENT POSITION ENTRY	98.38	HAP ALL
34-21-00	ADIRS - REFERENCE AIRPORT PRESENT POSITION ENTRY	98.40	HAP ALL
34-21-00	ADIRS - SCRATCHPAD PRESENT POSITION ENTRY	98.42	HAP ALL
34-21-00	ADIRS - GPS PRESENT POSITION ENTRY	98.44	HAP ALL
34-21-00	ADIRS - ISDU PRESENT POSITION ENTRY	98.46	HAP ALL
34-21-00	ADIRS - ALIGNMENT TIME	98.48	HAP ALL
34-21-00	ADIRS - IRS MOTION	98.52	HAP ALL
34-21-00	ADIRS - POSITION DIFFERENCE DURING ALIGNMENT	98.56	HAP ALL
34-21-00	ADIRS - POSITION DIFFERENCE AFTER ALIGNMENT 1	98.60	HAP ALL
34-21-00	ADIRS - POSITION DIFFERENCE AFTER ALIGNMENT 2	98.64	HAP ALL
34-21-00	ADIRS - NO PRESENT POSITION ENTRY	98.68	HAP ALL
34-21-00	ADIRS - ATTITUDE MODE	98.72	HAP ALL
34-21-00	ADIRS - IR MODES	98.76	HAP ALL

34-CONTENTS



CHAPTER 34 Navigation

<u>CH-SC-SU</u>	<u>Subject</u>	<u>Page</u>	<u>Effectivity</u>
34-21-00	ADIRS - ADIRS MAINTENANCE CODES	98.78	HAP ALL
34-21-00	ADIRS - TRAINING INFORMATION POINT - CDU ADIRS BITE PAGES - ADIRS BITE MAIN MENU	98.80	HAP ALL
34-21-00	ADIRS - TRAINING INFORMATION POINT - CDU ADIRS BITE PAGES - CURRENT STATUS	98.82	HAP ALL
34-21-00	ADIRS - TRAINING INFORMATION POINT - CDU ADIRS BITE PAGES - INFLIGHT FAULTS	98.84	HAP ALL
34-21-00	ADIRS - TRAINING INFORMATION POINT - CDU ADIRS BITE PAGES - GROUND TEST MENU	98.86	HAP ALL
34-21-00	ADIRS - TRAINING INFORMATION POINT - CDU ADIRS BITE PAGES - IR GROUND TEST	98.88	HAP ALL
34-21-00	ADIRS - TRAINING INFORMATION POINT - CDU ADIRS BITE PAGES - IR GROUND TEST RESULTS 1	98.90	HAP ALL
34-21-00	ADIRS - TRAINING INFORMATION POINT - CDU ADIRS BITE PAGES - IR GROUND TEST RESULTS 2	98.92	HAP ALL
34-21-00	ADIRS - TRAINING INFORMATION POINT - CDU ADIRS BITE PAGES - ADR GROUND TEST	98.94	HAP ALL
34-21-00	ADIRS - TRAINING INFORMATION POINT - CDU ADIRS BITE PAGES - ADR GROUND TEST RESULTS 1	98.96	HAP ALL
34-21-00	ADIRS - TRAINING INFORMATION POINT - CDU ADIRS BITE PAGES - ADR GROUND TEST RESULTS 2	98.98	HAP ALL
34-21-00	ADIRS - TRAINING INFORMATION POINT - CDU ADIRS BITE PAGES - IDENT/CONFIG	98.100	HAP ALL

34-CONTENTS

**CHAPTER 34
Navigation**

<u>CH-SC-SU</u>	<u>Subject</u>	<u>Page</u>	<u>Effectivity</u>
34-21-00	ADIRS - TRAINING INFORMATION POINT - CDU ADIRS BITE PAGES - ADIRS L + R GND TEST	98.102	HAP ALL
34-21-00	ADIRS - TRAINING INFORMATION POINT - CDU ADIRS BITE PAGES - ADIRS MAINTENANCE CODES	98.104	HAP ALL
34-21-00	ADIRS - SYSTEM SUMMARY 1	98.106	HAP ALL
34-21-00	ADIRS - SYSTEM SUMMARY 2	98.110	HAP ALL
34-22-00	RADIO MAGNETIC INDICATOR - INTRODUCTION	2	HAP ALL
34-22-00	RMI - GENERAL DESCRIPTION	4	HAP ALL
34-22-00	RMI - COMPONENT LOCATION	6	HAP ALL
34-22-00	RMI - RADIO MAGNETIC INDICATOR	8	HAP ALL
34-22-00	RMI - FUNCTIONAL DESCRIPTION	10	HAP ALL
34-23-00	STANDBY MAGNETIC COMPASS	2	HAP ALL
34-24-00	STANDBY ATTITUDE REFERENCE SYSTEM - INTRODUCTION	2	HAP 001-013, 015-026, 028-030
34-24-00	STANDBY ATTITUDE REFERENCE SYSTEM - GENERAL DESCRIPTION	4	HAP 001-013, 015-026, 028-030
34-24-00	STANDBY ATTITUDE REFERENCE SYSTEM - COMPONENT LOCATION	6	HAP 001-013, 015-026, 028-030
34-24-00	STANDBY ATTITUDE REFERENCE SYSTEM - STANDBY ATTITUDE INDICATOR	8	HAP 001-013, 015-026, 028-030
34-24-00	STANDBY ATTITUDE REFERENCE SYSTEM - FUNCTIONAL DESCRIPTION	10	HAP 001-013, 015-026, 028-030
34-24-00	STANDBY ATTITUDE REFERENCE SYSTEM - ILS SELF-TEST	13	HAP 001-013, 015-026, 028-030

34-CONTENTS



CHAPTER 34 Navigation

CH-SC-SU	Subject	Page	Effectivity
34-24-00	STANDBY ATTITUDE REFERENCE SYSTEM - INTRODUCTION	17	HAP 031-054, 101-999
34-24-00	STANDBY ATTITUDE REFERENCE SYSTEM - GENERAL DESCRIPTION	21	HAP 031-054, 101-999
34-24-00	STANDBY ATTITUDE REFERENCE SYSTEM - COMPONENT LOCATION	24	HAP 031-054, 101-999
34-24-00	STANDBY ATTITUDE REFERENCE SYSTEM - INTERFACE	28	HAP 031-054, 101-999
34-24-00	STANDBY ATTITUDE REFERENCE SYSTEM - INTEGRATED STANDBY FLIGHT DISPLAY	30	HAP 031-054, 101-999
34-24-00	STANDBY ATTITUDE REFERENCE SYSTEM - ISFD DEDICATED BATTERY/CHARGER	34	HAP 031-054, 101-999
34-24-00	STANDBY ATTITUDE REFERENCE SYSTEM - FUNCTIONAL DESCRIPTION	36	HAP 031-054, 101-999
34-24-00	STANDBY ATTITUDE REFERENCE SYSTEM - OPERATION - POWER-UP	40	HAP 031-054, 101-999
34-24-00	STANDBY ATTITUDE REFERENCE SYSTEM - OPERATION - ATTITUDE	43	HAP 031-054, 101-999
34-24-00	STANDBY ATTITUDE REFERENCE SYSTEM - OPERATION - AIRSPEED AND ALTITUDE	47	HAP 031-054, 101-999
34-24-00	STANDBY ATTITUDE REFERENCE SYSTEM - OPERATION - HEADING	52	HAP 031-054, 101-999
34-24-00	STANDBY ATTITUDE REFERENCE SYSTEM - OPERATION - APPROACH	55	HAP 031-054, 101-999
34-24-00	STANDBY ATTITUDE REFERENCE SYSTEM - TIP - BITE MENU	58	HAP 031-054, 101-999
34-24-00	STANDBY ATTITUDE REFERENCE SYSTEM - TIP - BITE - FUNCTIONAL TEST	60	HAP 031-054, 101-999

34-CONTENTS

**CHAPTER 34
Navigation**

<u>CH-SC-SU</u>	<u>Subject</u>	<u>Page</u>	<u>Effectivity</u>
34-24-00	STANDBY ATTITUDE REFERENCE SYSTEM - TIP - BITE - DISPLAY TEST	62	HAP 031-054, 101-999
34-24-00	STANDBY ATTITUDE REFERENCE SYSTEM - TIP - BITE - LRU IDENT	64	HAP 031-054, 101-999
34-24-00	STANDBY ATTITUDE REFERENCE SYSTEM - TIP - BITE - ENGINEERING DATA	66	HAP 031-054, 101-999
34-31-00	INSTRUMENT LANDING SYSTEM (ILS) - INTRODUCTION	1	HAP ALL
34-31-00	ILS - GENERAL DESCRIPTION	7	HAP ALL
34-31-00	ILS - ANTENNA AND ELECTRONIC EQUIPMENT COMPARTMENT - COMPONENT LOCATION	14	HAP ALL
34-31-00	ILS - POWER INTERFACES	18	HAP ALL
34-31-00	ILS - DIGITAL INTERFACE	22	HAP ALL
34-31-00	ILS - FREQUENCY TRANSFER AND INSTRUMENT SWITCHING	29	HAP ALL
34-31-00	ILS - ANTENNA INTERFACE	34	HAP ALL
34-31-00	ILS - ANALOG INTERFACES	38	HAP ALL
34-31-00	ILS - RECEIVER	41	HAP ALL
34-31-00	ILS - ANTENNAS	46	HAP ALL
34-31-00	ILS - NAVIGATION CONTROL PANEL	50	HAP ALL
34-31-00	ILS - FUNCTIONAL DESCRIPTION	57	HAP ALL
34-31-00	ILS - CONTROLS	65	HAP ALL
34-31-00	ILS - STANDBY ATTITUDE INDICATOR DISPLAYS	68	HAP 001-013, 015-026, 028-030
34-31-00	ILS - INTEGRATED STANDBY FLIGHT DISPLAY	70	HAP 031-054, 101-999

34-CONTENTS

**CHAPTER 34
Navigation**

<u>CH-SC-SU</u>	<u>Subject</u>	<u>Page</u>	<u>Effectivity</u>
34-31-00	ILS - ADI DISPLAYS	73	HAP ALL
34-31-00	ILS - EXPANDED ILS DISPLAY	77	HAP ALL
34-31-00	ILS - CENTERED ILS DISPLAY	81	HAP ALL
34-31-00	ILS - FRONT PANEL BITE	84	HAP ALL
34-31-00	ILS - SELF-TEST	88	HAP ALL
34-31-00	ILS - SYSTEM SUMMARY	92	HAP ALL
34-32-00	MARKER BEACON SYSTEM - INTRODUCTION	2	HAP ALL
34-32-00	MARKER BEACON SYSTEM - GENERAL DESCRIPTION	4	HAP ALL
34-32-00	MARKER BEACON SYSTEM - COMPONENT LOCATIONS	6	HAP ALL
34-32-00	MARKER BEACON SYSTEM - INTERFACES	8	HAP ALL
34-32-00	MARKER BEACON SYSTEM - VOR/MARKER BEACON RECEIVER	10	HAP ALL
34-32-00	MARKER BEACON SYSTEM - MARKER BEACON ANTENNA	12	HAP ALL
34-32-00	MARKER BEACON SYSTEM - DISPLAYS AND AUDIO OUTPUTS	14	HAP ALL
34-32-00	MARKER BEACON SYSTEM - FUNCTIONAL DESCRIPTION	16	HAP ALL
34-32-00	MARKER BEACON SYSTEM - TEST - 1	18	HAP ALL
34-32-00	MARKER BEACON SYSTEM - TEST - 2	20	HAP ALL
34-33-00	RADIO ALTIMETER SYSTEM - INTRODUCTION	1	HAP ALL
34-33-00	RA SYSTEM - GENERAL DESCRIPTION	4	HAP ALL
34-33-00	RA SYSTEM - COMPONENT LOCATION - 1	6	HAP ALL
34-33-00	RA SYSTEM - COMPONENT LOCATION - 2	8	HAP ALL

34-CONTENTS

**CHAPTER 34
Navigation**

<u>CH-SC-SU</u>	<u>Subject</u>	<u>Page</u>	<u>Effectivity</u>
34-33-00	RA SYSTEM - POWER, ANTENNA, AND DISCRETE INPUTS	10	HAP ALL
34-33-00	RA SYSTEM - DATA BUS OUTPUTS, DECISION HEIGHT INTERFACE	12	HAP ALL
34-33-00	RA SYSTEM - RA RECEIVER/TRANSMITTER	14	HAP ALL
34-33-00	RA SYSTEM - RA ANTENNA	16	HAP ALL
34-33-00	RA SYSTEM - OPERATION - 1	18	HAP ALL
34-33-00	RA SYSTEM - OPERATION - 2	24	HAP ALL
34-33-00	RA SYSTEM - RF PROCESSING	28	HAP ALL
34-33-00	RA SYSTEM - FAULT DETECTION	30	HAP ALL
34-33-00	RA SYSTEM - FRONT PANEL BITE	32	HAP ALL
34-33-00	RA SYSTEM - FLIGHT COMPARTMENT BITE DISPLAY	34	HAP ALL
34-33-00	RA SYSTEM - SYSTEM SUMMARY	38	HAP ALL
34-43-00	WEATHER RADAR SYSTEM - INTRODUCTION	1	HAP ALL
34-43-00	WXR SYSTEM - GENERAL DESCRIPTION	5	HAP ALL
34-43-00	WXR SYSTEM - COMPONENT LOCATION - FLIGHT COMPARTMENT	12	HAP ALL
34-43-00	WXR SYSTEM - COMPONENT LOCATION - FORWARD EQUIPMENT COMPARTMENT AND NOSE RADOME	14	HAP ALL
34-43-00	WXR SYSTEM - POWER AND ANALOG INTERFACES	17	HAP ALL
34-43-00	WXR SYSTEM - CONTROL AND DISPLAY INTERFACE	21	HAP ALL
34-43-00	WXR SYSTEM - PWS INTERFACES	25	HAP 008-013, 015-026, 028-054, 101-999
34-43-00	WXR SYSTEM - ANTENNA CONTROL INTERFACE	28	HAP ALL

34-CONTENTS



CHAPTER 34
Navigation

<u>CH-SC-SU</u>	<u>Subject</u>	<u>Page</u>	<u>Effectivity</u>
34-43-00	WXR SYSTEM - CONTROL PANEL	30	HAP ALL
34-43-00	WXR SYSTEM - RECEIVER/TRANSMITTER	34	HAP ALL
34-43-00	WXR SYSTEM - R/T MOUNT	36	HAP ALL
34-43-00	WXR SYSTEM - ANTENNA	39	HAP ALL
34-43-00	WXR SYSTEM - EFIS CONTROL PANEL - OPERATION	42	HAP ALL
34-43-00	WXR SYSTEM - SYSTEM SELECT AND SYSTEM ON/OFF	44	HAP ALL
34-43-00	WXR SYSTEM - NORMAL DISPLAYS	48	HAP ALL
34-43-00	WXR SYSTEM - PWS OPERATION	51	HAP 008-013, 015-026, 028-054, 101-999
34-43-00	WXR SYSTEM - PWS DISPLAYS	54	HAP 008-013, 015-026, 028-054, 101-999
34-43-00	WXR SYSTEM - OPERATION - FAILURE DISPLAYS	58	HAP ALL
34-43-00	WXR SYSTEM - ND RANGE DISAGREEMENT	62	HAP ALL
34-43-00	WXR SYSTEM - WXR R/T FUNCTIONAL DESCRIPTION	65	HAP ALL
34-43-00	WXR SYSTEM - ANTENNA FUNCTIONAL DESCRIPTION	72	HAP ALL
34-43-00	WXR SYSTEM - WXR R/T BITE - FUNCTIONAL DESCRIPTION	74	HAP ALL
34-43-00	WXR SYSTEM - SELF-TEST START	76	HAP ALL
34-43-00	WXR SYSTEM - SELF-TEST	79	HAP ALL
34-43-00	WXR SYSTEM - R/T SELF-TEST	84	HAP ALL
34-43-00	WXR SYSTEM - R/T MAINTENANCE MENU	86	HAP ALL
34-43-00	WXR SYSTEM - SYSTEM SUMMARY	88	HAP ALL

34-CONTENTS

**CHAPTER 34
Navigation**

<u>CH-SC-SU</u>	<u>Subject</u>	<u>Page</u>	<u>Effectivity</u>
34-45-00	TRAFFIC ALERT AND COLLISION AVOIDANCE SYSTEM - INTRODUCTION	1	HAP ALL
34-45-00	TCAS - GENERAL DESCRIPTION	4	HAP ALL
34-45-00	TCAS - COMPONENT LOCATION	8	HAP ALL
34-45-00	TCAS - ANTENNA LOCATION	10	HAP ALL
34-45-00	TCAS - POWER, ANTENNAS, ANALOG, DISCRETE INTERFACES AND PROGRAM PINS	13	HAP ALL
34-45-00	TCAS - DIGITAL INTERFACES	19	HAP ALL
34-45-00	TCAS - TCAS COMPUTER	23	HAP ALL
34-45-00	TCAS - ATC/TCAS CONTROL PANEL	28	HAP ALL
34-45-00	TCAS - TCAS DIRECTIONAL ANTENNA	30	HAP ALL
34-45-00	TCAS - FUNCTIONAL DESCRIPTION	33	HAP ALL
34-45-00	TCAS - BASIC OPERATION	41	HAP ALL
34-45-00	TCAS - SURVEILLANCE AREA	45	HAP ALL
34-45-00	TCAS - CONTROL AND DISPLAY	48	HAP ALL
34-45-00	TCAS - NAVIGATION DISPLAY	50	HAP ALL
34-45-00	TCAS - ATTITUDE INDICATOR DISPLAY	54	HAP ALL
34-45-00	TCAS - AURAL MESSAGES	56	HAP ALL
34-45-00	TCAS - SELF-TEST INDICATIONS ON DISPLAYS	63	HAP ALL
34-45-00	TCAS - SELF-TEST INDICATIONS ON TCAS COMPUTER FRONT PANEL	68	HAP 001-013, 015-026, 028-030

34-CONTENTS



CHAPTER 34 Navigation

<u>CH-SC-SU</u>	<u>Subject</u>	<u>Page</u>	<u>Effectivity</u>
34-45-00	TCAS - SUMMARY	70	HAP ALL
34-46-00	GROUND PROXIMITY WARNING SYSTEM - INTRODUCTION	1	HAP ALL
34-46-00	GPWS - GENERAL DESCRIPTION	4	HAP ALL
34-46-00	GPWS - FLIGHT COMPARTMENT COMPONENT LOCATION	8	HAP ALL
34-46-00	GPWS - COMPONENT LOCATION - 2	10	HAP ALL
34-46-00	GPWS - POWER AND ANALOG INTERFACES	13	HAP ALL
34-46-00	GPWS - DIGITAL INTERFACES	17	HAP ALL
34-46-00	GPWS - TERRAIN/WEATHER RELAY INTERFACE	26	HAP ALL
34-46-00	GPWS - GROUND PROXIMITY WARNING COMPUTER	29	HAP ALL
34-46-00	GPWS - EFIS CONTROL PANEL	32	HAP ALL
34-46-00	GPWS - GROUND PROXIMITY WARNING MODULE	35	HAP ALL
34-46-00	GPWS - MODE 1 DESCRIPTION	38	HAP ALL
34-46-00	GPWS - MODE 1 FUNCTIONAL DESCRIPTION	40	HAP ALL
34-46-00	GPWS - MODE 2A DESCRIPTION	42	HAP ALL
34-46-00	GPWS - MODE 2B DESCRIPTION	44	HAP ALL
34-46-00	GPWS - MODE 2 FUNCTIONAL DESCRIPTION	46	HAP ALL
34-46-00	GPWS - MODE 3 DESCRIPTION	50	HAP ALL
34-46-00	GPWS - MODE 3 FUNCTIONAL DESCRIPTION	52	HAP ALL
34-46-00	GPWS - MODE 4 DESCRIPTION	54	HAP ALL
34-46-00	GPWS - MODE 4 FUNCTIONAL DESCRIPTION	56	HAP ALL

34-CONTENTS

**CHAPTER 34
Navigation**

<u>CH-SC-SU</u>	<u>Subject</u>	<u>Page</u>	<u>Effectivity</u>
34-46-00	GPWS - MODE 5 DESCRIPTION	58	HAP ALL
34-46-00	GPWS - MODE 5 FUNCTIONAL DESCRIPTION	60	HAP ALL
34-46-00	GPWS - MODE 6 DESCRIPTION	62	HAP ALL
34-46-00	GPWS - MODE 7 DESCRIPTION	64	HAP ALL
34-46-00	GPWS - MODE 7 FUNCTIONAL DESCRIPTION	66	HAP ALL
34-46-00	GPWS - ENHANCED FEATURES FUNCTIONAL DESCRIPTION	69	HAP ALL
34-46-00	GPWS - TERRAIN CLEARANCE FLOOR	73	HAP ALL
34-46-00	GPWS - RUNWAY FIELD CLEARANCE FLOOR	77	HAP ALL
34-46-00	GPWS - VERTICAL SITUATION DISPLAY	81	HAP 031-054, 101-999; HAP 001-013, 015-026, 028-030 POST SB 737-31-1246 OR POST SB 737-31-1295
34-46-00	GPWS - SPEECH PROM	84	HAP ALL
34-46-00	GPWS - ENVELOPE MODULATION	86	HAP ALL
34-46-00	GPWS - DISPLAYS	89	HAP ALL
34-46-00	GPWS - TERRAIN AWARENESS DISPLAY	93	HAP ALL
34-46-00	GPWS - NON-NORMAL TERRAIN DISPLAYS	96	HAP ALL
34-46-00	GPWS - SELF-TEST - LEVEL ONE	98.1	HAP ALL
34-46-00	GPWS - SELF-TEST - LEVELS 2-5	98.5	HAP ALL
34-46-00	GPWS - SELF-TEST - LEVEL 6	98.8	HAP ALL
34-46-00	GPWS - STATUS LEDS	98.10	HAP ALL
34-46-00	GPWS - MODE DESCRIPTION SUMMARY	98.12	HAP ALL

34-CONTENTS



CHAPTER 34
Navigation

<u>CH-SC-SU</u>	<u>Subject</u>	<u>Page</u>	<u>Effectivity</u>
34-46-00	GPWS - SYSTEM SUMMARY	98.14	HAP ALL
34-51-00	VHF OMNIDIRECTIONAL RANGING (VOR) SYSTEM - INTRODUCTION	2	HAP ALL
34-51-00	VOR SYSTEM - GENERAL DESCRIPTION	4	HAP ALL
34-51-00	VOR SYSTEM - FLIGHT COMPARTMENT COMPONENT LOCATION	8	HAP ALL
34-51-00	VOR SYSTEM - ANTENNA AND ELECTRONIC EQUIPMENT COMPARTMENT COMPONENT LOCATIONS	10	HAP ALL
34-51-00	VOR SYSTEM - POWER AND ANALOG INTERFACE	13	HAP ALL
34-51-00	VOR SYSTEM - DIGITAL INTERFACE	18	HAP ALL
34-51-00	VOR SYSTEM - VOR/MB RECEIVER	22	HAP ALL
34-51-00	VOR SYSTEM - ANTENNA	24	HAP ALL
34-51-00	VOR SYSTEM - NAVIGATION CONTROL PANEL	27	HAP ALL
34-51-00	VOR SYSTEM - FUNCTIONAL DESCRIPTION	33	HAP ALL
34-51-00	VOR SYSTEM - FREQUENCY TRANSFER AND INSTRUMENT SWITCHING	38	HAP ALL
34-51-00	VOR SYSTEM - CONTROLS	40	HAP ALL
34-51-00	VOR SYSTEM - RADIO MAGNETIC INDICATOR DISPLAYS	42	HAP ALL
34-51-00	VOR SYSTEM - EFIS NORMAL DISPLAYS	45	HAP ALL
34-51-00	VOR SYSTEM - EFIS INVALID DISPLAYS	48	HAP ALL
34-51-00	VOR SYSTEM - FRONT PANEL BITE	50	HAP ALL
34-51-00	VOR SYSTEM - SELF TEST	52	HAP ALL
34-51-00	VOR SYSTEM - SYSTEM SUMMARY	56	HAP ALL

34-CONTENTS

**CHAPTER 34
Navigation**

<u>CH-SC-SU</u>	<u>Subject</u>	<u>Page</u>	<u>Effectivity</u>
34-53-00	AIR TRAFFIC CONTROL SYSTEM - INTRODUCTION	1	HAP ALL
34-53-00	ATC SYSTEM - GENERAL DESCRIPTION	4	HAP ALL
34-53-00	ATC SYSTEM - COMPONENT LOCATION	6	HAP ALL
34-53-00	ATC SYSTEM - ANTENNA INTERFACE	8	HAP ALL
34-53-00	ATC SYSTEM - POWER, IDENTITY, CONTROL, AND AIR DATA INTERFACES	10	HAP ALL
34-53-00	ATC SYSTEM - MMR AND MODE CONTROL PANEL INTERFACES	12	HAP ALL
34-53-00	ATC SYSTEM - MAINTENANCE INTERFACE	14	HAP ALL
34-53-00	ATC SYSTEM - TCAS INTERFACE AND PROGRAM PINS	16	HAP ALL
34-53-00	ATC SYSTEM - SUPPRESSION INTERFACE	18	HAP ALL
34-53-00	ATC SYSTEM - ATC/TCAS CONTROL PANEL	21	HAP ALL
34-53-00	ATC SYSTEM - ATC TRANSPONDER	24	HAP ALL
34-53-00	ATC SYSTEM - ATC ANTENNA	26	HAP ALL
34-53-00	ATC SYSTEM - ATC COAX SWITCH	28	HAP ALL
34-53-00	ATC SYSTEM - INPUTS AND CONTROL	31	HAP ALL
34-53-00	ATC SYSTEM - TRANSPONDER RECEIVE FUNCTION	34	HAP ALL
34-53-00	ATC SYSTEM - TRANSPONDER TRANSMIT FUNCTIONAL DESCRIPTION	36	HAP ALL
34-53-00	ATC SYSTEM - ANTENNA COAX SWITCH CONTROL	38	HAP ALL
34-53-00	ATC SYSTEM - SELF TEST	40	HAP ALL

34-CONTENTS



CHAPTER 34 Navigation

<u>CH-SC-SU</u>	<u>Subject</u>	<u>Page</u>	<u>Effectivity</u>
34-53-00	ATC SYSTEM - SYSTEM SUMMARY	42	HAP ALL
34-55-00	DISTANCE MEASURING EQUIPMENT - INTRODUCTION	1	HAP ALL
34-55-00	DME SYSTEM - GENERAL DESCRIPTION	4	HAP ALL
34-55-00	DME SYSTEM - COMPONENT LOCATION - FLIGHT COMPARTMENT	8	HAP ALL
34-55-00	DME SYSTEM - COMPONENT LOCATION - ELECTRONIC EQUIPMENT COMPARTMENT AND ANTENNAS	12	HAP ALL
34-55-00	DME SYSTEM - ARINC 429 INTERFACES	14	HAP ALL
34-55-00	DME SYSTEM - POWER, ANTENNA, ANALOG, AND DISCRETE INTERFACE	18	HAP ALL
34-55-00	DME SYSTEM - INTERROGATOR	20	HAP ALL
34-55-00	DME SYSTEM - ANTENNA	22	HAP ALL
34-55-00	DME SYSTEM - NAVIGATION CONTROL PANEL	25	HAP ALL
34-55-00	DME SYSTEM - OPERATION - CONTROLS	30	HAP ALL
34-55-00	DME SYSTEM - DISPLAY	32	HAP ALL
34-55-00	DME SYSTEM - FUNCTIONAL DESCRIPTION	35	HAP ALL
34-55-00	DME SYSTEM - SELF TEST	38	HAP ALL
34-55-00	DME SYSTEM - TEST DISPLAY	40	HAP ALL
34-55-00	DME SYSTEM - SYSTEM SUMMARY	42	HAP ALL
34-57-00	AUTOMATIC DIRECTION FINDER SYSTEM - INTRODUCTION	2	HAP ALL
34-57-00	ADF SYSTEM - GENERAL DESCRIPTION	4	HAP ALL
34-57-00	ADF SYSTEM - FLIGHT COMPARTMENT COMPONENT LOCATION	8	HAP ALL

34-CONTENTS

**CHAPTER 34
Navigation**

<u>CH-SC-SU</u>	<u>Subject</u>	<u>Page</u>	<u>Effectivity</u>
34-57-00	ADF SYSTEM - ELECTRONIC EQUIPMENT COMPARTMENT AND ANTENNA COMPONENT LOCATIONS	10	HAP ALL
34-57-00	ADF SYSTEM - POWER AND ANALOG INTERFACE	12	HAP ALL
34-57-00	ADF SYSTEM - DIGITAL INTERFACE	14	HAP ALL
34-57-00	ADF SYSTEM - RECEIVER	16	HAP ALL
34-57-00	ADF SYSTEM - ANTENNA	18	HAP ALL
34-57-00	ADF SYSTEM - CONTROL PANEL	21	HAP ALL
34-57-00	ADF SYSTEM - FUNCTIONAL DESCRIPTION	25	HAP ALL
34-57-00	ADF SYSTEM - CONTROLS	28	HAP ALL
34-57-00	ADF SYSTEM - RADIO MAGNETIC INDICATOR DISPLAYS	30	HAP ALL
34-57-00	ADF SYSTEM - EFIS NAV DISPLAYS	32	HAP ALL
34-57-00	ADF SYSTEM - FRONT PANEL BITE	34	HAP ALL
34-57-00	ADF SYSTEM - SELF-TEST	36	HAP ALL
34-58-00	GLOBAL POSITIONING SYSTEM - INTRODUCTION	2	HAP ALL
34-58-00	GPS - GENERAL DESCRIPTION	4	HAP ALL
34-58-00	GPS - FLIGHT COMPARTMENT COMPONENT LOCATION	8	HAP ALL
34-58-00	GPS - COMPONENT LOCATION	10	HAP ALL
34-58-00	GPS - ANTENNA LOCATIONS	12	HAP ALL
34-58-00	GPS - INTERFACES	15	HAP ALL
34-58-00	GPS - RECEIVER	20	HAP ALL

34-CONTENTS



737-600/700/800/900 AIRCRAFT MAINTENANCE MANUAL

CHAPTER 34 Navigation

<u>CH-SC-SU</u>	<u>Subject</u>	<u>Page</u>	<u>Effectivity</u>
34-58-00	GPS - GPS ANTENNA	24	HAP ALL
34-58-00	GPS - THEORY OF OPERATION - 1	27	HAP ALL
34-58-00	GPS - THEORY OF OPERATION - 2	30	HAP ALL
34-58-00	GPS - THEORY OF OPERATION - 3	33	HAP ALL
34-58-00	GPS - FUNCTIONAL DESCRIPTION	36	HAP ALL
34-58-00	GPS - GPS FAULT MONITORING - FUNCTIONAL DESCRIPTION	40	HAP ALL
34-58-00	GPS - CDU DISPLAYS	42	HAP ALL
34-58-00	GPS - TRAINING INFORMATION POINT - 1	46	HAP ALL
34-58-00	GPS - TRAINING INFORMATION POINT - 2	48	HAP ALL
34-58-00	GPS - MMR BITE	51	HAP ALL
34-61-00	FLIGHT MANAGEMENT COMPUTER SYSTEM - INTRODUCTION	2	HAP ALL
34-61-00	FMCS - GENERAL DESCRIPTION	8	HAP ALL
34-61-00	FMCS - FLIGHT COMPARTMENT COMPONENT LOCATIONS	12	HAP 001-011 PRE SB 737-31-1136
34-61-00	FMCS - FLIGHT COMPARTMENT COMPONENT LOCATION	14	HAP 012, 013, 015-026, 028-054, 101-999; HAP 001-011 POST SB 737-31-1136
34-61-00	FMCS - ELECTRONIC EQUIPMENT COMPARTMENT LOCATIONS	18	HAP ALL
34-61-00	FMCS - FMC AND CDU POWER INTERFACE	22	HAP ALL
34-61-00	FMCS - TRANSFER RELAY POWER INTERFACE	25	HAP ALL
34-61-00	FMCS - DIGITAL INPUT INTERFACE - 1	29	HAP ALL
34-61-00	FMCS - DIGITAL INPUT INTERFACE - 2	34	HAP ALL
34-61-00	FMCS - DIGITAL OUTPUT INTERFACE - 1	41	HAP ALL

34-CONTENTS

D633A101-HAP

BOEING PROPRIETARY - Copyright © - Unpublished Work - See title page for details.

Page 19
Jun 15/2009



737-600/700/800/900 AIRCRAFT MAINTENANCE MANUAL

CHAPTER 34 Navigation

<u>CH-SC-SU</u>	<u>Subject</u>	<u>Page</u>	<u>Effectivity</u>
34-61-00	FMCS - DIGITAL OUTPUT INTERFACE - 2	57	HAP ALL
34-61-00	FMCS - CDU INTERFACE	66	HAP ALL
34-61-00	FMCS - FMC DATA LOADER INTERFACE	69	HAP ALL
34-61-00	FMCS - CDU DATA LOADER INTERFACE	75	HAP 012, 013, 015-026, 028-054, 101-999; HAP 006-011 POST SB 737-31-1136; HAP 001-005 POST SB 737-34-1951 GRP 1 AND POST SB 737-31-1136
34-61-00	FMCS - ACARS INTERFACE	79	HAP 001-013, 015-026, 028-030
34-61-00	FMCS - ANALOG DISCRETES	82	HAP ALL
34-61-00	FMCS - STATUS ANNUNCIATOR INTERFACE	86	HAP ALL
34-61-00	FMCS - PROGRAM PIN INTERFACE	90	HAP ALL
34-61-00	FMCS - BITE PRINTER AND PORTABLE CDU RECEPTACLES	96	HAP ALL
34-61-00	FMCS - FLIGHT MANAGEMENT COMPUTER	98.2	HAP ALL
34-61-00	FMCS - FLIGHT MANAGEMENT COMPUTER - FUNCTIONAL DESCRIPTION	98.5	HAP ALL
34-61-00	FMCS - CONTROL DISPLAY UNIT	98.9	HAP ALL
34-61-00	FMCS - CONTROL DISPLAY UNIT - FUNCTIONAL DESCRIPTION	98.12	HAP ALL
34-61-00	FMCS - CONTROL DISPLAY UNIT - CONTROLS AND DISPLAYS	98.18	HAP ALL
34-61-00	FMCS - AIRBORNE DATA LOADER	98.24	HAP 031-054, 101-999
34-61-00	FMCS - TRANSFER RELAYS	98.26	HAP ALL
34-61-00	FMCS - FMC FUNCTIONAL DESCRIPTION - INTRODUCTION	98.29	HAP ALL

34-CONTENTS



CHAPTER 34 Navigation

<u>CH-SC-SU</u>	<u>Subject</u>	<u>Page</u>	<u>Effectivity</u>
34-61-00	FMCS - FMC FUNCTIONAL DESCRIPTION - NAVIGATION SUB-FUNCTION	98.35	HAP ALL
34-61-00	FMCS - FMC FUNCTIONAL DESCRIPTION - PERFORMANCE SUB-FUNCTION	98.43	HAP ALL
34-61-00	FMCS - FMC FUNCTIONAL DESCRIPTION - GUIDANCE SUB-FUNCTION	98.49	HAP ALL
34-61-00	FMCS - FMC FUNCTIONAL DESCRIPTION - GUIDANCE SUB-FUNCTION - LNAV AND VNAV MODE LOGIC	98.55	HAP ALL
34-61-00	FMCS - DISPLAYS - CDU - GROUND POWER UP - 1	98.58	HAP ALL
34-61-00	FMCS - DISPLAYS - CDU - GROUND POWER UP - 2	98.62	HAP ALL
34-61-00	FMCS - DISPLAYS - CDU - PRE-FLIGHT INTRODUCTION	98.65	HAP ALL
34-61-00	FMCS - DISPLAYS - CDU - IDENT PAGE	98.69	HAP ALL
34-61-00	FMCS - DISPLAYS - CDU - INIT/REF INDEX PAGE	98.73	HAP ALL
34-61-00	FMCS - DISPLAYS - CDU - POSITION PAGES	98.78	HAP ALL
34-61-00	FMCS - DISPLAYS - CDU - ROUTE PAGE	98.83	HAP ALL
34-61-00	FMCS - DISPLAYS - CDU - DEP/ARR INDEX PAGE	98.87	HAP ALL
34-61-00	FMCS - DISPLAYS - CDU - LEGS PAGE	98.90	HAP ALL
34-61-00	FMCS - DISPLAYS - CDU - PERF INIT PAGE	98.92	HAP ALL
34-61-00	FMCS - DISPLAYS - CDU - N1 LIMIT PAGE	98.97	HAP ALL
34-61-00	FMCS - DISPLAYS - CDU - TAKEOFF REF PAGE	98.102	HAP ALL
34-61-00	FMCS - DISPLAYS - CDU - CLIMB PAGES	98.108	HAP ALL

34-CONTENTS

**CHAPTER 34
Navigation**

<u>CH-SC-SU</u>	<u>Subject</u>	<u>Page</u>	<u>Effectivity</u>
34-61-00	FMCS - DISPLAYS - CDU - CRUISE PAGES	98.110	HAP ALL
34-61-00	FMCS - DISPLAYS - CDU - DESCENT PAGES	98.113	HAP ALL
34-61-00	FMCS - DISPLAYS - CDU - PROGRESS/NAV STATUS PAGES	98.116	HAP ALL
34-61-00	FMCS - DISPLAYS - CDU - ALTERNATE DESTINATION PAGES	98.123	HAP ALL
34-61-00	FMCS - DISPLAYS - CDU - LATERAL OFFSET PAGE	98.126	HAP ALL
34-61-00	FMCS - DISPLAYS - CDU - APPROACH REFERENCE PAGE	98.129	HAP ALL
34-61-00	FMCS - DISPLAYS - CDU - NAVIGATION REFERENCE PAGES	98.132	HAP ALL
34-61-00	FMCS - DISPLAYS - CDU - HOLD PAGE	98.137	HAP ALL
34-61-00	FMCS - DISPLAYS - CDU - FIX PAGE	98.140	HAP ALL
34-61-00	FMCS - DISPLAYS - CDU - MESSAGES	98.142	HAP ALL
34-61-00	FMCS - DISPLAYS - CDS - FLIGHT MODE ANNUNCIATIONS	98.156	HAP ALL
34-61-00	FMCS - DISPLAYS - CDS - THRUST MODE	98.158	HAP ALL
34-61-00	FMCS - DISPLAYS - CDS - AIRSPEED INDICATION	98.161	HAP ALL
34-61-00	FMCS - DISPLAYS - CDS - MAP DISPLAY	98.166	HAP ALL
34-61-00	FMCS - DISPLAYS - CDS - PLAN DISPLAY	98.170	HAP ALL
34-61-00	FMCS - DISPLAYS - CDS - NON-NORMAL DISPLAYS	98.174	HAP ALL
34-61-00	FMCS - VNAV - SPEED INTERVENTION	98.178	HAP ALL
34-61-00	FMCS - VNAV - ALTITUDE INTERVENTION	98.180	HAP ALL
34-61-00	FMCS - TRAINING INFORMATION POINT - FMC DATA LOADING	98.183	HAP ALL

34-CONTENTS



737-600/700/800/900 AIRCRAFT MAINTENANCE MANUAL

CHAPTER 34 Navigation

<u>CH-SC-SU</u>	<u>Subject</u>	<u>Page</u>	<u>Effectivity</u>
34-61-00	FMCS - TRAINING INFORMATION POINT - CDU DATA LOADING	98.189	HAP 012, 013, 015-026, 028-054, 101-999; HAP 006-011 POST SB 737-31-1136; HAP 001-005 POST SB 737-34-1951 GRP 1 AND POST SB 737-31-1136
34-61-00	FMCS - TRAINING INFORMATION POINT - DATABASE LOAD	98.194	HAP ALL
34-61-00	FMCS - TRAINING INFORMATION POINT - CROSSLOAD PAGES	98.196	HAP 037-054, 101-999
34-61-00	FMCS - TRAINING INFORMATION POINT - OFP CROSSLOAD PAGE	98.199	HAP 037-054, 101-999
34-61-00	FMCS - TRAINING INFORMATION POINT - DATABASE CROSSLOAD PAGE	98.203	HAP 037-054, 101-999
34-61-00	FMCS - TRAINING INFORMATION POINT - FMCS BITE PAGES - INTRODUCTION	98.207	HAP ALL
34-61-00	FMCS - TRAINING INFORMATION POINT - FMCS BITE PAGES - BITE ENTRY	98.214	HAP ALL
34-61-00	FMCS - TRAINING INFORMATION POINT - FMCS BITE PAGES - AUTOMATIC BITE ENTRY	98.222	HAP 037-054, 101-999
34-61-00	FMCS - TRAINING INFORMATION POINT - FMCS BITE PAGES - INFLIGHT FAULT	98.224	HAP ALL
34-61-00	FMCS - TRAINING INFORMATION POINT - FMCS BITE PAGES - CDU TEST	98.230	HAP ALL
34-61-00	FMCS - TRAINING INFORMATION POINT - FMCS BITE PAGES - SENSORS	98.235	HAP ALL
34-61-00	FMCS - TRAINING INFORMATION POINT - FMCS BITE PAGES - DISCRETES	98.241	HAP ALL
34-61-00	FMCS - TRAINING INFORMATION POINT - FMCS BITE PAGES - FMCS- FIXED OUTPUTS	98.246	HAP ALL

34-CONTENTS

D633A101-HAP

BOEING PROPRIETARY - Copyright © - Unpublished Work - See title page for details.

Page 23
Jun 15/2009



737-600/700/800/900 AIRCRAFT MAINTENANCE MANUAL

CHAPTER 34 Navigation

<u>CH-SC-SU</u>	<u>Subject</u>	<u>Page</u>	<u>Effectivity</u>
34-61-00	FMCS - TRAINING INFORMATION POINT - FMCS BITE PAGES - AIRPLANE MODEL AND ENGINE CONFIGURATION	98.250	HAP ALL
34-61-00	FMCS - TRAINING INFORMATION POINT - FMCS BITE PAGES - SOFTWARE OPTIONS	98.257	HAP ALL
34-61-00	FMCS - TRAINING INFORMATION POINT - FMCS BITE PAGES - PERFORMANCE FACTORS	98.265	HAP ALL
34-61-00	FMCS - TRAINING INFORMATION POINT - FMCS BITE PAGES - IRS MONITOR	98.272	HAP ALL
34-61-00	FMCS - TRAINING INFORMATION POINT - FMCS BITE PAGES - LCD CDU	98.276	HAP 006-013, 015-026, 028-054, 101-999; HAP 001-005 POST SB 737-34-1951 GRP 1
34-61-00	FMCS - TRAINING INFORMATION POINT - FMCS BITE PAGES - H/W CONFIG	98.280	HAP 030 PRE SB 737-34-1918; HAP 001-013, 015-026, 028, 029 POST SB 737-34-1666 AND PRE SB 737-34-1918
34-61-00	FMCS - TRAINING INFORMATION POINT - CDU BITE PAGES - FAULTS	98.283	HAP 006-013, 015-026, 028-054, 101-999; HAP 001-005 POST SB 737-34-1951 GRP 1
34-61-00	FMCS - TRAINING INFORMATION POINT - CDU BITE PAGES - KEY TEST	98.286	HAP 006-013, 015-026, 028-054, 101-999; HAP 001-005 POST SB 737-34-1951 GRP 1
34-61-00	FMCS - TRAINING INFORMATION POINT - CDU BITE PAGES - COLOR TEST	98.289	HAP 006-013, 015-026, 028-054, 101-999; HAP 001-005 POST SB 737-34-1951 GRP 1
34-61-00	FMCS - TRAINING INFORMATION POINT - CDU BITE PAGES - DISPLAY TEST	98.294	HAP 006-013, 015-026, 028-054, 101-999; HAP 001-005 POST SB 737-34-1951 GRP 1
34-61-00	FMCS - TRAINING INFORMATION POINT - CDU BITE PAGES - CONFIG	98.296	HAP 006-013, 015-026, 028-054, 101-999; HAP 001-005 POST SB 737-34-1951 GRP 1
34-61-00	FMCS - TRAINING INFORMATION POINT - CDU BITE PAGES - SW OPTIONS	98.298	HAP 006-013, 015-026, 028-054, 101-999; HAP 001-005 POST SB 737-34-1951 GRP 1

34-CONTENTS



737-600/700/800/900 AIRCRAFT MAINTENANCE MANUAL

CHAPTER 34 Navigation

<u>CH-SC-SU</u>	<u>Subject</u>	<u>Page</u>	<u>Effectivity</u>
34-61-00	FMCS - TRAINING INFORMATION POINT - CDU BITE PAGES - POWER SUPPLY	98.300	HAP 006-013, 015-026, 028-054, 101-999; HAP 001-005 POST SB 737-34-1951 GRP 1
34-61-00	FMCS - TRAINING INFORMATION POINT - CDU BITE PAGES - TEMP SENSORS	98.302	HAP 006-013, 015-026, 028-054, 101-999; HAP 001-005 POST SB 737-34-1951 GRP 1
34-61-00	FMCS - TRAINING INFORMATION POINT - CDU BITE PAGES - LIGHT SENSORS	98.304	HAP 006-013, 015-026, 028-054, 101-999; HAP 001-005 POST SB 737-34-1951 GRP 1
34-61-00	FMCS - TRAINING INFORMATION POINT - CDU BITE PAGES - LAMP TEST	98.306	HAP 006-013, 015-026, 028-054, 101-999; HAP 001-005 POST SB 737-34-1951 GRP 1
34-61-00	FMCS - TRAINING INFORMATION POINT - CDU BITE PAGES - CALIBRATION	98.308	HAP 006-013, 015-026, 028-054, 101-999; HAP 001-005 POST SB 737-34-1951 GRP 1
34-61-00	FMCS - SYSTEM SUMMARY	98.310	HAP 001-013, 015-026, 028-036
34-61-00	FMCS - SYSTEM SUMMARY	98.314	HAP 037-054, 101-999

34-CONTENTS

D633A101-HAP

BOEING PROPRIETARY - Copyright © - Unpublished Work - See title page for details.

Page 25
Jun 15/2009

THIS PAGE IS INTENTIONALLY LEFT BLANK

34-11-00

D633A101-HAP

Page 1
Oct 10/2002

STATIC AND TOTAL AIR PRESSURE SYSTEM - INTRODUCTION

General

The purpose of the static and total air pressure system is to measure pitot and static air pressure. These pressures are used to calculate flight parameters such as airspeed and altitude.

Abbreviations and Acronyms

- ADIRU - air data inertial reference unit
- ADM - air data module
- altn - alternate
- ARINC - Aeronautical Radio Incorporated
- aux - auxiliary
- capt - captain
- ft - feet
- F/O - first officer
- fwd - forward

HAP 031-054, 101-999

- ISFD - integrated standby flight display

HAP ALL

- L - left
- R - right

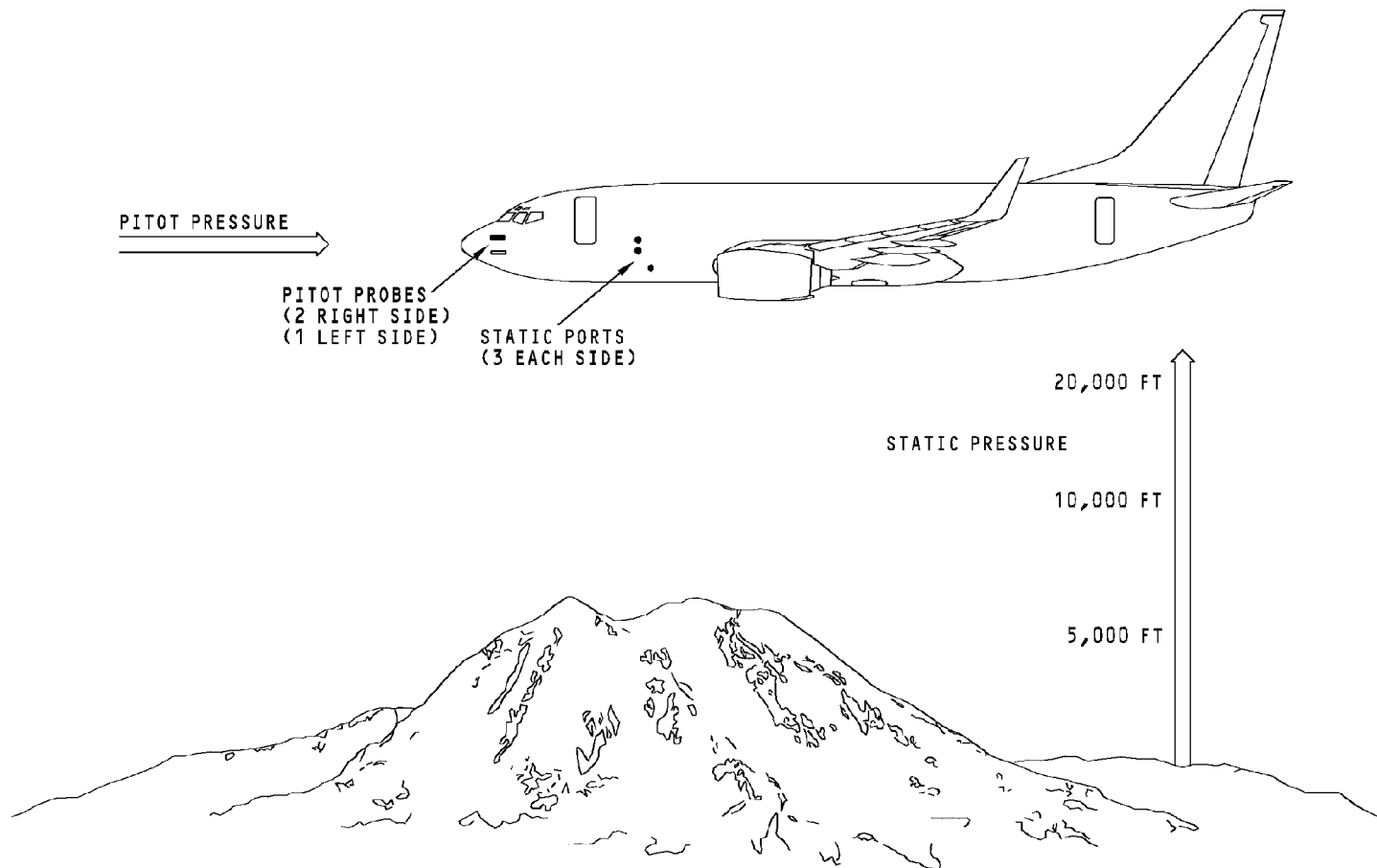

STATIC AND TOTAL AIR PRESSURE SYSTEM - INTRODUCTION

34-11-00-001

EFFECTIVITY
HAP ALL

34-11-00

D633A101-HAP

Page 3
Oct 10/2004

STATIC AND TOTAL AIR PRESSURE SYSTEM - GENERAL DESCRIPTION**General**

The static and total air pressure system gets air pressure inputs from three pitot probes and six static ports on the airplane fuselage.

These are the two types of air pressure:

- Static air pressure is the ambient air pressure around the airplane
- Pitot air pressure is the air pressure on the pitot probe tube as a result of the forward motion of the airplane.

The static and total air pressure system has these components:

- Three pitot probes
- Six static ports
- Five drain fittings.

Flexible and hard pneumatic tubing are used to connect the pitot-static components.

The system drains are used to remove condensation in the pitot-static lines.

Primary Static and Total Air Pressure System

The two primary pitot probes connect to two pitot air data modules (ADMs). Two pairs of the primary static ports connect to two static ADMs.

The ADMs change the air pressures to electrical signals and send them to the air data inertial reference units (ADIRUs) on ARINC 429 data buses. The ADIRUs use the signals to calculate flight parameters such as airspeed and altitude.

Each pitot line and each static line has a drain fitting.

HAP 001-013, 015-026, 028-030**Alternate Static and Total Air Pressure System**

The auxiliary pitot probe connects to the standby altimeter/airspeed indicator. The alternate static ports connect to the standby altimeter/airspeed indicator and to the cabin differential pressure indicator.

The standby static line has a drain fitting.

HAP 031-054, 101-999**Alternate Static and Total Air Pressure System**

The auxiliary pitot probe connects to the integrated standby flight display. The alternate static ports connect to the integrated standby flight display and to the cabin differential pressure indicator.

The standby static line has a drain fitting.

HAP ALL**34-11-00****EFFECTIVITY**
HAP ALL

D633A101-HAP

Page 4
Feb 15/2009

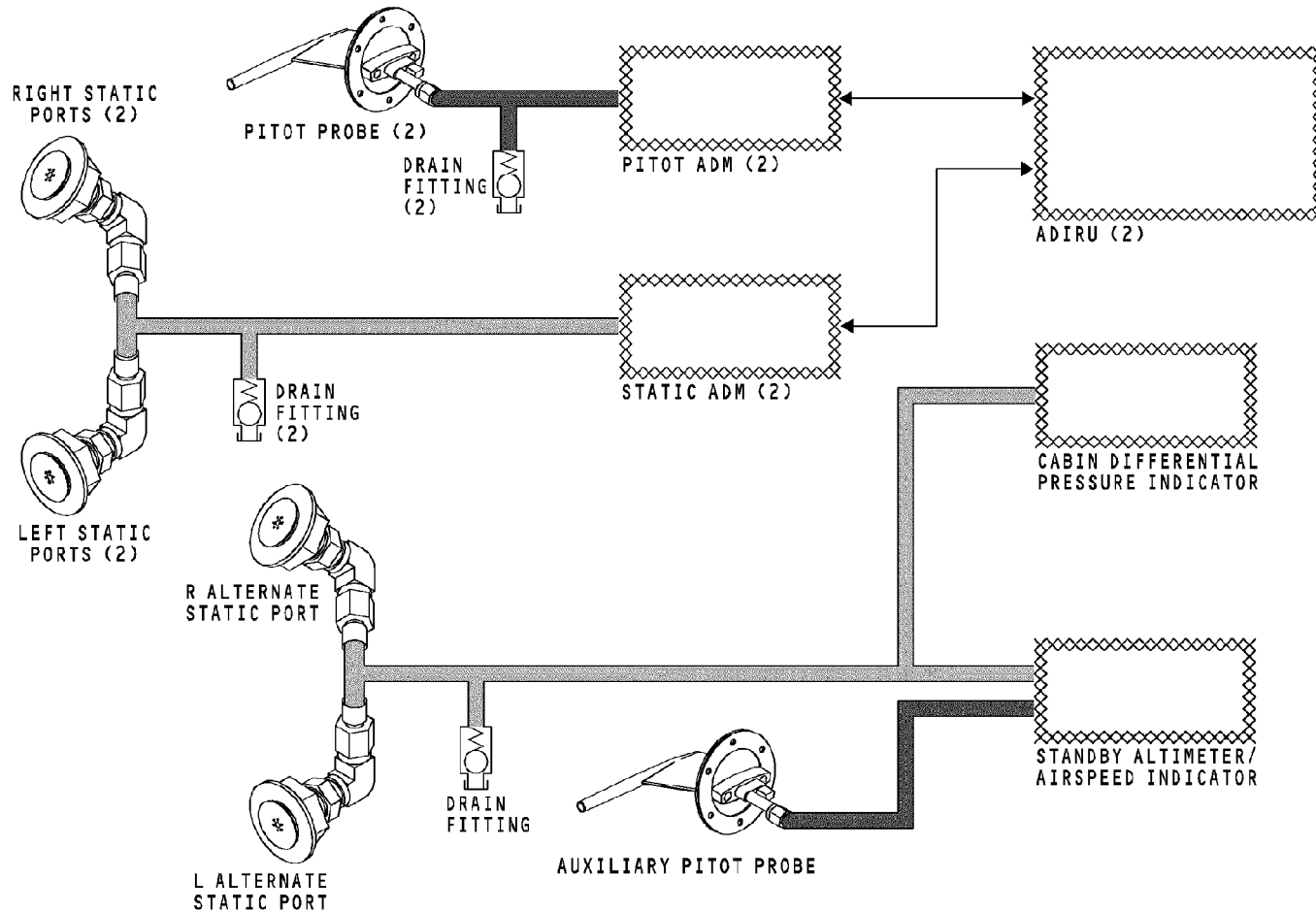

STATIC AND TOTAL AIR PRESSURE SYSTEM - GENERAL DESCRIPTION

34-11-00-002

EFFECTIVITY
HAP 001-013, 015-026, 028-030

34-11-00

D633A101-HAP

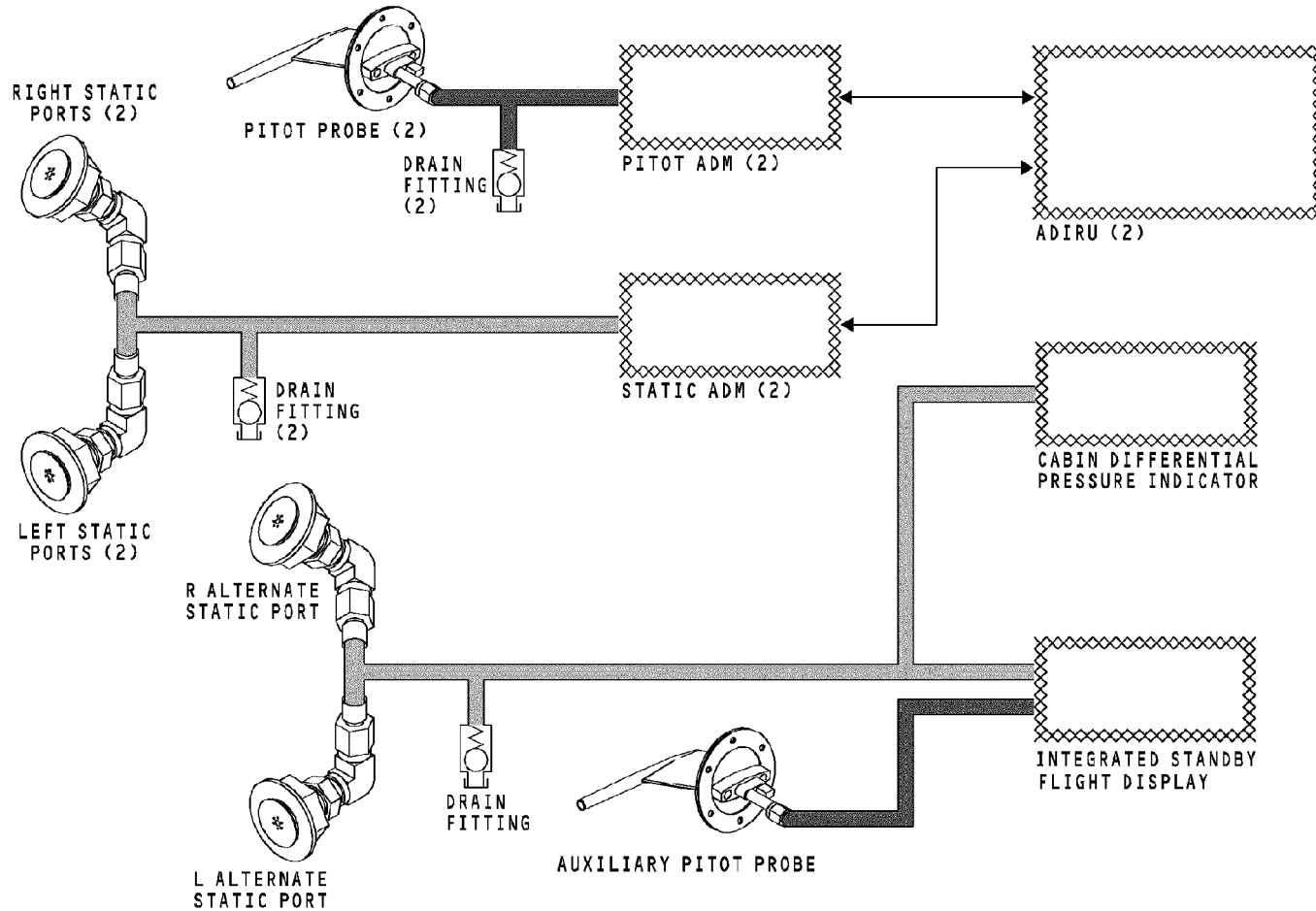

STATIC AND TOTAL AIR PRESSURE SYSTEM - GENERAL DESCRIPTION

EFFECTIVITY
HAP 031-054, 101-999

34-11-00

D633A101-HAP

THIS PAGE IS INTENTIONALLY LEFT BLANK

34-11-00

D633A101-HAP

Page 7
Feb 10/2006

STATIC AND TOTAL AIR PRESSURE SYSTEM - COMPONENT LOCATION - FORWARD EQUIPMENT COMPARTMENT

Primary Pitot Drain Fittings

The drain fittings for the captain and first officer pitot lines are in the forward equipment compartment adjacent to the compartment access door.

34-11-00-003

EFFECTIVITY
HAP ALL

34-11-00

D633A101-HAP

Page 8
Feb 10/2006

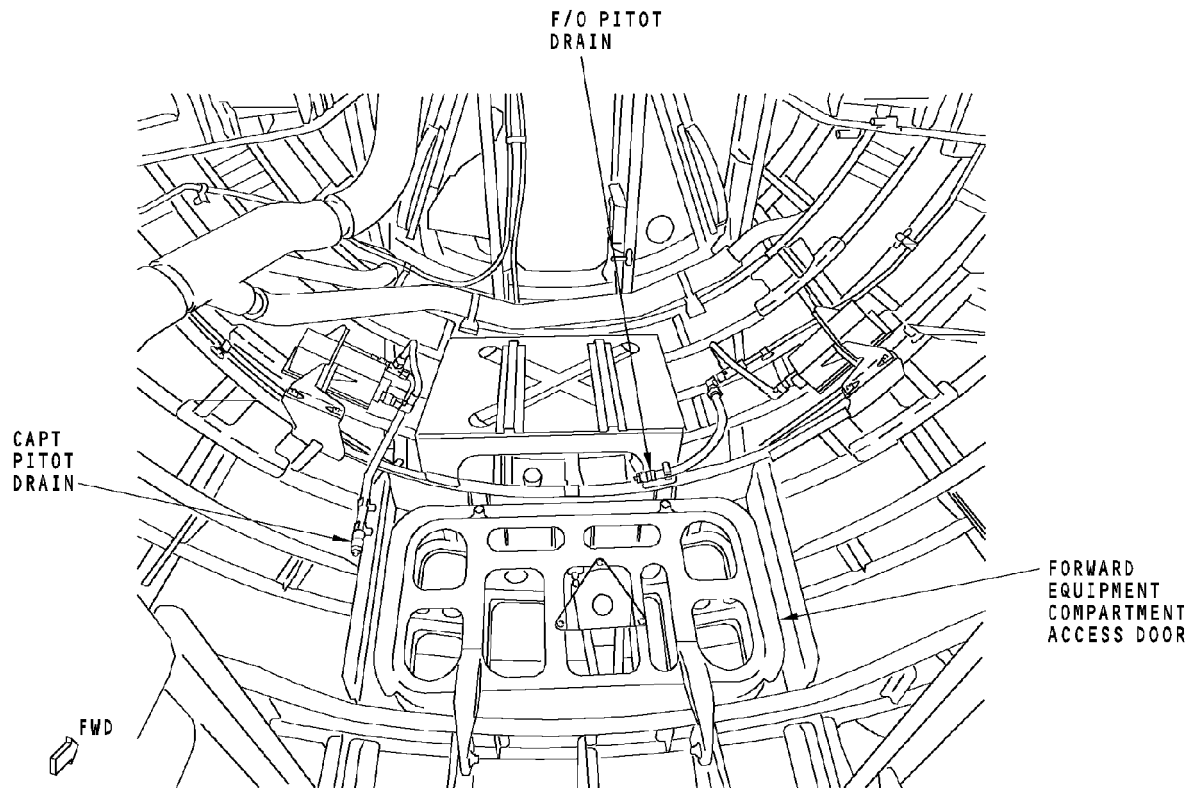

STATIC AND TOTAL AIR PRESSURE SYSTEM - COMPONENT LOCATION - FORWARD EQUIPMENT COMPARTMENT

34-11-00-003

EFFECTIVITY
HAP ALL

34-11-00

D633A101-HAP

Page 9
Feb 10/2006

STATIC AND TOTAL AIR PRESSURE SYSTEM - COMPONENT LOCATION - ELECTRONIC EQUIPMENT COMPARTMENT

Alternate Static Drain Fitting

The drain fitting in the alternate static line is in the electronic equipment compartment below the E-5 rack.

34-11-00-004



34-11-00

D633A101-HAP

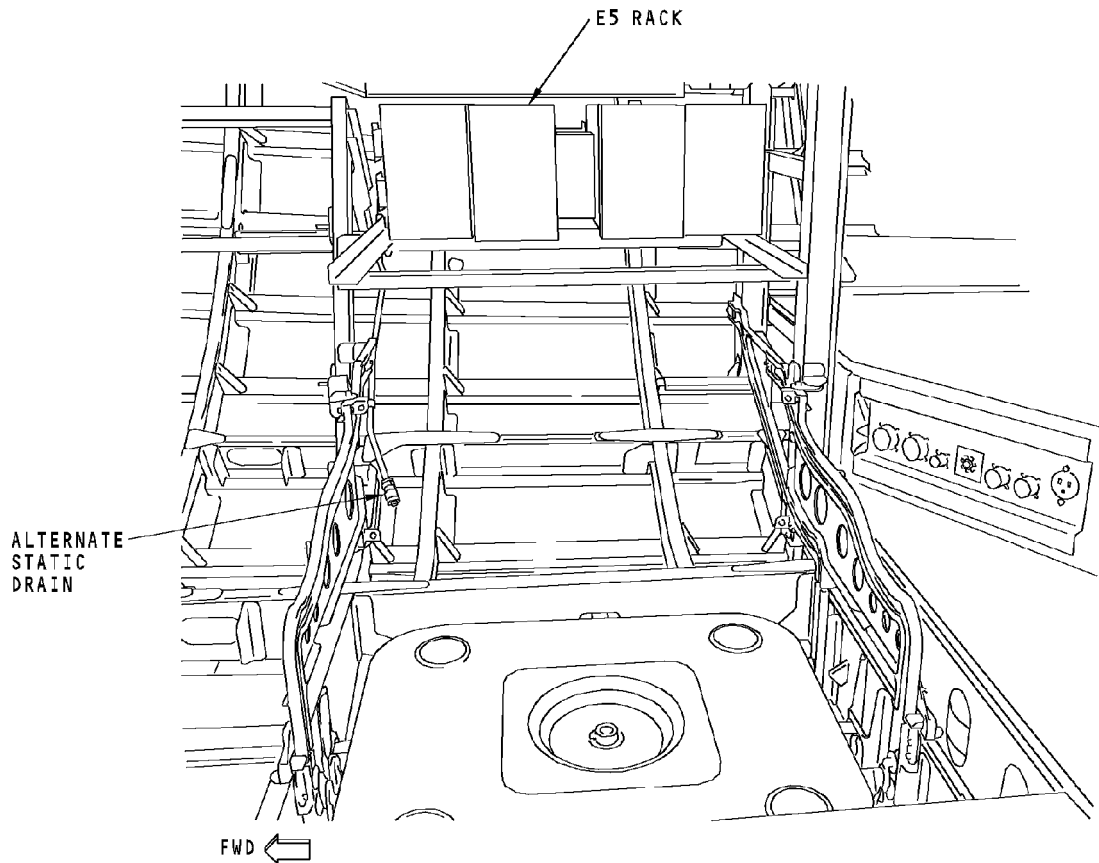

STATIC AND TOTAL AIR PRESSURE SYSTEM - COMPONENT LOCATION - ELECTRONIC EQUIPMENT COMPARTMENT

34-11-00-004

EFFECTIVITY
HAP ALL

34-11-00

D633A101-HAP

Page 11
Feb 10/2006

STATIC AND TOTAL AIR PRESSURE SYSTEM - COMPONENT LOCATION - FORWARD CARGO COMPARTMENT

Primary Static Drain Fittings

The drain fittings in the captain and first officer static lines are in the forward cargo compartment along the left side of the airplane. You must remove an access panel to get to the drain fittings.

34-11-00-005

EFFECTIVITY
HAP ALL

34-11-00

D633A101-HAP

Page 12
Feb 10/2006

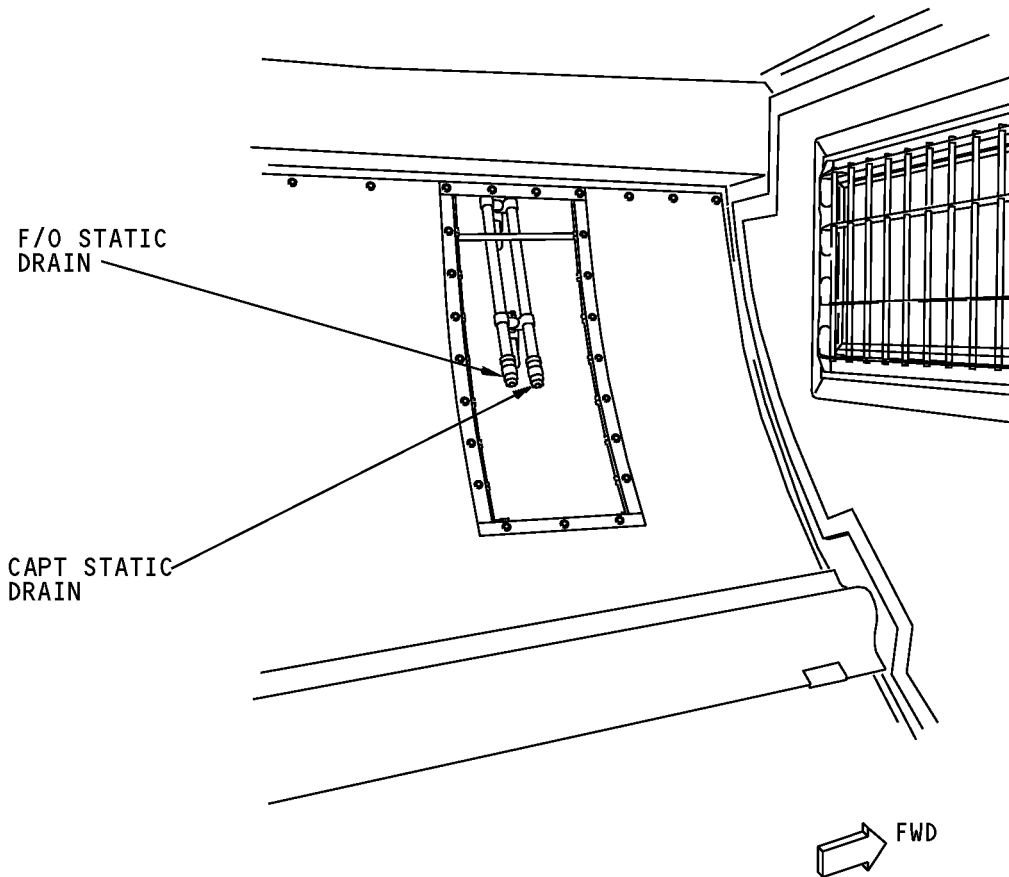

STATIC AND TOTAL AIR PRESSURE SYSTEM - COMPONENT LOCATION - FORWARD CARGO COMPARTMENT

34-11-00-005

EFFECTIVITY
HAP ALL

34-11-00

D633A101-HAP

Page 13
Feb 10/2006

STATIC AND TOTAL AIR PRESSURE SYSTEM - COMPONENT LOCATION - EXTERNAL**Pitot Probe Location**

The airplane has three pitot probes. The captain pitot probe is on the left side of the airplane. The first officer and the auxiliary pitot probes are on the right side of the airplane.

Static Port Location

The airplane has six static ports. There is a captain, first officer, and an alternate static port on each side of the airplane.

Alternate Static Ports Location

The airplane has two alternate static ports. There is one port on each side of the airplane.

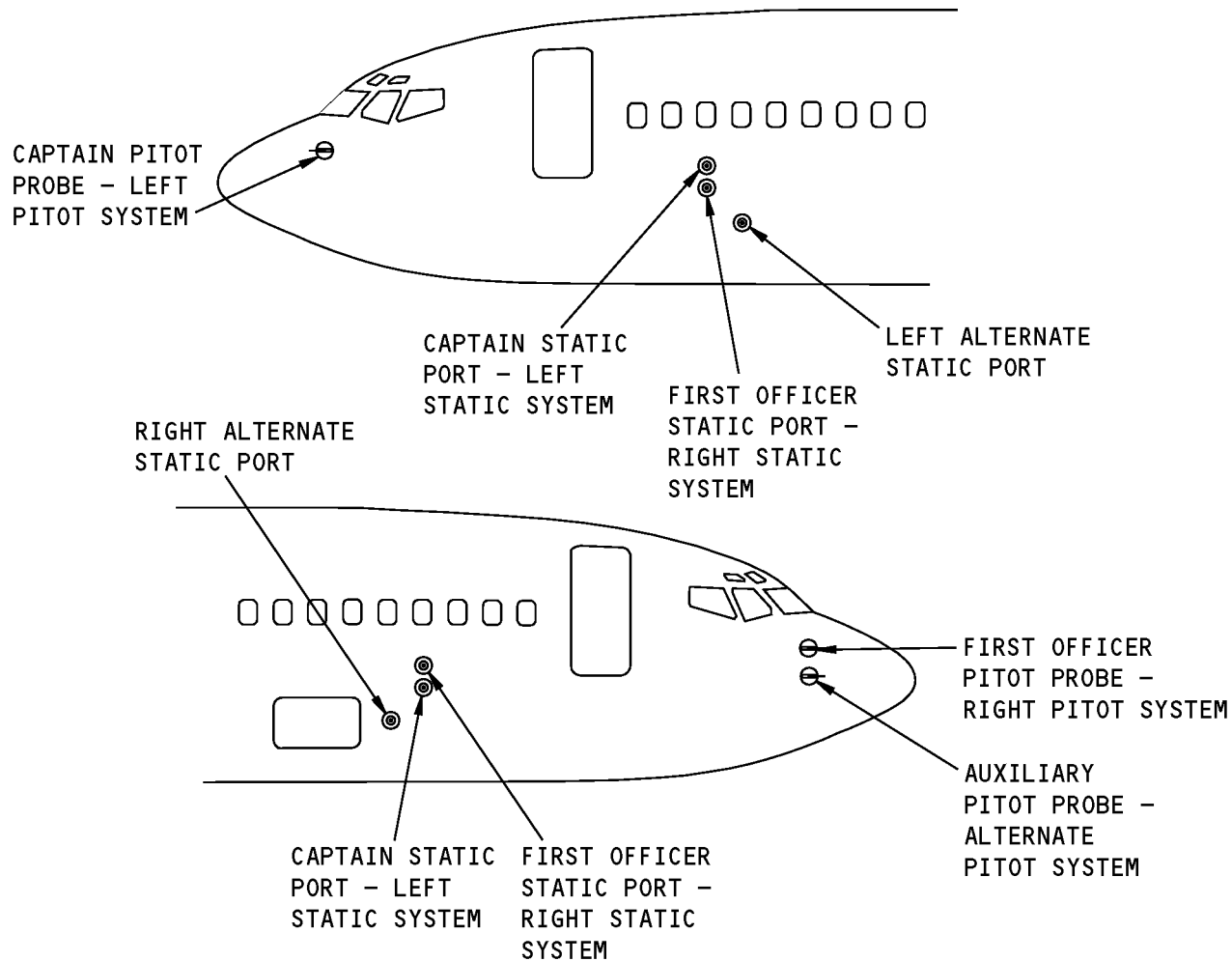

STATIC AND TOTAL AIR PRESSURE SYSTEM - COMPONENT LOCATION - EXTERNAL

34-11-00-006

EFFECTIVITY
HAP ALL

34-11-00

D633A101-HAP

STATIC AND TOTAL AIR PRESSURE SYSTEM - INTERFACE AND FUNCTIONAL DESCRIPTION**ARINC 429 Data**

These items send air pressure through pneumatic lines to the ADMs:

- Captain pitot probe
- First officer pitot probe
- Captain static ports
- First officer static ports.

The length of the pressure lines and the number of connectors are a minimum.

The left and right static ports are connected together. This gives an average ambient air pressure to the ADMs.

Pressure Lines**HAP 001-013, 015-026, 028-030**

The pressure lines from the auxiliary pitot probe and the alternate static ports go to the standby altimeter/airspeed indicator. The pressure lines from the alternate static ports also go to the cabin differential pressure indicator.

HAP 031-054, 101-999

The pressure lines from the auxiliary pitot probe and the alternate static ports go to the integrated standby flight display. The pressure lines from the alternate static ports also go to the cabin differential pressure indicator.

HAP ALL

The alternate static ports are connected together to give average ambient pressure.

Drain Fittings

Each static line has a drain fitting. The captain and first officer pitot lines also have drain fittings.

The auxiliary pitot line does not have a drain fitting. The probe is at the lowest part of the line so moisture can drain from the probe.

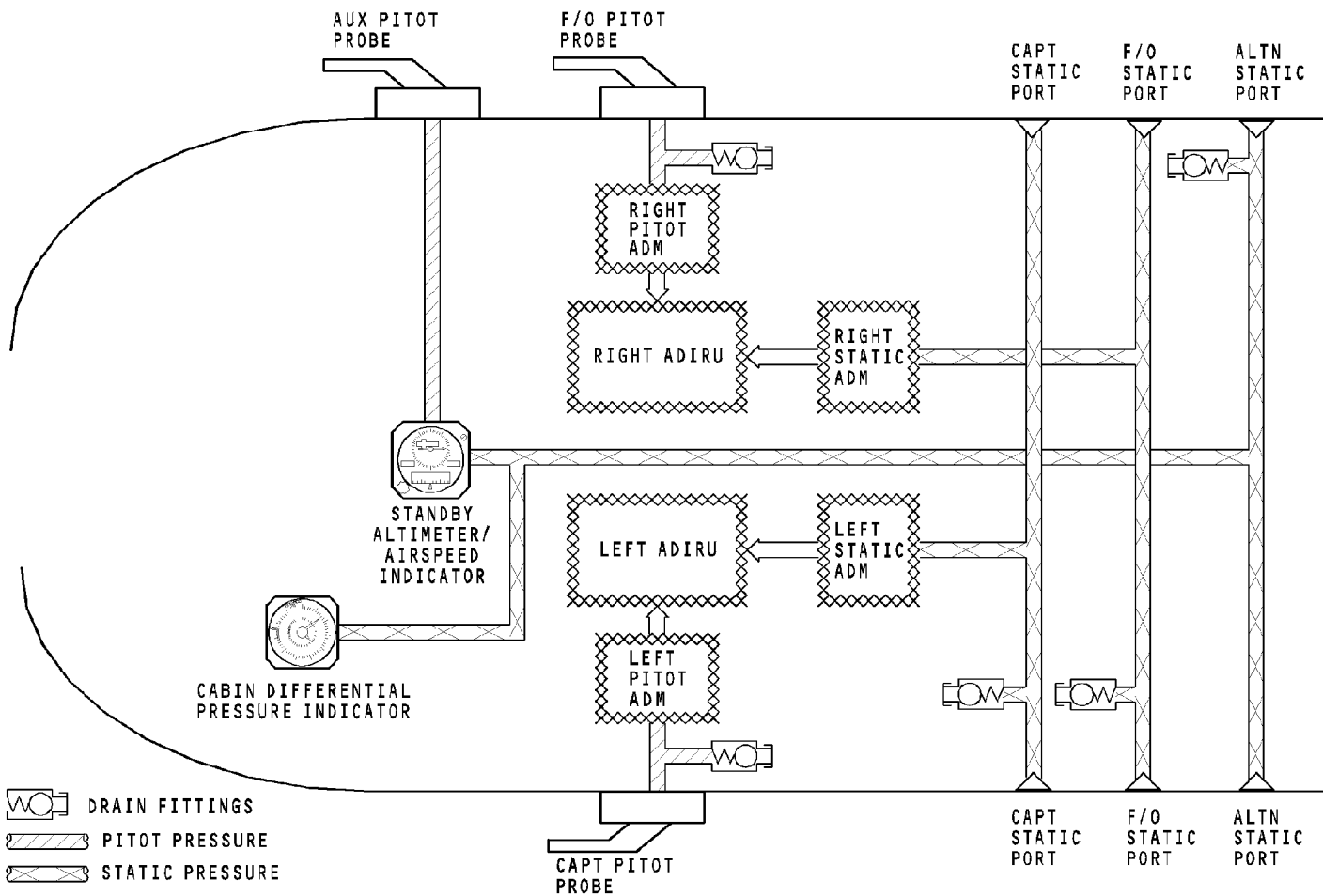

STATIC AND TOTAL AIR PRESSURE SYSTEM - INTERFACE AND FUNCTIONAL DESCRIPTION

EFFECTIVITY

HAP 001-013, 015-026, 028-030

34-11-00

D633A101-HAP

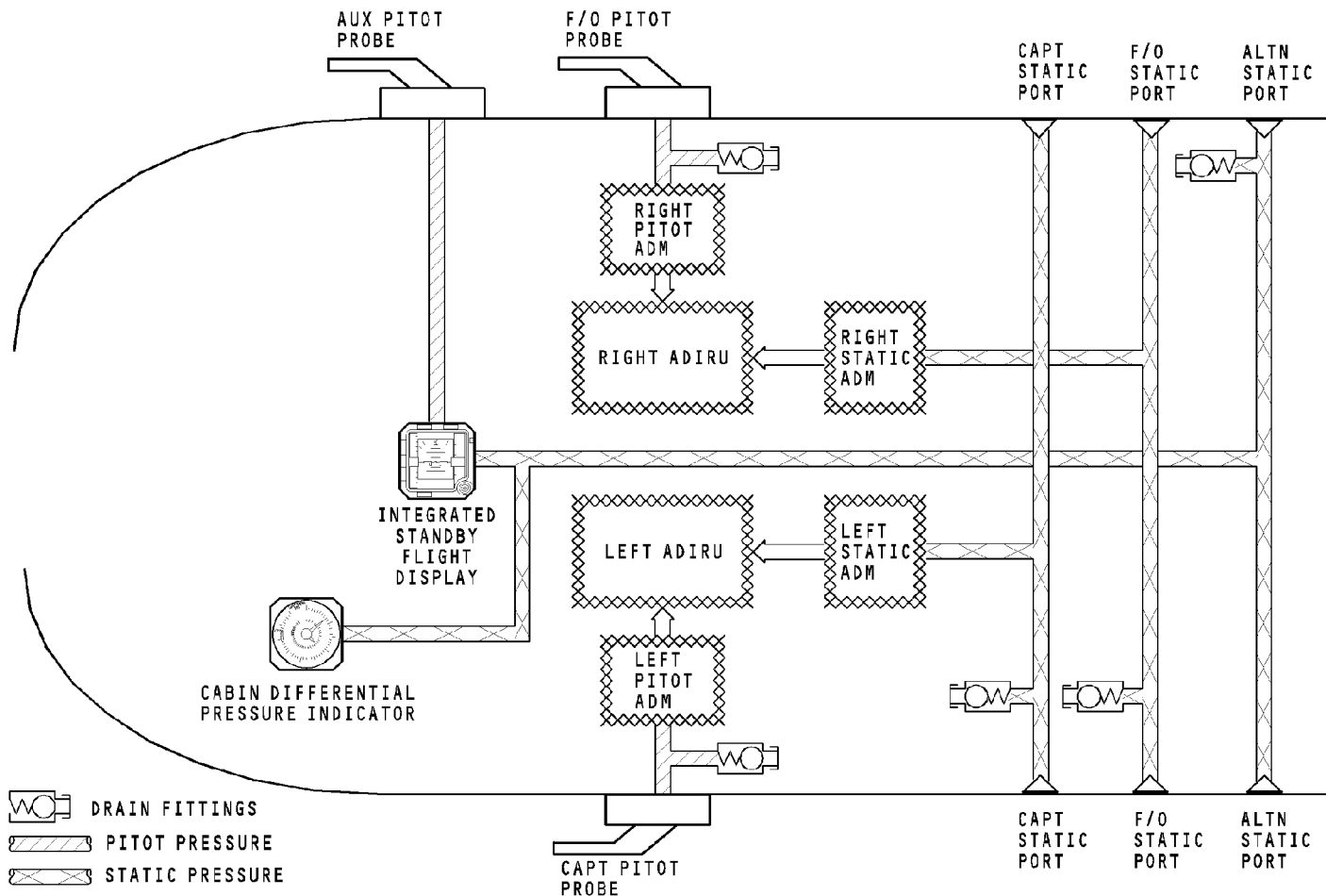

STATIC AND TOTAL AIR PRESSURE SYSTEM - INTERFACE AND FUNCTIONAL DESCRIPTION

EFFECTIVITY
 HAP 031-054, 101-999

34-11-00

D633A101-HAP

34-11-00-007

THIS PAGE IS INTENTIONALLY LEFT BLANK

34-11-00

D633A101-HAP

Page 19
Feb 10/2006

STATIC AND TOTAL AIR PRESSURE SYSTEM - PITOT PROBE**General**

The pitot probe measures pitot air pressure.

Physical Description

The pitot probe port points forward to measure pitot pressure. A strut moves the probe several inches from the airplane skin to decrease airflow turbulence effects. A base plate contains the electrical and pressure connectors. A gasket is between the probe base and the airplane structure to form a pressure seal.

An anti-icing heater is in the probe to prevent ice. The heater is attached to the electrical connector in the base plate.

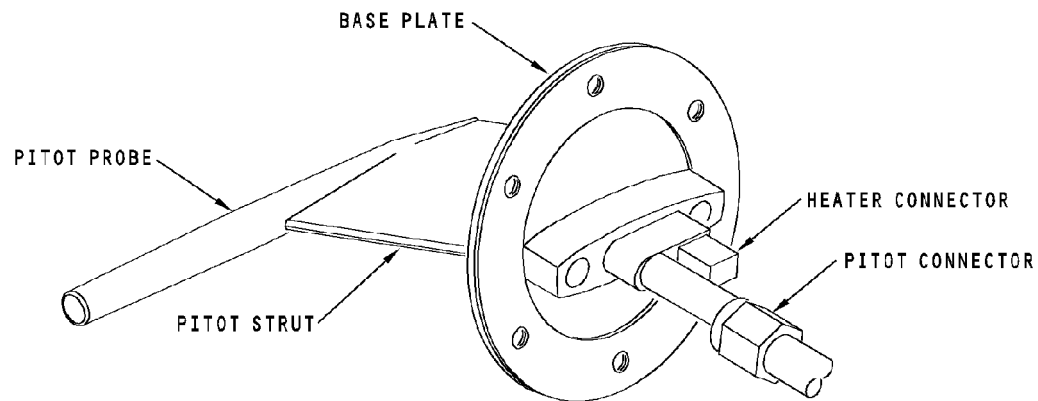

STATIC AND TOTAL AIR PRESSURE SYSTEM - PITOT PROBE

34-11-00-008

EFFECTIVITY
HAP ALL

34-11-00

D633A101-HAP

Page 21
Feb 10/2006

STATIC AND TOTAL AIR PRESSURE SYSTEM - STATIC PORT**General**

The static ports measure static (ambient) air pressure.

Physical Description

The static ports are flush-mounted on the fuselage skin. There is a circle around the port with a caution note.

CAUTION: DO NOT PLUG OR DEFORM HOLES. INDICATED AREAS MUST BE SMOOTH AND CLEAN.

The static ports do not have anti-icing heaters.

HAP 001-013, 015-026, 028-054

Training Information Point

The alternate static ports are not interchangeable with the primary static ports. The primary static ports have a flat face and the alternate static ports have a concave face.

HAP ALL

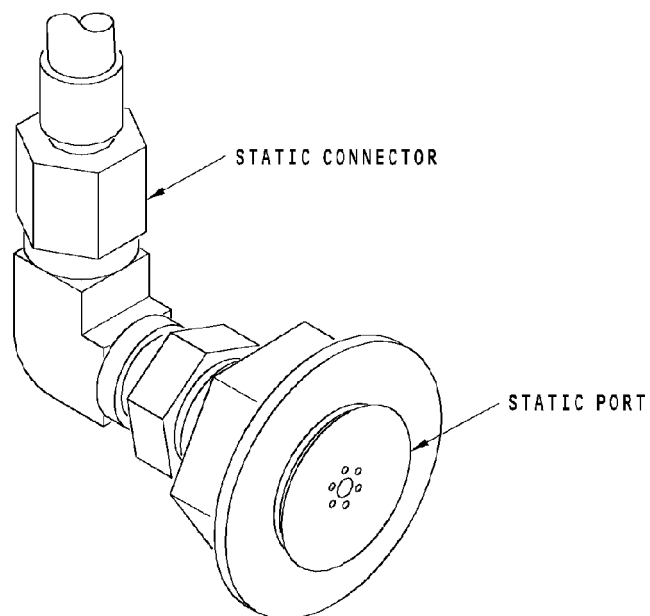

STATIC AND TOTAL AIR PRESSURE SYSTEM - STATIC PORT

34-11-00-009

EFFECTIVITY
HAP ALL

34-11-00

D633A101-HAP

Page 23
Feb 10/2006

STATIC AND TOTAL AIR PRESSURE SYSTEM - DRAIN FITTING**General**

The system drains remove condensation that collects in the pitot-static lines. The drain fittings have a reinforced transparent section of tubing with an orange float. This forms a sight gage to show the level of fluid that collects in the sump.

Operation

The lower part of the drain contains a valve covered by a bayonet cap. To drain the pitot-static line, remove the cap and insert the valve depressor on the cap into the valve. The liquid in the sump drains by gravity when you push the valve.

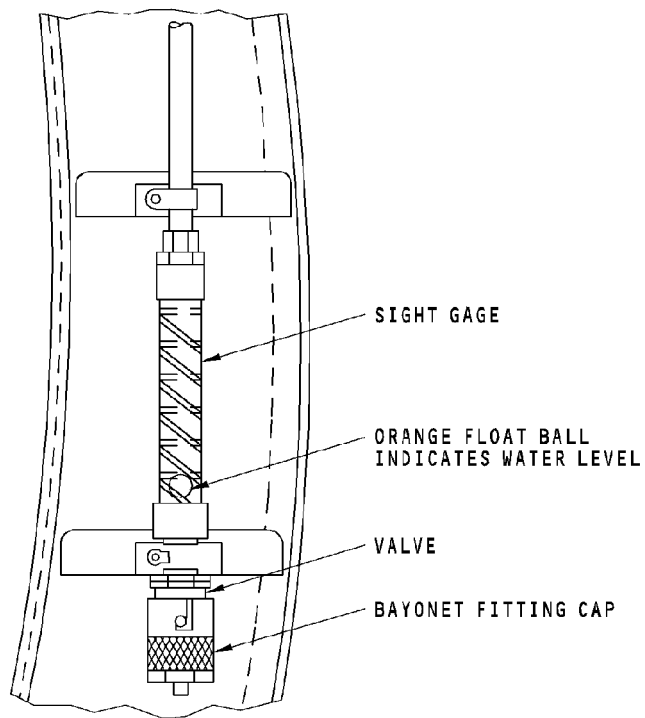

STATIC AND TOTAL AIR PRESSURE SYSTEM - DRAIN FITTING

34-11-00-010

EFFECTIVITY
HAP ALL

34-11-00

D633A101-HAP

THIS PAGE IS INTENTIONALLY LEFT BLANK

34-13-00

D633A101-HAP

Page 1
Oct 10/2002

AIR DATA INSTRUMENTS - INTRODUCTION**General**

The air data instruments supply the crew with standby indications of the airplane altitude and indicated airspeed (IAS).

Abbreviations and Acronyms

- alt - altitude
- BARO - barometric
- G/T - gear train
- IAS - indicated airspeed
- IN HG - inches of mercury
- MB - millibars

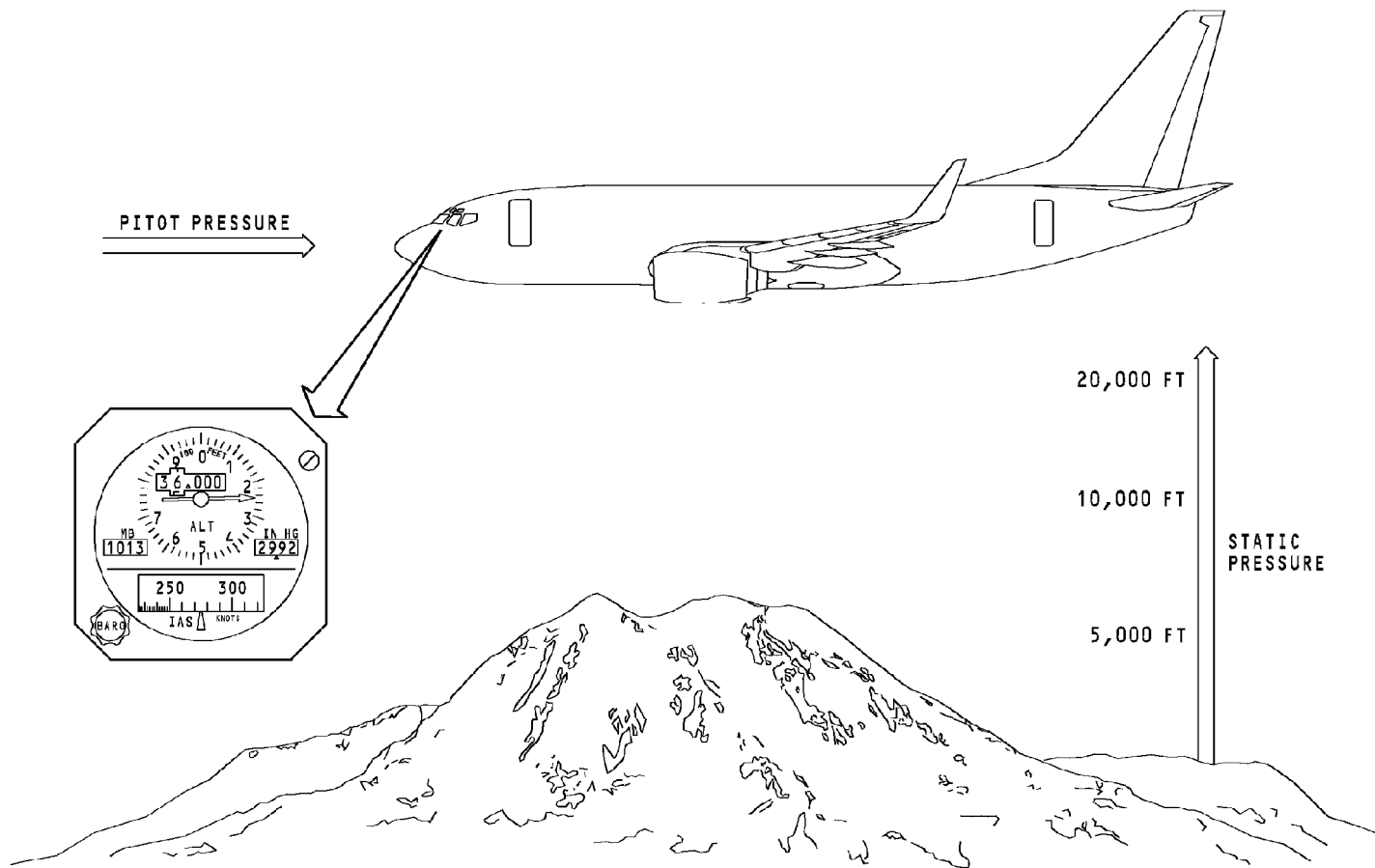

AIR DATA INSTRUMENTS - INTRODUCTION

EFFECTIVITY

HAP 001-013, 015-026, 028-030

34-13-00

D633A101-HAP

Page 3
Oct 10/2007

34-13-00-001

AIR DATA INSTRUMENTS - GENERAL DESCRIPTION**General**

The standby altimeter/airspeed indicator is two flight instruments in one component.

One instrument is a pneumatic altimeter. It gets static air pressure from the alternate static ports and shows barometric altitude.

The other instrument is a pneumatic airspeed indicator. This indicator gets pitot air pressure from the alternate pitot probe and static air pressure from the alternate static ports to show the indicated air speed.

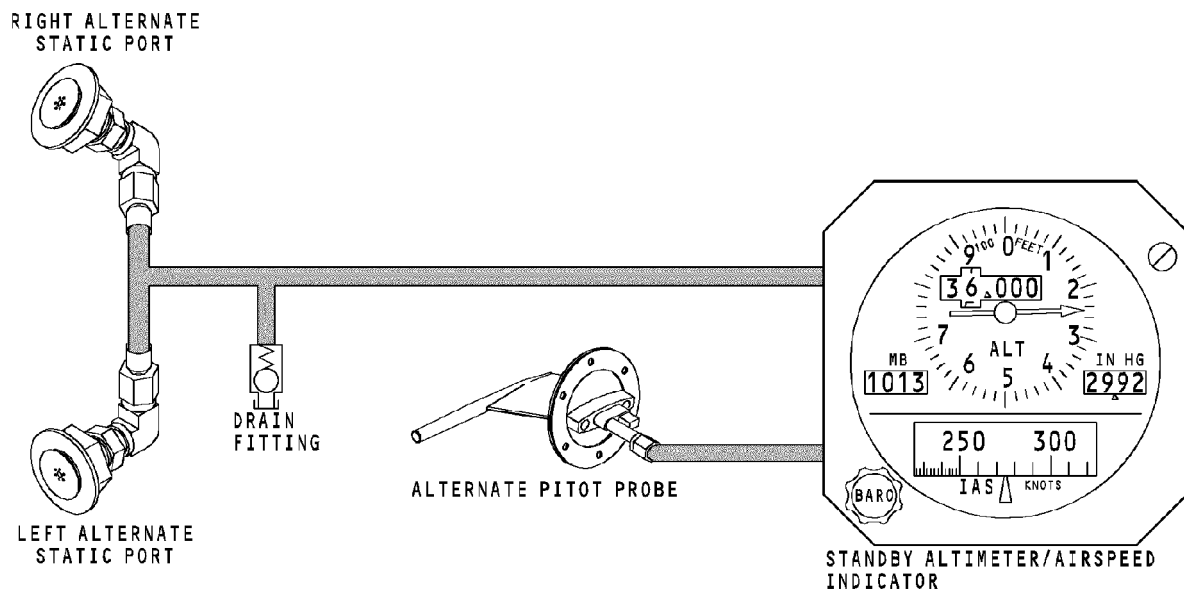

AIR DATA INSTRUMENTS - GENERAL DESCRIPTION

34-13-00-002

EFFECTIVITY
HAP 001-013, 015-026, 028-030

34-13-00

D633A101-HAP

AIR DATA INSTRUMENTS - COMPONENT LOCATION

General

The standby altimeter/airspeed indicator is in the flight compartment.

34-13-00-003

EFFECTIVITY
HAP 001-013, 015-026, 028-030

34-13-00

D633A101-HAP

Page 6
Oct 10/2007

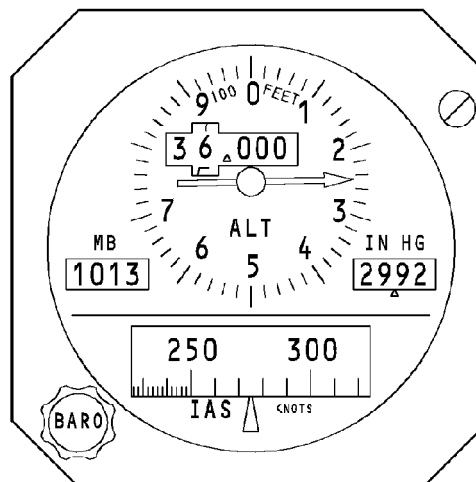
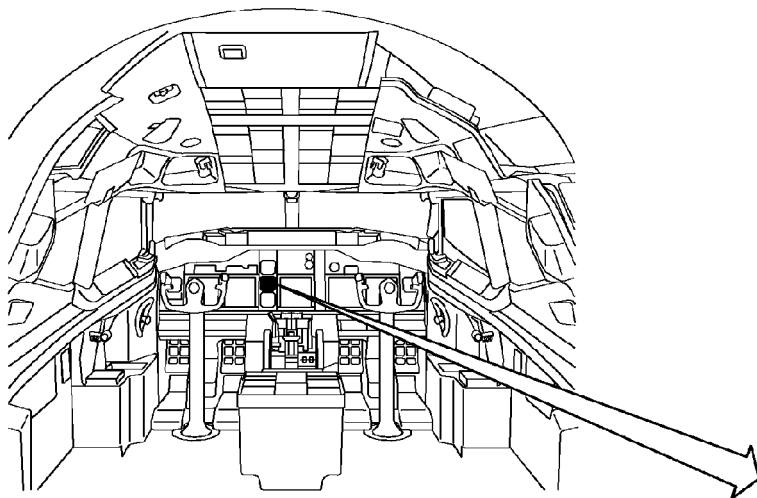

STANDBY ALTIMETER/AIRSPEED INDICATOR

AIR DATA INSTRUMENTS - COMPONENT LOCATION

34-13-00-003

EFFECTIVITY
HAP 001-013, 015-026, 028-030

34-13-00

D633A101-HAP

Page 7
Oct 10/2007

AIR DATA INSTRUMENTS - INTERFACE**Power**

The vibrator in the standby altimeter/airspeed indicator gets 28v dc from the dc standby bus, through the CAPT ALT/AS VIBRATOR circuit breaker.

The indicator gets 5v ac for the internal instrument lights from the master dim and test circuit.

Pitot-Static Interface

The alternate pitot probe sends pitot air pressure to the standby altimeter/airspeed indicator. The alternate static ports send static air pressure to the indicator.

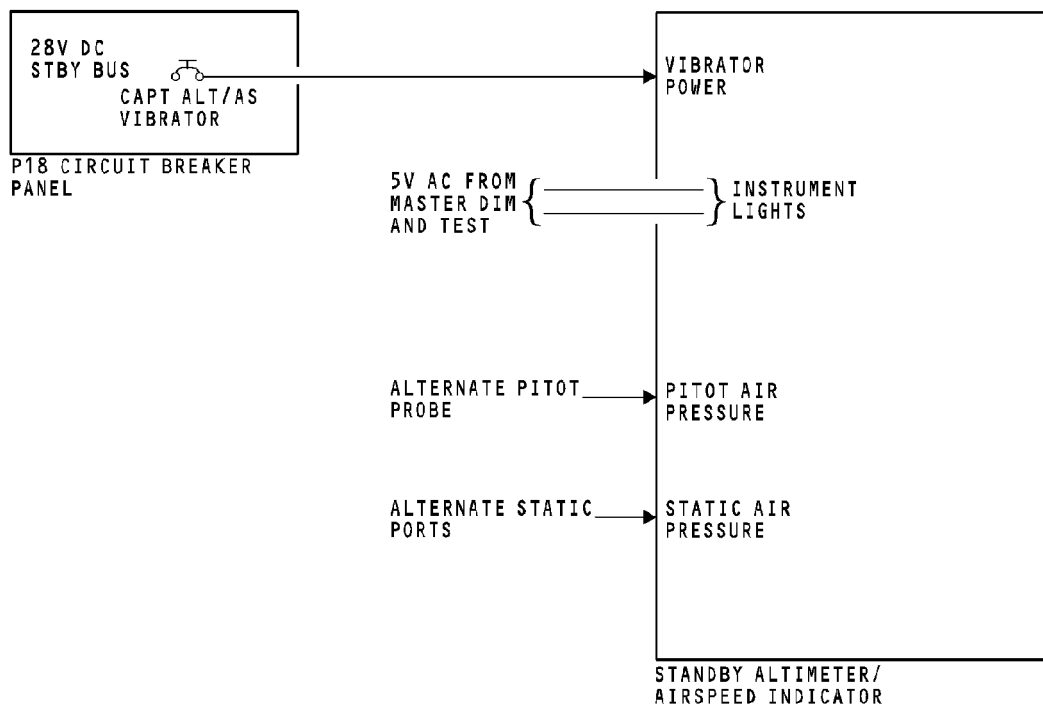

AIR DATA INSTRUMENTS - INTERFACE

EFFECTIVITY
HAP 001-013, 015-026, 028-030

34-13-00

D633A101-HAP

AIR DATA INSTRUMENTS - STANDBY ALTIMETER/AIRSPEED INDICATOR**General**

The standby altimeter/airspeed indicator shows air data information such as barometric altitude and indicated airspeed. The standby altimeter/airspeed indicator receives pitot pressure from the alternate pitot probe. It also receives static pressure from the alternate static ports.

Operation

The digital altitude display shows barometric altitude from -1000 to 50000 feet in thousands of feet. The altitude dial and pointer show altitude in 20 foot increments. One turn of the pointer is equal to 1000 feet.

Barometric pressure reference in inches of mercury (in hg) and millibars (mb) shows on the indicator. Rotate the barometric reference control knob to set the barometric pressure reference. It is adjustable from 745 to 1049.5 mb and from 22.00 to 30.99 in hg.

The zero adjust screw lets you adjust the altitude without changing the barometric reference settings.

The digital airspeed display shows airspeeds from 60 to 450 knots. A drum, graduated in knots, shows the indicated airspeed.

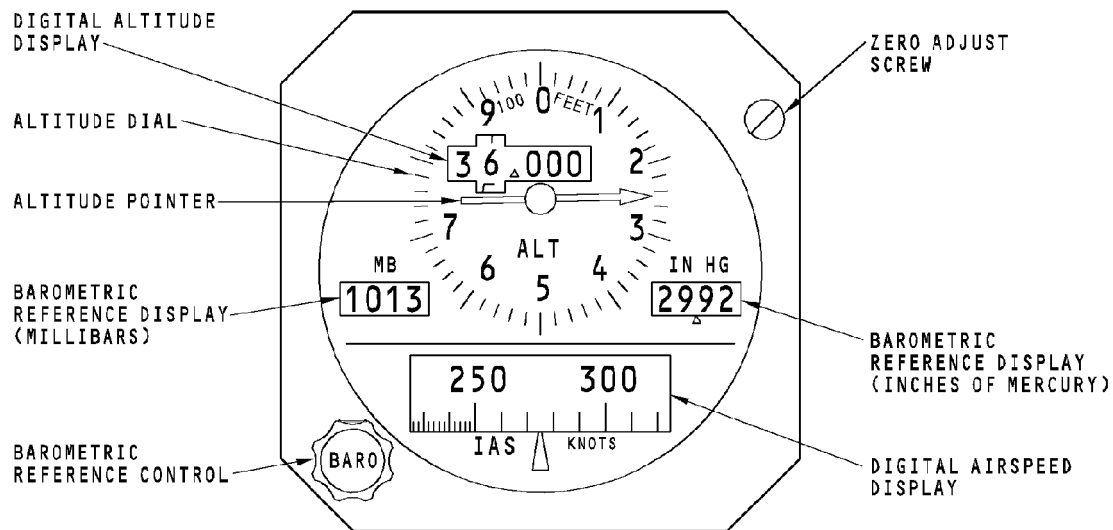

AIR DATA INSTRUMENTS - STANDBY ALTIMETER/AIRSPEED INDICATOR

34-13-00-005

EFFECTIVITY
HAP 001-013, 015-026, 028-030

34-13-00

D633A101-HAP

Page 11
Oct 10/2007

AIR DATA INSTRUMENTS - FUNCTIONAL DESCRIPTION

General

The standby altimeter/airspeed indicator consists of these two pneumatic instruments:

- Standby altimeter
- Standby airspeed indicator.

Standby Altimeter

A vibrator is on the instrument frame to reduce friction errors in the mechanical linkage and to improve indicator response. The vibrator receives 28 volts dc power from the 28v dc standby bus.

The standby altimeter gets static pressure from the two alternate static ports. The pressure sensor moves in response to the static pressure change. The sensor drives the altitude gear train which connects mechanically to the altitude counter and pointer.

Rotating the BARO set knob on the front panel corrects for local changes in barometric pressure.

Standby Airspeed Indicator

The indicator mechanism has two pressure ports. One port is for static pressure and the other port is for pitot pressure. The pressure sensor expands and contracts with changes in the pitot-static pressure. The movement is transmitted to a counter to indicate airspeed.

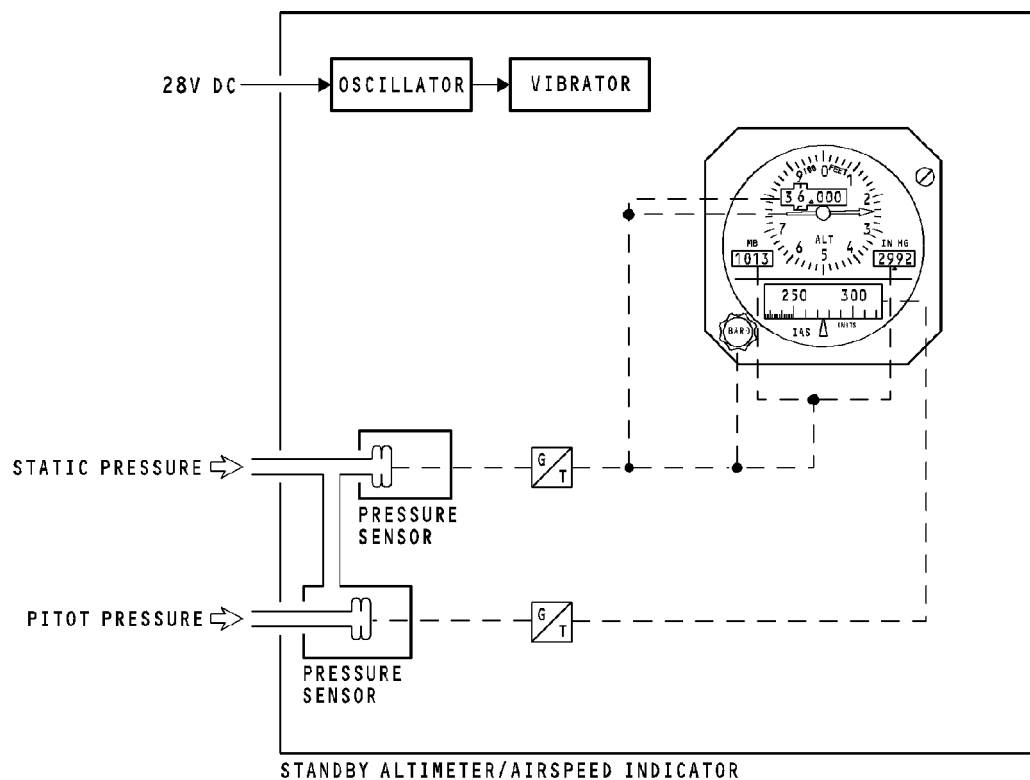

AIR DATA INSTRUMENTS - FUNCTIONAL DESCRIPTION

34-13-00-006

EFFECTIVITY
HAP 001-013, 015-026, 028-030

34-13-00

D633A101-HAP

THIS PAGE IS INTENTIONALLY LEFT BLANK

34-16-00

D633A101-HAP

Page 1
Oct 10/2002

OVERSPEED WARNING - INTRODUCTION**General**

The 737 has an airspeed and a mach limit to protect the airframe. The mach airspeed warning system gives an aural warning that tells the flight crew when the airspeed is more than the mach or airspeed limit.

The airplane maximum operating limit speed (VMO) is 340 kts when the airplane is at or below an altitude of 25,968 ft. Above this altitude, the airplane is limited by mach number. The maximum operating mach (MMO) is 0.82.

Abbreviations and Acronyms

- ADIRU - air data inertial reference unit
- ADM - air data module
- CAPT - captain
- FO - first officer
- MMO - maximum operating mach
- VMO - maximum operating limit speed
- kts - knots

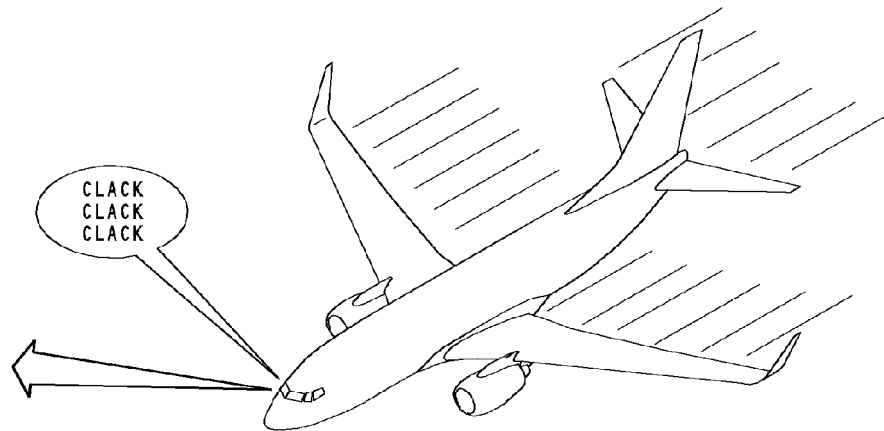
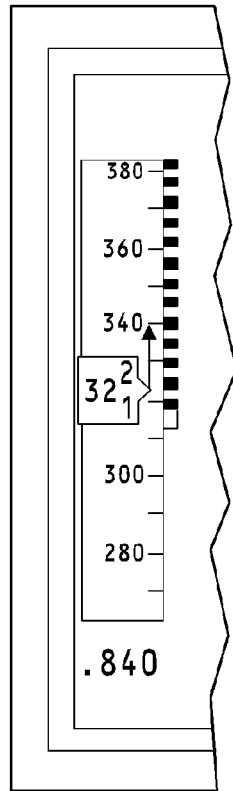

OVERSPEED WARNING - INTRODUCTION

34-16-00-001

EFFECTIVITY
HAP ALL

34-16-00

D633A101-HAP

Page 3
Oct 10/2004

OVERSPEED WARNING - GENERAL DESCRIPTION**VMO/MMO Overspeed Warning**

The mach airspeed warning system gets the overspeed warning signal from an ADIRU. The signal means that the airspeed is more than the maximum operating limit speed (VMO) or the maximum operating mach (MMO). This signal turns on the clacker sound in the aural warning module.

HAP 031-054, 101-999

For Flights that must be dispatched with the gear down and locked, the altitude alert system can be enabled by setting the ALTERNATE VMO/MMO select switch in the main E/E bay to the ALTERNATE position. This simulates a landing gear not down and locked condition by opening the ALL GEARS DOWN and LOCKED discrete.

HAP ALL**Test**

The mach airspeed warning system has a mach airspeed warning test switch. It is part of the flight recorder/mach airspeed warning panel. Push one of the two mach airspeed warning test switches to start the clacker sound in the aural warning module. Test switch No. 1 does a test of the overspeed warning circuit in the left ADIRU. Test switch No. 2 does a test of the overspeed warning circuit in the right ADIRU.

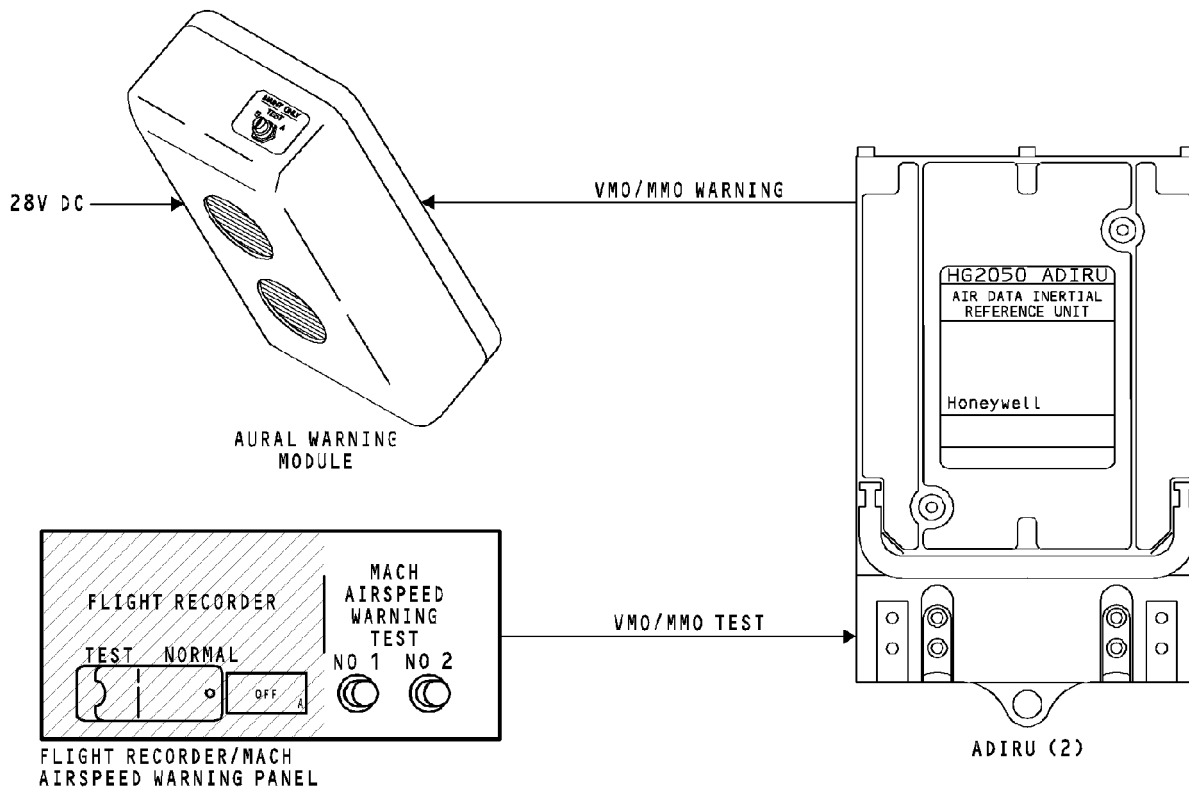

OVERSPEED WARNING - GENERAL DESCRIPTION

34-16-00-002

EFFECTIVITY
HAP ALL

34-16-00

D633A101-HAP

OVERSPEED WARNING - COMPONENT LOCATION

Flight Compartment

The flight recorder/mach airspeed warning panel is on the aft overhead panel. The aural warning module is on the bottom of the forward electronics panel.

34-16-00-003

EFFECTIVITY
HAP ALL

34-16-00

D633A101-HAP

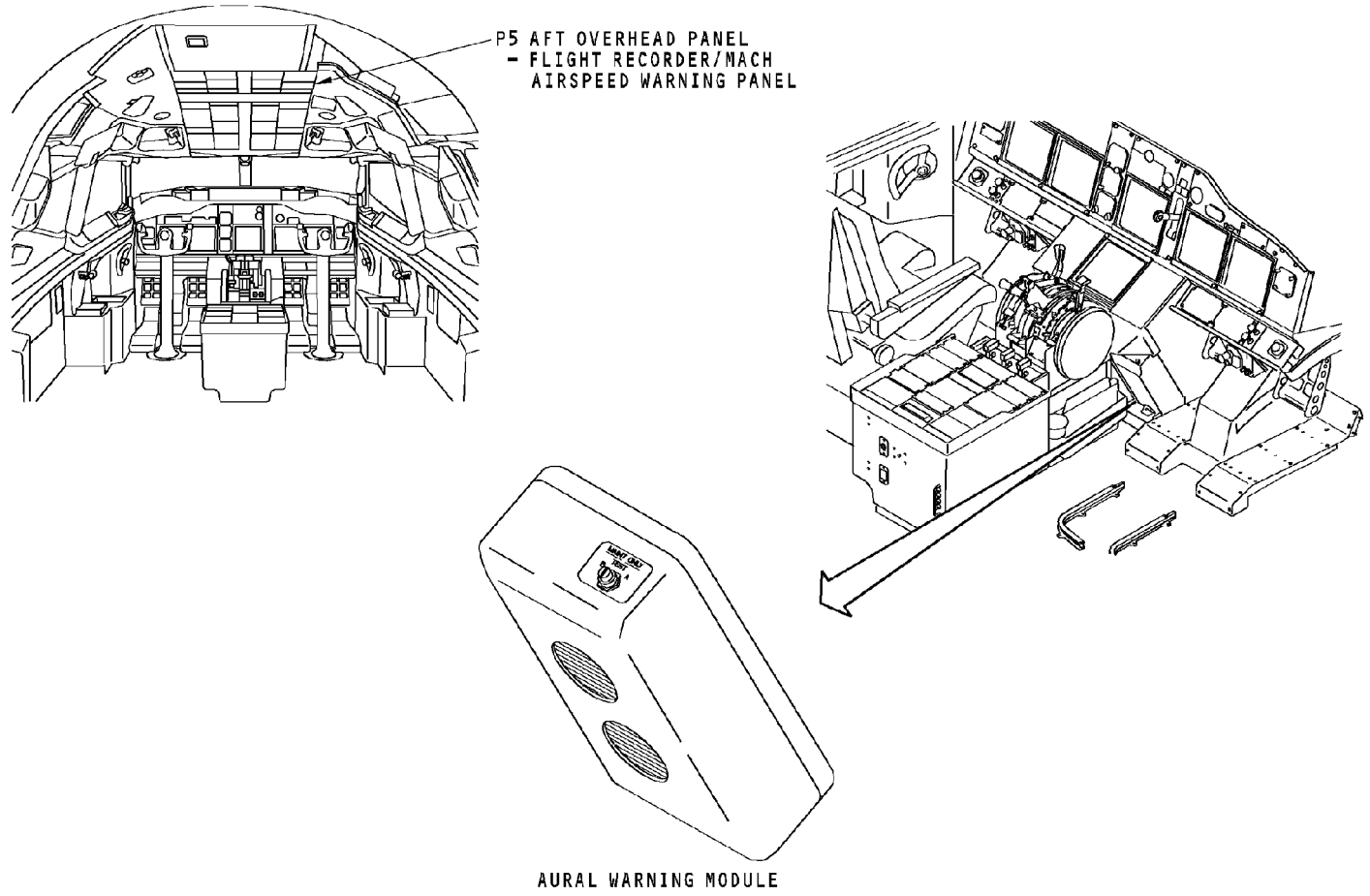

OVERSPEED WARNING - COMPONENT LOCATION

EFFECTIVITY
HAP ALL

34-16-00

D633A101-HAP

Page 7
Oct 10/2004

OVERSPEED WARNING - INTERFACE**General**

28v dc power goes to the aural warning module. When you push the test switch, a ground discrete goes to the air data inertial reference unit (ADIRU). The ADIRU sends an overspeed signal to the aural warning module. The aural warning module makes the clacker sound. Test switch 1 goes to the left ADIRU and test switch 2 goes to the right ADIRU.

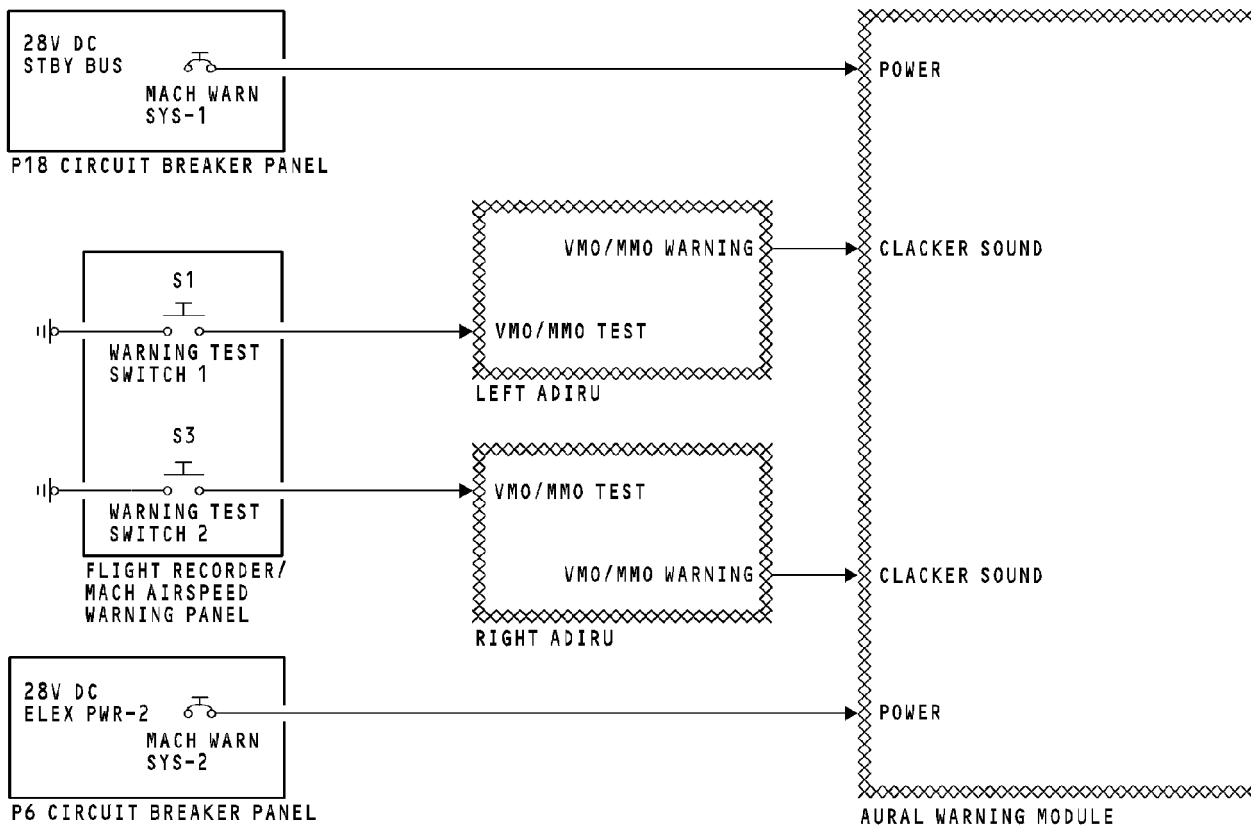

OVERSPEED WARNING - INTERFACE

34-16-00-004

EFFECTIVITY
HAP ALL

34-16-00

D633A101-HAP

OVERSPEED WARNING - MACH AIRSPEED WARNING TEST SWITCH

General

There are two mach airspeed warning test switches. They are momentary push switches. When you push the test switch, a ground discrete goes to the air data inertial reference unit (ADIRU).

34-16-00-005

EFFECTIVITY
HAP ALL

34-16-00

D633A101-HAP

Page 10
Oct 10/2004

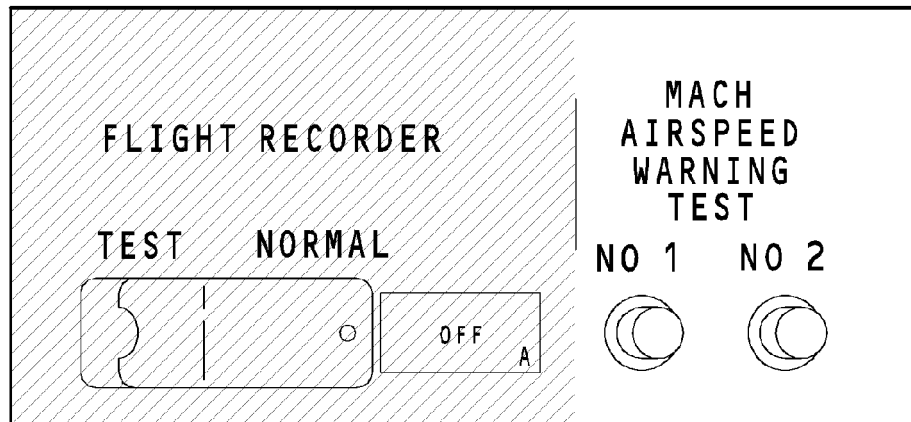

OVERSPEED WARNING - MACH AIRSPEED WARNING TEST SWITCH

34-16-00-005

EFFECTIVITY
HAP ALL

34-16-00

D633A101-HAP

AIR DATA INERTIAL REFERENCE SYSTEM - INTRODUCTION

Purpose

The air data inertial reference system (ADIRS) has two primary functions:

- Air data reference (ADR)
- Inertial reference (IR).

The ADR function calculates airspeed and barometric altitude. The IR function calculates this data:

- Attitude
- Present position
- Groundspeed
- Heading.

Abbreviations and Acronyms

- AACU - antiskid autobrake control unit
- AC - alternating current
- A/D - analog to digital
- ADF - automatic direction finder
- ADI - attitude direction indication
- ADIRS - air data inertial reference system
- ADIRU - air data inertial reference unit
- ADM - air data module
- ADR - air data reference
- alt - altimeter
- alt - altitude
- AOA - angle of attack
- ARINC - Aeronautical Radio, inc.
- A/T - autothrottle
- ATC - air traffic control

- att - attitude
- bat - battery
- baro - barometric
- brt - brightness
- capt - captain
- CAS - computed airspeed
- CDS - common display system
- CDU - control display unit
- clr - clear
- CPC - cabin pressure controller
- CPU - central processing unit
- DC - direct current

HAP 001-013, 015-026, 028-054, 104-999

- DIU - display interface unit

HAP ALL

- DEU - display electronics unit
- DU - display unit
- dspl - display
- EFIS - electronic flight instrument system
- elec - electronic
- elex - electrical
- ent - enter
- FCC - flight control computer
- FDAU - flight data acquisition unit
- FMC - flight management computer
- FMCS - flight management computer system
- F/O - first officer
- FPV - flight path vector
- FSEU - flap slat electronics unit
- FWD - forward
- GPS - global positioning system
- GPWC - ground proximity warning computer

34-21-00-001

EFFECTIVITY	
HAP ALL	

34-21-00

D633A101-HAP

AIR DATA INERTIAL REFERENCE SYSTEM - INTRODUCTION

- GS - ground speed
- hdg - heading
- HPA - hecto-pascals
- IFSAU - integrated flight systems accessory unit
- in - inches
- init - initialization
- instr - instrument
- IR - inertial reference
- IRS - inertial reference system
- ISDU - inertial system display unit

HAP 031-054, 101-999

- ISFD - integrated standby flight display

HAP ALL

- L - left
- LCD - liquid crystal display
- LSK - line select key
- MAG - magnetic
- MASI - mach airspeed indicator
- MCU - master caution unit
- MMR - multi-mode receiver
- MSU - mode select unit
- nav - navigation
- NCD - no computed data
- ND - navigation display
- NVM - non-volatile memory
- PPOS - present position
- pos - position
- PSEU - proximity switch electronics unit
- R - right
- ref - reference
- RMI - radio magnetic indicator
- R/T - receiver transmitter
- SAT - static air temperature

- sel - select
- SMYD - stall management yaw damper
- spd - speed
- stby - standby
- STS - status
- sw - switched
- sys - system
- TAS - true airspeed
- TAT - total air temperature
- TCAS - traffic collision avoidance system
- TK - track
- trk - track
- tru - true
- V - volts
- VOR - VHF omnidirectional range
- VSI - vertical speed indication
- WXR - weather radar
- xfr - transfer

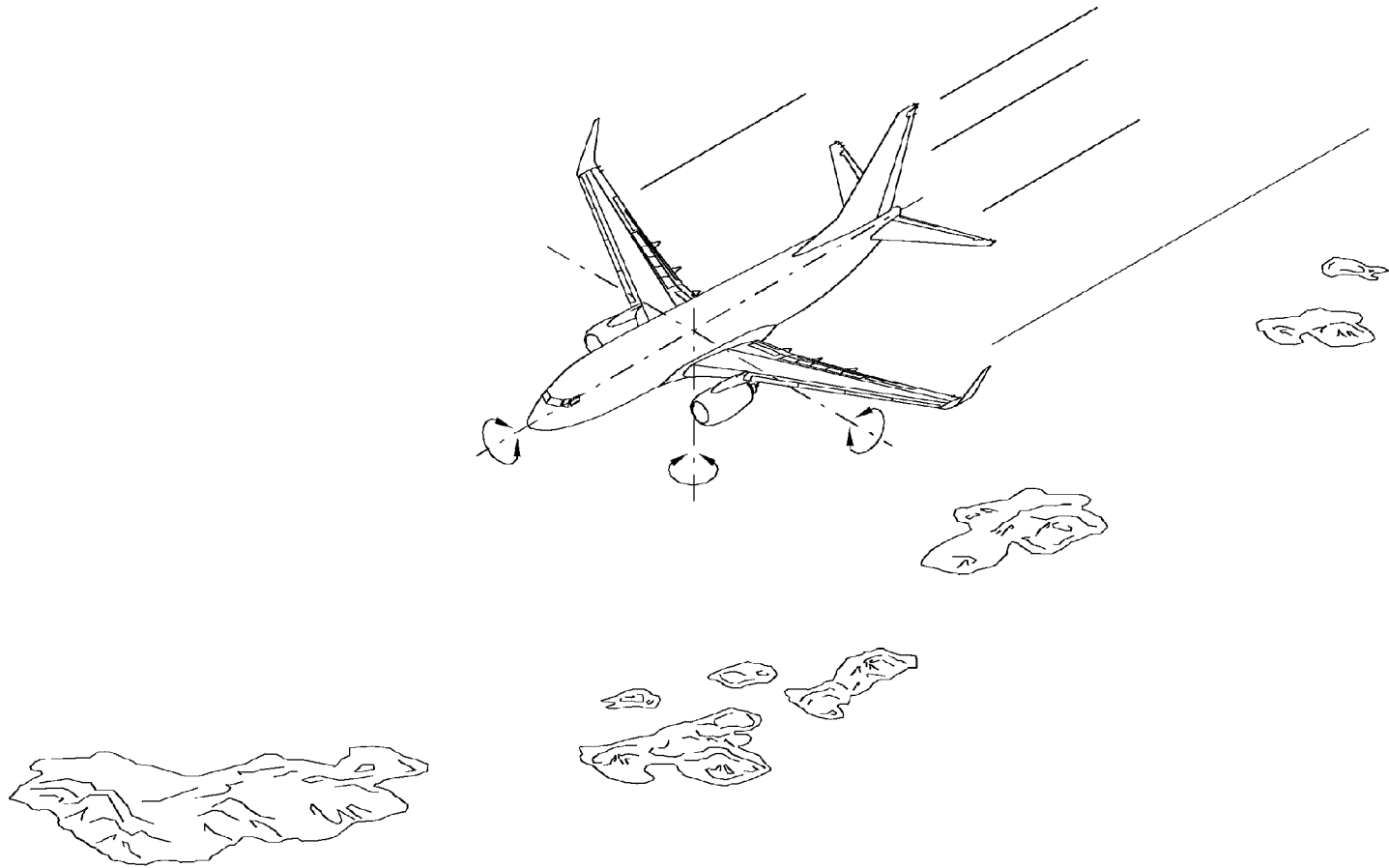

AIR DATA INERTIAL REFERENCE SYSTEM - INTRODUCTION

EFFECTIVITY
HAP ALL

34-21-00

D633A101-HAP

Page 3
Oct 10/2004

34-21-00-001

THIS PAGE IS INTENTIONALLY LEFT BLANK

34-21-00

D633A101-HAP

Page 4
Oct 10/2004

ADIRS - GENERAL DESCRIPTION

General

The air data inertial reference system (ADIRS) supplies these type of data to the aircrew and to the airplane systems:

- Altitude
- Airspeed
- Temperature
- Heading
- Attitude
- Present position.

The ADIRS has these components:

- Air data modules (ADMs) (4)
- Total air temperature (TAT) probe
- Angle of attack (AOA) sensors (2)
- Inertial system display unit (ISDU)
- Mode select unit (MSU)
- Air data inertial reference unit (ADIRU) (2)
- IRS master caution unit.

HAP 031-054, 101-999

- ALTERNATE VMO/MMO SWITCH.

HAP ALL

Functional Description

The TAT probe measures the outside air temperature. It changes the temperature value to an electrical signal. The electrical signal goes to the ADIRUs.

The AOA sensors measure and convert angle of attack to electrical signals. The electrical signals go to the ADIRUs.

The ISDU supplies initial position and heading data to the ADIRUs. It also supplies this data to the flight crew:

- Present position
- Heading
- Navigation
- Performance
- Status.

The MSU gives mode selection data to the ADIRUs. It also shows system operational and fault status to the flight crew.

The two ADIRUs calculate and send air data and inertial reference information on ARINC 429 data buses. Each ADIRU has two parts. One part is the air data reference (ADR) part. The other is the inertial reference (IR) part.

The ADIRUs use these inputs to calculate air data:

- Pitot pressure
- Static pressure
- Total air temperature
- Angle of attack
- Common display system (CDS) barometric correction
- IR data.

EFFECTIVITY
HAP ALL

ADIRS - GENERAL DESCRIPTION

Each ADIRU uses three accelerometers and three laser gyros to calculate inertial reference (IR) data. Initial present position information goes to the ADIRUs from the ISDU, or the flight management computer system (FMCS).

The IRS master caution unit sends fail discretes to the flight compartment master caution system.

HAP 031-054, 101-999

The ALTERNATE VMO/MMO SWITCH (GEAR DOWN DISPATCH SWITCH) give the input to ALTERNATE VMO/MMO in the ADIRU. When the switch is pushed up to the ALTERNATE position, the ADIRU adjusts the Vmo/Mmo curve to compensate for a flight with the landing gear down.

HAP ALL

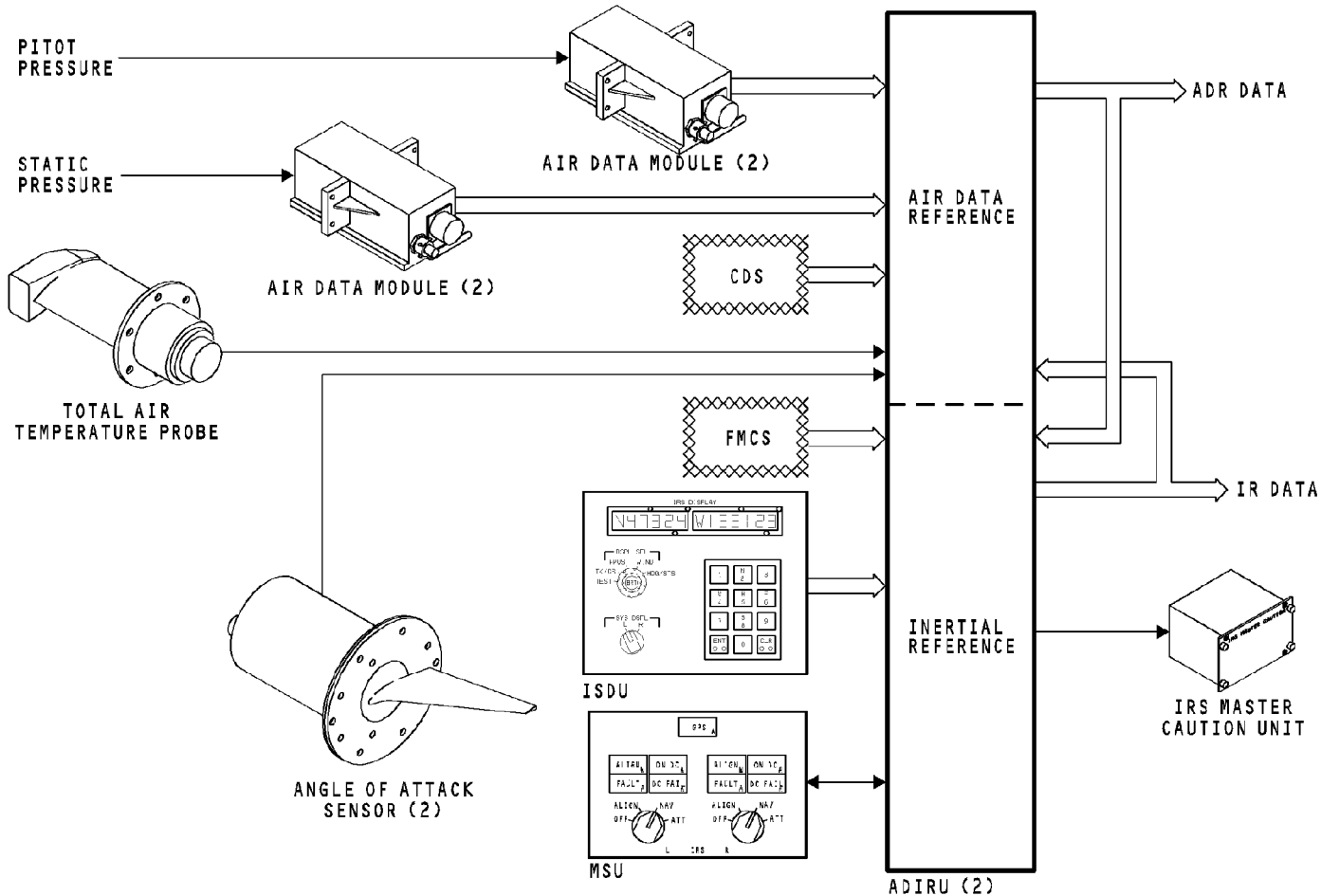

ADIRS - GENERAL DESCRIPTION

EFFECTIVITY
HAP 001-013, 015-026, 028-030

34-21-00

D633A101-HAP

34-21-00-002

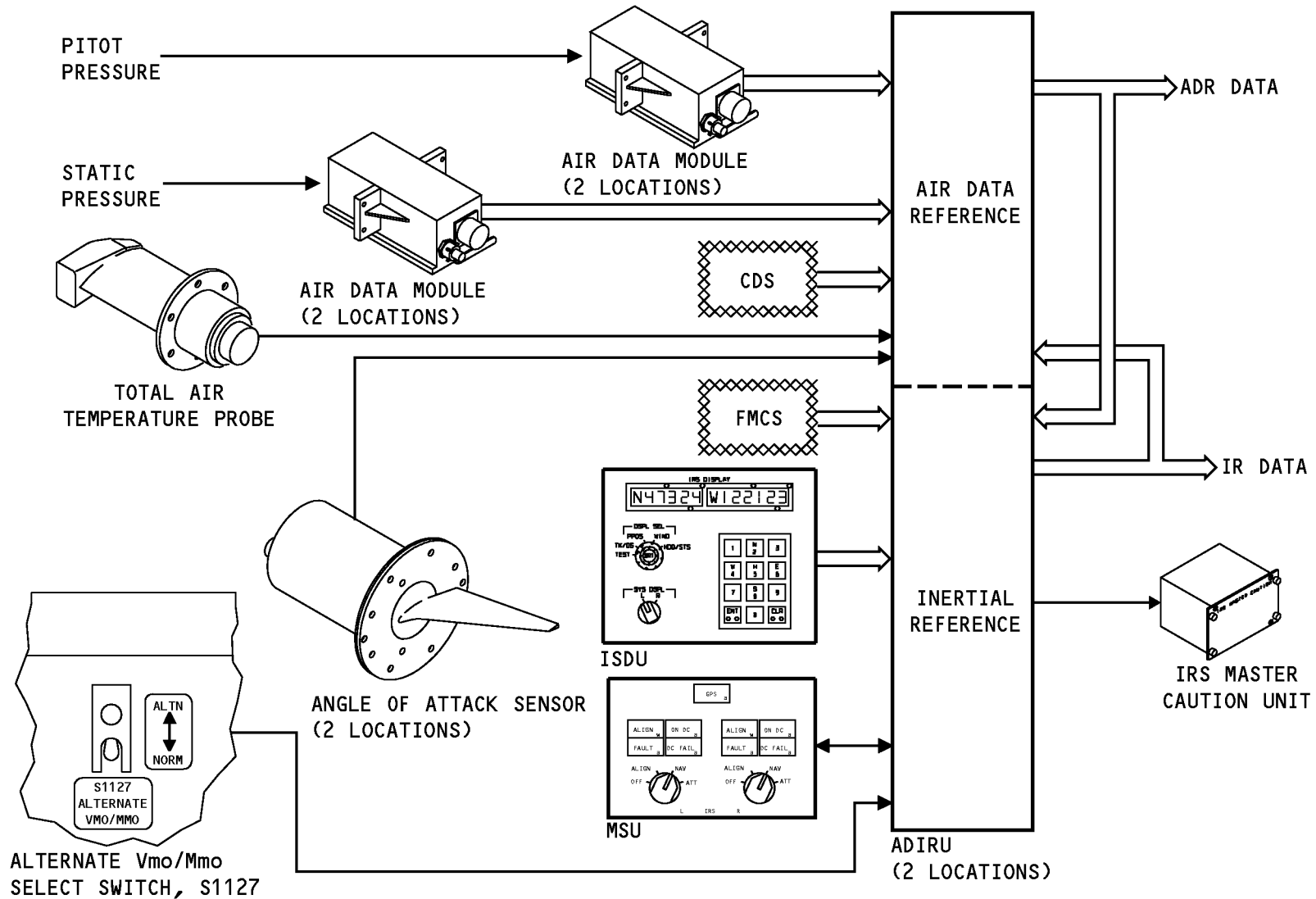

ADIRS - GENERAL DESCRIPTION

EFFECTIVITY

HAP 031-036, 038-054, 101-999

34-21-00

34-21-00-002

D633A101-HAP

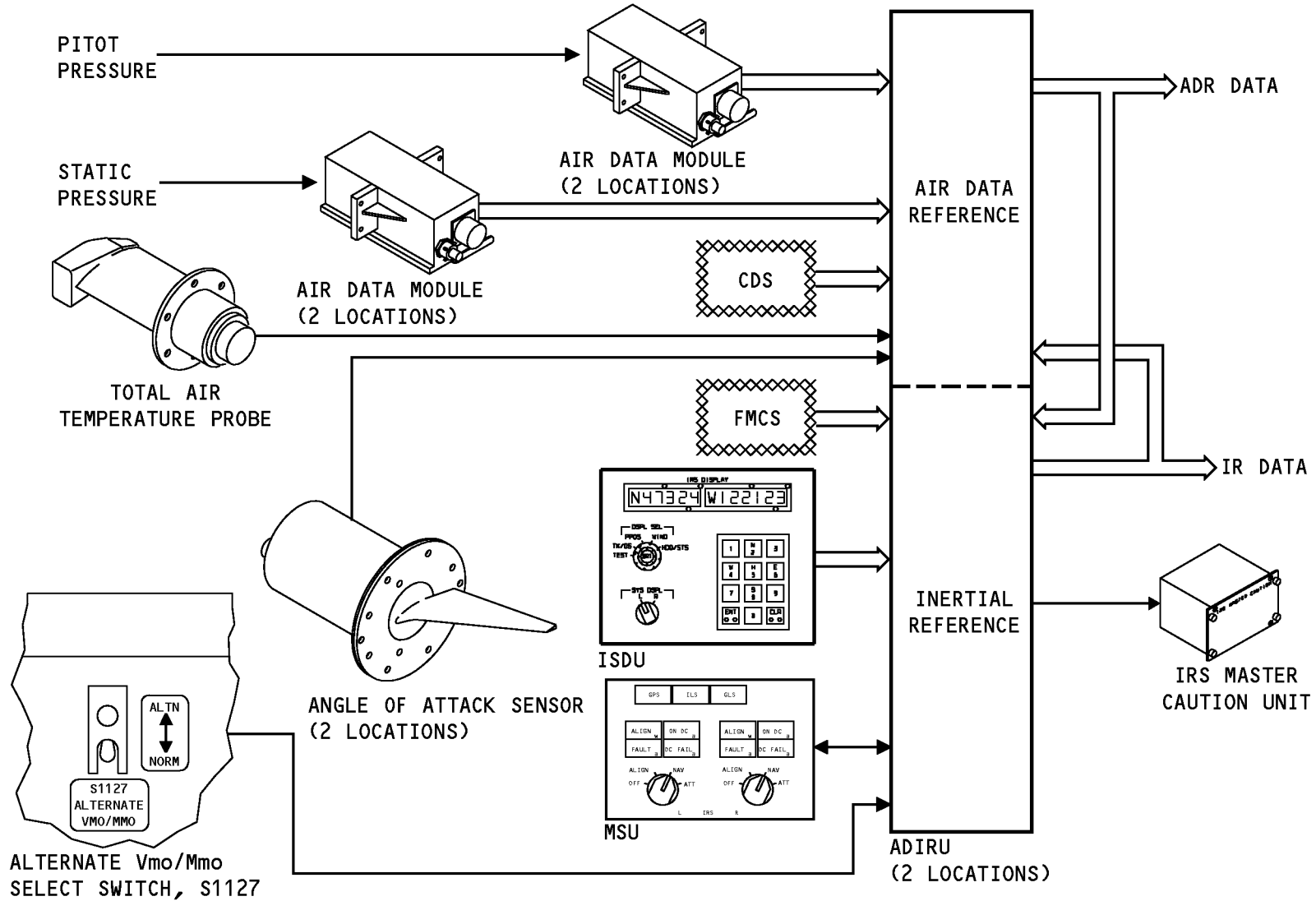

ADIRS - GENERAL DESCRIPTION

34-21-00-002

EFFECTIVITY
HAP 037

34-21-00

D633A101-HAP

ADIRS - COMPONENT LOCATION - FLIGHT COMPARTMENT

General

These are the ADIRS components in the flight compartment:

- Inertial system display unit (ISDU)
- Mode select unit (MSU)
- IRS master caution annunciator.

These are the components in the flight compartment that have an interface with the ADIRS:

- Left inboard and outboard display units
- Right inboard and outboard display units
- Upper center display unit
- IRS select switch
- Control display unit (CDU) 1 and 2
- Radio magnetic indicator (RMI)

HAP 031-054, 101-999

- Integrated standby flight display

HAP ALL

- Left and right EFIS control panels.

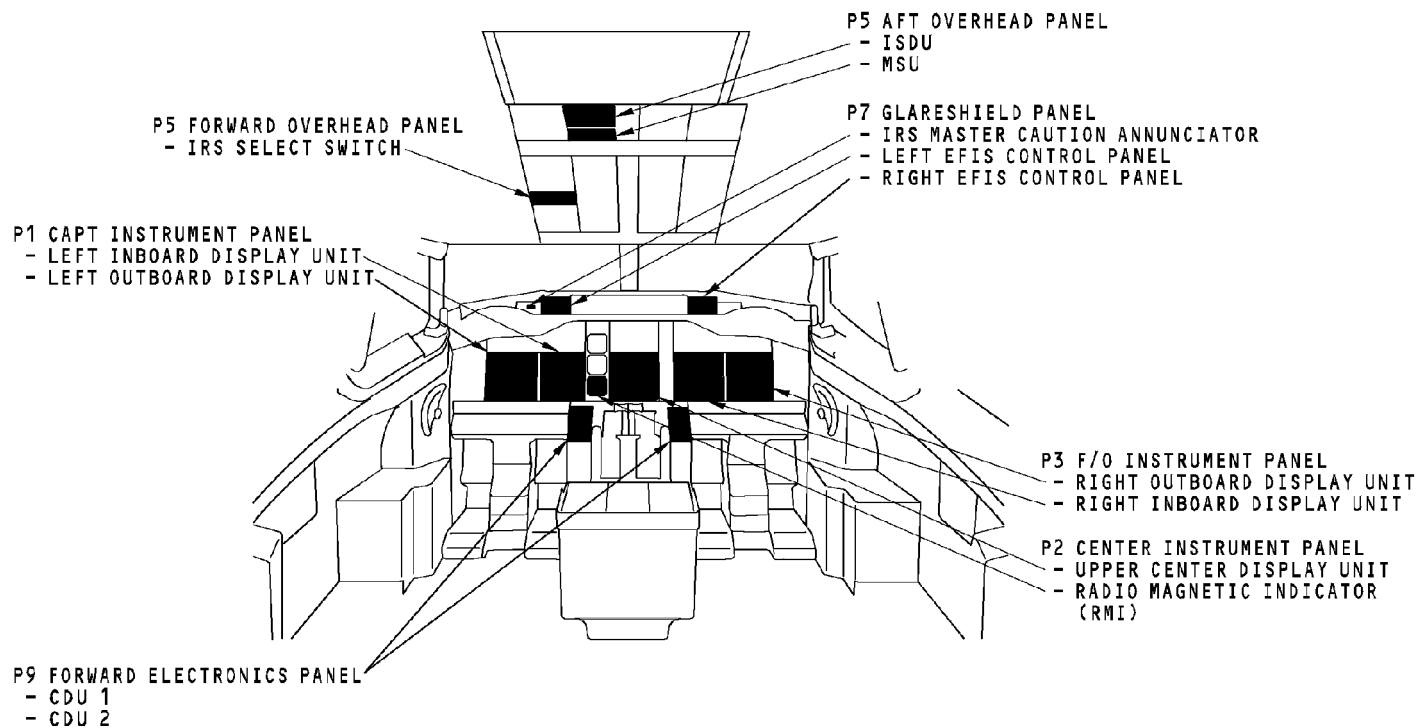

ADIRS - COMPONENT LOCATION - FLIGHT COMPARTMENT

34-21-00-003

EFFECTIVITY
 HAP 001-013, 015-026, 028-030

34-21-00

D633A101-HAP

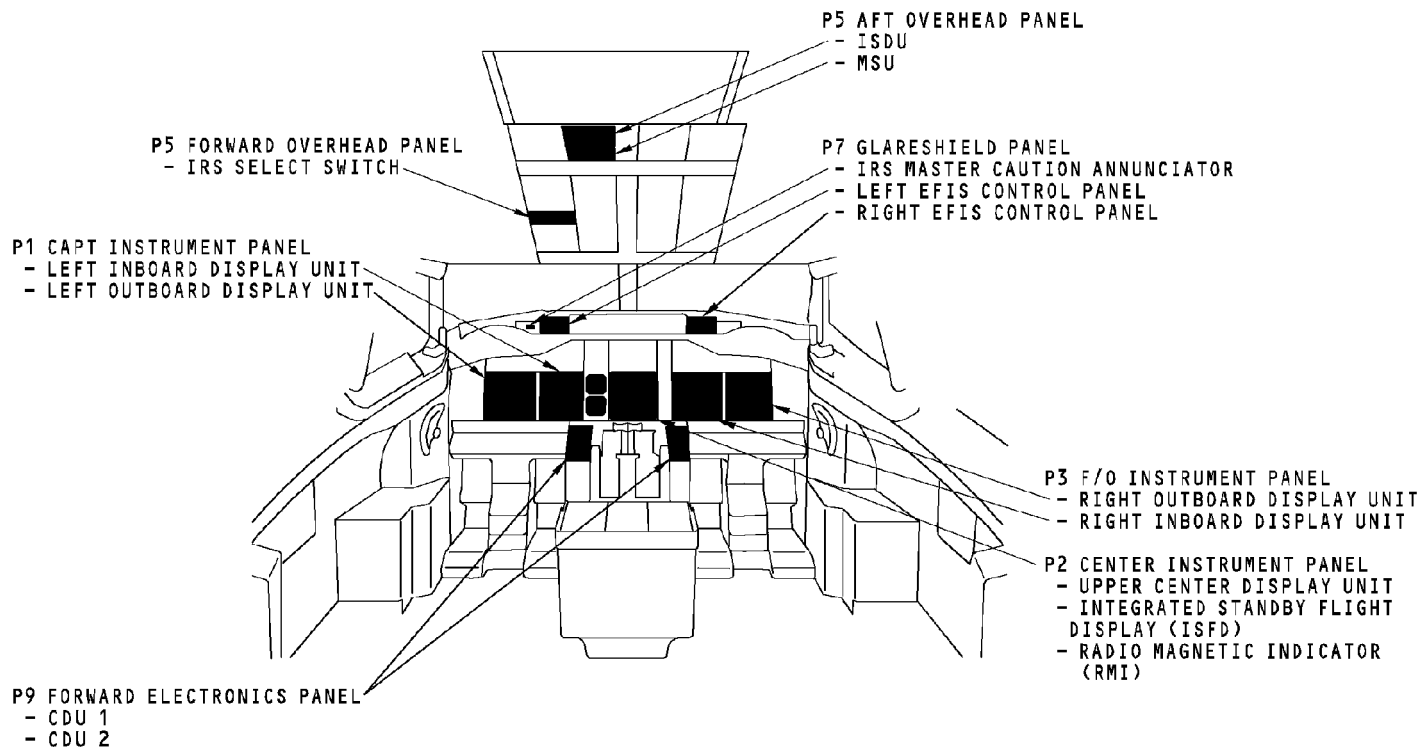

ADIRS - COMPONENT LOCATION - FLIGHT COMPARTMENT

EFFECTIVITY
HAP 031-054, 101-999

34-21-00

D633A101-HAP

THIS PAGE IS INTENTIONALLY LEFT BLANK

34-21-00

D633A101-HAP

Page 13
Oct 10/2006



ADIRS - COMPONENT LOCATION - IRS MASTER CAUTION UNIT

General

THE IRS master caution unit is in the flight compartment on the P61 panel.

34-21-00-063

EFFECTIVITY
HAP ALL

34-21-00

D633A101-HAP

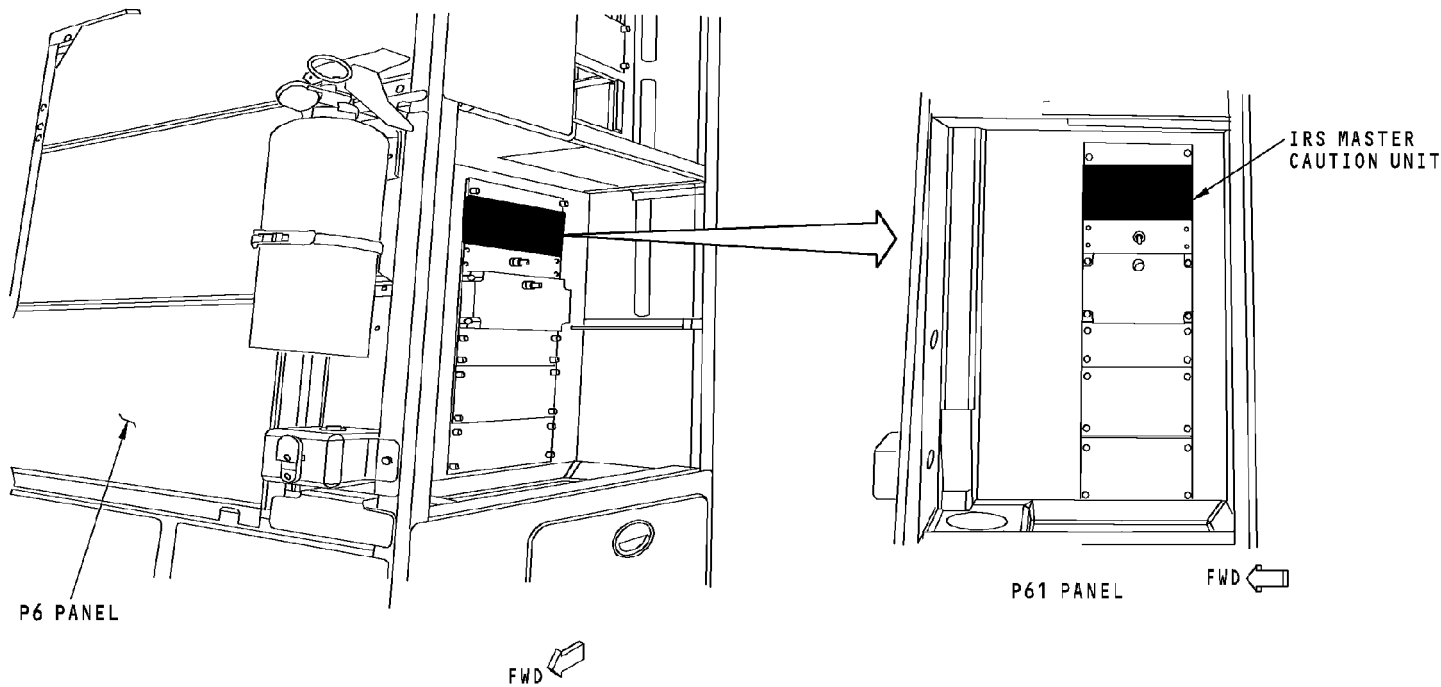

ADIRS - COMPONENT LOCATION - IRS MASTER CAUTION UNIT

34-21-00-063

EFFECTIVITY
HAP ALL

34-21-00

D633A101-HAP

ADIRS - COMPONENT LOCATION - EE COMPARTMENT

General

These are the ADIRS components in the electronic equipment (EE) compartment:

- Left air data inertial reference unit (ADIRU)
- Right ADIRU.

HAP 031-054, 101-999

- ALTERNATE VMO/MMO.

HAP ALL

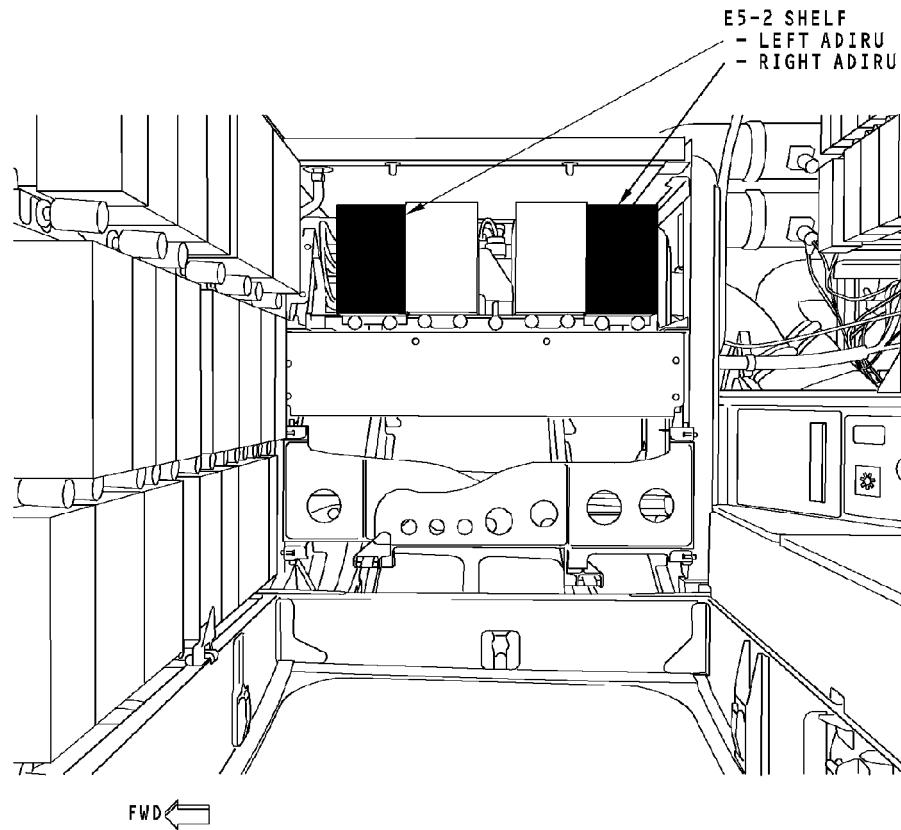

ADIRS - COMPONENT LOCATION - EE COMPARTMENT

34-21-00-004

EFFECTIVITY
HAP 001-013, 015-026, 028-030

34-21-00

D633A101-HAP

Page 17
Jun 10/2007

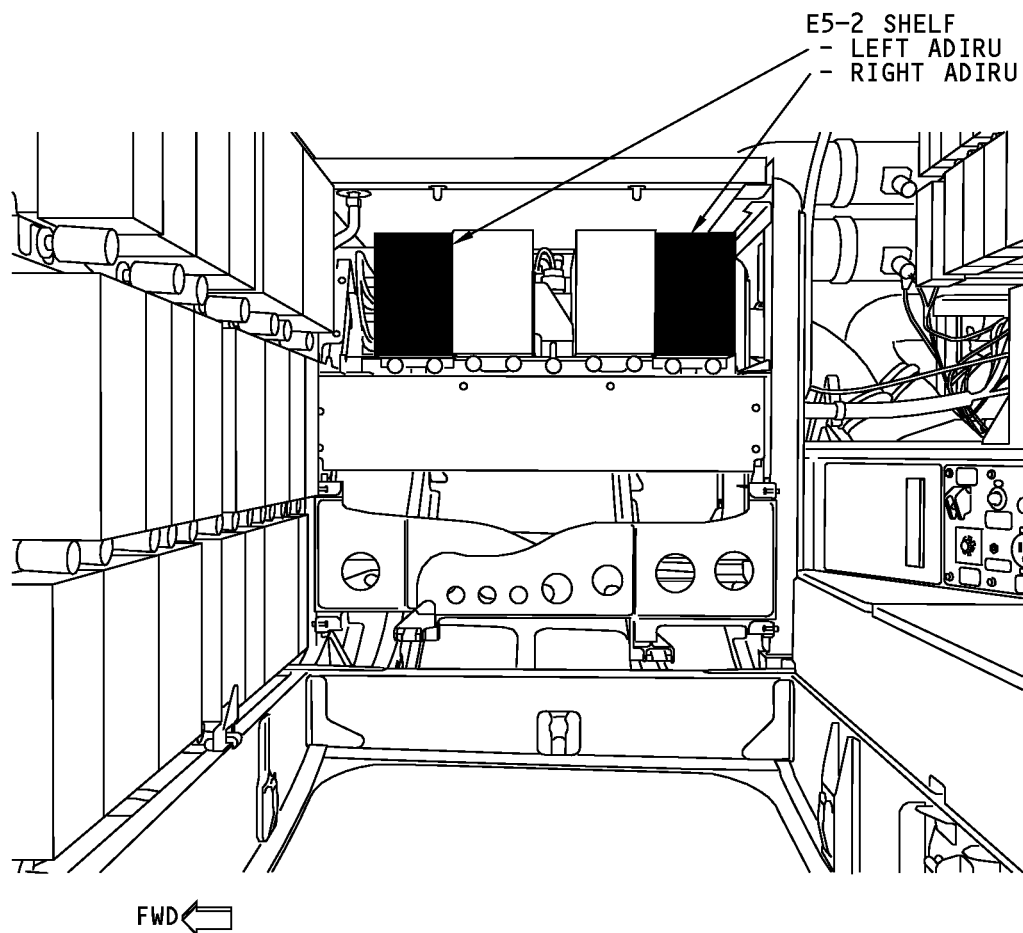

ADIRS - COMPONENT LOCATION - EE COMPARTMENT

EFFECTIVITY
HAP 031-054, 101-999

34-21-00

D633A101-HAP

THIS PAGE IS INTENTIONALLY LEFT BLANK

34-21-00

D633A101-HAP

Page 19
Feb 10/2007



ADIRS - COMPONENT LOCATION - PITOT AIR DATA MODULES

General

The pitot pressure air data modules (ADM) are in the forward equipment compartment.

34-21-00-005

EFFECTIVITY
HAP ALL

34-21-00

D633A101-HAP

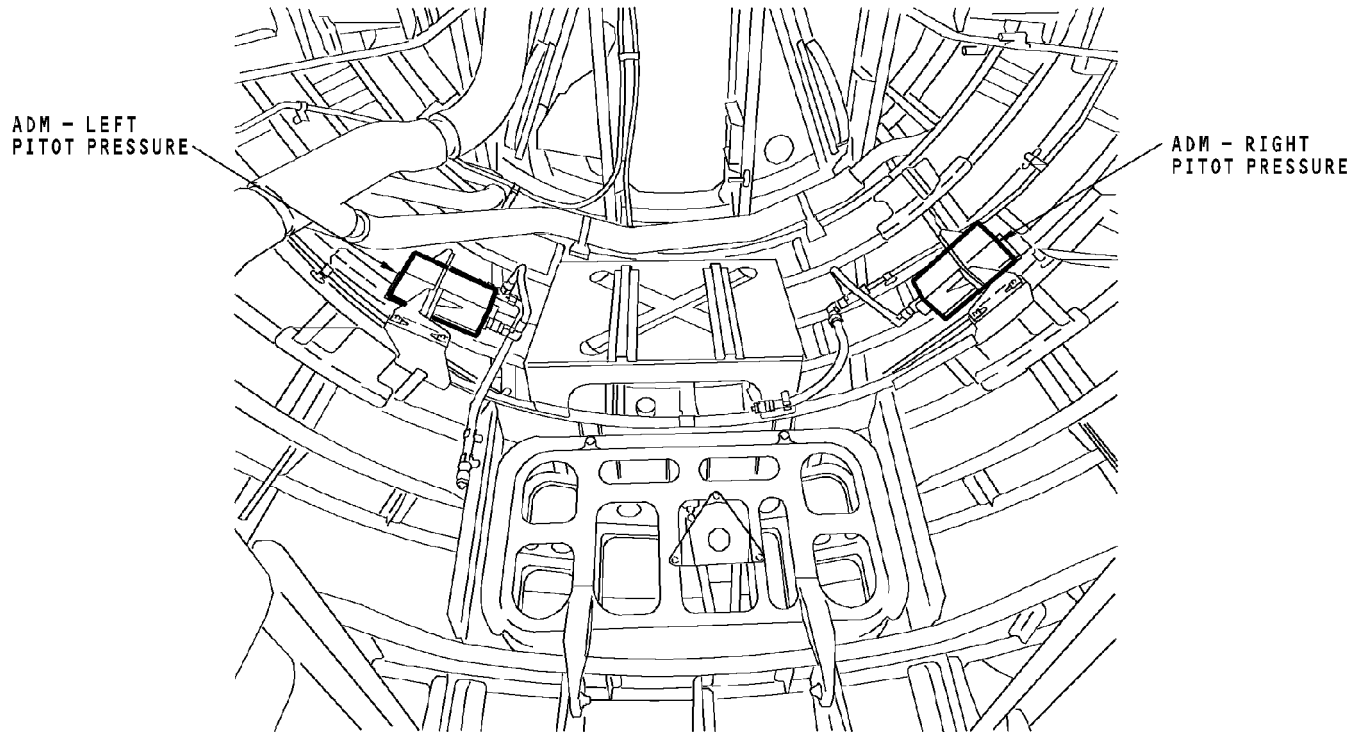

**FORWARD EQUIPMENT COMPARTMENT
(LOOKING FORWARD)**

ADIRS - COMPONENT LOCATION - PITOT AIR DATA MODULES

34-21-00-005

**EFFECTIVITY
HAP ALL**

34-21-00

D633A101-HAP

Page 21
Feb 10/2007



ADIRS - COMPONENT LOCATION - STATIC AIR DATA MODULES

General

The static pressure ADMs are in the forward cargo compartment, above the ceiling panels.

34-21-00-065

EFFECTIVITY
HAP ALL

34-21-00

D633A101-HAP

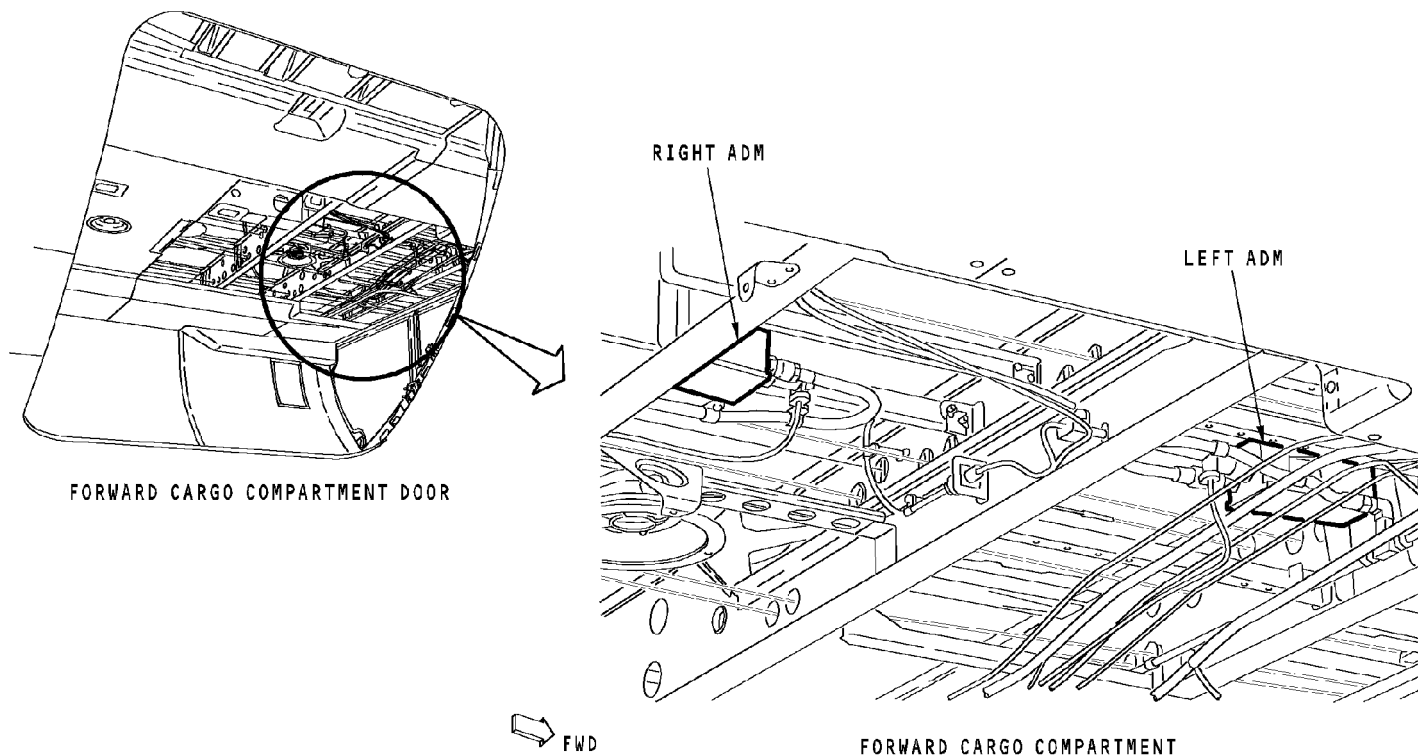

ADIRS - COMPONENT LOCATION - STATIC AIR DATA MODULES

34-21-00-065

EFFECTIVITY
HAP ALL

34-21-00

D633A101-HAP

Page 23
Feb 10/2007



ADIRS - COMPONENT LOCATION - AOA SENSORS AND TAT PROBE

General

The angle of attack (AOA) sensors are on both sides of the fuselage. The total air temperature (TAT) probe is on the left side.

34-21-00-006

EFFECTIVITY
HAP ALL

34-21-00

D633A101-HAP

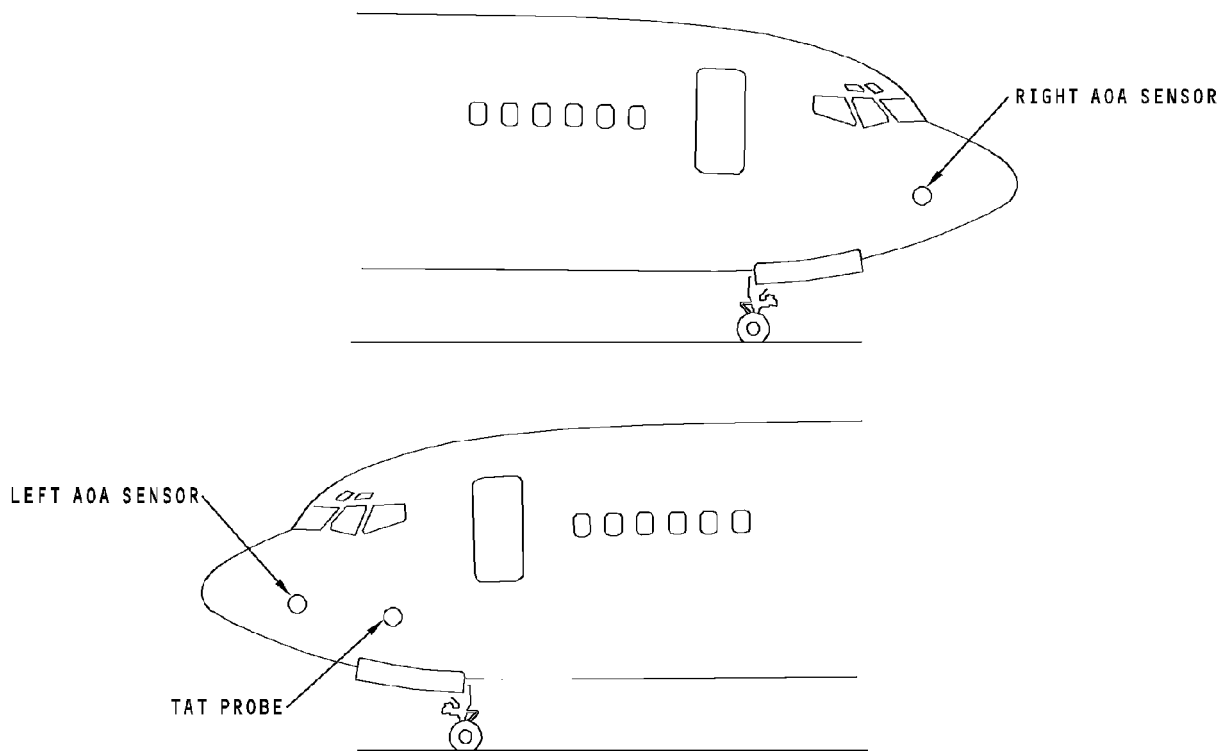

ADIRS - COMPONENT LOCATION - AOA SENSORS AND TAT PROBE

34-21-00-006

EFFECTIVITY
HAP ALL

34-21-00

D633A101-HAP

Page 25
Feb 10/2007

ADIRS - POWER**ADIRU**

The ADIRU operates with 115v ac or 28v dc. 115v ac is the normal power source.

Each ADIRU has a separate ac and dc power source. The left ADIRU gets power from these buses:

- 115v ac stby bus
- 28v dc sw hot battery bus.

The right ADIRU gets power from these buses:

- 115v ac xfr bus 2
- 28v dc sw hot battery bus.

AC Reference Voltage

The 28v ac stby bus supplies a servo reference voltage to the left ADIRU and to the left angle of attack (AOA) sensor. The 28v ac xfr bus 2 supplies servo reference voltage to the right ADIRU and to the right AOA sensor.

Integrated Flight Systems Accessory Unit

The integrated flight systems accessory unit (IFSAU) gets ac power from the 115v ac xfr bus 2. DC power comes from the 28v dc sw hot bat bus. The IFSAU uses these inputs to control power going to the right ADIRU and to supply power to the crew call horn when the ADIRUs operate with dc power on the ground.

Air Data Modules

The left ADIRU supplies 13.5v dc to the left pitot ADM and to the left static ADM. The right ADIRU supplies 13.5v dc to the right ADMs.

Inertial System Display Unit

The inertial system display unit (ISDU) gets 28v dc from the left and the right ADIRU.

IRS Master Caution Unit

The IRS master caution unit gets power from the 28v dc bat bus.

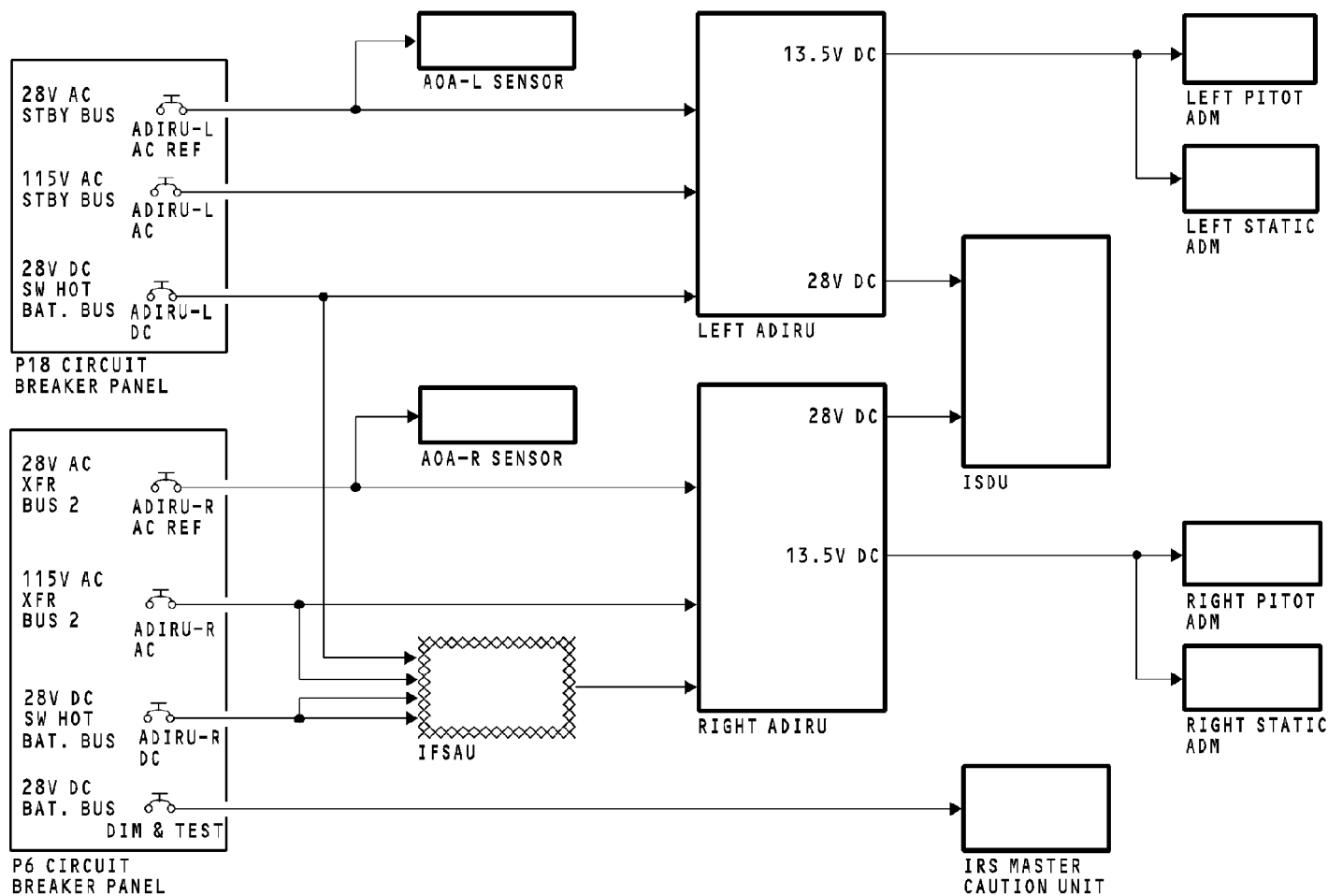

ADIRS - POWER

EFFECTIVITY
HAP ALL

34-21-00

D633A101-HAP

ADIRS - DC POWER OPERATION**General**

The ADIRUs operates with AC or DC power. AC power is the normal power source. If the AC power source is not available, DC power from the airplane battery will supply power to the ADIRUs.

Left ADIRU DC Operation

When AC power is not available, the left ADIRU will operate on DC power from the 28v dc sw hot battery bus. The left ADIRU will continue to operate on DC power until the battery power is less than 18v dc.

Right ADIRU DC Operation

DC power to the right ADIRU goes through a time delay circuit in the integrated flight systems accessory unit (IFSAU). When AC power is not available, a 5 minute time delay keeps the DC power relay energized, and the right ADIRU operates on DC power. After 5 minutes continuous operation on DC power, the time delay circuit deenergizes the relay and DC power to the right ADIRU is removed. This feature allows the airplane battery to drain at a slower rate.

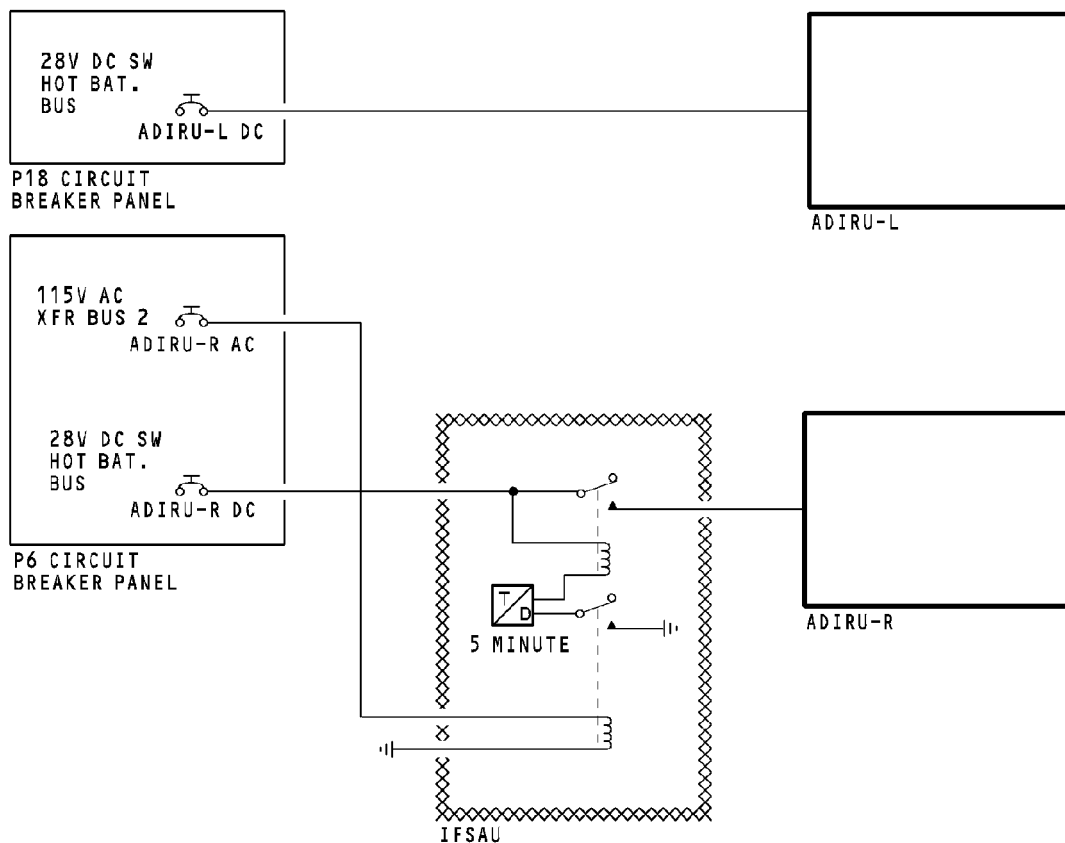

ADIRS - DC POWER OPERATION

34-21-00-016

EFFECTIVITY
HAP ALL

34-21-00

D633A101-HAP

ADIRS - NO COOLING AND ON DC WARNING**General**

The integrated flight systems accessory unit (IFSAU) contains a circuit which causes the ground crew call horn to tell maintenance personnel of unsafe ADIRU operation. This occurs when the airplane is on the ground and the ADIRUs are on dc power or when the equipment cooling system fails.

ADIRU DC Power Operation

The ADIRUs send 28v dc to the AND logic circuit in the IFSAU. When an ADIRU senses that it is on dc power, it sends an ON DC discrete to the IFSAU. The discrete goes through a 20 second delay to the AND gate logic. After twenty seconds of dc operation, the AND gate supplies power to the crew call horn relay. The relay energizes when the air/gnd relay is in the gnd position. The energized crew call relay closes the relay switch, and 28v dc power causes the horn to operate.

Equipment Cooling Failure

Two equipment cooling sensors monitor the cooling air flow to the ADIRUs. A low flow relay in the sensor will close when the cooling air flow fails. The closed relay lets 28v dc go to the IFSAU. The 28v dc discrete goes through a 20 second delay to the AND gate logic. After twenty seconds, the AND gate supplies power to the crew call horn relay. The relay energizes when the air/gnd relay is in the gnd position. The energized crew call horn relay closes the relay switch, and 28v dc power causes the horn to operate.

34-21-00-015

EFFECTIVITY
HAP ALL**34-21-00**

D633A101-HAP

Page 30
Feb 10/2007

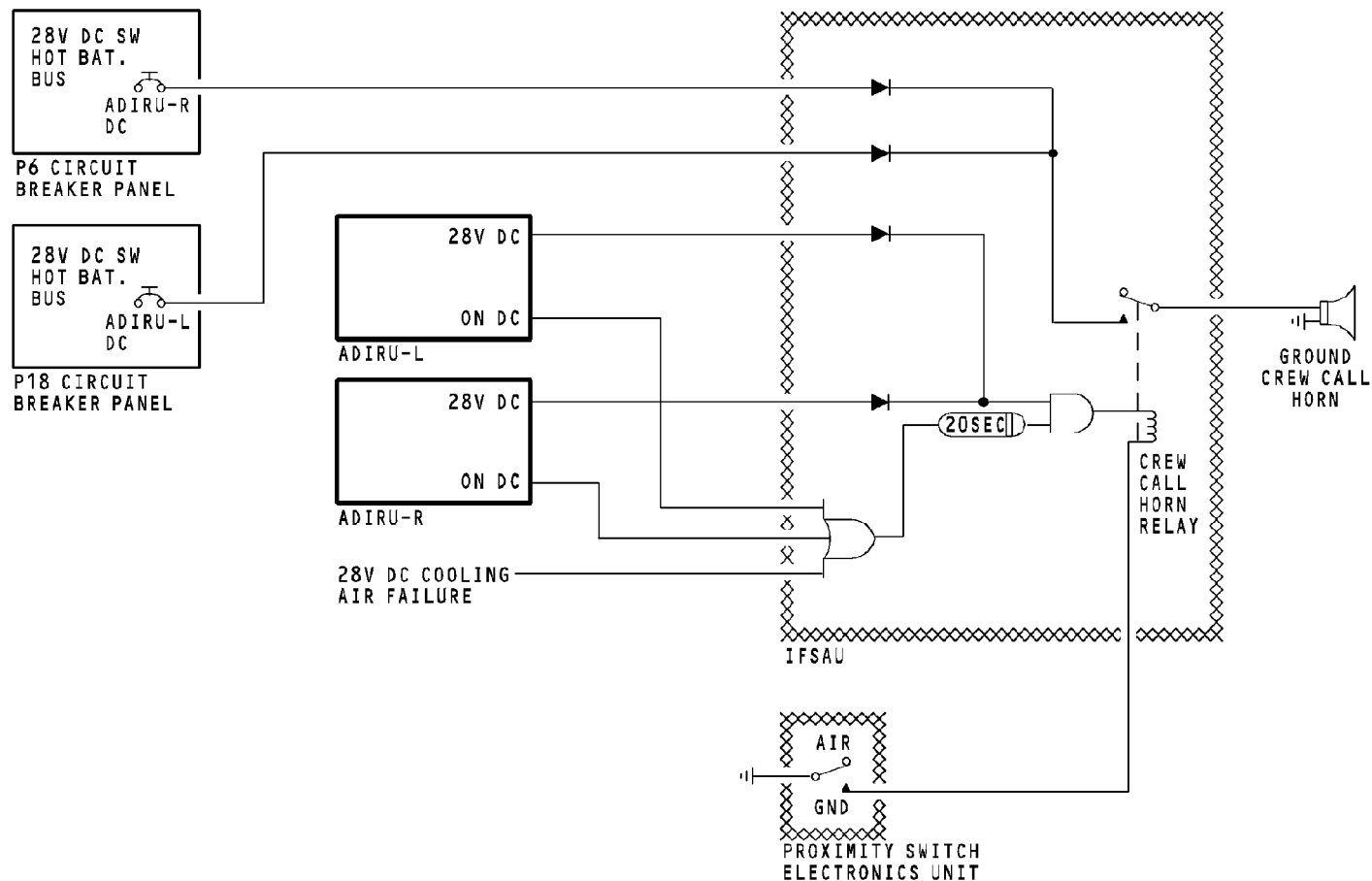

ADIRS - NO COOLING AND ON DC WARNING

34-21-00-015

**EFFECTIVITY
HAP ALL**

34-21-00

D633A101-HAP

Page 31
Feb 10/2007

ADIRS - CONTROL AND WARNING**General**

These are the units that interface to supply control and warning data to the pilots:

- ISDU
- MSU
- IRS master caution unit.

ISDU Interface

The ISDU supplies both ADIRUs with test discretes, heading data, and present position data. The ADIRUs supply IR data and fault data to the ISDU.

MSU Interface

The MSU supplies mode discretes to the ADIRUs. The ADIRUs supply align and fail discretes to the MSU. The MSU also receives an ON DC discrete from the ADIRUs. The ON DC discrete goes through the IRS master caution unit.

IRS Master Caution Unit Interface

The IRS master caution unit receives fail and ON DC discretes from the ADIRUs. The IRS master caution unit supplies discrete outputs to the MSU and to the master caution lights and annunciators.

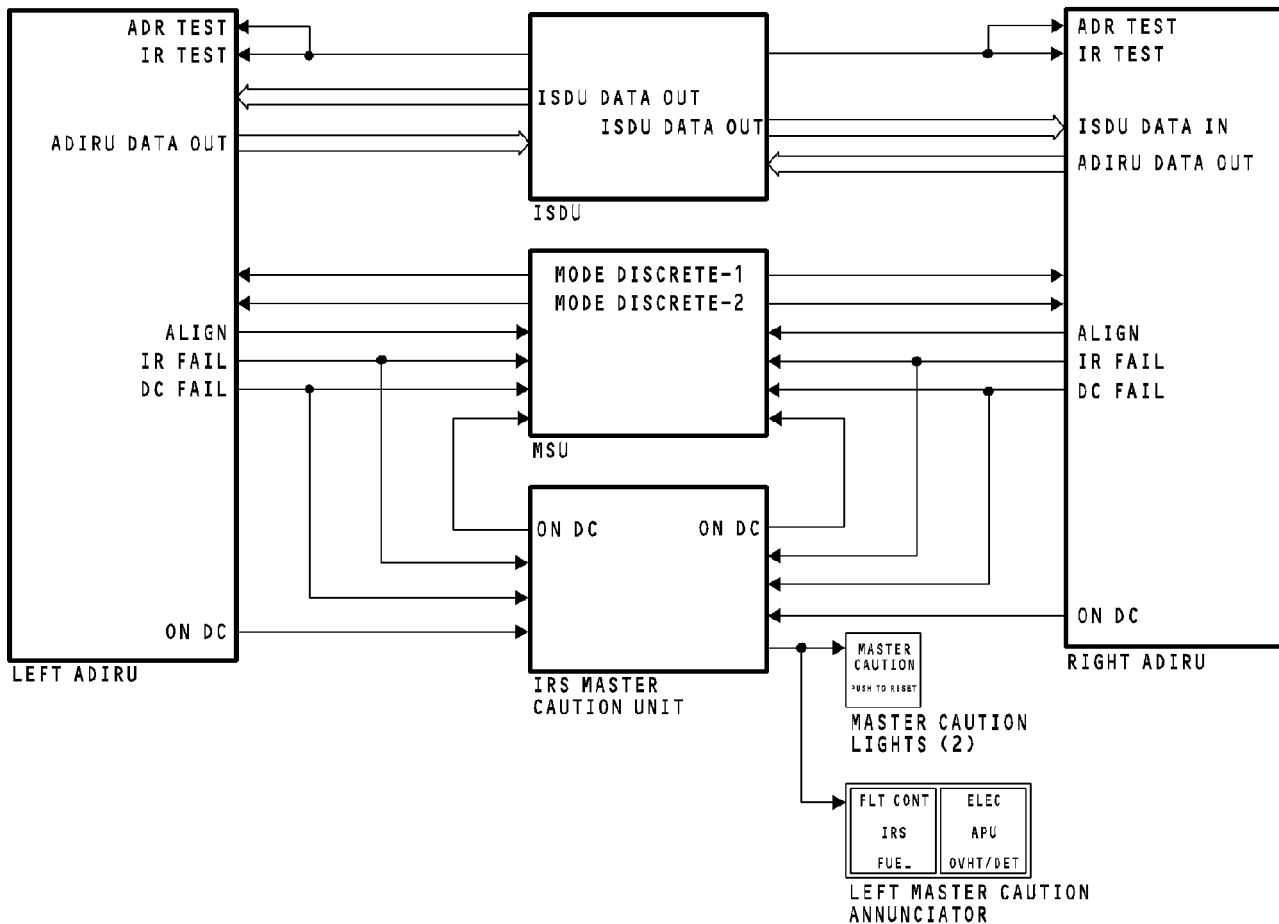

ADIRS - CONTROL AND WARNING

34-21-00-008

EFFECTIVITY
HAP ALL

34-21-00

D633A101-HAP

THIS PAGE IS INTENTIONALLY LEFT BLANK

34-21-00

D633A101-HAP

Page 34
Feb 10/2007

ADIRS - SYSTEM INPUTS

General

Each ADIRU receives inputs from these on-side components:

- AOA sensor
- Pitot ADM
- Static ADM.

The AOA sensor gives angle of attack information to the ADIRU. The ADIRU uses angle of attack to modify pitot and static values.

The pitot ADM gives the ADIRU total air pressure information. This is used to calculate airspeed and mach number.

The static ADM gives the ADIRU static air pressure information. This is used to calculate altitude and airspeed.

These components supply data to both ADIRUs:

- TAT probe
- DEU 1 and DEU 2
- Window and pitot heat module
- Inertial system display unit (ISDU)

HAP 001-013, 015-026, 028-036

- FMC 1.

HAP 037-054, 101-999

- FMC 1 and FMC 2.

HAP 031-054, 101-999

- ALTERNATE VMO/MMO SWITCH.

HAP ALL

The TAT probe gives total air temperature to the ADIRUs. The ADIRUs use TAT to compute TAS and SAT.

DEU 1 and DEU 2 give barometric correction to the ADIRUs. The ADIRUs use barometric correction to calculate corrected barometric altitude.

The window and pitot heat module sends a discrete signal to the ADIRUs when anti ice heat is on. The ADIRUs modify the input values of these components when anti ice heat is on:

- AOA sensor
- Pitot probe
- TAT probe.

The ISDU gives initial present position data and heading data to the ADIRUs. The ADIRUs use present position data during the align mode. Heading data is used during the attitude mode.

The FMC gives the ADIRUs this information:

- Present position
- Heading
- BITE command.

The ADIRUs use present position in the align mode. Heading data is used in the attitude mode. The BITE command starts the ADIRU Bite tests.

34-21-00-009

<p>EFFECTIVITY HAP ALL</p>
--

34-21-00

D633A101-HAP

ADIRS - SYSTEM INPUTS

Multi-mode receiver 1 (MMR 1) and MMR 2 have data buses to the ADIRUs. The MMRs do not supply any data to the ADIRUs. The data buses are for future use to send global positioning system (GPS) information.

HAP 031-054, 101-999

The ALTERNATE VMO/MMO SWITCH is used to provide an input to the ADIRU to vary the Vmo/Mmo curve. This is done to compensate for a flight with the landing gear down.

HAP ALL

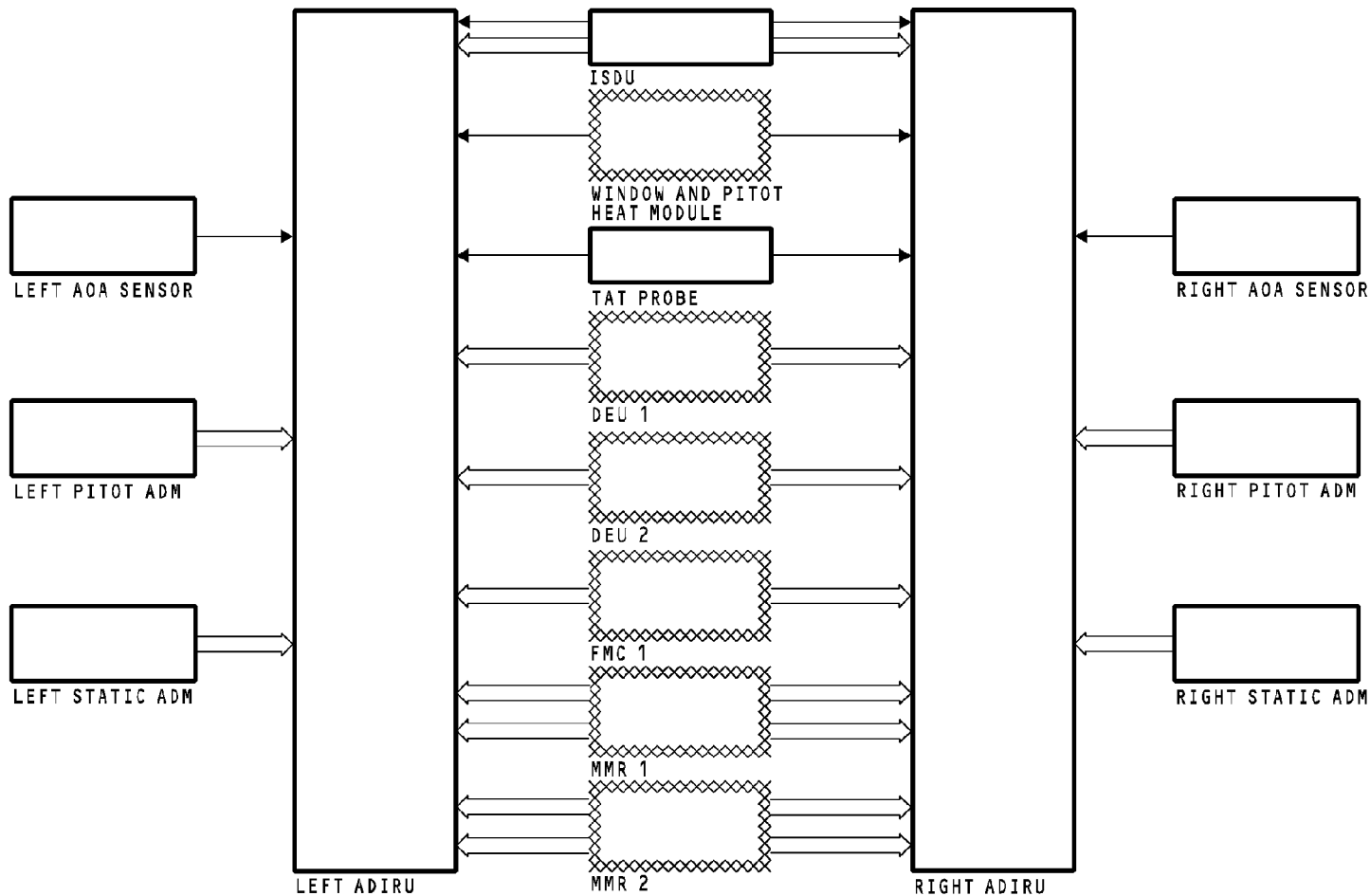

ADIRS - SYSTEM INPUTS

34-21-00-009

EFFECTIVITY
HAP 001-013, 015-026, 028-030

34-21-00

D633A101-HAP

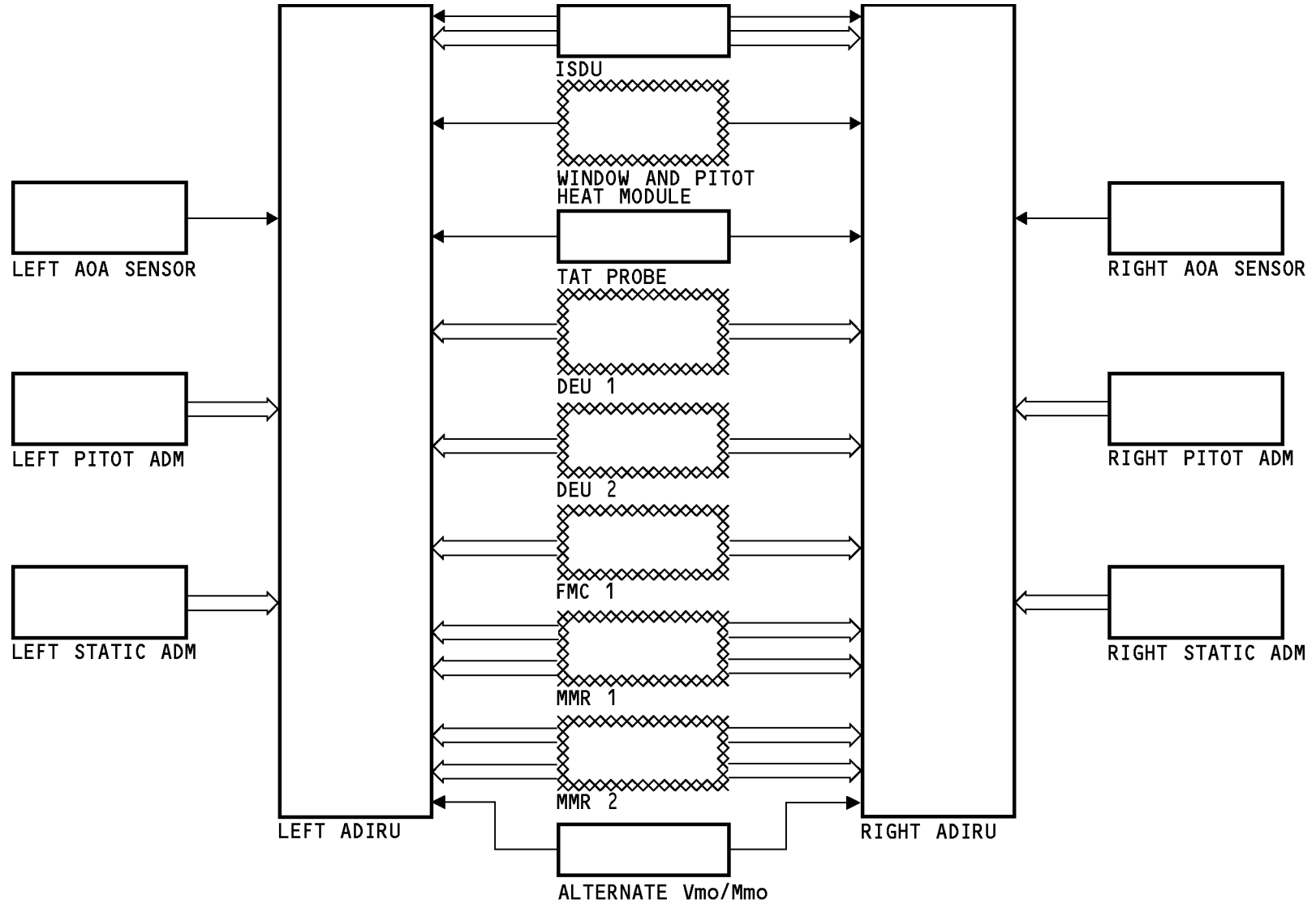

AIDRS - SYSTEM INPUTS

EFFECTIVITY
HAP 031-036

34-21-00

34-21-00-009

D633A101-HAP

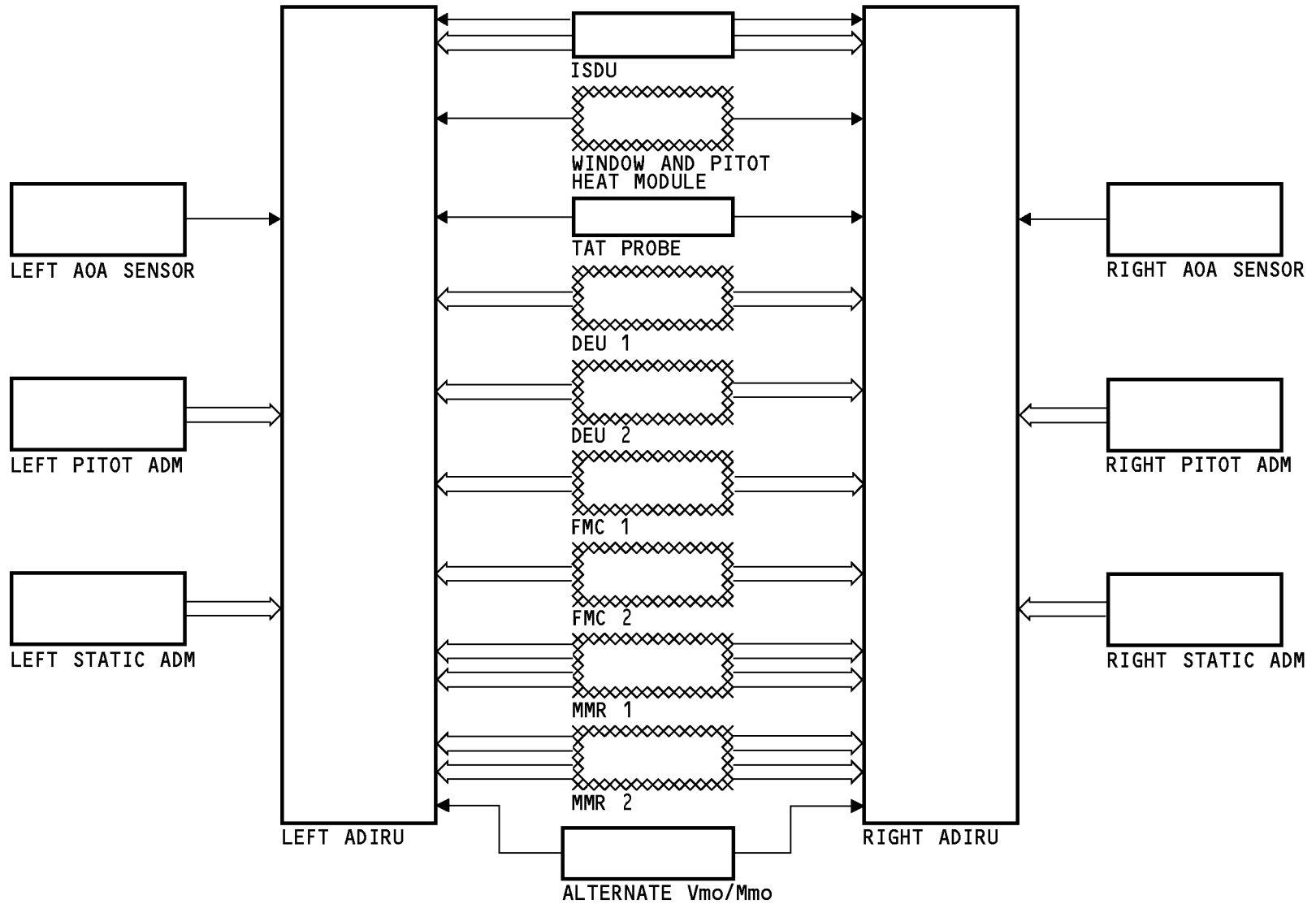

ADIRS - SYSTEM INPUTS

34-21-00-009

EFFECTIVITY
HAP 037-054, 101-999

34-21-00

D633A101-HAP

ADIRS - LEFT INERTIAL REFERENCE DIGITAL OUTPUTS

General

The left ADIRU supplies inertial reference (IR) data to many systems and components. IR data goes out on ARINC 429 data buses. The data on each bus is the same. One data bus goes from the IR section of the ADIRU to the air data reference (ADR) section. These are the components and systems that receive IR data from the left ADIRU:

- Display electronics unit (DEU) 1 and 2
- Radio magnetic indicator (RMI)
- Multi mode receiver (MMR) 1 and MMR 2
- Stall management yaw damper (SMYD) 1 and 2
- Flight control computer (FCC) A and B
- Ground proximity warning computer (GPWC)
- Weather radar receiver transmitter (WXR R/T)
- TCAS computer
- Integrated flight systems accessory unit (IFSAU)

HAP 031-054, 101-999

- Integrated standby flight display (ISFD)

HAP ALL

- Inertial system display unit (ISDU)
- Anti skid autobrake control unit (AACU)
- Autothrottle (A/T) computer

HAP 001-013, 015-026, 028-054, 104-999

- Digital interface unit (DIU)--is Airshow ASINC

HAP 037-054, 101-999

- Flight management computer (FMC) 1 and 2.

HAP 001-013, 015-026, 028-036

- Flight management computer (FMC) 1.

HAP ALL

DEU

The DEUs use this IR data from the ADIRUs to show information on the display units:

- Present position
- Track angle
- Magnetic heading
- Wind direction
- True heading
- Ground speed
- Drift angle
- Flight path angle
- Flight path acceleration
- Pitch angle
- Roll angle
- Body pitch rate
- Body roll rate
- Body yaw rate
- Body longitudinal acceleration
- Body lateral acceleration
- Body normal acceleration
- Track angle rate
- Pitch attitude rate
- Roll attitude rate
- Inertial altitude
- Along track horizontal acceleration
- Cross track horizontal acceleration
- Vertical acceleration
- Inertial vertical speed
- N-S velocity
- E-W velocity.

ADIRS - LEFT INERTIAL REFERENCE DIGITAL OUTPUTS

RMI

The RMI uses magnetic heading data to control the position of its compass card.

MMR

HAP 001-013, 015-026, 028-036, 038-054, 101-999

The MMRs use present position and inertial altitude for GPS calculations.

HAP 037

The MMRs use present position and inertial altitude for GPS calculations.

The GLS located inside the MMR uses these IR data.

- Latitude
- Longitude
- Ground Speed
- True Track Angle
- True Heading
- Magnetic Track Angle
- Drift Angle
- Pitch Angle
- Roll Angle
- Inertial Altitude
- Vertical Speed
- N-S Velocity

- E-W Velocity
- HAP ALL**

SMYD

SMYD 1 uses this IR data to calculate stall management and yaw damper values:

- Pitch angle
- Roll angle
- Body roll rate
- Body yaw rate
- Body longitudinal acceleration
- Body lateral acceleration
- Body normal acceleration
- Inertial vertical speed.

SMYD 2 uses this IR data to calculate yaw damper values:

- Roll angle
- Body roll rate
- Body yaw rate
- Body lateral acceleration.

DFCS

The flight control computers (FCC) use this IR data for autoflight calculations:

- Ground speed
- True track angle
- True heading

34-21-00-010

<p>EFFECTIVITY HAP ALL</p>
--

34-21-00

D633A101-HAP

ADIRS - LEFT INERTIAL REFERENCE DIGITAL OUTPUTS

- Wind speed
- True wind direction
- Magnetic track angle
- Flight path angle
- Flight path acceleration
- Pitch angle
- Body yaw rate
- Body longitudinal acceleration
- Body lateral acceleration
- Body normal acceleration
- Track angle rate
- Pitch attitude rate
- Roll attitude rate
- Inertial altitude
- Along track horizontal acceleration
- Cross track horizontal acceleration
- Vertical acceleration
- Inertial vertical speed.

GPWS

The GPWC uses this IR data to calculate unsafe conditions:

- Latitude
- Longitude
- HAP ● True track angle
- Magnetic track angle
- HAP I ● Groundspeed
- HAP ● True heading
- Inertial vertical speed
- Pitch angle
- Roll angle
- Inertial altitude

- Body normal acceleration
- Body longitudinal acceleration
- Inertial vertical acceleration
- Body pitch rate
- IR in attitude mode discrete.

WXR R/T

The ADIRU sends this IR data to the WXR R/T:

HAP 008-013, 015-026, 028-054, 101-999

- Groundspeed

HAP 008-011

- Magnetic track angle
- Inertial altitude
- N-S velocity
- E-W velocity

HAP ALL

- Pitch angle
- Roll angle.

HAP 008-013, 015-026, 028-054, 101-999

The WXR R/T uses this data for weather condition calculations and antenna stabilization.

HAP ALL

TCAS

HAP 001-013, 015-026, 028-030

The TCAS computer uses this IR data for display damping calculations:

34-21-00-010

EFFECTIVITY
HAP ALL

34-21-00

D633A101-HAP

ADIRS - LEFT INERTIAL REFERENCE DIGITAL OUTPUTS**HAP 001-013, 015-026, 028-030 (Continued)**

- Pitch attitude rate
- Roll attitude rate
- Magnetic heading.

HAP 031-054, 101-999

This IR data goes to the TCAS computer:

- Pitch attitude rate
- Roll attitude rate
- Magnetic heading.

TCAS does not use this data at this time.

HAP ALL**IFSAU**

The integrated flight systems accessory unit receives all IR data and sends it to the flight data acquisition unit for recording.

HAP 031-054, 101-999**ISFD**

The integrated standby flight display receives magnetic heading on the IR bus. The ISFD uses magnetic heading data to control the position of its compass display.

HAP ALL**ISDU**

The inertial system display unit receives this IR data to show on the IRS display:

- Present position
- True track
- Groundspeed
- Wind speed
- Wind direction
- True heading
- Time remaining until alignment complete
- Bite messages.

AACU

The anti-skid auto-brake control unit (AACU) uses this IR data for auto-brake calculations:

- Groundspeed
- Body longitudinal acceleration
- Pitch attitude.

A/T Computer

The ADIRU sends this IR data to the A/T computer:

- Pitch angle
- Roll angle
- Body longitudinal acceleration
- Body normal acceleration
- Groundspeed

ADIRS - LEFT INERTIAL REFERENCE DIGITAL OUTPUTS

- Inertial vertical speed.

The A/T computer uses this data for throttle command calculations.

HAP 001-013, 015-026, 028-054, 104-999**Passenger Entertainment System**

The passenger entertainment system DIU gets true heading and groundspeed data for the airshow display.

HAP ALL**FMCS**

The ADIRU sends this IR data to the flight management computer system (FMCS):

- Present position
- Groundspeed
- True heading
- Magnetic heading
- Pitch angle
- Roll angle
- Inertial altitude
- Inertial vertical speed
- N-S velocity
- E-W velocity.

The FMCS uses this data for performance and navigation calculations.

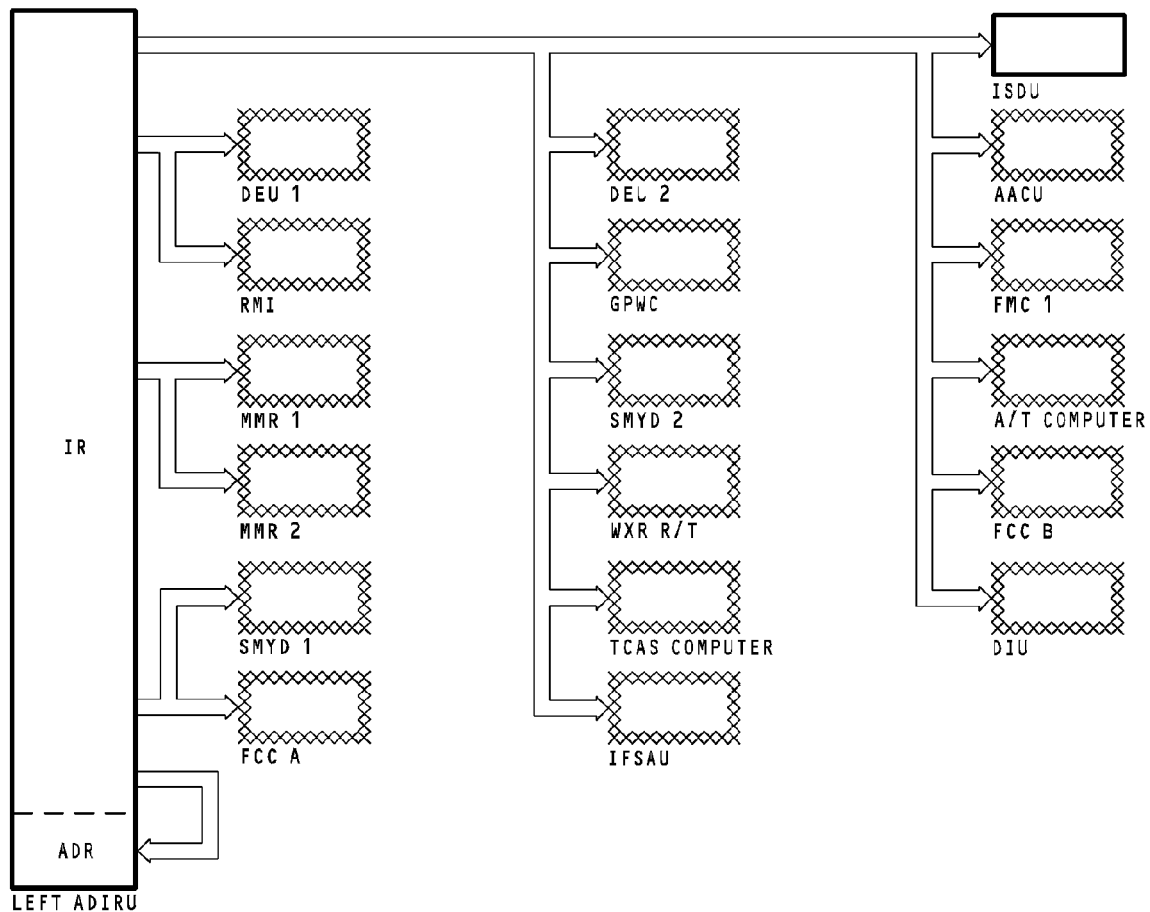

ADIRS - LEFT INERTIAL REFERENCE DIGITAL OUTPUTS

34-21-00-010

EFFECTIVITY
HAP 001-013, 015-026, 028-030

34-21-00

D633A101-HAP

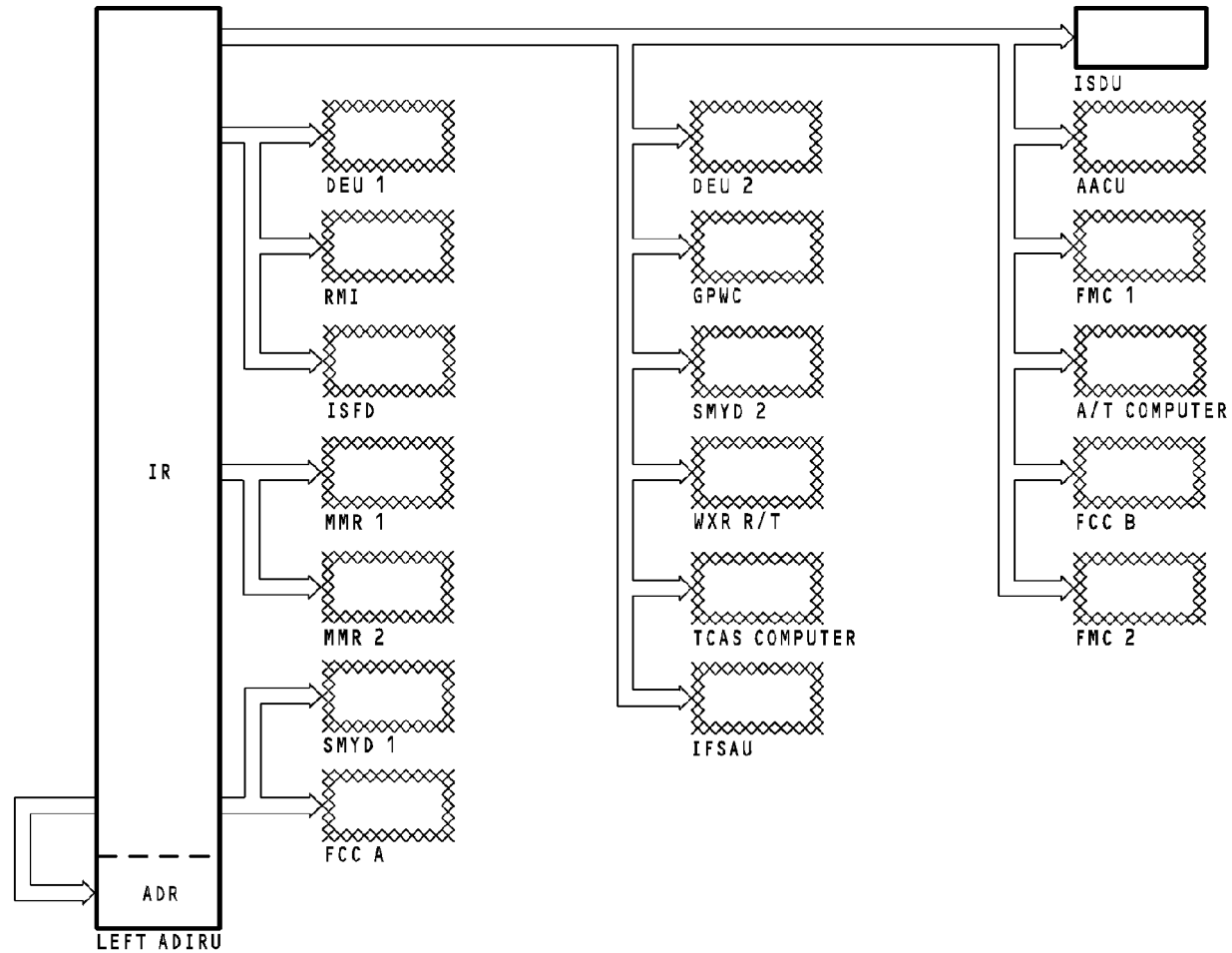

ADIRS - LEFT INERTIAL REFERENCE DIGITAL OUTPUTS

34-21-00-010

EFFECTIVITY
HAP 101-103

34-21-00

D633A101-HAP

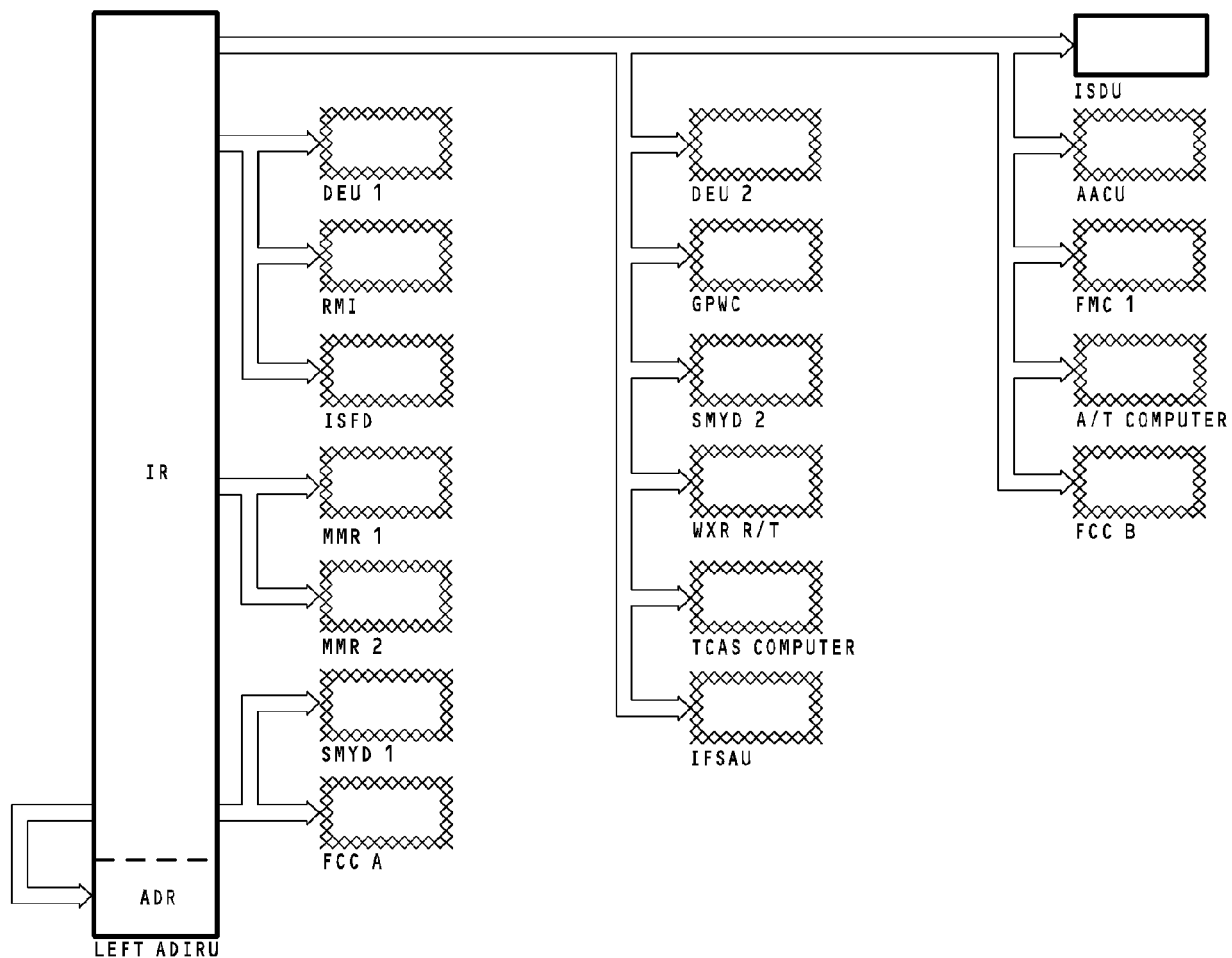

ADIRS - LEFT INERTIAL REFERENCE DIGITAL OUTPUTS

34-21-00-010

EFFECTIVITY
HAP 031-036

34-21-00

D633A101-HAP

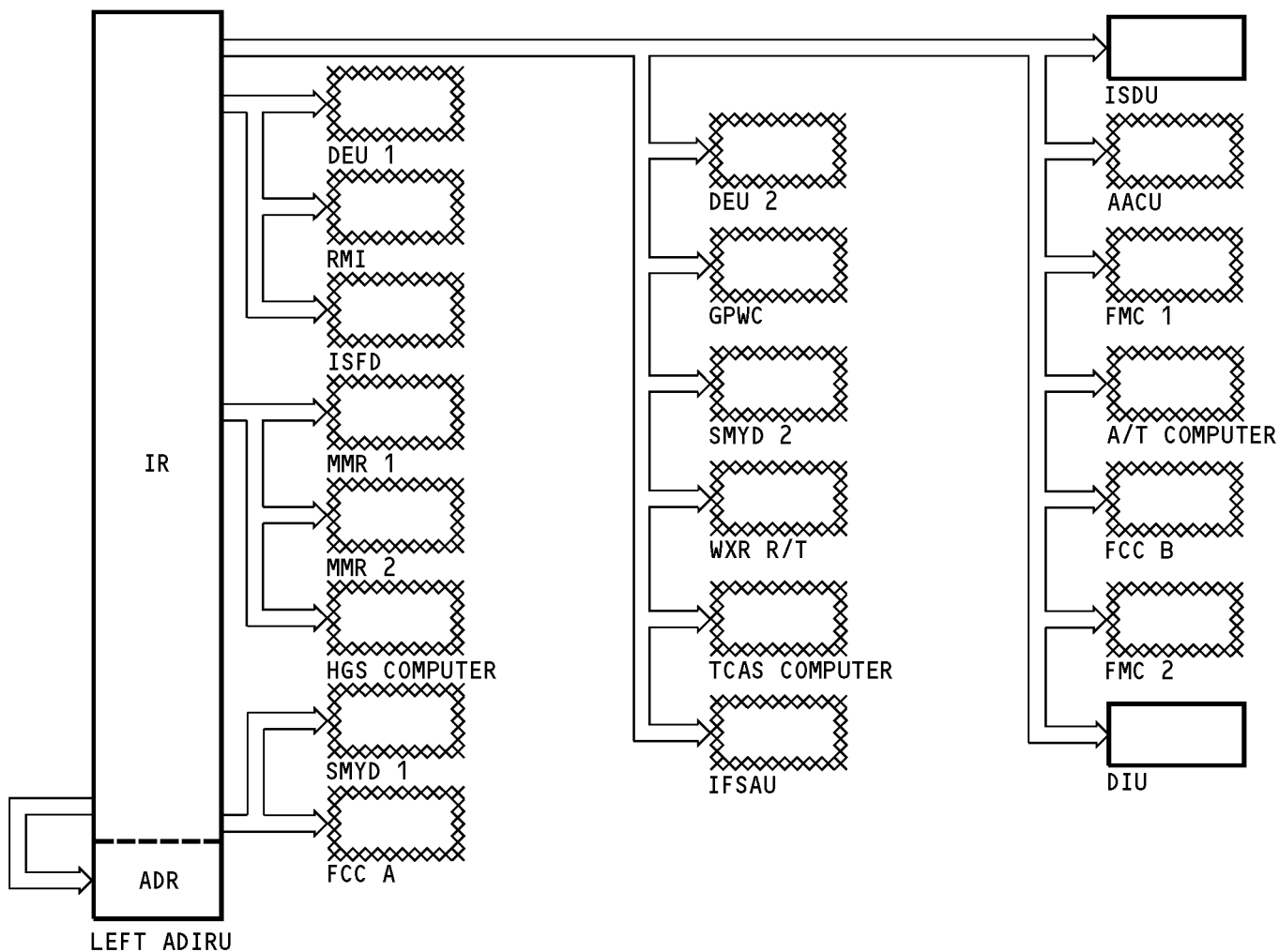

ADIRS - LEFT INERTIAL REFERENCE DIGITAL OUTPUTS

34-21-00-010

EFFECTIVITY
HAP 037-054, 104-999

34-21-00

D633A101-HAP

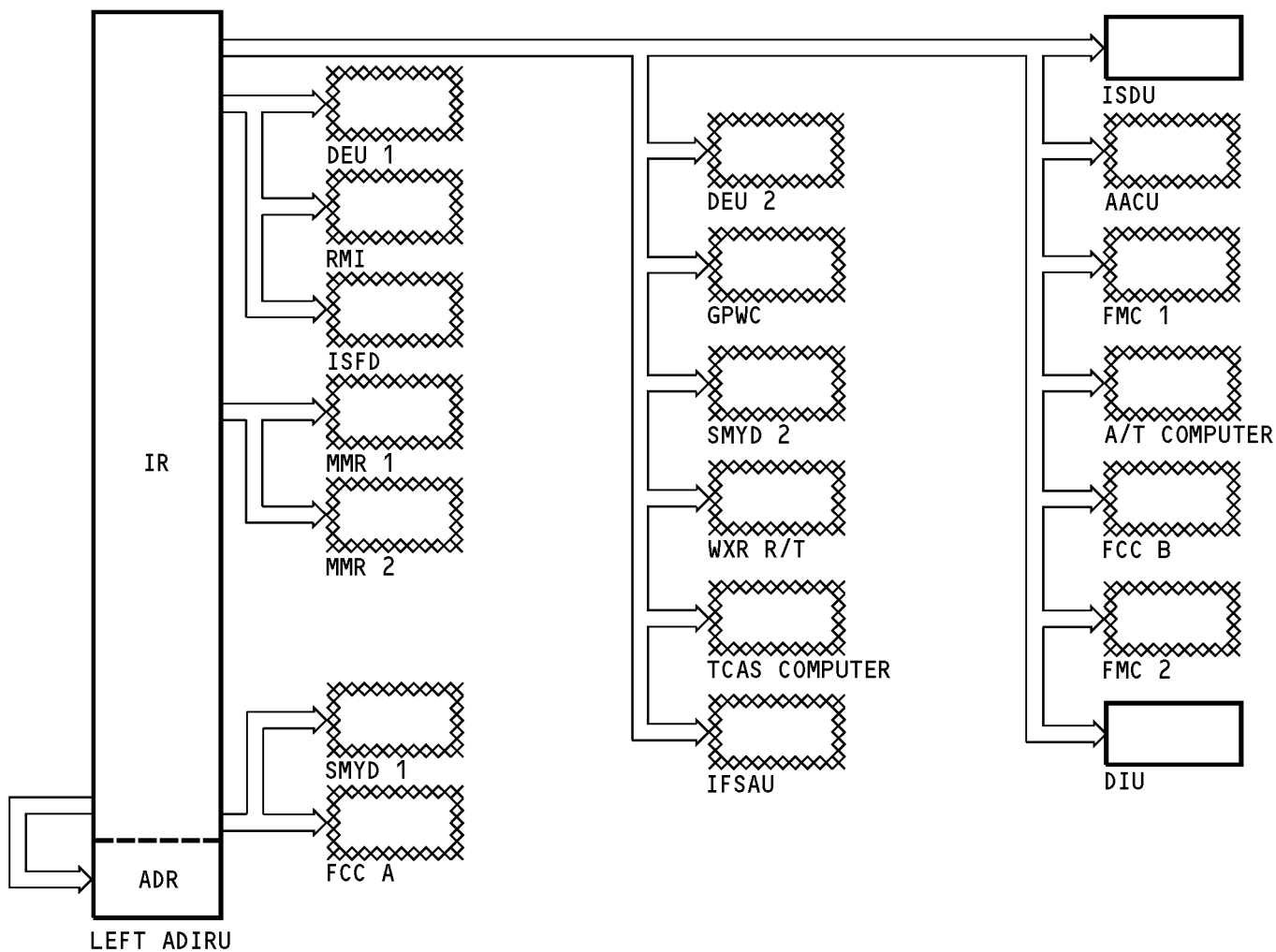

ADIRS - LEFT INERTIAL REFERENCE DIGITAL OUTPUTS

34-21-00-010

EFFECTIVITY
HAP 037-054, 104-999

34-21-00

D633A101-HAP

Page 49
Feb 15/2009

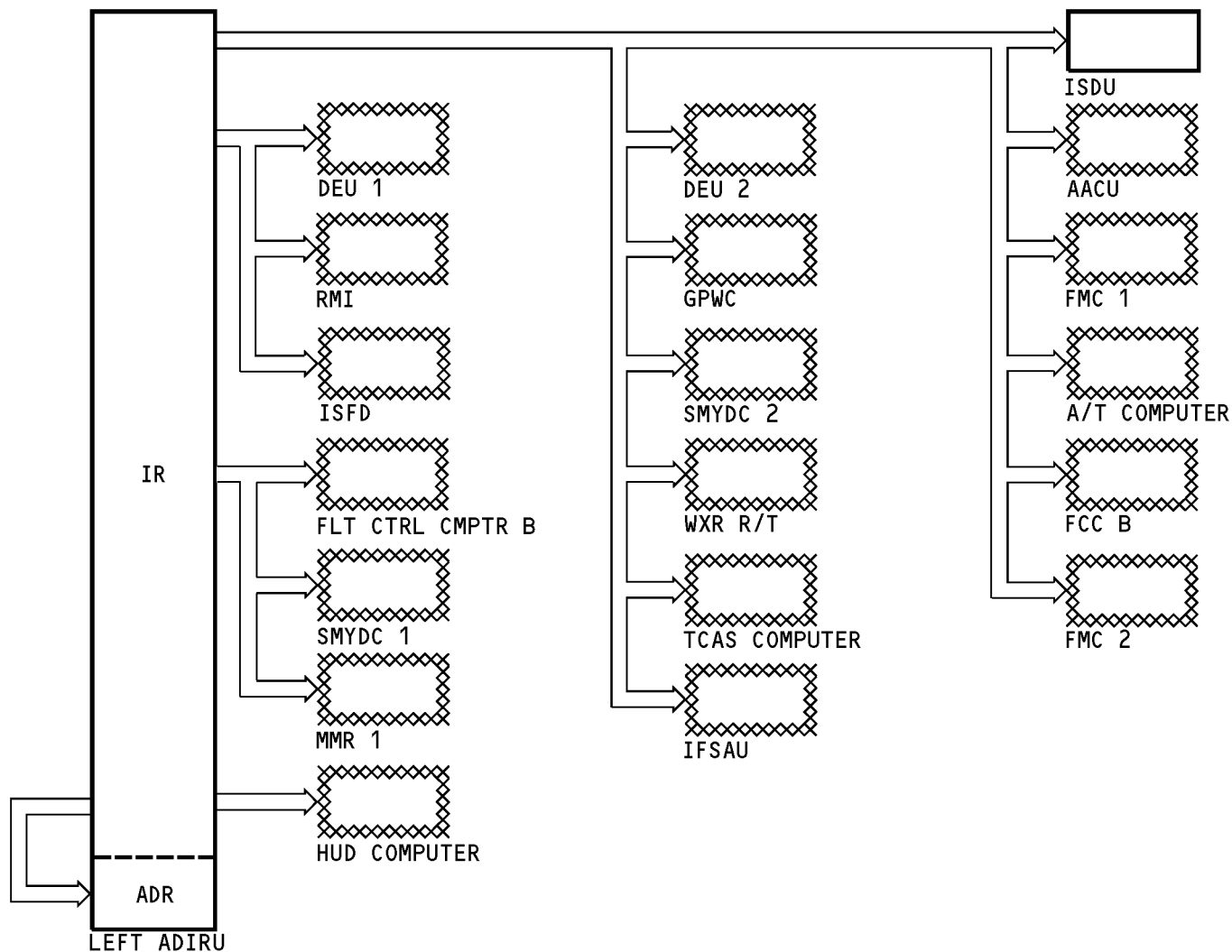

ADIRS - LEFT INERTIAL REDERENCE DIGITAL OUTPUTS

34-21-00-010

EFFECTIVITY
HAP 037

34-21-00

D633A101-HAP

Page 50
Jun 10/2007

ADIRS - RIGHT INERTIAL REFERENCE DIGITAL OUTPUTS

General

The right ADIRU supplies inertial reference (IR) data to many systems and components. IR data goes out on ARINC 429 data buses. The data on each bus is the same. One data bus goes from the IR part of the ADIRU to the air data reference (ADR) part. These are the components and systems that receive IR data from the right ADIRU:

- Display electronics unit (DEU) 1 and 2
- Radio magnetic indicator (RMI)
- Multi-mode receiver (MMR)1 and 2
- Stall management yaw damper (SMYD) 1 and 2
- Flight control computer (FCC) A and B
- Weather radar receiver transmitter (WXR R/T)
- Integrated flight systems accessory unit (IFSAU)
- Inertial system display unit (ISDU)
- Antiskid autobrake control unit (AACU)
- Autothrottle (A/T) computer

HAP 037-054, 101-999

- Flight management computer (FMC) 1 and 2.

HAP 001-013, 015-026, 028-036

- Flight management computer (FMC) 1.

HAP ALL

DEU

The DEUs use this IR data from the ADIRU to show information on the display units:

- Present position
- Track angle

- Magnetic heading
- Wind direction
- True heading
- Ground speed
- Drift angle
- Flight path angle
- Flight path acceleration
- Pitch angle
- Roll angle
- Body pitch rate
- Body roll rate
- Body yaw rate
- Body longitudinal acceleration
- Body lateral acceleration
- Body normal acceleration
- Track angle rate
- Pitch attitude rate
- Roll attitude rate
- Inertial altitude
- Along track horizontal acceleration
- Cross track horizontal acceleration
- Vertical acceleration
- Inertial vertical speed
- N-S velocity
- E-W velocity.

RMI

The RMI uses magnetic heading data to position its compass card.

34-21-00-011

<p>EFFECTIVITY HAP ALL</p>
--

34-21-00

D633A101-HAP

ADIRS - RIGHT INERTIAL REFERENCE DIGITAL OUTPUTS**MMR****HAP 001-013, 015-026, 028-036, 038-054, 101-999**

The MMRs use present position and inertial altitude for GPS calculations.

HAP 037

The MMRs use present position and inertial altitude for GPS calculations.

The GLS located inside the MMR uses these IR data.

- Latitude
- Longitude
- Ground Speed
- True Track Angle
- True Heading
- Magnetic Track Angle
- Drift Angle
- Pitch Angle
- Roll Angle
- Inertial Altitude
- Vertical Speed
- N-S Velocity
- E-W Velocity

HAP ALL**SMYDs**

SMYD 1 uses this IR data to calculate yaw damper values:

- Roll angle
- Body roll rate
- Body yaw rate
- Body lateral acceleration.

SMYD 2 uses this IR data to calculate stall management and yaw damper values:

- Pitch angle
- Roll angle
- Body roll rate
- Body yaw rate
- Body longitudinal acceleration
- Body lateral acceleration
- Body normal acceleration
- Inertial vertical speed.

DFCS

The flight control computers (FCC) use this IR data for autoflight calculations:

- Ground speed
- True track angle
- True heading
- Wind speed
- True wind direction
- Magnetic track angle
- Flight path angle
- Flight path acceleration
- Pitch angle

ADIRS - RIGHT INERTIAL REFERENCE DIGITAL OUTPUTS

- Body yaw rate
- Body longitudinal acceleration
- Body lateral acceleration
- Body normal acceleration
- Track angle rate
- Pitch attitude rate
- Roll attitude rate
- Inertial altitude
- Along track horizontal acceleration
- Cross track horizontal acceleration
- Vertical acceleration
- Inertial vertical speed.

WXR R/T

The ADIRU sends this IR data to the WXR R/T:

HAP 008-013, 015-026, 028-054, 101-999

- Groundspeed

HAP 008-011

- Magnetic track angle
- Inertial altitude
- N-S velocity
- E-W velocity

HAP ALL

- Pitch angle
- Roll angle.

HAP 008-013, 015-026, 028-054, 101-999

The WXR R/T uses this data for weather condition calculations and antenna stabilization.

HAP ALL

IFSAU

The integrated flight systems accessory unit receives all IR data and sends it to the flight data acquisition unit for recording.

ISDU

The inertial system display unit (ISDU) receives this IR data to show on the IRS display:

- Present position
- True track
- Groundspeed
- Wind speed
- Wind direction
- True heading
- Time remaining until alignment complete
- Bite messages.

AACU

The anti-skid auto-brake control unit (AACU) uses this IR data for auto-brake calculations:

- Groundspeed
- Body longitudinal acceleration

34-21-00-011

<p>EFFECTIVITY HAP ALL</p>
--

34-21-00

D633A101-HAP

ADIRS - RIGHT INERTIAL REFERENCE DIGITAL OUTPUTS

- Pitch attitude.

The FMCS uses this data for performance and navigation calculations.

A/T Computer

The ADIRU sends this IR data to the A/T computer:

- Pitch angle
- Roll angle
- Body longitudinal acceleration
- Body normal acceleration
- Groundspeed
- Inertial vertical speed.

The A/T computer uses this data for throttle command calculations.

FMCS

The ADIRU sends this IR data to the flight management computer system (FMCS):

- Present position
- Groundspeed
- True heading
- Magnetic heading
- Pitch angle
- Roll angle
- Inertial altitude
- Inertial vertical speed
- N-S velocity
- E-W velocity.

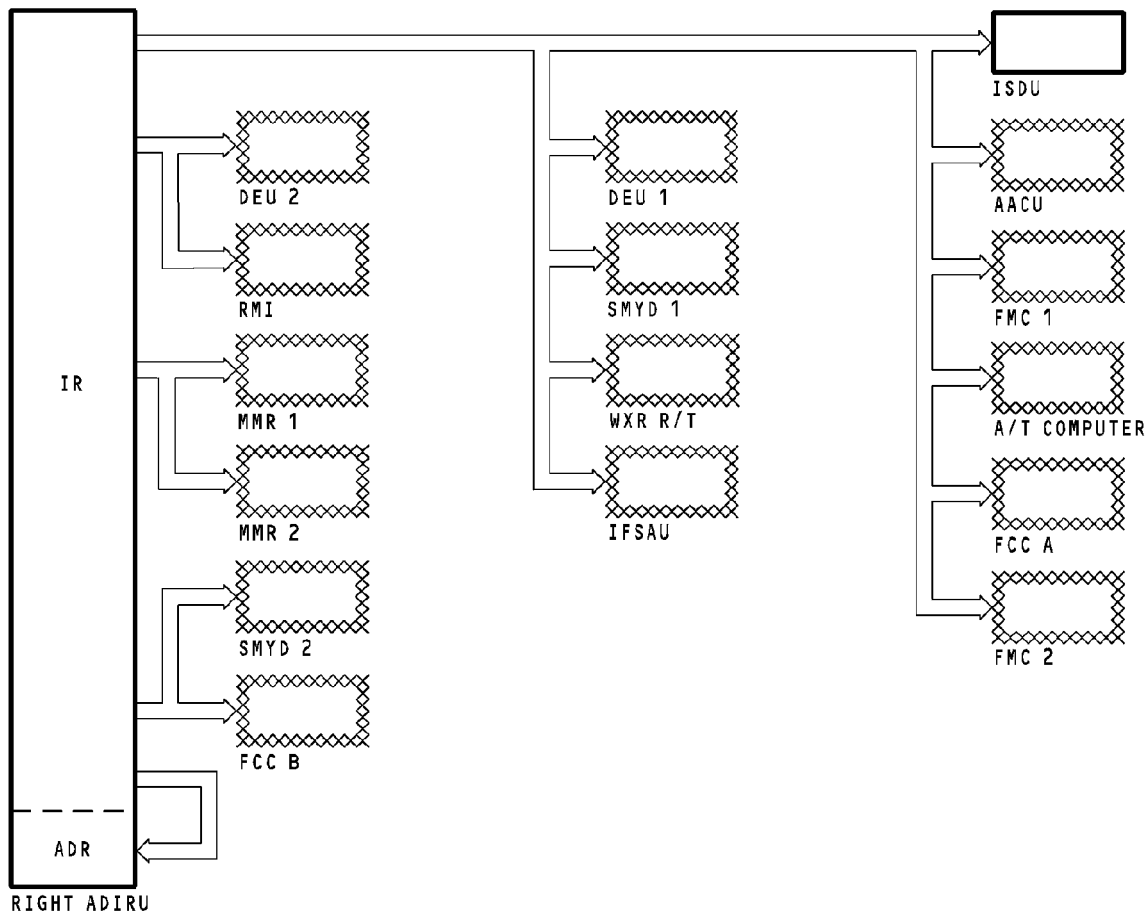

ADIRS - RIGHT INERTIAL REFERENCE DIGITAL OUTPUTS

34-21-00-011

EFFECTIVITY
HAP 037-054, 101-999

34-21-00

D633A101-HAP

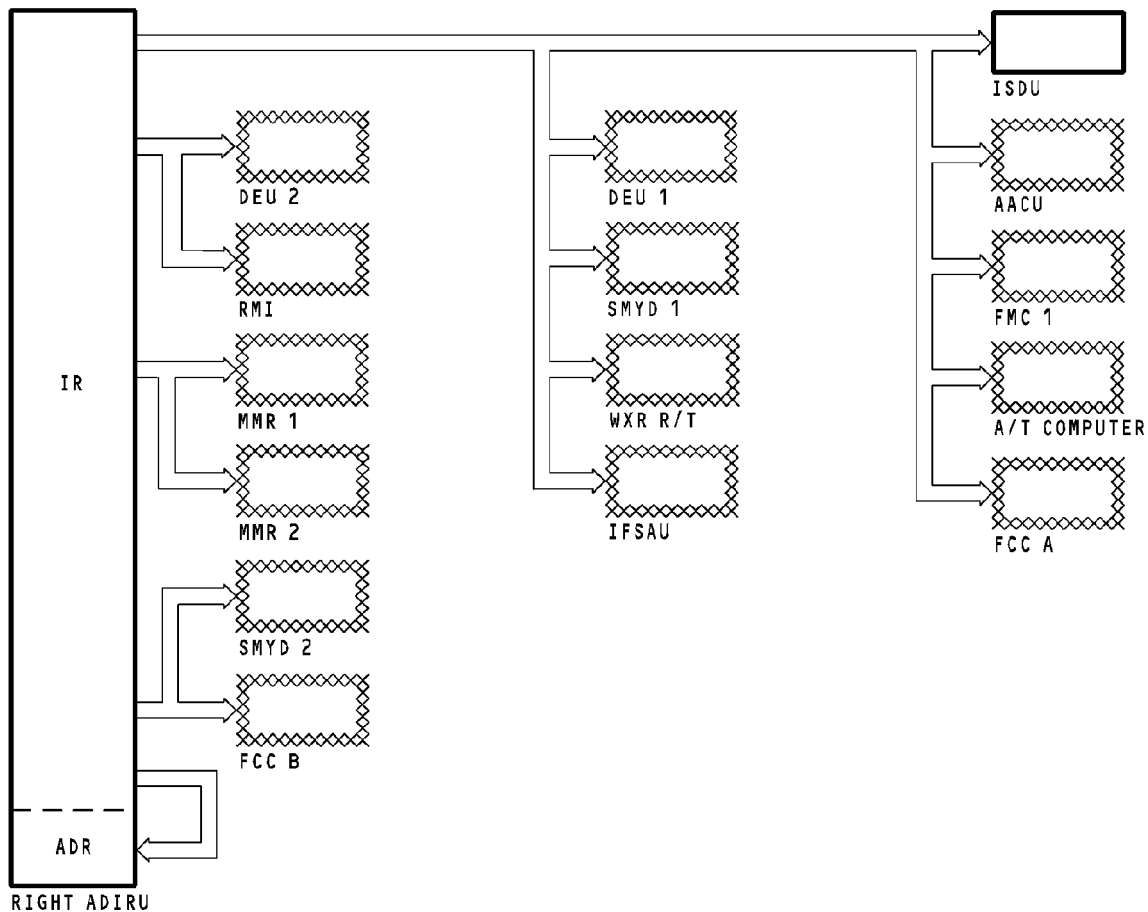

ADIRS - RIGHT INERTIAL REFERENCE DIGITAL OUTPUTS

34-21-00-011

EFFECTIVITY
HAP 001-013, 015-026, 028-036

34-21-00

D633A101-HAP

THIS PAGE IS INTENTIONALLY LEFT BLANK

34-21-00

D633A101-HAP

Page 57
Jun 10/2007

ADIRS - LEFT AIR DATA OUTPUTS

General

The left ADIRU supplies air data reference (ADR) data to many systems and components. ADR data is on ARINC 429 data buses. The data on each bus is the same. One data bus goes from the ADR section of the ADIRU to the IR section. These components and systems receive ADR data from the left ADIRU:

- Auto-throttle (A/T) computer
- Display electronics unit (DEU) 1 and 2
- Flight control computer (FCC) A
- Flight data acquisition unit (FDAU)
- Air traffic control (ATC) 1 and 2
- Flap/slat electronics unit (FSEU)
- Ground proximity warning computer (GPWC)
- Stall management yaw damper (SMYD) 1
- Cabin pressure controller 1 and 2
- Weather radar receiver transmitter (WXR R/T)

HAP 001-013, 015-026, 028-054, 104-999

- Display interface unit

HAP 037-054, 101-999

- Flight management computer (FMC) 1 and 2.

HAP 001-013, 015-026, 028-036

- Flight management computer (FMC) 1.

HAP ALL

A/T Computer

The ADIRU sends this ADR data to the A/T computer for throttle command calculations:

- Computed airspeed

- True airspeed
- Maximum operating speed
- Mach
- Maximum operating mach
- Uncorrected barometric altitude
- Corrected barometric altitude
- Static air temperature
- Total air temperature
- Static pressure
- Angle of attack.

DEU

The ADIRU sends this ADR data to the DEUs:

- Computed airspeed
- Mach
- True airspeed
- Total pressure
- Corrected barometric altitude
- Uncorrected barometric altitude
- Total air temperature
- Air data discretes.

The DEU uses this data for display information and sends it on to other systems such as the electronic engine control (EEC).

FCC A

The ADIRU sends this ADR data to FCC A:

- Computed airspeed
- True airspeed

34-21-00

EFFECTIVITY
HAP ALL

D633A101-HAP

ADIRS - LEFT AIR DATA OUTPUTS

- Corrected baro altitude
- Uncorrected barometric altitude
- Altitude rate
- Static pressure
- Mach.

FCC A uses this information for automatic flight control mode calculations.

FDAU

The ADIRU sends all ADR data to the flight data acquisition unit (FDAU). The FDAU selects and formats this data and then sends it to the digital flight data recorder (DFDR) to be recorded.

ATC Transponders

The ADIRU sends uncorrected baro altitude data to the ATC transponders for altitude reporting.

FSEU

The ADIRU sends computed airspeed to the flap slat electronics unit (FSEU) for flap load relief calculations and as part of its uncommanded motion detection logic.

GPWC

The ADIRU sends this ADR data to the GPWC:

- Computed airspeed
- Altitude rate

- Corrected baro altitude
- Uncorrected baro altitude
- True airspeed.

The GPWC uses this data to detect unsafe flight conditions.

SMYD 1

The ADIRU sends this data to SMYD 1:

- Mach
- True airspeed
- Computed airspeed
- Impact pressure.

The SMYD 1 uses this data for stall management and yaw damper calculations.

CPC

The ADIRU sends this ADR data to cabin pressure controller (CPC) 1 and 2 to calculate pressurization values:

- Corrected baro altitude
- Uncorrected baro altitude
- Static pressure.

WXR R/T**HAP 001-007**

The ADIRU sends true airspeed data to the WXR R/T for turbulence and ground clutter detection.

ADIRS - LEFT AIR DATA OUTPUTS**HAP 001-007 (Continued)**

- Total air temperature
- Static air temperature.

HAP 008-013, 015-026, 028-054, 101-999

The ADIRU sends this ADR data to the WXR R/T:

- Uncorrected baro altitude
- Corrected baro altitude
- True airspeed
- Computed airspeed.

The WXR R/T uses this data for weather condition determination.

The FMCS uses this data for performance calculations.

HAP 001-013, 015-026, 028-054, 104-999**DIU**

The ADIRU sends airspeed and altitude data to the passenger entertainment system DIU for display.

HAP ALL**FMCS**

The ADIRU sends this ADR data to the FMCS:

- Computed airspeed
- True airspeed
- Mach
- Corrected baro altitude
- Uncorrected baro altitude

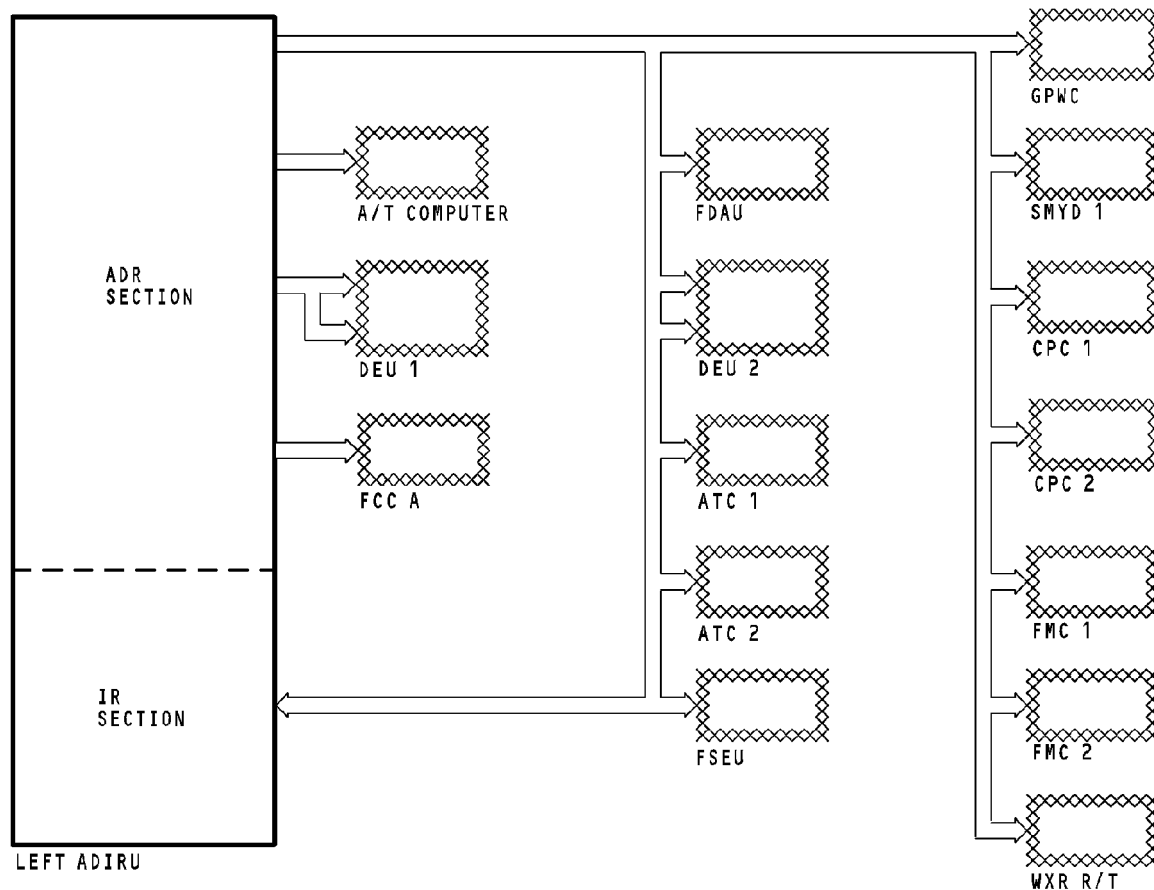

ADIRS - LEFT AIR DATA OUTPUTS

34-21-00-012

EFFECTIVITY
HAP 037, 039, 040, 101-103

34-21-00

D633A101-HAP

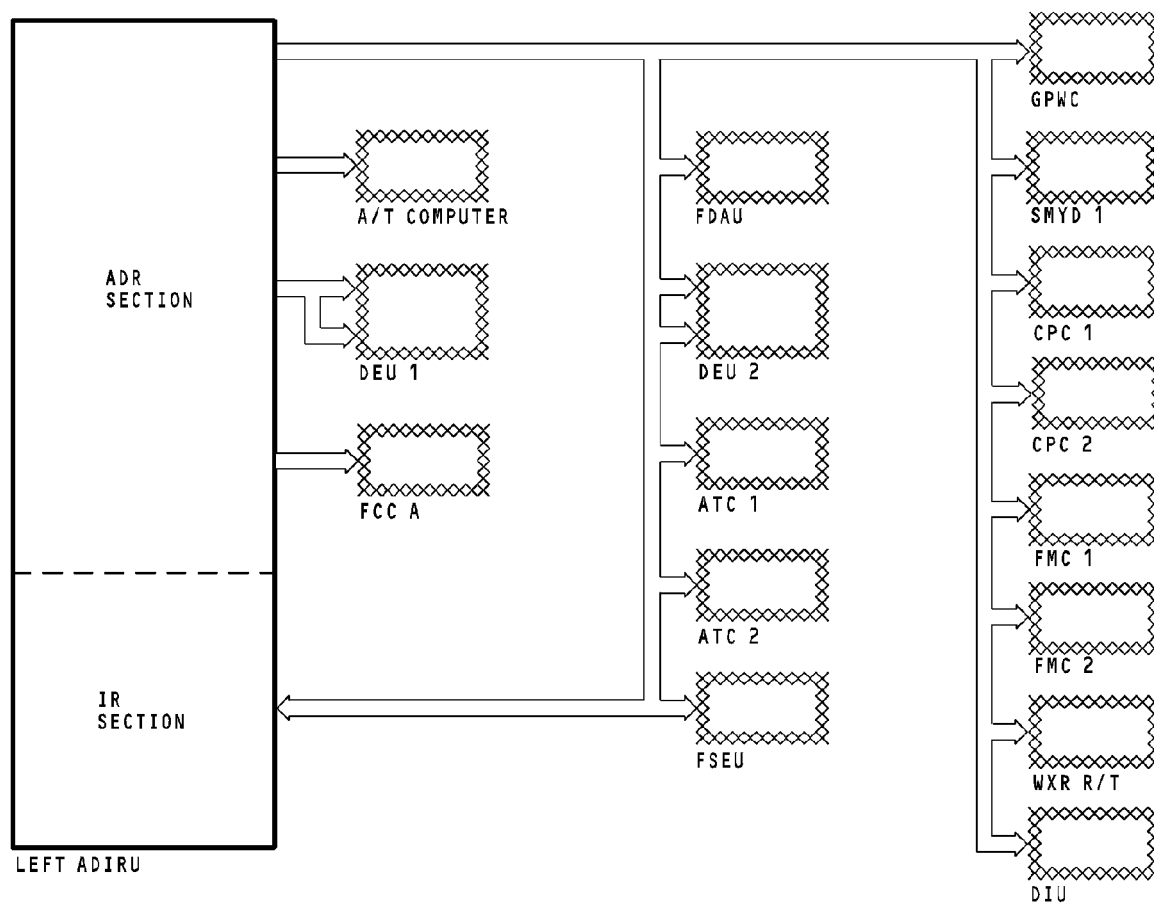

ADIRS - LEFT AIR DATA OUTPUTS

EFFECTIVITY

HAP 038, 041-054, 104-999

34-21-00

D633A101-HAP

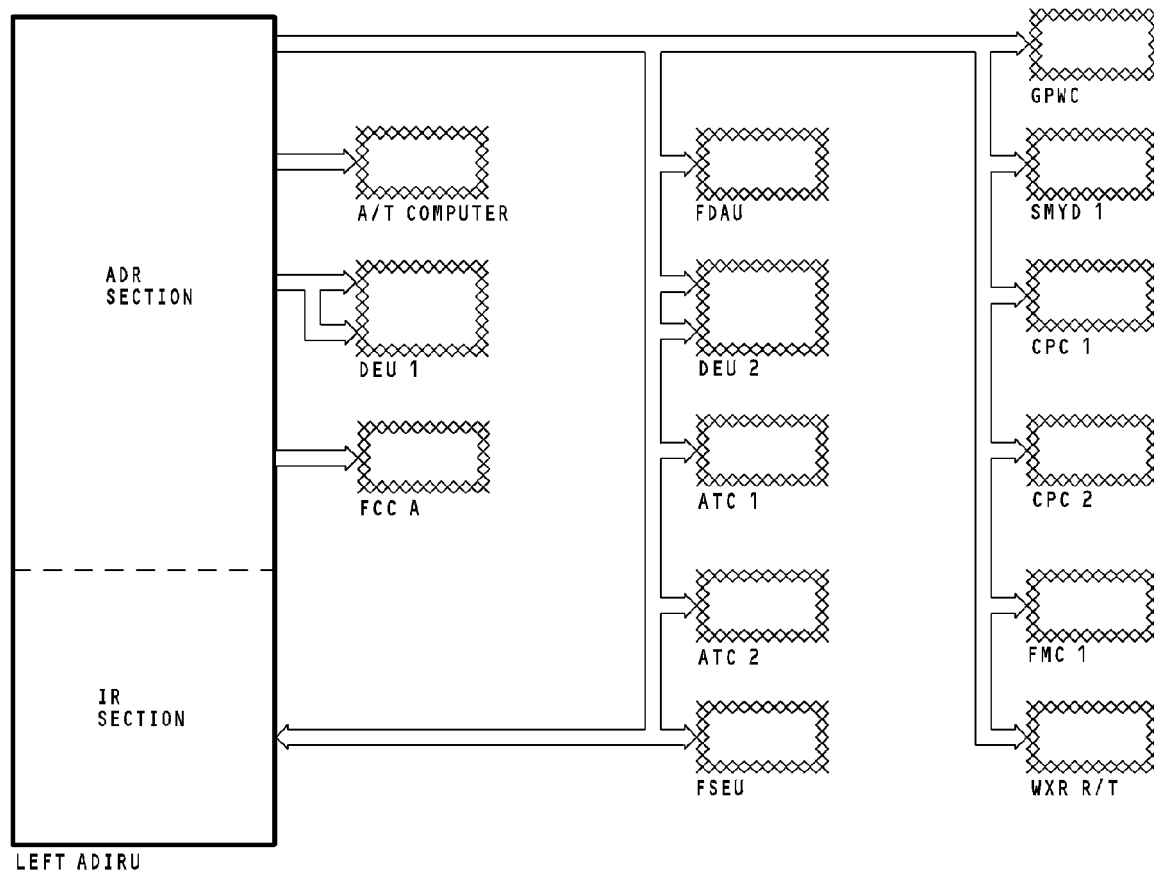

ADIRS - LEFT AIR DATA OUTPUTS

34-21-00-012

EFFECTIVITY
HAP 031-036

34-21-00

D633A101-HAP

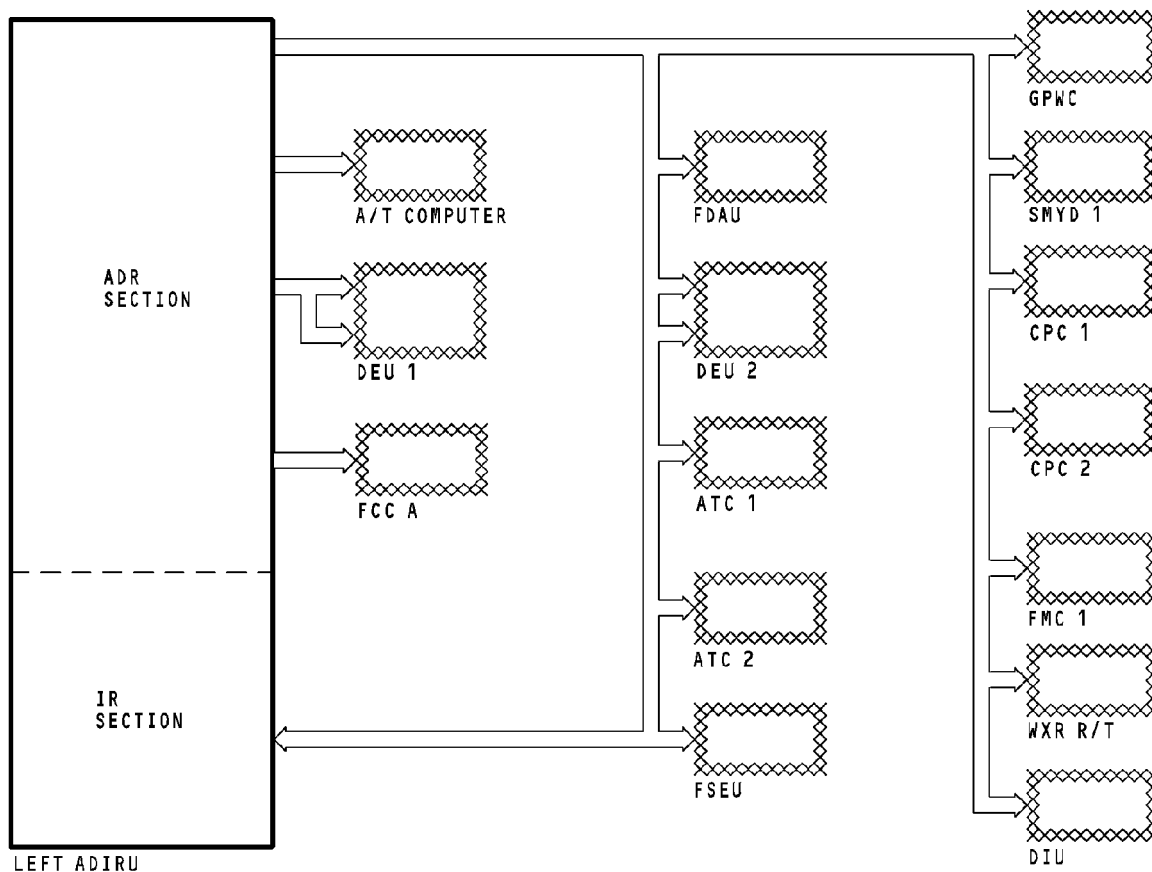

ADIRS - LEFT AIR DATA OUTPUTS

34-21-00-012

EFFECTIVITY
HAP 001-013, 015-026, 028-030

34-21-00

D633A101-HAP

THIS PAGE IS INTENTIONALLY LEFT BLANK

34-21-00

D633A101-HAP

Page 65
Jun 10/2007

ADIRS - RIGHT AIR DATA OUTPUTS

General

The right ADIRU supplies air data reference (ADR) data to many systems and components. ADR data is on ARINC 429 data buses. The data on each bus is the same. One data bus goes from the ADR section of the ADIRU to the IR section. These components and systems receive ADR data from the right ADIRU:

- Autothrottle (A/T) computer
- Display electronics unit (DEU) 1 and 2
- Flight control computer (FCC) B
- Air traffic control (ATC) 1 and 2
- Stall management yaw damper (SMYD) 2
- Cabin pressure controller 1 and 2
- Weather radar receiver transmitter (WXR R/T)

HAP 037-054, 101-999

- Flight management computer (FMC) 1 and 2.

HAP 001-013, 015-026, 028-036

- Flight management computer (FMC) 1.

HAP ALL

A/T Computer

The ADIRU sends this ADR data to the A/T computer for throttle command calculations:

- Computed airspeed
- True airspeed
- Maximum operating speed
- Mach
- Maximum operating mach

- Uncorrected barometric altitude
- Corrected barometric altitude
- Static air temperature
- Total air temperature
- Static pressure
- Angle of attack.

DEU

The ADIRU sends this ADR data to the DEUs:

- Computed airspeed
- Mach
- True airspeed
- Total pressure
- Corrected barometric altitude
- Uncorrected barometric altitude
- Total air temperature
- Air data discretes.

The DEUs use this data for display information and sends it on to other systems such as the electronic engine control (EEC).

FCC B

The ADIRU sends this ADR data to FCC B:

- Computed airspeed
- True airspeed
- Corrected baro altitude
- Uncorrected barometric altitude
- Altitude rate
- Static pressure

EFFECTIVITY
HAP ALL

34-21-00

D633A101-HAP

ADIRS - RIGHT AIR DATA OUTPUTS

- Mach.

FCC B uses this information for automatic flight control mode calculations.

ATC Transponders

The ADIRU sends uncorrected baro altitude data to the ATC transponders for altitude reporting.

SMYD 2

The ADIRU sends this data to SMYD 2:

- Mach
- True airspeed
- Computed airspeed
- Impact pressure.

The SMYD 2 uses this data for stall management and yaw damper calculations.

CPC

The ADIRU sends this ADR data to cabin pressure controller (CPC) 1 and 2 to calculate pressurization values:

- Corrected baro altitude
- Uncorrected baro altitude
- Static pressure.

WXR R/T

HAP 001-007

The ADIRU sends true airspeed data to the WXR R/T for turbulence and ground clutter detection.

HAP 008-013, 015-026, 028-054, 101-999

The ADIRU sends this ADR data to the WXR R/T:

- Uncorrected baro altitude
- Corrected baro altitude
- True airspeed
- Computed airspeed.

The WXR R/T uses this data for weather condition determination.

HAP ALL

FMCS

The ADIRU sends this ADR data to the FMCS:

- Computed airspeed
- True airspeed
- Mach
- Corrected baro altitude
- Uncorrected baro altitude
- Total air temperature
- Static air temperature.



ADIRS - RIGHT AIR DATA OUTPUTS

The FMCS uses this data for performance and guidance calculations.

34-21-00-013

EFFECTIVITY
HAP ALL

34-21-00

D633A101-HAP

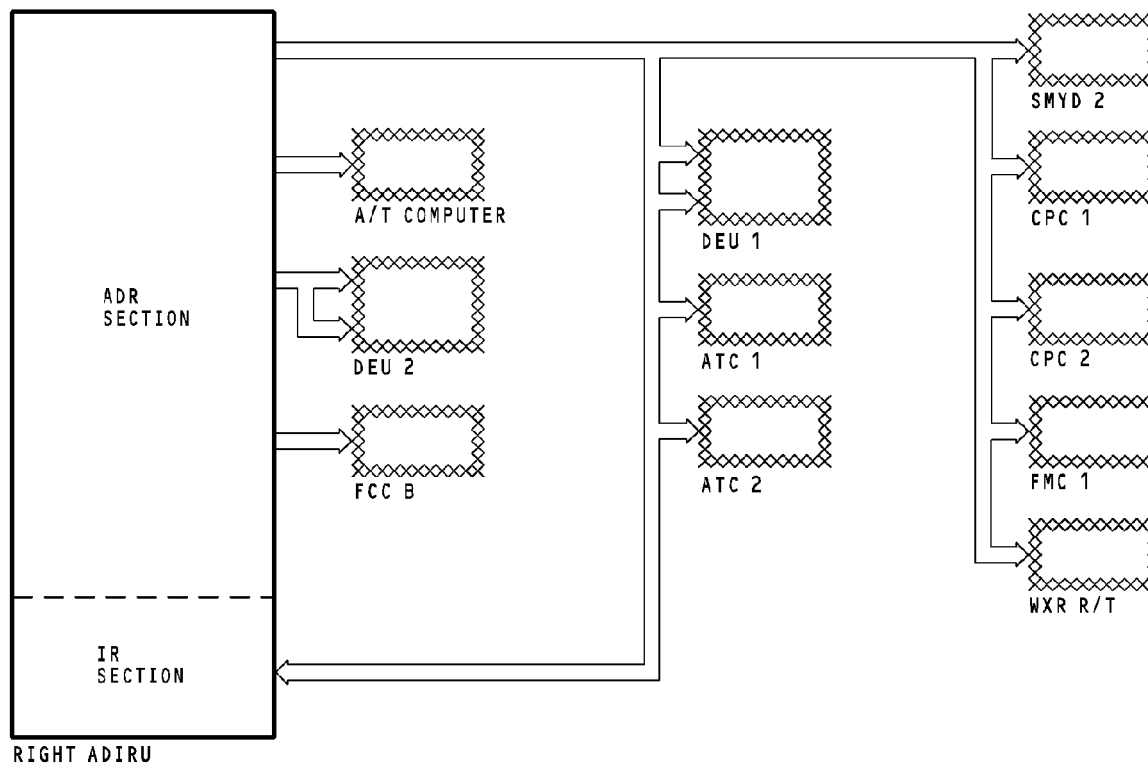

ADIRS - RIGHT AIR DATA OUTPUTS

34-21-00-013

EFFECTIVITY
HAP 001-013, 015-026, 028-036

34-21-00

D633A101-HAP

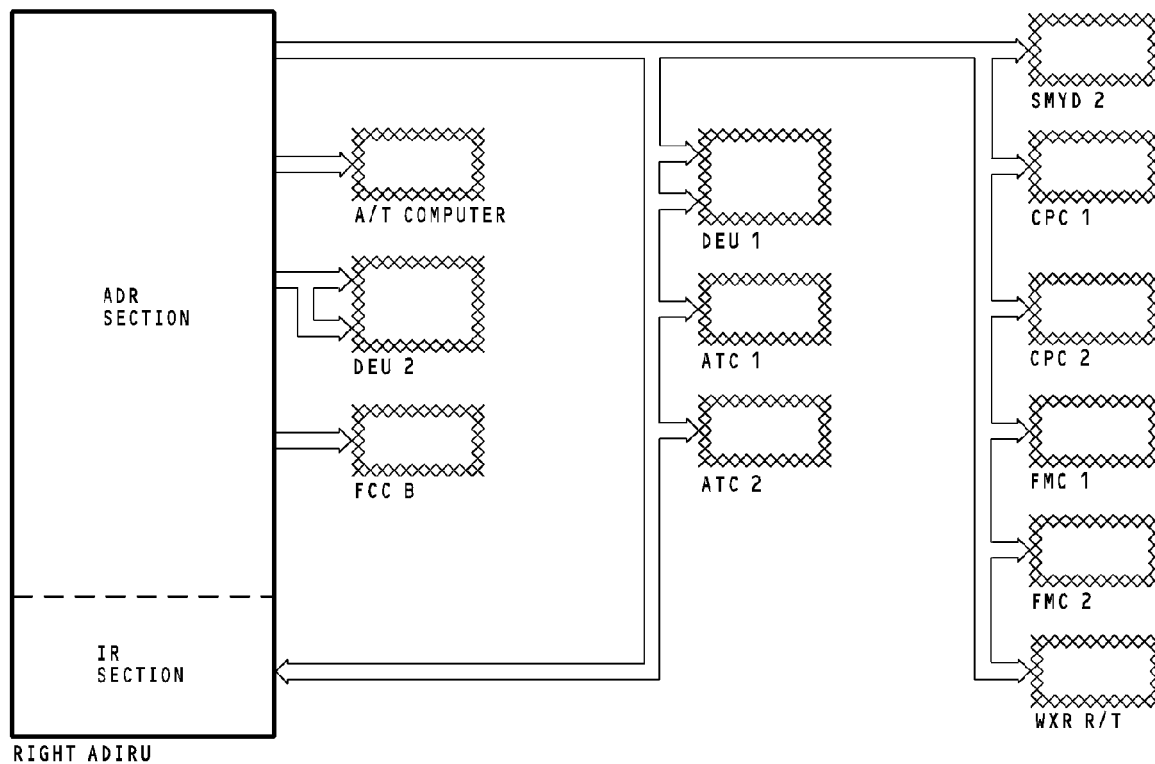

ADIRS - RIGHT AIR DATA OUTPUTS

EFFECTIVITY
HAP 037-054, 101-999

34-21-00

D633A101-HAP

THIS PAGE IS INTENTIONALLY LEFT BLANK

34-21-00

D633A101-HAP

Page 71
Jun 10/2007

ADIRS - IR SIGNAL SWITCHING

General

The IRS transfer switch on the instrument switching module selects the ADIRU to supply inertial reference (IR) data to components and systems. The IRS transfer switch does not affect air data reference (ADR) signals.

IRS Transfer Switch

The IRS transfer switch is a three-position switch. These are the three positions:

- Normal
- Both on L
- Both on R.

The normal position sends discrete signals that tell the components to use their usual source of IR data.

The BOTH ON L and BOTH ON R switch positions tell the components to use only left IR data or only right IR data.

The CDS display electronics units (DEUs) cause the INSTR SWITCH message to show on the display units when the IRS transfer switch is in the BOTH ON L or BOTH ON R position.

IFSAU Relay

The position of a relay in the integrated flight systems accessory unit (IFSAU) sets the source of IR data to the flight data acquisition unit (FDAU). The usual source of IR data is the left ADIRU. Set the IRS transfer switch to BOTH ON R to energize the relay in the IFSAU. The energized relay sets the IR data source to the right ADIRU.

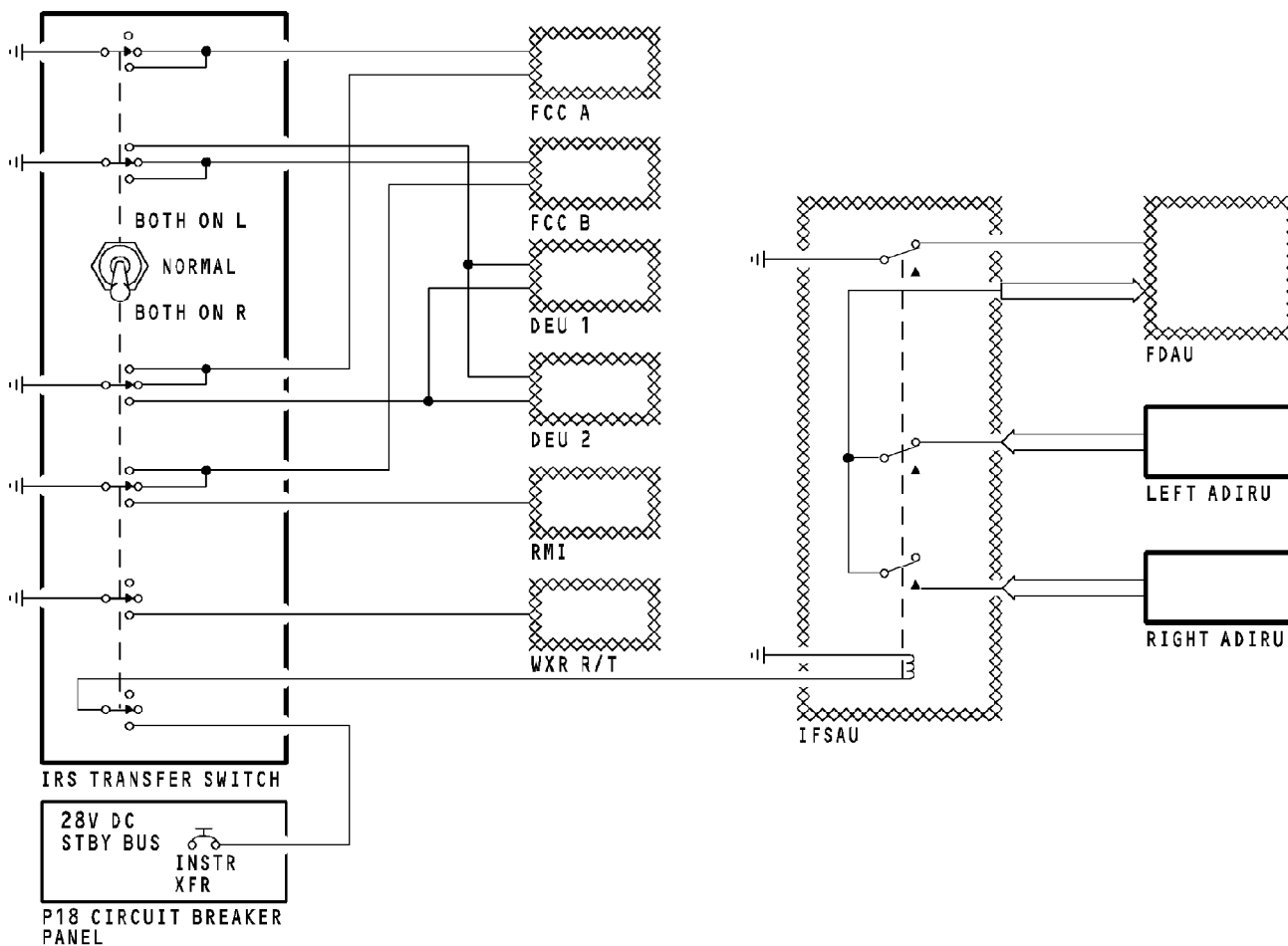

ADIRS - IR SIGNAL SWITCHING

34-21-00-014

EFFECTIVITY
HAP ALL

34-21-00

D633A101-HAP

Page 73
Jun 10/2007

ADIRS - AIR DATA INERTIAL REFERENCE UNIT**General**

The air data inertial reference unit (ADIRU) has two functions:

- Air data reference (ADR) calculations
- Inertial reference (IR) calculations.

The ADIRU has three parts. These are the three parts:

- Power supply
- Air data
- Inertial reference.

Physical Properties

These are the physical properties of the ADIRU:

- Length - 15.12 inches
- Width - 4.88 inches
- Height - 7.64 inches
- Weight - 28 pounds
- Power - 69 watts AC, 64 watts DC steady state.

Power Supply

The power supply is the only part of the ADIRU used by both the ADR function and the IR function. The power supply receives 115v ac and 28v dc from the airplane buses and supplies operating voltages to the ADR and IR.

Air Data Reference

The ADR function receives digital inputs of pitot and static pressure from the air data modules and temperature inputs from the total air temperature probe. It uses these inputs to calculate the air data parameters. It also receives analog inputs from the AOA vane for error correction.

Inertial Reference

The inertial reference function has three accelerometers and three laser gyros which sense motion and angular movements. The IR function uses these sensor signals to calculate these and other parameters:

- Airplane attitude
- Heading
- Acceleration
- Position.

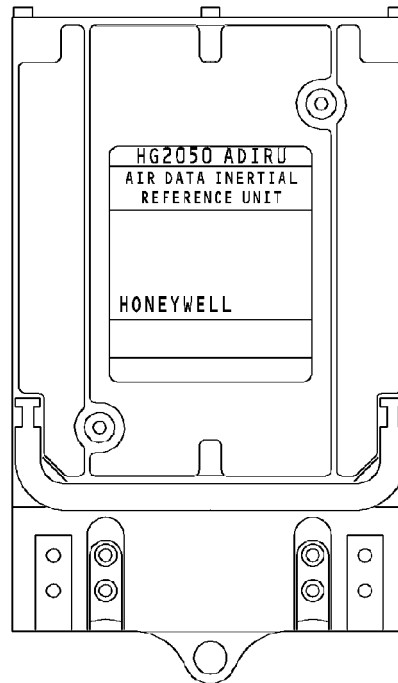

ADIRS - AIR DATA INERTIAL REFERENCE UNIT

34-21-00-017

EFFECTIVITY
HAP ALL

34-21-00

D633A101-HAP

ADIRS - INERTIAL SYSTEM DISPLAY UNIT**Purpose**

The inertial system display unit (ISDU) has an interface with the ADIRUs. You can send digital data to the ADIRUs and show digital information and maintenance information from the ADIRUs.

Physical Properties

These are the properties of the ISDU:

- Height - 4.5 inches
- Width - 5.75 inches
- Depth - 5.25 inches
- Weight - 3.7 pounds
- Power - 11 watts steady state.

Features

Use the keyboard on the front panel to enter latitude, longitude, and heading data.

The SYS DSPL switch selects left or right ADIRU data to show on the IRS display.

The IRS display is a 13-character display that can show numbers and the letters N, S, E, and W. The characters are incandescent filaments. Each character is line replaceable.

The DSPL SEL switch selects the data to show from the ADIRU. The DSPL SEL switch has these positions:

- TEST
- TK/GS (track/ground speed)
- PPOS (present position)
- WIND (wind speed/wind direction)
- HDG/STS (heading/status).

A BRT control is on the center of the DSPL SEL switch. Use the BRT control to adjust the brightness of the ISDU display and back lights.

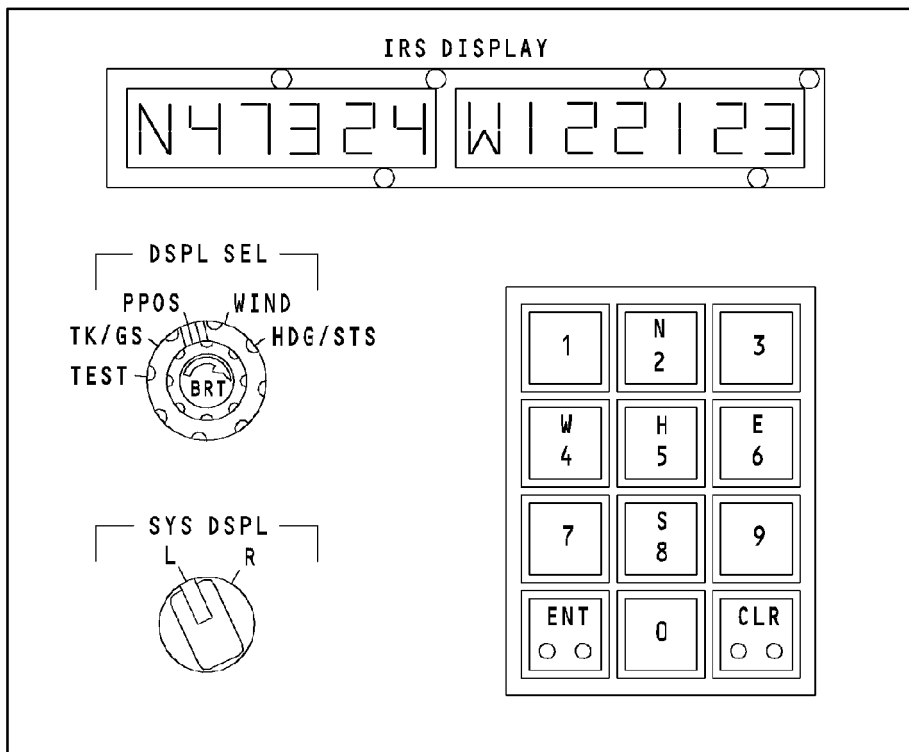

ADIRS - INERTIAL SYSTEM DISPLAY UNIT

34-21-00-018

EFFECTIVITY
HAP ALL

34-21-00

D633A101-HAP

Page 77
Jun 10/2007

ADIRS - MODE SELECT UNIT**Purpose**

The mode select unit (MSU) sends IR mode selection instructions to the ADIRUs. It also gives visual indications of ADIRS operation and failures.

Physical Properties

CAUTION: SOME SWITCHES MUST BE PULLED AND THEN TURNED. IF YOU TRY TO TURN THESE SWITCHES BEFORE YOU PULL THEM, YOU CAN DAMAGE THE SWITCH.

The MSU has two mode selectors. One for the left ADIRU, and one for the right ADIRU. Each mode selector has four positions. These are the four positions:

- OFF. Causes the ADIRU not to operate
- ALIGN. Causes the ADIRU to start the alignment process
- NAV. Causes the ADIRU to enter the navigation mode after a successful alignment
- ATT. Causes the ADIRU to enter the attitude mode.

The mode selectors have a feature to decrease the risk that the flight crew will accidentally put the ADIRU in a mode that will disable its operation. When the selector is in the NAV position, the operator must pull the knob to put it in the ATT mode. When the selector is in the ALIGN position, the operator must pull the knob to put the selector in the OFF position. All other position changes do not require the operator to pull the knob.

The MSU has two sets of annunciators. One set is for the left ADIRU and one set is for the right ADIRU. Each set has these annunciators:

- ALIGN. A white annunciator that comes on steady during ADIRU alignment. The annunciator will flash when the ADIRU needs information.
- ON DC. An amber annunciator that comes on steady when the ADIRU is on the 28v dc power source.
- FAULT. An amber annunciator that comes on steady when the IR function of the ADIRU fails.
- DC FAIL. An amber annunciator that comes on steady when the DC power source is less than 18v dc.

HAP 001-013, 015-026, 028-036, 038-054, 101-999

An amber GPS annunciator on the MSU indicates a failure of the global positioning system.

HAP 037

An amber ILS annunciator on the MSU indicates a failure of the instrument landing system.

An amber GLS annunciator on the MSU indicates a failure of the global landing system.

HAP ALL

EFFECTIVITY
HAP ALL

34-21-00

D633A101-HAP

Page 78
Feb 15/2009

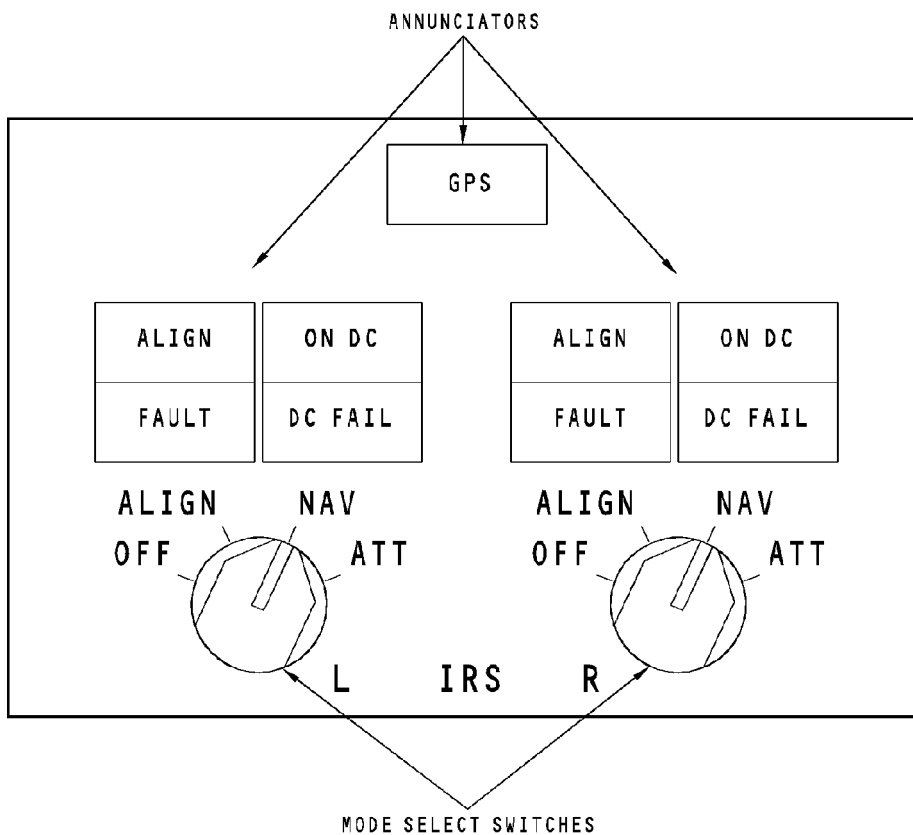

ADIRS - MODE SELECT UNIT

EFFECTIVITY

HAP 001-013, 015-026, 028-036, 038-054, 101-999

34-21-00

D633A101-HAP

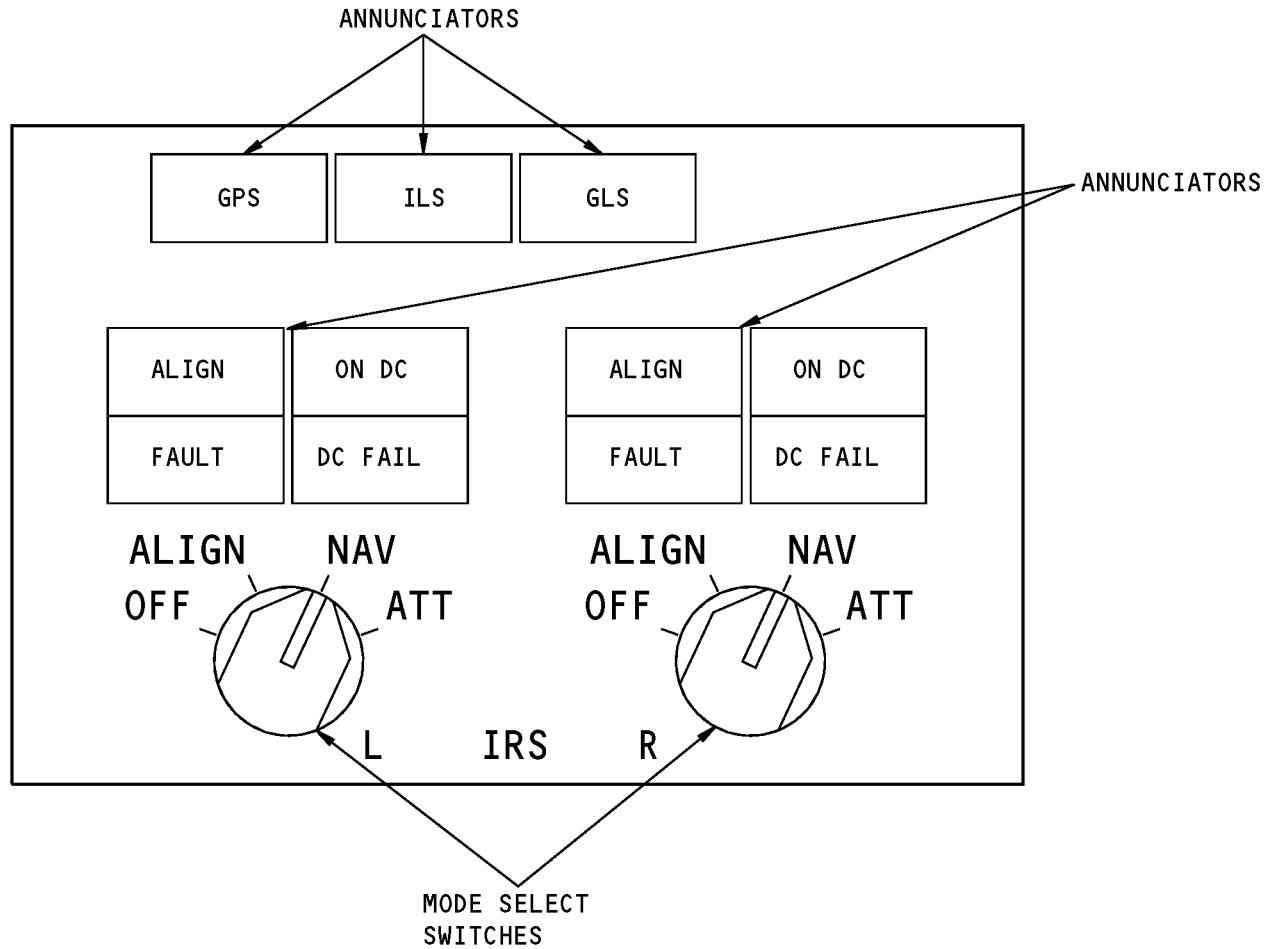

ADIRS - MODE SELECT UNIT

EFFECTIVITY
HAP 037

34-21-00

D633A101-HAP

THIS PAGE IS INTENTIONALLY LEFT BLANK

34-21-00

D633A101-HAP

Page 81
Jun 10/2007

ADIRS - IRS MASTER CAUTION UNIT

Purpose

The IRS master caution unit monitors the ADIRS for unsatisfactory conditions. It controls the IRS light on the master caution annunciator and it supplies discrete signals to the master caution lights.

Physical Properties

The IRS master caution unit contains circuit cards. The cards do these functions:

- Monitors ON DC, IR FAULT, and DC FAIL logic from the ADIRUs
- Monitors GPS status
- Controls the IRS light on the master caution annunciator.

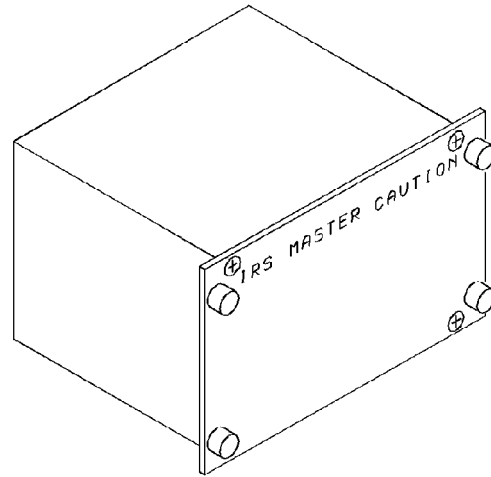

ADIRS - IRS MASTER CAUTION UNIT

34-21-00-020

EFFECTIVITY
HAP ALL

34-21-00

D633A101-HAP

ADIRS - AIR DATA MODULE**General**

The ADIRS has four air data modules (ADMs). One ADM is for each of these components:

- Captain's pitot probe
- Captain's static port
- First officer's pitot probe
- First officer's static port.

Purpose

The ADM measures air pressure and changes the measured value to ARINC 429 data. The ADM transmits the data to the ADIRU.

Physical Properties

The ADM has these dimensions:

- Height - 2.5 in (6.35 cm)
- Width - 3 in (7.62 cm)
- Length - 6 in (15.24 cm).

The ADM mounts to the airframe with the two flanges on the sides of the unit. The ADM weighs less than 2 pounds. It does not need to be cooled. The ADMs are interchangeable.

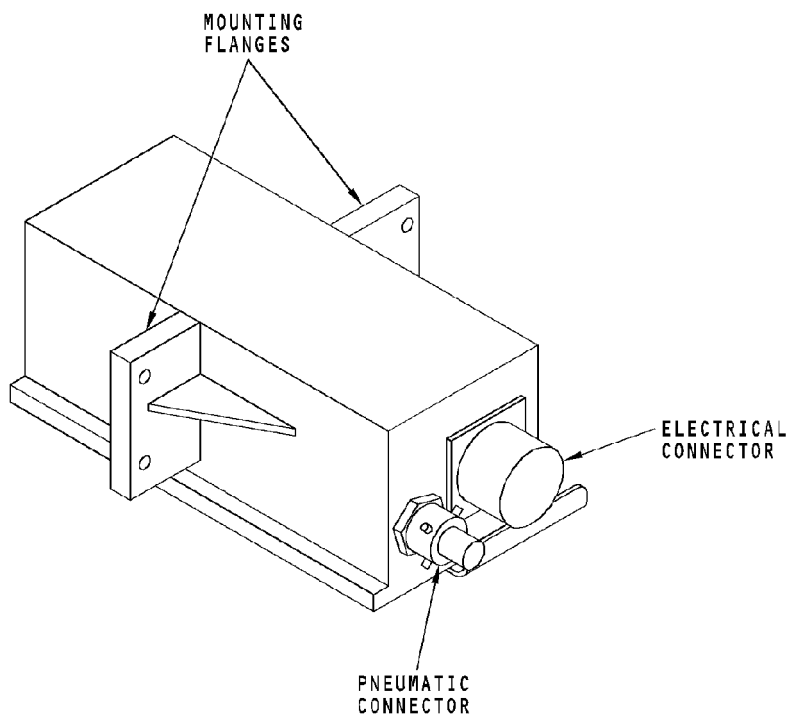

ADIRS - AIR DATA MODULE

34-21-00-021

EFFECTIVITY
HAP ALL

34-21-00

D633A101-HAP

ADIRS - ANGLE OF ATTACK SENSOR**General**

The angle of attack (AOA) sensor measures the direction of airflow relative to the fuselage.

Physical Properties

These are the physical properties of the AOA sensor:

- Length - 7.5 inches (19 cm)
- Diameter - 3.2 inches (8.1 cm)
- Weight - 2.5 pounds (1.1 kg).

Resolvers

There are two resolvers in each AOA sensor.

The AOA data from the two resolvers in the left AOA sensor go to the left ADIRU and to the stall management yaw damper (SMYD) 1. The AOA data from the two resolvers in the right AOA sensor goes to the right ADIRU and to the SMYD 2.

Electrical Connector

The angle of attack sensor has two electrical connectors. One connector receives heater power and supplies resolver 1 data to the SMYD. The other connector supplies resolver 2 data to the ADIRU.

Installation

You install the AOA sensor from the outside of the airplane.

HAP 031-054, 101-999**AOA Cross Compare**

AOA DISAGREE alert message displayed on PFD if left/right AOA disagree.

HAP ALL**Training Information Point**

There are two alignment pins on the AOA sensor. Make sure the pins fit in their holes when you install the AOA sensor.

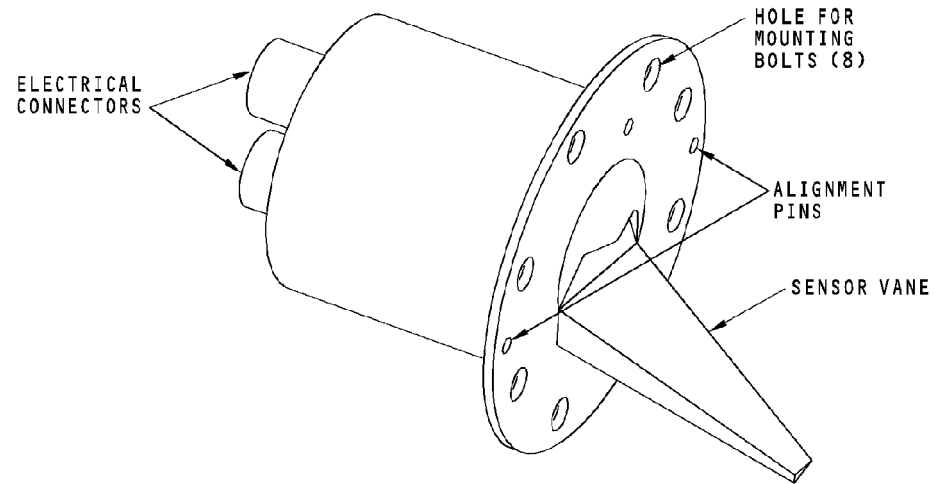

ADIRS - ANGLE OF ATTACK SENSOR

EFFECTIVITY
HAP ALL

34-21-00

D633A101-HAP

ADIRS - TOTAL AIR TEMPERATURE PROBE**General**

The total air temperature (TAT) probe measures the air temperature outside the airplane. An opening in the front of the sensor lets air flow through and around the sensing elements and exit through ports in the rear of the probe.

Sensing Elements

There are two sense elements in the TAT probe. Each sense element is a resistive element. The value of resistance changes when the temperature of the air flow across the element changes.

Electrical Connector

The analog connection to the ADIRUs and to the heater power connection comes through the electrical connector. The heater in the TAT probe prevents ice.

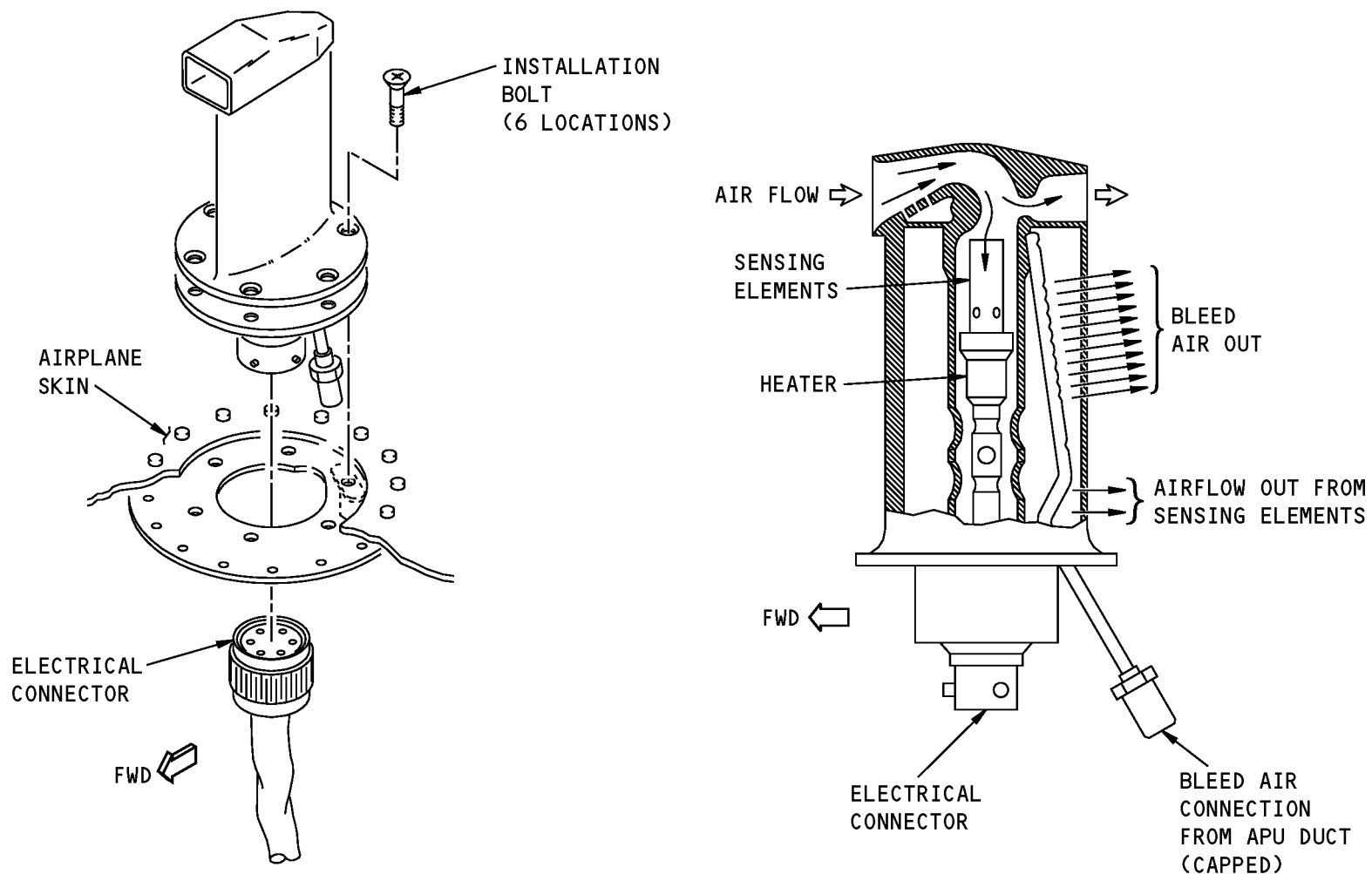

ADIRS - TOTAL AIR TEMPERATURE PROBE

34-21-00-023

EFFECTIVITY
HAP ALL

34-21-00

D633A101-HAP

Page 89
Jun 10/2007

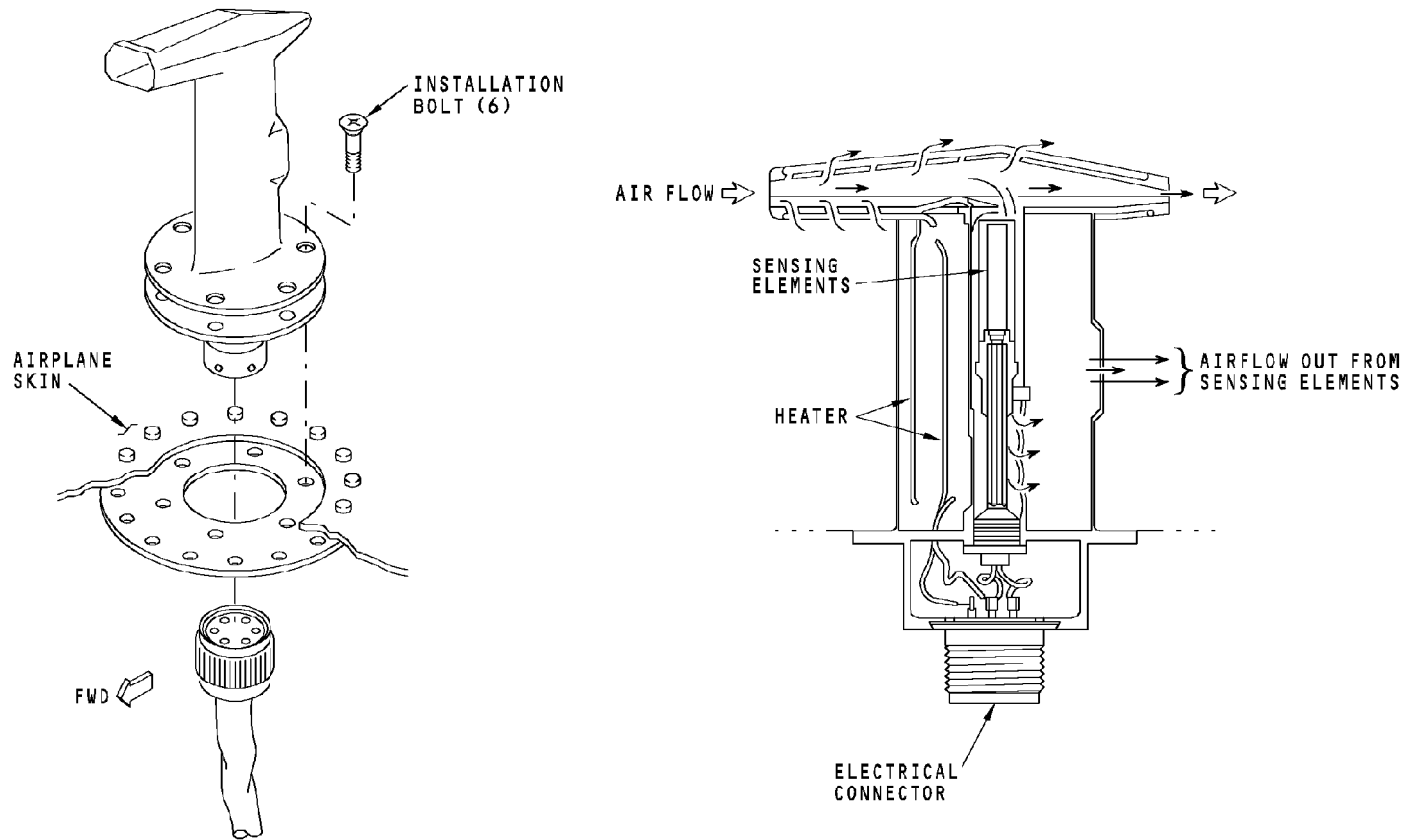

ADIRS - TOTAL AIR TEMPERATURE PROBE

EFFECTIVITY
HAP ALL

34-21-00

D633A101-HAP

THIS PAGE IS INTENTIONALLY LEFT BLANK

34-21-00

D633A101-HAP

Page 91
Jun 10/2007

I **ADIRS - ALTERNATE VMO/MMO SWITCH****ALTERNATE VMO/MMO SWITCH**

The ALTERNATE VMO/MMO get the signal from the ALTERNATE VMO/MMO SWITCH(Gear Down Dispatch Switch). The ALTERNATE VMO/MMO switch input is provided to the ADIRU. When the switch is pushed up to the ALTERNATE position, the ADIRU adjusts the Vmo/Mmo curve to compensate for a flight with the landing gear down. The ALTERNATE VMO/MMO is located in the E/E bay on the Main Equipment Center Service Panel.

ALTERNATE Vmo/Mmo
SELECT SWITCH, S1127

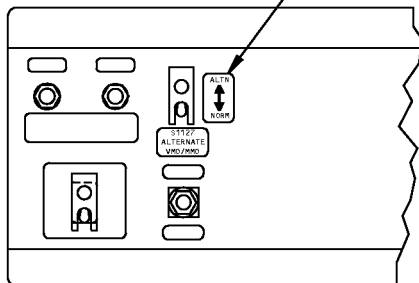

**MAIN EQUIPMENT CENTER
SERVICE PANEL**

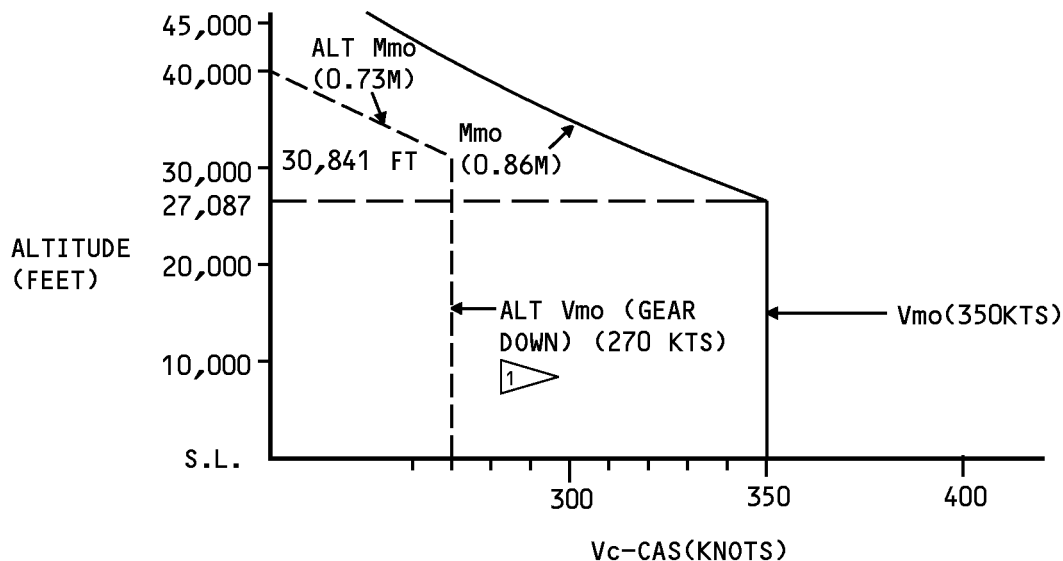

NORMAL Vmo/Mmo OVERSPEED DISCRETE ACTIVATION POINTS
 $V_c \geq 352 \pm 0.25$ KNOTS
 $M_c \geq 0.8630 \pm 0.0005$ MACH

ALTERNATE Vmo/Mmo OVERSPEED SWITCH ACTUATION POINTS

$V_c \geq 272.0 \pm 0.25$ KNOTS
 $M_c \geq 0.7330 \pm 0.0005$ MACH

Vmo = MAX OPERATING AIRSPEED
Vc = COMPUTED AIRSPEED OUTPUT, OF ACTUATION POINT, KNOTS
Mc = MACH NUMBER OUTPUT OF ACTUATION POINT
Mmo = MAX OPERATING MACH

ALTERNATE VMO/MMO SWITCH

EFFECTIVITY
HAP 031-054, 101-999

34-21-00

D633A101-HAP

Page 93
Feb 15/2009

34-21-00-077

ADIRS - IR GENERAL THEORY 1**General**

The inertial reference function of the ADIRU supplies heading and attitude information. The ADIRU calculates this information with accelerometer and laser gyro sensed data.

The ADIRU has three accelerometers and three laser gyros. The accelerometer orientation in the ADIRU is on the x, y, and z axes of the airplane. This orientation allows the ADIRU to sense accelerations in each of the three axes. The three laser gyros sense pitch, roll, and yaw rotation around the x, y, and z axes.

The accelerometers and laser gyros are in a strap-down configuration. This means that their orientation is on the x, y, and z axes of the airplane and they move with the airplane when it moves around or along the axes.

The IR processor in the ADIRU uses the sensor signals to calculate IR data.

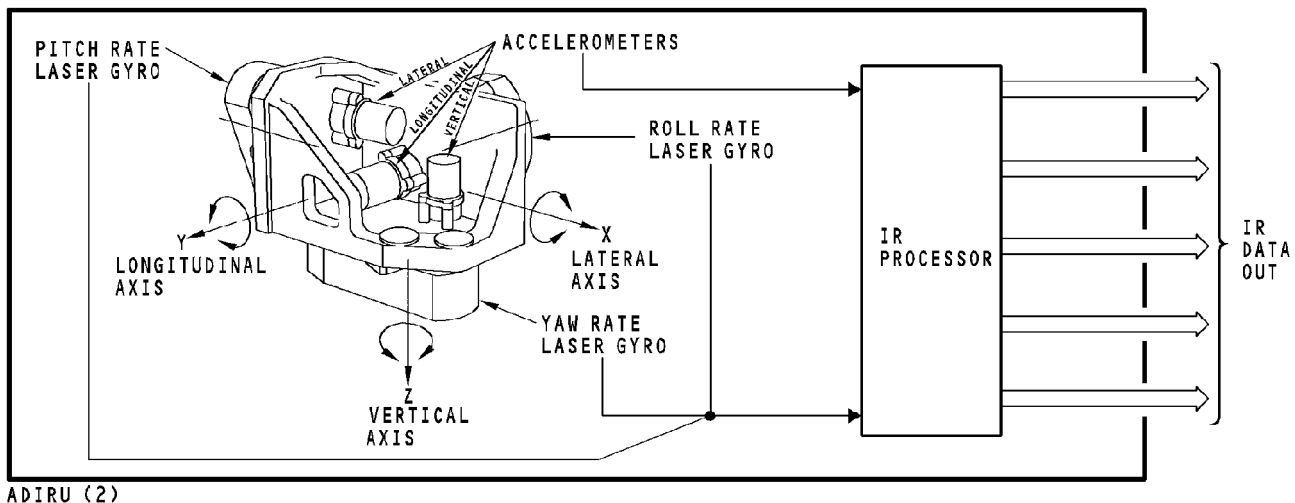
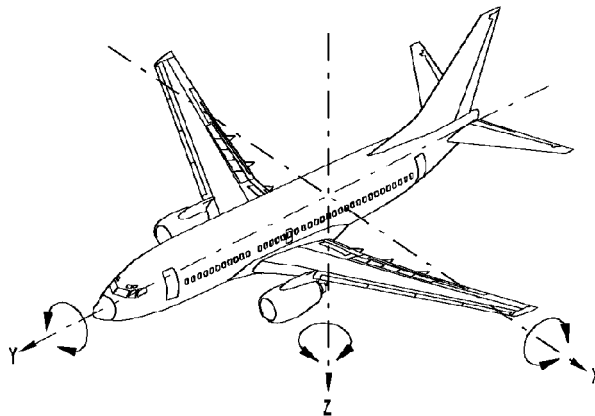

ADIRS - IR GENERAL THEORY 1

34-21-00-069

EFFECTIVITY
HAP ALL

34-21-00

D633A101-HAP

ADIRS - IR GENERAL THEORY 2

General

The ADIRU uses three accelerometers to sense motion along the x, y, and z axes. Each accelerometer senses acceleration along one axis. The accelerometer can sense very large and very small accelerations along this axis.

Each accelerometer measures acceleration along a different axis than the other two accelerometers.

Operation

The accelerometer is a mass centered in an outer case by two springs. When the airplane accelerates, the mass moves from the center and makes an electrical signal through the pickoffs. An amplifier then amplifies this signal and sends it to the recentering coil which moves the mass back to center. The amount of the signal necessary to keep the mass centered is proportional to airplane acceleration.

The IR processor integrates the feedback signal with time to calculate velocity and then integrates the calculated velocity with time to calculate distance flown.

The IR processor then adds distance flown to the initial position to calculate present position.

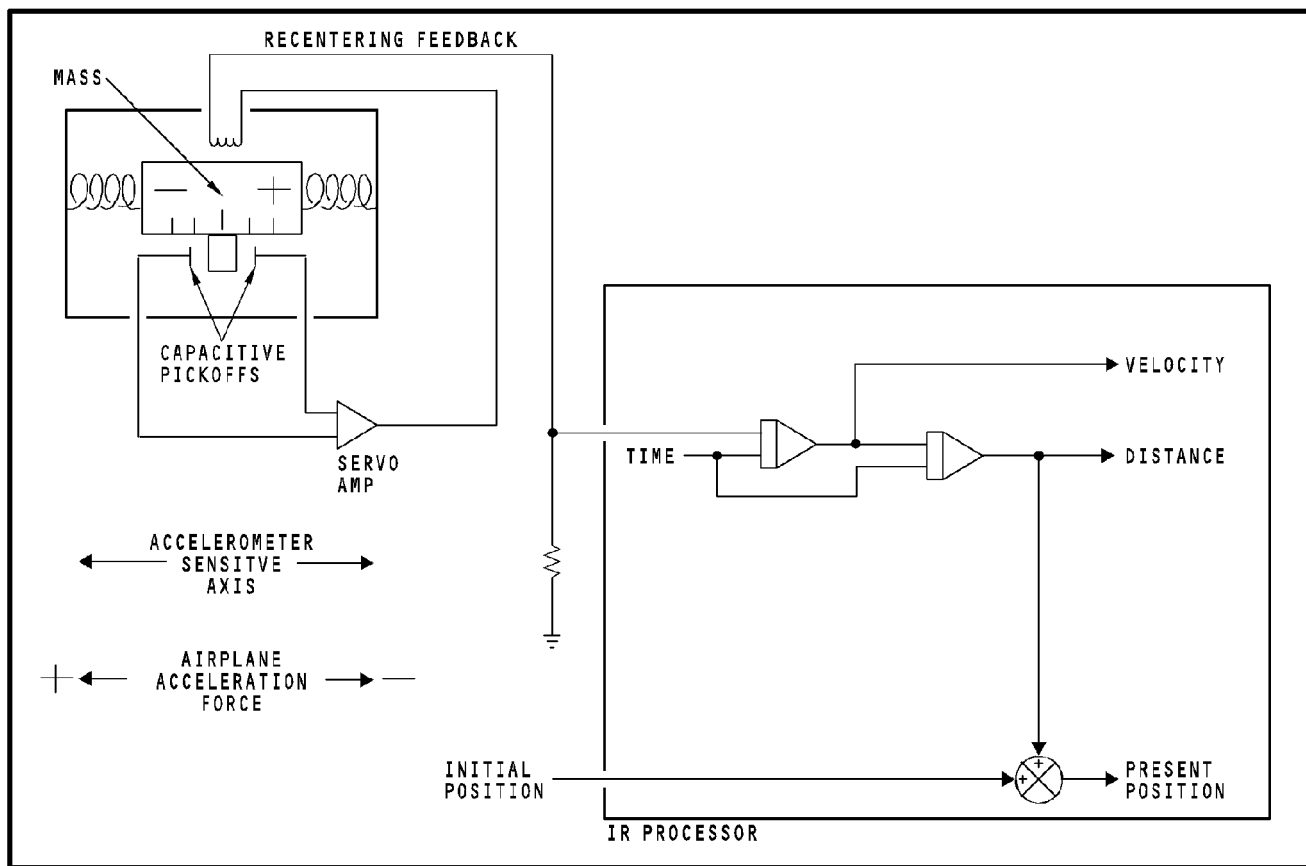

ADIRU

ADIRS - IR GENERAL THEORY 2

34-21-00

34-21-00-070

EFFECTIVITY
HAP ALL

D633A101-HAP

Page 97
Jun 10/2007

ADIRS - IR GENERAL THEORY 3

General

Each gyro is a triangular shaped, helium-neon laser that creates two light beams. One light beam travels in the clockwise direction. The other light beam travels in the counter-clockwise direction.

Laser Beam Generation

Light beam production, or lasing, occurs when a high voltage discharge between the anodes and the cathode causes ionization of a low pressure mixture of helium-neon gas in the gas discharge region of the gyro. The ionized particles in the gas discharge region begin to glow creating light. Mirrors in each corner of the triangle reflect this light around the triangle creating the clockwise and counter-clockwise light beams. One of the corners of the gyro contains a partially silvered mirror and a corner prism which lets the two light beams mix together to form a fringe pattern on the detector.

Operation

While the gyro is stationary, the fringe pattern is also stationary because the frequencies of both light beams are the same. When the gyro turns around the axis perpendicular to the lasing plane, the two light beam phases become slightly different. The phase of the two light beams are different during the turn because of the rotation rate. The difference in light beam phase causes the fringe pattern to move left or right depending on the direction of gyro movement. Photo diodes in the detector change the fringe pattern movement into a signal that is equal to the rotation rate of the gyro.

The measured rotation rate is integrated with time to calculate the attitude of the airplane.

Dither Motor

During low gyro rotation rates the two light beams can get coupled together in a condition called laser lock-in. To prevent a loss of information at low rotation rates, a piezo-electric dither motor vibrates the gyro assembly through the lock in region. The gyro sensed signals that are caused by these vibrations, are de-coupled from the gyro output to prevent errors during operation.

34-21-00-073

EFFECTIVITY
HAP ALL

34-21-00

D633A101-HAP

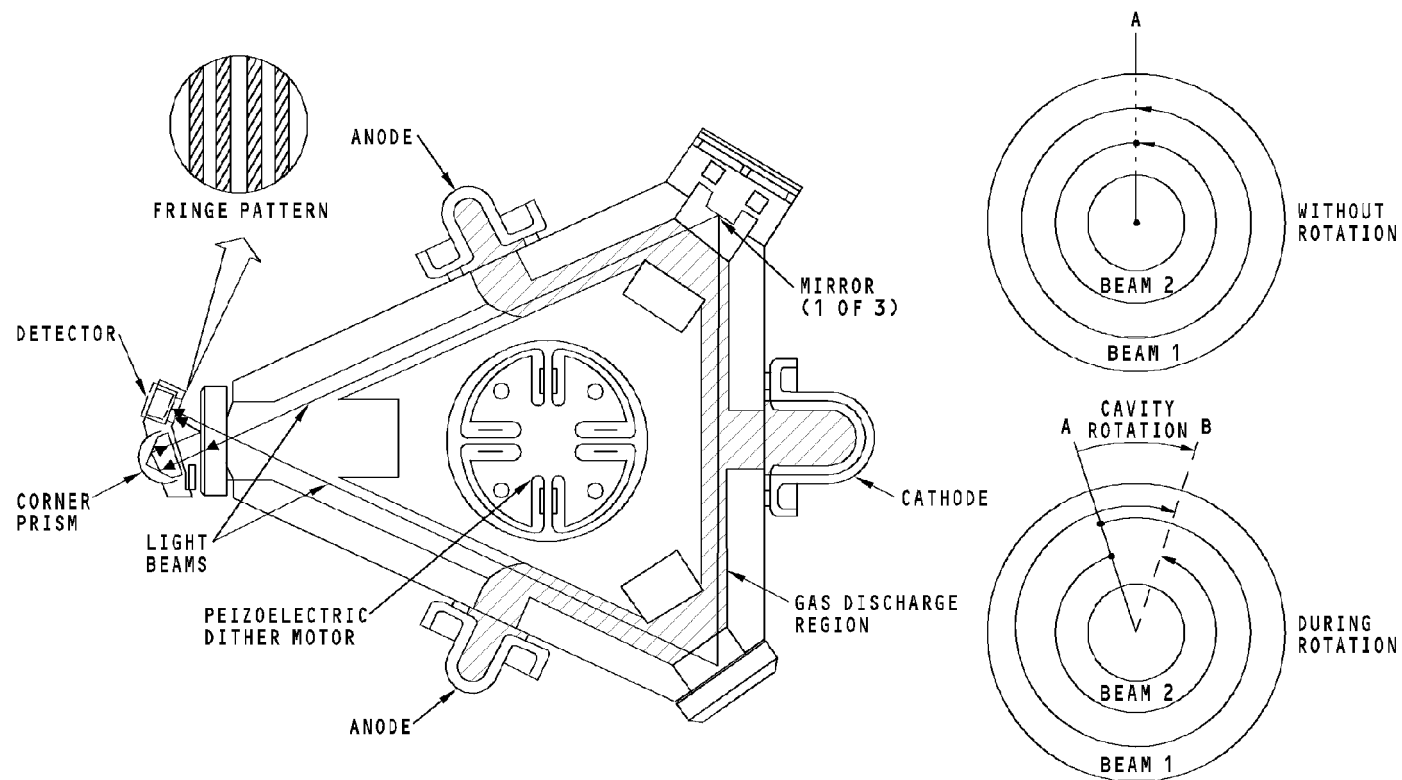

ADIRS - IR GENERAL THEORY 3

34-21-00-073

EFFECTIVITY
HAP ALL

34-21-00

D633A101-HAP

Page 98.1
Jun 10/2007

ADIRS - IR GENERAL THEORY 4

Alignment

The ADIRU uses accelerometers and gyros to sense the earth rotation rate and gravity. Earth rate and gravity are then used to calculate:

- Local vertical
- True north
- Present position latitude.

After the ADIRU has measured these values and present position (latitude and longitude) is entered, the ADIRU completes its alignment to true north and is then ready to navigate. ADIRS alignment time will vary based on local latitude.

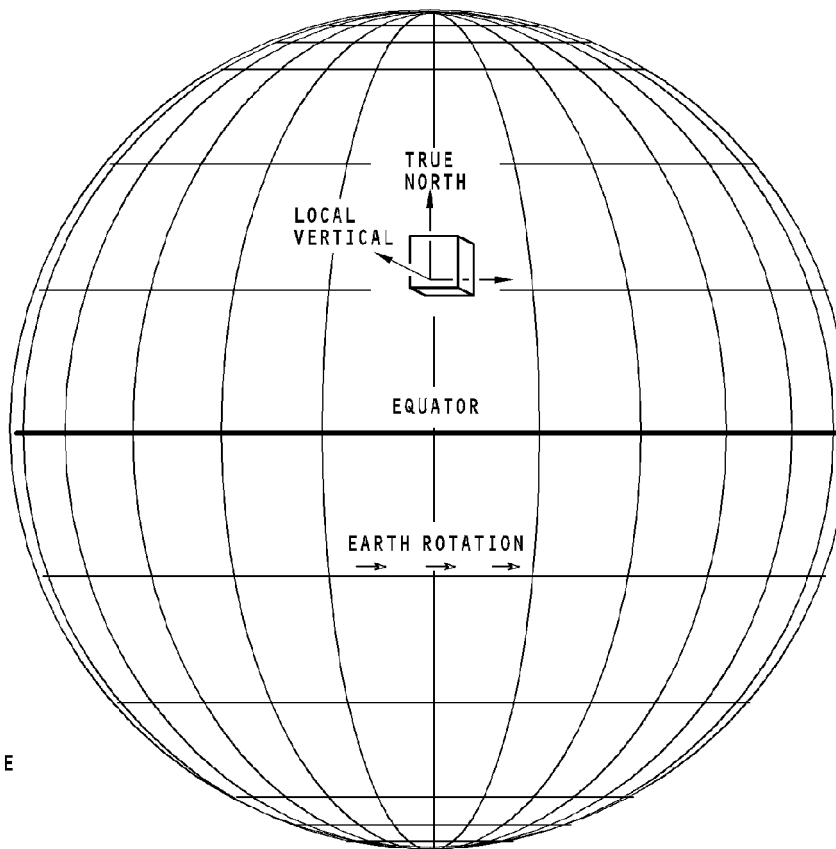
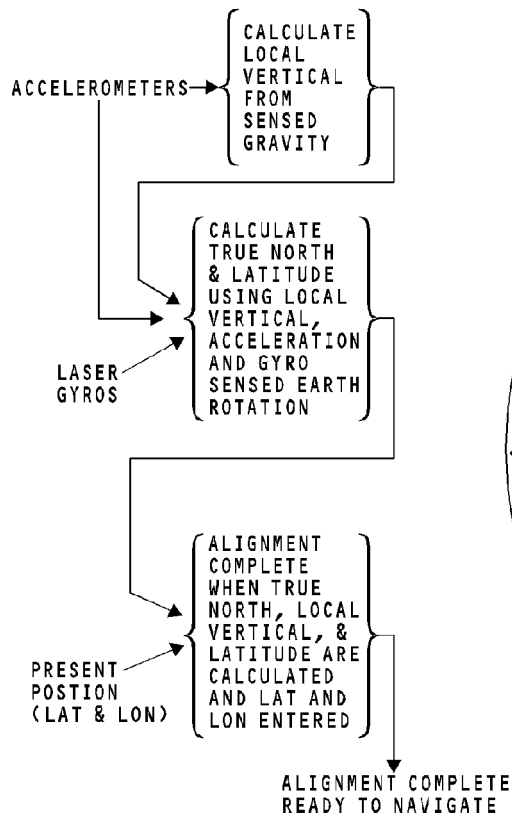

ADIRS - IR GENERAL THEORY 4

34-21-00-074

EFFECTIVITY
HAP ALL

34-21-00

D633A101-HAP

Page 98.3
Jun 10/2007

ADIRS - IR GENERAL THEORY 5**General**

In the navigation mode, the IR processor uses the initial starting point and gyro and accelerometer values to calculate attitude, heading, velocity, and distance flown. The IR processor continuously updates this data over time to calculate present position and all other IR data values.

The IR processor also gets data from the ADR section of the ADIRU. The IR processor uses this input to calculate some of its IR data values.

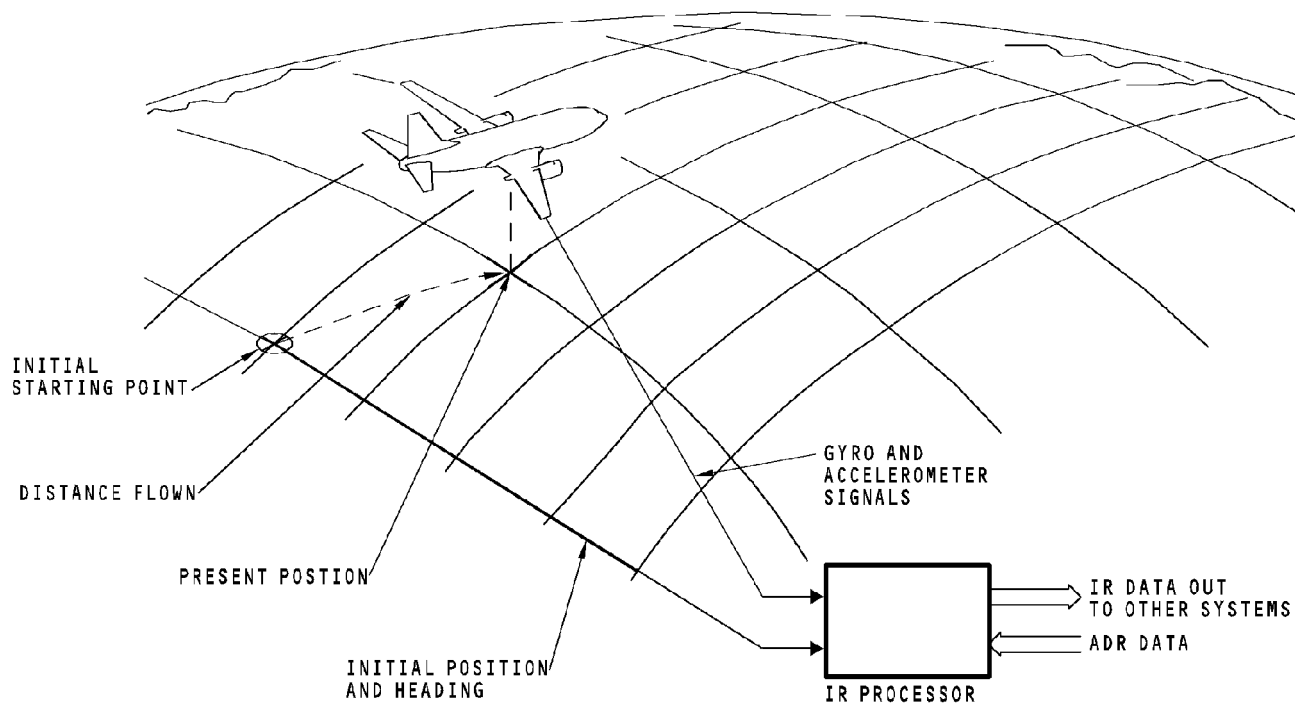

ADIRS - IR GENERAL THEORY 5

34-21-00-075

EFFECTIVITY
HAP ALL

34-21-00

D633A101-HAP

THIS PAGE IS INTENTIONALLY LEFT BLANK

34-21-00

D633A101-HAP

Page 98.6
Jun 10/2007

ADIRS - ADIRU FUNCTIONAL DESCRIPTION

General

The ADIRU has these three parts:

- Power supply
- Inertial reference (IR)
- Air data reference (ADR).

Power Supply

The power supply receives 115v ac and 28v dc. The ADIRU operates with either power source. The power supply gives power to the ADR and the IR. Power also goes to the ISDU and to the ADMs.

The power supply monitor sends BITE data to the IR section. The power supply monitors for these conditions:

- AC power failure
- DC power failure.

Inertial Reference

The ISDU or the FMC supplies bite commands and initial position data to the IR processor. The mode of operation comes from the MSU. The gyros and accelerometers supply movement data to the IR processor. The ADR data bus gives altitude, altitude rate, and true airspeed to the IR processor. The IR uses this ADR data as part of its inertial altitude, vertical speed and wind calculations.

The IR processor calculates these IR data values:

- Pitch
- Roll
- Yaw
- Latitude
- Longitude
- True heading
- Magnetic heading
- Inertial velocity vectors
- Linear accelerations
- Angular rates
- Track angle
- Wind speed and direction
- Inertial altitude
- Vertical speed and acceleration
- Ground speed
- Drift angle
- Flight path angle and acceleration.

The IR data goes out on ARINC 429 data buses.

The IR processor sets the ALIGN discrete during the alignment mode.

Air Data Reference

Static and pitot air pressure come from the air data modules (ADM). Barometric correction comes from the common display system (CDS).

ADIRS - ADIRU FUNCTIONAL DESCRIPTION

The ISDU or the IR data bus supplies bite commands to the ADR processor. The IR data bus also gives pitch, roll, vertical speed, and acceleration to the ADR processor. The ADR uses this IR data to calculate thrust and ground effect compensation values. The ADR then uses the calculated thrust and ground effect compensation values as part of its static source error correction calculation.

Total air temperature (TAT) and angle of attack (AOA) data is converted from analog data to digital data by the A/D converter before the data is received by the ADR processor.

The ADR processor calculates these values:

- Altitude
- Baro-corrected altitude
- Altitude rate
- Computed airspeed
- Maximum allowable airspeed
- Mach
- True airspeed
- Static air temperature
- Total air temperature
- Impact pressure
- Static pressure
- Total pressure.

The ADR data goes out on ARINC 429 data buses.

BITE

The IR processor monitors and reports BITE. Detected faults from the ADR or power supply go to the IR processor for processing and storage. The IR processor sends fault data and status data out on ARINC 429 data buses.

IR faults cause the IR processor to set the FAULT discrete.

Power supply faults cause the IR processor to set the DC FAIL or the ON DC discrettes.

Alignment problems cause the IR processor to set the ALIGN discrete to an intermittent flash.

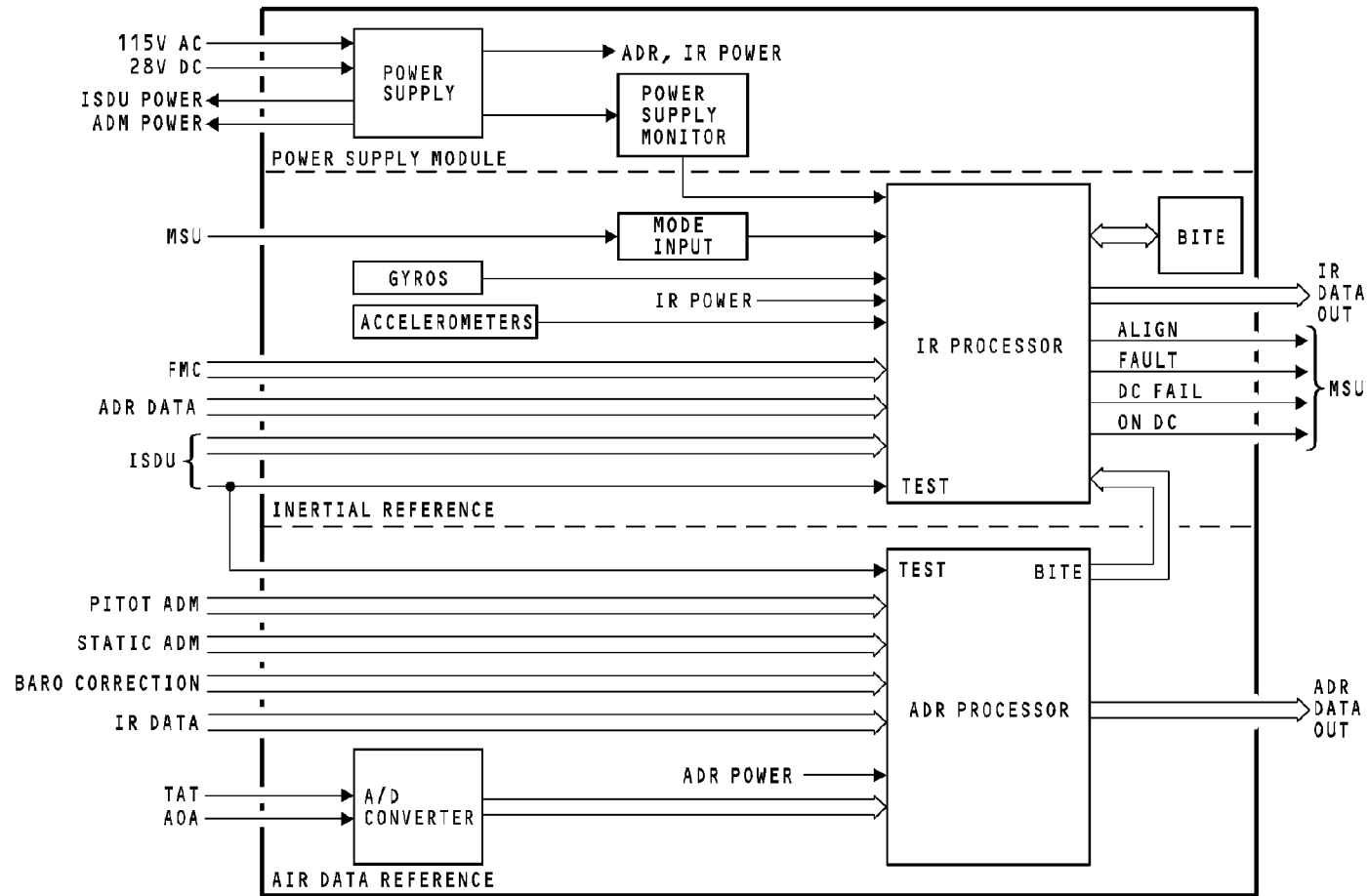

ADIRS - ADIRU FUNCTIONAL DESCRIPTION

EFFECTIVITY
HAP ALL

34-21-00

D633A101-HAP

ADIRS - PFD AND ND INDICATIONS DURING ALIGNMENT

General

These are the indications on the CDS when the ADIRU is in the align mode:

- The PFD shows no computed data (NCD) indications for attitude, heading, and track data
- The PFD shows NCD indication for vertical speed
- The ND shows NCD indications for track and heading data.

Air data from the ADIRU is not affected by the inertial reference (IR) mode of operation. The PFD shows air data information on the speed tape and altitude tape.

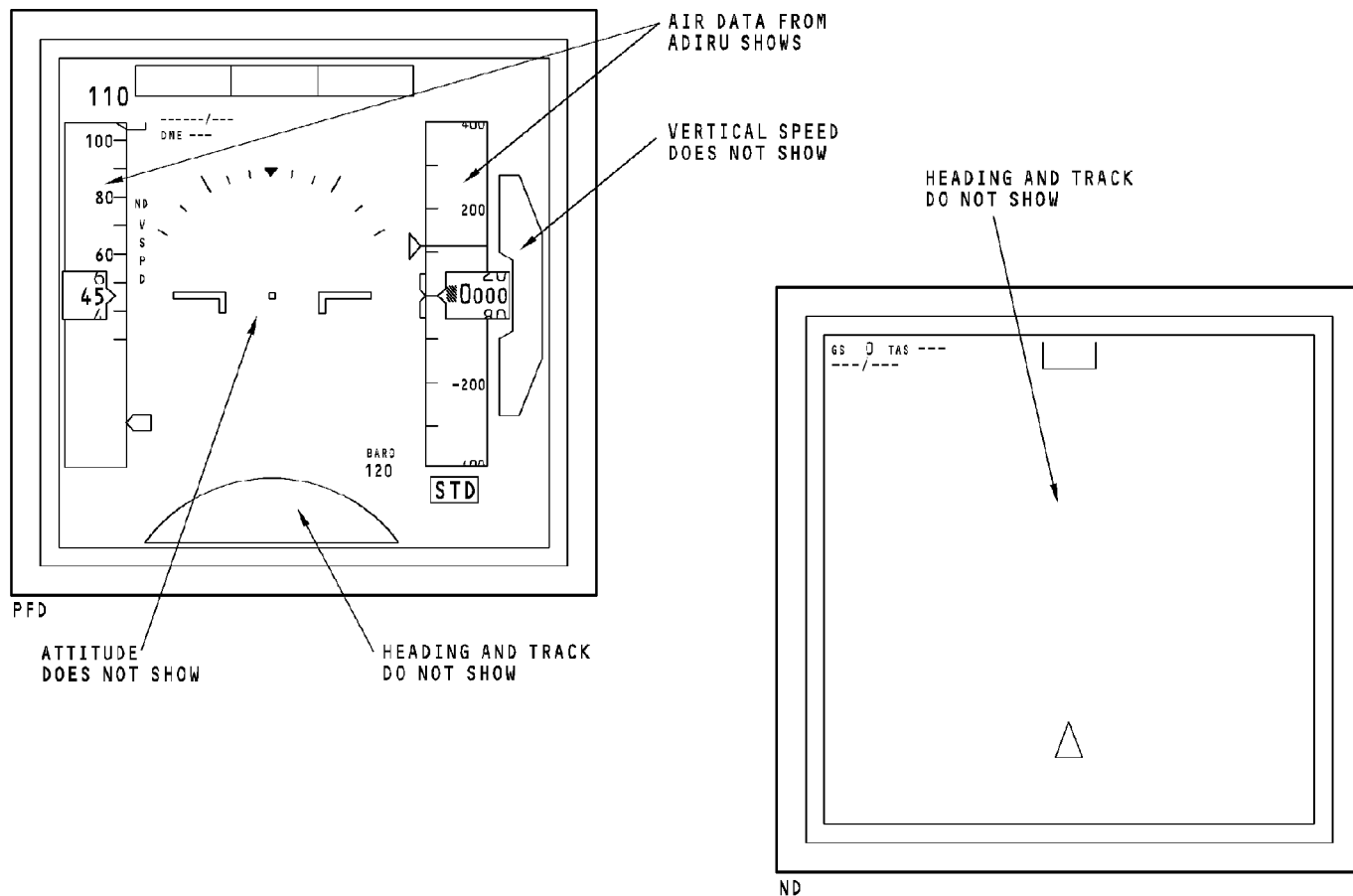

ADIRS - PFD AND ND INDICATIONS DURING ALIGNMENT

34-21-00-066

EFFECTIVITY
HAP ALL

34-21-00

D633A101-HAP

Page 98.11
Jun 10/2007

THIS PAGE IS INTENTIONALLY LEFT BLANK

34-21-00

D633A101-HAP

Page 98.12
Jun 10/2007

ADIRS - PFD AND ND INDICATIONS AFTER ALIGNMENT

General

When the ADIRU alignment is complete and the ADIRU is in the NAV mode, the PFD and ND show ADIRU inertial reference (IR) data. The PFD shows this data:

- Horizon and sky/ground shading
- Pitch scale
- Bank (roll) pointer
- Slip/skid indicator
- Heading pointer
- Track line
- Flight path vector
- Selected heading
- Mag/Tru annunciation
- Vertical speed scale.

HAP 031-054, 101-999

- Angle of attack indication.

HAP ALL

The ND shows this data:

HAP 038, 042-046, 050-053; HAP 037, 039, 040 POST SB 737-31-1370

- Heading or track

HAP 001-013, 015-026, 028-036, 041, 047-049, 054, 101-999; HAP 037, 039, 040 PRE SB 737-31-1370

- Heading

HAP ALL

- Magnetic or true annunciation
- Track/heading scale
- Selected heading

- Ground speed
- Track line.

In flight, the ND also shows this data:

- True airspeed
 - Wind speed
 - Wind direction.
- HAP 031-054, 101-999**
- Angle of attack indication.

HAP ALL

Display Source Priority

Track and ground speed data comes from the FMC and the ADIRS. The data that shows on the CDS is normally FMC track and FMC ground speed. If the FMC fails, the CDS shows ADIRS track and ground speed.

True Airspeed and Wind Speed and Direction

True airspeed does not show on the ND until TAS is more than 100 kts. The normal display when TAS is 100 kts or less is three dashes. This is the NCD indication.

Wind speed and direction does not show until TAS is more than 100 kts. When TAS is 100 kts or less, wind speed and direction is blank.

34-21-00-067

<p>EFFECTIVITY</p> <p>HAP ALL</p>

34-21-00

D633A101-HAP

ADIRS - PFD AND ND INDICATIONS AFTER ALIGNMENT**Flight Path Vector**

The flight path vector (FPV) shows on the PFD when you make a selection on the EFIS control panel. The flight path vector symbol shows the motion of the airplane relative to the horizon and the airplane heading. The FPV moves perpendicular to the horizon to show flight path angle and moves parallel to the horizon to show drift angle. On the ground, the flight path vector is centered on the horizon line.

HAP 038, 042-046, 050-053; HAP 037, 039, 040 POST SB 737-31-1370

Heading or Track Up Display

The ND reference is airplane heading in the VOR and APP modes. The ND reference is airplane track in the MAP and Plan modes.

HAP ALL

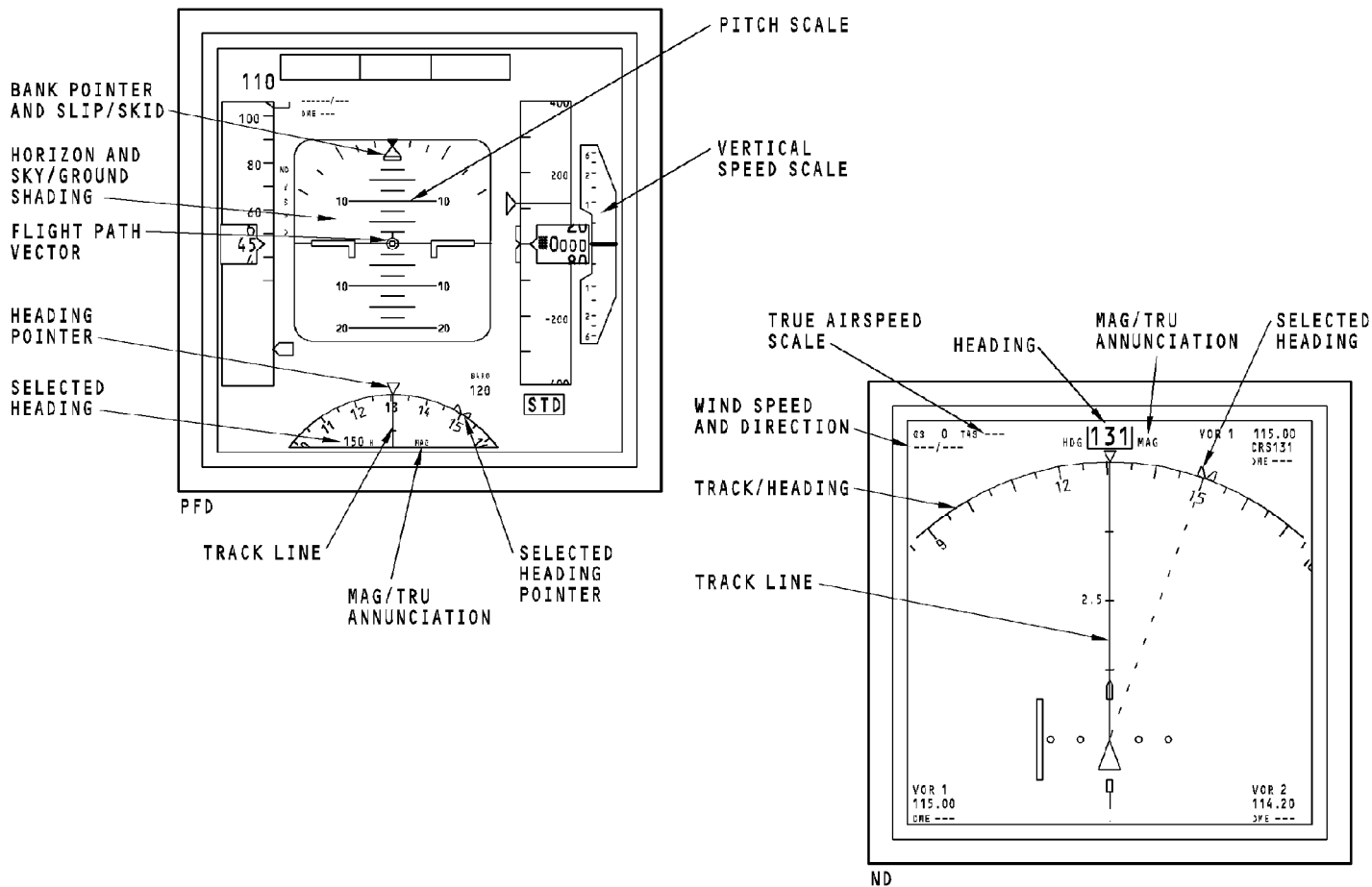

ADIRS - PFD AND ND INDICATIONS AFTER ALIGNMENT

EFFECTIVITY

HAP 001-013, 015-026, 028-036, 041, 047-049, 054, 101-999; HAP 037, 039, 040 PRE SB 737-31-1370

34-21-00

D633A101-HAP

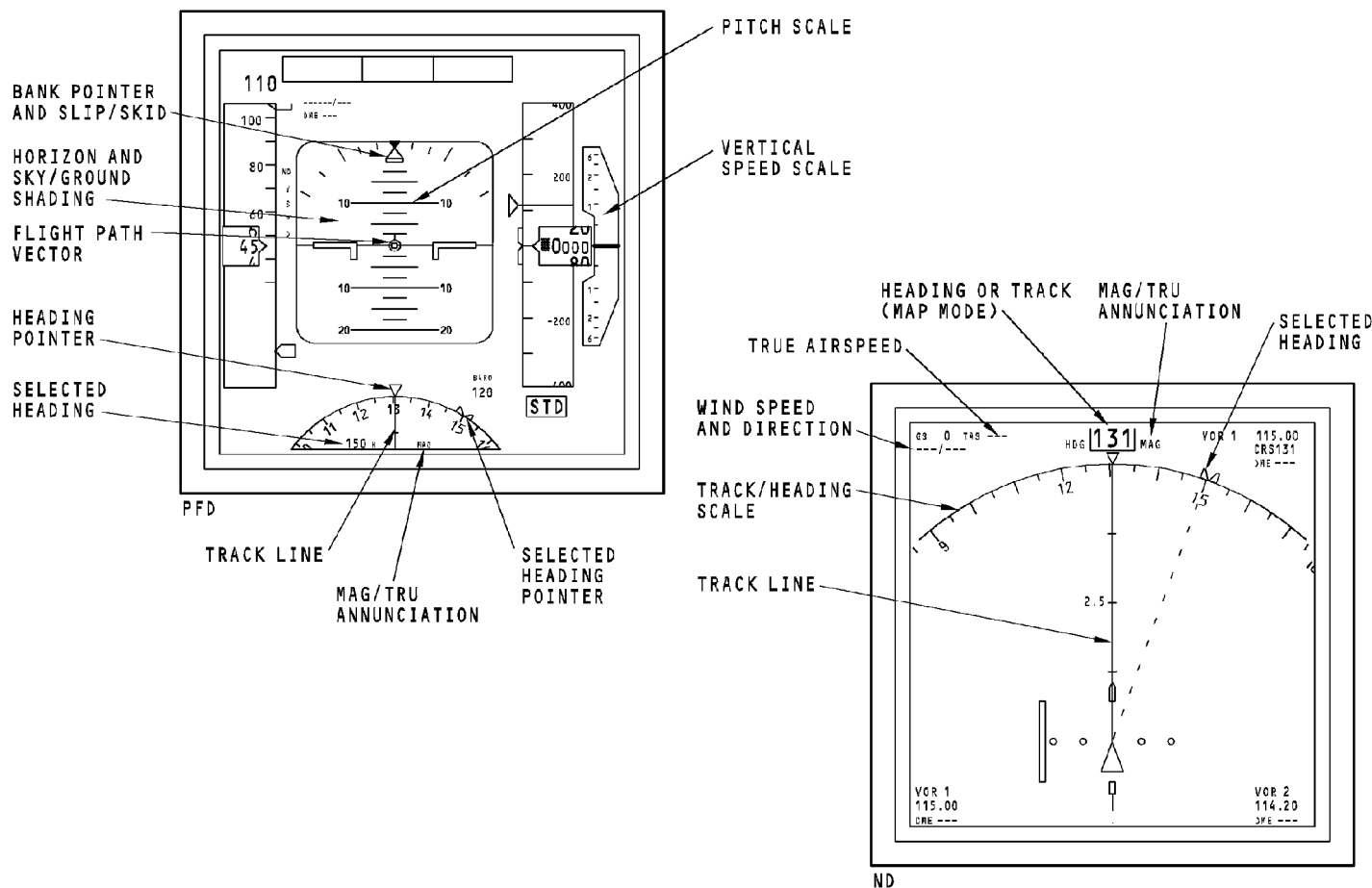

ADIRS - PFD AND ND INDICATIONS AFTER ALIGNMENT

EFFECTIVITY

HAP 038, 042-046, 050-053; HAP 037, 039, 040 POST SB 737-31-1370

34-21-00

D633A101-HAP

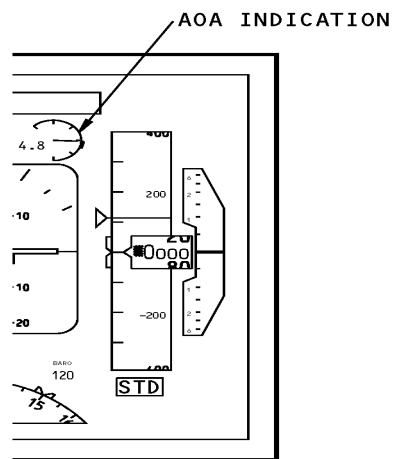

ADIRS - PFD AND ND INDICATION AFTER ALIGNMENT WITH AOA INDICATION

34-21-00-067

EFFECTIVITY
HAP 031-054, 101-999

34-21-00

D633A101-HAP

Page 98.17
Feb 15/2009

THIS PAGE IS INTENTIONALLY LEFT BLANK

34-21-00

D633A101-HAP

Page 98.18
Jun 10/2007

ADIRS - PFD AND ND INVALID ADIRS DATA

General

Failure flags show on the PFD and ND for invalid inertial reference (IR) or invalid air data reference (ADR) conditions.

The PFD shows these flags for invalid ADIRS data:

- ATT for invalid attitude data
- ALT for invalid baro altitude data
- FPV for invalid flight path vector data
- HDG for invalid heading data
- SPD for invalid airspeed data
- VERT for invalid vertical speed data.

HAP 001-013, 015-026, 028-036, 041, 047-049, 054, 101-999; HAP 037, 039, 040 PRE SB 737-31-1370

The ND shows the HDG flag for invalid heading data.

HAP 038, 042-046, 050-053; HAP 037, 039, 040 POST SB 737-31-1370

The ND shows the HDG flag for invalid heading data in the VOR and APP modes. The TRK flag will show in the MAP mode or PLAN mode.

HAP ALL

Attitude Flag

When attitude data from the ADIRU is invalid, the PFD shows the ATT flag. The PFD does not show these values:

- Horizon line
- Sky/ground shading
- Bank pointer
- Slip/skid indicator
- Pitch scale.

Altitude Flag

The ALT flag shows on the PFD for invalid altitude data from the ADIRU. The PFD does not show the altitude tape.

Flight Path Vector Flag

The FPV flag will show on the PFD when attitude data from the ADIRU is invalid. The PFD does not show the flight path vector.

HAP 001-013, 015-026, 028-036, 041, 047-049, 054, 101-999; HAP 037, 039, 040 PRE SB 737-31-1370

Heading Flag

The HDG flag shows on the PFD and the ND when ADIRU heading data is invalid. Heading and track data does not show.

34-21-00-068



34-21-00

D633A101-HAP

ADIRS - PFD AND ND INVALID ADIRS DATA

**HAP 001-013, 015-026, 028-036, 041, 047-049, 054, 101-999;
HAP 037, 039, 040 PRE SB 737-31-1370 (Continued)
HAP 038, 042-046, 050-053; HAP 037, 039, 040 POST SB
737-31-1370**

Heading/Track Flag

The HDG flag shows on the PFD, and the HDG or TRK flag shows on the ND when the ADIRU heading data is invalid. Heading and track data do not show.

HAP ALL**Speed Flag**

The SPD flag shows on the PFD when ADIRS airspeed data is invalid. The Speed tape does not show on the PFD.

Vertical Speed Flag

The VERT flag shows on the PFD when ADIRS vertical speed data is invalid. The vertical speed scale and pointer do not show on the PFD.

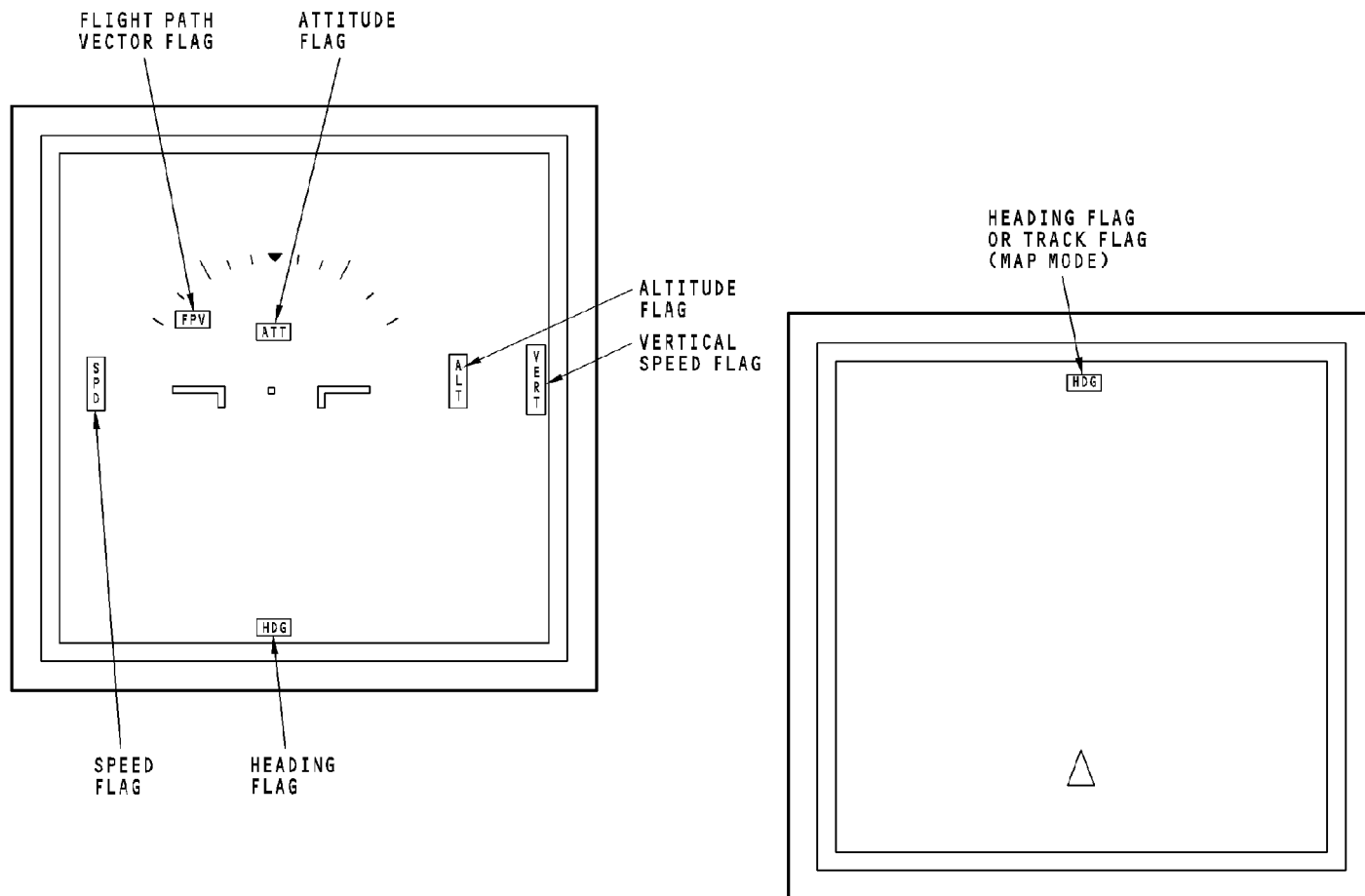

ADIRS - PFD AND ND INVALID ADIRS DATA

EFFECTIVITY

HAP 038, 042-046, 050-053; HAP 037, 039, 040 POST SB 737-31-1370

34-21-00

D633A101-HAP

Page 98.21
Feb 15/2009

34-21-00-068

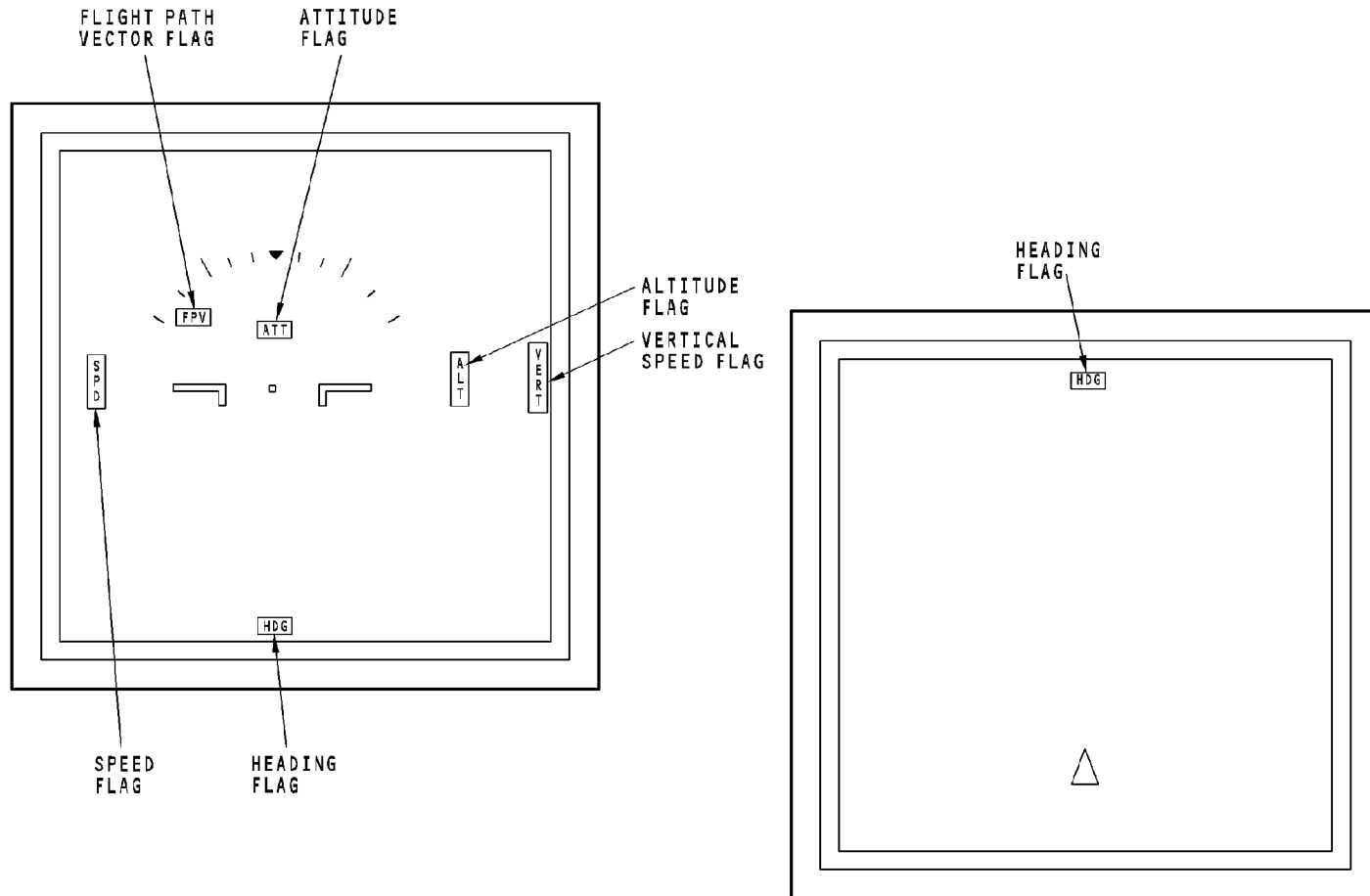

ADIRS - PFD AND ND INVALID ADIRS DATA

EFFECTIVITY

HAP 001-013, 015-026, 028-036, 041, 047-049, 054, 101-999; HAP 037, 039, 040 PRE SB 737-31-1370

34-21-00

D633A101-HAP

THIS PAGE IS INTENTIONALLY LEFT BLANK

34-21-00

D633A101-HAP

Page 98.23
Jun 10/2007

ADIRS - BAROMETRIC CORRECTION INDICATION**General**

Barometric correction adjusts the barometric altitude value that shows on the altimeter indication. This adjusts for changes in barometric pressure.

When you set a new barometric correction value and STD is active, the new value will show below the STD value. Push the STD switch to remove the STD value and make the new value active.

Barometric Correction Controls

The barometric correction controls are on the EFIS control panels. The controls select and set barometric correction reference, values, and displays. These are the barometric controls:

- Barometric reference selector - selects inches of mercury (IN) or hectopascals (HPA) as the barometric reference
- Barometric correction selector - sets the value of barometric correction
- Barometric standard (STD) switch - push the switch to set the barometric standard to 29.92 in hg, 1013 hPa.

Barometric Correction Display

Barometric correction shows on the PFD below the altitude tape. The barometric correction shows in hg or hPa. The EFIS control panel barometric reference selector determines the format that shows.

Push the STD switch to show standard barometric correction. When the barometric altitude of the airplane is at or below the FMC transition altitude plus 300 feet, a yellow boxed STD replaces the standard barometric correction value.

**34-21-00**

D633A101-HAP

Page 98.24
Jun 10/2007

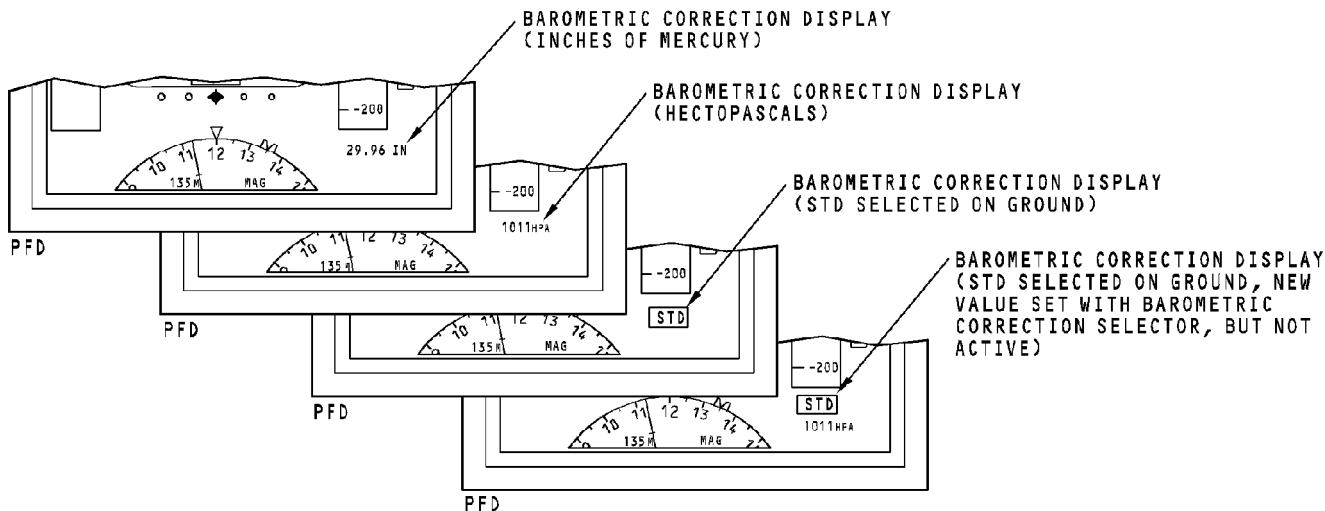
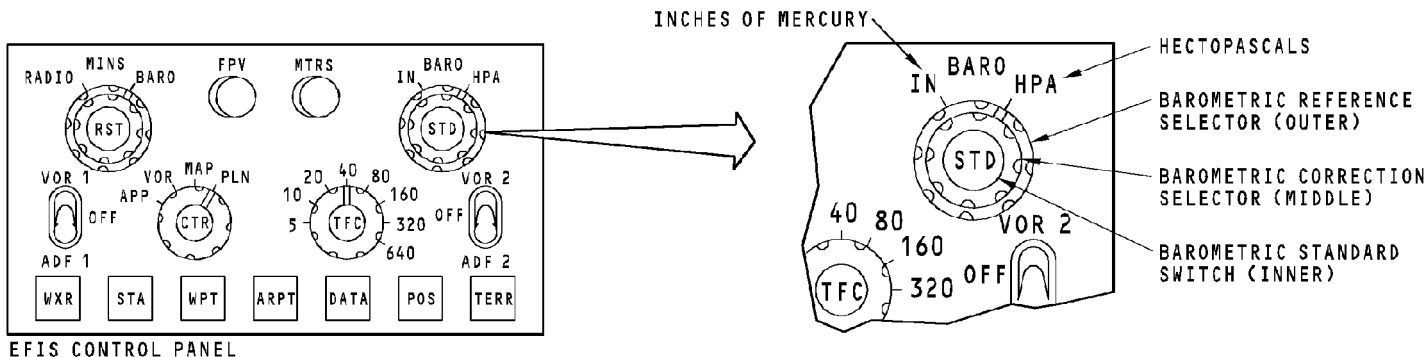

ADIRS - BAROMETRIC CORRECTION INDICATION

34-21-00-026

EFFECTIVITY
HAP ALL

34-21-00

D633A101-HAP

Page 98.25
Jun 10/2007

ADIRS - TAT INDICATION

General

Total air temperature (TAT) from the ADIRUs shows on the top of the engine display. The TAT value that shows is from the left ADIRU. When the left ADIRU TAT is invalid, the right ADIRU TAT value shows. TAT goes out of view when the data from both ADIRUs is invalid.

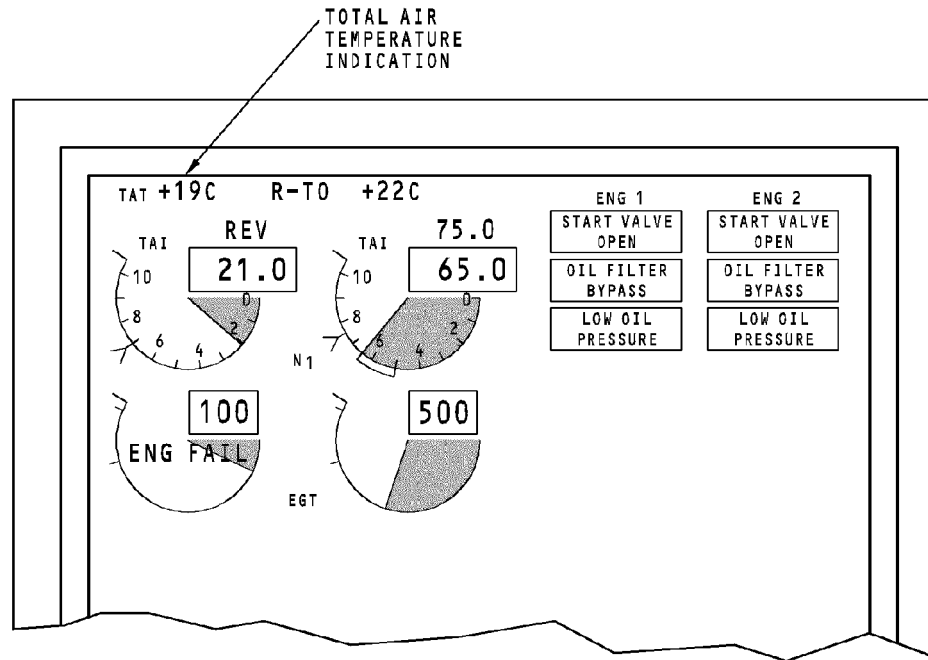

TOTAL AIR TEMPERATURE INDICATION

ENGINE DISPLAY

ADIRS - TAT INDICATION

EFFECTIVITY
HAP ALL

34-21-00

D633A101-HAP

ADIRS - ANGLE OF ATTACK INDICATION**General**

The angle of attack (AOA) indicator is an optional display feature located in the same position as the round dial radio altitude option. The indicator consists of a digital AOA numeric readout and analog dial. The AOA indicator and numeric are displayed when the option is selected and when there is valid data. If no valid angle of attack is available the "AOA" fail flag is displayed. The analog pointer is limited to -5 and +21 AOA.

AOA Cross Compare

AOA DISAGREE alert message displayed on PFD if left/right AOA disagree.

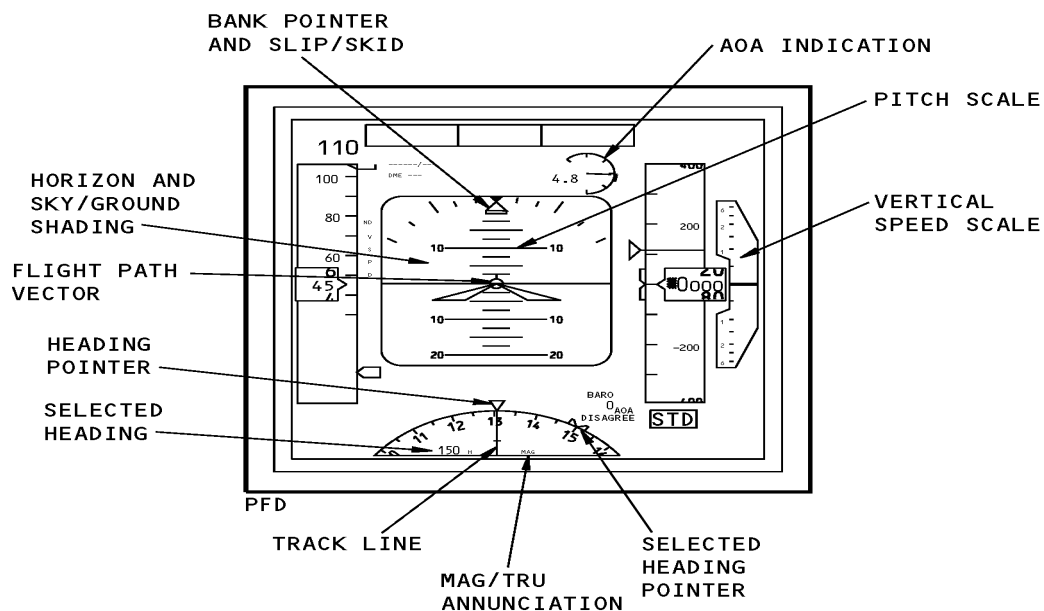

ADIRS - ANGLE OF ATTACK INDICATION

34-21-00-076

EFFECTIVITY
HAP 031-054, 101-999

34-21-00

D633A101-HAP

Page 98.29
Feb 15/2009

ADIRS - ALIGNMENT PROCEDURE 1**General**

The ADIRS alignment time will change between a minimum of 5 minutes at the equator to 17 minutes maximum at 78.25 degrees, north or south latitudes.

The alignment time will not be more than 10 minutes if the present position latitude is between 60.0 degrees north or south. The alignment time is fixed at 10 minutes between latitudes of 60.0 and 70.2 degrees north or south. The alignment time is fixed at 17 minutes between latitudes of 70.2 and 78.25 degrees north or south.

The ADIRU will not align at a latitude more than 78.25 north or south.

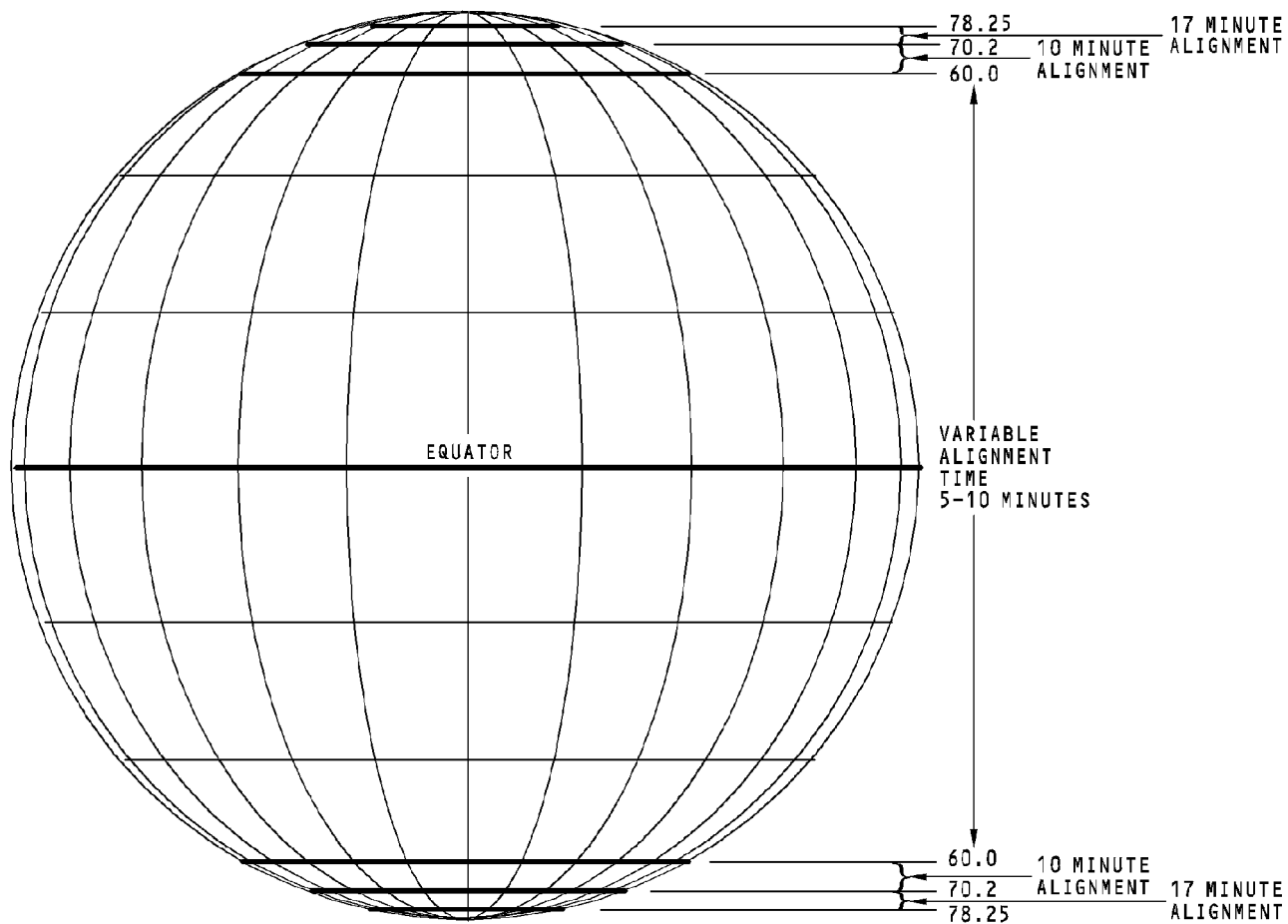

ADIRS - ALIGNMENT PROCEDURE 1

34-21-00-034

EFFECTIVITY
HAP ALL

34-21-00

D633A101-HAP

Page 98.31
Jun 10/2007

ADIRS - ALIGNMENT PROCEDURE 2**Alignment Mode**

CAUTION: SOME SWITCHES MUST BE PULLED AND THEN TURNED. IF YOU TRY TO TURN THESE SWITCHES BEFORE YOU PULL THEM, YOU CAN DAMAGE THE SWITCH.

Use the mode selector on the MSU to start the ADIRU alignment. Move the selector from OFF to NAV. The left selector controls the left ADIRU and the right selector controls the right ADIRU.

The ON DC light comes on for 5 seconds. During this time, the ADIRU does a check of its dc power source. After 5 seconds, the ON DC light goes off and the ALIGN light comes on. The ADIRU is now in the alignment mode.

Training Information Point

If the ADIRU detects airplane movement during the alignment mode, the alignment process will stop. After the motion stops, a new alignment will start.

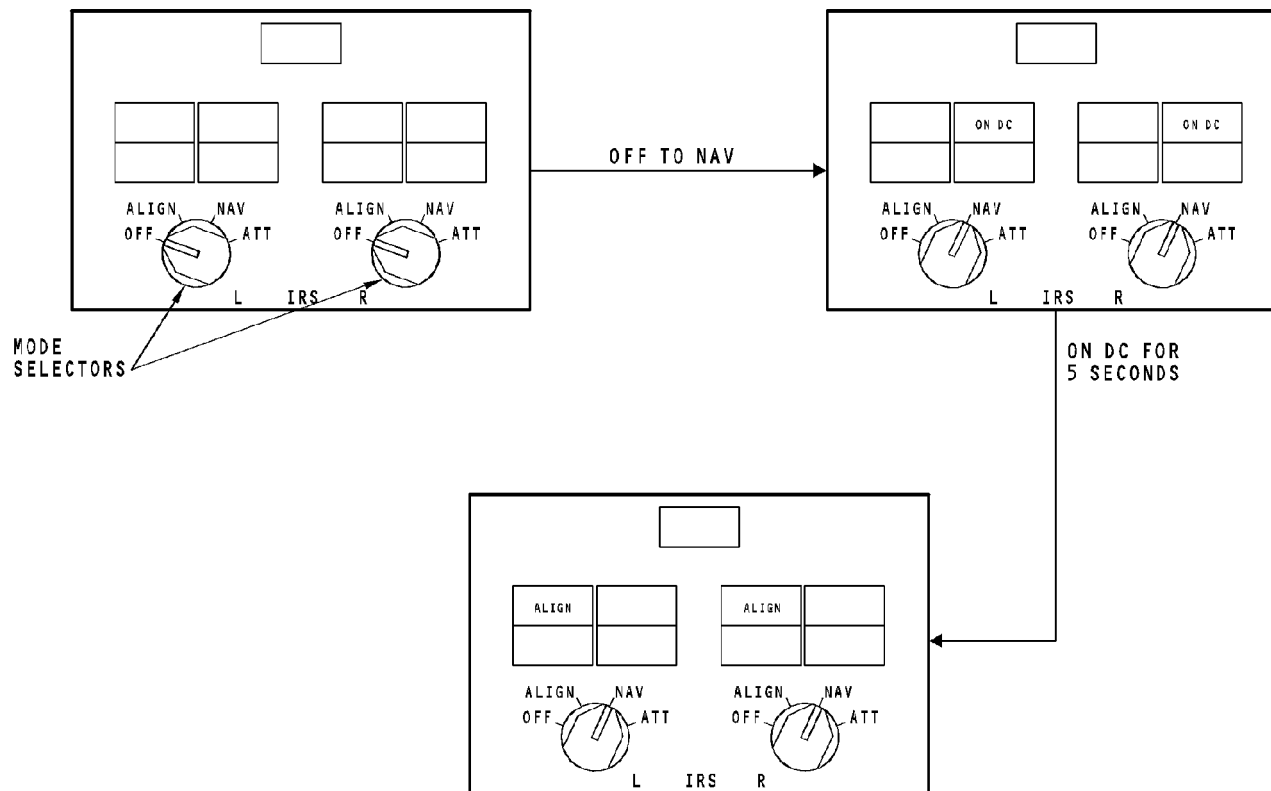

ADIRS - ALIGNMENT PROCEDURE 2

34-21-00-035

EFFECTIVITY
HAP 001-013, 015-026, 028-036, 038-054, 101-999

34-21-00

D633A101-HAP

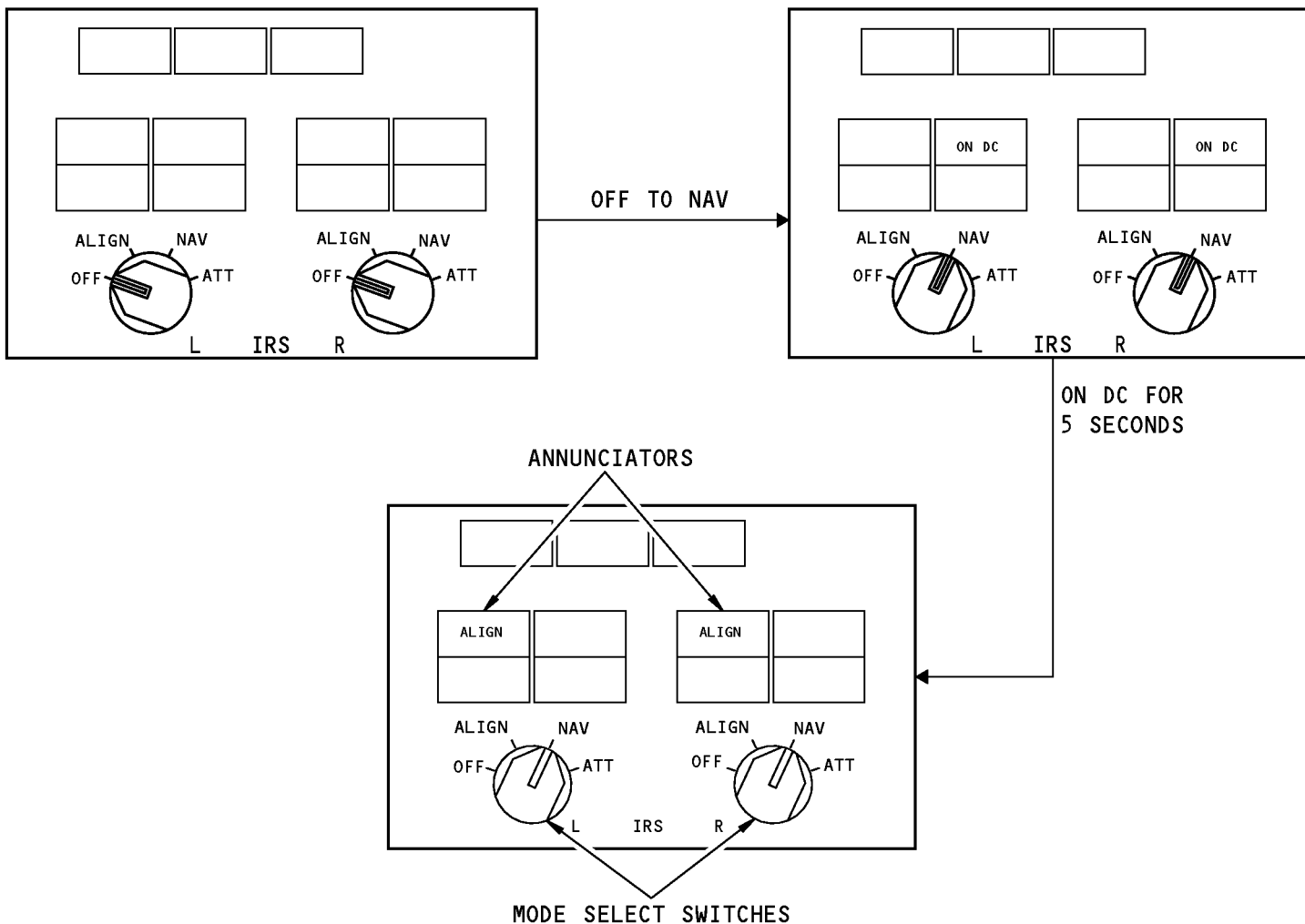

1565840 S0000290305_V1

ADIRS - ALIGNMENT PROCEDURE 2

EFFECTIVITY
HAP 037

34-21-00

D633A101-HAP

Page 98.34
Oct 15/2008

34-21-00-035

THIS PAGE IS INTENTIONALLY LEFT BLANK

34-21-00

D633A101-HAP

Page 98.35
Jun 15/2008

ADIRS - ALIGNMENT PROCEDURE 3**Present Position Entry**

You must enter present position data for the ADIRU during alignment. The ADIRU calculates present position latitude but it cannot calculate present position longitude. The ADIRU uses your entry for latitude and longitude. The ADIRU compares your latitude entry to its calculated value to make sure its calculation of latitude is correct.

You can use the ISDU or the FMC CDU to enter present position data. When both ADIRUs are in alignment mode, you only need to enter the data one time. The data goes to both ADIRUs. If you make a wrong entry, you can enter the data again. The ADIRUs use the last data entry that you make.

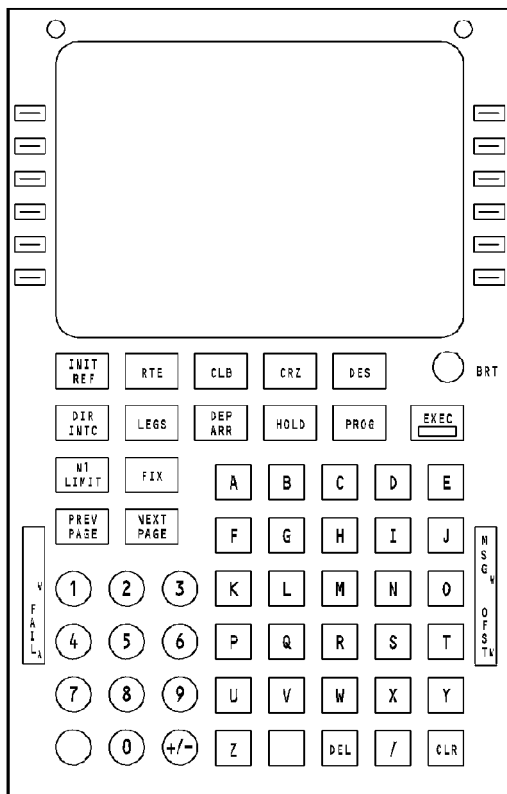

FMCS CDU

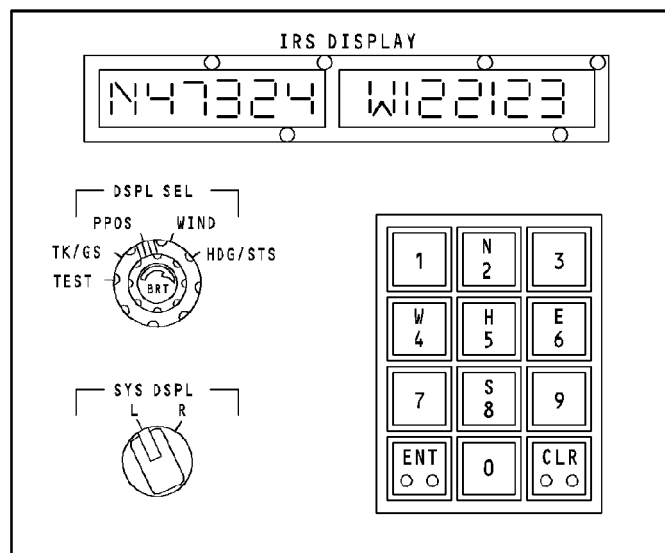

ISDU

ADIRS - ALIGNMENT PROCEDURE 3

34-21-00-036

EFFECTIVITY
HAP ALL

34-21-00

D633A101-HAP

Page 98.37
Jun 15/2008

ADIRS - LAST POSITION PRESENT POSITION ENTRY**CDU Present Position Entry**

ADIRS present position can be set using the FMC CDU. Push the INIT/REF key on the CDU to show the position initialization (POS INIT) page. From this page, there are these three procedures that you can use to enter present position for the ADIRUs:

- Transfer position data from LAST POS line
- Transfer position data from REF AIRPORT line
- Enter position data using CDU keyboard.

You can also transfer GPS present position from the CDU POS REF page.

LAST POS Transfer

Do this to transfer position data from the LAST POS line on the CDU to the ADIRUs:

- Push line select key (LSK) 1R. The position data moves to the scratchpad
- Push LSK 4R. Position data moves from scratchpad to the SET IRS POS boxes.

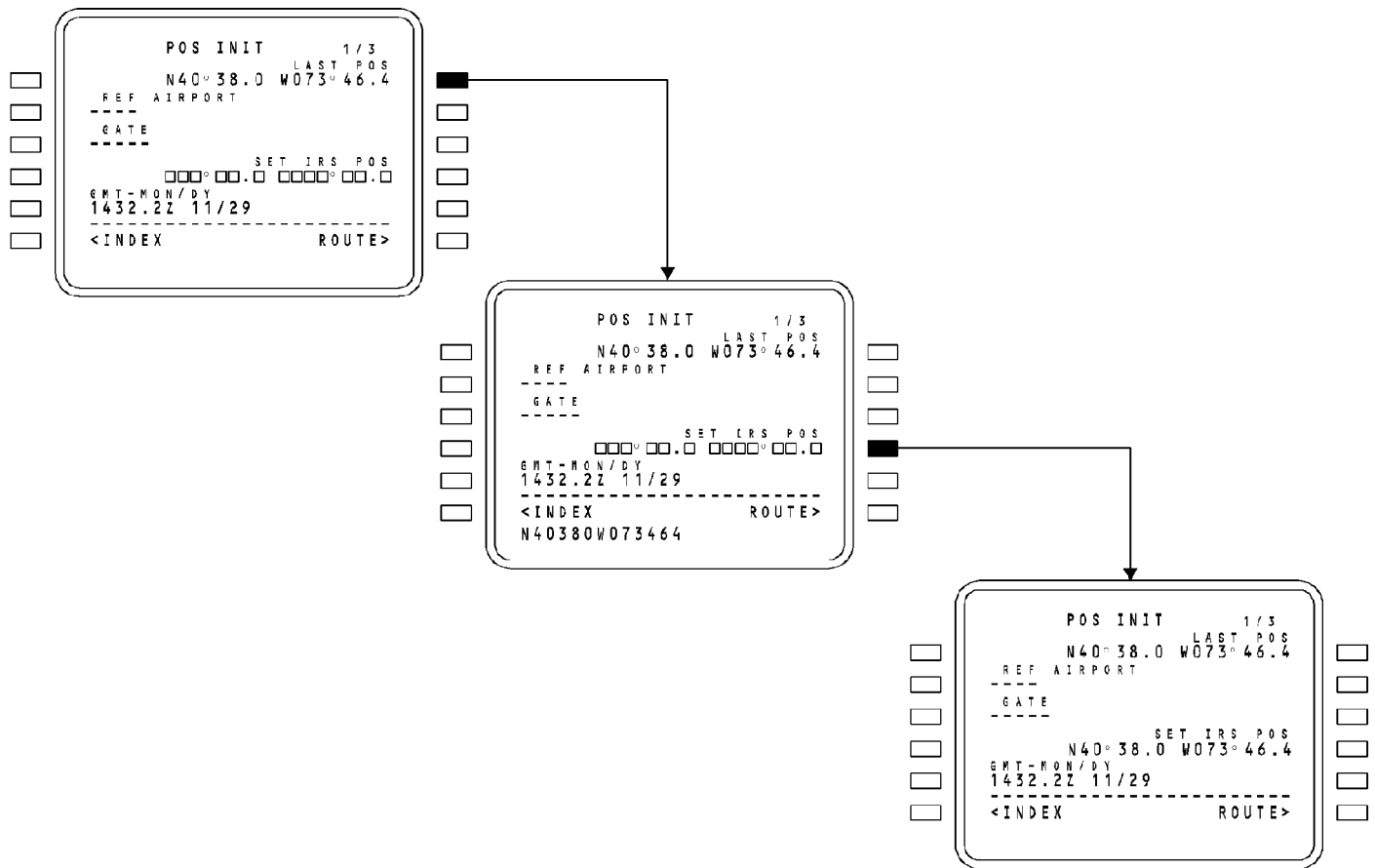

ADIRS - LAST POSITION PRESENT POSITION ENTRY

34-21-00-037

EFFECTIVITY
HAP ALL

34-21-00

D633A101-HAP

ADIRS - REFERENCE AIRPORT PRESENT POSITION ENTRY

REF AIRPORT Transfer

Do this to transfer position data from the REF AIRPORT line on the CDU to the ADIRUs:

- Use the CDU keyboard to enter the airport code in the scratchpad.
- Push LSK 2L. The airport code moves to REF AIRPORT and airport position data shows.
- Push line select key (LSK) 2R. The position data moves to the scratchpad.
- Push LSK 4R. The position data moves from the scratchpad to the SET IRS POS boxes.

NOTE: Some reference airports also have the position of gates. Enter the gate number in the scratchpad after you push LSK 2L. Push LSK 3L and the gate position will show. This position may be used as present position.

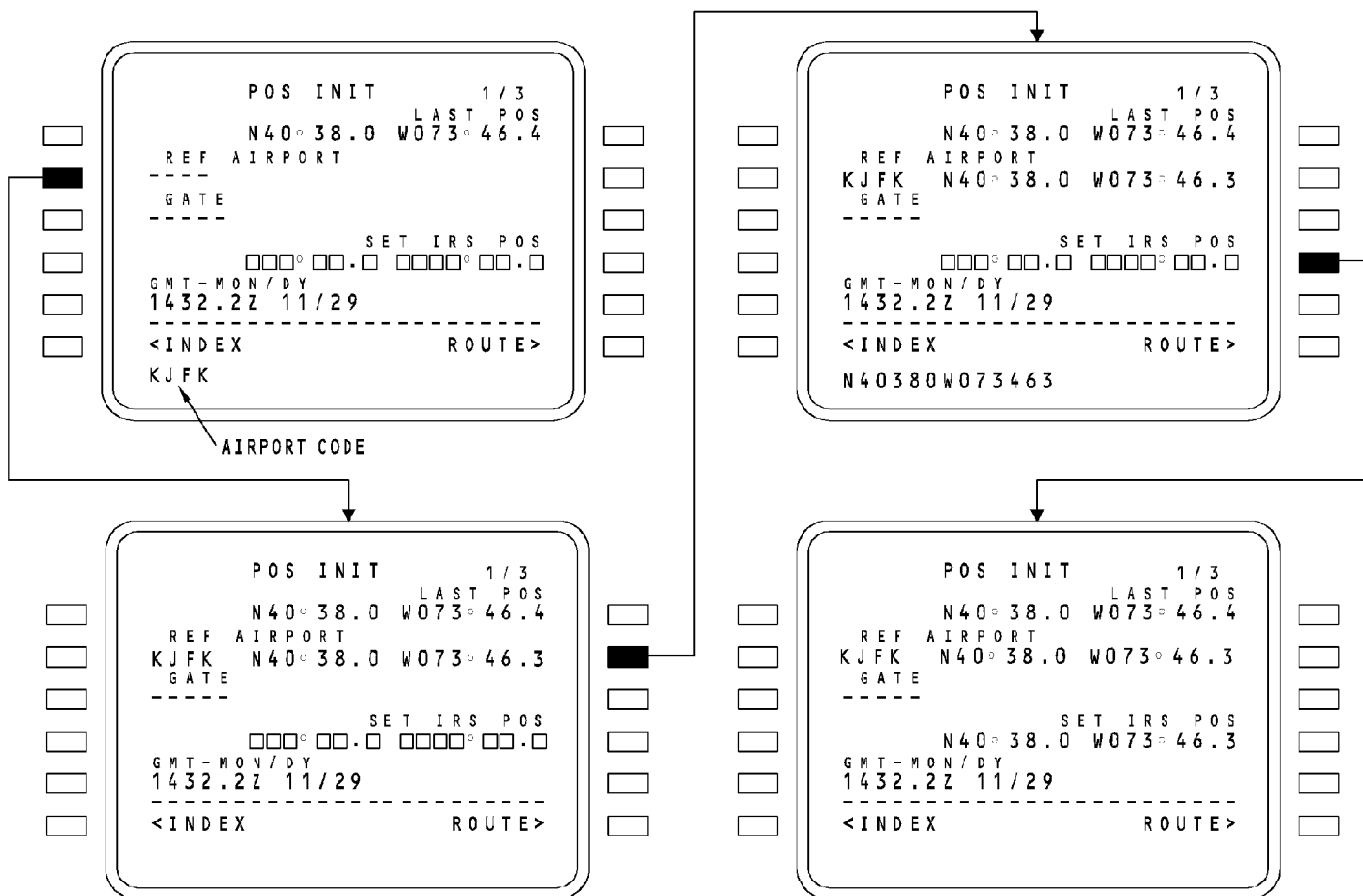

ADIRS - REFERENCE AIRPORT PRESENT POSITION ENTRY

EFFECTIVITY
HAP ALL

34-21-00

D633A101-HAP

Page 98.41
Jun 15/2008

34-21-00-038

ADIRS - SCRATCHPAD PRESENT POSITION ENTRY

CDU Keyboard Entry

Do this to enter position data from the keyboard on the CDU to the ADIRUs:

- Use the keyboard to enter the position data into the scratchpad. You do not need to use spaces or decimal points (.).
- Push LSK 4R. Position data moves from the scratchpad to the SET IRS POS boxes.

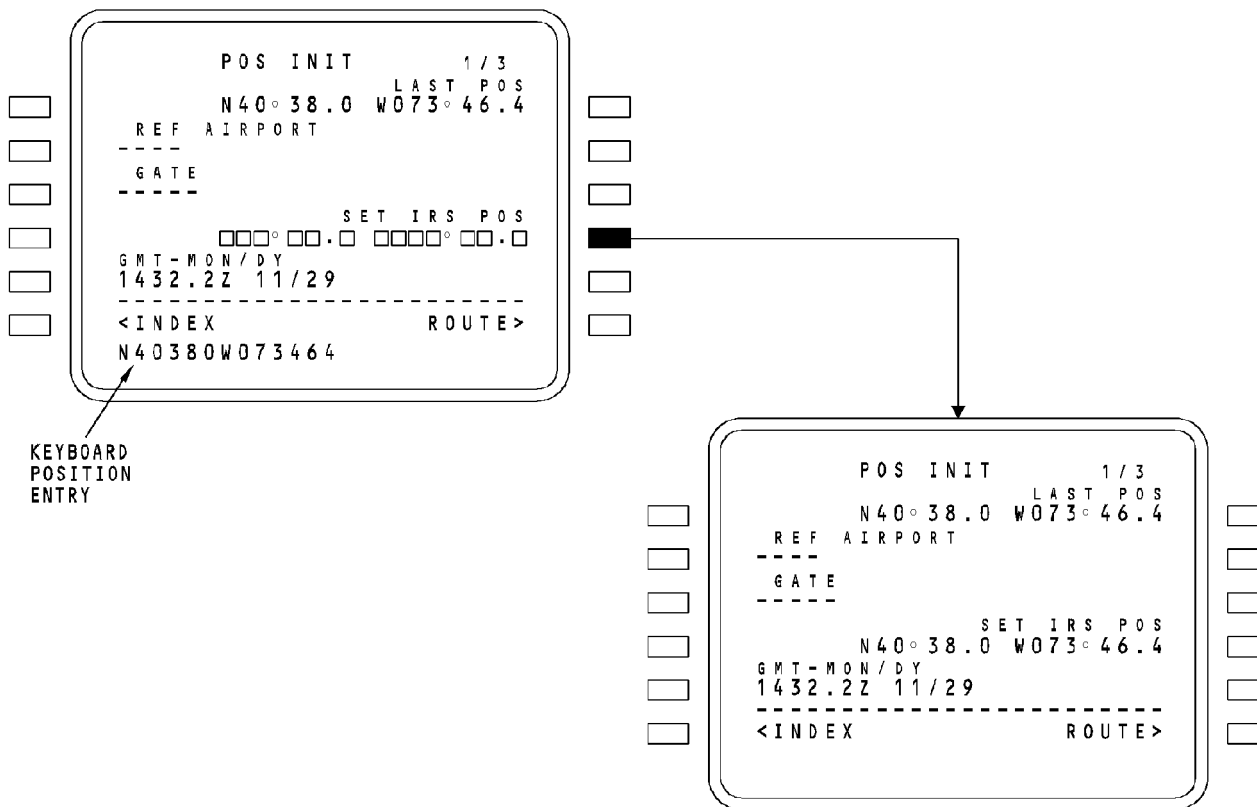

ADIRS - SCRATCHPAD PRESENT POSITION ENTRY

34-21-00-039

EFFECTIVITY
HAP ALL

34-21-00

D633A101-HAP

ADIRS - GPS PRESENT POSITION ENTRY**GPS Position Transfer**

Do this to transfer GPS position data from the POS REF page on the CDU to the ADIRUs:

- Push the NEXT PAGE key on the CDU. The INIT REF page changes to the POS REF page.
- Push LSK 4L, or LSK 5L. The GPS L or GPS R position data moves to the scratchpad.
- Push the PREV PAGE key on the CDU. The POS REF page changes to the INIT REF page. The GPS position data stays in the scratchpad.
- Push LSK 4R. The GPS position data moves from the scratchpad to the SET IRS POS boxes.

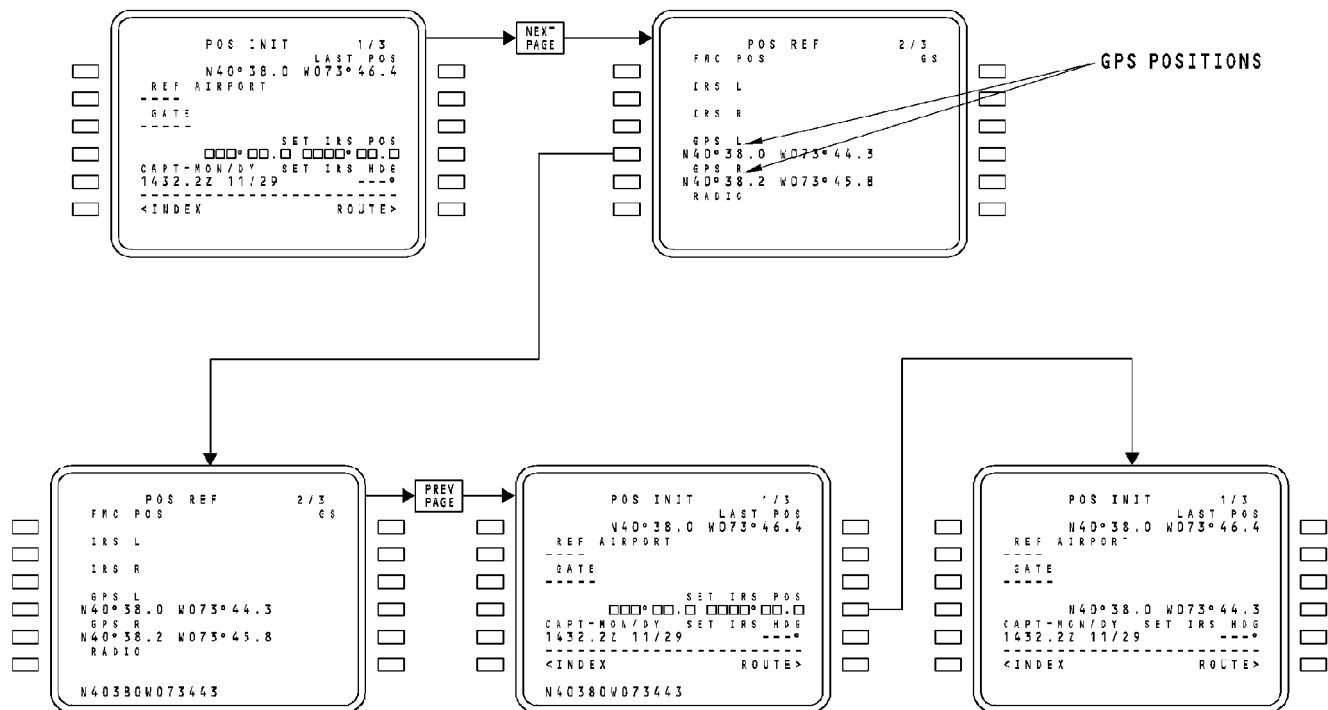

ADIRS - GPS PRESENT POSITION ENTRY

34-21-00-064

EFFECTIVITY
HAP ALL

34-21-00

D633A101-HAP

Page 98.45
Jun 15/2008

ADIRS - ISDU PRESENT POSITION ENTRY**ISDU Present Position Entry**

You can use the ISDU keyboard to enter present position data for the ADIRUs. The display selector (DSPL SEL) can not be in TEST. You can enter latitude or longitude first.

Push the CLR key to clear the invalid position entry.

Latitude Entry

Push the N2 or S8 key to enter latitude. The letter N or S shows in the left IRS DISPLAY and the light on the ENT key comes on. Push the keys to enter the latitude data. When you push each key, the number appears at the far right of the left IRS DISPLAY. Numbers entered before will shift one space to the left. Push the ENT key to send the data to the ADIRUs. The light on the ENT key goes off. If the display selector is in a position other than PPOS, the IRS DISPLAY will change to the information that showed before you started the position entry.

Longitude Entry

The longitude entry is similar to the latitude entry. Push the W4 or E6 key to enter longitude. The longitude data will show in the right IRS DISPLAY.

Invalid Position Entry

These keyboard entries cause the CLR key light to come on when you push the ENT key:

- Latitude greater than 90 degrees
- Longitude greater than 180 degrees
- Minute value greater than 59.9.

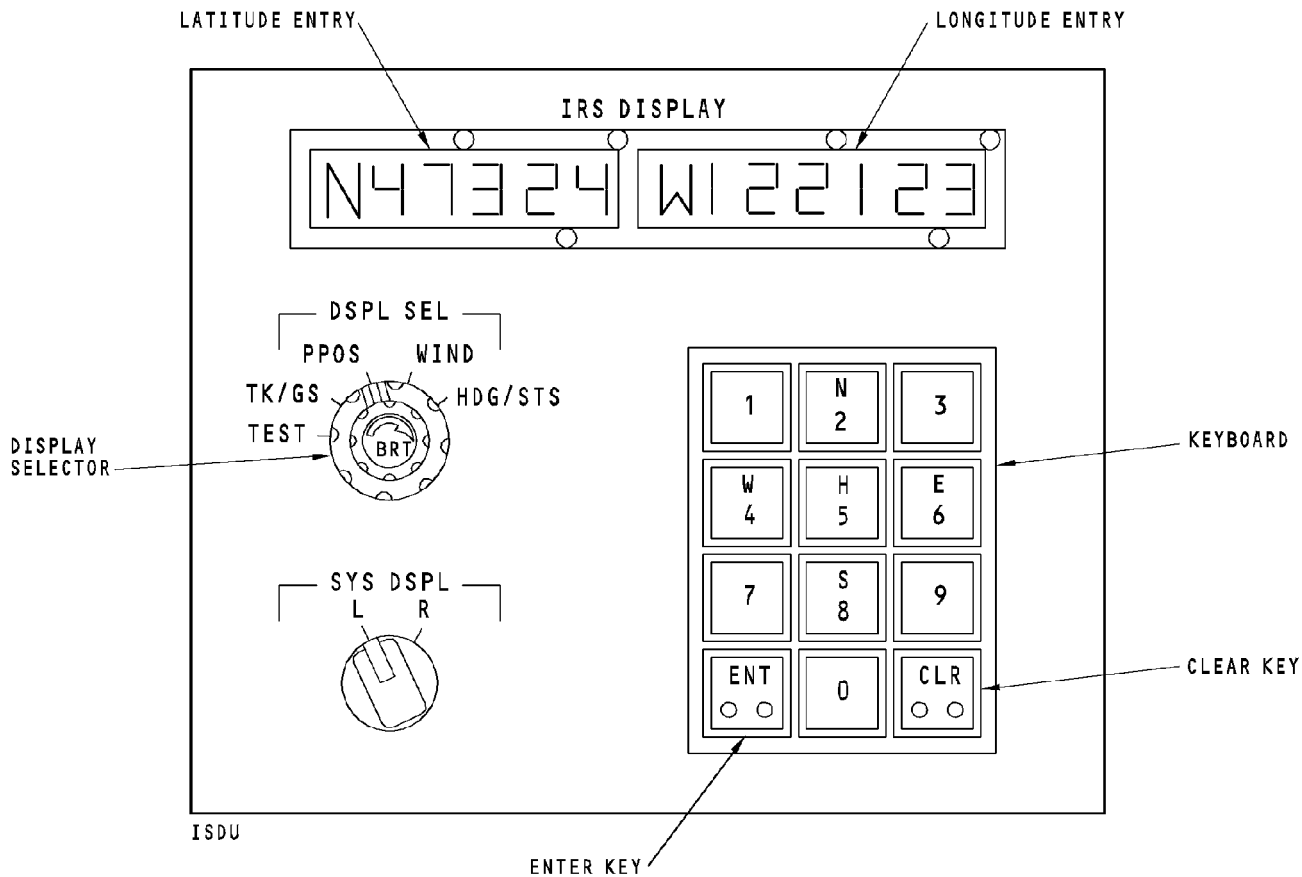

ADIRS - ISDU PRESENT POSITION ENTRY

34-21-00-040

EFFECTIVITY
HAP ALL

34-21-00

D633A101-HAP

Page 98.47
Jun 15/2008

ADIRS - ALIGNMENT TIME**General**

You can see the time remaining to alignment on the ISDU. Set the DSPL SEL switch to the HDG/STS position. The right IRS DISPLAY shows the time in minutes until the ADIRU is aligned. For 17 minute alignments, 15 shows in the right IRS DISPLAY for the first three minutes. After three minutes, the display counts down to zero.

The ADIRU goes to the navigation mode at the end of the alignment time if the mode select switch is in the NAV position and present position has been entered.

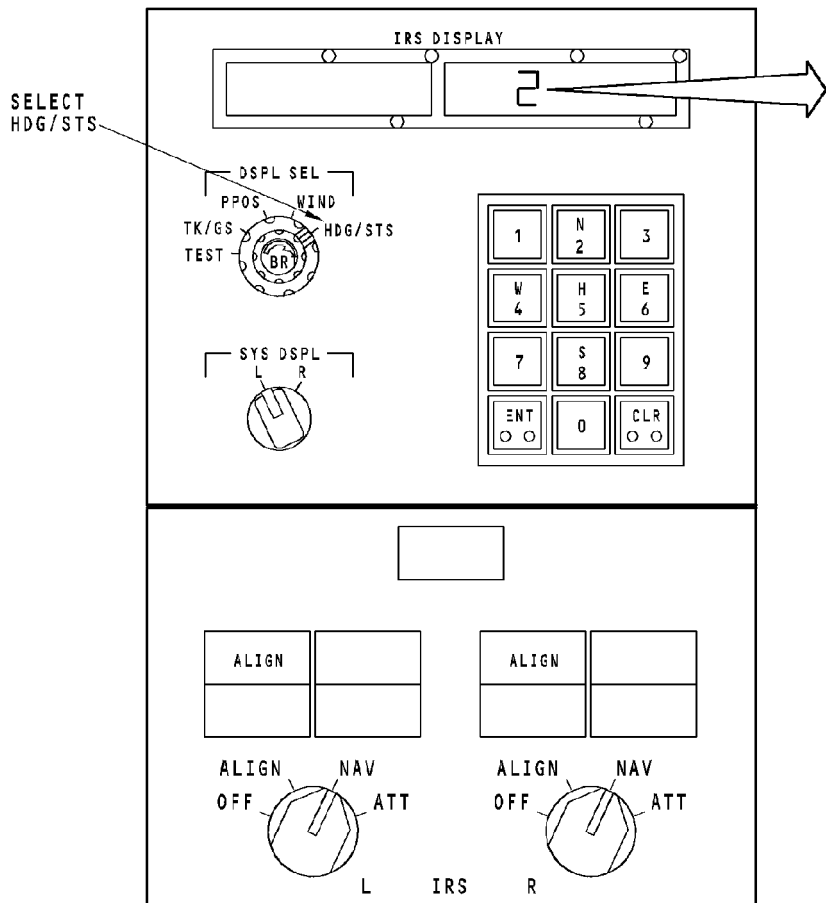

MINUTES REMAINING	SHOW NUMBER
17	15
16	15
15	15
14	14
13	13
12	12
11	11
10	10
9	9
8	8
7	7
6	6
5	5
4	4
3	3
2	2
1	1
0	0

ADIRS - ALIGNMENT TIME

EFFECTIVITY
HAP 001-013, 015-026, 028-036, 038-054, 101-999

34-21-00

D633A101-HAP

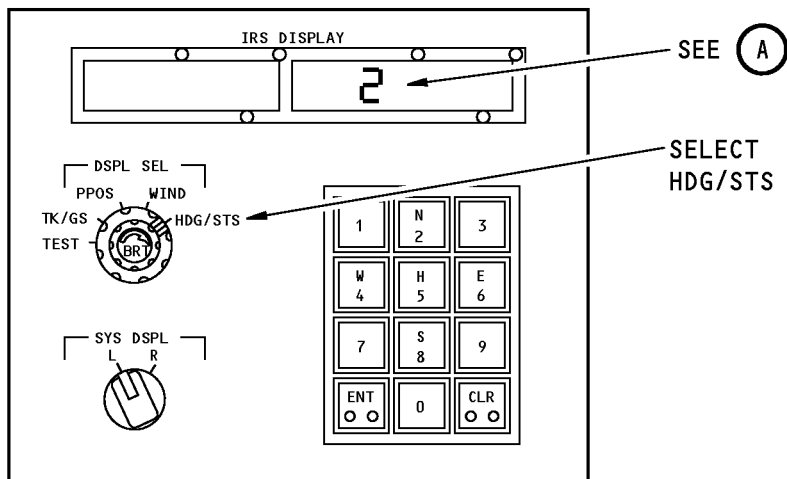

MINUTES REMAINING	SHOW NUMBER
17	15
16	15
15	15
14	14
13	13
12	12
11	11
10	10
9	9
8	8
7	7
6	6
5	5
4	4
3	3
2	2
1	1
0	0

(A)

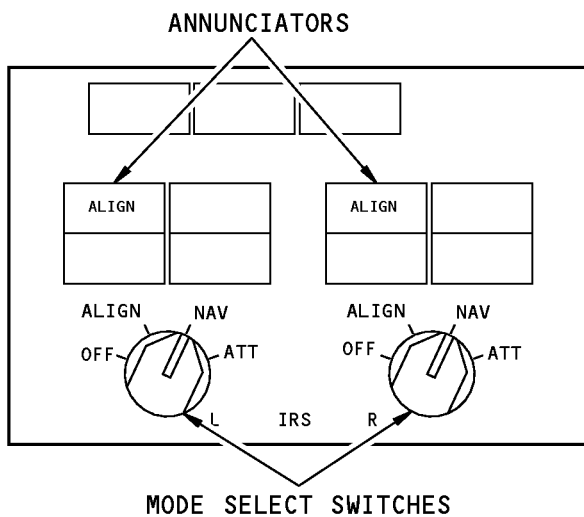

ADIRS - ALIGNMENT TIME

1565831 S0000290306_V1

EFFECTIVITY
HAP 037

34-21-00

D633A101-HAP

Page 98.50
Oct 15/2008

34-21-00-041

THIS PAGE IS INTENTIONALLY LEFT BLANK

34-21-00

D633A101-HAP

Page 98.51
Jun 15/2008

ADIRS - IRS MOTION**General**

When the ADIRUs are in the alignment mode and the ADIRUs detect airplane movement, the alignment mode stops. A status code 3 shows on the ISDU and IRS MOTION shows on the CDU scratchpad. After 30 seconds, the ADIRUs do a check for airplane motion. When the motion stops, the ADIRUs start new alignments. When the new alignment starts, the status code 3 goes out of view. You push the CLR key on the CDU to remove the IRS MOTION message from the CDU scratchpad.

NOTE: The display selector must be in the HDG/STS position to see the status code 3.

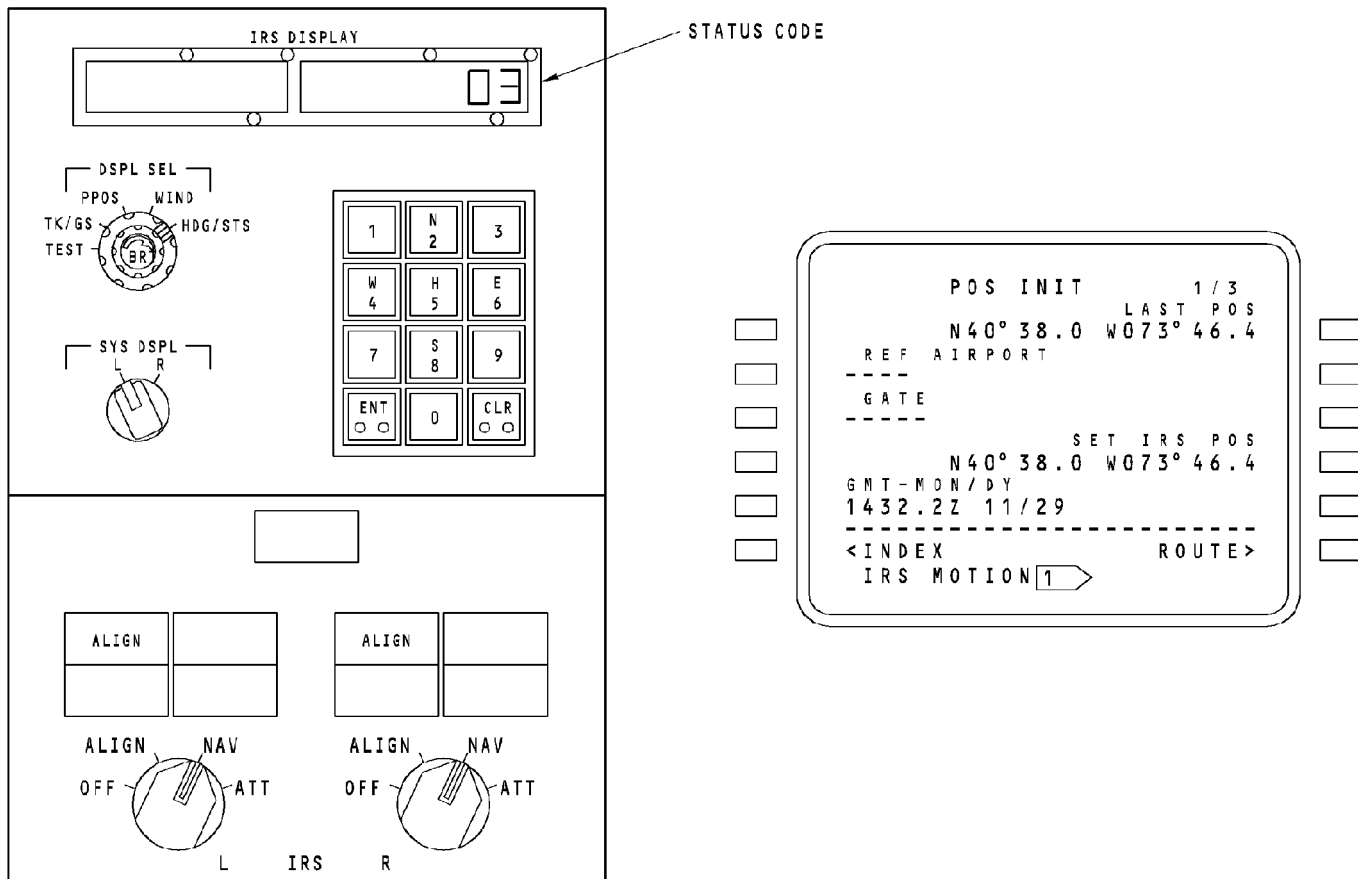

1 MESSAGE SHOWS ON ALL CDU PAGES

ADIRS - IRS MOTION

34-21-00-042

EFFECTIVITY
 HAP 001-013, 015-026, 028-036, 038-054, 101-999

34-21-00

D633A101-HAP

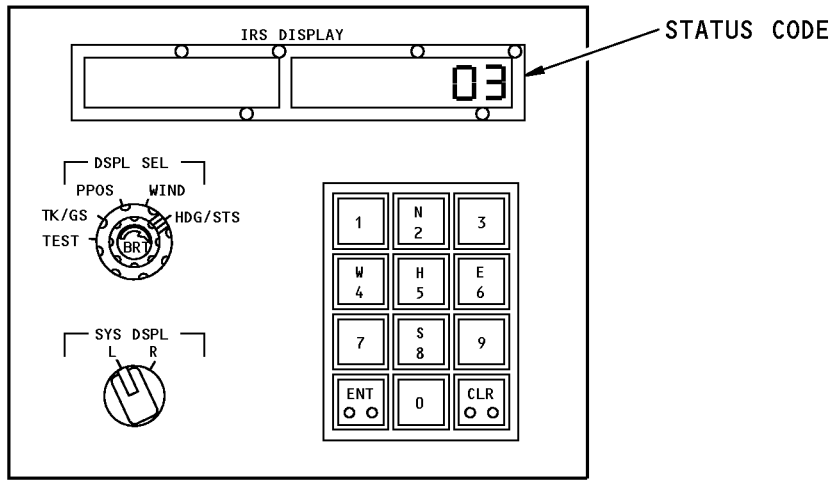

ANNUNCIATORS

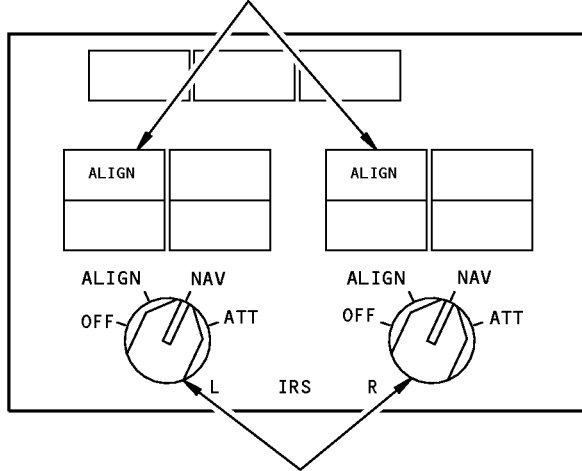

MODE SELECT SWITCHES

1 MESSAGE SHOWS ON ALL CDU PAGES

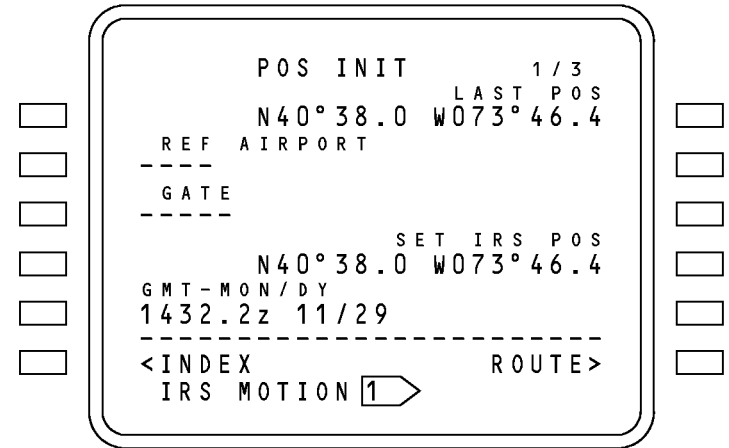

ADIRS - IRS MOTION

1565823 S0000290307_V1

EFFECTIVITY
HAP 037

34-21-00

D633A101-HAP

Page 98.54
Oct 15/2008

THIS PAGE IS INTENTIONALLY LEFT BLANK

34-21-00

D633A101-HAP

Page 98.55
Jun 15/2008

ADIRS - POSITION DIFFERENCE DURING ALIGNMENT

General

The ADIRU keeps a record of its last position. You must enter position data during the alignment mode. When you enter position data that is more than 1 degree different than the recorded latitude or 1 degree different than the recorded longitude, these things occur:

- ALIGN light flashes
- Status code 4 shows on ISDU
- ENTER IRS POSITION shows on CDU.

Enter the same position data again to cause these to occur:

- Align light on (no flash)
- Status code 4 goes out of view
- ENTER IRS POSITION goes out of view.

NOTE: The ADIRU does not calculate longitude. The ADIRU will not detect an incorrect longitude entry after alignment is complete.

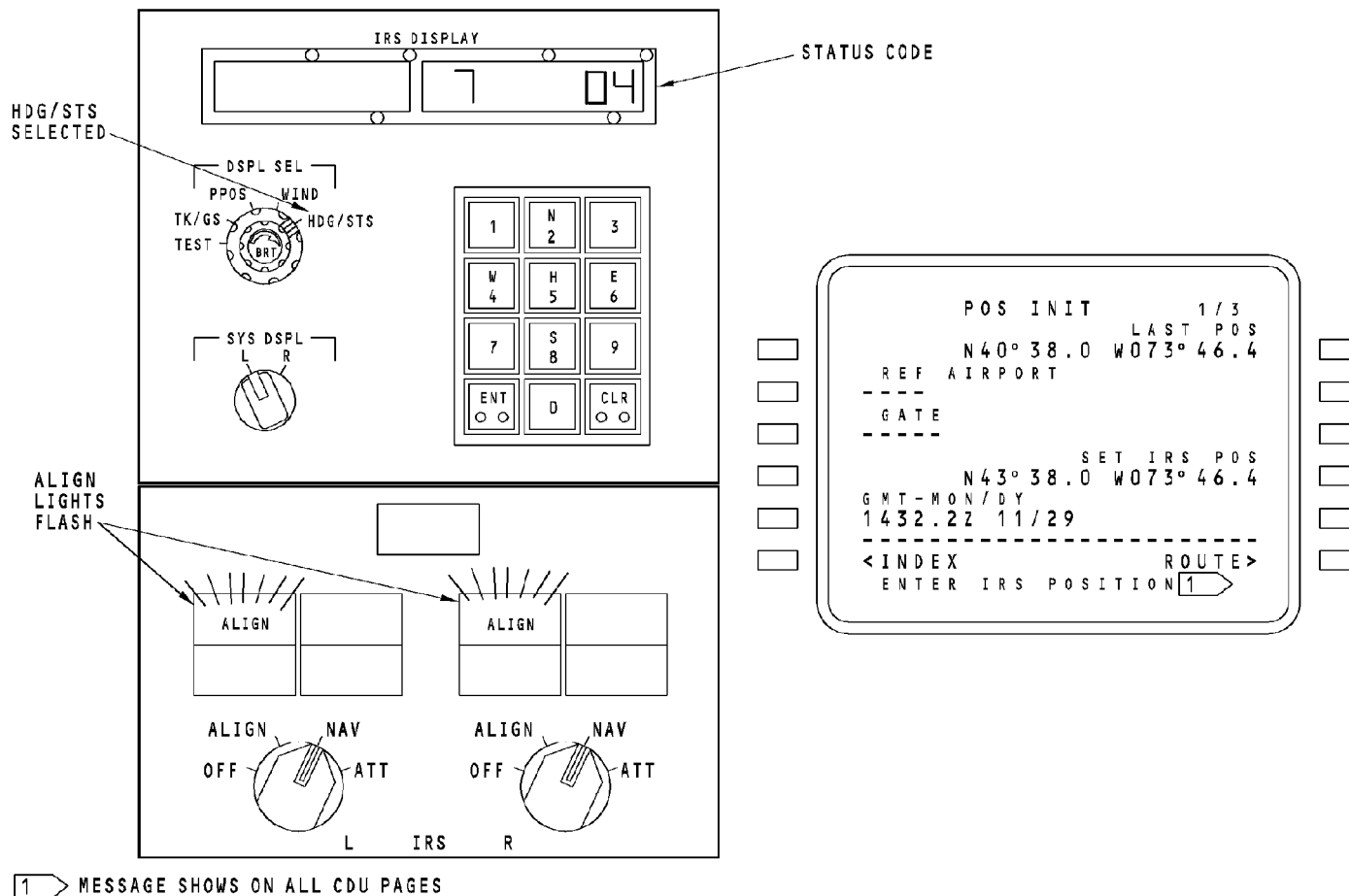

ADIRS - POSITION DIFFERENCE DURING ALIGNMENT

EFFECTIVITY

HAP 001-013, 015-026, 028-036, 038-054, 101-999

34-21-00

D633A101-HAP

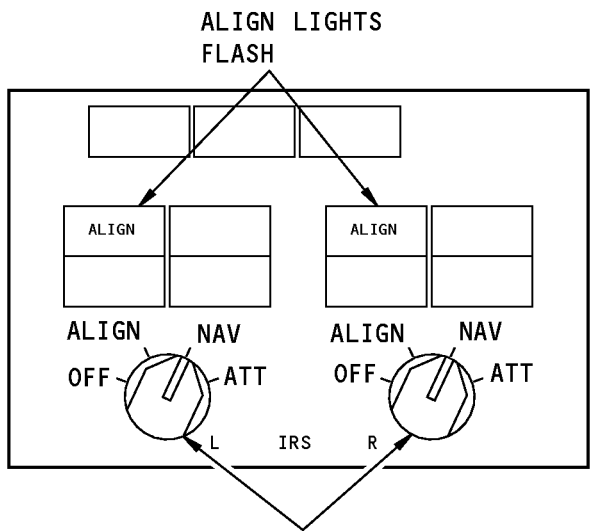
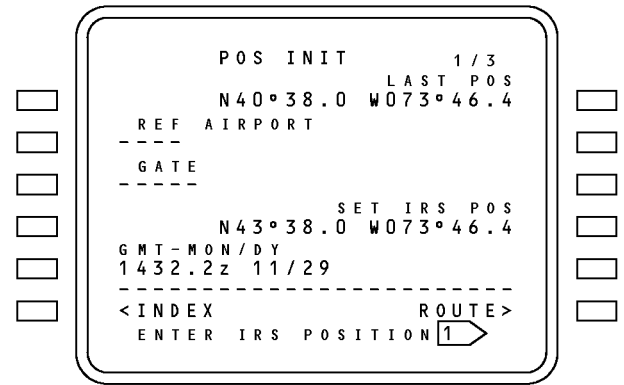
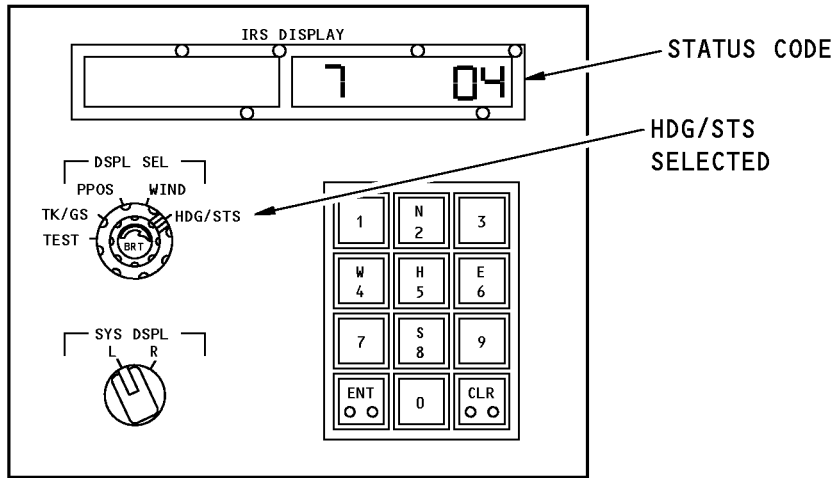

MODE SELECT SWITCHES
 1 MESSAGE SHOWS ON ALL CDU PAGES

ADIRS - POSITION DIFFERENCE DURING ALIGNMENT

EFFECTIVITY
HAP 037

34-21-00

D633A101-HAP

34-21-00-043

THIS PAGE IS INTENTIONALLY LEFT BLANK

34-21-00

D633A101-HAP

Page 98.59
Jun 15/2008

ADIRS - POSITION DIFFERENCE AFTER ALIGNMENT 1**General**

At the end of the alignment period, if the ADIRU calculated latitude is different than the latitude you entered, you will see these conditions:

- ALIGN light flash
- SET IRS POSITION shows on CDU
- Alignment time shows 0 on ISDU
- Status code out of view on ISDU.

If you enter the same latitude again, you will see these conditions:

- ALIGN light on
- FAULT light on
- SET IRS POSITION on CDU goes out of view
- Alignment time shows 0 on ISDU
- Status code 2 shows on ISDU.

One of these will cause a latitude difference:

- ADIRU calculated latitude error
- Latitude entry error.

ADIRU Calculated Latitude Error

A calculated latitude error usually will occur in one ADIRU. If the position difference is in one ADIRU, start a new alignment. If the new alignment has a position difference, refer to troubleshooting procedures in part two of the maintenance manual.

Latitude Entry Error

A latitude entry error gives the wrong latitude to both ADIRUs. If the position difference is in the left and right ADIRU, correct position can be entered without starting a new alignment.

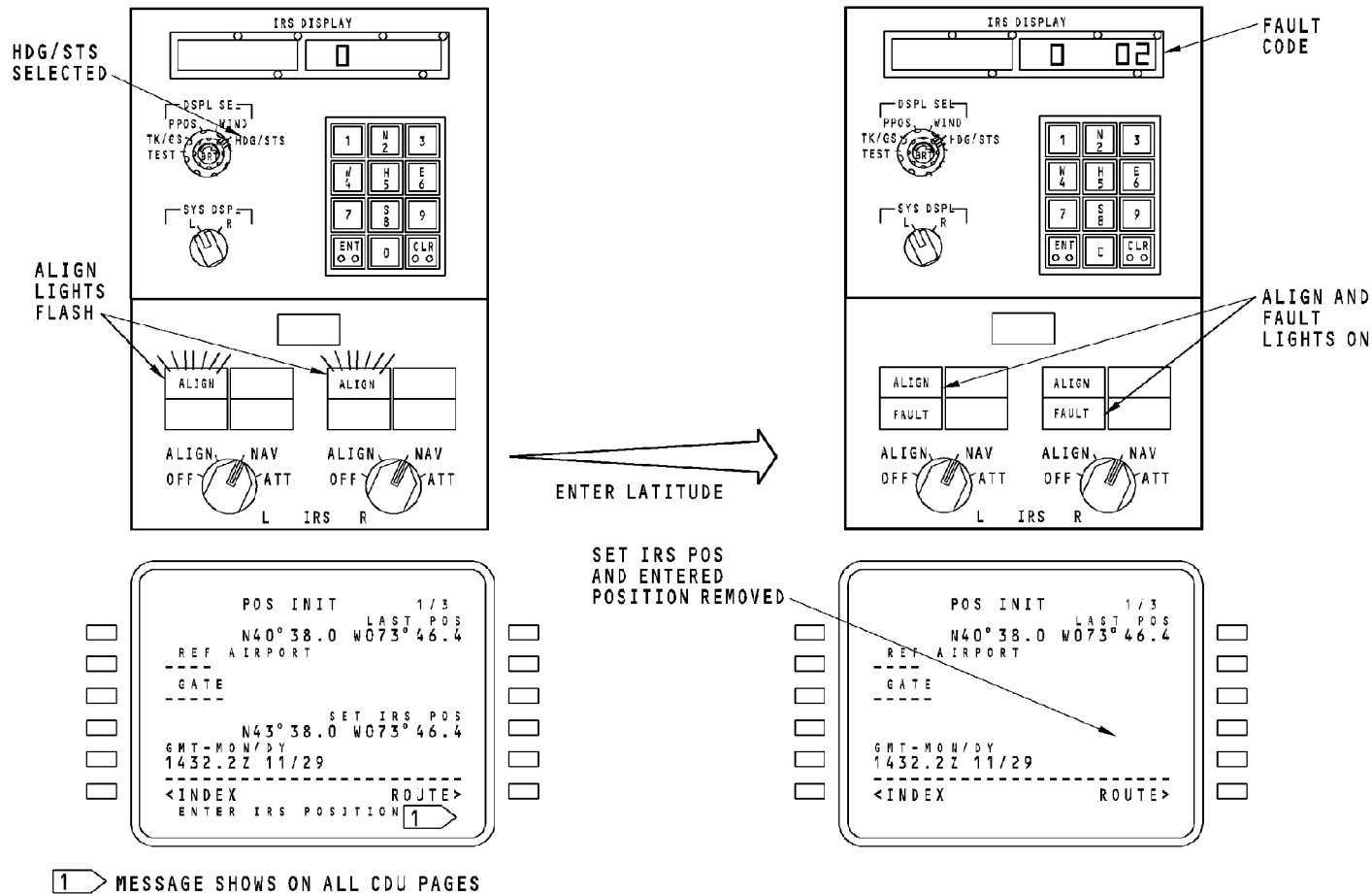

ADIRS - POSITION DIFFERENCE AFTER ALIGNMENT 1

EFFECTIVITY
 HAP 001-013, 015-026, 028-036, 038-054, 101-999

34-21-00

D633A101-HAP

Page 98.61
 Feb 15/2009

34-21-00-044

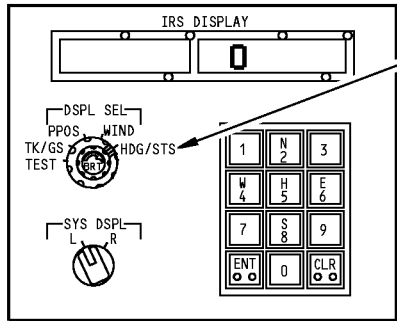

HDG/STS
SELECTED

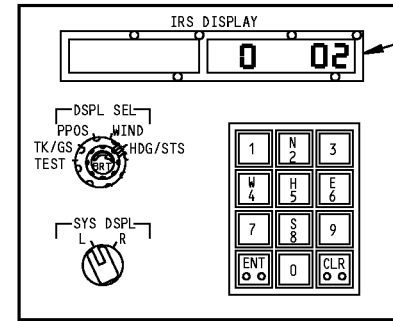

FAULT CODE

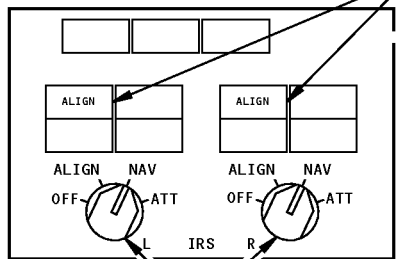

ALIGN LIGHTS
FLASHES

ALIGN AND FAULT
LIGHTS ON

ENTER LATITUDE

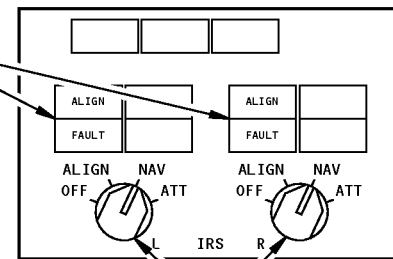

MODE SELECT SWITCHES

MODE SELECT SWITCHES

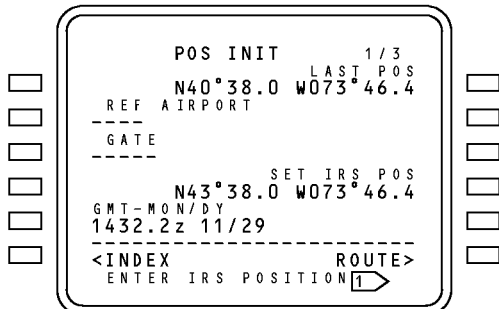

1 MESSAGE SHOWS ON ALL CDU PAGES

SET IRS POS
AND ENTERED
POSITION
REMOVED

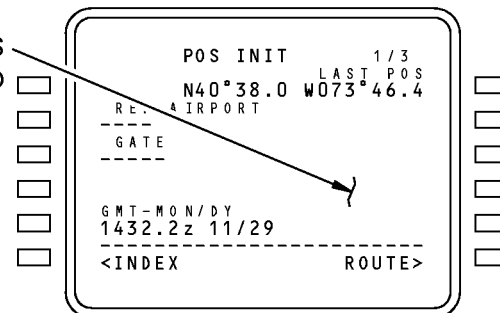

ADIRS - POSITION DIFFERENCE AFTER ALIGNMENT 1

EFFECTIVITY
HAP 037

34-21-00

D633A101-HAP

Page 98.62
Oct 15/2008

THIS PAGE IS INTENTIONALLY LEFT BLANK

34-21-00

D633A101-HAP

Page 98.63
Jun 15/2008

ADIRS - POSITION DIFFERENCE AFTER ALIGNMENT 2**Correct Position Entry**

Move the mode selector on the MSU to ALIGN. Use the keyboard on the ISDU to enter the correct latitude and longitude. The FAULT light goes off when the correct latitude is entered.

Move the mode selector to NAV. The ALIGN lights go out and the ADIRUs enter navigation mode.

If the ADIRUs do not enter the navigation mode, start a new alignment. Refer to the fault isolation manual (FIM) section 34-21 for troubleshooting procedures.

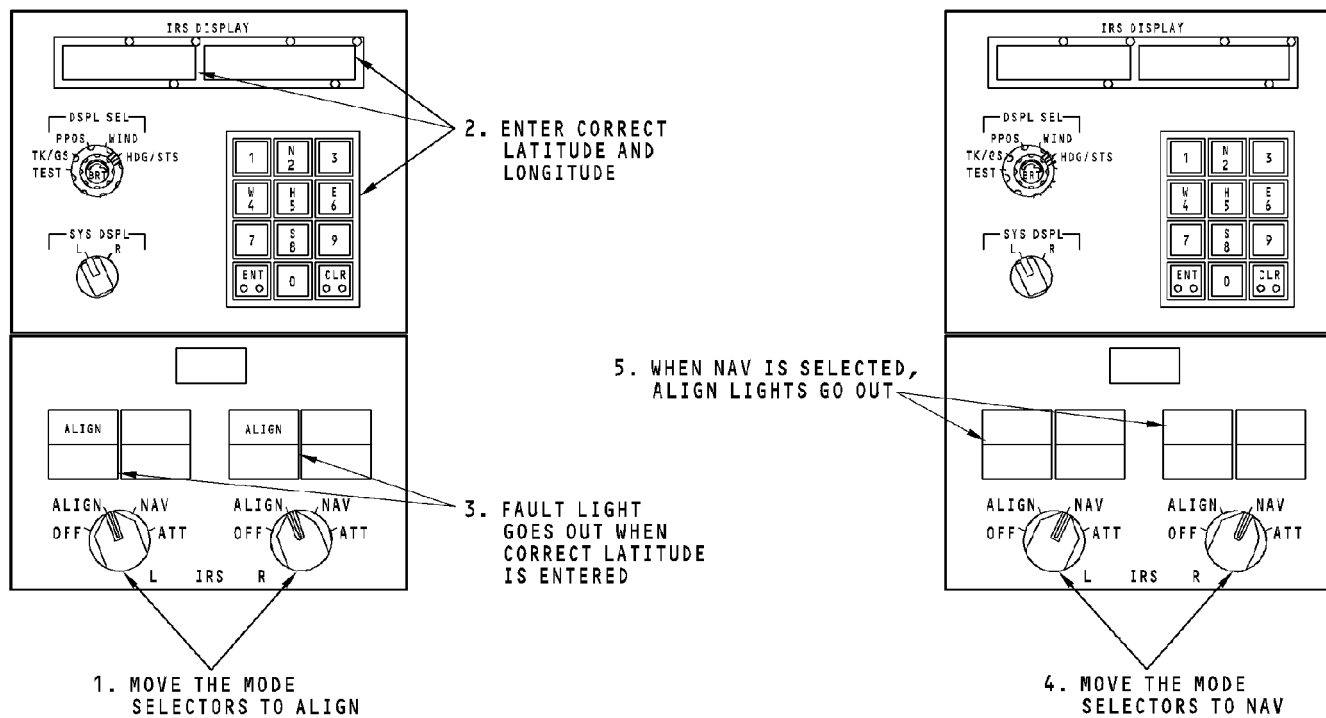

ADIRS - POSITION DIFFERENCE AFTER ALIGNMENT 2

34-21-00-045

EFFECTIVITY
 HAP 001-013, 015-026, 028-036, 038-054, 101-999

34-21-00

D633A101-HAP

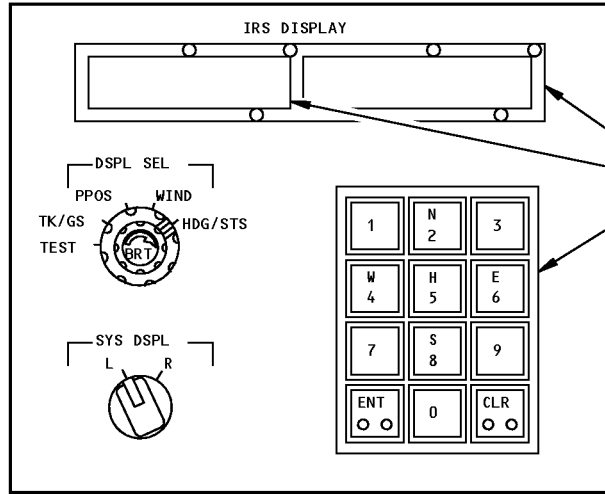

2. ENTER CORRECT LATITUDE AND LONGITUDE

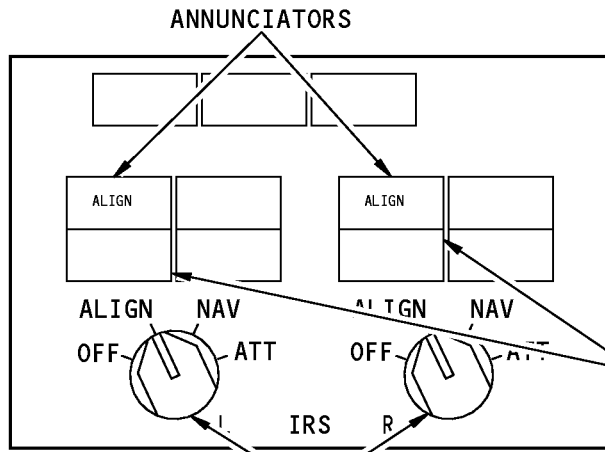
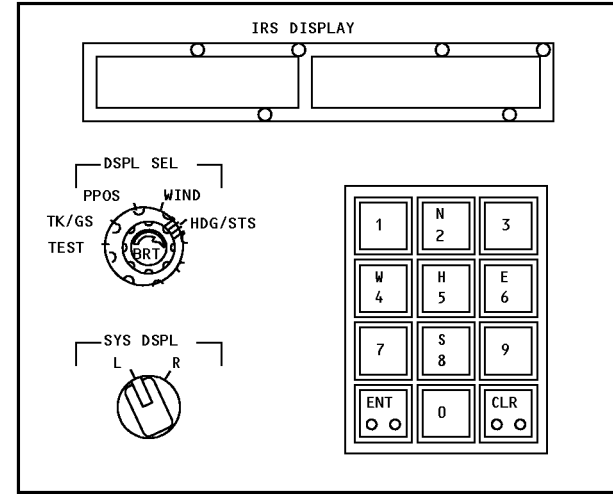

1. MOVE THE MODE SELECTORS TO ALIGN

3. FAUL LIGHT GOES OUT WHEN CORRECT LATITUDE IS ENTERED

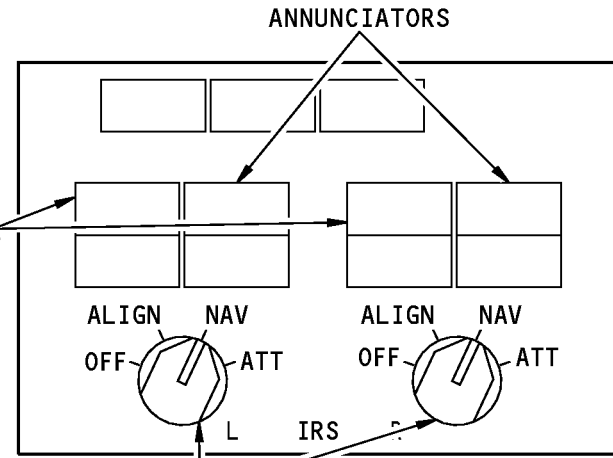

4. MOVE THE MODE SELECTORS TO NAV

1565786 S0000290310_V1

ADIRS - POSITION DIFFERENCE AFTER ALIGNMENT 2

EFFECTIVITY
HAP 037

34-21-00

34-21-00-045

D633A101-HAP

Page 98.66
Oct 15/2008

THIS PAGE IS INTENTIONALLY LEFT BLANK

34-21-00

D633A101-HAP

Page 98.67
Jun 15/2008

ADIRS - NO PRESENT POSITION ENTRY**General**

You must enter present position during the alignment period. If the alignment period ends and present position has not been entered, these conditions show:

- ALIGN light flashes
- Status code 8 shows on ISDU
- ENTER IRS POSITION shows on CDU.

Use the CDU or the ISDU to enter present position. When you enter present position these conditions show:

- ALIGN light goes off
- Status code 8 goes out of view
- ENTER IRS POSITION goes out of view.

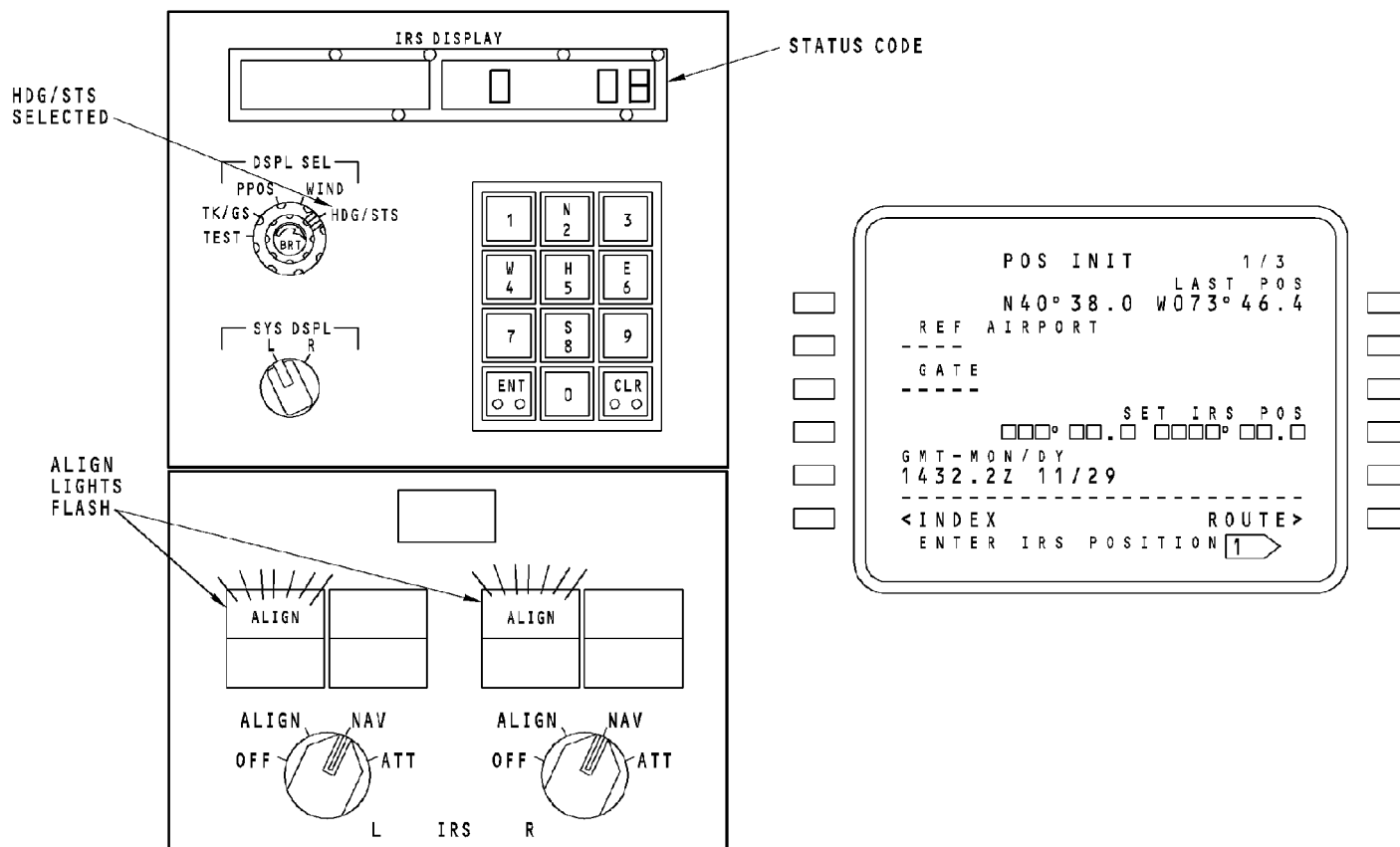

1 MESSAGE SHOWS ON ALL CDU PAGES

ADIRS - NO PRESENT POSITION ENTRY

EFFECTIVITY

HAP 001-013, 015-026, 028-036, 038-054, 101-999

34-21-00

D633A101-HAP

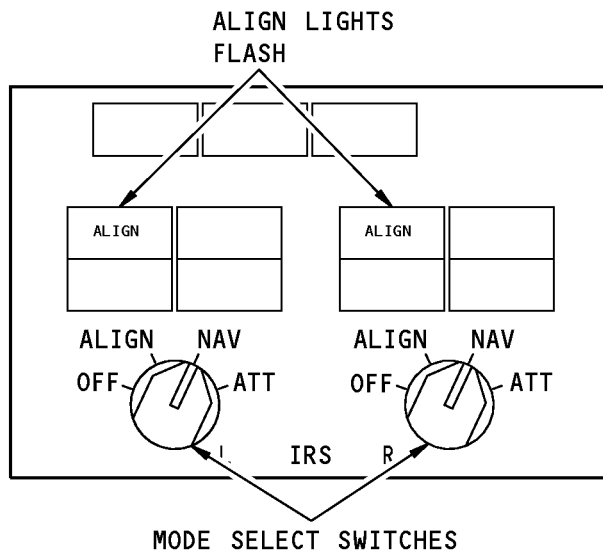
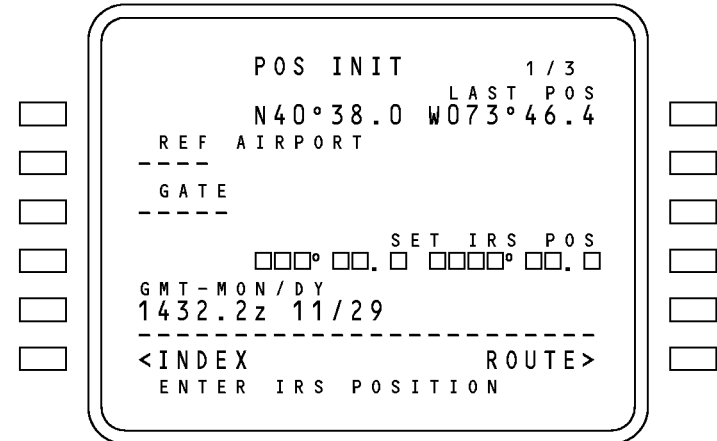
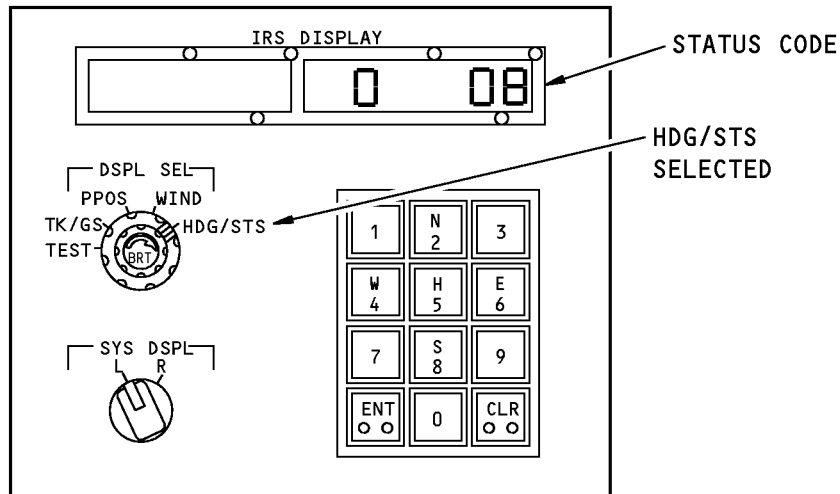

ADIRS - NO PRESENT POSITION ENTRY

1565762 S0000290311_V1

EFFECTIVITY
HAP 037

34-21-00

D633A101-HAP

Page 98.70
Oct 15/2008

34-21-00-046

THIS PAGE IS INTENTIONALLY LEFT BLANK

34-21-00

D633A101-HAP

Page 98.71
Jun 15/2008

ADIRS - ATTITUDE MODE**General**

Use the attitude (ATT) mode when you only need pitch and roll data, or when the navigation function of the ADIRU fails. You can select the attitude mode on the ground or in the air.

Attitude Mode Selection

Move the mode selector to ATT to select the attitude mode. The ADIRU goes to the attitude mode 2 seconds after the mode is selected. The two second delay prevents accidental selection of the mode.

Attitude Alignment

When you select the attitude mode, the ALIGN light comes on for 30 seconds. During this time, the ADIRU calibrates to 0 degrees in pitch and roll. If the airplane is in the air, the pilot must keep the airplane straight and level and not accelerate until the ALIGN light goes off.

Heading Entry

The ADIRU uses manual heading in the ATT mode. Status code 9 shows on the ISDU until you enter magnetic heading. Enter magnetic heading with the ISDU or CDU.

On the ISDU, push the H5 key and the number keys. Heading shows on the IRS DISPLAY. Push the ENT key to enter the heading in the ADIRU.

On the CDU, enter the three digit heading value in the scrtatchpad. Use the line select key (LSK) 5R to enter the heading in the ADIRU. The heading shows on the CDU.

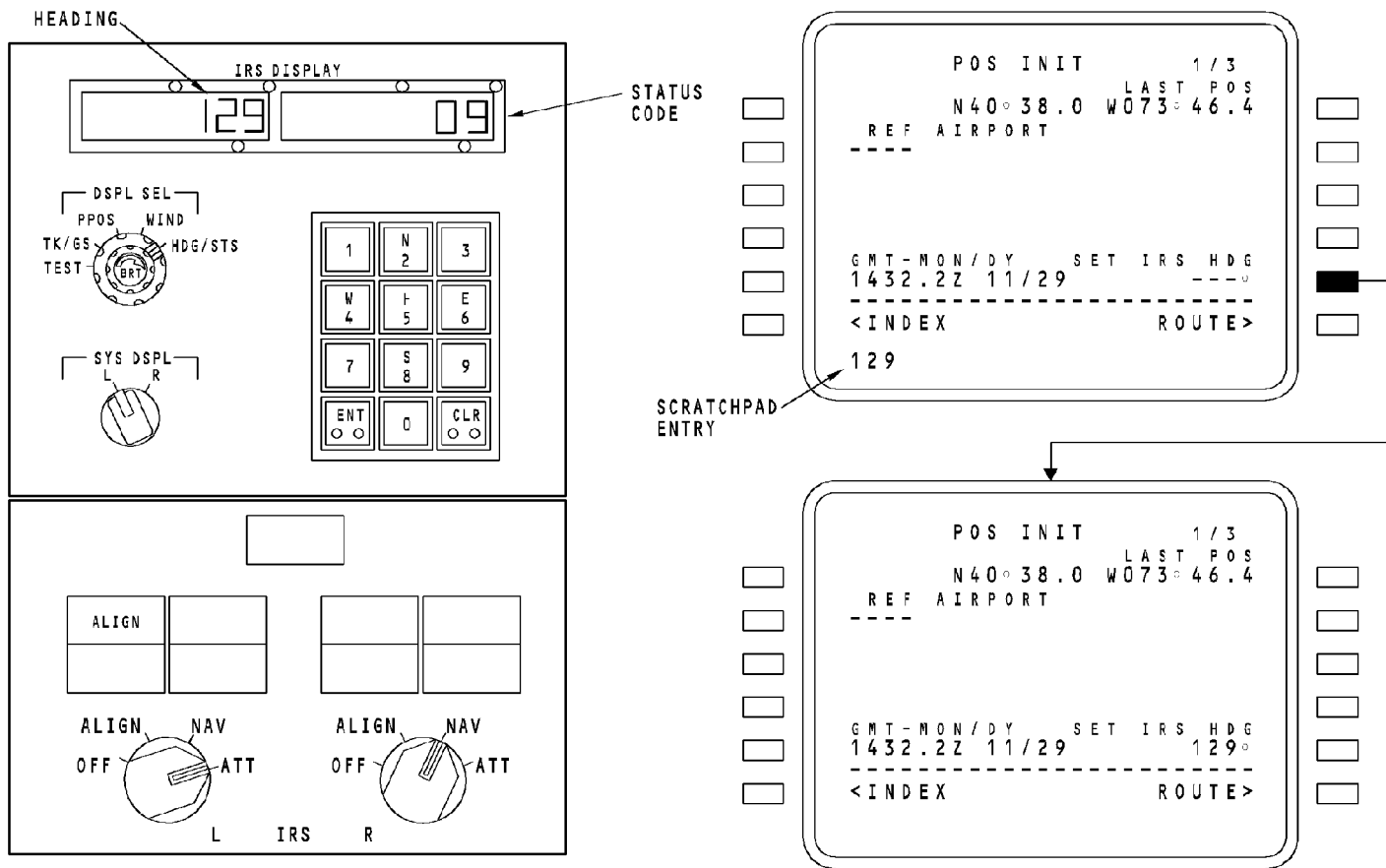

ADIRS - ATTITUDE MODE

EFFECTIVITY

HAP 001-013, 015-026, 028-036, 038-054, 101-999

34-21-00

D633A101-HAP

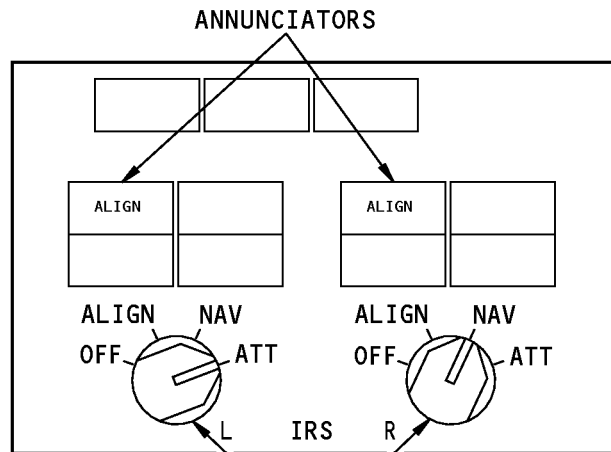
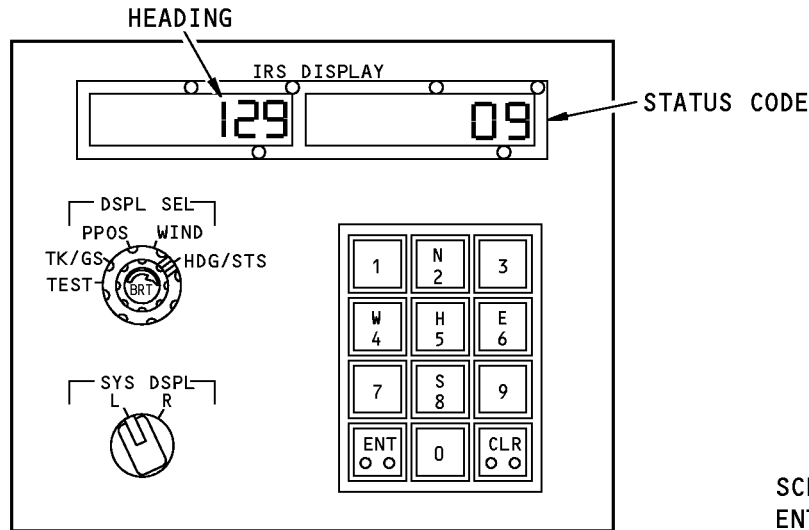

MODE SELECT SWITCHES

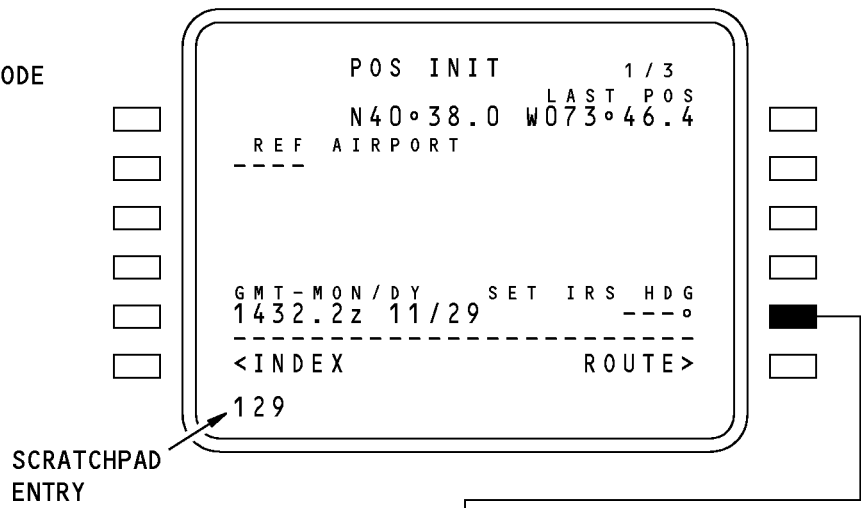

SCRATCHPAD ENTRY

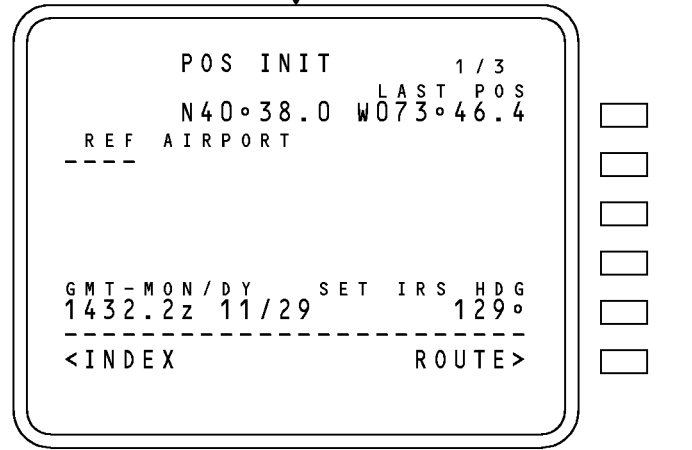

ADIRS - ATTITUDE MODE

1565753 S0000290312_V1

EFFECTIVITY
HAP 037

34-21-00

D633A101-HAP

Page 98.74
Oct 15/2008

THIS PAGE IS INTENTIONALLY LEFT BLANK

34-21-00

D633A101-HAP

Page 98.75
Jun 15/2008



ADIRS - IR MODES

GENERAL

The chart shows the mode sequences of the MSU mode selector.

34-21-00-048



34-21-00

D633A101-HAP

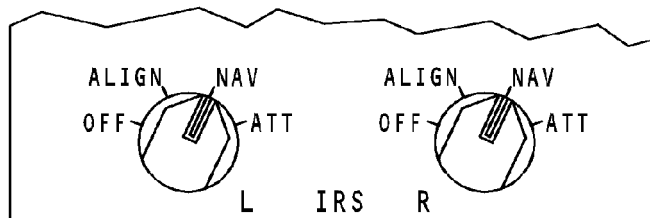

MODE SELECT SWITCH SEQUENCE	RESULT
OFF TO ALIGN (AIRPLANE NOT MOVING)	ADIRU GOES TO ALIGNMENT MODE. ALIGN LIGHT COMES ON.
OFF TO NAV (AIRPLANE NOT MOVING)	ADIRU GOES TO ALIGNMENT MODE. ADIRU AUTOMATICALLY GOES TO NAV MODE AT END OF ALIGNMENT PERIOD IF PRESENT POSITION IS ENTERED.
NAV TO ALIGN TO NAV (AIRPLANE NOT MOVING)	ADIRU VELOCITY SET TO 0. RESET LEVEL. ALIGN LIGHT COMES ON FOR 30 SECONDS.
NAV TO ALIGN (AIRPLANE NOT MOVING)	SETS VELOCITY TO 0. RESETS LEVEL AND HEADING. ALIGN LIGHT COMES ON.
OFF, ALIGN, OR NAV TO ATT	ADIRU GOES TO ATTITUDE MODE AFTER 2 SECONDS. ALIGN LIGHT COMES ON FOR 30 SECONDS. HEADING CAN BE ENTERED.
ATT TO NAV OR ALIGN	ADIRU IN ATTITUDE MODE UNTIL SWITCH IS MOVED TO OFF.
ATT TO OFF	ALIGN LIGHT COMES ON FOR 30 SECONDS. AFTER 30 SECONDS, ADIRU GOES OFF.
NAV OR ALIGN TO OFF	ALIGN LIGHT COMES ON FOR 30 SECONDS. FAULTS AND POSITION DATA STORED IN MEMORY. AFTER 30 SECONDS, ADIRU GOES OFF.

ADIRS - IR MODES

EFFECTIVITY
HAP ALL

34-21-00

D633A101-HAP

Page 98.77
Jun 15/2008

ADIRS - ADIRS MAINTENANCE CODES**General**

ADIRS maintenance codes show on the IRS DISPLAY of the ISDU. Some codes give the condition of ADIRS components and signals. Some codes give instructions.

Two or more codes cause the ISDU CLR key light to come on. Push the CLR key to show the codes in sequence.

The ADIRS maintenance codes come from the ADIRUs. Put the SYS DSPL selector in the L position to see codes from left ADIRU. The right shows codes from the right ADIRU.

NOTE: Maintenance codes 26 and 36 are not used.

CDU Display Pages

You can see the list of ADIRS maintenance codes on the CDU. The list is a part of the ADIRS BITE.

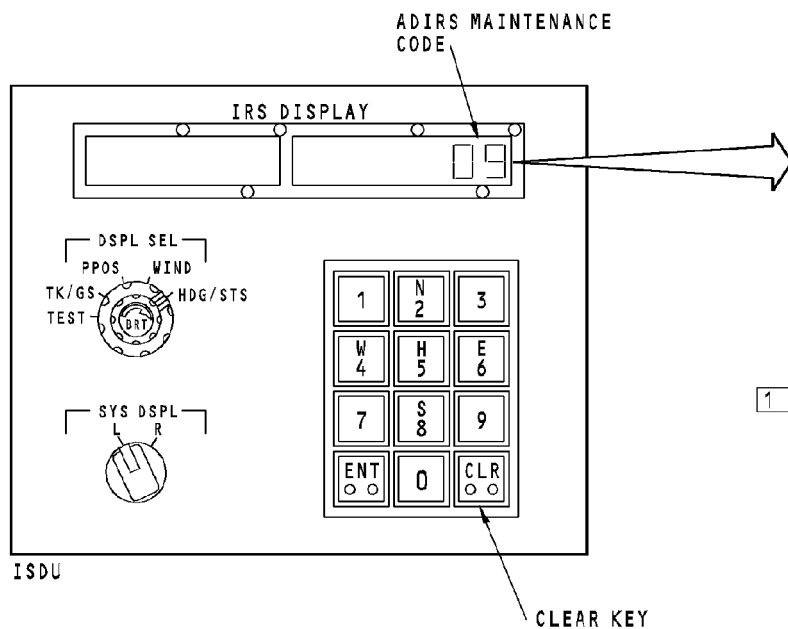

1 NOT USED

CODE TABLE	
01	ISDU FAIL
02	IR FAILURE
03	EXCESSIVE MOTION
04	ALIGN FAULT
07	ADR DATA INVLD
08	ENTER PPOS
09	ENTER HEADING
10	ISDU POWER LOSS
18	NO ADR DATA
19	IR PROG PIN INVLD
20	ADR FAIL
21	ADR PROG PIN INVLD
22	TAT PROBE SIGNAL FAIL
23	AOA SIGNAL FAIL
24	NO AOA REF SIGNAL
26	NO BARO 3 REF SIGNAL
27	NO PITOT ADM DATA
28	NO STATIC ADM DATA
29	NO BARO 1 DATA
30	NO BARO 2 DATA
31	NO IR DATA
32	PITOT ADM DATA INVLD
33	STATIC ADM DATA INVLD
34	BARO 1 DATA INVLD
35	BARO 2 DATA INVLD
36	BARO 3 SIGNAL FAIL
37	IR DATA INVLD
38	AIR/GND LOGIC INVLD

ADIRS - ADIRS MAINTENANCE CODES

EFFECTIVITY
HAP ALL

34-21-00

D633A101-HAP

Page 98.79
Jun 15/2008

ADIRS - TRAINING INFORMATION POINT - CDU ADIRS BITE PAGES - ADIRS BITE MAIN MENU**General**

The ADIRS has maintenance information that you can get access to through the flight management computer control display unit (CDU).

To see the maintenance information, select ADIRS on line select key (LSK) 4L from the MAINT BITE INDEX. This shows the ADIRS BITE page.

On the ADIRS BITE page, select either ADIRS L on LSK 1L or ADIRS R on LSK 2L. This shows the ADIRS BITE main menu for the left ADIRU or the right ADIRU.

ADIRS BITE Main Menu

There are four maintenance procedures that you can select through the ADIRS BITE main menu. These are the selections:

- Current status
- Inflight faults
- Ground test
- Ident/config.

To show the current status, select LSK 1L.

To show the inflight faults, select LSK 2L.

To operate a ground test, select LSK 3L.

To show the identification and configuration information, select LSK 4L.

The input monitoring line is not active.

Select LSK 6I to return to the ADIRS BITE page.

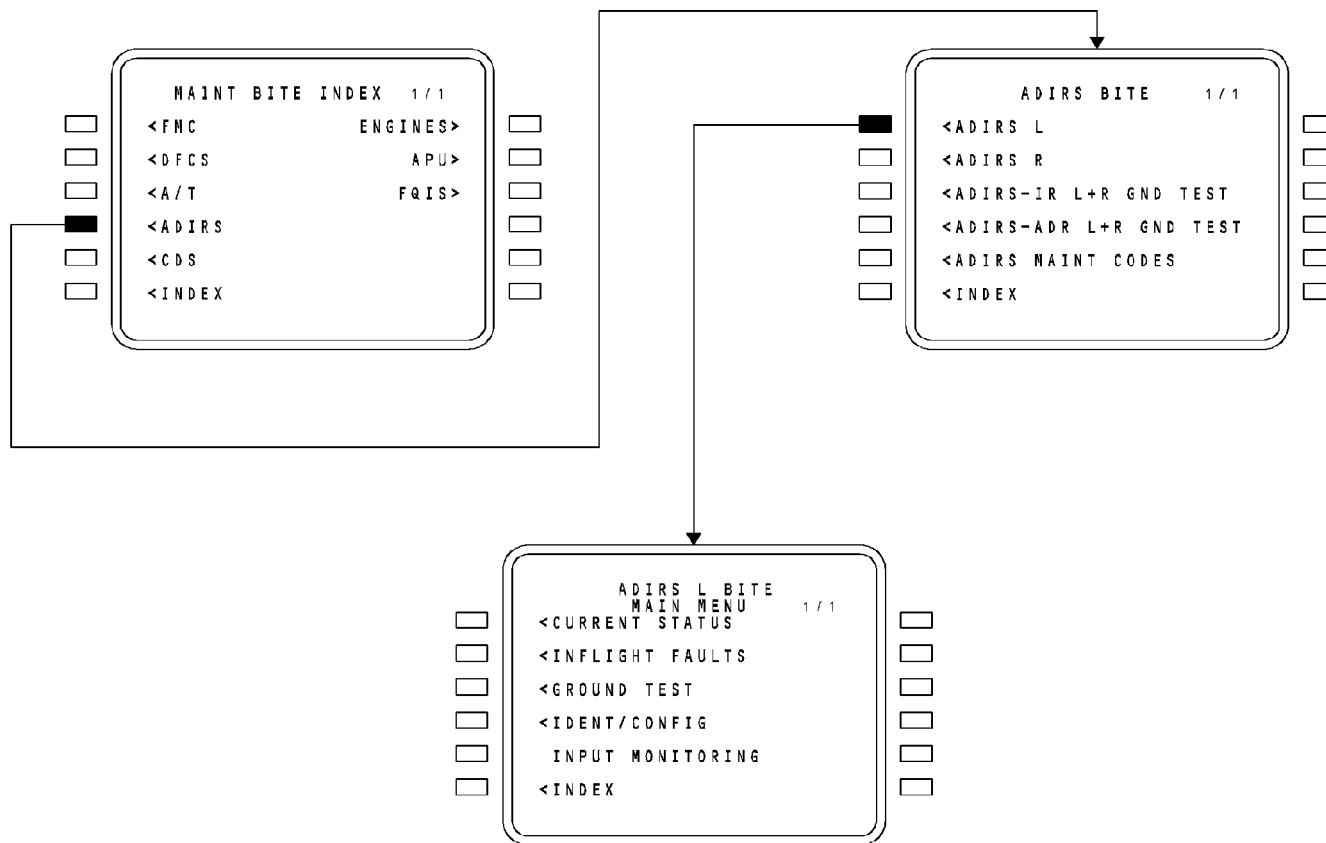

ADIRS - TRAINING INFORMATION POINT - CDU ADIRS BITE PAGES - ADIRS BITE MAIN MENU

34-21-00-050

EFFECTIVITY
HAP ALL

34-21-00

D633A101-HAP

Page 98.81
Jun 15/2008

ADIRS - TRAINING INFORMATION POINT - CDU ADIRS BITE PAGES - CURRENT STATUS**General**

To show the current status, select CURRENT STATUS on line select key (LSK) 1L from the ADIRS L BITE MAIN MENU. This shows the CURRENT FAULTS page.

It shows active faults detected by the ADIRU. If there are no active faults detected by the ADIRU, the message page NO CURRENT FAULTS shows.

CURRENT FAULTS Page

Three faults show on a page. The number of current faults pages show on the top right. To show the next current faults page, select the NEXT PAGE key on the FMC CDU keypad.

The faults show in the order that the ADIRU detects the faults. If the ADIRU detects a new fault while current faults show, the new fault shows after the last detected fault.

This information shows for a fault:

- Maintenance message number
- Fault description.

The maintenance message number is a number assigned to the fault. You can use the maintenance message number index in the fault isolation manual (FIM) to find the correct fault isolation procedure to fix the fault.

The fault description is a short description of the fault.

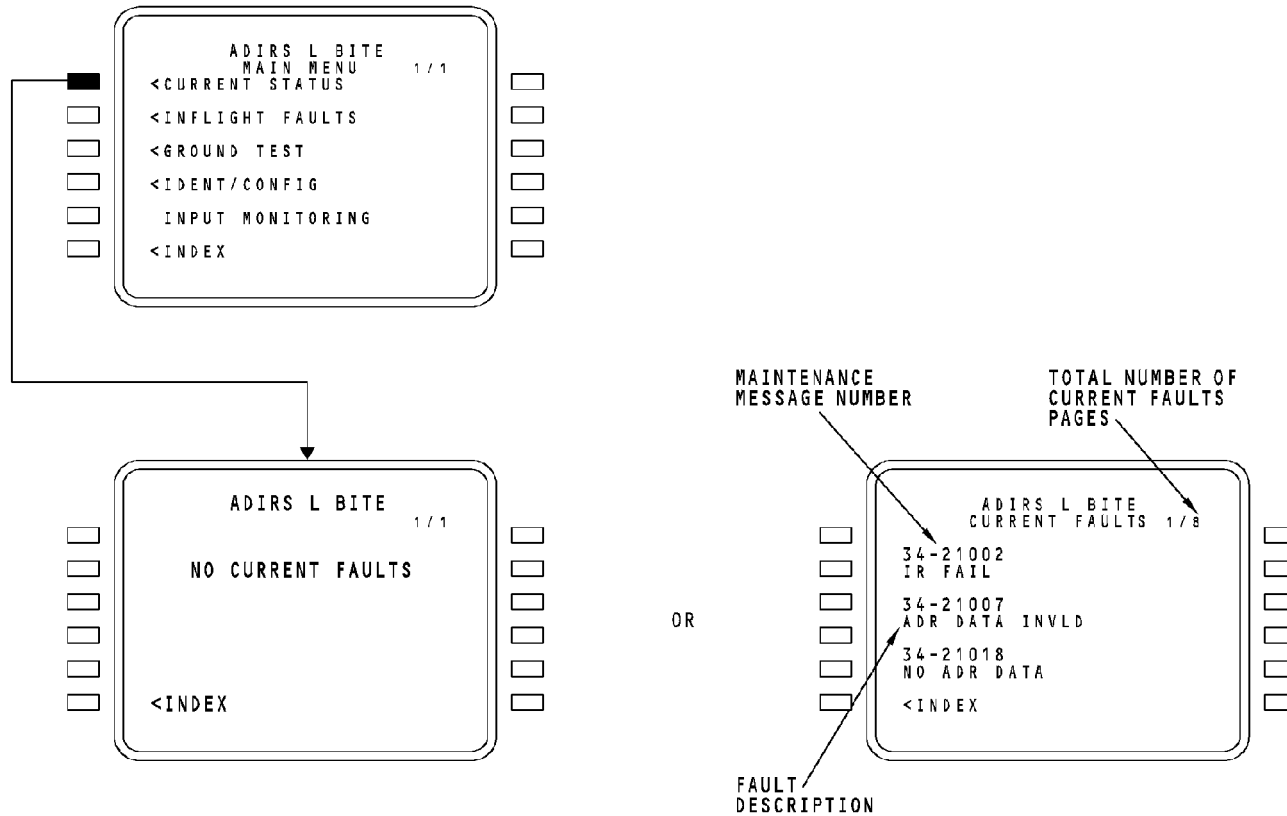

ADIRS - TRAINING INFORMATION POINT - CDU ADIRS BITE PAGES - CURRENT STATUS

34-21-00-051

EFFECTIVITY
HAP ALL

34-21-00

D633A101-HAP

Page 98.83
Jun 15/2008

ADIRS - TRAINING INFORMATION POINT - CDU ADIRS BITE PAGES - INFLIGHT FAULTS**General**

To show the inflight faults, select INFLIGHT FAULTS on line select key (LSK) 2L from the ADIRS L BITE MAIN MENU. This shows the INFLIGHT FAULTS MENU page.

The ADIRU stores faults for up to 9 flight legs. The ADIRU can store up to 26 faults for each flight leg.

A new flight leg starts when the airplane takes off. The flight leg ends when the airplane lands. If a fault occurs on the ground, the ADIRU stores the fault as a current fault. If the fault exists when a new flight leg starts, the ADIRU stores the fault in the new flight leg.

INFLIGHT FAULTS MENU Page

The INFLIGHT FAULTS MENU page shows a list of the flight legs that have faults in the ADIRU memory. The number of inflight faults for the flight leg shows below the flight leg number.

To show the faults for a flight leg, select the LSK next to the flight leg. This shows the first three faults in that flight leg. Leg 01 is the most current flight leg.

LEG XX FAULTS Page

Up to three faults show on a page. If the fault leg has more than three faults, the additional faults show on additional pages for the flight leg. The number of pages shows on the top of the page.

This information shows for a single fault:

- Maintenance message number
- Fault description.

The maintenance message number is a number assigned to this fault. You can use the maintenance message number index in the fault isolation manual (FIM) to find the correct fault isolation procedure to fix the fault.

The fault description is a short description of the fault.

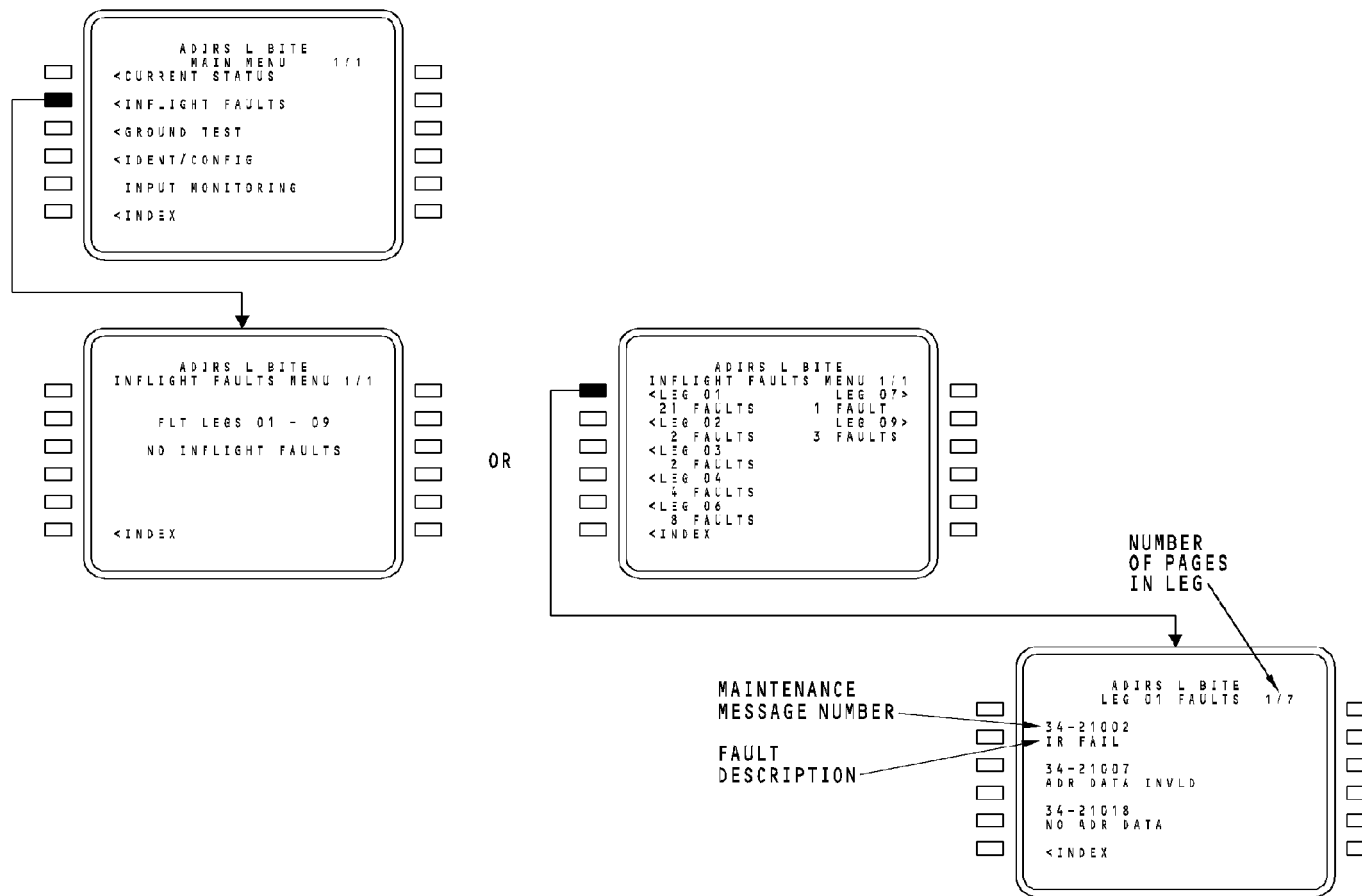

ADIRS - TRAINING INFORMATION POINT - CDU ADIRS BITE PAGES - INFLIGHT FAULTS

34-21-00-052

EFFECTIVITY
HAP ALL

34-21-00

D633A101-HAP

ADIRS - TRAINING INFORMATION POINT - CDU ADIRS BITE PAGES - GROUND TEST MENU**General**

To operate a ground test, select line select key (LSK) 3L, GROUND TEST from the ADIRS BITE MAIN MENU. This shows the GROUND TEST page.

GROUND TEST Page

The GROUND TEST page shows a list of the ground tests you can operate. These are the ground tests:

- IR ground test
- ADR ground test.

To operate the IR ground test, select LSK 2L.

To operate the ADR ground test, select LSK 3L.

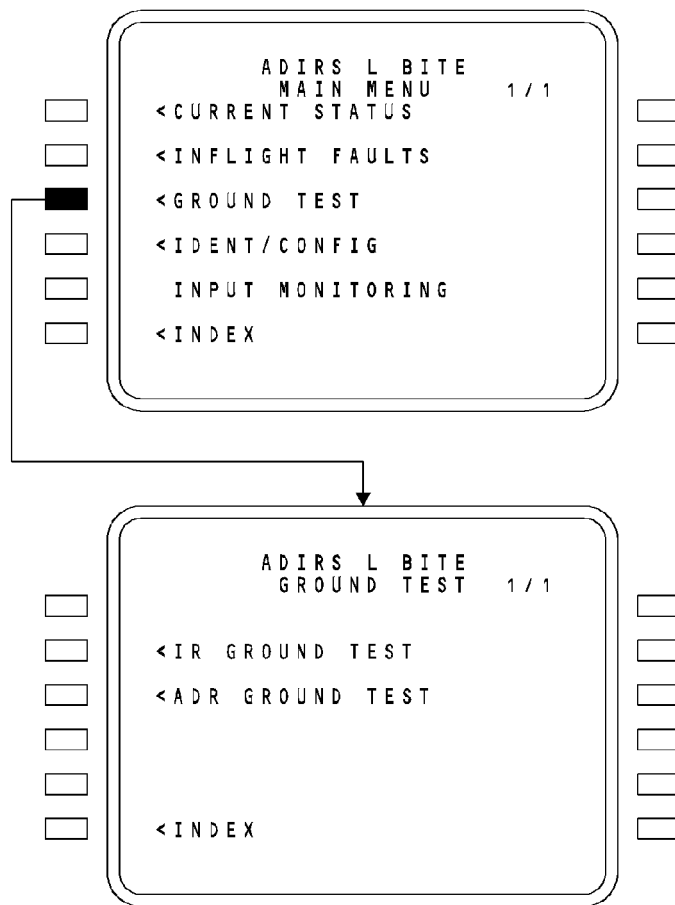

ADIRS - TRAINING INFORMATION POINT - CDU ADIRS BITE PAGES - GROUND TEST MENU

34-21-00-053

EFFECTIVITY
HAP ALL

34-21-00

D633A101-HAP

Page 98.87
Jun 15/2008

ADIRS - TRAINING INFORMATION POINT - CDU ADIRS BITE PAGES - IR GROUND TEST**General**

To operate the IR GROUND TEST, select line select key (LSK) 2L. ADIRS X BITE IR GROUND TEST page shows.

The IR ground test will not operate if the ground speed is more than 20 knots, or IR is in the attitude mode. TEST INOP shows on all IR GROUND TEST pages, and TEST START goes out of view.

IR GROUND TEST Pages

The IR GROUND TEST pages show information about the self test. There are three IR GROUND TEST pages.

The IR GROUND TEST pages do not show test data when the self test runs. The IR GROUND TEST pages only show test values that you verify during the test.

Page 1 gives a description of the test. Page 2 and page 3 show the test values for the IR ground test. Verify the values on the flight compartment instruments. To move between pages 1, 2, and 3, use the NEXT PAGE and PREV PAGE keys on the CDU.

You can start the IR ground test from page 1, 2 or 3. Push LSK 5L to start the test. LSK 5L is next to the START TEST prompt.

When the IR ground test starts, the TEST START prompt goes out of view. The TEST STOP prompt shows. The IR ground test continues until you select TEST STOP or INDEX. TEST STOPS show on page 1, page 2 and page 3. INDEX shows on page 1, 2 and 3. Push LSK 5R or 6L to stop the test and return to the GROUND TEST menu.

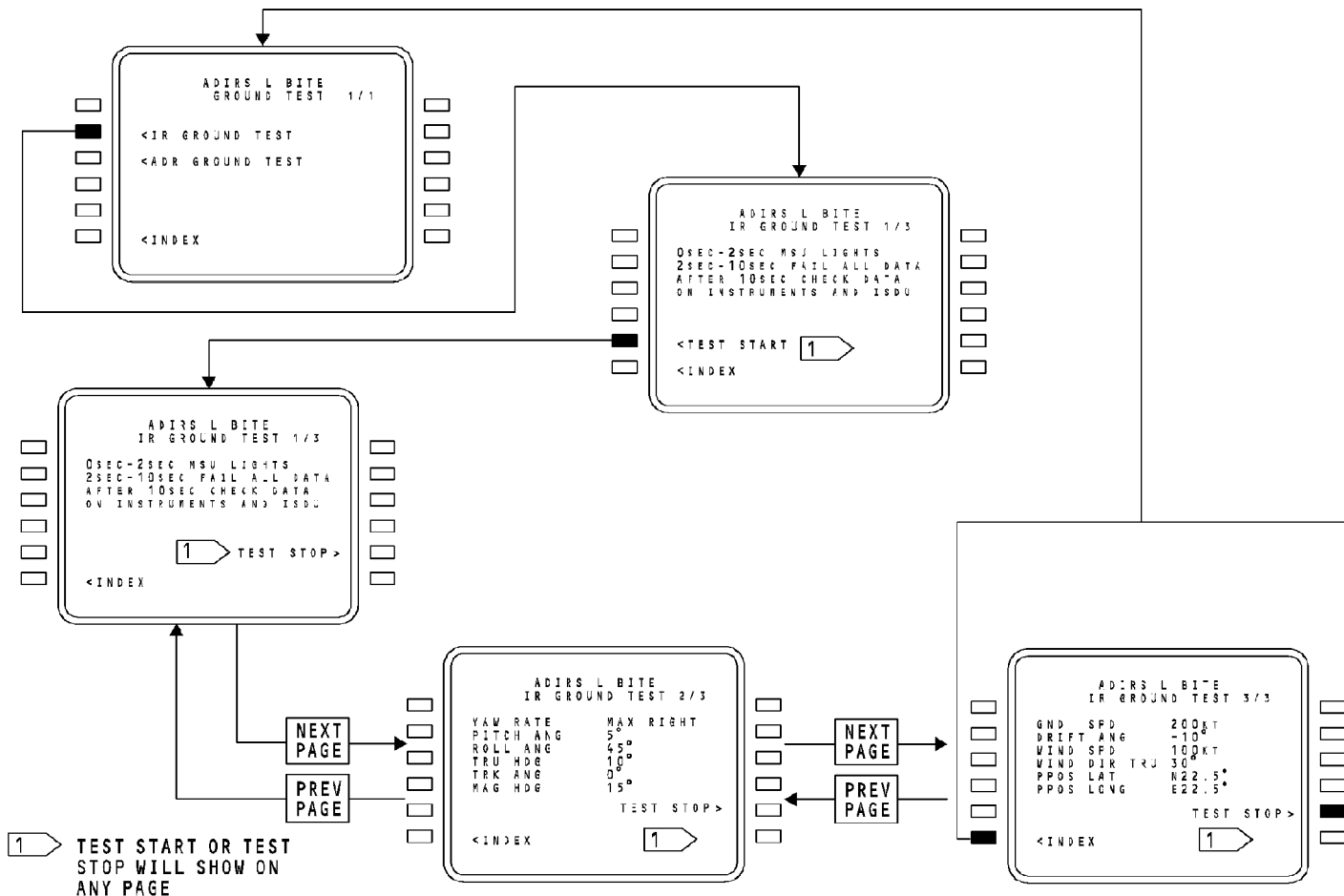

ADIRS - TRAINING INFORMATION POINT - CDU ADIRS BITE PAGES - IR GROUND TEST

34-21-00-054

EFFECTIVITY
HAP ALL

34-21-00

D633A101-HAP

Page 98.89
Jun 15/2008

ADIRS - TRAINING INFORMATION POINT - CDU ADIRS BITE PAGES - IR GROUND TEST RESULTS 1

General

Push LSK 5L to start the IR ground test. Test values show in the flight compartment.

0-2 Seconds

When the test starts, all the lights on the MSU and ISDU come on for 2 seconds.

2-10 Seconds

Between 2 and 10 seconds, all IR data fails. Components and displays that use IR data show failure flags and failure conditions.

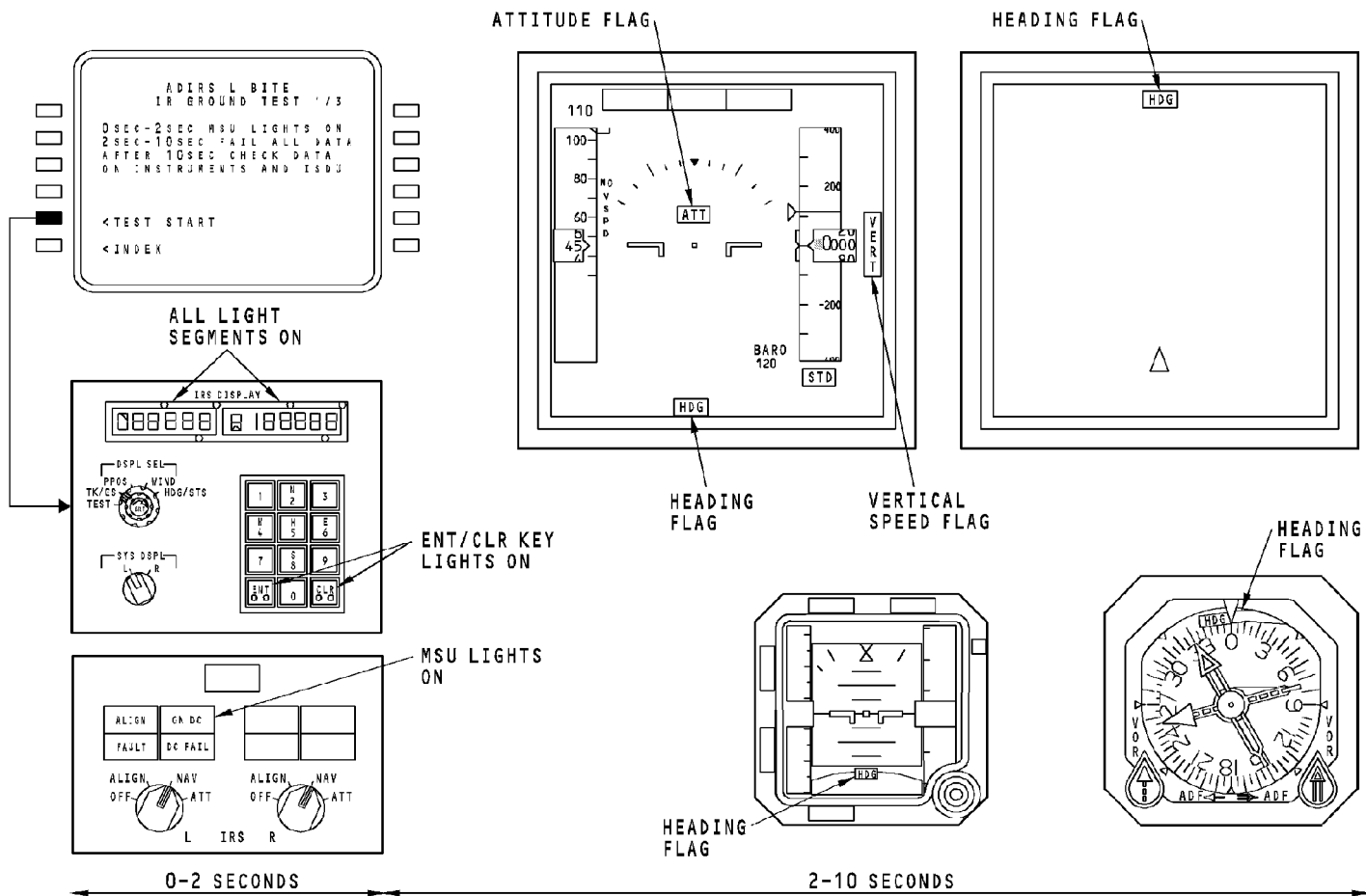

ADIRS - TRAINING INFORMATION POINT - CDU ADIRS BITE PAGES - IR GROUND TEST RESULTS 1

34-21-00-055

EFFECTIVITY
HAP 031-054, 101-999

34-21-00

D633A101-HAP

Page 98.91
Feb 15/2009

ADIRS - TRAINING INFORMATION POINT - CDU ADIRS BITE PAGES - IR GROUND TEST RESULTS 2

10 Seconds To End of Test

Ten seconds after the IR ground test starts, the ADIRU sends test values on its data buses. The test values show on the page 2 and 3 of the IR GROUND TEST.

Look at the flight compartment displays to verify test values.

YAW RATE MAX RIGHT can not be verified. It does not show on flight compartment displays.

NOTE: When you start the IR ground test from the CDU, ground speed and track data on the NAV display comes from the FMC. Use the value that shows on the ISDU to verify the IR ground test.

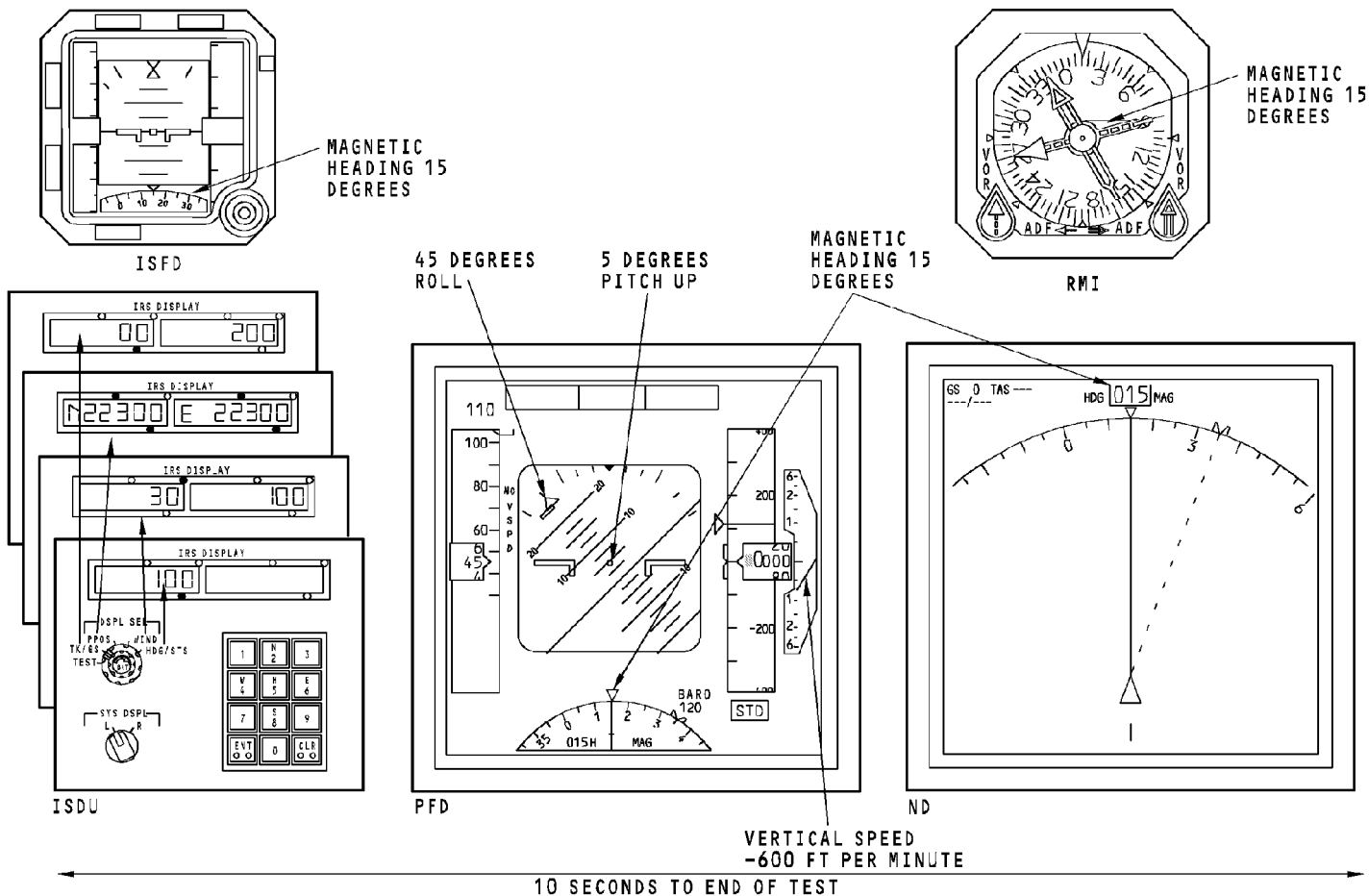

ADIRS - TRAINING INFORMATION POINT - CDU ADIRS BITE PAGES - IR GROUND TEST RESULTS 2

34-21-00-056

EFFECTIVITY
HAP 031-054, 101-999

34-21-00

D633A101-HAP

Page 98.93
Feb 15/2009

ADIRS - TRAINING INFORMATION POINT - CDU ADIRS BITE PAGES - ADR GROUND TEST**General**

To operate the ADR GROUND TEST, push line select key (LSK) 3L. ADIRS X BITE ADR GROUND TEST page shows.

ADR GROUND TEST Pages

The ADR GROUND TEST pages show information about the self test. There are two ADR GROUND TEST pages.

The ADR GROUND TEST pages do not show test data when the self test runs. The ADR GROUND TEST pages only show test values that you verify during the test.

Page 1 gives a description of the test. Page 2 shows the test values for the ADR ground test. Verify the values on the flight compartment instruments. To move between page 1 and page 2, use the NEXT PAGE and PREV PAGE keys on the CDU.

Push LSK 5L or 5R to start and stop the ADR ground test. <TEST START shows on the test pages when the test is not running. TEST STOP > shows on the pages when the test runs. When you start the test, it continues to run until you select TEST STOP.

The ADR ground test is inhibited when computed airspeed is more than 30 knots. TEST INOP replaces TEST START on the ground test pages.

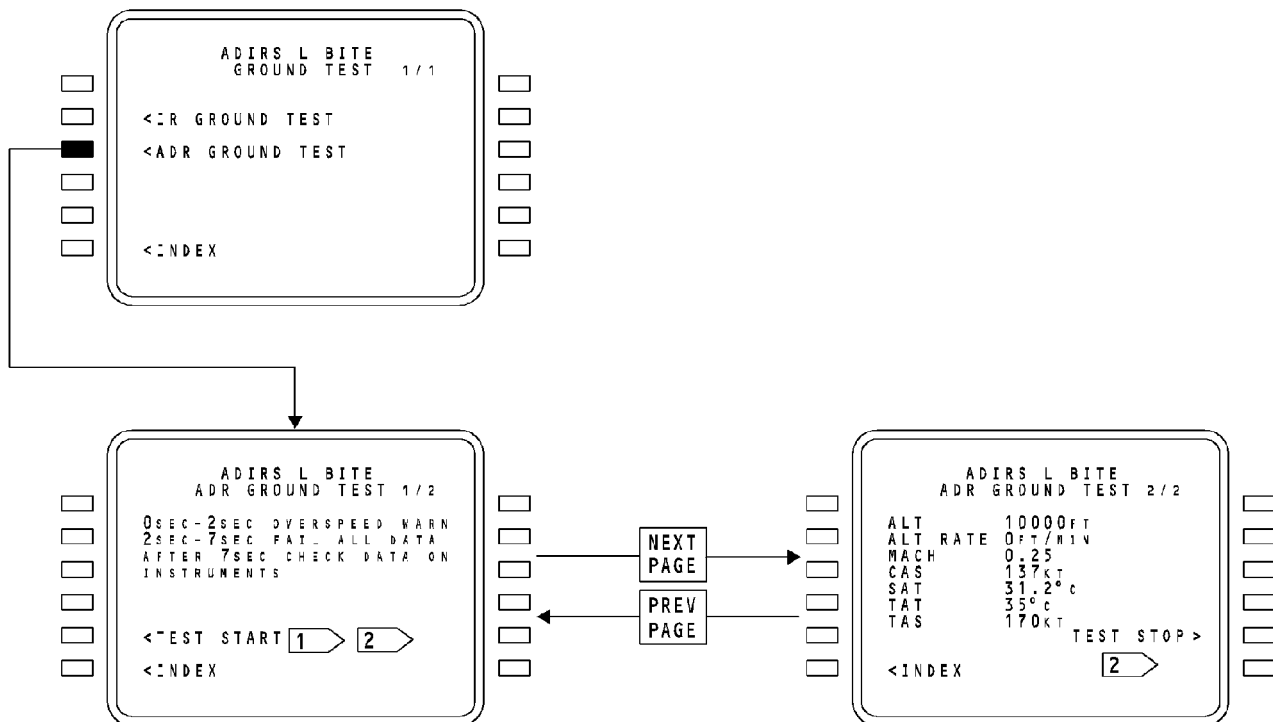

1 IF THE ADIRU INHIBITS THE GROUND TEST, TEST INOP REPLACES TEST START.

2 TEST START OR TEST STOP SHOW ON BOTH GROUND TEST PAGES.

ADIRS - TRAINING INFORMATION POINT - CDU ADIRS BITE PAGES - ADR GROUND TEST

34-21-00-057

EFFECTIVITY
HAP ALL

34-21-00

D633A101-HAP

Page 98.95
Jun 15/2008

ADIRS - TRAINING INFORMATION POINT - CDU ADIRS BITE PAGES - ADR GROUND TEST RESULTS 1**General**

Push LSK 5L to start the ADR ground test. Test values show in the flight compartment.

0-2 Seconds

When the test starts, you hear the overspeed warning for 2 seconds.

2-7 Seconds

Between 2 and 7 seconds, all ADR data fails. Components and displays that use ADR data show failure flags and failure conditions.

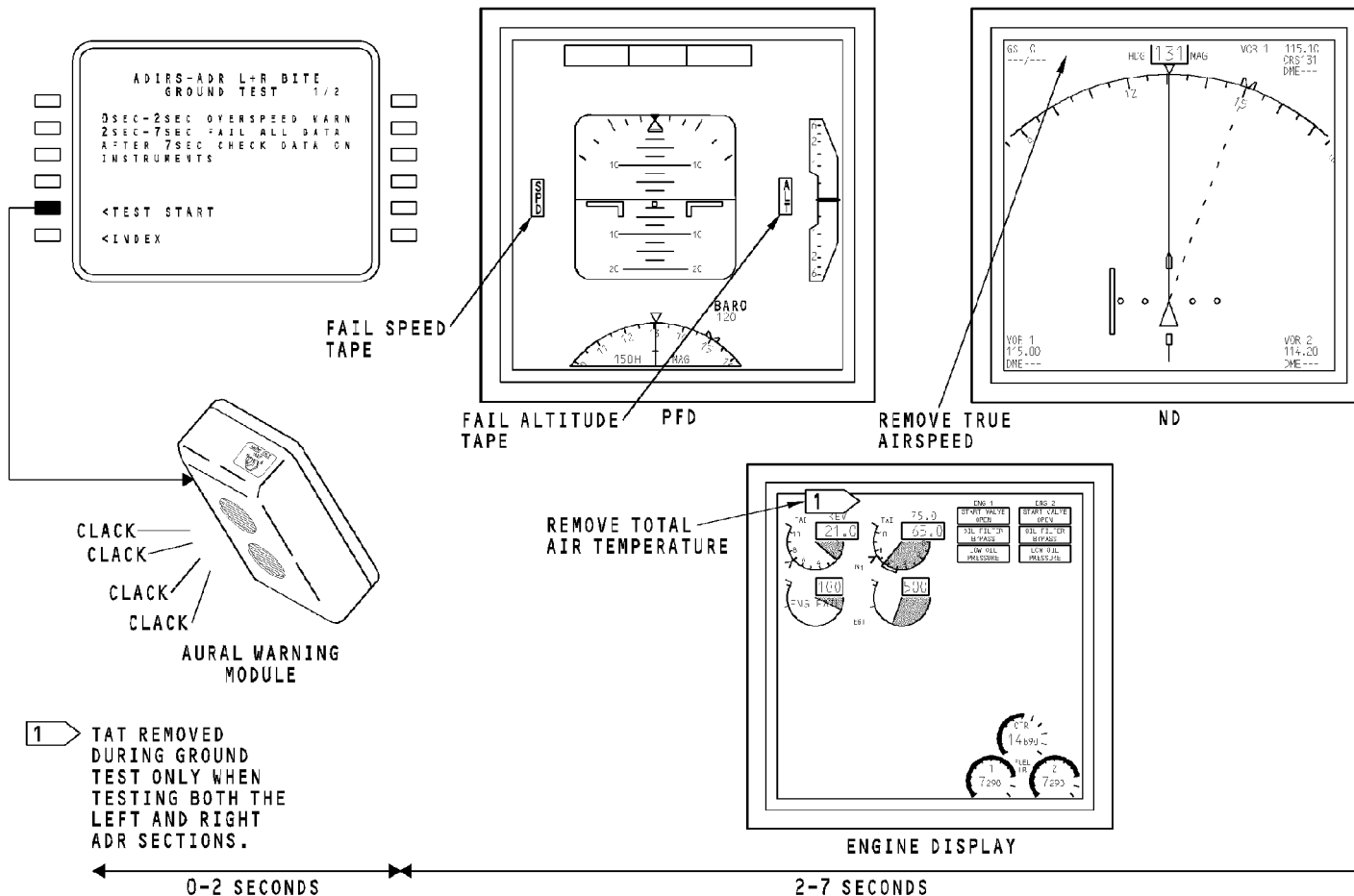

ADIRS - TRAINING INFORMATION POINT - CDU ADIRS BITE PAGES - ADR GROUND TEST RESULTS 1

34-21-00-058

EFFECTIVITY
HAP ALL

34-21-00

D633A101-HAP

Page 98.97
Jun 15/2008

ADIRS - TRAINING INFORMATION POINT - CDU ADIRS BITE PAGES - ADR GROUND TEST RESULTS 2

Seven Seconds To End of Test

Seven seconds after the ADR ground test starts, the ADIRU sends test values on its data buses. The test values show on page 2 of the ADR GROUND TEST. Not all test values on page 2 show in the flight compartment. These are the values that you can see:

- ALT; 10000 FT
- Airspeed; 137 KT
- TAT; 35C
- TAS; 170 KT.

Look at flight compartment displays to verify test values.

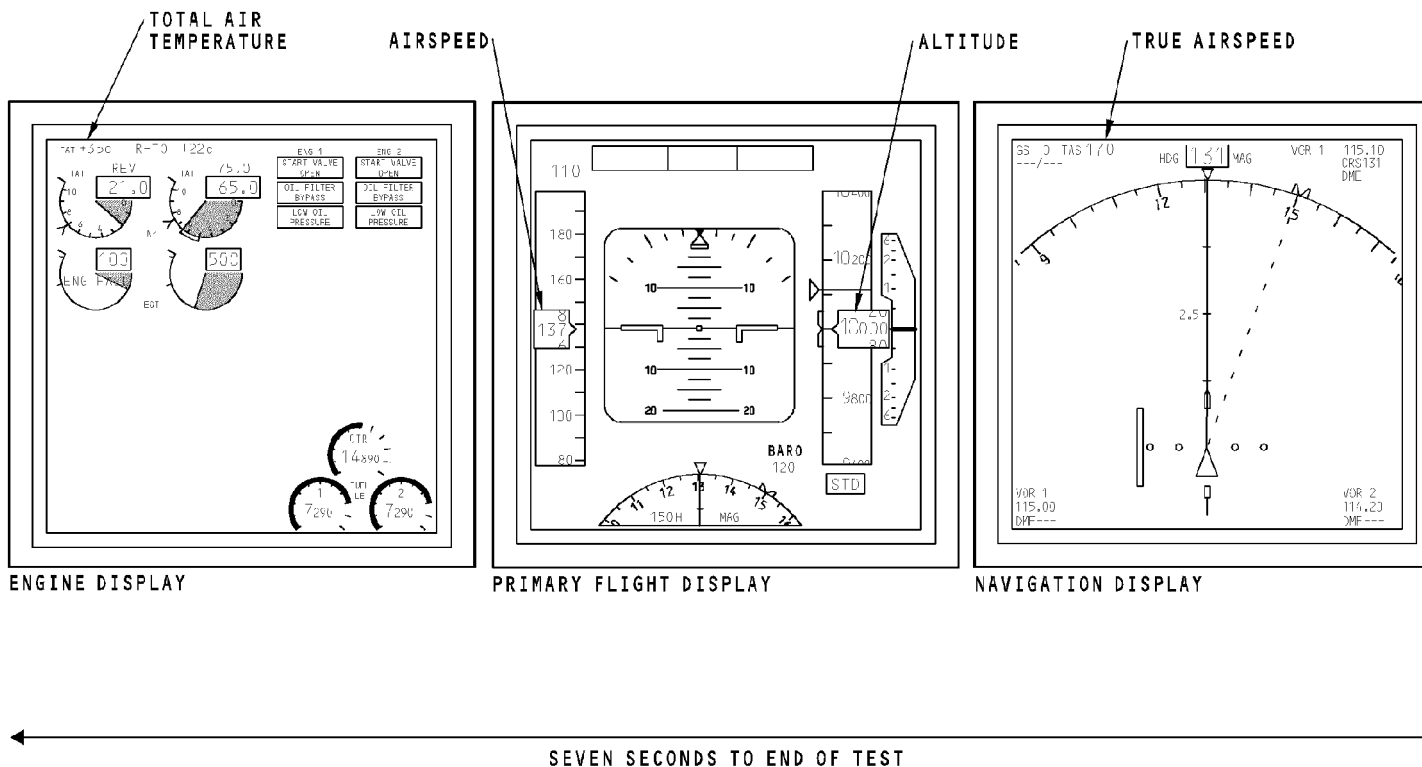

ADIRS - TRAINING INFORMATION POINT - CDU ADIRS BITE PAGES - ADR GROUND TEST RESULTS 2

34-21-00-059

EFFECTIVITY
HAP ALL

34-21-00

D633A101-HAP

ADIRS - TRAINING INFORMATION POINT - CDU ADIRS BITE PAGES - IDENT/CONFIG**General**

To show the configuration information, select IDENT/CONFIG on line select key (LSK) 4L from the ADIRS X BITE MAIN MENU. This shows the IDENT/CONFIG page.

IDENT/CONFIG Page

The IDENT/CONFIG page shows this information:

- ADIRU hardware part number
- Serial number.

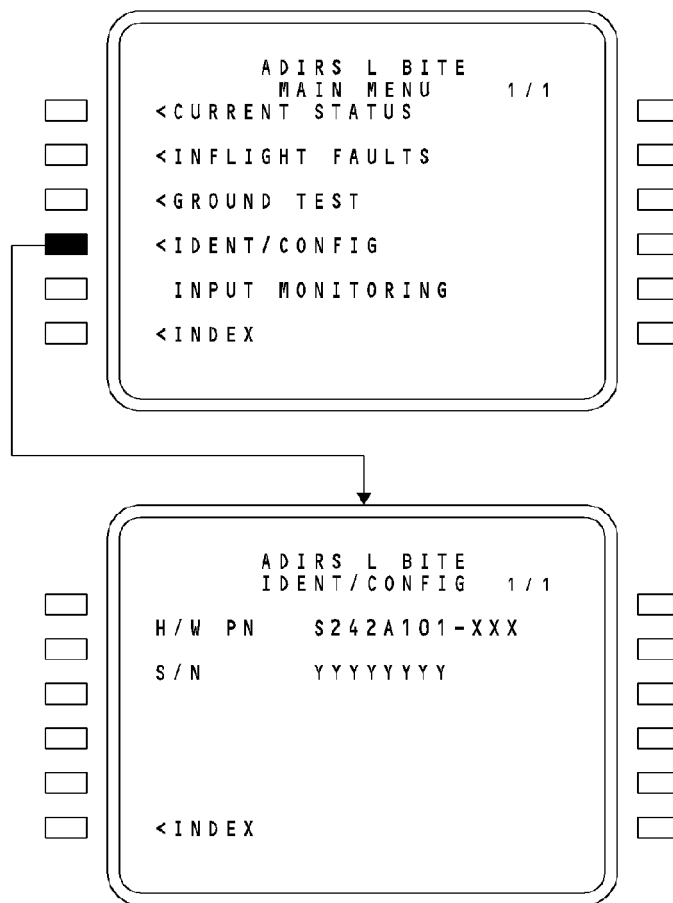

ADIRS - TRAINING INFORMATION POINT - CDU ADIRS BITE PAGES - IDENT/CONFIG

34-21-00-060

EFFECTIVITY
HAP ALL

34-21-00

D633A101-HAP

Page 98.101
Jun 15/2008

ADIRS - TRAINING INFORMATION POINT - CDU ADIRS BITE PAGES - ADIRS L + R GND TEST

General

The ADIRS-IR L + R GROUND TEST and the ADIRS-ADR L + R GROUND TEST are similar to the IR and ADR ground tests. The only difference is that the L + R ground tests allow you to test both ADIRUs at the same time.

To access the L + R ground tests, select ADIRS on line select key (LSK) 4L from the MAINT BITE INDEX. This shows the ADIRS BITE page.

On the ADIRS BITE page select either ADIRS-IR L + R GND TEST on LSK 3L or ADIRS-ADR L + R GND TEST on LSK 4L.

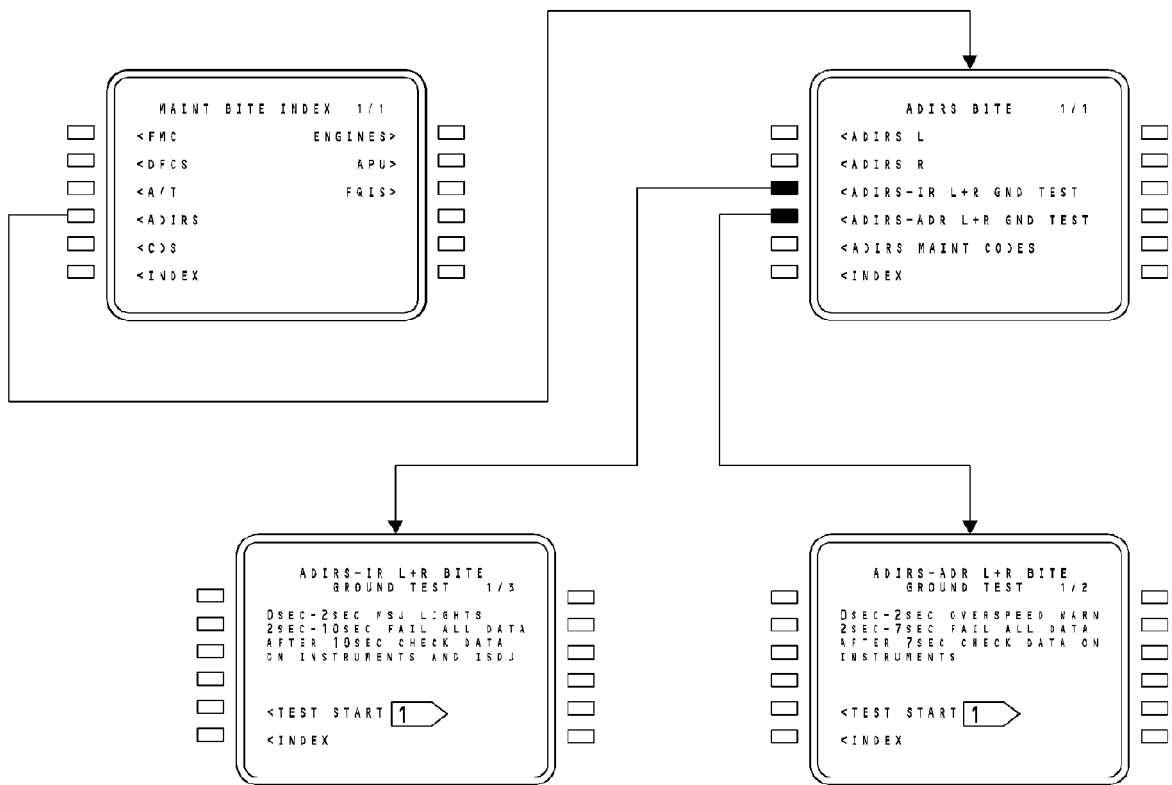

1 IF ADIRU INHIBITS GROUND TEST, TEST INOP REPLACES TEST START

ADIRS - TRAINING INFORMATION POINT - CDU ADIRS BITE PAGES - ADIRS L + R GND TEST

34-21-00-061

EFFECTIVITY
HAP ALL

34-21-00

D633A101-HAP

Page 98.103
Jun 15/2008

ADIRS - TRAINING INFORMATION POINT - CDU ADIRS BITE PAGES - ADIRS MAINTENANCE CODES**General**

These pages have the description of the ADIRS maintenance codes that can show on the ISDU. Forty codes are permitted, but not all codes are in use. Only the codes in use show on the CDU.

To show the ADIRS maintenance codes, push LSK 5L on the ADIRS BITE page. Page 1 of the ADIRS MAINT CODES pages shows.

Use the NEXT PAGE and PREV PAGE keys on the CDU to move between the ADIRS MAINT CODES pages.

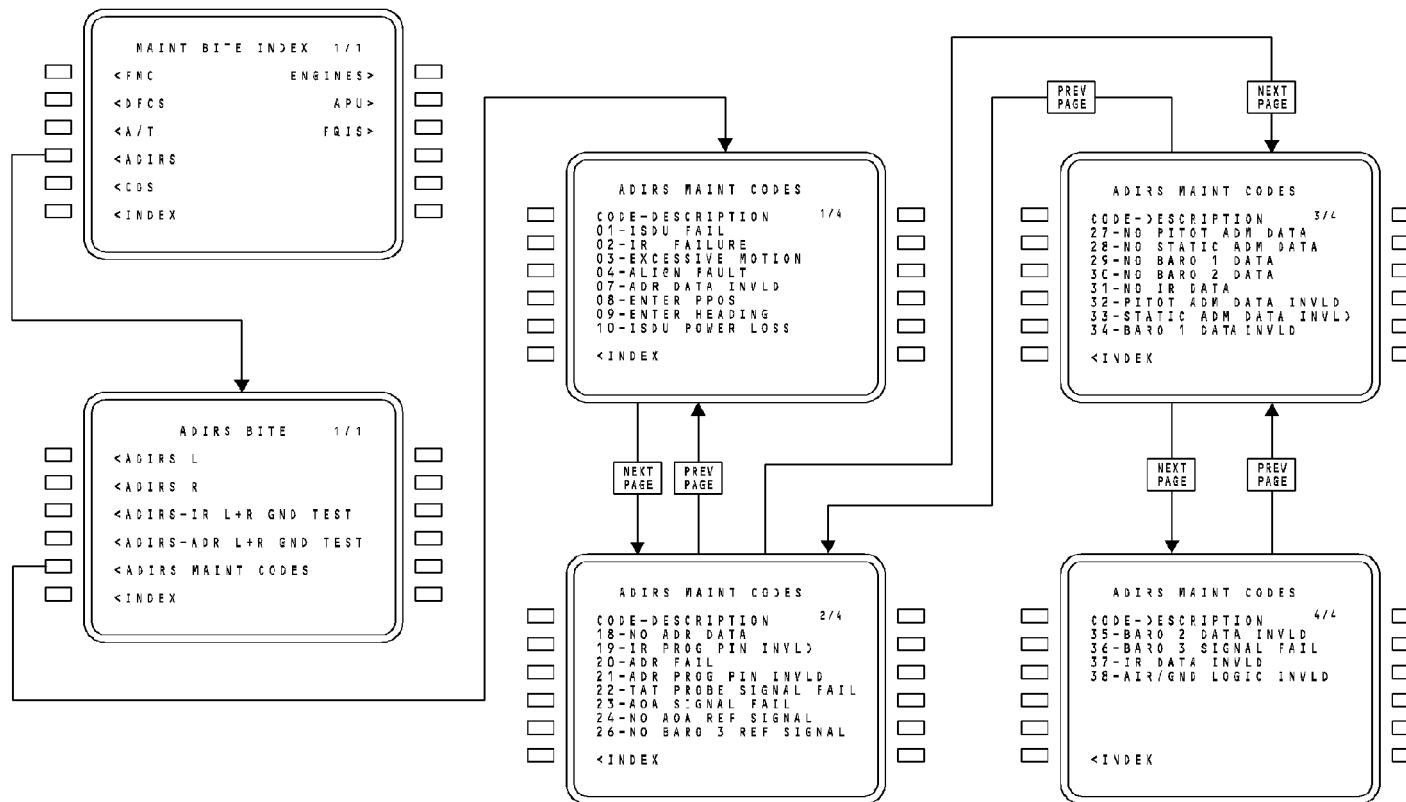

ADIRS - TRAINING INFORMATION POINT - CDU ADIRS BITE PAGES - ADIRS MAINTENANCE CODES

34-21-00-062

EFFECTIVITY
HAP ALL

34-21-00

D633A101-HAP

Page 98.105
Jun 15/2008



ADIRS - SYSTEM SUMMARY 1

General

This page is for reference.

34-21-00-071

EFFECTIVITY
HAP ALL

34-21-00

D633A101-HAP

Page 98.106
Jun 15/2008

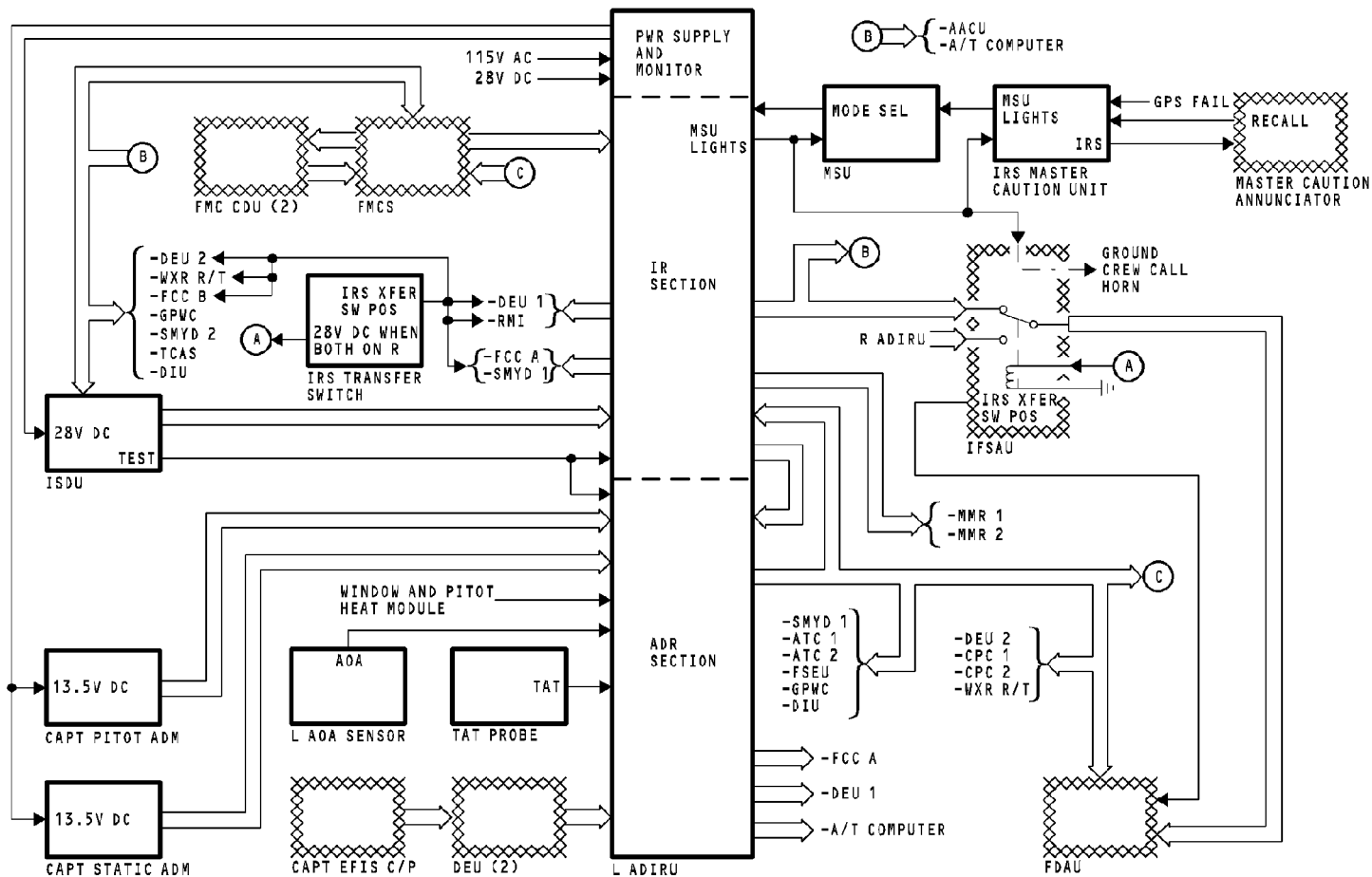

ADIRS - SYSTEM SUMMARY 1

34-21-00-071

EFFECTIVITY
HAP 001-013, 015-026, 028-030

34-21-00

D633A101-HAP

Page 98.107
Jun 15/2008

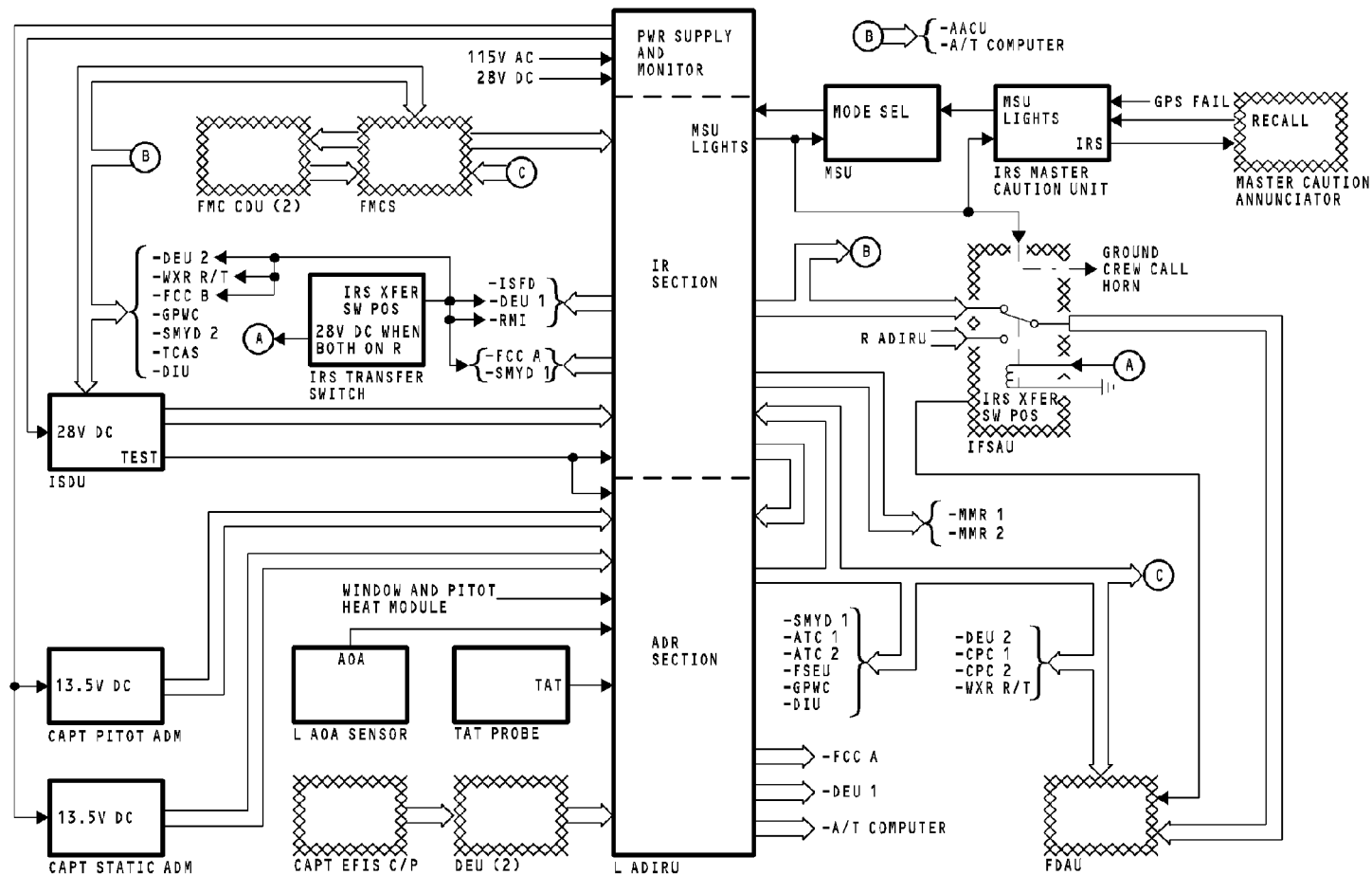

ADIRS - SYSTEM SUMMARY 1

EFFECTIVITY

HAP 038, 041-054, 104-999

34-21-00

34-21-00-071

D633A101-HAP

Page 98.108
Feb 15/2009

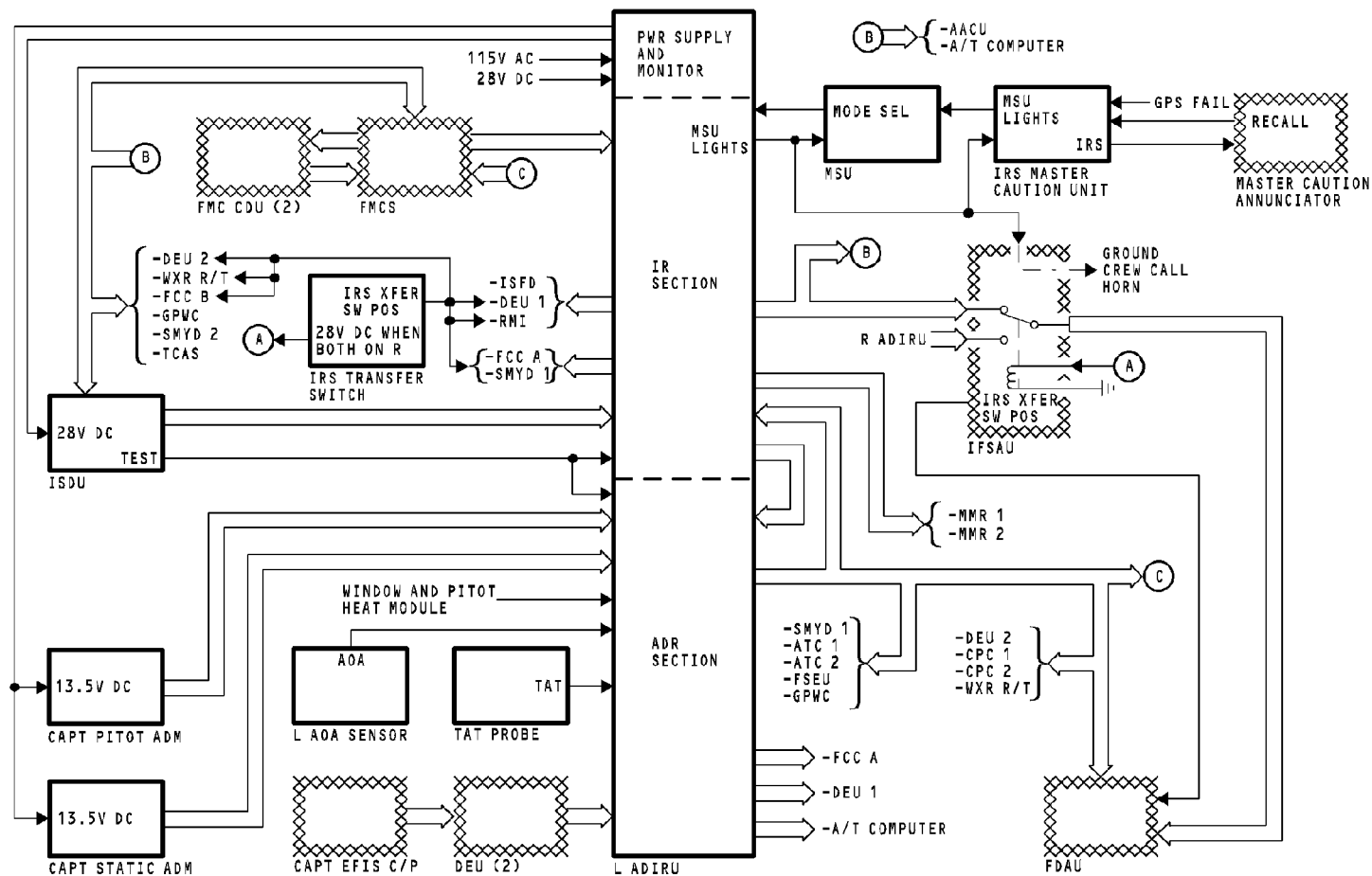

ADIRS - SYSTEM SUMMARY 1

EFFECTIVITY

HAP 031-037, 039, 040, 101-103

34-21-00

D633A101-HAP

Page 98.109
Jun 15/2008

34-21-00-071



ADIRS - SYSTEM SUMMARY 2

General

This is for reference.

34-21-00-072

EFFECTIVITY
HAP ALL

34-21-00

D633A101-HAP

Page 98.110
Jun 15/2008

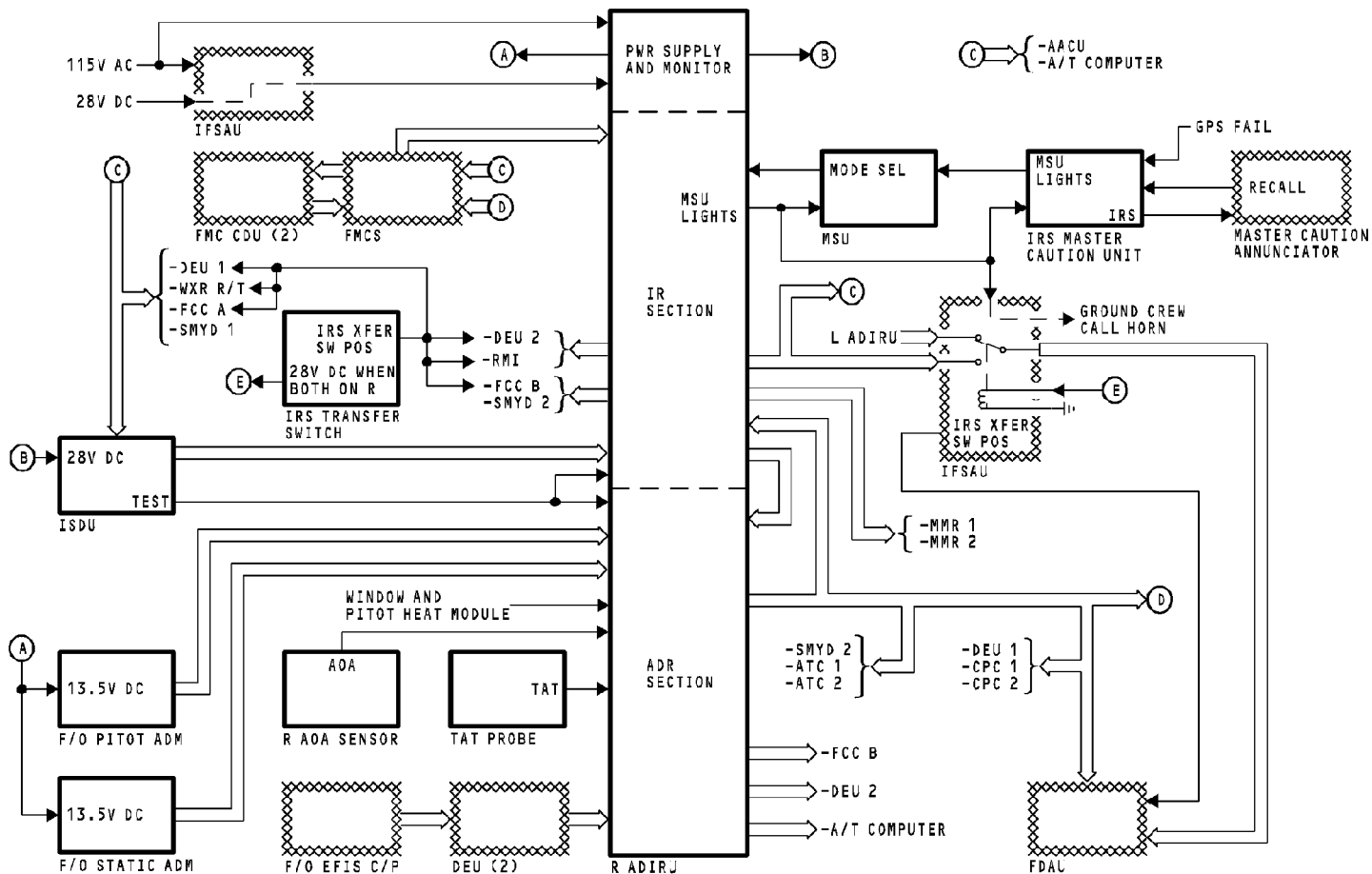

ADIRS - SYSTEM SUMMARY 2

34-21-00-072

EFFECTIVITY
HAP ALL

34-21-00

D633A101-HAP

Page 98.111
Jun 15/2008

THIS PAGE IS INTENTIONALLY LEFT BLANK

34-22-00

D633A101-HAP

Page 1
Oct 10/2002

RADIO MAGNETIC INDICATOR - INTRODUCTION

General

The radio magnetic indicator is a standby instrument. Its purpose is to show relative bearing to VOR and ADF stations. It also shows airplane magnetic heading.

Abbreviations and Acronyms

- ac - alternating current
- ADF - attitude direction finder
- ADIRS - air data inertial reference system
- ADIRU - air data inertial reference unit
- ARINC - Aeronautical Radio, Inc.
- cm - centimeter
- HDG - heading
- IRS - inertial reference system
- kg - kilogram
- L - left
- MB - marker beacon
- R - right
- RMI - radio magnetic indicator
- v - volts
- VHF - very high frequency
- VOR - VHF omnidirectional range

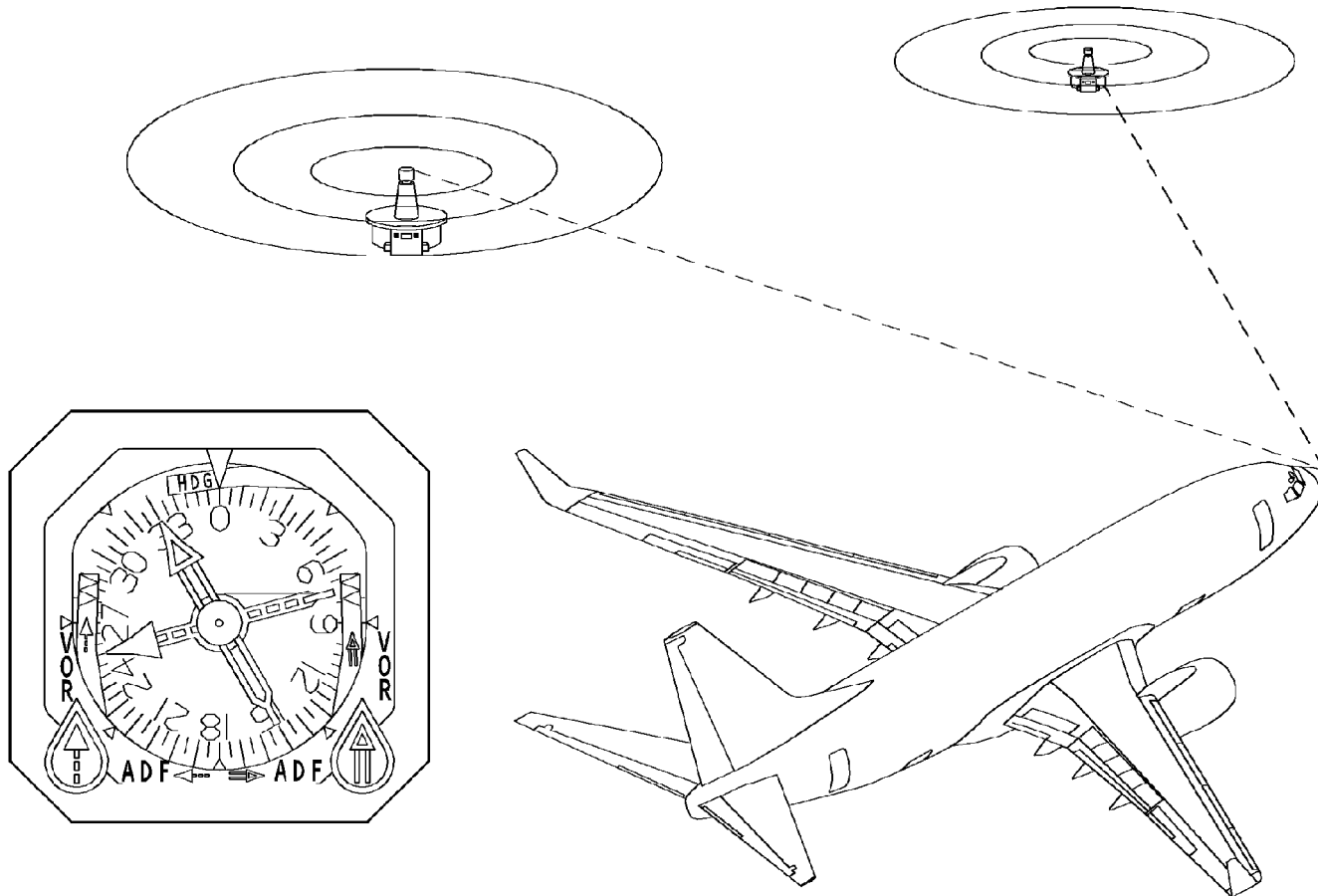

RADIO MAGNETIC INDICATOR - INTRODUCTION

EFFECTIVITY
HAP ALL

34-22-00

D633A101-HAP

Page 3
Oct 10/2004

34-22-00-001

RMI - GENERAL DESCRIPTION**Heading Input**

The RMI receives digital heading data from the air data inertial reference units (ADIRUs). The heading data sets the compass card to the magnetic heading of the airplane.

IRS Transfer Switch Input

The RMI uses the heading data from the left ADIRU with the IRS transfer switch in the normal or both on left position. Move the switch to the both on right position to use heading data from the right ADIRU.

VOR/ADF Bearing

The RMI receives digital bearing data from the VOR and ADF receivers. The RMI uses the bearing data to set the position of the bearing pointers.

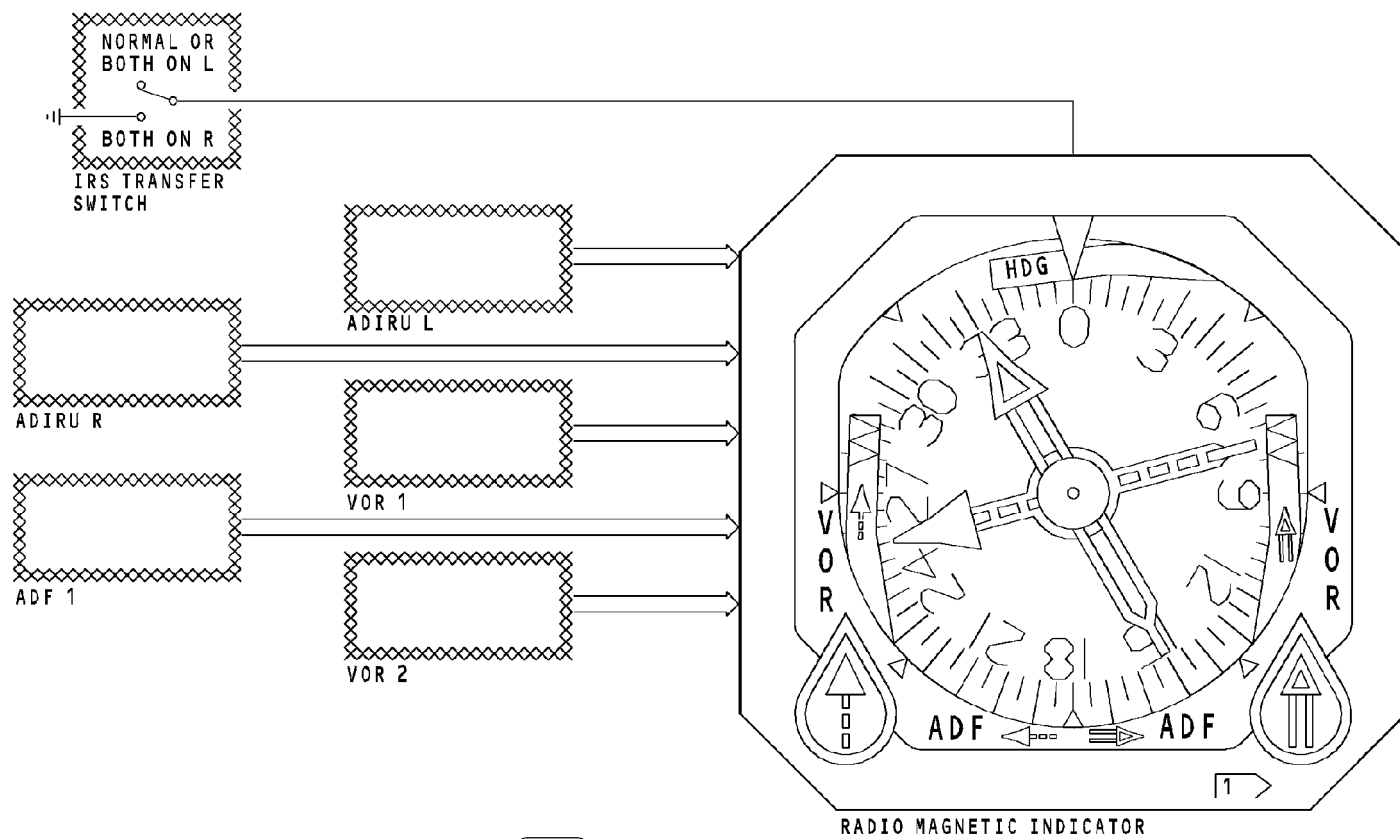

1 **INOP**
 INOP PLACARDS ARE ON THE RMI NEXT TO ANY RECEIVER THAT IS NOT CONNECTED.

RMI - GENERAL DESCRIPTION

EFFECTIVITY
HAP ALL

34-22-00

D633A101-HAP



RMI - COMPONENT LOCATION

General

The RMI is in the flight compartment on the P2 center instrument panel.

34-22-00-003

EFFECTIVITY
HAP ALL

34-22-00

D633A101-HAP

P2 CENTER INSTRUMENT PANEL
- RADIO MAGNETIC INDICATOR

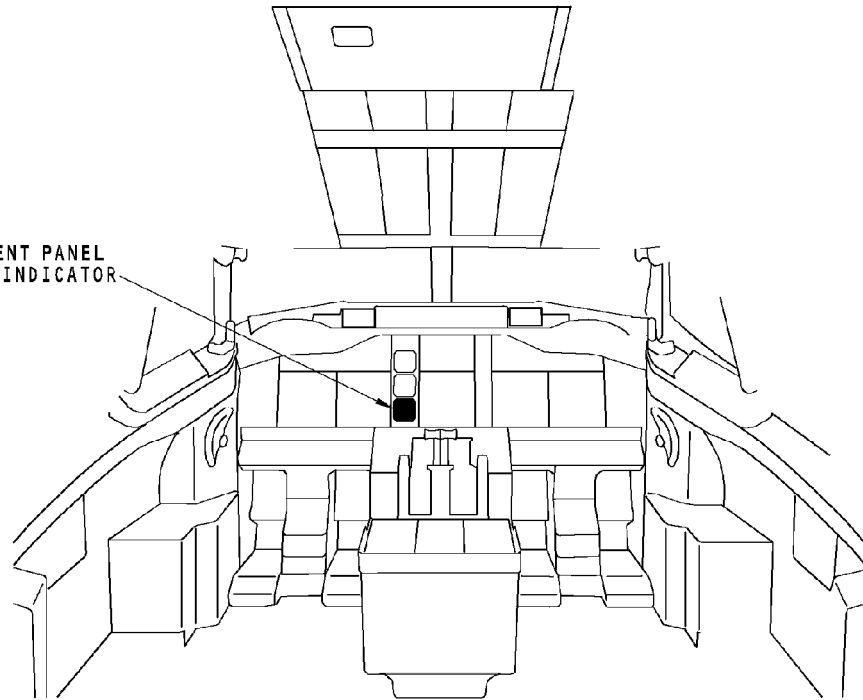

RMI - COMPONENT LOCATION

34-22-00-003

EFFECTIVITY
HAP ALL

34-22-00

D633A101-HAP

Page 7
Oct 10/2004

RMI - RADIO MAGNETIC INDICATOR**Purpose**

The radio magnetic indicator (RMI) is a standby instrument. It shows heading and bearing information.

Physical Properties

These are the physical properties of the RMI:

- Height - 3.26 in (8.28 cm)
- Width - 3.26 in (8.28 cm)
- length - 10 in (25.4 cm)
- Weight - 4.83 lb (2.2 kg).

Controls and Indicators

The RMI has two controls. They are the ADF/VOR 1, and ADF/VOR 2 bearing pointer selectors. Turn the selector to select ADF or VOR bearing inputs to control the position of bearing pointer 1 or 2.

The RMI has these indicators:

- Lubber line; a fixed heading reference
- Compass card; shows ADIRS heading with reference to the lubber line
- Bearing pointers (2); shows ADF or VOR bearing relative to the compass card.

Failure Flags

The RMI has these three failure flags:

- Heading flag; shows when heading input fails
- Bearing pointer 1 warning flag; shows when ADF 1 or VOR 1 bearing input fails or is NCD
- Bearing pointer 2 warning flag; shows when ADF 2 or VOR 2 bearing input fails or is NCD.

34-22-00-004

EFFECTIVITY
HAP ALL**34-22-00**

D633A101-HAP

Page 8
Oct 10/2004

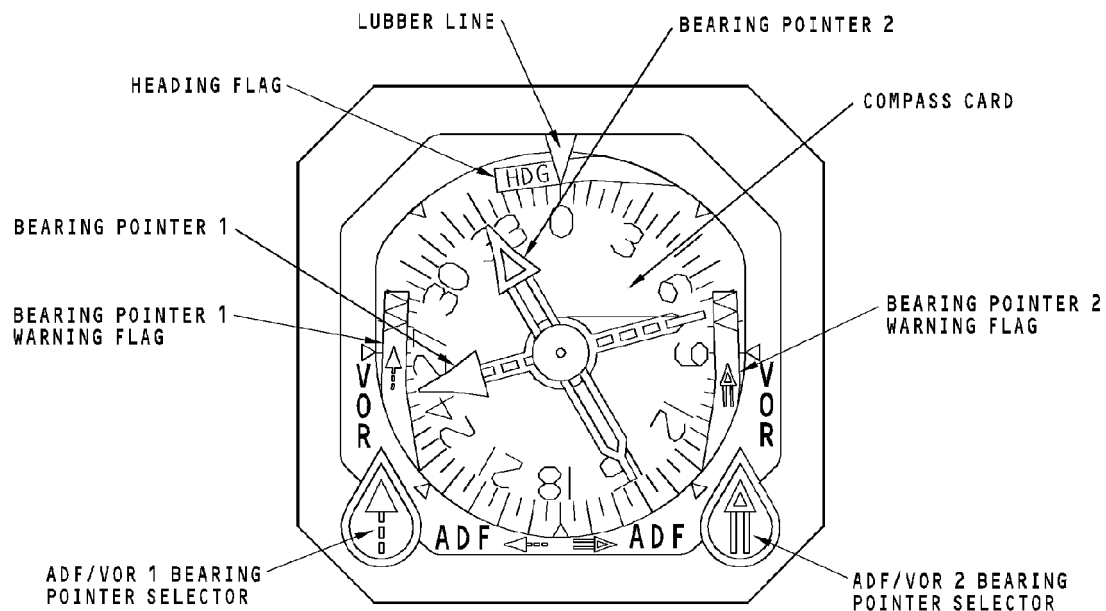

RMI - RADIO MAGNETIC INDICATOR

34-22-00-004

EFFECTIVITY
HAP ALL

34-22-00

D633A101-HAP

Page 9
Oct 10/2004

RMI - FUNCTIONAL DESCRIPTION**Power**

The radio magnetic indicator (RMI) receives 115v ac from the 115v ac standby bus. The power goes through the RMI circuit breaker on the P18 panel.

Heading Input

The RMI receives digital heading data from the air data inertial reference units (ADIRU). The heading data sets the compass card to the magnetic heading of the airplane.

The RMI uses heading data from one ADIRU. The position of the IRS transfer switch selects the ADIRU that gives data to the RMI. Put the switch in NORMAL or BOTH ON L for the left ADIRU to give data to the RMI. Put the switch in BOTH ON R for the right ADIRU to give data to the RMI.

VOR/ADF Bearing

The RMI receives digital bearing data from the VOR and ADF receivers. The RMI uses the bearing data to set the position of the bearing pointers.

Each bearing pointer can show VOR bearing or ADF bearing. Use the VOR/ADF bearing pointer selector to select VOR or ADF data.

The number 2 VOR/ADF bearing pointer shows only VOR 2 bearing. The ADF selector position is inop.

34-22-00-005

EFFECTIVITY
HAP ALL**34-22-00**

D633A101-HAP

Page 10
Jun 10/2007

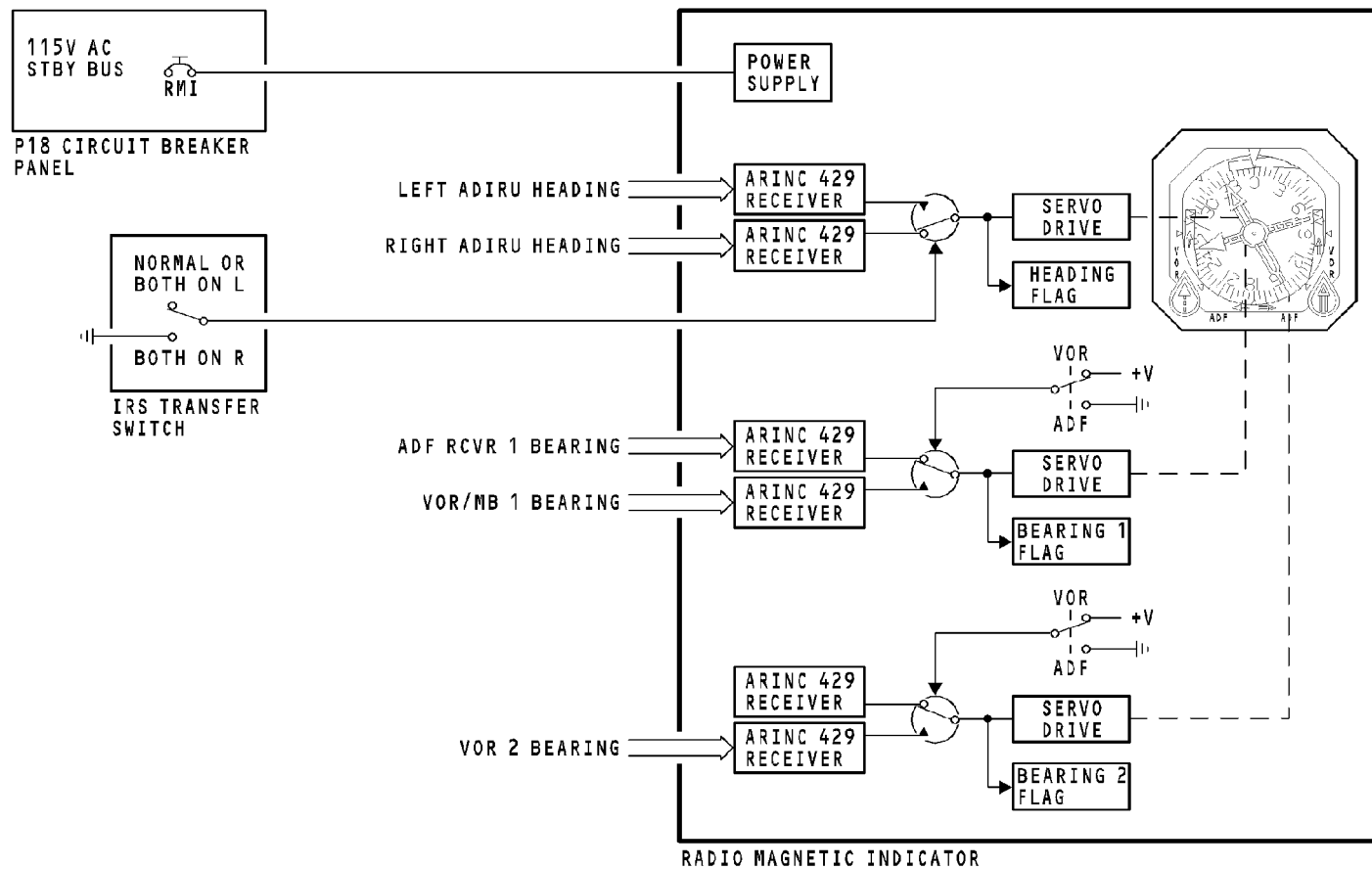

RMI - FUNCTIONAL DESCRIPTION

34-22-00-005

EFFECTIVITY
HAP ALL

34-22-00

D633A101-HAP

THIS PAGE IS INTENTIONALLY LEFT BLANK

34-23-00

D633A101-HAP

Page 1
Oct 10/2002

STANDBY MAGNETIC COMPASS**Purpose**

The standby magnetic compass is a backup magnetic heading reference.

Location

The standby magnetic compass is below the P5 forward overhead panel.

Power

The standby magnetic compass has a 28v dc light bulb. A lamp access cover permits replacement of the bulb.

Characteristics

The standby magnetic compass has a circular heading indicator card. The card floats in a case filled with liquid. The liquid does not permit the card to move quickly.

There are two magnets in the standby magnetic compass. The magnets are parallel to each other, and they are in the horizontal plane. The magnets align the compass with the magnetic flux lines of the earth.

Adjustment

The standby magnetic compass has N-S (north-south) and E-W (east-west) compensation screws. These screws change the position of the magnets.

Use the compensation screws to correct for magnetic deviation. Use only non-magnetic tools to turn the compensation screws.

There is a compass correction card near the compass. Use this card to write small errors that the compensation screws cannot remove.

Training Information Point

Four screws hold the standby magnetic compass in place. Use only non-magnetic tools and screws to remove and install the standby magnetic compass.

You must do a compass swing after you replace the standby magnetic compass.

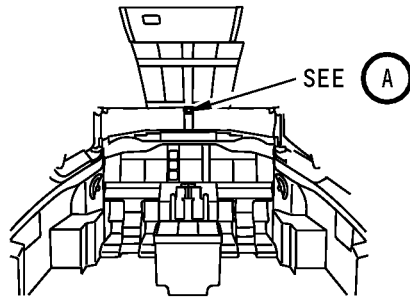

FLIGHT COMPARTMENT

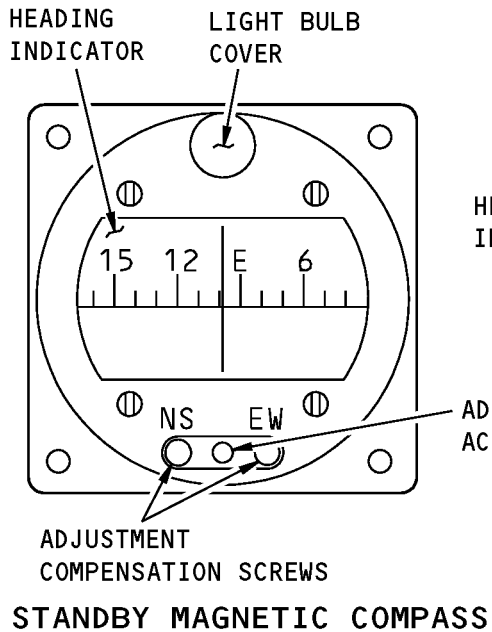
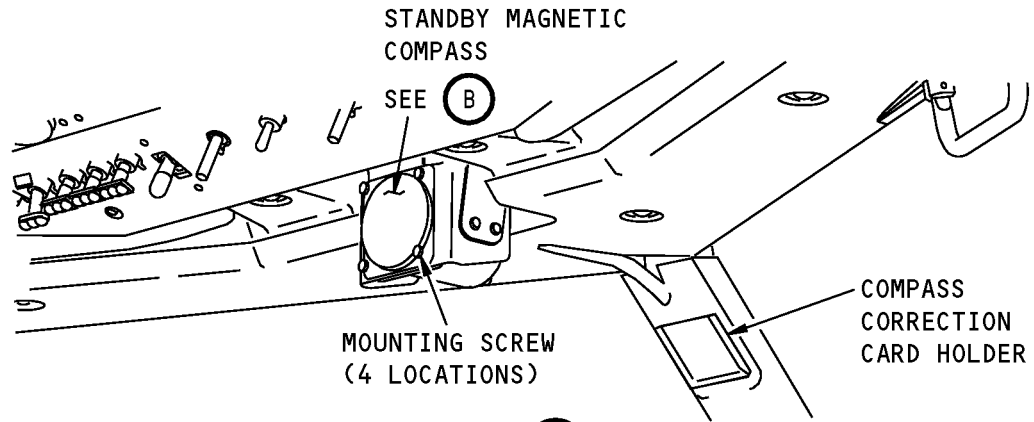

(B) 1

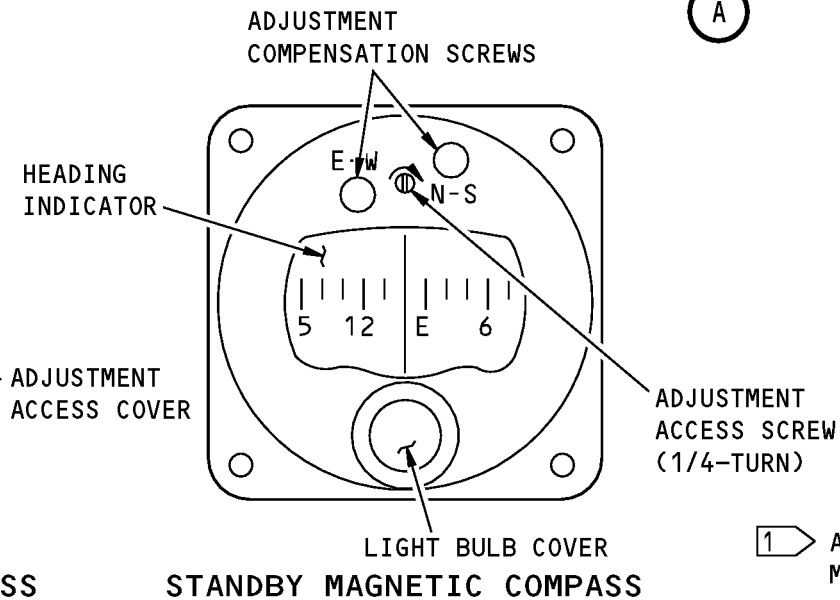

(B) 2

STANDBY MAGNETIC COMPASS

- 1 AIRPLANES WITH STANDBY MAGNETIC COMPASS P/N C-5C
- 2 AIRPLANES WITH STANDBY MAGNETIC COMPASS P/N C-5L

34-23-00-001

EFFECTIVITY
HAP ALL

34-23-00

D633A101-HAP

THIS PAGE IS INTENTIONALLY LEFT BLANK

34-24-00

D633A101-HAP

Page 1
Oct 10/2002

STANDBY ATTITUDE REFERENCE SYSTEM - INTRODUCTION**Purpose**

The standby attitude reference system is a backup system. It gives the pilots indications of airplane attitude in pitch and roll. The standby attitude reference system also shows either the deviation from the instrument landing system (ILS) or the global landing system (GLS) localizer and glideslope deviation.

General

The standby attitude reference system operates independently of the air data inertial reference system.

Abbreviations and Acronyms

- AC - alternating current
- APP - approach
- ARINC - Aeronautical Radio, Inc.
- B/CRS - back course
- DC - direct current
- GLS - Global Landing System
- G/S - glideslope
- ILS - instrument landing system
- LOC - localizer
- NCD - no computed data
- V - volts

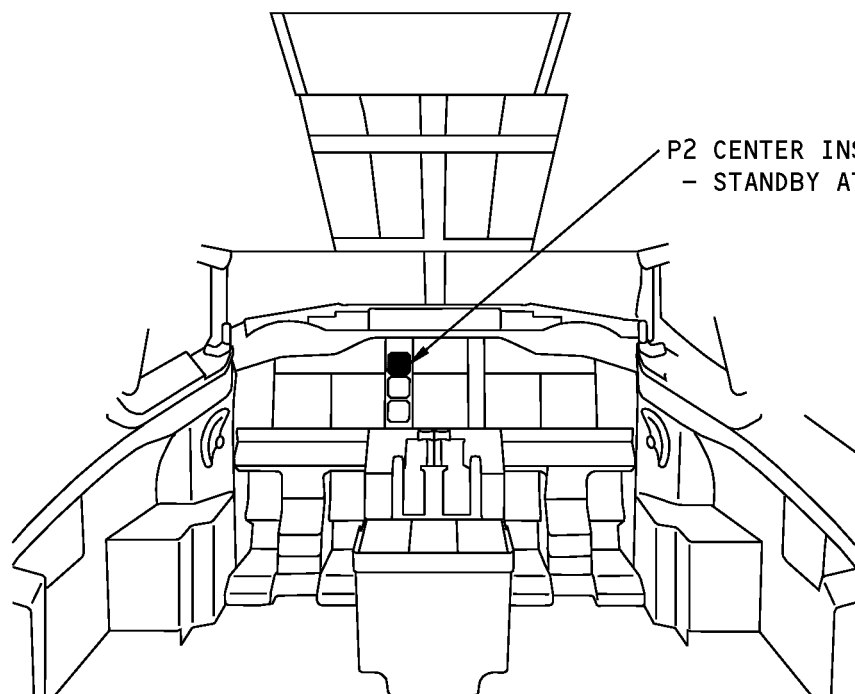

P2 CENTER INSTRUMENT PANEL
- STANDBY ATTITUDE INDICATOR

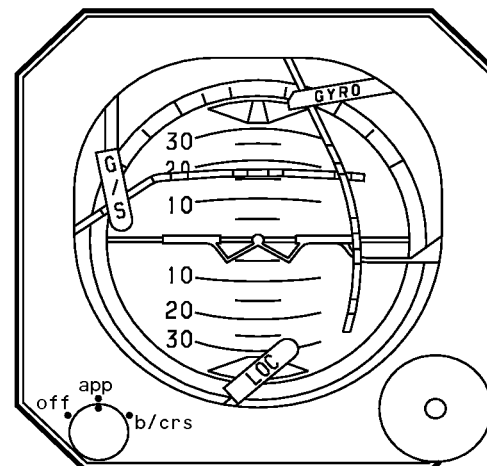

STANDBY ATTITUDE REFERENCE SYSTEM - INTRODUCTION

34-24-00-001

EFFECTIVITY
HAP 001-013, 015-026, 028-030

34-24-00

D633A101-HAP

Page 3
Jun 10/2007

STANDBY ATTITUDE REFERENCE SYSTEM - GENERAL DESCRIPTION

General

The standby attitude reference system is an alternate source of airplane pitch and roll attitude information.

The standby attitude reference system can also show instrument landing system (ILS) or global landing system (GLS) localizer and glideslope deviation. ILS and GLS data is from multi mode receiver (MMR) 1.

The failure flags on the standby attitude indicator tell the flight crew if there is an ILS, GLS, or indicator failure.

Power

28v dc from the battery bus supplies power for the standby attitude reference system.

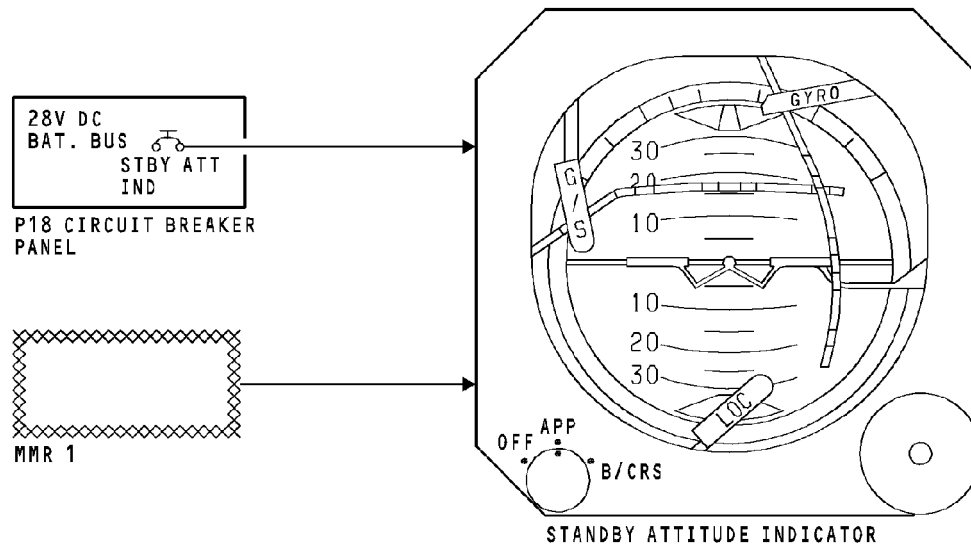

STANDBY ATTITUDE REFERENCE SYSTEM - GENERAL DESCRIPTION

EFFECTIVITY

HAP 001-013, 015-026, 028-030

34-24-00

D633A101-HAP



STANDBY ATTITUDE REFERENCE SYSTEM - COMPONENT LOCATION

General

The standby attitude indicator is on the P2 center instrument panel, refer to illustration Standby Attitude Reference System Introduction.

34-24-00-003

EFFECTIVITY
HAP 001-013, 015-026, 028-030

34-24-00

D633A101-HAP

Page 6
Jun 10/2007

THIS PAGE INTENTIONALLY LEFT BLANK

Blank Page

EFFECTIVITY
HAP 001-013, 015-026, 028-030

34-24-00

D633A101-HAP

Page 7
Jun 10/2007

34-24-00-003

STANDBY ATTITUDE REFERENCE SYSTEM - STANDBY ATTITUDE INDICATOR**General**

The standby attitude indicator has a gyro-stabilized ball that shows horizon position to the pilots. A roll scale is on the top of the indicator case. The roll indication shows with marks at 0, 10, 20, 30, 45, and 60 degrees.

A pitch scale is on the face of the attitude ball. The pitch angle shows with marks at each five degree increment. Numerals show at each ten degree increment. The fixed airplane symbol is on the case of the indicator and does not move.

Control

The standby attitude indicator gyro will align to vertical in these two ways:

- In the automatic mode, application of power causes the gyro to align to vertical at a rate of three degrees per minute
- In the manual mode, let the gyro spin for thirty seconds. After thirty seconds, pull the cage knob. The cage knob aligns the gyro to vertical and makes the attitude ball stable at zero degrees pitch and roll.

The approach mode selector has these positions:

- Off - no ILS or GLS data on indicator
- APP - ILS or GLS localizer and glideslope data shows
- B/CRS - back course ILS localizer data shows.

Indications

The normal ILS or GLS indications are the glideslope and localizer deviation pointers in view and the LOC flag and G/S flag out of view.

When the ILS or GLS data is no computed data (NCD), the related deviation pointer goes out of view.

When the indicator receives incorrect ILS or GLS data, the related deviation pointer goes out of view and you can see the failure flag.

When you select B/CRS, the localizer deviation pointer reverses polarity for the approach display. The glideslope deviation pointer is NCD and is not in view during B/CRS approaches.

Training Information Point

It is necessary to remove power from the standby attitude indicator twenty minutes before you remove the indicator. This will give the gyro time to stop spinning.

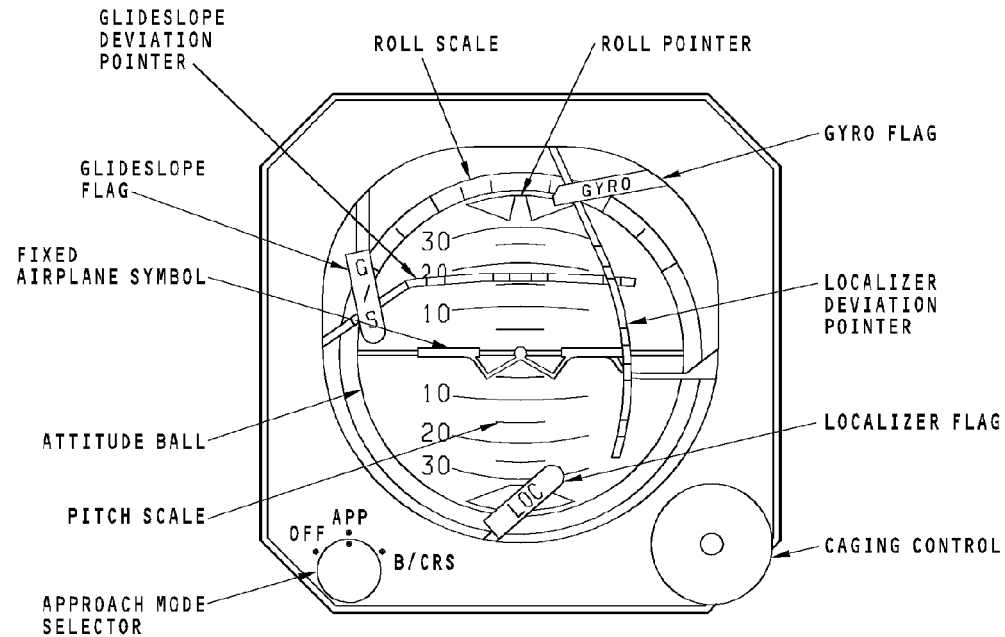

STANDBY ATTITUDE REFERENCE SYSTEM - STANDBY ATTITUDE INDICATOR

34-24-00-004

EFFECTIVITY
HAP 001-013, 015-026, 028-030

34-24-00

D633A101-HAP

STANDBY ATTITUDE REFERENCE SYSTEM - FUNCTIONAL DESCRIPTION**General**

The standby attitude indicator uses a gyro stabilized attitude ball to show airplane attitude.

The gyro starts to operate when you apply power. The gyro normally aligns to vertical at a rate of three degrees per minute. You can pull the cage knob to align the gyro to vertical in a few seconds.

The standby attitude indicator uses inputs from ILS receiver 1 to supply a backup glideslope and localizer display.

Power

The static inverter/power supply gives 115v ac to the gyro motor. A gyro current monitor circuit causes the gyro flag to come into view when gyro power is not there or is incorrect. The static inverter/power supply also gives dc voltages for circuit functions.

ILS Operation

ILS or GLS deviation data goes to the ARINC 429 receiver. The ARINC 429 receiver sends the data to the logic and drive circuits. These circuits control the localizer deviation pointer and the failure flag. They also control the glideslope deviation pointer and failure flag.

An ILS mode select discrete and the approach mode selector position sets the ILS mode and validity.

When you select the OFF mode or when an NCD or incorrect data signal is present, the deviation pointers go out of view.

When you select the APP mode and the ILS or GLS data is correct, the localizer and glideslope deviation pointers show ILS or GLS deviation.

When you select the B/CRS mode, the localizer deviation pointer signal reverses, and the glideslope deviation pointer goes out of view. Since there is no GLS backcourse signal, B/CRS can not be used when under GLS guidance.

ILS Failure Flags

The ILS failure flags are normally out of view. When ILS or GLS data is incorrect, the G/S flag, the LOC flag, or both flags will come into view.

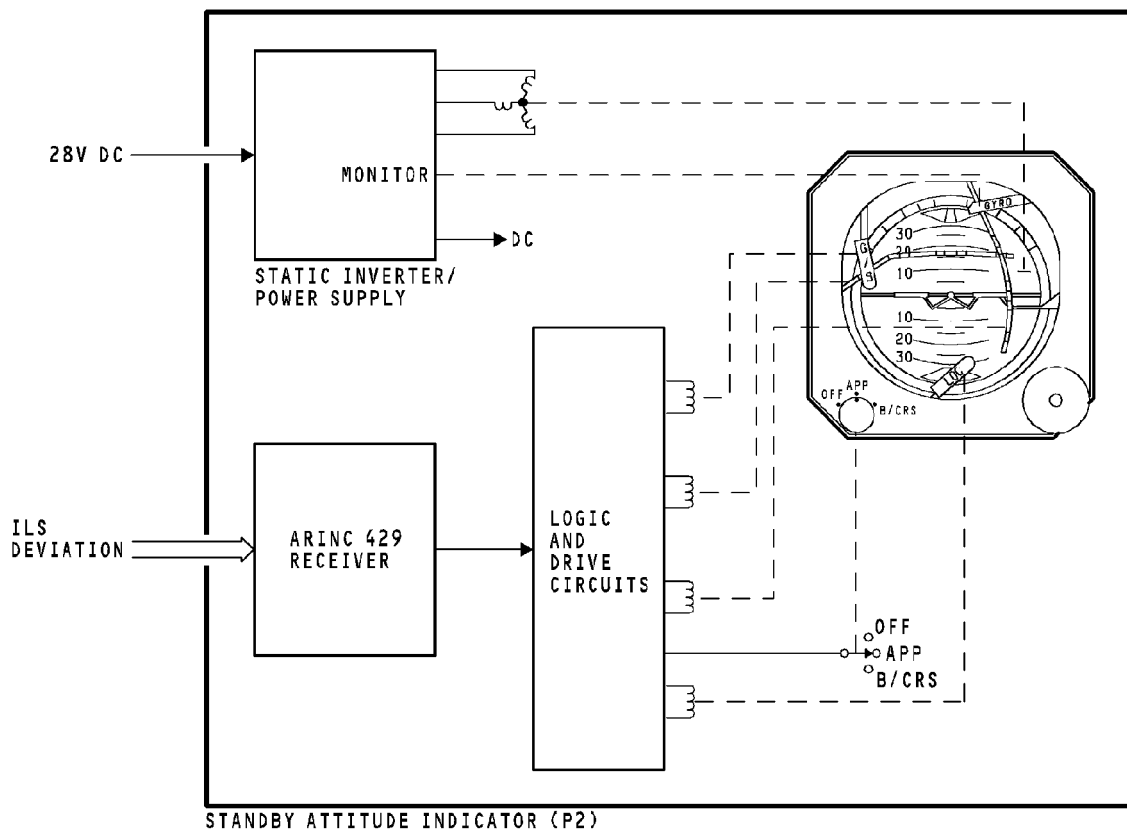

STANDBY ATTITUDE REFERENCE SYSTEM - FUNCTIONAL DESCRIPTION

34-24-00-005

EFFECTIVITY
HAP 001-013, 015-026, 028-030

34-24-00

D633A101-HAP

Page 11
Jun 10/2007

THIS PAGE IS INTENTIONALLY LEFT BLANK

34-24-00

D633A101-HAP

Page 12
Oct 10/2004

STANDBY ATTITUDE REFERENCE SYSTEM - ILS SELF-TEST**General**

There are no special tests for the standby attitude reference system. You do a check of the approach display with an ILS receiver 1 self-test.

Start the ILS self-test from the test switch on the navigation control panel. You can also start it from the test switch on the ILS receiver 1. The approach mode selector must be in the APP position.

There are four display sequences that occur on the standby attitude indicator during the ILS self-test:

- Invalid data
- No computed data (NCD)
- Data correct - up/left
- Data correct - down/right.

The length of the self test sequence is 14 seconds.

Invalid Data Display

Invalid data is the first display in the self-test sequence. It shows on the standby attitude indicator for three seconds. Invalid data causes these indications:

- LOC flag comes into view
- G/S flag comes into view
- Deviation pointers go out of view.

NCD Display

NCD is the second display in the self-test sequence. It shows on the standby attitude indicator for two seconds. NCD causes these indications:

- LOC flag goes out of view
- G/S flag goes out of view
- Deviation pointers go out of view.

Data Correct - Up/Left Display

Data correct - up/left is the third display in the self-test sequence. It shows for three seconds on the standby attitude indicator. Data correct - up/left causes these indications:

- LOC flag goes out of view
- G/S flag goes out of view
- Localizer pointer shows one dot of left deviation
- Glideslope pointer shows one dot of up deviation.

Data Correct - Down/Right Display

Data correct - down/right is the fourth display in the self-test sequence. It shows for six seconds on the standby attitude indicator. Data correct - down/right causes these indications:

- LOC flag goes out of view
- G/S flag goes out of view
- Localizer pointer shows one dot of right deviation
- Glideslope pointer shows one dot of down deviation.



STANDBY ATTITUDE REFERENCE SYSTEM - ILS SELF-TEST

The approach display goes back to normal indications at the end of the self-test sequence.

34-24-00-006

EFFECTIVITY
HAP 001-013, 015-026, 028-030

34-24-00

D633A101-HAP

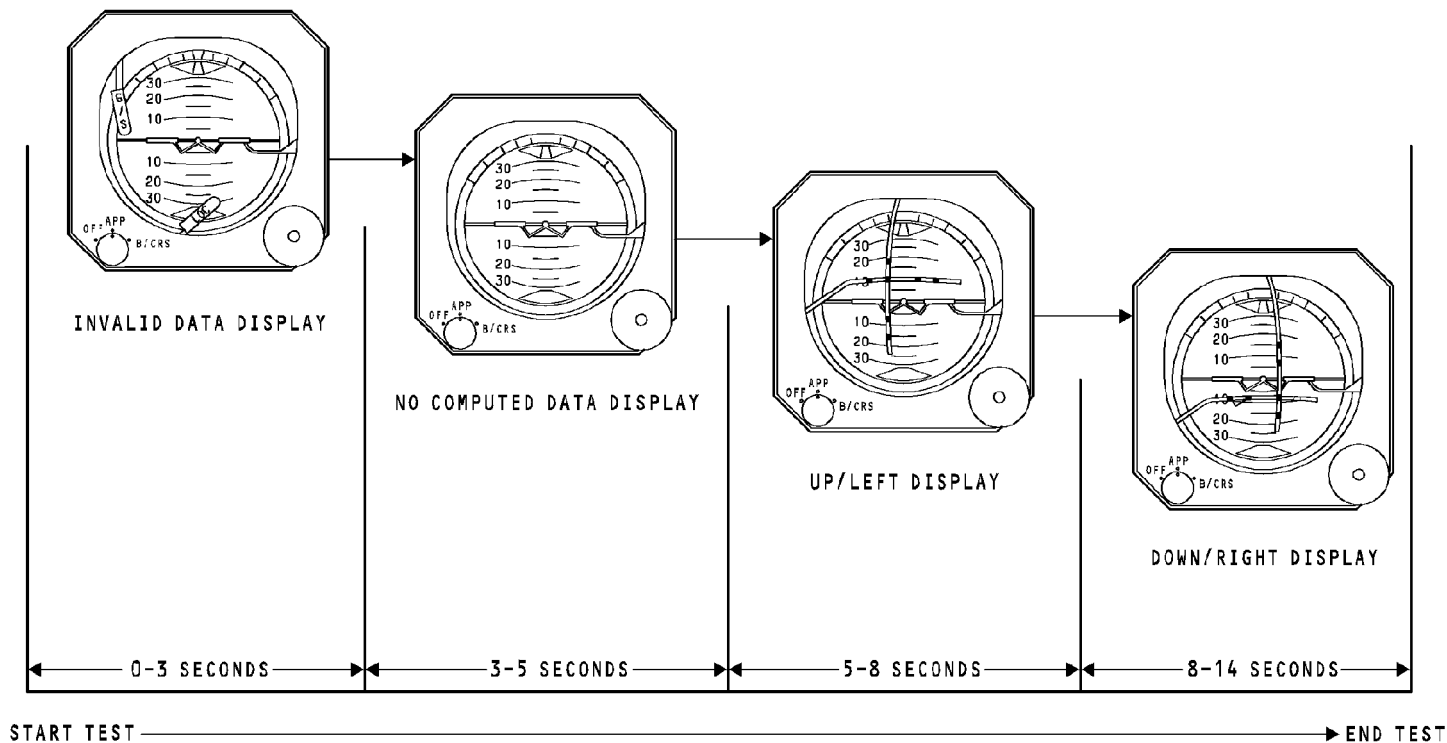

STANDBY ATTITUDE REFERENCE SYSTEM - ILS SELF-TEST

EFFECTIVITY

HAP 001-013, 015-026, 028-030

34-24-00

D633A101-HAP

THIS PAGE IS INTENTIONALLY LEFT BLANK

34-24-00

D633A101-HAP

Page 16
Oct 10/2005

STANDBY ATTITUDE REFERENCE SYSTEM - INTRODUCTION**Purpose**

The standby attitude reference system is a backup system. It shows the pilots this data:

- Pitch attitude
- Roll attitude
- Altitude
- Heading (program pin selection display)
- Indicated airspeed (IAS)
- ILS localizer and glideslope deviation.

General

For all data except the (program pin selection) heading display, the standby attitude reference system operates independently of the air data inertial reference system.

Abbreviations and Acronyms

- AC - alternating current
- ADIRS - air data inertial reference system
- ADIRU - air data inertial reference unit
- ARINC - Aeronautical Radio, Inc.
- alt - altitude
- amp - amperes
- app - approach
- att - attitude
- baro - barometric
- bat - battery
- BCRS - back course
- BITE - built-in test equipment
- C - degrees Celsius

- DC - direct current
- F - degrees Fahrenheit
- fail warn - failure warning
- fwd - forward
- g - grams
- g - acceleration due to gravity
- G/S - glideslope
- hdg - heading
- HP - hectopascal
- hPa - hectopascal
- IAS - indicated airspeed
- ident - identification
- ILS - instrument landing system
- GLS - global landing system
- IN - inches of mercury
- in Hg - inches of mercury
- init - initialization
- IR - inertial reference
- IRS - inertial reference system
- ISFD - integrated standby flight display
- kg - kilograms
- kts - knots
- LCD - liquid crystal display
- LOC - localizer
- LRU - line replaceable unit
- m - meters
- mbar - millibars
- mm - millimeters
- MMR - multi-mode receiver
- NCD - no computed data
- P/N - hardware part number
- rst - reset



STANDBY ATTITUDE REFERENCE SYSTEM - INTRODUCTION

- s - seconds
- S/N - software part number
- spd - airspeed
- V - volts
- wrg - wiring

34-24-00-101

EFFECTIVITY
HAP 031-054, 101-999

34-24-00

D633A101-HAP

Page 18
Feb 15/2009

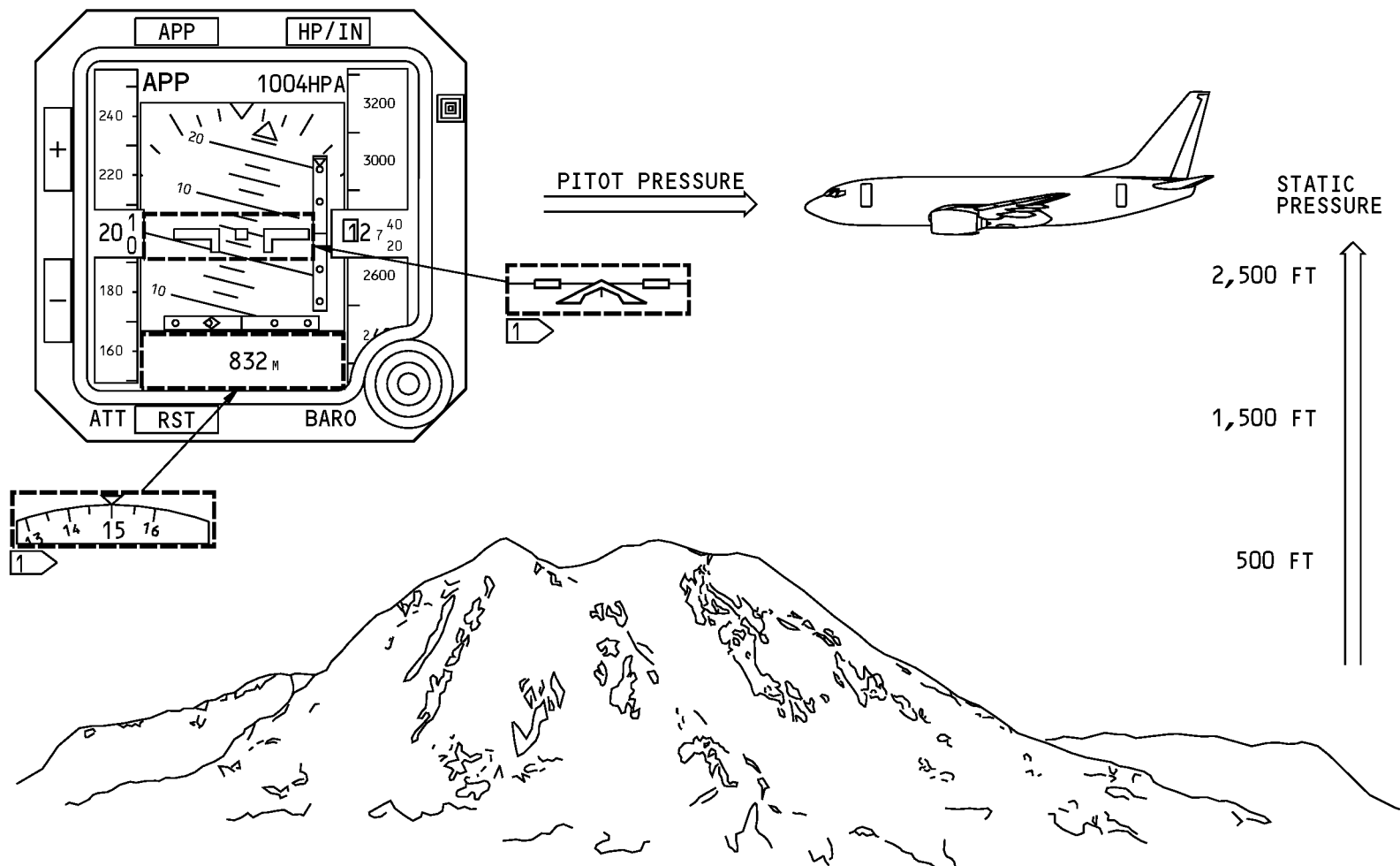

1 PROGRAM PIN SELECTION

STANDBY ATTITUDE REFERENCE SYSTEM - INTRODUCTION

EFFECTIVITY
HAP 031-054, 101-999

34-24-00

D633A101-HAP

Page 19
Feb 15/2009

34-24-00-101

THIS PAGE IS INTENTIONALLY LEFT BLANK

34-24-00

D633A101-HAP

Page 20
Oct 10/2005

STANDBY ATTITUDE REFERENCE SYSTEM - GENERAL DESCRIPTION**General**

The standby attitude reference system consists of an integrated standby flight display (ISFD) and an ISFD dedicated battery system.

The ISFD shows this standby data:

- Attitude
- Airspeed
- Altitude.

The ISFD can also show heading (program pin selection) from the air data inertial reference system (ADIRS).

The display is a color liquid crystal display (LCD).

Power

Airplane power goes through the ISFD dedicated battery system to the ISFD. The battery bus provides the 28v dc power.

The battery switch on the electrical meters, battery, and galley power module controls the power to the ISFD.

When the battery switch is on, the battery/charger sends power to the ISFD. The battery bus supplies power to the ISFD through the battery/charger. The battery bus also charges a battery in the battery/charger.

If there is not sufficient power on the battery bus to operate the ISFD, the battery in the battery/charger supplies power to the ISFD.

When the battery switch is off, the battery/charger removes power to the ISFD.

Attitude

Pitch and roll attitude come from the inertial sensors in the ISFD.

Pitch and roll attitude show as an attitude ball in the center of the display.

Altitude and Airspeed

The ISFD is a pneumatic altimeter and airspeed indicator.

The ISFD gets static pressure from the alternate static ports and pitot pressure from the alternate pitot probe.

The ISFD uses pitot and static pressure to show indicated airspeed (IAS). IAS shows on the airspeed tape on the left side of the display.

The ISFD uses static pressure to show barometric altitude. Barometric altitude shows on the altitude tape on the right side of the display.

STANDBY ATTITUDE REFERENCE SYSTEM - GENERAL DESCRIPTION

The ISFD can also show the barometric altitude in meters in a digital format on the bottom of the display (program pin selection).

Heading

The air data inertial reference system (ADIRS) provides heading to the ISFD from the left air data inertial reference unit (ADIRU).

Heading shows on the compass rose on the bottom of the display (program pin selection).

Localizer and Glideslope Deviation

The standby attitude reference system also shows information from the instrument landing system (ILS) or (GLS).

When you select the approach (APP) mode on the ISFD, the localizer deviation scale shows on the bottom of the attitude ball and the glideslope deviation scale shows on the right side of the attitude ball.

Push the approach mode switch (APP) two times to select the back course mode. When you select the back course (BCRS) mode on the ISFD, the localizer deviation scale shows on the bottom of the attitude ball. The ISFD also moves the localizer deviation pointer to the opposite side of the scale. The glideslope deviation scale does not show.

Multi-mode receiver (MMR) 1 sends localizer and glideslope deviation to the ISFD.

Air Data Inertial Reference Unit

The ADIRU sends inertial reference data to the ISFD.

The ISFD shows heading on the bottom of the display (program pin selection).

The ISFD uses ground speed to sense when the airplane is on the ground.

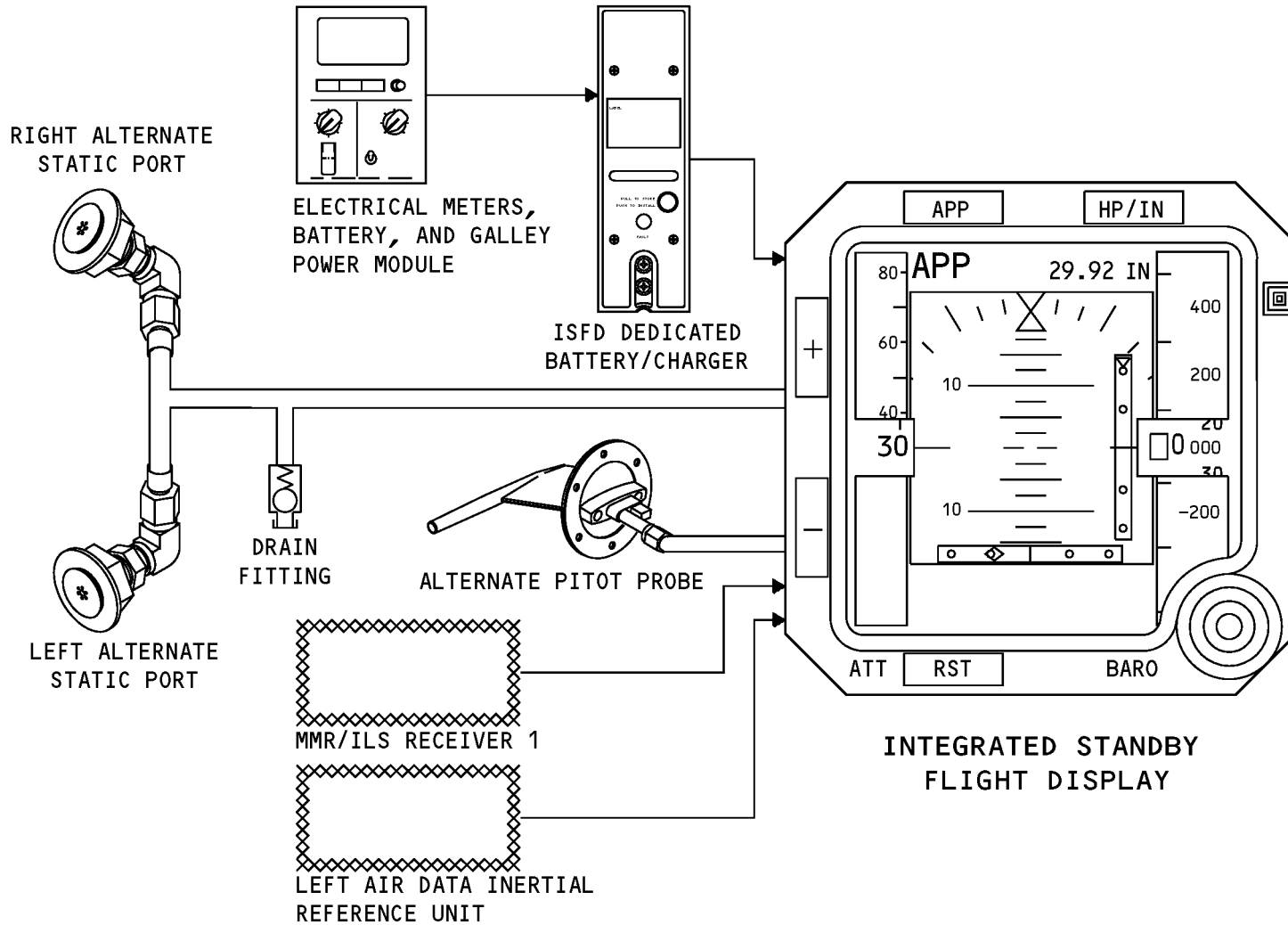

Standby Attitude Reference System - General Description

34-24-00-102

EFFECTIVITY
HAP 031-054, 101-999

34-24-00

D633A101-HAP

STANDBY ATTITUDE REFERENCE SYSTEM - COMPONENT LOCATION**General**

The components for the standby attitude reference system are in the flight compartment and the electronic equipment compartment.

Flight Compartment

The integrated standby flight display (ISFD) is on the P2 center instrument panel.

Electronic Equipment Compartment**HAP 031-037, 049, 102, 103**

The ISFD dedicated battery system is in the electronic equipment compartment on the E1 rack, shelf E1-3.

HAP 038-048, 050-054, 101, 104-999

The ISFD dedicated battery system is in the electronic equipment compartment on the E4 rack, shelf E4-1.

HAP 031-054, 101-999

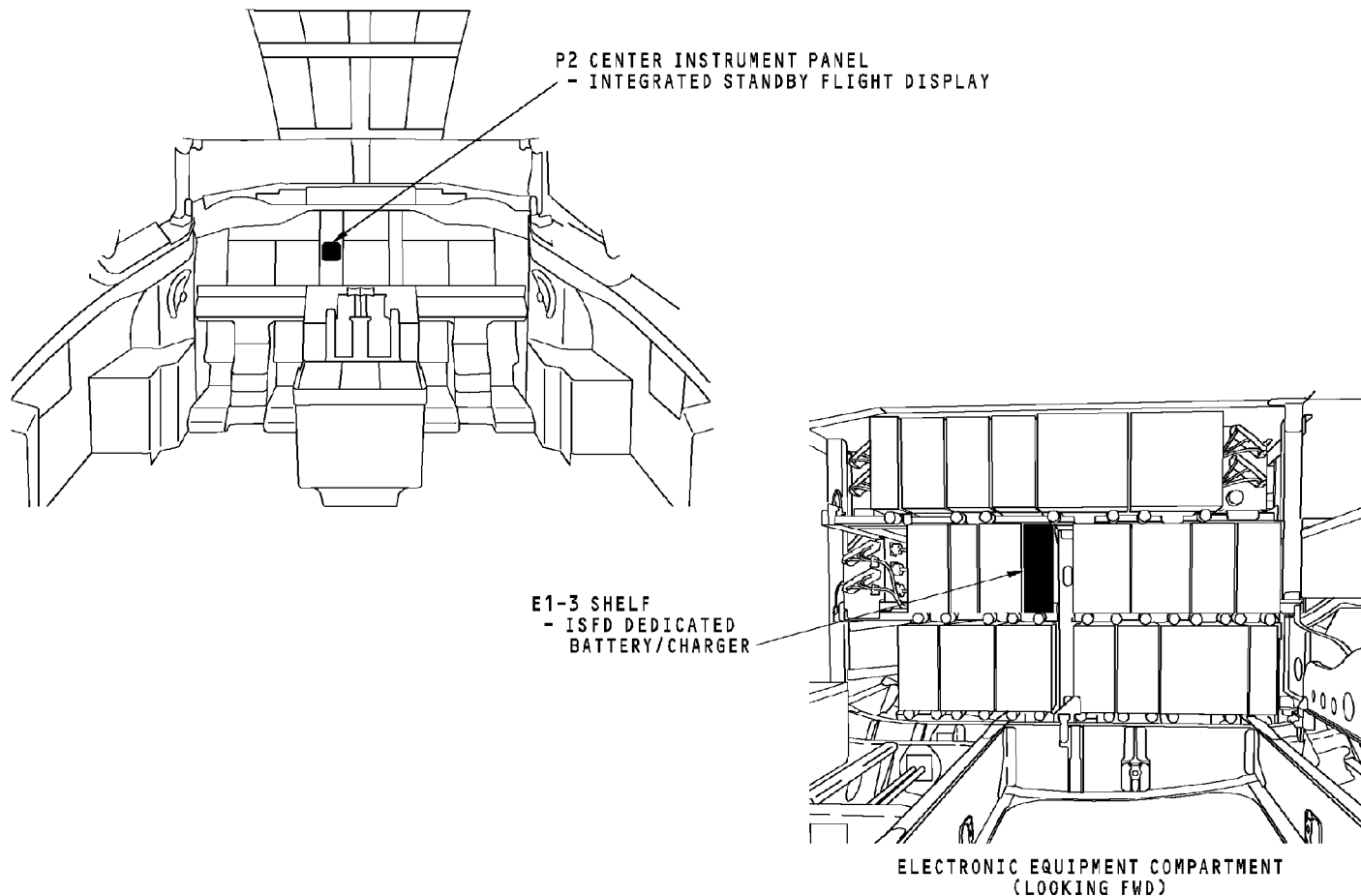

STANDBY ATTITUDE REFERENCE SYSTEM - COMPONENT LOCATION

EFFECTIVITY
HAP 031-037, 049, 102, 103

34-24-00

D633A101-HAP

Page 25
Jun 15/2008

34-24-00-103

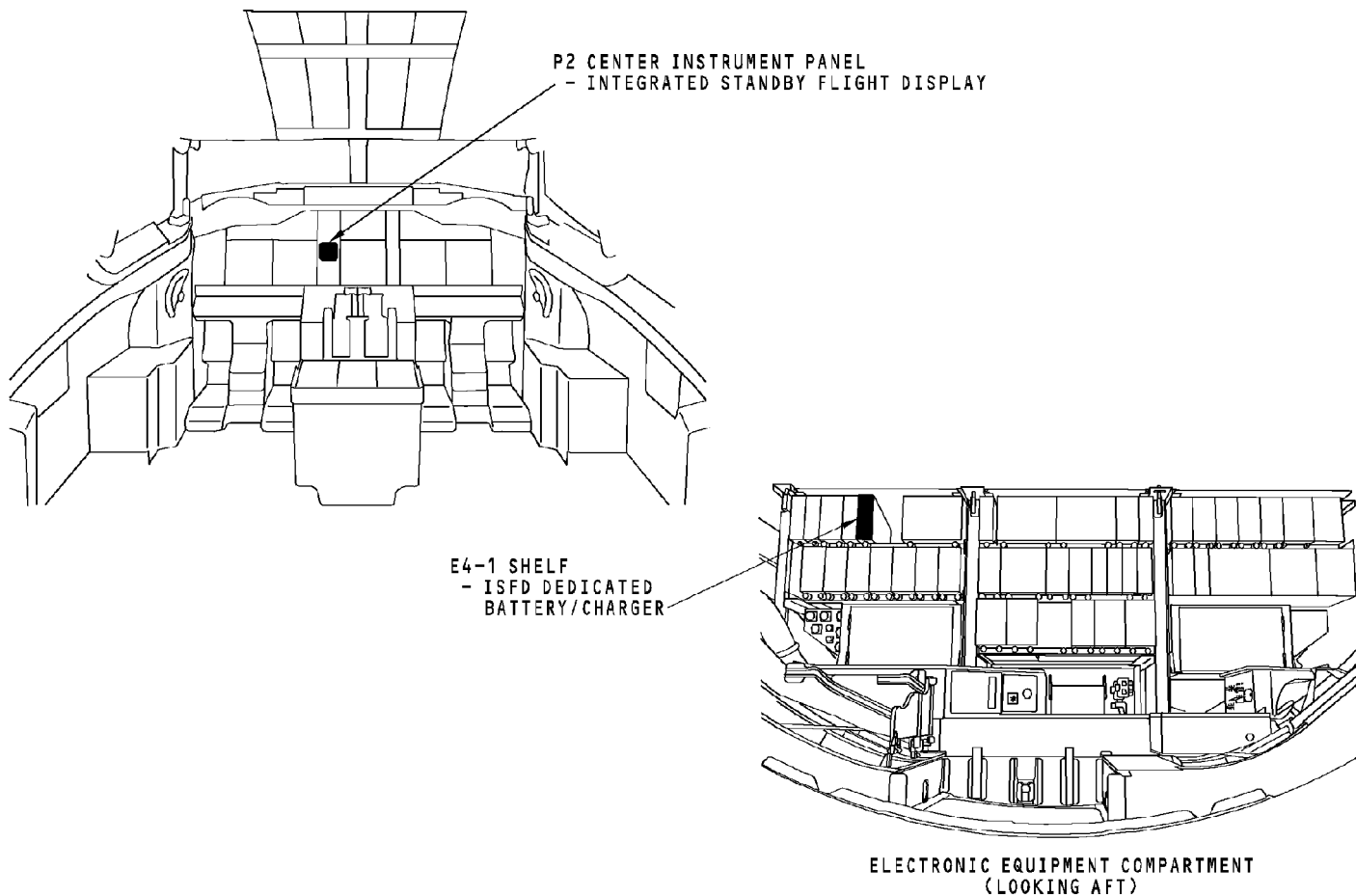

STANDBY ATTITUDE REFERENCE SYSTEM - COMPONENT LOCATION

EFFECTIVITY

HAP 038-048, 050-054, 101, 104-999

34-24-00

D633A101-HAP

THIS PAGE IS INTENTIONALLY LEFT BLANK

34-24-00

D633A101-HAP

Page 27
Oct 10/2006

STANDBY ATTITUDE REFERENCE SYSTEM - INTERFACE**Power**

The integrated standby flight display (ISFD) gets 28v dc from the ISFD dedicated battery/charger.

The ISFD dedicated battery system gets 28v dc from the battery bus. The battery/charger sends the 28v dc power to the ISFD. The battery/charger also uses the 28v dc power to charge its internal battery.

A signal from the battery switch on the electrical meters, battery, and galley power module goes to the battery/charger. When the battery switch is on, the battery/charger supplies 28v dc power to the ISFD. When the battery switch is off, the ISFD does not receive 28v dc power.

The ISFD gets 5v ac for the front panel lights from the master dim and test circuit.

Pitot-Static Interface

The alternate pitot probe sends pitot pressure to the integrated standby flight display.

The alternate static ports send static pressure to the indicator.

The ISFD uses static pressure to show barometric altitude. The ISFD uses pitot and static air pressure to show indicated airspeed (IAS).

Instrument Landing System (ILS) Interface

Multi-mode receiver 1 sends localizer deviation and glideslope deviation to the ISFD on an ARINC 429 data bus.

The ISFD shows localizer and glideslope deviation on the attitude display.

Air Data Inertial Reference System (ADIRS) Interface

The left air data inertial reference unit (ADIRU) sends inertial reference data to the integrated standby flight display on an ARINC 429 data bus.

The ISFD uses magnetic heading data to show on the compass rose on the bottom of the display.

The ISFD uses ground speed to sense when the airplane is on the ground.

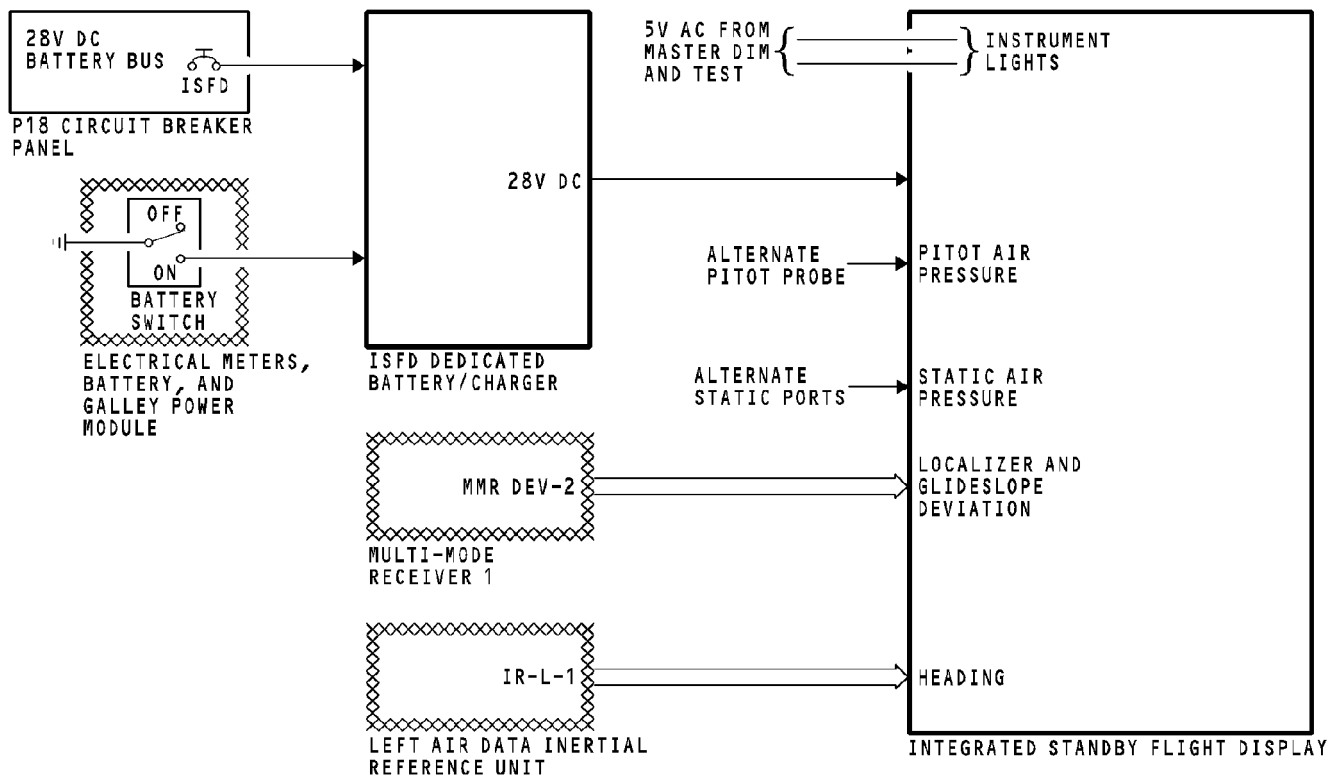

STANDBY ATTITUDE REFERENCE SYSTEM - INTERFACE

34-24-00-104

EFFECTIVITY
HAP 031-054, 101-999

34-24-00

D633A101-HAP

STANDBY ATTITUDE REFERENCE SYSTEM - INTEGRATED STANDBY FLIGHT DISPLAY**General**

The integrated standby flight display (ISFD) provides the flight crew a single integrated display of these parameters:

- Pitch and roll attitude
- Indicated airspeed
- Altitude
- Metric altitude (program pin selection)
- Heading (program pin selection)
- Localizer and glideslope deviation.

The ISFD is a single unit which has these components:

- Color liquid crystal display
- Solid state rate sensors
- Accelerometers
- Pitot and static air pressure sensors.

The ISFD calculates attitude, altitude, and airspeed internally.

The ISFD receives heading data from the air data inertial reference unit (ADIRU). The heading display is selected by program pin.

The ISFD receives localizer and glideslope deviation data from the multi-mode receiver (MMR).

Physical Properties

These are the physical properties of the ISFD:

- Length - 11.4 inches (289 mm)
- Width - 3.27 inches (83.0 mm)
- Height - 3.27 inches (83.0 mm)
- Weight - 4.41 pounds (2.0 kg)
- Power - 20 watts dc.

The ISFD has three connectors at the rear of the unit. One electrical connector supplies the wiring interface for all electrical power and interface signals. Two pneumatic connectors are for the pitot air pressure and the static air pressure inputs to the ISFD.

The ISFD is passively cooled. Forced air cooling is not necessary.

Controls

The ISFD has these controls on the front of the display:

- Display brightness switches (+, -)
- Approach mode switch (APP)
- Barometric reference switch (HP/IN)
- Barometric control (BARO)
- Standard select switch
- Attitude reset switch (ATT RST).

Display Brightness Switches (+, -)

Use the display brightness switches to adjust the intensity of the display manually. Push the + switch to increase the intensity. Push the - switch to decrease the intensity.

STANDBY ATTITUDE REFERENCE SYSTEM - INTEGRATED STANDBY FLIGHT DISPLAY

The ISFD uses the light sensor on the front of the display to control the intensity of the display automatically.

Approach Mode Switch (APP)

The approach mode switch controls the display of the localizer and glideslope deviation.

When the ISFD comes on, the ISFD shows no localizer scale and no glideslope scale. Push the APP mode switch once to make the front course approach mode come on. The ISFD shows the localizer and the glideslope deviation scales.

Push the APP mode switch a second time to make the back course approach mode come on. The ISFD shows only the localizer scale. The ISFD also moves the localizer deviation pointer to the opposite side of the scale.

Push the APP mode switch a third time to make the approach mode displays go off.

Barometric Reference Switch (HP/IN)

The barometric reference switch controls the units for the barometric correction. The barometric correction shows in units of hectopascals or inches of mercury. Push the switch to change the reference between hectopascals and inches of mercury. The display shows HP for hectopascals (hPa) and IN for inches of mercury (in Hg).

Barometric Control (BARO)

The barometric control is a rotary knob and a push-button switch.

Turn the control to set the barometric correction. The barometric correction shows on the top right side of the display in units of hectopascals (hPa) or inches of mercury (in Hg). The range of the barometric correction is 22.00 to 32.48 in Hg (745 to 1100 hPa).

Standard Select Switch

Push the standard select switch in the center of the BARO control to set the standard barometric correction of 29.92 in Hg (1013 hPa). The ISFD shows STD in place of the barometric correction. Push the switch again to set the barometric correction manually.

Attitude Reset Switch (ATT RST)

The attitude reset switch controls the alignment of the attitude display manually.

Built-in Test Equipment

The ISFD has built-in test equipment (BITE) which monitors inputs to the ISFD and internal circuits.

STANDBY ATTITUDE REFERENCE SYSTEM - INTEGRATED STANDBY FLIGHT DISPLAY

The ISFD can show BITE data on the display. When the airplane is on the ground, push the approach (APP) mode switch and the barometric reference switch (HP/IN) for 2 seconds. The display shows a BITE menu.

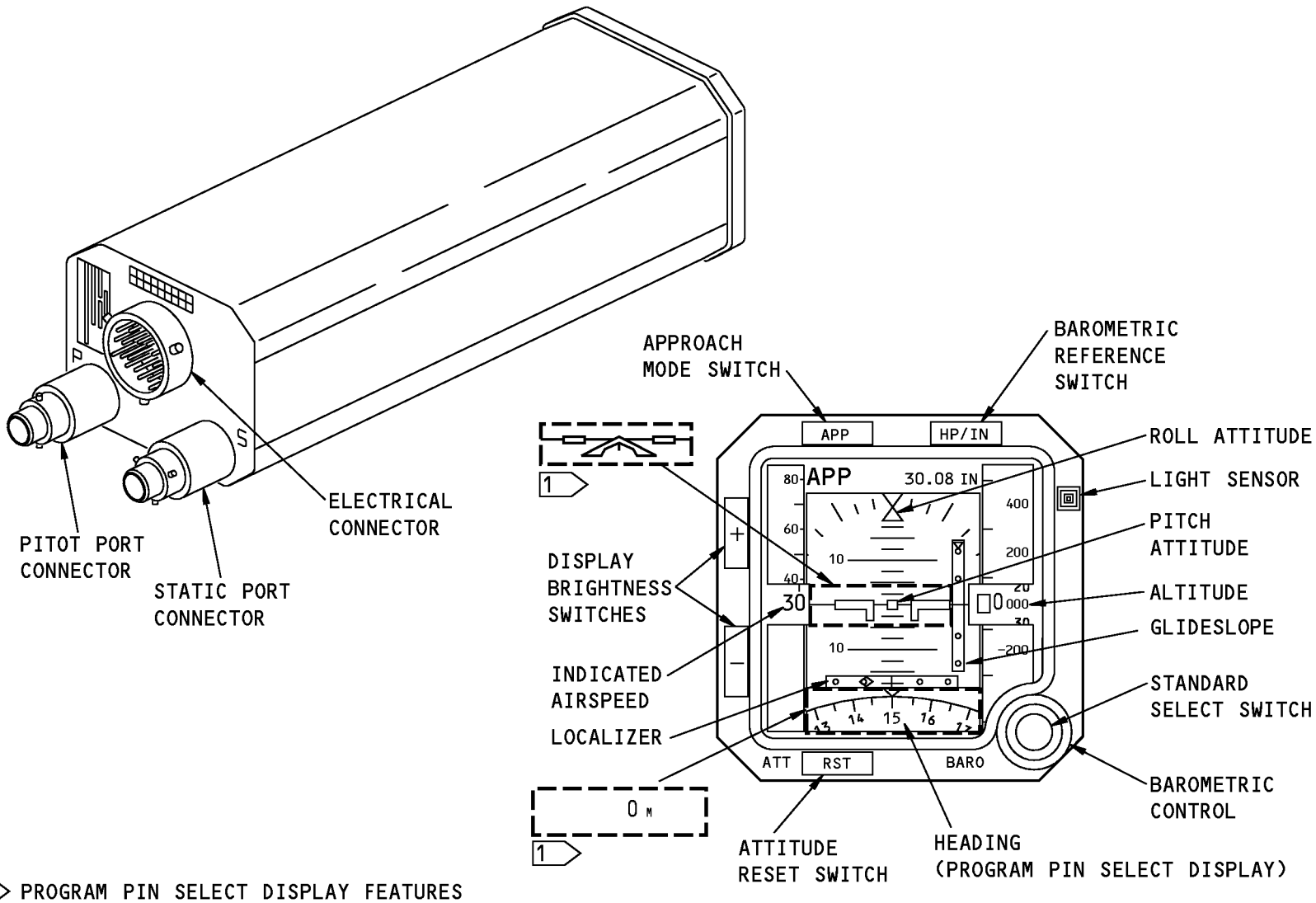

1 PROGRAM PIN SELECT DISPLAY FEATURES

Standby Attitude Reference System - Integrated Standby Flight Display

EFFECTIVITY
HAP 031-054, 101-999

34-24-00

D633A101-HAP

STANDBY ATTITUDE REFERENCE SYSTEM - ISFD DEDICATED BATTERY/CHARGER**General**

The integrated standby flight display (ISFD) dedicated battery system provides power to the ISFD when the power from the airplane battery bus is not available.

The battery/charger is a single unit which has a battery pack and battery charger circuits.

Physical Properties

These are the physical properties of the battery/charger:

- Length - 12.5 inches (318 mm)
- Width - 2.3 inches (58.4 mm)
- Height - 7.8 inches (198 mm)
- Weight - 11 pounds (5.0 kg).

The battery/charger has one connector at the rear of the unit.

The battery pack in the battery/charger contains 11 lead-acid cells which are bonded together and covered in a sleeve.

Operation

The charger circuits in the battery/charger keep the battery pack charged while there is electrical power on the airplane battery bus.

The battery/charger also uses the power from the airplane battery bus to supply power to the ISFD.

If the airplane battery bus goes off, the battery pack can provide 28v dc power to the ISFD for 150 minutes.

When the battery switch in the flight compartment is set to OFF, the battery/charger removes the battery pack from the circuit. This causes no power to go to the ISFD and the ISFD goes off.

Controls and Indication

The battery/charger has these components on the front of the unit:

- Circuit breaker (2.5 amp)
- Fault light.

Fault Light

If there are failures in the battery/charger, the fault light comes on. The fault light comes on if one of these conditions occur:

- Operating temperature is more than the maximum or less than the minimum. The maximum operating temperature is 180F (83C). The minimum operating temperature is 5F (-15C).
- Battery charger circuits do not give the correct output voltage.
- Voltage levels of the cells in the battery pack are not equal.

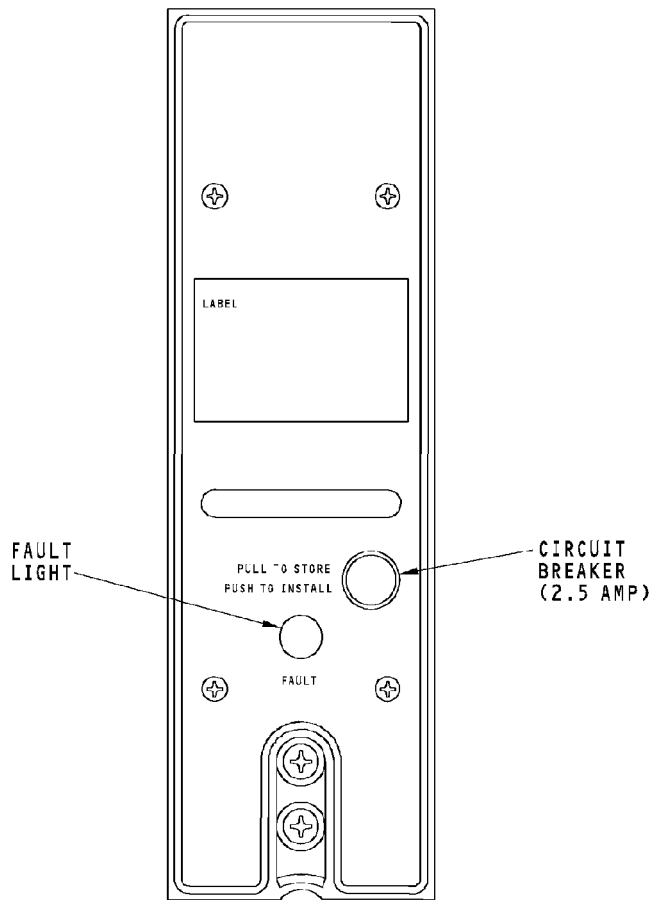

STANDBY ATTITUDE REFERENCE SYSTEM - ISFD DEDICATED BATTERY/CHARGER

34-24-00-112

EFFECTIVITY
HAP 031-054, 101-999

34-24-00

D633A101-HAP

STANDBY ATTITUDE REFERENCE SYSTEM - FUNCTIONAL DESCRIPTION**General**

The components of the standby attitude reference system are the integrated standby flight display (ISFD) and the dedicated battery system.

The ISFD shows these parameters from alternate sources:

- Attitude
- Airspeed
- Altitude.

The ISFD also shows these parameters from other sources on the airplane:

- Magnetic heading from the air data inertial reference system (ADIRS)
- Localizer deviation from the instrument landing system (ILS) or global landing system (GLS).
- Glideslope deviation from the ILS or GLS.

The battery/charger uses airplane power to charge an internal battery and to supply power to the ISFD. If airplane power is not available, the battery/charger uses its battery to supply power to the ISFD.

Power

The battery bus supplies 28v dc power to the battery/charger. The 28v dc power goes through a diode and a 2.5 amp circuit breaker in the battery/charger to the ISFD.

NOTE: The 2.5 amp circuit breaker is on the front face of the battery/charger.

The battery bus also supplies 28v dc power to charge the battery in the battery/charger.

The monitors and switch logic in the battery/charger measures the input voltage from the input power. When the voltage on the input power goes to less than 20v dc, the monitors and switch logic closes the switch that connects the battery to the output circuitry of the battery/charger. This lets the battery in the battery/charger supply power to the ISFD.

The battery in the battery/charger is a pack of 11 lead-acid cells. The battery pack can supply power to the ISFD for a maximum of 150 minutes.

The power supply in the ISFD provides these voltage levels for internal components:

- +/- 5v dc
- +/- 15v dc
- + 28v dc.

STANDBY ATTITUDE REFERENCE SYSTEM - FUNCTIONAL DESCRIPTION**Program Pins**

The program pins tell the ISFD the airplane model and the optional parameters.

The program pins that identify the airplane model set these parameters:

- Tilt angle - To correct the attitude as a function of the angle of the main instrument panel
- Static source error correction - To correct the static pressure as a function of the Mach number
- Air data aiding - To correct the attitude as a function of airspeed.

Other program pins identify display options.

The ISFD uses one program pin, called the parity pin, to make sure the airplane model and optional functions are correct. The sum of all the program pins and the parity pin must be an even number. If the sum is odd, there is a fault and the ISFD shows the message PROGRAM PIN ERROR.

ARINC 429 Interfaces

The ISFD receives data from these components on ARINC 429 data buses:

- Multi-mode receiver (MMR) number 1 - localizer deviation and glideslope deviation

- Left air data inertial reference unit (ADIRU) - magnetic heading.

Pneumatic Inputs

There are two pneumatic sensors in the ISFD that sense pitot and static pressures.

One sensor receives pitot pressure from the alternate pitot probe. The other sensor receives static pressure from the alternate static ports.

Pitot and static pressure data goes to the data control and system processing. The processor uses static pressure to calculate altitude and airspeed. The processor uses pitot pressure to calculate airspeed.

Inertial Sensors

The ISFD has inertial sensors that sense angular rate and linear acceleration. The ISFD uses the inertial sensors to calculate pitch and roll attitude.

The angular rate data comes from solid-state quartz rate sensors. Rotational movement about the sensor axis gives a DC voltage that is in proportion to the angular rate.

STANDBY ATTITUDE REFERENCE SYSTEM - FUNCTIONAL DESCRIPTION

The linear acceleration data comes from silicon accelerometers. Each accelerometer has a single silicon crystal. Gravity and acceleration forces change the capacitance of the crystal. The accelerometer gives a DC voltage that is in proportion to the acceleration.

Bezel Controls

The front face of the ISFD has five push-buttons and one rotary knob to control the operation.

There is one light sensor on the bezel. The ISFD uses the light sensor to control the intensity of the display as the ambient light changes.

Data Control and System Processing

All inputs and controls go to the data control and system processing section of the ISFD. The processor does these functions:

- Calculates airspeed and altitude from the pressure sensor signals
- Calculates pitch and roll attitude from the inertial sensor signals
- Changes calculated data to graphics data for the graphics processing
- Controls brightness
- Changes the display in response to inputs from the bezel controls.

Graphics Processing and Display

The graphics processor does these functions:

- Calculates graphic data for each parameter from the system processor
- Controls the liquid crystal display (LCD) matrix drivers
- Refreshes the display.

The display has a color active matrix LCD and a back-lighting box. The back-lighting box has these components:

- Three fluorescent tubes
- Reflector
- Diffuser.

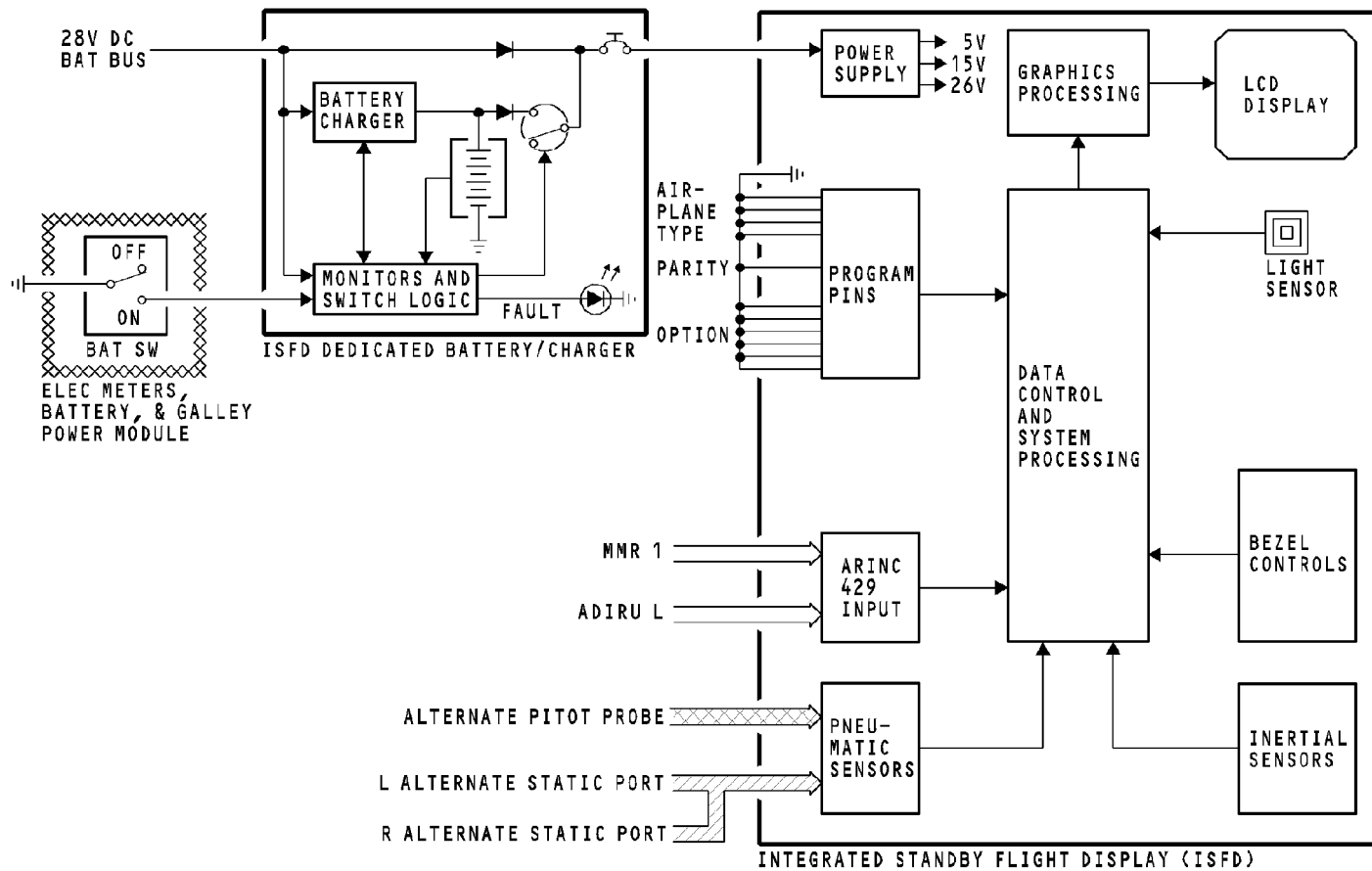

STANDBY ATTITUDE REFERENCE SYSTEM - FUNCTIONAL DESCRIPTION

34-24-00-121

EFFECTIVITY
HAP 031-054, 101-999

34-24-00

D633A101-HAP

STANDBY ATTITUDE REFERENCE SYSTEM - OPERATION - POWER-UP**Power-Up Display**

The ISFD shows flags when you first apply power to it.

For the first 15 seconds, the display shows these flags:

- ATT - attitude flag
- SPD - airspeed flag
- ALT - altitude flag.

The airspeed and altitude functions in the ISFD complete the initialization after 15 seconds. After 15 seconds, the display removes the SPD and ALT flags and shows the altitude and airspeed.

The attitude function in the ISFD completes the initialization after 90 seconds. After 90 seconds, the display removes the ATT flag and shows the pitch and roll attitude.

Failure Displays

If there are failures in the ISFD, the display shows failure messages when you apply power to it.

The display shows PROGRAM PIN ERROR if either one of these conditions occur:

- Parity for the program pins is odd.
- Program pins sense an airplane type or option combination that is not valid.

NOTE: The ISFD uses one program pin, called the parity pin, to make sure the airplane model and optional functions are correct. The sum of all the program pins and the parity pin must be an even number. If the sum is odd, there is a fault.

The display shows OUT OF ORDER if the ISFD has a fault. The display also shows a fault code. The bench technicians use the fault code to troubleshoot failures inside the ISFD.

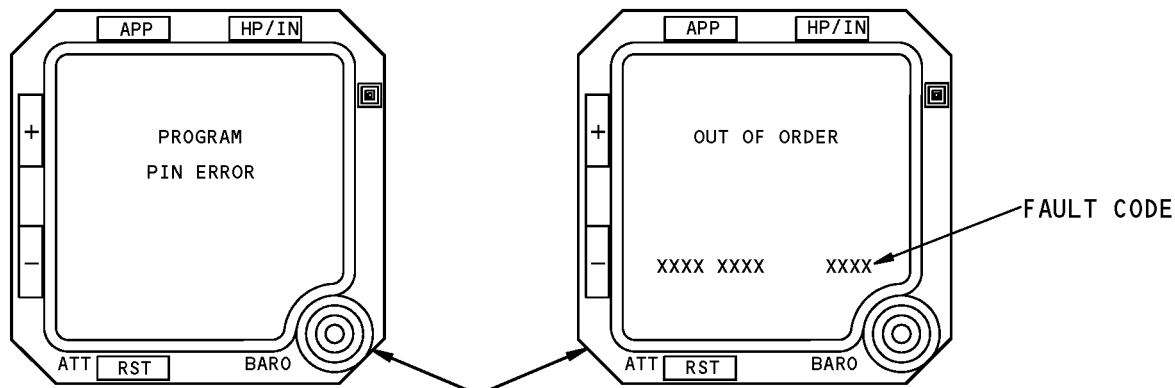
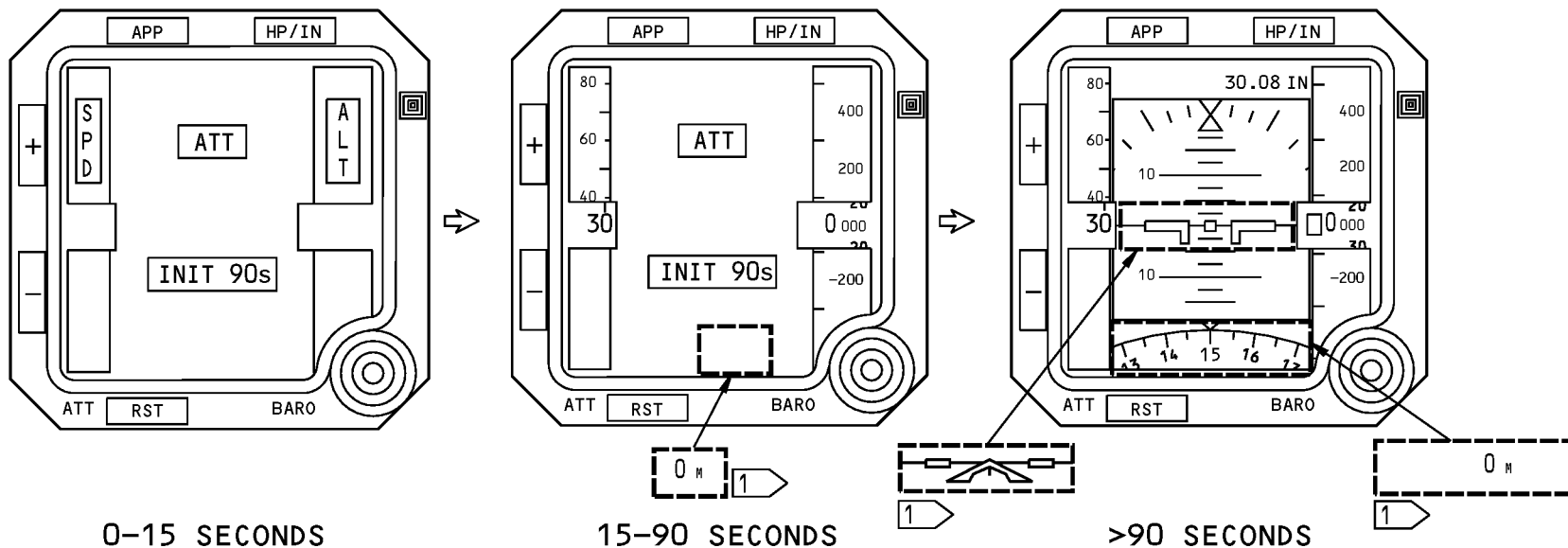

1 PROGRAM PIN SELECT DISPLAY FEATURES

FAILURE DISPLAYS

Standby Attitude Reference System - Operation - Power-Up

EFFECTIVITY
HAP 031-054, 101-999

34-24-00

D633A101-HAP

Page 41
Feb 15/2009

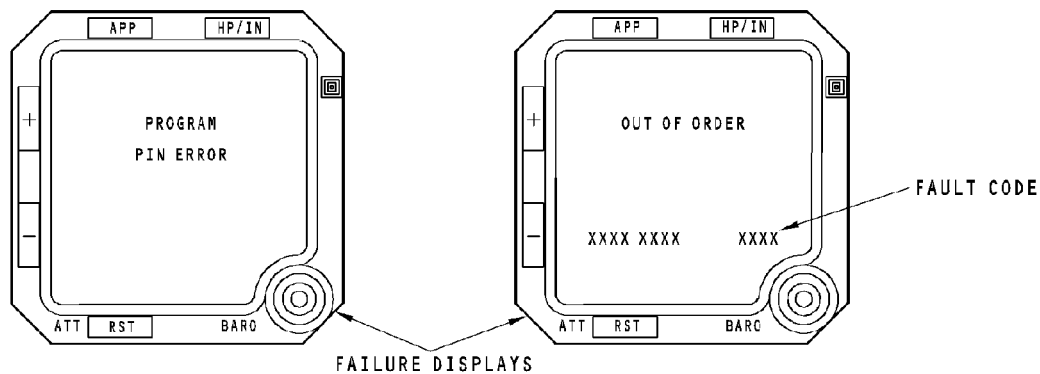
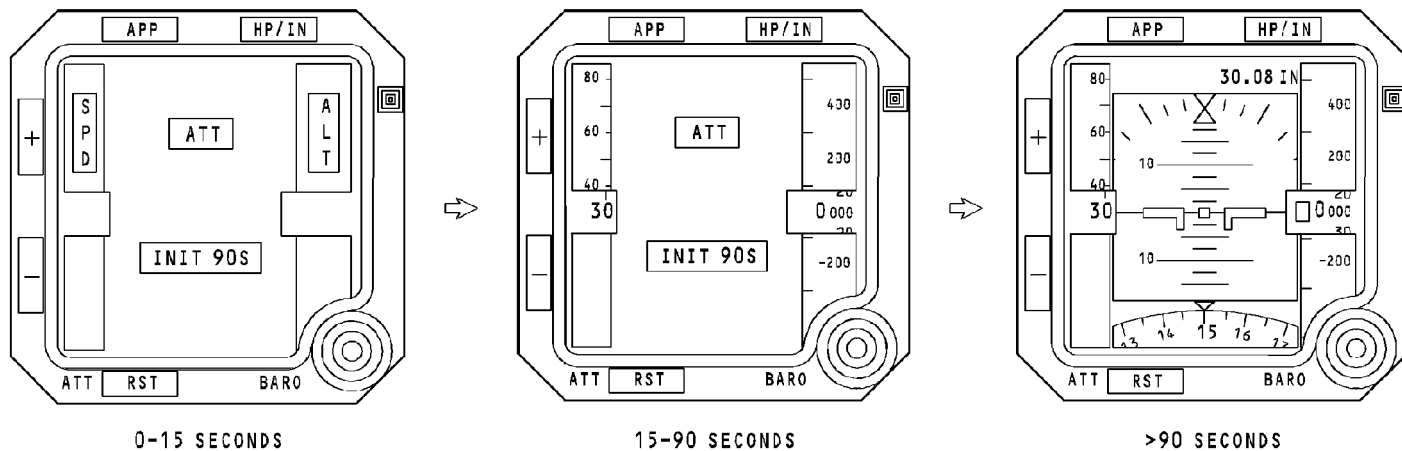

STANDBY ATTITUDE REFERENCE SYSTEM - OPERATION - POWER-UP

EFFECTIVITY
HAP 031-054, 101-999

34-24-00

D633A101-HAP

STANDBY ATTITUDE REFERENCE SYSTEM - OPERATION - ATTITUDE**Normal Display**

The ISFD shows pitch and roll attitude.

The ISFD goes through alignment when it first receives power. 90 seconds after the ISFD receives power, the pitch and roll attitude scales and pointer show on the display.

The pitch attitude scale shows as horizontal markers from the top to the bottom of the display. There are 2.5 degrees between each marker. The airplane symbol is fixed at the center of the display. The pitch attitude scale moves up or down as the pitch angle changes.

When the pitch attitude scale shows pitch attitude more than 30 degrees, large red arrowheads show. The arrowheads point in the direction of 0 degrees pitch attitude.

The roll attitude scale is at the top of the display. The markers are at 0, 10, 20, 30, 45 and 60 degrees of bank angle.

The resolution of the display is 0.25 degree for pitch and 0.5 degree for roll.

Failure Display

If the ISFD finds a failure of the attitude function, the display shows the attitude (ATT) flag. The ISFD removes the pitch and roll scales and pointers.

Messages

The ISFD shows these messages on the attitude display:

- INIT 90s (initialize for 90 seconds)
- WAIT ATT (wait attitude)
- ATT 10s (attitude 10 seconds)
- ATT:RST (attitude reset).

The initialization 90 seconds (INIT 90s) message shows during power-up. The ISFD takes 90 seconds to align the pitch and roll attitude during power-up. When the attitude alignment is complete, the ISFD shows the pitch and roll attitude scales and pointer.

The wait attitude (WAIT ATT) message shows when the inertial sensors sense the angular rate or the acceleration is more than the maximum. The maximum angular rate is 100 degrees per second. The maximum acceleration is 3.2g.

When the angular rate and acceleration go less than the maximum, the ISFD removes the message and shows the attitude scales and pointer.

If the angular rate or acceleration is more than the maximum for more than 10 seconds, the ISFD shows the ATT:RST message.

STANDBY ATTITUDE REFERENCE SYSTEM - OPERATION - ATTITUDE

The attitude 10 seconds (ATT 10s) messages shows after you push the attitude reset switch. The ISFD aligns the attitude for 10 seconds. After 10 seconds, the ISFD shows the attitudes scales and pointer.

The attitude reset (ATT:RST) message shows if the inertial sensors sense angular rate or acceleration more than the maximum for more than 10 seconds. The maximum angular rate is 100 degrees per second. The maximum acceleration is 3.2g. Push the attitude reset switch to make the ISFD begin an attitude alignment.

Attitude Reset Switch (ATT RST)

Use the attitude reset switch to make the ISFD reset the attitude. Do this if there is an error between the ISFD attitude and the real airplane attitude, or if the ATT:RST message shows.

Push the attitude reset switch for a minimum of 2 seconds to start the attitude reset. The ISFD shows the message, ATT 10s. After 10 seconds, the message goes off and the attitude scales and pointer show.

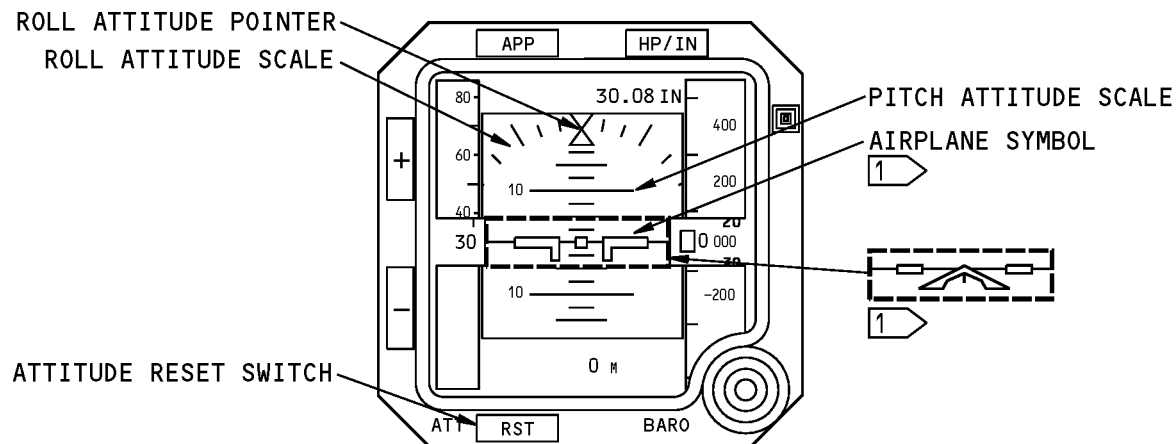

NORMAL DISPLAY

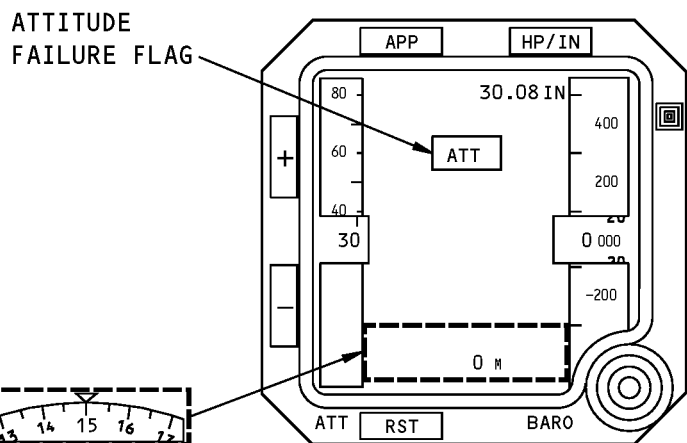

FAILURE DISPLAY

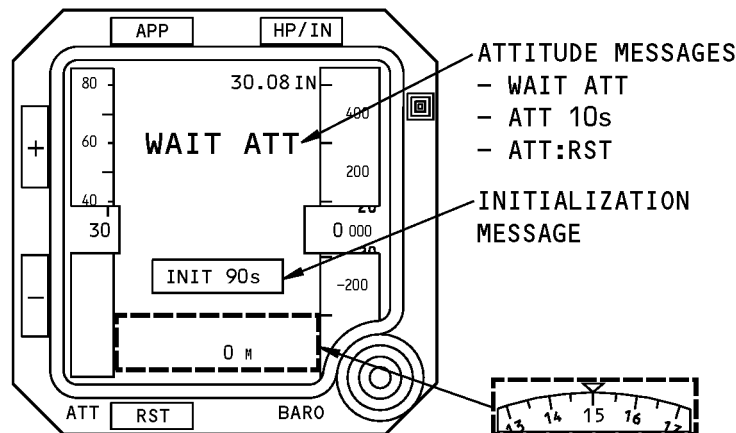

MESSAGES

1 PROGRAM PIN SELECT DISPLAY FEATURES

Standby Attitude Reference System - Operation - Attitude

EFFECTIVITY
HAP 031-054, 101-999

34-24-00

D633A101-HAP

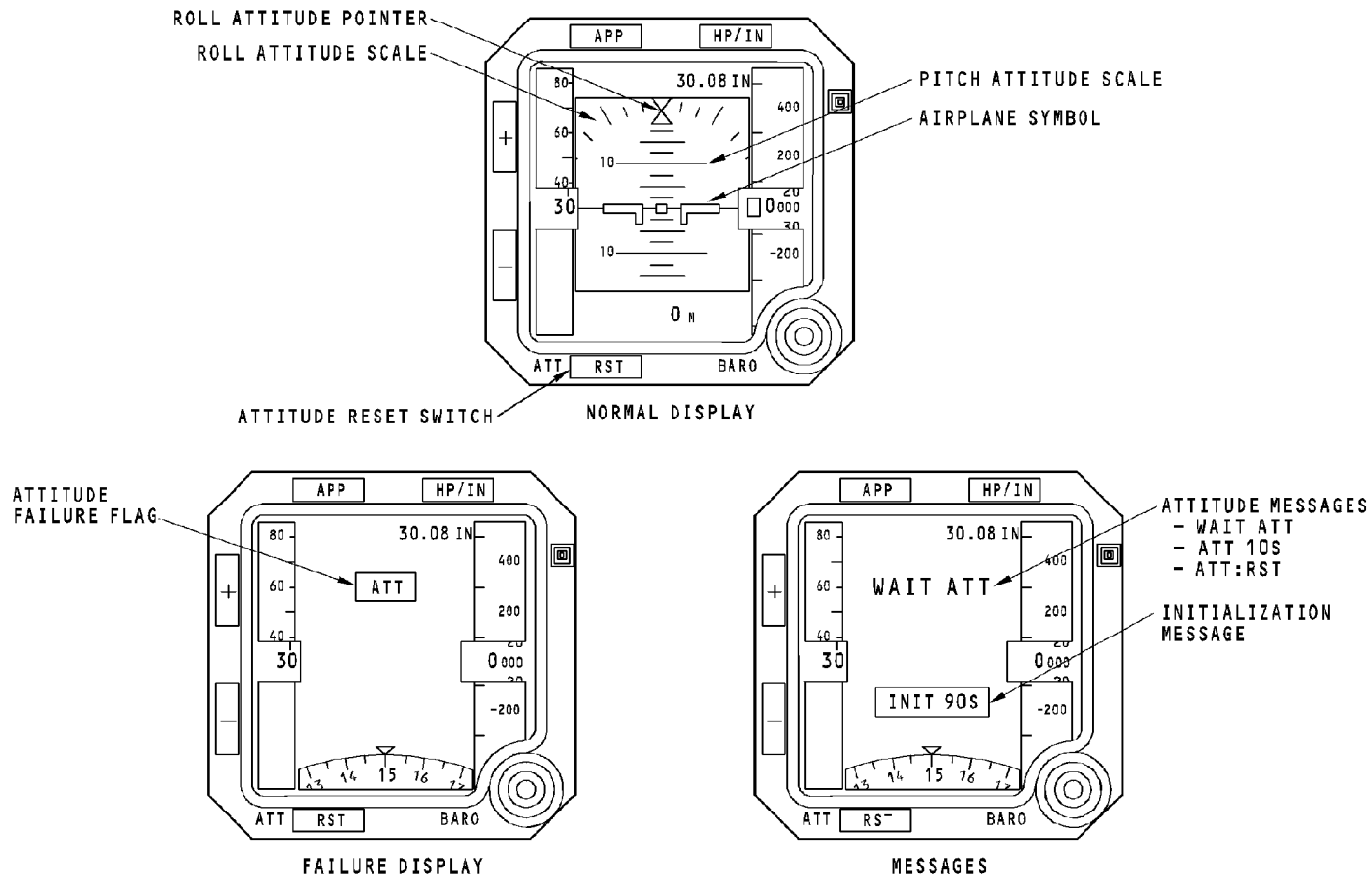

STANDBY ATTITUDE REFERENCE SYSTEM - OPERATION - ATTITUDE

EFFECTIVITY
HAP 031-054, 101-999

34-24-00

D633A101-HAP

STANDBY ATTITUDE REFERENCE SYSTEM - OPERATION - AIRSPEED AND ALTITUDE**General**

The ISFD uses pneumatic inputs from alternate pitot and static ports to calculate indicated airspeed and altitude.

Indicated Airspeed

The airspeed tape shows on the left side of the display. Indicated airspeed shows in a digital display box with rolling digits.

The range of the indicated airspeed is 30 to 520 knots.

Altitude

The altitude tape shows on the right side of the display. Altitude shows in a digital display box with rolling digits.

The range of the altitude is -2,000 to 50,000 feet. The resolution of the altitude display is 10 feet.

Barometric Reference

The ISFD shows the barometric reference setting on the top right side of the display. Use the barometric control and the barometric reference switch to control the barometric reference setting.

Rotate the barometric control to change the barometric reference setting and set the barometric corrected altitude. The ISFD shows the barometric reference setting in units of hectopascals (hPa) or inches of mercury (in Hg). The ISFD shows HPA for hectopascals or IN for inches of mercury.

Use the barometric reference switch to change the units of the barometric reference setting. Push the switch to change the units from HPA to IN. Push the switch again to change the units to HPA.

Standard Barometric Pressure

Use the standard select switch in the center of the barometric control to set the standard barometric pressure (29.92 in Hg or 1013 hPa).

Push the standard select switch to change the barometric reference setting to the standard barometric pressure. The display shows STD for the barometric reference setting. Push the switch again to remove the standard setting. This lets you manually set the barometric reference.

Failure Displays

If the ISFD can not calculate the indicated airspeed, the airspeed tape and the indicated airspeed displays go off. The display shows the airspeed flag (SPD).



STANDBY ATTITUDE REFERENCE SYSTEM - OPERATION - AIRSPEED AND ALTITUDE

If the ISFD can not calculate the altitude, the altitude tape and the altitude displays go off. The display shows the altitude flag (ALT).

34-24-00-133

EFFECTIVITY
HAP 031-054, 101-999

34-24-00

D633A101-HAP

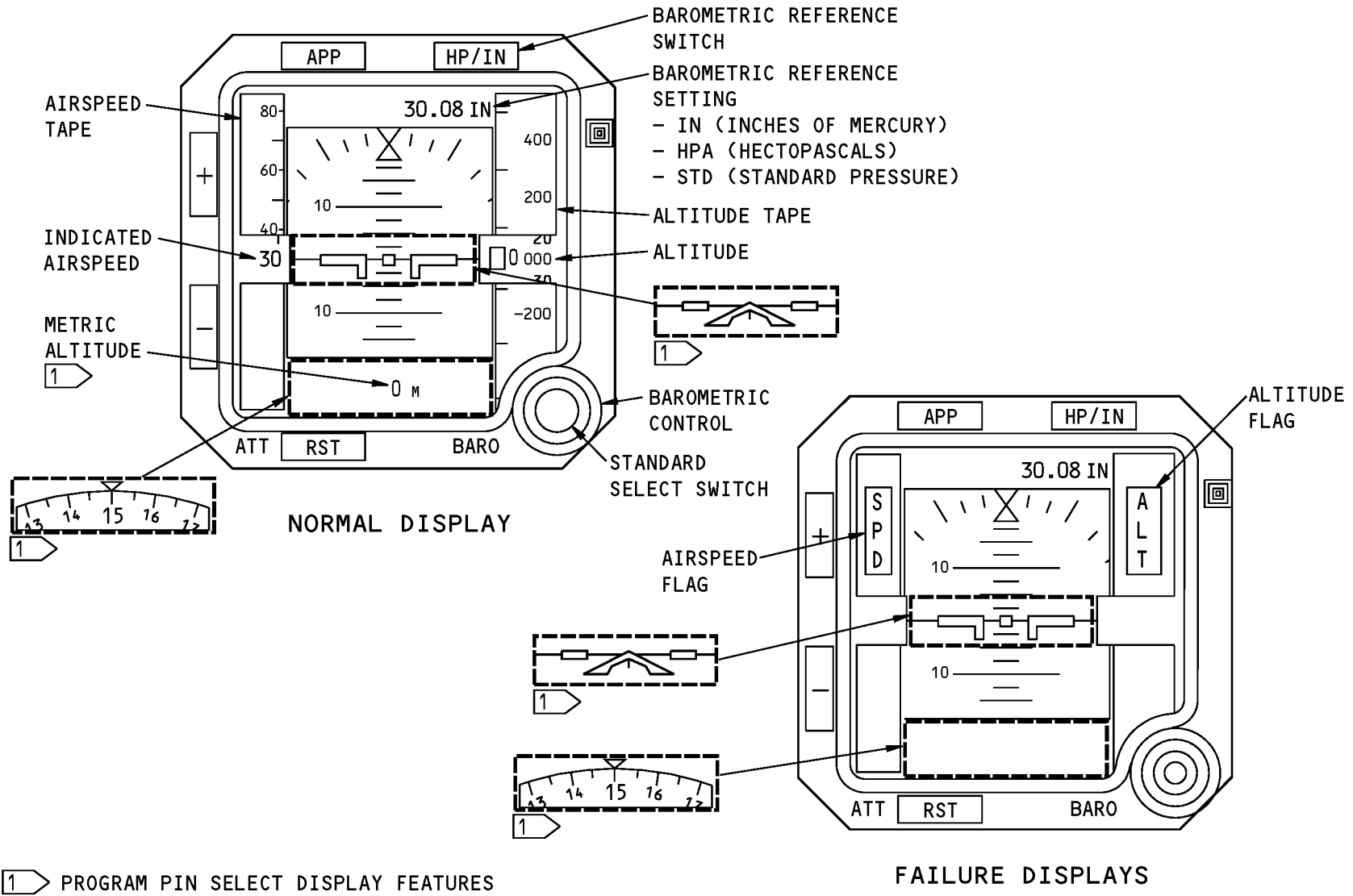

Standby Attitude Reference System - Operation - Airspeed and Altitude

34-24-00-133

EFFECTIVITY
HAP 031-054, 101-999

34-24-00

D633A101-HAP

Page 49
Feb 15/2009

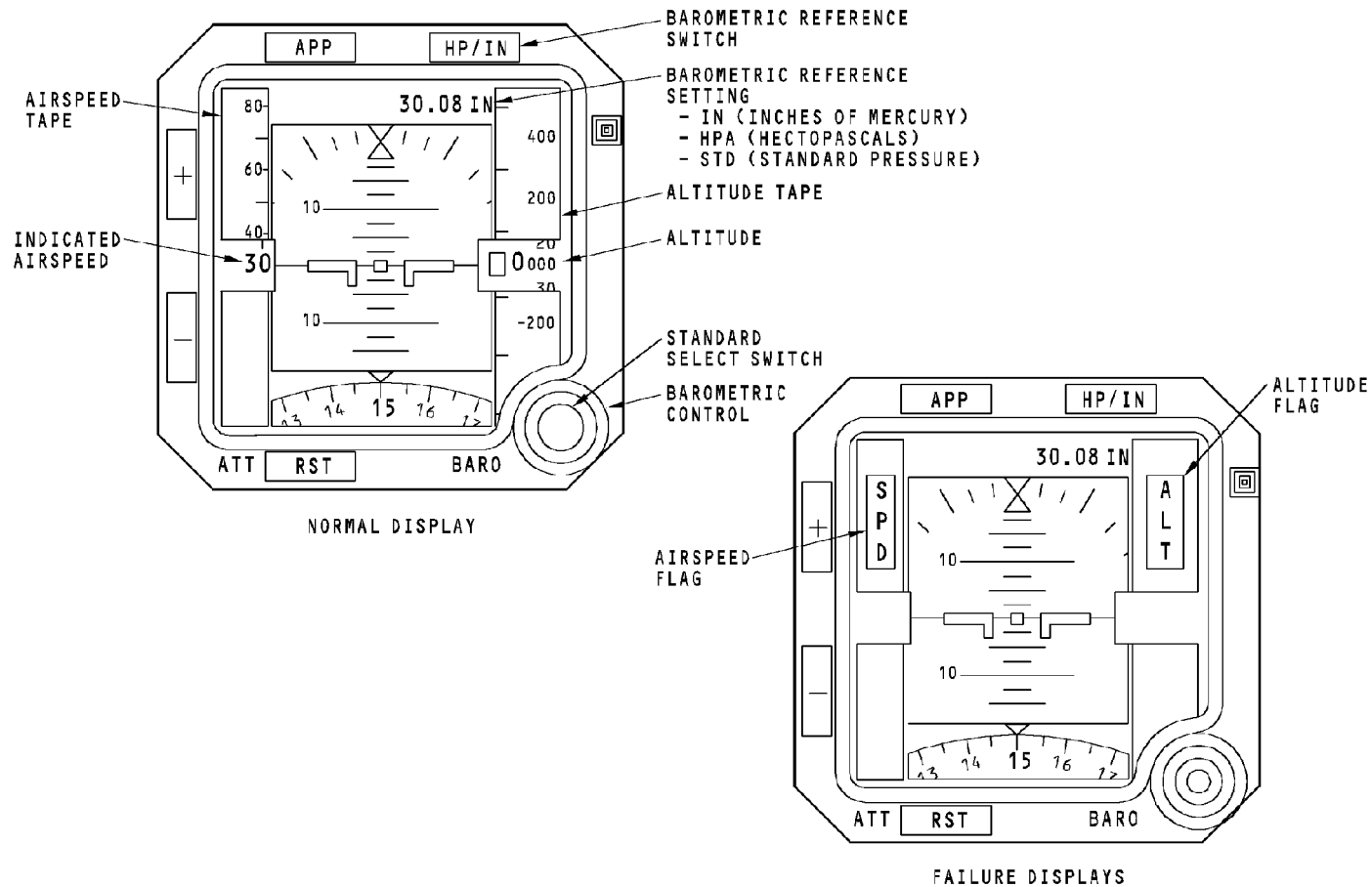

STANDBY ATTITUDE REFERENCE SYSTEM - OPERATION - AIRSPEED AND ALTITUDE

EFFECTIVITY
HAP 031-054, 101-999

34-24-00

D633A101-HAP

THIS PAGE IS INTENTIONALLY LEFT BLANK

34-24-00

D633A101-HAP

Page 51
Oct 10/2006

STANDBY ATTITUDE REFERENCE SYSTEM - OPERATION - HEADING**General**

The integrated standby flight display (ISFD) receives magnetic heading data from the air data inertial reference system (ADIRS).

The ISFD shows the magnetic heading on a compass rose at the bottom of the display.

The range of the heading is from 0 to 360 degrees. The display resolution for heading is 1 degree.

Failure Display

The ISFD shows the heading flag (HDG) and removes the compass rose if one of these conditions occurs:

- ISFD does not receive the magnetic heading data (ARINC 429 label 320) from the air data inertial reference unit (ADIRU)
- Magnetic heading data is no computed data (NCD)
- Magnetic heading data word has a failure warning (FAIL WARN).

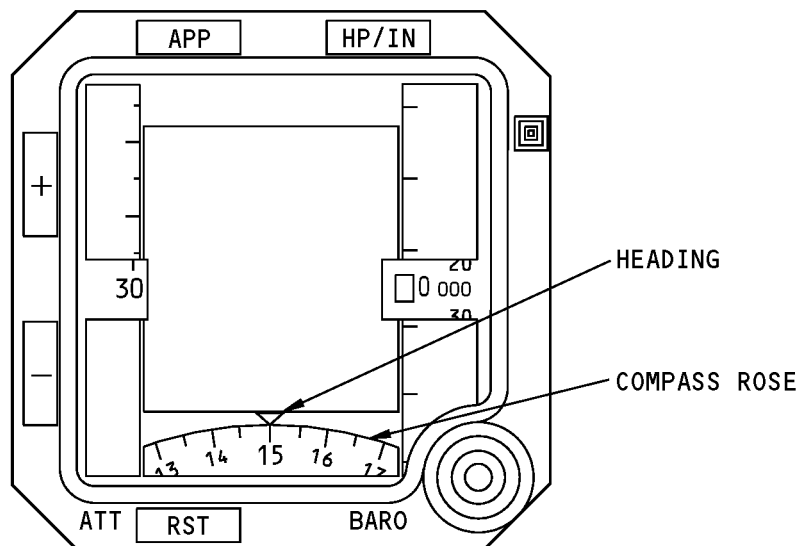

NORMAL DISPLAY

HEADING
COMPASS ROSE

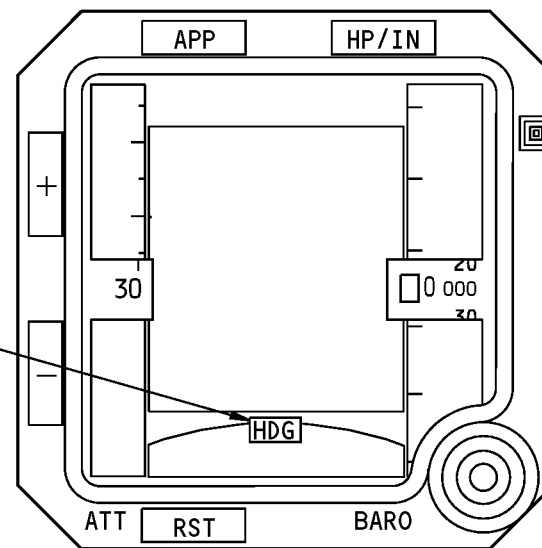

FAILURE DISPLAY

HEADING
FLAG

Standby Attitude Reference System - Operation - Heading

34-24-00-134

EFFECTIVITY
HAP 031-054, 101-999

34-24-00

D633A101-HAP

Page 53
Feb 15/2009

THIS PAGE IS INTENTIONALLY LEFT BLANK

34-24-00

D633A101-HAP

Page 54
Oct 10/2006

STANDBY ATTITUDE REFERENCE SYSTEM - OPERATION - APPROACH**General**

There are no special ILS tests for the integrated standby flight display (ISFD). You do a check of the approach display with a multi-mode receiver (MMR) 1 self-test.

Start the ILS self-test from the test switch on the navigation control panel. You can also start it from the test switch on MMR 1. Push the APP switch on the ISFD so that the APP annunciation shows on the display.

NOTE: The ISFD does not show ILS or GLS data at power-up. The first push of the APP switch shows normal ILS or GLS indications and the APP annunciation.

NOTE: The next push of the APP switch removes the glideslope scale, shows the localizer scale, and shows the BCRS annunciation.

NOTE: The next push of the APP switch removes all ILS or GLS indications and no ILS GLS annunciations show.

These is the display sequences on the ISFD during the ILS self-test:

- Invalid data
- No computed data (NCD)
- Data correct - up/left
- Data correct - down/right.

The length of the self-test sequence is 14 seconds.

Invalid Data Display

Invalid data is the first display in the self-test sequence. It shows on the ISFD for three seconds. Invalid data causes these indications:

- LOC flag comes into view
- G/S flag comes into view
- Deviation scales go out of view
- Deviation pointers go out of view.

NCD Display

NCD is the second display in the self-test sequence. It shows on the ISFD for two seconds. NCD causes these indications:

- LOC flag goes out of view
- G/S flag goes out of view
- Deviation scales come into view
- Deviation pointers stay out of view.

Data Correct - Up/Left Display

Data correct - up/left is the third display in the self-test sequence. It shows for three seconds on the ISFD. Data correct - up/left causes these indications:

- LOC flag stays out of view
- G/S flag stays out of view
- Localizer pointer shows one dot of left deviation
- Glideslope pointer shows one dot of up deviation.

STANDBY ATTITUDE REFERENCE SYSTEM - OPERATION - APPROACH

Data Correct - Down/Right Display

Data correct - down/right is the fourth display in the self-test sequence. It shows for six seconds on the ISFD. Data correct - down/right causes these indications:

- LOC flag stays out of view
- G/S flag stays out of view
- Localizer pointer shows one dot of right deviation
- Glideslope pointer shows one dot of down deviation.

The approach display goes back to normal indications at the end of the self-test sequence.

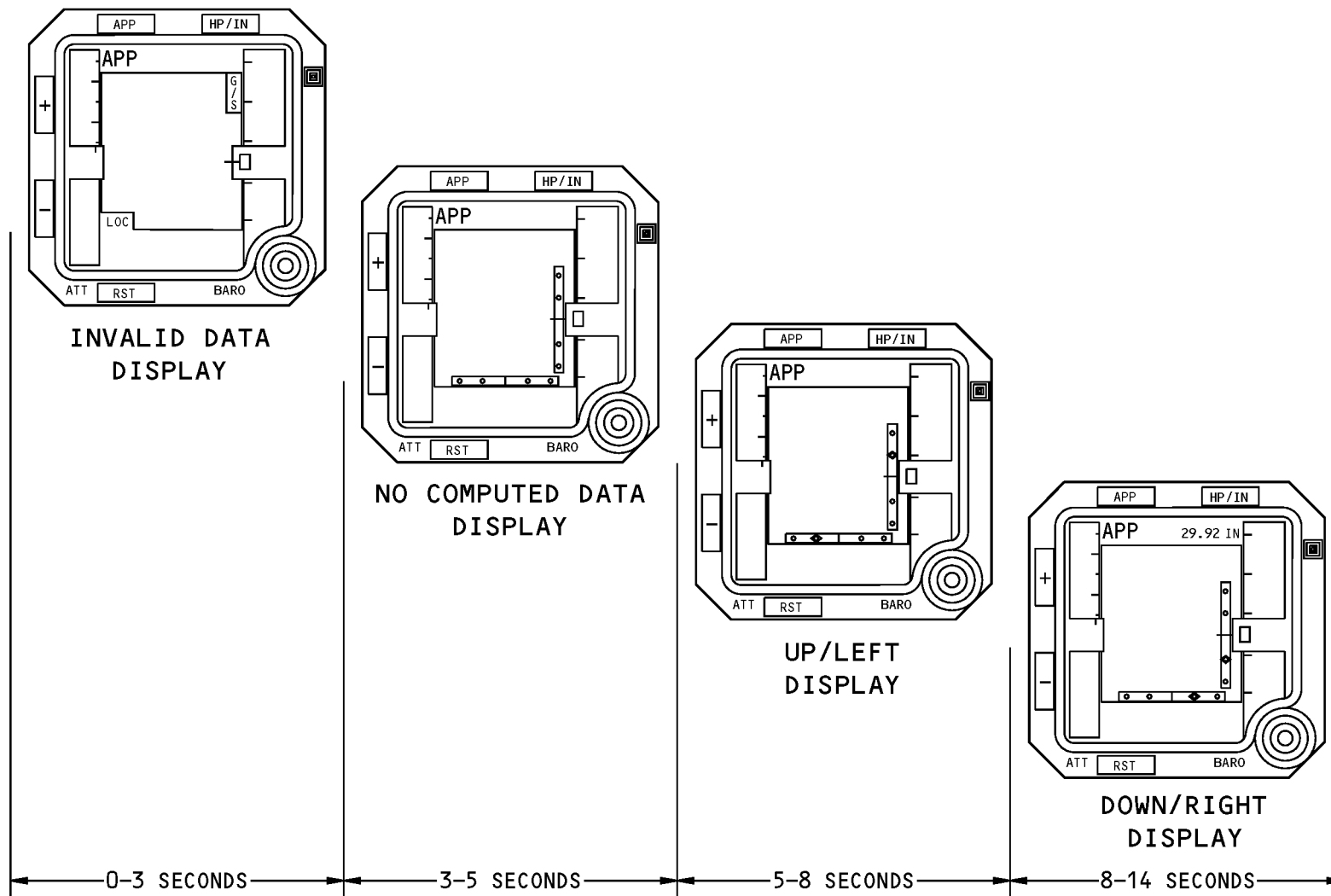

Standby Attitude Reference System - Operation - Approach

34-24-00-136

EFFECTIVITY
HAP 031-054, 101-999

34-24-00

D633A101-HAP

Page 57
Feb 15/2009

STANDBY ATTITUDE REFERENCE SYSTEM - TIP - BITE MENU**General**

The ISFD has internal BITE that lets you monitor and do tests. To show the BITE displays, the airplane must be on the ground and the ISFD power-up complete.

NOTE: The ISFD uses internal calculations of computed air speed or, as a backup, ADIRU ground speed to determine the on ground condition. The threshold speed is 100 kts.

ISFD Tests

To start the BITE, simultaneously push and hold the APP and the HP/IN switches for at least two seconds. After two seconds, the TESTS and OTHER DATA page shows. From this BITE page you can go the other BITE pages or return to the normal display operation.

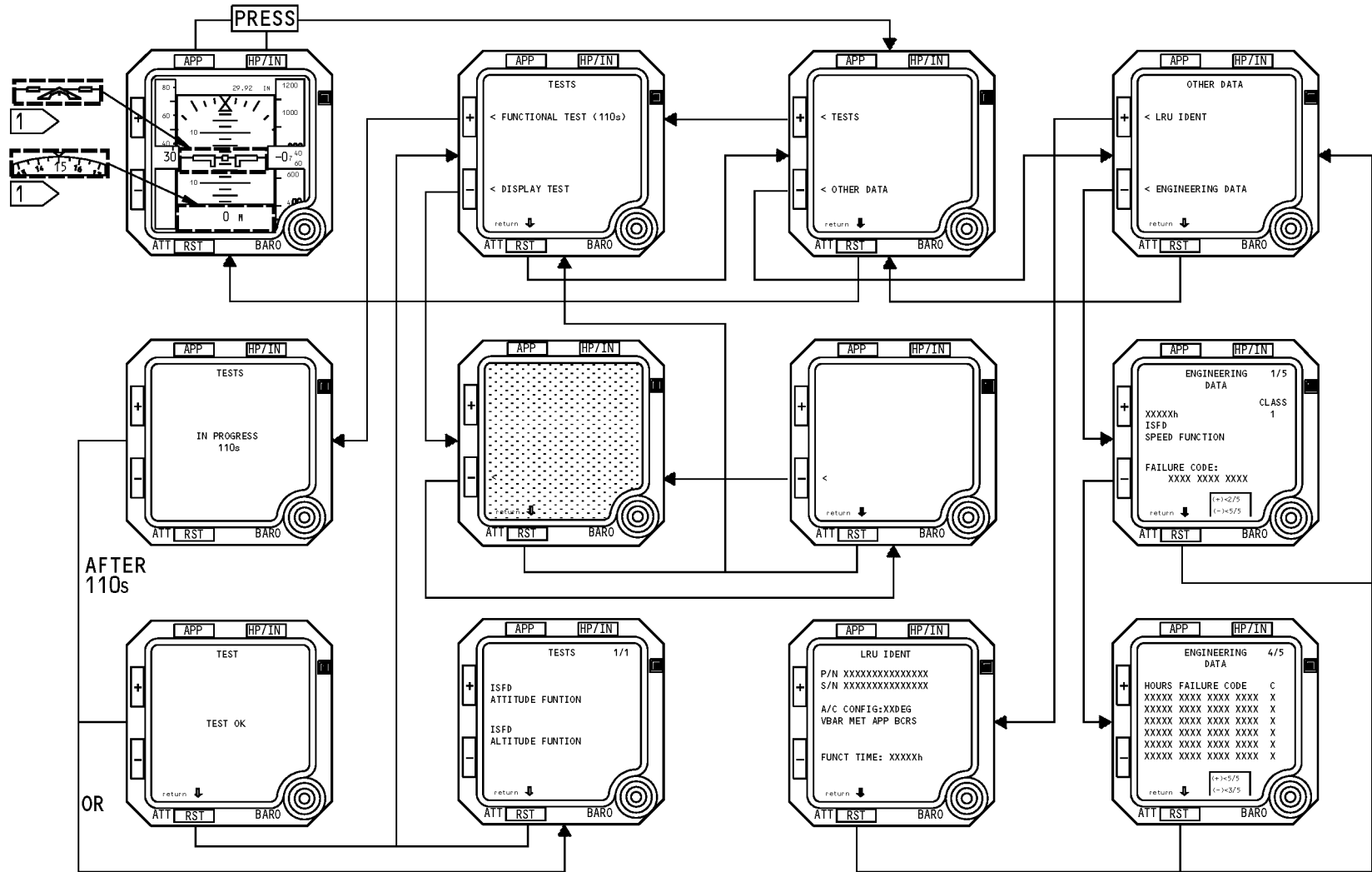

1 PROGRAM PIN SELECT DISPLAY FEATURES

Standby Attitude Reference System - Tip -BITE Menu

34-24-00-151

EFFECTIVITY
HAP 031-054, 101-999

34-24-00

D633A101-HAP

Page 59
Feb 15/2009

STANDBY ATTITUDE REFERENCE SYSTEM - TIP - BITE - FUNCTIONAL TEST

General

The functional test checks the operation of the integrated standby flight display (ISFD) and the input signals to the ISFD.

Access

Push and hold the approach mode (APP) and the barometric reference setting (HP/IN) switches for 2 seconds. The ISFD shows the menu with TESTS and OTHER DATA prompts.

Push the + switch to show the TESTS menu.

Push the + switch to start the functional test. The display shows the TEST page with the IN PROGRESS 110s message.

Functional Test

The functional test checks the internal operation of the ISFD. It also checks the input signals to the ISFD. For example, the test checks the program pins and the ARINC 429 input from the air data inertial reference unit (ADIRU).

The test lasts for about 110 seconds. When the ISFD completes the test, the display shows TEST OK or the display shows the fault messages.

When the TEST OK shows, all circuits are operating correctly. When a fault message shows, there is a failure.

Fault Messages

At the end of the functional test, the ISFD BITE shows fault messages if there are faults. The table below shows the possible fault messages and the flight deck effects.

Flight Deck Effect	Fault Message	Internal or External
OUT OF ORDER	ISFD	Internal
PROGRAM PIN ERROR	WRG: MODE DISCRETE/ ISFD	External
PROGRAM PIN ERROR	WRG: PARITY PIN- PROG/ ISFD	External
ATT	ISFD ATTITUDE_FUNCTION	Internal
SPD	ISFD SPEED_FUNCTION__	Internal
ALT	ISFD ALTITUDE_FUNCTION	Internal
G/S and/or LOC	ILS OR MMR/ ISFD	External
HDG	ADIRU BUS IR OR IRS/ ISFD	External
no effect	POWER SUPPLY INTERRUPT	External
no effect	WRG TEST DISCRETE/ ISFD	External

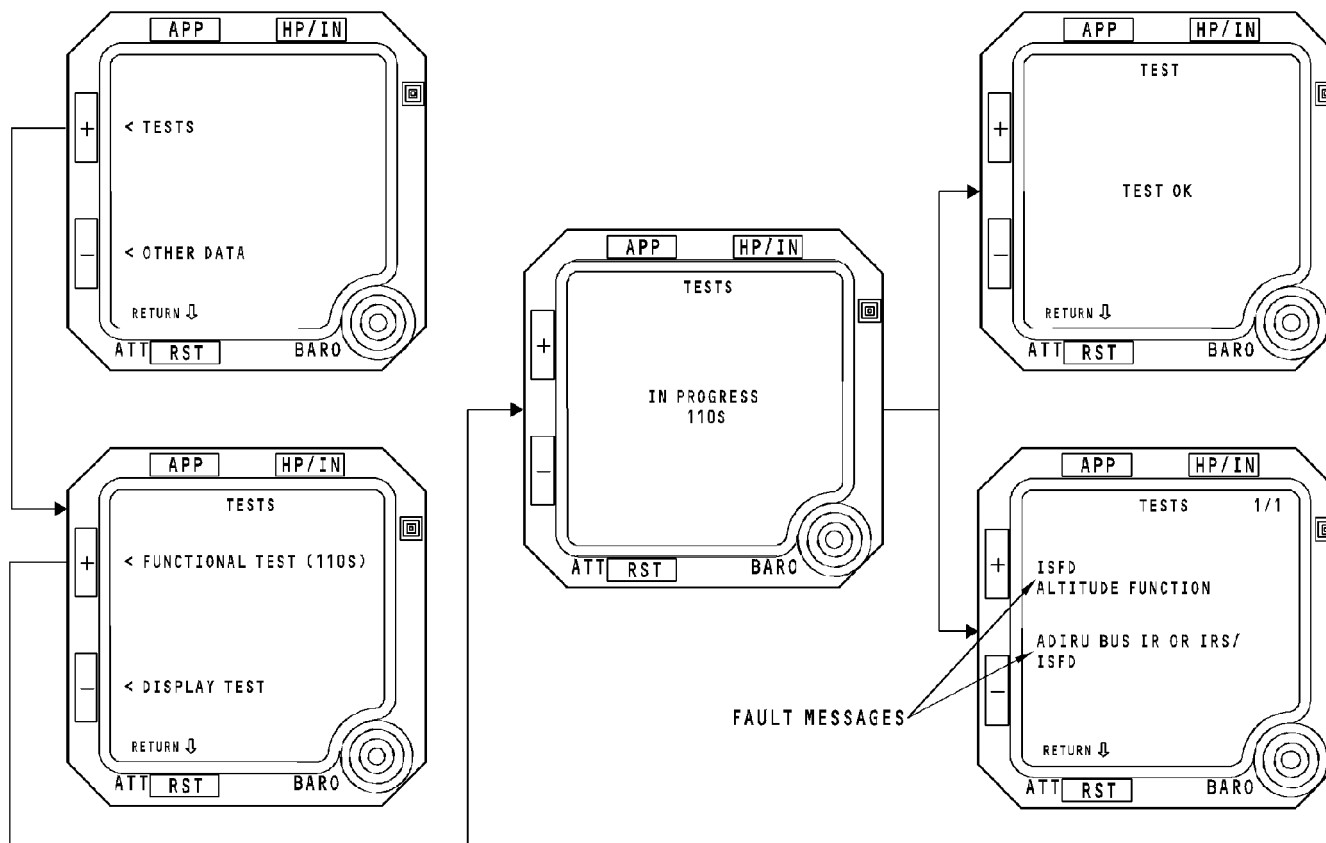

STANDBY ATTITUDE REFERENCE SYSTEM - TIP - BITE - FUNCTIONAL TEST

34-24-00-152

EFFECTIVITY
HAP 031-054, 101-999

34-24-00

D633A101-HAP

Page 61
Feb 15/2009

STANDBY ATTITUDE REFERENCE SYSTEM - TIP - BITE - DISPLAY TEST**General**

The display test checks the operation of the liquid crystal display (LCD) matrix in the integrated standby flight display (ISFD).

Access

Push and hold the approach mode (APP) and the barometric reference setting (HP/IN) switches for 2 seconds. The ISFD shows the menu with TESTS and OTHER DATA prompts.

Push the + switch to show the TESTS menu.

Display Test

When the ISFD starts the display test, the display shows white.

Push the - switch again to make the display show black.

Continue to push the - switch to show white and black screens.

Push the attitude reset (RST) switch to return to the tests menu.

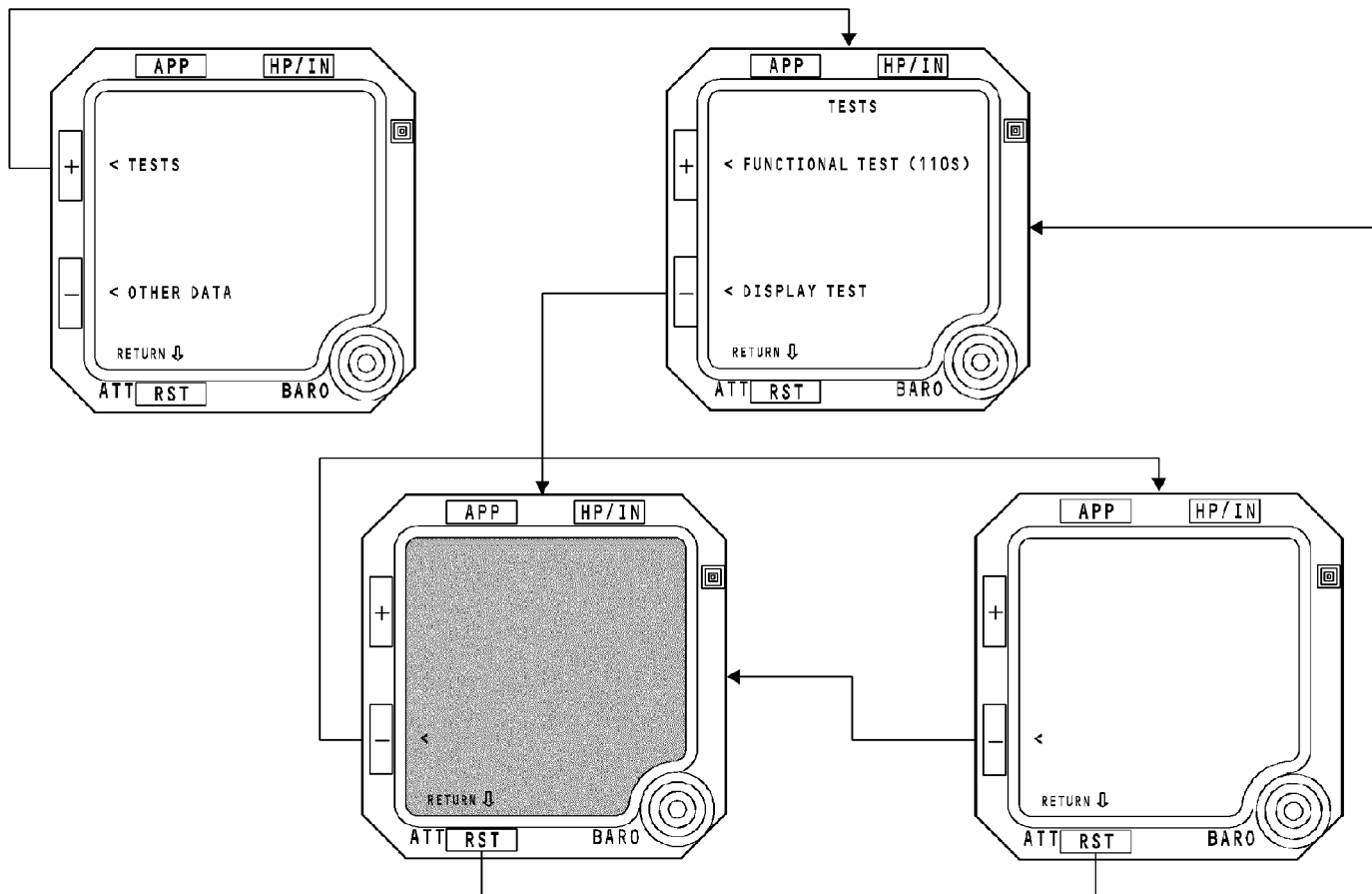

STANDBY ATTITUDE REFERENCE SYSTEM - TIP - BITE - DISPLAY TEST

34-24-00-153

EFFECTIVITY
HAP 031-054, 101-999

34-24-00

D633A101-HAP

Page 63
Feb 15/2009

STANDBY ATTITUDE REFERENCE SYSTEM - TIP - BITE - LRU IDENT**General**

The LRU IDENT (line-replaceable-unit identification) page lets you see identification data for the ISFD.

Access

Push and hold the approach mode (APP) and the barometric reference setting (HP/IN) switches for two seconds. The ISFD shows the menu with TESTS and OTHER DATA prompts.

Push the - switch to show the OTHER DATA menu.

Push the + switch to show the LRU IDENT page.

LRU Ident

The LRU ident page shows these parameters about the ISFD:

- Hardware part number
- Software part number
- Airplane configuration which shows the tilt angle for the airplane model
- Options set by the program pins
- Time in operation.

Push the attitude reset (RST) switch to return to the OTHER DATA menu.

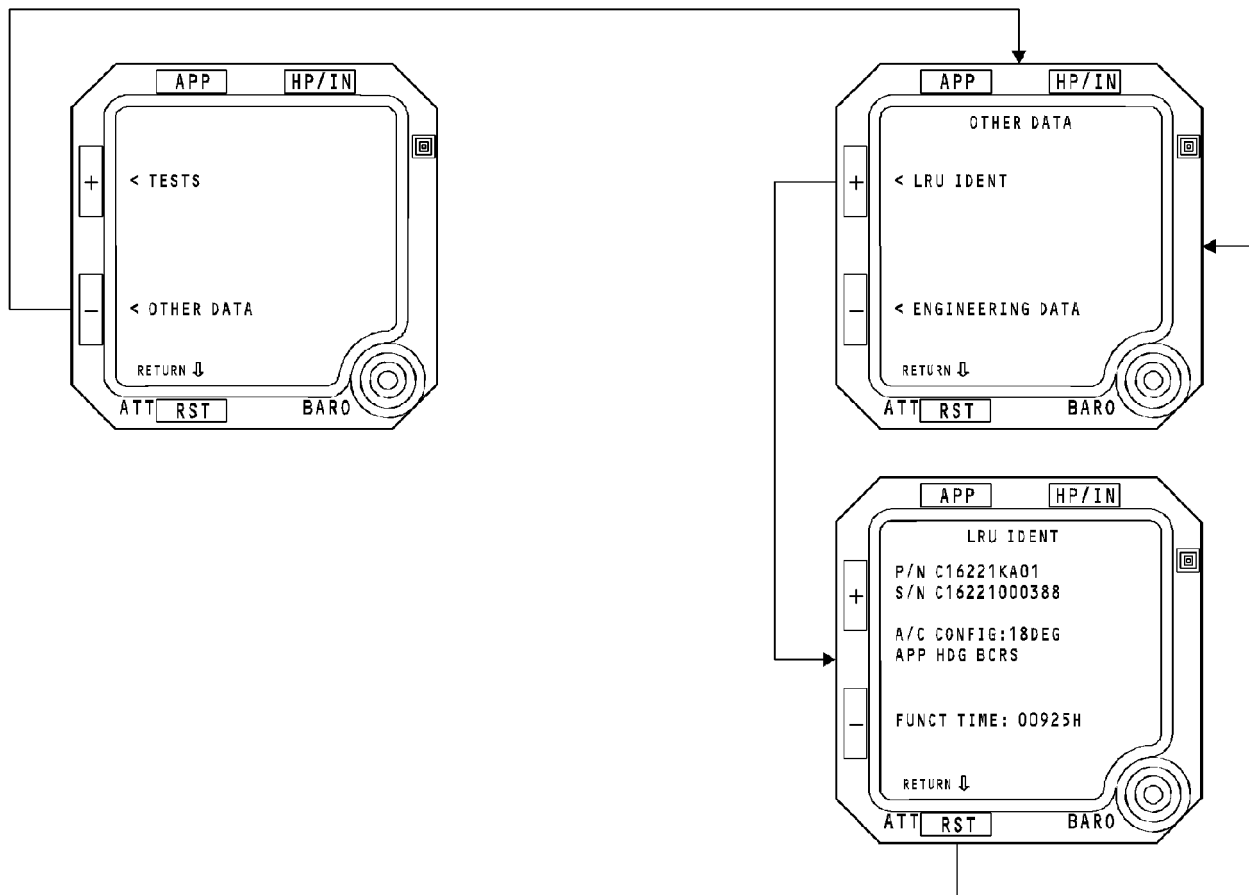

STANDBY ATTITUDE REFERENCE SYSTEM - TIP - BITE - LRU IDENT

34-24-00-154

EFFECTIVITY
HAP 031-054, 101-999

34-24-00

D633A101-HAP

STANDBY ATTITUDE REFERENCE SYSTEM - TIP - BITE - ENGINEERING DATA**General**

The ENGINEERING DATA page lets you see information about faults.

Access

Push and hold the approach mode (APP) and the barometric reference setting (HP/IN) switches for two seconds. The ISFD shows the menu with TESTS and OTHER DATA prompts.

Push the - switch to show the OTHER DATA menu.

Push the - switch to show the ENGINEERING DATA page.

LRU Ident

The engineering data page shows these parameters about failures:

- Time of failure
- Class (1, 2, or 3)
- Fault message
- Failure code.

The ISFD shows 1, 2, or 3 pages of engineering data which show the fault message and failure code. These pages show one fault per page.

The ISFD shows 1 or 2 pages of engineering data which show a list of the time of failure, the failure code, and the class of the failure.

These are the classes of failures:

- Class 1 - A failure which has a flight deck effect and must be reported.
- Class 2 - A failure which is less important than a class 1 failure.
- Class 3 - A failure which has no flight deck effect and has no effect on the operation of the airplane systems.

Push the attitude reset (RST) switch to return to the OTHER DATA menu.

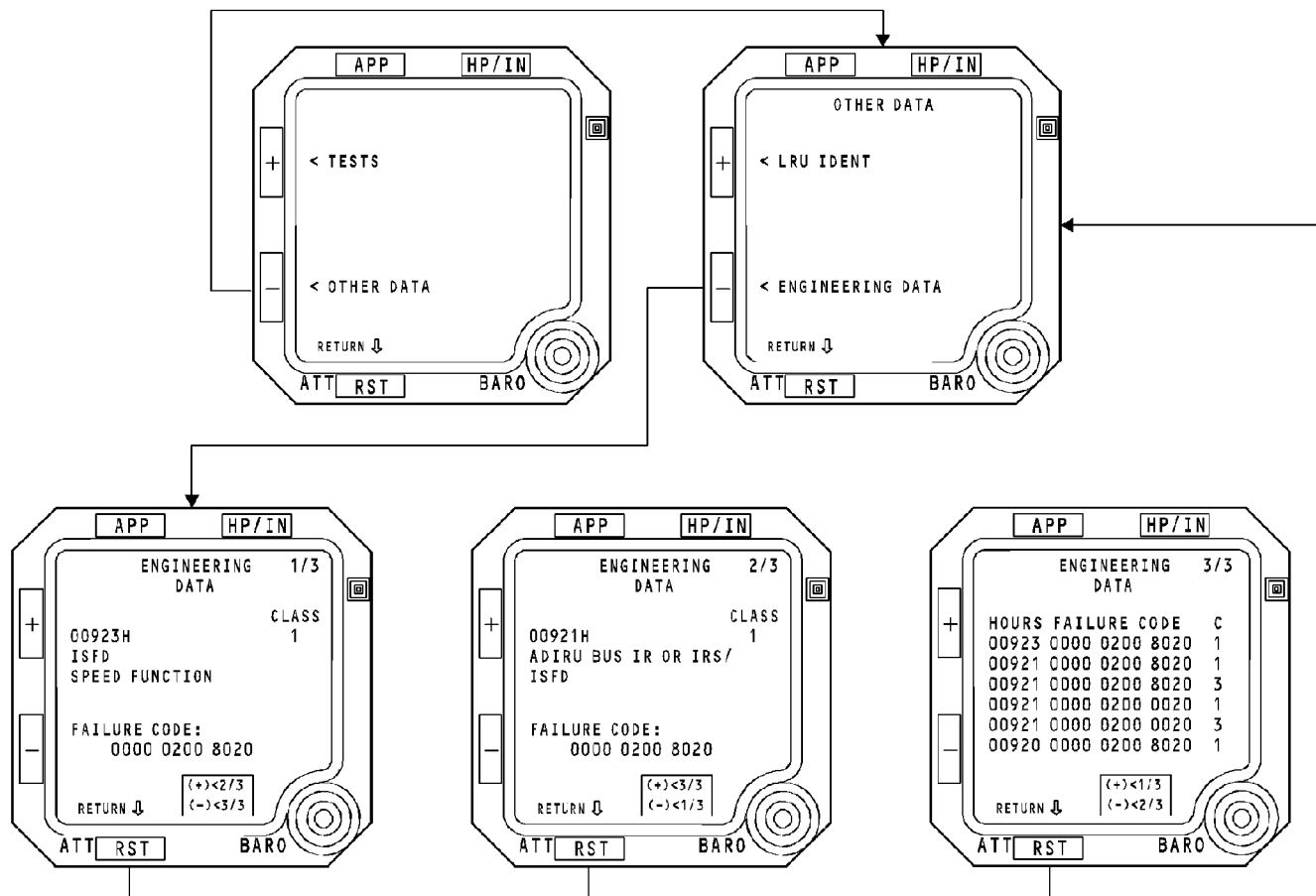

STANDBY ATTITUDE REFERENCE SYSTEM - TIP - BITE - ENGINEERING DATA

EFFECTIVITY
HAP 031-054, 101-999

34-24-00

D633A101-HAP

Page 67
Feb 15/2009

34-24-00-155

INSTRUMENT LANDING SYSTEM (ILS) - INTRODUCTION**Purpose****HAP 001-013, 015-026, 028-036, 038-054, 101-999**

The multi-mode receiver (MMR) contains the instrument landing system and the global positioning system functions. This section only covers the instrument landing system function.

HAP 037

The multi-mode receiver (MMR) contains the instrument landing system (ILS), the global navigation satellite system (GNSS) landing system (GLS) and the global positioning system functions. This section only covers the GNSS landing system function.

The GNSS landing system (GLS) provides lateral and vertical position data in an ILS look-alike manner necessary to put the airplane on the runway for approach. The system uses signals from satellites and ground based augmentation system (GBAS) ground station.

The Global Navigation Satellite System (GNSS) receiving through the GPS antenna and the GBAS ground station signals to provides aircraft position. The Ground Based Augmentation System (GBAS) receiving through the VOR antenna provided GNSS differential corrections and Final Approach Segment (FAS).

HAP ALL

The instrument landing system (ILS) provides lateral and vertical position data necessary to put the airplane on the runway for approach. The system uses signals from a glideslope ground station and a localizer ground station.

The glideslope ground station transmits signals to give the airplane a descent path to the touchdown point on the runway. The localizer ground station transmits signals to give the airplane lateral guidance to the runway centerline.

Abbreviations and Acronyms

- AC - alternating current
- ACP - audio control panel
- alt - alternate
- altn - alternate
- app - approach
- ARINC - Aeronautical Radio, Inc.
- BITE - built-in test equipment
- BL - buttock line
- CAPT - captain
- DC - direct current
- DEU - display electronics unit
- DME - distance measurement equipment
- EFIS - electronic flight instrument system
- F/O - first officer
- FCC - flight control computer
- FDAU - flight data acquisition unit
- FMC - flight management computer
- freq - frequency
- fwd - forward

INSTRUMENT LANDING SYSTEM (ILS) - INTRODUCTION

HAP 037

- GBAS - ground based augmentation system
- GLS - GNSS landing system
- GNSS - global navigation satellite system
- GPIP - glidepath intercept point

HAP ALL

- grd - ground

HAP 031-054, 101-999

- ISFD - integrated standby flight display

HAP ALL

- ILS - instrument landing system
- LCD - liquid crystal display
- LED - light emitting diode
- LRU - line replaceable unit
- maint - maintenance

HAP 037

- MCU - master caution unit

HAP ALL

- MHz - megahertz
- MMR - multi-mode receiver
- MKR - marker beacon
- NAV - navigation
- NCD - no computed data
- ND - navigation display
- norm - normal
- PFD - primary flight display
- rcvr - receiver
- REU - remote electronics unit
- RF - radio frequency
- spkr - speaker
- sta - station
- tfr - transfer
- V - volts

HAP 037

- VDB - VHF data broadcast

HAP ALL

- xfr - transfer
- xmtr - transmitter

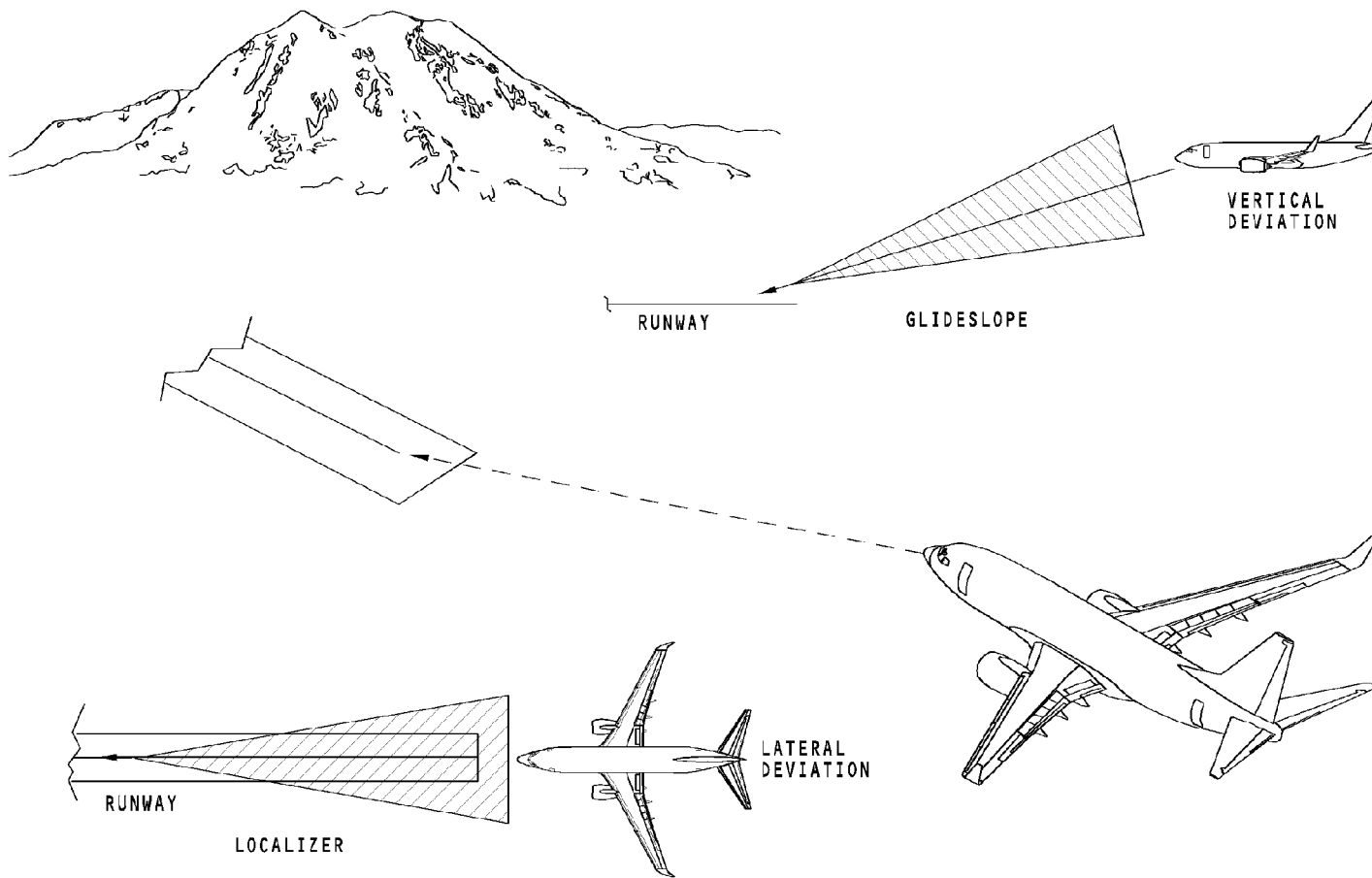

INSTRUMENT LANDING SYSTEM (ILS) - INTRODUCTION

34-31-00-001

EFFECTIVITY
HAP ALL

34-31-00

D633A101-HAP

Page 3
Oct 10/2004

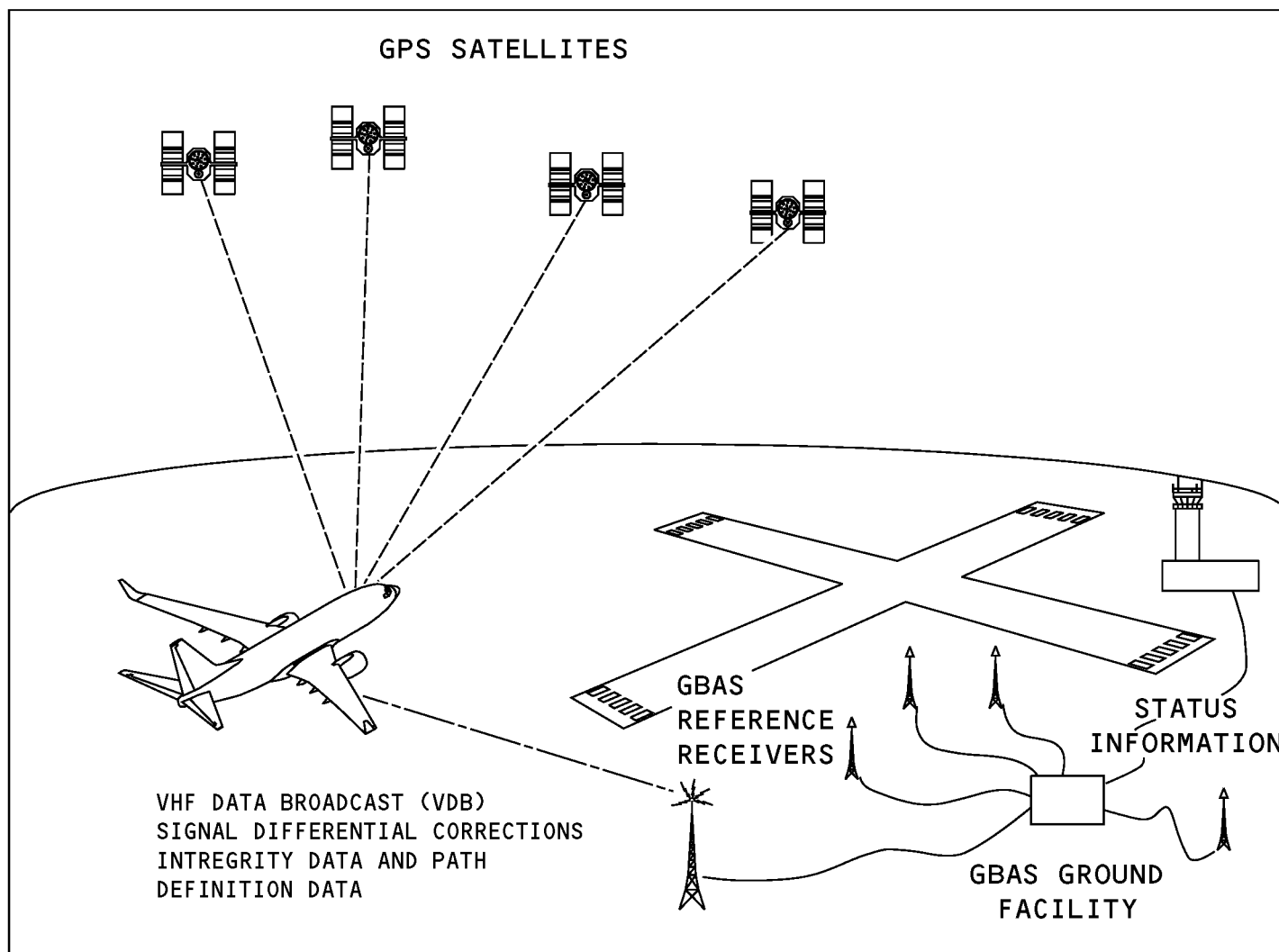

INSTRUMENT LANDING SYSTEM (ILS) - INTRODUCTION

EFFECTIVITY	
HAP 037	

34-31-00

D633A101-HAP

34-31-00-001

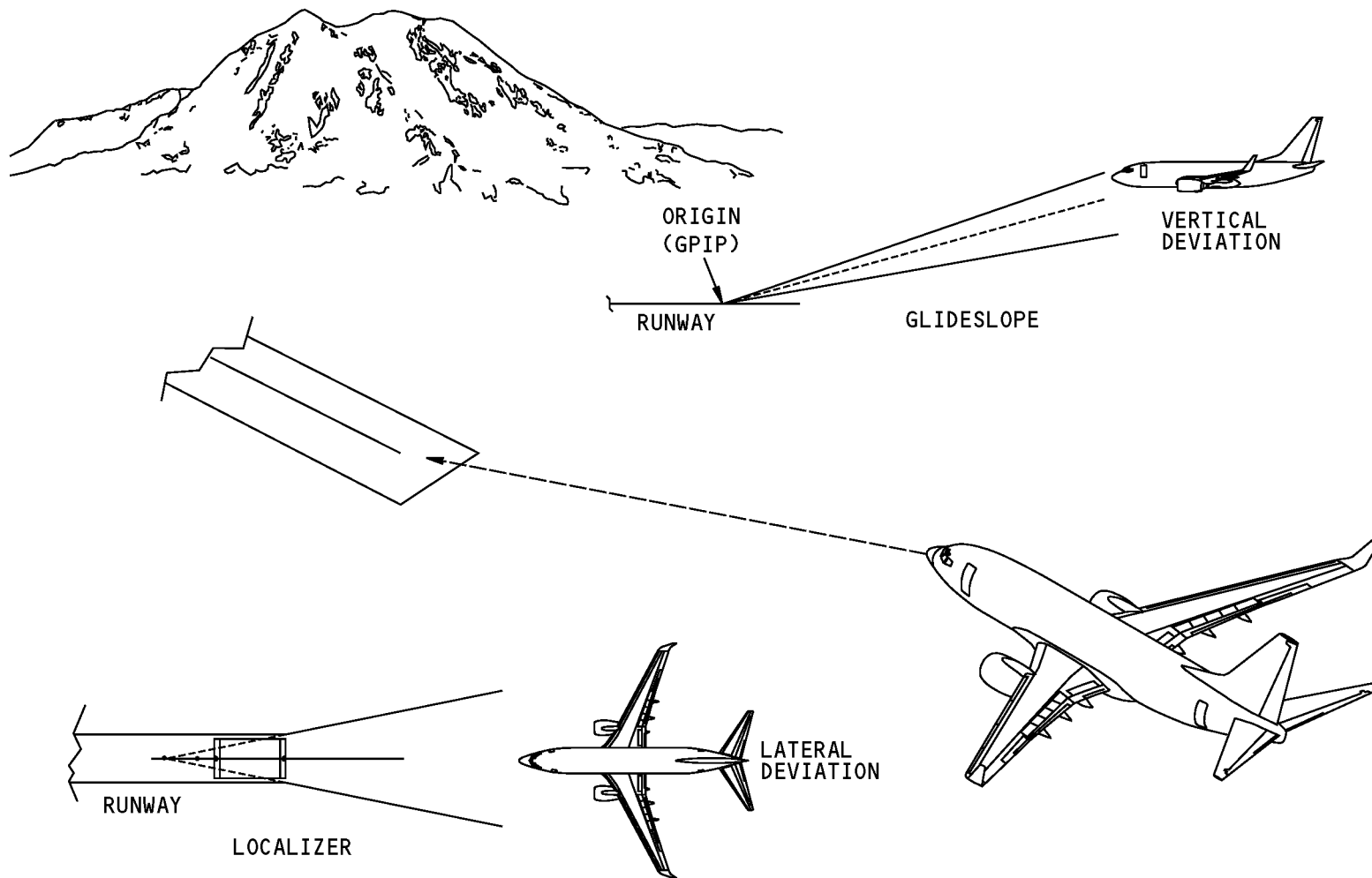

INSTRUMENT LANDING SYSTEM (ILS) - INTRODUCTION

EFFECTIVITY
HAP 037

34-31-00

D633A101-HAP

Page 5
Jun 10/2007

THIS PAGE IS INTENTIONALLY LEFT BLANK

34-31-00

D633A101-HAP

Page 6
Jun 10/2007

ILS - GENERAL DESCRIPTION**General**

The instrument landing system (ILS) has two multi-mode receivers (MMRs) that contain the ILS function. The ILS function in the MMRs receive inputs from these antennas:

HAP 037

The GNSS landing system (GLS) has two multi-mode receivers (MMRs) that contain the GLS function. The GLS function in the MMRs receive inputs from these antennas:

HAP ALL

- VOR/LOC antenna
- Localizer antenna
- Glideslope antenna.

HAP 037

- VDB antenna (VOR/LOC antenna)
- GPS antennas.

HAP ALL**Description**

The receivers get manual tune inputs from the navigation (NAV) control panels.

The VOR/LOC antenna and the localizer antenna send localizer signals through the localizer antenna switches to the MMRs. The localizer antenna switches select the VOR/LOC antenna or the localizer antenna as the source of RF input to the MMR. The glideslope antenna sends glideslope signals to the multi mode receivers.

HAP 037

The VOR/LOC antenna received VHF Data Broadcast (VDB) signal from the Ground Based Augmentation System (GBAS) and send the signals to the MMR through the antenna switch which is controlled by the Autopilot FCC. The GPS antenna receive GPS signals from orbiting satellites and sends GPS signals to the multi-mode receivers.

HAP 001-013, 015-026, 028-030

The multi-mode receivers send ILS deviation data to these LRUs:

- DEUs
- REU
- GPWC
- FCC
- FDAU
- FMC
- Standby attitude indicator.

ILS - GENERAL DESCRIPTION**HAP 001-013, 015-026, 028-030 (Continued)****HAP 031-054, 101-999**

The multi-mode receivers send ILS deviation data to these LRUs:

HAP 037

The multi-mode receivers send GLS deviation data to these LRUs:

HAP 031-054, 101-999

- DEUs
- REU
- GPWC
- FCC
- FDAU
- FMC
- Integrated standby flight display.

HAP 037

- MCU

HAP ALL

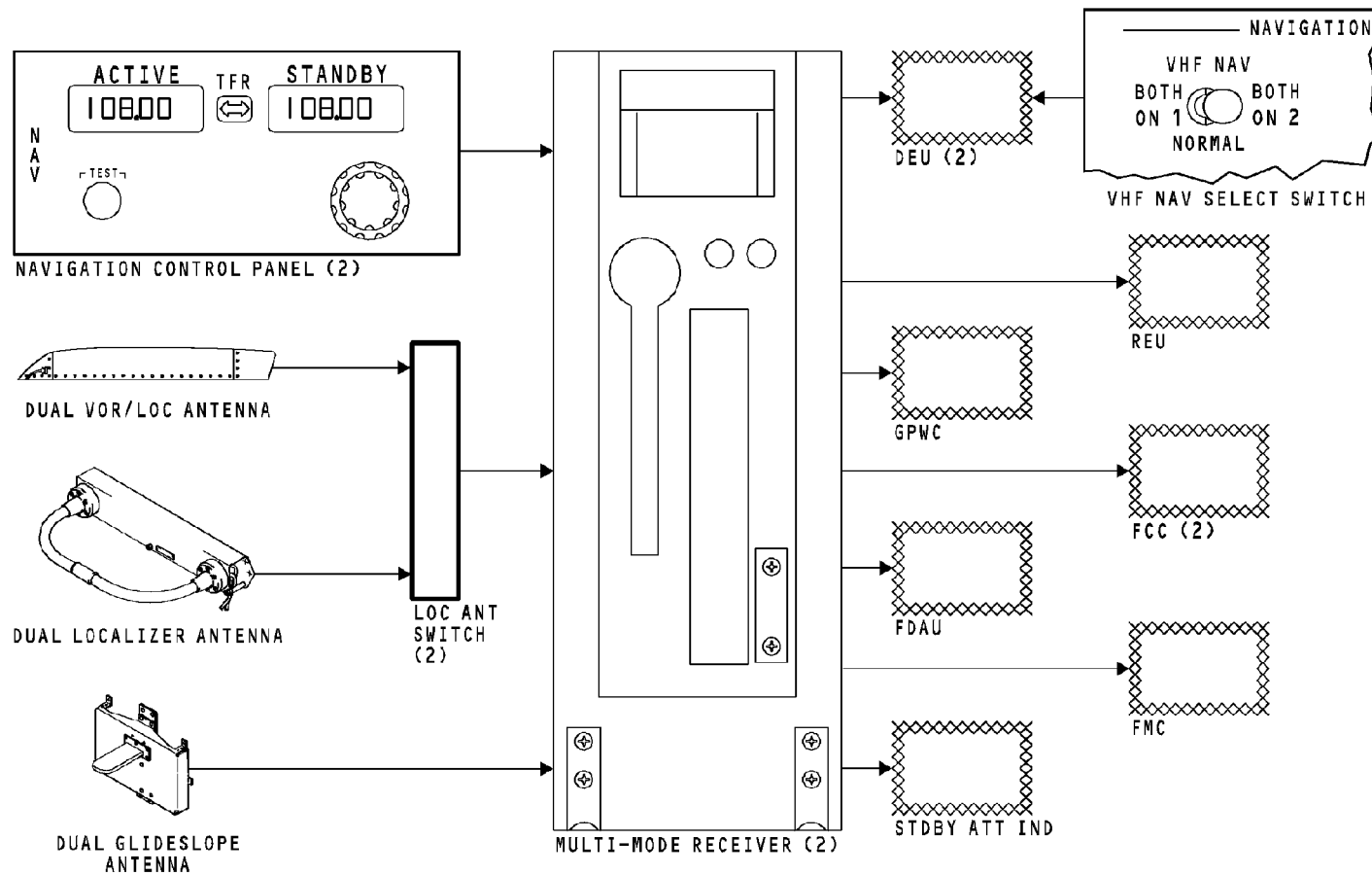

ILS - GENERAL DESCRIPTION

34-31-00-002

EFFECTIVITY
HAP 001-013, 015-026, 028-036

34-31-00

D633A101-HAP

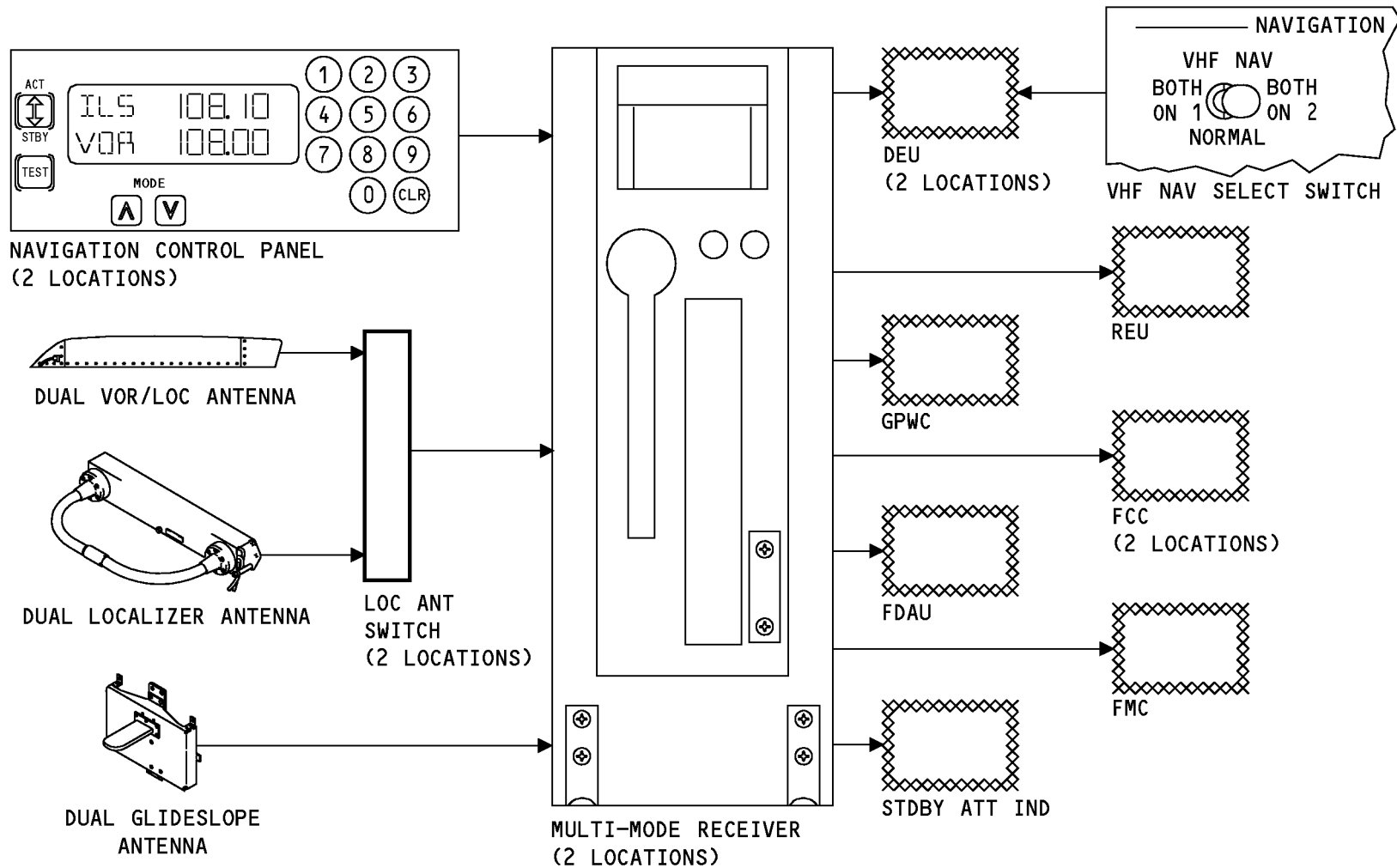

1738897 S0000314649_V1

ILS - GENERAL DESCRIPTION

EFFECTIVITY
HAP 038-054, 101-999

34-31-00

D633A101-HAP

34-31-00-002

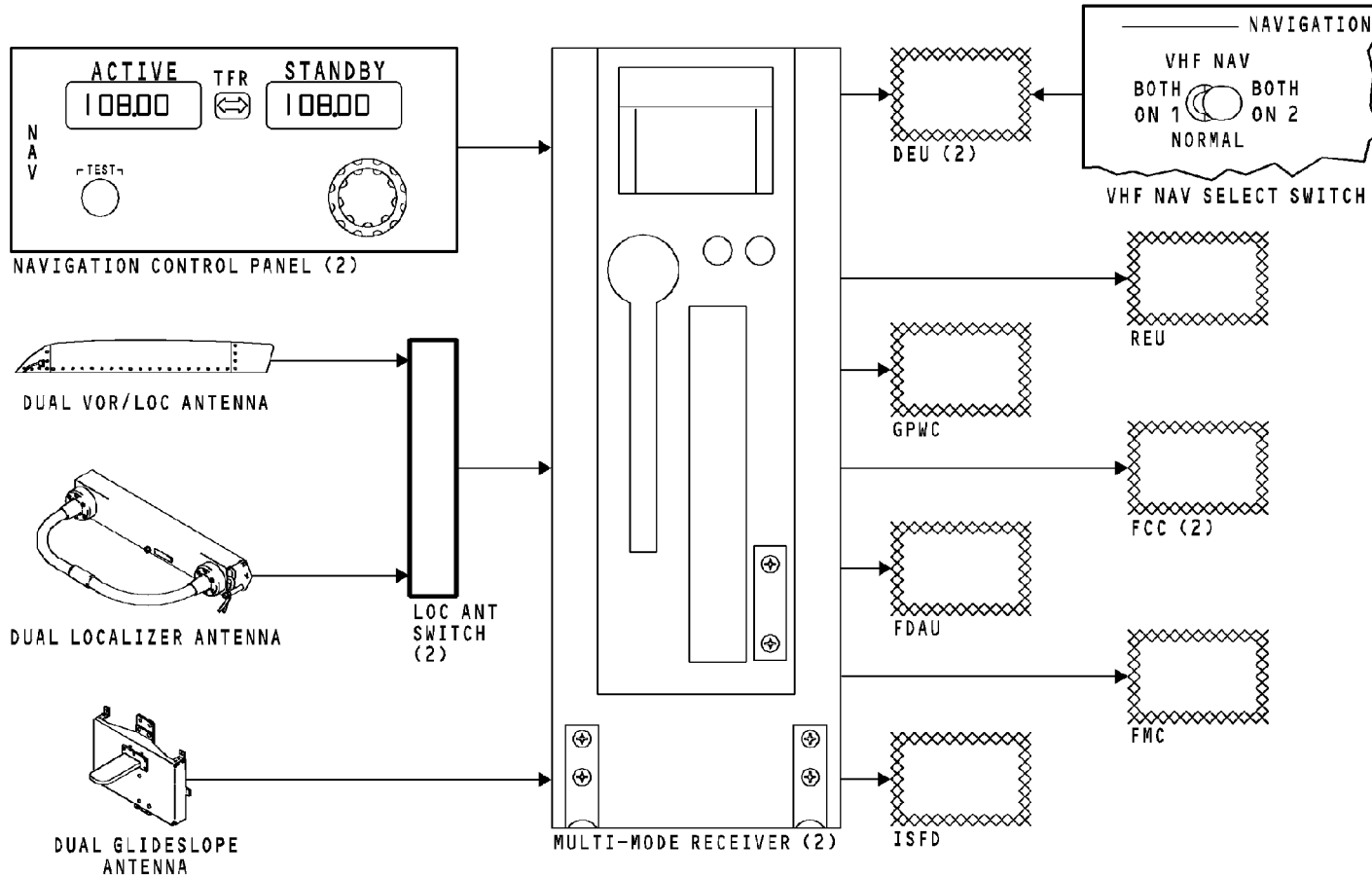

ILS - GENERAL DESCRIPTION

34-31-00-002

EFFECTIVITY
HAP 031-036, 038-054, 101-999

34-31-00

D633A101-HAP

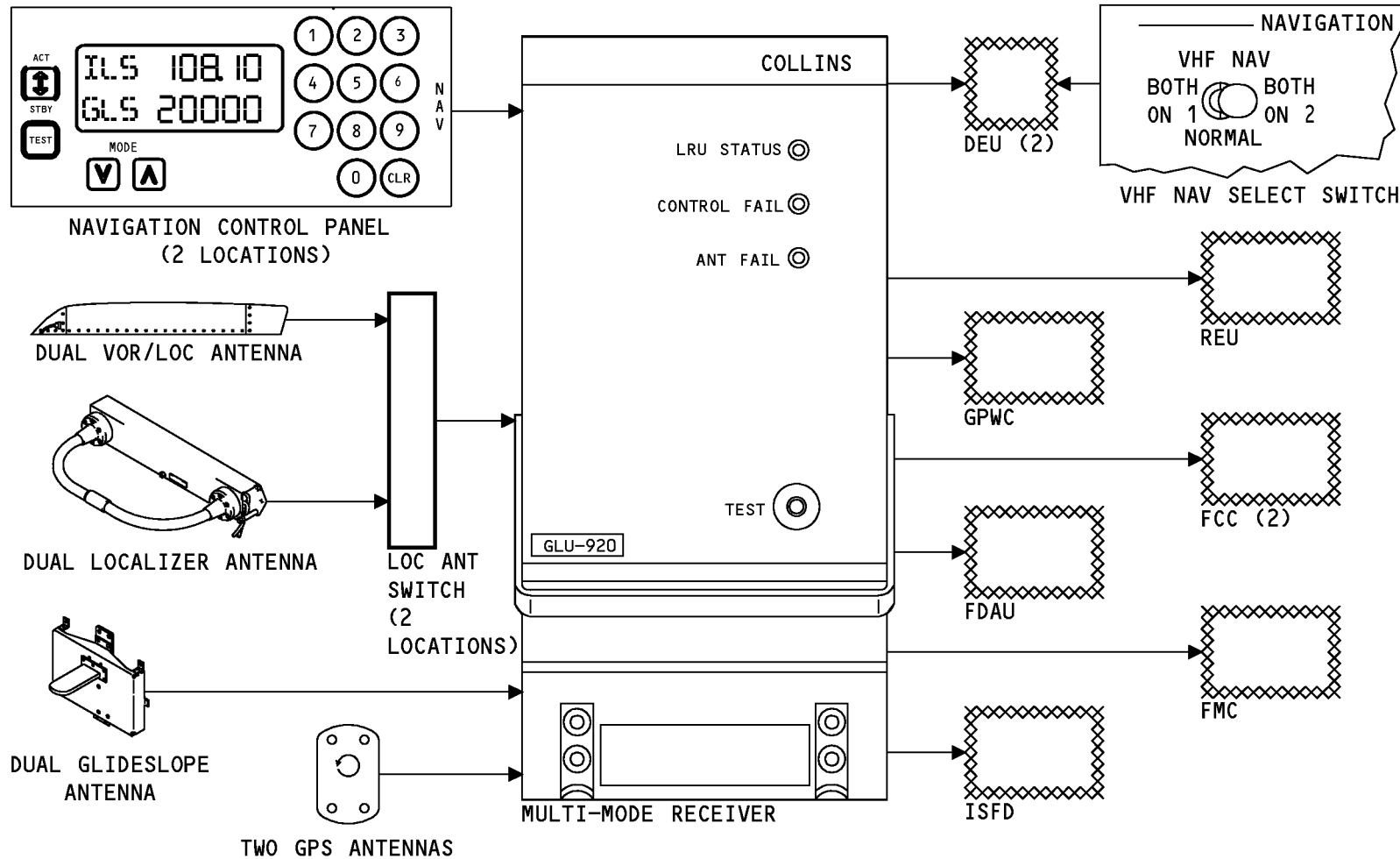

D89090 S0000166544_V2

ILS - GENERAL DESCRIPTION

EFFECTIVITY
HAP 037

34-31-00

D633A101-HAP

Page 12
Feb 15/2009

34-31-00-002

THIS PAGE IS INTENTIONALLY LEFT BLANK

34-31-00

D633A101-HAP

Page 13
Feb 15/2009

ILS - ANTENNA AND ELECTRONIC EQUIPMENT COMPARTMENT - COMPONENT LOCATION**Electronic Equipment Compartment**

The multi-mode receivers (MMRs) are in the electronic equipment compartment. MMR 1 is on the E1-2 shelf. MMR 2 is on the E1-4 shelf. The LOC antenna switches are on the side of the E1 rack.

Nose Radome

The glideslope and localizer antennas are in the nose radome. The glideslope antenna is above the weather radar antenna. The localizer antenna is below the weather radar antenna.

HAP 037**GLS Antenna**

The GPS antenna is on top of the airframe. The VDB antenna (VOR/LOC antenna) is on the vertical stabilizer.

HAP ALL

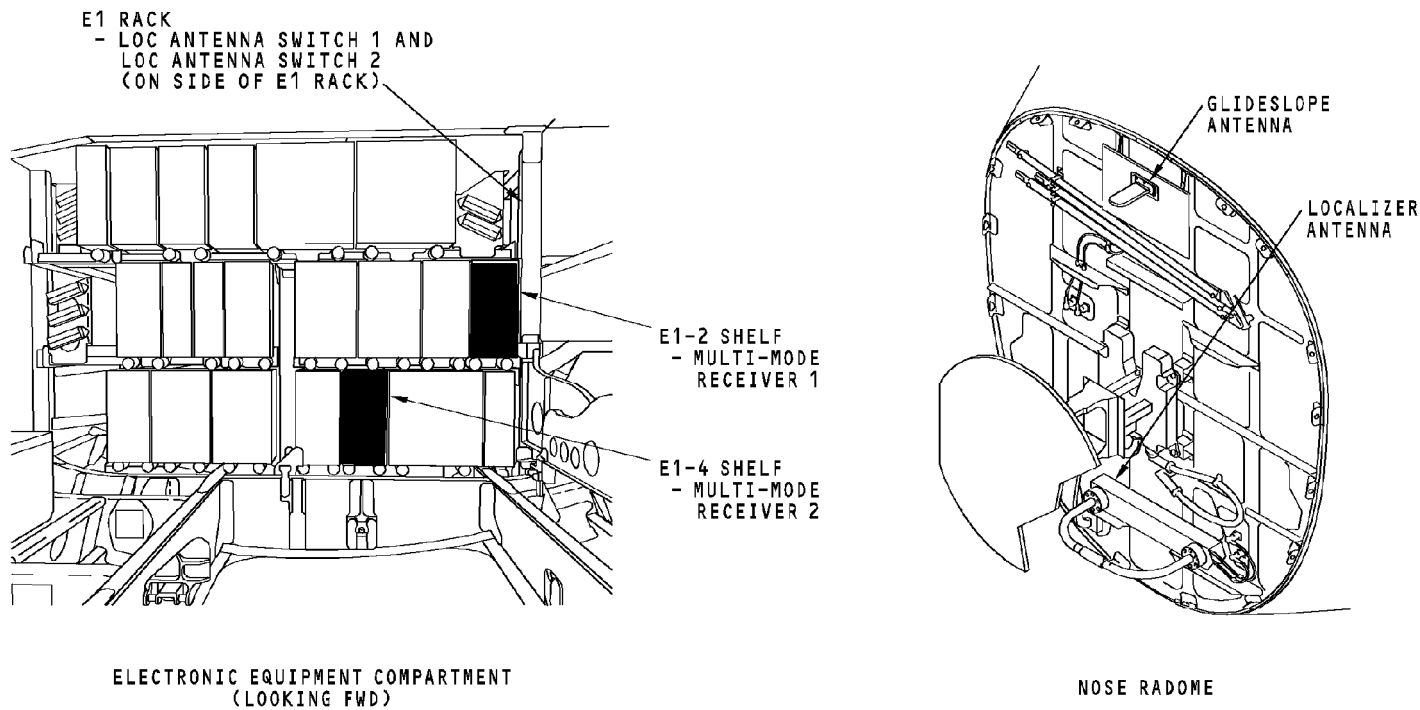

ILS - ANTENNA AND ELECTRONIC EQUIPMENT COMPARTMENT - COMPONENT LOCATION

34-31-00-004

EFFECTIVITY
HAP ALL

34-31-00

D633A101-HAP

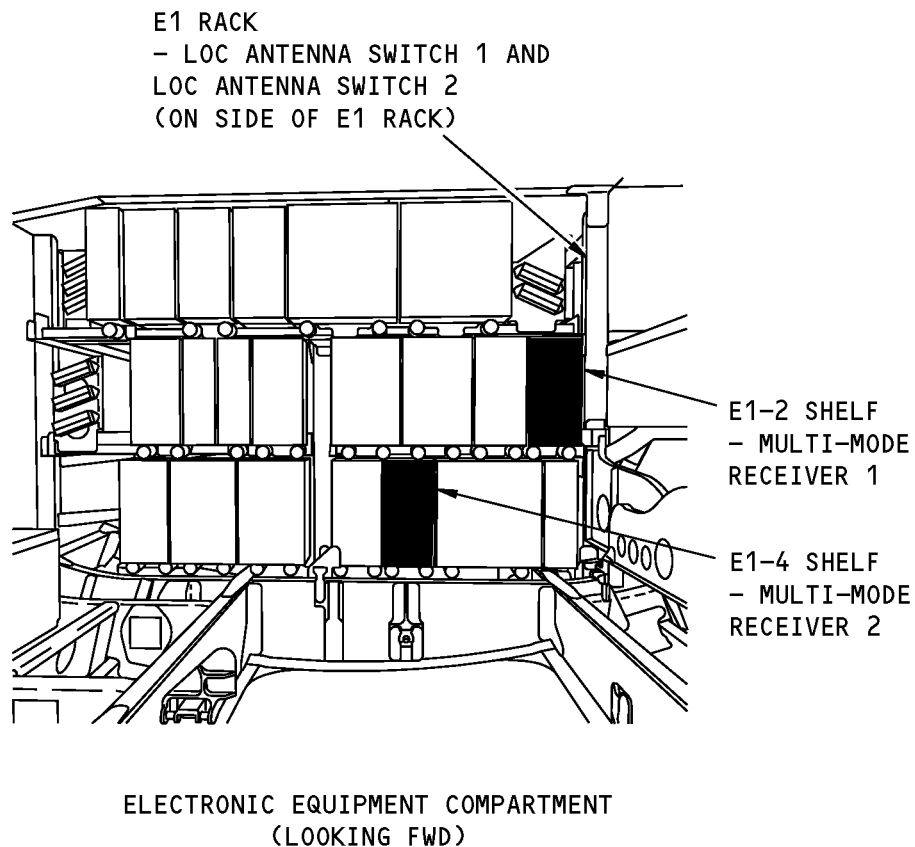

GPS 1 ANTENNA
(500A + 15, LBL 5)

GPS 2 ANTENNA
(STA 500A + 15, LBL 5)

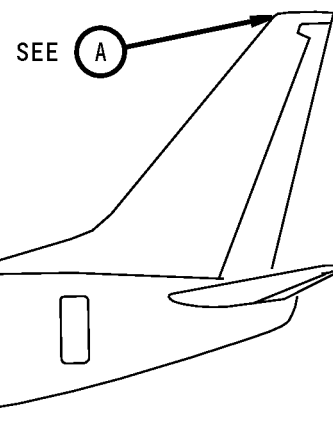
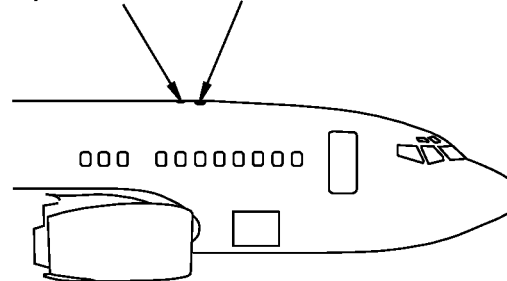

GLS ANTENNA



VOR/LOC ANTENNA



ILS - ANTENNA AND ELECTRONIC EQUIPMENT COMPARTMENT - COMPONENT LOCATION

EFFECTIVITY
HAP 037

34-31-00

D633A101-HAP

THIS PAGE IS INTENTIONALLY LEFT BLANK

34-31-00

D633A101-HAP

Page 17
Feb 15/2009

ILS - POWER INTERFACES**Power Inputs**

The P18-1 circuit breaker panel contains the MMR 1 and NAV CONT PNL 1 circuit breakers. The circuit breakers receive 115v ac from the 115v ac standby bus section 1. The circuit breakers supply power to the multi mode receiver 1 and the captain's NAV control panel.

The P18-1 circuit breaker panel also contains the NAV SENSOR DC 1 circuit breakers. The circuit breakers receive 28v dc from the 28v dc standby bus and the 28v dc bus. The circuit breakers send 28v dc to the NAV control panels and to the integrated flight system accessory unit (IFSAU). The IFSAU contains circuits that supply a discrete signal to the LOC antenna switches for operation. The IFSAU uses the 28v dc from the NAV control panel and a discrete signal from the FCC to set the logic to send a discrete signal to operate the LOC antenna switches.

The P6-1 circuit breaker panel contains the NAV CONT PNL 2 and the MMR 2 circuit breakers. The circuit breakers receive 115v ac from the 115v ac transfer bus section 2. The circuit breakers supply power to the first officer's NAV control panel and the multi mode receiver 2.

The P6-1 circuit breaker panel also contains the NAV SENSOR DC 2 circuit breakers. The circuit breakers receive 28v dc from the 28v dc standby bus and the 28v dc bus. The circuit breakers send 28v dc to the NAV control panels and to the integrated flight system accessory unit (IFSAU). The IFSAU contains circuits that supply a discrete signal to the LOC antenna switches for operation. The IFSAU uses the 28v dc from the NAV control panel and a discrete signal from the FCC to set the logic to send a discrete signal to operate the LOC antenna switches.

When you tune an ILS frequency on the NAV control panels, 28v dc goes to the on-side FCC and LOC antenna switch. The FCC's use the 28v dc for mode selection. The LOC antenna switches use the 28v dc for operation.

HAP 037

When you tune an GLS channel on the NAV control panels, 28v dc goes to the on-side FCC and LOC antenna switch. The FCC's use the 28v dc for mode selection. The LOC antenna switches use the 28v dc for operation.

HAP ALL

EFFECTIVITY
HAP ALL

34-31-00

D633A101-HAP

Page 18
Feb 15/2009

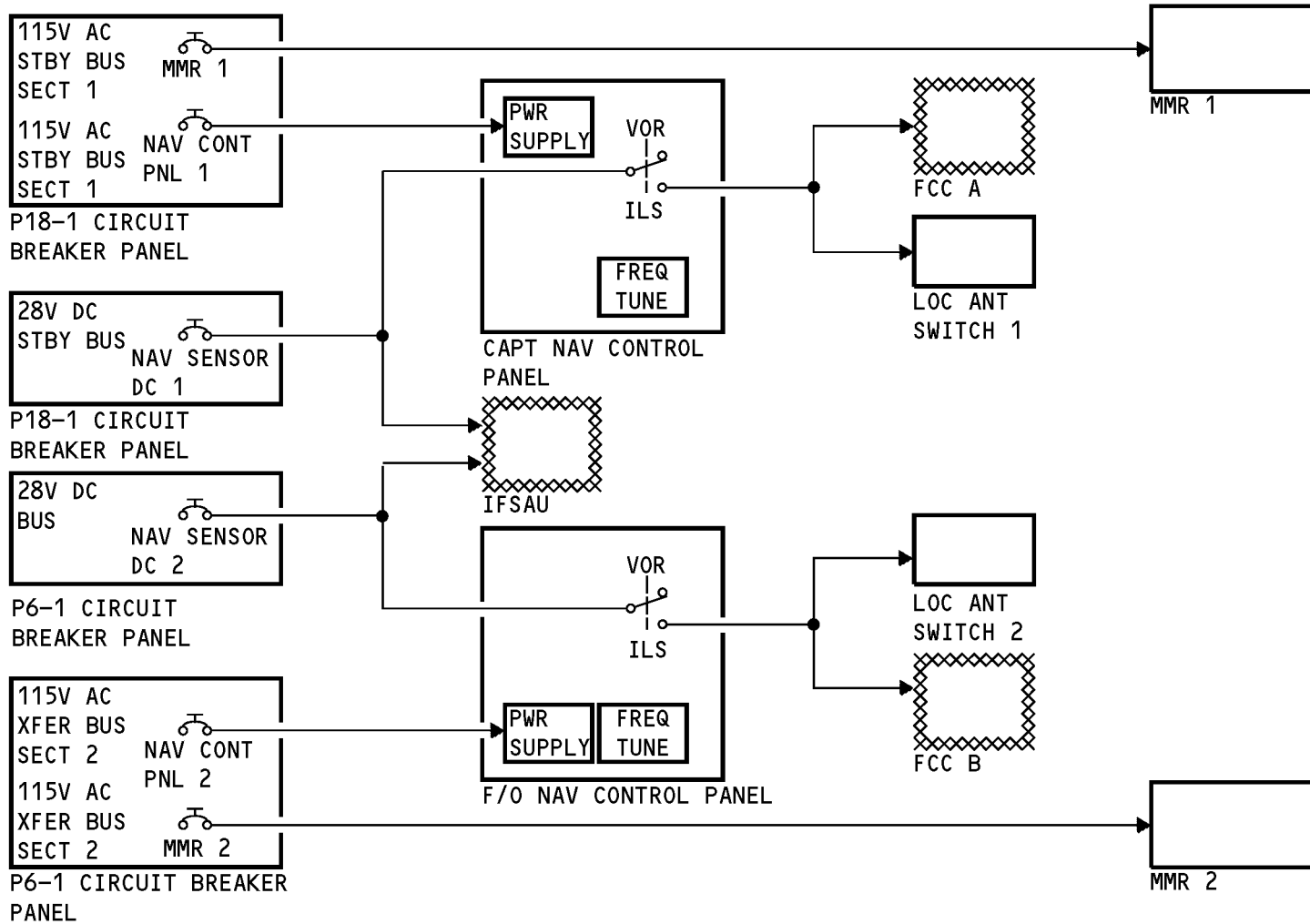

ILS - POWER INTERFACES

34-31-00-005

EFFECTIVITY
HAP ALL

34-31-00

D633A101-HAP

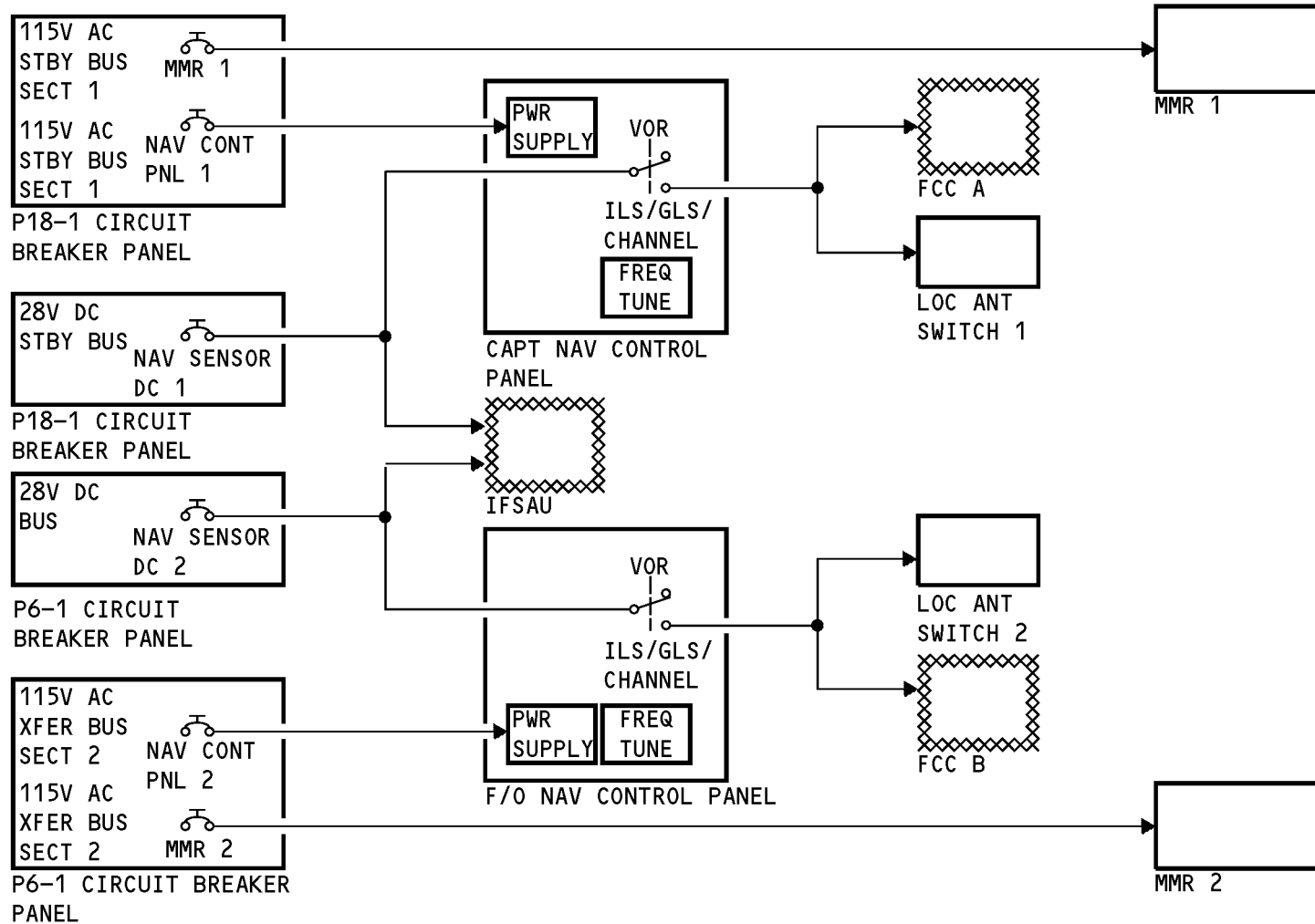

ILS - POWER INTERFACE

EFFECTIVITY
HAP 037

34-31-00

D633A101-HAP

THIS PAGE IS INTENTIONALLY LEFT BLANK

34-31-00

D633A101-HAP

Page 21
Feb 15/2009

ILS - DIGITAL INTERFACE**General**

These are the components that have a digital interface with the multi-mode receivers:

- Captain and first officer NAV control panels
- Flight data acquisition unit (FDAU)

HAP 001-013, 015-026, 028-030

- Standby attitude indicator

HAP 031-054, 101-999

- Integrated standby flight display (ISFD)

HAP ALL

- Ground proximity warning computer (GPWC)

HAP 037-054, 101-999

- Flight management computer (FMC) 1 and 2

HAP 001-013, 015-026, 028-036

- Flight management computer (FMC)

HAP 037

- Master Caution Unit (MCU)

HAP ALL

- Display electronics units (DEU)
- FCC A and FCC B.

Digital Inputs

The NAV control panels supply frequency tune inputs to the multi-mode receivers. The NAV control panels also send tune inputs to the VOR and DME systems on a separate data bus.

Digital Outputs

Each MMR has two output data buses. Output data bus 1 goes to the FCCs. Output data bus 2 goes to many components.

The FDAU receives ILS data and status of the MMR receivers. The FDAU processes the data for the flight data recorder.

HAP 037

The FDAU receives GLS data and status of the MMR receivers. The FDAU processes the data for the flight data recorder.

The MCU monitors for MMR receivers and mode(s) failures. If one occur, the MCU send signals to the MSU to annunciate the failures.

HAP 001-013, 015-026, 028-030

The standby attitude indicator uses localizer and glideslope deviations for the ILS deviation bar operation. Only MMR 1 sends ILS data to the standby attitude indicator.

HAP 031-054, 101-999

The integrated standby flight display uses localizer and glideslope deviations for the ILS deviation bar operation. Only MMR 1 sends ILS data to the ISFD.

HAP 037

The integrated standby flight display uses localizer and glideslope deviations for the GLS deviation bar operation. Only MMR 1 sends GLS data to the ISFD.

HAP ALL**EFFECTIVITY****HAP ALL****34-31-00**

D633A101-HAP

Page 22
Feb 15/2009

ILS - DIGITAL INTERFACE

The GPWC receives glideslope data from both ILS receivers for mode 5 (below glideslope) warnings.

HAP 037

The GPWC receives glideslope data from both GLS receivers for mode 5 (below glideslope) warnings.

HAP 001-013, 015-026, 028-036

The FMC receives ILS data and receiver condition from the two MMRs. The FMC uses the ILS data for position update calculations.

HAP 037-054, 101-999

FMC 1 and FMC 2 receive ILS data and receiver status from the two MMRs. The FMCS uses the ILS data for position update calculations.

HAP 037

FMC 1 and FMC 2 receive GLS data and receiver status from the two MMRs. The FMCS uses the GLS data for position update calculations.

HAP ALL

The FCCs use ILS data to calculate airplane steering commands for the digital flight control system (DFCS) autopilot and flight director modes.

HAP 037

The FCCs use GLS data to calculate airplane steering commands for the digital flight control system (DFCS) autopilot and flight director modes.

HAP ALL

The DEU 1 receives two inputs from MMR 1 and two inputs from MMR 2. DEU 2 also receives two inputs from MMR 1 and two inputs from MMR 2. The CDS uses the ILS data to calculate the localizer deviation and glideslope deviation displays.

HAP 037

The DEU 1 receives two inputs from MMR 1 and two inputs from MMR 2. DEU 2 also receives two inputs from MMR 1 and two inputs from MMR 2. The CDS uses the GLS data to provide localizer deviation and glideslope deviation displays.

HAP ALL

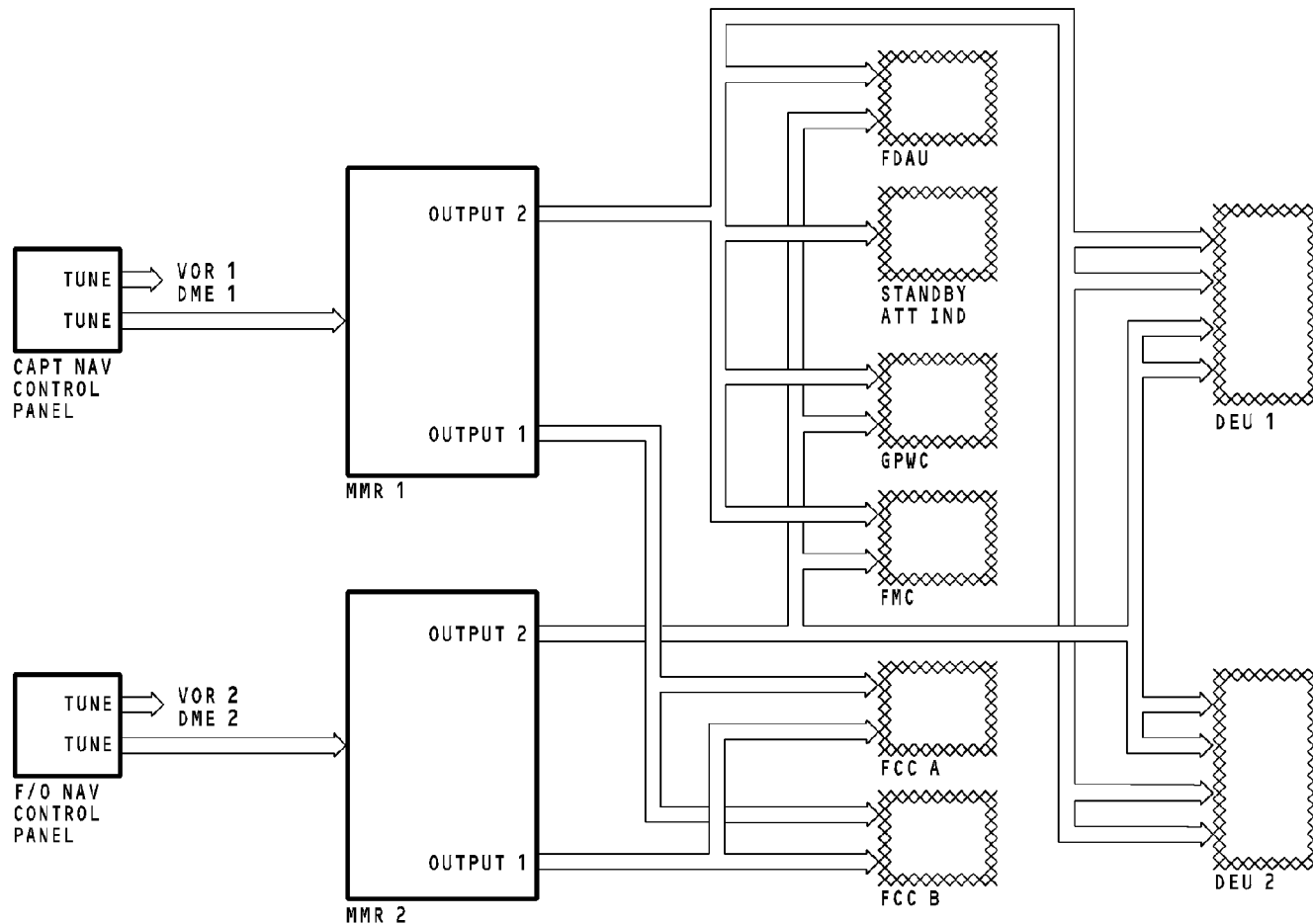

ILS - DIGITAL INTERFACE

EFFECTIVITY

HAP 001-013, 015-026, 028-030

34-31-00

D633A101-HAP

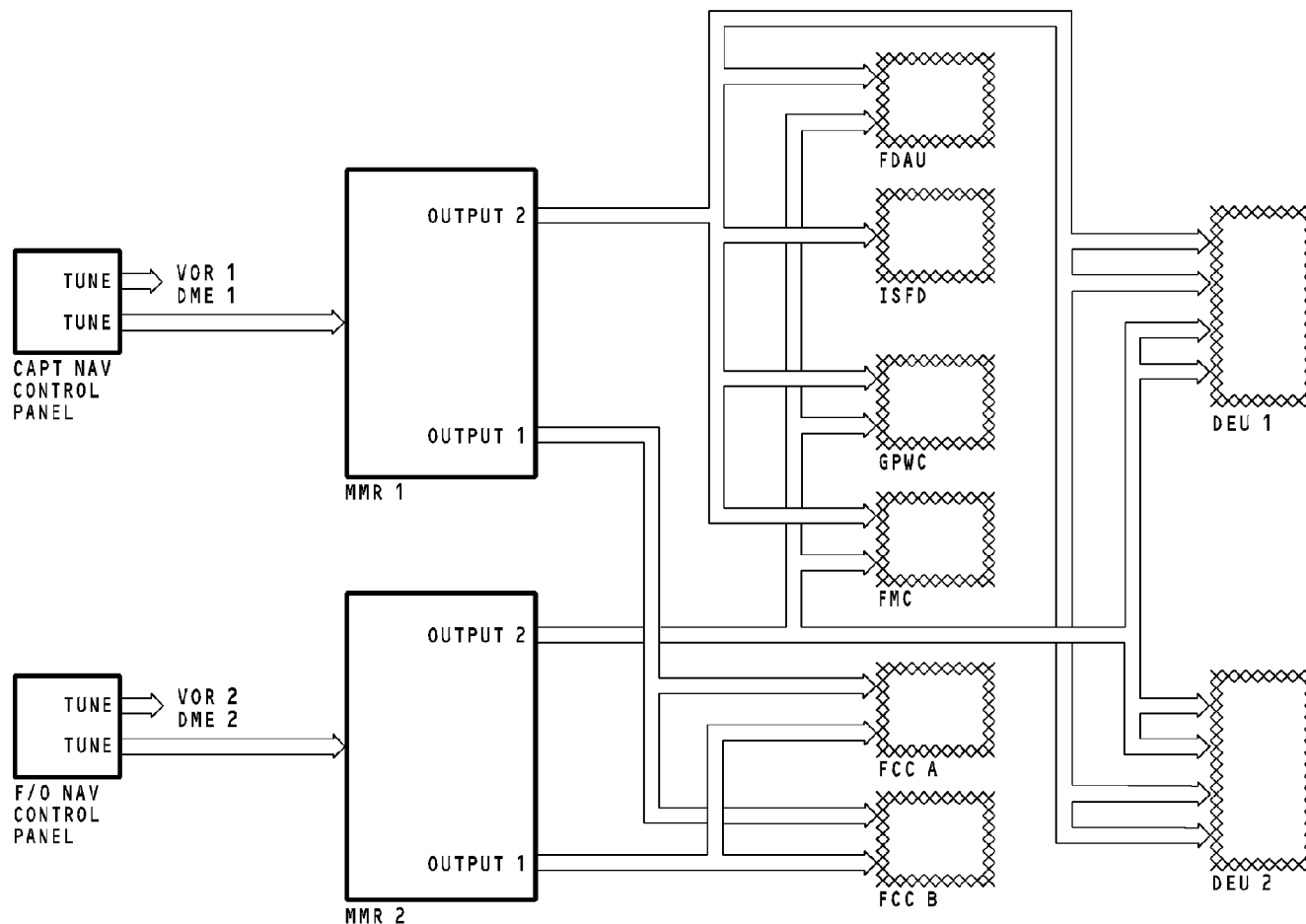

ILS - DIGITAL INTERFACE

34-31-00-006

EFFECTIVITY
HAP 031-036

34-31-00

D633A101-HAP

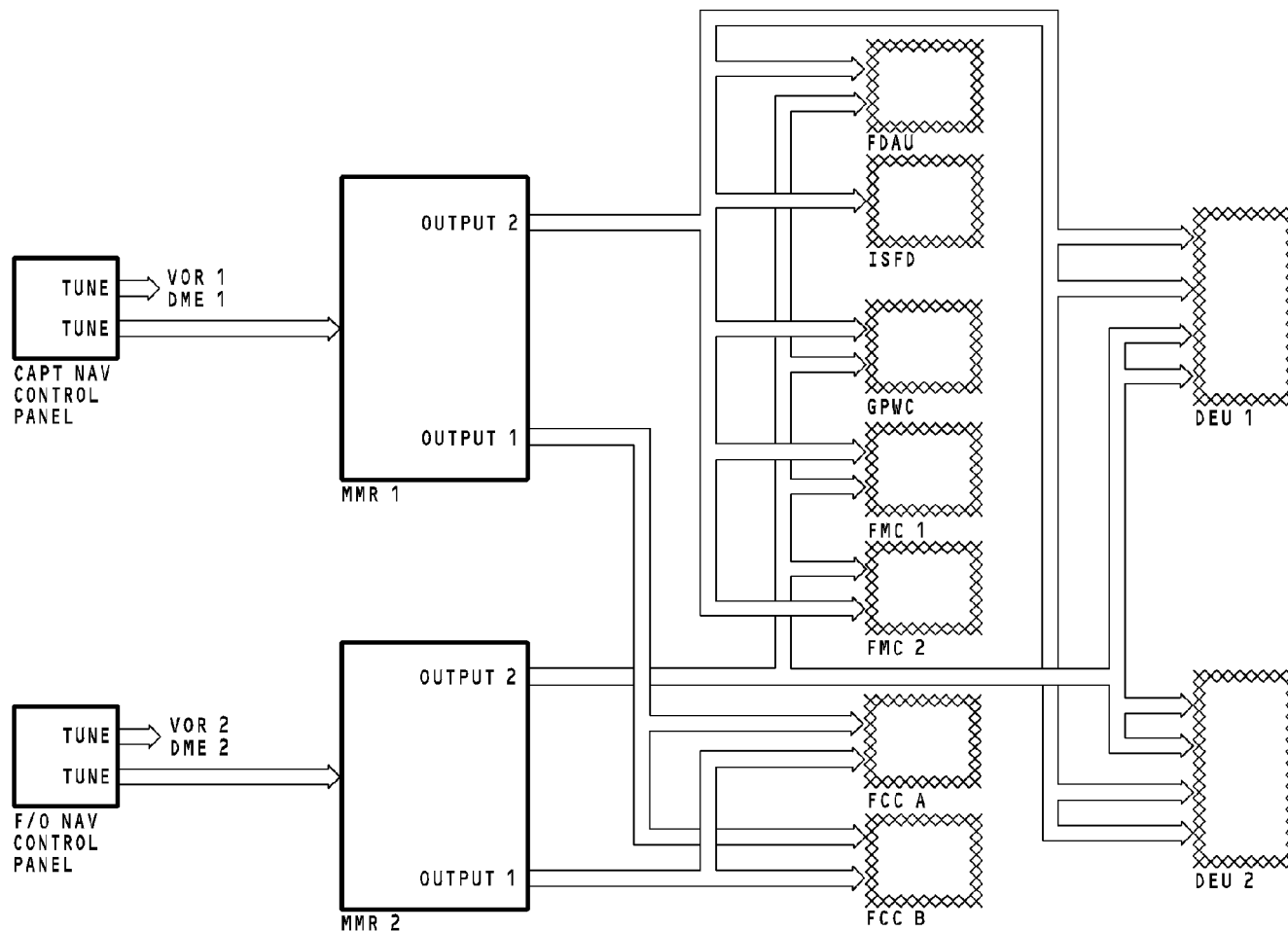

ILS - DIGITAL INTERFACE

EFFECTIVITY
HAP 037-054, 101-999

34-31-00

D633A101-HAP

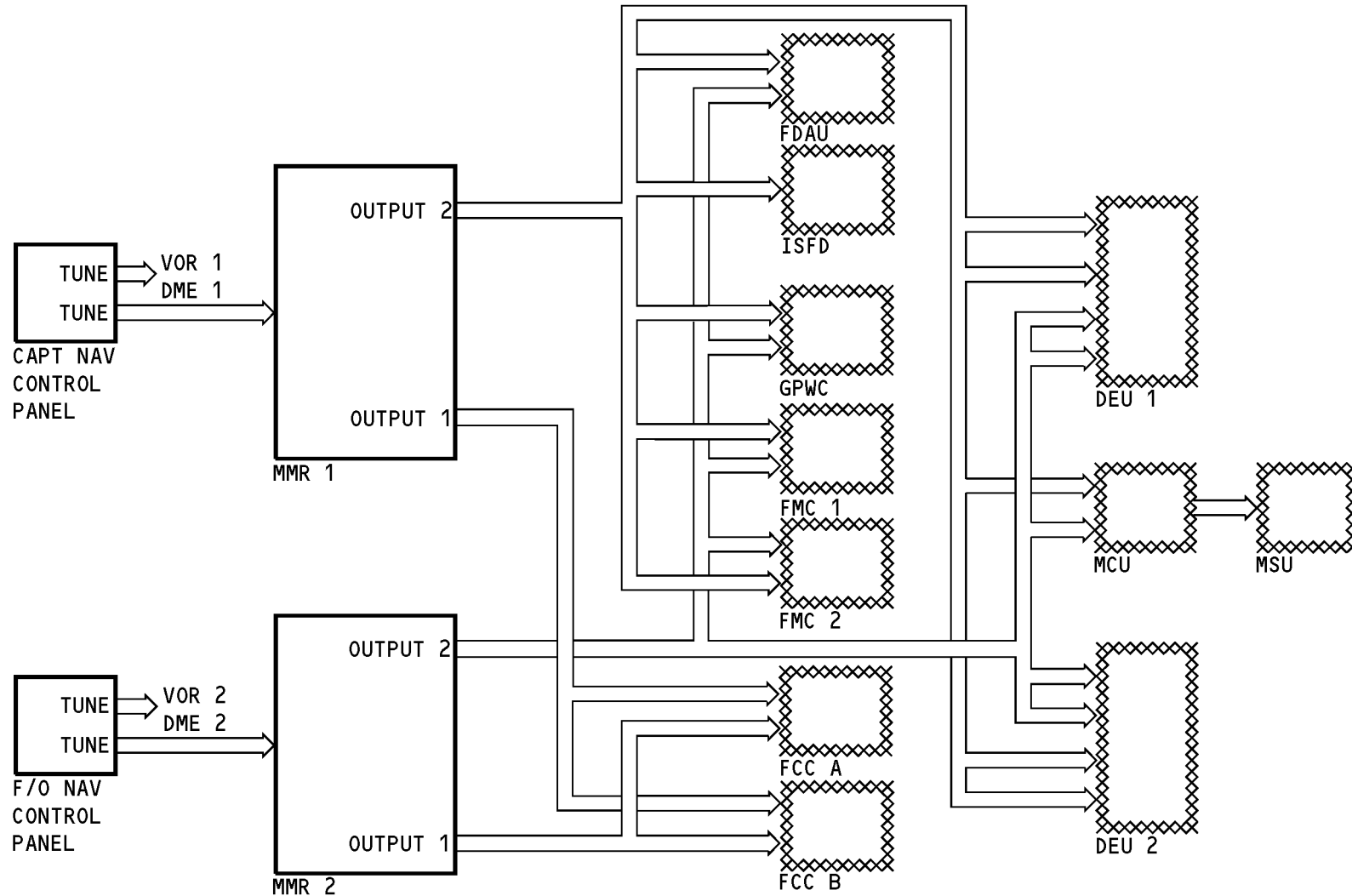

ILS - DIGITAL INTERFACE

34-31-00-006

EFFECTIVITY
HAP 037

34-31-00

D633A101-HAP

THIS PAGE IS INTENTIONALLY LEFT BLANK

34-31-00

D633A101-HAP

Page 28
Feb 15/2009

ILS - FREQUENCY TRANSFER AND INSTRUMENT SWITCHING**General**

The frequency transfer switch on the NAV control panel and the VHF NAV transfer switch on the navigation/displays source select panel have interface with the FCCs and DEUs.

HAP 001-013, 015-026, 028-036, 038-054, 101-999

Frequency Transfer Switch

The frequency transfer switch on the NAV control panel permits the crew to transfer the frequency from the standby display window on the NAV control panel, to the active display window.

The transfer switch is a momentary action switch. When you push the switch, it changes the discrete level to the FCCs. The discrete tells the FCC when there is an ILS frequency change.

HAP 037**Mode Frequency/Channel Transfer Button**

The mode frequency/channel transfer button on the NAV control panel permits the crew to transfer the mode frequency/channel from the standby display window on the NAV control panel, to the active display window.

The transfer button is a momentary action button. When you push the button, it changes the discrete level to the FCCs. The discrete tells the FCC when there is an ILS frequency or GLS channel change.

HAP ALL**Navigation/Displays Source Select Panel**

The VHF NAV switch on the navigation/displays source select panel is a three position switch. The positions are; BOTH ON 1, NORMAL, and BOTH ON 2. This switch changes the source of the data that the DEUs use for the ILS displays.

HAP 037

The VHF NAV switch on the navigation/displays source select panel is a three position switch. The positions are; BOTH ON 1, NORMAL, and BOTH ON 2. This switch changes the source of the data that the DEUs use for the GLS displays.

HAP ALL

In the NORMAL position, MMR 1 supplies data for the captain displays and MMR 2 supplies data for the first officer displays. When you select BOTH ON 1, the DEUs use MMR 1 as the source for the captains displays and first officers displays. When you select BOTH ON 2, MMR 2 is the source for the captains displays and first officers displays.

EFFECTIVITY
HAP ALL



ILS - FREQUENCY TRANSFER AND INSTRUMENT SWITCHING

Discrete signals also go to the flight control computers (FCCs) to signal that the switch is not in the normal position.

34-31-00-007

EFFECTIVITY
HAP ALL

34-31-00

D633A101-HAP

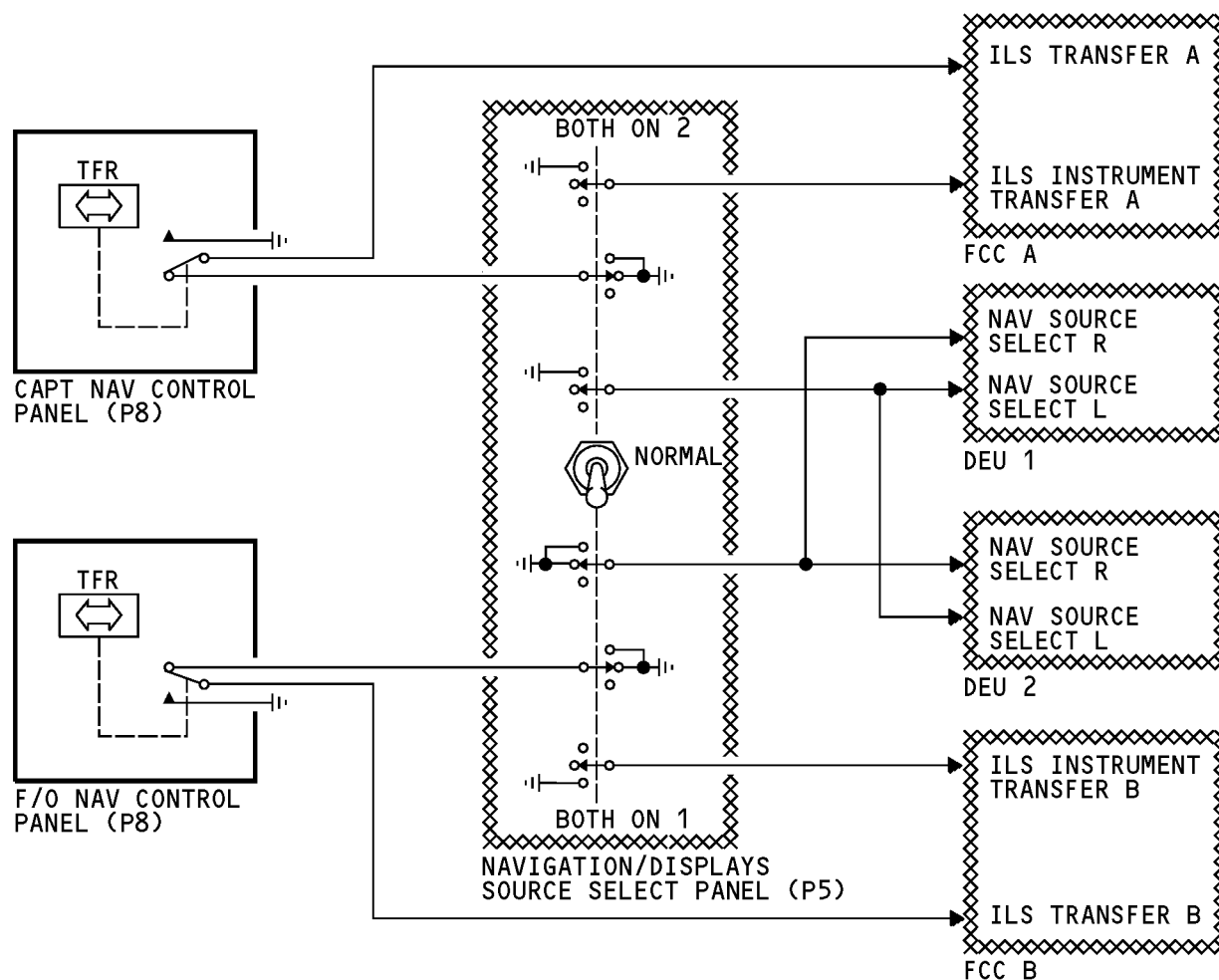

ILS - FREQUENCY TRANSFER AND INSTRUMENT SWITCHING

34-31-00-007

EFFECTIVITY
 HAP 001-013, 015-026, 028-036, 038-054, 101-999

34-31-00

D633A101-HAP

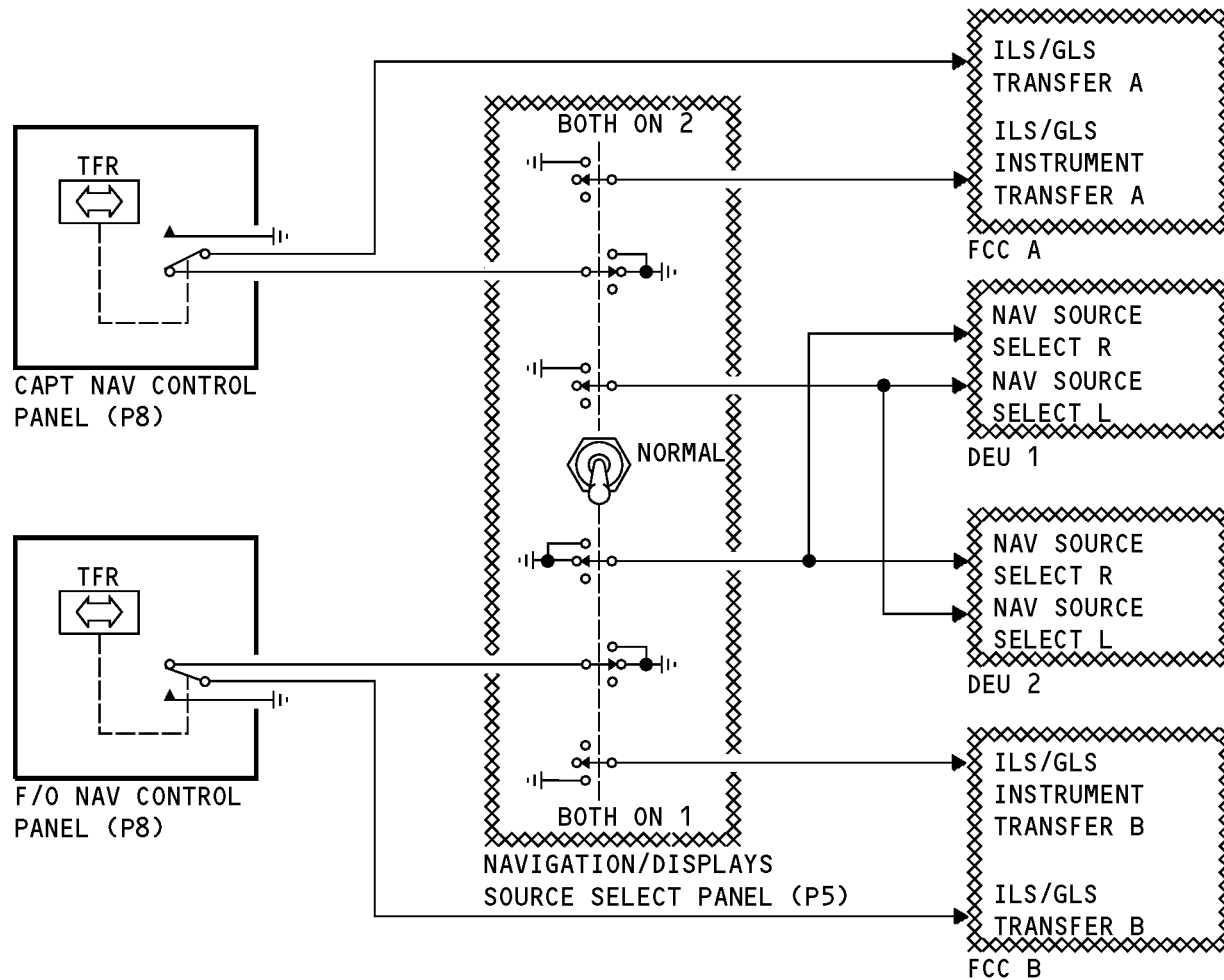

ILS - FREQUENCY TRANSFER

EFFECTIVITY
HAP 037

34-31-00

D633A101-HAP

THIS PAGE IS INTENTIONALLY LEFT BLANK

34-31-00

D633A101-HAP

Page 33
Feb 15/2009

ILS - ANTENNA INTERFACE**General**

The multi-mode receivers (MMRs) get RF inputs from these antennas:

- VOR/LOC antenna on the vertical stabilizer
- Localizer antenna in the nose radome
- Glideslope antenna in the nose radome.

HAP 037

- VOR/LOC antenna on the vertical stabilizer
- GPS antenna on top of the airframe.

HAP ALL

The VOR/LOC antenna RF inputs go through the power dividers then to the localizer (LOC) antenna (ANT) switches.

The localizer antenna RF inputs go directly to the LOC ANT switches. The antenna switches select the VOR/LOC antenna or localizer antenna as the source of the localizer RF signal input to the MMRs.

HAP 037

The antenna switches select the VOR/LOC antenna or localizer antenna as the source of the localizer RF signal input to the MMRs.

HAP ALL

The glideslope antenna inputs do not go through the antenna switches. Glideslope antenna RF inputs go directly to the MMRs.

HAP 037

The GPS antennas inputs do not go through the antenna switches. GPS antennas RF inputs go directly to the MMRs.

HAP ALL

When you tune an ILS frequency on the navigation (NAV) control panels, they send 28v dc to the LOC antenna switches. The LOC ANT switches use 28v dc from the NAV control panels and a discrete signal from the integrated flight system accessory unit (IFSAU) for operation.

HAP 037

When you tune a GLS channel on the navigation (NAV) control panels, they send 28v dc to the LOC antenna switches. The LOC ANT switches use 28v dc from the NAV control panels and a discrete signal from the integrated flight system accessory unit (IFSAU) for operation.

HAP ALL

The IFSAU sends the discrete when it receives a discrete from the Flight Control Computers (FCCs). The FCCs send the discrete when you select the approach (APP) or localizer (LOC) mode on the DFCS mode control panel.

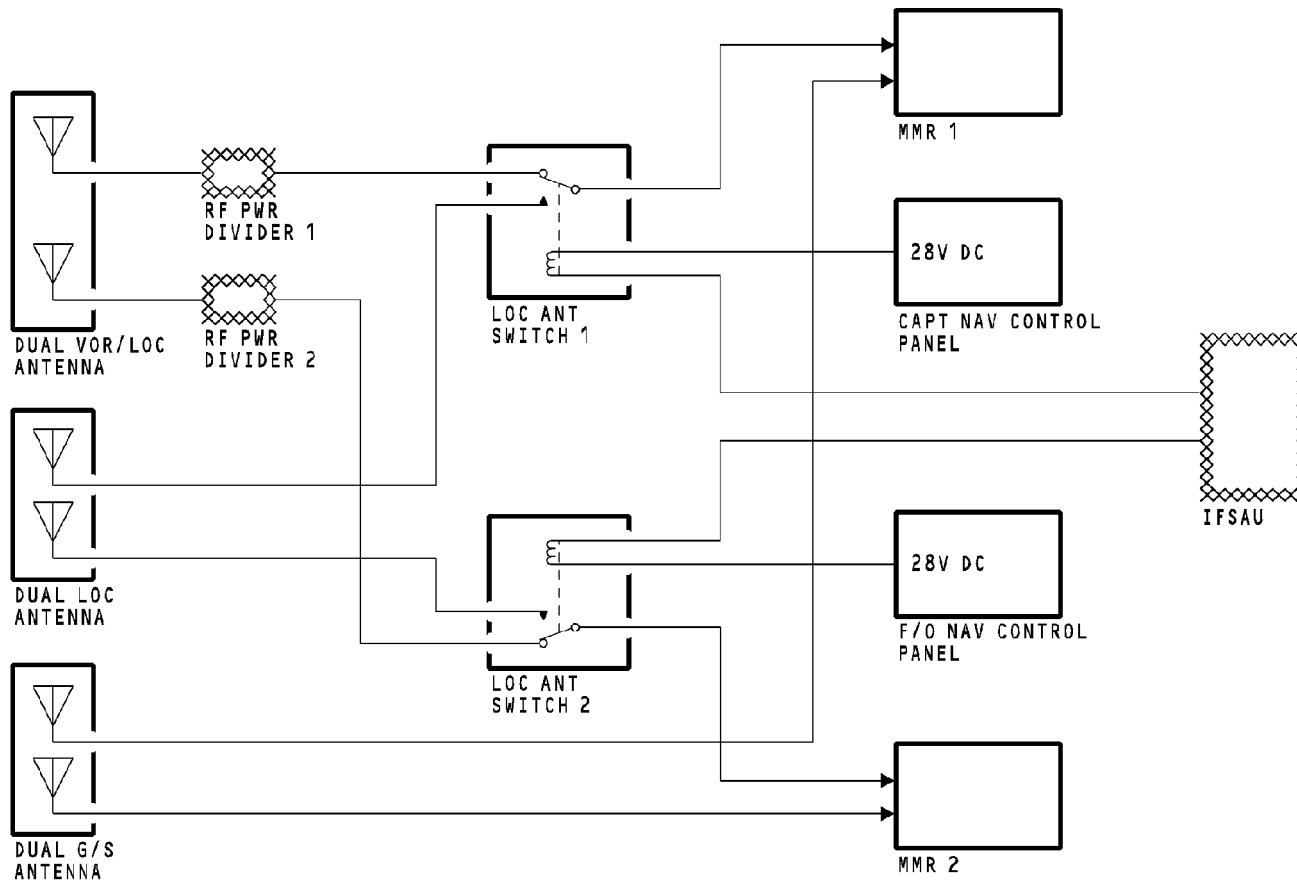

ILS - ANTENNA INTERFACE

34-31-00-008

EFFECTIVITY
HAP ALL

34-31-00

D633A101-HAP

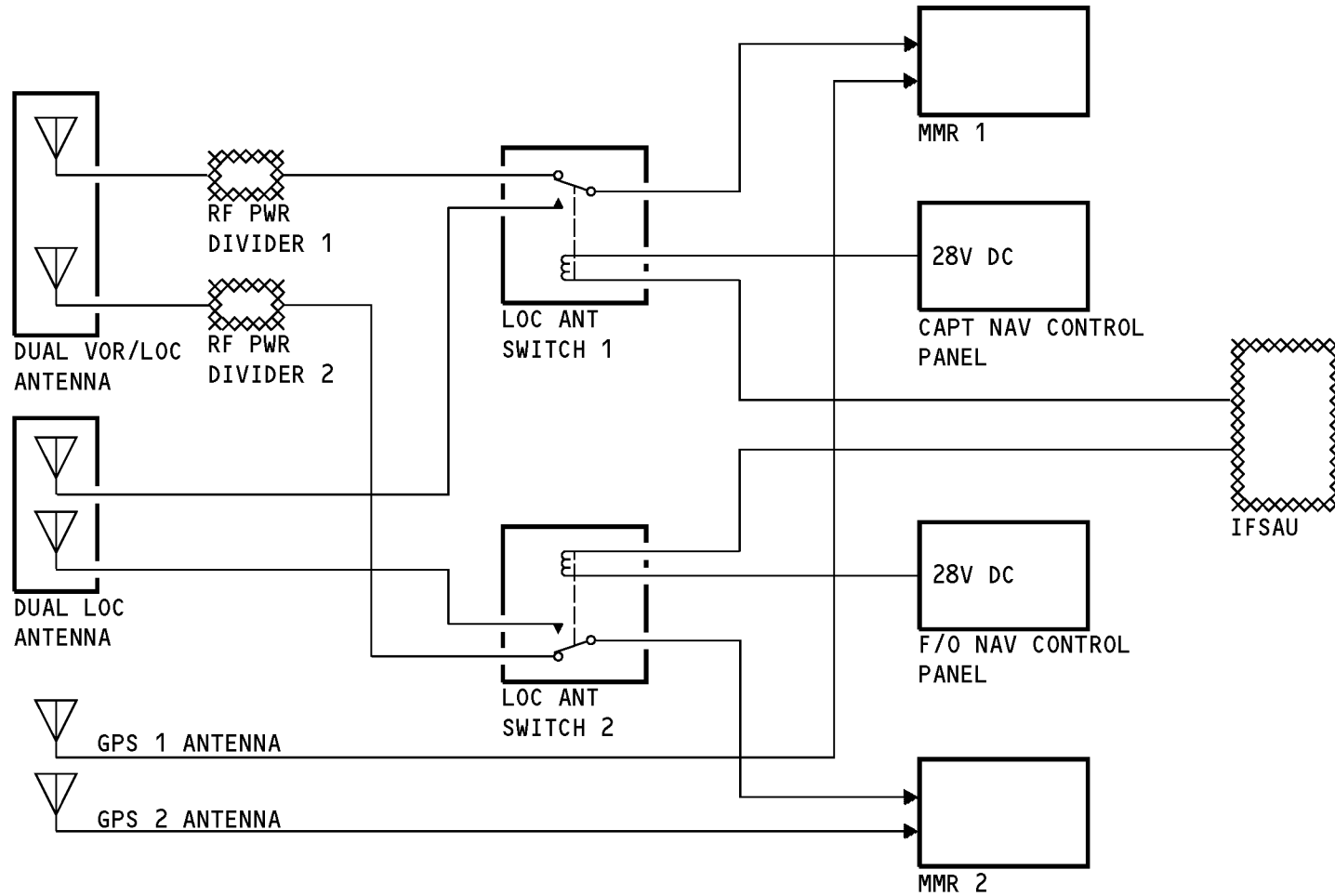

ILS - ANTENNA INTERFACE

EFFECTIVITY
HAP 037

34-31-00

D633A101-HAP

THIS PAGE IS INTENTIONALLY LEFT BLANK

34-31-00

D633A101-HAP

Page 37
Feb 15/2009

ILS - ANALOG INTERFACES**General**

When you tune an ILS frequency on the NAV control panels, discrete signals go to the DEUs to tell if the frequency is an ILS or VOR frequency. Each NAV control panel sends the discrete signal to the DEU 1 and DEU 2.

The FCCs send an ILS tune inhibit to the ILS function of the MMRs during the approach (APP) mode of operation. The ILS receiver will not accept another tune frequency during this mode.

The PSEU sends air/ground discrete signals to the MMRs to set the flight leg count in the internal memory, and also inhibit test in the air.

The MMRs send ILS ground station audio to the REU. The REU sends the audio to the flight compartment.

HAP 037**General**

When you tune a GLS channel on the NAV control panels, discrete signals go to the DEUs to tell if the frequency/channel is an ILS frequency, GLS channel or VOR frequency. Each NAV control panel sends the discrete signal to the DEU 1 and DEU 2.

The FCCs send a ILS/GLS tune inhibit to the ILS/GLS function of the MMRs during the approach (APP) mode of operation. The MMR will not accept another tune mode frequency/channel during this mode.

The PSEU sends air/ground discrete signals to the MMRs to set the flight leg count in the internal memory, and also inhibit test in the air.

The MMRs send GLS ground station audio to the REU. The REU sends the audio to the flight compartment.

HAP ALL

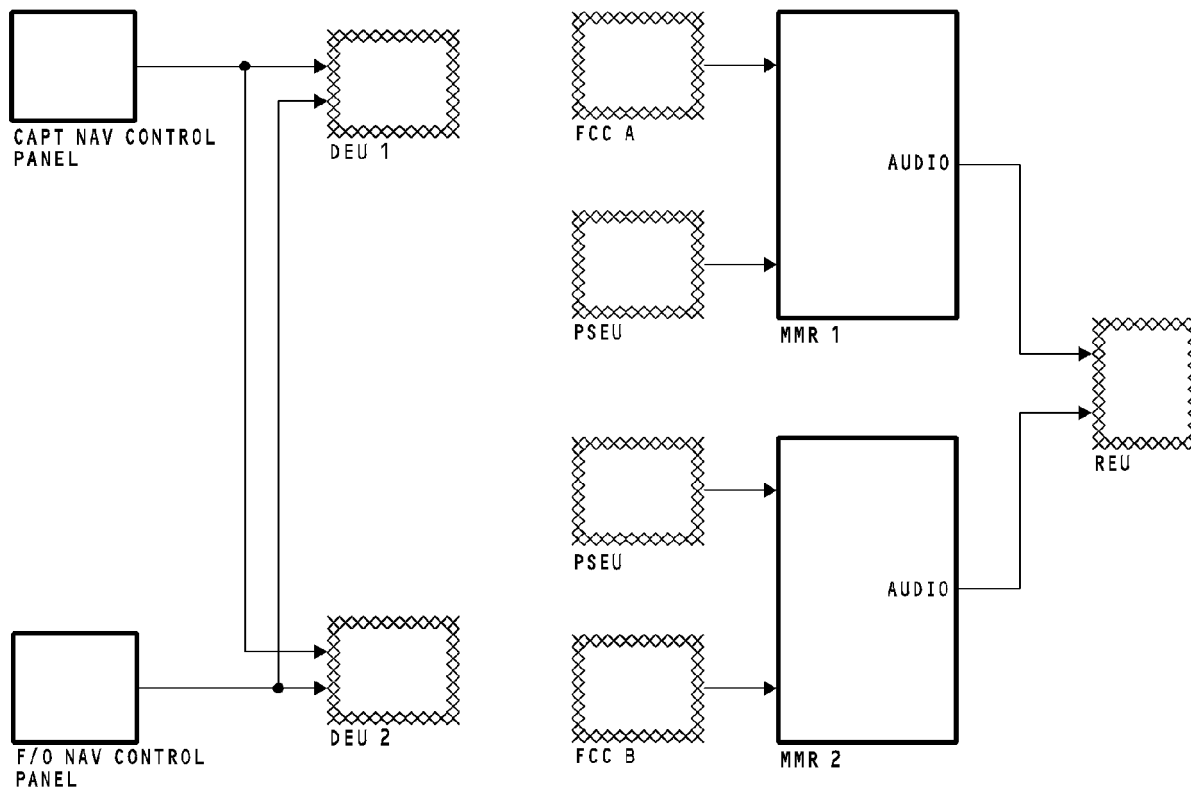

ILS - ANALOG INTERFACES

34-31-00-009

EFFECTIVITY
HAP ALL

34-31-00

D633A101-HAP

THIS PAGE IS INTENTIONALLY LEFT BLANK

34-31-00

D633A101-HAP

Page 40
Feb 15/2009

ILS - RECEIVER**HAP 001-013, 015-026, 028-036, 038-054, 101-999****Purpose**

The multi-mode receiver contains an ILS receiver and a global positioning system (GPS) sensor unit. The ILS receiver function supplies localizer and glideslope deviation to different airplane systems. The GPS sensor unit supplies position data and time to the flight management computer system (FMCS).

HAP 037**Purpose**

The multi-mode receiver contains an ILS receiver and a GLS receiver and a global positioning system (GPS) sensor unit. The ILS receiver function provides ILS localizer and glideslope deviations and the GPS receiver function supplies an ILS look-alike localizer and glideslope deviations to different airplane systems. The GPS receiver supplies position data and time to the different airplane systems.

HAP ALL**Description****HAP 001-013, 015-026, 028-036, 038-054, 101-999**

The MMR is a standard ARINC 600 3 MCU unit with dimensions 3.58 x 7.64 x 12.76 inches. The receiver weighs 8.6 pounds and uses 115v ac 400 Hz power for operation.

HAP 037

The MMR is a standard ARINC 600 3 MCU unit with dimensions 3.75 x 7.75 x 14.6 inches. The receiver weighs 10 pounds and uses 115v ac 400 Hz power for operation.

HAP ALL**Test and Indication****HAP 037**

There are status LED indicators and a test switch on the front of the multi mode receiver. The test switch starts a functional test of the receiver. The LED status indicators show test results.

HAP 001-013, 015-026, 028-036, 038-054, 101-999

There are two switches and an LCD on the front panel of the MMR. You use one of the two switches to start a test of the MMR. The LCD shows the test results.

There is a memory card slot on the front of the MMR. Shop personnel use this feature to put in a flash memory card which loads software into the LRU. The memory card can also store LRU data sent by the LRU during operation. These features are not used by line maintenance personnel.



ILS - RECEIVER

HAP 001-013, 015-026, 028-036, 038-054, 101-999 (Continued)

Shop personnel use the RS 232 connector to connect shop test equipment to the LRU. This feature is not used by line maintenance personnel.

HAP ALL

34-31-00-010

EFFECTIVITY
HAP ALL

34-31-00

D633A101-HAP

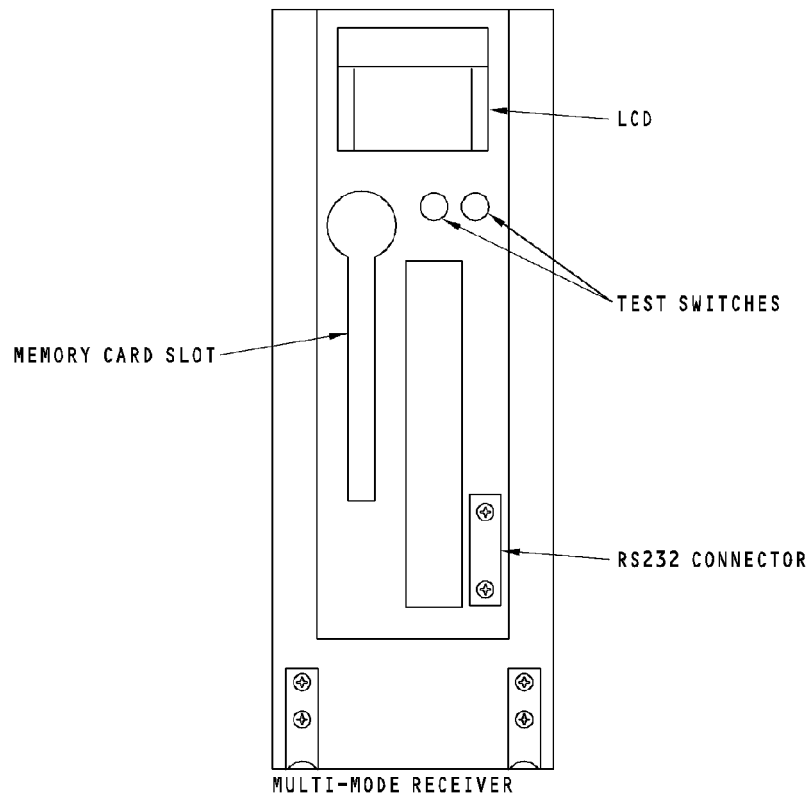

ILS - RECEIVER

34-31-00-010

EFFECTIVITY
HAP 001-013, 015-026, 028-036, 038-054, 101-999

34-31-00

D633A101-HAP

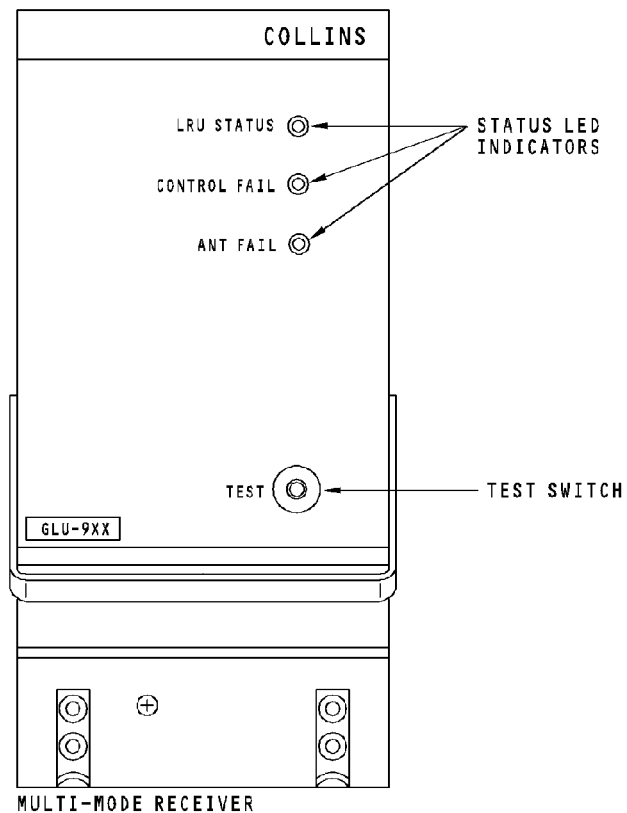

ILS - RECEIVER

EFFECTIVITY
HAP 037

34-31-00

D633A101-HAP

THIS PAGE IS INTENTIONALLY LEFT BLANK

34-31-00

D633A101-HAP

Page 45
Feb 15/2009

ILS - ANTENNAS**Localizer Antenna**

The localizer antenna has two elements. One element supplies RF inputs to ILS receiver 1 and one element supplies RF inputs to ILS receiver 2. The localizer antenna receives frequencies from 108.1 Mhz to 111.95 Mhz at odd tenth intervals.

HAP 037**VDB Antenna**

The VDB antenna has two elements. One element supplies RF inputs to GLS receiver 1 and one element supplies RF inputs to GLS receiver 2. The VDB antenna receives frequencies from 108.000 Mhz to 117.975 Mhz with increments of 25 MHz.

HAP ALL**Glideslope Antenna**

The glideslope antenna also has two elements. One element supplies RF signal inputs to MMR 1 and one element supplies RF signal inputs to MMR 2. The glideslope antenna receives frequencies from 328.6 Mhz to 335.4 Mhz.

HAP 037**GPS Antenna**

The two GPS antennas on top of the airframe. GPS 1 antenna supplies RF inputs to MMR 1 and GPS 2 antenna supplies RF inputs to MMR 2. The GPS antenna works with a 20MHz band centered about GPS L1 carrier frequency of 1575.42 MHz. The GPS antenna is powered by 12v dc provided by the MMR through the coaxial cable center conductor.

HAP ALL

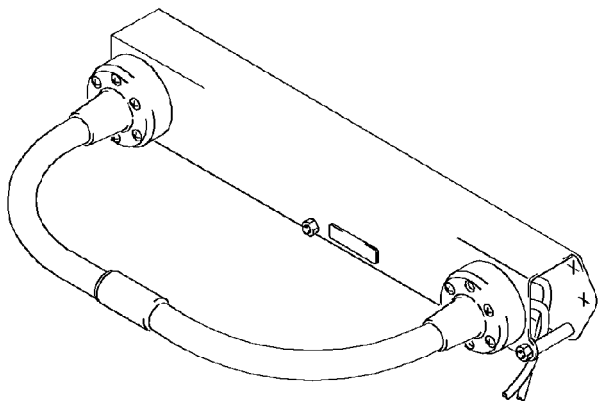

LOCALIZER ANTENNA

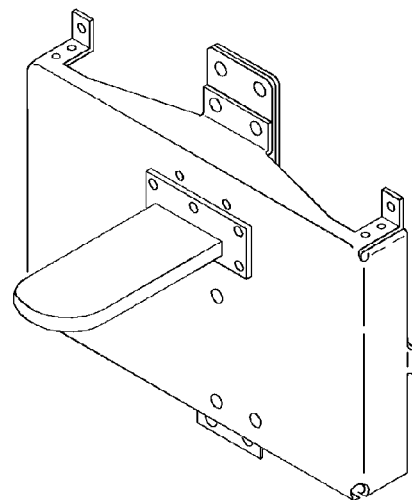

GLIDESLOPE ANTENNA

ILS - ANTENNAS

34-31-00-011

EFFECTIVITY
HAP ALL

34-31-00

D633A101-HAP

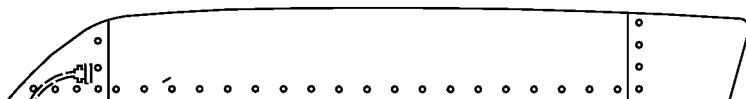

VOR/LOC ANTENNA

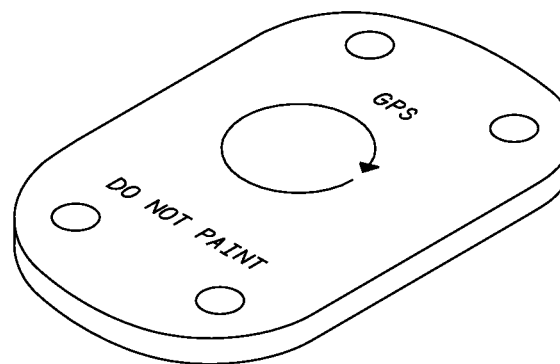

GPS ANTENNA

ILS - ANTENNAS

EFFECTIVITY
HAP 037

34-31-00

D633A101-HAP

THIS PAGE IS INTENTIONALLY LEFT BLANK

34-31-00

D633A101-HAP

Page 49
Feb 15/2009

ILS - NAVIGATION CONTROL PANEL**General**

The navigation (NAV) control panels supply frequency control and test signals to the DME, the MMR, and the VOR navigation radios.

HAP 001-013, 015-026, 028-036, 038-054, 101-999

Operation

The NAV control panels have an active frequency indicator and a standby frequency indicator. The frequency that shows in the active frequency indicator is the frequency the navigation radios use for operation. The standby frequency indicator shows the next frequency you will use.

The frequency transfer switch is a momentary action switch. It transfers the frequency in the standby frequency indicator to the active frequency indicator. When you push the switch, the frequency in the active frequency indicator transfers to the standby frequency indicator.

The frequency selectors are continuous rotary selectors. There is an inner selector and an outer selector. The outer selector sets the tens and ones numbers. The inner selector sets the tenth and one hundredth numbers. The frequency selectors only change the numbers in the standby frequency indicator.

At power up, the frequency displays show the last frequency entry before power down.

The NAV control panel continuous BITE function monitors the operation. The NAV control panel shows FAIL in the active and the standby frequency indicators when there is a control panel failure.

An internal monitor in the NAV control panel monitors the 28v dc input. If the monitor does not see the 28v dc, it shows the message BLANK in the active and the standby frequency indicators.

HAP 037**Operation**

The NAV control panels have an active mode frequency/channel indicator and a standby mode frequency/channel indicator. The mode frequency/channel that shows in the active frequency/channel indicator is the mode frequency/channel the navigation radios use for operation. The standby mode frequency/channel indicator shows the next frequency/channel you will use.

ILS - NAVIGATION CONTROL PANEL**HAP 037 (Continued)**

The mode frequency/channel transfer button is a momentary action button. It transfers the mode frequency/channel in the standby frequency/channel indicator to the active frequency/channel indicator. When you push the button, the frequency/channel in the active frequency/channel indicator transfers to the standby frequency/channel indicator.

At power up, the frequency displays show the last frequency entry before power down.

The NAV control panel continuous BITE function monitors the operation. The NAV control panel shows FAIL in the active and the standby frequency indicators when there is a control panel failure.

An internal monitor in the NAV control panel monitors the 28v dc input. If the monitor does not see the 28v dc, it shows the message BLANK in the active and the standby frequency indicators.

HAP ALL**Test****HAP 001-013, 015-026, 028-036, 038-054, 101-999**

When you push the NAV control panel test switch, a test command goes out on the data bus. If a VOR frequency is active, the VOR receiver starts a self test. If an ILS frequency is active, the MMR receiver starts a self test. If a DME frequency is paired with the VOR or ILS frequency, the DME interrogator starts a self test at the same time.

HAP 037

When you push the NAV control panel test button, a test command goes out on the data bus. If a VOR frequency is active, the VOR receiver starts a self test. If an ILS frequency or a GLS channel is active, the MMR receiver starts a self test. If a DME frequency is paired with the VOR or ILS frequency, the DME interrogator starts a self test at the same time.

HAP 001-013, 015-026, 028-036, 038-054, 101-999

When you do a test of the master dim and test system, the NAV control panel shows 188.88. The display shows for two seconds on, then one second off until the test is complete.

ILS - NAVIGATION CONTROL PANEL**HAP 001-013, 015-026, 028-036, 038-054, 101-999 (Continued)****HAP 037**

When you do a test of the master dim and test system, the NAV control panel shows 888.88. The display shows for two seconds on, then one second off until the test is complete.

HAP ALL

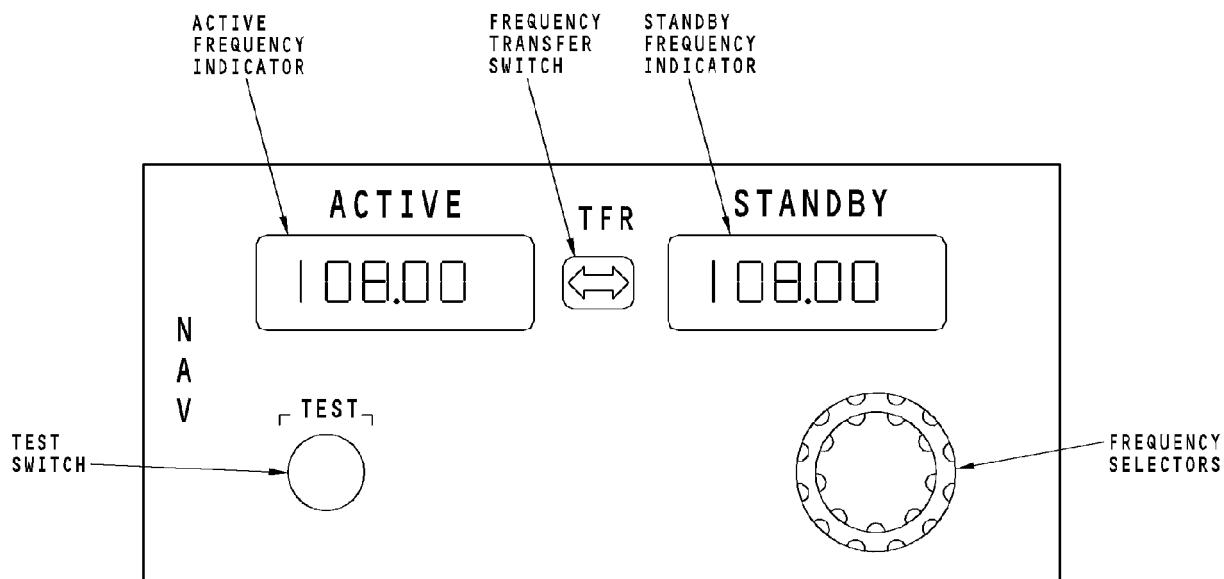

ILS - NAVIGATION CONTROL PANEL

34-31-00-012

EFFECTIVITY
HAP 001-013, 015-026, 028-036

34-31-00

D633A101-HAP

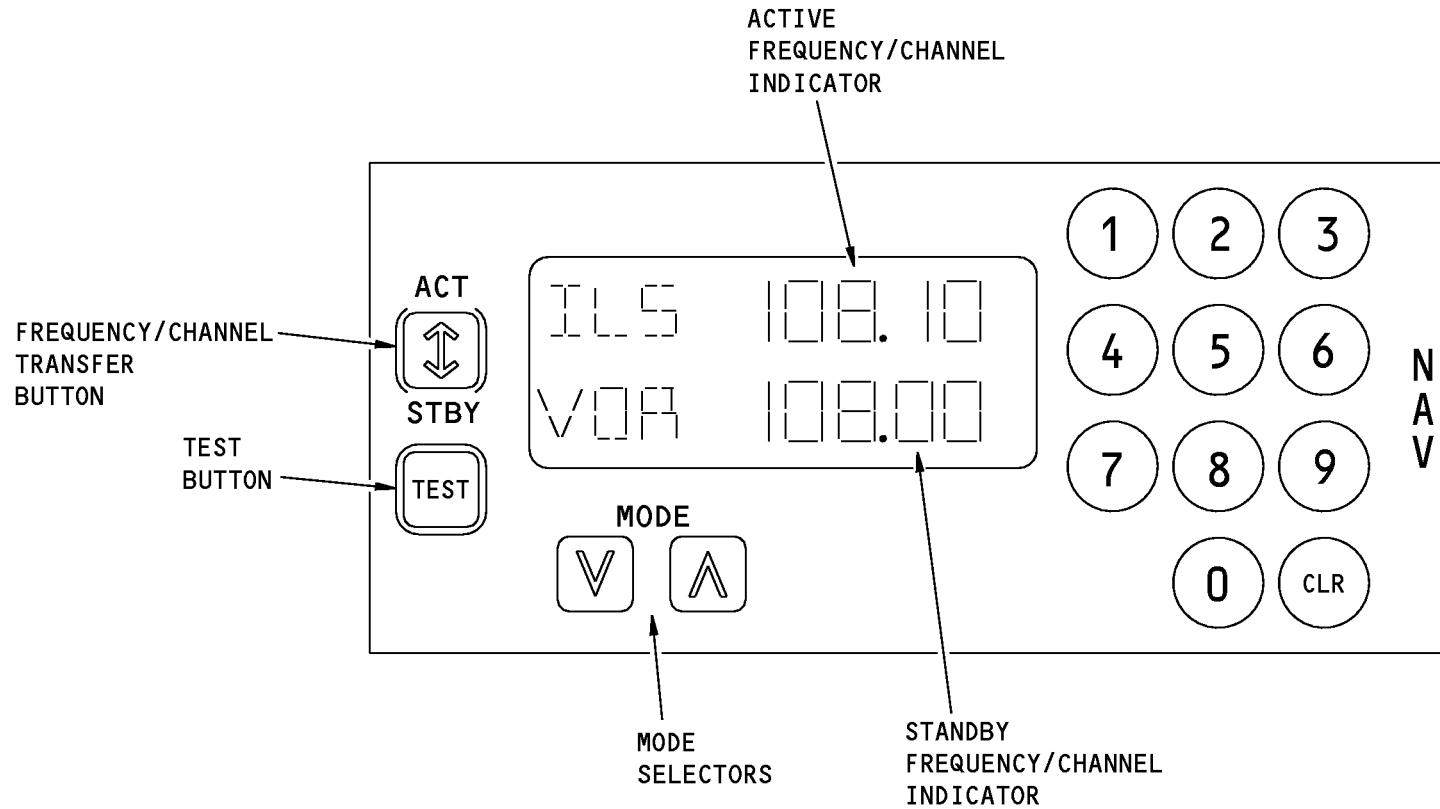

1738899 S0000314650_V1

ILS - NAVIGATION CONTROL PANEL

34-31-00-012

EFFECTIVITY
HAP 038-054, 101-999

34-31-00

D633A101-HAP

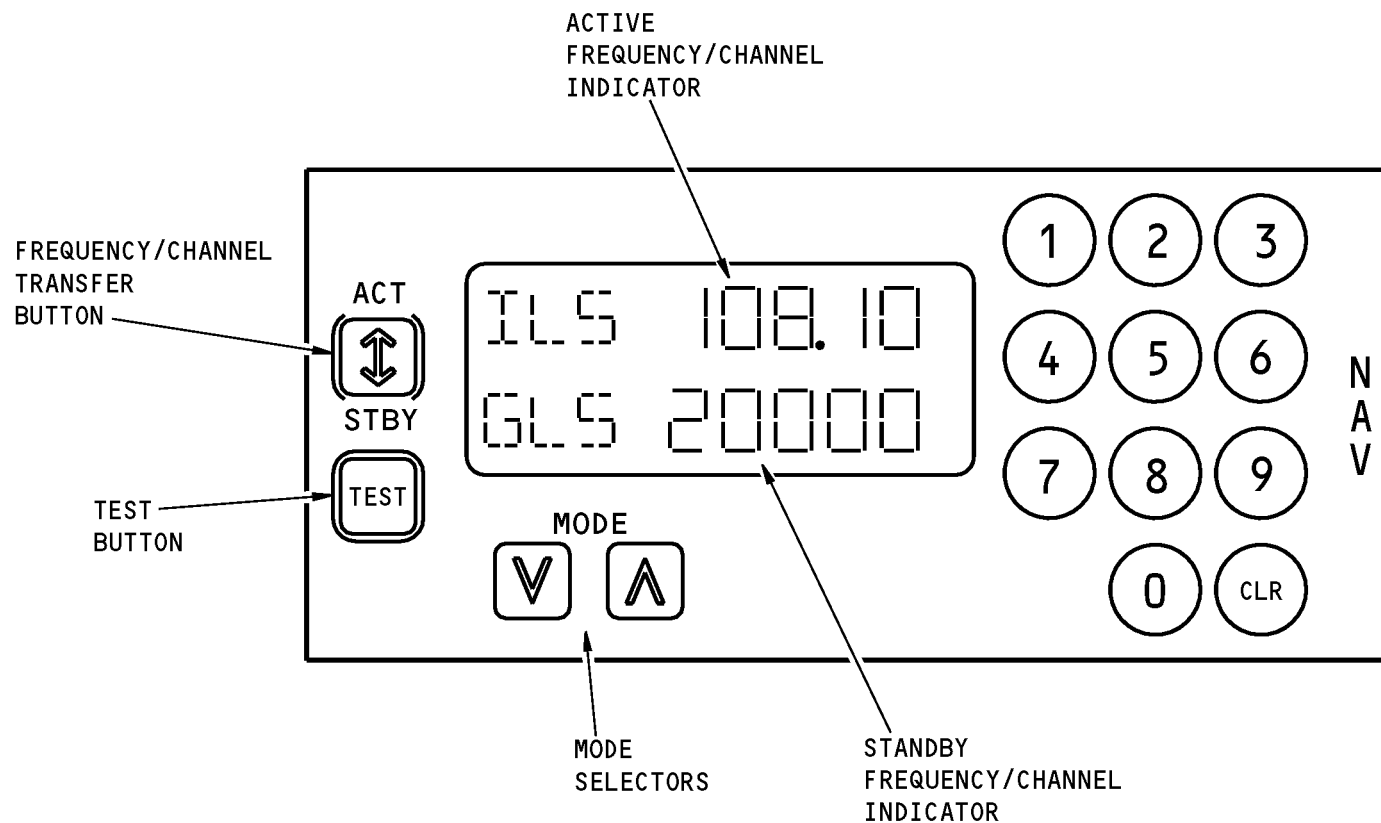

ILS - NAVIGATION CONTROL PANEL

34-31-00-012

EFFECTIVITY
HAP 037

34-31-00

D633A101-HAP

THIS PAGE IS INTENTIONALLY LEFT BLANK

34-31-00

D633A101-HAP

Page 56
Feb 15/2009

ILS - FUNCTIONAL DESCRIPTION**Power Interface**

The NAV control panel uses 115v ac power for operation. It also uses 28v dc for an internal monitor. The NAV control panel uses 5v ac from the master dim and test for panel lights.

ARINC 429 Interfaces

Frequency tune inputs and test commands from the NAV control panel go to the MMR on an ARINC 429 bus.

HAP 001-013, 015-026, 028-036, 038-054, 101-999

When you tune an ILS frequency, the frequency tune circuits operate switches in the NAV control panel that send these discrete signals:

HAP 037

When you tune an ILS frequency or GLS channel, the frequency tune circuits operate switches in the NAV control panel that send these discrete signals:

HAP ALL

- Open discrete to the REU
- Ground discrete to the DEUs
- 28v dc to the FCCs
- 28v dc to the LOC antenna switches.

Discrete Interfaces**HAP 001-013, 015-026, 028-036, 038-054, 101-999**

The REU uses the open discrete to select ILS audio. The DEUs use the ground discrete to set the ILS displays. The NAV control panel sends the 28v dc to the FCCs when an ILS frequency is active. It also sends 28v dc to the LOC antenna switches when an ILS frequency is active for switch operation.

HAP 037

The REU uses the open discrete to select ILS/GLS audio. The DEUs use the ground discrete to set the ILS/GLS displays. The NAV control panel sends the 28v dc to the FCCs when an ILS frequency or GLS channel is active. It also sends 28v dc to the LOC antenna switches when an ILS frequency or GLS channel is active for switch operation.

HAP ALL

The on-side FCC supplies a discrete during an AFDS approach mode. The discrete causes the MMR to not accept any frequency changes. The discrete also goes to the NAV control panel. When the discrete is set, It prevents any frequency change to the output data word that goes to the MMR. The MMR uses the air/ground discrete for flight leg count.

ILS - FUNCTIONAL DESCRIPTION**HAP 037**

The on-side FCC supplies a discrete during an AFDS approach mode. The discrete causes the MMR to not accept any mode frequency/channel changes. The discrete also goes to the NAV control panel. When the discrete is set, it prevents any mode frequency/channel change to the output data word that goes to the MMR. The MMR uses the air/ground discrete for flight leg count.

HAP ALL**RF Interfaces**

RF signals from the VOR/LOC antenna or localizer antenna in the nose radome, go to the localizer receiver circuits in the MMR. RF signals from the glideslope antenna in the nose radome go to the glideslope receiver circuits in the MMR.

Receiver Functional Description

All inputs to the receiver go through a high intensity radiated frequency (HIRF) filter. This filter provides protection to internal circuits.

HAP 001-013, 015-026, 028-036, 038-054, 101-999

Tune inputs from the NAV control panel go to the main processor. The processor sends the tune frequency to the frequency synthesizer circuits. The frequency synthesizer circuits tune the localizer receiver and glideslope receiver.

HAP 037

Tune inputs from the NAV control panel go to the main processor. The processor sends the tune frequency to the frequency synthesizer circuits. The frequency synthesizer circuits tune the localizer receiver for the VDB signal.

HAP ALL

The receiver circuits send the RF signal inputs from the antennas to the main processor. The processor computes localizer deviation and glideslope deviation.

HAP 001-013, 015-026, 028-030

ILS data goes out on two ARINC 429 buses. Output 1 goes to FCC A and FCC B. Output 2 goes to these LRUs:

- FDAU
- Standby attitude indicator
- GPWC
- FMC
- DEUs.

HAP 031-054, 101-999

ILS data goes out on two ARINC 429 buses. Output 1 goes to FCC A and FCC B. Output 2 goes to these LRUs:

ILS - FUNCTIONAL DESCRIPTION**HAP 031-054, 101-999 (Continued)****HAP 037**

GLS data goes out on the same two ARINC 429 buses as with ILS data. Output 1 goes to FCC A and FCC B. Output 2 goes to these LRUs:

HAP 031-054, 101-999

- FDAU
- ISFD
- GPWC

HAP 037

- MCU

HAP 031-054, 101-999

- FMC
- DEUs.

HAP 001-013, 015-026, 028-036, 038-054, 101-999

The localizer receiver sends audio from the localizer ground station to the audio processor. The audio processor sends ILS audio to the REU. Audio also goes through a detector that decodes the ground stations morse code station identifier. If there is a station identifier with the station audio, the detector sends it through the ARINC transmitter on the output data bus. When there is an identifier on the data bus, the DEU replaces the frequency display with the four letter station identifier.

HAP 037

The A/D function of the receiver converts the audio from the localizer ground station from an analog to a digital format. The audio then goes to the main processor. The main processor sends the audio to the REU. The processor also detects any morse code station identifier and sends it out on the data buses. When there is a station identifier on the data bus, the DEUs replace the frequency display with the four letter station identifier.

HAP ALL**Test****HAP 001-013, 015-026, 028-036, 038-054, 101-999**

To start an ILS test, push the NAV control panel test switch when there is an ILS frequency active or push one of the front panel test switches. When the processor receives a test signal, it does a test of operation and MMR condition. Test results show on the LCD when you do a test from the front panel switches.

ILS - FUNCTIONAL DESCRIPTION**HAP 001-013, 015-026, 028-036, 038-054, 101-999 (Continued)****HAP 037**

To start an ILS test, push the NAV control panel test switch when there is an ILS frequency active or push the front panel test switch. When the processor receives a test signal, it does a test of operation and receiver condition. Test results show on the front panel LED status indicators. The LRU status LED shows red for test faults or green if there are no faults. The control fail LED comes on red if there is no tuning input data from the control panel. The control fail LED will show green for valid tune inputs.

HAP ALL

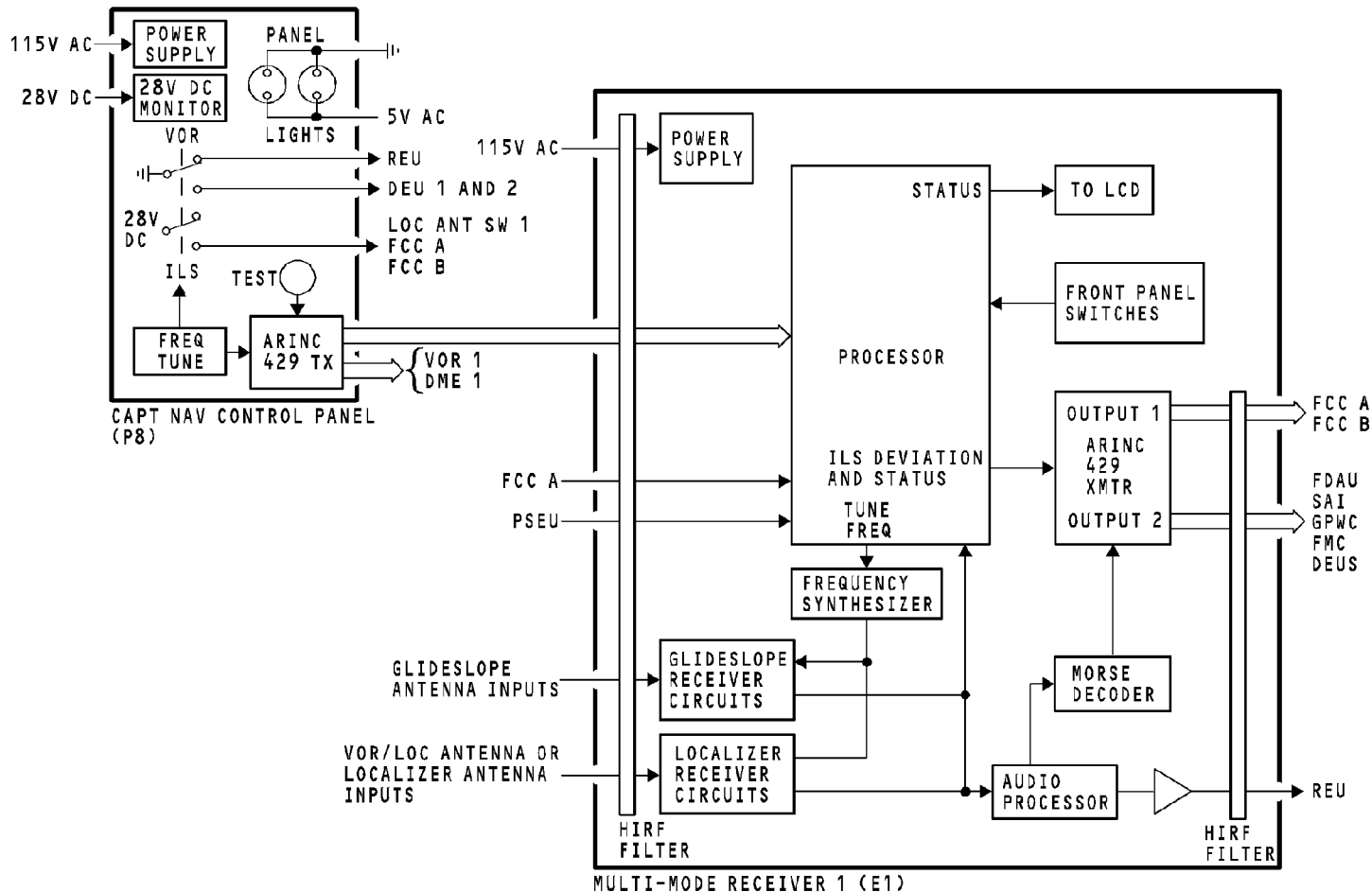

ILS - FUNCTIONAL DESCRIPTION

34-31-00-013

EFFECTIVITY
HAP 001-013, 015-026, 028-030

34-31-00

D633A101-HAP

Page 61
Feb 15/2009

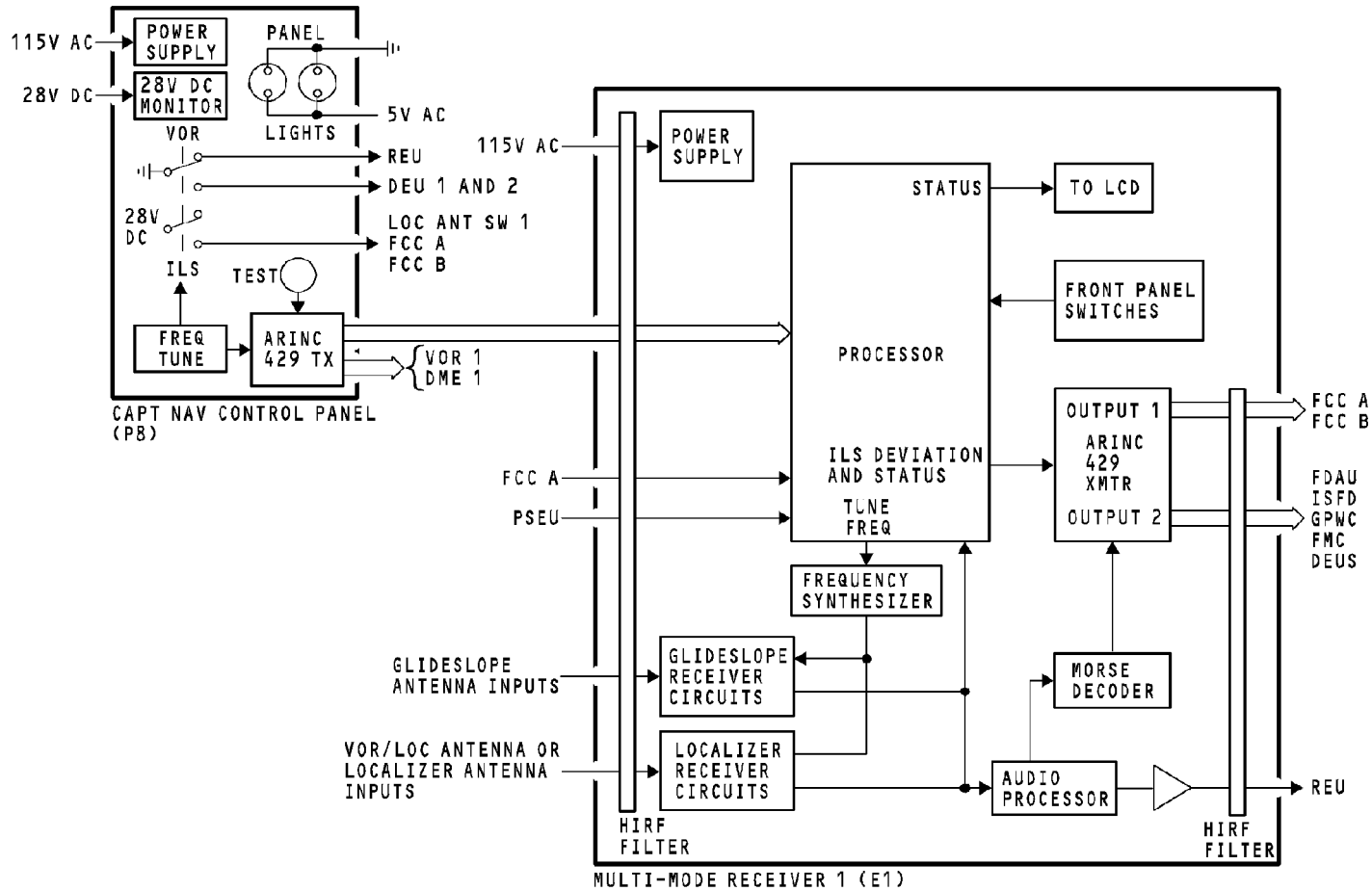

ILS - FUNCTIONAL DESCRIPTION

EFFECTIVITY

HAP 031-036, 038-054, 101-999

34-31-00

D633A101-HAP

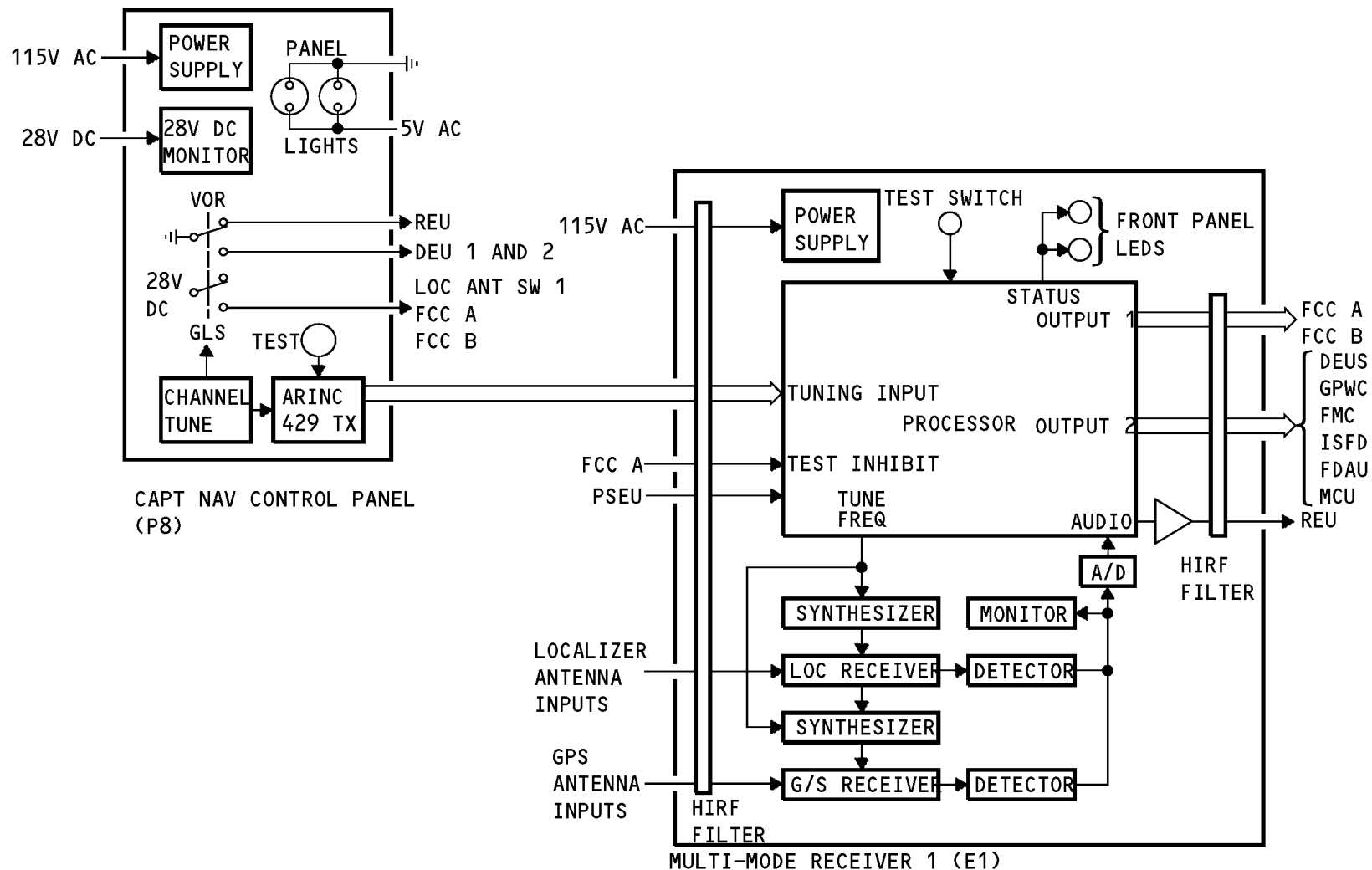

ILS - FUNCTIONAL DESCRIPTION

34-31-00-013

EFFECTIVITY
HAP 037

34-31-00

D633A101-HAP

Page 63
Feb 15/2009

THIS PAGE IS INTENTIONALLY LEFT BLANK

34-31-00

D633A101-HAP

Page 64
Feb 15/2009

ILS - CONTROLS**EFIS Controls****HAP 001-013, 015-026, 028-036, 038-054, 101-999**

To show ILS data on the captain's and F/O's displays, set the mode selector on the EFIS control panel to the APP position.

HAP 037

To show GLS data on the captain's and F/O's displays, set the mode selector on the EFIS control panel to the APP position.

HAP ALL**DFCS Controls****HAP 001-013, 015-026, 028-036, 038-054, 101-999**

The digital flight control system (DFCS) mode control panel (MCP) supplies runway heading data to the display electronics unit (DEU) for ILS displays. You use the DFCS MCP course selector to set the course for approach.

HAP 037

The digital flight control system (DFCS) mode control panel (MCP) supplies runway heading data to the display electronics unit (DEU) for GLS displays. You use the DFCS MCP course selector to set the course for approach.

HAP 001-013, 015-026, 028-036, 038-054, 101-999

The DEU uses the course input and ILS deviation to calculate the airplane's deviation from the runway centerline. The DEUs compare the course input to the airplane's track to calculate if this is a back course approach. If the course input and airplane track are different by more than 90 degrees, the DEUs show backcourse ILS displays.

HAP 037

The DEU uses the course input and GLS lateral deviations to provide the display of the airplane's deviation from the runway centerline. If the course input and airplane track are different by more than 90 degrees, the DEUs would blank the G/S deviation display.

HAP ALL**Audio Control Panel Controls****HAP 001-013, 015-026, 028-036, 038-054, 101-999**

The audio control panels (ACPs) lets the crew listen to ILS station audio or the morse code station identifier.

HAP 037

The audio control panels (ACPs) lets the crew listen to GLS station identifier in morse code.

ILS - CONTROLS**HAP 037 (Continued)****HAP ALL**

You use the ACP receiver switches to select the ILS audio you want to listen to. The NAV 1 receiver switch selects the MMR 1 audio and the NAV 2 receiver switch selects the MMR 2 audio.

HAP 037

You use the ACP receiver switches to select the GLS audio you want to listen to. The NAV 1 receiver switch selects the MMR 1 audio and the NAV 2 receiver switch selects the MMR 2 audio.

HAP ALL

The filter switch lets you listen to only voice audio in the voice (V) position. The range (R) position lets you listen to the station morse code identifier. With selector in the both (B) position you can listen to both the voice audio and the morse code station identifier.

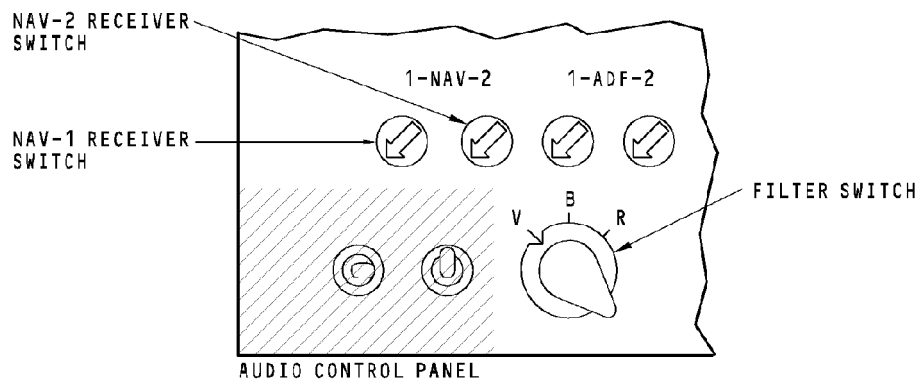
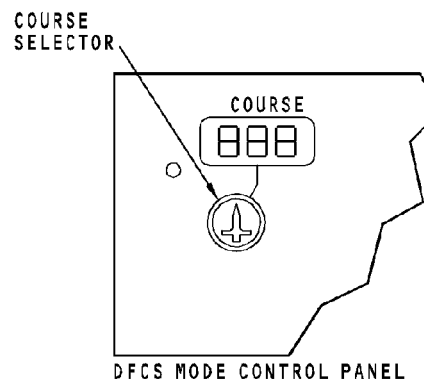
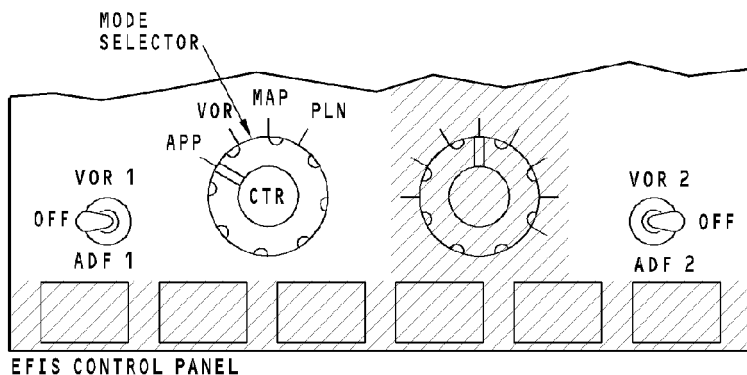

ILS - CONTROLS

34-31-00-014

EFFECTIVITY
HAP ALL

34-31-00

D633A101-HAP

ILS - STANDBY ATTITUDE INDICATOR DISPLAYS**General**

The standby attitude indicator gives the crew an alternate attitude indication source. The indicator also provides ILS data. You use the approach selector on the indicator to show ILS data. The approach selector has these positions:

- Off - no ILS data on indicator
- APP - ILS localizer and glideslope data shows
- B/CRS - back course ILS localizer data shows.

Indications

When the selector is in the OFF position, the localizer and glideslope deviation bars do not show. When the selector is in the APP position, the localizer and glideslope deviation bars show. When you select B/CRS, the localizer deviation bar reverses polarity for the approach display and the glideslope deviation bar goes out of view.

When the indicator receives invalid ILS data, the localizer or glideslope deviation bars go out of view and the glideslope flag or localizer flag shows.

When the ILS data is no computed data (NCD) for localizer or glideslope data, the related deviation bar goes out of view.

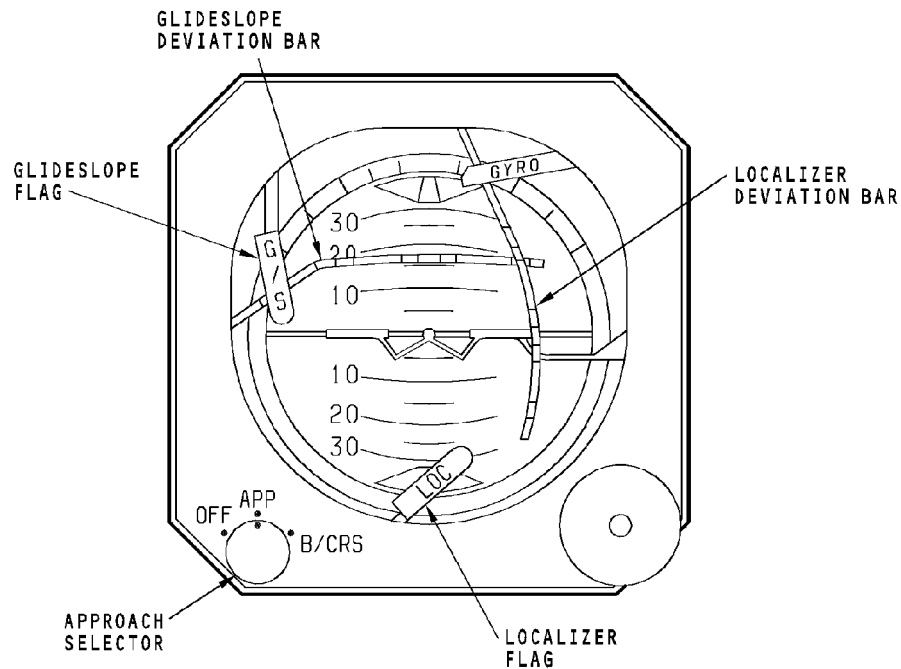

ILS - STANDBY ATTITUDE INDICATOR DISPLAYS

34-31-00-016

EFFECTIVITY
HAP 001-013, 015-026, 028-030

34-31-00

D633A101-HAP

Page 69
Feb 15/2009

ILS - INTEGRATED STANDBY FLIGHT DISPLAY**General**

The integrated standby flight display (ISFD) gives the flight crew a single integrated display of these parameters:

- Pitch and roll attitude
- Indicated airspeed
- Altitude
- Heading
- Localizer and glideslope deviation.

The ISFD receives localizer and glideslope deviation data from the multi-mode receiver (MMR).

Approach Mode Switch (APP)

The approach mode switch controls the display of the localizer and glideslope deviation.

When the ISFD comes on, the ISFD shows no localizer scale and no glideslope scale. Push the APP mode switch once to make the frontcourse approach mode come on. The ISFD shows the localizer and the glideslope deviation scales.

Indications

When the frontcourse approach mode is set and the ISFD receives invalid ILS data, the deviation pointers and the scales are removed. The LOC and G/S flags show.

HAP 037

When the frontcourse approach mode is set and the ISFD receives invalid GLS data, the deviation pointers and the scales are removed. The LOC and G/S flags show.

HAP 031-054, 101-999

When the frontcourse approach mode is set and the ISFD receives NCD ILS data, the related pointers go out of view and the scales show.

HAP 037

When the frontcourse approach mode is set and the ISFD receives NCD GLS data, the related pointers go out of view and the scales show.

HAP 031-054, 101-999

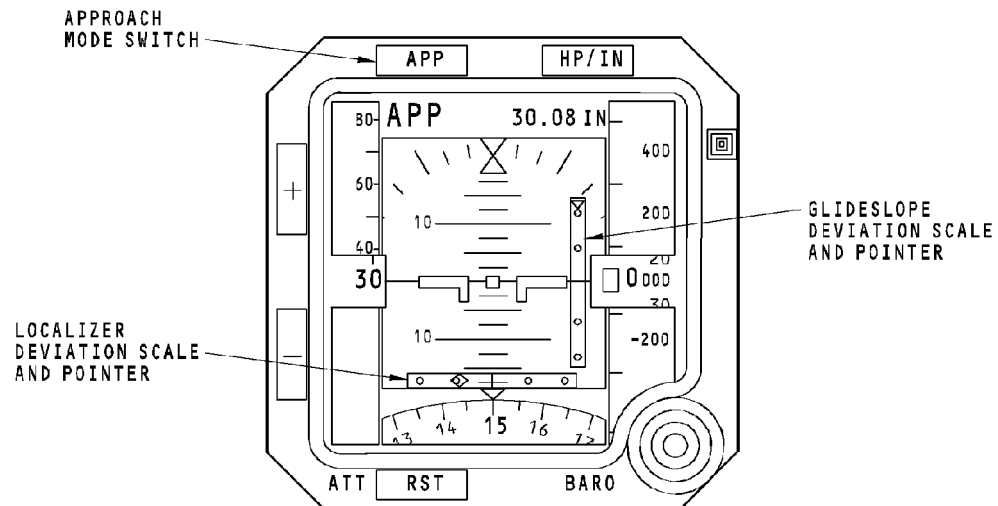

ILS - INTEGRATED STANDBY FLIGHT DISPLAY

34-31-00-023

EFFECTIVITY
HAP 031-054, 101-999

34-31-00

D633A101-HAP

Page 71
Feb 15/2009

THIS PAGE IS INTENTIONALLY LEFT BLANK

34-31-00

D633A101-HAP

Page 72
Feb 15/2009

ILS - ADI DISPLAYS

General

To show ILS displays on the ADI you must tune a valid ILS frequency on the NAV control panel and select it to the active display window.

HAP 037

To show GPS displays on the ADI you must tune a valid GLS channel on the NAV control panel and select it to the active display window.

HAP ALL

Normal Display

The localizer deviation pointer and scale show at the bottom of the attitude display. The scale is a standard four dot scale. One dot equals 1 degree of deviation. The deviation indication shows deviation to the left or right of the runway centerline. The localizer scale shows in white and the localizer pointer shows in magenta.

The localizer scale can show the standard display or the expanded scale. A two-dot expanded scale can replace the four-dot scale. For the expanded scale, each dot equals 0.5 degrees of deviation. The white expanded scale goes to amber and flashes when the autopilot sends an ILS deviation warning. The expanded scale shows for these conditions:

HAP 037

The localizer scale can show the standard display or the expanded scale. A two-dot expanded scale can replace the four-dot scale. For the expanded scale, each dot equals 0.5 degrees of deviation. The white expanded scale goes to amber and flashes when the autopilot sends an GLS deviation warning. The expanded scale shows for these conditions:

HAP ALL

- LOC deviation is less than 5/8 dot
- LOC or APP mode is engaged
- ILS course and the airplane track are within 5 degrees of each other

HAP 037

- GLS course and the airplane track are within 5 degrees of each other

HAP ALL

- An autopilot is in CMD.

The glideslope deviation pointer and scale show to the right of the attitude display. The scale is a standard four-dot scale. One dot equals 0.35 degrees of deviation. The pointer gives fly-to commands to intercept the glideslope beam. The glideslope scale shows in white and the glideslope pointer shows in magenta. There is no expanded scale for glideslope deviation.

34-31-00-017



34-31-00

D633A101-HAP

ILS - ADI DISPLAYS

The ILS station frequency and course show above and to the right of the ADI. If the ILS ground station transmits a morse coded station identifier, the stations letter identifier replaces the numeric frequency display when the receiver captures the signal.

HAP 037

The GLS channel and course show above and to the left of the PFD. The stations letter identifier replaces the numeric channel display when the receiver captures the signal from the ground station.

HAP 037-054, 101-999**Rising Runway**

The rising runway shows when there is a LOC signal capture and the radio altitude is below 2500 feet. The symbol goes out of view above 2500 feet. The rising runway symbol is green with a magenta stem.

The rising runway symbol represents the radio altitude above the runway. It moves laterally with the localizer deviation pointer to show localizer deviation. The symbol starts to move when the radio altitude is 200 feet. It touches the airplane symbol when the radio altitude is 0 or at touchdown.

HAP 021-026, 028-054, 101-999**NCD Display**

When the ILS data goes to an NCD condition, the CDS shows the localizer and glideslope scales and removes the pointers.

HAP ALL**Fail Display**

The amber LOC flag replaces the localizer deviation pointer and scale when the localizer receiver function has a failure. The amber G/S flag replaces the glideslope deviation pointer and scale when the glideslope receiver function has a failure.

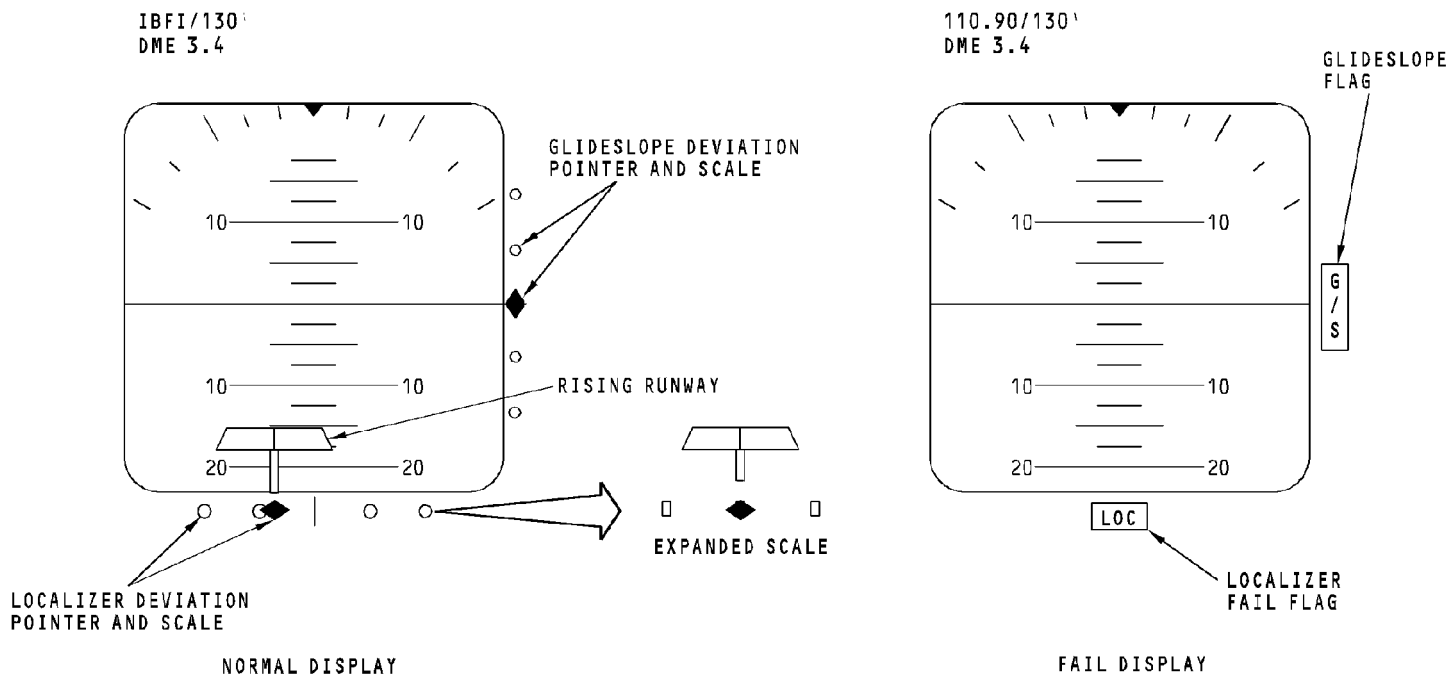

ILS - ADI DISPLAYS

34-31-00-017

EFFECTIVITY
HAP 037-054, 101-999

34-31-00

D633A101-HAP

Page 75
Feb 15/2009

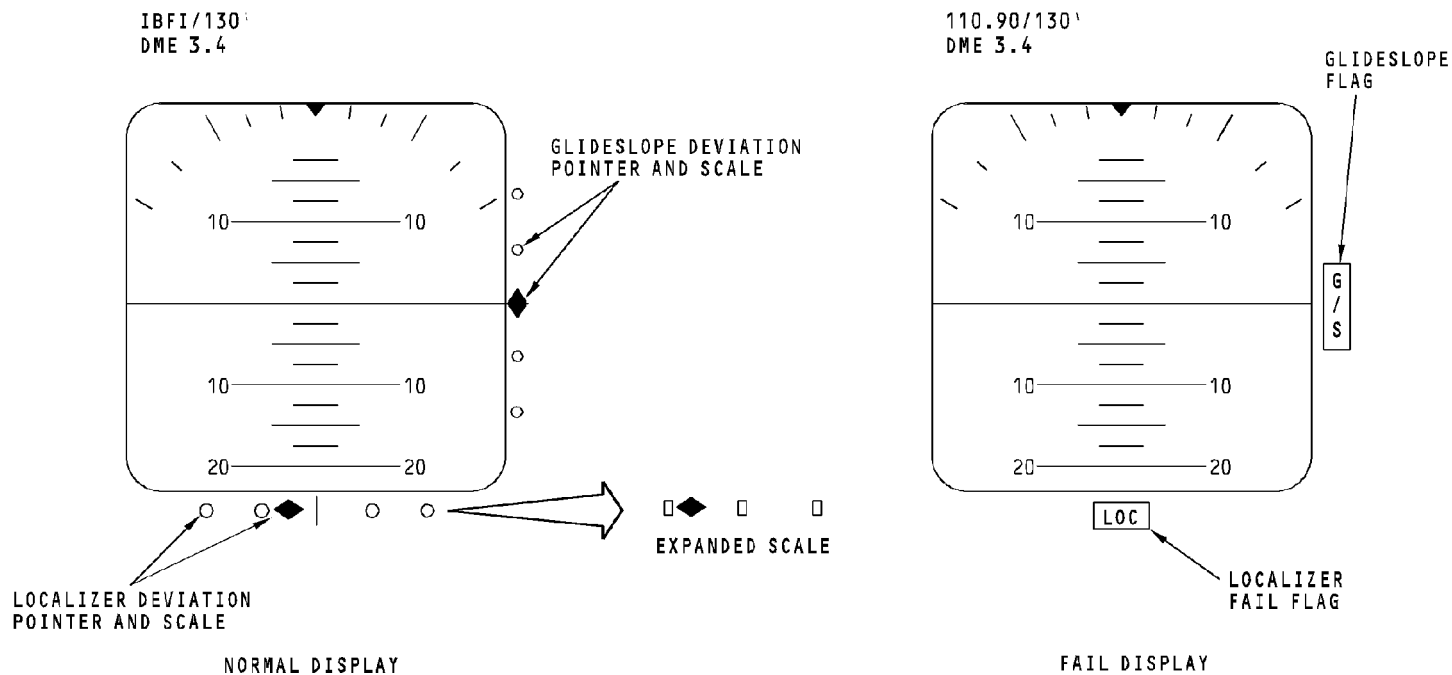

ILS - ADI DISPLAYS

EFFECTIVITY

HAP 001-013, 015-026, 028-036

34-31-00

D633A101-HAP

ILS - EXPANDED ILS DISPLAY**General****HAP 001-013, 015-026, 028-036, 038-054, 101-999**

To show ILS displays on the CDS, set the EFIS control panel mode selector to the APP position. You must also tune a valid ILS frequency on the NAV control panel.

HAP 037

To show ILS/GLS displays on the CDS, set the EFIS control panel mode selector to the APP position. You must also tune a valid ILS frequency or a valid GLS channel on the NAV control panel.

HAP ALL**Normal Display**

The glideslope deviation pointer and scale show at the right of the NAV display. The glideslope deviation pointer is magenta and the scale is white.

The glideslope scale is the standard four dot scale where each dot equals 0.35 degrees of deviation. The glideslope deviation pointer gives fly-to signals to intercept the glideslope beam.

The course pointer points to the number that you set on the DFCS MCP.

The localizer deviation indicator and scale shows at the bottom of the NAV display. The localizer scale is white and the localizer deviation indicator is magenta.

The deviation scale is the standard four dot scale. One dot is equal to 1 degree of deviation. The localizer deviation indicator shows the deviation to the left or right of the runway centerline.

HAP 001-013, 015-026, 028-036, 038-054, 101-999

The NAV data source shows in white at the upper right corner of the display. It shows the source of the data for the ILS displays. To the right of the NAV data source is the active ILS frequency display.

HAP 037

The NAV data source shows in white at the upper right corner of the display. It shows the source of the data for the ILS/GLS displays. To the right of the NAV data source is the active ILS frequency or GLS channel display.

HAP 001-013, 015-026, 028-036, 038-054, 101-999

The ILS frequency display shows the active ILS frequency and the selected course. If the ILS ground station transmits a morse coded station identifier, the letter identifier replaces the numeric frequency when the receiver captures the ground station signal.

EFFECTIVITY
HAP ALL

ILS - EXPANDED ILS DISPLAY**HAP 001-013, 015-026, 028-036, 038-054, 101-999 (Continued)****HAP 037**

The ILS frequency or GLS channel display shows the active ILS frequency or GLS channel and the selected course. If the ILS/GLS ground station transmits a morse coded station identifier, the letter identifier replaces the numeric frequency when the receiver captures the ground station signal.

HAP 021-026, 028-054, 101-999**NCD Display**

When the ILS data goes to an NCD condition, the CDS shows the localizer and glideslope scales and removes the pointers.

HAP ALL**Fail Display****HAP 001-013, 015-026, 028-036, 038-054, 101-999**

For invalid ILS data, the CDS replaces the localizer deviation scale and indicator with the amber LOC flag when the localizer receiver fails. The amber G/S flag replaces the glideslope deviation scale and pointer when the glideslope receiver fails.

HAP 037

For invalid ILS/GLS data, the CDS replaces the localizer deviation scale and indicator with the amber LOC flag when the localizer receiver fails. The amber G/S flag replaces the glideslope deviation scale and pointer when the glideslope receiver fails.

HAP ALL

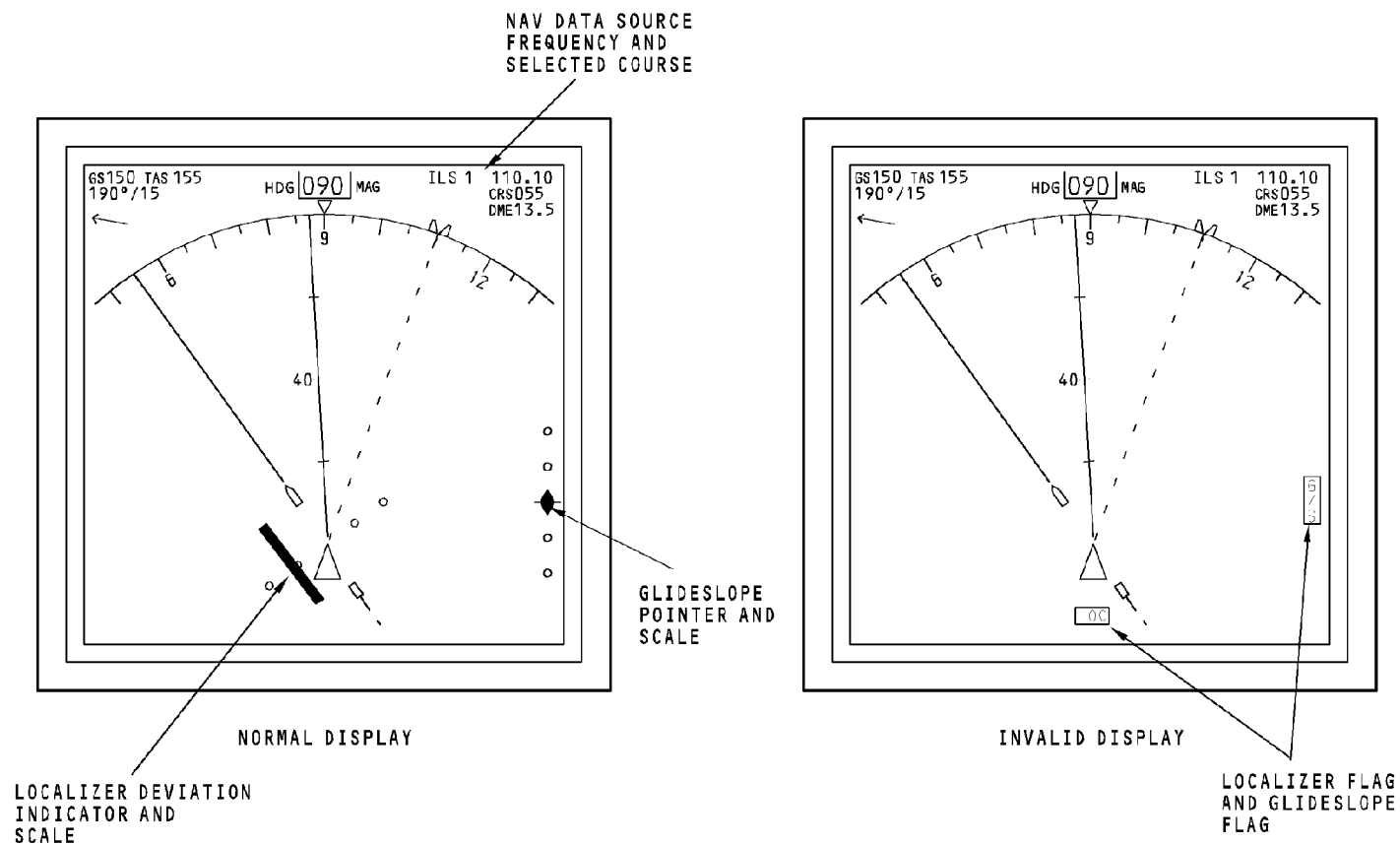

ILS - EXPANDED ILS DISPLAY

EFFECTIVITY
HAP ALL

34-31-00

D633A101-HAP

Page 79
Feb 15/2009

34-31-00-018

THIS PAGE IS INTENTIONALLY LEFT BLANK

34-31-00

D633A101-HAP

Page 80
Feb 15/2009

ILS - CENTERED ILS DISPLAY**General****HAP 001-013, 015-026, 028-036, 038-054, 101-999**

To show the centered ILS NAV display, push the CTR switch on the EFIS control panel mode selector switch.

HAP 037

To show the centered ILS/GLS NAV display, push the CTR switch on the EFIS control panel mode selector switch.

HAP ALL**Normal Displays**

The glideslope deviation pointer and scale show to the right of the HSI display. The glideslope pointer is magenta and the scale is white.

The glideslope scale is the standard four dot scale. Each dot equals 0.35 degrees of deviation. The pointer gives fly-to commands to intercept the glideslope beam.

The course pointer points to the number that you set on the DFCS MCP.

The localizer deviation indicator and scale show in the center of the HSI compass card. The localizer deviation indicator is magenta and the scale is white.

The localizer scale is the standard four dot scale. Each dot is equal to 1 degree of deviation. The deviation indicator shows the deviation to the left or the right of the runway centerline.

HAP 001-013, 015-026, 028-036, 038-054, 101-999

The NAV data source shows in white in the upper right corner of the display. It shows the source of data for the ILS display. The active ILS frequency shows to the right of the NAV data source.

HAP 037

The NAV data source shows in white in the upper right corner of the display. It shows the source of data for the ILS/GLS display. The active ILS frequency or GLS channel shows to the right of the NAV data source.

HAP 001-013, 015-026, 028-036, 038-054, 101-999

The ILS frequency display shows the active ILS frequency and the selected course. If the ILS ground station transmits a morse coded station identifier, then the letter identifier replaces the numeric frequency when the receiver captures the ground station signal.

EFFECTIVITY
HAP ALL

ILS - CENTERED ILS DISPLAY**HAP 001-013, 015-026, 028-036, 038-054, 101-999 (Continued) HAP 037****HAP 037**

The ILS frequency or GLS channel display shows the active ILS frequency or GLS channel and the selected course. If the ILS/GLS ground station transmits a morse coded station identifier, then the letter identifier replaces the numeric frequency/channel when the receiver captures the ground station signal.

For invalid ILS/GLS data, the CDS replaces the localizer scale and deviation indicator with the amber LOC flag when the localizer receiver fails. The amber G/S flag replaces the glideslope scale and pointer when the glideslope receiver fails.

HAP ALL**HAP 021-026, 028-054, 101-999****NCD Display**

For an ILS NCD condition, the CDS displays the localizer and glideslope scales and removes the deviation bar and glideslope pointer.

HAP ALL**Fail Display****HAP 001-013, 015-026, 028-036, 038-054, 101-999**

For invalid ILS data, the CDS replaces the localizer scale and deviation indicator with the amber LOC flag when the localizer receiver fails. The amber G/S flag replaces the glideslope scale and pointer when the glideslope receiver fails.

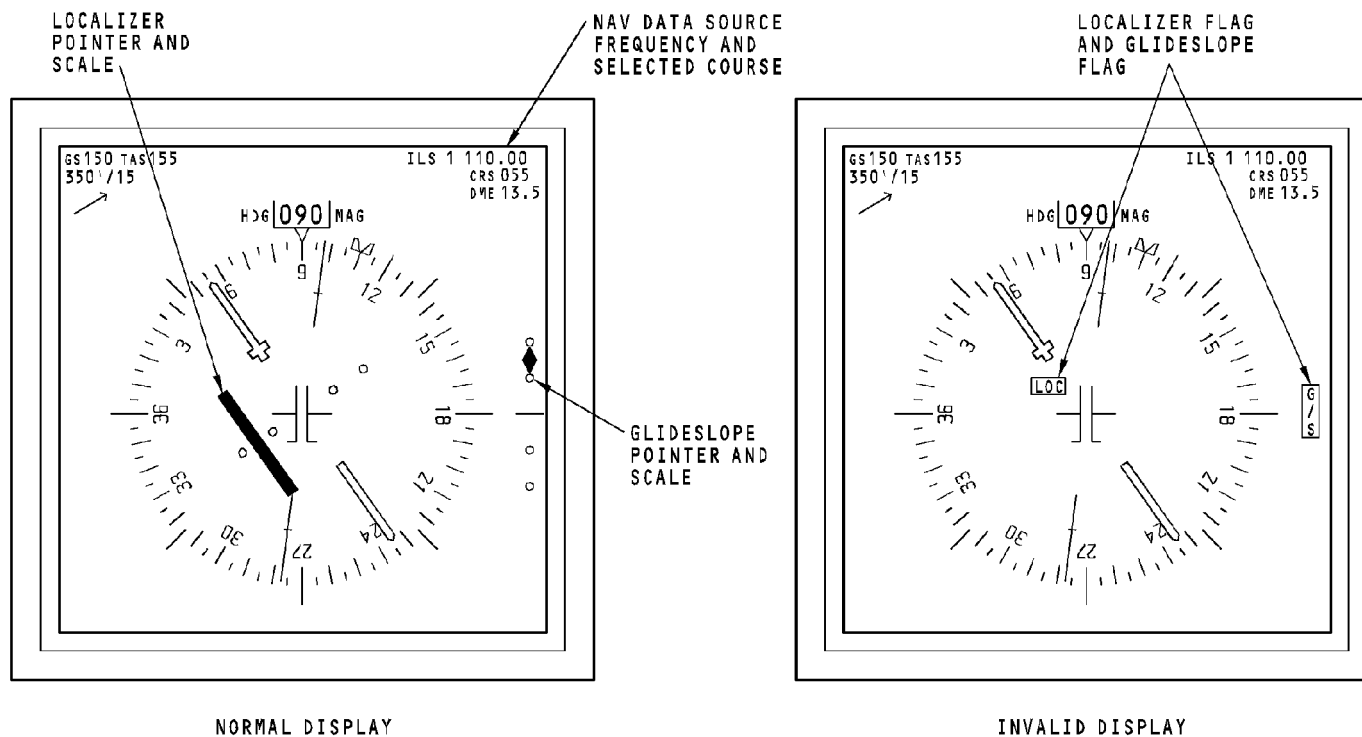

ILS - CENTERED ILS DISPLAY

34-31-00-019

EFFECTIVITY
HAP ALL

34-31-00

D633A101-HAP

Page 83
Feb 15/2009

ILS - FRONT PANEL BITE

HAP 001-013, 015-026, 028-036, 038-054, 101-999

Test

Push one of the two test switches on the front of the receiver to start a test of the MMR. The receiver does a check of the internal receiver operation and of its interfaces. The test results show on the LCD on the front of the receiver.

When you push the test switch, the test in progress page shows and the receiver does a self-test that continues for approximately five seconds. A five-second scale shows at the bottom of the page. You can monitor the test time by the line of Xs that show below the scale.

The TEST COMPLETE NO FAILURES display shows for a test pass condition. The TEST COMPLETE FAILURES display shows for a test fail condition.

These are the selections that can show above the receiver front panel switches during the test sequence:

- MAINT - this selection shows pages that contain program pin selections and discrete interface condition
- RETURN - this selection causes the display to go back to the start test page
- WHY? - this selection comes on when there are failures. You push this selection to show the failures

- MORE - this selection shows when there are more pages of data to follow.

HAP 037

Test

When you push the test switch, the MMR does a check of the internal operation and its interface with other airplane systems. The test takes approximately 44 seconds. This is the test sequence that shows on the LED status indicators during the test:

- 0 to 2 seconds - the LRU STATUS, the CONTROL FAIL, and the ANT FAIL LEDs come on red
- 2 to 4 seconds - the LRU STATUS LED is green and the CONTROL FAIL LED is red
- 4 to 16 seconds - all LEDs go off
- 16 to 44 seconds - test status shows.

The LRU STATUS segment shows red when there is an internal failure in the MMR. Green shows that the MMR is operating normally.

The CONTROL FAIL segment shows red when an interface to the MMR has a failure. Green shows that all the interfaces to the MMR are normal.

HAP ALL



34-31-00

D633A101-HAP

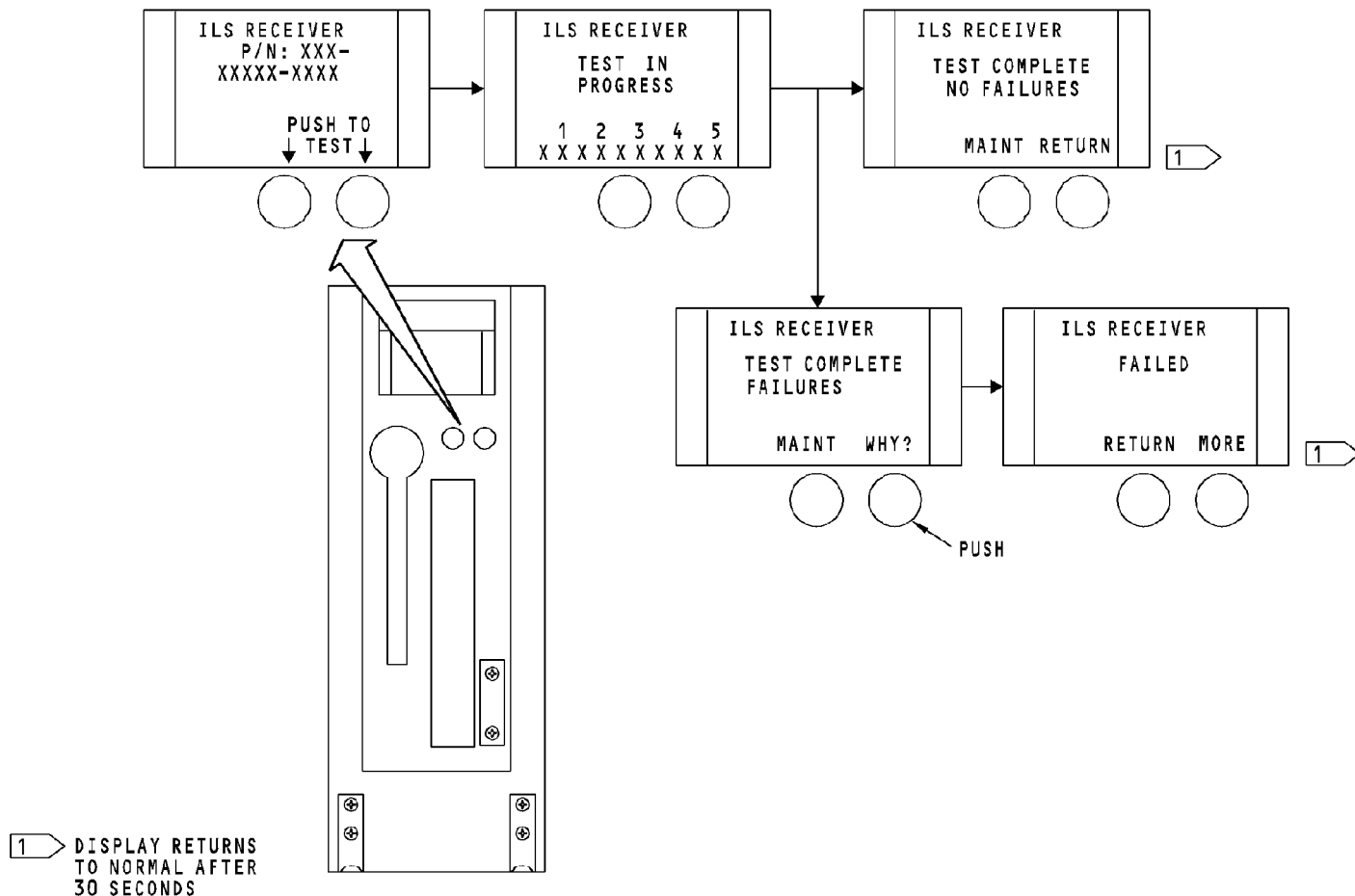

ILS - FRONT PANEL BITE

EFFECTIVITY

HAP 001-013, 015-026, 028-036, 038-054, 101-999

34-31-00

D633A101-HAP

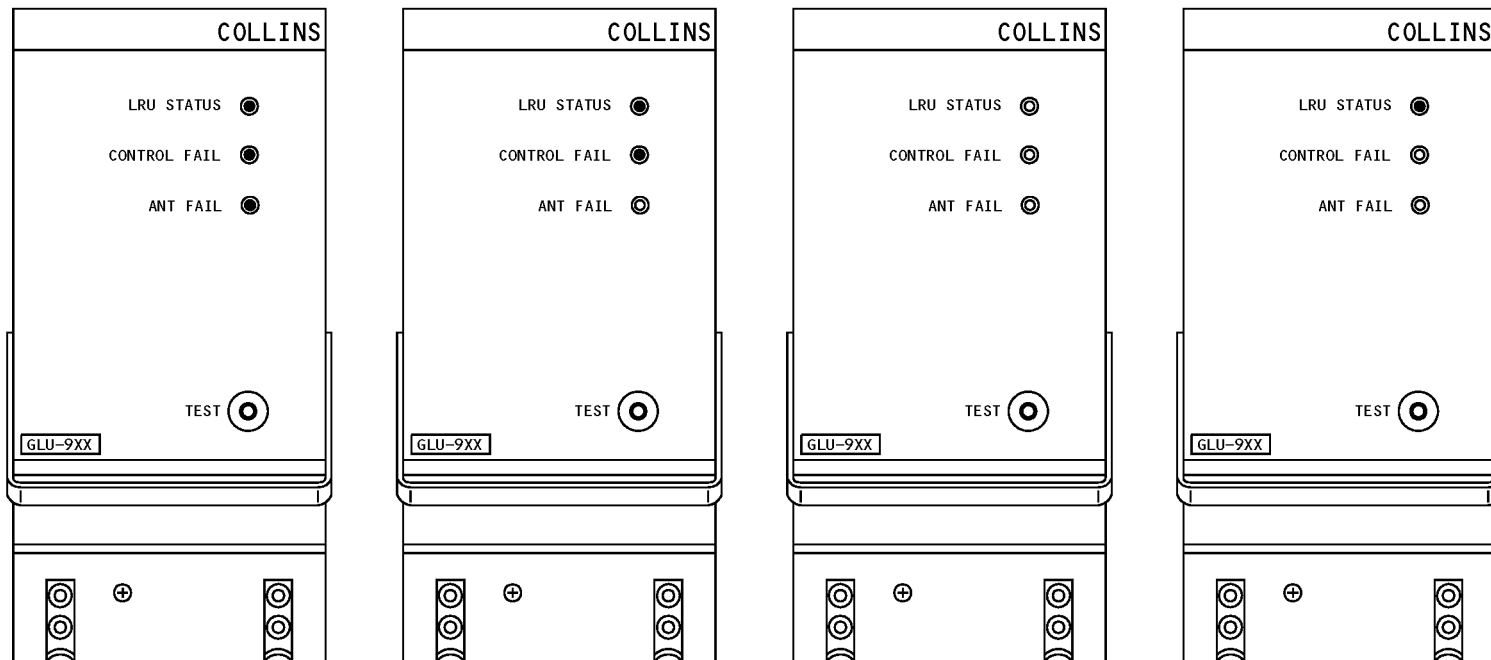

0-2 SECONDS
 THE LRU STATUS, CONTROL FAIL, AND ANT FAIL LEDS COME ON. (THE ANT FAIL LED COMES ON FOR THE LAMP TEST ONLY AND WILL REMAIN OFF FOR THE REST OF THE TEST).

2-4 SECONDS
 THE LRU STATUS IS GREEN AND THE CONTROL FAIL IS RED.

4-16 SECONDS
 THE LEDS GO OFF.

16-44 SECONDS
 THE TEST STATUS SHOWS.

ILS - FRONT PANEL BITE

EFFECTIVITY
 HAP 037

34-31-00

D633A101-HAP

THIS PAGE IS INTENTIONALLY LEFT BLANK

34-31-00

D633A101-HAP

Page 87
Jun 15/2008

ILS - SELF-TEST

Test

You use the NAV control panels to do an ILS test from the flight compartment. The captain NAV control panel does a test of MMR 1 and the first officer NAV control panel does a test of MMR 2.

HAP 037

You use the NAV control panels to do an GLS test from the flight compartment. The captain NAV control panel does a test of MMR 1 and the first officer NAV control panel does a test of MMR 2.

NOTE: Ground Based Augmentation System (GBAS) must be available to run the GLS test.

HAP ALL

You need to set these controls to do an ILS test:

- Enter a valid ILS frequency into the active frequency display window on the NAV control panel
- Set a course on the DFCS mode control panel that is within 90 degrees of the airplane heading
- Push the test switch on the NAV control panel.

HAP 037

You need to set these controls to do an GLS test:

- Enter a valid GLS channel into the active channel display window on the NAV control panel

- Set a course on the DFCS mode control panel that is within 90 degrees of the airplane heading
- Push the test button on the NAV control panel.

HAP ALL

To see the ILS test on the NAV display, you must select the approach (APP) mode on the EFIS control panel mode selector.

This is the display sequence that shows on the CDS during the ILS test:

HAP 037

To see the GLS test on the NAV display, you must select the approach (APP) mode on the EFIS control panel mode selector.

This is the display sequence that shows on the CDS during the GLS test:

HAP ALL

- For the first 3 seconds, one dot left of localizer deviation and one dot up of glideslope deviation
- For the next 3 seconds, one dot right of localizer deviation and one dot down of glideslope deviation
- Displays return to normal indications.

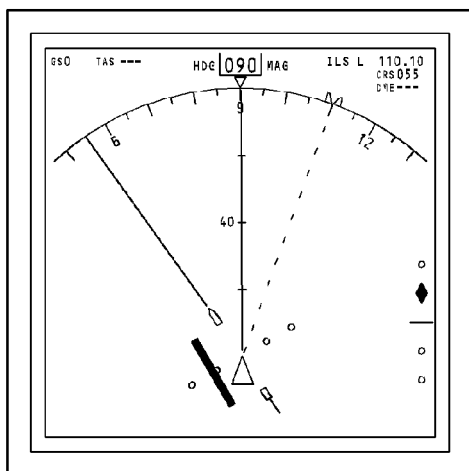
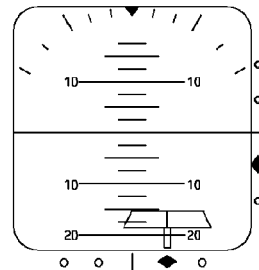
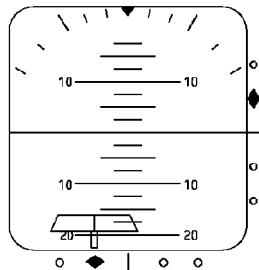

FIRST 3 SECONDS OF TEST

LOCALIZER = ONE DOT LEFT DISPLAY
GLIDESLOPE = ONE DOT UP DISPLAY

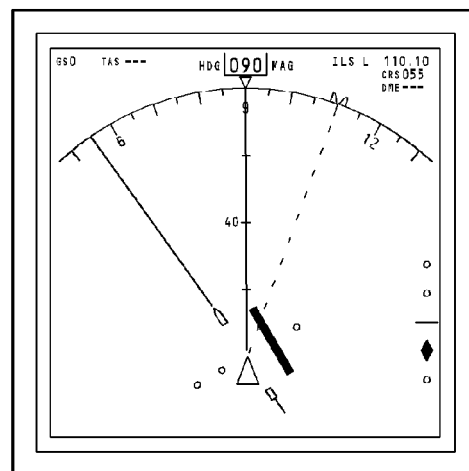

NEXT 3 SECONDS OF TEST

LOCALIZER = ONE DOT RIGHT DISPLAY
GLIDESLOPE = ONE DOT DOWN DISPLAY

ILS - SELF-TEST

34-31-00-021

EFFECTIVITY
HAP 037-054, 101-999

34-31-00

D633A101-HAP

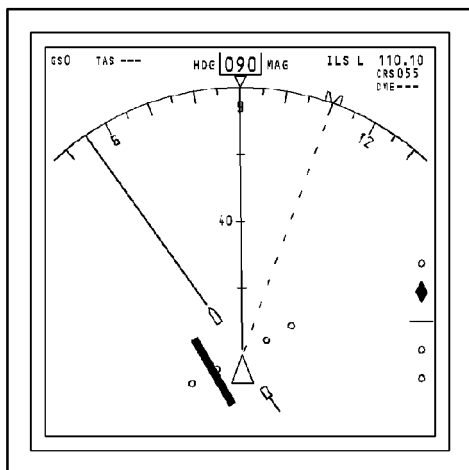
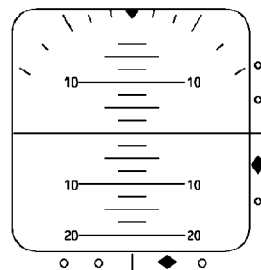
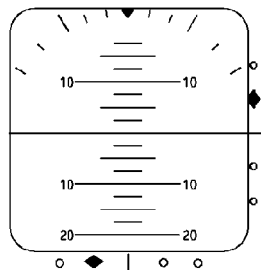

FIRST 3 SECONDS OF TEST

LOCALIZER = ONE DOT LEFT DISPLAY
GLIDESLOPE = ONE DOT UP DISPLAY

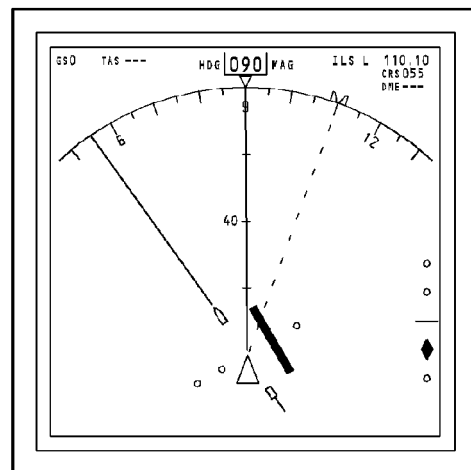

NEXT 3 SECONDS OF TEST

LOCALIZER = ONE DOT RIGHT DISPLAY
GLIDESLOPE = ONE DOT DOWN DISPLAY

ILS - SELF-TEST

EFFECTIVITY

HAP 001-013, 015-026, 028-036

34-31-00

D633A101-HAP

THIS PAGE IS INTENTIONALLY LEFT BLANK

34-31-00

D633A101-HAP

Page 91
Feb 15/2009



ILS - SYSTEM SUMMARY

General

This page is for reference.

34-31-00-022

EFFECTIVITY
HAP ALL

34-31-00

D633A101-HAP

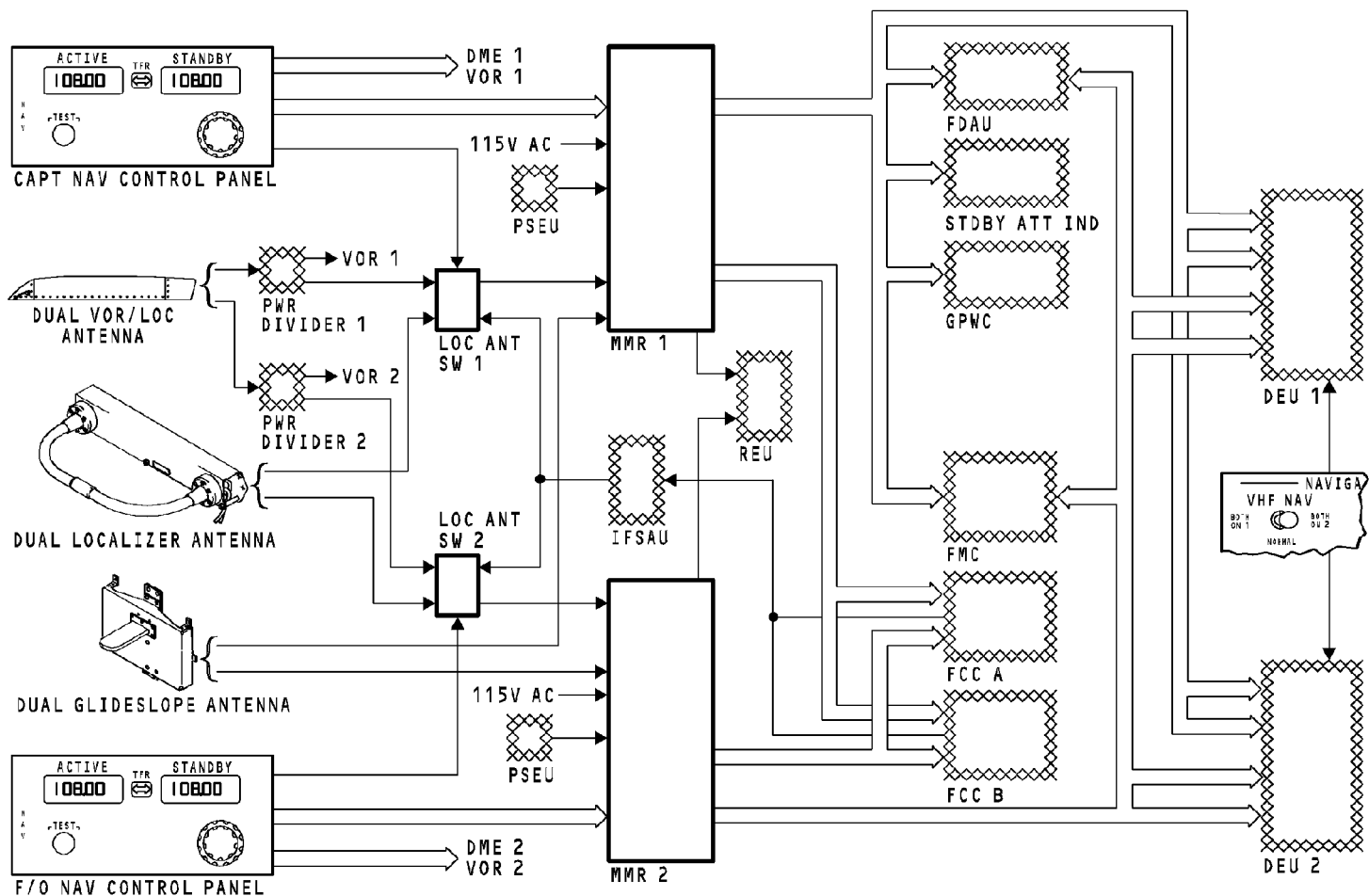

ILS - SYSTEM SUMMARY

34-31-00-022

EFFECTIVITY
 HAP 001-013, 015-026, 028-030

34-31-00

D633A101-HAP

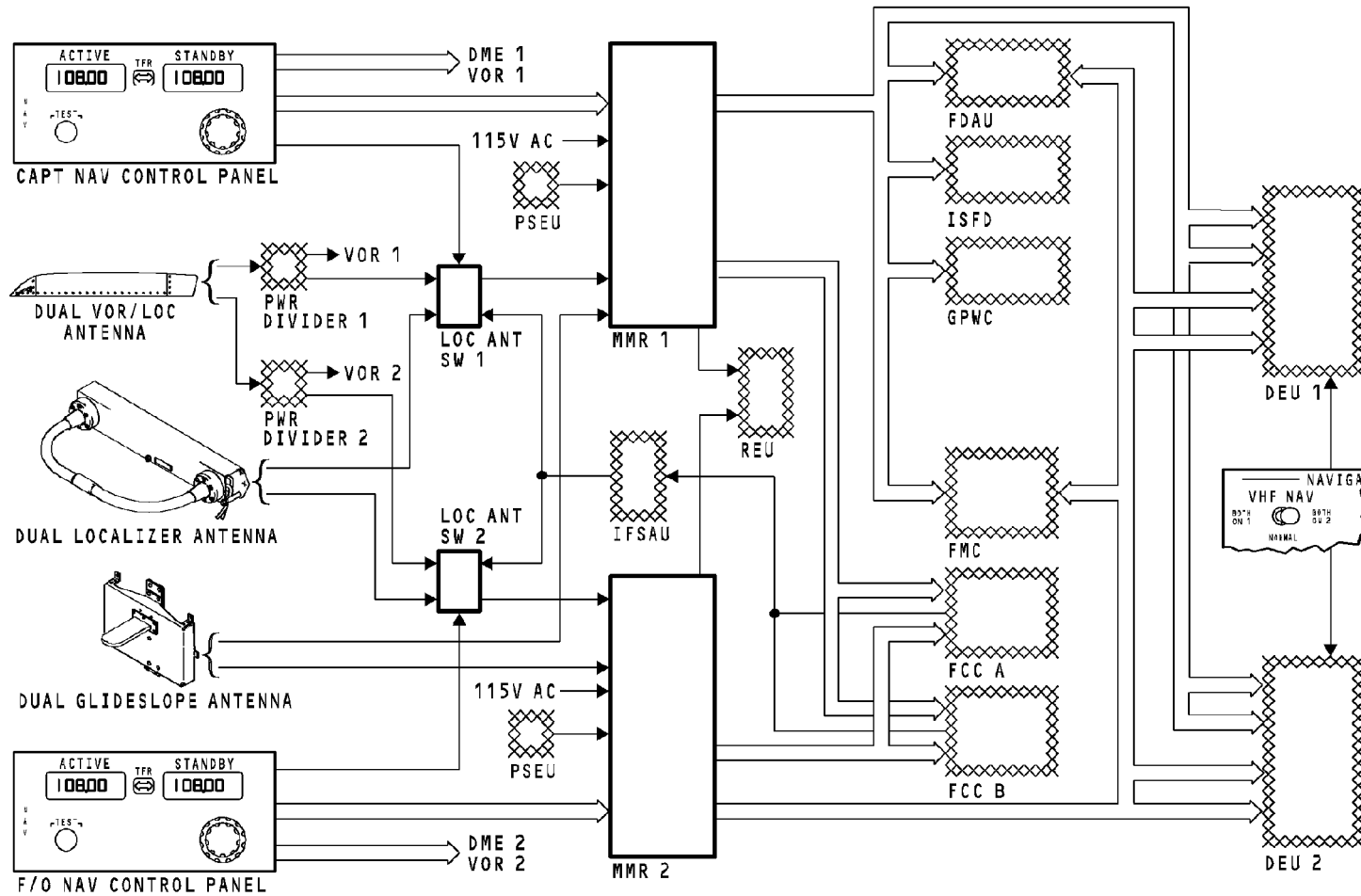

ILS - SYSTEM SUMMARY

EFFECTIVITY
HAP 031-036

34-31-00

34-31-00-022

D633A101-HAP

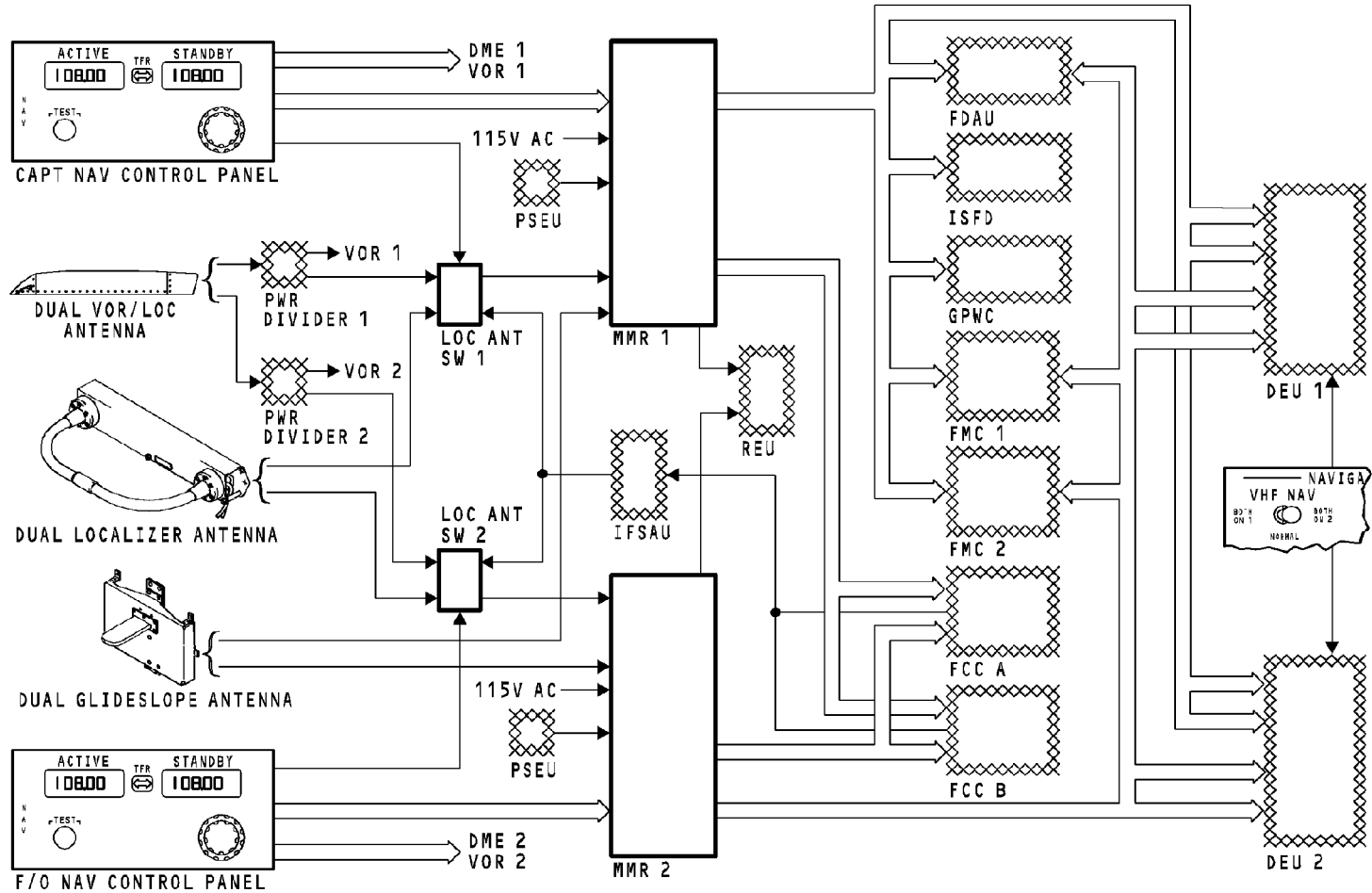

ILS - SYSTEM SUMMARY

34-31-00-022

EFFECTIVITY
HAP 038-054, 101-999

34-31-00

D633A101-HAP

Page 95
Feb 15/2009

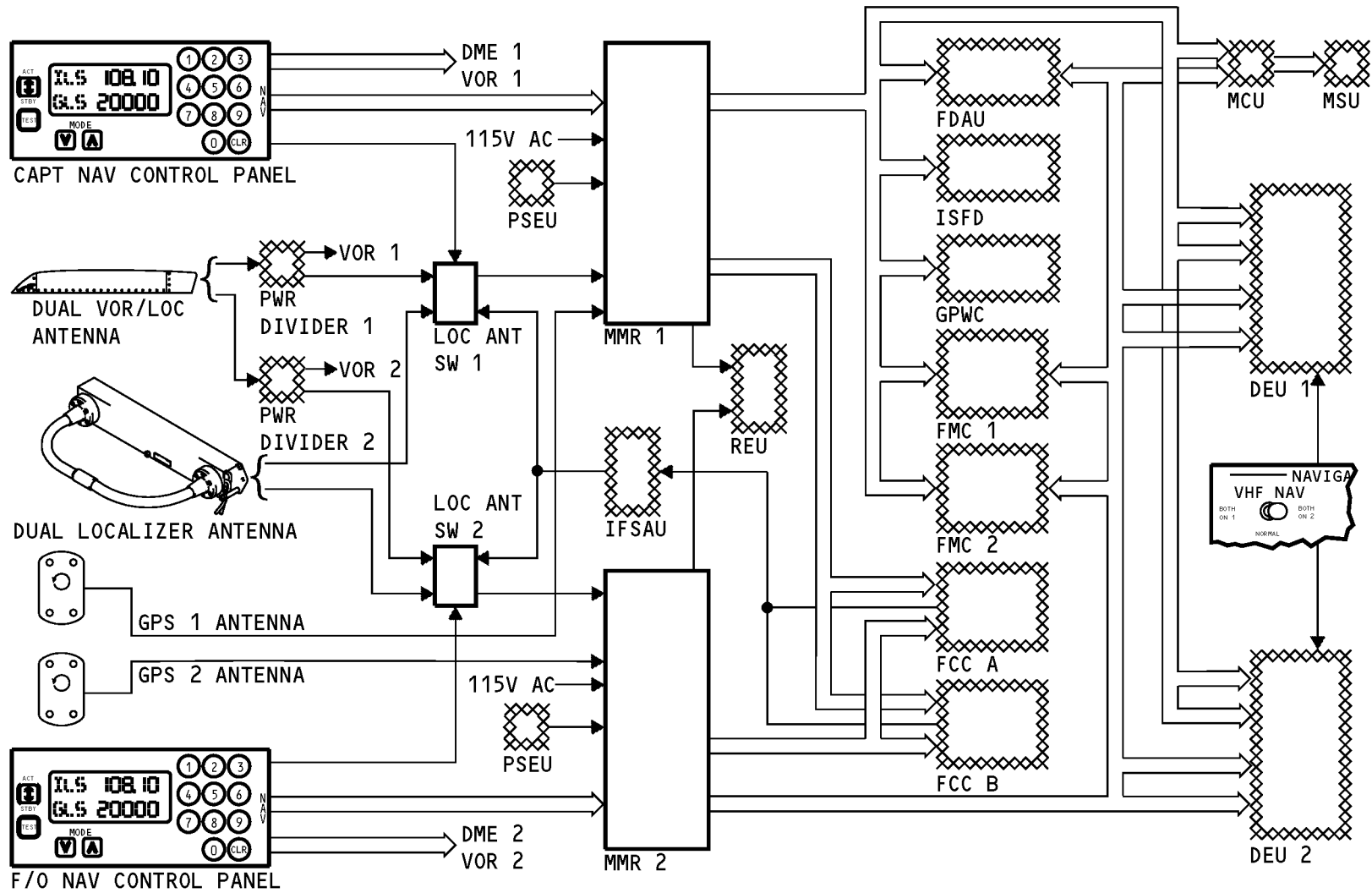

ILS - SYSTEM SUMMARY

EFFECTIVITY
HAP 037

34-31-00

34-31-00-022

D633A101-HAP

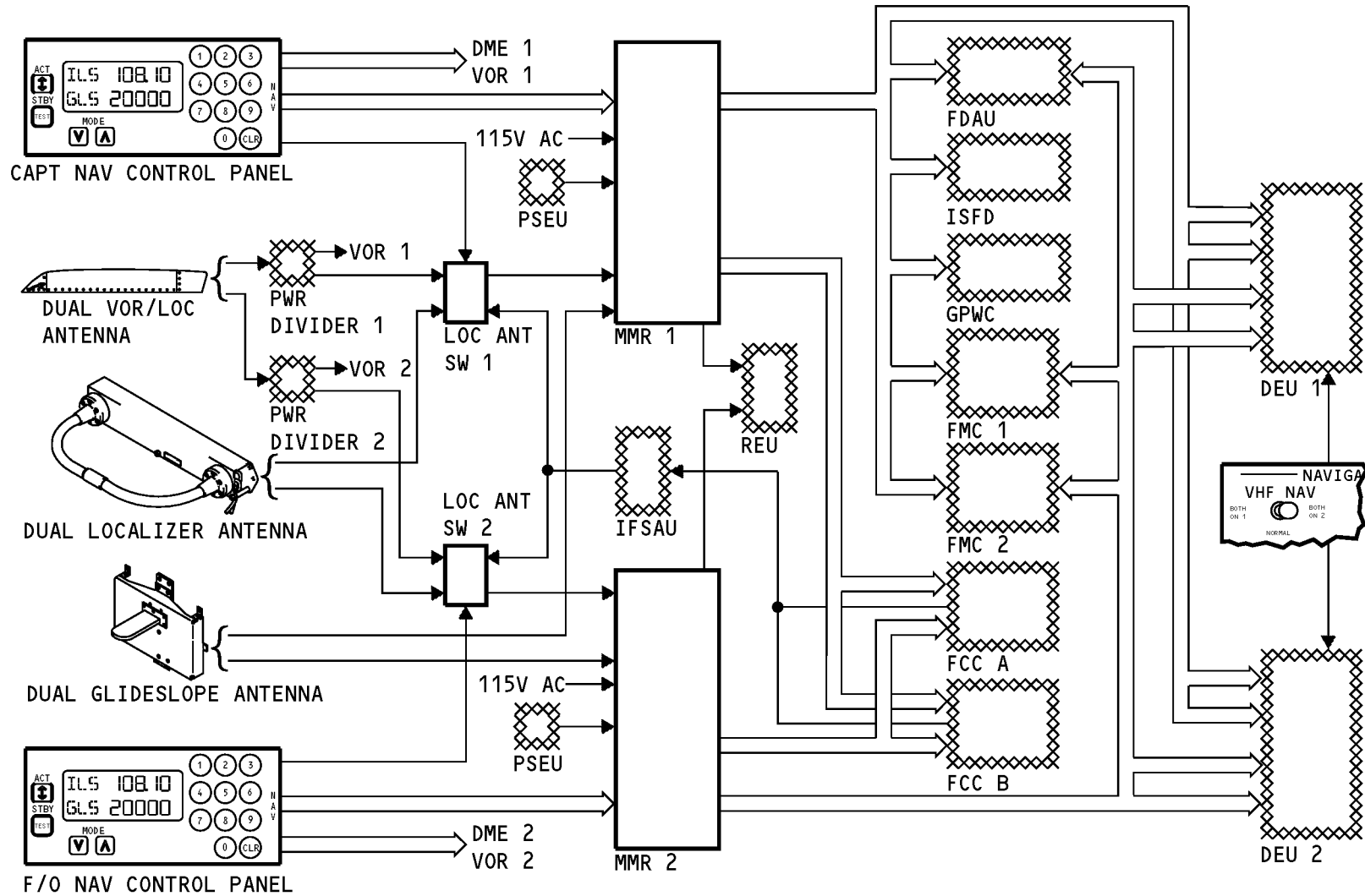

ILS - SYSTEM SUMMARY

34-31-00-022

EFFECTIVITY
HAP 037

34-31-00

D633A101-HAP

Page 97
Feb 15/2009

THIS PAGE IS INTENTIONALLY LEFT BLANK

34-32-00

D633A101-HAP

Page 1
Oct 10/2002

MARKER BEACON SYSTEM - INTRODUCTION

General

The marker beacon system supplies visual and aural indications when the airplane flies over airport runway marker beacon transmitters.

Abbreviations and Acronyms

- A/P - autopilot
- AC - alternating current
- ACP - audio control panel
- ALT - alternate
- AMP - amplifier
- B - both
- BITE - built-in test equipment
- CDS - common display system
- DEU - display electronics unit
- DME - distance measuring equipment
- FDAU - flight data acquisition unit
- DU - display unit
- FT - functional test
- GND - ground
- Hz - hertz
- I/C - intercom
- ILS - instrument landing system
- IM - inner marker
- I/O - input/output
- LCD - liquid crystal display
- LED - light emitting diode
- LRU - line replaceable unit
- MAINT - maintenance
- MB - marker beacon
- MHz - mega hertz
- MM - middle marker
- NAV - navigation
- NC - not connected
- ND - navigation display
- NORM - normal
- NVM - non-volatile memory
- OM - outer marker
- PFD - primary flight display
- R - range
- REU - remote electronics unit
- RF - radio frequency
- R/T - receive/transmit
- RCVR - receiver
- STA - station
- TFR - transfer
- V - voice
- V - volt
- VHF - very high frequency
- VOR - vhf omnidirectional ranging

EFFECTIVITY

HAP ALL

34-32-00

D633A101-HAP

Page 2
Oct 10/2002

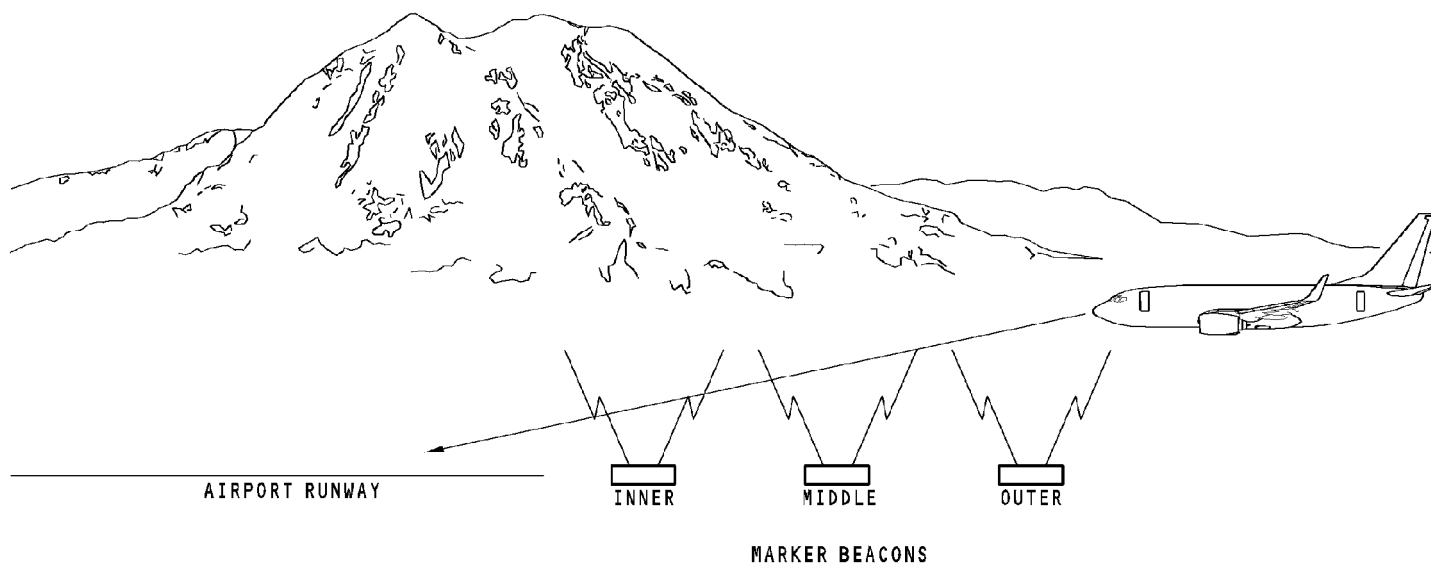

MARKER BEACON SYSTEM - INTRODUCTION

EFFECTIVITY
HAP ALL

34-32-00

D633A101-HAP

34-32-00-001

MARKER BEACON SYSTEM - GENERAL DESCRIPTION**General**

The marker beacon system has an antenna and a VOR/marker beacon (VOR/MB) receiver. The marker beacon function only operates in the VOR/MB receiver 1 position.

Operation

The marker beacon antenna receives the marker beacon signals. The signals go to the VOR/MB receiver 1. The VOR/MB receiver 1 supplies this data:

- Marker beacon audio to the remote electronics unit (REU)
- Marker beacon data to the common display system (CDS) display electronics unit (DEU)
- Marker beacon data to the flight data acquisition unit (FDAU).

The displays show marker beacon data.

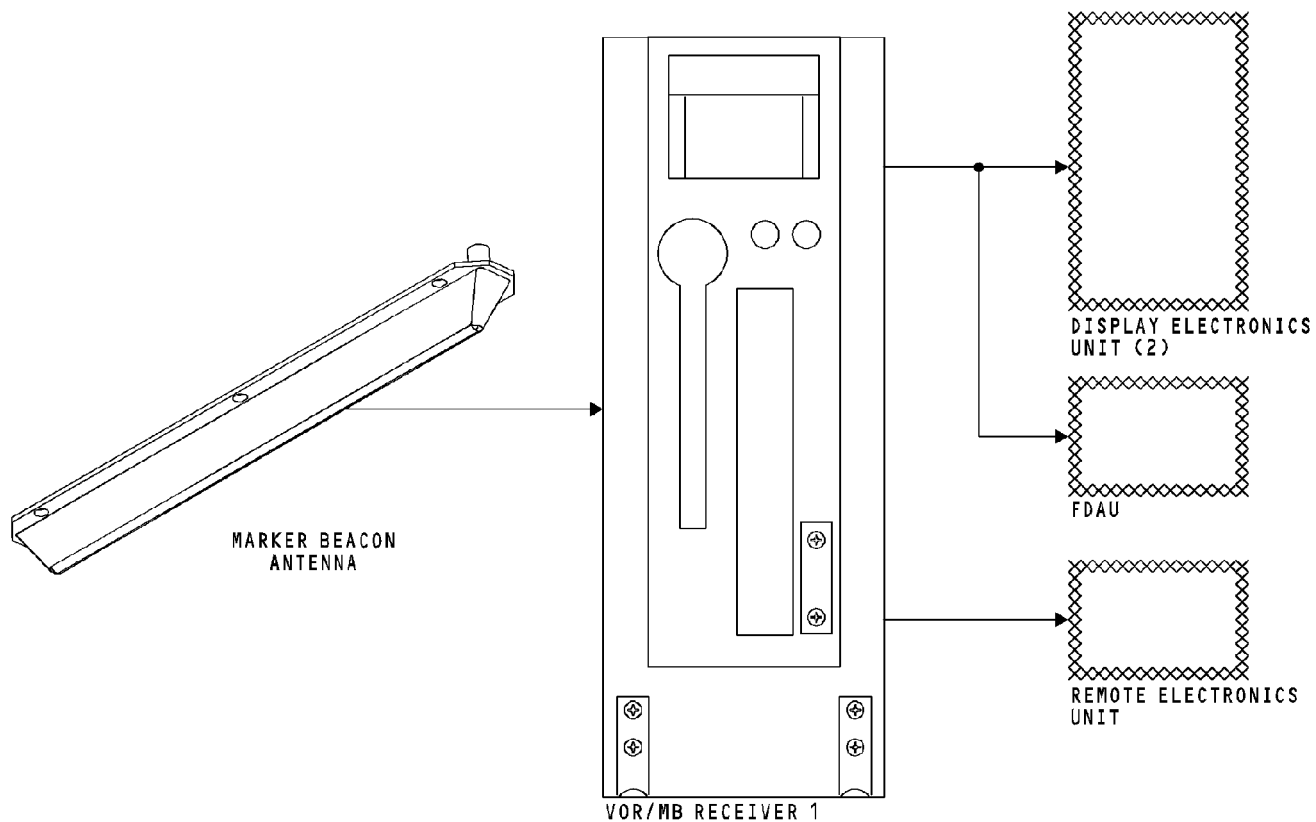

MARKER BEACON SYSTEM - GENERAL DESCRIPTION

34-32-00-002

EFFECTIVITY
HAP ALL

34-32-00

D633A101-HAP

MARKER BEACON SYSTEM - COMPONENT LOCATIONS

General

The marker beacon antenna is on the bottom of the fuselage.

The VOR/MB receiver 1 is in the electronic equipment compartment E1-2.

The marker beacon data shows on these display units:

- Left outboard display unit
- right outboard display unit.

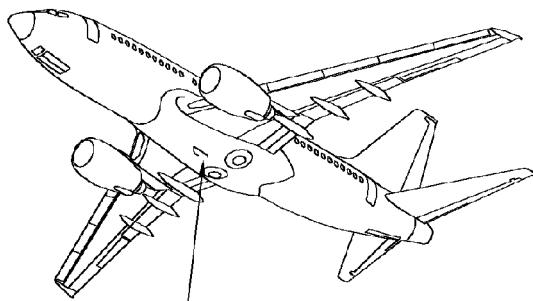

MARKER BEACON ANTENNA
(STA 610, BL 0)

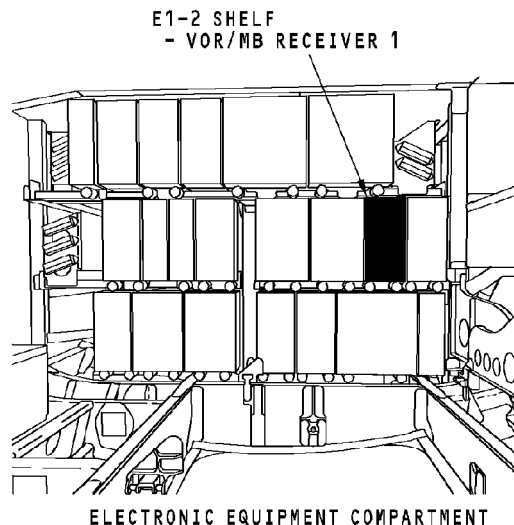
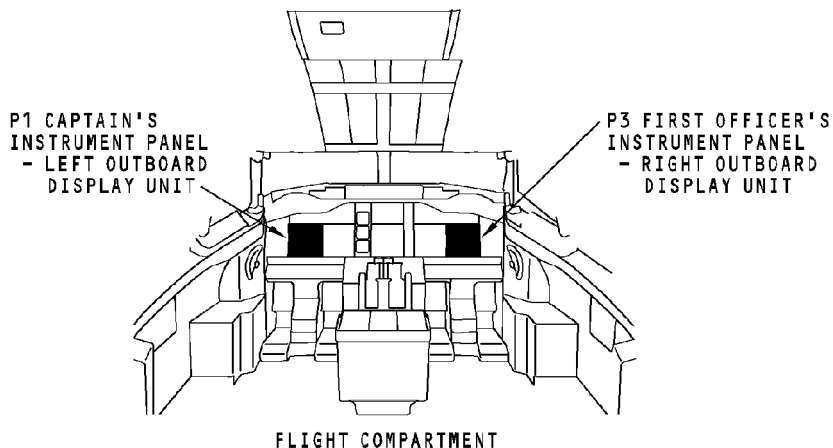

MARKER BEACON SYSTEM - COMPONENT LOCATIONS

34-32-00-003

EFFECTIVITY
HAP ALL

34-32-00

D633A101-HAP

MARKER BEACON SYSTEM - INTERFACES**Power**

The VOR/marker beacon (VOR/MB) receiver 1 uses 115v ac power from the standby bus.

Antenna Interface

The marker beacon antenna sends radio frequency (RF) signals to the VOR/MB receiver 1.

PSEU

The proximity switch electronics unit (PSEU) supplies an air/ground discrete signal to the VOR/MB receiver 1. The VOR/MB receiver uses this signal for these functions:

- Prevent a test in the air
- Count flight legs.

Audio Interface

The VOR/MB receiver 1 sends marker beacon audio to the remote electronics unit (REU). The REU supplies marker beacon audio to the flight compartment.

Marker Beacon Data

The VOR/MB receiver 1 supplies marker beacon data to the 1 and 2 common display system (CDS) display electronics units (DEU). The receiver also supplies marker beacon data to the FDAU.

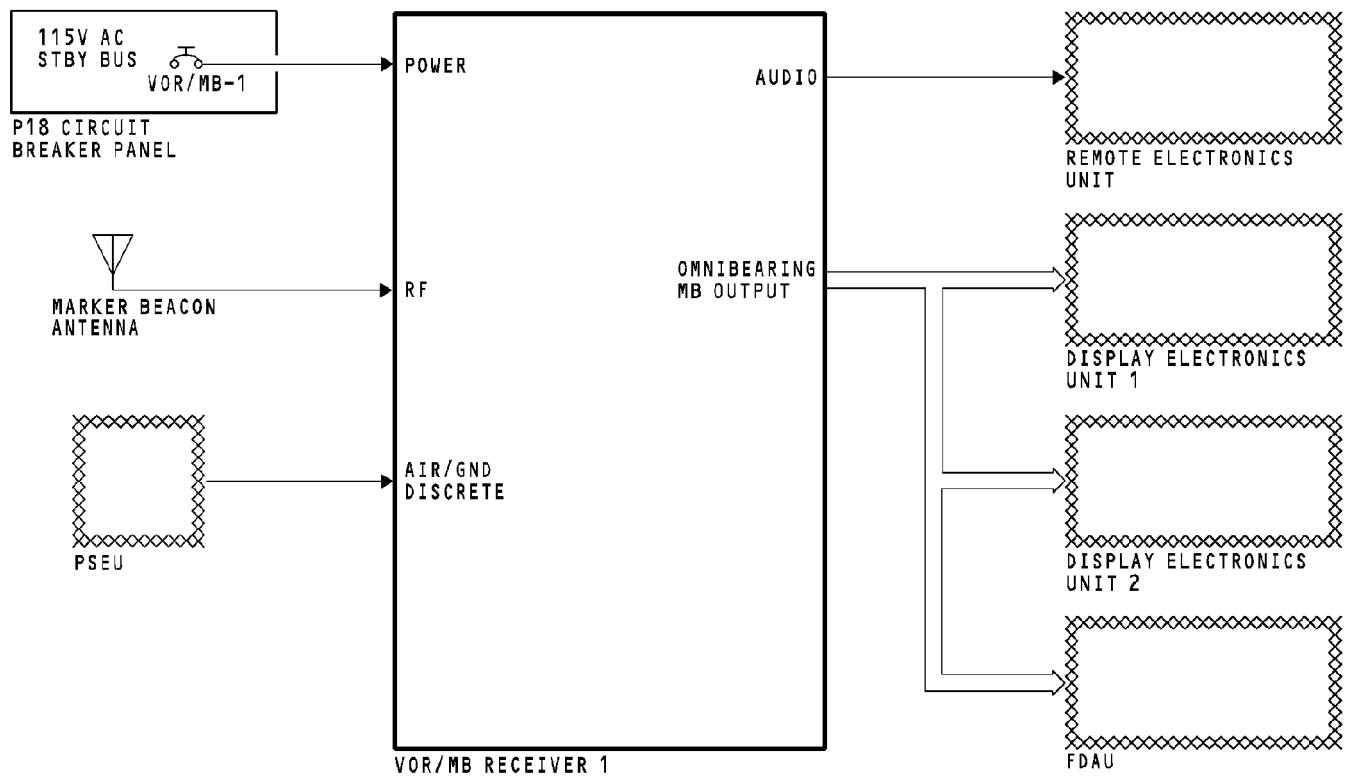

MARKER BEACON SYSTEM - INTERFACES

34-32-00-004

EFFECTIVITY
HAP ALL

34-32-00

D633A101-HAP

MARKER BEACON SYSTEM - VOR/MARKER BEACON RECEIVER**General**

The VOR/marker beacon (VOR/MB) receiver has these two parts:

- VOR receiver
- Marker beacon receiver.

The marker beacon system operates in the VOR/MB receiver 1 position. The marker beacon receiver receives 75 MHz signals.

Test and Indications

You do a test of the these VOR/MB receiver 1 functions at the same time:

- VOR function
- MB function.

There are two switches and a liquid crystal display (LCD) on the front panel of the VOR/MB receiver. You use one of the two switches to start a test of the VOR/MB receiver. The LCD shows the test results.

Software Loading

There is a memory card slot on the front of the VOR/MB receiver. Shop personnel put a flash memory card into the slot which loads software into the LRU. The memory card can also keep LRU condition data sent by the LRU during operation. These features are not for use by line maintenance personnel.

Shop personnel use the RS 232 connector to connect shop test equipment to the LRU. This feature is not for use by line maintenance personnel.

Flight Fault Memory

The VOR/MB receiver has a nonvolatile flight fault memory. Maintenance personnel can read the memory.

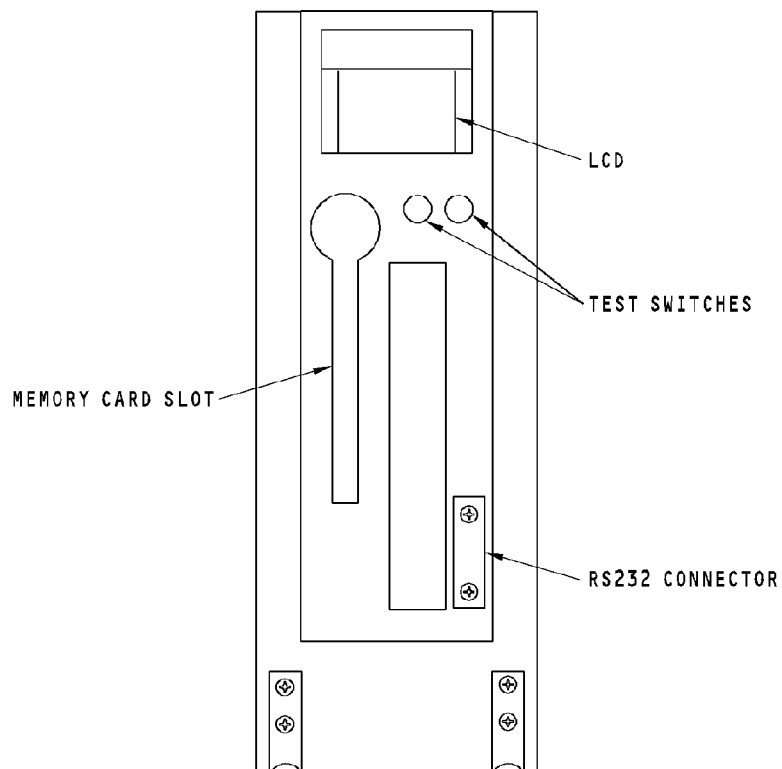

MARKER BEACON SYSTEM - VOR/MARKER BEACON RECEIVER

34-32-00-005

EFFECTIVITY
HAP ALL

34-32-00

D633A101-HAP

MARKER BEACON SYSTEM - MARKER BEACON ANTENNA

General

The marker beacon antenna receives signals from marker beacon ground stations.

Six screws hold the antenna to the fuselage.

34-32-00-006

EFFECTIVITY
HAP ALL

34-32-00

D633A101-HAP

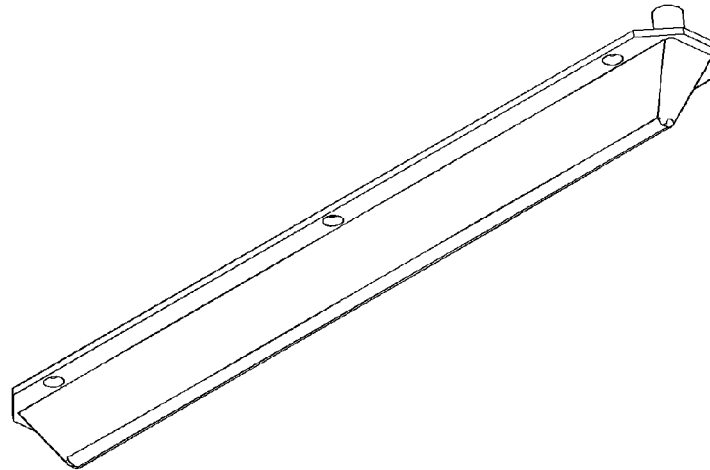

MARKER BEACON SYSTEM - MARKER BEACON ANTENNA

34-32-00-006

EFFECTIVITY
HAP ALL

34-32-00

D633A101-HAP

MARKER BEACON SYSTEM - DISPLAYS AND AUDIO OUTPUTS

General

When the airplane goes above a marker beacon transmitter, marker beacon data shows on the primary flight display (PFD).

If you want to hear marker beacon audio, you select the marker beacon audio on the audio control panel (ACP).

Display Types

OM shows when the airplane goes above the outer marker. The OM letters are cyan.

MM shows when the airplane goes above the middle marker. The MM letters are yellow.

IM shows when the airplane goes above the inner marker, backcourse marker, or an airways marker. The letters IM are white.

NCD/Fail Display

If marker beacon data fails or is no computed data (NCD), the display does not show.

Audio General

The ACP supplies control signals to the remote electronics unit (REU). The REU uses the control signals to select the audio that goes to the flight interphone speakers and headsets.

Use the ACP to listen to marker beacon audio.

Audio Operation

You make these ACP selections to listen to marker beacon audio:

- Push the marker beacon receiver volume control to make the marker beacon audio come on
- Turn the marker beacon receiver volume control to change the volume level.

Audio Outputs

These are the marker beacon audio outputs:

- Outer marker (OM) is 400 Hz, continuous dashes (- - - -)
- Middle marker (MM) is 1300 Hz, alternate dots and dashes (- .-.-.-)
- Inner marker (IM) is 3000 Hz, continuous dots (.....)
- Backcourse marker is 3000 Hz, continuous paired dots (..)
- Airways marker is 3000 Hz with the morse code. identifier for that station.

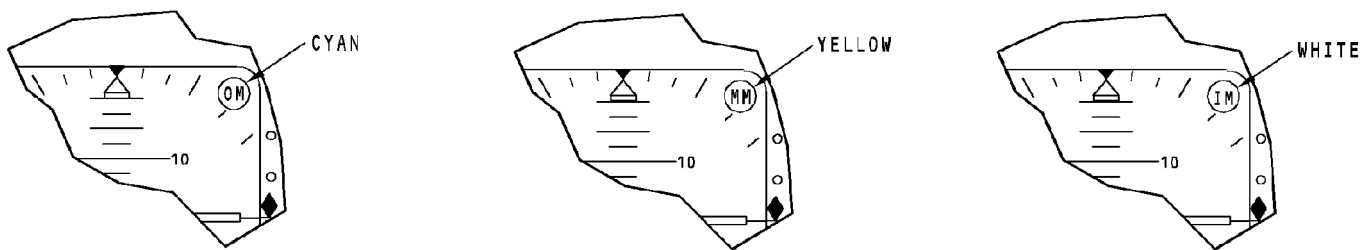

MARKER BEACON DISPLAYS (PFD)

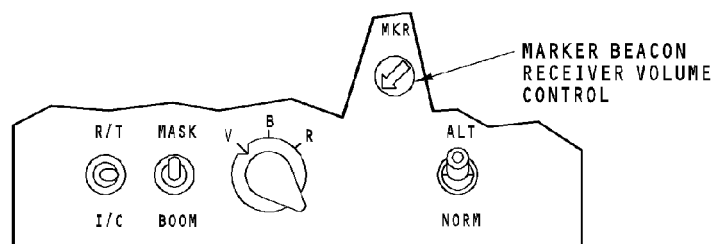

AUDIO CONTROL PANEL



MARKER BEACON AUDIO OUTPUTS

MARKER BEACON SYSTEM - DISPLAYS AND AUDIO OUTPUTS

34-32-00-007

EFFECTIVITY
HAP ALL

34-32-00

D633A101-HAP

MARKER BEACON SYSTEM - FUNCTIONAL DESCRIPTION**Marker Beacon Signal**

The marker beacon antenna receives the 75 MHz signal and sends it to a 75 MHz filter in the VOR/marker beacon (VOR/MB) receiver 1. This filter tunes and rejects unwanted signals. The output goes to a radio frequency (RF) amplifier. A detector receives the amplifier output and sends the demodulated signal to three bandpass filters.

The bandpass filters are at 400 Hz, 1300 Hz, and 3000 Hz. The filters send the signals to an audio amplifier and to an input/output (I/O) card. The audio amplifier sends audio tones to the REU. The I/O card sends data to the DEU and the flight data acquisition unit (FDAU).

The DEU shows marker beacon data on the PFDs.

Monitor and Test

The test switches start a test of the VOR/MB receiver. The BITE circuits do a test of the VOR/MB receiver. The results of the test show on the common display, unit LCD, and through the flight interphone speakers and headsets.

During the test, a self-test frequency generator gives a 75 MHz RF signal that has 400 Hz, 1300 Hz, and 3000 Hz audio signals. The bandpass filters find the audio signals and send them to the audio amplifier. The audio amplifier sends the audio signals to the REU. The REU sends the audio signals to the flight interphone speakers and headsets in the flight deck.

The BITE circuits monitor the condition of the output data of the VOR/MB receiver.

PSEU

The VOR/MB receiver gets an air/ground discrete signal from the proximity switch electronics unit (PSEU). The VOR/MB receiver uses this signal to prevent a test in the air.

An internal nonvolatile fault memory (NVM) in the BITE circuits use the air/ground discrete signal. The NVM uses this signal to calculate flight legs.

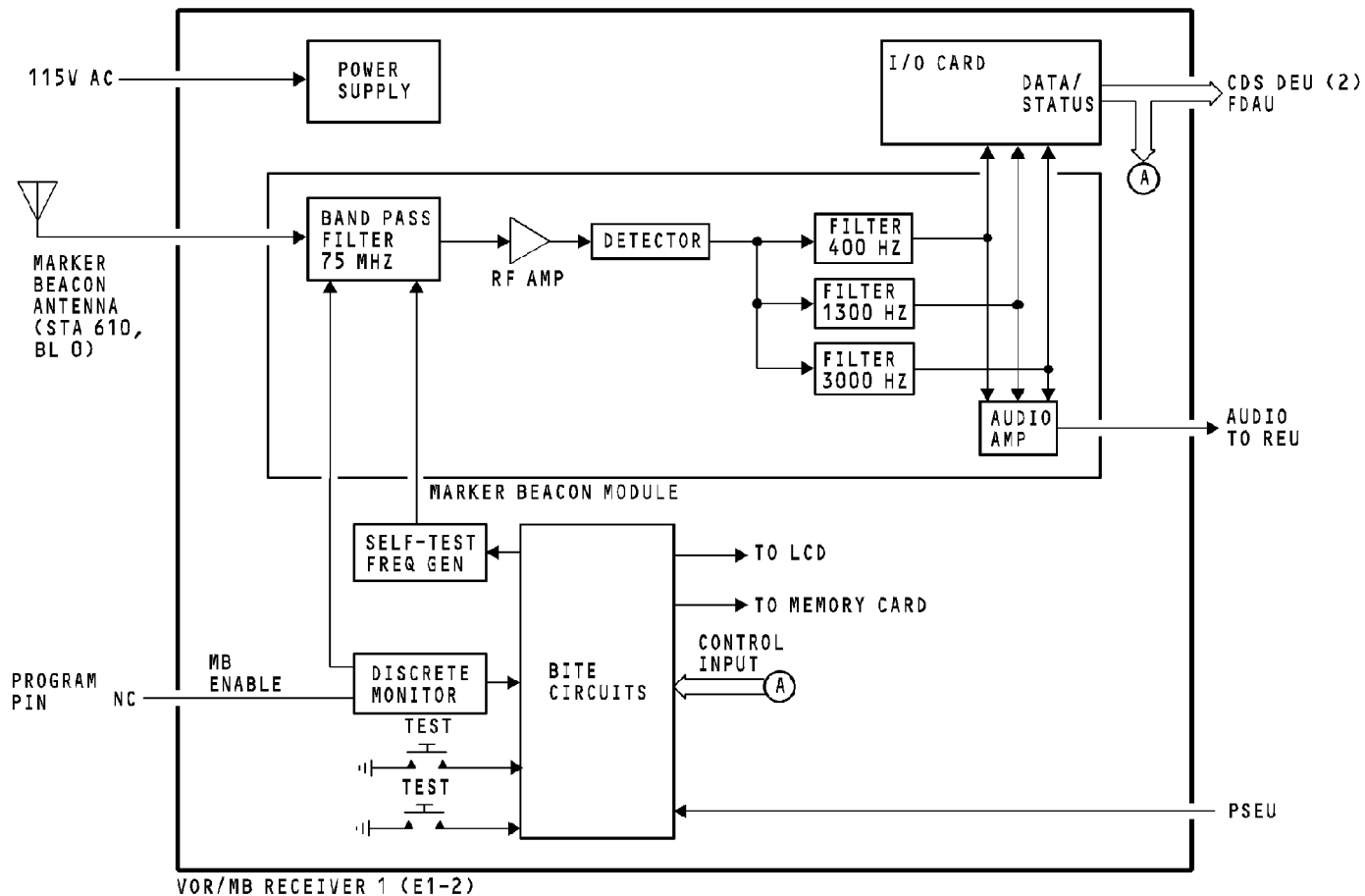

MARKER BEACON SYSTEM - FUNCTIONAL DESCRIPTION

EFFECTIVITY
HAP ALL

34-32-00

D633A101-HAP

34-32-00-008

MARKER BEACON SYSTEM - TEST - 1**General**

When you do a test of the marker beacon system, you test the VOR receiver 1 at the same time.

Operation

Push one of the test switches on the front of the receiver to start a test of the VOR/MB receiver 1. The receiver then does a check of the internal receiver operation and of the interfaces. The test results show on the LCD.

When you push the test switch, the test in progress page shows and the receiver goes through a self test that lasts approximately five seconds. A five-second scale shows at the bottom of the page. You can monitor the test time by the line of Xs that show below the scale.

The TEST COMPLETE NO FAILURES display shows for a test pass condition. The TEST COMPLETE FAILURES display shows for a test fail condition.

These are the selections that can show above the receiver front panel switches during the test sequence:

- MAINT - this selection shows pages that contain program pin selections and discrete interface status
- RETURN - this selection causes the display to go back to the start test page

- WHY? - this selection comes on when there are failures. Push this selection to show the failures
- MORE - this selection shows any time there are more pages of data to follow.

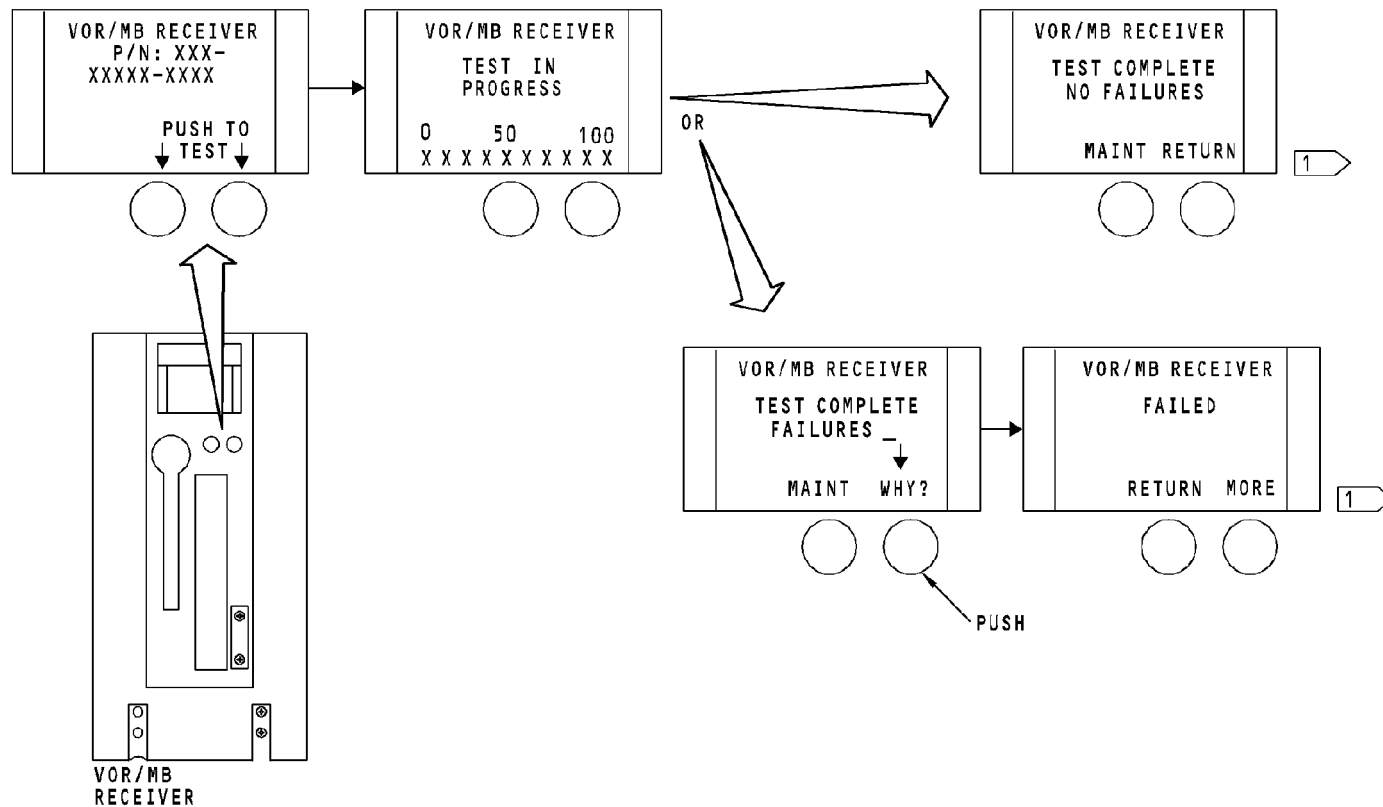

1 DISPLAY RETURNS TO NORMAL AFTER 30 SECONDS

MARKER BEACON SYSTEM - TEST - 1

EFFECTIVITY
HAP ALL

34-32-00

D633A101-HAP

MARKER BEACON SYSTEM - TEST - 2

General

You do a remote test of the navigation receivers with the navigation control panel. The navigation control panel does a test of these receivers:

- VOR/MB receiver
- ILS receiver.

When you do a test of the marker beacon system, you do a test of the VOR/MB receiver 1 at the same time.

Operation

To do a test of the VOR/MB receiver 1, select a VOR frequency and push the test switch on the front panel of the navigation control panel. FT shows for common display system indications.

You must select marker beacon audio on at least one of the ACPs to hear the audio tones. All the marker beacon audio tones come on in the flight compartment when you do the test. The audio tones come on continuously and you hear the outer, middle, and inner at the same time.

PUSH TEST SWITCH
WITH VOR FREQUENCY
SELECTED TO START A TEST

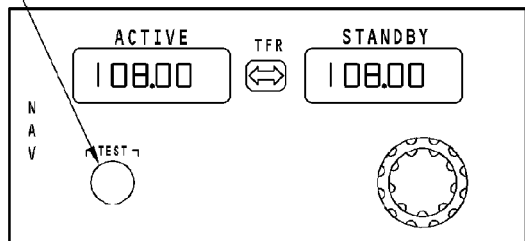

CAPTAIN NAVIGATION CONTROL PANEL

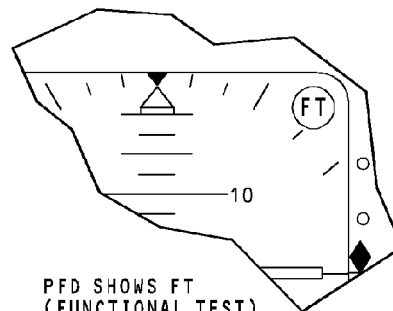

PFD SHOWS FT
(FUNCTIONAL TEST)
WHEN THE VOR/MB
RECEIVER 1
IS IN TEST

ALL MARKER
BEACON AUDIO
TONES COME ON
CONTINUOUSLY
IN THE FLIGHT
COMPARTMENT DURING
THE TEST



MARKER BEACON SYSTEM - TEST - 2

34-32-00-010

EFFECTIVITY
HAP ALL

34-32-00

D633A101-HAP

RADIO ALTIMETER SYSTEM - INTRODUCTION**General**

The radio altimeter (RA) system measures the vertical distance from the airplane to the ground. The radio altitude shows in the flight compartment on the display units (DU). The radio altitude is computed with the receiver transmitter unit by comparing the transmitted signal to the received signal. The R/T unit transmits a radio signal then receives the reflected RF signal back from the ground to determine the altitude of the aircraft. The R/T sends computed altitude data out on two ARINC 429 data buses to user systems on the aircraft.

The flight crew and other airplane systems use the altitude data during low altitude flight, approach, and landing.

The system has a range of -20 to 2500 feet.

An adjustable radio minimums alert operates with the radio altitude system and is independently selectable from 0 to 999 feet on the captains and first officers EFIS control panels. The radio minimums altitude selection is compared and processed in the display electronics units (DEUs) with the existing radio altitude value output from the radio altitude R/T. When the airplane descends to the selected radio minimums altitude a flashing radio minimums alert is displayed on the applicable DU.

Abbreviations and Acronyms

- ADI - attitude direction indication

- AID - aircraft installed delay
- altm - altimeter
- ant - antenna
- approx - approximately
- ARINC - Aeronautical Radio, Inc.
- BITE - built-in test equipment
- CAPT - captain
- CDS - common display system
- conn - connector
- CP - control panel
- CW - continuous wave
- DEU - display electronics unit
- DH - decision height
- DME - distance measuring equipment
- DU - display unit
- EFIS - electronic flight instrument system
- F - frequency
- FCC - flight control computer
- FDAU - flight data acquisition unit
- FM - frequency modulation
- F/O - first officer
- freq - frequency
- fwd - forward
- gnd - ground
- GPWC - ground proximity warning computer
- ILS - instrument landing system
- LCD - liquid crystal display
- LED - light emitting diode
- LRU - line replaceable unit
- maint - maintenance
- MDA - minimum descent altitude
- mins - minimums

RADIO ALTIMETER SYSTEM - INTRODUCTION

- PFD - primary flight display
- P/N - part number
- RA - radio altimeter
- RA - radio altitude
- rec - receiver
- RF - radio frequency
- rst - reset
- R/T - receiver transmitter
- S/W - software
- sys - system
- T - time
- TCAS - traffic alert and collision avoidance system
- VCO - voltage controlled oscillator
- WXR - weather radar
- xmit - transmit

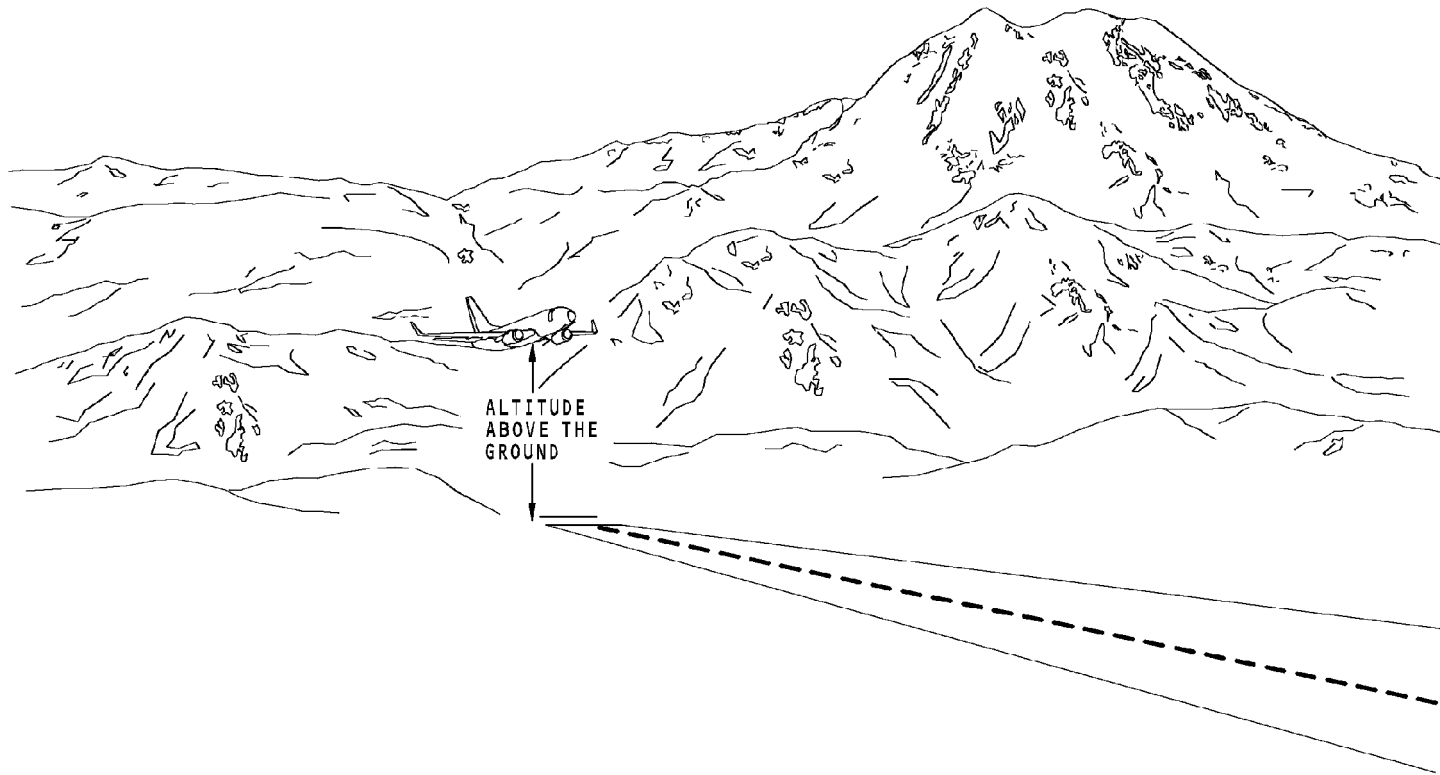

RADIO ALTIMETER SYSTEM - INTRODUCTION

EFFECTIVITY
HAP ALL

34-33-00

D633A101-HAP

Page 3
Oct 10/2004

34-33-00-001

RA SYSTEM - GENERAL DESCRIPTION**General**

The radio altimeter system has two receiver/transmitters (R/Ts). Each R/T has a transmit and a receive antenna. The radio altimeter R/T makes a frequency modulated continuous wave RF signal that is sent to the ground and reflected back to the airplane. The time that it takes for the signal to travel from the transmit circuit of the R/T to the receive circuit of the R/T is changed into absolute altitude. The number one system altitude shows on the captain display and the number two system shows on the first officer display.

The receiver/transmitters get discrete inputs from the proximity switch electronics unit (PSEU) used to count flight legs for fault recording.

The altitude data and signal validity is sent on two ARINC 429 data buses.

ARINC 429 data bus 1 sends data to these components:

- Flight control computers (FCC)
- Autothrottle computer.

ARINC 429 data bus 2 sends data to these components:

- Ground proximity warning computer (GPWC)
- Traffic alert and collision avoidance system (TCAS) computer
- Flight data acquisition unit (FDAU)
- Weather Radar (WXR)
- Common display system (CDS) display electronic units (DEU).

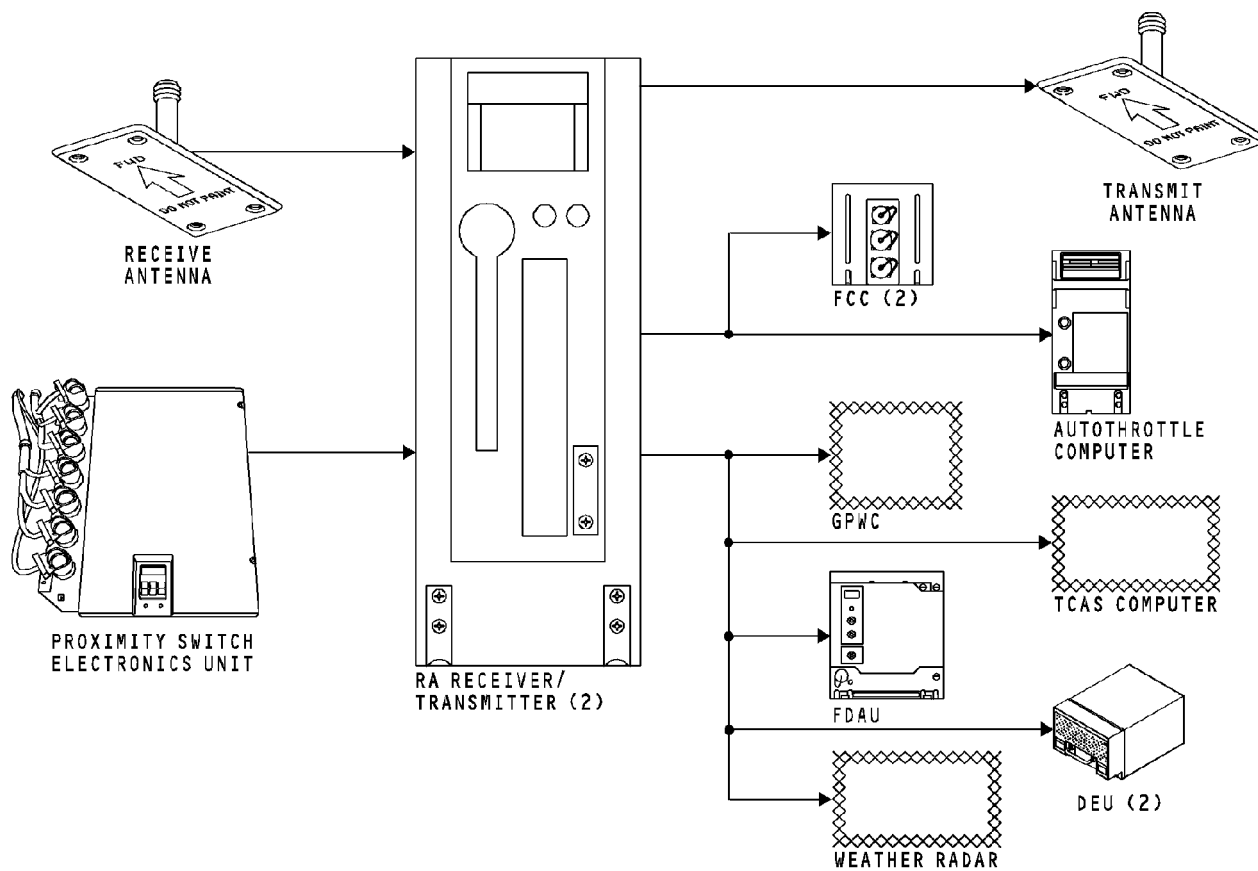

RA SYSTEM - GENERAL DESCRIPTION

34-33-00-002

EFFECTIVITY
HAP ALL

34-33-00

D633A101-HAP

RA SYSTEM - COMPONENT LOCATION - 1

General

The RA receiver/transmitters are on the E3 rack in the electronic equipment (EE) compartment.

The RA antennas are on the bottom of the fuselage.

34-33-00-003

EFFECTIVITY
HAP ALL

34-33-00

D633A101-HAP

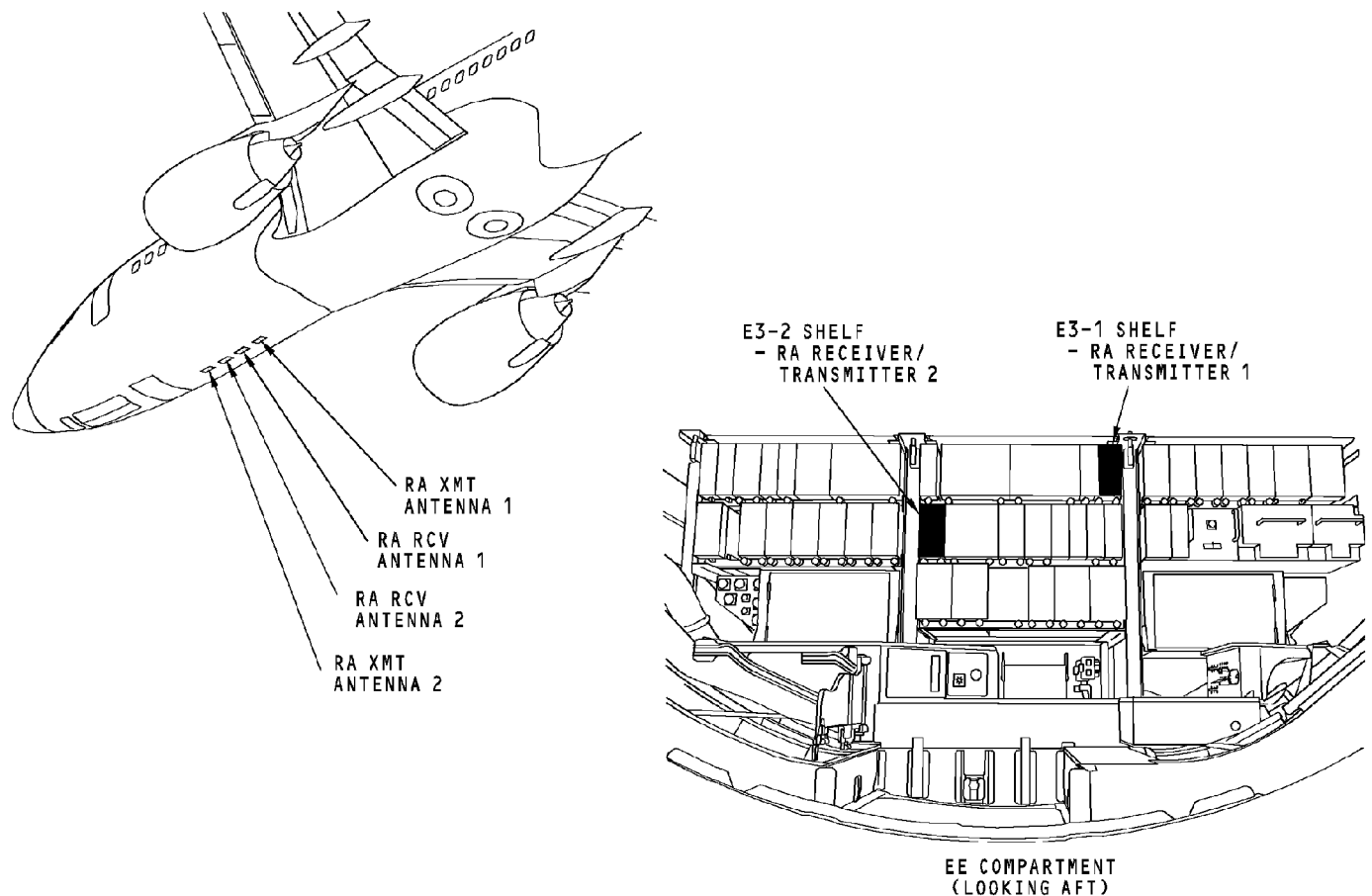

RA SYSTEM - COMPONENT LOCATION - 1

34-33-00-003

EFFECTIVITY
HAP ALL

34-33-00

D633A101-HAP

RA SYSTEM - COMPONENT LOCATION - 2

General

These are the components in the flight compartment that interface with the RA system:

- Left and right EFIS control panels
- Common display system (CDS) display units (DU).

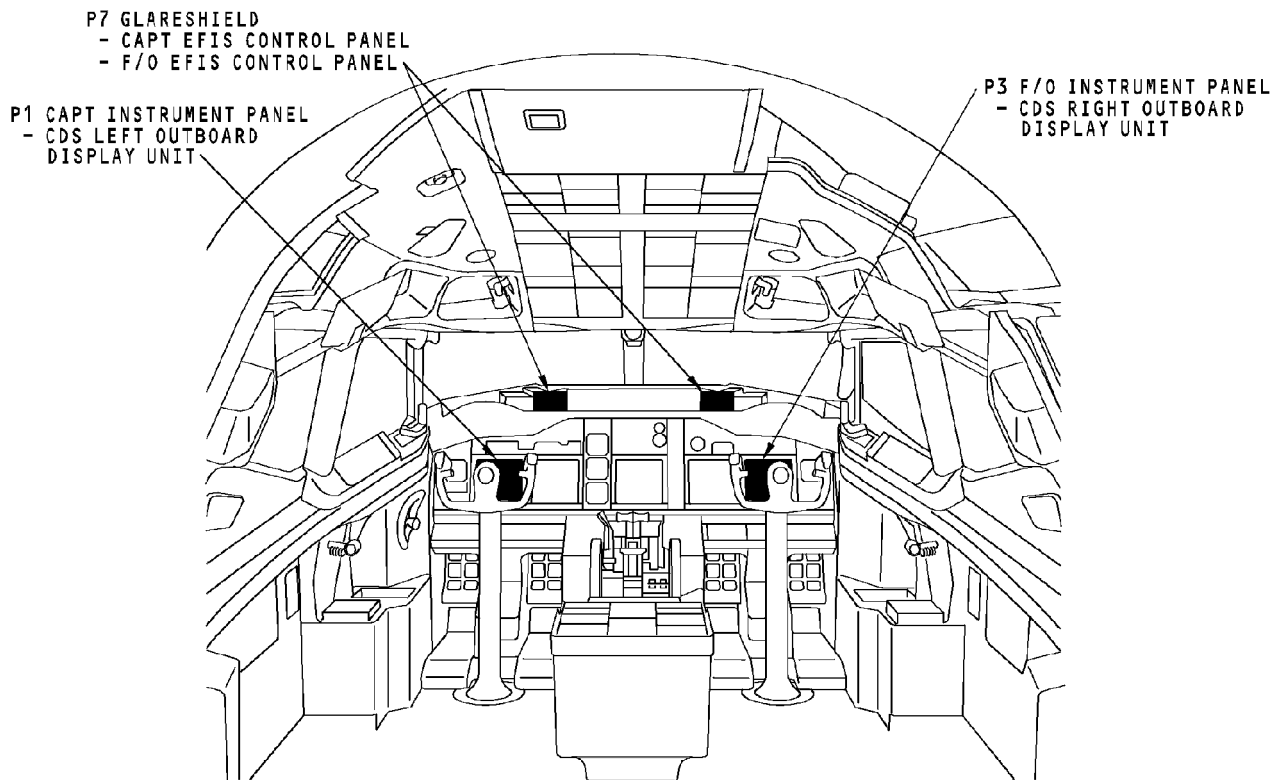

RA SYSTEM - COMPONENT LOCATION - 2

34-33-00-004

EFFECTIVITY
HAP ALL

34-33-00

D633A101-HAP

RA SYSTEM - POWER, ANTENNA, AND DISCRETE INPUTS**Power**

Power for the RA receiver/transmitter 1 is 115v ac from xfer bus 1. RA receiver/transmitter 2 receives 115v ac from xfer bus 2.

Antenna Interfaces

The transmit antenna sends radio frequency (RF) signals to the ground. The receive antenna sends reflected RF signals to the receiver circuits of the RA receiver/transmitter.

Flight Control Computer Discrete

The flight control computers (FCC) supply a test inhibit signal to the RA receiver/transmitter. This signal prevents an RA test when ILS mode is selected.

PSEU

The RA receiver/transmitter keeps internal and external faults in a nonvolatile fault memory. The RA receiver/transmitter keeps these faults by flight segments. The RA identifies the faults as airborne faults or ground faults. The proximity switch electronics unit (PSEU) gives the air/ground condition.

Input Program Pins

These are the radio altimeter program pins:

- Continuous data. When grounded, lets continuous altitude data be transmitted to user systems

- Aircraft installed delay (AID) of 57 feet. This lets the RA system compensate the altitude calculation for antenna cable length and distance of the RA system antennas from the ground at touchdown
- System select. Used to identify which system.

Indicator Discrete

The indicator discrete supplies the status of flight compartment radio altitude indicators. This system does not use radio altitude indicators.

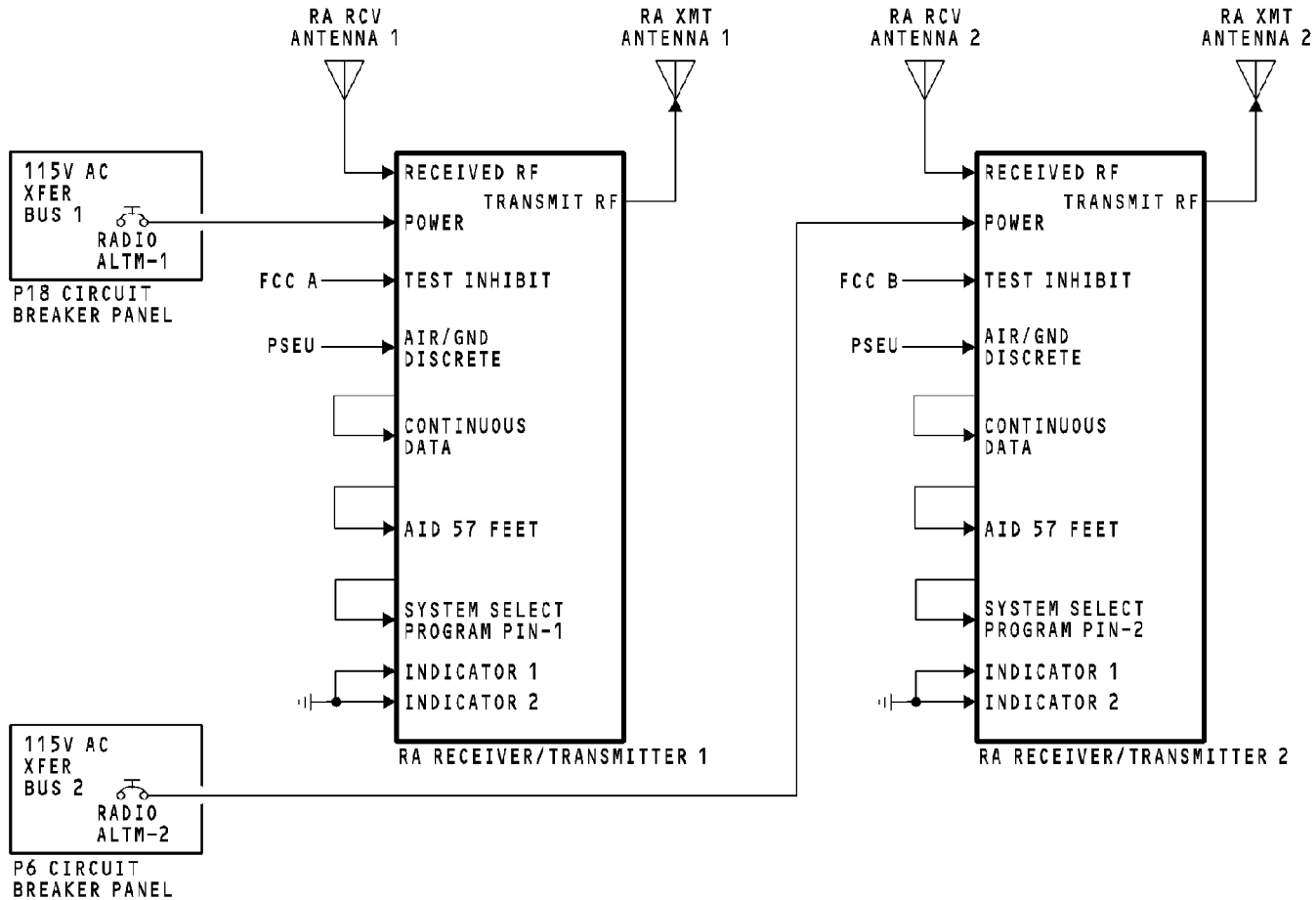

RA SYSTEM - POWER, ANTENNA, AND DISCRETE INPUTS

34-33-00-005

EFFECTIVITY
HAP ALL

34-33-00

D633A101-HAP

RA SYSTEM - DATA BUS OUTPUTS, DECISION HEIGHT INTERFACE**General**

The RA system supplies radio altitude (RA) data to these components:

- FCC A and the FCC B
- Autothrottle computer
- Display electronics unit (DEU) 1 and the DEU 2
- Weather radar R/T
- GPWC
- FDAU
- TCAS computer.

RA Receiver/Transmitter Outputs

Each FCC uses radio altitude from its on-side RA receiver/transmitter. The FCCs use radio altitude in the approach control and low altitude flight calculations.

The autothrottle uses radio altitude in the TO/GA calculations and autothrottle flare calculations.

The DEUs use radio altitude data to calculate the type of radio altitude display and the radio altitude value to show on the display units.

The weather radar R/T uses radio altitude to turn on or off the predictive windshear function and to enable/disable display and alert functions.

The GPWC uses radio altitude in its ground proximity alert and warning logic calculations.

The FDAU records radio altitude values.

The TCAS computer uses radio altitude to set the sensitivity levels for intruder advisory calculations and to find if an intruder aircraft is on the ground.

EFIS Control Panel Interface

The EFIS control panels supply radio minimums values to the DEUs. The DEUs use radio minimums and radio altitude to calculate radio minimums alerts that show on the display units.

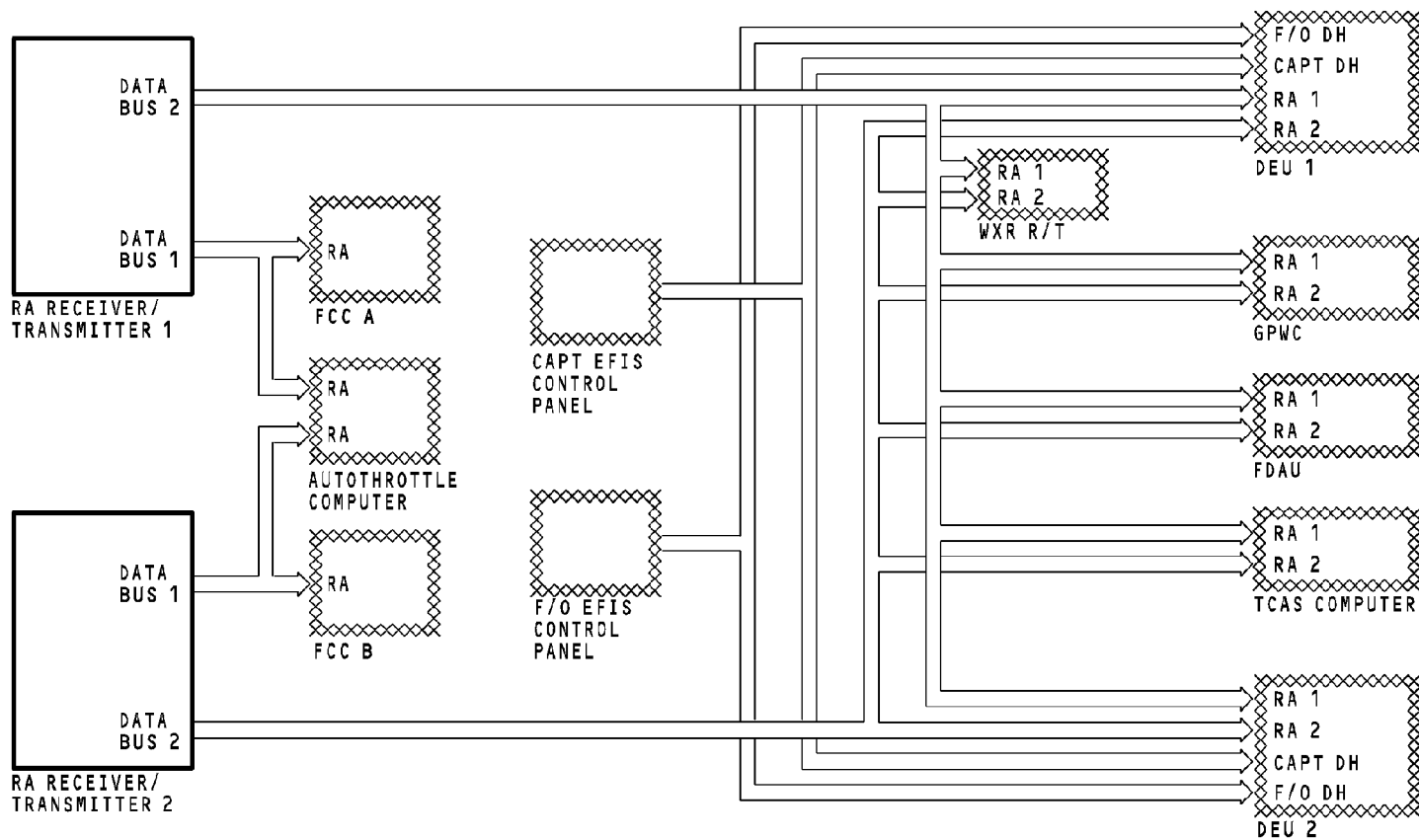

RA SYSTEM - DATA BUS OUTPUTS, DECISION HEIGHT INTERFACE

34-33-00-006

EFFECTIVITY
HAP ALL

34-33-00

D633A101-HAP

RA SYSTEM - RA RECEIVER/TRANSMITTER**Purpose**

The RA receiver/transmitter calculates radio altitude.

Shop personnel use the RS 232 connector to connect shop test equipment to the LRU. This feature is not for use by line maintenance personnel.

The RA receiver/transmitter has a non-volatile memory which stores fault information. Only shop personnel read the non-volatile memory information.

Description

These are the operation limits of the receiver/transmitter:

- Frequency = 4235 Mhz to 4365 Mhz
- Transmit power = 500 mw nominal
- Operating range = -20 to 2500 feet.

Operation

There are two switches and an LCD on the front panel of the RA receiver/transmitter. You use any of the two switches to start a test of the RA receiver/transmitter. The LCD shows the test results.

There is a memory card slot on the front of the RA receiver/transmitter. Shop personnel use this slot to put in a flash memory card which loads software into the LRU. A memory card can also keep LRU condition data sent by the LRU during operation. These features are not for use by line maintenance personnel.

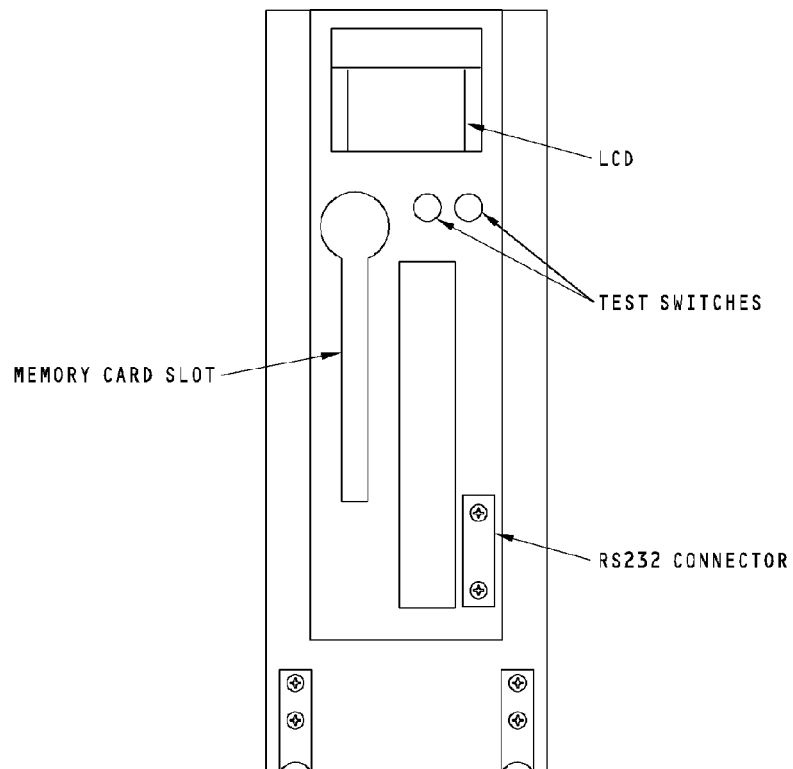

RA SYSTEM - RA RECEIVER/TRANSMITTER

34-33-00-007

EFFECTIVITY
HAP ALL

34-33-00

D633A101-HAP

RA SYSTEM - RA ANTENNA**Purpose**

The RA system uses four antennas that transmit and receive RF signals. Each RA receiver/transmitter has a transmit and receive antenna. The transmit and receive antennas are the same and interchangeable.

Physical Description

Four screws attach each antenna to the bottom of the fuselage. There is an O-ring seal in a groove around the coax connector. The O-ring seal gives moisture protection. The radiation side of the antenna has red markings "FWD" and "DO NOT PAINT".

Training Information Point

Do not paint the radiation surface or the back plate of the antenna. Paint does not permit the antenna to send or receive RF signals.

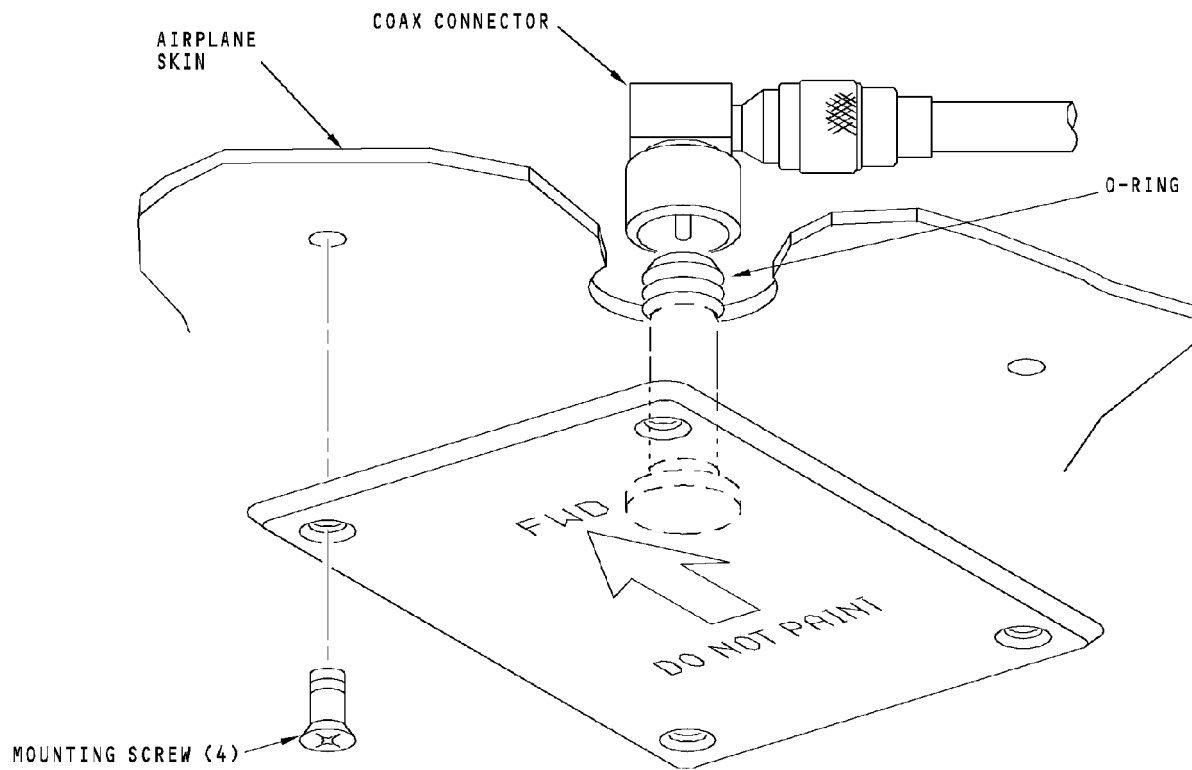

RA SYSTEM - RA ANTENNA

34-33-00-008

EFFECTIVITY
HAP ALL

34-33-00

D633A101-HAP

Page 17
Oct 10/2004

RA SYSTEM - OPERATION - 1

EFIS Control Panel

The EFIS control panel controls the radio minimums value and resets the radio minimums alert display to a normal display. The radio minimums shows on the captain and first officer display units. The left EFIS control panel controls the captain display units. The right EFIS control panel controls the first officer display units.

The minimums controls have these three controls:

- A two-position rotary switch (minimums reference selector)
- A spring loaded rotary switch (minimums altitude selector)
- A radio minimums reset (RST) switch.

You use the radio position on the minimums reference selector to set the radio minimums.

To set a radio minimums value, use the rotary switch to adjust the value between -1 feet and +999 feet.

Push the radio minimums reset (RST) switch to set the radio minimums alert display back to normal.

Display Unit

The display unit (DU) shows radio altitude and radio minimums values. The flight crew uses this data during an approach and a landing.

Radio altitude shows in white for airplane altitude between -20 and 2500 feet. This is when the radio altitude values update:

- Two foot increments from -20 to 100 feet
- Ten foot increments from 100 to 500 feet
- Twenty foot increments from 500 to 2500 feet.

The radio altitude does not show above 2500 feet.

The radio altitude display shows a white highlight box around it for ten seconds when the radio altitude initially shows on the display unit.

HAP 001-013, 015-026, 028-030 POST SB 737-31-1246 OR POST SB 737-31-1295

The white radio altitude shows as a digital display on the DU for altitudes between -20 and 2500 feet. For altitudes between 0 and 1000 feet, a round dial shows around the digital display. The dial has increments of 100 feet. As the radio altitude increases or decreases, the display adds or removes the perimeter of the dial. A green radio minimums bug moves around the dial and shows the value selected from the EFIS control panel radio minimums altitude selector.

HAP ALL

The green radio minimums display shows below the ADI display. The radio minimums display does not show for these reasons:

EFFECTIVITY
HAP ALL

34-33-00

D633A101-HAP

Page 18
Jun 15/2009

RA SYSTEM - OPERATION - 1

- Baro minimums is selected on the EFIS control panel
- Radio minimums reset switch is pushed
- Radio minimums value is less than zero.

HAP 001-013, 015-026, 028-030 POST SB 737-31-1246 OR POST SB 737-31-1295

The green radio minimums display shows above the digital radio altitude display when the airplane is on the ground or when radio altitude is more than 1000 feet. If the radio minimums value is selected to a value less than zero feet, the display is removed.

HAP ALL

Radio Minimums Alert

A radio minimums alert occurs when the radio altitude of the aircraft is the same as the selected radio mins altitude value from the EFIS control panel. The radio minimums alerts occur separately between the captain and first officer displays.

When a radio minimums alert occurs, the radio altitude display changes from white to amber.

HAP 031-054, 101-999; HAP 001-013, 015-026, 028-030 PRE SB 737-31-1246 AND PRE SB 737-31-1295

Also, the radio minimums display changes from green to amber and goes off and on for three seconds.

HAP 001-013, 015-026, 028-030 POST SB 737-31-1246 OR POST SB 737-31-1295

Also, the radio altitude dial changes from white to amber and goes on and off for three seconds and the decision height bug changes from green to amber and goes on and off for three seconds.

HAP ALL

After three seconds, the display continues to show amber until it is set back to normal.

Each of these procedures sets the radio minimums alert back to normal:

- Push the reset (RST) switch on the EFIS control panel
- The airplane climbs to 75 feet above the radio minimums value
- The airplane lands.

HAP 001-013, 015-026, 028-030 POST SB 737-31-1246 OR POST SB 737-31-1295

When radio minimums is set to normal, the radio altitude and the radio altitude dial go back to white, and the radio minimums bug goes back to green.

34-33-00-009

EFFECTIVITY
HAP ALL

34-33-00

D633A101-HAP

RA SYSTEM - OPERATION - 1

**HAP 001-013, 015-026, 028-030 POST SB 737-31-1246 OR
POST SB 737-31-1295 (Continued)**

**HAP 031-054, 101-999; HAP 001-013, 015-026, 028-030 PRE SB
737-31-1246 AND PRE SB 737-31-1295**

When radio minimums is set to normal, the radio altitude goes back to white, and the radio minimums display goes back to green.

HAP 037-054, 101-999

Rising Runway

The rising runway shows in two colors, a magenta stem with a green trapezoid box on the top. The rising runway shows at the bottom of the ADI when these conditions occur:

- Radio altitude is less than 2500 feet
- ILS localizer deviation shows on the ADI.

The rising runway symbol moves toward the airplane symbol on the ADI as the airplane altitude decreases from 200 feet to 0 feet. At 0 feet, the rising runway shows at the bottom of the airplane symbol. The rising runway symbol also moves left and right to stay aligned with the ILS localizer deviation pointer.

HAP ALL

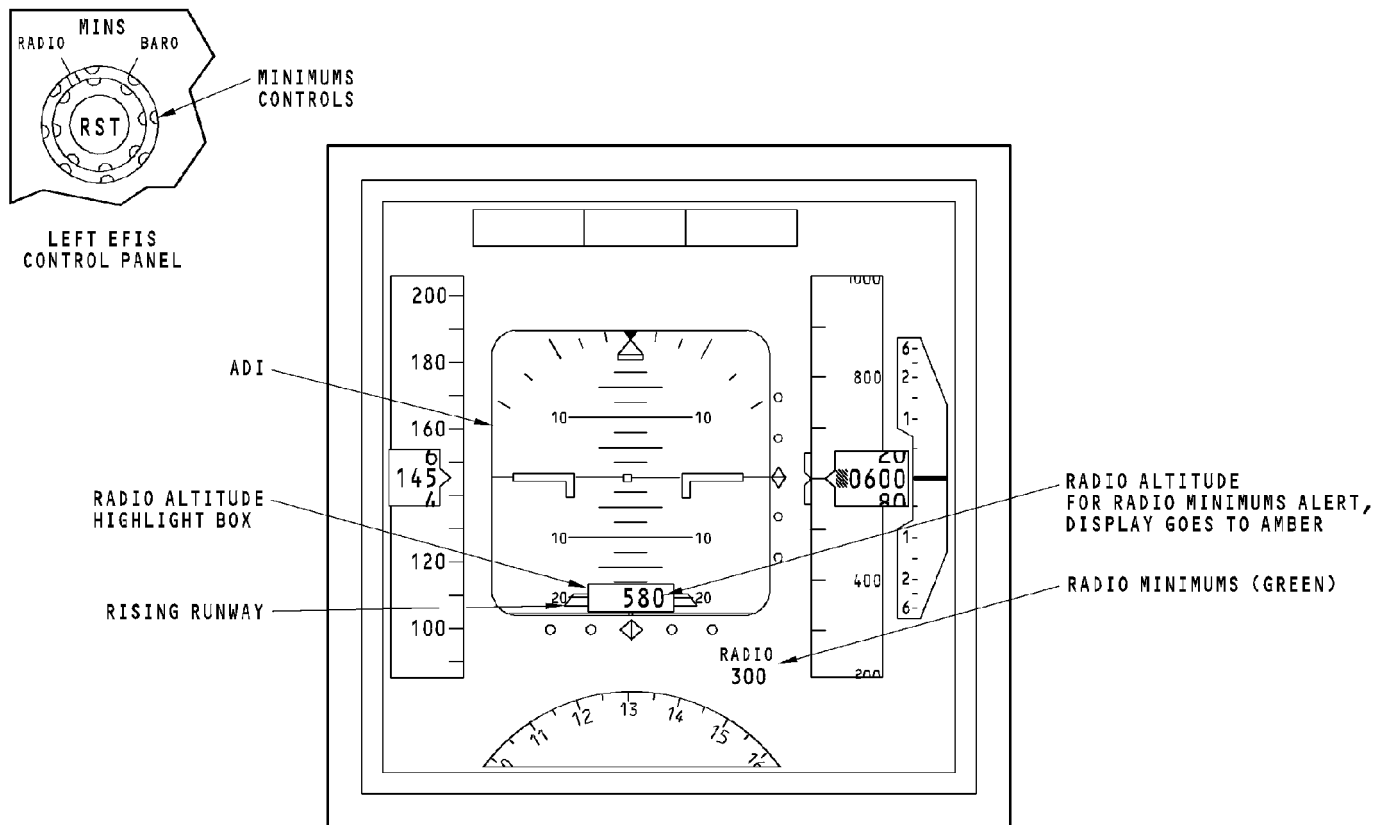

RA SYSTEM - OPERATION - 1

34-33-00-009

EFFECTIVITY
HAP 037-054, 101-999

34-33-00

D633A101-HAP

Page 21
Feb 15/2009

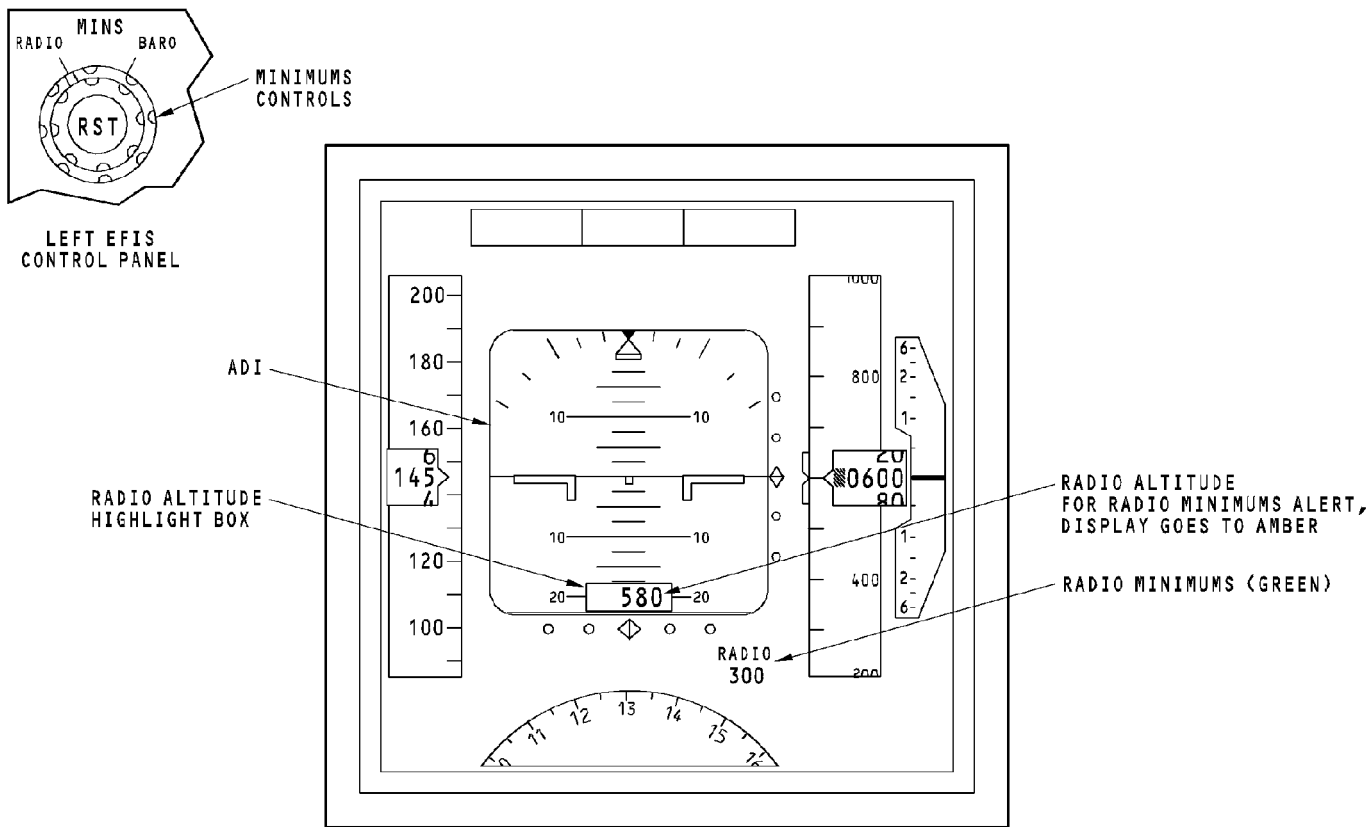

RA SYSTEM - OPERATION - 1

EFFECTIVITY

HAP 031-036; HAP 001-013, 015-026, 028-030 PRE SB 737-31-1246 AND PRE SB 737-31-1295

34-33-00

D633A101-HAP

THIS PAGE IS INTENTIONALLY LEFT BLANK

34-33-00

D633A101-HAP

Page 23
Jun 10/2006

RA SYSTEM - OPERATION - 2**HAP 037-054, 101-999****RA Data NCD**

RA data NCD causes the RA display and rising runway symbol to be removed. The NCD occurs when the return RA signals are too weak or the radio altitude is more than 2500 feet. Also, the rising runway will not show when the ILS is not captured.

RA Data Invalid

Invalid RA data causes a amber RA flag to show in the radio altitude position. Invalid RA also causes the rising runway symbol to be removed. The invalid data occurs when the RA receiver/transmitter finds a failure in the RA system.

HAP ALL**Radio Minimums Data Invalid****HAP 001-013, 015-026, 028-030 POST SB 737-31-1246 OR POST SB 737-31-1295**

Invalid EFIS control panel data on the ground or above 1000 feet causes the amber displays control panel flag to show and the letters RADIO and the radio minimums value to go out of view. Between 0 and 1000 feet, the amber controls display panel flag shows and the radio minimums bug is removed.

HAP 031-054, 101-999; HAP 001-013, 015-026, 028-030 PRE SB 737-31-1246 AND PRE SB 737-31-1295

Invalid EFIS control panel data causes the amber displays control panel flag to show and the letters RADIO and the radio minimums value to be removed.

HAP ALL

Also, the vertical speed indication (VSI) is grey. There is no VSI fail flag for this condition.

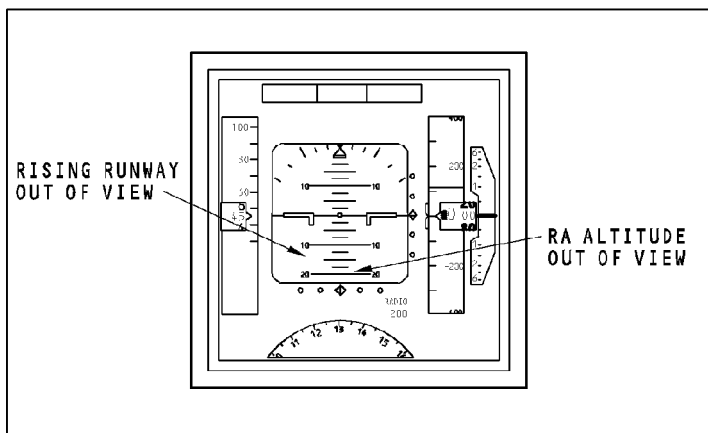

RA DATA NCD

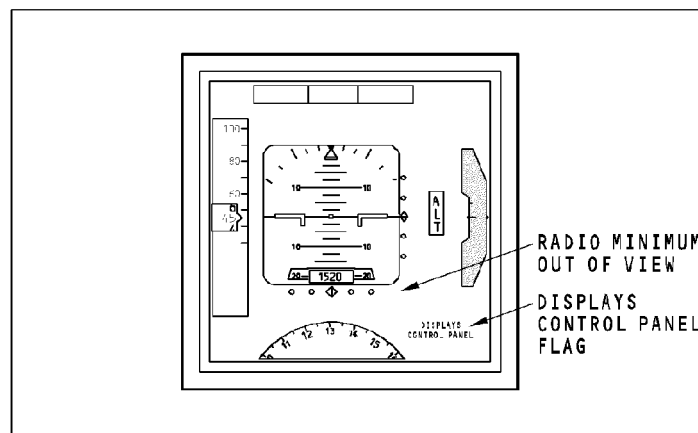

RADIO MINIMUMS DATA INVALID

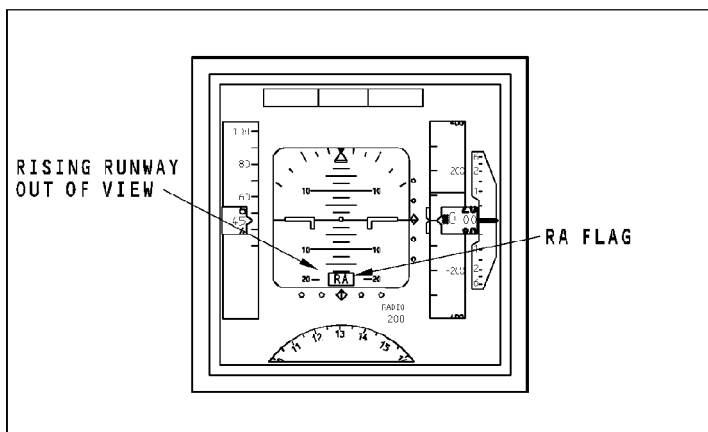

RA DATA INVALID

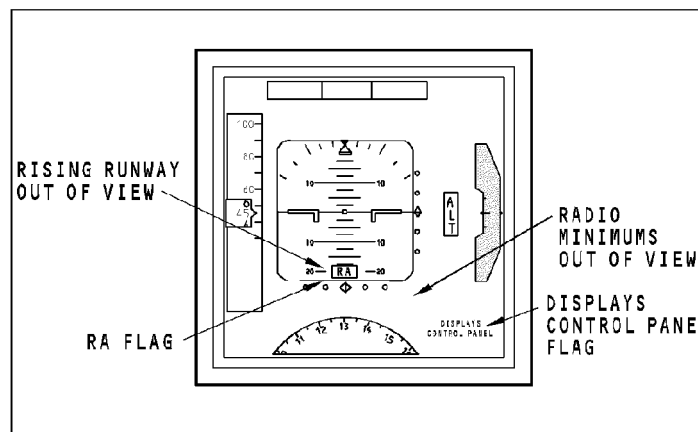

RA INVALID AND RADIO MINIMUMS INVALID

RA SYSTEM - OPERATION - 2

34-33-00-010

EFFECTIVITY
HAP 037-054, 101-999

34-33-00

D633A101-HAP

Page 25
Feb 15/2009

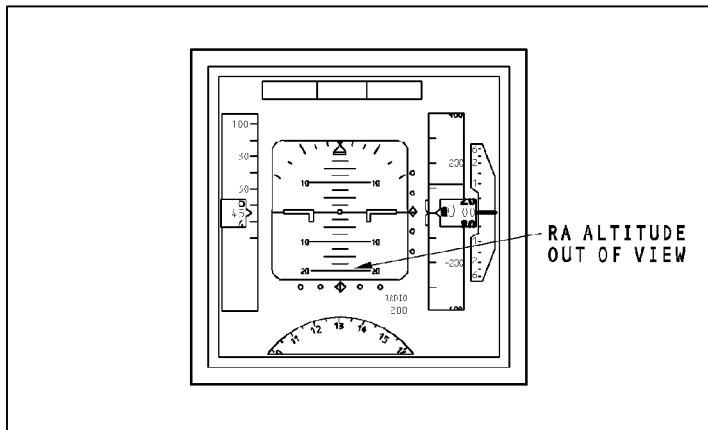

RA DATA NCD

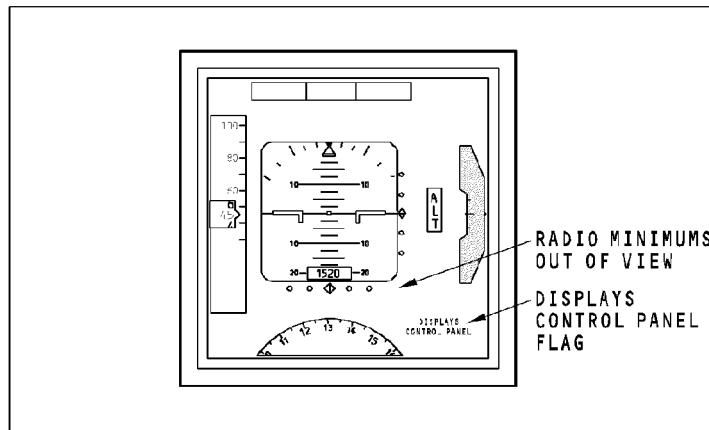

RADIO MINIMUMS DATA INVALID

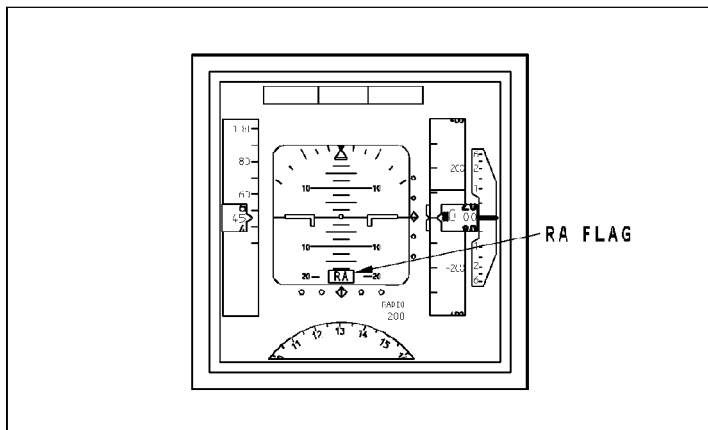

RA DATA INVALID

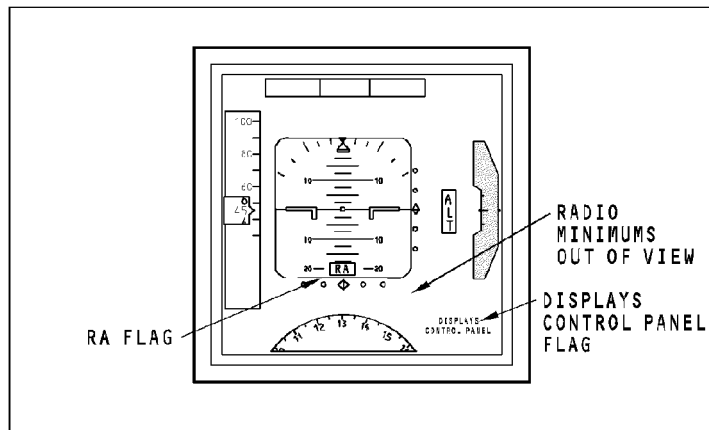

RA INVALID AND RADIO MINIMUMS INVALID

RA SYSTEM - OPERATION - 2

EFFECTIVITY

HAP 031-036; HAP 001-013, 015-026, 028-030 PRE SB 737-31-1246 AND PRE SB 737-31-1295

34-33-00

34-33-00-010

D633A101-HAP

THIS PAGE IS INTENTIONALLY LEFT BLANK

34-33-00

D633A101-HAP

Page 27
Jun 10/2006

RA SYSTEM - RF PROCESSING**General**

The altitude calculation starts with a signal in the RF processor. The frequency of the signal is adjusted with an up-down ramp from 4,260 to 4,340 MHz. These values are adjusted to keep the frequency difference between transmit and receive signals to 40 KHz or less:

- The maximum difference permitted
- The difference frequency
- The ramp slope.

Transmit and Receive

The ground causes a reflection of the transmit signal. The receive antenna receives the signal. The RF processor mixes the transmit and receive signals to make a difference frequency. The difference frequency is in proportion to the time it takes the signal to go to the ground and come back. The main processor changes the difference frequency to radio altitude. The radio altitude goes out on two ARINC 429 data buses. The two buses supply radio altitude and status information to these components:

- FCC A or FCC B
- Autothrottle computer
- DEU 1 and DEU 2
- GPWC
- TCAS computer
- FDAU.

Input Program Pins

The system select program pin input sets the system modulation rate and system identification. The modulation rate for the RA 1 system is 145Hz, the RA 2 system is 155Hz.

The aircraft installation delay (AID) program pin is grounded to the 57 feet selection. This calibrates the system so that the radio altitude is 0 feet at touchdown. It makes an allowance for these conditions:

- Length of the antenna cables
- Fuselage to ground distance
- Flare angle.

When grounded, the continuous data program pin selects non-interrupted RA data output at all times.

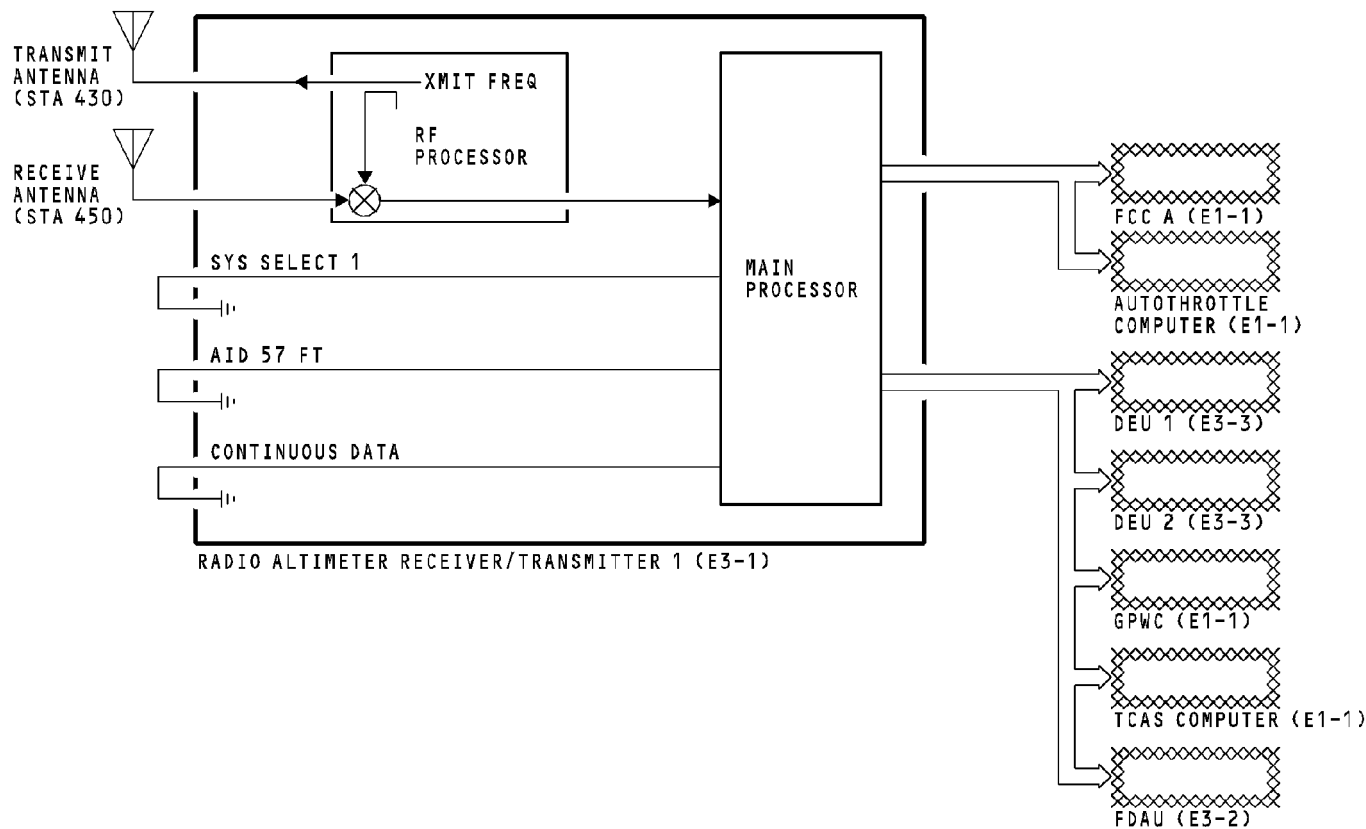

RA SYSTEM - RF PROCESSING

34-33-00-011

EFFECTIVITY
HAP ALL

34-33-00

D633A101-HAP

RA SYSTEM - FAULT DETECTION**Fault Monitoring**

The RF processor sends the difference frequency to the main processor. The difference frequency goes from the main processor to the monitor processor.

The main processor and the monitor processor change the difference frequency to altitude. The main processor sends the altitude to the airplane systems and to the monitor processor. The monitor processor compares the altitude from the main processor with the altitude that the monitor processor calculates. If a difference is detected, the monitor processor sends a shutdown command to the main processor and the radio altimeter fails.

BITE Logic

The built-in test equipment (BITE) logic monitors the circuits in the RA receiver/transmitter for faults. The BITE logic faults are stored in a non-volatile fault memory card.

The air/ground relay supplies a discrete signal to the main processor. This discrete defines flight legs for the nonvolatile fault memory.

Test

The test switches on the front of the RA receiver/transmitter start an RA self-test. The LCD shows the results of the self-test.

The self-tests do a check of these:

- Receiver/transmitter internal status
- ARINC 429 output transmitters status
- Antennas and coaxial cables.

The flight control computers (FCCs) supply a test inhibit signal to the receiver/transmitters. This prevents an RA test when the FCC is in the approach mode.

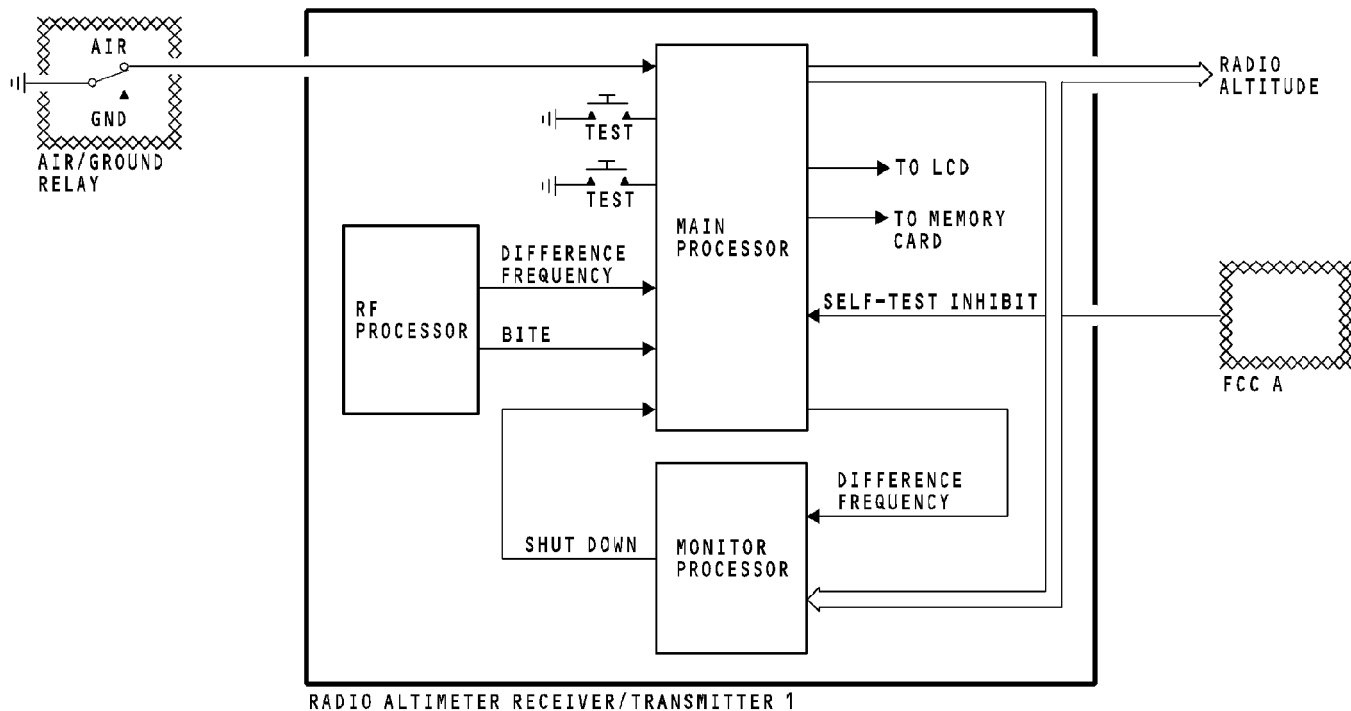

RA SYSTEM - FAULT DETECTION

34-33-00-012

EFFECTIVITY
HAP ALL

34-33-00

D633A101-HAP

Page 31
Jun 10/2006

RA SYSTEM - FRONT PANEL BITE

Test

Push one of the test switches on the front of the receiver to start a test of the radio altimeter system. The BITE does a check of internal transceiver operation and of its interfaces. The test results show on the LCD on the front of the transceiver.

When you push the test switch, the TEST IN PROGRESS page shows and the transceiver goes through a self-test. The test continues for five seconds. A five-second scale shows at the bottom of the page. You can monitor the test time by the line of Xs that come into view below the scale.

The TEST COMPLETE NO FAILURES display shows for a test pass condition. The TEST COMPLETE FAILURES display shows for a test fail condition.

These are the selections that can show above the receiver front panel switches during the test sequence:

- MAINT - This selection shows pages that contain program pin selections and discrete interface status
- RETURN - This selection causes the display to go back to the start test page
- WHY? - This selection comes on when there are failures. Push this selection to show the failures
- MORE - This selection shows any time there are more pages of data to follow.

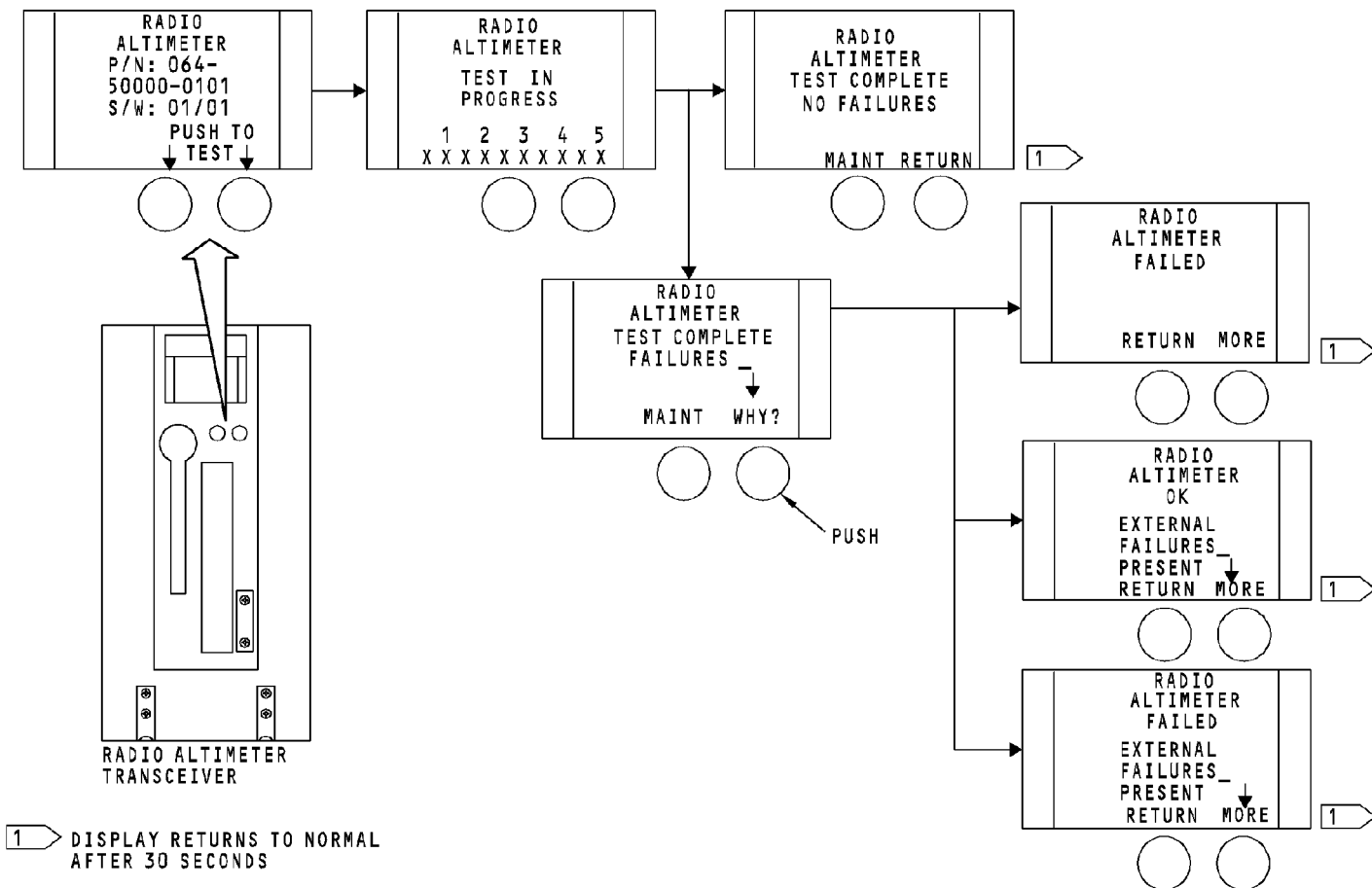

RA SYSTEM - FRONT PANEL BITE

34-33-00-013

EFFECTIVITY
HAP ALL

34-33-00

D633A101-HAP

RA SYSTEM - FLIGHT COMPARTMENT BITE DISPLAY

General

The front panel BITE test causes the RA receiver/transmitter to send a test altitude to the flight compartment display units. The test altitude is 40 feet. The test altitude shows during the full test. The altitude display goes back to normal when the test is complete.

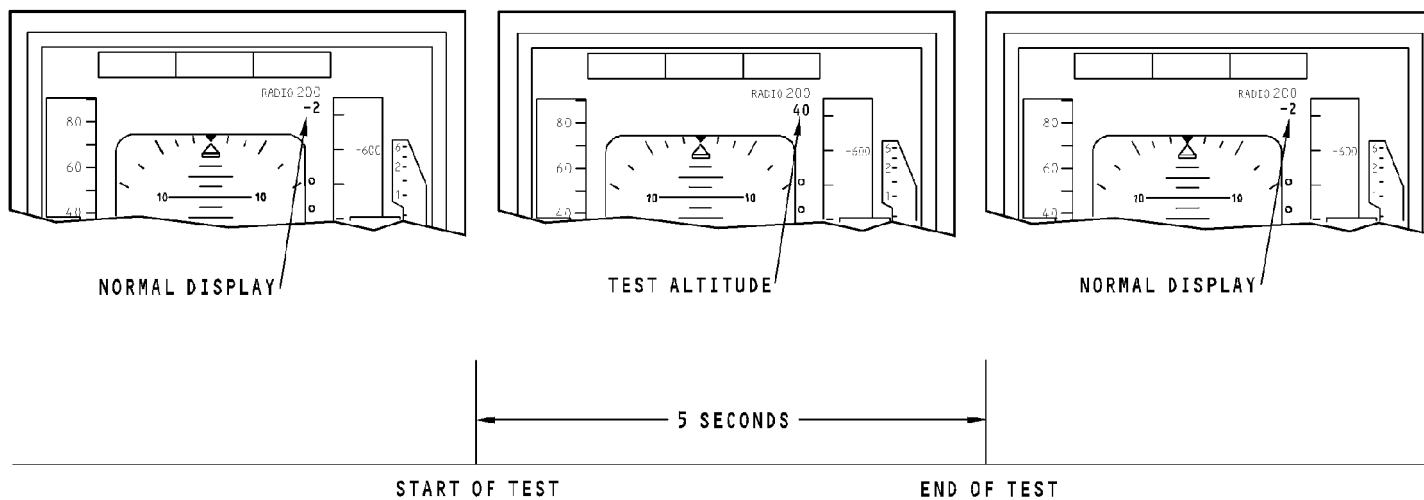

RA SYSTEM - FLIGHT COMPARTMENT BITE DISPLAY

34-33-00-014

EFFECTIVITY
HAP 001-013, 015-026, 028-030 POST SB 737-31-1246 OR POST SB 737-31-1295

34-33-00

D633A101-HAP

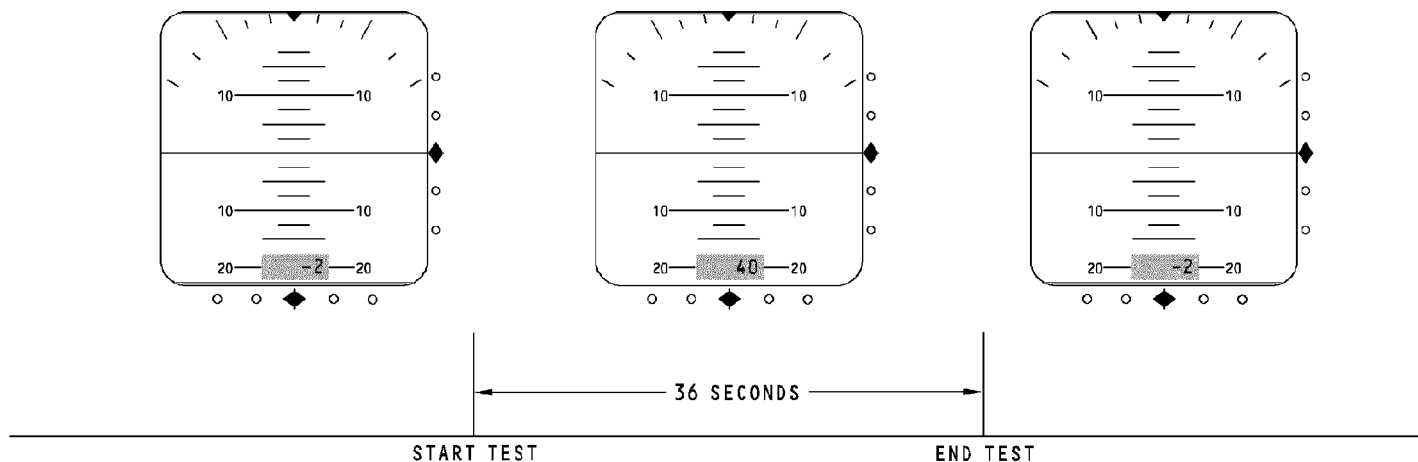

RA SYSTEM - FLIGHT COMPARTMENT BITE DISPLAY

EFFECTIVITY

HAP 031-054, 101-999; HAP 001-013, 015-026, 028-030 PRE SB 737-31-1246 AND PRE SB 737-31-1295

34-33-00

D633A101-HAP

THIS PAGE IS INTENTIONALLY LEFT BLANK

34-33-00

D633A101-HAP

Page 37
Feb 15/2009



RA SYSTEM - SYSTEM SUMMARY

General

This page is for reference purpose.

34-33-00-015

EFFECTIVITY
HAP ALL

34-33-00

D633A101-HAP

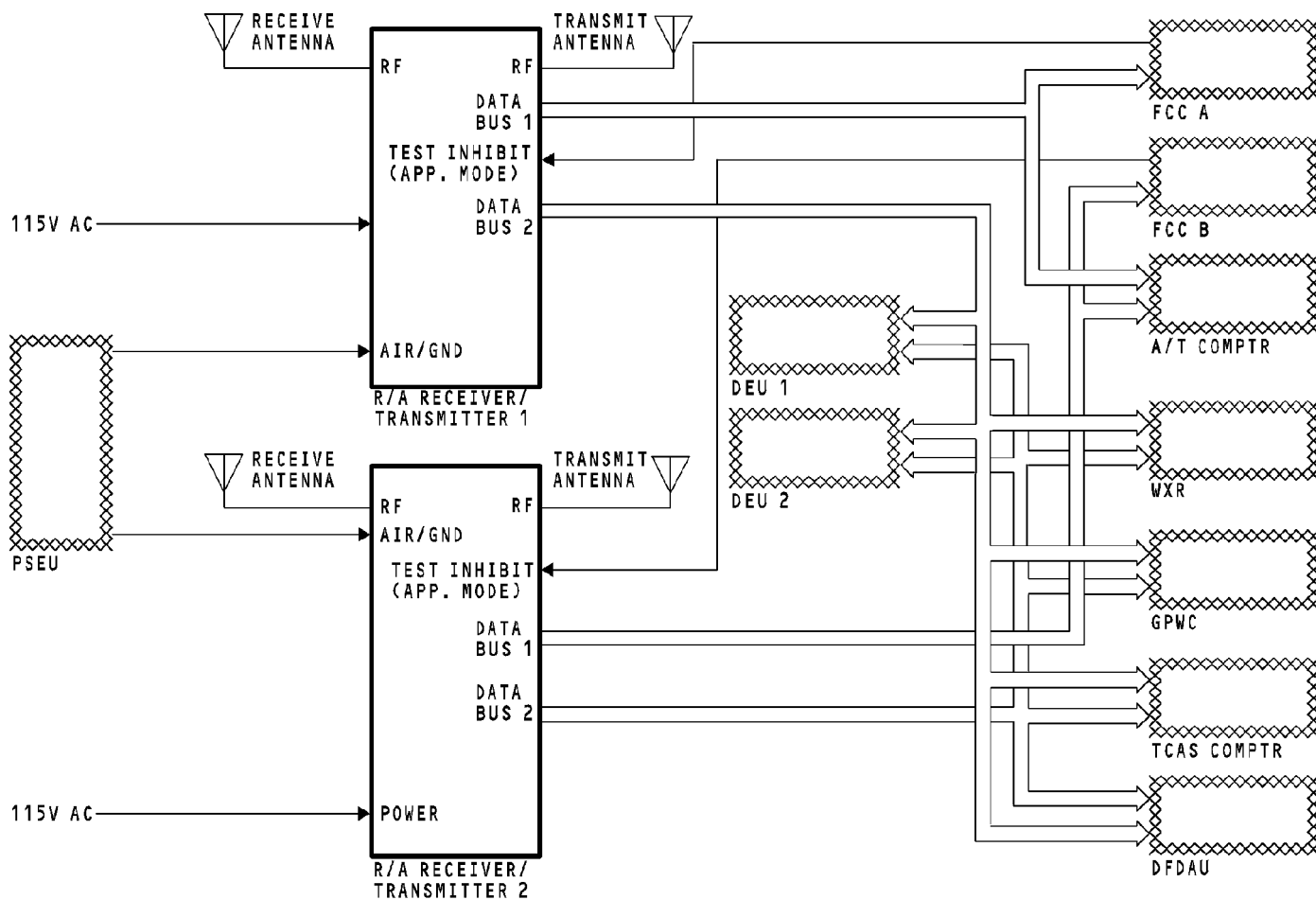

RA SYSTEM - SYSTEM SUMMARY

34-33-00-015

EFFECTIVITY
HAP ALL

34-33-00

D633A101-HAP

WEATHER RADAR SYSTEM - INTRODUCTION**Purpose**

The weather radar (WXR) system supplies these visual indications:

- Weather conditions
- HAP 008-013, 015-026, 028-054, 101-999**
- Windshear events
- HAP ALL**
- Land contours.

Description**HAP 001-007**

WXR operates on the same principle as an echo. The WXR system transmits radio frequency (RF) pulses in a 180 degree area forward of the airplane. Objects reflect the pulses back to the receiver. The receiver processes the return signal to show weather and terrain.

HAP 008-013, 015-026, 028-054, 101-999

WXR operates on the same principle as an echo. The WXR system transmits radio frequency (RF) pulses in a 180 degree area forward of the airplane. Objects reflect the pulses back to the receiver. The receiver processes the return signal to show weather, terrain, and windshear events.

HAP ALL**Display**

The WXR returns show in four different colors on the navigation displays (ND). Colors of the indications give the crew information about the intensity of the returns.

HAP 008-013, 015-026, 028-054, 101-999

The predictive wind shear (PWS) cautions and warnings show in amber and red on the ND and PFD displays. Also, there are aural alerts for PWS cautions and warnings.

HAP ALL**Abbreviations and Acronyms**

- ac - alternating current
- ADF - automatic direction finder
- ADIRS - air data inertial reference system
- ADIRU - air data inertial reference unit
- alt - altitude
- ant - antenna
- app - approach
- ARINC - Aeronautical Radio, Inc.
- arpt - airport
- AZ - azimuth
- baro - barometric
- BITE - built-in test equipment
- BL - buttock line
- CAL - calibrate
- capt - captain
- CDU - control display unit
- con - control

EFFECTIVITY
HAP ALL

WEATHER RADAR SYSTEM - INTRODUCTION

- CP - control panel
- CPU - central processing unit
- dc - direct current
- DEU - display electronics unit
- DH - decision height
- dn - down
- EFIS - electronic flight instrument system

HAP 008-013, 015-026, 028-054, 101-999

- EGPWS - enhanced ground proximity warning system

HAP ALL

- EL - elevation
- elex - electric
- F/O - first officer
- FMC - flight management computer
- FMCS - flight management computing system
- FPV - flight path vector
- fwd - forward
- gnd - ground
- GS - ground speed
- hPa - hectopascals
- in - inch
- intlk - interlock
- IRS - inertial reference system
- kg - kilograms
- L - left

HAP 001-005

- LCD - liquid crystal display

HAP ALL

- lb - pounds
- mag - magnetic
- max - maximum
- MDA - minimum descent altitude
- MHz - megahertz

- MINS - minimums
- MTRS - meters
- nav - navigation
- NCD - no computed data
- ND - navigation display
- NM - nautical miles
- OK - good or pass
- PFD - primary flight display
- pos - position
- PRF - pulse repetition frequency

HAP 008-013, 015-026, 028-054, 101-999

- PWS - predictive windshear

HAP ALL

- R - right
- rad - radio
- RF - radio frequency
- R/T - receiver/transmitter
- sta - station
- stab - stabilization
- stb - stabilization
- std - standard
- TAS - true air speed
- TCAS - traffic alert and collision avoidance
- trk - track
- TRU - true
- V - volts
- VOR - very high frequency omnidirectional range
- wpt - waypoint
- WX - weather
- WX/TURB - weather/turbulence
- WX + TURB - weather + turbulence
- WXR - weather radar
- Z - zulu (universal coordinated time)

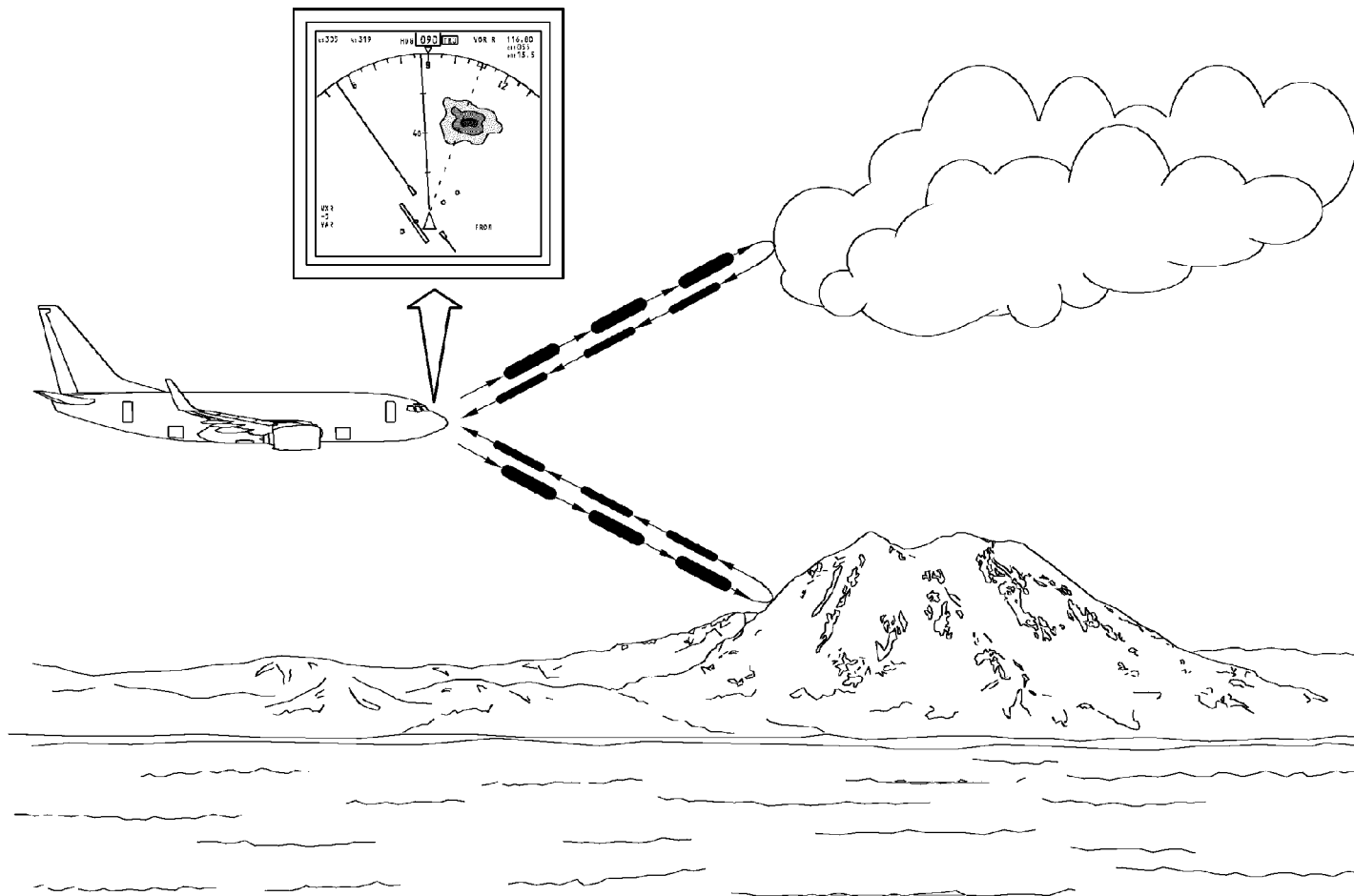

WEATHER RADAR SYSTEM - INTRODUCTION

34-43-00-001

EFFECTIVITY
HAP ALL

34-43-00

D633A101-HAP

Page 3
Oct 10/2004

THIS PAGE IS INTENTIONALLY LEFT BLANK

34-43-00

D633A101-HAP

Page 4
Oct 10/2004

WXR SYSTEM - GENERAL DESCRIPTION**Control**

These components supply weather radar (WXR) system control:

- Left and right EFIS control panels
- Weather radar control panel.

HAP 008-013, 015-026, 028-054, 101-999**System Inputs**

These components supply signals to the WXR transceiver for predictive windshear:

- Air data inertial reference system sends air data for the PWS function
- Radio altimeters send altitude to enable or disable PWS during takeoff and approach
- Autothrottle switch packs enable PWS during takeoff
- Landing gear lever switch sends a landing gear down discrete to enable PWS during approach
- An air/ground relay sends an air/ground discrete for flight leg counting.

System Outputs

The weather radar transceiver sends these signals out for predictive windshear:

- PWS video to the WXR/TERR relays

- PWS warnings or cautions to the GPWS to prioritize any callouts
- Audio inhibit to TCAS when there is a PWS warning
- Audio to the REU for PWS.

HAP ALL**Display****HAP 001-007**

WXR data shows on the navigation displays (NDs). The weather data from the WXR receiver/transmitter (R/T) goes to the display electronics units (DEUs) for display.

HAP 008-013, 015-026, 028-054, 101-999

WXR data shows on the navigation displays (NDs). The weather data from the WXR receiver/transmitter (R/T) goes to the weather radar/terrain (WXR/TERR) relays.

The ground proximity warning computer (GPWC) controls and switches the relays. If TERR is selected on the EFIS control panel or there is a Terrain Awareness/Terrain Clearance Floor warning from the GPWC, then the EGPWS terrain data shows on the navigation display (ND). If TERR is not selected and there are no EGPWS warnings, WXR data shows on the ND.

HAP ALL

WXR SYSTEM - GENERAL DESCRIPTION

Antenna

The WXR antenna sends the RF pulses and receives the RF returns. The R/T gets air data inertial reference unit (ADIRU) pitch and roll data for antenna stabilization.

Receiver/Transmitter (R/T)

The primary component of the WXR system is the weather radar R/T. The WXR R/T does these functions:

- Transmits RF pulses
- Processes the RF returns

HAP 008-013, 015-026, 028-054, 101-999

- Detects windshear events and sends warnings and cautions to the flight crew

HAP ALL

- Supplies the WXR display data.

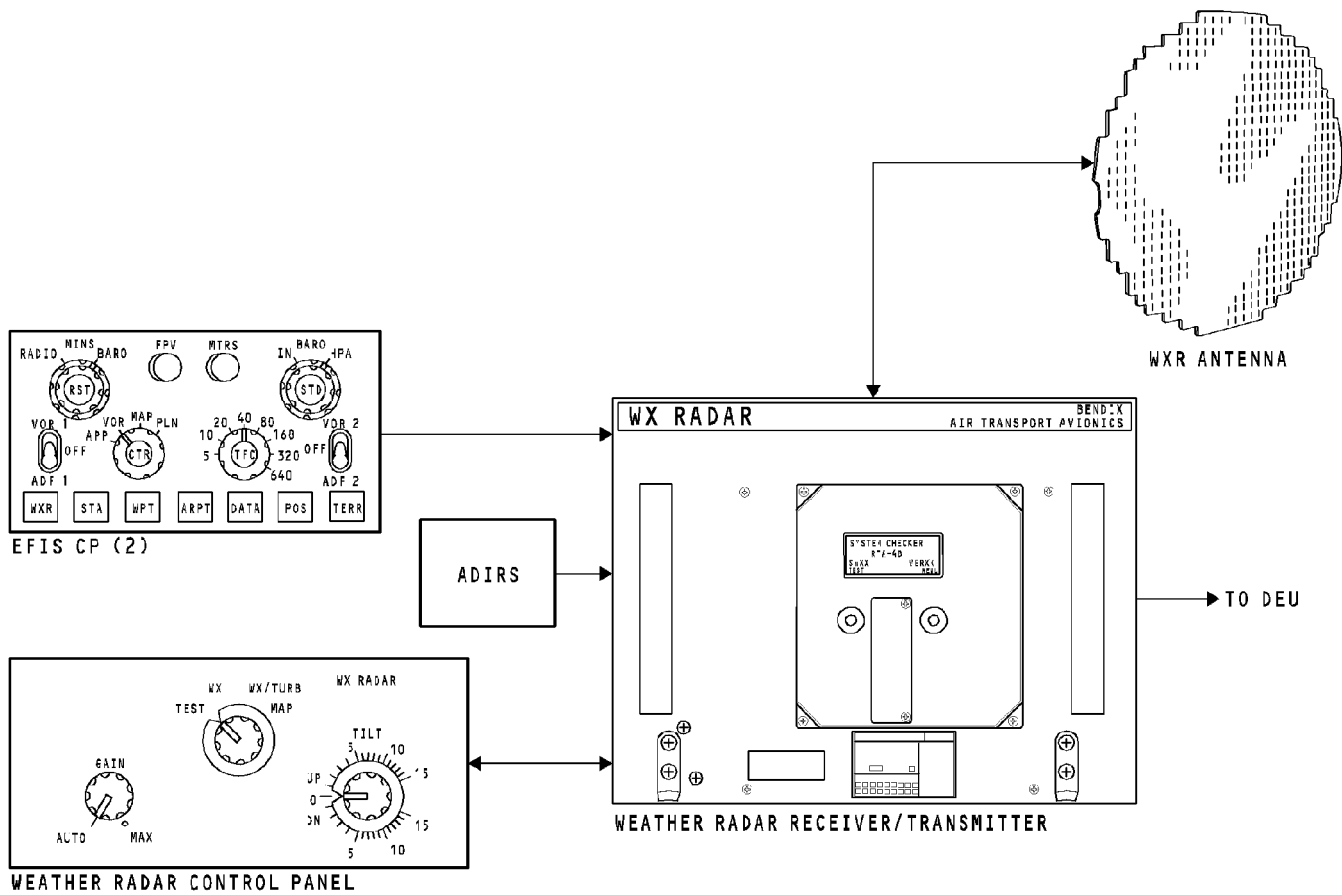

WXR SYSTEM - GENERAL DESCRIPTION

34-43-00-002

EFFECTIVITY
HAP 001-005

34-43-00

D633A101-HAP

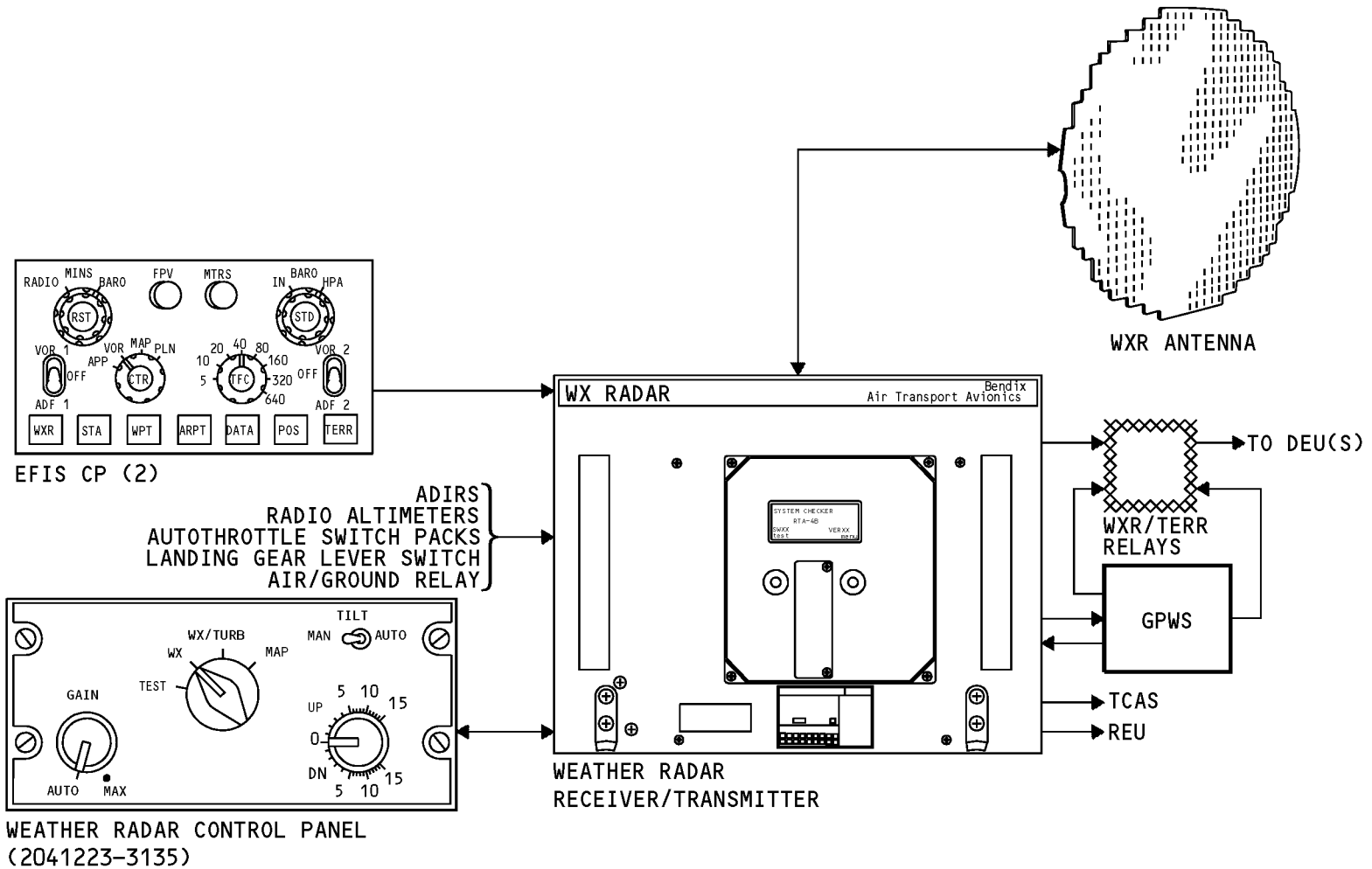

WXR SYSTEM - GENERAL DESCRIPTION

EFFECTIVITY
 HAP 031-054, 101-999

34-43-00

D633A101-HAP

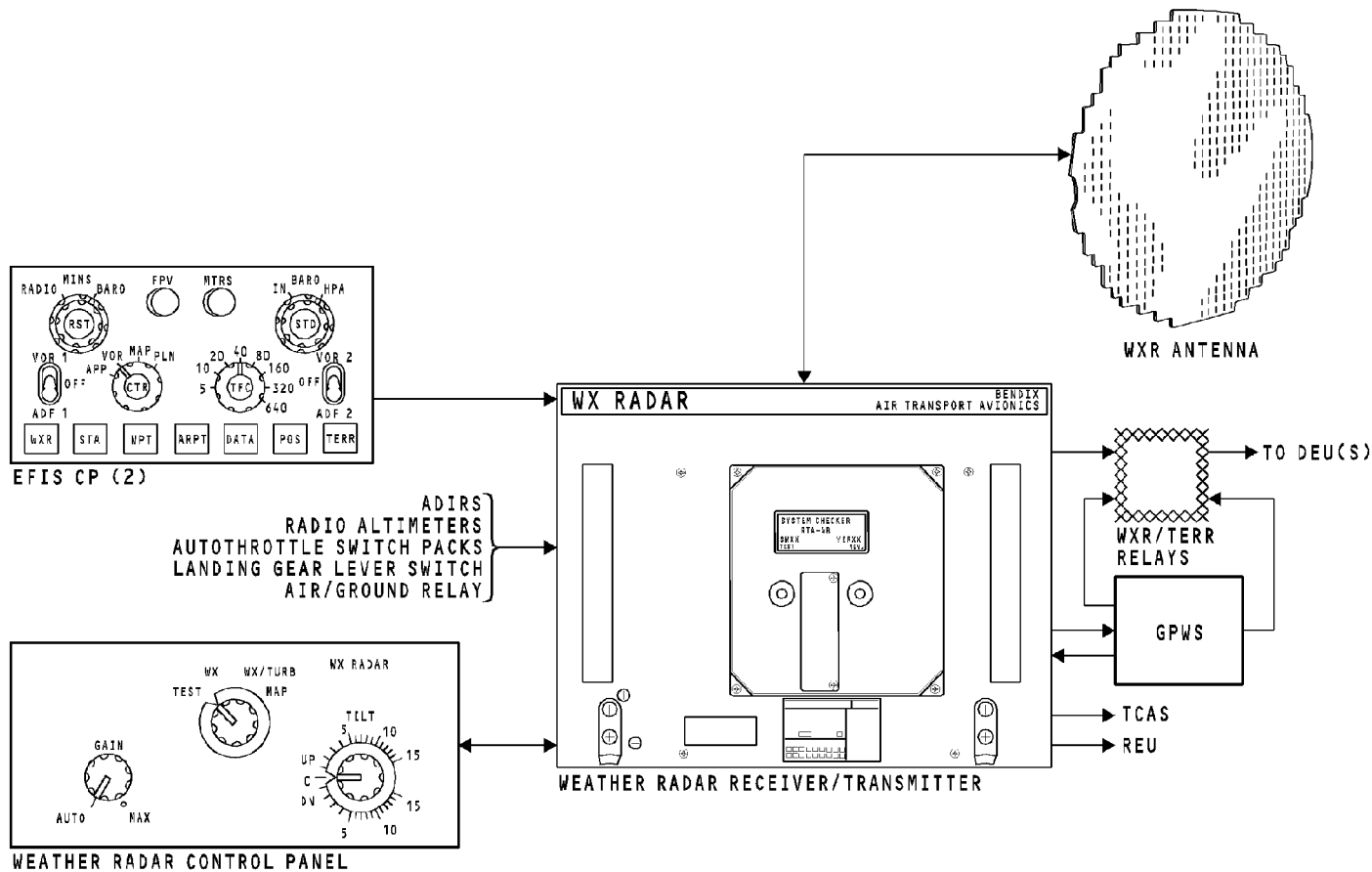

WXR SYSTEM - GENERAL DESCRIPTION

34-43-00-002

EFFECTIVITY
HAP 008-013, 015-026, 028-030

34-43-00

D633A101-HAP

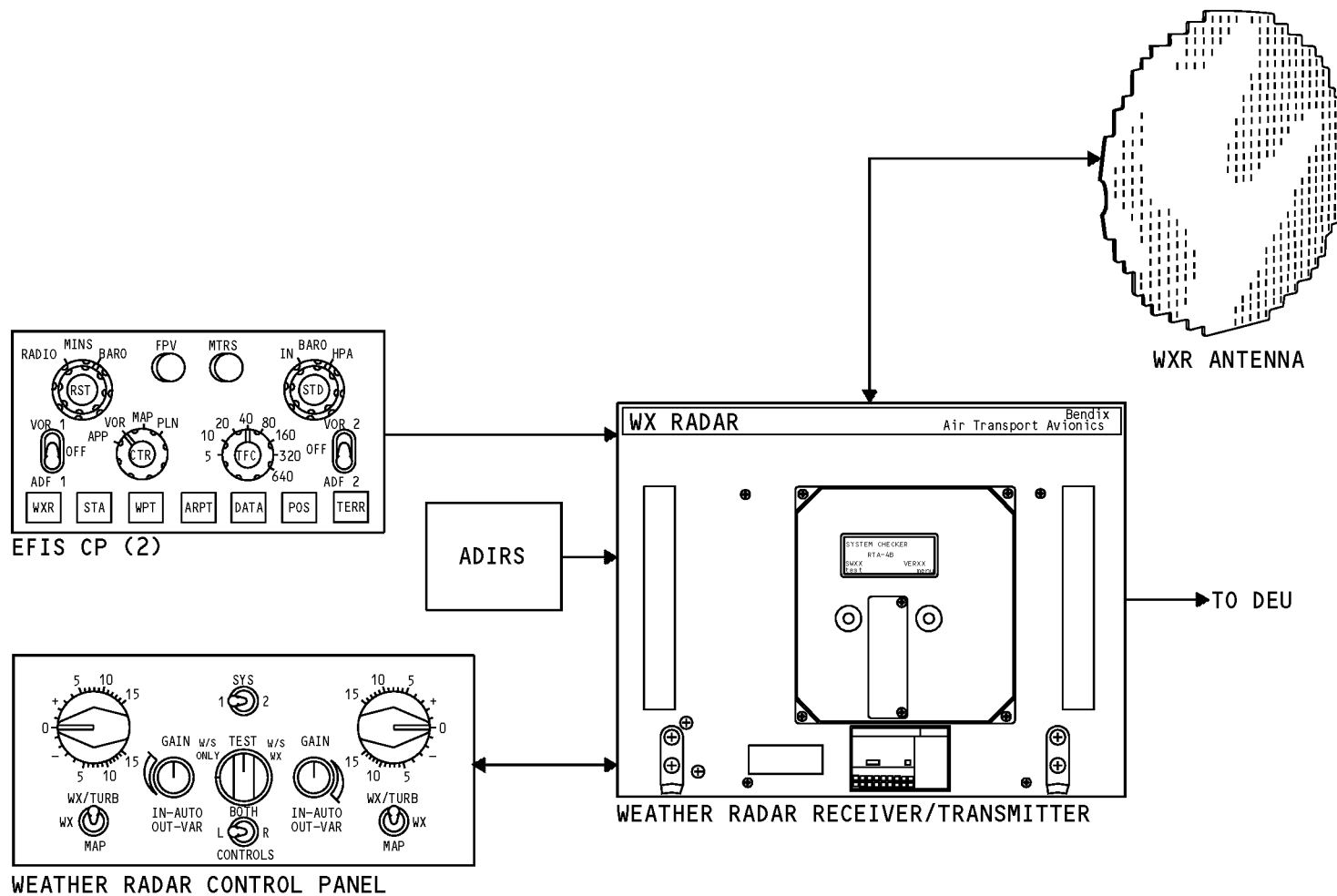

WXR SYSTEM - GENERAL DESCRIPTION

EFFECTIVITY
HAP 001-007

34-43-00

D633A101-HAP

THIS PAGE IS INTENTIONALLY LEFT BLANK

34-43-00

D633A101-HAP

Page 11
Feb 15/2008

WXR SYSTEM - COMPONENT LOCATION - FLIGHT COMPARTMENT**WXR System Components**

The weather radar control panel is on the P8 aft electronic panel in the flight compartment.

WXR System Interface Components

These are the flight compartment components that have an interface with the WXR system:

- Left EFIS control panel (P7)
- Right EFIS control panel (P7)
- Left inboard display unit (P1)
- Right inboard display unit (P3)
- IRS select switch on the navigation/displays source select panel (P5).

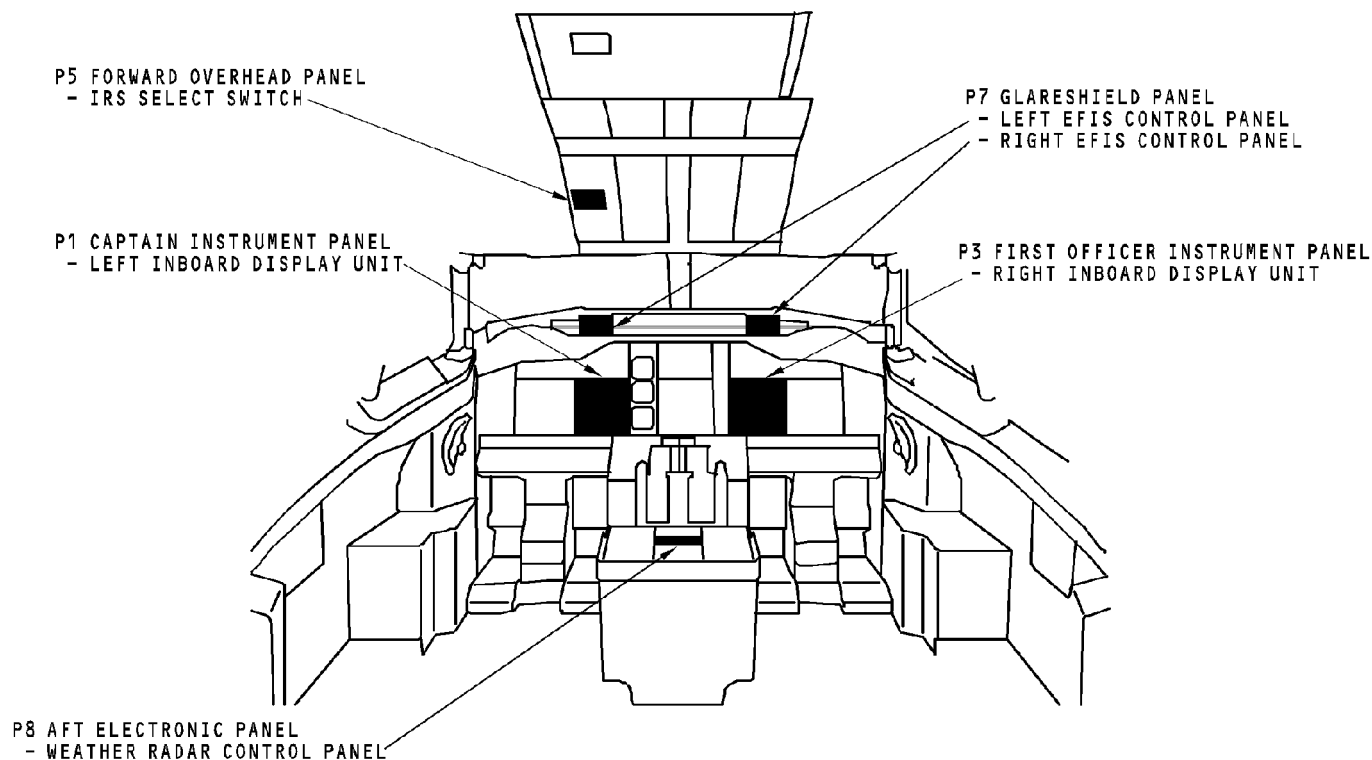

WXR SYSTEM - COMPONENT LOCATION - FLIGHT COMPARTMENT

34-43-00-003

EFFECTIVITY
HAP ALL

34-43-00

D633A101-HAP

WXR SYSTEM - COMPONENT LOCATION - FORWARD EQUIPMENT COMPARTMENT AND NOSE RADOME**General**

The WXR antenna is on the forward bulkhead behind the nose radome.

These are the WXR system components in the forward equipment compartment:

- WXR R/T
- WXR R/T mount.

CAUTION: WHEN REMOVING OR INSTALLING THE WEATHER RADAR R/T, CARE SHOULD BE TAKEN TO AVOID DAMAGE TO THE CAPTAIN PITOT AIR DATA MODULE FLEXIBLE HOSE.

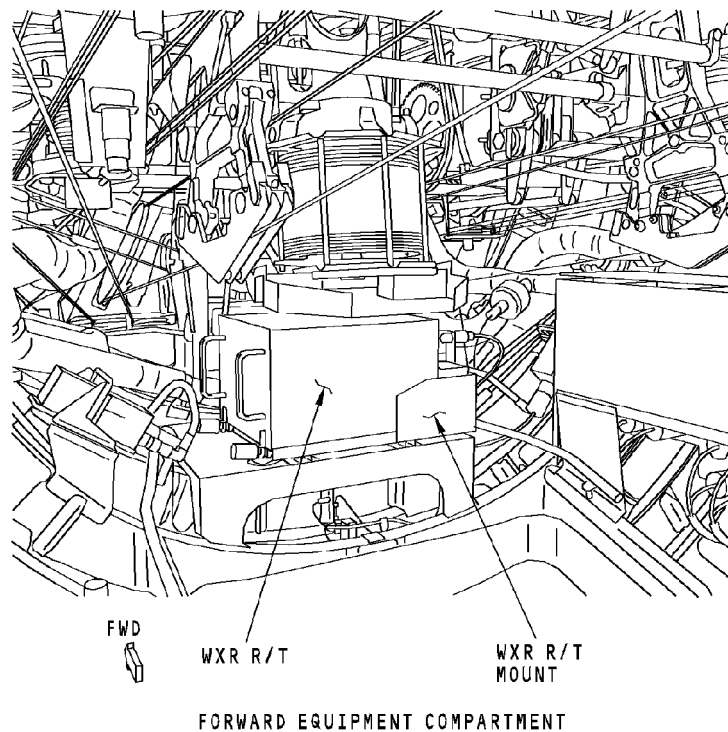
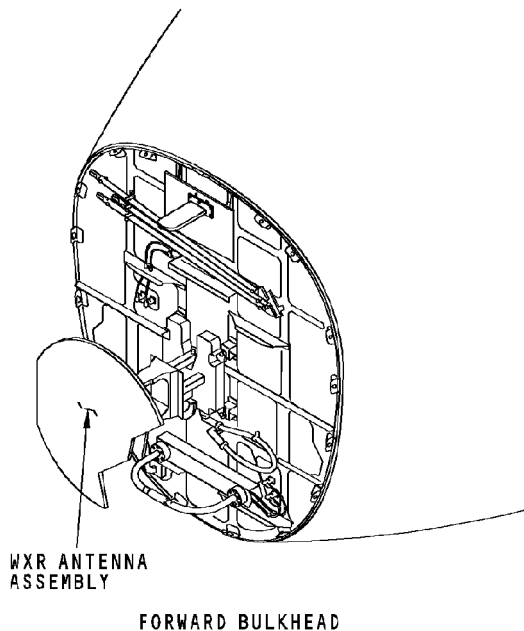

WXR SYSTEM - COMPONENT LOCATION - FORWARD EQUIPMENT COMPARTMENT AND NOSE RADOME

34-43-00-004

EFFECTIVITY
HAP ALL

34-43-00

D633A101-HAP

Page 15
Feb 15/2008

THIS PAGE IS INTENTIONALLY LEFT BLANK

34-43-00

D633A101-HAP

Page 16
Feb 15/2008

WXR SYSTEM - POWER AND ANALOG INTERFACES

System Power and ON/OFF

The WXR receiver transmitter (R/T) gets 115v ac through the WXR RT circuit breaker from the 115v ac XFR BUS 2 (P6 circuit breaker panel). The WXR R/T circuit breaker also sends 115v ac to the WXR R/T mount for fan operation.

The left and right EFIS control panels (CP) send the ON/OFF data to display electronics unit (DEU) 1 and DEU 2. The DEUs make sure the navigation display is in a mode that can show WXR data. If the navigation display is in a correct mode, the DEUs send an ON/OFF discrete to the WXR control panel.

The ON/OFF discrete goes through the WXR control panel to the WXR R/T. This discrete lets the WXR R/T operate.

When the WXR R/T gets the ON signal, it sends 12v dc and 28v dc to the power supply in the WXR control panel (CP).

The 12v dc starts the ARINC 429 transmitter output from the WXR control panel. The ARINC 429 transmitter sends mode data in a digital word to the WXR R/T. Then the R/T starts to operate.

The 28v dc to the WXR control panel is for the power interlock discrete. The 28v dc goes through the interlock discrete circuit then to the WXR R/T. The WXR R/T uses the 28v dc to turn on the WXR R/T power supply. The WXR control panel interlock circuit makes sure the WXR R/T will not operate if the control panel fails or if the control panel is removed.

The WXR antenna gets 115v ac from the WXR R/T.

The fan gets 115v ac for the ac XFR BUS 2. The fan operates when the circuit breaker is closed.

Discrettes

HAP 008-013, 015-026, 028-054, 101-999

The GPWS sends an inhibit discrete to the PWS. The discrete inhibits PWS aural alerts if the GPWS alerts are a higher priority.

The PWS will complete the current alert if a higher GPWS alert is received.

The landing gear lever sends a landing gear down discrete to enable PWS during an approach.

HAP 001-007

The landing gear lever discrete is not used at this time.

34-43-00-005

<p>EFFECTIVITY HAP ALL</p>
--

34-43-00

D633A101-HAP

WXR SYSTEM - POWER AND ANALOG INTERFACES

HAP 001-007 (Continued)**HAP ALL**

The air/ground discrete defines flight legs in the WXR R/T.

HAP 008-013, 015-026, 028-054, 101-999

The left and right auto throttle switch packs send discretes (QFR A) to enable the PWS function. When the throttles move through 53 degrees and the aircraft is below 2300 feet RA, the radar turns on.

The audio inhibit discrete goes to the TCAS. The TCAS uses this discrete to downgrade all RAs to TAs and inhibit all aural alerts.

HAP ALL**RF Transmission and Reception**

Transmit radio frequency (RF) goes from the R/T through the waveguide to the weather radar antenna. The receive RF goes from the antenna through the waveguide to the R/T.

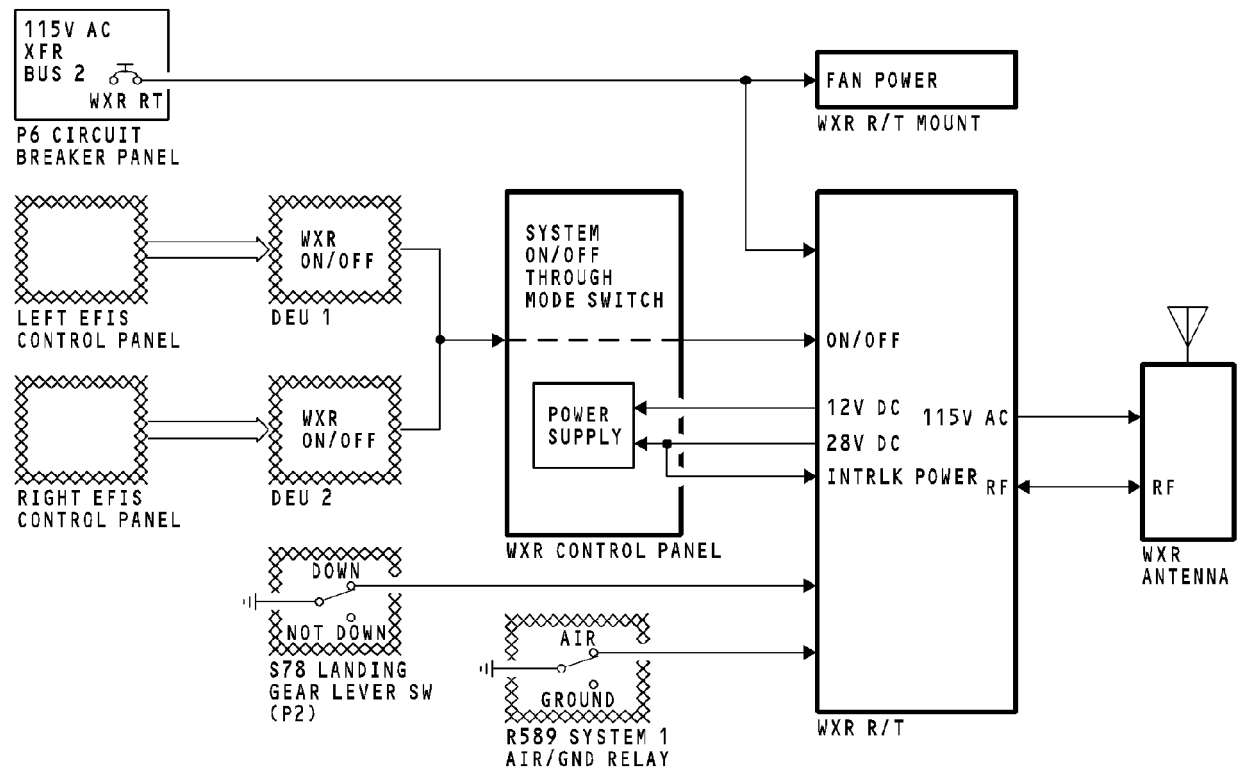

WXR SYSTEM - POWER AND ANALOG INTERFACES

34-43-00-005

EFFECTIVITY
HAP 001-007

34-43-00

D633A101-HAP

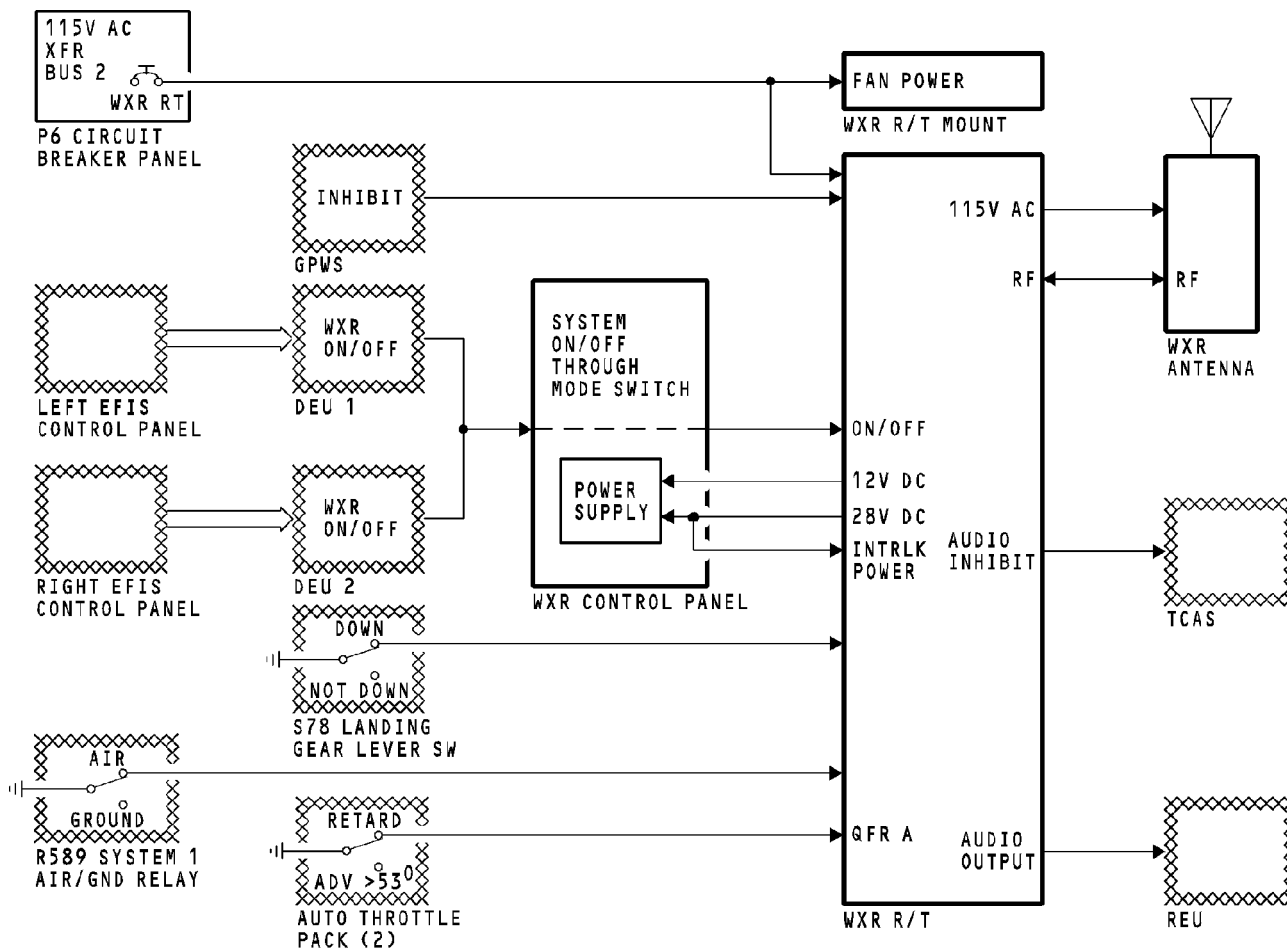

WXR SYSTEM - POWER AND ANALOG INTERFACES

EFFECTIVITY

HAP 008-013, 015-026, 028-054, 101-999

34-43-00

D633A101-HAP

WXR SYSTEM - CONTROL AND DISPLAY INTERFACE

Digital Inputs

The WXR R/T receives data from these systems:

- Air data inertial reference system (ADIRS)

HAP 008-013, 015-026, 028-054, 101-999

- Radio altimeter (RA) system

HAP ALL

- Common display system (CDS).

Air Data Inertial Reference System

The ADIRS sends this inertial reference (IR) data to the WXR R/T on a high-speed ARINC 429 data bus:

- Ground speed
- True heading
- Track angle
- Magnetic heading
- Drift angle
- Pitch angle
- Roll angle
- Inertial altitude
- N-S velocity
- E-W velocity.

HAP 008-013, 015-026, 028-054, 101-999

The WXR R/T uses the attitude data for stabilization, E-W and N-S velocity data for velocity calculations, and true heading for scan-to-scan integration. Ground speed and track angle are used for backup data for velocity calculations.

HAP 001-007

The WXR R/T uses the IR data for antenna stabilization.

HAP 008-013, 015-026, 028-054, 101-999

The ADIRS sends this air data (AD) to the WXR R/T on a low-speed ARINC 429 data bus:

- Uncorrected baro altitude
- Corrected baro altitude
- True airspeed
- Computed airspeed.

The WXR R/T uses altitude and airspeed data for windshear calculation. The WXR R/T also uses altitude data for sensitivity time control calculations.

Radio Altimeter System

The radio altimeters send radio altitude on a low-speed ARINC 429 data bus to the WXR R/T for the predictive windshear (PWS) function. The PWS uses this data to do these functions:

- Turn PWS on and off
- Enable/disable display and alert functions.

HAP ALL

34-43-00-006

<p>EFFECTIVITY HAP ALL</p>
--

34-43-00

D633A101-HAP

WXR SYSTEM - CONTROL AND DISPLAY INTERFACE**Common Display System**

The EFIS control panels send range data and the WXR on/off discrete to the display electronic units (DEUs) on an ARINC 429 data bus.

The DEUs send range data from the EFIS control panel to the WXR R/T on ARINC 429 data buses. The DEUs send the WXR on/off discrete to the WXR control panel on a discrete wire.

Control Inputs

The WXR control panel supplies this data to the WXR R/T:

- Transmit mode
- Tilt
- Gain control
- On/off discrete.

WXR Output Data and Display**HAP 001-007**

The WXR R/T sends display data on an ARINC 453 data bus to the display electronic units (DEUs) to show on the navigation displays.

HAP 008-013, 015-026, 028-054, 101-999

The WXR R/T sends display data on an ARINC 453 data bus to the terrain weather relays. The display data goes from the terrain weather relays to the DEUs to show on the navigation displays. The terrain/weather radar relays are controlled by the ground proximity warning computer (GPWC).

The WXR R/T sends windshear alert data on an ARINC 708A hazard bus to the ground proximity warning system (GPWS). The GPWS uses this data to prioritize alert callouts. If a higher GPWS alert exists, the GPWC switches the terrain weather relays and terrain data is shown on the NDs.

HAP ALL

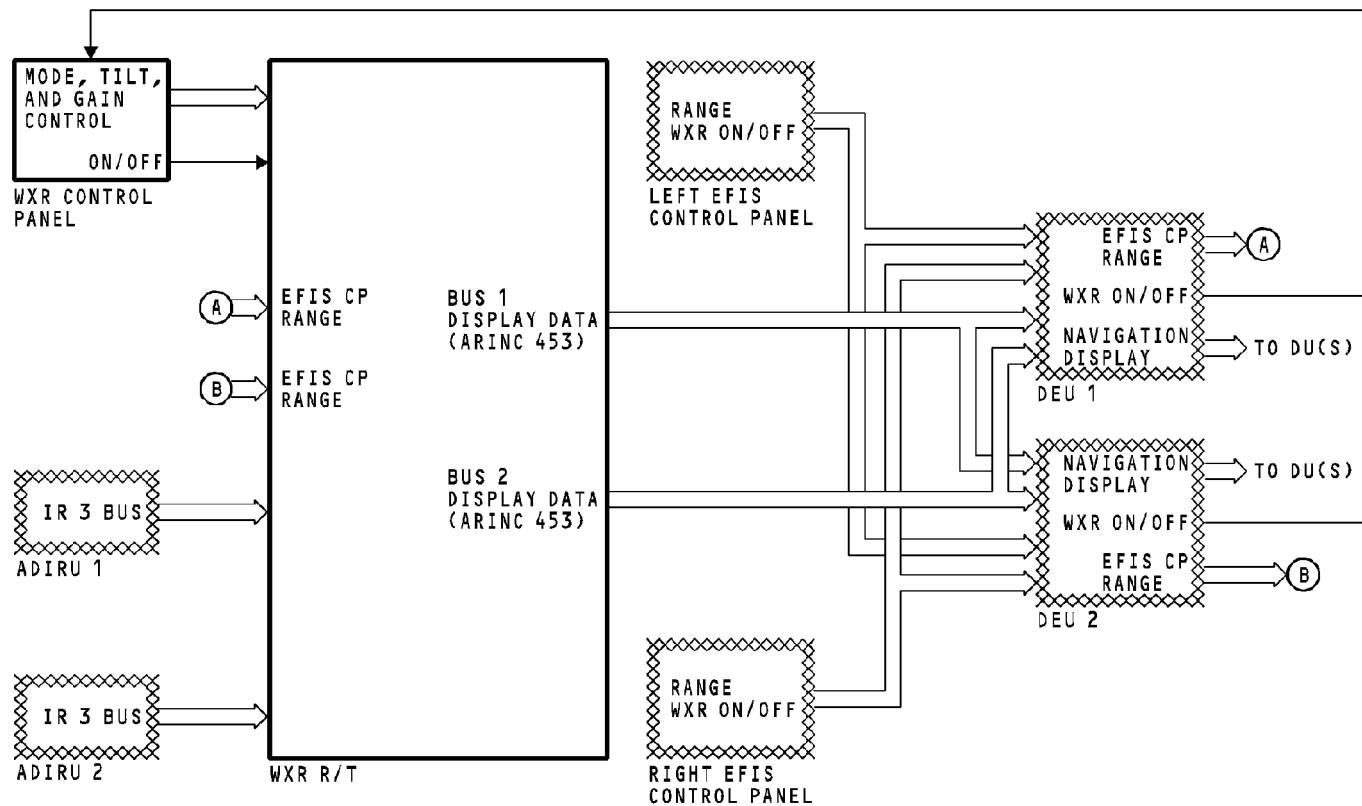

WXR SYSTEM - CONTROL AND DISPLAY INTERFACE

34-43-00-006

EFFECTIVITY
HAP 001-007

34-43-00

D633A101-HAP

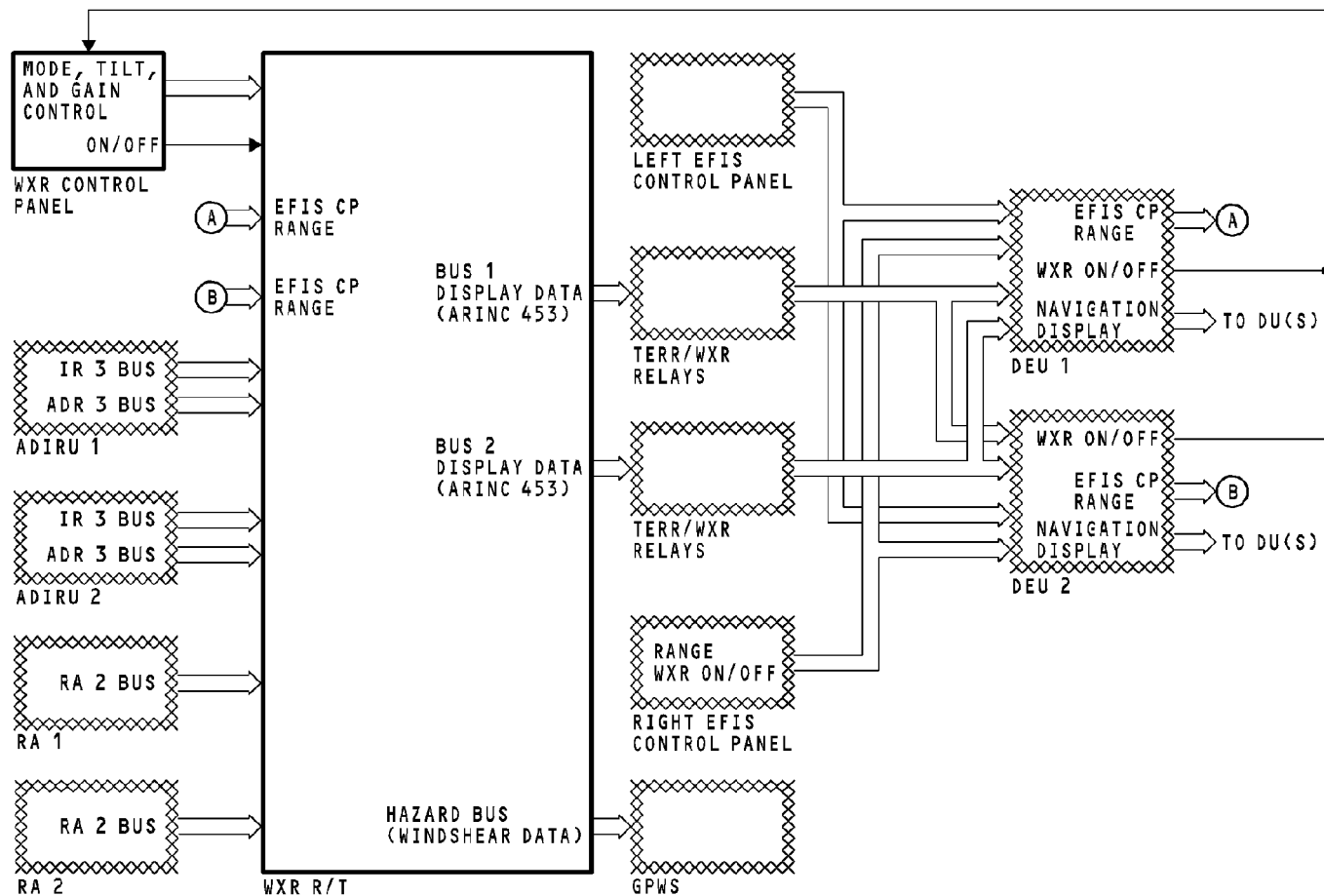

WXR SYSTEM - CONTROL AND DISPLAY INTERFACE

EFFECTIVITY

HAP 008-013, 015-026, 028-054, 101-999

34-43-00

D633A101-HAP

WXR SYSTEM - PWS INTERFACES**General Description**

The predictive windshear (PWS) part of the weather radar (WXR) system interfaces with other airplane systems and components.

Air Data Inertial Reference System

The air data inertial reference system (ADIRS) sends this data to PWS:

- Attitude Data
- Heading data
- Air data.

Ground Proximity Warning Computer

PWS sends windshear alert data to the ground proximity warning computer (GPWC) on the ARINC 708A hazard bus. The GPWC uses this data to prioritize alerts. If there is a higher priority alert, the GPWC sends an inhibit discrete to the WXR. This discrete inhibits the PWS alert output.

Landing Gear Control Lever Module

The landing gear control lever module sends an analog discrete to PWS. PWS uses this discrete in its takeoff/approach alert logic.

Radio Altimeter

The radio altimeter (RA) provides radio altitude data to PWS. PWS uses radio altitude data to do these functions:

- Turn PWS on and off
- Enable/disable display and alert functions.

Remote Electronic Unit

The WXR sends the PWS aural alerts to the remote electronic unit (REU).

Autothrottle Microswitch Pack

The left and right autothrottle microswitch packs send a discrete to the PWS. The PWS uses this discrete to determine the throttle lever position for the automatic turn on.

Display Electronic Unit

The WXR sends the following discrettes to the display electronic units:

- PWS warning
- PWS caution
- PWS fail.

WXR SYSTEM - PWS INTERFACES

Traffic Alert and Collision Avoidance System

WXR sends an inhibit discrete to the traffic alert and collision avoidance system (TCAS) computer when there is a PWS alert. This discrete does these functions:

- Changes resolution advisories (RAs) to traffic advisories (TAs)
- Inhibits all TCAS audio alerts.

EFFECTIVITY

HAP 008-013, 015-026, 028-054, 101-999

34-43-00

D633A101-HAP

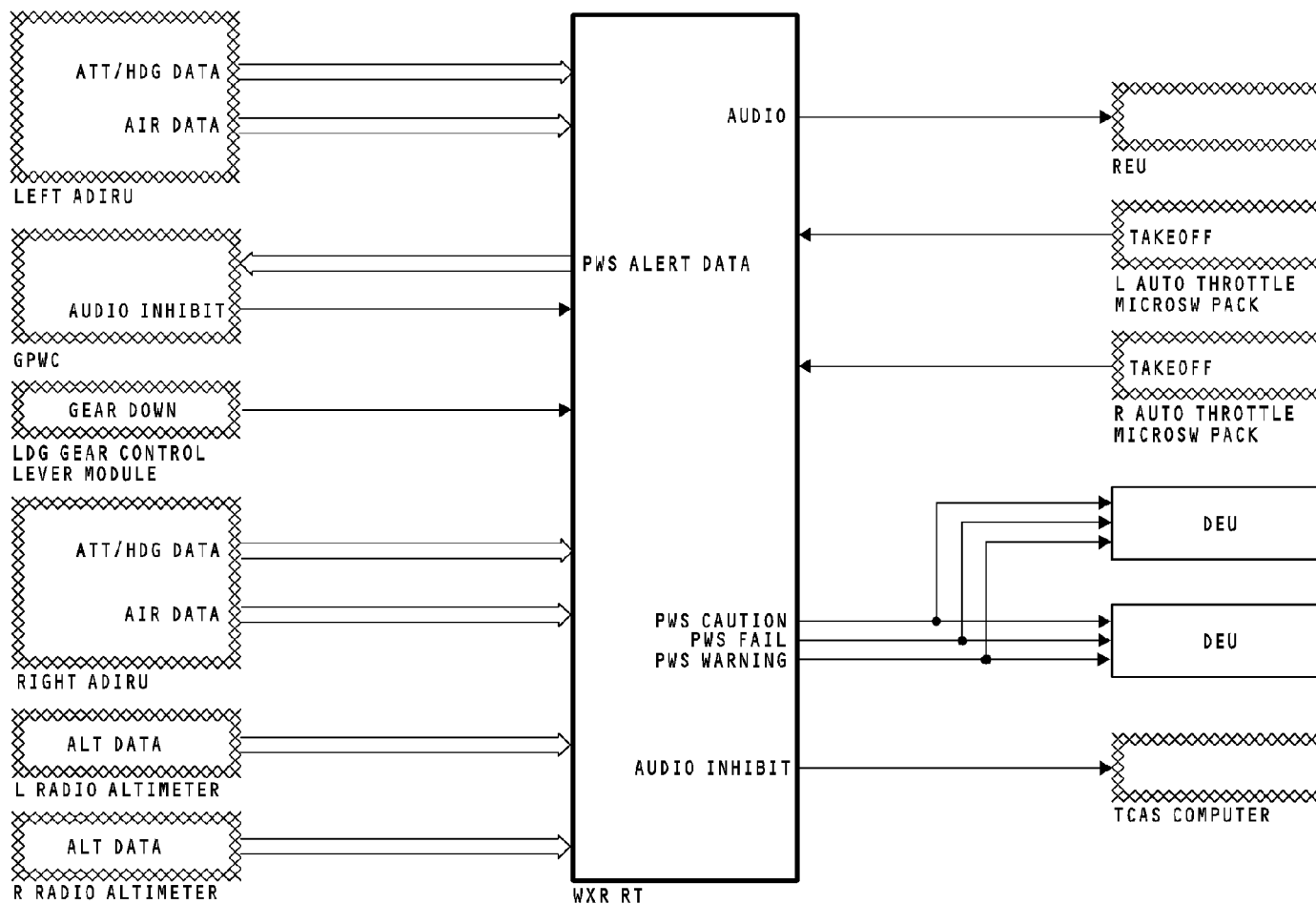

WXR SYSTEM - PWS INTERFACES

34-43-00-025

EFFECTIVITY
HAP 008-013, 015-026, 028-054, 101-999

34-43-00

D633A101-HAP

WXR SYSTEM - ANTENNA CONTROL INTERFACE**Antenna Tilt**

The WXR panel supplies antenna tilt control signals to the WXR R/T.

Attitude Sources

The WXR R/T uses ADIRU attitude data to stabilize the antenna.

The left ADIRU signals connect to the on-side attitude input of the WXR R/T. The right ADIRU signals connect to the off-side attitude input of the WXR R/T.

Attitude Source Select Discrete

Use the IRS select switch to choose the ADIRU source to the WXR R/T. Set the switch to NORMAL or BOTH ON L to use the left ADIRU input. Set the switch to BOTH ON R to use the right ADIRU input.

WXR R/T Antenna Control

The WXR R/T sends signals to the WXR antenna assembly to control it and make it stable.

Antenna Position Monitoring

The WXR antenna sends antenna position data to the WXR R/T for scan and elevation feedback.

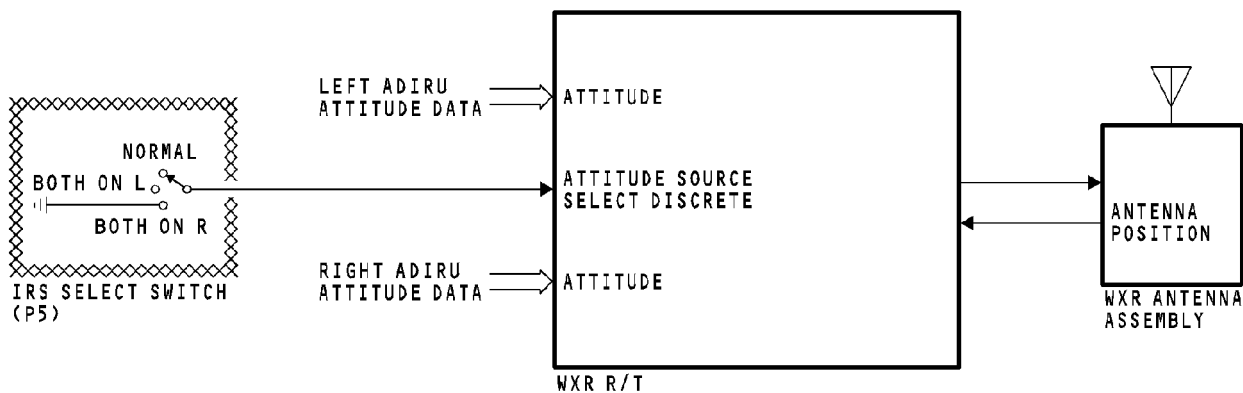

WXR SYSTEM - ANTENNA CONTROL INTERFACE

34-43-00-007

EFFECTIVITY
HAP ALL

34-43-00

D633A101-HAP

WXR SYSTEM - CONTROL PANEL

General

The weather radar (WXR) control panel has these functions:

- Mode selection
- Tilt control
- Gain control.

Mode Selector

HAP 001-013, 015-026, 028-030

The mode selector has these positions:

HAP 031-054, 101-999

The mode selector has these positions:

HAP 001-013, 015-026, 028-030

- TEST - starts a self-test of the R/T and shows the test results on the NDs
- WX - R/T shows the weather data on the NDs
- WX/TURB - R/T shows weather and turbulence data on the NDs. The turbulence range is up to a maximum of 40 nautical miles (NM). If a range more than 40 NM is set on the EFIS control panel, the NDs show weather plus turbulence data up to a range of 40 NM and weather data only beyond 40 NM.
- MAP - R/T shows ground and terrain features on the NDs.

HAP 031-054, 101-999

- TILT - Tilt switch shows the selection of the automatic or manual tilt mode.
- TEST - starts a self-test of the R/T and shows the test results on the NDs.

- WX - R/T shows the weather data on the NDs.
- WX/TURB - R/T shows weather and turbulence data on the NDs. The turbulence range is up to a maximum of 40 nautical miles (NM). If a range more than 40 NM is set on the EFIS control panel, the NDs show weather plus turbulence data up to a range of 40 NM and weather data only beyond 40 NM.
- MAP - R/T shows ground and terrain features on the NDs.

HAP ALL

Tilt Control

The tilt control adjusts the antenna tilt angle from + 15 degrees to -15 degrees.

Gain Control

HAP 001-013, 015-026, 028-030

The gain control adjusts the gain for the WXR R/T signal returns. In the AUTO position, the gain is set to a calibrated level by the R/T.

HAP 031-054, 101-999

The gain control adjusts the gain for the WXR R/T signal returns. In the AUTO position, the gain is set to a calibrated level by the R/T.

HAP ALL

EFFECTIVITY
HAP ALL

34-43-00

D633A101-HAP

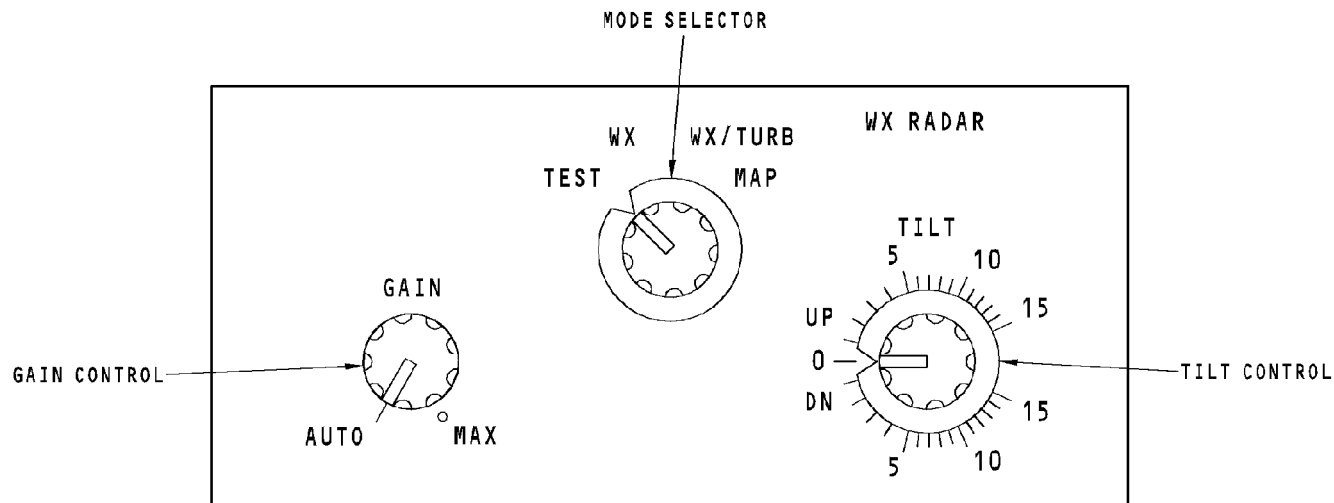

WXR SYSTEM - CONTROL PANEL

34-43-00-008

EFFECTIVITY
HAP 001-013, 015-026, 028-030

34-43-00

D633A101-HAP

Page 31
Feb 15/2008

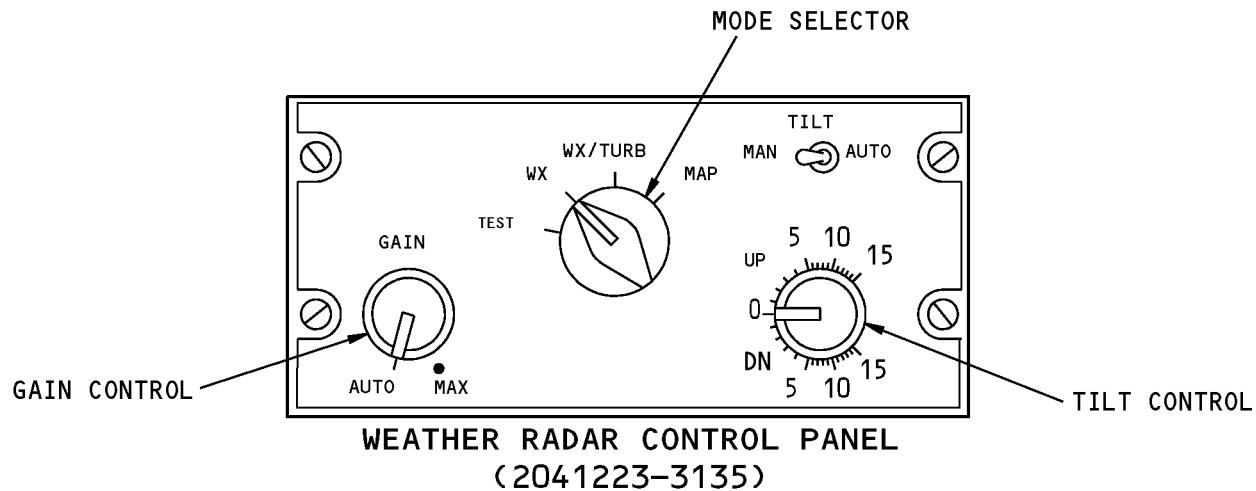

WXR SYSTEM - CONTROL PANEL

34-43-00-008

EFFECTIVITY
HAP 031-054, 101-999

34-43-00

D633A101-HAP

THIS PAGE IS INTENTIONALLY LEFT BLANK

34-43-00

D633A101-HAP

Page 33
Feb 15/2008

WXR SYSTEM - RECEIVER/TRANSMITTER**Purpose**

These are the functions of the WXR receiver/transmitter (R/T):

- Make and transmit RF pulses
- Process RF return signals
- Make display data
- Send display data to the DEUs
- Supply antenna stabilization
- Monitor and do system operation test
- Record and show fault status and test results
- Send fault status and test data to the DEUs
- Make WXR display test patterns show on the display units.

The WXR R/T provides these displays to the DEUs:

- Test
- Weather
- Map (ground mapping).

Physical Description

The WXR R/T weighs approximately 29.5lbs (13.4 kg). Forced air from the WXR R/T mount cools the WXR R/T. The front panel of the R/T has these items:

- Liquid crystal display (LCD)
- Two test switches
- RS232 test connector.

LCD Display

The LCD is a four-line display. It shows test results and maintenance data.

Test Switches

Push the left test switch to start the self-test of the WXR R/T.

RS232 Test Connector

There is an RS232 test connector. Line maintenance personnel do not use it.

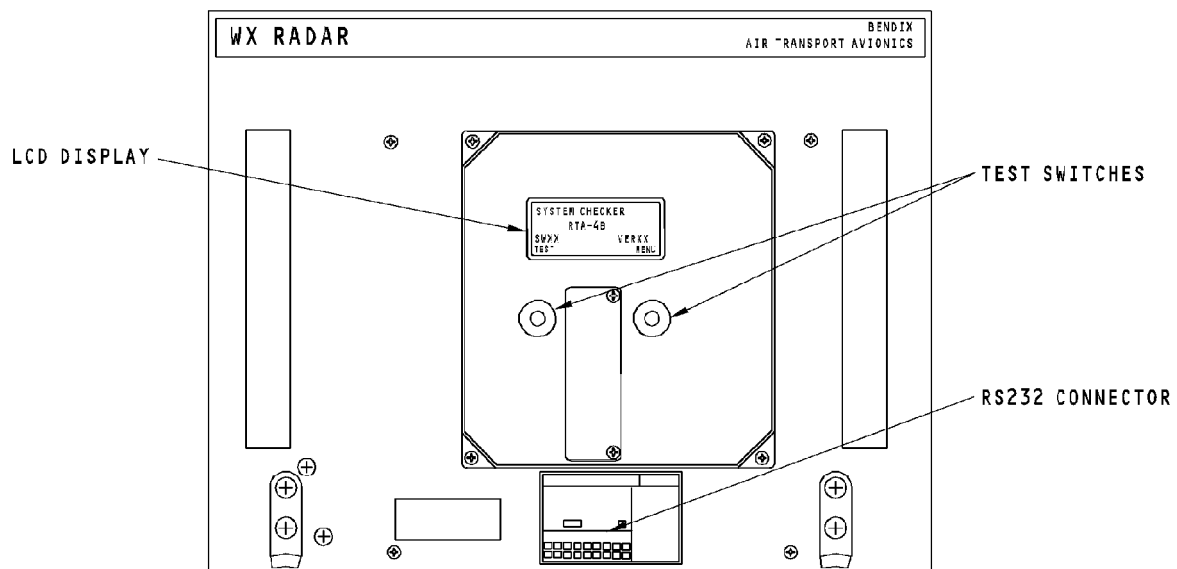

WXR SYSTEM - RECEIVER/TRANSMITTER

34-43-00-009

EFFECTIVITY
HAP ALL

34-43-00

D633A101-HAP

WXR SYSTEM - R/T MOUNT**Purpose**

The WXR R/T mount:

- Holds the R/T
- Connects the R/T to the airplane wiring
- Connects the R/T to the waveguide
- Supplies cooling air to the R/T.

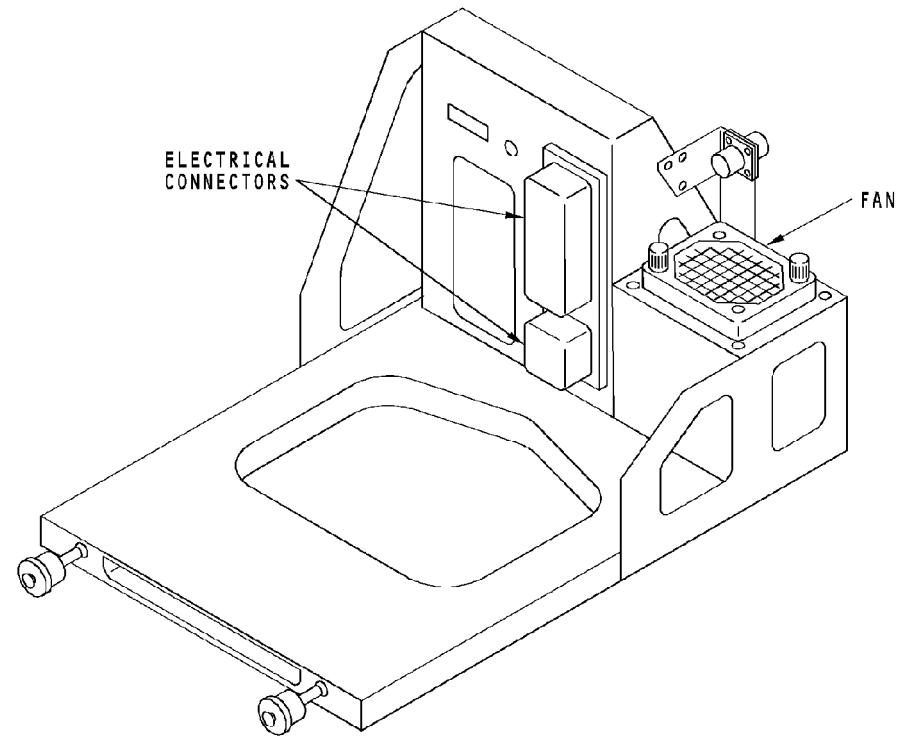

WXR SYSTEM - R/T MOUNT

34-43-00-010

EFFECTIVITY
HAP ALL

34-43-00

D633A101-HAP

THIS PAGE IS INTENTIONALLY LEFT BLANK

34-43-00

D633A101-HAP

Page 38
Feb 15/2008

WXR SYSTEM - ANTENNA**Antenna Assembly**

These are the parts of the antenna:

- Flat plate antenna
- Antenna pedestal.

Flat Plate Antenna

The flat plate antenna transmits and receives RF pulses.

The flat plate antenna is an array of radiation slots. The RF pulses radiate from each of the slots. The antenna makes a beam 3.6 degrees high and 3.4 degrees wide. The antenna weighs 6.5 lb (3 kg). It is 23 inches wide.

Antenna Pedestal

The antenna pedestal contains these items:

- Scan motors
- Antenna position transmitters
- Elevation and scan disable switches.

The antenna pedestal receives 115v ac power from the WXR R/T for operation.

There is a horizontal scan motor to move the antenna +/- 90 degrees from the airplane centerline. There is also an elevation scan motor to move the antenna +/- 40 degrees up or down. This value includes manual tilt selection from the WXR control panel.

There are elevation and azimuth synchros. These synchros send the antenna positions to the WXR R/T. The WXR R/T gets antenna position data from the synchros. The WXR R/T also has a command position. The monitor circuit in the R/T tells when there is a difference between the two values. Then it sets an antenna failure.

There are elevation and scan disable switches on the antenna pedestal. They remove power to the scan and elevation motors. Use these switches to prevent movement of the antenna during maintenance. The switches do not stop RF transmissions from the WXR R/T.

A torque spring in the antenna pedestal balances the weight of the antenna. When you remove the antenna, the torque spring moves the elevation drive to the upper position.

Training Information Point

Use the elevation and scan disable switches for safety to make sure that the antenna does not move while you work on or around it.

WXR SYSTEM - ANTENNA

WARNING: DO NOT OPEN THE NOSE RADOME IF THE WIND IS MORE THAN 15 KNOTS. IF YOU OPEN THE RADOME IN A WIND, THE RADOME CAN MOVE QUICKLY. THIS CAN CAUSE INJURY TO PERSONS OR DAMAGE TO EQUIPMENT.

WARNING: DO NOT OPERATE THE WEATHER RADAR UNLESS ALL PERSONNEL ARE MORE THAN 50 FT (15 M) FROM THE RADAR. DO NOT OPERATE THE WEATHER RADAR IN A HANGAR. IF YOU DO NOT OBEY THESE PRECAUTIONS, INJURIES TO PERSONNEL CAN OCCUR.

WARNING: IF THERE IS FUEL LEAKAGE OR AN OPEN FUEL CELL LESS THAN 50 FT (15 M) FROM THE RADAR, DO NOT OPERATE THE WEATHER RADAR. IF THERE IS FUEL IN THE 50-FOOT RADIUS AROUND THE RADAR, IT CAN CAUSE A FIRE AND EXPLOSION. THESE CAN CAUSE INJURIES TO PERSONNEL, AND DAMAGE TO EQUIPMENT. THESE CAN KILL PERSONNEL.

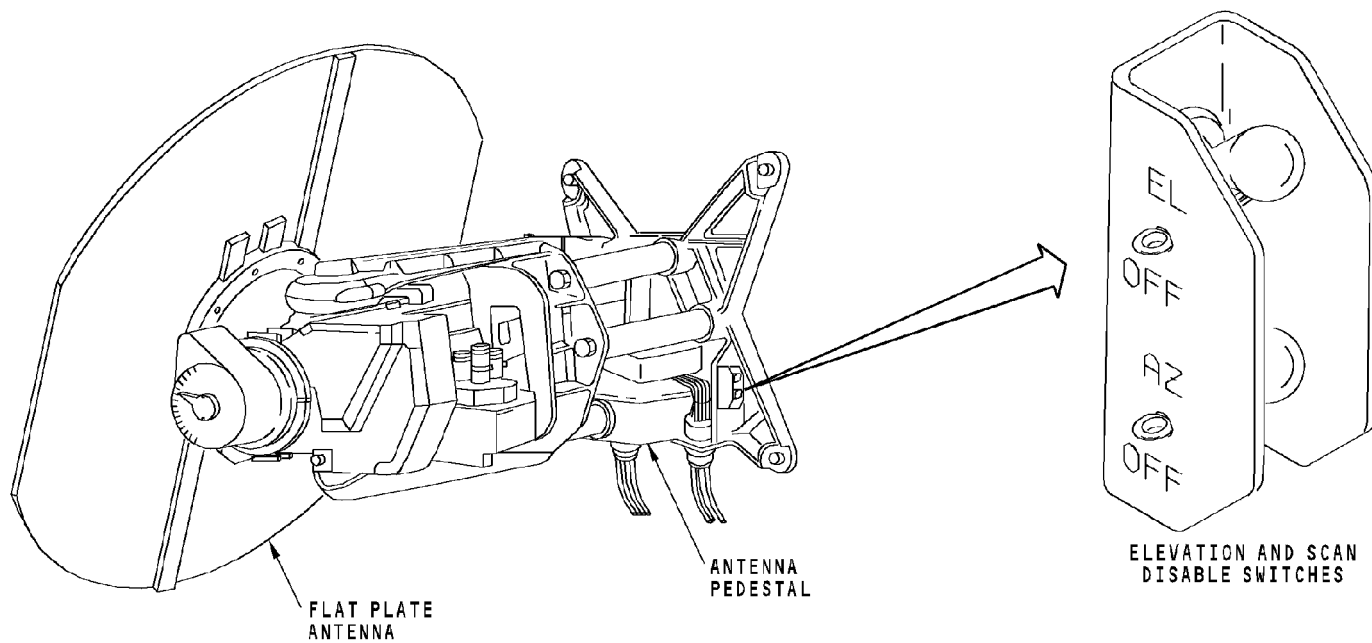

WXR SYSTEM - ANTENNA

34-43-00-011

EFFECTIVITY
HAP ALL

34-43-00

D633A101-HAP

Page 41
Feb 15/2008

WXR SYSTEM - EFIS CONTROL PANEL - OPERATION**EFIS Control Panel**

These are the functions of the EFIS control panel (CP) for WXR control:

- Supplies the on and off control of the WXR R/T
- Enables the navigation displays (ND) to show WXR data
- Supplies the selection of different ND modes
- Supplies the selection of different ranges for WXR data to show on the NDs.

WXR Map Switch

These are the things that occur when you push the WXR map switch:

- The WXR R/T starts to operate
- The WXR data shows on the on-side ND.

To stop the operation of the WXR R/T, the WXR map switches on both EFIS control panels must be off.

Mode Selector

Use the mode selector switch to select an ND mode. A WXR display can show in these ND modes:

- Expanded APP (approach) mode
- Expanded VOR mode
- Expanded MAP mode
- Centered MAP mode.

Range Selector

The EFIS control panel range selector has eight positions. The range selections are 5, 10, 20, 40, 80, 160, 320, and 640 nautical miles (NM). With the 640 NM range selection, the 640 NM range shows on the ND. But the WXR R/T only shows weather displays out to a maximum range of 320 NM.

The weather/turbulence mode shows turbulence data up to a maximum range of 40 nautical miles (NM). If a range more than 40 NM is set on the EFIS control panel, the NDs show weather and turbulence data up to a range of 40 NM and weather data only beyond 40 NM.

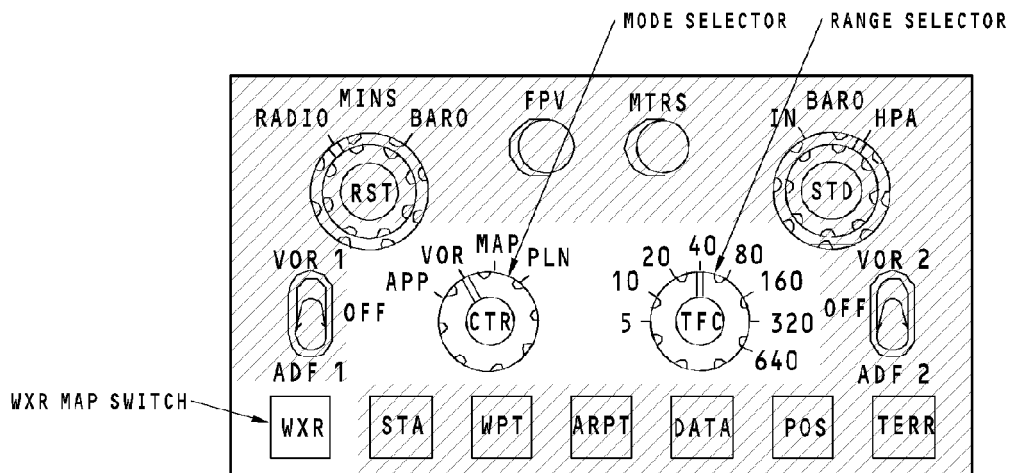

WXR SYSTEM - EFIS CONTROL PANEL - OPERATION

34-43-00-012

EFFECTIVITY
HAP ALL

34-43-00

D633A101-HAP

WXR SYSTEM - SYSTEM SELECT AND SYSTEM ON/OFF**System Select**

The receiver transmitter (R/T) gets 115v ac from XFR bus 2. The power supply makes 12v dc and 28v dc. The WXR R/T sends 12v dc and 28v dc to the voltage regulator in the control panel. It also sends 115v ac to the R/T and the fan when the WXR is selected ON.

System On

To make the WXR system operate, push the WXR switch on one of the EFIS control panels.

When you push the WXR switch, the on-side display electronics units (DEU) supplies a ground through the WXR control panel. When the R/T gets the ON discrete, it turns on the power supply and supplies these voltages:

- 12v dc to the control panel
- 28v dc to the control panel
- 115v ac to the antenna and the fan.

The 12v dc power to the control panel starts the ARINC 429 transmitter output. This allows the WXR control panel mode information to be sent to the R/T. The 28v dc goes back to the R/T to start the ARINC 429 receiver and the micro processor. The R/T starts to operate when it gets the digital mode information.

HAP 008-013, 015-026, 028-054, 101-999

Certain conditions cause the predictive windshear (PWS) function to turn the WXR system on automatically. When this happens, the ground signal comes from the PWS card in the R/T instead of the DEUs.

HAP ALL**System Off**

To make the WXR system go OFF, push the WXR switch on the EFIS control panel to OFF. This removes the ON discrete from the DEU. If more than one WXR switch is on, push all of the switches to OFF.

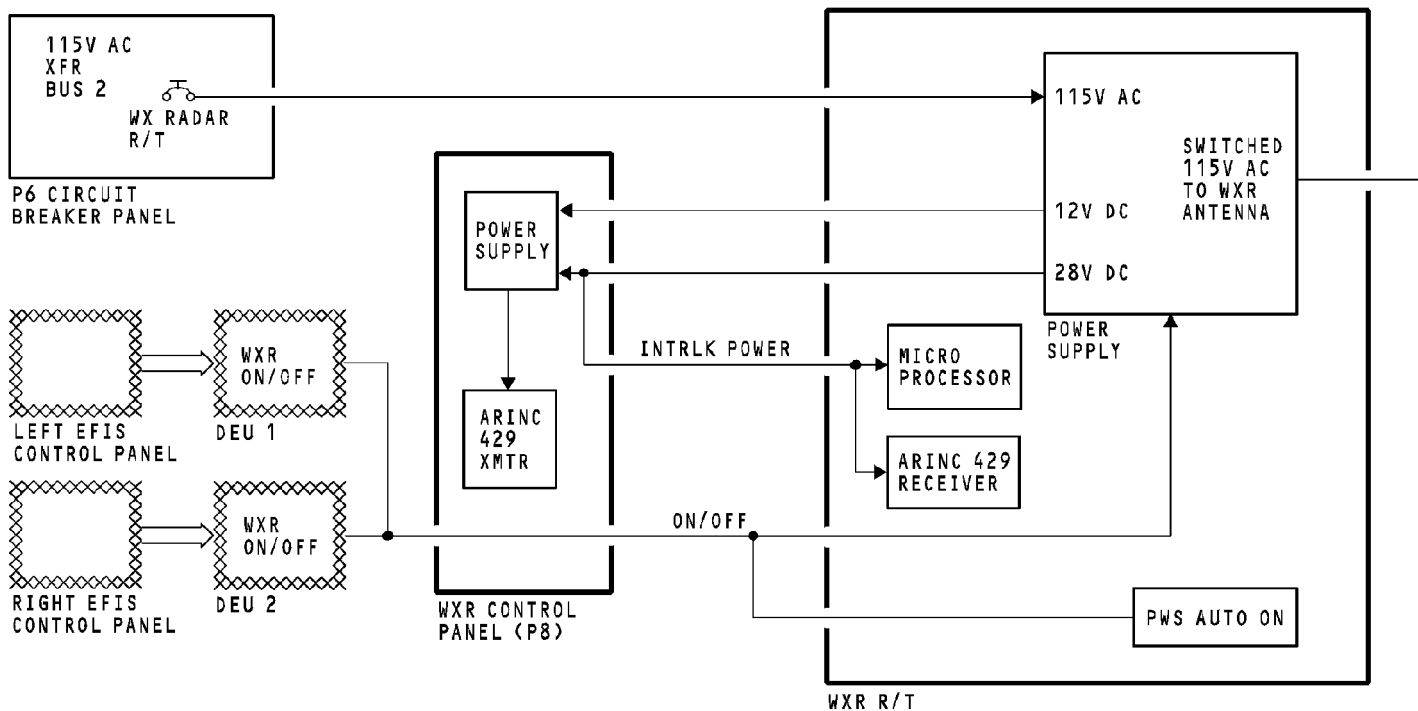

WXR SYSTEM - SYSTEM SELECT AND SYSTEM ON/OFF

34-43-00-014

EFFECTIVITY
HAP 008-013, 015-026, 028-054, 101-999

34-43-00

D633A101-HAP

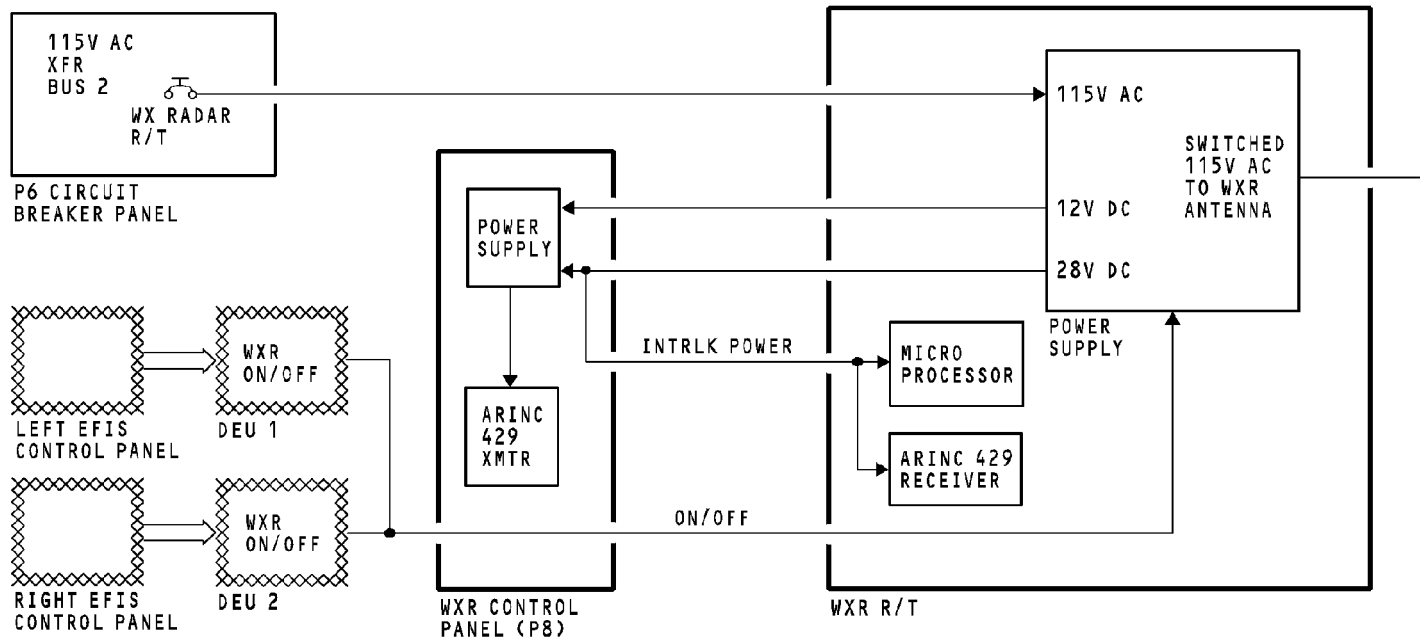

WXR SYSTEM - SYSTEM SELECT AND SYSTEM ON/OFF

EFFECTIVITY
HAP 001-007

34-43-00

D633A101-HAP

THIS PAGE IS INTENTIONALLY LEFT BLANK

34-43-00

D633A101-HAP

Page 47
Feb 15/2008

WXR SYSTEM - NORMAL DISPLAYS**Display Modes**

The navigation display (ND) shows WXR system data in these modes:

- Expanded approach
- Expanded VOR
- Center MAP
- Expanded MAP.

WXR System Display Data

The ND shows these displays:

- WXR data
- WXR system messages
- WXR alert messages.

WXR Displays

The WXR data on the ND shows the weather or the terrain in front of the airplane. Colors show the strength of the RF return signals from the weather or the terrain. These are the four colors for the WXR displays:

- Green - light weather
- Yellow - medium weather
- Red - heavy weather
- Magenta - turbulence.

The WXR system calculates and shows turbulence only to 40 NM.

WXR System Messages

This weather radar data shows on three lines in the bottom left of the navigation display:

- Mode
- Antenna tilt
- Gain.

Line 1 shows mode. Mode shows this data:

- WXR
- MAP
- WX + T
- TEST.

Line 2 shows the antenna tilt value set on the WXR panel. Antenna tilt shows 0.0 to + 15 or - 15 degrees.

Line 3 shows gain. Gain shows this data:

- VAR - R/T has gain set by gain switch
- Blank - normal operation (gain switch in AUTO).

All WXR system messages show cyan. There is no annunciation for the standby mode.

WEATHER DATA:

- GREEN = LIGHT WEATHER
- YELLOW = MEDIUM WEATHER
- RED = HEAVY WEATHER
- MAGENTA = TURBULENCE

WEATHER SYSTEM MESSAGES:

- WEATHER MODE
- ANTENNA TILT
- GAIN VALUE

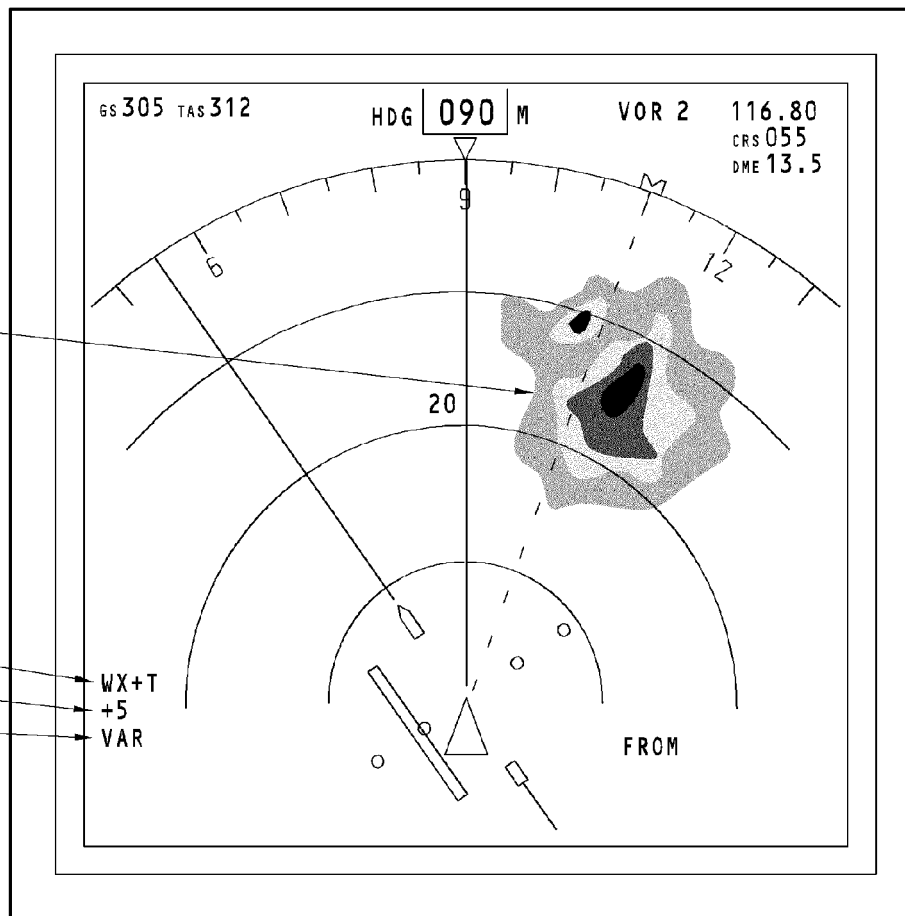

WXR SYSTEM - NORMAL DISPLAYS

34-43-00-013

EFFECTIVITY
HAP ALL

34-43-00

D633A101-HAP

THIS PAGE IS INTENTIONALLY LEFT BLANK

34-43-00

D633A101-HAP

Page 50
Feb 15/2008

WXR SYSTEM - PWS OPERATION**General Description**

If the PWS detects a windshear threat, it makes an alert. The alert may be a warning or a caution. The alert the crew receives depends upon these conditions:

- Position of the windshear relative to airplane heading
- Distance to the windshear
- Airplane flight phase - takeoff or approach.

PWS Warning Area

During takeoff, PWS gives a warning if it detects a windshear threat in this area:

- Less than 0.25 NM on either side of the airplane projected magnetic heading
- More than 0.5 NM but less than 3 nm ahead of the airplane.

During approach, PWS gives a warning if it detects a windshear threat in this area:

- Less than 0.25 NM on either side of the airplane projected magnetic heading
- More than 0.5 NM but less than 1.5 nm ahead of the airplane.

PWS inhibits new windshear warnings during takeoff and approach if both of these conditions exist:

- Airspeed more than 100 knots
- Less than 50 feet radio altitude.

PWS Caution Area

PWS gives a caution if it detects a windshear threat in this area:

- Within 25 degrees on either side of the airplane projected magnetic heading
- More than 0.5 nm but less than 3 nm ahead of the airplane
- Not in the PWS warning area.

PWS inhibits new windshear cautions during takeoff and approach if both of these conditions exist:

- Airspeed more than 80 knots
- Less than 400 feet radio altitude

All PWS alerts are inhibited above 1200 feet radio altitude.

PWS Warning - Flight Deck Effects

A PWS warning has these visual and aural annunciations:

- Red WINDSHEAR message on the PFD
- Red WINDSHEAR message on the ND
- Aural annunciation - WINDSHEAR AHEAD, WINDSHEAR AHEAD (takeoff)
- Aural annunciation - GO AROUND, WINDSHEAR AHEAD (approach).

PWS Caution - Flight Deck Effects

A PWS caution has these visual and aural annunciations:

- Amber WINDSHEAR message on the ND



WXR SYSTEM - PWS OPERATION

- Windshear symbol on the ND
- Aural annunciation - MONITOR RADAR DISPLAY.

34-43-00-024

EFFECTIVITY
HAP 008-013, 015-026, 028-054, 101-999

34-43-00

D633A101-HAP

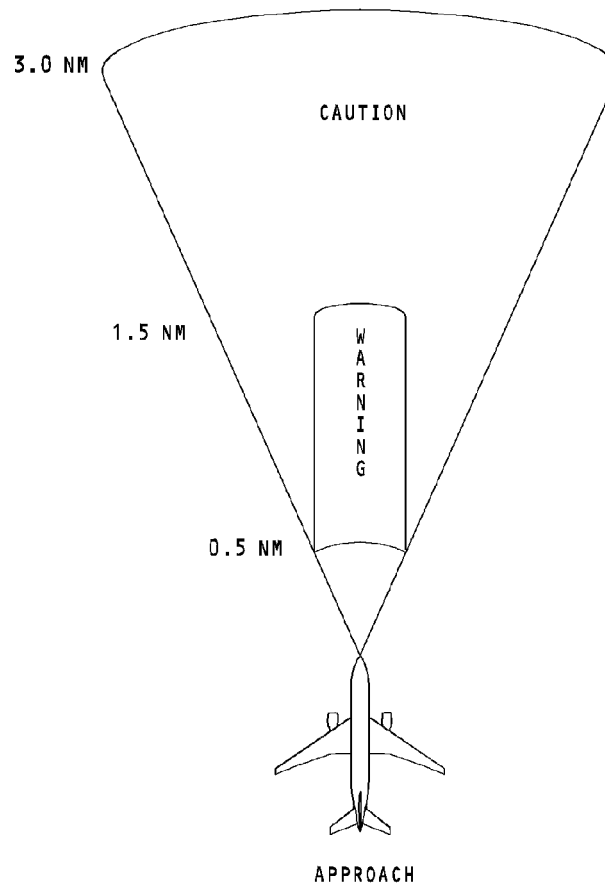
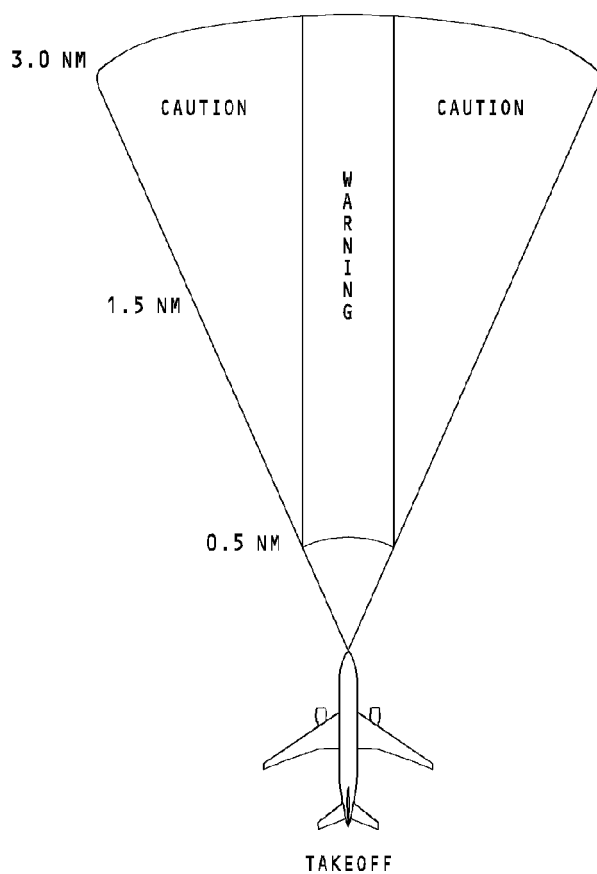

WXR SYSTEM - PWS OPERATION

EFFECTIVITY

HAP 008-013, 015-026, 028-054, 101-999

34-43-00

D633A101-HAP

WXR SYSTEM - PWS DISPLAYS**General Description**

Weather radar with predictive windshear (PWS) detects windshear ahead of the airplane. PWS uses this data to detect windshear:

- Doppler radar returns
- Inertial data
- Air data.

If PWS detects a windshear condition, it alerts the flight crew with visual and aural annunciations.

System On/Off - Takeoff

PWS turns on when the airplane is on the ground and has one of these conditions:

- Throttles move through 53 degrees
- Flight crew pushes the WXR button on an EFIS control panel.

The WXR button on the EFIS CP does not turn off the PWS if the throttle levers are above 53 degrees. PWS turns off automatically when the airplane climbs above 2300 feet radio altitude.

System On/Off - Approach

PWS turns on automatically when the airplane descends below 2300 feet radio altitude. PWS turns off when one of these conditions occur:

- Airspeed is less than 60 knots
- Airplane climbs above 2300 feet radio altitude.

If PWS is on and WXR is not selected on the EFIS CP, all antenna sweeps search for windshear. If WXR is selected, the antenna uses one sweep to search for windshear and the other sweep to search for normal weather returns. PWS operation does not affect the WXR mode or range selected by the flight crew.

PWS Display

If PWS detects windshear, it makes a windshear symbol on the ND. The symbol is red and black bars. Yellow bars go from the edges of the symbol to the compass rose. The yellow bars help the crew to see the PWS symbol.

The ND mode selector must be in a correct mode for the windshear data to show. These are the ND modes that show windshear data:

- Expanded APP
- Expanded VOR
- Expanded MAP
- Centered MAP.

PWS cautions or warnings are inhibited above 1200 feet radio altitude.

New PWS cautions are inhibited between 80 knots computed airspeed on the ground and 400 feet radio altitude.

EFFECTIVITY

HAP 008-013, 015-026, 028-054, 101-999

34-43-00

WXR SYSTEM - PWS DISPLAYS

New PWS warnings are inhibited between 100 knots computed airspeed and 50 feet radio altitude.

These inhibits apply to both takeoff and approach modes.

NOTE: These inhibits do not remove a PWS caution or warning that already exists.

Sweep Patterns

The sweep pattern is different in approach and takeoff modes.

In the takeoff mode, the WXR data is updated every fourth sweep as the antenna scans through -90 to +90 degrees. The other three sweeps are used for PWS updates.

PWS and WXR Sweep Pattern in Takeoff Mode					
Position	Dir	Radar Sweep	Paint Sweep	Angle (Degrees)	Time
Sweep 1	L-R	Both WXR data update	Both WXR + icons painted	-90 to +90	4
Sweep 2	R-L	Both PWS data updated	Both PWS icons painted	+90 to -60	3
Sweep 3	L-R	Both PWS data updated	Both PWS icons painted	-60 to +60	2
Sweep 4	R-L	Both PWS data updated	Both PWS icons updated	+60 to -90	3

In the approach mode, the WXR data is updated every second sweep.

PWS and WXR Sweep Pattern in Approach Mode					
Position	Dir	Radar Sweep	Paint Sweep	Angle (Degrees)	Time
Sweep 1	L-R	Both WXR data update	Both WXR + icons painted	-90 to +90	4
Sweep 2	R-L	Both PWS data updated	Both PWS icons painted	+90 to -90	4
Sweep 3	L-R	Both PWS data updated	Both PWS icons painted	-90 to +90	4
Sweep 4	R-L	Both PWS data updated	Both PWS icons updated	+90 to -90	4

The sweep pattern may go to a PWS only mode during takeoff and approach when WXR is not selected and PWS is automatically activated. The scan is -60 to +60 degrees.

PWS Sweep Pattern					
Position	Dir	Radar Sweep	Paint Sweep	Angle (Degrees)	Time
Sweep 1	L-R	Both WXR data update	Both WXR + icons painted	-60 to +60	4

<p>EFFECTIVITY HAP 008-013, 015-026, 028-054, 101-999</p>
--

WXR SYSTEM - PWS DISPLAYS

PWS Sweep Pattern					
Sweep 2	R-L	Both PWSs data updated	Both PWS icons painted	+60 to -60	3
Sweep 3	L-R	Both PWSs data updated	Both PWS icons painted	-60 to +60	2
Sweep 4	R-L	Both PWSs data updated	Both PWS icons updated	+60 to -60	3

NOTE: The system only takes PWS data between -45 degrees and +45 degrees. The rest of the scan is done to position the antenna for the WXR sweeps.

34-43-00-026

EFFECTIVITY
HAP 008-013, 015-026, 028-054, 101-999

34-43-00

D633A101-HAP

Page 56
Feb 15/2009

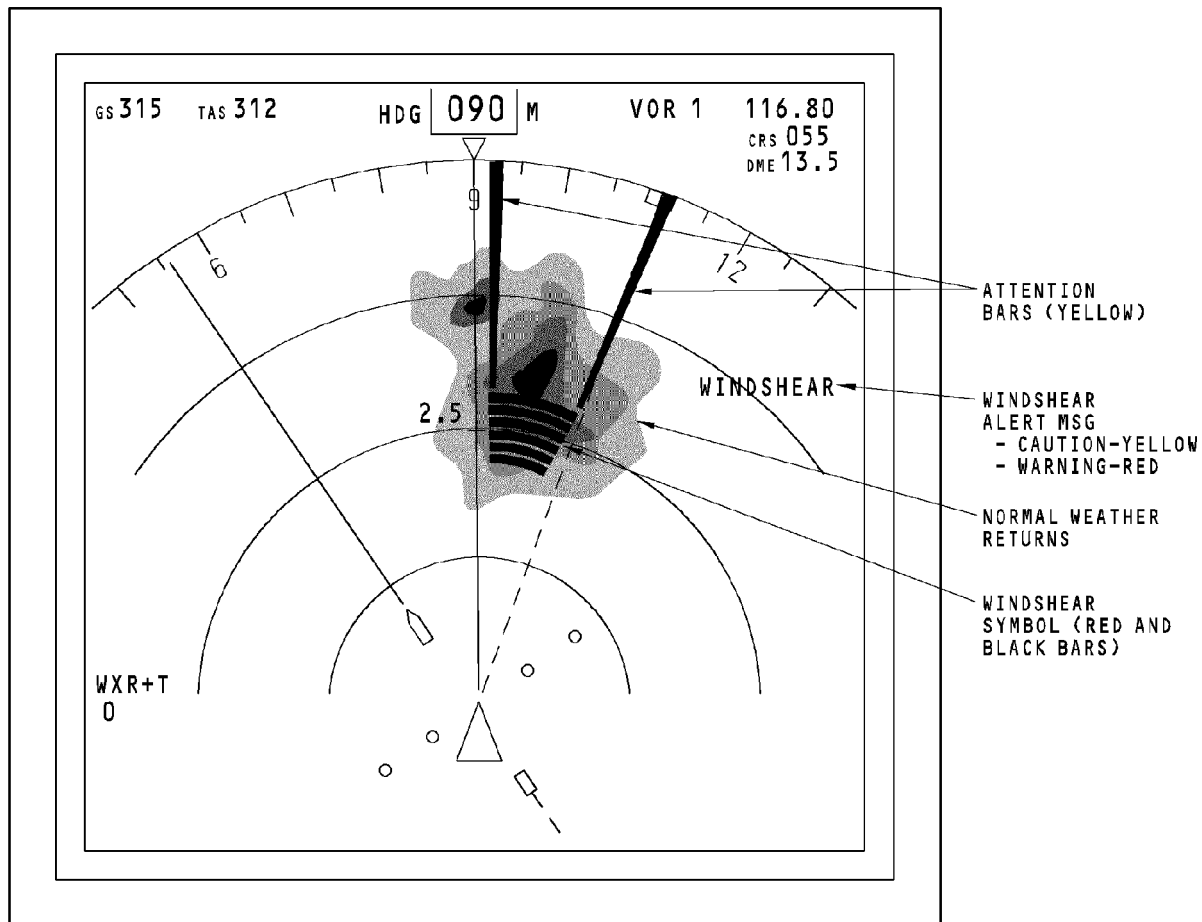

WXR SYSTEM - PWS DISPLAYS

34-43-00-026

EFFECTIVITY
HAP 008-013, 015-026, 028-054, 101-999

34-43-00

D633A101-HAP

Page 57
Feb 15/2009

WXR SYSTEM - OPERATION - FAILURE DISPLAYS

WXR System Alert Messages and Display

Alert messages show on the ND when the R/T processes data that is not satisfactory. The WXR display will continue to show with an alert message.

Only one alert message shows on the ND. When the R/T processes unsatisfactory data from more than one source only the highest priority message shows. These are the alert messages and priority from highest to lowest:

- WXR WEAK shows for an R/T gain calibration failure
- WXR ATT shows when the selected attitude input fails
- WXR STAB shows when stabilization is off.

The alert messages show on these alert lines:

- Line 1 shows WXR in amber
- Line 2 shows WEAK, ATT, or STAB in amber.

WXR System Fail Messages and Display

A failure of these components causes a WXR failure:

- R/T
- WXR control panel
- WXR antenna.

A WXR failure causes these conditions:

- WXR FAIL message shows on ND
- Mode, tilt, and gain messages go out of view

- WXR display goes out of view.

The fail message shows on these alert lines:

- Line 1 shows WXR in amber
- Line 2 shows FAIL in amber.

HAP 008-013, 015-026, 028-054, 101-999

A failure of these components will cause a PWS failure:

- Loss of any RA
- Scan and tilt antenna faults
- Internal WXR faults.

A failure of the predictive windshear causes an amber PWS FAIL message on the ND.

HAP ALL

EFFECTIVITY
HAP ALL

34-43-00

D633A101-HAP

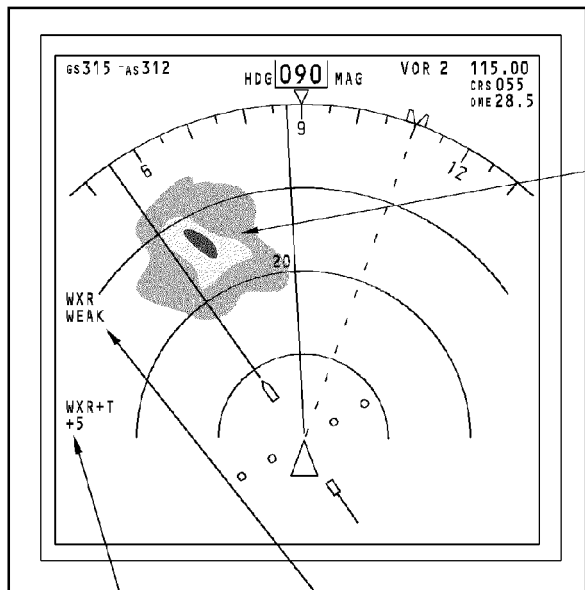

WEATHER SYSTEM MESSAGES STAY IN VIEW
 ALERT MESSAGES - WXR (AMBER)
 - WEAK, ATT OR STAB (AMBER)

WXR SYSTEM ALERT MESSAGES AND DISPLAY

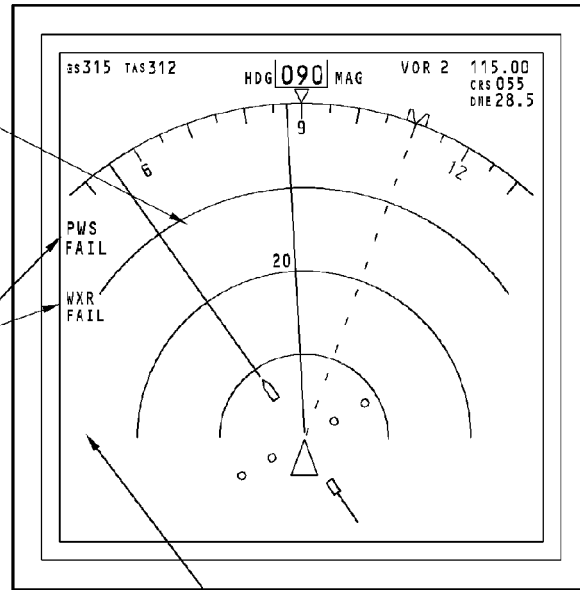

WEATHER DISPLAY IS REMOVED

WEATHER DISPLAY STAYS IN VIEW

FAIL MESSAGES - WXR (AMBER)
 - FAIL (AMBER)
 - PWS FAIL (AMBER)

WEATHER SYSTEM MESSAGES REMOVED

WXR SYSTEM FAIL MESSAGES AND DISPLAY

WXR SYSTEM - OPERATION - FAILURE DISPLAYS

EFFECTIVITY

HAP 008-013, 015-026, 028-054, 101-999

34-43-00

D633A101-HAP

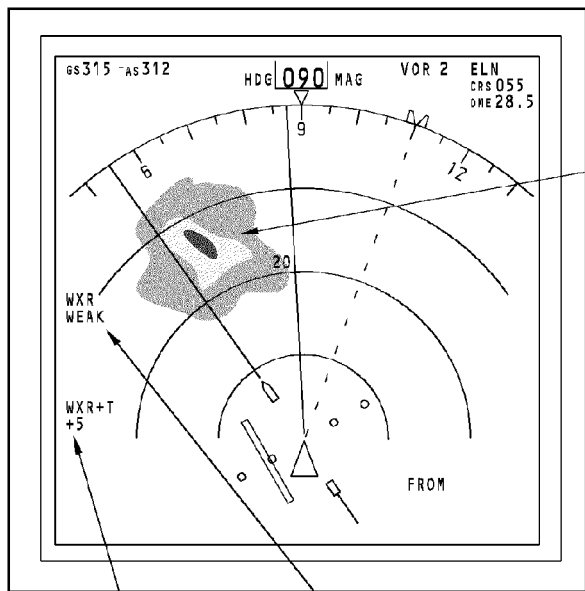

WEATHER SYSTEM MESSAGES STAY IN VIEW

ALERT MESSAGES
- WXR (AMBER)
- WEAK, ATT OR STAB (AMBER)

WXR SYSTEM ALERT MESSAGES AND DISPLAY

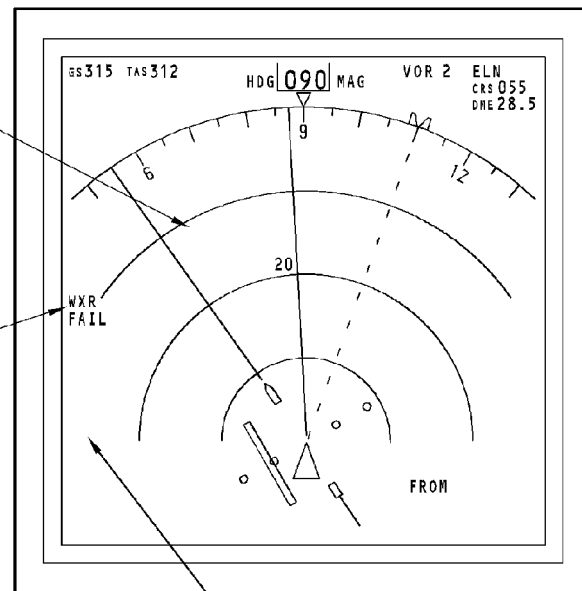

WEATHER DISPLAY IS REMOVED

WEATHER DISPLAY STAYS IN VIEW

FAIL MESSAGES
- WXR (AMBER)
- FAIL (AMBER)

WEATHER SYSTEM MESSAGES REMOVED

WXR SYSTEM FAIL MESSAGES AND DISPLAY

WXR SYSTEM - OPERATION - FAILURE DISPLAYS

EFFECTIVITY
HAP 001-007

34-43-00

D633A101-HAP

THIS PAGE IS INTENTIONALLY LEFT BLANK

34-43-00

D633A101-HAP

Page 61
Feb 15/2008

WXR SYSTEM - ND RANGE DISAGREEMENT

General

The DEUs compare the ND ranges from these components:

- EFIS CP
- WXR R/T
- Flight management computer (FMC).

A difference between any of these ranges causes an amber range disagreement message on alert line 3.

These WXR range disagreement messages are possible:

- WXR RANGE DISAGREE; shows when there is a difference between the EFIS CP range and the WXR R/T range
- MAP/WXR RANGE DISAGREE; shows when there is a difference between the EFIS CP range, the WXR R/T range, and the FMC range.

WXR RANGE DISAGREE will show in these modes:

- Expanded approach
- Expanded VOR
- Expanded map
- Centered map.

MAP/WXR RANGE DISAGREE will show in these modes:

- Expanded map
- Centered map.

This happens during a range disagreement:

- WXR display goes out of view
- mode, tilt, and gain messages show
- FMC range shows.

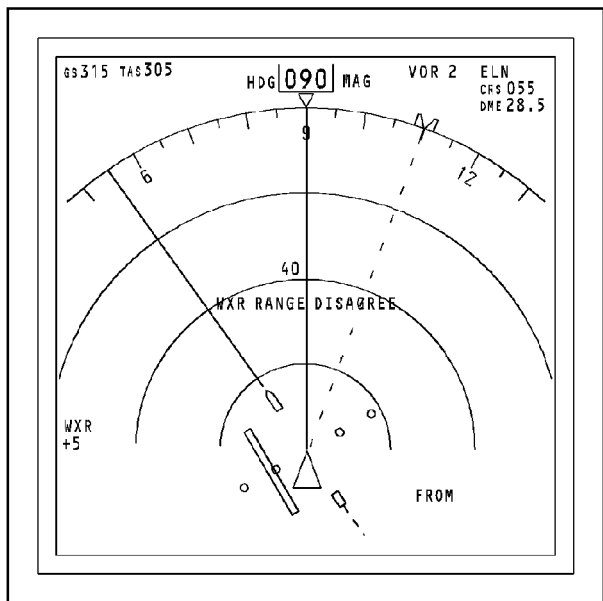

- MODES:
- EXPANDED APPROACH
 - EXPANDED VOR
 - EXPANDED MAP
 - CENTERED MAP

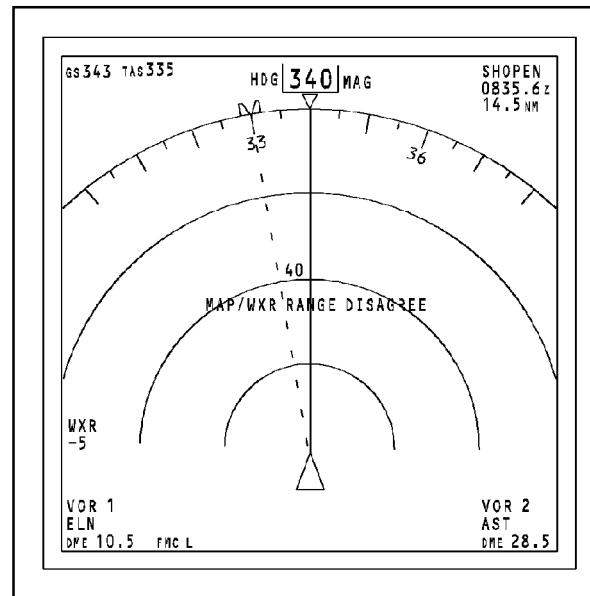

- MODES:
- EXPANDED MAP
 - CENTERED MAP

WXR SYSTEM - ND RANGE DISAGREEMENT

34-43-00-016

EFFECTIVITY
HAP ALL

34-43-00

D633A101-HAP

Page 63
Feb 15/2008

THIS PAGE IS INTENTIONALLY LEFT BLANK

34-43-00

D633A101-HAP

Page 64
Feb 15/2008

WXR SYSTEM - WXR R/T FUNCTIONAL DESCRIPTION

General

The WXR R/T makes RF pulses and sends them to the antenna. The antenna transmits pulses and receives the return signals and sends them to the WXR R/T. The R/T processes the return signals to make display data that shows on the NDs. The WXR data on the ND shows the weather patterns in front of the airplane.

HAP 008-013, 015-026, 028-054, 101-999

The WXR R/T also comes on automatically during take off and approach to detect windshear events in front of the airplane. If a windshear event is detected, the WXR sends cautions or warnings to the flight compartment.

HAP ALL

Control Inputs

The EFIS control panel (EFIS CP) sends the WXR system ON/OFF discrete on a digital bus to the display electronics unit (DEU). The DEU sends a discrete to the WXR R/T to turn ON the weather radar. The discrete goes through the WXR control panel to ensure the panel is in the airplane. The DEUs only send the ON discrete if the navigation display is in the correct mode. The EFIS CP sends range data to the WXR R/T.

The WXR control panel sends control data on a bus to the WXR R/T. The WXR CP sends these signals:

- Gain
- Tilt
- Mode of operation.

HAP 008-013, 015-026, 028-054, 101-999

Predictive Windshear Inputs

These are the inputs to the WXR R/T for predictive windshear (PWS):

- Ground proximity warning system inhibit discrete
- Auto throttle 1 switch pack throttle position discrete
- Auto throttle 2 switch pack throttle position discrete
- Radio altimeter 1 and 2.

The GPWS determines the priority for the aural warnings and cautions to the flight compartment. If the PWS CPU finds there is a windshear condition, the WXR R/T sends the warning or caution to the GPWS.

The auto throttle packs determine the position of the throttles. When the airplane is on the ground and either throttle is moved more than 53 degrees, the PWS comes on automatically.

34-43-00-017

<p>EFFECTIVITY HAP ALL</p>
--

34-43-00

D633A101-HAP

WXR SYSTEM - WXR R/T FUNCTIONAL DESCRIPTION**HAP 008-013, 015-026, 028-054, 101-999 (Continued)**

The PWS CPU uses the radio altimeter input to turn the PWS on or off. When the airplane goes below 2300 feet radio altitude on approach, the PWS is turned on. When the altitude goes above 2300 feet during takeoff, the PWS is turned off.

HAP ALL**Antenna Control**

The WXR R/T gets attitude data for antenna stabilization from the ADIRUs. When the IRS select switch on the navigation/displays source select panel is in NORMAL or BOTH ON L, the R/T uses the left ADIRU for stabilization. You put the IRS select switch to BOTH ON R to change to the right ADIRU stabilization data. The IRS select switch sends a ground discrete to the WXR R/T.

HAP 001-007**Central Processor Unit**

The central processor unit (CPU) uses the control data to control the operation of the R/T and the antenna drive. The CPU sends these control signals to the transmitter circuits:

- Range
- Gain
- Mode.

Also, the CPU makes the scan and elevation signals from the ADIRU attitude data. It sends these signals to the antenna for antenna stabilization. The CPU also gets antenna position signals from the antenna assembly.

HAP 008-013, 015-026, 028-054, 101-999**WXR Central Processor Unit**

The WXR central processor unit (CPU) uses the control data to control the operation of the R/T and the antenna drive. The CPU sends these control signals to the transmitter circuits:

- Range
- Gain
- Mode.

Also, the WXR CPU makes the scan and elevation signals from the ADIRU attitude data. It sends these signals to the antenna for antenna stabilization. The WXR CPU also gets antenna position signals from the antenna assembly.

Predictive Windshear Central Processor Unit

The PWS CPU uses inputs from these systems to turn on the WXR PWS function:

- Auto throttle switch packs
- Radio altimeters.

WXR SYSTEM - WXR R/T FUNCTIONAL DESCRIPTION**HAP 008-013, 015-026, 028-054, 101-999 (Continued)**

The PWS CPU controls the antenna scan and pulse repetition frequency of the transmitter to detect windshear events directly in front of the airplane. The area is limited to a very small range because of the high pulse repetition frequency.

When the PWS CPU detects a windshear, it sends the warning or caution to the GPWS. The GPWS has the priority logic for warnings and cautions. If there is no higher priority warning or caution, the PWS CPU sends the windshear display to the DEUs and sends the aural signal to the REU. Also, the PWS CPU sends an aural inhibit to the TCAS computer to inhibit any aural signals from TCAS.

HAP ALL**Oscillator/Transmitter Circuits**

The oscillator/transmitter circuit makes RF pulse patterns and sends them out through the WXR antenna.

RF Transmit

The RF pulses go from the transmitter circuits through the duplexer. The duplexer connects the antenna to the transmitter during RF transmission. It also connects the antenna to the receiver circuits to get the return RF pulses. From the duplexer, the RF goes to the WXR antenna.

RF Receive

The antenna receives the RF return signals. Then the RF goes through the duplexer to the receiver circuits. The receiver circuits process the return signals and send them to the CPU. The CPU uses the strength of the RF return signals to calculate the intensity of the precipitation and to make the WXR display data.

HAP 008-013, 015-026, 028-054, 101-999

When the PWS is on, the return signals may also contain windshear information. The PWS CPU processes the windshear returns and makes the aural signals and display signals.

HAP ALL**WXR Display Data**

The CPU puts this data into the ARINC 453 format:

- WXR display data
- Range processed
- System mode
- Status data.

The CPU sends the output data to the ARINC 453 transmitters. The 453 transmitters send the data on the high speed ARINC 453 DATA BUS 1 and DATA BUS 2 to the DEUs.

WXR SYSTEM - WXR R/T FUNCTIONAL DESCRIPTION

System Status Data

The BITE module continuously gets system status data. The BITE module stores the faults in memory. The system status and the faults show on the ND alert lines. The LCD on the front of the R/T shows system failures and fault history.

34-43-00-017

EFFECTIVITY
HAP ALL

34-43-00

D633A101-HAP

Page 68
Feb 15/2008

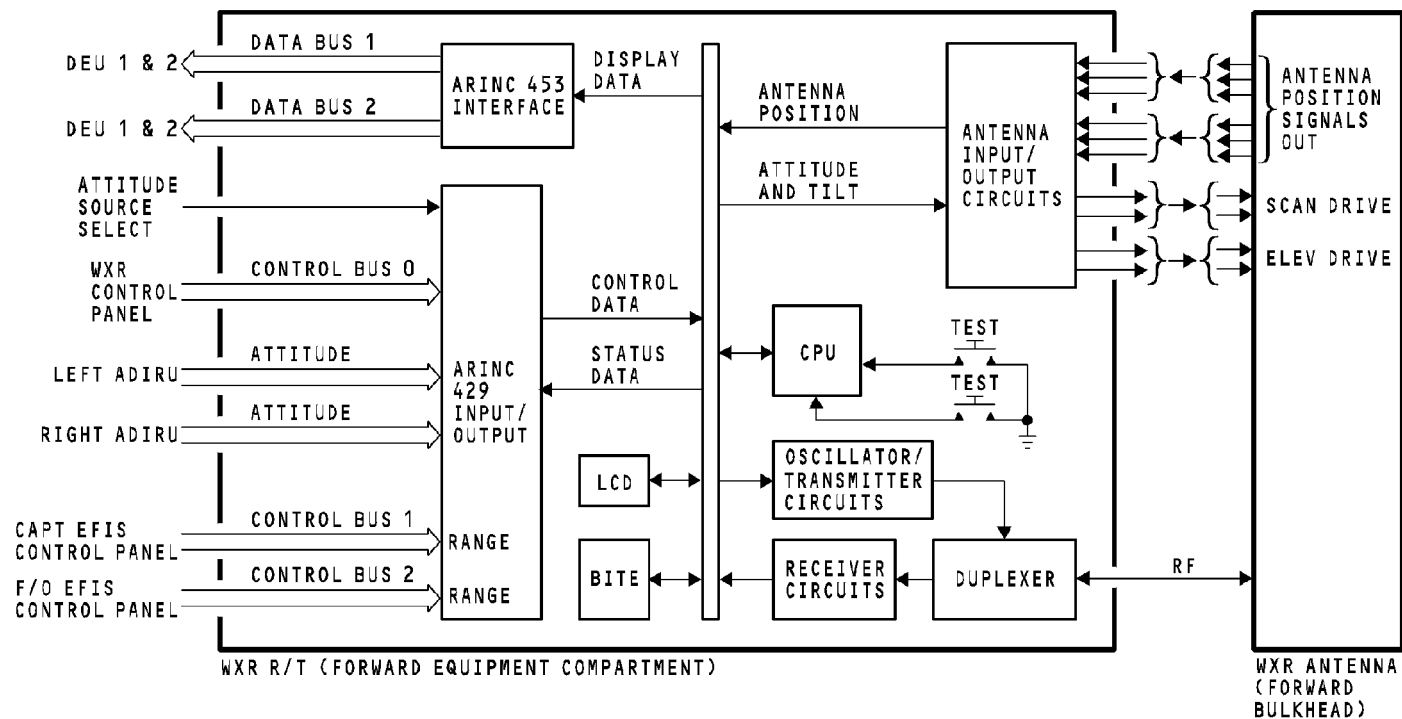

WXR SYSTEM - WXR R/T FUNCTIONAL DESCRIPTION

34-43-00-017

EFFECTIVITY
HAP 001-007

34-43-00

D633A101-HAP

Page 69
Feb 15/2008

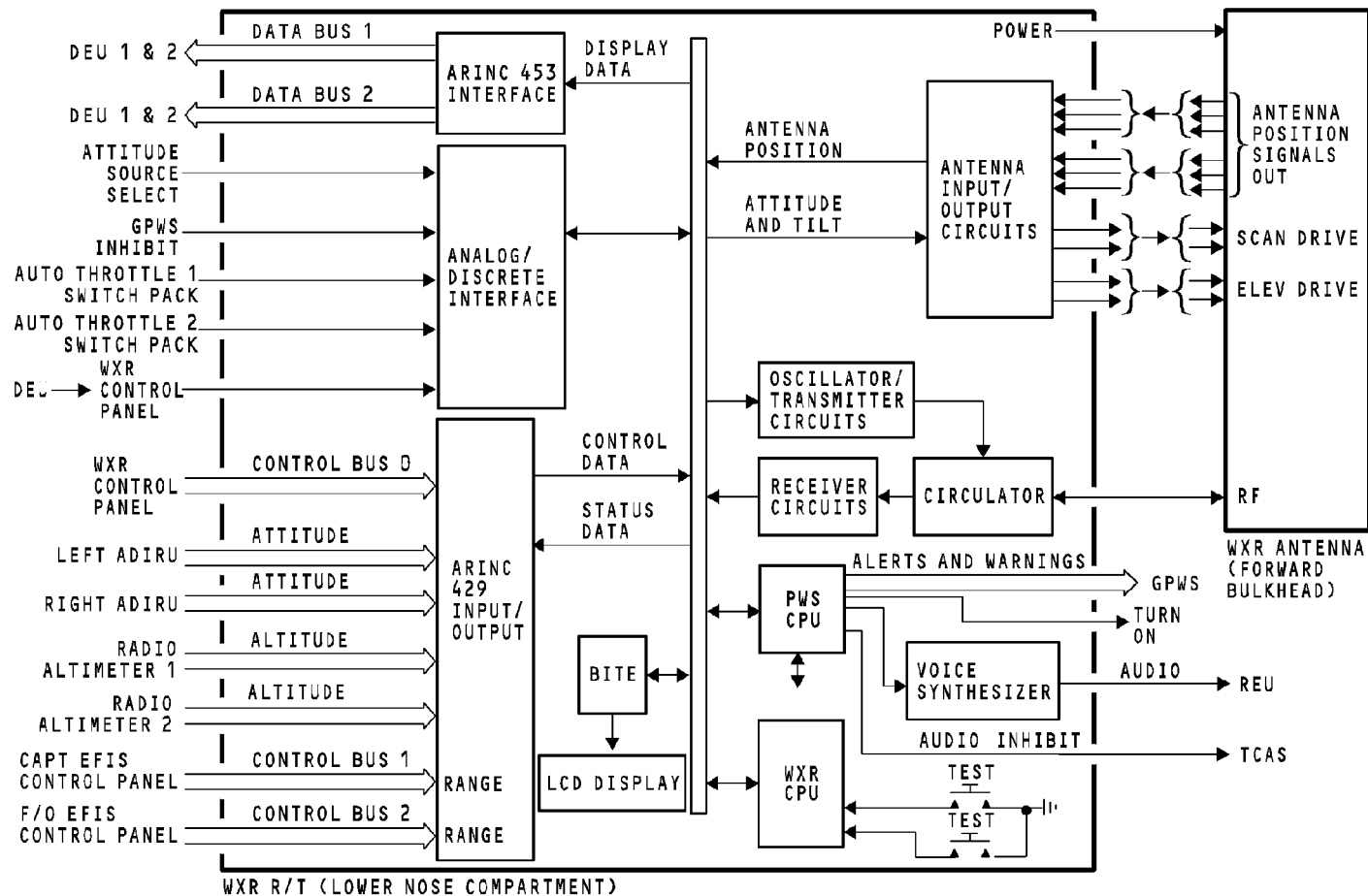

WXR SYSTEM - WXR R/T FUNCTIONAL DESCRIPTION

34-43-00-017

EFFECTIVITY
HAP 008-013, 015-026, 028-054, 101-999

34-43-00

D633A101-HAP

THIS PAGE IS INTENTIONALLY LEFT BLANK

34-43-00

D633A101-HAP

Page 71
Feb 15/2008

WXR SYSTEM - ANTENNA FUNCTIONAL DESCRIPTION**Antenna Control**

The CPU in the WXR R/T controls and monitors the antenna operation.

Antenna Stabilization

The WXR R/T uses attitude inputs from the ADIRU for antenna stabilization. The CPU uses the attitude inputs to calculate and control the scan and elevation movements. It sends the scan and elevation drive signals to the antenna.

Antenna Operation

The antenna gets 115v ac from the WXR R/T. The scan and elevation motors receive command signals from the R/T. The WXR R/T also sends 26v ac to the scan and elevation position synchros.

Antenna Drive

The antenna has one scan motor and one elevation motor. The scan motor drives a geartrain which moves the antenna horizontally. It moves the antenna |90 degrees from the centerline of the airplane. The elevation motor drives a gear train which moves the antenna vertically. It moves the antenna up and down |40 degrees. This elevation range includes |15 degrees for the manual tilt.

Antenna Position Feedback

There are monitors in the WXR R/T. One is for the scan motor and one is for the elevation motor.

Antenna Position Compare

The monitors use the position and the command signals. They compare the actual antenna position with the desired antenna position. When the two are not the same, the WXR R/T sets the antenna fault.

Disable Switches

The disable switches are on the antenna pedestal. The scan disable switch disconnects the scan motor from the motor drive. The elevation disable switch disconnects the elevation motor from the motor drive. Because the motors disconnect from the motor drives, the antenna does not move.

CAUTION: AN OPEN DISABLE SWITCH DOES NOT STOP RF TRANSMISSION FROM THE ANTENNA.

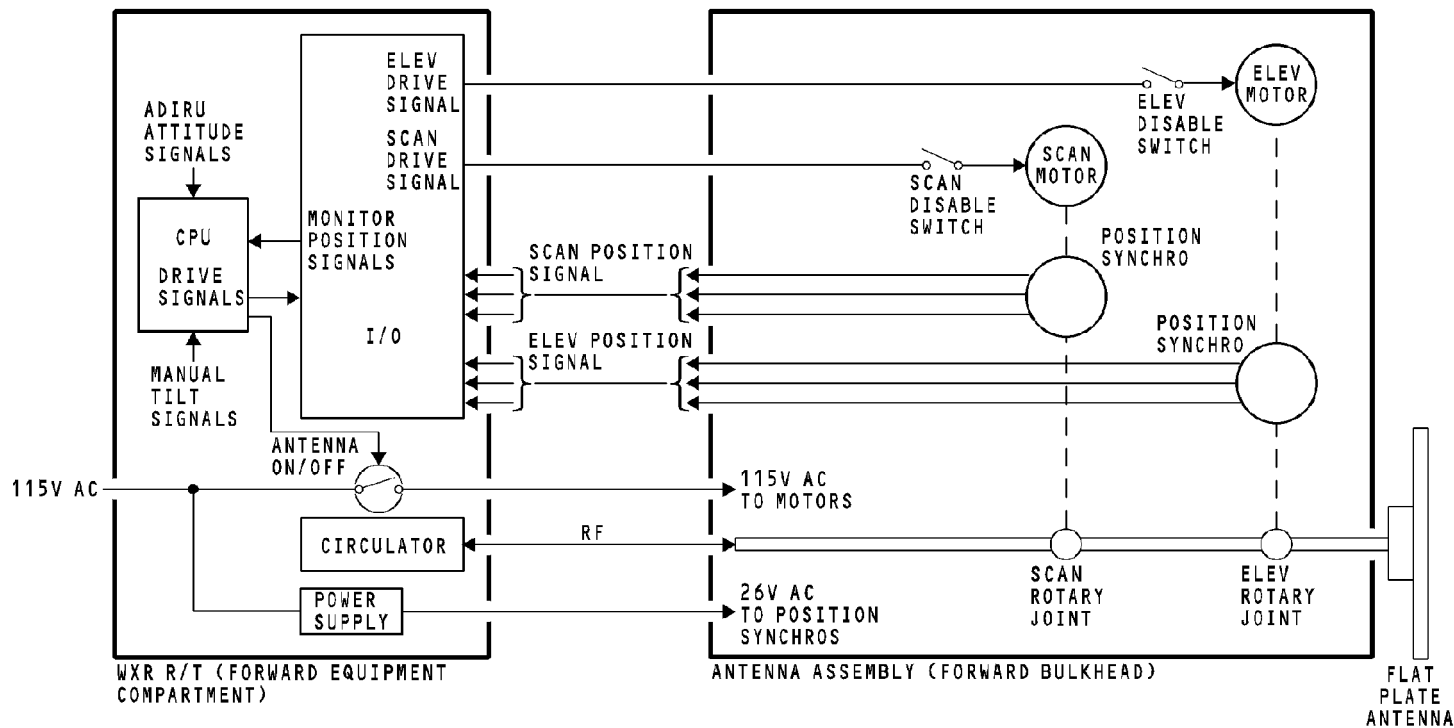

WXR SYSTEM - ANTENNA FUNCTIONAL DESCRIPTION

EFFECTIVITY
HAP ALL

34-43-00

D633A101-HAP

34-43-00-018

WXR SYSTEM - WXR R/T BITE - FUNCTIONAL DESCRIPTION**General**

The CPU in the WXR R/T controls the operation of the BITE module. These are the functions of the BITE module:

- Gets status information from the interface components
- Gets internally monitored data
- Does a self-test when it gets a command from the WXR CP
- Sends a test pattern to the DEUs to show on the ND

HAP 001-005

- Shows faults and fault history on LCD display
- Stores faults in nonvolatile fault memory

HAP ALL

- Sends system status data to the DEUs to show on the ND.

Internal Input Monitoring

The BITE monitors these things:

- Over temperature from the power supply
- Control and range from the WXR panel on control bus 0
- Range inputs from the EFIS control panels on control bus 1 and 2
- Antenna scan and elevation position from the CPU.

HAP 001-005**Self Test**

Push the left test switch on the front of the R/T to start a test of the WXR R/T. The R/T then does a test of its internal operation and interfaces. The test results show on the LCD.

HAP ALL

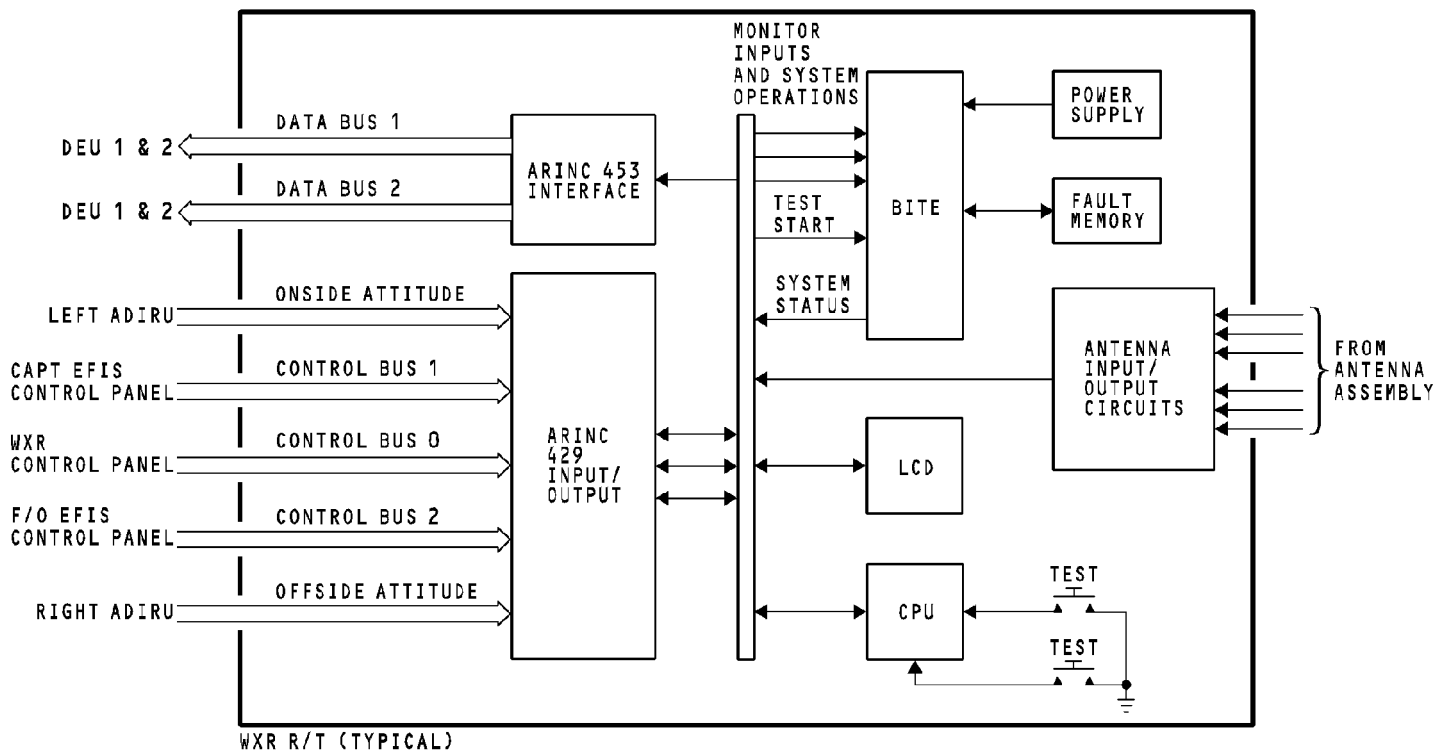

WXR SYSTEM - WXR R/T BITE - FUNCTIONAL DESCRIPTION

34-43-00-019

EFFECTIVITY
HAP ALL

34-43-00

D633A101-HAP

Page 75
Feb 15/2008

WXR SYSTEM - SELF-TEST START**General**

WARNING: DO NOT OPERATE THE WEATHER RADAR UNLESS ALL PERSONNEL ARE MORE THAN 50 FT (15 M) FROM THE RADAR. DO NOT OPERATE THE WEATHER RADAR IN A HANGAR. IF YOU DO NOT OBEY THESE PRECAUTIONS, INJURIES TO PERSONNEL CAN OCCUR.

WARNING: IF THERE IS FUEL LEAKAGE OR AN OPEN FUEL CELL LESS THAN 50 FT (15 M) FROM THE RADAR, DO NOT OPERATE THE WEATHER RADAR. IF THERE IS FUEL IN THE 50-FOOT RADIUS AROUND THE RADAR, IT CAN CAUSE A FIRE AND EXPLOSION. THESE CAN CAUSE INJURIES TO PERSONNEL, AND DAMAGE TO EQUIPMENT. THESE CAN KILL PERSONNEL.

CAUTION: MAKE SURE NO LARGE METALLIC OBJECTS ARE CLOSER THAN 300 FEET FOR THE 180-DEGREE AREA IN FRONT OF THE AIRPLANE WHEN THE RADAR OPERATES. LARGE METAL OBJECTS CAN INCLUDE HANGARS, TRUCKS, OR OTHER AIRPLANES. DAMAGE TO THE TRANSCEIVER COULD OCCUR IF OBJECTS ARE IN THIS AREA. THIS DOES NOT APPLY WHEN THE WEATHER RADAR OPERATES IN THE TEST MODE.

Test Preparation

On the WXR control panel, select these functions:

- Set the mode selector to the TEST position.
- Set the tilt control to 0 degrees. (For the WXR-CP 622-5129-802 and WXR-CP G7407-05 select the “AUTO” tilt switch to OFF, or WXR-CP 2041223-3135 select the “TILT” switch to MAN (manual) prior to set tilt control to 0 degrees).
- For Allied Signal and Bendix WXR control panel: Set the gain control to the Auto position.
- For Collins dual weather radar R/Ts system, on the WXR control panel: Set the “L/R” switch to the Left (out) [Right (in)] position. The “L/R” switch on the control panel switches between the Left and Right Transceivers.

On the EFIS control panel, select these functions:

- Set the range selector to the 40 NM position.
- Set the mode selector to the correct ND mode (expanded APP, expanded VOR, expanded MAP or centered MAP).

Also, adjust the inner ND brightness control to the middle position.

Test Start

Push the WXR switch on the EFIS control panel to apply power to the WXR R/T.

① SELECT TEST

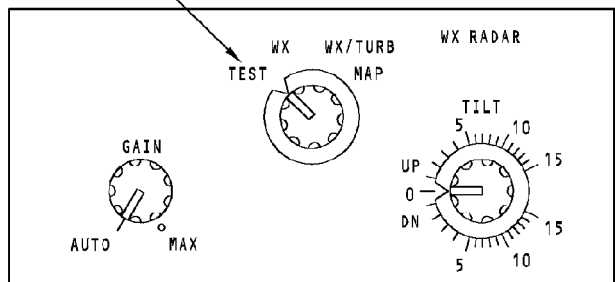

WEATHER RADAR CONTROL PANEL

② SELECT WXR DISPLAY MODE

③ PUSH WXR SWITCH

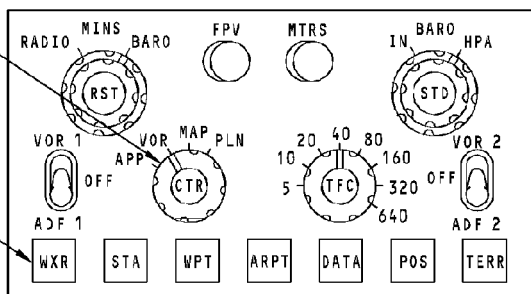

EFIS CONTROL PANEL

④ ADJUST THE ND BRIGHTNESS TO THE MID POSITION

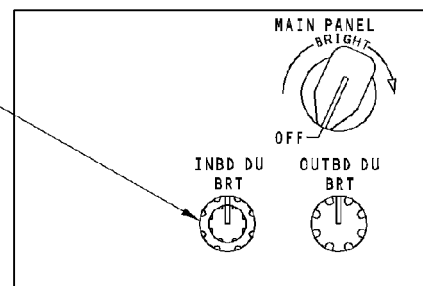

BRIGHTNESS CONTROL PANEL

WXR SYSTEM - SELF-TEST START

34-43-00-023

EFFECTIVITY
HAP 001-013, 015-026, 028-030

34-43-00

D633A101-HAP

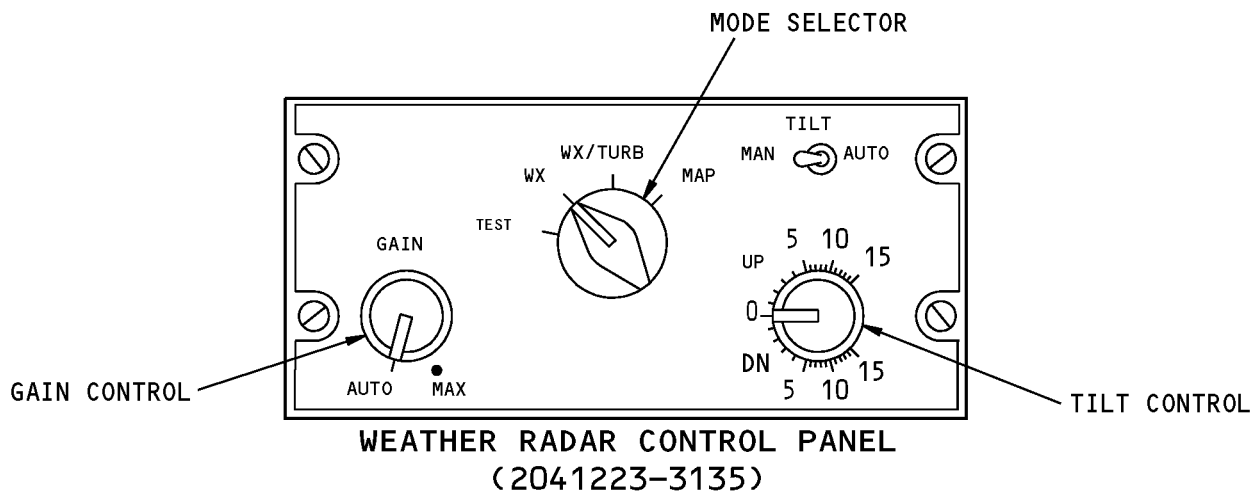

② SELECT WXR DISPLAY MODE

③ PUSH WXR SWITCH

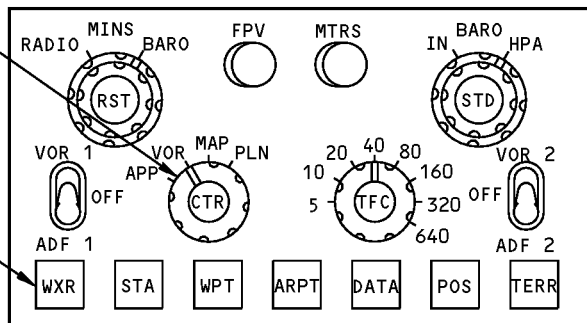

④ ADJUST THE ND BRIGHTNESS TO THE MID POSITION

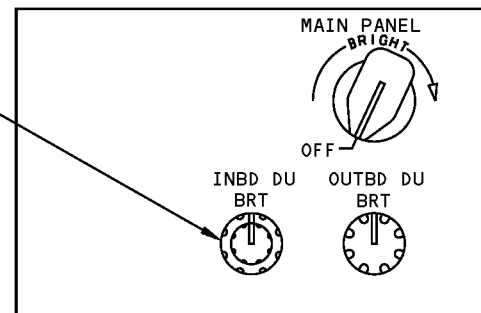

EFIS CONTROL PANEL

BRIGHTNESS CONTROL PANEL

WXR - SELT TEST START

EFFECTIVITY
HAP 031-054, 101-999

34-43-00

D633A101-HAP

WXR SYSTEM - SELF-TEST

Training Information Point

During a test, the weather radar (WXR) system transmits a few pulses to let the BITE monitor the operation. Do not do a test of the WXR system in a hanger. Make sure the nose of the airplane points away from buildings and other aircraft or large metal objects.

Test Preparation

On the WXR control panel, select these functions:

- Set the mode selector to the TEST position
- Set the tilt control to 0 degrees
- Set the gain control to the AUTO position.

On the EFIS control panel, select these functions:

- Set the range selector to 40 NM
- Set the mode selector to the correct ND mode (expanded APP, expanded VOR, expanded MAP or centered MAP).

Also, adjust the inner ND brightness control to the middle position.

Test Start

Push the WXR switch on the EFIS control panel to apply power to the WXR R/T.

Test Operation

During the test, these things happen:

- R/T transmits a few pulses to let the BITE monitor for correct operation
- R/T makes a test pattern and sends it to the DEU to show on the NDs
- R/T sends test messages and mode, gain, and tilt information to the DEUs to show on the NDs
- WXR test pattern shows on ND.

HAP 008-013, 015-026, 028-054, 101-999

The PWS symbol does not show in the TEST pattern. If PWS finds a windshear threat while in TEST mode, the test stops. PWS then shows the actual display data and alert annunciations.

HAP ALL

The test pattern shows until you select another mode on the WXR panel or EFIS control panel.

Test Pass

For a valid WXR self-test, CDS shows these displays:

- WXR test pattern
- HAP 008-013, 015-026, 028-054, 101-999**
- Amber WINDSHEAR message on ND
- Aural message - MONITOR RADAR DISPLAY
- Red WINDSHEAR message on ND and PFD

34-43-00-020



34-43-00

D633A101-HAP

WXR SYSTEM - SELF-TEST

HAP 008-013, 015-026, 028-054, 101-999 (Continued)

- Aural message - GO AROUND, WINDSHEAR AHEAD, (pause) WINDSHEAR AHEAD, WINDSHEAR AHEAD

HAP ALL

- WXR on alert message line one
- TEST on alert message line two.

Test Fail

For a test that fails, these are the indications on the ND:

- WXR test pattern does not show
- WXR shows on alert message on line one
- FAIL shows on alert message on line two
- Line three shows all of the failures.

These are the messages that can show on line three:

- R/T - receiver/transmitter fault
- ANT - antenna fault
- CONT - control panel fault
- ATT - attitude input fault
- WEAK - calibration fault.
- External Fault Tilt Code

Attitude - Left	-1
Attitude - Right	+1
Radio Altitude - Left	-2
Radio Altitude - Right	+2
DADC - Left	-3
DADC - Right	+3

EIFIS - Left	-4
EIFIS - Right	+4
Qualifier Reasonableness	-5
Pitch/Roll Reasonableness	-6
Air/Ground Reasonableness	-7
W/S Inhibit Input	-8

HAP 008-013, 015-026, 028-054, 101-999

There is no Aural output from WXR if the test fails.

HAP ALL

Training Information Point

There are bite instructions to do a manual test of the weather radar in the CDS DEU BITE menu. This test is WXR INTERFACE TEST and shows three pages of instructions. This test is for the CDS/WXR interface.

<p>EFFECTIVITY</p> <p>HAP ALL</p>	
--	--

34-43-00

D633A101-HAP

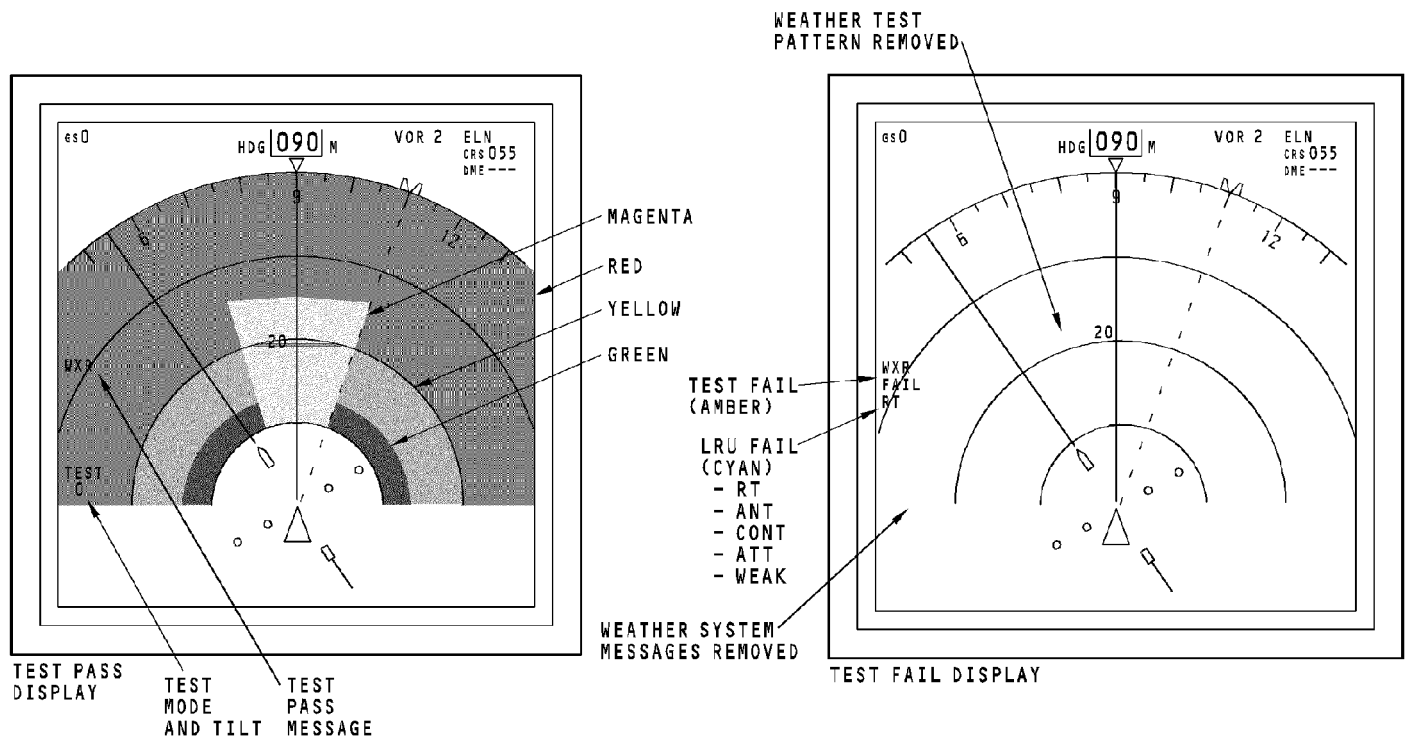

WXR SYSTEM - SELF-TEST

EFFECTIVITY
HAP 001-007

34-43-00

D633A101-HAP

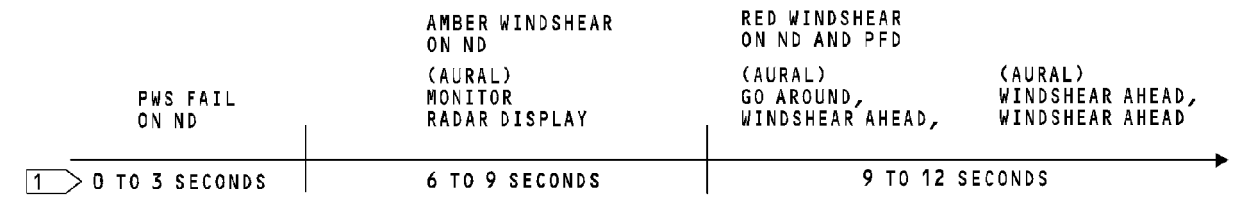
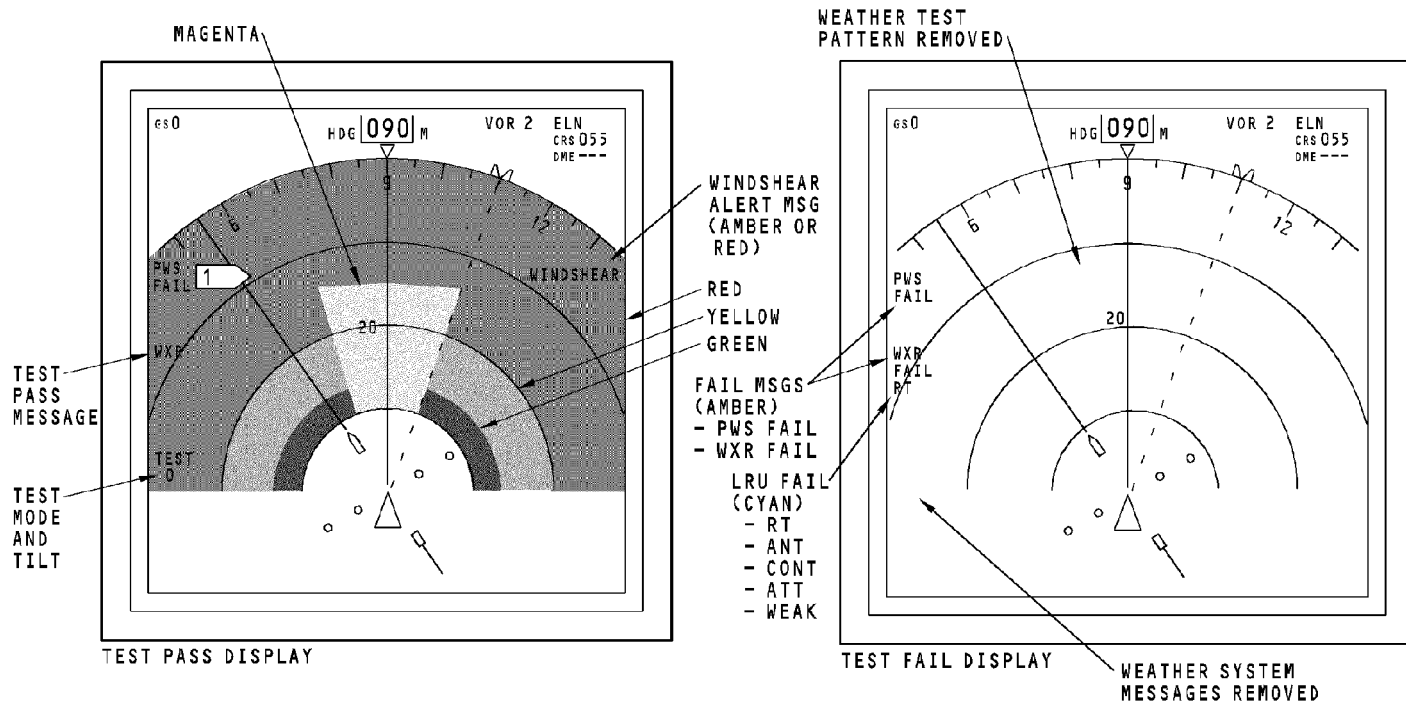

WXR SYSTEM - SELF-TEST

EFFECTIVITY

HAP 008-013, 015-026, 028-054, 101-999

34-43-00

D633A101-HAP

THIS PAGE IS INTENTIONALLY LEFT BLANK

34-43-00

D633A101-HAP

Page 83
Feb 15/2008

WXR SYSTEM - R/T SELF-TEST

R/T Self-Test

Push the left self-test switch to start a test of the weather radar system. The system operates six seconds and the display shows TEST IN PROGRESS. After the test, the display shows one of these three displays:

- RADAR OK and INPUTS OK (radar system and the inputs are good)
- R/T FAULT, ANT FAULT, CON FAULT, and/or COOLING FAULT (one or more of the weather radar components has a fault)
- RADAR OK and INPUT FAULTS (radar system is good but an input has a failure).

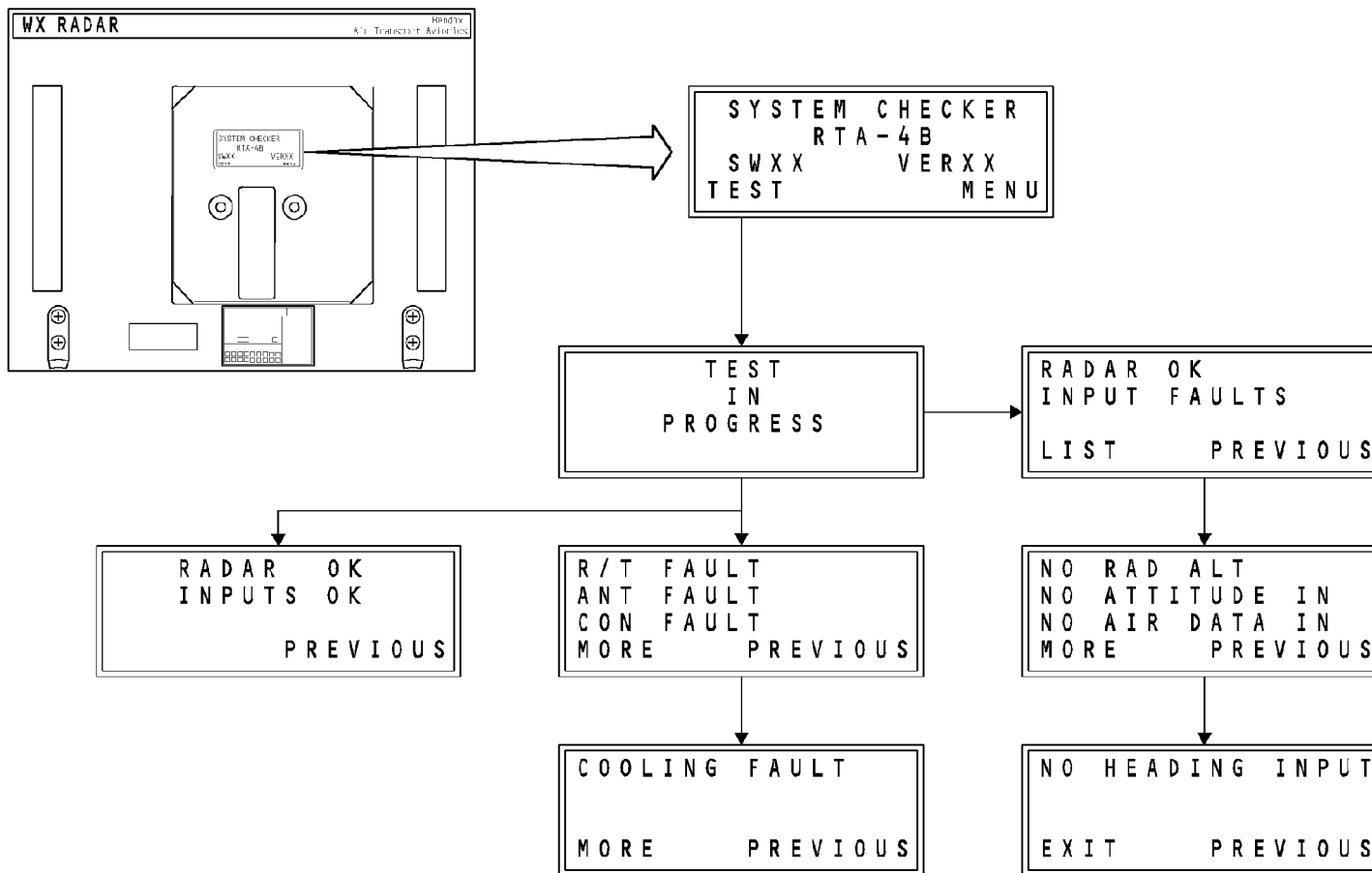

WXR SYSTEM - R/T SELF-TEST

34-43-00-021

EFFECTIVITY
HAP ALL

34-43-00

D633A101-HAP

WXR SYSTEM - R/T MAINTENANCE MENU**General**

The WXR R/T maintenance menu shows two types of data, inputs and fault memory.

Scroll and Enter

The TEST switch under SCROLL moves the list up and the arrow position does not move. Push the TEST switch under enter to show the data that the arrow is on.

Inputs

The INPUTS position shows all the inputs to the R/T. This data will help troubleshooting of the WXR system. The INPUTS shows these selections:

- PREVIOUS MENU
- DIGITAL INPUTS
- ANALOG INPUTS
- RADAR INPUTS
- EXIT TO MAIN.

PREVIOUS MENU and EXIT TO MAIN let you move through the display. The others show all the inputs. This lets you do troubleshooting without a tester. You can see these functions:

- Mode
- Gain
- Tilt
- Other control changes on the LCD.

Program pins and discretes also show.

Fault Memory

The fault memory shows all the faults in the 64 flight legs in the R/T memory. Fault memory shows these selections:

- PREVIOUS MENU
- READ FM: MANUAL
- READ FM: AUTO
- CLEAR FAULT MEMORY
- EXIT TO MAIN.

PREVIOUS MENU and EXIT TO MAIN let you move through the display. In the READ FM: AUTO position, the display quickly shows all the failures in memory. In the READ FM: MANUAL position, you push the TEST switch under enter to see each failure. CLEAR FAULT MEMORY removes all failures from the memory.

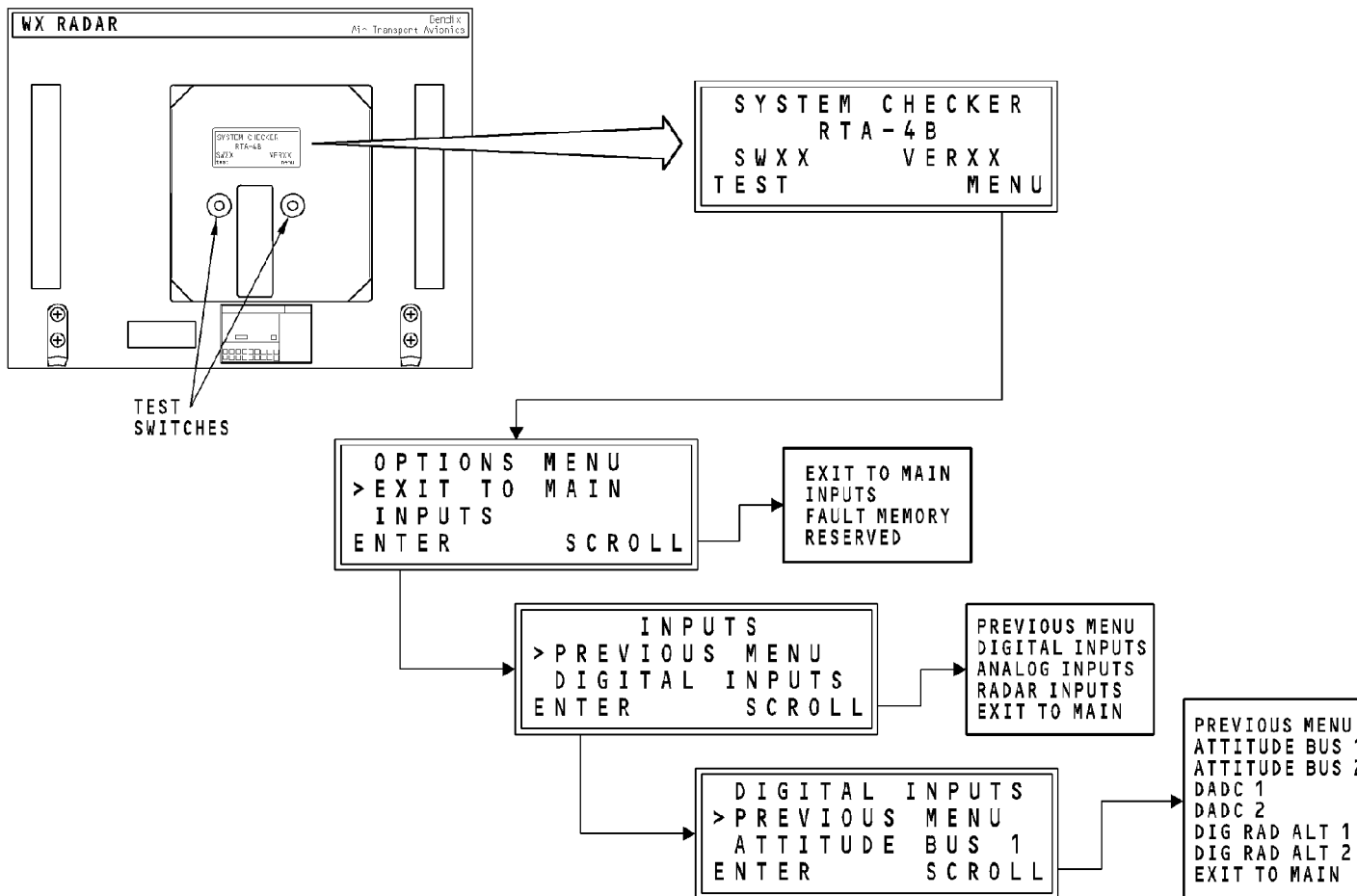

WXR SYSTEM - R/T MAINTENANCE MENU

EFFECTIVITY
HAP ALL

34-43-00

D633A101-HAP



WXR SYSTEM - SYSTEM SUMMARY

General

This page is for reference.

34-43-00-027

EFFECTIVITY
HAP ALL

34-43-00

D633A101-HAP

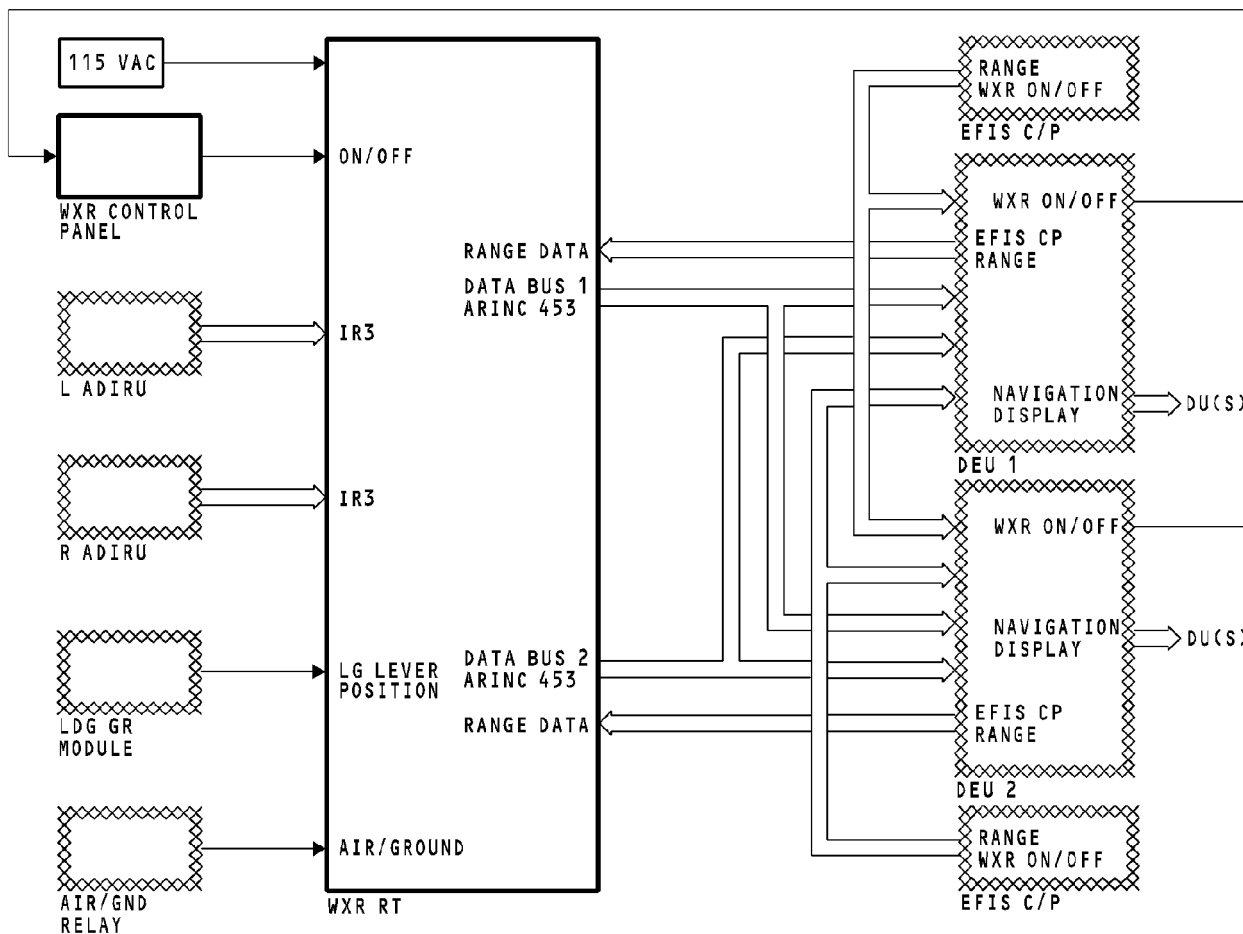

WXR SYSTEM - SYSTEM SUMMARY

34-43-00-027

EFFECTIVITY
HAP 001-007

34-43-00

D633A101-HAP

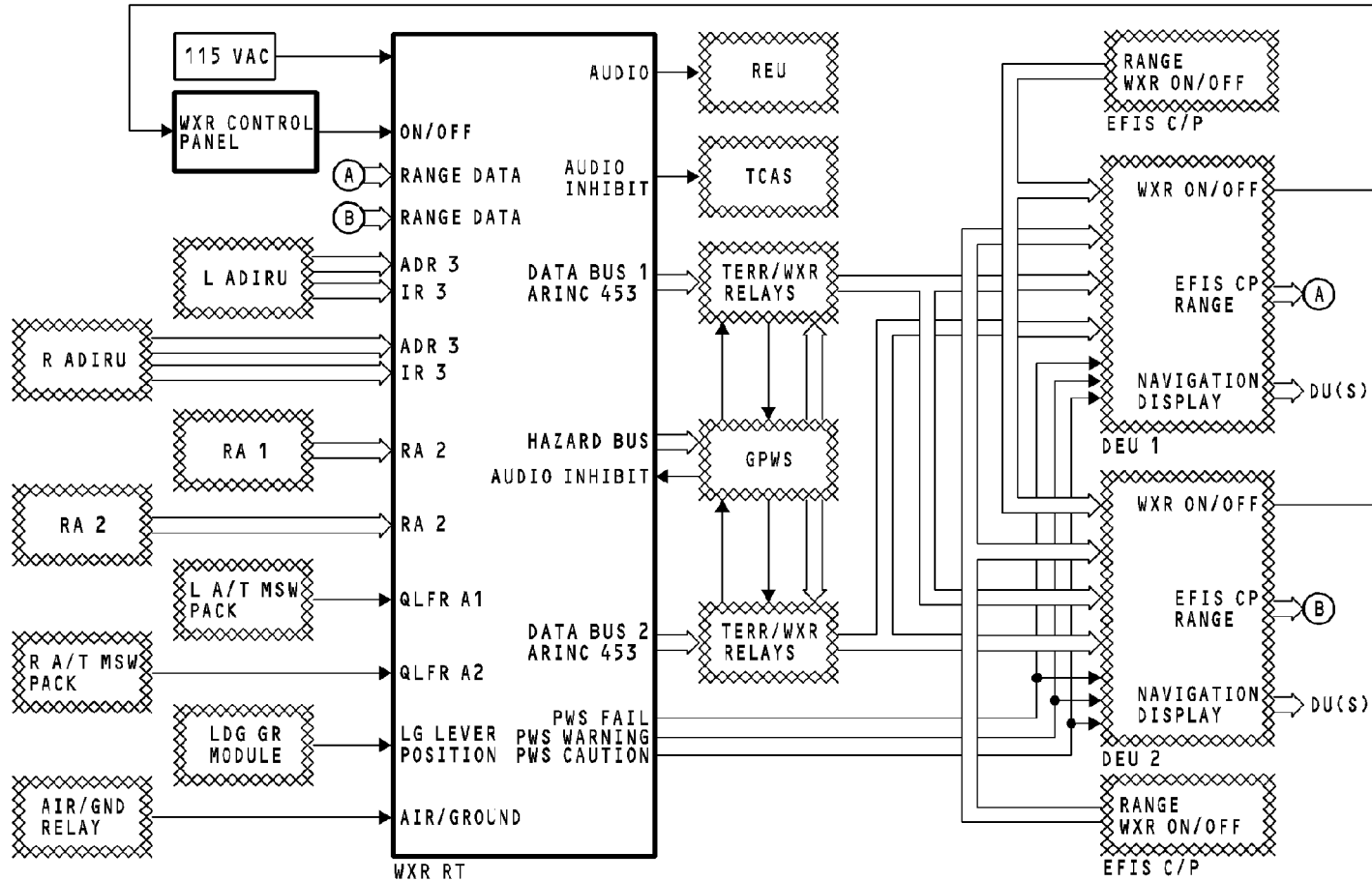

WXR SYSTEM - SYSTEM SUMMARY

EFFECTIVITY

HAP 008-013, 015-026, 028-054, 101-999

34-43-00

34-43-00-027

D633A101-HAP

TRAFFIC ALERT AND COLLISION AVOIDANCE SYSTEM - INTRODUCTION**General**

The traffic alert and collision avoidance system (TCAS) helps the flight crew maintain safe air traffic separation from other ATC transponder equipped airplanes. TCAS is an airborne system and operates independently of the ground-based ATC system.

TCAS sends interrogation signals to nearby airplanes. These airplanes which are equipped with an air traffic control radar beacon system (ATCRBS) transponder or an air traffic control (ATC) mode S transponder respond to these interrogations. TCAS uses these response signals to calculate the range, relative bearing, and altitude of the responding airplane. If a responding airplane does not report altitude, TCAS cannot calculate the altitude of that airplane. Airplanes tracked by TCAS are called targets.

Using the information from the response signals and altitude of own airplane, TCAS calculates the relative movement between own airplane and the target. TCAS then calculates how close the target will be to own airplane at the closest point of approach (CPA).

Targets are classified as one of these four types depending on the separation at CPA and the time it will take until CPA occurs:

- Other traffic
- Proximate traffic

- Intruders
- Threats.

Each type of target has a different symbol on the display.

If the separation at CPA is within certain limits, TCAS provides advisory messages to the flight crew. TCAS provides two levels of advisories to the flight crew, traffic advisory (TA) and resolution advisory (RA). The type of advisory is determined by a combination of altitude, the time to CPA, and the separation at CPA. The TA shows for relatively longer times to CPA and relatively larger separation at CPA and is for intruder targets. The RA shows for relatively shorter times to CPA and relatively smaller separation at CPA and is for threat targets.

The TA shows the range, bearing, and relative altitude (if relative altitude is known) of the intruder target. The RA also gives visual and aural commands to the flight crew to make sure there is safe vertical separation from the threat target.

TCAS also communicates with other airplanes that have TCAS to coordinate the flight movement to prevent a collision.

Abbreviations and Acronyms

- abs - absolute
- abv - above
- ADIRU - air data inertial reference unit
- AGL - above ground level
- AI - attitude indicator

TRAFFIC ALERT AND COLLISION AVOIDANCE SYSTEM - INTRODUCTION

- ant - antenna
- arpt - airport
- ATC - air traffic control
- ATCRBS - air traffic control radar beacon system
- BITE - built-in-test equipment
- blw - below
- CDS - common display system
- CPA - closest point of approach
- CPU - central processing unit
- CTR - center
- DEU - display electronics unit
- DME - distance measuring equipment
- EFIS - electronic flight instrument system
- exp - expanded
- FDAU - flight data acquisition unit
- FL - flight level
- FPM - feet per minute
- fwd - forward
- gnd - ground
- GPWC - ground proximity warning computer
- grd - ground
- ident - identification
- IF - intermediate frequency
- INT - interrogator
- I/O - input/output
- L - left
- LED - light emitting diode
- max - maximum
- MHz - megahertz
- NCD - no computed data
- NM - nautical miles
- norm - normal
- R - right
- RA - resolution advisory
- rel - relative
- REU - remote electronic unit
- RF - radio frequency
- R/T - receiver/transmitter
- stby - standby
- sw - switch
- TA - traffic advisory
- TAS - true airspeed
- TAU - time to closest point of approach
- TCAS - traffic alert and collision avoidance system
- tfc - traffic
- trk - track
- VOR - very high frequency omnidirectional range
- VSI - vertical speed indicator
- wpt - waypoint
- xfr - transfer
- xpndr - transponder

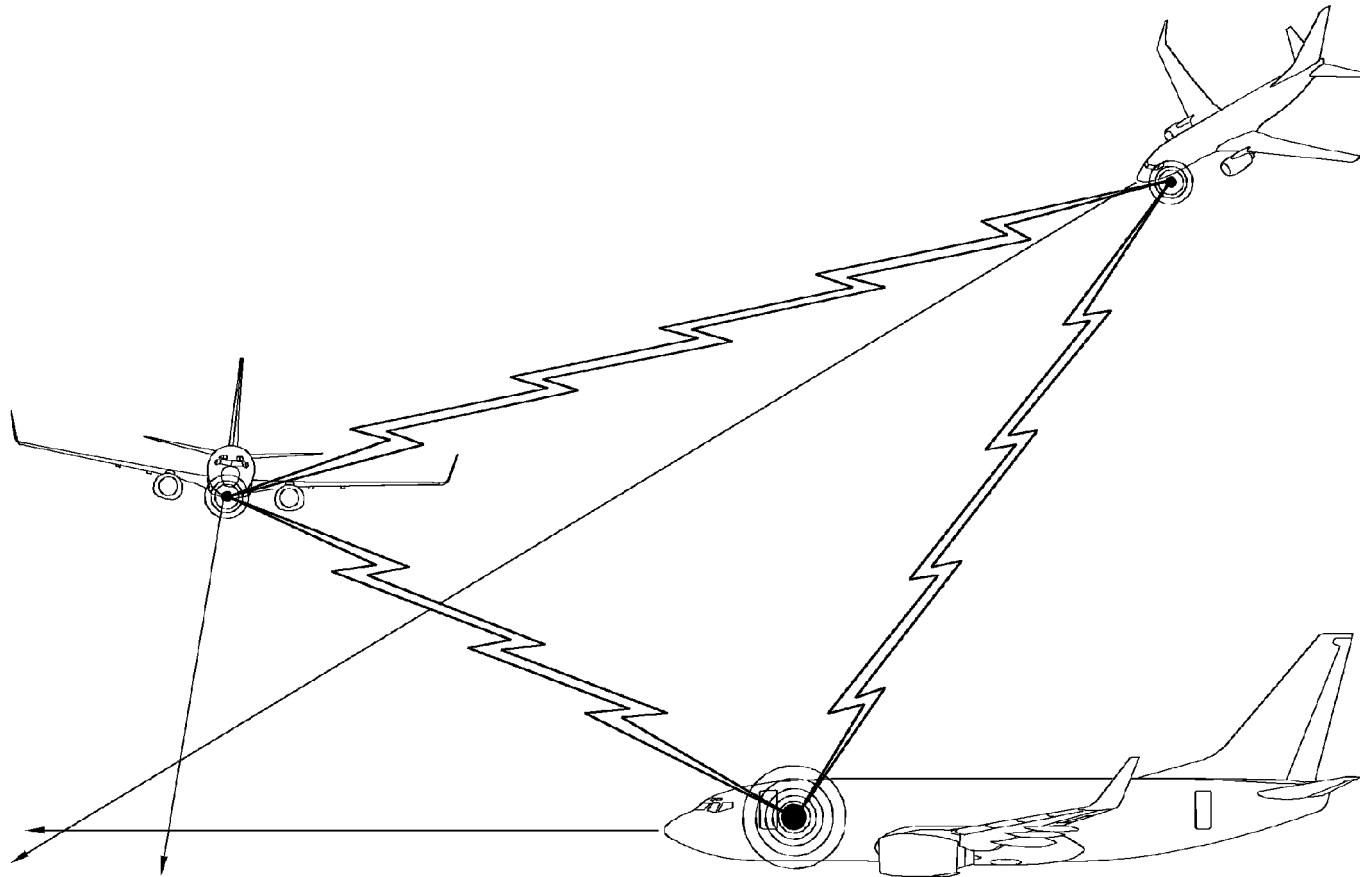

TRAFFIC ALERT AND COLLISION AVOIDANCE SYSTEM - INTRODUCTION

EFFECTIVITY
HAP ALL

34-45-00

D633A101-HAP

Page 3
Oct 10/2004

34-45-00-001

TCAS - GENERAL DESCRIPTION**General**

The TCAS transmits to and receives signals from other airplanes to get altitude, range, and bearing data. The other airplanes report their own altitudes. The range of the other airplanes is calculated by measurement of the time between the transmission of an interrogation and the reception of a response from the other airplanes. Bearing is calculated by the use of directional antennas. TCAS uses these data and inputs from other onboard airplane systems to provide visual indications of the position of other airplanes and to provide visual and aural traffic avoidance alerts.

General Description

These are the TCAS components:

- TCAS directional antennas (2)
- TCAS computer
- ATC/TCAS control panel.

TCAS interfaces with these other system components:

- ATC transponders (2)
- Landing gear lever
- PSEU
- Common display system (CDS) display electronic units (DEUs) (2)
- Remote electronics unit (REU)
- Radio altimeters (2)
- Ground proximity warning computer (GPWC)

HAP 008-013, 015-026, 028-054, 101-999

- Weather radar

HAP ALL

- Left air data inertial reference unit (ADIRU)
- Suppression coax tees
- Flight data acquisition unit (FDAU).

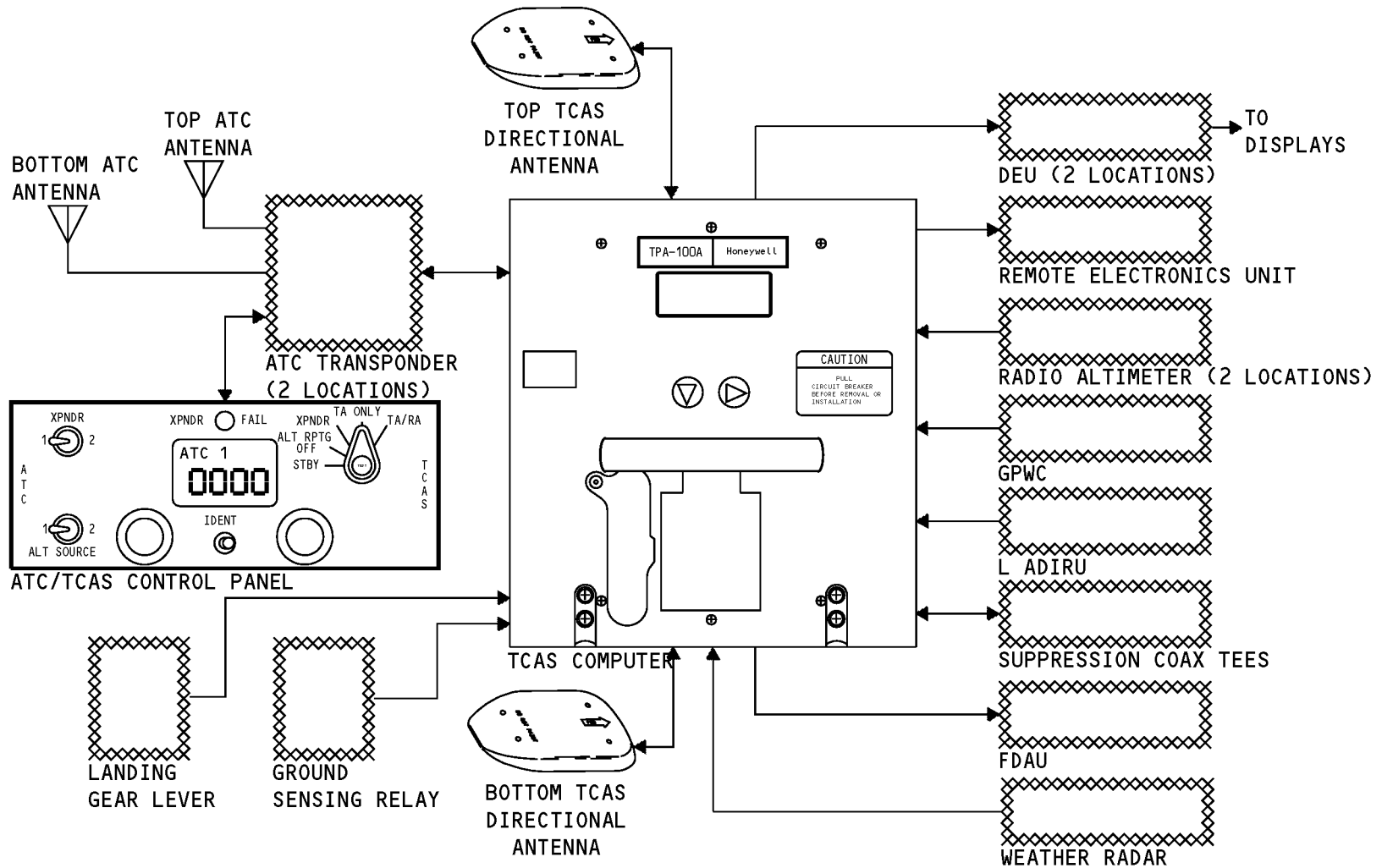

TCAS - GENERAL DESCRIPTION

34-45-00-002

EFFECTIVITY
HAP 031-054, 101-999

34-45-00

D633A101-HAP

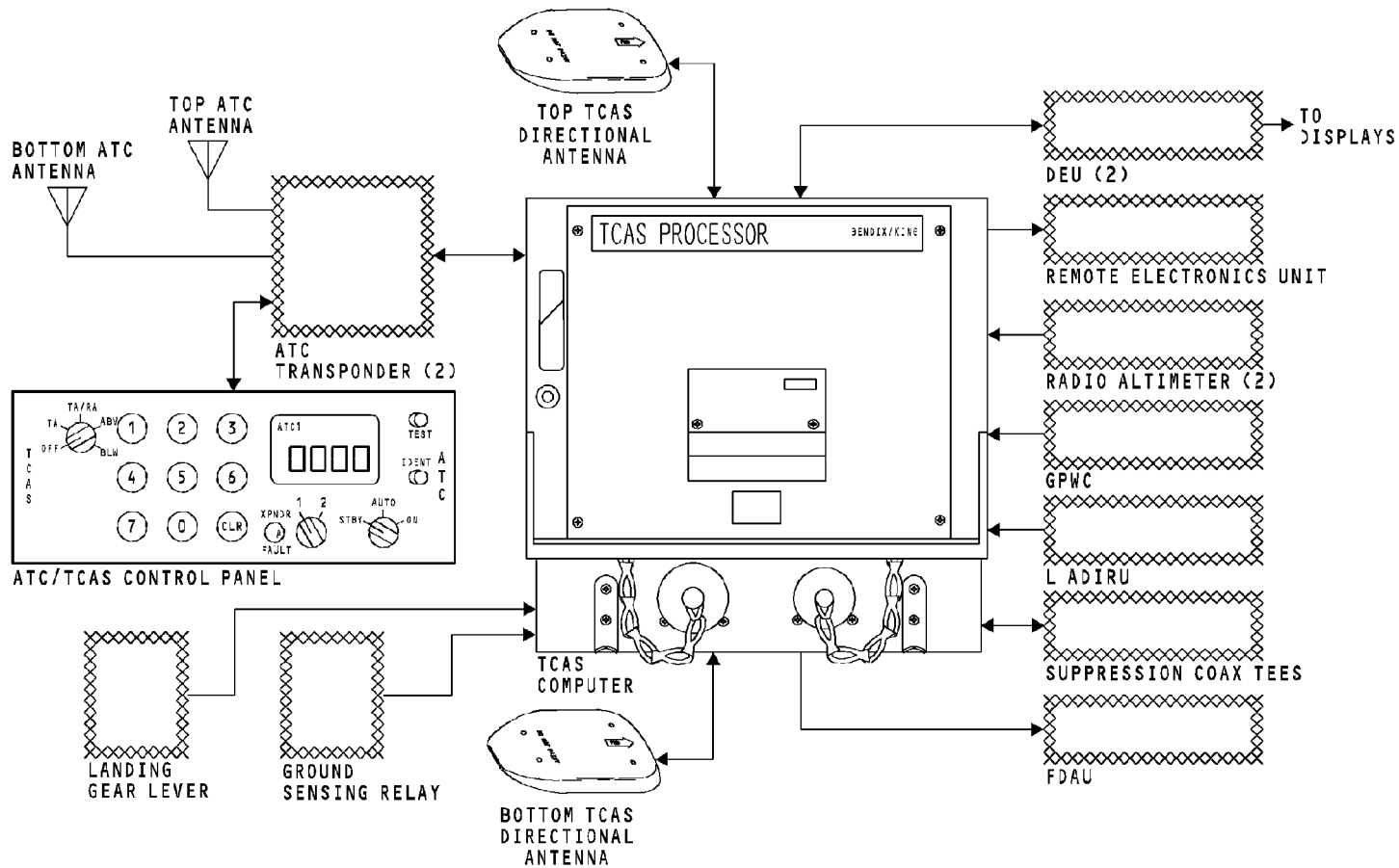

TCAS - GENERAL DESCRIPTION

EFFECTIVITY
HAP 001-007

34-45-00

D633A101-HAP

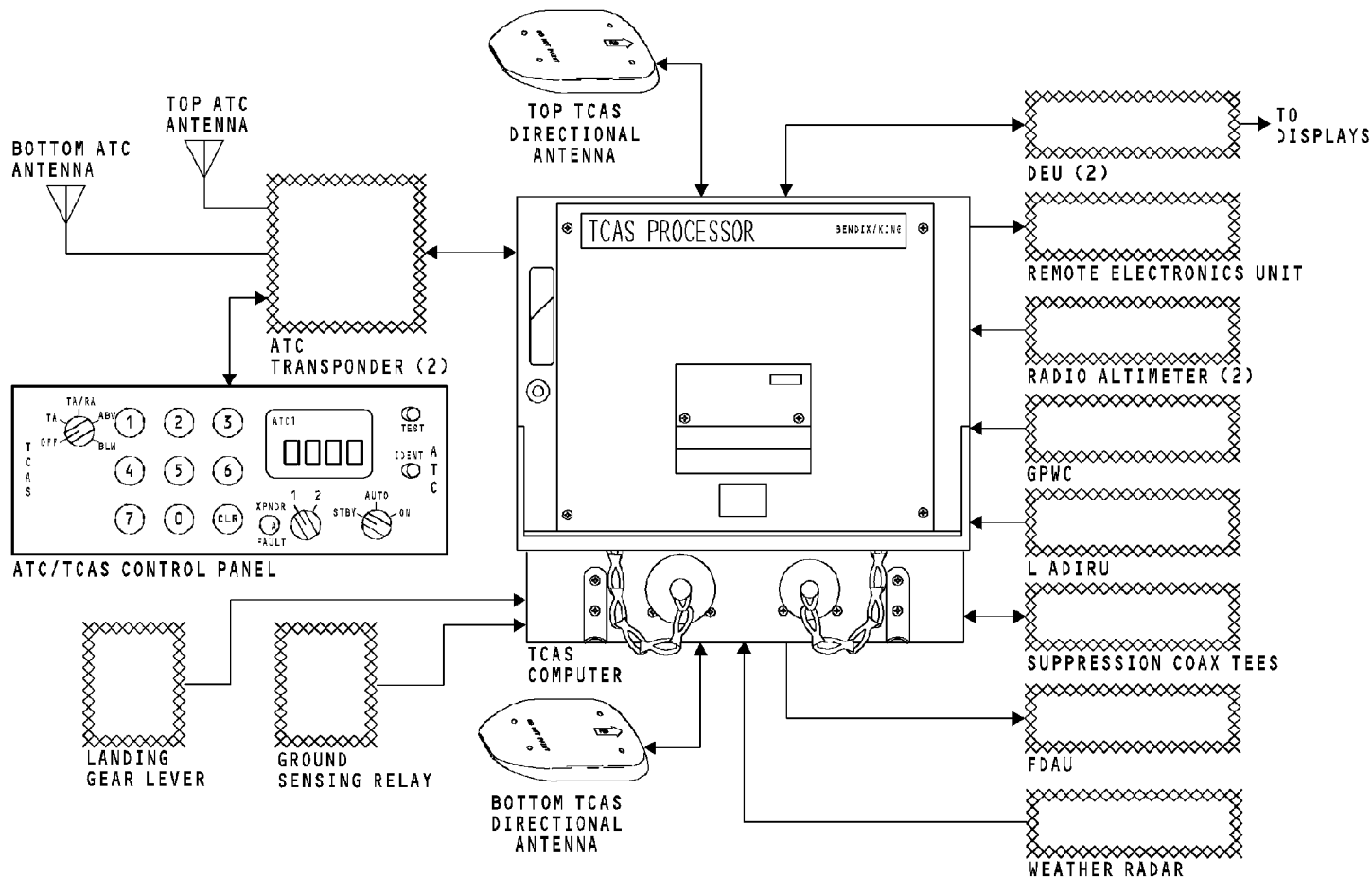

TCAS - GENERAL DESCRIPTION

34-45-00-002

EFFECTIVITY
HAP 008-013, 015-026, 028-030

34-45-00

D633A101-HAP

TCAS - COMPONENT LOCATION

Electronic Equipment Compartment

The TCAS computer is in the electronic equipment compartment.

Flight Compartment

These are the components in the flight compartment that interface with TCAS:

- Left electronic flight instrument system (EFIS) control panel
- Left outboard display unit
- Left inboard display unit
- Right EFIS control panel
- Right outboard display unit
- Right inboard display unit
- ATC/TCAS control panel.

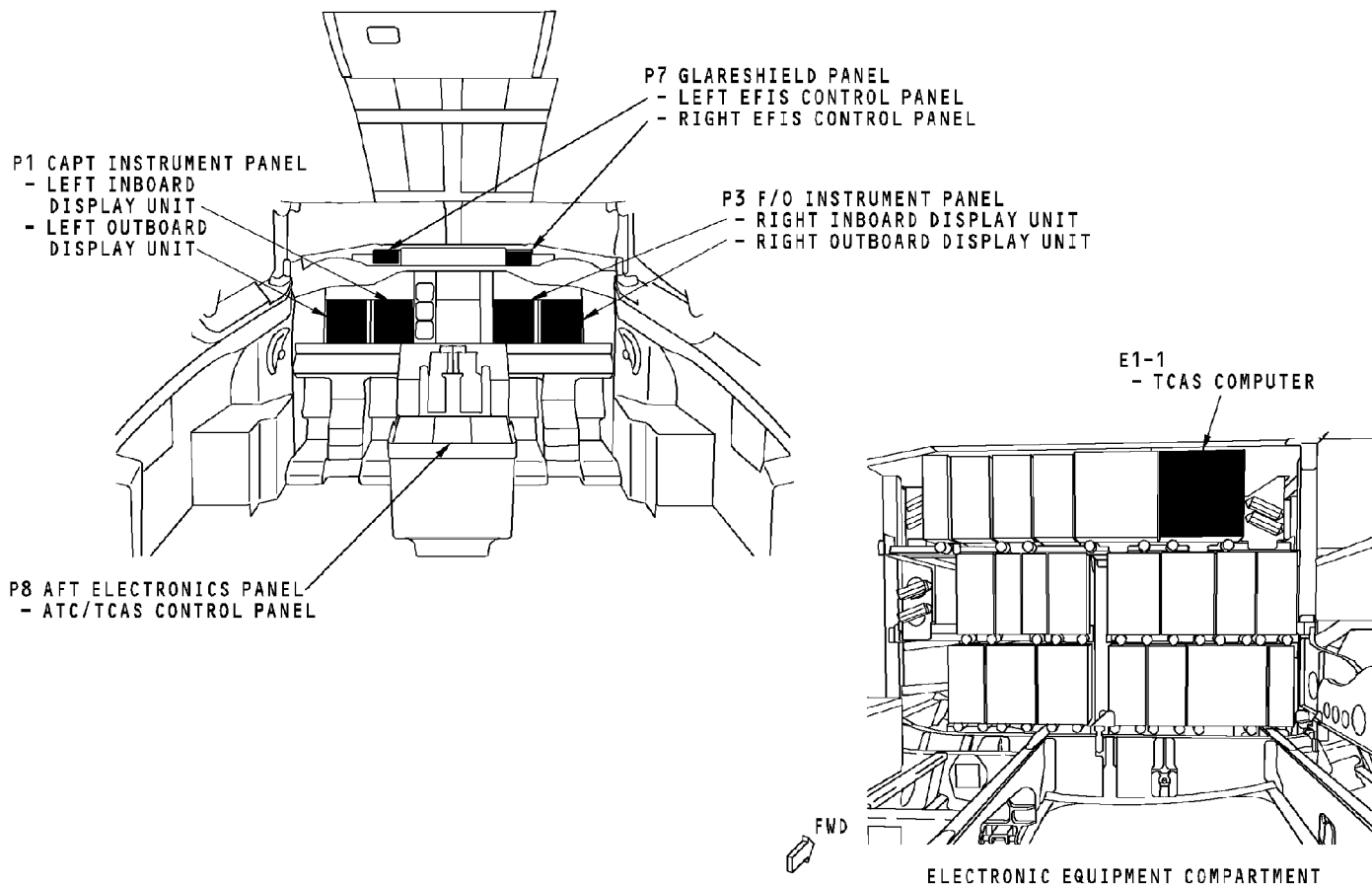

TCAS - COMPONENT LOCATION

EFFECTIVITY
HAP ALL

34-45-00

D633A101-HAP



TCAS - ANTENNA LOCATION

General

The top TCAS directional antenna is at station 385 on top of the fuselage. The bottom TCAS directional antenna is at station 305 on the bottom of the fuselage.

34-45-00-004

EFFECTIVITY
HAP ALL

34-45-00

D633A101-HAP

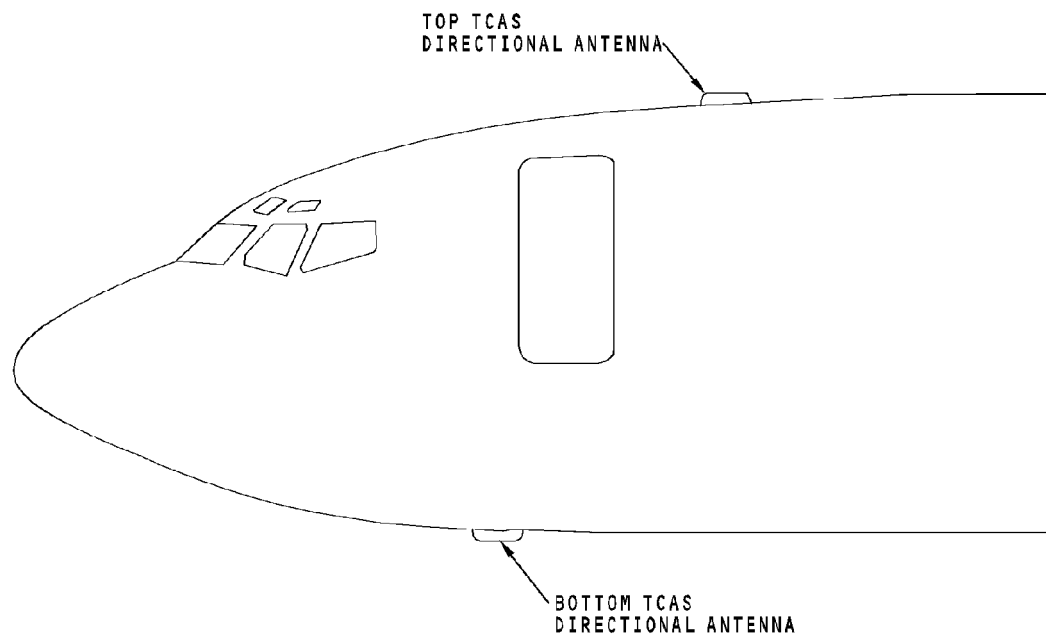

TCAS - ANTENNA LOCATION

34-45-00-004

EFFECTIVITY
HAP ALL

34-45-00

D633A101-HAP

THIS PAGE IS INTENTIONALLY LEFT BLANK

34-45-00

D633A101-HAP

Page 12
Jun 15/2009

TCAS - POWER, ANTENNAS, ANALOG, DISCRETE INTERFACES AND PROGRAM PINS

General

The TCAS computer has analog and discrete interfaces with these components:

- Top and bottom TCAS directional antennas
- Landing gear lever switch
- Proximity Switch Electronics Unit (PSEU)
- Ground proximity warning computer (GPWC)

HAP 008-013, 015-026, 028-054, 101-999

- Weather radar

HAP ALL

- DME/ATC/TCAS suppression coax tees
- Display electronic unit (DEU) 1 and 2
- Remote electronics unit (REU).

Program pins control the configuration of the TCAS computer.

Power

The TCAS computer gets 115v ac from AC transfer bus-1 through the TCAS circuit breaker on the P18 circuit breaker panel.

Antennas

There are two TCAS directional antennas. The TCAS directional antennas receive traffic airplane reply signals. They also transmit the TCAS interrogation signals.

Landing Gear Lever Switch

The discrete from the landing gear lever switch tells the TCAS computer that the landing gear is down. When the TCAS computer gets this discrete, the TCAS computer makes the bottom directional antenna become an omnidirectional antenna.

PSEU

The discrete from the PSEU supplies in-air or on-ground status to the TCAS computer. The air/ground discrete inhibits TCAS operation on the ground and inhibits tests when in the air. The air/ground discrete also controls flight leg increments in the TCAS nonvolatile memory.

GPWC - Advisory Inhibit Discretes

HAP

The GPWC sends one discrete to the TCAS computer. This discrete inhibits TCAS aural and visual warnings when the GPWC makes any voice message.

HAP
HAP
HAP

HAP 008-013, 015-026, 028-054, 101-999

Weather Radar

The TCAS computer gets one discrete from the weather radar. This discrete inhibits all TCAS aural warnings and changes RAs to TAs when the weather radar makes a predictive windshear warning.

34-45-00-006

<p>EFFECTIVITY HAP ALL</p>

34-45-00

D633A101-HAP

TCAS - POWER, ANTENNAS, ANALOG, DISCRETE INTERFACES AND PROGRAM PINS**HAP 008-013, 015-026, 028-054, 101-999 (Continued)**
HAP ALL**Suppression Input/Output**

The TCAS computer gets a suppression pulse when an ATC transponder or DME interrogator transmits. When the TCAS computer transmits, it sends a suppression pulse to the ATC transponders and the DME interrogators.

DEU - Display Status

A discrete from either DEU goes to the TCAS computer when the DEU loses the ability to show TCAS displays. When the TCAS computer gets this discrete, the TCAS computer does not do these functions:

- Send TCAS display outputs to the DEU
- Send TCAS aural to the REU
- Transmit coordination data to traffic airplanes with TCAS.

REU - TCAS Aural - Voice Outputs

The TCAS computer sends resolution advisory (RA) and traffic advisory (TA) aural signals to the remote electronic unit (REU). The REU amplifies the RA and TA aural. Then it sends them to the flight interphone speakers in the flight compartment to alert the flight crew.

Program Pins**HAP 001-013, 015-026, 028-030**

These are the functions that the program pins on the TCAS computer permit:

- Shows a maximum of 8 targets
- Goes to the standby mode when the airplane is on the ground.
- Does not show airplanes that are on the ground when own airplane is below 1750 feet AGL
- Inhibits self-test in the air
- Controls the audio level of the voice outputs
- Sets the airplane altitude limit of 48,000 feet so TCAS does not command a climb or increase climb above this altitude.

HAP 031-054, 101-999

These are the functions for the program pins on the TCAS computer:

- Does not show airplanes that are on the ground when own airplane is below 1750 feet AGL
- Inhibits self-test in the air
- Controls the audio level of the voice outputs
- Sets the airplane altitude limit of 48,000 feet so TCAS does not command a climb or increase climb above this altitude.

HAP ALL

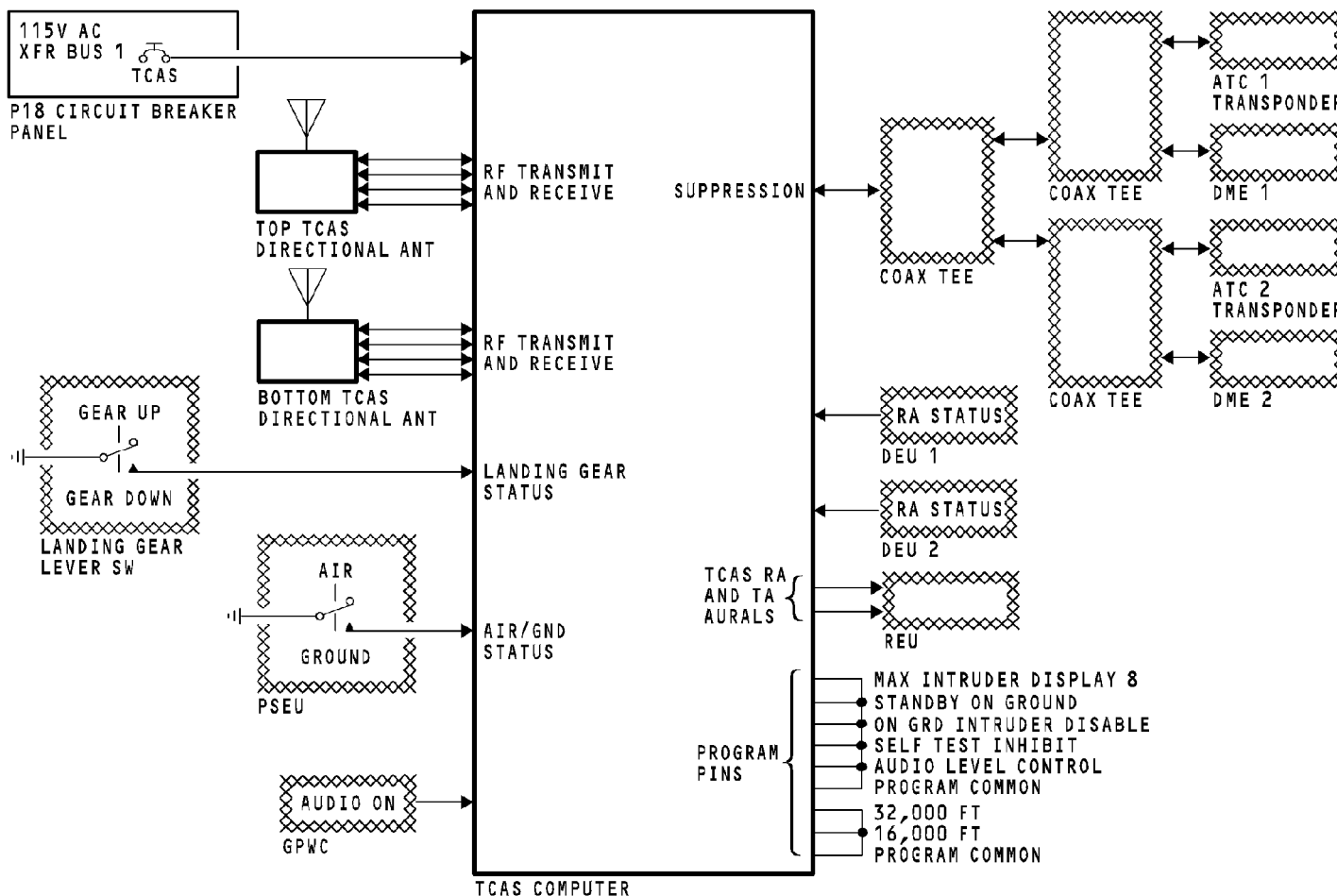

TCAS - POWER, ANTENNAS, ANALOG, DISCRETE INTERFACES AND PROGRAM PINS

34-45-00-006

EFFECTIVITY
HAP 001-007

34-45-00

D633A101-HAP

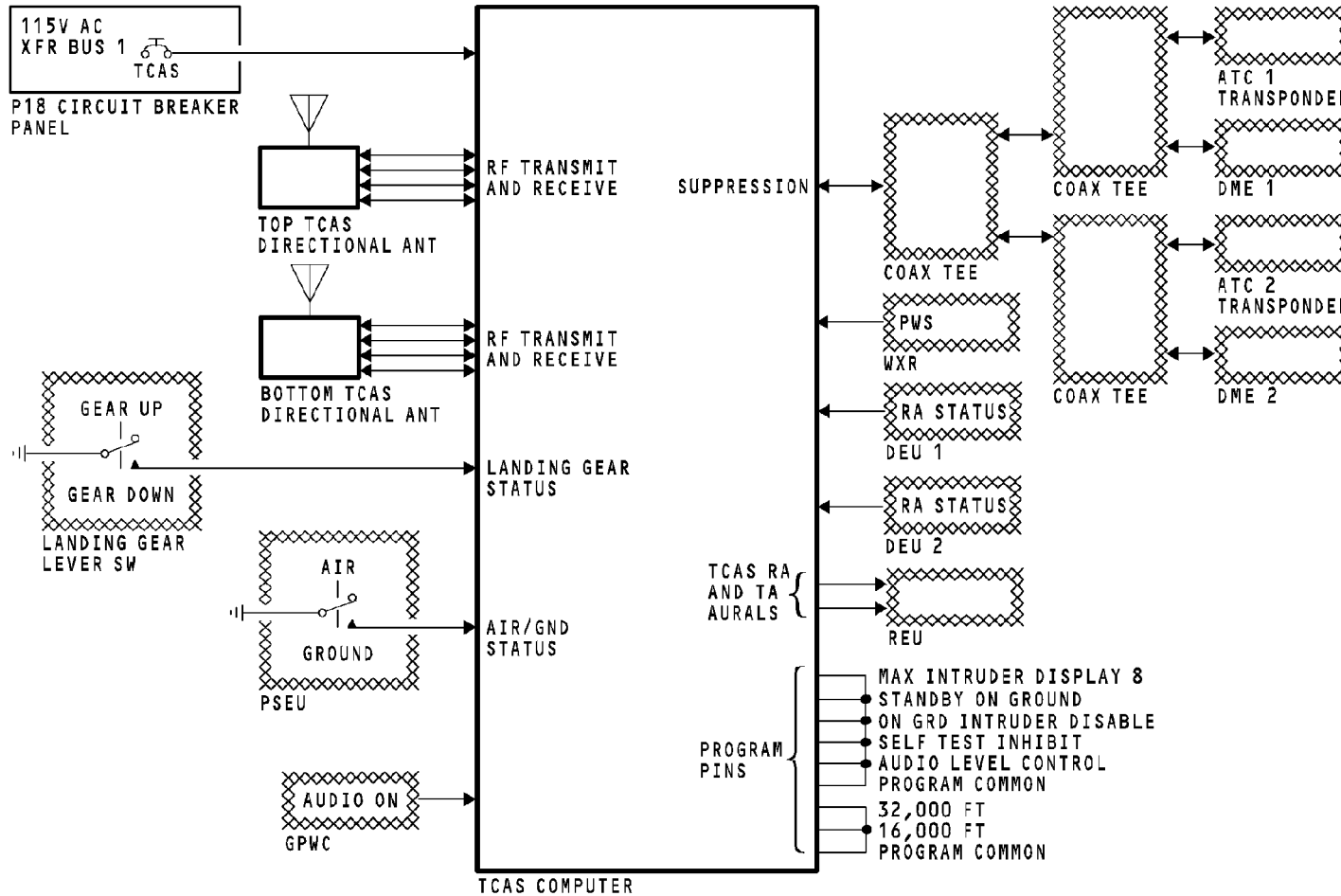

TCAS - POWER, ANTENNAS, ANALOG, DISCRETE INTERFACES AND PROGRAM PINS

EFFECTIVITY

HAP 008-013, 015-026, 028-030

34-45-00

34-45-00-006

D633A101-HAP

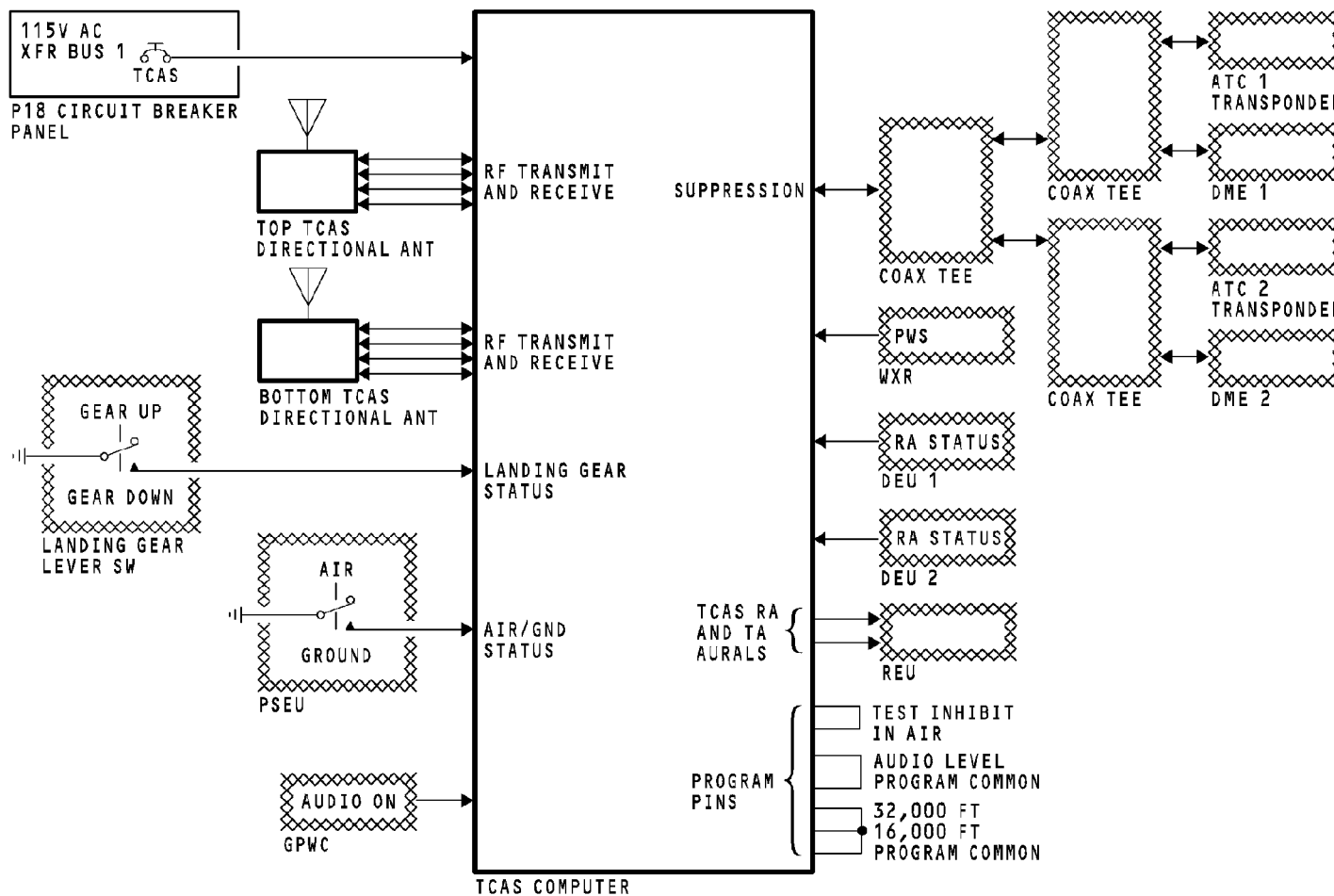

TCAS - POWER, ANTENNAS, ANALOG, DISCRETE INTERFACES AND PROGRAM PINS

34-45-00-006

EFFECTIVITY
HAP 031-054, 101-999

34-45-00

D633A101-HAP

THIS PAGE IS INTENTIONALLY LEFT BLANK

34-45-00

D633A101-HAP

Page 18
Oct 10/2005

TCAS - DIGITAL INTERFACES**General**

The TCAS computer has digital interfaces with these components:

- ATC 1 transponder
- ATC 2 transponder
- Radio altimeter 1 transceiver
- Radio altimeter 2 transceiver
- Left air data inertial reference unit (ADIRU)
- Display electronic unit 2 (DEU 2)
- Display electronic unit 1 (DEU 1)
- Flight data acquisition unit (FDAU).

ATC Transponder - Control and Coordination Data

When you select an ATC transponder, it sends this ATC control panel data to the TCAS computer:

- The TCAS mode selection (TA only or TA/RA)
- Control of the altitude limits for the TCAS display that shows on the navigation display (ND).

The TCAS computer uses this data from the ATC transponder to calculate the climb or descent to prevent a collision:

- 24-bit airplane address
- Barometric altitude
- Maximum true airspeed.

The TCAS computer sends this to the ATC transponder:

- General TCAS operational status
- Mode S coordination data.

Radio Altimeter Inputs

The TCAS computer gets radio altitude from radio altimeter 1 and 2 transceivers although only one input is necessary for TCAS operation. The data is used by the TCAS computer to calculate some sensitivity levels.

At approximately 1700 feet, the TCAS computer uses radio altitude together with barometric altitude to determine intruders that are on the ground and therefore no threat to the TCAS airplane.

At 1000 feet radio altitude, the TCAs computer inhibits resolution advisories and TA ONLY will show on the NDs.

TCAS Inputs from ADIRU

The left ADIRU supplies these inputs to the TCAS computer:

- Airplane roll attitude
- Airplane pitch attitude
- Airplane heading.

HAP 031-054, 101-999

NOTE: These inputs are not used by the TCAS computer at this time.

HAP ALL

EFFECTIVITY
HAP ALL

34-45-00

D633A101-HAP

Page 19
Feb 15/2009

TCAS - DIGITAL INTERFACES

TCAS Outputs to DEUs

The TCAS computer supplies resolution advisory (RA) and traffic advisory (TA) data to the DEUs. This includes all traffic data for TCAS displays.

TCAS Outputs to the FDAU

The FDAU receives the same TCAS data that goes to the DEUs.

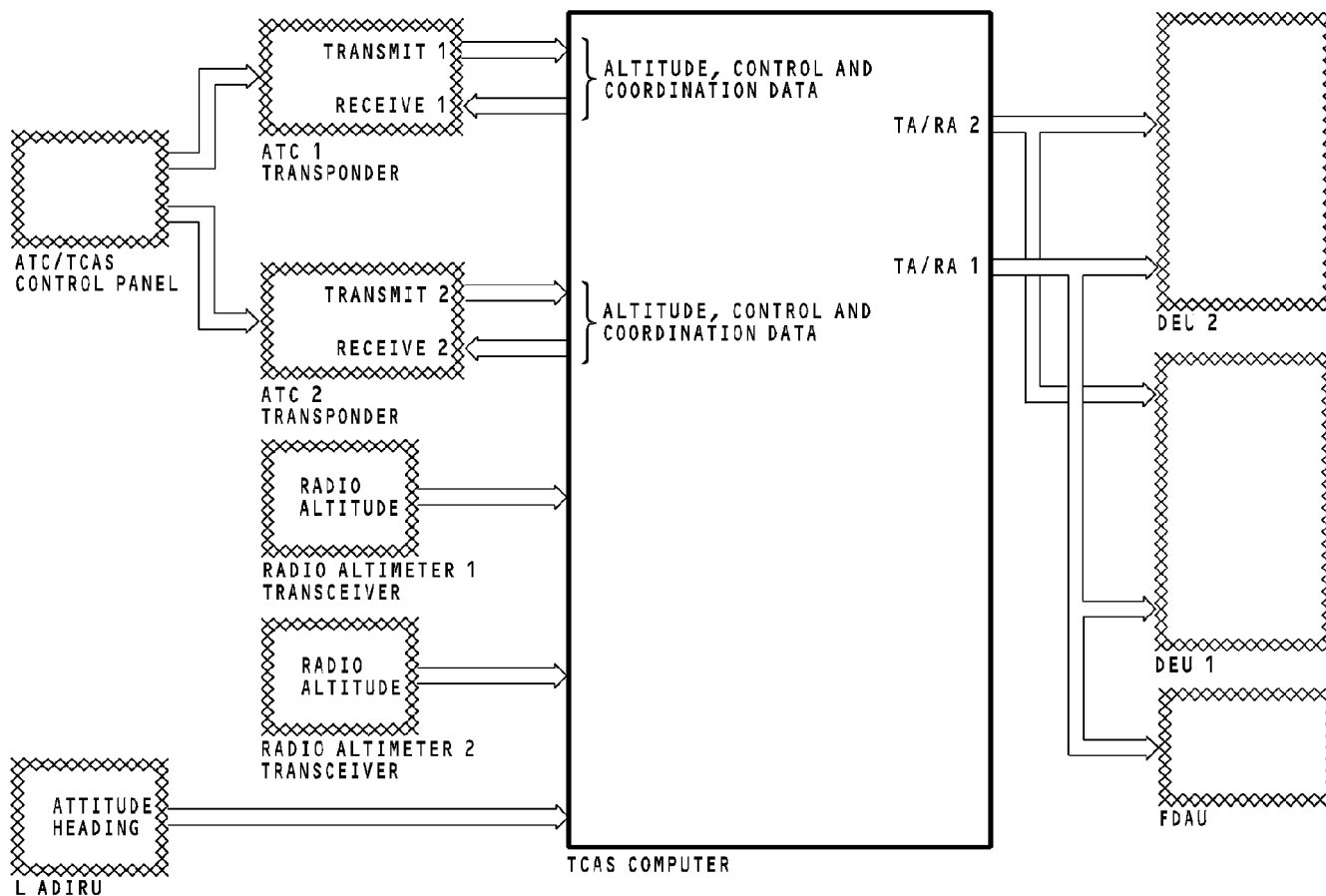

TCAS - DIGITAL INTERFACES

34-45-00-007

EFFECTIVITY
HAP ALL

34-45-00

D633A101-HAP

THIS PAGE IS INTENTIONALLY LEFT BLANK

34-45-00

D633A101-HAP

Page 22
Oct 10/2006

TCAS - TCAS COMPUTER

Purpose

The TCAS computer is the main component of the TCAS. It controls these functions:

- Surveillance
- Tracking
- Advisory
- Air-to-air maneuver coordination.

The TCAS computer sends signals which tell the flight crew to make one of these maneuvers:

- Keep the current flight plan
- Make flight maneuvers to prevent a possible collision with other airplanes in the area.

Physical Description

The TCAS computer is a 6 MCU size unit. It weighs 28 lbs (11.3 kg).

Functional Description

The TCAS computer transmits 1030 MHz pulse-coded interrogation signals. It receives 1090 MHz pulse-coded reply signals from intruder airplanes with an ATC transponder.

Front Panel LED Indications

HAP 031-054, 101-999

The front panel of the computer contains a four-line, 16 characters per line liquid crystal display (LCD) and two pushbutton controls. You use the left button to scroll and the right button for item selection.

HAP 001-013, 015-026, 028-030

Two alphanumeric LEDs show fail conditions of the TCAS computer and systems that have interfaces with the TCAS computer.

Front Panel Self-Test

You push the test switch on the front panel to start a test of the TCAS. The LED indications come on to show system status.

HAP 031-054, 101-999

Performance Management Recording

The TCAS computer has a slot for a Personal Computer Memory Card International (PCMCIA) card. The recorder function provides the capability to store information about TCAS events for post-flight analysis. The PCMCIA card device programming is done at depot level, or by a field service representative in the event of very problematical troubleshooting.

TCAS - TCAS COMPUTER

HAP 031-054, 101-999 (Continued)

HAP ALL

Front Panel Connectors

HAP 001-013, 015-026, 028-030

There are two connectors on the front panel. One is to load software and one is for automated test equipment.

HAP 031-054, 101-999

There is one connector on the front panel. You use it to load revised software.

HAP ALL

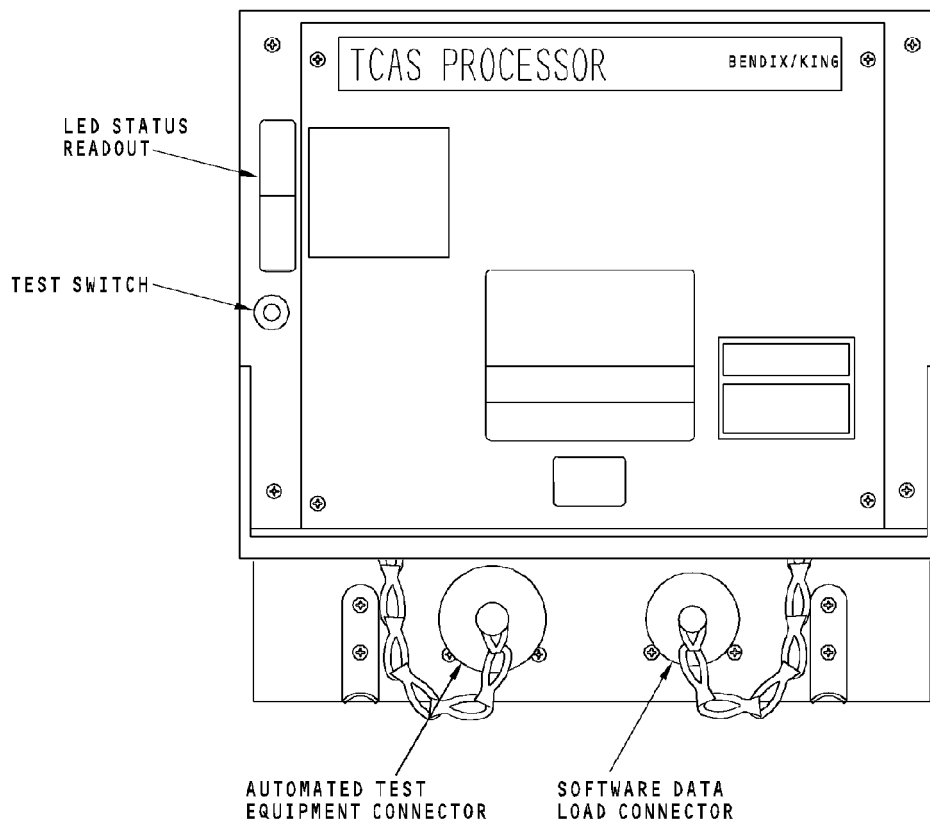

TCAS - TCAS COMPUTER

34-45-00-008

EFFECTIVITY
HAP 001-013, 015-026, 028-030

34-45-00

D633A101-HAP

Page 25
Jun 10/2007

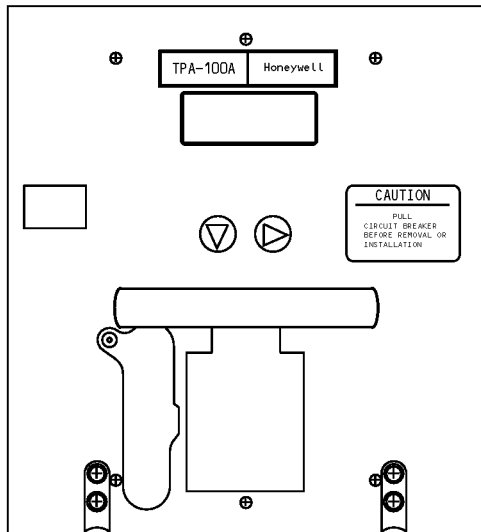

TCAS - TCAS COMPUTER

EFFECTIVITY
HAP 031-054, 101-999

34-45-00

D633A101-HAP

THIS PAGE IS INTENTIONALLY LEFT BLANK

34-45-00

D633A101-HAP

Page 27
Jun 10/2007

TCAS - ATC/TCAS CONTROL PANEL**General**

The ATC/TCAS control panel controls the TCAS computer.

Function Select Switch

You use the function select switch to select one of these TCAS modes:

- TA mode. This is the TA only mode. The displays show all targets except RAs.
- TA/RA mode. The displays show all targets. This is the normal mode of operation for TCAS.
- ABV mode. This makes the display show other traffic that is from 2700 feet below to 7000 feet above the present airplane altitude.
- BLW mode. This makes the display show other traffic that is from 7000 feet below to 2700 feet above the present airplane altitude.

Test Switch

You can use the test switch on the front of the control panel to do a test of the ATC and TCAS systems.

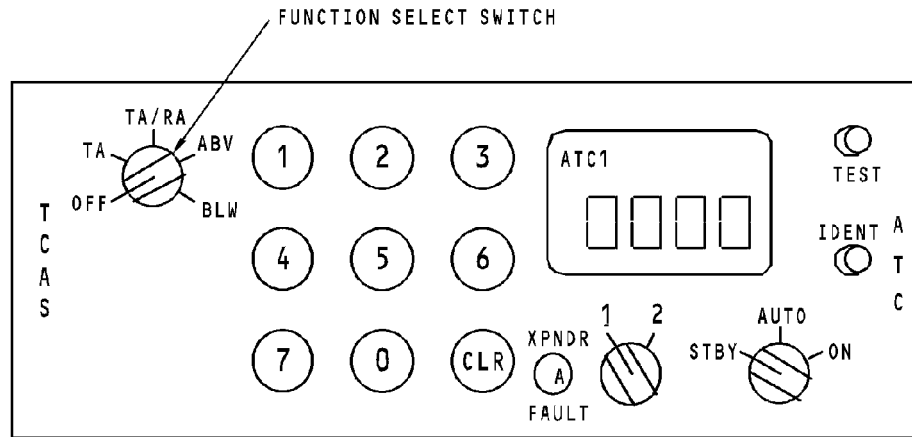

TCAS - ATC/TCAS CONTROL PANEL

34-45-00-009

**EFFECTIVITY
HAP ALL**

34-45-00

D633A101-HAP

TCAS - TCAS DIRECTIONAL ANTENNA

General

The TCAS uses a top and bottom directional antenna. The antennas are the same and interchangeable.

Physical Description

The directional antenna is a phased array antenna. There are four array elements on the antenna. Each element has a color coded connector. The TCAS computer sends transmit interrogation signals to the array elements with different phases. This makes the interrogation signal directional.

To attach the antenna cables, connect each coaxial cable with the array element connector that has the same color band.

Four screws attach the antenna to the airplane. The radiation side of the antenna shows FWD and DO NOT PAINT.

CAUTION: DO NOT PAINT THE RADIATION SURFACE OR THE BACKPLATE OF THE ANTENNA. PAINT DOES NOT PERMIT THE ANTENNA TO RADIATE OR RECEIVE RF SIGNALS.

CAUTION: TO PREVENT DAMAGE TO THE ANTENNA CABLES, DO NOT PULL ON THEM.

Training Information Point

An antenna connection includes the coax cable and an antenna element. The TCAS computer checks the resistance of each antenna connection at power-up. The TCAS computer reports an antenna fault when it detects that the resistance of the connection is out of range. If you do not connect the coax cable to the correct element, the TCAS computer reports an antenna fault.

EFFECTIVITY
HAP ALL

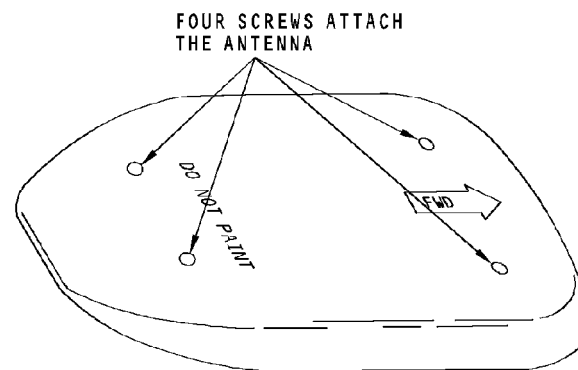
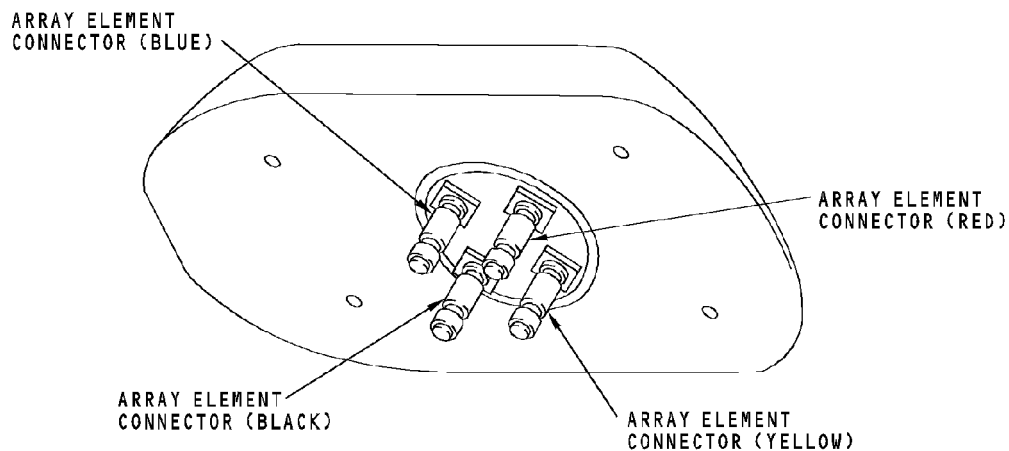

TCAS - TCAS DIRECTIONAL ANTENNA

34-45-00-010

EFFECTIVITY
HAP ALL

34-45-00

D633A101-HAP

THIS PAGE IS INTENTIONALLY LEFT BLANK

34-45-00

D633A101-HAP

Page 32
Feb 15/2009

TCAS - FUNCTIONAL DESCRIPTION

General

The TCAS computer transmits interrogations to and receives replies from other airplanes. Airplanes that are tracked by TCAS are called targets. The TCAS computer uses these replies and data from other airplane systems to calculate if a target is a collision threat. The TCAS computer can communicate with other airplanes that have TCAS. The two TCAS computers can use the shared data to perform coordinated maneuvers and avoid potential collisions.

The TCAS computer also gets analog and digital inputs from other airplane systems. These inputs control TCAS and provide data for TCAS to track intruders. The TCAS computer sends display data to the common display system (CDS) display electronic units (DEUs).

The TCAS computer has these circuits:

- Input/output (I/O)
- Speech Processor
- Central processing unit (CPU) and memory
- Suppression circuit
- Signal Processor
- Receiver
- Transmitter
- Beam steering and attenuator
- BITE.

I/O

The I/O circuit gets this on-board airplane systems data:

HAP 001-013, 015-026, 028-030

- Magnetic heading, pitch, and roll IRU data from the left ADIRU

HAP 031-054, 101-999

- The left ADIRU data is not used.

HAP ALL

- Coordination and control data from the ATC transponder system
- Barometric altitude from the left or right ADIRU from the active ATC
- Radio altitude from the radio altimeters
- Resolution advisory status from the DEUs
- Landing gear down discrete from the landing gear lever switch
- Aural inhibit discrete interface with the GPWC

HAP 008-013, 015-026, 028-054, 101-999

- Aural inhibit discrete interface with the weather radar

HAP ALL

- Air/ground data from the PSEU.

Program pins set these parameters in the TCAS computer:

- Altitude limits
- Aural warning volume levels
- Self test inhibits

HAP 001-013, 015-026, 028-030

- Maximum number of intruders to show

HAP ALL

34-45-00-011

<p>EFFECTIVITY HAP ALL</p>
--

34-45-00

D633A101-HAP

TCAS - FUNCTIONAL DESCRIPTION

- Standby on ground
- Intruders on ground disabled.

The I/O circuits send this data to the CPU.

CPU

The CPU gets the data from the inputs of the I/O and puts it into memory. The CPU combines the input data and the data it receives from the signal processor. The CPU makes the necessary calculations for the TCAS displays and aural messages.

The CPU sends TCAS display data to the CDS DEUs. It shows on these indicators:

- Attitude indicators (AI)
- Navigation display (ND)

The CPU sends the display data to the flight data acquisition unit (FDAU).

It also sends signals through the speech processor circuits to the REU to make TCAS aurals.

Signal Processor

The signal processor gets bearing information from the receiver/processor and changes it to digital signals. The signal processor does these functions:

- Uses time measurement logic and the bearing information to calculate the intruder airplane range and bearing
- Detects the mode C or mode S pulses
- Controls the suppression circuit to send the suppression pulse when TCAS transmits
- Makes all signals necessary to receive and transmit mode S and ATCRBS interrogations through the receiver/transmitter circuits.

Suppression

The suppression circuit sends a suppression pulse when the TCAS computer transmits. The TCAS computer receives a suppression pulse when an onboard ATC transponder or DME interrogator system transmits. This suppression pulse stops the TCAS computer receiver and transmitter circuits.

HAP 001-013, 015-026, 028-030

The BITE circuit in the CPU monitors the suppression circuit by sending a test interrogation. If the suppression circuit has a fault, TCAS fails.

HAP ALL**Speech Processor**

When there is a TA, RA, or during a self-test, the TCAS computer sends signals to the speech processor. The speech processor sends the aural alerts to the REU. The REU sends them to the flight compartment.

TCAS - FUNCTIONAL DESCRIPTION

HAP During aural annunciations the GPWC sends an analog discrete
HAP to the TCAS computer to prevent TCAS advisories.

I HAP 008-013, 015-026, 028-054, 101-999

During predictive windshear annunciations the weather radar sends an analog discrete to the TCAS computer to prevent TCAS advisories.

HAP ALL

Receiver Processor

HAP 001-013, 015-026, 028-030

The receiver gets the target replies from the antennas. The receiver uses the phase of the received signals to determine the bearing of the target. The receiver sends the signal to the signal processor to calculate the range to the target. The receiver decodes the target altitude from the reply signal. The receiver also receives and decodes coordination replies from targets equipped with TCAS.

HAP 031-054, 101-999

The receiver gets the target replies from the antennas. The receiver uses the strength of the received signals to determine the bearing of the target. The receiver sends the signal to the signal processor to calculate the range to the target. The receiver decodes the target altitude from the reply signal. The receiver also receives and decodes coordination replies from targets equipped with TCAS.

HAP ALL

Transmitter

The transmitter has a 1030 MHz output. The transmitter gets signals from the signal processor. The transmitter sends the formatted signals to the beam steering and attenuator (ATT) circuits. The transmitter controls the beam steering circuits and whisper/shout attenuator.

Beam Steering and Attenuator Circuits

HAP 001-013, 015-026, 028-030

The beam steering circuits send the signals to the four antenna elements. During transmit, the beam steering circuit controls the phase relationships of the four RF outputs. The whisper/shout attenuator makes the output power smaller or larger based on the control signals from the transmitter.

34-45-00-011

<p>EFFECTIVITY HAP ALL</p>

34-45-00

D633A101-HAP

TCAS - FUNCTIONAL DESCRIPTION**HAP 001-013, 015-026, 028-030 (Continued)****HAP 031-054, 101-999**

The beam steering circuits send the signals to the four antenna elements. During transmit, the beam steering circuit controls strength of the output signal to each antenna element. This directs the interrogation. The whisper/shout attenuator also makes the output power smaller or larger based on the control signals from the transmitter. This is used for ATRBS intruders.

HAP 001-013, 015-026, 028-030

During receive, the phase of the received signals is different in each element. These beam steering circuit sends the signals to the receiver.

HAP 031-054, 101-999

During receive, the strength of the received signals is different in each element. These beam steering circuit sends the signals to the receiver.

HAP ALL

The TCAS computer receives a discrete input from the landing gear lever switch. When the landing gear lever is down, the TCAS computer uses all four antenna elements equally for the bottom antenna. Thus, the bottom antenna operates as an omnidirectional antenna.

BITE

The TCAS computer has BITE. The BITE continuously monitors TCAS for system faults and interface faults during normal operation. Also, when you start a self-test, the BITE makes test signals and sends them to the signal processor and receiver/transmitter circuits. The BITE monitors for system faults and interface faults during the self-test.

When the BITE detects a fault through the continuous fault monitor, the fault goes into the fault memory. It also goes to the I/O circuits for output to the CDS DEUs and the FDAU.

When the BITE detects a fault during a self-test, the fault data goes to the I/O and then to these systems:

- DEUs
- REU
- FDAU
- TCAS computer status LEDs if test is done from computer front panel.

Directional Antenna

The directional antenna has four elements spaced 90 degrees apart. Each element is independent of the others and has its own coaxial connector.

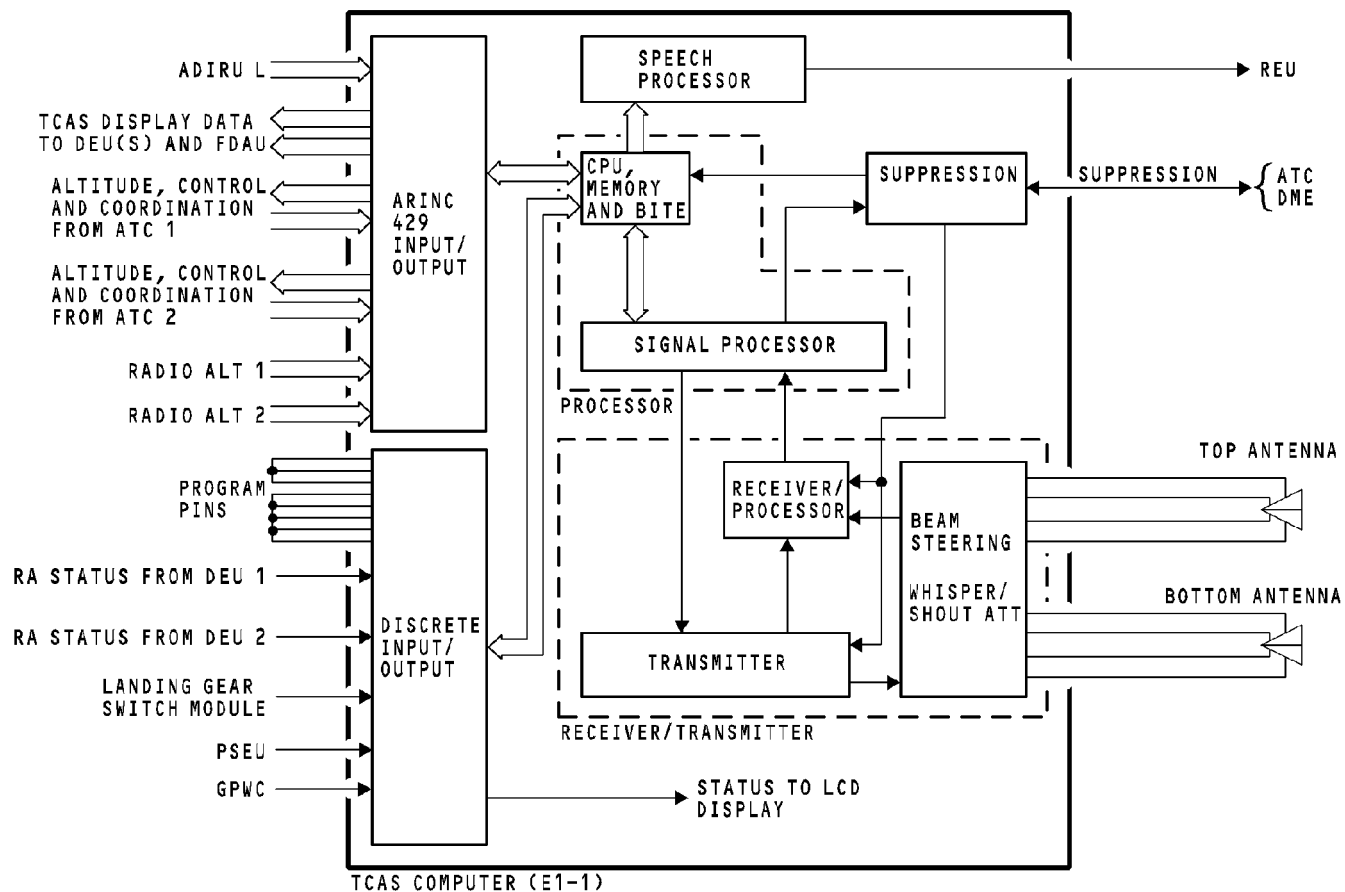

TCAS - FUNCTIONAL DESCRIPTION

34-45-00-011

EFFECTIVITY
HAP 001-007

34-45-00

D633A101-HAP

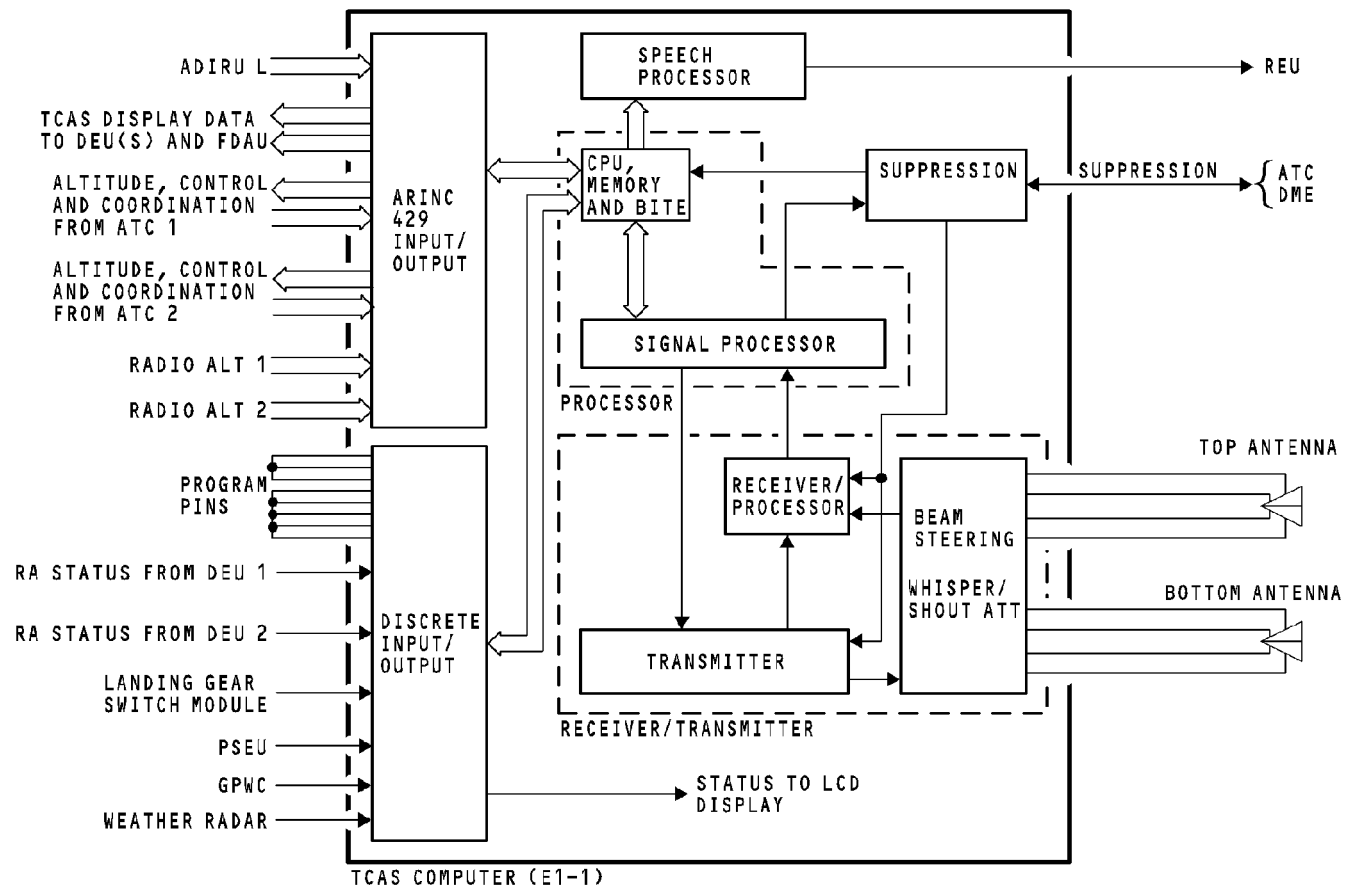

TCAS - FUNCTIONAL DESCRIPTION

EFFECTIVITY

HAP 008-013, 015-026, 028-030

34-45-00

D633A101-HAP

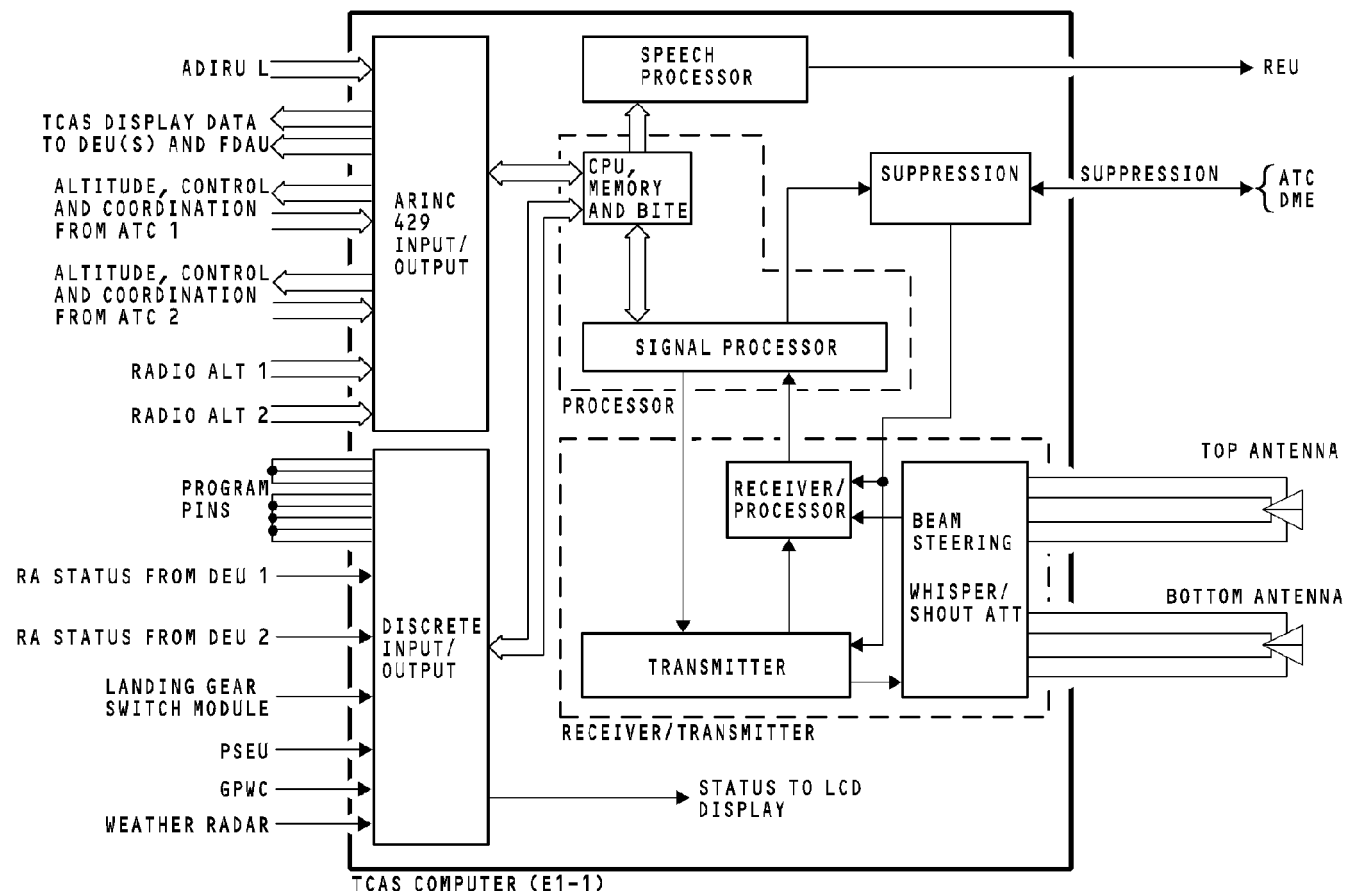

TCAS - FUNCTIONAL DESCRIPTION

34-45-00-011

EFFECTIVITY
HAP 031-054, 101-999

34-45-00

D633A101-HAP

THIS PAGE IS INTENTIONALLY LEFT BLANK

34-45-00

D633A101-HAP

Page 40
Oct 10/2006

TCAS - BASIC OPERATION**General**

TCAS transmits these two types of interrogation signals:

- Whisper-shout for ATCRBS transponders
- Mode S.

The TCAS finds and monitors all of the airplanes within range that have ATCRBS or mode S transponders. The TCAS operates with its mode S transponders to interrogate traffic airplanes and calculate if they are a threat. The TCAS does not track airplanes that do not have a transponder. The TCAS tracks airplanes with transponders that do not reply with mode C information. These airplanes send framing pulses in response to a mode C interrogation. The TCAS uses the framing pulse replies to give range and bearing to the target. TCAS cannot give RAs for targets that do not report altitude.

The TCAS can calculate maneuver commands to prevent possible collisions with target airplanes.

If the traffic airplane also has TCAS, the two airplanes can agree on maneuvers that give a safe distance between them.

Whisper-Shout Interrogation

The TCAS uses an ATCRBS all-call whisper-shout interrogation to look for airplanes that have an ATCRBS transponder. The whisper-shout procedure changes the strength of the interrogation pulse in many steps. This lets TCAS interrogate intruders at different ranges. Intruders that reply are put on the TCAS roll call list and TCAS monitors them.

The airplanes that are near receive the lower power (whisper) interrogations. The airplanes that are far away do not receive these low power signals so they do not respond.

The TCAS transmits a suppression pulse as the interrogation power increases. The airplanes that are farther away receive the higher power (shout) interrogations. The airplanes that are near receive the interrogation and the suppression pulse so they do not reply.

Mode S Interrogation

Mode S transponders transmit a squitter signal once each second. The signals contain a 24-bit airplane address. The TCAS listens for mode S squitter signal transmissions from airplanes that have mode S transponders. When the TCAS receives an address, it puts that airplane on a roll call list. The TCAS then interrogates the mode S transponder of the traffic airplane with the discrete 24-bit airplane address on the roll call list.

TCAS - BASIC OPERATION**TCAS Data Calculation**

When the TCAS interrogates a target, the reply signal from the target usually contains the airplane altitude and any information requested by TCAS.

The TCAS computer uses the round-trip time of the reply signal to calculate the range and range rate of the target. It uses the direction of the reply to calculate bearing of the target. If the TCAS computer receives altitude data, it calculates these parameters of the traffic airplane:

- altitude
- altitude rate
- relative altitude.

The TCAS computer uses the target data to calculate if the target is on a possible collision or near collision course with its flight path. If it is, the TCAS computer calculates traffic coordination maneuver data. This data and the position data go to the DEUs to make the TCAS displays. If TCAS advises that a maneuver be made it also sends an aural command to the flight crew.

Air-to-Air Coordination

If the target also has TCAS, the two TCAS computers communicate with each other using the mode S transponders. Both TCAS computers calculate an escape path if it is necessary. Both TCAS computers send the escape path to the mode S transponder in the other airplane. This sets up the air-to-air mode S data link between the airplanes.

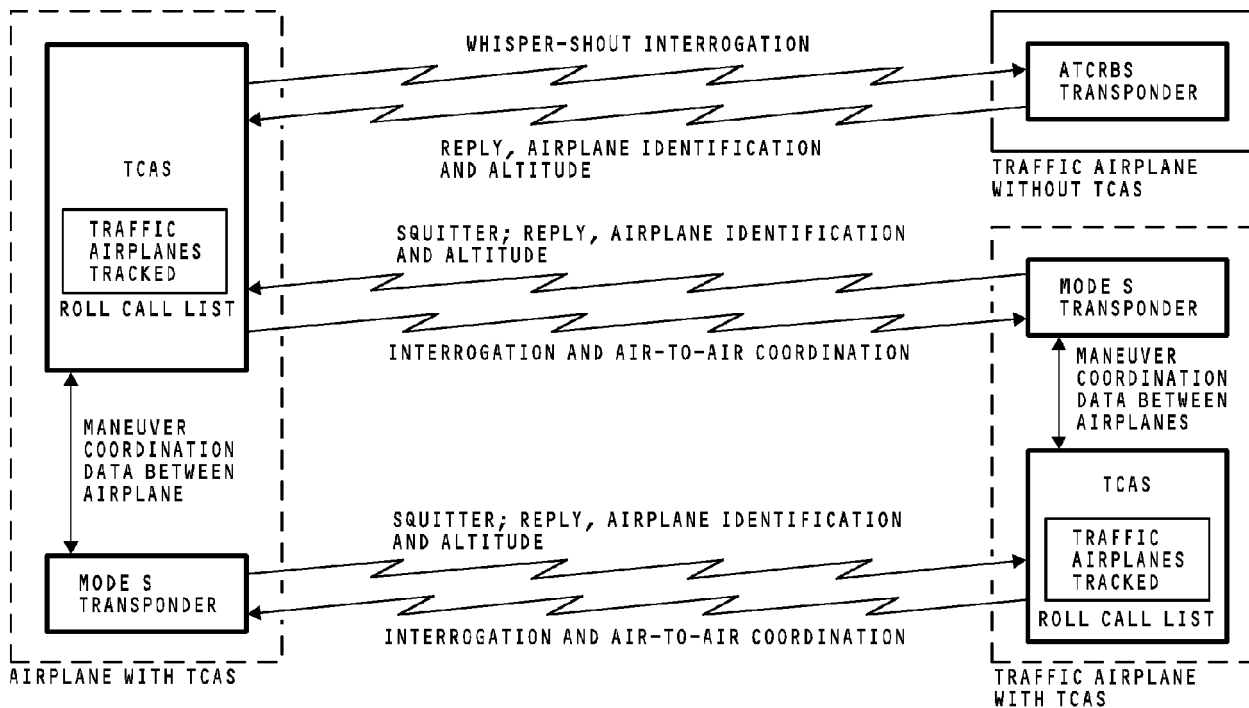

TCAS - BASIC OPERATION

34-45-00-012

EFFECTIVITY
HAP ALL

34-45-00

D633A101-HAP

THIS PAGE IS INTENTIONALLY LEFT BLANK

34-45-00

D633A101-HAP

Page 44
Oct 10/2006

TCAS - SURVEILLANCE AREA

General**HAP 031-054, 101-999**

The TCAS tracks and evaluates up to 30 airplanes that are in the surveillance area. Airplanes in the surveillance area are put into one of these four groups:

- Resolution advisory (RA) group
- Traffic advisory (TA) group
- Proximate traffic
- Other traffic.

HAP 001-013, 015-026, 028-030

The TCAS tracks and evaluates up to 45 airplanes that are in the surveillance area. Airplanes in the surveillance area are put into one of these four groups:

- Resolution advisory (RA) group
- Traffic advisory (TA) group
- Proximate traffic
- Other traffic.

TCAS has a maximum surveillance area that is 8700 feet above and below your airplane. It has a range of 40 nm.

HAP 031-054, 101-999

TCAS has a maximum surveillance area that is 8700 feet above and below your airplane. It has a variable range.

HAP ALL**RA and TA Groups**

The TCAS forms two protected areas around its own airplane. The dimensions of these protected areas change with airspeed and altitude of the TCAS airplane and the closure rate of the target.

The protected area represents the time until the target will be at the closest point of approach (CPA) to the TCAS airplane. This protected area is called the TAU area.

To calculate the TAU, the TCAS computer uses this data:

- Own airplane altitude
- Target closure rate
- Target range and altitude.

Traffic advisory TAU and resolution advisory TAU define areas around the TCAS airplane that, if penetrated by a target within the required altitude restrictions, would produce the appropriate warning from the TCAS computer.

The TCAS computer uses six sensitivity levels (2-7). Level 7 is the most sensitive. At level 2, no resolution advisories may occur. Below 1000 feet, level 2 is used and above 20000 feet, level 7 is used. Sensitivity levels are set by the TCAS computer based on own airplane altitude.

TCAS - SURVEILLANCE AREA

The TA and RA times vary with sensitivity level. At sensitivity level 3, RA TAU is 15 seconds while at sensitivity level 7, RA TAU is 35 seconds.

Proximate Traffic and Other Traffic

Proximate traffic is an airplane with a relative altitude separation less than 1200 feet, is in a 6 nm radius of your airplane, and is not a TA or RA threat.

Other traffic is an airplane with a range more than 6 nm that is not a TA or RA threat. If the range is less than 6 nm, the relative altitude must be more than 1200 feet.

34-45-00-013

EFFECTIVITY
HAP ALL**34-45-00**

D633A101-HAP

Page 46
Feb 15/2009

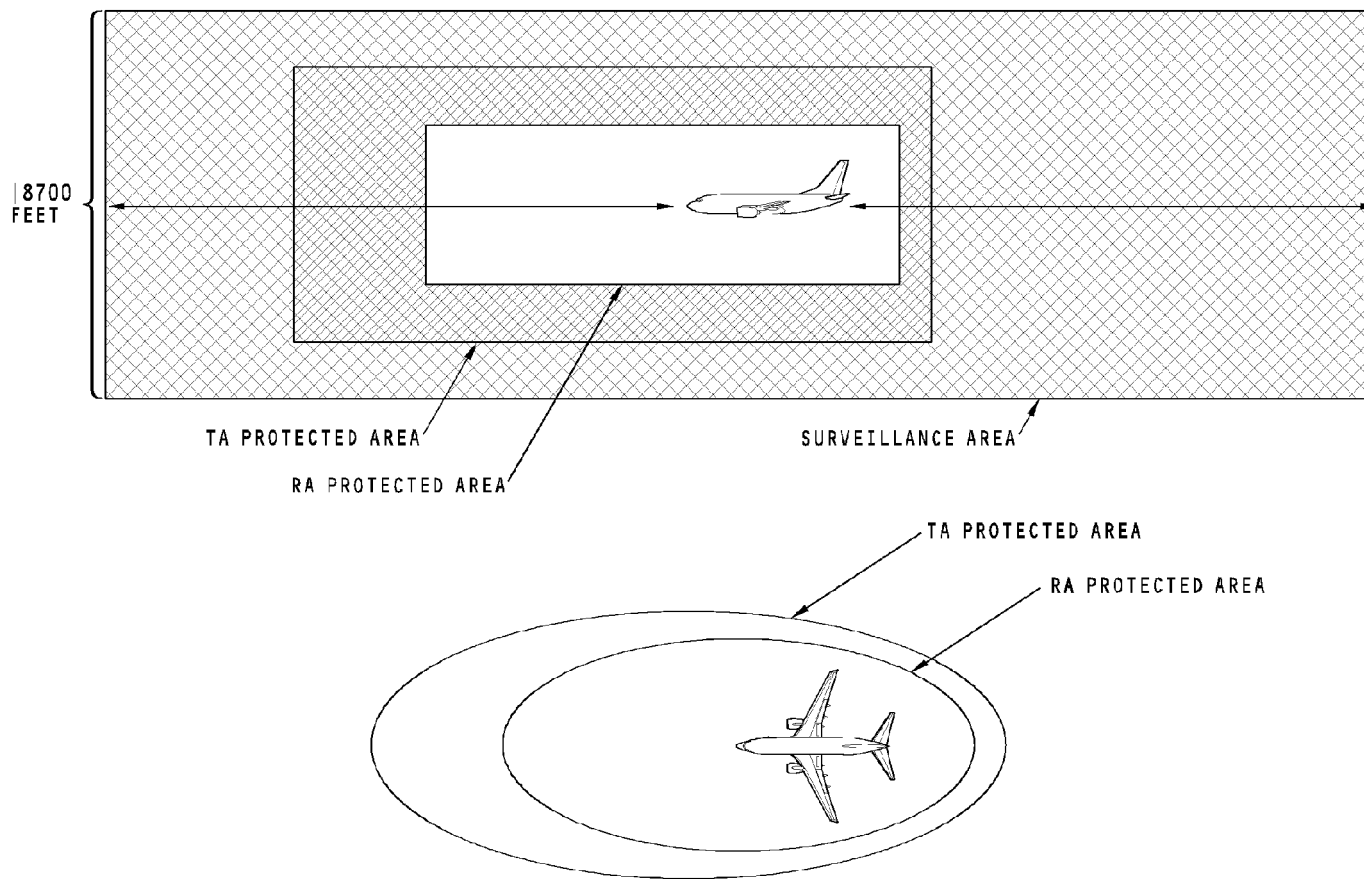

TCAS - SURVEILLANCE AREA

34-45-00-013

EFFECTIVITY
HAP ALL

34-45-00

D633A101-HAP

TCAS - CONTROL AND DISPLAY**General**

The EFIS control panel and the ATC control panel control the TCAS data that shows on the displays.

EFIS Control Panel

To show the TCAS data on the display, put the mode selector on the EFIS control panel in one of these modes:

- Expanded approach
- Expanded VOR
- Expanded map
- Centered map.

The range selector selects the range for the ND.

Push the TFC (traffic) switch on the range selector to let the ND show the TCAS data. When you do this, the TFC message and the TCAS symbols of any targets show on the display.

If the function selector on the ATC control panel is not in the TA or TA/RA position, the display does this:

- Shows an amber message, TCAS OFF (TCAS OFF shows in all ND modes)
- Removes all TCAS target symbols.

To remove the TCAS messages and symbols from the display, push the TFC switch again.

ATC/TCAS Control Panel

The ATC/TCAS control panel sends control data through the ATC Mode S transponder to the TCAS computer. The TCAS computer sends this data to the DEU for display.

The function selector puts the TCAS computer in the TA only or TA/RA mode. In the TA only mode, the TCAS does not supply RA traffic symbols or advisories. It also does not supply RA aural messages. The function selector can also put the TCAS computer in the test mode.

The ND shows the relative altitude of the target above or below the symbol.

The function selector in the ABV or BLW position changes the relative altitude limits for other traffic that show on the ND.

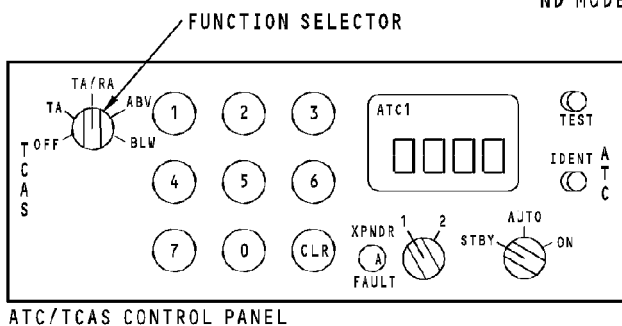
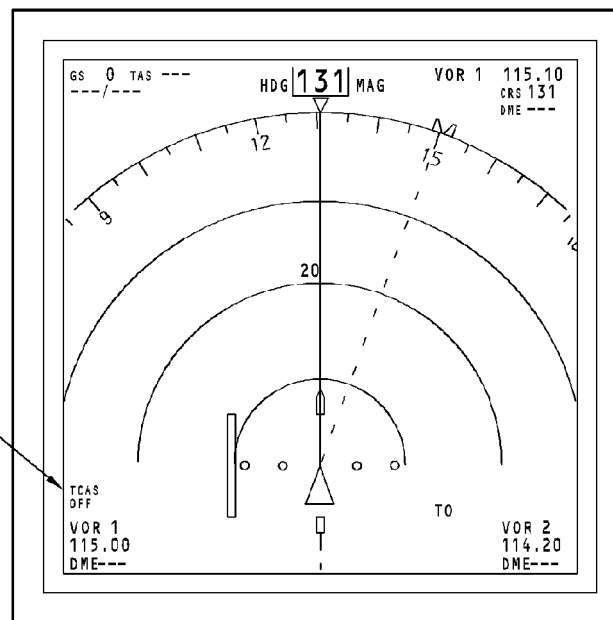
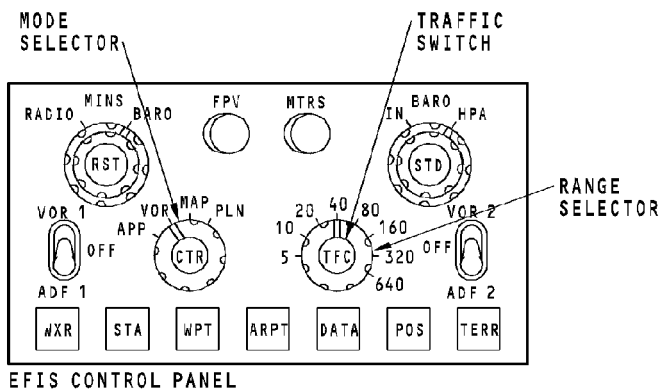

TCAS - CONTROL AND DISPLAY

34-45-00-014

EFFECTIVITY
HAP ALL

34-45-00

D633A101-HAP

TCAS - NAVIGATION DISPLAY**General**

The TCAS computer puts traffic into these four groups:

- Other traffic shows as a white open diamond, and the altitude readout is white text
- Proximate traffic shows as a solid white diamond, and the altitude readout is white text
- Traffic advisory (TA) shows as a solid amber circle, and the altitude readout is amber text
- Resolution advisory (RA) shows as a solid red square and the altitude readout is red text.

Each traffic symbol has an altitude readout. A vertical motion arrow is also shown if the airplane vertical speed is greater than 500 feet per minute (fpm). The traffic symbols show in these navigation display modes:

- Center (CTR) MAP
- Expanded (EXP) MAP
- Expanded (EXP) VOR
- Expanded (EXP) APP.

Range Data

Push the TFC switch on the EFIS control panel to show TCAS data. The range the EFIS control panel selects also shows on the ND.

Also, when you push the TFC switch, range arcs show on the ND.

Altitude Readout

Relative altitude shows in the same color as the traffic symbol on the NDs.

Altitude Separation

The TCAS computer calculates the altitude separation between own airplane and the target. It uses the barometric altitudes of the airplanes to do this. The altitude separation shows on the ND in hundreds of feet. If the traffic is above, the digits show above the traffic symbol with a plus (+) sign. If the traffic is below, the digits show below the traffic symbol with a minus (-) sign.

If the altitude separation is less than 100 feet, 00 shows.

If the altitude separation cannot be calculated, the altitude display does not show.

Absolute Altitude

The target sends barometric altitude to the TCAS computer. This altitude shows in thousands and hundreds of feet. If the traffic is above, the digits show above the traffic symbol. If the traffic is below, the digits show below the traffic.

If the altitude cannot be calculated, the altitude display does not show.

TCAS - NAVIGATION DISPLAY**Vertical Motion Arrow**

A vertical motion arrow shows on the right side of the traffic symbol. It is the same color as the traffic symbol.

The arrow points down if the traffic airplane goes down at a rate more than or equal to 500 fpm. The arrow points up if the traffic airplane is in a climb at a rate more than or equal to 500 fpm. The arrow does not show for rates less than 500 fpm.

TCAS Messages

The ND can show these messages for TCAS:

- TFC shows in cyan in the CTR MAP and EXP MAP, VOR and APP modes. It shows the TCAS traffic display is active. The TFC switch on the EFIS control panel must be set to ON.
- TA ONLY shows in cyan and in all modes. It shows that TCAS is not calculating RAs. It shows if the TFC switch on the EFIS control panel is set to ON or OFF.
- TCAS TEST shows in cyan and in all modes. It shows that TCAS is in the test mode. It shows if the TFC switch on the EFIS control panel is set to ON or OFF.
- TCAS TEST FAIL shows on two lines when in test mode and the TCAS has a failure. TCAS and FAIL show in amber and TEST shows in cyan. It shows if the TFC switch on the EFIS control panel is set to ON or OFF.
- TCAS FAIL shows in amber and in all modes. It shows that TCAS has failed. The TFC switch on the EFIS control panel must be set to ON.

- TCAS OFF shows on two lines in amber and in all modes. It shows that the ATC mode switch is not in TA or TA/RA. It shows if the TFC switch on the EFIS control panel is set to ON or OFF.

OFFSCALE

The OFFSCALE message shows on the ND when an RA or TA is outside the current ND display area. The TFC switch on the EFIS control panel must be set to ON to show the OFFSCALE message. If an RA is outside the ND range, the OFFSCALE message shows in red. If a TA is outside the ND range, the OFFSCALE message shows in amber. If both a TA and RA are outside the ND range, the OFFSCALE message shows in red. This message shows in these navigation display modes:

- Center (CTR) MAP
- Expanded (EXP) MAP
- Expanded (EXP) VOR
- Expanded (EXP) APP.

TRAFFIC

The red TRAFFIC message shows any time there is an RA. The amber TRAFFIC message shows any time there is a TA and no RA. The TRAFFIC message shows in all ND formats with the TFC switch on the EFIS control panel set to ON or OFF.

TCAS - NAVIGATION DISPLAY**RA and TA No-Bearing Traffic**

The no-bearing RA and TA messages show on the ND when TCAS loses the bearing of the RA or TA traffic. The bottom directional antenna becomes an omnidirectional antenna when the landing gear is down. When this happens, the bottom antenna cannot find the bearing of the intruder traffic. The bearing is NCD. Because of this, the no-bearing messages show on the ND.

If a TA becomes no-bearing traffic, an amber TA with the range, altitude, and vertical motion arrow shows on the ND. If an RA becomes no-bearing traffic, a red RA with the range, altitude, and vertical motion arrow shows on the ND. Only two no-bearing traffics may show.

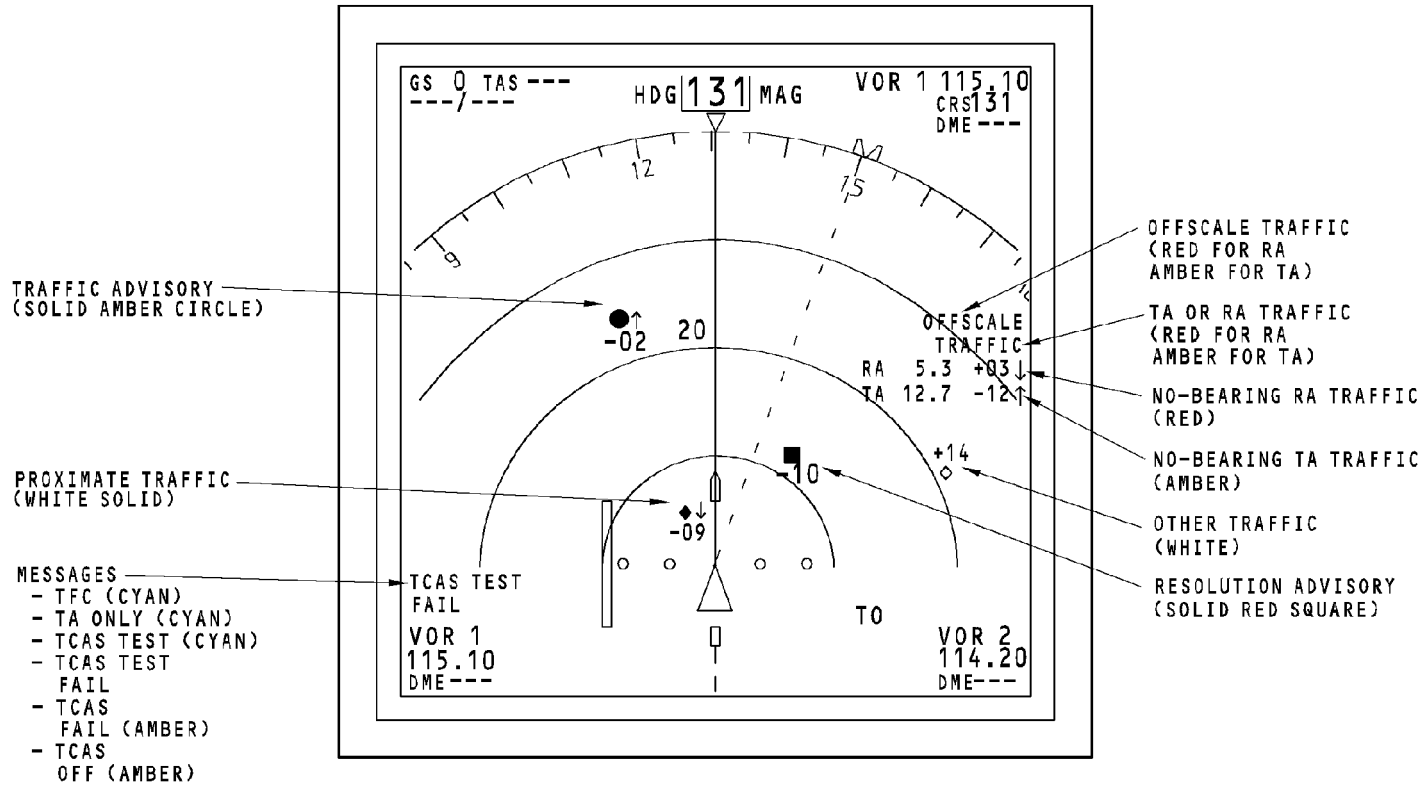

TCAS - NAVIGATION DISPLAY

34-45-00-015

EFFECTIVITY
HAP ALL

34-45-00

D633A101-HAP

TCAS - ATTITUDE INDICATOR DISPLAY

General

These are the two types of TCAS vertical resolution advisories that can show on the attitude indicator (AI):

- TCAS RA - down advisory
- TCAS RA - up advisory.

These symbols only show for an RA when:

- The function selector on the ATC control panel is in the TA/RA position
- The TCAS communicates with threat airplanes that give their altitude.

Description

The red advisories show on the attitude display. They tell the flight crew to avoid some pitch movements.

The flight crew uses the advisories to avoid a possible collision with threat airplanes.

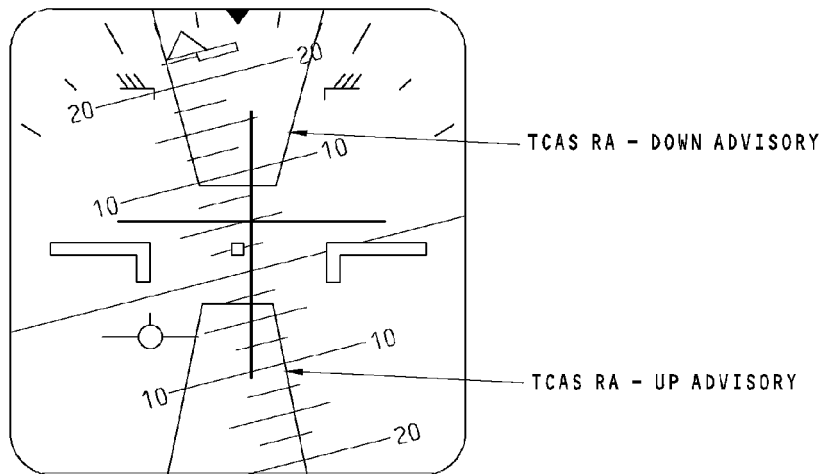

TCAS - ATTITUDE INDICATOR DISPLAY

34-45-00-016

EFFECTIVITY
HAP ALL

34-45-00

D633A101-HAP

TCAS - AURAL MESSAGES**General**

Aural advisory messages occur during these conditions:

- Traffic advisories (TA)
- Resolution advisories (RA)
- TCAS system tests.

Traffic Advisory Aural

When a traffic advisory occurs, the aural message TRAFFIC TRAFFIC comes on. This message tells the flight crew to monitor the display for intruder traffic.

Resolution Advisory

These are the two types of aural messages that can come on during a resolution advisory (RA):

- Preventive action RA
- Corrective action RA.

HAP 031-054, 101-999; HAP 001-011 PRE SB 737-34-1544 AND PRE SB 737-34-1670

Preventive Action RA

This type of RA occurs when at the closest point of approach (CPA) the present vertical speed results in a safe altitude separation from the threat airplane. When this happens, the aural advisory is MONITOR VERTICAL SPEED - MONITOR VERTICAL SPEED. This message tells the flight crew to do these things:

- Maintain the flight path
- Do not fly into the area of RA pitch symbol on the ADI
- Maintain the vertical speed rate.

HAP 012, 013, 015-026, 028-030; HAP 001-011 (POST SB 737-34-1544 AND PRE SB 737-34-1670) OR POST SB 737-34-1670

Preventive Action RA

This type of RA occurs when at the closest point of approach (CPA) the present vertical speed results in a safe altitude separation from the threat airplane. When this happens, the aural advisory comes on.

These are the aural messages for the preventive action RA:

- MONITOR VERTICAL SPEED
- MAINTAIN VERTICAL SPEED, MAINTAIN

TCAS - AURAL MESSAGES

HAP 012, 013, 015-026, 028-030; HAP 001-011 (POST SB 737-34-1544 AND PRE SB 737-34-1670) OR POST SB 737-34-1670 (Continued)

- MAINTAIN VERTICAL SPEED, CROSSING MAINTAIN.

The preventive action RA messages tell the flight crew to do these things:

- Maintain the flight path
- Do not fly into the area of RA pitch symbol on the ADI
- Maintain the vertical speed rate.

HAP 031-054, 101-999; HAP 001-011 PRE SB 737-34-1544 AND PRE SB 737-34-1670

Corrective Action RA

This type of RA occurs when the altitude separation at the CPA is not safe. These RA aural advisories tell the flight crew to take corrective action to avoid a possible collision:

- CLIMB - CLIMB - CLIMB. The flight crew must climb at a rate to avoid the preventive up advisory.
- CLIMB CROSSING CLIMB - CLIMB CROSSING CLIMB. The flight crew must climb at a rate to avoid the preventive up advisory. The flight path crosses through the flight path of the threat.
- REDUCE CLIMB - REDUCE CLIMB. The flight crew must reduce the rate of climb to avoid the preventive down advisory.

- DESCEND - DESCEND - DESCEND. The flight crew must descend at a rate to avoid the preventive down advisories.
- DESCEND CROSSING DESCEND - DESCEND CROSSING DESCEND. The flight crew must descend at a rate to avoid the preventive down advisory. The flight path crosses through the flight path of the threat.
- REDUCE DESCENT - REDUCE DESCENT. The flight crew must reduce the rate of descent to avoid the preventive up advisory.

HAP 012, 013, 015-026, 028-030; HAP 001-011 (POST SB 737-34-1544 AND PRE SB 737-34-1670) OR POST SB 737-34-1670

Corrective Action RA

This type of RA occurs when the altitude separation at the CPA is not safe. These RA aural advisories tell the flight crew to take corrective action to avoid a possible collision:

- CLIMB - CLIMB. The flight crew must climb at a rate to avoid the preventive up advisory.
- CLIMB CROSSING CLIMB - CLIMB CROSSING CLIMB. The flight crew must climb at a rate to avoid the preventive up advisory. The flight path crosses through the flight path of the threat.
- ADJUST VERTICAL SPEED - ADJUST. The flight crew must reduce the rate of climb to avoid the preventive down advisory.
- DESCEND - DESCEND. The flight crew must descend at a rate to avoid the preventive down advisories.

34-45-00-018

EFFECTIVITY	
HAP ALL	

34-45-00

D633A101-HAP

TCAS - AURAL MESSAGES

HAP 012, 013, 015-026, 028-030; HAP 001-011 (POST SB 737-34-1544 AND PRE SB 737-34-1670) OR POST SB 737-34-1670 (Continued)

- DESCEND CROSSING DESCEND - DESCEND CROSSING DESCEND. The flight crew must descend at a rate to avoid the preventive down advisory. The flight path crosses through the flight path of the threat.
- ADJUST VERTICAL SPEED - ADJUST. The flight crew must reduce the rate of descent to avoid the preventive up advisory.

HAP ALL

Increase Corrective Action RA

This type of RA tells the flight crew to increase the corrective maneuvers because of maneuver changes from the threat airplane or because the flight crew did not react quickly enough to the initial RA:

- INCREASE CLIMB - INCREASE CLIMB. This follows the CLIMB advisory. The range of advised climb rates shifts to tell the flight crew to increase the climb rate.
- INCREASE DESCENT - INCREASE DESCENT. This follows the DESCEND advisory. The range of advised descent rates shifts to tell the flight crew to increase the descent rate.
- CLIMB, CLIMB NOW - CLIMB, CLIMB NOW. This follows the DESCEND advisory. A climb is now necessary to give safe vertical separation at CPA.
- DESCEND, DESCEND NOW - DESCEND, DESCEND NOW. This follows the CLIMB advisory. A descent is now necessary to give safe vertical separation at CPA.

Clear of Conflict

When the range of the threat airplane that causes an RA increases, the aural message CLEAR OF CONFLICT comes on.

HAP 031-054, 101-999

Self-Test Aural

At the start of the self-test, the TCAS computer sends TCAS TEST to the flight compartment. At the completion of the self-test, the TCAS computer sends the status aural to the flight compartment.

HAP 001-013, 015-026, 028-030

Self-Test Aural

At the completion of the self-test, the TCAS computer sends the status aural to the flight compartment.

HAP ALL

34-45-00-018

<p>EFFECTIVITY</p> <p>HAP ALL</p>
--

34-45-00

D633A101-HAP

AURAL MESSAGE	MESSAGE TYPE
TRAFFIC, TRAFFIC	TRAFFIC ADVISORY
MONITOR VERTICAL SPEED, MONITOR VERTICAL SPEED ¹	RESOLUTION ADVISORY (PREVENTIVE ACTION)
CLIMB, CLIMB, CLIMB	RESOLUTION ADVISORY (CORRECTIVE ACTION)
DESCEND, DESCEND, DESCEND	
CLIMB, CROSSING CLIMB CLIMB, CROSSING CLIMB	
DESCEND, CROSSING DESCEND DESCEND, CROSSING DESCEND	
REDUCE CLIMB, REDUCE CLIMB	
REDUCE DESCENT, REDUCE DESCENT	
CLIMB, CLIMB NOW CLIMB, CLIMB NOW	
DESCEND, DESCEND NOW DESCEND, DESCEND NOW	
INCREASE CLIMB, INCREASE CLIMB	
INCREASE DESCENT, INCREASE DESCENT	
CLEAR OF CONFLICT ³	CLEARED RESOLUTION ADVISORY
TCAS SYSTEM TEST PASS	SYSTEM TEST RESULTS
TCAS SYSTEM TEST FAIL	

- ¹ MONITOR VERTICAL SPEED COMES ON ONCE IF THE RA IS DOWNGRADED FROM A CORRECTIVE ADVISORY TO A PREVENTIVE ADVISORY
- ² INCREASED CORRECTIVE ACTION RA FOLLOWS A CORRECTIVE ACTION RA
- ³ OCCURS WHEN THE RANGE OF THE THREAT INCREASES TO PREVENT THREAT

TCAS - AURAL MESSAGES

EFFECTIVITY
HAP 001-011 PRE SB 737-34-1544 AND PRE SB 737-34-1670

34-45-00

D633A101-HAP

AURAL MESSAGE	MESSAGE TYPE
TRAFFIC, TRAFFIC	TRAFFIC ADVISORY
MONITOR VERTICAL SPEED	RESOLUTION ADVISORY (PREVENTIVE ACTION) 1
MAINTAIN VERTICAL SPEED, MAINTAIN	
MAINTAIN VERTICAL SPEED, CROSSING MAINTAIN	
CLIMB, CLIMB	RESOLUTION ADVISORY (CORRECTIVE ACTION)
DESCEND, DESCEND	
CLIMB, CROSSING CLIMB CLIMB, CROSSING CLIMB	
DESCEND, CROSSING DESCEND DESCEND, CROSSING DESCEND	
ADJUST VERTICAL SPEED, ADJUST	
CLIMB, CLIMB NOW CLIMB, CLIMB NOW	RESOLUTION ADVISORY (INCREASED CORRECTIVE ACTION) 2
DESCEND, DESCEND NOW DESCEND, DESCEND NOW	
INCREASE CLIMB, INCREASE CLIMB	
INCREASE DESCENT, INCREASE DESCENT	
CLEAR OF CONFLICT 3	CLEARED RESOLUTION ADVISORY
TCAS SYSTEM TEST PASS	SYSTEM TEST RESULTS
TCAS SYSTEM TEST FAIL	

- 1 MONITOR/MAINTAIN VERTICAL SPEED COMES ON ONCE IF THE RA IS DOWNGRADED FROM A CORRECTIVE ADVISORY TO A PREVENTIVE ADVISORY
- 2 INCREASED CORRECTIVE ACTION RA FOLLOWS A CORRECTIVE ACTION RA
- 3 OCCURS WHEN THE RANGE OF THE THREAT INCREASES TO PREVENT THREAT



TCAS - AURAL MESSAGES

EFFECTIVITY

HAP 012, 013, 015-026, 028-030; HAP 001-011 (POST SB 737-34-1544 AND PRE SB 737-34-1670) OR POST SB 737-34-1670

34-45-00

D633A101-HAP

AURAL MESSAGE	MESSAGE TYPE
TRAFFIC, TRAFFIC	TRAFFIC ADVISORY
MONITOR VERTICAL SPEED,  MONITOR VERTICAL SPEED	RESOLUTION ADVISORY (PREVENTIVE ACTION)
CLIMB, CLIMB, CLIMB	RESOLUTION ADVISORY (CORRECTIVE ACTION)
DESCEND, DESCEND, DESCEND	
CLIMB, CROSSING CLIMB CLIMB, CROSSING CLIMB	
DESCEND, CROSSING DESCEND DESCEND, CROSSING DESCEND	
REDUCE CLIMB, REDUCE CLIMB	
REDUCE DESCENT, REDUCE DESCENT	
CLIMB, CLIMB NOW CLIMB, CLIMB NOW	
DESCEND, DESCEND NOW DESCEND, DESCEND NOW	
INCREASE CLIMB, INCREASE CLIMB INCREASE DESCENT, INCREASE DESCENT	
CLEAR OF CONFLICT 	CLEARED RESOLUTION ADVISORY
TCAS TEST	TEST START
TCAS TEST PASS	SYSTEM TEST RESULTS
TCAS TEST FAIL	

 MONITOR VERTICAL SPEED COMES ON ONCE IF THE RA IS DOWNGRADED FROM A CORRECTIVE ADVISORY TO A PREVENTIVE ADVISORY

 INCREASED CORRECTIVE ACTION RA FOLLOWS A CORRECTIVE ACTION RA

 OCCURS WHEN THE RANGE OF THE THREAT INCREASES TO PREVENT THREAT

TCAS - AURAL MESSAGES

EFFECTIVITY
HAP 031-054, 101-999

34-45-00

D633A101-HAP

Page 61
Feb 15/2009

THIS PAGE IS INTENTIONALLY LEFT BLANK

34-45-00

D633A101-HAP

Page 62
Jun 10/2007

TCAS - SELF-TEST INDICATIONS ON DISPLAYS

General

You can start a self-test from the ATC/TCAS control panel or from the TCAS computer front panel test switch.

During a test, TCAS test signals go to these:

- NDs
- ADIs
- Front panel of the TCAS computer.

At the end of the test, a TCAS test aural goes to the flight interphone speakers.

TCAS Self-Test Indications - ND

If the test passes, the ND shows this data:

- A cyan message, TCAS TEST
- A red message, TRAFFIC

HAP 001-013, 015-026, 028-030

- Amber TA traffic symbol at the 9:00 position, -200 feet relative altitude with an up vertical motion arrow and 2 nm from the airplane

HAP 031-054, 101-999

- Amber TA traffic symbol at the 9:00 position, -300 feet relative altitude with an up vertical motion arrow and 2 nm from the airplane

HAP 001-013, 015-026, 028-030

- White other traffic symbol at the 11:00 position, +1000 feet relative altitude with no vertical motion arrow and 3.6 nm from the airplane

HAP 031-054, 101-999

- White other traffic symbol at the 11:00 position, +2000 feet relative altitude with no vertical motion arrow and 3.6 nm from the airplane

HAP 001-013, 015-026, 028-030

- White proximate traffic symbol at the 1:00 position, +200 feet relative altitude with a down vertical motion arrow and 3.6 nm from the airplane

HAP 031-054, 101-999

- White proximate traffic symbol at the 1:00 position, -1100 feet relative altitude with a down vertical motion arrow and 3.6 nm from the airplane

HAP 001-013, 015-026, 028-030

- Red RA traffic symbol at the 3:00 position, -1000 feet relative altitude with no vertical motion arrow and 2 nm from the airplane.

HAP 031-054, 101-999

- Red RA traffic symbol at the 3:00 position, +200 feet relative altitude with no vertical motion arrow and 2 nm from the airplane.

HAP ALL

If the test fails, the message TCAS TEST FAIL replaces the TCAS TEST message and no traffic shows. TCAS and FAIL shows in amber and TEST shows in cyan.

34-45-00-019

EFFECTIVITY
HAP ALL

34-45-00

D633A101-HAP

TCAS - SELF-TEST INDICATIONS ON DISPLAYS**TCAS Self-Test Indications - AI**

If the test passes, the AI shows the red RA up and down advisory cues.

If the test fails, the AI does not show any RA advisories.

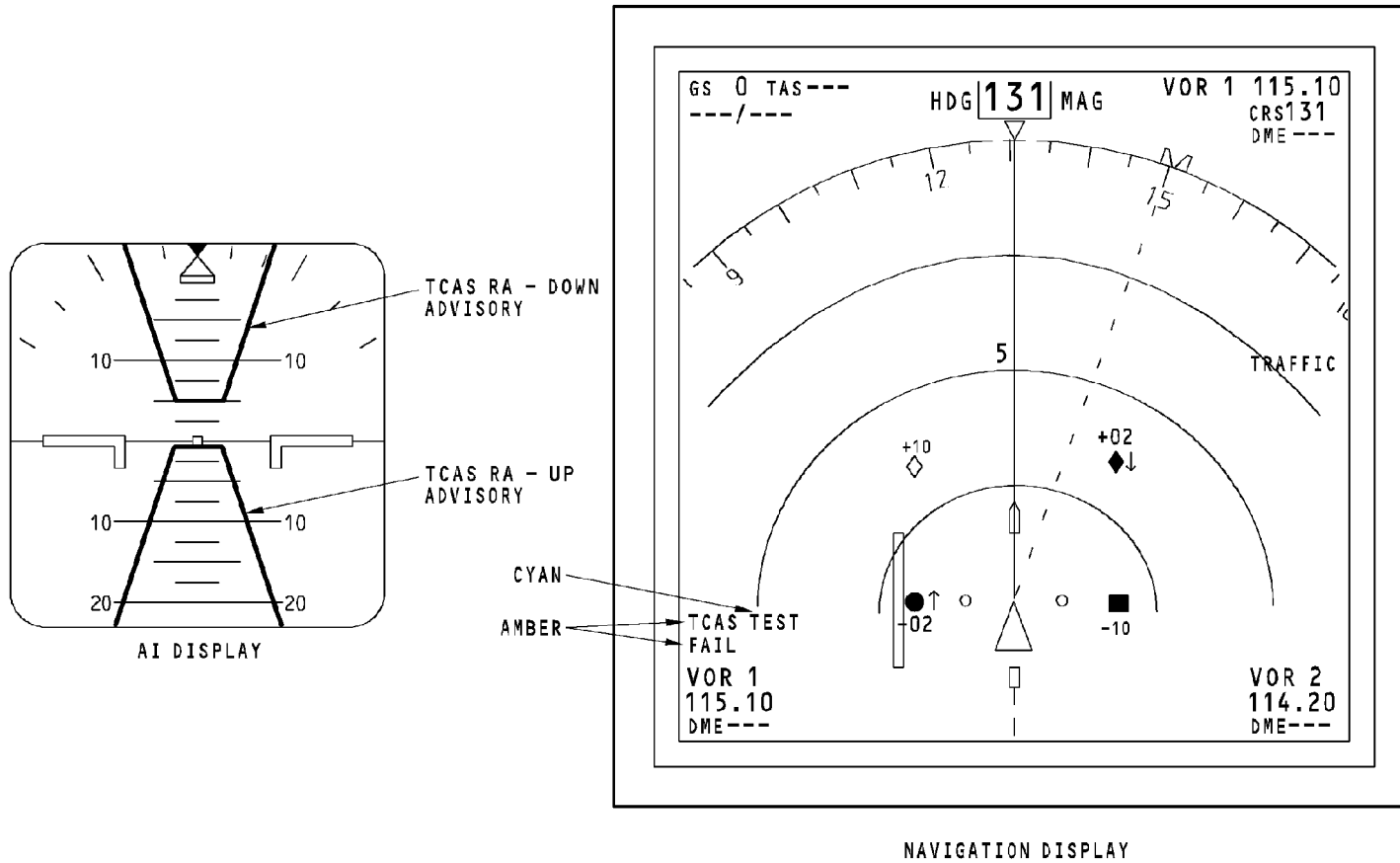

TCAS - SELF-TEST INDICATIONS ON DISPLAYS

34-45-00-019

EFFECTIVITY
HAP 001-013, 015-026, 028-030

34-45-00

D633A101-HAP

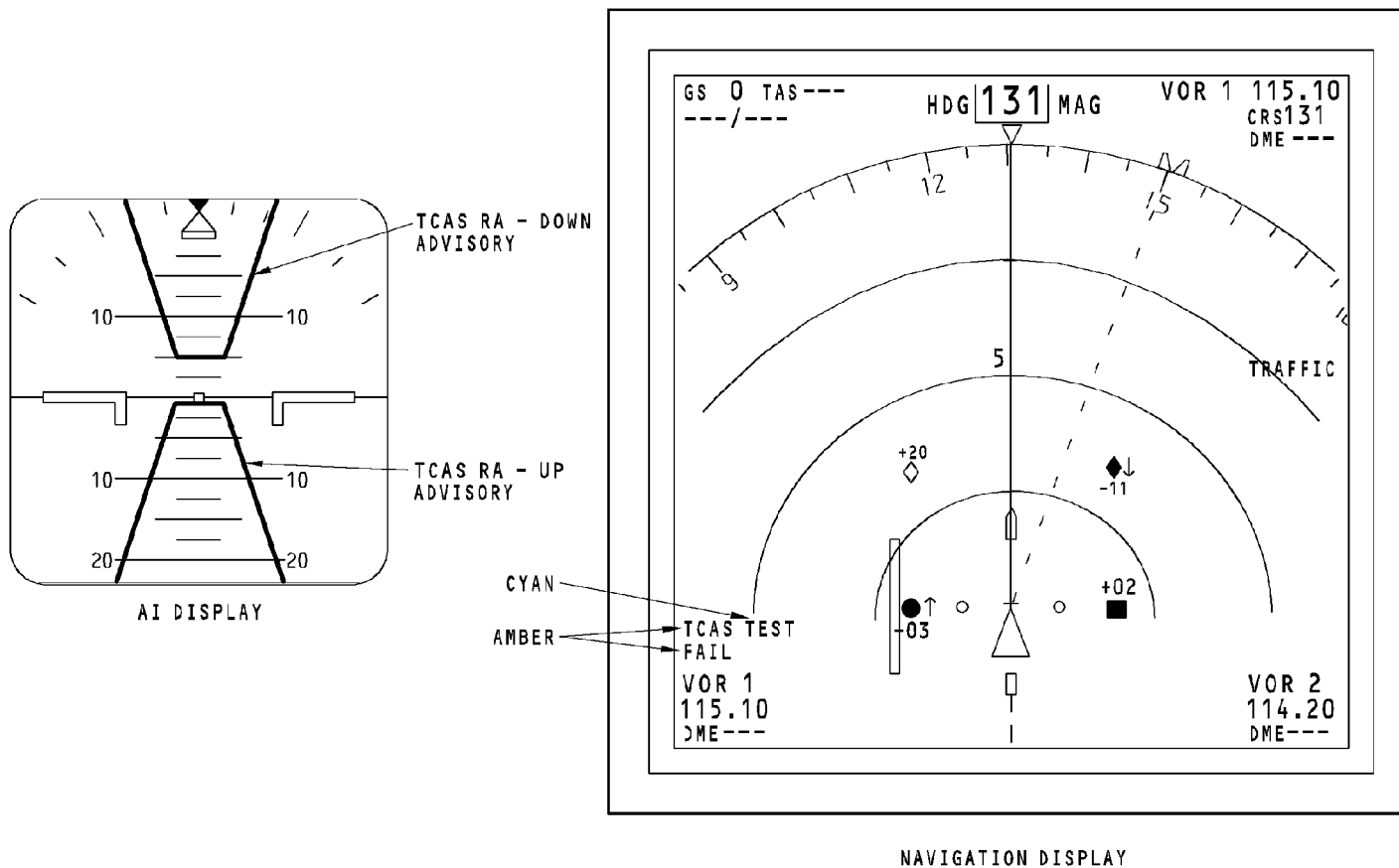

TCAS - SELF-TEST INDICATIONS ON DISPLAYS

EFFECTIVITY
HAP 031-054, 101-999

34-45-00

D633A101-HAP

THIS PAGE IS INTENTIONALLY LEFT BLANK

34-45-00

D633A101-HAP

Page 67
Jun 10/2007

TCAS - SELF-TEST INDICATIONS ON TCAS COMPUTER FRONT PANEL**Front Panel Self-Test**

Push and hold the test switch on the front panel to start a self-test. During the test, the LED segments on the front panel turn on in this sequence:

- All LED display segments come on for three seconds
- All LED segments go off for three seconds
- Applicable LED code shows the status of TCAS.

If the test passes, OK will show on the LEDs. If there is a failure, the fault code shows. The fault codes show in order for multiple failures. The display blanks for one second between faults.

These are the TCAS fault codes:

- OK - no failure
 - TP - TCAS computer failed
 - T1 - top antenna element 1 failed
 - T2 - top antenna element 2 failed
 - T3 - top antenna element 3 failed
 - T4 - top antenna element 4 failed
 - B1 - bottom antenna element 1 failed
 - B2 - bottom antenna element 2 failed
 - B3 - bottom antenna element 3 failed
 - B4 - bottom antenna element 4 failed
 - X1 - ATC transponder 1 failed
 - X2 - ATC transponder 2 failed
 - RA - radio altimeters 1 and 2 failed
 - PT - pitch data from ADIRU failed
 - RL - roll data from ADIRU failed
 - HD - heading data from ADIRU failed
- RD - AIs and VSIs failed
 - PP - program pins changed from initial configuration
 - SP - suppression bus failed
 - AG - air/ground input failed or the airplane shows it is on the ground while the radio altimeters show above 1000 feet.

EFFECTIVITY

HAP 001-013, 015-026, 028-030

34-45-00

D633A101-HAP

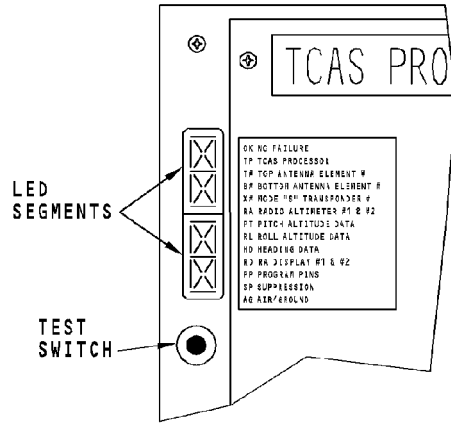

① ALL LED SEGMENTS COME ON FOR 3 SECONDS

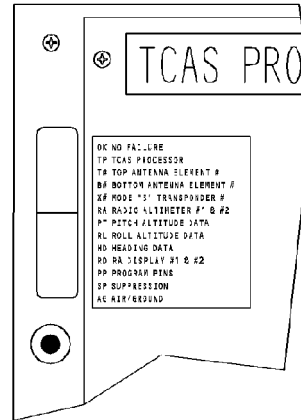

② ALL LED SEGMENTS GO OFF FOR 3 SECONDS

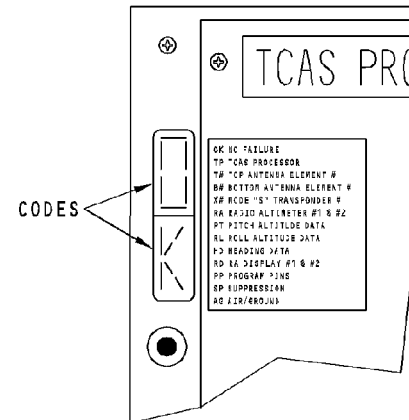

③ THE APPLICABLE LED CODES COME ON TO SHOW THE STATUS OF TCAS

TCAS - SELF-TEST INDICATIONS ON TCAS COMPUTER FRONT PANEL

34-45-00-020

EFFECTIVITY
 HAP 001-013, 015-026, 028-030

34-45-00

D633A101-HAP



TCAS - SUMMARY

General

This page is for reference purposes.

34-45-00-025

EFFECTIVITY
HAP ALL

34-45-00

D633A101-HAP

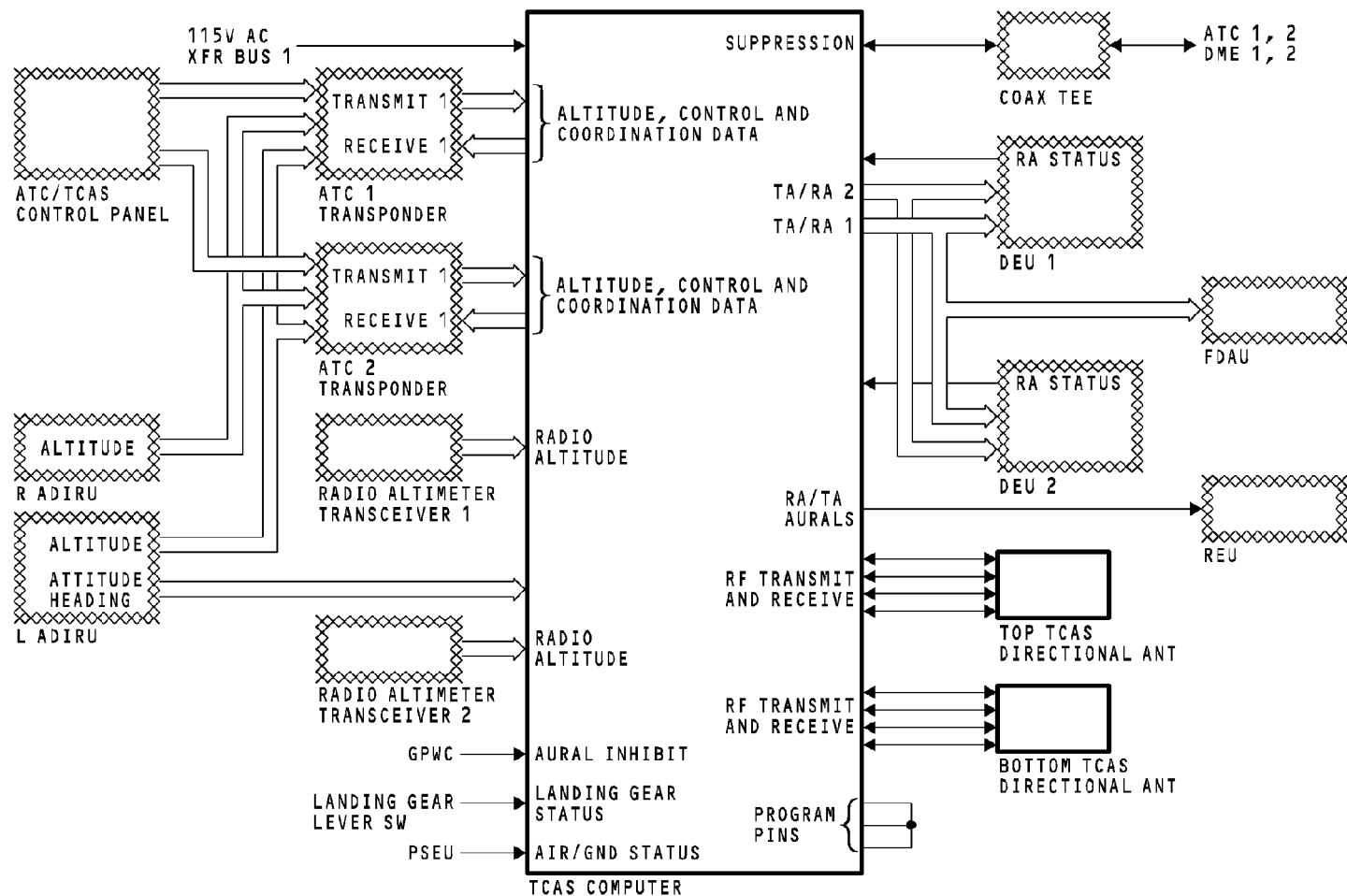

TCAS - SUMMARY

34-45-00-025

EFFECTIVITY
HAP 001-007

34-45-00

D633A101-HAP

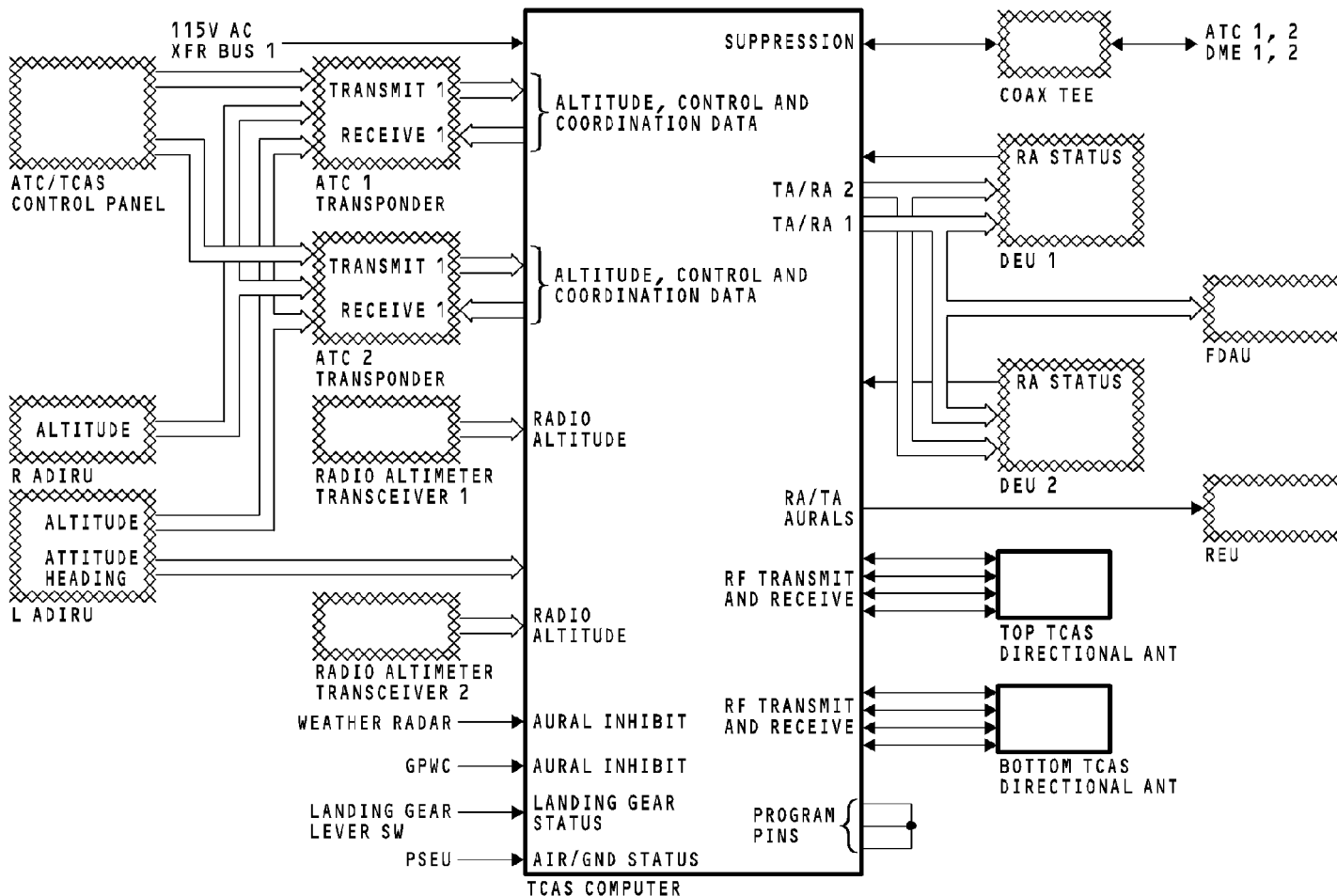

TCAS - SUMMARY

EFFECTIVITY

HAP 008-013, 015-026, 028-054, 101-999

34-45-00

D633A101-HAP

GROUND PROXIMITY WARNING SYSTEM - INTRODUCTION

Purpose

The ground proximity warning system (GPWS) alerts the flight crew of an unsafe condition when the airplane is near the terrain. It also supplies a warning for windshear conditions.

In addition to the GPWS modes 1 through 7, these two additional functions are used:

HAP
HAP
HAP
HAP

- Terrain clearance floor - early descent on approach
- Terrain awareness - display of terrain around the airplane.

Abbreviations and Acronyms

- ADI - attitude display indicator
- ADIRU - air data inertial reference unit
- alt - altitude
- AOA - angle of attack
- approx - approximately
- BITE - built-in test equipment
- capt - captain
- DEU - display electronics unit
- DFCS - digital flight control system
- FDAU - flight data acquisition unit
- FMC - flight management computer
- F/O - first officer
- FPM - feet per minute
- FPS - feet per second
- GND PROX - ground proximity
- GPS - global positioning system
- GPWC - ground proximity warning computer
- GPWM - ground proximity warning module
- GPWS - ground proximity warning system
- G/S - glideslope
- ILS - instrument landing system
- inop - inoperative
- IVS - inertial vertical speed
- LED - light emitting diode
- LRU - line replaceable unit

HAP

HAP The GPWS uses global positioning system (GPS) and disk
HAP loadable software data bases to give the flight crew improved
HAP terrain awareness. This is done by the display of detailed
HAP terrain information for the area around the aircraft. The GPWS
HAP also warns the flight crew of an early descent.

Description

The GPWS uses aural messages, lights, and displays to give alerts in the flight compartment.

GPWS Modes

These are the GPWS modes:

- Mode 1 - Large descent rates
- Mode 2 - Too much of a closure rate when approaching terrain that is rising
- Mode 3 - Too much altitude loss during climbout (at takeoff or in go around) when the airplane is not in the landing configuration
- Mode 4 - Not enough terrain clearance
- Mode 5 - Too much deviation below the glideslope
- Mode 6 - Aural callouts when the airplane descends through selected radio altitudes
- Mode 7 - Warning for windshear conditions.

34-46-00-001

<p>EFFECTIVITY HAP ALL</p>

34-46-00

D633A101-HAP

GROUND PROXIMITY WARNING SYSTEM - INTRODUCTION

- MCP - mode control panel
- mod - module
- HAP ● ND - navigation display
- ovrd - override
- P - press
- PFD - primary flight display
- pos - position
- PSEU - proximity switch electronic unit
- PWS - predictive windshear
- RA - radio altitude
- REU - remote electronics unit
- sec - second
- sw - switch
- sys - system
- TCAS - traffic alert and collision avoidance system
- HAP | ● TCF - terrain clearance floor
- HAP | ● TERR - terrain
- HAP ● WXR - weather radar system
- vert - vertical
- xfr - transfer
- xmtr - transmitter

**HAP 031-054, 101-999; HAP 001-013, 015-026, 028-030 POST SB
737-31-1246 OR POST SB 737-31-1295**

- VSD - vertical situation display

HAP ALL

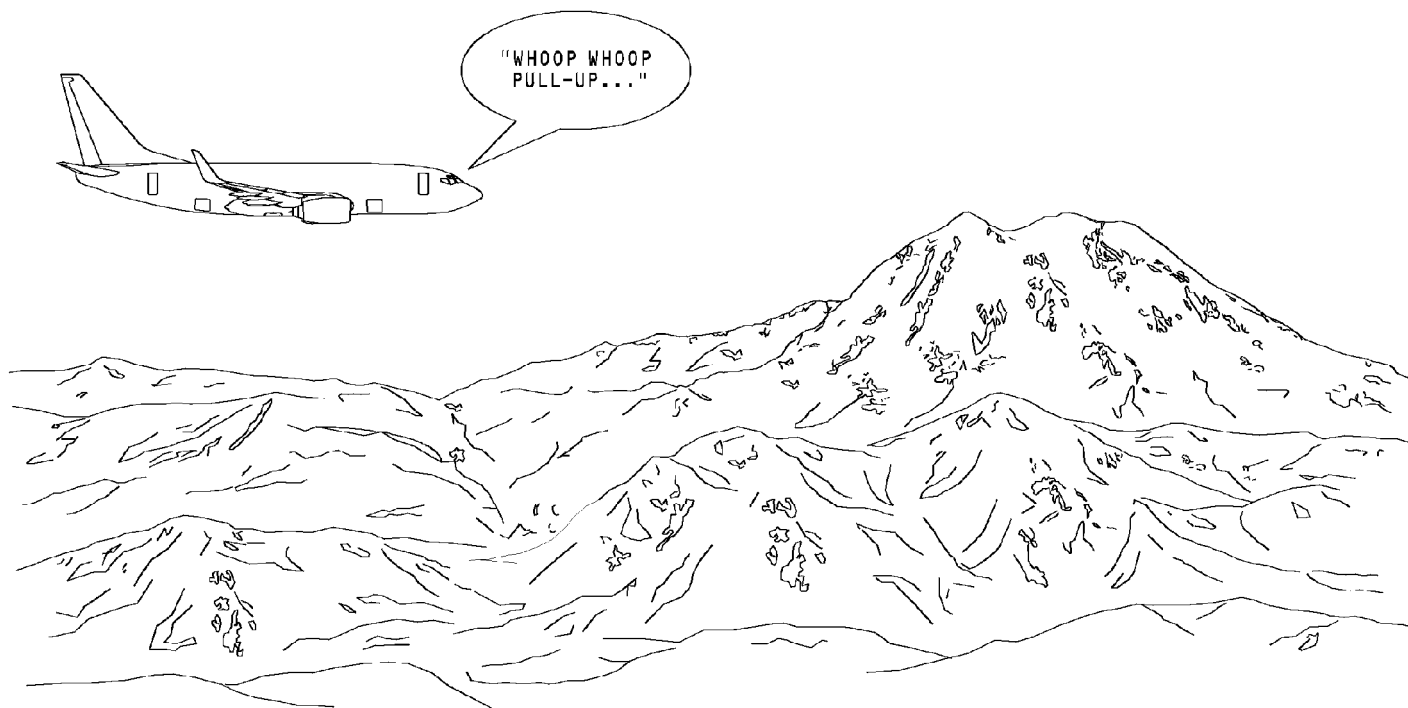

GROUND PROXIMITY WARNING SYSTEM - INTRODUCTION

EFFECTIVITY
HAP ALL

34-46-00

D633A101-HAP

Page 3
Oct 10/2004

34-46-00-001

GPWS - GENERAL DESCRIPTION

General Description

The GPWS gives the pilots aural and visual warnings of unsafe conditions. The warnings continue until the pilots correct the condition. The system operates when the airplane is less than 2450 feet above the ground.

HAP The enhanced GPWS function contains a worldwide terrain data
HAP base. The GPWC compares airplane position and track with this
HAP data base to find if there is a warning condition. This is the
HAP terrain awareness function.

HAP The enhanced GPWS also contains an airport data base. This
HAP data base contains terrain information for all hard surface
HAP runways that are more than 3500 feet or longer. The GPWC
HAP compares airplane position and runway location to find if there
HAP is a warning condition. This is the terrain clearance floor (TCF)
HAP function.

The GPWS uses inputs from these units to calculate warning conditions:

- Ground proximity warning module (GPWM)
- Radio altimeter (RA)
- Air data inertial reference system (ADIRS)
- Stall management yaw dampers (SMYDs)
- Multi-mode receivers (MMRs)
- Flight management computer system (FMCS)
- DFCS MCP
- Weather radar (WXR)

HAP

- Display electronics units (DEUs).

GPWS visual warnings show on the common display system (CDS) display units, the below glideslope annunciators, and the GPWM.

GPWS aural warnings go through the remote electronics unit to the pilots headsets and flight deck speakers.

The GPWS sends inhibit signals to the TCAS and weather radar systems when GPWS calculates cautions and warnings. HAP HAP

The GPWS shows terrain that is forward of the airplane. This information goes to the terrain/weather relays and then to the DEUs for display. Alerts to the flight crew of an early descent during a landing go directly to the DEUs for display. HAP HAP HAP HAP

Visual indications show on these:

- Captain and first officer primary flight displays
- Captain and first officer navigation displays
- Captain and first officer glideslope inhibit switches
- GPWM.

HAP

GPWS cautions and warnings go to the flight data acquisition unit (FDAU).

Aural messages go to the remote electronics unit (REU).

34-46-00-002

EFFECTIVITY
HAP ALL

34-46-00

D633A101-HAP

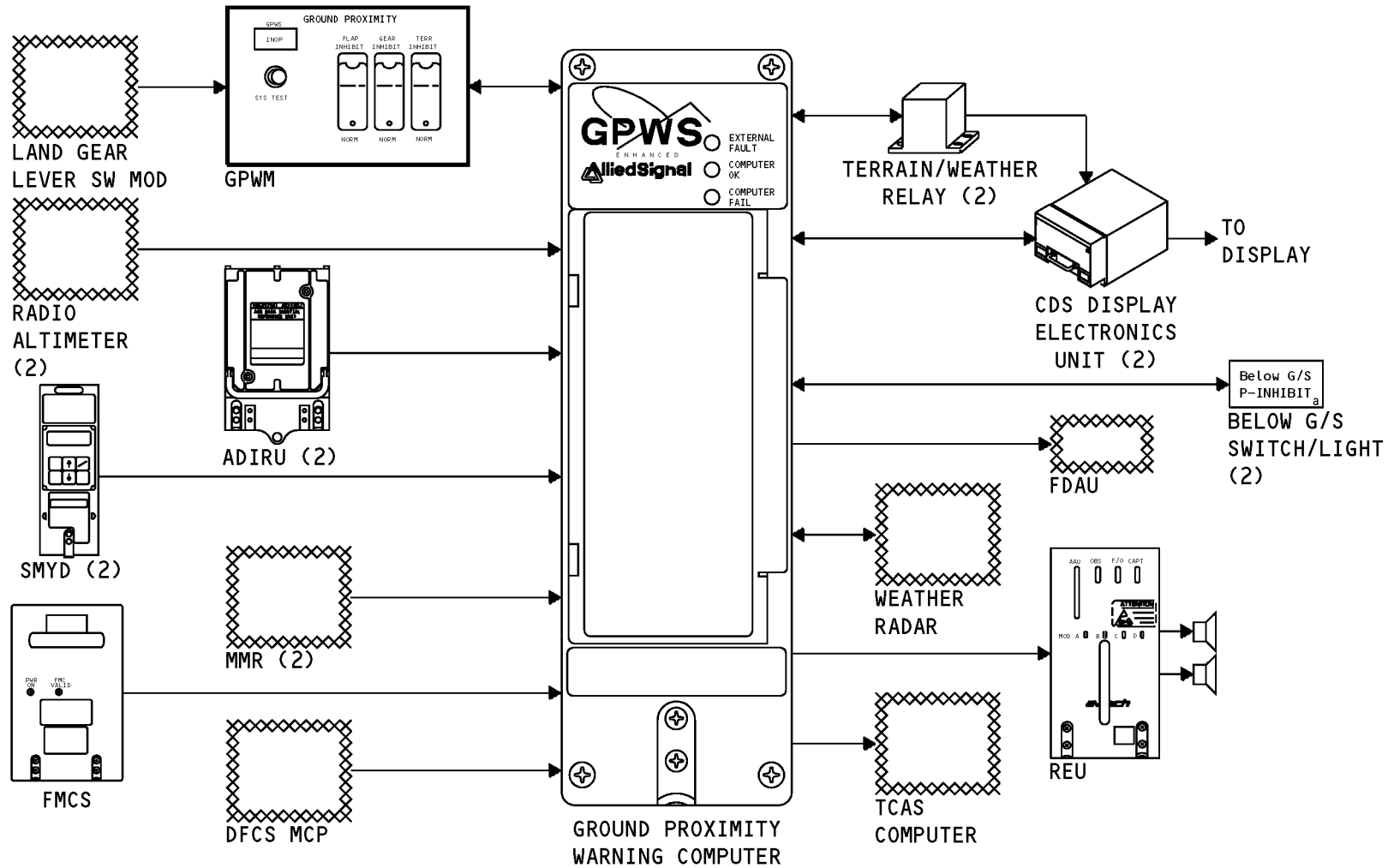

GPWS - GENERAL DESCRIPTION

34-46-00-002

EFFECTIVITY
HAP 001-013, 015-022

34-46-00

D633A101-HAP

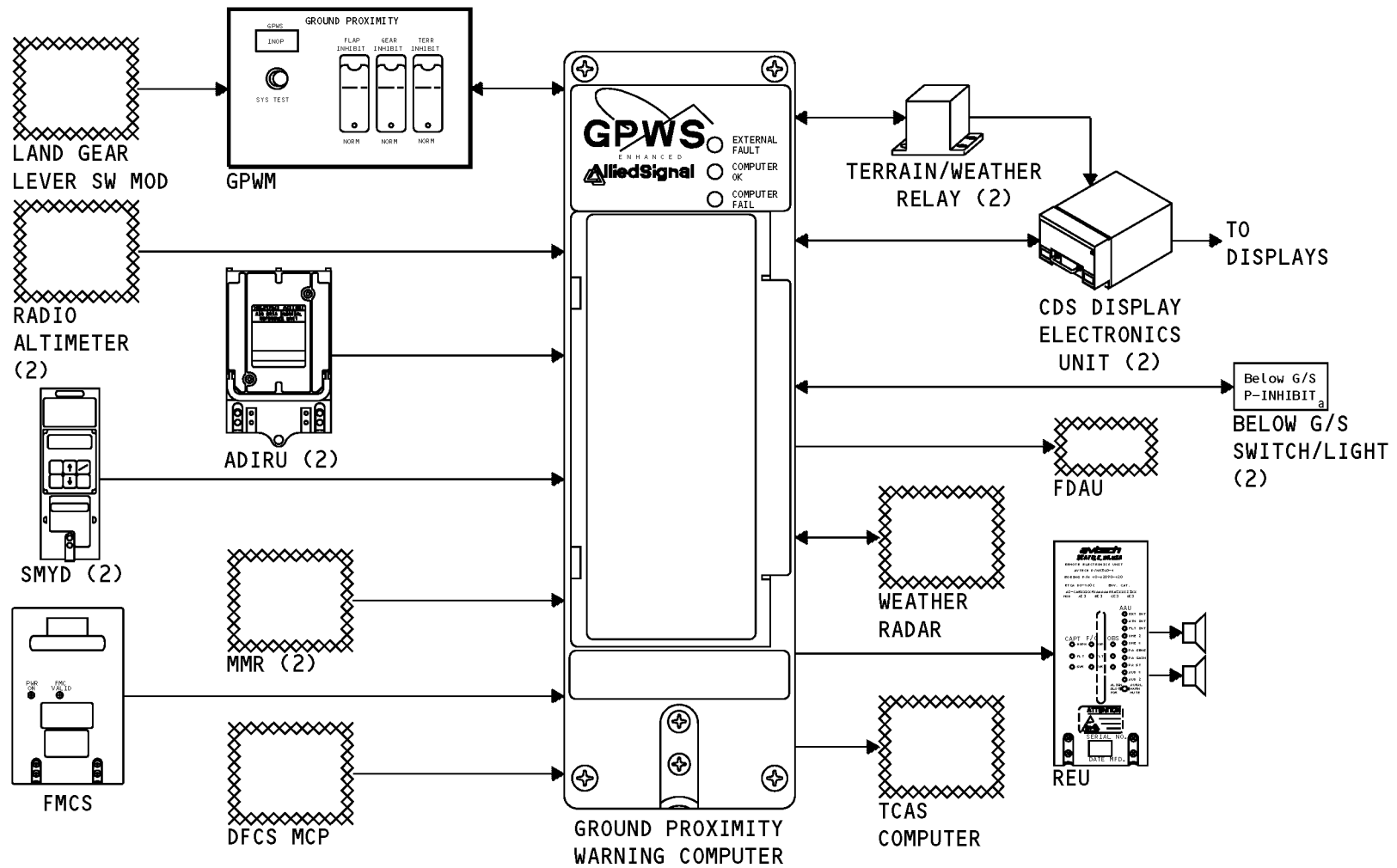

GPWS - GENERAL DESCRIPTION

34-46-00-002

EFFECTIVITY
HAP 023-026, 028-054, 101-999

34-46-00

D633A101-HAP

THIS PAGE IS INTENTIONALLY LEFT BLANK

34-46-00

D633A101-HAP

Page 7
Jun 15/2009

GPWS - FLIGHT COMPARTMENT COMPONENT LOCATION

Flight Compartment Locations

These are the GPWS components in the flight compartment:

- Capt and F/O Below G/S Switch/Light
- Ground proximity warning module.

These are the components in the flight compartment that interface with the GPWS:

- HAP
- Capt and F/O display units
 - Capt and F/O EFIS control panels

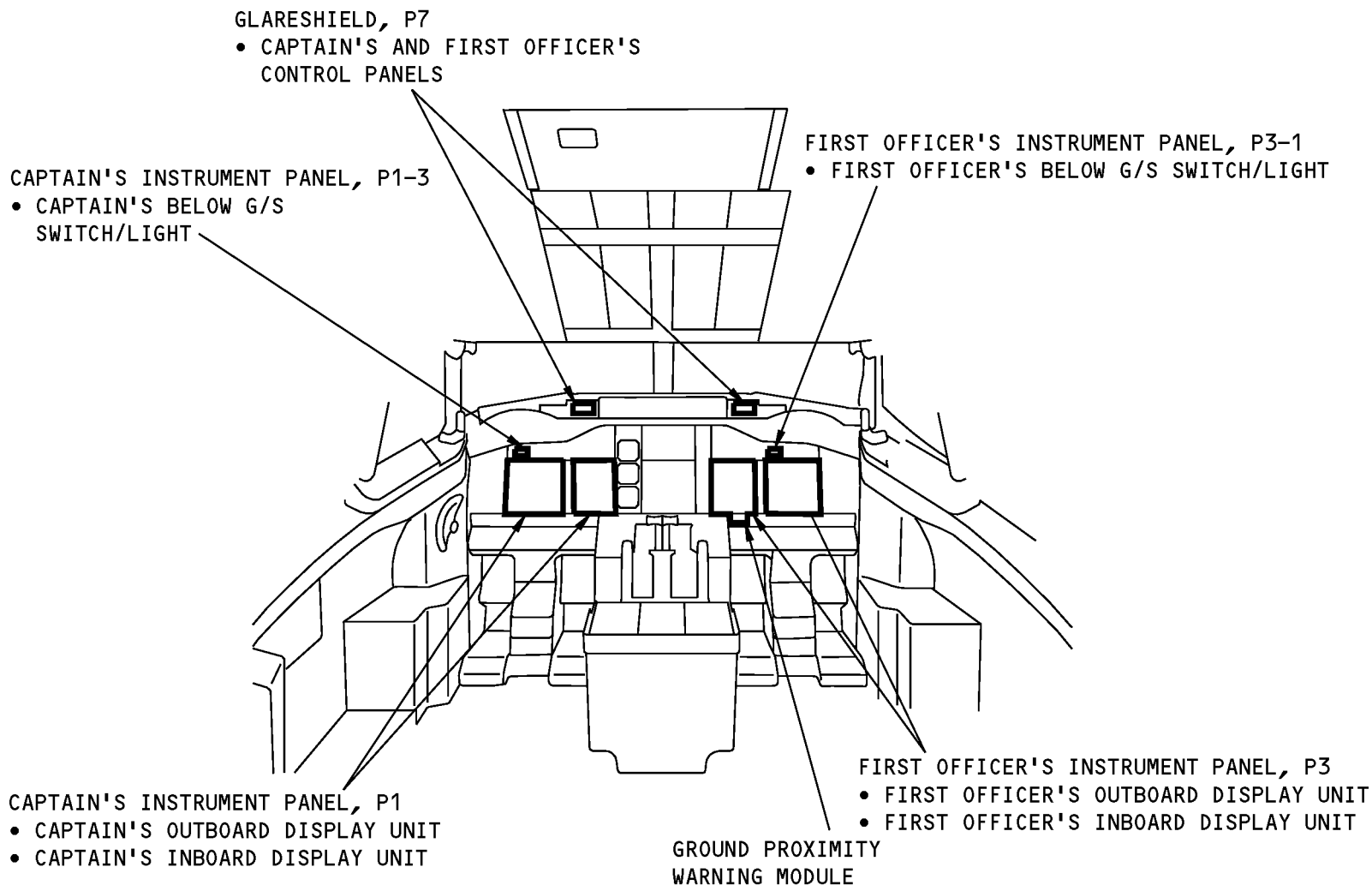

GPWS - FLIGHT COMPARTMENT COMPONENT LOCATION

34-46-00-003

	EFFECTIVITY	
	HAP ALL	

34-46-00

D633A101-HAP

GPWS - COMPONENT LOCATION - 2

General

The ground proximity warning computer (GPWC) and the GPWS program switch module are on the electronic equipment compartment on the E1-1 shelf.

HAP The terrain weather relay 745 is in the J24 box. The J24 box is in
HAP the nose wheel well on the right side and behind the forward
HAP access panel.

HAP The terrain weather relay 746 is in the J22 electrical junction
HAP box. The J22 box is in the nose wheel well on the left side and
HAP behind the forward access panel.

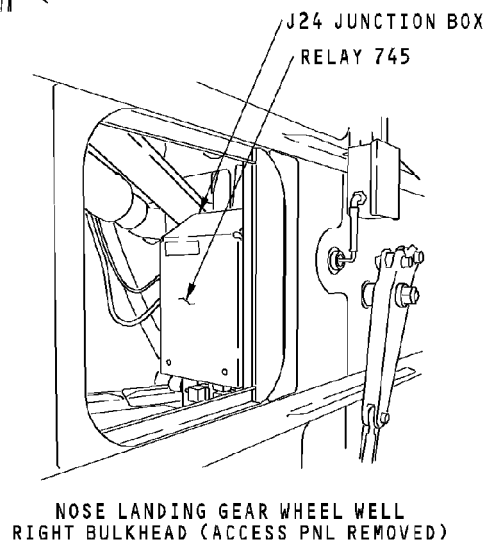
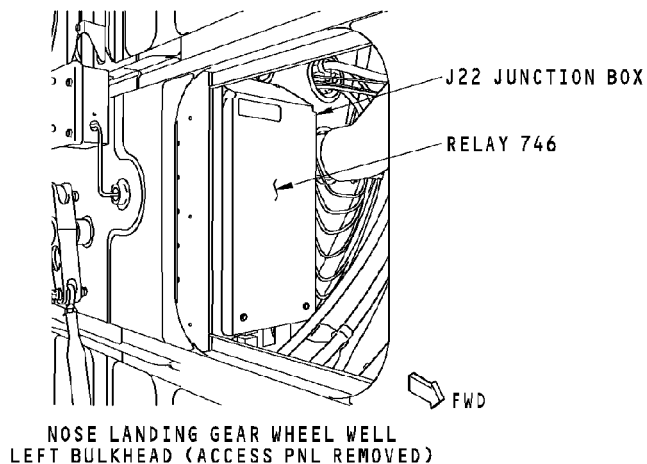
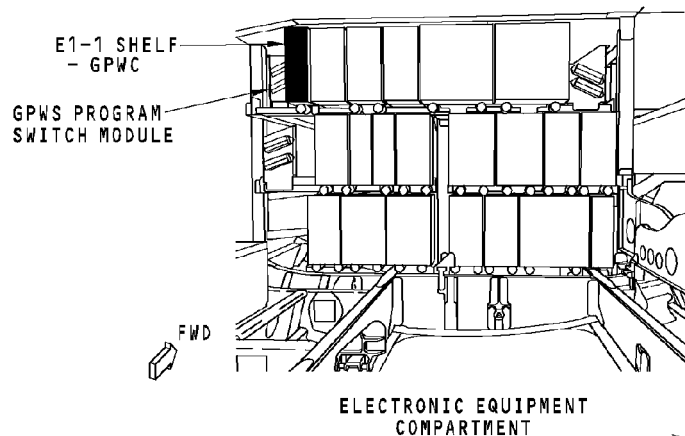

GPWS - COMPONENT LOCATION - 2

34-46-00-004

EFFECTIVITY
HAP ALL

34-46-00

D633A101-HAP

THIS PAGE IS INTENTIONALLY LEFT BLANK

34-46-00

D633A101-HAP

Page 12
Jun 15/2009

GPWS - POWER AND ANALOG INTERFACES

General

The ground proximity warning computer (GPWC) receives 115v ac from the GND PROX WARN circuit breaker on the P18 circuit breaker panel.

HAP The terrain weather relays receive 28v dc from the TERRAIN
HAP DISPLAY circuit breaker on the P18 circuit breaker panel.

HAP | The GPWC provides a ground discrete (terrain select) to
HAP energize the terrain weather relays. This discrete energizes the
HAP TERR/WXR relays to connect the GPWC to the DEUs so that
HAP terrain data shows on the navigation displays.

HAP | The terrain select discrete can be set manually with the TERR
HAP switch on the EFIS control panel or automatically by the pop up
HAP function. The pop up function lets terrain data show
HAP automatically on the navigation displays when there is a
HAP terrain awareness caution or warning. This function only occurs
HAP when both of the navigation displays are not currently showing
HAP terrain data.

HAP | When the terrain weather relays energize, they send 28v dc to
HAP the GPWC relay monitors to show relay position.

Gear position from the landing gear lever switch module on P2-3 goes to the gear inhibit switch in the ground proximity warning module (GPWM). The GPWM sends the landing gear position discrete to the GPWC.

The gear inhibit switch in the inhibit position sends a discrete to the GPWC that simulates the landing gear in the extended position. GPWC uses gear position for these modes:

- Mode 2
- Mode 3
- Mode 4
- Mode 5.

When the flap inhibit switch on the GPWM is in the inhibit position, a flap inhibit discrete signal goes to the GPWC. This simulates a flaps landing position in the GPWC.

The GPWM terrain inhibit discrete prevents the enhanced function of the GPWS. The discrete does not affect the operation of modes 1 thru 7. These items are inhibited:

- Terrain cautions
- Terrain warnings
- Terrain displays
- Terrain aural messages.

The GPWM also sends a test discrete signal to the GPWC. The GPWC uses the test discrete to start a self-test of the GPWS.

The GPWC sends a GPWC INOP discrete to the GPW control module to turn on the amber INOP light.

The PSEU sends air/ground discrete data to the GPWC for in-air logic. This logic is used in these modes:

HAP
HAP
HAP

HAP
HAP
HAP
HAP

HAP

34-46-00-005

<p>EFFECTIVITY HAP ALL</p>

34-46-00

D633A101-HAP

GPWS - POWER AND ANALOG INTERFACES

- Mode 2
 - Mode 3
 - Mode 4
- HAP
- Inhibit BITE in air
 - Flight leg counting.

HAP The GPWC sends an inhibit discrete to the TCAS computer
HAP when the GPWC has a higher priority alert. This discrete
HAP inhibits the TCAS aural messages and downgrades TCAS
HAP resolution advisories (RAs) to traffic alerts.

GPWC aural messages have a higher priority than the TCAS aural messages with the exception of mode 6 aural messages. Mode 6 aural messages can occur at the same time as TCAS aural messages.

HAP The GPWC also sends a predictive windshear inhibit discrete to
HAP the weather radar receiver transmitter when the GPWC has a
HAP higher priority alert. This discrete inhibits the PWS aural
HAP messages.

The program switch module supplies program pin selections to the GPWC. The options determine such parameters as:

- Airplane type
- Mode 6 callouts
- High or low audio volume.

The GPWC sends discrettes to the captain and first officer glideslope inhibit switches. The lights come on for GPWC mode 5 alerts. When you push the light assemblies, a discrete goes to the GPWC to turn off the lights and stop the aural warnings.

GPWS alert and warning aural messages go to the remote electronics unit (REU). The REU sends the aural messages to the flight compartment.

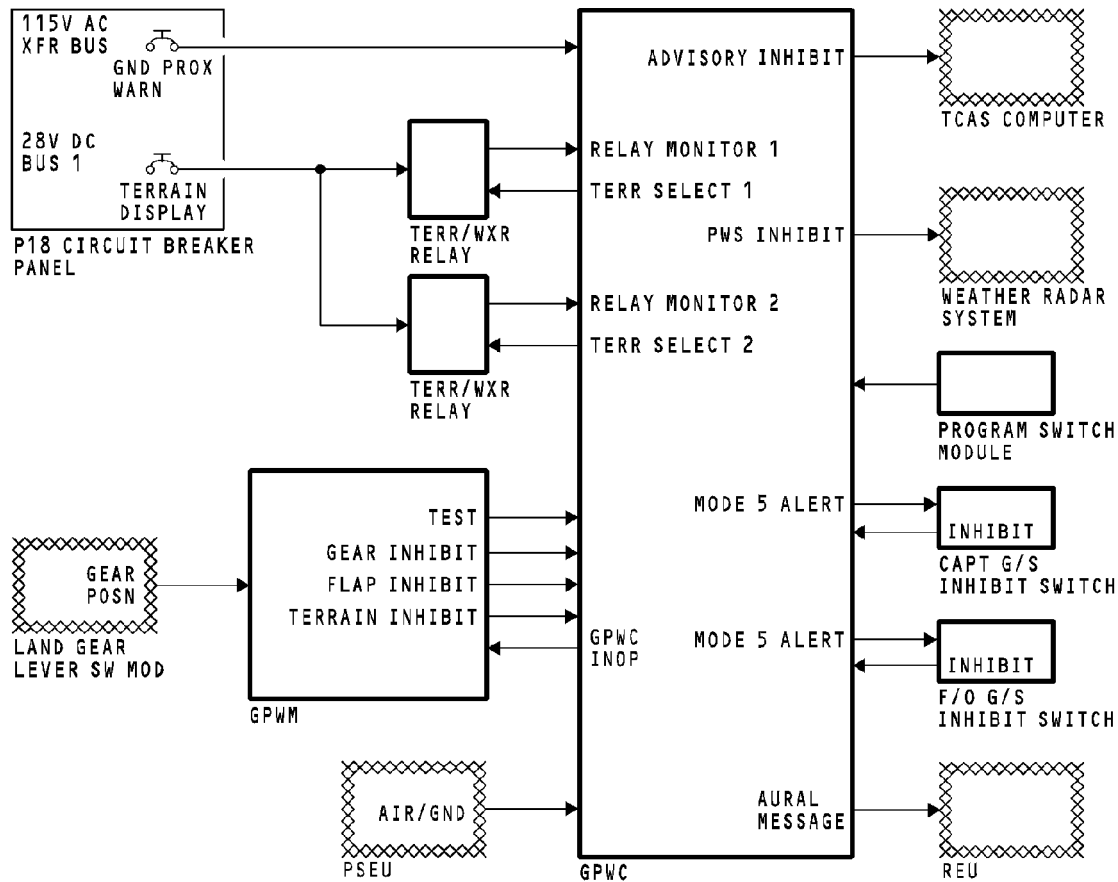

GPWS - POWER AND ANALOG INTERFACES

34-46-00-005

EFFECTIVITY
HAP ALL

34-46-00

D633A101-HAP

THIS PAGE IS INTENTIONALLY LEFT BLANK

34-46-00

D633A101-HAP

Page 16
Jun 15/2009

GPWS - DIGITAL INTERFACES

General

The GPWC interfaces with other airplane systems on ARINC 429 data buses. These systems have digital interfaces with the GPWC:

- HAP • Left and right air data inertial reference units
- Radio altimeter 1 and 2
- Multi mode receivers 1 and 2
- HAP 001-013, 015-026, 028-036**
- Flight management computer (FMC)
- HAP 037-054, 101-999**
- Flight management computer 1 and 2
- HAP ALL**
- DFCS mode control panel
- Stall management yaw damper 1 and 2
- HAP • Weather radar (WXR)
- Display electronics unit (DEU) 1 and 2
- HAP • Terrain/weather relays
- Flight data acquisition unit (FDAU).

Air Data Inertial Reference Unit

HAP The left and right ADIRU ADR buses send this data to the
HAP GPWC:

- HAP • Computed airspeed
- HAP • True airspeed
- HAP • Barometric altitude rate
- HAP • Uncorrected altitude
- HAP • Barometric altitude.

This air data is used to determine cautions and warnings for GPWS modes 1, 2, 3, 4, and 7. The GPWC uses the data from the left ADIRU. If the left ADIRU data is invalid, it uses data from the right ADIRU.

The left and right ADIRU IR bus sends these inputs to the GPWC:

- Latitude
- Longitude
- Inertial altitude
- Inertial vertical speed
- Track angle magnetic
- Pitch attitude
- Roll attitude
- Body longitudinal acceleration
- Body normal acceleration
- Inertial vertical acceleration
- Pitch rate
- Ground speed
- True track
- True heading
- IR mode.

This IR data is used to determine cautions and warnings for GPWS modes 1, 2, 3, 7, terrain clearance floor (TCF), and terrain awareness. The GPWC uses the data from from the left ADIRU. If the left ADIRU data is invalid, it uses data from the right ADIRU.

34-46-00-006

<p>EFFECTIVITY HAP ALL</p>

34-46-00

D633A101-HAP

GPWS - DIGITAL INTERFACES

Radio Altimeter Receiver-Transmitter

HAP The radio altimeters (RA) send radio altitude data to the GPWC.
 HAP This data is used in modes 1 to 7 and TCF. The GPWC uses the
 HAP data from from RA 1. If RA 1 data is invalid, it uses data from RA
 HAP 2.

Instrument Landing System

HAP 001-013, 015-022

The ILS receiver in MMR 1 sends localizer and glideslope deviation data to the GPWC. Localizer deviation data is used in the envelope modulation function. Glideslope deviation data is used in mode 5 and the envelope modulation function.

HAP 023-026, 028-054, 101-999

The ILS receiver in both MMRs send localizer and glideslope deviation data to the GPWC. Localizer deviation data is used in the envelope modulation function. Glideslope deviation data is used in mode 5 and the envelope modulation function. The GPWC uses the ILS data from from MMR 1. If MMR 1 data is invalid, it uses ILS data from MMR 2.

HAP

HAP | **HAP ALL**

HAP **Global Position System**

HAP The GPS in the MMRs sends this data to the GPWC:

- HAP ● Latitude (coarse)

- Longitude (coarse) HAP
- Latitude (fine) HAP
- Longitude (fine) HAP
- Ground speed HAP
- True track. HAP
- Altitude HAP
- Vertical velocity HAP
- Horizontal dilution of precision (HDOP) HAP
- Vertical dilution of precision (VDOP) HAP
- Horizontal figure of merit (HFOM) HAP
- Vertical figure of merit (VFOM) HAP
- Date HAP
- Time (UTC) HAP
- Horizontal integrity limit (HIL) HAP
- Sensor status. HAP

The GPWC uses the GPS data from from MMR 1. If MMR 1 data is invalid, it uses GPS data from MMR 2. HAP

Latitude and longitude (coarse and fine) information gives airplane position for the TCF and terrain awareness functions. HAP

Ground speed, true track, altitude, and vertical velocity are used in the terrain awareness function. HAP

Horizontal dilution of precision, vertical dilution of precision, horizontal figure of merit, and vertical figure of merit data is used for airplane position accuracy calculations. HAP

34-46-00-006

EFFECTIVITY	
HAP ALL	

34-46-00

D633A101-HAP

GPWS - DIGITAL INTERFACES

HAP Date and time information is used in the fault monitor process,
HAP which labels each fault with the date and time of occurrence.

HAP The horizontal integrity limit is used to determine the current
HAP integrity limit and GPS non-isolatable satellite failures.

HAP Sensor status lets the GPWC monitor the status of the GPS
HAP receiver IN THE MMR.

Flight Management Computer System

HAP 001-013, 015-026, 028-036

The FMC sends latitude, longitude, and magnetic track data to the GPWC. The GPWC uses this data in the envelope modulation function. If the FMC input is invalid, the GPWC uses latitude, longitude and magnetic track data from the ADIRS.

HAP 037-054, 101-999

The primary FMC sends latitude, longitude, and magnetic track data to the GPWC. The GPWC uses this data in the envelope modulation function. If the FMC input is invalid, the GPWC uses latitude, longitude and magnetic track data from the ADIRS.

HAP ALL

DFCS MCP

The digital flight control system (DFCS) mode control panel (MCP) sends selected course data to the GPWC. This data is used in mode 5 and the envelope modulation function.

Stall Management Yaw Damper

The stall management yaw dampers (SMYD) send this data to the GPWC:

- Indicated angle of attack (AOA)
- Corrected AOA
- Stick shaker AOA
- Flap position
- Minimum operating speed.

The inputs from the SMYD are used primarily in wind shear calculations.

DEUs

The display electronic units (DEUs) send this data from the EFIS control panels to the GPWC:

- Range
- Terrain select

HAP 031-054, 101-999; HAP 001-013, 015-026, 028-030 POST SB 737-31-1246 OR POST SB 737-31-1295

- Data select

HAP ALL

- Radio minimums

**I HAP
HAP**

34-46-00-006

<p>EFFECTIVITY HAP ALL</p>
--

34-46-00

D633A101-HAP

GPWS - DIGITAL INTERFACES

- Baro minimums.

HAP Weather Radar Receiver-Transmitter

HAP The weather radar RT sends predictive windshear caution and
HAP warning data to the GPWC. The GPWC contains aural
HAP prioritization logic that uses this data to determine which
HAP system cautions and warnings to inhibit. The GPWS, TCAS, and
HAP PWS systems are prioritized by the GPWC.

GPWC Outputs

HAP The GPWC sends system status, caution, and warning data on
HAP an ARINC 429 data bus to the DEUs. The DEUs show system
HAP status, caution and warning annunciations on the captain and
HAP first officer primary flight display and the navigation display.

The GPWC sends caution, warning, and status discretes to the flight data acquisition unit (FDAU). The FDAU sends the GPWC data to the flight data recorder.

HAP The GPWC sends terrain display data on an ARINC 453 data bus
HAP to the terrain weather relays. The display data then goes from
HAP the terrain weather relays to the DEUs to show on the
HAP navigation displays.

The terrain data is sent when TERR is selected on the EFIS control panel or automatically for the pop-up mode. The pop-up mode occurs when a terrain caution or warning is calculated and the captain and the first officer navigation displays are not selected to show terrain data.

HAP
HAP
HAP
HAP
HAP

HAP 031-054, 101-999

The GPWC sends tilt angle data on an ARINC 429 bus to the weather radar transceiver for use with the autotilt function.

HAP 031-054, 101-999; HAP 001-013, 015-026, 028-030 POST SB 737-31-1246 OR POST SB 737-31-1295

The vertical situation data is sent when DATA is selected on the EFIS control panel.

HAP ALL

34-46-00-006

EFFECTIVITY
HAP ALL

34-46-00

D633A101-HAP

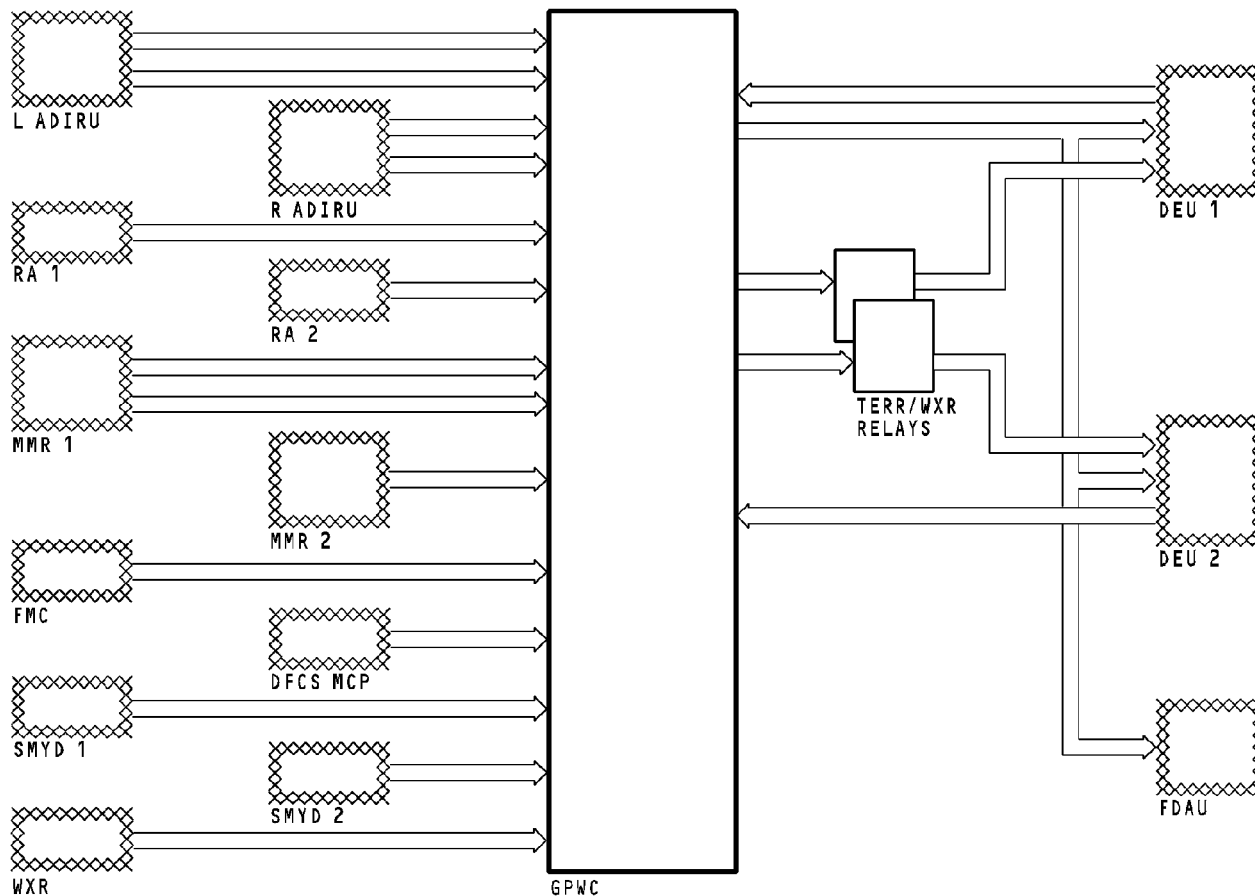

GPWS - DIGITAL INTERFACES

34-46-00-006

EFFECTIVITY
HAP 001-013, 015-022

34-46-00

D633A101-HAP

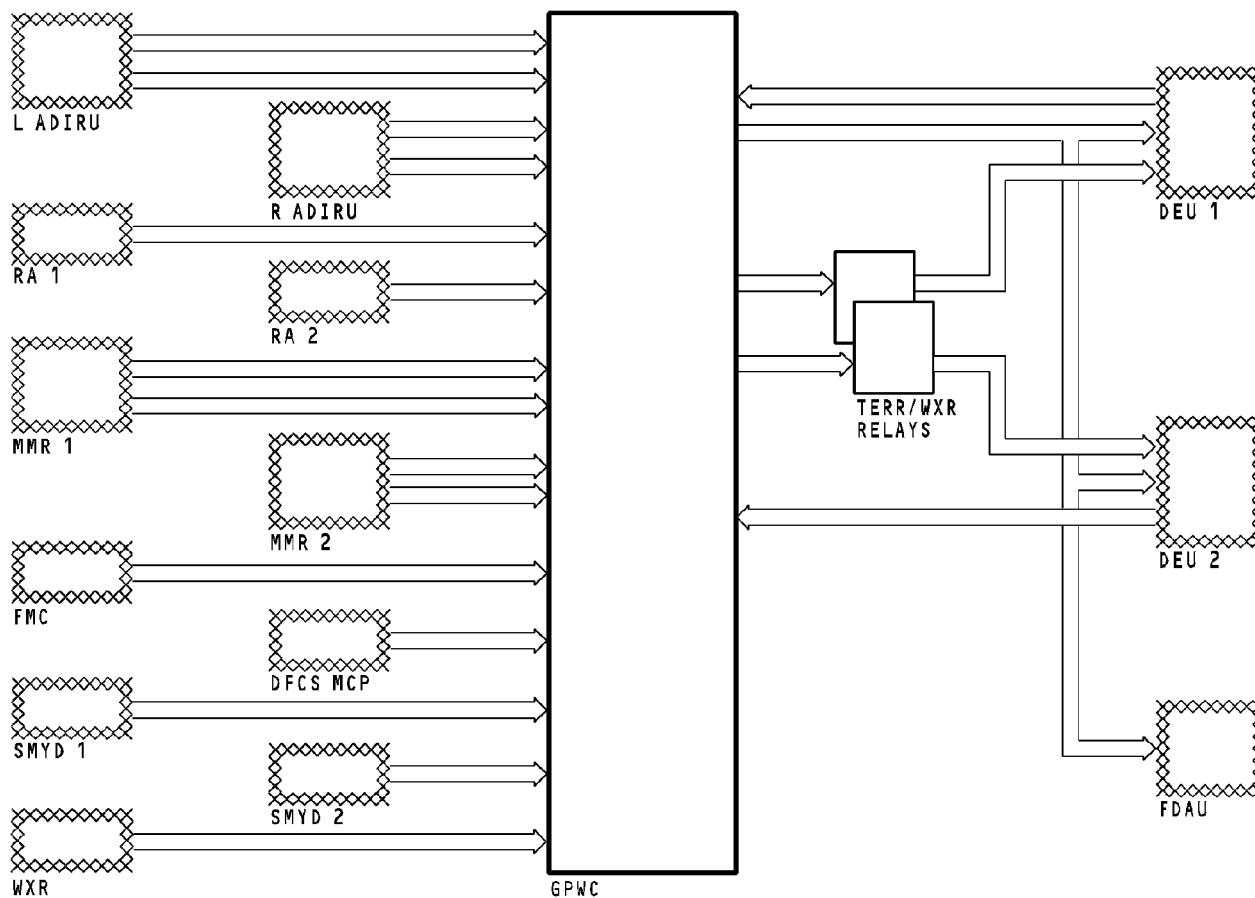

GPWS - DIGITAL INTERFACES

EFFECTIVITY
HAP 023-026, 028-036

34-46-00

D633A101-HAP

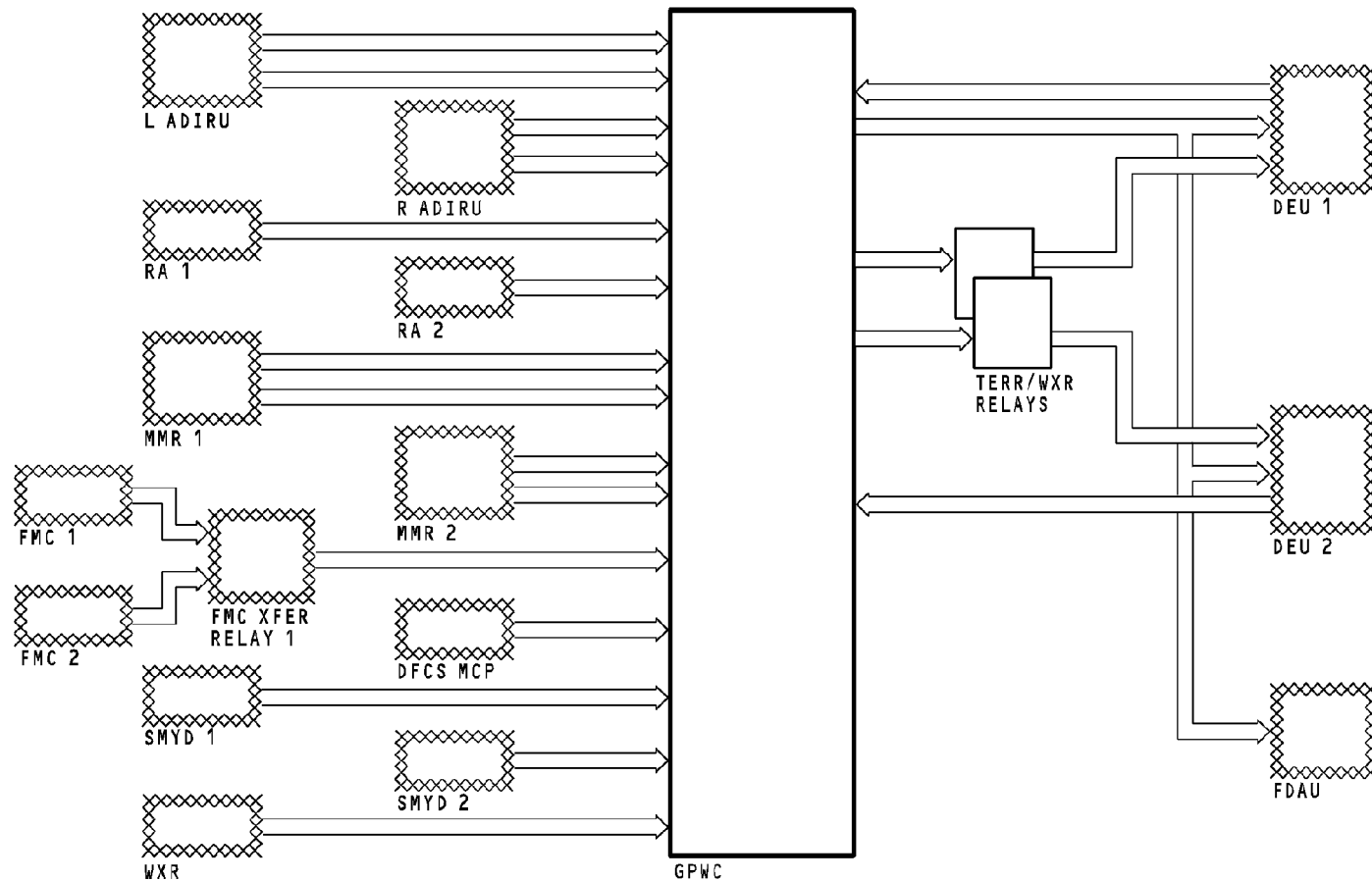

GPWS - DIGITAL INTERFACES

34-46-00-006

EFFECTIVITY
HAP 037-054, 101-999

34-46-00

D633A101-HAP

Page 23
Jun 15/2009

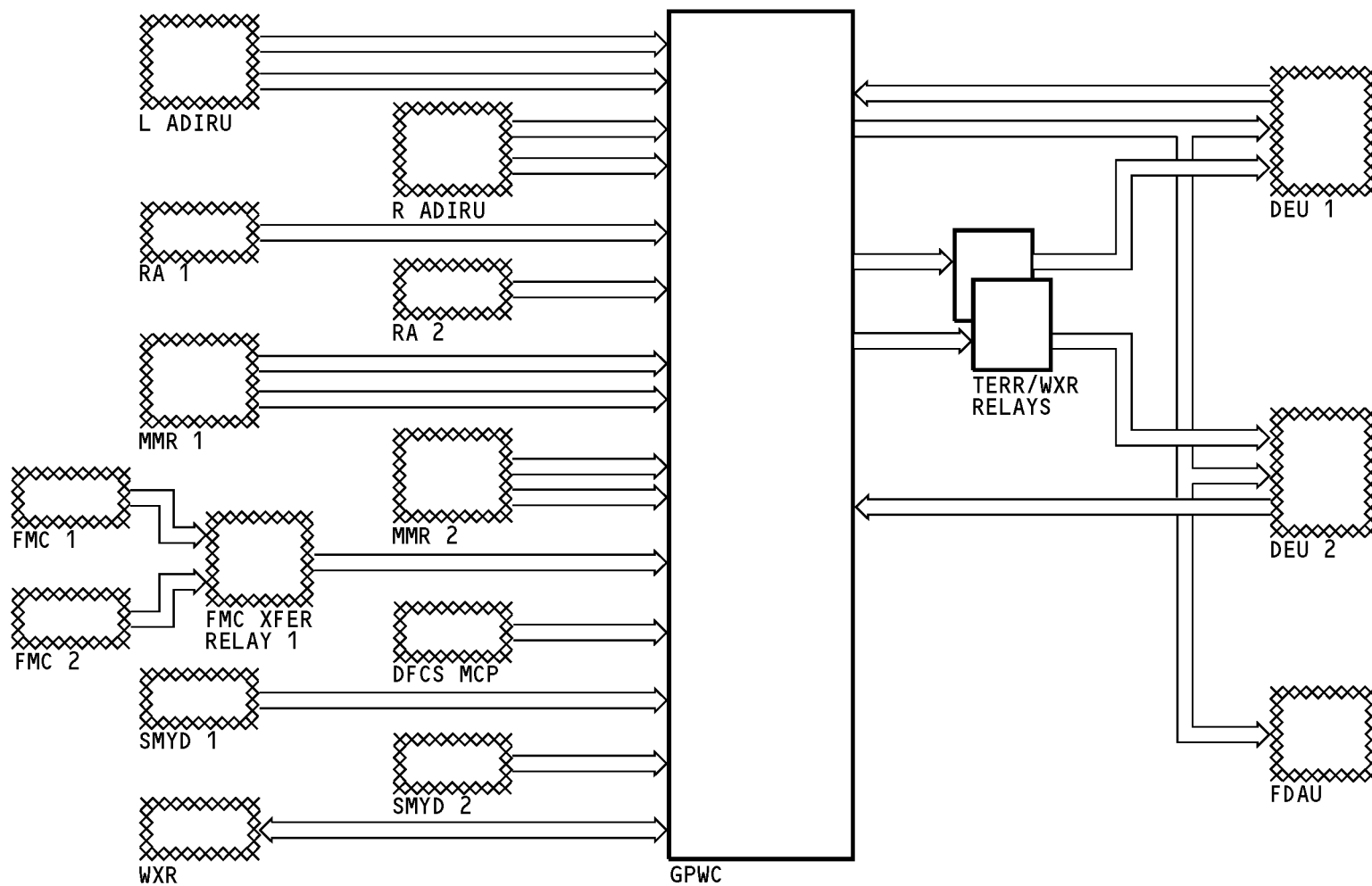

GPWS - DIGITAL INTERFACES

EFFECTIVITY
HAP 037-054, 101-999

34-46-00

D633A101-HAP

Page 24
Jun 15/2009

34-46-00-006

THIS PAGE IS INTENTIONALLY LEFT BLANK

34-46-00

D633A101-HAP

Page 25
Jun 15/2009

GPWS - TERRAIN/WEATHER RELAY INTERFACE

HAP **Purpose**

HAP The ground proximity warning computer (GPWC) and the
HAP weather radar (WXR) receiver-transmitter send display data
HAP that shows on the navigational displays (NDs). Two terrain
HAP weather select relays control which data shows on each ND.

HAP **Relay Power**

HAP The terrain weather select relays get 28v dc from the terrain
HAP display circuit breaker on the P18 circuit breaker panel.

HAP **Digital Relay Interfaces**

HAP The GPWC and WXR send data to both terrain weather select
HAP relays on ARINC 453 data buses.

HAP The terrain weather select relays send data to the display
HAP electronics units on ARINC 453 data buses. The display
HAP electronics units shows the data on the NDs.

Relay Control

When you push the WXR switch on the EFIS control panel, the normal relay position lets the weather radar data show on the NDs. When you push the TERR switch on either EFIS control panel (CP), the on side DEU sends a discrete to the GPWC. When the GPWC receives the DEU discrete, it sends a terrain select ground discrete signal to energize the relay. This lets the terrain data connect to the DEUs for display on the NDs. When you push the TERR switch again, the relay deenergizes. The relay now connects the WXR to the DEUs.

Relay Monitor

The terrain weather select relays send a signal to the GPWC when it energizes. The GPWC uses these inputs to identify which position the relays are in. When the relays are in the normal position, the GPWC monitor senses no voltage. When the relays are in the energized position, the GPWC monitor senses 28v dc.

HAP

HAP
HAP
HAP
HAP
HAP
HAP
HAP

HAP

HAP
HAP
HAP
HAP
HAP

34-46-00-031

EFFECTIVITY
HAP ALL

34-46-00

D633A101-HAP

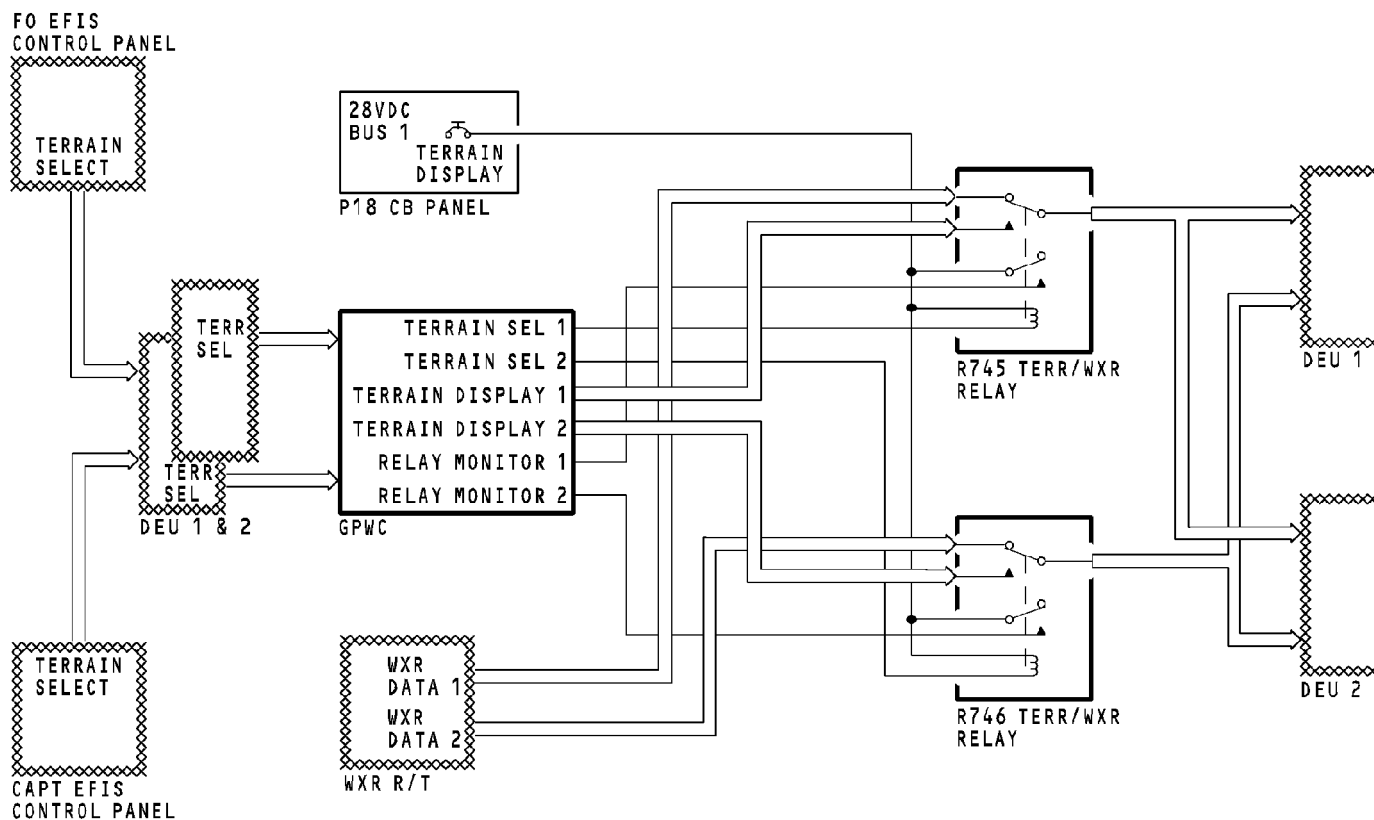

GPWS - TERRAIN/WEATHER RELAY INTERFACE

34-46-00-031

EFFECTIVITY
HAP ALL

34-46-00

D633A101-HAP

THIS PAGE IS INTENTIONALLY LEFT BLANK

34-46-00

D633A101-HAP

Page 28
Jun 15/2009

GPWS - GROUND PROXIMITY WARNING COMPUTER

Purpose

HAP The ground proximity warning computer (GPWC) compares the
HAP airplanes flight profile, flap and gear position, and terrain
HAP clearance to find if there is a warning condition.

Description

HAP The GPWC is the main component of the GPWS. The computer
HAP front panel contains three LEDs that show internal and external
HAP failures. The front panel also contains a self-test switch. The
HAP switch provides access to six self-test modes. The faults are
HAP annunciated through the flight deck speakers or through
HAP headphones connected to the jack below the switch.

HAP You can update the computer operational software and terrain
HAP database with a download from a PC card that you put into the
HAP front panel PCMCIA interface slot. When you put the card in, the
HAP computer downloads data without further action. There are four
HAP status LEDs to show the progress of the memory card data
HAP transfer. A blank formatted card may be used to download
HAP GPWS fault history data.

HAP The computer has a front panel, 15-pin, D-type portable PC test
HAP connector (RS-232) for a serial data connection to a PC
HAP compatible computer.

Physical Description

The GPWC is a standard ARINC 600, 2 MCU. The dimensions are 2.4 inches wide, 7.9 inches high, and 14.3 long. The computer weighs 7 pounds and uses 115v ac, 400 HZ single-phase power for operation.

The GPWC is cooled with air from the equipment cooling sytem. The cooling air for the GPWC is blow-through.

Front Panel

The GPWC front panel has three status LEDs and a door.

These are the three status LEDs on the front panel:

- EXTERNAL FAULT - amber LED turns on for a failure external to the GPWC
- COMPUTER OK - green LED stays on when GPWC has power and operates normally
- COMPUTER FAIL - red LED stays on when the GPWC has an internal failure.

The front panel door gives access to these:

- SELF-TEST switch - starts a test of the GPWS
- Headphone jack - lets you hear self-test audio
- Memory card slot - lets you upload software from a memory card or download fault and warning history data
- Upload/download status indicators - show conditions of the upload or download operation

HAP

HAP

HAP

HAP

HAP

HAP

HAP

HAP

HAP

HAP

HAP

HAP

HAP

HAP

HAP

HAP

34-46-00-007

EFFECTIVITY
HAP ALL

34-46-00

D633A101-HAP



GPWS - GROUND PROXIMITY WARNING COMPUTER

- HAP • RS-232 connector - used for shop test, or for the upload/
HAP download of data with a compatible PC computer.

HAP

34-46-00-007

EFFECTIVITY
HAP ALL

34-46-00

D633A101-HAP

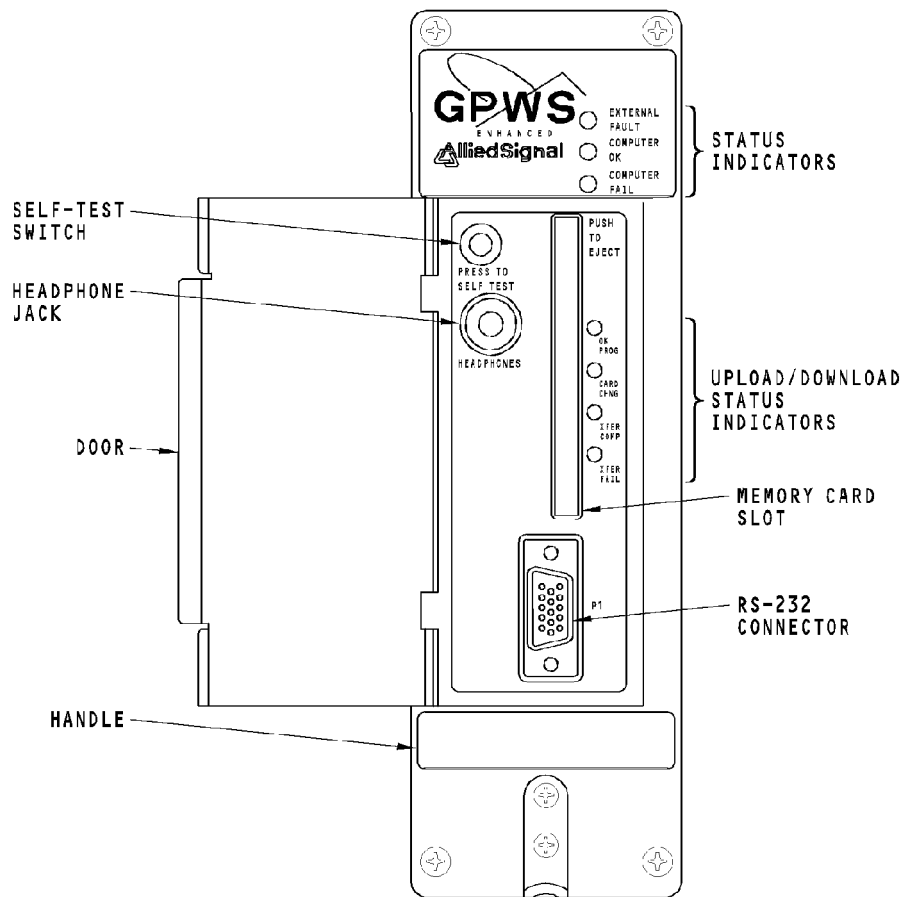

GPWS - GROUND PROXIMITY WARNING COMPUTER

34-46-00-007

EFFECTIVITY
HAP ALL

34-46-00

D633A101-HAP

Page 31
Jun 15/2009

GPWS - EFIS CONTROL PANEL

HAP Description

HAP The EFIS control panel lets the flight crew choose the
 HAP information they want to show on the navigation displays.
 HAP These controls interface with the GPWS:

- HAP • TERR Map switch
- HAP | **HAP 031-054, 101-999; HAP 001-013, 015-026, 028-030 POST SB**
- HAP | **737-31-1246 OR POST SB 737-31-1295**
- HAP • DATA switch
- HAP | **HAP ALL**
- HAP • ND mode selector
- HAP • ND range selector.

HAP TERR Map Switch

HAP When you push the TERR map switch on the EFIS control panel,
 HAP terrain data shows on the on-side ND. Push the TERR map
 HAP switch again to remove the terrain data.

HAP | **HAP 031-054, 101-999; HAP 001-013, 015-026, 028-030 POST SB**
 HAP | **737-31-1246 OR POST SB 737-31-1295**

HAP DATA Switch

HAP When you push the DATA switch on the EFIS control panel, the
 HAP vertical situation data shows on the on-side ND. Push the DATA
 HAP switch again to remove the vertical situation data.

HAP | **HAP ALL**

ND Mode Selector

Use the ND mode selector to choose an ND mode. These are the ND modes that show terrain data:

- Expanded APP (approach) mode
- Expanded VOR mode
- Expanded MAP mode
- Centered MAP mode.

When you push the TERR map switch the terrain data arms, even if it is not in the correct mode. The terrain data shows when you change the ND selector to a correct mode. The terrain data stays armed even if you push the TERR map switch again. Push the WXR map switch to disarm the terrain data and arm the weather data.

ND Range Selector

The EFIS control panel has an eight-position range selector. The range selections are 5,10, 20, 40, 80, 160, 320, and 640 NM. The map mode shows the range at all times. Terrain data shows only in the 5NM through 320 NM selections. When the range selector is in the 640NM range, terrain data will only show to 320NM.

HAP

HAP
HAP

HAP
HAP
HAP
HAP

HAP
HAP
HAP
HAP
HAP

HAP

HAP
HAP
HAP
HAP
HAP

34-46-00-040

EFFECTIVITY
HAP ALL

34-46-00

D633A101-HAP

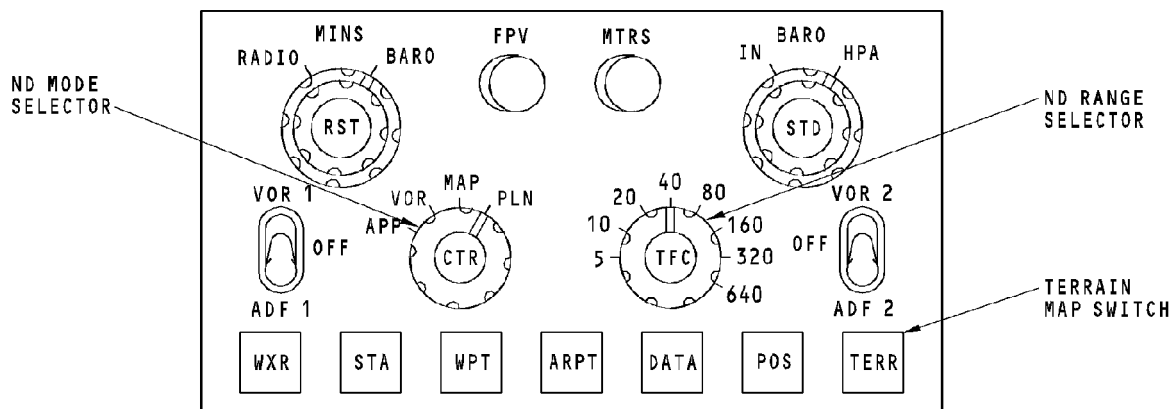

GPWS - EFIS CONTROL PANEL

34-46-00-040

EFFECTIVITY

HAP 001-013, 015-026, 028-030 PRE SB 737-31-1246 AND PRE SB 737-31-1295

34-46-00

D633A101-HAP

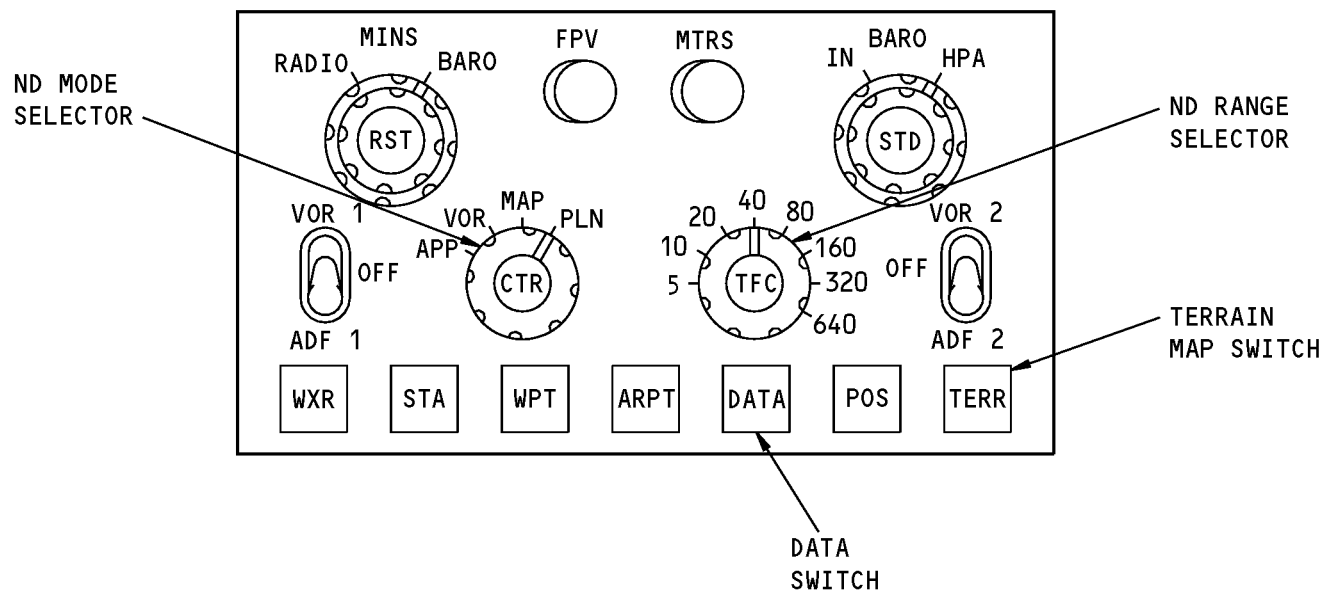

GPWS - EFIS CONTROL PANEL

EFFECTIVITY

HAP 031-054, 101-999; HAP 001-013, 015-026, 028-030 POST SB 737-31-1246 OR POST SB 737-31-1295

34-46-00

D633A101-HAP

GPWS - GROUND PROXIMITY WARNING MODULE

General

The ground proximity warning module (GPWM) is the interface between the flightcrew and the GPWS. The GPWM has an amber GPWS INOP light. The panel also has these switches:

- Test switch
- Flap inhibit switch
- Gear inhibit switch.
- Terrain inhibit switch.

HAP

INOP light

The amber INOP light on the GPWM comes on when there is a failure of the GPWC or if there is a failure of a critical input to the GPWC. The INOP light also comes on if the GPWC can not calculate windshear conditions. During a GPWC self test, the INOP light comes on.

Test Switch

The test switch is a momentary action switch that lets you do a self-test of the GPWC from the flight compartment.

Momentarily push the test switch to start a self-test. There are six levels of self-tests that can be done from the GPWM. To make navigation of self-test levels faster, the test switch can be used to cancel self-test sequences and self-test levels. A short cancel stops a test sequence and a long cancel stops a self-test level. Push the test switch for less than two seconds for a short cancel and push the test switch for more than two seconds for a long cancel.

HAP
HAP
HAP
HAP
HAP
HAP
HAP
HAP

Inhibit Switches

The flap, gear, and terrain inhibit switches supply discrete signals to the GPWC.

HAP
HAP

The flap inhibit switch simulates a flaps down condition to the GPWC. The use of this switch prevents warnings when the flight crew makes a flaps up approach. When selected, the mode 4 warning TOO LOW FLAP is inhibited.

HAP
HAP
HAP
HAP

The gear inhibit switch simulates a gear down condition to the GPWC. The use of this switch prevents warnings when the flight crew makes a gear up approach. When selected, the mode 4 warning TOO LOW GEAR is inhibited.

HAP
HAP
HAP
HAP

34-46-00-008

EFFECTIVITY
HAP ALL

34-46-00

D633A101-HAP

Page 35
Jun 15/2009

GPWS - GROUND PROXIMITY WARNING MODULE

HAP | The terrain inhibit switch sends a discrete ground to the GPWC.
HAP The discrete ground inhibits the terrain clearance floor (TCF)
HAP function and the terrain awareness function. When the switch is
HAP in the inhibit position, TCF and terrain awareness cautions and
HAP warnings do not show on the navigation displays and are not
HAP heard over the flight deck speakers. Also, when the terrain
HAP inhibit switch is in the inhibit position, the amber TERR INHIBIT
HAP message shows on both navigation displays.

34-46-00-008

EFFECTIVITY
HAP ALL**34-46-00**

D633A101-HAP

Page 36
Jun 15/2009

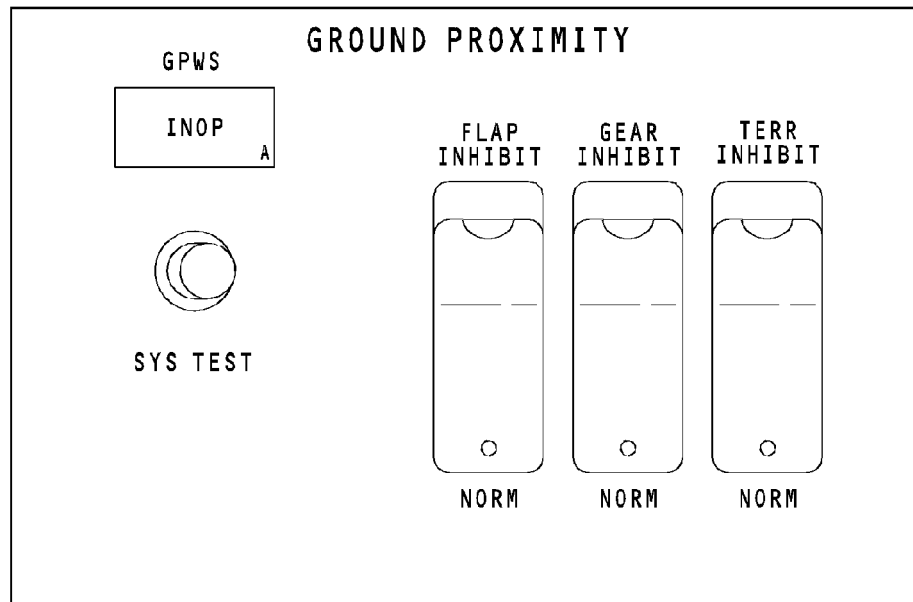

GPWS - GROUND PROXIMITY WARNING MODULE

34-46-00-008

EFFECTIVITY
HAP ALL

34-46-00

D633A101-HAP

GPWS - MODE 1 DESCRIPTION**Purpose**

Mode 1 supplies alerts and warnings for large descent rates when the airplane is near the terrain. This mode is independent of flap or gear positions.

Description

The alert condition gives the aural message, SINK RATE and makes the PULL UP display on the attitude indication (AI). If the descent rate does not decrease, the alert condition changes to a warning condition.

The warning condition makes the red PULL UP warning on the AI and gives the aural message, WHOOP WHOOP PULL UP.

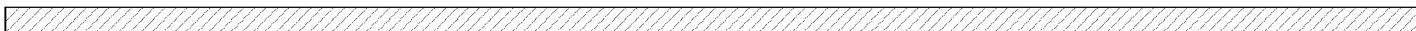
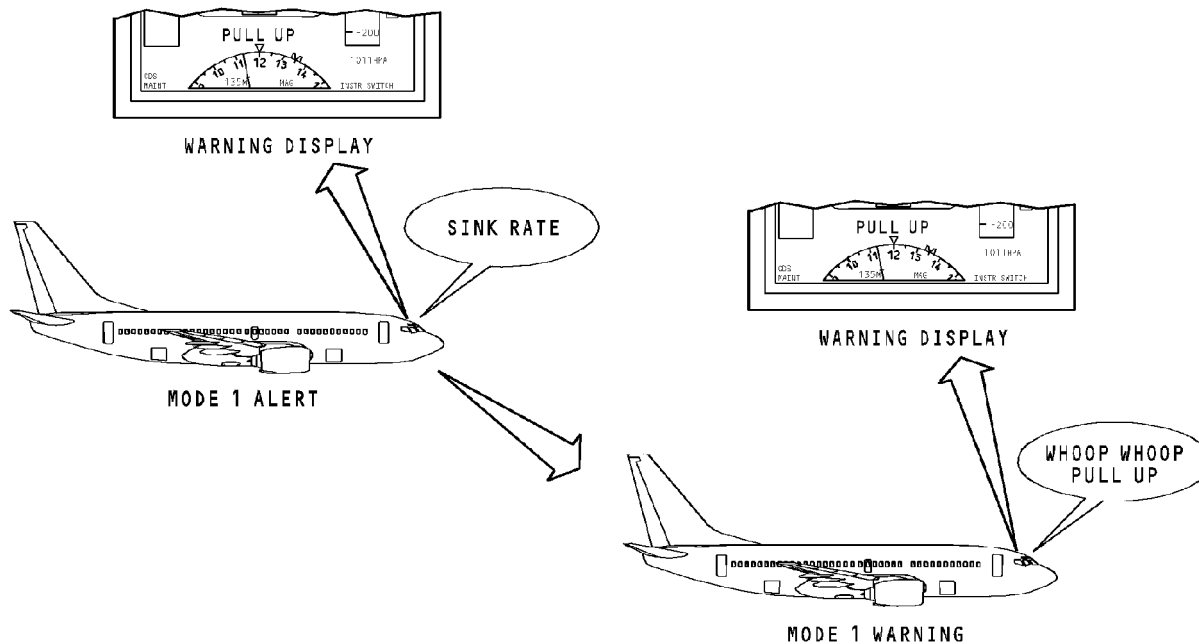

GPWS - MODE 1 DESCRIPTION

34-46-00-009

EFFECTIVITY
HAP ALL

34-46-00

D633A101-HAP

GPWS - MODE 1 FUNCTIONAL DESCRIPTION

General

Mode 1 alert conditions and warning conditions can occur between 2450 feet and 10 feet radio altitude. The type of annunciation depends on the rate of descent and the radio altitude. The first annunciation is a caution. If the rate of descent does not decrease, the annunciation changes to a warning.

When there is a caution or warning condition, the mode detector sends a discrete to the speech prom to make the aural messages come on. The aural messages go to the remote electronics unit (REU) which sends them to the flight compartment speakers.

Caution and warning conditions cause the mode detector to send a signal on the ARINC 429 transmitter to the DEUs to show the PULL UP display.

When the GPWC gives an aural message, a discrete goes to the TCAS computer to inhibit TCAS aural messages.

HAP The LRUs that supply inputs for mode 1 operation are the radio
HAP altimeter transceivers and the left and right ADIRUs.

The GPWC uses this data to detect mode 1 cautions and warnings:

- Radio altitude
- Inertial vertical speed
- Barometric altitude rate.

The mode detector in the GPWC calculates the descent rate from the inertial vertical speed input. If it is not available, the mode detector uses an internally calculated altitude rate. If the IVS and the internally calculated rates are invalid, the barometric altitude rate from the ADIRU is used. When the GPWC uses barometric altitude rate, the lower altitude cutoff changes from 10 feet to 30 feet.

34-46-00-010

EFFECTIVITY
HAP ALL

34-46-00

D633A101-HAP

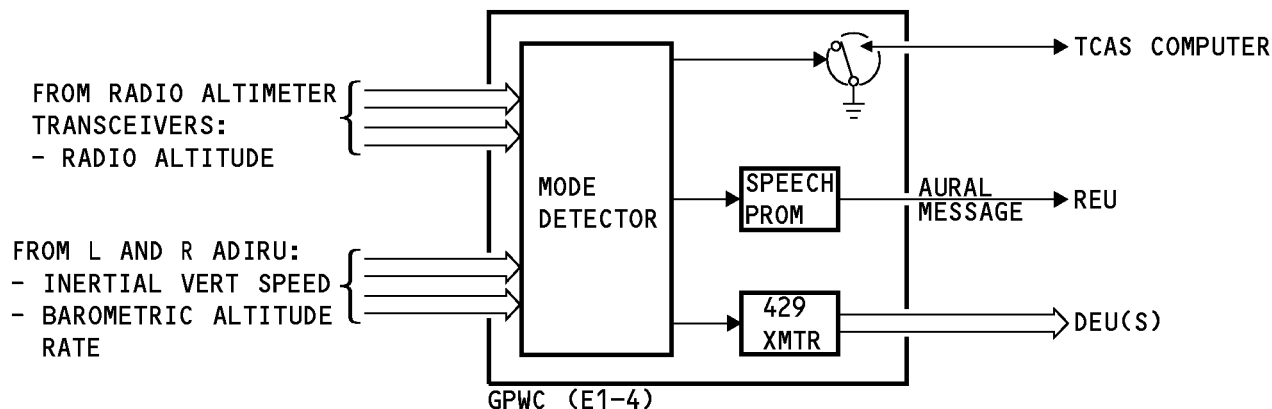
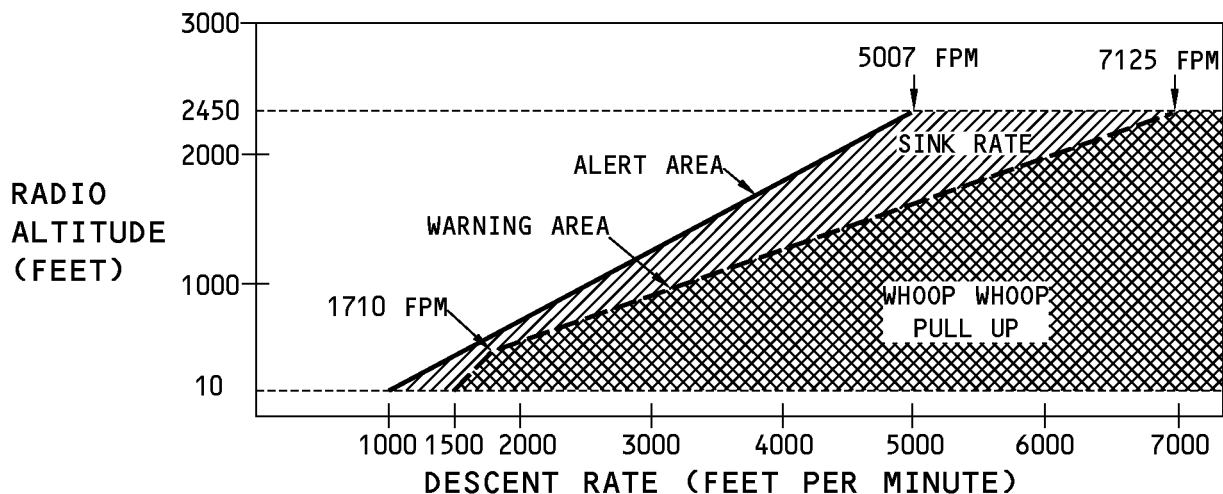

GPWS - MODE 1 FUNCTIONAL DESCRIPTION

34-46-00-010

EFFECTIVITY
HAP ALL

34-46-00

D633A101-HAP

GPWS - MODE 2A DESCRIPTION**Purpose**

Mode 2 supplies alerts and warnings when the closure rate to the terrain is too large. Mode 2 has two submodes, mode 2A and mode 2B.

After a 300 feet increase in inertial altitude or the landing gear comes down, the PULL UP indications on the PFD stop and the aural warnings stop.

Description

Mode 2A occurs for a large closure rate if the flaps are not in the landing configuration and glideslope deviation is more than 2 dots. Flaps 30 or more is a landing configuration. Mode 2A can have two alert levels, a caution condition or a warning condition.

If the terrain closure is too large, the GPWC gives the TERRAIN aural caution message twice and PULL UP shows on the primary flight display (PFD).

If the condition is not corrected, the caution aural message changes to the warning WHOOP WHOOP PULL UP message and PULL UP still shows on the PFD.

When the mode 2A envelope is no longer active due to either a terrain drop off or a pull up maneuver by the flight crew, the altitude gain function operates. PULL UP continues to show on the PFD until the altitude increases 300 feet or 45 seconds have elapsed. If there is still a terrain closure rate during this period, however, the GPWC also gives the TERRAIN aural caution message.

34-46-00-011

EFFECTIVITY
HAP ALL**34-46-00**

D633A101-HAP

Page 42
Jun 15/2009

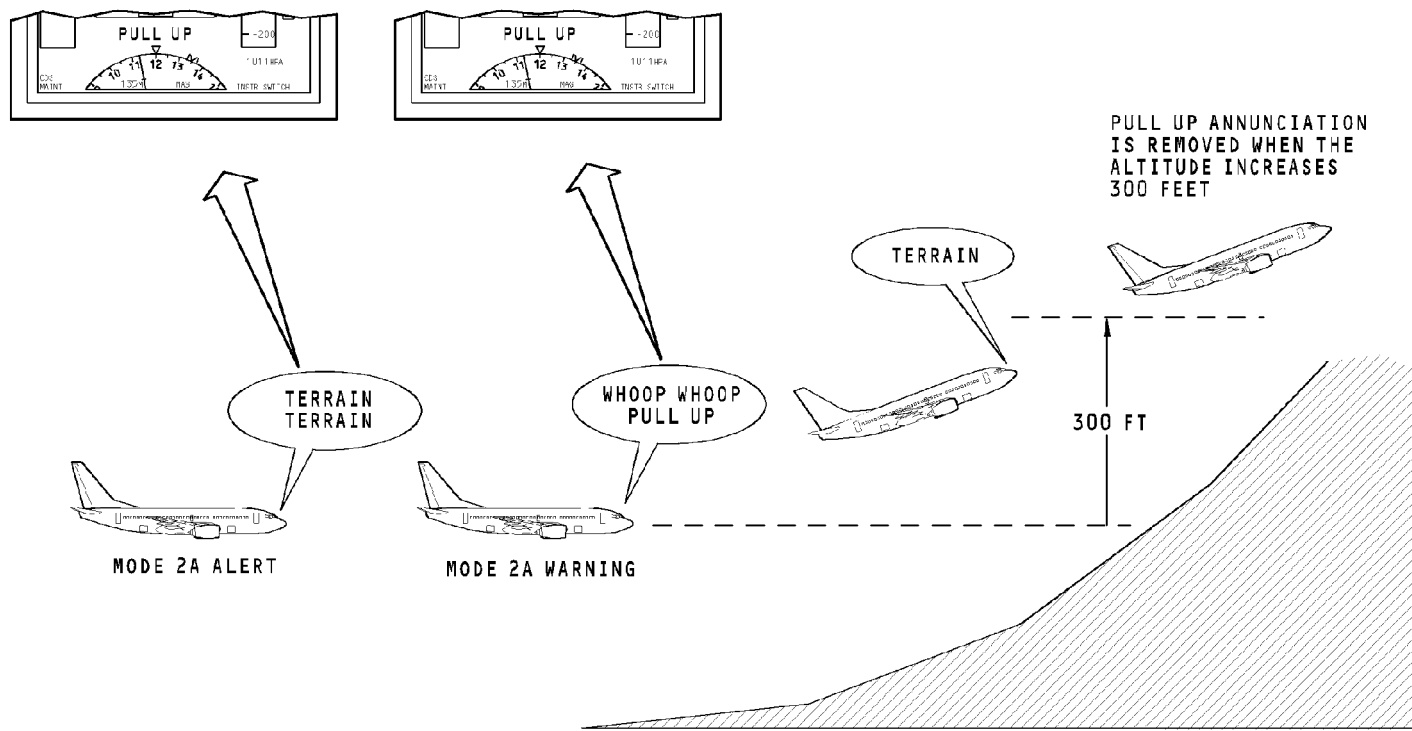

GPWS - MODE 2A DESCRIPTION

34-46-00-011

EFFECTIVITY
HAP ALL

34-46-00

D633A101-HAP

GPWS - MODE 2B DESCRIPTION**Purpose**

Mode 2B gives alerts for a large closure rate if the flaps are in the landing configuration (30 units or more).

Description

Mode 2B can have a caution condition or a warning condition.

If the terrain closure is excessive, the ground proximity warning computer (GPWC) gives the TERRAIN aural caution message repeatedly. If this condition lasts for more than 1.6 seconds, the GPWC gives the WHOOP WHOOP PULL UP aural warning message and a PULL UP annunciation on the PFD.

If the terrain closure is excessive and the landing gear is extended, the PULL UP aural warning message is replaced with the TERRAIN aural caution message.

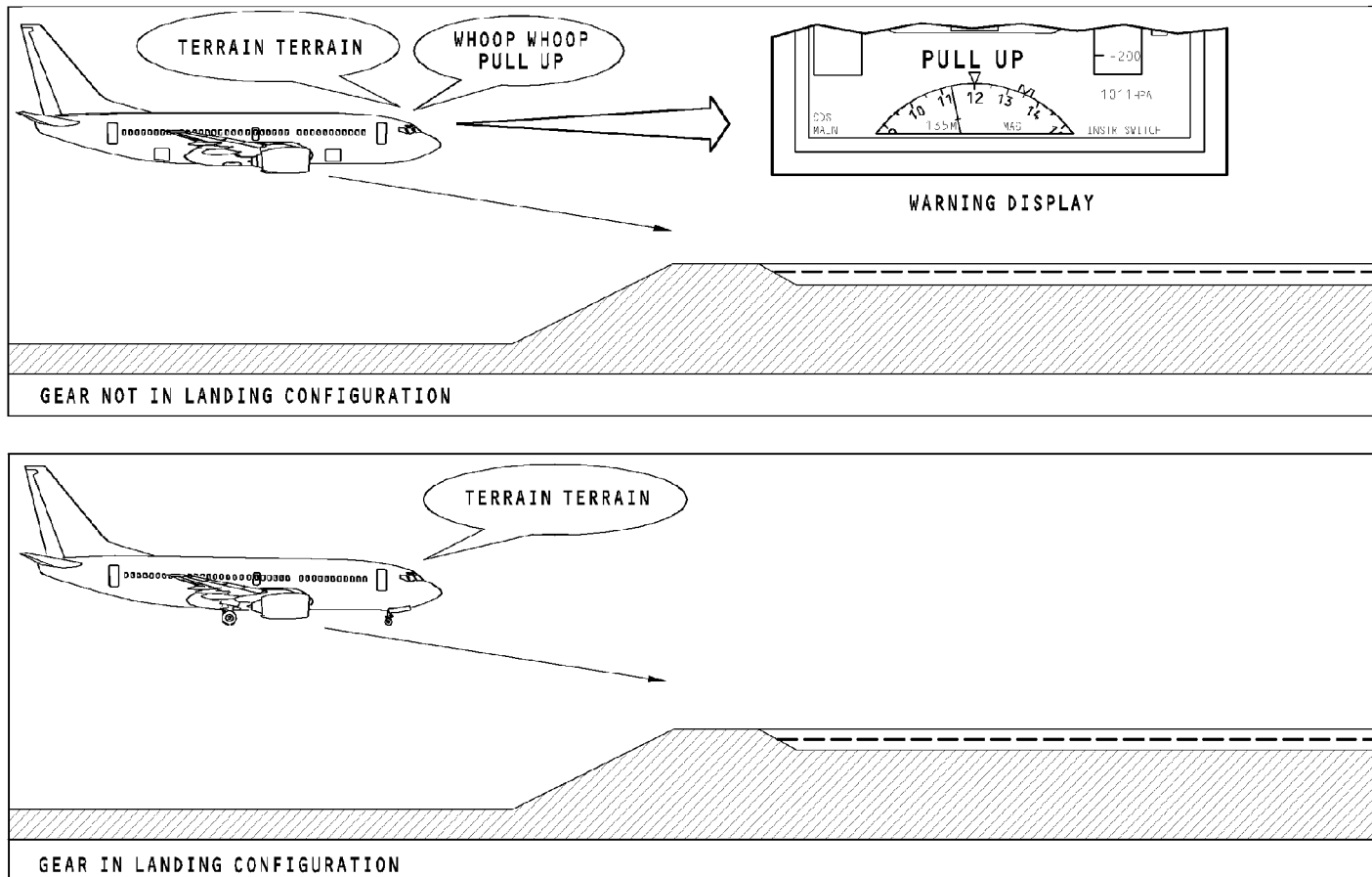

GPWS - MODE 2B DESCRIPTION

34-46-00-012

EFFECTIVITY
HAP ALL

34-46-00

D633A101-HAP

GPWS - MODE 2 FUNCTIONAL DESCRIPTION

General

Mode 2A annunciations occur between 1650 feet radio altitude and 30 feet radio altitude for airspeed less than 220 knots. The top limit increases to 2450 feet radio altitude for airspeed between 220 knots and 310 knots.

Mode 2B annunciations can occur between 789 feet radio altitude and 30 feet radio altitude. The lower limit is between 30 feet and 600 feet radio altitude. The GPWC uses flap configuration and altitude descent rate to calculate the lower limit.

These are the LRUs that supply inputs for mode 2 operation:

HAP

- Left and right radio altimeter transceivers
- Left and right ADIRUs
- GPW module
- Stall management yaw dampers (SMYDs)

HAP 001-013, 015-022

- Multi-mode receiver (MMR) 1

HAP 023-026, 028-054, 101-999

- Multi-mode receiver (MMR) 1 and 2

HAP ALL

- Proximity switch electronic unit (PSEU).

This is the data the GPWC uses to detect mode 2 alerts and warnings:

- Radio altitude
- Inertial vertical speed (IVS)

- Barometric altitude rate
- Barometric altitude
- Computed airspeed
- Flap and gear position
- Glideslope deviation
- Air/ground inputs.

When there is an alert condition or warning condition, the mode detector sends a discrete to the speech prom to make the aural messages come on. The aural messages go to the REU which sends them to the flight compartment speakers.

When there is a mode 2 warning condition, the mode detector also sends a signal on the ARINC 429 transmitter to the DEUs and the PULL UP message shows on the PFD.

When the GPWC gives a mode 2 aural message, a discrete goes to the TCAS computer to inhibit TCAS resolution advisories and TCAS aural messages.

34-46-00-013

EFFECTIVITY
HAP ALL

34-46-00

D633A101-HAP

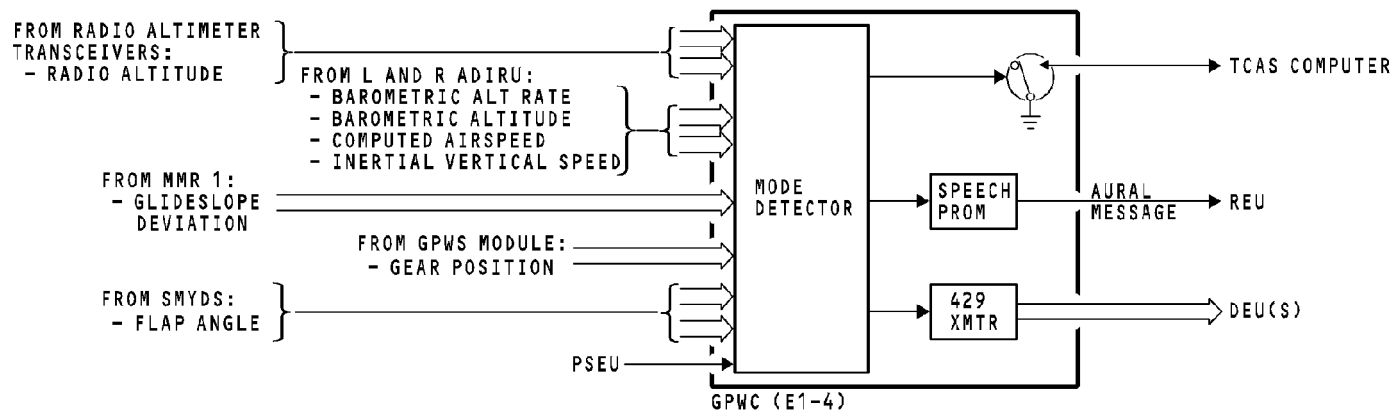
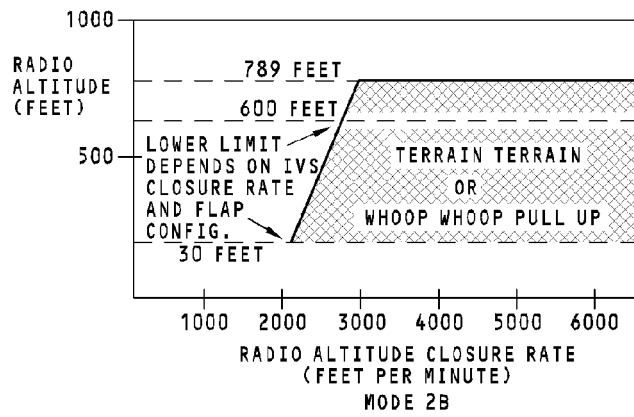
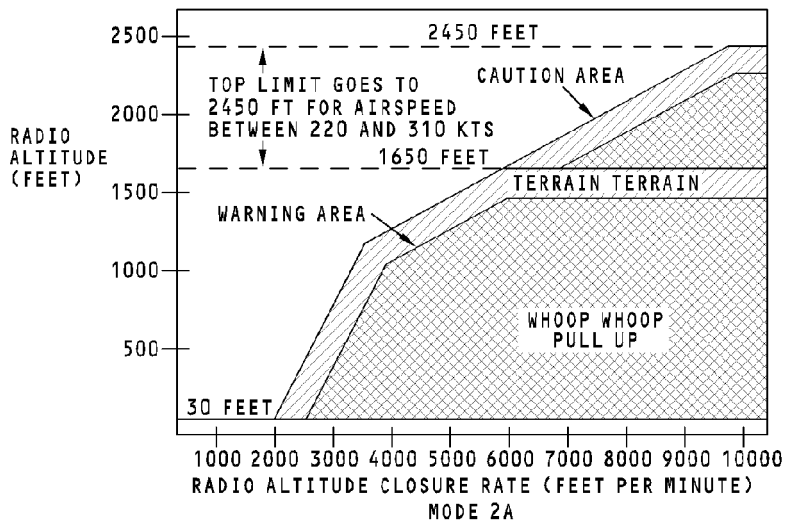

GPWS - MODE 2 FUNCTIONAL DESCRIPTION

34-46-00-013

EFFECTIVITY
HAP 001-013, 015-022

34-46-00

D633A101-HAP

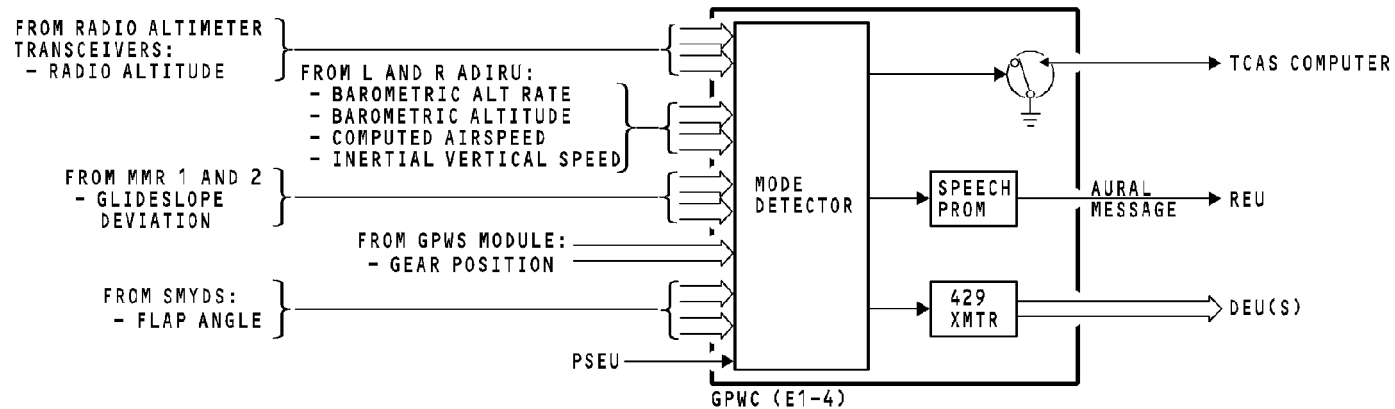
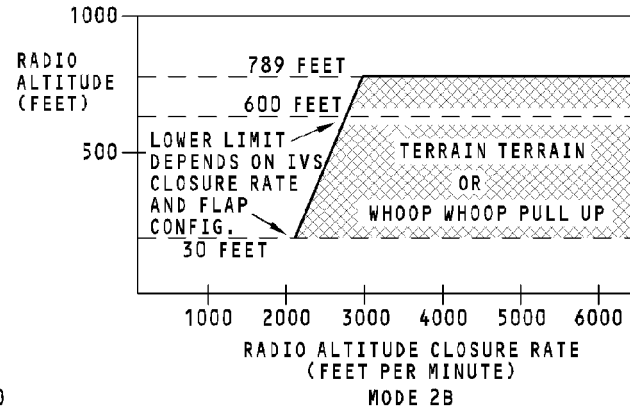
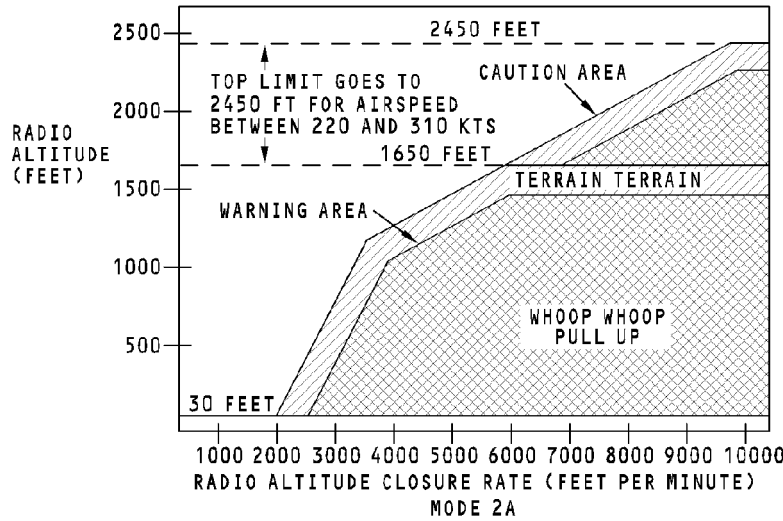

GPWS - MODE 2 FUNCTIONAL DESCRIPTION

EFFECTIVITY

HAP 023-026, 028-054, 101-999

34-46-00

34-46-00-013

D633A101-HAP

THIS PAGE IS INTENTIONALLY LEFT BLANK

34-46-00

D633A101-HAP

Page 49
Jun 15/2009

GPWS - MODE 3 DESCRIPTION**Purpose**

Mode 3 supplies alerts for a large altitude loss during takeoff or during a missed approach with the flaps not in the landing configuration (landing configuration for the flaps is 30 units or more) or landing gear not down. Mode 3 has two submodes (3A and 3B). After the airplane gets to 1500 feet radio altitude, Mode 3 is not armed. When Mode 3 is not armed, Mode 4 is armed.

Description

Submode 3A gives an alert when the airplane loses too much inertial altitude after takeoff. The amount of inertial loss depends on the climb rate and radio altitude of the airplane. Submode 3A gives the aural message, DONT SINK.

Submode 3B gives an alert for minimum terrain clearance. The minimum terrain clearance increases with radio altitude during takeoff and climb. Submode 3B gives the aural message, TOO LOW TERRAIN.

When there is a GPWS mode 3 alert, the PFD shows the message, PULL UP.

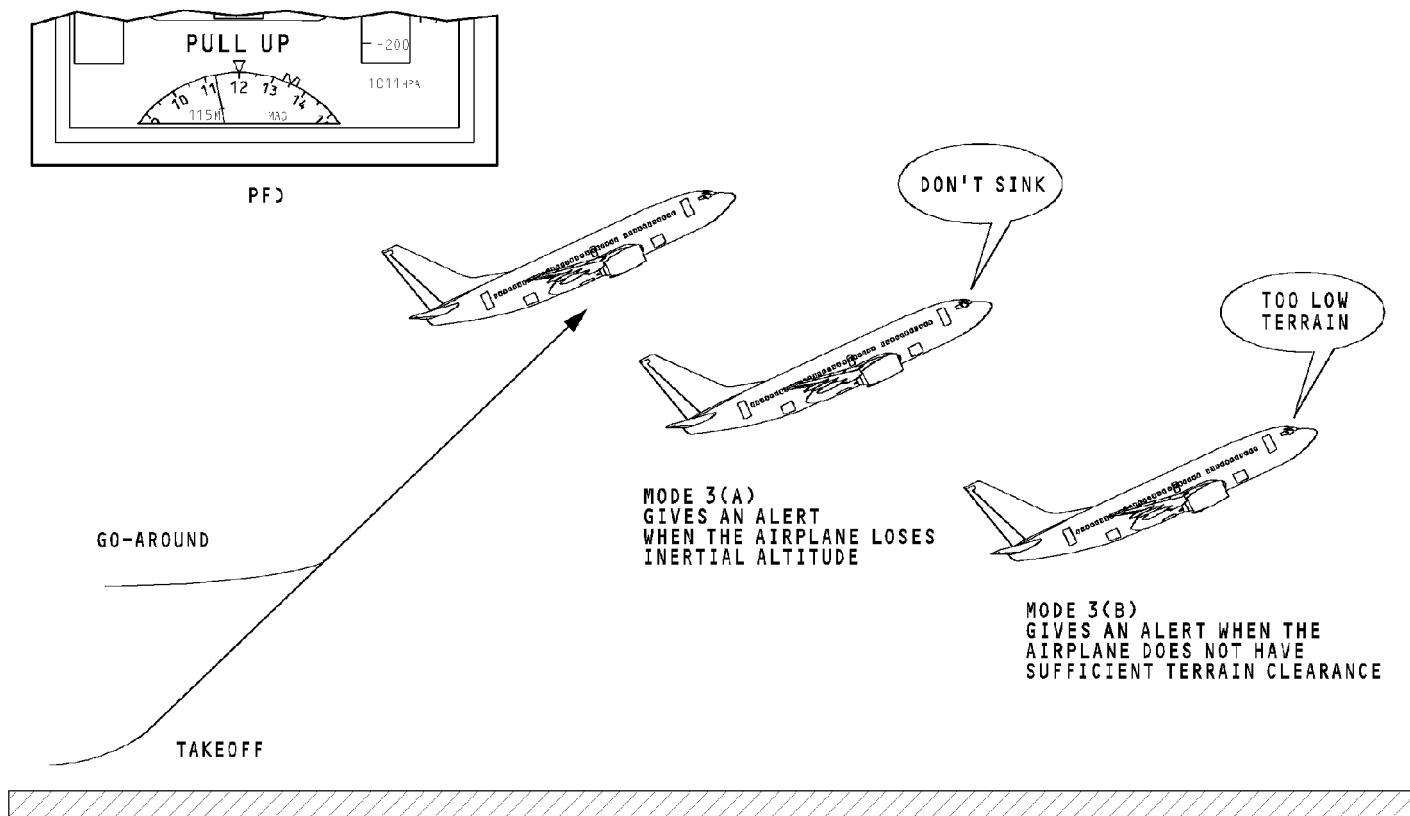

MODE 3(A)
GIVES AN ALERT
WHEN THE AIRPLANE LOSES
INERTIAL ALTITUDE

MODE 3(B)
GIVES AN ALERT WHEN THE
AIRPLANE DOES NOT HAVE
SUFFICIENT TERRAIN CLEARANCE

GPWS - MODE 3 DESCRIPTION

EFFECTIVITY
HAP ALL

34-46-00

D633A101-HAP

GPWS - MODE 3 FUNCTIONAL DESCRIPTION

General

Mode 3 operates when either of these conditions is true:

- Airplane climbs after going below 245 feet in landing configuration (gear down, flaps more than 30 units)
- Airplane takes off.

The Mode 3A alerts occur between 1500 feet and 30 feet. The alert conditions change with the airplane climb rate.

The Mode 3B alerts occur when the airplane altitude is lower than the altitude value the GPWC stores in a filter. The filter begins operation during climb at 150 feet and stores 75 percent of the altitude. The filter stores up to 500 feet altitude for airspeed less than 190 knots (500 feet in the filter equals an airplane altitude of 667 feet). When the airspeed goes above 250 knots, the top limit goes to 1000 feet (1000 feet in the filter equals an airplane altitude of 1333 feet). Mode 3 changes to Mode 4 when the altitude gain filter gets to the upper limits.

These are the LRUs that supply inputs for Mode 3 operation:

- Radio altimeter transceivers
- Left and right ADIRUs
- GPWS module
- Landing gear handle switch
- Stall management yaw damper (SMYD) 1 and 2.

- Radio altitude
- Inertial altitude
- Inertial vertical speed
- Barometric altitude
- Barometric altitude rate
- Flap angle
- Gear position.

When there is a Mode 3A or Mode 3B condition, the mode detector sends a discrete to the speech PROM to make the aural messages. The aural messages go to the REU which sends them to the flight compartment speakers. Also, when there is any Mode 3 condition, the mode detector sends a discrete on an ARINC 429 data bus to the DEUs to show the warning message.

When the GPWC gives a mode 3 aural message, a discrete goes to the TCAS computer to inhibit TCAS advisories and TCAS aural messages.

HAP

The GPWC uses this data to detect mode 3 alerts:

EFFECTIVITY
HAP ALL

34-46-00

D633A101-HAP

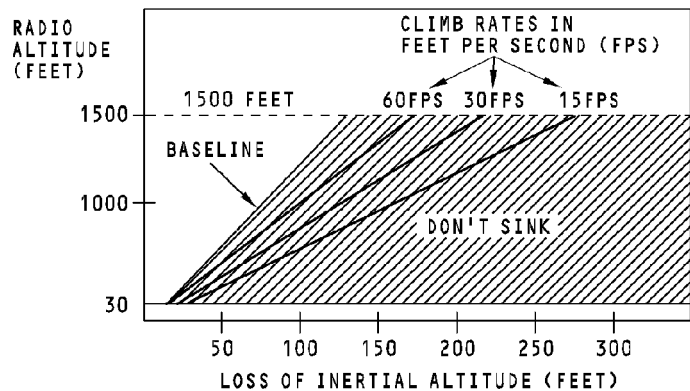

MODE 3A

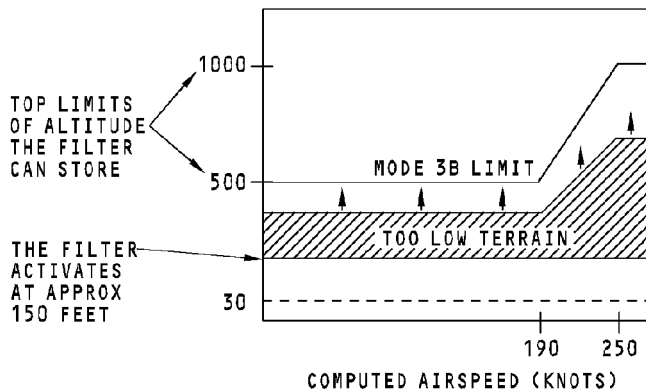

MODE 3B

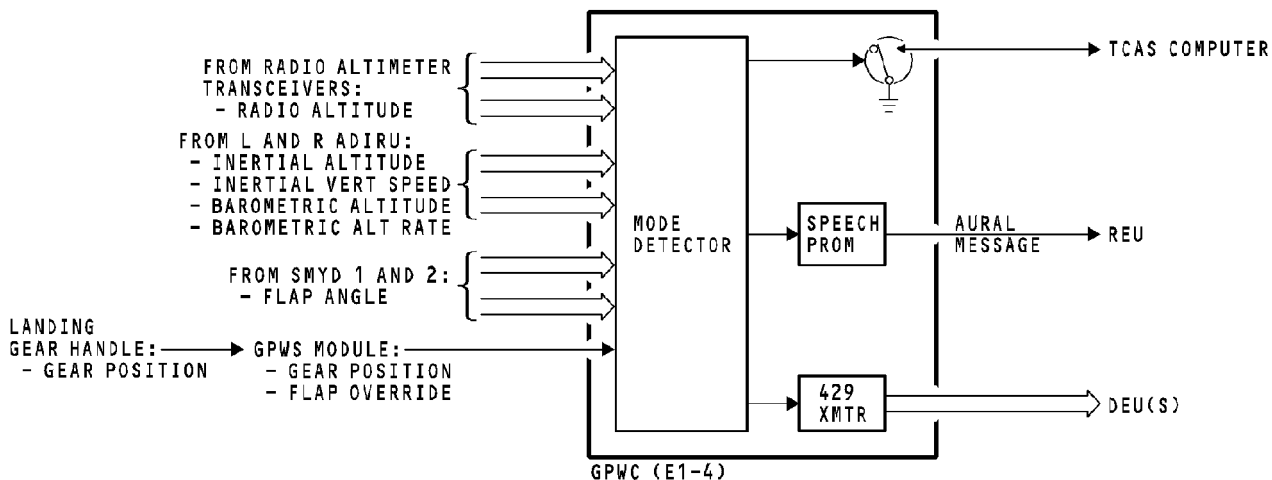

GPWS - MODE 3 FUNCTIONAL DESCRIPTION

34-46-00-015

EFFECTIVITY
HAP ALL

34-46-00

D633A101-HAP

GPWS - MODE 4 DESCRIPTION**Purpose**

Mode 4 supplies alerts when the airplane is too close to the terrain and the landing gear or flaps are not in the landing configuration (landing configuration for the flaps is 30 units or greater). Mode 4 has two submodes (4A and 4B).

Description

The GPWC gives a Mode 4A alert when the landing gear is not down. Mode 4A gives the aural messages TOO LOW GEAR at low airspeeds, or TOO LOW TERRAIN at high airspeeds.

The GPWC gives a Mode 4B alert when the landing gear is down and the flaps are not in landing configuration. Mode 4B gives the aural messages TOO LOW FLAPS if the airplane is at low airspeed, or TOO LOW TERRAIN at high airspeeds.

When the GPWC gives a Mode 4 alert, the mode detector also sends a discrete on an ARINC 429 data bus to the DEUs to show the PULL UP message on the PFD.

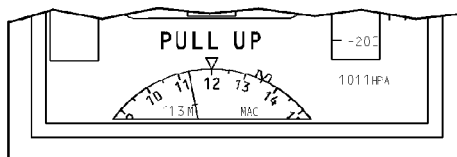

PFD DISPLAY

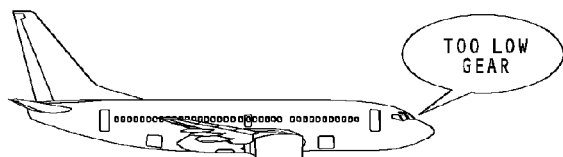

MODE 4A: AURAL MESSAGE FOR GEAR UP AT LOW AIRSPEEDS

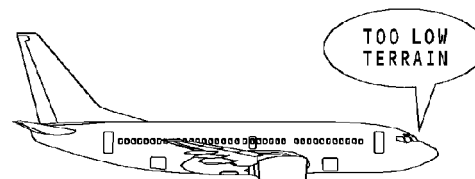

MODE 4A: AURAL MESSAGE FOR GEAR UP AT HIGH AIRSPEEDS

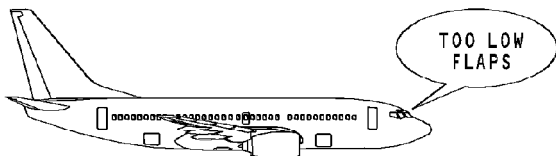

MODE 4B: AURAL MESSAGE FOR FLAPS UP AT LOW AIRSPEEDS

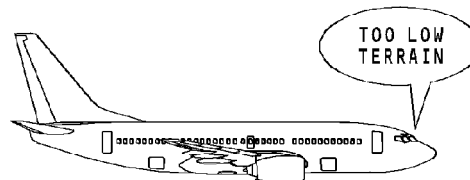

MODE 4B: AURAL MESSAGE FOR FLAPS UP AT HIGH AIRSPEEDS

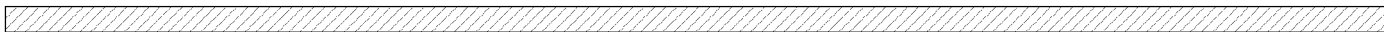

GPWS - MODE 4 DESCRIPTION

EFFECTIVITY
HAP ALL

34-46-00

D633A101-HAP

GPWS - MODE 4 FUNCTIONAL DESCRIPTION**General**

Mode 4 alerts occur between 1000 feet and 30 feet. The altitude limits for mode 4A and mode 4B are lower at low airspeed.

The Mode 4A alert occurs if the landing gear is not down below the altitude limit. The mode 4A altitude limit is 500 feet when the airspeed is less than 190 knots and it is 1000 feet at high airspeed. The mode 4A aural message TOO LOW GEAR changes to the aural message TOO LOW TERRAIN when the airspeed is more than 190 knots.

The Mode 4B alert occurs if the landing gear is down and the flaps are not in a landing configuration below the altitude limit (landing configuration for the flaps is 30 units or more). The Mode 4B altitude limit is 245 feet when the airspeed is less than 159 knots and it is 1000 feet at high airspeed. The mode 4B aural message TOO LOW FLAPS changes to the aural message TOO LOW TERRAIN when the airspeed is more than 159 knots.

The LRUs that supply inputs for mode 4 are:

- Left and right radio altimeter transceivers
- Left ADIRU IRS and air data buses
- Stall management yaw damper computers (SMYD)
- Landing gear handle switch
- GPWS module.

The GPWC uses this data to detect mode 4 alerts:

- Radio altitude
- Computed airspeed
- Flap angle
- Gear position.

When there is a Mode 4 condition, the mode detector sends a discrete to the speech PROM to make the aural message come on. The aural message goes to the REU which sends it to the flight compartment. When the GPWC gives an aural message, a discrete goes to the TCAS computer to inhibit TCAS aural messages. The mode detector also sends a discrete on an ARINC 429 data bus to the DEUs to show the PULL UP message for any Mode 4 alert condition.

Mode 4 changes to mode 3 if the airplane goes below 245 feet in landing configuration (flaps down and gear down).

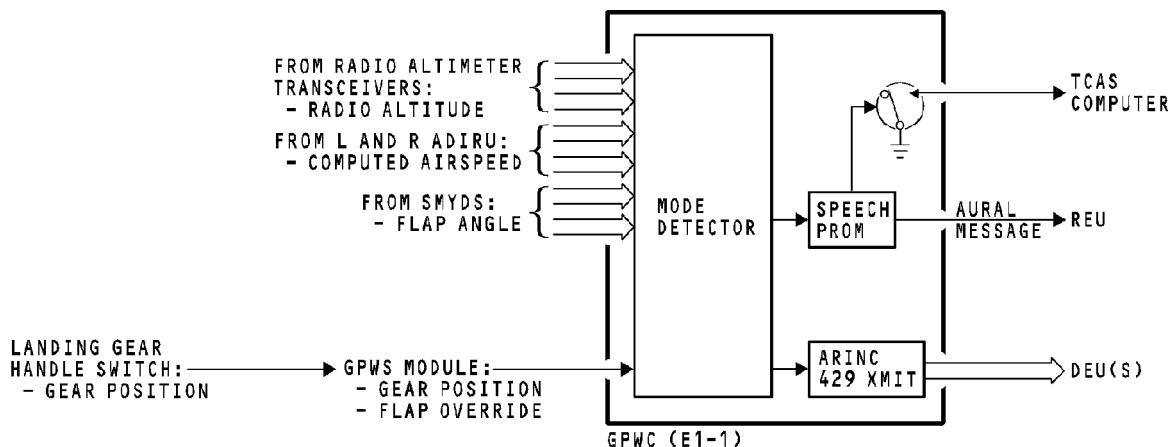
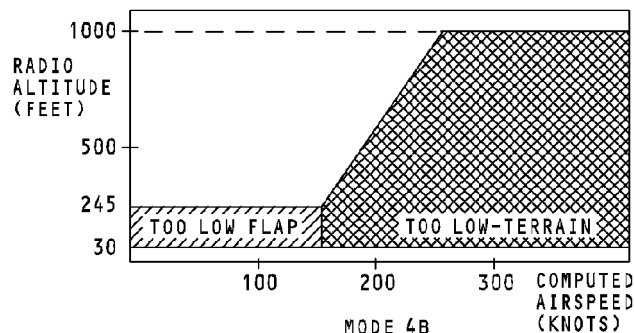
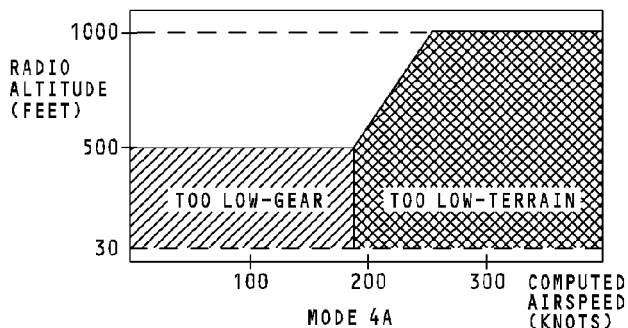

GPWS - MODE 4 FUNCTIONAL DESCRIPTION

34-46-00-017

EFFECTIVITY
HAP ALL

34-46-00

D633A101-HAP

GPWS - MODE 5 DESCRIPTION**Purpose**

The GPWC gives a mode 5 alert when the airplane goes below the glideslope during approach if the landing gear is down.

Description

For mode 5 alerts, the GPWC gives the aural message GLIDESLOPE and the below glideslope lights come on. The volume level of the aural message increases and the message repeats faster as the terrain gets closer. You push the glideslope inhibit switch to inhibit or cancel mode 5 alerts.

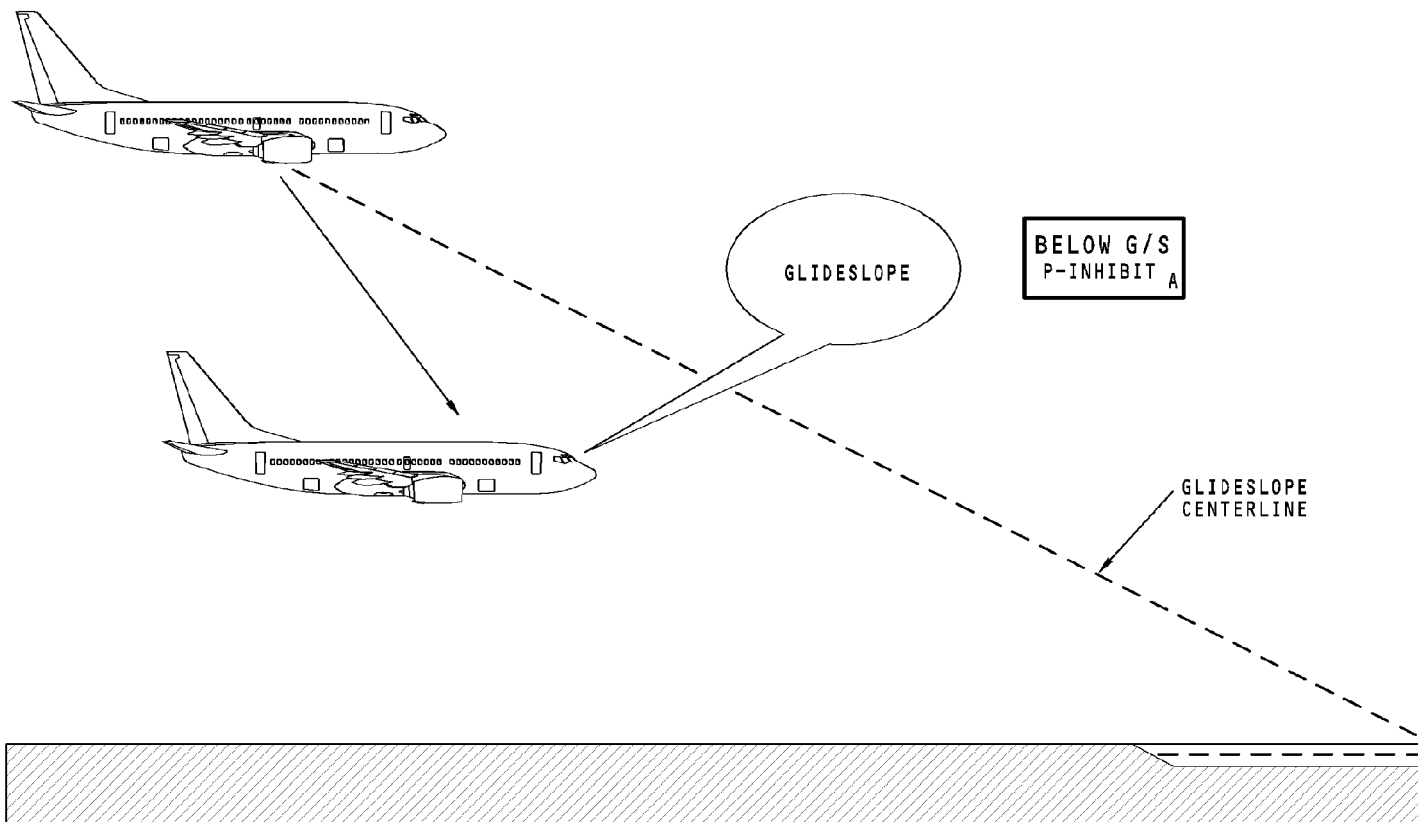

GPWS - MODE 5 DESCRIPTION

EFFECTIVITY
HAP ALL

34-46-00

D633A101-HAP

Page 59
Jun 15/2009

34-46-00-018

GPWS - MODE 5 FUNCTIONAL DESCRIPTION**General**

Mode 5 alerts can occur between 1000 and 30 feet radio altitude. The interval between aural messages depends on altitude and glideslope deviation. Low volume audio occurs below 1000 feet down to 30 feet when the deviation is more than 1.3 dots. Normal volume audio occurs below 300 feet when the deviation is more than 2 dots.

These LRUs supply inputs for mode 5 operation:

- Radio altimeter transceivers
- DFCS mode control panel
- Landing gear handle switch
- MMRs
- FMCS
- GPW module.

The GPWC uses this data to calculate mode 5 alerts:

- Radio altitude.
- Selected runway heading
- Gear position
- Magnetic track
- Localizer and glideslope deviation

When there is an alert condition, the mode detector sends a discrete to the speech prom to make the aural message. The aural message goes to the REU which sends it to the flight compartment. Mode 5 arms when this data is true:

- Terrain clearance is less than 1000 feet
- Landing gear is down
- Glideslope signal is valid
- Airplane is not in a backcourse approach
- Localizer signal is captured.

Push the ground proximity Below G/S Switch/Light to inhibit or cancel mode 5 aural and visual alerts. If you push the switch before mode 5 alerts begin, you inhibit the aural message and visual annunciations. If you push the ground proximity glideslope inhibit switch during a mode 5 alert, you cancel the aural message and visual annunciations.

When you inhibit or cancel the alert, you can not activate it again unless the airplane leaves the mode 5 alert conditions or you cycle the landing gear.

When the GPWC gives an aural message, a discrete goes to the TCAS computer to inhibit TCAS advisories and aural messages.

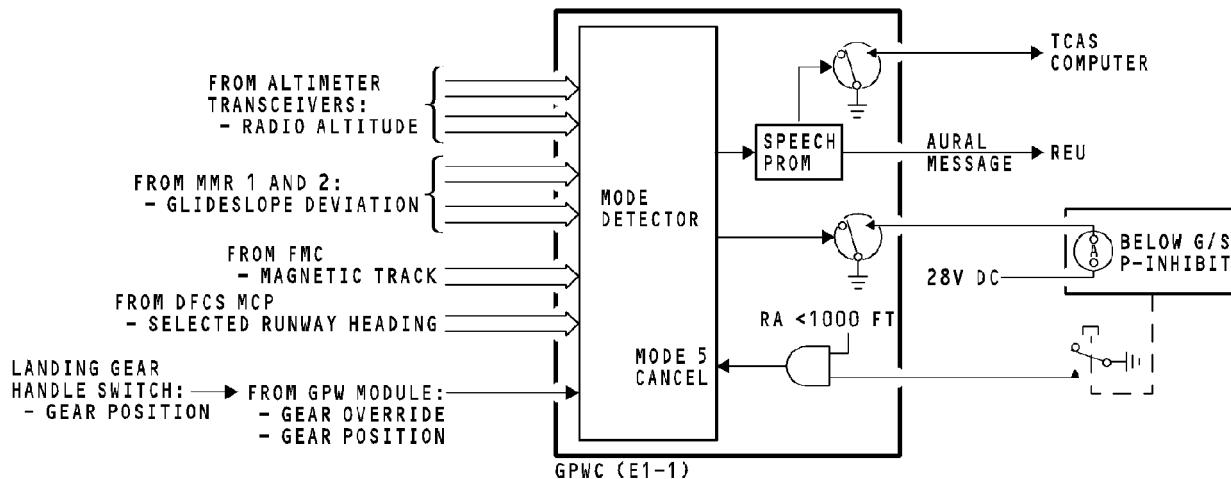
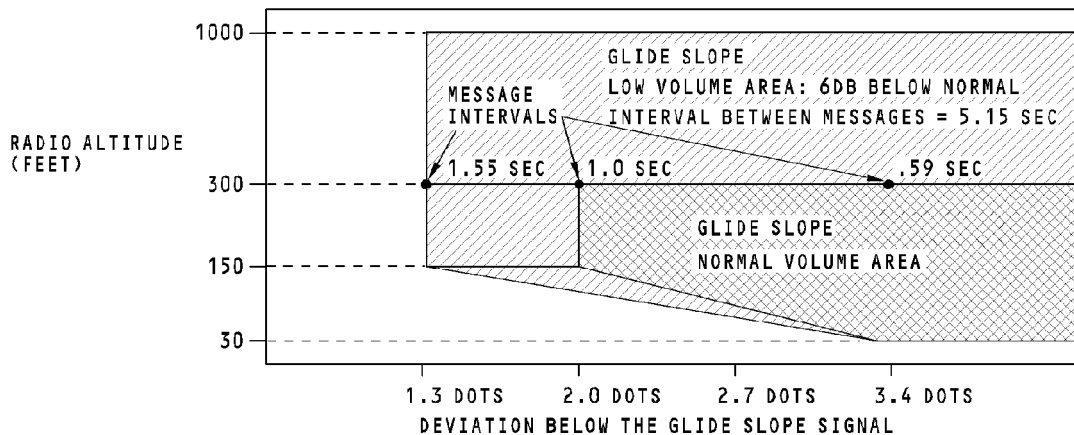

GPWS - MODE 5 FUNCTIONAL DESCRIPTION

34-46-00-019

EFFECTIVITY
HAP ALL

34-46-00

D633A101-HAP

GPWS - MODE 6 DESCRIPTION

Purpose

The GPWC mode 6 supplies aural callouts when the airplane descends through set altitudes with the landing gear down. These are the options available for mode 6:

- Altitude callouts
- Minimums callout
- Approaching minimums callout
- Bank angle (roll alert) callout.

Altitude callouts start at 2500 feet. At 2500 feet, there is an option to give the aural TWENTY FIVE HUNDRED or give the aural, RADIO ALTITUDE.

The minimums callout option gives an aural callout when the airplane descends through the decision height altitude set on the EFIS control panels. These are the aural callouts the GPWC can give for decision height:

- MINIMUMS
- MINIMUMS, MINIMUMS
- DECISION HEIGHT.

There is also an approaching minimums option callout that tells the pilots when the airplane is near the decision height set on the EFIS control panel. The callout normally comes on when the airplane altitude is 80 feet above the decision height. The aural callouts for this option are:

- APPROACHING MINIMUMS

- APPROACHING DECISION HEIGHT
- PLUS HUNDRED (for this callout the altitude selection is set for decision height + 100 feet).

Mode 6 bank angle callouts occur when the airplane bank angle is more than 10 degrees between 30 feet and 130 feet altitude. Above 130 feet, the callout occurs at 35 degrees, 40 degrees, and 45 degrees. The aural message is BANK ANGLE, BANK ANGLE.

Description

The GPWC receives inputs from these units:

- Radio altimeter transceivers
- GPWS module
- Program switch module
- left and right ADIRUs
- DEU 1 and 2.

HAP

The GPWC uses this data to calculate mode 6 alerts:

- Radio altitude
- Landing gear position
- Program pin selection
- Roll attitude
- Decision height.

Mode 6 is armed when the airplane climbs through 1000 feet radio altitude. To reset mode 6, the airplane must climb above the radio altitude where the first altitude callout occurs.

34-46-00-020

<p>EFFECTIVITY HAP ALL</p>

34-46-00

D633A101-HAP



THESE ARE THE AVAILABLE
RADIO ALTITUDE CALLOUT
OPTIONS FOR MODE 6

RADIO ALTITUDE	2500 FEET	TWENTY FIVE HUNDRED...OR...RADIO ALTITUDE
	1000 FEET	ONE THOUSAND
	DECISION HEIGHT PLUS 100 FEET	PLUS HUNDRED
	DECISION HEIGHT PLUS 80 FEET	APPROACHING MINIMUMS
	DECISION HEIGHT	MINIMUMS, MINIMUMS...OR...MINIMUMS
	500 FEET	FIVE HUNDRED
	400 FEET	FOUR HUNDRED
	300 FEET	THREE HUNDRED
	200 FEET	TWO HUNDRED
	100 FEET	ONE HUNDRED
	50 FEET	FIFTY
	40 FEET	FORTY
	30 FEET	THIRTY
	20 FEET	TWENTY
10 FEET	TEN	

NOTE: THE ABOVE SHOWS ALL THE AVAILABLE CALLOUT OPTIONS.

GPWS - MODE 6 DESCRIPTION

EFFECTIVITY
HAP ALL

34-46-00

D633A101-HAP

GPWS - MODE 7 DESCRIPTION

Purpose

The GPWC gives mode 7 warnings when there are horizontal and vertical windshear conditions during approach or takeoff.

Description

Windshear is the effect of large volumes of air that change direction rapidly. The most dangerous type of windshear is the microburst. When the airplane is near the terrain, a downward microburst gives the pilots very little time to react to the windshear effects.

The initial effects on an airplane when it encounters the microburst are an increase in airspeed and lift. Because of the increased lift, the airplane increases altitude.

As the airplane continues through the microburst, the effects rapidly change to a loss in airspeed and lift. The airplane altitude now rapidly decreases.

For mode 7 warnings, the GPWC gives the aural message WINDSHEAR WINDSHEAR WINDSHEAR with a siren. The GPWC sends a discrete to the DEUs to make the red WINDSHEAR message show on the primary flight displays. Mode 7 warnings have the highest priority.

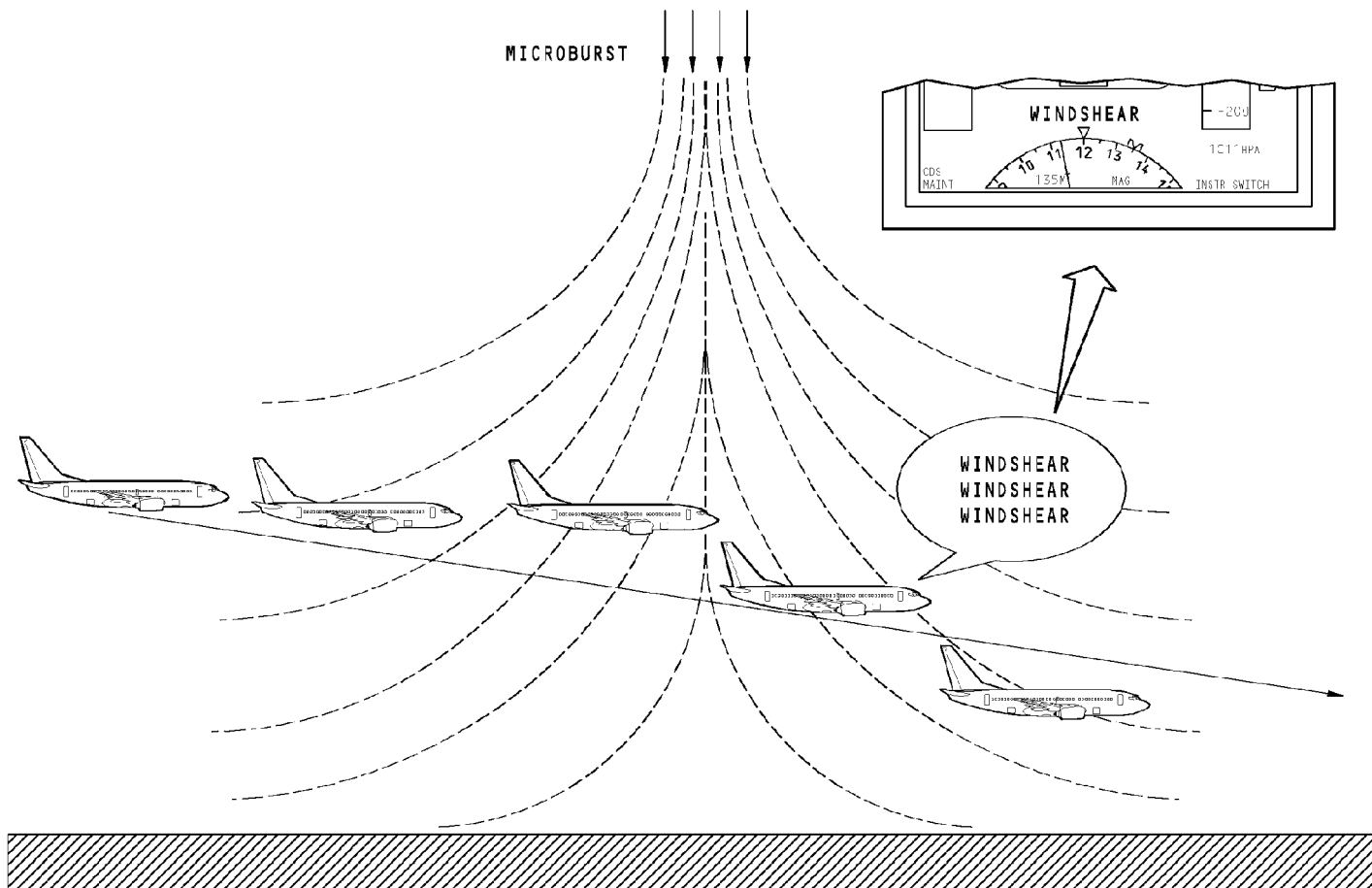

GPWS - MODE 7 DESCRIPTION

EFFECTIVITY
HAP ALL

34-46-00

D633A101-HAP

Page 65
Jun 15/2009

34-46-00-021

GPWS - MODE 7 FUNCTIONAL DESCRIPTION**General**

These LRUs supply data for mode 7 operation:

HAP

- Radio altimeter 1 AND 2
- Left and right ADIRUs
- Stall management yaw damper 1 and 2.

The GPWC uses this data to detect windshear:

- Radio altitude
- Inertial vertical speed
- Pitch and roll angle
- Pitch rate
- Longitudinal acceleration
- Normal acceleration
- Vertical acceleration
- Indicated angle of attack (AOA)
- Corrected AOA
- Stick shaker AOA
- Flap angle
- Minimum operating speed
- True airspeed
- Computed airspeed.

When there is an windshear condition, the mode detector sends a discrete to the speech prom to make the aural message. The aural message goes to the remote electronic unit (REU) which sends it to the flight compartment.

When the GPWC gives an aural message, a discrete goes to the TCAS computer to inhibit TCAS aural messages and downgrade TCAS resolution advisories to traffic alerts.

The mode detector also sends a discrete on the ARINC 429 data bus to the DEUs to show the WINDSHEAR message on the primary flight display (PFD).

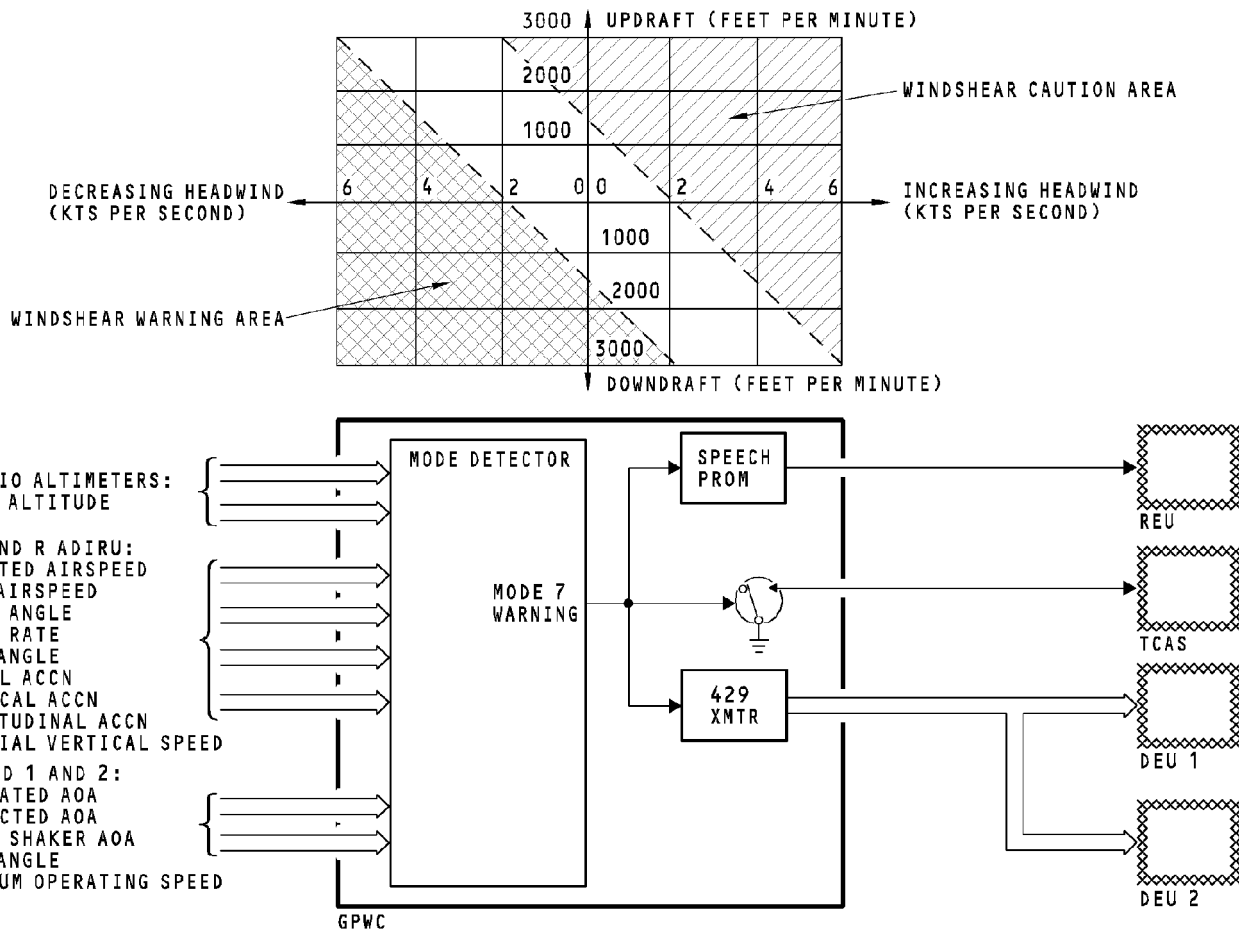

GPWS - MODE 7 FUNCTIONAL DESCRIPTION

34-46-00-042

EFFECTIVITY
HAP ALL

34-46-00

D633A101-HAP

THIS PAGE IS INTENTIONALLY LEFT BLANK

34-46-00

D633A101-HAP

Page 68
Jun 15/2009



GPWS - ENHANCED FEATURES FUNCTIONAL DESCRIPTION

HAP **Purpose**

HAP The ground proximity warning computer compares the airplane
HAP position, flap and gear position, and terrain clearance to find if
HAP an alert or warning condition exists.

HAP **Terrain Awareness Inputs**

HAP The GPWC receives inputs from these systems for the terrain
HAP awareness function:

HAP **HAP 031-054, 101-999; HAP 001-013, 015-026, 028-030 POST SB**
HAP **737-31-1246 OR POST SB 737-31-1295**

HAP • FMCS

HAP **HAP ALL**

HAP • GPS 1

HAP • GPS 2

HAP • ADIRU L

HAP • ADIRU R

HAP • CDS

HAP • Landing gear switch module

HAP • Weather Radar.

HAP Aircraft position from the GPS 1 system is the primary input. If
HAP GPS 1 position is not valid, GPS 2 position is used. ADIRU
HAP position can be used for short periods of time when neither GPS
HAP 1 or 2 position is not valid.

Terrain Awareness Calculation

The GPWC has a world-wide terrain database in memory. The
GPWC compares airplane position and track to the terrain
database. If the GPWC finds there is a terrain threat, it makes an
alert.

Terrain Display Output

The GPWC makes a digital map of the terrain forward of the
airplane. It sends this digital map to the display electronics units
(DEUs) to show on the navigational displays (NDs). The display
uses different colored dots to show terrain altitude relative to
airplane altitude.

Terrain Alert Outputs

If the GPWC finds the airplane is 60 seconds from a terrain
conflict, it makes a terrain caution alert. These are the caution
alert indications:

- Alert aural message, CAUTION TERRAIN
- Amber message, TERRAIN on the ND
- Terrain display on both NDs (pop up function)
- Threat terrain on the ND changes from dots to a solid yellow color.

If the GPWC finds the airplane is 30 seconds from a terrain
conflict, it makes a terrain warning alert. These are the warning
alert indications:

- Aural message, TERRAIN, TERRAIN PULL UP

34-46-00-032

EFFECTIVITY
HAP ALL

34-46-00

D633A101-HAP

GPWS - ENHANCED FEATURES FUNCTIONAL DESCRIPTION

- HAP ● Red PULL UP message on the PFD
- HAP ● Red TERRAIN message on the ND
- HAP ● Terrain display on both NDs if not selected on either one (pop up function)
- HAP ● Threat terrain on the ND changes from dots to a solid red color.

Terrain Functional Description

The GPWC I/O processes input signals selection and formats the signals into the proper form for use by the GPWC.

The terrain processor function gets terrain data from the terrain and airport databases to create a set of digital elevation matrix overlays for use by the terrain threat detection and display processor function. Data for the nearest runway is processed for use by the terrain threat detection and display processor functions for the terrain clearance floor function. This data contains the length, runway center position, and altitude for the nearest runway that is 3500 feet or longer and is hard surfaced.

The terrain threat detection and display processor function does the threat analysis with the terrain data within calculated caution and warning envelope boundaries below and forward of the aircraft. The results of this threat assessment are combined with background terrain data and the nearest runway data. This information is formatted into a terrain display image which goes to the terrain display output processor. When there is a terrain caution or warning condition, an aural alert goes to the audio output function.

The terrain display logic processes the display format data. Inputs from the CDS system, weather radar, and the terrain threat detection and display processor are used to determine the scale and what information is to show. From the CDS system, the terrain logic processor uses terrain select digital discrete to select terrain to show on the DUs and range selection data. The terrain display logic processor lets each terrain display be scaled independently of each other. The weather radar has alerts that may have a higher priority than the GPWC. If there is a predictive windshear alert with a higher priority than the GPWC, the windshear alert and display show. Also, if the weather mode is selected for the captain and first officer displays and a terrain alert is detected, the pop-up mode will be enabled. This lets terrain alert information show automatically on the DUs.

NOTE: If either captain or first officer display has terrain selected, the pop up feature does not operate.

The terrain display output processor maintains a background display of terrain forward of the aircraft. When a caution or warning goes from the terrain threat detection and display processor, the background image is enhanced to highlight the terrain threat forward of the aircraft. The display scale is from the terrain display logic function. The background data shows as a variable density dot pattern in green, yellow, or red. The density and color show how close the relative terrain is to the aircraft altitude. The heading inputs are used to calculate the radar-like sweep display ahead of the aircraft. The terrain data goes out on two ARINC 453 data buses to the terrain/weather relays. Alert displays go out on an ARINC 429 data bus to the DEUs.

34-46-00-032

	EFFECTIVITY
	HAP ALL

34-46-00

D633A101-HAP

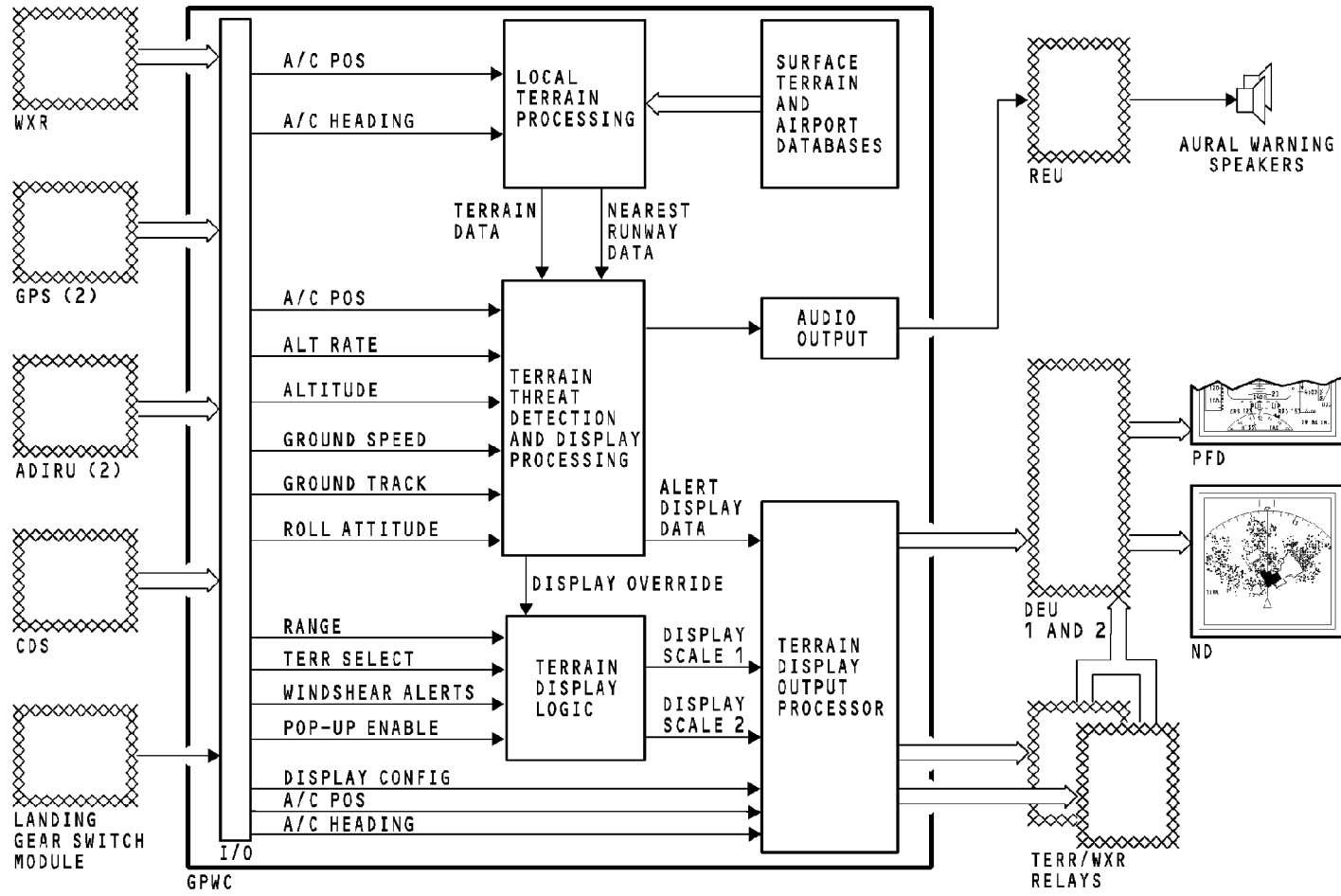

GPWS - ENHANCED FEATURES FUNCTIONAL DESCRIPTION

34-46-00-032

EFFECTIVITY
HAP 001-013, 015-026, 028-030 PRE SB 737-31-1246 AND PRE SB 737-31-1295

34-46-00

D633A101-HAP

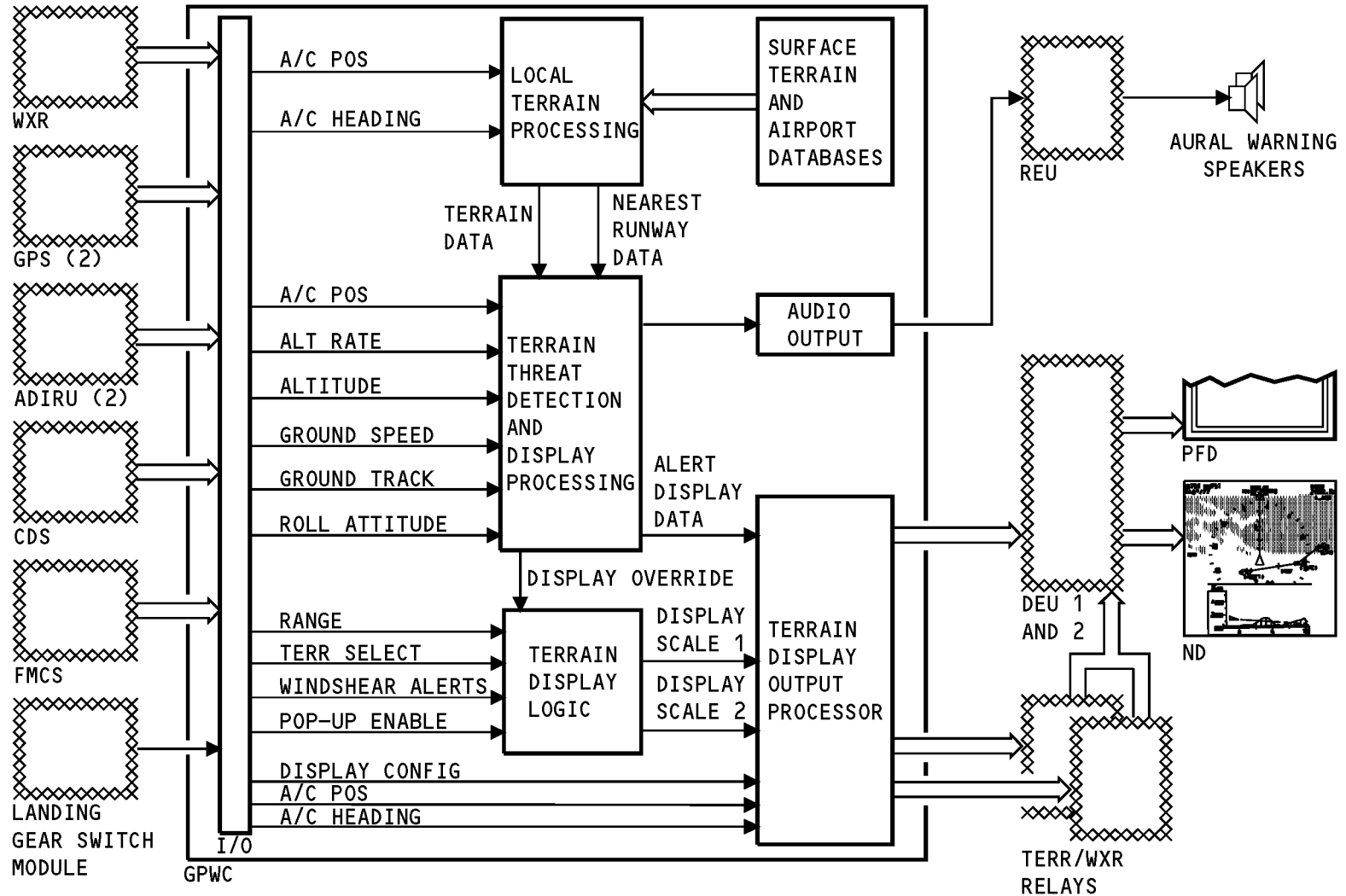

GPWS - ENHANCED FEATURES FUNCTIONAL DESCRIPTION

EFFECTIVITY

HAP 031-054, 101-999; HAP 001-013, 015-026, 028-030 POST SB 737-31-1246 OR POST SB 737-31-1295

34-46-00

D633A101-HAP

GPWS - TERRAIN CLEARANCE FLOOR

HAP | Description

HAP Terrain clearance floor (TCF) alerts the flight crew when the
HAP airplane descends too low on approach. TCF uses airplane
HAP position and a runway database to find if there is an alert
HAP condition.

HAP Terrain Clearance Floor Inputs

HAP The ground proximity warning system (GPWS) receives
HAP airplane data from these systems:

- HAP ● Global positioning system (GPS)
- HAP ● Air data inertial reference system (ADIRS)
- HAP ● Radio altitude (RA) system.

HAP TCF uses this data:

- HAP ● Latitude
- HAP ● Longitude
- HAP ● Radio altitude.

HAP TCF uses GPS data for latitude and longitude. It uses IRS data if
HAP GPS data is not valid.

Terrain Clearance Floor Logic

The GPWC has a runway database in memory. The runway
database is in the terrain database. The runway database
contains the location of all hard surface runways in the world
that are longer than 3,500 feet. TCF makes a terrain clearance
envelope around the runway. The altitude of the envelope
increases as the distance from the airport increases. GPWC
compares airplane latitude, longitude, and radio altitude with
TCF envelope data. If the airplane descends through the floor of
the envelope, the GPWC makes an alert.

TCF makes an alert even if the airplane is in landing
configuration.

The TCF function is active through the entire flight. When the
aircraft is 15nm or more from a runway the floor is 700 feet AGL
until the aircraft approaches another runway that meets the
requirements. Then the floor decreases as shown on the
graphic.

Terrain Clearance Floor Alert

If the GPWC finds that the airplane is below the TCF, it makes
this caution alert:

- Aural message TOO LOW TERRAIN. This message repeats
for each 20 percent loss of altitude.
- Message, TERRAIN on the ND in amber.

HAP

HAP
HAP
HAP
HAP
HAP
HAP
HAP
HAP

HAP
HAP

HAP
HAP
HAP
HAP

HAP

HAP
HAP

HAP
HAP
HAP

34-46-00-033

EFFECTIVITY
HAP ALL

34-46-00

D633A101-HAP

Page 73
Jun 15/2009

GPWS - TERRAIN CLEARANCE FLOOR

HAP If descent continues, these alerts happen:

- HAP • Aural message PULL UP
- HAP • Message, TERRAIN on the ND in red
- HAP • Message, PULL UP on the PFD.

The GPWC inhibits TCF alerts for any of these conditions:

- Airplane is on the ground
- Less than 20 seconds after takeoff
- Less than 30 feet radio altitude.

34-46-00-033

EFFECTIVITY
HAP ALL

34-46-00

D633A101-HAP

Page 74
Jun 15/2009

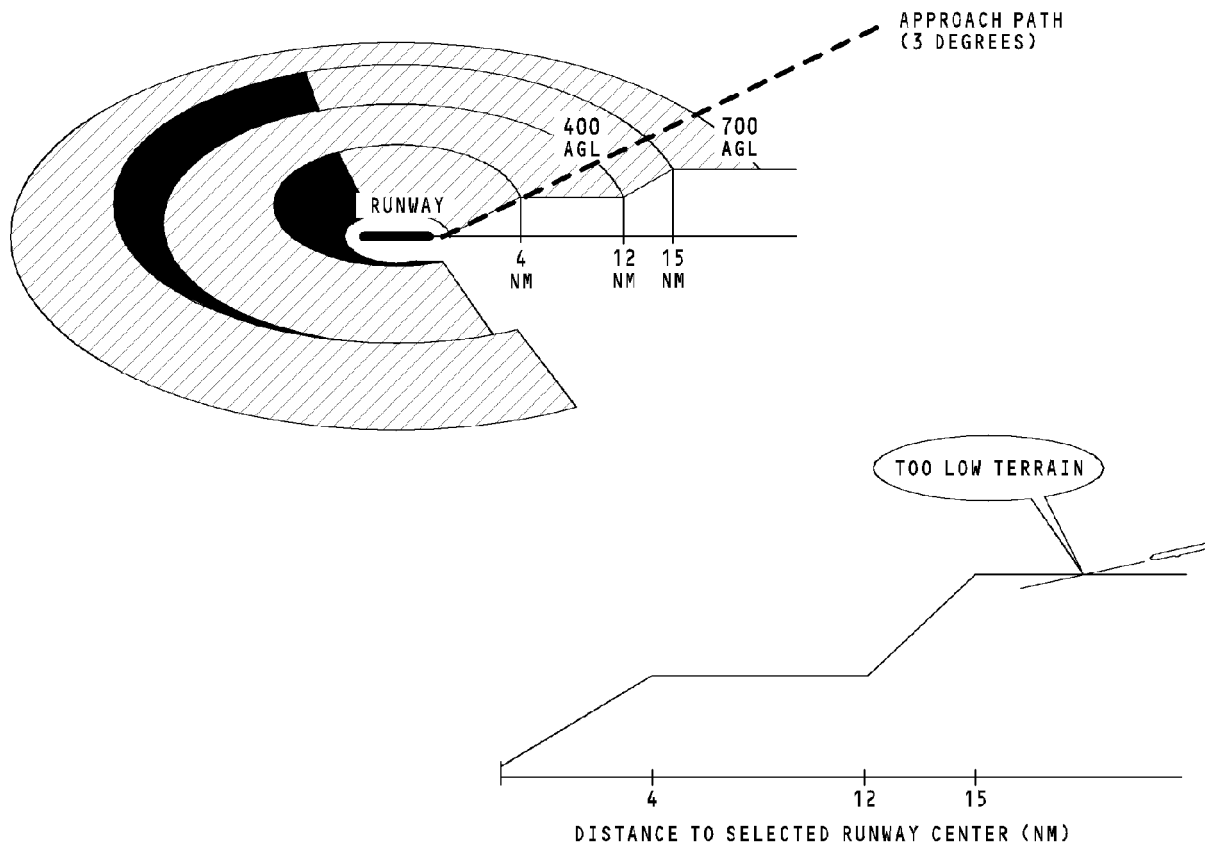

GPWS - TERRAIN CLEARANCE FLOOR

34-46-00-033

EFFECTIVITY
HAP ALL

34-46-00

D633A101-HAP

I

THIS PAGE IS INTENTIONALLY LEFT BLANK

34-46-00

D633A101-HAP

Page 76
Jun 15/2009

GPWS - RUNWAY FIELD CLEARANCE FLOOR

HAP	Description		
HAP	Runway field clearance floor (RFCF) alerts the flight crew when	Geometric altitude is a calculated airplane altitude with these	HAP
HAP	the airplane descends too low on approach. RFCF provides	inputs:	HAP
HAP	improved alerts for runways at higher elevations when	<ul style="list-style-type: none"> ● Pressure altitude ● GPS altitude ● Radio altitude ● Terrain elevation data ● Runway elevation data. 	HAP
HAP	compared to the terrain below the approach path of the		HAP
HAP	airplane.		HAP
HAP	Runway Field Clearance Floor Inputs		
HAP	The ground proximity warning system (GPWS) receives	Geometric altitude decreases errors in corrected barometric	HAP
HAP	airplane data from these systems:	altitudes which may have been caused by temperature	HAP
HAP	<ul style="list-style-type: none"> ● Global positioning system (GPS) ● Air data inertial reference system (ADIRS) ● Radio altitude (RA) system. 	extremes, non-standard altitude conditions or altimeter miss-	HAP
HAP		sets.	HAP
HAP	TCF uses this data:	The RFCF creates a circular band centered over the selected	HAP
HAP	<ul style="list-style-type: none"> ● Latitude ● Longitude ● Radio altitude. 	runway. Unlike the TCF envelope, the RFCF envelope extends	HAP
HAP		only 5 nautical miles (NM) past the end of the runway and rises	HAP
HAP		to a maximum height of 300 feet above the runway. The RFCF	HAP
HAP		function also calculates a runway position error (KRF) based	HAP
HAP		upon geometric altitude and runway data quality.	HAP
HAP		Runway Field Clearance Floor Alert	HAP
HAP	RFCF uses GPS data for latitude and longitude. It uses IRS data	If the GPWC finds that the airplane is below the RFCF, it makes	HAP
HAP	if GPS data is not valid.	this caution alert:	HAP
HAP	Runway Field Clearance Floor Logic	<ul style="list-style-type: none"> ● Aural message, TOO LOW TERRAIN. ● Message, TERRAIN on the ND in amber. 	HAP
HAP	Field clearance (height above the runway) is calculated by		HAP
HAP	subtracting the elevation of the selected destination runway	If descent continues, these alerts happen:	HAP
HAP	from the current altitude. Geometric altitude is used to find		
HAP	current altitude.		

34-46-00-043

EFFECTIVITY
HAP ALL

34-46-00

D633A101-HAP

Page 77
Jun 15/2009

GPWS - RUNWAY FIELD CLEARANCE FLOOR

- HAP • Aural message, PULL UP
- HAP • Message, TERRAIN on the ND in red
- HAP • Message, PULL UP on the PFD.

The GPWC inhibits RFCF alerts for any of these conditions:

- Airplane is on the ground
- Less than 20 seconds after takeoff
- Less than 30 feet radio altitude.

34-46-00-043

EFFECTIVITY
HAP ALL

34-46-00

D633A101-HAP

Page 78
Jun 15/2009

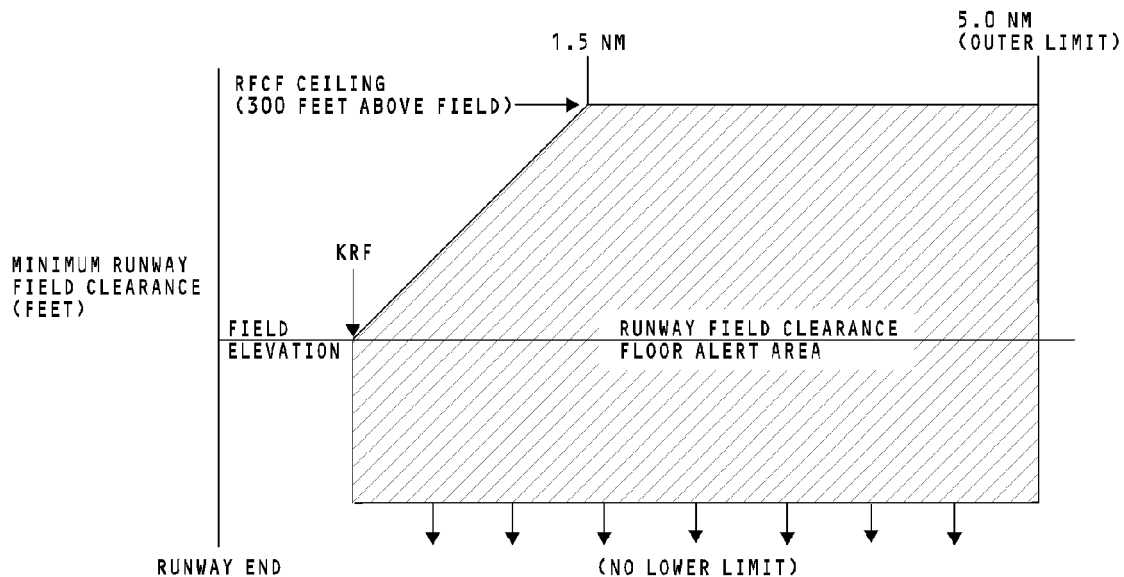

GPWS - RUNWAY FIELD CLEARANCE FLOOR

34-46-00-043

EFFECTIVITY
HAP ALL

34-46-00

D633A101-HAP

THIS PAGE IS INTENTIONALLY LEFT BLANK

34-46-00

D633A101-HAP

Page 80
Jun 15/2009

GPWS - VERTICAL SITUATION DISPLAY**Purpose**

The purpose of the Vertical Situation Display (VSD) is to present a clear graphical picture of the airplane's vertical flight path for enhancing the flight crews' vertical situation awareness.

Description

The VSD depicts the vertical situation of the airplane relative to the terrain throughout all phases of flight. The VSD also depicts the vertical situation of the airplane relative to the runway during final approach.

The VSD complements the increased use of constant-angle, area navigation, and required navigation performance (RNP) approaches by providing immediate validation of the selected approach path and allowing full-time monitoring of the airplane position relative to the selected glide path.

The VSD basic features depicted in the side -looking vertical profile include:

- Altitude reference scale
- Horizontal distance scale
- Airplane symbol
- Vertical flight path trend vector
- Terrain depiction
- Navigation aids
- Glideslope depiction
- Speed dot predictor

- Various information selected by flight crew and FMC such as the mode control panel (MPC):selected altitude, minimum decision altitude, and selected vertical speed predictor.

The VSD depicts a finite swath of the horizontal map with features which include:

- Swath width is RNP based
- Profile swath depiction shown on horizontal map
- VSD depiction is always the airplane's current track with some bias into the direction of turns

Operation

The VSD is selected on and off using the DATA button on the EFIS control panel.

When selected on, the VSD display will appear on the bottom of the Navigation Display (ND).

The distance range of the VSD will be the same as that presented on the horizontal map and controlled via the same knob.

The altitude reference scale will be based on the same data as the primary altimeter.

The altitude reference scale to horizontal distance scale ratio will be fixed so that a three degree approach angle appears the same on all EFIS control panel settings up to 80 nm.

EFFECTIVITY

HAP 031-054, 101-999; HAP 001-013, 015-026, 028-030 POST SB 737-31-1246 OR POST SB 737-31-1295

GPWS - VERTICAL SITUATION DISPLAY

If the range scale setting is 160 nm or greater, then the data information will also appear on the ND. If the range scale setting is 80 nm or less, then the data information will not appear on the ND.

Terrain will be depicted on the VSD even if WXR is being presented on the horizontal map.

EFFECTIVITY

HAP 031-054, 101-999; HAP 001-013, 015-026, 028-030 POST SB 737-31-1246 OR POST SB 737-31-1295

34-46-00

D633A101-HAP

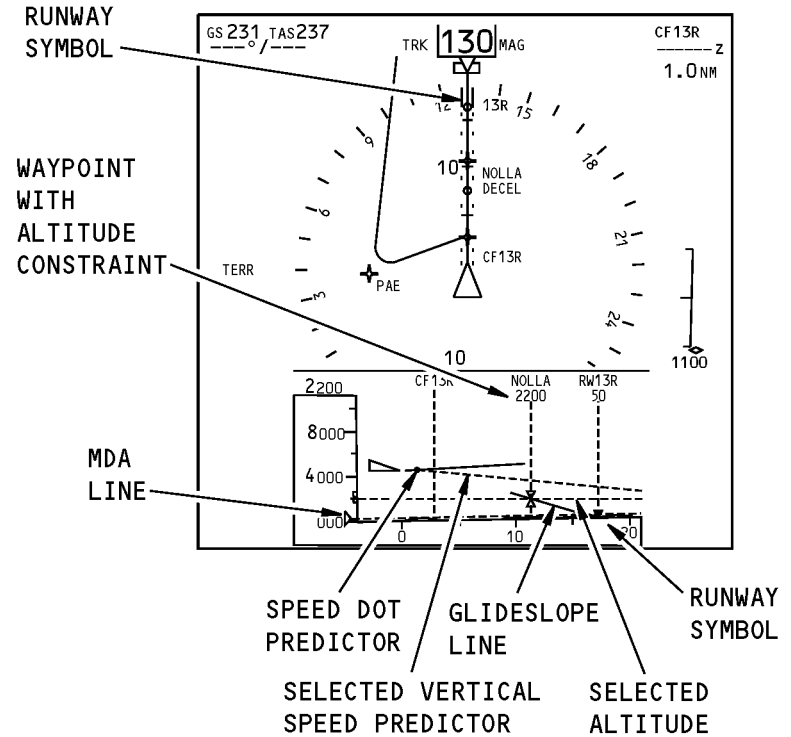
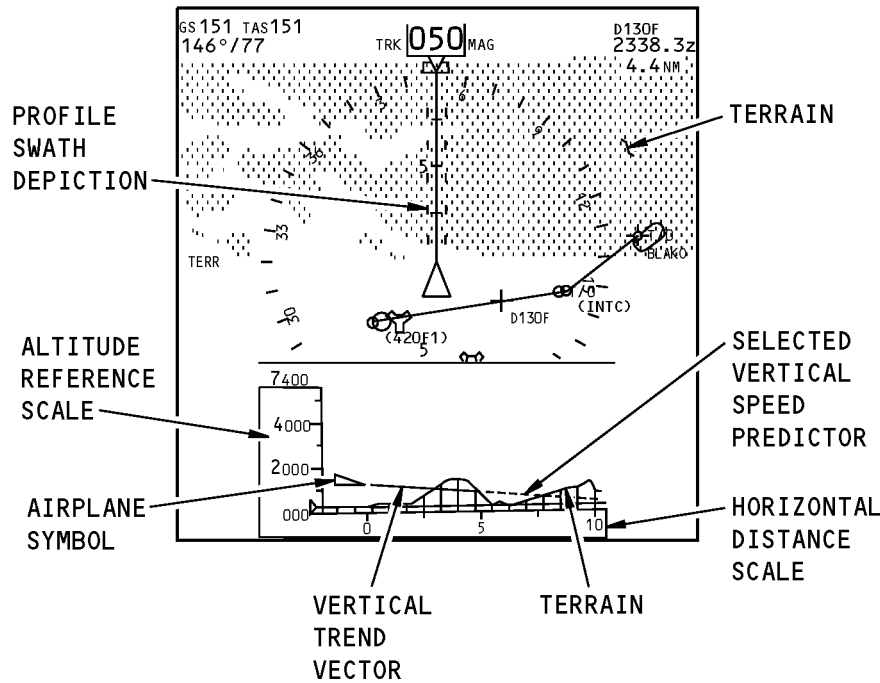

GPWS - VERTICAL SITUATION DISPLAY

34-46-00-044

EFFECTIVITY
 HAP 031-054, 101-999; HAP 001-013, 015-026, 028-030 POST SB 737-31-1246 OR POST SB 737-31-1295

34-46-00

D633A101-HAP

GPWS - SPEECH PROM

General

HAP The audio generator supplies aural messages for modes 1
HAP through 7, TA, and TCF. The audio generator also contains
HAP callouts for:

- HAP • Selected radio altitudes
- HAP • Radio minimums
- HAP • Bank angle
- HAP • V1.

Description

HAP The audio generator sends only one message at a time to the
HAP audio amplifier. If more than one message discrete comes from
HAP the mode detector, the audio generator sends the message that
HAP has the highest priority. This makes sure only one message is
HAP sent at a time. From the audio amplifier, the audio goes to the
HAP remote electronics unit and on to the flight compartment
HAP speakers and headphones. Some remote electronics units have
HAP an AURAL WARN MUTE switch that can inhibit audio to the
HAP headphones. Warnings and cautions also go to the flight data
HAP acquisition unit for recording. There are hundreds of words
HAP necessary for the annunciation of all the possible BITE, caution,
HAP and warning messages. The graphic shows the possible GPWS
HAP modes with the caution and warning aural messages and their
HAP priority.

HAP | The audio generator gets inputs for message requests and
HAP volume levels from the mode logic detector. The test circuit
HAP gives an input for annunciation of all BITE information.

34-46-00-022



34-46-00

D633A101-HAP

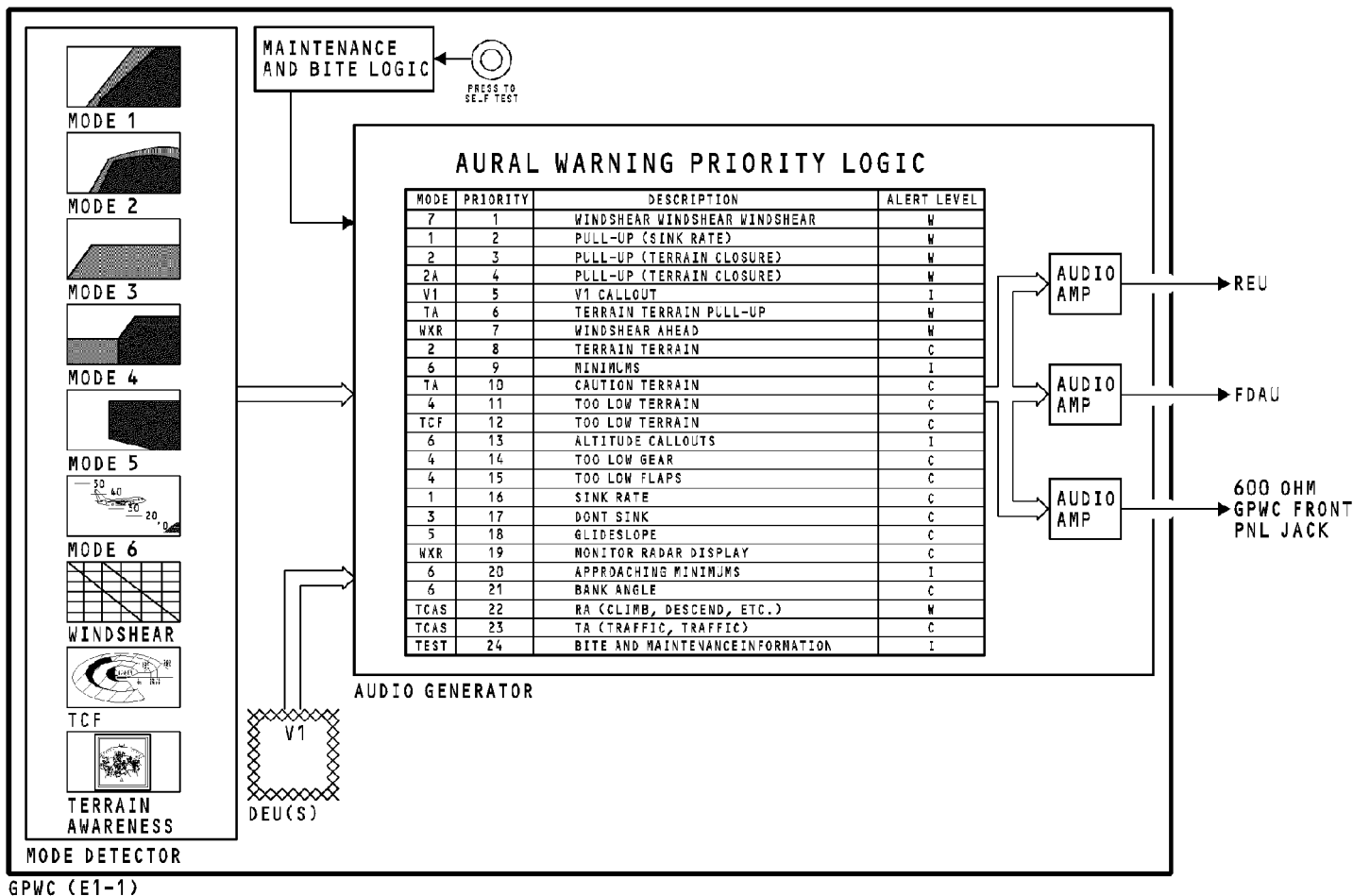

GPWS - SPEECH PROM

34-46-00

34-46-00-022

EFFECTIVITY
HAP ALL

D633A101-HAP

GPWS - ENVELOPE MODULATION**Purpose**

Some airports have unusual terrain clearances near the runway that cause nuisance messages by the GPWS. The most common is a mode 2 warning for an excessive closure rate due to rising terrain located at the end of a runway. Other GPWS modes affected by unusual terrain are modes 1, 4, and 5. Envelope modulation changes the different alert and warning areas to prevent alert messages that are not necessary.

Description

The airports that need envelope modulation are in the GPWC non-volatile memory and identified by their latitude and longitude. This latitude and longitude is called a snapshot area. A snapshot area is then followed, on an approach, by the envelope modulation area. The envelope modulation area has its own latitude and longitude. When the airplane is in a snapshot area, the GPWC looks at other airplane parameters to ensure that all the required data is valid and within tolerances. Once the snapshot requirements have been verified by the GPWC, and depending on which airport the airplane is approaching, one or more of the listed GPWS modes can be modified.

- Mode 1 - to allow higher altitude descent rates
- Mode 2(A and B) - to allow higher closure rates
- Mode 4 - to allow less minimum terrain clearance
- Mode 5 - to allow GLIDE SLOPE warnings at higher altitudes.

Not all airports require The same parameters. These are the monitored inputs:

- Latitude
- Longitude
- Radio altitude
- Localizer deviation
- Magnetic track
- Selected runway heading
- Barometric corrected altitude.

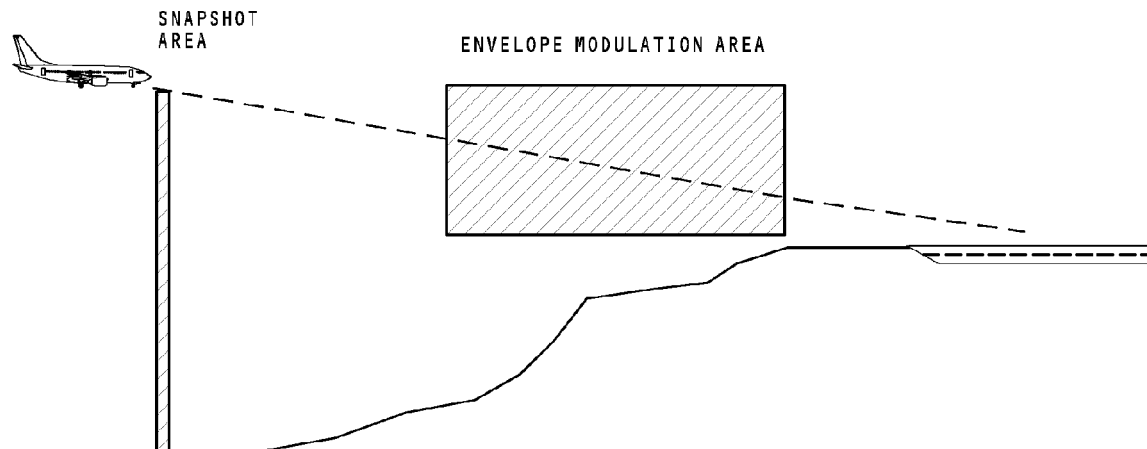

MODE	TYPE OF MODULATION	PURPOSE OF MODULATION
1	INCREASE ALLOWABLE DESCENT RATE	ALLOWS HIGHER BAROMETRIC DESCENT RATES WITHOUT ALERTS OR WARNINGS
2	DECREASE THE ALERT/WARNING RADIO ALTITUDE LIMITS	LETS THE AIRPLANE FLY CLOSER TO THE TERRAIN WITHOUT ALERTS OR WARNINGS
4	DECREASE THE ALERT/WARNING RADIO ALTITUDE LIMITS	DECREASES THE MINIMUM TERRAIN CLEARANCE FOR AIRSPEEDS MORE THAN 250 KTS FOR ALERTS
5	INCREASE ALERT AREA RA LIMITS REMOVE GEAR DOWN REQUIREMENTS	ALLOWS MODE 5 ANNUNCIATIONS AT HIGHER ALTITUDES OR WITHOUT GEAR DOWN

GPWS - ENVELOPE MODULATION

34-46-00-023

EFFECTIVITY
HAP ALL

34-46-00

D633A101-HAP

THIS PAGE IS INTENTIONALLY LEFT BLANK

34-46-00

D633A101-HAP

Page 88
Jun 15/2009

GPWS - DISPLAYS

CDS Warning Annunciations

The common display system (CDS) can show these two warning annunciations in the GPWS message field on the AI display:

- PULL UP (red)
- WINDSHEAR (red).

The PULL UP warning annunciation shows for mode 1, 2, 3 and 4 conditions. The WINDSHEAR warning annunciation shows for a mode 7 condition.

Below G/S Switch/Light

There are two BELOW G/S Switch/Lights. One for the captain and one for the first officer. The switch/lights are amber and come on for mode 5 alerts. The Below G/S Switch/Light can be pushed to stop the alert. This will also cancel the aural warning.

Ground Proximity INOP Light

The INOP light on the ground proximity warning module comes on for these conditions:

- GPWS inoperative
- Windshear inoperative.

Each of these conditions has inputs that are used to determine whether to turn the INOP light on or off. The inputs change when the aircraft is in the air mode or ground mode. These are the inputs for each condition and mode.

GPWS inop in air:

- SMYD
- ADIRU
- RA
- HAP 031-054, 101-999; HAP 001-013, 015-026, 028-030 POST SB 737-34-1875**
- ILS
- HAP ALL**
- Program pin error
- Flap position error
- Air ground error
- Mode failure.

GPWS inop on ground:

- SMYD
- ADIRU
- RA
- DEU
- ILS
- Program pin error
- Flap position error
- Air ground error
- Mode failure.

Altitude callouts inop in air:

- DEU
- ADIRU
- RA
- Invalid altitude callout selection.

34-46-00-025

<p>EFFECTIVITY</p> <p>HAP ALL</p>

34-46-00

D633A101-HAP

GPWS - DISPLAYS

Altitude callouts inop on ground:

- DEU
- ADIRU (air data)
- RA
- Invalid altitude callout selection.

Windshear inop in air:

- RA
- ADIRU
- SMYD
- DEU
- Program pin error

Windshear inop on ground:

- RA
- ADIRU
- SMYD
- Program pin error.

NOTE: ADIRU in the attitude mode will not cause the windshear to be inop in air.

GPWS MESSAGE FIELD

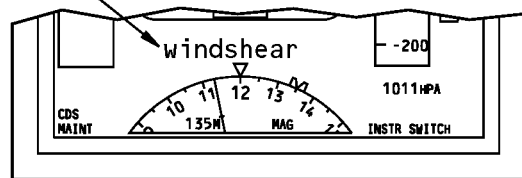

WARNING ANNUNCIATION

BELOW G/S
P-INHIBIT^a

BELOW G/S
SWITCH/LIGHT
(P1 AND P3)

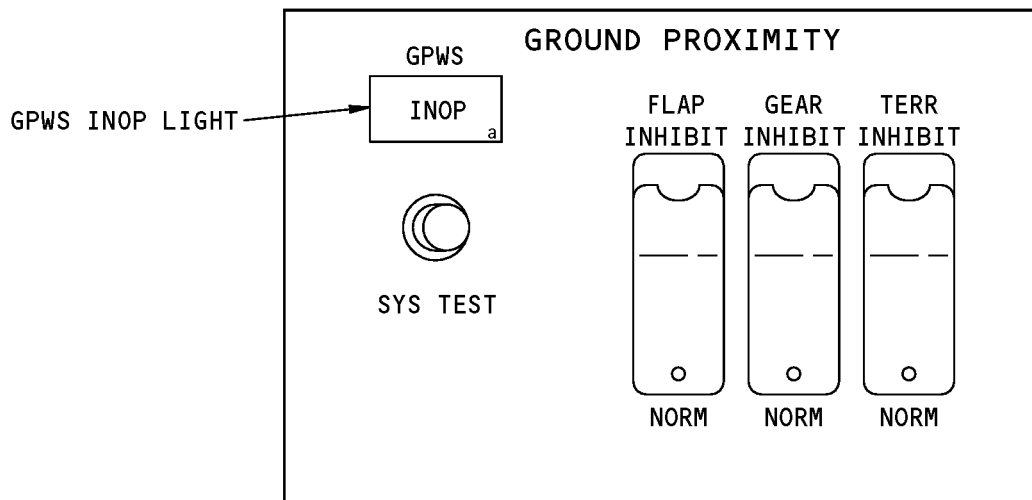

GPW MODULE (P3)

GPWS - DISPLAYS

34-46-00-025

**EFFECTIVITY
HAP ALL**

34-46-00

D633A101-HAP

THIS PAGE IS INTENTIONALLY LEFT BLANK

34-46-00

D633A101-HAP

Page 92
Jun 15/2009

GPWS - TERRAIN AWARENESS DISPLAY

HAP Terrain Awareness Display Data

HAP The navigation displays (NDs) show this GPWS data:

- HAP ● Terrain awareness display
- HAP ● Vertical situation display
- HAP ● GPWS system messages
- HAP ● GPWS alert messages.

HAP Terrain Awareness Display

HAP The terrain awareness display on the NDs uses dots to show
HAP the terrain ahead of the airplane. Dot color and dot pattern
HAP density are based on the terrain altitude and airplane altitude.
HAP These are the dot colors and patterns the terrain display uses:

- HAP ● High density red - Terrain more than 2,000 feet above
HAP airplane altitude
- HAP ● High density yellow - Terrain 1,000 feet to 2,000 feet above
HAP airplane altitude
- HAP ● Medium density yellow - Terrain 500 feet below to 1,000 feet
HAP above airplane altitude. Gear down changes this to 500 feet
HAP below to 250 feet above
- HAP ● Medium density green - Terrain 500 feet below to 1,000 feet
HAP below airplane altitude. Gear down changes this to 500 feet
HAP below to 250 feet below
- HAP ● Low density green - Terrain 1,000 feet below to 2,000 feet
HAP below airplane altitude
- HAP ● Black - Terrain more than 2,000 feet below airplane altitude
- HAP ● Magenta - Unknown terrain.

If GPWS detects a terrain caution alert, the threat terrain changes from dots to a solid yellow color. If GPWS detects a terrain warning alert, the threat terrain changes from dots to a solid red color.

HAP
HAP
HAP
HAP

On final approach, terrain near the runway does not show.

HAP
HAP

HAP 001-013, 015-026, 028, 029, 031-054, 101-999

I HAP

Peaks Mode Display

HAP

The peaks mode display shows terrain below the airplane on the navigation displays (NDs) during cruise. The display shows terrain data at all altitudes with various densities of green to show highest, mid, and lower level non-threatening terrain.

HAP
HAP
HAP
HAP

Terrain elevation numbers show in the bottom left of the navigation display for the highest and lowest terrain shown. The color of the numbers (red, amber and green) corresponds to the height from highest to lowest. These numbers show terrain in hundreds of feet above mean sea level (MSL). The display of red or yellow terrain is unchanged.

HAP
HAP
HAP
HAP
HAP
HAP

34-46-00-034

EFFECTIVITY
HAP ALL

34-46-00

D633A101-HAP

GPWS - TERRAIN AWARENESS DISPLAY

HAP 001-013, 015-026, 028, 029, 031-054, 101-999
(Continued)

HAP I Obstacles Mode Display

HAP The obstacle display and alerting display provides cautions and
HAP warnings for man-made obstacles 100 feet and higher.
HAP Obstacles show in the same way as terrain displays. The
HAP GPWC gives a CAUTION OBSTACLE aural message for a
HAP caution condition. For a warning condition, the aural message is
HAP OBSTACLE OBSTACLE PULL UP and PULL up shows on the
HAP PFD.

I HAP ALL

GPWS System Messages

These GPWS system messages show in cyan on the left side of the ND:

- TERR shows when terrain data displays
- TERR TEST show when the GPWS is in self-test mode.

GPWS Alert Messages

These GPWS alert messages show on the right side of the ND:

- TERRAIN (red) shows when a terrain awareness warning occurs
- TERRAIN (amber) shows when a terrain awareness caution occurs.

34-46-00-034

EFFECTIVITY
HAP ALL

34-46-00

D633A101-HAP

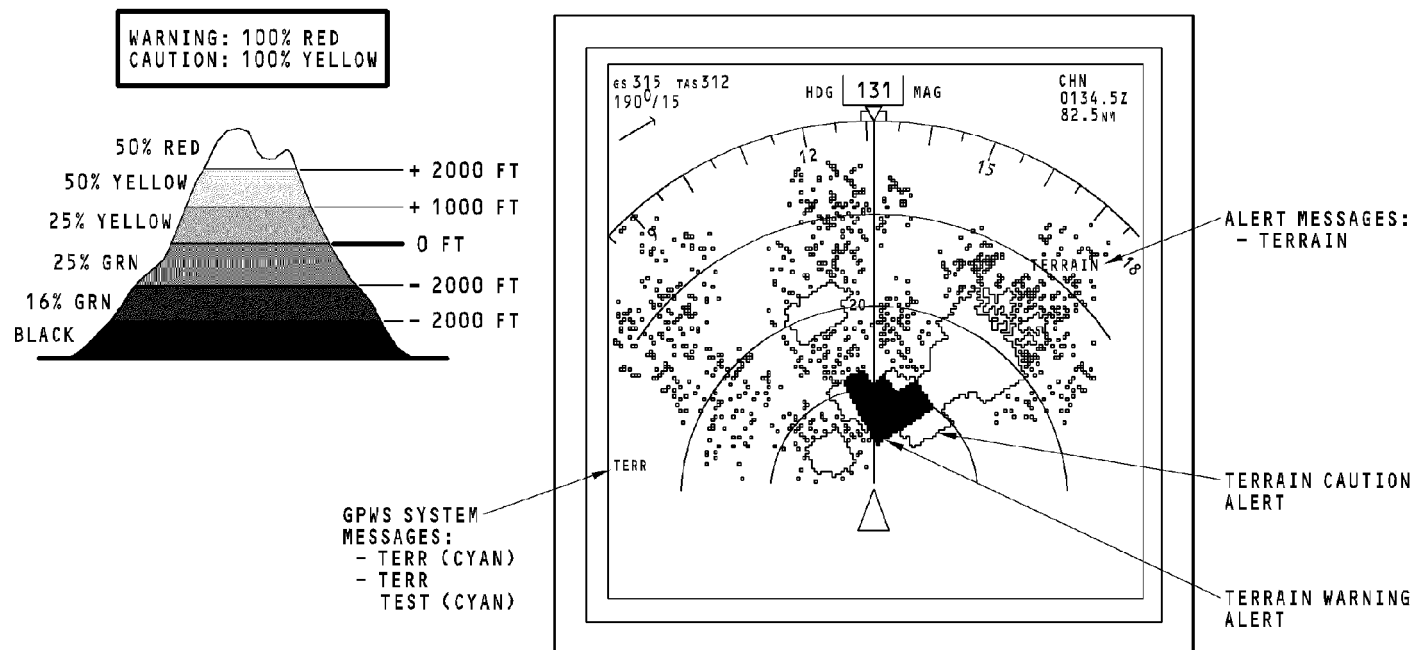

GPWS - TERRAIN AWARENESS DISPLAY

34-46-00-034

EFFECTIVITY
HAP ALL

34-46-00

D633A101-HAP

GPWS - NON-NORMAL TERRAIN DISPLAYS

HAP | GPWS Non-Normal Messages

Terrain data does not show on the ND if there is a range disagree message. HAP
HAP

HAP These messages show on the navigation display (ND) for GPWS
HAP non-normal conditions:

- HAP • System alert messages
- HAP • Range disagree messages.

HAP | GPWS System Alert Messages

HAP These messages show in amber on the left side of the ND:

- HAP • TERR POS shows when airplane position data is not valid
- HAP • TERR INHIBIT shows when you push the terrain override
HAP switch on the GPW module
- HAP • TERR FAIL shows when the TCF or terrain awareness
HAP functions have failed.

HAP NOTE: The TERR FAIL message shows in all display modes.

HAP
HAP Terrain data does not show on either ND if there is a system
HAP alert message.

HAP | Range Disagree Messages

HAP These alert messages show in amber on the ND when there is a
HAP range disagree fault:

- HAP • TERR RANGE DISAGREE shows when the GPWS range
HAP disagrees with the range selected on the on-side EFIS
HAP control panel
- HAP • MAP/TERR RANGE DISAGREE shows when the GPWS
HAP range, the on-side EFIS range, and the FMC range disagree.

34-46-00-035

EFFECTIVITY
HAP ALL

34-46-00

D633A101-HAP

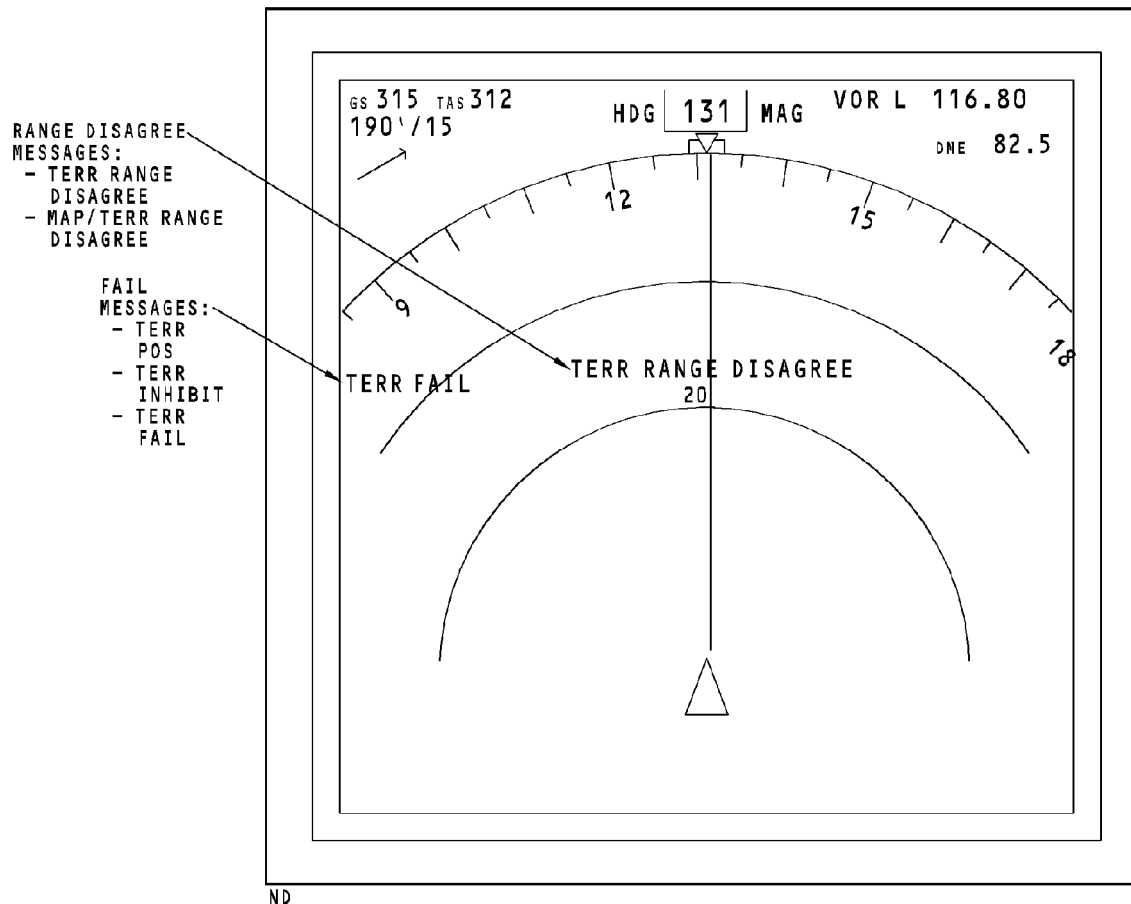

GPWS - NON-NORMAL TERRAIN DISPLAYS

34-46-00-035

EFFECTIVITY
HAP ALL

34-46-00

D633A101-HAP

I

THIS PAGE IS INTENTIONALLY LEFT BLANK

34-46-00

D633A101-HAP

Page 98
Jun 15/2009

GPWS - SELF-TEST - LEVEL ONE

HAP General

HAP The ground proximity warning system (GPWS) has six levels of
HAP self-test. Each level provides different information about the
HAP GPWS. These are the six levels of self-test:

- HAP ● GO/NO-GO operational test
- HAP ● Current faults
- HAP ● System configuration
- HAP ● Fault history
- HAP ● Alert/warning history
- HAP ● Discrete input test.

HAP Level one is the GO/NO-GO operational test. A level one test
HAP provides visual and aural annunciations on the flight deck.

HAP Level One Test Preparation

HAP These conditions must be true to do a level one test of the
HAP GPWS:

- HAP ● Airplane on ground
- HAP ● GPWS power on
- HAP ● EFIS ND mode selector in correct mode (expanded APP,
HAP VOR, MAP, and centered MAP)
- HAP ● TERR switch on EFIS control panel (CP) selected
- HAP ● All interfacing systems installed and energized.

Level One Test Procedure

Use the test switch on the ground proximity warning module to
begin a level one test. A level one test first does a test of these
configuration conditions:

- Program pin parity
- Airplane configuration database validity
- Airplane type.

If the test finds a configuration fault, the self-test annunciates the
fault and the self-test ends. If the GPWS passes the
configuration test, the level one test continues.

Training Information Point

You can start a level one test from the front panel of the GPWC,
but you cannot see the flight deck annunciations. Use the GPW
module to start an operational test of the GPWS.

Short Level One Test - Normal Indications

These visual and aural annunciations are for a normal level one
test:

- ND system message TERR TEST shows in cyan
- Ground proximity warning light on 0.7 seconds
- Glideslope lights on 0.7 sec and aural message
GLIDESLOPE
- Pull-up message below the ADI on for 0.7 sec and aural
WHOO WHOO PULL-UP

HAP

HAP
HAP
HAP

HAP
HAP
HAP

HAP
HAP
HAP

HAP

HAP
HAP
HAP

HAP

HAP
HAP

HAP
HAP
HAP
HAP
HAP

34-46-00-036

EFFECTIVITY
HAP ALL

34-46-00

D633A101-HAP

Page 98.1
Jun 15/2009

GPWS - SELF-TEST - LEVEL ONE

- HAP • Windshear message below the ADI on 0.7 sec and a two tone
- HAP siren followed by the aural WINDSHEAR, WINDSHEAR,
- HAP WINDSHEAR
- HAP • Terrain test pattern on the ND for 12 seconds and the aural
- HAP message TERRAIN, TERRAIN, PULL-UP.
- HAP • Terrain database version number in the center of the terrain
- HAP test pattern on the ND.

Long Level One Test

To start the long level one test, push and hold the test button for 5 seconds. This will do the short level one test then continue to give voice callouts for all customer selected items.

Training Information Point

To continue the GPWS BITE to the next level, push the test button after the GO-NO-GO (level 1) test is complete. No annunciation will instruct the operator to push the test button on the GPWM at the end of the go-no-go (level 1) test to continue with the BITE.

Level One Self Test - Non-Normal Indications

The GPWS level one test fails for any of these conditions:

- Terrain test pattern does not show
- TERR FAIL message on the ND stays on
- You do not see and hear all annunciations.

Training Information Point

Some GPWS modes have the same annunciations. If you do not see and hear all annunciations, the test fails.

GPWS Mode Failures

These aural messages are for GPWS modes that do not function:

- GLIDESLOPE INOP
- GPWS INOP
- BANK ANGLE INOP
- CALLOUTS INOP
- WINDSHEAR INOP
- TERRAIN INOP.

HAP

34-46-00-036

I	EFFECTIVITY
	HAP ALL

34-46-00

D633A101-HAP

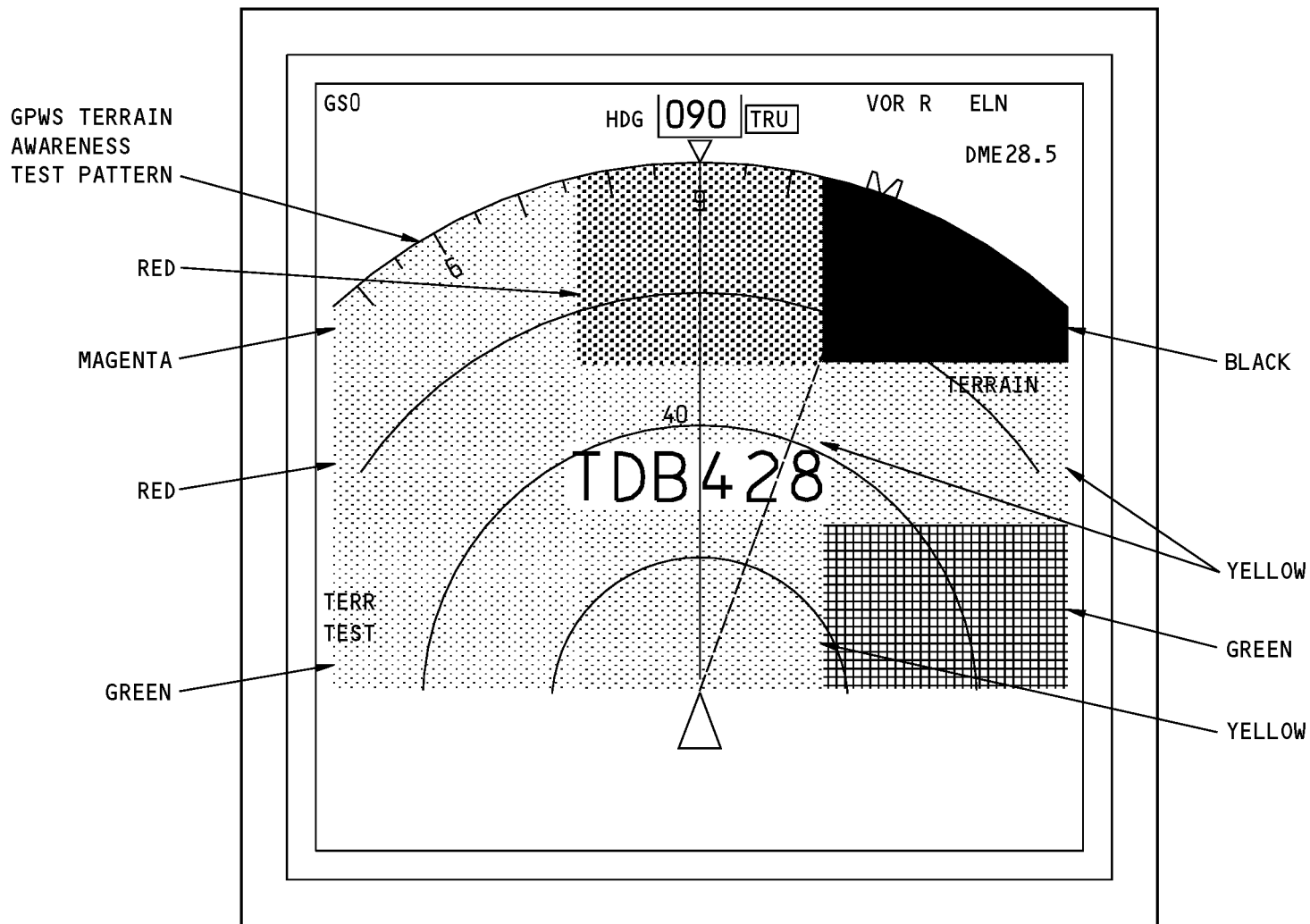

GPWS - SELF-TEST - LEVEL ONE

34-46-00-036

EFFECTIVITY
HAP ALL

34-46-00

D633A101-HAP

Page 98.3
Jun 15/2009

I

THIS PAGE IS INTENTIONALLY LEFT BLANK

34-46-00

D633A101-HAP

Page 98.4
Jun 15/2009

GPWS - SELF-TEST - LEVELS 2-5

HAP **General Description**

HAP The ground proximity warning computer (GPWC) has six levels
HAP of self test:

- HAP ● 1 - GO/NO-GO operational test
- HAP ● 2 - Current faults
- HAP ● 3 - System configuration
- HAP ● 4 - Fault history
- HAP ● 5 - Alert/warning history
- HAP ● 6 - Discrete input test.

HAP Self-test levels 2-6 access is through the GPW module and the
HAP GPWC. When you use the GPWC, a 600 ohm headphone is
HAP necessary to listen to the test information. Plug the headphone
HAP into the jack on the front panel of the GPWC. If you do the tests
HAP from the flight deck, the information comes over the flight deck
HAP speakers.

HAP Use the self-test button on the front panel of the GPWC or the
HAP self-test button on the GPW module to get access to levels 2-6.
HAP The self-test button has these two modes:

- HAP ● Short cancel - push the button for less than two seconds
- HAP ● Long cancel - push the button for more than two seconds.

HAP Use the self-test buttons for these functions:

- HAP ● Start self-test level one
- HAP ● Go to the next item or flight leg within a test
- HAP ● Go to the next self-test level

- End the self-test.

When test level 1 ends, there is no aural message, push the test button to continue. If you do not push the self-test button within three seconds, self-test ends. When test levels 2 through 5 end, there is an aural message PRESS TO CONTINUE. Push the self-test button to go to the next test level.

Level Two Self-test - Current Faults

A level two test begins with the aural message, CURRENT FAULTS. If there are no current faults, you hear the aural message NO FAULTS. If there are faults, the GPWC annunciates the faults one at a time. A short or long cancel ends the level two test.

Level Three Self-test - System Configuration

A level three test annunciates the GPWS configuration. A level three test begins with the aural message SYSTEM CONFIGURATION. A short cancel causes the test to go immediately to the next configuration item. A long cancel ends the level three test. A level three test provides this information:

- GPWC part number
- GPWC modification status
- GPWC serial number
- Software version
- Terrain database version
- Envelope modulation database version
- Boot code version

HAP

HAP
HAP
HAP
HAP
HAP

HAP

HAP
HAP
HAP
HAP
HAP

HAP

HAP
HAP
HAP
HAP
HAP
HAP

HAP
HAP
HAP
HAP

34-46-00-037

<p>EFFECTIVITY HAP ALL</p>

34-46-00

D633A101-HAP

GPWS - SELF-TEST - LEVELS 2-5

- Aircraft type
- Audio menu
- Altitude callout menu number
- Selected options.

Level Four Self-test - Fault History

Level four test shows the GPWS fault history over the last ten flights.

A level four test begins with the aural message FAULT HISTORY. If there are no faults in the flight history memory, you hear the aural message NO FAULTS. If there are faults in the flight history memory, you hear the most recent faults announce first. You hear the faults in this order:

- FLIGHT X (X is the most recent flight leg number)
- Internal faults for flight X
- External faults for flight X
- Go to next oldest flight leg and repeat.

A short cancel causes the test to go immediately to the next flight leg. A long cancel ends test level four.

Level Five Self-test - Warning History

Level five test show GPWS alerts over the last ten flights.

A level five test begins with the aural message WARNING HISTORY. If there are no alerts in the flight history memory, you hear the aural message NO WARNINGS. If there are alerts in the flight history memory, you hear the most recent alerts first. You hear the alerts in this order:

- FLIGHT X (X is the most recent flight leg number)
- GPWS alerts for flight X
- Go to next oldest flight leg and repeat.

A short cancel cause the test to go immediately to the next flight leg. A long cancel ends test level four.

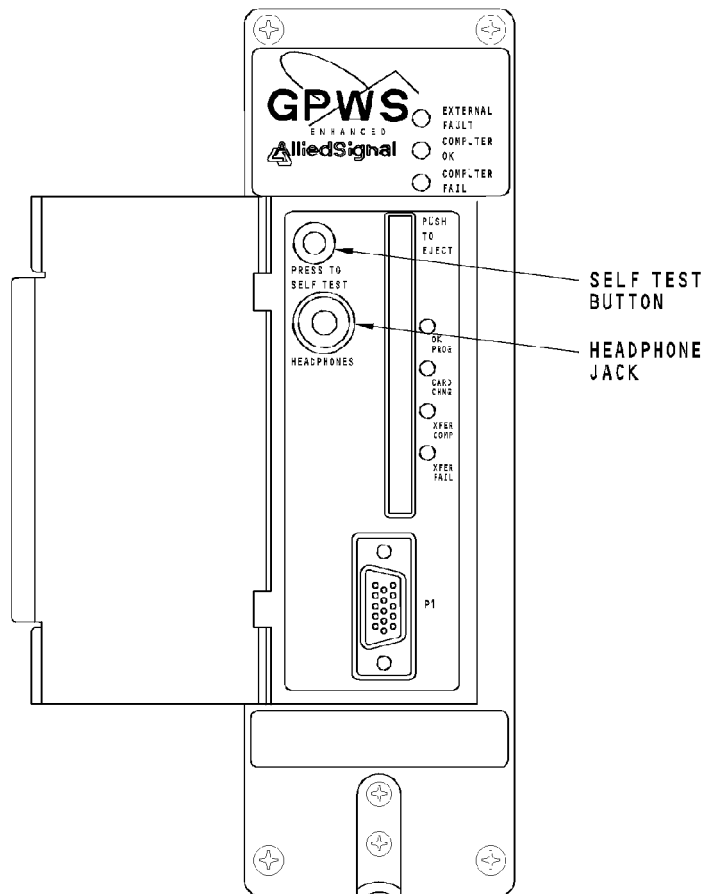
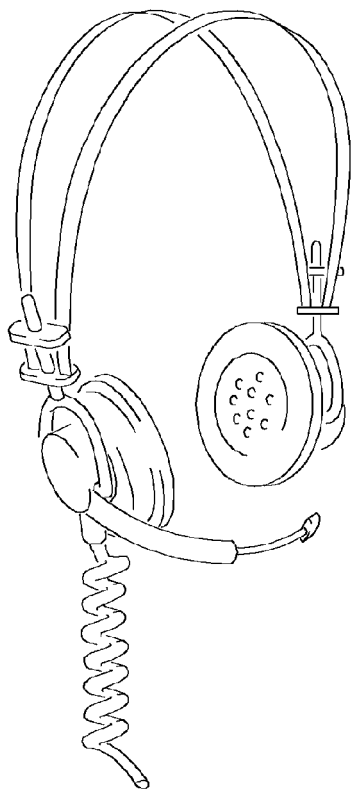

GPWS - SELF-TEST - LEVELS 2-5

34-46-00-037

EFFECTIVITY
HAP ALL

34-46-00

D633A101-HAP

DISCRETE INPUT	INPUT SOURCE	ANNUNCIATIONS
GEAR INHIBIT SWITCH	GPW MODULE	LANDING GEAR DOWN LANDING GEAR UP
FLAP INHIBIT SWITCH	GPW MODULE	LANDING FLAPS NOT LANDING FLAPS
BELOW G/S SWITCH/LIGHT	P1-3 AND P3-1	GLIDESLOPE CANCELLED GLIDESLOPE ENABLE
TERRAIN INHIBIT SWITCH	GPW MODULE	TERRAIN OFF TERRAIN ON
TERRAIN RELAY 1	LEFT EFIS TERR SWITCH	TERRAIN RELAY 1 ON TERRAIN RELAY 1 OFF
TERRAIN RELAY 2	RIGHT EFIS TERR SWITCH	TERRAIN RELAY 2 ON TERRAIN RELAY 2 OFF

LEVEL 6 DISCRETE INPUT TEST

GPWS - SELF-TEST - LEVEL 6

34-46-00-038

EFFECTIVITY
HAP ALL

34-46-00

D633A101-HAP

GPWS - STATUS LEDS

HAP | **Purpose**

HAP There are three status LEDs on the front panel of the ground
HAP proximity warning computer (GPWC). The LED indicators show
HAP the status of the GPWC when power is supplied. The LEDs turn
HAP on for these conditions:

- HAP • External fault - yellow
- HAP • Computer OK - green
- HAP • Computer fail - red.

HAP The yellow external fault LED shows that the GPWC has
HAP detected an external interface fault. The green computer OK
HAP LED shows that the GPWC is operating with no internal faults.
HAP The red computer fail LED shows that the GPWC has an internal
HAP fault.

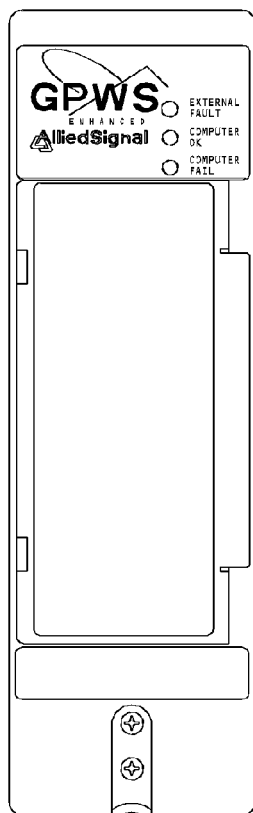

EXTERNAL FAULT	COMPUTER OK	COMPUTER FAIL	CONDITION
OFF	OFF	OFF	GPWC POWER OFF
OFF	OFF	RED	GPWC INTERNAL FAULT
OFF	GREEN	OFF	NORMAL OPERATION
OFF	GREEN	RED	GPWC INTERNAL FAULT
YELLOW	OFF	OFF	GPWS INTERNAL FAULT
YELLOW	OFF	RED	BOTH GPWC INTERNAL AND GPWS EXTERNAL FAULTS
YELLOW	GREEN	OFF	GPWS EXTERNAL FAULT
YELLOW	GREEN	RED	GPWC INTERNAL FAULT

GPWS - STATUS LEDS

34-46-00-039

EFFECTIVITY
HAP ALL

34-46-00

D633A101-HAP

GPWS - MODE DESCRIPTION SUMMARY**General**

This summary shows this information:

- GPWS modes
- Mode conditions
- Aural messages for each mode
- Annunciators or displays that come on.

MODES	CONDITION		AURAL MESSAGE	PFD-RED MESSAGE	ND MESSAGE	GND PROX-G/S INHIBIT LIGHT
1	INITIAL ANNUNCIATION		SINK RATE...	PULL UP		
	WARNING		PULL UP...	PULL UP		
2A	INITIAL ANNUNCIATION		TERRAIN TERRAIN	PULL UP		
	WARNING		PULL UP...	PULL UP		
	FLAPS <30 AND G/S AND LOC DEV >2 DOTS	ALTIMETER GAIN FUNCTION: - STARTS WHEN MODE 2 CONDITION STOPS - STOPS WHEN 300 FT OF INERTIAL ALT IS GAINED OR 45 SECS ELAPSED		TERRAIN..	PULL UP	
FLAPS AND GEAR DOWN		TERRAIN..	PULL UP			
2B	FLAPS >30 AND G/S OR LOC DEV <2 DOTS	FLAPS OR GEAR UP	INITIAL ANNUNCIATION	TERRAIN TERRAIN..	PULL UP	
		WARNING		PULL UP..	PULL UP	
3A	FLAPS <30 OR GEAR UP (FOR ALTITUDE LOSS OF 10% TO 20%)		DON'T SINK...	PULL UP		
3B	FLAPS <30 OR GEAR UP. RA LESS THAN THRESHOLD VALUE.		TOO LOW TERRAIN..	PULL UP		
4A	GEAR UP AND FLAPS <30	AIRSPEED <190 KNOTS AND RA <500 FT	TOO LOW GEAR..	PULL UP		
		AIRSPEED >190 KNOTS AND RA <1000FT	TOO LOW TERRAIN..	PULL UP		
4B	GEAR DOWN AND FLAPS <30	AIRSPEED <159 KNOTS AND RA <245 FT	TOO LOW FLAPS..	PULL UP		
		AIRSPEED >159 KNOTS AND RA <100FT	TOO LOW TERRAIN..	PULL UP		
5	APPROACH AND GEAR DOWN	RA <1000 FT AND G/S DEVIATION >1.3 DOTS	GLIDE SLOPE... AT 1/2 VOLUME, FREQ PROPORTIONAL TO DEVIATION AND GROUND PROXIMITY.			X
		RA <300 FT AND G/S DEVIATION >2.0 DOTS	GLIDE SLOPE... AT FULL VOLUME, FREQ PROPORTIONAL TO G/S DEVIATION AND GROUND PROXIMITY.			X
6	PROGRAM PIN SELECTABLE		RADIO ALTITUDE CALLOUTS AS SELECTED BY PROGRAM PINS			
7	WINDSHEAR CONDITION		SIREN, THEN WINDSHEAR, WINDSHEAR, WINDSHEAR...	WINDSHEAR		
TA	60 SEC TO THREAT TERRAIN		CAUTION, TERRAIN..		TERRAIN	
	30 SEC TO THREAT TERRAIN		TERRAIN, TERRAIN, PULL UP..	PULL UP	TERRAIN	
TCF & RFCF	INITIAL PENETRATION OF TCF AND AFTER EACH 20% FURTHER RA LOSS		TOO LOW TERRAIN..		TERRAIN	
	WARNING		PULL UP...	PULL UP	TERRAIN	

GPWS - MODE DESCRIPTION SUMMARY

34-46-00-041

EFFECTIVITY
HAP ALL

34-46-00

D633A101-HAP



GPWS - SYSTEM SUMMARY

General

This graphic is for reference only.

34-46-00-028

EFFECTIVITY
HAP ALL

34-46-00

D633A101-HAP

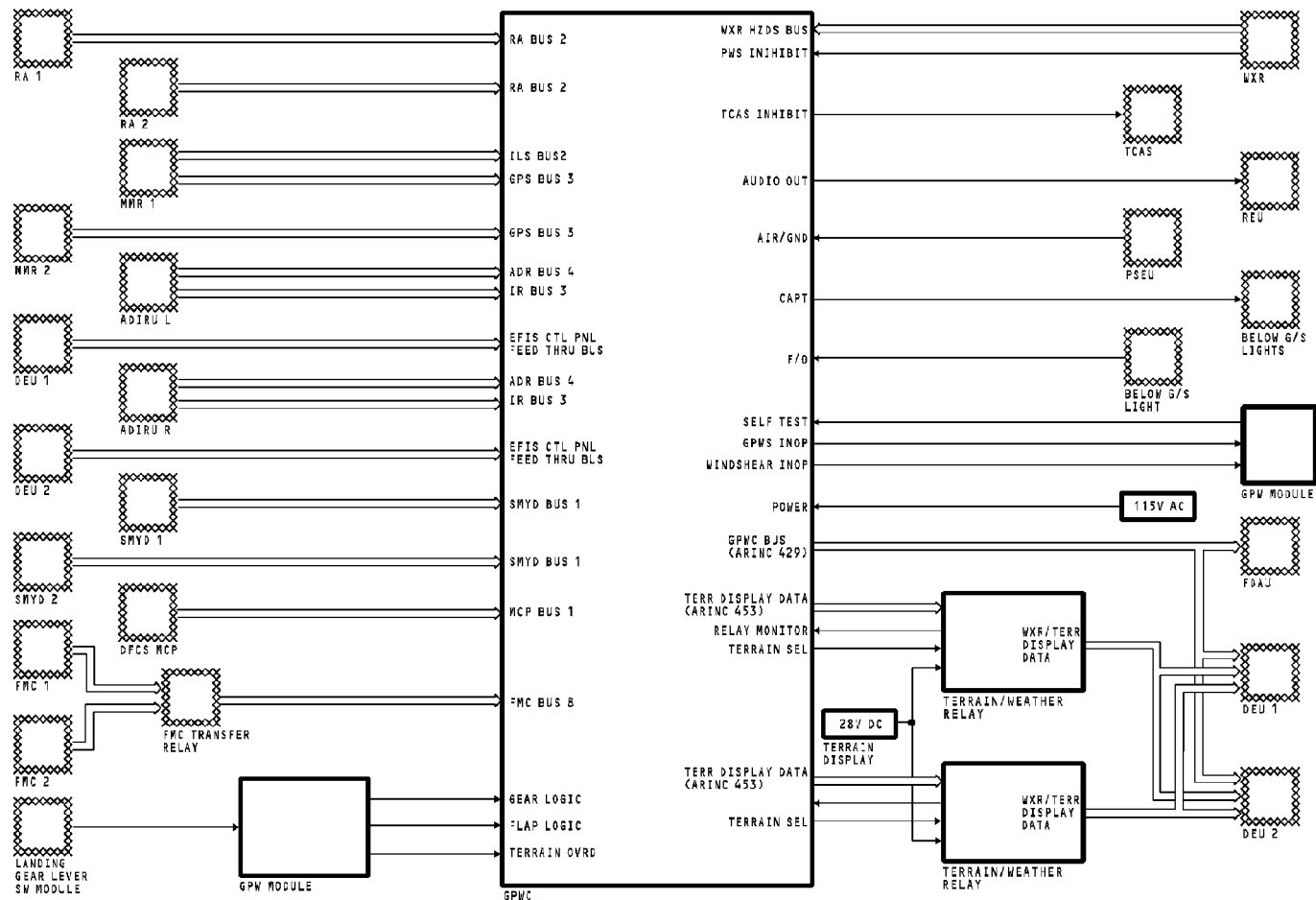

GPWS - SYSTEM SUMMARY

34-46-00-028

EFFECTIVITY
HAP 037-054, 101-999

34-46-00

D633A101-HAP

Page 98.15
Jun 15/2009

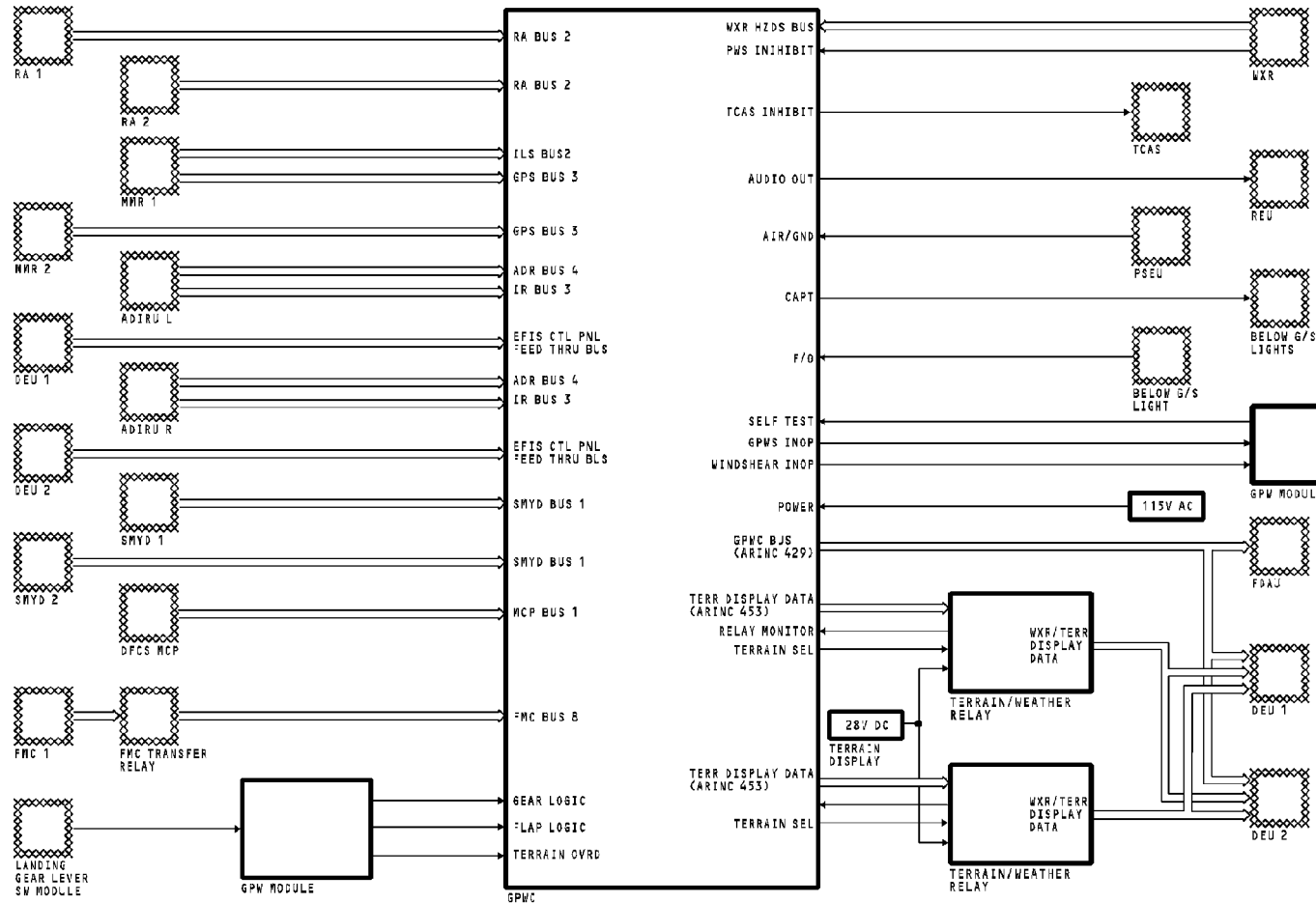

GPWS - SYSTEM SUMMARY

EFFECTIVITY

HAP 008-013, 015-026, 028-036

34-46-00

D633A101-HAP

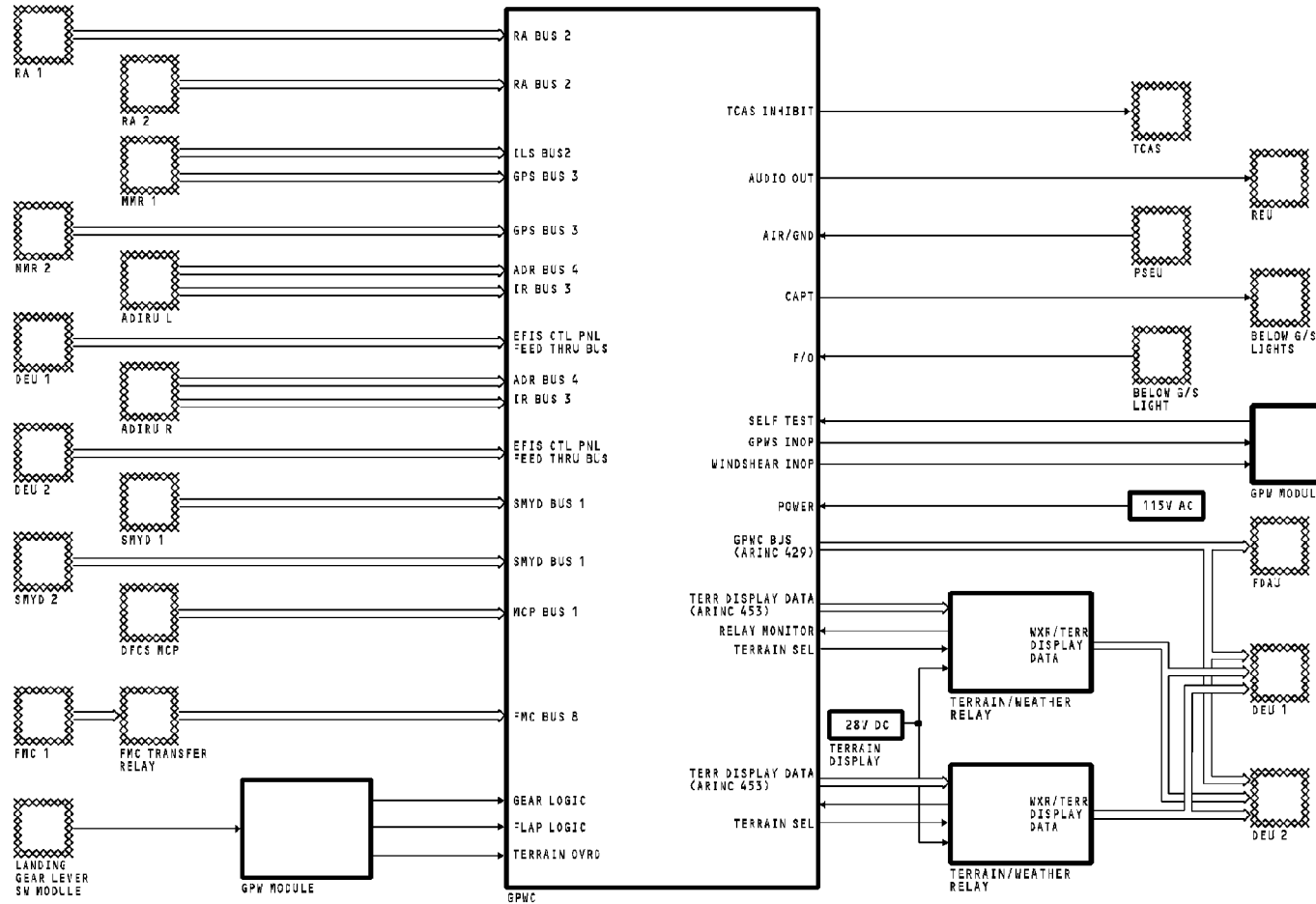

GPWS - SYSTEM SUMMARY

34-46-00-028

EFFECTIVITY
HAP 001-007

34-46-00

D633A101-HAP

Page 98.17
Jun 15/2009

THIS PAGE IS INTENTIONALLY LEFT BLANK

34-51-00

D633A101-HAP

Page 1
Oct 10/2002

VHF OMNIDIRECTIONAL RANGING (VOR) SYSTEM - INTRODUCTION**Purpose**

The VHF omnidirectional ranging (VOR) system is a navigation aid that gives magnetic bearing data from a VOR ground station to the airplane.

- RF - radio frequency
- RMI - radio magnetic indicator
- VOR - VHF omnidirectional ranging.

The VOR ground stations transmit signals that give magnetic radial information from 000 degrees to 359 degrees. All VOR stations reference the 000 degree to magnetic north.

Abbreviations and Acronyms

- ACP - audio control panel
- DEU - display electronic unit
- DFCS - digital flight control system
- DME - distance measurement equipment
- EFIS - electronic flight instrument system
- FCC - flight control computer
- FDAU - flight data acquisition unit
- FMC - flight management computer

HAP 037

- GLS - GNSS Landing System
- GNSS - global navigation satellite system

HAP ALL

- HSI - horizontal situation indicator
- ILS - instrument landing system
- LCD - liquid crystal display
- MCP - mode control panel
- NAV - navigation
- NCD - no computed data
- PWR - power
- REU - remote electronic unit

EFFECTIVITY**HAP ALL****34-51-00**

D633A101-HAP

Page 2
Jun 10/2007

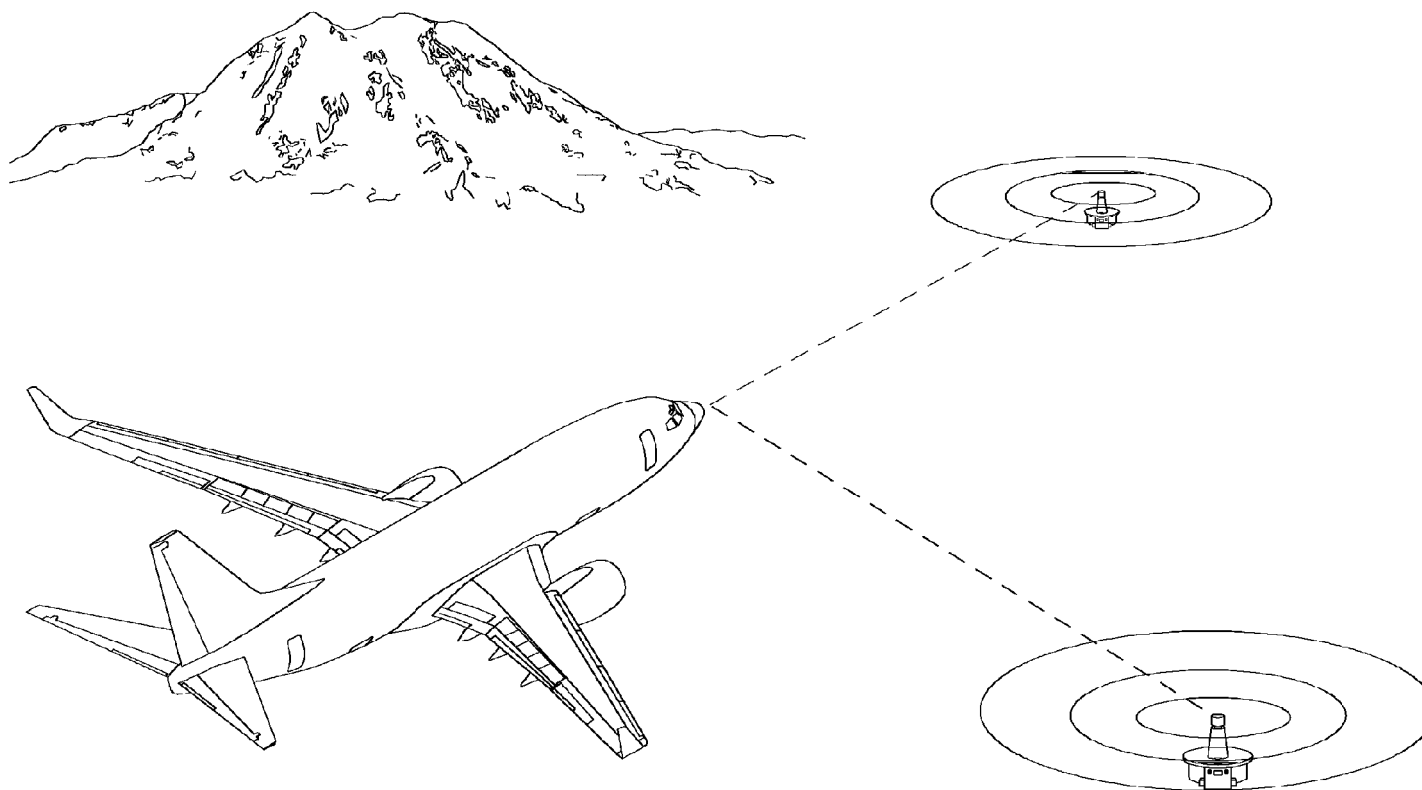

VHF OMNIDIRECTIONAL RANGING (VOR) SYSTEM - INTRODUCTION

EFFECTIVITY
HAP ALL

34-51-00

D633A101-HAP

Page 3
Oct 10/2004

34-51-00-001

VOR SYSTEM - GENERAL DESCRIPTION**General**

The VOR system has two VOR/marker beacon (VOR/MB) receivers. The receivers have VOR and marker beacon functions. This section covers only the VOR operation of the VOR/MB receivers.

The receiver sends VOR bearing data to the FCCs for the DFCS VOR/LOC mode of operation. The bearing data also goes to the FMCS as a radio navigation aid for present position calculations.

Description

The navigation (NAV) control panels give manual tune inputs to the VOR/MB receivers. There are two NAV control panels, one for the captain and one for the first officer.

RF signals from the VOR/LOC antenna go through power dividers, then to the VOR/MB receivers. The VOR/MB receivers use the RF signals to calculate station bearing and decode the morse code station identifier signal and station audio.

The receivers send VOR bearing to the remote magnetic indicator (RMI). You can select the RMI bearing pointers to show VOR or ADF station bearing with the RMI bearing pointer selectors.

The receivers send VOR bearing data to the display electronic units (DEU) for display. The NAV select switch lets the crew select VOR/MB receiver 1 or VOR/MB receiver 2 as the source for the captain and first officer displays.

The receivers send station audio and morse code station identifier signals to the remote electronic unit (REU).

EFFECTIVITY**HAP ALL****34-51-00**

D633A101-HAP

Page 4
Oct 10/2004

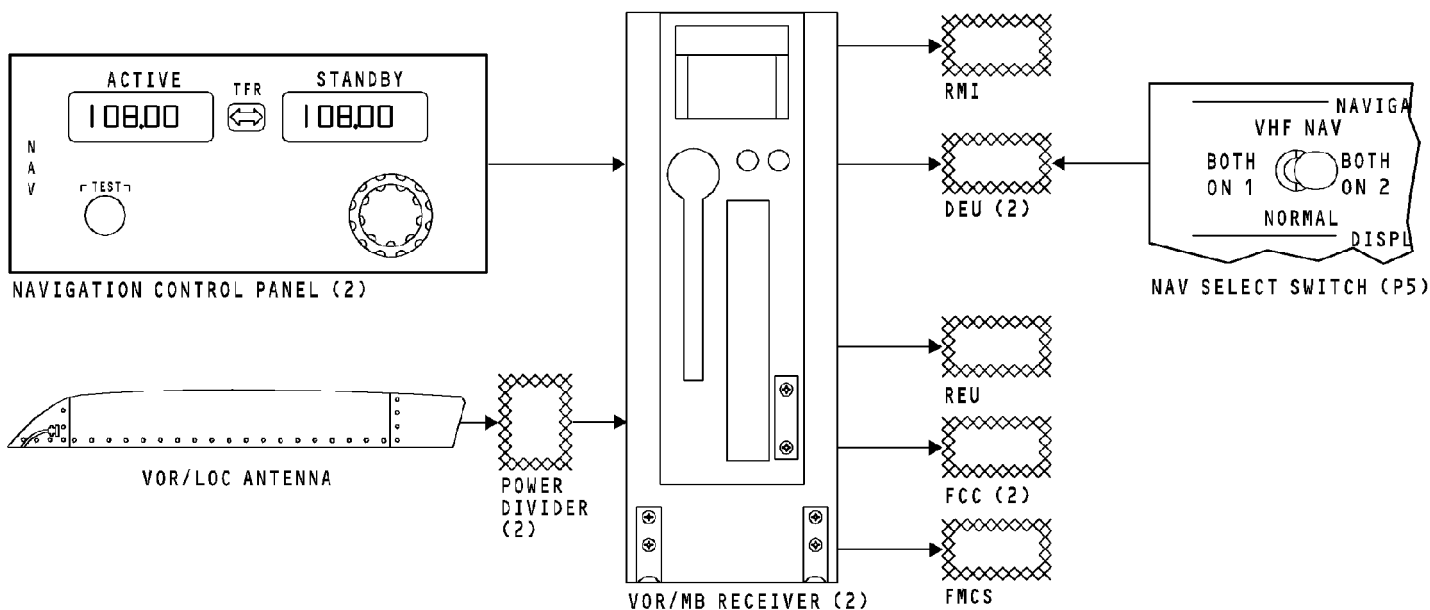

VOR SYSTEM - GENERAL DESCRIPTION

34-51-00-002

EFFECTIVITY
HAP 001-013, 015-026, 028-037

34-51-00

D633A101-HAP

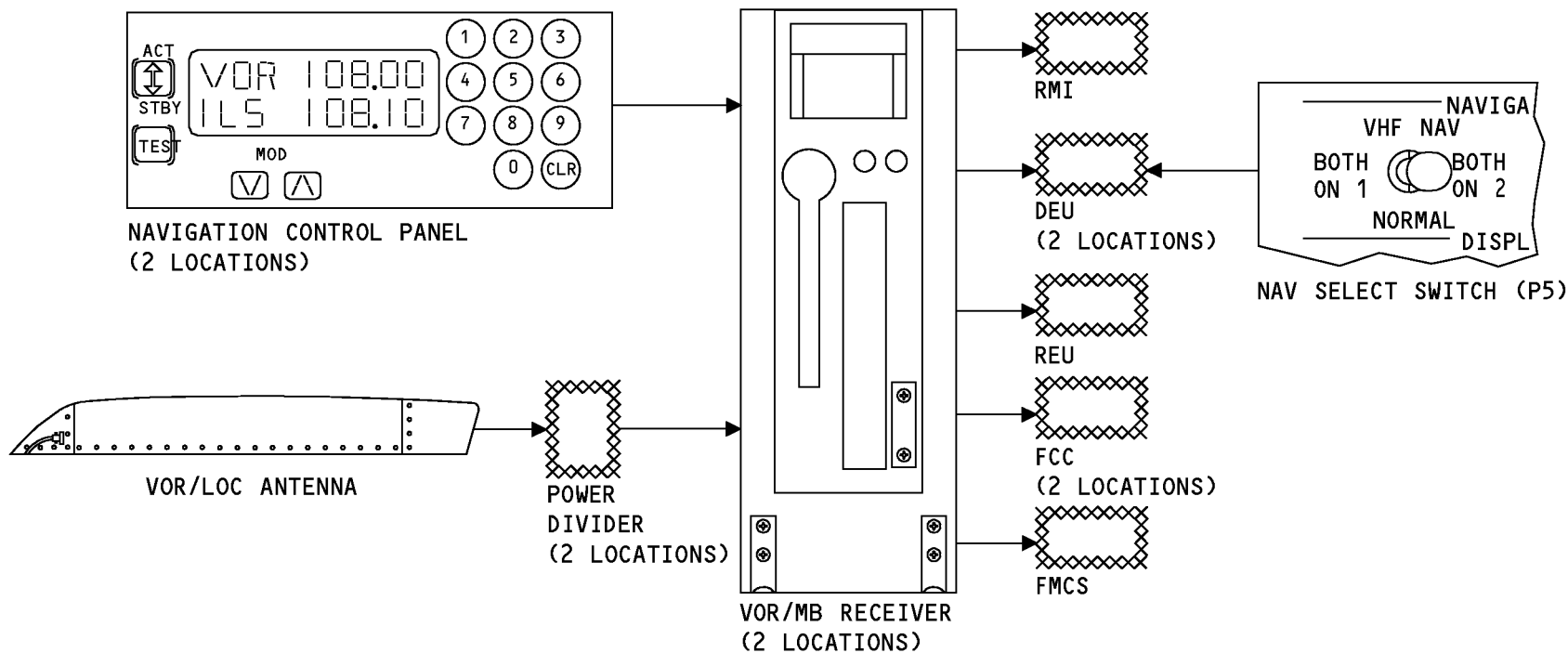

1738920 S0000314633_V1

VOR SYSTEM - GENERAL DESCRIPTION

34-51-00-002

EFFECTIVITY
HAP 038-054, 101-999

34-51-00

D633A101-HAP

Page 6
Jun 15/2009

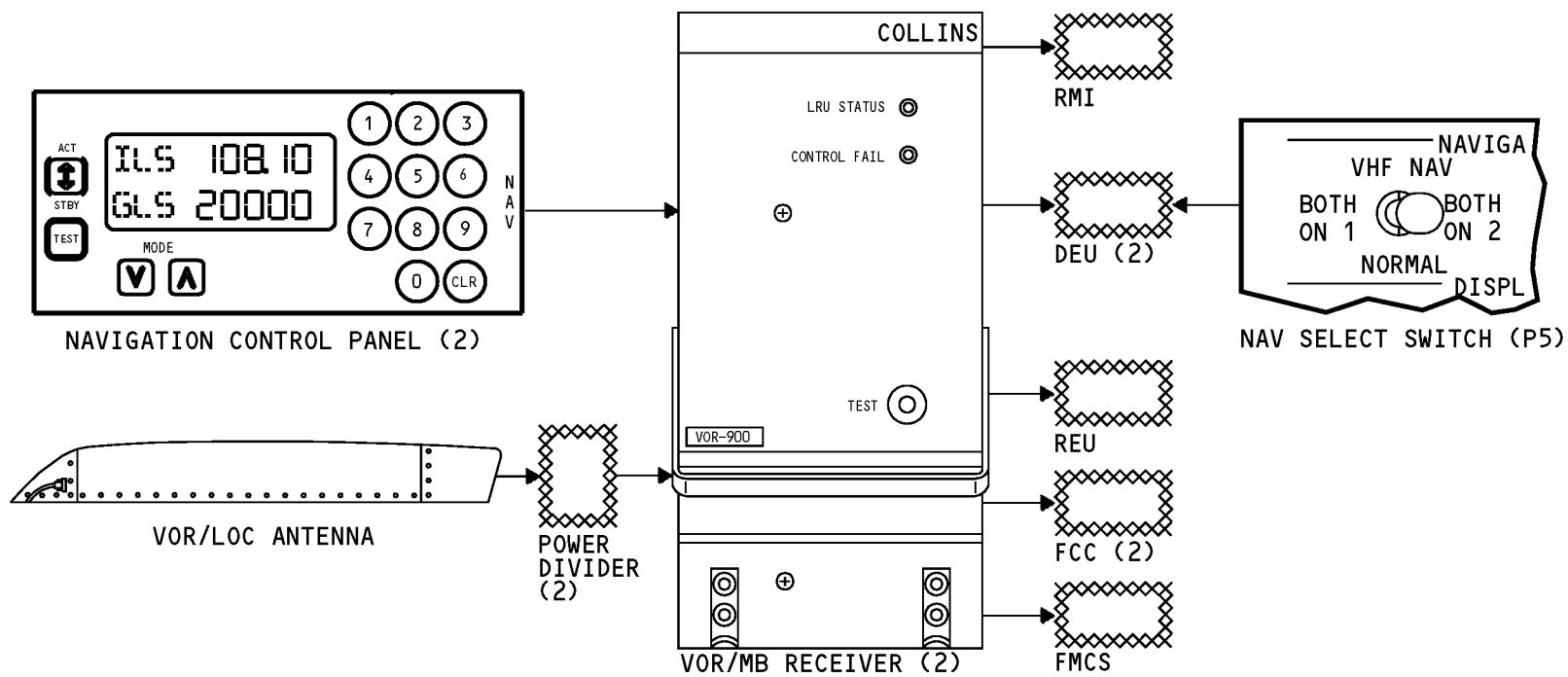

VOR SYSTEM - GENERAL DESCRIPTION

34-51-00-002

EFFECTIVITY
HAP 037

34-51-00

D633A101-HAP

VOR SYSTEM - FLIGHT COMPARTMENT COMPONENT LOCATION

General

These are the components in the flight compartment that interface with the VOR system:

- Captain's primary and secondary EFIS displays
- Left and right EFIS control panels
- First officer's primary and secondary EFIS displays
- Captain's and first officer's NAV control panel
- Captain's and first officer's audio control panel
- VHF NAV transfer switch.

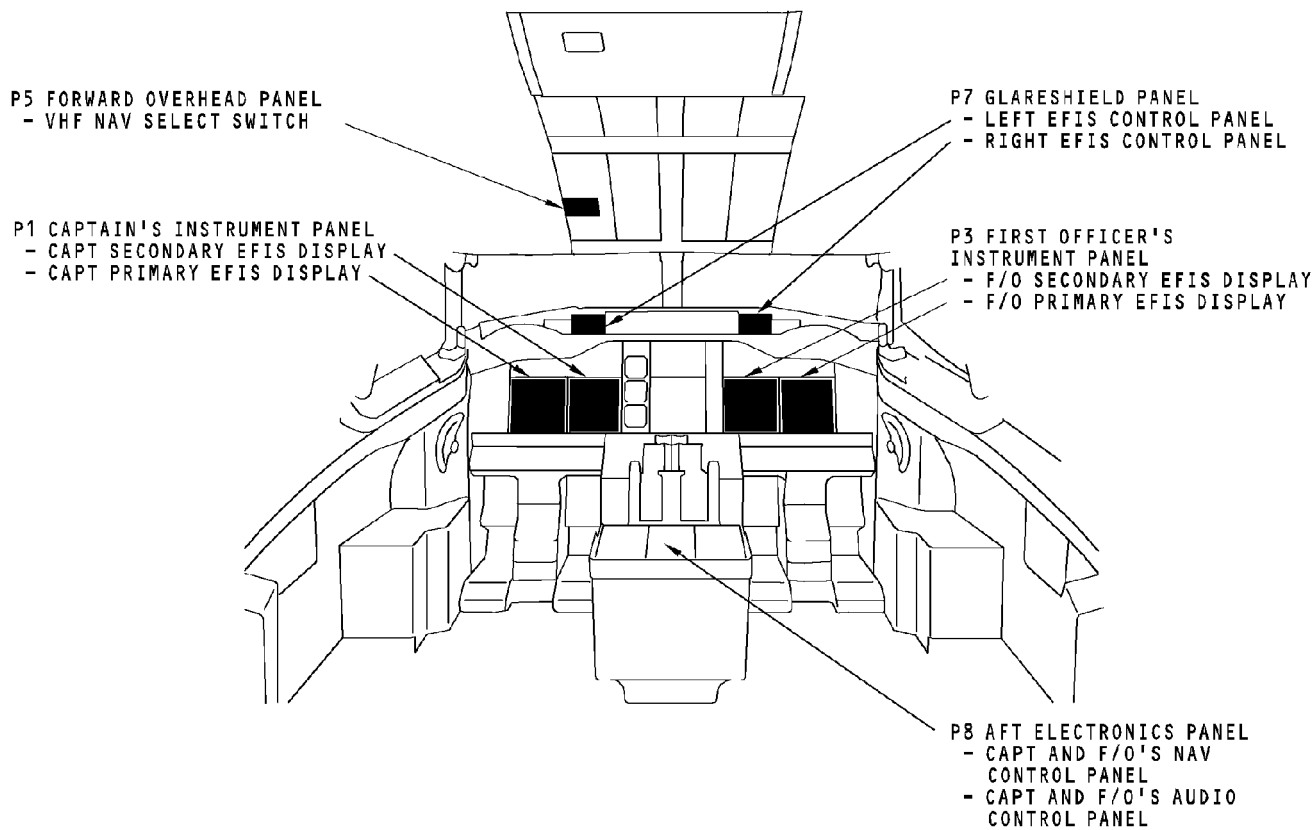

VOR SYSTEM - FLIGHT COMPARTMENT COMPONENT LOCATION

34-51-00-003

EFFECTIVITY
HAP ALL

34-51-00

D633A101-HAP

VOR SYSTEM - ANTENNA AND ELECTRONIC EQUIPMENT COMPARTMENT COMPONENT LOCATIONS

General

The VOR/LOC antenna is at the top of the vertical stabilizer.

VOR/MB receiver 1 is on the E1-2 shelf and VOR/MB receiver 2 is on the E1-4 shelf.

34-51-00-004

EFFECTIVITY
HAP ALL

34-51-00

D633A101-HAP

Page 10
Jun 10/2007

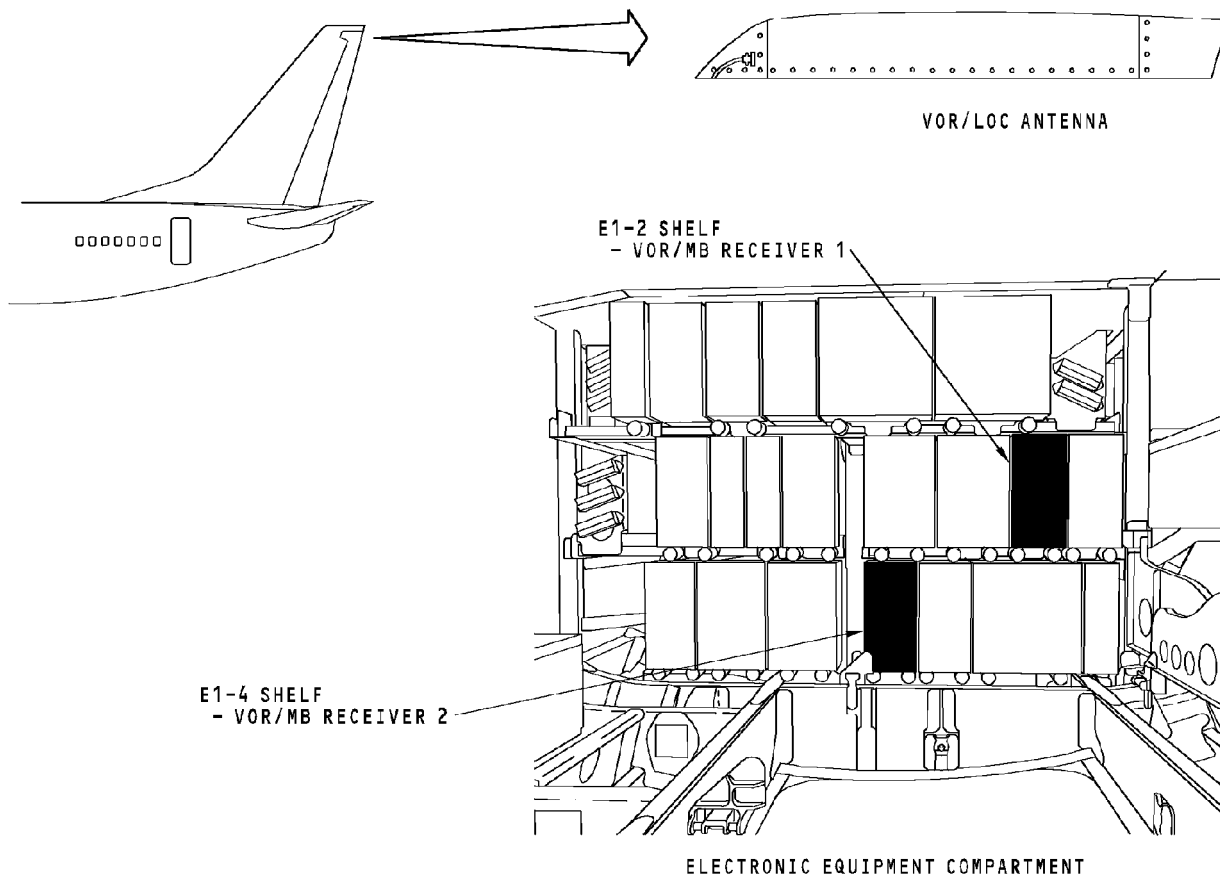

VOR SYSTEM - ANTENNA AND ELECTRONIC EQUIPMENT COMPARTMENT COMPONENT LOCATIONS

34-51-00-004

EFFECTIVITY
HAP ALL

34-51-00

D633A101-HAP

THIS PAGE IS INTENTIONALLY LEFT BLANK

34-51-00

D633A101-HAP

Page 12
Jun 10/2007

VOR SYSTEM - POWER AND ANALOG INTERFACE**General**

These are the components that have power and analog interface with the VOR system:

- Circuit breakers
- VOR antenna
- Navigation control panels
- Card files
- Remote electronics unit.

Circuit breakers

The VOR circuit breakers supply 115v ac power for receiver operation. VOR/MB receiver 1 gets power from the ac standby bus, section 1 and VOR/MB receiver 2 gets power from the ac transfer bus 2, section 2.

The NAV control panel circuit breakers supply 115v ac for control panel operation. The captain control panel gets power from the ac standby bus and the first officer control panel gets power from the ac transfer bus 2.

The NAV control panels receive 28v dc for control panel monitor operation and for the ILS 28v dc ILS tuned output when you tune an ILS frequency. The captain control panel receives 28v dc from the 28v dc standby bus, NAV sensor DC-1 circuit breaker. The first officer control panel receives 28v dc from the 28v dc bus 2, NAV sensor DC-2 circuit breaker.

HAP 037

The NAV control panels receive 28v dc for control panel monitor operation and for the GLS 28v dc GLS tuned output when you tune a GLS channel. The captain control panel receives 28v dc from the 28v dc standby bus, NAV sensor DC-1 circuit breaker. The first officer control panel receives 28v dc from the 28v dc bus 2, NAV sensor DC-2 circuit breaker.

HAP 001-013, 015-026, 028-036, 038-054, 101-999**VOR/LOC Antenna**

The VOR/LOC antenna sends RF signals through the RF power divider 1 and RF power divider 2, to the VOR/MB receivers.

HAP 037**VOR/LOC/GLS Antenna**

The VOR/LOC/GLS antenna sends RF signals through the RF power divider 1 and RF power divider 2, to the VOR/MB receivers.

HAP ALL

34-51-00-005

EFFECTIVITY
HAP ALL**34-51-00**

D633A101-HAP

Page 13
Feb 15/2009

VOR SYSTEM - POWER AND ANALOG INTERFACE**PSEU**

The VOR/MB receivers get air/ground inputs from the proximity switch electronics unit (PSEU). The receiver uses the inputs to set the flight leg count for internal memory, and also inhibit test in the air.

REU

The remote electronics unit (REU) receives morse code station identifier signals and station audio from the VOR/MB receivers and supplies them to the flight interphone speakers and headsets.

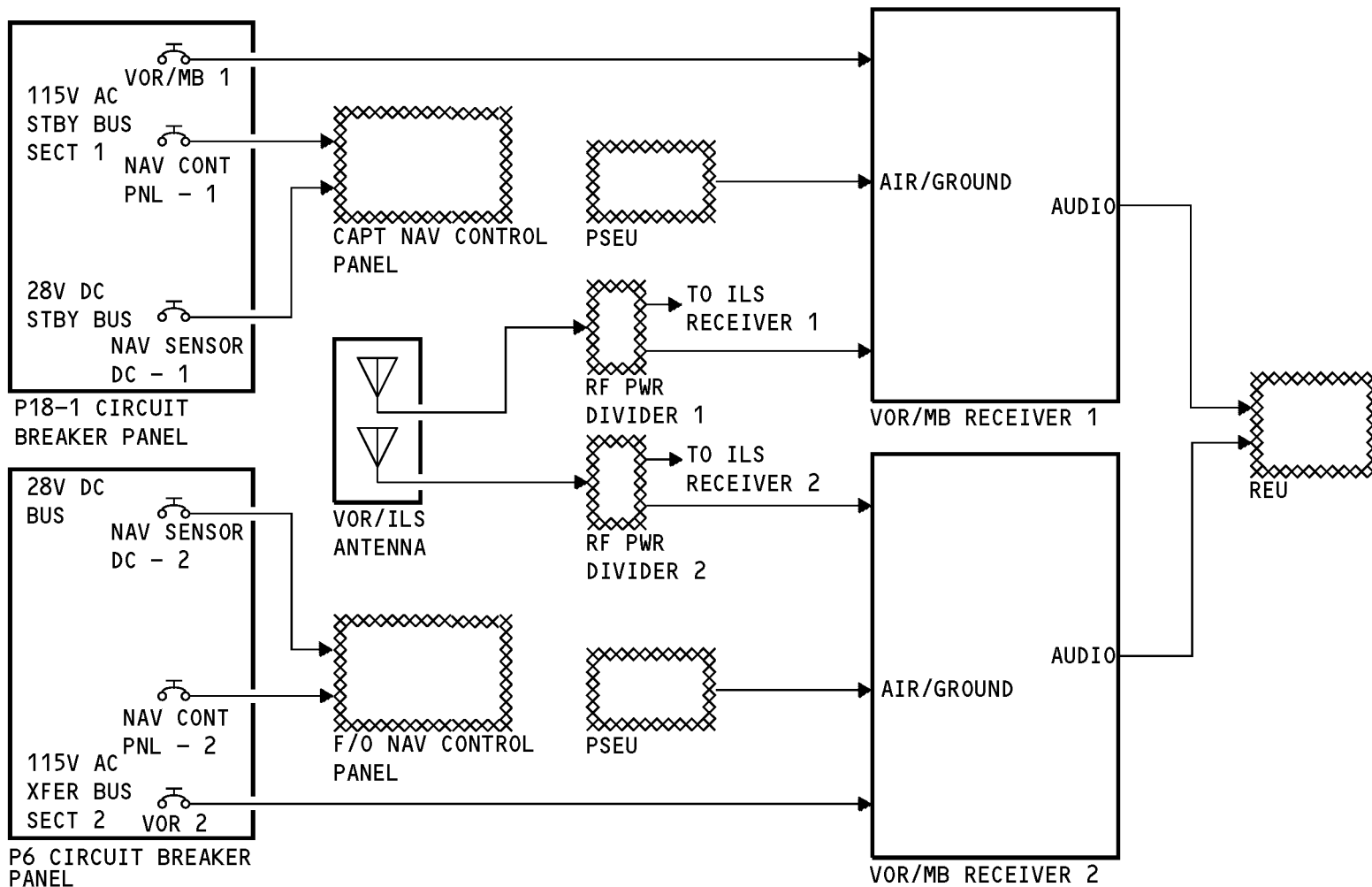

VOR SYSTEM - POWER AND ANALOG INTERFACE

EFFECTIVITY

HAP 001-013, 015-026, 028-036, 038-054, 101-999

34-51-00

D633A101-HAP

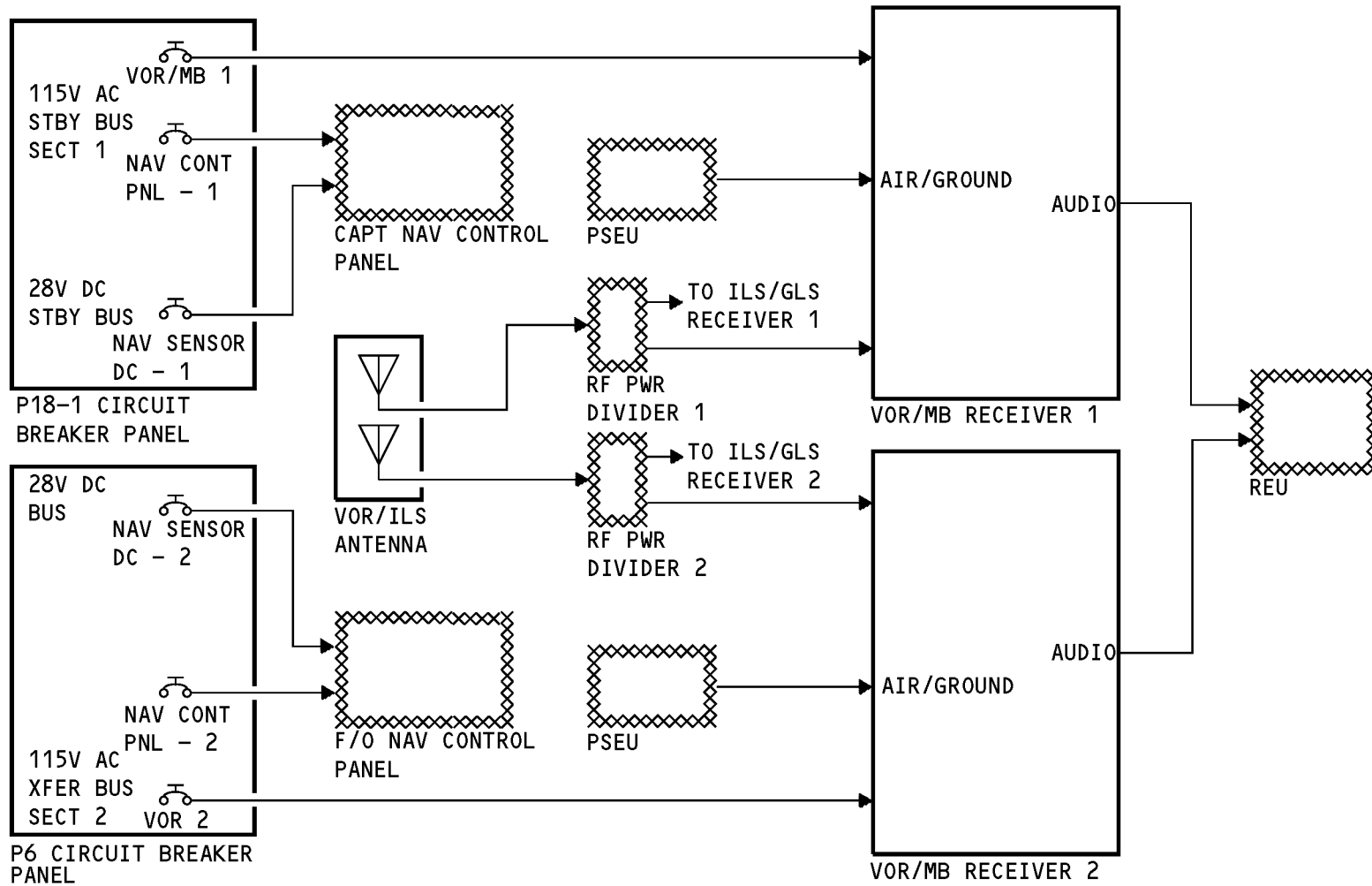

VOR SYSTEM - POWER AND ANALOG INTERFACE

EFFECTIVITY
HAP 037

34-51-00

D633A101-HAP

THIS PAGE IS INTENTIONALLY LEFT BLANK

34-51-00

D633A101-HAP

Page 17
Jun 10/2007

VOR SYSTEM - DIGITAL INTERFACE

General

All digital interfaces are on ARINC 429 data buses. These are the components that have digital interface with the VOR/MB receivers:

- Captain and first officer NAV control panel
- Flight data acquisition unit (FDAU)
- Radio magnetic indicator (RMI)

HAP 001-013, 015-026, 028-036

- Flight management computer (FMC)

HAP 037-054, 101-999

- Flight management computers (FMC 1, FMC 2)

HAP ALL

- Flight control computer (FCC) A
- FCC B
- Display electronics unit (DEU) 1
- DEU 2.

NAV Control Panel

The captain and first officer NAV control panels send manual tune and test command inputs to the VOR/MB receivers. The NAV control panels send tune inputs and test commands out on two data buses. One data bus goes to the multi mode receivers (MMR) and one data bus goes to both the VOR receiver and the DME interrogators.

VOR/MB Output

The VOR/MB receivers each have two output buses. One output bus from each receiver goes to the on-side FCC. VOR/MB receiver 1 supplies VOR data and status to FCC A. VOR/MB receiver 2 supplies VOR data and status to FCC B. The FCCs use the data for the autopilot VOR mode of operation.

The other output bus of each receiver sends VOR data and status to these components:

- FDAU for data to record by the digital flight data recorder
- RMI for bearing pointer displays

HAP 001-013, 015-026, 028-036

- FMC for position update calculations

HAP 037-054, 101-999

- FMC 1 and FMC 2 for position update calculations

HAP ALL

- DEUs for VOR displays.

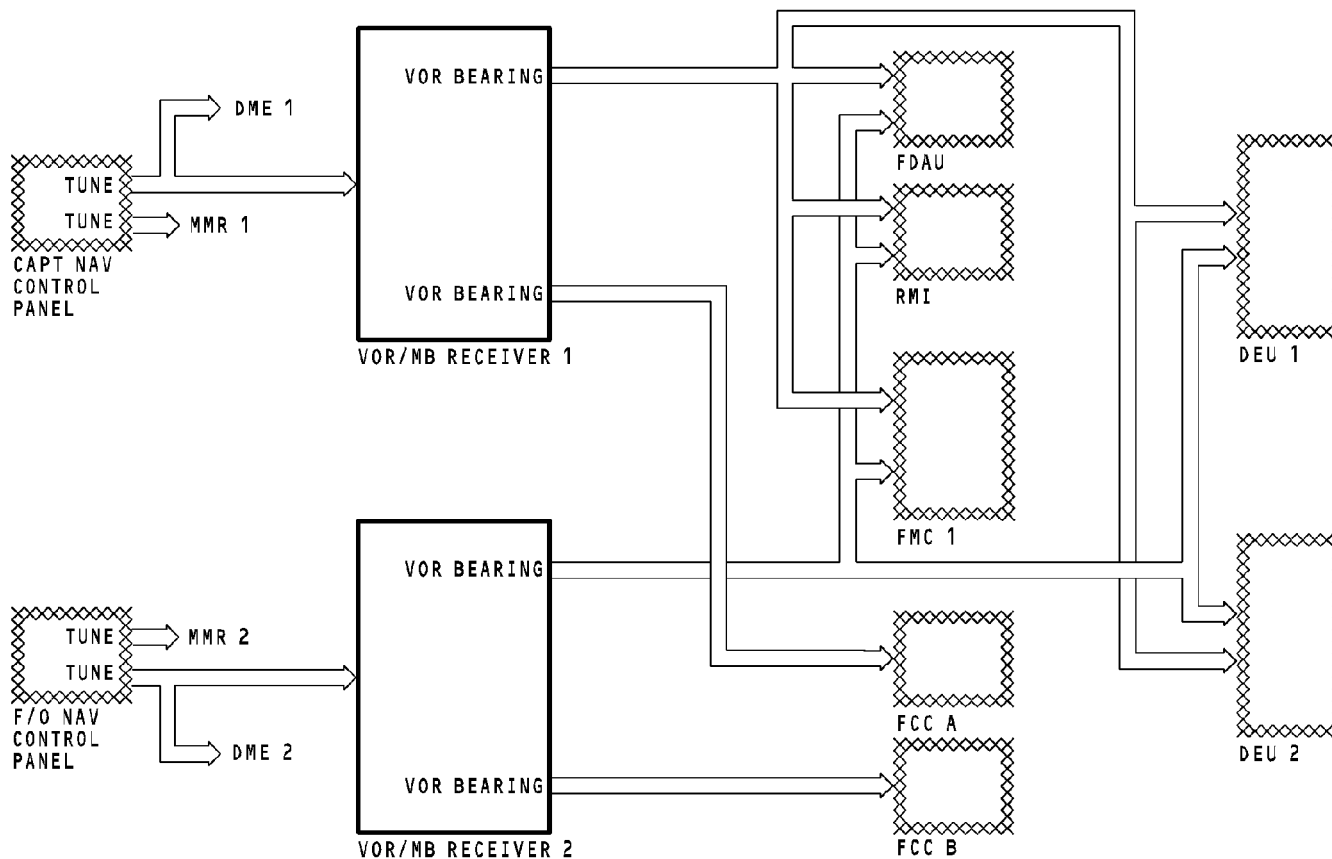

VOR SYSTEM - DIGITAL INTERFACE

34-51-00-006

EFFECTIVITY
HAP 001-013, 015-026, 028-036

34-51-00

D633A101-HAP

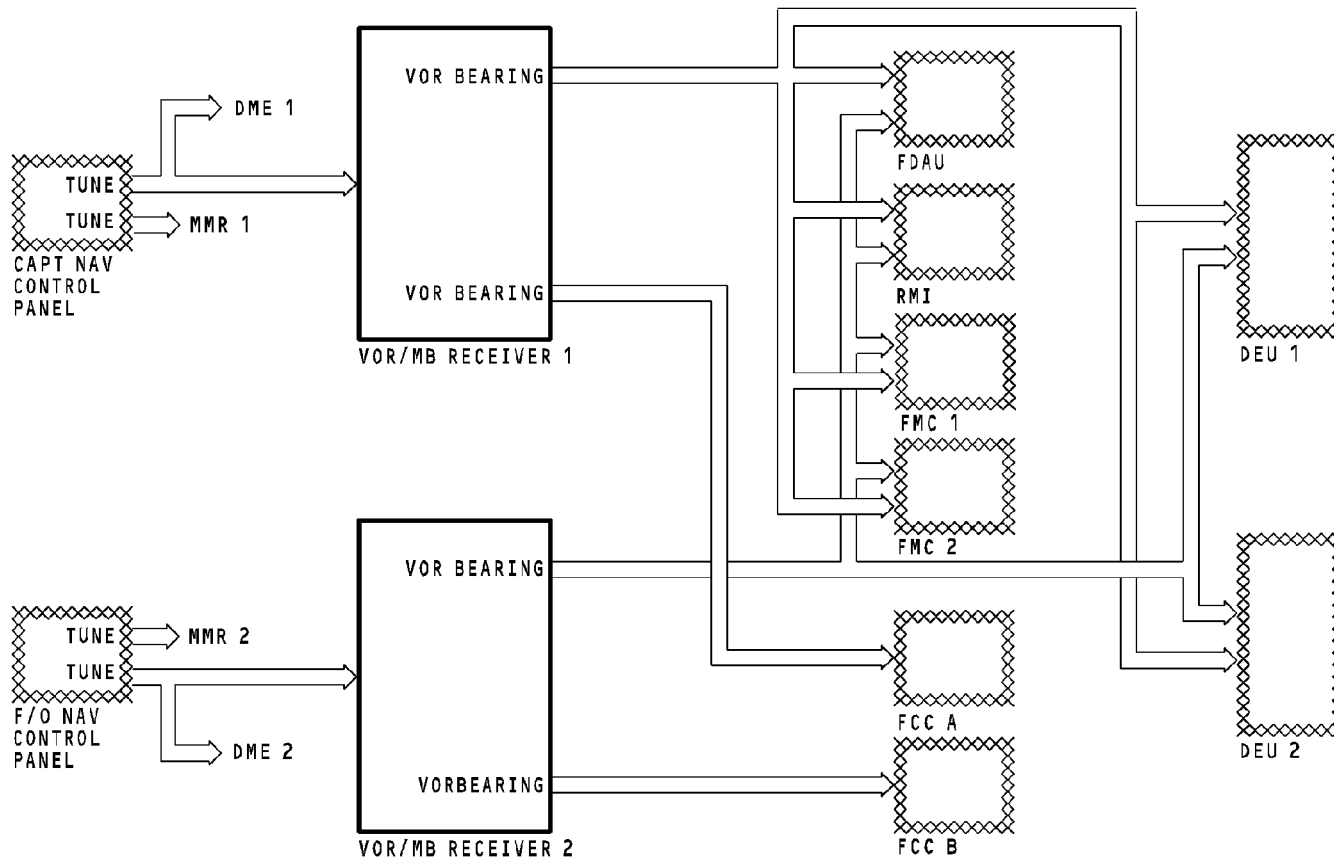

VOR SYSTEM - DIGITAL INTERFACE

EFFECTIVITY
HAP 037-054, 101-999

34-51-00

D633A101-HAP

THIS PAGE IS INTENTIONALLY LEFT BLANK

34-51-00

D633A101-HAP

Page 21
Jun 10/2007

VOR SYSTEM - VOR/MB RECEIVER**General**

The VOR/marker beacon (VOR/MB) receiver contains the VOR receiver function and the marker beacon function. The VOR/MB receiver supplies magnetic bearing data from a VOR ground station.

Description

The VOR/MB receiver is a standard ARINC 3 MCU unit with dimensions approximately 3.58"x 7.64"x 12.56". The receiver weighs 8.6 pounds and uses 115v ac 400 Hz power for operation.

The receiver has a non-volatile flight fault memory. Only shop personnel can use this feature.

Test and Indications

There are two switches and an LCD on the front panel of the VOR/MB receiver. You use one of the two switches to start a test of the VOR/MB receiver. The LCD shows the test results. When you do a test of the VOR/MB receiver, you do a test of the VOR function and the marker beacon function in the receiver at the same time.

There is a memory card slot on the front of the VOR/MB receiver. Shop personnel use this feature to put in a flash memory card. The flash memory card loads software into the LRU. The memory card can also store LRU data sent by the LRU during operation. These features are not for use by line maintenance personnel.

Shop personnel use the RS 232 connector to connect shop test equipment to the LRU. This feature is not for use by line maintenance personnel.

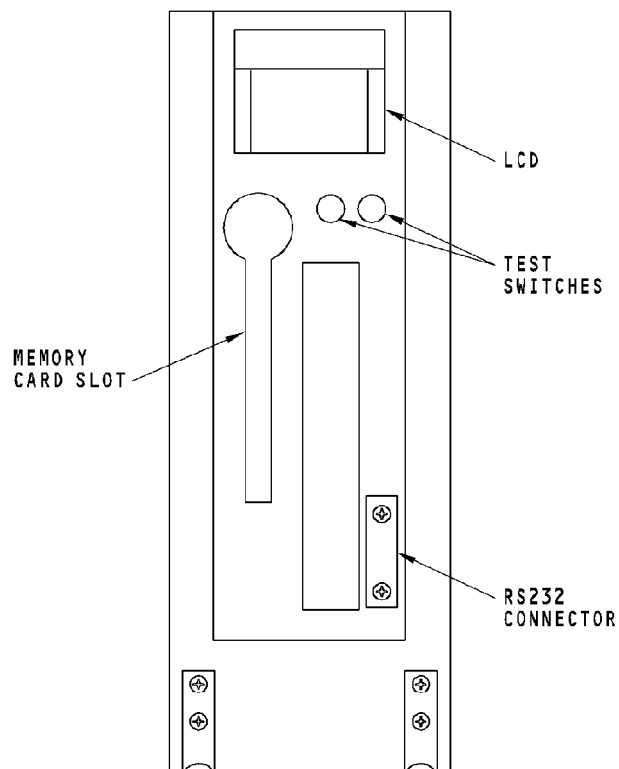

VOR SYSTEM - VOR/MB RECEIVER

EFFECTIVITY
HAP ALL

34-51-00

D633A101-HAP

Page 23
Jun 10/2007

34-51-00-007

VOR SYSTEM - ANTENNA

General

The VOR/LOC antenna is on the top of the vertical stabilizer.

The VOR antenna receives RF signals in the frequency range of 108 MHz to 117.95 MHz. The antenna receives VOR and localizer frequencies. The VOR/LOC antenna sends VOR signals to both VOR/MB receivers.

34-51-00-008

EFFECTIVITY
HAP ALL

34-51-00

D633A101-HAP

Page 24
Oct 10/2007

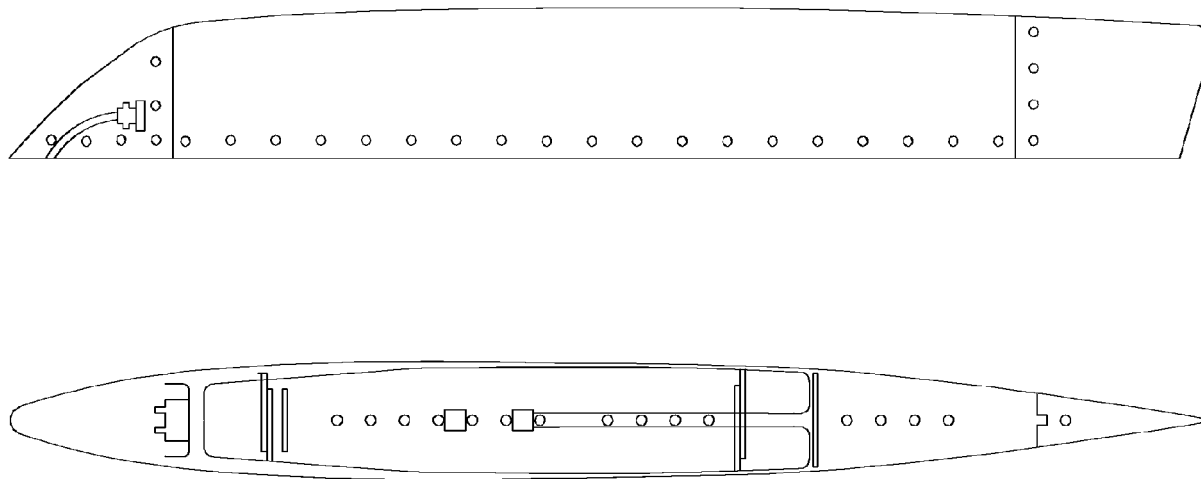

VOR SYSTEM - ANTENNA

34-51-00-008

EFFECTIVITY
HAP ALL

34-51-00

D633A101-HAP

THIS PAGE IS INTENTIONALLY LEFT BLANK

34-51-00

D633A101-HAP

Page 26
Jun 10/2007

VOR SYSTEM - NAVIGATION CONTROL PANEL**General****HAP 001-013, 015-026, 028-036, 038-054, 101-999**

The navigation (NAV) control panel supplies frequency inputs and test commands to the DME, ILS, and VOR navigation radios.

HAP 037

The navigation (NAV) control panel supplies frequency/channel inputs and test commands to the DME, ILS, GLS and VOR navigation radios.

HAP ALL**Operation**

The NAV control panel has an active frequency display window and a standby frequency display window. The frequency that shows in the active frequency display window is the frequency that the navigation radios use for operation. The standby frequency display window shows the next frequency you want to use.

The transfer switch is a momentary action switch that transfers the frequency in the standby frequency display window to the active frequency display window. When you push the switch, the frequency that is in the active frequency display window transfers to the standby frequency display window.

HAP 001-013, 015-026, 028-036, 038-054, 101-999

The frequency select control is a continuous rotary knob. There is an inner knob and an outer knob. The outer knob sets the tens and ones digits. The inner knob sets the tenths and one hundredths digits.

HAP ALL

At power up, the frequency displays show the last frequency entry before power down.

The NAV control panel continuous bite monitors control panel operation. The NAV control panel shows FAIL in the active and standby frequency display windows when there is a failure.

An internal monitor in the NAV control panel monitors the 28v dc input. If the monitor does not see the 28v dc input, it will show the message BLANK in both the active and standby frequency display windows.

When you set a VOR frequency in the range of 108 Mhz to 117.95 Mhz, the NAV control panel sends the frequency to the VOR/MB receivers and DME interrogators. The control panel sets the data word to the ILS receivers to NCD.

EFFECTIVITY
HAP ALL

VOR SYSTEM - NAVIGATION CONTROL PANEL**HAP 037**

When you set a VOR frequency in the range of 108 Mhz to 117.95 Mhz, the NAV control panel sends the frequency to the VOR/MB receivers and DME interrogators. The control panel sets the data word to the GLS receivers to NCD.

HAP ALL**Test****HAP 001-013, 015-026, 028-036, 038-054, 101-999**

When you push the NAV control panel test switch, a test command goes out to the VOR/MB receiver, ILS receiver, and DME interrogator. If a VOR frequency shows in the active frequency window, the test command goes to only the VOR/MB receiver. IF an ILS frequency shows in the active frequency window, the control panel sends a test command to only the ILS receiver. If there is a DME frequency that is paired with the VOR or ILS frequency, a test command also goes to the DME interrogators.

HAP 037

When you push the NAV control panel test switch, a test command goes out to the VOR/MB receiver, ILS receiver, GLS receiver, and DME interrogator. If a VOR frequency shows in the active frequency window, the test command goes to only the VOR/MB receiver. IF an ILS frequency or GLS channel shows in the active frequency window, the control panel sends a test command to the ILS receiver or GLS receiver. If there is a DME frequency that is paired with the VOR or ILS frequency, a test command also goes to the DME interrogators.

NOTE: Ground Based Augmentation System (GBAS) must be available to run the GLS test.

HAP ALL

When you do a test of the master dim and test system, the NAV control panel shows 188.88. The display shows for two seconds on then one second off until the test is complete.

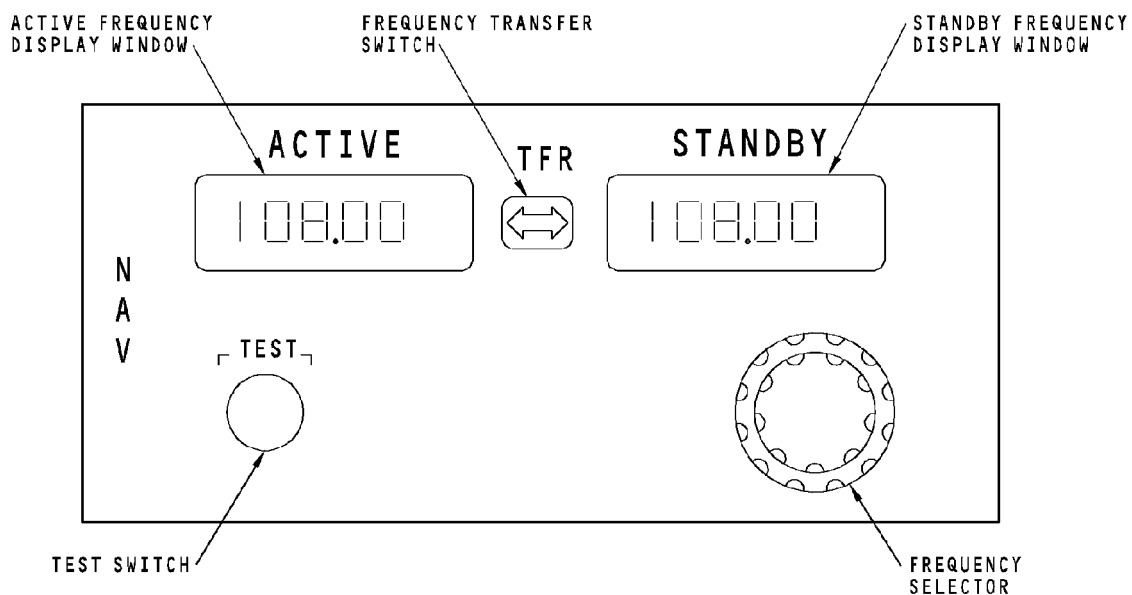

VOR SYSTEM - NAVIGATION CONTROL PANEL

34-51-00-009

EFFECTIVITY
HAP 001-013, 015-026, 028-036

34-51-00

D633A101-HAP

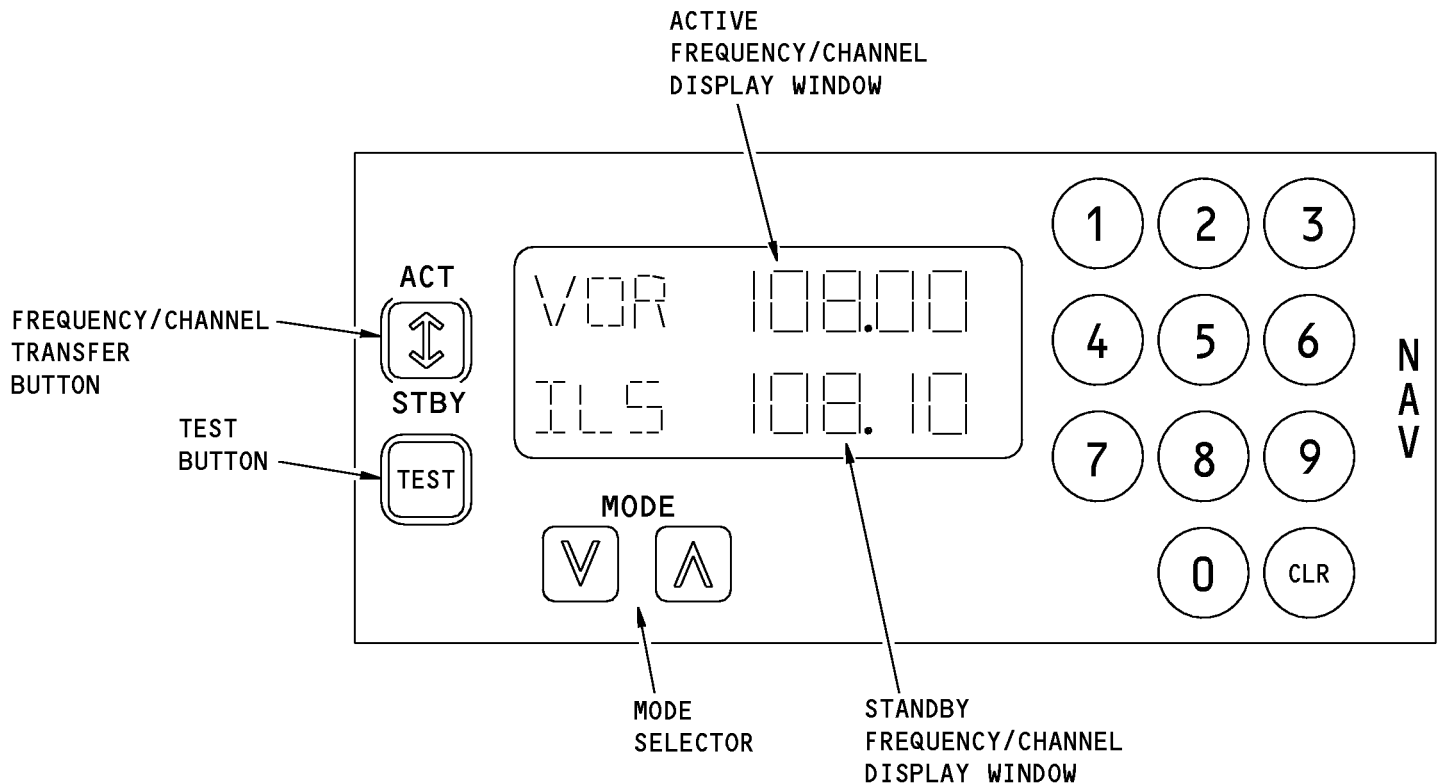

1738911 S0000314648_V1

VOR SYSTEM - NAVIGATION CONTROL PANEL

34-51-00-009

EFFECTIVITY
HAP 038-054, 101-999

34-51-00

D633A101-HAP

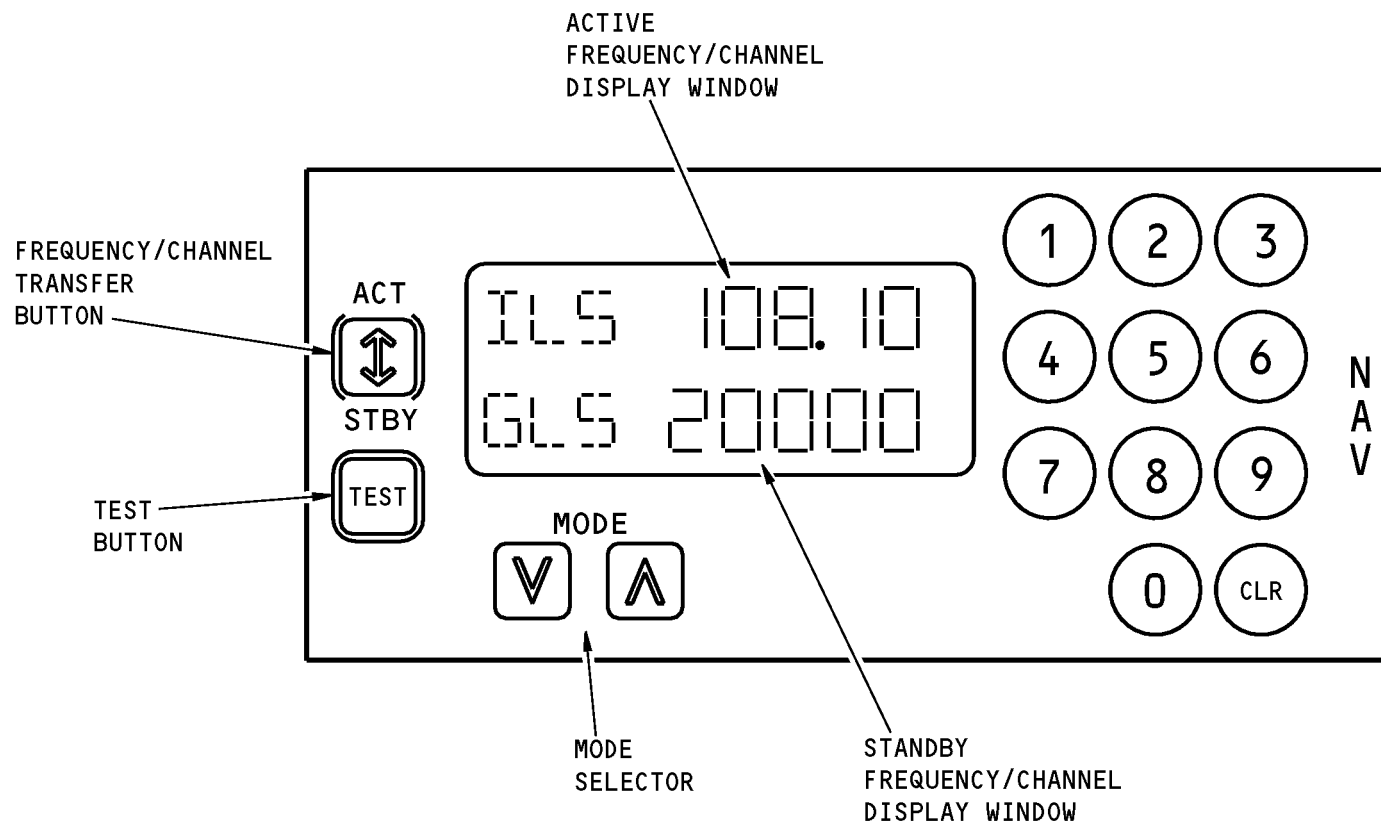

VOR SYSTEM - NAVIGATION CONTROL PANEL

34-51-00-009

EFFECTIVITY
HAP 037

34-51-00

D633A101-HAP

THIS PAGE IS INTENTIONALLY LEFT BLANK

34-51-00

D633A101-HAP

Page 32
Feb 15/2009

VOR SYSTEM - FUNCTIONAL DESCRIPTION**General**

The receiver contains VOR and marker beacon functions. This section only covers the VOR function.

Operation

Frequency tune inputs from the NAV control panel go to an ARINC 429 receiver in the VOR/MB receiver, then to the processor. The processor sends the tune inputs to the frequency synthesizer to tune the receiver circuits.

The control panel sends a discrete to the REU when you tune a VOR frequency. The REU uses the discrete to select VOR audio inputs.

HAP 001-013, 015-026, 028-036, 038-054, 101-999

When you tune a VOR frequency, the control panel also sends a discrete to the DEUs. The DEUs use the discrete to display VOR or ILS as the frequency data source on the lower left corner of the captain and first officer NAV displays.

HAP 037

When you tune a VOR frequency, the control panel also sends a discrete to the DEUs. The DEUs use the discrete to display VOR, ILS or GPS as the frequency/channel data source on the lower left corner of the captain and first officer NAV displays.

HAP ALL

The processor sends fault data to the memory card. Only shop personnel can read the memory card contents.

The air/ground discrete input from the PSEU inhibits a VOR test when the airplane is in the air. The receiver also uses the discrete for flight leg count.

HAP 001-013, 015-026, 028-036, 038-054, 101-999

RF input signals from the VOR/ILS antenna go through the power divider then to the receiver circuits in the VOR/MB receiver. The receiver circuits send audio and morse code station identifier signals from the ground station to the audio processor.

HAP 037

RF input signals from the VOR/ILS/GLS antenna go through the power divider then to the receiver circuits in the VOR/MB receiver. The receiver circuits send audio and morse code station identifier signals from the ground station to the audio processor.

HAP ALL

The audio processor sends the audio and morse code station identifier signal to the audio output circuits then to the remote electronics unit.

VOR SYSTEM - FUNCTIONAL DESCRIPTION

The morse decoder circuit decodes the station identifier and puts it in digital format then sends it to the ARINC 429 transmitter. The display electronic units (DEU 1 & 2), use the data to show the station identifier.

The VOR/MB VOR receiver circuits send the antenna inputs to the bearing processor which calculates the VOR station bearing. Data from the bearing processor goes to the ARINC 429 transmitter. The VOR/MB receiver transmits VOR bearing and receiver status on two output buses.

Output bus 1 goes to the onside FCC. Output bus 2 goes to these components:

- Flight data acquisition unit (FDAU)
- Radio magnetic indicator (RMI)
- Flight management computers (FMC)
- Display electronic units (DEU).

Test

When you push the test switch on the NAV control panel, a test command goes to the receiver when a VOR frequency is the active frequency. When the processor receives a test command, it monitors the VOR/MB receiver operation and control input status. Test results show on the LCD when you do a test from the front panel switches.

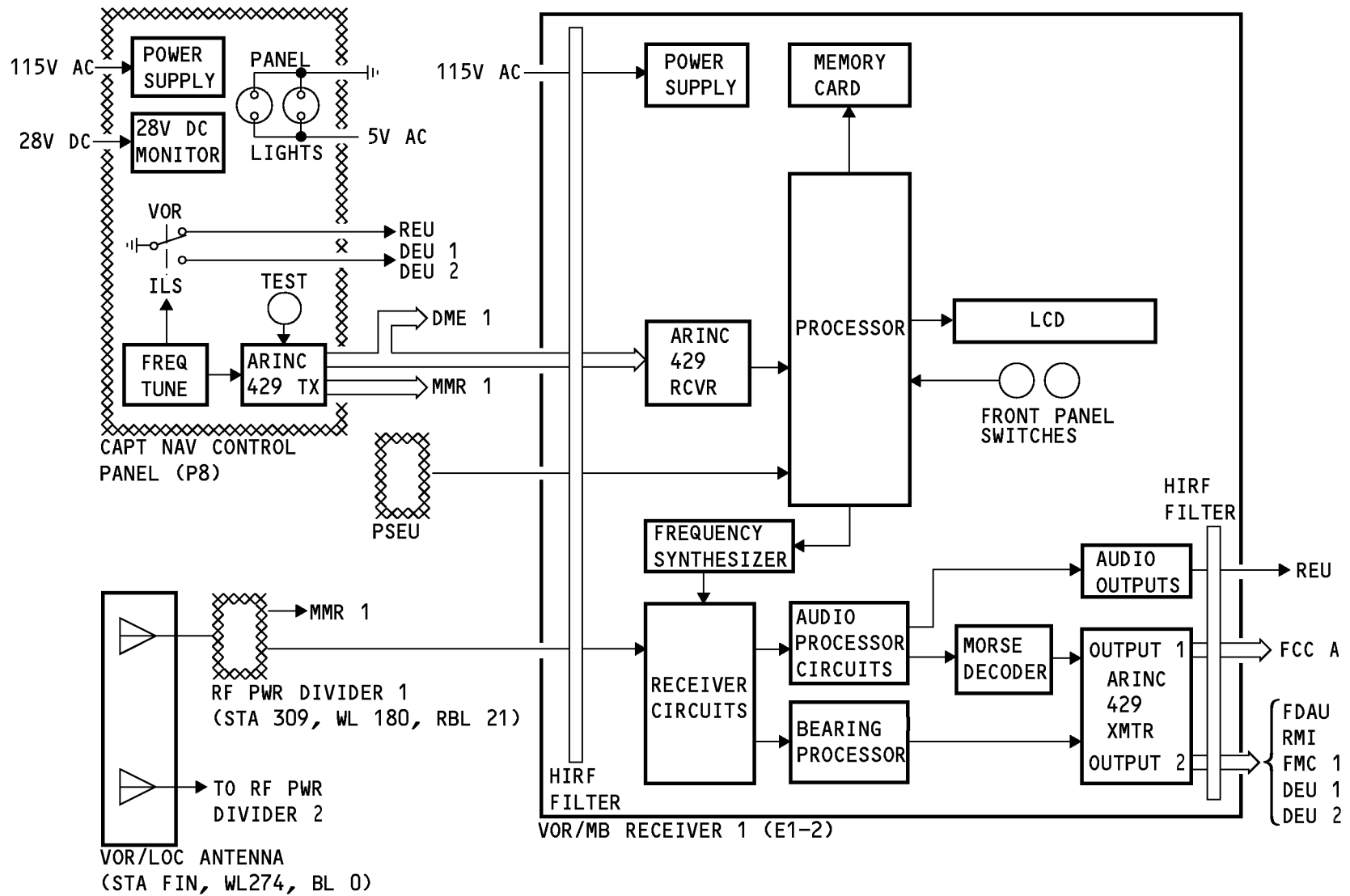

VOR SYSTEM - FUNCTIONAL DESCRIPTION

34-51-00-010

EFFECTIVITY
HAP ALL

34-51-00

D633A101-HAP

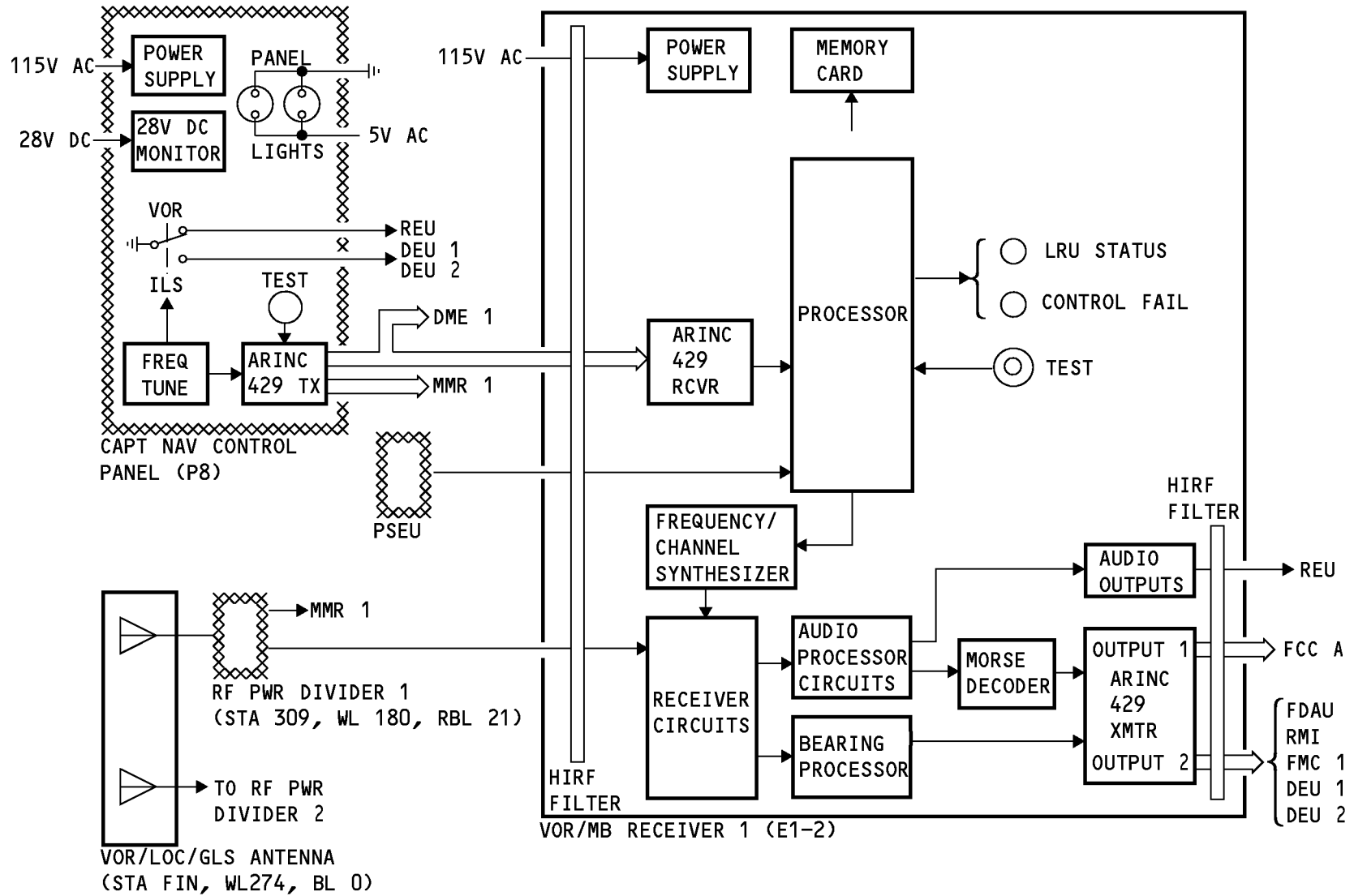

VOR SYSTEM - FUNCTIONAL DESCRIPTION

EFFECTIVITY
HAP 037

34-51-00

D633A101-HAP

THIS PAGE IS INTENTIONALLY LEFT BLANK

34-51-00

D633A101-HAP

Page 37
Feb 15/2009

VOR SYSTEM - FREQUENCY TRANSFER AND INSTRUMENT SWITCHING

Frequency Transfer Switch

The frequency transfer switch on the NAV control panel transfers the frequency in the standby window display, to the active window display.

The transfer switch also provides a discrete to the FCCs. The FCCs use the discrete to disengage the autopilot when the autopilot system is in the VOR mode and the crew changes the VOR frequency.

Instrument Switching Module

The instrument switching module on the P5 overhead panel provides discrettes to the display electronics unit (DEU) for display switching when you move the switch to the both on 1 or both on 2 position.

With the switch in the both on 1 position, the DEU's use VOR data from VOR/MB receiver 1 for display. With the switch in the both on 2 position the DEU's use VOR data from VOR/MB receiver 2 for display.

The instrument switching module also sends discrettes to the FCC when you move the switch out of the normal position.

34-51-00-011



34-51-00

D633A101-HAP

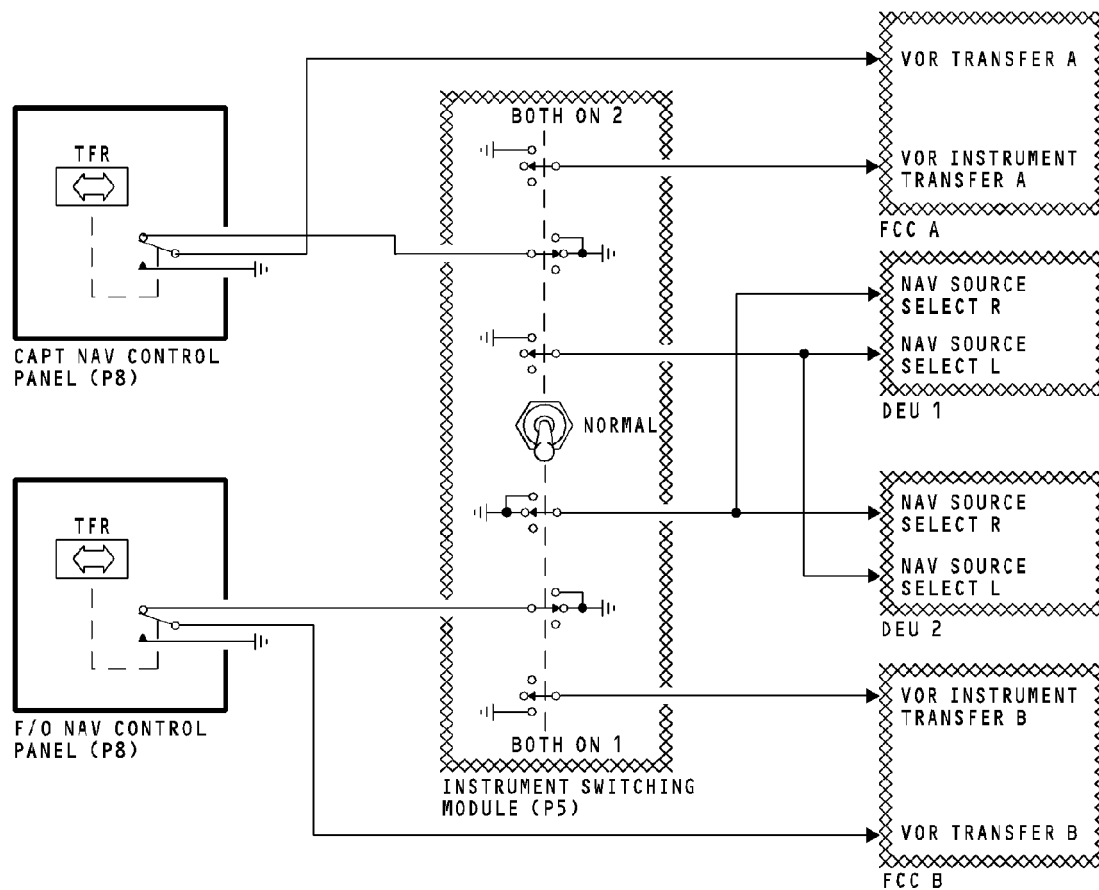

VOR SYSTEM - FREQUENCY TRANSFER AND INSTRUMENT SWITCHING

34-51-00-011

**EFFECTIVITY
HAP ALL**

34-51-00

D633A101-HAP

VOR SYSTEM - CONTROLS**EFIS Controls**

To show VOR displays on the captain's and F/O's secondary EFIS display, set the mode selector on the EFIS control panel to the VOR position.

VOR data shows when the mode selector is in the VOR position and a valid VOR frequency is active on the NAV control panels.

The VOR/ADF switches make the NAV display bearing pointers show either VOR or ADF station bearing. In the OFF position, the bearing pointers go out of view.

DFCS Controls

The digital flight control system (DFCS) mode control panel (MCP) supplies course data to the display electronics unit (DEU) for VOR displays. You use the DFCS MCP course select control to enter a course for the VOR station.

The DEU uses the course input and VOR bearing data from the VOR/MB receiver to calculate the airplane deviation from the VOR course.

Audio Control Panel Controls

The audio control panels (ACP) permit the crew to listen to VOR station audio or the morse code station identifier.

You use the ACP volume control switches to select the VOR/MB system you want to listen to. The NAV 1 volume control selects the VOR/MB receiver 1 audio and the NAV 2 volume control selects VOR/MB receiver 2 audio.

The voice/range selector permits you to listen to only voice audio in the voice (V) position. The range (R) position permits you to listen to the station morse code identifier. With the selector in the both (B) position, you can listen to both the voice audio and the morse code station identifier.

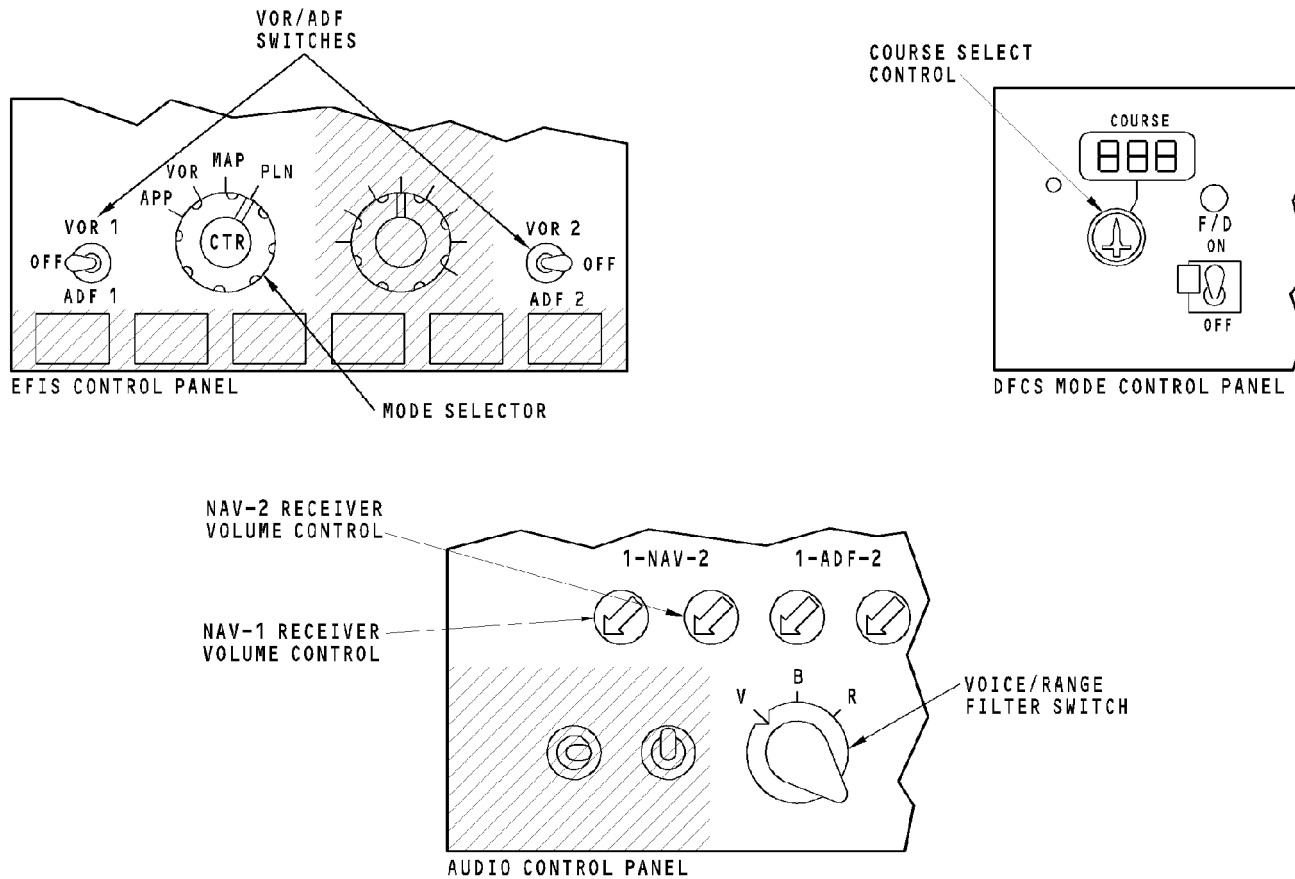

VOR SYSTEM - CONTROLS

34-51-00-012

EFFECTIVITY
HAP ALL

34-51-00

D633A101-HAP

VOR SYSTEM - RADIO MAGNETIC INDICATOR DISPLAYS**General**

The radio magnetic indicator (RMI) shows bearing data to a VOR or ADF station with reference to the airplane magnetic heading.

The RMI has two bearing pointers. There is a fail flag for bearing pointer 1, and a fail flag for bearing pointer 2. The bearing pointer 1 and flag 1 show bearing and status from the VOR/MB receiver 1 or ADF receiver 1. The bearing pointer 2 and flag 2 show bearing and status from the VOR/MB receiver 2 or ADF receiver 2.

Set the bearing pointer VOR/ADF selectors to VOR to show VOR bearing on bearing pointers 1 and 2.

With the VOR/ADF selectors in the VOR position, the fail flags show for invalid data from the VOR/MB receivers.

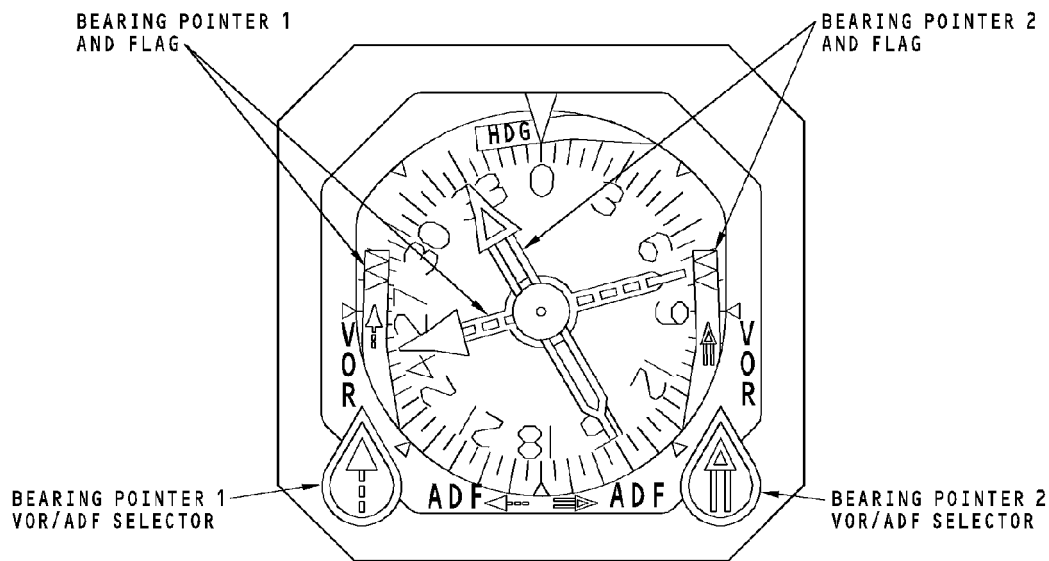

VOR SYSTEM - RADIO MAGNETIC INDICATOR DISPLAYS

34-51-00-015

EFFECTIVITY
HAP ALL

34-51-00

D633A101-HAP

Page 43
Feb 15/2009

THIS PAGE IS INTENTIONALLY LEFT BLANK

34-51-00

D633A101-HAP

Page 44
Feb 15/2009

VOR SYSTEM - EFIS NORMAL DISPLAYS**General**

VOR data shows on the captain and first officer displays. To show VOR displays, you must select the VOR mode on the EFIS control panels and enter a valid VOR frequency on the NAV control panels.

Bearing Pointers

Bearing pointers 1 and 2 show in green around the edge of the compass rose when you set the VOR/ADF switches on the EFIS control panels to the VOR position. There is a pointer head and tail for both bearing pointers. The bearing pointers show on the expanded displays if the VOR bearing is in the compass rose display limit. The bearing pointers can show VOR data in the APP, VOR, and MAP modes.

The DEUs remove the bearing pointers when the VOR bearing from the VOR/MB receivers is NCD. The DEUs also remove the bearing pointers when you set the VOR/ADF selector switches on the EFIS control panels to OFF.

The NAV data source shows in green at the bottom left and right corners of the display for bearing pointers 1 or 2. The display also shows the frequency or identifier for the active station.

Deviation Bar and Scale

The VOR deviation bar shows in magenta. The DEUs use VOR bearing from the VOR/MB receivers and course inputs from the DFCS mode control panel to calculate VOR deviation.

The scale is the standard four dot scale. One dot equals five degrees of deviation.

The DEUs remove the deviation bar for NCD deviation inputs from the VOR/MB receivers.

Selected Course Pointer

The course select control on the DFCS mode control panel sets the position of the selected course pointer.

TO/FROM Pointer and Indicator

The TO/FROM pointer is a small white triangle that shows as part of the selected course pointer. The TO/FROM pointer shows on the centered VOR display only.

The TO/FROM indicator shows at the bottom right corner of both the centered and expanded VOR displays. The DEUs use VOR bearing from the VOR/MB receivers and course inputs from the DFCS MCP to calculate TO/FROM pointer and indicator displays.

VOR SYSTEM - EFIS NORMAL DISPLAYS

The TO indication shows when you enter a course on the DFCS MCP that takes you to the VOR station. The FROM indication shows when you enter a course that takes you away from the VOR station.

The DEUs remove the TO/FROM pointer and indicators for NCD and invalid displays.

NAV Data Source

The DEUs show the source of the data for the ND display in the upper right corner. The normal source for the captain NAV display is the VOR/MB receiver 1 and the normal source for the first officer is the VOR/MB receiver 2.

VOR Frequency

The VOR frequency shows in the upper right next to the NAV data source. The frequency from the NAV control panel goes through the VOR/MB receivers, then to the DEUs for display. The frequency shows in green. IF the VOR receiver gets a valid station identifier from the VOR station, the station identifier replaces the VOR frequency.

The DEUs change the VOR frequency to dashes for NCD inputs from the VOR/MB receivers.

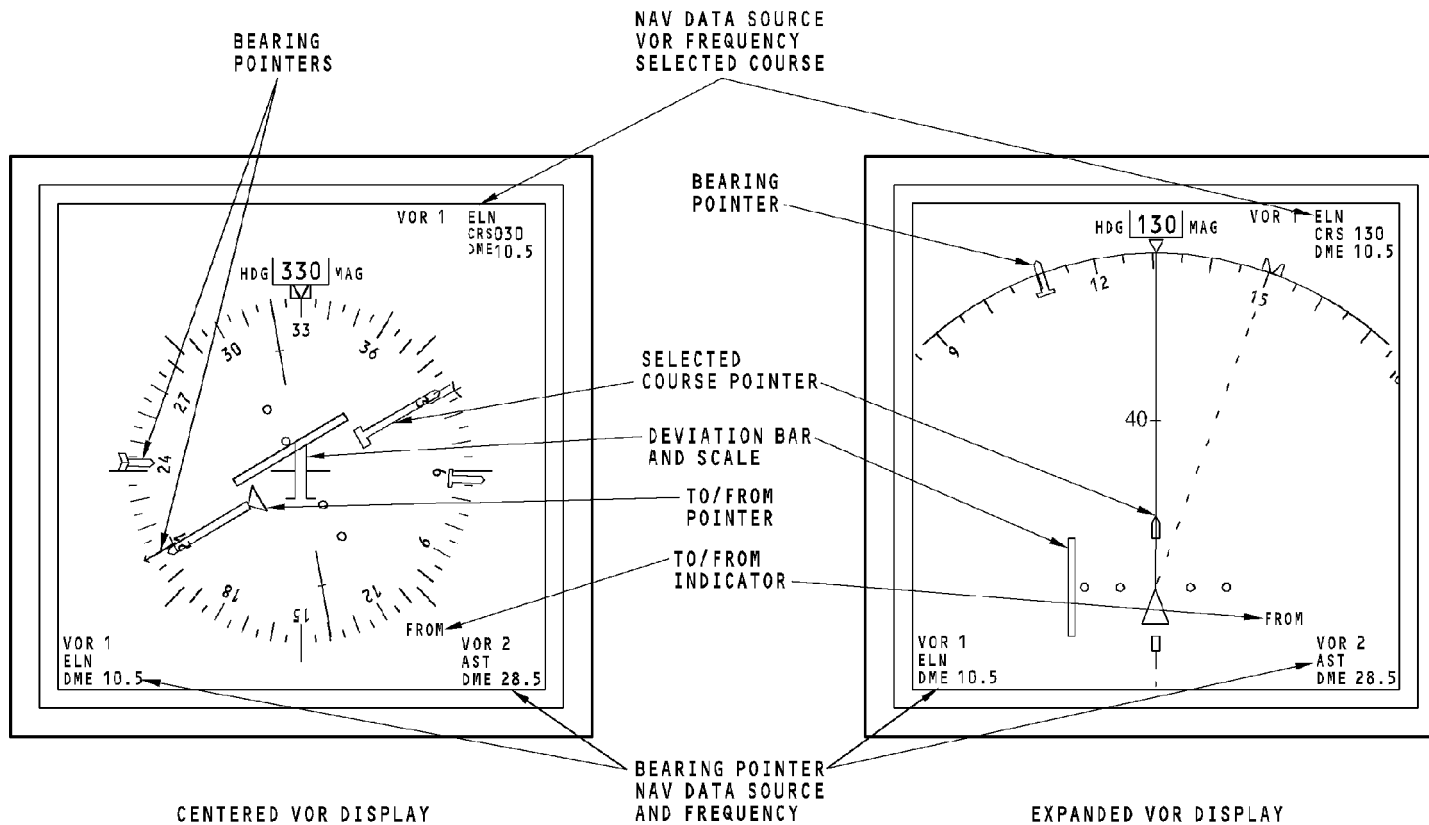

VOR SYSTEM - EFIS NORMAL DISPLAYS

34-51-00-017

EFFECTIVITY
HAP ALL

34-51-00

D633A101-HAP

Page 47
Feb 15/2009

VOR SYSTEM - EFIS INVALID DISPLAYS

Invalid Display

The DEUs remove these displays for invalid VOR/MB receiver inputs:

- Deviation bar and scale
- TO/FROM pointer and indicator
- VOR frequency
- NAV data source
- Bearing pointers.

The DEUs show the amber VOR flags on both the centered and expanded VOR displays for VOR/MB receiver failures.

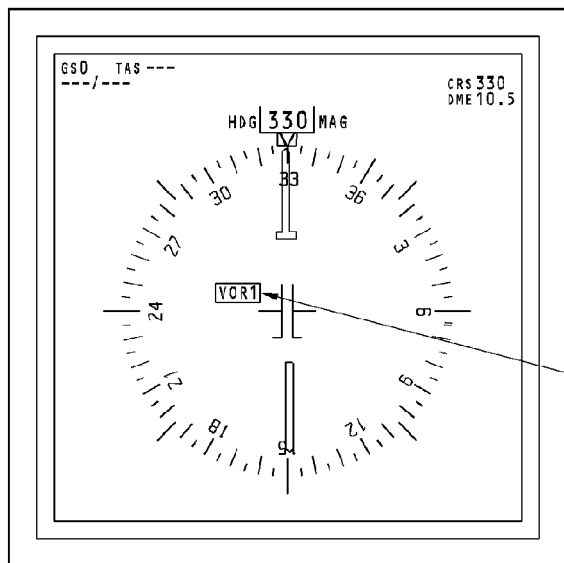

CENTERED VOR DISPLAY

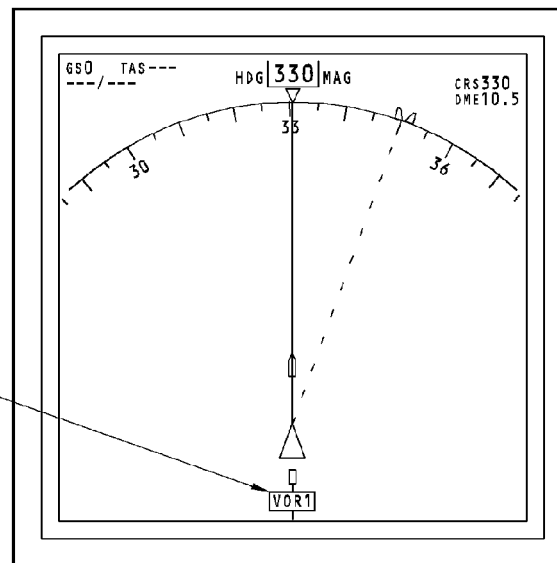

EXPANDED VOR DISPLAY

VOR SYSTEM - EFIS INVALID DISPLAYS

34-51-00-018

EFFECTIVITY
HAP ALL

34-51-00

D633A101-HAP

Page 49
Feb 15/2009

VOR SYSTEM - FRONT PANEL BITE

Test

Push one of the test switches on the front of the receiver to start a test of the VOR/MB receiver. The receiver does a check of the internal receiver operation and its interfaces. The test results show in the LCD on the front of the receiver.

When you push the test switch, the test in progress page shows and the receiver goes through a self-test that continues for five seconds. A five-second scale shows at the bottom of the page. You can monitor the test time by the line of Xs that show below the scale.

The TEST COMPLETE NO FAILURES display shows for a test pass condition. The TEST COMPLETE FAILURES display shows for a test fail condition.

These are the selections that can show above the receiver front panel switches during the test sequence:

- MAINT - this selection shows pages that contain program pin selections and discrete interface conditions
- RETURN - this selection causes the display to go back to the start test page
- WHY? - this selection comes on when there are failures. Push this selection to show the failures
- MORE - this selection shows any time there are more pages of data to follow.

EFFECTIVITY
HAP ALL

34-51-00

D633A101-HAP

Page 50
Feb 15/2009

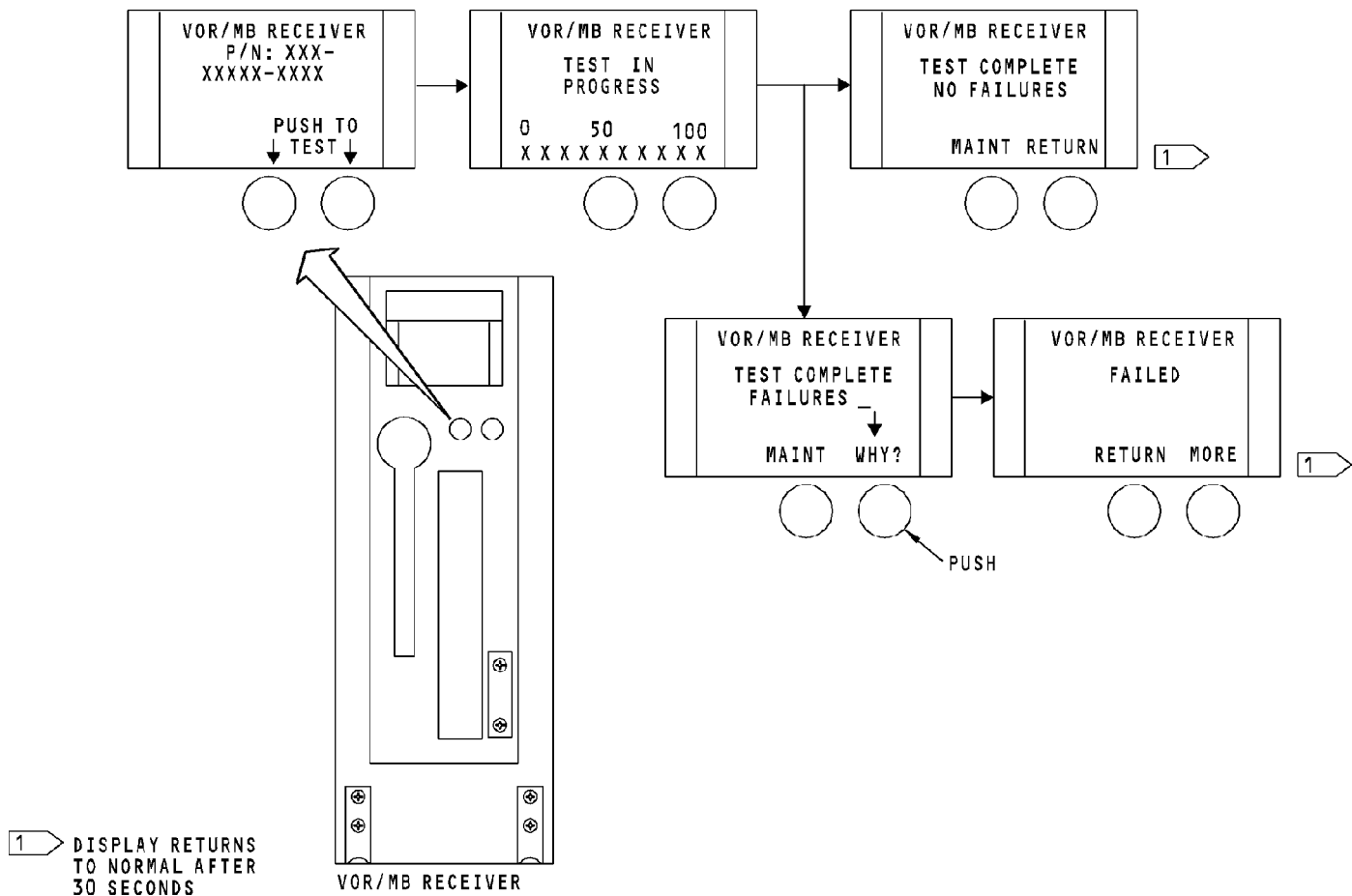

VOR SYSTEM - FRONT PANEL BITE

34-51-00-019

EFFECTIVITY
HAP ALL

34-51-00

D633A101-HAP

VOR SYSTEM - SELF TEST

Test

You can do a test of the VOR/MB receivers from the flight compartment with the NAV control panels. The captain's NAV control panel does a test of VOR/MB receiver 1 and the first officer's NAV control panel does a test of VOR/MB receiver 2.

You need to set these controls to do a test of the VOR/MB receivers:

- Enter a valid VOR frequency into the active frequency display window on the NAV control panel
- Set a selected course of 000 on the DFCS mode control panel
- Set the mode selector on the EFIS control panel to the VOR position
- Push the test switch on the NAV control panel.

This is the flight compartment display sequence that shows during the VOR test:

- Invalid display (VOR flag)
- NCD display (deviation bar out of view)
- Test display (deviation bar centered).

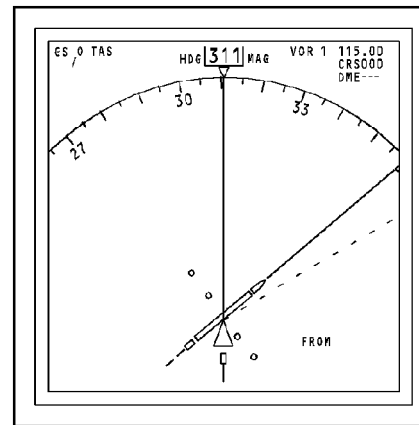
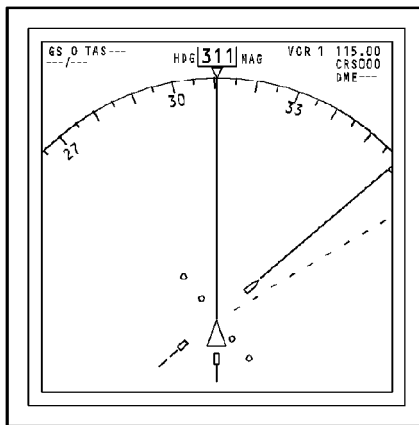
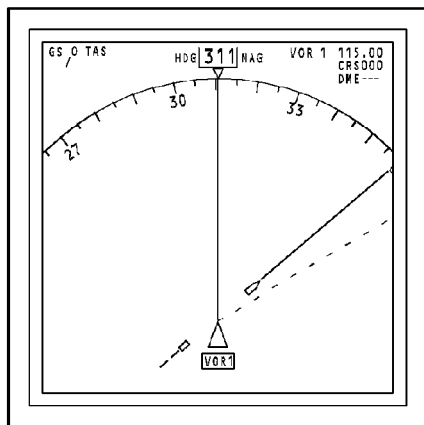
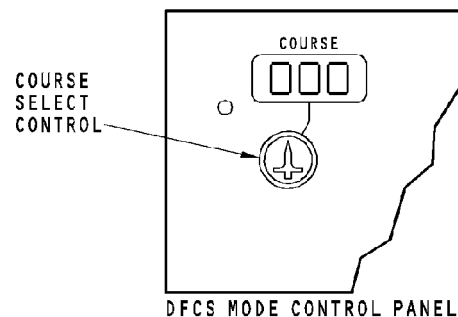
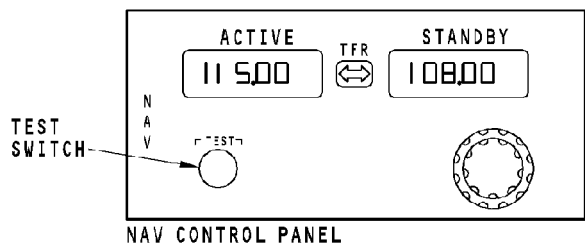

VOR SYSTEM - SELF TEST

EFFECTIVITY

HAP 001-013, 015-026, 028-036, 038-054, 101-999

34-51-00

D633A101-HAP

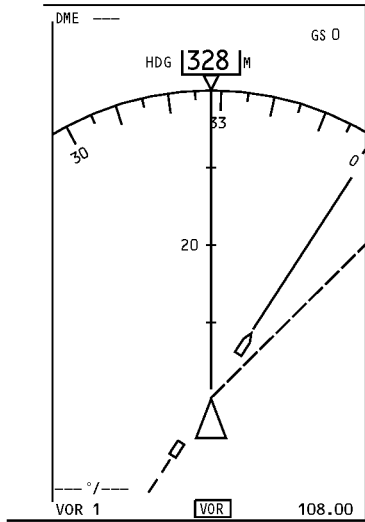
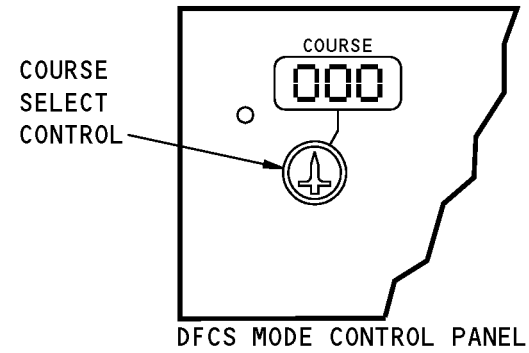
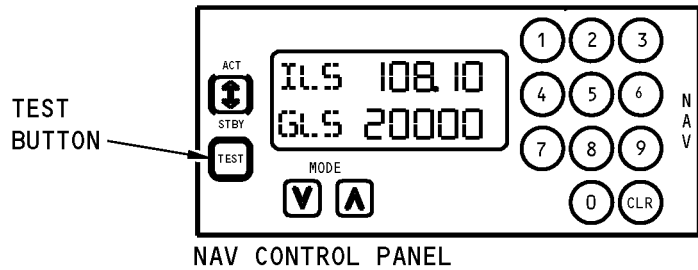

INVALID DISPLAY

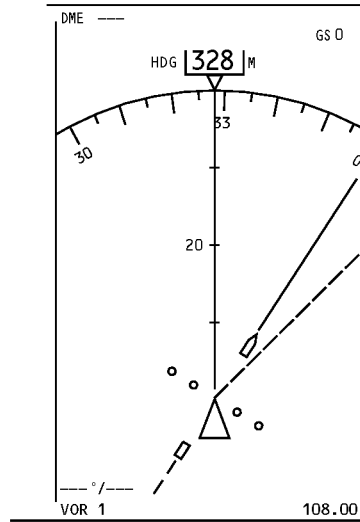

NCD DISPLAY

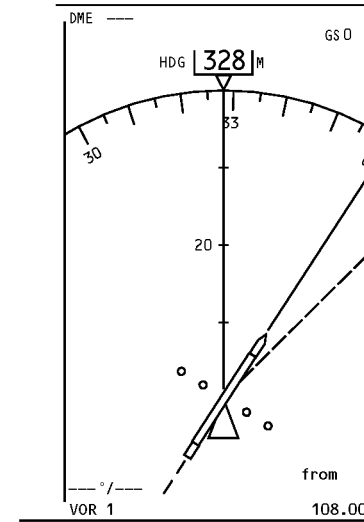

TEST DISPLAY

VOR SYSTEM - SELF TEST

EFFECTIVITY
HAP 037

34-51-00

D633A101-HAP

THIS PAGE IS INTENTIONALLY LEFT BLANK

34-51-00

D633A101-HAP

Page 55
Feb 15/2009



VOR SYSTEM - SYSTEM SUMMARY

General

This page is for reference.

34-51-00-021

EFFECTIVITY
HAP ALL

34-51-00

D633A101-HAP

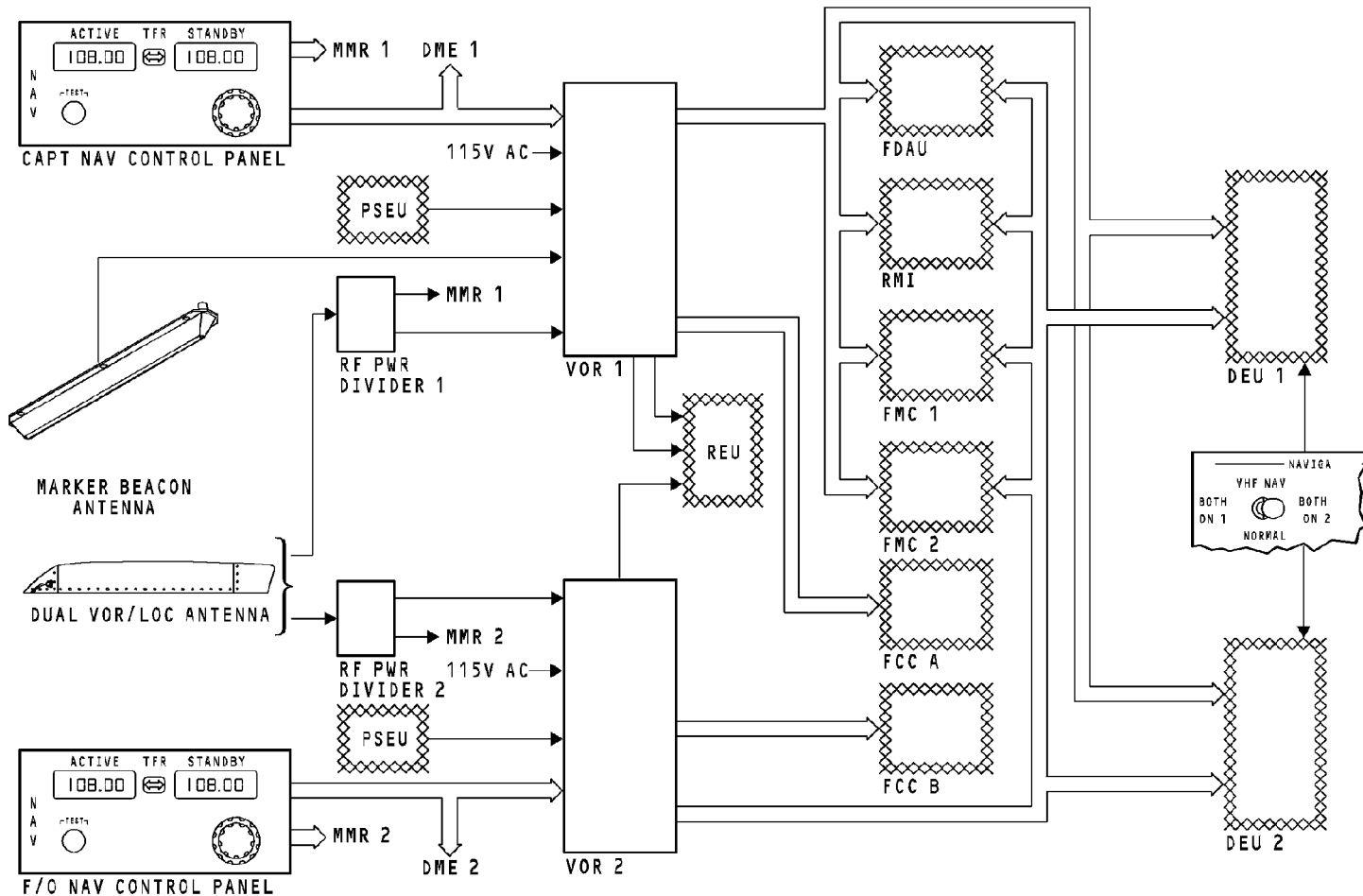

VOR SYSTEM - SYSTEM SUMMARY

34-51-00-021

EFFECTIVITY
HAP 038-054, 101-999

34-51-00

D633A101-HAP

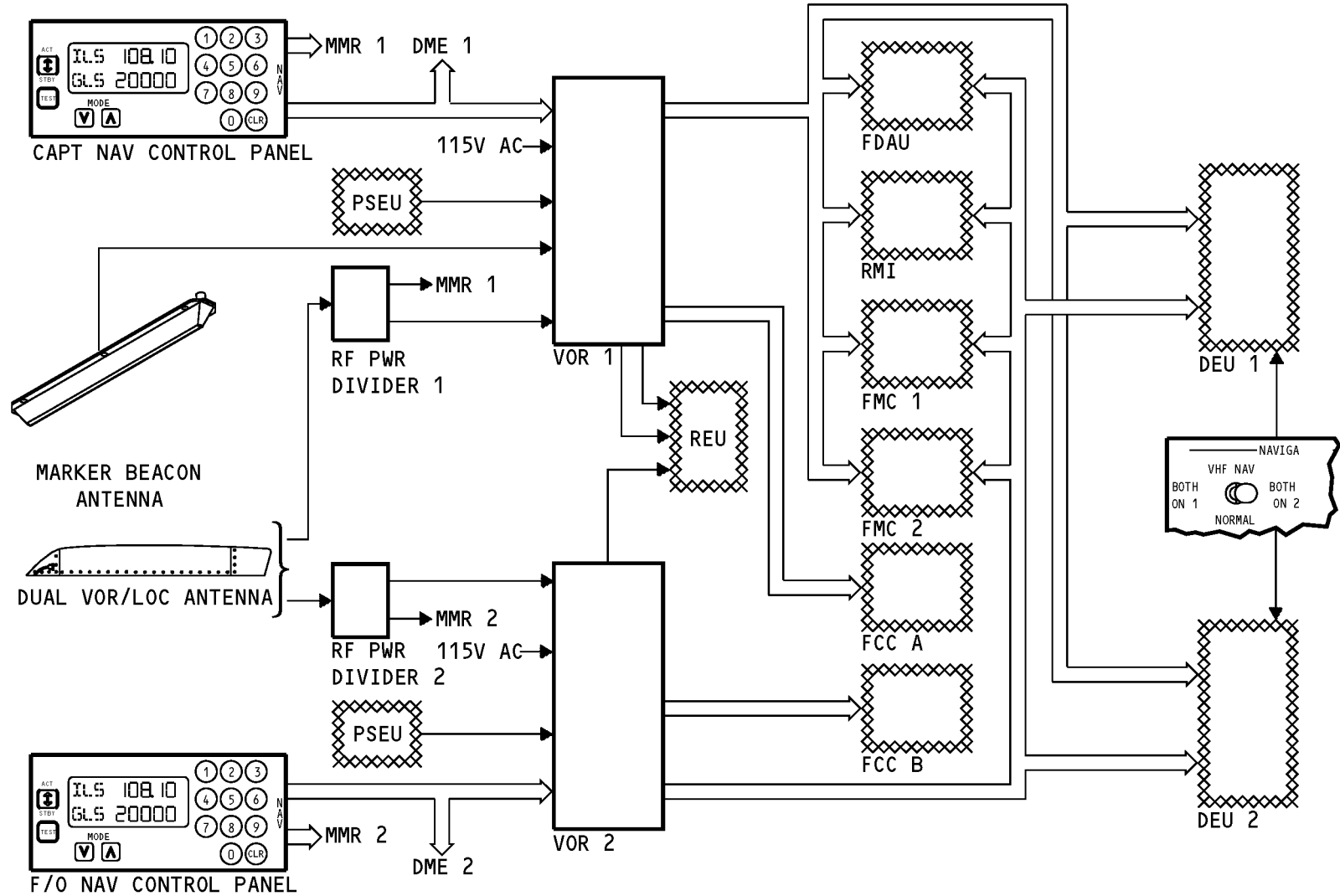

VOR SYSTEM - SYSTEM SUMMARY

EFFECTIVITY
HAP 037

34-51-00

D633A101-HAP

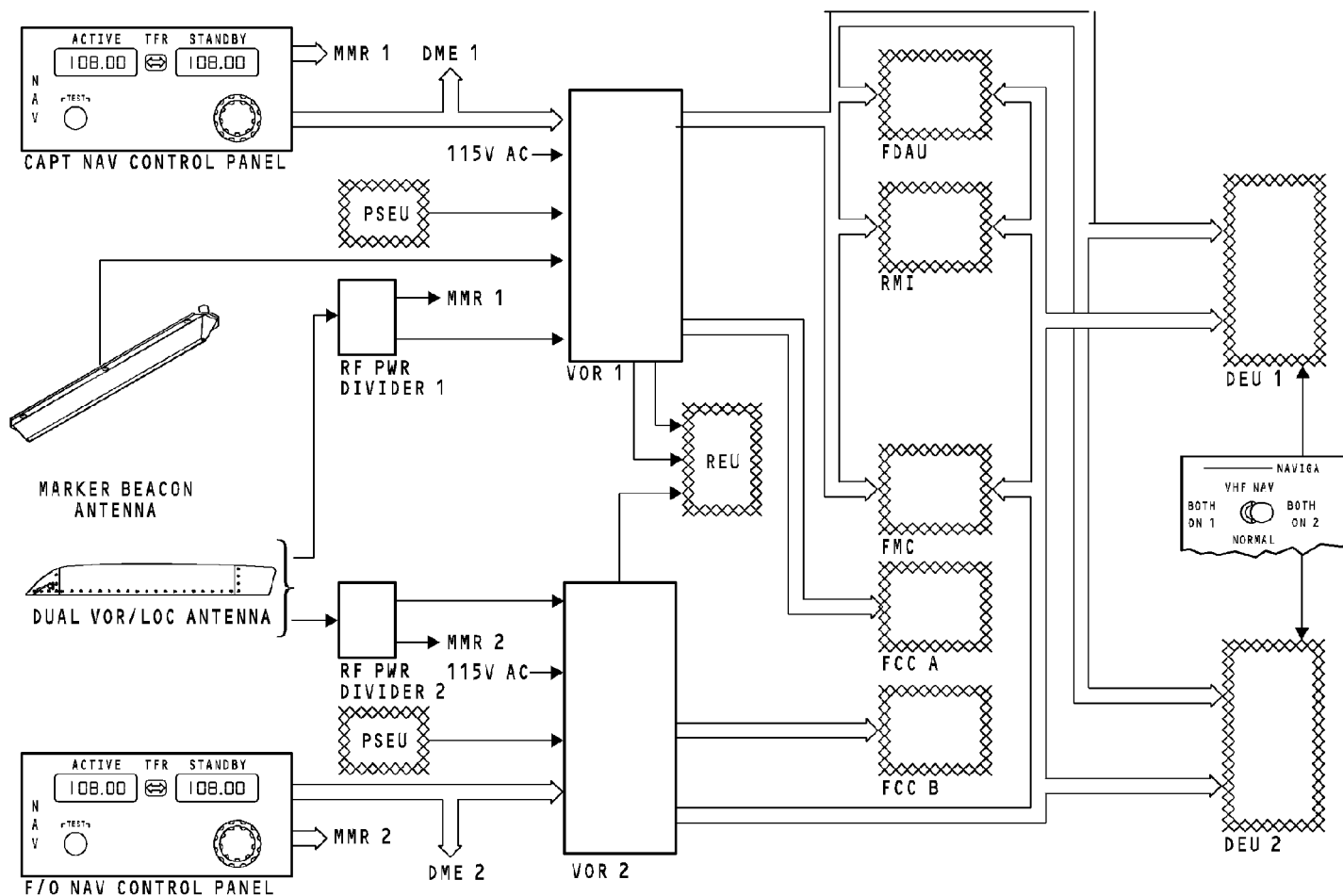

VOR SYSTEM - SYSTEM SUMMARY

34-51-00-021

EFFECTIVITY
HAP 001-013, 015-026, 028-036

34-51-00

D633A101-HAP

AIR TRAFFIC CONTROL SYSTEM - INTRODUCTION**General**

The air traffic control (ATC) ground stations interrogate the airborne ATC system. The ATC transponder replies to the interrogations in the form of coded information that the ground station uses.

The ATC transponder also replies to mode S interrogations from the traffic alert and collision avoidance systems (TCAS) of other airplanes or ground stations.

When a ground station or a TCAS computer from another airplane interrogates the ATC system, the transponder transmits a pulse-coded reply signal. The reply signal identifies and shows the altitude of the airplane.

- Maximum airspeed
- TCAS coordinating signals
- TCAS status
- Altitude
- Mode A identity code
- Twenty-four bit address.

Abbreviations and Acronymns

- abs - absolute
- abv - above
- ADIRS - air data inertial reference system
- ADIRU - air data inertial reference unit
- AD - air data
- ADR - air data reference

- alt - altitude
- amp - amplifier
- ant - antenna
- ATC - air traffic control
- ATCRBS - air traffic control radar beacon system
- BITE - built-in test equipment
- blw - below
- bot - bottom
- coax - coaxial
- cntl - control
- CPU - central processing unit
- DME - distance measuring equipment
- ELEX - electrical
- FL - flight level
- gnd - ground
- ID - identification
- I/O - input/output
- ident - identification
- INS - instrument
- INT - interrogator
- LED - light emitting diode
- MAX - maximum
- MHz - mega hertz
- N - normal
- NC - not connected
- norm - normal
- pnl - panel
- PSR - primary surveillance radar
- RA - resolution advisory
- REL - relative
- RF - radio frequency
- rptg - reporting

AIR TRAFFIC CONTROL SYSTEM - INTRODUCTION

- RX - receive
- SDI - source destination identifier
- sig - signal
- SLS - side lobe suppression
- SSR - secondary surveillance radar
- SPI - special purpose identification
- stby - standby
- sw - switch
- TA - traffic advisory
- TAS - true air speed
- TCAS - traffic alert and collision avoidance system
- tpr - transponder
- TX - transmit
- XFR - transfer
- xmtr - transmitter
- xpdr - transponder
- xpndr - transponder

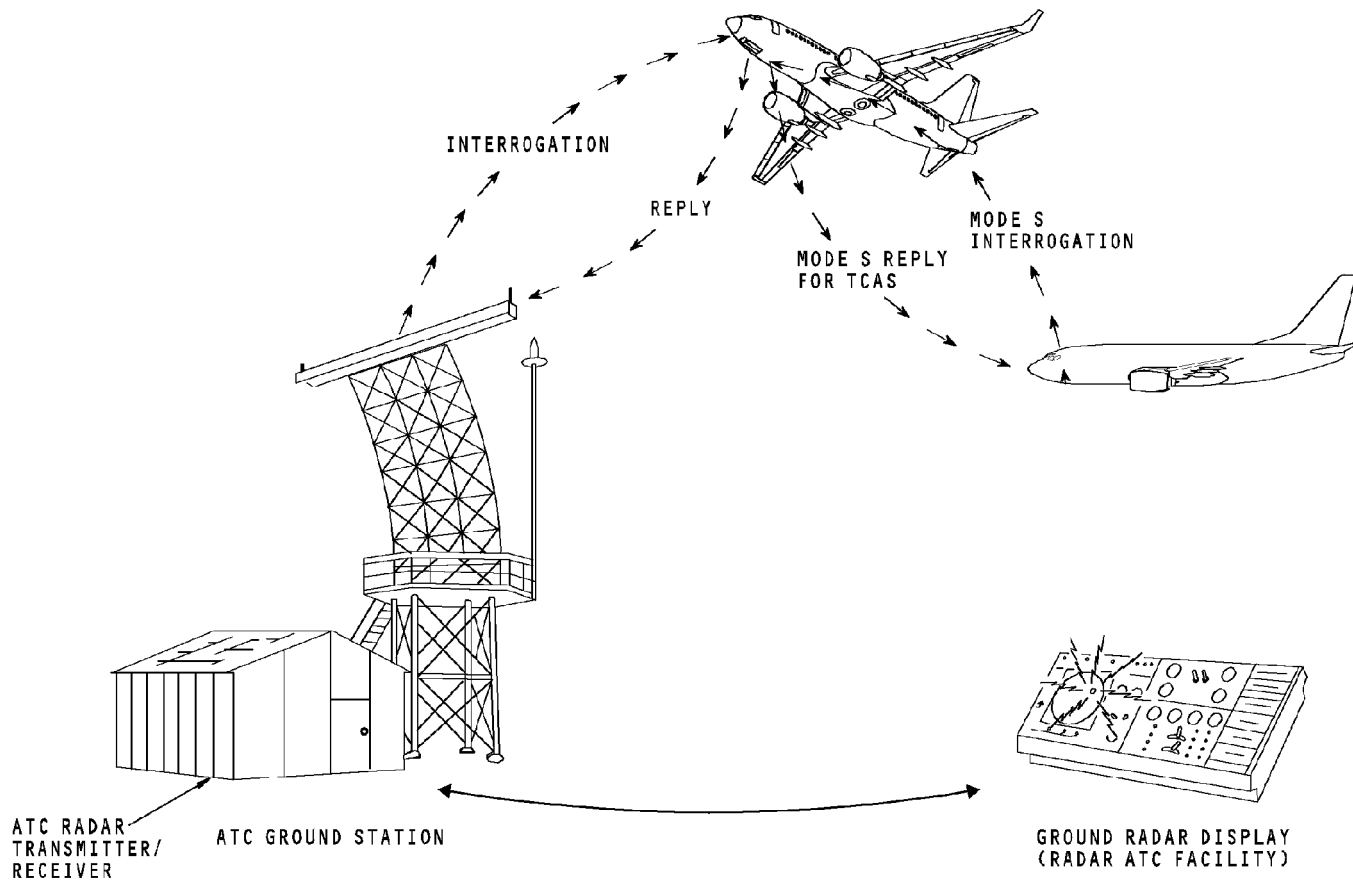

AIR TRAFFIC CONTROL SYSTEM - INTRODUCTION

EFFECTIVITY
HAP ALL

34-53-00

D633A101-HAP

34-53-00-001

ATC SYSTEM - GENERAL DESCRIPTION**General Description**

These are the components of the ATC system:

- Top antenna
- Bottom antenna
- ATC coaxial switch (2)
- ATC/TCAS control panel
- ATC transponder (2).

The two antennas transmit signals from the ATC transponder and send received signals to the ATC transponder. These signals go through the ATC coax switches.

The ATC/TCAS control panel sends identification and control data to the transponders. The ATC/TCAS control panel also allows selection of either transponder 1 or transponder 2.

The air data inertial reference units (ADIRUs) supply barometric altitude data to the ATC transponders.

HAP 001-013, 015-026, 028-036

The ATC transponders receive selected altitude from the digital flight control system mode control panel (MCP), GPS position from the multi-mode receivers (MMRs), and flight number ID data from the flight management computer (FMC).

HAP 037-054, 101-999

The ATC transponders receive selected altitude from the digital flight control system mode control panel (MCP), GPS position from the multi-mode receivers (MMRs), and flight number ID data from the flight management computers (FMCs).

HAP ALL

The ATC transponders interface with the TCAS system.

The ATC transponders send and receive suppression pulses through the suppression coax tees. This prevents ATC transmissions from interfering with the DME and TCAS system operations.

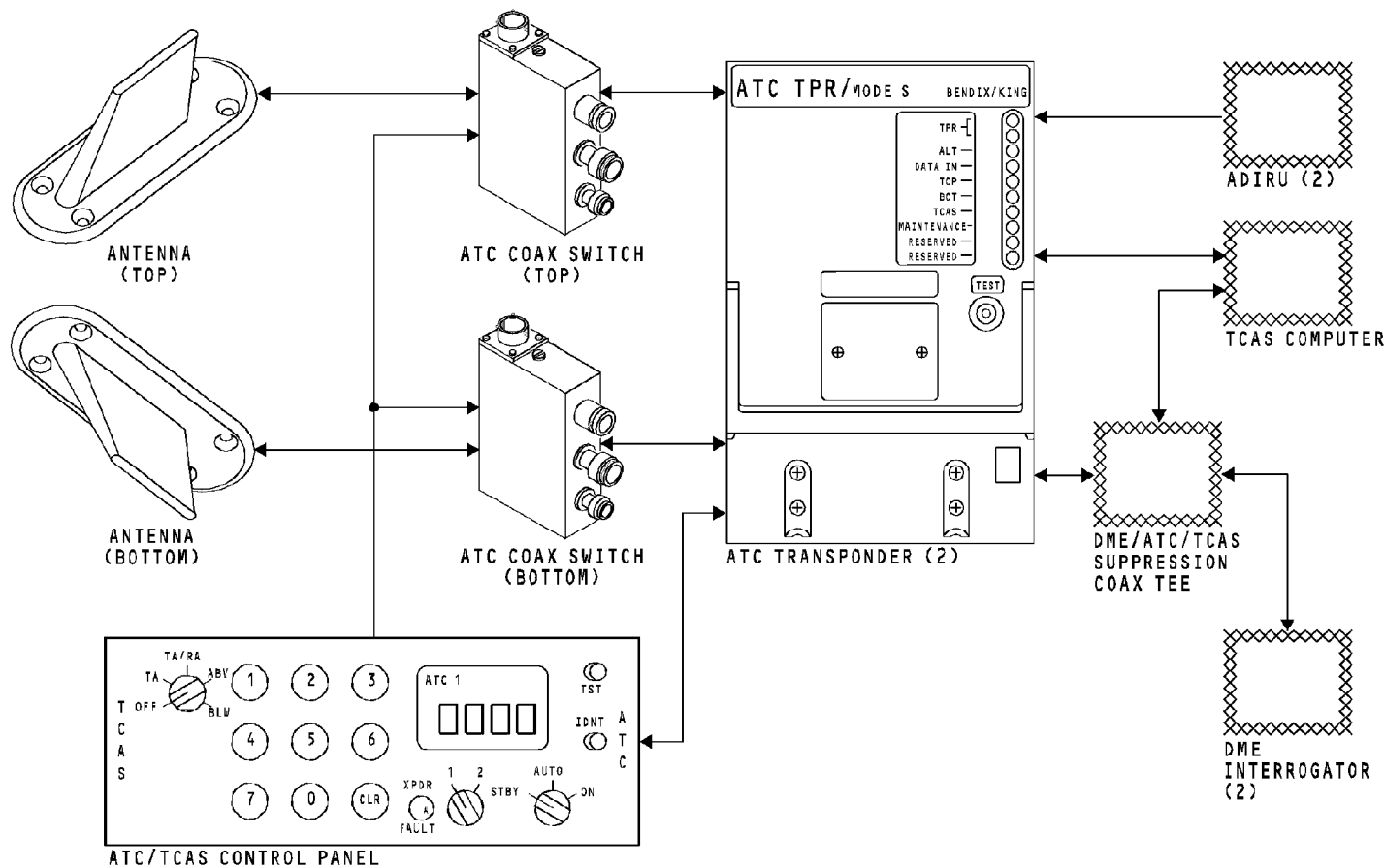

ATC SYSTEM - GENERAL DESCRIPTION

34-53-00-002

EFFECTIVITY
HAP ALL

34-53-00

D633A101-HAP

Page 5
Feb 10/2006

ATC SYSTEM - COMPONENT LOCATION**Flight Compartment**

The ATC/TCAS control panel is on the P8 aft electronics panel.

Electronic Equipment Compartment

These are the ATC transponder system components in the electronic equipment compartment:

- ATC transponder 1
- ATC transponder 2
- Program switch module (2)
- Top ATC coax switch
- Bottom ATC coax switch.

ATC Antenna Location

The ATC antennas are on the forward fuselage near the centerline. The top ATC antenna is at STA 430.25. The bottom ATC antenna is at STA 355.

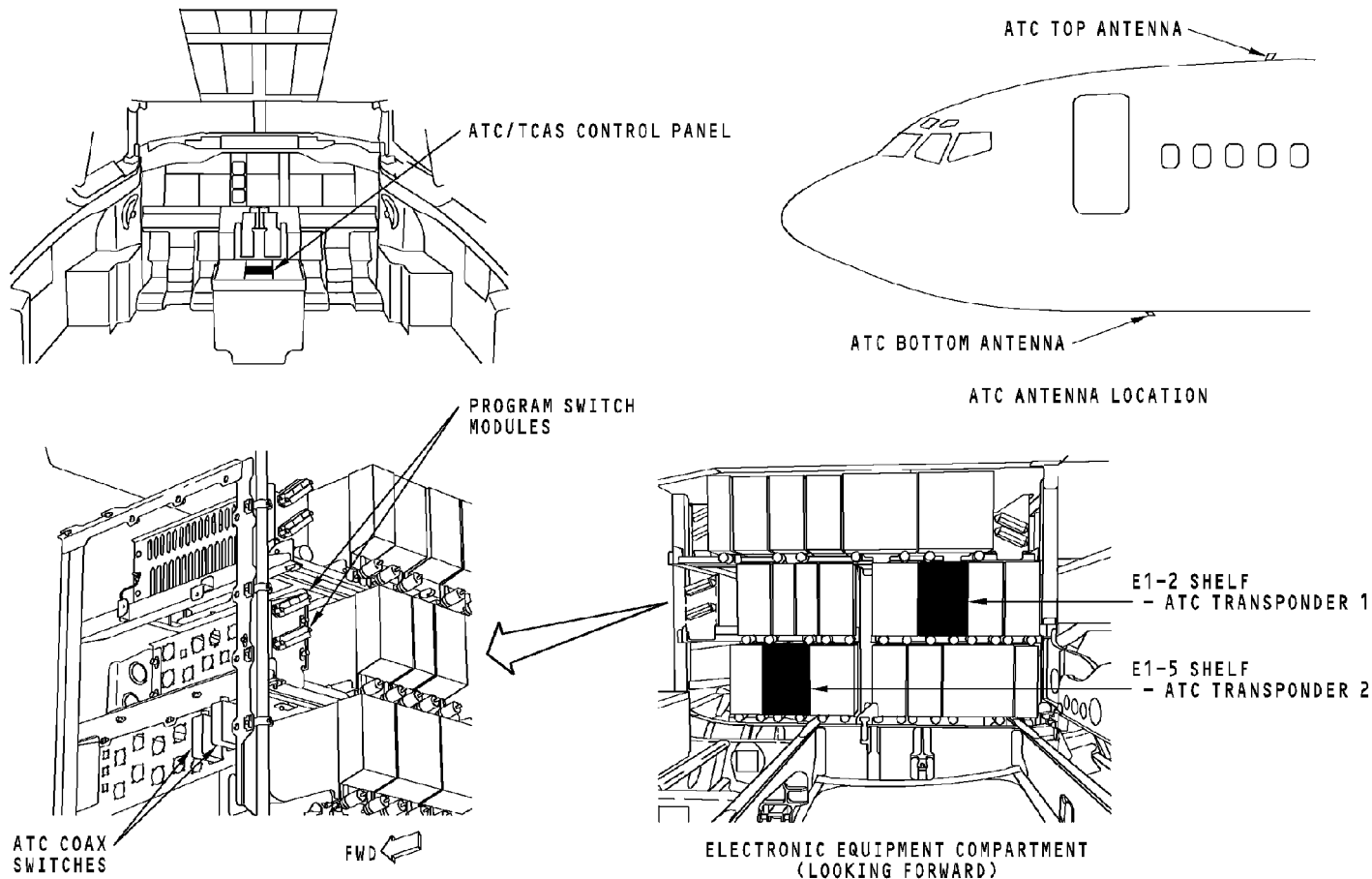

ATC SYSTEM - COMPONENT LOCATION

34-53-00-003

EFFECTIVITY
HAP ALL

34-53-00

D633A101-HAP

ATC SYSTEM - ANTENNA INTERFACE**General**

The ATC coax switches get power through the ATC ANT SWITCH circuit breaker. When you select ATC transponder 1 on the ATC/TCAS control panel, the ATC coax switches do not energize and the antennas connect to ATC transponder 1. When you select ATC transponder 2, the ATC/TCAS control panel sends a discrete ground to the ATC coax switches. This energizes the coax switches and connects the top and bottom antennas to ATC transponder 2.

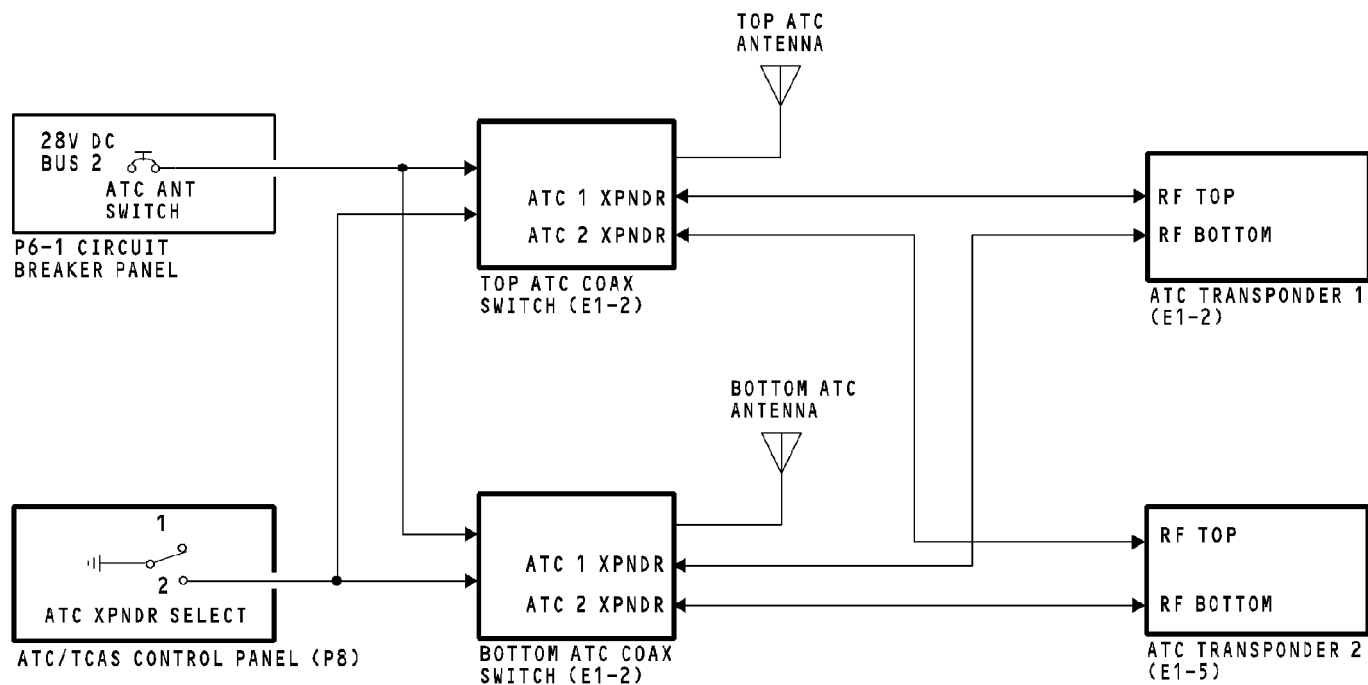

ATC SYSTEM - ANTENNA INTERFACE

34-53-00-004

EFFECTIVITY
HAP ALL

34-53-00

D633A101-HAP

ATC SYSTEM - POWER, IDENTITY, CONTROL, AND AIR DATA INTERFACES**Power**

ATC transponder 1 gets 115v ac power from standby bus 1. ATC transponder 2 gets 115v ac power from transfer (xfr) bus 2. The ATC/TCAS control panel gets 115v ac power from both standby bus 1 and xfr bus 2.

Standby/On Discrete

The ATC/TCAS control panel sends a ground standby discrete to the transponder that is not in use.

Identity Code

The flight crew sets the four digit identity code and it shows on the ATC/TCAS control panel. Both transponders get the identity code from the ATC/TCAS control panel.

Control Data

The ATC/TCAS control panel also sends control data to the transponders. This control data does these functions:

- Permits mode C and mode S operation.
- Lets the transponder send the special position identification (SPI) pulse or airplane identification code.

Air Data

The air data inertial reference units (ADIRU) send air data to the ATC transponders.

ATC transponder 1 gets air data at AD input 1 from the left ADIRU air data reference (ADR) bus 4. The left ADIRU also supplies air data to the ATC 2 transponder from ADR bus 4.

ATC transponder 2 gets air data at AD input 1 from the right ADIRU air data reference (ADR) bus 4. The right ADIRU also supplies air data to the ATC 1 transponder from ADR bus 4.

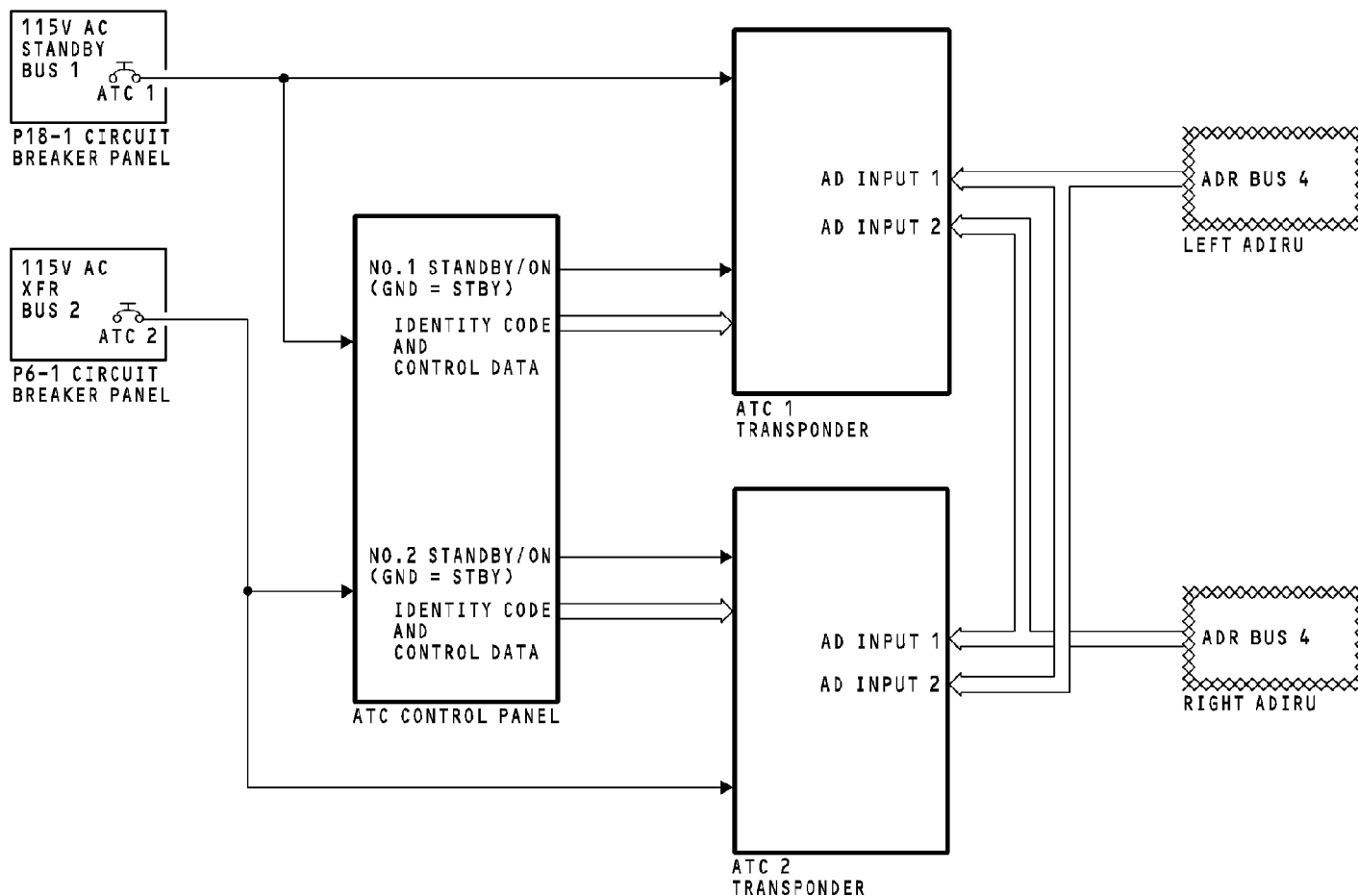

ATC SYSTEM - POWER, IDENTITY, CONTROL, AND AIR DATA INTERFACES

34-53-00-006

EFFECTIVITY
HAP ALL

34-53-00

D633A101-HAP



ATC SYSTEM - MMR AND MODE CONTROL PANEL INTERFACES

General

Each multi-mode receiver (MMR) can provide GPS position data to the two ATC transponders. The mode control panel (MCP) provides each transponder with data for selected altitude.

34-53-00-019

EFFECTIVITY
HAP ALL

34-53-00

D633A101-HAP

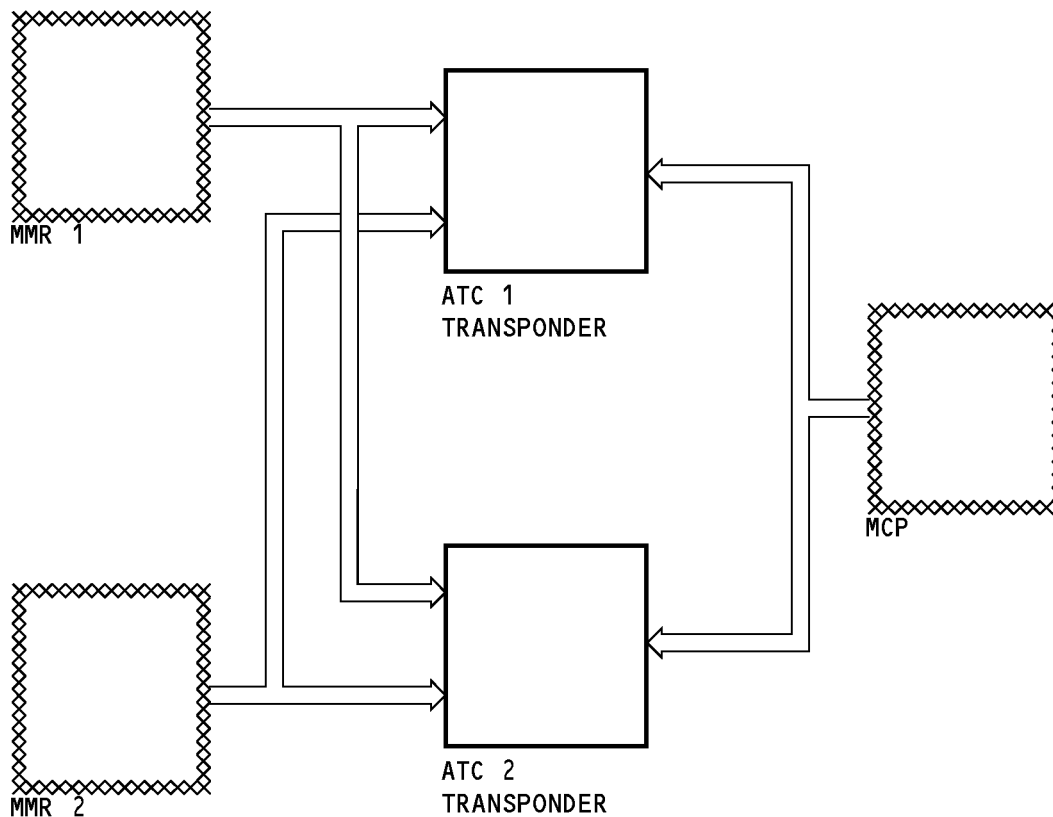

ATC SYSTEM - MMR AND MODE CONTROL PANEL INTERFACES

34-53-00-019

EFFECTIVITY
HAP ALL

34-53-00

D633A101-HAP

ATC SYSTEM - MAINTENANCE INTERFACE**PSEU**

The proximity switch electronics unit (PSEU) sends air/ground discretes through the ATC/TCAS control panel to the transponders.

These are the purposes of the air/ground discretes:

- Prevent ground tests of the ATC system in the air
- Prevent mode A and mode C replies on the ground
- Defines flight legs in the non-volatile memory.

Transponder Fail Discretes

Each transponder built-in test equipment (BITE) continually monitors the equipment for failures. If the BITE detects a failure, the transponder sends the fail discretes to the ATC/TCAS control panel.

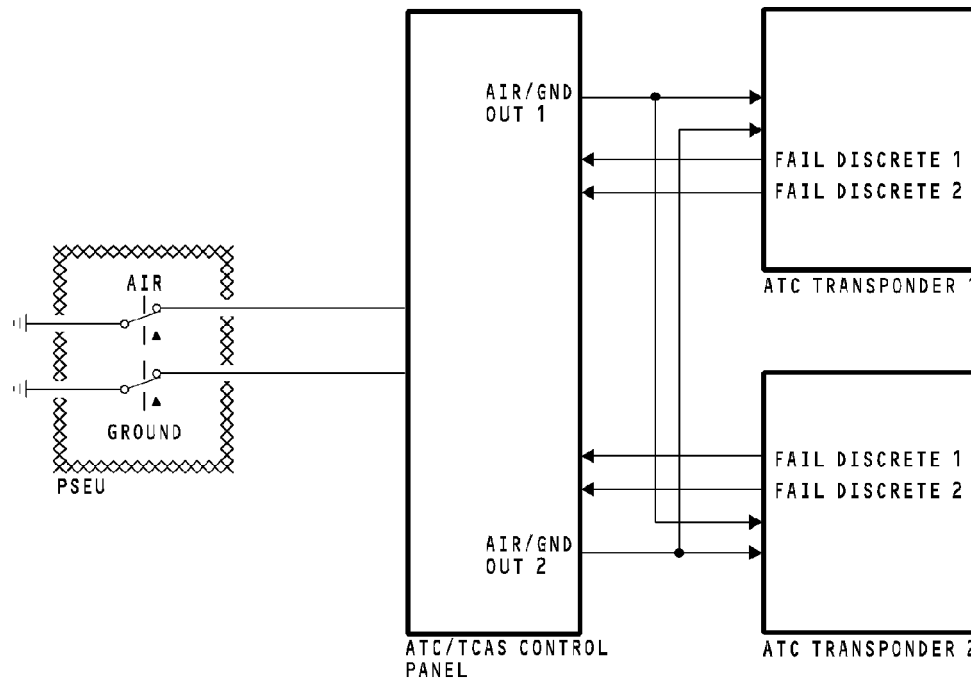

ATC SYSTEM - MAINTENANCE INTERFACE

34-53-00-007

EFFECTIVITY
HAP ALL

34-53-00

D633A101-HAP

ATC SYSTEM - TCAS INTERFACE AND PROGRAM PINS**Program Pins**

Each ATC transponder has these program pins:

- Airplane mode S address
- Source destination identifier (SDI)
- Maximum true airspeed.

There are 24 airplane address program pins on each transponder. A program switch module connects to the program pins. The program switch module supplies the open and ground connections necessary to make the 24-bit unique airplane identification.

The SDI defines the transponder as the ATC 1 or ATC 2 transponder.

The maximum true airspeed pins define the maximum true airspeed for the airplane. The transponder formats and sends the maximum true airspeed to the TCAS computer.

Digital Data to TCAS

The active ATC transponder sends this data to the traffic alert and collision avoidance system (TCAS) computer:

- The 24-bit mode S airplane identification. TCAS needs the airplane mode S identification for maneuver coordination.
- Barometric altitude
- Maximum true airspeed
- TCAS coordination message data

- ATC transponder system failure data.

TCAS to Active Transponder

The TCAS computer sends this data to the active transponder:

- General TCAS operational data
- Coordination update data.

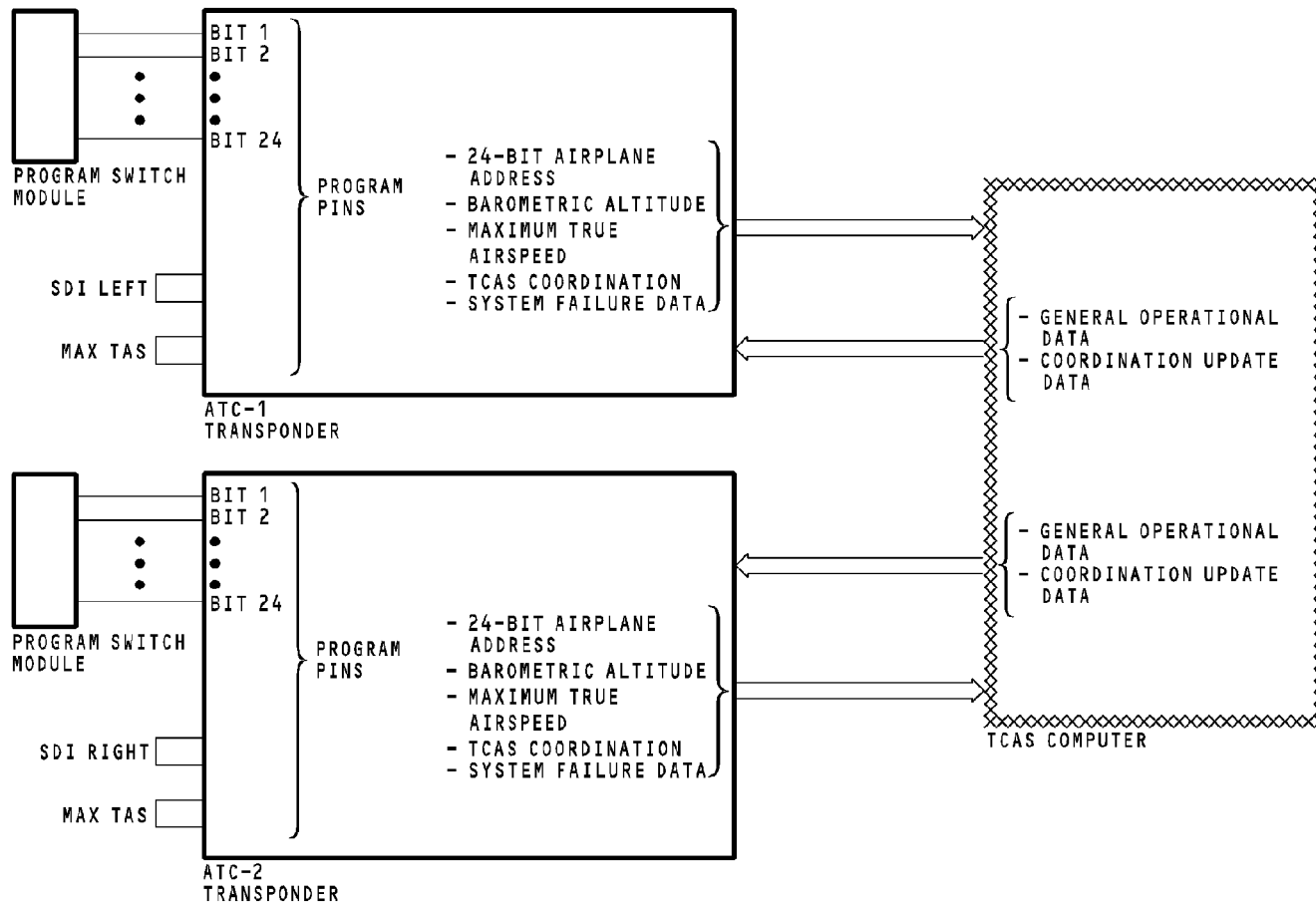

ATC SYSTEM - TCAS INTERFACE AND PROGRAM PINS

34-53-00-008

EFFECTIVITY
HAP ALL

34-53-00

D633A101-HAP

ATC SYSTEM - SUPPRESSION INTERFACE**General**

The ATC transponders, TCAS, and the DME interrogators operate in the same frequency band. There is a suppression interface between these units. This prevents damage to the receiver circuits during a signal transmission. The suppression circuits also prevent responses from onboard equipment.

The first unit to transmit sends a suppression pulse to a coax tee. The coax tee divides the suppression pulse and sends it to the different units, or to a different coax tee. This suppression pulse prevents the operation of the receiver circuits in the other units.

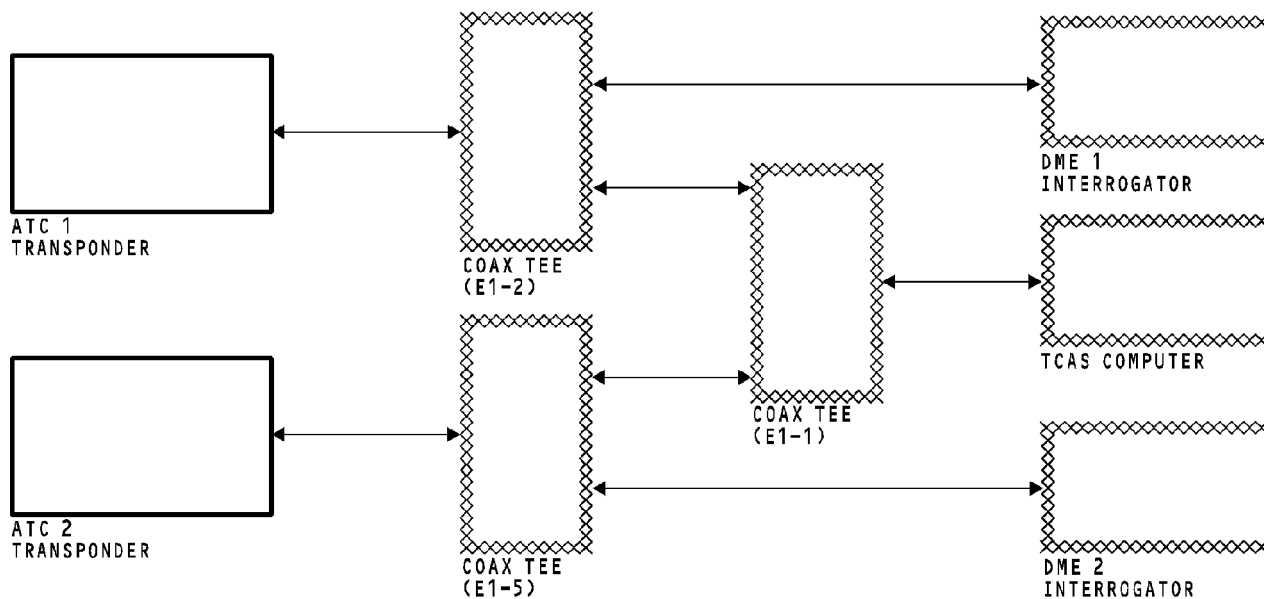

ATC SYSTEM - SUPPRESSION INTERFACE

34-53-00-009

EFFECTIVITY
HAP ALL

34-53-00

D633A101-HAP

THIS PAGE IS INTENTIONALLY LEFT BLANK

34-53-00

D633A101-HAP

Page 20
Feb 15/2008

ATC SYSTEM - ATC/TCAS CONTROL PANEL**General**

The dual ATC/TCAS control panel controls the ATC transponder and the TCAS computer.

These are the ATC controls and displays on the ATC/TCAS control panel:

- Transponder select switch
- Active system display
- Transponder code selectors
- Four digit identification code
- Test Switch
- IDENT switch
- Reply selector
- Fail light.

See THE TCAS section for more information on TCAS controls. (SECTION 34-45)

Transponder Select Switch and Active System Display

The transponder select switch is a two-position switch used to select ATC transponder 1 or ATC transponder 2 as the active transponder. When the flight crew selects the 1 position, the control panel sends a ground standby/on discrete to transponder 2 only. Transponder 2 is in standby. Transponder 1 is active.

When the flight crew selects the 2 position, the control panel sends an open standby/on discrete to transponder 2 to make it active. A ground standby/on discrete goes to transponder 1 and an antenna transfer discrete goes to the ATC coax switches. This puts transponder 1 in standby and makes the relays connect the ATC antennas to transponder 2.

The selected ATC system shows on the LCD active system display.

Identification Code Display and Selection

The flight crew uses the code selectors to set the four digits of the identification code. The four digits show on the liquid crystal display (LCD). Codes are from 0000 to 7777, with 4096 different selections.

CAUTION: DO NOT SELECT CODES 7500, 7600 OR 7700. THESE CODES ARE USED ONLY FOR EMERGENCIES.

IDENT Switch

When the ATC controller requests the airplane identifier, the flight crew pushes the momentary IDENT switch. The transponder adds a special position identification (SPI) pulse to the interrogation reply for the next 18 seconds.

Reply Selector

The reply selector has these three positions:

**34-53-00**

D633A101-HAP

Page 21
Feb 15/2008

ATC SYSTEM - ATC/TCAS CONTROL PANEL

- STBY - Sets the active transponder to the standby mode. In the standby mode, the transponder will not reply to ATC/Mode S interrogations.
- ON - Sets the active transponder to on. In this mode, the transponder will reply to ATC/Mode S interrogations.
- AUTO - Sets the active transponder to the auto mode. In this mode, the transponder will reply to ATC/Mode S interrogations when the airplane is in the air and will respond only to Mode S interrogations when on the ground.

TEST SWITCH

This push button on the top of the ATC/TCAS control panel starts an ATC transponder functional self-test.

XPDR FAULT Light

The XPDR FAULT light comes on for these conditions:

- Transponder failure
- Antenna failure
- Control data failure.
- Altitude input failure.

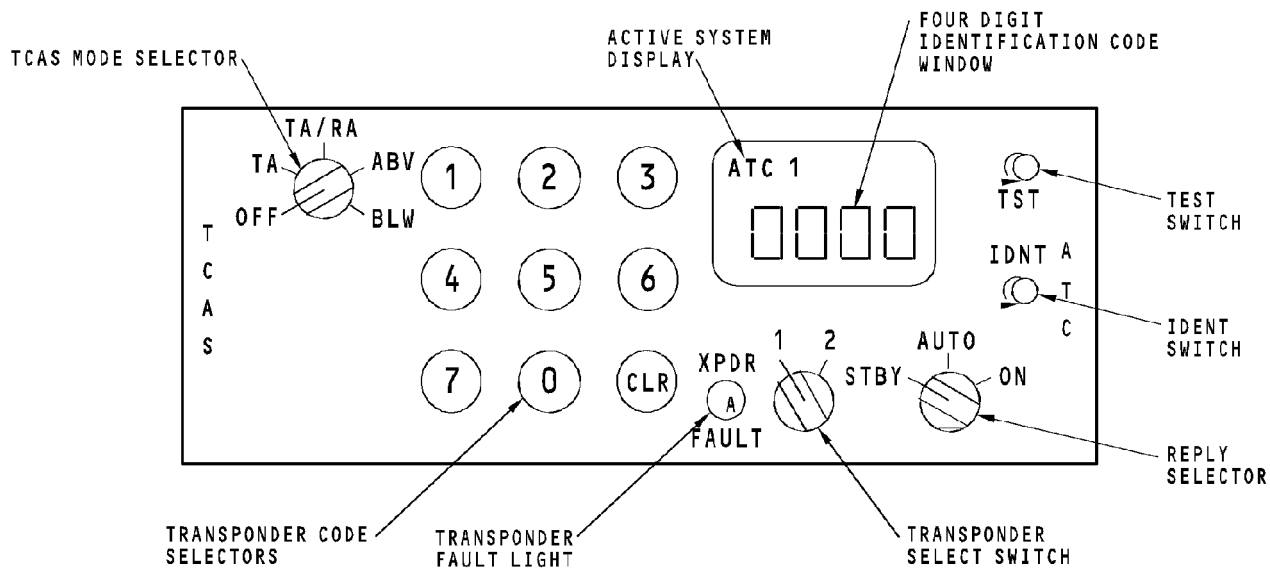

ATC SYSTEM - ATC/TCAS CONTROL PANEL

34-53-00-011

EFFECTIVITY
HAP ALL

34-53-00

D633A101-HAP

ATC SYSTEM - ATC TRANSPONDER**General**

The ATC ground station interrogates the ATC transponder with a pulse-coded signal at a frequency of 1030 MHz.

The transponder responds with pulse-coded signals at a frequency of 1090 MHz.

- MAINTENANCE, not used
- RESERVED(2), not used.

Characteristics

The transponder responds to air traffic control radar beacon system (ATCRBS) mode A and mode C interrogations. The transponder also responds to air traffic control and the TCAS computer with the mode select (mode S) format.

The ATC transponder has a non-volatile flight-fault memory.

Front Panel Indications

The test switch starts a self-test.

The light emitting diode (LED) status indicators on the front panel show for these conditions:

- TPR LED (green), if there are no LRU failures
- TPR LED (red), if there is an LRU failure
- ALT, if the altitude input from the ADIRU fails
- DATA IN, if the control panel input fails
- TOP, if the top antenna fails
- BOT, if bottom antenna fails
- TCAS, if the interface with TCAS fails

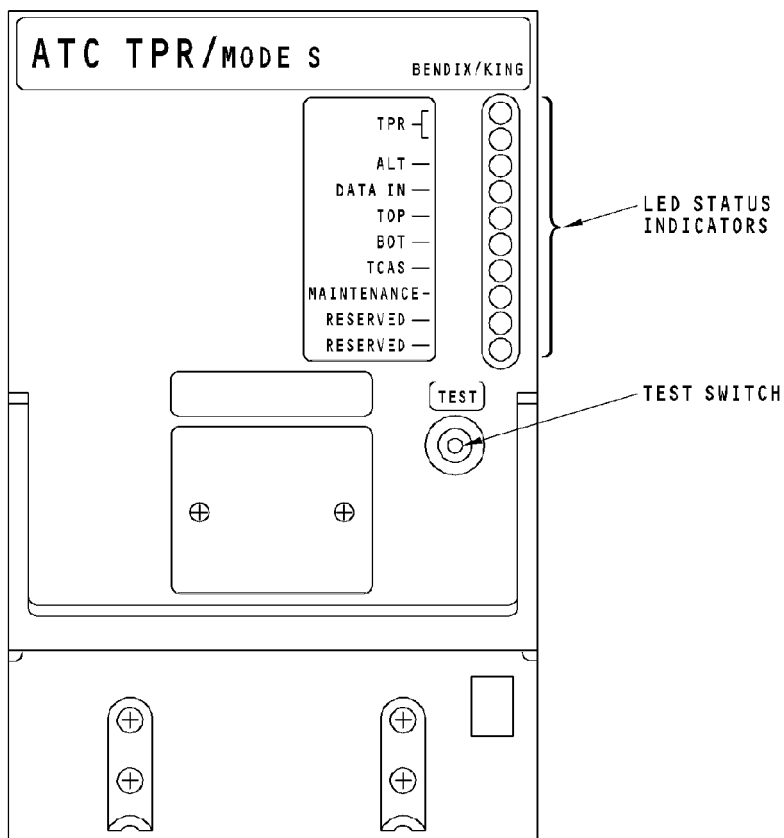

ATC SYSTEM - ATC TRANSPONDER

34-53-00-010

EFFECTIVITY
HAP ALL

34-53-00

D633A101-HAP

ATC SYSTEM - ATC ANTENNA**Purpose**

The ATC L-band blade antenna receives 1030 MHZ interrogation signals from ATC ground stations and other airplanes that have TCAS. The ATC transponder transmits the reply signals through the L-band antenna.

Physical Description

The coaxial cable connector connects to the antenna. The antenna has an O-ring moisture seal and attaches to the airplane by four screws. The ATC and DME antennas are the same and are interchangeable.

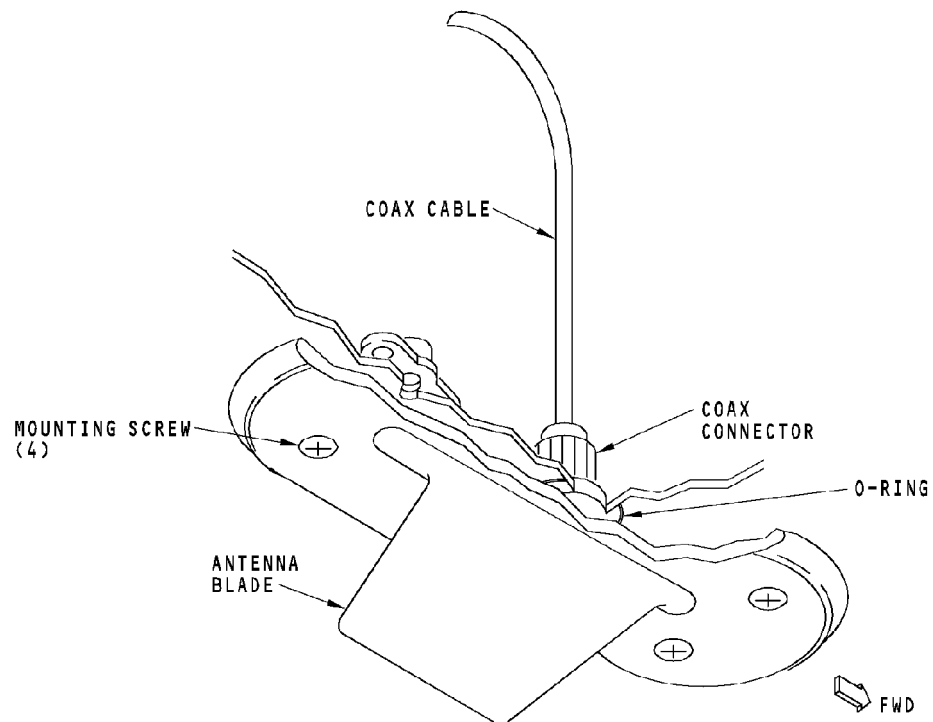

ATC SYSTEM - ATC ANTENNA

34-53-00-012

EFFECTIVITY
HAP ALL

34-53-00

D633A101-HAP

Page 27
Feb 15/2008

ATC SYSTEM - ATC COAX SWITCH

General

The ATC coax switches connect the active ATC transponder to the top and bottom ATC antennas.

These are the electrical connector inputs:

- ATC antenna switch circuit breaker
- ATC/TCAS control panel.

The ATC coax switches supply an RF interface for the ATC system interrogation and reply signals. These are the connectors:

- ATC transponder 1 connector
- ATC antenna connector
- ATC transponder 2 connector.

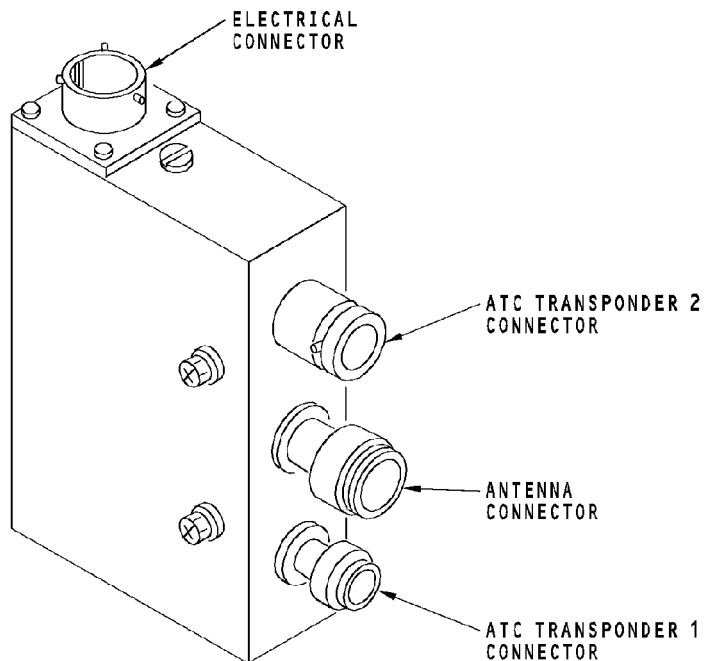

ATC SYSTEM - ATC COAX SWITCH

34-53-00-013

EFFECTIVITY
HAP ALL

34-53-00

D633A101-HAP

Page 29
Feb 15/2008

THIS PAGE IS INTENTIONALLY LEFT BLANK

34-53-00

D633A101-HAP

Page 30
Feb 15/2008

ATC SYSTEM - INPUTS AND CONTROL**ATC Control Panel**

The ATC/TCAS control panel controls the operation of the ATC transponders.

The microprocessor in the control panel gets inputs from these:

- Code selectors
- IDENT switch
- Mode selector.

The microprocessor changes these inputs into ARINC 429 digital data. The ATC control panel sends this data on an ARINC 429 data bus to the selected transponder:

- The identity code the flight crew selects to reply to interrogations
- Digital discretes for the position of the IDENT switch
- Digital discrete for TEST.

The transponder select switch selects one transponder for operation. The selected transponder receives an open discrete from the control panel. A ground discrete goes from the panel to the other transponder to put it in the standby mode. This discrete also goes to the ATC antenna coax switches to connect the two ATC antennas to the selected transponder.

The STBY position of the reply selector sets the selected transponder to standby mode.

Air/Ground Input

The transponder can receive an air/ground discrete input from the proximity switch electronics unit (PSEU) through the control panel reply selector. Set the reply selector to ON and the discrete open causes the transponder to reply to all interrogations in the air and on the ground. Set the reply selector to AUTO for the air/ground discrete to control transponder replies. In the air, the transponder will reply to interrogations. On the ground, the transponder will not reply to mode A and mode C interrogations.

ATC Transponder Inputs

The transponder has an input/output (I/O) that has an interface with the ARINC 429 data and analog discretes from the control panel.

Control Inputs

The digital data bus from the control panel has three digital discretes. One shows the position the TCAS mode selector on the panel is set to.

The second digital discrete from the control panel shows the position of the IDENT switch. The pilot momentarily pushes the IDENT switch at the request of the ATC ground station. When this happens, the transponder sends a special position identification (SPI) pulse at the end of every normal mode A reply. It continues for 18 seconds. The SPI causes the airplane to be highlighted on the air traffic controller's radar screen.

ATC SYSTEM - INPUTS AND CONTROL

The third digital discrete from the control panel shows if TEST is selected. If it is, the transponder starts a functional self-test.

Altitude Inputs

The air data inertial reference units (ADIRUs) send barometric altitude to each transponder. Each transponder uses only one ADIRU altitude input. If the input fails, the transponder will not use the other input. Altitude input 1 is the source for ATC transponder 1. Input 2 is the source for ATC transponder 2.

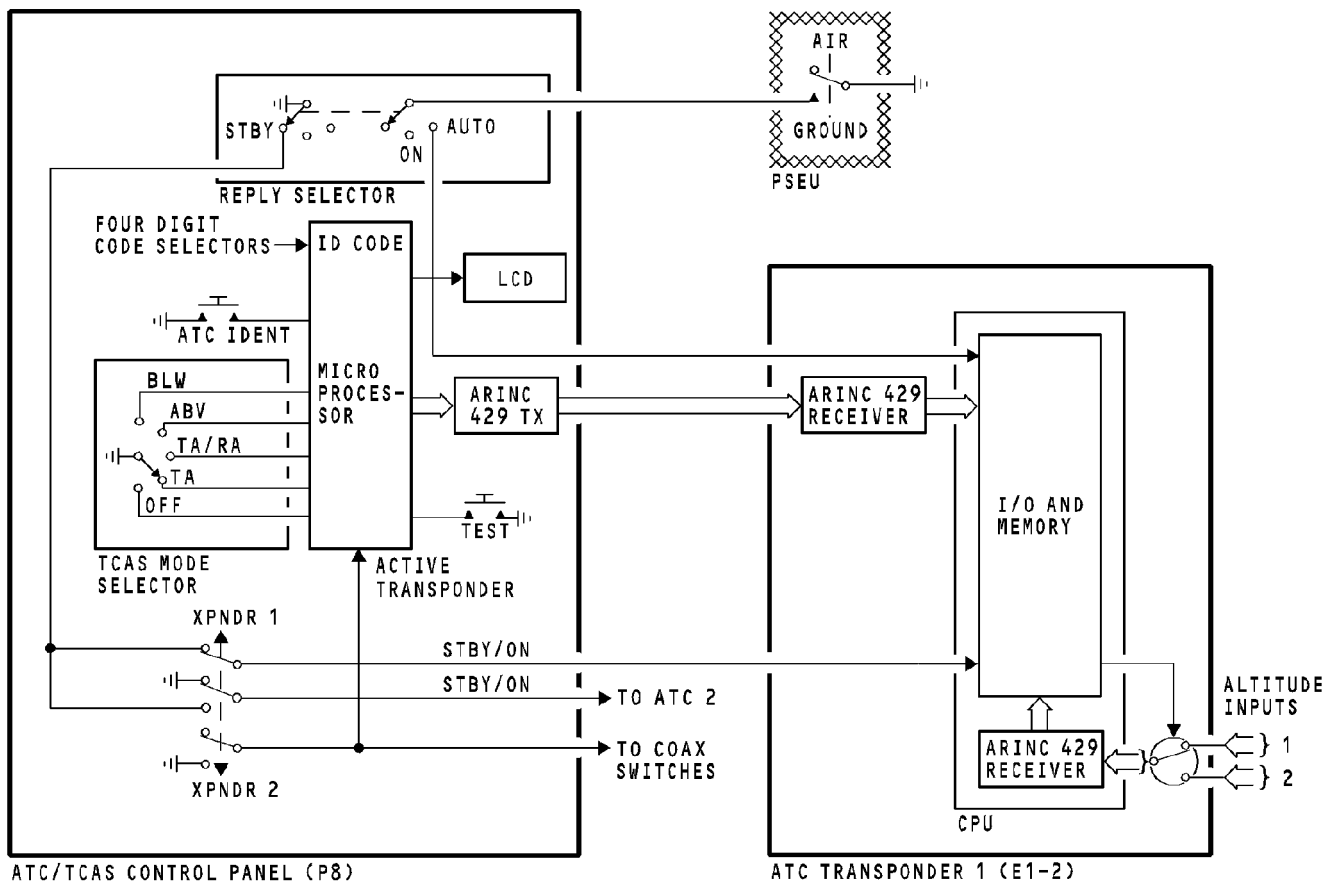

ATC SYSTEM - INPUTS AND CONTROL

34-53-00-014

EFFECTIVITY
HAP ALL

34-53-00

D633A101-HAP

ATC SYSTEM - TRANSPONDER RECEIVE FUNCTION**General**

The antennas send the interrogation signals to the transponder. The signals go through the diplexer circuits to two receivers. The 1030 MHz interrogation signal mixes with a 1090 MHz signal from the 1090 MHz oscillator. This makes an intermediate frequency signal that the signal processor uses.

Suppression

When the transponder gets a suppression pulse from another system, the signal processor circuits do not permit the receiver circuits to operate.

Antenna Select

The antenna select circuit chooses the diplexer and antenna that supplies the strongest receiver signal. The transmission of the reply signal goes through the selected diplexer and antenna.

Signal Processor

The signal processor determines if the transponder receives a valid interrogation signal. It also determines the correct reply mode; mode A, mode C, or mode S.

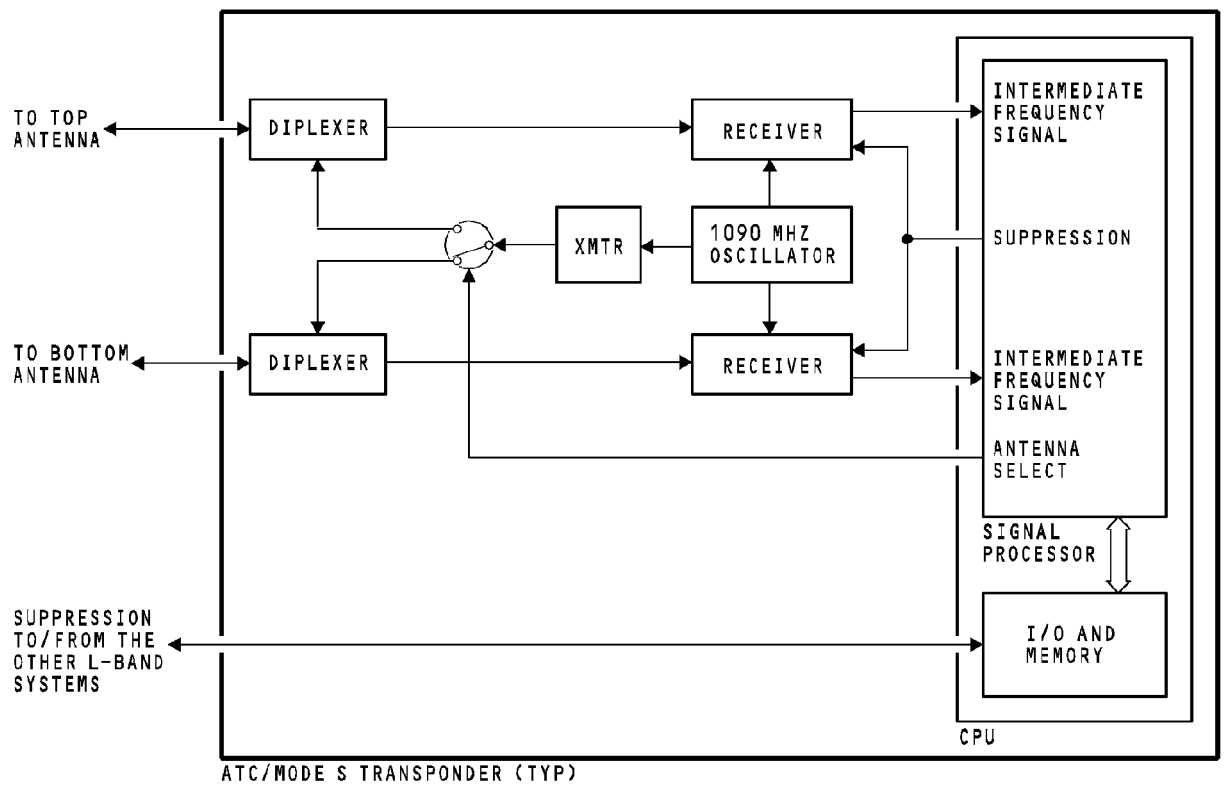

ATC SYSTEM - TRANSPONDER RECEIVE FUNCTION

34-53-00-015

EFFECTIVITY
HAP ALL

34-53-00

D633A101-HAP

ATC SYSTEM - TRANSPONDER TRANSMIT FUNCTIONAL DESCRIPTION**Transmit**

The central processor unit (CPU) controls the transponder to reply to a mode A, mode C, or mode S interrogation. The mode format circuits use the identity code, airplane altitude and the unique 24-bit airplane address from the memory to format the data for the reply signals.

The mode A reply contains the airplane identity code.

The mode C reply contains the airplane altitude.

The mode S replies contain a unique 24-bit airplane address, identity code, altitude information, and TCAS information.

After the signal processor chooses the correct mode for the reply data, the modulator makes a reply signal in that format. The modulator uses the signal processor output to modulate a 1090 MHz carrier to make the transmission reply signal. The transmission reply signal goes to the power amplifier and then to the diplexer and to the ATC antenna.

The antenna select circuit makes the transmission signal go to the antenna that receives the strongest interrogation signal.

Test

When you apply power or do a test of the ATC transponder system, the built-in test equipment (BITE) does a check of the operational status of all the internal circuits and for the correct antenna impedance. The BITE circuits identify any failures and put them into the non-volatile memory.

The LEDs on the front panel of the transponder come on to report these conditions:

- Transponder status
- Antenna status
- Transponder control interface status
- Altitude interface status.

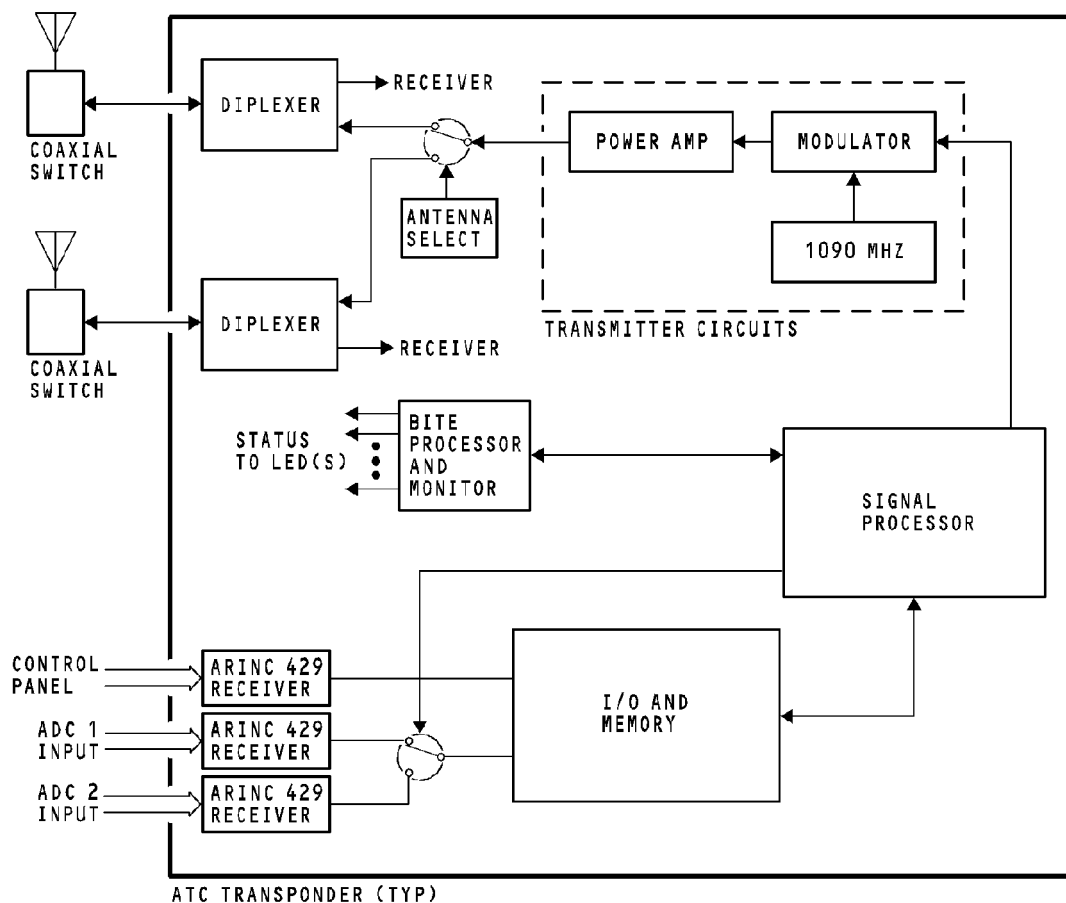

ATC SYSTEM - TRANSPONDER TRANSMIT FUNCTIONAL DESCRIPTION

34-53-00-016

EFFECTIVITY
HAP ALL

34-53-00

D633A101-HAP

Page 37
Feb 15/2008

ATC SYSTEM - ANTENNA COAX SWITCH CONTROL**General**

Use the ATC/TCAS control panel to select the active ATC system. When you do this, the ATC/TCAS control panel sends a discrete open or ground to the top and bottom ATC coax switches. This connects the ATC transponder 1 or the ATC transponder 2 to the top and bottom ATC antennas.

ATC 1 System Select or Standby

When the airplane power is on and when the ATC/TCAS control panel has the ATC transponder 1 selected, the S1 switches energize. This removes the ground to relays R1 and R2. They do not energize. The top and bottom antennas connect to ATC transponder 1.

ATC 2 System Select

With the ATC transponder 2 selected, switch S1 deenergizes to supply a ground to energize relay R1 and R2. The top and bottom antennas connect to the ATC transponder 2.

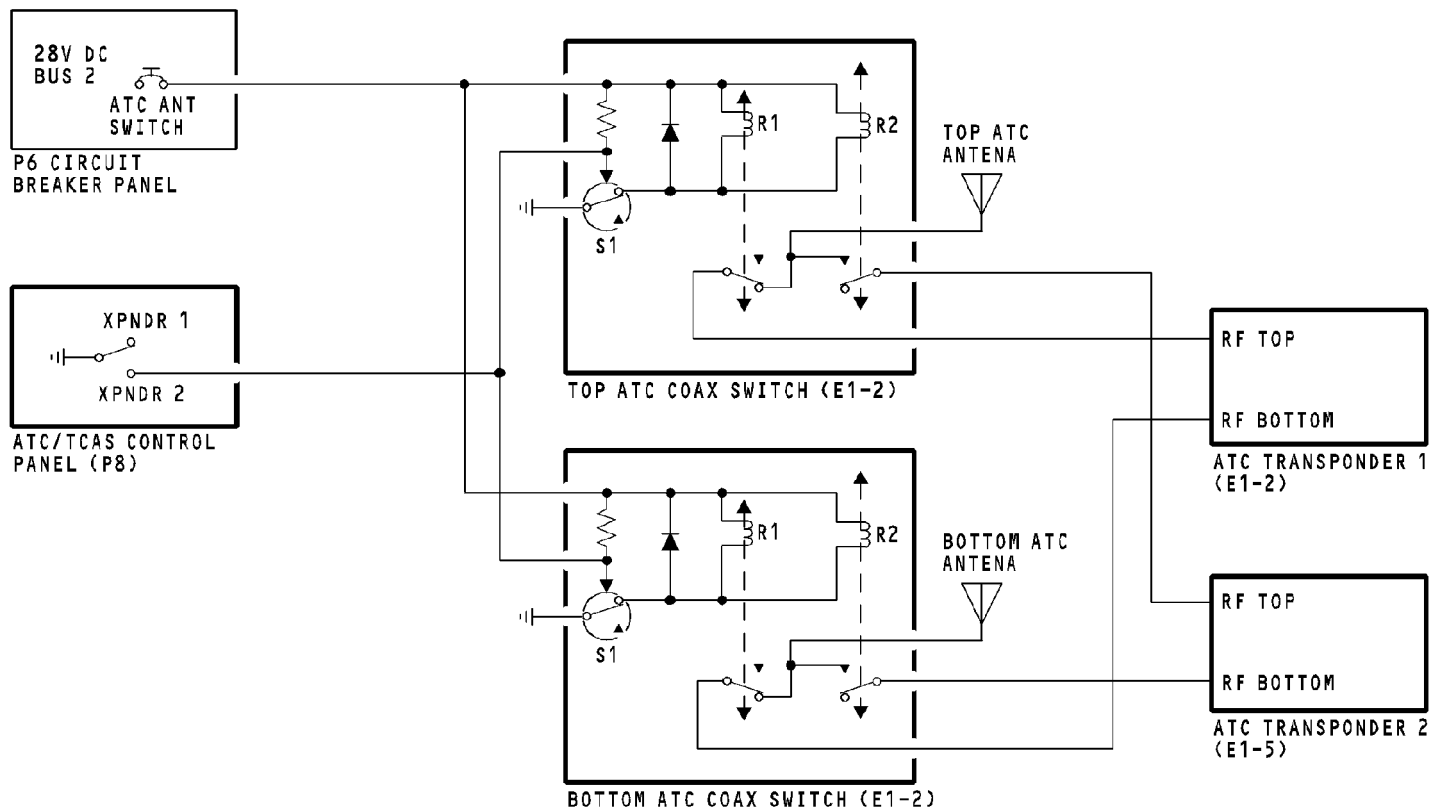

ATC SYSTEM - ANTENNA COAX SWITCH CONTROL

EFFECTIVITY
HAP ALL

34-53-00

D633A101-HAP

Page 39
Feb 15/2008

34-53-00-017

ATC SYSTEM - SELF TEST**General**

Push the TEST switch on the front of the transponder or select TEST on the ATC/TCAS control panel to start a self-test of the ATC system. During the test, the transponder BITE circuits do these functions:

- Normal operation test
- Memory tests
- Simulated interrogation test of the receiver circuits
- Antenna impedance test
- TCAS interface test
- Valid control and altitude inputs monitor.

Test From the Front Panel

Push and hold the test switch. All front panel light emitting diode (LED) status indicators come on for three seconds. Then all the LEDs go off for two seconds. Continue to hold the test switch to see the applicable LEDs come on to show the condition of the ATC transponder system.

These are the LED status indicators and their related conditions:

- TPR green - no LRU failures
- TPR red - LRU failure
- ALT - altitude input from the ADIRU fails
- DATA IN - control panel input fails
- TOP - top antenna fails
- BOT - bottom antenna fails

- TCAS - interface with TCAS fails
- MAINTENANCE - not used
- RESERVED(2) - not used.

Test From the Control Panel

Push and release the test button on the control panel to start a self-test of the ATC system. The XPDR FAULT light comes on for three seconds and then goes off if the test is successful. The XPDR FAULT light stays on for any of these conditions:

- Antenna failure
- Transponder failure
- Control data failure
- Altitude input failure.

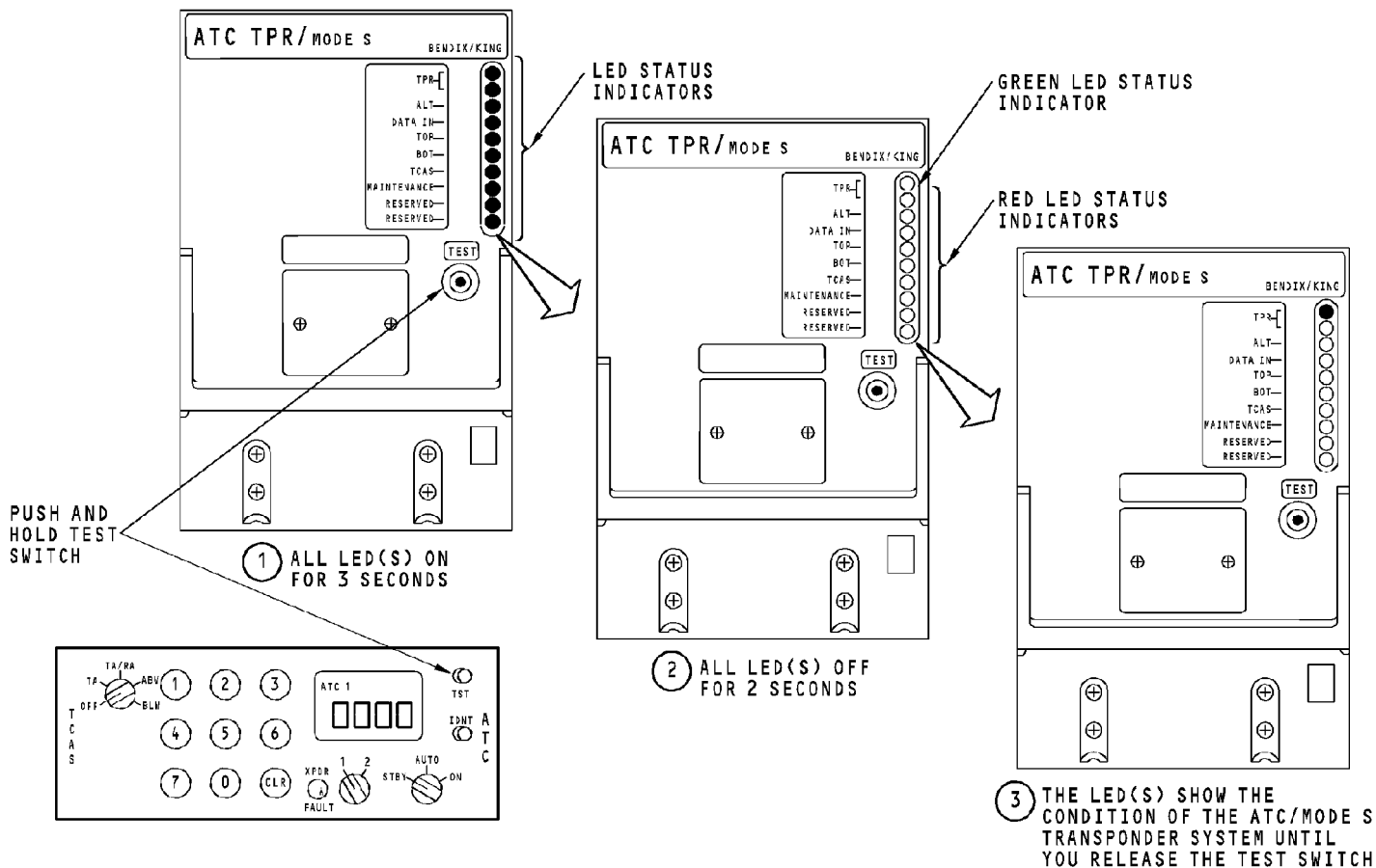

ATC SYSTEM - SELF TEST

EFFECTIVITY
HAP ALL

34-53-00

D633A101-HAP



ATC SYSTEM - SYSTEM SUMMARY

General

This graphic is for reference purposes only.

34-53-00-005

EFFECTIVITY
HAP ALL

34-53-00

D633A101-HAP

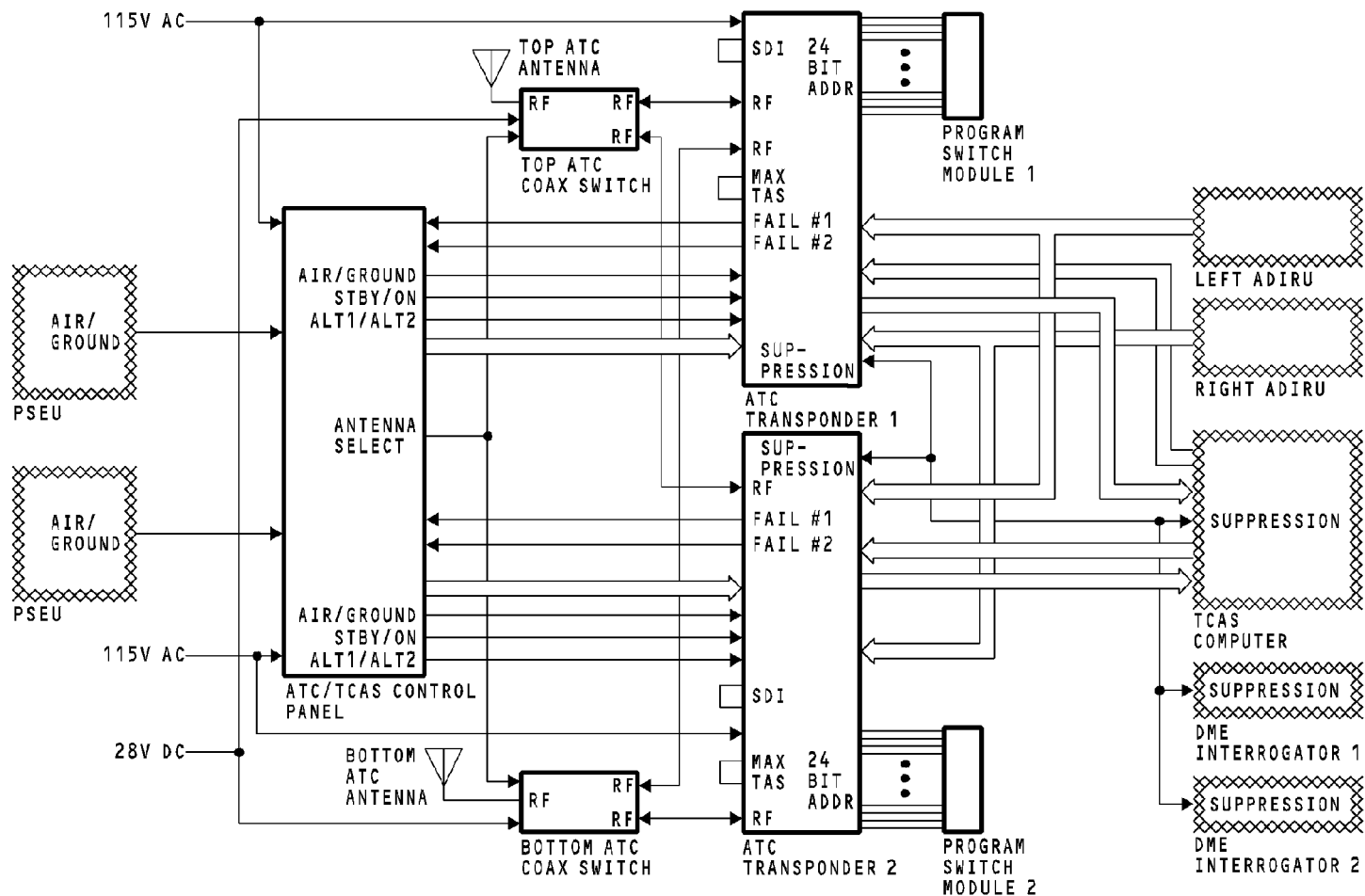

ATC SYSTEM - SYSTEM SUMMARY

34-53-00-005

EFFECTIVITY
HAP ALL

34-53-00

D633A101-HAP

DISTANCE MEASURING EQUIPMENT - INTRODUCTION**Purpose**

The distance measuring equipment (DME) system supplies slant range (line of sight) distance measurement between the airplane and the ground station.

Abbreviations and Acronyms

- AC - alternating current
- ACP - audio control panel
- ADF - automatic direction finder
- alt - alternate
- altn - alternate
- app - approach
- ARINC - Aeronautical Radio, Inc.
- ATC - air traffic control
- ATE - automatic test equipment
- auto - automatic
- B - both
- BITE - built-in test equipment
- BL - buttock line
- CAPT - captain
- CDU - control display unit
- circ - circulator
- CPU - central (control) processing unit
- DC - direct current
- DEU - display electronics unit
- DME - distance measurement equipment
- EFIS - electronic flight instrument system
- F/O - first officer
- FCC - flight control computer
- FDAU - flight data acquisition unit
- FMC - flight management computer

- FMCS - flight management computer system
- freq - frequency
- fwd - forward

HAP 037

- GLS - GNSS Landing System
- GNSS - global navigation satellite system

HAP ALL

- grd - ground
- I/C - intercom
- ILS - instrument landing system
- LCD - liquid crystal display
- LED - light emitting diode
- LRU - line replaceable unit
- maint - maintenance
- MHz - megahertz
- MKR - marker beacon
- nav - navigation
- NCD - no computed data
- ND - navigation display
- NORM - normal
- PFD - primary flight display
- R - range
- rcvr - receiver
- REU - remote electronics unit
- RF - radio frequency
- rly - relay
- R/T - receive/transmit
- spkr - speaker
- sta - station
- TCAS - traffic alert and collision avoidance system
- TFR - transfer
- TX - transmitter



DISTANCE MEASURING EQUIPMENT - INTRODUCTION

- V - voice
- V - volts
- VHF - very high frequency
- xfr - transfer
- xmtr - transmitter
- xpndr - transponder

34-55-00-001

EFFECTIVITY
HAP ALL

34-55-00

D633A101-HAP

Page 2
Jun 10/2007

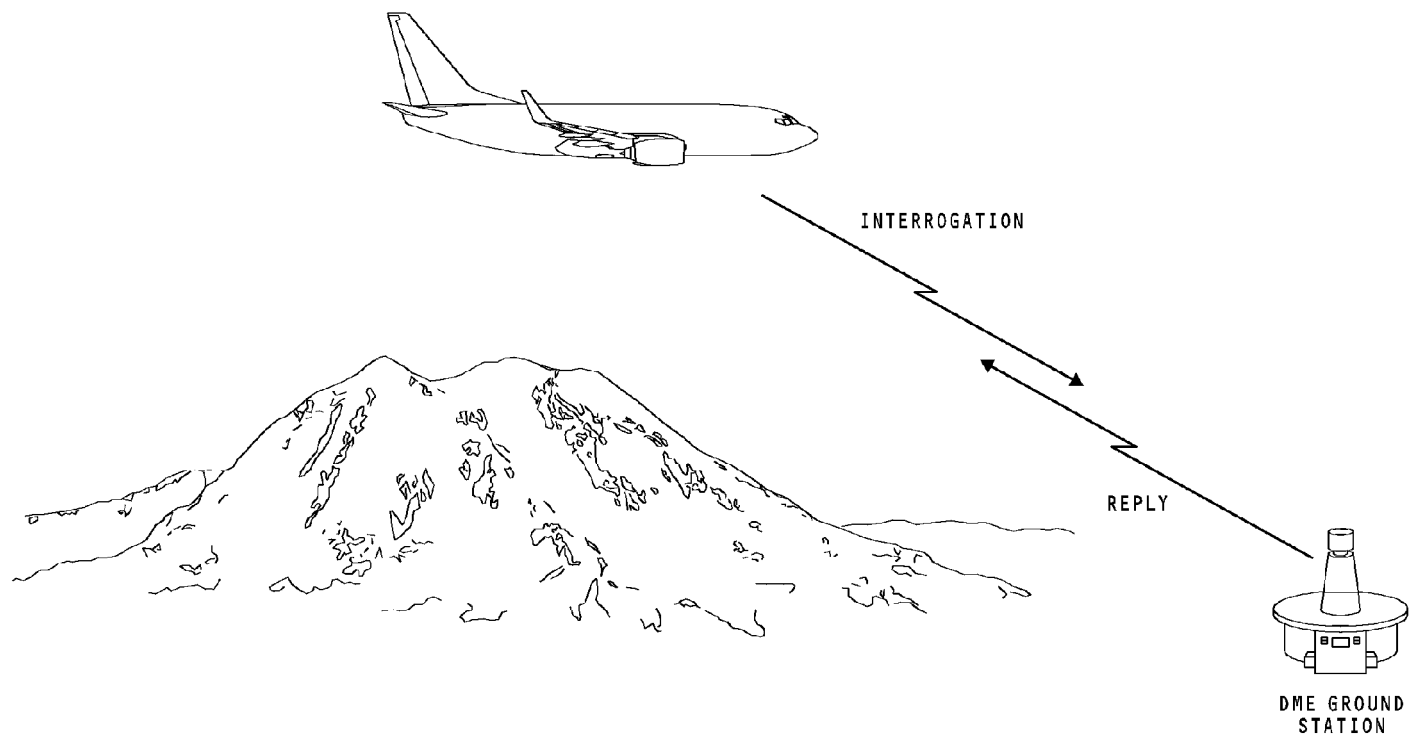

DISTANCE MEASURING EQUIPMENT - INTRODUCTION

EFFECTIVITY
HAP ALL

34-55-00

D633A101-HAP

Page 3
Oct 10/2004

34-55-00-001

DME SYSTEM - GENERAL DESCRIPTION**General**

The DME system has two DME interrogators and two antennas.

Description

The interrogators get manual tune inputs and flight management computer system (FMCS) autotune inputs from the navigation control panel. If the NAV control panel tune inputs fail, the interrogators get autotune inputs directly from the FMC.

The DME system sends data to the display electronics units to show on the primary flight displays (PFDs) and navigation displays (NDs).

The DME system sends data to these units:

- Flight control computers (FCC)
- Flight management computer System (FMCS)
- Flight data acquisition unit (FDAU)
- Remote Electronics Unit (REU).

The FCCs use DME data as an input to calculate the VOR capture point in the autopilot VOR mode. The DME data is also used in the VOR mode to find when over station is sensed (OSS) for the VOR ground station.

The FMCS uses DME data to calculate FMC position updates.

The flight data acquisition unit receives DME data, formats it, and sends it to the flight data recorder.

The REU receives audio from the DME station and sends it to the flight deck headsets and speakers.

The DME system sends and receives a suppression pulse between these units:

- DME
- ATCs
- TCAS.

The DME interrogator receives the station audio identifiers and sends them to the remote electronics unit (REU).

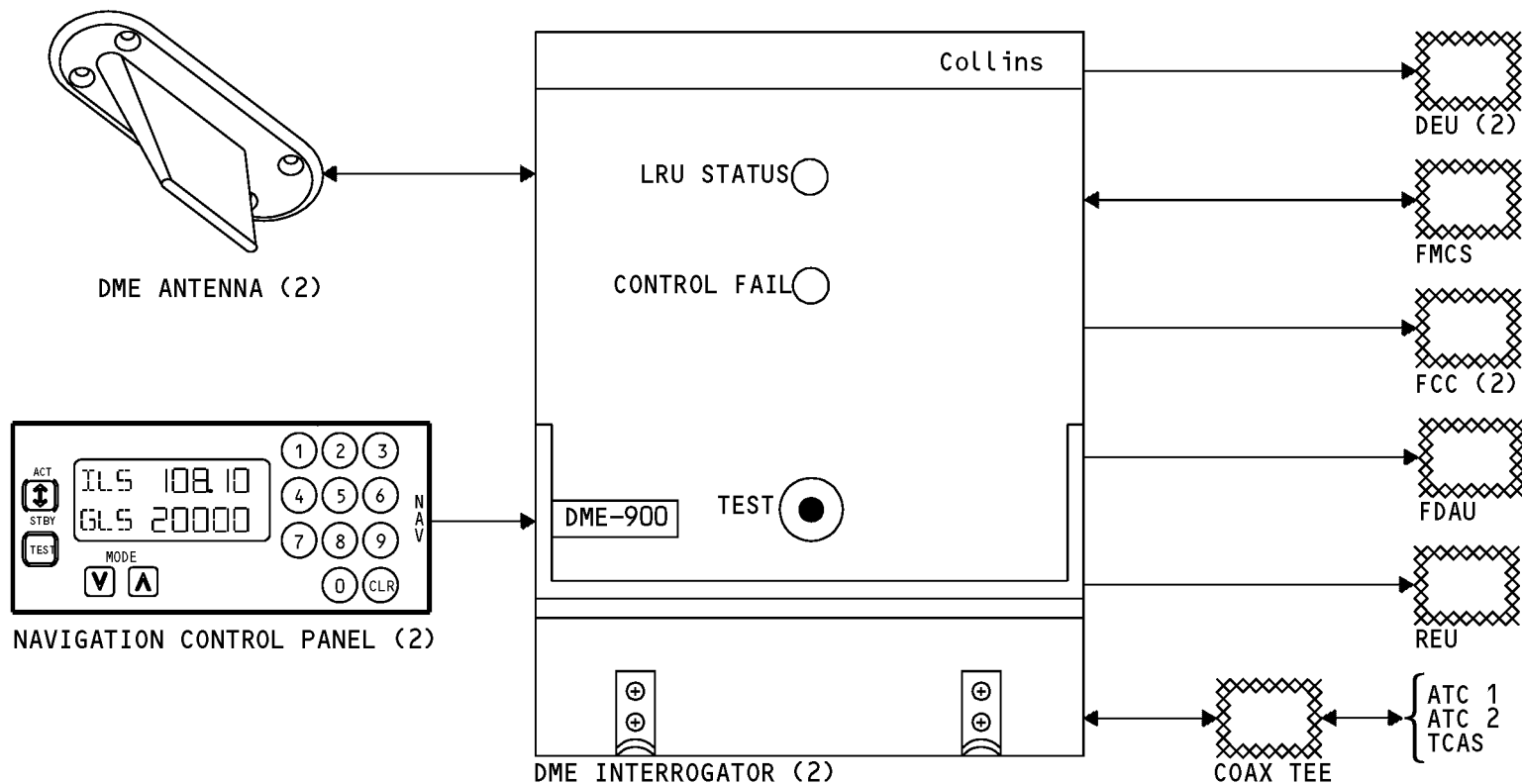

DME SYSTEM - GENERAL DESCRIPTION

34-55-00-002

EFFECTIVITY
HAP 037

34-55-00

D633A101-HAP

Page 5
Jun 10/2007

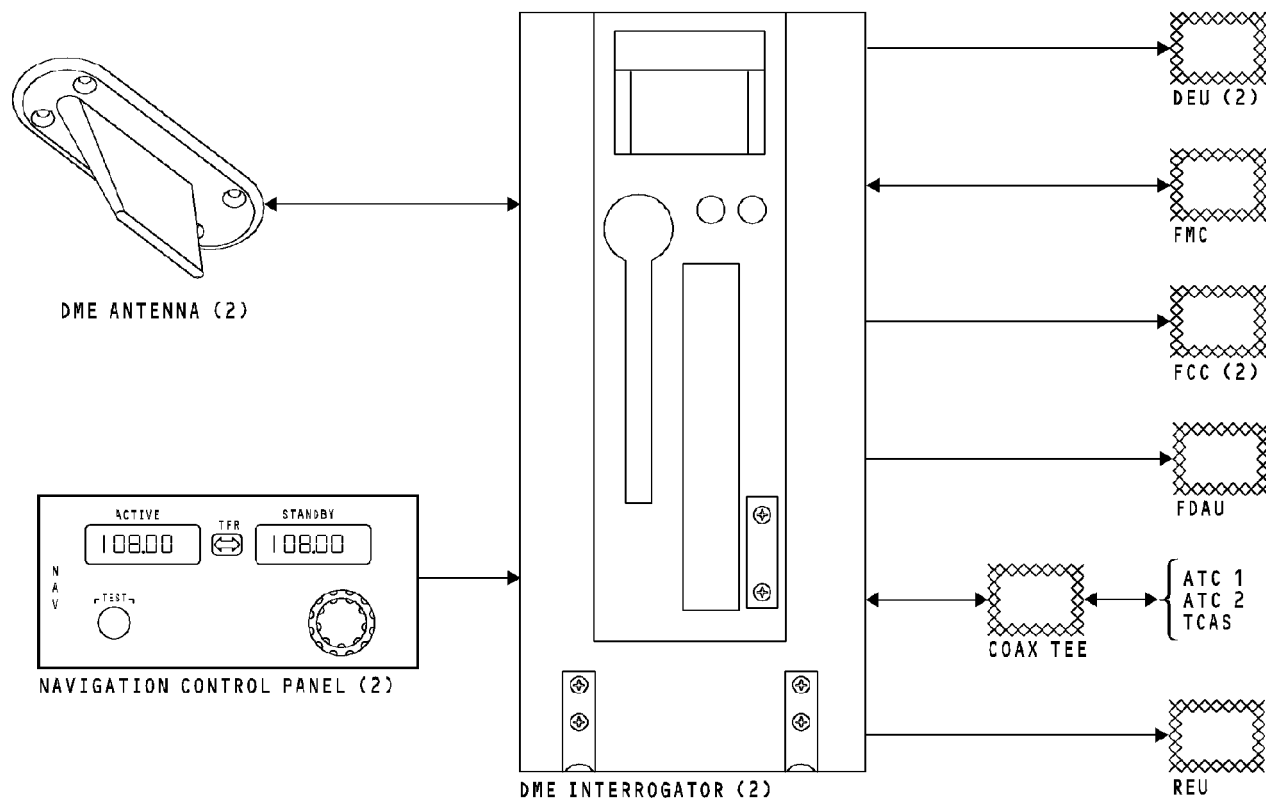

DME SYSTEM - GENERAL DESCRIPTION

EFFECTIVITY
HAP ALL

34-55-00

D633A101-HAP

THIS PAGE IS INTENTIONALLY LEFT BLANK

34-55-00

D633A101-HAP

Page 7
Jun 10/2007

DME SYSTEM - COMPONENT LOCATION - FLIGHT COMPARTMENT

General

These are the components in the flight compartment that have an interface with the DME system:

HAP 037-054, 101-999

- FMC source select switch

HAP ALL

- Left inboard and outboard display units
- Left and right EFIS control panels
- Right inboard and outboard display units
- Captain's and first officer's NAV control panel
- Captain's and first officer's audio control panel.

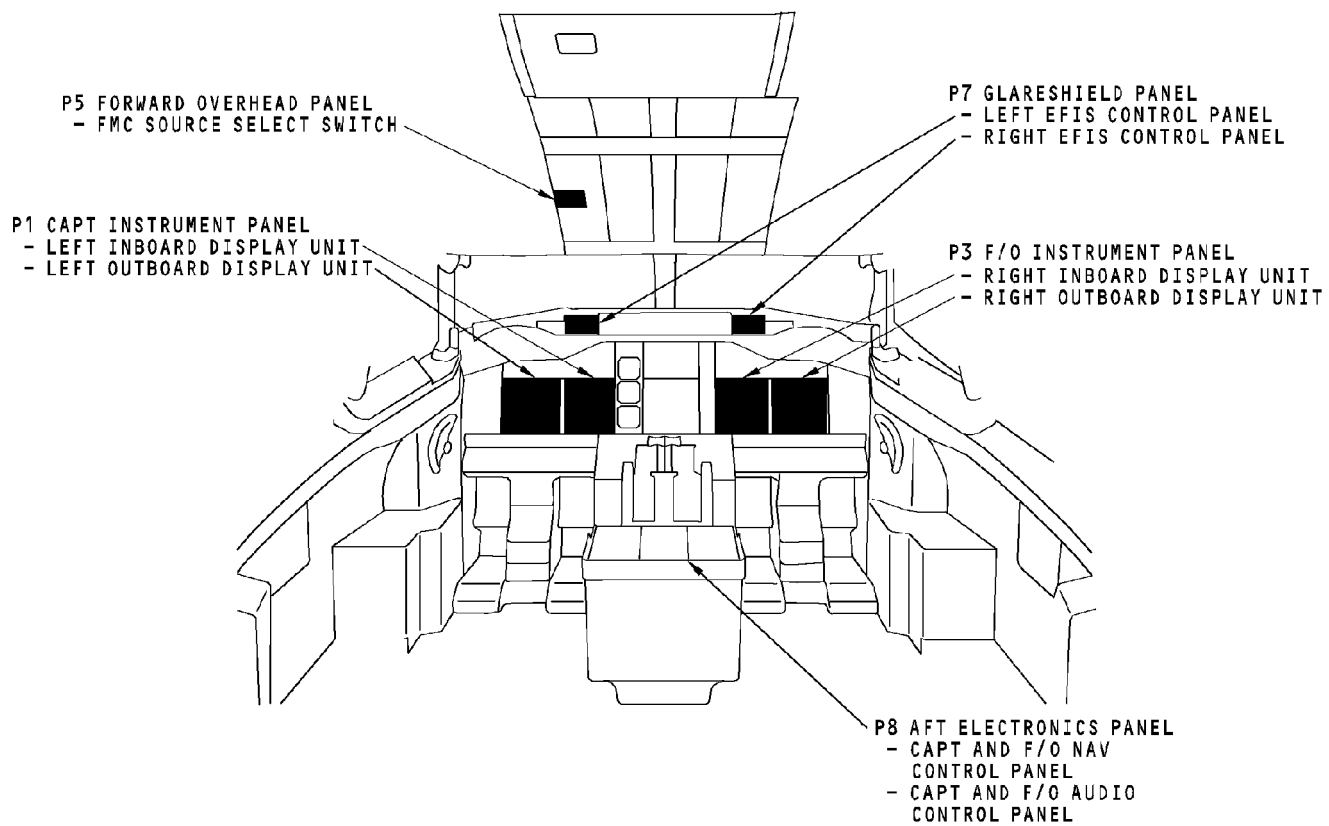

DME SYSTEM - COMPONENT LOCATION - FLIGHT COMPARTMENT

34-55-00-003

EFFECTIVITY
HAP 037-054, 101-999

34-55-00

D633A101-HAP

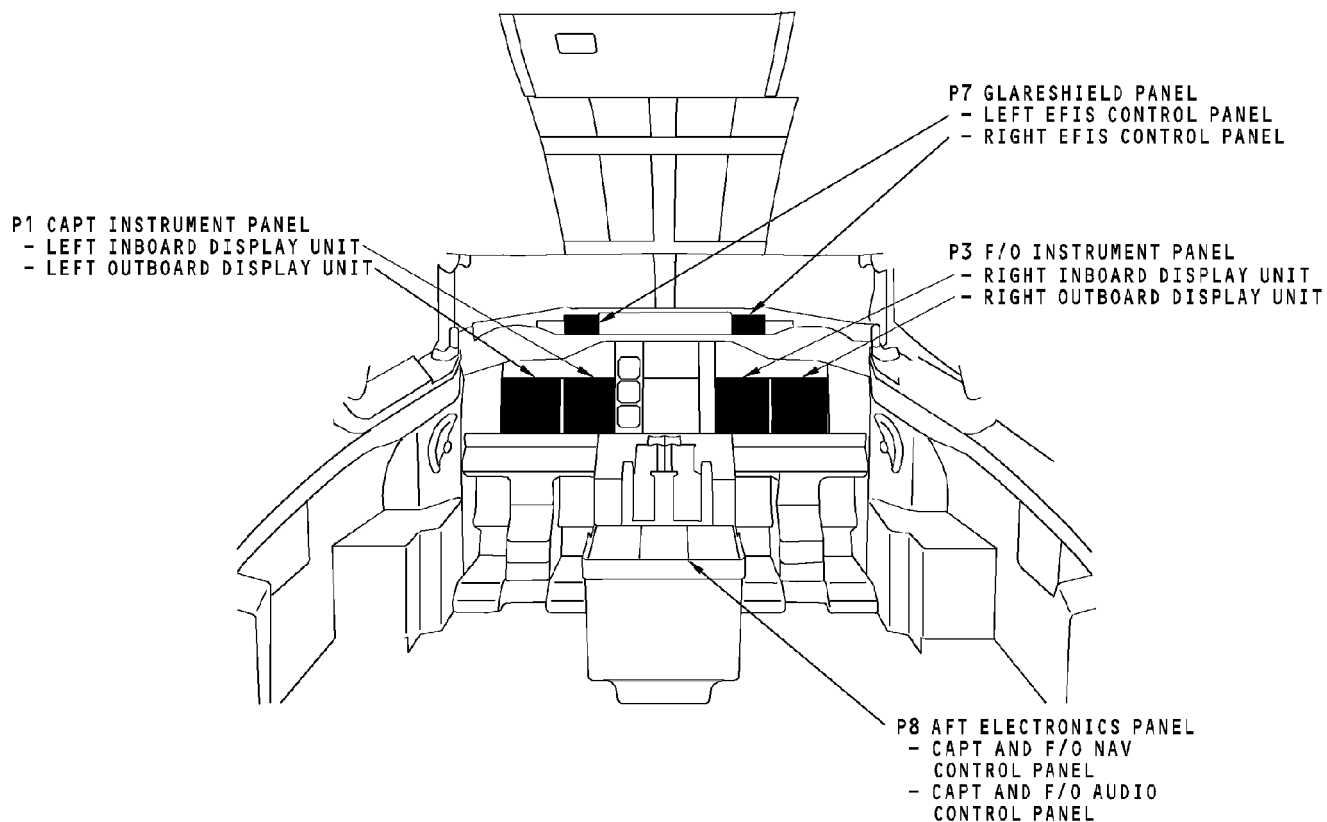

DME SYSTEM - COMPONENT LOCATION - FLIGHT COMPARTMENT

EFFECTIVITY

HAP 001-013, 015-026, 028-036

34-55-00

D633A101-HAP

THIS PAGE IS INTENTIONALLY LEFT BLANK

34-55-00

D633A101-HAP

Page 11
Jun 10/2007

DME SYSTEM - COMPONENT LOCATION - ELECTRONIC EQUIPMENT COMPARTMENT AND ANTENNAS**DME Component Locations**

These components are in the electronics equipment compartment:

- DME 1 interrogator
- DME 2 interrogator.

These components are on the exterior of the airplane:

- DME 1 antenna
- DME 2 antenna.

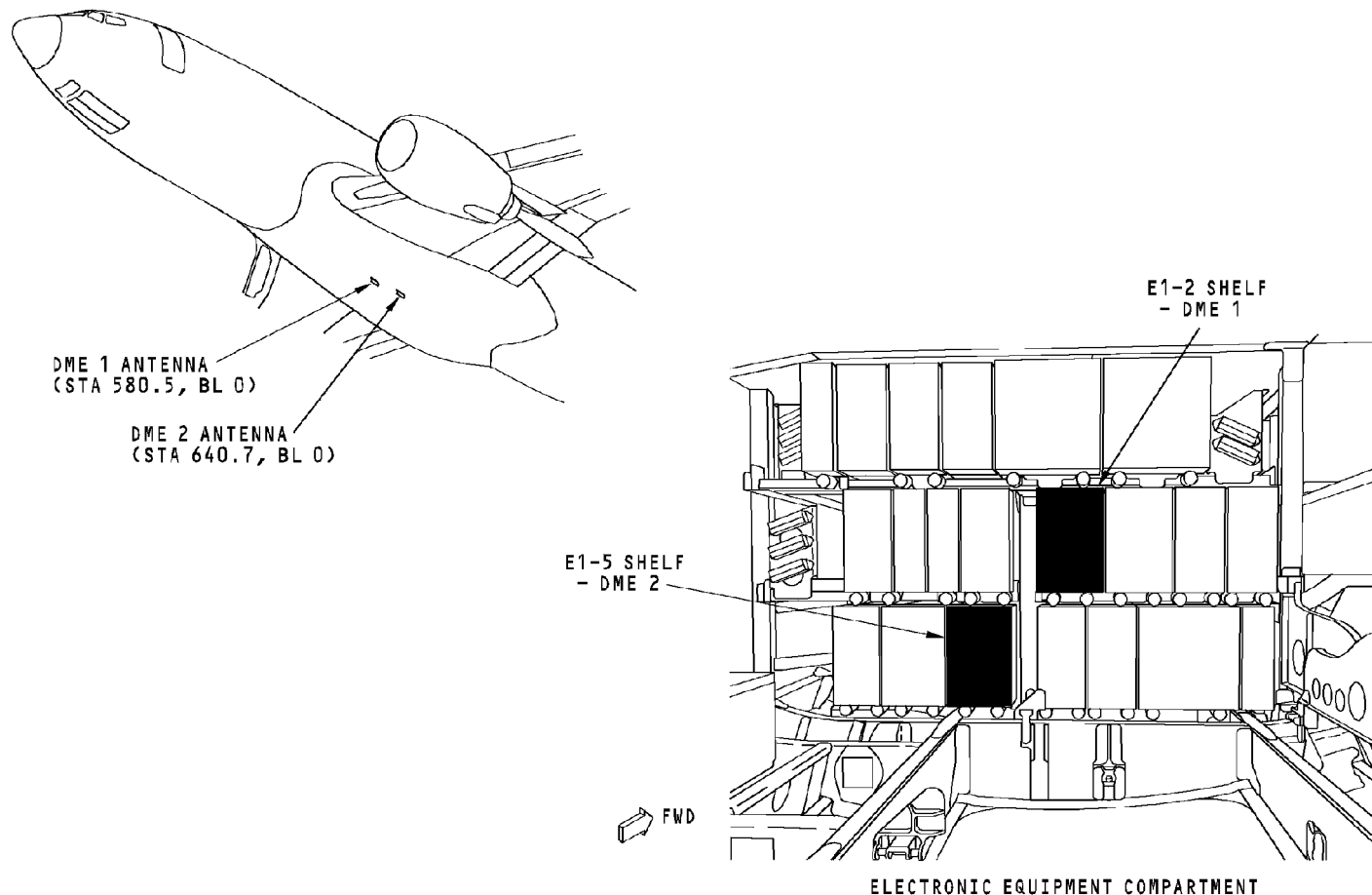

DME SYSTEM - COMPONENT LOCATION - ELECTRONIC EQUIPMENT COMPARTMENT AND ANTENNAS

34-55-00-004

EFFECTIVITY
HAP ALL

34-55-00

D633A101-HAP

Page 13
Jun 10/2007

DME SYSTEM - ARINC 429 INTERFACES**Navigation Control Panel**

The navigation control panels supply a manual tune frequency input to the DME interrogator. They also send four auto tune frequency inputs from the Flight Management Computer (FMC).

The control panels send tune and test data on two output data buses. One output data bus goes to the MMR receiver and one output data bus goes to both the DME interrogator and VOR receiver.

DME Outputs

Each DME interrogator has two output buses. One output bus supplies data to the on-side flight control computer (FCC). DME 1 sends data to FCC A and DME 2 sends data to FCC B. the other Output bus supplies data to these units:

- Flight management computer system (FMCS).
- Display electronics units 1 and 2
- Flight data acquisition unit (FDAU).

The FMCS uses DME distance to calculate position updates.

The DEUs use DME distance for displays.

The FDAU receives DME distance and formats it for the flight data recorder.

Flight Management Computer

The FMC supplies auto tune commands through the navigation control panel to the DME interrogator. If the navigation control panel has a failure, the DME gets auto tune signals directly from the FMC.

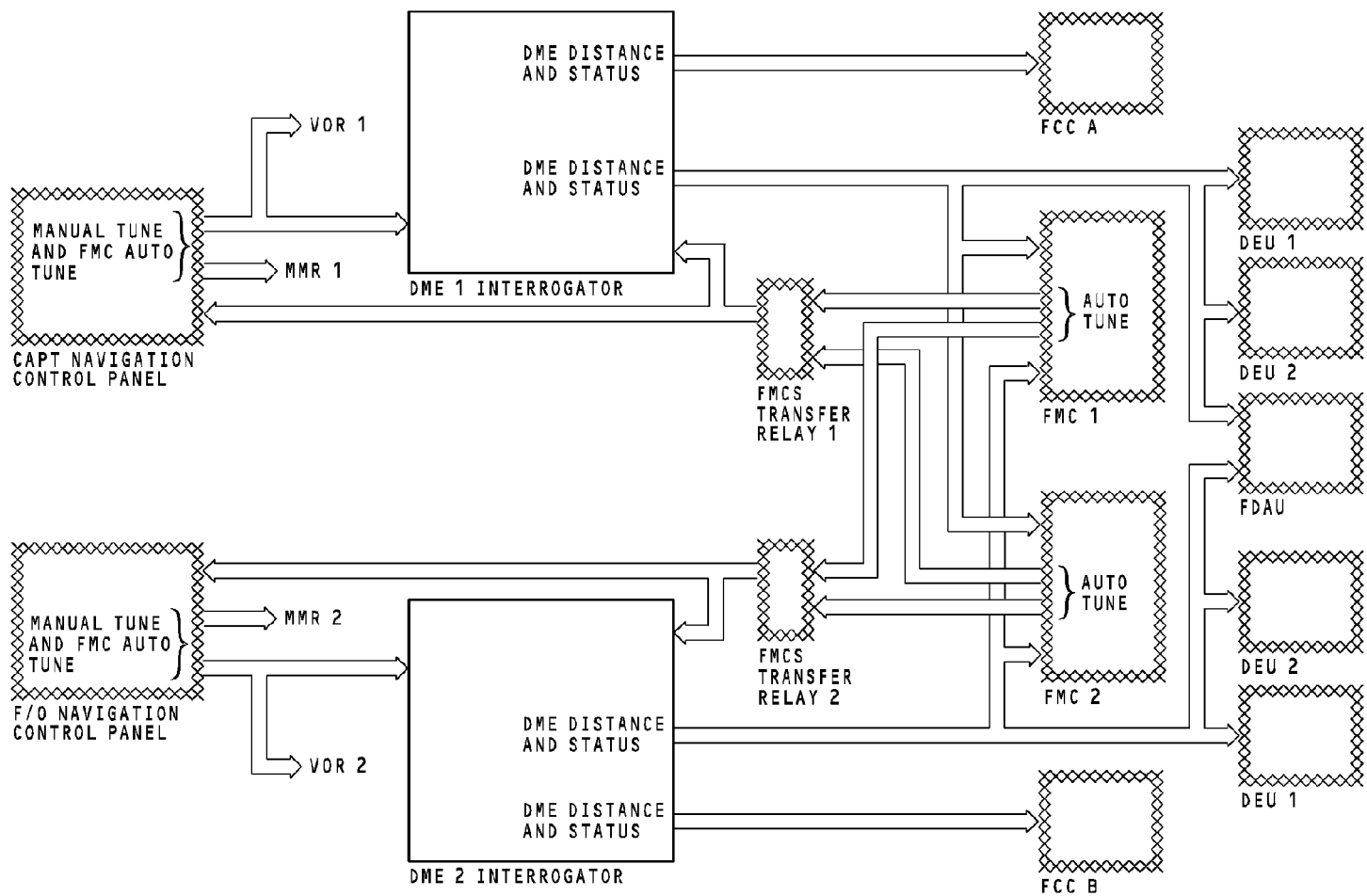

DME SYSTEM - ARINC 429 INTERFACES

34-55-00-005

EFFECTIVITY
HAP 037-054, 101-999

34-55-00

D633A101-HAP

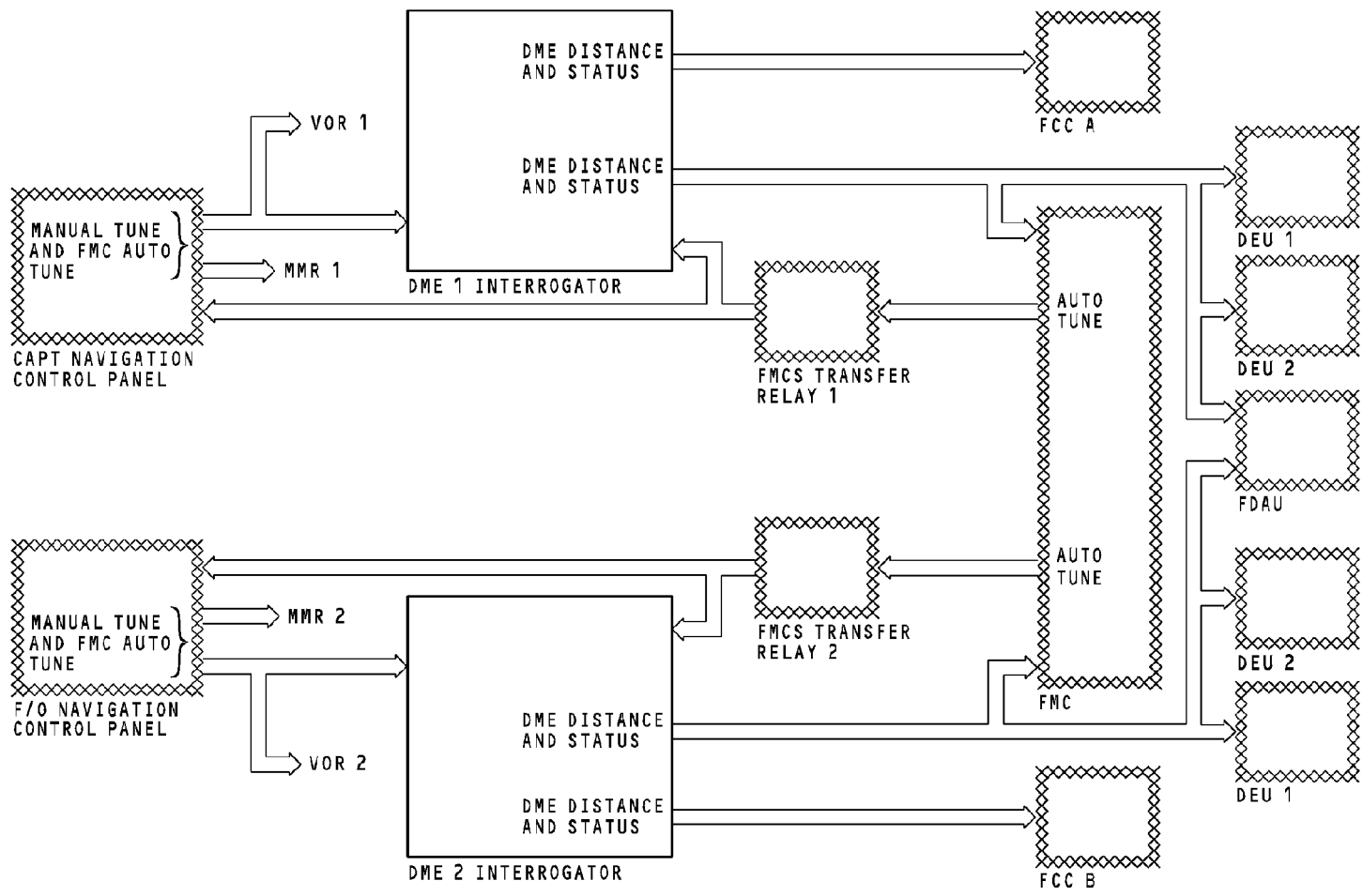

DME SYSTEM - ARINC 429 INTERFACES

EFFECTIVITY

HAP 001-013, 015-026, 028-036

34-55-00

34-55-00-005

D633A101-HAP

THIS PAGE IS INTENTIONALLY LEFT BLANK

34-55-00

D633A101-HAP

Page 17
Jun 10/2007

DME SYSTEM - POWER, ANTENNA, ANALOG, AND DISCRETE INTERFACE**Power Interface**

Each DME interrogator receives 115v ac from the DME circuit breakers.

DME Antenna Interface

The DME antennas transmit and receive DME signals. The antennas transmit signals to the ground stations. They then receive the reply signals from the DME ground station and send them to the interrogator.

Source Select Discrete

The source select discrete controls the ARINC 429 receive ports in the DME interrogator. With the source select open, the DME interrogator gets manual and auto tune commands from the navigation control panel. If the navigation control panel has a failure, the source select discrete goes to ground. The DME then gets auto tune signals directly from the FMC.

PSEU

The proximity switch electronics unit (PSEU), supplies an air/ground discrete inputs to the DME interrogators to set flight leg count. The air/ground discrete also goes to the navigation control panels to inhibit test commands in the air.

Default Scan Inhibit Discrete

The default scan inhibit discrete locks the DME interrogator so it can not make a scan of all the DME frequencies. It tunes to five channels controlled by the navigation control panel and the flight management computer.

DME/ATC/TCAS Suppression

These systems operate in the same frequency band:

- DME
- Air traffic control (ATC)
- Traffic alert and collision avoidance system (TCAS).

When a DME interrogator, an ATC transponder, or the TCAS computer transmits, it sends a suppression pulse through the suppression lines. This pulse stops the reception of the other four units. This prevents damage to the receiver circuits of the other LRUs.

DME Audio

The DME interrogator sends the DME station audio identifier to the remote electronics unit (REU). The audio goes to the headsets and the flight interphone speakers.

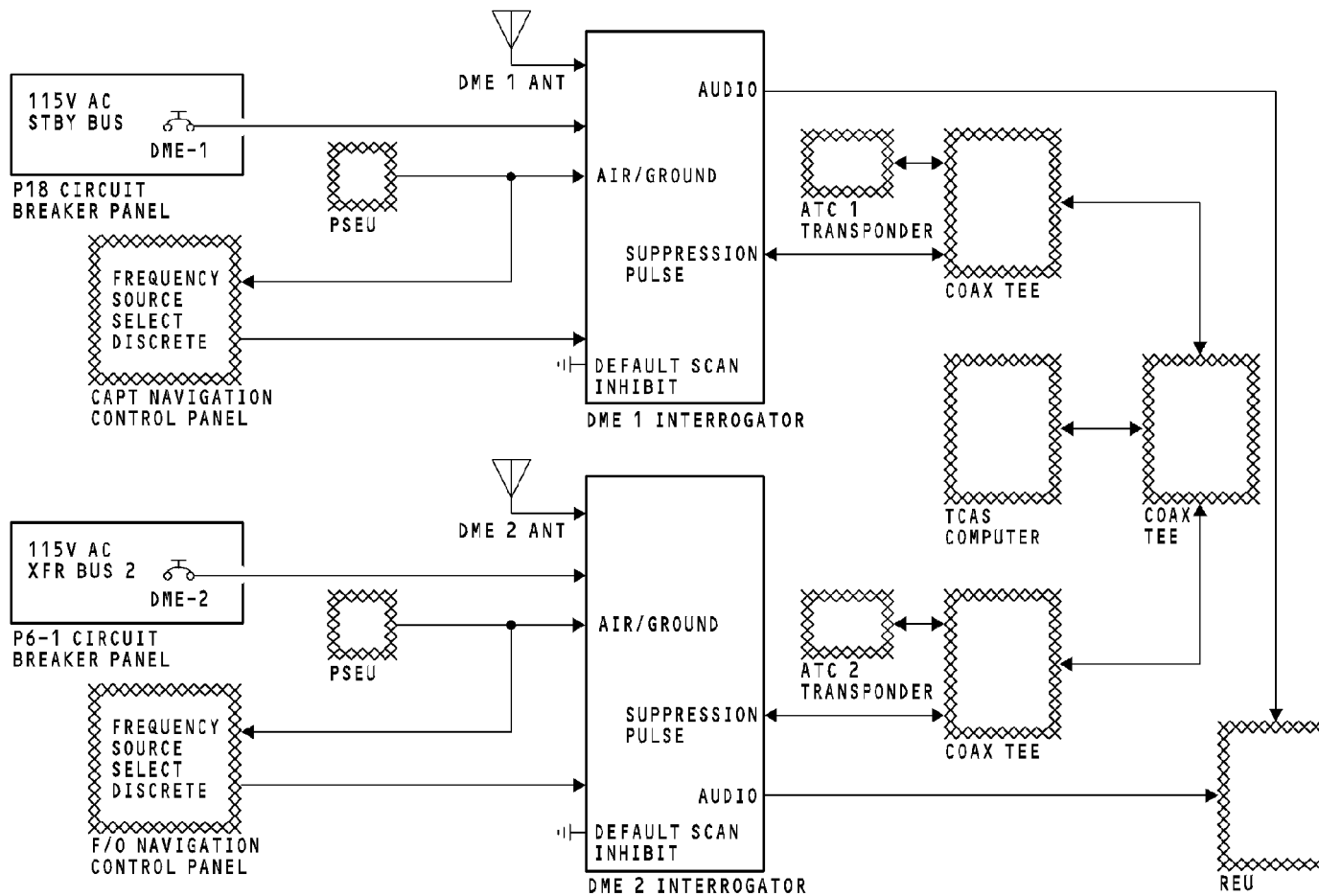

DME SYSTEM - POWER, ANTENNA, ANALOG, AND DISCRETE INTERFACE

34-55-00-006

EFFECTIVITY
HAP ALL

34-55-00

D633A101-HAP

DME SYSTEM - INTERROGATOR**General**

The DME interrogator tunes to 252 channels and calculates distance information for all the channels in the DME range. There are 200 DME channels for the VHF NAV frequencies. The other 52 channels are for military TACAN functions. The DME receive frequency is 63 MHz above or below the transmit frequency.

Purpose

These are the purposes of the DME interrogator:

- Interrogate DME stations
- Receive the station replies
- Receive audio identifiers
- Calculate slant range distances.

Frequencies

These DME tuning frequencies are in the VHF band:

- 108.00 to 117.95 MHz for DME stations with VOR or ILS
- 133.30 to 135.95 MHz for DME only stations.

Front Panel

There are two switches and an LCD on the front panel of the DME interrogator. You use any of the two switches to start a test of the DME interrogator. The LCD shows the test results.

There is a memory card slot on the front of the DME interrogator. Shop personnel use this to put in a flash memory card which loads software into the LRU. The memory card can also keep LRU condition data sent by the LRU during operation.

Shop personnel use the RS 232 connector to connect shop test equipment to the LRU. This feature is not for use by line maintenance personnel.

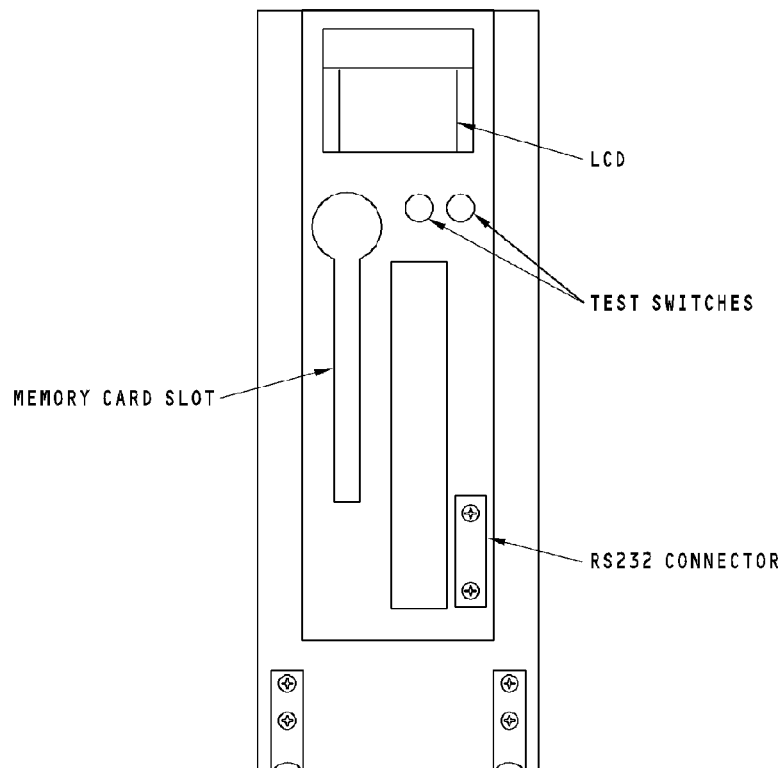

DME SYSTEM - INTERROGATOR

34-55-00-007

EFFECTIVITY
HAP ALL

34-55-00

D633A101-HAP

Page 21
Jun 10/2007

DME SYSTEM - ANTENNA**General**

The L-band DME antenna transmits the interrogator output signal and receives the ground station reply and identification signals.

Physical Description

The antenna has an o-ring moisture seal and attaches to the airplane with four screws. The DME and the ATC antennas are the same and are interchangeable.

Training Information Point

Extra force on the antenna may be necessary to break the weatherproofing seal. To prevent damage to aircraft skin or electrical cable at the antenna base, carefully pry around the antenna with a sealant removal tool.

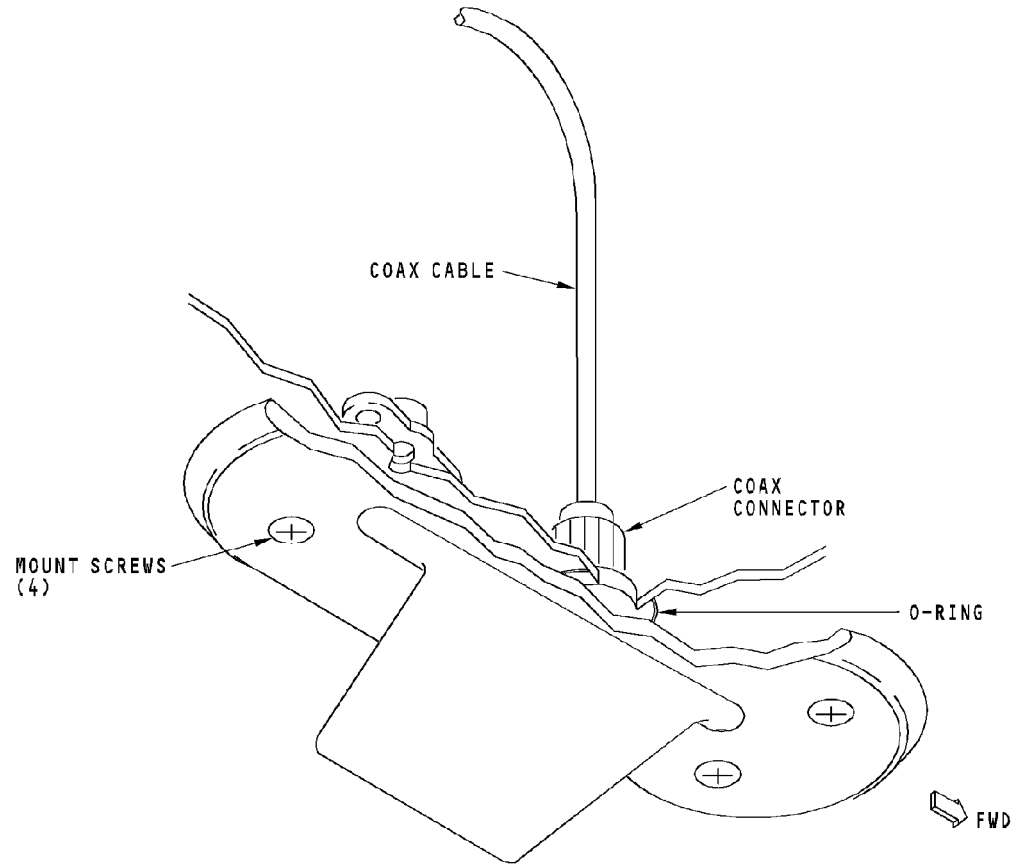

DME SYSTEM - ANTENNA

34-55-00-008

EFFECTIVITY
HAP ALL

34-55-00

D633A101-HAP

THIS PAGE IS INTENTIONALLY LEFT BLANK

34-55-00

D633A101-HAP

Page 24
Jun 10/2007

DME SYSTEM - NAVIGATION CONTROL PANEL

General

The navigation (NAV) control panels supply frequency inputs and test commands to these navigation radios:

- DME
- ILS
- VOR.

When you put a paired VOR or ILS frequency into the navigation control panel, it also goes to the DME interrogator. The DME tunes a DME frequency in the range of 108MHz to 117.95MHZ.

Set the frequency on the navigation control panel for these audio outputs:

- VOR and DME station identification
- ILS and DME station identification.

Operation

The NAV control panels have an active frequency display window and a standby frequency display window. The frequency that shows in the active frequency display window is the frequency that the navigation radios use for operation. The standby frequency display window shows the next frequency you will use.

The transfer switch is a momentary action switch. It transfers the frequency in the standby frequency display window to the active frequency display window. When you push the switch, the frequency that is in the active frequency display window transfers to the standby frequency display window.

HAP 001-013, 015-026, 028-036, 038-054, 101-999

The frequency select control is a continuous rotary knob. There is an inner knob and an outer knob. The outer knob sets the tens and ones. The inner knob sets the tenth and one hundredth numbers.

HAP ALL

At power up, the frequency displays show the last frequency entry before power down.

The NAV control panel continuous BITE function monitors the operation. The NAV control panel shows FAIL in the active and the standby frequency display windows when there is a failure.

The monitor in the NAV control panel monitors the 28v dc input. If the monitor does not get the 28v dc, the frequency display windows are blank.

DME SYSTEM - NAVIGATION CONTROL PANEL**Test****HAP 001-013, 015-026, 028-036, 038-054, 101-999**

When you push the test switch, the NAV control panel sends a test command out on it's output bus. If a VOR frequency shows in the active frequency window, the test command goes to the VOR receiver. IF an ILS frequency shows in the active frequency window, the control panel sends a test command to the ILS receivers. If there is a DME frequency that is paired with the VOR or ILS frequency, a test command also goes to the DME interrogators.

When you do a test of the master dim and test system, the NAV control panel shows 188.88. The display shows for two seconds on then one second off until the test is complete.

HAP 037

When you push the test button, the NAV control panel sends a test command out on it's output bus. If a VOR frequency shows in the active frequency window, the test command goes to the VOR receiver. IF an ILS frequency or a GLS channel shows in the active frequency/channel window, the control panel sends a test command to the MMR. If there is a DME frequency that is paired with the VOR or ILS frequency, a test command also goes to the DME interrogators.

When you do a test of the master dim and test system, the NAV control panel shows 888.88. The display shows for two seconds on then one second off until the test is complete.

HAP ALL

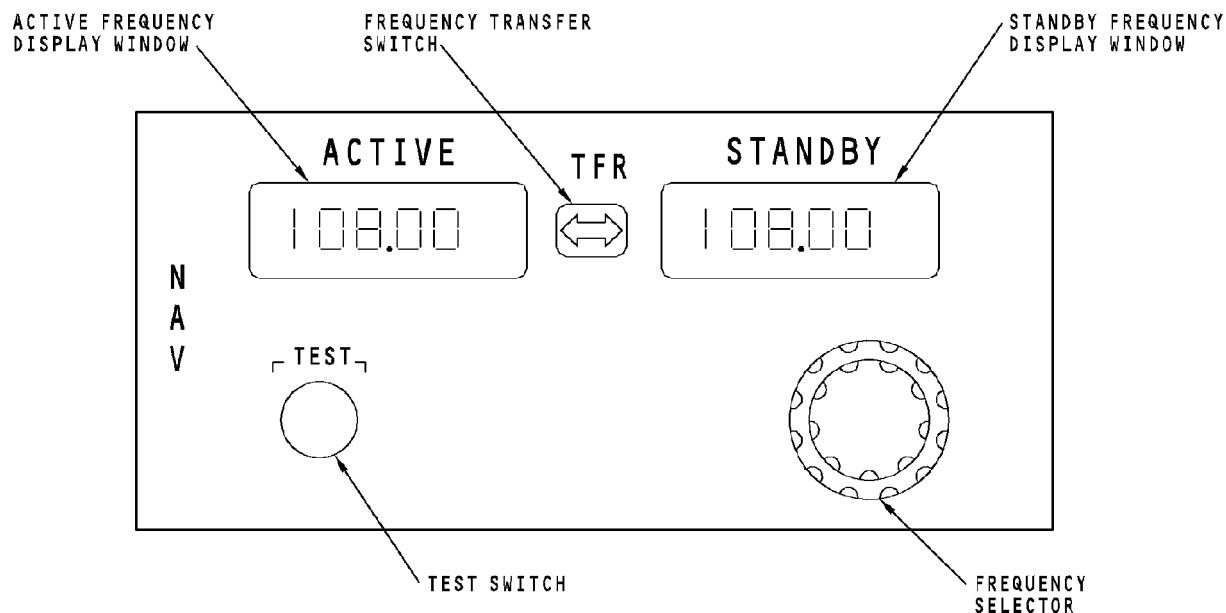

DME SYSTEM - NAVIGATION CONTROL PANEL

34-55-00-009

EFFECTIVITY
HAP 001-013, 015-026, 028-036, 038-054, 101-999

34-55-00

D633A101-HAP

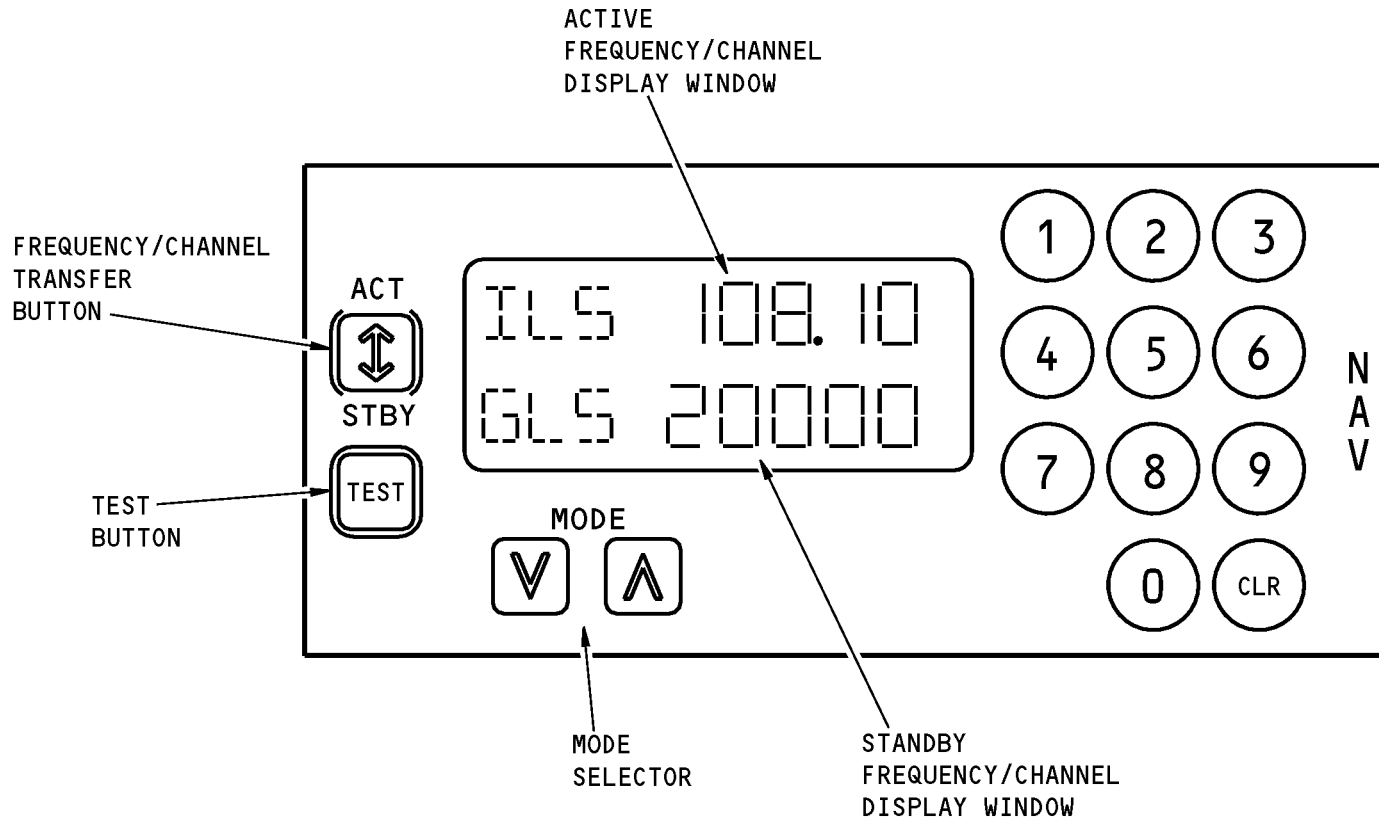

DME SYSTEM - NAVIGATION CONTROL PANEL

EFFECTIVITY
HAP 037

34-55-00

D633A101-HAP

THIS PAGE IS INTENTIONALLY LEFT BLANK

34-55-00

D633A101-HAP

Page 29
Jun 10/2007

DME SYSTEM - OPERATION - CONTROLS**General**

The audio control panels (ACP) permit the crew to hear the DME station identification signals. The identification signals are 1350 Hz.

The EFIS control Panel mode selector switch selects the NAV display modes that show DME distance.

Audio Controls

Set these controls on the audio control panel to listen to DME audio:

- Push ON the NAV receiver volume control (NAV 1 for DME 1 and NAV 2 for DME 2)
- Select B (both) or R (range) on the voice range filter switch
- Set the NAV receiver volume control.

The voice/range selector permits you to hear DME audio. You will hear the DME audio when the voice/range selector is in the R or B position.

EFIS Controls

The EFIS control panel mode selector switch must be in the VOR/ILS position to show DME distance on the top right of the ND.

You put the VOR/ADF 1 switch to VOR 1 to show DME 1 in the lower left corner of the ND. DME 2 shows in the lower right corner of the ND when the VOR/ADF 2 switch is put to VOR 2.

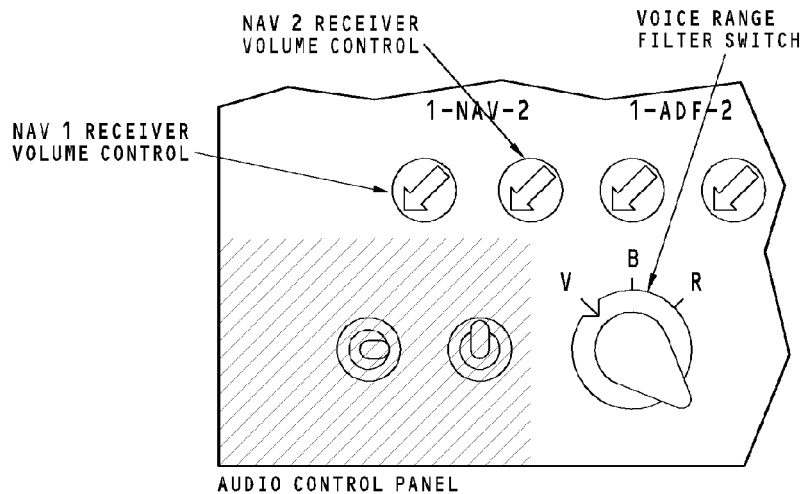
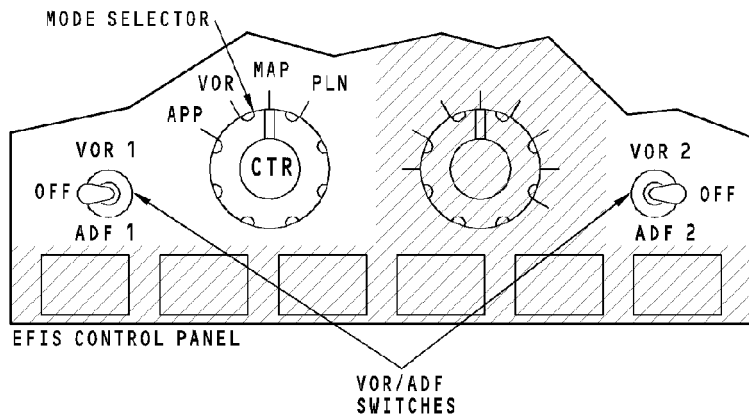

DME SYSTEM - OPERATION - CONTROLS

34-55-00-010

EFFECTIVITY
HAP ALL

34-55-00

D633A101-HAP

DME SYSTEM - DISPLAY**Normal PFD Display**

The left PFD shows DME 1 data. The right PFD shows the DME 2 data. The DME distance display shows in white letters and numbers.

Normal ND Display

DME distance shows on the top right corner of these ND displays:

- Expanded and centered VOR
- Expanded and centered ILS.

The DME also shows in the lower left (VOR 1) and the lower right (VOR 2) corner of the ND if you select VOR on the EFIS control panel.

DME NCD or Failed Displays

White dashes replace numbers when the DME distance is no computed data (NCD). If the DME has a failure, an amber DME flag replaces the DME distance. The NCD and fail flag show in amber.

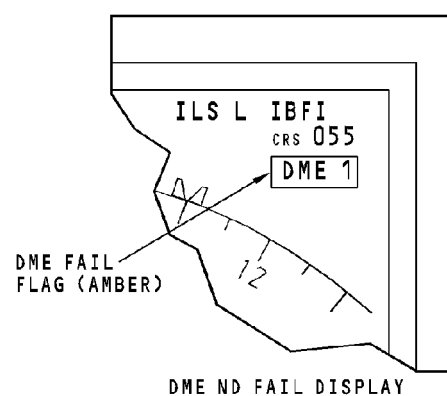
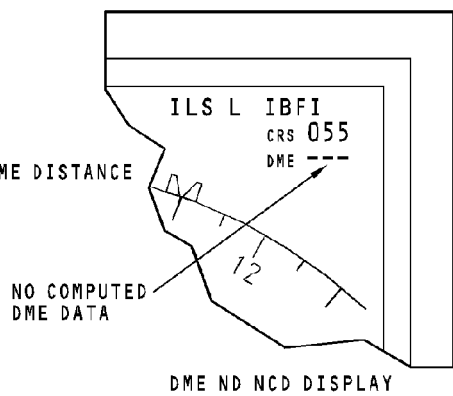
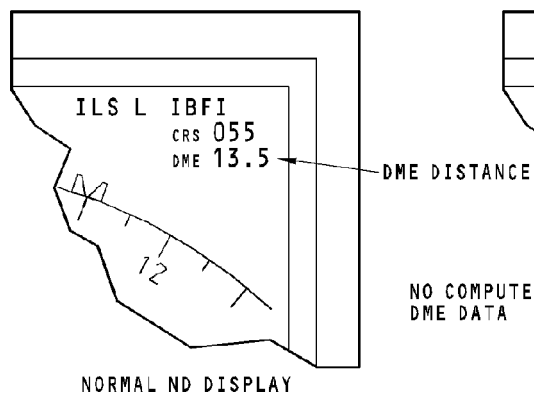
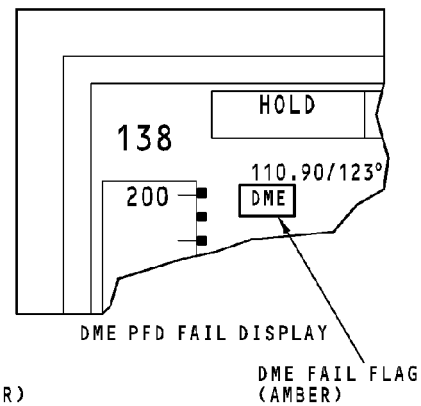
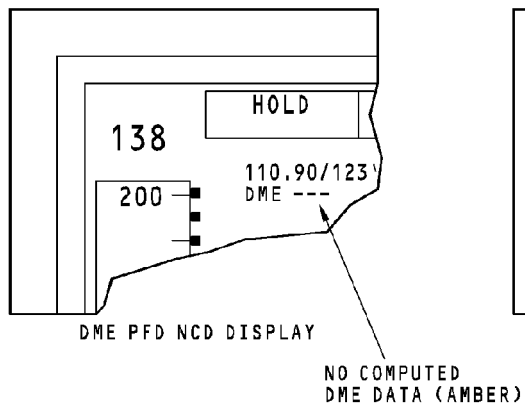
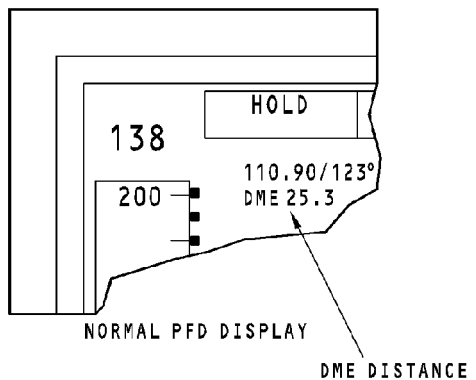

DME SYSTEM - DISPLAY

34-55-00-011

EFFECTIVITY
HAP ALL

34-55-00

D633A101-HAP

THIS PAGE IS INTENTIONALLY LEFT BLANK

34-55-00

D633A101-HAP

Page 34
Jun 10/2007

DME SYSTEM - FUNCTIONAL DESCRIPTION**Normal Tune Input**

The navigation control panel is the normal source for tune inputs. The flight management computer (FMC) sends up to four channels of auto tune signals to the navigation control panel. The navigation control panel adds one manual channel and sends five tune channels to the DME interrogator.

Alternate Tune Input

If the navigation control panel has a failure, the FMC sends auto signals directly to the DME interrogator.

Discrete Inputs

When the navigation control panel has a failure, it grounds a source select discrete to the DME central processing unit (CPU). The CPU changes the input from the navigation control panel to the FMC.

The proximity switch electronics unit (PSEU) supplies an air/ground discrete to prevent a DME test when the aircraft is in the air. The discrete also supplies flight leg data.

Operation

The CPU uses tune inputs to tune the frequency synthesizer. The CPU give a signal to the transmitter to send interrogation pulses. The transmit pulses go through a circulator then to the DME antenna.

The transmitter sends a signal to the suppression circuits. During a transmission, the suppression circuit in the DME 1 interrogator sends a suppression pulse to these units:

- DME 2 interrogator
- ATC 1 and 2 transponders (XPNDR)
- TCAS computer.

The suppression pulse stops receiver operation in the other LRUs to prevent damage to internal circuits.

There is an interface with the CPU and a memory card slot on the receiver. The card slot is for shop use and can download fault memory information.

Receive

The circulator sends the RF pulse pairs it receives from the antenna to the receiver. The receiver sends the pulse pair to the CPU. The CPU calculates the slant range distance. It uses the time it takes to transmit pulse pairs and get a reply from the ground station. When another L-band system transmits, a suppression pulse stops the receiver operation.

DME SYSTEM - FUNCTIONAL DESCRIPTION**Interrogator Output**

After the CPU calculates slant range distance, the CPU sends it to two ARINC 429 transmitters. One ARINC 429 transmitter sends the range data to the DEUs for the flight deck displays and to other systems. A second ARINC 429 transmitter sends range data to the flight control computer. The CPU sends the pulse pairs to the pulse pair decoder. The decoder sends the DME audio to the REU.

Bite Module

The built-in test equipment (BITE) in the CPU monitors the circuits in the DME interrogator for faults. The fault memory in the DME keeps the number of faults per flight. Shop personnel can read the fault memory contents.

Test

The CPU does a test of the interrogator when it receives a test command from the navigation control panel. You can also push a test switch on the front panel of the interrogator. The test results show on the LCD display on the front panel of the DME interrogator.

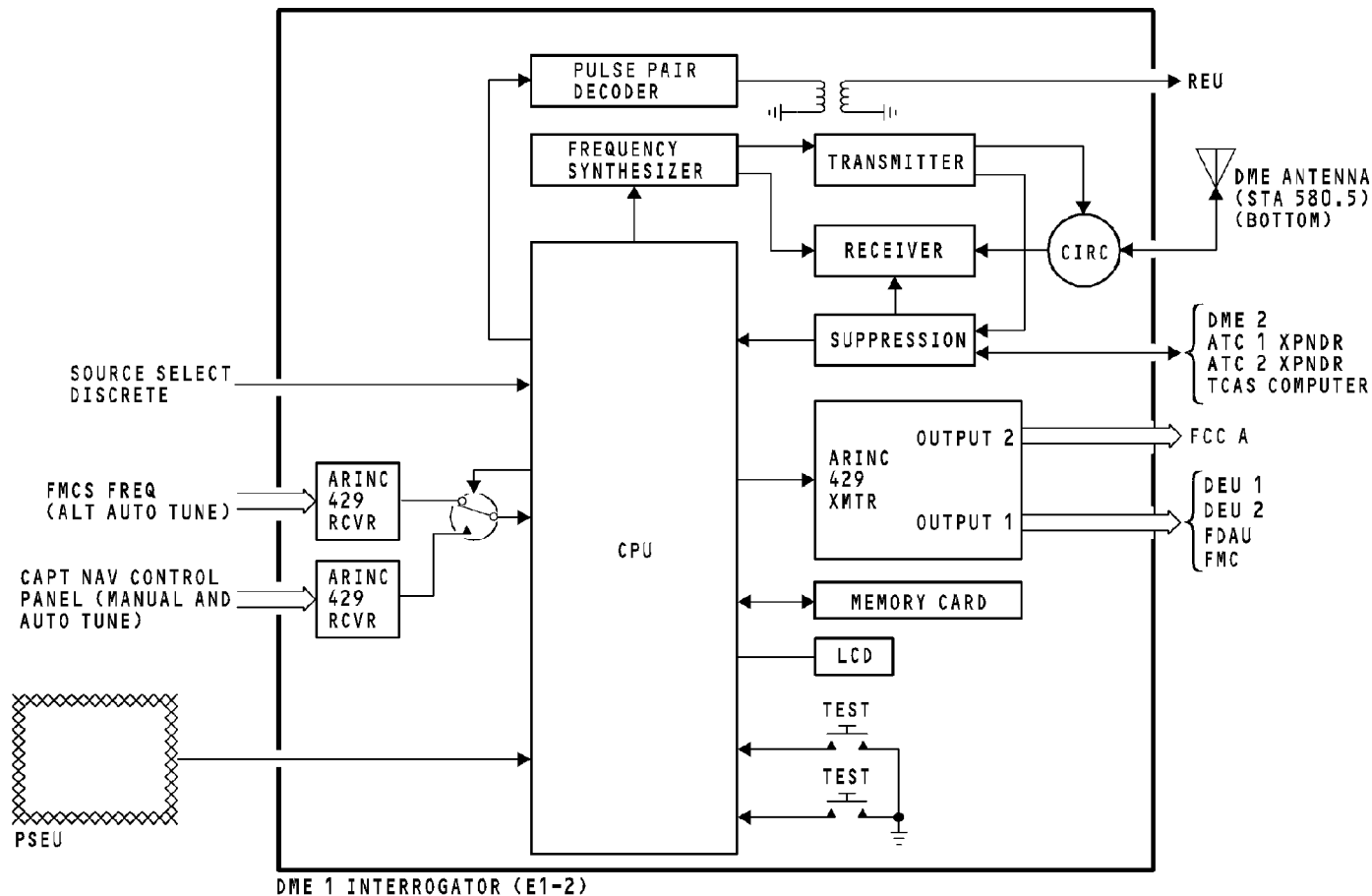

DME SYSTEM - FUNCTIONAL DESCRIPTION

EFFECTIVITY
HAP ALL

34-55-00

D633A101-HAP

Page 37
Jun 10/2007

34-55-00-012

DME SYSTEM - SELF TEST

Self Test

Push any test switch on the front of the receiver to start a test of the DME interrogator. The interrogator then does a test of its internal operation and interfaces. The test results show on the LCD.

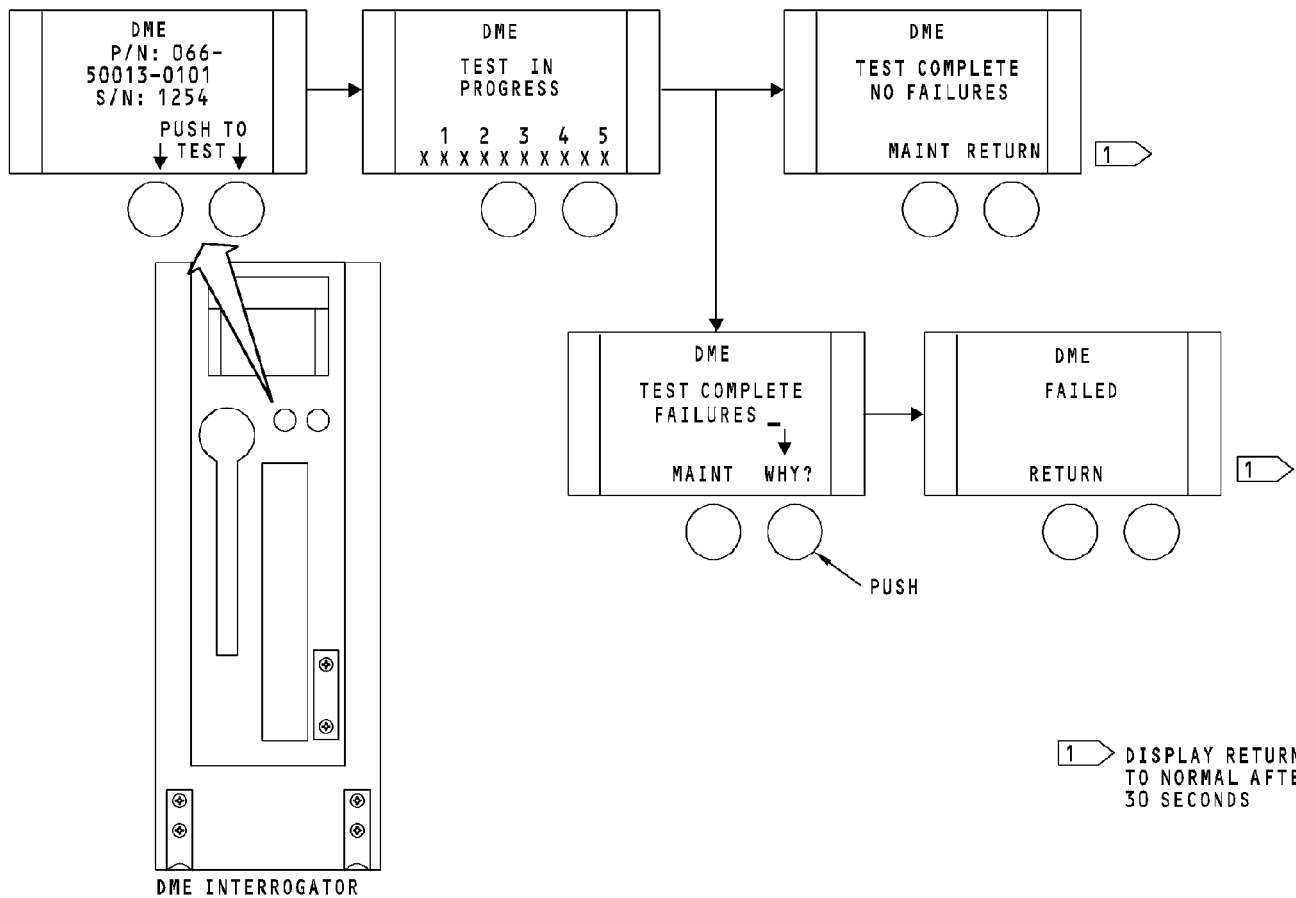

DME SYSTEM - SELF TEST

34-55-00-014

**EFFECTIVITY
HAP ALL**

34-55-00

D633A101-HAP

DME SYSTEM - TEST DISPLAY**General**

During a ground test or a self test, the display units show these indications:

- The DME fail condition for two seconds
- The DME NCD condition for the next two seconds
- The DME normal condition to end the test.

The DME normal condition is the distance that shows before the test starts.

DME indications also show in the lower left (VOR 1) and lower right (VOR 2) corner of the ND when you select VOR on the VOR/ADF switches on the EFIS control panels.

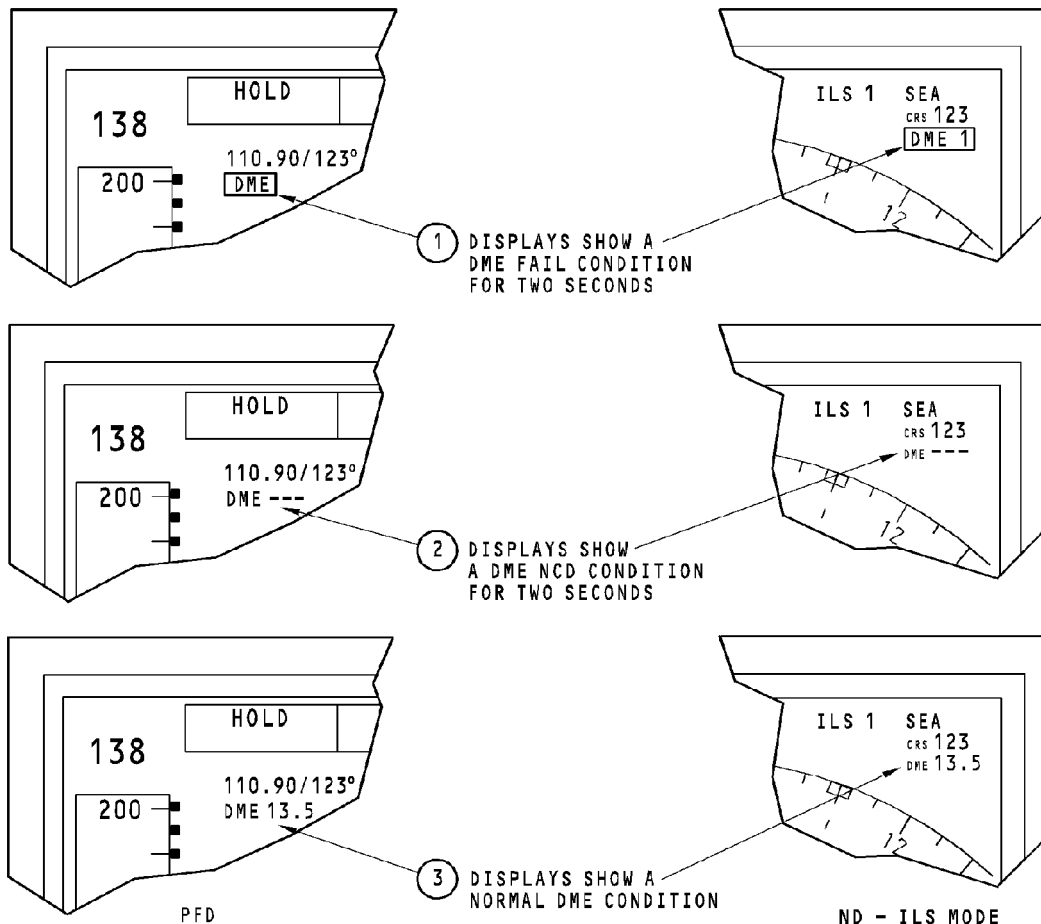

NOTE:
 THE GRAPHIC SHOWS A TEST DISPLAY OF DME INTERROGATOR 1 ON THE CAPTAIN PFD AND ND WITH THE APP MODE SELECTED ON THE EFIS CONTROL PANEL. THE TEST IS THE SAME FOR DME INTERROGATOR 2 ON THE FIRST OFFICER DISPLAYS.

YOU CAN ALSO SEE THE DME TEST ON THE ND IN THE VOR DISPLAY MODE.

DME SYSTEM - TEST DISPLAY

34-55-00-015

EFFECTIVITY
HAP ALL

34-55-00

D633A101-HAP



DME SYSTEM - SYSTEM SUMMARY

General

This page is for reference.

34-55-00-016

EFFECTIVITY
HAP ALL

34-55-00

D633A101-HAP

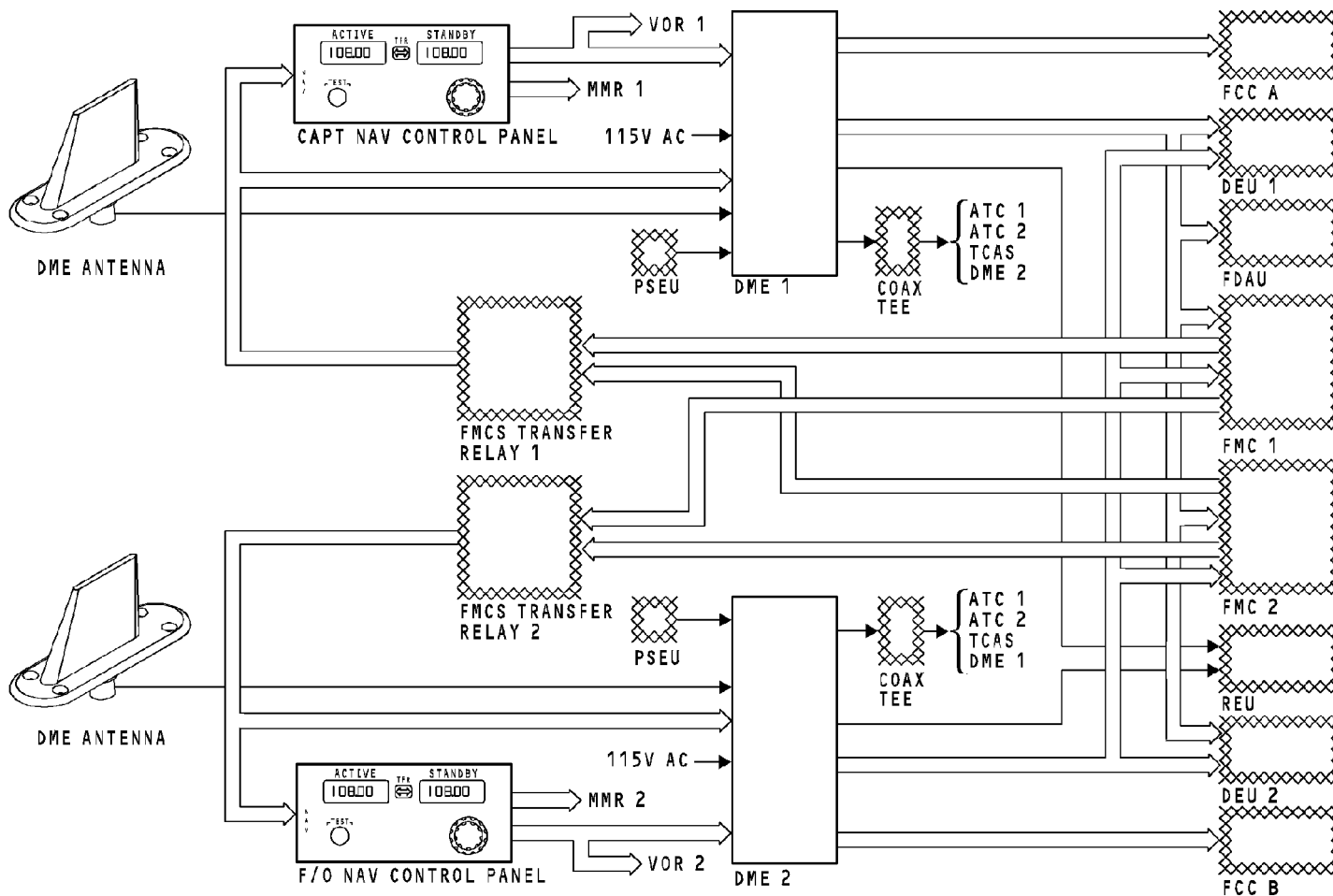

DME SYSTEM - SYSTEM SUMMARY

34-55-00-016

EFFECTIVITY
HAP 038-054, 101-999

34-55-00

D633A101-HAP

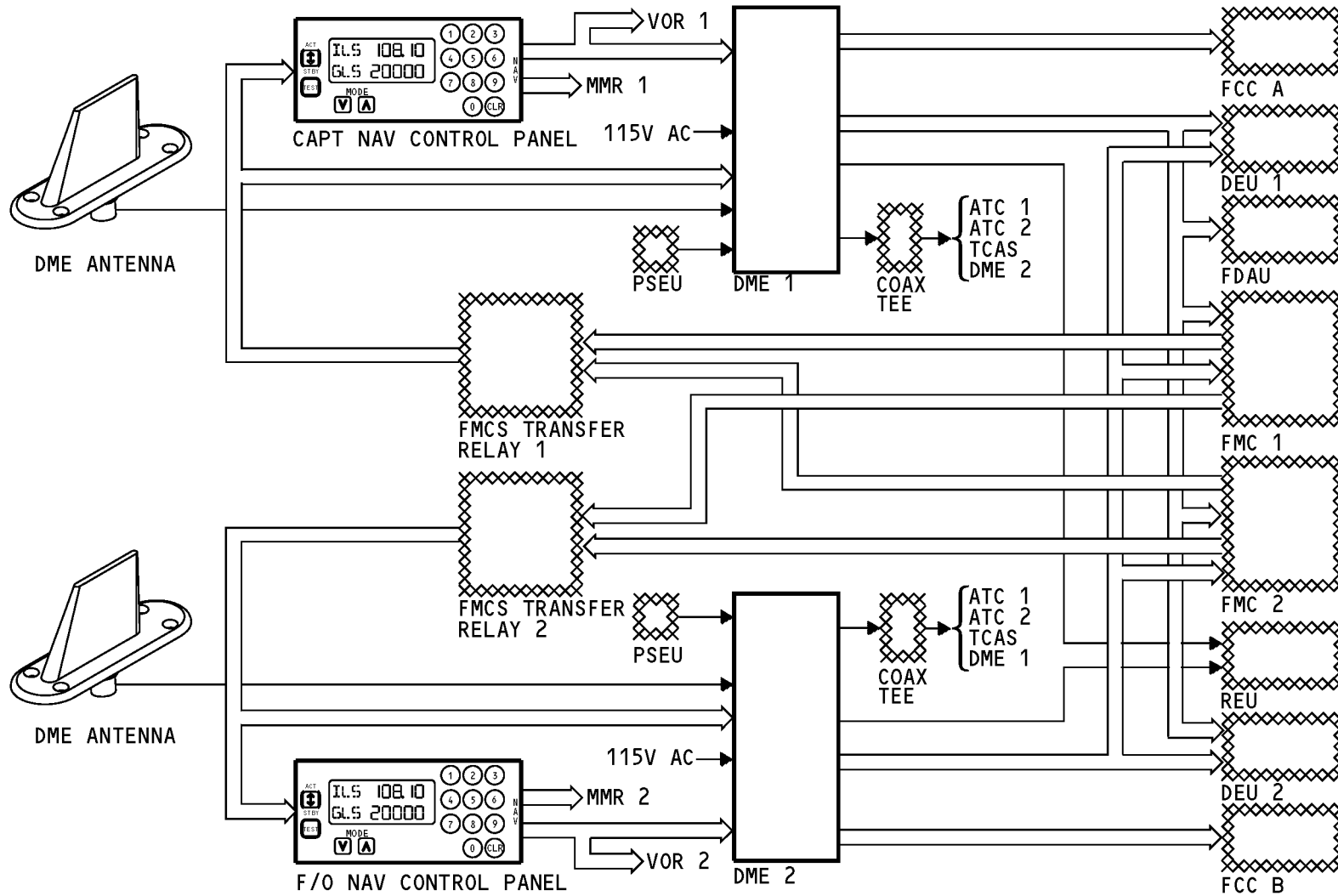

DME SYSTEM - SYSTEM SUMMARY

EFFECTIVITY
HAP 037

34-55-00

D633A101-HAP

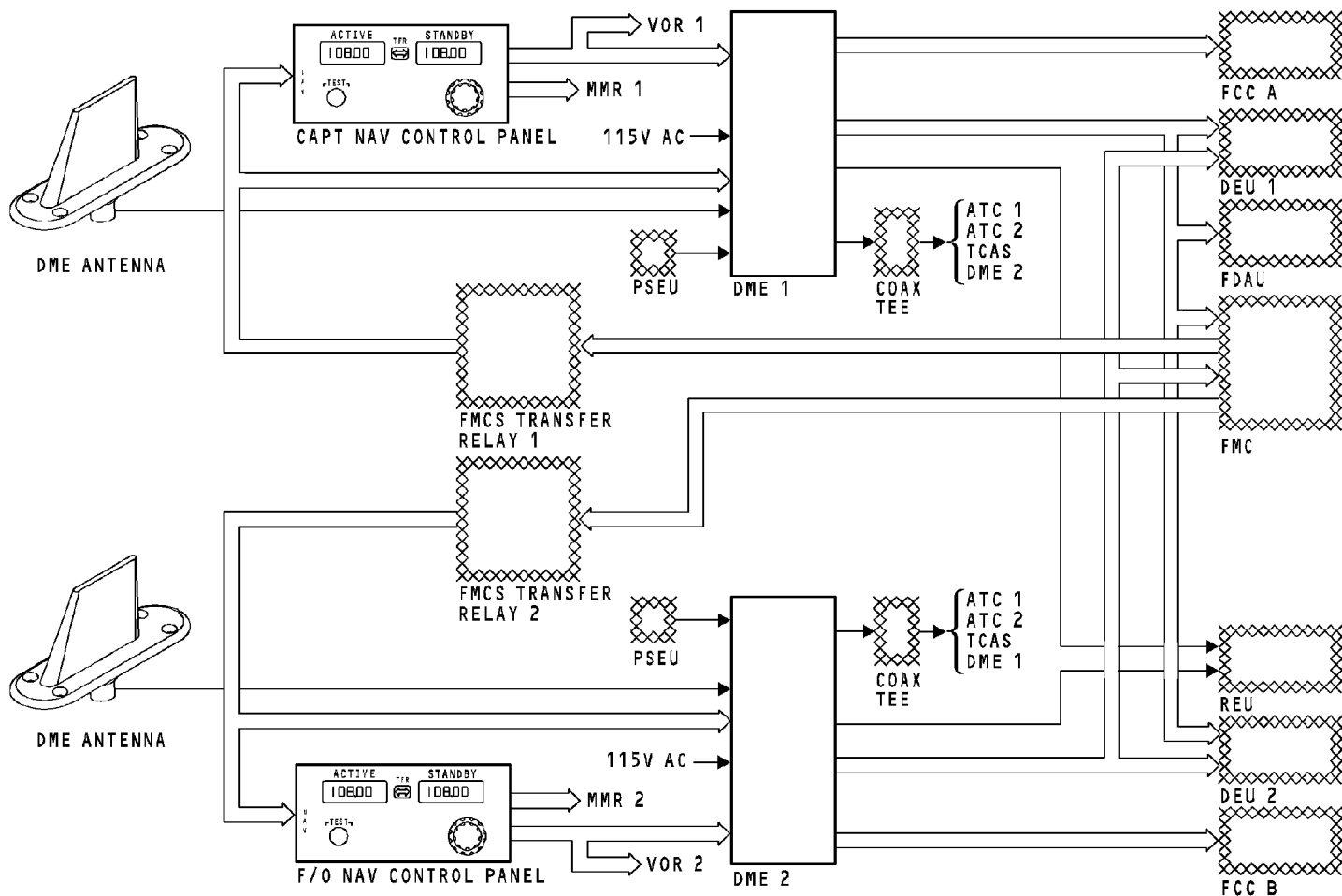

DME SYSTEM - SYSTEM SUMMARY

EFFECTIVITY

HAP 001-013, 015-026, 028-036

34-55-00

D633A101-HAP

THIS PAGE IS INTENTIONALLY LEFT BLANK

34-57-00

D633A101-HAP

Page 1
Oct 10/2002

AUTOMATIC DIRECTION FINDER SYSTEM - INTRODUCTION**Purpose**

The automatic direction finder (ADF) system is a navigation aid. The ADF receiver uses amplitude modulated (AM) signals from ground stations to calculate the bearing to the ADF station from the airplane longitudinal axis. The ADF system also receives standard AM radio broadcasts.

- sta - station
- V - volts
- VOR - VHF omnidirectional ranging
- xmtr - transmitter

Abbreviations and Acronyms

- AC - alternating current
- AM - amplitude modulated
- ACP - audio control panel
- ADF - automatic direction finder
- AM - amplitude modulation
- ant - antenna
- app - approach
- ARINC - Aeronautical Radio, Inc.
- BFO - beat frequency oscillator
- Capt - captain
- DC - direct current
- DEU - display electronics unit
- EFIS - electronic flight instrument system
- F/O - first officer
- gnd - ground
- Hz - hertz
- LCD - liquid crystal display
- LRU - line replaceable unit
- nav - navigation
- NCD - no computed data
- QEC - quadrantal error correction
- RBL - right buttock line
- RMI - radio magnetic indicator

EFFECTIVITY**HAP ALL****34-57-00**

D633A101-HAP

Page 2
Oct 10/2002

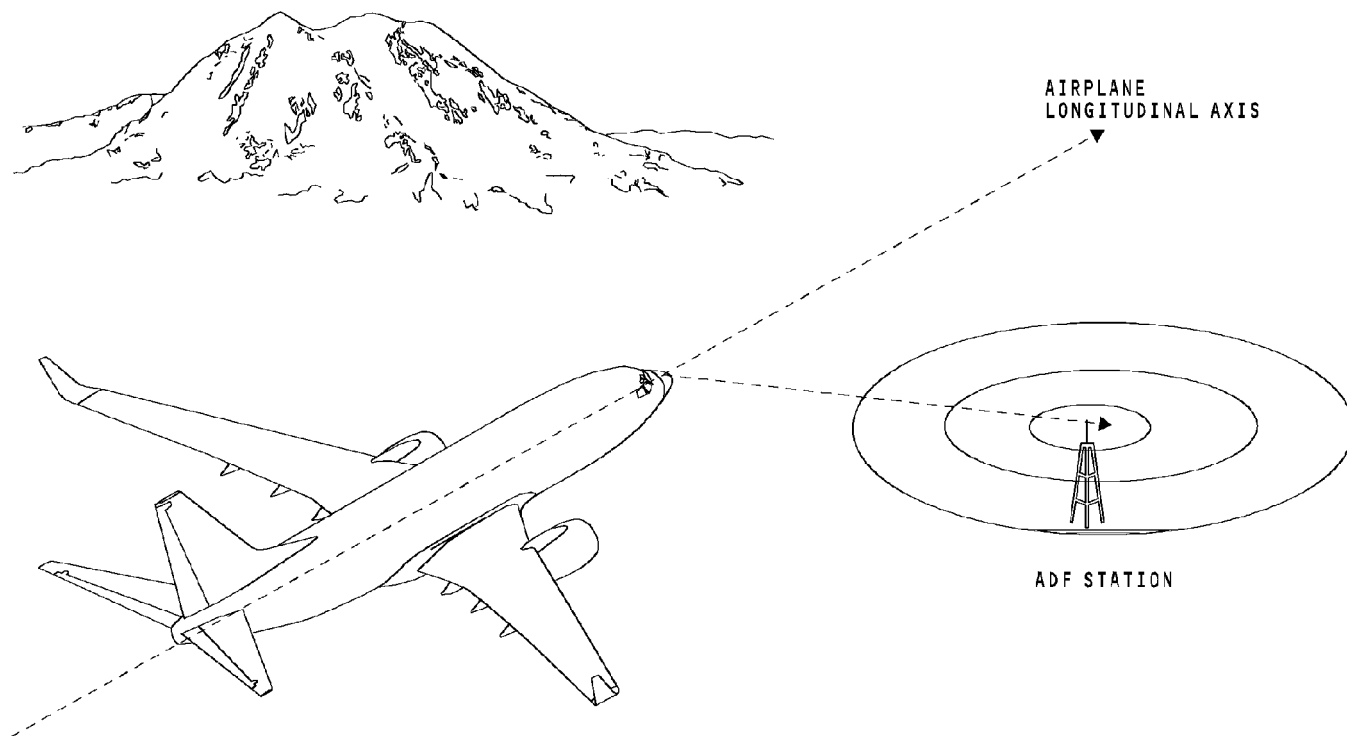

AUTOMATIC DIRECTION FINDER SYSTEM - INTRODUCTION

EFFECTIVITY
HAP ALL

34-57-00

D633A101-HAP

Page 3
Oct 10/2004

34-57-00-001

ADF SYSTEM - GENERAL DESCRIPTION**Description**

The ADF control panel supplies manual tune inputs to the ADF receiver. The ADF antenna assembly contains the loop antennas and the sense antennas.

The ADF receiver calculates the bearing to the ADF ground stations and sends it to the DEUs for display. The ADF bearing also goes to the radio magnetic indicator (RMI). The ADF receiver processes audio from the ground stations and sends it to the remote electronics unit (REU).

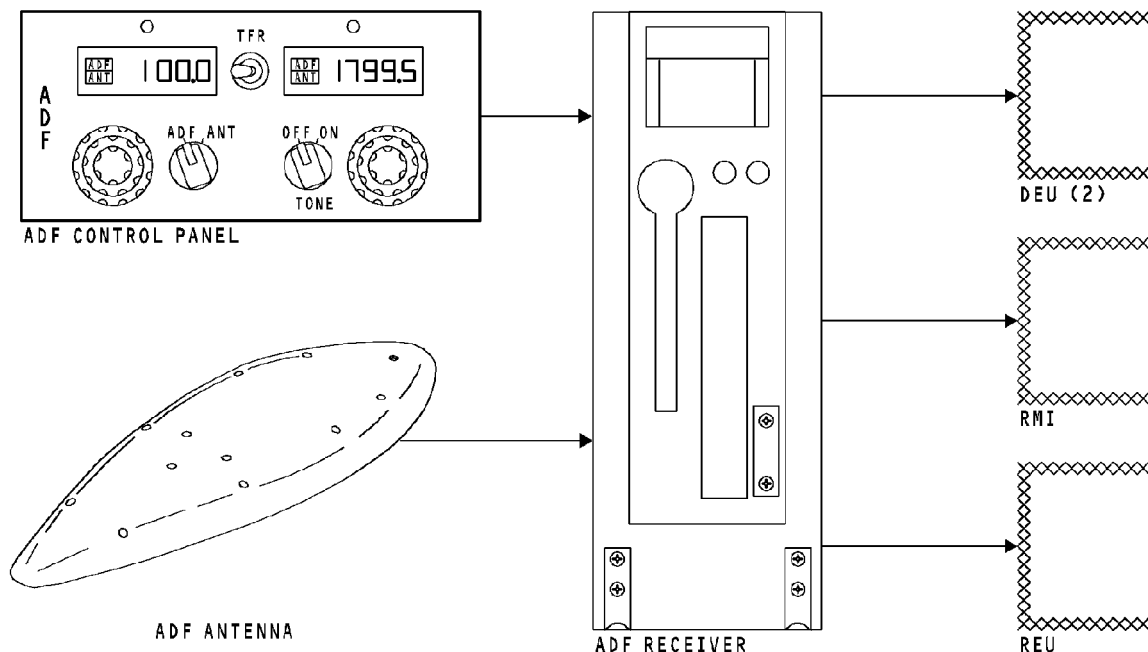

ADF SYSTEM - GENERAL DESCRIPTION

34-57-00-002

EFFECTIVITY
HAP 001, 006, 007

34-57-00

D633A101-HAP

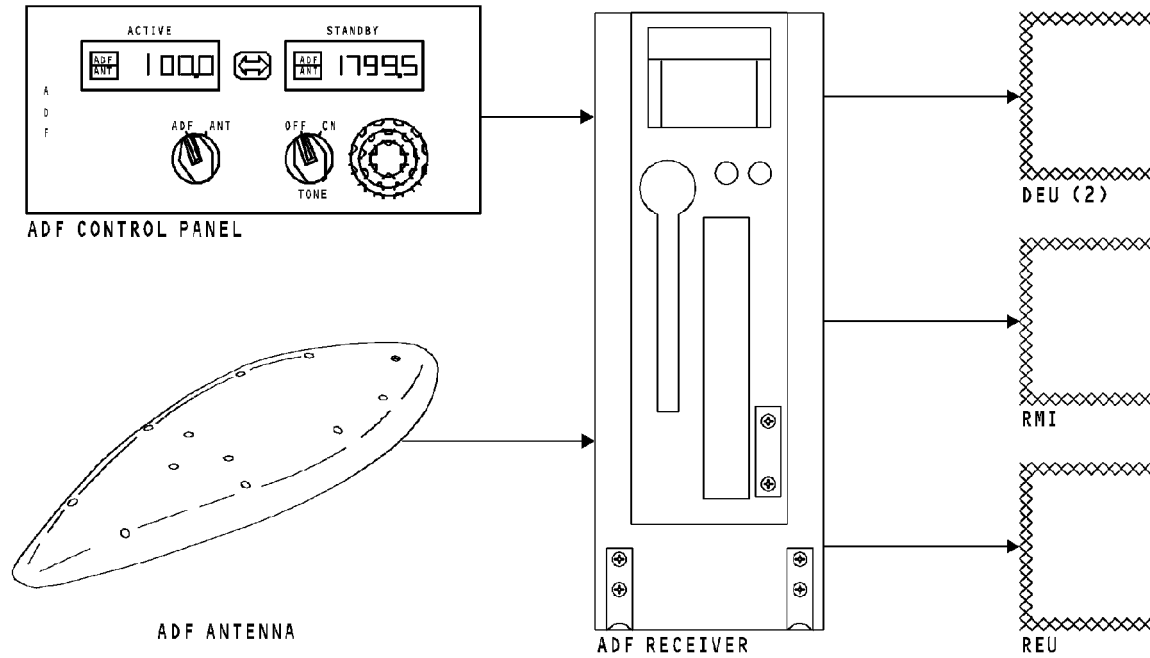

ADF SYSTEM - GENERAL DESCRIPTION

EFFECTIVITY

HAP 002-005, 008-013, 015-026, 028-054, 101-999

34-57-00

D633A101-HAP

THIS PAGE IS INTENTIONALLY LEFT BLANK

34-57-00

D633A101-HAP

Page 7
Jun 10/2007

ADF SYSTEM - FLIGHT COMPARTMENT COMPONENT LOCATION

ADF System Components

The ADF control panel is on the P8 aft electronics panel.

Interface Components

These flight compartment components have an interface with the ADF system.

- Left and right EFIS control panels
- Left inboard and outboard display units
- Right inboard and outboard display units
- Capt and F/O audio control panels.

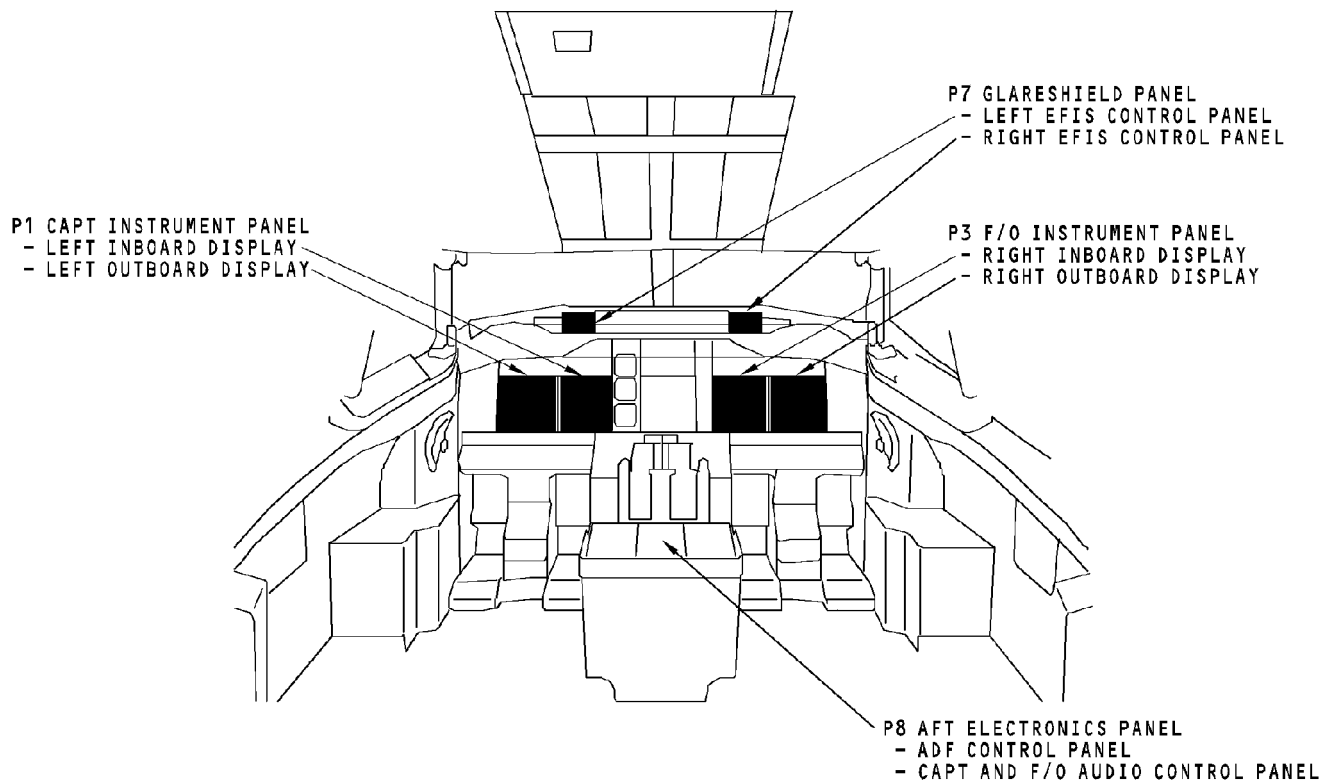

ADF SYSTEM - FLIGHT COMPARTMENT COMPONENT LOCATION

34-57-00-003

EFFECTIVITY
HAP ALL

34-57-00

D633A101-HAP

ADF SYSTEM - ELECTRONIC EQUIPMENT COMPARTMENT AND ANTENNA COMPONENT LOCATIONS

Electronic Equipment Compartment

The ADF receiver is in the electronic equipment compartment on the E3-1 shelf.

ADF Antenna

The ADF antenna is on the top of the fuselage at fuselage station 694.

34-57-00-004

EFFECTIVITY
HAP ALL

34-57-00

D633A101-HAP

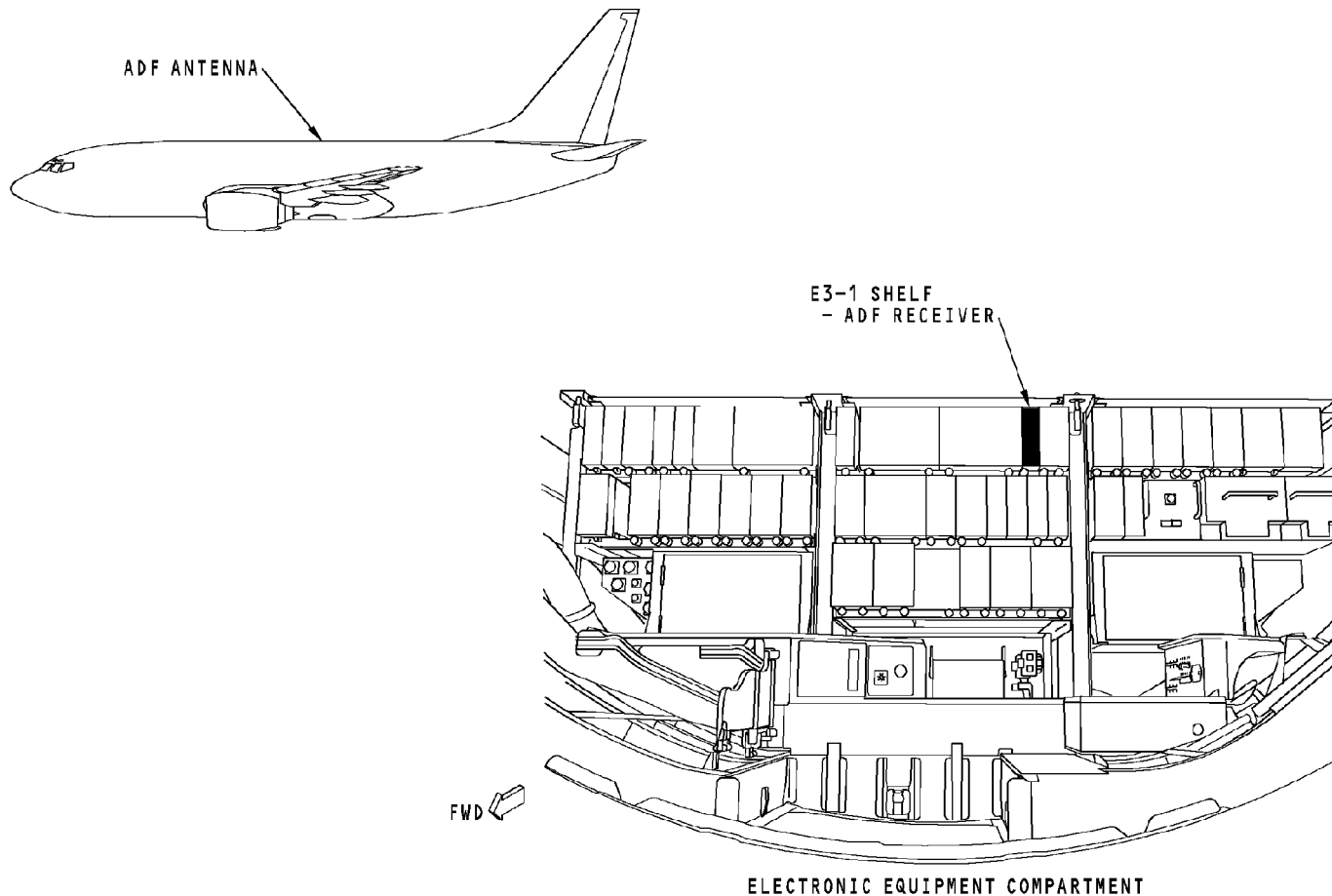

ADF SYSTEM - ELECTRONIC EQUIPMENT COMPARTMENT AND ANTENNA COMPONENT LOCATIONS

34-57-00-004

EFFECTIVITY
HAP ALL

34-57-00

D633A101-HAP

Page 11
Jun 10/2007

ADF SYSTEM - POWER AND ANALOG INTERFACE**Power**

115v ac power from the ADF circuit breaker goes to the ADF control panel. The ADF control panel uses the 115v ac power for operation. The ADF control panel sends 115v ac power to the ADF receiver for operation. The ADF receiver sends 12v dc power to the ADF antenna for operation.

PSEU

The proximity switch electronics unit (PSEU) supplies an air/ground discrete input to the ADF receiver. The ADF receiver uses the air/ground input to calculate the flight leg count for the internal memory.

ADF Antenna

The ADF antenna assembly contains the loop antennas and the sense antenna. The antenna assembly also contains signal amplifiers for the loop and the sense antenna. The loop antennas supply direction data and the sense antenna supplies station audio.

REU

The ADF receiver sends station audio to the remote electronics unit (REU). The REU sends the station audio to the flight compartment headsets and speakers.

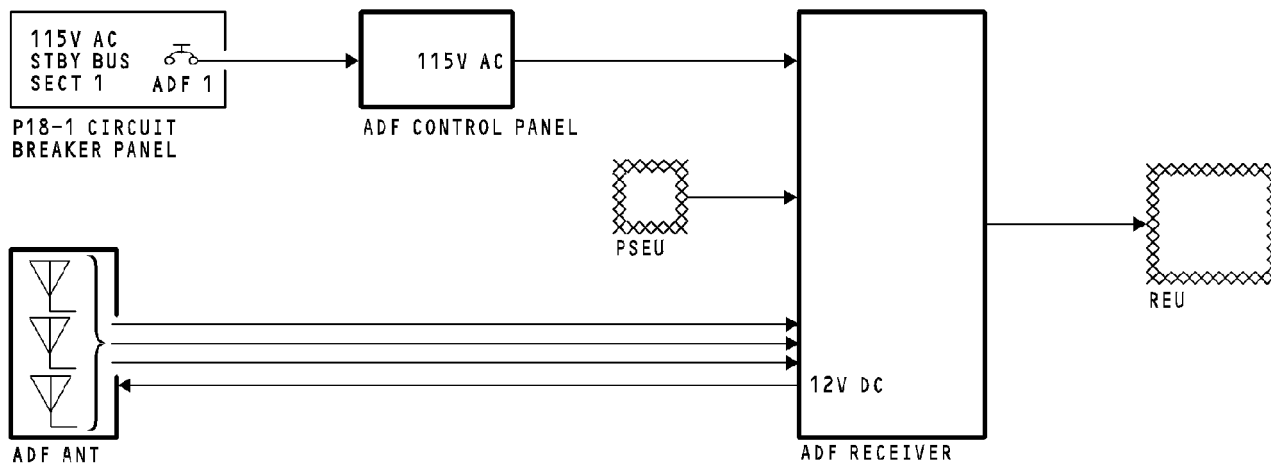

ADF SYSTEM - POWER AND ANALOG INTERFACE

34-57-00-005

EFFECTIVITY
HAP ALL

34-57-00

D633A101-HAP

ADF SYSTEM - DIGITAL INTERFACE**General**

The ADF receiver has an interface with the display electronics units (DEUs) and the radio magnetic indicator (RMI). The interface is on ARINC 429 data buses.

ADF Control Panel

The ADF control panel sends tune frequency inputs to the ADF receiver. The ADF control panel sends a data word that contains the ADF mode or ANT mode selection. The ADF control panel sets a bit that enables ADF receiver beat frequency oscillator (BFO) operation when you turn on the tone selector.

Digital Output

The ADF receiver sends this data on two output data buses:

- ADF station bearing
- Test signals
- Receiver condition.

Output data bus 1 from the ADF receiver goes to the radio magnetic indicator (RMI). The RMI uses the station bearing data to control the RMI bearing pointers.

Output data bus 2 goes to the DEUs for display.

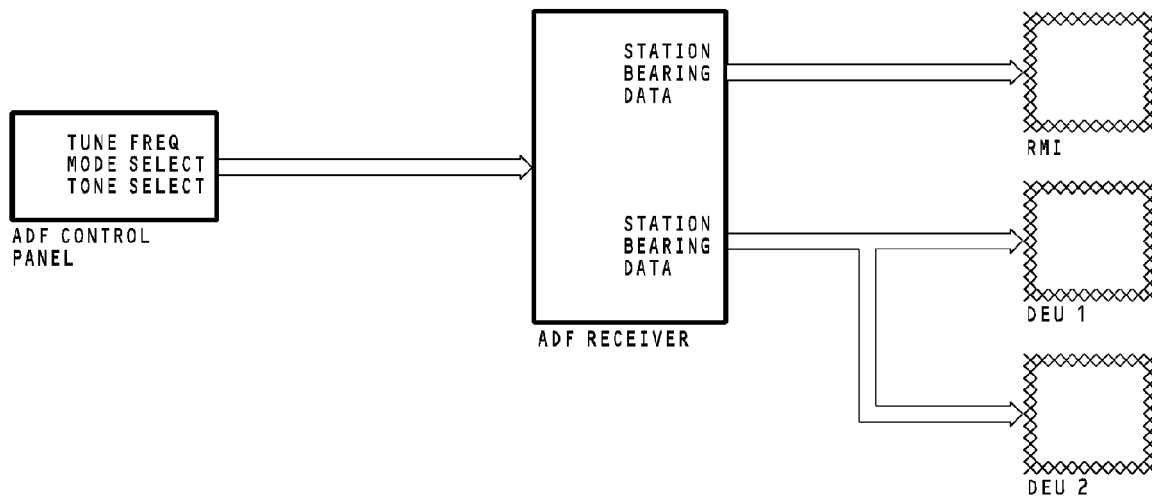

ADF SYSTEM - DIGITAL INTERFACE

34-57-00-006

EFFECTIVITY
HAP ALL

34-57-00

D633A101-HAP

ADF SYSTEM - RECEIVER**Purpose**

The ADF receiver calculates bearing to a station that transmits in the frequency range of 190 KHz to 1750 KHz. The receiver also receives station identifiers and AM broadcasts.

Description

The ADF receiver is a standard ARINC 600 2 MCU unit with dimensions approximately 2.3 in. x 7.6 in. x 12.6 in. The receiver weighs approximately 8 pounds and uses 115v ac 400 Hz power for operation. The receiver has a non-volatile flight fault memory. Only shop personnel can use this feature.

Test and Indication

There are two switches and an LCD on the front panel of the ADF receiver. You use one of the two switches to start a test of the ADF receiver. The LCD shows the test results.

There is a memory card slot on the front of the ADF receiver. Shop personnel use this slot to put in a flash memory card which loads software into the LRU. The memory card can also keep LRU data the LRU sends during operation. The memory card slot is not for use by line maintenance personnel.

Shop personnel use the RS 232 connector to connect shop test equipment to the LRU. The RS 232 connector is not for use by line maintenance personnel.

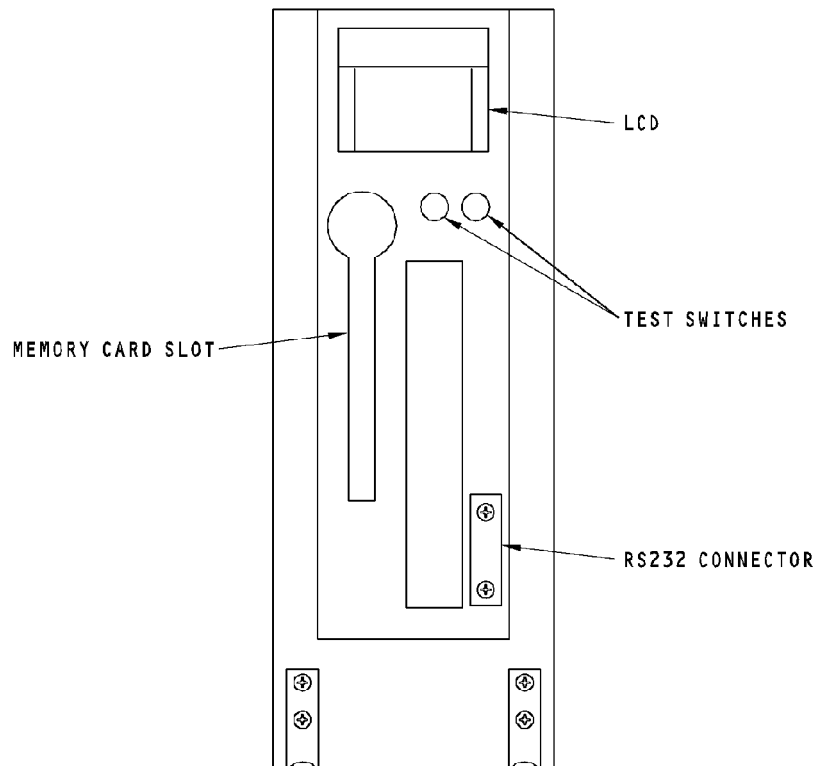

ADF SYSTEM - RECEIVER

34-57-00-007

EFFECTIVITY
HAP ALL

34-57-00

D633A101-HAP

ADF SYSTEM - ANTENNA

Purpose

The ADF antenna receives electromagnetic signals from ground stations. The sense antenna receives the electrical part of the signal. The loop antenna receives the magnetic part of the ground station signal.

Description

The antenna assembly is a one piece molded shell. The antenna attaches to the airplane with 12 bolts. The antenna assembly contains these components:

- Loop antenna elements (2)
- Sense antenna (1)
- Electronics assembly.

The ADF antenna electronics assembly contains amplifiers for each of the antenna elements. The amplifiers receive 12v dc power from the ADF receiver.

The electrical connectors connect the antenna assembly to the ADF receiver.

The preferred resistance measurement point uses one of the mounting bolt holes counterbore. There is also an alternate resistance measurement point. The alternate measurement is done from the inside of the airplane.

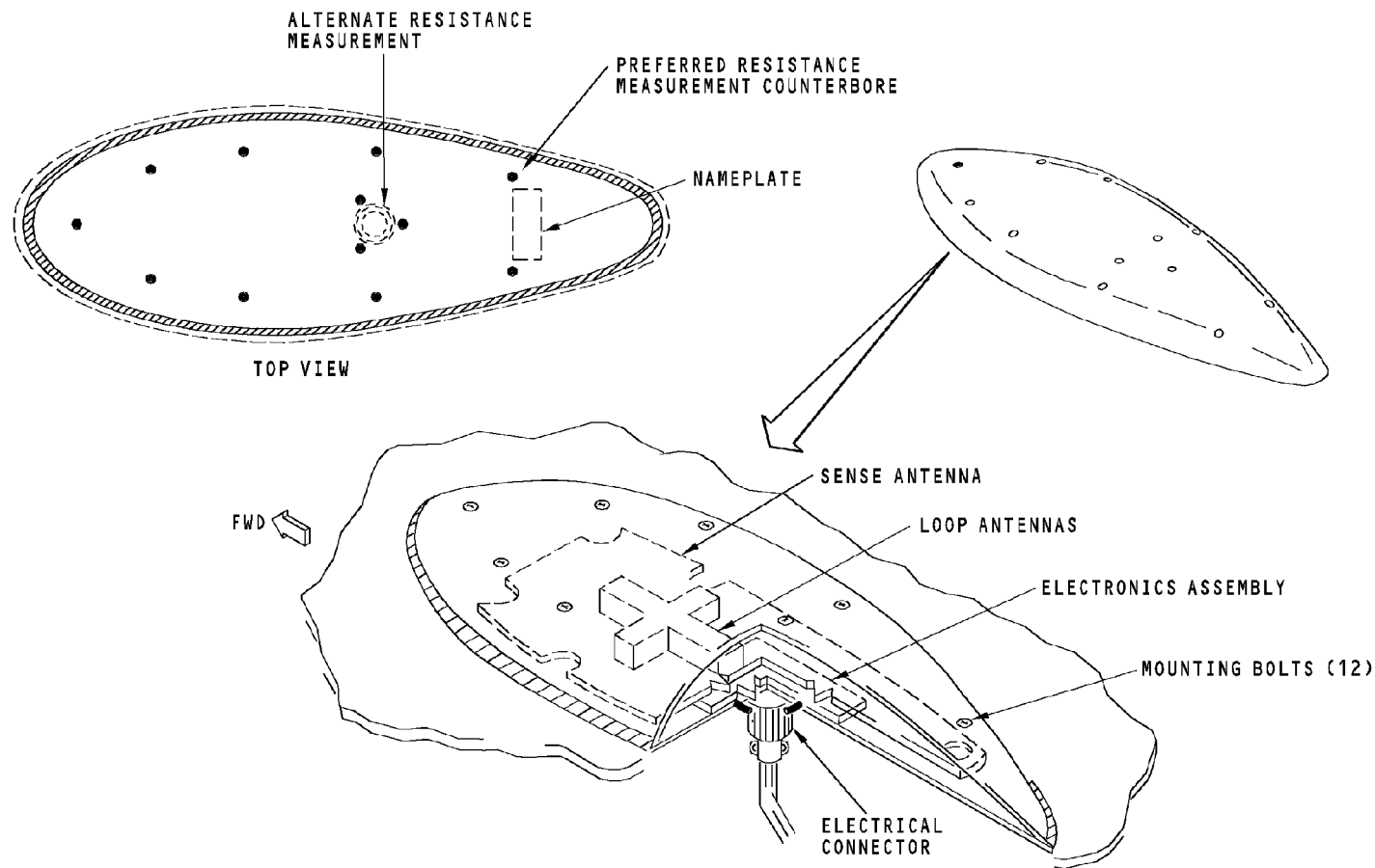

ADF SYSTEM - ANTENNA

EFFECTIVITY
HAP ALL

34-57-00

D633A101-HAP

THIS PAGE IS INTENTIONALLY LEFT BLANK

34-57-00

D633A101-HAP

Page 20
Oct 10/2004

ADF SYSTEM - CONTROL PANEL**Purpose**

The ADF control panel supplies tune frequencies and system mode selection to the ADF receiver.

HAP 001, 006, 007**Description**

There are two frequency display windows. The windows show the frequency that you set with the frequency selectors. There are indicators in the display windows that show if the system is in the ADF mode or the antenna (ANT) mode.

There are two active frequency lights. There is a light above each frequency display window. The lights are white and come on when the frequency display window is the active frequency.

The transfer (TFR) switch is a two position toggle switch. The TFR switch selects which frequency display window is active.

There are two frequency selectors. Each frequency selector sets the frequency for the display window that is directly above it. The selectors each have three controls. There is an outer, middle, and inner control. The inner control sets the tenths and ones numbers. The middle control sets the tens number. The outer control sets the hundreds number.

The mode selector selects the ADF or ANT modes. In the ADF position, the receiver sends bearing data and station audio. In the ANT mode, the receiver sends only station audio.

The tone selector turns on the beat frequency oscillator (BFO) in the ADF receiver. There are some ADF stations that turn their transmitters on and off to transmit their morse code station identifier. To process this type of signal, the receiver must be in the BFO mode.

HAP 002-005, 008-013, 015-026, 028-054, 101-999**Description**

There are two display windows. There is an active display and a standby display. The transfer button that is between the display windows transfers the frequency in the standby window to the active window. The frequency selector changes the frequency in the standby window.

The mode selector selects either the ADF mode or the antenna (ANT) mode. The selected mode shows in the display windows. In the ADF mode, the receiver processes the bearing data and the station audio. In the ANT mode, the receiver only processes the station audio.

ADF SYSTEM - CONTROL PANEL

HAP 002-005, 008-013, 015-026, 028-054, 101-999 (Continued)

The tone selector turns on the beat frequency oscillator (BFO) in the ADF receiver. There are some ADF stations that turn their transmitters on and off to transmit their morse code station identifier. To process this type of signal, the receiver must be in the BFO mode.

HAP ALL

34-57-00-009

EFFECTIVITY
HAP ALL

34-57-00

D633A101-HAP

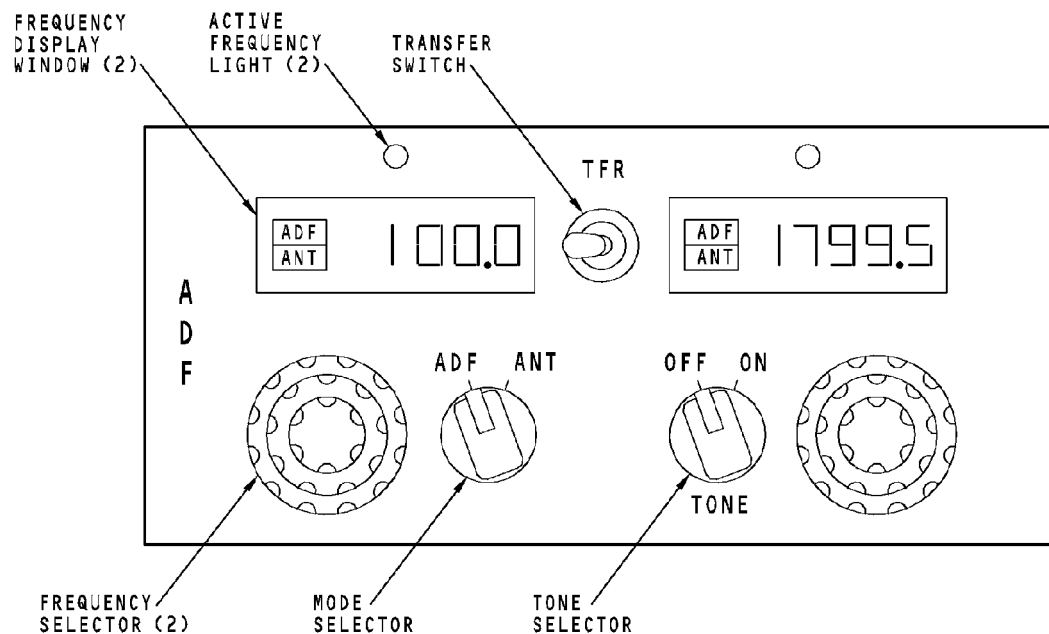

ADF SYSTEM - CONTROL PANEL

34-57-00-009

EFFECTIVITY
HAP 001, 006, 007

34-57-00

D633A101-HAP

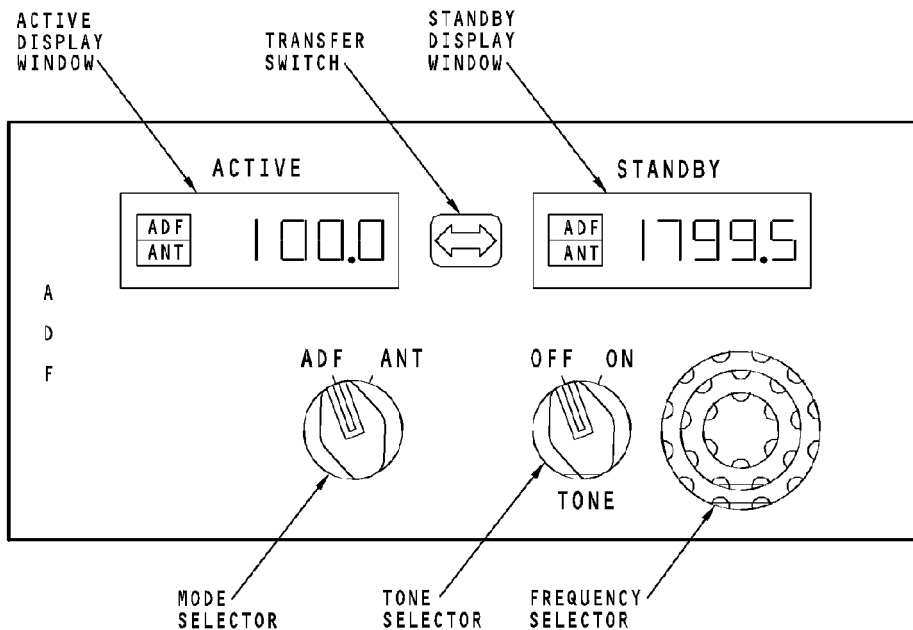

ADF SYSTEM - CONTROL PANEL

EFFECTIVITY

HAP 002-005, 008-013, 015-026, 028-054, 101-999

34-57-00

D633A101-HAP

ADF SYSTEM - FUNCTIONAL DESCRIPTION**Antenna Inputs**

The loop antenna contains two identical antenna loops (sine and cosine) that are mechanically displaced ninety degrees from each other and share a common ferrite core. The sense antenna and loop antenna sine and cosine outputs are coupled through an L- band filter and static protection circuit. The signals then go to separate but identical low noise, wide dynamic range FET input amplifiers. The antenna outputs go to the antenna modulators in the ADF receiver.

ADF Control Panel Inputs

The ADF receiver system processor receives manual tune inputs and control panel mode selections from the ADF control panel on an ARINC 429 data bus.

PSEU

The proximity switch electronics unit (PSEU) sends an air ground discrete to the system processor. The discrete sets the flight leg count for the fault memory.

Program Pin Inputs

The ADF receivers get program pin discrettes from a dip switch. The bearing computer circuit uses quadrantal error correction (QEC) program pin inputs to adjust for the signal distortion caused by the airplane structure.

A discrete identifies the antenna location as a top mounted antenna.

Receiver Operation

The ADF receiver contains two major assemblies, The RF module and the main processor.

The RF module contains the receiver section the loop modulation and summation section, the receiver section, and the synthesizer section.

The loop modulation and summation section receives the input signals from the antenna. The loop antenna inputs are modulated with a 95 Hz signal from the signal processor. The loop antenna inputs are then mixed with the sense antenna inputs. The signal then goes to an RF band filter.

The RF band filter is a seven-band filter that covers the ADF RF frequency range. The filter selection is determined by tuning data from the signal processor

The signal from the RF band filter is then mixed with a local oscillator signal from the synthesizer and filtered in the dual IF conversion section to produce an intermediate frequency signal that can be processed by the signal processor. The synthesizer section receives the local oscillator injection frequencies from tuning data from the signal processor.

ADF SYSTEM - FUNCTIONAL DESCRIPTION

The RF signal then goes from the RF module to an analog to digital (A/D) circuit that converts the signal to a digital format for the signal processor. The signal processor takes the signal and compares it to a local 95 Hz signal to compute bearing data. The signal processor also performs these functions:

- Generate automatic gain (AGC) control for the RF module
- Station audio filtering
- Morse code tone detection
- Monitor BITE
- Programs the synthesizer from ADF control panel tune data.

Bearing, audio, and morse code identifier data from the signal processor go to the 486 processor. The dual port ram serves as a data link between the two processors. The 486 processor, processes BIT data from the signal processor for information to the front panel display. It also provides the data and control signals to the input output (I/O) sections. This processor controls all major functions of the ADF receiver. It also supplies the interface to the internal memory and data recorder/data loader flash card device. The processor performs the QEC and top/bottom compensation on the bearing data received from the signal processor before it outputs the data to external systems.

All data that comes in or goes out through the I/O sections, first goes through the 486 processor. The I/O section sends audio to the REU. It also sends data out on 2 ARINC 429 data buses. Output 1 goes to the RMI. Output 2 goes to the DEUs.

Power

The ADF receiver power supply receives 115v ac, 400 Hz power from the ADF control panel. The power supply provides -12v dc, +12v dc, and +5v dc for internal use. The antenna power switch in the RF module sends the 12v dc power outputs to the ADF antenna for operation.

Test

The test switches send test commands to the 486 processor. The signal commands the signal processor to start an internal circuit test of the RF module and main processor functions. The signal processor also checks the ADF control panel data word input. The antenna power switch removes power to the antenna assembly amplifiers. This causes no RF signal inputs to the loop modulation and summation section. A test RF signal replaces the antenna RF input and the receiver sends the signal through its internal circuits. The 486 processor then displays the test results on the front panel display.

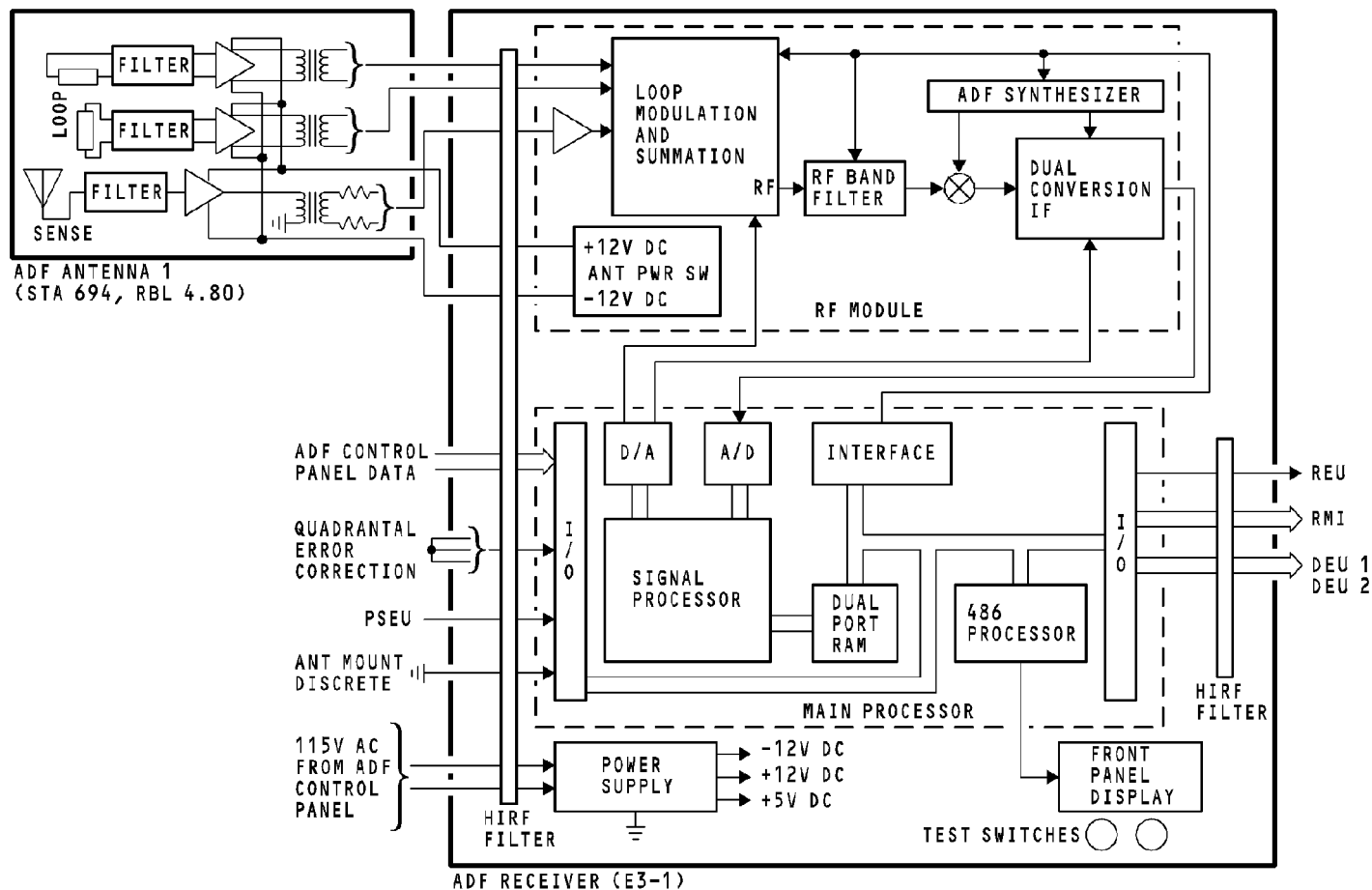

ADF SYSTEM - FUNCTIONAL DESCRIPTION

34-57-00-010

EFFECTIVITY
HAP ALL

34-57-00

D633A101-HAP

ADF SYSTEM - CONTROLS**EFIS Control Panel**

The ADF bearing data can show on the NAV display in the VOR, APP, and MAP modes. You use the mode selector on the EFIS control panel to select the display mode for the NAV display.

The VOR/ADF switches select the VOR system or the ADF system as the source of the bearing pointer data on the NAV display. To show ADF bearing, set the VOR 1/ADF 1 switch on the EFIS control panels to the ADF 1 position.

Audio Control Panel Controls

The audio control panels (ACP) let the crew listen to ADF station audio or the morse code station identifier. You use the ACP ADF 1 receiver switch to listen to the ADF receiver audio.

The voice/range selector permits you to listen to only voice audio in the voice (V) position. The range (R) position permits you to listen to the station morse code identifier. With the selector in the both (B) position, you can listen to both the voice audio and the morse code station identifier.

Navigation aid stations transmit their morse code identifier signals on a typical 1020 Hz signal. There are some ADf stations that transmit their morse code identifier on a 400 Hz signal. The voice/range selector has no effect on these stations, the station morse code identifier will always be present.

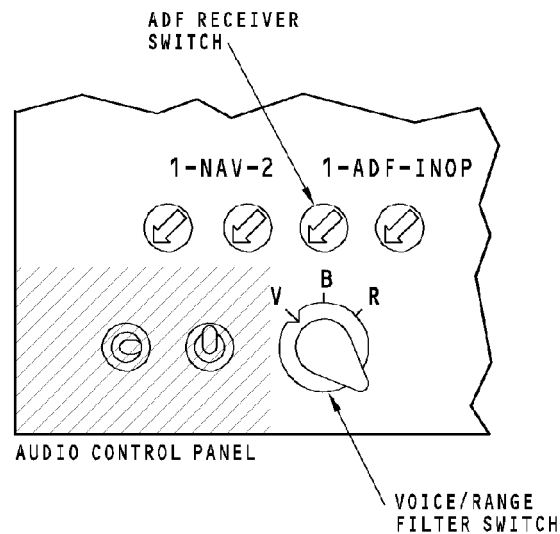
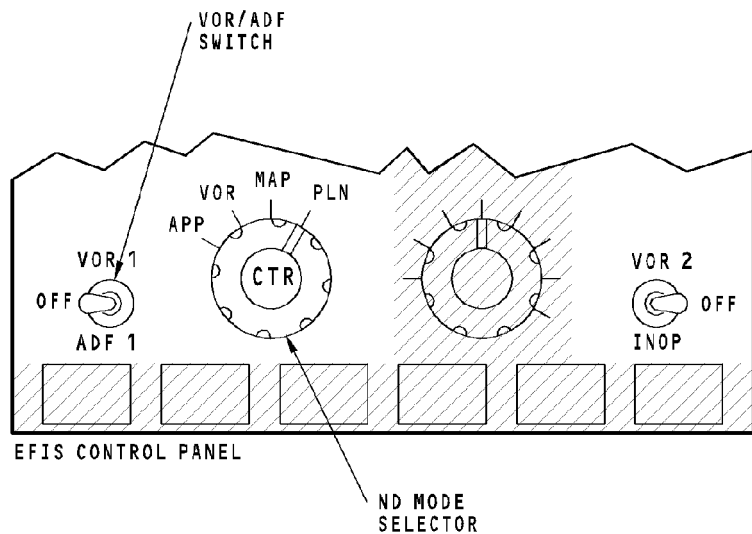

ADF SYSTEM - CONTROLS

34-57-00-011

EFFECTIVITY
HAP ALL

34-57-00

D633A101-HAP

ADF SYSTEM - RADIO MAGNETIC INDICATOR DISPLAYS**General**

The radio magnetic indicator (RMI) shows bearing to a VOR or ADF station relative to the airplane magnetic heading.

The RMI has two bearing pointers. The bearing pointers can show ADF or VOR data. You use the selectors on the front of the RMI to select between VOR or ADF as the source of data. The RMI has two amber flags, one for each bearing pointer. The flags come into view if the selected data source inputs fail.

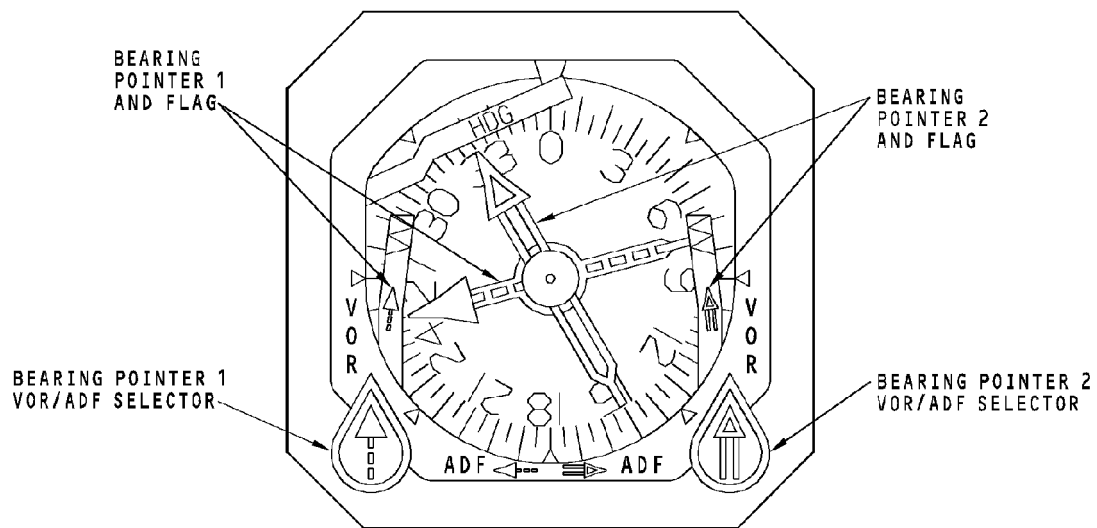

ADF SYSTEM - RADIO MAGNETIC INDICATOR DISPLAYS

34-57-00-012

EFFECTIVITY
HAP ALL

34-57-00

D633A101-HAP

Page 31
Jun 10/2007

ADF SYSTEM - EFIS NAV DISPLAYS**General**

The ADF data shows on the captain and first officer NAV displays in the VOR, APP, and MAP modes. The bearing pointers around the compass rose show VOR or ADF bearing data. To show ADF bearing, set the EFIS control panel VOR/ADF switches to ADF and set the EFIS mode selector to the VOR, APP, or MAP display modes. The bearing pointers are cyan when they show ADF data. The ADF source data and frequency or identifier shows in cyan at the bottom corners of the displays.

The bearing pointers show in the expanded and centered displays. The bearing pointers show on the expanded displays if the ADF bearing is in the compass rose display limit. This graphic shows the displays in the centered NAV display mode.

Bearing Pointers

Only bearing pointer 1 can show ADF bearing. To show ADF bearing, set the VOR/ADF 1 switch to the ADF position. When you select the ADF position, the bearing pointer shows in cyan. The DEUs remove the bearing pointer when the receiver data goes to an NCD condition, or when you set the VOR/ADF 1 switch to the off position.

Invalid Display

The amber ADF fail flags show in the lower corners of the display when there is a failure of the ADF receivers. The ADF flags show in the same location for the expanded display.



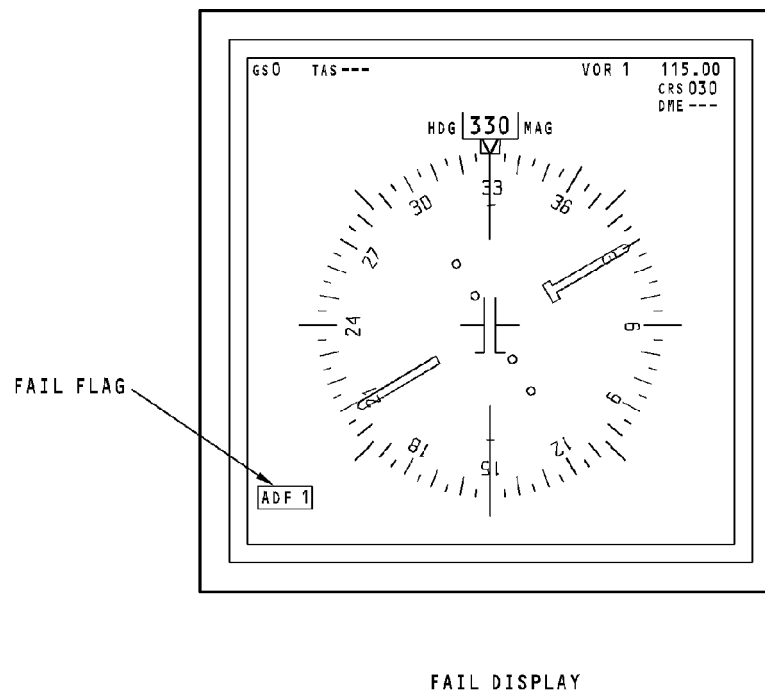
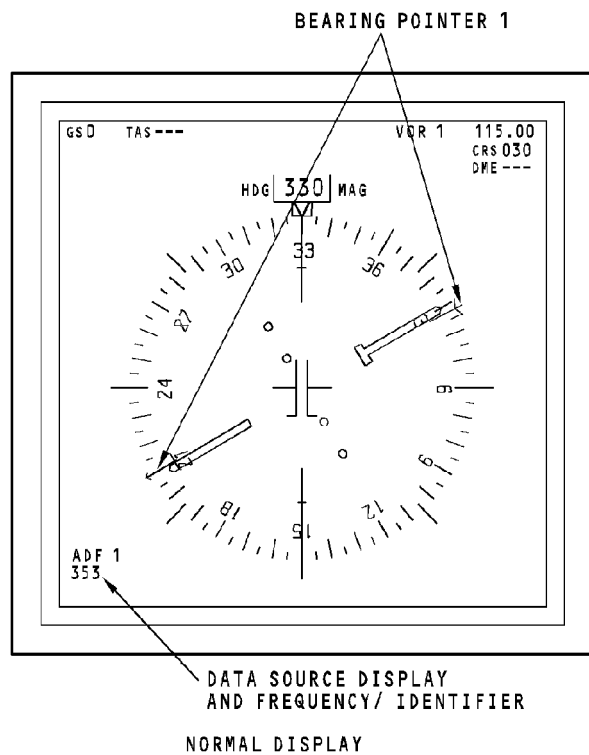

ADF SYSTEM - EFIS NAV DISPLAYS

34-57-00-014

EFFECTIVITY
HAP ALL

34-57-00

D633A101-HAP

Page 33
Jun 10/2007

ADF SYSTEM - FRONT PANEL BITE**Test**

Push any test switch on the front of the ADF receiver to start a test. The receiver does a check of the internal receiver operation and of its interface with the control panel. The test results show on the LCD on the front of the receiver.

When you push the test switch, the TEST IN PROGRESS page shows and the receiver does a self test. It continues for 10 seconds. A 10-second scale shows at the bottom of the page. You can monitor the test time by the line of Xs that show below the scale.

The TEST COMPLETE NO FAILURES display shows for a test pass condition. The TEST COMPLETE FAILURES display shows for a test failure condition.

These are the selections that can show above the receiver front panel switches during the test sequence:

- MAINT - shows pages that have program pin selections and discrete interface condition
- RETURN - causes the display to go back to the start test page
- WHY? - comes on when there are failures. You push this selection to show the failures
- MORE - shows any time there are more pages of data to follow.

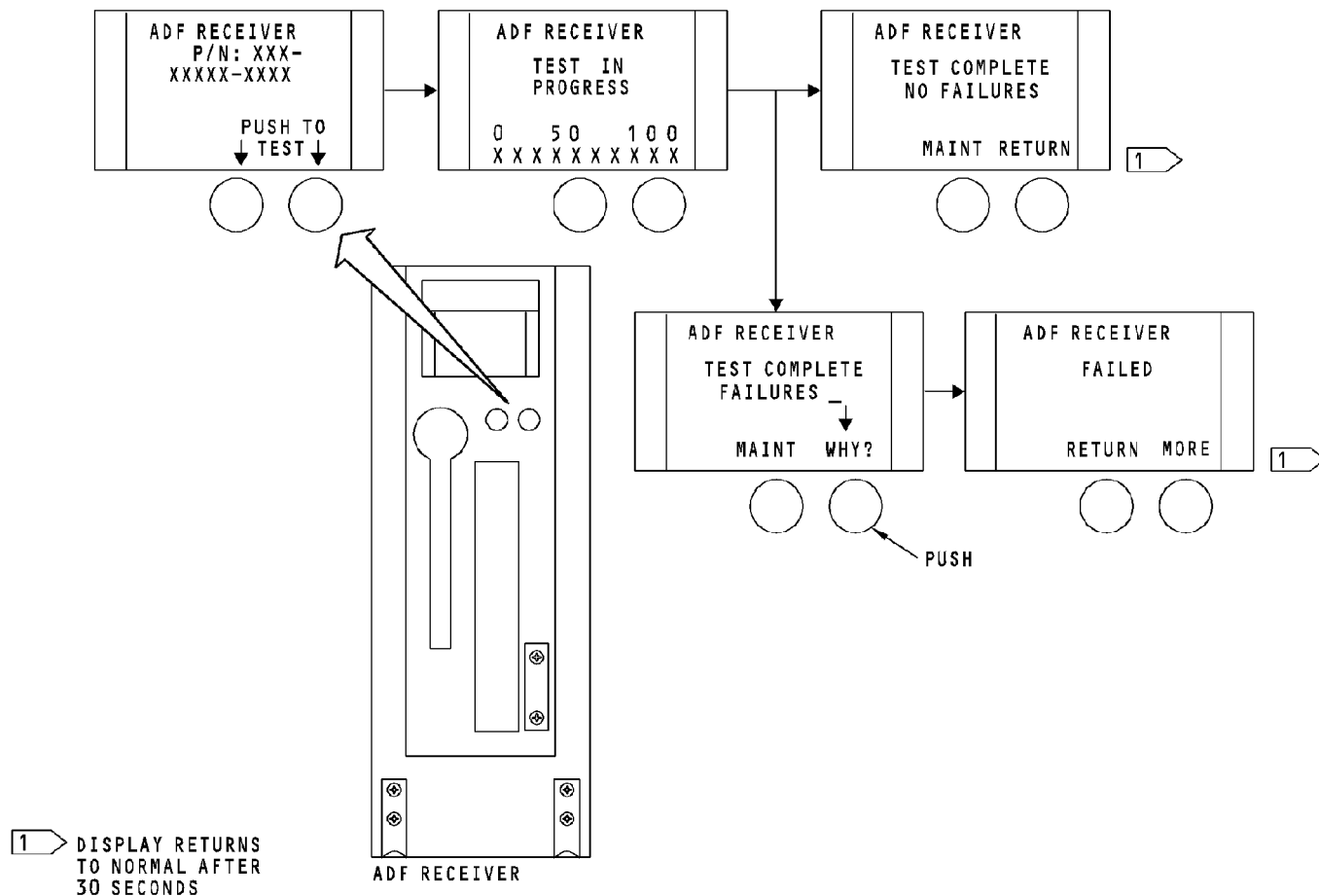

ADF SYSTEM - FRONT PANEL BITE

34-57-00-015

**EFFECTIVITY
HAP ALL**

34-57-00

D633A101-HAP

ADF SYSTEM - SELF-TEST

Test

To see the ADF test sequence, select VOR or APP on the EFIS control panel mode selector.

A maintenance person must be in the E/E compartment to start the test from the front of the ADF receiver.

During the first two seconds of the test, the receiver output goes to a fail condition. The pointer goes out of view and the amber ADF flag shows momentarily.

For the next two seconds, the receiver output goes to an NCD condition. During this time, the amber ADF flag goes out of view and the pointer stays out of view.

Next, the test display shows and the pointer goes to a test position of 135 degrees from the heading lubber line until the end of test.

NOTE: The graphic shows a test of ADF receiver 1. For a dual system, the test is the same for ADF receiver 2.

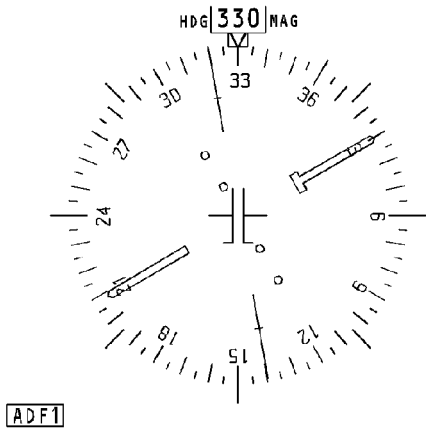

0 TO 2 SECONDS:

THE RECEIVER OUTPUT GOES TO A FAIL CONDITION. THE ADF DATA GOES OUT OF VIEW. THE AMBER ADF FLAG SHOWS MOMENTARILY.

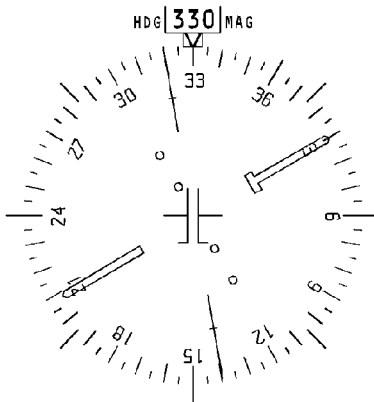

2 TO 4 SECONDS:

THE RECEIVER OUTPUT GOES TO NO COMPUTED DATA (NCD) AND THE FLAG GOES OUT OF VIEW. THE ADF POINTERS STAY OUT OF VIEW.

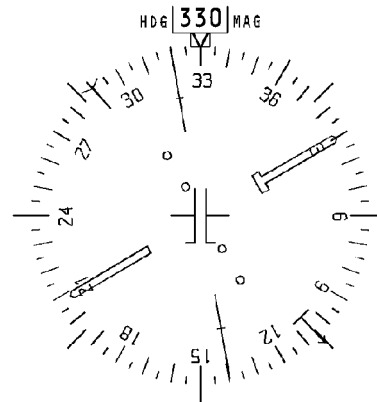

FROM 4 SECONDS TO END OF TEST:

THE POINTERS GO TO THE TEST POSITION (APPROX. 135 DEGREES FROM THE HEADING LUBBER LINE).

NOTE: THIS SHOWS A TEST OF ADF RECEIVER 1. FOR DUAL SYSTEMS, THE TEST IS THE SAME FOR ADF RECEIVER 2.

ADF SYSTEM - SELF-TEST

34-57-00-016

EFFECTIVITY
HAP ALL

34-57-00

D633A101-HAP

Page 37
Jun 10/2007

THIS PAGE IS INTENTIONALLY LEFT BLANK

34-58-00

D633A101-HAP

Page 1
Oct 10/2002

GLOBAL POSITIONING SYSTEM - INTRODUCTION**Purpose**

The global positioning system (GPS) uses navigation satellites to supply airplane position to airplane systems and to the flight crew.

Abbreviations and Acronyms

- ADIRU - air data inertial reference unit
- AMP - amplifier
- APU - auxiliary power unit
- ARINC - Aeronautical Radio, Inc.
- ATT - attitude
- A/D - analog to digital
- BITE - built-in test equipment
- CDU - control display unit
- CONV - convertor
- dc - direct current
- DET - detection
- D/A - digital to analog
- ELEC - electrical
- flt - flight
- FMC - flight management computer
- GP - general purpose
- GPS - global positioning system
- HEX - hexadecimal
- IRS - inertial reference system
- L - left
- LBL - left buttock line
- MMR - multi mode receiver
- nav - navigation
- NCD - no computed data
- NVM - non volatile memory
- ovht - overheat
- pos - position
- PPS - precision positioning service
- R - right
- RAIM - receiver autonomous integrity monitor
- RBL - right buttock line
- rcvr - receiver
- RF - radio frequency
- SAT - satellite
- SCR - silicon controlled rectifier
- SPS - standard positioning service
- SS - single shot
- sta - station
- UTC - universal time (coordinated)
- Δ tBIAS - clock bias
- V - volts
- WL - water line

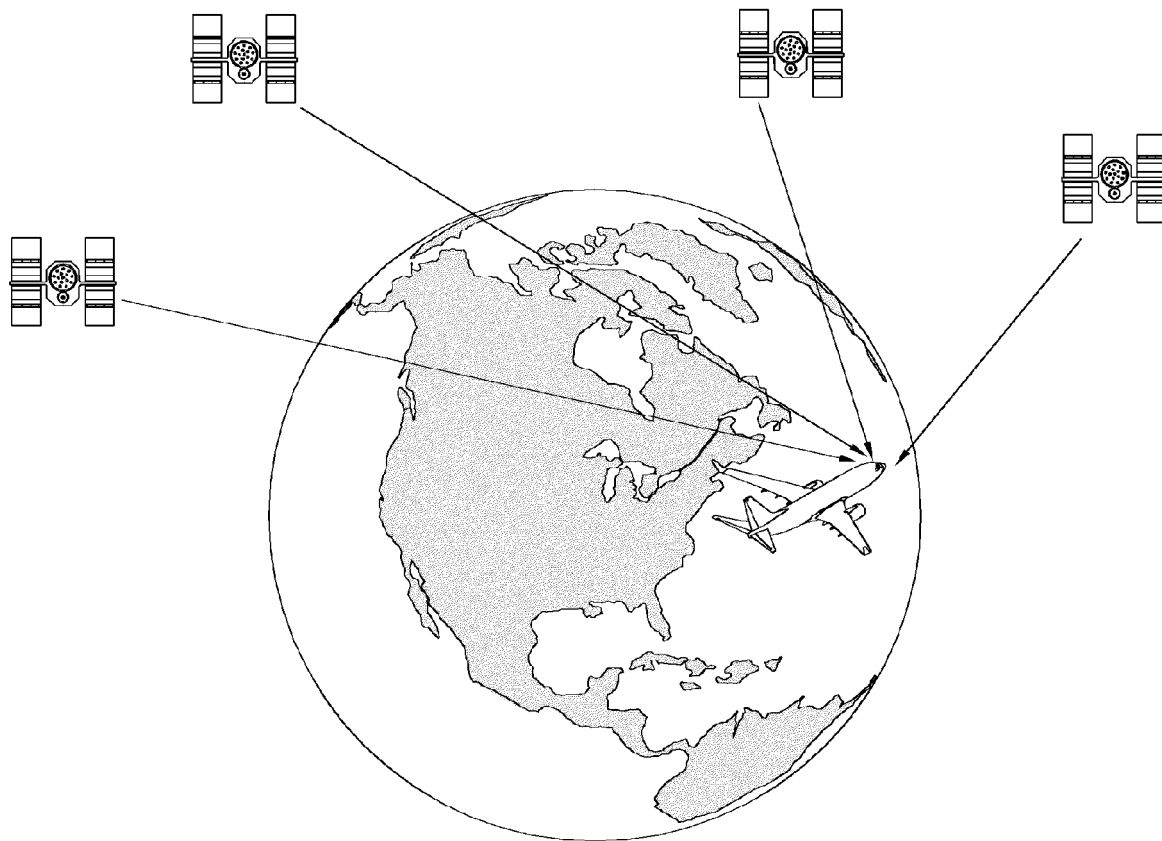

GLOBAL POSITIONING SYSTEM - INTRODUCTION

EFFECTIVITY
HAP ALL

34-58-00

D633A101-HAP

Page 3
Oct 10/2004

34-58-00-001

GPS - GENERAL DESCRIPTION

General

The global positioning system (GPS) calculates this data:

- Latitude
- Longitude
- Altitude
- Accurate time
- Ground speed.

There are two GPS systems. Antenna 1 receives satellite signals and sends them to multi mode receiver (MMR) 1. Antenna 2 connects to MMR 2. The MMRs calculate the airplane position and accurate time. This data goes to the flight management computer system (FMCS) and the IRS master caution unit. The FMCS uses GPS or navigation radio position with inertial reference data to calculate the airplane position.

The ADIRU sends position data to the MMRs.

The IRS master caution unit gets GPS data from both MMRs. It causes the GPS fail light on the IRS mode select unit to come on when the two units have a failure or if one unit fails and the master caution annunciator is pushed.

HAP The ground proximity warning computer gets GPS position and
HAP velocity data from the MMRs.

HAP 008-013, 015-026, 028-030

The clock gets GPS time and date from the MMRs.

HAP ALL

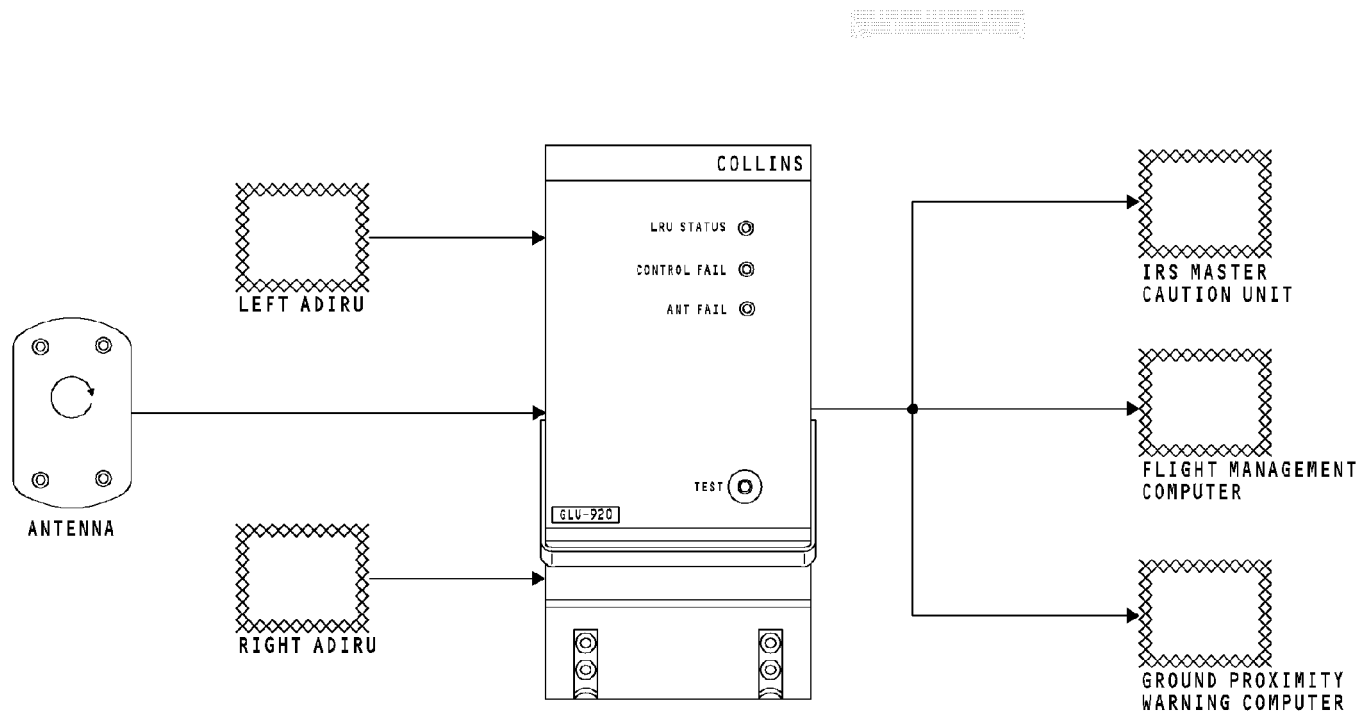

GPS - GENERAL DESCRIPTION

34-58-00-002

EFFECTIVITY
HAP 037

34-58-00

D633A101-HAP

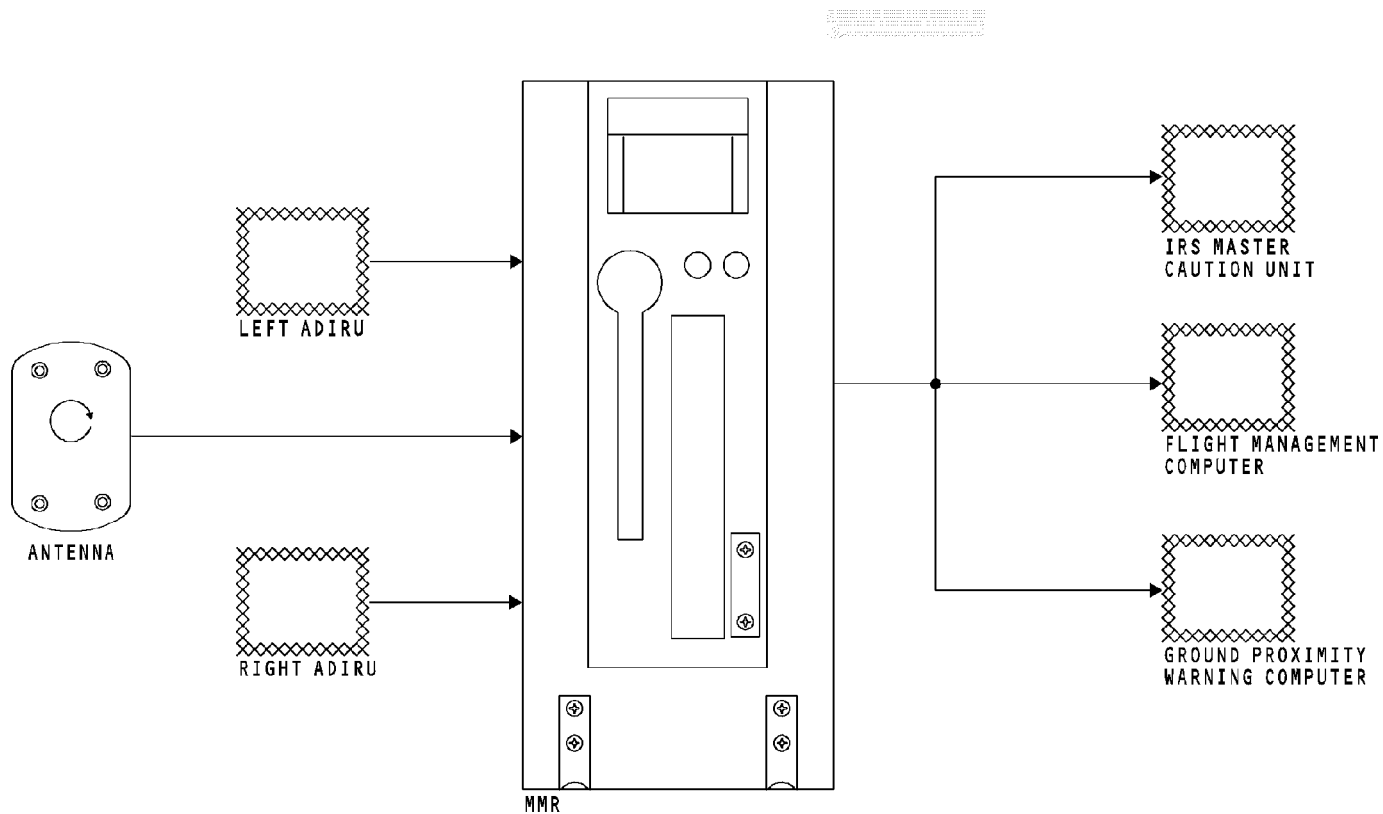

GPS - GENERAL DESCRIPTION

EFFECTIVITY

HAP 001-007, 031-036, 038-054, 101-999

34-58-00

D633A101-HAP

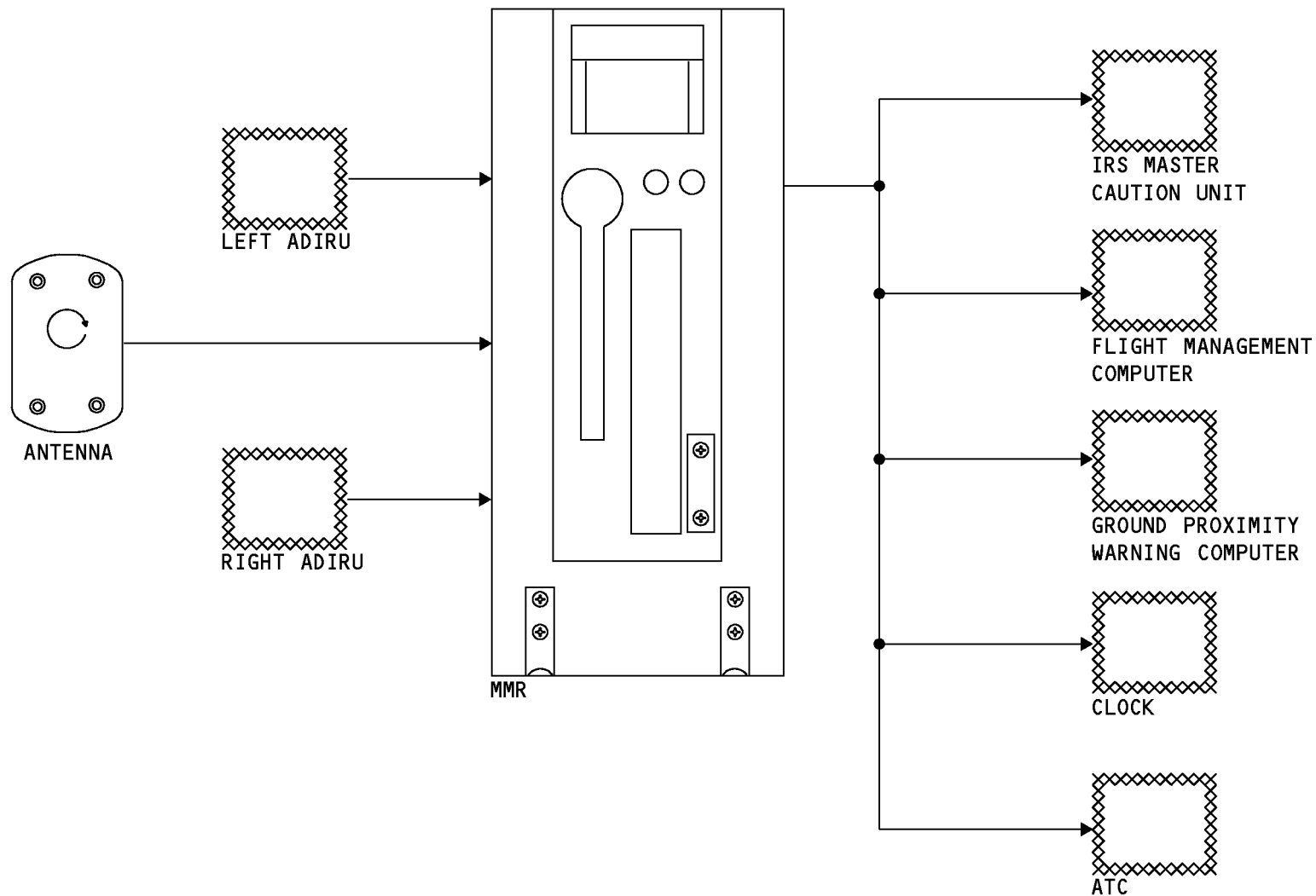

1545794 S0000282811_V1

GPS - GENERAL DESCRIPTION

EFFECTIVITY

HAP 008-013, 015-026, 028-030

34-58-00

D633A101-HAP

Page 7
Jun 15/2009

34-58-00-002

GPS - FLIGHT COMPARTMENT COMPONENT LOCATION

General

These are the components in the flight compartment that have a relation to the GPS:

- Control display units
- Master caution annunciator
- Master caution lights
- IRS master caution unit
- Annunciation and dimming module
- IRS mode select unit.

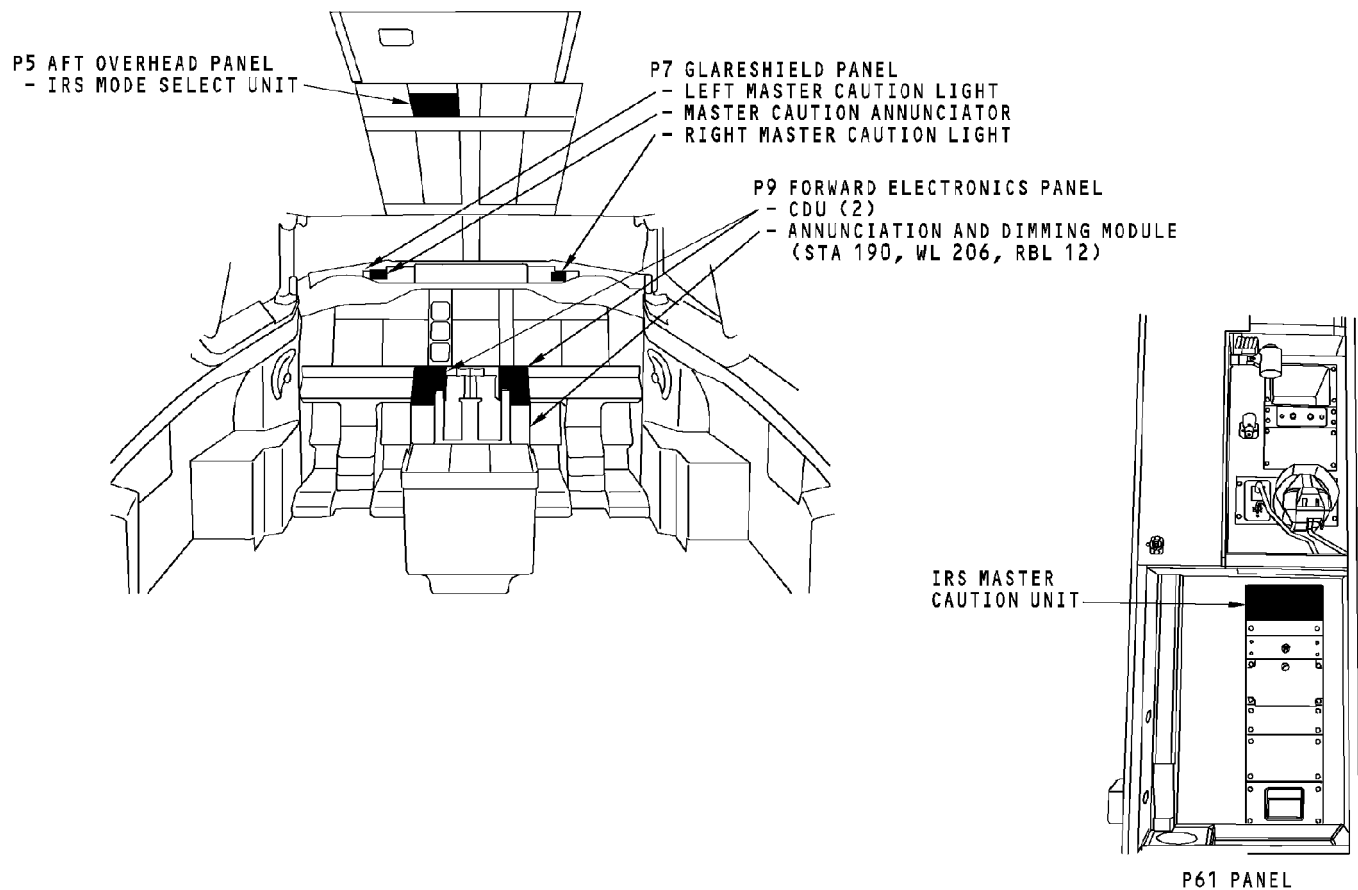

GPS - FLIGHT COMPARTMENT COMPONENT LOCATION

34-58-00-013

EFFECTIVITY
HAP ALL

34-58-00

D633A101-HAP

GPS - COMPONENT LOCATION

General

GPS sensor units are in the multi mode receivers (MMR). The MMRs are in the electronic equipment compartment. MMR 1 is on the E1-2 shelf. MMR 2 is on the E1-4 shelf.

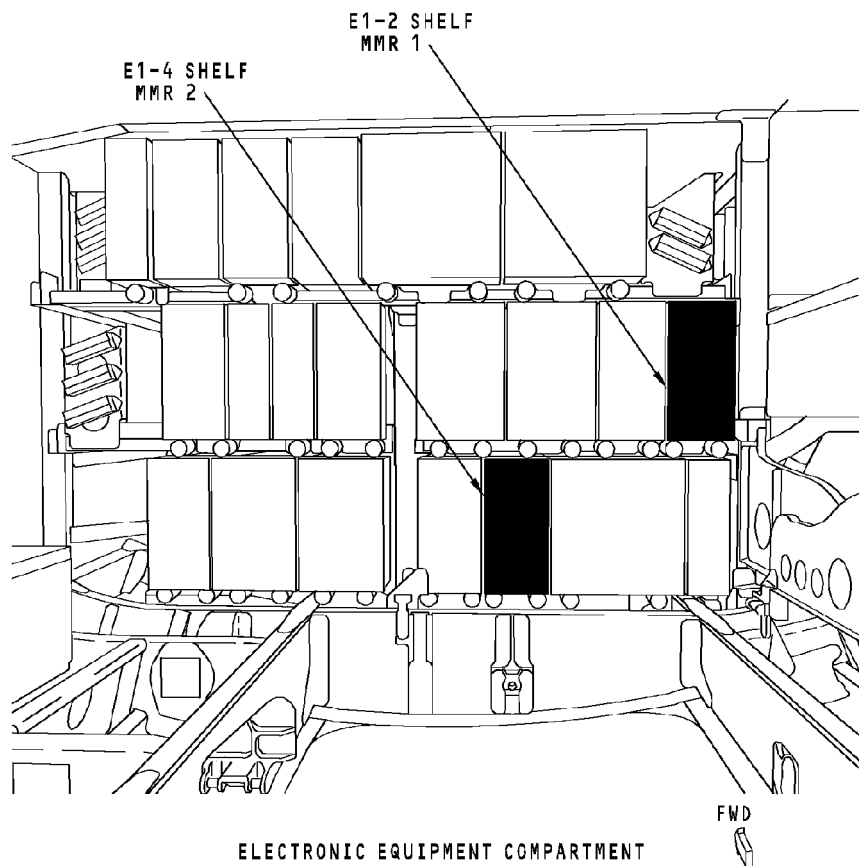

GPS - COMPONENT LOCATION

34-58-00-003

EFFECTIVITY
HAP ALL

34-58-00

D633A101-HAP



GPS - ANTENNA LOCATIONS

General

The GPS antennas are on the top of the fuselage.

34-58-00-004

EFFECTIVITY
HAP ALL

34-58-00

D633A101-HAP

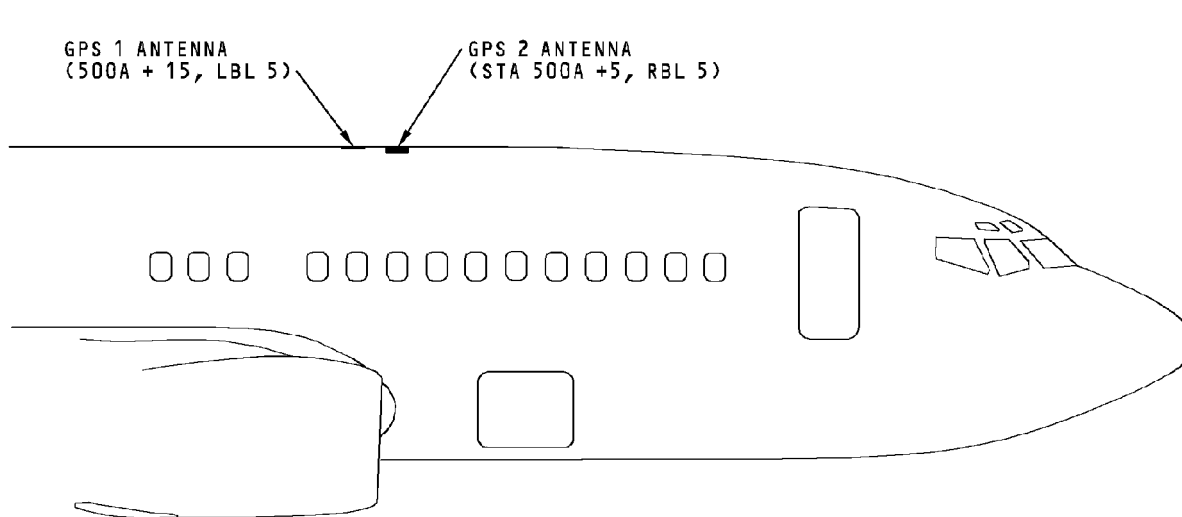

GPS - ANTENNA LOCATIONS

34-58-00-004

EFFECTIVITY
HAP ALL

34-58-00

D633A101-HAP

THIS PAGE IS INTENTIONALLY LEFT BLANK

34-58-00

D633A101-HAP

Page 14
Jun 15/2009

GPS - INTERFACES

Power and Antenna Interface

Each multi-mode receiver (MMR) has a circuit breaker. The 115v ac buses supply power to the MMRs.

Each MMR receives a radio frequency (RF) signal from a GPS antenna.

ADIRU Data Buses

The MMRs get inertial reference data from the ADIRUs. Each MMR receives IR data from its inside ADIRU and the offside ADIRU. During normal operation, MMR 1 uses L ADIRU data and MMR 2 uses R ADIRU data. If there is a loss of data from an ADIRU, the MMR will use the data from the offside ADIRU.

The MMRs use this data for system initialization and to help system operation during periods of low satellite coverage.

MMR Data Output Bus

The MMR sends out this data:

- GPS latitude
- GPS latitude Fine
- GPS longitude
- GPS longitude fine
- Clock time and date
- GPS status
- Horizontal figure of merit
- Horizontal integrity limit.

The MMR sends the data to these units:

- FMC 1

HAP 037-054, 101-999

- FMC 2

HAP 008-013, 015-026, 028-030

- Clocks, captain and first officer

HAP ALL

- Ground proximity warning computer (GPWC)
- IRS master caution unit.

Flight Management Computer (FMC)

The MMRs send these GPS parameters to the FMC:

- Latitude
- Longitude
- Time
- Horizontal figure of merit
- Horizontal integrity limit.

The FMC uses the data for FMC position update and actual navigation performance (ANP) calculation.

HAP 008-013, 015-026, 028-030

Clock

The clock uses GPS time and date.

HAP

GPS - INTERFACES

HAP **HAP 008-013, 015-026, 028-030 (Continued)**
HAP **I HAP ALL**

HAP **Ground Proximity Warning Computer**

HAP The MMRs send these GPS parameters to the ground proximity
HAP warning computer:

- HAP ● Latitude (coarse)
- HAP ● Longitude (coarse)
- HAP ● Latitude (fine)
- HAP ● Longitude (fine)
- HAP ● Ground speed
- HAP ● True track
- HAP ● Altitude
- HAP ● Vertical velocity
- HAP ● Horizontal dilution of precision (HDOP)
- HAP ● Vertical dilution of precision (VDOP)
- HAP ● Horizontal figure of merit (HFOM)
- HAP ● Vertical figure of merit (VFOM)
- HAP ● Date
- HAP ● Time (UTC)
- HAP ● Horizontal integrity limit (HIL)
- HAP ● Sensor status.

HAP Latitude and longitude (coarse and fine) information gives
HAP airplane position for the TCF and terrain awareness functions.

HAP Ground speed, true track, altitude, and vertical velocity are used
HAP in the terrain awareness function.

Horizontal dilution of precision, vertical dilution of precision, HAP
horizontal figure of merit and vertical figure of merit information HAP
are used for airplane position accuracy calculations. HAP

Date and time information is used in the fault monitor process, HAP
which labels each fault with the date and time of occurrence. HAP

The horizontal integrity limit is used to determine the current HAP
integrity limit and GPS non-isolatable satellite failures. HAP

Sensor status lets the GPWC monitor the status of the GPS HAP
receiver. HAP

IRS Master Caution Unit

The IRS master caution unit monitors data from the MMRs.

SDI Program Pins

Three program pins tell the MMR if it is number 1 or 2.

34-58-00-005

<p>EFFECTIVITY HAP ALL</p>

34-58-00

D633A101-HAP

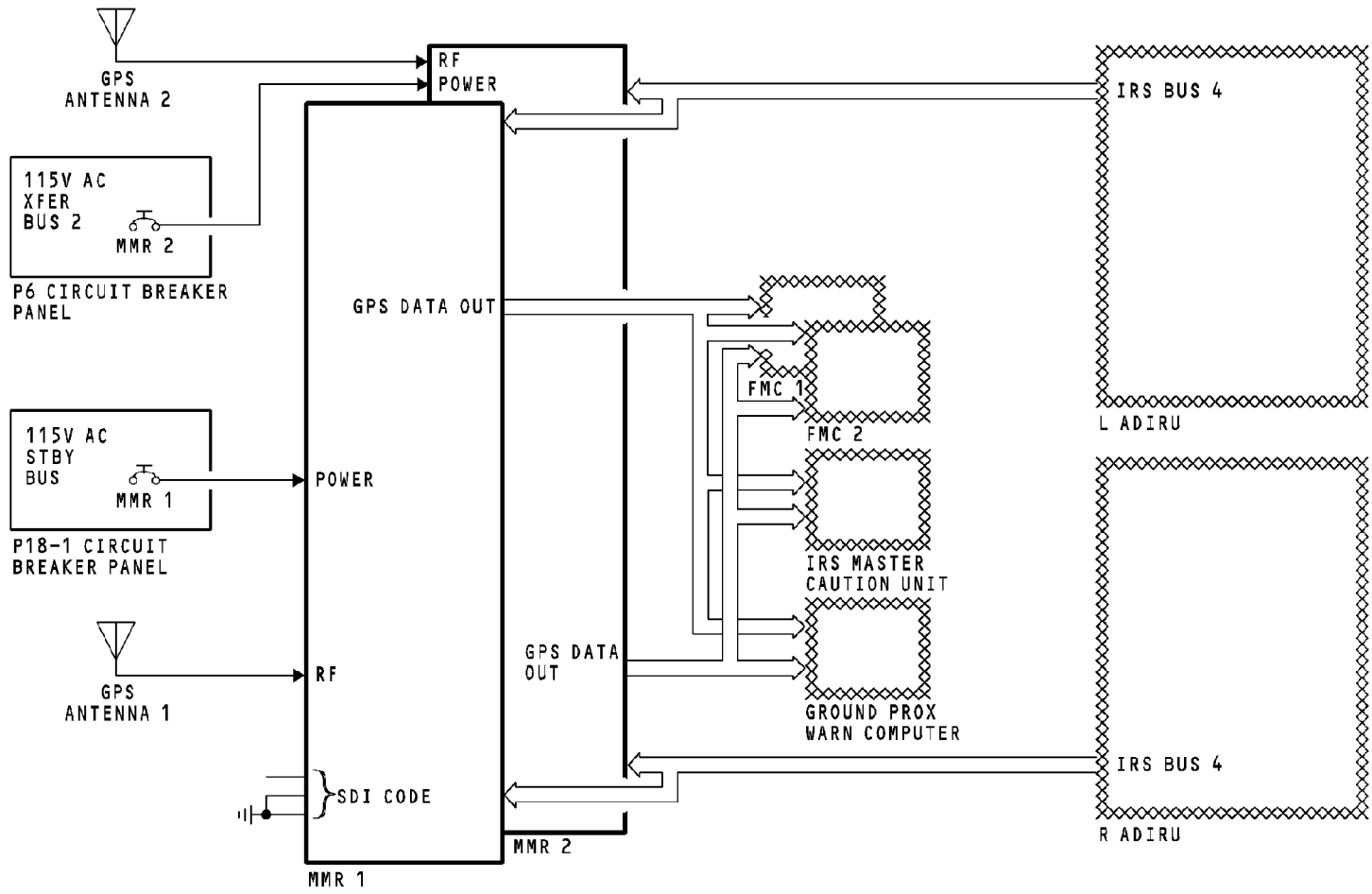

GPS - INTERFACES

34-58-00-005

EFFECTIVITY
HAP 037-054, 101-999

34-58-00

D633A101-HAP

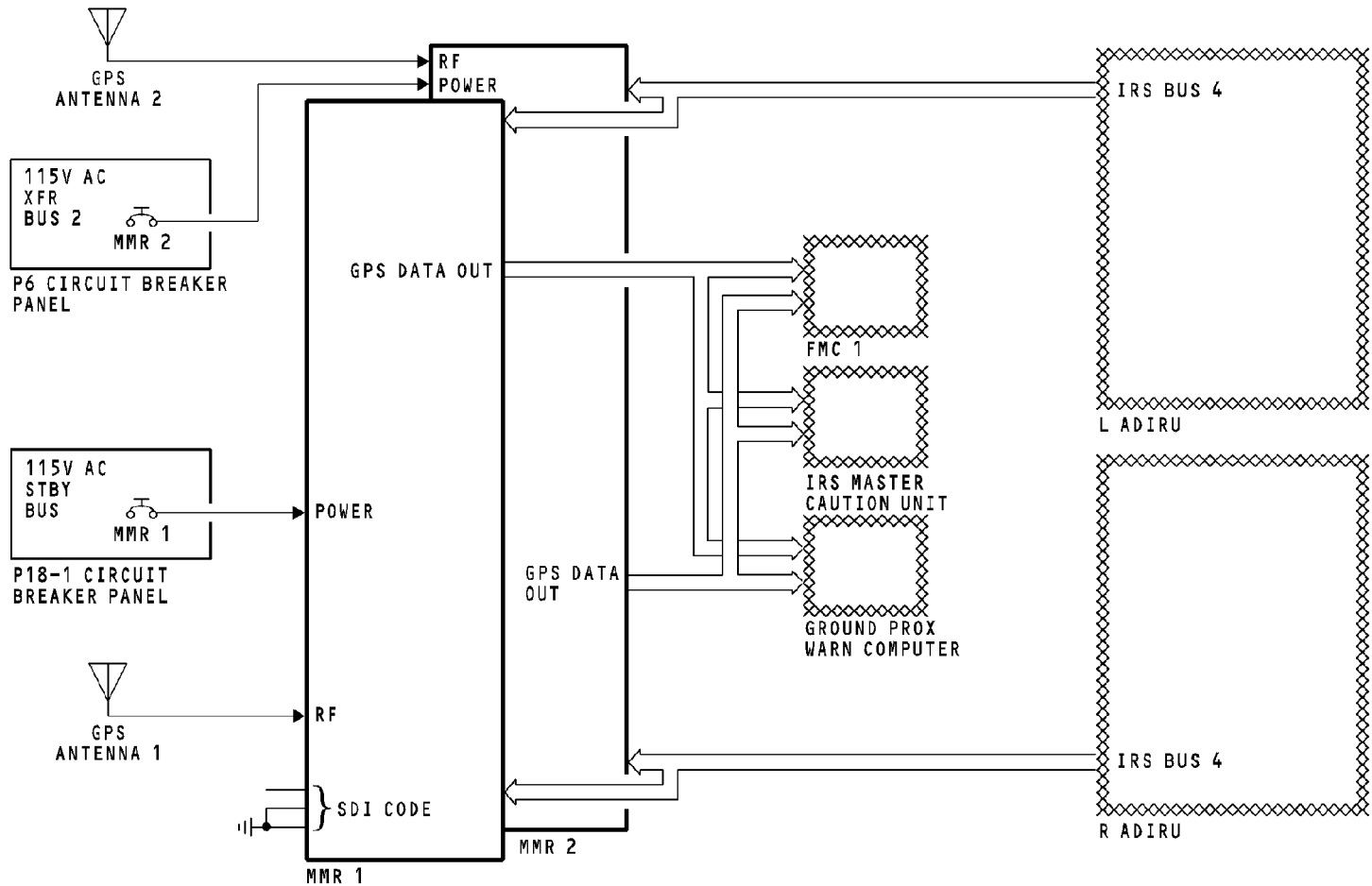

GPS - INTERFACES

EFFECTIVITY
HAP 001-007, 031-036

34-58-00

D633A101-HAP

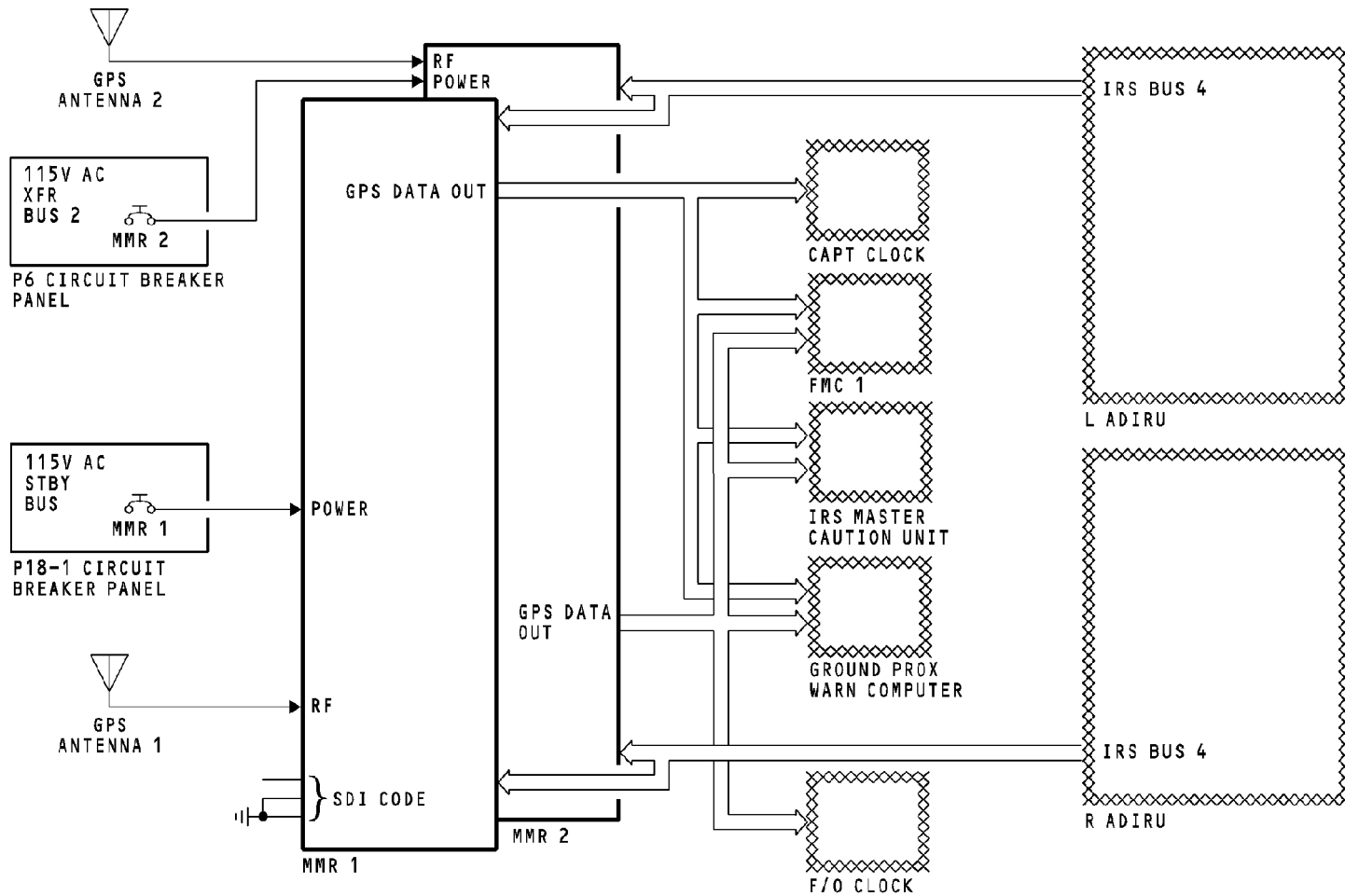

GPS - INTERFACES

34-58-00-005

EFFECTIVITY
HAP 008-013, 015-026, 028-030

34-58-00

D633A101-HAP

GPS - RECEIVER

Purpose

The multi-mode receiver (MMR) contains the GPS receiver. The GPS receiver receives navigation satellite signals to calculate GPS data.

Physical Description

The MMR is a standard ARINC 600 3 MCU unit 3.6 inches wide, 7.9 inches high, and 14.6 inches long. It has passive cooling. The MMR weighs 10 pounds and uses 115v ac, 400Hz power for operation.

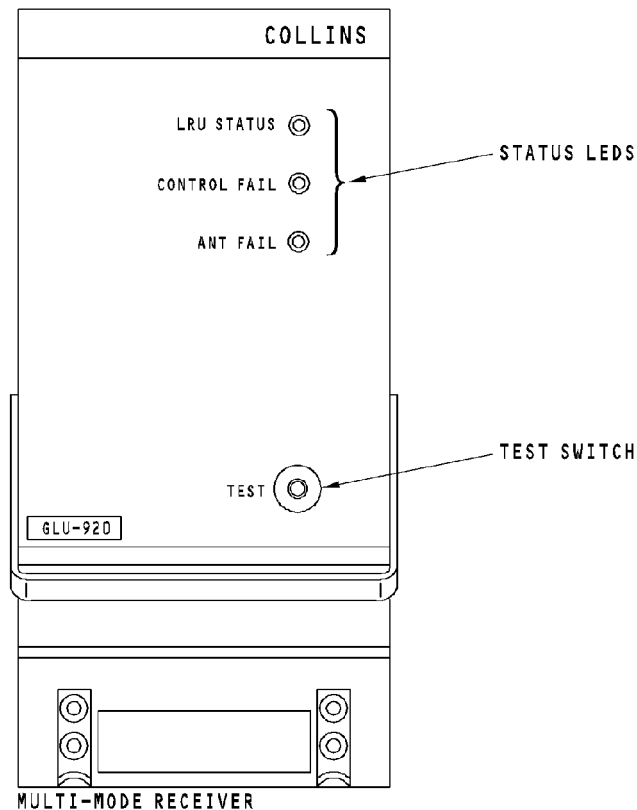

GPS - RECEIVER

34-58-00-006

EFFECTIVITY
HAP 037

34-58-00

D633A101-HAP

Page 21
Jun 15/2009

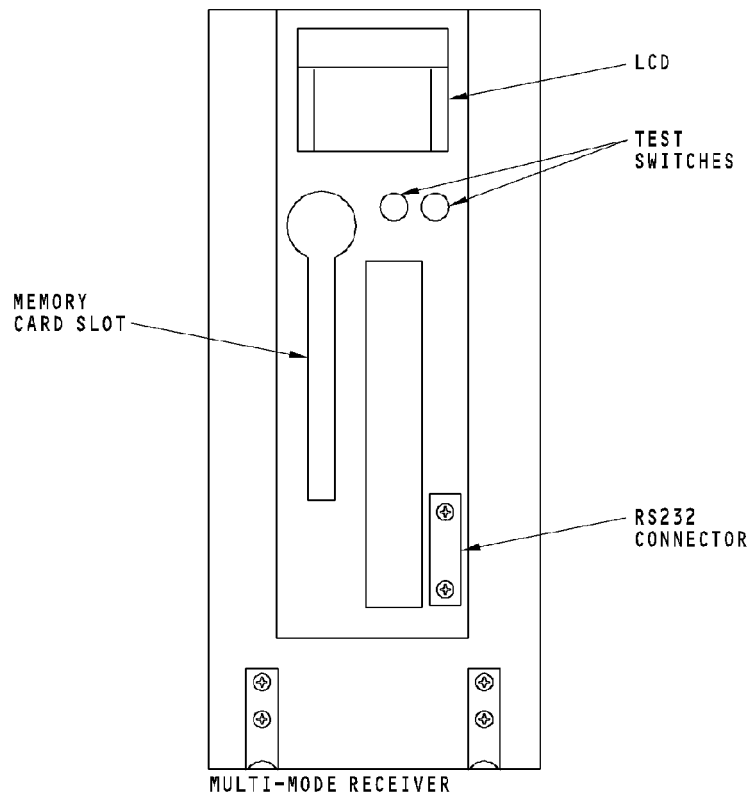

GPS - RECEIVER

EFFECTIVITY

HAP 001-013, 015-026, 028-036, 038-054, 101-999

34-58-00

D633A101-HAP

THIS PAGE IS INTENTIONALLY LEFT BLANK

34-58-00

D633A101-HAP

Page 23
Jun 10/2007

GPS - GPS ANTENNA

General

The GPS antennas receive L-band frequency signals (1575.42 MHz) and sends them to the multi mode receivers (MMR).

Each antenna contains an integrated preamplifier to increase the signal level to the MMR. The antenna preamplifiers use 12v dc which comes from the power supply in the MMR.

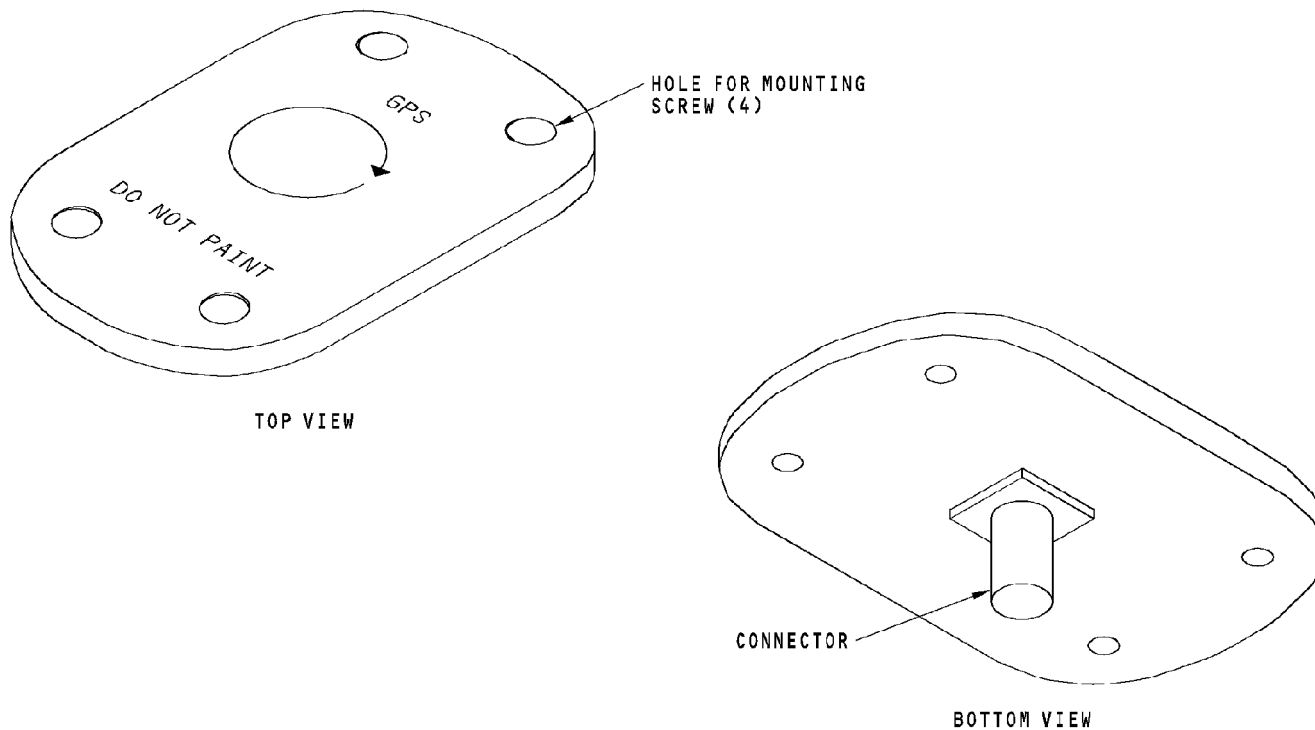

GPS - GPS ANTENNA

34-58-00-007

EFFECTIVITY
HAP ALL

34-58-00

D633A101-HAP

THIS PAGE IS INTENTIONALLY LEFT BLANK

34-58-00

D633A101-HAP

Page 26
Jun 15/2009

GPS - THEORY OF OPERATION - 1

GPS Segments

The GPS has these three segments:

- Satellite
- User
- Control.

Satellite Segment

The satellite segment is a group of satellites that orbit 10,900 nautical miles above the earth. Each satellite makes an orbit once every 12 hours. There are 21 operational satellites and 3 spares.

The satellites continuously transmit radio signals with navigation data, range code, and the exact time.

User Segment

The user segment is the GPS receiver unit on the airplane. It receives the satellite signals. The GPS uses the satellite data to calculate the airplane position.

Control Segment

The control segment has control and monitor stations on earth that continuously monitor and track the satellites. The control segment does these things:

- Monitor and correct satellite orbits and clocks

- Calculate and format a satellite navigation message. This message has up-to-date descriptions of the satellites future positions, and a collection of the latest data on all GPS satellites
- Update the satellite navigation message regularly.

The control segment has one master control station and five monitor stations. Three of the monitor stations are also upload stations.

The master control station is in Colorado Springs, USA. The master control station is the operational center of the GPS. The master control station controls all operations in the control segment. The master control station has an atomic clock, this clock is the reference for the GPS.

The monitor stations track the satellites 24 hours a day. The master control station remotely controls the monitor stations through on-line connections. The monitor stations are in these locations:

- Ascension island
- Colorado Springs
- Diego Garcia island
- Hawaii
- Kwajalein island.

The monitor stations receive the same information from the satellites that the GPS receiver unit in the airplane receives. The monitor stations do these things:

EFFECTIVITY
HAP ALL

GPS - THEORY OF OPERATION - 1

- Record the accuracy of the satellite clocks
- Collect and relay to the control station meteorologic data such as barometric pressure, temperature, and dew point. The master control station uses this data to calculate the tropospheric signal delay
- Continuously measure the ranges to all visible satellites. The master control station uses this data to calculate and predict the satellites orbits.

The master control station uses the upload stations to send this data:

- Orbit correction commands to the satellites. The satellites use control rockets to correct their orbits
- The navigation message to the satellites.

The upload stations are on Ascension island, Diego Garcia island, and Kwajalein island.

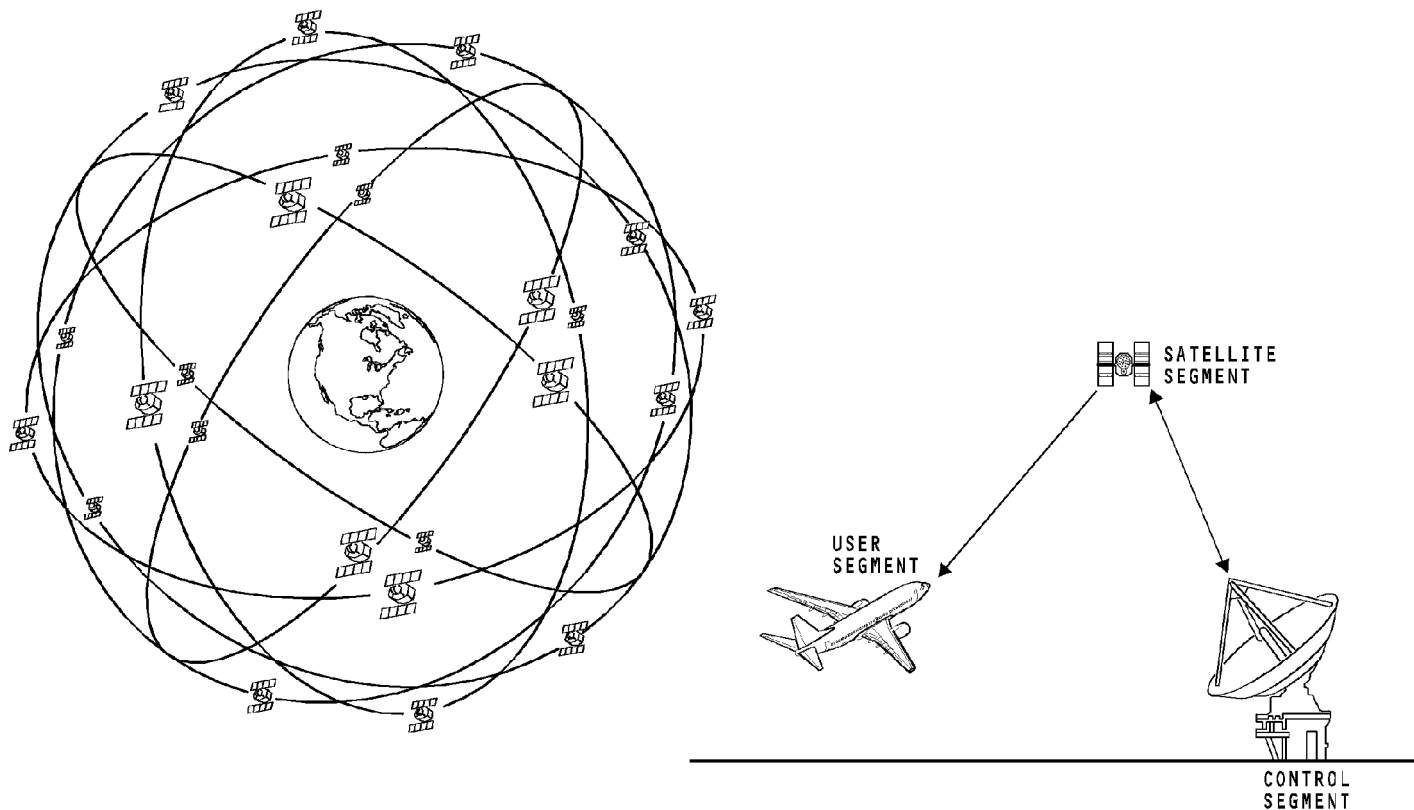

GPS - THEORY OF OPERATION - 1

34-58-00-008

EFFECTIVITY
HAP ALL

34-58-00

D633A101-HAP

Page 29
Jun 15/2009

GPS - THEORY OF OPERATION - 2**Ranging**

The GPS receivers use the principle of ranging to measure the distance between the receiver and the satellites. The receiver always has the location of the satellites in their orbits in memory.

The receiver measures the time it takes for a radio signal to go from a satellite to the airplane. Since the receiver knows the location of the satellite and that the radio signal travels at the speed of light, it can calculate the distance to the satellite.

The receiver uses one way ranging. The receiver must know exactly at what time the satellite sent the radio signal. The receiver compares the satellite signal to a signal that the receiver makes at the same time as the satellite. The difference between the two signals (Δt) is the time the satellite signal took to get to the receiver.

Each satellite has an atomic clock to keep accurate time. All the satellites have precisely the same time. The receiver in the airplane has an internal clock but it is not atomic. It is not as accurate. Thus, it is not possible for the receiver to have precisely the same time as the satellite.

The receiver assumes that its internal clock is off by some clock bias (Δt_{BIAS}). This Δt_{BIAS} is an unknown that the receiver must calculate. The Δt_{BIAS} is the difference between the receiver time and GPS time.

To calculate the airplane position (latitude, longitude, and altitude) and the Δt_{BIAS} , the receiver must know the position of at least four satellites. The receiver then measures the distances to all the satellites at the same time. It then solves for these four unknowns with four range equations:

- Latitude
- Longitude
- Altitude
- Δt_{BIAS} .

GPS Time

All the satellites synchronize to universal time (coordinated) (UTC). The satellites transmit this time to the receiver. The accuracy of the satellite UTC is approximately 100 nanoseconds. The receiver transmits UTC on an ARINC 429 format. The receiver also transmits a very accurate time mark once per second.

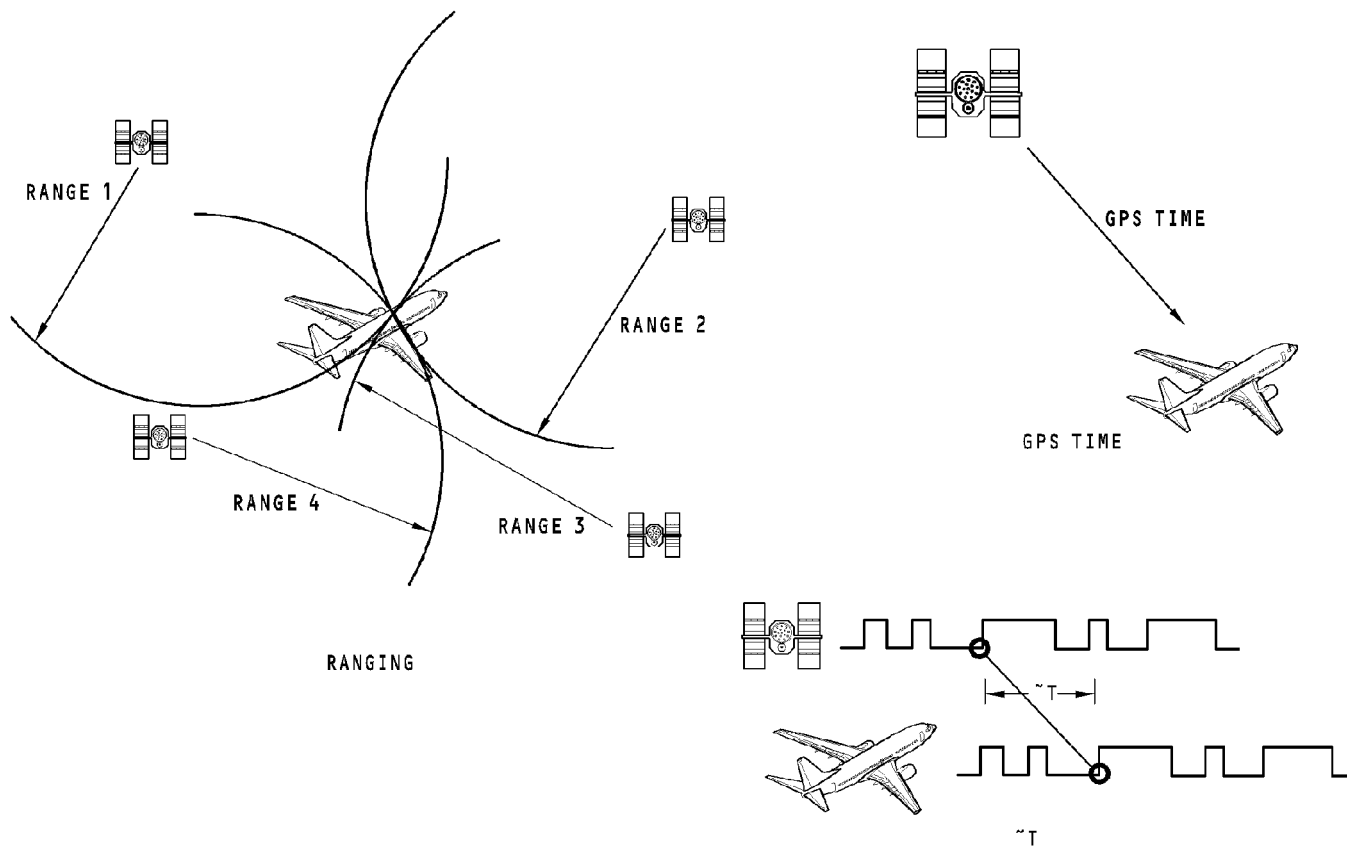

GPS - THEORY OF OPERATION - 2

34-58-00-009

EFFECTIVITY
HAP ALL

34-58-00

D633A101-HAP

Page 31
Jun 15/2009

THIS PAGE IS INTENTIONALLY LEFT BLANK

34-58-00

D633A101-HAP

Page 32
Jun 15/2009

GPS - THEORY OF OPERATION - 3**GPS Modes of Operation**

The GPS operates in these modes:

- Acquisition mode
- Navigation mode
- Altitude aided mode
- Aided mode.

Acquisition Mode

The GPS looks for and locks on to the satellite signals. The GPS must find at least 4 satellites before it starts to calculate GPS data. The GPS gets data from the air data inertial reference system (ADIRS). The GPS uses this data from air data inertial reference unit (ADIRU) when it is in the acquisition mode:

- Present position
- Altitude.

The GPS uses this data and its internal database to calculate which satellites are available at the present airplane position. The GPS takes less time to get to the navigation mode with this data.

If the ADIRU data is not available, the GPS can still acquire satellite signals. It takes longer to acquire the satellite signals because it has to look for all the satellites. When the GPS finds the satellites, it calculates which ones it can use.

The GPS takes approximately 75 seconds to acquire the satellite signals when the ADIRU data is available. The GPS takes approximately 4 minutes (maximum of 10 minutes) to acquire the satellites when the ADIRU data is not available.

Navigation Mode

The GPS enters the navigation mode after it acquires and locks on to at least 4 satellites. When the GPS is in the navigation mode, it calculates GPS data.

Altitude Aided Mode

With four satellites available, the GPS stores the difference between the ADIRU inertial altitude and the GPS altitude.

The GPS stores the difference between inertial and GPS altitude so that it can estimate the GPS altitude when only three satellites are available.

In the altitude aided mode, the GPS sums the airplane altitude from the ADIRU and the length of the earth radius as the fourth range.

The GPS enters the altitude aided mode only after these three conditions are true:

- The GPS was in the navigation mode
- There are only 3 satellites available with good geometry for position fixes

GPS - THEORY OF OPERATION - 3

- The GPS stores the difference between inertial and GPS altitude in memory.

The GPS starts normal operation again when a fourth satellite comes into view.

Aided Mode

The GPS enters the aided mode during short periods (less than 30 seconds) of bad satellite coverage. An example of bad satellite coverage is where at least four satellites are available but the airplane banks and loses satellite reception.

In the aided mode, the GPS receives inertial altitude, track angle, and groundspeed from the ADIRU. The GPS uses the ADIRU data to go back quickly to the navigation mode when there is good satellite coverage again. The GPS output is NCD in this mode.

If the GPS cannot track any satellites for 30 seconds or more, the GPS goes to the acquisition mode.

GPS Frequencies

The satellites transmit to the GPS in the airplane on the L1 (1575.42 MHz) and L2 (1227.6 MHz) frequencies. The satellites downlink satellite status data to the monitor stations on 1783.74 MHz.

The upload stations send information to the satellites on 2227.5 MHz.

Autonomous Integrity Limit

The GPS has a receiver autonomous integrity monitor (RAIM) function. The RAIM monitors the status of the satellites that the GPS uses for calculations. The output of the RAIM function is an estimate of the GPS position error. The autonomous integrity monitor value goes to the FMC. The FMC uses the autonomous integrity monitor to determine if it can use GPS data for navigation.

Values Calculated by the GPS

These are some of the values that the GPS calculates:

- Latitude
- Longitude
- Altitude
- Universal time (coordinated) (UTC)
- Date
- North/south velocity
- East/west velocity
- Vertical velocity
- Track angle
- Autonomous integrity limit
- Satellite position
- GPS status.

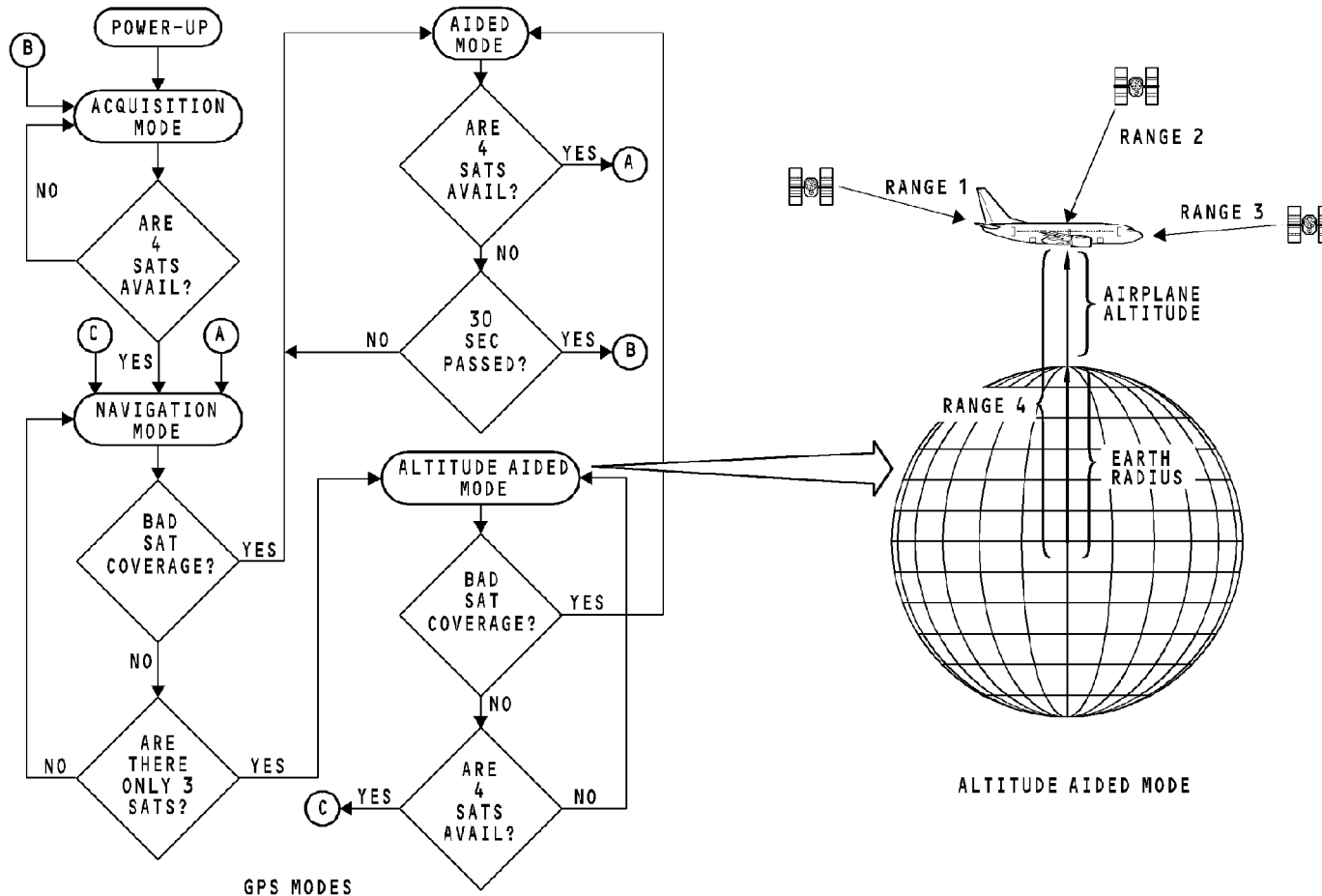

GPS - THEORY OF OPERATION - 3

34-58-00-010

EFFECTIVITY
HAP ALL

34-58-00

D633A101-HAP

Page 35
Jun 15/2009

GPS - FUNCTIONAL DESCRIPTION

Power

The power supply makes various dc voltages from the 115v ac input to the multi-mode receiver (MMR).

Satellite Signal Processing

The GPS antenna first amplifies the satellite signals and then sends them to the MMR. The low noise amplifier (LNA) in the MMR receives and amplifies the satellite signals from the GPS antenna. The receiver detects the satellite signal and sends it to an analog to digital converter (A/D). The A/D sends the digitized signal to the microprocessor. The microprocessor calculates the airplane position and other GPS data. The GPS data goes to these units:

- HAP
 - Ground proximity warning computer (GPWC)
HAP 008-013, 015-026, 028-030
 - Clocks
HAP 037-054, 101-999
 - Flight management computers (FMC 1 and 2).
HAP 001-013, 015-026, 028-036
 - Flight management computer (FMC 1).
HAP ALL

The IRS master caution unit receives digital fault data from GPS systems 1 and 2.

Inputs

The ADIRU sends inertial reference data on output bus 4 for initialization. The MMR uses this data in the aided and altitude aided modes.

The program pins tell position to the MMR. This is used for the source destination identifier (SDI) code in ARINC 429 data.

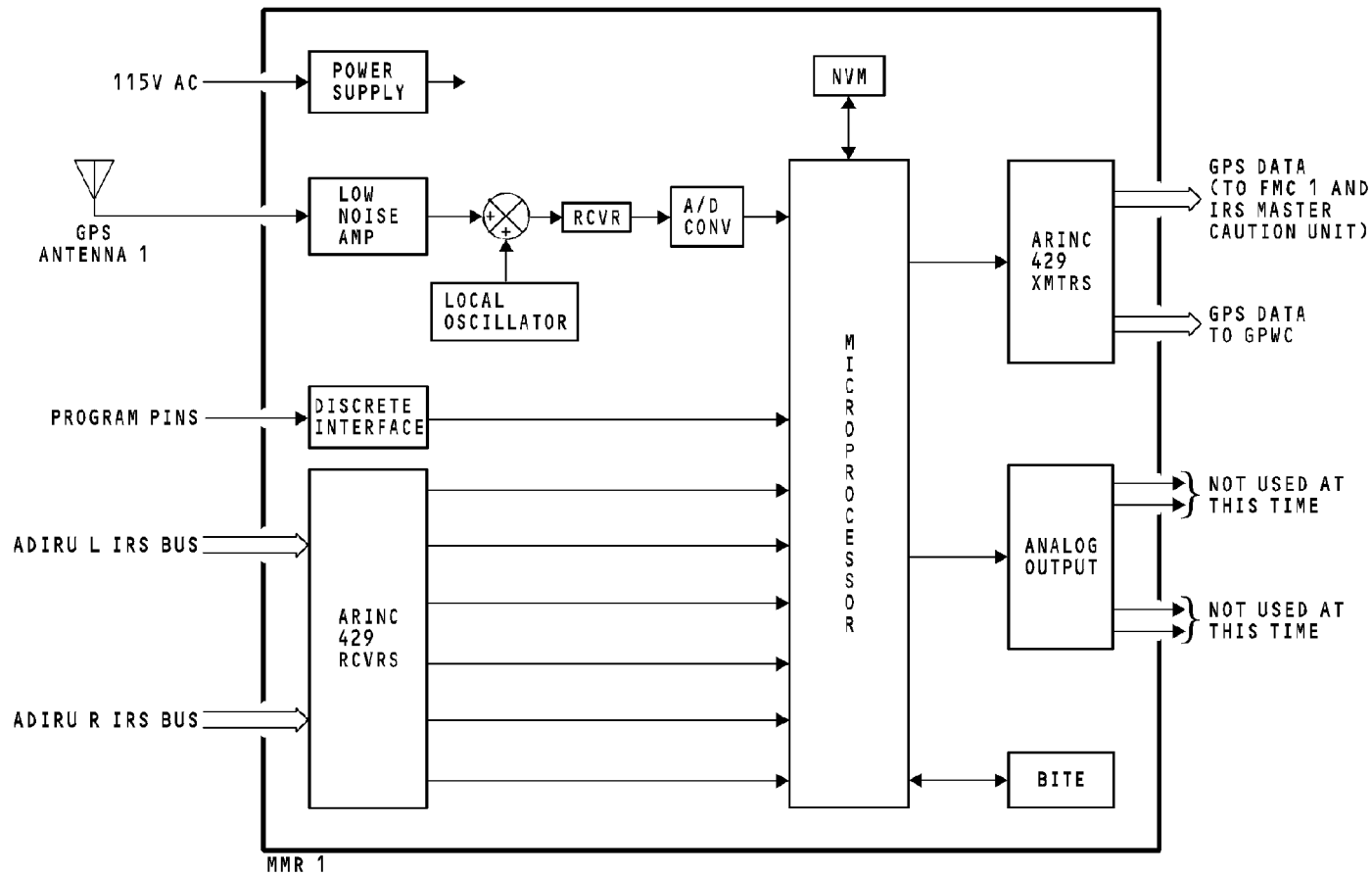

GPS - FUNCTIONAL DESCRIPTION

34-58-00-011

EFFECTIVITY
HAP 001-007, 031-036

34-58-00

D633A101-HAP

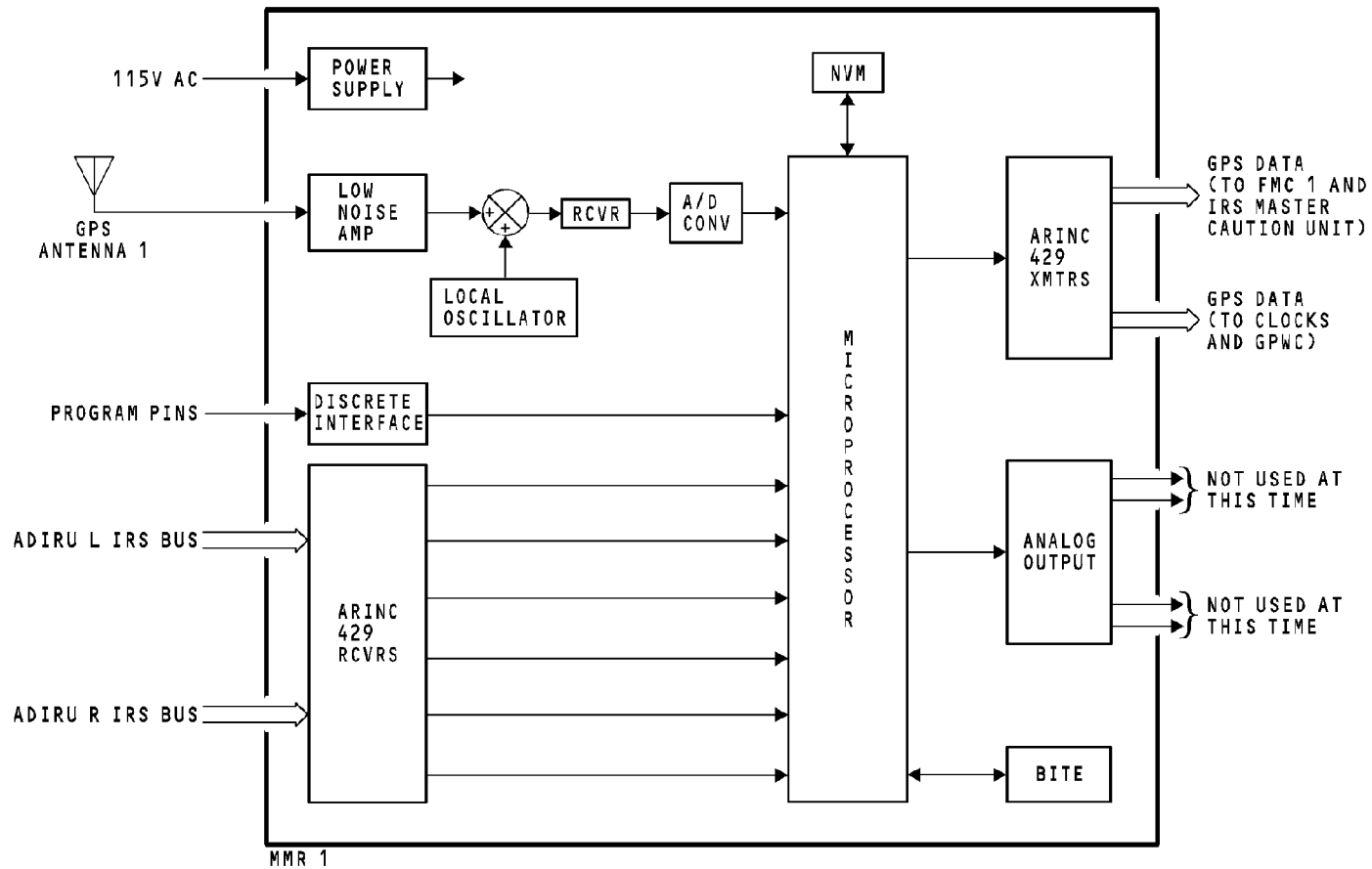

GPS - FUNCTIONAL DESCRIPTION

EFFECTIVITY

HAP 008-013, 015-026, 028-030

34-58-00

D633A101-HAP

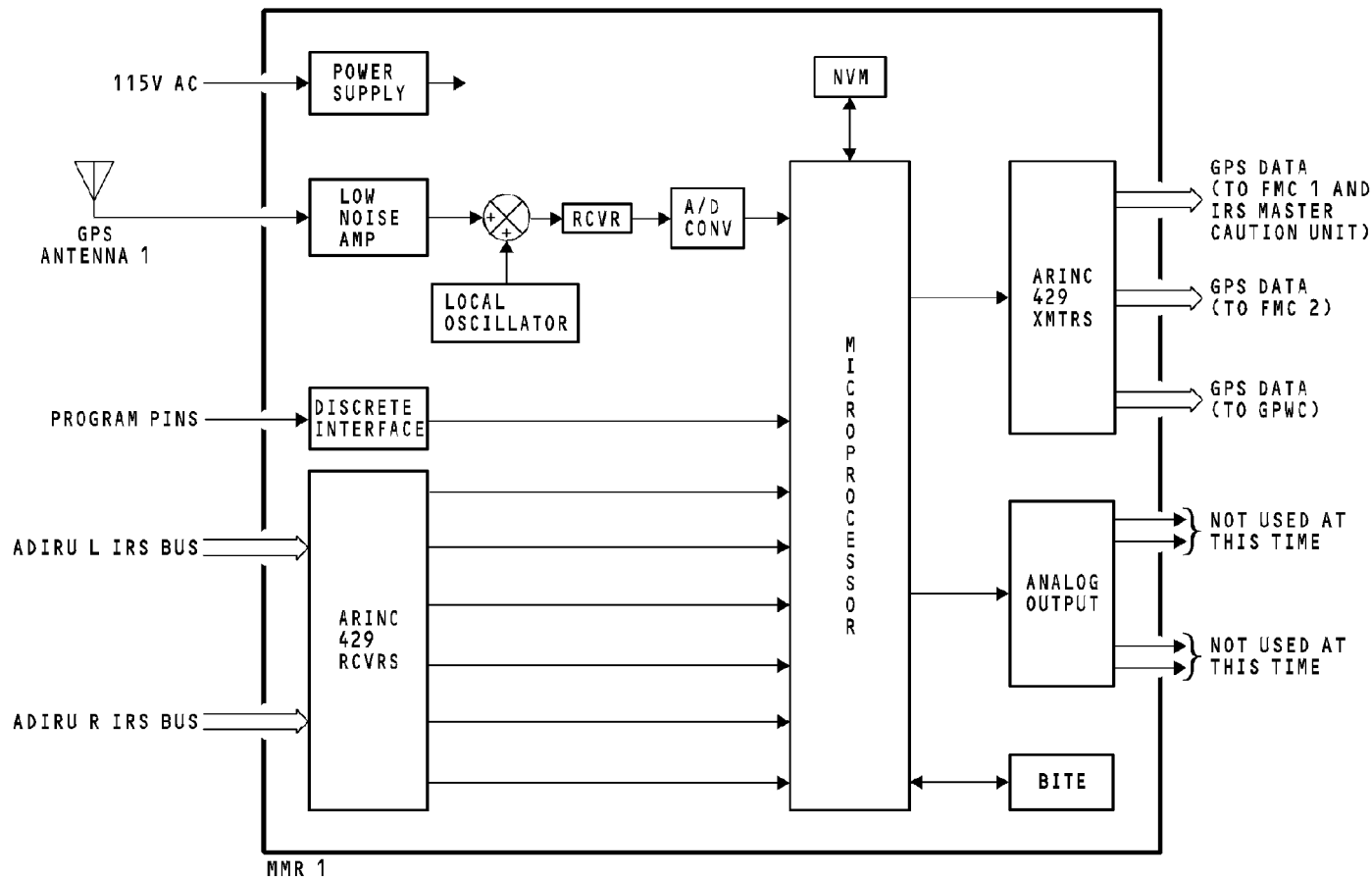

GPS - FUNCTIONAL DESCRIPTION

34-58-00-011

EFFECTIVITY
HAP 037-054, 101-999

34-58-00

D633A101-HAP

GPS - GPS FAULT MONITORING - FUNCTIONAL DESCRIPTION**One GPS Failure**

If there is one GPS failure, there is no annunciation until you push the system status annunciator panel assembly (recall). When you push the annunciator panel, these annunciations show:

- GPS light on the IRS mode select unit
- IRS light on the system status annunciator
- Left and right master caution lights.

When you release the annunciator panel assembly, all the annunciations stay on until you reset by a push of either the left or right master caution light (reset).

Two GPS Failures

If both GPS systems have a failure, these annunciations show:

- GPS light on the IRS mode select unit
- IRS light on the system status annunciator
- Left and right master caution lights.

When you push and release either the left or right master caution light, the IRS light and master caution lights go out but the GPS light stays on.

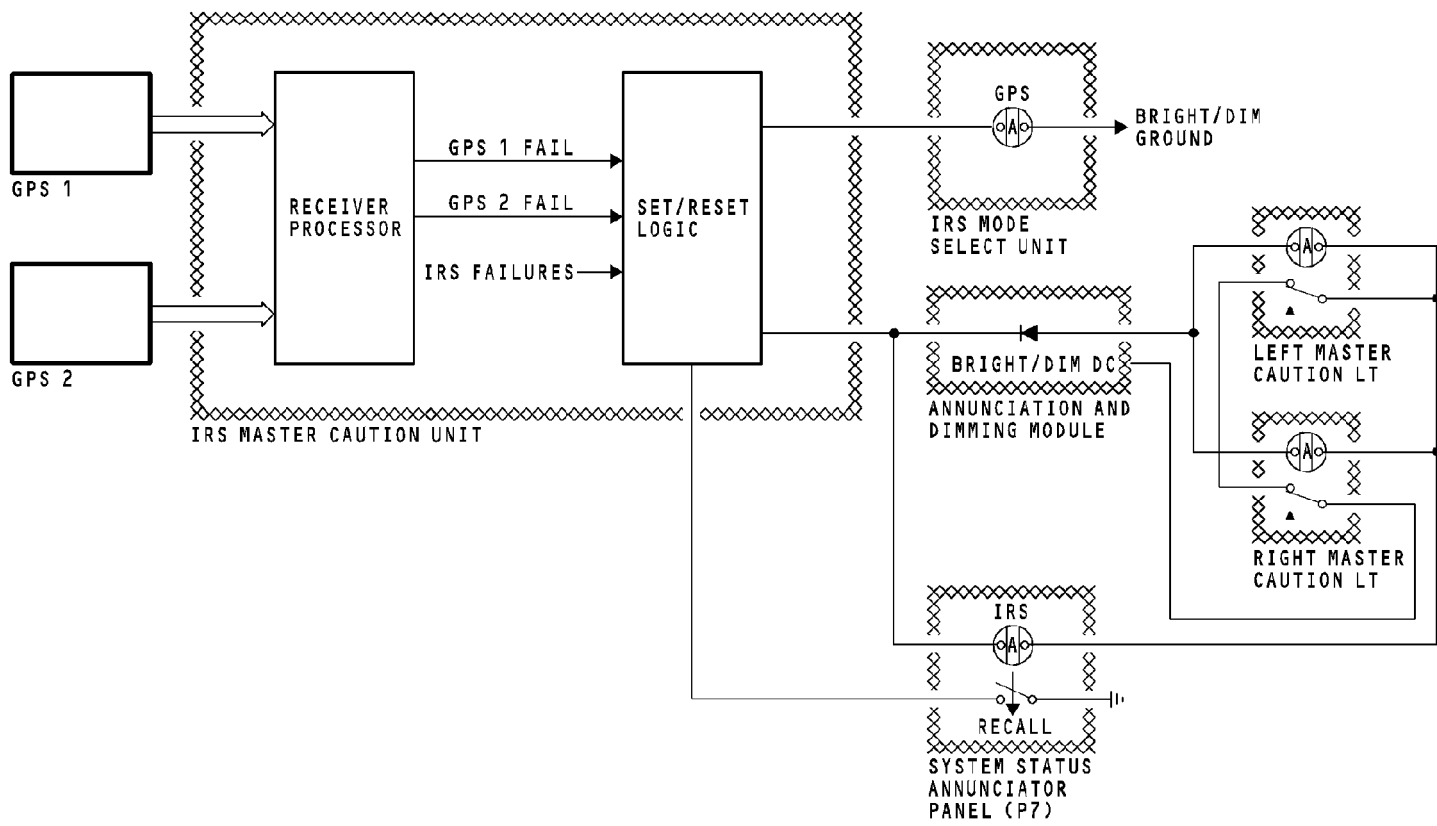

GPS - GPS FAULT MONITORING - FUNCTIONAL DESCRIPTION

34-58-00-012

EFFECTIVITY
HAP ALL

34-58-00

D633A101-HAP

GPS - CDU DISPLAYS**General**

GPS data shows on the control display unit (CDU). The position pages show this data. These are the three position pages:

- Position initialization (1/3)
- Position reference (2/3)
- Position shift (3/3).

You use the next and previous key to see all three position pages. These are the pages that show GPS data:

- Position reference (POS REF)
- Position shift (POS SHIFT).

POS REF Page

The POS REF page shows GPS L (1) and R (2) positions.

POS SHIFT Page

The POS SHIFT page shows the GPS position from the flight management computer (FMC) position. The GPS position shows in these two parts divided by a slash (/):

- Bearing of the GPS position from the FMC position
- Distance of the GPS position from the FMC position in nautical miles (NM).

Training Information Point

For all CDU displays that show GPS data, the displays refer to GPS 1 as GPS L and GPS 2 as GPS R.

The POS SHIFT page does not show information in the data fields when the airplane is on the ground.

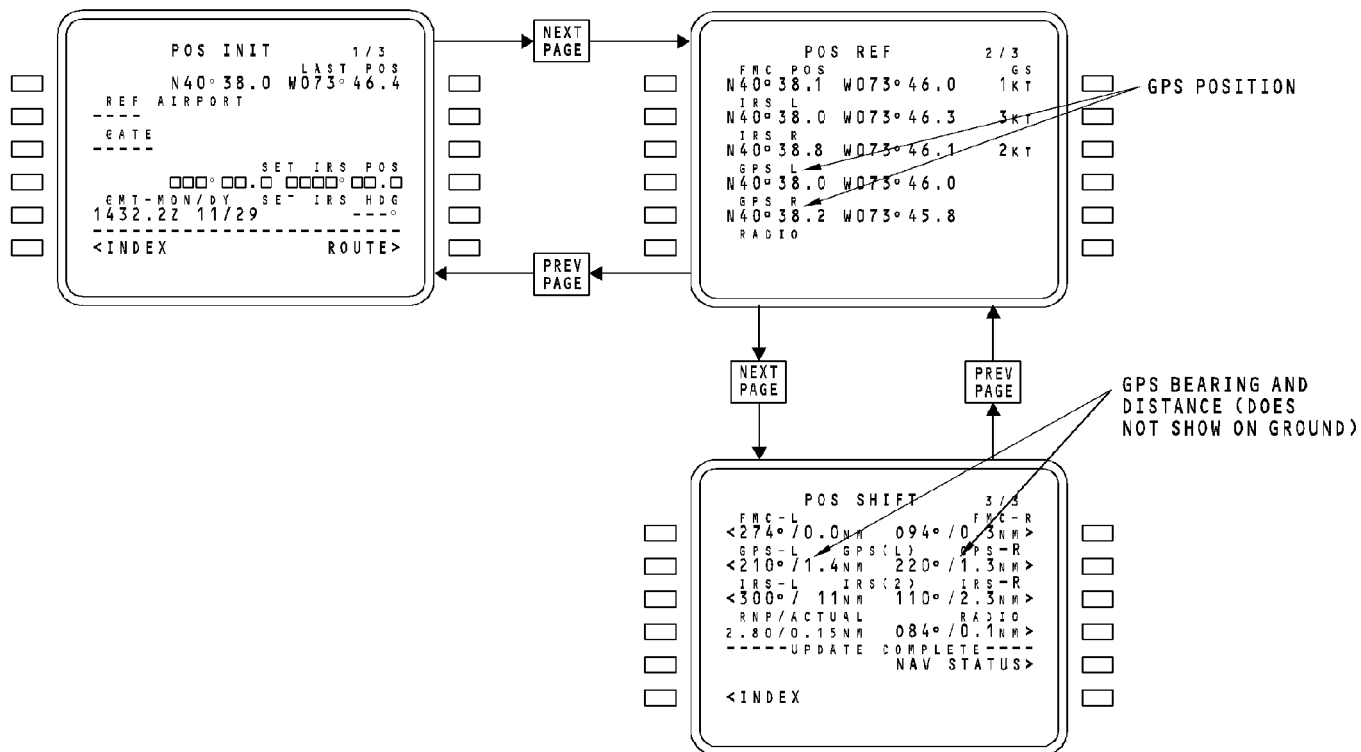

GPS - CDU DISPLAYS

34-58-00

EFFECTIVITY
HAP 037-054, 101-999

D633A101-HAP

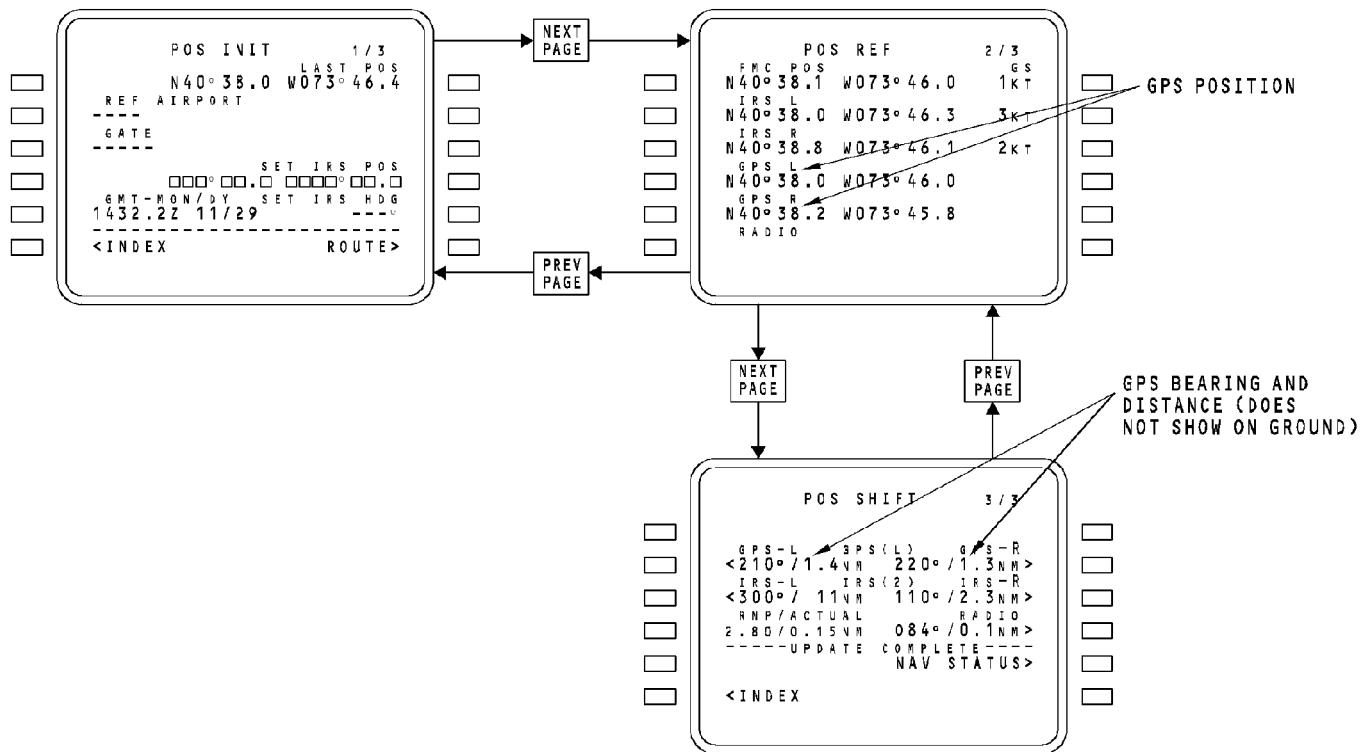

GPS - CDU DISPLAYS

EFFECTIVITY

HAP 001-013, 015-026, 028-036

34-58-00

D633A101-HAP

THIS PAGE IS INTENTIONALLY LEFT BLANK

34-58-00

D633A101-HAP

Page 45
Jun 10/2007

GPS - TRAINING INFORMATION POINT - 1

General

The GPS has continuous monitor BITE. These are the three ways to detect GPS failures:

- When both GPS system 1 and GPS system 2 have failures, the GPS fail light comes on.
- When you push a master caution annunciator and a GPS system has a failure, the GPS fail light comes on.
- The FMC SENSOR STATUS page shows MMR failures. The FMC SENSOR DATA page shows the internal failure in the MMR.

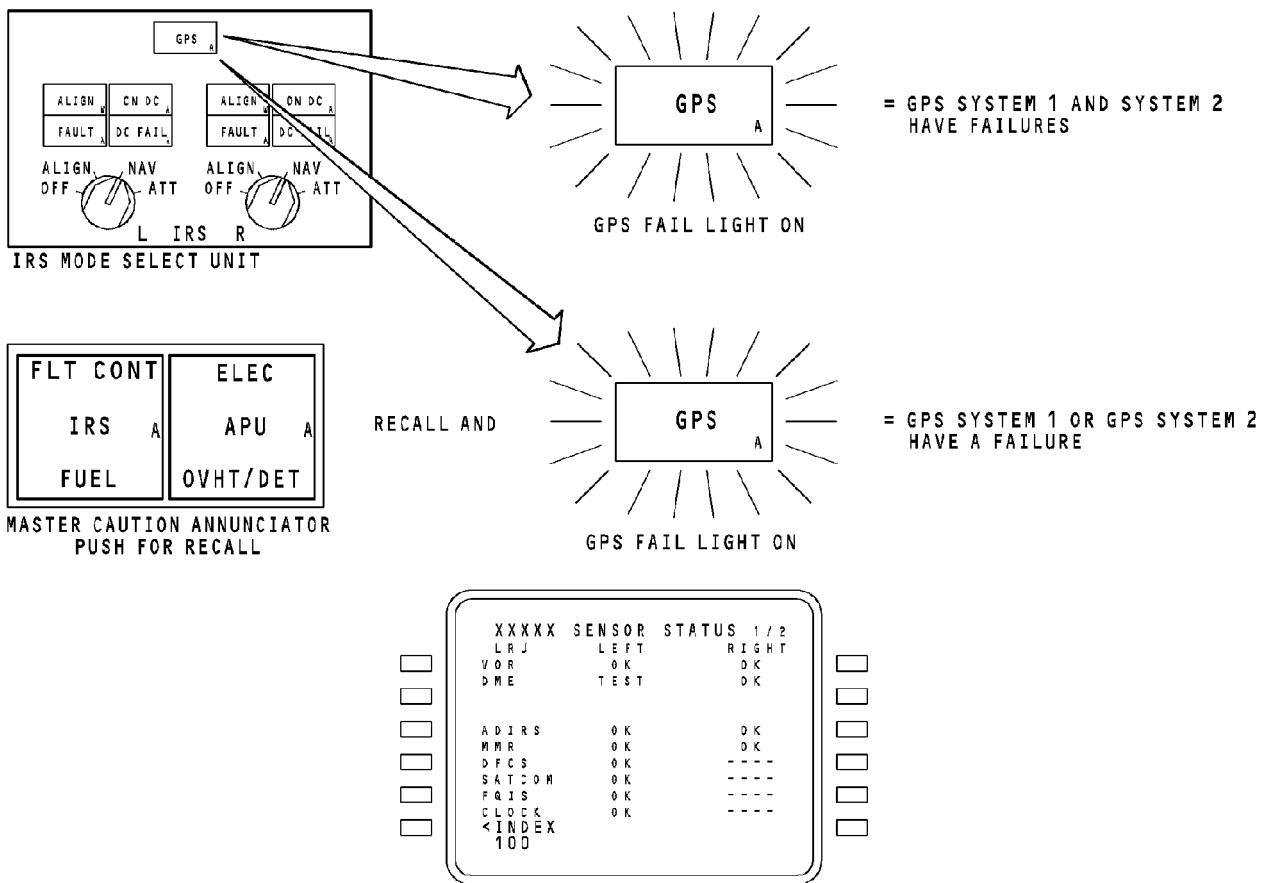

GPS - TRAINING INFORMATION POINT - 1

34-58-00-015

EFFECTIVITY
HAP ALL

34-58-00

D633A101-HAP

GPS - TRAINING INFORMATION POINT - 2**General**

These are the two pages that show GPS maintenance data:

- FMCS SENSOR STATUS page
- FMCS SENSOR DATA page.

FMCS SENSOR STATUS Page

The FMCS SENSOR STATUS page shows the status of the GPS systems. It shows OK for systems that are valid and FAIL for a GPS system that has failed.

To get access to the engineering data for the failures, type 100 in to the scratch pad and select line select key 6 right (LSK 6R).

FMCS SENSOR DATA Page

When GPS L (1) or GPS R (2) has a failure, the engineering data will show. If both GPS systems are valid, no engineering data for the GPS systems will show on this page.

This is the data that will show:

- System code
- Label code
- Fault state
- Failure time
- Monitor code.

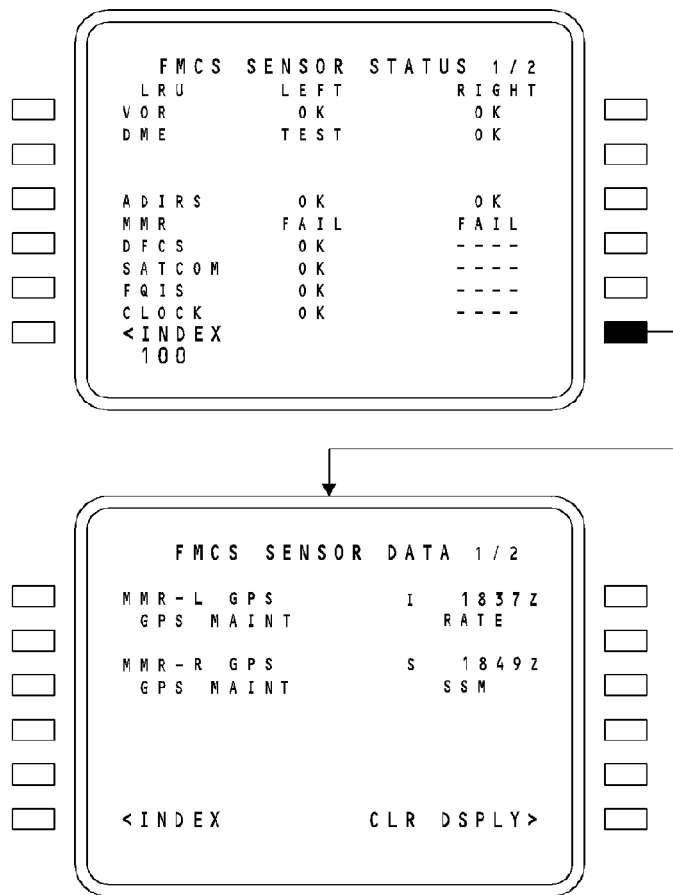

GPS - TRAINING INFORMATION POINT - 2

34-58-00-016

EFFECTIVITY
HAP 001-013, 015-026, 028-036

34-58-00

D633A101-HAP

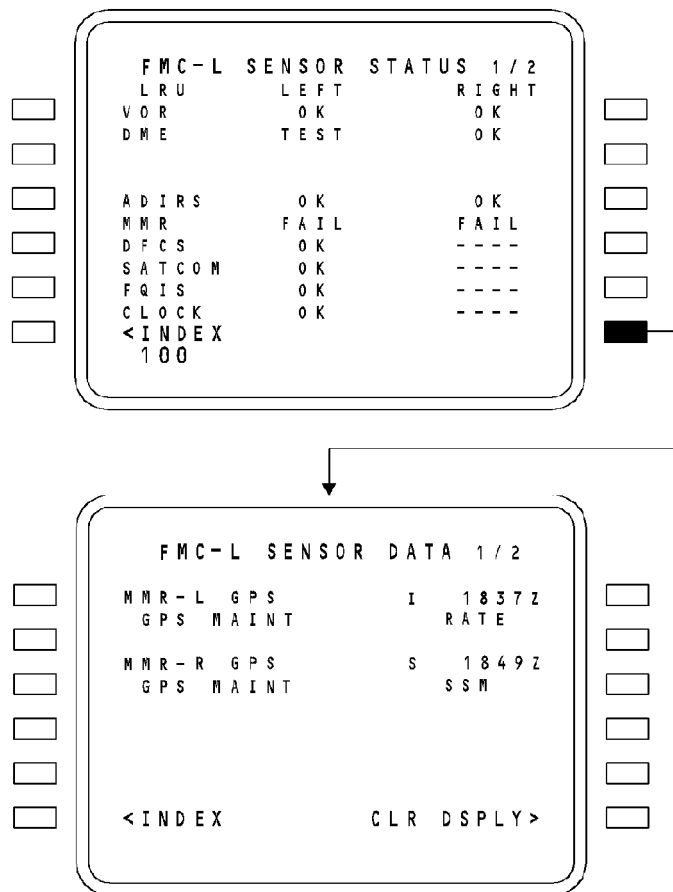

GPS - TRAINING INFORMATION POINT - 2

EFFECTIVITY
HAP 037-054, 101-999

34-58-00

D633A101-HAP

GPS - MMR BITE

HAP 037

Front Panel Self-Test

When you push the test switch, the MMR does a check of the internal operation and its interface with the GPS antenna. The test takes approximately 36 seconds. This is the test sequence that shows on the status LEDs during the test:

- 0 to 2 seconds, the LRU STATUS and the CONTROL FAIL LEDs are red
- 2 to 4 seconds, the LRU STATUS LED is green and the CONTROL FAIL LED is red
- 4 to 6 seconds, all LEDs go off
- 6 to 36 seconds, test status shows.

NOTE: The ANT FAIL LED is not used at this time.

The LRU STATUS LED shows red when there is an internal failure in the MMR. A green LED shows that the MMR is normal.

The CONTROL FAIL LED shows red when an interface to the MMR has a failure.

HAP 001-013, 015-026, 028-036, 038-054, 101-999

Front Panel Self-Test

Push one of the test switches on the front of the receiver to start a test of the multi mode receiver (MMR). The MMR then does a check of the internal receiver operation and of the interfaces. The test results show on the LCD.

When you push the test switch, the test in progress page shows and the receiver goes through a self test that lasts approximately five seconds. A five second scale shows at the bottom of the page. You can monitor the test time by the line of X's that show below the scale.

The TEST COMPLETE NO FAILURES display shows for a test pass condition. The TEST COMPLETE FAILURES display shows for a test fail condition.

These are the selections that can show above the receiver front panel switches during the test sequence:

- MAINT; this selection shows pages that contain program pin selections and discrete interface status
- RETURN; this selection causes the display to go back to the start test page
- WHY?; this selection comes on when there are failures. Push this selection to show the failures
- MORE; this selection shows any time there are more pages of data to follow.



GPS - MMR BITE

HAP 001-013, 015-026, 028-036, 038-054, 101-999 (Continued)

HAP ALL

34-58-00-018

EFFECTIVITY
HAP ALL

34-58-00

D633A101-HAP

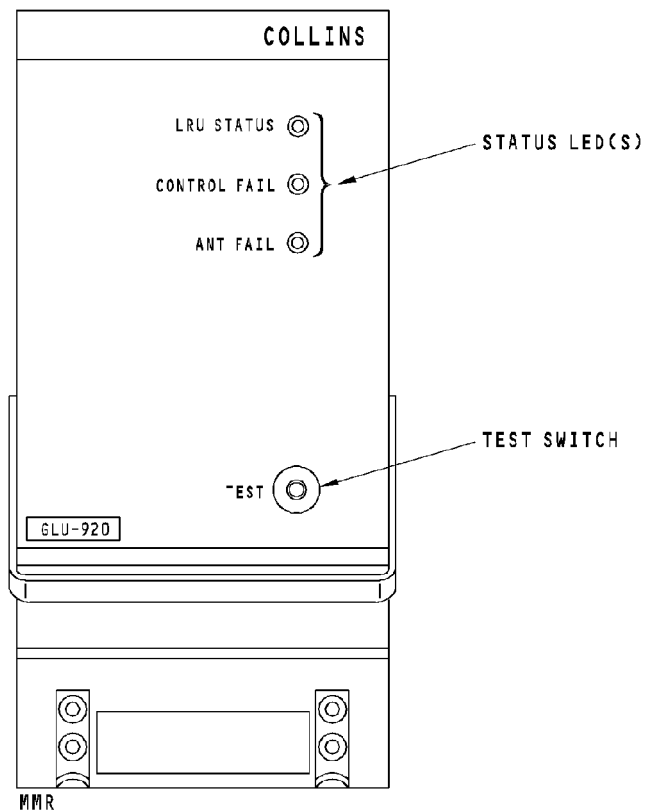

GPS - MMR BITE

EFFECTIVITY
HAP 037

34-58-00

D633A101-HAP

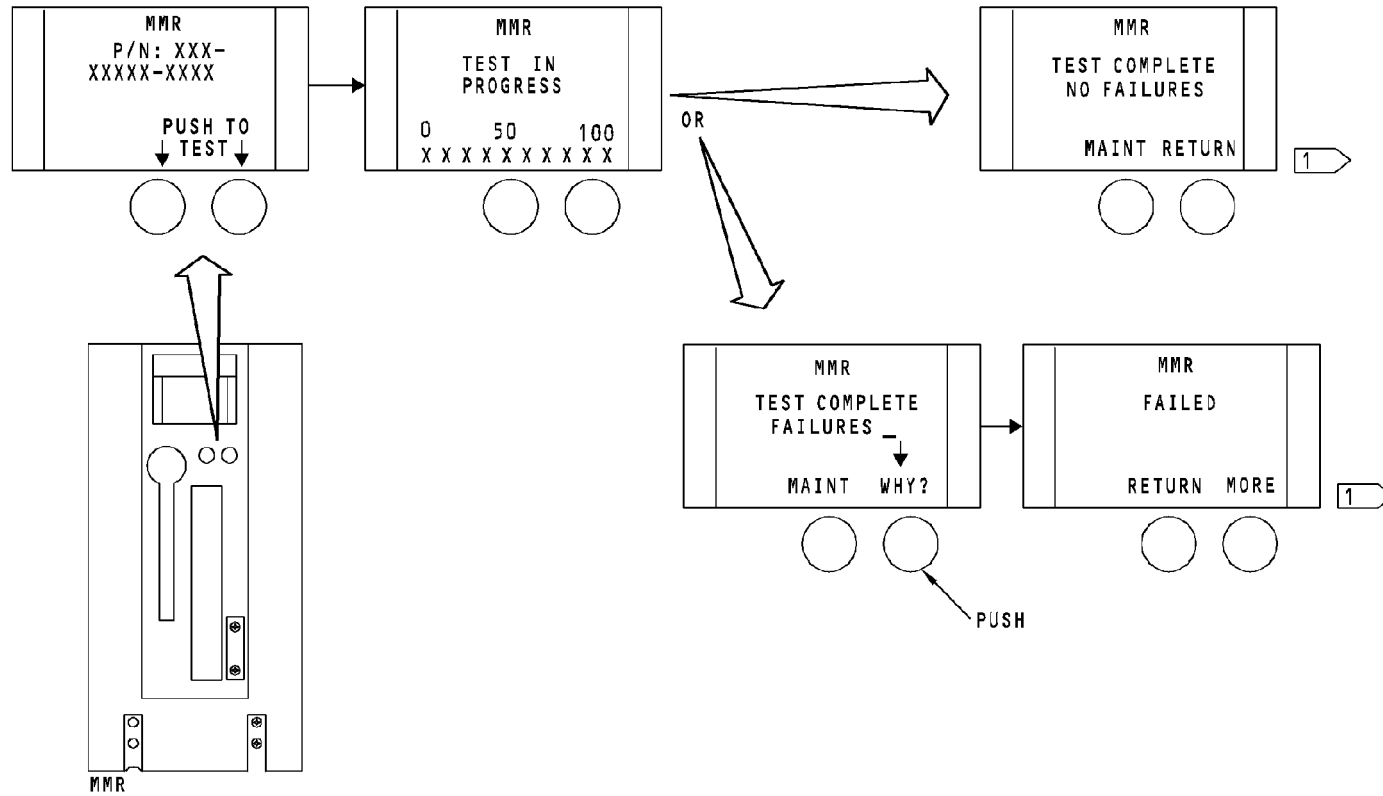

1 DISPLAY RETURNS TO NORMAL AFTER 30 SECONDS

GPS - MMR BITE

EFFECTIVITY

HAP 001-013, 015-026, 028-036, 038-054, 101-999

34-58-00

D633A101-HAP

THIS PAGE IS INTENTIONALLY LEFT BLANK

34-61-00

D633A101-HAP

Page 1
Oct 10/2002

FLIGHT MANAGEMENT COMPUTER SYSTEM - INTRODUCTION**General**

The flight crew uses the flight management computer system (FMCS) to enter route and vertical performance flight plan data for a flight.

With ACARS, the FMC can receive flight plan data from a ground station and can send flight status information to a ground station.

With the flight plan and inputs from the airplane sensors, the FMCS does these functions:

- Navigation
- Performance
- Guidance.

Navigation

A navigation data base is in the FMC memory. It includes the navigation data for the area of operation. The pilot can use the navigation data base to set the entire flight plan before a flight.

The FMC calculates the airplane position during the flight. To do the calculation, it uses the inertial reference function and the radio navigation aids, if available.

The FMC can also use the global positioning system (GPS) to calculate the airplane position.

The FMC compares the calculated position with the flight plan for LNAV control. The FMC shows the calculated position and the flight plan on the navigation display.

Performance

A performance data base in the FMC contains data to model the airplane and the engines. The flight crew puts this data in the FMC:

- Airplane gross weight
- Cruise altitude
- Cost index.

The FMC uses the data to calculate these functions:

- Economy speeds
- Best flight altitude
- Top of descent point.

The common display system (CDS) shows target speeds and altitudes.

Guidance

The FMC sends commands to the digital flight control system (DFCS) and the autothrottle (A/T). The DFCS and the A/T use these signals to control the airplane in the lateral (LNAV) and vertical (VNAV) modes of flight.

FLIGHT MANAGEMENT COMPUTER SYSTEM - INTRODUCTION

Built-In Test equipment

You use the FMCS CDU to select and control BITE for these systems:

- FMCS
- Digital flight control system (DFCS)
- Autothrottle (A/T)
- Air data inertial reference unit (ADIRU)
- Common display system (CDS)
- Electronic engine controller (EEC)
- APU engine control unit (ECU)
- Fuel quantity indication system (FQIS).

Abbreviations and Acronyms

HAP

- AA - autoflight status annunciator
- AADD - ACARS adaptable datalink database
- act - active
- AC - alternating current
- ACARS - aircraft communications addressing and reporting system
- ACMS - airplane conditioning monitoring system
- ADIRU - air data inertial reference unit
- ADIRS - air data inertial reference system
- ADL - airborne data loader
- alt - altitude
- appr - approach
- APU - auxiliary power unit
- ARINC - aeronautical radio incorporated
- arr - arrival
- ASA - autoflight status annunciator
- ASIC - application specific integrated circuit

- A/S - airspeed
- A/T - autothrottle
- ATA - actual time of arrival
- ATC - air traffic control
- BIT - built in test
- BITE - built in test equipment
- brg - bearing
- C - celsius
- calc - calculate
- CAS - computed airspeed
- CAPT - captain
- CDS - common display system
- CDU - control display unit
- clb - climb
- clr - clear
- CO - company
- CON - continuous
- cmd - command
- chng - change
- comp - complete
- crs - course
- crz - cruise
- ctr - center
- DC - direct current
- del - delete
- dep - departure
- des - descent
- dest - destination
- DEU - display electronic unit
- dev - deviation
- DFDAU - digital flight data acquisition unit
- DFCS - digital flight control system

34-61-00-001

<p>EFFECTIVITY HAP ALL</p>

34-61-00

D633A101-HAP

FLIGHT MANAGEMENT COMPUTER SYSTEM - INTRODUCTION

- DIR - direct
- dist - distance
- dspl - display
- DTG - distance-to-go
- DME - distance measuring equipment
- E - east
- E/O - engine out
- econ - economy
- ECU - engine control unit
- E/D - end of descent
- EEC - electronic engine control
- EEPROM - electrically erasable programmable read only memory
- ELEX - electronics

HAP 031-054, 101-999

- ELT - emergency locator transmitter

HAP ALL

- eng - engine
- ENG - engaged
- ETA - estimated time of arrival
- EXEC - execute
- F - fahrenheit
- FANS - future air navigation system
- FF - fuel flow
- FL - flight level
- FDAU - flight data acquisition unit
- F/O - first officer
- flt - flight
- FMA - flight mode annunciation
- FMC - flight management computer
- FMCS - flight management computer system
- FPA - flight path angle
- FQIS - fuel quantity indicating system

- FQPU - fuel quantity processor unit
- fwd - forward
- G - ground
- G/A - go-around
- GMT - Greenwich mean time
- GPS - global positioning system
- GPWC - ground proximity warning computer
- GRWT - gross weight
- GS - ground speed
- HF - high frequency
- hdg - heading
- hrdw - hardware
- ident - identification
- IFSAU - integrated flight system accessory unit
- ILS - instrument landing system
- inbd - inboard
- info - information
- INIT/REF - initialization/reference
- INTC - intercept
- ISA - international standard atmosphere
- ISB - intersystem bus
- KTS - nautical miles per hour (knots)
- L - left
- lat - latitude
- LED - light emitting diode
- lim - limit
- LNAV - lateral navigation
- long - longitude
- LVL CHG - level change
- MAINT - maintenance
- MASI - mach airspeed indicator
- max - maximum

EFFECTIVITY

HAP ALL

34-61-00

D633A101-HAP

Page 4
Feb 15/2009

FLIGHT MANAGEMENT COMPUTER SYSTEM - INTRODUCTION

HAP 001-005

- MCDU - multi-purpose control display unit

HAP ALL

- MCP - mode control panel
- MEDB - model/engine data base
- MMR - multi mode receiver
- mod - modification
- msg - message
- M - meters
- N - north
- nav - navigation
- NAV RAD - navigation radio
- NDB - navigation database
- NM - nautical miles
- NV - non volatile
- OAT - outside air temperature
- OFP - operational flight program
- OFST - offset
- OFP - operational flight program
- OPS - operational program software
- PDB - performance data base
- PDDDB - performance default data base
- PDL - portable data loader
- perf - performance
- pln - plan
- pos - position
- PPOS - present position
- pred - predicted
- preflit - preflight
- proc - procedure
- prof - profile
- PROG - progress

- PSEU - proximity switch electronics unit
- PTH - path
- QFE - altimeter setting to show altitude above reference airfield
- QNH - altimeter setting to show altitude above mean sea level
- QUAD - quadrant
- qty - quantity
- R - right
- rad - radio
- RAM - random access memory
- RDY - ready
- REC - recorder
- ref - reference
- RTA - required time of arrival
- rte - route
- R/W - read/write
- rwy - runway
- S - south
- S/C - step climb
- SAT - static air temperature
- sel - selector
- SID - standard instrument departure
- SMYD - stall management yaw damper
- SPD - speed
- SRAM - scratch random access memory
- STAR - standard terminal arrival route
- SW - software
- TACAN - tactical air navigation
- TAS - true airspeed
- TAT - total air temperature
- T/C - top of climb
- T/D - top of descent

34-61-00-001

<p>EFFECTIVITY</p> <p>HAP ALL</p>

34-61-00

D633A101-HAP

FLIGHT MANAGEMENT COMPUTER SYSTEM - INTRODUCTION

- tgt - target
- thr - thrust
- thr ref - thrust reference
- TO/GA - takeoff/go-around
- trans - transition
- trk - track
- UTC - universal time (coordinated)
- V1 - takeoff decision speed
- V2 - climbout speed
- v - volt
- V - volt
- VNAV - vertical navigation
- VR - rotation speed
- VREF - reference speed
- V/S - vertical speed
- VTK - vertical track
- W - west
- wpt - waypoint
- wt - weight
- XFR - transfer
- XTK - cross track
- Z - zulu
- ZFW - zero fuel weight

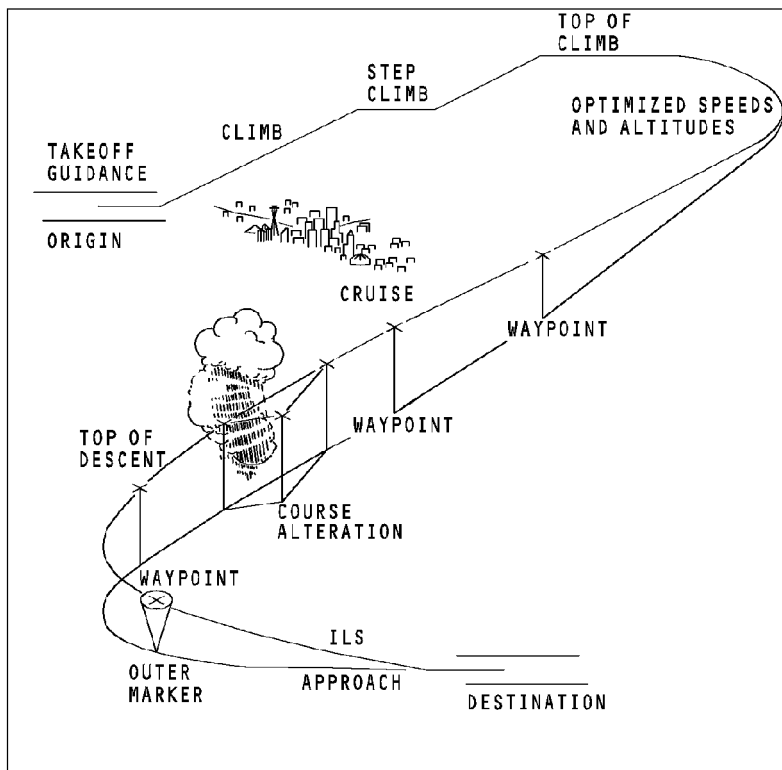
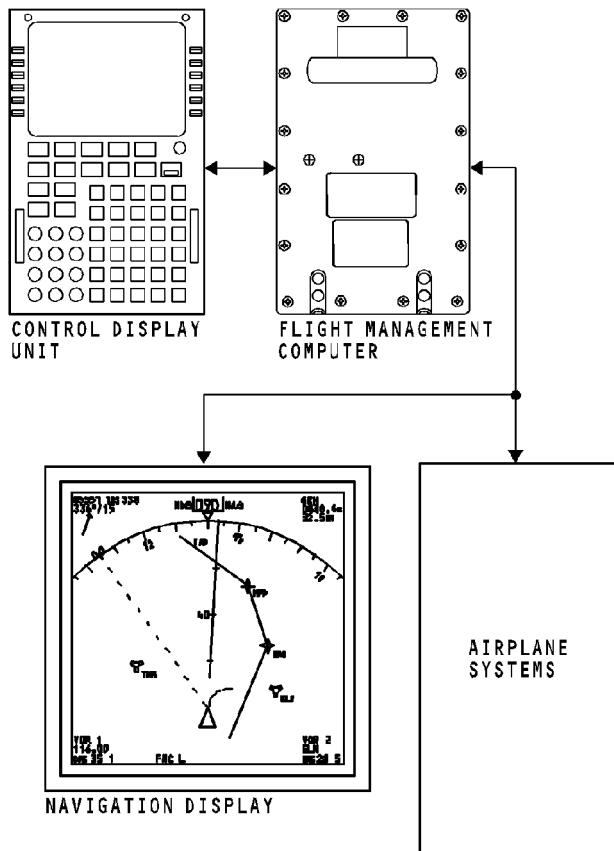

FLIGHT MANAGEMENT COMPUTER SYSTEM - INTRODUCTION

34-61-00-001

EFFECTIVITY
HAP ALL

34-61-00

D633A101-HAP

Page 7
Feb 10/2003

FMCS - GENERAL DESCRIPTION**General**

The flight management computer system (FMCS) reduces flight crew workload with automatic control of the airplane navigation, performance and guidance functions. It also gives access to the BITE functions of other systems.

HAP 001-013, 015-026, 028-036

The main components of the FMCS are the flight management computer (FMC) which does all the FMCS calculations and two multi-purpose control display units (MCDU) which provide the interface between the system and the flight crew.

HAP 037-054, 101-999

The main components of the FMCS are two flight management computers (FMC) which do all the FMCS calculations and two multi-purpose control display units (CDU) which provide the interface between the system and the flight crew.

HAP ALL

The FMCs receive data from other airplane systems to calculate navigation and performance data. This data shows on the common display system (CDS) for use by the flight crew.

The navigation and performance functions also go to the digital flight control system (DFCS) and the autothrottle (A/T) to provide automatic control of the airplane flight path in both the vertical (VNAV) and lateral (LNAV) modes. This is the guidance function of the FMC.

FMC display data goes directly to CDS and present position data goes directly to the air data inertial reference units (ADIRU). The ADIRUs use present position during the alignment.

All other data goes through two transfer relays to the user systems.

The FMC input and output data format is ARINC 429 digital data and analog discretes.

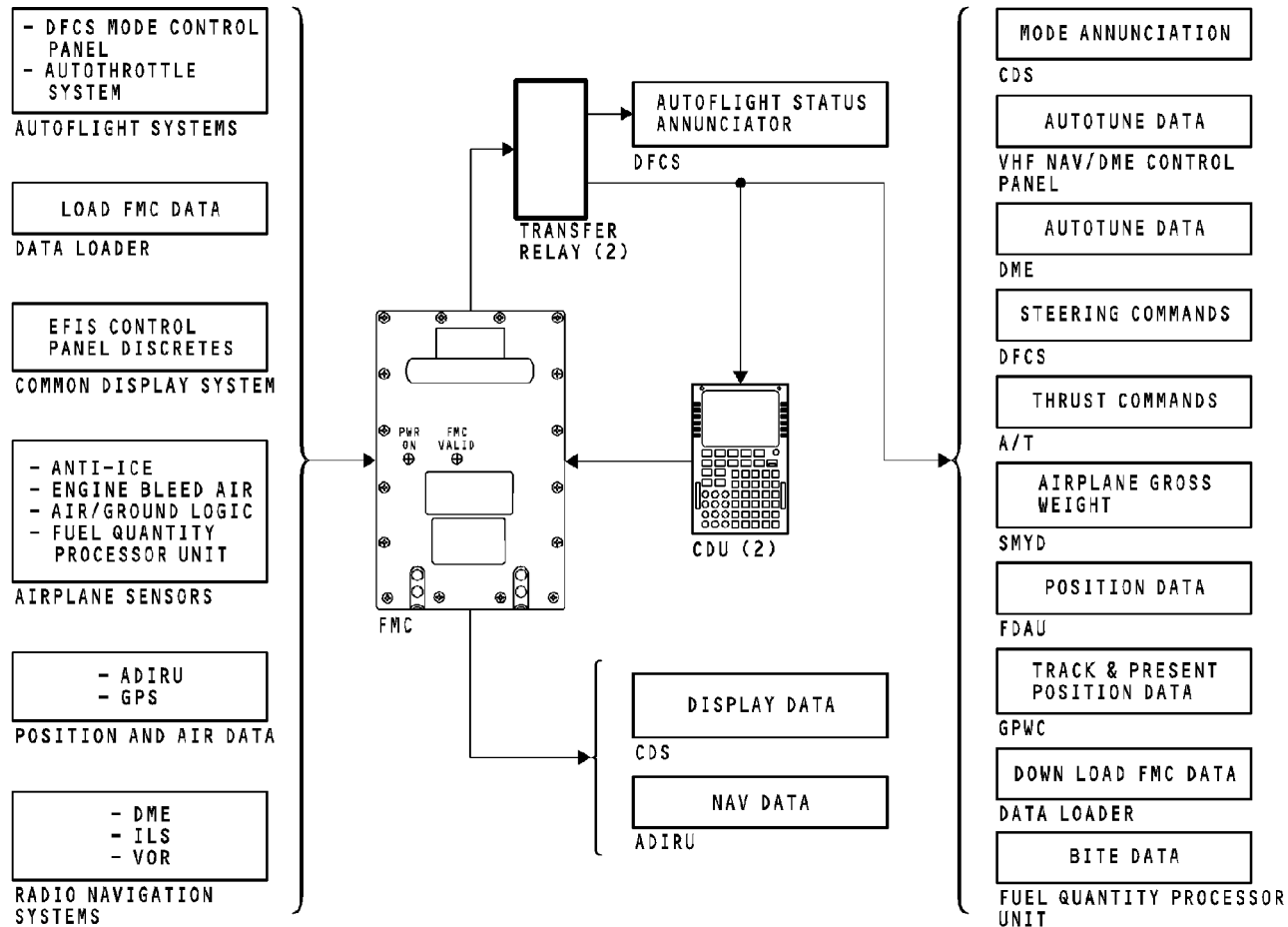

FMCS - GENERAL DESCRIPTION

34-61-00-002

EFFECTIVITY
HAP 031-036

34-61-00

D633A101-HAP

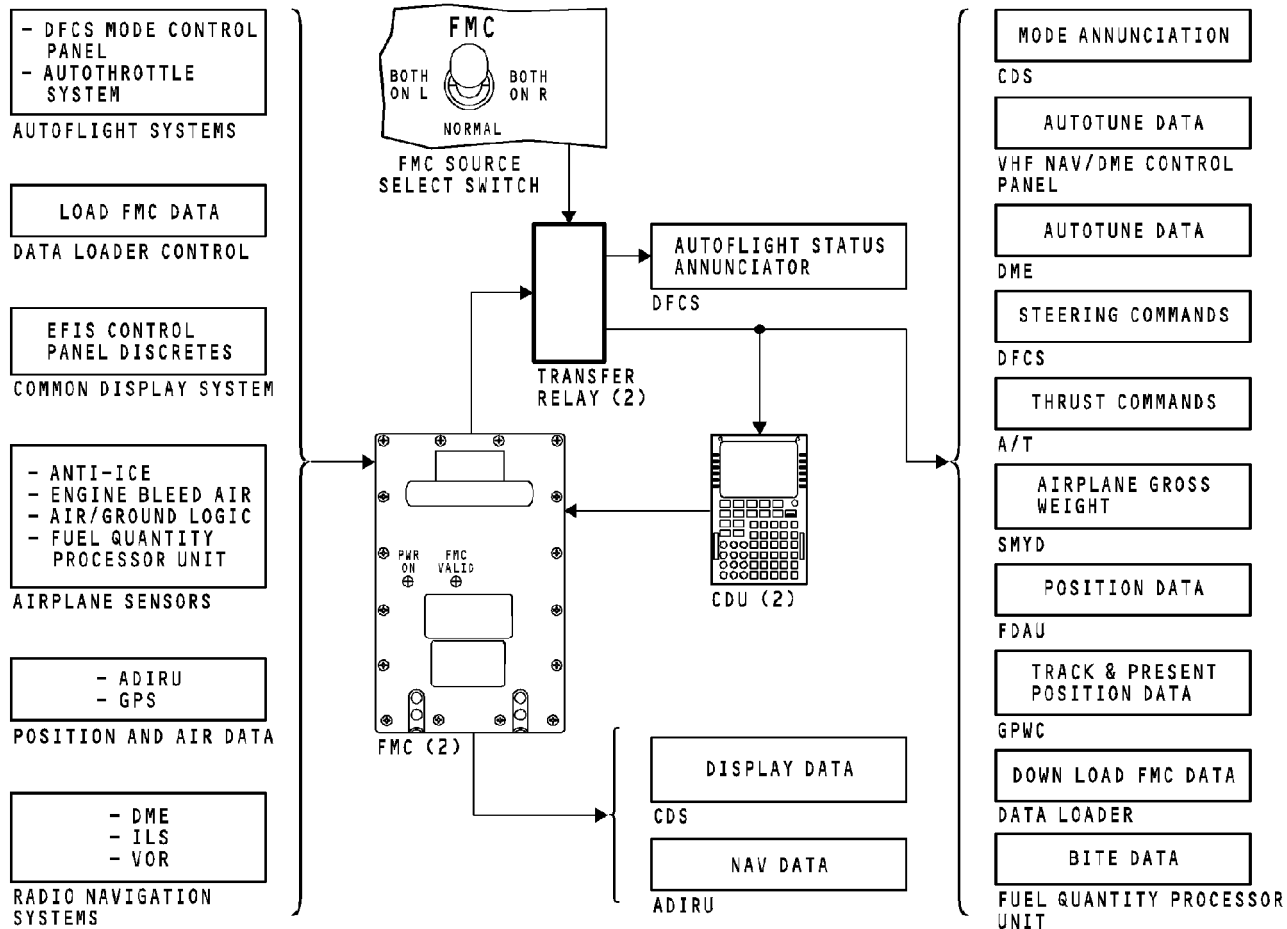

FMCS - GENERAL DESCRIPTION

EFFECTIVITY

HAP 037-054, 101-999

34-61-00

D633A101-HAP

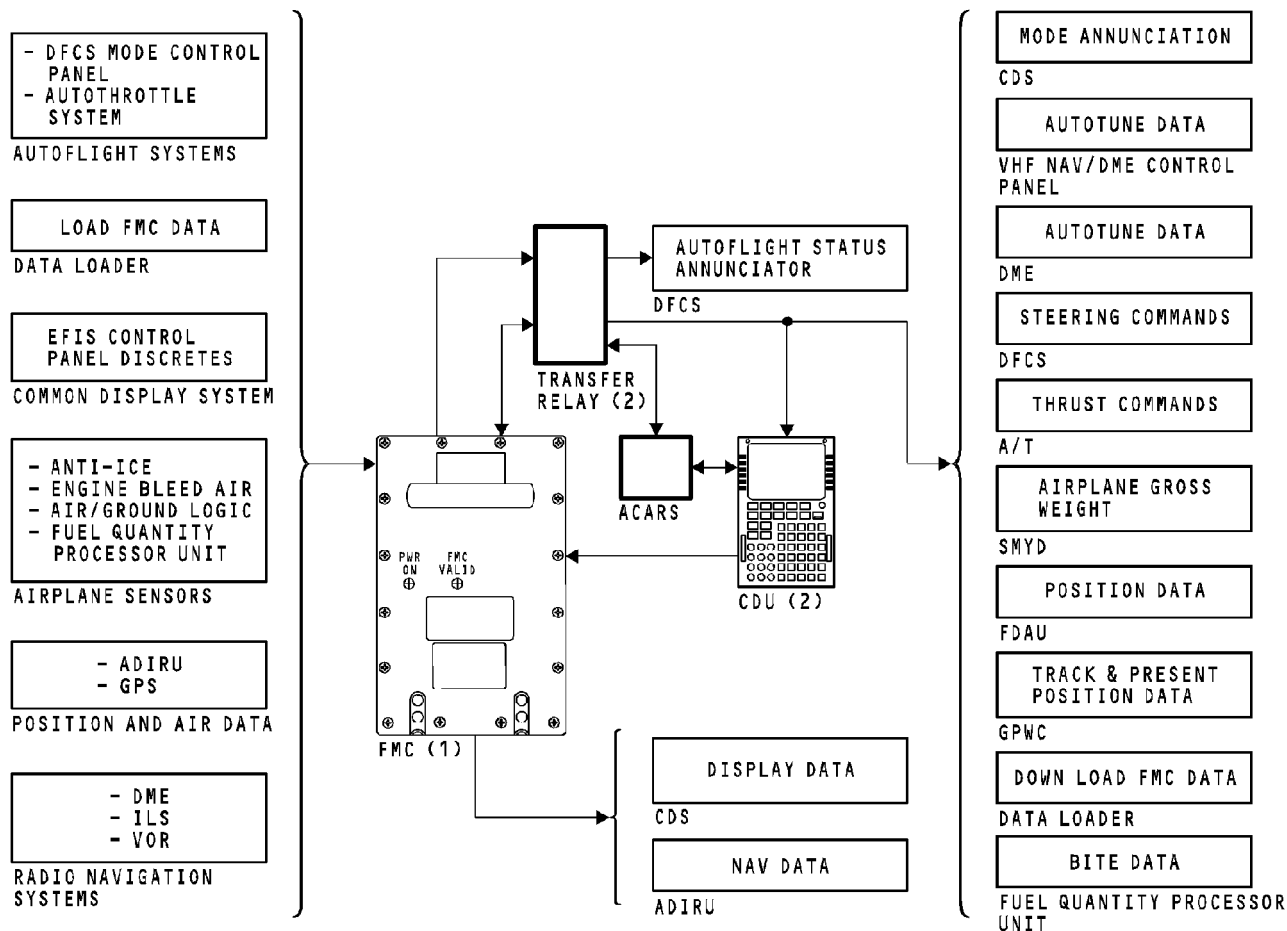

FMCS - GENERAL DESCRIPTION

34-61-00-002

EFFECTIVITY
HAP 001-013, 015-026, 028-030

34-61-00

D633A101-HAP

Page 11
Jun 10/2007

FMCS - FLIGHT COMPARTMENT COMPONENT LOCATIONS**FMCS Component Locations - P9 Forward Electronics Panel**

These are the FMCS components on the P9 forward electronics panel:

- MCDU 1
- MCDU 2.

FMCS Component Locations - P61 Panel

These are the FMCS components on the P61 panel:

- Data transfer unit receptacle
- Data loader control panel.

FMCS Component Locations - P18 Panel

The BITE printer receptacle is on the P18 panel. When a portable printer is connected to this receptacle, you can print CDU and FMC data.

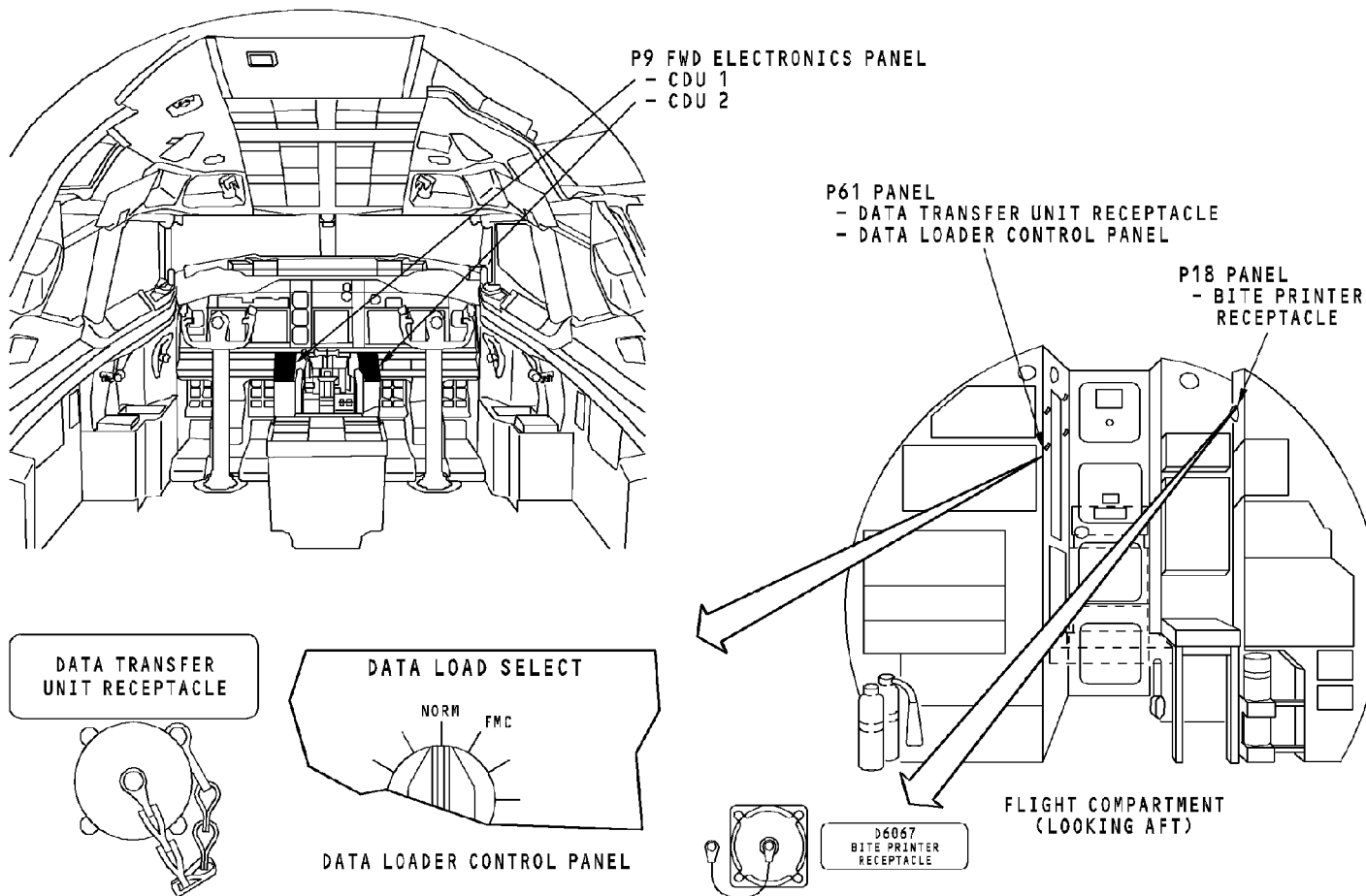

FMCS - FLIGHT COMPARTMENT COMPONENT LOCATIONS

34-61-00-003

EFFECTIVITY
HAP 001-011 PRE SB 737-31-1136

34-61-00

D633A101-HAP

FMCS - FLIGHT COMPARTMENT COMPONENT LOCATION**P9 Forward Electronics Panel**

These are the FMCS components on the P9 forward electronics panel:

- CDU 1
- CDU 2.

HAP 037-054, 101-999**P5 FWD Overhead Panel**

The FMC source select switch is on the P5-28 forward overhead panel.

HAP 031-036**P5 FWD Overhead Panel**

The FMC source select switch is on the P5 forward overhead panel. The switch does not function for the single FMC configuration.

HAP 012, 013, 015-026, 028-054, 101-999; HAP 001-011 POST SB 737-31-1136

P61 Panel

These are the FMCS components on the P61 panel:

HAP 031-054, 101-999

- Airborne data loader

HAP 012, 013, 015-026, 028-030; HAP 001-011 POST SB 737-31-1136

- Data transfer unit receptacle

HAP 012, 013, 015-026, 028-054, 101-999; HAP 001-011 POST SB 737-31-1136

- Data loader control panel.

P18 Panel

The BITE printer receptacle is on the P18 panel. When a portable printer is connected to this receptacle, you can print CDU and FMC data.

EFFECTIVITY

HAP 012, 013, 015-026, 028-054, 101-999; HAP 001-011 POST SB 737-31-1136

34-61-00

D633A101-HAP

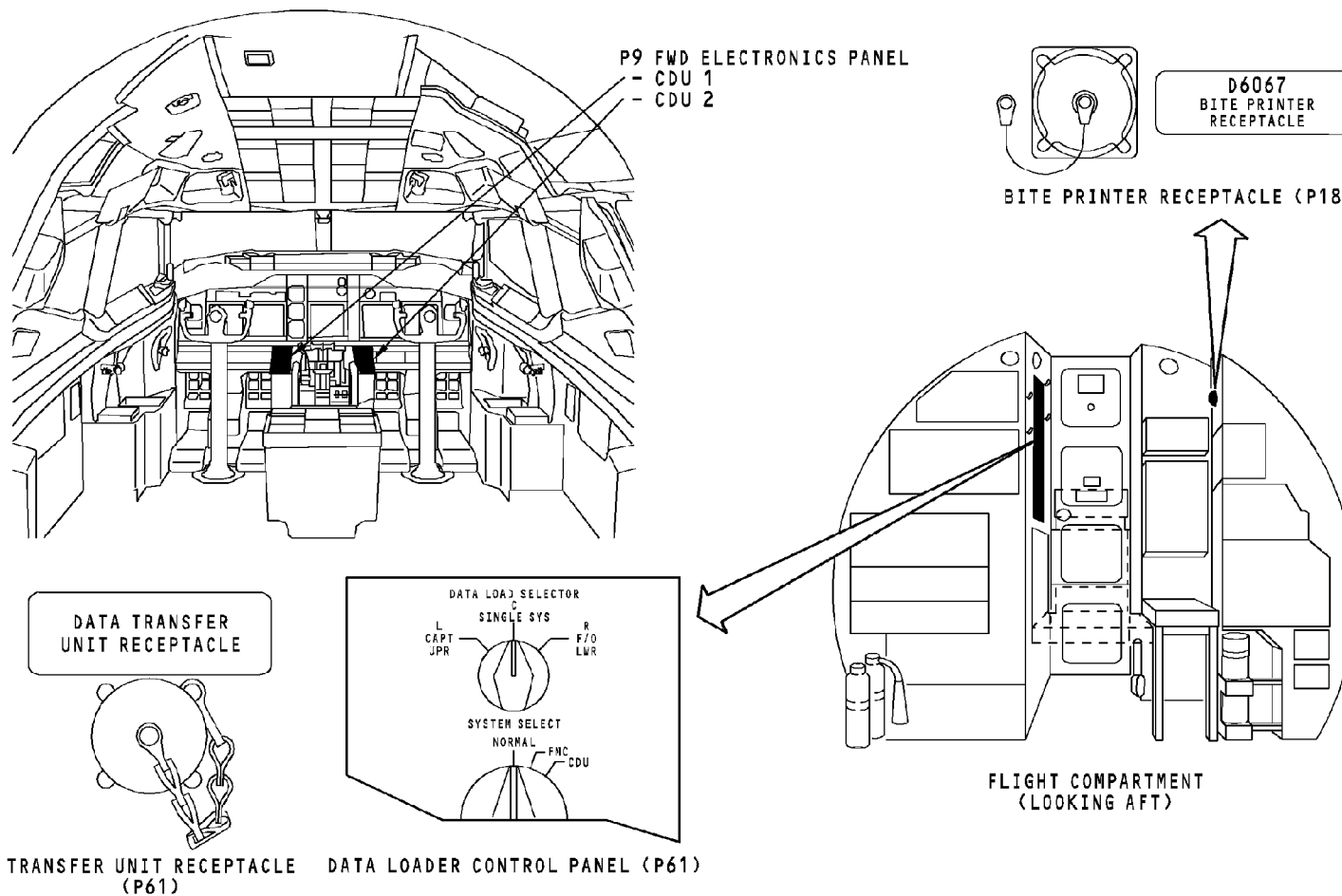

FMCS - FLIGHT COMPARTMENT COMPONENT LOCATION

EFFECTIVITY

HAP 012, 013, 015-026, 028-030; HAP 001-011 POST SB 737-31-1136

34-61-00

D633A101-HAP

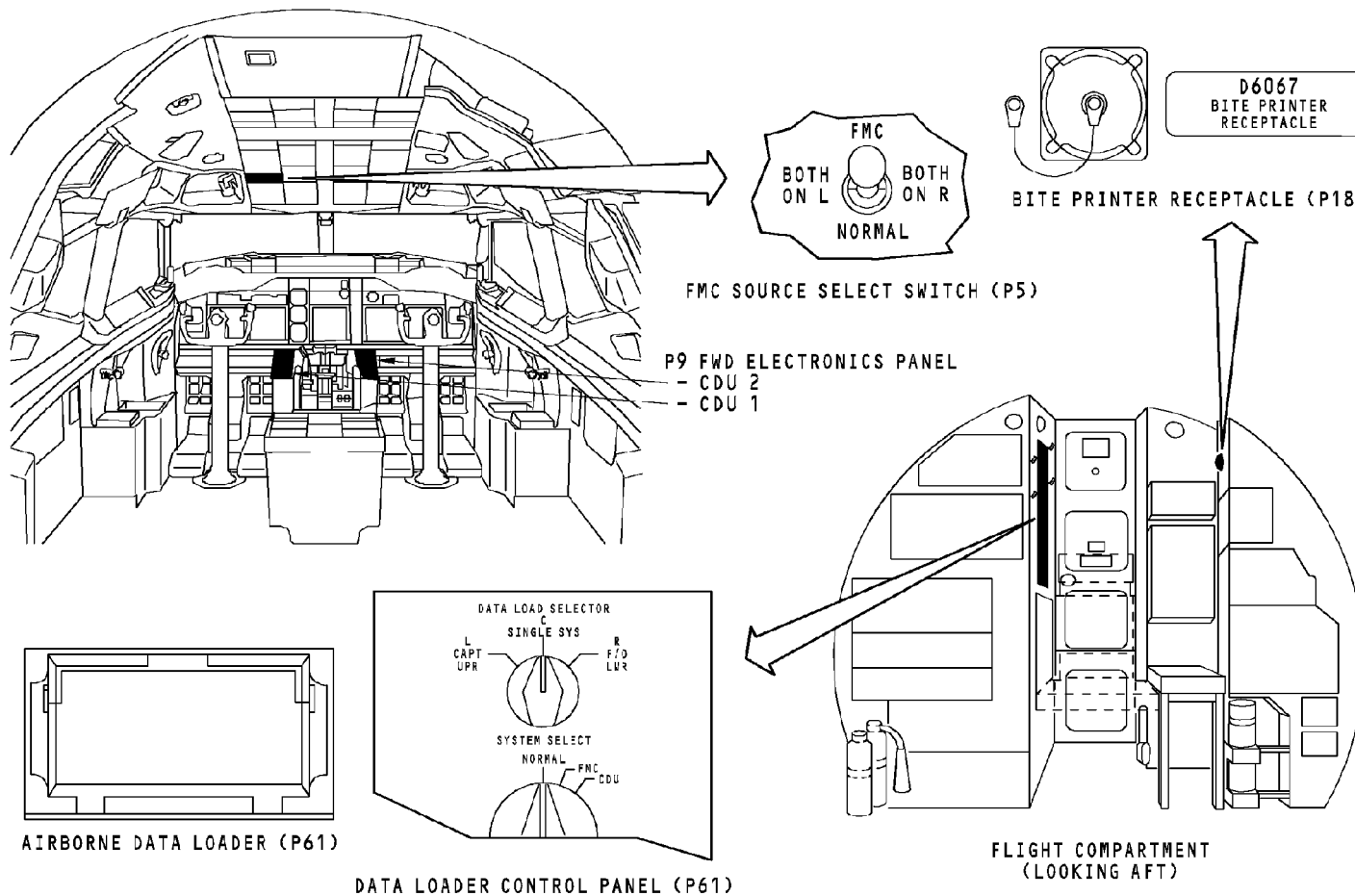

FMCS - FLIGHT COMPARTMENT COMPONENT LOCATION

EFFECTIVITY
HAP 037-054, 101-999

34-61-00

D633A101-HAP

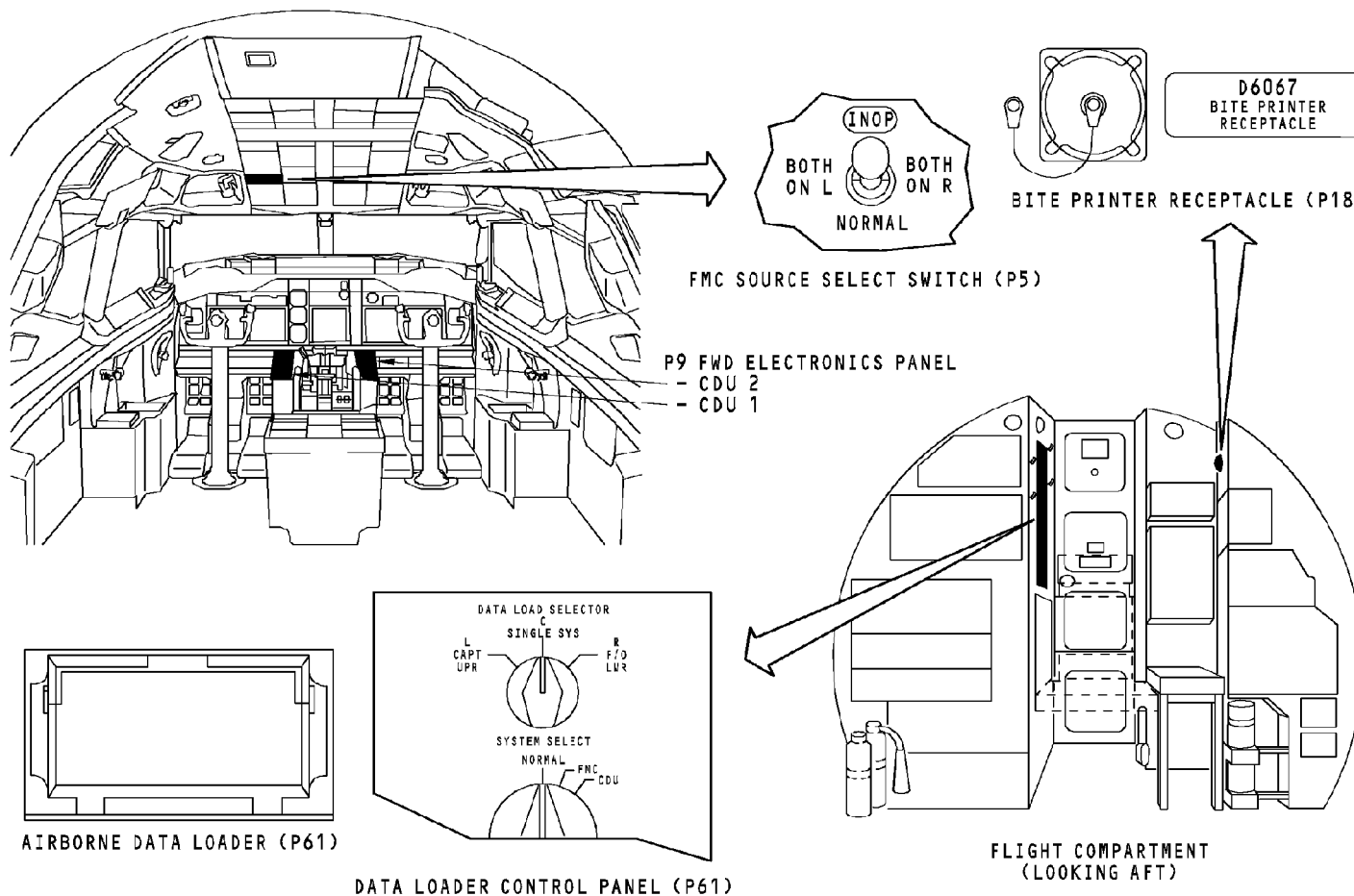

FMCS - FLIGHT COMPARTMENT COMPONENT LOCATION

34-61-00-093

EFFECTIVITY
 HAP 031-036

34-61-00

D633A101-HAP

Page 17
 Jun 10/2007

FMCS - ELECTRONIC EQUIPMENT COMPARTMENT LOCATIONS

FMCS - Component Location - Electronic Equipment Shelf

These are the FMCS components on the E5-2 shelf:

- FMC 1

HAP 037-054, 101-999

- FMC 2

HAP ALL

- Portable CDU receptacle
- FMCS program switch modules
- FMCS transfer relay 1
- FMCS transfer relay 2.

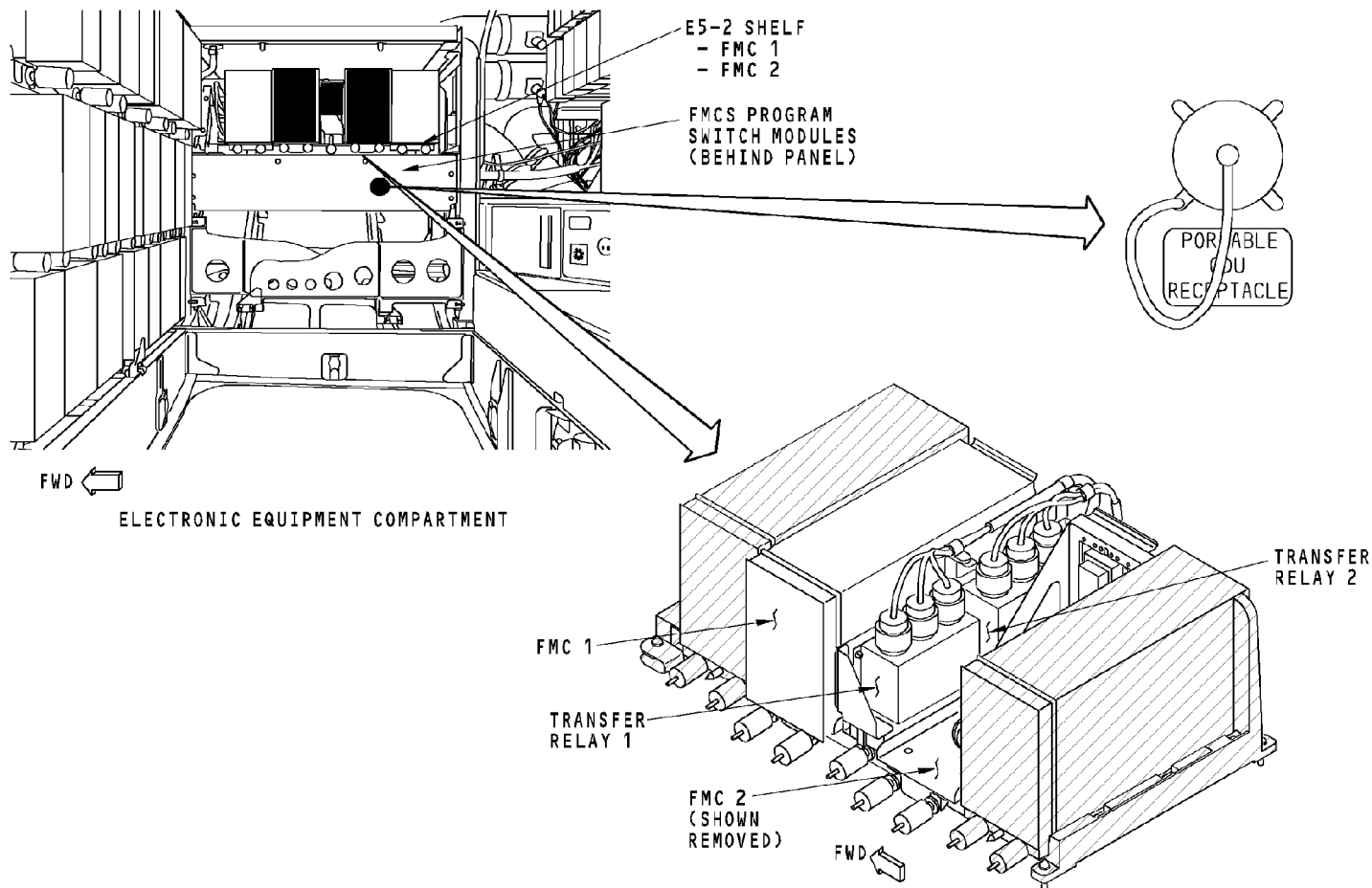

FMCS - ELECTRONIC EQUIPMENT COMPARTMENT LOCATIONS

34-61-00-004

EFFECTIVITY
HAP 037-054, 101-999

34-61-00

D633A101-HAP

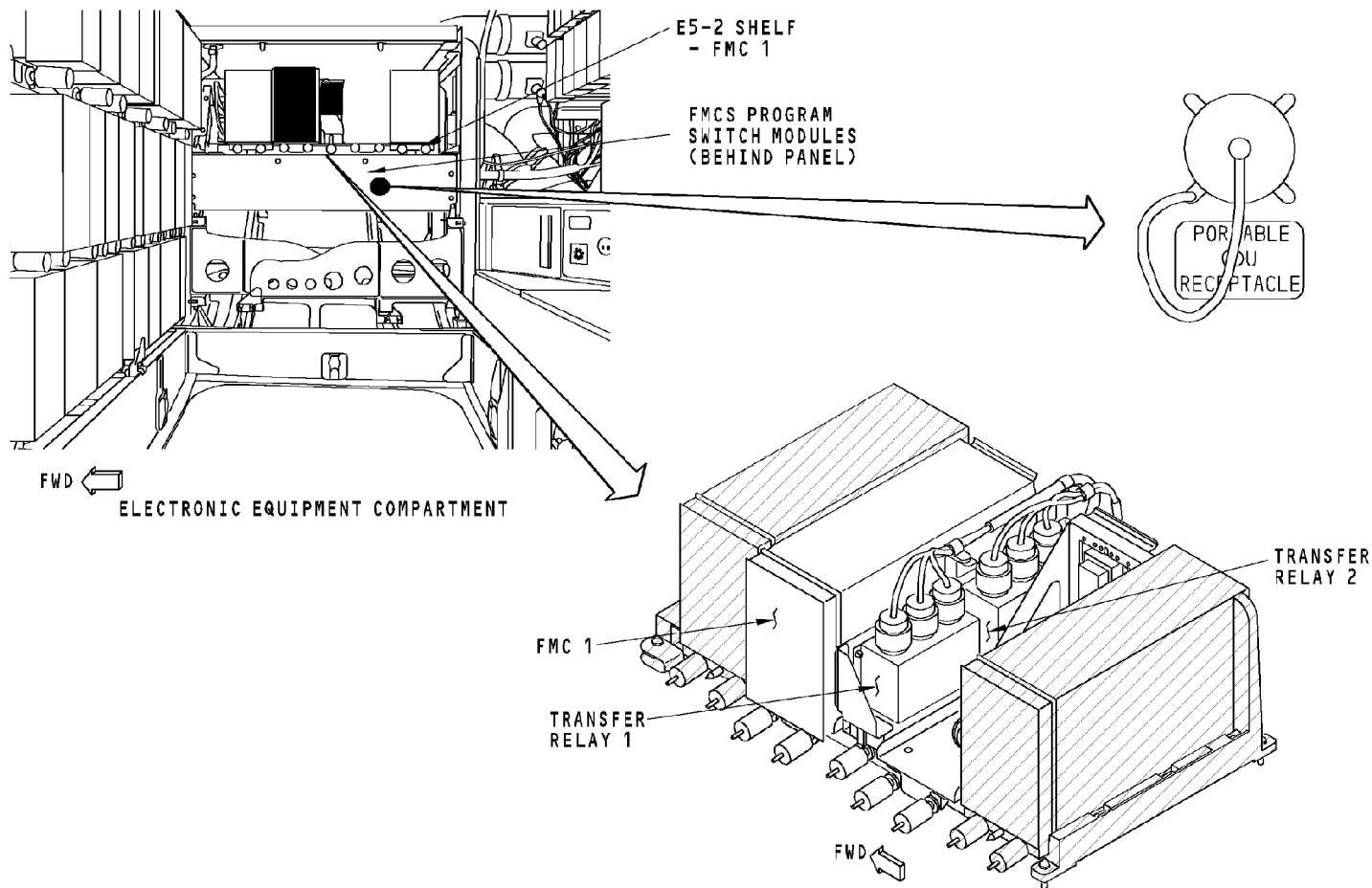

FMCS - ELECTRONIC EQUIPMENT COMPARTMENT LOCATIONS

EFFECTIVITY

HAP 001-013, 015-026, 028-036

34-61-00

34-61-00-004

D633A101-HAP

THIS PAGE IS INTENTIONALLY LEFT BLANK

34-61-00

D633A101-HAP

Page 21
Jun 10/2006



FMCS - FMC AND CDU POWER INTERFACE

General

The FMC and CDU primary power is 115v ac from the AC standby bus and AC transfer bus 2.

34-61-00-005

EFFECTIVITY
HAP ALL

34-61-00

D633A101-HAP

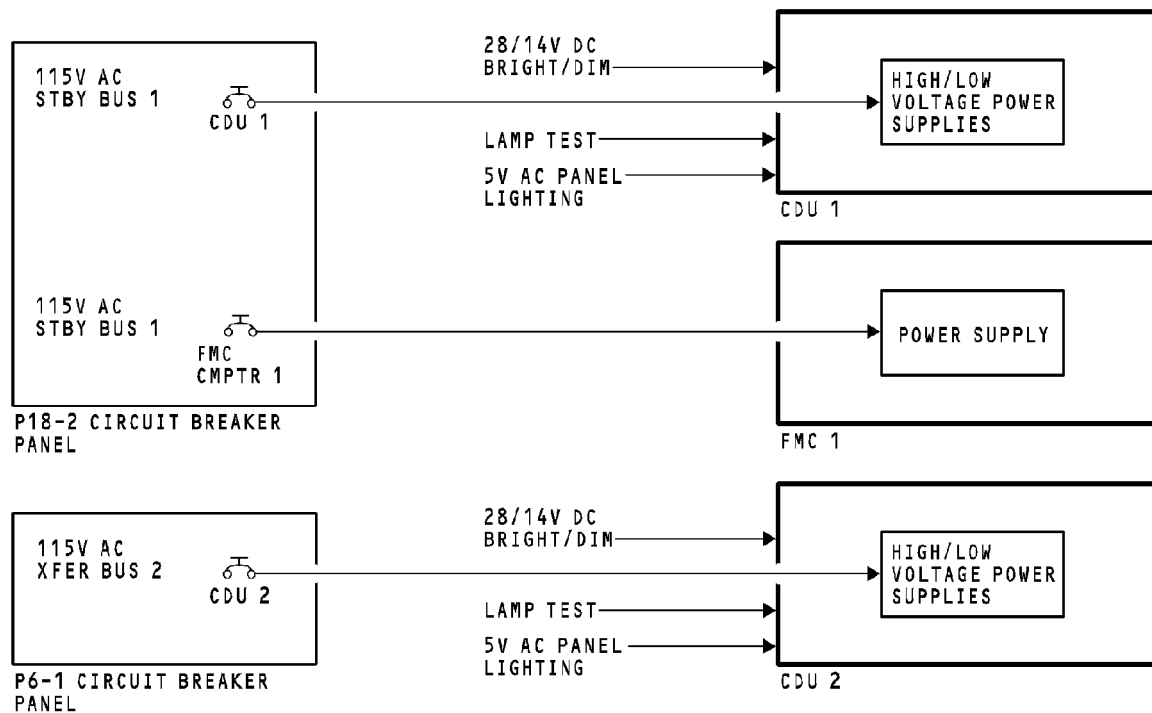

FMCS - FMC AND CDU POWER INTERFACE

34-61-00-005

EFFECTIVITY
HAP 001-013, 015-026, 028-036

34-61-00

D633A101-HAP

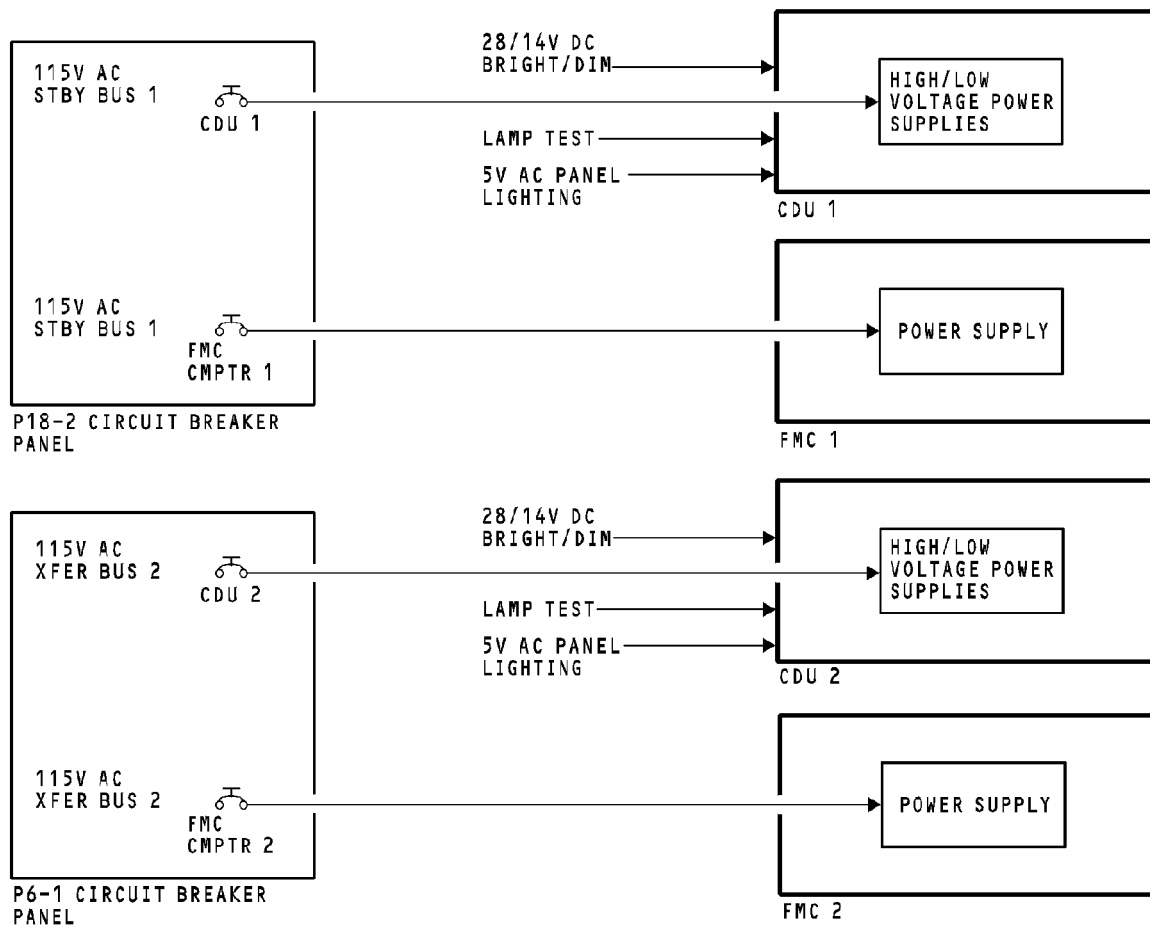

FMCS - FMC AND CDU POWER INTERFACE

EFFECTIVITY
HAP 037-054, 101-999

34-61-00

D633A101-HAP

FMCS - TRANSFER RELAY POWER INTERFACE**HAP 001-013, 015-026, 028-036****General**

The transfer relays are Ledex type relays. The relays are mechanically latched to the FMC 1 position.

HAP 037-054, 101-999**General**

The transfer relays are Ledex type relays. They mechanically latch to the position you select.

The FMCS source select switch controls the FMCS transfer relays. These are the switch positions:

- NORMAL
- BOTH ON L (both on left FMC)
- BOTH ON R (both on right FMC).

HAP 001-013, 015-026, 028-036**Operation**

The open input to the DEUs and DFDAU cause these systems to select FMC 1 for data.

The open input to the source select bits of FMC 1 tell the FMC that there is only one FMC installed.

HAP 037-054, 101-999**Operation**

The transfer relay power is 28v dc from electronics bus 2. The FMC source select switch controls the dc power to the transfer relays.

With the FMC source select switch in the NORMAL position, both transfer relays go to the normal position and mechanically latch in that position.

When the FMC source select switch is set to the BOTH ON R position, 28v dc goes from the source select switch, through a contact on transfer relay 2, to relay 1 coil winding. Relay 1 moves to the BOTH ON R position and mechanically latches to that position. Relay 2 does not change because the BOTH ON R and NORMAL positions are the same.

When the FMC source select switch is set to the BOTH ON L position, 28v dc goes from the source select switch, to the coil on relay 1. Relay one latches in the BOTH ON L/NORMAL position. The FMC source select switch then sends 28v dc through a contact on transfer relay 1 to the relay 2 coil winding. Relay 2 moves to the BOTH ON L position and mechanically latches to that position.

FMCS - TRANSFER RELAY POWER INTERFACE**HAP 037-054, 101-999 (Continued)**

Other contacts on the transfer relays supply the necessary logic to tell these LRUs the position of the transfer relays:

- DEU (1&2)
- FDAU
- FMC (1&2).

HAP ALL**Training Information Point**

You use the FMCS BITE on the ANALOG DISCRETES page 3/4 to do a check of the FMC source selection.

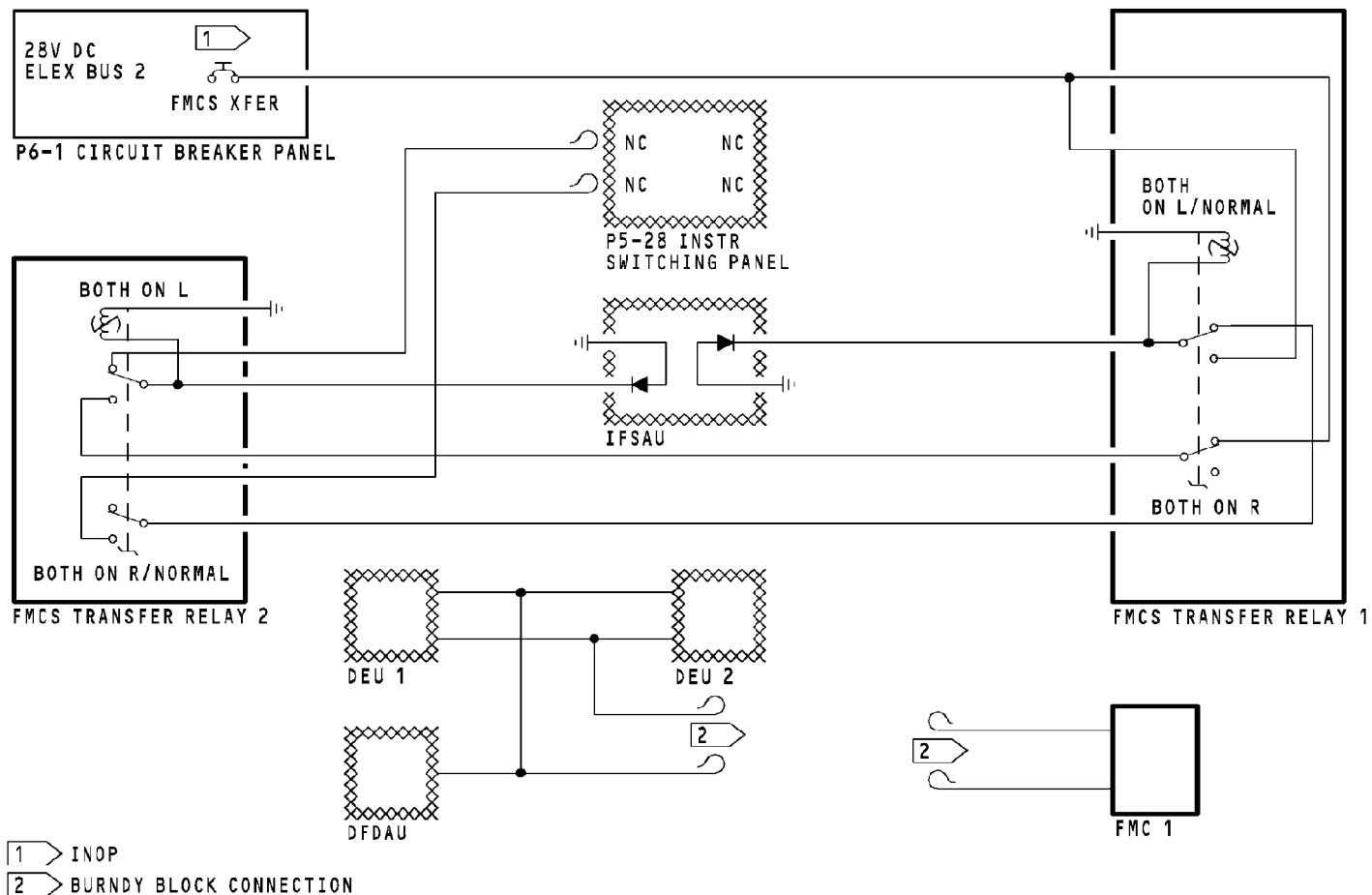

FMCS - TRANSFER RELAY POWER INTERFACE

EFFECTIVITY

HAP 001-013, 015-026, 028-036

34-61-00

D633A101-HAP

Page 27
Jun 10/2007

34-61-00-006

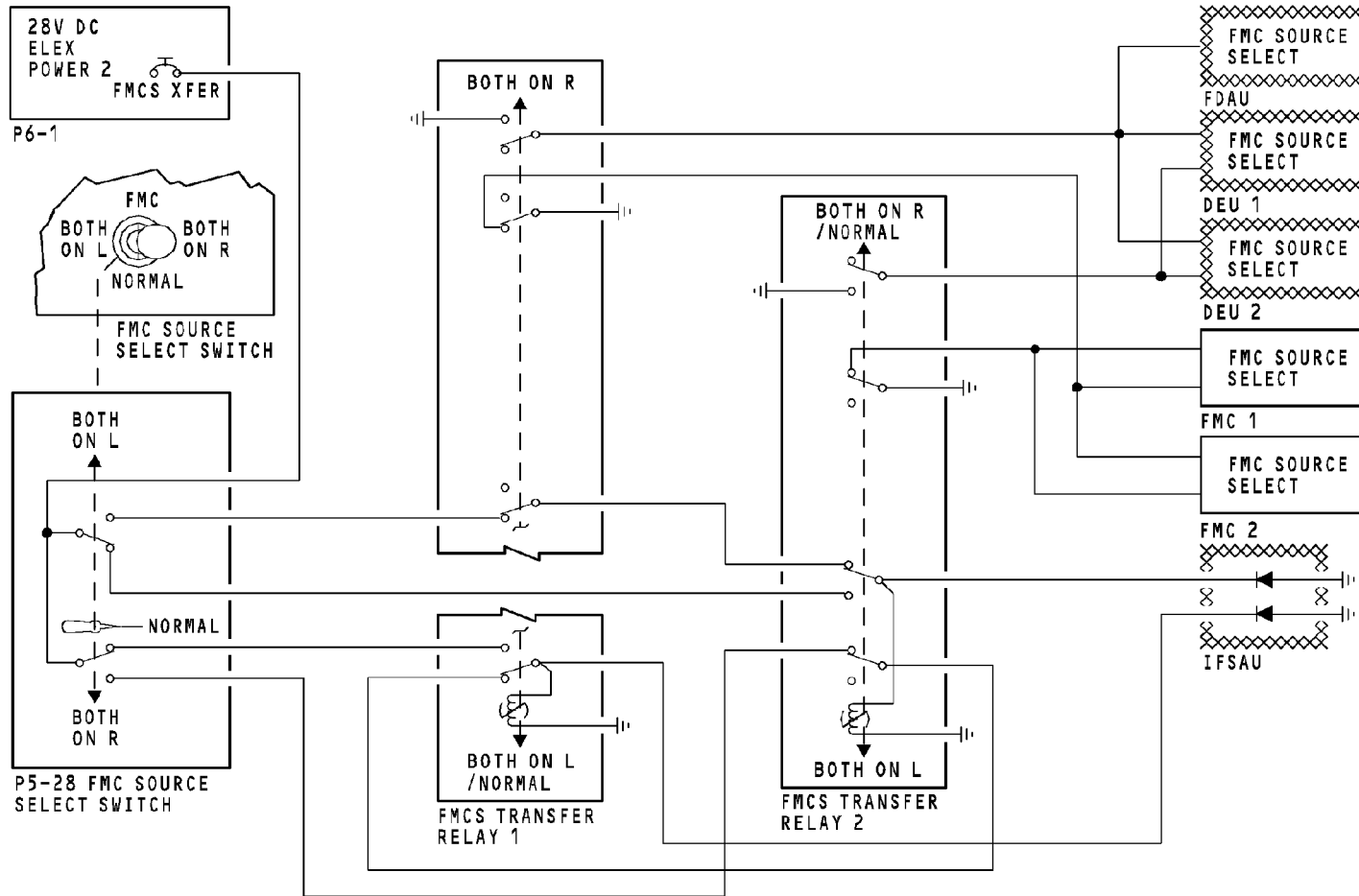

FMCS - TRANSFER RELAY POWER INTERFACE

EFFECTIVITY
HAP 037-054, 101-999

34-61-00

34-61-00-006

D633A101-HAP

Page 28
Feb 15/2009

FMCS - DIGITAL INPUT INTERFACE - 1

General

These LRUs supply data to the FMCS:

- VOR/MB
- MMR
- DME.

VOR/MB

VOR 1 and VOR 2 receivers give the bearing and the frequency data of the VOR stations that are manually tuned by the flight crew.

The FMC uses this data for FMC position updating in the VOR/DME mode. The effective range for this mode is up to a maximum of 25NM.

ILS/GPS/MMR

MMR 1 and MMR 2 give localizer deviation and the station frequency data of the ILS transmitters that are manually tuned by the flight crew.

The FMC uses this data for FMC position updating during a final approach. The airplane must be within 20NM of the tuned ILS transmitter and below 6000 feet.

The GPS receivers in the MMRs give this data to the FMC:

- Latitude
- Longitude
- Time
- Horizontal Figure of Merit
- Horizontal Integrity Limit

The FMC uses this data for FMC position updating and actual navigation performance (ANP) calculation.

DME

DME 1 and DME 2 interrogators give the slant range distance and the station frequency data that are automatically tuned by the FMC.

The FMC corrects this slant range for airplane altitude and uses the data for FMC position updating in the DME/DME or VOR/DME modes.

Clock

HAP 001-013, 015-026, 028-036

With the GPS valid, clock input comes from the selected GPS. If the GPS is not valid, you can set the time with the CDU and the FMC calculates time.

HAP 037-054, 101-999

The clock input to both FMCs is from the selected GPS. If the GPS is not valid, you can set the time with the CDU and the FMCs calculate time.

EFFECTIVITY
HAP ALL

FMCS - DIGITAL INPUT INTERFACE - 1

HAP 037-054, 101-999 (Continued)

Intersystem Bus

The intersystem bus is used to compare data between the primary and secondary FMCs.

HAP ALL

34-61-00-007

EFFECTIVITY
HAP ALL

34-61-00

D633A101-HAP

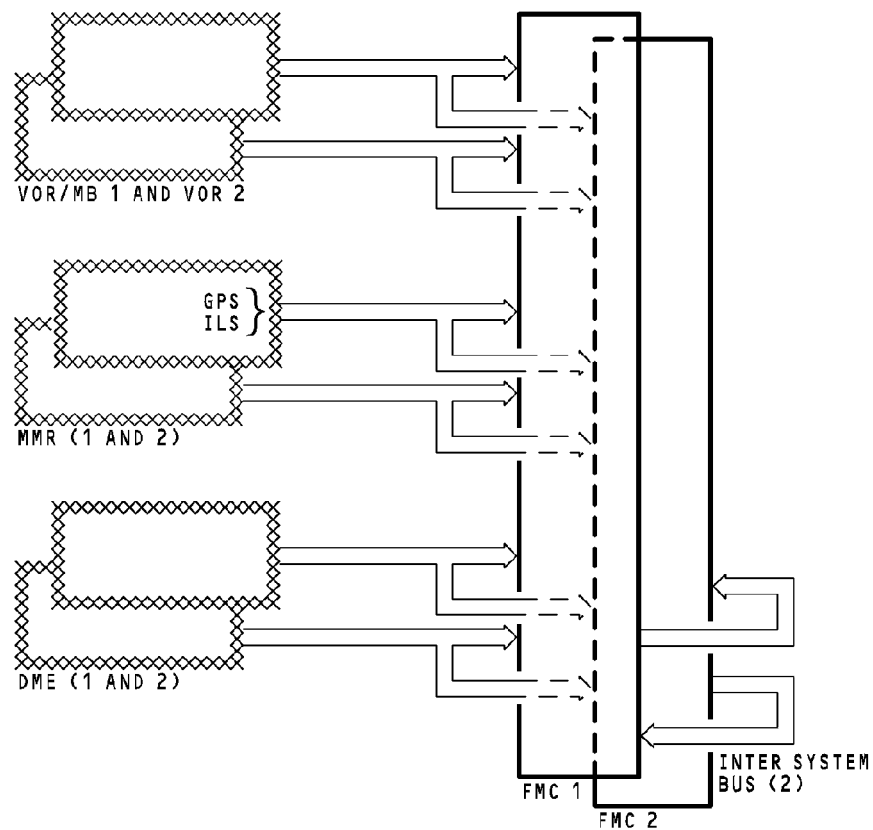

FMCS - DIGITAL INPUT INTERFACE - 1

34-61-00-007

EFFECTIVITY
HAP 037-054, 101-999

34-61-00

D633A101-HAP

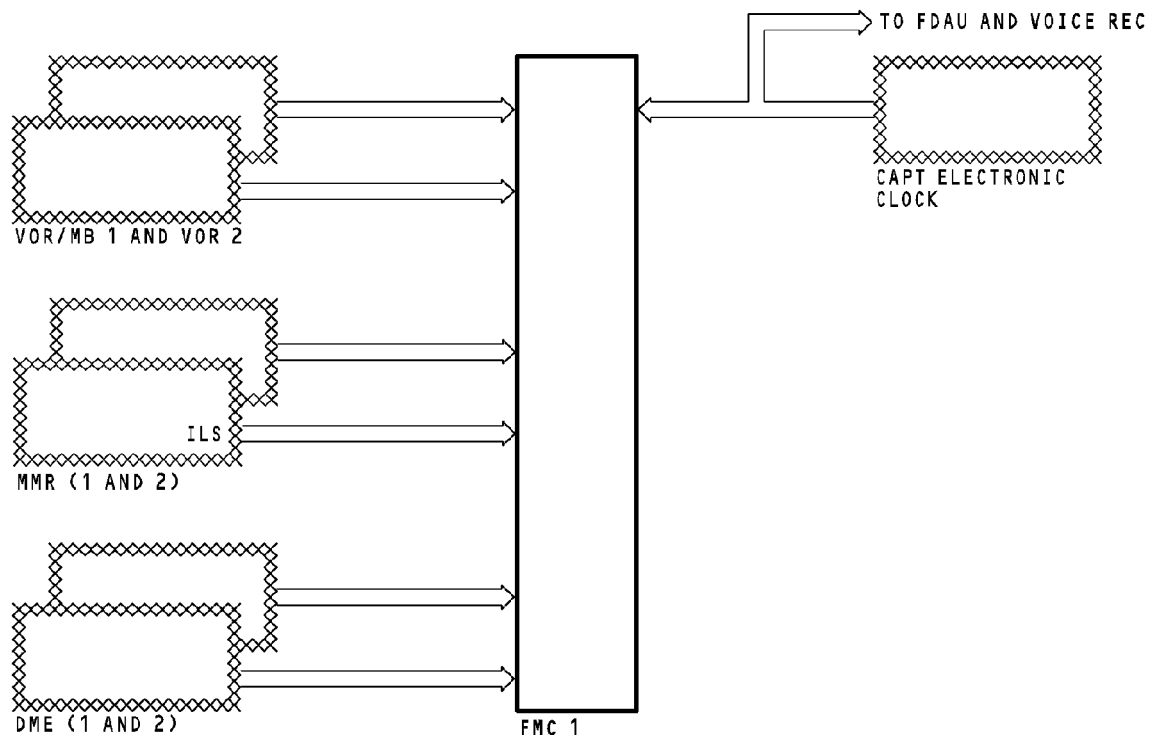

FMCS - DIGITAL INPUT INTERFACE - 1

34-61-00-007

EFFECTIVITY
HAP 001-013, 015-026, 028-036

34-61-00

D633A101-HAP

Page 32
Feb 15/2008

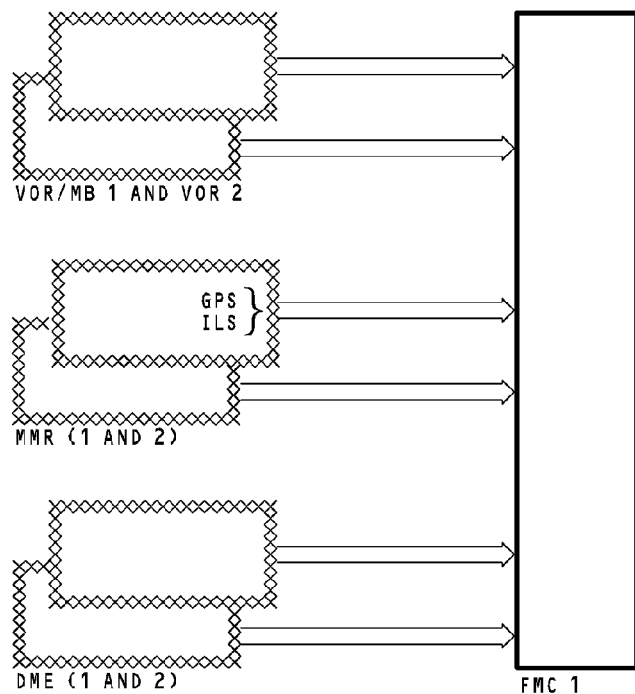

FMCS - DIGITAL INPUT INTERFACE - 1

34-61-00-007

EFFECTIVITY
HAP 001-013, 015-026, 028-036

34-61-00

D633A101-HAP

FMCS - DIGITAL INPUT INTERFACE - 2**General**

These components send data to the FMCS:

- DFCS MCP
- A/T
- ADIRU
- DEU
- Engine electronic control (EEC)
- APU engine control unit (ECU)
- FQPU.

HAP 001-013, 015-026, 028-030

DFCS

The flight control computers (FCC) send data to the DFCS mode control panel (MCP).

The MCP sends this data to the FMCS:

- Local selected course
- Foreign selected course
- Selected altitude
- Trailing edge flap position
- DFCS mode discrettes
- DFCS BITE response
- Selected airspeed
- Selected mach.

The FMCS uses the selected course data in the navigation sub-function. The selected altitude and trailing edge flap position are used in the performance and guidance sub-functions. The mode discrettes show VNAV/LNAV switch position, TO/GA switch position, and system status.

The selected airspeed and selected mach number are used in the speed intervention mode. The selected altitude is also used in the altitude intervention mode.

A/T

The autothrottle computer sends A/T BITE response to the FMCS.

HAP 031-054, 101-999

DFCS

The flight control computers (FCC) send data to the DFCS mode control panel (MCP).

The MCP sends this data to the FMCS:

- Local selected course
- Foreign selected course
- Selected altitude
- Trailing edge flap position
- DFCS mode discrettes
- DFCS BITE response
- Selected airspeed

FMCS - DIGITAL INPUT INTERFACE - 2**HAP 031-054, 101-999 (Continued)**

- Selected mach.

The FMCS uses the selected course data in the navigation sub-function. The selected altitude and trailing edge flap position are used in the performance and guidance sub-functions. The mode discrettes show VNAV/LNAV switch position, TO/GA switch position, and system status.

The selected airspeed and selected mach number are used in the speed intervention mode. The selected altitude is also used in the altitude intervention mode.

The FCC also sends A/T BITE response to the FMCS.

HAP ALL**ADIRU**

The ADIRUs send this inertial reference (IR) data to the FMCS:

- Present position Latitude
- Present position Longitude
- Ground speed
- True heading
- Magnetic heading
- Pitch angle
- Roll angle
- Inertial altitude
- Inertial vertical speed
- N-S velocity
- E-W velocity.

The ADIRUs send this air data reference (ADR) data to the FMCS:

- Uncorrected barometric altitude
- Baro corrected altitude
- Mach
- Computed airspeed
- True airspeed
- Total air temperature
- Static air temperature.

The FMCS uses this data to calculate these functions:

- Aircraft position (latitude, longitude and altitude)
- Groundspeed
- Flight path angle
- Drift angle
- Track angle
- Wind velocity and direction
- Horizontal position accuracy (actual navigation performance).

ADIRU Selection

The FMC sees the inertial reference (IR) data and the air data reference (ADR) data as two different sensors.

FMCS - DIGITAL INPUT INTERFACE - 2

HAP 037-054, 101-999

Usually, the FMCS receive inertial data from their on-side ADIRU (left ADIRU to FMC 1 and right ADIRU to FMC 2). If the on-side ADIRU malfunctions or it is in the ATT or ALIGN mode, the FMC uses the data from the other ADIRU.

The FMCS use the same air data source as the DFCS. Flight control computer (FCC) A gets ADR data from the left ADIRU and FCC B gets ADR data from the right ADIRU. If FCC A is engaged, the FMCS use ADR data from the left ADIRU. If FCC B is engaged, the FMCS use ADR data from the right ADIRU.

HAP 001-013, 015-026, 028-036

Usually, the FMC receives inertial data from the left ADIRU. If the left ADIRU malfunctions or is in the ATT or ALIGN mode, the FMC uses the data from the right ADIRU.

The FMC uses the same air data source as the DFCS. Flight control computer (FCC) A gets ADR data from the left ADIRU and FCC B gets ADR data from the right ADIRU. If FCC A is engaged, the FMC uses ADR data from the left ADIRU. If FCC B is engaged, the FMC uses ADR data from the right ADIRU.

HAP ALL

DEU

The display electronic units (DEUs) send CDS BITE response data and EFIS control panel mode discretes to the FMCS.

The DEUs send these EFIS control panel discretes to the FMC:

- Center display format
- HAP 001-013, 015-026, 028-036, 041, 047-049, 054, 101-999; HAP 037, 039, 040 PRE SB 737-31-1370**

- Heading up map format

HAP ALL

- Airports selected
- Route data selected
- Waypoint selected
- Ground station data selected
- Position data selected
- PFD/ND display format
- Plan mode selected
- Map mode selected
- VOR mode selected
- Approach mode selected
- Range selected.

The DEUs also send APU and main engine EEC BITE response data on the same bus. There is no direct BITE interface between the FMCS and the APU and EEC. The DEUs are a buffer between the APU, EEC, and the FMCS.

FQPU

The fuel quantity processor unit (FQPU) calculates total fuel weight and sends it to the FMCS. Fuel quantity BITE response data also comes from the FQPU.

34-61-00-008

<p>EFFECTIVITY</p> <p>HAP ALL</p>
--

34-61-00

D633A101-HAP

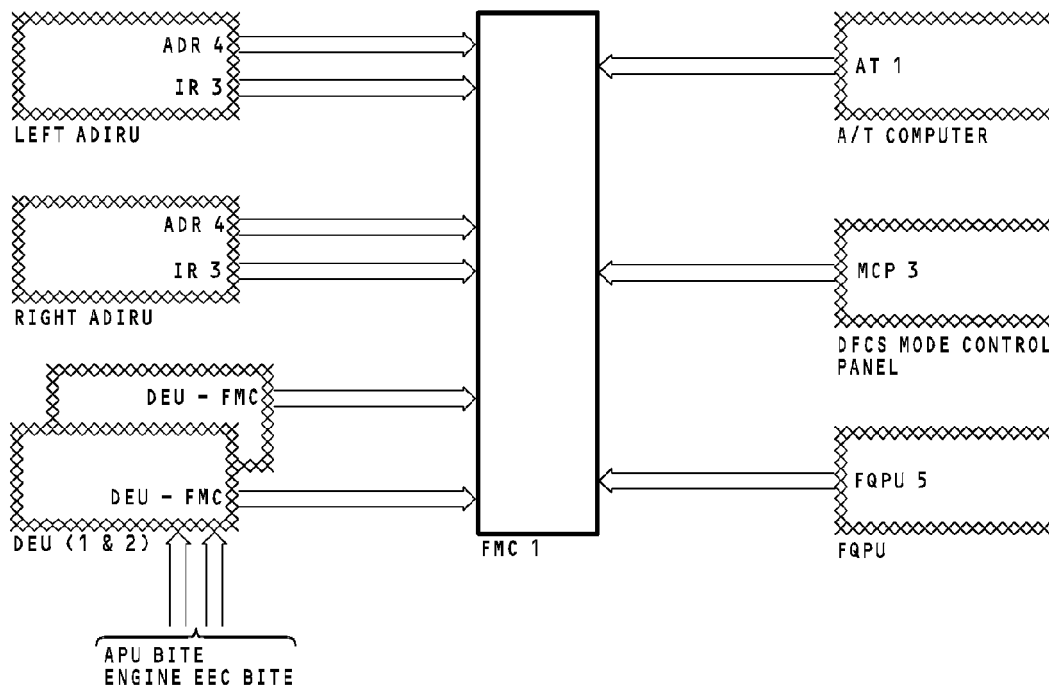

FMCS - DIGITAL INPUT INTERFACE - 2

34-61-00-008

EFFECTIVITY
HAP 001-013, 015-026, 028-030

34-61-00

D633A101-HAP

Page 37
Jun 10/2007

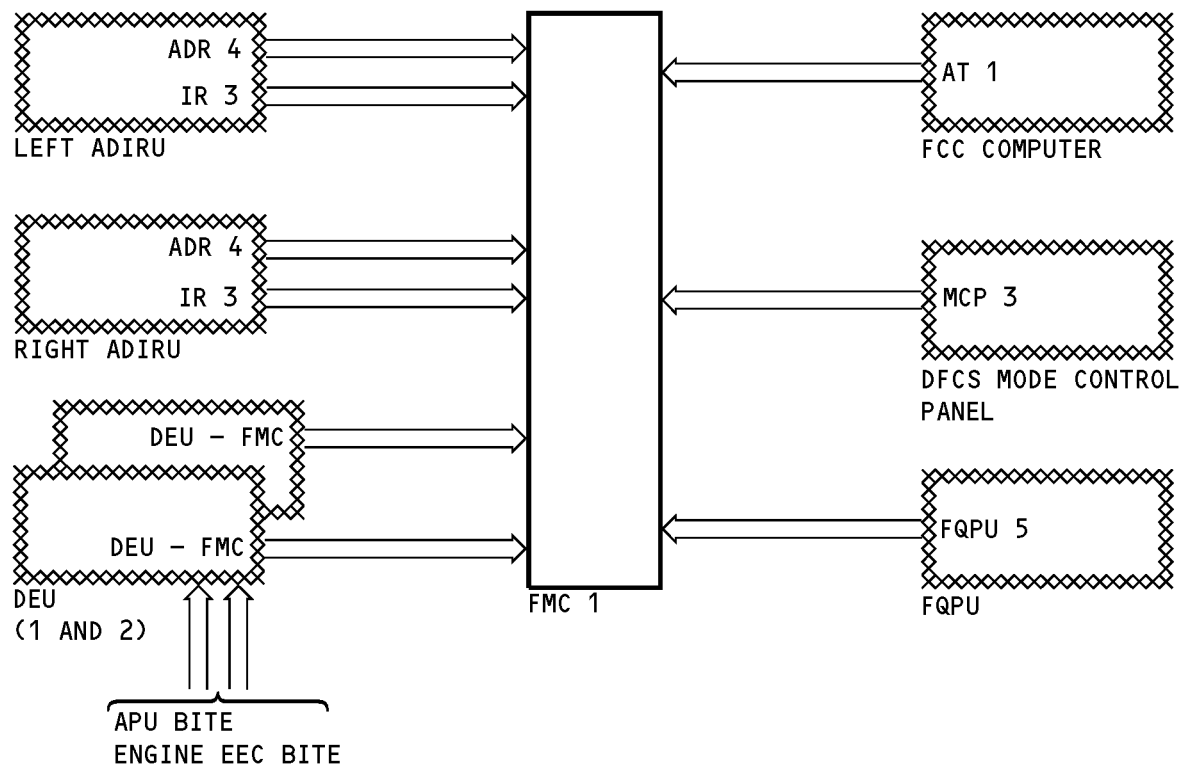

FMCS - DIGITAL INPUT INTERFACE - 2

EFFECTIVITY
HAP 031-036

34-61-00

D633A101-HAP

34-61-00-008

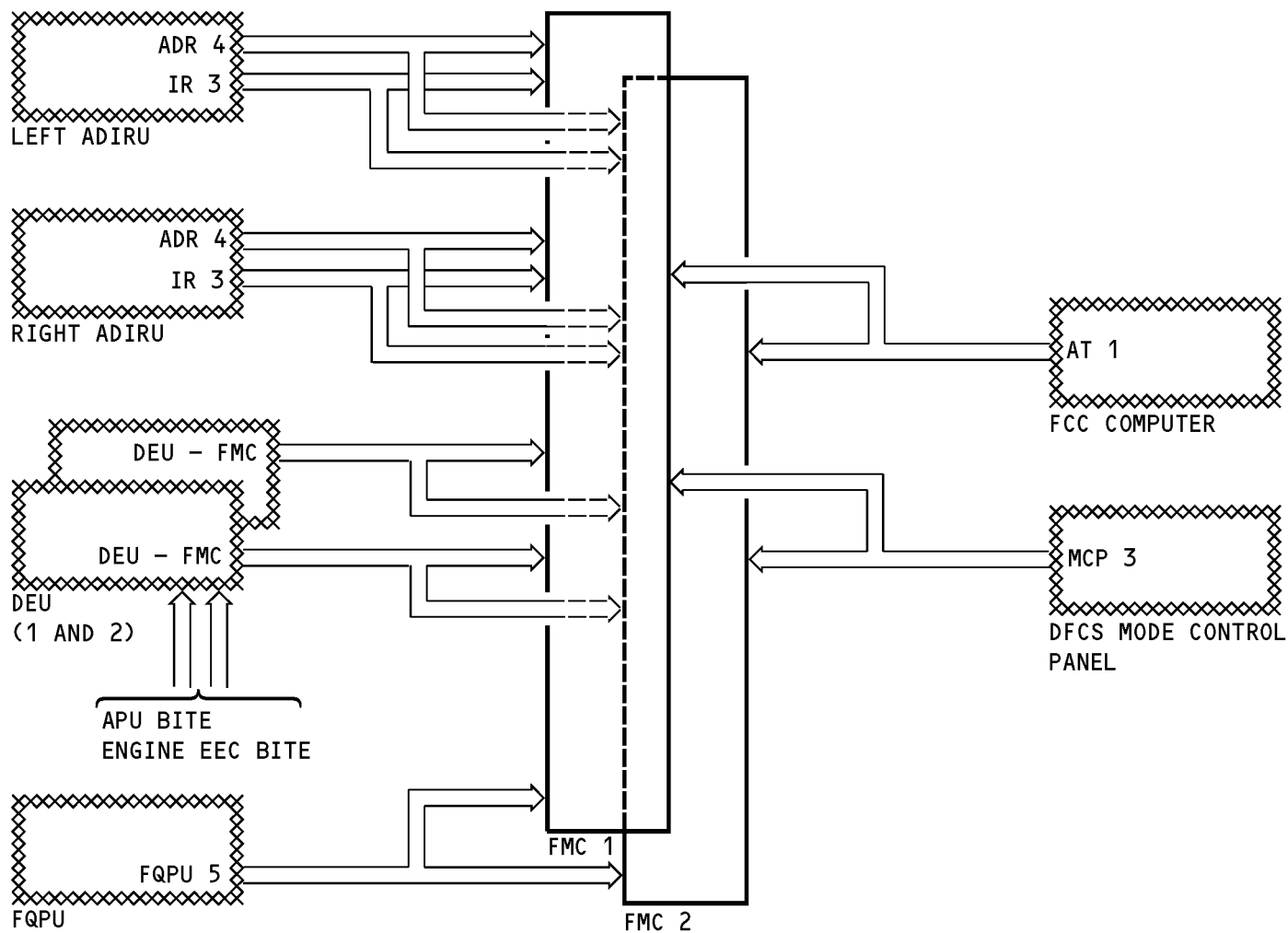

FMCS - DIGITAL INPUT INTERFACE - 2

34-61-00-008

EFFECTIVITY
HAP 037-054, 101-999

34-61-00

D633A101-HAP

THIS PAGE IS INTENTIONALLY LEFT BLANK

34-61-00

D633A101-HAP

Page 40
Jun 10/2007

FMCS - DIGITAL OUTPUT INTERFACE - 1

General

The FMC data on bus 01 and 02 goes directly to the ADIRUs. The other user systems get this FMC data through the transfer relays.

Data Output

Bus 01 and 02 have this data:

- Distance-to-go (waypoint)
- Groundspeed
- VOR/DME frequencies
- Set latitude
- Set longitude
- Set magnetic heading
- Origin/destination
- Destination runway
- Destination estimated time of arrival (ETA)
- Gross weight
- Total fuel
- FMC target altitude
- FMC target airspeed
- FMC target mach number
- Horizontal command
- Vertical speed command
- Desired track
- Waypoint bearing
- Cross-track deviation
- Vertical deviation
- Magnetic track angle
- Drift angle

- GMT
- Date
- Static air temperature (SAT)
- Selected temperature
- Flight number
- Minimum airspeed
- Minimum buffet airspeed
- Maximum buffet airspeed
- Continuous N1 limit
- Go-around N1 limit
- Cruise N1 limit
- Climb N1 limit
- Target N1
- NDB effectivity
- BITE test word
- FMC discrete word 1
- FMC discrete word 2
- FMC discrete word 3.
- ATC data interface

FMC discrete word 1 has this data:

**HAP 001-009 PRE SB 737-71-1395 AND PRE SB 737-71-1455;
HAP 010-013, 015-017 PRE SB 737-71-1455**

- Takeoff bump
- HAP ALL**
- Isolation valve open
 - Wing antice on
 - Cowl-R antice on
 - Cowl-L antice on
 - ECS pack-R H/L
 - ECS pack-L H/L
 - ECS pack-R

34-61-00-009

<p>EFFECTIVITY HAP ALL</p>
--

34-61-00

D633A101-HAP

FMCS - DIGITAL OUTPUT INTERFACE - 1

- ECS pack-L
- Engine bleed 2 on
- Engine bleed 1 on

FMC discrete word 2 has this data:

- Lateral alert
- Computer master/slave
- Annunciator test
- FMC valid
- Offset
- Dead reckoning
- Vertical alert.

FMC discrete word 3 has this data:

- IAS/mach
- Engine out engaged
- Landing flaps selected
- Manual N1 select
- Level decel
- Autothrottle to idle arm
- Autothrottle to arm
- FMC vertical speed
- N1 limit mode
- Speed on elevator
- Reduced thrust (derate)
- LNAV takeoff enabled
- Level change request
- VNAV valid
- Thrust cutback enable
- Initiate thrust cutback.

ADIRU

HAP 037-054, 101-999

The ADIRUs use this data from the selected FMC:

- Set latitude
- Set longitude
- Set heading
- BITE test word.

HAP 001-013, 015-026, 028-036

The ADIRUs use this data from FMC 1:

- Set latitude
- Set longitude
- Set heading
- BITE test word.

HAP ALL

The ADIRUs use the latitude and longitude data during alignment. Magnetic heading is used when the ADIRU is in the attitude mode (ATT) and the BITE test word is used to start BITE through the CDUs.

HAP 001-013, 015-026, 028-030

Autothrottle

The autothrottle computer uses this data from FMC 1:

- Target N1

EFFECTIVITY
HAP ALL

34-61-00

D633A101-HAP

Page 42
Feb 15/2009

FMCS - DIGITAL OUTPUT INTERFACE - 1**HAP 001-013, 015-026, 028-030 (Continued)**

- FMC gross weight
- Minimum airspeed
- N1 limit mode
- FMC altitude
- GMT and date
- Static air temperature
- N1 thrust limits (CLB, CRZ, CONT, and GA)
- BITE test words.

The autothrottle computer uses this data to maintain specific engine N1 targets or airspeeds from takeoff to touchdown.

The autothrottle computer changes the target N1 values to an equivalent thrust resolver angle (TRA) target. The target N1 rating is dependent on the FMC engaged mode.

Gross weight is used in the A/T go-around control logic and approach control logic.

Minimum airspeed is the lowest airspeed that is acceptable by the A/T during VNAV operations.

The N1 limit mode discretely are used to determine control law gains and limits.

FMC altitude is used by the autothrottle computer for anticipation of altitude acquire during VNAV operation.

GMT and date are used in A/T BITE for fault data storage.

SAT is used by the autothrottle computer to calculate a backup TRA limit value.

N1 thrust limits are used to limit A/T authority and prevent possible engine overboost.

HAP 001-005

BITE data is used for interactive display on the MCDUs

HAP ALL**DEU****HAP 037-054, 101-999**

The DEUs use this data from the selected FMC:

- N1 limit mode
- Target N1
- Gross weight
- GMT and date
- BITE test words.

HAP 001-013, 015-026, 028-036

The DEUs use this data from FMC 1:

- N1 limit mode
- Target N1

FMCS - DIGITAL OUTPUT INTERFACE - 1**HAP 001-013, 015-026, 028-036 (Continued)**

- Gross weight
- GMT and date
- BITE test words.

HAP ALL

The DEUs use this data to show the thrust modes on the center upper display unit (DU). Target N1 shows on the engine display. Gross weight is used by the CDS to calculate the flap maneuver speeds that show on the PFD speed tape. GMT and date are used in BITE for fault data storage.

Target N1, GMT, and date also go from the DEUs to the engine electronic controls (EEC). The EECs use the N1 target to calculate an equivalent TRA for engine control. GMT and date are used in EEC BITE.

The BITE test words are for the DEUs and these systems:

- Engines (EEC)
- APU (ECU).

HAP 037-054, 101-999

There is no direct BITE interface between the FMCs and the electronic engine controls (EECs) and APU ECU. The DEUs are the interface between the EEC, APU ECU, and the selected FMC.

HAP 001-013, 015-026, 028-036

There is no direct BITE interface between FMC 1 and the electronic engine controls (EECs) and the APU ECU. The DEUs are the interface between the EEC, APU ECU, and the FMC.

HAP 001-013, 015-026, 028-030**FCC**

The FCCs use this data from FMC 1:

- FMC target altitude
- FMC target airspeed
- FMC target mach number
- Horizontal command
- Vertical speed command
- GMT and date
- Flight number
- FMC discrete words
- BITE test word.

The FCCs use the altitude, airspeed, mach number, horizontal commands, vertical commands, and FMC discretetes to control the airplane lateral and vertical flight profile.

GMT and date, flight number, and the BITE test word are used by the FCC in the BITE function.

FMCS - DIGITAL OUTPUT INTERFACE - 1

HAP 001-013, 015-026, 028-030 (Continued)
HAP 031-054, 101-999

FCC

HAP 037-054, 101-999

The autothrottle function of the FCC uses this data from the selected FMC:

- Target N1
- FMC gross weight
- Minimum airspeed
- N1 limit mode
- FMC altitude
- GMT and date
- Static air temperature
- N1 thrust limits (CLB, CRZ, CONT & GA)
- BITE test words.

HAP 031-036

The autothrottle function of the FCC uses this data from FMC 1:

- Target N1
- FMC gross weight
- Minimum airspeed
- N1 limit mode
- FMC altitude
- GMT and date
- Static air temperature
- N1 thrust limits (CLB, CRZ, CONT, and GA)

- BITE test words.
- HAP 031-054, 101-999**

The autothrottle function uses this data to maintain specific engine N1 targets or airspeeds from takeoff to touchdown.

The autothrottle function changes the target N1 values to an equivalent thrust resolver angle (TRA) target. The target N1 rating is dependent on the FMC engaged mode.

Gross weight is used in the A/T go-around control logic and approach control logic.

Minimum airspeed is the lowest airspeed that is acceptable by the A/T during VNAV operations.

The N1 limit mode discretely are used to determine control law gains and limits.

FMC altitude is used by the autothrottle computer for anticipation of altitude acquire during VNAV operation.

GMT and date are used in A/T BITE for fault data storage.

SAT is used by the autothrottle function to calculate a backup TRA limit value.

FMCS - DIGITAL OUTPUT INTERFACE - 1

HAP 031-054, 101-999 (Continued)

N1 thrust limits are used to limit A/T authority and prevent possible engine overboost.

BITE data is used for interactive display on the MCDUs

HAP 037-054, 101-999

The flight profile function of the FCCs use this data from the selected FMC:

- FMC target altitude
- FMC target airspeed
- FMC target mach number
- Horizontal command
- Vertical speed command
- GMT and date
- Flight number
- FMC discrete words
- BITE test word.

HAP 031-036

The flight profile function of the FCCs use this data from FMC 1:

- FMC target altitude
- FMC target airspeed
- FMC target mach number
- Horizontal command
- Vertical speed command
- GMT and date

- Flight number
- FMC discrete words
- BITE test word.

HAP 031-054, 101-999

The FCCs use the altitude, airspeed, mach number, horizontal commands, vertical commands, and FMC discretetes to control the airplane lateral and vertical flight profile.

GMT and date, flight number, and the BITE test word are used by the FCC in the BITE function.

HAP 037-054, 101-999

You select the source of FMC data with the FMC source select switch.

FMC SOURCE SELECT SWITCH POSITION	FCC A	FCC B
NORMAL	FMC 1	FMC 2
BOTH ON LEFT	FMC 1	FMC 1
BOTH ON RIGHT	FMC 2	FMC 2

HAP ALL

SMYD

HAP 037-054, 101-999

The SMYDs use this data from the selected FMC:

34-61-00-009

EFFECTIVITY	
HAP ALL	

34-61-00

D633A101-HAP

FMCS - DIGITAL OUTPUT INTERFACE - 1**HAP 037-054, 101-999 (Continued)**

- Gross weight
- Lower buffet margin speeds
- Upper buffet margin speeds
- Landing flap position.

HAP 001-013, 015-026, 028-036

The SMYDs use this data from FMC 1:

- Gross weight
- Lower buffet margin speeds
- Upper buffet margin speeds
- Landing flap position.

HAP ALL

The SMYDs use gross weight to adjust the gain in the yaw damper command signal. They use all the FMC inputs to calculate the upper and lower amber bands on the airspeed indication for CDS. The flap input enables the pitch limit indication on CDS.

DME**HAP 037-054, 101-999**

The DMEs use four autotune frequencies (channels 2 - 5) from the selected FMC.

HAP 001-013, 015-026, 028-036

The DME interrogators use four autotune frequencies (channels 2 - 5) from FMC 1.

HAP 037-054, 101-999

In normal operation, the FMCs autotune the DME interrogators through their on-side NAV control panels. If a NAV control panel fails, its on-side DME interrogator is autotuned directly from the selected FMC.

HAP 001-013, 015-026, 028-036

In normal operation, FMC 1 autotunes the DME interrogators through the NAV control panels. If a NAV control panel fails, its on-side DME interrogator is autotuned directly from FMC 1.

HAP ALL**Fuel Quantity Processor Unit****HAP 037-054, 101-999**

The fuel quantity processor unit uses a BITE word from the selected FMC to start the BITE program.

HAP 001-013, 015-026, 028-036

The fuel quantity processor unit uses a BITE test word from FMC 1 to start the BITE program.

FMCS - DIGITAL OUTPUT INTERFACE - 1

HAP 001-013, 015-026, 028-036 (Continued)
HAP 001-013, 015-026, 028-030, 038, 041-054, 104-999

Passenger Flight Information System (Airshow)

HAP 038, 041-054, 104-999

The passenger flight information system uses this data from the selected FMC:

- Distance-to-go (waypoint).
- Groundspeed
- Origin/destination
- GMT
- Date
- Destination estimated time of arrival (ETA)
- Static air temperature.

HAP 001-013, 015-026, 028-030

The passenger flight information system uses this data from FMC 1:

- Distance-to-go (waypoint).
- Groundspeed
- Origin/destination
- GMT
- Date
- Destination estimated time of arrival (ETA)
- Static air temperature.

HAP 001-013, 015-026, 028-030, 038, 041-054, 104-999

It uses this data with other navigation sensors to format and show flight progress information to the passengers.

HAP ALL

FDAU

HAP 037-054, 101-999

Navigation data from the selected FMC goes to the FDAU where it is stored in the solid state memory.

HAP 001-013, 015-026, 028-036

Navigation data from FMC 1 goes to the FDAU where it is stored in the solid state memory.

HAP ALL

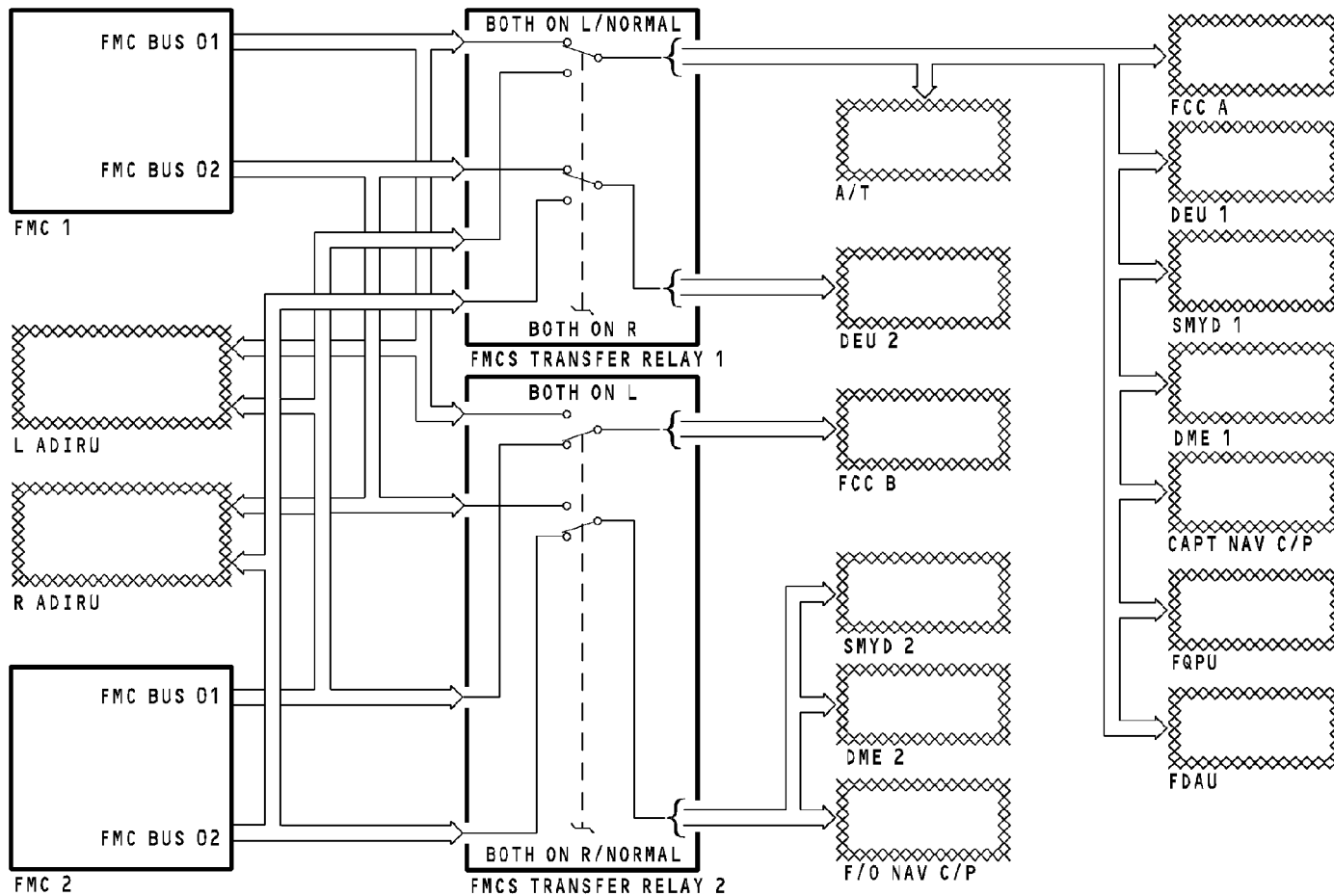

FMCS - DIGITAL OUTPUT INTERFACE - 1

34-61-00-009

EFFECTIVITY
HAP 037, 039, 040, 101-103

34-61-00

D633A101-HAP

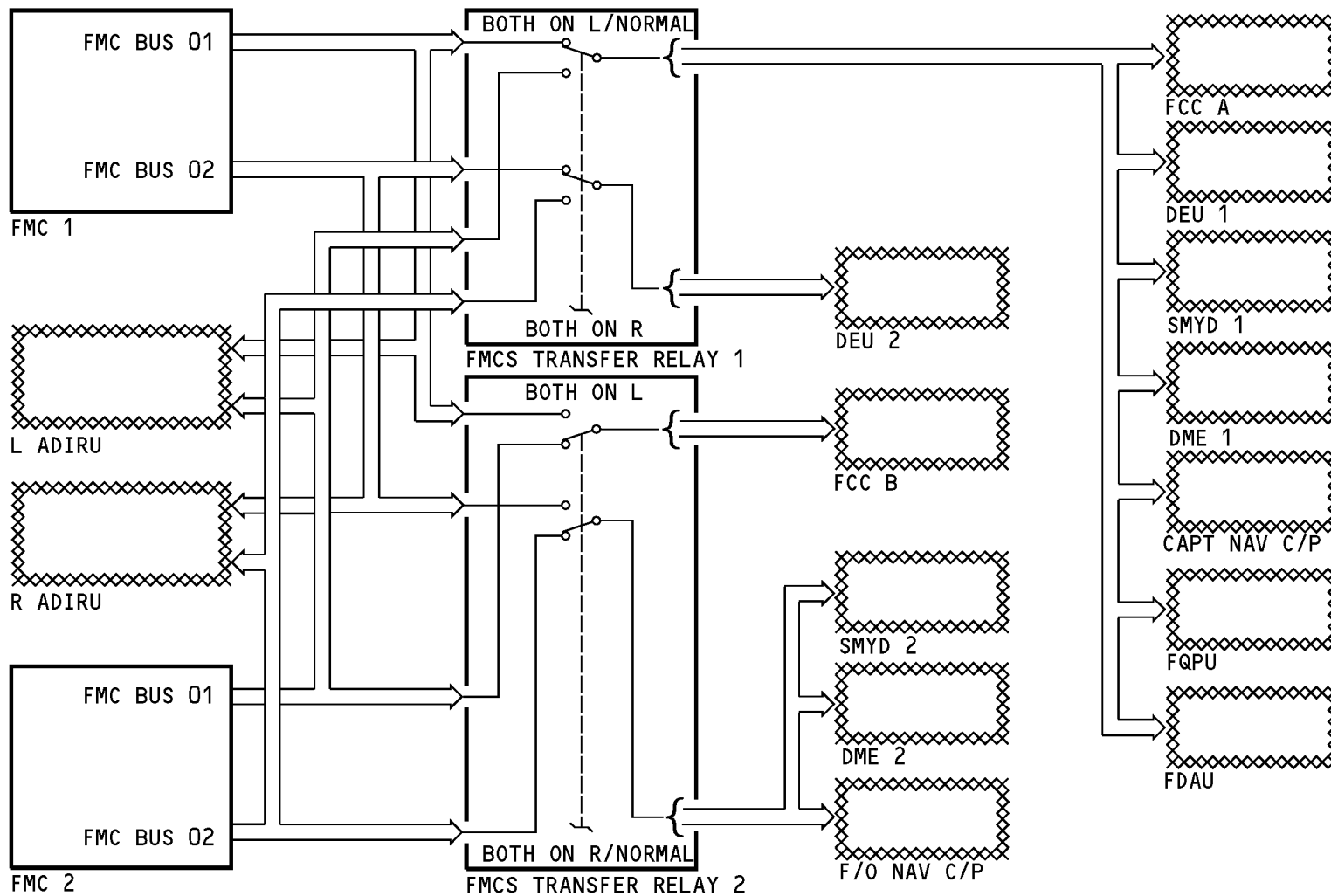

FMCS - DIGITAL OUTPUT INTERFACE - 1

EFFECTIVITY
HAP 101-103

34-61-00

D633A101-HAP

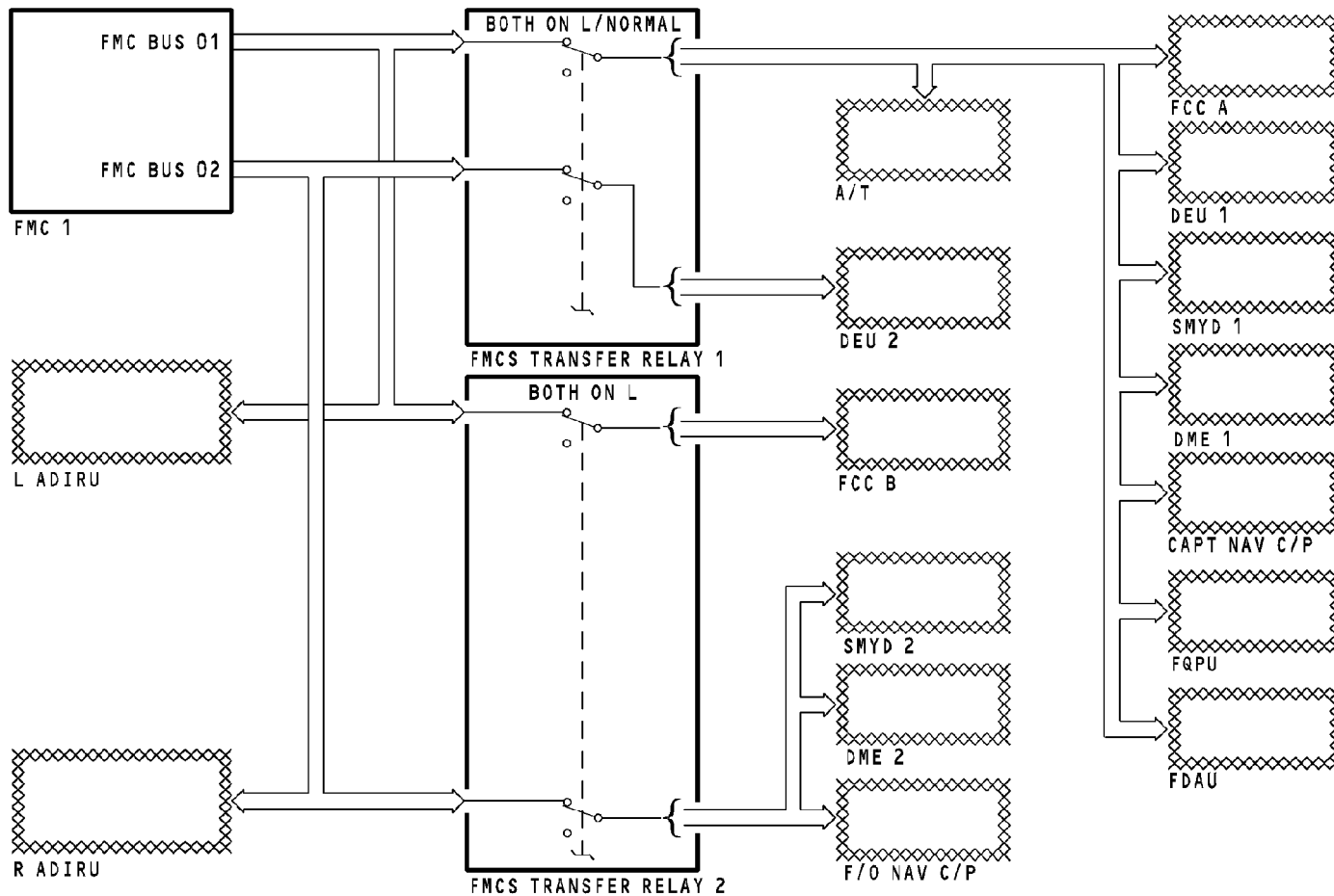

FMCS - DIGITAL OUTPUT INTERFACE - 1

34-61-00-009

EFFECTIVITY
HAP 031-036

34-61-00

D633A101-HAP

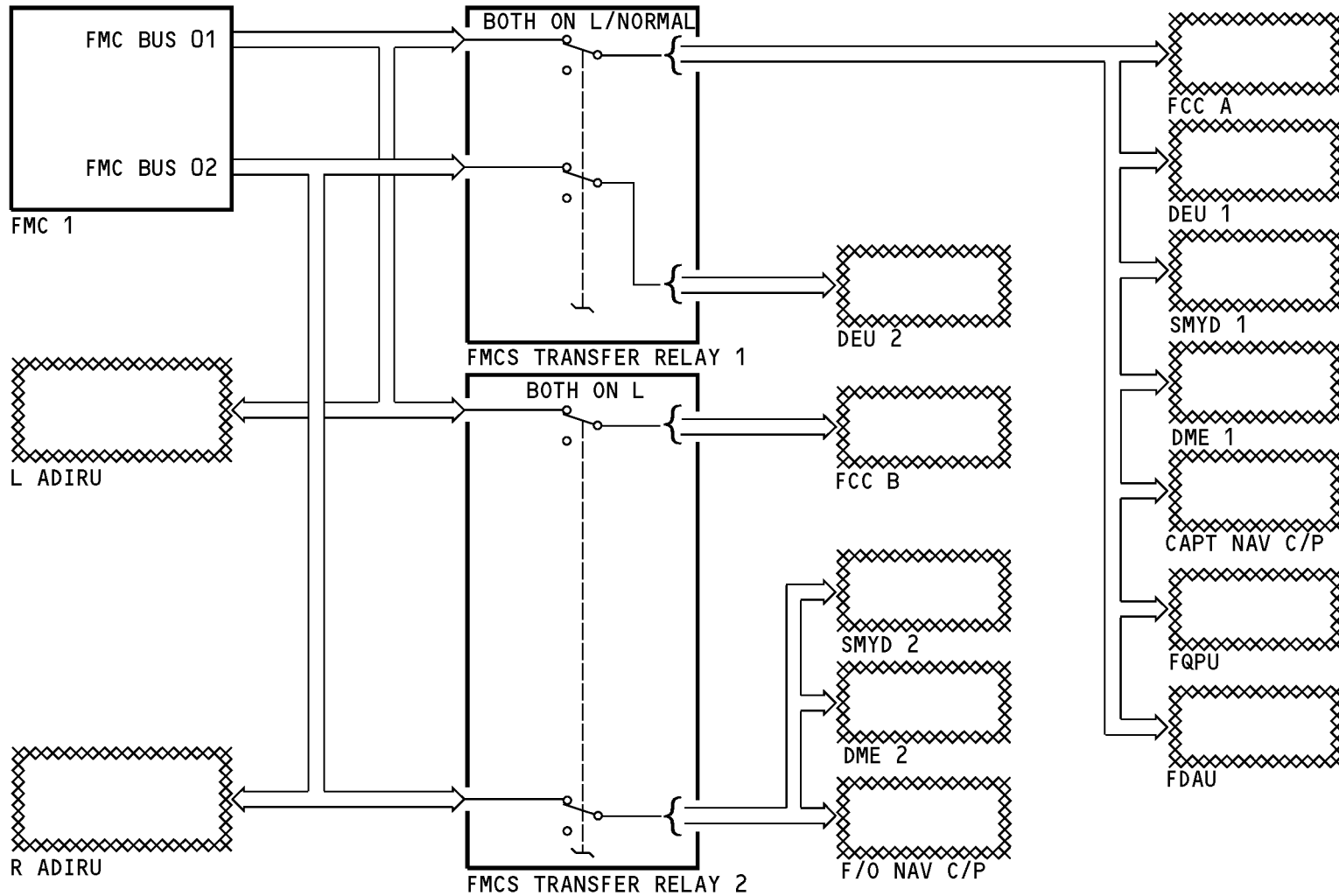

FMCS - DIGITAL OUTPUT INTERFACE - 1

EFFECTIVITY

HAP 031-036

34-61-00

34-61-00-009

D633A101-HAP

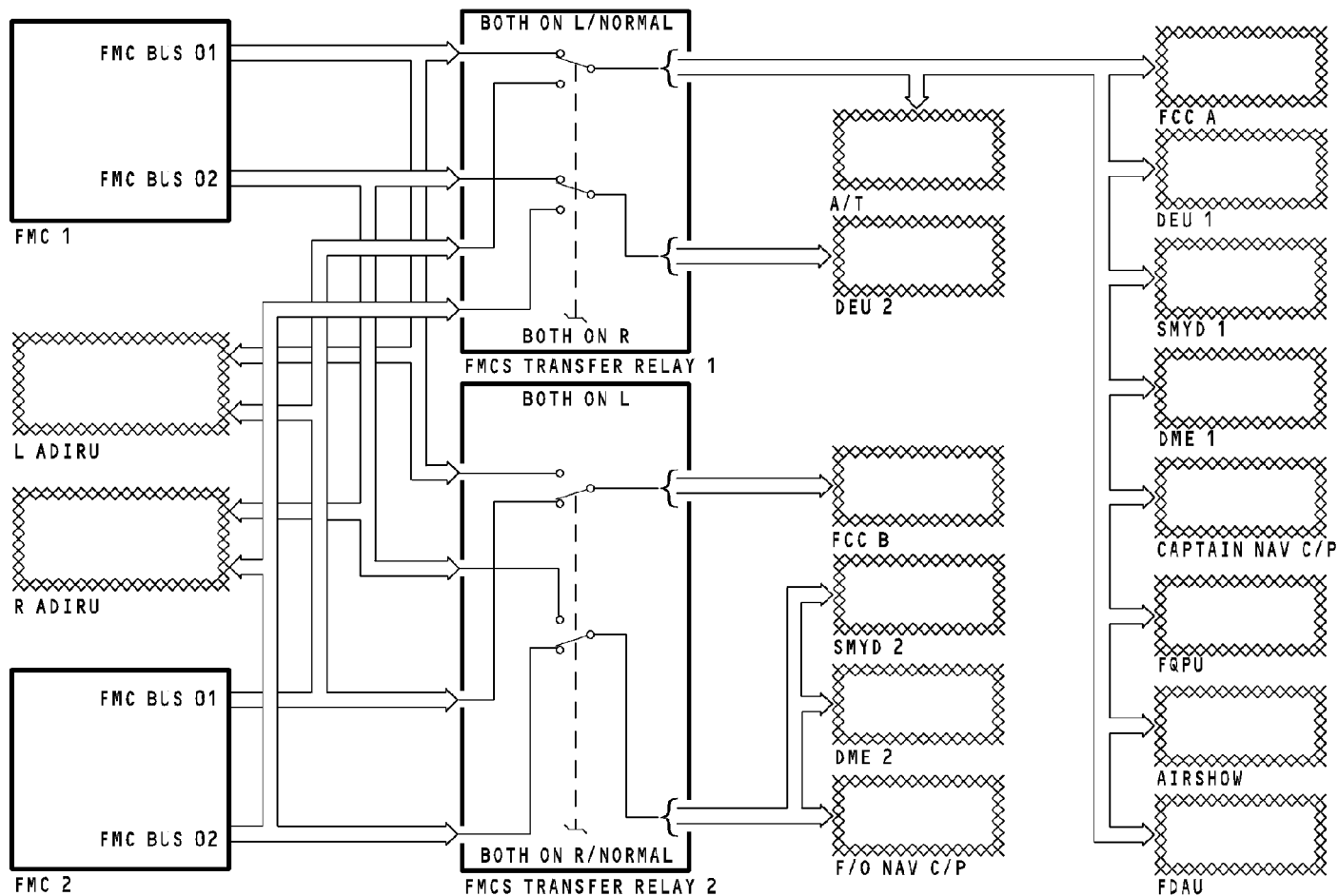

FMCS - DIGITAL OUTPUT INTERFACE - 1

34-61-00-009

EFFECTIVITY
 HAP 038, 041-054, 104-999

34-61-00

D633A101-HAP

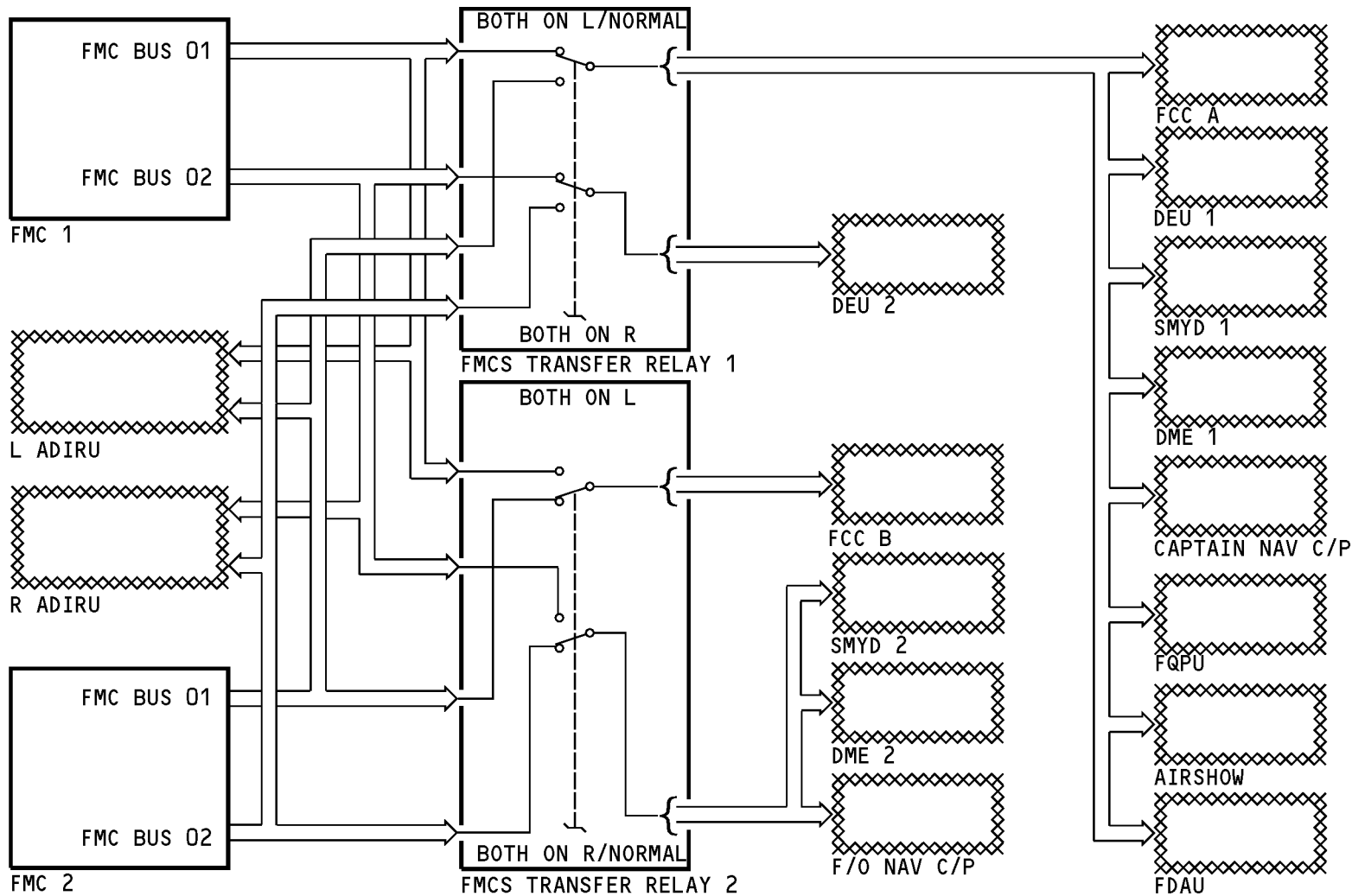

FMCS - DIGITAL OUTPUT INTERFACE - 1

EFFECTIVITY

HAP 038, 041-054, 104-999

34-61-00

34-61-00-009

D633A101-HAP

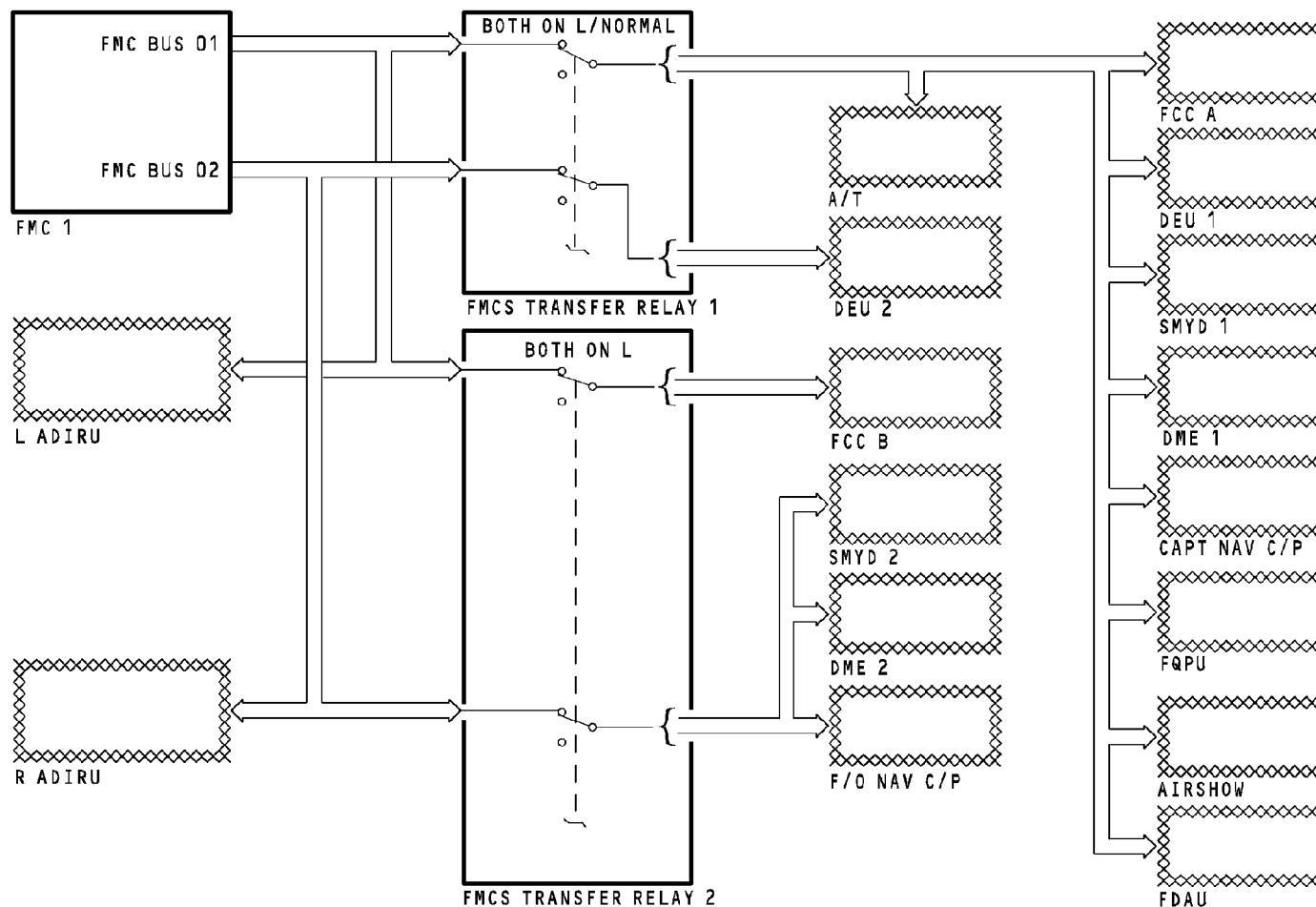

FMCS - DIGITAL OUTPUT INTERFACE - 1

34-61-00-009

EFFECTIVITY
HAP 001-013, 015-026, 028-030

34-61-00

D633A101-HAP

THIS PAGE IS INTENTIONALLY LEFT BLANK

34-61-00

D633A101-HAP

Page 56
Jun 15/2009

FMCS - DIGITAL OUTPUT INTERFACE - 2

General

The FMC data on bus 08 and 09 goes directly to the DEUs. The other user systems get this data through the transfer relays.

Data Output

The buses 08 and 09 have this data:

- Distance to go (waypoint)
- Groundspeed
- Estimated time of arrival (ETA)
- V speeds
- GPS position data
- Desired track
- Waypoint bearing
- Cross-track deviation
- Range to altitude
- Vertical deviation
- Set landing altitude
- DME elevation
- Transition altitude
- Clean
- Speedbrakes
- FMC navigation source (GPS, VOR, LOC, ADIRU)
- Map background word/block count
- Dynamic data start word
- FMC position
- Track angle (magnetic and true)
- Wind speed and direction
- Drift angle
- Flight path angle

- Alphanumeric display data (wpt, nav aids etc.)
- Flight number
- FMC discrete word 2
- FMC discrete word 3.

The FMC discrete word 2 has this data:

HAP 050, 053, 054

- VNAV ALT annunciation

HAP ALL

- ADIRU position difference
- Alerts (lateral and vertical)

HAP 037-054, 101-999

- FMC source select annunciation

HAP ALL

- Annunciator test
- FMC valid
- Offset
- Dead reckoning.

The FMC discrete word 3 has this data:

- IAS/Mach
- Engine out engaged
- Man N1 select
- Level decel
- A/T to idle arm
- A/T to arm
- FMC vertical speed
- Speed on elevator
- Reduced thrust derate
- Level change request
- VNAV valid

34-61-00-010

<p>EFFECTIVITY HAP ALL</p>
--

34-61-00

D633A101-HAP

FMCS - DIGITAL OUTPUT INTERFACE - 2

- Thrust cutback enable
- Initiate thrust cutback
- Landing flaps selected
- N1 limit mode.

DEU**HAP 037-054, 101-999**

The DEUs get navigation and flight display data from both FMCS. There are two types of data, dynamic data and background data. Dynamic data changes as a function of time while background data does not change as a function of time.

HAP 001-013, 015-026, 028-036

The DEUs get navigation and flight display data from FMC 1. There are two types of data, dynamic data and background data. Dynamic data changes as a function of time while background data does not change as a function of time.

HAP ALL

Dynamic data has the following information:

- Distance-to-go
- Groundspeed
- Estimated time of arrival
- V speeds
- GPS position data
- Desired track
- Waypoint bearing
- Cross-track deviation

- Range to altitude
- Vertical deviation
- Set landing altitude
- DME elevation
- Transition altitude
- FMC discrete word 2
- FMC discrete word 3
- FMC position
- Track angle (magnetic and true)
- Wind speed and direction
- Drift angle
- Flight path angle
- Alpha numeric display data
- Flight number.

Background data has this type of information:

- Vector lines
- Special symbols
- Standard character text messages
- Discrete words defining map/plan mode and range data.

This data is formatted and sent by the DEUs to the display units (DUs) to show the airplane position with respect to the flight plan path and navigation facilities (navaids, waypoints, airports etc.).

FMCS - DIGITAL OUTPUT INTERFACE - 2**GPWC****HAP 037-054, 101-999**

The GPWC uses magnetic track and present position (latitude and longitude) from the selected FMC for its envelope modulation calculations.

HAP 001-013, 015-026, 028-036

The GPWC uses magnetic track and present position (latitude and longitude) from FMC 1 for its envelope modulation calculations.

HAP ALL**FDAU****HAP 037-054, 101-999**

Display data from the selected FMC goes to the FDAU where it is stored in the solid state memory.

HAP 001-013, 015-026, 028-036

Display data from FMC 1 goes to the FDAU where it is stored in the solid state memory.

HAP 031-054, 101-999**ELT Program and Position Interface Unit****HAP 037-054, 101-999**

The emergency locator transmitter (ELT) uses FMC position from the selected FMC. It goes through the ELT program and position interface unit.

HAP 031-036

The emergency locator transmitter (ELT) uses FMC position from FMC 1. It goes through the ELT program and position interface unit.

HAP 028-030; HAP 001-007 POST SB 737-23-1119**Passenger Flight Information System (Airshow)**

The passenger flight information system uses this data from the FMC:

- Distance-to-go (waypoint)
- Groundspeed
- Origin/destination
- GMT
- Date
- Destination estimated time of arrival (ETA)
- Static air temperature

EFFECTIVITY HAP ALL



FMCS - DIGITAL OUTPUT INTERFACE - 2

HAP 028-030; HAP 001-007 POST SB 737-23-1119
(Continued)

It uses this data with other navigation sensors to format and show flight progress information to the passengers.

HAP ALL

34-61-00-010

EFFECTIVITY
HAP ALL

34-61-00

D633A101-HAP

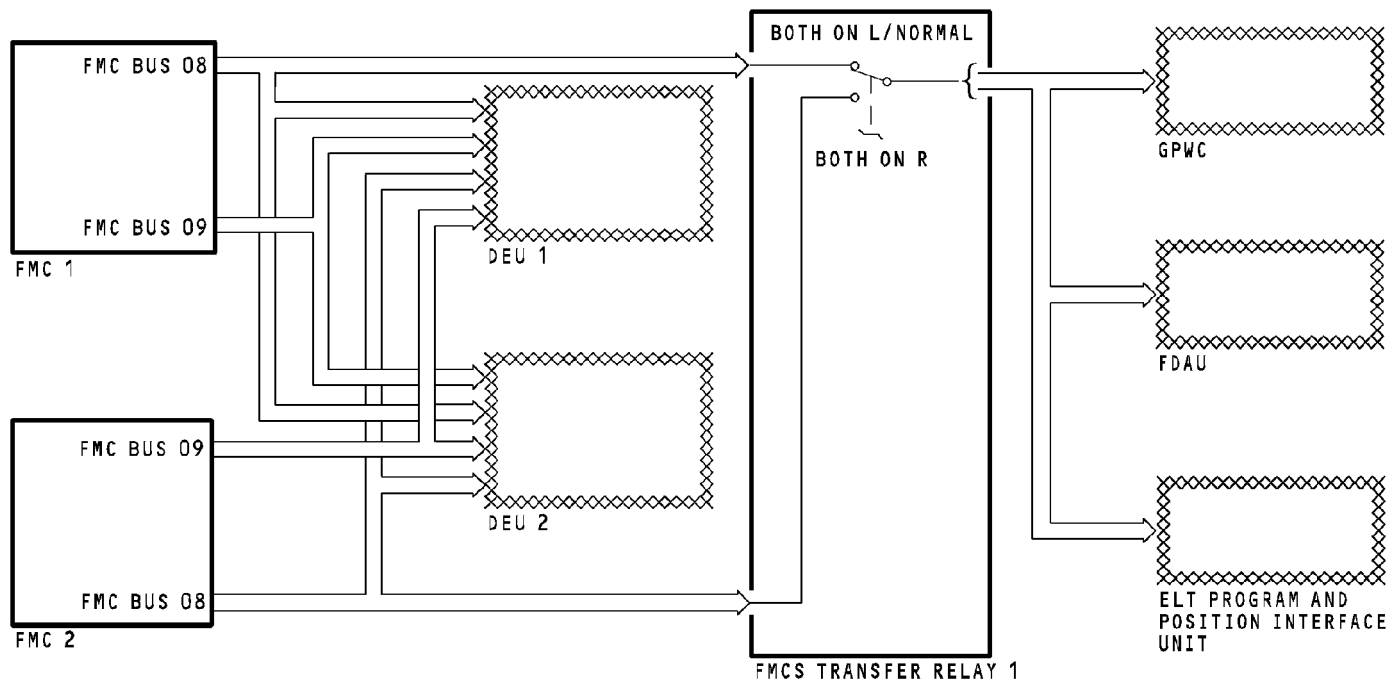

FMCS - DIGITAL OUTPUT INTERFACE - 2

34-61-00-010

EFFECTIVITY
HAP 037-054, 101-999

34-61-00

D633A101-HAP

Page 61
Jun 15/2009

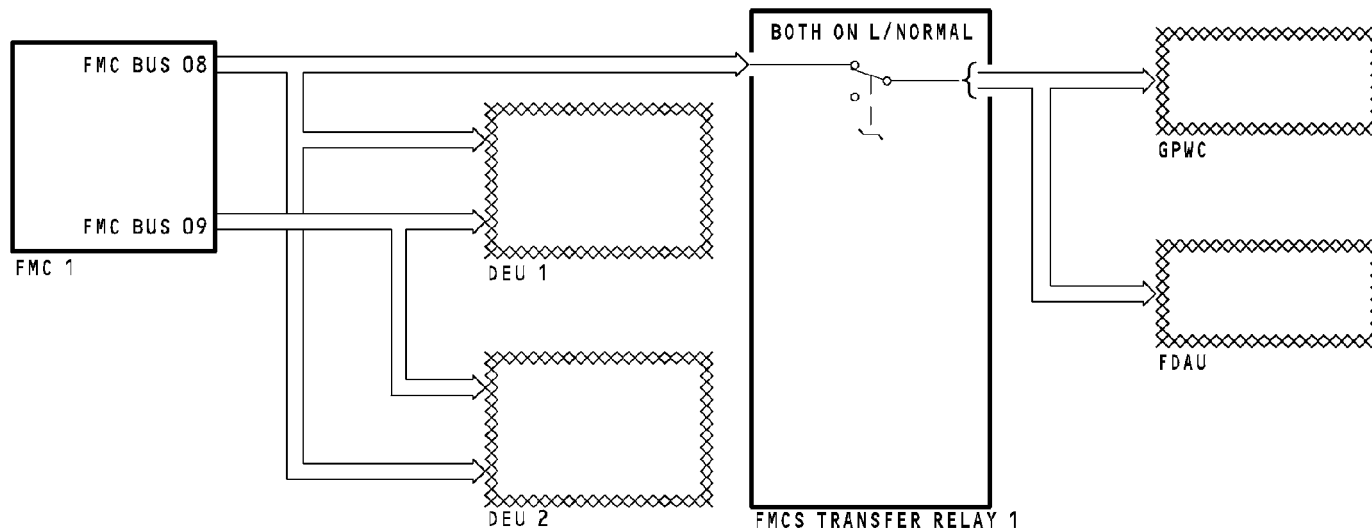

FMCS - DIGITAL OUTPUT INTERFACE - 2

EFFECTIVITY

HAP 008-013, 015-026; HAP 001-007 PRE SB 737-23-1119

34-61-00

D633A101-HAP

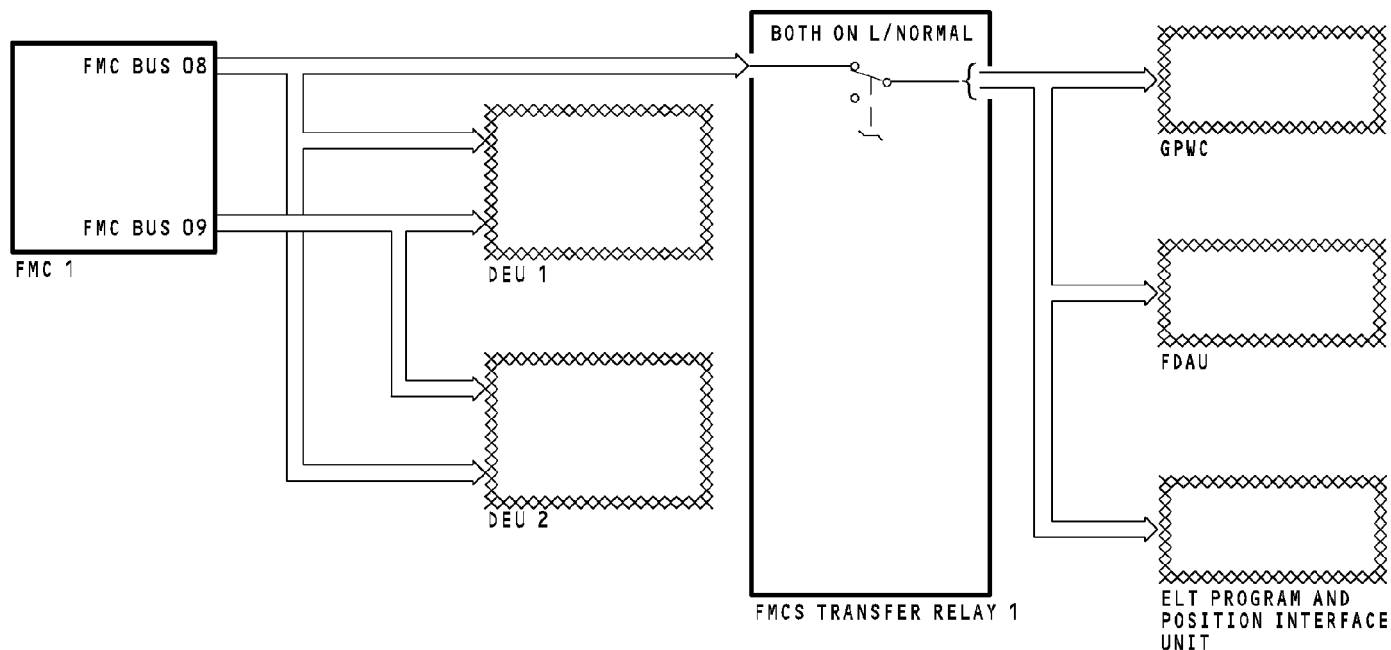

FMCS - DIGITAL OUTPUT INTERFACE - 2

34-61-00-010

EFFECTIVITY
HAP 031-036

34-61-00

D633A101-HAP

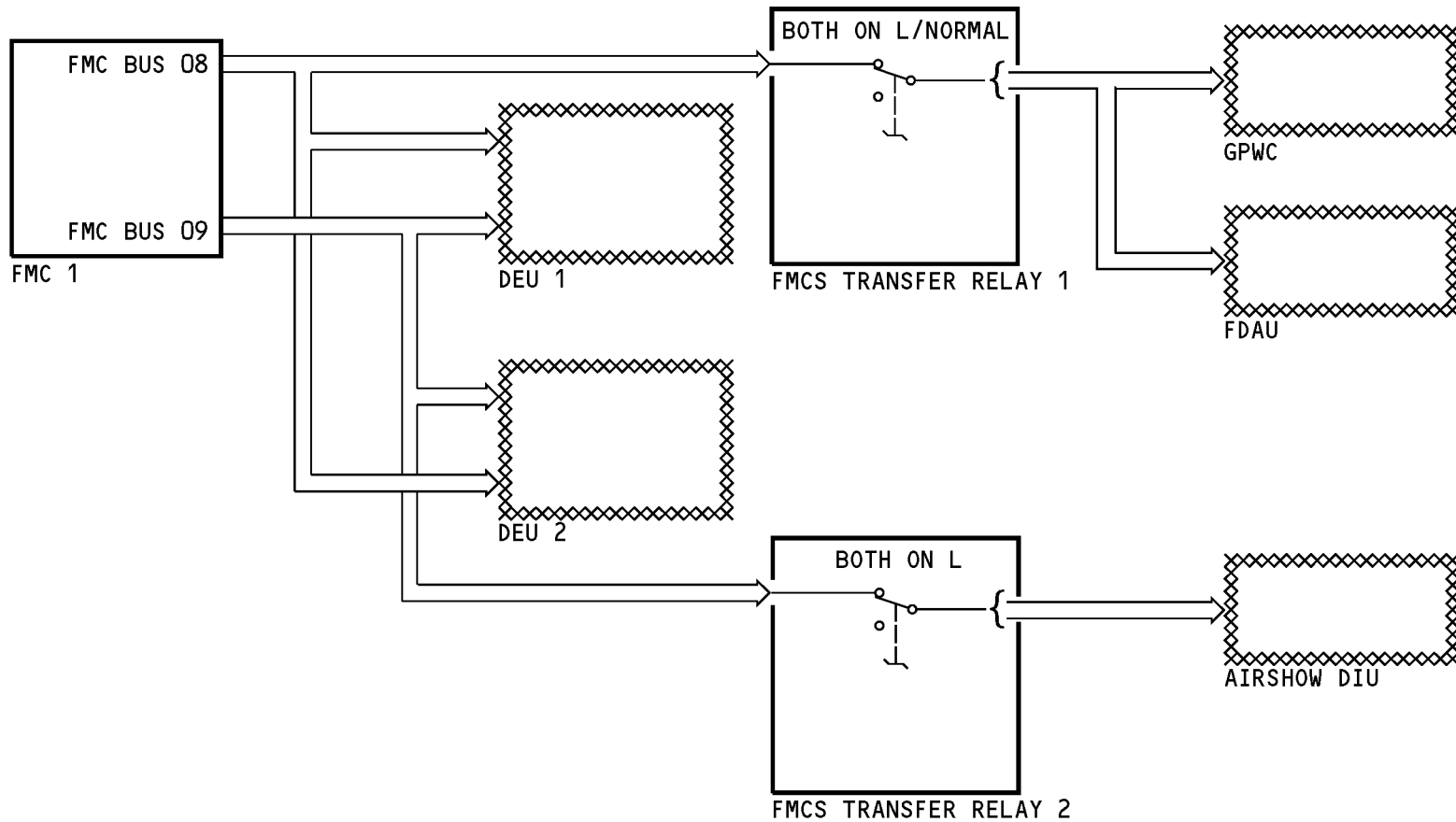

FMCS - DIGITAL OUTPUT INTERFACE - 2

EFFECTIVITY

HAP 028-030; HAP 001-007 POST SB 737-23-1119

34-61-00

34-61-00-010

D633A101-HAP

THIS PAGE IS INTENTIONALLY LEFT BLANK

34-61-00

D633A101-HAP

Page 65
Jun 15/2009

FMCS - CDU INTERFACE**FMC Digital Output****HAP 037-054, 101-999**

When the FMC source select switch is set to the BOTH ON L or the NORMAL position, CDU 1 and CDU 2 get data from FMC 1. When the source select switch is set to the BOTH ON R position, both CDUs get data from FMC 2.

HAP 001-013, 015-026, 028-036

The FMCS transfer relay 1 is mechanically latched to the BOTH ON L/NORMAL position. CDU 1 and CDU 2 get their data from FMC 1.

HAP ALL**FMC Digital Input****HAP 037-054, 101-999**

CDU 1 sends data through the integrated flight system accessory unit (IFSAU) to FMC 1 and FMC 2. This allows a portable CDU to be connected in the electronic equipment compartment in place of CDU 1. CDU 2 sends data directly to both FMCs.

HAP 001-013, 015-026, 028-036

CDU 1 sends data through the integrated flight system accessory unit (IFSAU) to FMC 1. This allows a portable CDU to be connected in the electronic equipment compartment in place of CDU 1. CDU 2 sends data directly to FMC 1.

HAP ALL**CDU Analog Output****HAP 037-054, 101-999**

Each CDU sends an analog discrete to both FMCs to show a failure of the CDU.

HAP 001-013, 015-026, 028-036

Each CDU sends an analog discrete to FMC 1 to show a failure of the CDU.

HAP ALL

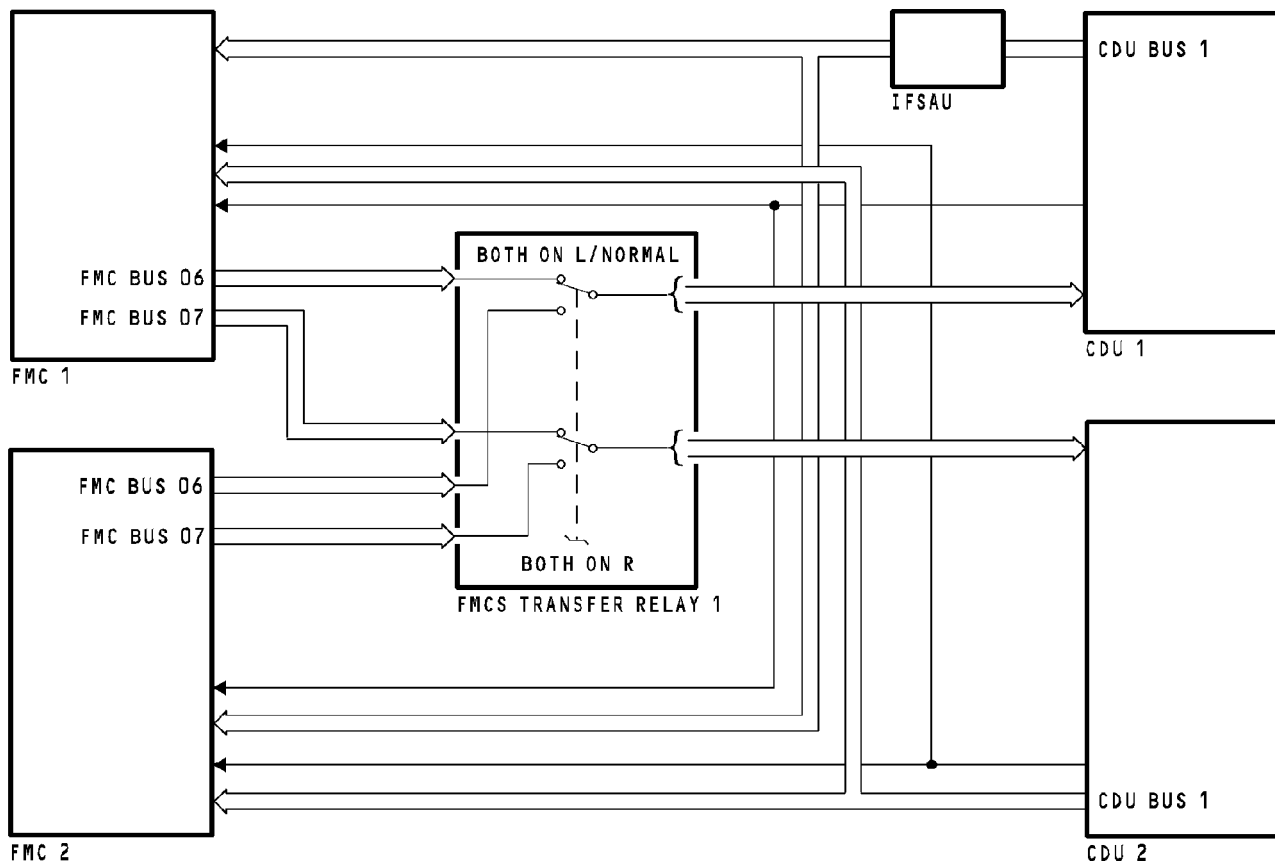

FMCS - CDU INTERFACE

34-61-00-011

EFFECTIVITY
HAP 037-054, 101-999

34-61-00

D633A101-HAP

Page 67
Jun 15/2009

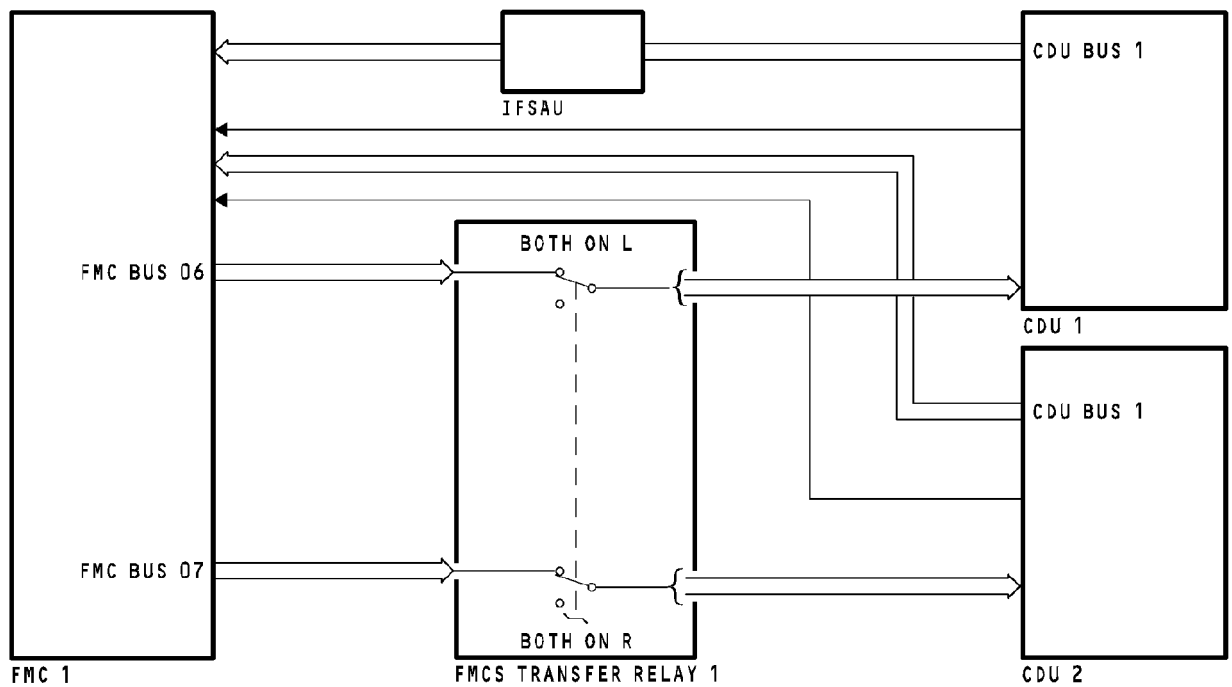

FMCS - CDU INTERFACE

EFFECTIVITY

HAP 001-013, 015-026, 028-036

34-61-00

D633A101-HAP

FMCS - FMC DATA LOADER INTERFACE

General

HAP 031-054, 101-999

The airborne data loader (ADL) connects to the FMCs through the data loader control panel.

HAP 001-013, 015-026, 028-030

You must connect a portable data loader to the data transfer unit receptacle before you can transfer data to or from the FMCs. The receptacle connects the portable data loader to the FMCs through the data loader control panel.

HAP 031-054, 101-999

The data loader gets 115v ac power from the P18 circuit breaker panel. It goes through the data loader control panel to the airborne data loader.

HAP 001-013, 015-026, 028-030

The data loader gets 115v ac power from the P18 circuit breaker panel. It goes through the data loader control panel to the data transfer unit receptacle.

HAP 037-054, 101-999

The data loader digital inputs and output connect to FMC 1 and FMC 2 through the data loader control panel. The control panel must be set to the FMC position to transfer data to and from the FMCs.

HAP 001-013, 015-026, 028-036

The data loader digital inputs and output connect to the FMC through the data loader control panel. The control panel must be set to the FMC position to transfer data to and from the FMC.

HAP 037-054, 101-999

When the data loader 3-position switch is set to the L position, the data is loaded into FMC 1. When the data loader 3-position switch is set to the R position, the data is loaded into FMC 2. The new data base(s) may then be crossloaded between the FMCs.

NOTE: The FMC source select switch on the P5-28 panel must be set in the BOTH ON L or NORMAL positions to see the load progress on the MCDUs if FMC 1 is being loaded. If the 3-position switch is in the R position, the FMC source select switch must be set to BOTH ON R to see the load progress on the MCDUs.

HAP 012, 013, 015-026, 028-036; HAP 001-011 POST SB 737-31-1136

When the 3-position switch is set to the L position, the data is loaded into the FMC.

NOTE: The FMC cannot be loaded with the switch in any other position but L.

34-61-00-012

<p>EFFECTIVITY HAP ALL</p>
--

34-61-00

D633A101-HAP

FMCS - FMC DATA LOADER INTERFACE

HAP 012, 013, 015-026, 028-036; HAP 001-011 POST SB 737-31-1136 (Continued)

HAP 001-011 PRE SB 737-31-1136

The FMCS digital input to the data loader goes through the FMCS transfer relay 1. The transfer relay is mechanically latched to the BOTH ON L position.

A function discrete from the data loader goes through the data loader control panel and the FMC transfer relay 1 to the FMC. This is the load enable signal to the FMC.

HAP 012, 013, 015-026, 028-054, 101-999; HAP 001-011 POST SB 737-31-1136

A function discrete from the data loader goes through the data loader control panel to the FMC. This is the load enable signal to the FMC.

HAP ALL

The data loader control panel also has other digital inputs and outputs to other airplane systems. In this way, these other systems can be updated through the data loader.

34-61-00-012



34-61-00

D633A101-HAP

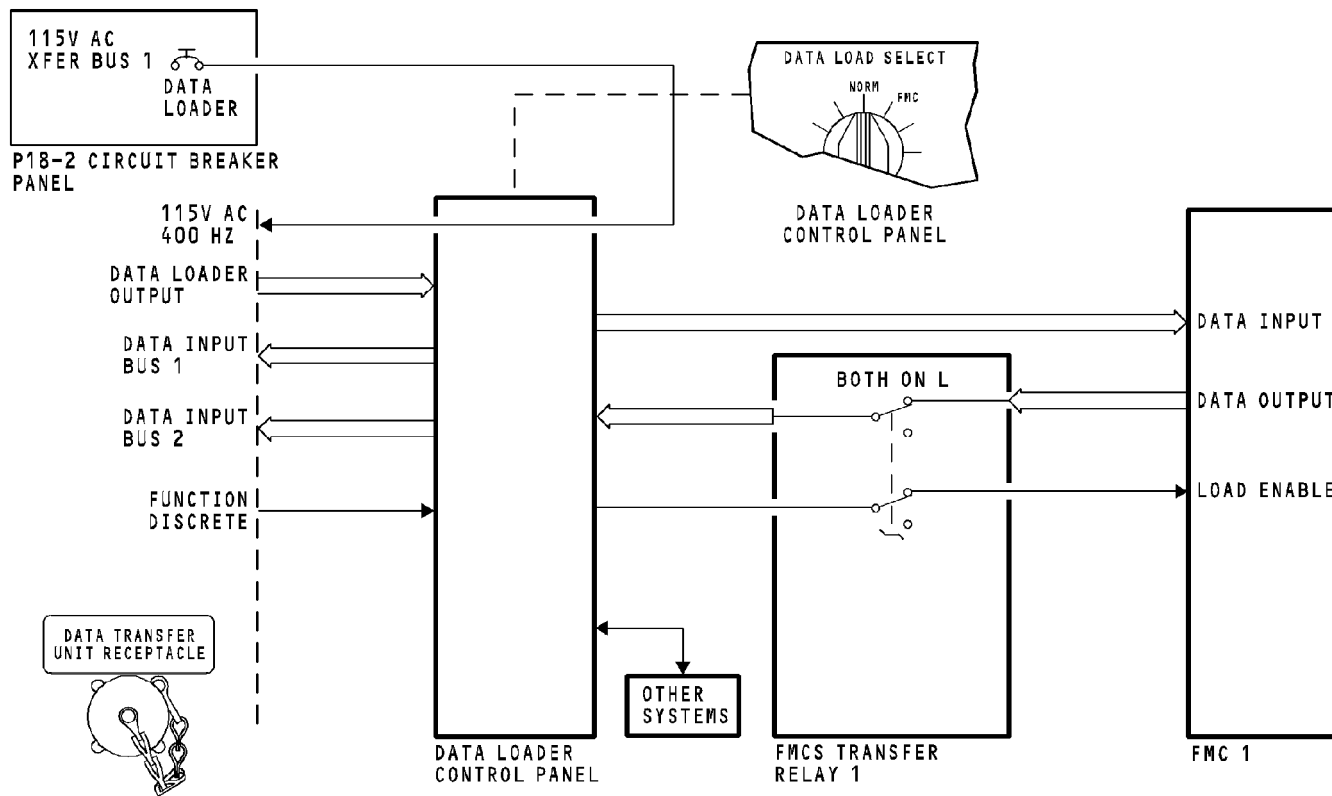

FMCS - FMC DATA LOADER INTERFACE

34-61-00-012

EFFECTIVITY
HAP 001-011 PRE SB 737-31-1136

34-61-00

D633A101-HAP

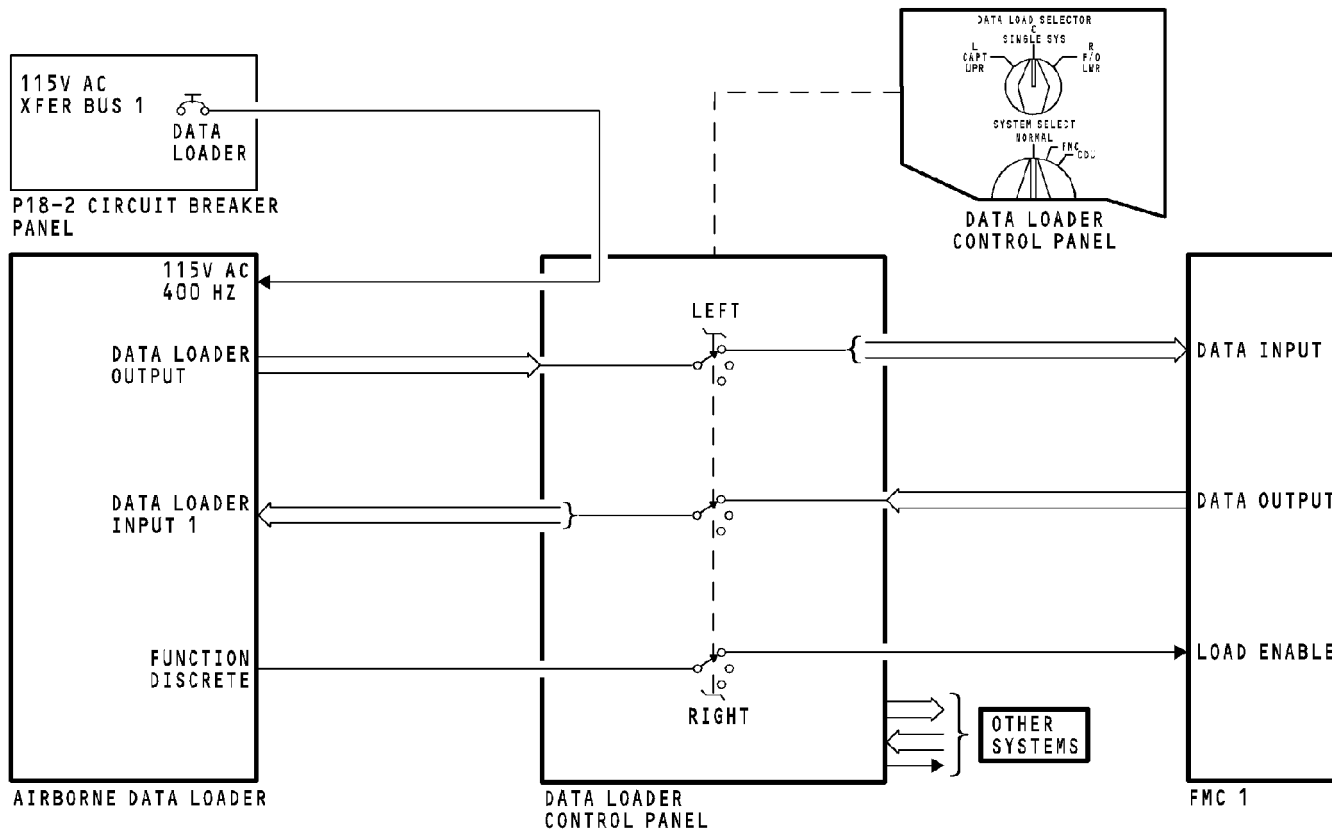

FMCS - FMC DATA LOADER INTERFACE

EFFECTIVITY
HAP 031-036

34-61-00

D633A101-HAP

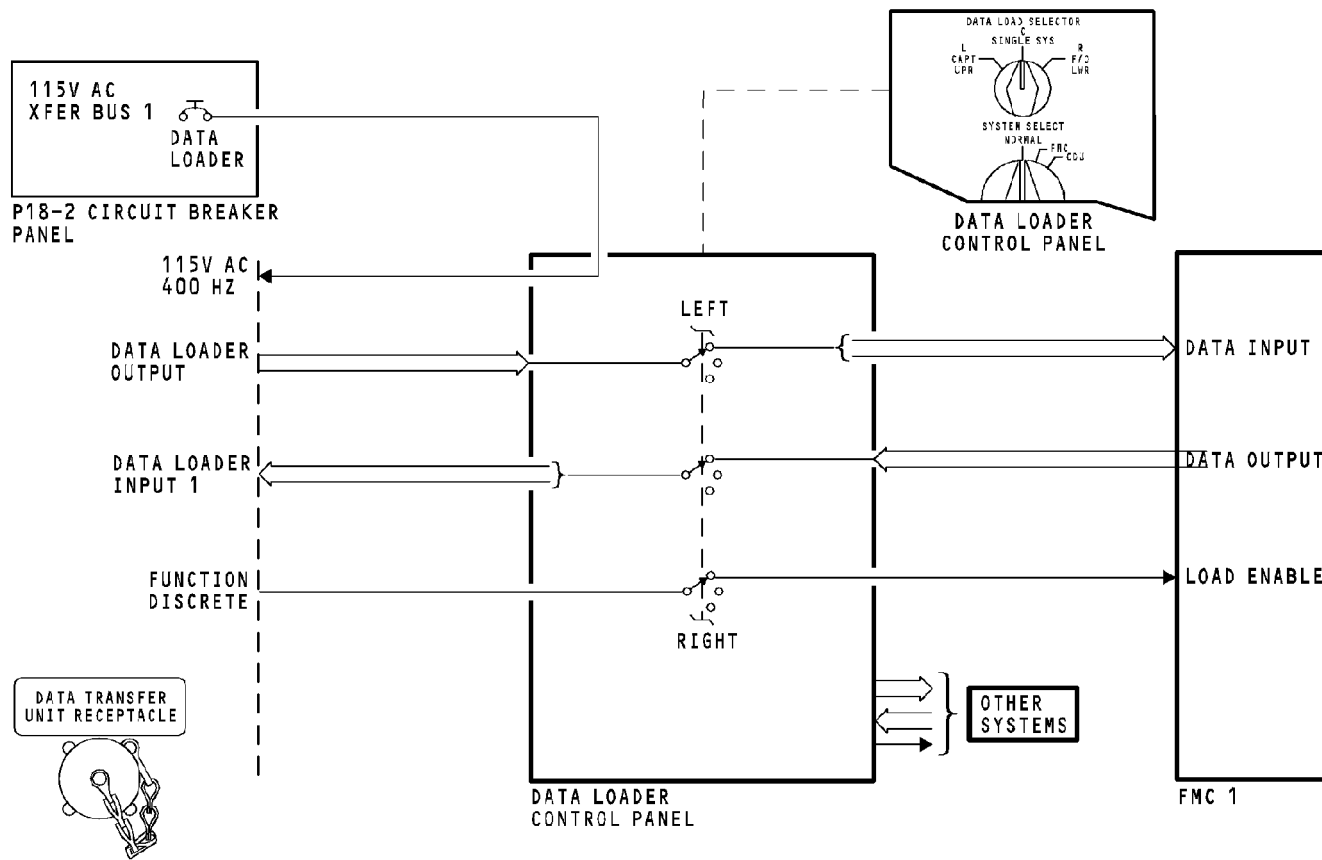

FMCS - FMC DATA LOADER INTERFACE

EFFECTIVITY

HAP 012, 013, 015-026, 028-030; HAP 001-011 POST SB 737-31-1136

34-61-00

D633A101-HAP

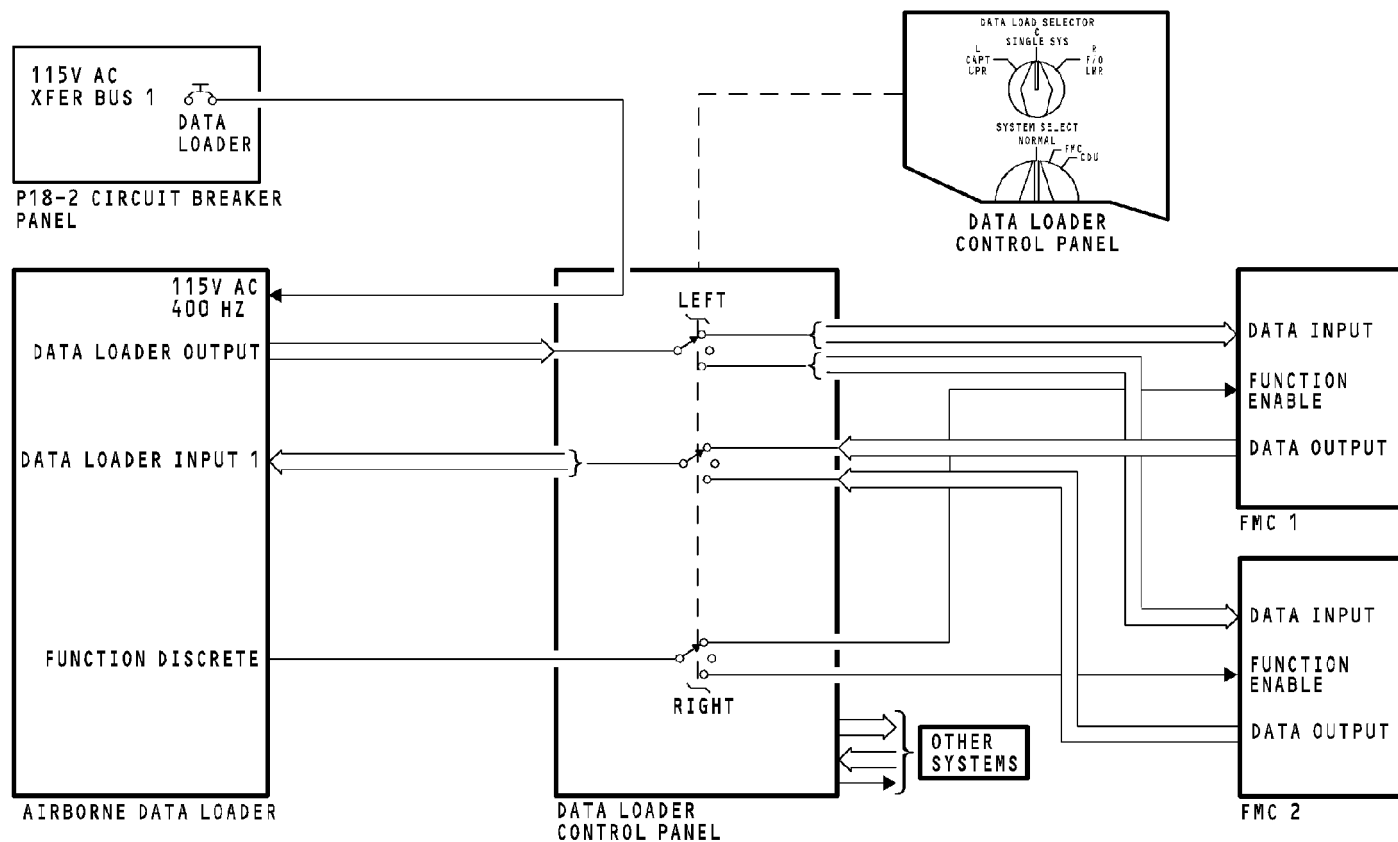

FMCS - FMC DATA LOADER INTERFACE

EFFECTIVITY
HAP 037-054, 101-999

34-61-00

D633A101-HAP

FMCS - CDU DATA LOADER INTERFACE

General**HAP 031-054, 101-999**

The airborne data loader (ADL) connects to the CDUs through the data loader control panel.

HAP 012, 013, 015-026, 028-030; HAP 006-011 POST SB 737-31-1136; HAP 001-005 POST SB 737-34-1951 GRP 1 AND POST SB 737-31-1136

You connect a portable data loader to the data transfer unit receptacle to transfer data to or from the CDUs. The receptacle connects the portable data loader to the CDUs through the data loader control panel.

HAP 031-054, 101-999

The data loader gets 115v ac power from the P18 circuit breaker panel. It goes through the data loader control panel to the airborne data loader.

HAP 012, 013, 015-026, 028-030; HAP 006-011 POST SB 737-31-1136; HAP 001-005 POST SB 737-34-1951 GRP 1 AND POST SB 737-31-1136

The data loader gets 115v ac power from the P18 circuit breaker panel. It goes through the data loader control panel to the data transfer unit receptacle.

HAP 012, 013, 015-026, 028-054, 101-999; HAP 006-011 POST SB 737-31-1136; HAP 001-005 POST SB 737-34-1951 GRP 1 AND POST SB 737-31-1136

The data loader digital input and output connect to CDU 1 and CDU 2 through the data loader control panel. The control panel must be set to the CDU position to transfer data to the CDUs.

When the data loader 3-position switch is set to the L position, the data is loaded into CDU 1. When the data loader 3-position switch is set to the R position, the data is loaded into CDU 2.

A function discrete from the data loader goes through the data loader control panel to the CDU. This is the load enable signal to the CDU.

Also, a system 1 air/ground relay provides a ground to the CDU to enable the loader function when the airplane is on the ground.

EFFECTIVITY

HAP 012, 013, 015-026, 028-054, 101-999; HAP 006-011 POST SB 737-31-1136; HAP 001-005 POST SB 737-34-1951 GRP 1 AND POST SB 737-31-1136

34-61-00

D633A101-HAP

Page 75
Jun 15/2009



FMCS - CDU DATA LOADER INTERFACE

The data loader control panel also has other digital inputs and outputs to other airplane systems. In this way, these other systems can be updated through the data loader.

34-61-00-091

EFFECTIVITY

HAP 012, 013, 015-026, 028-054, 101-999; HAP 006-011 POST SB 737-31-1136; HAP 001-005 POST SB 737-34-1951 GRP 1 AND POST SB 737-31-1136

34-61-00

D633A101-HAP

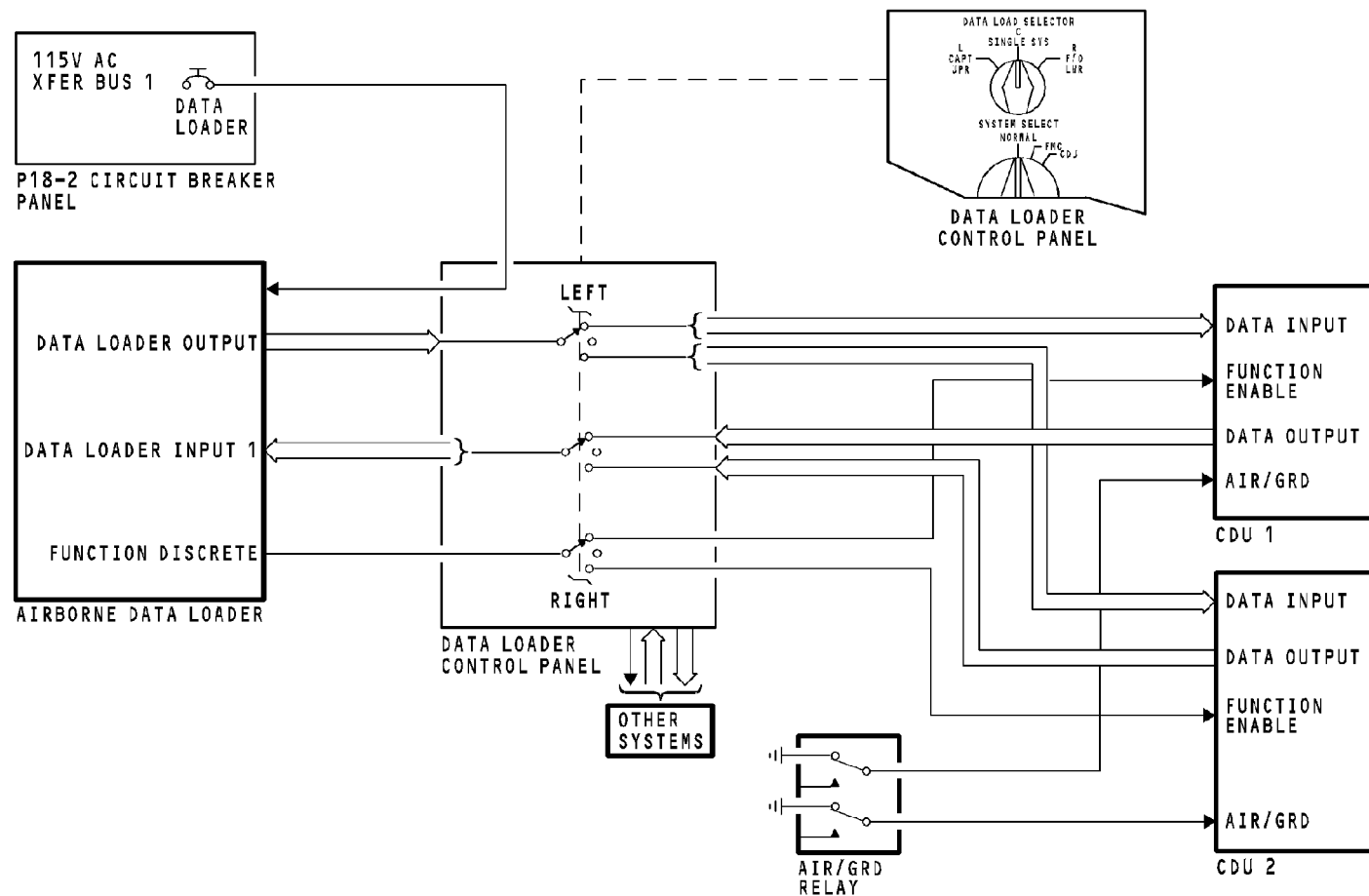

FMCS - CDU DATA LOADER INTERFACE

34-61-00-091

EFFECTIVITY
HAP 031-054, 101-999

34-61-00

D633A101-HAP

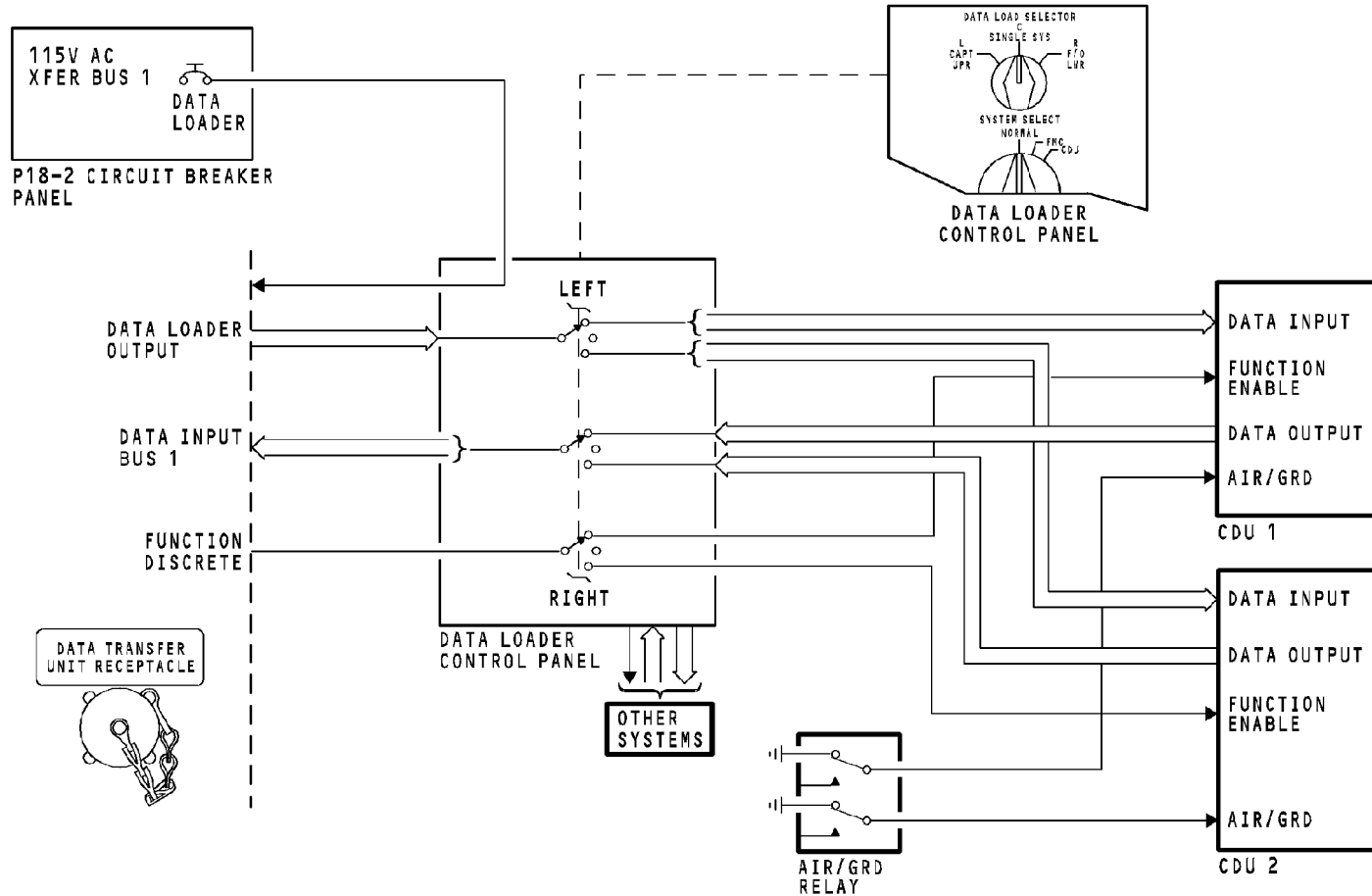

FMCS - CDU DATA LOADER INTERFACE

EFFECTIVITY

HAP 012, 013, 015-026, 028-030; HAP 006-011 POST SB 737-31-1136; HAP 001-005 POST SB 737-34-1951 GRP 1 AND POST SB 737-31-1136

34-61-00

D633A101-HAP

FMCS - ACARS INTERFACE

HAP **General**

HAP ACARS data for THE CDUs is direct and does not go through the
 HAP transfer relays. Uplink and downlink data is sent through the
 HAP transfer relay 1.

HAP **Data Output**

HAP The bus 02 has this data:

- HAP ● Distance to go (waypoint)
- HAP ● Groundspeed
- HAP ● VOR/DME frequencies
- HAP ● Set latitude
- HAP ● Set longitude
- HAP ● Set magnetic heading
- HAP ● Origin/destination
- HAP ● Destination runway
- HAP ● Destination estimated time of arrival (ETA)
- HAP ● Gross weight
- HAP ● Total fuel
- HAP ● FMC target altitude
- HAP ● FMC target airspeed
- HAP ● FMC target mach number
- HAP ● Horizontal command
- HAP ● Vertical speed command
- HAP ● Desired track
- HAP ● Waypoint bearing
- HAP ● Cross-track deviation
- HAP ● Vertical deviation
- HAP ● Magnetic track angle
- HAP ● Drift angle

- GMT
- Date
- Static air temperature (SAT)
- Selected temperature
- Flight number
- Minimum airspeed
- Minimum buffet airspeed
- Maximum buffet airspeed
- Continuous N1 limit
- Go-around N1 limit
- Cruise N1 limit
- Climb N1 limit
- Target N1
- NDB effectivity
- BITE test word
- FMC discretes.

HAP
 HAP
 HAP
 HAP
 HAP

The FMC discretes have this data:

- IAS/mach
- Engine out engaged
- Landing flaps selected
- Manual N1 select
- Level decel
- Autothrottle to idle arm
- Autothrottle to arm
- FMC vertical speed
- N1 limit mode
- Speed on elevator
- Reduced thrust (derate)
- Level change request
- VNAV valid

34-61-00-013

<p>EFFECTIVITY HAP 001-013, 015-026, 028-030</p>
--

34-61-00

D633A101-HAP

FMCS - ACARS INTERFACE

- Thrust cutback enable
- Initiate thrust cutback.

The bus 05 has FMC system status.

HAP **ACARS**

HAP The FMC/ACARS interface allows the receipt (uplink) and
HAP transmission (downlink) of FMC data from or to the customers
HAP ground computers via the ACARS management unit.

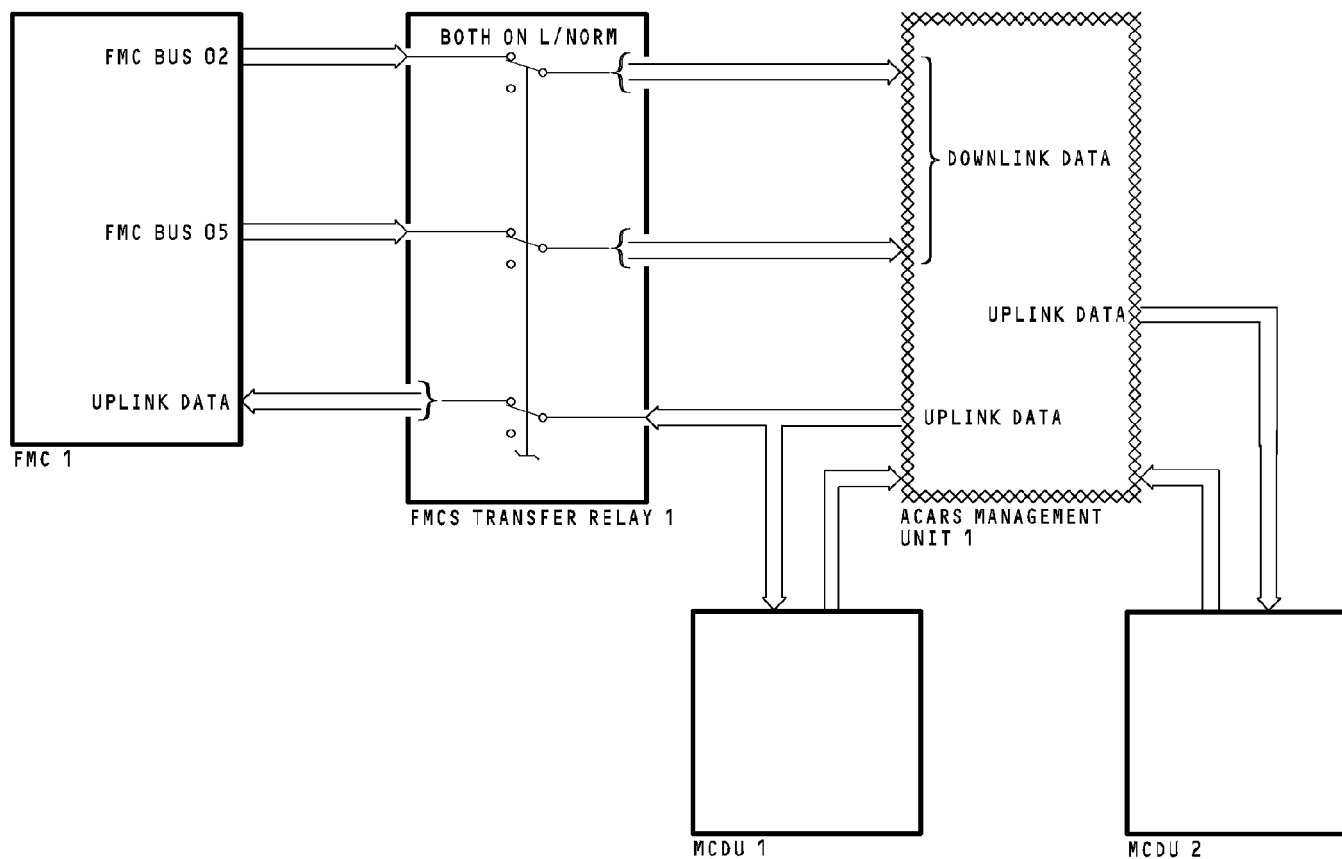

FMCS - ACARS INTERFACE

34-61-00-013

EFFECTIVITY
HAP 001-013, 015-026, 028-030

34-61-00

D633A101-HAP

FMCS - ANALOG DISCRETES**General**

Inputs from switches and valves give engine bleed air data to the FMCS. The FMCS uses these signals to calculate the N1 limits for the engines.

The program pin selectable options customize the FMCS to the airline configuration.

The proximity switch electronics unit (PSEU), supplies an air/ground discrete input to the FMCS to set flight leg count. The air/ground discrete also goes to the FMC to inhibit data load in the air.

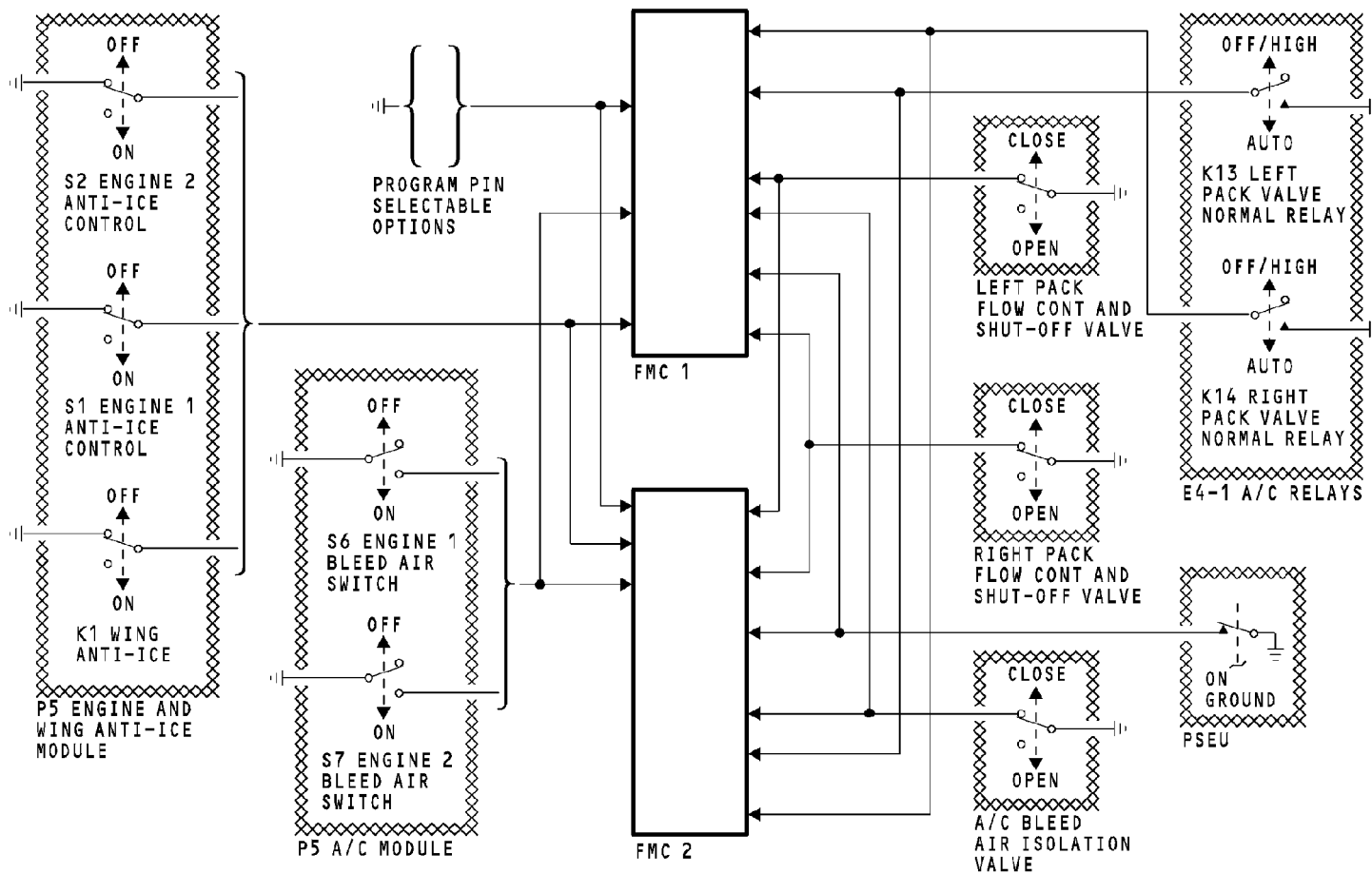

FMCS - ANALOG DISCRETES

34-61-00-014

EFFECTIVITY
HAP 037-054, 101-999

34-61-00

D633A101-HAP

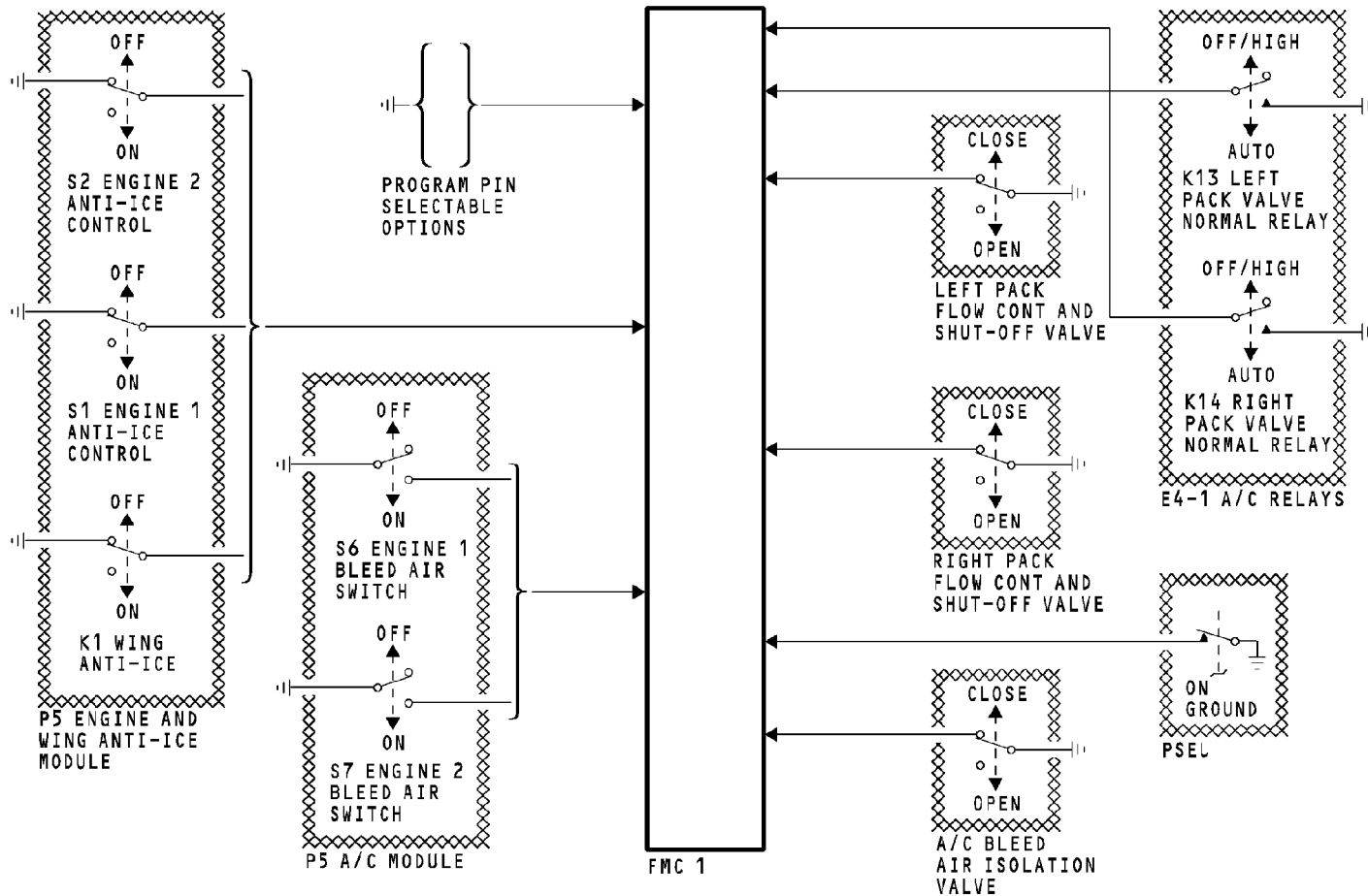

FMCS - ANALOG DISCRETES

EFFECTIVITY

HAP 001-013, 015-026, 028-036

34-61-00

34-61-00-014

D633A101-HAP

THIS PAGE IS INTENTIONALLY LEFT BLANK

34-61-00

D633A101-HAP

Page 85
Jun 15/2009

FMCS - STATUS ANNUNCIATOR INTERFACE**General**

The autoflight status annunciators (ASAs), have three warning lights. The warning lights are push to reset. The ASA also has a TEST switch.

The ASAs show a change of condition for these systems:

- Autopilot
- Autothrottle
- Flight management computer system (FMCS).

FMCS

The FMC warning light is amber when an FMC has an alert message or when an FMC fails. The light also comes on when you put the TEST switch in position 1 or 2.

Push the FMC warning light to reset the latch and turn the light off.

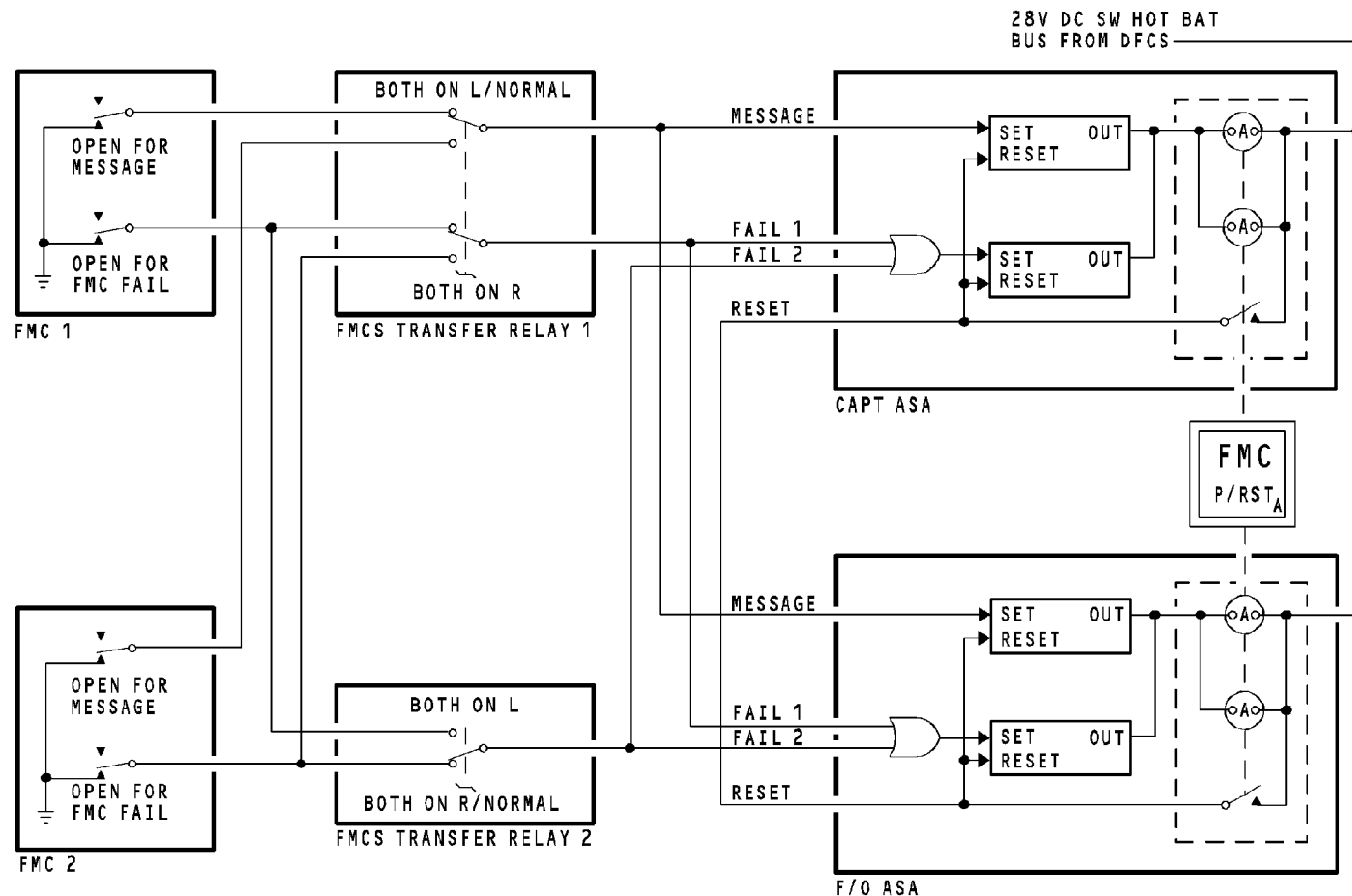

FMCS - STATUS ANNUNCIATOR INTERFACE

34-61-00-015

EFFECTIVITY
HAP 037-054, 101-999

34-61-00

D633A101-HAP

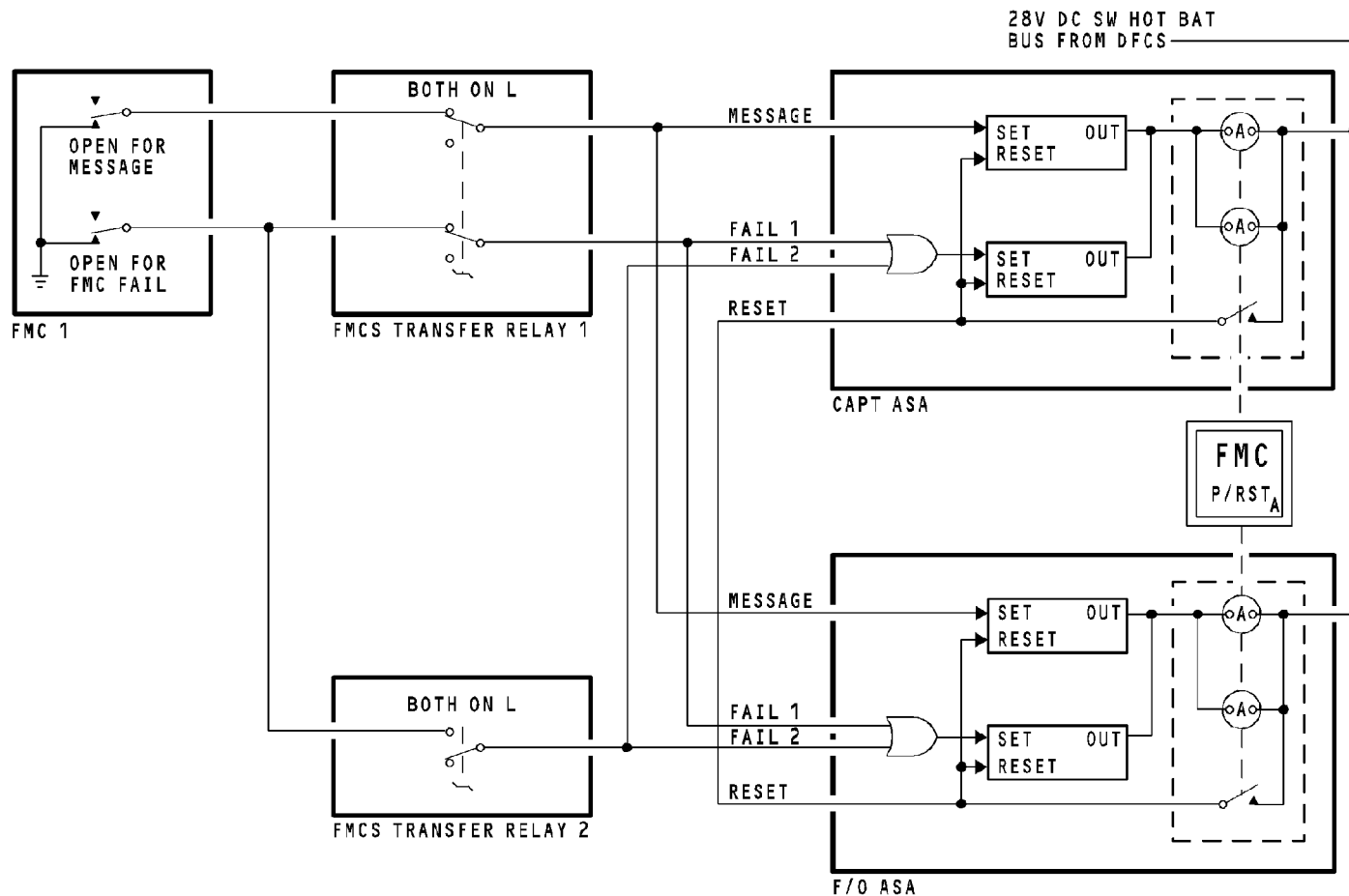

FMCS - STATUS ANNUNCIATOR INTERFACE

EFFECTIVITY

HAP 001-013, 015-026, 028-036

34-61-00

34-61-00-015

D633A101-HAP

THIS PAGE IS INTENTIONALLY LEFT BLANK

34-61-00

D633A101-HAP

Page 89
Jun 15/2009

FMCS - PROGRAM PIN INTERFACE**General**

FMCS hardware program pin options are set with the FMC program switch modules. The program pins customize the FMCS to your airline configuration.

NOTE: Program pin status can be verified on the FMCS BITE analog discrettes pages and model engine configuration pages on the CDU.

Options

These are your FMCS options:

HAP 101-999

- Airplane model 737-700

HAP 001-013, 015-026, 028-054

- Airplane model 737-800

I HAP 101, 104-106 PRE SB 737-71-1612

- Thrust rating 20,000

I HAP 102, 103, 107-999; HAP 101, 104-106 POST SB 737-71-1612

- Thrust rating 22,000

HAP 010-013, 015-017, 028-036, 041, 047-050, 053, 054; HAP 001-009 POST SB 737-71-1455 OR (PRE SB 737-71-1395 AND PRE SB 737-71-1455); HAP 018-026 POST SB 737-71-1455; HAP 037, 039, 040 PRE SB 737-71-1605

- Thrust rating 26,400

HAP 038, 042-046, 051, 052; HAP 001-009 POST SB 737-71-1395 AND PRE SB 737-71-1455; HAP 010-013, 015-026 PRE SB 737-71-1455; HAP 037, 039, 040 POST SB 737-71-1605

- Thrust rating 27,300

HAP 101-999

- Standard brakes

HAP 001-013, 015-026, 028-054

- Heavy duty brakes

HAP ALL

- Engine single combustor
- Performance code 1
- Source/Destination Identifier

HAP 001-013, 015-026, 028-036

- Single FMC

HAP 037-054, 101-999

- Dual FMC

HAP 041, 047-053, 101-999; HAP 006, 007, 010-013, 015, 016, 031-037, 039, 040 PRE SB 737-34-2083; HAP 008, 009, 017-026, 028-030, 038, 042-046, 054 PRE SB 737-34-2107

- JAA flight rules

HAP 006, 007, 010-013, 015, 016, 031-037, 039, 040 POST SB 737-34-2083; HAP 001, 002, 008, 009, 017-026, 028-030, 038, 042-046, 054 POST SB 737-34-2107

- FAA flight rules

HAP 001-013, 015-026, 028-030, 050, 053, 054

- Runway position update on TOGA

HAP 031-049, 051, 052, 101-999

- Runway position update with CDU

HAP 001-005

- Takeoff profile

HAP ALL

- Weight in kilograms
- Degrees C default

HAP 031-054, 101-999

- Autotune navaid suppression on EFIS

HAP ALL

- Selected course radial shown on the navigation display
- Flight number entry

FMCS - PROGRAM PIN INTERFACE**HAP 001-013, 015-026, 028-030**

- ACARS installed

HAP 012, 013, 015-026, 028-054, 101-999; HAP 001-011 POST SB 737-31-1136

- SELECT CONFIG Mode.

HAP ALL**Configuration Options**

The airframe/engine configuration is found by a combination of eight program pins. This combination sets these conditions:

- Airplane model
- Engine thrust
- Engine combustor type
- Brake type.

The next generation 737 program pin determines that the aero/propulsion data is stored in the model engine data base (MEDB).

The airframe/engine parity pin determines that the airframe/engine configuration is valid. Odd parity is used.

The performance option code defines levels of reduced climb thrust so that climb thrust can not be more than take off thrust.

The source/destination identifier identifies the FMC as left or right. It is always set to left.

Computation Options**HAP 041, 047-053, 101-999; HAP 006, 007, 010-013, 015, 016, 031-037, 039, 040 PRE SB 737-34-2083; HAP 008, 009, 017-026, 028-030, 038, 042-046, 054 PRE SB 737-34-2107**

The JAA flight rules option sets the default values for cruise center of gravity (CG) and maneuver margin.

HAP 006, 007, 010-013, 015, 016, 031-037, 039, 040 POST SB 737-34-2083; HAP 001, 002, 008, 009, 017-026, 028-030, 038, 042-046, 054 POST SB 737-34-2107

The FAA flight rules option sets the default values for cruise center of gravity (CG) and maneuver margin.

HAP 001-013, 015-026, 028-030, 050, 053, 054

The runway position update on TOGA option enables the FMC to update the FMC position to the present runway position when the TOGA switch is pushed.

HAP 031-049, 051, 052, 101-999

The runway position update with CDU option lets the flight crew update the FMC position through the CDU.

FMCS - PROGRAM PIN INTERFACE**HAP 031-049, 051, 052, 101-999 (Continued)****HAP 001-005**

The takeoff profile option lets the FMC control the altitude at which thrust is decreased from T/O thrust to climb thrust.

HAP ALL**Display Options**

The kilogram weight option sets the weight default for CDU entries.

The degrees C default option sets the temperature default for CDU entries.

HAP 031-054, 101-999

The autotune navaid suppression option inhibits the display of autotuned nav aids on the CDS map display.

HAP ALL

The selected course option displays the selected course radials for manually tuned nav aids on the navigation display.

Interface Options

The flight number entry option lets the crew enter flight number which shows on the PROGRESS pages.

The ACARS installed option enables the interface between the MCDU and the ACARS management unit.

HAP 012, 013, 015-026, 028-054, 101-999; HAP 001-011 POST SB 737-31-1136

The SEL CONFIG mode option is used to see the configuration data for the loadable software of a non FMC system.

HAP ALL

EFFECTIVITY
HAP ALL

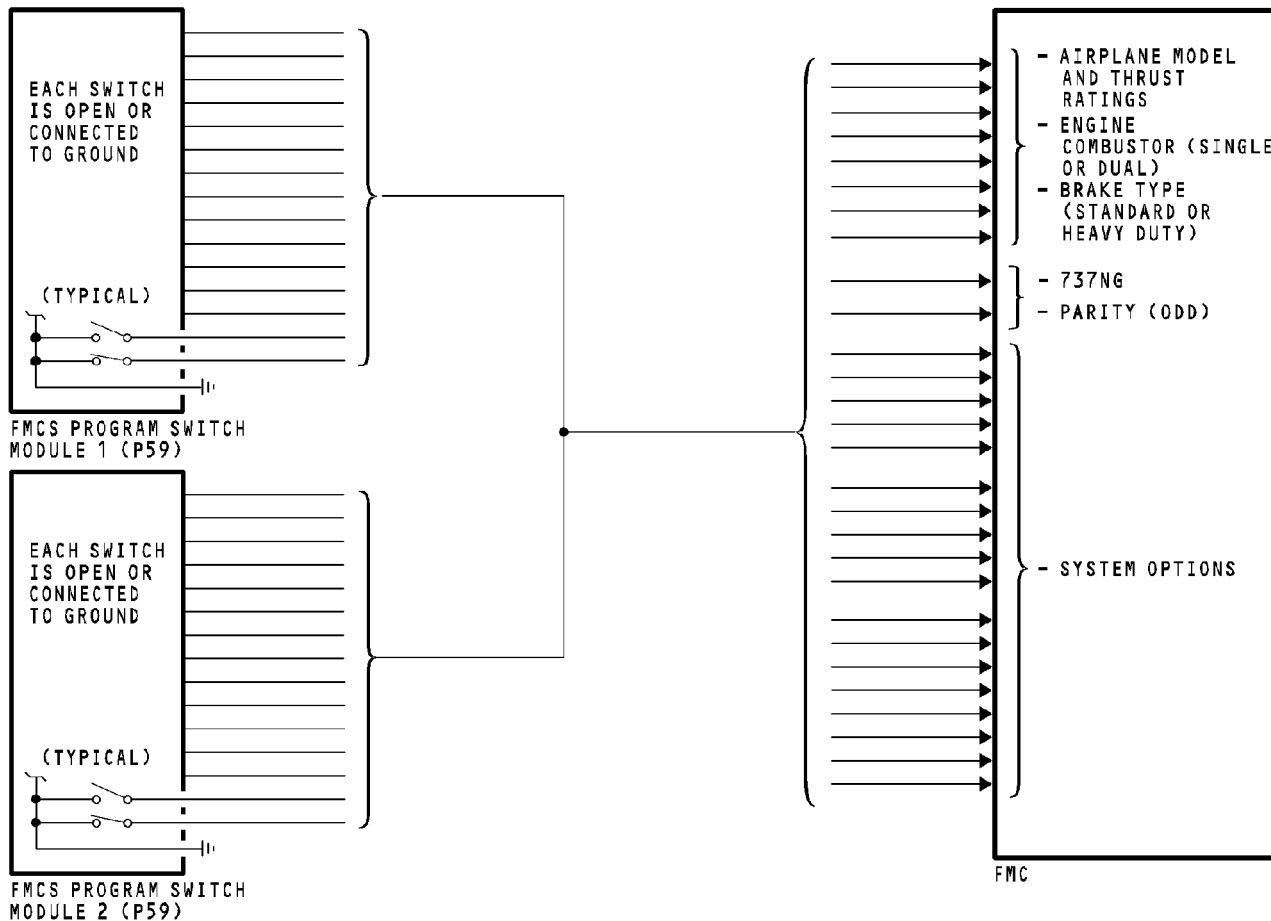

FMCS - PROGRAM PIN INTERFACE

34-61-00-016

EFFECTIVITY
HAP 001-013, 015-026, 028-036

34-61-00

D633A101-HAP

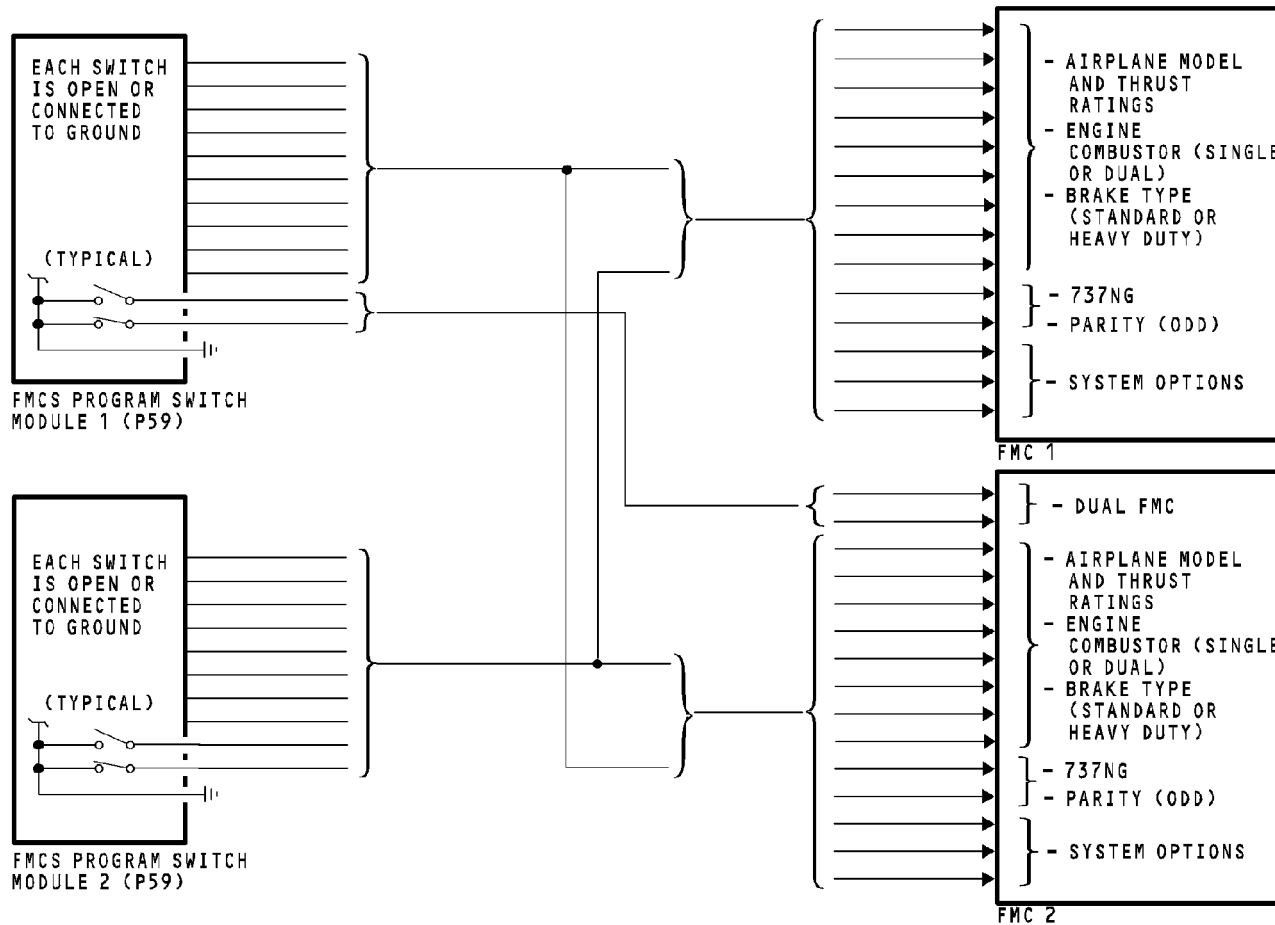

FMCS - PROGRAM PIN INTERFACE

EFFECTIVITY
HAP 037-054, 101-999

34-61-00

D633A101-HAP

THIS PAGE IS INTENTIONALLY LEFT BLANK

34-61-00

D633A101-HAP

Page 95
Jun 15/2009

FMCS - BITE PRINTER AND PORTABLE CDU RECEPTACLES**Printer Receptacle**

You can connect a portable printer to the BITE printer receptacle connector on the P-18 panel. When the printer is connected, you can print CDU and FMC data.

The printer is supplied by the customer.

Portable CDU Receptacle

You can connect a portable CDU to the portable CDU receptacle connector in the main electronic equipment compartment. With the CDU connected, you can do maintenance BITE in the electronic equipment compartment.

The portable CDU is supplied by the customer.

NOTE: Data will still show on CDU 1 while the portable CDU is connected.

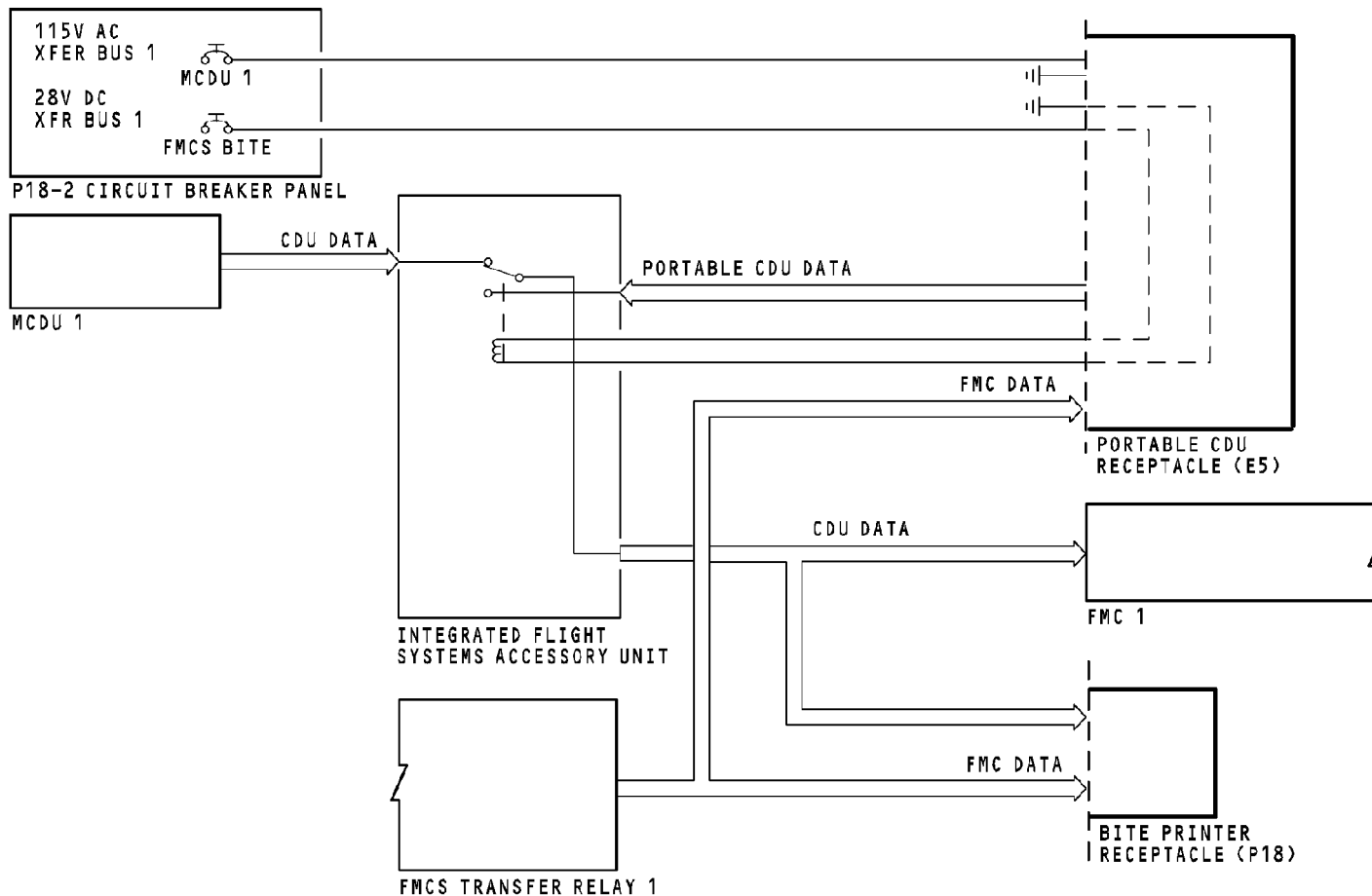

FMCS - BITE PRINTER AND PORTABLE CDU RECEPTACLES

34-61-00-053

EFFECTIVITY
HAP 001-013, 015-026, 028-036

34-61-00

D633A101-HAP

Page 97
Jun 15/2009

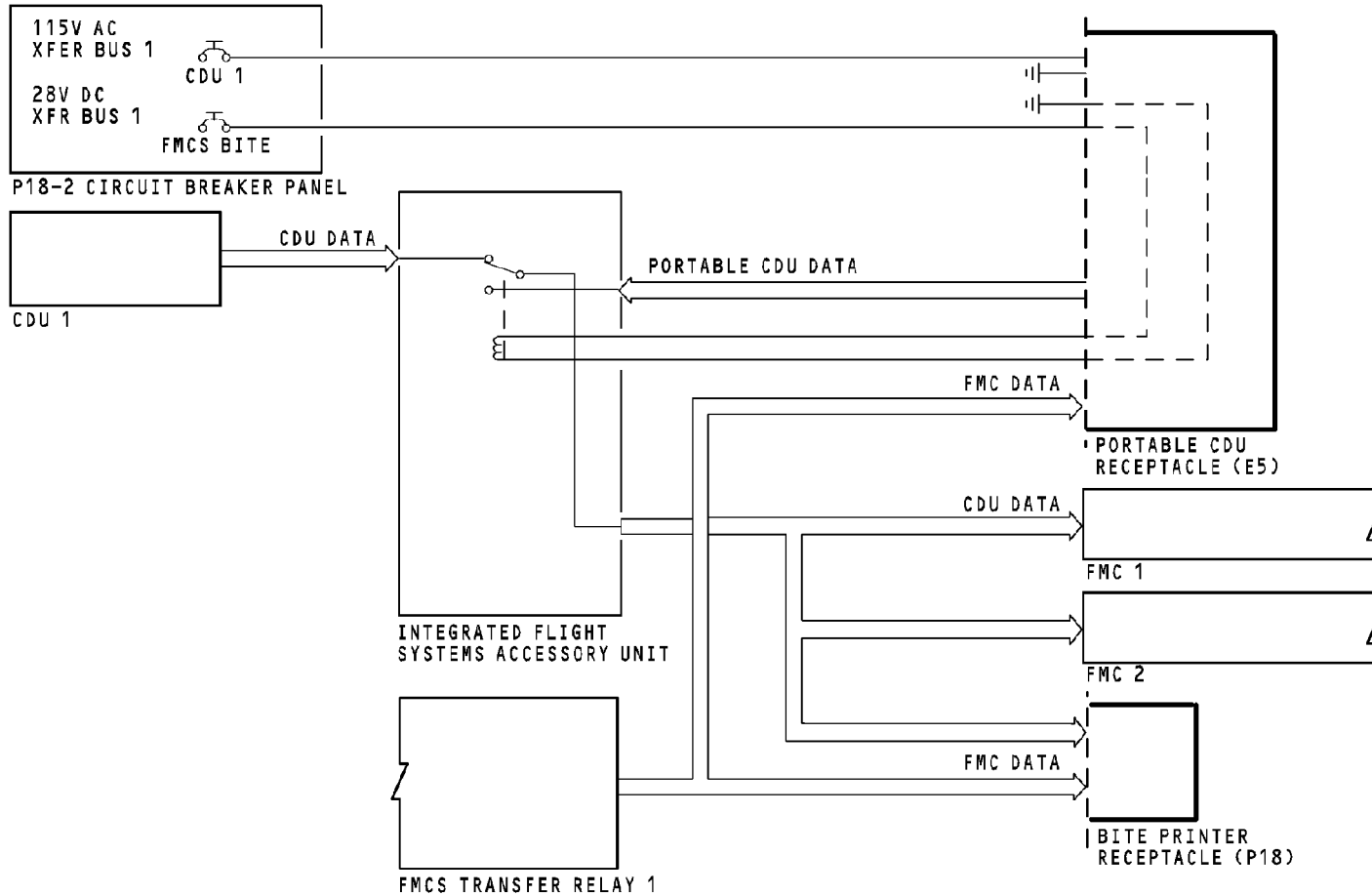

FMCS - BITE PRINTER AND PORTABLE CDU RECEPTACLES

EFFECTIVITY
HAP 037-054, 101-999

34-61-00

D633A101-HAP

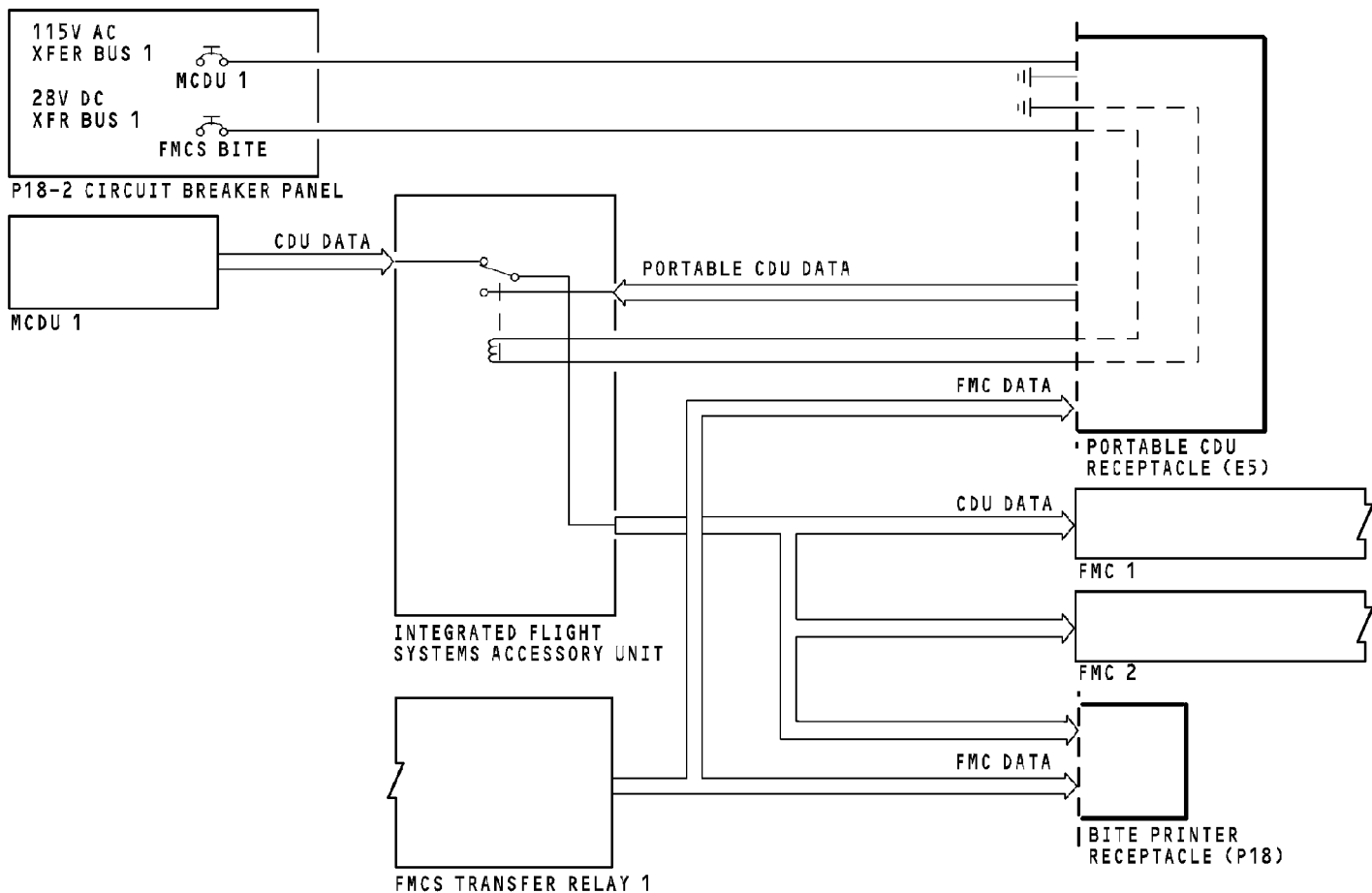

FMCS - BITE PRINTER AND PORTABLE CDU RECEPTACLES

34-61-00-053

EFFECTIVITY
HAP 037-054, 101-999

34-61-00

D633A101-HAP

Page 98.1
Jun 15/2009

FMCS - FLIGHT MANAGEMENT COMPUTER**Purpose**

The FMC uses data from the airplane sensors and data stored in the FMC to do the calculations for navigation, performance, and guidance of the airplane.

Physical Description

The FMC is a rack-mounted chassis assembly in an ARINC 600, 4 MCU box. It weighs less than 22 pounds (10 kilograms). It uses 115V AC, 400 Hz single phase electrical power.

HAP 037-054, 101-999

The FMCs are cooled with air from the equipment cooling supply and exhaust systems. Cooling air for FMC 1 is blow-through. Cooling air for FMC 2 is draw-through.

HAP 001-013, 015-026, 028-036

The FMC is cooled with air from the equipment cooling supply system.

HAP ALL

Two green light emitting diodes (LEDs) show through openings in the front of the unit. The PWR ON LED comes on when the FMC has power. The FMC VALID LED comes on after power is on and the unit passes internal tests.

CAUTION: FAILURE TO OBSERVE ELECTROSTATIC DISCHARGE PRECAUTIONARY PROCEDURES WHEN TOUCHING, REMOVING, OR INSERTING PARTS OF ASSEMBLIES, MAY RESULT IN DEGRADATION OR FAILURE OF THE FMC.

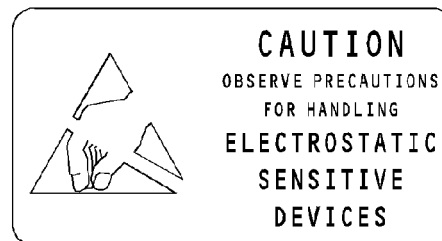
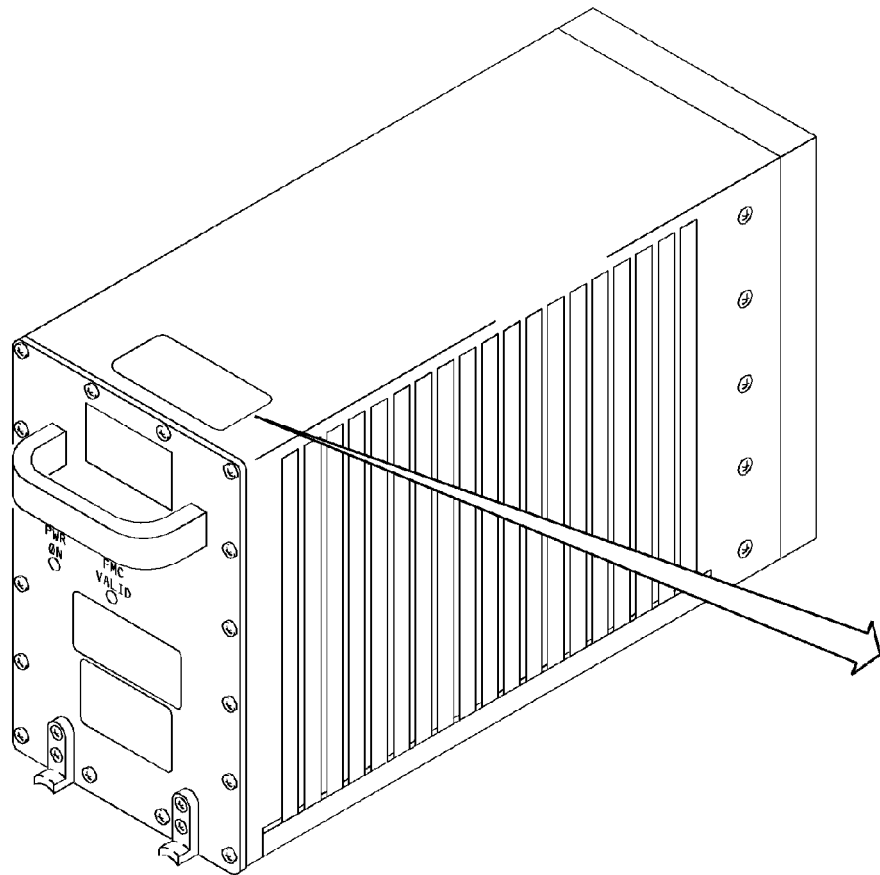

FMCS - FLIGHT MANAGEMENT COMPUTER

34-61-00-017

EFFECTIVITY
HAP ALL

34-61-00

D633A101-HAP

Page 98.3
Jun 15/2009

THIS PAGE IS INTENTIONALLY LEFT BLANK

34-61-00

D633A101-HAP

Page 98.4
Jun 15/2009

FMCS - FLIGHT MANAGEMENT COMPUTER - FUNCTIONAL DESCRIPTION**General**

These are the primary components of the FMC:

- Processor card
- Memory card
- ARINC I/O module
- Power supply.

Processor Card

The primary components of the processor card are the processor and the application specific integrated circuit (ASIC).

The processor card does these functions:

- Flight plan management
- Navigation and navaid tuning function
- Performance management function
- Guidance function
- Control and display functions.

The processor card also has the memory for the FMC boot and maintenance programs. The random access memory (RAM) is used for the scratchpad memory.

HAP 001-013, 015-026, 028-036

The processor card ASIC controls the real time clock and the system reset and power down logic. It also controls the MAINT BITE processing.

HAP 037-054, 101-999

The ASIC controls the intersystem bus (ISB) between the two FMCs and the MAINT BITE processing. It also controls the real time clock and the system reset and power down logic.

HAP ALL**Memory Card**

The memory card contains the memory used for the storage of the operational flight program (OFF). It also contains these data bases:

- Navigation data base (NDB)
- Model/Engine data base (MEDB)
- ACARS datalink data base
- Software options data base.

All memory on the memory card is electrically erasable programmable read only memory (EEPROM).

ARINC I/O Card

The I/O card does all the functions necessary for communication between the FMC and external systems. The card is divided into a discrete I/O function and an ARINC 429 I/O function.

EFFECTIVITY
HAP ALL

FMCS - FLIGHT MANAGEMENT COMPUTER - FUNCTIONAL DESCRIPTION

The I/O card also includes an ASIC which acts as the primary controller for the I/O function. There are 16 ARINC 429 output drivers, 32 ARINC input translators, 6 discrete outputs and 6 discrete inputs.

An LED on the I/O card comes on when there is a BIT failure.

Power Supply

The power supply uses 115v ac, single phase from the aircraft electrical system. It supplies + 5v dc, + 15v dc and -15v dc to internal components of the FMC. Total output power is 40 watts. There is a 50 microsecond hold up feature for short term power interrupts.

An LED on the power supply card comes on when the power supply is valid.

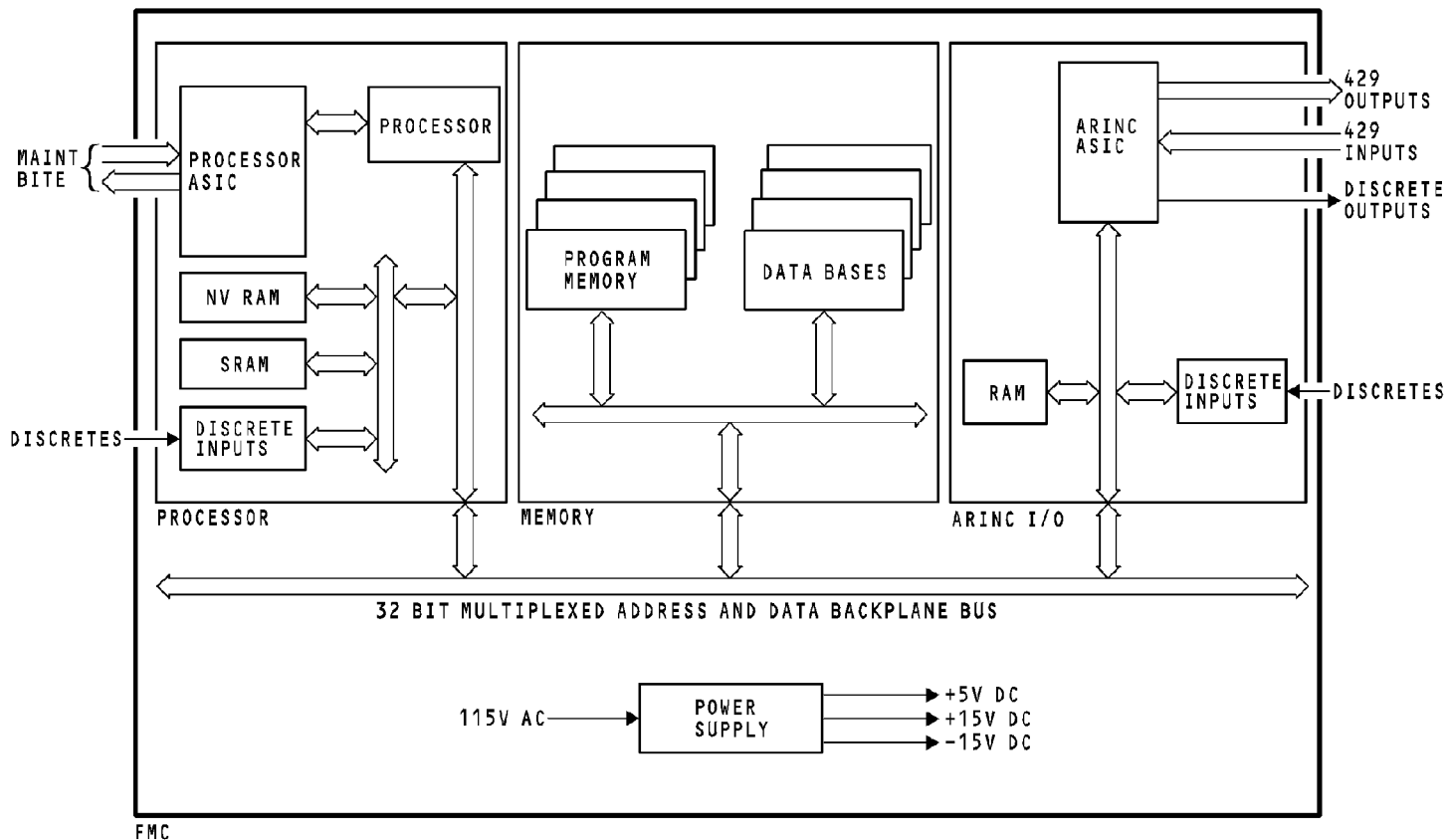

FMCS - FLIGHT MANAGEMENT COMPUTER - FUNCTIONAL DESCRIPTION

EFFECTIVITY
HAP 001-013, 015-026, 028-036

34-61-00

D633A101-HAP

Page 98.7
Jun 15/2009

34-61-00-018

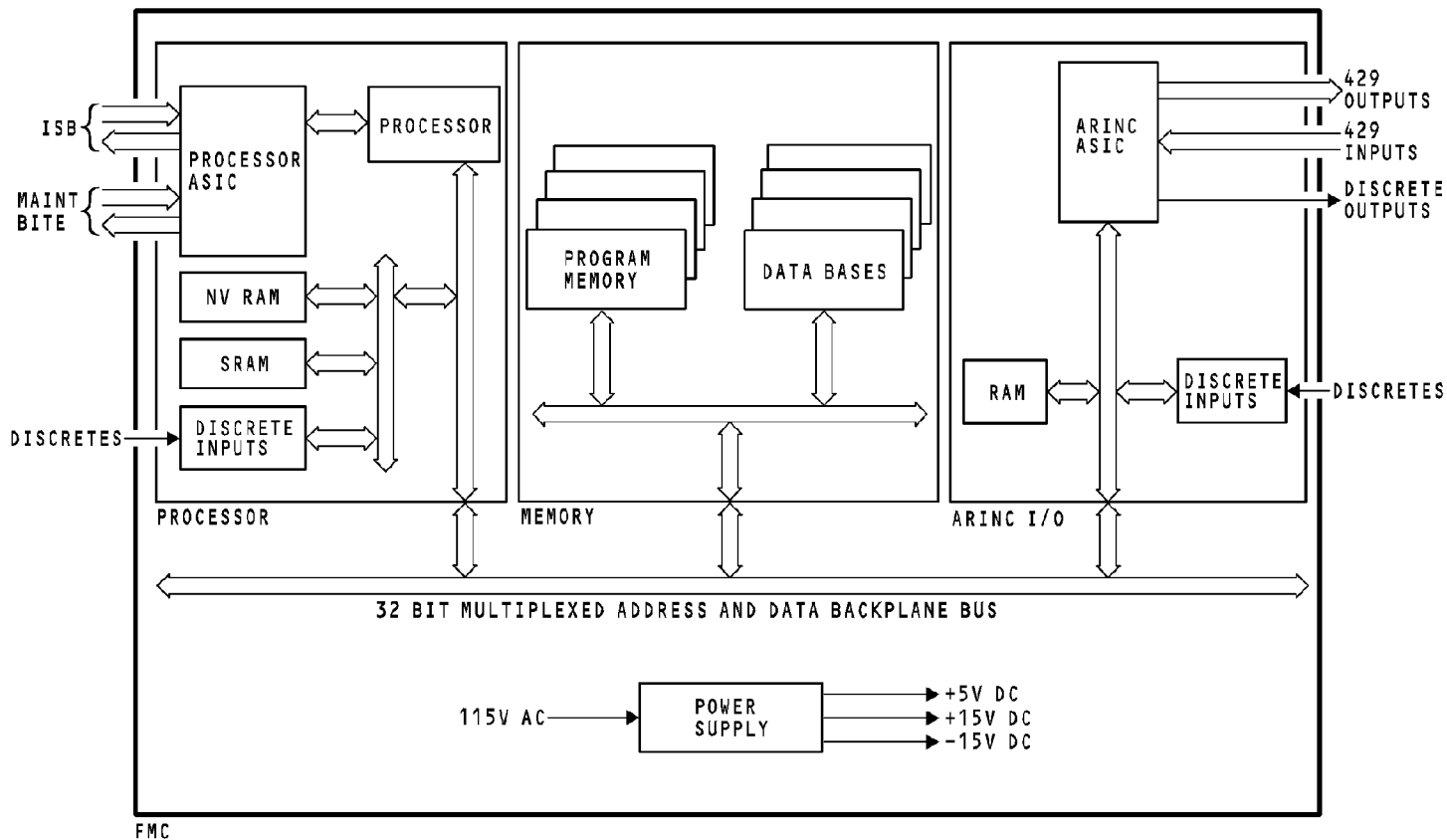

FMCS - FLIGHT MANAGEMENT COMPUTER - FUNCTIONAL DESCRIPTION

EFFECTIVITY
HAP 037-054, 101-999

34-61-00

D633A101-HAP

Page 98.8
Jun 15/2009

34-61-00-018

FMCS - CONTROL DISPLAY UNIT**Purpose**

The flight crew uses the control display unit (CDU) to put in flight data and to select displays and modes of operation. They also use the CDU to start ADIRU alignment. You use the CDU to do tests of the FMCS and other systems.

There are two CDUs in the airplane. They are functionally and physically interchangeable.

Physical Description**HAP 001-005**

The CDU weighs 20 pounds (9.1 kg).

HAP 006-013, 015-026, 028-054, 101-999; HAP 001-005 POST SB 737-34-1951 GRP 1

The CDU weighs 9 pounds (4.1 kg).

HAP ALL

There are holes in the chassis for cooling air. The equipment cooling system supplies cooling for the CDUs. Keep dust and dirt build-up from the vent and surfaces. The procedures to clean the CDU are in the maintenance practices section.

The CDU has these annunciators:

- Fail

- CALL
- MSG (message)
- OFST (offset).

The annunciators each use a two-lamp circuit board assembly. Each board assembly is line replaceable.

The execute (EXEC) key is on the right of the CDU. This key has a lamp assembly with two lamps. The lamp assembly is line replaceable.

The lighted switch panel is line replaceable. Six screws hold the panel in place.

CAUTION: FAILURE TO OBSERVE ELECTROSTATIC DISCHARGE PRECAUTIONARY PROCEDURES WHEN TOUCHING, REMOVING, OR INSERTING PARTS OR ASSEMBLIES MAY RESULT IN DEGRADATION OR FAILURE OF THE CONTROL DISPLAY UNIT.

Training Information Point

If you remove CDU 2, install the ground lock assemblies on the landing gear. Put the control lever for the landing gear in the OFF position.

EFFECTIVITY HAP ALL

FMCS - CONTROL DISPLAY UNIT

CAUTION: MAKE SURE THAT YOU INSTALL THE GROUND LOCK ASSEMBLIES ON THE LANDING GEAR BEFORE YOU MOVE THE CONTROL LEVER FOR THE LANDING GEAR. YOU WILL DAMAGE THE AIRPLANE IF YOU RETRACT THE LANDING GEAR WHILE THE AIRPLANE IS ON THE GROUND.

34-61-00-019

EFFECTIVITY
HAP ALL

34-61-00

D633A101-HAP

Page 98.10
Jun 15/2009

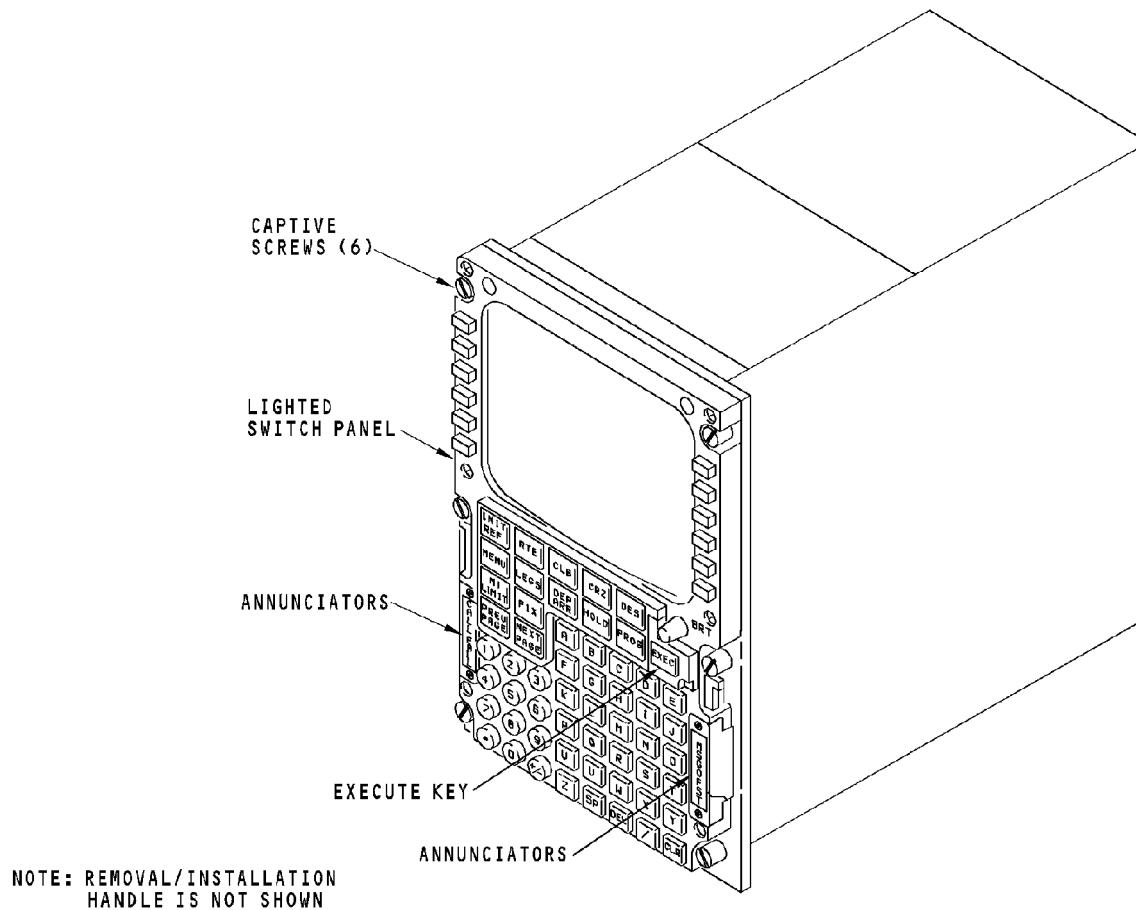

FMCS - CONTROL DISPLAY UNIT

34-61-00-019

EFFECTIVITY
HAP ALL

34-61-00

D633A101-HAP

Page 98.11
Jun 15/2009

FMCS - CONTROL DISPLAY UNIT - FUNCTIONAL DESCRIPTION**HAP 006-013, 015-026, 028-054, 101-999; HAP 001-005 POST SB 737-34-1951 GRP 1****General**

The LCD CDU has these sub-assemblies:

- Low voltage power supply
- Rear connector filter assembly
- Processor and interface circuit card assembly
- LCD module
- Backlight assembly
- Lighted switch panel.

HAP ALL**Power Supplies****HAP 001-005**

A low voltage power supply in the CDU supplies power to operate the circuit cards. The high voltage power supply supplies power to operate the cathode ray tube (CRT).

HAP 006-013, 015-026, 028-054, 101-999; HAP 001-005 POST SB 737-34-1951 GRP 1

The low voltage power supply module in the CDU receives 115v ac, 400Hz, single phase power from the airplane electrical system. It provides the following operating voltages within the LCD CDU:

- +5v dc
- +12.7v dc
- -12.7v dc
- +26v dc
- +28v dc
- Switched +28v dc (used for the backlight and LCD heaters).

HAP ALL

The airplane master dim and test circuits supply 28v dc to the CDU for annunciator power and lamp test. Also, 5v ac power is used for the lighted switch panel lighting.

HAP 006-013, 015-026, 028-054, 101-999; HAP 001-005 POST SB 737-34-1951 GRP 1**Rear Connector Filter Assembly**

The CDU receives data on up to seven ARINC data buses and four discrete inputs. Output data is sent over two ARINC data buses and one discrete output. All input and output data goes through the rear connector filter assembly (RCFA) which provides electromagnetic interference (EMI) protection.

Processor/Interface Circuit Card

The processor and interface circuit card (P&I CCA) provides all of the control and external interface circuitry for the CDU. It provides the following functions:

- Read lighted switch panel inputs to determine CDU modes/inputs

FMCS - CONTROL DISPLAY UNIT - FUNCTIONAL DESCRIPTION**HAP 006-013, 015-026, 028-054, 101-999; HAP 001-005 POST SB 737-34-1951 GRP 1 (Continued)**

- Receive ARINC inputs from other airplane systems
- Read and interpret airplane discrete inputs
- Generate CDU fail output discrete
- Control CDU annunciator operation
- Send ARINC outputs to FMCS
- Communicate with other airplane sub-systems
- Generate data for LCD and backlight assembly
- Perform BITE.

LCD Module

The LCD module provides the display of 24 columns and 14 rows. It is a non-light emitting device that requires a separate light source (backlight assembly) to make the display viewable.

During power-up, the LCD provides a display within 10 seconds at normal operating temperatures (0-55 degrees C, 32-131 degrees F). At or below freezing temperatures, the LCD can take up to 2 minutes to provide a normal display. The LCD contains a temperature regulating function which improves operation over a wide range of temperatures.

Backlight Assembly

The backlight assembly has a lamp and control circuitry to provide the required illumination for the LCD. It is controlled by the P&I CCA.

The backlight assembly also sends ambient light level information to the P&I CCA so that it can adjust the luminance level for the LCD. The backlight assembly also sends temperature information to the P&I CCA so that, when necessary, it can turn on the LCD heater.

Lighted Switch Panel

The lighted switch panel provides the interface between the operator and the FMCS through the CDU. The panel contains two ambient light sensors which are used to adjust the display brightness and contrast.

HAP 001-005**Display Control**

The display control makes characters and symbols for display on the CRT screen. These circuits also send and receive the digital data.

CDU Control

The CDU control and keyboard/annunciator interface circuits have a microprocessor and programmed memory. These circuits decode the keyboard and control data that shows on the CRT. They also control the annunciators.



FMCS - CONTROL DISPLAY UNIT - FUNCTIONAL DESCRIPTION

HAP 001-005 (Continued)

Deflection Circuits

Video and deflection circuits control the horizontal and vertical deflection of the characters on the CRT screen.

HAP ALL

34-61-00-020

EFFECTIVITY
HAP ALL

34-61-00

D633A101-HAP

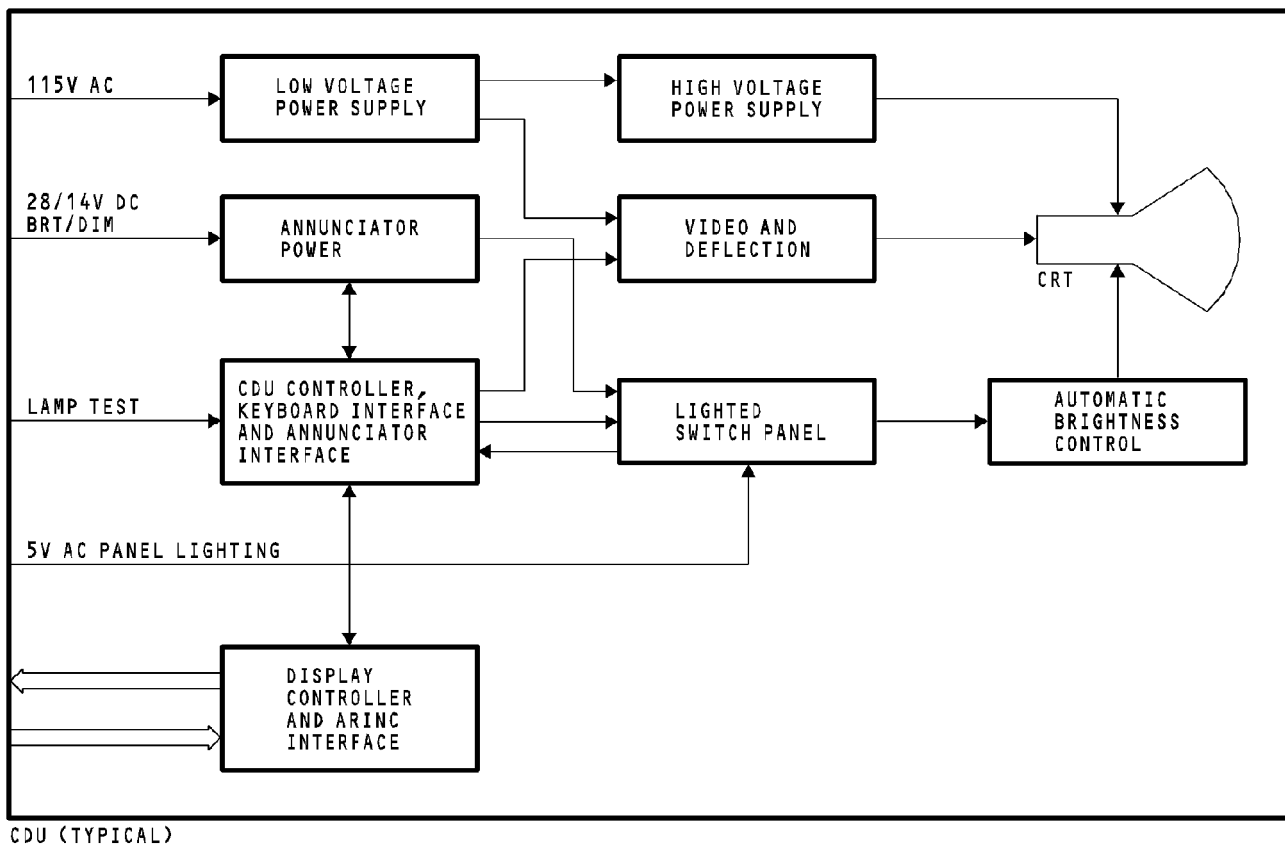

FMCS - CONTROL DISPLAY UNIT - FUNCTIONAL DESCRIPTION

EFFECTIVITY
HAP 001-005

34-61-00

D633A101-HAP

Page 98.15
Jun 15/2009

34-61-00-020

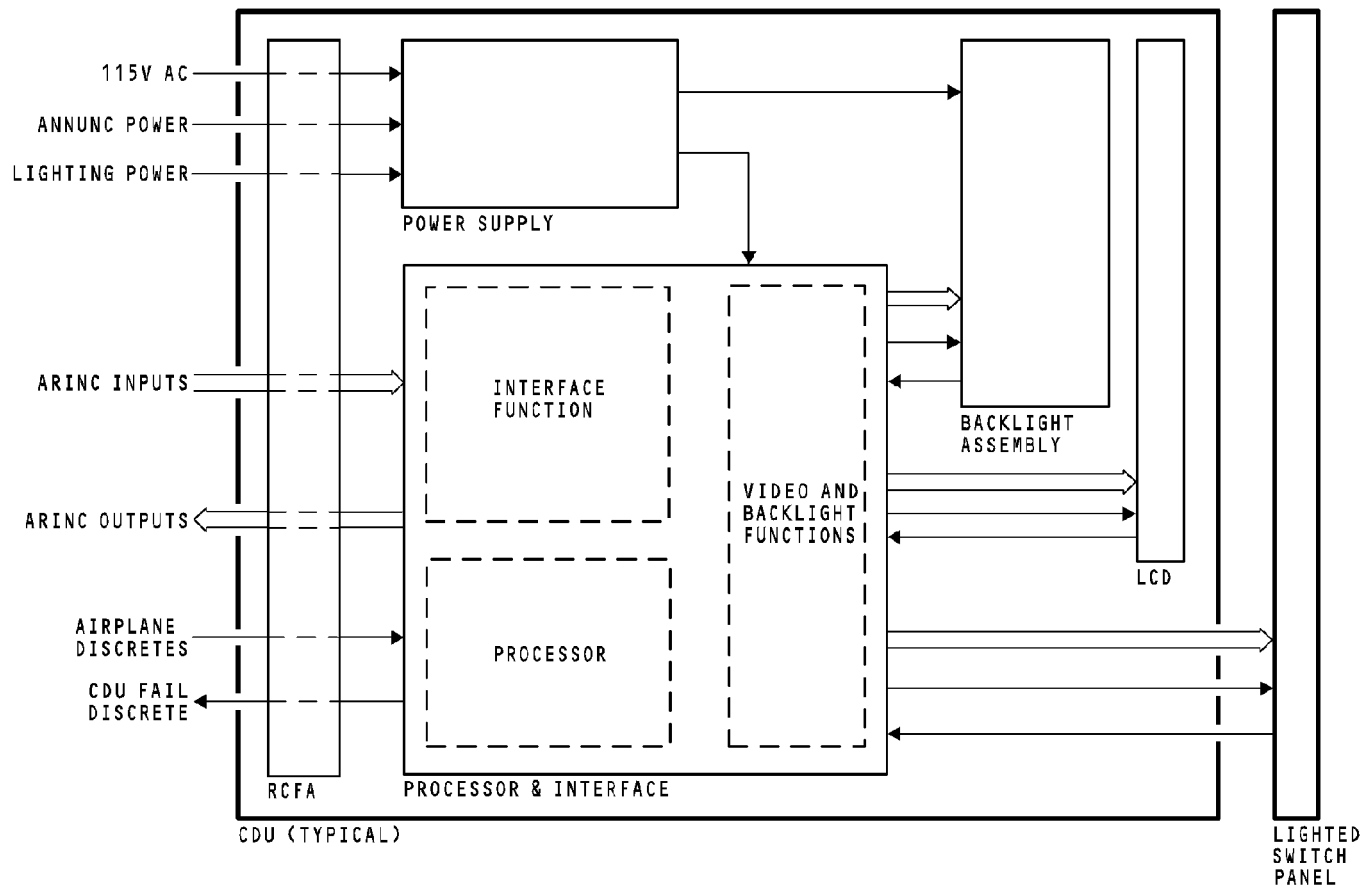

FMCS - CONTROL DISPLAY UNIT - FUNCTIONAL DESCRIPTION

EFFECTIVITY

HAP 006-013, 015-026, 028-054, 101-999; HAP 001-005 POST SB 737-34-1951 GRP 1

34-61-00

D633A101-HAP

THIS PAGE IS INTENTIONALLY LEFT BLANK

34-61-00

D633A101-HAP

Page 98.17
Jun 15/2009

FMCS - CONTROL DISPLAY UNIT - CONTROLS AND DISPLAYS**Display Format****HAP 001-005**

The multi-purpose control display unit (MCDU) data shows on the five-inch CRT. The basic display is a set of fourteen lines. Each line can show 24 characters. Each line can show alphanumeric characters and symbols.

HAP 006-013, 015-026, 028-054, 101-999; HAP 001-005 POST SB 737-34-1951 GRP 1

The multi-purpose control display unit (MCDU) data shows on the five-inch liquid crystal display (LCD). The basic display is a set of fourteen lines. Each line can show 24 characters. Each line can show alphanumeric characters and symbols.

HAP ALL**Color****HAP 001-005**

The MCDU cathode ray tube (CRT) uses green text on a black background.

HAP 006-013, 015-026, 028-054, 101-999; HAP 001-005 POST SB 737-34-1951 GRP 1

The MCDU contains a liquid crystal display (LCD). It shows white text on a black background.

HAP 012, 013, 015-026, 028-054, 101-999; HAP 001-011 POST SB 737-34-1951 GRP 1

The LCD uses different colors to show flight activity and modes. Data shows in these colors:

- Black - background
- White - default color for text
- Magenta - active waypoint, active speed target and active altitude target in flight plan
- Green - actively tuned VOR, ILS and DME data (frequency, station ID and course). Also, green will be used for data fields that can be toggled on and off in which case the active state is green

HAP 037-054, 101-999

- Amber - FMC mismatch indications on maintenance BITE pages

HAP 012, 013, 015-026, 028-054, 101-999; HAP 001-011 POST SB 737-34-1951 GRP 1

- Cyan - Inactive route page titles
- Shaded white - data that modifies the flight plan until the EXEC key is pushed.

The MCDU shows this data in white:

- Text
- Scratchpad messages
- Header line titles
- Box prompts
- Dashes, except when the dash is an integral part of the data field (i.e. negative temperature) in which case it will be the same color as the data

FMCS - CONTROL DISPLAY UNIT - CONTROLS AND DISPLAYS

HAP 012, 013, 015-026, 028-054, 101-999; HAP 001-011 POST SB 737-34-1951 GRP 1 (Continued)

- Slashes, except when the slash has data on both sides in which case it will be the same color as the data.

HAP ALL

Display Layout

The first line shows these data blocks:

- Status
- Title
- Page number.

Status shows that the information on the display is the active executed plan (ACT) or a modified plan (MOD). When the data on the display is not active or not a part of the flight plan, the status block is blank.

The next block is the title for the display. An example of a title is POS INIT.

The last character spaces in the first line show the page number for each display. This tells the operator the active page and the total number of pages.

Data on lines two through thirteen (data field) applies to operation of the airplane.

Line fourteen is a scratch pad to enter data from the keyboard. Also, this line shows this data:

- Failure messages
- Alerts during operation
- Advisory prompts.

Alphanumeric Key Board

You use the key board to enter data into the FMCS and to make changes to a flight plan.

Each time you push an alphanumeric key, the entry shows in the scratch pad (line 14). In the scratch pad, you can edit the entry or clear it.

Function and Mode Keys

These are the function and mode keys:

- INIT REF
- RTE
- CLB
- CRZ
- DES
- MENU
- LEGS
- DEP ARR
- HOLD
- PROG
- N1 LIMIT
- FIX

34-61-00-021



34-61-00

D633A101-HAP

FMCS - CONTROL DISPLAY UNIT - CONTROLS AND DISPLAYS

- EXEC.

The INIT REF key supplies access to a selection of data pages necessary to start the FMCS and ADIRU. Also, the operator can access navigation data and maintenance pages.

The RTE key selects the page you use to enter route data. This includes the flight origin and destination plus the takeoff runway number.

The CLB key shows the climb modes. Top-of-climb (T/C) altitude and speed/altitude restrictions show here. Information about time and distance to the next waypoint is also shown here.

The CRZ key shows the cruise modes. Information about optimum altitude, maximum altitude, step climb savings and turbulence N1 targets also show.

The DES key shows the descent modes. The end-of-descent altitude and speed/altitude restrictions show here. Information about flight path angle, airplane vertical speed and vertical bearing also show.

The MENU key gives access to other airplane data communication systems.

The LEGS key shows and accepts input of data about each leg of the flight plan. Information about heading between the waypoints, speed and altitude is also shown.

The DEP/ARR key supplies access to a selection of departure and arrival runways and procedures for the origin and destination airports.

The HOLD key lets you plan or start a hold at a waypoint or present position.

The PROG key shows this current flight status information.

The N1 LIMIT key shows the FMC calculated N1 thrust limits for specific flight phases.

This page also shows the reduced climb thrust limits CLB-1 (Climb 1) and CLB-2 (Climb 2). The flight crew can set N1 limit data from this page.

The FIX key shows range and bearing data from the present position to a selected reference position (SRP).

The EXEC key is used to make active or to modify a page with data entry when the EXEC light comes on.

Page Select Keys

You push the NEXT PAGE key to advance the display to the next higher number page. You push the PREV PAGE key to back-up the display to the next lower number page.

FMCS - CONTROL DISPLAY UNIT - CONTROLS AND DISPLAYS

The page strings are continuous. If the first page of a string is shown (1/9) and you push the PREV PAGE key, the display shows the last page in the string (9/9). If you go past the last page in a string (past 9/9 for example), this takes the display back to the first page in the string (1/9).

Line Select Keys

You use the line select keys for these operations:

- Move data from the scratch pad to a data field
- Copy data from a data field to the scratch pad
- Remove data from a data field
- Select a BITE operation from the maintenance bite index.

Lighted Annunciators

These are the active annunciators:

- CALL
- MSG (Message)
- OFST (Offset).

The CALL light is on when there is a call from another system other than the FMCS.

The MSG light is on to show there is an alert or advisory message. The MSG light stays on until you clear the message.

The OFST light is on when a parallel offset is active.

Special Keys

The keyboard has special keys in addition to the alpha-numeric keys. These are the special keys:

- Change sign (+/-)
- Space (SP)
- Delete (DEL).
- Slash (/)
- Clear (CLR).

The change sign (+/-) and slash (/) keys are standard keys on a keyboard.

The space key (SP) puts a space into the scratchpad. This will allow the flight crew to write messages into the scratchpad.

A push of the DEL key puts the word DELETE in the CDU scratch pad. This lets the operator delete a data field with the line select key next to the data field. The DEL key does not work when the scratchpad contains data. Some data fields do not permit the DEL key function. In this case, the INVALID DELETE message shows in the CDU scratchpad.

Push the CLR key once to remove one alphanumeric character in the scratch pad or an alert or advisory message from the scratch pad. Hold the CLR key down for one second to remove all scratch pad data.





FMCS - CONTROL DISPLAY UNIT - CONTROLS AND DISPLAYS

BITE

The FMCS BITE function does a check of all key functions.

34-61-00-021

EFFECTIVITY
HAP ALL

34-61-00

D633A101-HAP

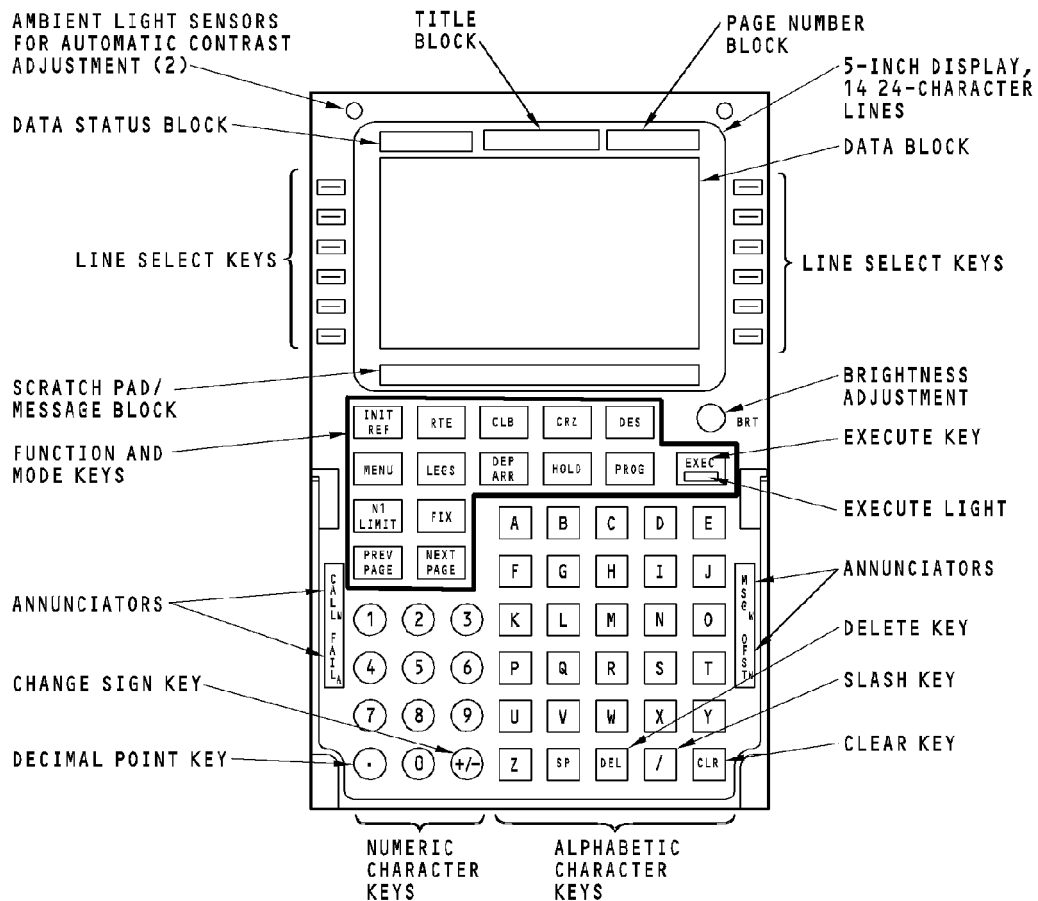

FMCS - CONTROL DISPLAY UNIT - CONTROLS AND DISPLAYS

34-61-00-021

EFFECTIVITY
HAP ALL

34-61-00

D633A101-HAP

Page 98.23
Jun 15/2009

FMCS - AIRBORNE DATA LOADER**Purpose**

You use the airborne data loader (ADL) to load data into selected LRUs and to record data from selected LRUs. You use the data loader control panel to select the LRU.

Physical Description/Features

The airborne data loader (ADL) is an ARINC-615 high speed loader. These are the ADL features:

- Access door
- Disk drive
- Disk drive light
- Disk drive eject button
- Display.

These messages show on the display:

- PROG (Data transfer in progress)
- CHNG (Diskette change required)
- COMP (Data transfer complete)
- RDY (The loader is ready for operation. If RDY flashes, the LRU has stopped the data transfer to check the data. The transfer will continue automatically)
- XFER (Data transfer failure)
- R/W (Unable to access diskette data)
- HRDW (Internal loader failure. If HRDW flashes, there is no communication between the loader and the LRU).

The data loader does an internal self test at power up. During the self test, all the front panel status indicators flash. At the end of the self test, the indicators go off. If there is a failure at power up, the message HRDW shows on the display. If the self test is satisfactory, the message RDY shows. The other indicators come on as the data loader moves through the load or transfer.

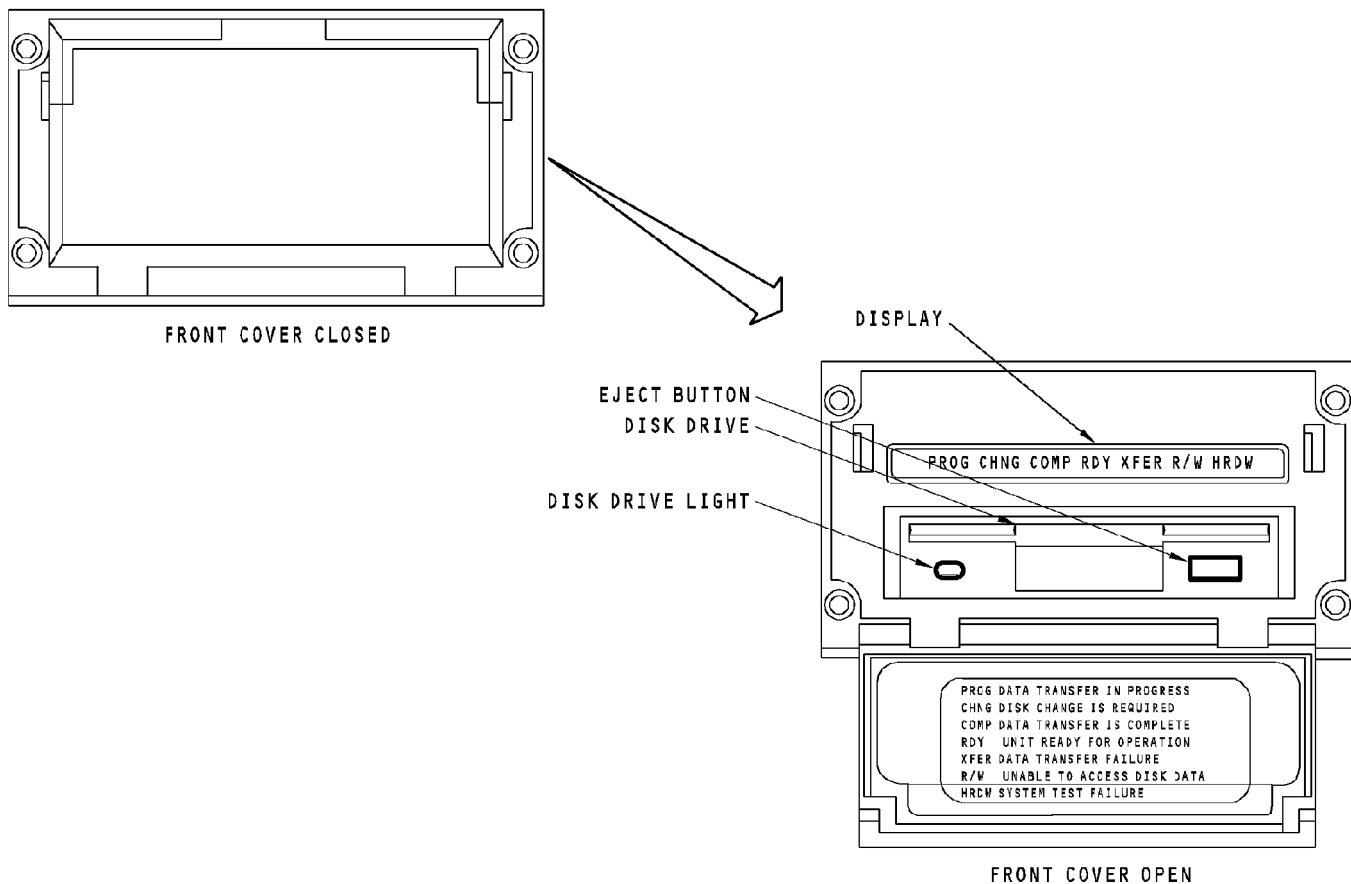

FMCS - AIRBORNE DATA LOADER

34-61-00-022

EFFECTIVITY
 HAP 031-054, 101-999

34-61-00

D633A101-HAP

Page 98.25
 Jun 15/2009

FMCS - TRANSFER RELAYS**Purpose****HAP 001-013, 015-026, 028-036**

There are two FMCS transfer relays. Output data from the FMC goes through the relays. The relays are mechanically latched to the BOTH ON L position.

HAP 037-054, 101-999

There are two FMCS transfer relays. The relays select the FMC to send data to the systems that interface with the FMCS. The FMC SOURCE SELECT SWITCH controls the relays. The source select switch is in the flight deck.

HAP ALL**Location**

The relays are on the E5-2 shelf in the electronic equipment compartment.

Physical Description

The relays are Ledex type relays. They mechanically latch and are hermetically sealed.

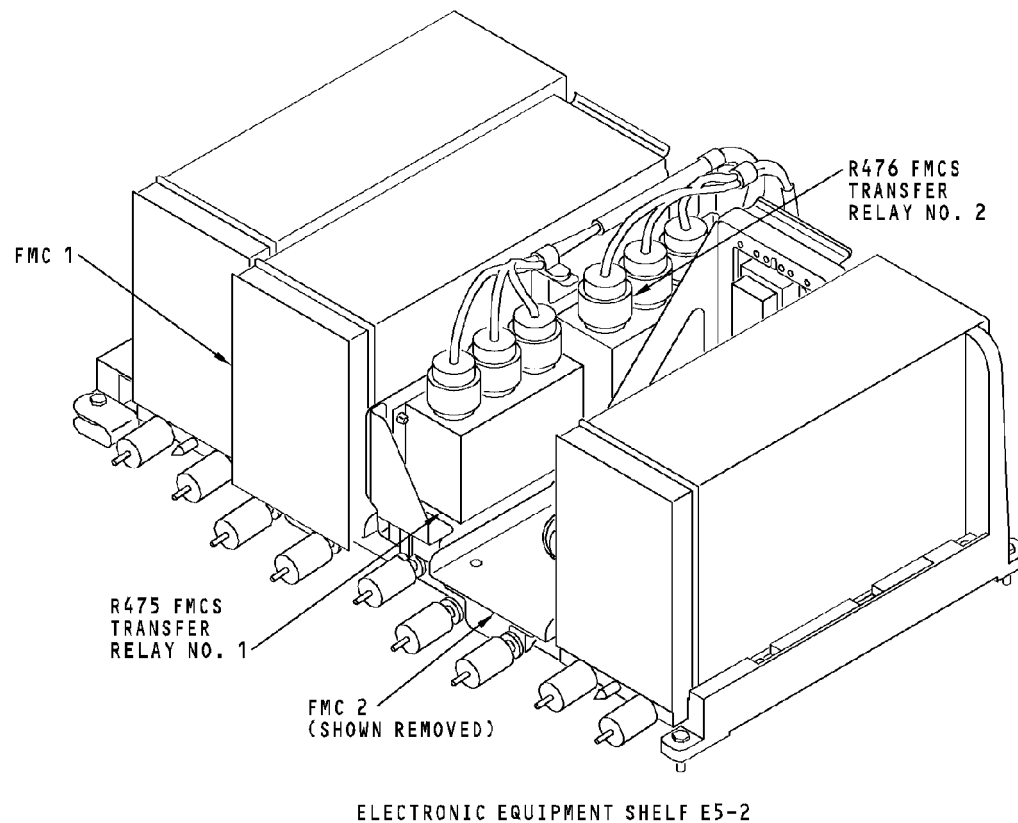

FMCS - TRANSFER RELAYS

34-61-00-023

EFFECTIVITY
HAP 037-054, 101-999

34-61-00

D633A101-HAP

Page 98.27
Jun 15/2009

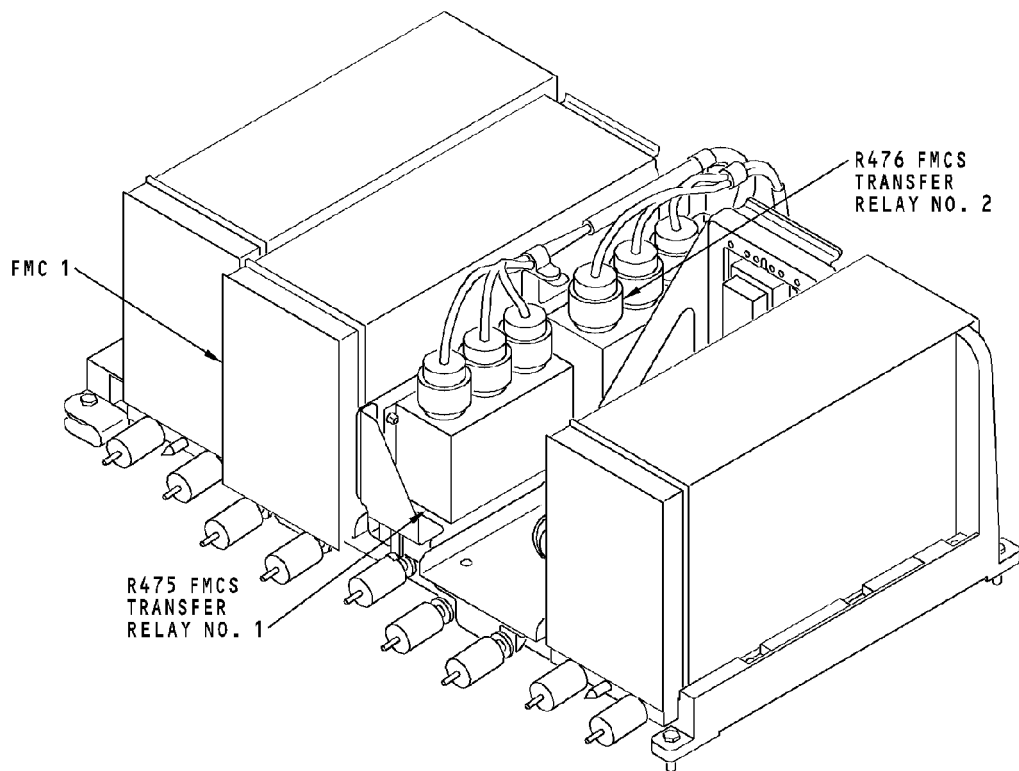

ELECTRONIC EQUIPMENT SHELF E5-2

FMCS - TRANSFER RELAYS

EFFECTIVITY

HAP 001-013, 015-026, 028-036

34-61-00

D633A101-HAP

Page 98.28
Jun 15/2009

34-61-00-023

FMCS - FMC FUNCTIONAL DESCRIPTION - INTRODUCTION

General

These are the primary FMC functions:

- Navigation
- Performance
- Guidance.

The FMC does the primary functions with data input from these sources:

- Flight crew
- Airplane system sensors
- Data stored in the FMC memory.

This is the data in memory:

- Operational flight program (OFF)
- Navigation data base (NDB)
- Performance default data base (PDDB)
- Airplane model/engine performance data base (MEDB)
- ACARS adaptable datalink data base (AADD)
- Software options data base.

NOTE: Operational flight program (OFF) is also referred to as operational program software (OPS).

FMC Data Bases

The operational flight program is the computer software that the FMCS uses to do the navigation, performance, and guidance functions.

The navigation data base contains all the data necessary for the airplane operation over a defined route network. This type of information is available:

- Waypoints
- Nav aids
- Airport data
- Airway data
- Standard instrument departures (SIDs)
- Standard terminal arrival routes (STARs).

There are two navigation data bases, the current and a set of update revisions, stored in the FMC.

The performance default data base is part of the operational flight program. It has an aerodynamic model of the 737-300/400/500 series airplanes and a fuel flow/N1 thrust model for the specific engine on the airplane. This data is used to predict the performance characteristics that give the optimum vertical profile for the airplane.

The performance default data base (PDDB) for the 737-600/700/800 series airplanes is customizable by the airline through the FMCS OEM and is not part of the operational flight program. The PDDB is loadable through the data base loader. Default performance data is stored in the operational program for use if the airline custom PDDB is not loaded.

The aerodynamic model includes this data:

FMCS - FMC FUNCTIONAL DESCRIPTION - INTRODUCTION

- Optimum altitudes
- Speed schedules
- Operating limits
- Drag data for dual and single engine operation.

The fuel flow/N1 thrust model is used to calculate fuel flows and thrust limits corrected for the effects of air conditioning and airframe anti-ice bleed air demands.

The model/engine performance data base (MEDB) has the same type of information and does the same function as the performance default data base. However, the MEDB contains the data for the 737-600/700/800 series airplanes. The MEDB is loadable through the data base loader and is not part of the operational flight program.

The software options data base has the software options that have been selected. These are the software options:

HAP 001-013, 015-026, 028-030, 050, 053, 054

- Runway position update (runway offset in meters)

HAP 050, 053, 054

- VNAV ALT enable

HAP ALL

- GPS navigation
- GPS direct input
- AOC datalink

HAP 001-013, 015-026, 028-030

- Abeam waypoints

HAP ALL

- Alternate destination

- Altitude/speed intervention

HAP 001-013, 015-026, 028-030, 048, 049, 051-053, 107-999

- Plan fuel

HAP ALL

- Default RNP
- NDB size

HAP 012, 013, 015-026, 028-054, 101-999; HAP 001-011 POST SB 737-34-1951 GRP 1

- CDU color

HAP ALL

- Geometric path descent

HAP 031-054, 101-999; HAP 001-013, 015-026, 028-030 POST SB 737-34-1680

- Engine out SIDS

HAP 048

- Missed approach color

HAP ALL

The ACARS datalink data base has the software that permits the uplink and downlink of data between the FMC and a ground network.

All these data bases are loadable with a data base loader.

Navigation

The navigation function gives airplane position (FMC position) and autotuning capability for the navigation radios.

The FMCS uses these sensors to calculate the FMC position:

EFFECTIVITY**HAP ALL****34-61-00**

D633A101-HAP

Page 98.30
Jun 15/2009

FMCS - FMC FUNCTIONAL DESCRIPTION - INTRODUCTION

- Global positioning system
- NAV radio data
- ADIRS.

The flight crew can manually build the route or select it from the company navigation data base. When the route has been activated, it shows on the navigation display of the CDS.

Performance

The performance function gives flight profile information and target engine N1 speeds. This lets the airplane fly at the most economical altitudes and speeds for the conditions.

The FMC uses this information to calculate performance data:

- CDU data (cost index, CRZ altitude, etc.)
- Air data and inertial reference information
- Fuel weight
- Engine bleed air data
- Airplane and engine information from the model/engine performance database.

The economy mode is the primary performance mode for the climb, cruise, and descent phase of flight. The flight crew can select other operating modes at any time.

Guidance

The guidance function sends flight path and steering commands to the digital flight control system (DFCS) and the autothrottle (A/T).

For lateral navigation (LNAV), the FMC calculates the route and compares it to the FMC position. If they are different, the FMC calculates a roll steering command and sends it to the DFCS.

For vertical navigation (VNAV), the FMC calculates speed and vertical speed targets and sends them to the the DFCS. The FMC also calculates N1 thrust and speed targets and sends them to the A/T. The autothrottle and autopilot follow the targets and commands to keep the airplane on the calculated flight path.

During climb or descent, the FMCS sends speed and altitude targets to the DFCS. During level flight, the FMCS sends speed commands to the A/T.

Other Functions

The aircraft communications and reporting system (ACARS) lets the FMC receive (uplink) and send (downlink) messages to the operators ground network. The uplink can be used to send flight plan data, weather or other pertinent information. The downlink can be used by the flight crew to request flight planning or performance data.

The ACARS function controls the messages sent to and from the ground with ACARS. Some messages show when the crew selects the correct command on the CDU. Other messages are automatic. The ACARS configuration data base controls the automatic messages.

FMCS - FMC FUNCTIONAL DESCRIPTION - INTRODUCTION

The display function sends display data to the common display system and the CDUs. The data includes route and position data and N1 data.

The ALERT function does a check of the FMC status. It turns on the FMC light on the autoflight status annunciators when the FMC fails or when there is a message that makes flight crew awareness and subsequent action necessary.

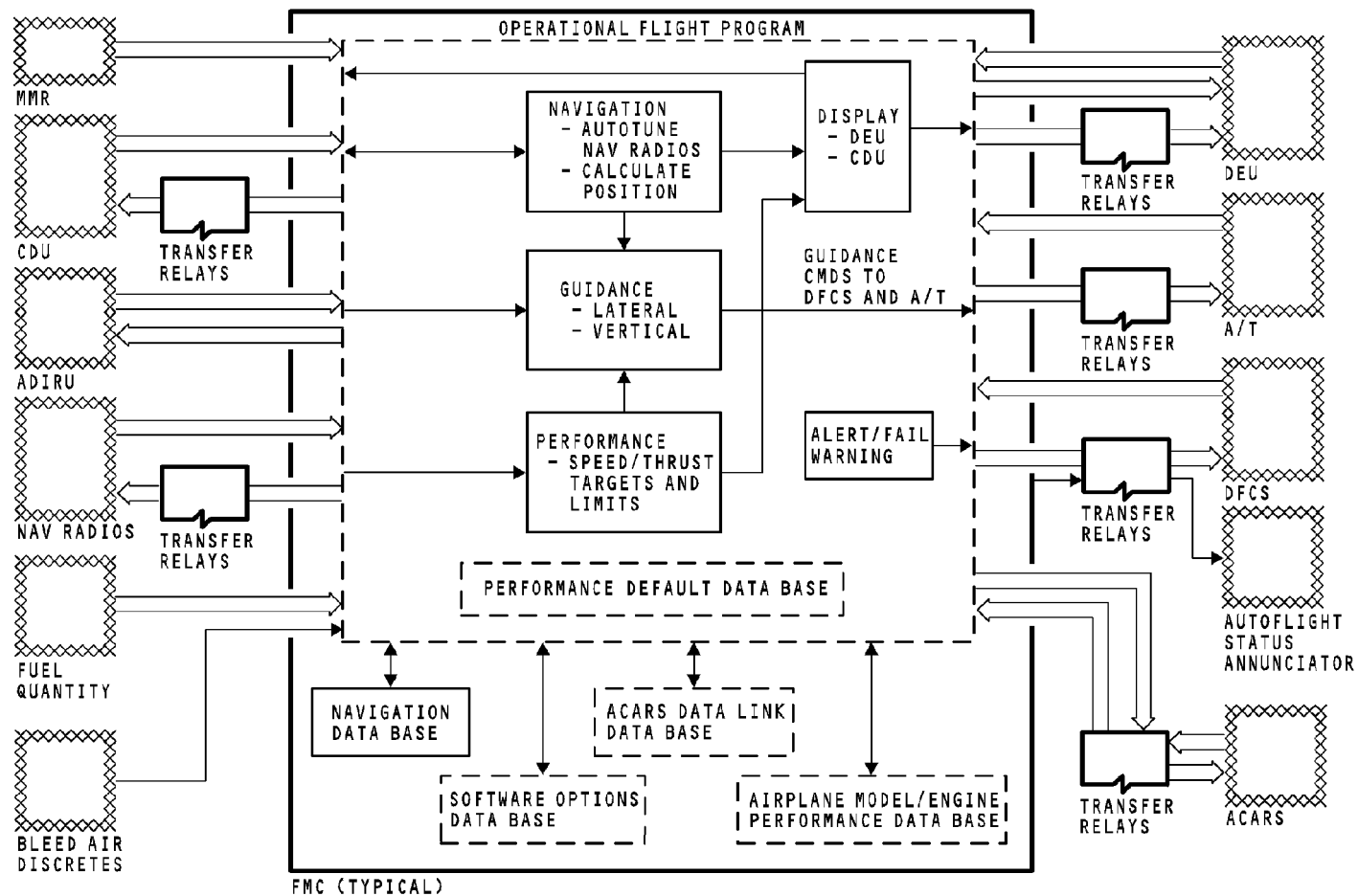

FMCS - FMC FUNCTIONAL DESCRIPTION - INTRODUCTION

34-61-00-024

EFFECTIVITY
HAP 037-054, 101-999

34-61-00

D633A101-HAP

Page 98.33
Jun 15/2009

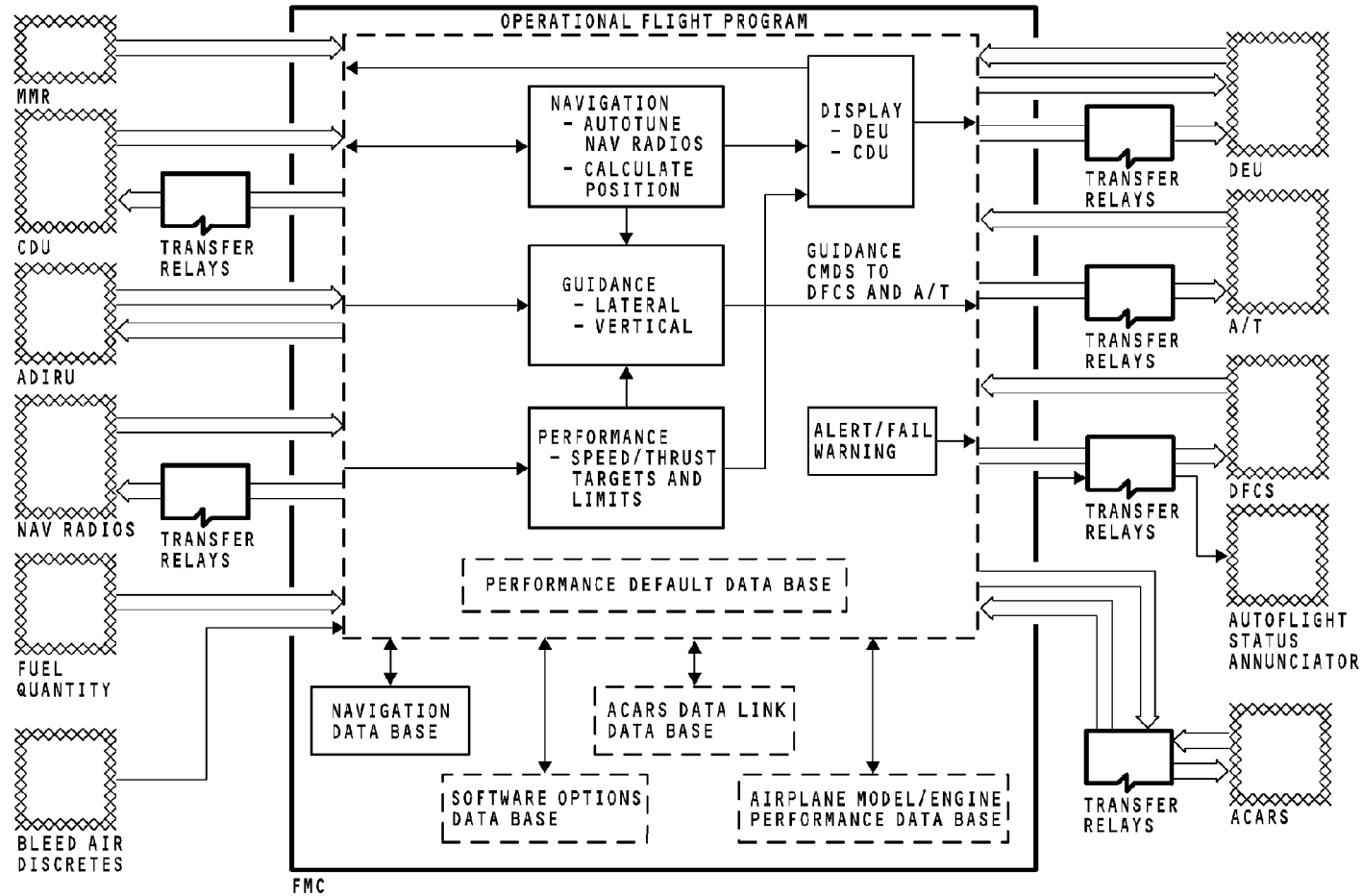

FMCS - FMC FUNCTIONAL DESCRIPTION - INTRODUCTION

EFFECTIVITY

HAP 001-013, 015-026, 028-036

34-61-00

34-61-00-024

D633A101-HAP

FMCS - FMC FUNCTIONAL DESCRIPTION - NAVIGATION SUB-FUNCTION**General**

The FMCS navigation sub-function calculates this data:

- Lateral position
- Vertical position
- Actual navigation performance (ANP).

HAP 001-005

The FMCS navigation function also tunes the DME interrogators and supplies radio tuning data for display on the MCDU NAV STATUS page.

HAP ALL

The primary data source for the lateral and vertical position calculations is the ADIRU. Because the ADIRU data drifts over time, the FMC navigation function uses data from other sensors to correct the ADIRU data that it receives.

The FMC uses independent measurements from the navigation sensors filtered with ADIRU position, heading and velocity data to produce an accurate calculation of the airplane's position in the horizontal plane.

NOTE: The ADIRU must be in the NAV mode to provide valid data to the FMC.

The FMC will select only one navigation update mode at a time. The navigation update mode with the least amount of position uncertainty will be used.

These are the sensors used to calculate/update the FMC position and their selection priority:

- ADIRU/GPS
- ADIRU/DME/DME
- ADIRU/DME/VOR
- ADIRU/DME/LOC
- ADIRU ONLY.

The first priority for FMC position updating is GPS data from the GPS receiver in the MMRs.

The next priority is a pair of DME stations that have the best range and geometry. The maximum range for DME/DME updating is nominally 200 nautical miles (NM) but the FMC will always use those stations that are nearest the airplane position. The FMC will also always tune two DMEs that are not within 30 degrees of each other or not greater than 150 degrees apart (90 degrees being the optimum angle).

If there are not two DME stations within range or that do not have the necessary geometry, the FMC uses DME distance and VOR bearing from a co-located VOR/DME station. The maximum range for VOR/DME update is 25 nautical miles.

NOTE: The FMC will autotune the DME interrogators but VOR must be manually tuned by the flight crew.

FMCS - FMC FUNCTIONAL DESCRIPTION - NAVIGATION SUB-FUNCTION

In an airport terminal area when the airplane is on a localizer approach, the FMC uses localizer deviation and DME distance to update the FMC position. The maximum range for LOC/DME update is 20 nautical miles and the airplane altitude must not be greater than 6000 feet above the localizer station elevation. Also, the airplane track must be within 45 degrees of the localizer inbound course and localizer deviation must be less than 1.25 dots for at least 5 seconds.

With all VHF NAV radio updates, the FMC will correct the DME slant range distance for airplane altitude.

If GPS data and NAV radio data are not available or become invalid, the FMC uses ADIRU data only corrected by a fixed error bias calculated by the FMC.

The FMCS can use GPS data on the ground to update the FMC position if the GPS data is valid. VHF NAV radio update is not enabled on the ground.

The navigation sub-function also calculates the following nav data:

- Airplane position (latitude, longitude and altitude)
- Groundspeed
- Flight path angle
- Drift angle
- Track angle
- Wind velocity and direction

- Horizontal position accuracy (actual navigation performance).

The FMC uses the following inputs to calculate these parameters:

- Inertial position (latitude, longitude and inertially smoothed altitude)
- Vertical speed (inertially smoothed)
- Groundspeed components (N-S, E-W velocity vectors)
- Heading (magnetic and true)
- Pressure altitude (uncorrected and baro-corrected)
- True airspeed
- GPS data
- DME slant range
- VOR bearing
- ILS LOC deviation.

Lateral Position

This function calculates latitude and longitude.

HAP 001-013, 015-026, 028-036

The FMC uses the position calculated from the GPS data and the ADIRU inputs to correct its ADIRU based inertial lateral position. This is the FMC position and is calculated in terms of latitude and longitude. The FMC will use its onside GPS input from the multi mode receivers (MMR) if the data is valid. The offside GPS data will be used if the onside data is invalid.

<p>EFFECTIVITY</p> <p>HAP ALL</p>
--

FMCS - FMC FUNCTIONAL DESCRIPTION - NAVIGATION SUB-FUNCTION

HAP 001-013, 015-026, 028-036 (Continued)

HAP 037-054, 101-999

The FMCs use the position calculated from the GPS data and the ADIRU inputs to correct their ADIRU based inertial lateral positions. These are the FMC positions and are calculated in terms of latitude and longitude. The FMCs will use their onside GPS input from the multi mode receivers (MMR) if the data is valid. The offside GPS data will be used if the onside data is invalid.

HAP ALL

Vertical Position

This function calculates altitude and flight path angle (FPA).

Altitude is calculated from ADIRU inertial altitude corrected by barometric pressure altitude. Flight path angle is calculated from inertial vertical speed and FMC calculated ground speed. The FPA is zero when the airplane is on the ground.

HAP 037-054, 101-999

FMCS Composite Position

Each FMC sends its FMC position to the other FMC with a confidence factor. The confidence factors are based on the estimated accuracy of each FMC and the navigation sensors that are being used in the position calculations.

In each FMC, FMC 1 position and FMC 2 position are used to give a final FMC position. This final position calculation from each FMC is a combination of the two positions weighted from their respective confidence factors. This final FMCS position and navigation data is continually compared between the two FMCs.

HAP ALL

Actual Navigation Performance (ANP)

The ANP is the accuracy of the FMC calculated position. It is calculated in nautical miles by the FMCS during all parts of the flight. It is measured in nautical miles and it shows the radius of a circle around the calculated FMC position where the probability of the airplane being inside the circle is 95%.

The ANP calculation uses this data:

- The NAV stations in use
- GPS availability and accuracy
- Accuracy of DME range data
- Accuracy of VOR bearing data
- ADIRU drift.

The required navigation performance (RNP) is the accuracy requirement of the FMC navigation performance within a defined airspace. It is calculated in nautical miles and represents the radius of a circle where the probability of the airplane being within that circle is more than 95%. The default values for RNP are contained in the navigation data base.

34-61-00-025

<p>EFFECTIVITY HAP ALL</p>
--

34-61-00

D633A101-HAP

FMCS - FMC FUNCTIONAL DESCRIPTION - NAVIGATION SUB-FUNCTION

The default values for RNP are as follows:

- Oceanic - 12.0 NM
- Enroute - 2.0 NM
- Terminal - 1.0 NM
- Approach - 0.5 NM.

HAP 001-005

RNP can also be set manually on the LEGS or POS SHIFT pages on the MCDU by the flight crew. The manually set value of RNP can not be more than the default RNP value.

ANP is compared with RNP and both show on the CDU LEGS and POS SHIFT pages. When the ANP exceeds the RNP, the message UNABLE REQD NAV PERF-RNP will show in the scratchpad on the MCDUs.

HAP ALL**NAVAID Selection and Tuning****HAP 037-054, 101-999**

The primary FMC selects the nav aids that both FMCs use. It selects the nav aids that give the most accurate estimate of position and have the best range and geometry.

Each FMC sends four nav aid frequencies to its on-side navigation control panel. The frequencies then go to the DME interrogators. If there is a fault with a control panel, the DME interrogators get the data directly from the FMC.

Each FMC is allocated two nav aid pairs for position updating. These pairs will be dissimilar with at most one nav aid in common between the two FMCs. The primary FMC will use the best and third best pairs and the secondary will use the second and fourth best pairs.

If there is only one nav aid pair available, the primary FMC will use that data for position updating while the secondary FMC will propagate its position using ADIRU data only corrected by a fixed error bias. This enables some independence in the individual FMC position calculations.

HAP 001-013, 015-026, 028-036

The FMC sends four nav aid frequencies to the navigation control panels. The frequencies then go to the DME interrogators. If there is a fault with a control panel, the DME interrogators get the data directly from the FMC.

HAP ALL**Navigation Data Base**

The navigation data base is stored in the flash EEPROM memory of the FMC in two parts. There is the main body of active data which is effective until a specified expiration date and also a set of data revisions for the next period of effectivity.

This information is in the navigation data base:

- VOR, DME, VORTAC, and TACAN navigation aids

EFFECTIVITY
HAP ALL

34-61-00

D633A101-HAP

Page 98.38
Jun 15/2009

FMCS - FMC FUNCTIONAL DESCRIPTION - NAVIGATION SUB-FUNCTION

- Waypoints
- Airports and runways
- Standard instrument departures (SIDs)
- Standard terminal arrival routes (STARs)
- Procedure turns and holds
- Holding patterns
- Missed approaches
- Approach Procedures
- Approach and departures transitions
- Company route structure
- Terminal gates.

- Transmit the initial alignment position to the ADIRUs.

Dual FMC Operation

When the source select switch is in the NORMAL position, dual mode operation is enabled. The secondary FMC is synchronized with the primary FMC at all times. The FMCs compare this data:

- Current aircraft state data
- Static data.

Current aircraft state data consists of the following output data from the FMC navigation sub-function:

- Airplane position (latitude and longitude)
- Magnetic heading
- Magnetic track
- Magnetic variation
- Roll angle
- Drift angle
- Airplane altitude
- Flight path angle
- Wind components (headwind and crosswind components, wind speed and direction).

HAP 037-054, 101-999

FMC Selection

You use the FMC source select switch to select the primary FMC.

FMC Source Select Switch Position	Primary FMC	Secondary FMC
NORMAL	FMC 1	FMC 2
BOTH ON L	FMC 1	FMC 2
BOTH ON R	FMC 2	FMC 1

Static data consists of the following data:

The primary FMC does these functions:

- Selects the nav aids for tuning for both FMCs
- Determine the navigation update mode (ADIRU/DME/DME etc.)

- Power up data
- Flight plan data
- Fix page data
- Supp/temp navigation data

34-61-00-025

<p>EFFECTIVITY HAP ALL</p>

34-61-00

D633A101-HAP

FMCS - FMC FUNCTIONAL DESCRIPTION - NAVIGATION SUB-FUNCTION**HAP 037-054, 101-999 (Continued)**

- Navigation option page data.

In the dual mode, if the current aircraft state data and static data do not compare within tolerance, the data is automatically crossloaded from the primary FMC to the secondary FMC (synchronization). The data is then compared again and if it is satisfactory, dual FMC operation is maintained.

If the secondary FMC is set to a conditional fail state, the intersystem bus between the FMCs will remain active and both FMCs will continue to process data. All outputs from the secondary FMC will be set to no computed data (NCD).

Following a failure to restore dual operation by movement of the FMC source select switch, an additional attempt at synchronization will be made 5 minutes after the failure. This attempt will only be made if the FMC source select switch is in the BOTH ON L or BOTH ON R positions.

When one FMC has conditionally failed and the FMC source select switch is in the BOTH ON L or the BOTH ON R position, the calculations from the selected FMC are used. The output systems receive data from the selected FMC.

HAP ALL

34-61-00-025

EFFECTIVITY
HAP ALL**34-61-00**

D633A101-HAP

Page 98.40
Jun 15/2009

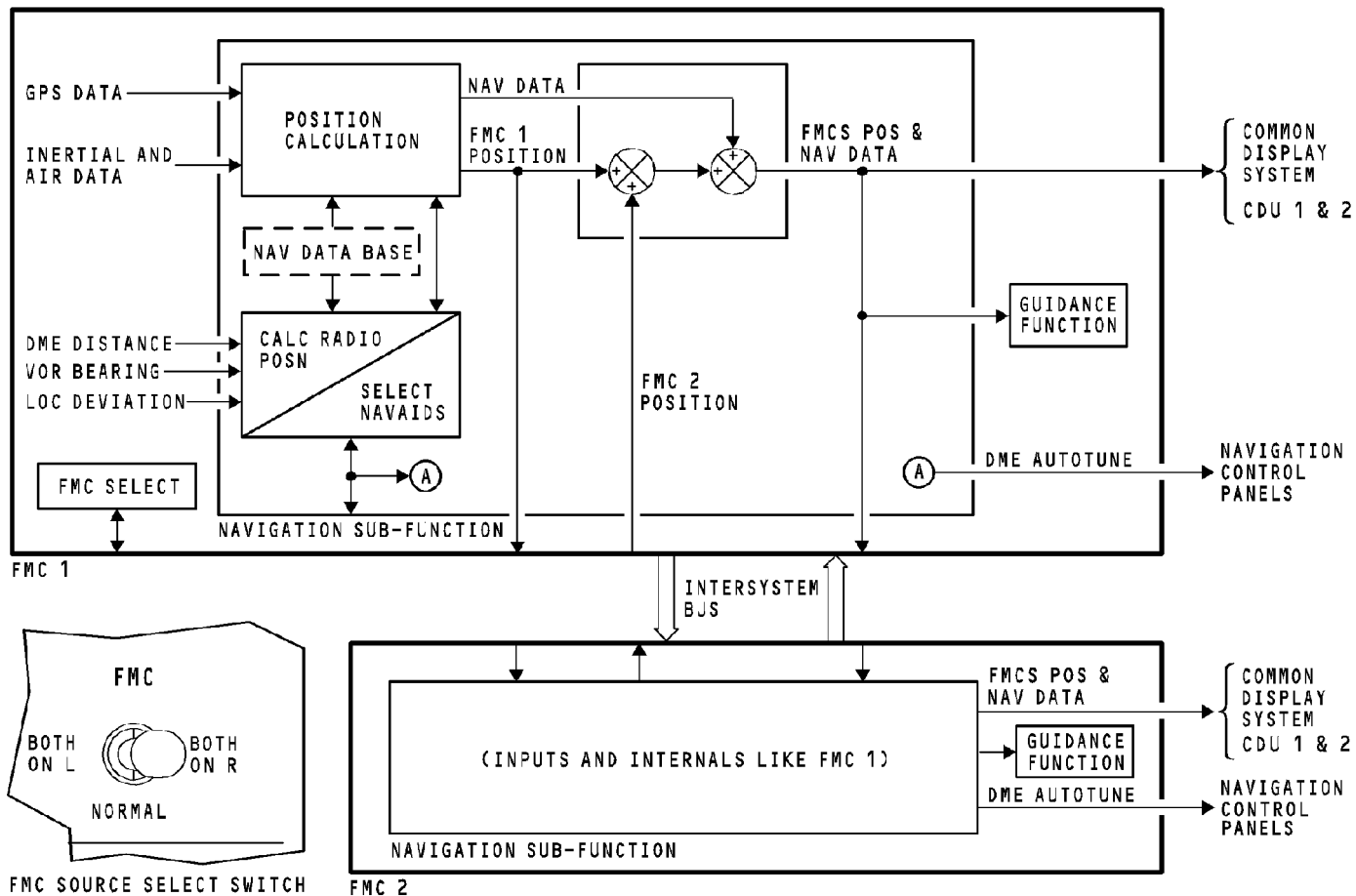

FMCS - FMC FUNCTIONAL DESCRIPTION - NAVIGATION SUB-FUNCTION

34-61-00-025

EFFECTIVITY
HAP 037-054, 101-999

34-61-00

D633A101-HAP

Page 98.41
Jun 15/2009

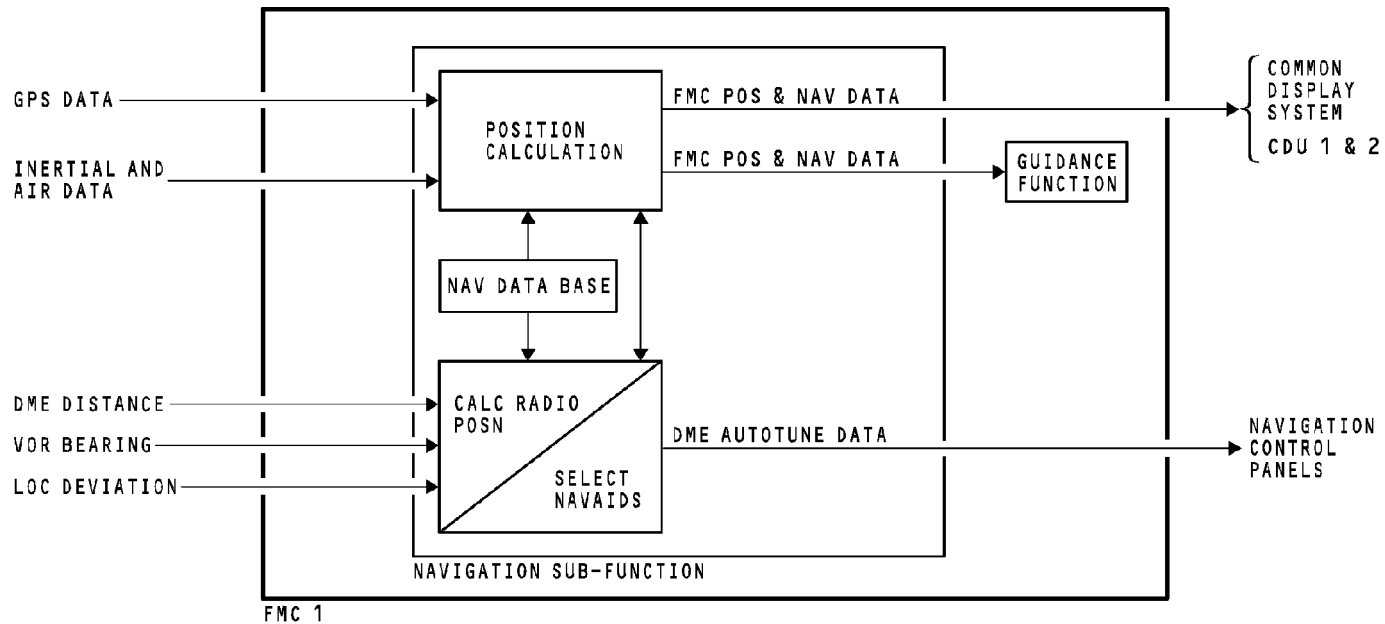

FMCS - FMC FUNCTIONAL DESCRIPTION - NAVIGATION SUB-FUNCTION

EFFECTIVITY

HAP 001-013, 015-026, 028-036

34-61-00

D633A101-HAP

FMCS - FMC FUNCTIONAL DESCRIPTION - PERFORMANCE SUB-FUNCTION**General**

The performance sub-function provides optimum values for airspeed and engine thrusts to provide the most economical vertical path profile. It uses aerodynamic and engine models to do these calculations. It calculates this data:

- Speed targets
- Speed limits
- N1 targets
- N1 limits
- Airplane gross weight.

Speed and Thrust Targets

The performance sub-function calculates the optimum speed and thrust targets. These calculations occur during climb, cruise and the descent phases of flight. The economy mode (ECON) is the default mode for each flight phase.

In the economy mode of operation, the FMC uses the data input from the flight crew (cruise altitude, cost index etc.) to calculate the most cost efficient flight profile. Other modes (maximum rate climb, long range cruise, speed descent etc.) are also available and can be selected by the flight crew through the MCDU.

When the VNAV mode is engaged, the speed and thrust targets go to the FMC guidance function. The guidance function then sends out commands to the DFCS and the autothrottle computer to control the vertical flight path of the airplane.

Speed targets do not go to the DFCS during takeoff or approach/go-around operation. Only target N1 (limit value or reduced value if engine derate has been selected) is used.

Speed and Thrust Limits

The performance sub-function also calculates minimum and maximum speed and thrust limits for the climb, cruise and descent phases of the flight. These make sure that the airplane operates within its flight envelope and the engines are protected against possible overboost.

Gross Weight

The FMCS calculates airplane gross weight or the flight crew manually enters the data. Total fuel weight from the fuel quantity processor unit goes to the FMC. The flight crew can enter either gross weight or zero fuel weight through the MCDUs.

If the flight crew enter gross weight, the FMC subtracts total fuel weight from gross weight to calculate zero fuel weight. If the flight crew enter zero fuel weight, the FMC adds total fuel weight and zero fuel weight to calculate gross weight.

FMCS - FMC FUNCTIONAL DESCRIPTION - PERFORMANCE SUB-FUNCTION**Performance Data**

The FMC uses this data for the performance calculations:

- Air data
- Cruise altitude
- Cost index
- Fuel weight
- Engine bleed air sensors
- Model/engine data base.

Air Data

The FMC uses this air data from the ADIRUs:

- Air temperature is used to calculate thrust limits.
- Altitude is used to calculate speed and thrust targets and limits.
- Airspeed is used to calculate DFCS/Autothrottle commands.

Cruise Altitude

Cruise altitude is entered by the flight crew through the MCDUs. It is used to establish the altitude for the top of climb (T/C) point.

Cost Index

The cost index is a number which is a ratio of the operator time costs (such as labor) to the fuel cost.

A low value for cost index means that fuel costs are more important than time costs. A high cost index means that time costs are more important than fuel costs. For flights where fuel costs are high, the performance economy speed schedules are slower. For flights where time costs are high, the economy speed schedules are faster.

The flight crew enters the cost index in the MCDU and changes the data as necessary. The range is from 000 (most economical) to 200 (time critical). This lets the operator adjust the economy speed schedules (climb, cruise and descent) for the conditions and routes they operate.

Fuel Weight

Fuel weight data is sent by the fuel quantity processor unit to the FMC. It is used by the FMC in the gross weight calculations.

If the total fuel weight data from the fuel quantity processor unit is invalid, the flight crew can manually input the fuel weight to the FMC on the MCDUs. Every 30 minutes, the FMC prompts the flight crew to enter a new fuel weight with the message VERIFY GW AND FUEL. After the airplane is past the T/D (top of descent) and a Vref value is entered, the FMC will not show this message.

FMCS - FMC FUNCTIONAL DESCRIPTION - PERFORMANCE SUB-FUNCTION**Engine Bleed Air Sensors**

The FMC receives analog discretes from the air conditioning system and the thermal antice (TAI) systems for both the engines and wings. The FMC uses this data to correct calculated thrust values.

Model/Engine Data Base (MEDB)

The MEDB contains this data:

- An aerodynamic model of the airplane. This consists of recommended speed schedules, optimum operating altitudes, buffet limit envelope and the certified operating limits for the airplane. Engine out operating conditions including speed and drag data are also contained in this data base.
- Fuel flow and N1 thrust models for the engine thrust rating selected on the airplane. These are used to calculate fuel flow, thrust limits, engine limits and to compensate for engine air bleed loads.

Flight Envelope Protection

The operational flight program (OFF) continually monitors computed performance targets against the airplane operation limits. If any performance target is more than the limit, the FMC will restrict the performance target to the correct value and maintain both airplane and engine optimal performance.

HAP 037-054, 101-999**Dual FMC Operation**

When the source select switch is in the NORMAL position, dual mode operation is enabled. The secondary FMC is synchronized with the primary FMC at all times. The FMCs compare this static performance data.

Static data consists of the following data:

- Flight plan data
- Performance data
- Takeoff reference page data
- Approach reference page data
- N1 limit page data
- Switchable discrete data.

In the dual mode, if the static data does not compare within tolerance, the data is automatically crossloaded from the primary FMC to the secondary FMC (synchronization). The data is then compared again and if it is satisfactory, dual FMC operation is maintained.

If the data still miscompares after this synchronization, the failure is logged into BITE against the secondary FMC and the system reverts to single FMC operation. The message SINGLE FMC OPERATION shows in the MCDU scratchpads. In this configuration, the calculations from the primary FMC are used and the secondary FMC is set to a conditional fail state.

FMCS - FMC FUNCTIONAL DESCRIPTION - PERFORMANCE SUB-FUNCTION**HAP 037-054, 101-999 (Continued)**

If the secondary FMC is set to a conditional fail state, the intersystem bus between the FMCs will remain active and both FMCs will continue to process data. All outputs from the secondary FMC will be set to no computed data (NCD).

After one FMC has become conditionally failed and the FMC source select switch is set to the BOTH ON L or BOTH ON R positions, synchronization will be attempted again between the FMCs using data from the primary FMC as the source for the synchronization. If the synchronization is successful, the message DUAL FMC OP RESTORED shows on the MCDU and the system goes to dual operation.

Following a failure to restore dual operation by movement of the FMC source select switch, an additional attempt at synchronization will be made 5 minutes after the failure. This attempt will only be made if the FMC source select switch is in the BOTH ON L or BOTH ON R positions.

When one FMC has conditionally failed and the FMC source select switch is in the BOTH ON L or the BOTH ON R position, the calculations from the selected FMC are used. The output systems receive data from the selected FMC.

The primary FMC processes all CDU operations and sends them to the secondary FMC via the intersystem bus. This ensures that the secondary FMC is synchronized to the primary FMC with regard to MCDU keypush events.

HAP ALL

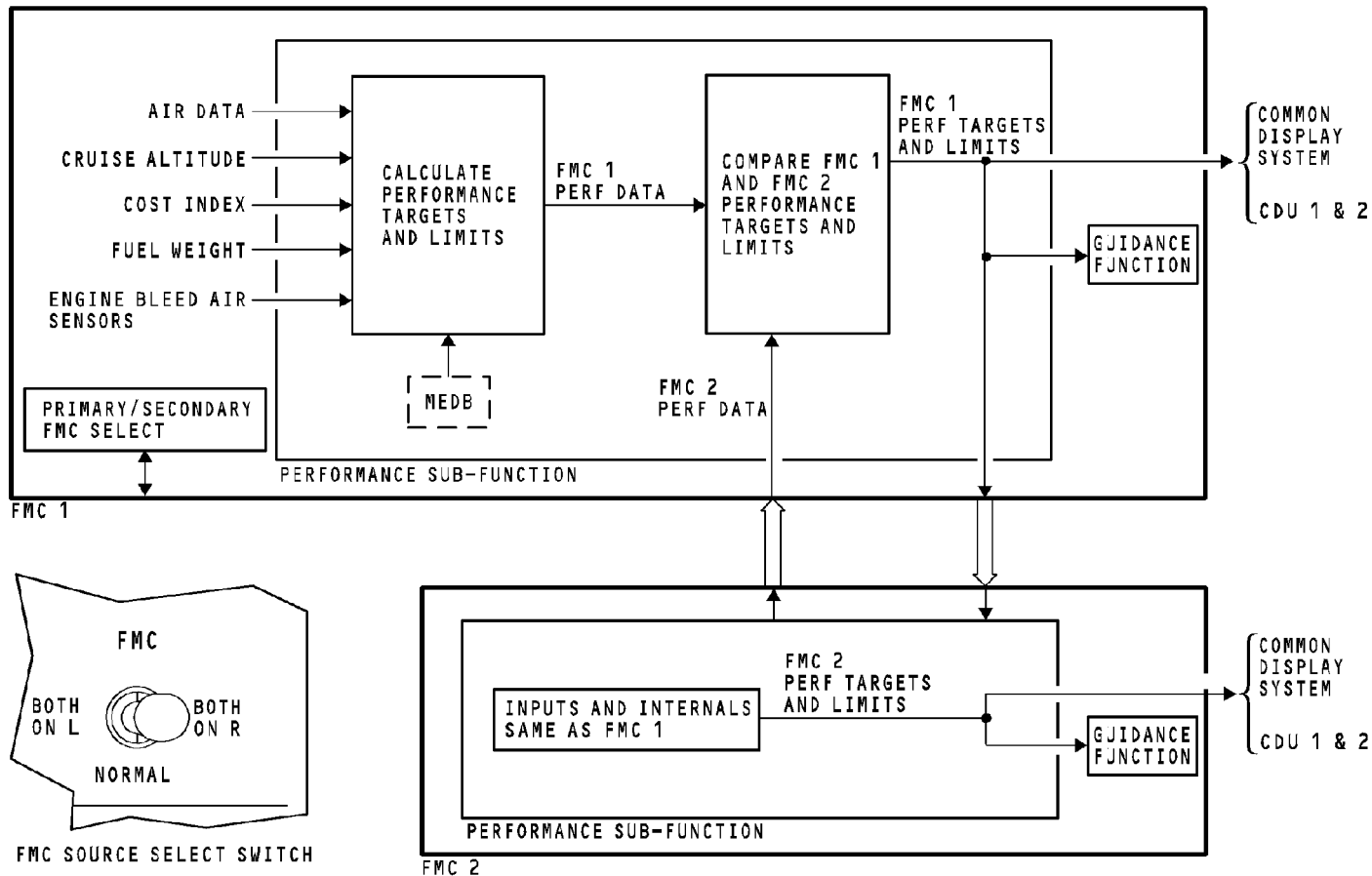

FMCS - FMC FUNCTIONAL DESCRIPTION - PERFORMANCE SUB-FUNCTION

EFFECTIVITY
 HAP 037-054, 101-999

34-61-00

D633A101-HAP

Page 98.47
 Jun 15/2009

34-61-00-026

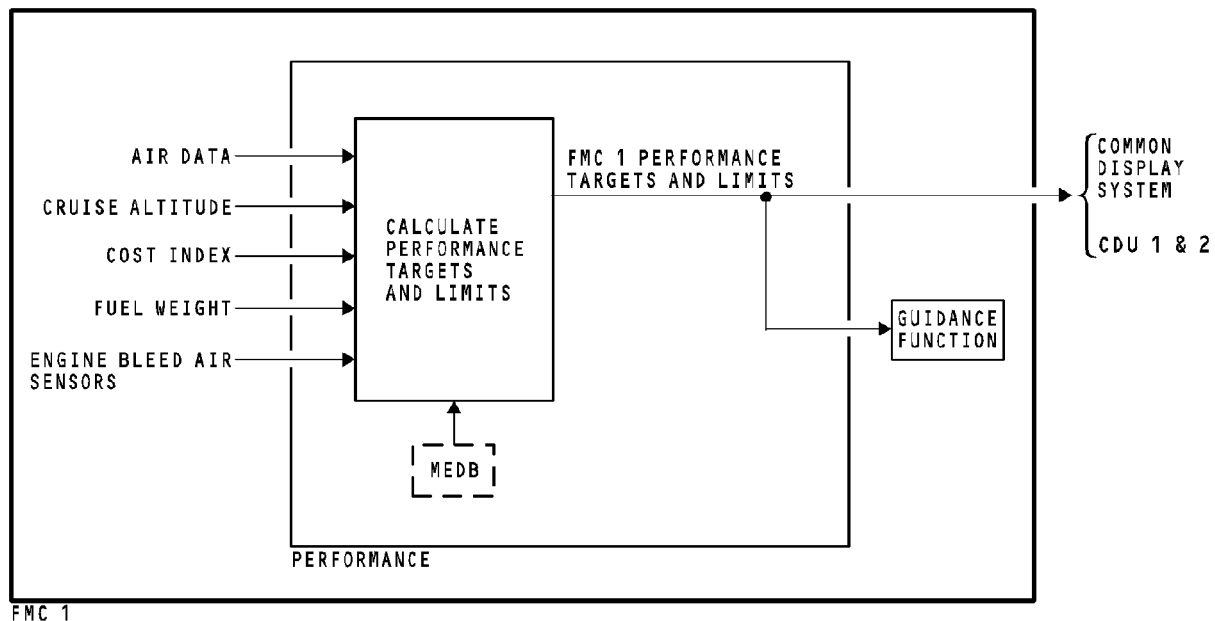

FMCS - FMC FUNCTIONAL DESCRIPTION - PERFORMANCE SUB-FUNCTION

EFFECTIVITY
 HAP 001-013, 015-026, 028-036

34-61-00

D633A101-HAP

34-61-00-026

FMCS - FMC FUNCTIONAL DESCRIPTION - GUIDANCE SUB-FUNCTION

General

The guidance sub-function calculates data for the lateral and vertical guidance functions and supplies guidance commands to the digital flight control system (DFCS) and autothrottle (A/T) system. The calculations start when the guidance sub-function receives an active route (lateral flight plan) and an active performance plan (vertical flight plan).

The DFCS and A/T use the commands to automatically guide the airplane along a lateral path and to control airspeeds, vertical speeds and N1 targets/limits. The LNAV mode must be active to enable the lateral guidance function and the VNAV mode must be active to enable the vertical guidance function.

NOTE: In path descents, LNAV must be valid and a valid end of descent point must be defined in order to engage the VNAV mode.

These are the major parts of the guidance sub-function:

- Flight plan management
- Lateral guidance commands
- Vertical guidance commands.

Flight Plan Management

The lateral route is a set of navigation legs. A navigation leg is a path between two waypoints. The flight plan management process calculates the great circle and turn segments for each path. Navigation legs are great circle tracks between the flight plan waypoints or constant heading legs.

A waypoint shows as latitude, longitude and altitude. The waypoints come from the navigation data base or are put in by the flight crew.

This data is calculated for each way point:

- Predicted altitude
- Time-of-arrival
- Speed
- Fuel remaining
- Distance between the waypoints
- Flight path course between the waypoints.

The performance plan (ZFW, cost index, cruise altitude, performance modes) determines the performance speed schedules and thrust that will be calculated by the FMC. The path calculations then use the performance data to calculate altitude, time, airspeed and fuel for each waypoint. If there are any speed or altitude restrictions attached to the lateral waypoints in the flight plan, these will be incorporated into the vertical flight profile calculated by the FMC.

34-61-00-027

<p>EFFECTIVITY HAP ALL</p>

34-61-00

D633A101-HAP

FMCS - FMC FUNCTIONAL DESCRIPTION - GUIDANCE SUB-FUNCTION

Initially the flight plan management calculates the parameters for the waypoints in the climb and cruise phases but the top of descent (T/D) waypoint will be unknown.

The T/D is calculated using the last waypoint in the flight plan and working backwards. The approximate T/D is estimated to get a descent speed schedule and descent path gradient together with fuel remaining. Range in descent is first calculated from the altitude change in descent and an assumed flight path angle. The T/D will be calculated by subtracting range in descent from the total flight plan range.

Next the estimated fuel remaining at T/D and wind profile are used to calculate descent range, speed schedules, path gradient and final fuel remaining. Then the full descent leg is calculated using the last set of data backward from the terminal waypoint. This gives the T/D and a predicted fuel remaining value. The descent phase of the flight plan is now combined with the climb and cruise phases to complete the flight plan predictions.

Lateral Guidance Commands

When a complete route has been activated in the FMCS and the LNAV mode is valid, the lateral guidance function sends lateral steering commands to the DFCS.

If the LNAV function is not valid and lateral guidance outputs are not calculated, the FMCS sets the lateral guidance outputs to no computed data (NCD). The DFCS disconnects the LNAV mode and reverts to control wheel steering (CWS).

Vertical Guidance Commands

The vertical guidance function calculates and sends airspeed or vertical speed targets to the DFCS. Airspeed, N1 limit and mode commands are also calculated and sent to the A/T system.

These are the two basic modes for vertical guidance:

- Airspeed (VNAV SPD)
- Path (VNAV PATH).

In the airspeed mode, the DFCS controls the airplane to a target FMCS airspeed while thrust is set to an N1 climb limit rating or idle. Both the speed target and the thrust limit values are provided by the FMCS. VNAV SPD will show on the flight mode annunciators (FMA). Speeds set on the MCP (speed intervention) can also be used.

In the path sub-mode, the DFCS controls the airplane to a target FMCS vertical speed. This path will be calculated for a specified speed/thrust profile. In descents, the default will be idle thrust and economy speeds. VNAV PATH will show on the FMAs.

FMCS - FMC FUNCTIONAL DESCRIPTION - GUIDANCE SUB-FUNCTION

HAP 001-005

If the VNAV function is not valid and vertical guidance outputs are not calculated, the FMCS sets the vertical steering command to no computed data (NCD). The DFCS disconnects the VNAV mode and reverts to CWS mode. The FMC lights on the ASAs will illuminate to alert the flight crew to this condition together with the VNAV DISCONNECT message in the MCDU scratchpads.

HAP ALL

For descent, a vertical path deviation display is sent to the common display system. The deviation shows the difference between the reference altitude on the vertical reference path and the current airplane altitude.

CDS Function

This function provides the common display system (CDS) with display/background data to accurately show the airplane's position with respect to the flight plan path.

The following data is sent to the CDS:

- FMC present position (Lat & Long)
- Distance to go to a waypoint
- Groundspeed
- Estimated time of arrival
- Desired track
- Cross track distance

- Vertical deviation
- Range to altitude
- Navigation sensor position (IRS, GPS, radio)
- V1 speed
- VR speed
- Speed targets
- Waypoint bearing
- True track angle
- Magnetic track angle
- Wind speed and direction
- Drift angle
- Flight path angle
- Waypoint, navaid, airport symbology
- Discrete word.

The discrete word contains the following data:

- To/from
- IRS source
- IRS position difference
- N1 limit mode
- Reduced thrust derate

HAP 050, 053, 054

- VNAV ALT annunciation

HAP 037-054, 101-999

- FMC source select annunciation.

Dual FMC Operation

When the FMC source select switch is in the NORMAL position, dual mode operation is enabled. The secondary FMC is synchronized with the primary FMC at all times.

34-61-00-027

<p>EFFECTIVITY HAP ALL</p>

34-61-00

D633A101-HAP

FMCS - FMC FUNCTIONAL DESCRIPTION - GUIDANCE SUB-FUNCTION**HAP 037-054, 101-999 (Continued)**

FMC 1 supplies the guidance commands and N1 thrust targets to flight control computer (FCC) A and the autothrottle computer while FMC 2 supplies FCC B.

The common display system will use onside FMC dynamic/background data for the captain's and F/O's navigation displays.

With regard to the guidance sub-function, the FMCs compare dynamic data:

Dynamic data consists of the following output data:

- DFCS data
- Autothrottle data
- CDS data.

In the dual mode, if the dynamic data does not compare within tolerance, the guidance data is automatically crossloaded from the primary FMC to the secondary FMC (synchronization). The data is then compared again and if it is satisfactory, dual FMC operation is maintained.

If the data still mismatches after this synchronization, the guidance data calculations are initiated again in each FMC and compared again.

If the secondary FMC is set to a conditional fail state, the intersystem bus between the FMCs will remain active and both FMCs will continue to process data. All outputs from the secondary FMC will be set to no computed data (NCD).

After a failure to restore dual operation by movement of the FMC source select switch, an additional attempt at synchronization is made 5 minutes after the failure. This attempt is only made if the FMC source select switch is in the BOTH ON L or BOTH ON R positions.

When one FMC has conditionally failed and the FMC source select switch is in the BOTH ON L or the BOTH ON R position, the calculations from the selected FMC are used. The output systems receive data from the selected FMC.

HAP ALL

EFFECTIVITY
HAP ALL

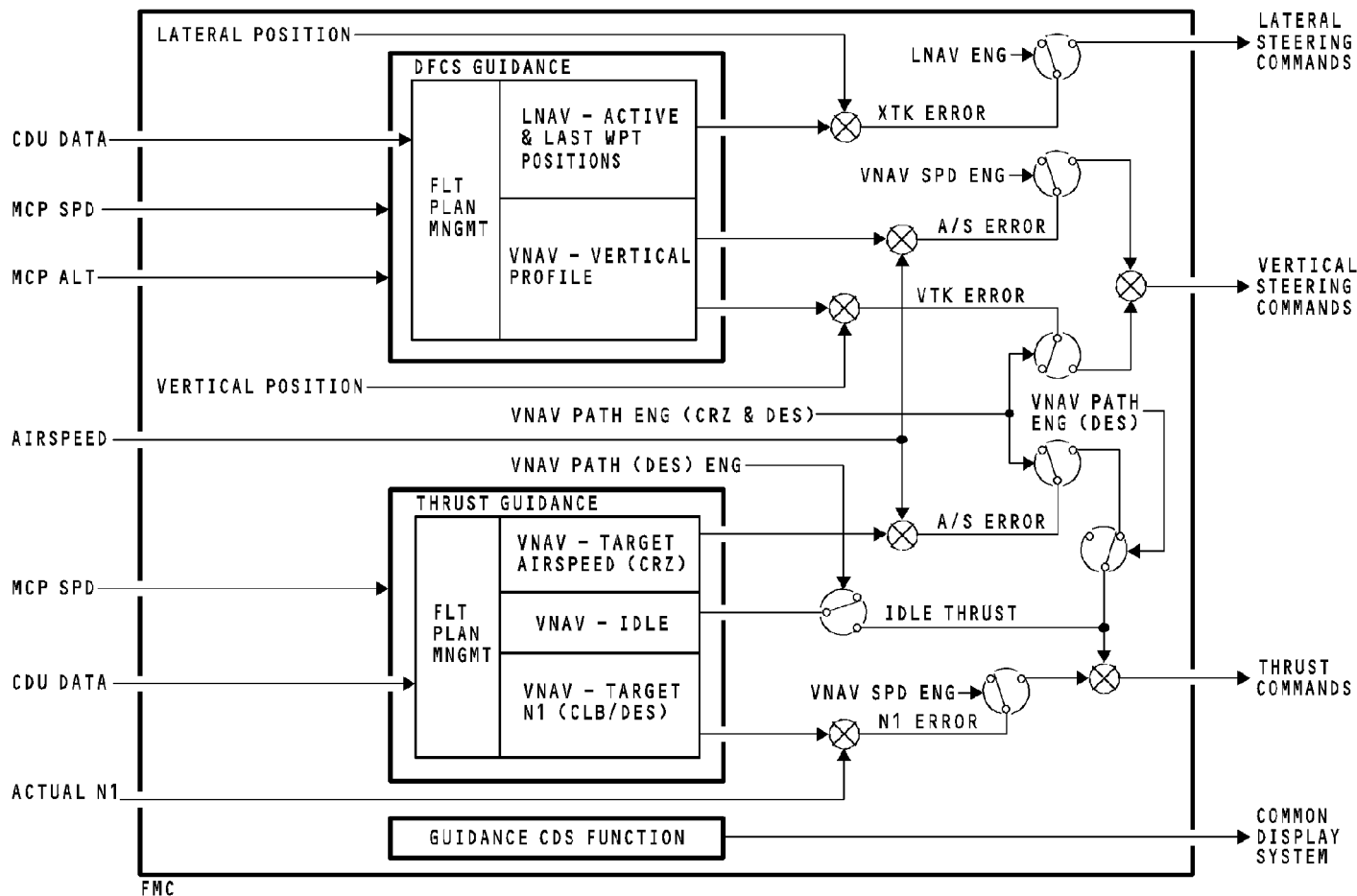

FMCS - FMC FUNCTIONAL DESCRIPTION - GUIDANCE SUB-FUNCTION

34-61-00-027

EFFECTIVITY
HAP ALL

34-61-00

D633A101-HAP

Page 98.53
Jun 15/2009

THIS PAGE IS INTENTIONALLY LEFT BLANK

34-61-00

D633A101-HAP

Page 98.54
Jun 15/2009

FMCS - FMC FUNCTIONAL DESCRIPTION - GUIDANCE SUB-FUNCTION - LNAV AND VNAV MODE LOGIC

General

LNAV and VNAV logic uses inputs from several sources to engage the LNAV and VNAV modes.

The FMCS guidance sub-function needs these logic inputs to complete its guidance command output path to the DFCS and the A/T system.

LNAV/VNAV Mode Activation

To engage LNAV or VNAV, push the LNAV or VNAV switch on the mode control panel (MCP). The MCP then sends the mode requests by way of the flight control computers (FCCs) to the guidance sub-function in the FMC.

FMC LNAV Logic

These are the inputs to the FMCS necessary to engage the LNAV mode:

- ADIRU in the Nav mode and the data is valid
- LNAV capture criteria is satisfied (The present airplane track will intercept the active flight leg at an angle of 90 degrees or less and the crosstrack deviation is less than 3 nautical miles)
- Active route (no discontinuity to the next waypoint)
- Localizer mode is not active
- Go-around mode is not active
- LNAV arm/operate (MCP).

FMC VNAV Logic

These inputs to the FMCS are necessary to engage the VNAV mode:

- Airplane in the air
- ADIRU in the Nav mode and the data is valid
- Performance data (ZFW or GW, fuel reserves, cost index and cruise altitude) is valid
- Glideslope mode is not active
- Go-around mode is not active
- VNAV arm/operate.

VNAV will engage in VNAV SPEED mode when:

- A climb or a speed descent flight phase is active
- The airplane is not in level flight
- VNAV mode is active.

VNAV will engage in VNAV PATH mode when:

- The airplane is holding altitude or a path descent is active
- Active lateral route (LNAV engaged)
- VNAV mode is active.

The climb flight phase is active when the flight crew sets a new altitude on the CDU cruise (CRZ) page or selects altitude intervention, and the airplane climbs to a new altitude.

The speed descent flight phase is active when the flight crew selects the SPEED prompt on the CDU descent (DES) page.

34-61-00-028

<p>EFFECTIVITY HAP ALL</p>

34-61-00

D633A101-HAP



FMCS - FMC FUNCTIONAL DESCRIPTION - GUIDANCE SUB-FUNCTION - LNAV AND VNAV MODE LOGIC

The path descent flight phase is active when the flight crew selects PATH on the CDU descent (DES) page.

34-61-00-028

EFFECTIVITY
HAP ALL

34-61-00

D633A101-HAP

Page 98.56
Jun 15/2009

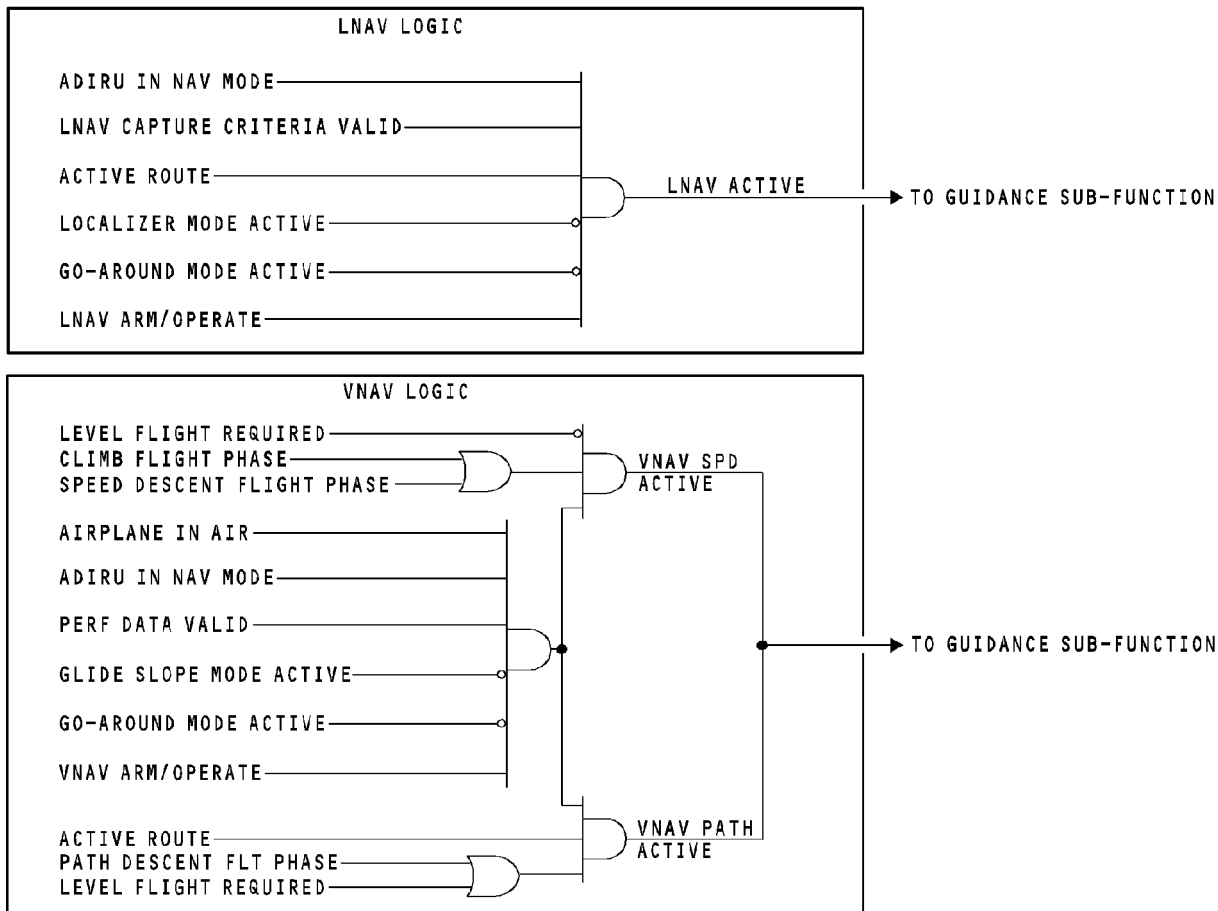

FMCS - FMC FUNCTIONAL DESCRIPTION - GUIDANCE SUB-FUNCTION - LNAV AND VNAV MODE LOGIC

34-61-00-028

EFFECTIVITY
HAP ALL

34-61-00

D633A101-HAP

FMCS - DISPLAYS - CDU - GROUND POWER UP - 1

General

The MCDU and FMCS both do internal BITE tests at power up. If the power up test is normal, the MCDUs show the MENU page.

The MENU page always shows the FMC prompt at line select key 1L. The other available sub-systems show below the FMC prompt.

Selection of the FMC prompt or any FMCS mode key on the MCDU makes the FMCS the active user and the IDENT page shows.

The status of the sub-systems shows on the MENU page by the label <ACT> to the right of the active sub-system. The label <REQ> shows to the right of a sub-system if it is not active but has sent a request to the MCDU to request operator attention.

HAP 001-013, 015-026, 028-036

The MENU page automatically shows if the FMC fails but the FMC prompt will not show.

HAP 037-054, 101-999

The MENU page automatically shows if the primary FMC fails but the FMC prompt will not show.

HAP ALL

EFFECTIVITY
HAP ALL

34-61-00

D633A101-HAP

Page 98.58
Jun 15/2009

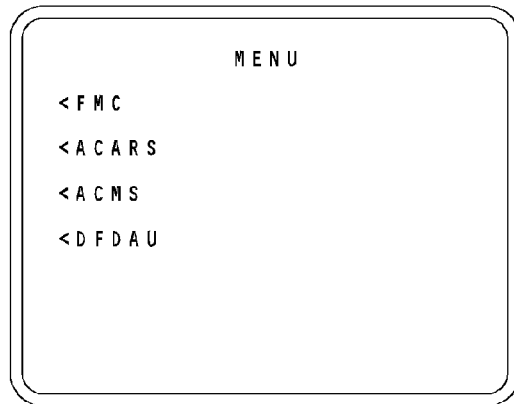

INITIAL PAGE

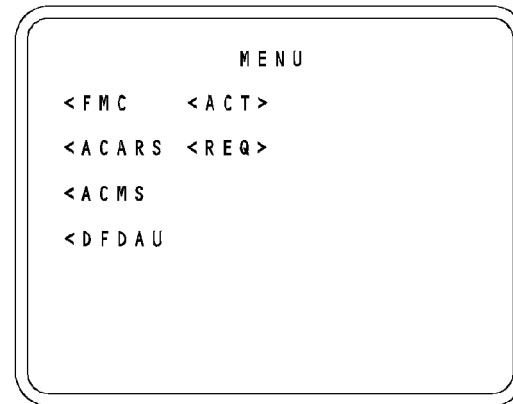

MENU PAGE

FMCS - DISPLAYS - CDU - GROUND POWER UP - 1

34-61-00-029

EFFECTIVITY
HAP 001-013, 015-026, 028-030

34-61-00

D633A101-HAP

Page 98.59
Jun 15/2009

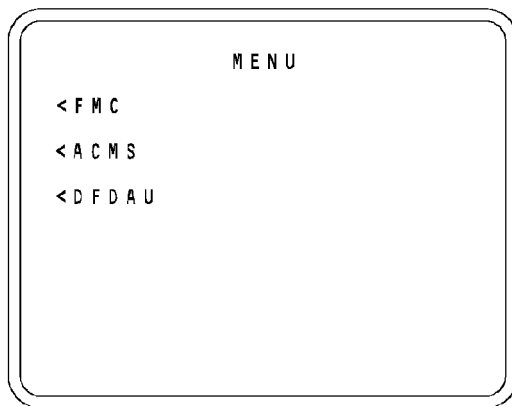

INITIAL PAGE

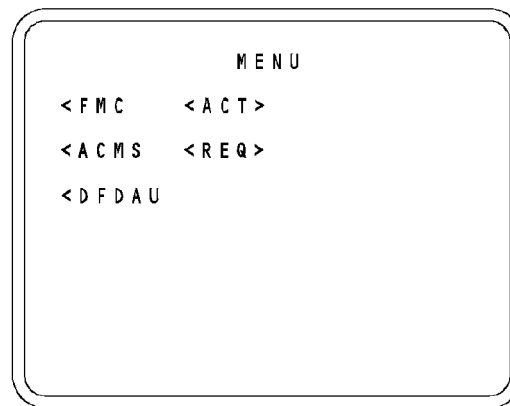

MENU PAGE

FMCS - DISPLAYS - CDU - GROUND POWER UP - 1

EFFECTIVITY
HAP 031-054, 101-999

34-61-00

D633A101-HAP

THIS PAGE IS INTENTIONALLY LEFT BLANK

34-61-00

D633A101-HAP

Page 98.61
Jun 15/2009

FMCS - DISPLAYS - CDU - GROUND POWER UP - 2**FMC****HAP 037-054, 101-999**

At power-up, each FMC does a check of the status of the other FMC. During power-up, the MCDU annunciators come on momentarily. If the primary FMC fails at power-up, the FMC prompt does not show on the MENU page. The FMC warning light on the autoflight status annunciators also comes on. If the secondary FMC fails, the primary FMC shows the SINGLE FMC OPERATION message in the scratch pad on the IDENT page. If the transfer switch is in normal, the FMC warning light comes on.

HAP 001-013, 015-026, 028-036

At power-up, the FMC does a BITE check. During the power-up, the MCDU annunciators come on momentarily. If the FMC fails at power-up, the FMC menu page does not show the FMC prompt.

HAP ALL**MCDU**

A MCDU display is blank if the MCDU fails at power-up.

HAP 037-054, 101-999**Other Tests**

The FMCs also do a check of these functions at power-up:

- Airplane and engine configuration program pins for parity
- Cross compare FMC 1 and FMC 2 data bases and operational flight programs.

For example, the message OP PROGRAM INVALID shows if the operational flight program (OPF) of the primary FMC is invalid at power-up. If the secondary FMC has a valid OPF, the message tells the operator to switch to the both on right position.

HAP 001-013, 015-026, 028-036**Other Tests**

At power-up, the FMC also does a parity check of the airplane and engine configuration program pins.

HAP ALL

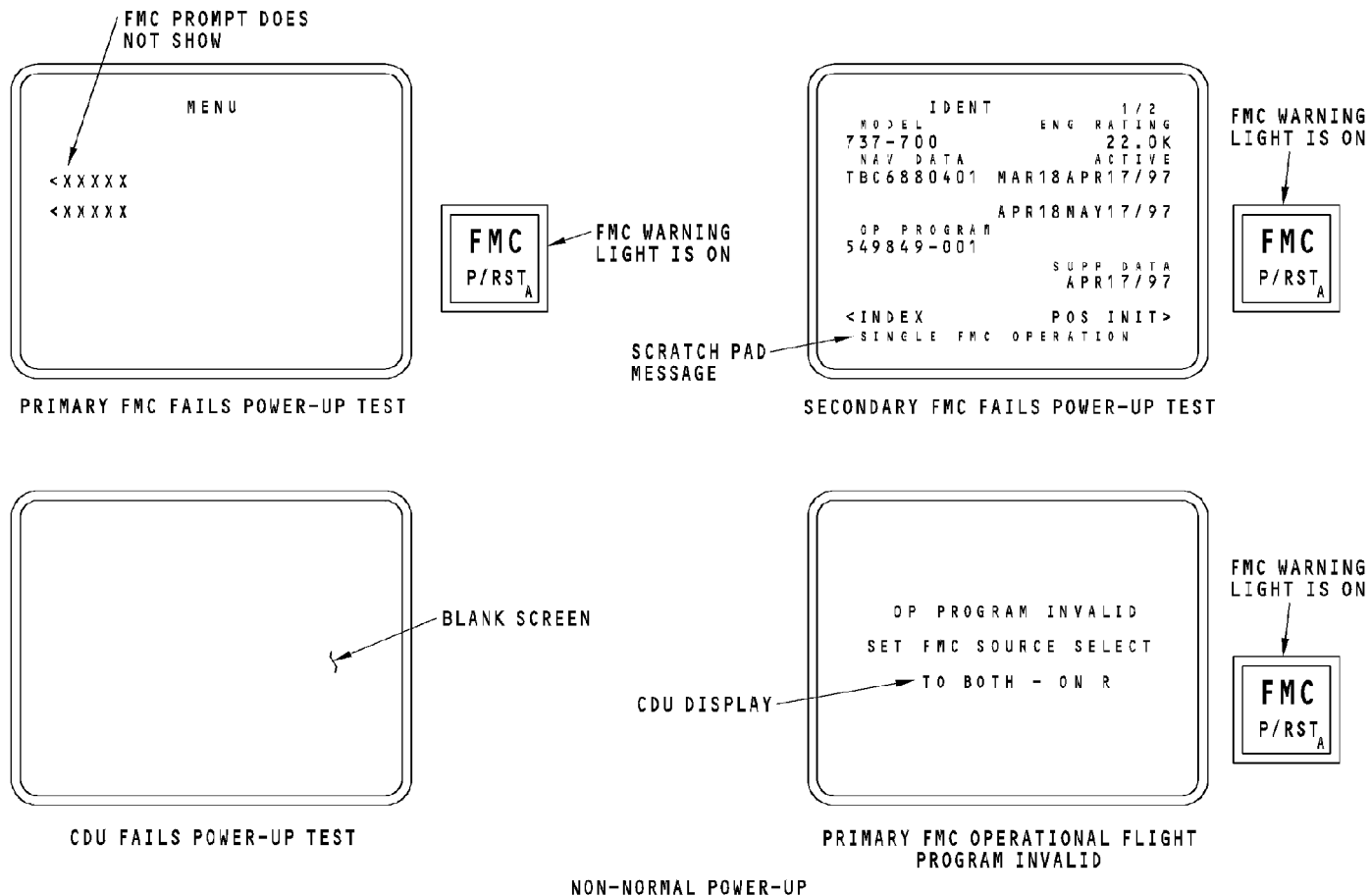

FMCS - DISPLAYS - CDU - GROUND POWER UP - 2

34-61-00-030

EFFECTIVITY
HAP 037-054, 101-999

34-61-00

D633A101-HAP

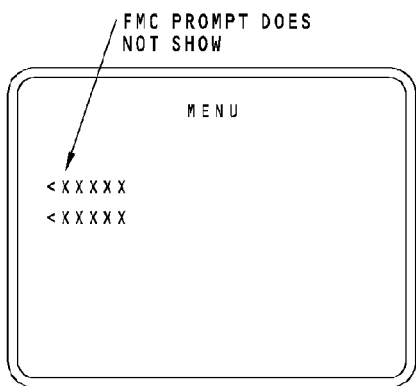

FMC FAILS POWER-UP TEST

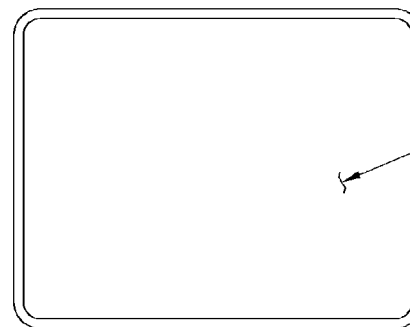

CDU FAILS POWER-UP TEST

NON-NORMAL POWER-UP

FMCS - DISPLAYS - CDU - GROUND POWER UP - 2

EFFECTIVITY

HAP 001-013, 015-026, 028-036

34-61-00

D633A101-HAP

FMCS - DISPLAYS - CDU - PRE-FLIGHT INTRODUCTION**General**

This is an introduction to the MCDU pages the flight crew uses to enter pre-flight data into the FMCS. More information about each page is described in detail on subsequent pages.

Data

The flight crew uses this type of data to pre-flight the FMCS:

- Airplane initial position
- Route structure
- Performance data.

The flight crew uses the line select keys (LSK) and function keys to enter and verify data on these pages:

- IDENT
- POS INIT
- RTE
- DEP/ARR INDEX
- PERF INIT
- N1 LIMIT
- TAKEOFF REF.

IDENT Page

This page lets the flight crew verify the FMCS operational flight program and data base identification numbers.

POS INIT Page

This page lets the flight crew set the reference airplane initial position. This data is necessary to start ADIRU alignment. Access to the POS REF and POS SHIFT pages is from this page.

RTE Page

This page lets the flight crew make a flight plan or set a company route from the navigation data base. If the entered route or company route does not have an origin departure or destination approach the crew must also select a departure runway and arrival data.

DEP/ARR INDEX Page

This page lets the flight crew select the departure runway and standard instrument departure (SID) data. The standard terminal arrival route (STAR), approach, and destination runway can also be selected on this page.

PERF INIT Page

This page lets the flight crew enter aircraft and atmospheric parameters necessary for the FMCS to calculate the vertical flight profile performance data.

FMCS - DISPLAYS - CDU - PRE-FLIGHT INTRODUCTION

N1 LIMIT Page

This page lets the flight crew select the engine thrust limits for display by the N1 limit bugs on the engine indication and for use by the autothrottle. Outside air temperature is also selected from this page.

TAKEOFF REF Page

This page lets the flight crew select the takeoff flaps setting and takeoff V speed values.

CAUTION: ANY FMC ENTRIES MADE ON NON-BITE PAGES SHOULD BE REMOVED AT THE COMPLETION OF MAINTENANCE ACTIVITIES. THIS PREVENTS MAINTENANCE ACTIVITIES FROM HAVING AN UNINTENTIONAL IMPACT ON FMC FLIGHT OPERATIONS. FMC ENTRIES MAY BE REMOVED BY USING THE DELETE KEY OR BY TURNING OFF POWER TO THE FMC FOR AT LEAST TEN SECONDS.

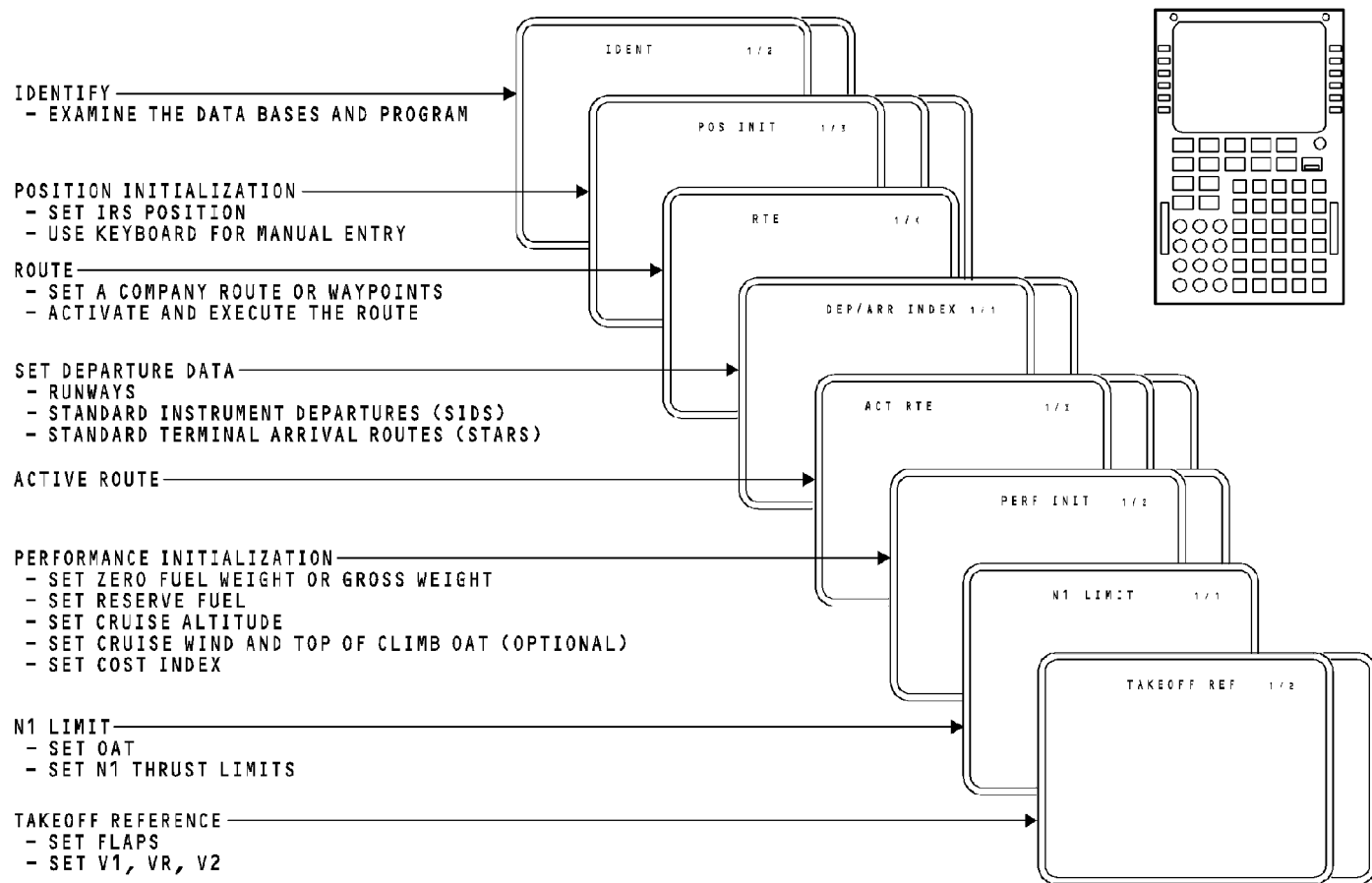

FMCS - DISPLAYS - CDU - PRE-FLIGHT INTRODUCTION

EFFECTIVITY
HAP ALL

34-61-00

D633A101-HAP

THIS PAGE IS INTENTIONALLY LEFT BLANK

34-61-00

D633A101-HAP

Page 98.68
Jun 15/2009

FMCS - DISPLAYS - CDU - IDENT PAGE**Purpose**

The IDENT page lets the crew verify the FMCS operational flight program and data base identification numbers. Also, you can select the POS INIT and INDEX pages from the IDENT page.

Page Access

The IDENT page is the first page that shows on the MCDU when you select the FMC prompt on the MENU page. It can also be selected from the INIT/REF INDEX page.

Page 1 Information

Line 1L shows the airplane model. The airframe/engine program pin configuration sets this information. This line is blank if the FMC finds a parity error for the airframe/engine program pins or a valid performance data base is not loaded into the FMC. It is also blank if the loaded performance data base does not contain data for the current airframe/engine program pin configuration.

Line 2L shows the navigation data base identification number loaded in the FMC. This data field is blank if a navigation data base is not loaded.

Line 4L shows the FMC operational program software part number and the update version.

Line 5L can show the Smiths Industries operational program software part number. To show the number, enter the word SIPART into the scratch pad and select key 5L. This line is blank when the part number is not shown.

Line 6L shows the INDEX prompt. This selects the INIT/REF page.

Line 1R shows the engine thrust rating. This information is set by the airframe/engine program pin configuration. This line is blank if the FMC finds a parity error for the airframe/engine program pins or a valid performance data base is not loaded into the FMC. It is also blank if the loaded performance data base does not contain data for the current airframe/engine program pin configuration.

Lines 2R and 3R show the effective dates of the active and inactive navigation data bases. You can exchange the data on these two lines to activate a new data base or recall the old one. The exchange can only be done when the airplane is on the ground. The active data base is compared to the FMC clock input at initial power-up and if the active data base is out of date, the CDU message NAV DATA OUT OF DATE shows in the scratchpad.

Line 5R shows there is supplemental data and gives the effective date of that data. The line is blank if an effective date is not set or there is no supplemental data.

EFFECTIVITY
HAP ALL

FMCS - DISPLAYS - CDU - IDENT PAGE

Line 6R shows the POS INIT prompt. This selects the POS INIT page.

Page 2 Information

Line 1L shows the identification number of the performance default data base in the FMC operational flight program.

Line 2L shows the identification number of the software options data base.

Line 4L shows the identification number of the ACARS datalink configuration file.

Line 5L shows the identification number of the model/engine performance data base. This line is blank if the data base is not loaded.

Line 6L shows the INDEX prompt. This selects the INIT/REF page.

Line 6R shows the POS INIT prompt. This selects the POS INIT page.

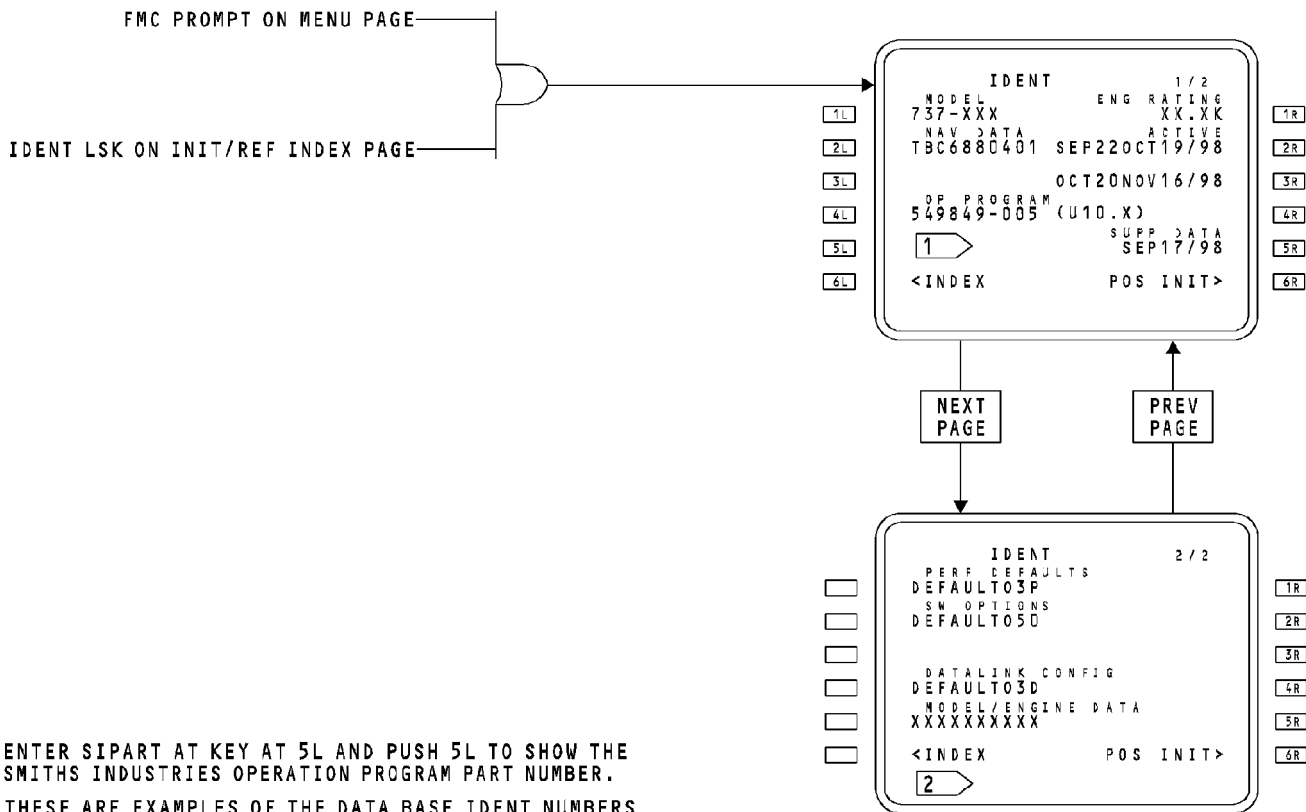

FMCS - DISPLAYS - CDU - IDENT PAGE

34-61-00-032

EFFECTIVITY
HAP ALL

34-61-00

D633A101-HAP

THIS PAGE IS INTENTIONALLY LEFT BLANK

34-61-00

D633A101-HAP

Page 98.72
Jun 15/2009

FMCS - DISPLAYS - CDU - INIT/REF INDEX PAGE

Purpose

The INIT/REF INDEX page shows a menu of pages you can use to initialize the following:

- FMCS
- ADIRU
- Other reference data.

Also, you can use this page to go to the FMCS MAINT BITE INDEX page.

Page Access

To select this page, push line select key 6L on pages that show the index prompt and are not BITE pages. The INDEX prompt on BITE pages changes the display back to the last menu.

Information

Line select key 1L (LSK) shows the first page of the configuration identification IDENT pages. These pages show the FMCS data base and program configuration data.

LSK 2L shows the first page of the position initialization (POS) pages. These pages are for ADIRS initialization and to show navigation sensor positions.

LSK 3L shows the first page of the performance initialization (PERF) pages. These pages are to enter the airplane parameters that the FMC needs for VNAV calculations.

LSK 4L shows the first page of the TAKEOFF pages. These pages are to select takeoff thrusts and speeds.

LSK 5L shows the approach reference (APPROACH) page. This page gives specific information on the condition of the airplane and the selected runway and approach procedures of the flight plan.

LSK 6L shows the OFFSET page. This page is to start and end an offset to the flight plan route.

LSK 1R shows the navigation data reference (NAV DATA) page. This page is to enter this data into the temporary navigation data base:

- Waypoints
- Navaids
- Airports.

LSK 3R shows the alternate destination (ALTN DEST) page. This page is used to find this data for a specified alternate destination:

- Distance
- Time
- Fuel remaining.

LSK 4R shows the ACARS page. This page is customer defined and shows prompts to uplink/downlink FMC data.

FMCS - DISPLAYS - CDU - INIT/REF INDEX PAGE**HAP 012, 013, 015-026, 028-054, 101-999; HAP 001-011 POST SB
737-31-1136**

LSK 5R shows the selectable configuration (SEL CONFIG) page. This page is used to see the configuration data for loadable software. It shows only when the airplane is on the ground.

HAP ALL

LSK 6R shows the maintenance bite index MAINT page. The MAINT prompt shows only when the airplane is on the ground and the groundspeed is less than 20 knots. When the airplane is in the air, the NAV STATUS prompt shows in place of the MAINT prompt.

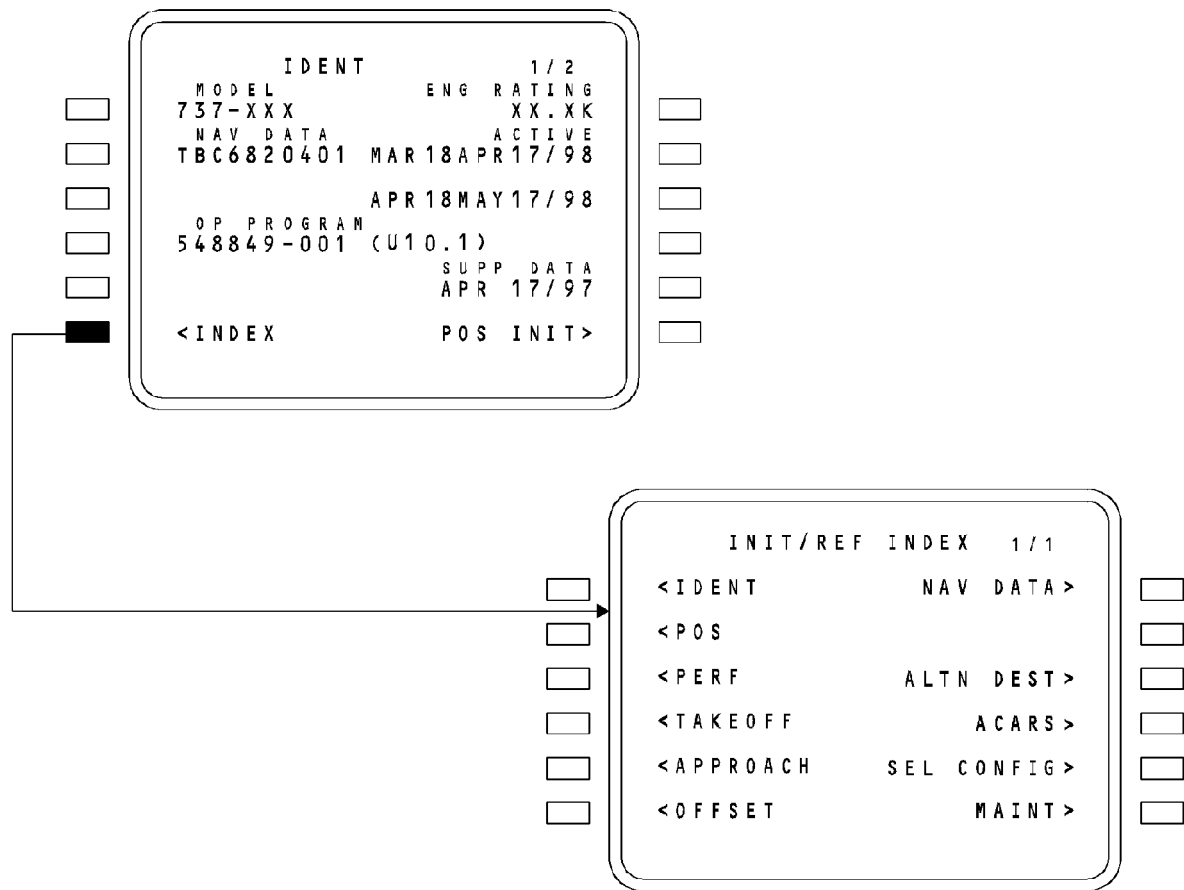

FMCS - DISPLAYS - CDU - INIT/REF INDEX PAGE

EFFECTIVITY

HAP 012, 013, 015-026, 028-054, 101-999; HAP 001-011 POST SB 737-31-1136

34-61-00

D633A101-HAP

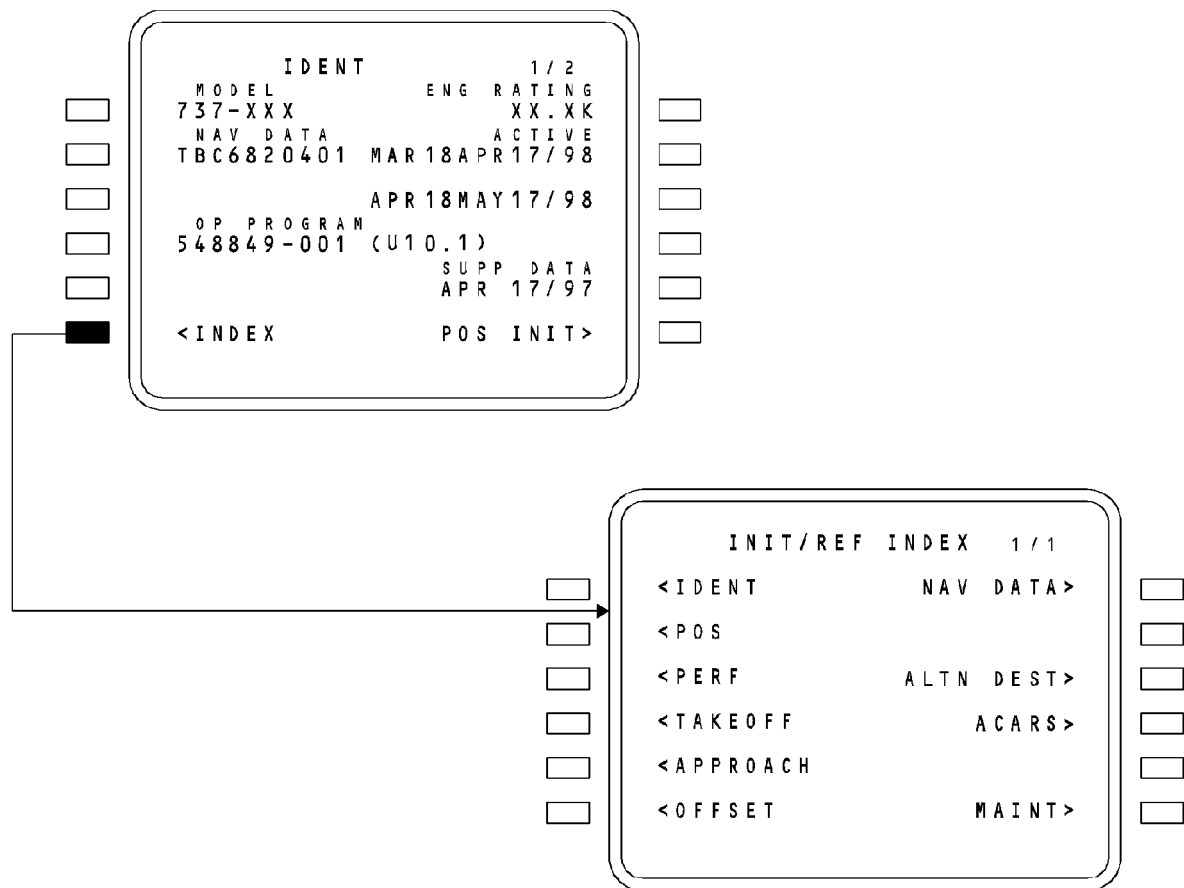

FMCS - DISPLAYS - CDU - INIT/REF INDEX PAGE

EFFECTIVITY
HAP 001-011 PRE SB 737-31-1136

34-61-00

D633A101-HAP

THIS PAGE IS INTENTIONALLY LEFT BLANK

34-61-00

D633A101-HAP

Page 98.77
Jun 15/2009

FMCS - DISPLAYS - CDU - POSITION PAGES**Purpose**

These are the three position pages:

- Position initialization (POS INIT)
- Position reference (POS REF)
- Position shift (POS SHIFT).

The POS INIT page is used to enter the present position for ADIRU alignment.

The box prompts show that data must be entered to complete the preflight. The dash prompts show that the data entry is optional.

The POS REF page shows airplane position and groundspeed as calculated by the FMC, each ADIRU, each GPS, and radio position.

The POS SHIFT page is used to shift the FMC position to the specified navigation sensor position.

Page Access

You use the INIT REF function key or these CDU pages, to go to the first position page:

- INIT/REF INDEX
- IDENT
- TAKEOFF REF.

POS INIT Page

Line 2L shows dash prompts for an airport identifier. The identifiers you put here must also be in the navigation data base. If the identifier you put in is valid and is in the data base, the latitude/longitude (LAT/LON) for the airport shows at LSK 2R.

Line 3L shows dash prompts for airport gate identifiers. If the identifier you put in is valid and is in the data base, the LAT/LON for the gate shows at LSK 3R. The airport identifier must have been entered first.

HAP 037-054, 101-999

Line 5L shows airplane clock input. The clock input (time and date) to both FMCs is from the GPS. If GPS is not valid, the FMCs calculate time with an FMC internal clock. The time may be set on this page.

HAP 001-013, 015-026, 028-036

Line 5L shows airplane clock input. The clock input (time and date) to the FMC is from the GPS. If GPS is not valid, the FMC calculates time with an FMC internal clock. The time may be set on this page.

HAP ALL

Line 6L shows the INDEX prompt. This selects the INIT/REF INDEX page.

EFFECTIVITY
HAP ALL

34-61-00

D633A101-HAP

Page 98.78
Jun 15/2009

FMCS - DISPLAYS - CDU - POSITION PAGES**HAP 001-013, 015-026, 028-036**

Line 1R shows the last calculated FMC present position. This data is saved in the FMC at power down.

HAP 037-054, 101-999

Line 1R shows the last calculated present position of the primary FMC. This data is saved in the FMC at power down.

HAP ALL

Lines 2R and 3R show the LAT/LON position for the reference airport and gate identifiers set at Line 2L and 3L.

Line 4R shows the header SET IRS POS and box prompts. This data field is used to enter present position for initialization of the ADIRUs when the airplane is on the ground.

Line 5R shows the header SET IRS HDG. This data field is used to enter heading data when any ADIRU is in the attitude (ATT) mode. It will be blank if there is no ADIRU in the ATT mode.

Line 6R shows the ROUTE prompt. This selects the route page.

POS REF Page

This page shows the airplane position and ground speed calculated by the FMC, each ADIRU, each GPS and radio position. Any data field may be selected to the scratchpad and used to initialize the ADIRUs. These data fields will be blank if the position data is invalid.

The radio position will always be blank on the ground.

POS SHIFT Page**HAP 001-013, 015-026, 028-036**

This page shows the bearing and distance between the FMCS calculated position shown on the POS REF page and the position of the ADIRUs, GPS, and radio systems. This page also provides the capability to update the FMCS calculated position to one of the positions shown when the airplane is in the air.

HAP 037-054, 101-999

This page shows the bearing and distance between the FMCS calculated position shown on the POS REF page and the position of the individual FMCs, ADIRUs, GPS, and radio systems. This page also provides the capability to update the FMCS calculated position to one of the positions shown when the airplane is in the air.

HAP ALL

FMCS - DISPLAYS - CDU - POSITION PAGES

The FMC position may be overridden by selection of the particular navigation sensor position with the line select key. The selected sensor will now be highlighted and the EXEC light will come on. When you select EXEC, the FMC navigation position changes to the selected sensor position and UPDATE COMPLETE will show at line 5L in small font.

HAP 001-013, 015-026, 028-036

The ADIRU, GPS, and radio data fields are blank on the ground.

HAP 037-054, 101-999

The FMC, ADIRU, GPS, and radio data fields are blank on the ground.

HAP ALL

Line 4L shows the RNP/ANP values.

Line 5L shows UPDATE COMPLETE in small font after a position shift has been selected and executed (EXEC).

Line 6L shows the INDEX prompt. This selects the INIT/REF INDEX page.

Line 5R shows the NAV STATUS prompt. This selects the NAV STATUS pages.

Line 6R shows the CANCEL prompt. This shows only when a sensor has been selected for position shift. This lets the crew cancel the selected sensor for position shift.

The data in the center of the GPS and IRS data fields at line 2 and 3 shows that both GPSs and ADIRUs are used in the FMC position calculation.

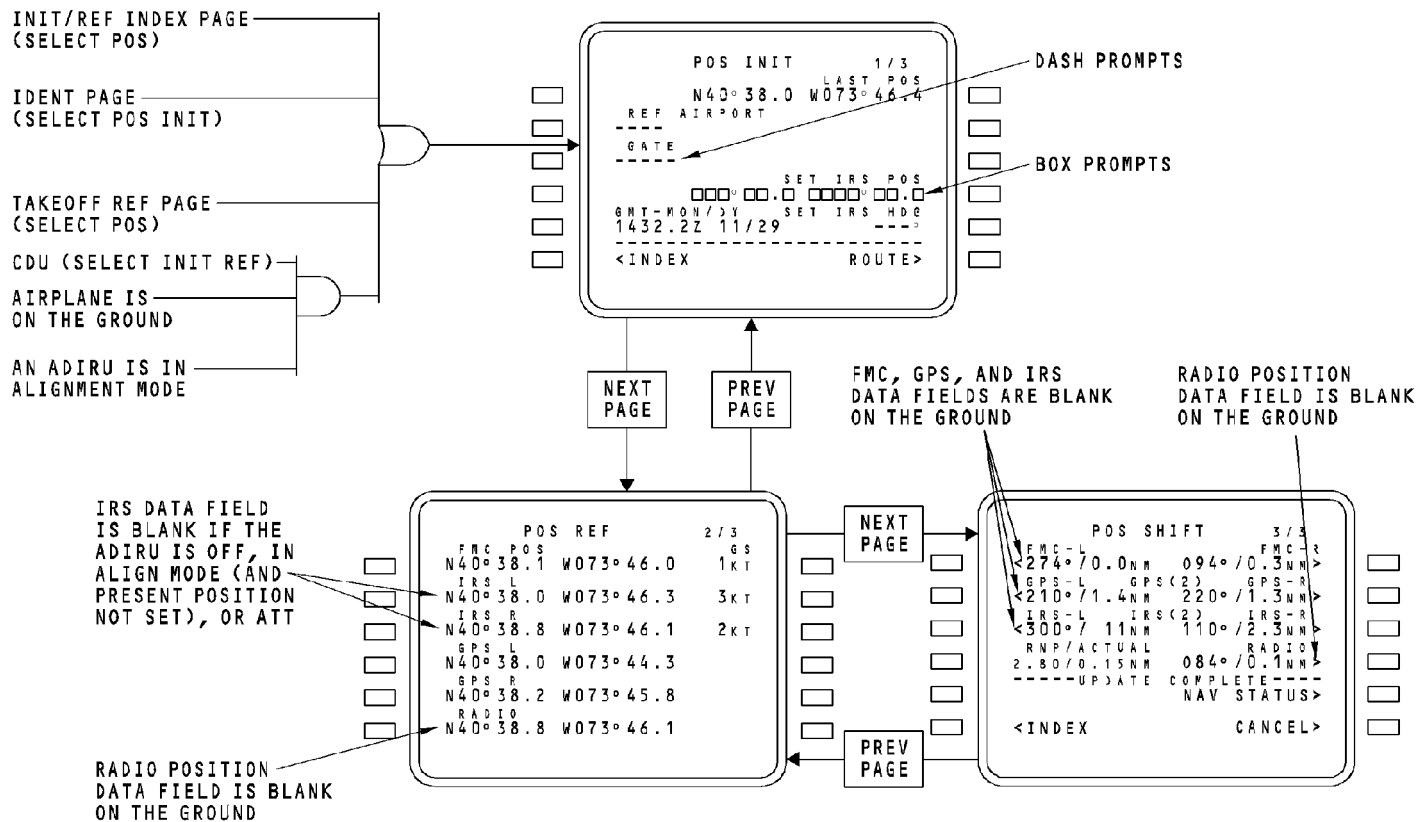

FMCS - DISPLAYS - CDU - POSITION PAGES

EFFECTIVITY
 HAP 037-054, 101-999

34-61-00

D633A101-HAP

Page 98.81
 Jun 15/2009

34-61-00-034

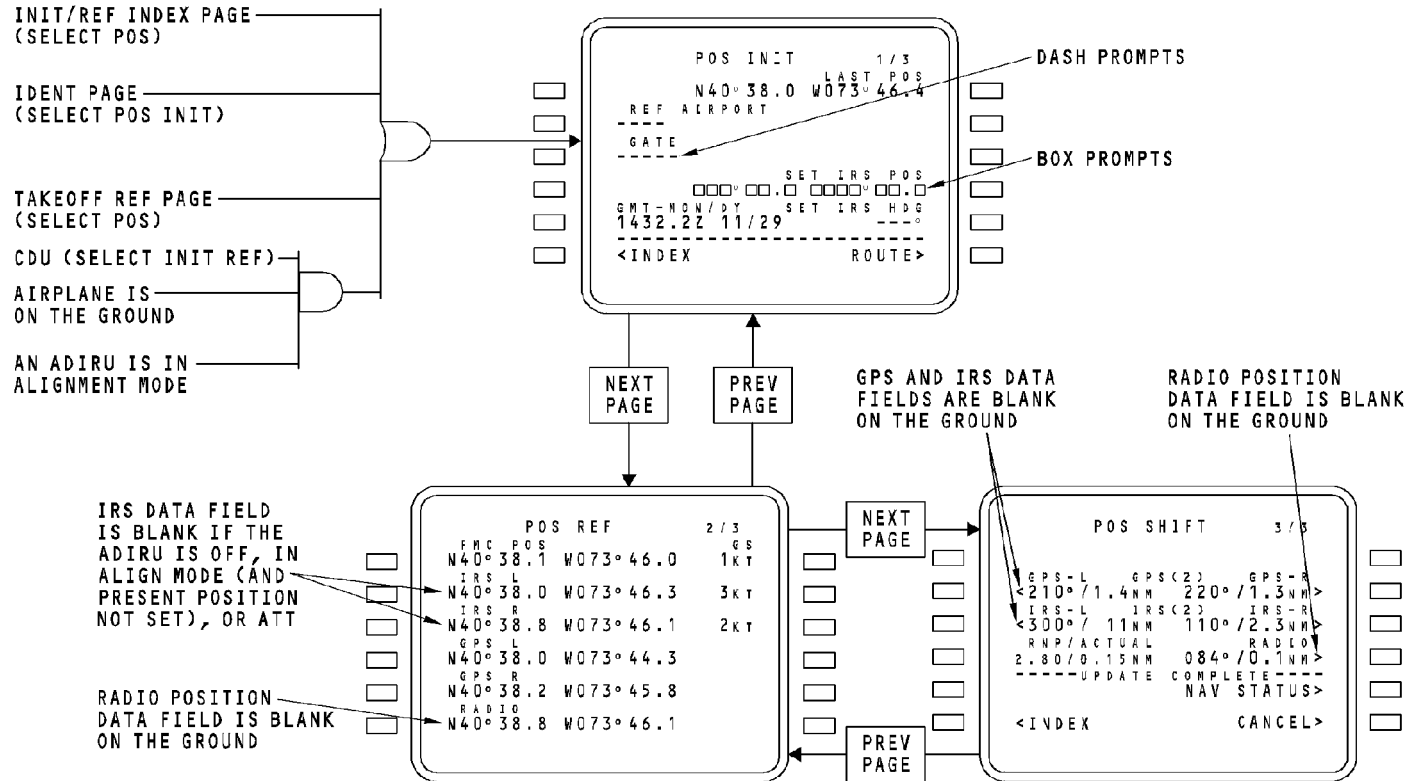

FMCS - DISPLAYS - CDU - POSITION PAGES

EFFECTIVITY

HAP 001-013, 015-026, 028-036

34-61-00

D633A101-HAP

FMCS - DISPLAYS - CDU - ROUTE PAGE

Purpose

The route (RTE) page lets the flight crew enter the route into the FMCS.

The route may be entered manually or uplinked on an ACARS message.

Page Access

Access to this page may be from any of these pages:

- POS INIT
- TAKEOFF REF
- DEP/ARR
- SELECT DESIRED WPT.

Also, selection of the RTE mode key on the MCDU will get access to this page.

Page 1/X Information

Line 1L shows dash prompts for an origin airport identifier. The origin airport may be entered here or it may be in the company route data. The navigation data base must contain the airport identifier. Entry or re-entry of the origin airport identifier will clear any existing route.

Line 2L shows dash prompts for a company route. The company route can be entered either manually or uplinked via an ACARS message. After it is set, the route structure shows on the route pages. The navigation data base must contain the company route.

If the company route is uplinked on an ACARS message and the route is not in the navigation data base but a valid origin airport identifier has been loaded, the uplinked company route shows in the data field. For this condition, the message NOT IN THE DATABASE does not show in the scratch pad and the data header field changes to REF CO ROUTE.

Line 3L shows dash prompts for a departure runway. The runway may be set from this page or the DEP/ARR pages. Alternatively, it may be uplinked on an ACARS message. The navigation data base must contain the runway identifier. This data field is removed when the airplane gets to the first waypoint in the flight plan.

Lines 4L and 5L show the VIA prompt. The VIA data fields show the lateral path AIRWAYS, SIDs, STARs, and DIRECT great circle paths. When a waypoint is set into the TO field, DIRECT shows in the VIA field.

Line 6L can show one of these prompts:

EFFECTIVITY
HAP ALL

FMCS - DISPLAYS - CDU - ROUTE PAGE

- ERASE - This shows on all modified pages. It lets you delete a route modification and return the display to the first active RTE page
- LOAD - This shows when there is an ACARS uplink to load. Selection uplinks the flight plan data and the ERASE prompt shows
- ALTN DEST - This lets the flight crew select the alternate destination page. It will not show if there is an ACARS uplink pending.
- ACTIVATE - This shows only on non-active route pages. Selection causes the EXEC light. After the EXEC key is selected, the PERF INIT prompt shows
- PERF INIT - This shows on the ground on active or modified pages if the PERF INIT page is not complete. This selects the PERF INIT page
- TAKEOFF - This shows on the ground on active or modified pages if the PERF INIT page is complete. This selects the TAKEOFF REF page
- OFFSET - This shows only in the air on active or modified pages. This selects the LATERAL OFFSET page.

Line 1R shows box prompts for a route destination identifier. The destination may be entered here or it may be in the company route data, either of which may be uplinked via an ACARS message. The navigation data base must contain the identifier. A valid entry is necessary in this data field to enable VNAV.

Line 2R shows dash prompts for a flight number. The flight number shows on the PROGRESS page title line. This data field shows dashes again at flight completion.

Line 3R shows the REQUEST prompt. This lets the flight crew request flight plan data on an ACARS uplink message.

Lines 4R and 5R show the TO prompt. The TO data fields show valid navaid or waypoint identifiers in the route that are in the data base or have been entered on the keyboard.

Line 6R can show one of these prompts:

**34-61-00**

D633A101-HAP

Page 98.84
Jun 15/2009

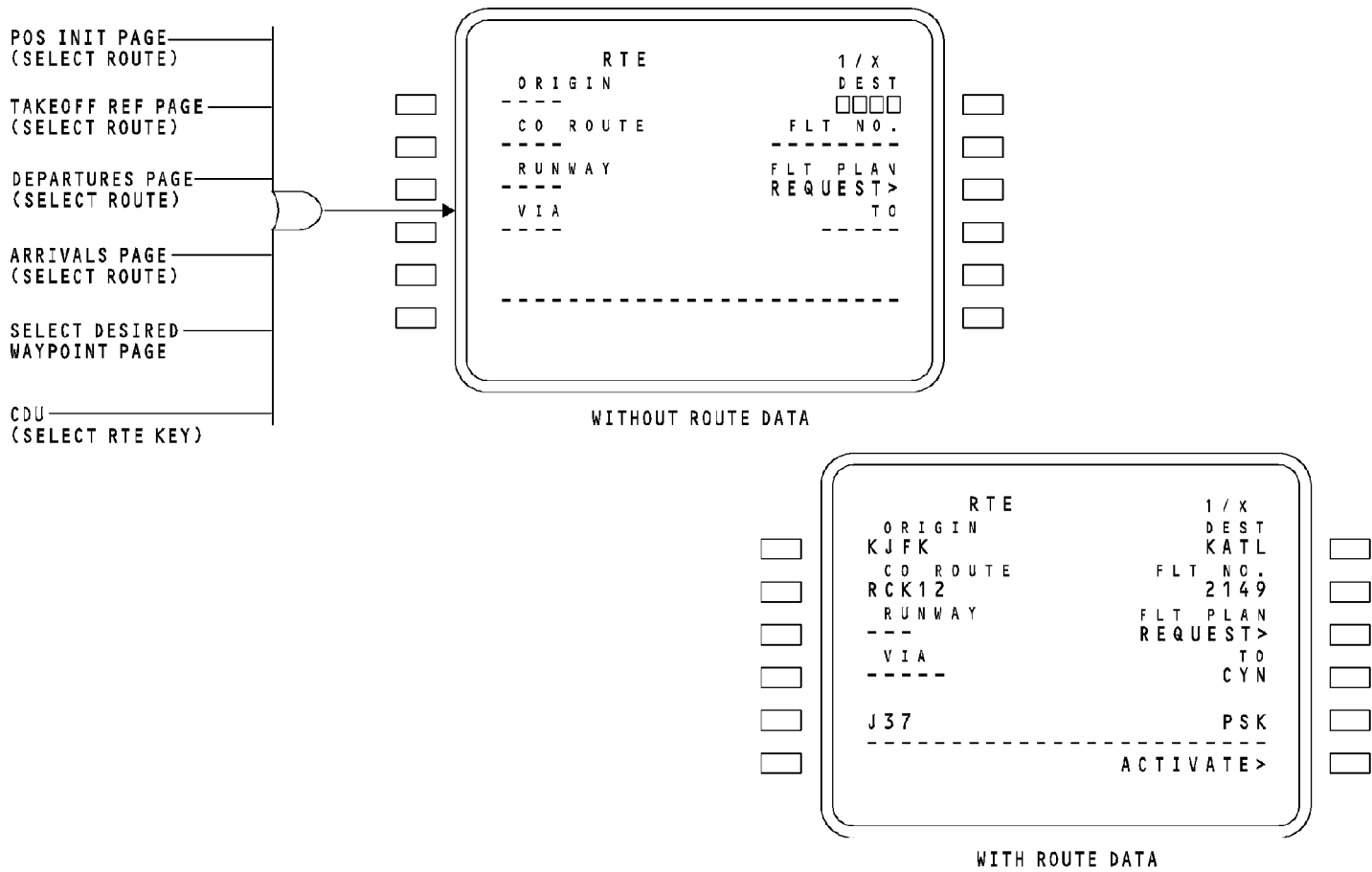

FMCS - DISPLAYS - CDU - ROUTE PAGE

34-61-00-035

EFFECTIVITY
HAP ALL

34-61-00

D633A101-HAP

THIS PAGE IS INTENTIONALLY LEFT BLANK

34-61-00

D633A101-HAP

Page 98.86
Jun 15/2009

FMCS - DISPLAYS - CDU - DEP/ARR INDEX PAGE**Purpose**

The DEP/ARR INDEX page gives access to the departure and arrival data for the origin and destination of each of the stored routes and for other selected airports in the navigation data base.

Page Access

Select the DEP/ARR mode select key on the CDU to get access to this page.

DEP/ARR INDEX Page

Line 1L shows the <DEP prompt for the origin airport (KJFK in this example). This selects the DEPARTURE page for that airport.

Line 6L shows the OTHER DEP prompt. This lets the flight crew enter other airport identifiers that are in the navigation data base. After an airport identifier is entered, the DEPARTURES page for that airport shows.

Line 1R shows the ARR > prompt for the origin airport (KJFK). This selects the ARRIVALS page for that airport.

Line 2R shows the ARR > prompt for the destination airport (KATL). This selects the ARRIVALS page for that airport.

Line 6R shows the OTHER ARR prompt. This lets the flight crew enter other airport identifiers that are in the navigation data base. After an airport identifier is entered, the ARRIVALS page for that airport shows.

DEPARTURES Page

This page lets the flight crew select a departure procedure from the origin airport.

Lines 1L through 5L show an alphabetical list of the standard instrument departures (SIDs) for the selected airport. When you select one of the SIDs, the selected SID shows and the EXEC light comes on.

Line 6L shows the INDEX prompt. This selects the DEP/ARR INDEX page.

Lines 1R through 5R show a numerical list of the runways for the selected airport. When you select one of the runways, the selected runway shows and the EXEC light comes on.

Line 6R shows the ROUTE prompt. This selects the ROUTE page.

ARRIVALS Page

This page lets the flight crew select an arrival procedure for the destination airport.

EFFECTIVITY
HAP ALL



FMCS - DISPLAYS - CDU - DEP/ARR INDEX PAGE

Lines 1L through 5L show an alphabetical list of the standard terminal arrival routes (STARs) for the selected airport. When you select one of the STARs, the selected STAR shows and the EXEC light comes on.

Line 6L shows the INDEX prompt. This selects the DEP/ARR INDEX page.

Lines 1R through 5R show a list of approaches followed by a list of runways for the selected airport. When you select one, the selected approach/runway shows and the EXEC light comes on.

Line 6R shows the ROUTE prompt. This selects the ROUTE page.

34-61-00-036

EFFECTIVITY
HAP ALL

34-61-00

D633A101-HAP

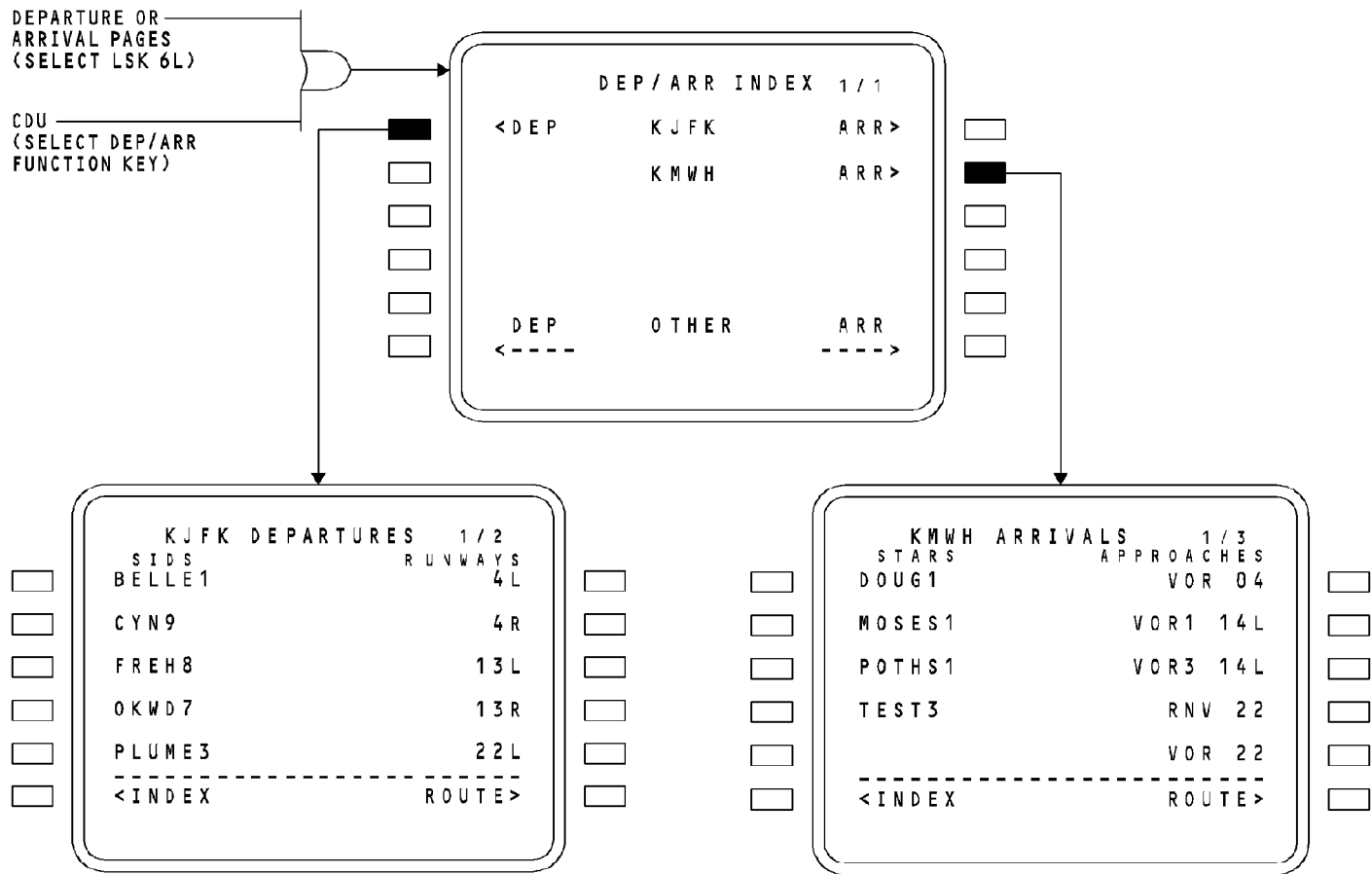

FMCS - DISPLAYS - CDU - DEP/ARR INDEX PAGE

EFFECTIVITY
HAP ALL

34-61-00

D633A101-HAP

Page 98.89
Jun 15/2009

34-61-00-036

FMCS - DISPLAYS - CDU - LEGS PAGE

General

The LEGS page is used by the flight crew to enter and review data for each leg of the active route.

Page Access

This page may be accessed from any of these pages:

- RTE DATA
- SELECT DESIRED WPT page.

HAP 001-005

Alternatively, selecting the LEGS mode key on the MCDU will access this page.

HAP ALL

Legs Page Information

Line select key 1L shows the active waypoint in the flight plan. The computed course to the active waypoint is shown above the identifier as well as the distance to go (DTG) to the active waypoint. Speed and altitude at the waypoint are also shown.

Line select keys 2L through 5L show subsequent waypoints in the active flight plan with this data:

- Computed course to waypoint
- Computed leg length
- Speed and altitude.

NOTE: If the leg is a great circle track, the computed course to the next waypoint will be shown. If the leg is a constant heading leg, the computed course will be shown with the suffix HDG.

Line select key 6L shows these prompts:

- ERASE (shows when data is being modified)
- LOAD (shows when data may be uplinked via an ACARS message)
- RNP/ACTUAL (required navigation performance/actual navigation performance).

Line select key 6R shows these prompts:

- RTE DATA (selects the RTE DATA page)
- ACTIVATE (shown before the route has been activated and executed by the flight crew)
- MAP CTR STEP.

The MAP CTR STEP function is enabled when the PLAN mode has been selected on the EFIS control panel. It lets the flight crew step through the active flight plan and review the data for each waypoint. The selected waypoint will be shown in the center of the navigation display. The <CTR> prompt shows the selected waypoint on the LEGS page.

ACT RTE	LEGS	1 / X
321° HDG	8 NM	
MARK1	175 /	1220
240°	7 NM	
IAN	240 /	2200
222°	3 NM	
CHNO1	250 /	2500A
222°	9 NM	
DOT46	250 /	5000
218°	12 NM	
NICK2	250 /	8760
RNP / ACTUAL	-----	
<1.0 / 0.05NM	RTE DATA	>

MAP MODE SELECTED ON ND

ACT RTE	LEGS	1 / X
321° HDG	8 NM	
MARK1	175 /	1220
240°	7 NM	
IAN	<CTR> 240 /	2200
222°	3 NM	
CHNO1	250 /	2500A
222°	9 NM	
DOT46	250 /	5000
218°	12 NM	
NICK2	250 /	8760
RNP / ACTUAL	-----	
<1.0 / 0.05NM	MAP CTR	STEP >

PLAN MODE SELECTED ON ND

FMCS - DISPLAYS - CDU - LEGS PAGE

34-61-00-073

EFFECTIVITY
HAP ALL

34-61-00

D633A101-HAP

FMCS - DISPLAYS - CDU - PERF INIT PAGE**General**

The performance initialization pages let you initialize the FMCS for performance calculations. The data may be entered by the flight crew or uplinked with an ACARS message.

Page Access

Access to this page is from any one of these pages:

- ROUTE
- TAKEOFF REF
- INIT/REF INDEX
- INIT/REF mode key (if ADIRUs are aligned and the airplane is on the ground).

Performance Initialization Page

Line 1L shows the GW/CRZ CG prompt. This lets the flight crew enter the airplane gross weight.

If zero fuel weight (LSK 3L) was entered first, the calculated gross weight will show here automatically.

HAP 001-013, 015-026, 028-030, 048, 049, 051-053, 107-999

Line 2L shows the PLAN/FUEL prompt. Total fuel weight from the fuel quantity indicating system (FQIS) shows. If a fuel value is set for PLAN fuel, this value is used in place of the total fuel weight from the FQIS for the calculation of gross weight. This allows performance calculations during airplane refueling. The PLAN display will be blank at engine start, at entry of a new gross weight, or when the airplane is in the air.

HAP 031-047, 050, 054, 101-106

Line 2L shows the FUEL data field. This shows the total fuel weight from the fuel quantity indication system (FQIS).

HAP ALL

Line 3L shows the ZFW prompt. This lets the flight crew enter the airplane zero fuel weight.

If gross weight (LSK 1L) was entered first, the calculated zero fuel weight will show automatically.

Line 4L shows the RESERVES prompt. This lets the flight crew enter the reserve fuel weight.

Line 5L shows the COST INDEX prompt. The default value for this data field is box prompts. The range of values is 0-200.

Line 6L shows one of these prompts:

**34-61-00**

D633A101-HAP

Page 98.92
Jun 15/2009

FMCS - DISPLAYS - CDU - PERF INIT PAGE

- INDEX (selects the INIT/REF INDEX page)
- LOAD (shows when data may be uplinked with an ACARS message)
- ERASE (shows when data is modified).

LOAD shows when the ACARS performance initialization data has the highest load priority.

This data may be uplinked with an ACARS message:

- Gross weight
- Cruise center of gravity

HAP 001-013, 015-026, 028-030, 048, 049, 051-053, 107-999

- Plan fuel

HAP ALL

- Zero fuel weight
- Reserve fuel
- Cost Index
- Trip/cruise altitude
- Cruise wind
- Top of climb outside air temperature
- Transition altitude.

Line 1R shows the TRIP/CRZ ALT data field. The trip altitude gives the crew a reference to select the cruise altitude. Trip altitude is the best cost altitude for the minimum cruise time. It is calculated and shows after this data is set:

- Origin and destination airports (ROUTE page)
- Gross weight
- Cost index.

The CRZ ALT box prompt lets the flight crew enter the cruise altitude. The cruise altitude set on this page also shows on the CLIMB, CRUISE, and RTE legs pages. CRZ ALT may be entered as an altitude (feet) or a flight level.

Line 2R shows the CRZ WIND prompt. This lets the flight crew enter the cruise wind speed and direction. The default is 000/000.

Line 3R shows the T/C OAT prompt. This shows the forecast top of climb outside air temperature. The data format is +/-XX F or +/-XX C.

Line 4R shows the TRANS ALT data field. This shows the altitude where the FMCS changes to standard barometric altitude. The default value is 18000 feet. However, the flight crew may enter another value. It will change automatically if the departure procedure has a different transition altitude and the crew does not enter a value manually.

Line 5R shows the PERF INIT REQUEST prompt. This lets the flight crew uplink the performance initialization data with an ACARS message.

Line 6R shows the N1 LIMIT prompt. This selects the N1 LIMIT page.

These data fields will clear at flight completion:

<p>EFFECTIVITY HAP ALL</p>
--

34-61-00

D633A101-HAP

Page 98.93
Jun 15/2009

FMCS - DISPLAYS - CDU - PERF INIT PAGE

- Gross weight
- Cruise center of gravity
- Zero fuel weight
- Reserves
- Trip/cruise altitude
- Cruise wind
- Top of climb OAT.

Performance Limits page

Line 1L shows the TIME ERROR TOLERANCE data field. This shows the time error tolerance at a waypoint which is used by the required time of arrival (RTA) function. The FMCS uses this tolerance to calculate the airplane speed. The data entry range is five seconds to 30 seconds. The default value is 30 seconds.

Lines 2L and 2R through 4L and 4R show the minimum and maximum speed limits for climb, cruise and descent. The flight crew may change the values in these data fields.

Line 5L shows the PERF LIM REPORT prompt. This lets the flight crew downlink the performance limits with an ACARS message.

Line 6L shows one of these prompts:

- INDEX (selects the INIT/REF INDEX page)
- LOAD (shows when data may be uplinked with an ACARS message)

- ERASE (shows when data is modified).

Line 5R shows the PERF LIM REQUEST prompt. This lets the flight crew uplink the performance limits with an ACARS message.

Line 6R shows the RTA prompt. This selects the RTA PROGRESS page.

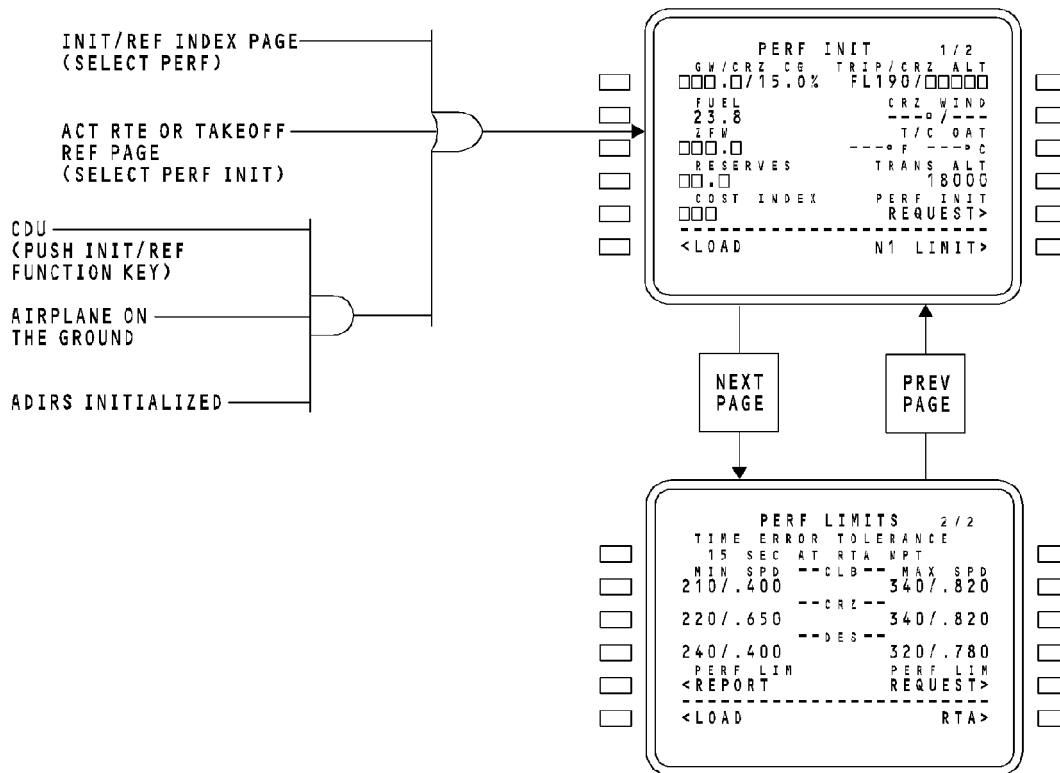

FMCS - DISPLAYS - CDU - PERF INIT PAGE

EFFECTIVITY
HAP 031-047, 050, 054, 101-106

34-61-00

D633A101-HAP

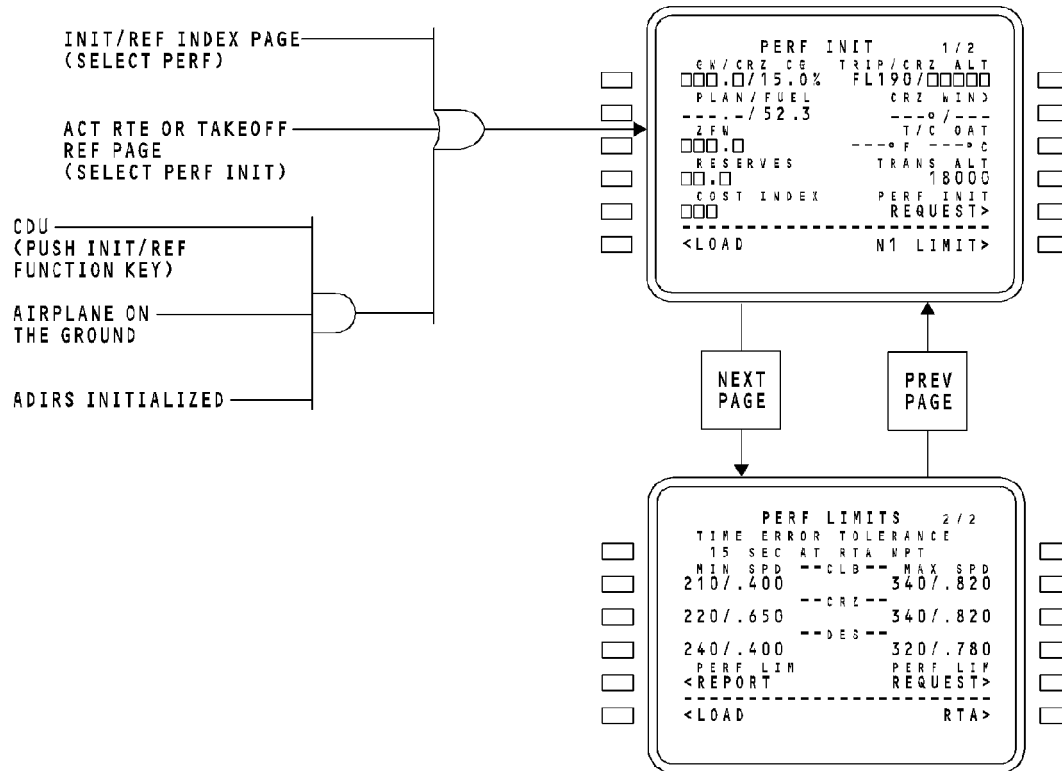

FMCS - DISPLAYS - CDU - PERF INIT PAGE

EFFECTIVITY
 HAP 001-013, 015-026, 028-030, 048, 049, 051-053, 107-999

34-61-00

D633A101-HAP

FMCS - DISPLAYS - CDU - N1 LIMIT PAGE**General**

The N1 LIMIT pages let the flight crew select engine thrust limits to show on the common display system (CDS) and for use by the autothrottle.

Page Access

Access to these pages is by selection of the N1 LIMIT mode select key on the CDU or the N1 LIMIT prompt on the PERF INIT or TAKEOFF REF pages.

N1 Limits Page (On Ground)

Line 1L shows the SEL/OAT prompt. This data field lets the flight crew enter the outside air temperature (OAT). An assumed temperature (SEL) can also be entered for reduced thrust takeoffs.

Line 2L shows the TO prompt. This selects full takeoff thrust.

I HAP 001-013, 015-026, 028-047, 054, 101-106

Line 3L shows The TO-1 prompt. This selects the first reduced takeoff thrust.

Line 4L shows the TO-2 prompt. This selects the second reduced takeoff thrust.

**HAP 001-009 PRE SB 737-71-1395 AND PRE SB 737-71-1455;
HAP 010-013, 015-017 PRE SB 737-71-1455**

Line 5L shows the TO-B prompt. This selects the bump level of takeoff thrust.

HAP ALL

When a specific takeoff thrust is selected, the < ACT > prompt shows adjacent to the selected thrust. The FMCS always selects the highest possible climb thrust which would not result in a thrust increase when a takeoff thrust is selected. This prevents a throttle push at transition from takeoff thrust to climb thrust.

Line 6L shows the PERF INIT prompt. This selects the PERF INIT page.

Line 1R shows the TAKEOFF N1 prompt. This data field shows the active takeoff thrust calculated by the FMCS.

Line 2R shows the CLB prompt. This enables and shows the maximum climb thrust for the autothrottle and the N1 bugs after transition from the takeoff mode.

Line 3R shows the CLB-1 prompt. This selects the first derate climb thrust to be used after transition from takeoff mode.

FMCS - DISPLAYS - CDU - N1 LIMIT PAGE

Line 4R shows the CLB-2 prompt. This selects the second derate climb thrust to be used after transition from takeoff mode.

The selected climb thrust shows by the < SEL > prompt in large font adjacent to the selected thrust data field.

Line 6R shows the TAKEOFF prompt. This selects the TAKEOFF REF page.

N1 Limits Page (In Air)

The N1 limit page lets the flight crew select an N1 limit for these thrust limit modes:

- Go-around (GA)
- Continuous (CON)
- Climb (CLB)
- Cruise (CRZ)
- Climb - 1
- Climb - 2.

Line 1L shows the AUTO prompt. This selection lets the FMCS calculate N1 limit values. AUTO is the default selection.

Line 2L and 2R show the GA (go-around) N1 limit.

Line 3L and 3R show the CON (continuous) N1 limit.

Line 4L and 4R show the CLB (climb) N1 limit.

Line 5L and 5R show the CRZ (cruise) N1 limit.

Line 6L and 6R show the CLB-1 and CLB-2 prompts. Selection will show the reduced climb N1 limit.

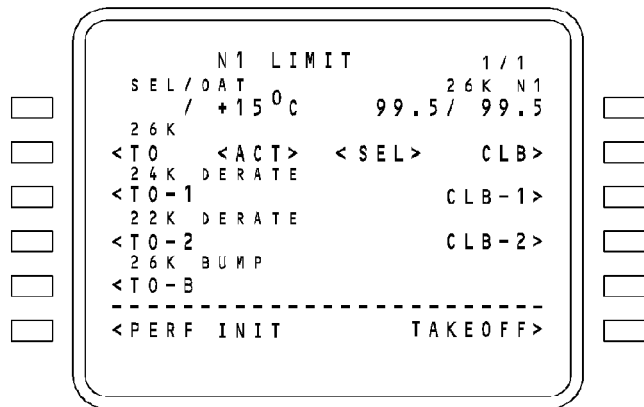

N1 LIMIT (ON GROUND)

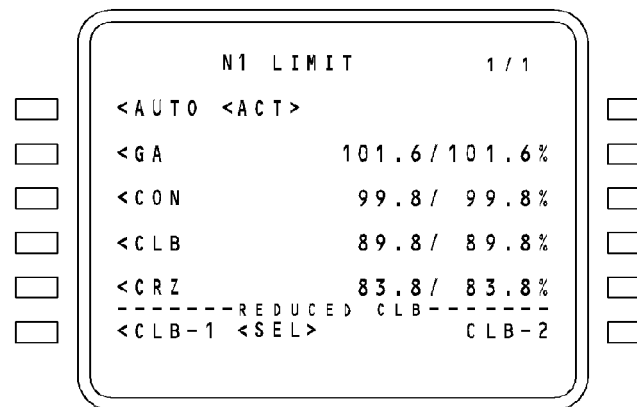

N1 LIMIT (IN AIR)

FMCS - DISPLAYS - CDU - N1 LIMIT PAGE

EFFECTIVITY

HAP 001-009 PRE SB 737-71-1395 AND PRE SB 737-71-1455; HAP 010-013, 015-017 PRE SB 737-71-1455

34-61-00

D633A101-HAP

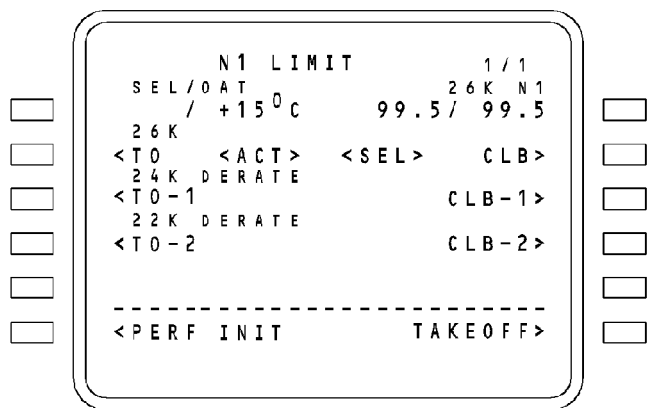

N1 LIMIT (ON GROUND)

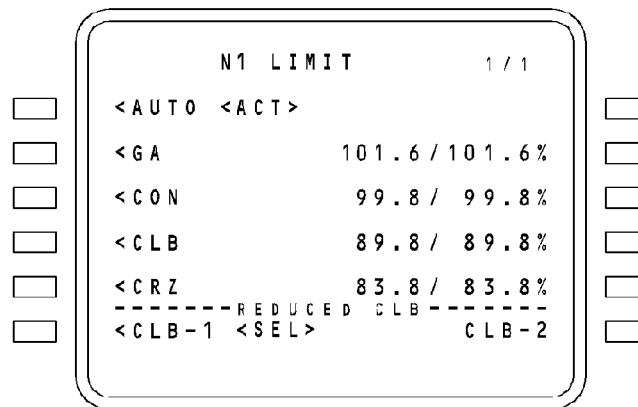

N1 LIMIT (IN AIR)

FMCS - DISPLAYS - CDU - N1 LIMIT PAGE

EFFECTIVITY

HAP 018-026, 028-054, 101-999; HAP 001-009 POST SB 737-71-1395 OR
POST SB 737-71-1455; HAP 010-013, 015-017 POST SB 737-71-1455

34-61-00

D633A101-HAP

Page 98.100
Jun 15/2009

THIS PAGE IS INTENTIONALLY LEFT BLANK

34-61-00

D633A101-HAP

Page 98.101
Jun 15/2009

FMCS - DISPLAYS - CDU - TAKEOFF REF PAGE

Purpose

The takeoff reference pages show this data for takeoff:

- Temperature
- Takeoff thrust
- V speed data
- Runway data.

Page Access

You get access to this page from one of these pages:

- INIT/REF INDEX
- PERF INIT
- RTE.

Page 1 Information

This page lets the flight crew see FMC calculated takeoff thrusts, crew entered takeoff data, and V speed data.

Line 1L shows the FLAPS prompt. This lets the flight crew enter the takeoff flap setting. Box prompts show before there is a valid entry. Allowable entries are flaps 1, 5, 10, 15, and 25. This data field may also be uplinked in an ACARS takeoff data message.

Line 2L shows the active N1 takeoff thrust calculated by the FMCS. The data field header line changes to show whether it is one of these:

- Full rated thrust
 - Reduced thrust from a SEL (assumed) temperature entry
- HAP 001-009 PRE SB 737-71-1395 AND PRE SB 737-71-1455;
HAP 010-013, 015-017 PRE SB 737-71-1455**
- Takeoff bump thrust rating
- HAP ALL**
- First takeoff derate thrust
 - Second takeoff derate thrust.

If the takeoff N1 value is calculated from ACARS uplinked data, the N1 values show in small font until the flight crew accepts the data.

Line 3L shows the prompts for center of gravity (CG) and TRIM. This lets the flight crew enter CG. If gross weight is entered, the trim will be calculated and shown. This data field may be uplinked in an ACARS data message. The CG/TRIM values show in small font until the crew accepts the data.

Line 4L shows the TAKEOFF DATA REQUEST prompt. This lets the flight crew request takeoff data from the ACARS datalink. Selection will result in the TAKEOFF DATA REJECT prompt in this data field and the ACCEPT prompt at line 5R.

Line 6L shows one of these prompts:

- POS INIT
- PERF INIT
- ROUTE
- DEPARTURE
- INDEX.

34-61-00-066

<p>EFFECTIVITY</p> <p>HAP ALL</p>
--

34-61-00

D633A101-HAP

FMCS - DISPLAYS - CDU - TAKEOFF REF PAGE

The INDEX prompt shows when the necessary data is set in the pre-flight pages and the pre-flight is complete. If one of the other prompts show, the necessary data is not complete for that page. When all the necessary data is entered, the INDEX prompt shows.

Lines 1R, 2R, and 3R are for the flight crew to set calculated takeoff speeds (V1, VR, and V2). Dash prompts show if a new performance value is set that affects the calculation of the speeds (gross weight, zero fuel weight, reserve fuel, cost index or cruise altitude).

Line 4R shows the GW/TOW prompt. The GW data field shows the current airplane gross weight. The TOW data field shows the GW that corresponds to the large font takeoff speeds in lines 1R, 2R, and 3R.

Line 5R shows the ACCEPT prompt. This prompt shows when the flight crew requests takeoff data from an ACARS uplink (LSK 4L). This lets the flight crew accept the uplinked takeoff data. Selection results in the V speeds in large font and the V speed data on the common display system (CDS).

Page 2 Information

This page lets the flight crew see the takeoff runway data and takeoff thrusts. It also lets them select a reduced takeoff thrust limit and select the appropriate runway surface condition.

Line 1L shows the RW/WIND prompt. This lets the flight crew enter the takeoff wind conditions. If this data is uplinked in an ACARS message, it shows in small font until the flight crew accepts the takeoff data. When it is accepted, it will show in large font. The default value is 000/0 and dashes shown before an entry.

Line 2L shows the RW SLOPE/HDG prompt. This lets the flight crew enter the runway gradient and the runway heading. It is entered as a percentage either U (+) or D (-) from the runway threshold. If the selected takeoff runway is in the navigation data base, the runway heading shows. Otherwise, it must be entered manually. If this data is uplinked in an ACARS message, it shows in small font until the flight crew accepts the takeoff data. When it is accepted, it will show in large font.

Line 4L shows the SEL OAT prompt. This lets the flight crew enter the outside air temperature or an assumed temperature for a reduced thrust takeoff. Before entry, dashes show in the SEL data field and box prompts show in the OAT data field. Both the SEL and OAT may be uplinked in an ACARS message.

The temperature is set in degrees Celsius. The temperature is set in Fahrenheit if you put in the temperature followed by the letter F.

Line 6L shows the INDEX prompt. This selects the INIT/REF INDEX page.

FMCS - DISPLAYS - CDU - TAKEOFF REF PAGE

Line 4R shows the active N1 takeoff thrust calculated by the FMCS. The header line changes to show whether it is one of these:

- Full rated thrust
- Reduced thrust from a SEL (assumed) temperature entry

**HAP 001-009 PRE SB 737-71-1395 AND PRE SB 737-71-1455;
HAP 010-013, 015-017 PRE SB 737-71-1455**

- Takeoff bump thrust rating

HAP ALL

- First takeoff derate
- Second takeoff derate.

HAP 001-005

Line 5R shows the THR REDUCTION prompt. This lets the flight crew select a different barometric altitude where the FMCS commands a transition from takeoff thrust to the selected climb thrust. The default altitude is 1500 feet and allowable entries are from 800 feet to 9999 feet AGL. The selected climb thrust rating will also show on this line (CLB, CLB-1, or CLB-2).

HAP ALL

WARNING: DO NOT CHANGE THE TAKEOFF REF PAGES. IF YOU MADE CHANGES, REMOVE ALL THE CHANGES. MAKE SURE THERE ARE NO FIXED DERATES SELECTED. MAKE SURE THE SEL TEMP FIELD ON PAGES 1/2 AND 2/2 IS EMPTY. CHANGES TO THE TAKEOFF REF PAGES CAN CAUSE A LOWER THRUST AT TAKEOFF THAN THE THRUST THAT THE FLIGHT CREW CALCULATED.

EFFECTIVITY**HAP ALL****34-61-00**

D633A101-HAP

Page 98.104
Jun 15/2009

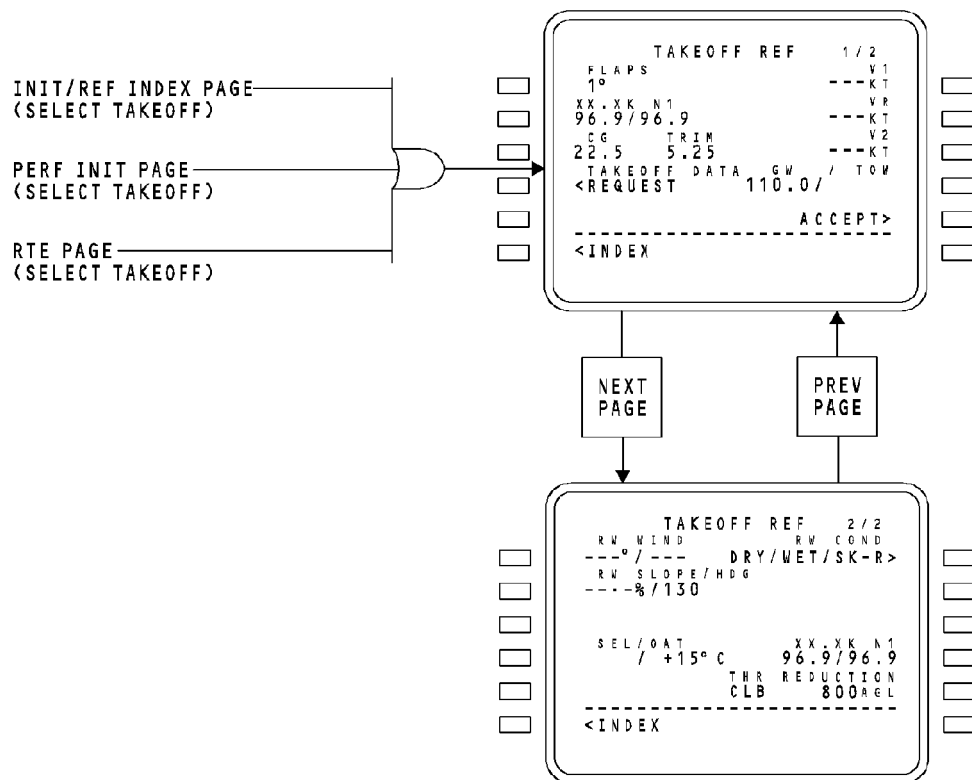

FMCS - DISPLAYS - CDU - TAKEOFF REF PAGE

34-61-00-066

EFFECTIVITY
HAP 001-005

34-61-00

D633A101-HAP

Page 98.105
Jun 15/2009

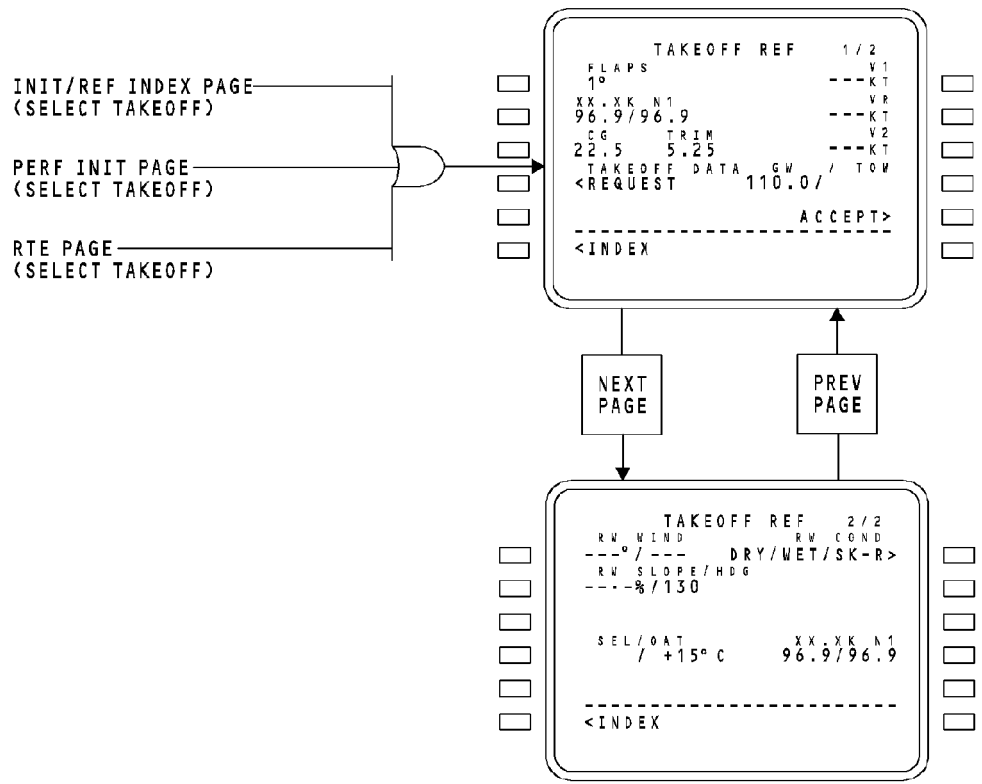

FMCS - DISPLAYS - CDU - TAKEOFF REF PAGE

EFFECTIVITY

HAP 006-013, 015-026, 028-054, 101-999

34-61-00

D633A101-HAP

THIS PAGE IS INTENTIONALLY LEFT BLANK

34-61-00

D633A101-HAP

Page 98.107
Jun 15/2009

FMCS - DISPLAYS - CDU - CLIMB PAGES**Purpose**

The CLB pages let the flight crew review and select one of these climb performance modes:

- Economy climb (ECON CLB)
- Maximum angle climb (MAX ANGLE CLB)
- Manual speed climb (XXX KT CLB)
- Maximum rate of climb (MAX RATE CLB)
- Step climb during cruise (CRZ CLB)
- Required time of arrival (RTA CLB).

Also, there is an ENG OUT page which shows advisory information only (VNAV cannot be engaged in this mode).

Page Access

Selection of the CLB mode key on the CDU provides access to the climb page.

Climb Pages

The default climb mode is the economy (ECON) mode but the other modes may be selected from this page.

The CRZ CLB page will show automatically when the flight crew enter a higher cruise altitude on the CRZ page. Cruise climbs give the flight crew the means of initiating step climbs during cruise. These climbs will be done at the airplane's cruise speed.

The MANUAL SPD CLB page will show automatically when the flight crew enters a different target speed.

This data shows on each page:

- Target cruise altitude
- Target speed (highlighted)
- Speed restriction
- Active waypoint
- Distance and time to active waypoint or flight level
- Predicted undershoot at active waypoint
- Target N1.

On the CRZ CLB page, the predicted undershoot is replaced by the wind speed and direction data.

Also on the CRZ CLB page, the target N1 values are replaced by the savings/penalty for the specified step climb. These values show as a percentage.

On the RTA CLB page, time and distance to the active waypoint is replaced by the time error at the active waypoint.

```

ACT ECON CLB      1/1
CRZ ALT           AT CR102
FL330
TGT SPD          TO CR102
280/.720        2004.3z/ 19NM
SPD REST        ERR CR102
250/10000      310L0
-----
CLB 1-N1
97.3/ 97.3%
-----
<MAX RATE      ENG OUT>
<MAX ANGLE     RTA>
    
```

ECON CLB

```

ACT MAX ANGLE CLB 1/1
CRZ ALT           AT CR102
FL330
TGT SPD          TO CR102
220/.700        2004.3z/ 19NM
SPD REST        ERR CR102
250/10000      260L0
-----
CLB 2-N1
<ECON          93.8/ 93.8%
-----
<MAX RATE      ENG OUT>
<MAX ANGLE     RTA>
    
```

MAX ANGLE CLB

```

ACT 280KT CLB    1/1
CRZ ALT           AT CR102
FL350
TGT SPD          TO FL350
280/.720        2056.2z/ 88NM
SPD REST
250/10000
-----
CLB 2-N1
<ECON          93.8/ 93.8%
-----
<MAX RATE      ENG OUT>
<MAX ANGLE     RTA>
    
```

MANUAL SPD CLB

```

ACT MAX RATE CLB 1/1
CRZ ALT           AT CR102
FL350
TGT SPD          TO FL350
265/.720        2043.6z/ 82NM
SPD REST
250/10000
-----
CLB 2-N1
<ECON          93.8/ 93.8%
-----
ENG OUT>
<MAX ANGLE     RTA>
    
```

MAX RATE CLB

```

MOD CRZ CLB      1/1
CRZ ALT           AT CR102
FL290
TGT SPD          TO FL290
1780            2145.3z/ 15NM
SPD REST        ACTUAL WIND
250/10000      290/14
-----
PENALTY
<ECON          1.1%
-----
<MAX RATE      ENG OUT>
<MAX ANGLE     ERASE>
    
```

CRZ CLB

```

ACT RTA CLB      1/1
CRZ ALT           AT LACRE
FL250
TGT SPD          TIME ERROR
294/.703        ON TIME
SPD REST
250/10000
-----
<ECON
-----
<MAX RATE      ENG OUT>
<MAX ANGLE     RTA>
    
```

RTA CLB

FMCS - DISPLAYS - CDU - CLIMB PAGES

EFFECTIVITY
HAP ALL

34-61-00

D633A101-HAP

Page 98.109
Jun 15/2009

FMCS - DISPLAYS - CDU - CRUISE PAGES

Purpose

The cruise pages let the flight crew review and select one of these cruise performance modes:

- Economy cruise (ECON CRZ)
- Long range cruise (LRC CRZ)
- Manual speed cruise (XXX KT CLB)
- Required time of arrival cruise (RTA CRZ).

In addition there is an ENG OUT page which shows advisory information only (VNAV cannot be engaged in this mode).

Page Access

Selection of the CRZ mode key on the CDU provides access to the cruise page.

Cruise Pages

The default cruise mode is the economy (ECON) mode but the other modes may be selected from this page.

The MANUAL SPD CRZ page will show automatically when the flight crew enter a different target cruise speed.

This data shows on each page:

- Actual cruise altitude
- Optimum and maximum cruise altitudes
- Target speed (highlighted)

- Turbulence N1 target
- Fuel remaining at destination
- Step to altitude
- Step point (ETA and DTG)
- Current wind speed and direction
- Predicted savings/penalty if airplane is flown to a selected step altitude.

The turbulence N1 target is advisory information for the flight crew only and cannot be used by the FMCS.

On the RTA CRZ page, the turbulence N1 target is replaced by the RTA time error.

On the ENG OUT page, the fuel remaining data field is replaced by the maximum continuous N1 thrust. The STEP data field is replaced by the engine out maximum altitude and the STEP POINT is replaced by the time and distance to the top of descent point.

NOTE: Entry of a different cruise altitude on the CRZ page brings up either the CRZ CLB or CRZ DES pages.

```

ACT ECON CRZ      1 / 1
CRZ ALT OPT/MAX  STEP
FL330 FL340/361  FL350
TGT SPD          STEP POINT
.780            2004.5z/100NM
TURB N1         ACTUAL WIND
87.3/ 87.3%    1290 / 14
FUEL AT KATL   SAVINGS
W/STEP 12.5     1.3%
-----
<ECON          ENG OUT>
<LRC          RTA>
    
```

ECON CRZ

```

MOD LRC CRZ      1 / 1
CRZ ALT OPT/MAX  STEP
FL330 FL340/361  FL390
TGT SPD          STEP POINT
.770            2004.5z/100NM
TURB N1         ACTUAL WIND
87.3/ 87.3%    1290 / 14
FUEL AT KATL   SAVINGS
W/STEP 12.5     1.3%
-----
<ECON          ENG OUT>
<LRC          ERASE>
    
```

LRC CRZ

```

ACT N.780 CRZ    1 / 1
CRZ ALT OPT/MAX  STEP
FL330 FL340/361  FL350
TGT SPD          STEP POINT
.780            2004.5z/100NM
TURB N1         ACTUAL WIND
87.3/ 87.3%    1290 / 14
FUEL AT KATL   SAVINGS
W/STEP 12.5     1.3%
-----
<ECON          ENG OUT>
<LRC          RTA>
    
```

MANUAL SPD CRZ

```

ACT RTA CRZ      1 / 1
CRZ ALT OPT/MAX  STEP
FL250 FL340/361  FL350
TGT SPD          STEP POINT
.703            2004.5z/100NM
TIME ERROR ACTUAL WIND
EARLY 05:31
FUEL AT KEGG   SAVINGS
W/STEP 12.5     1.3%
-----
<ECON          ENG OUT>
<LRC          RTA>
    
```

RTA CRZ

```

ACT ENG OUT CRZ  1 / 1
CRZ ALT MAX ALT  STEP
FL330 FL187      FL350
TGT SPD          STEP POINT
280KT           1314.0z/ 26NM
N1
97.9%
-----
<LT ENG OUT  RT ENG OUT>
<ECON
<LRC          RTA>
    
```

ENG OUT CRZ

FMCS - DISPLAYS - CDU - CRUISE PAGES

34-61-00-075

EFFECTIVITY
HAP ALL

34-61-00

D633A101-HAP

Page 98.111
Jun 15/2009

THIS PAGE IS INTENTIONALLY LEFT BLANK

34-61-00

D633A101-HAP

Page 98.112
Jun 15/2009

FMCS - DISPLAYS - CDU - DESCENT PAGES

Purpose

The descent pages let the flight crew review and select one of the following descent performance modes:

- Economy descent (ECON DES)
- Step descent during cruise (CRZ DES)
- Required time of arrival descents (RTA DES).

Page Access

Selection of the DES mode key on the CDU provides access to the descent page.

Descent pages

The economy (ECON) descent mode has a maximum speed restriction of 240 knots below 10000 feet.

If the flight crew starts an early descent, the initial descent rate is 1000 feet per minute until the descent path is captured.

The CRZ DES page will show automatically when the flight crew select an altitude that is below the cruise altitude.

This data shows on each page:

- End of descent altitude
- Target speed (highlighted)
- Speed restriction
- Vertical deviation

- Active waypoint
- Distance and time to top of descent, waypoint or flight level
- Waypoint and altitude used for FPA, V/B and V/S
- Flight path angle (FPA)
- Vertical bearing (V/B)
- Vertical speed (V/S).

On the CRZ DES page, the E/D ALT is replaced by the new cruise altitude (CRZ ALT). The waypoint and altitude data is replaced by the actual wind speed and direction data. Also, the savings/penalty for the specified cruise descent shows. These values show as a percentage.

On the RTA DES pages, the distance and time is replaced by the time error.

Descent Forecasts Page

The descent forecasts page lets the flight crew enter other performance values to more accurately define the calculated descent profile.

Access to this page is through the FORECASTS prompt (LSK 6L).

This data shows on the descent forecasts page:

- Transition level
- Cabin rate of descent
- Altitude wind speed and direction data



FMCS - DISPLAYS - CDU - DESCENT PAGES

- TAI on/off altitudes
- ISA DEV/QNH selections.

34-61-00-094

EFFECTIVITY
HAP ALL

34-61-00

D633A101-HAP

Page 98.114
Jun 15/2009

```

ACT ECON      DES 1/1
E/D ALT      AT MACEY
2013         230/6000A
TGT SPD      TO MACEY
.720/280     2004.32/19NM
SPD REST     WPT/ALT
240/10000    MACEY/6000
VERT DEV     FPA V/B V/S
88 HI       3.8 6.2 2360
-----
<FORECAST      RTA>
  
```

ECON DES

```

MOD CRZ DES      1/1
CRZ ALT
FL310
TGT SPD          TO FL310
.780/2145.32/15NM
SPD REST        ACTUAL WIND
240/10000       1290/14
                SAVINGS
                1.3%
-----
                PLANNED DES>
<FORECAST      RTA>
  
```

CRZ DES

```

ACT RTA      DES 1/1
E/D ALT      AT MACEY
2013         230/6000A
TGT SPD      TIME ERROR
.740/260     ON TIME
SPD REST     WPT/ALT
240/10000    MACEY/6000
VERT DEV     FPA V/B V/S
24 HI       3.8 6.2 2360
-----
<ECON
<FORECAST      RTA>
  
```

RTA DES

```

ACT RTA CRZ DES 1/1
CRZ ALT      TIME ERROR
10000        LATE 10:54
TGT SPD      TO FL100
.491/1548.62/6.6NM
SPD REST     ACTUAL WIND
240/10000    0000/0
-----
                PLANNED DES>
<FORECAST      RTA>
  
```

RTA CRZ DES

```

MOD DES FORECASTS 1/1
TRANS LVL      TAI ON/OFF
FL180          -----/-----
CABIN RATE     ISA DEV/QNH
480FPM         ---0C/-----
ALT-----WIND---DIR/SPD
FL210          0780/69KT
5000           1300/29KT
-----        ---0/---KT
                ERASE>
  
```

DES FORECASTS

FMCS - DISPLAYS - CDU - DESCENT PAGES

34-61-00-094

EFFECTIVITY
HAP ALL

34-61-00

D633A101-HAP

Page 98.115
Jun 15/2009

FMCS - DISPLAYS - CDU - PROGRESS/NAV STATUS PAGES**General**

The progress pages let the flight crew monitor the progress during the flight. The navigation status/options pages let the flight crew monitor the status of the nav aids tuned by the FMCS.

Page Access

Access to the PROGRESS page is by selection of the PROG mode key on the MCDU.

Access to the NAV STATUS page is from one of these pages:

- POS SHIFT page
- PROGRESS page
- INIT/REF INDEX page (in the air).

Progress Page 1/3

This page shows airplane progress on the active route. The flight number entered on the ROUTE page shows in the title line. The flight number may contain up to 8 alphanumeric characters. The flight number clears when the flight is complete.

Select the PROG mode select key on the CDU to get access to this page.

Lines 1L and 1R show the FROM data field. They show the waypoint identifier, heading, altitude, actual time of arrival (ATA) and fuel at the last waypoint.

Lines 2L and 2R show the TO data field. They show this data:

- Active waypoint
- Heading
- Distance-to-go (DTG)
- Estimated time of arrival (ETA)
- Fuel remaining at that waypoint.

The active waypoint is highlighted.

Lines 3L and 3R show the NEXT data field. They show this data:

- Subsequent waypoint
- DTG
- ETA
- Fuel remaining.

Lines 4L and 4R show the DESTINATION data field. It shows the same data as 3L and 3R for the destination airport.

Line 5L shows the TO data field. This shows the time at and distance to one of these:

- T/C (top of climb)
- STEP POINT
- T/D (top of descent)
- E/D (end of descent).

Line 6L shows the WIND data field. This shows the wind speed and direction.

FMCS - DISPLAYS - CDU - PROGRESS/NAV STATUS PAGES

Line 5R shows the FUEL data field. This shows the current fuel quantity from the fuel quantity indicating system (FQIS).

Line 6R shows the NAV STATUS prompt. This selects the NAV STATUS page.

Progress Page 2/3

This page lets the flight crew set the required time of arrival (RTA) function.

The flight number does not show on this page.

Line 1L shows the RTA WPT prompt. This lets the flight crew enter the waypoint identifier for the RTA function. Entry of an RTA waypoint shows the remainder of the data fields and headers for this page after the EXEC key is pushed.

This data field will show dashes if no RTA waypoint is entered and no other data shows on this page.

Line 2L shows the RTA SPD data field. This shows the speed schedule for the current flight phase necessary to meet the RTA.

Line 3L shows the SPD REST data field. This shows the active default speed restriction during climb and descent. This data field is blank during cruise and on the ground.

Line 4L shows the DIST TO data field. This shows the distance from the present position to the RTA waypoint.

Lines 5L and 5R show the RTA WINDOW data field. This shows the earliest and latest arrival times at the RTA waypoint.

Line 6L shows one of these prompts:

- LIMITS (selects the PERF LIMITS page)
- ERASE (shows when RTA data is being modified)
- LOAD (shows when RTA data may be uplinked with an ACARS message).

Line 1R shows the RTA prompt. The RTA time is entered in this data field by the flight crew. If no RTA waypoint is entered in LSK 1L, this data field is blank.

Line 2R shows the TIME ERROR data field. This shows the most current time error at the RTA waypoint.

Line 3R shows the GMT data field. This shows current time.

Line 4R shows the ALT/ETA data field. This shows the predicted altitude and the estimated time of arrival at the RTA waypoint.

Progress Page 3/3

This page shows wind data and vertical and lateral track deviation.

FMCS - DISPLAYS - CDU - PROGRESS/NAV STATUS PAGES

The flight number entered on the ROUTE page shows in the title line.

Line 1L shows the HEADWIND data field. This shows the current headwind or tailwind component. The header changes to reflect the wind component.

Line 2L shows the WIND data field. This shows the current wind speed and direction.

Line 3L shows the XTK ERROR data field. This shows the current crosstrack error direction and magnitude.

Line 5L shows the PRE-FLIGHT REPORT prompt. This lets the flight crew downlink the pre-flight report with an ACARS message.

Line 6L shows the WEATHER REQUEST prompt. This lets the flight crew request the weather for the destination and alternate airports with an ACARS message.

Line 1R shows the CROSSWIND data field. This shows the current crosswind component direction and speed.

Line 2R shows the SAT/ISA DEV data field. This shows the current static air temperature (SAT) and the equivalent international standard atmosphere (ISA) deviation. The SAT indication is blank on the ground.

Line 3R shows the VERT DEV data field. This shows the present vertical deviation from the calculated vertical guidance path during descent. In climb and cruise, this data field is blank.

Line 4R shows the TAS data field. This shows the current true airspeed.

Line 5R shows the PROGRESS REPORT prompt. This lets the flight crew downlink a flight progress report with an ACARS message.

Line 6R shows the POSITION REPORT prompt. This lets the flight crew downlink a position report with an ACARS message.

Nav Status Page

This page shows the status of the navaids tuned or in use by the FMCS.

Line 1L and 1R show the VOR/ILS data fields. This shows the VOR or ILS identifiers and frequencies that are currently tuned on the navigation control panels.

The frequency is prefixed by a single character code in small font. This shows the method used to tune the frequency. These codes can show:

- M (manual tuning)
- P (procedural tuning)

FMCS - DISPLAYS - CDU - PROGRESS/NAV STATUS PAGES

- A (auto tuning).

Line 2L - 2R through 4L - 4R show the DME data fields. This shows the status of the DME identifiers of frequencies that are tuned by the FMCS through the DME interrogators.

The status of each tuned DME identifier/frequency shows this information:

- If the navaid input is used in the navigation calculation, the navaid identifier and frequency are in large font and the identifier has a highlight
- If the navaid input is received but is not used in the navigation calculation, the identifier and frequency are in large font and there is no highlight
- If the frequency is tuned but valid data is not received, the identifier and frequency are in small font and there is no highlight
- If no frequency is received or the frequency sign status matrix (SSM) is fail, FAIL shows in small font.
- If there is no identifier for a frequency shown, the identifier field is blank
- If the navaid frequency SSM is no computed data (NCD), the identifier and frequency are blank.

Lines 5L and 5R show the currently selected GPS and IRS used in the FMCS navigation sub-function calculations. The GPS display is blank if the GPS is inhibited for use in the navigation sub-function.

Line 6L shows the INDEX prompt. This selects the INIT/REF INDEX page.

Line 6R shows the POS SHIFT prompt. This selects the POS SHIFT page.

Nav Options page

This page lets the flight crew inhibit the use of specific nav aids in the FMCS navigation sub-function.

Lines 1L and 1R show the DME INHIBIT prompt. This lets the flight crew inhibit the use of up to two DME nav aids.

Lines 2L and 2R show the VOR INHIBIT prompt. This lets the flight crew inhibit the use of up to two VOR nav aids.

Line 3L shows the DME UPDATE ON/OFF prompt. This lets the flight crew select the DME update mode. The default is DME update ON. Selection toggles the DME update mode between ON and OFF. The current selected mode shows in large font and the non-selected mode shows in small font.

Line 4L shows the VOR UPDATE ON/OFF prompt. This lets the flight crew select the VOR update mode. The default is VOR update ON. Selection toggles the VOR update mode between ON and OFF. The current selected mode shows in large font and the non selected mode shows in small font.

34-61-00-040

<p>EFFECTIVITY HAP ALL</p>
--

34-61-00

D633A101-HAP

Page 98.119
Jun 15/2009



FMCS - DISPLAYS - CDU - PROGRESS/NAV STATUS PAGES

Line 6L shows the INDEX prompt. This selects the INIT/REF INDEX page.

Line 3R shows the GPS UPDATE ON/OFF prompt. This lets the flight crew select the GPS update mode. The default is GPS update ON. Selection toggles the GPS update mode between ON and OFF. The current selected mode shows in large font and the non selected mode shows in small font.

34-61-00-040



34-61-00

D633A101-HAP

Page 98.120
Jun 15/2009

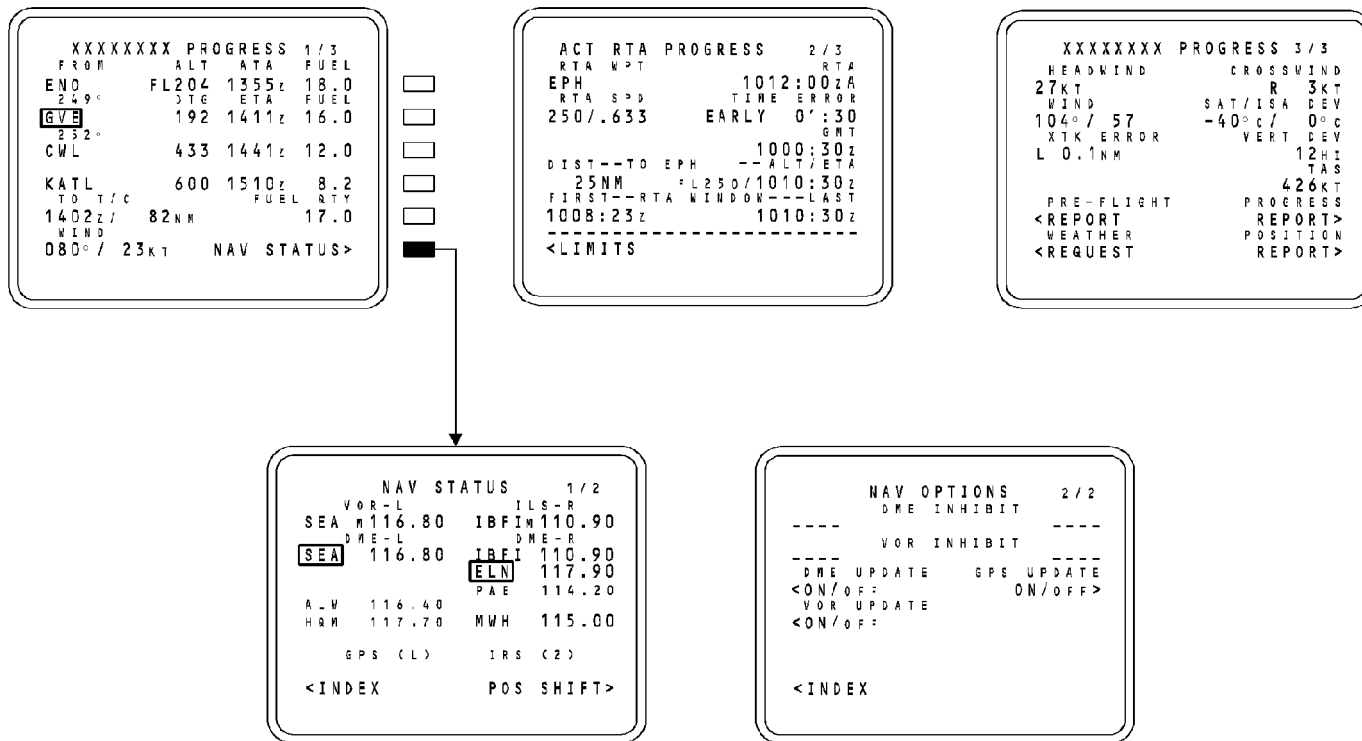

FMCS - DISPLAYS - CDU - PROGRESS/NAV STATUS PAGES

34-61-00-040

EFFECTIVITY
HAP ALL

34-61-00

D633A101-HAP

Page 98.121
Jun 15/2009

THIS PAGE IS INTENTIONALLY LEFT BLANK

34-61-00

D633A101-HAP

Page 98.122
Jun 15/2009

FMCS - DISPLAYS - CDU - ALTERNATE DESTINATION PAGES

General

The alternate destination pages let the flight crew review and select several different alternate destinations.

Page Access

Access to this page is from any one of these pages:

- INIT/REF INDEX
- APPROACH REF
- ROUTE.

Initial Page

Lines 1L through 5L show ALTN prompts. These data fields let the flight crew enter alternate destination identifiers. Valid entries are airports, nav aids, or waypoints. The identifiers must be 5 characters or less.

Line 6L shows the WEATHER REQUEST prompt. This lets the flight crew request weather data for the original destination airport and the alternate destinations.

Lines 1R through 5R show carets. Selection of a caret selects the individual alternate destination page.

Line 6R shows the NEAREST AIRPORTS prompt. Selection of this key causes the FMCS to search the navigation data base for the five airports that are nearest to the present position. The nearest airport shows in line 1L, the second nearest in line 2L etc.

Nearest Airports Page

Lines 1L through 5L show the alternate destination airports and this data:

- VIA (direct-to route to the alternate destination or missed approach from original destination airport to the alternate destination)
- DTG (distance to alternate destination)
- ETA (estimated time of arrival at alternate destination)
- FUEL (fuel remaining at alternate destination).

The default for the VIA data field is the DIRECT-TO route to the alternate destination. For this, the FMCS calculates the data for a direct route to the alternate destination.

Line 6L shows the WEATHER REQUEST prompt. This lets the flight crew request weather data for the original destination airport and the alternate destinations.

Line 6R shows the PREVIOUS prompt. This selects the initial alternate destination page and any previously saved alternate destinations.



FMCS - DISPLAYS - CDU - ALTERNATE DESTINATION PAGES

Alternate Destination Individual Pages

This page lets the flight crew enter or review an alternate destination.

Line 1L shows the ALTN prompt. This shows the alternate destination identifier. The data field at 1C shows the VIA information, either DIRECT or MISAPP.

Line 2L shows the DTG data field. This shows the distance to the alternate destination.

Line 3L shows the ETA data field. This shows the estimated time of arrival at the alternate destination.

Line 4L shows the FUEL data field. This shows the predicted fuel remaining at the alternate destination.

Line 5L shows the MISSED APP prompt. This lets the flight crew select a missed approach route to the alternate destination airport. The FMCS calculates the data based on descent to the original destination followed by a missed approach and then climb, cruise, and descent to the alternate destination. When MISSED APP is selected, the prompt changes to DIRECT-TO.

Line 6L shows the INDEX prompt. This selects the initial alternate destination page.

Line 1R shows the TRIP ALT data field. This shows the FMCS calculated optimum cruise altitude to the alternate destination.

Line 2R shows the WIND data field. This shows the current wind speed and direction.

Line 3R shows the DESTINATION-ALTERNATE data field only when the missed approach mode is selected at LSK 5L. This shows the calculated distance from the original destination to the alternate destination.

Line 6R shows the NEAREST AIRPORTS prompt. Selection of this key causes the FMCS to search the navigation data base for the five airports that are nearest to the present position.

34-61-00-041

EFFECTIVITY
HAP ALL

34-61-00

D633A101-HAP

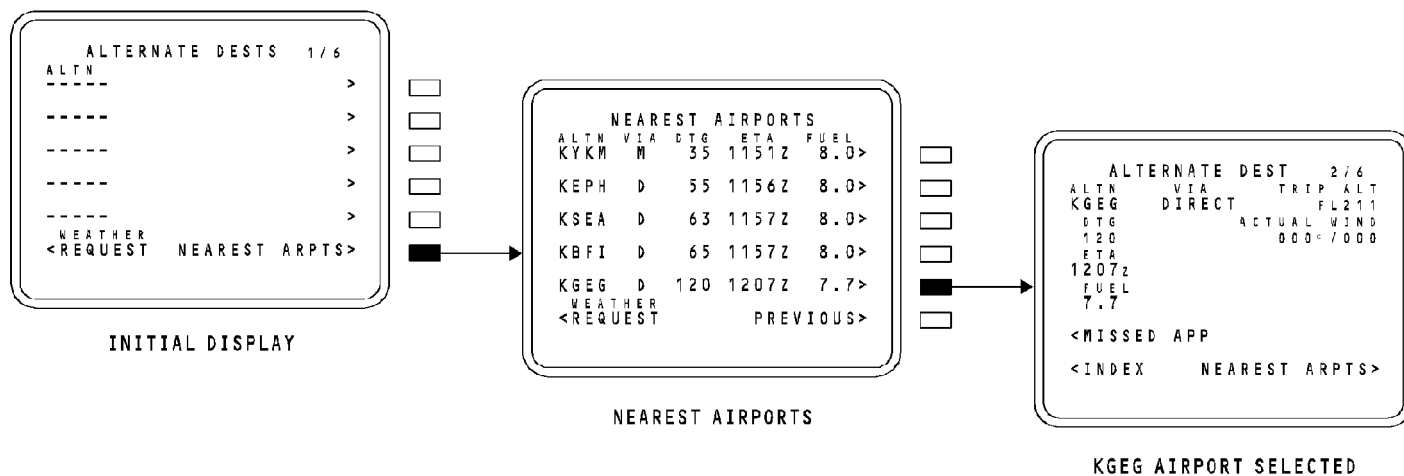

FMCS - DISPLAYS - CDU - ALTERNATE DESTINATION PAGES

34-61-00-041

EFFECTIVITY
HAP ALL

34-61-00

D633A101-HAP

Page 98.125
Jun 15/2009

FMCS - DISPLAYS - CDU - LATERAL OFFSET PAGE**General**

The LATERAL OFFSET page lets the flight crew select a lateral offset to the left or the right of the normal route. Offsets are available from 0.1 nautical miles (nm) up to a maximum of 99.9 nm and are set in 0.1 nm increments.

Page Access

Access to this page is from these pages:

- ROUTE
- INIT/REF INDEX.

Lateral Offset Page

Line 2L shows the OFFSET DIST prompt. This lets the flight crew enter the specific distance for the offset route. Dashes show initially.

Line 3L shows the START WAYPOINT prompt. This lets the flight crew enter the specific waypoint where the offset will begin. This data field is blank until a valid distance is entered in LSK 2L. Then the box prompts show.

Line 4L shows the END WAYPOINT prompt. This lets the flight crew enter the specific waypoint where the offset is to end. This data field also is blank until a valid distance is entered in LSK 2L. Then the box prompts show.

Waypoint identifiers may contain up to 6 alphanumeric characters. If the entered identifier is not a valid waypoint, the message INVALID ENTRY shows in the scratchpad.

If the entered waypoint identifier is valid but is not in the flight plan, the message NOT IN FLIGHT PLAN shows.

If the entered waypoint identifier is a non-offsetable waypoint, the entry is rejected and the message NO OFFSET AT LEG XXXXX shows in the scratchpad.

After the data is entered, the EXEC light comes on. Push the EXEC key to activate the offset route. The OFST annunciators on the CDUs come on to show that the offset is active and the offset route shows on each crew members navigation display.

Line 6L shows the ERASE prompt. This shows on pages that are modified and they let the flight crew erase the entered data and return to the initial lateral offset page.

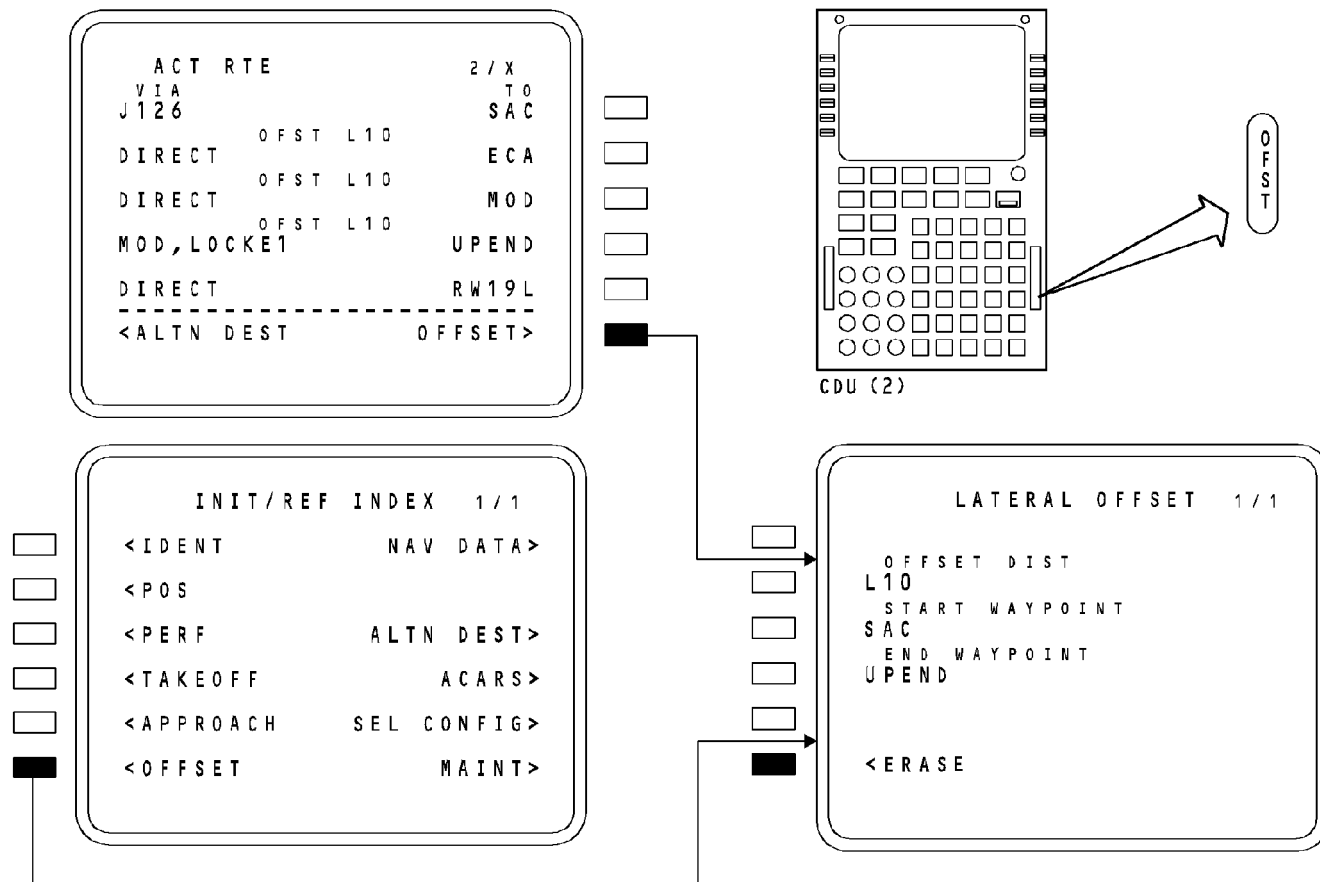

FMCS - DISPLAYS - CDU - LATERAL OFFSET PAGE

34-61-00-042

EFFECTIVITY
HAP ALL

34-61-00

D633A101-HAP

Page 98.127
Jun 15/2009

THIS PAGE IS INTENTIONALLY LEFT BLANK

34-61-00

D633A101-HAP

Page 98.128
Jun 15/2009

FMCS - DISPLAYS - CDU - APPROACH REFERENCE PAGE**General**

The APPROACH REF page lets the flight crew review performance data related to the approach phase of the flight.

Page Access

This page may be accessed by selection of the INIT/REF mode select key on the CDU when the airplane is in flight or from the APPROACH prompt on the INIT/REF INDEX page.

Approach Reference Page

The approach reference (APPROACH REF) page shows the following data:

- Gross weight
- Go-around N1
- Runway length
- ILS frequency and identifier
- VREF speeds for specific landing flap settings
- Wind correction values
- Front course.

Line 1L shows the GROSS WT prompt. Calculated gross weight as shown on the PERF INIT page or pilot entered value is shown. If the calculated gross weight is not valid, box prompts show.

Line 2L shows the GA N1 prompt. The go-around N1 Limit shows for both engines.

Line 4L shows the runway length prompt. This data field shows the runway length for the destination runway in feet and meters. This data field clears at flight completion.

Line 5L shows the arrivals approach identifier. If an ILS approach is selected in the active flight plan, the ILS frequency and identifier shows. If there is no ILS approach selected in the flight plan, this header and data field is blank.

Line 6L shows the INIT/REF INDEX prompt. This selects the INIT/REF INDEX page.

Lines 1R, 2R, and 3R show the VREF prompts. These show the calculated VREF speeds for the three flap settings at the calculated gross weight. Initially, the VREF speeds shows in small font until the flight crew selects one specific speed, then it shows in large font. In the example shown, the VREF speed for flaps 30 was selected by the flight crew.

Line 4R shows the WIND CORR prompt. The wind correction is added to the VREF speed selected in the VREF speed data field. The default value is +05 knots and the allowable entry range is 0 to 20 knots.

Line 5R shows the FRONT CRS prompt. This shows the front course if an ILS or LOC shows in line 5L. If there is no ILS or LOC in line 5L, this data field is blank. The front course value has a suffix of a T if the course is relative to true north.



FMCS - DISPLAYS - CDU - APPROACH REFERENCE PAGE

Line 6R shows the ALTN DEST prompt. This selects the alternate destination pages.

34-61-00-096

EFFECTIVITY
HAP ALL

34-61-00

D633A101-HAP

Page 98.130
Jun 15/2009

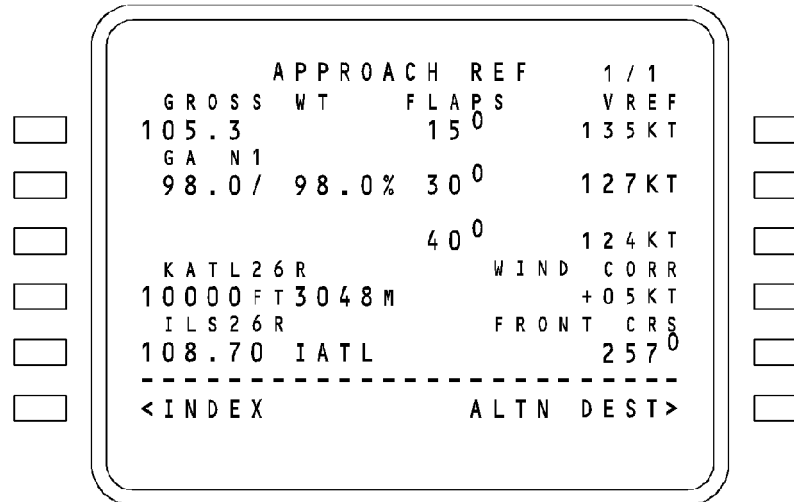

FMCS - DISPLAYS - CDU - APPROACH REFERENCE PAGE

EFFECTIVITY
HAP ALL

34-61-00

D633A101-HAP

Page 98.131
Jun 15/2009

FMCS - DISPLAYS - CDU - NAVIGATION REFERENCE PAGES**General**

The navigation reference data pages let the flight crew review data from the permanent, temporary, or supplemental navigation data base for these references:

- Waypoint
- Navaid
- Runway
- Airport.

Waypoints, nav aids, and airports not in the data base are entered into the temporary navigation data base from these pages. This is the reference data the crew can see on the CDUs:

- Reference navigation data (REF NAV DATA)
- Temporary navigation data (TEMP NAV DATA)
- Supplementary navigation data (SUPP NAV DATA).

Reference Navigation Data

On these pages, the crew examines navigation data for these references that are in the data base:

- Waypoints
- Airports
- Nav aids
- Runways.

You get access to this page by selection of NAV DATA (LSK 1R) on the INIT/REF INDEX page. Also, you get access by selection of INDEX on the NAV SUMMARY page or the individual identifier pages.

Line 1L shows the WPT IDENT prompt. The waypoint or runway identifier is entered here.

The waypoint identifier page shows this data for the specified waypoint:

- Latitude and longitude
- Magnetic variation
- Reference identifier
- Radial/distance.

The runway identifier page shows this data in feet and meters for the specified runway:

- Airport identifier
- Latitude and longitude
- Elevation
- Runway length (feet and meters).

Line 2L shows the AIRPORT IDENT prompt. The airport identifier is entered here.

The airport identifier page shows this data:

- Latitude and longitude

FMCS - DISPLAYS - CDU - NAVIGATION REFERENCE PAGES

- Elevation
- Magnetic variation for the airport.

Line 6L shows the INDEX prompt. This selects the INIT/REF INDEX page.

Line 1R shows the NAVAID IDENT prompt. The navaid identifier is entered here.

The navaid identifier page shows this data for the entered navaid:

- Classification
- Latitude and longitude
- Frequency
- Elevation
- Magnetic variation.

If the identifier that is entered is not in the permanent, temporary, or supplemental data base, a display that shows only box prompts in all the data fields except the entered identifier shows.

In the example, the navaid identifier SEA was entered and the data base does not contain any data for this identifier.

Line 2R shows the SUMMARY prompt. This selects the NAV SUMMARY page that shows the temporary and supplemental data base data. The temporary data shows first. If there is no temporary or supplemental data, this data field is blank.

Line 6R shows the NAV OPTIONS prompt. This selects the NAV OPTIONS page.

Temporary Navigation Data

The temporary navigation data base holds up to this many items:

HAP 031-054, 101-999; HAP 030 POST SB 737-34-1918; HAP 001-013, 015-026, 028, 029 PRE SB 737-34-1666 OR POST SB 737-34-1918

- 20 waypoints
- HAP ALL**
- 40 navaids
 - 6 airports.

The total storage capacity of the temporary navigation data base is shared with the supplemental data base. The entries in this data base are deleted at flight completion.

This page may be accessed by selecting the SUMMARY prompt on the REF NAV DATA page.

Supplementary Navigation Data

The supplemental navigation data base provides long term storage of navigation data that is not in the permanent data base. The supplemental data base holds up to this many items:

<p>EFFECTIVITY HAP ALL</p>
--

34-61-00

D633A101-HAP



FMCS - DISPLAYS - CDU - NAVIGATION REFERENCE PAGES

HAP 031-054, 101-999; HAP 030 POST SB 737-34-1918; HAP 001-013, 015-026, 028, 029 PRE SB 737-34-1666 OR POST SB 737-34-1918

- 20 waypoints

HAP ALL

- 40 nav aids
- 6 airports.

To get access to this page, enter SUPP in the scratchpad on the INIT/REF INDEX page and select NAV DATA (LSK 1R). Also, you can get access by selection of INDEX from the SUPP SUMMARY page or the individual identifier pages.

Line 3R shows the effectivity date of the supplemental data base. For this data base to be valid, an effectivity date must be entered. If no valid date has been entered, box prompts show in this data field. This effectivity date also shows on the IDENT page.

Line 4L and 4R show the ACARS prompts. This lets the flight crew uplink or downlink the contents of the supplemental data base in an ACARS message.

Individual entries are removed with the DEL key on the CDU or all of the supplemental data base is removed by selection of DELETE ALL SUPP DATA (LSK 6R).

34-61-00-067

EFFECTIVITY
HAP ALL

34-61-00

D633A101-HAP

```

REF NAV DATA
WPT IDENT  NAVAID IDENT
-----
A:RPORT IDENT  SUMMARY>
-----
<INDEX      NAV OPTIONS>
    
```

INITIAL REF NAV DATA PAGE

```

REF NAV DATA
WPT IDENT  NAVAID IDENT
MACON
-----
LATITUDE  LONGITUDE
N30°36.4   W082°16.4
MAG VAR
W 50
REF IDENT  RADIAL/DIST
SAVNH     270 / 150NM
-----
<INDEX
    
```

WAYPOINT IDENTIFIER

```

REF NAV DATA
NAVAID IDENT
SEA
CLASS
VTHA
-----
LATITUDE  LONGITUDE
N47°26.1   W122°18.5
FREQ      ELEVATION
116.80    340 FT
MAG VAR
E 220
-----
<INDEX
    
```

NAVAID IDENTIFIER

```

REF NAV DATA
RWY WPT IDENT
RW09
A:RPORT IDENT
KATL
-----
LATITUDE  LONGITUDE
N31°48.7   W082°12.3
ELEVATION
1572 FT
LENGTH
9000 FT / 2748 M
-----
<INDEX
    
```

RUNWAY IDENTIFIER

```

REF NAV DATA
R/WY WPT IDENT
-----
A:RPORT IDENT
KATL
-----
LATITUDE  LONGITUDE
N31°48.7   W082°12.3
ELEVATION
1572 FT
MAG VAR
E 210
-----
<INDEX
    
```

AIRPORT IDENTIFIER

```

REF NAV DATA
NAVAID IDENT
SEA
CLASS
-----
LATITUDE  LONGITUDE
-----
FREQ      ELEVATION
-----
MAG VAR
-----
<INDEX
    
```

IDENTIFIER NOT IN DATA BASE

```

TEMP NAV SUMMARY 1/1
WAYPOINTS
DCSD  N19°56.3W063°11.4
DUKAC  N23°41.7W052°47.6
NAVAID
POL  N39°26.2W055°14.1
-----
<INDEX
    
```

TEMP DATA BASE SUMMARY

```

SUPP NAV DATA
WPT IDENT  NAVAID IDENT
-----
A:RPORT IDENT  SUMMARY>
-----
RFF FRK  ROM SVFR
SUPP NAV  JAN 15/99
<REPORT  SUPP NAV  REQUES>
-----
DELETE ALL
<INDEX  SUPP DATA>
    
```

SUPP NAV DATA PAGE

```

SUPP NAV SUMMARY 1/2
WAYPOINTS
ABC>  N22°36.4W082°16.4
TDLTL  N42°25.9W120°55.6
BAKER  HURPP 055/102
COM-2  N43°19.0W121°12.6
DFK  RDR 025/5
SQUAK  S13°45.9E064°11.6
NAVAIDS
RDR  N37°46.2W075°54.1
BFI  N45°23.1W122°55.3
ISS  N45°02.6E128°54.2
-----
<INDEX
    
```

SUPP DATA BASE SUMMARY

FMCS - DISPLAYS - CDU - NAVIGATION REFERENCE PAGES

34-61-00-067

EFFECTIVITY
HAP ALL

34-61-00

D633A101-HAP

Page 98.135
Jun 15/2009

THIS PAGE IS INTENTIONALLY LEFT BLANK

34-61-00

D633A101-HAP

Page 98.136
Jun 15/2009

FMCS - DISPLAYS - CDU - HOLD PAGE**GENERAL**

The RTE LEGS HOLD AT page is used by the flight crew to select the airplanes present position or any other waypoint as a holding pattern fix.

The RTE HOLD page is used by the flight crew to enter and review data for a specific holding pattern.

Page Access

The RTE LEGS HOLD AT page is accessed from the RTE LEGS page by selecting the HOLD mode key on the MCDU.

The RTE HOLD page is accessed from the HOLD AT page by:

- Entering HOLD AT XXXXX in the scratchpad and selecting LSK 6L
- Entering the holding pattern fix waypoint in line 6L and selecting LSK 6L
- Entering PPOS at line 6R and selecting LSK 6R.

Rte Legs Hold At Page Information

Line select keys 1L through 5L show the active waypoint and subsequent waypoints in the active flight plan with this data:

- Computed course to waypoint
- Computed leg length
- Speed and altitude.

Line select key 6L shows the HOLD AT box prompts. The flight crew enters the desired waypoint for the holding pattern fix point.

Line select key 6R shows the PPOS prompt. The flight crew enters the desired position for the holding pattern fix point.

Rte Hold Page

Line select key 1L shows the FIX data. This is the holding pattern fix point as defined on the HOLD AT page.

Line select key 4L shows the LEG TIME prompt. The leg time is entered through the MCDU. The default times are 1.5 minutes above 14000 feet and 1.0 minutes at or below 14000 feet.

Line select key 5L shows the LEG DIST (leg distance) prompt. This data field lets the flight crew enter the leg distance for the holding pattern.

Line select key 6L shows one of these prompts:

- NEXT HOLD (selects the HOLD AT page)
- ERASE (shows when data is being modified).

Line select key 2R shows the FIX ETA prompt. This data field shows the time at which the holding pattern fix is reached.

FMCS - DISPLAYS - CDU - HOLD PAGE

Line select key 3R shows the EFC TIME prompt. This data field shows the time at which the holding pattern is exited.

Line select key 4R shows the HOLD AVAIL prompt. This data field shows the holding time available before exit is necessary to reach the destination with the necessary fuel reserves.

Line select key 5R shows the BEST SPEED prompt. This data field shows the best holding speed for the current altitude and conditions.

Line select key 6R shows the EXIT HOLD prompt. This data field shows when the airplane is in an active holding pattern. After selection of this prompt, the EXEC key lights and EXIT HOLD is replaced with EXIT ARMED. When the EXEC key is pushed, the airplane exits the holding pattern from the FIX point and resumes the active flight plan.

ACT RTE	LEGS	1/XX
321° HDG	9.7 NM	BYPASS
MARK1	250 / 7000	
324°	27 NM	
IAN	320 / 10500	
247°	65 NM	
CHN01	.790 / FL230	
249°	73 NM	
DOT46	.800 / FL350	
258°	117 NM	
NICK2	.800 / FL350	
----- HOLD AT -----		
□□□□		PPOS>

RTE LEGS HOLD AT PAGE

MOD RTE	HOLD	1/X
FIX	SPD/TGT	ALT
MARK1	210 / FL240	
QUAD/RADIAL	FIX	ETA
NE/030°	1034.5Z	
INBD CRS/DIR	EFC	TIME
210°/R TURN		-----Z
LEG TIME	HOLD	AVAIL
1.5 MIN		0+48
LEG DIST	BEST	SPEED
---.NM		220KT

<ERASE		

RTE HOLD PAGE

FMCS - DISPLAYS - CDU - HOLD PAGE

34-61-00-074

EFFECTIVITY
HAP ALL

34-61-00

D633A101-HAP

Page 98.139
Jun 15/2009

FMCS - DISPLAYS - CDU - FIX PAGE

General

The FIX INFO page is used by the flight crew to show the current bearing and distance from a selected reference point (SRP). It is also used to calculate the abeam point of the airplane along the flight plan route from the entered SRP.

Page Access

To get access to the FIX INFO page push the FIX mode key on the MCDU.

Fix Info Page Information

Line select key 1L shows the FIX prompt. The FIX identifier is entered here by typing the identifier in the scratchpad and line selecting it. These are the valid entries kept in the navigation data base:

- Airports
- Navaids
- Waypoints (up to a maximum of six alphanumeric characters).

After you enter the fix identifier, the bearing and distance from that fix is shown in line 1 on the MCDU. The fix identifier is also shown on the CDS navigation display.

Line select keys 2L through 4L are used by the flight crew to enter bearings or distances from the fix identifier. The entered data is again typed in the scratchpad and line selected.

These bearings and distances also are calculated and shown from the fix identifier:

- Estimated time of arrival (ETA)
- Distance to the fix waypoint (DTG)
- Altitude (ALT) at the fix waypoint.

The specific radial is then shown on the CDS navigation displays.

Line select key 5L shows the ABM prompt. Selection of this prompt causes the FMC to calculate and show the abeam point with these results:

- Bearing/distance
- ETA
- DTG
- Altitude at the abeam point.

Any of the fix waypoints in LSK 2L through 5L is line selected to the scratchpad for possible use on the RTE or LEGS pages as a waypoint.

The DELETE key is used to erase the FIX identifier and its entries.

The second FIX INFO page lets the flight crew select a second fix waypoint and enter the bearings and/or distances to that fix waypoint. The FMC is limited to a maximum of two FIX INFO pages.

EFFECTIVITY
HAP ALL

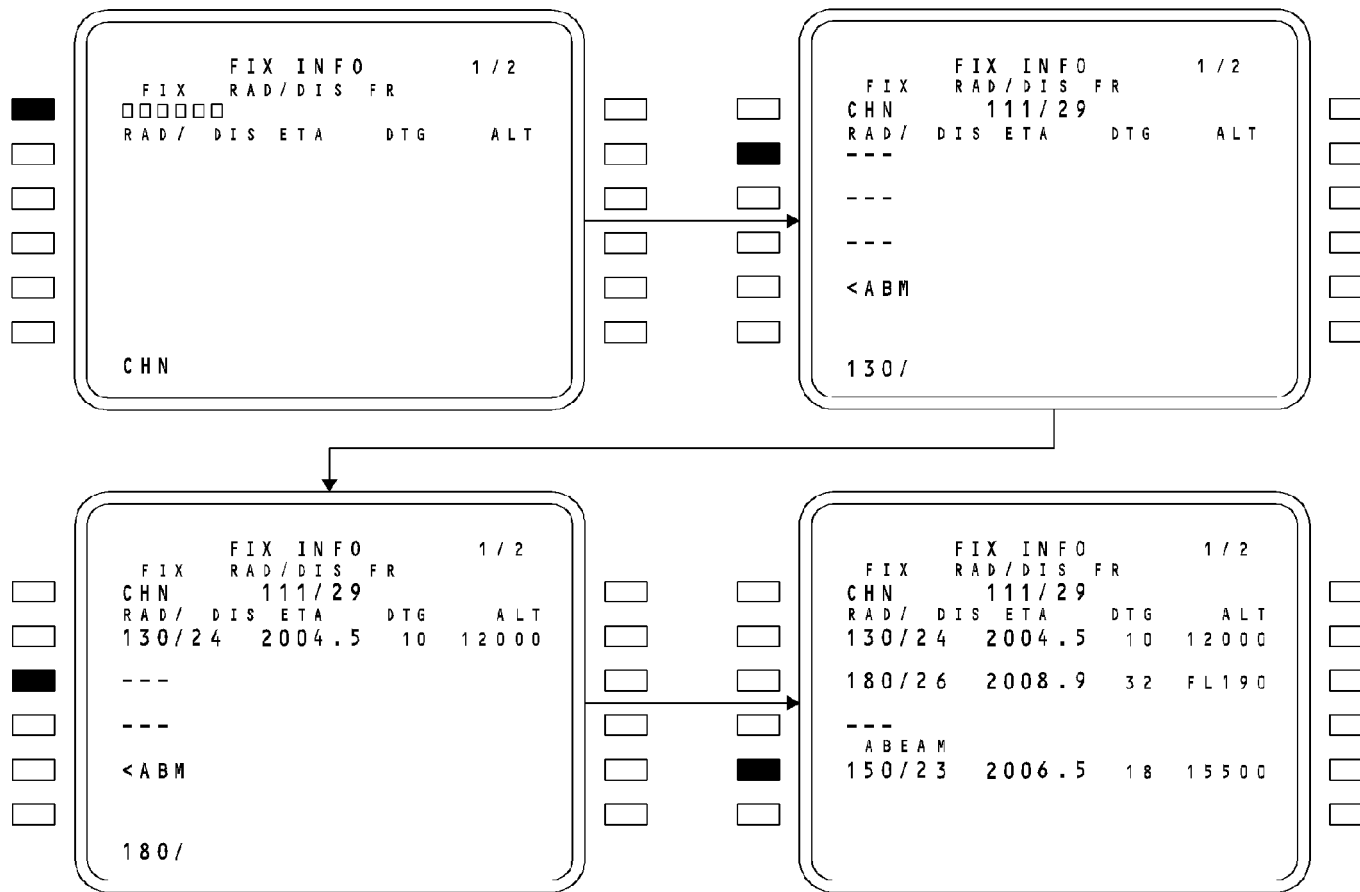

FMCS - DISPLAYS - CDU - FIX PAGE

34-61-00-090

EFFECTIVITY
HAP ALL

34-61-00

D633A101-HAP

Page 98.141
Jun 15/2009

FMCS - DISPLAYS - CDU - MESSAGES

General

The FMCS shows alerting or advisory messages when there is a condition that degrades the system. The FMCS also shows entry error and ACARS messages.

The messages are prioritized and show in the CDU scratch pad. This is the priority:

- Data entry error advisory
HAP 001-013, 015-026, 028-030
- ACARS uplink alerting messages
HAP ALL
- Alerting messages
- Advisory messages.
- ACARS status messages.

Entry error messages show that the entered data is not correct. The message must first be cleared and then the data must be entered correctly. These messages will only show on the CDU on which the incorrect data entry was made. The MSG annunciator on the CDU on which the invalid entry was made will be on for these messages.

HAP **HAP 001-013, 015-026, 028-030**

HAP ACARS uplink alerting messages show the status of the current
HAP uplink data. The MSG annunciators will be on for these
HAP messages as well as the FMC warning lights on the autoflight
HAP status annunciators (ASA).

HAP **HAP ALL**

Alerting messages show an FMC condition that must be shown to the flight crew and corrected before further FMC operation is advisable or possible. The MSG annunciators will be on for these messages as well as the FMC warning lights on the ASAs.

Advisory messages show the FMCS status and certain flight profile parameters and requirements. The MSG annunciators will be on for these messages.

ACARS status messages show ACARS system availability and status. The MSG annunciators will not be on for these messages.

The message with the highest priority will show in the scratch pad. If there are two messages of the same priority, the one that occurred first will show. When it is cleared the next message will show.

To clear a message, push the CLR key or remove the conditions that caused the message. Some messages clear when you change the page. The PROGRAM PIN ERROR message cannot be cleared with the CLR key or a page change.

Below are the messages in the different categories. The airplane operations manual contains a complete list of the CDU messages.

EFFECTIVITY
HAP ALL

34-61-00

D633A101-HAP

Page 98.142
Jun 15/2009



FMCS - DISPLAYS - CDU - MESSAGES

HAP 001-013, 015-026, 028-030 (Continued)

	ACARS UPLINK ALERTING MESSAGE	CAUSE	CORRECTIVE ACTION
HAP HAP	CRZ WIND UPLINK READY	ACARS UPLINK OF CRUISE WIND DATA HAS BEEN RECEIVED	SELECT THE RTE DATA PAGE AND SELECT THE LOAD PROMPT.
HAP HAP HAP	CRZ WIND XXXXX UPLINK	ACARS UPLINK OF CRUISE WIND DATA HAS BEEN LOADED INTO THE FMC	REVIEW AND EXEC OR ERASE THE CRUISE WIND DATA.
HAP HAP HAP	DATALINK CONFIG INVALID	THE LOADED DATALINK CONFIG TABLE FAILED ITS CRC CHECK	RELOAD THE TABLE.
HAP HAP HAP HAP	DESCENT FORECASTS UPLINK	ACARS UPLINK OF OF DESCENT FORECASTS DATA HAS BEEN LOADED INTO THE FMC	REVIEW AND EXEC OR ERASE THE DESCENT FORECASTS DATA.
HAP HAP HAP HAP HAP	FORECASTS UPLINK READY	ACARS UPLINK OF DESCENT FORECASTS DATA HAS BEEN RECEIVED	SELECT THE DESCENT FORECASTS PAGE AND LOAD THE DATA BY SELECTION OF THE LOAD PROMPT.
	ACARS UPLINK ALERTING MESSAGE	CAUSE	CORRECTIVE ACTION
HAP HAP	INVALID TAKEOFF XXXXXXX (RUNWAY IDENT)	ACARS UPLINK DATA RECEIVED FOR SELECTED RUNWAY SHOWS AIRPLANE IS PERFORMANCE LIMITED	LIMIT TAKEOFF WEIGHT OF AIRPLANE OR SELECT A NEW RUNWAY.
HAP HAP HAP	NAV DATA UPLINK	ACARS UPLINK OF SUPP NAV DATA HAS BEEN LOADED	REVIEW DATA AND CLEAR MESSAGE.
HAP HAP HAP	PARTIAL ALTN UPLINK	DUE TO ERRORS, ONLY A PARTIAL ALTN DEST UPLINK WAS RECEIVED	EXEC, ERASE, OR REQUEST A NEW UPLINK OF THE DATA.

ACARS UPLINK ALERTING MESSAGE	CAUSE	CORRECTIVE ACTION	
PARTIAL ATC ROUTE UPLINK	DUE TO ERRORS, ONLY A PARTIAL ATC ROUTE UPLINK WAS RECEIVED	EXEC, ERASE, OR REQUEST NEW ROUTE DATA.	HAP HAP HAP
PARTIAL FORECATS UPLINK	DUE TO ERRORS, ONLY A PARTIAL DESCENT FORECASTS UPLINK WAS RECEIVED	EXEC, ERASE, OR REQUEST NEW DESCENT FORECASTS DATA.	HAP HAP HAP HAP

ACARS UPLINK ALERTING MESSAGE	CAUSE	CORRECTIVE ACTION	
PARTIAL LIMITS UPLINK	DUE TO ERRORS, ONLY A PARTIAL PERFORMANCE LIMITS UPLINK WAS RECEIVED	EXEC, ERASE, OR REQUEST NEW PERFORMANCE LIMITS DATA.	HAP HAP HAP HAP
PARTIAL NAV DATA UPLINK	DUE TO ERRORS, ONLY A PARTIAL SUPP NAV DATA BASE UPLINK WAS RECEIVED	REVIEW, EDIT, OR DELETE UNNECESSARY SUPP NAV DATA AND REQUEST NEW UPLINK.	HAP HAP HAP HAP
PARTIAL PERF INIT UPLINK	DUE TO ERRORS, ONLY A PARTIAL PERF INIT UPLINK WAS RECEIVED	EXEC, ERASE, OR REQUEST NEW PERF INIT DATA.	HAP HAP HAP
PARTIAL ROUTE UPLINK	DUE TO ERRORS, ONLY A PARTIAL NON-ATC ROUTE UPLINK WAS RECEIVED	EXEC, ERASE, OR REQUEST NEW ROUTE DATA.	HAP HAP HAP HAP
PERF INIT UPLINK	PERF INIT DATA FROM THE ACARS UPLINK HAS BEEN LOADED	REVIEW AND EXEC OR ERASE THE PERF INIT UPLINK DATA.	HAP HAP HAP
PERF INIT UPLINK READY	UPLINK OF PERF INIT DATA HAS BEEN RECEIVED	SELECT THE PERF INIT PAGE AND LOAD THE DATA.	HAP HAP HAP

<p>34-61-00-044</p>	<p>EFFECTIVITY</p> <p>HAP ALL</p>
---------------------	--

34-61-00

FMCS - DISPLAYS - CDU - MESSAGES

HAP 001-013, 015-026, 028-030 (Continued)

	ACARS UPLINK ALERTING MESSAGE	CAUSE	CORRECTIVE ACTION
HAP HAP	PERF LIMITS UPLINK	PERF LIMITS DATA FROM AN ACARS UPLINK HAS BEEN LOADED	REVIEW AND EXEC OR ERASE THE PERF LIMITS UPLINK DATA.
HAP HAP HAP	PERF LIMITS UPLINK READY	UPLINK OF PERF LIMITS DATA HAS BEEN RECEIVED	SELECT THE PERF LIMITS PAGE AND LOAD THE DATA.
HAP HAP HAP HAP	RESEND MESSAGE	A CDU DOWNLINK MESSAGE IS STARTED AND THE FMC IS UNABLE TO SEND THE MESSAGE TO THE ACARS MU	CLEAR MESSAGE AND RE-START THE DOWNLINK.
HAP HAP HAP	ROUTE DATA UPLINK	NON-ATC ROUTE DATA FROM AN ACARS UPLINK HAS BEEN RECEIVED	REVIEW AND EXEC OR ERASE THE NON-ATC ROUTE DATA UPLINK.
HAP HAP HAP HAP HAP	ROUTE UPLINK READY	NON-ATC ROUTE DATA FROM AN ACARS UPLINK IS READY TO BE LOADED INTO THE FMC	SELECT THE LOAD PROMPT ON THE RTE OR LEGS PAGE TO LOAD THE ROUTE DATA UPLINK.
HAP HAP	ACARS UPLINK ALERTING MESSAGE	CAUSE	CORRECTIVE ACTION
HAP HAP HAP	RTA DATA UPLINK	RTA DATA FROM AN ACARS UPLINK HAS BEEN LOADED	REVIEW AND EXEC OR ERASE THE NON-ATC ROUTE DATA UPLINK.
HAP HAP HAP HAP	TAKEOFF DATA LOADED	THE SELECTED DEPARTURE RUNWAY MATCHES ONE OF THE TAKEOFF DATA SETS	REVIEW AND ACCEPT OR REJECT THE ENTERED TAKEOFF DATA.
HAP HAP HAP	TAKEOFF DATA UPLINK	TAKEOFF DATA FROM AN ACARS UPLINK HAS BEEN LOADED	REVIEW AND ACCEPT OR REJECT THE TAKEOFF DATA.

ACARS UPLINK ALERTING MESSAGE	CAUSE	CORRECTIVE ACTION
TAKEOFF SPEEDS DELETED	MANUALLY SELECTED TAKEOFF SPEEDS DELETED DUE TO CHANGE OF DEPARTURE RUNWAY	RESELECT DESIRED TAKEOFF SPEEDS AND CLEAR MESSAGE.

HAP
HAP

HAP
HAP
HAP
HAP
HAP

HAP

HAP ALL

Alerting Messages

ALERTING MESSAGE	CAUSE	CORRECTIVE ACTION
CYCLE IRS OFF -NAV	IRS LOGIC REQUIRES MANUALLY RESTART OF THE ALIGNMENT	TURN THE IRS MODE SWITCH TO OFF AND THEN TO NAV.
DATA BASE INVALID	VALIDITY TEST OF NAV DATA BASE HAS FAILED	RELOAD THE DATA BASE
DISCO INSRTD AFTR XXXXX	GEOMETRY OF NEXT WPTS WILL NOT ALLOW THE FMC TO FLY THE ACTIVE PLAN WITHOUT BYPASS OF MORE THAN ONE WPT	CHANGE THE ACTIVE FLIGHT PLAN.
DISCONTINUITY	PASSED THE LAST WPT IN THE PLAN PRIOR TO A ROUTE DISCONTINUITY	SELECT THE RTE OR RTE LEGS PAGE TO SPECIFY THE WPTS FOR A CONTINUOUS PLAN OR CAPTURE NEXT LEG.
HAP 039-047, 054, 101-106; HAP 001-013, 015-026, 028-038 POST SB 737-34-1918		
DRAG REQ AFTER XXXXX	PREDICTED SPEED AT WAYPOINT XXXXX IS GREATER THAN 10 KTS ABOVE WAYPOINT SPEED CONSTRAINT	CLEAR MESSAGE AND NOTIFY ATC IF NECESSARY..

34-61-00-044

EFFECTIVITY
HAP ALL

34-61-00

D633A101-HAP

Page 98.145
Jun 15/2009

FMCS - DISPLAYS - CDU - MESSAGES

ALERTING MESSAGE	CAUSE	CORRECTIVE ACTION
HAP ALL		
ALERTING MESSAGE	CAUSE	CORRECTIVE ACTION
END OF OFFSET	2 MINS PRIOR TO PASSING OFFSET LEG TERMINATION	NONE REQUIRED.
END OF ROUTE	PASSING LAST ROUTE LEG TERMINATION	GO TO RTE OR RTE LEGS PAGE AND EXEC A ROUTE MODIFICATION.
ENTER IRS POSITION	IRS DID NOT ALIGN TO THE SET POSITION OR IRS IS IN THE ALIGN MODE AND NEEDS A POSITION ENTRY	ENTER THE IRS POSITION ON THE POS INIT PAGE.
HAP 037-054, 101-999		
FMC DISAGREE	DURING APPROACH OR WHEN THE AIRPLANE IS ON THE GROUND, THE FMC SENSES A DISAGREEMENT IN MONITORED PARAMETERS REQUIRED FOR DUAL FMC OPERATION.	MONITOR FMC'S CLOSELY. BOTH FMC'S REMAIN ONLINE. LIMIT APPROACHES TO SINGLE FMC ONLY. IF DESIRED, REVERT TO SINGLE FMC OPERATION.
HAP ALL		
INSUFFICIENT FUEL	CHANGE IN CONDITIONS OR FLIGHT PLAN ROUTE CAUSES PREDICTIONS TO SHOW LESS THAN 2000LBS FUEL AT DESTINATION	MODIFY ROUTE PLAN OR CRUISING ALTITUDE OR DIVERT FOR ADDITIONAL FUEL.
IRS MOTION	IRS DETECTED EXCESSIVE MOTION DURING ALIGNMENT	CLEAR THE MESSAGE AND REDUCE AIRPLANE MOTION.

ALERTING MESSAGE	CAUSE	CORRECTIVE ACTION
IRS NAV ONLY	FMC HAS CHANGED TO THE DEAD RECKONING MODE OF NAVIGATION	CLEAR MESSAGE AND CHECK NAV RADIO AUTOTUNE FUNCTION.
HAP 039-047, 054, 101-106; HAP 001-013, 015-026, 028-038 POST SB 737-34-1918		
IRS POS / ORIGIN DISAGREE FMC POS/RW DISAGREE (Msgs enabled on ground)	FMCS AND POSITION SENSORS EXCEED ALLOWABLE TOLERANCES	CLEAR MESSAGE CHECK POSITIONS ON THE POS SHIFT PAGE.
HAP ALL		
LNAV BANK ANGLE LIMITED	AIRPLANE IS WITHIN 5 MINUTES OF TURN AND WILL EXCEED AIRSPACE CONTAINMENT AREA	CLEAR MESSAGE AND NOTIFY ATC IF NECESSARY
MAX ALT FL XXX	ALTITUDE INTERVENTION ATTEMPT TO RAISE CRZ ALT WHEN MCP ALT IS ABOVE THE MAX ALTITUDE	CLEAR MESSAGE.
MISSED CAPTURE	PROPER LOC CAPTURE STARTED BUT DFCS DID NOT CAPTURE	CLEAR MESSAGE.
MODEL ENGINE DATA INVALID	THE AIRPLANE MODEL/ ENGINE PERFORMANCE DATA BASE IS NOT LOADED OR IS NOT VALID	RELOAD THE DATA BASE.
NAV DATA OUT OF DATE	NAV DATA BASE DATE DOES NOT MATCH CLOCK DATE	SELECT CORRECT NAV DATA BASE OR LOAD NEW NAV DATA BASE

EFFECTIVITY
HAP ALL

34-61-00

D633A101-HAP

Page 98.146
Jun 15/2009

FMCS - DISPLAYS - CDU - MESSAGES

ALERTING MESSAGE	CAUSE	CORRECTIVE ACTION
NAV INVALID-TUNE XXXXX	FMC IS UNABLE TO AUTOTUNE OR RECEIVE APPROACH PROCEDURE NAVAID	CROSS CHECK RADIOS AND MANUALLY TUNE SPECIFIED NAVAID.
OVERSPEED DISCONNECT	AIRPLANE EXCEEDS DESCENT SPEED RESTRICTION BY 15 KTS OR MORE	SLOW AIRPLANE TO WITHIN 10 KTS OF SPEED TARGET AND RE-ENGAGE VNAV.
PERF DEFAULTS INVALID	LOADED PERF DEFAULTS DATA BASE IS FAILING ITS CRC CHECK	RELOAD THE PERF DEFAULTS DATA BASE.
RESET MCP ALTITUDE	WITHIN 5NM OF TOP OF DESCENT AND MCP ALTITUDE IS AT CRZ ALTITUDE	SELECT CORRECT MCP ALTITUDE AS CLEARANCES PERMIT
RTA UNACHIEVABLE	RTA IS CURRENTLY OUTSIDE THE COMPUTED WINDOW PLUS A TIME MARGIN AND NO CORRECTIVE ACTION MAY BE MADE DUE TO SPEED CONSTRAINTS	CLEAR MESSAGE, EXIT RTA FUNCTION OR ENTER ACHIEVABLE RTA.

ALERTING MESSAGE	CAUSE	CORRECTIVE ACTION
SCANNING DME FAIL	INPUTS FROM FREQUENCY SCANNING DME HAVE FAILED	CLEAR THE MESSAGE AND CHECK NAV RADIO FUNCTION
SELECT MODE AFTER RTA	RTA FUNCTION EXITED VIA WPT DELETION OR RTA WPT SEQUENCED	CLEAR MESSAGE OR SELECT ALTERNATE PERF MODE OR MESSAGE IS CLEARED WHEN AIRPLANE IS NO LONGER IN SAME FLIGHT PHASE.

ALERTING MESSAGE	CAUSE	CORRECTIVE ACTION
SINGLE FMC OPERATION (DUAL FMC ONLY)	THE PRIMARY FMC HAS DETERMINED THAT THE SECONDARY FMC HAS FAILED	MOVE FMC SOURCE SELECT SWITCH TO BOTH ON L OR BOTH ON R
TAKEOFF SPEEDS DELETED	MANUALLY SELECTED TAKEOFF SPEEDS DELETED DUE TO CHANGE IN ONE OR MORE REQUIRED PARAMETERS	CLEAR MESSAGE AND RESELECT DESIRED TAKEOFF SPEEDS.
UNABLE HOLD AIRSPACE	HOLD PATTERN BUILT BY FMCS GUIDANCE FUNCTION EXCEEDS HOLD AIRSPACE	CLEAR MESSAGE AND NOTIFY ATC IF NECESSARY.

ALERTING MESSAGE	CAUSE	CORRECTIVE ACTION
UNABLE NEXT ALT	NEXT CLB/DESC CONSTRAINT XANNOT BE ACHIEVED	CLEAR MESSAGE AND REVIEW FMCS ERROR AT PREDICTION.
UNABLE REQD NAV PERF-RNP	ACTUAL NAV PERFORMANCE IS NOT SUFFICIENT FOR MANUALLY ENTERED RNP VALUES	CLEAR MESSAGE AND VERIFY FMCS POSITION DATA ON POS SHIFT PAGE.

HAP 039-047, 054, 101-106; HAP 001-013, 015-026, 028-038 POST SB 737-34-1918		
UNABLE XXX KTS AT YYYYY	NEXT WAYPOINT(YYYYY) SPEED(XXX) RESTRICTION CANNOT BE MET	CLEAR MESSAGE AND NOTIFY ATC IF NECESSARY.
HAP ALL		

34-61-00-044

EFFECTIVITY
HAP ALL

34-61-00

D633A101-HAP

Page 98.147
Jun 15/2009

FMCS - DISPLAYS - CDU - MESSAGES

ALERTING MESSAGE	CAUSE	CORRECTIVE ACTION
VERIFY GW AND FUEL	FAILURE OF TOTAL FUEL QTY OR IT HAS BEEN 30 MINUTES SINCE MANUAL FUEL QTY ENTRY. MESSAGE INHIBITED IN DESCENT	CLEAR MESSAGE AND CHECK GW AND FUEL. MAKE MANUAL ENTRY OF GW AS REQUIRED.
HAP 048-053, 107-999; HAP 001-013, 015-026, 028-038 PRE SB 737-34-1918		
VERIFY POSITION	FMCS AND POSITION SENSORS EXCEED ALLOWABLE TOLERANCES	CLEAR MESSAGE CHECK POSITIONS ON THE POS SHIFT PAGE.
HAP 039-047, 054, 101-106; HAP 001-013, 015-026, 028-038 POST SB 737-34-1918		
VERIFY POS: IRS-IRS VERIFY POS: IRS-FMC VERIFY POS: IRS-RADIO VERIFY POS: FMC-RADIO VERIFY POS: FMC-GPS VERIFY POS: FMC-FMC (Msgs enabled during flight)	FMCS AND POSITION SENSORS EXCEED ALLOWABLE TOLERANCES	CLEAR MESSAGE CHECK POSITIONS ON THE POS SHIFT PAGE.
HAP ALL		
VERIFY RNP	DEFAULT VALUE OF RNP IS LESS THAN THE MANUALLY ENTERED VALUE	CLEAR MESSAGE AND CHECK MANUALLY ENTERED RNP VALUE.

ALERTING MESSAGE	CAUSE	CORRECTIVE ACTION
VERIFY TAKEOFF SPEEDS	SYSTEM GROSS WEIGHT OR ZERO FUEL WEIGHT CHANGED SINCE THE T/O REF SPEEDS WERE SELECTED	RESELECT TAKEOFF SPEEDS.
VNAV DISCONNECT	CRITERIA FOR VNAV ENGAGEMENT NO LONGER EXISTS	MANUALLY CONTROL THE VERTICAL PATH. MESSAGE CLEARS IF VNAV RE-ENGAGED.

Advisory Messages

ADVISORY MESSAGE	CAUSE	CORRECTIVE ACTION
ABOVE MAX CERT ALT	AIRPLANE EXCEEDS ITS MAXIMUM CERTIFIED ALTITUDE	DESCEND TO AN ALTITUDE BELOW THE MAXIMUM CERTIFIED ALTITUDE.
ALT CONSTRAINT XXXXX	FLIGHT PLAN EDIT HAS CAUSED AN ALTITUDE CONSTRAINT TO CONFLICT WITH A CONSTRAINT ALTITUDE AT OTHER WPTS IN THE ROUTE. XXXXX IS THE FIRST WPT	EDIT FLIGHT PLAN TO REMOVE THE ALT CONSTRAINT CONFLICT AND CLEAR MESSAGE.
APPRCH VREF NOT SELECTED	FMC IN APPROACH ENVIRONMENT AND VREF NOT SELECTED	SELECT VREF ON APPROACH REF PAGE.
ARR N/A FOR RUNWAY	RUNWAY OR APPROACH SELECTED IS NOT COMPATIBLE WITH ARRIVAL SELECTED	GO TO ARRIVALS PAGE AND MODIFY SELECTION.

EFFECTIVITY
HAP ALL

34-61-00

D633A101-HAP

Page 98.148
Jun 15/2009

FMCS - DISPLAYS - CDU - MESSAGES

ADVISORY MESSAGE	CAUSE	CORRECTIVE ACTION
BUFFET ALERT	CURRENT CONDITIONS RESULT IN MANEUVER MARGIN LESS THAN THAT SELECTED FOR AIRPLANE	BRING AIRPLANE BACK TO WITHIN OPERATING ENVELOPE.
CHECK FMC FUEL QUANTITY	THE FMCS DETECTED A DROP IN FUEL QUANTITY (> 1500 LBS FOR 120 SECONDS)	CHECK THE FUEL QUANTITY SYSTEM
DESCENT PATH UNACHIEVABLE	WHILE IN DESCENT, THE FMC PREDICTIONS SHOW THE PROFILE CONSTRAINTS AT THE NEXT WPT CANNOT BE MADE	MODIFY THE ACTIVE ROUTE LEGS OR DES PAGE PLANS AND RE-ENGAGE LNAV AND VNAV.
DRAG REQUIRED	DUE TO UNFORECAST CONDITIONS, THE AIRPLANE IS 10 KTS OR MORE ABOVE FMCS TARGET SPEED OR WITHIN 5 KTS OF VMO	USE SPEEDBRAKES OR TRIM AS NECESSARY TO BRING AIRPLANE BELOW FMCS TARGET SPEED.

ADVISORY MESSAGE	CAUSE	CORRECTIVE ACTION
DUAL FMC OP RESTORED (DUAL FMC ONLY)	MOVEMENT OF FMC SOURCE SELECT SWITCH CAUSED A RESYNCH AND DUAL FMC OPERATION IS RESTORED	NONE REQUIRED.
INVALID OFFSET	ANY FLIGHT PLAN MOD THAT CAUSES THE START OF THE OFFSET TO BECOME OFF-SETTABLE	ERASE MOD AND ENTER VALID WPT FOR OFFSET START.
INVALID QUAD	INCORRECT DATA ENTERED IN QUAD FIELD ON HOLD PAGE	CLEAR MESSAGE AND ENTER CORRECT DATA.

ADVISORY MESSAGE	CAUSE	CORRECTIVE ACTION
LOC CAP ACTIVE	AIRCRAFT APPROACHES ITS TURN ONTO LOC COURSE	CLEAR MESSAGE OR WAIT FOR DFCS TO RESET
LOC CAP CANCELLED	FLIGHT PLAN MOD OR AIRPLANE CONDITION DID NOT FACILITATE LOC CAPTURE	CLEAR MESSAGE OR WAIT FOR DFCS TO SIGNAL RESET STATUS TO THE FMCS.
MAX ALT FL XXX	ALT ENTRY ON ANY PAGE IS ABOVE MAXIMUM ALTITUDE FOR ECON MODE	CLEAR MESSAGE AND AMEND DATA ENTRY IN SCRATCH PAD.

ADVISORY MESSAGE	CAUSE	CORRECTIVE ACTION
MAX CAS XXX	ENTERED TARGET SPEED IS LIMITED BECAUSE IT EXCEEDS THE MAX BUFFET SPEED	ACCEPT LIMITED SPEED AND CLEAR MESSAGE OR ENTER NEW TARGET SPEED.
MAX MACH XXX	ENTERED TARGET SPEED IS LIMITED BECAUSE IT EXCEEDS THE MAX BUFFET SPEED	ACCEPT LIMITED SPEED AND CLEAR MESSAGE OR ENTER NEW TARGET SPEED.
MIN CAS XXX	ENTERED TARGET SPEED IS LIMITED BECAUSE IT IS LESS THAN MIN BUFFET SPEED	ACCEPT LIMITED SPEED AND CLEAR MESSAGE OR ENTER NEW TARGET SPEED.
MIN MACH XXX	ENTERED TARGET SPEED IS LIMITED BECAUSE IT IS LESS THAN MIN BUFFET SPEED	ACCEPT LIMITED SPEED AND CLEAR MESSAGE OR ENTER NEW TARGET SPEED.
NO DES PATH AFTER XXXXX	THE PROFILE CONSTRAINTS CANNOT BE ACHIEVED AND THE PATH MAINTAINED AS PLANNED	SELECT RTE LEGS OR DES PAGES TO DELETE OR MODIFY THE CONSTRAINTS AT THE DESCENT WPTS.

34-61-00-044

EFFECTIVITY
HAP ALL

34-61-00

D633A101-HAP

Page 98.149
Jun 15/2009

FMCS - DISPLAYS - CDU - MESSAGES

ADVISORY MESSAGE	CAUSE	CORRECTIVE ACTION
NOT ON INTERCEPT HEADING	AIRCRAFT IS NOT WITHIN LEG CAPTURE CRITERIA	MANUALLY STEER AIRCRAFT ONTO HEADING WHICH WILL INTERCEPT PLANNED ROUTE
OFFSET DELETED	THE START WPT IS DELETED FROM THE FLIGHT PLAN VIA A FLIGHT PLAN EDIT ON OTHER THAN THE OFFSET PAGE	RE-ENTER THE OFFSET AS APPROPRIATE FOR THE NEW FLIGHT PLAN.
OFFSET ENDS ABEAM XXXXX	ENTRY OF AN END WPT WHICH RESULTS IN A NON-OFFSETTABLE LEG EXISTING BETWEEN THE END WPT AND THE START OF THE OFFSET	MODIFY THE OFFSET PARAMETERS TO PROVIDE A COMPLETE OFFSET PATH.
PROGRAM PIN ERROR	THE AIRFRAME /ENGINE PROGRAM PIN PARITY IS NOT VALID OR THE FMC IDENTIFICATION DISCRETES ARE NOT VALID	POWER DOWN THE FMCS AND CORRECT THE PROBLEM. THE CLEAR KEY OR A PAGE CHANGE WILL NOT CLEAR THE MESSAGE

ADVISORY MESSAGE	CAUSE	CORRECTIVE ACTION
PROGRAM PIN NOT IN DB	THE AIRFRAME OR ENGINE PROGRAM PINS DO NOT COMPARE TO DATA IN THE AIRPLANE MODEL/ENGINE PERFORMANCE DATA BASE	CORRECT THE PROGRAM PIN CONFIGURATION OR LOAD THE CORRECT AIRPLANE MODEL/ENGINE PERFORMANCE DATA BASE
RESET MCP ALTITUDE	NORMAL FMCS OPERATION WOULD TAKE AIRCRAFT AWAY FROM MCP ALTITUDE	RESET MCP ALTITUDE TO CORRECT VALUE

ADVISORY MESSAGE	CAUSE	CORRECTIVE ACTION
ROUTE FULL	NO MEMEORY SPACE AVAILABLE FOR PHANTOM WPTS REQUIRED BY THE VERTICAL FLIGHT PLAN	CLEAR MESSAGE AND REVIEW EXISTING AND DESIRED ROUTE SEGMENTS FOR POSSIBLE DELETION.
RUNWAY N/A FOR SID	THE SELECTED RUNWAY IS NOT APPLICABLE TO THE SELECTED DEPARTURE PROCEDURE	CLEAR MESSAGE AND CHECK SELECTIONS.

ADVISORY MESSAGE	CAUSE	CORRECTIVE ACTION
SELECT ACTIVE WPT/ LEG	POWER-UP RESTART OR INSERTION OF A DIFFERENT FLIGHT PLAN WHILE AIRBORNE	EXECUTE A DIRECT-TO OR LEG-INTERCEPT TO TELL FMCS WHICH LEG IS ACTIVE.
STEEP DES AFTER XXXXX	FMC ALTITUDE CONSTRAINT AT XXXXX RESULTS IN A STEEP DESCENT TO NEXT WPT	CHECK CONSTRAINT AND REMOVE IF ALLOWED.
TAI ON ABOVE 10 DEGREES C	AIRCRAFT OPERATES WITH ANTI-ICING WITH TAT ABOVE 10 DEGREES C	CLEAR MESSAGE AND CHECK USE OF ANTI-ICING
UNABLE CRZ ALT	FMCS PREDICTS NO CRUISE TIME POSSIBLE AT ENTERED CRZ ALT	CLEAR MESSAGE AND REVIEW CRZ ALT SELECTION.
UNABLE MACH .XXX	SPEED ENTERED INTO TARGET SPEED FIELD IS IMPOSSIBLE TO ACHIEVE AT ANY ALTITUDE AT THE CURRENT AIRPLANE WEIGHT	RE-ENTER A NEW TARGET SPEED.

EFFECTIVITY
HAP ALL

34-61-00

D633A101-HAP

Page 98.150
Jun 15/2009

FMCS - DISPLAYS - CDU - MESSAGES

ADVISORY MESSAGE	CAUSE	CORRECTIVE ACTION
UNABLE TO OFFSET	A VALID LATERAL OFFSET CANNOT BE MADE DUE TO INABILITY TO FIT THE TURN SEGMENTS TO AND FROM THE OFFSET PATH	VERIFY THE NEED TO FLY A LATERAL OFFSET AND MODIFY THE FLIGHT PLAN ACCORDINGLY.
V SPEEDS UNAVAILABLE	FMC IS UNABLE TO CALCULATE T/O SPEEDS	CLEAR AND REVISE AND RE-ENTER INPUTS FOR THE T/O SPEED CALCULATIONS
USING RSV FUEL	A CHANGE IN ROUTE OR CONDITIONS CAUSES PREDICTED FUEL AT DESTINATION TO BE LESS THAN THE ENTERED RESERVES	CLEAR MESSAGE AND CHANGE THE ACTIVE FLIGHT PLAN IF NECESSARY.
VERIFY RNP VALUE	MANUALLY ENTERED RNP IS LARGER THAN DEFAULT VALUE	CLEAR MESSAGE AND VERIFY MANUALLY ENTERED VALUE

ADVISORY MESSAGE	CAUSE	CORRECTIVE ACTION
XXXX (AIRPORT NAME)	A REF AIRPORT IS ENTERED ON THE POS INIT PAGE AND NO ENTRY OF ORIGIN YET APPEARS ON RTE PAGE 1	SELECT THE AIRPORT IDENTIFIER INTO THE ORIGIN DATA FIELD.
XXXXX	RESETTING MCP ALTITUDE TO A VALUE NOT EQUAL TO THE CRZ ALT CAUSES THE VALUE TO APPEAR IN THE SCRATCH PAD	SELECT MCP ALTITUDE INTO THE APPROPRIATE TARGET ALTITUDE FIELD OR CLEAR THE DATA.

ACARS Status Messages

ACARS MESSAGE	CAUSE	CORRECTIVE ACTION
ACARS ALERT	FLIGHT CREW ACTION REQUESTED FOR ACARS	SELECT ACARS MU ON MCDU AND DO NECESSARY ACTION. CLEAR MESSAGE.
ACARS CALL	THE ACARS MU REQUESTS SERVICE FROM THE FLIGHT CREW	SELECT THE ACARS MU ON THE MCDU MENU PAGE.
ACARS MU FAIL	THE ACARS MU HAS A HARDWARE FAILURE	VERIFY ACARS MU HAS POWER.
ACARS NO COMM	THERE IS NO ACARS LINK AVAILABLE (SAT, VHF OR MODE S)	CLEAR THE MESSAGE AND VERIFY COMMS STATUS.
ACARS UPLINK	ACARS MESSAGE WAITING	SELECT ACARS MU ON MCDU AND DO NECESSARY ACTION. CLEAR MESSAGE.
ACARS VOICE	VHF TRANSCEIVER SET TO VOICE	CLEAR MESSAGE.

ACARS MESSAGE	CAUSE	CORRECTIVE ACTION
ACARS VOICE BUSY	ALL VHF CIRCUITS ARE BUSY	MESSAGE WILL CLEAR WHEN A CIRCUIT BECOMES AVAILABLE.
ACARS MESSAGES 7 THRU 19	USER DEFINED	USER DEFINED.
PRINTER FAIL (OPTIONAL)	FLIGHT DECK PRINTER FAILED	CHECK PRINTER AND CLEAR MESSAGE.
PRINTER UPLINK (OPTIONAL)	ACARS UPLINK HAS A MESSAGE FOR THE PRINTER	SELECT ACARS MU ON THE MCDU AND DO NECESSARY ACTIONS. CLEAR MESSAGE.

34-61-00-044

EFFECTIVITY
HAP ALL

34-61-00

D633A101-HAP

Page 98.151
Jun 15/2009



737-600/700/800/900 AIRCRAFT MAINTENANCE MANUAL

FMCS - DISPLAYS - CDU - MESSAGES



34-61-00-044

EFFECTIVITY
HAP ALL

34-61-00

D633A101-HAP

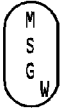
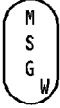
Page 98.152
Jun 15/2009

TYPE OF MESSAGE	OTHER INDICATION FOR THIS MESSAGE	EXAMPLE CDU MESSAGES
ACARS UPLINK ALERTING ALERTING	 	ROUTE UPLINK READY TAKEOFF DATA LOADED DATA BASE INVALID IRS MOTION MODEL ENGINE DATA INVALID RESET MCP ALTITUDE
ENTRY ERROR ADVISORY		INVALID ENTRY NOT IN DATA BASE
ADVISORY		PROGRAM PIN ERROR CHECK FMC FUEL QUANTITY PROGRAM PIN NOT IN DB
ACARS STATUS	NONE	ACARS NO COMM



FMCS - DISPLAYS - CDU - MESSAGES

34-61-00-044

EFFECTIVITY
HAP 001-013, 015-026, 028-030

34-61-00

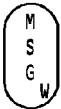
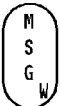
D633A101-HAP

TYPE OF MESSAGE	OTHER INDICATION FOR THIS MESSAGE	EXAMPLE CDU MESSAGES
ALERTING	 	DATA BASE INVALID NAV DATA OUT OF DATE ENTER IRS POSITION CYCLE IRS OFF-NAV IRS MOTION MODEL ENGINE DATA INVALID
ENTRY ERROR ADVISORY		INVALID ENTRY NOT IN DATA BASE
ADVISORY		PROGRAM PIN ERROR CHECK FMC FUEL QUANTITY PROGRAM PIN NOT IN DB

FMCS - DISPLAYS - CDU - MESSAGES

EFFECTIVITY
HAP 031-054, 101-999

34-61-00

D633A101-HAP

Page 98.154
Jun 15/2009

34-61-00-044

THIS PAGE IS INTENTIONALLY LEFT BLANK

34-61-00

D633A101-HAP

Page 98.155
Jun 15/2009

FMCS - DISPLAYS - CDS - FLIGHT MODE ANNUNCIATIONS

FMCS Flight Mode Annunciation

The DFCS makes all the FMC flight mode annunciations (FMAs). They show in green at the top of the primary flight displays.

These are the active FMCS flight mode annunciations that can show during FMCS operation:

- Autothrottle (A/T) mode annunciation
- Pitch mode annunciation
- Roll mode annunciation.

Autothrottle Mode Annunciation

These are the autothrottle modes that can show during FMCS operation:

- FMC SPD
- N1
- RETARD
- ARM.

Pitch Mode Annunciations

These are the pitch modes that can show during FMCS operation:

- VNAV PTH
- HAP 050, 053, 054**
- VNAV ALT
- HAP ALL**

- VNAV SPD.

Roll Mode Annunciation

The roll mode annunciation LNAV can show during FMCS operation.

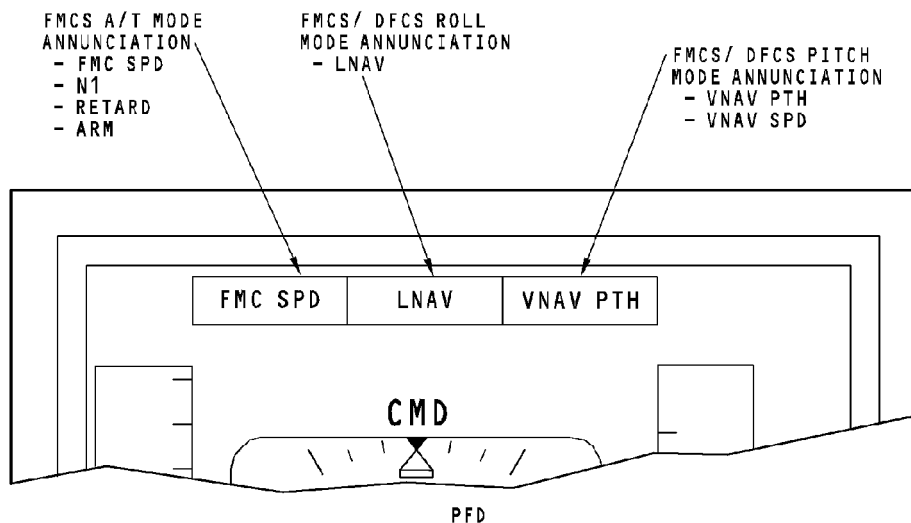

FMCS - DISPLAYS - CDS - FLIGHT MODE ANNUNCIATIONS

34-61-00-045

EFFECTIVITY
HAP ALL

34-61-00

D633A101-HAP

Page 98.157
Jun 15/2009

FMCS - DISPLAYS - CDS - THRUST MODE**General**

The thrust mode annunciation display shows the active N1 limit mode calculated by the FMCS. The reference N1 bugs (2) show the N1 limit for the active mode. The N1 limit mode controls the N1 limit for autothrottle operation.

The reference N1 readouts may be set manually. They are set with the N1 SET CONTROL inner knob. When the reference N1 readout is set manually, the N1 bugs show the N1 reference readout value. These manually set limits have no effect on autothrottle operation.

Thrust Mode Display

These thrust modes show on the engine display:

- TO (Takeoff)
- R-TO (Reduced takeoff)
- CLB (Climb)
- R-CLB (Reduced climb)
- CRZ (Cruise)
- CON (Continuous)
- GA (Go-around)
- - - - (no computed data from the FMCS).

Only one thrust mode can show and be active.

Display Control

When the N1 SET CONTROL outer knob is set to the AUTO position, the thrust mode display and N1 bug position are set by the FMCS as a function of DFCS mode logic. To override automatic control, you can line select another mode from the N1 limit page. The displays go back to automatic control when the DFCS pitch mode changes.

When the outer knob is set to the BOTH, 1 or 2 position, you can manually set the reference N1 bugs and the N1 reference readouts will be displayed above the digital N1 displays. With the outer knob in the AUTO position, the readout is blank.

Non-Normal Operation

In automatic operation, the thrust mode display and reference N1 bug readout are calculated by the FMCS. If the FMCS calculations are not valid, the autothrottle limit message A/T LIM shows. The autothrottle computer then calculates a single N1 limit for both engines.

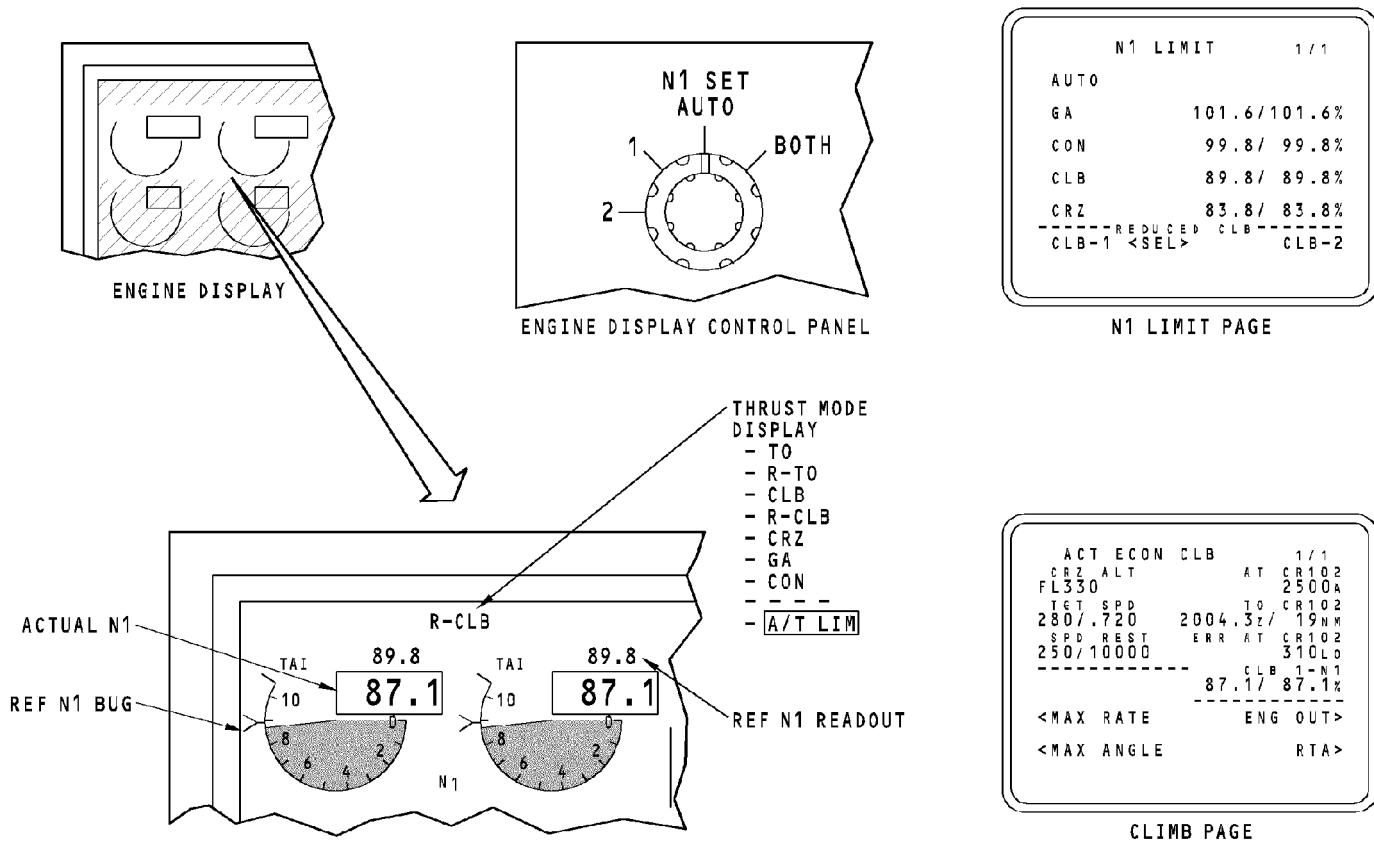

FMCS - DISPLAYS - CDS - THRUST MODE

EFFECTIVITY
HAP 006-013, 015-026, 028-054, 101-999

34-61-00

D633A101-HAP

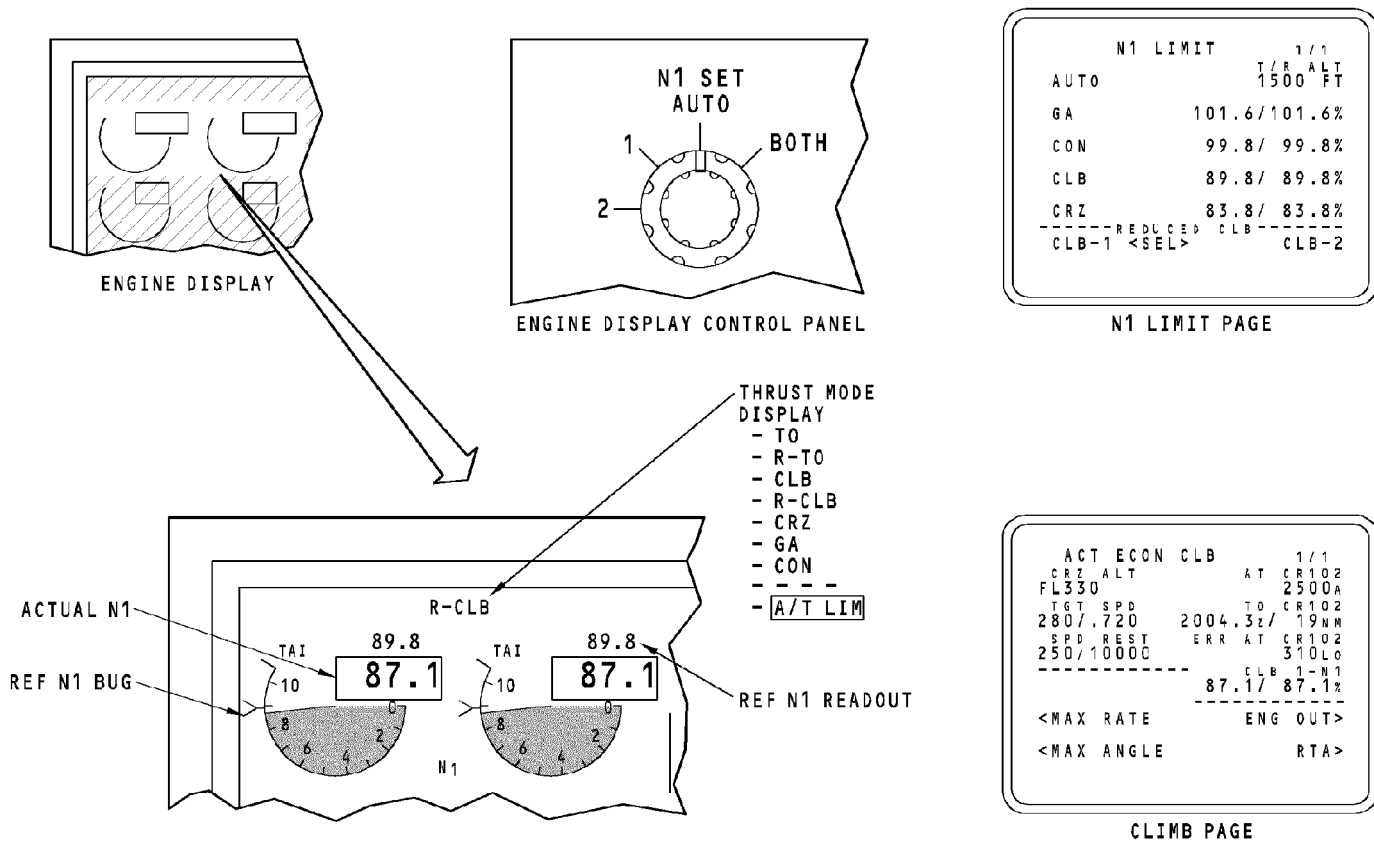

FMCS - DISPLAYS - CDS - THRUST MODE

EFFECTIVITY
HAP 001-005

34-61-00

D633A101-HAP

34-61-00-046

FMCS - DISPLAYS - CDS - AIRSPEED INDICATION

General

The takeoff and landing airspeed bugs show on the PFD speed tape indication. The bugs are set automatically by the FMC or, they can be set manually by the flight crew using the speed reference selector on the engine control panel. When set manually, the airspeeds show on the PFD speed tape indication and a digital display of the set value shows.

You also use the speed reference selector to manually set the airplane takeoff or landing gross weight. CDS will use this weight value to calculate and display the flap maneuvering speeds.

Speed Reference Selector

The outer control has these functions:

- AUTO (the FMCS supplies the reference airspeeds and gross weight automatically)
- V1 (shows the takeoff decision speed on the ground and shows INVALID ENTRY in-flight)
- VR (shows takeoff rotation speed on the ground and shows INVALID ENTRY in-flight)
- WT (the pilot can set the gross weight manually)
- VREF (shows the landing reference speed (REF) in the air and shows INVALID ENTRY on the ground)
- Triangle symbol (shows an airspeed bug the pilot can set)
- SET (the FMC and the inner control cannot move the airspeed bugs).

The inner control sets the selected bug to the desired airspeed or sets gross weight. The control is spring loaded to center.

Takeoff

This data shows on the PFD speed tape indication:

- Digital display (the display shows if the airspeed bug(s) or weight is set with the speed reference selector)
- V1 (decision speed)
- VR (rotation speed)
- Selected speed (indicates the airspeed manually set in the IAS/MACH display on the DFCS mode control panel (MCP) or the FMC computed airspeed when the IAS/MACH window is blank)
- V2 (single engine climb speed)
- V2+15 (single engine climb speed plus 15 knots)
- Flap maneuver speed (maneuver speed for flap position shown. It does not show for 30 or 40 units of flap.)
- Flaps up speed (shows after zero fuel weight is set in the CDU and takeoff gross weight is calculated, or after takeoff gross weight is set with the speed reference selector)

HAP 031-054, 101-999

- Airspeed bug at 80 knots (this shows during preflight and is removed when the flaps start to retract).

HAP 001-013, 015-026, 028-030

- Airspeed bug at 100 knots (this shows during preflight and is removed when the flaps start to retract).

HAP ALL

Approach/Landing

This data can show on the PFD speed tape during approach:

<p>EFFECTIVITY HAP ALL</p>
--

34-61-00

D633A101-HAP

Page 98.161
Jun 15/2009

FMCS - DISPLAYS - CDS - AIRSPEED INDICATION

- REF (landing reference speed VREF is set on the CDU APPROACH REF page or set with the speed reference selector)
- VREF + 15 (this shows after VREF is set)
- Flap maneuver speed (maneuver speed for flap position shown).

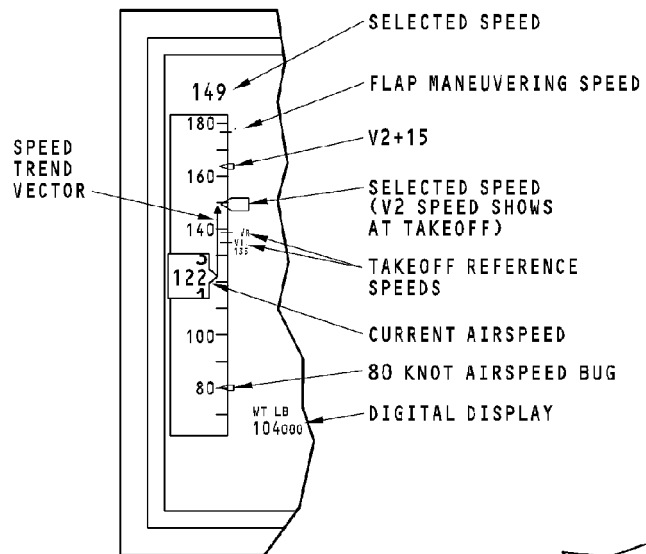

TAKEOFF (TYPICAL)

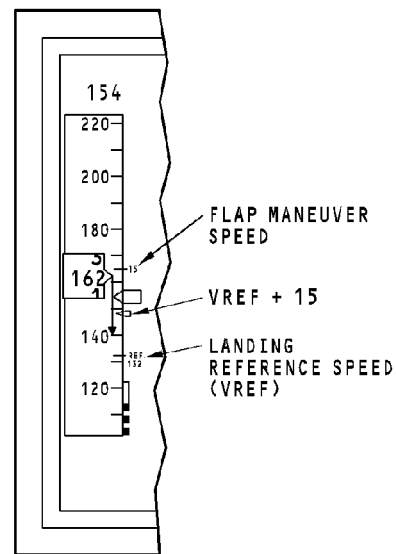

APPROACH/LANDING (TYPICAL)

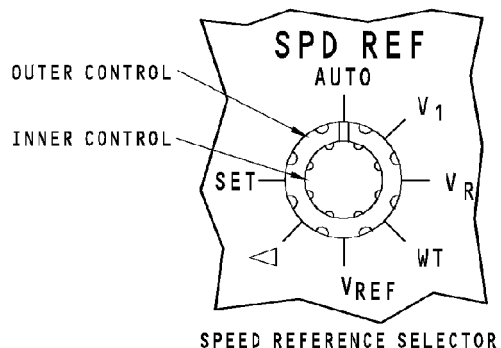

SPEED REFERENCE SELECTOR

FMCS - DISPLAYS - CDS - AIRSPEED INDICATION

34-61-00-047

EFFECTIVITY
HAP 031-054, 101-999

34-61-00

D633A101-HAP

Page 98.163
Jun 15/2009

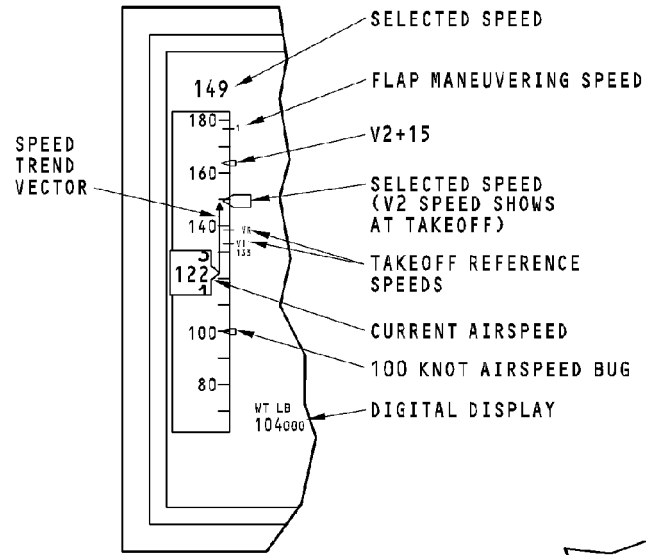

TAKEOFF (TYPICAL)

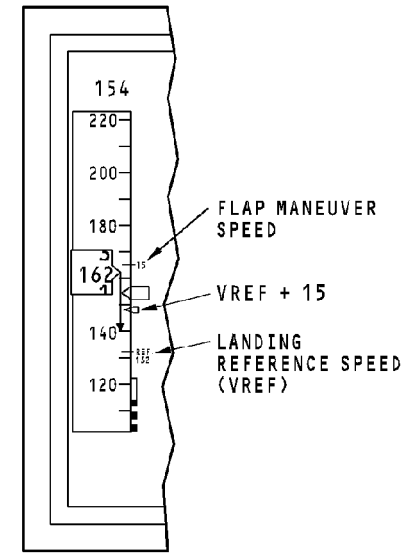

APPROACH/LANDING (TYPICAL)

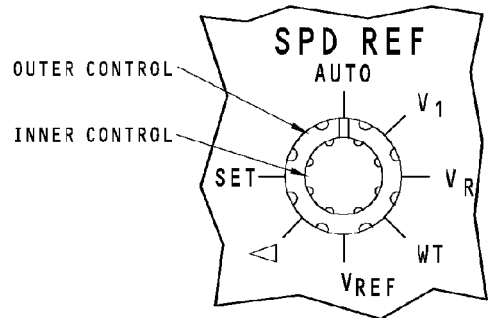

SPEED REFERENCE SELECTOR

FMCS - DISPLAYS - CDS - AIRSPEED INDICATION

EFFECTIVITY

HAP 001-013, 015-026, 028-030

34-61-00

D633A101-HAP

THIS PAGE IS INTENTIONALLY LEFT BLANK

34-61-00

D633A101-HAP

Page 98.165
Jun 15/2009

FMCS - DISPLAYS - CDS - MAP DISPLAY

General

The FMCS provides the navigation data for the MAP mode displays on the common display system (CDS). There are two types of navigation data, dynamic data and background data. Dynamic data changes as a function of time while background data is stationary data that does not move as a function of time.

The FMCS formats and transmits the data (FMC bus 08 and FMC bus 09) to show the airplane position with respect to the flight plan and vertical profile. The CDS controls symbol color, size, and brightness.

Map Mode

The map mode shows the progress of the flight and is the normal display the crew uses for navigation in flight. This display may show in either the expanded mode or the centered mode. The display is dynamic and moves as the airplane moves.

Symbol Definitions

This data is shown:

- Active waypoint distance (distance to go to the active waypoint. White)
- Active waypoint ETA (estimated time of arrival for the active waypoint. White)
- T/C altitude profile point (top of climb position in the active route. Green)

- T/D altitude profile point (top of descent position in the active route. Green)
- E/D altitude profile point (end of descent position in the active route. Green)
- S/C altitude profile point (step climb position in the active route. Green)
- Speed profile point (deceleration point in the active route. Green)
- Active waypoint (next waypoint in the active route. Magenta)
- Range to altitude arc (range at which the airplane will reach the MCP altitude. Green)
- Trend vector (predicted position of airplane at the end of 30, 60 or 90 second intervals. White)
- Inactive waypoint (waypoint other than the active waypoint in the active route. White)
- Vertical deviation scale (vertical deviation from the calculated descent profile. Scale is white and pointer is magenta)
- Map options (options selected on the EFIS control panel. Cyan)
- Wind data (wind speed and direction. White)
- Map source (source of dynamic and background data. Green)
- Navaids (navigation stations within the selected map area. Cyan)
- Off route waypoints (waypoints within the selected map area but not in the active route. Cyan)
- Airports (airports within the selected map area. Cyan)
- Route data (altitude constraints and ETAs for the waypoint in the active route. Magenta or white)
- Track angle (airplane track. White).

EFFECTIVITY
HAP ALL

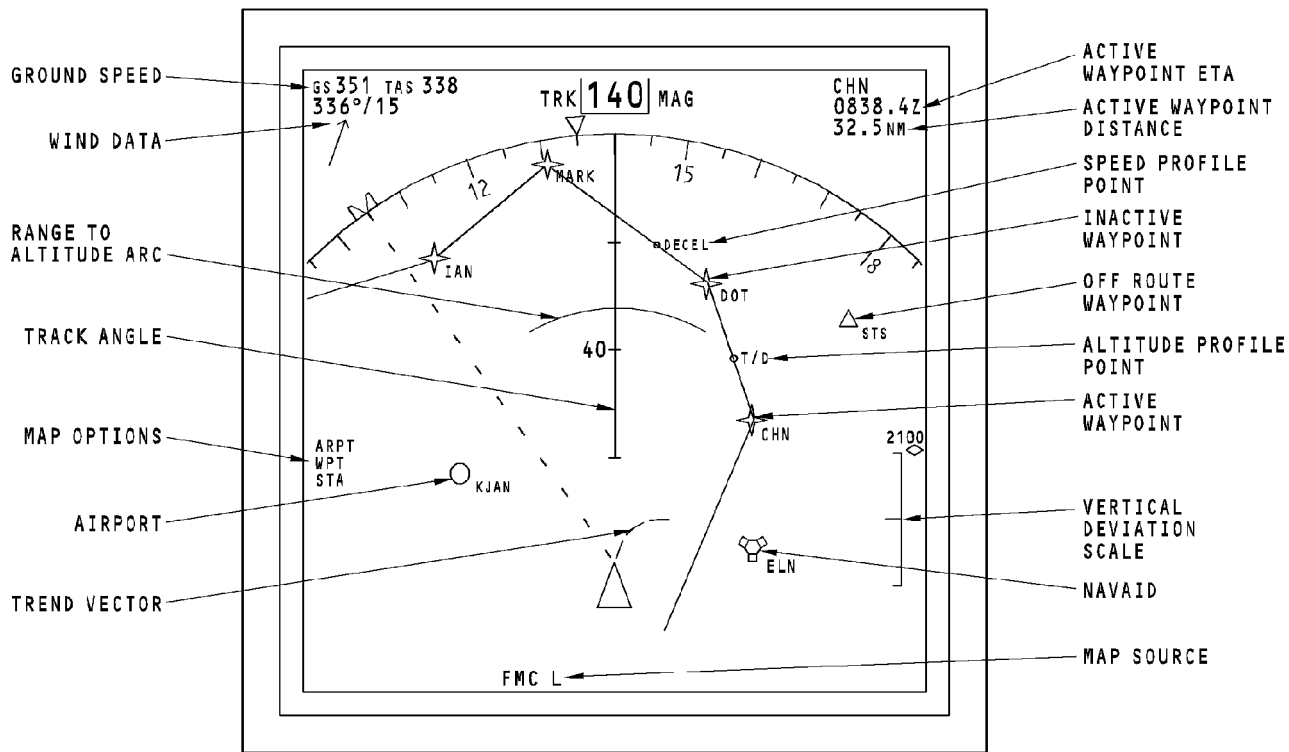

EXPANDED MAP MODE

FMCS - DISPLAYS - CDS - MAP DISPLAY

34-61-00-048

EFFECTIVITY
 HAP 038, 042-046, 050-053; HAP 037, 039, 040 POST SB 737-31-1370

34-61-00

D633A101-HAP

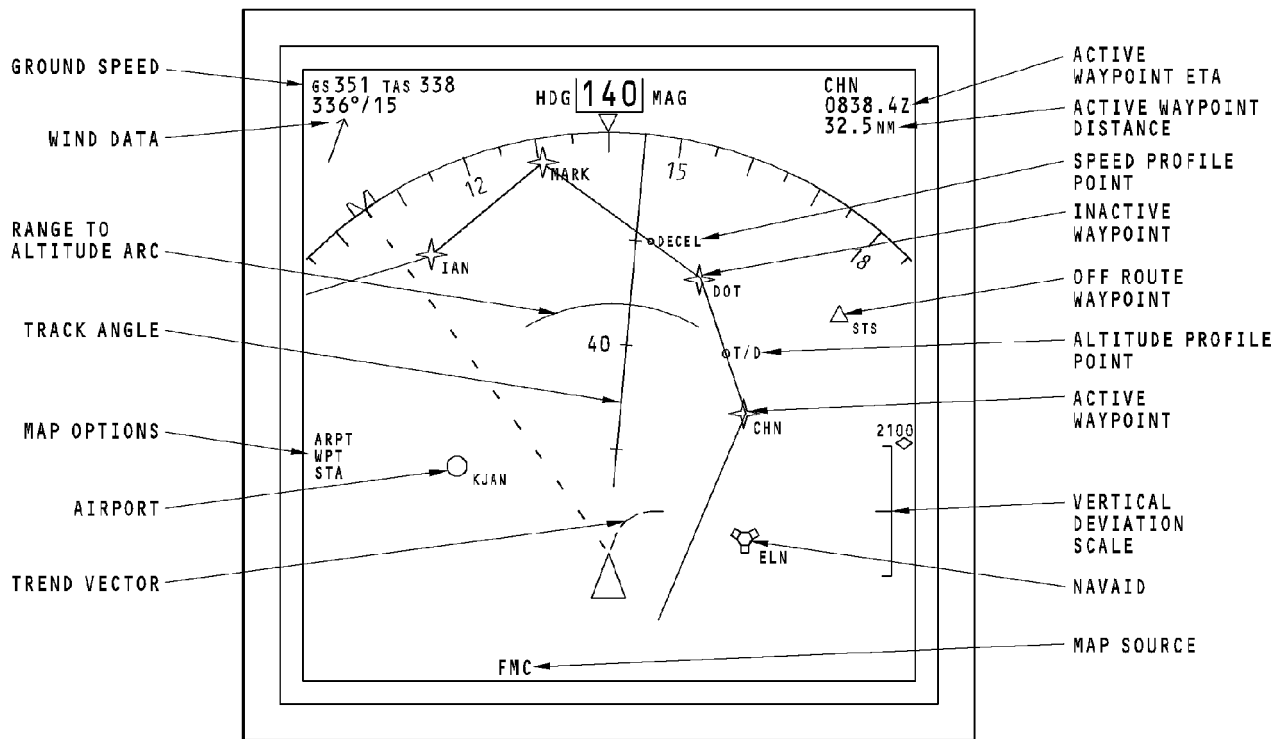

EXPANDED MAP MODE

FMCS - DISPLAYS - CDS - MAP DISPLAY

EFFECTIVITY

HAP 001-013, 015-026, 028-036

34-61-00

D633A101-HAP

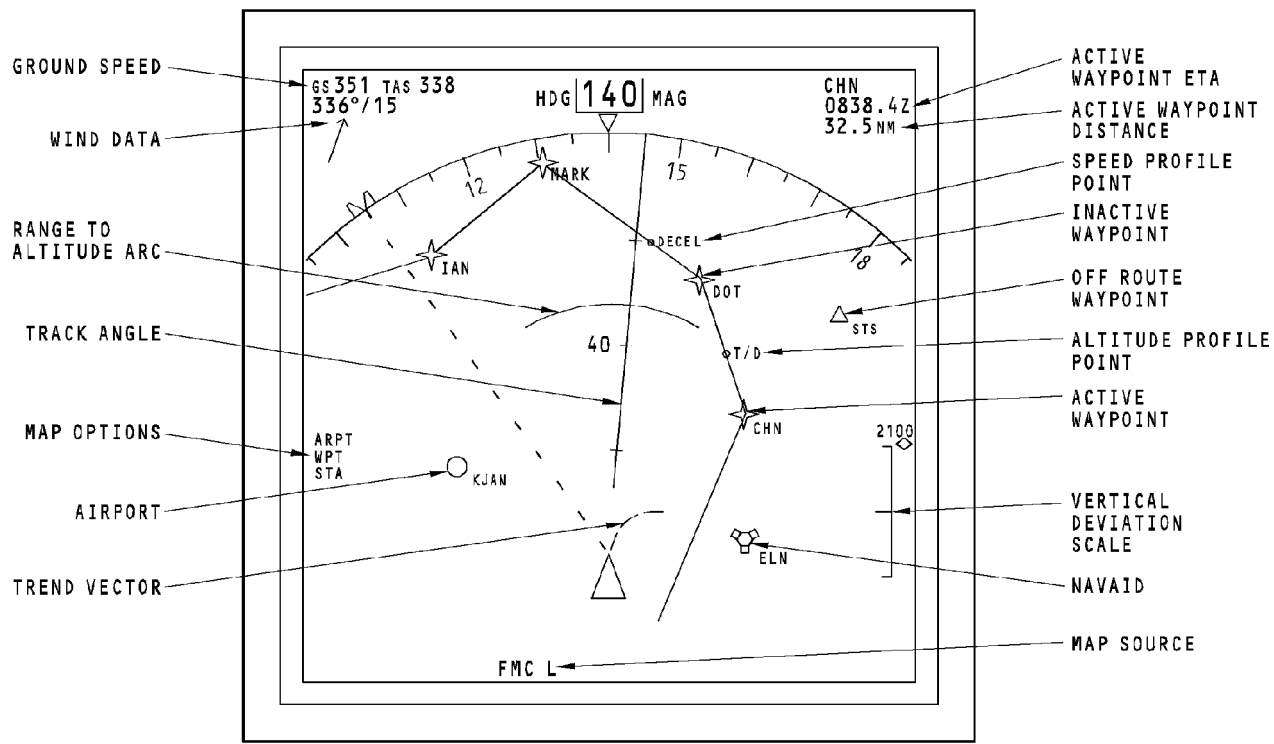

EXPANDED MAP MODE

FMCS - DISPLAYS - CDS - MAP DISPLAY

EFFECTIVITY

HAP 041, 047-049, 054, 101-999; HAP 037, 039, 040 PRE SB 737-31-1370

34-61-00

D633A101-HAP

FMCS - DISPLAYS - CDS - PLAN DISPLAY**General**

The FMCS provides the navigation data for the PLAN mode displays on the common display system (CDS). There are two types of navigation data, dynamic data and background data. Dynamic data changes as a function of time while background data is stationary data that does not move as a function of time.

The FMCS formats and transmits the data (FMC bus 08 and FMC bus 09) to accurately show the airplane position with respect to the flight plan and vertical profile. The CDS controls symbol color, size, and brightness.

Plan Mode

The plan mode shows NORTH UP. The crew uses the plan mode with the FMC/CDU LEGS page and the STEP line select key to review the route. The plan mode display is a static display.

Range information shows as circles around the reference point that is in the middle of the display.

The airplane symbol shows the current position and track if the airplane is in the range of the flight plan shown.

Display Data

Ground speed, wind data, and true airspeed show the same as for the APP, VOR, and MAP modes except that the wind direction arrow does not show.

This data shows in the upper right corner:

- Active waypoint identifier
- Estimated time of arrival at the active waypoint
- Distance to the waypoint.

Only TCAS traffic data messages show in the plan mode. TCAS mode/status information shows in the lower left corner.

Symbol Definitions

This data shows:

- Distance to go to the active waypoint (white)
- Estimated time of arrival for the active waypoint (white)
- Active waypoint (next waypoint in active route) (magenta)
- Waypoints other than the active waypoint in the active route (white)
- Options selected on the EFIS control panel (cyan)
- Source of the dynamic and background data (green).

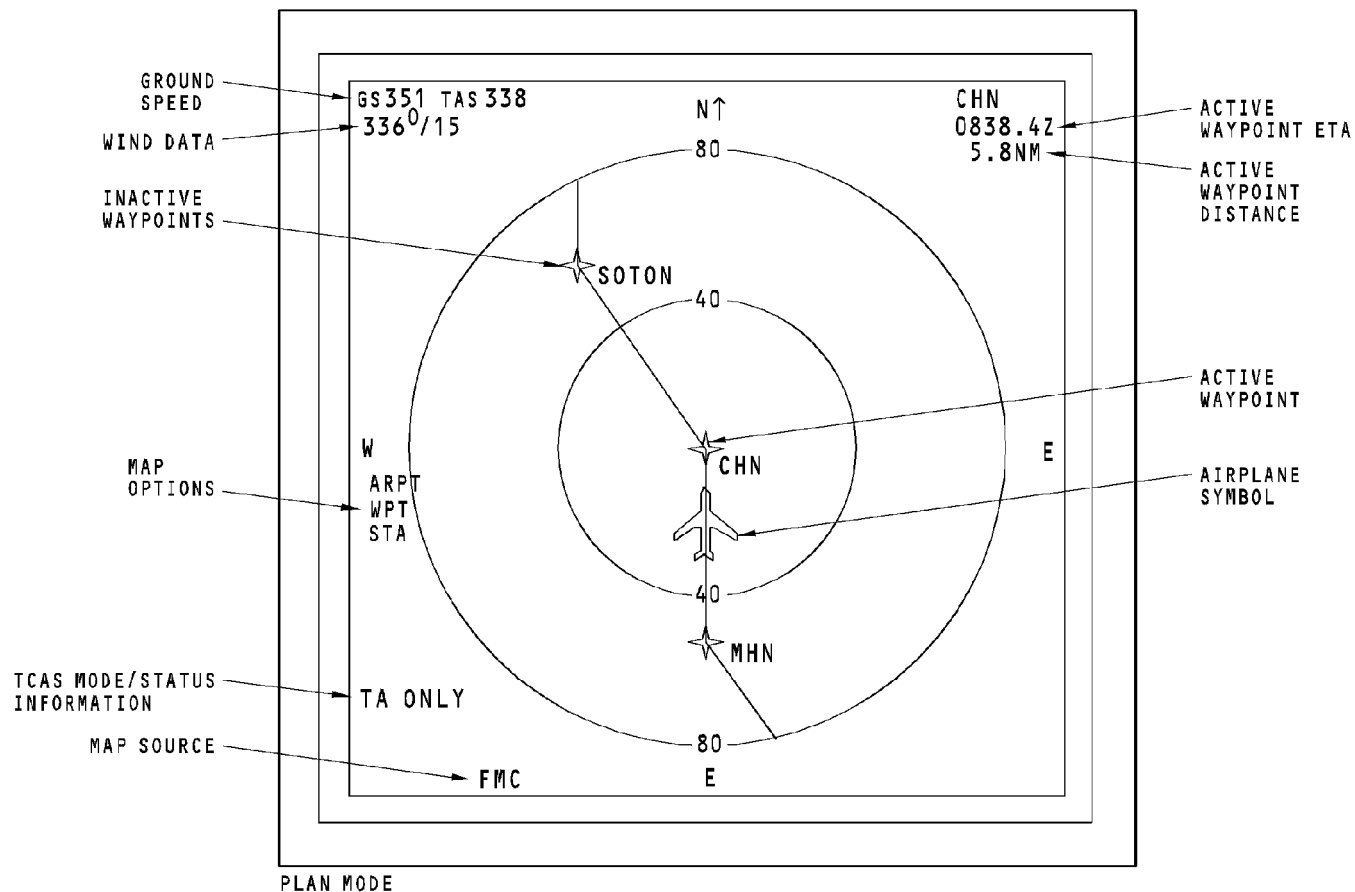

FMCS - DISPLAYS - CDS - PLAN DISPLAY

34-61-00-095

EFFECTIVITY
HAP 001-013, 015-026, 028-036

34-61-00

D633A101-HAP

Page 98.171
Jun 15/2009

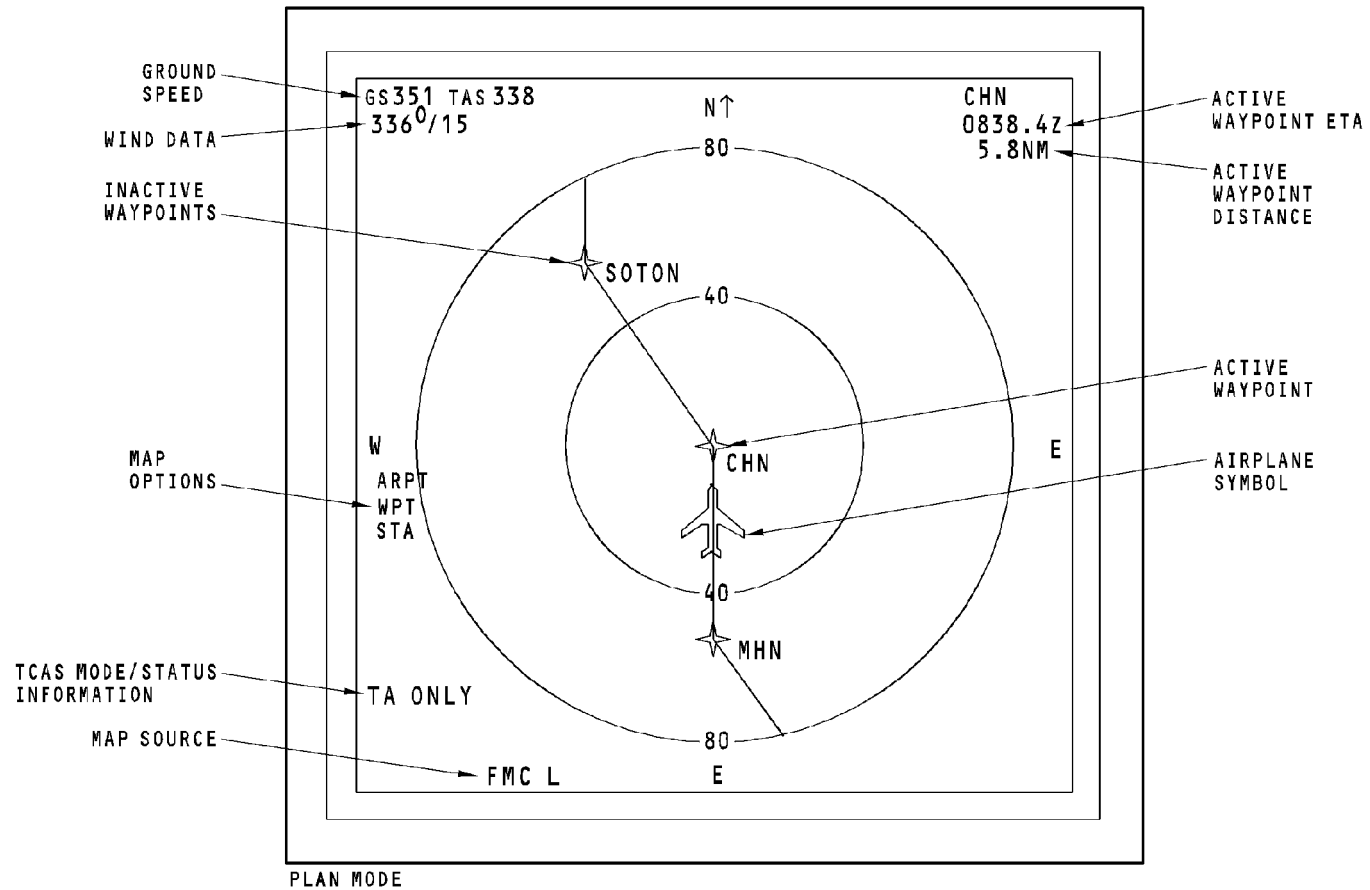

FMCS - DISPLAYS - CDS - PLAN DISPLAY

EFFECTIVITY
HAP 037-054, 101-999

34-61-00

D633A101-HAP

THIS PAGE IS INTENTIONALLY LEFT BLANK

34-61-00

D633A101-HAP

Page 98.173
Jun 15/2009

FMCS - DISPLAYS - CDS - NON-NORMAL DISPLAYS**General**

These non-normal messages can show:

- UNABLE REQD NAV PERF - RNP
- MAP RANGE DISAGREE.

These non-normal flags can show:

- MAP flag
- Vertical track (VTK).

The UNABLE REQD NAV PERF - RNP message shows when the actual navigation performance (ANP) exceeds the required navigation performance (RNP) for the current flight environment. The map data is not blanked in this condition.

The MAP RANGE DISAGREE message shows when a new range has been selected on the EFIS control panel and new map data is not received from the FMC. All map data is blanked in this condition.

The MAP flag shows if the map data from the FMC is invalid or NCD. All map data is blanked in this condition.

The VTK (vertical track) flag shows when the vertical deviation data from the FMC is invalid or NCD. Only the vertical deviation scale is blanked in this condition.

All these non-normal messages and flags can show in the map and plan modes. They are amber.

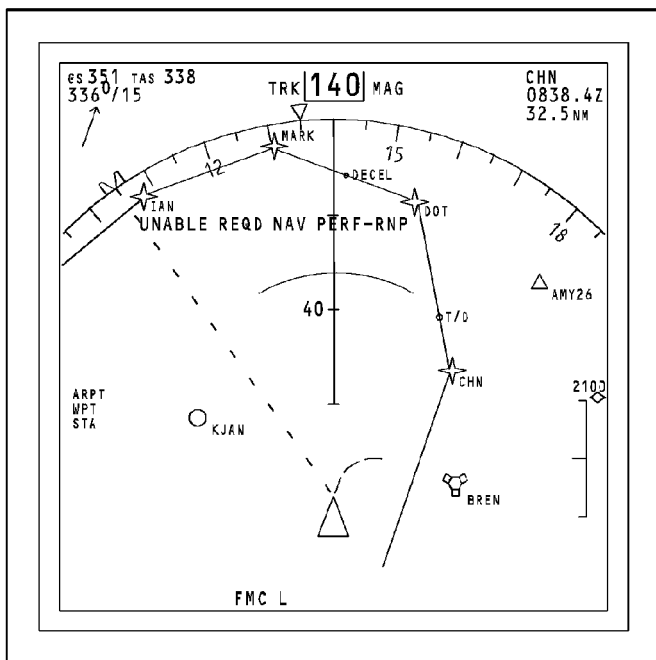

EXPANDED MAP MODE

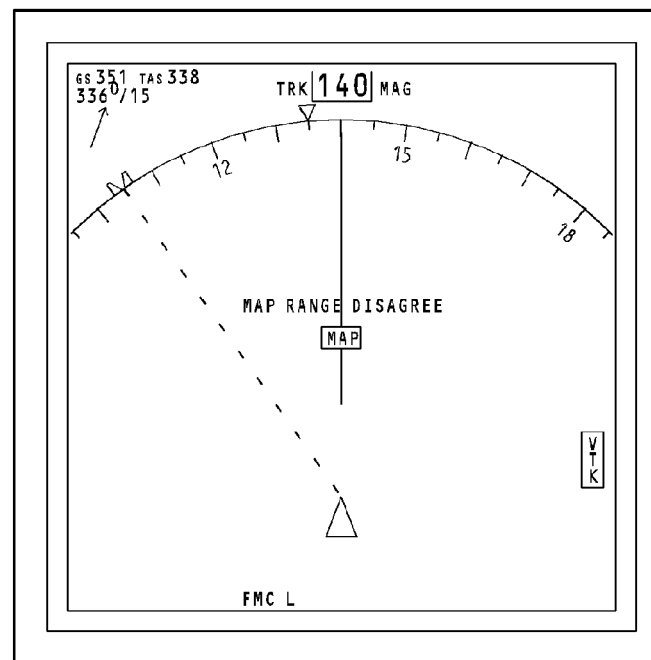

EXPANDED MAP MODE

FMCS - DISPLAYS - CDS - NON-NORMAL DISPLAYS

EFFECTIVITY

HAP 038, 042-046, 050-053; HAP 037, 039, 040 POST SB 737-31-1370

34-61-00

D633A101-HAP

Page 98.175
Jun 15/2009

34-61-00-097

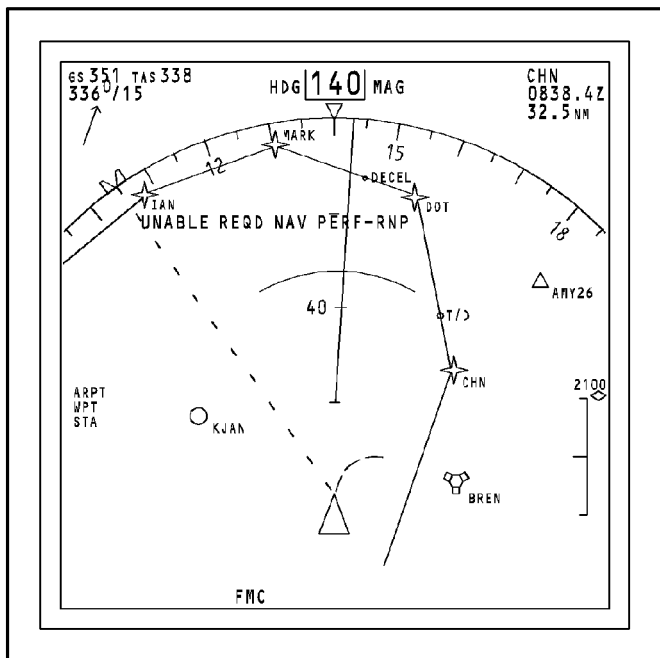

EXPANDED MAP MODE

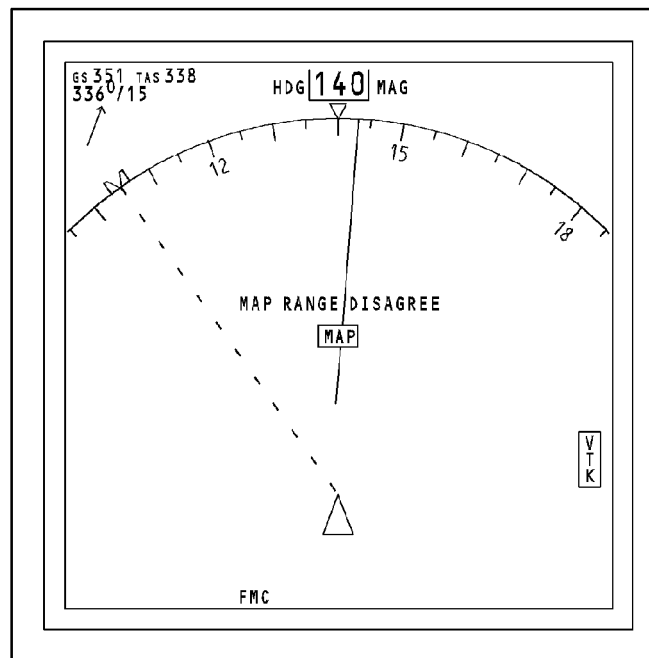

EXPANDED MAP MODE

FMCS - DISPLAYS - CDS - NON-NORMAL DISPLAYS

EFFECTIVITY

HAP 001-013, 015-026, 028-036

34-61-00

D633A101-HAP

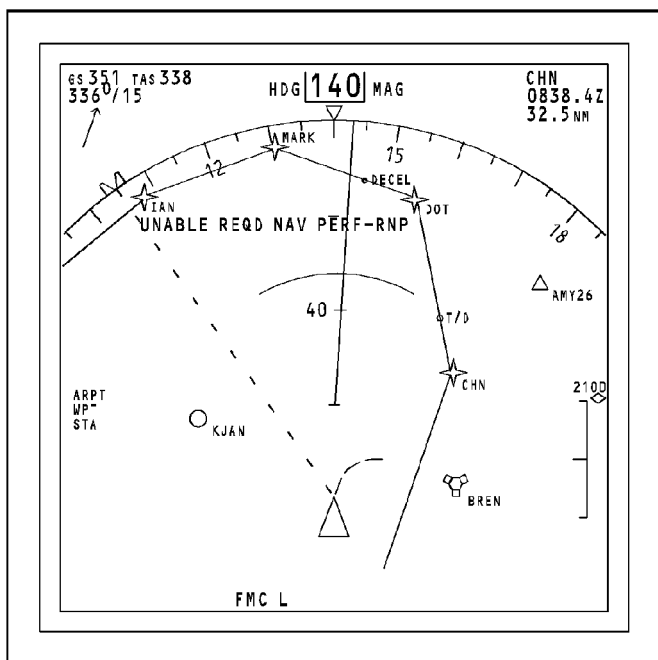

EXPANDED MAP MODE

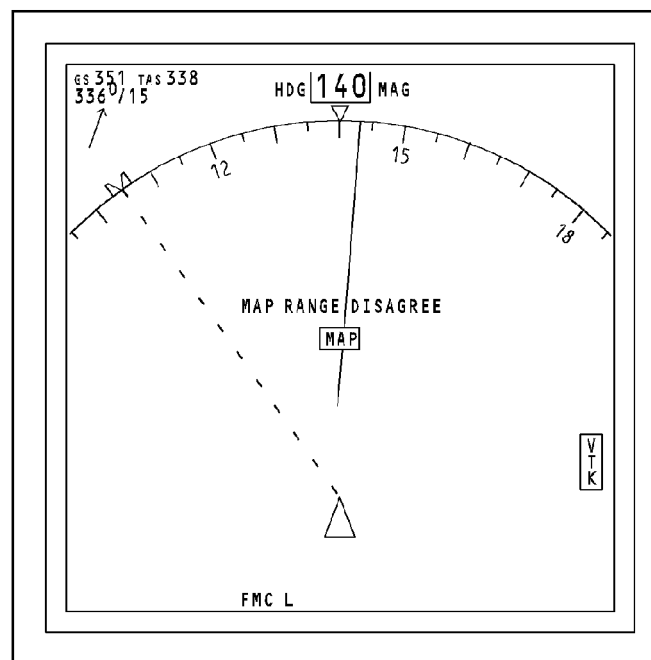

EXPANDED MAP MODE

FMCS - DISPLAYS - CDS - NON-NORMAL DISPLAYS

EFFECTIVITY

HAP 041, 047-049, 054, 101-999; HAP 037, 039, 040 PRE SB 737-31-1370

34-61-00

D633A101-HAP

FMCS - VNAV - SPEED INTERVENTION**General**

The speed intervention function lets the flight crew change the FMC target airspeed without having to disengage VNAV.

Speed Intervention

The flight crew enable speed intervention by pushing the speed intervention pushbutton on the DFCS mode control panel (MCP). The current FMC target airspeed now shows in the MCP speed window and the pilot can change the target speed to the desired value and use the MCP speed selector.

The FMC now uses the entered target airspeed instead of its own calculated value and the active flight plan is not affected. The new selected airspeed shows on the IAS/MACH display and the applicable CLB/CRZ/DES page on the MCDUs.

Speed intervention is exited when you push the speed intervention pushbutton again and the FMC now reverts to its own calculated target airspeed. The MCP speed window is blank again. Disengaging VNAV also disables speed intervention.

NOTE: If the FMC is flying a path descent (VNAV PATH) and speed intervention is selected, the FMC changes to a speed descent (VNAV SPD).

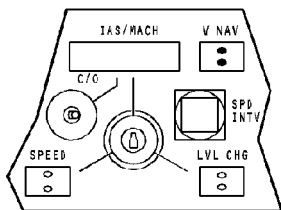

MCP

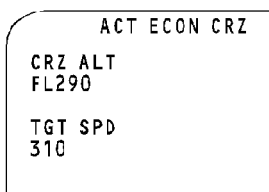

CDU

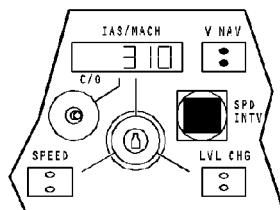

MCP

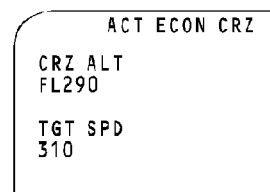

CDU

1 - VNAV ACTIVE SO FMC TARGET SPEED DOES NOT SHOW IN IAS/MACH DISPLAY.

2 - PUSH SPEED INTERVENTION PUSHBUTTON AND FMC TARGET SPEED SHOWS IN IAS/MACH DISPLAY.

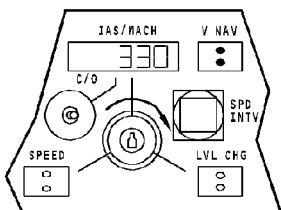

MCP

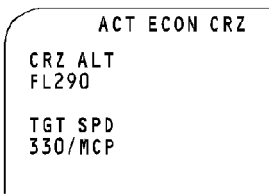

CDU

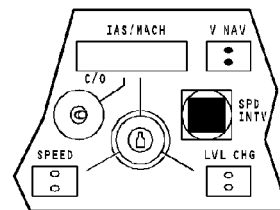

MCP

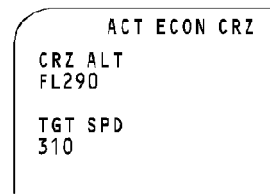

CDU

3 - TURN IAS/MACH SELECTOR TO SELECT NEW FMC SPEED. NEW SPEED SHOWS ON CDU.

4 - PUSH SPEED INTERVENTION PUSHBUTTON TO RETURN TO ORIGINAL FMC TARGET SPEED.

FMCS - VNAV - SPEED INTERVENTION

34-61-00-071

EFFECTIVITY
HAP ALL

34-61-00

D633A101-HAP

Page 98.179
Jun 15/2009

FMCS - VNAV - ALTITUDE INTERVENTION**General**

The altitude intervention function allows the flight crew to do these operations without having to disengage VNAV:

- Delete the next altitude constraint (climb or descent)
- Increase the cruise altitude while in the climb phase
- Resume a climb or descent after holding an MCP altitude
- Cruise climb/descent transition.

Altitude Constraint Deletion

During a climb or a descent, the next altitude constraint may be deleted by setting the DFCS mode control panel (MCP) altitude above/below the next altitude constraint in the flight plan and pressing the altitude intervention pushbutton. The airplane will now climb/descend to the MCP selected altitude. Up to a maximum of eight altitude constraints can be deleted using the altitude intervention pushbutton.

During a descent, if the MCP altitude is set to or above the end of descent (E/D) altitude, the airplane will descend at 1000 feet/minute until it gets to the altitude from where it can make the planned VNAV PATH descent. If the MCP altitude is set to below the E/D altitude, the airplane will descend in VNAV SPD mode.

Increase Cruise Altitude during Climb

During the climb or cruise phases of the flight, the flight crew can increase the cruise altitude by setting the higher altitude in the MCP and pressing the altitude intervention pushbutton. In order to do this in the climb, there must be no altitude constraints in the climb phase.

If the selected altitude is above the maximum allowable cruise altitude, the use of the altitude intervention pushbutton does not change the cruise altitude and the message MAX ALT FLXXX shows in the MCDU scratchpad.

NOTE: Cruise altitude can not be decreased using altitude intervention.

Resuming Climb/Descent

During a hold of the selected MCP altitude, the flight crew can resume the climb/descent by setting the new altitude in the MCP and pressing the altitude intervention pushbutton.

Cruise Climb/Descent Transition

During the cruise phase of the flight, the flight crew can select a cruise climb to a higher altitude by setting the new altitude on the MCP and pressing the altitude intervention pushbutton.

Also, the flight crew can select a lower altitude on the MCP and pressing the altitude intervention pushbutton will initiate a transition to descent to the selected altitude.

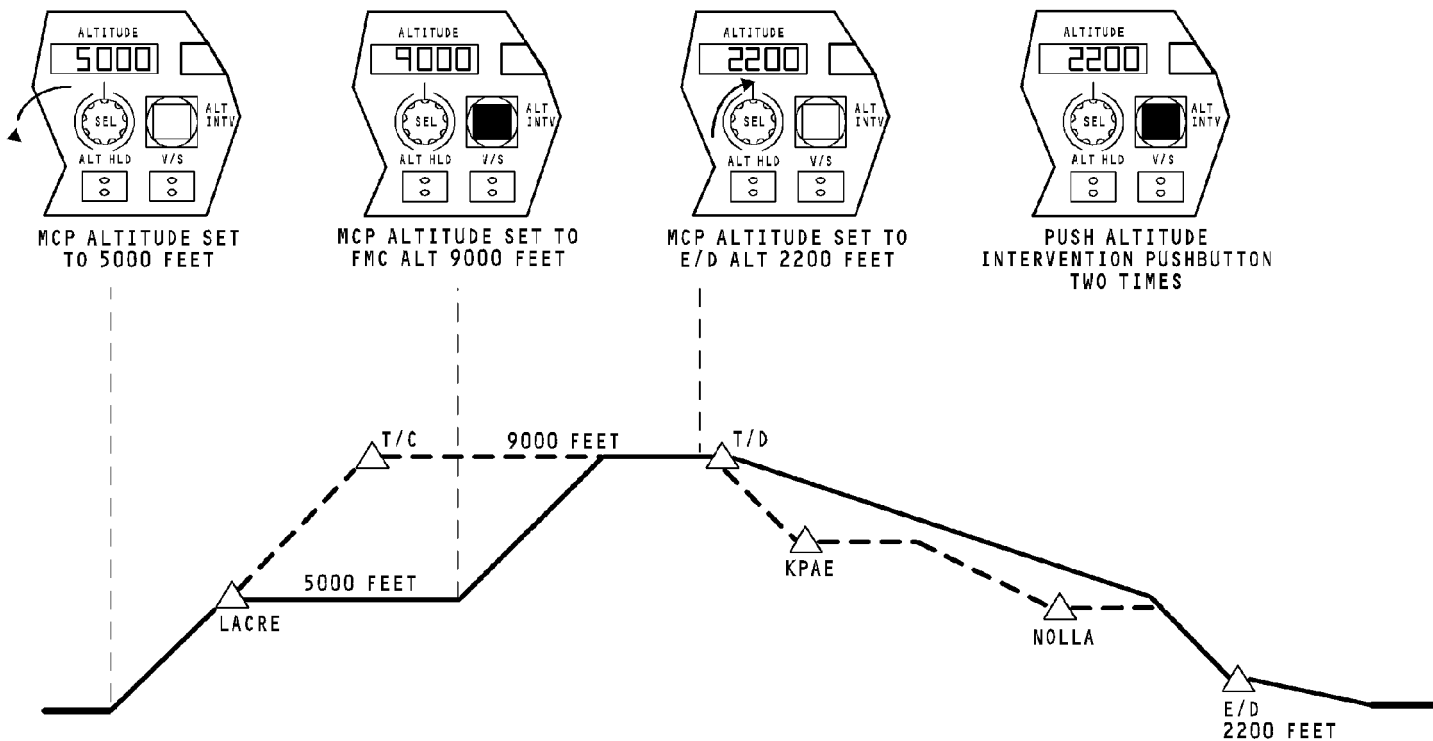

FMCS - VNAV - ALTITUDE INTERVENTION

34-61-00-089

EFFECTIVITY
HAP ALL

34-61-00

D633A101-HAP

THIS PAGE IS INTENTIONALLY LEFT BLANK

34-61-00

D633A101-HAP

Page 98.182
Jun 15/2009

FMCS - TRAINING INFORMATION POINT - FMC DATA LOADING**General****HAP 031-054, 101-999**

You use the airborne data loader (ADL) to load data into the FMCS and other airplane systems. The steps to load data into the FMCS and the other systems are similar.

HAP 001-013, 015-026, 028-030

You use the portable data loader (PDL) to load data into the FMCS and other airplane systems. The steps to load data into the FMCS and the other systems are similar.

NOTE: The portable data loader is not a Boeing supplied item. This coverage is included for information only. See the data loader instructions, which are supplied by the vendor.

HAP 037-054, 101-999

To load data into the FMCS, you set the data loader control panel selector to the FMC position. This connects the loader to the primary FMC.

HAP 001-013, 015-026, 028-036

To load data into the FMC, set the data load selector to the FMC position. This connects the data loader to FMC 1.

HAP ALL

You can load these databases into the FMCS:

- Operational flight program (OFF)
- Navigation data base
- Performance default data base
- Airplane model/engine performance data base
- ACARS data link data base
- Software options data base.

Preparation

The information below shows the steps to load a navigation data base. The procedure to load the other systems data or the other FMCS data is similar.

HAP 031-054, 101-999

This is a summary of the steps to load data with an ADL:

- Airplane must be on the ground
- Apply electrical power to the airplane

HAP 031-036

- Set the data loader 3-position switch to the L position to load the FMC

HAP 037-054, 101-999

- Set the data loader 3-position switch to the FMC you will load (the L position will load FMC 1 and the R position will load FMC 2)

HAP 031-054, 101-999

- Set the data load selector to the FMC position
- Open the data loader access door
- Put the necessary diskette into the ADL.

FMCS - TRAINING INFORMATION POINT - FMC DATA LOADING**HAP 031-054, 101-999 (Continued)****HAP 001-011 PRE SB 737-31-1136**

This is a summary of the steps to load data with a PDL:

- Airplane must be on the ground
- Apply electrical power to the airplane
- Open the DATA LOADER circuit breaker
- Connect the PDL to the data transfer receptacle
- Close the DATA LOADER circuit breaker
- Set the data load selector to the FMC position
- Open the data loader access door
- Put the necessary diskette into the PDL.

HAP 012, 013, 015-026, 028-030; HAP 001-011 POST SB 737-31-1136

This is a summary of the steps to load data with a PDL:

- Airplane must be on the ground
- Apply electrical power to the airplane
- Open the DATA LOADER circuit breaker
- Connect the PDL to the data transfer receptacle
- Close the DATA LOADER circuit breaker
- Set the data loader 3-position switch to the L position to load the FMC
- Set the data load selector to the FMC position
- Open the data loader access door
- Put the necessary diskette into the PDL.

HAP 037-054, 101-999

NOTE: The FMC source select switch on the P5 panel must be set in the BOTH ON L or NORMAL positions to see the load progress on the MCDUs if FMC 1 is loaded. If the 3-position switch is in the R position, the FMC source select switch must be set to BOTH ON R to see the load progress on the MCDUs.

HAP ALL

The CDUs automatically go to the FMCS DATALOAD page when the CDU receives valid data from the loader.

HAP 001-013, 015-026, 028-036

The data load process is automatic. Except to change diskettes, no further operation is necessary after you do the above steps.

HAP 037-054, 101-999

The data load process is automatic. When the data loader 3-position switch is set to the L position, the data loads into FMC 1. You then do a crossload and load the data into FMC 2 via the FMCS inter system bus.

HAP ALL

Return the data loader control panel to the NORM position after the transfer is complete.

NOTE: Do not interrupt electrical power to the system during software loading. If power is interrupted, you will need to do the software load procedure again.

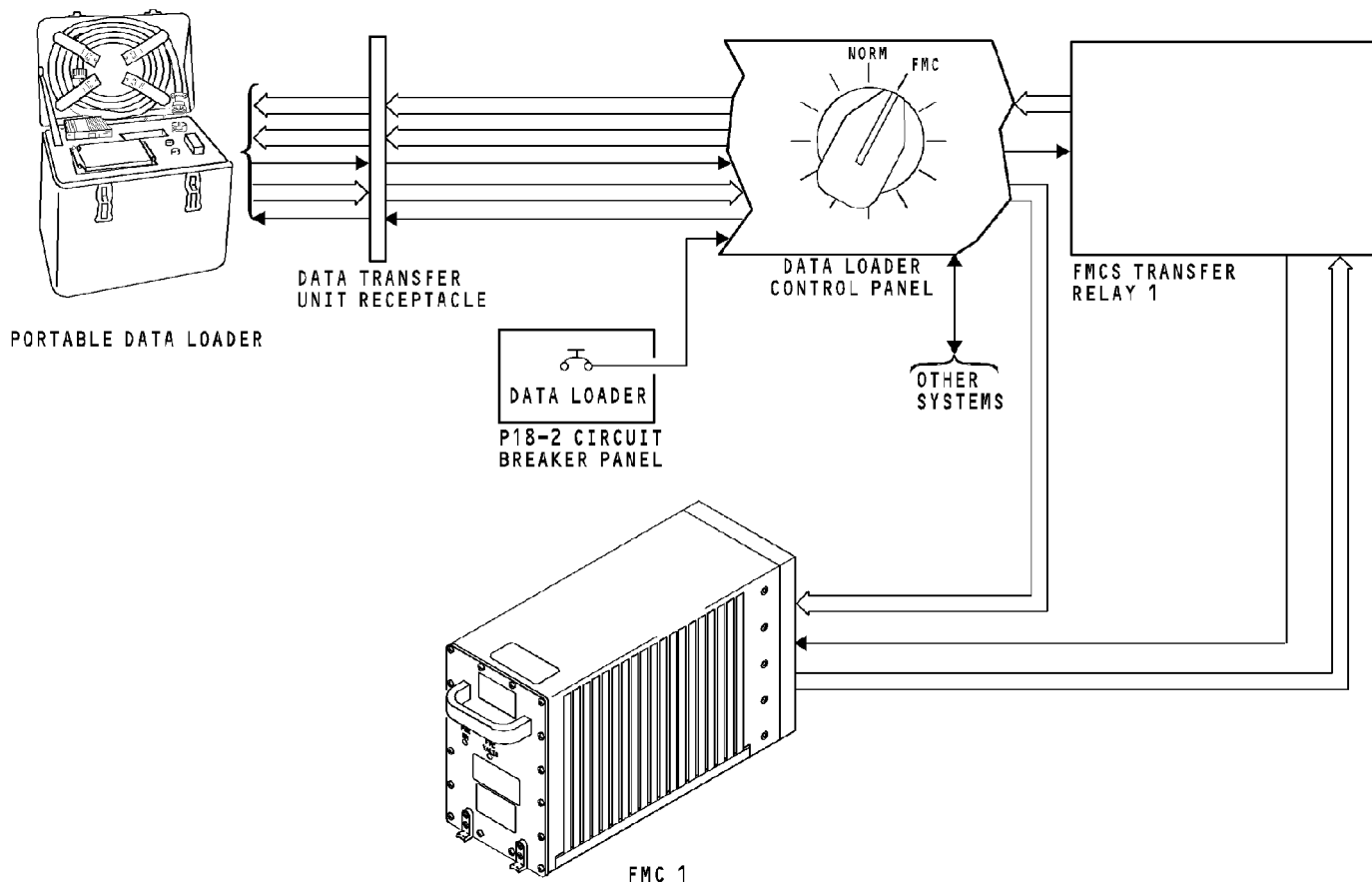

FMCS - TRAINING INFORMATION POINT - FMC DATA LOADING

EFFECTIVITY
HAP 001-011 PRE SB 737-31-1136

34-61-00

D633A101-HAP

Page 98.185
Jun 15/2009

34-61-00-049

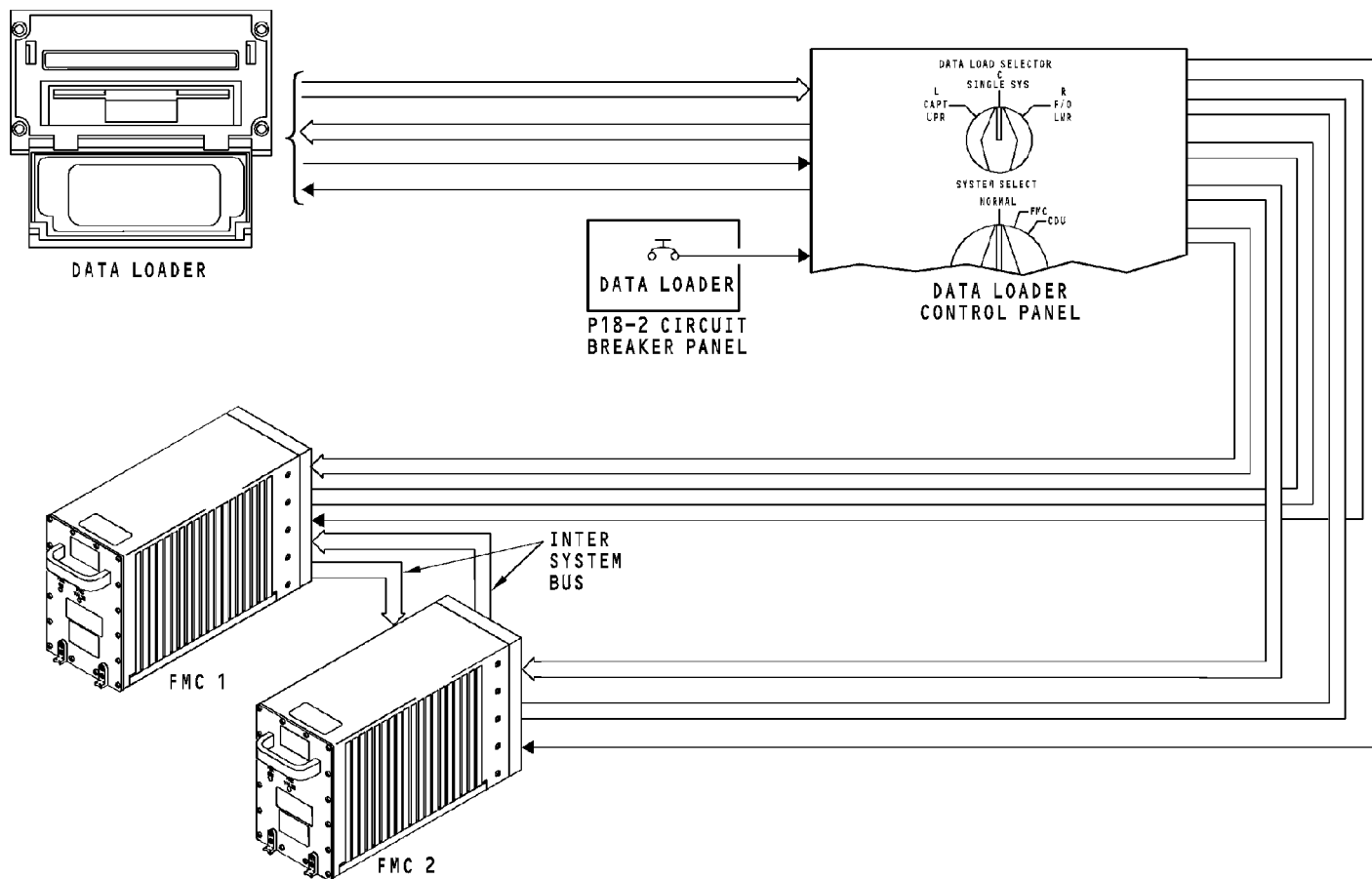

FMCS - TRAINING INFORMATION POINT - FMC DATA LOADING

EFFECTIVITY
HAP 037-054, 101-999

34-61-00

D633A101-HAP

Page 98.186
Jun 15/2009

34-61-00-049

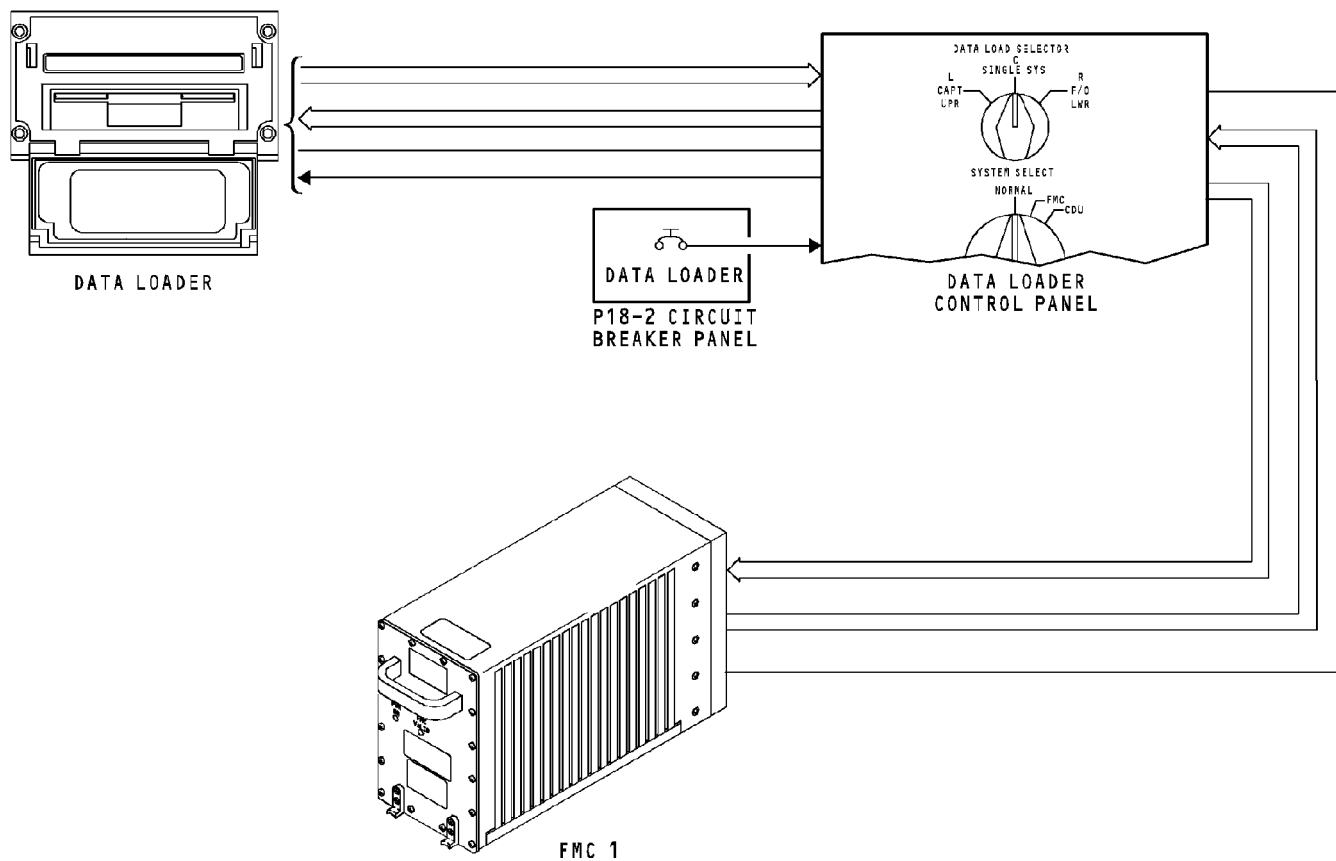

FMCS - TRAINING INFORMATION POINT - FMC DATA LOADING

34-61-00-049

EFFECTIVITY
HAP 031-036

34-61-00

D633A101-HAP

Page 98.187
Jun 15/2009

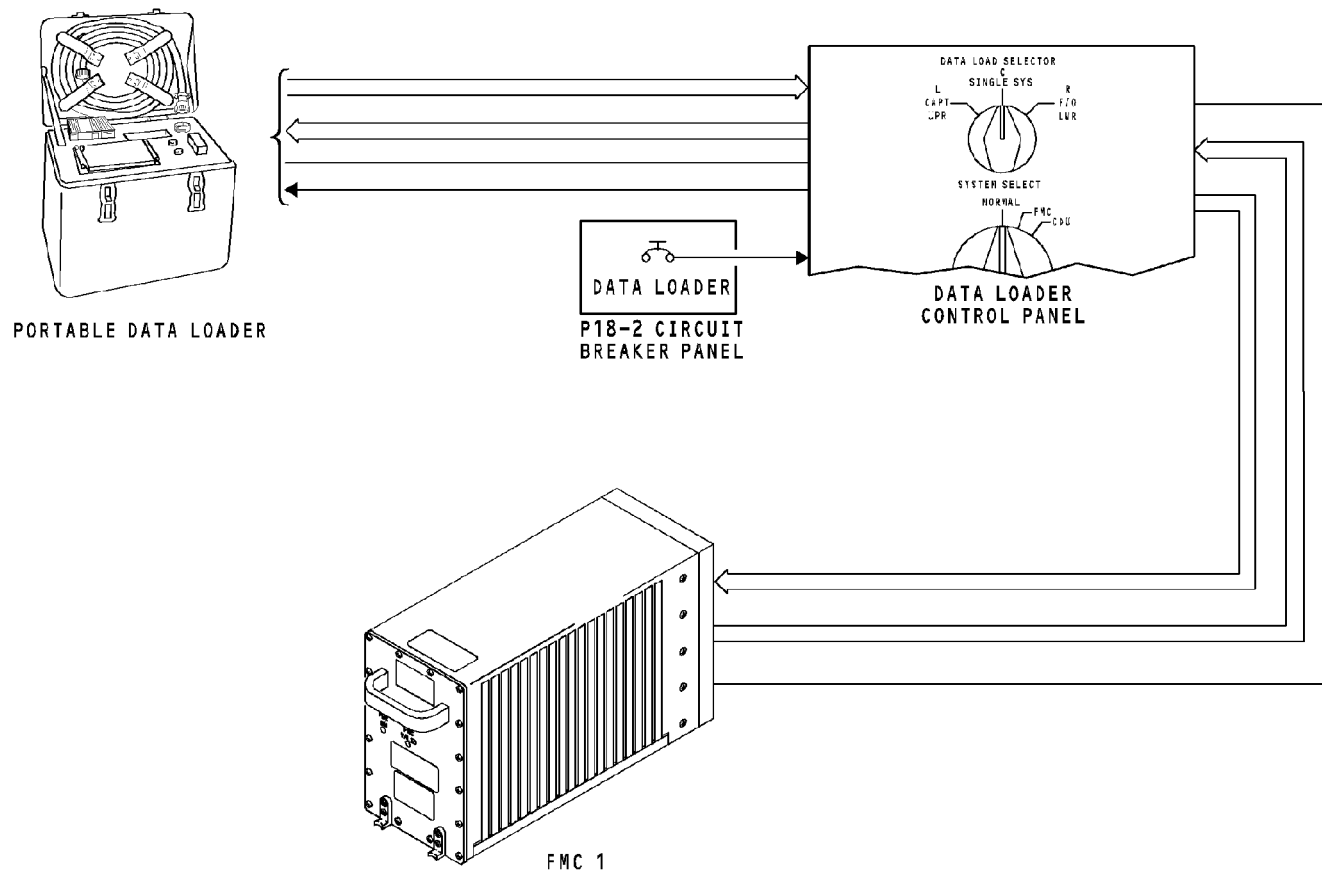

FMCS - TRAINING INFORMATION POINT - FMC DATA LOADING

EFFECTIVITY

HAP 012, 013, 015-026, 028-030; HAP 001-011 POST SB 737-31-1136

34-61-00

D633A101-HAP

FMCS - TRAINING INFORMATION POINT - CDU DATA LOADING**General****HAP 031-054, 101-999**

You use the airborne data loader (ADL) to load the operational program software (OPS) into the CDUs.

HAP 012, 013, 015-026, 028-030; HAP 006-011 POST SB 737-31-1136; HAP 001-005 POST SB 737-34-1951 GRP 1 AND POST SB 737-31-1136

You use the portable data loader (PDL) to load the operational program software (OPS) into the CDUs.

NOTE: The portable data loader is not a Boeing supplied item. This coverage is included for information only. See the data loader instructions, which are supplied by the vendor.

HAP 012, 013, 015-026, 028-054, 101-999; HAP 006-011 POST SB 737-31-1136; HAP 001-005 POST SB 737-34-1951 GRP 1 AND POST SB 737-31-1136

To load the OPS into the CDUs, set the data loader selector to the CDU position and the data loader 3-position switch to the L or R position depending on which CDU is to be loaded. This connects the loader to the CDU being loaded.

Preparation**HAP 031-054, 101-999**

This is a summary of the steps to load the OPS with an ADL:

- Airplane must be on the ground
- Apply electrical power to the airplane
- Set the data loader selector to the CDU position
- Set the data loader 3-position switch to the CDU you will load (the L position loads CDU 1 and the R position loads CDU 2)
- Open the data loader access door
- Put the CDU OPS software diskette into the ADL.

HAP 012, 013, 015-026, 028-030; HAP 006-011 POST SB 737-31-1136; HAP 001-005 POST SB 737-34-1951 GRP 1 AND POST SB 737-31-1136

This is a summary of the steps to load data with a PDL:

- Airplane must be on the ground
- Apply electrical power to the airplane
- Open the DATA LOADER circuit breaker on the P18-2 panel
- Connect the PDL to the data transfer receptacle
- Close the DATA LOADER circuit breaker
- Turn the PDL on
- Set the data loader selector to the CDU position
- Set the data loader 3-position switch to the CDU you will load (the L position loads CDU 1 and the R position loads CDU 2)
- Open the data loader access door
- Put the CDU OPS software diskette into the PDL.

HAP 012, 013, 015-026, 028-054, 101-999; HAP 006-011 POST SB 737-31-1136; HAP 001-005 POST SB 737-34-1951 GRP 1 AND POST SB 737-31-1136

The CDUs show the DATA LOADER page when the CDU receives valid data from the loader.

EFFECTIVITY

HAP 012, 013, 015-026, 028-054, 101-999; HAP 006-011 POST SB 737-31-1136; HAP 001-005 POST SB 737-34-1951 GRP 1 AND POST SB 737-31-1136

FMCS - TRAINING INFORMATION POINT - CDU DATA LOADING**HAP 031-054, 101-999**

The data load process is automatic. When the CDU shows the message LOAD COMPLETE, remove the diskette from the ADL and perform the applicable software verification procedure.

HAP 012, 013, 015-026, 028-030; HAP 006-011 POST SB 737-31-1136; HAP 001-005 POST SB 737-34-1951 GRP 1 AND POST SB 737-31-1136

The data load process is automatic. When the CDU shows the message LOAD COMPLETE, remove the diskette from the PDL and perform the applicable software verification procedure.

HAP 031-054, 101-999

Return the data loader selector to the NORM position after the transfer is complete.

HAP 012, 013, 015-026, 028-030; HAP 006-011 POST SB 737-31-1136; HAP 001-005 POST SB 737-34-1951 GRP 1 AND POST SB 737-31-1136

Return the data loader selector to the NORM position after the transfer is complete and disconnect the PDL from the data transfer unit receptacle.

HAP 012, 013, 015-026, 028-054, 101-999; HAP 006-011 POST SB 737-31-1136; HAP 001-005 POST SB 737-34-1951 GRP 1 AND POST SB 737-31-1136

NOTE: Do not interrupt electrical power to the system during software loading. If power is interrupted, you will need to do the software load procedure again.

EFFECTIVITY

HAP 012, 013, 015-026, 028-054, 101-999; HAP 006-011 POST SB 737-31-1136; HAP 001-005 POST SB 737-34-1951 GRP 1 AND POST SB 737-31-1136

34-61-00

D633A101-HAP

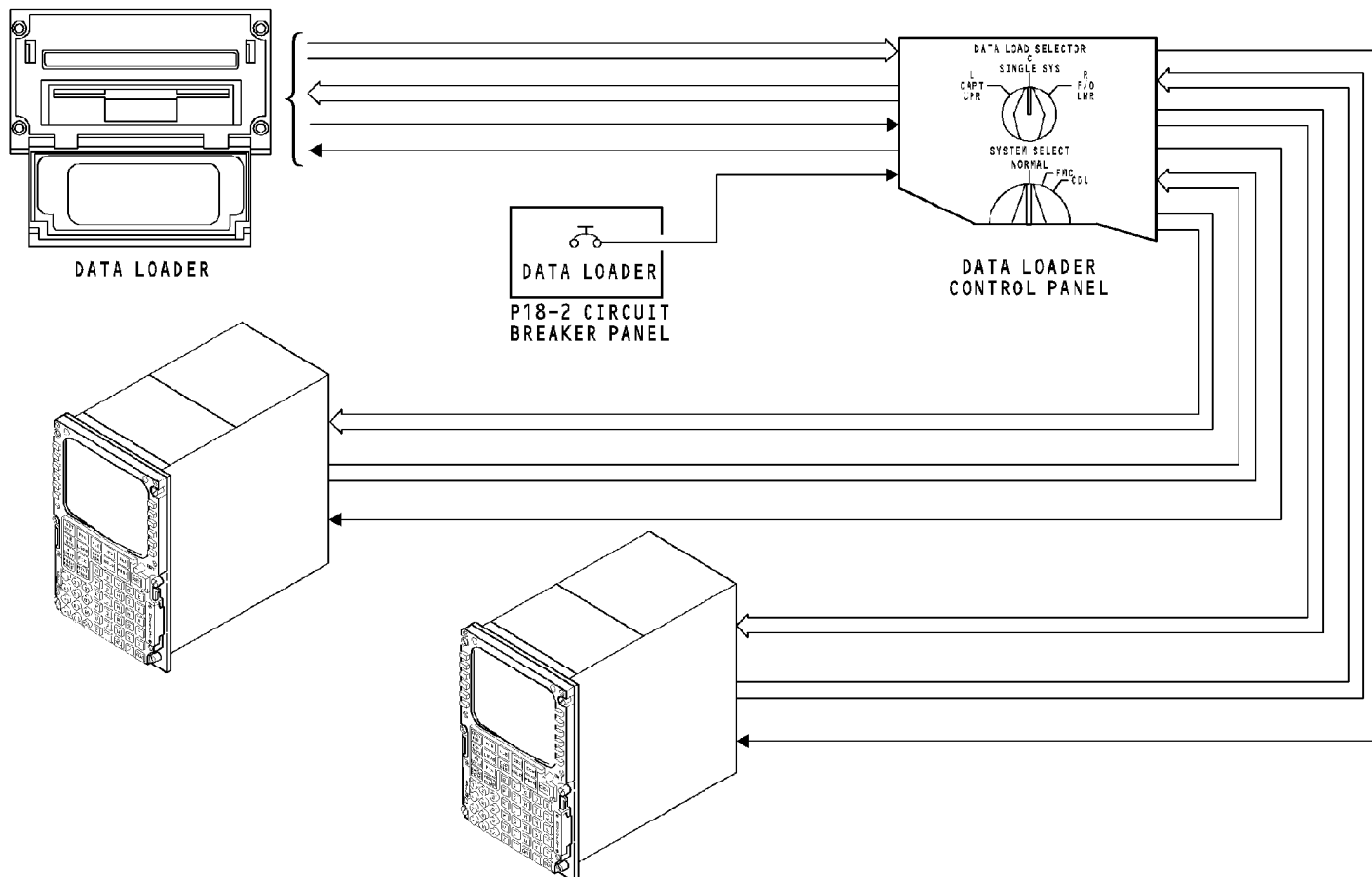

FMCS - TRAINING INFORMATION POINT - CDU DATA LOADING

34-61-00-092

EFFECTIVITY
HAP 031-054, 101-999

34-61-00

D633A101-HAP

Page 98.191
Jun 15/2009

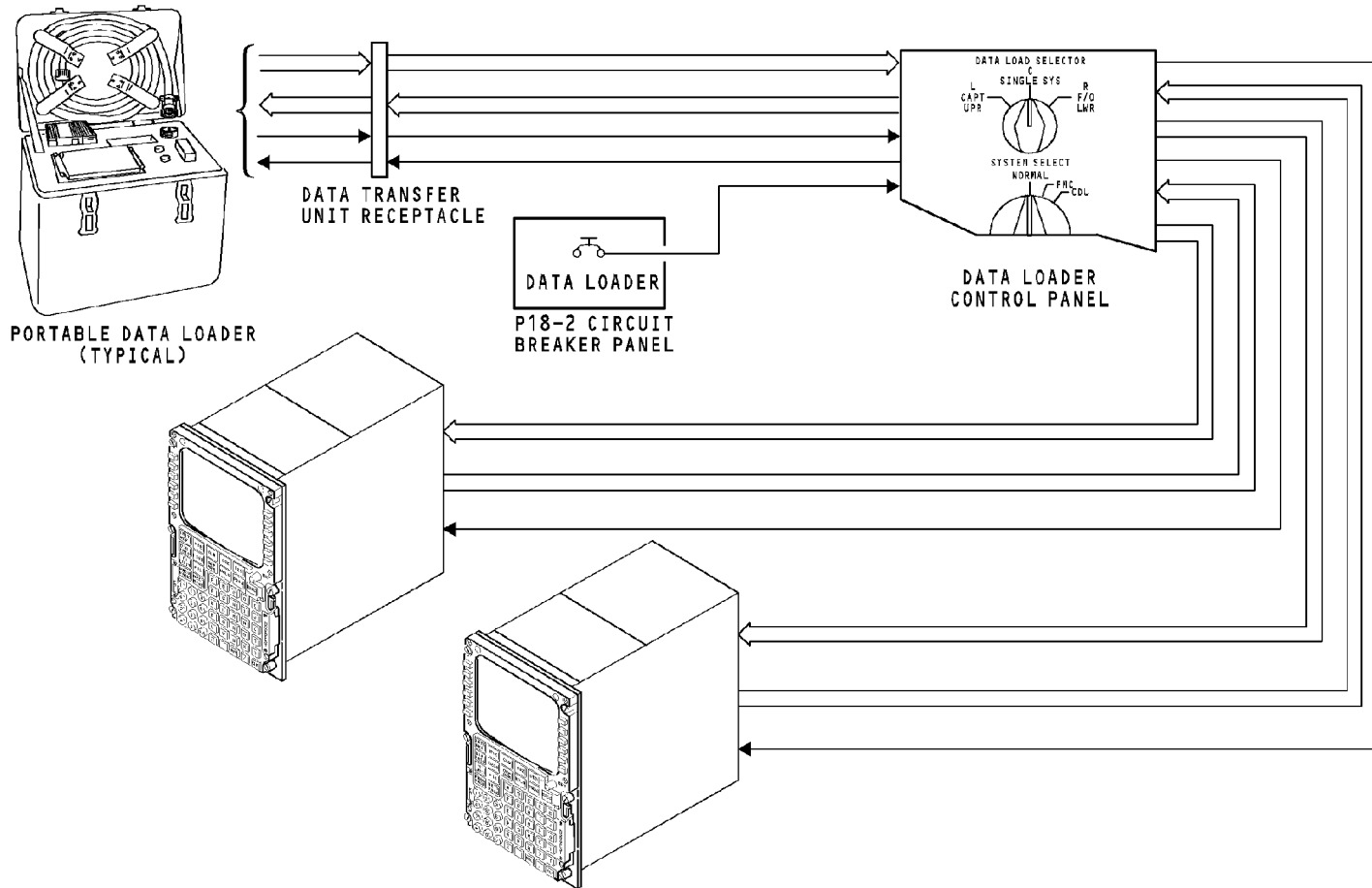

FMCS - TRAINING INFORMATION POINT - CDU DATA LOADING

EFFECTIVITY

HAP 012, 013, 015-026, 028-030; HAP 006-011 POST SB 737-31-1136; HAP 001-005 POST SB 737-34-1951 GRP 1 AND POST SB 737-31-1136

34-61-00

D633A101-HAP

THIS PAGE IS INTENTIONALLY LEFT BLANK

34-61-00

D633A101-HAP

Page 98.193
Jun 15/2009

FMCS - TRAINING INFORMATION POINT - DATABASE LOAD**Load**

After you put the diskette into the loader, the load process is automatic. Except to change diskettes, no further operation is necessary.

CURRENT RECORD shows the number of data base records that are loaded into the FMC data base memory. TOTAL RECORDS show the total number of records to be loaded into the FMC data base memory.

During the loading process, the message LOAD IN PROGRESS shows. INSERT NEXT DISK shows during multi-disk data base load.

The load is complete when LOAD COMPLETE shows on the CDU. Push the eject button on the loader to remove the diskette.

Load Failure Indications

If the loader finds a problem, a message shows on the data loader display and DATA LOAD INOP shows on the CDUs.

If the FMC finds a problem with the data from the loader, the CDU shows one of these messages:

- CHECK DBL OR INTERFACE (there is a problem that the FMCS cannot isolate to the FMC or the loader)
- DB EXCEEDS FMC (the data on the disk is too large for FMC memory)

- RESET COUNT EXCEEDED (five load attempts have failed)
- DB-OPF INCOMPATIBLE (the data on the disk does not compare with the FMC operational program)
- CHECK MEDIA (part of the data on the disk cannot be read by the loader)
- INCORRECT DISK INSERTED (the diskette does not compare with the diskette you used before).

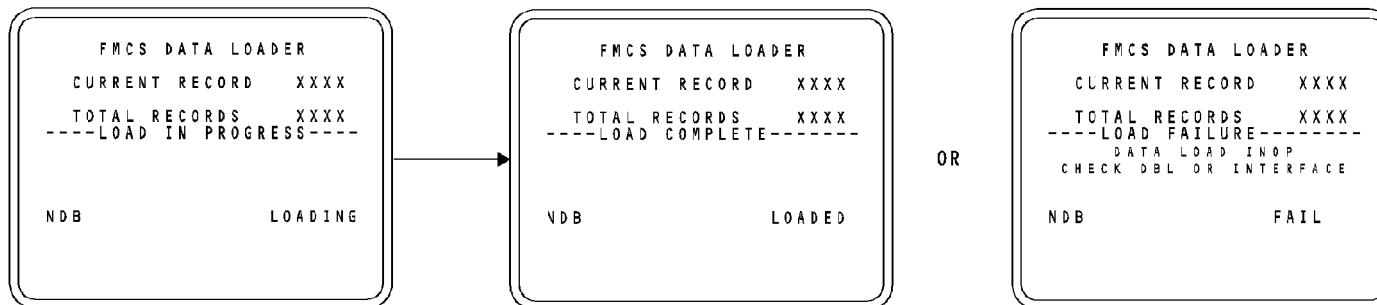

NORMAL LOAD INDICATION

LOAD FAILURE

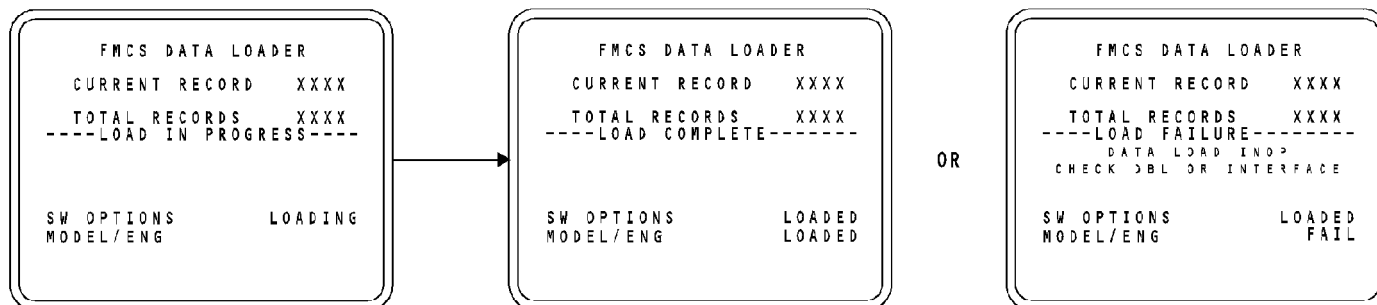

NORMAL LOAD INDICATION

LOAD FAILURE

FMCS - TRAINING INFORMATION POINT - DATABASE LOAD

34-61-00-050

EFFECTIVITY
HAP ALL

34-61-00

D633A101-HAP

FMCS - TRAINING INFORMATION POINT - CROSSLOAD PAGES**General**

These are the two crossload pages that can show on the MCDU:

- OFP CROSSLOAD
- DATABASE CROSSLOAD.

NOTE: The OFP CROSSLOAD page will have priority over the DATA BASE CROSSLOAD page.

The OFP CROSSLOAD page shows for any of these conditions:

- If, during ground power up, the primary FMC finds a mismatch between its valid OFP and that of the secondary FMC
- An OFP with a different update version is loaded into one FMC
- Selecting the CROSSLOAD prompt on the FMCS BITE INDEX page if an OFP mismatch currently exists.

NOTE: If the OFP in the primary FMC is not valid, the MCDU shows a message to set the FMC source select switch to the BOTH ON R position.

If there is no mismatch between the OFPs but there is an analog discrete mismatch, the ANALOG DISCRETE page will show with the specific mismatch highlighted.

The DATABASE CROSSLOAD page will show if there are not any OFP or analog discrete mismatches for any of these conditions:

- If, during ground power up, there is a data base mismatch between the primary and secondary FMCs.
- A database with a different update version is loaded into one FMC
- Selecting the CROSSLOAD prompt on the FMCS BITE INDEX page if a data base mismatch currently exists.

The database pages show only the databases that do not match between FMCs. The data and header fields will be blank if there is no mismatch.

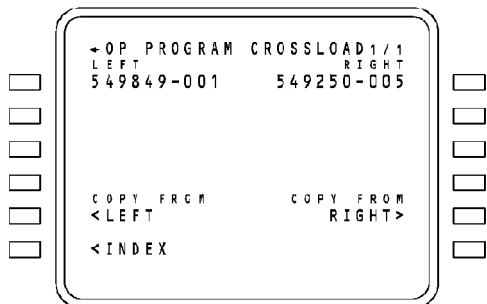

OPERATIONAL PROGRAM CROSSLOAD PAGE

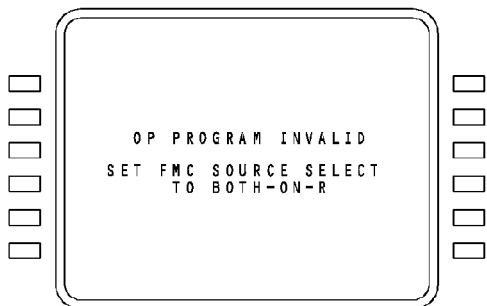

PRIMARY FMC OPF INVALID

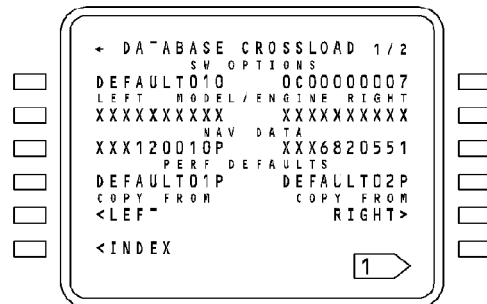

NEXT PAGE

PREV PAGE

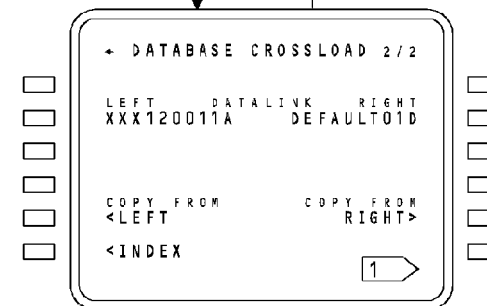

DATABASE CROSSLOAD PAGES

1 THE EXAMPLE IN THE GRAPHIC SHOWS THE CONDITION WHERE ALL THE DATABASES DO NOT MATCH.

FMCS - TRAINING INFORMATION POINT - CROSSLOAD PAGES

34-61-00-051

EFFECTIVITY
HAP 037-054, 101-999

34-61-00

D633A101-HAP

Page 98.197
Jun 15/2009

THIS PAGE IS INTENTIONALLY LEFT BLANK

34-61-00

D633A101-HAP

Page 98.198
Jun 15/2009

FMCS - TRAINING INFORMATION POINT - OFP CROSSLOAD PAGE**General**

The OFP CROSSLOAD page lets you review and, if necessary, transfer the operational flight program (OFP) between the primary and secondary FMCs.

Page Access

This page shows for any of these conditions:

- If, during ground power-up, the primary FMC finds a mismatch between its valid OFP and that of the secondary FMC
- An OFP with a different update version is loaded into one FMC
- Selection of the CROSSLOAD prompt on the FMCS BITE INDEX page if there is an OFP mismatch currently.

If there is no mismatch between the OFPs but there is an analog discrete mismatch, the ANALOG DISCRETE page shows with the specific mismatch highlighted.

OFP Crossload Page Information

Line select key 1L and 1R show the OFP software part numbers for the left and right FMCs if there is an OFP mismatch. If there is no mismatch these data fields are blank.

Line select key 5L and 5R show the crossload status. These messages may show:

- COPY FROM < LEFT/RIGHT >

- CROSSLOAD FMC-L TO FMC-R
- CROSSLOAD FMC-R TO FMC-L
- CROSSLOAD IN PROGRESS
- CROSSLOAD COMPLETE
- CROSSLOAD FAIL (the data base in the source FMC did not crossload to the target FMC)
- CROSSLOAD UNAVAILABLE (the source FMC can not interface with the other FMC)
- SET FMC SOURCE SELECT TO BOTH ON R (shows when the primary FMC is also the target FMC).

To start the crossload, select COPY FROM LEFT or COPY FROM RIGHT on the MCDU and push the EXEC key. The message CROSSLOAD IN PROGRESS shows during the crossload process. At the end of the crossload, the message CROSSLOAD COMPLETE shows on the MCDU.

Line select key 6L shows one of these prompts:

- INDEX (selects the FMCS BITE INDEX page)
- CANCEL (shows when the source FMC for the crossload has been selected but the EXEC key has not been pressed)
- NEXT MISMATCH.

The NEXT MISMATCH prompt shows either the specified ANALOG DISCRETE page if there is a discrete mismatch currently or the DATABASE CROSSLOAD page if there is not a discrete mismatch but there is a data base mismatch.

If there are no more mismatches between the FMCs, the INDEX prompt shows.



FMCS - TRAINING INFORMATION POINT - OFP CROSSLOAD PAGE

This line is blank while the crossload is in progress.

NOTE: The example on the graphic shows a mismatch between the OFPs and also the position of the right ECS pack switch and a navigation data base mismatch between the FMCS.

34-61-00-076

EFFECTIVITY
HAP 037-054, 101-999

34-61-00

D633A101-HAP

Page 98.200
Jun 15/2009

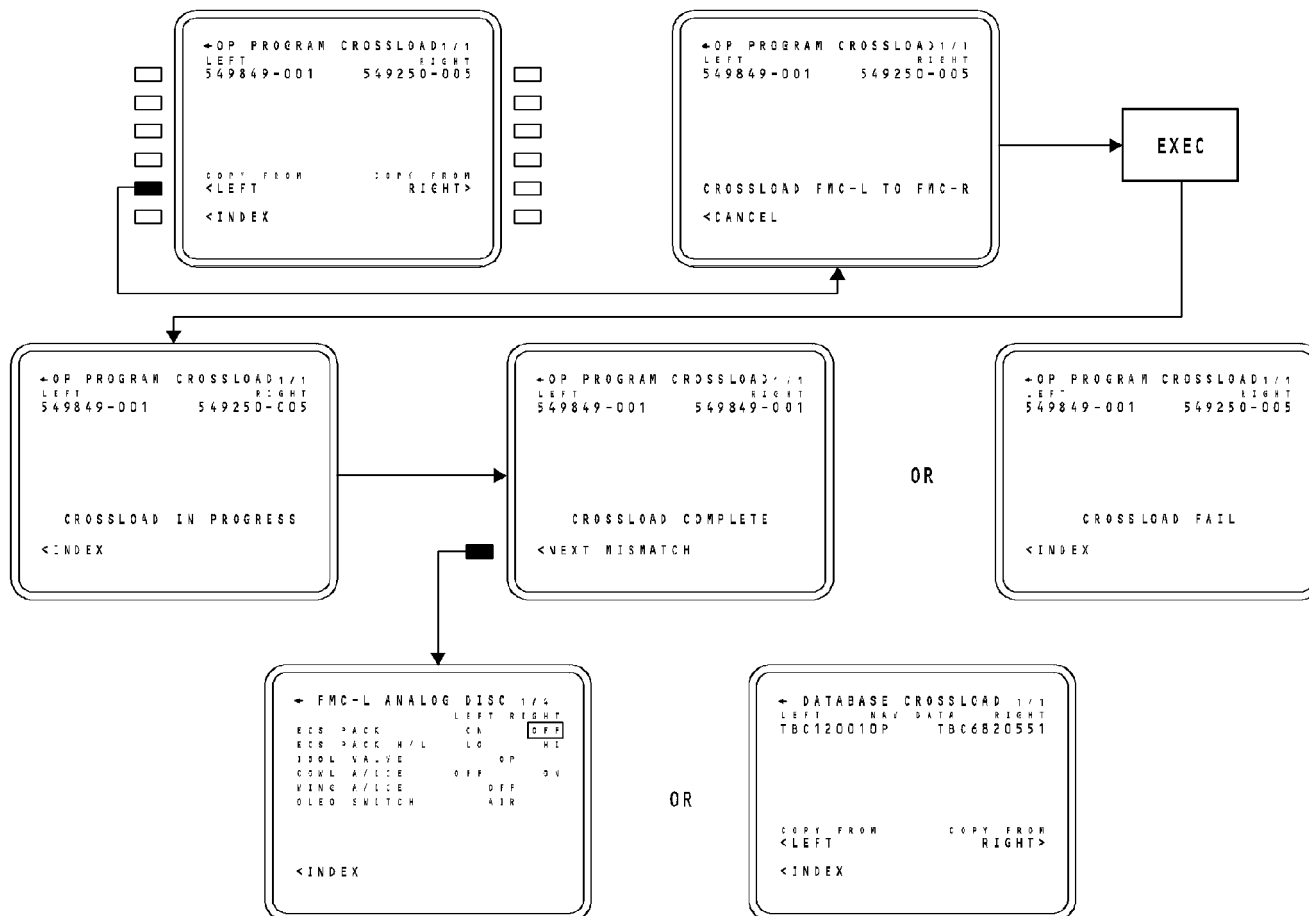

FMCS - TRAINING INFORMATION POINT - OFF CROSSLOAD PAGE

34-61-00-076

EFFECTIVITY
HAP 037-054, 101-999

34-61-00

D633A101-HAP

Page 98.201
Jun 15/2009

THIS PAGE IS INTENTIONALLY LEFT BLANK

34-61-00

D633A101-HAP

Page 98.202
Jun 15/2009

FMCS - TRAINING INFORMATION POINT - DATABASE CROSSLLOAD PAGE**General**

The database crossload page lets you review and, if necessary, transfer the various data bases between the FMCSs.

These are the applicable data bases:

- Model/engine
- Navigation
- Performance defaults
- ACARS datalink
- Software options.

Page Access

This page shows for any of these conditions:

- During ground power-up, if there is a data base mismatch between the primary and secondary FMCSs
- Data base with a different update version is loaded into one FMCS
- Selection of the CROSSLOAD prompt on the FMCS BITE INDEX page if there is a data base mismatch.

NOTE: The data base crossload page shows if there is not an OFP mismatch or an analog discrete mismatch between the FMCSs. These have higher priority than the data base crossload pages.

Data Base Crossload Page Information

Lines 1L through 4L show the data fields for the individual data bases. If there are no mismatches, the data fields are blank.

Lines 5L and 5R show the crossload status. These messages may show:

- COPY FROM < LEFT/RIGHT >
- CROSSLOAD FMC-L TO FMC-R
- CROSSLOAD FMC-R TO FMC-L
- CROSSLOAD IN PROGRESS
- CROSSLOAD COMPLETE
- CROSSLOAD FAIL (the data base in the source FMCS did not crossload to the target FMCS)
- CROSSLOAD UNAVAILABLE (the source FMCS cannot interface with the other FMCS)
- SET FMC SOURCE SELECT TO BOTH ON R (shown when the primary FMCS is also the target FMCS).

To start the crossload, select COPY FROM LEFT or COPY FROM RIGHT on the MCDU and push the EXEC key. The message, CROSSLOAD IN PROGRESS shows during the crossload process. At the end of the crossload, the message, CROSSLOAD COMPLETE shows on the MCDU.

Line 6L shows one of these prompts:

- INDEX (selects the FMCS BITE INDEX page)
- CANCEL (shows when the source FMCS for the crossload is selected but the EXEC key was not pushed)

FMCS - TRAINING INFORMATION POINT - DATABASE CROSSLLOAD PAGE

- NEXT MISMATCH (shows when there is another data base that has a mismatch).

If there are no more mismatches between the FMCS, the INDEX prompt shows.

This line is blank while the crossload is in progress.

NOTE: The example on the graphic shows a mismatch between the navigation data bases of the two FMCS.

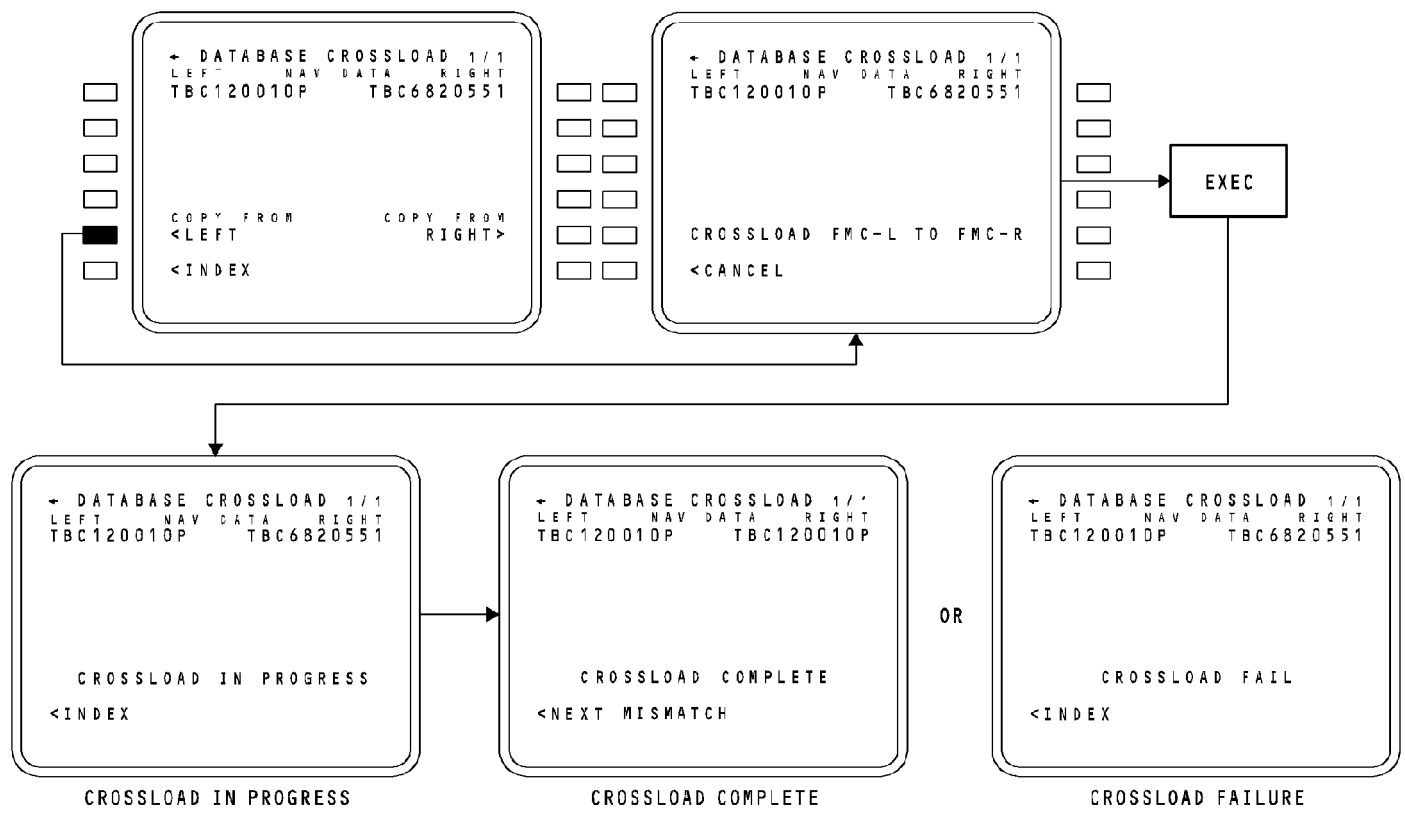

FMCS - TRAINING INFORMATION POINT - DATABASE CROSSLOAD PAGE

34-61-00-052

EFFECTIVITY
HAP 037-054, 101-999

34-61-00

D633A101-HAP

Page 98.205
Jun 15/2009

THIS PAGE IS INTENTIONALLY LEFT BLANK

34-61-00

D633A101-HAP

Page 98.206
Jun 15/2009

FMCS - TRAINING INFORMATION POINT - FMCS BITE PAGES - INTRODUCTION**General**

The FMCS has BITE functions for maintenance and test of the system. The BITE is in the FMC. You operate the BITE with the MCDUs.

The BITE functions continuously monitor the status of the FMC and MCDU. The functions also continuously monitor the status of airplane sensor systems which interface with the FMCS. The monitors operate at all times. This includes power-up.

These are the BITE functions:

- INFLT FAULTS
- CDU TEST
- SENSORS
- DISCRETES
- FMCS - FIXED OUTPUTS
- MODEL/ENG
- SW OPTIONS
- PERF FACTR
- IRS MONITOR

HAP 006-013, 015-026, 028-054, 101-999; HAP 001-005 POST SB 737-34-1951 GRP 1

- LCD CDU.

HAP 030 PRE SB 737-34-1918; HAP 001-013, 015-026, 028, 029 POST SB 737-34-1666 AND PRE SB 737-34-1918

- H/W CONFIG

HAP ALL

INFLT FAULTS**HAP 001-013, 015-026, 028-036**

The FMC records its in-flight faults and in-flight faults for the MCDUs and the LRUs it interfaces with. It has storage capacity for nine flights. Also, the FMC stores ground faults for both MCDUs and the FMC.

HAP 037-054, 101-999

The FMCs record their in-flight faults and in-flight faults for the MCDUs and the LRUs they interface with. They have storage capacity for nine flights. Also, the FMCs record their ground faults and ground faults for the MCDUs.

HAP ALL**CDU TEST**

The MCDU test page shows the tests for the MCDU display and keyboard.

SENSORS**HAP 037-054, 101-999**

The sensor status pages show the current status of all the sensors that send data to the FMC selected as the BITE source.

FMCS - TRAINING INFORMATION POINT - FMCS BITE PAGES - INTRODUCTION**HAP 037-054, 101-999 (Continued)****HAP 001-013, 015-026, 028-036**

The sensor status pages show the current status of all the sensors that send data to the FMC.

HAP ALL**DISCRETES****HAP 037-054, 101-999**

These pages show the current status of the analog discrettes that send data to the FMC selected as the BITE source.

HAP 001-013, 015-026, 028-036

These pages show the current status of the analog discrettes that send data to the FMC.

HAP ALL**FMCS - FIXED OUTPUTS**

This function shows the values of the FMCS outputs to the common display system (CDS) and the autoflight status annunciators (ASA).

MODEL/ENG

The model/engine configuration page shows the airplane and engine configuration. It also shows the engine combustor type and the brake option selected.

SW OPTIONS

The software option pages show the status of the options that are in the software options database.

PERF FACTOR

The performance factors page permits the display and entry of performance factors to optimize airplane performance for individual operators or airplane characteristics.

IRS MONITOR

This page shows the ADIRU position error rate calculated by the FMC.

LCD CDU

The LCD CDU page shows the MCDU BITE pages.

HAP 030 PRE SB 737-34-1918; HAP 001-013, 015-026, 028, 029 POST SB 737-34-1666 AND PRE SB 737-34-1918

H/W CONFIG

This page shows data for the installed hardware.

HAP ALL**EFFECTIVITY****HAP ALL****34-61-00**

D633A101-HAP

Page 98.208
Jun 15/2009

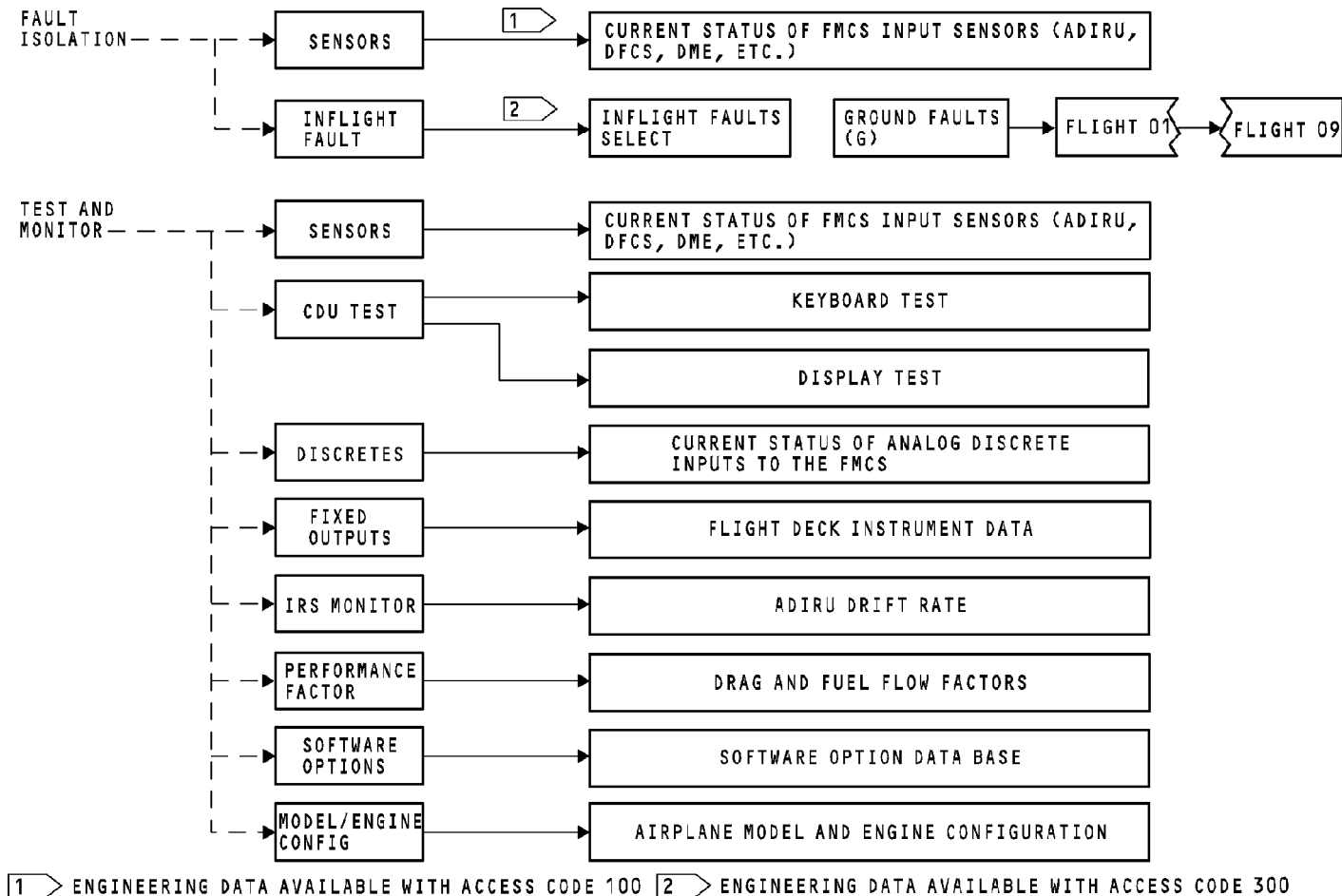

FMCS - TRAINING INFORMATION POINT - FMCS BITE PAGES - INTRODUCTION

EFFECTIVITY

HAP 001-005 PRE SB 737-34-1951 GRP 1 AND (PRE SB 737-34-1666 OR POST SB 737-34-1918)

34-61-00

D633A101-HAP

Page 98.209
Jun 15/2009

34-61-00-054

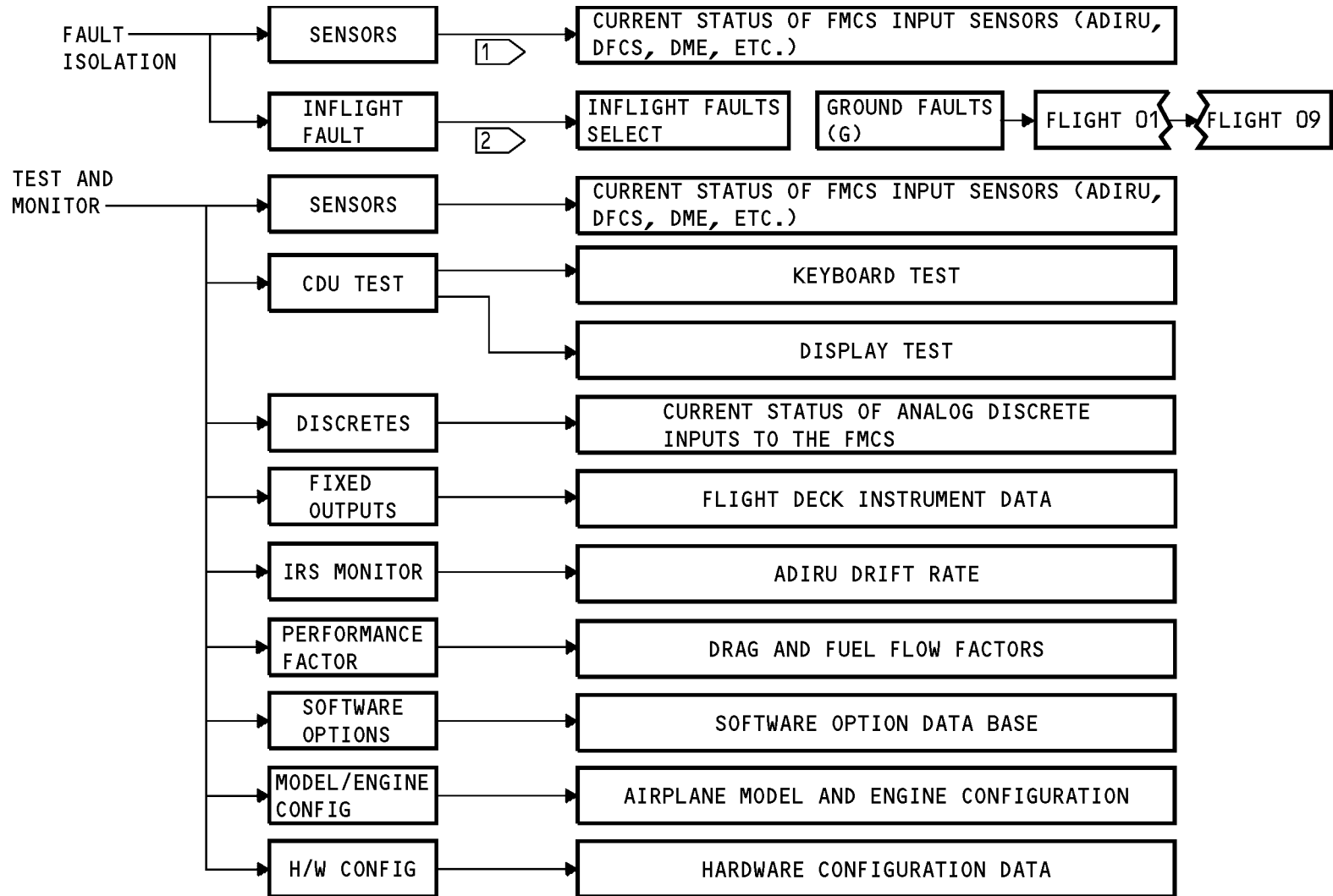

1 ENGINEERING DATA AVAILABLE WITH ACCESS CODE 100

2 ENGINEERING DATA AVAILABLE WITH ACCESS CODE 300

FMCS - TRAINING INFORMATION POINT - FMCS BITE PAGES - INTRODUCTION

EFFECTIVITY

HAP 001-005 POST SB 737-34-1666 AND PRE SB 737-34-1918 AND PRE SB 737-34-1951 GRP 1

34-61-00

D633A101-HAP

Page 98.210
Jun 15/2009

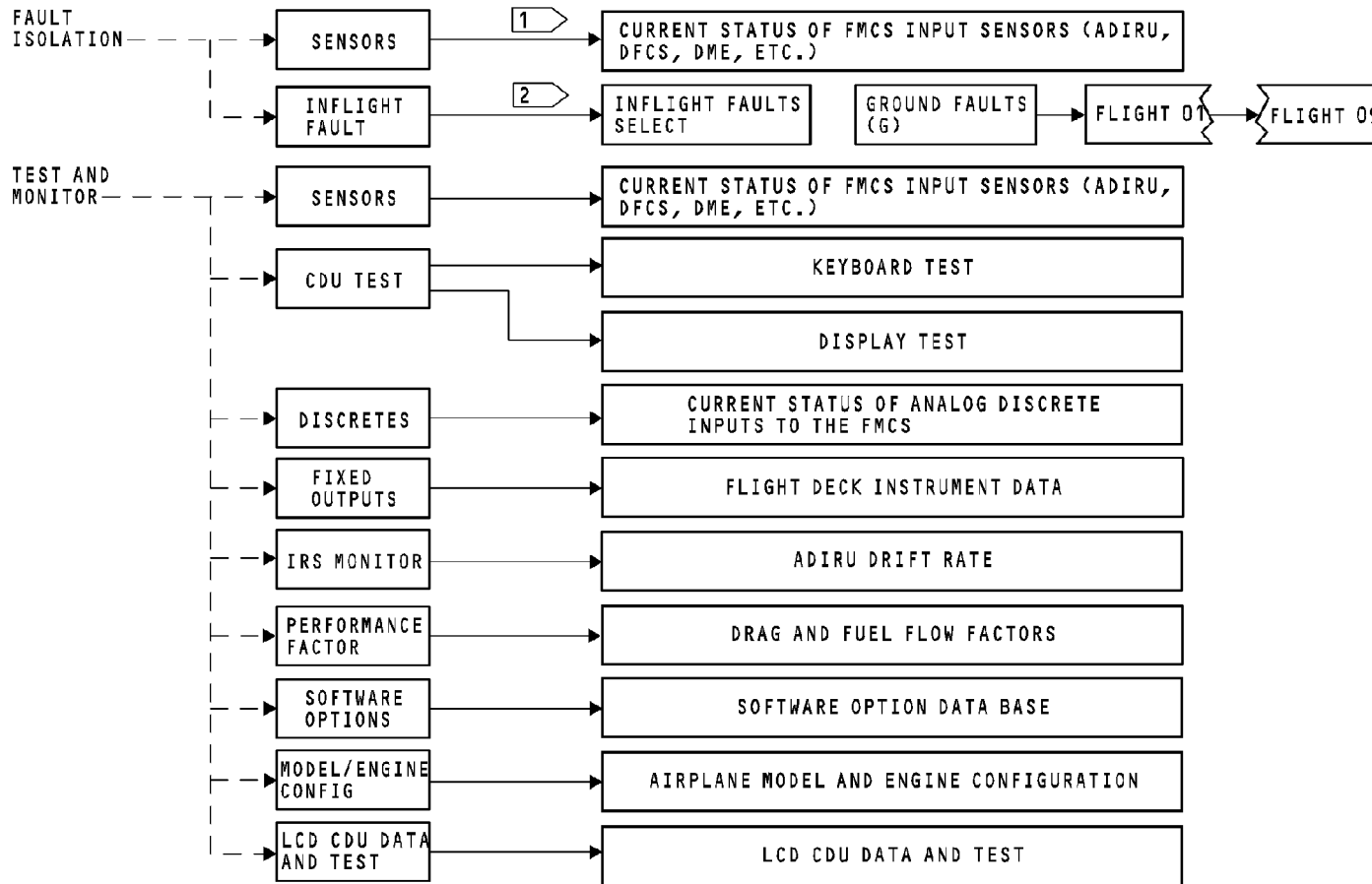

1 ENGINEERING DATA AVAILABLE WITH ACCESS CODE 100 2 ENGINEERING DATA AVAILABLE WITH ACCESS CODE 300

FMCS - TRAINING INFORMATION POINT - FMCS BITE PAGES - INTRODUCTION

EFFECTIVITY

HAP 031-054, 101-999; HAP 030 POST SB 737-34-1918; HAP 006-013, 015-026, 028, 029
 PRE SB 737-34-1666 OR POST SB 737-34-1918; HAP 001-005 POST SB 737-34-1951 GRP 1
 AND (PRE SB 737-34-1666 OR POST SB 737-34-1918)

34-61-00

D633A101-HAP

Page 98.211
 Jun 15/2009

34-61-00-054

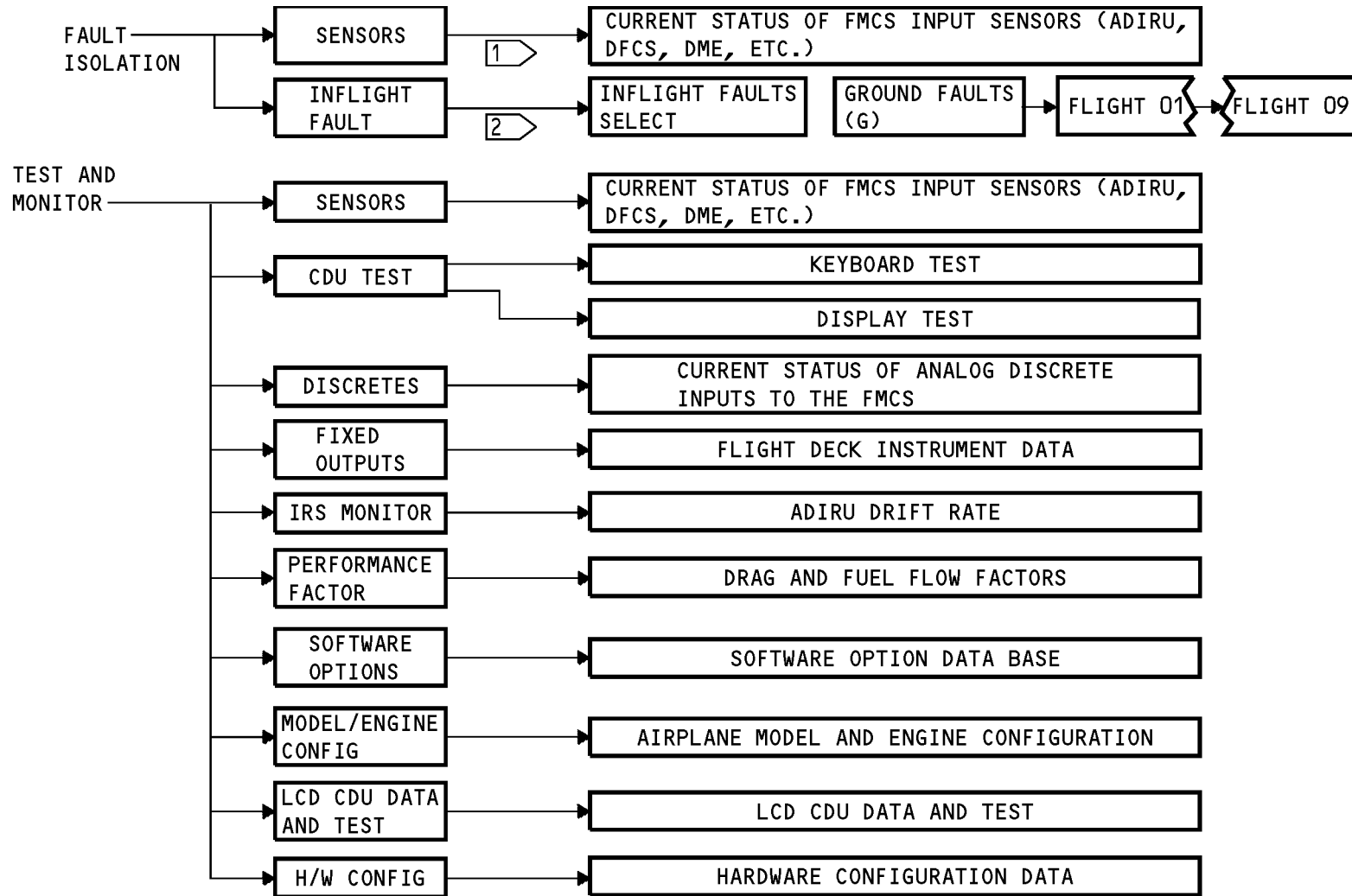

1 ENGINEERING DATA AVAILABLE WITH ACCESS CODE 100

2 ENGINEERING DATA AVAILABLE WITH ACCESS CODE 300

FMCS - TRAINING INFORMATION POINT - FMCS BITE PAGES - INTRODUCTION

EFFECTIVITY

HAP 030 PRE SB 737-34-1918; HAP 006-013, 015-026, 028, 029 POST SB 737-34-1666 AND PRE SB 737-34-1918; HAP 001-005 POST SB 737-34-1951 GRP 1 AND POST SB 737-34-1666 AND PRE SB 737-34-1918

34-61-00

D633A101-HAP

Page 98.212
Jun 15/2009

THIS PAGE IS INTENTIONALLY LEFT BLANK

34-61-00

D633A101-HAP

Page 98.213
Jun 15/2009

FMCS - TRAINING INFORMATION POINT - FMCS BITE PAGES - BITE ENTRY**General**

To get access to the MAINT BITE INDEX page, use the MAINT > prompt (LSK 6R) on the INIT/REF INDEX page.

The MAINT prompt only shows if the airplane is on the ground and the groundspeed (as sensed by the IR section of the ADIRU) is less than 20 knots.

NOTE: In the air on the INIT/REF INDEX page, NAV STATUS shows at LSK 6R.

The MAINT BITE INDEX page shows these airplane sub-systems:

- FMCS
- DFCS
- A/T
- ADIRS
- CDS
- ENGINE
- APU
- FQIS.

Also, there is a prompt for FMC DOWNLOAD at LSK 6R.

HAP 001-013, 015-026, 028-036

On the MAINT BITE INDEX page, select FMCS to get access to FMCS BITE.

HAP 037-054, 101-999

On the FMCS BITE page, either FMC LEFT (FMC 1) or FMC RIGHT (FMC 2) can be selected as the BITE data source.

It is possible to select FMC 1 as the BITE data source on the left CDU and FMC 2 as the BITE data source on the right CDU. In this configuration, sensor data can be compared for both FMCs.

If the BITE information from the FMC is not available or invalid, the caret (<) does not show and the message LEFT (or RIGHT) FMC BITE INOP shows.

The CROSSLOAD prompt gives the capability for crossload of the OFP or other data bases between FMCs.

The process starts by selection of the CROSSLOAD prompt (LSK 6R). The CDU then shows the FMCS CROSSLOAD page which has instructions for crossloading the applicable data base between FMCs.

Primary/Secondary FMC Select

The primary FMC provides the CDU display data. The arrow direction in the top left corner of the CDUs shows which FMC is primary. You use the FMCS transfer switch to select the primary FMC.

FMCS - TRAINING INFORMATION POINT - FMCS BITE PAGES - BITE ENTRY

HAP 037-054, 101-999 (Continued)

In the example on the graphic, the arrow points to the left to show that FMC 1 is the primary FMC. If the arrow points to the right, this shows that FMC 2 is the primary FMC.

When the FMC select switch on the P5 overhead panel is in the NORMAL or BOTH-ON-LEFT position, FMC 1 is the primary FMC. In the BOTH-ON-RIGHT position, FMC 2 is the primary FMC.

HAP ALL

FMCS BITE Page

The FMCS BITE page has these FMC maintenance categories:

- INFLT FAULTS
- CDU TEST
- SENSORS
- DISCRETES
- FIXED OUTPUTS
- MODEL/ENG
- SW OPTIONS
- PERF FACTOR

HAP 006-013, 015-026, 028-054, 101-999; HAP 001-005 POST SB 737-34-1951 GRP 1

- LCD CDU

HAP ALL

- IRS MONITOR.

HAP 030 PRE SB 737-34-1918; HAP 001-013, 015-026, 028, 029 POST SB 737-34-1666 AND PRE SB 737-34-1918

- H/W CONFIG

HAP ALL

FMC Download

HAP 031-054, 101-999

The FMC DOWNLOAD prompt gives the capability to copy FMC internal diagnostic data to a 3.5-inch diskette without removal of the FMC from the airplane. The data is downloaded to the airborne data loader (ADL) from specially formatted diskettes.

HAP 001-013, 015-026, 028-030

The FMC DOWNLOAD prompt gives the capability to copy FMC internal diagnostic data to a 3.5 inch diskette without removal of the FMC from the airplane. The data is downloaded to a portable data loader (PDL) from specially formatted diskettes.

HAP 031-054, 101-999

The process starts by selection of the FMC DOWNLOAD prompt (LSK 6R). The CDU shows the FMCS DATA LOADER page which has instructions for downloading the data to the ADL.

HAP 001-013, 015-026, 028-030

The process starts by selection of the FMC DOWNLOAD prompt (LSK 6R). The CDU shows the FMCS DATA LOADER page which has instructions for downloading the data to the PDL.

34-61-00-055

<p>EFFECTIVITY HAP ALL</p>
--

34-61-00

D633A101-HAP

Page 98.215
Jun 15/2009



FMCS - TRAINING INFORMATION POINT - FMCS BITE PAGES - BITE ENTRY

HAP 001-013, 015-026, 028-030 (Continued)

HAP 037-054, 101-999

The position of the FMC select switch determines which FMC gives the download data.

HAP ALL

34-61-00-055

EFFECTIVITY
HAP ALL

34-61-00

D633A101-HAP

Page 98.216
Jun 15/2009

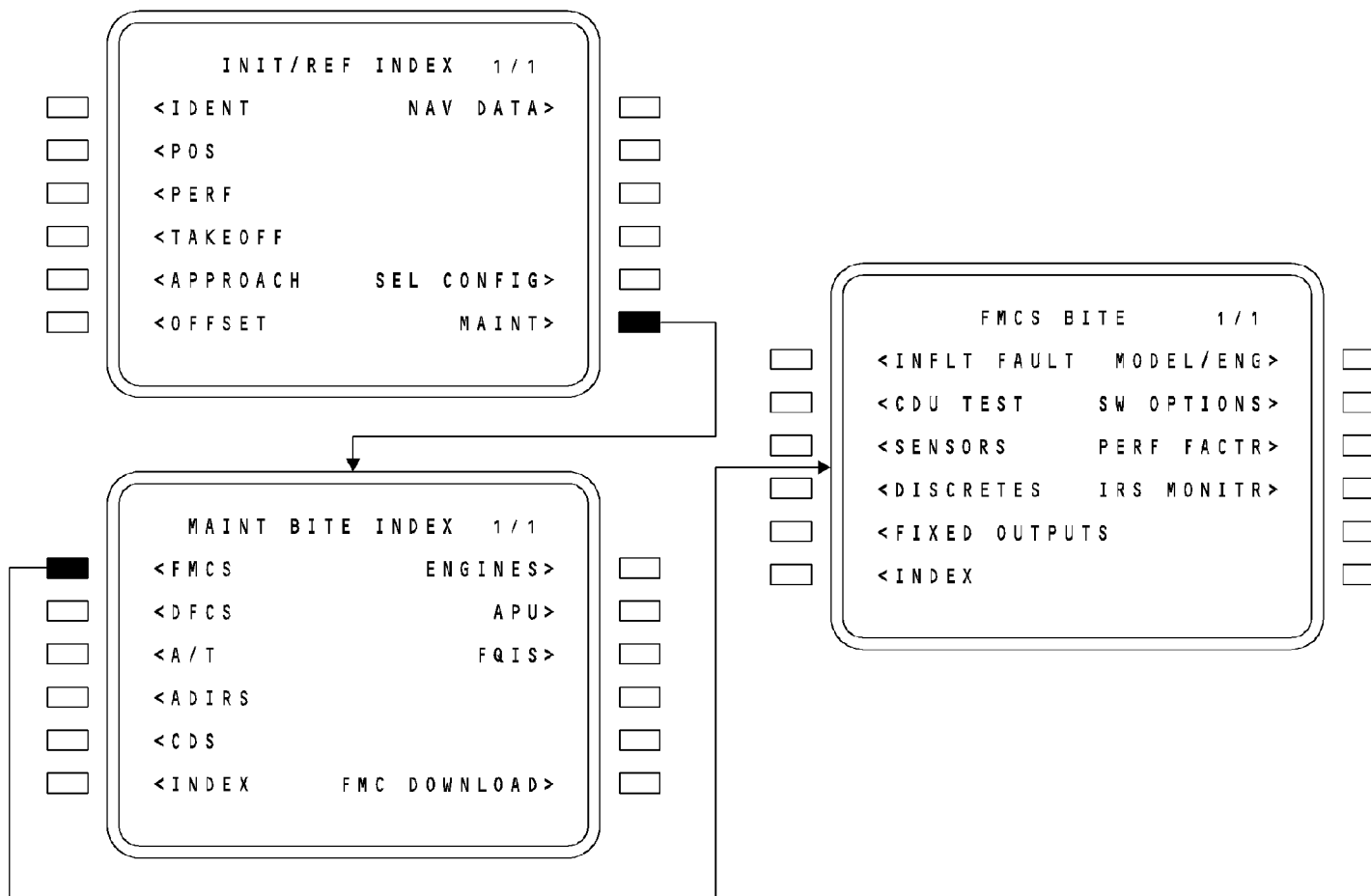

FMCS - TRAINING INFORMATION POINT - FMCS BITE PAGES - BITE ENTRY

EFFECTIVITY

HAP 001-005 PRE SB 737-34-1951 GRP 1 AND (PRE SB 737-34-1666 OR POST SB 737-34-1918)

34-61-00

D633A101-HAP

Page 98.217
Jun 15/2009

34-61-00-055

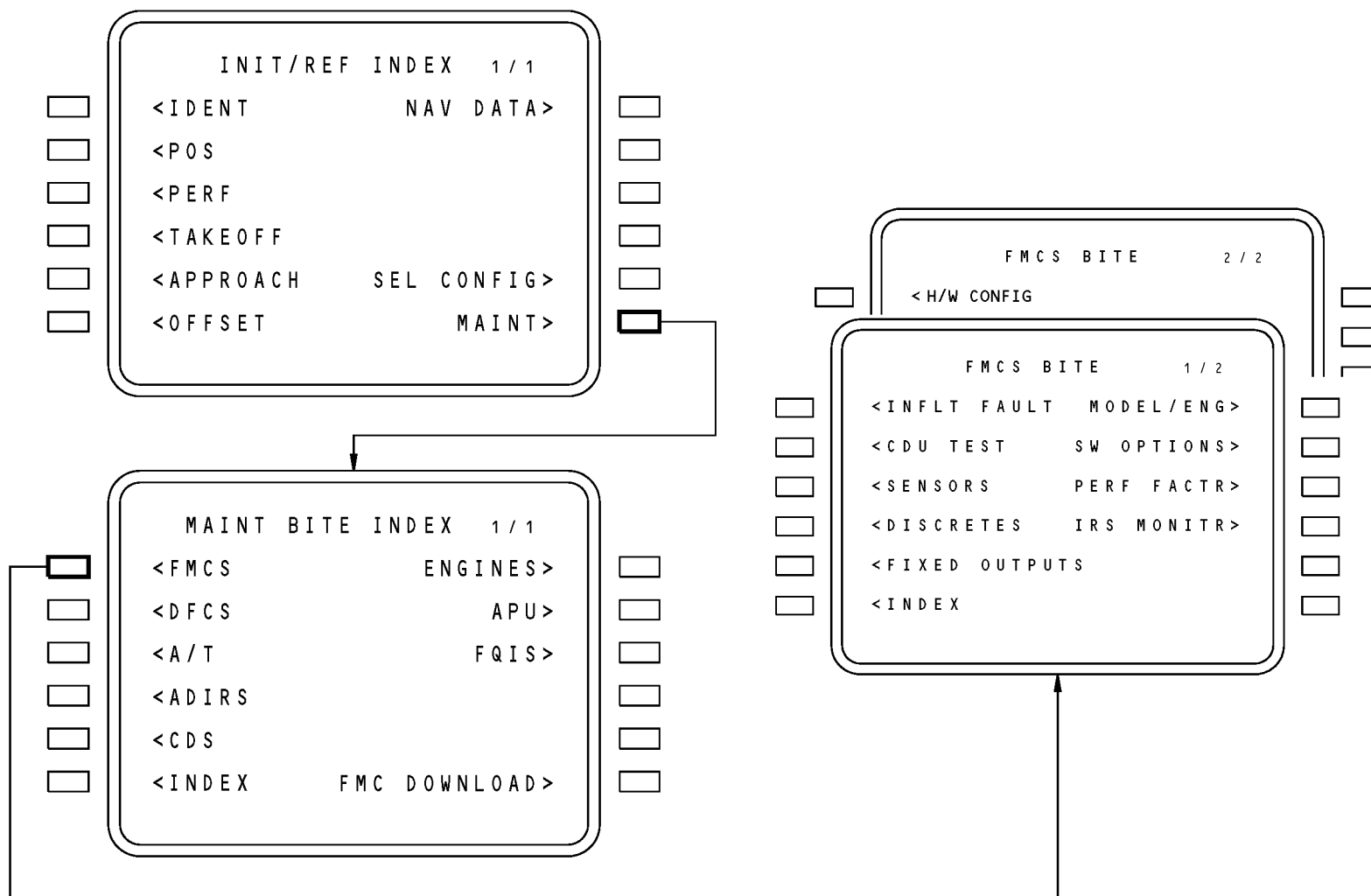

FMCS - TRAINING INFORMATION POINT - FMCS BITE PAGES - BITE ENTRY

EFFECTIVITY

HAP 001-005 POST SB 737-34-1666 AND PRE SB 737-34-1918 AND PRE SB 737-34-1951 GRP 1

34-61-00

D633A101-HAP

Page 98.218
Jun 15/2009

34-61-00-055

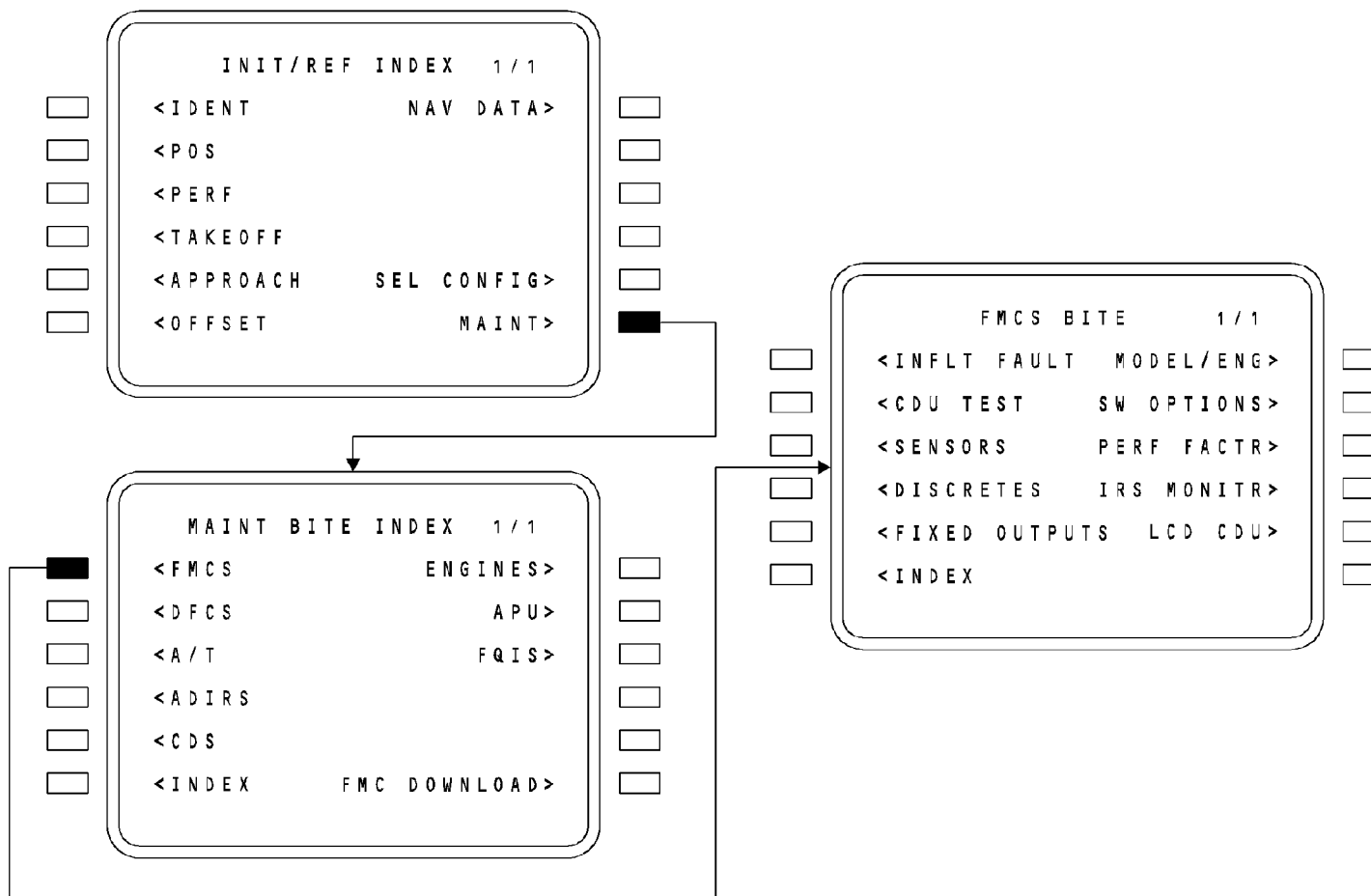

FMCS - TRAINING INFORMATION POINT - FMCS BITE PAGES - BITE ENTRY

EFFECTIVITY

HAP 031-036; HAP 030 POST SB 737-34-1918; HAP 006-013, 015-026, 028, 029 PRE SB 737-34-1666 OR POST SB 737-34-1918; HAP 001-005 POST SB 737-34-1951 GRP 1 AND (PRE SB 737-34-1666 OR POST SB 737-34-1918)

34-61-00

D633A101-HAP

Page 98.219
Jun 15/2009

34-61-00-055

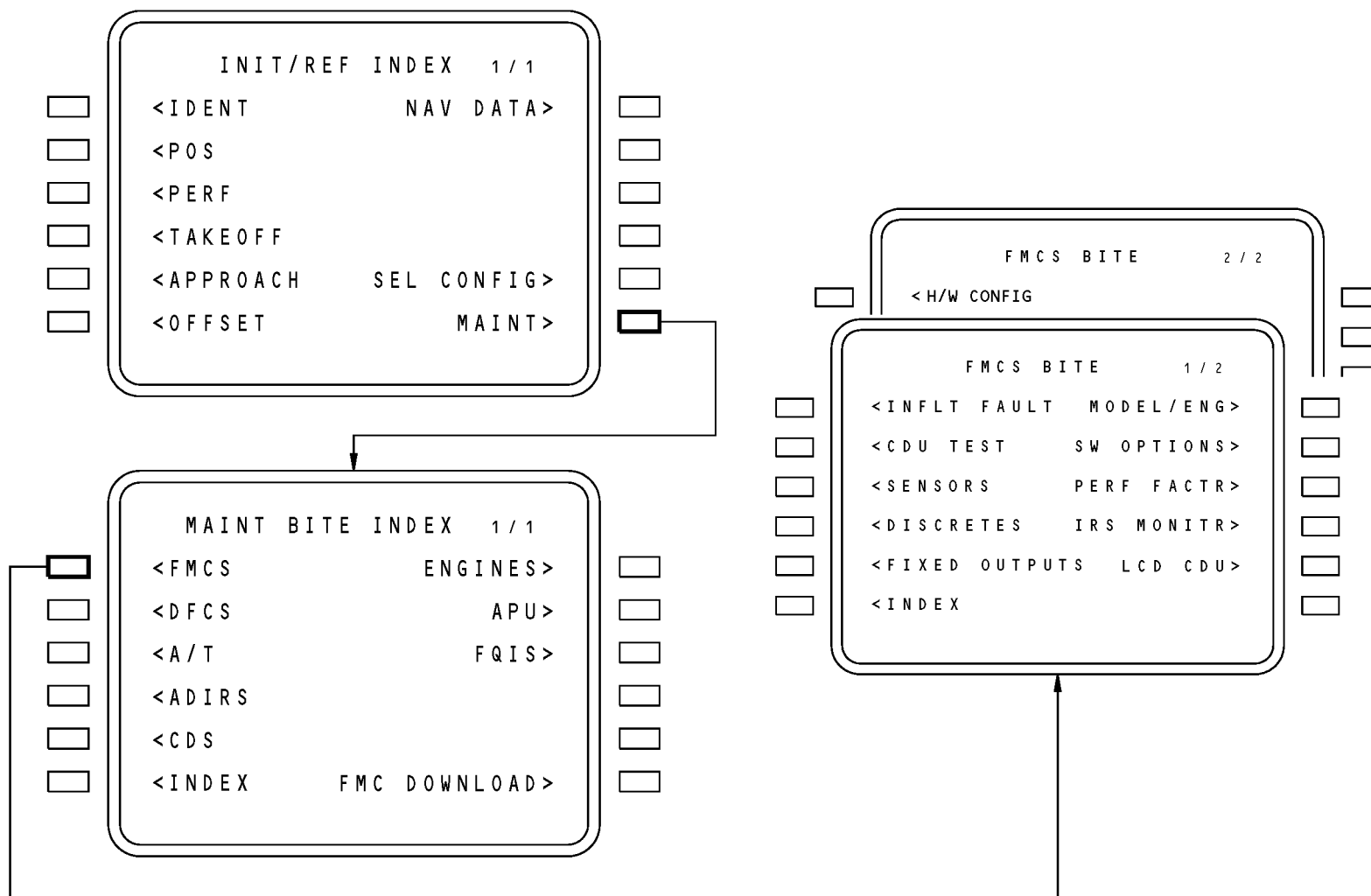

FMCS - TRAINING INFORMATION POINT - FMCS BITE PAGES - BITE ENTRY

EFFECTIVITY

HAP 030 PRE SB 737-34-1918; HAP 006-013, 015-026, 028, 029 POST SB 737-34-1666 AND PRE SB 737-34-1918; HAP 001-005 POST SB 737-34-1951 GRP 1 AND POST SB 737-34-1666 AND PRE SB 737-34-1918

34-61-00

D633A101-HAP

Page 98.220
Jun 15/2009

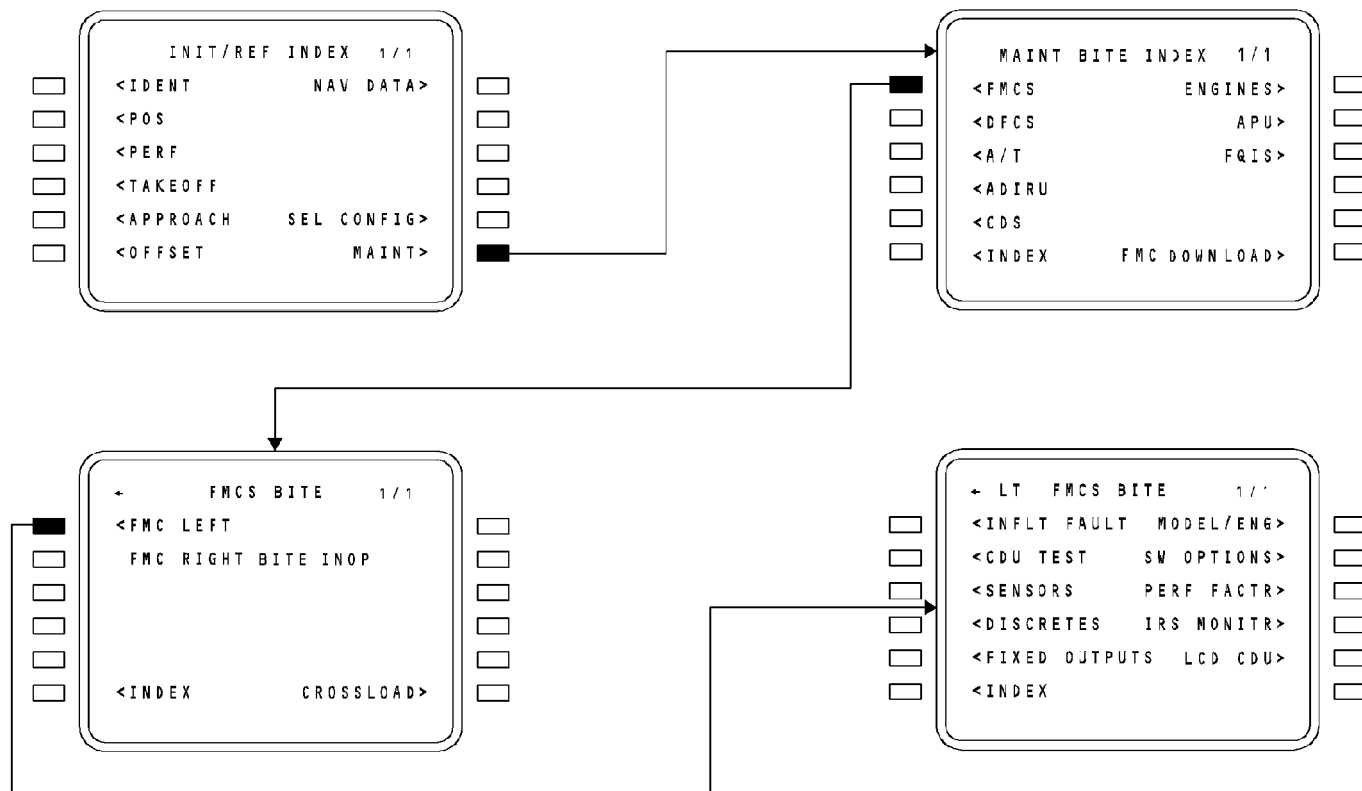

FMCS - TRAINING INFORMATION POINT - FMCS BITE PAGES - BITE ENTRY

EFFECTIVITY
HAP 037-054, 101-999

34-61-00

D633A101-HAP

Page 98.221
Jun 15/2009

34-61-00-055

FMCS - TRAINING INFORMATION POINT - FMCS BITE PAGES - AUTOMATIC BITE ENTRY**General**

At start-up on the ground, the primary and secondary FMCS compare this information over the intersystem bus from one FMCS to the other:

- Operational flight programs (OFP)
- Navigation data base
- Supplemental navigation data base
- Model/Engine data base
- ACARS datalink data base
- Software options data base
- Analog discretes/program pins
- Performance factors.

Ground Start-up

If the two OFPs do not agree, the primary FMCS shows the OP PROGRAM CROSSLOAD page. You use this page to crossload the correct OFP.

If the databases do not agree, a crossload page for that particular database shows on the CDU.

If an analog discrete/program pin or a performance factor does not agree, the analog discrete or the performance factor page shows. A highlight shows around the item that does not agree.

If you exit BITE before corrective action is taken, the secondary FMCS is conditionally failed and the message SINGLE FMCS OPERATION shows in the scratchpad on the CDUs.

In Flight Restarts

For in flight restarts, the two FMCS also compare their information. If the information does not agree, the secondary FMCS is conditionally failed and the message SINGLE FMCS OPERATION shows in the scratchpad on the CDUs.

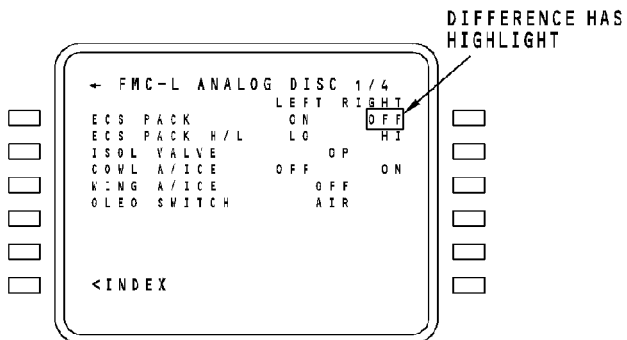

ANALOG DISCRETES
DISAGREE AT POWER UP

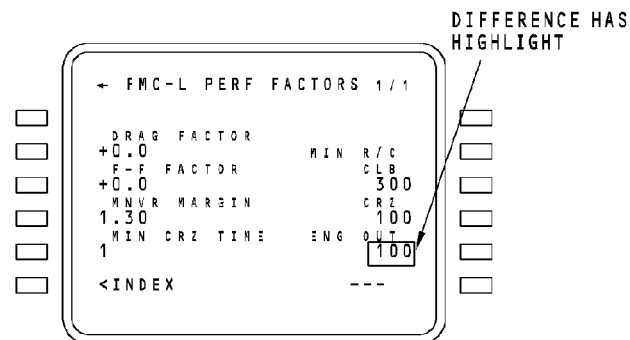

PERFORMANCE FACTORS
DISAGREE AT POWER UP

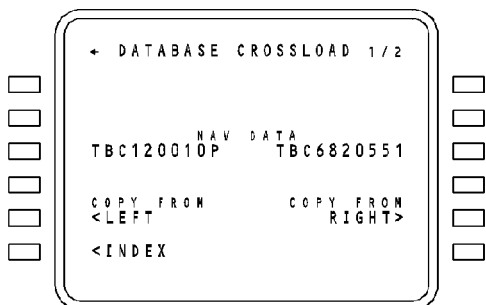

NAV DATABASE
DISAGREE AT POWER UP

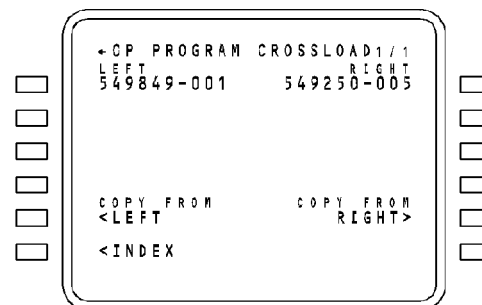

OPERATION FLIGHT PROGRAM
DISAGREE AT POWER UP

FMCS - TRAINING INFORMATION POINT - FMCS BITE PAGES - AUTOMATIC BITE ENTRY

34-61-00-056

EFFECTIVITY
HAP 037-054, 101-999

34-61-00

D633A101-HAP

Page 98.223
Jun 15/2009

FMCS - TRAINING INFORMATION POINT - FMCS BITE PAGES - INFLIGHT FAULT**General**

To see in-flight faults, select INFLT FAULT (LSK 1L) on the FMCS BITE page.

The FMC stores in-flight faults for the last nine flight legs and faults that occur on the ground. The FMC can store up to 20 faults for each flight leg.

A new flight leg starts when the groundspeed is more than 20 knots and the airplane goes into the air mode. The flight stops when the airplane touches down and the groundspeed is less than 20 knots.

Faults that occur on the ground are stored as ground faults. These faults clear from the non-volatile memory in the FMC when the groundspeed is more than 20 knots and the airplane becomes airborne. If the fault is still present at this time, it becomes an in-flight fault.

In-Flight Faults Page

The in-flight faults page shows this data:

- Name of the LRU/sub-system
- Where the fault occurred (in flight or on the ground)

HAP 037-054, 101-999

- Fault was recorded by one or both FMCs

HAP ALL

- Flight leg when the fault occurred.

All of the LRU/sub-systems that interface with the FMCS show on the IN FLTS FAULTS pages. These LRU/sub-systems show on pages 1, 2, and 3:

- Air data inertial reference system (ADIRS)
- Digital flight control system (DFCS)
- Distance measuring equipment (DME)
- Fuel quantity indicating system (FQIS)
- Common display system (CDS)
- VHF omni-directional range (VOR)
- Multi-mode receiver (MMR)
- Clock

HAP 001-013, 015-026, 028-030

- Airborne communication and reporting system (ACARS)

HAP ALL

- Control display unit (CDU).
- Flight management computer (FMC)

HAP 001-013, 015-026, 028-036

The LRU/sub-systems with a failure show the number from 1 through 9. This number is the flight leg when the fault occurred.

HAP 037-054, 101-999

The LRU/sub-systems with a failure show one of these letters:

- L (FMC 1)
- R (FMC 2)
- B (FMC 1 and FMC 2).

FMCS - TRAINING INFORMATION POINT - FMCS BITE PAGES - INFLIGHT FAULT

HAP 037-054, 101-999 (Continued)

This shows the FMC that recorded the fault. The alpha-numeric characters at the top of the page show which flight leg the fault occurred in or if it occurred on the ground.

HAP ALL

Flight number 1 is the last flight and flight number 9 is 9 flights ago. The letter G shows that the fault was recorded on the ground after the last flight.

NOTE: Ground faults are FMC and MCDU faults only.

If no faults were recorded by the FMCS for that LRU, the display to the right of the LRU is blank.

Line select key 6L shows the INDEX prompt. This selects the FMCS BITE INDEX page.

To see more details about the possible LRU failures, you can set the engineering code 300 into the scratch pad and push LSK 6R. This shows the flight select page.

Flight Select Page

This page shows a menu of the flight legs that have faults recorded. If no faults were recorded by the FMCS for a particular flight leg, the flight leg does not show on the CDU.

The engineering data can be selected for a particular flight leg or ground fault from this page and show on the FLIGHT page.

Line select key 6L shows the INDEX prompt. This selects the IN FLT FAULTS page.

Flight Page

This page shows the engineering data for the selected flight leg. The faults show in chronological order

This engineering data shows for each fault:

- System code
- Label code
- Fault state
- Failure time
- Monitor code.

The system code shows the failed LRU or sub-system.

For an FMCS fault, the label code shows the failed circuitry or a program fault in the FMC. For a sensor input fault, the label code identifies the ARINC word with the fault.

Fault condition shows if the fault was steady (S) or intermittent (I). All faults are initially recorded as a steady fault. If the fault goes away, the indication changes to intermittent.

34-61-00-057

EFFECTIVITY
HAP ALL

34-61-00

D633A101-HAP

Page 98.225
Jun 15/2009

FMCS - TRAINING INFORMATION POINT - FMCS BITE PAGES - INFLIGHT FAULT

Failure time shows the GMT of the first occurrence of the fault. This time does not change if the fault goes away and then comes back.

For an FMCS fault, the monitor code shows the type of program fault in the FMC. For a sensor input fault, the monitor code shows the specific type of ARINC 429 failure.

These are the monitor codes for ARINC 429 failures:

- Rate (receive rate failure)
- Parity (parity failure)
- SSM (sign/status matrix failure)
- Reason (reasonableness failure).

Line select key 6L shows the INDEX prompt. This selects the FLIGHT SELECT page.

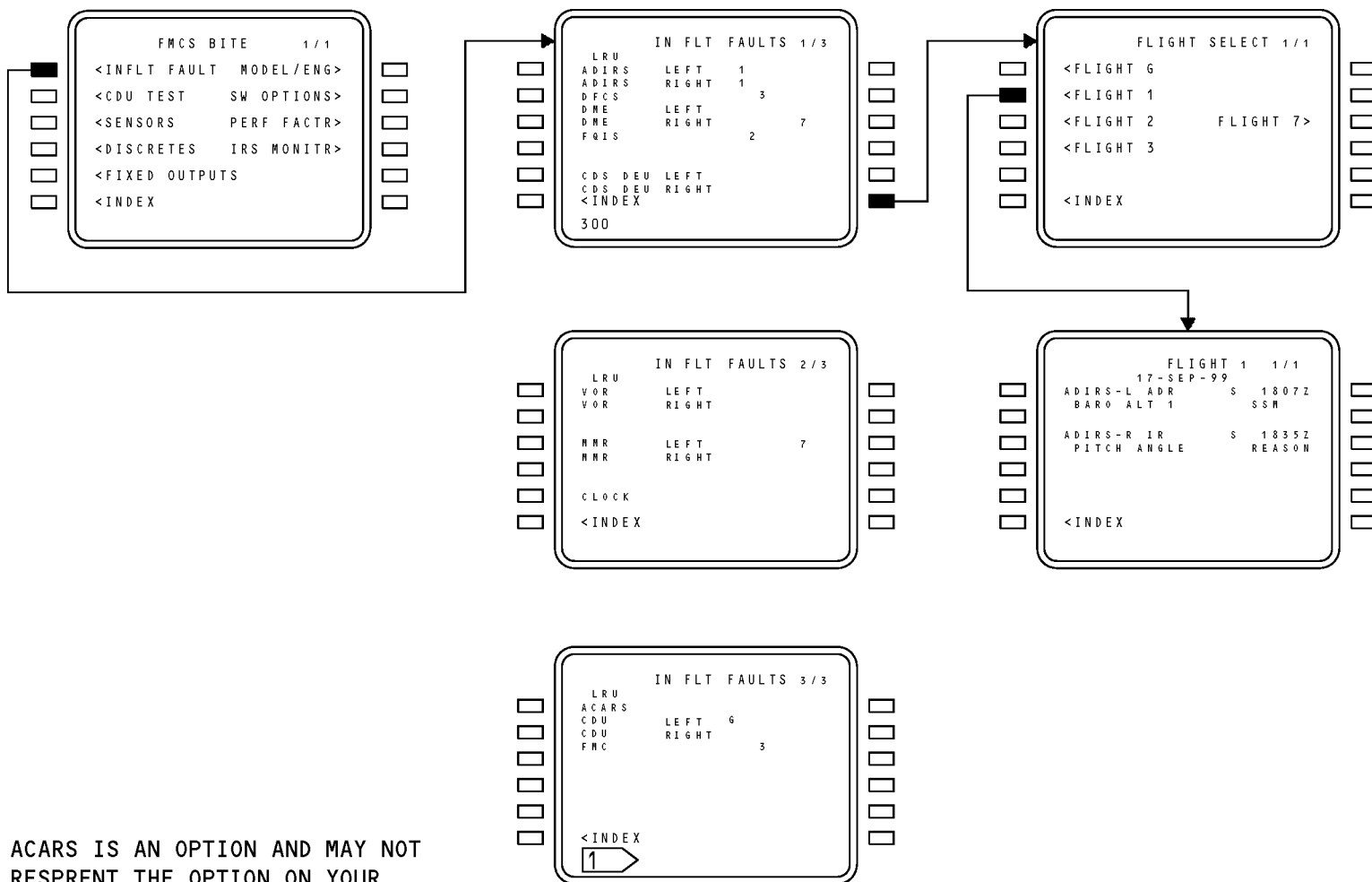

1 ACARS IS AN OPTION AND MAY NOT RESPRENT THE OPTION ON YOUR AIRPLANE(S).

FMCS - TRAINING INFORMATION POINT - FMCS BITE PAGES - INFLIGHT FAULT

EFFECTIVITY
HAP 001-005 PRE SB 737-34-1951 GRP 1

34-61-00

D633A101-HAP

Page 98.227
Jun 15/2009

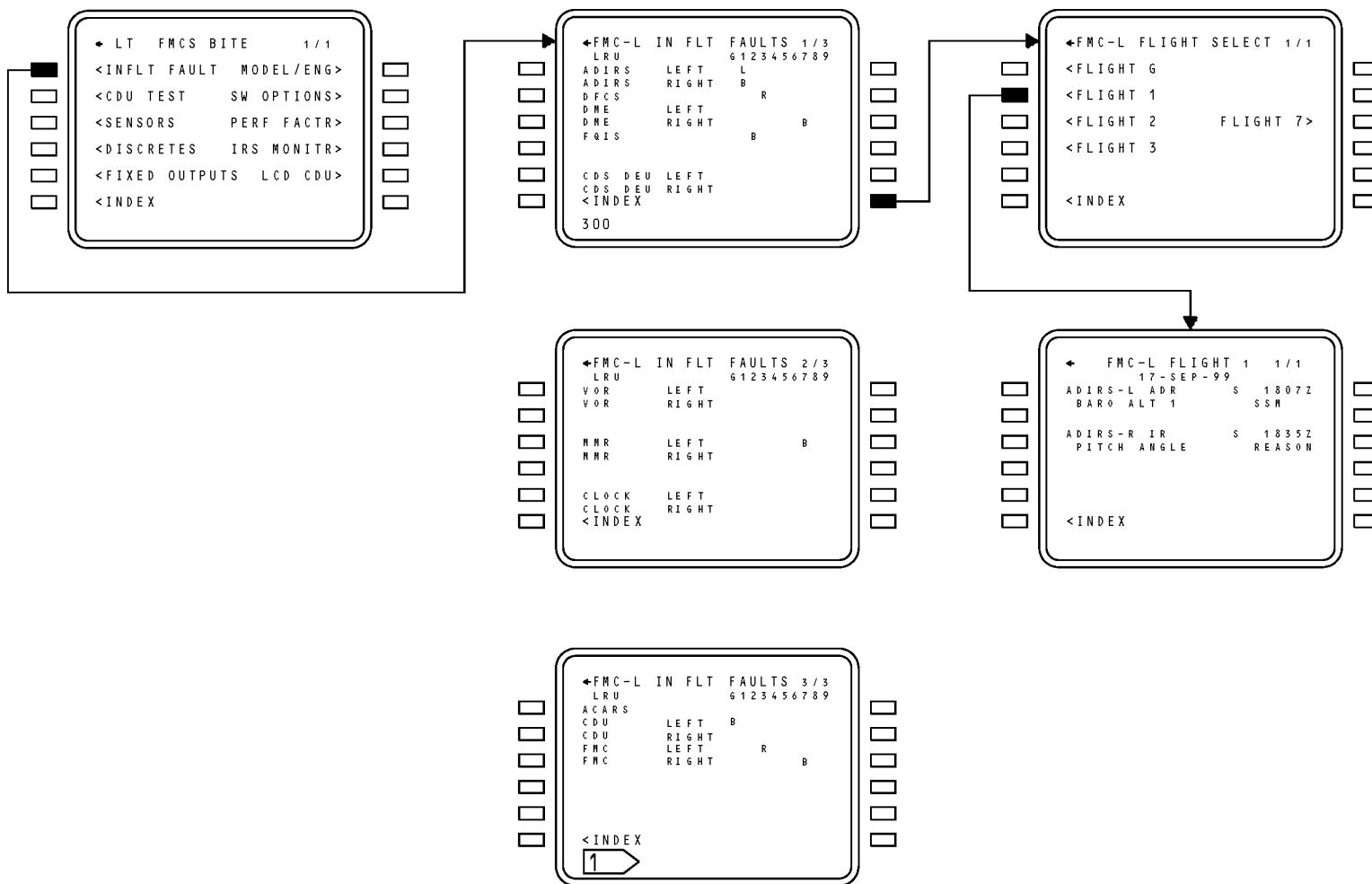

1 ACARS IS AN OPTION AND MAY NOT REPRESENT THE OPTION ON YOUR AIRPLANE(S).

FMCS - TRAINING INFORMATION POINT - FMCS BITE PAGES - INFLIGHT FAULT

EFFECTIVITY
HAP 037-054, 101-999

34-61-00

D633A101-HAP

Page 98.228
Jun 15/2009

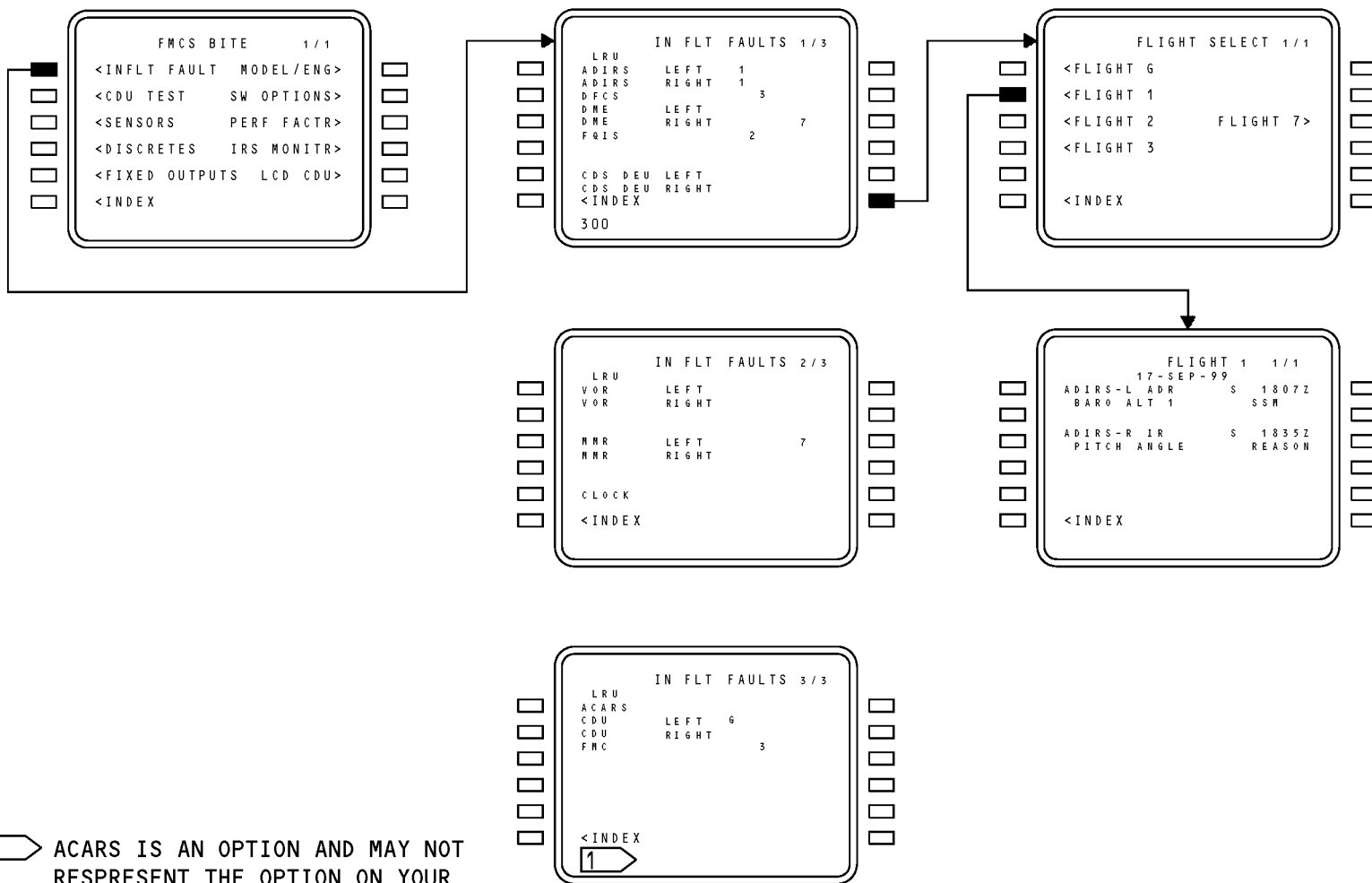

1 ACARS IS AN OPTION AND MAY NOT REPRESENT THE OPTION ON YOUR AIRPLANE(S).

FMCS - TRAINING INFORMATION POINT - FMCS BITE PAGES - INFLIGHT FAULT

EFFECTIVITY

HAP 006-013, 015-026, 028-036; HAP 001-005 POST SB 737-34-1951 GRP 1

34-61-00

D633A101-HAP

Page 98.229
Jun 15/2009

FMCS - TRAINING INFORMATION POINT - FMCS BITE PAGES - CDU TEST**General**

To test the MCDUs, select CDU TEST on line select key (LSK) 2L, from the FMCS BITE page.

The CDU TEST is an interactive self test that shows the MCDU characters. It also tests the MCDU push buttons and annunciators.

FMCS CDU TEST Page

On this page you can select the CDU DSPLY TEST (LSK 5R) or the CDU KEY TEST (LSK 5L).

FMCS DSPLY TEST Page

This test shows the complete MCDU character set.

Push LSK 6L to go back to the FMCS CDU TEST page.

FMCS KEY TEST

This test shows the MCDU faceplate keys on the MCDU screens. As you push each key on a keyboard, the MCDUs highlight the key on the screen while the scratchpad shows the name of the key you pushed.

When you push LSK 6L the second time, the MCDU goes back to the FMCS CDU TEST page.

When you push the INIT/REF key the second time, the MCDU goes back to the INIT/REF page.

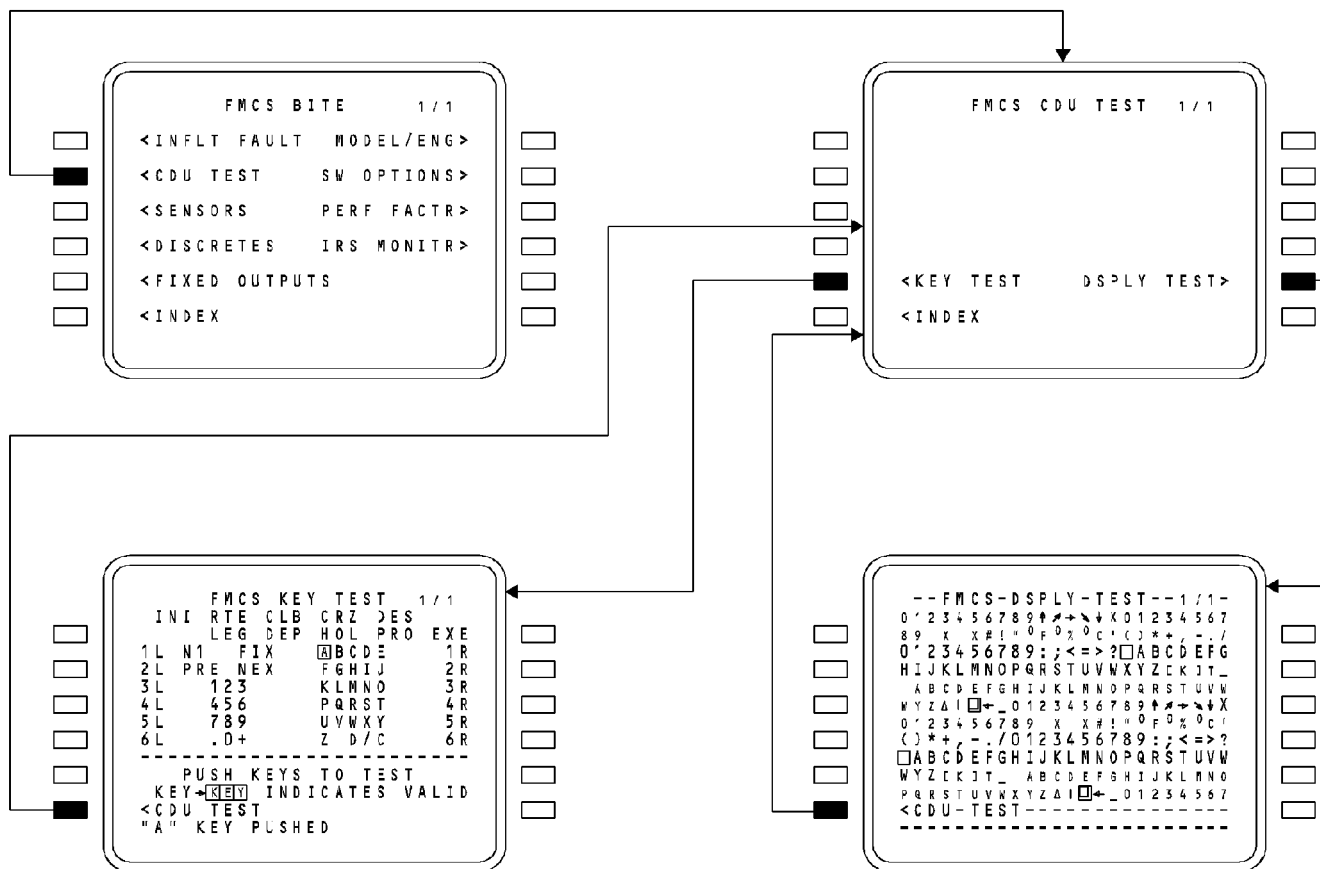

FMCS - TRAINING INFORMATION POINT - FMCS BITE PAGES - CDU TEST

34-61-00-058

EFFECTIVITY
HAP 001-005

34-61-00

D633A101-HAP

Page 98.231
Jun 15/2009

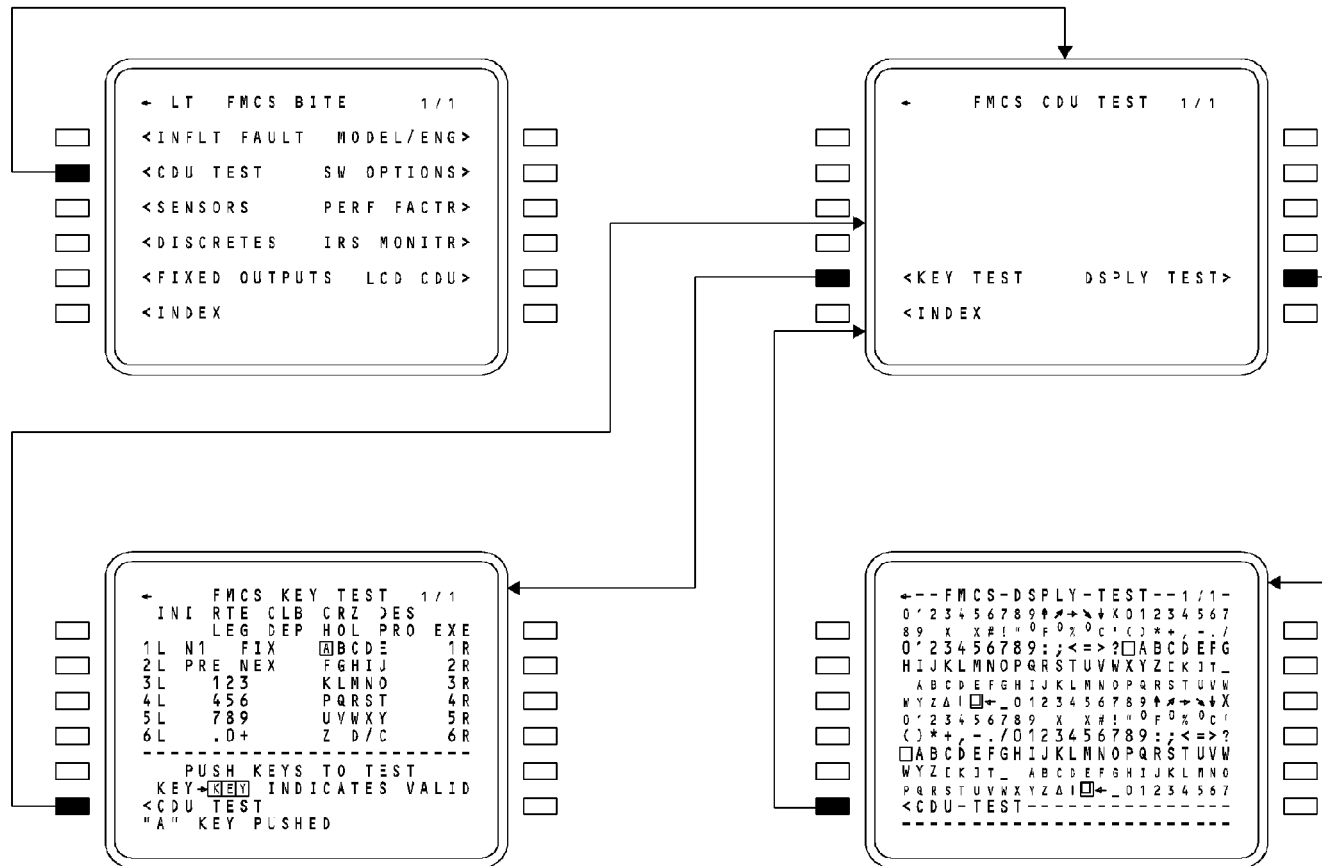

FMCS - TRAINING INFORMATION POINT - FMCS BITE PAGES - CDU TEST

EFFECTIVITY
HAP 037-054, 101-999

34-61-00

D633A101-HAP

Page 98.232
Jun 15/2009

34-61-00-058

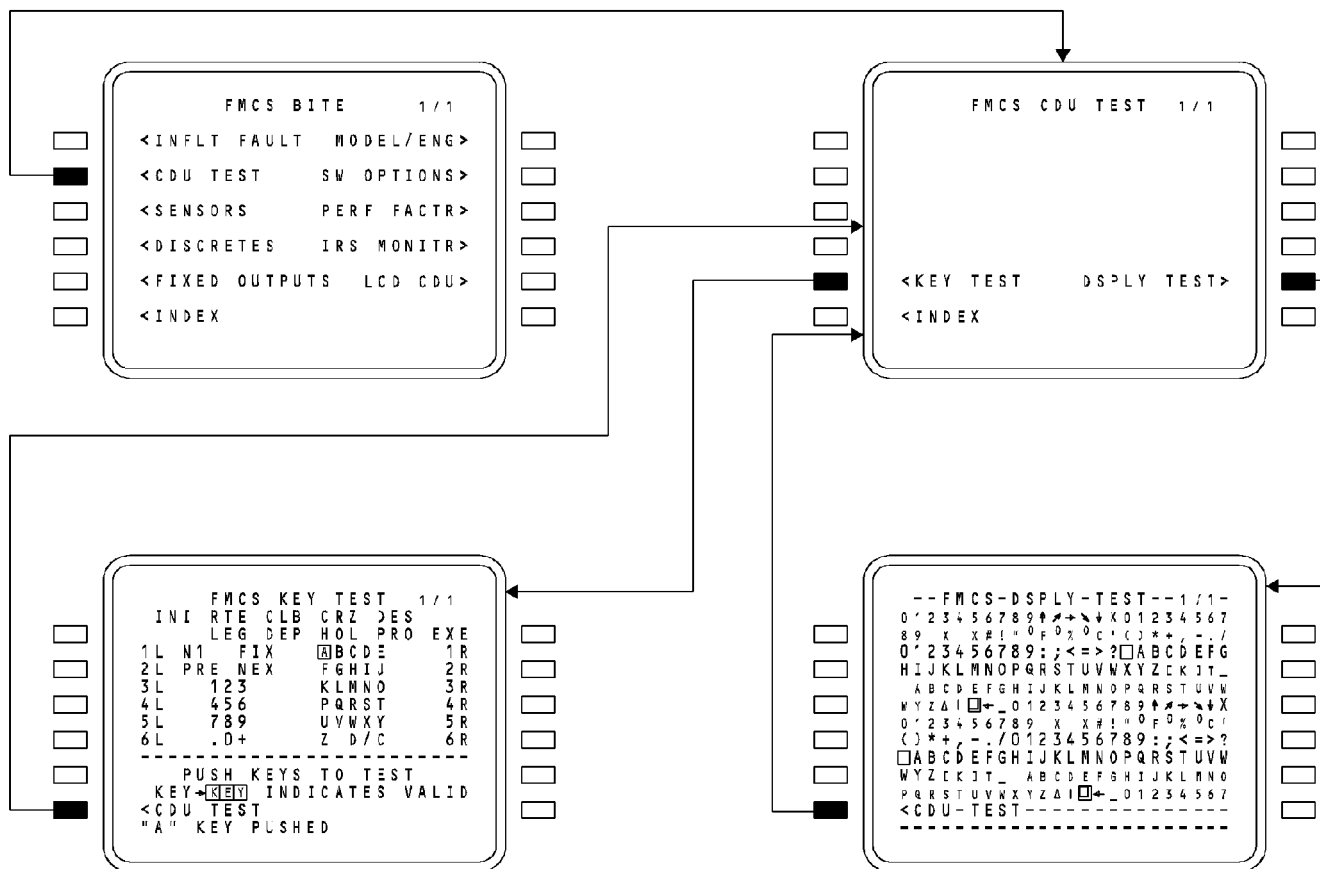

FMCS - TRAINING INFORMATION POINT - FMCS BITE PAGES - CDU TEST

EFFECTIVITY

HAP 006-013, 015-026, 028-036; HAP 001-005 POST SB 737-34-1951 GRP 1

34-61-00

D633A101-HAP

Page 98.233
Jun 15/2009

34-61-00-058

THIS PAGE IS INTENTIONALLY LEFT BLANK

34-61-00

D633A101-HAP

Page 98.234
Jun 15/2009

FMCS - TRAINING INFORMATION POINT - FMCS BITE PAGES - SENSORS**General**

To see FMCS sensor status, select SENSORS on line select key (LSK) 3L from the FMCS BITE page.

Sensor Status Pages**HAP 037-054, 101-999**

The sensor status pages show the current status of all the sensors that send data to the FMC selected as the BITE source.

HAP 001-013, 015-026, 028-036

The sensor status pages show the current status of all the sensors that send data to the FMC.

HAP ALL

These systems send data to the FMCS:

- VOR
- DME
- ADIRS
- MMR (ILS & GPS)
- DFCS
- FQIS
- Clock
- ACARS

HAP 037-054, 101-999

- FMC

HAP ALL

- CDS DEU.

HAP 037-054, 101-999

If the two FMCs do not agree on the status of an LRU, a highlight shows around the status field for that IRU. In the example shown on the graphic, FMC L and FMC R do not agree on the status of the right VOR.

Dashed lines in the status field show the LRU does not exist or the FMC selected as the BITE source does not interface with the LRU. In the example shown on the graphic, the DFCS FCC A is the master FCC and it is the FCC that reports DFCS status to FMC 1 and FMC 2.

HAP 001-013, 015-026, 028-036

Dashed lines in the status field show the LRU does not exist or the FMC does not interface with the LRU. In the example shown on the graphic, the master FCC is the FCC that reports DFCS status to FMC 1.

HAP 037-054, 101-999

The elapsed time indication (ETI) shows the current value in hours for the selected FMC. In the example shown on the graphic, the ETI for the left FMC is shown.

EFFECTIVITY
HAP ALL

34-61-00

D633A101-HAP

Page 98.235
Jun 15/2009

FMCS - TRAINING INFORMATION POINT - FMCS BITE PAGES - SENSORS**HAP 037-054, 101-999 (Continued)****HAP 001-013, 015-026, 028-036**

The elapsed time indication (ETI) shows the current value in hours for the FMC.

HAP ALL

To see the engineering data for the current faults, you can set the engineering code 100 in the scratch pad and select LSK 6R. This will show the sensor data pages.

Sensor Data Pages

This page shows engineering data for sensors which have a FAIL status on a SENSOR STATUS page. The faults show in chronological order.

This engineering information shows for each fault:

- System code
- Label code
- Fault state
- Failure time
- Monitor code.

The system code shows the failed LRU or sub-system.

The label code shows the ARINC word for the fault.

Fault state shows if the fault was steady (S) or intermittent (I). All faults are initially recorded as a steady fault. If the fault later goes away, the indication changes to intermittent.

Failure time shows the GMT of the first occurrence of the fault. This time does not change if the fault goes away and then comes back later.

The monitor code shows the specific type of ARINC 429 failure.

These are the monitor codes for ARINC 429 failures:

- Rate (receive rate failure)
- Parity (parity failure)
- SSM (sign/status matrix failure)
- Reason (reasonableness failure).

To clear the screen, push LSK 6R. After you push the key, only engineering data for faults that are still current will show.

HAP 037-054, 101-999

The clear key only clears the engineering data for the FMC selected as the BITE source. It does not clear the data for both FMCs.

HAP ALL

EFFECTIVITY
HAP ALL

34-61-00

D633A101-HAP

Page 98.236
Jun 15/2009

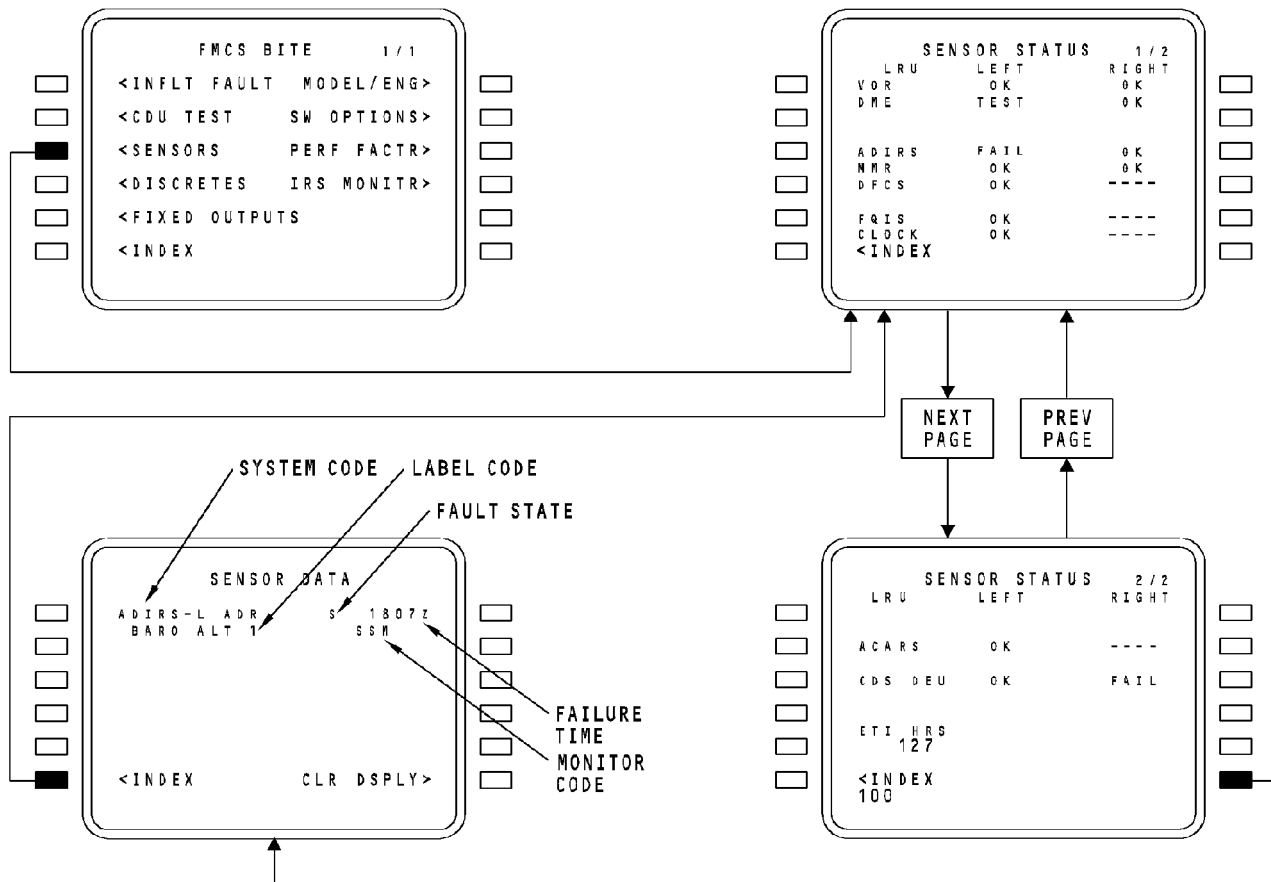

FMCS - TRAINING INFORMATION POINT - FMCS BITE PAGES - SENSORS

34-61-00-059

EFFECTIVITY
HAP 001-005

34-61-00

D633A101-HAP

Page 98.237
Jun 15/2009

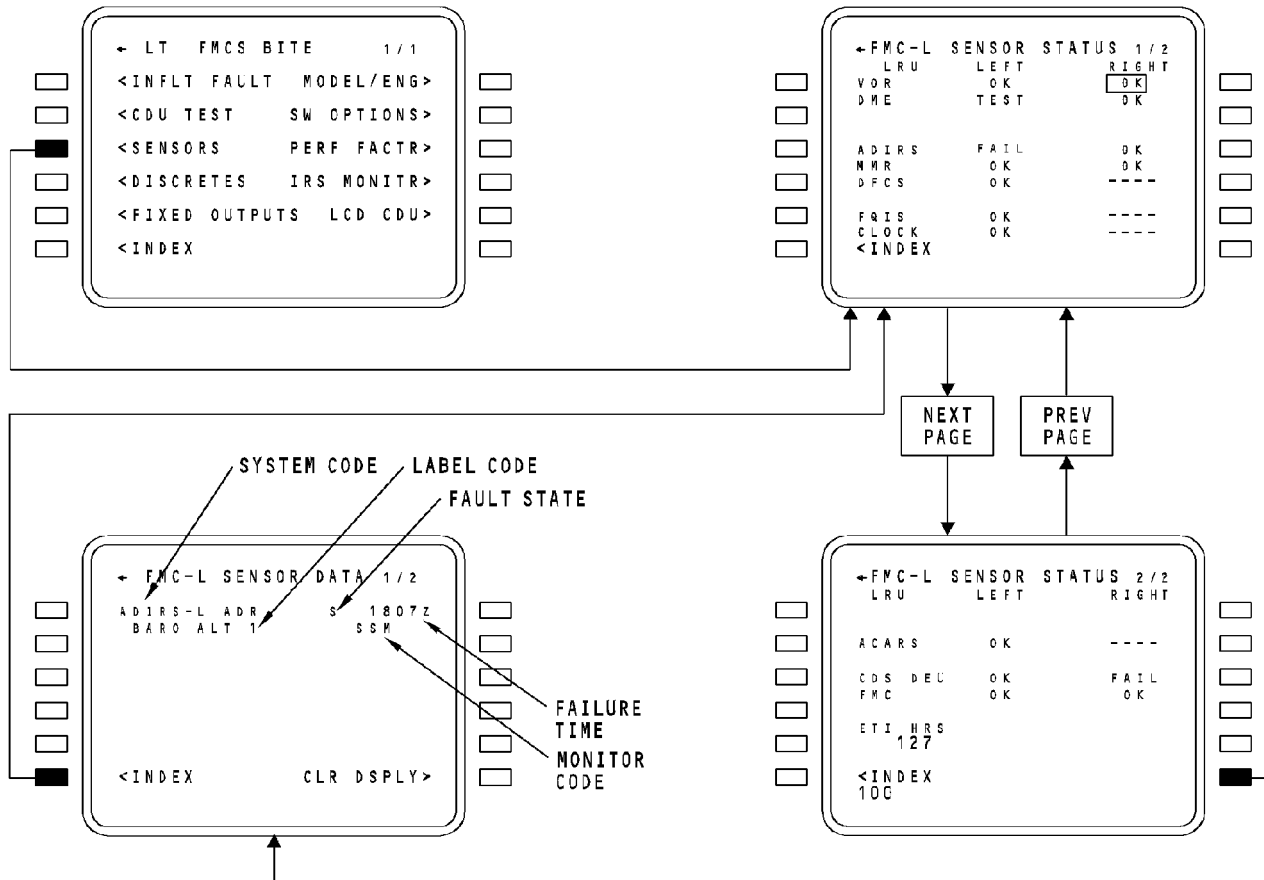

FMCS - TRAINING INFORMATION POINT - FMCS BITE PAGES - SENSORS

EFFECTIVITY
HAP 037-054, 101-999

34-61-00

D633A101-HAP

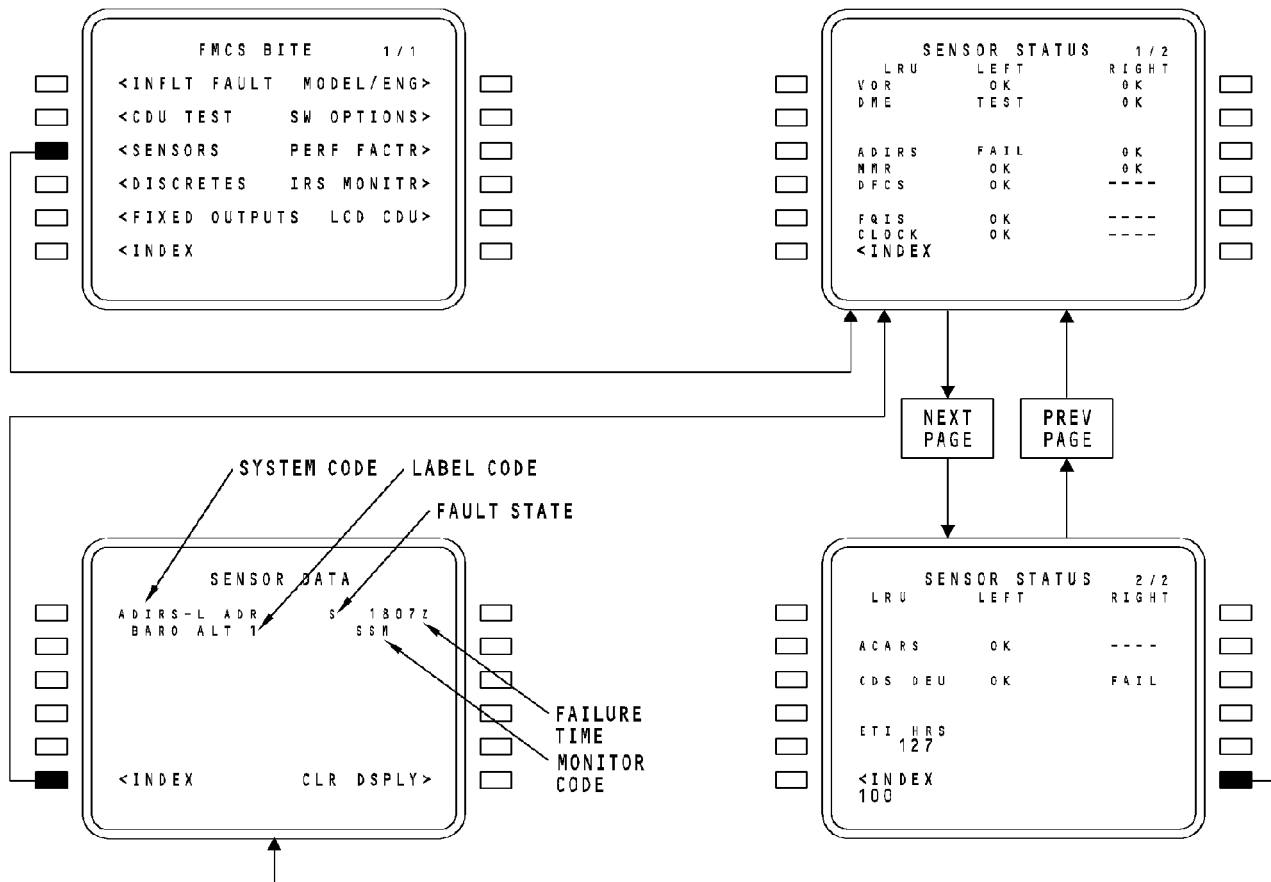

FMCS - TRAINING INFORMATION POINT - FMCS BITE PAGES - SENSORS

34-61-00-059

EFFECTIVITY
 HAP 006-013, 015-026, 028-036; HAP 001-005 POST SB 737-34-1951 GRP 1

34-61-00

D633A101-HAP

Page 98.239
 Jun 15/2009

THIS PAGE IS INTENTIONALLY LEFT BLANK

34-61-00

D633A101-HAP

Page 98.240
Jun 15/2009

FMCS - TRAINING INFORMATION POINT - FMCS BITE PAGES - DISCRETES

General

To do a check of FMCS discretes status, select DISCRETES on LSK 4L, from the FMCS BITE page.

DisCRETes Pages

HAP 001-013, 015-026, 028-036

These pages shows the current status of the analog discretes that send data to the FMC.

HAP 037-054, 101-999

These pages show the current status of the analog discretes that send data to the FMC selected as the BITE source.

If the two FMCs do not agree on the status of a discrete, a highlight shows around the status field for that discrete. In the example shown on the graphic, FMC 1 does not see the right ECS PACK on.

If the two FMCs do not agree on the status of a discrete, that discrete will be shown in amber. In the example shown on the graphic, FMC 1 does not see the right ECS PACK on.

HAP ALL

These are the discretes that you can see on page 1:

- ECS PACK. Shows the position of the ECS flow control and shut off valve in each pack.
- ECS PACK H/L. Shows if the pack is in normal or high flow mode.
- ISOL VALVE. Shows the position of the bleed air isolation valve.
- COWL A/ICE. Shows the position of the engine cowl anti-ice switches on the P5 overhead panel.
- WING A/ICE. Shows the position of the wing anti-ice switches on the P5 overhead panel.
- OLEO SWITCH. Shows the airplane in the ground or air modes. This input comes from the proximity switch electronic unit (PSEU).

These are the discretes that you can see on page 2:

- FAA/JAA FLIGHT RULES - This option sets the CG for the applicable regulatory flight rules.
- KILOGRAM OPTION - This option sets the default for weight entries on the CDU.
- MAG/TRUE - This option is not used.
- SRCE/DEST IDENT. This option is used to identify the FMC. It is always configured to left.
- ASPIRATED TAT - This option is enabled when an aspirated TAT probe is installed on the airplane.
- DEGREE C/DEGREE F DEFAULT. This option sets the default for temperature entries on the CDU.
- PERF CODE - This option sets the performance code for the FMC. It is normally set to 1.

All the options on page 2 are set with the programmable switch modules.

34-61-00-060



34-61-00

D633A101-HAP

Page 98.241
Jun 15/2009

FMCS - TRAINING INFORMATION POINT - FMCS BITE PAGES - DISCRETES

These are the discrettes that you can see on page 3:

HAP 037-054, 101-999

- FMC SOURCE SEL. Shows the position of the FMC source select switch on the P5 overhead panel.

HAP ALL

- MODEL/ENGINE. Shows the current status of the engine/airframe program pins to the FMC. This is set through the programmable switch modules.
- ENGINE BLEED. Shows the position of the engine bleed air switches on the P5 overhead panel.
- SEL CONFIG MODE. This option enables the loadable software configuration. This is set through the programmable switch modules.

These are the discrettes that you can see on page 4:

- VOR INHIBIT - This option disables VOR inputs for the navigation function.
- FLIGHT NUMBER - This option lets the crew enter the flight number on the RTE page.
- TOGA RW POS UPD - This option lets the FMC do a position update when the TOGA switches are pushed on the ground.
- TAKEOFF PROFILE - This option gives FMC control of the altitude at which takeoff thrust is reduced to climb thrust.
- TAKEOFF SPEEDS - This option enables the FMC to calculate the takeoff speeds based on the QRH and shows them on the TAKEOFF page.
- NAVAID SUPPRESS - This option suppresses autotuned nav aids on the CDS map display.
- SEL CRS INHIBIT - This option suppresses selected course radials for manually tuned nav aids on the CDS map display.
- ACARS INSTALLED - This option enables the ACARS/FMC interface.

All the options on page 4 are set with the programmable switch modules.

WARNING: MAKE SURE THAT PERSONS AND EQUIPMENT ARE CLEAR OF THE SLATS BEFORE YOU REMOVE ELECTRICAL POWER FROM THE AIR/GROUND RELAYS. THE SLATS CAN MOVE AUTOMATICALLY WHEN FLAPS ARE IN POSITION 1, 2, OR 5, AND THE NOSE OR MAIN LANDING GEAR AIR/GROUND RELAYS INDICATE AN AIRBORNE CONDITION. THIS CAN CAUSE INJURY TO PERSONS OR DAMAGE TO EQUIPMENT.

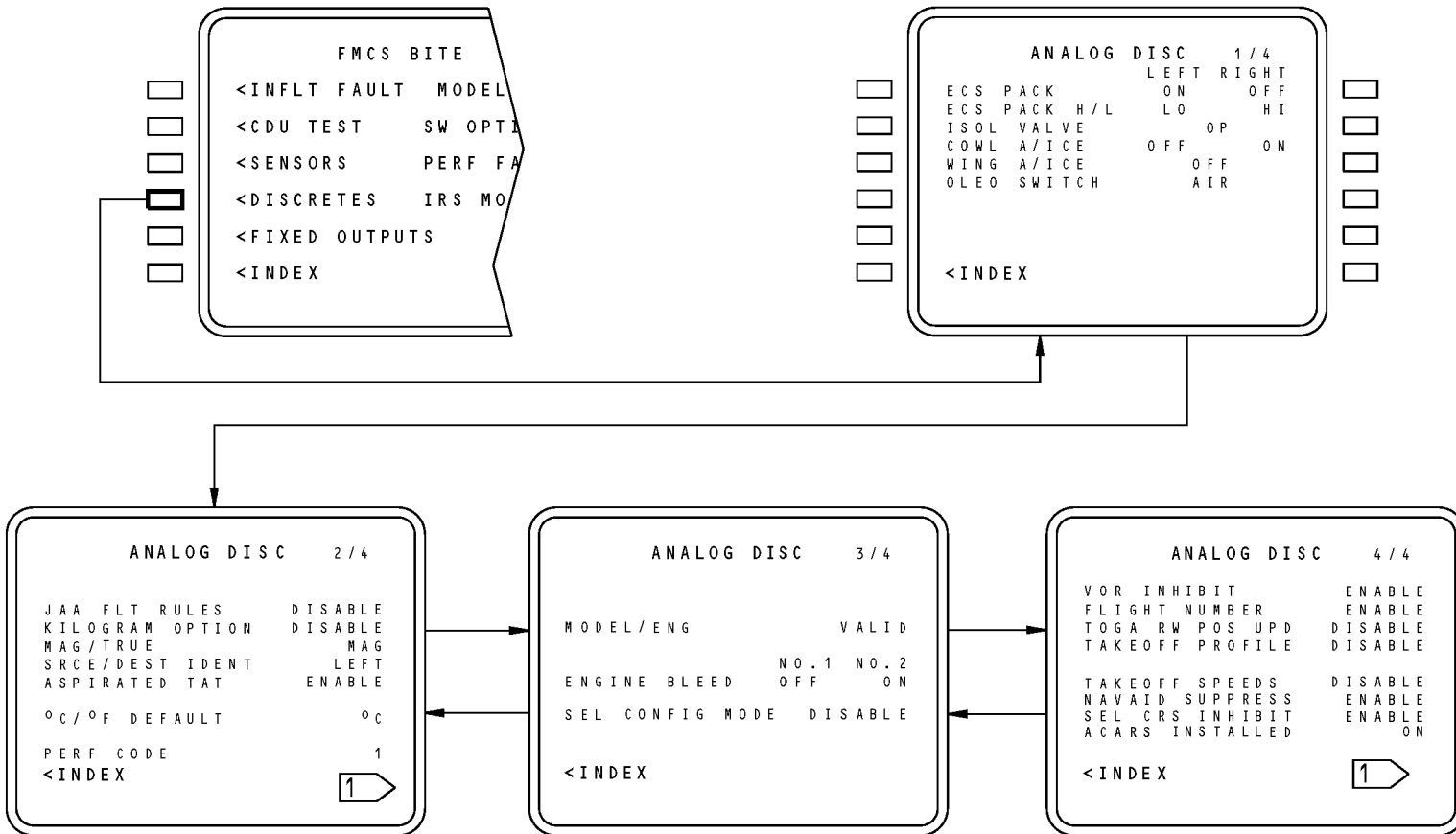

1 THESE ARE EXAMPLES OF THE PROGRAM PIN OPTIONS AND MIGHT NOT REPRESENT THE OPTIONS ON YOUR AIRPLANE(S).

FMCS - TRAINING INFORMATION POINT - FMCS BITE PAGES - DISCRETES

EFFECTIVITY
 HAP 001-005 PRE SB 737-34-1918

34-61-00

D633A101-HAP

Page 98.243
 Jun 15/2009

34-61-00-060

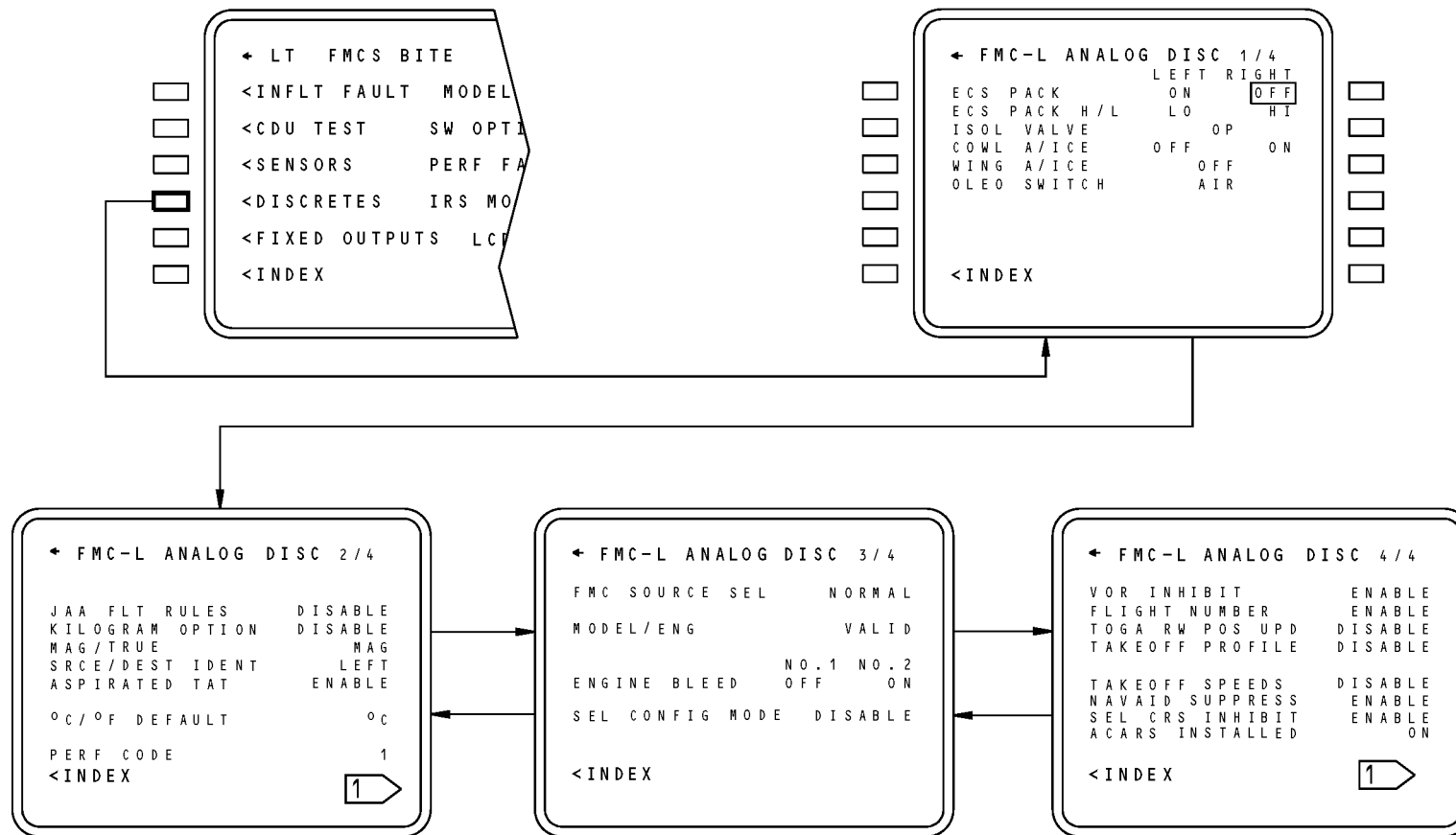

1 THESE ARE EXAMPLES OF THE PROGRAM PIN OPTIONS AND MIGHT NOT REPRESENT THE OPTIONS ON YOUR AIRPLANE(S).

FMCS - TRAINING INFORMATION POINT - FMCS BITE PAGES - DISCRETES

EFFECTIVITY
HAP 037-054, 101-999

34-61-00

D633A101-HAP

Page 98.244
Jun 15/2009

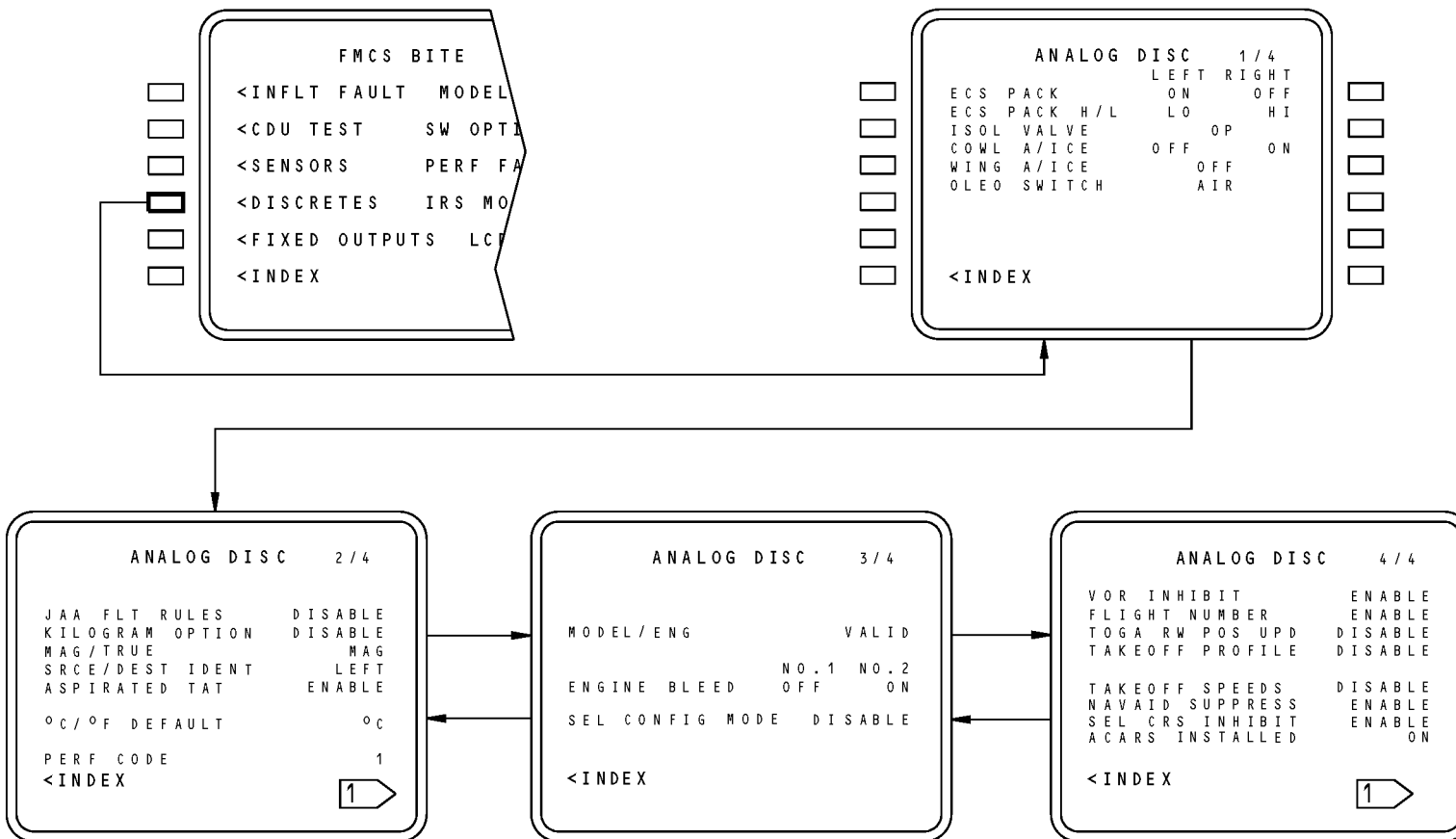

1 THESE ARE EXAMPLES OF THE PROGRAM PIN OPTIONS AND MIGHT NOT REPRESENT THE OPTIONS ON YOUR AIRPLANE(S).

FMCS - TRAINING INFORMATION POINT - FMCS BITE PAGES - DISCRETES

EFFECTIVITY

HAP 006-013, 015-026, 028-036; HAP 001-005 POST SB 737-34-1951 GRP 1

34-61-00

D633A101-HAP

Page 98.245
Jun 15/2009

34-61-00-060

FMCS - TRAINING INFORMATION POINT - FMCS BITE PAGES - FMCS-FIXED OUTPUTS**General**

To look at the FMCS fixed outputs, select FIXED OUTPUTS on line select key (LSK) 5L from the FMCS BITE page. The mode selectors on both EFIS control panels should also be set to the MAP mode.

FIXED OUTPUTS Page 1/2

This page shows FMCS data that goes to the thrust mode annunciation (TMA) on the CDS engine display.

The thrust modes show in sequence on the TMA. The word ON shows on the CDUs as each mode comes into view on the TMA.

On the CDS navigation displays, the message FMC INTERFACE OK will show.

FIXED OUTPUTS Page 2/2

These CDU annunciators are ON during the FIXED OUTPUTS test:

- MSG
- FAIL
- OFST.

On the autoflight status annunciators (ASA), both FMC annunciators will also be on.



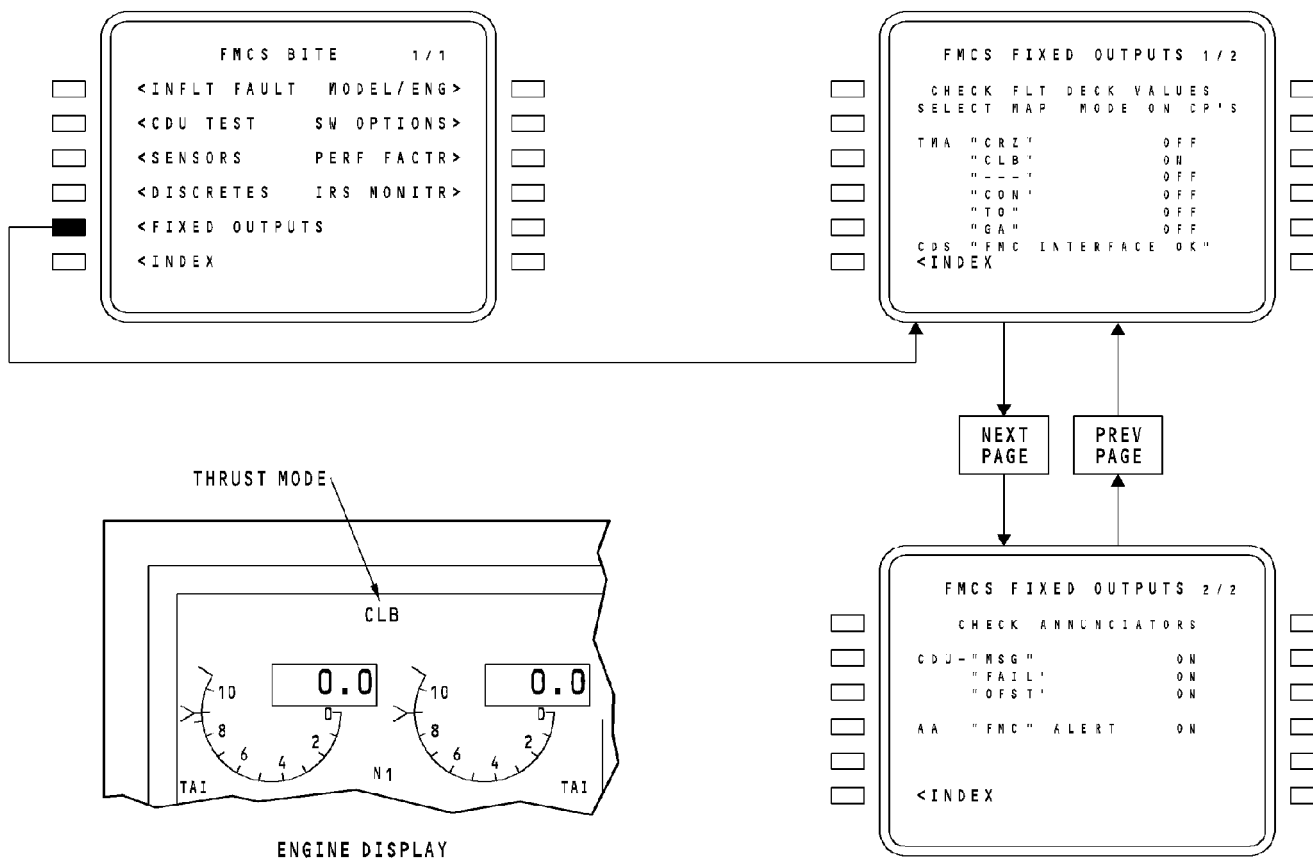

FMCS - TRAINING INFORMATION POINT - FMCS BITE PAGES - FMCS-FIXED OUTPUTS

34-61-00-061

EFFECTIVITY
HAP 001-005

34-61-00

D633A101-HAP

Page 98.247
Jun 15/2009

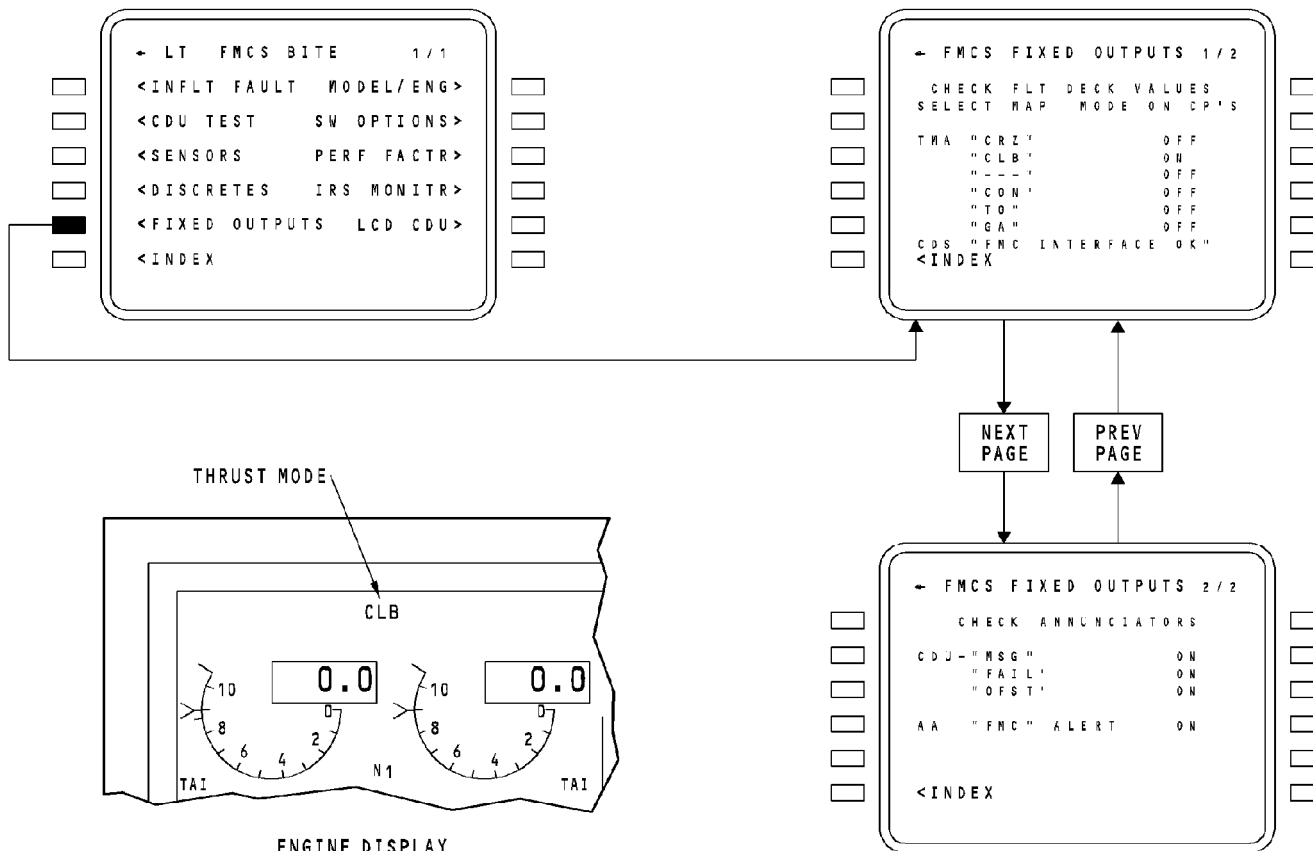

FMCS - TRAINING INFORMATION POINT - FMCS BITE PAGES - FMCS-FIXED OUTPUTS

EFFECTIVITY
HAP 037-054, 101-999

34-61-00

D633A101-HAP

Page 98.248
Jun 15/2009

34-61-00-061

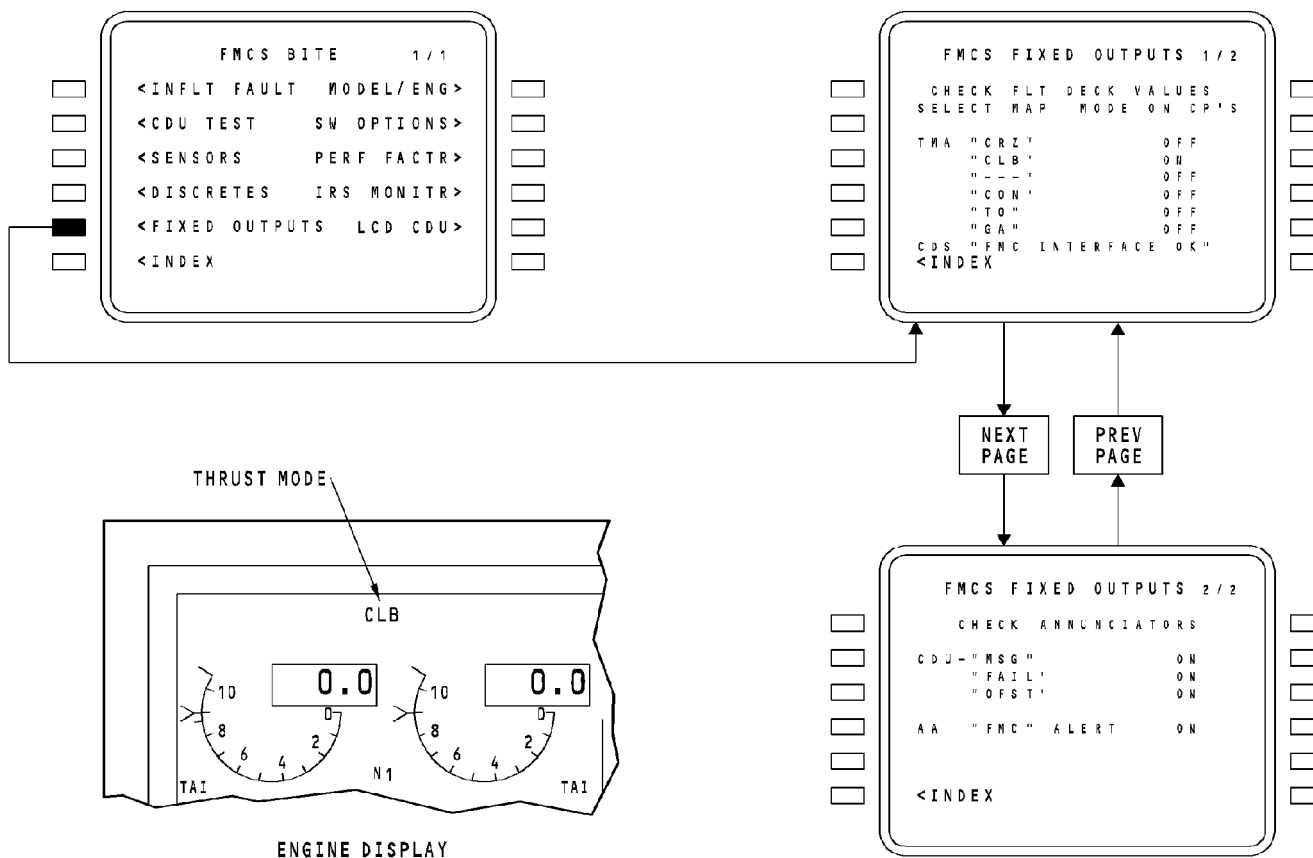

FMCS - TRAINING INFORMATION POINT - FMCS BITE PAGES - FMCS-FIXED OUTPUTS

34-61-00-061

EFFECTIVITY
 HAP 006-013, 015-026, 028-036; HAP 001-005 POST SB 737-34-1951 GRP 1

34-61-00

D633A101-HAP

Page 98.249
 Jun 15/2009

FMCS - TRAINING INFORMATION POINT - FMCS BITE PAGES - AIRPLANE MODEL AND ENGINE CONFIGURATION**General**

The model/engine configuration page shows the airplane and engine configuration. It also shows the engine combustor type and the brake option selected. The engine ratings will show this data:

HAP 039-047, 054, 101-106; HAP 001-013, 015-026, 028-038 POST SB 737-34-1918

- Full rated takeoff thrust
- Takeoff bump thrust rating (if selected).

HAP 039-047, 054, 101-106; HAP 001-013, 015-026, 028, 029 (POST SB 737-34-1666 AND PRE SB 737-34-1918) OR PRE SB 737-34-1918; HAP 030-038 PRE SB 737-34-1918

- Full rated takeoff thrust
- First takeoff derate thrust
- Second takeoff derate thrust
- Takeoff bump thrust rating (if selected).

If the takeoff derate (TO-1 or TO-2) or the takeoff bump rating do not exist for the selected engine/airframe configuration, NONE will be shown in that thrust data field.

HAP 039-047, 054, 101-106; HAP 001-013, 015-026, 028-038 POST SB 737-34-1918

If the takeoff bump rating do not exist for the selected engine/airframe configuration, NONE will be shown in that thrust data field.

The CONFIG number represents a specific model/engine configuration set with dip switches in the M1990-FMCS Dip Switch Module (P59).

HAP ALL

To access this page select MODEL/ENG (LSK 1R) from the FMCS BITE page.

FMC MODEL/ENG Pages

When you power up, the FMC monitors the airframe/engine configuration program pins to make sure the configuration is valid. If there is a non-normal condition, one of these messages shows:

- Message PARITY ERROR shows if the airframe/engine configuration program pins are not set to odd parity. It also shows for an invalid SDI discrete configuration
- INVALID shows if the model/engine performance database is not installed or the loaded MEDB has failed its validity check
- PROGRAM PIN NOT IN MODEL/ENGINE DATA BASE shows if the airframe/engine configuration program pins do not match the data in the model/engine performance database.

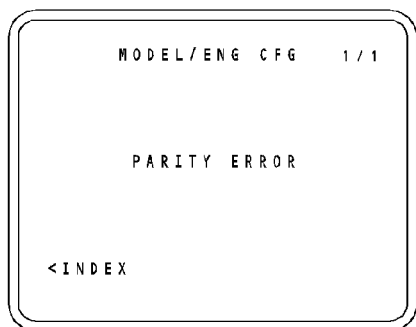
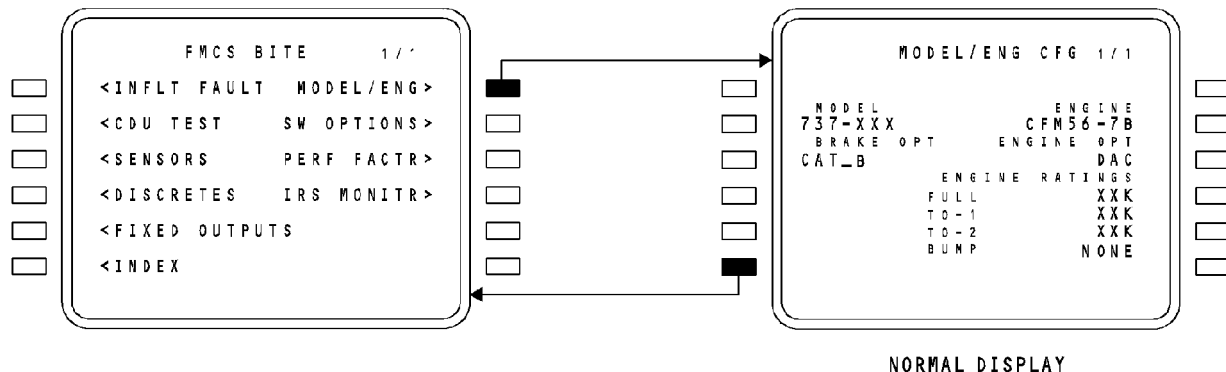

FMCS PROGRAM PIN PARITY IS NOT ODD PARITY

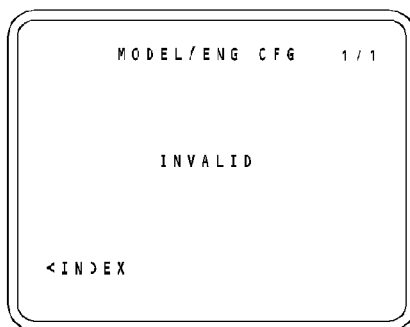

THE MODEL/ENGINE PERFORMANCE DATABASE IS NOT INSTALLED

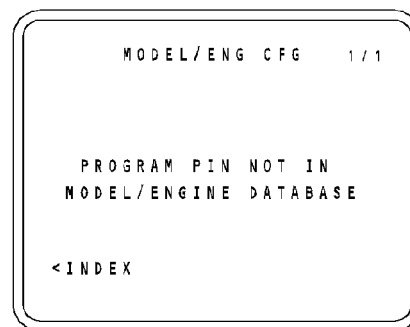

FMCS PROGRAM PINS DO NOT MATCH THE MODEL/ENGINE PERFORMANCE DATABASE

FMCS - TRAINING INFORMATION POINT - FMCS BITE PAGES - AIRPLANE MODEL AND ENGINE CONFIGURATION

34-61-00-065

EFFECTIVITY
HAP 001-005 PRE SB 737-34-1918

34-61-00

D633A101-HAP

Page 98.251
Jun 15/2009

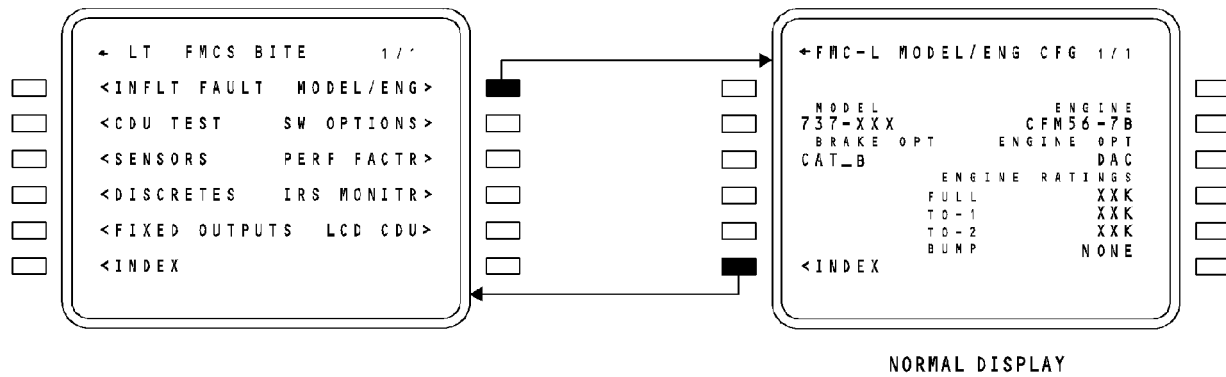

NORMAL DISPLAY

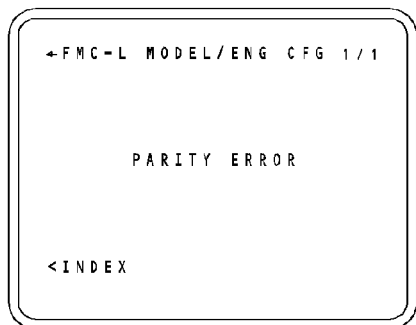

FMCS PROGRAM PIN PARITY IS NOT ODD PARITY

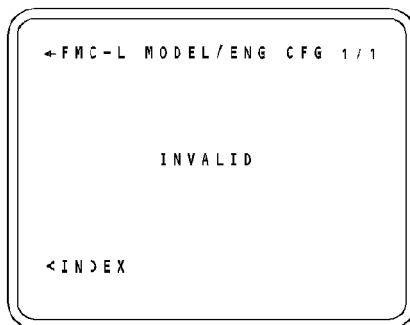

THE MODEL/ENGINE PERFORMANCE DATABASE IS NOT INSTALLED

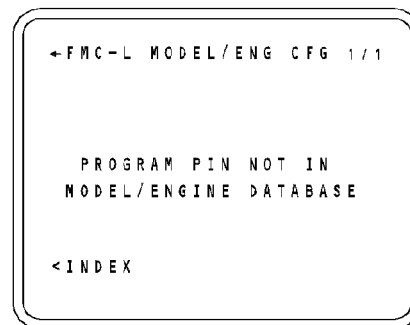

FMCS PROGRAM PINS DO NOT MATCH THE MODEL/ENGINE PERFORMANCE DATABASE

FMCS - TRAINING INFORMATION POINT - FMCS BITE PAGES - AIRPLANE MODEL AND ENGINE CONFIGURATION

EFFECTIVITY

HAP 048-053, 107-999; HAP 037, 038 PRE SB 737-34-1918

34-61-00

D633A101-HAP

Page 98.252
Jun 15/2009

34-61-00-065

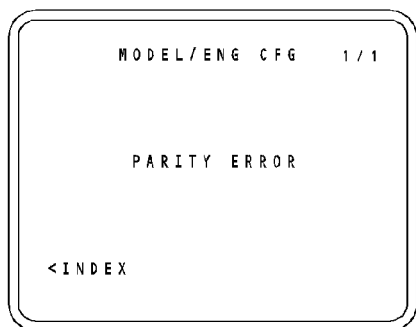
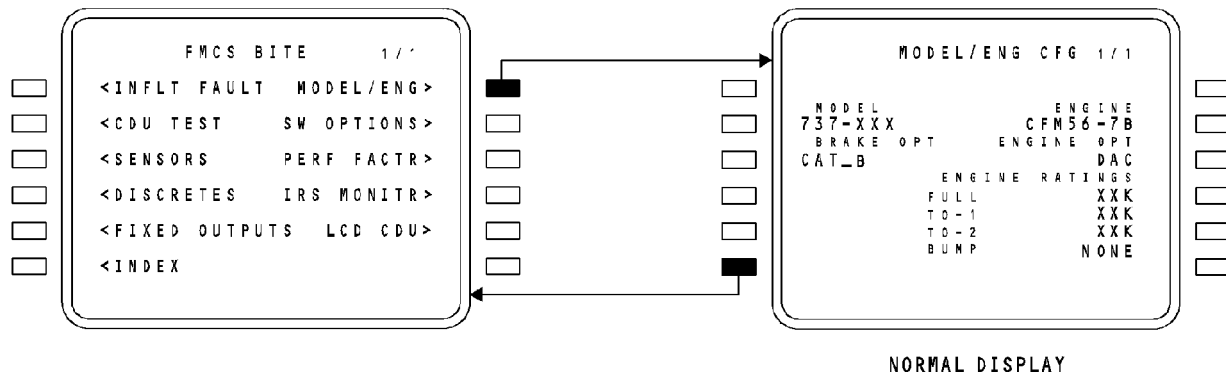

FMCS PROGRAM PIN PARITY IS NOT ODD PARITY

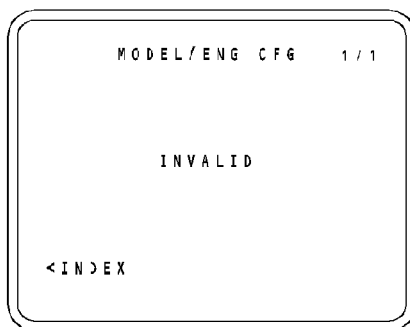

THE MODEL/ENGINE PERFORMANCE DATABASE IS NOT INSTALLED

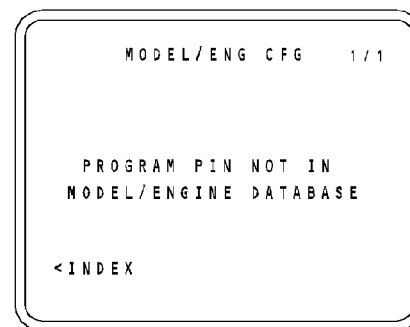

FMCS PROGRAM PINS DO NOT MATCH THE MODEL/ENGINE PERFORMANCE DATABASE

FMCS - TRAINING INFORMATION POINT - FMCS BITE PAGES - AIRPLANE MODEL AND ENGINE CONFIGURATION

34-61-00-065

EFFECTIVITY
HAP 006-013, 015-026, 028-036 PRE SB 737-34-1918; HAP 001-005 POST SB 737-34-1951 GRP 1 AND PRE SB 737-34-1918

34-61-00

D633A101-HAP

Page 98.253
Jun 15/2009

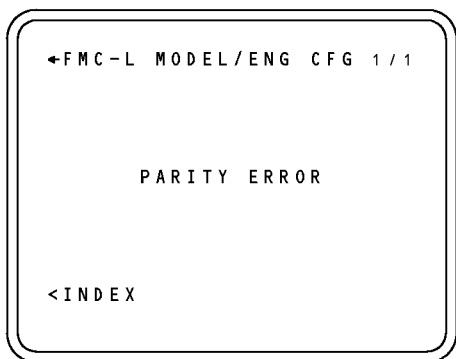
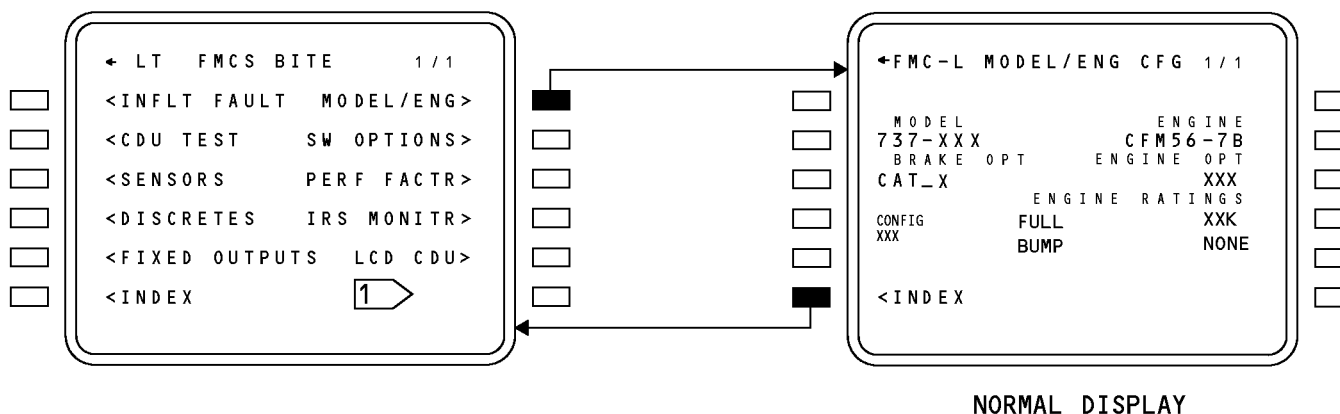

FMCS PROGRAM PIN PARITY IS NOT ODD PARITY

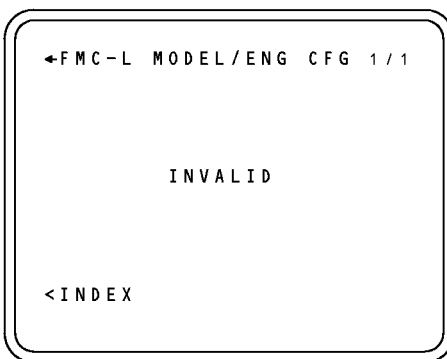

THE MODEL/ENGINE PERFORMANCE DATABASE IS NOT INSTALLED

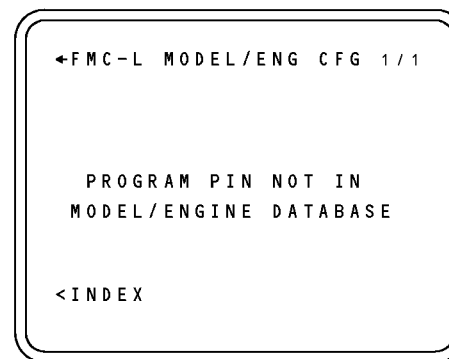

FMCS PROGRAM PINS DO NOT MATCH THE MODEL/ENGINE PERFORMANCE DATABASE

1 AIRPLANES WITH LCD CDU

1538586 S0000280029_V2

FMCS - TRAINING INFORMATION POINT - FMCS BITE PAGES - AIRPLANE MODEL AND ENGINE CONFIGURATION

EFFECTIVITY

HAP 039-047, 054, 101-106; HAP 037, 038 POST SB 737-34-1918

34-61-00

D633A101-HAP

Page 98.254
Jun 15/2009

34-61-00-065

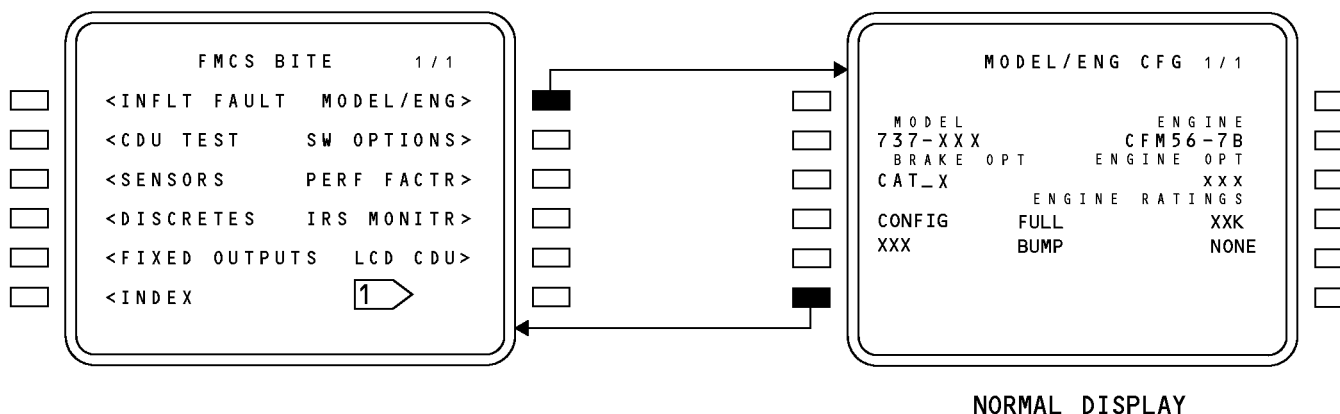

NORMAL DISPLAY

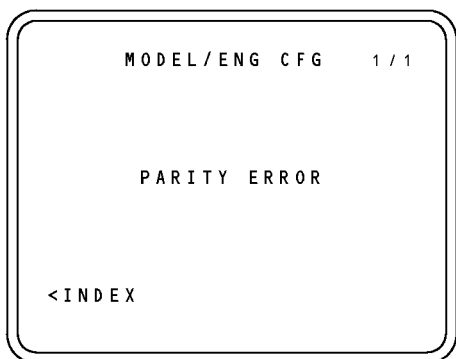

FMCS PROGRAM PIN PARITY IS NOT ODD PARITY

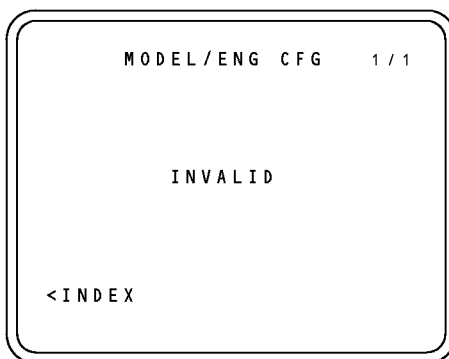

THE MODEL/ENGINE PERFORMANCE DATABASE IS NOT INSTALLED

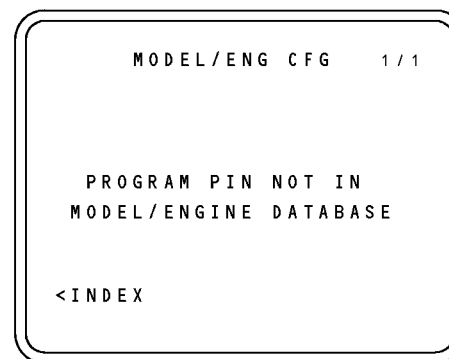

FMCS PROGRAM PINS DO NOT MATCH THE MODEL/ENGINE PERFORMANCE DATABASE

1 AIRPLANES WITH LCD CDU

1541077 S0000281344_V1

FMCS - TRAINING INFORMATION POINT - FMCS BITE PAGES - AIRPLANE MODEL AND ENGINE CONFIGURATION

EFFECTIVITY

HAP 001-013, 015-026, 028-036 POST SB 737-34-1918

34-61-00

D633A101-HAP

Page 98.255
Jun 15/2009

34-61-00-065

THIS PAGE IS INTENTIONALLY LEFT BLANK

34-61-00

D633A101-HAP

Page 98.256
Jun 15/2009

FMCS - TRAINING INFORMATION POINT - FMCS BITE PAGES - SOFTWARE OPTIONS

General

To show the FMCS software options, select SW OPTIONS on line select key (LSK) 3R, from the FMCS BITE page.

Software Option Pages

The software options pages show the size of the navigation database, software option code, default values for RNP, and a listing of the software options that are enabled. The graphics show pages with example options.

HAP 030 PRE SB 737-34-1918; HAP 001-013, 015-026, 028, 029 POST SB 737-34-1666 AND PRE SB 737-34-1918

The navigation data base default size is 3.5 Mwords or 7 Mbytes.

HAP 048-053, 107-999; HAP 001-013, 015-026, 028-038 PRE SB 737-34-1918

The software option code is a 12 digit hexadecimal number that indicates the software options that are enabled. Each option has a hexadecimal code. The codes for the enabled options are summed, and this is shown on the software options page. These are the software options your airline selected:

HAP 039-047, 054, 101-106; HAP 001-013, 015-026, 028-038 POST SB 737-34-1918

The software option code is a 16 digit hexadecimal number that indicates the software options that are enabled. Each option has a hexadecimal code. The codes for the enabled options are summed, and this is shown on the software options page. These are the software options your airline selected:

HAP ALL

HAP 001-013, 015-026, 028-030, 050, 053, 054

- Position Update - Runway offset in meters - This option permits the entry of the airplane position as an offset distance from the runway threshold.

HAP 048

- Missed approach on map in cyan - This option shows the missed approach part of the active flight plan in cyan until a missed approach becomes active. It then shows in magenta.

HAP 050, 053, 054

- VNAV ALT - This option is only enabled when the flight crew selects altitude intervention on the MCP. It shows VNAV ALT on the FMA in CDS at airplane level-off instead of ALT HOLD.

HAP ALL

- GPS with integrity - This option lets the FMC use GPS data as the primary source for position update.
- Direct GPS input - This option permits the FMC to receive GPS data from the MMRs.
- Manual RNP entry - This option lets the flight crew enter different values for the RNP if they do not exceed the default values.

34-61-00-064

EFFECTIVITY
HAP ALL

34-61-00

D633A101-HAP

Page 98.257
Jun 15/2009

FMCS - TRAINING INFORMATION POINT - FMCS BITE PAGES - SOFTWARE OPTIONS**HAP 001-013, 015-026, 028-030**

- Abeam waypoints - This option lets the flight crew select a direct route to a waypoint in the flight plan. This causes the abeam waypoints to be put as waypoints in the direct leg of the flight plan.

HAP ALL

- AOC datalink - This option lets the FMC uplink and downlink data through ACARS.
- Alternate destination - This option lets the flight crew review the distance, time, and fuel that remains for diversions to alternate airports.
- ALT/SPD intervention - This option lets the flight crew override the FMC target altitudes and airspeeds without VNAV disengage.

HAP 001-013, 015-026, 028-030, 048, 049, 051-053, 107-999

- Plan fuel entry - This option lets the flight crew input the final fuel load before refueling has been completed. Thus, the FMC flight plan can be activated while the airplane is being refueled. At engine start, in air, or entry of a new gross weight, any entered plan fuel will be invalid.

HAP 012, 013, 015-026, 028-054, 101-999; HAP 001-011 POST SB 737-34-1951 GRP 1

- CDU Color - This option enables the use of color displays on the LCD MCDUs.

HAP ALL

- Geometric Path Descents - This option lets the flight crew select a calculated gradient path between altitude restrictions during descent.
- Quiet climb system (QCS) - This option lets the flight crew use noise abatement procedures during the climb out.

HAP 031-054, 101-999; HAP 001-013, 015-026, 028-030 POST SB 737-34-1680

- Engine out SIDS - This option lets the flight crew see a list of standard instrument departures (SIDs) that are designed for engine out operations.

HAP 037

- GPS Landing System Approach - This option lets the flight crew select a GLS approach from the FMCS NDB.

HAP ALL

- Common VNAV - This option lets the FMC use VNAV SPD as the speed on elevator reversion mode for over-speed reversions instead of disengaging VNAV.

HAP 001-013, 015-026, 028-030, 036, 038, 042-046, 048, 050-054

- Aircraft Communications Addressing and Reporting System - This option lets the FMC OPC software transmit intent data to ACARS on an existing databus. ACARS transmits the FMC intent data from the airplane to the ground.

HAP ALL**EFFECTIVITY****HAP ALL****34-61-00**

D633A101-HAP

Page 98.258
Jun 15/2009

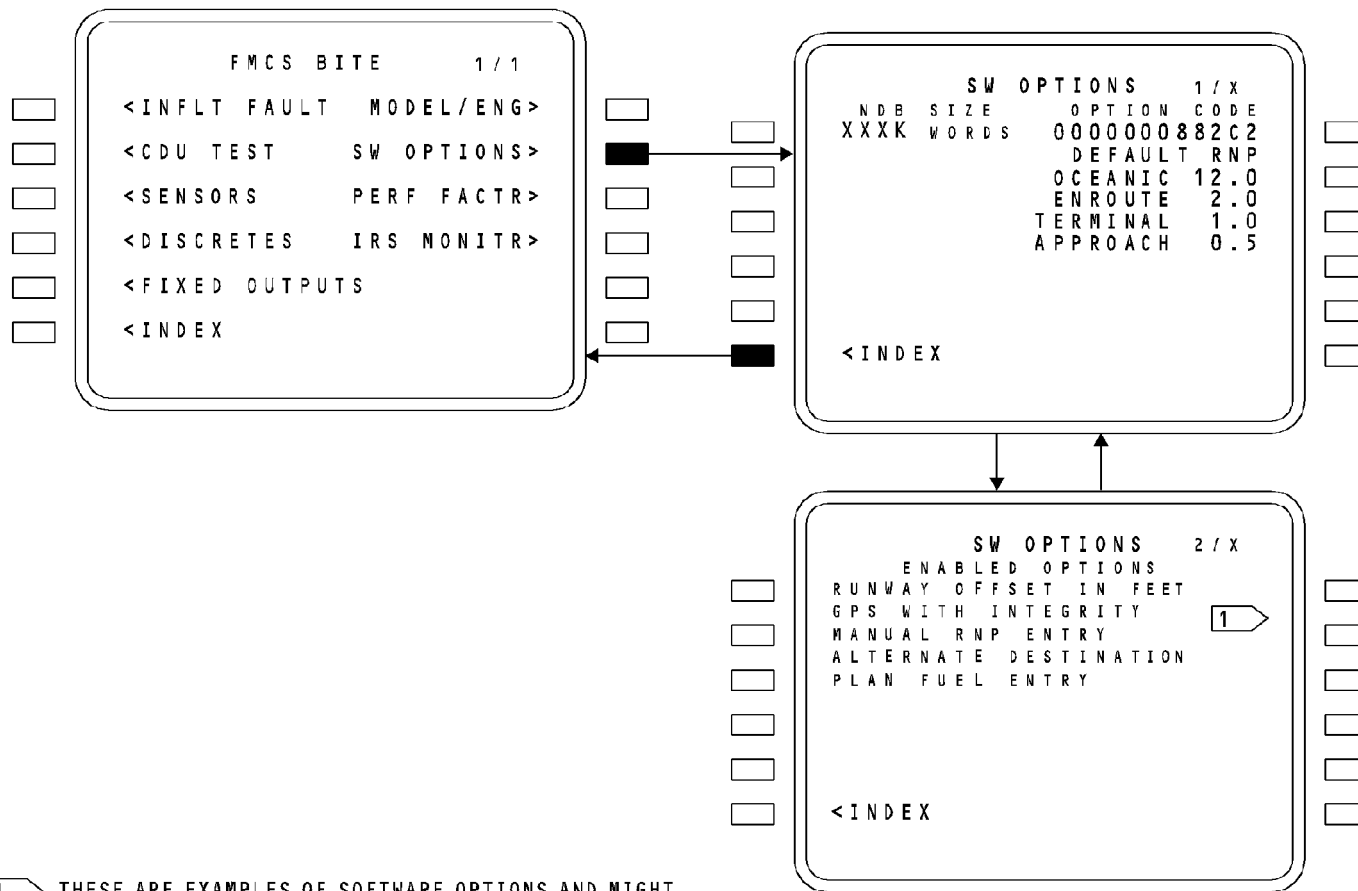

1 THESE ARE EXAMPLES OF SOFTWARE OPTIONS AND MIGHT NOT REPRESENT THE OPTIONS ON YOUR AIRPLANE(S).

FMCS - TRAINING INFORMATION POINT - FMCS BITE PAGES - SOFTWARE OPTIONS

EFFECTIVITY
HAP 001-005

34-61-00

D633A101-HAP

Page 98.259
Jun 15/2009

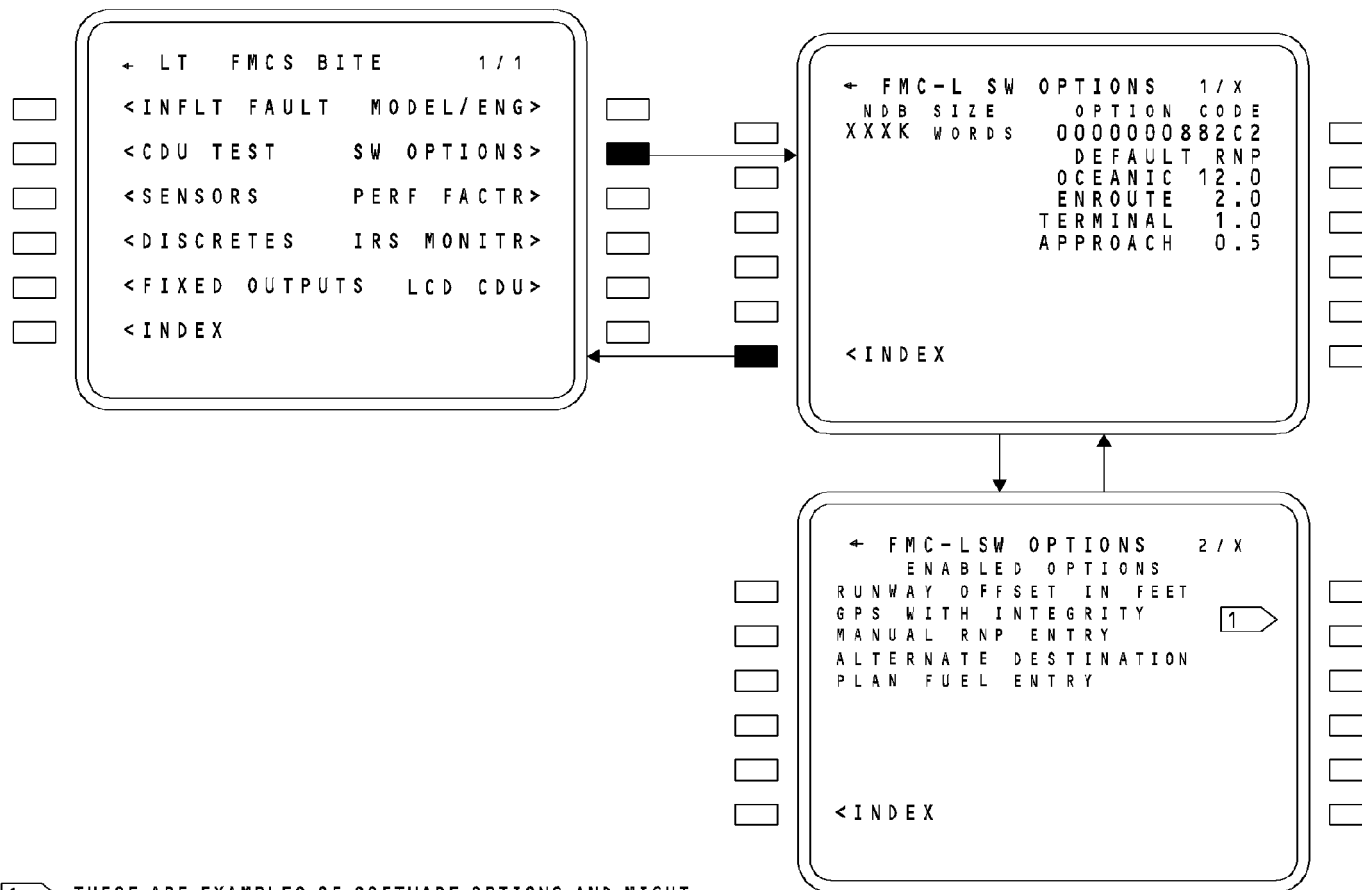

1 THESE ARE EXAMPLES OF SOFTWARE OPTIONS AND MIGHT NOT REPRESENT THE OPTIONS ON YOUR AIRPLANE(S).

FMCS - TRAINING INFORMATION POINT - FMCS BITE PAGES - SOFTWARE OPTIONS

EFFECTIVITY
HAP 037-054, 101-999

34-61-00

D633A101-HAP

Page 98.260
Jun 15/2009

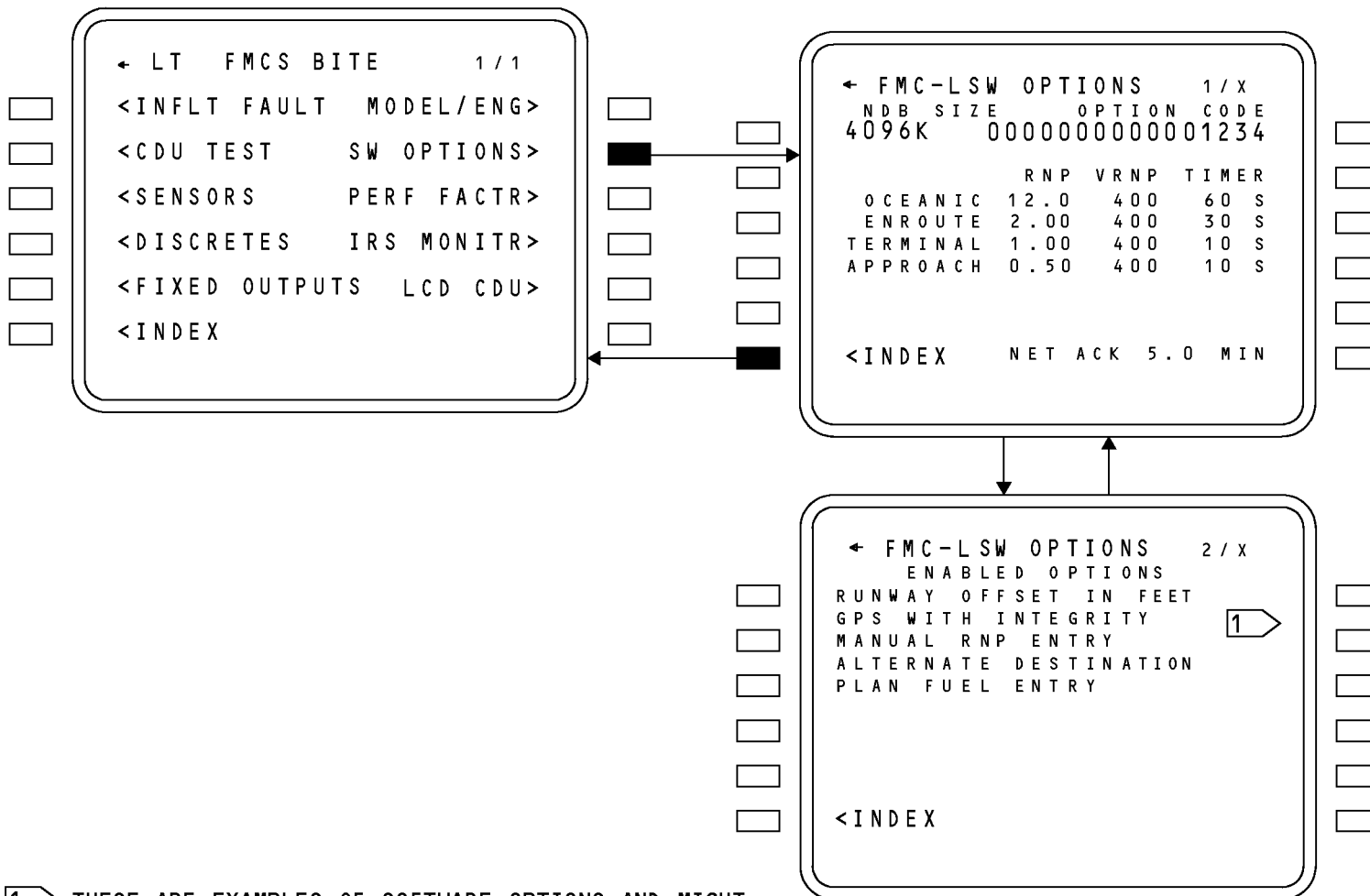

1 THESE ARE EXAMPLES OF SOFTWARE OPTIONS AND MIGHT NOT REPRESENT THE OPTIONS ON YOUR AIRPLANE(S).

FMCS - TRAINING INFORMATION POINT - FMCS BITE PAGES - SOFTWARE OPTIONS

EFFECTIVITY

HAP 039-047, 054, 101-106; HAP 037, 038 POST SB 737-34-1918

34-61-00

D633A101-HAP

Page 98.261
Jun 15/2009

34-61-00-064

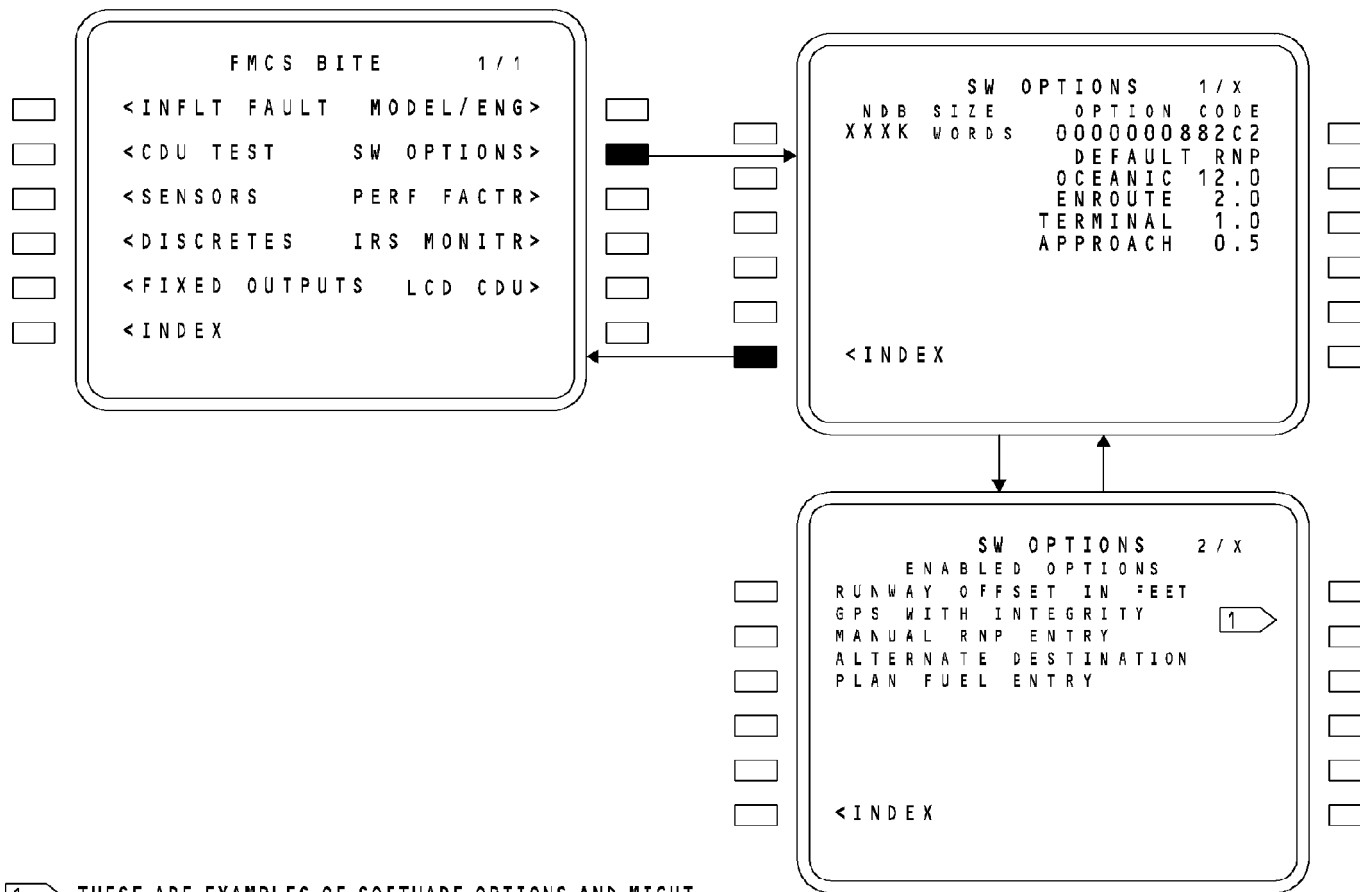

1 THESE ARE EXAMPLES OF SOFTWARE OPTIONS AND MIGHT NOT REPRESENT THE OPTIONS ON YOUR AIRPLANE(S).

FMCS - TRAINING INFORMATION POINT - FMCS BITE PAGES - SOFTWARE OPTIONS

EFFECTIVITY

HAP 006-013, 015-026, 028-036; HAP 001-005 POST SB 737-34-1951 GRP 1

34-61-00

D633A101-HAP

Page 98.262
Jun 15/2009

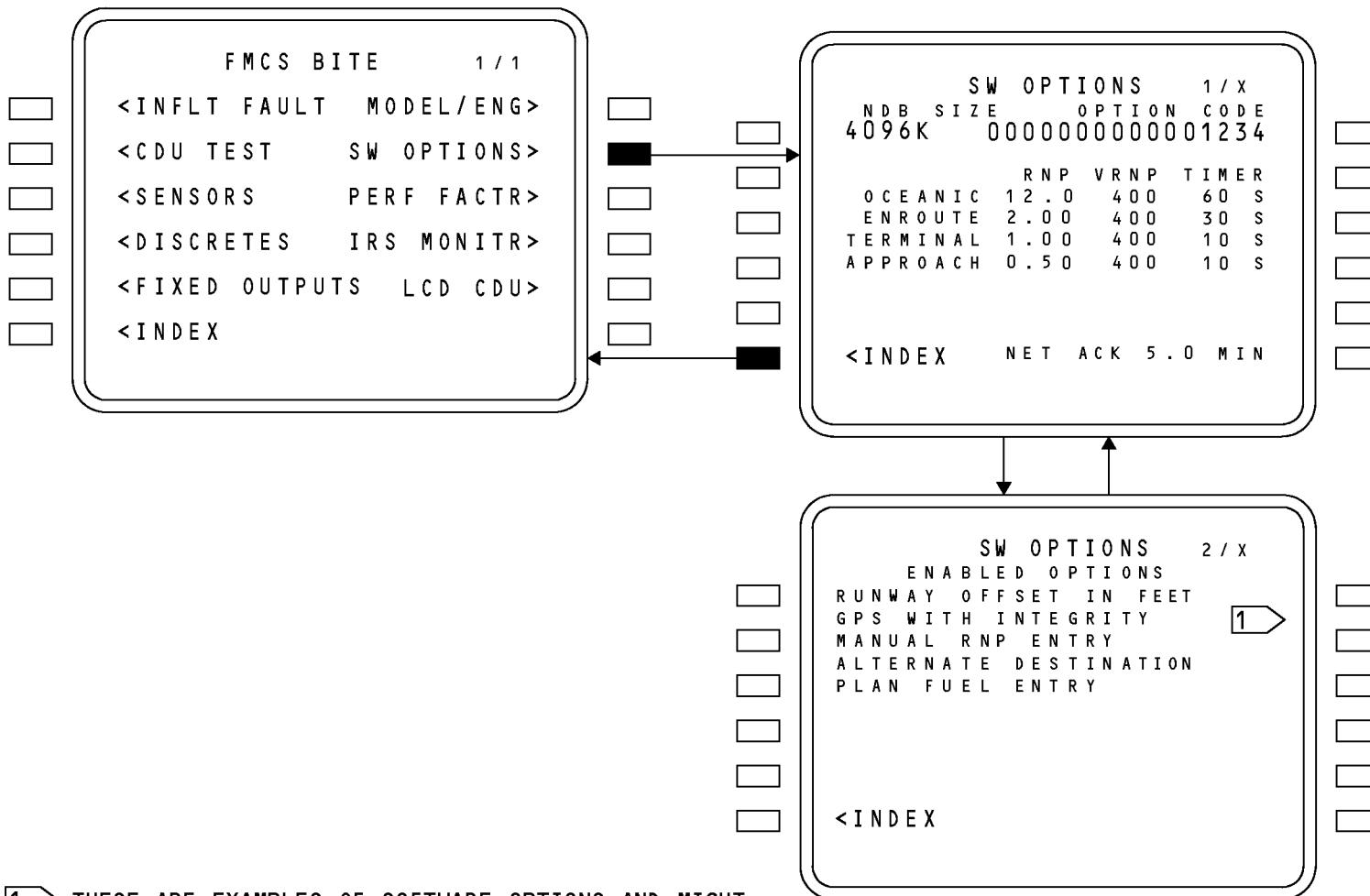

1 THESE ARE EXAMPLES OF SOFTWARE OPTIONS AND MIGHT NOT REPRESENT THE OPTIONS ON YOUR AIRPLANE(S).

FMCS - TRAINING INFORMATION POINT - FMCS BITE PAGES - SOFTWARE OPTIONS

EFFECTIVITY
HAP 001-013, 015-026, 028-036 POST SB 737-34-1918

34-61-00

D633A101-HAP

Page 98.263
Jun 15/2009

34-61-00-064

THIS PAGE IS INTENTIONALLY LEFT BLANK

34-61-00

D633A101-HAP

Page 98.264
Jun 15/2009

FMCS - TRAINING INFORMATION POINT - FMCS BITE PAGES - PERFORMANCE FACTORS**Purpose**

The performance factors page permits the display and entry of performance factors to optimize airplane performance for individual operators or airplane characteristics.

Page Access

You use the PERF FACTR line select key (3R) on the FMCS BITE page to get access to the performance factors page.

This page will automatically show if there is a performance factors mismatch during power-up and it is the only mismatch.

Performance Factors Page

The aerodynamic and engine models in the performance data base are from airplane design and flight test data. Since each production airplane may be different, the FMCS PERF FACTORS page lets the operator make adjustments for some of the factors in the model/engine database.

HAP 037-054, 101-999

If the two FMCs do not agree on the value for a performance factor, the factor is highlighted. In the example shown on the graphic, FMC 2 does not agree with the value for the engine out minimum rate of climb.

HAP 039-047, 054, 101-106; HAP 001-013, 015-026, 028-038 POST SB 737-34-1918

Line select key 1L shows the GEO DES mode. The geometric path descent feature uses computed gradients for the entire descent profile when FULL mode is selected. The FULL mode is the default mode and can only be changed to the APP mode with the Loadable Defaults Data Base. In the APP mode the gradients are only used on approach or approach transition legs.

HAP ALL

Line select key 2L shows the DRAG FACTOR value. This is a correction factor applied to drag calculations and is a percentage. The default value is 0.0 and the allowable entry range is - 9.9 to + 9.9

Line select key 3L shows the fuel flow (F-F) value. This is a correction factor applied to fuel flow calculations and is a percentage. The default value is 0.0 and the allowable entry range is - 9.9 to + 9.9.

HAP 006, 007, 010-013, 015, 016, 031-037, 039, 040 POST SB 737-34-2083; HAP 001, 002, 008, 009, 017-026, 028-030, 038, 042-046, 054 POST SB 737-34-2107

Line select key 4L shows the maneuver margin (MNVR MARGIN) value. The maneuver margin is used for flight envelope and bank angle calculations. The default value is 1.3g and the allowable entry range is 1.2g to 1.6g.

FMCS - TRAINING INFORMATION POINT - FMCS BITE PAGES - PERFORMANCE FACTORS

HAP 006, 007, 010-013, 015, 016, 031-037, 039, 040 POST SB 737-34-2083; HAP 001, 002, 008, 009, 017-026, 028-030, 038, 042-046, 054 POST SB 737-34-2107 (Continued)

HAP 041, 047-053, 101-999; HAP 006, 007, 010-013, 015, 016, 031-037, 039, 040 PRE SB 737-34-2083; HAP 008, 009, 017-026, 028-030, 038, 042-046, 054 PRE SB 737-34-2107

Line select key 4L shows the maneuver margin (MNVR MARGIN) value. The maneuver margin is used for flight envelope and bank angle calculations. The default value is 1.3g and the allowable entry range is 1.3 to 1.6.

HAP ALL

Line select key 5L shows the minimum cruise time (MIN CRZ TIME) value in minutes. This value is a lower limit to the minimum cruise time from the performance data base for trip altitude calculations. The default value is 1.0 and the allowable entry range is 1.0 to 20.

Line select key 6L shows the INDEX prompt. This selects the FMCS BITE page.

Line select key 3R shows the minimum rate of climb (MIN R/C CLB) value in feet/minute. This is a margin for flight envelope calculations at climb speed and maximum climb thrust. The default value is 300 and the allowable entry range is 0.0 to 999.

Line select key 4R shows the minimum rate of climb (MIN R/C CRZ) value in feet/minute. This is a rate of climb margin for flight envelope calculations at cruise speed and maximum cruise thrust. The default value is 300 and the allowable entry range is 0 to 999.

Line select key 5R shows the minimum rate of climb (MIN R/C ENG OUT) value in feet/minute. This is a margin for flight envelope calculations at engine out speed and maximum continuous thrust. The default value is 300 and the allowable entry range is 0 to 500.

Line select key 6R permits the entry of the word ARM. This is a necessary entry to enable data entry on this page. After you enter ARM and push LSK 6R, you may enter the new value into the scratch pad and line select it to the applicable performance factor.

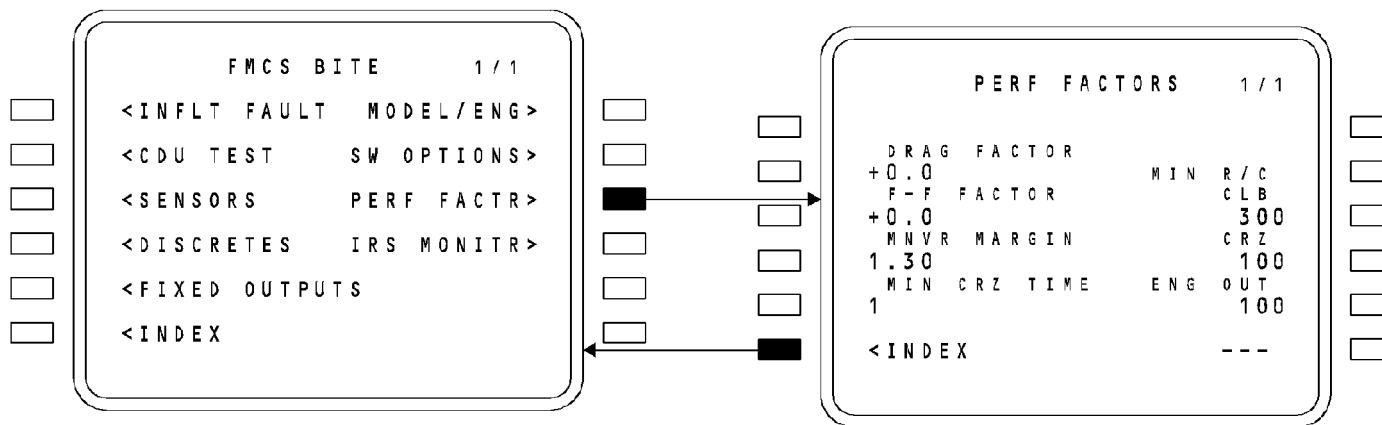

FMCS - TRAINING INFORMATION POINT - FMCS BITE PAGES - PERFORMANCE FACTORS

34-61-00-063

EFFECTIVITY
HAP 001-005

34-61-00

D633A101-HAP

Page 98.267
Jun 15/2009

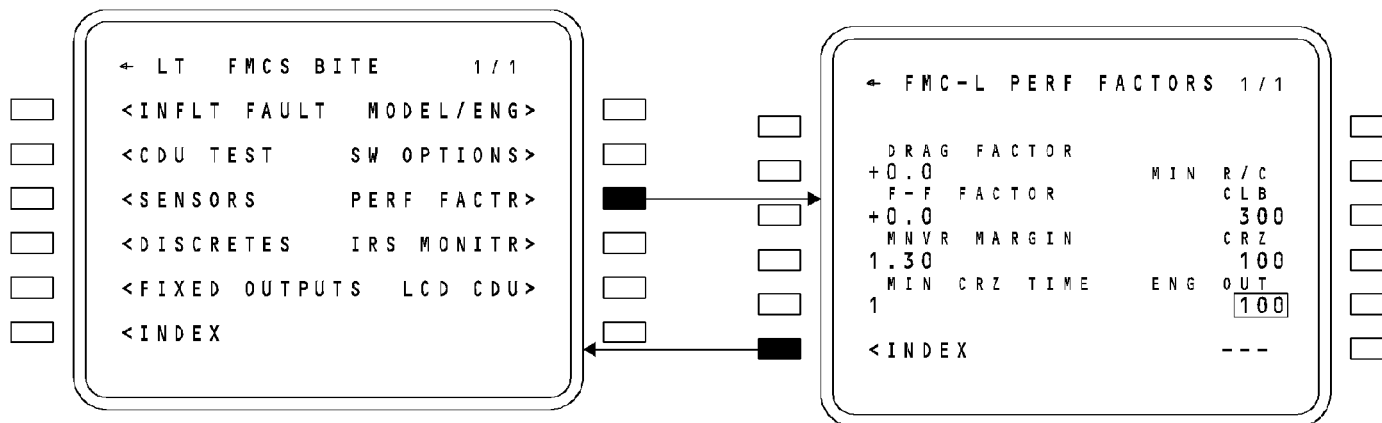

FMCS - TRAINING INFORMATION POINT - FMCS BITE PAGES - PERFORMANCE FACTORS

EFFECTIVITY

HAP 048-053, 107-999; HAP 037, 038 PRE SB 737-34-1918

34-61-00

D633A101-HAP

Page 98.268
Jun 15/2009

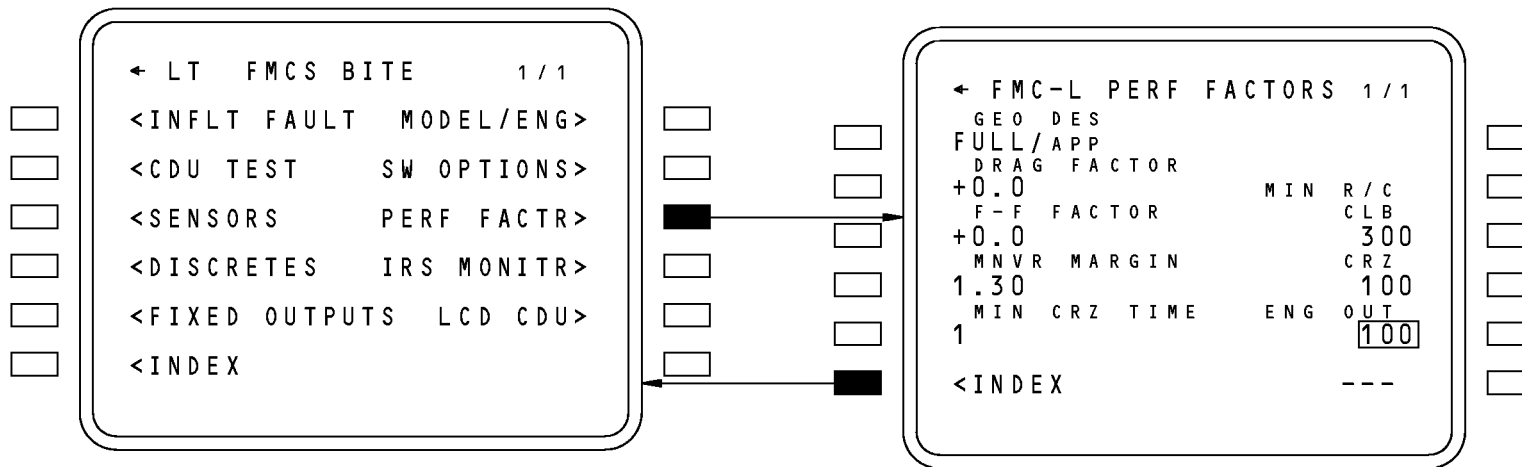

FMCS - TRAINING INFORMATION POINT - FMCS BITE PAGES - PERFORMANCE FACT

34-61-00-063

EFFECTIVITY
HAP 039-047, 054, 101-106; HAP 037, 038 POST SB 737-34-1918

34-61-00

D633A101-HAP

Page 98.269
Jun 15/2009

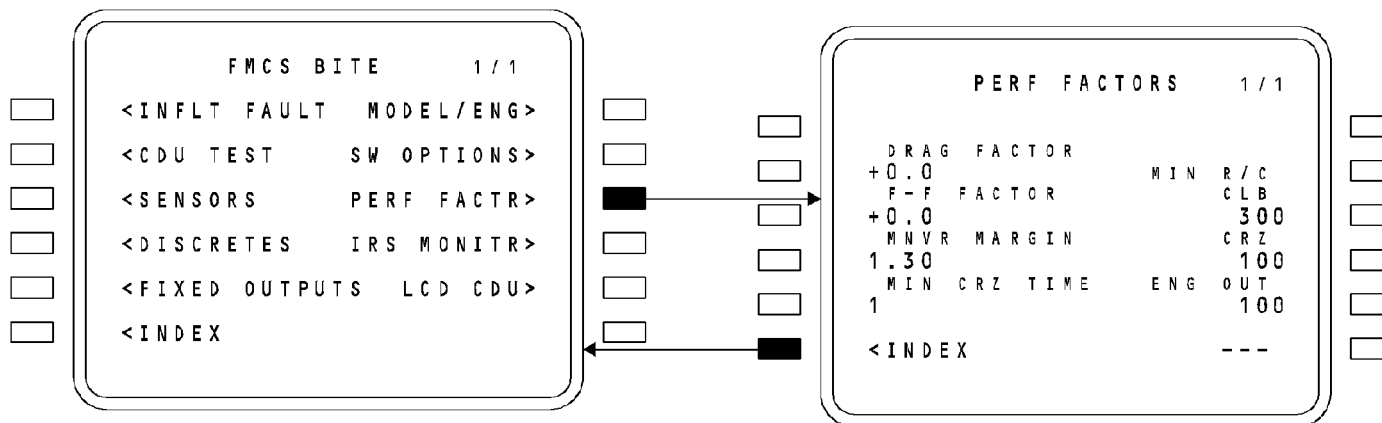

FMCS - TRAINING INFORMATION POINT - FMCS BITE PAGES - PERFORMANCE FACTORS

EFFECTIVITY

HAP 001-013, 015-026, 028-036 PRE SB 737-34-1918

34-61-00

D633A101-HAP

Page 98.270
Jun 15/2009

34-61-00-063

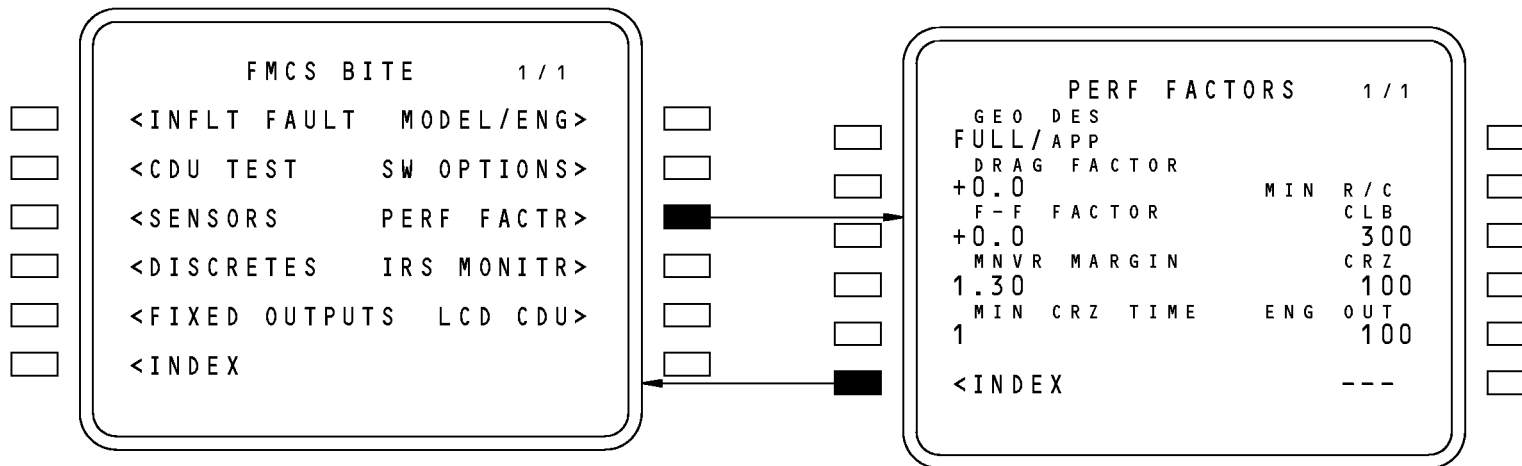

FMCS - TRAINING INFORMATION POINT - FMCS BITE PAGES - PERFORMANCE FACT

EFFECTIVITY

HAP 006-013, 015-026, 028-036 POST SB 737-34-1918; HAP 001-005 POST SB 737-34-1918 AND POST SB 737-34-1951 GRP 1

34-61-00

D633A101-HAP

Page 98.271
Jun 15/2009

34-61-00-063

FMCS - TRAINING INFORMATION POINT - FMCS BITE PAGES - IRS MONITOR

General

To see the ADIRU inertial reference position error rate, select IRS MONITOR on line select key (LSK) 5R, from the FMCS BITE page.

IRS MONITOR Page

The position error rate (nautical miles per hour) for each ADIRU inertial reference shows at LSK 2L and 5L on this page.

To calculate the position error rate, the FMCS divides the difference between the FMCS position and ADIRU position by the total flight time. The FMCS calculates this error rate at the end of each flight. The display is cleared when the airplane is in the air.

The position error rate will be blank if the ADIRU is not in the NAV mode.

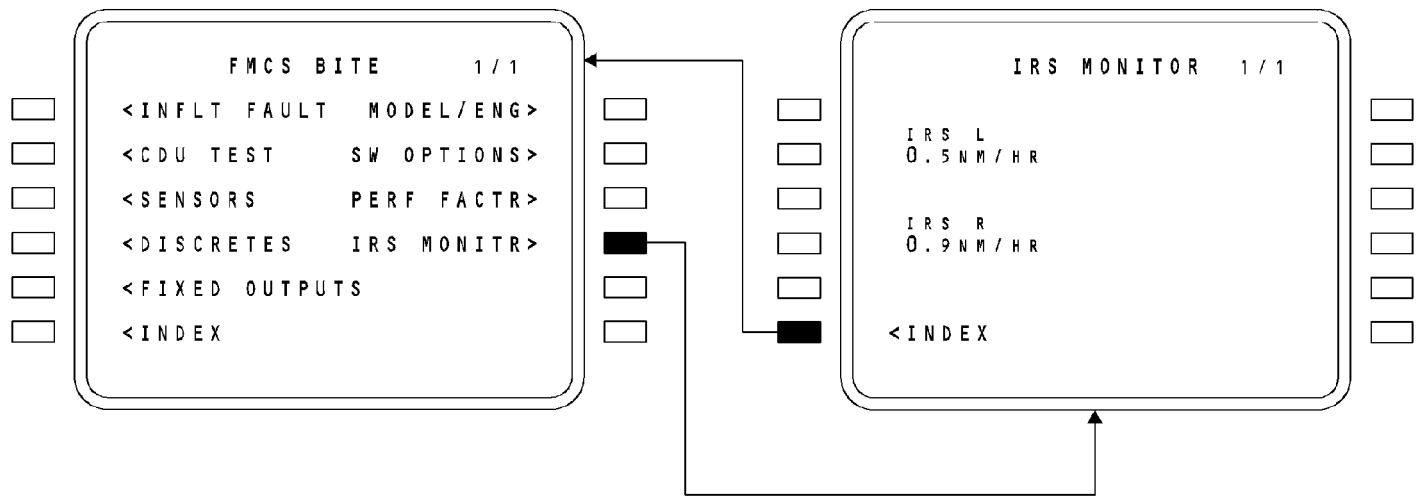

FMCS - TRAINING INFORMATION POINT - FMCS BITE PAGES - IRS MONITOR

34-61-00-062

EFFECTIVITY
HAP 001-005

34-61-00

D633A101-HAP

Page 98.273
Jun 15/2009

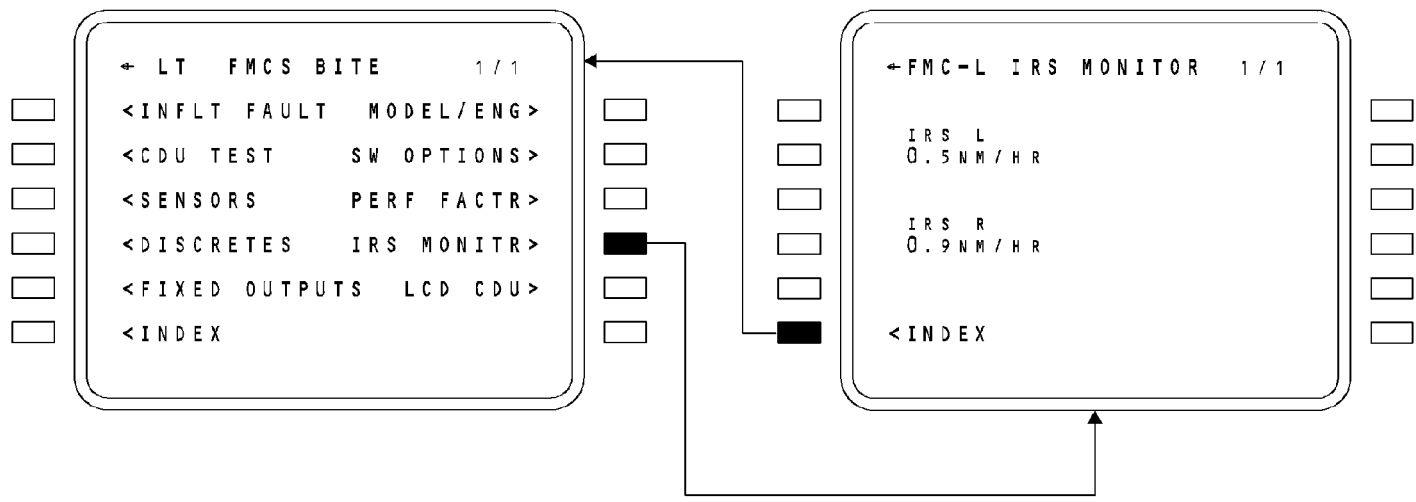

FMCS - TRAINING INFORMATION POINT - FMCS BITE PAGES - IRS MONITOR

EFFECTIVITY
HAP 037-054, 101-999

34-61-00

D633A101-HAP

Page 98.274
Jun 15/2009

34-61-00-062

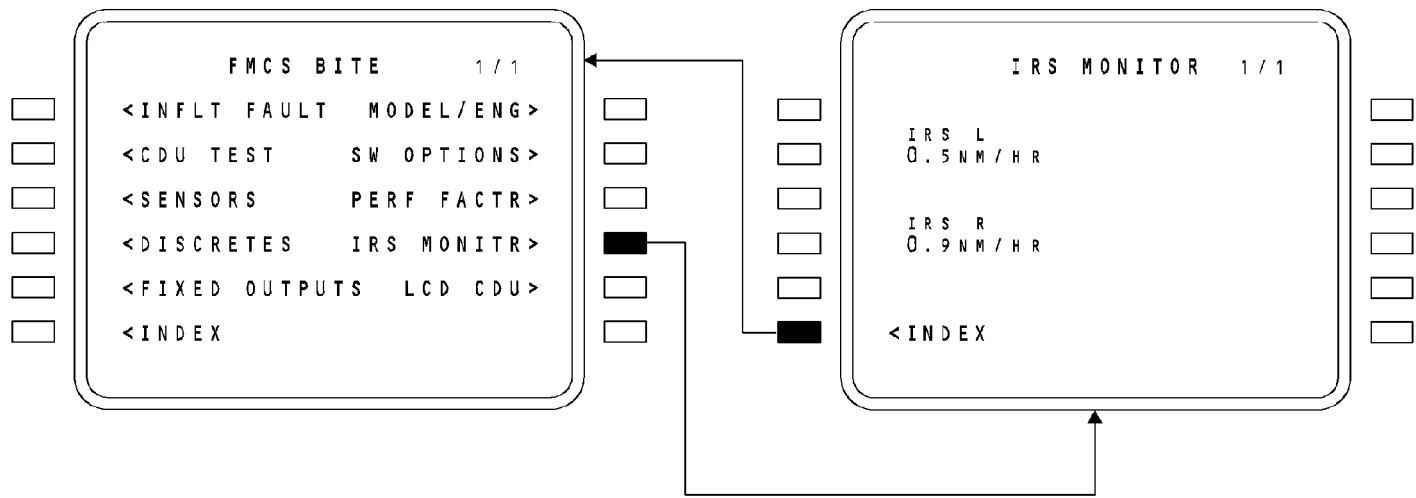

FMCS - TRAINING INFORMATION POINT - FMCS BITE PAGES - IRS MONITOR

EFFECTIVITY

HAP 006-013, 015-026, 028-036; HAP 001-005 POST SB 737-34-1951 GRP 1

34-61-00

D633A101-HAP

Page 98.275
Jun 15/2009

34-61-00-062

FMCS - TRAINING INFORMATION POINT - FMCS BITE PAGES - LCD CDU**GENERAL**

To see the CDU MAINT BITE INDEX page, use the LCD CDU prompt (LSK 5R) on the FMCS BITE INDEX page.

The CDU MAINT BITE INDEX page has these CDU maintenance categories:

- FAULTS
- KEY TEST
- COLOR TEST
- DISPLAY TEST
- CONFIG
- SOFTWARE OPTIONS
- POWER SUPPLY (P/S)
- TEMPERATURE
- LIGHT
- LAMP TEST
- CALIBRATION.

NOTE: Power supply, temperature, light, lamp test, and calibration are used primarily for bench test of the CDU.

The EXIT prompt (LSK 6L) selects the FMCS BITE INDEX page.

EFFECTIVITY

HAP 006-013, 015-026, 028-054, 101-999; HAP 001-005 POST SB 737-34-1951 GRP 1

34-61-00

D633A101-HAP

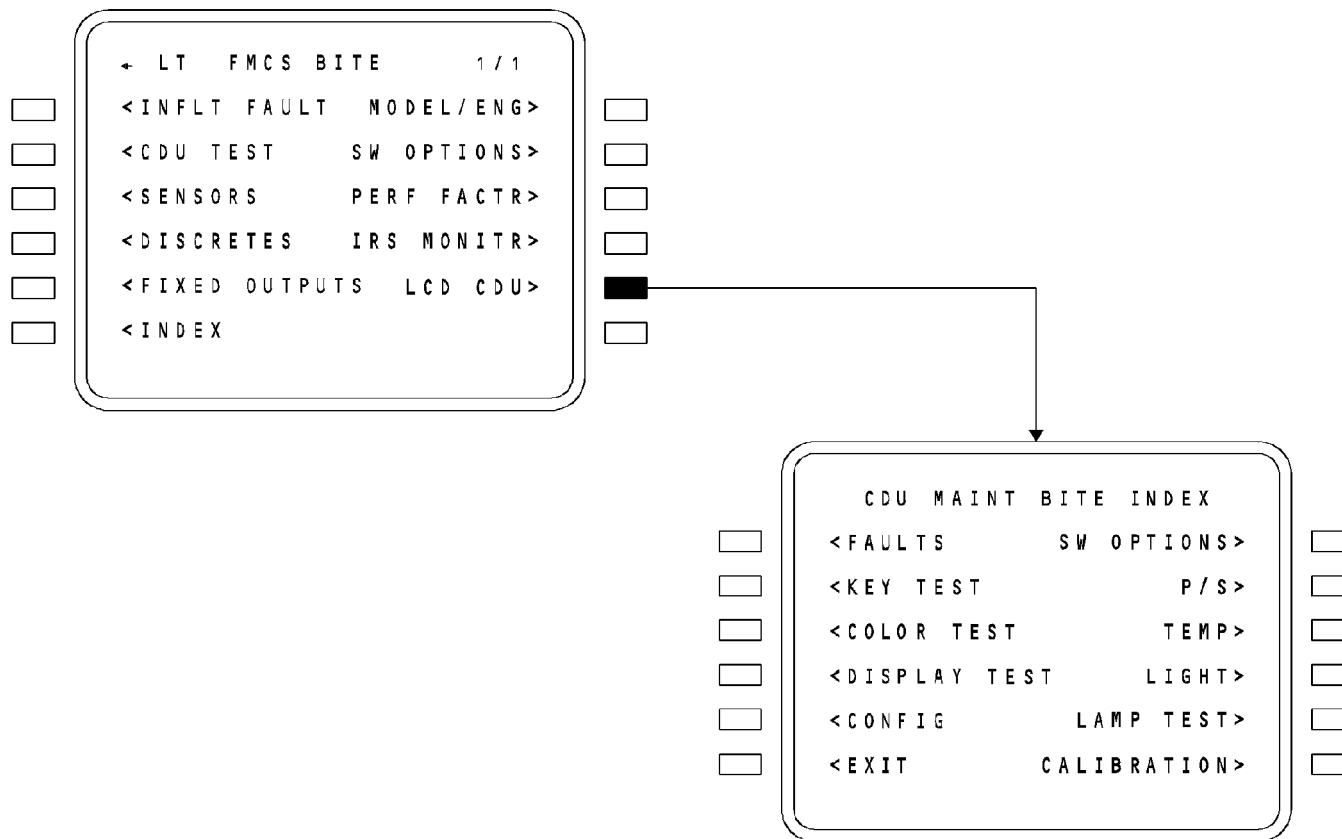

FMCS - TRAINING INFORMATION POINT - FMCS BITE PAGES - LCD CDU

EFFECTIVITY
HAP 037-054, 101-999

34-61-00

D633A101-HAP

Page 98.277
Jun 15/2009

34-61-00-077

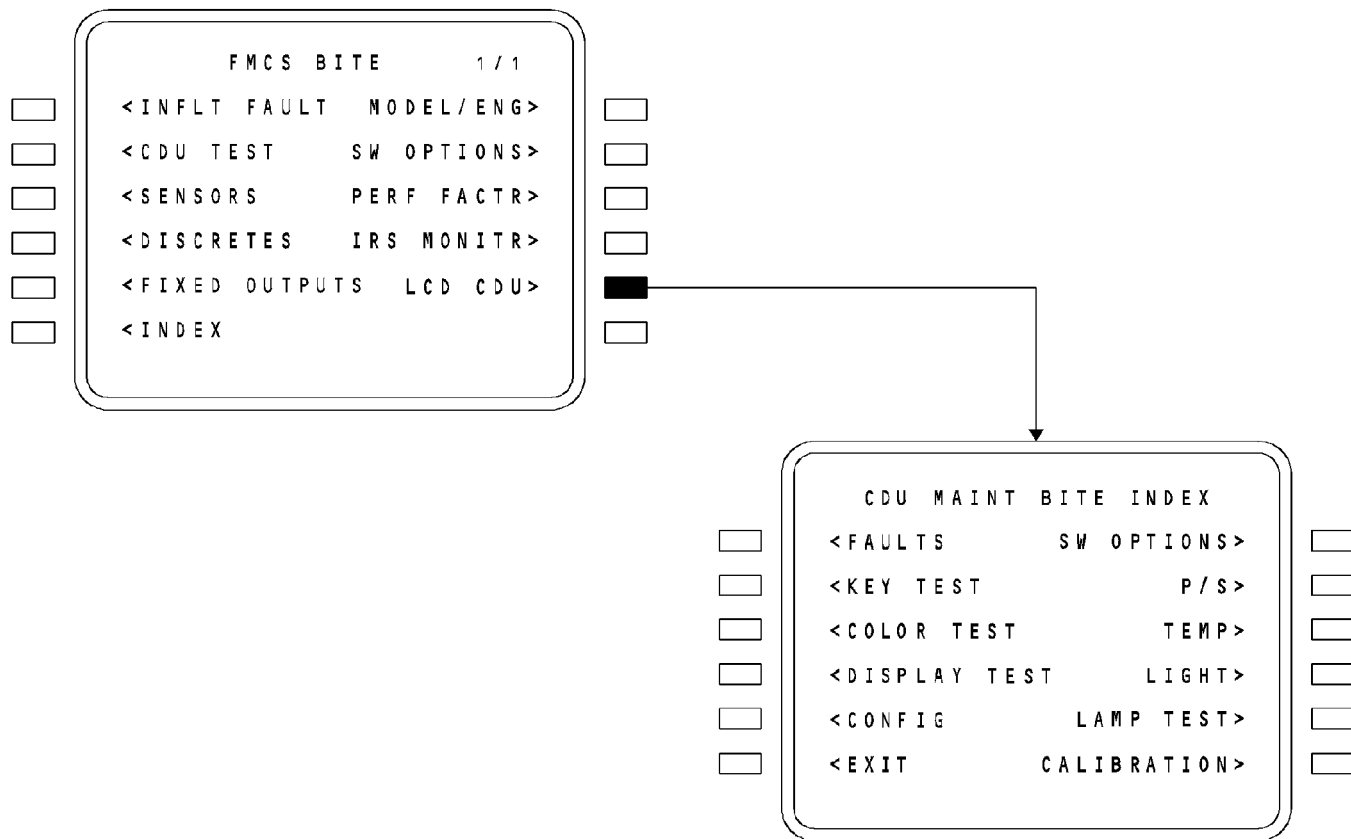

FMCS - TRAINING INFORMATION POINT - FMCS BITE PAGES - LCD CDU

EFFECTIVITY

HAP 006-013, 015-026, 028-036; HAP 001-005 POST SB 737-34-1951 GRP 1

34-61-00

D633A101-HAP

Page 98.278
Jun 15/2009

34-61-00-077

THIS PAGE IS INTENTIONALLY LEFT BLANK

34-61-00

D633A101-HAP

Page 98.279
Jun 15/2009

FMCS - TRAINING INFORMATION POINT - FMCS BITE PAGES - H/W CONFIG**GENERAL**

A second FMCS BITE maintenance page is for selection of the hardware configuration (H/W CONFIG) page.

The H/W CONFIG page shows this data for the FMC:

- Hardware part number
- Serial number
- Elapsed Time Indicator (ETI)
- Processor speed.

The INDEX prompt (LSK 6L) selects the FMCS BITE page 2/2.

EFFECTIVITY

HAP 030 PRE SB 737-34-1918; HAP 001-013, 015-026, 028, 029 POST SB
737-34-1666 AND PRE SB 737-34-1918

34-61-00

D633A101-HAP

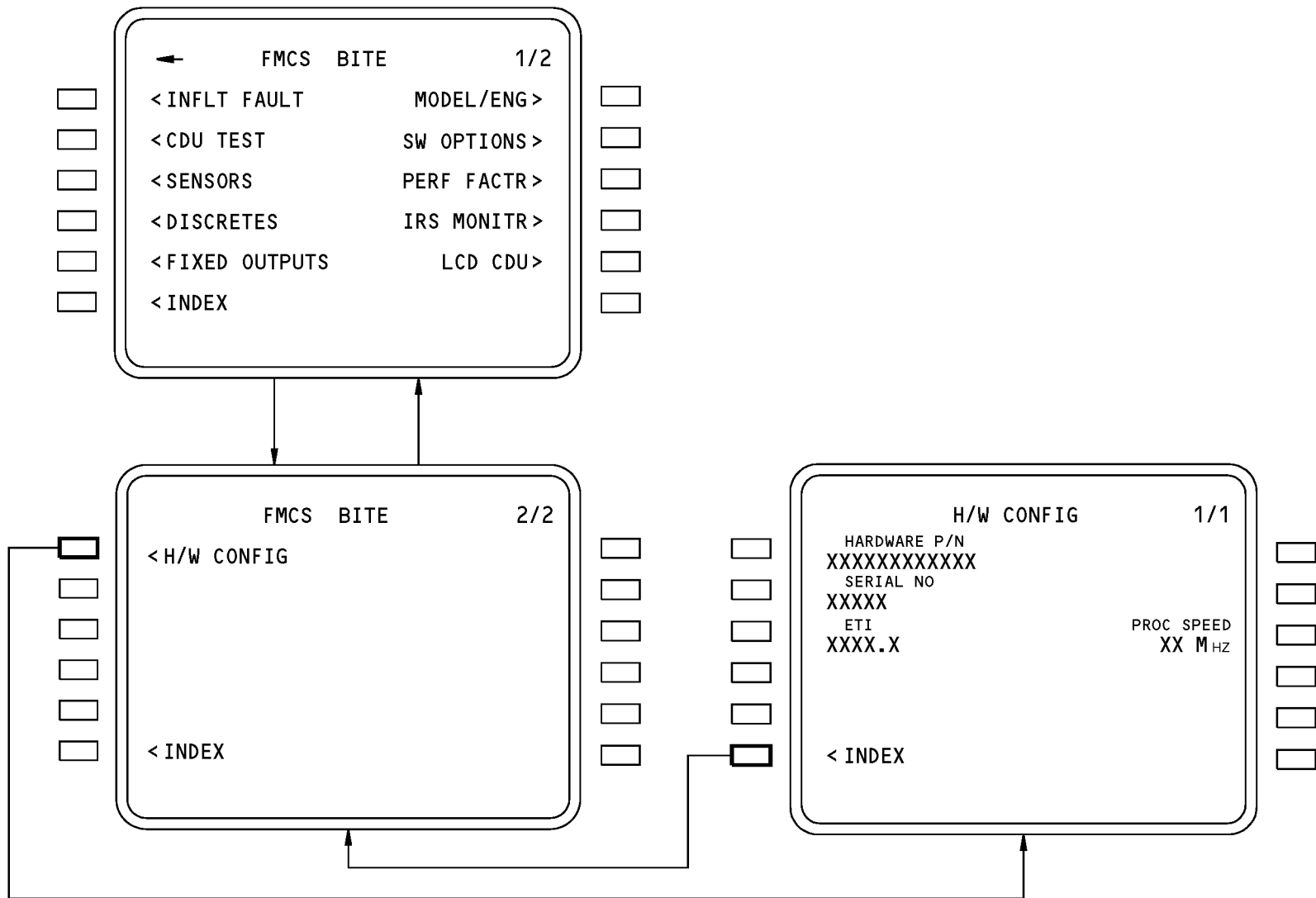

FMCS - TRAINING INFORMATION POINT - FMCS BITE PAGES - H/W CONFIG

EFFECTIVITY

HAP 030 PRE SB 737-34-1918; HAP 001-013, 015-026, 028, 029 POST SB 737-34-1666 AND PRE SB 737-34-1918

34-61-00

D633A101-HAP

Page 98.281
Jun 15/2009

34-61-00-098

THIS PAGE IS INTENTIONALLY LEFT BLANK

34-61-00

D633A101-HAP

Page 98.282
Jun 15/2009

FMCS - TRAINING INFORMATION POINT - CDU BITE PAGES - FAULTS

General

To see the CDU faults page, first select FAULTS on line select key (LSK) 1L from the CDU MAINT BITE INDEX page. This selects the CDU BITE DISPLY INDEX page.

CDU BITE DISPLAY INDEX Page

This page shows the fault history for the last ten full power-up cycles. When no faults are recorded during a cycle, the data field is blank.

To see the fault data for a specific cycle, select that line select key. This selects the CDU BITE DISPLAY page for that power up cycle.

Line select key 6L shows the INDEX prompt. This selects the CDU MAINT BITE INDEX page.

CDU BITE DISPLAY Page

This page shows the fault data for a specific cycle. Up to a maximum of five faults are recorded per cycle. The header shows the cycle number.

This data shows for each fault:

- Failed unit
- Failure description
- Fault state

- Failure frequency
- Failure time
- Extended fault code.

The failed unit can show FMC, CDU, or USER 1-5 where USER is an airplane sub-system.

These are the failure descriptions that can show:

- PROCESSOR
- WATCHDOG TIMER
- 429 FAULT
- ANNUN FAULT
- LCD
- KEYBOARD
- MEMORY
- R/C TIMER (resistor/capacitor)
- POWER SUPPLY
- LIGHT SENSOR
- ADC (analog to digital converter)
- TEMP SENSOR
- FMC FAULT
- SUB-SYSTEM FAULT
- EDC (error detection and correction logic)
- SOFTWARE FAULT
- FONTROM (read only memory).

The fault state shows if the fault is steady (S) or intermittent (I). All faults are initially recorded as a steady fault. If the fault later goes away, the indication changes to intermittent.

EFFECTIVITY

HAP 006-013, 015-026, 028-054, 101-999; HAP 001-005 POST SB 737-34-1951 GRP 1



FMCS - TRAINING INFORMATION POINT - CDU BITE PAGES - FAULTS

The failure frequency shows the number of times the fault occurs.

The failure time shows the CDU elapsed time indication when the fault first occurred.

The extended fault code is used by shop personnel only.

Line select key 6L shows the INDEX prompt. This selects the CDU MAINT BITE INDEX page.

34-61-00-078

EFFECTIVITY

HAP 006-013, 015-026, 028-054, 101-999; HAP 001-005 POST SB 737-34-1951 GRP 1

34-61-00

D633A101-HAP

Page 98.284
Jun 15/2009

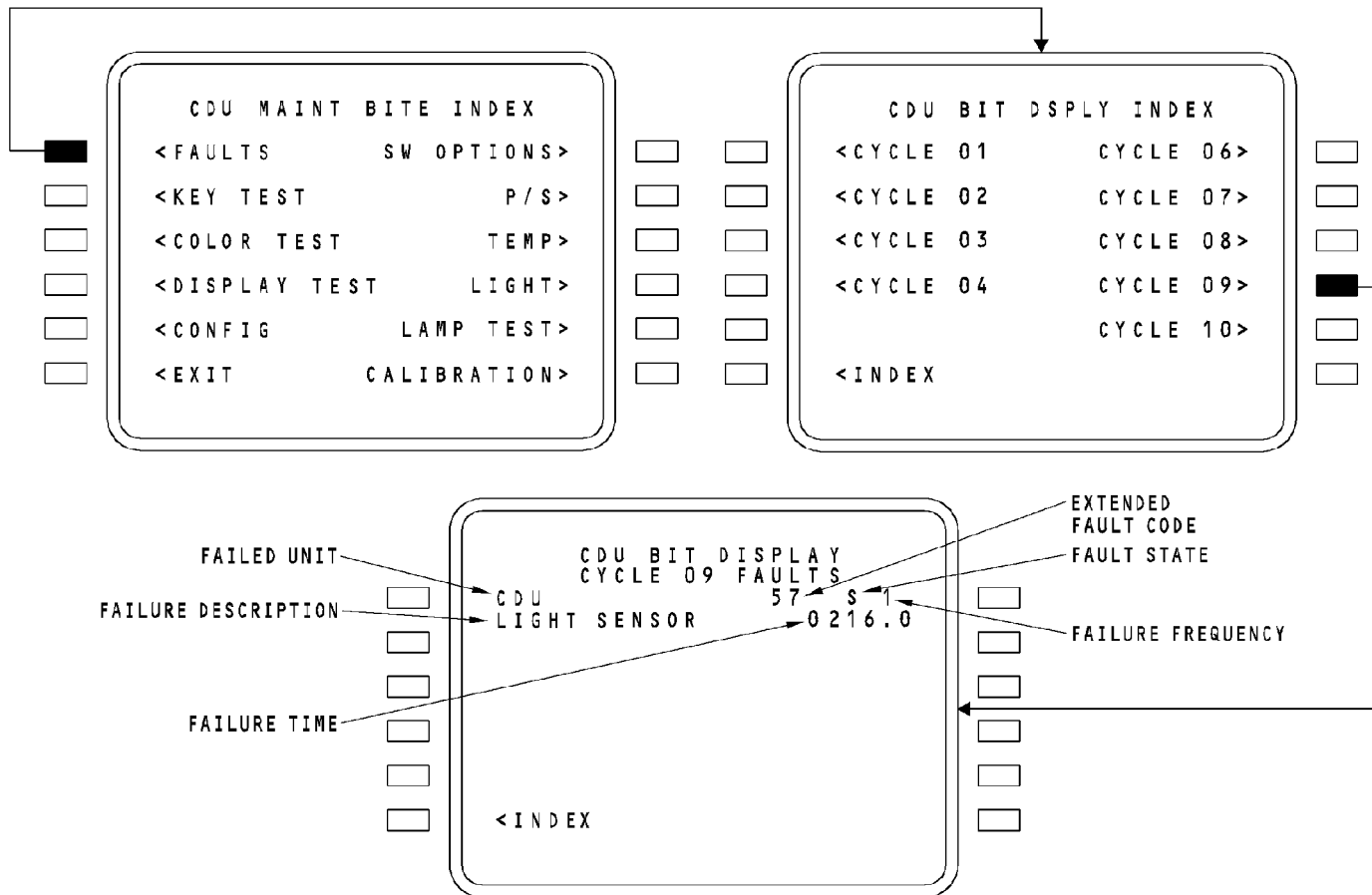

FMCS - TRAINING INFORMATION POINT - CDU BITE PAGES - FAULTS

EFFECTIVITY

HAP 006-013, 015-026, 028-054, 101-999; HAP 001-005 POST SB 737-34-1951 GRP 1

34-61-00

D633A101-HAP

FMCS - TRAINING INFORMATION POINT - CDU BITE PAGES - KEY TEST

General

To see the CDU KEY TEST page, select KEY TEST on LSK 2L from the CDU MAINT BITE INDEX page.

Key Test Page

This page shows the test displays for the MCDU faceplate keys on the MCDU screens. As you push each key on the keyboard, the corresponding character set will be highlighted (shaded white) on the CDU screen. Push the same key again to return the character set to normal.

Line select key 6L shows the INDEX prompt. This selects the CDU MAINT BITE INDEX page.

EFFECTIVITY

HAP 006-013, 015-026, 028-054, 101-999; HAP 001-005 POST SB 737-34-1951 GRP 1

34-61-00

D633A101-HAP

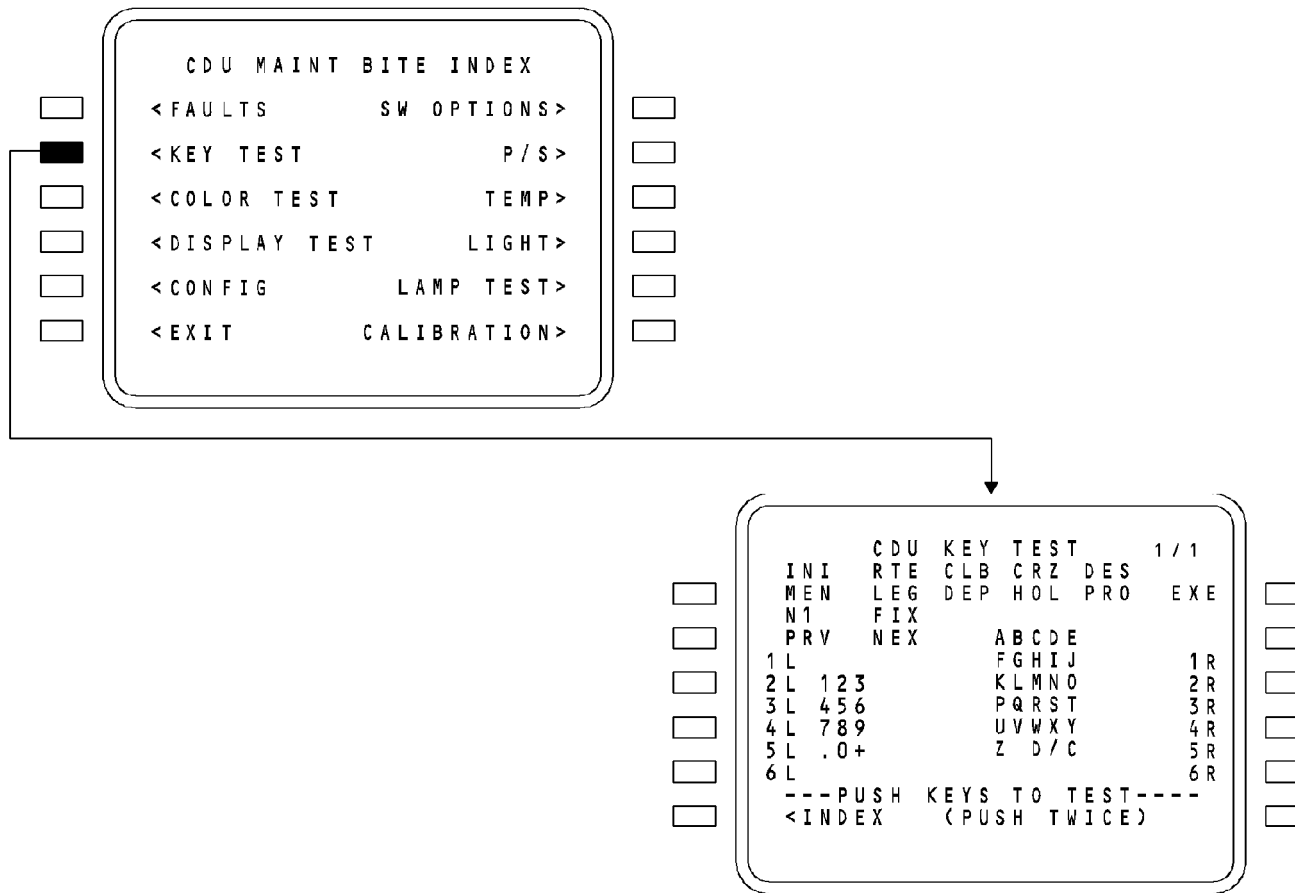

FMCS - TRAINING INFORMATION POINT - CDU BITE PAGES - KEY TEST

34-61-00-079

EFFECTIVITY
HAP 006-013, 015-026, 028-054, 101-999; HAP 001-005 POST SB 737-34-1951 GRP 1

34-61-00

D633A101-HAP

THIS PAGE IS INTENTIONALLY LEFT BLANK

34-61-00

D633A101-HAP

Page 98.288
Jun 15/2009

FMCS - TRAINING INFORMATION POINT - CDU BITE PAGES - COLOR TEST**General**

To see the CDU color test page, select COLOR TEST on LSK 3L from the CDU MAINT BITE INDEX page.

HAP 012, 013, 015-026, 028-054, 101-999; HAP 001-011 POST SB 737-34-1951 GRP 1

Color Test Page

Line 1L shows the RED prompt. This selects a full screen display of the color red.

Line 2L shows the GREEN prompt. This selects a full screen display of the color green.

Line 3L shows the BLUE prompt. This selects a full screen display of the color blue.

Line 4L shows the AMBER prompt. This selects a full screen display of the color amber.

Line 5L shows the MAGENTA prompt. This selects a full screen display of the color magenta.

Line 6L shows the INDEX prompt. This selects the CDU MAINT BITE INDEX page.

Line 1R shows the CYAN prompt. This selects a full screen display of the color cyan.

Line 2R shows the WHITE prompt. This selects a full screen display of the color white.

Line 3R shows the GRAY SCALE prompt. This selects a display of the eight brightness levels for the gray scale.

Line 4R shows the CHECKERBOARD prompt. This selects a full screen display of a black and white checkerboard pattern.

Push the LSK a second time to return the MCDU screen to normal.

HAP 006-011 PRE SB 737-34-1951 GRP 1

Color Test Page

Line 6L shows the INDEX prompt. This selects the CDU MAINT BITE INDEX page.

Line 2R shows the WHITE prompt. This selects a full screen display of the color white.

Line 3R shows the GRAY SCALE prompt. This selects a display of the eight brightness levels for the gray scale.

EFFECTIVITY

HAP 006-013, 015-026, 028-054, 101-999; HAP 001-005 POST SB 737-34-1951 GRP 1

34-61-00

D633A101-HAP

Page 98.289
Jun 15/2009



FMCS - TRAINING INFORMATION POINT - CDU BITE PAGES - COLOR TEST

HAP 006-011 PRE SB 737-34-1951 GRP 1 (Continued)

Line 4R shows the CHECKERBOARD prompt. This selects a full screen display of a black and white checkerboard pattern.

Push the LSK a second time to return the MCDU screen to normal.

HAP 006-013, 015-026, 028-054, 101-999; HAP 001-005 POST SB 737-34-1951 GRP 1

34-61-00-080

EFFECTIVITY

HAP 006-013, 015-026, 028-054, 101-999; HAP 001-005 POST SB 737-34-1951 GRP 1

34-61-00

D633A101-HAP

Page 98.290
Jun 15/2009



FMCS - TRAINING INFORMATION POINT - CDU BITE PAGES - COLOR TEST

EFFECTIVITY
HAP 006-011 PRE SB 737-34-1951 GRP 1

34-61-00

D633A101-HAP

Page 98.291
Jun 15/2009

34-61-00-080

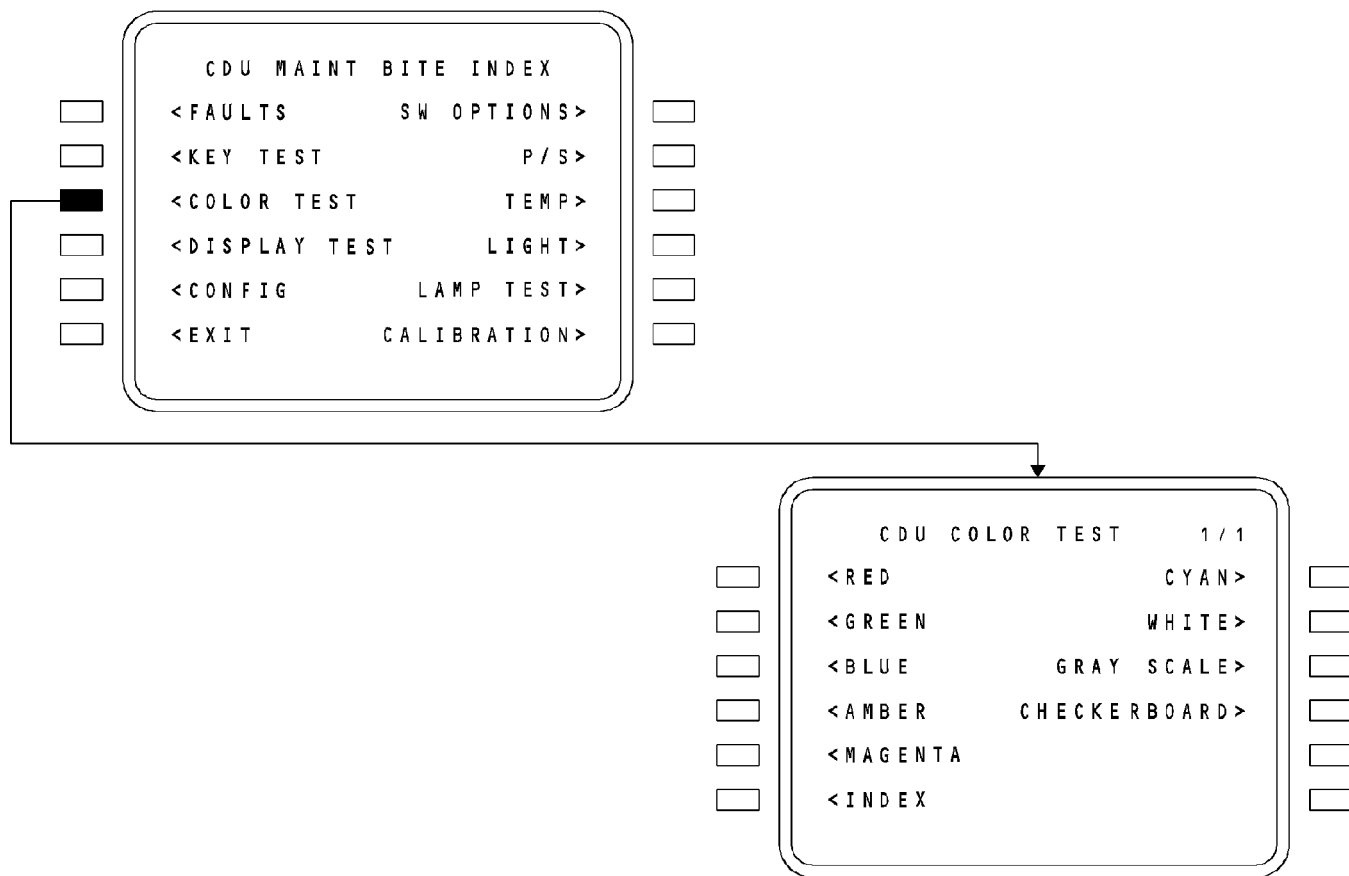

FMCS - TRAINING INFORMATION POINT - CDU BITE PAGES - COLOR TEST

EFFECTIVITY

HAP 012, 013, 015-026, 028-054, 101-999; HAP 001-011 POST SB 737-34-1951 GRP 1

34-61-00

D633A101-HAP

THIS PAGE IS INTENTIONALLY LEFT BLANK

34-61-00

D633A101-HAP

Page 98.293
Jun 15/2009

FMCS - TRAINING INFORMATION POINT - CDU BITE PAGES - DISPLAY TEST

General

To see the CDU display test page, select the DISPLAY TEST prompt on LSK 4L from the MAINT BITE INDEX page.

Display Test Page**HAP 006-011 PRE SB 737-34-1951 GRP 1**

This page shows the complete MCDU character set.

HAP 012, 013, 015-026, 028-054, 101-999; HAP 001-011 POST SB 737-34-1951 GRP 1

This page shows the complete MCDU character set. Selection of the PREV PAGE or NEXT PAGE pushbuttons steps the display through the next seven pages. Each page shows one of the seven colors.

HAP 006-013, 015-026, 028-054, 101-999; HAP 001-005 POST SB 737-34-1951 GRP 1

Line 6L shows the INDEX prompt. This selects the CDU MAINT BITE INDEX page.

EFFECTIVITY

HAP 006-013, 015-026, 028-054, 101-999; HAP 001-005 POST SB 737-34-1951 GRP 1

34-61-00

D633A101-HAP

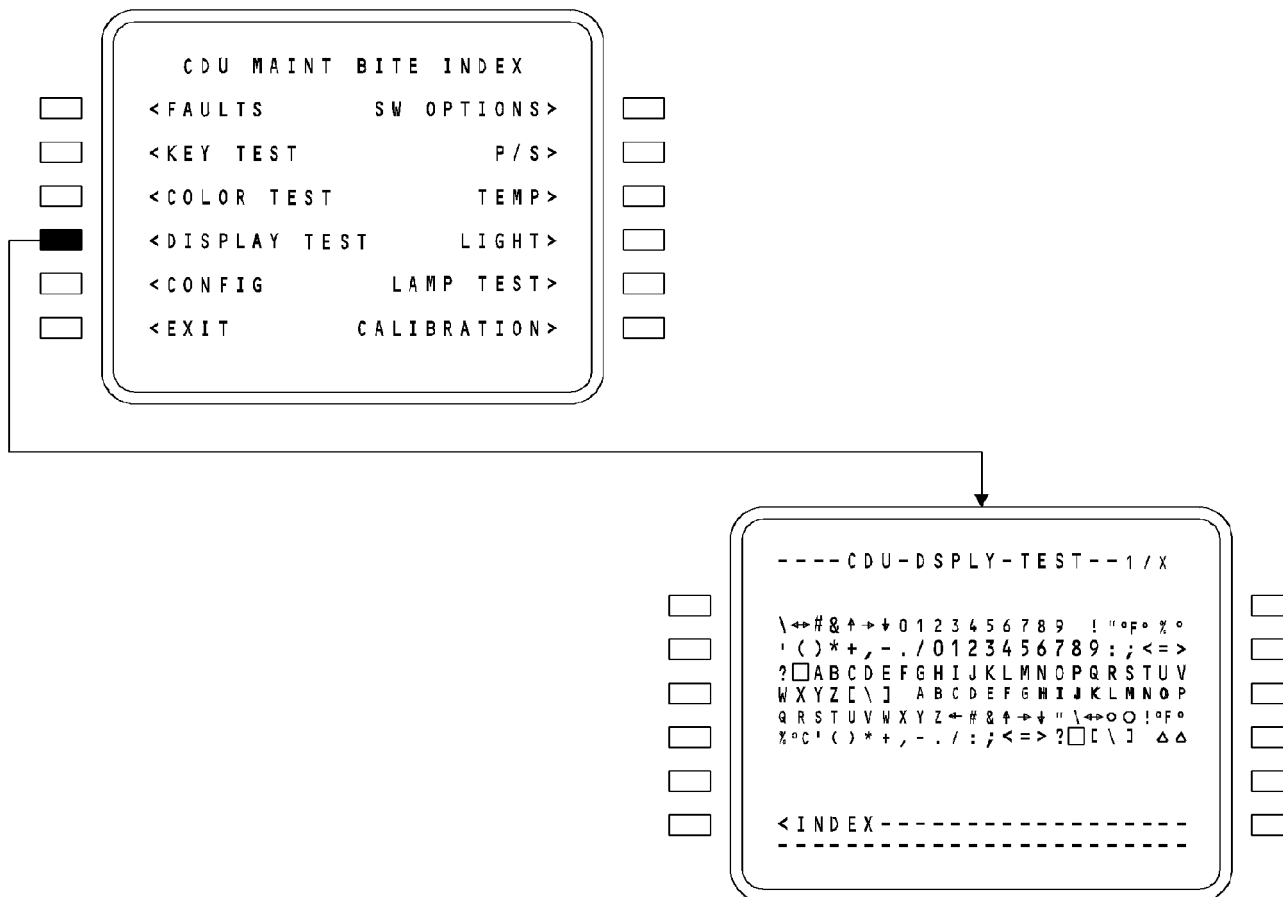

FMCS - TRAINING INFORMATION POINT - CDU BITE PAGES - DISPLAY TEST

EFFECTIVITY

HAP 006-013, 015-026, 028-054, 101-999; HAP 001-005 POST SB 737-34-1951 GRP 1

34-61-00

D633A101-HAP

FMCS - TRAINING INFORMATION POINT - CDU BITE PAGES - CONFIG

General

To see the CDU CONFIGURATION page, select CONFIG on LSK 5L from the CDU MAINT BITE INDEX page.

Configuration Page

The CDU CONFIGURATION page shows this information:

- Software part number
- Operating mode (CDU, MCDU, or FANS MCDU)
- Location (left or right)
- Elapsed time indicator
- CDU serial number.

Line 6L shows the INDEX prompt. This selects the CDU MAINT BITE INDEX page.

EFFECTIVITY

HAP 006-013, 015-026, 028-054, 101-999; HAP 001-005 POST SB 737-34-1951 GRP 1

34-61-00

D633A101-HAP

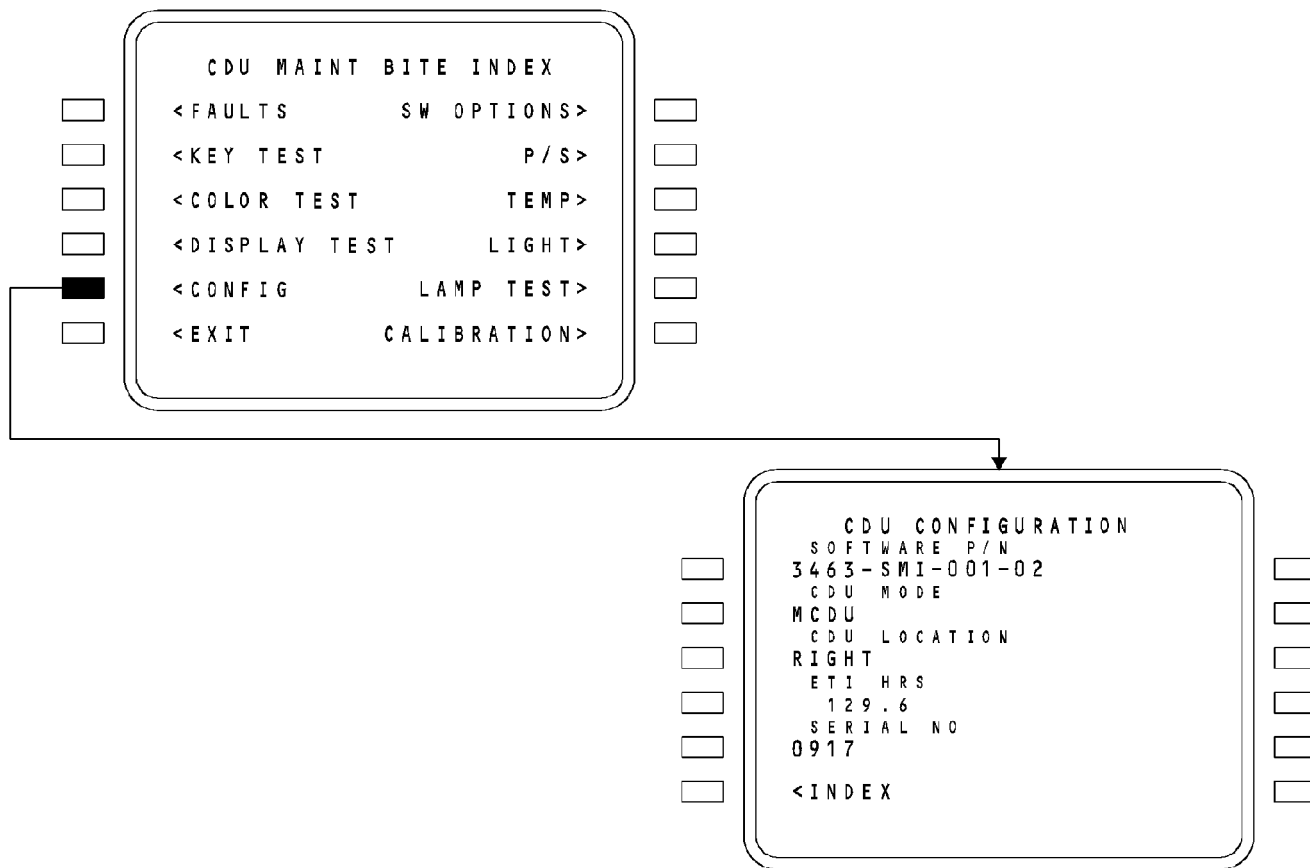

FMCS - TRAINING INFORMATION POINT - CDU BITE PAGES - CONFIG

EFFECTIVITY

HAP 006-013, 015-026, 028-054, 101-999; HAP 001-005 POST SB 737-34-1951 GRP 1

34-61-00

D633A101-HAP

FMCS - TRAINING INFORMATION POINT - CDU BITE PAGES - SW OPTIONS**General**

To see the software options page, select SW OPTIONS on LSK 1R from the CDU MAINT BITE INDEX page.

Software Options Page

The software option page shows the status of the options that are in the CDU software options database.

The software option code is an eight-digit hexadecimal number. These options are available:

- Switching mode
- ARINC 739 color usage
- ALT NAV - GPS
- ALT NAV - IRS
- WXR MAP

The enabled options show at line 3L. If there are no option codes enabled, NONE shows.

Line 6L shows the INDEX prompt. This selects the CDU MAINT BITE INDEX page.

EFFECTIVITY

HAP 006-013, 015-026, 028-054, 101-999; HAP 001-005 POST SB 737-34-1951 GRP 1

34-61-00

D633A101-HAP

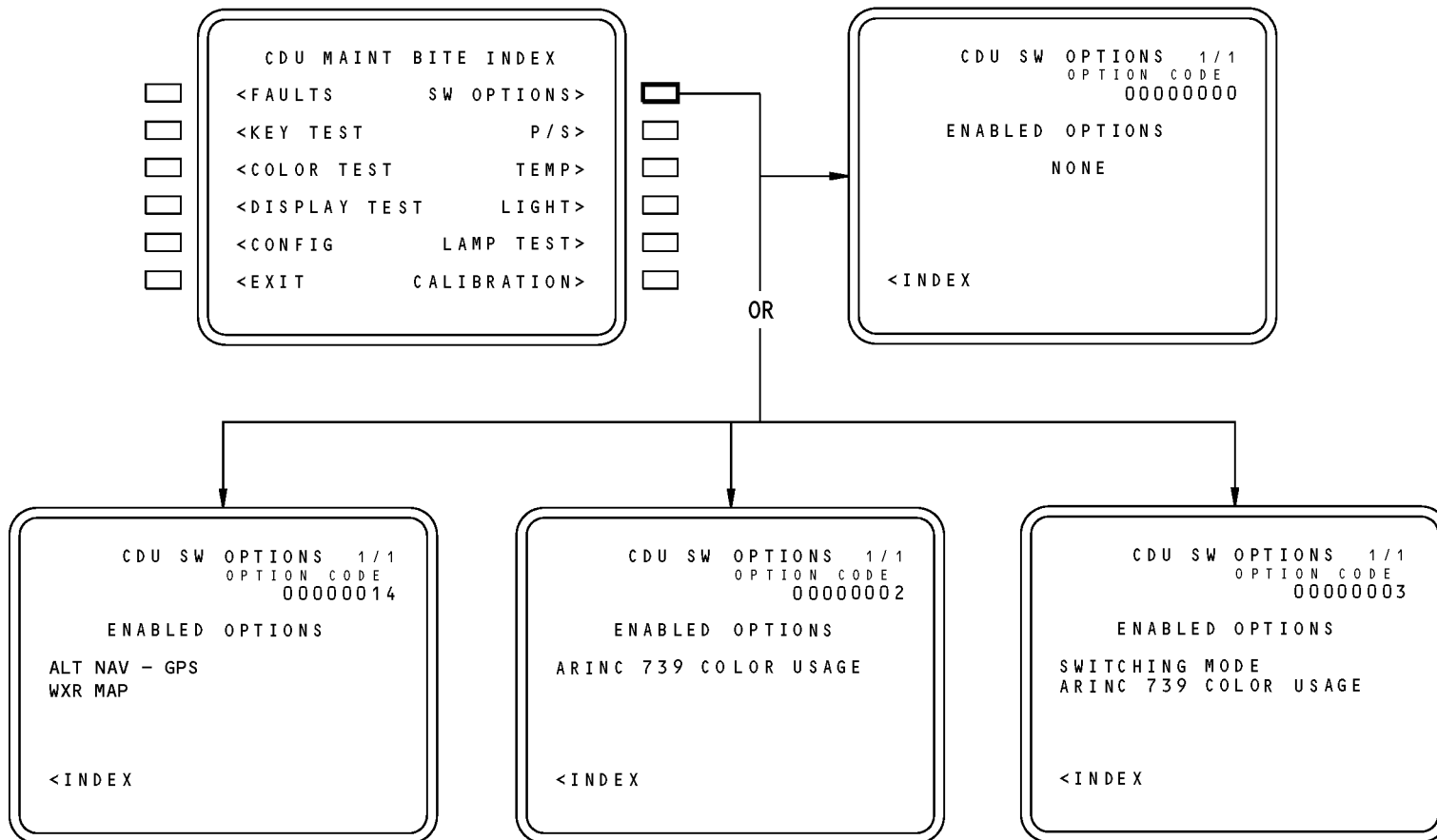

FMCS - TRAINING INFORMATION POINT - CDU BITE PAGES - SW OPTIONS

EFFECTIVITY

HAP 006-013, 015-026, 028-054, 101-999; HAP 001-005 POST SB 737-34-1951 GRP 1

34-61-00

D633A101-HAP

Page 98.299
Jun 15/2009

34-61-00-083

FMCS - TRAINING INFORMATION POINT - CDU BITE PAGES - POWER SUPPLY

General

To see the CDU power supply page, select P/S on LSK 2R from the CDU MAINT BITE INDEX page.

Power Supply Page

This page shows the voltage levels from the MCDU power supply. These voltages come the power supply:

- +5v dc
- +12v dc
- -12v dc
- +26v dc
- +28v dc
- Switched +28v dc
- Annunciator +5v dc.

NOTE: The switched 28v dc power supply is only active when the CDU heater is on and the voltage will be displayed. If the heater is off, the data field will be blank.

Line 6L shows the INDEX prompt. This selects the CDU MAINT BITE INDEX page.

EFFECTIVITY

HAP 006-013, 015-026, 028-054, 101-999; HAP 001-005 POST SB 737-34-1951 GRP 1

34-61-00

D633A101-HAP

Page 98.300
Jun 15/2009

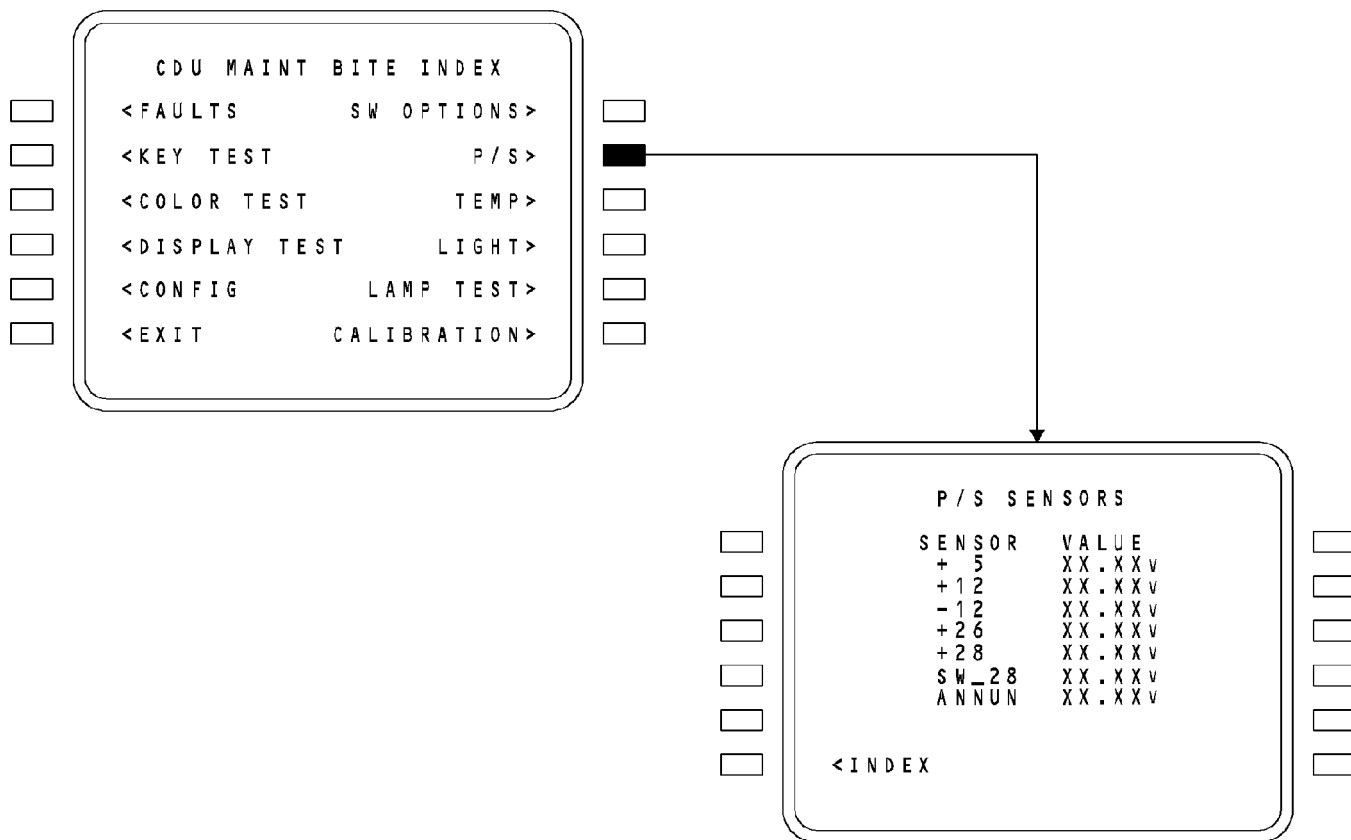

FMCS - TRAINING INFORMATION POINT - CDU BITE PAGES - POWER SUPPLY

EFFECTIVITY

HAP 006-013, 015-026, 028-054, 101-999; HAP 001-005 POST SB 737-34-1951 GRP 1

34-61-00

D633A101-HAP

FMCS - TRAINING INFORMATION POINT - CDU BITE PAGES - TEMP SENSORS**General**

To see the CDU TEMP SENSORS page, select TEMP on LSK 3R from the CDU MAINT BITE INDEX page.

Temperature Sensors Page

This page shows the temperature values from the sensors in the LCD module and the backlight assembly. It also shows the operational status of the thermal electric coolers (TEC) and the heater.

Line 6L shows the INDEX prompt. This selects the CDU MAINT BITE INDEX page.

EFFECTIVITY

HAP 006-013, 015-026, 028-054, 101-999; HAP 001-005 POST SB 737-34-1951 GRP 1

34-61-00

D633A101-HAP

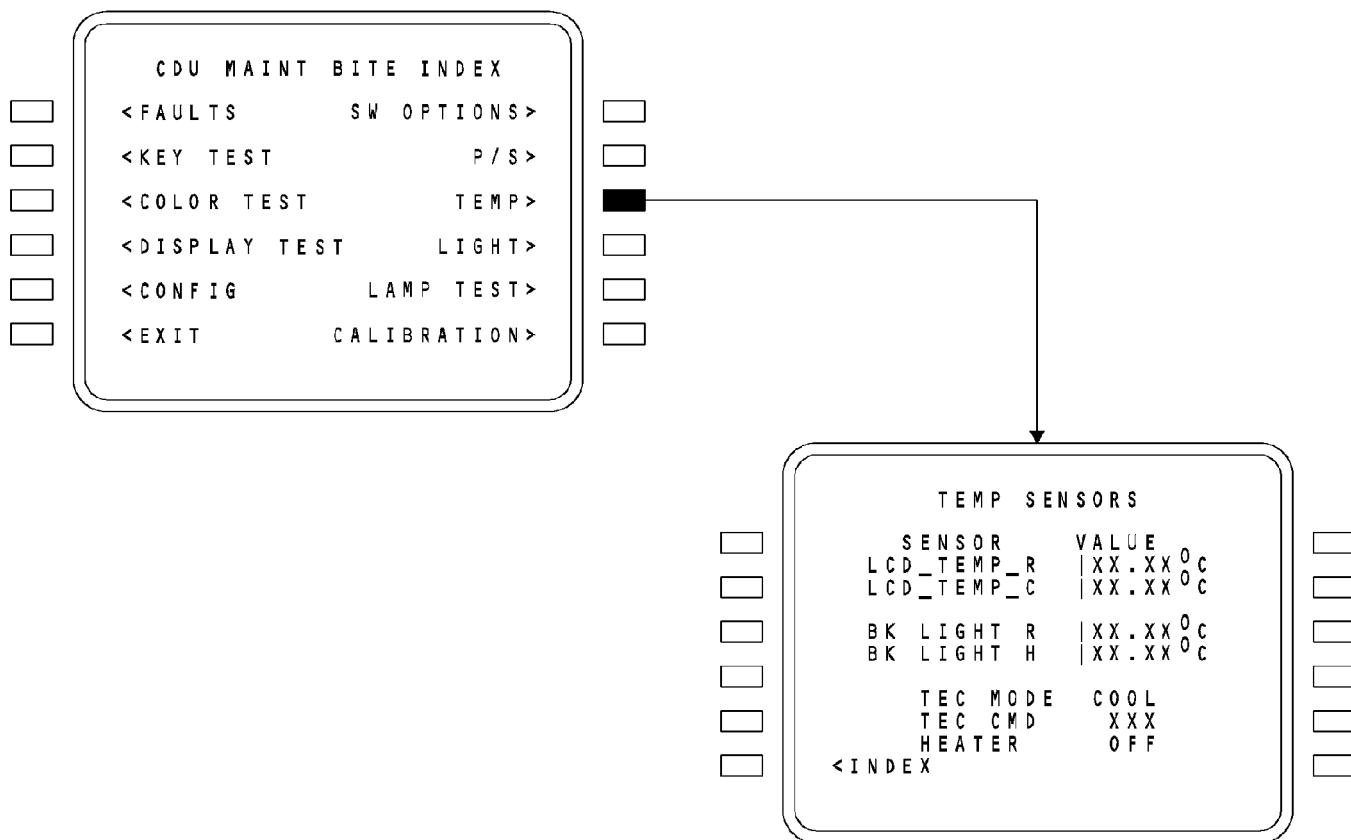

FMCS - TRAINING INFORMATION POINT - CDU BITE PAGES - TEMP SENSORS

EFFECTIVITY

HAP 006-013, 015-026, 028-054, 101-999; HAP 001-005 POST SB 737-34-1951 GRP 1

34-61-00

D633A101-HAP

FMCS - TRAINING INFORMATION POINT - CDU BITE PAGES - LIGHT SENSORS**General**

To see the CDU LIGHT SENSORS page, select LIGHT on LSK 4R from the CDU MAINT BITE INDEX page.

Light Sensors Page

This page shows the voltage levels from the MCDU light sensors.

Line 6L shows the INDEX prompt. This selects the CDU MAINT BITE INDEX page.

EFFECTIVITY

HAP 006-013, 015-026, 028-054, 101-999; HAP 001-005 POST SB 737-34-1951 GRP 1

34-61-00

D633A101-HAP

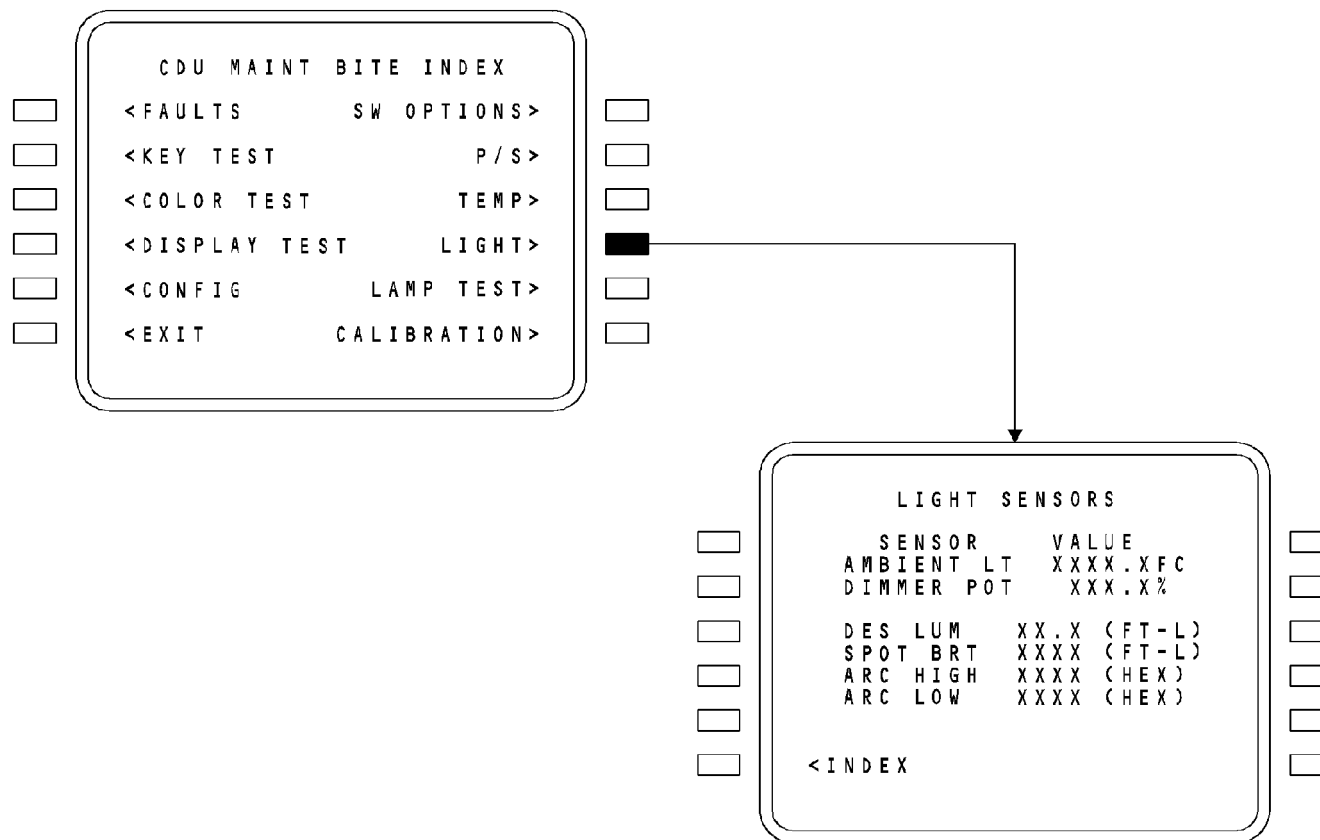

FMCS - TRAINING INFORMATION POINT - CDU BITE PAGES - LIGHT SENSORS

34-61-00-086

EFFECTIVITY
HAP 006-013, 015-026, 028-054, 101-999; HAP 001-005 POST SB 737-34-1951 GRP 1

34-61-00

D633A101-HAP

Page 98.305
Jun 15/2009

FMCS - TRAINING INFORMATION POINT - CDU BITE PAGES - LAMP TEST

General

To see the CDU lamp test page, select LAMP TEST on LSK 5R from the CDU MAINT BITE INDEX page.

Lamp Test Page

This page does a test of the MCDU annunciators. The message ANNUNCIATORS ALL LT shows on the CDU and these annunciators come on:

- CALL
- FAIL
- MSG
- OFST
- EXEC.

Line 6L shows the INDEX prompt. This selects the CDU MAINT BITE INDEX page and the annunciators go out.

EFFECTIVITY

HAP 006-013, 015-026, 028-054, 101-999; HAP 001-005 POST SB 737-34-1951 GRP 1

34-61-00

D633A101-HAP

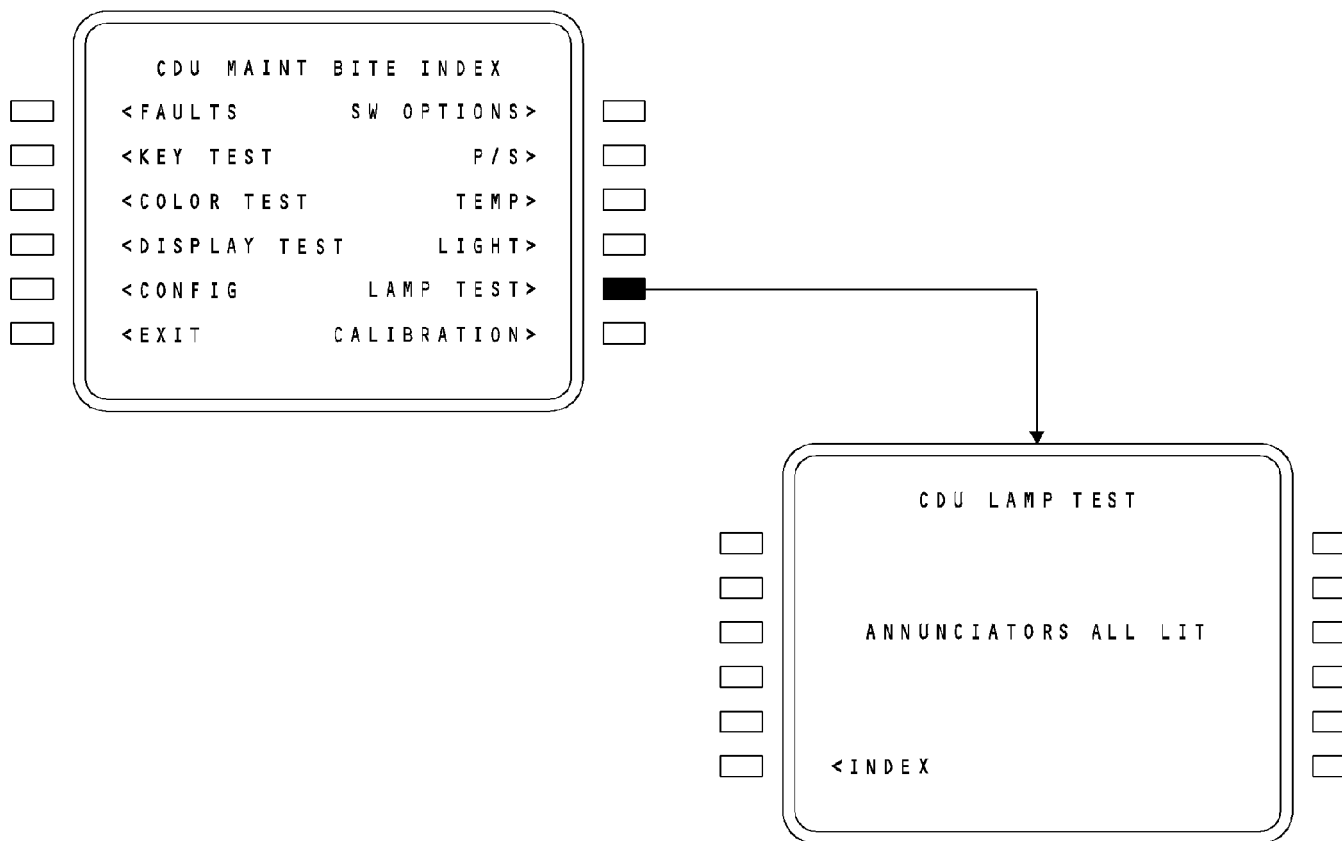

FMCS - TRAINING INFORMATION POINT - CDU BITE PAGES - LAMP TEST

EFFECTIVITY

HAP 006-013, 015-026, 028-054, 101-999; HAP 001-005 POST SB 737-34-1951 GRP 1

34-61-00

D633A101-HAP

Page 98.307
Jun 15/2009

34-61-00-087

FMCS - TRAINING INFORMATION POINT - CDU BITE PAGES - CALIBRATION

General

To see the CDU calibration page, select CALIBRATION on line select key (LSK) 6R from the CDU MAINT BITE INDEX page.

Calibration Page

This page shows the current deflection voltages and calibration factors for the LCD module. It also shows the light sensor bias level and the scale factor used.

The scratchpad shows the source of the currently used data. If the software uses calibrated data, then CALIBRATED will be shown. If it uses hardcoded defaults, then DEFAULTS will be shown.

Line select key 6L shows the INDEX prompt. This selects the CDU MAINT BITE INDEX page.

EFFECTIVITY

HAP 006-013, 015-026, 028-054, 101-999; HAP 001-005 POST SB 737-34-1951 GRP 1

34-61-00

D633A101-HAP

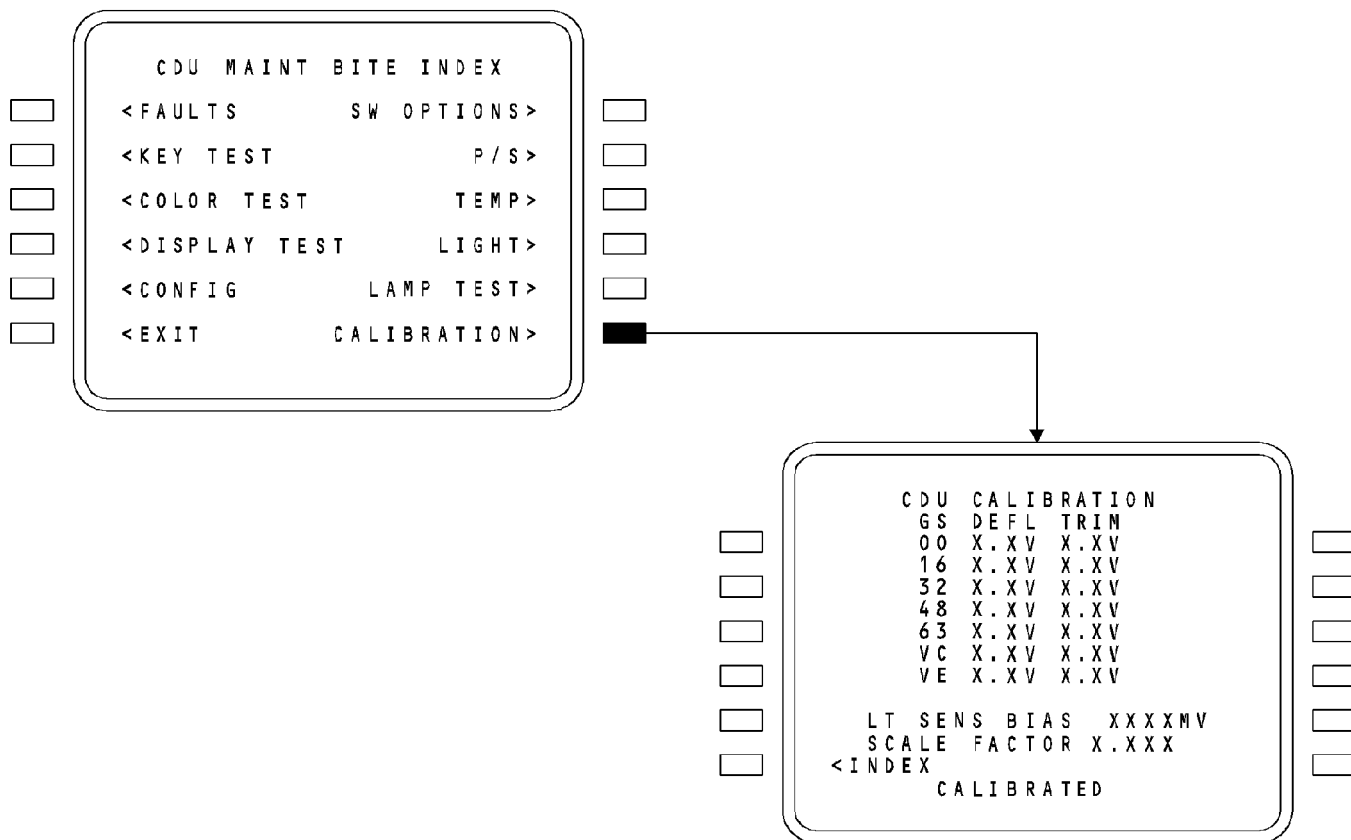

FMCS - TRAINING INFORMATION POINT - CDU BITE PAGES - CALIBRATION

EFFECTIVITY

HAP 006-013, 015-026, 028-054, 101-999; HAP 001-005 POST SB 737-34-1951 GRP 1

34-61-00

D633A101-HAP

Page 98.309
Jun 15/2009

34-61-00-088



FMCS - SYSTEM SUMMARY

General

This page is for reference.

34-61-00-069

EFFECTIVITY
HAP 001-013, 015-026, 028-036

34-61-00

D633A101-HAP

Page 98.310
Jun 15/2009

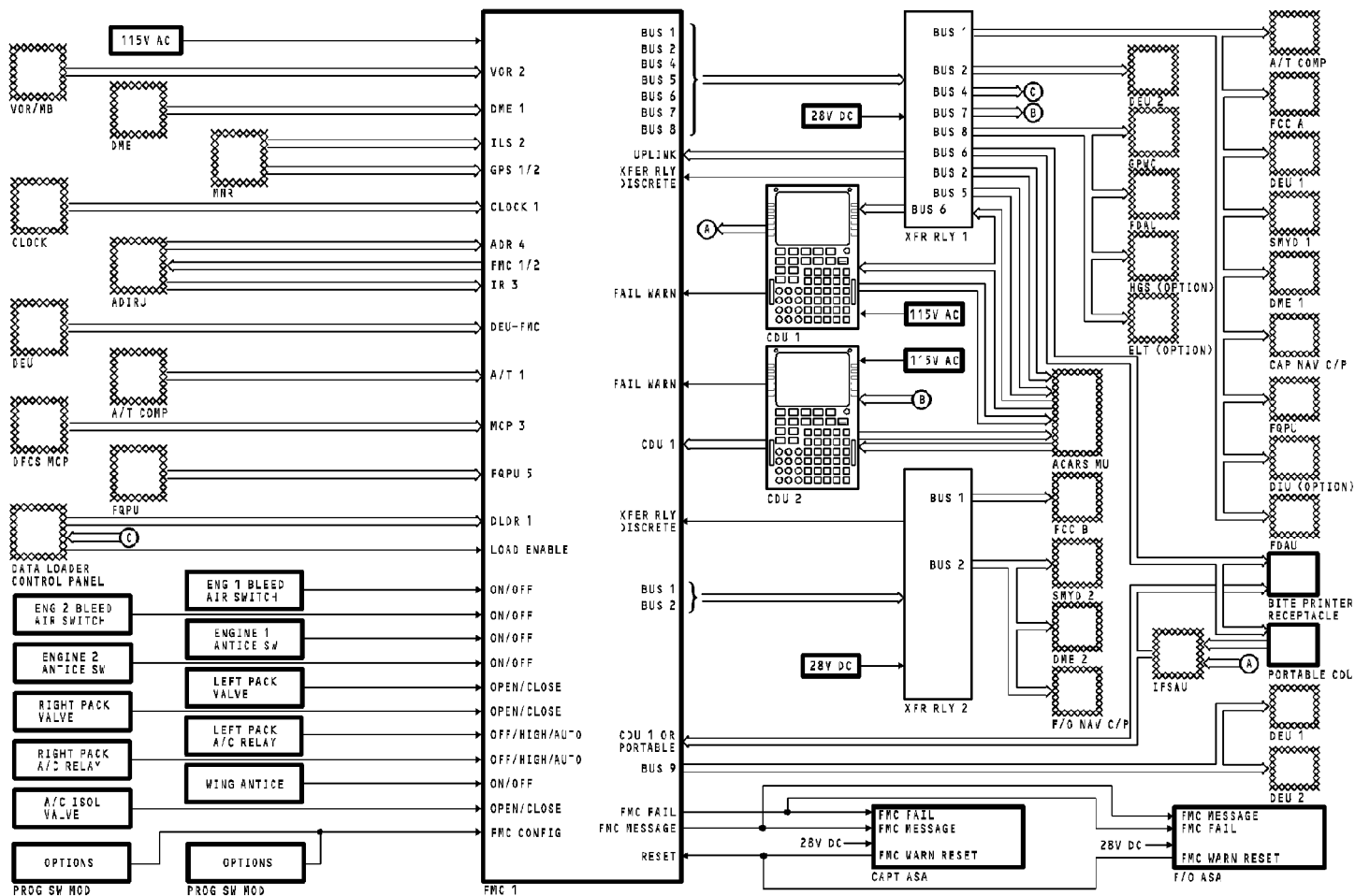

FMCS - SYSTEM SUMMARY

34-61-00-069

EFFECTIVITY
HAP 001-011 PRE SB 737-31-1136

34-61-00

D633A101-HAP

Page 98.311
Jun 15/2009

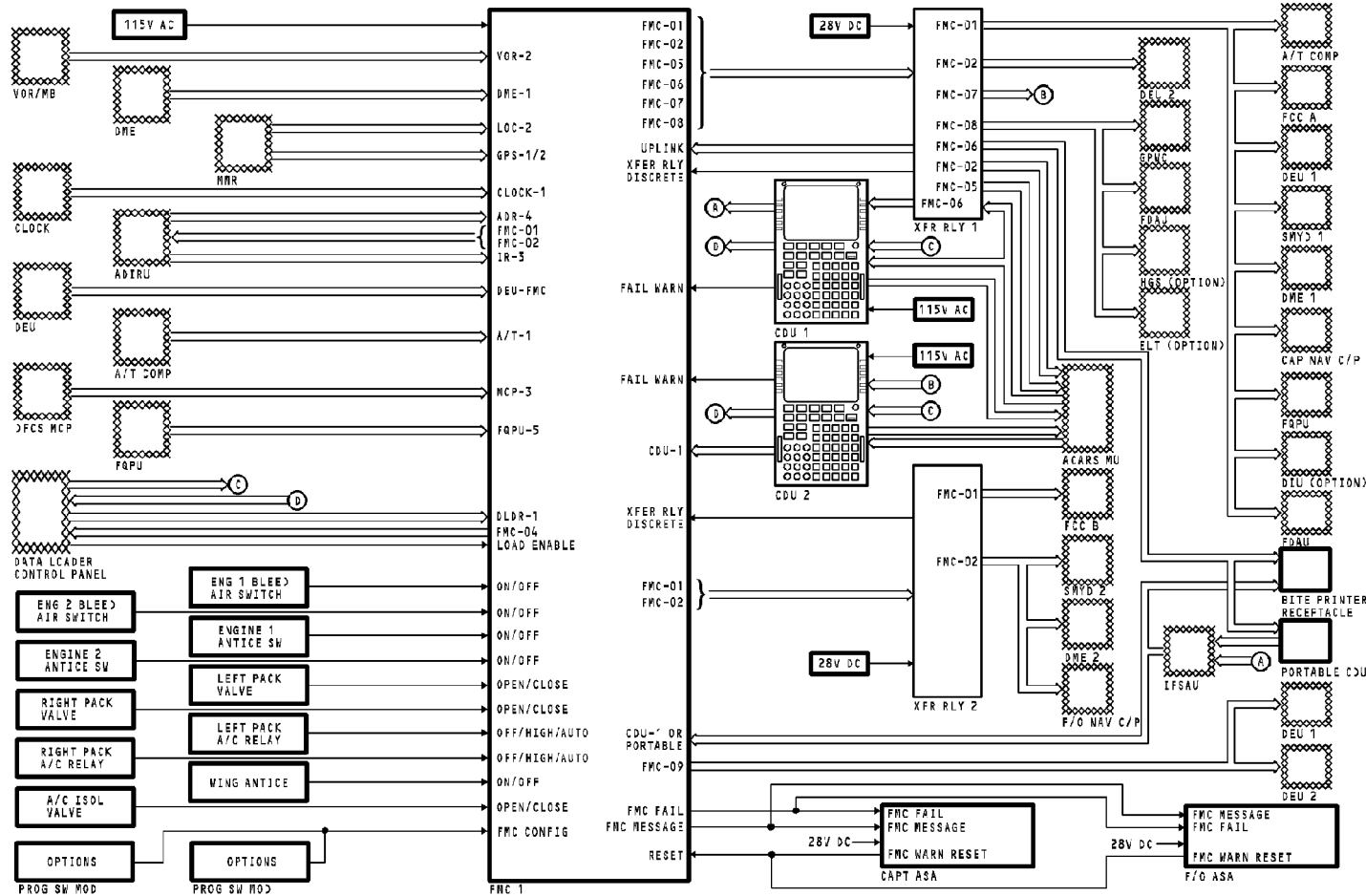

FMCS - SYSTEM SUMMARY

EFFECTIVITY

HAP 012, 013, 015-026, 028-036; HAP 001-011 POST SB 737-31-1136

34-61-00

D633A101-HAP

Page 98.312
Jun 15/2009

34-61-00-069

THIS PAGE IS INTENTIONALLY LEFT BLANK

34-61-00

D633A101-HAP

Page 98.313
Jun 15/2009



FMCS - SYSTEM SUMMARY

General

This page is for reference.

34-61-00-070

EFFECTIVITY
HAP 037-054, 101-999

34-61-00

D633A101-HAP

Page 98.314
Jun 15/2009

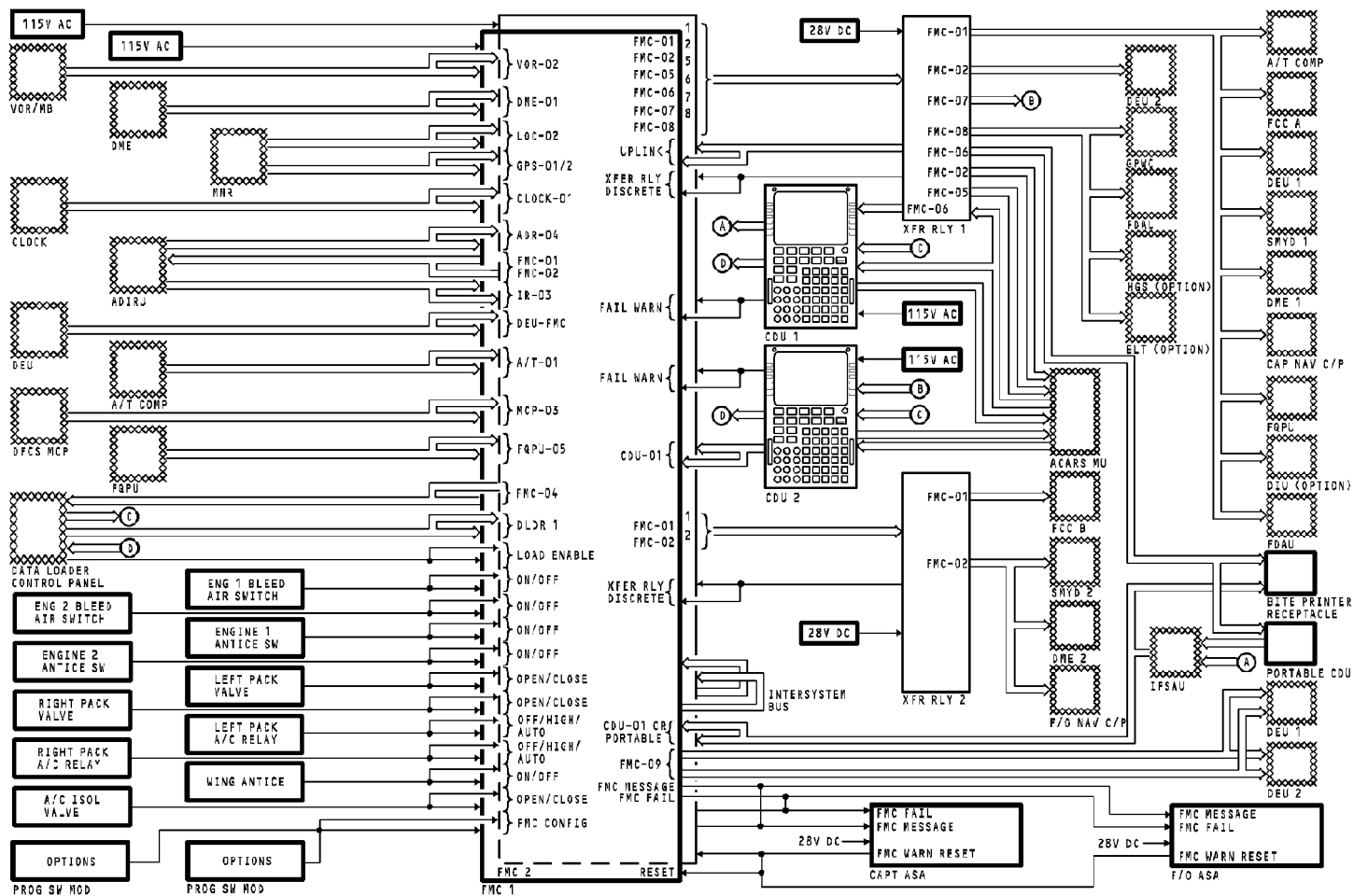

FMCS - SYSTEM SUMMARY

34-61-00-070

EFFECTIVITY
HAP 037-054, 101-999

34-61-00

D633A101-HAP

Page 98.315
Jun 15/2009