

CHAPTER

23

COMMUNICATIONS



CHAPTER 23
COMMUNICATIONS

CH-SC-SU	Schem	Page	Sheet	Date	CH-SC-SU	Schem	Page	Sheet	Date	
23-EFFECTIVE PAGES					23-11-11 (cont.)					
		1 thru 7		Aug 10/2009	D		102.1	2	Aug 10/2009	
		8		BLANK	A		102A	1	Aug 10/2009	
23-CONTENTS					A			2	Aug 10/2009	
R		1		Aug 10/2009	R		103	1	Aug 10/2009	
O		2		Aug 10/2009	R			2	Aug 10/2009	
O		3		Aug 10/2009	A		103.1	1	Aug 10/2009	
O		4		Aug 10/2009	A			2	Aug 10/2009	
O		5		Aug 10/2009	R		104	1	Aug 10/2009	
O		6		Aug 10/2009	R			2	Aug 10/2009	
O		7		Aug 10/2009	R		105	1	Aug 10/2009	
O		8		Aug 10/2009	R			2	Aug 10/2009	
O		9		Aug 10/2009	A		106	1	Aug 10/2009	
R		10		Aug 10/2009	A			2	Aug 10/2009	
O		11		Aug 10/2009	23-11-21					
		12		BLANK				101	1	Feb 09/2009
23-ALPHABETICAL INDEX								2	Feb 09/2009	
		1		Jan 18/2007			101.1	1	May 13/2008	
		2		Jan 18/2007				2	May 13/2008	
	23-11-11						102	1	Feb 09/2009	
R		101	1	Aug 10/2009				2	Feb 09/2009	
R			2	Aug 10/2009			103	1	Feb 09/2009	
D		102	1	Aug 10/2009				2	Feb 09/2009	
D			2	Aug 10/2009			104	1	Feb 09/2009	
D		102.1	1	Aug 10/2009						

A = Added, R = Revised, D = Deleted, O = Overflow

23-EFFECTIVE PAGES

Page 1
Aug 10/2009

D280A203



CHAPTER 23
COMMUNICATIONS

CH-SC-SU	Schem	Page	Sheet	Date	CH-SC-SU	Schem	Page	Sheet	Date
23-11-21 (cont.)		104			23-12-41 (cont.)				
			2	Feb 09/2009			105		Feb 09/2009
		105	1	Feb 09/2009			106		Feb 09/2009
			2	Feb 09/2009	23-22-11				
23-12-11							101		Jul 17/2007
	101.1			Aug 13/2008			102		Oct 20/2006
	102			Jul 17/2007			103		Feb 09/2009
	103			Oct 20/2006			103.1		May 13/2008
	104			Feb 09/2009			104		Feb 09/2009
23-12-21							105		Feb 09/2009
	101.1			Aug 13/2008	23-24-11				
	102			Jul 17/2007			101		Jul 17/2007
	103			Oct 20/2006			102		Feb 09/2009
	104			Feb 09/2009			103		Apr 18/2007
23-12-31					23-27-11				
	101			Jul 17/2007			101		Jul 26/2006
	101A			Oct 15/2007			101A		Oct 15/2007
	102			Oct 20/2006			102		Jul 17/2007
	103			Feb 09/2009			102A		Oct 15/2007
23-12-41					23-27-12				
	101			Oct 20/2006			101		Jul 17/2007
	102			Feb 09/2009	23-27-13				
	103			Feb 09/2009			101		Jul 17/2007
	104			Feb 09/2009					

A = Added, R = Revised, D = Deleted, O = Overflow

23-EFFECTIVE PAGES

Page 2
Aug 10/2009

D280A203



CHAPTER 23
COMMUNICATIONS

CH-SC-SU	Schem	Page	Sheet	Date	CH-SC-SU	Schem	Page	Sheet	Date
23-27-14		101		Jul 17/2007	23-27-37		101		Feb 09/2009
23-27-15		101		Jul 17/2007	23-27-38		101		Feb 09/2009
23-27-16		101		Jul 17/2007			102		Nov 11/2008
		101A		Oct 15/2007	23-27-39		101		Feb 09/2009
23-27-31		101		Oct 20/2006	23-31-11		101		Mar 31/2005
		102		Feb 09/2009			101.1		May 13/2008
		103		Feb 12/2008			102		Jul 17/2007
23-27-32		101		Oct 20/2006			103		Feb 09/2009
		102		Feb 09/2009			104		Jan 14/2008
23-27-33		101		Oct 20/2006	23-31-12		101		Jul 17/2007
		102		Feb 09/2009			102		Feb 09/2009
		103		Aug 13/2008	23-31-13		101		Jul 17/2007
23-27-34		101		Jan 14/2008			102	1	Feb 09/2009
		102		Feb 09/2009				2	Feb 09/2009
23-27-35		101		Oct 20/2006			103	1	Jan 14/2008
		102		Feb 09/2009				2	Jan 14/2008
					23-31-14		101	1	Jul 17/2007

A = Added, R = Revised, D = Deleted, O = Overflow

23-EFFECTIVE PAGES

Page 3
Aug 10/2009

D280A203



CHAPTER 23
COMMUNICATIONS

CH-SC-SU	Schem	Page	Sheet	Date	CH-SC-SU	Schem	Page	Sheet	Date
23-31-14 (cont.)		101			23-32-11 (cont.)				
			2	Jul 17/2007			107	1	Nov 11/2008
		102	1	Feb 09/2009				2	Jan 14/2008
			2	Feb 09/2009				3	Jan 14/2008
		103		Jan 14/2008			108	1	Feb 12/2008
23-32-11								2	Feb 12/2008
		101	1	Mar 31/2005				3	Feb 12/2008
			2	Mar 31/2005	23-32-12				
			3	Mar 31/2005			101		Jul 17/2007
		102	1	Jul 17/2007			102		Oct 20/2006
			2	Jul 17/2007			103		Jan 14/2008
			3	Jul 17/2007			104		Feb 09/2009
		103	1	Mar 31/2005			105		Feb 09/2009
			2	Mar 31/2005			106		May 13/2008
			3	Mar 31/2005			107		May 13/2008
		104	1	Feb 09/2009	23-32-31				
			2	Feb 09/2009			101		Mar 31/2005
			3	Feb 09/2009			102		Mar 31/2005
		105	1	Nov 11/2008			103		Jul 17/2007
			2	Jan 14/2008			104		Feb 09/2009
			3	Jan 14/2008			105		Jan 14/2008
		106	1	Jan 14/2008	23-32-32				
			2	Jan 14/2008			101		Mar 31/2005
			3	Jan 14/2008			102		Jul 17/2007

A = Added, R = Revised, D = Deleted, O = Overflow

23-EFFECTIVE PAGES

Page 4
Aug 10/2009

D280A203



CHAPTER 23
COMMUNICATIONS

CH-SC-SU	Schem	Page	Sheet	Date	CH-SC-SU	Schem	Page	Sheet	Date
23-32-32 (cont.)		103		Feb 09/2009	23-32-51 (cont.)		102		Jul 17/2007
		104		Jan 14/2008			103		Feb 09/2009
23-32-33							104		Jan 14/2008
		101		Feb 09/2009	23-32-52				
		102		Jan 14/2008			101		Mar 31/2005
23-32-34							102		Jul 17/2007
		101		Feb 09/2009			103		Feb 09/2009
23-32-41							104		Jan 14/2008
		101		Mar 31/2005	23-32-53				
		102		Jul 17/2007			101		Mar 31/2005
		103		Feb 09/2009			102		Jul 17/2007
		104		Jan 14/2008			103		Feb 09/2009
23-32-42					23-32-61				
		101		Mar 31/2005			101		Mar 31/2005
		102		Jul 17/2007			102		Jul 17/2007
		103		Feb 09/2009			103		Aug 13/2008
		104		Jan 14/2008			104		Feb 09/2009
23-32-43							105		Jan 14/2008
		101		Mar 31/2005	23-32-62				
		102		Jul 17/2007			101		Mar 31/2005
		103		Feb 09/2009			102		Jul 17/2007
23-32-51							103		Feb 09/2009
		101		Mar 31/2005			104		Jan 14/2008

A = Added, R = Revised, D = Deleted, O = Overflow

23-EFFECTIVE PAGES

Page 5
Aug 10/2009

D280A203



CHAPTER 23
COMMUNICATIONS

CH-SC-SU	Schem	Page	Sheet	Date	CH-SC-SU	Schem	Page	Sheet	Date
23-32-63		101		Mar 31/2005	23-42-12		101		Jul 17/2007
		102		Jul 17/2007			102		Feb 09/2009
		103		Feb 09/2009			103		Jan 14/2008
23-34-01		101	1	Mar 31/2005	23-43-11		101		Jul 17/2007
			2	Mar 31/2005			102		Feb 09/2009
		101.1	1	May 13/2008	23-51-11				
			2	May 13/2008			101	1	Mar 31/2005
		102	1	Jul 17/2007				2	Mar 31/2005
			2	Jul 17/2007				3	Mar 31/2005
		103	1	Mar 31/2005				4	Mar 31/2005
			2	Mar 31/2005				5	Mar 31/2005
		104	1	Feb 09/2009			102	1	Jul 17/2007
			2	Feb 09/2009				2	Jul 17/2007
			3	Feb 09/2009				3	Jul 17/2007
			4	Feb 09/2009				4	Jul 17/2007
23-41-11								5	Jul 17/2007
		101		Feb 09/2009	A		102.1	1	Aug 10/2009
23-42-11					A			2	Aug 10/2009
		101		Jul 17/2007	A			3	Aug 10/2009
		102		Oct 20/2006	A			4	Aug 10/2009
		103		Feb 09/2009	A			5	Aug 10/2009
		104		Jan 14/2008			103	1	Oct 20/2006

A = Added, R = Revised, D = Deleted, O = Overflow

23-EFFECTIVE PAGES



CHAPTER 23
COMMUNICATIONS

CH-SC-SU	Schem	Page	Sheet	Date	CH-SC-SU	Schem	Page	Sheet	Date
23-51-11 (cont.)		103			23-71-11 (cont.)				
			2	Oct 20/2006			104		May 13/2008
			3	Oct 20/2006					
			4	Oct 20/2006					
		104	1	Aug 13/2008					
			2	Aug 13/2008					
			3	Aug 13/2008					
			4	Aug 13/2008					
			5	Aug 13/2008					
		105	1	Feb 09/2009					
			2	Feb 09/2009					
			3	Feb 09/2009					
			4	Feb 09/2009					
			5	Feb 09/2009					
23-70-11									
		101A	1	Jul 17/2007					
			2	Jul 17/2007					
		102		Oct 20/2006					
		103	1	Feb 09/2009					
			2	Feb 09/2009					
23-71-11									
		101.1		Jul 26/2006					
		102		Aug 13/2008					
		103		Feb 09/2009					

A = Added, R = Revised, D = Deleted, O = Overflow

23-EFFECTIVE PAGES

Page 7
Aug 10/2009

D280A203



CHAPTER 23
COMMUNICATIONS

Title	CH-SC-SU	Schem	Page	Sheet	Date	Effectivity
<u>HIGH FREQUENCY (HF) COMMUNICATION SYSTEM</u>						
HF COMMUNICATIONS 1	23-11-11		101	1	Aug 10/2009	YC001-YC004
				2	Aug 10/2009	YC001-YC004
			102A	1	Aug 10/2009	YC005-YC007
				2	Aug 10/2009	YC005-YC007
			103	1	Aug 10/2009	YK907-YK909 YL401
				2	Aug 10/2009	YK907-YK909 YL401
			103.1	1	Aug 10/2009	YK907-YK909
				2	Aug 10/2009	YK907-YK909
			104	1	Aug 10/2009	YK910-YK920
				2	Aug 10/2009	YK910-YK920
			105	1	Aug 10/2009	YL421-YL430
				2	Aug 10/2009	YL421-YL430
			106	1	Aug 10/2009	YM643-YM670
				2	Aug 10/2009	YM643-YM670
HF COMMUNICATIONS 2	23-11-21		101	1	Feb 09/2009	YK907-YK909 YL401
				2	Feb 09/2009	YK907-YK909 YL401
			101.1	1	May 13/2008	YK907-YK909
				2	May 13/2008	YK907-YK909
			102	1	Feb 09/2009	YK910-YK920
				2	Feb 09/2009	YK910-YK920
			103	1	Feb 09/2009	YL421
				2	Feb 09/2009	YL421



CHAPTER 23
COMMUNICATIONS

Title	CH-SC-SU	Schem	Page	Sheet	Date	Effectivity
HF COMMUNICATIONS 2 (cont.)	23-11-21		104	1	Feb 09/2009	YL422-YL430
				2	Feb 09/2009	YL422-YL430
			105	1	Feb 09/2009	YM643-YM670
				2	Feb 09/2009	YM643-YM670
<u>VERY HIGH FREQUENCY (VHF) COMMUNICATION SYSTEM</u>						
VHF COMMUNICATIONS 1	23-12-11		101.1		Aug 13/2008	YC001-YC016
					Jul 17/2007	YC017-YC050
					Oct 20/2006	YK901-YK906
					Feb 09/2009	YK907-YM670
VHF COMMUNICATIONS 2	23-12-21		101.1		Aug 13/2008	YC001-YC016
					Jul 17/2007	YC017-YC050
					Oct 20/2006	YK901-YK906
					Feb 09/2009	YK907-YM670
VHF COMMUNICATIONS 3	23-12-31		101		Jul 17/2007	YC001-YC050
					Oct 15/2007	YC001-YC030
					Oct 20/2006	YK901-YK906
					Feb 09/2009	YK907-YM670
VHF/HF COMMUNICATIONS	23-12-41		101		Oct 20/2006	YK901-YK906
					Feb 09/2009	YK907-YK909 YL401
					Feb 09/2009	YK910-YK920
					Feb 09/2009	YL421
					Feb 09/2009	YL422-YL430
					Feb 09/2009	YM643-YM670

CHAPTER 23
COMMUNICATIONS

Title	CH-SC-SU	Schem	Page	Sheet	Date	Effectivity
<u>SELCAL SYSTEM</u>						
SELCAL	23-22-11		101		Jul 17/2007	YC001-YC050
			102		Oct 20/2006	YK901-YK906
			103		Feb 09/2009	YK907-YK909 YL401
			103.1		May 13/2008	YK907-YK909
			104		Feb 09/2009	YK910-YK920 YL421-YL430
			105		Feb 09/2009	YM643-YM670
<u>EMERGENCY LOCATOR TRANSMITTER SYSTEM</u>						
EMERGENCY LOCATOR TRANSMITTER (ELT)	23-24-11		101		Jul 17/2007	YC001-YC050
			102		Feb 09/2009	YK901-YL401 YL424-YM670
			103		Apr 18/2007	YL421-YL423
<u>AIRCRAFT COMMUNICATIONS ADDRESSING AND REPORTING SYSTEM (ACARS)</u>						
ACARS (724B) POWER, COMM AND ANNUNCIATION INTERFACES	23-27-11		101		Jul 26/2006	YC001-YC011
			101A		Oct 15/2007	YC001-YC011
			102		Jul 17/2007	YC012-YC050
			102A		Oct 15/2007	YC012-YC030
ACARS (724B) - DFDAU AND OOOI INTERFACES	23-27-12		101		Jul 17/2007	YC001-YC050
ACARS (724B) CONTROL AND DISPLAY	23-27-13		101		Jul 17/2007	YC001-YC050
ACARS (724B) FMC, PRINTER AND DISCRETE INTERFACES	23-27-14		101		Jul 17/2007	YC001-YC050
ACARS (724B) SATCOM AND AIRSHOW INTERFACES	23-27-15		101		Jul 17/2007	YC001-YC050
ACARS (724B) REGISTRY AND AIRLINE ID CODING	23-27-16		101		Jul 17/2007	YC001-YC050

CHAPTER 23
COMMUNICATIONS

Title	CH-SC-SU	Schem	Page	Sheet	Date	Effectivity
ACARS (724B) REGISTRY AND AIRLINE ID CODING (cont.)	23-27-16		101A		Oct 15/2007	YC001-YC030
ACARS/CMU - POWER & CONTROL	23-27-31		101		Oct 20/2006	YK901-YK906
			102		Feb 09/2009	YK907-YL430
			103		Feb 12/2008	YM643-YM670
ACARS/CMU - OUTPUT BUS 1 INTERFACES	23-27-32		101		Oct 20/2006	YK901-YK906
			102		Feb 09/2009	YK907-YM670
ACARS/CMU - OUTPUT BUS 2 INTERFACES	23-27-33		101		Oct 20/2006	YK901-YK906
			102		Feb 09/2009	YK907-YK920 YL421-YM670
			103		Aug 13/2008	YL401
ACARS/CMU - OUTPUT BUS 3 INTERFACES	23-27-34		101		Jan 14/2008	YK901-YK909 YM643-YM646
			102		Feb 09/2009	YK910-YL430 YM647-YM670
ACARS/CMU - 716 VHF AND FMC INTERFACES	23-27-35		101		Oct 20/2006	YK901-YK906
			102		Feb 09/2009	YK907-YM670
CMU - OUTPUT BUS 6 AND BUS 7 INTERFACES	23-27-37		101		Feb 09/2009	YK901-YM670
ACARS/CMU - OOOI, CREW ADVISORIES AND OUTPUT 8	23-27-38		101		Feb 09/2009	YK901-YL426 YM643-YM670
			102		Nov 11/2008	YL427-YL430
ACARS/CMU - DATA LOADER AND PROGRAM PINS	23-27-39		101		Feb 09/2009	YK901-YM670
<u>PASSENGER ADDRESS SYSTEM</u>						
PASSENGER ADDRESS SYSTEM	23-31-11		101		Mar 31/2005	YC001-YC013
			101.1		May 13/2008	YC001-YC013
			102		Jul 17/2007	YC015-YC050

CHAPTER 23
COMMUNICATIONS

Title	CH-SC-SU	Schem	Page	Sheet	Date	Effectivity
PASSENGER ADDRESS SYSTEM (cont.)	23-31-11		103		Feb 09/2009	YK901-YL430
			104		Jan 14/2008	YM643-YM670
PRE-RECORDER ANNOUNCEMENT MACHINE	23-31-12		101		Jul 17/2007	YC001-YC030
			102		Feb 09/2009	YK901-YM670
INTEGRATED HANDSET CONTROLLER	23-31-13		101		Jul 17/2007	YC001-YC050
			102	1	Feb 09/2009	YK901-YL430
				2	Feb 09/2009	YK901-YL430
			103	1	Jan 14/2008	YM643-YM670
				2	Jan 14/2008	YM643-YM670
PASSENGER ADDRESS SYSTEM SPEAKERS	23-31-14		101	1	Jul 17/2007	YC001-YC050
				2	Jul 17/2007	YC001-YC050
			102	1	Feb 09/2009	YK901-YL430
				2	Feb 09/2009	YK901-YL430
			103		Jan 14/2008	YM643-YM670
<u>PASSENGER VIDEO SYSTEM</u>						
VIDEO CONTROL CENTER	23-32-11		101	1	Mar 31/2005	YC001-YC011
				2	Mar 31/2005	YC001-YC011
				3	Mar 31/2005	YC001-YC011
			102	1	Jul 17/2007	YC012-YC026
				2	Jul 17/2007	YC012-YC026
				3	Jul 17/2007	YC012-YC026
			103	1	Mar 31/2005	YC028-YC030
				2	Mar 31/2005	YC028-YC030



CHAPTER 23
COMMUNICATIONS

Title	CH-SC-SU	Schem	Page	Sheet	Date	Effectivity		
VIDEO CONTROL CENTER (cont.)	23-32-11			3	Mar 31/2005	YC028-YC030		
			104	1	Feb 09/2009	YK901-YL401		
				2	Feb 09/2009	YK901-YL401		
				3	Feb 09/2009	YK901-YL401		
			105	1	Nov 11/2008	YL421-YL425		
				2	Jan 14/2008	YL421-YL425		
				3	Jan 14/2008	YL421-YL425		
			106	1	Jan 14/2008	YL426-YL430		
				2	Jan 14/2008	YL426-YL430		
				3	Jan 14/2008	YL426-YL430		
			107	1	Nov 11/2008	YM643-YM646		
				2	Jan 14/2008	YM643-YM646		
				3	Jan 14/2008	YM643-YM646		
			108	1	Feb 12/2008	YM647-YM670		
				2	Feb 12/2008	YM647-YM670		
				3	Feb 12/2008	YM647-YM670		
		PASSENGER FLIGHT INFORMATION SYSTEM	23-32-12		101		Jul 17/2007	YC001-YC030
					102		Oct 20/2006	YK901-YK906
	103				Jan 14/2008	YK907-YK909 YM643-YM646		
	104				Feb 09/2009	YK910 YK918 YL426		
	105				Feb 09/2009	YK911-YK917 YK919-YL401 YL427-YL430		
	106				May 13/2008	YL421-YL425		



CHAPTER 23
COMMUNICATIONS

Title	CH-SC-SU	Schem	Page	Sheet	Date	Effectivity
PASSENGER FLIGHT INFORMATION SYSTEM (cont.)	23-32-12		107		May 13/2008	YM647-YM670
VIDEO ENTERTAINMENT SYSTEM TRAY 1 VDU 1	23-32-31		101		Mar 31/2005	YC001-YC007
			102		Mar 31/2005	YC008-YC011
			103		Jul 17/2007	YC012-YC030
			104		Feb 09/2009	YK901-YL430
			105		Jan 14/2008	YM643-YM670
VIDEO ENTERTAINMENT SYSTEM TRAY 1 VDU 2	23-32-32		101		Mar 31/2005	YC001-YC011
			102		Jul 17/2007	YC012-YC050
			103		Feb 09/2009	YK901-YL430
			104		Jan 14/2008	YM643-YM670
VIDEO ENTERTAINMENT SYSTEM TRAY 1 VDU 3	23-32-33		101		Feb 09/2009	YK901-YL430
			102		Jan 14/2008	YM643-YM670
VIDEO ENTERTAINMENT SYSTEM TRAY 1 VDU 4	23-32-34		101		Feb 09/2009	YK901-YL430
VIDEO ENTERTAINMENT SYSTEM TRAY 2 VDU 5	23-32-41		101		Mar 31/2005	YC001-YC011
			102		Jul 17/2007	YC012-YC030
			103		Feb 09/2009	YK901-YL430
			104		Jan 14/2008	YM643-YM670
VIDEO ENTERTAINMENT SYSTEM TRAY 2 VDU 6	23-32-42		101		Mar 31/2005	YC001-YC011
			102		Jul 17/2007	YC012-YC050
			103		Feb 09/2009	YK901-YL430
			104		Jan 14/2008	YM643-YM670
VIDEO ENTERTAINMENT SYSTEM TRAY 2 VDU 7	23-32-43		101		Mar 31/2005	YC001-YC011
			102		Jul 17/2007	YC012-YC050



CHAPTER 23
COMMUNICATIONS

Title	CH-SC-SU	Schem	Page	Sheet	Date	Effectivity
VIDEO ENTERTAINMENT SYSTEM TRAY 2 VDU 7 (cont.)	23-32-43		103		Feb 09/2009	YK901-YL430
VIDEO ENTERTAINMENT SYSTEM TRAY 3 VDU 9	23-32-51		101		Mar 31/2005	YC001-YC011
			102		Jul 17/2007	YC012-YC030
			103		Feb 09/2009	YK901-YL430
			104		Jan 14/2008	YM643-YM670
VIDEO ENTERTAINMENT SYSTEM TRAY 3 VDU 10	23-32-52		101		Mar 31/2005	YC001-YC011
			102		Jul 17/2007	YC012-YC050
			103		Feb 09/2009	YK901-YL430
			104		Jan 14/2008	YM643-YM670
VIDEO ENTERTAINMENT SYSTEM TRAY 3 VDU 11	23-32-53		101		Mar 31/2005	YC001-YC011
			102		Jul 17/2007	YC012-YC050
			103		Feb 09/2009	YK901-YL430
VIDEO ENTERTAINMENT SYSTEM TRAY 4 VDU 13	23-32-61		101		Mar 31/2005	YC001-YC011
			102		Jul 17/2007	YC012-YC030
			103		Aug 13/2008	YK901-YK909 YL401-YL430
			104		Feb 09/2009	YK910-YK920
			105		Jan 14/2008	YM643-YM670
VIDEO ENTERTAINMENT SYSTEM TRAY 4 VDU 14	23-32-62		101		Mar 31/2005	YC001-YC011
			102		Jul 17/2007	YC012-YC050
			103		Feb 09/2009	YK901-YL430
			104		Jan 14/2008	YM643-YM670
VIDEO ENTERTAINMENT SYSTEM TRAY 4 VDU 15	23-32-63		101		Mar 31/2005	YC001-YC011
			102		Jul 17/2007	YC012-YC050

CHAPTER 23
COMMUNICATIONS

Title	CH-SC-SU	Schem	Page	Sheet	Date	Effectivity
VIDEO ENTERTAINMENT SYSTEM TRAY 4 VDU 15 (cont.)	23-32-63		103		Feb 09/2009	YK901-YL430
<u>PASSENGER AUDIO SYSTEM</u>						
AUDIO ENTERTAINMENT SYSTEM	23-34-01		101	1	Mar 31/2005	YC001-YC013
				2	Mar 31/2005	YC001-YC013
			101.1	1	May 13/2008	YC001-YC013
				2	May 13/2008	YC001-YC013
			102	1	Jul 17/2007	YC015-YC026
				2	Jul 17/2007	YC015-YC026
			103	1	Mar 31/2005	YC028-YC030
				2	Mar 31/2005	YC028-YC030
			104	1	Feb 09/2009	YK901-YM670
				2	Feb 09/2009	YK901-YM670
				3	Feb 09/2009	YK901-YM670
				4	Feb 09/2009	YK901-YM670
<u>SERVICE INTERPHONE SYSTEM</u>						
INTERPHONE ATTENDANT AND SERVICE	23-41-11		101		Feb 09/2009	ALL
<u>CABIN INTERPHONE SYSTEM</u>						
CABIN INTERPHONE - IHC CONNECTIONS	23-42-11		101		Jul 17/2007	YC001-YC050
FLIGHT AND GROUND CREW CALL	23-42-11		102		Oct 20/2006	YK901-YK906
			103		Feb 09/2009	YK907-YL430
			104		Jan 14/2008	YM643-YM670
CABIN INTERPHONE - BASELINE HANDSETS	23-42-12		101		Jul 17/2007	YC001-YC050



CHAPTER 23
COMMUNICATIONS

Title	CH-SC-SU	Schem	Page	Sheet	Date	Effectivity			
CABIN INTERPHONE - BASELINE HANDSETS (cont.)	23-42-12		102		Feb 09/2009	YK901-YL430			
			103		Jan 14/2008	YM643-YM670			
<u>GROUND CREW CALL SYSTEM</u>									
GROUND CREW CALL	23-43-11		101		Jul 17/2007	YC001-YK906			
			102		Feb 09/2009	YK907-YM670			
<u>FLIGHT INTERPHONE SYSTEM</u>									
FLIGHT INTERPHONE	23-51-11		101	1	Mar 31/2005	YC001-YC009			
				2	Mar 31/2005	YC001-YC009			
				3	Mar 31/2005	YC001-YC009			
				4	Mar 31/2005	YC001-YC009			
				5	Mar 31/2005	YC001-YC009			
			102	1	Jul 17/2007	YC010-YC050			
				2	Jul 17/2007	YC010-YC050			
				3	Jul 17/2007	YC010-YC050			
				4	Jul 17/2007	YC010-YC050			
				5	Jul 17/2007	YC010-YC050			
			102.1	1	Aug 10/2009	YC028-YC029			
				2	Aug 10/2009	YC028-YC029			
				3	Aug 10/2009	YC028-YC029			
				4	Aug 10/2009	YC028-YC029			
				5	Aug 10/2009	YC028-YC029			
			103			103	1	Oct 20/2006	YK901-YK906
						103	2	Oct 20/2006	YK901-YK906



CHAPTER 23
COMMUNICATIONS

Title	CH-SC-SU	Schem	Page	Sheet	Date	Effectivity	
FLIGHT INTERPHONE (cont.)	23-51-11			3	Oct 20/2006	YK901-YK906	
				4	Oct 20/2006	YK901-YK906	
				104	1	Aug 13/2008	YK907-YK909 YL401-YM670
				2	Aug 13/2008	YK907-YK909 YL401-YM670	
				3	Aug 13/2008	YK907-YK909 YL401-YM670	
				4	Aug 13/2008	YK907-YK909 YL401-YM670	
				5	Aug 13/2008	YK907-YK909 YL401-YM670	
				105	1	Feb 09/2009	YK910-YK920
				2	Feb 09/2009	YK910-YK920	
				3	Feb 09/2009	YK910-YK920	
4	Feb 09/2009	YK910-YK920					
5	Feb 09/2009	YK910-YK920					
<u>AUDIO AND VIDEO MONITORING</u>							
VIDEO SURVEILLANCE SYSTEM	23-70-11			101A	1	Jul 17/2007	YC001-YC030
					2	Jul 17/2007	YC001-YC030
				102		Oct 20/2006	YK901-YK906
				103	1	Feb 09/2009	YK907-YM670
					2	Feb 09/2009	YK907-YM670
<u>VOICE RECORDER SYSTEM</u>							
VOICE RECORDER	23-71-11			101.1		Jul 26/2006	YC001-YC007
				102		Aug 13/2008	YC008-YK910 YL401-YL430
				103		Feb 09/2009	YK911-YK920
				104		May 13/2008	YM643-YM670

**CHAPTER 23
COMMUNICATIONS**

CH-SC-SU	Title
23-27-12	ACARS (724B) - DFDAU AND OOOI INTERFACES
23-27-13	ACARS (724B) CONTROL AND DISPLAY
23-27-14	ACARS (724B) FMC, PRINTER AND DISCRETE INTERFACES
23-27-11	ACARS (724B) POWER, COMM AND ANNUNCIATION INTERFACES
23-27-16	ACARS (724B) REGISTRY AND AIRLINE ID CODING
23-27-15	ACARS (724B) SATCOM AND AIRSHOW INTERFACES
23-27-35	ACARS/CMU - 716 VHF AND FMC INTERFACES
23-27-39	ACARS/CMU - DATA LOADER AND PROGRAM PINS
23-27-38	ACARS/CMU - OOOI, CREW ADVISORIES AND OUTPUT 8
23-27-32	ACARS/CMU - OUTPUT BUS 1 INTERFACES
23-27-33	ACARS/CMU - OUTPUT BUS 2 INTERFACES
23-27-34	ACARS/CMU - OUTPUT BUS 3 INTERFACES
23-27-31	ACARS/CMU - POWER & CONTROL
23-34-01	AUDIO ENTERTAINMENT SYSTEM
23-42-12	CABIN INTERPHONE - BASELINE HANDSETS
23-42-11	CABIN INTERPHONE - IHC CONNECTIONS
23-27-37	CMU - OUTPUT BUS 6 AND BUS 7 INTERFACES
23-24-11	EMERGENCY LOCATOR TRANSMITTER (ELT)

CH-SC-SU	Title
23-51-11	FLIGHT INTERPHONE
23-43-11	GROUND CREW CALL
23-11-11	HF COMMUNICATIONS 1
23-11-21	HF COMMUNICATIONS 2
23-31-13	INTEGRATED HANDSET CONTROLLER
23-41-11	INTERPHONE ATTENDANT AND SERVICE
23-31-11	PASSENGER ADDRESS SYSTEM
23-31-14	PASSENGER ADDRESS SYSTEM SPEAKERS
23-32-12	PASSENGER FLIGHT INFORMATION SYSTEM
23-31-12	PRE-RECORDER ANNOUNCEMENT MACHINE
23-22-11	SELCAL
23-12-11	VHF COMMUNICATIONS 1
23-12-21	VHF COMMUNICATIONS 2
23-12-31	VHF COMMUNICATIONS 3
23-12-41	VHF/HF COMMUNICATIONS
23-32-11	VIDEO CONTROL CENTER
23-32-31	VIDEO ENTERTAINMENT SYSTEM TRAY 1 VDU 1
23-32-32	VIDEO ENTERTAINMENT SYSTEM TRAY 1 VDU 2
23-32-33	VIDEO ENTERTAINMENT SYSTEM TRAY 1 VDU 3

23-ALPHABETICAL INDEX

**CHAPTER 23
COMMUNICATIONS**

CH-SC-SU	Title
23-32-34	VIDEO ENTERTAINMENT SYSTEM TRAY 1 VDU 4
23-32-41	VIDEO ENTERTAINMENT SYSTEM TRAY 2 VDU 5
23-32-42	VIDEO ENTERTAINMENT SYSTEM TRAY 2 VDU 6
23-32-43	VIDEO ENTERTAINMENT SYSTEM TRAY 2 VDU 7
23-32-52	VIDEO ENTERTAINMENT SYSTEM TRAY 3 VDU 10
23-32-53	VIDEO ENTERTAINMENT SYSTEM TRAY 3 VDU 11
23-32-51	VIDEO ENTERTAINMENT SYSTEM TRAY 3 VDU 9
23-32-61	VIDEO ENTERTAINMENT SYSTEM TRAY 4 VDU 13
23-32-62	VIDEO ENTERTAINMENT SYSTEM TRAY 4 VDU 14
23-32-63	VIDEO ENTERTAINMENT SYSTEM TRAY 4 VDU 15
23-70-11	VIDEO SURVEILLANCE SYSTEM
23-71-11	VOICE RECORDER

CH-SC-SU	Title
-----------------	--------------

23-ALPHABETICAL INDEX

THIS PAGE INTENTIONALLY LEFT BLANK

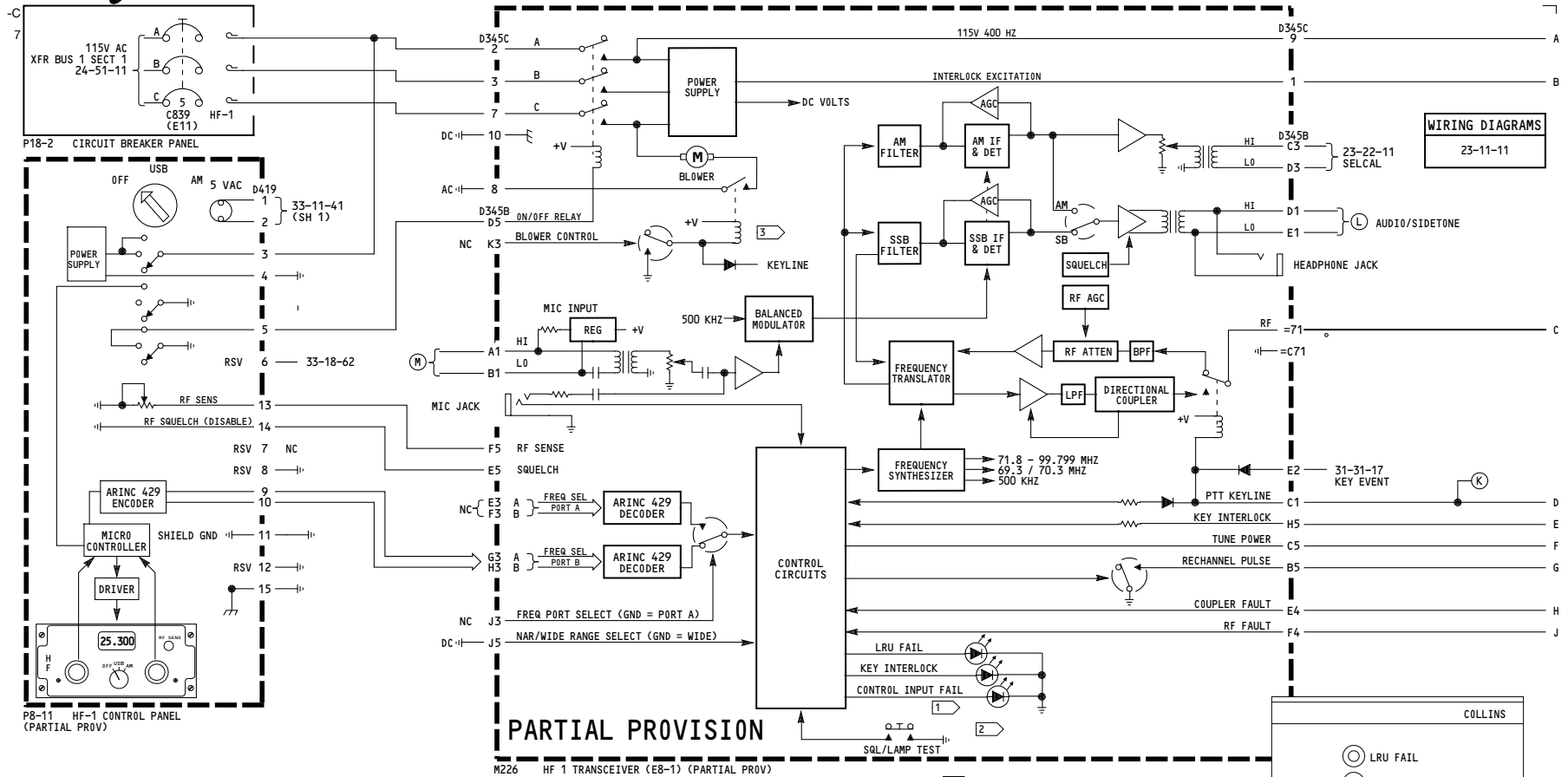

WIRING DIAGRAMS
23-11-11

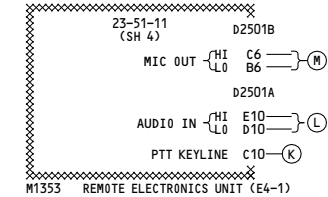
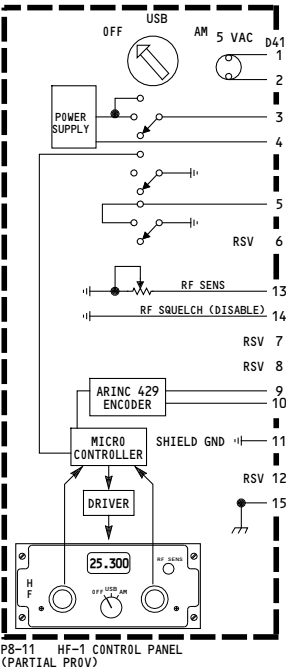

PARTIAL PROVISION

M226 HF 1 TRANSCEIVER (E8-1) (PARTIAL PROV)

NOTES:

- 1 FAULT INDICATION (ALL INDICATOR LIGHTS ARE RED LEDS)
- LRU FAIL = LOW XMTX POWER OR POWER SUPPLY VOLTAGE
LOSS OF SYNTHESIZER LOCK OR PROCESSOR FAILURE
- KEY INTERLOCK = ANTENNA COUPLER FAULT
- CONTROL INPUT FAIL = CONTROL DATA INPUT FAULT

- 2 SQL/LAMP TEST BUTTON DISABLES SQUELCH CIRCUIT AND ILLUMINATES FRONT PANEL LEDS
- 3 BLOWER OPERATION:
PIN K3 NC = CONTINUOUS WITH POWER ON
PIN K3 GND = OPERATION ONLY WHEN KEYED

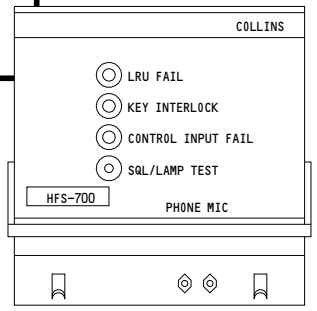

YC001-YC004

HF COMMUNICATIONS 1

D280A203

23-11-11

WIRING DIAGRAMS
23-11-11

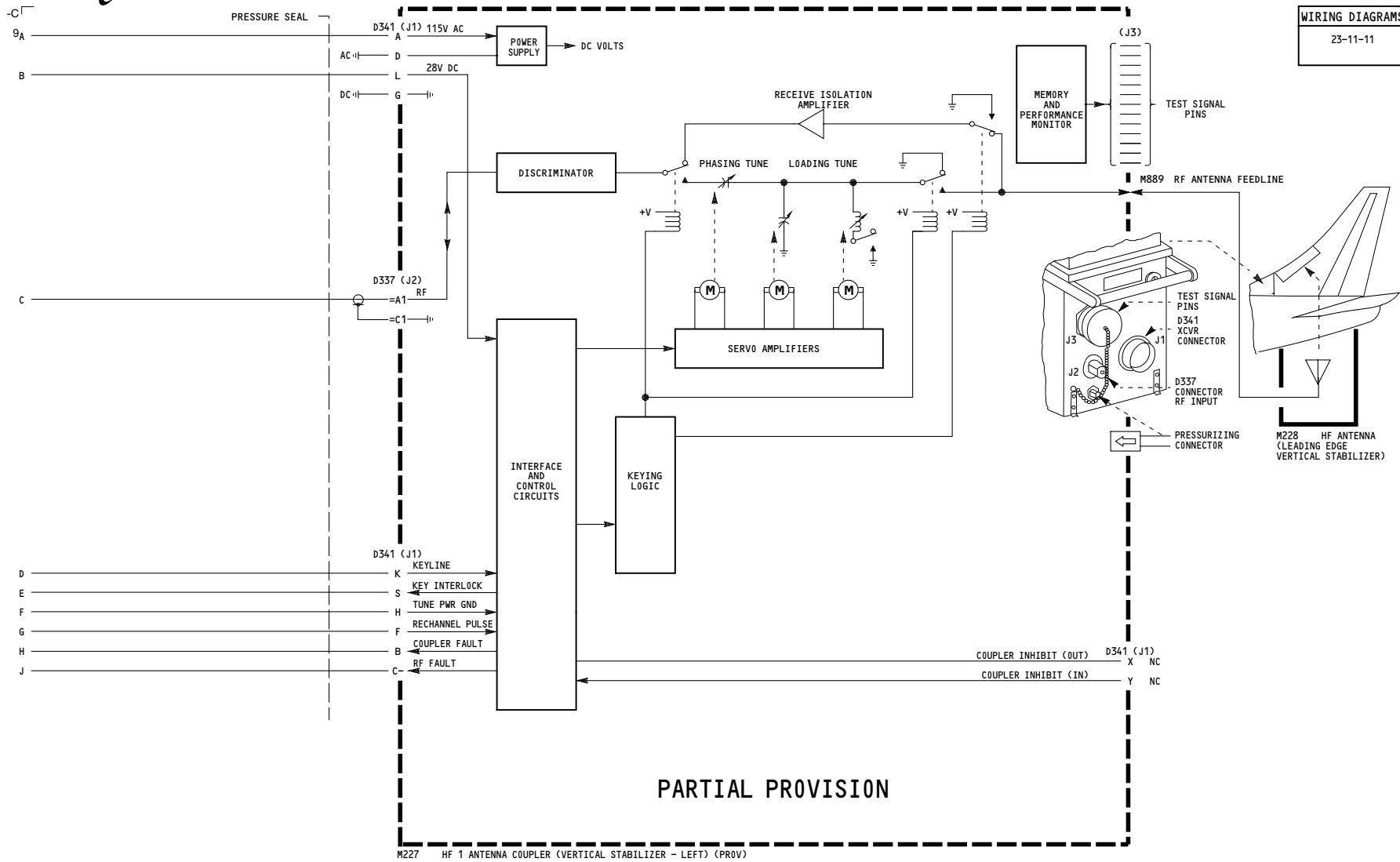

YC001-YC004	<p align="center">HF COMMUNICATIONS 1</p> <p align="center">D280A203</p>
-------------	---

23-11-11

Page 101
Sheet 2
Aug 10/2009

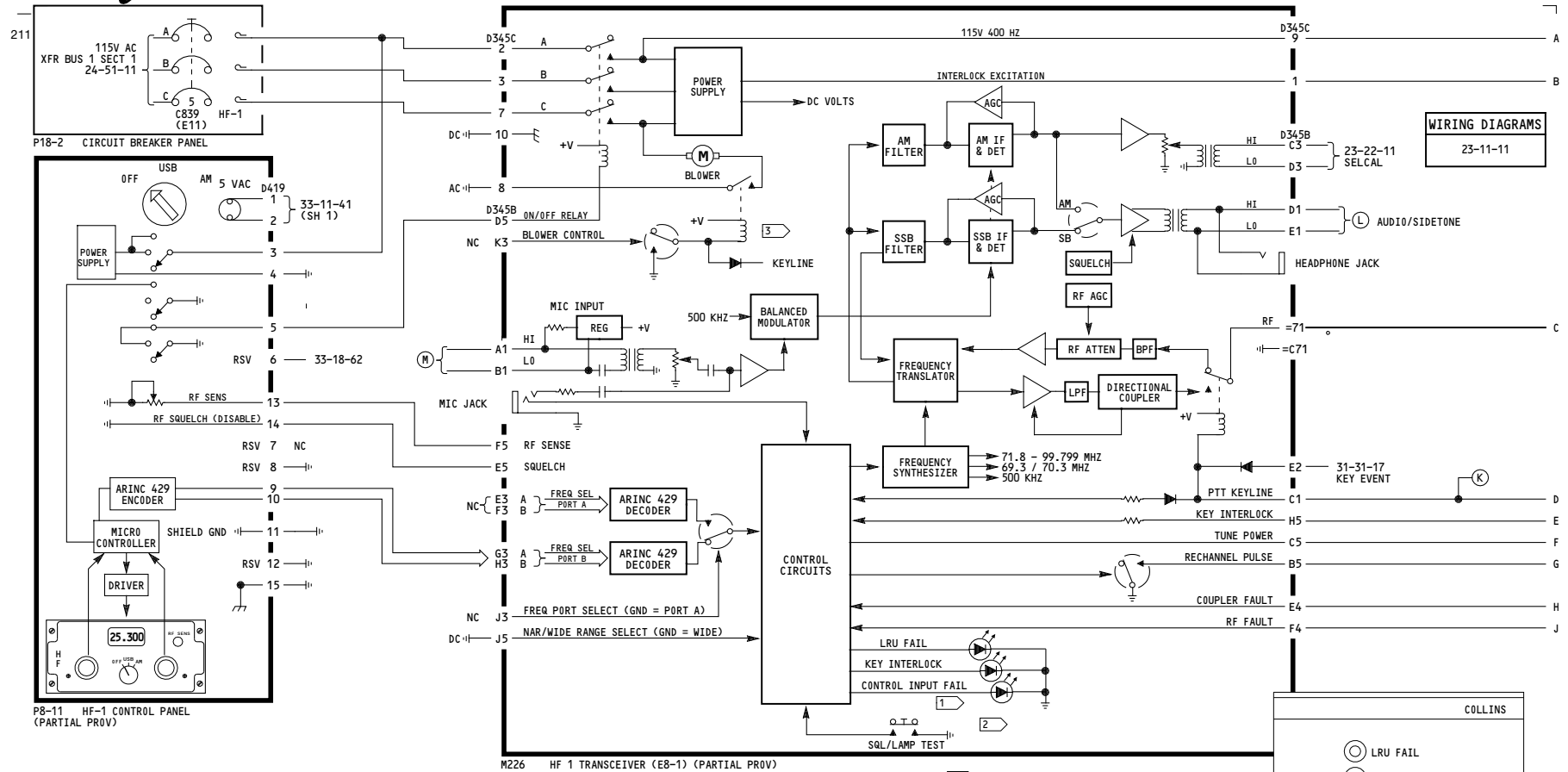

WIRING DIAGRAMS
23-11-11

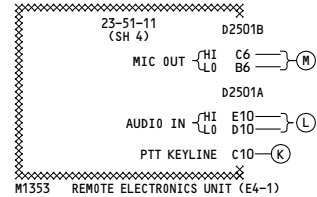

NOTES:

1 FAULT INDICATION (ALL INDICATOR LIGHTS ARE RED LEDS)

LRU FAIL = LOW XMTX POWER OR POWER SUPPLY VOLTAGE
LOSS OF SYNTHESIZER LOCK OR PROCESSOR FAILURE

KEY INTERLOCK = ANTENNA COUPLER FAULT

CONTROL INPUT FAIL = CONTROL DATA INPUT FAULT

2 SQL/LAMP TEST BUTTON DISABLES SQUELCH CIRCUIT AND ILLUMINATES FRONT PANEL LEDS

3 BLOWER OPERATION:
PIN K3 NC = CONTINUOUS WITH POWER ON
PIN K3 GND = OPERATION ONLY WHEN KEYED

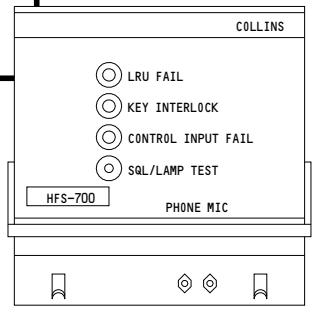

YC005-YC007

HF COMMUNICATIONS 1

Incorporates MR 39273-4

D280A203

23-11-11

WIRING DIAGRAMS
23-11-11

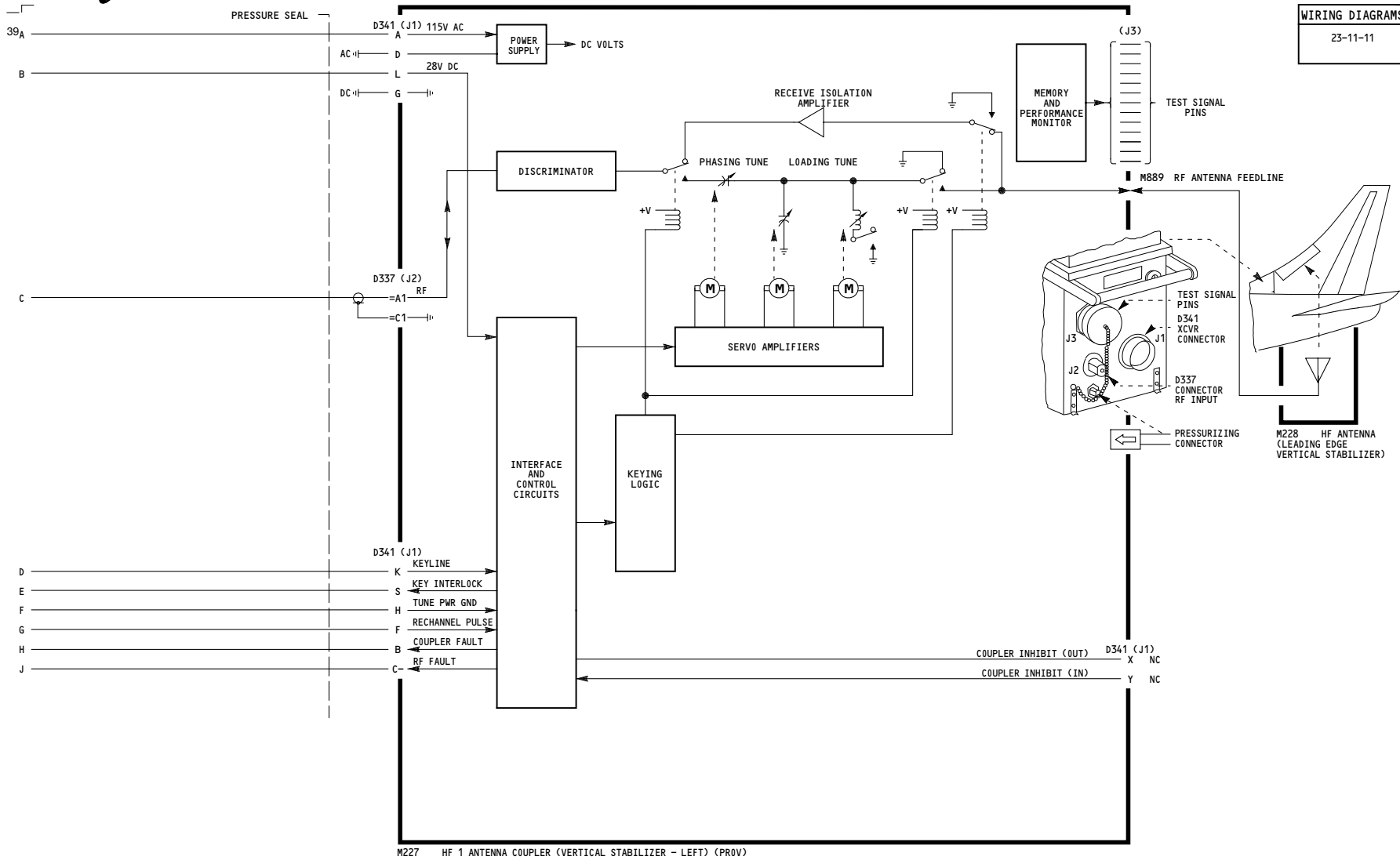

<p>YC005-YC007</p>	<p>HF COMMUNICATIONS 1</p> <p style="text-align: right;">Incorporates MR 39273-4</p> <p style="text-align: center;">D280A203</p>
--------------------	---

23-11-11

Page 102A
Sheet 2
Aug 10/2009

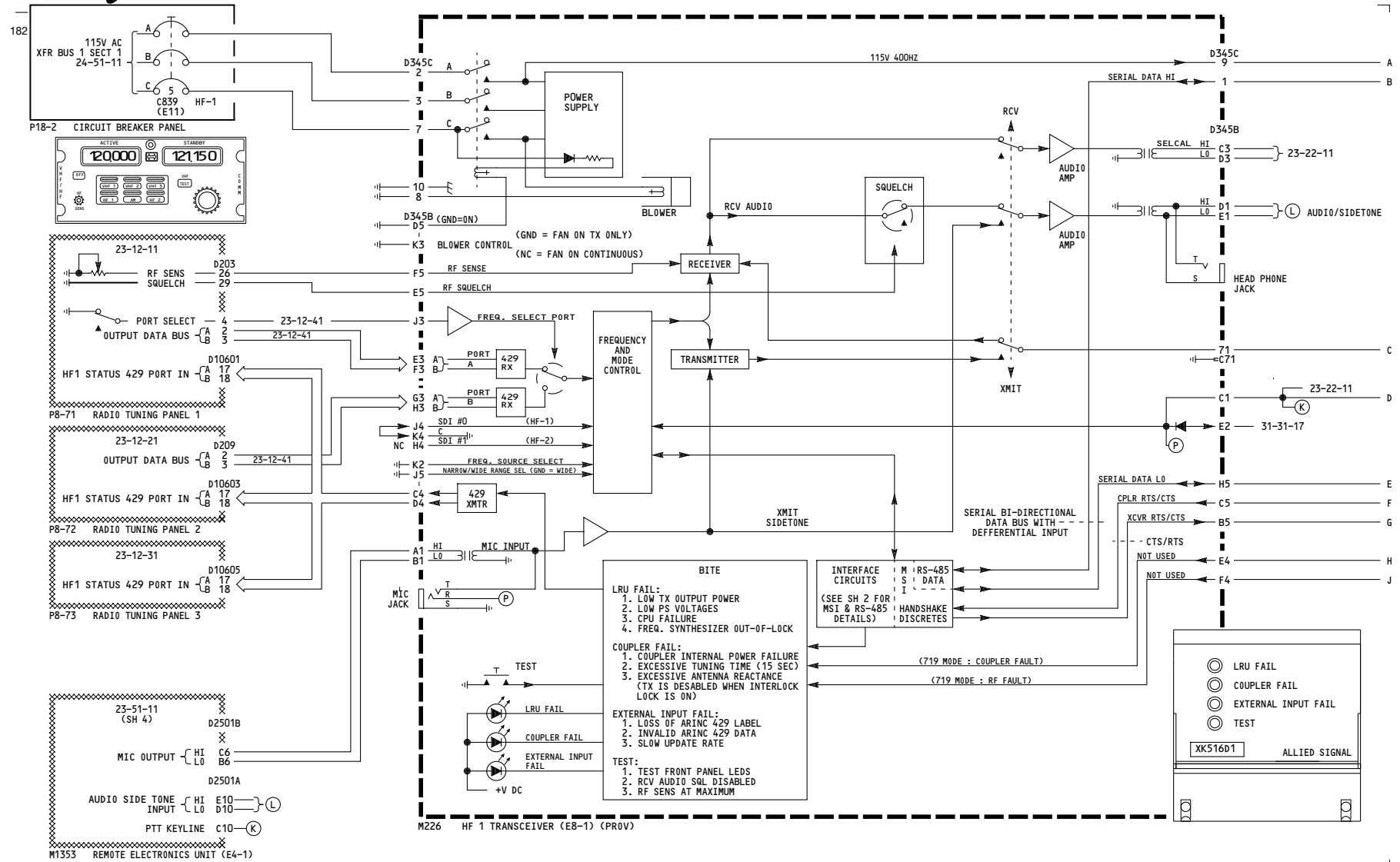

YK907-YK909, YL401

HF COMMUNICATIONS 1

23-11-11

D280A203

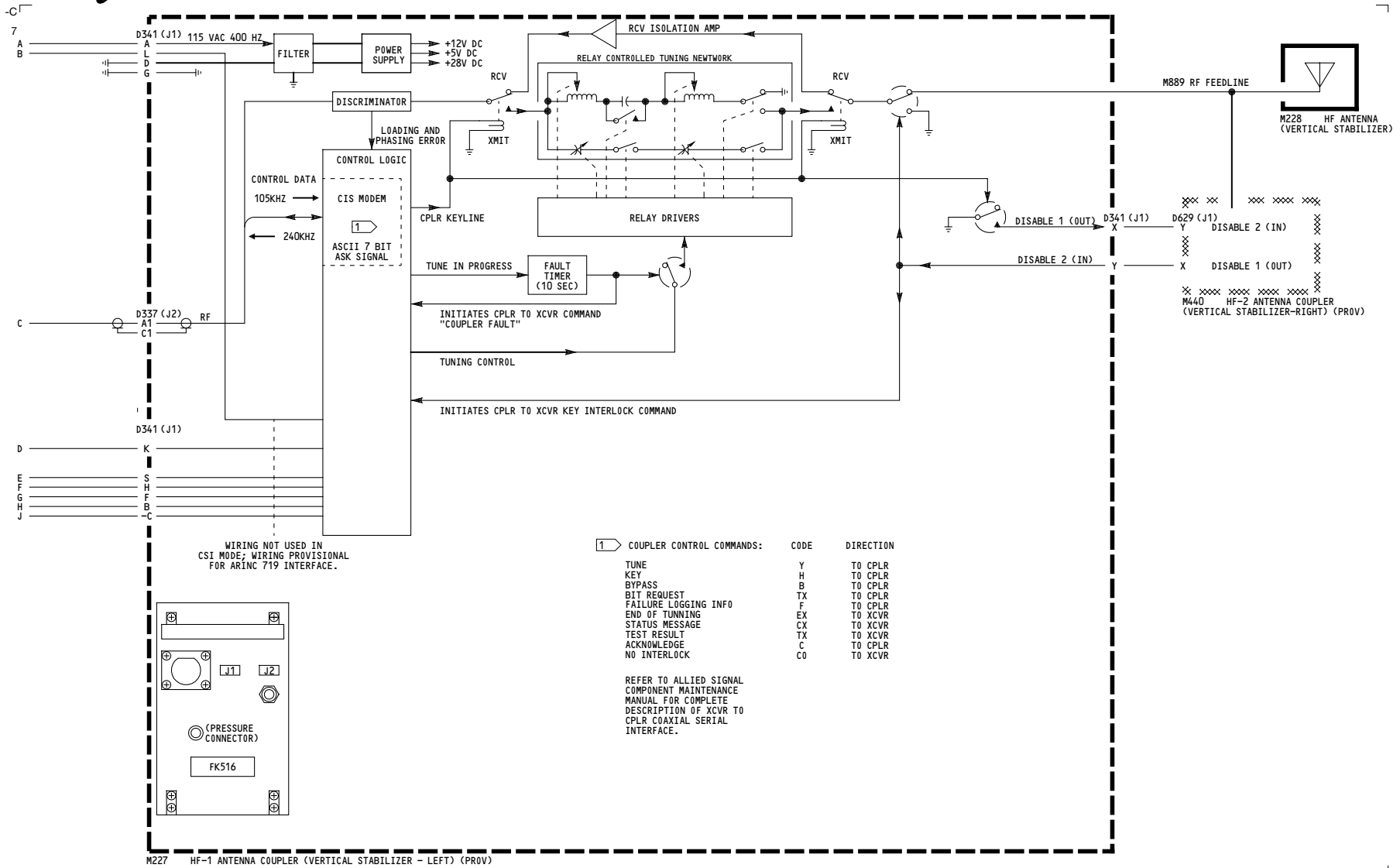

YK907-YK909, YL401

HF COMMUNICATIONS 1

D280A203

23-11-11

Page 103
Sheet 2
Aug 10/2009

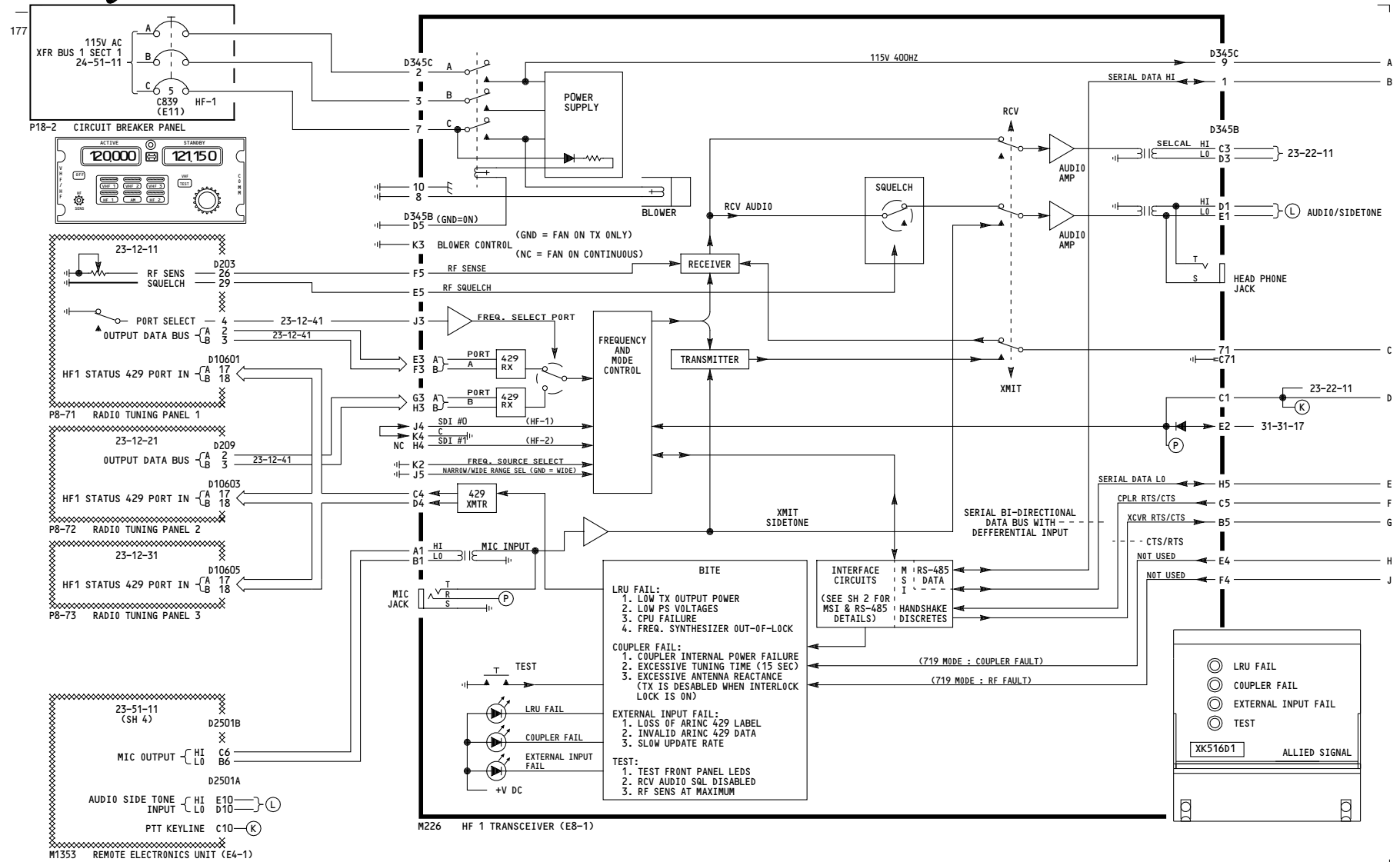

YK907-YK909

HF COMMUNICATIONS 1

Incorporates
23-1299

D280A203

23-11-11

Page 103.1
Sheet 1
Aug 10/2009

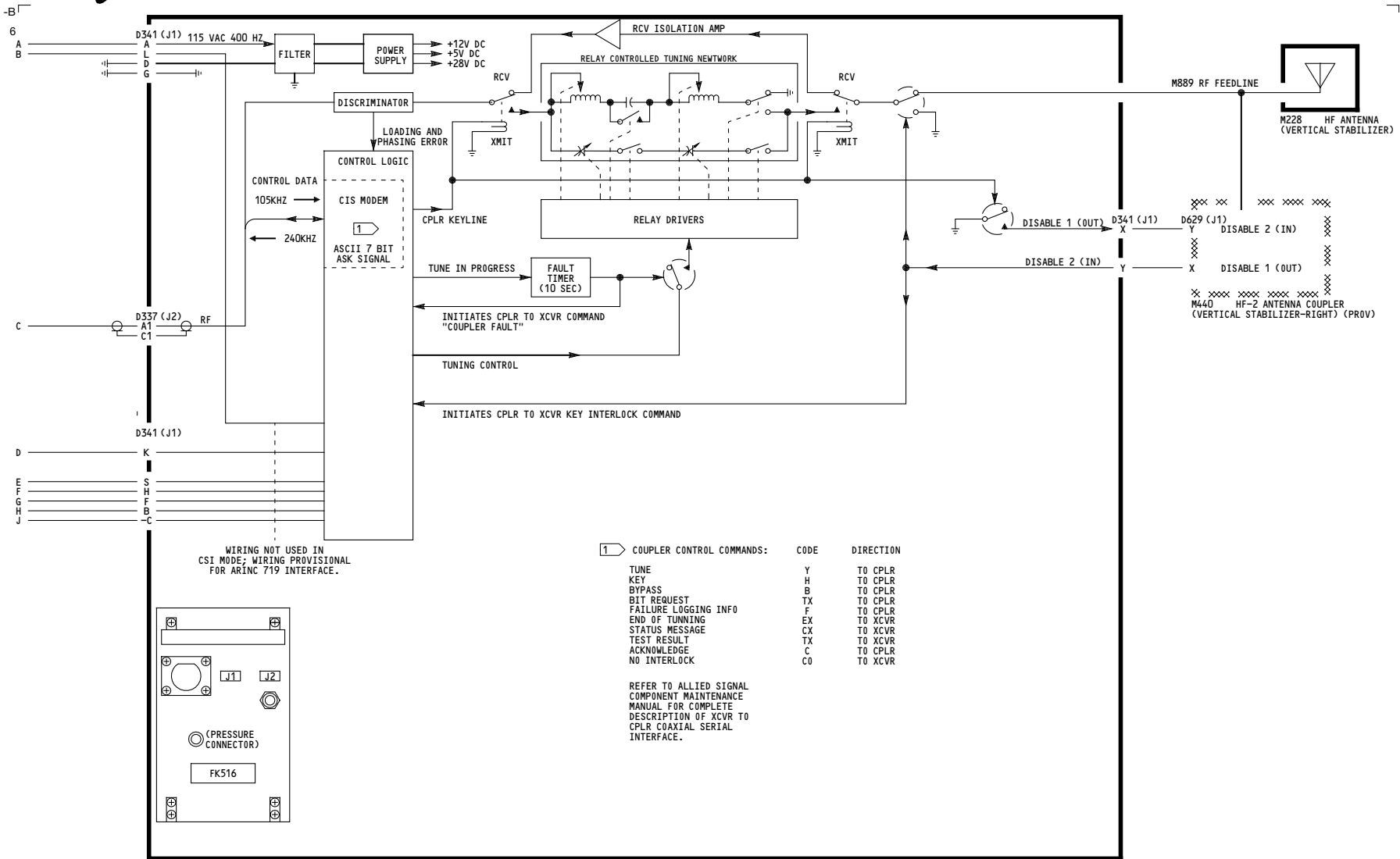

M227 HF-1 ANTENNA COUPLER (VERTICAL STABILIZER - LEFT)

YK907-YK909

HF COMMUNICATIONS 1

Incorporates
23-1299

D280A203

23-11-11

Page 103.1
Sheet 2
Aug 10/2009

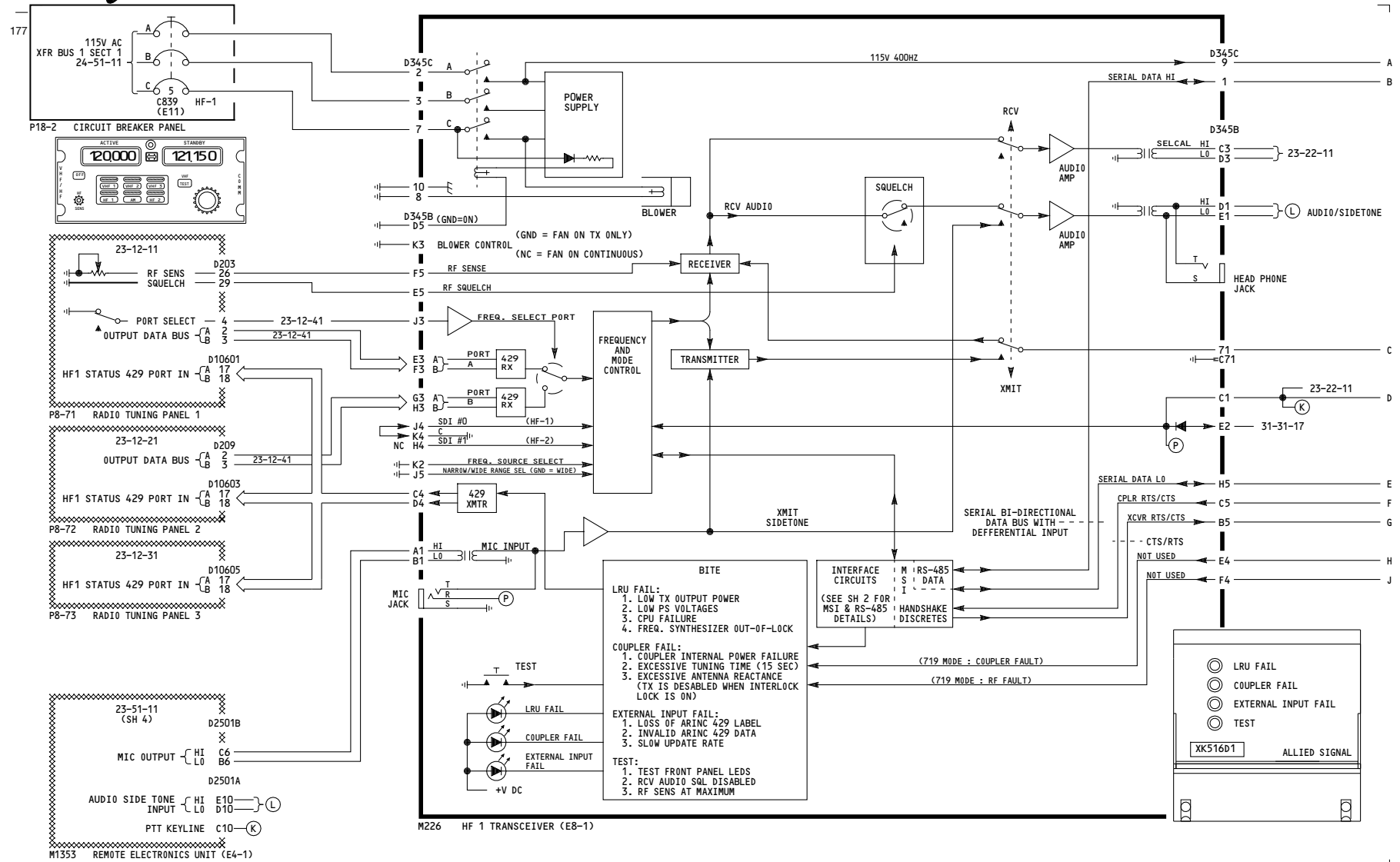

YK910-YK920

HF COMMUNICATIONS 1

23-11-11

D280A203

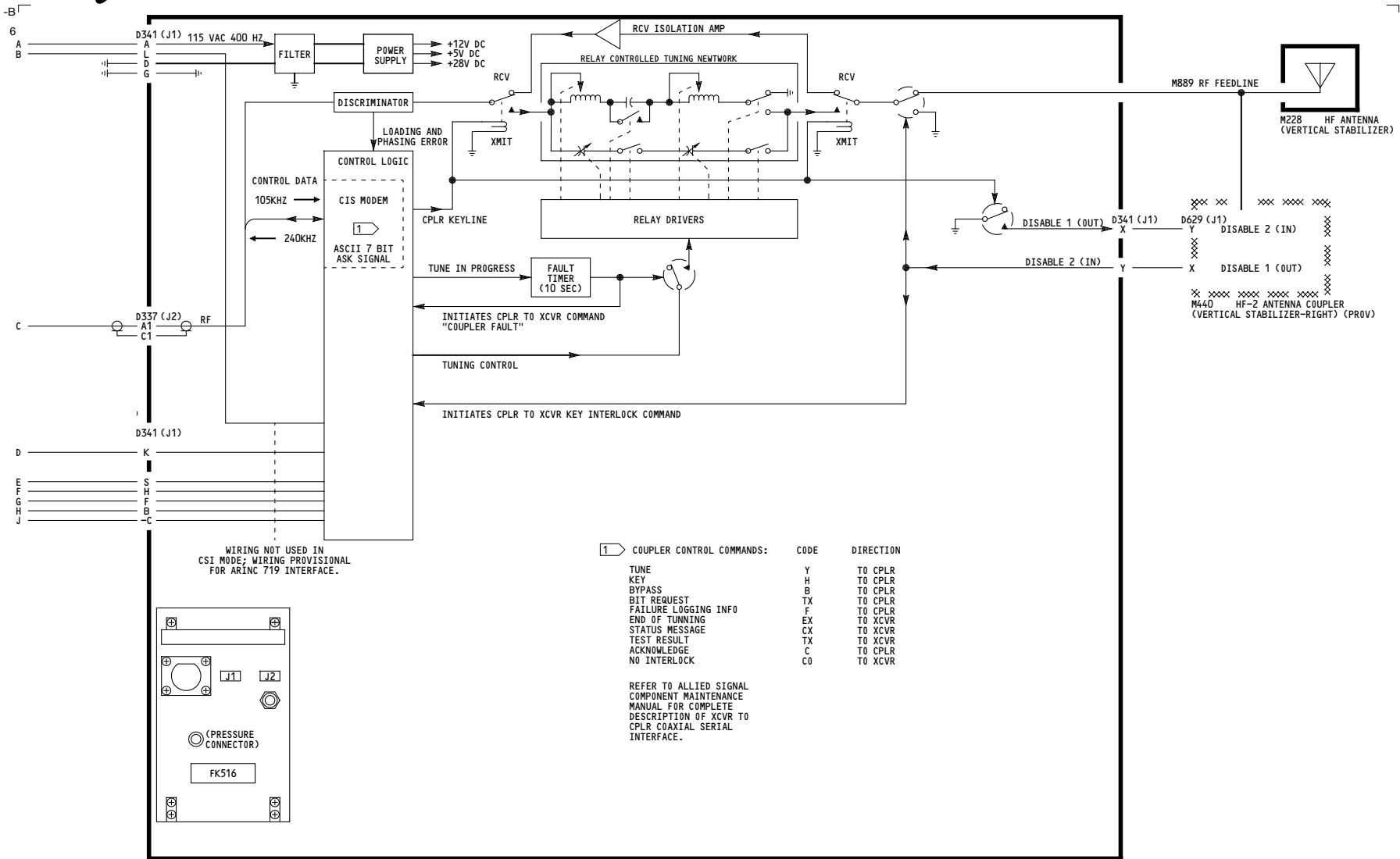

M227 HF-1 ANTENNA COUPLER (VERTICAL STABILIZER - LEFT)

YK910-YK920

HF COMMUNICATIONS 1

D280A203

23-11-11

Page 104
Sheet 2
Aug 10/2009

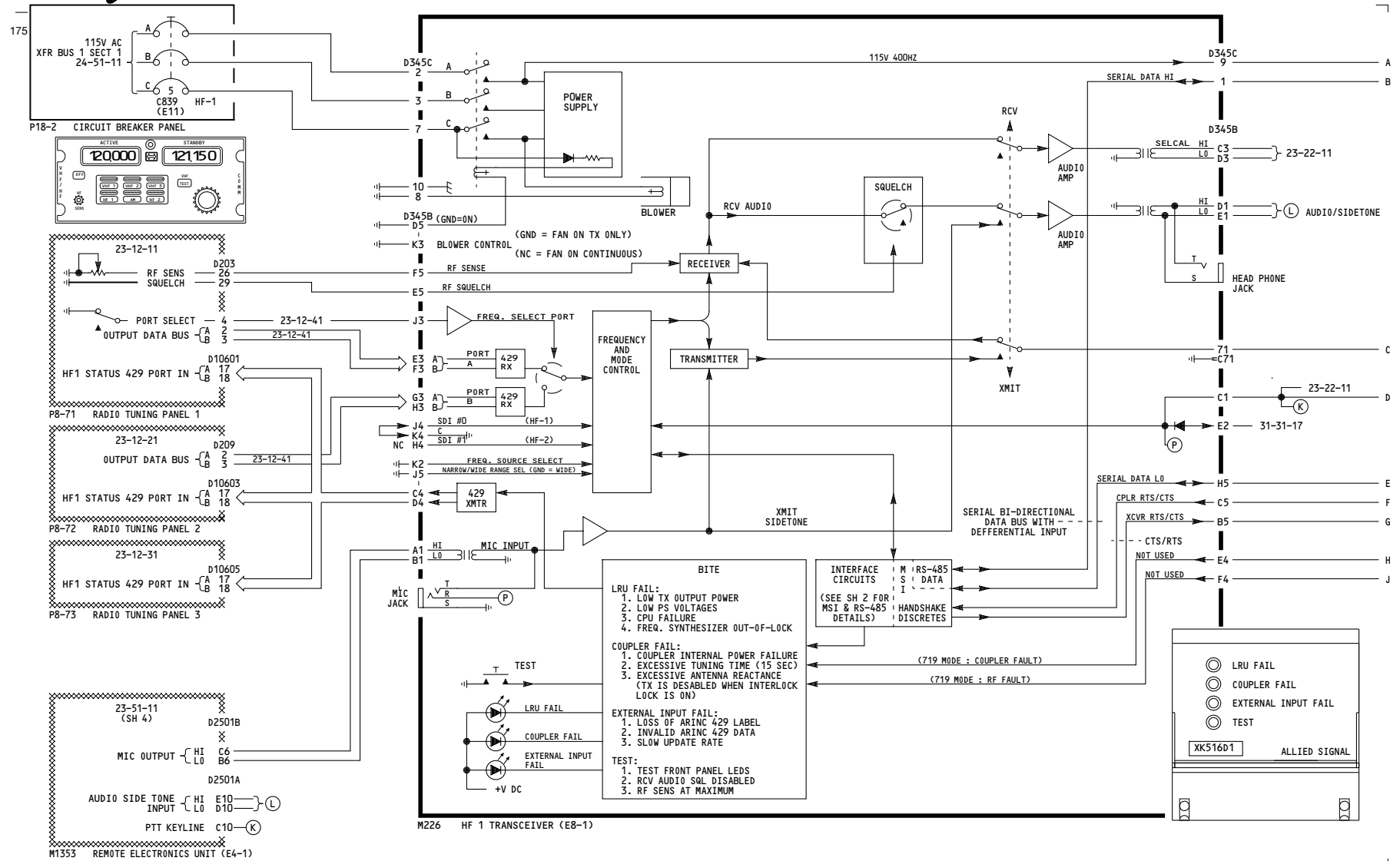

YL421-YL430

HF COMMUNICATIONS 1

23-11-11

D280A203

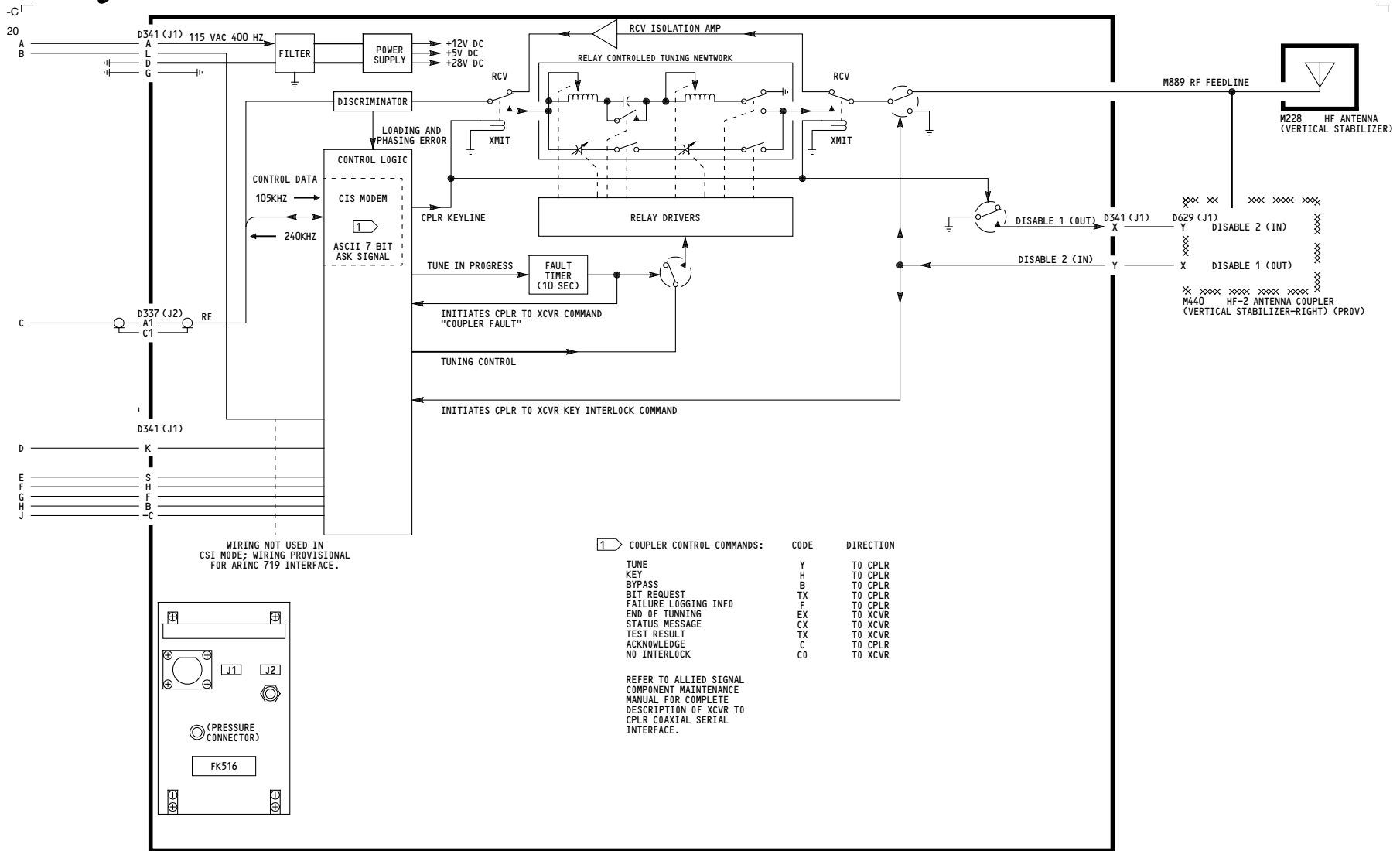

M227 HF-1 ANTENNA COUPLER (VERTICAL STABILIZER - LEFT)

YL421-YL430

HF COMMUNICATIONS 1

D280A203

23-11-11

Page 105
Sheet 2
Aug 10/2009

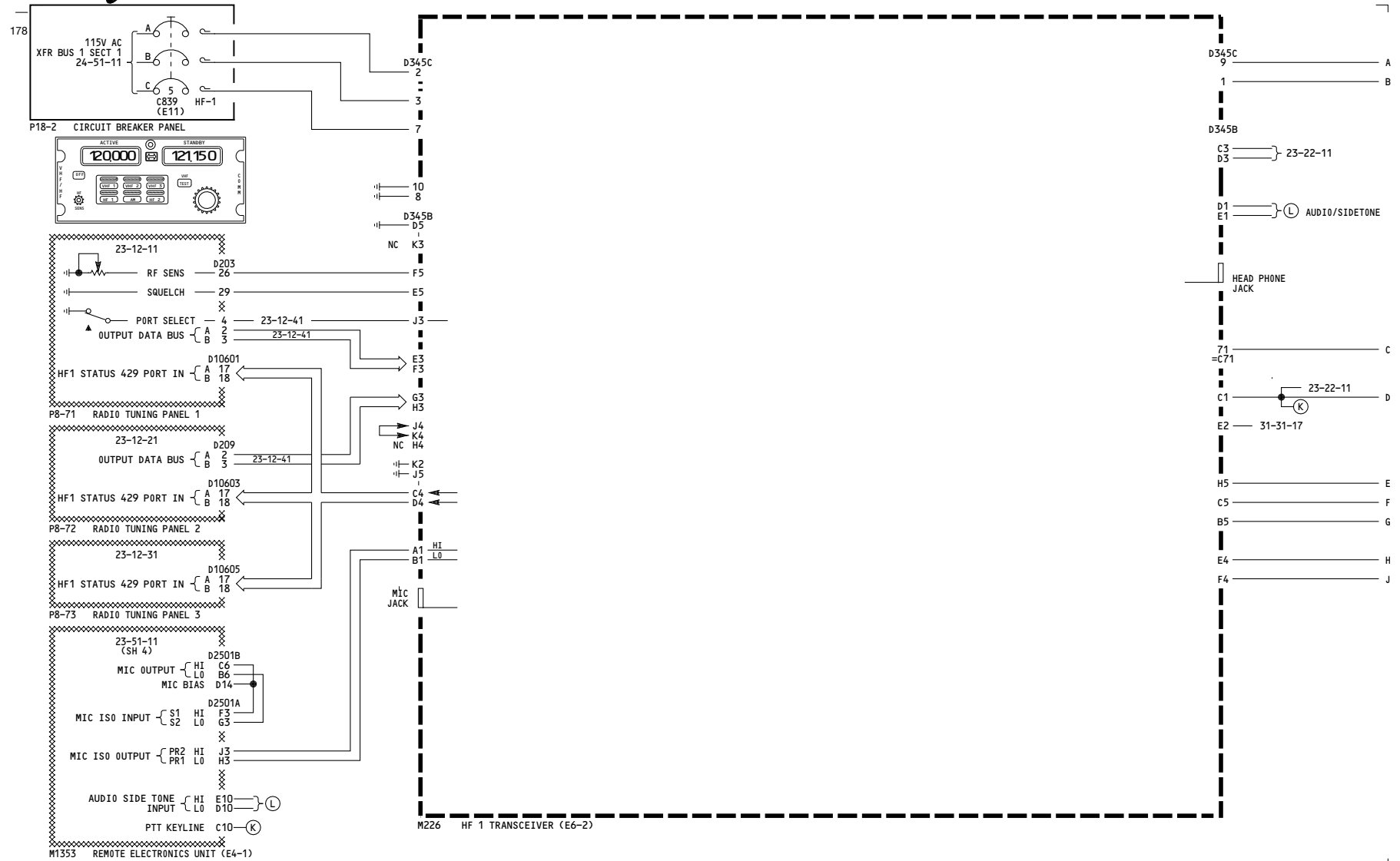

YM643-YM670

HF COMMUNICATIONS 1

23-11-11

D280A203

Page 106
Sheet 1
Aug 10/2009

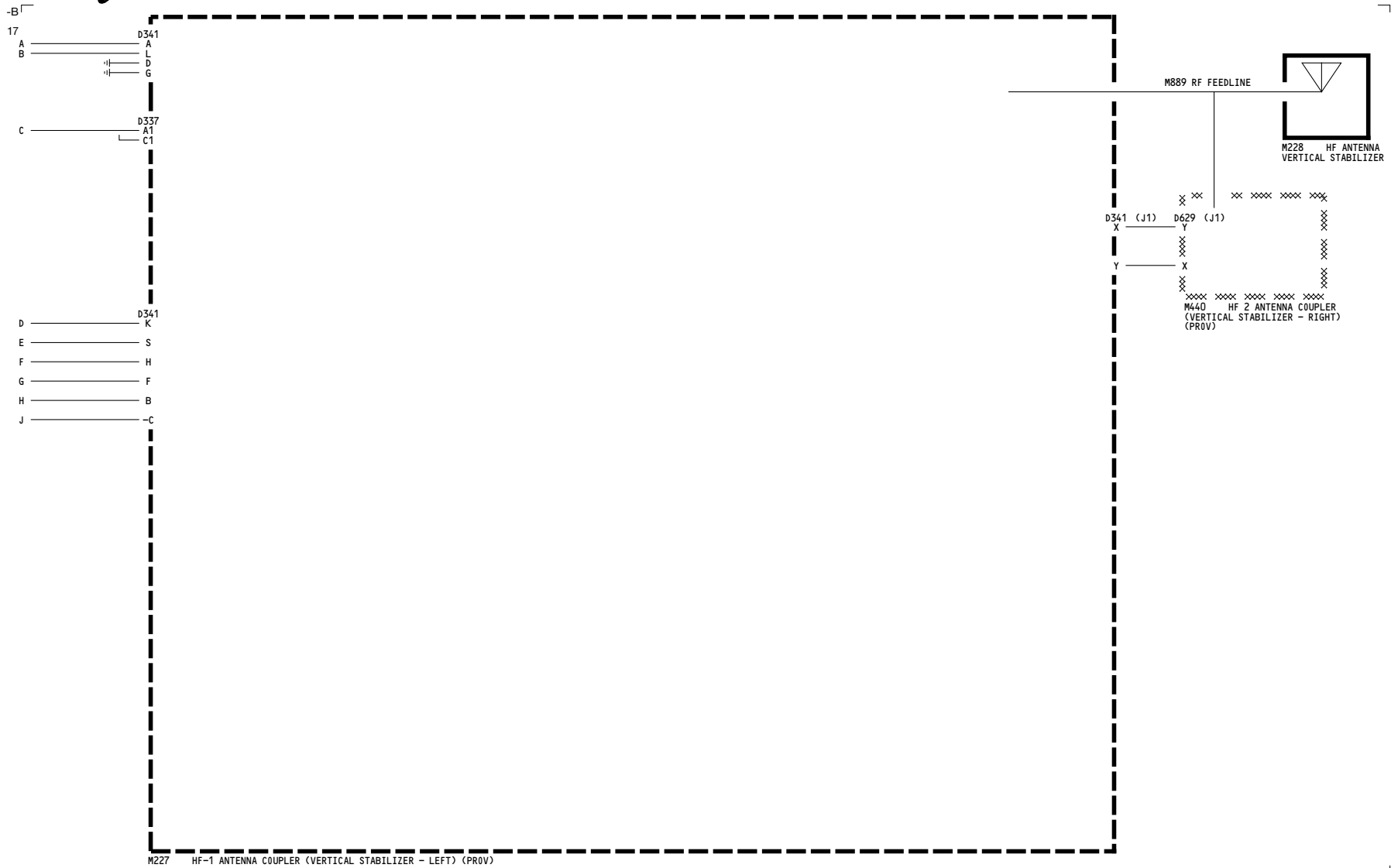

YM643-YM670

HF COMMUNICATIONS 1

D280A203

23-11-11

Page 106
Sheet 2
Aug 10/2009

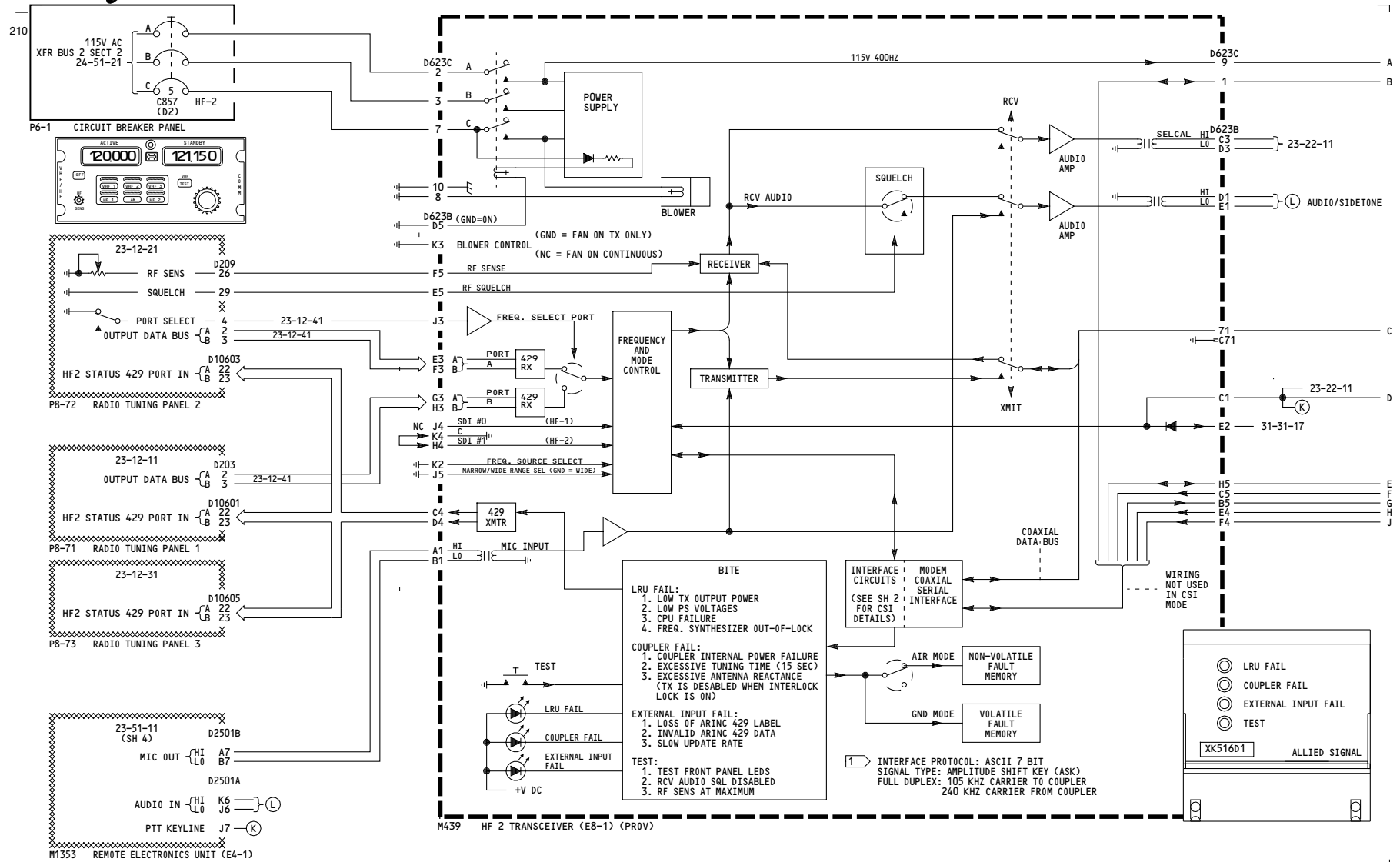

YK907-YK909, YL401

HF COMMUNICATIONS 2

23-11-21

D280A203

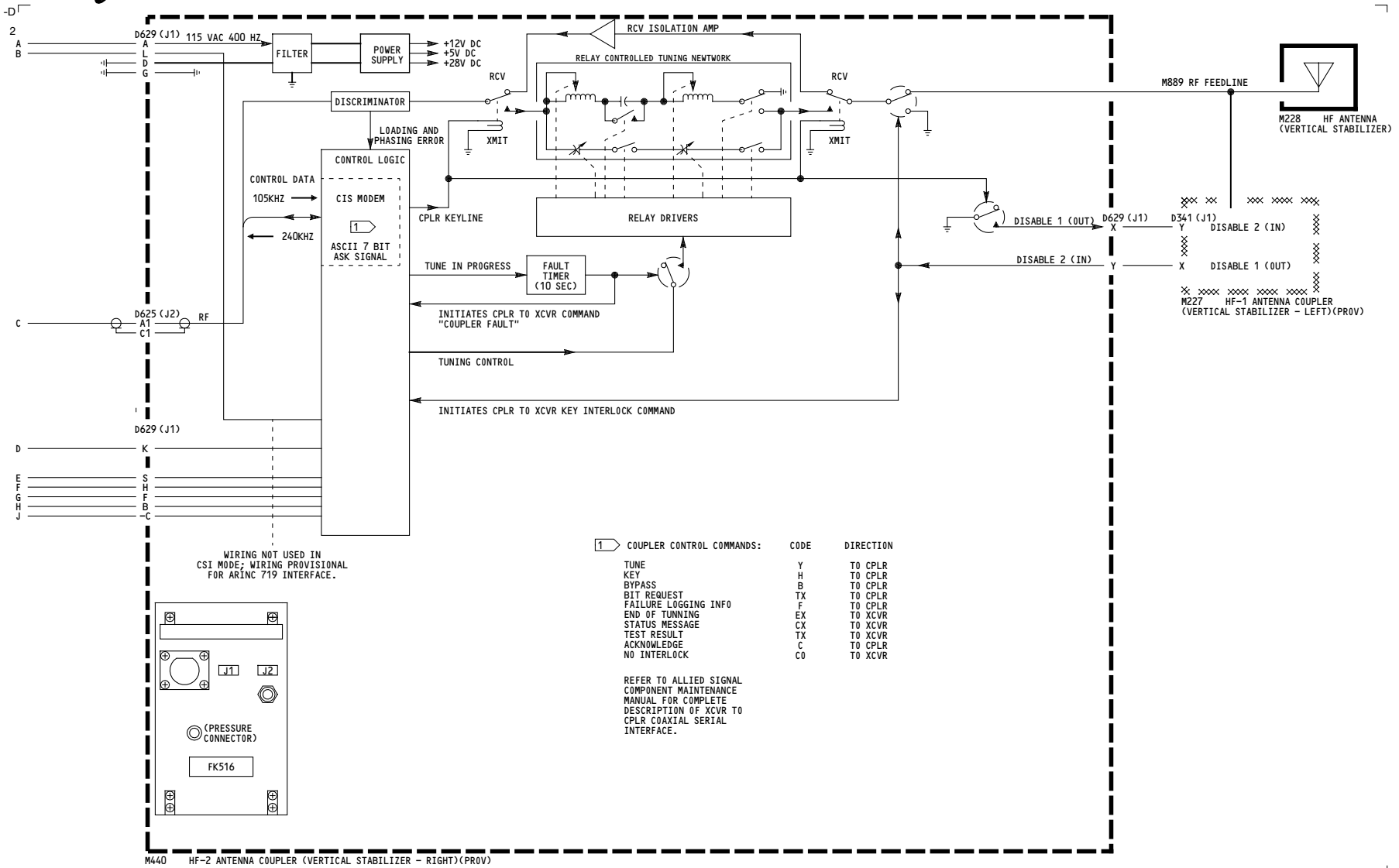

YK907-YK909, YL401

HF COMMUNICATIONS 2

D280A203

23-11-21

Page 101
Sheet 2
Feb 09/2009

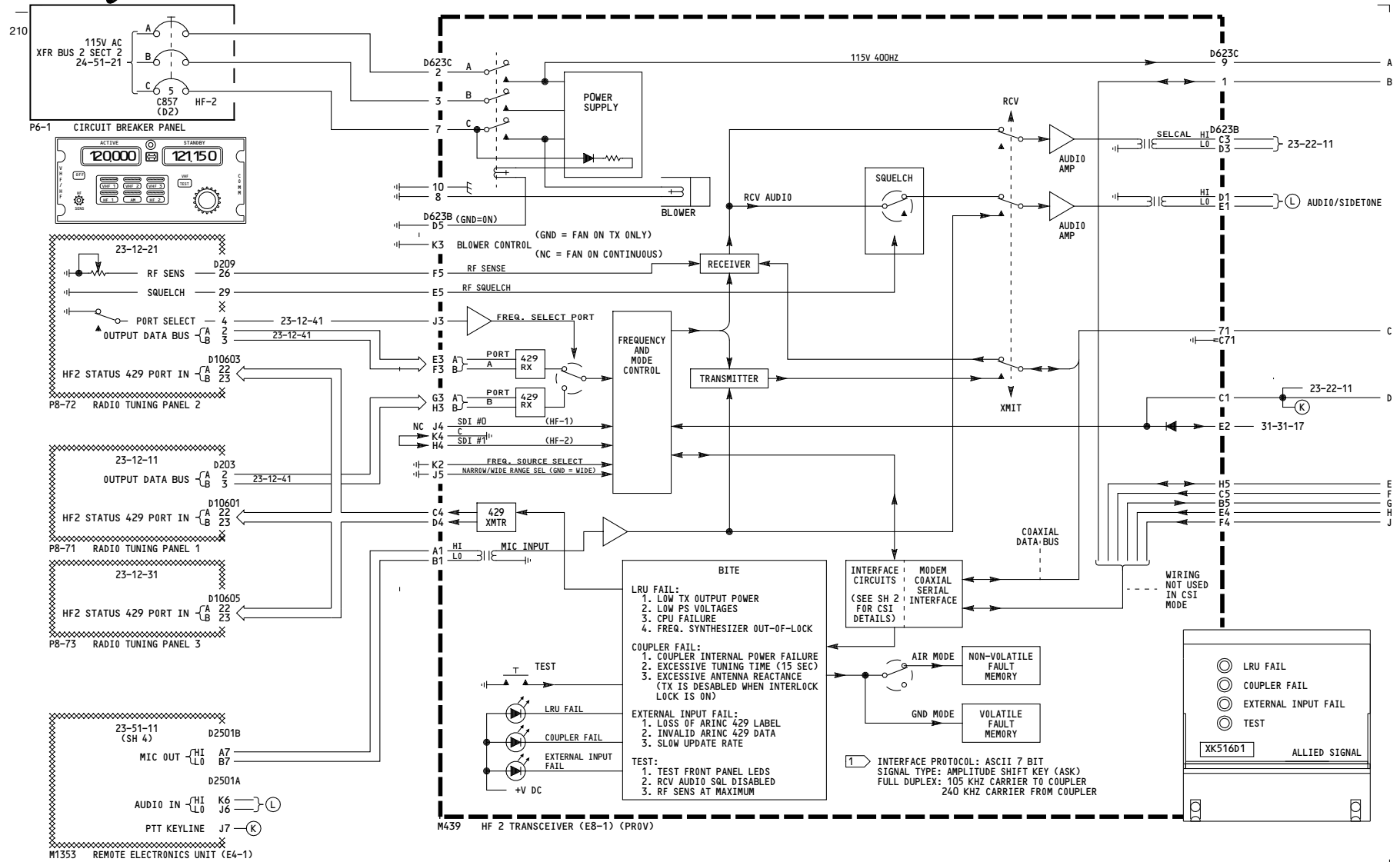

YK907-YK909	HF COMMUNICATIONS 2
	D280A203

23-11-21

Page 101.1
Sheet 1
May 13/2008

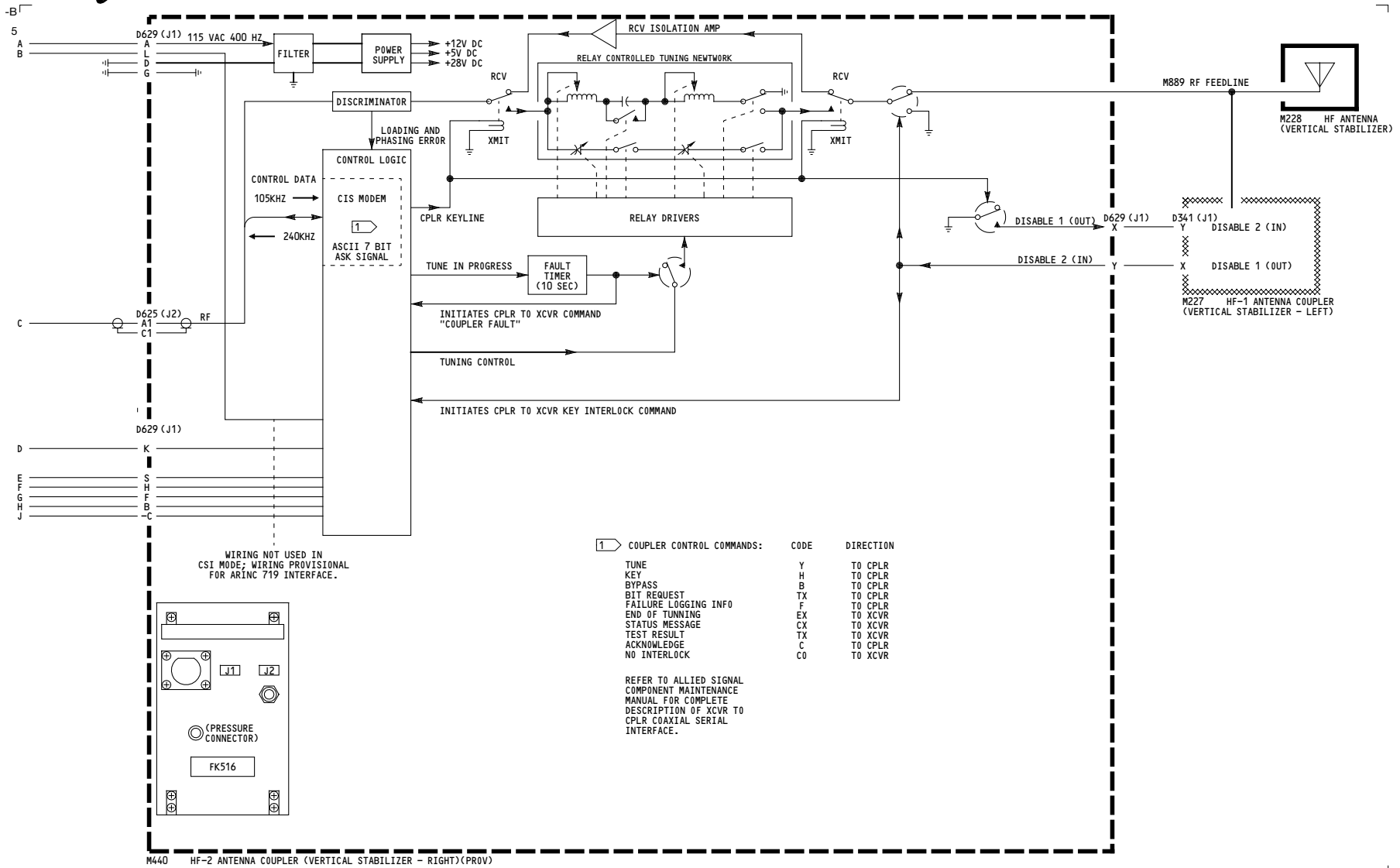

YK907-YK909

HF COMMUNICATIONS 2

Incorporates
23-1299

D280A203

23-11-21

Page 101.1
Sheet 2
May 13/2008

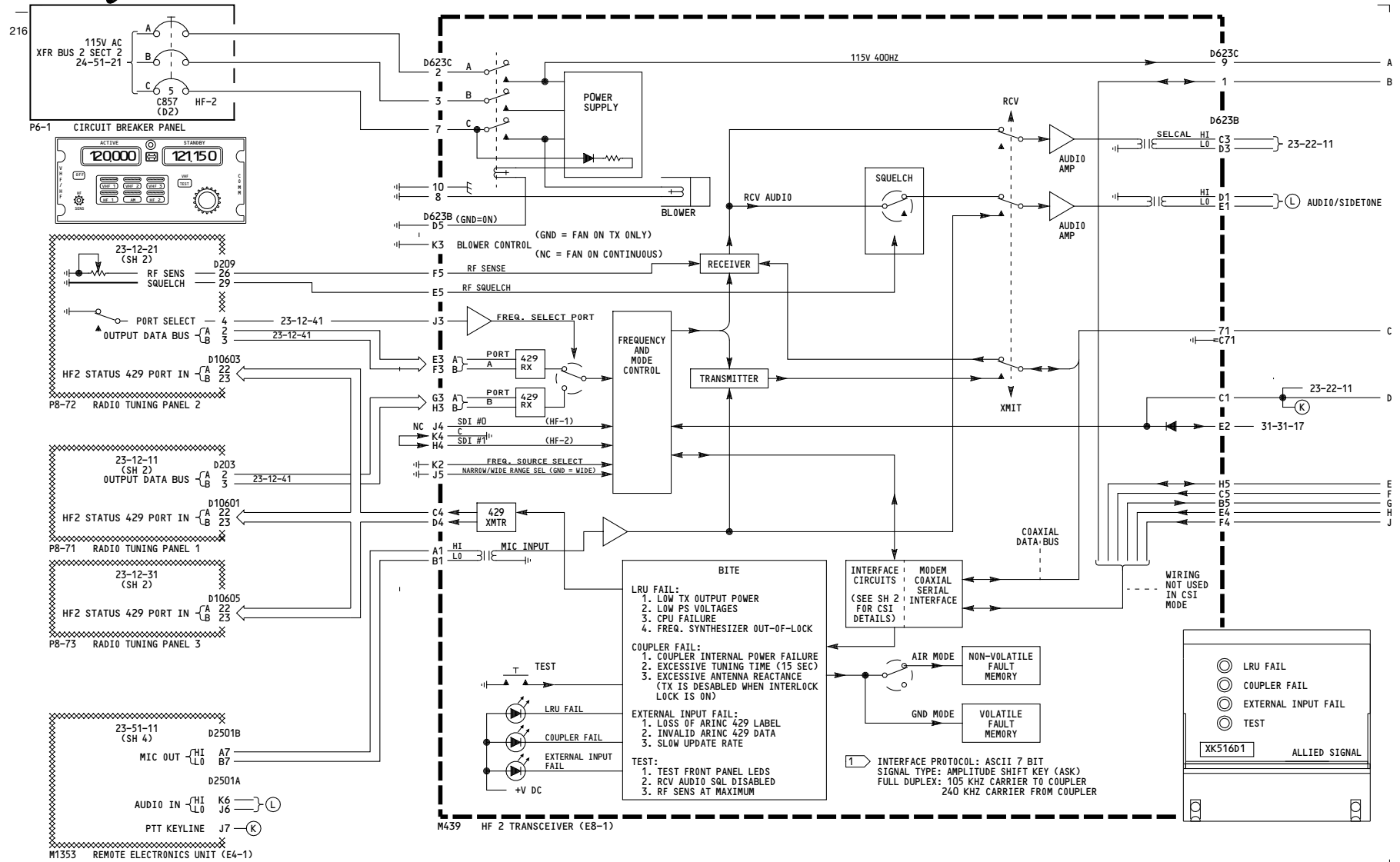

YK910-YK920

HF COMMUNICATIONS 2

23-11-21

D280A203

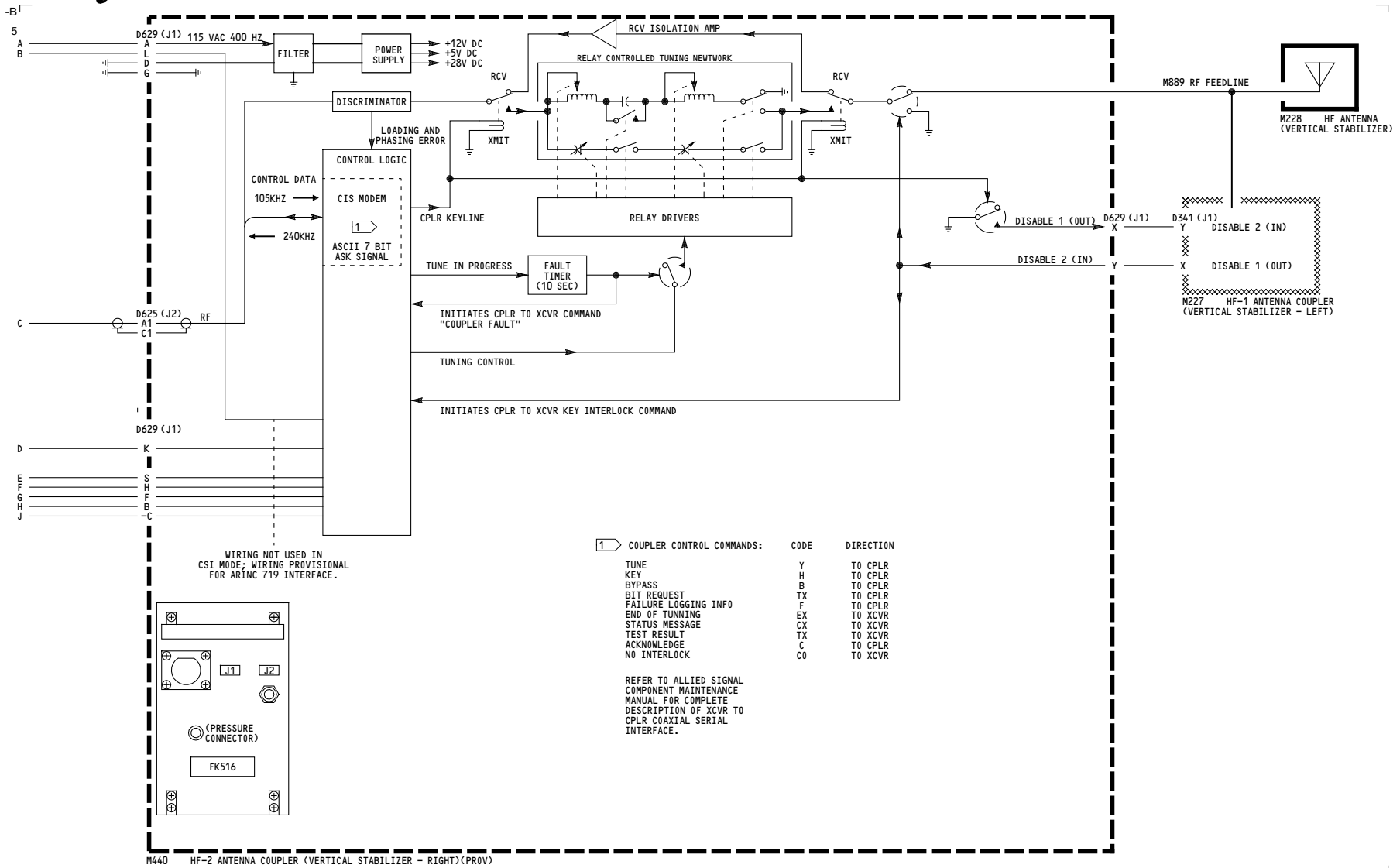

YK910-YK920

HF COMMUNICATIONS 2

D280A203

23-11-21

Page 102
Sheet 2
Feb 09/2009

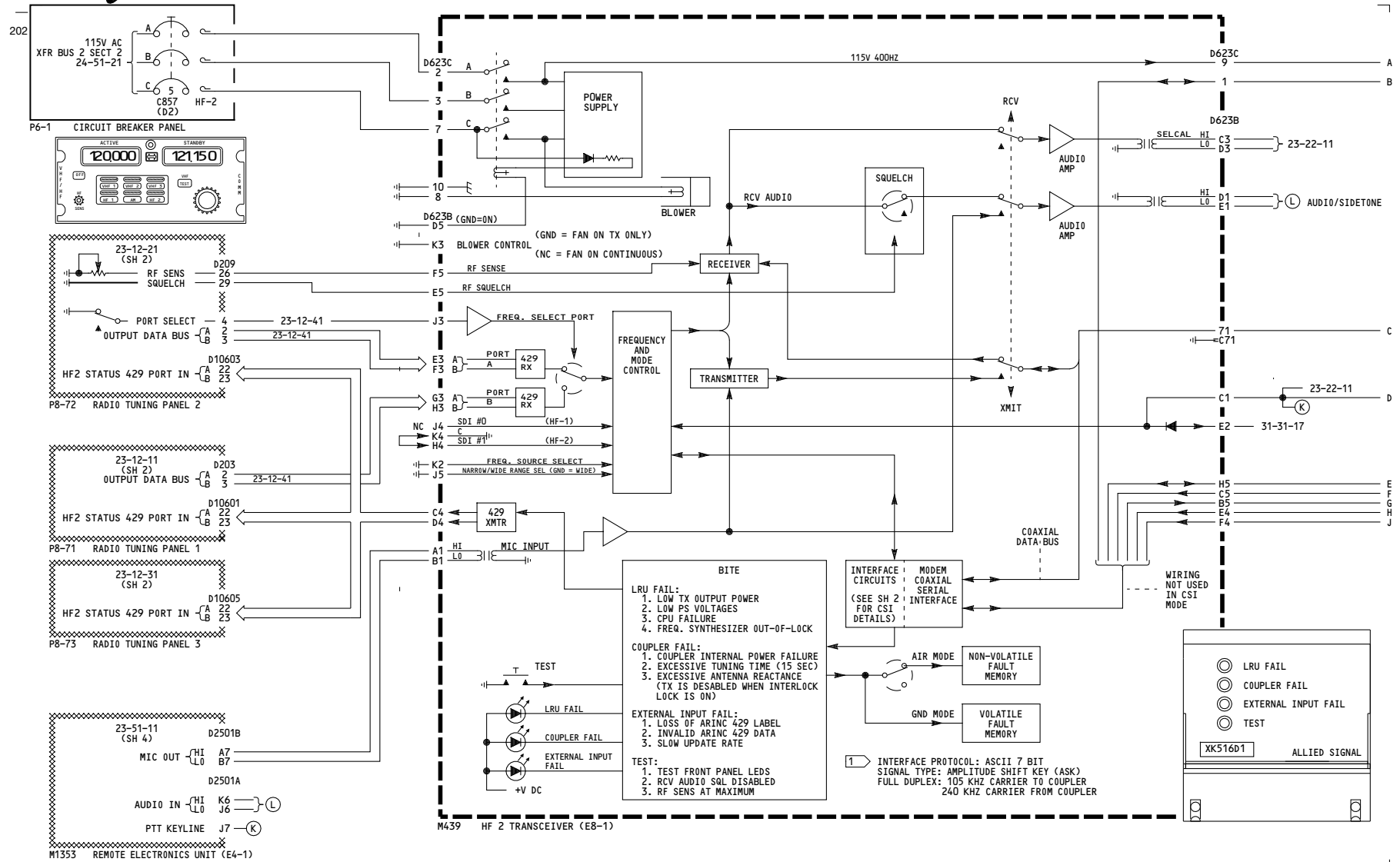

YL421	HF COMMUNICATIONS 2
	D280A203

23-11-21

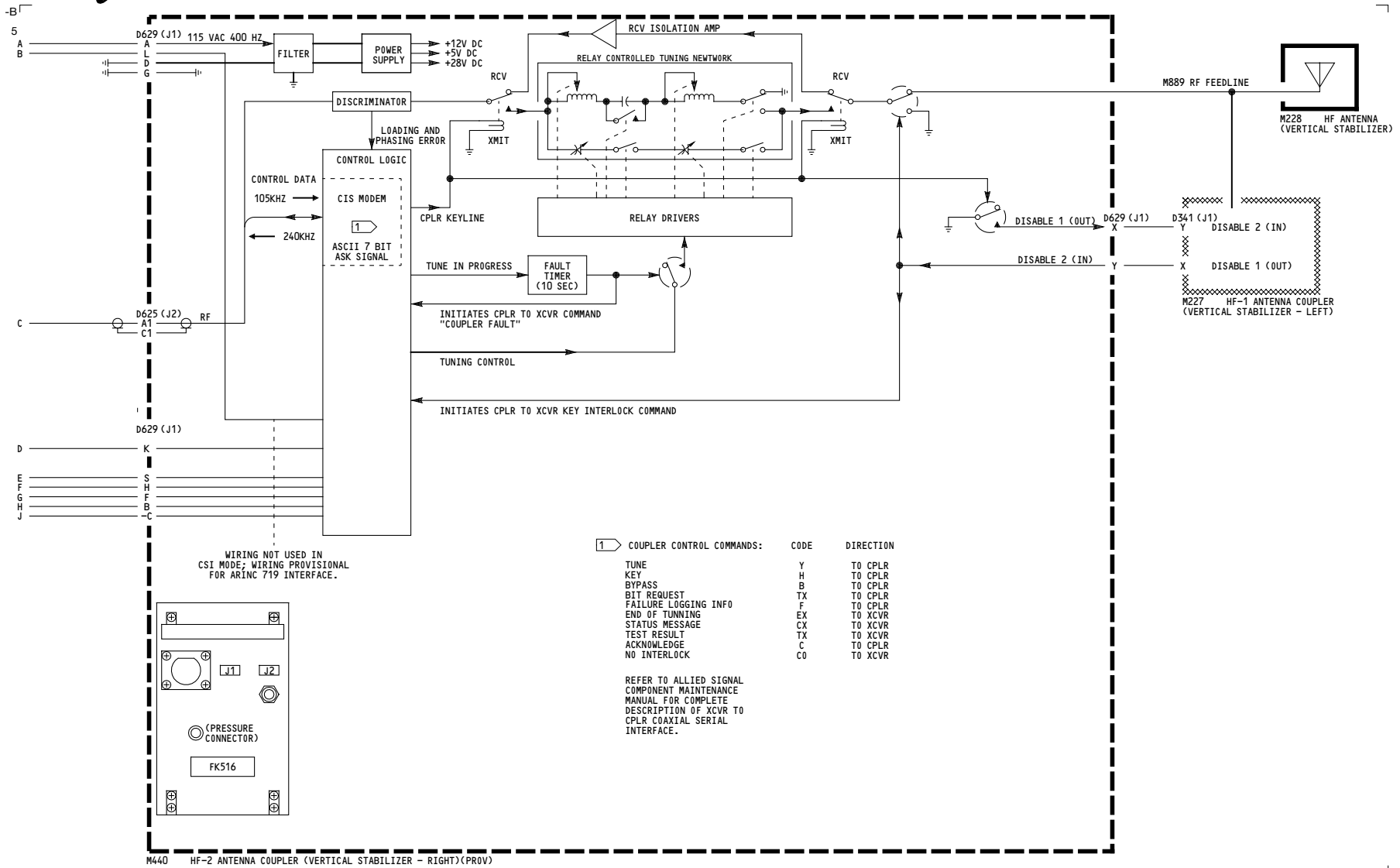

YL421

HF COMMUNICATIONS 2

D280A203

23-11-21

Page 103
Sheet 2
Feb 09/2009

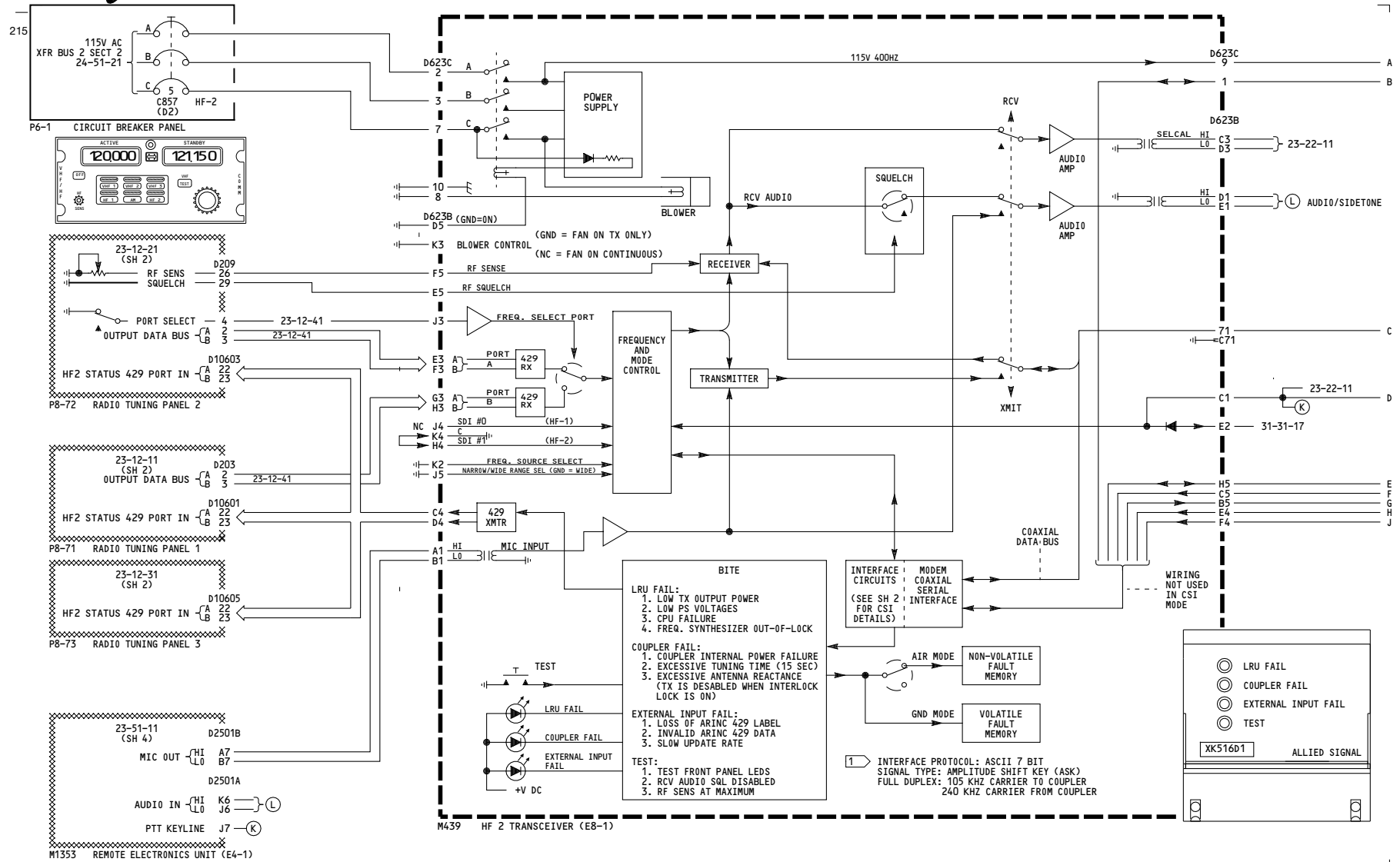

YL422-YL430

HF COMMUNICATIONS 2

D280A203

23-11-21

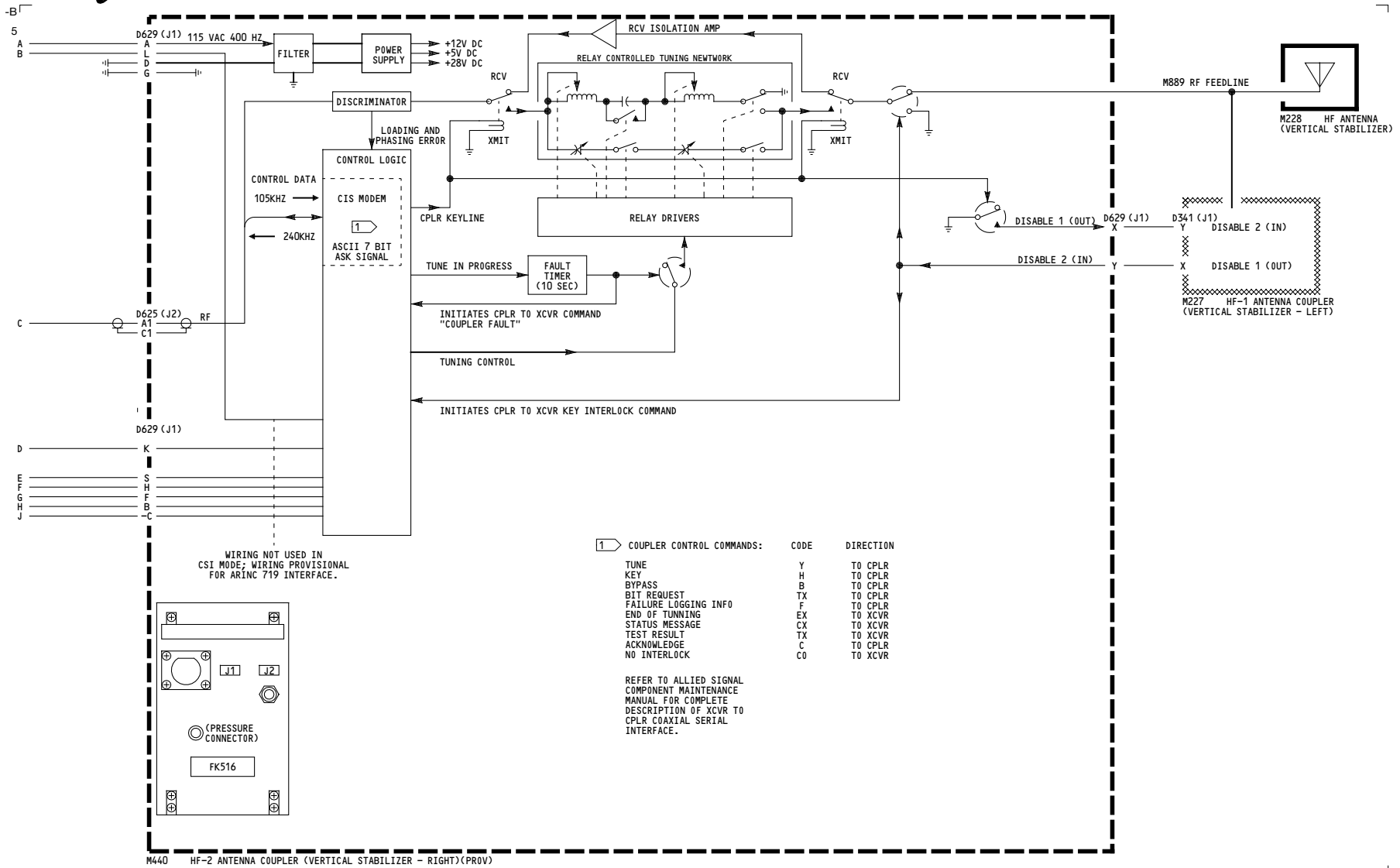

YL422-YL430

HF COMMUNICATIONS 2

D280A203

23-11-21

Page 104
Sheet 2
Feb 09/2009

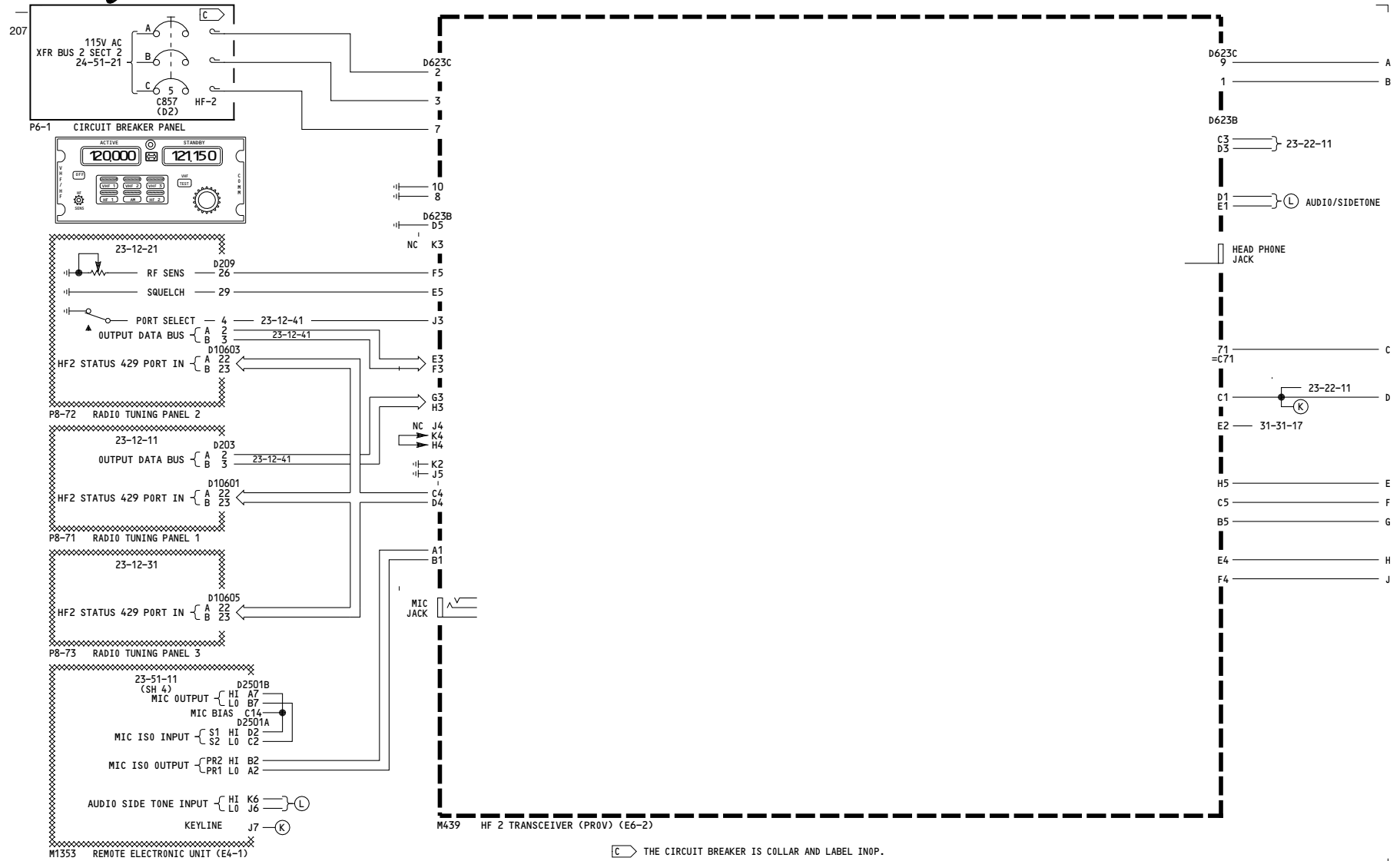

YM643-YM670

HF COMMUNICATIONS 2

D280A203

23-11-21

Page 105
Sheet 1
Feb 09/2009

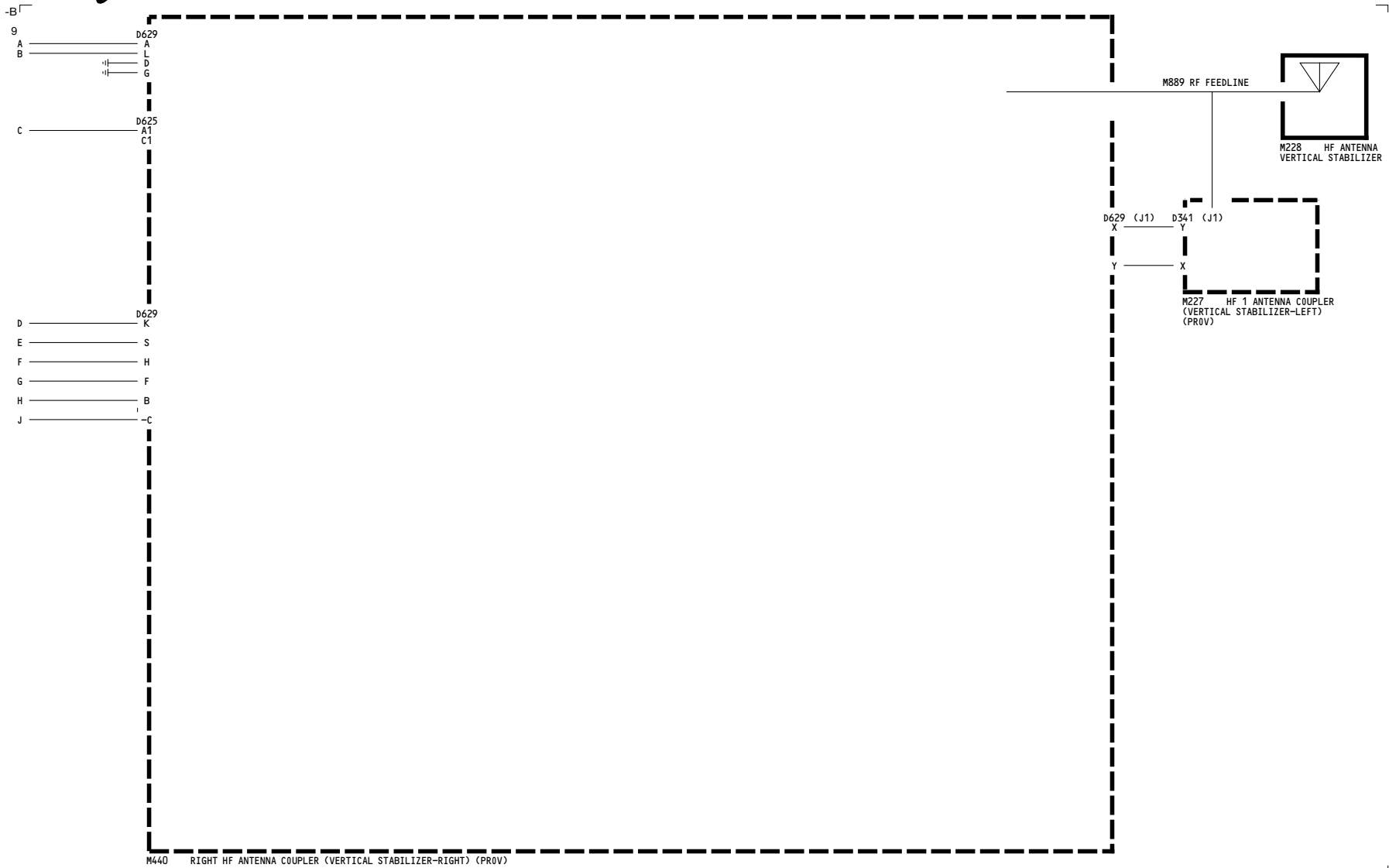

YM643-YM670

HF COMMUNICATIONS 2

D280A203

23-11-21

Page 105
Sheet 2
Feb 09/2009

WIRING DIAGRAMS
23-12-11

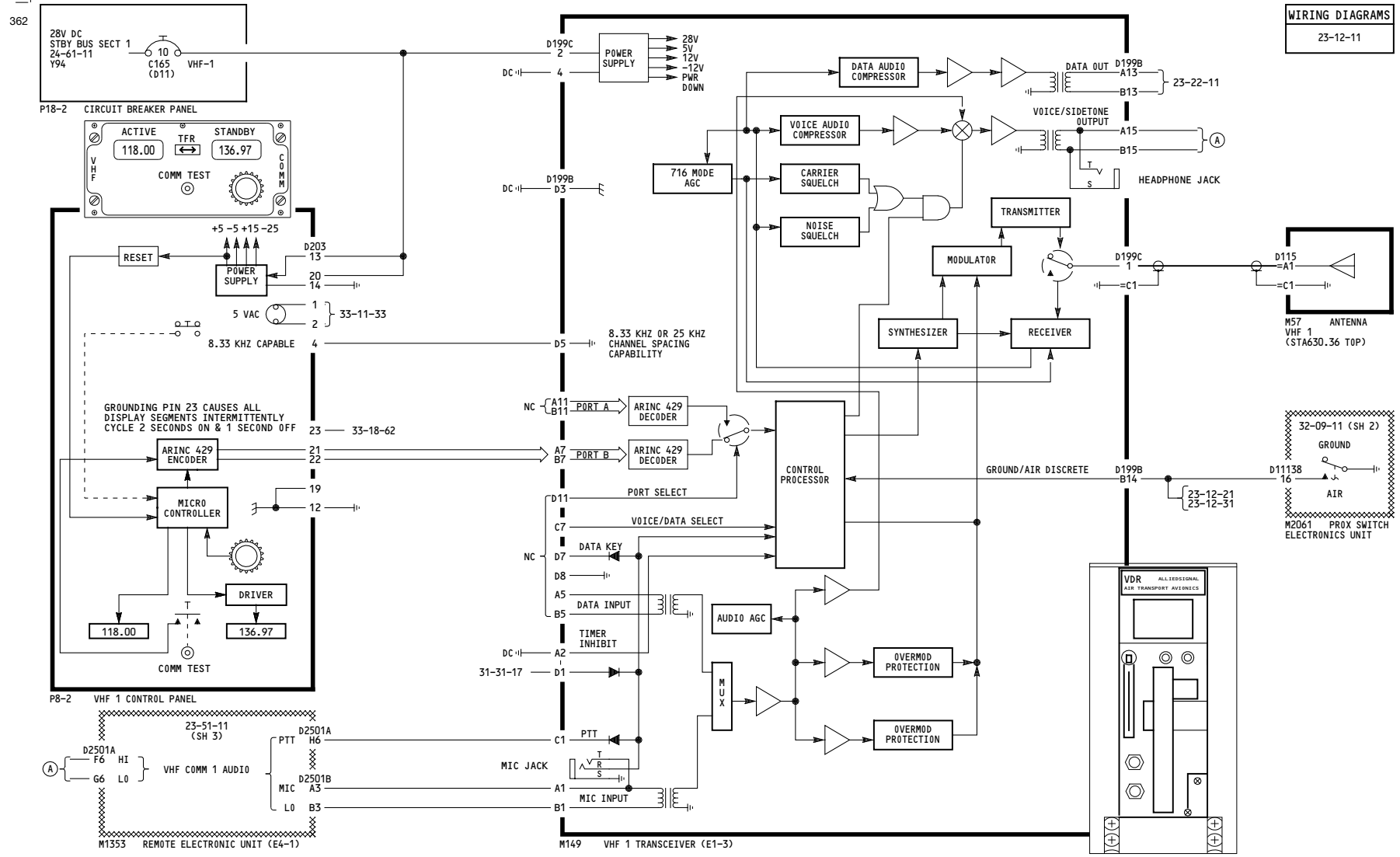

YC001-YC016

VHF COMMUNICATIONS 1

Incorporates
23A1170 R02

D280A203

23-12-11

Page 101.1

Aug 13/2008

WIRING DIAGRAMS
23-12-11

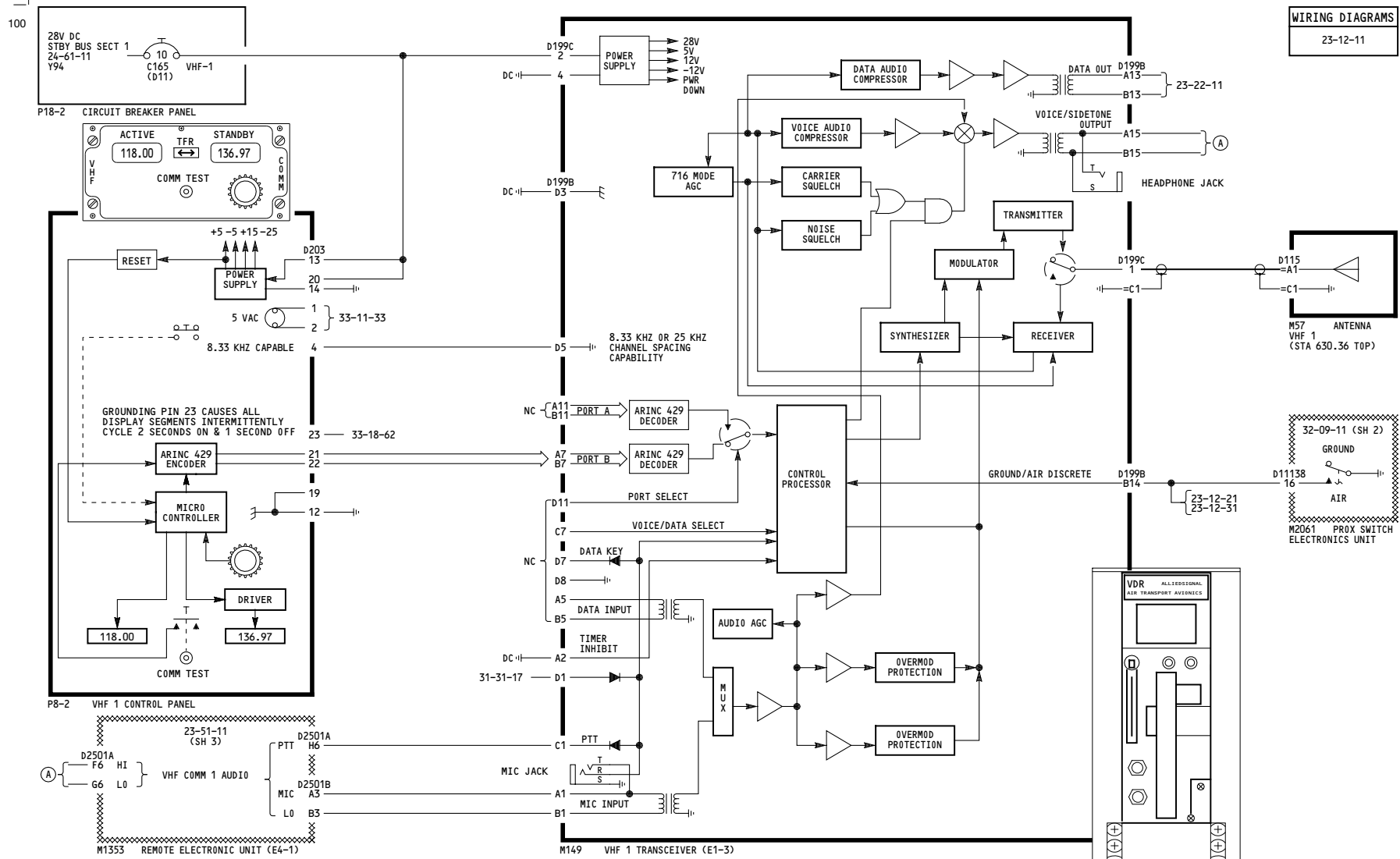

YC017-YC050

VHF COMMUNICATIONS 1

D280A203

23-12-11

Page 102

Jul 17/2007

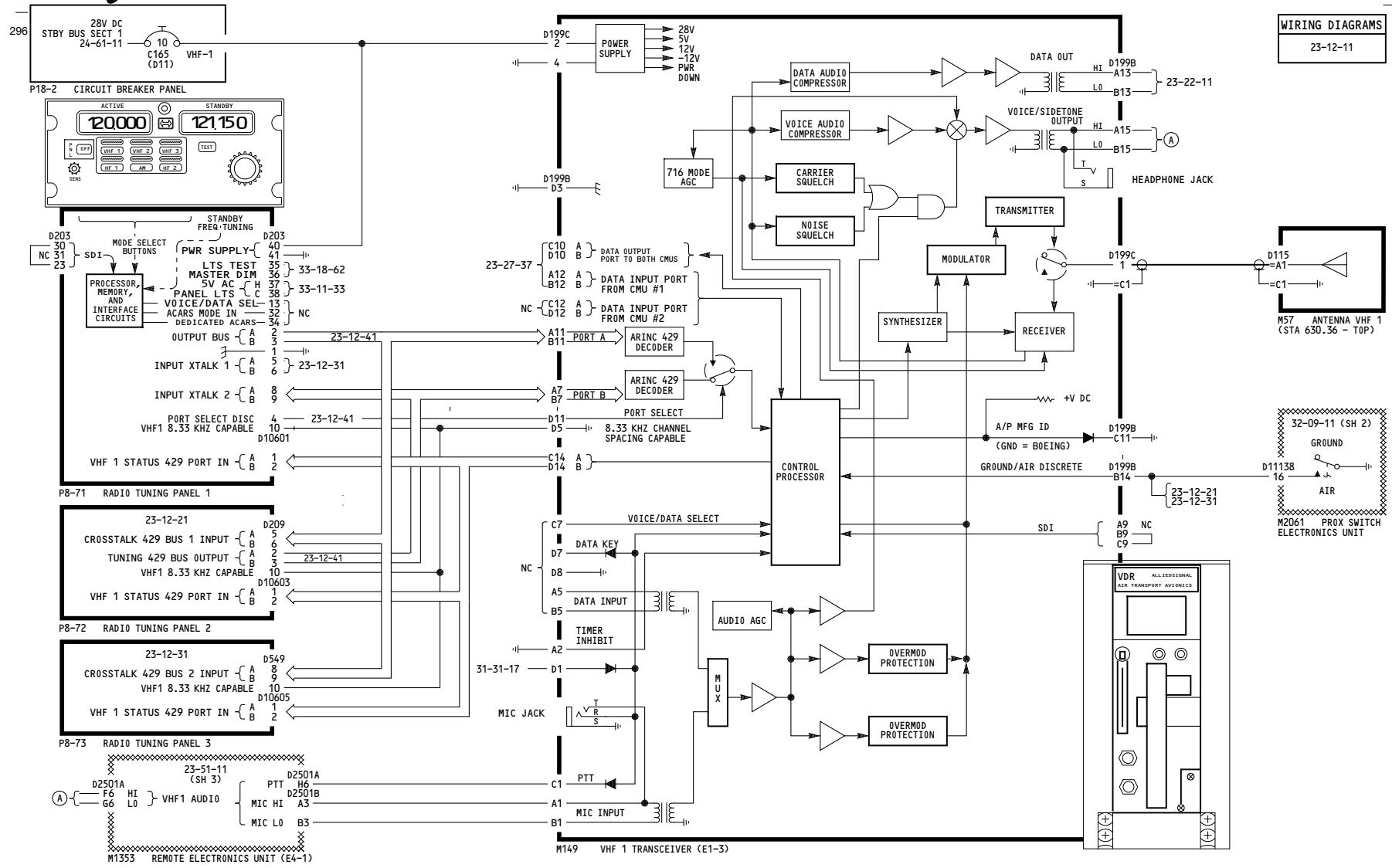

WIRING DIAGRAMS
23-12-11

M57 ANTENNA VHF 1
(STA 630.36 - TOP)

32-09-11 (SH 2)
GROUND
AIR
M2061 PROX SWITCH
ELECTRONICS UNIT

YK901-YK906	VHF COMMUNICATIONS 1
D280A203	

23-12-11

Page 103

Oct 20/2006

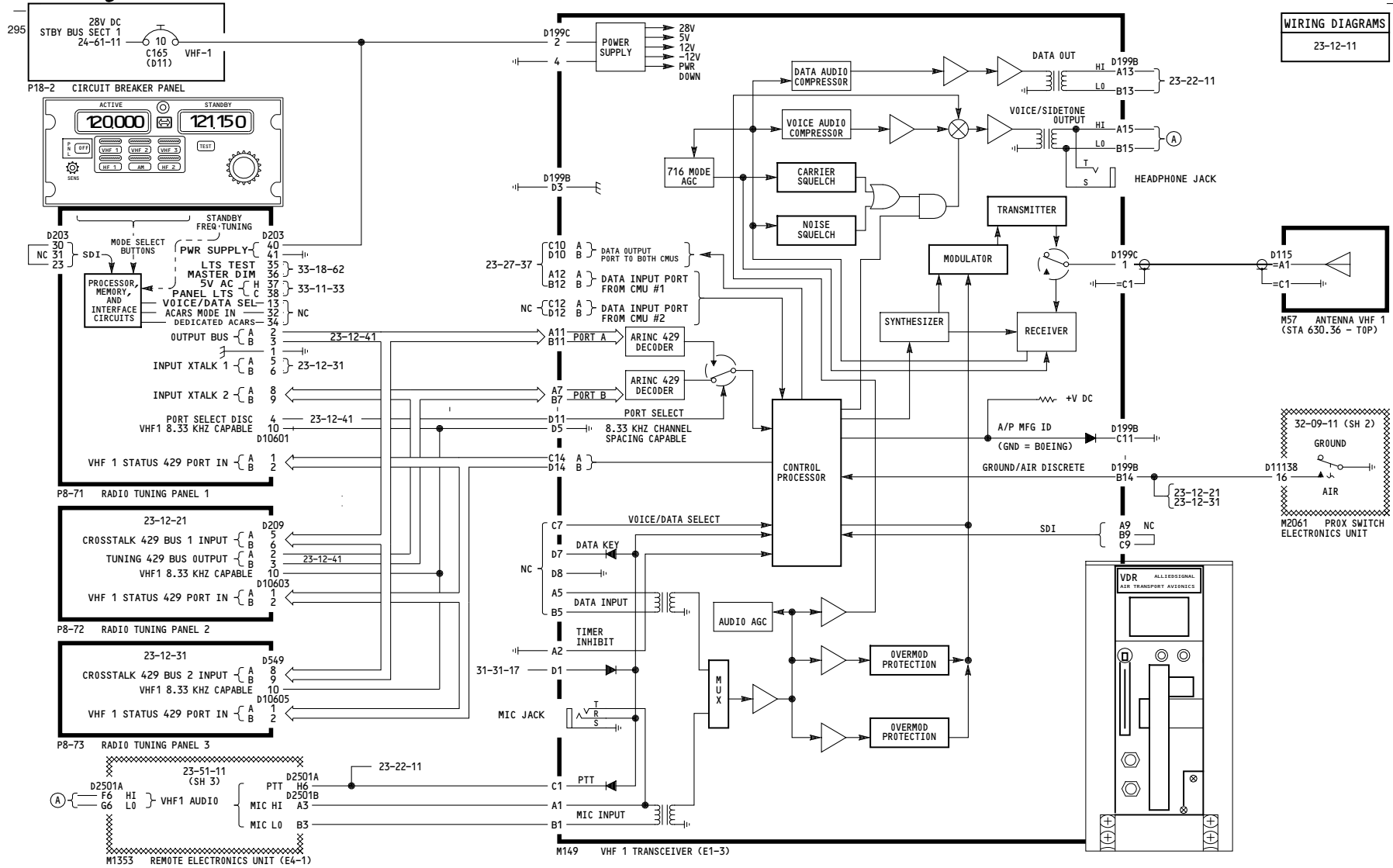

WIRING DIAGRAMS
23-12-11

YK907-YM670

VHF COMMUNICATIONS 1

D280A203

23-12-11

WIRING DIAGRAMS
23-12-21

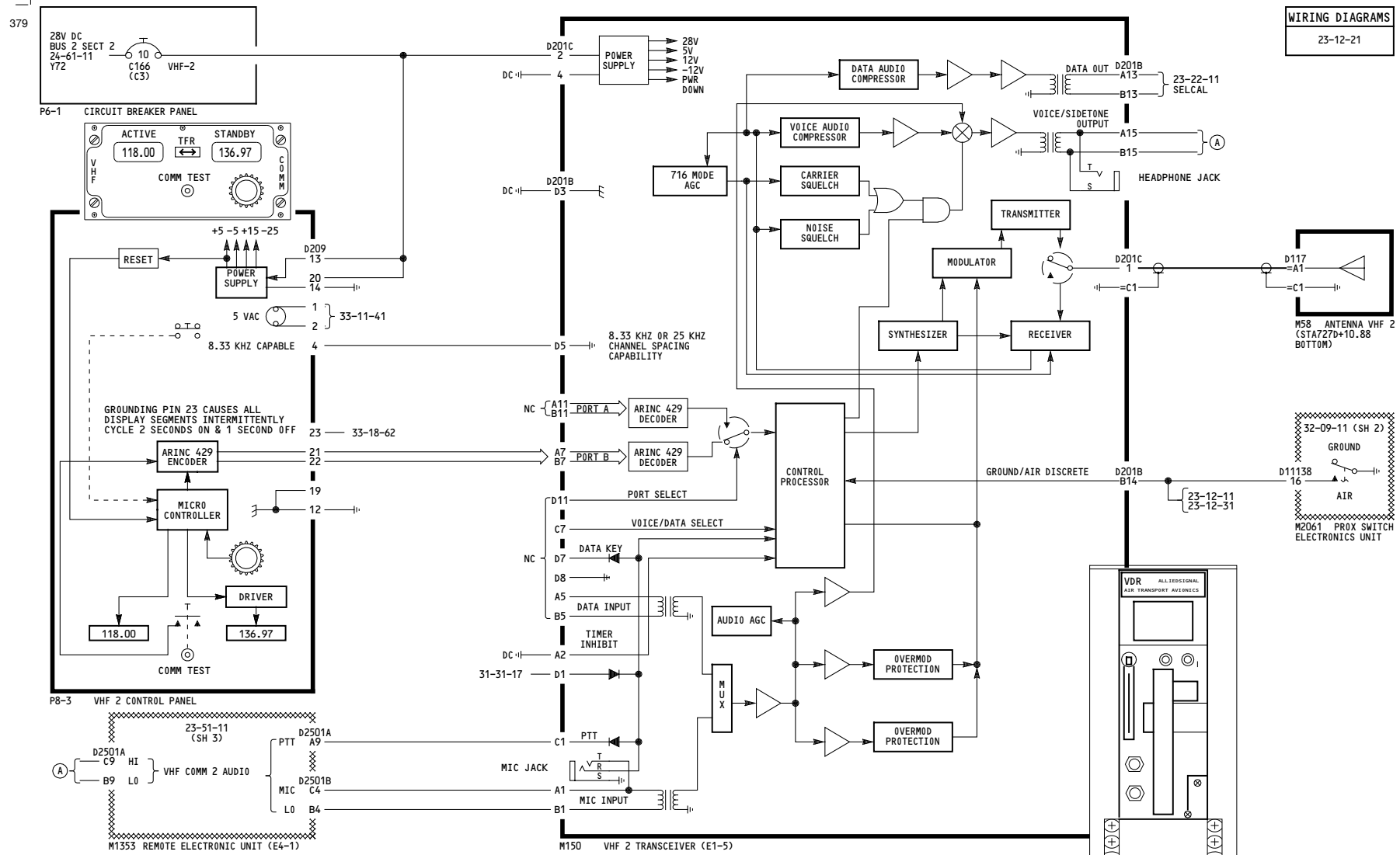

YC001-YC016

VHF COMMUNICATIONS 2

Incorporates
23A1170 R02

23-12-21

Page 101.1

Aug 13/2008

D280A203

WIRING DIAGRAMS
23-12-21

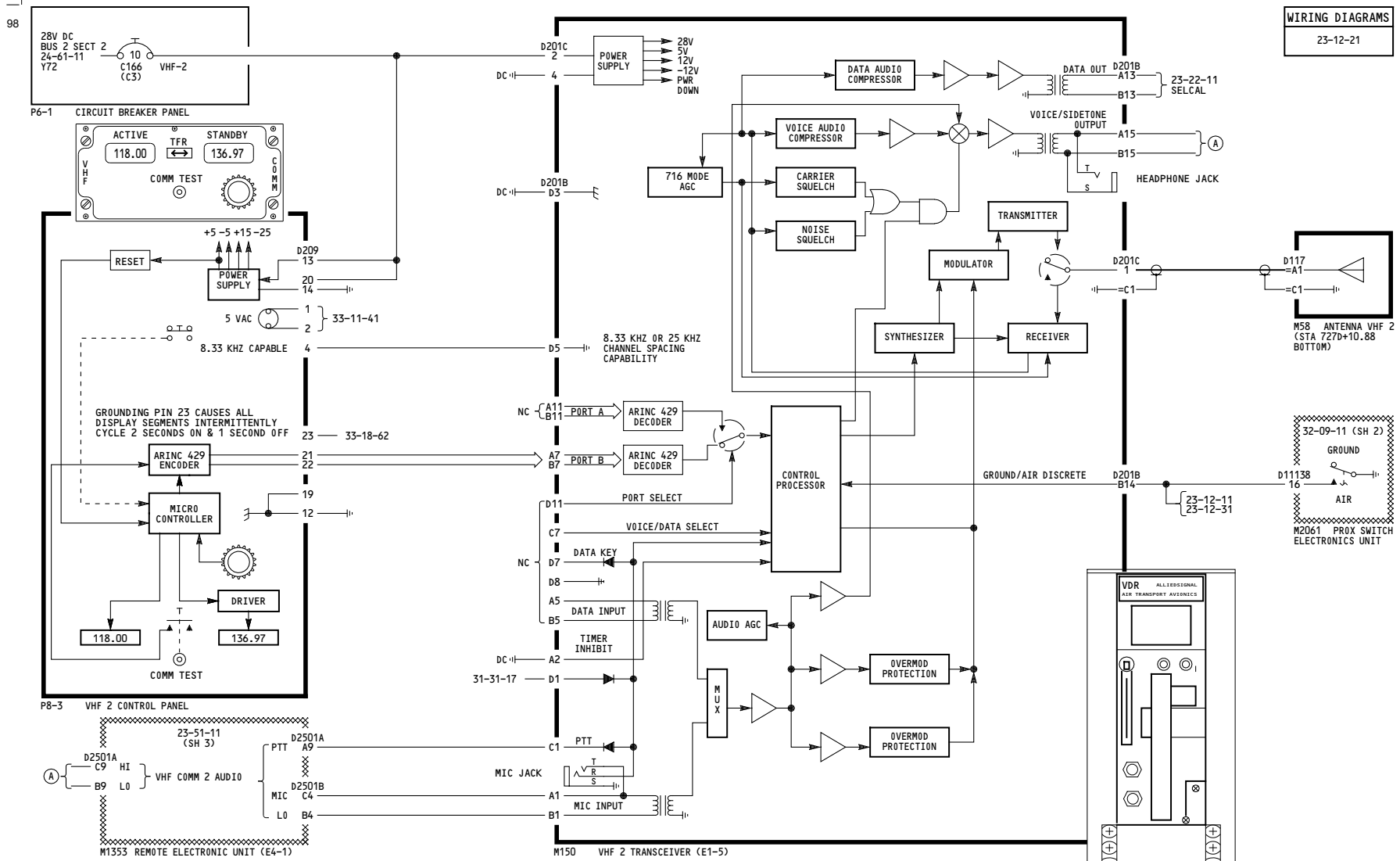

YC017-YC050

VHF COMMUNICATIONS 2

D280A203

23-12-21

Page 102

Jul 17/2007

WIRING DIAGRAMS
23-12-21

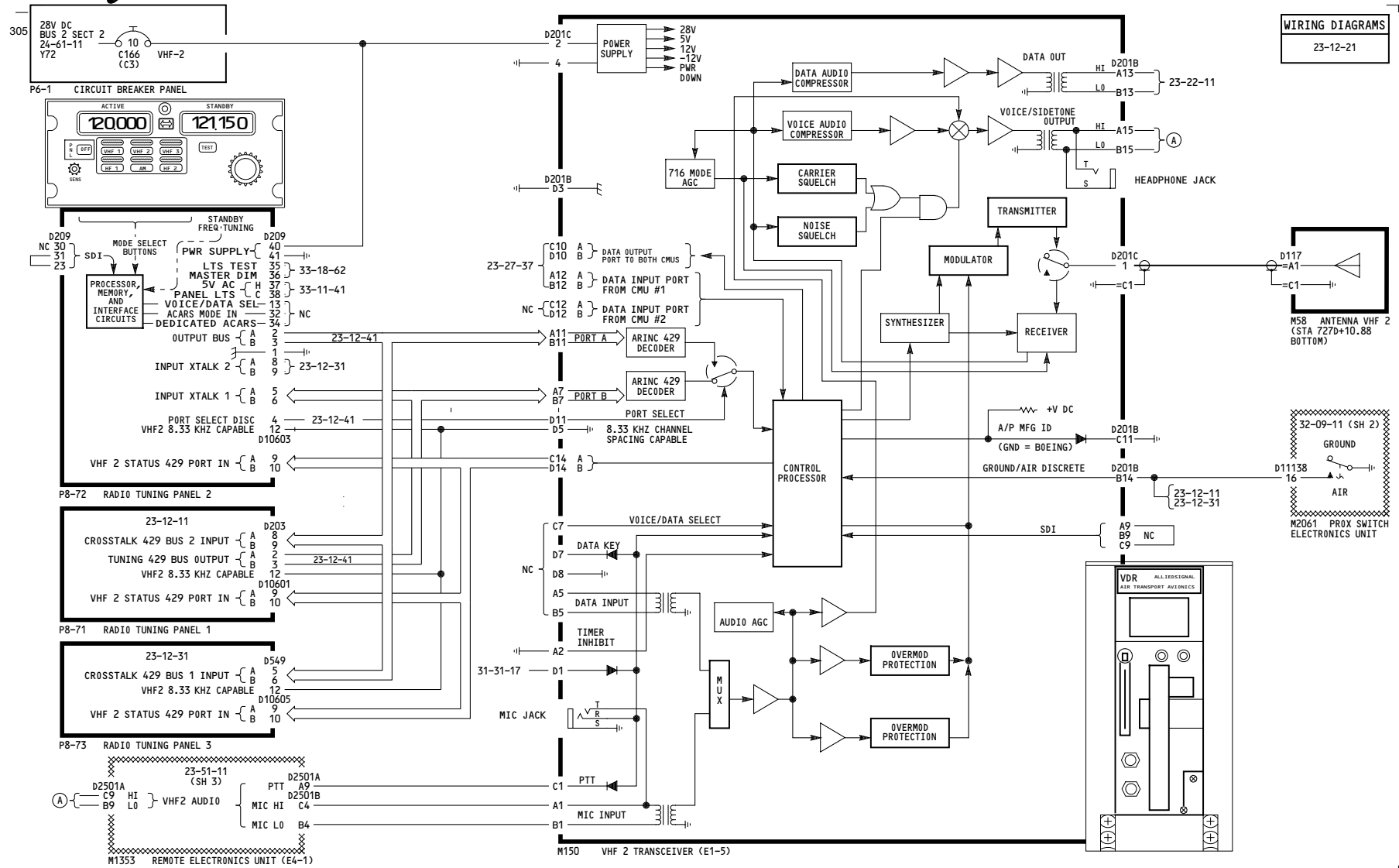

YK901-YK906	VHF COMMUNICATIONS 2
D280A203	

23-12-21

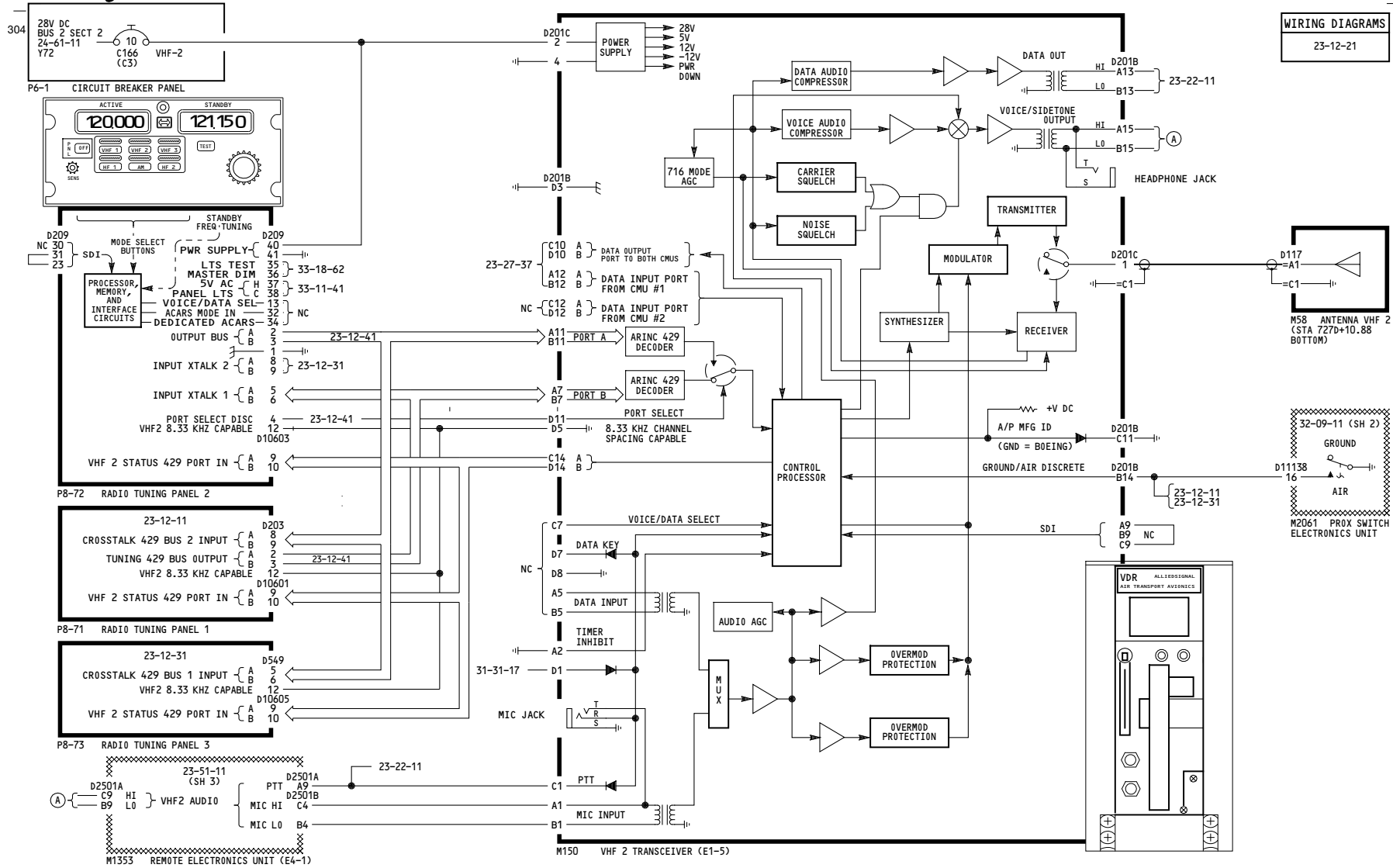

YK907-YM670

VHF COMMUNICATIONS 2

D280A203

23-12-21

WIRING DIAGRAMS
23-12-31

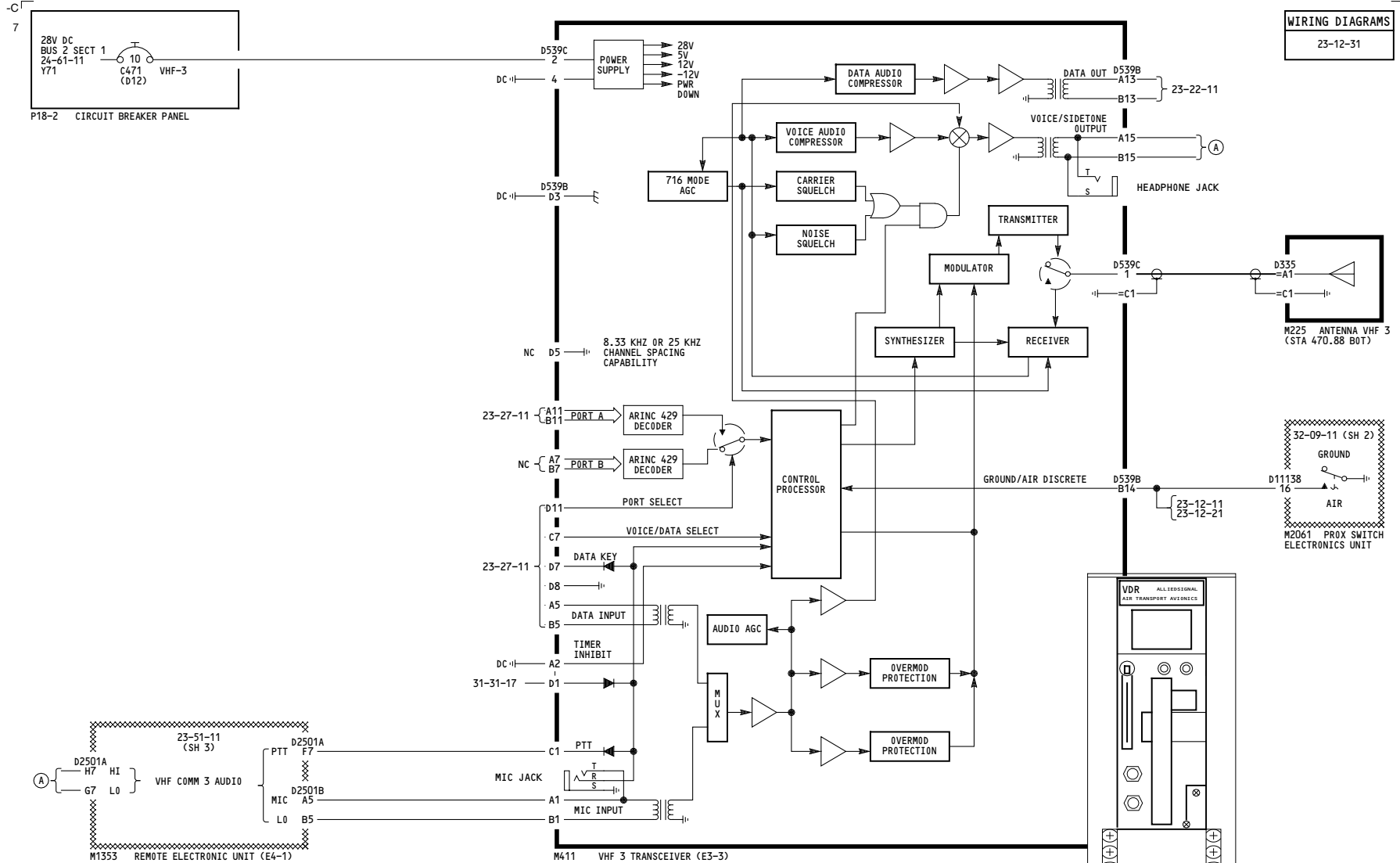

<p>YC001-YC050</p>	<p>VHF COMMUNICATIONS 3</p> <p>D280A203</p>
--------------------	--

23-12-31

Page 101

Jul 17/2007

WIRING DIAGRAMS
23-12-31

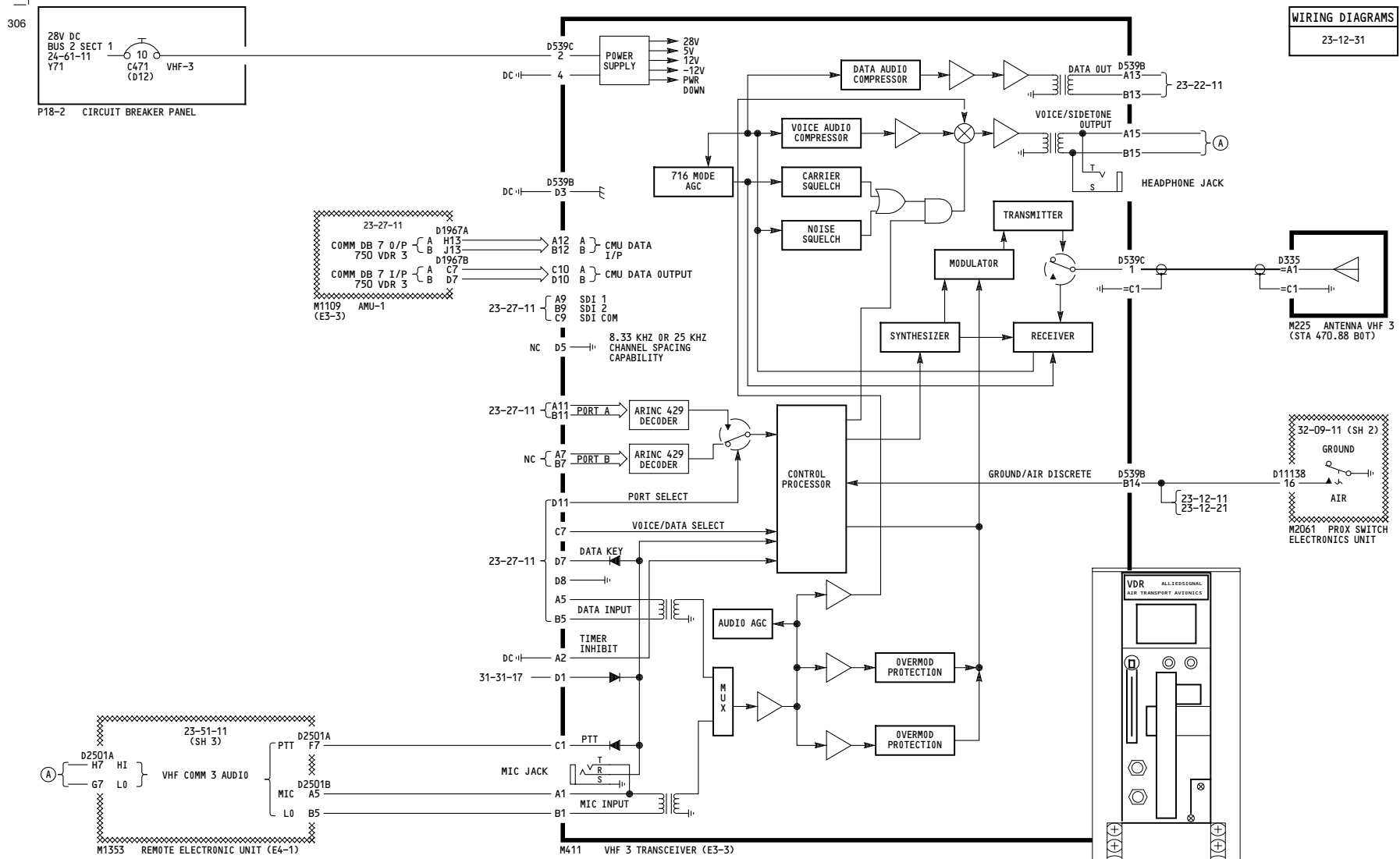

YC001-YC030	VHF COMMUNICATIONS 3	Incorporates EO 23-80059-6
	D280A203	

23-12-31

Page 101A

Oct 15/2007

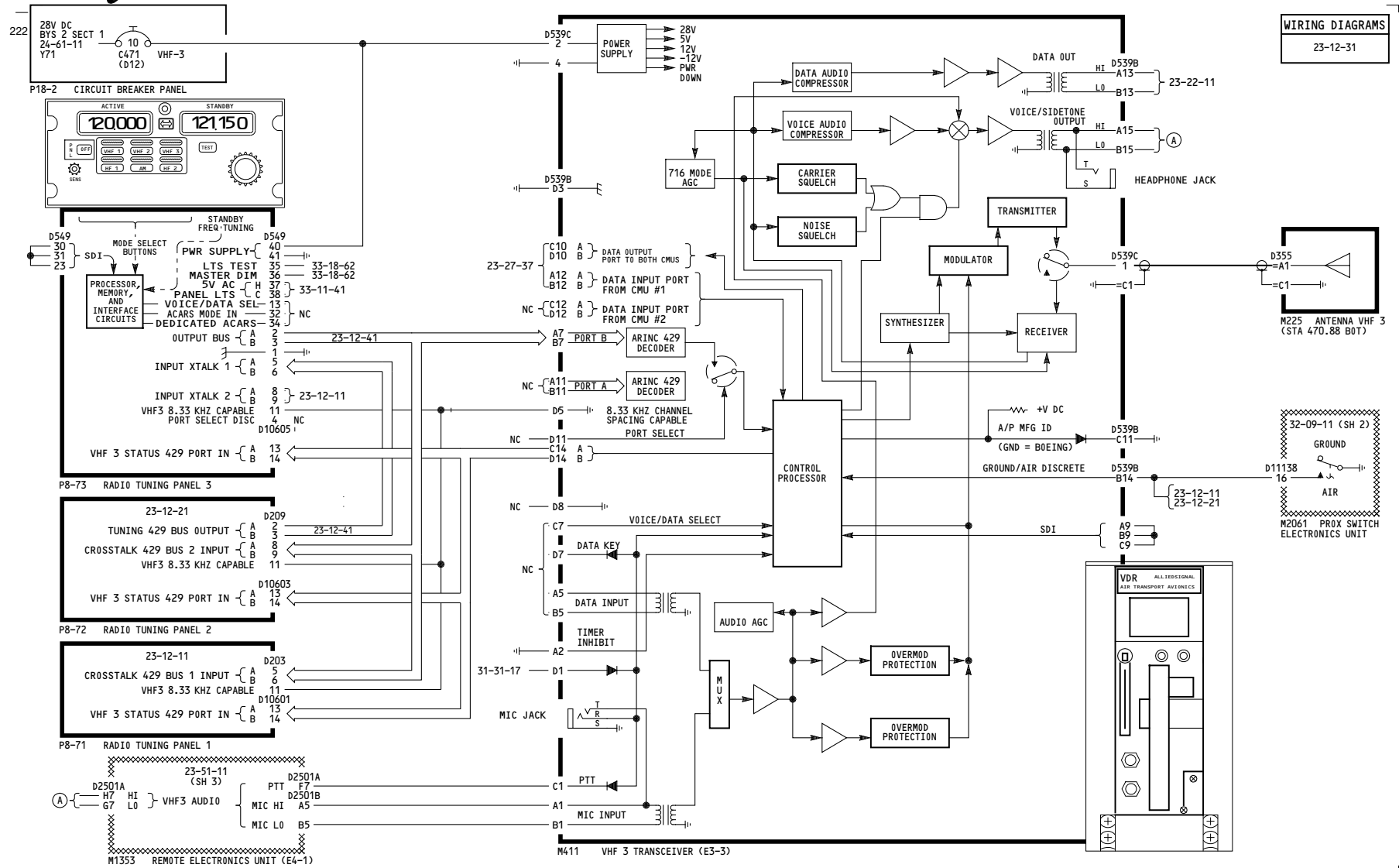

WIRING DIAGRAMS
23-12-31

YK901-YK906

VHF COMMUNICATIONS 3

23-12-31

D280A203

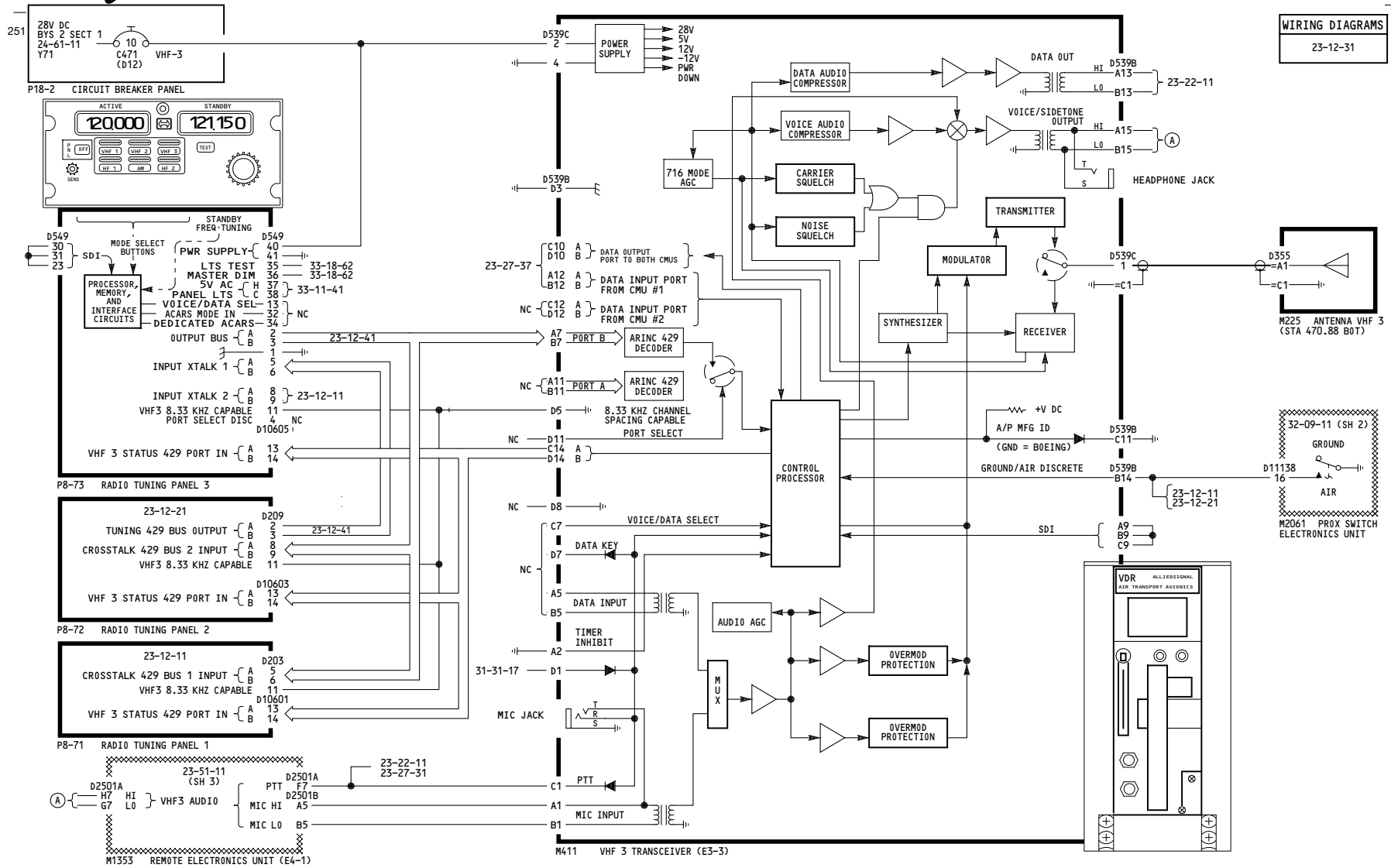

WIRING DIAGRAMS
23-12-31

YK907-YM670

VHF COMMUNICATIONS 3

D280A203

23-12-31

121

WIRING DIAGRAMS
23-12-41

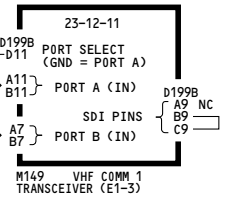
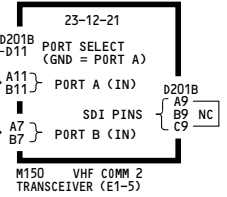
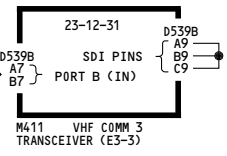
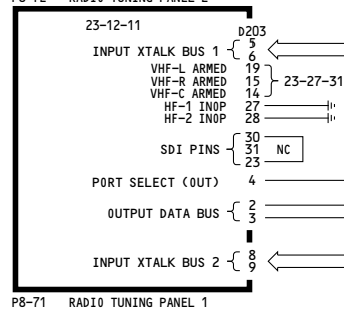
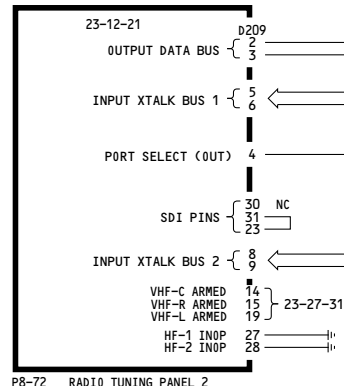
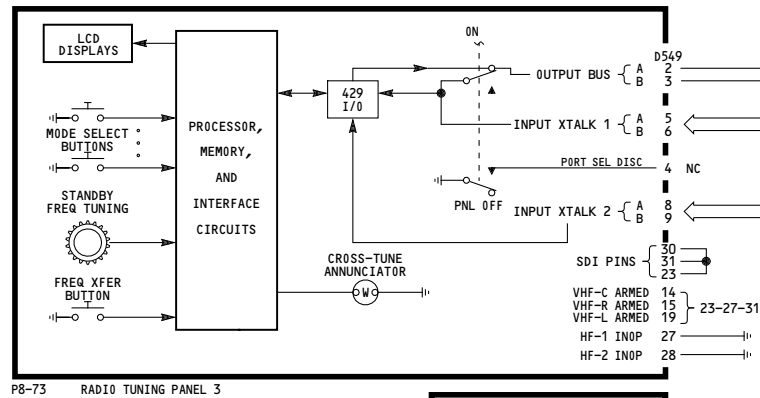

YK901-YK906	<p align="center">VHF/HF COMMUNICATIONS</p> <p align="center">D280A203</p>
-------------	---

23-12-41

Page 101

Oct 20/2006

147
WIRING DIAGRAMS
23-12-31

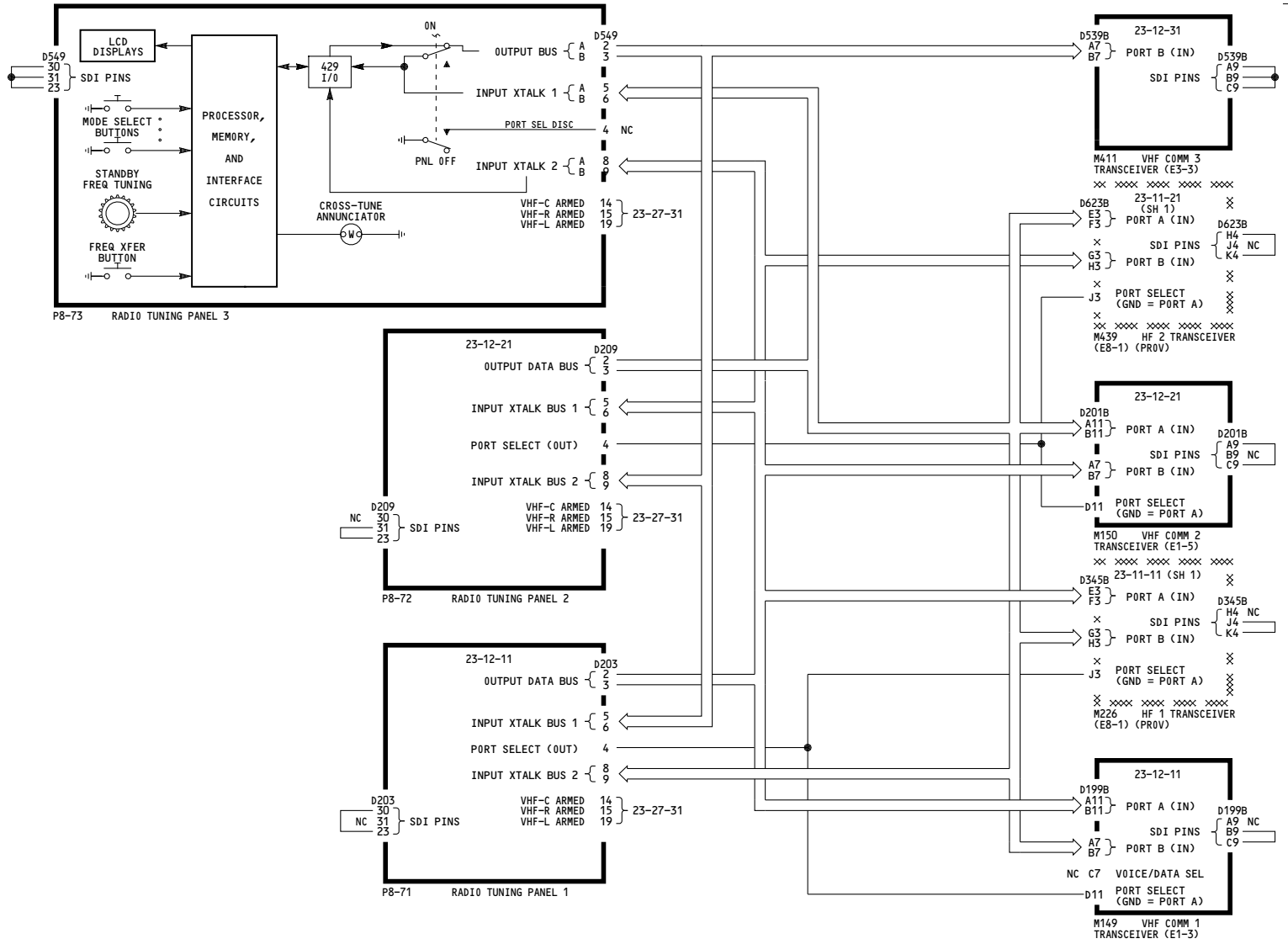

YK907-YK909, YL401

VHF/HF COMMUNICATIONS

D280A203

23-12-41

153
WIRING DIAGRAMS
23-12-31

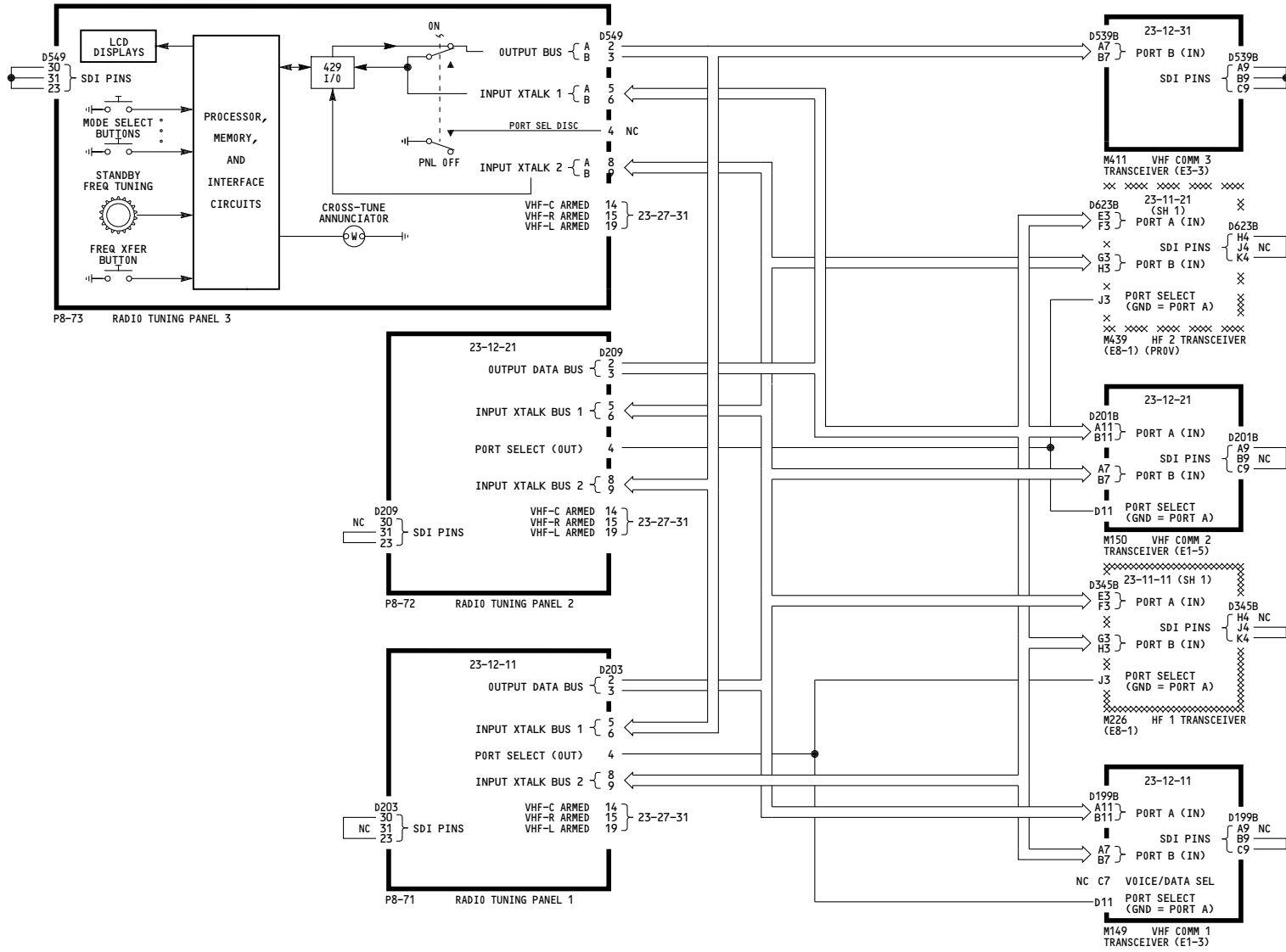

YK910-YK920	VHF/HF COMMUNICATIONS
	D280A203

23-12-41

142
WIRING DIAGRAMS
23-12-31

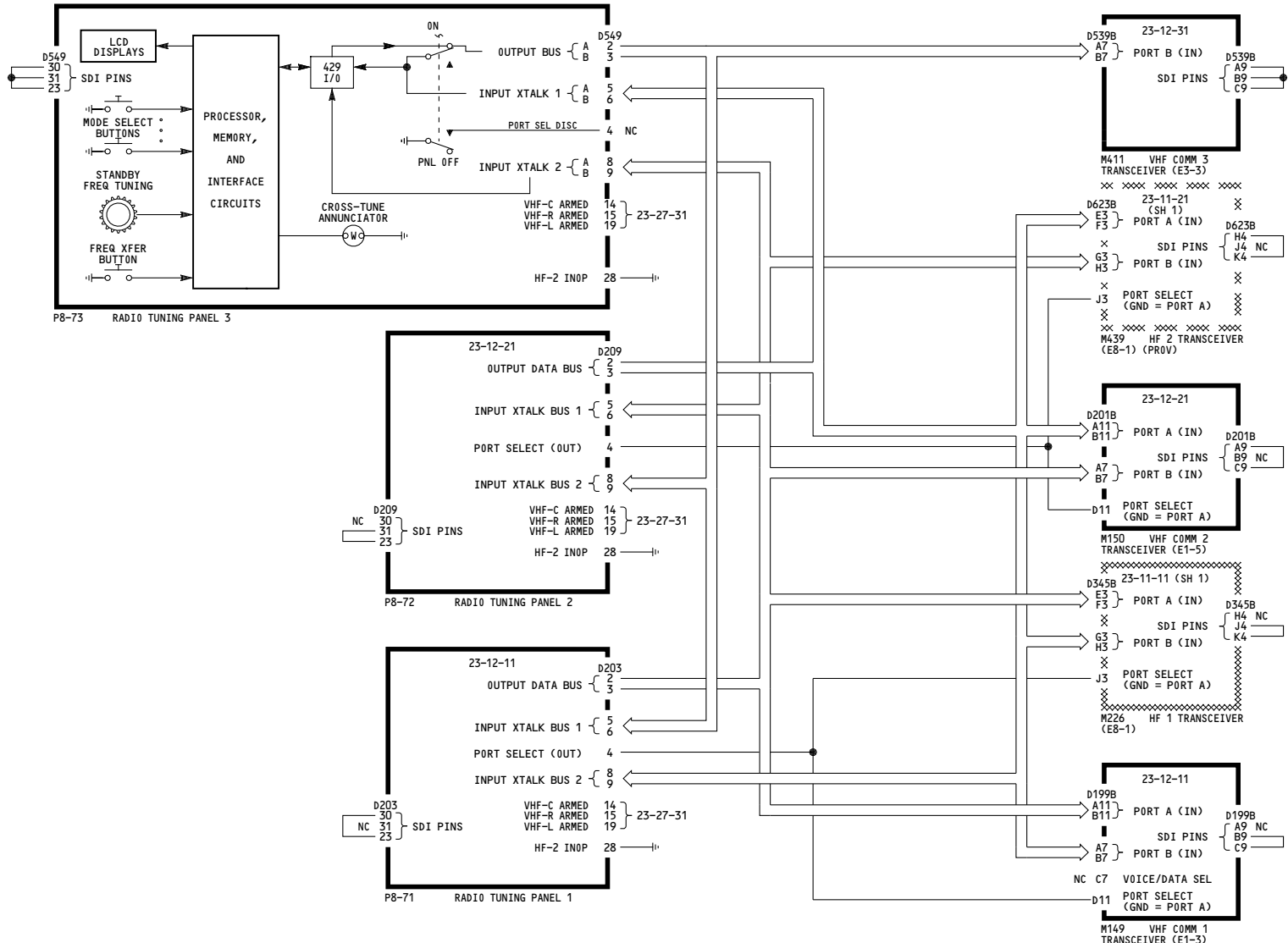

YL421	<p>VHF/HF COMMUNICATIONS</p> <p>D280A203</p>
-------	---

23-12-41

150
WIRING DIAGRAMS
23-12-31

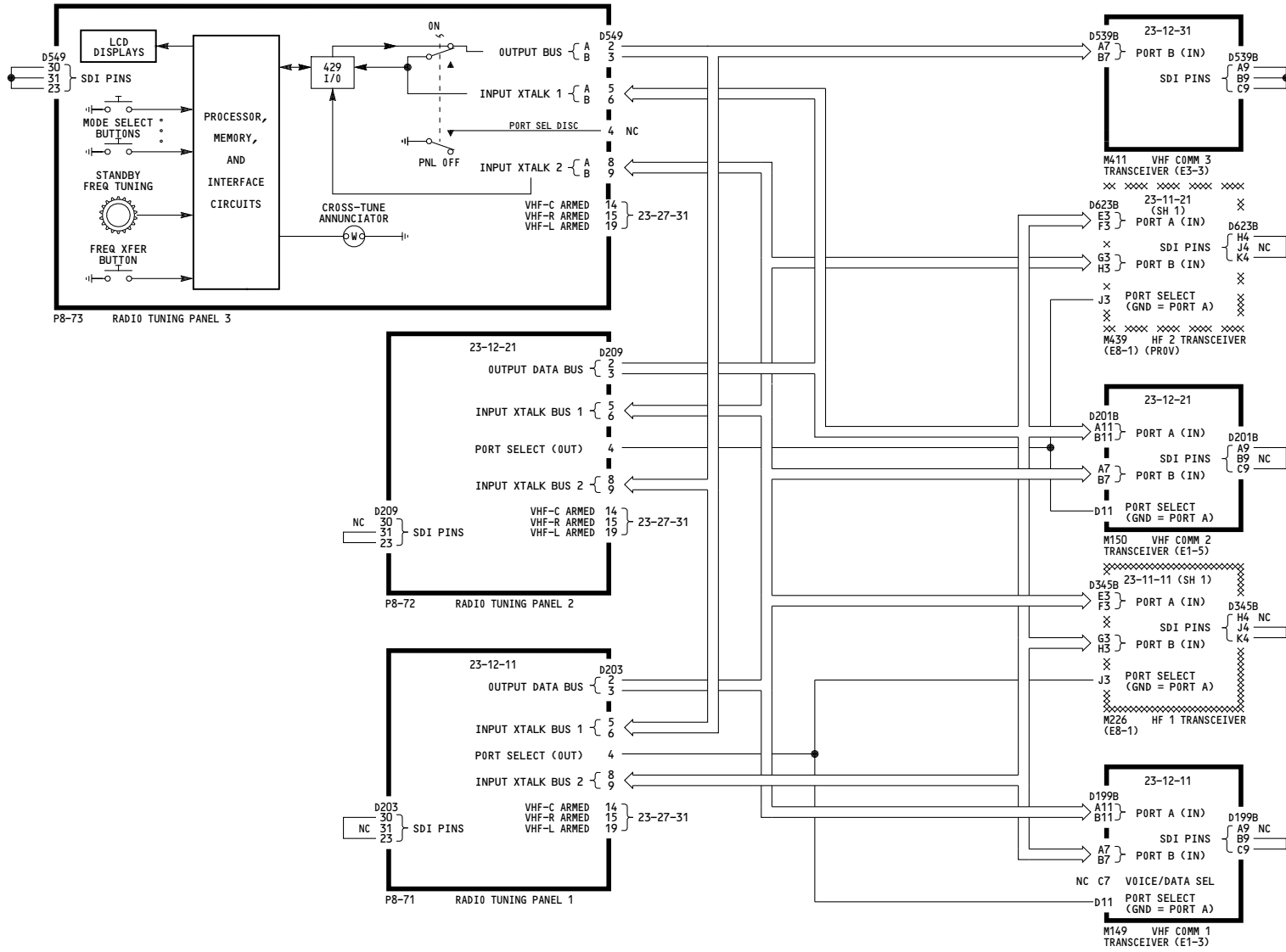

YL422-YL430	VHF/HF COMMUNICATIONS
	D280A203

23-12-41

140
WIRING DIAGRAMS
23-12-31

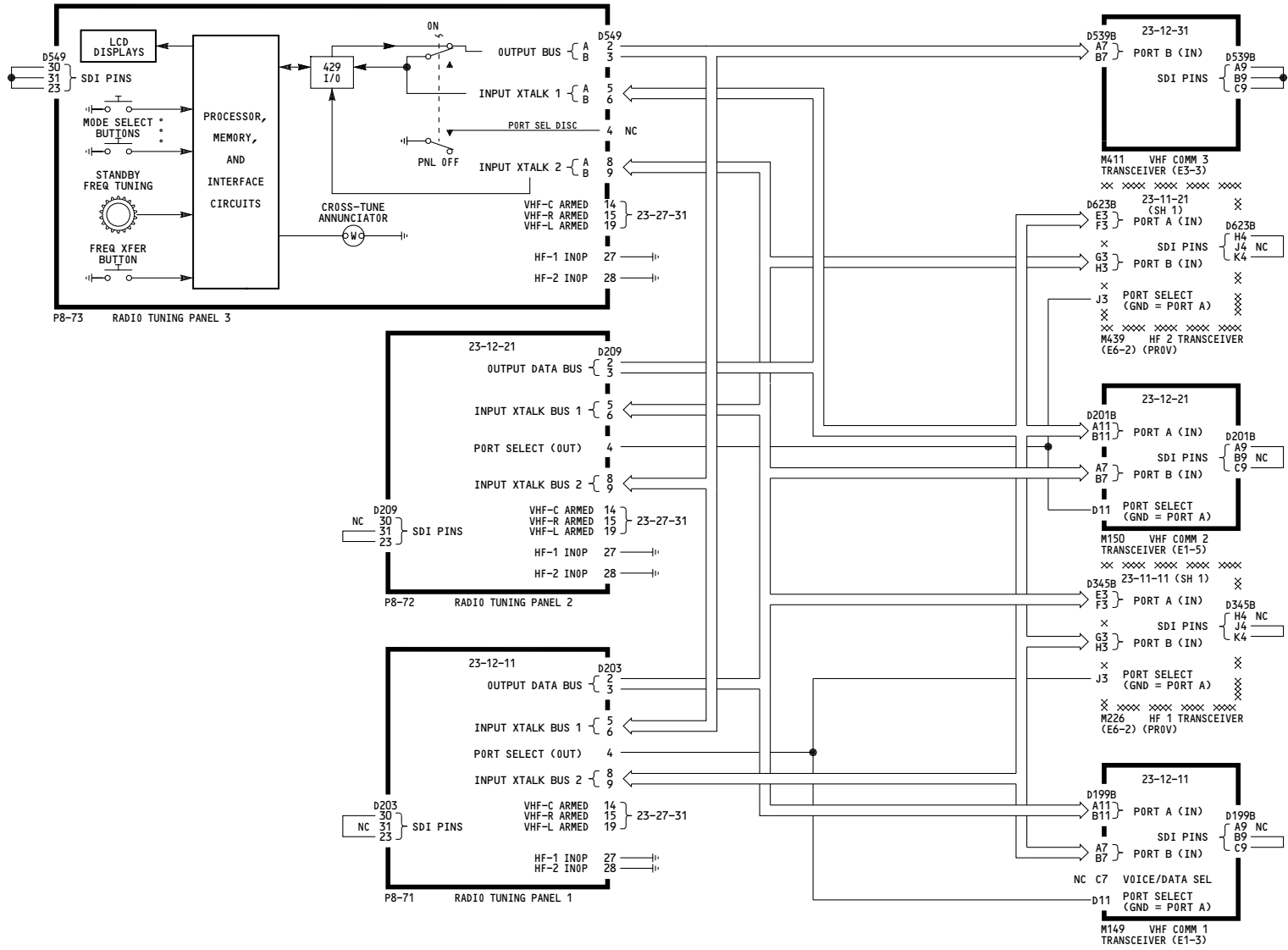

YM643-YM670

VHF/HF COMMUNICATIONS

D280A203

23-12-41

Page 106

Feb 09/2009

WIRING DIAGRAMS
23-22-11

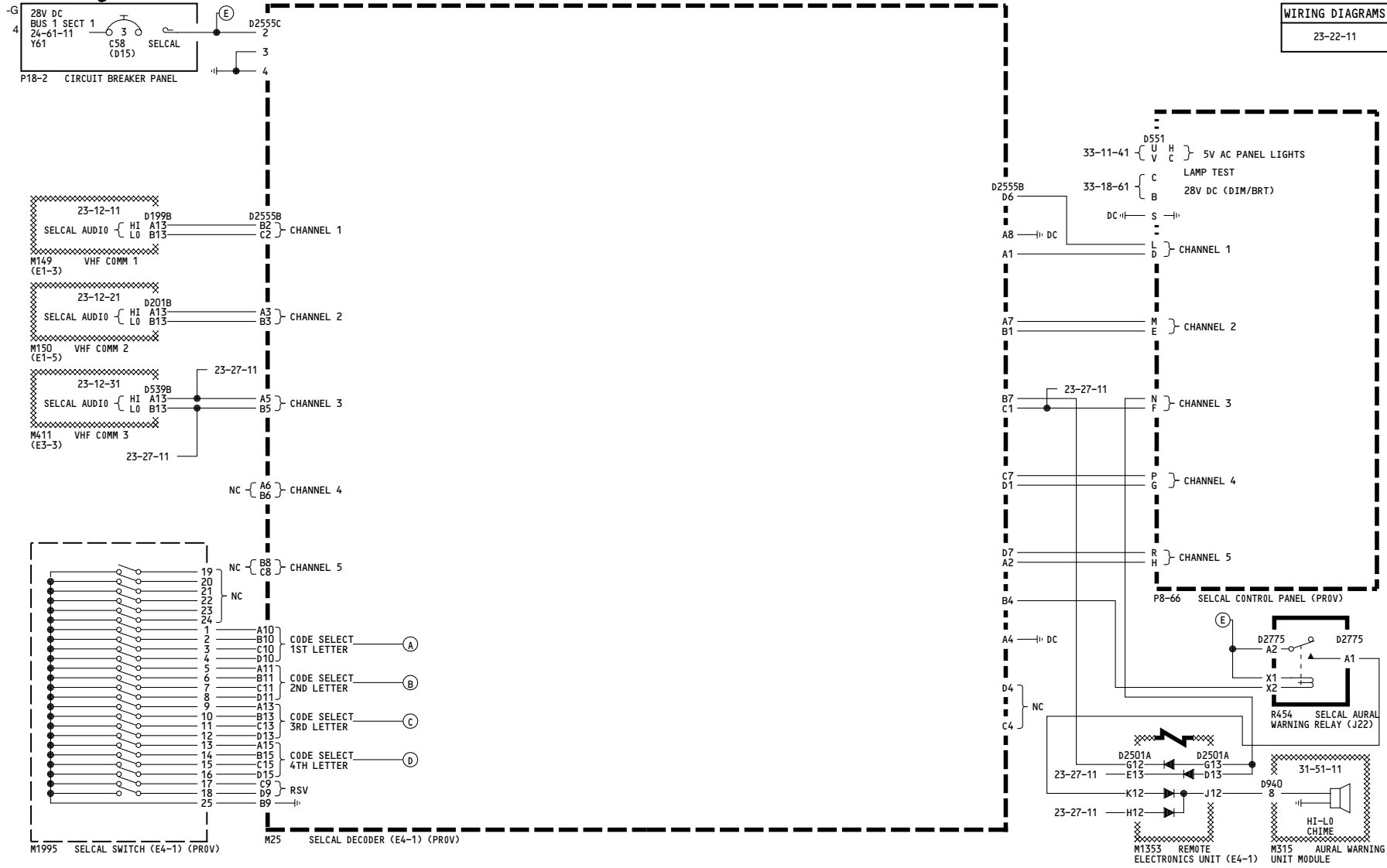

YC001-YC050	SELCAL
	D280A203

23-22-11

WIRING DIAGRAMS
23-22-11

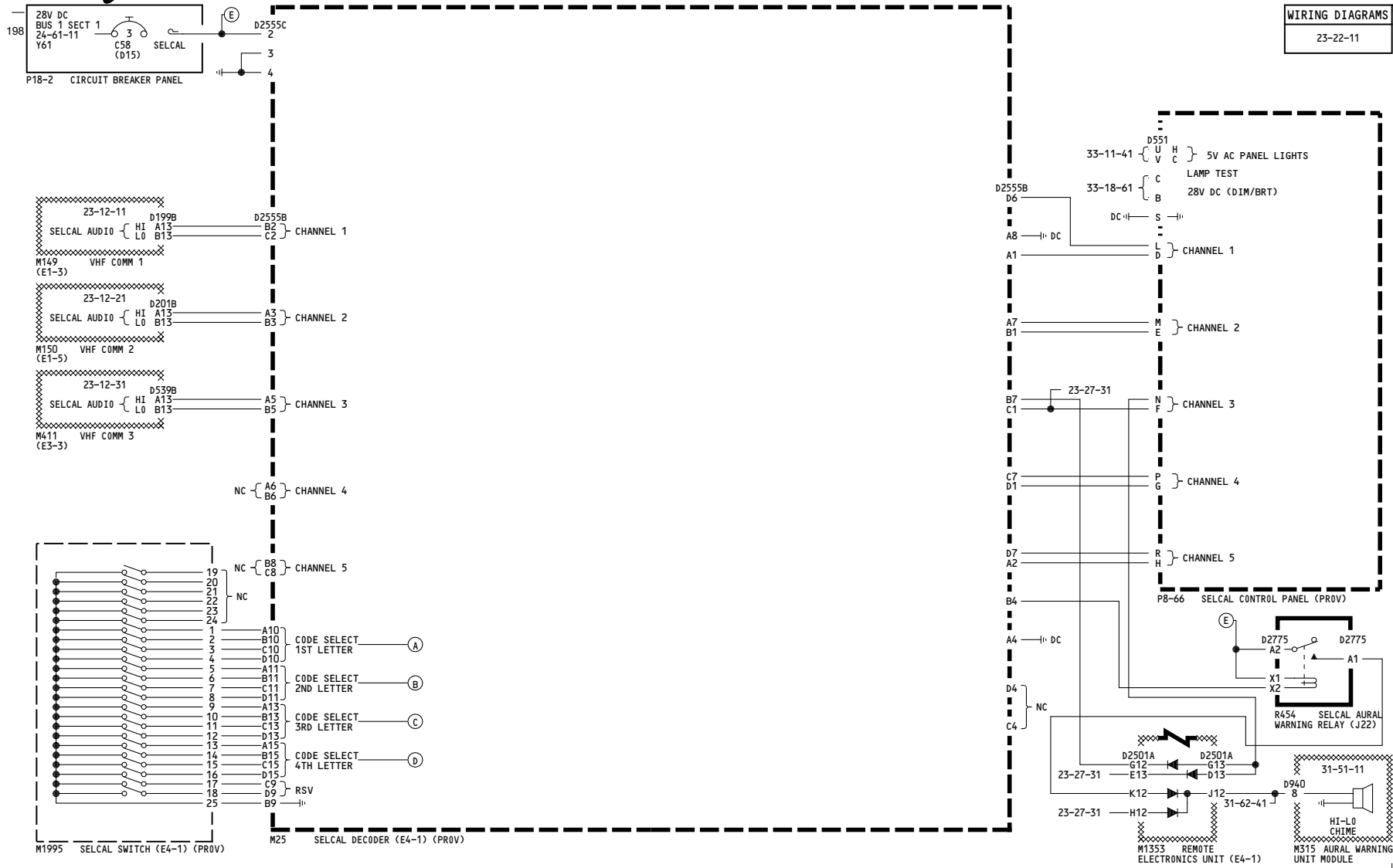

YK901-YK906	SELCAL
	D280A203

23-22-11

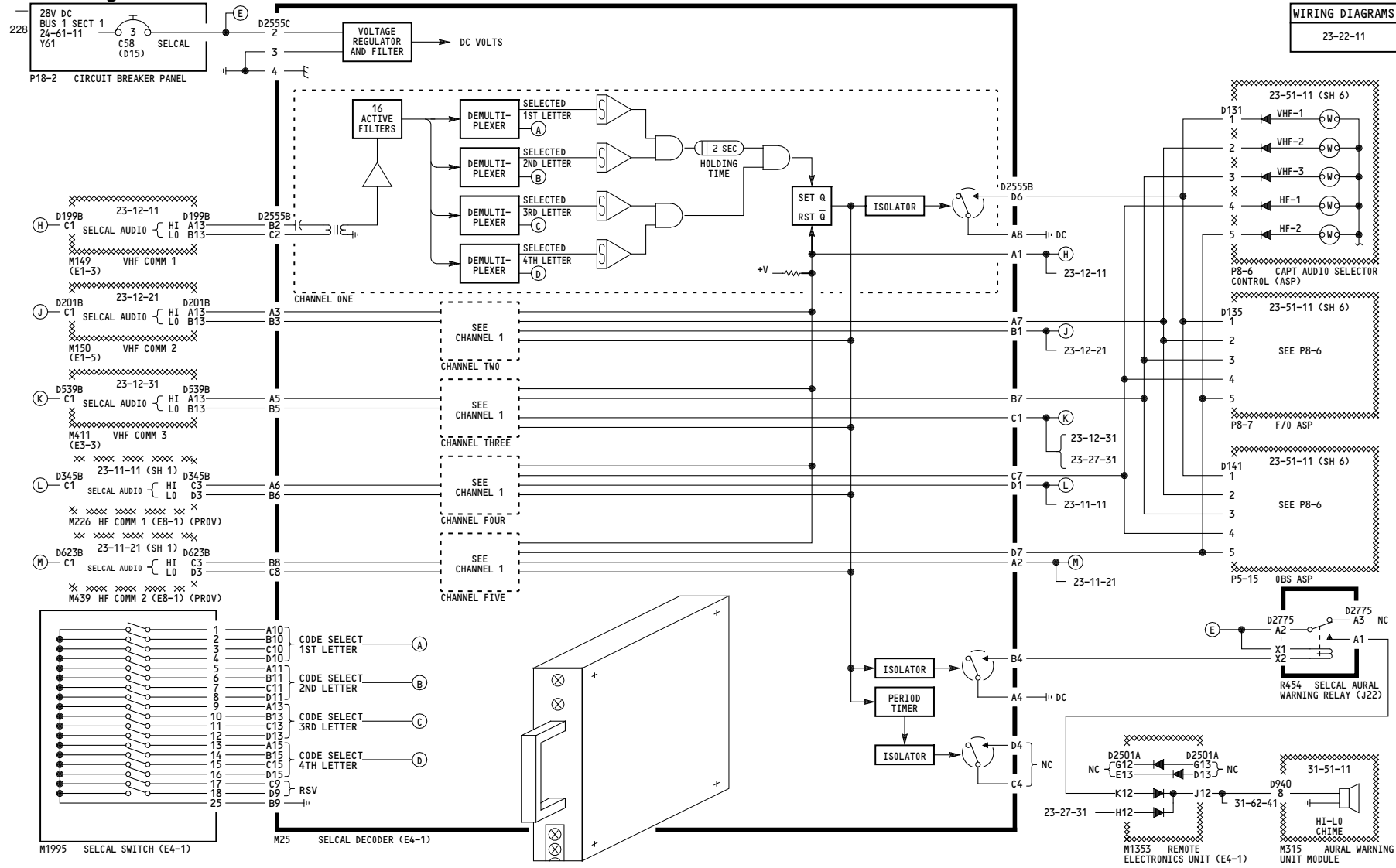

YK907-YK909, YL401	SELCAL
	D280A203

23-22-11

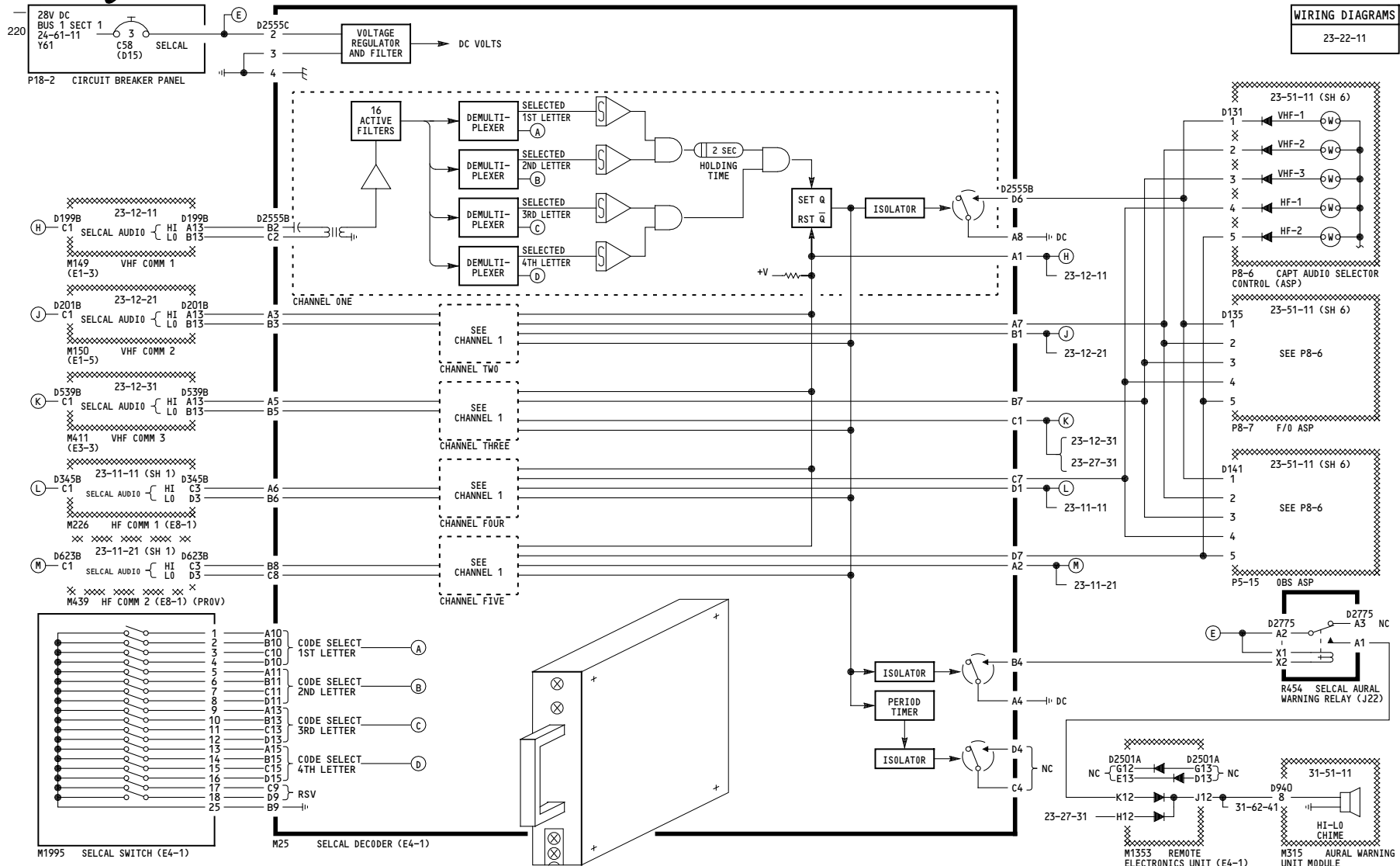

YK907-YK909

SELCAL

Incorporates 23-1299

D280A203

23-22-11

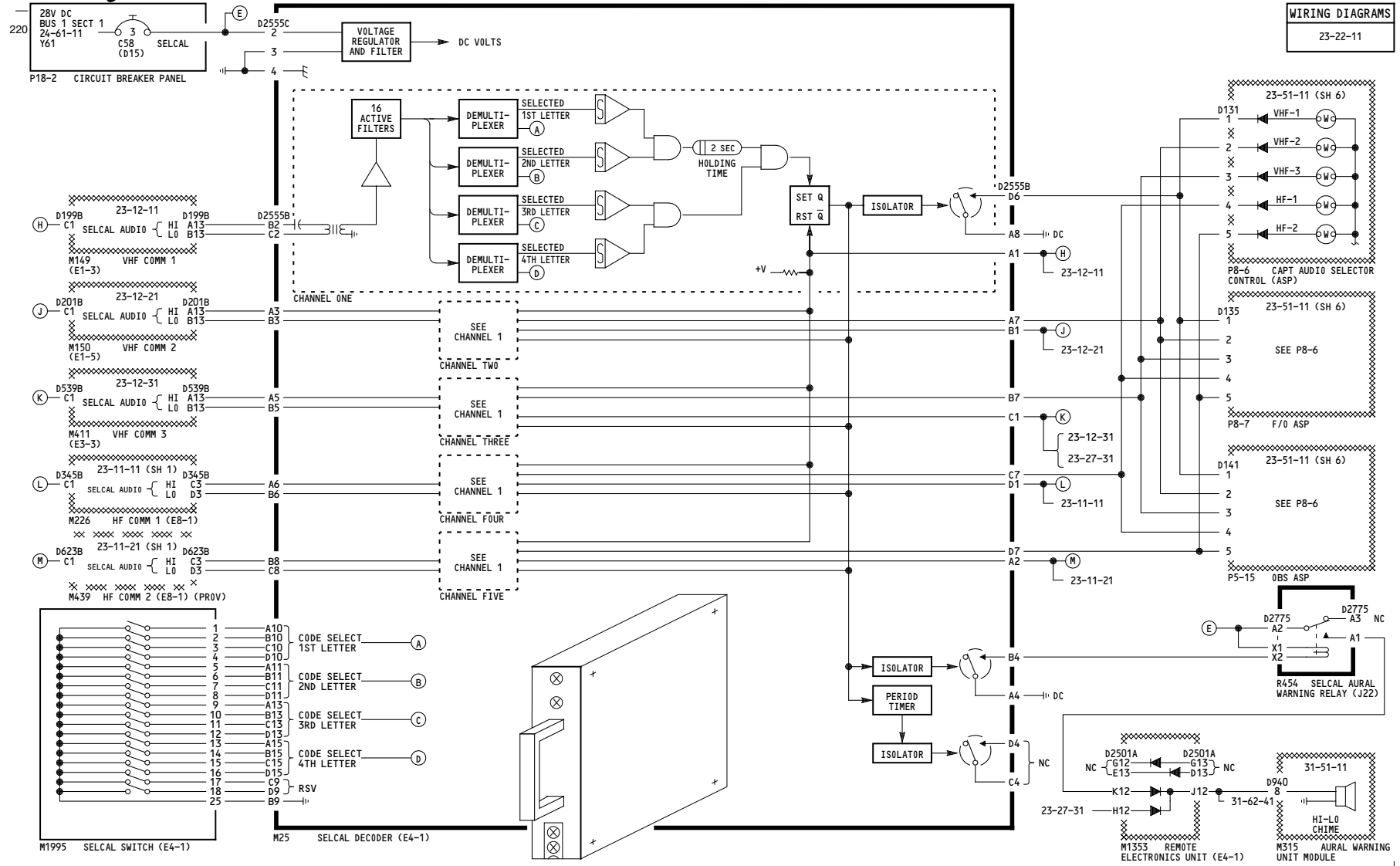

YK910-YK920, YL421-YL430	SELCAL
	D280A203

23-22-11

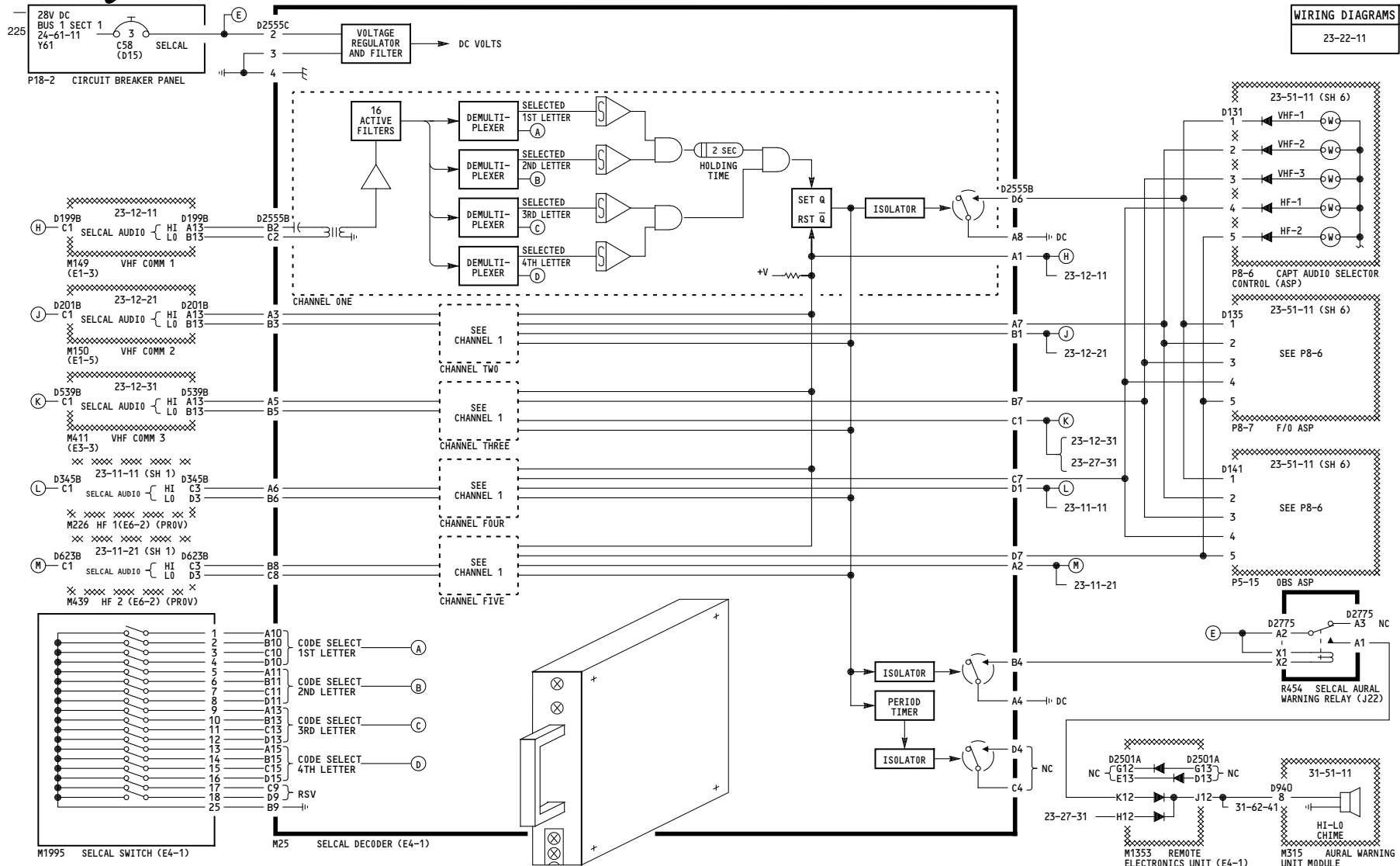

YM643-YM670	SELCAL
	D280A203

23-22-11

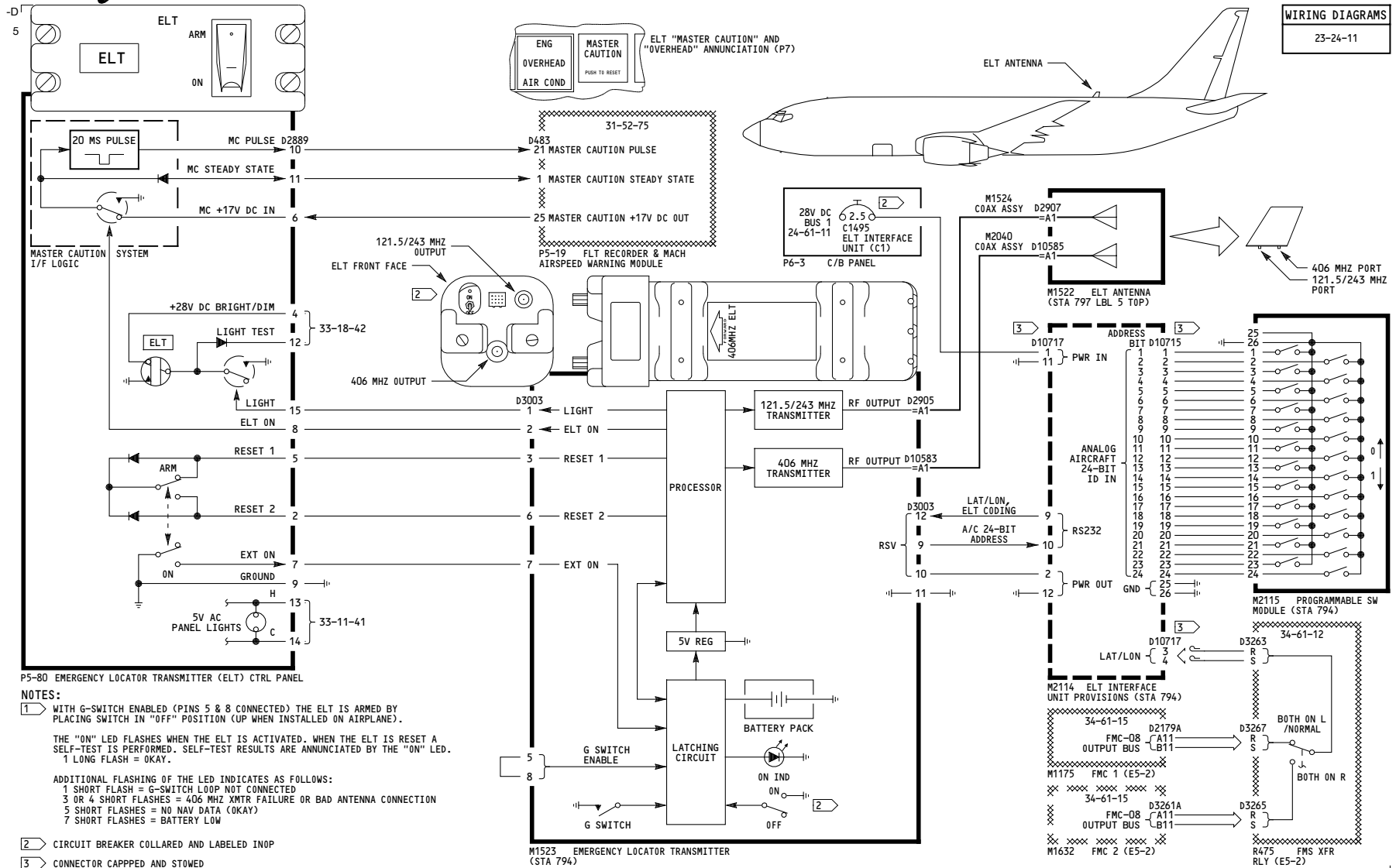

NOTES:

1 WITH G-SWITCH ENABLED (PINS 5 & 8 CONNECTED) THE ELT IS ARMED BY PLACING SWITCH IN "OFF" POSITION (UP WHEN INSTALLED ON AIRPLANE).
THE "ON" LED FLASHES WHEN THE ELT IS ACTIVATED. WHEN THE ELT IS RESET A SELF-TEST IS PERFORMED. SELF-TEST RESULTS ARE ANNUNCIATED BY THE "ON" LED.
1 LONG FLASH = OKAY.

ADDITIONAL FLASHING OF THE LED INDICATES AS FOLLOWS:
1 SHORT FLASH = G-SWITCH LOOP NOT CONNECTED
3 OR 4 SHORT FLASHES = 406 MHZ XMTR FAILURE OR BAD ANTENNA CONNECTION
5 SHORT FLASHES = NO NAV DATA (OKAY)
7 SHORT FLASHES = BATTERY LOW

2 CIRCUIT BREAKER COLLARED AND LABELED INOP
3 CONNECTOR CAPPPED AND STOWED

YC001-YC050

EMERGENCY LOCATOR TRANSMITTER (ELT)

D280A203

23-24-11

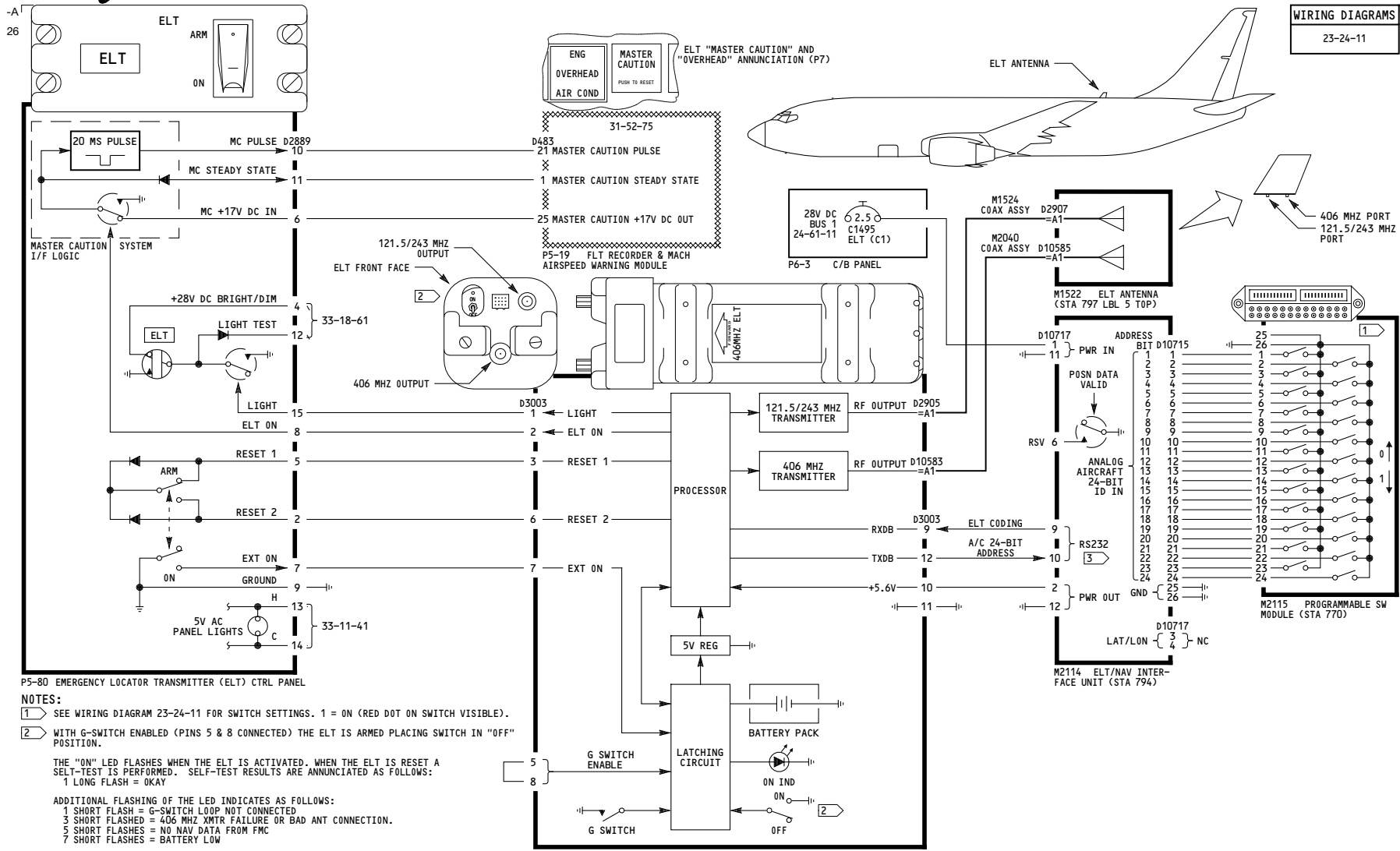

P5-80 EMERGENCY LOCATOR TRANSMITTER (ELT) CTRL PANEL

- NOTES:**
- 1 SEE WIRING DIAGRAM 23-24-11 FOR SWITCH SETTINGS. 1 = ON (RED DOT ON SWITCH VISIBLE).
 - 2 WITH G-SWITCH ENABLED (PINS 5 & 8 CONNECTED) THE ELT IS ARMED PLACING SWITCH IN "OFF" POSITION.
- THE "ON" LED FLASHES WHEN THE ELT IS ACTIVATED. WHEN THE ELT IS RESET A SELF-TEST IS PERFORMED. SELF-TEST RESULTS ARE ANNUNCIATED AS FOLLOWS:
1 LONG FLASH = OKAY
- ADDITIONAL FLASHING OF THE LED INDICATES AS FOLLOWS:
1 SHORT FLASH = G-SWITCH LOOP NOT CONNECTED
3 SHORT FLASHES = 406 MHZ XMTR FAILURE OR BAD ANT CONNECTION.
5 SHORT FLASHES = NO NAV DATA FROM FMC
7 SHORT FLASHES = BATTERY LOW
- 3 UPON PWR-UP, THE ELT I/F UNIT COMPARES THE ANALOG DISCRETE A/C 24-BIT ID INPUT TO THE ELT PROGRAMMED ADDRESS. IF THE ADDRESSES DIFFER, THE ELT I/F UNIT REPROGRAMS THE ELT.

M2123 EMERGENCY LOCATOR TRANSMITTER (STA 794 WL 301 LBL 10)

YK901-YL401, YL424-YM670

EMERGENCY LOCATOR TRANSMITTER (ELT)

D280A203

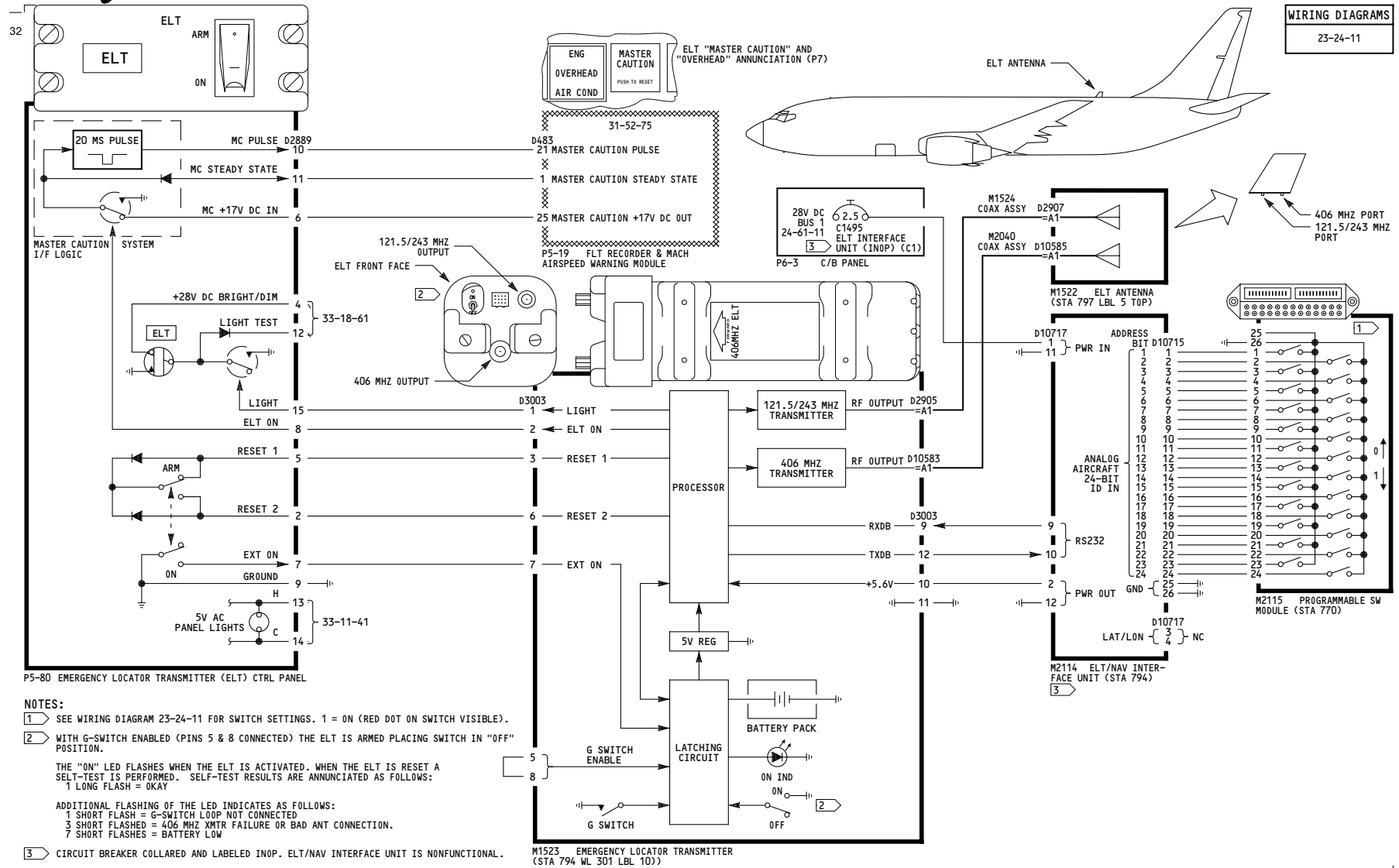

- NOTES:**
- 1 SEE WIRING DIAGRAM 23-24-11 FOR SWITCH SETTINGS. 1 = ON (RED DOT ON SWITCH VISIBLE).
 - 2 WITH G-SWITCH ENABLED (PINS 5 & 8 CONNECTED) THE ELT IS ARMED PLACING SWITCH IN "OFF" POSITION.
- THE "ON" LED FLASHES WHEN THE ELT IS ACTIVATED. WHEN THE ELT IS RESET A SELF-TEST IS PERFORMED. SELF-TEST RESULTS ARE ANNUNCIATED AS FOLLOWS:
1 LONG FLASH = OKAY
- ADDITIONAL FLASHING OF THE LED INDICATES AS FOLLOWS:
1 SHORT FLASH = G-SWITCH LOOP NOT CONNECTED
3 SHORT FLASHES = 406 MHZ XMTR FAILURE OR BAD ANT CONNECTION.
7 SHORT FLASHES = BATTERY LOW
- 3 CIRCUIT BREAKER COLLARED AND LABELED INOP. ELT/NAV INTERFACE UNIT IS NONFUNCTIONAL.

M1523 EMERGENCY LOCATOR TRANSMITTER (STA 794 WL 301 LBL 10)

YL421-YL423	EMERGENCY LOCATOR TRANSMITTER (ELT)
D280A203	

WIRING DIAGRAMS
23-27-11

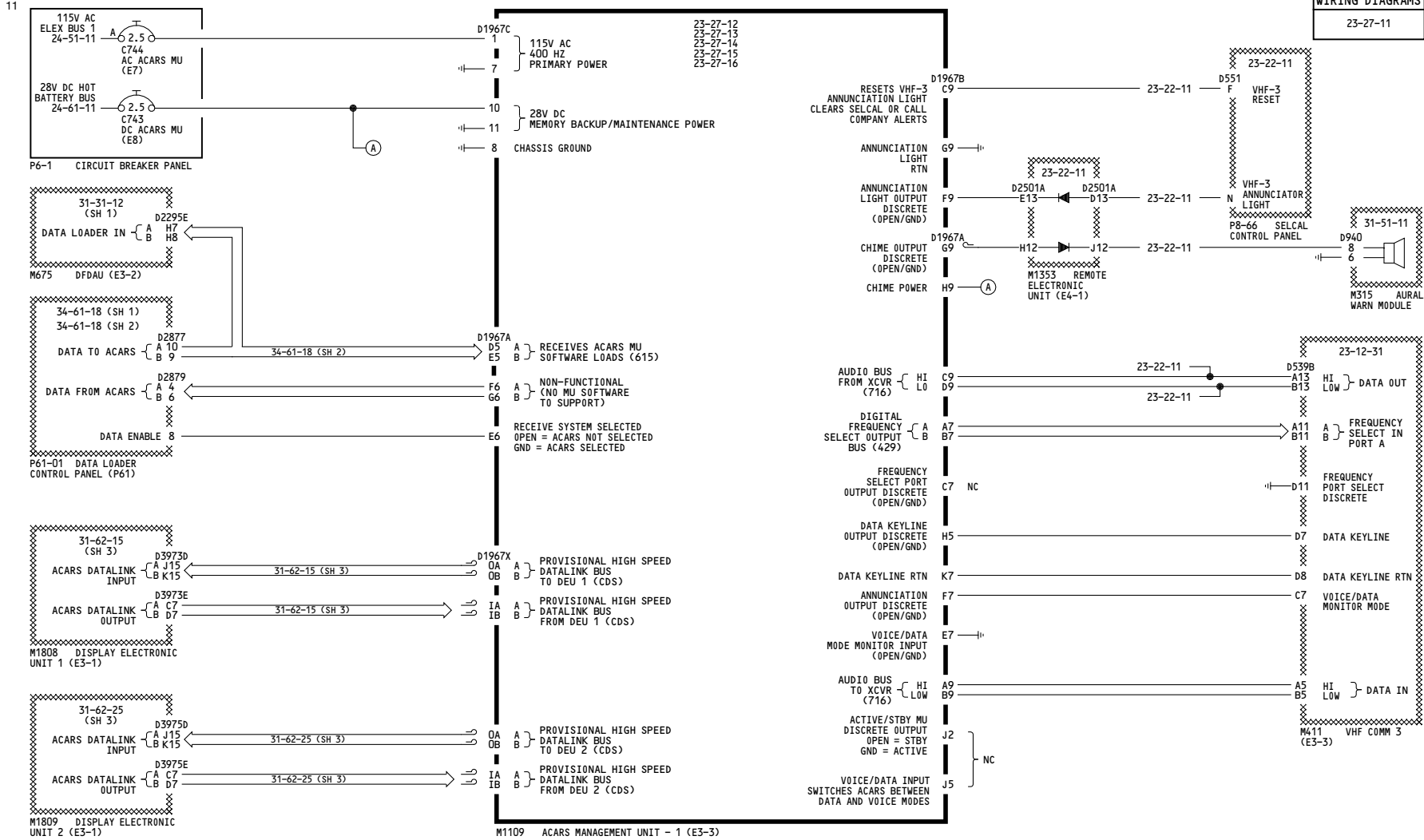

YC001-YC011

ACARS (724B) POWER, COMM AND ANNUNCIATION INTERFACES

D280A203

23-27-11

113

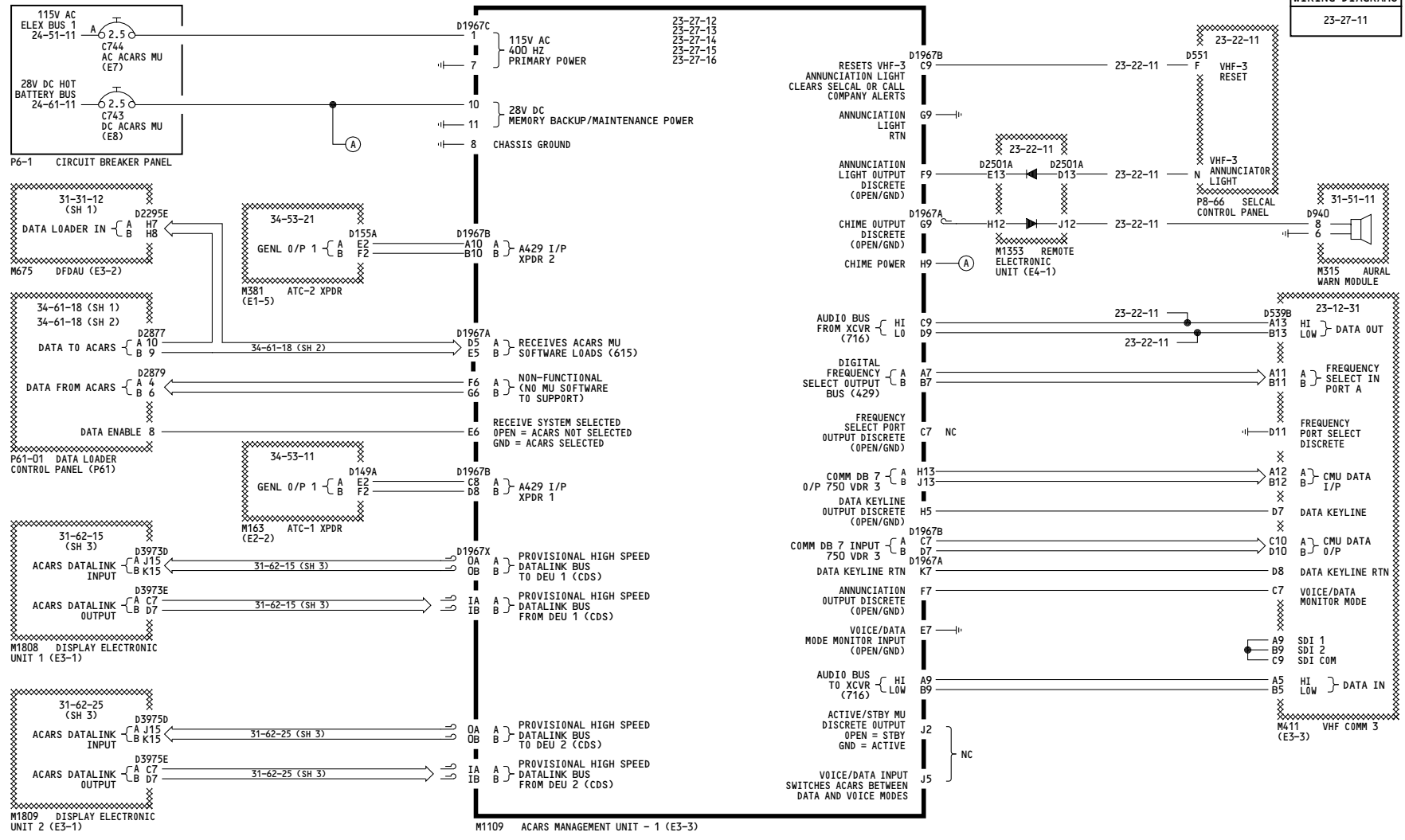

YC001-YC011

ACARS (724B) POWER, COMM AND ANNUNCIATION INTERFACES

D280A203

Incorporates
EO 23-80059-6

23-27-11

Page 101A

Oct 15/2007

WIRING DIAGRAMS
23-27-11

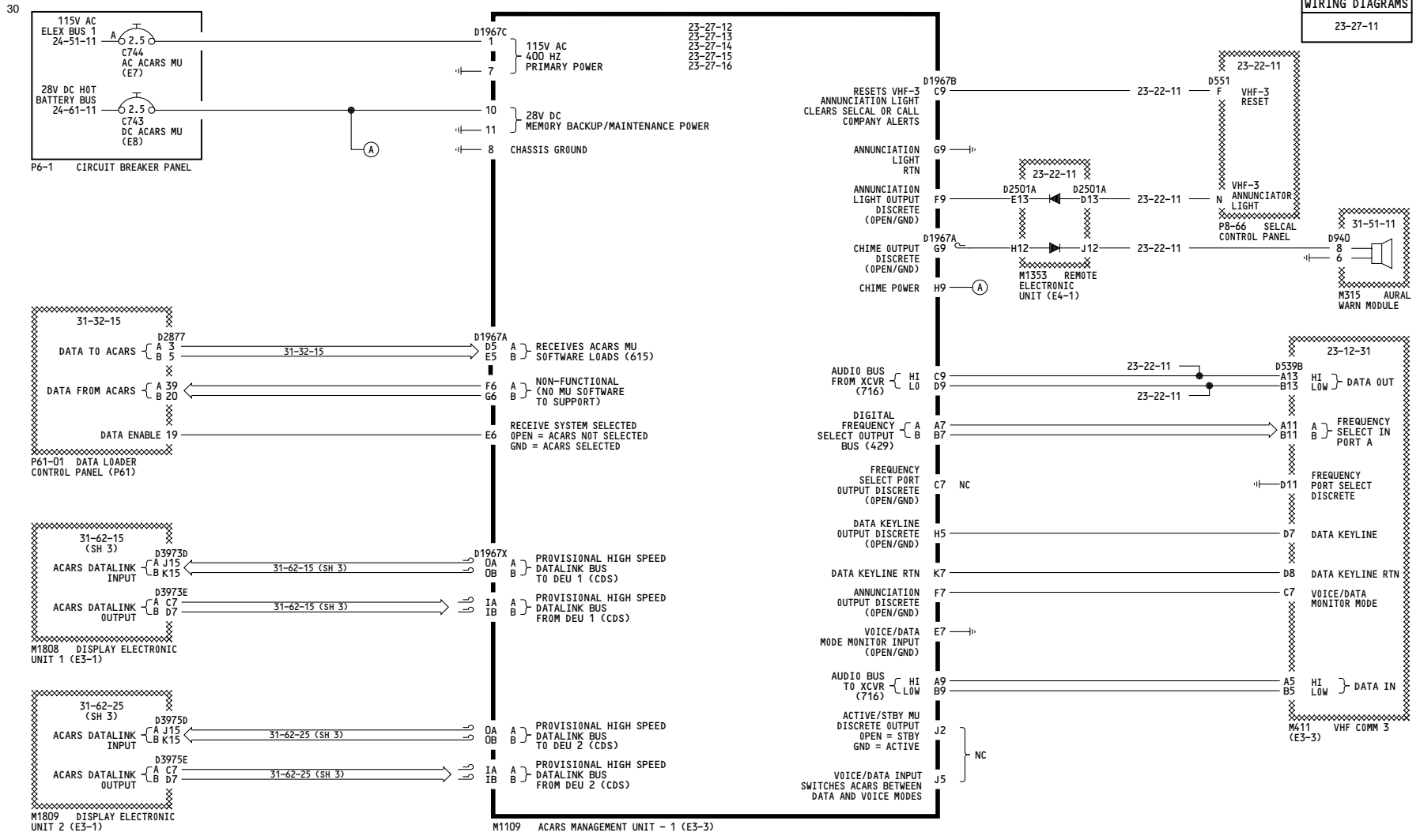

YC012-YC050

ACARS (724B) POWER, COMM AND ANNUNCIATION INTERFACES

D280A203

23-27-11

WIRING DIAGRAMS
23-27-11

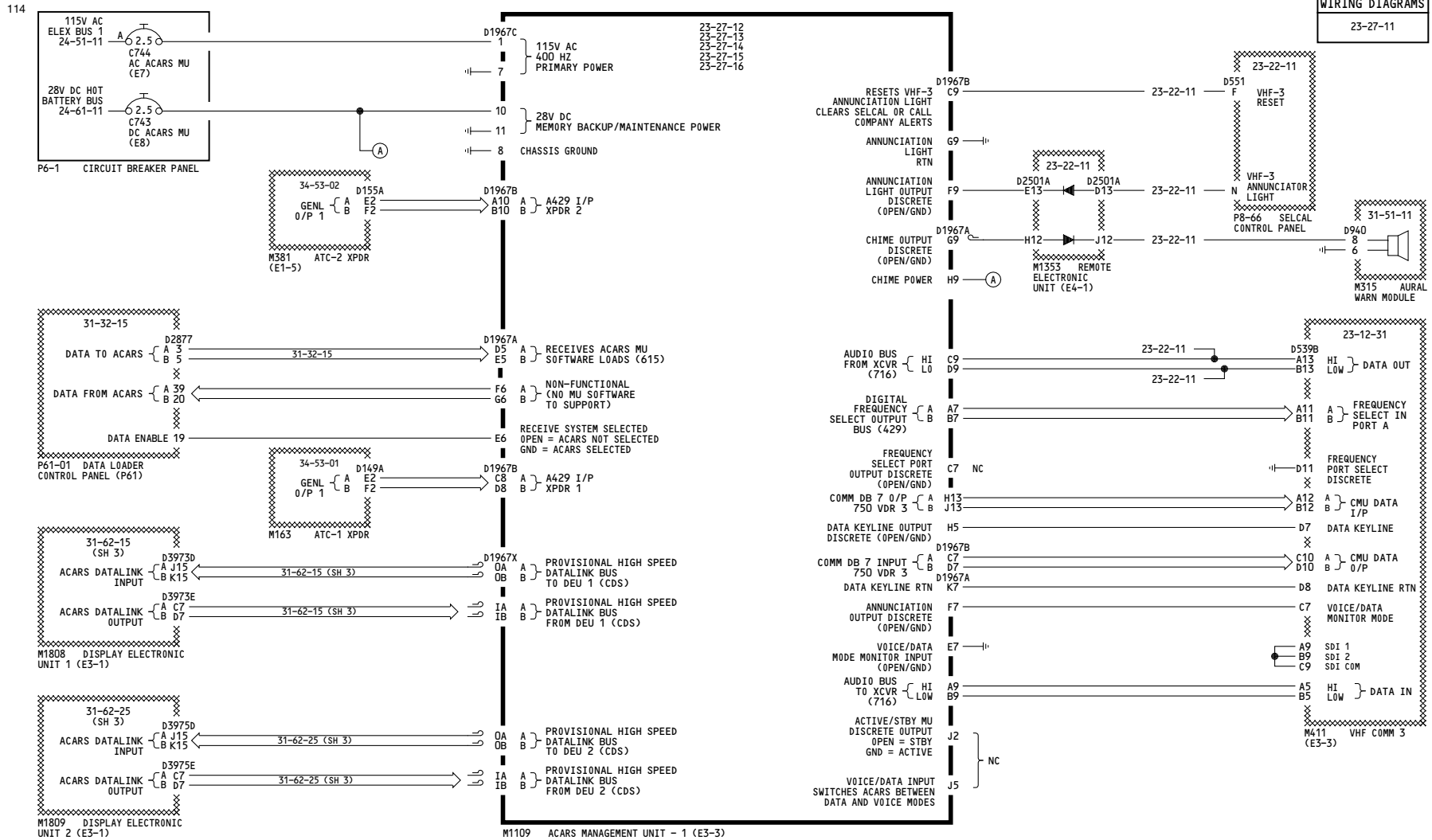

YC012-YC030

ACARS (724B) POWER, COMM AND ANNUNCIATION INTERFACES

D280A203

Incorporates
EO 23-80059-6

23-27-11

Page 102A

Oct 15/2007

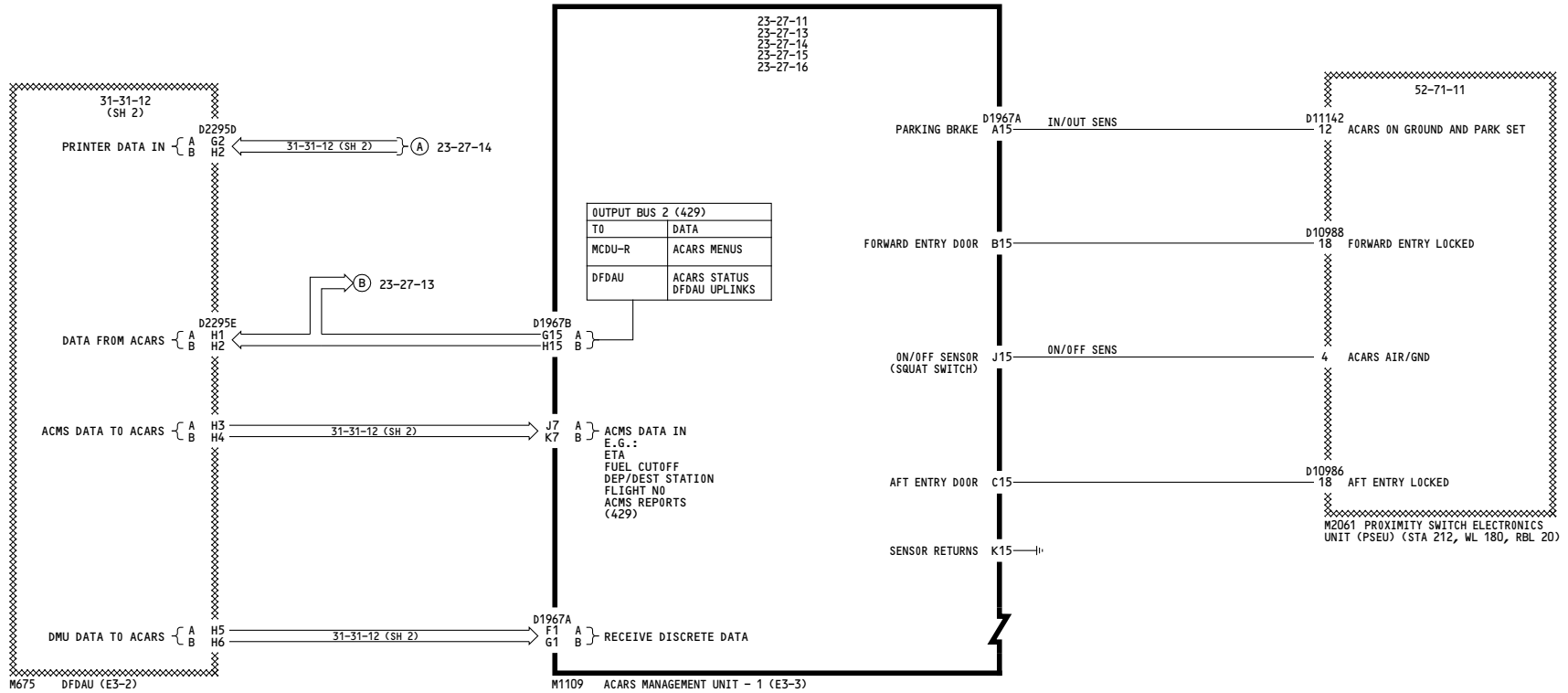

YC001-YC050	ACARS (724B) - DFD AU AND OOOI INTERFACES
	D280A203

-B
5

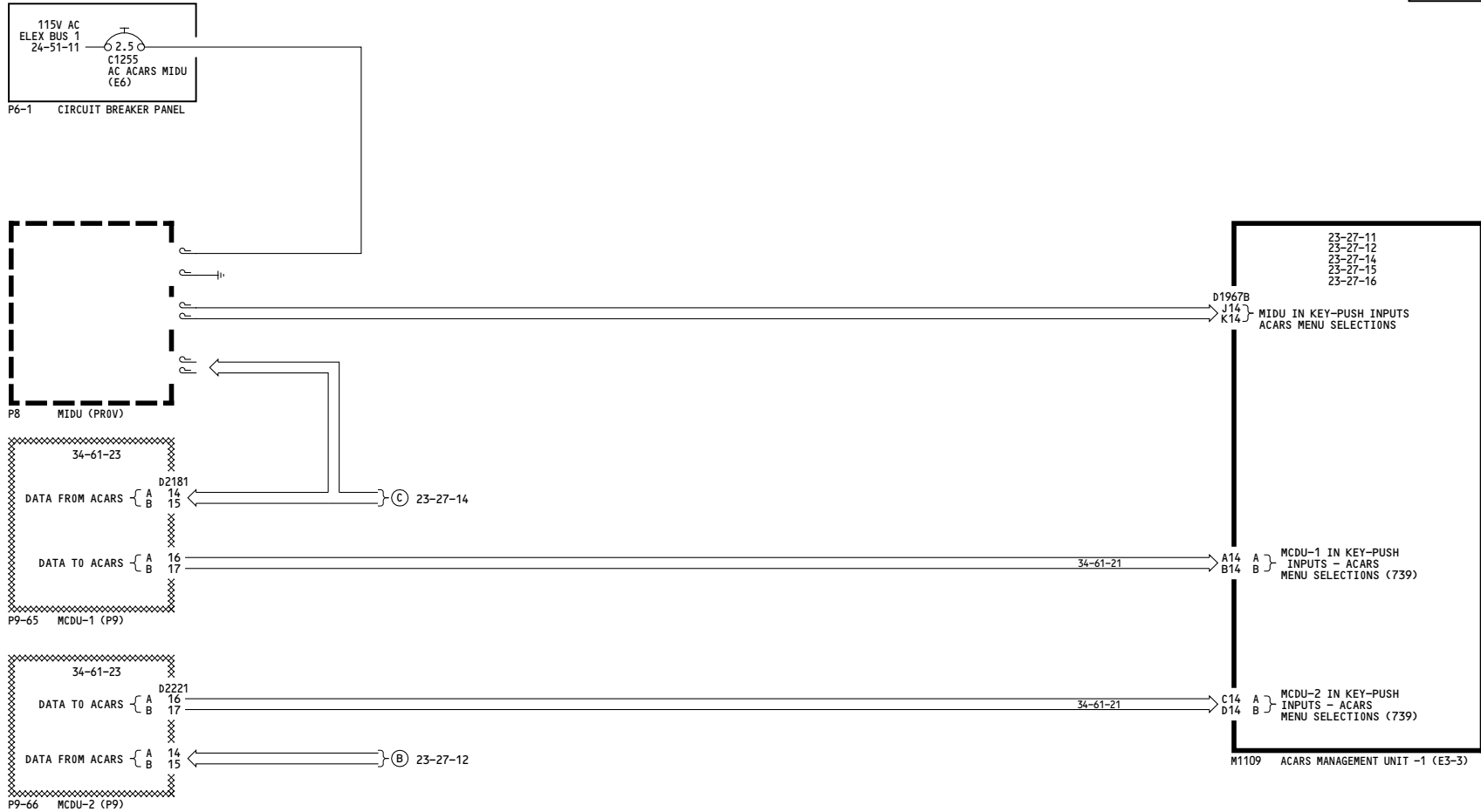

YC001-YC050	<p align="center">ACARS (724B) CONTROL AND DISPLAY</p> <p align="center">D280A203</p>
-------------	--

23-27-13

Page 101

Jul 17/2007

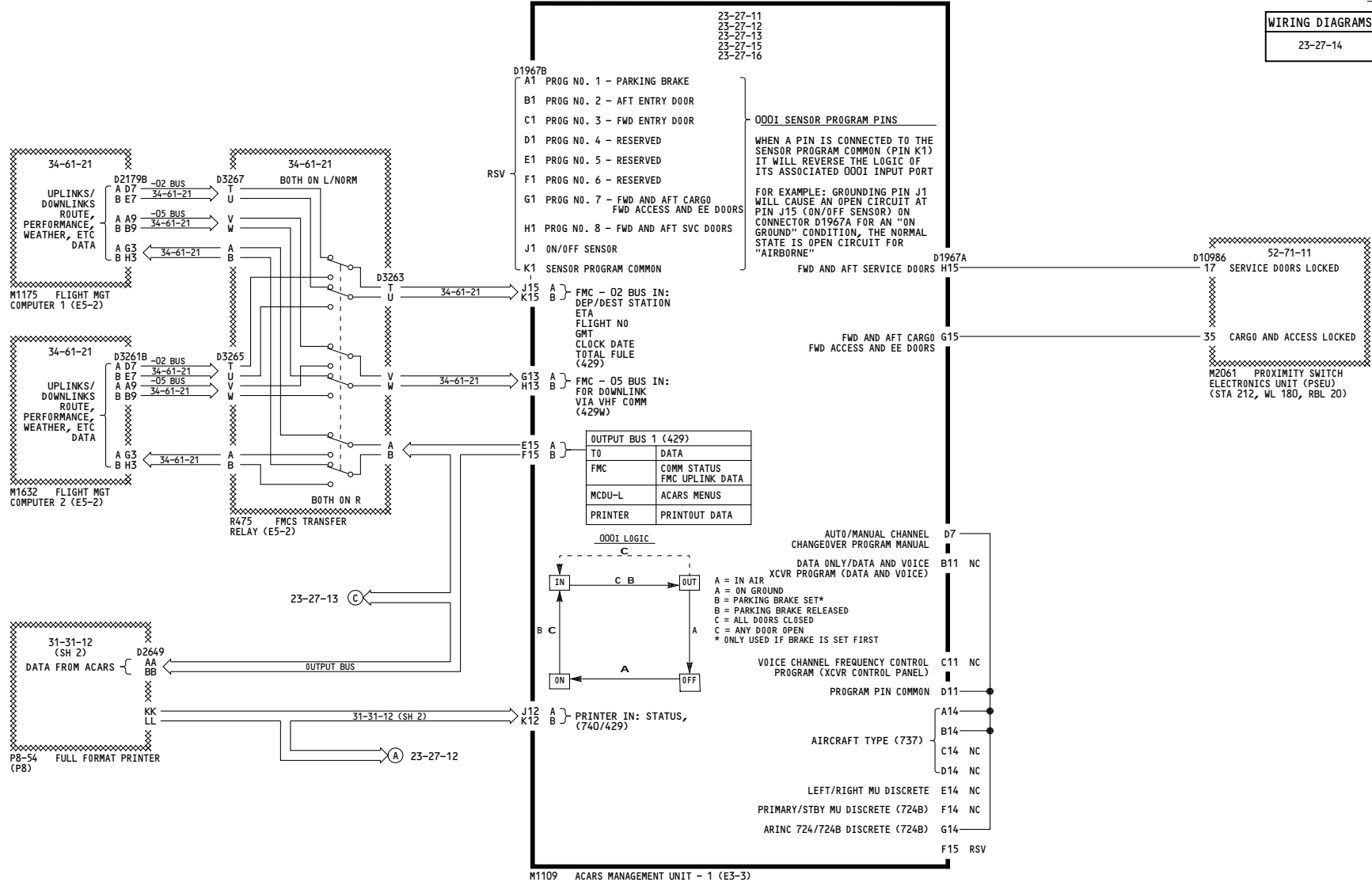

YC001-YC050

ACARS (724B) FMC, PRINTER AND DISCRETE INTERFACES

D280A203

23-27-14

1

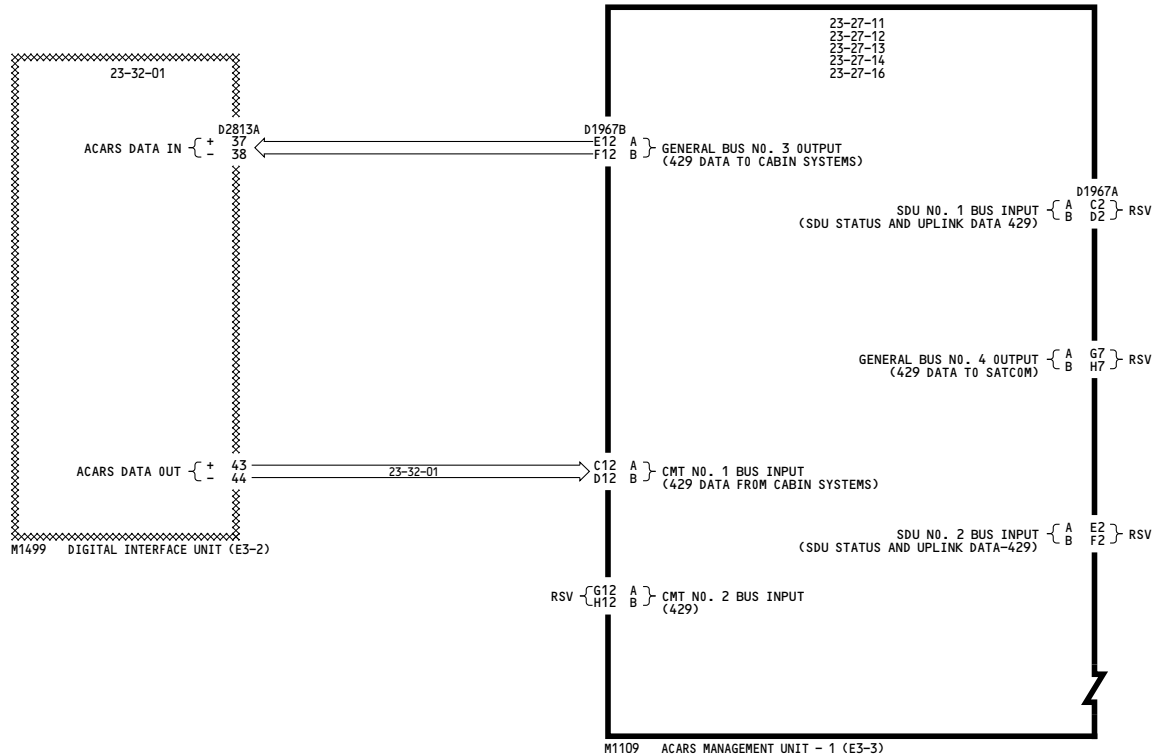

YC001-YC050	<p align="center">ACARS (724B) SATCOM AND AIRSHOW INTERFACES</p> <p align="center">D280A203</p>
-------------	--

23-27-15

Page 101

Jul 17/2007

-K
2

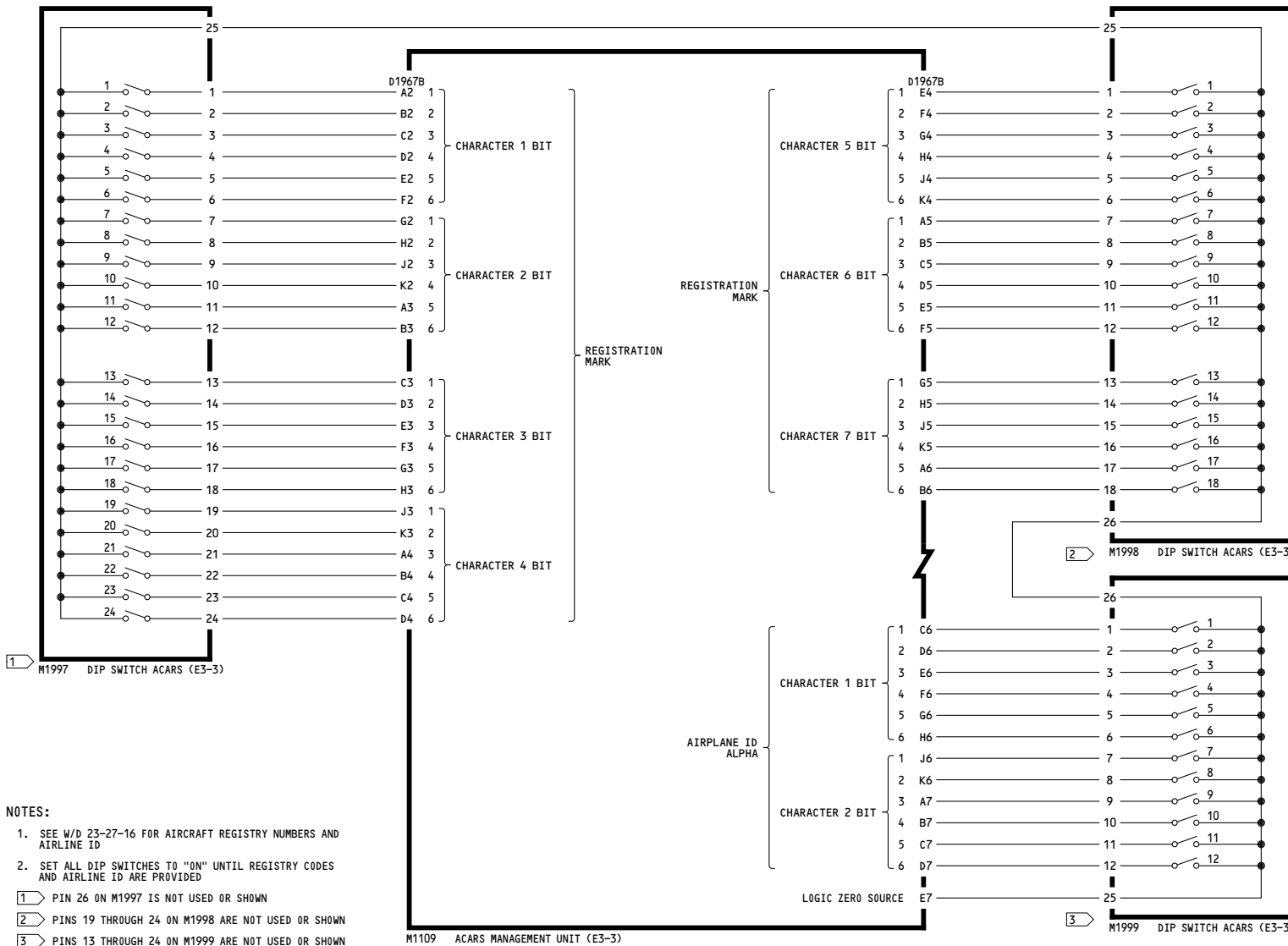

NOTES:

1. SEE W/D 23-27-16 FOR AIRCRAFT REGISTRY NUMBERS AND AIRLINE ID
 2. SET ALL DIP SWITCHES TO "ON" UNTIL REGISTRY CODES AND AIRLINE ID ARE PROVIDED
- 1 → PIN 26 ON M1997 IS NOT USED OR SHOWN
 2 → PINS 19 THROUGH 24 ON M1998 ARE NOT USED OR SHOWN
 3 → PINS 13 THROUGH 24 ON M1999 ARE NOT USED OR SHOWN

YC001-YC050	ACARS (724B) REGISTRY AND AIRLINE ID CODING
D280A203	

23-27-16

Page 101

Jul 17/2007

13

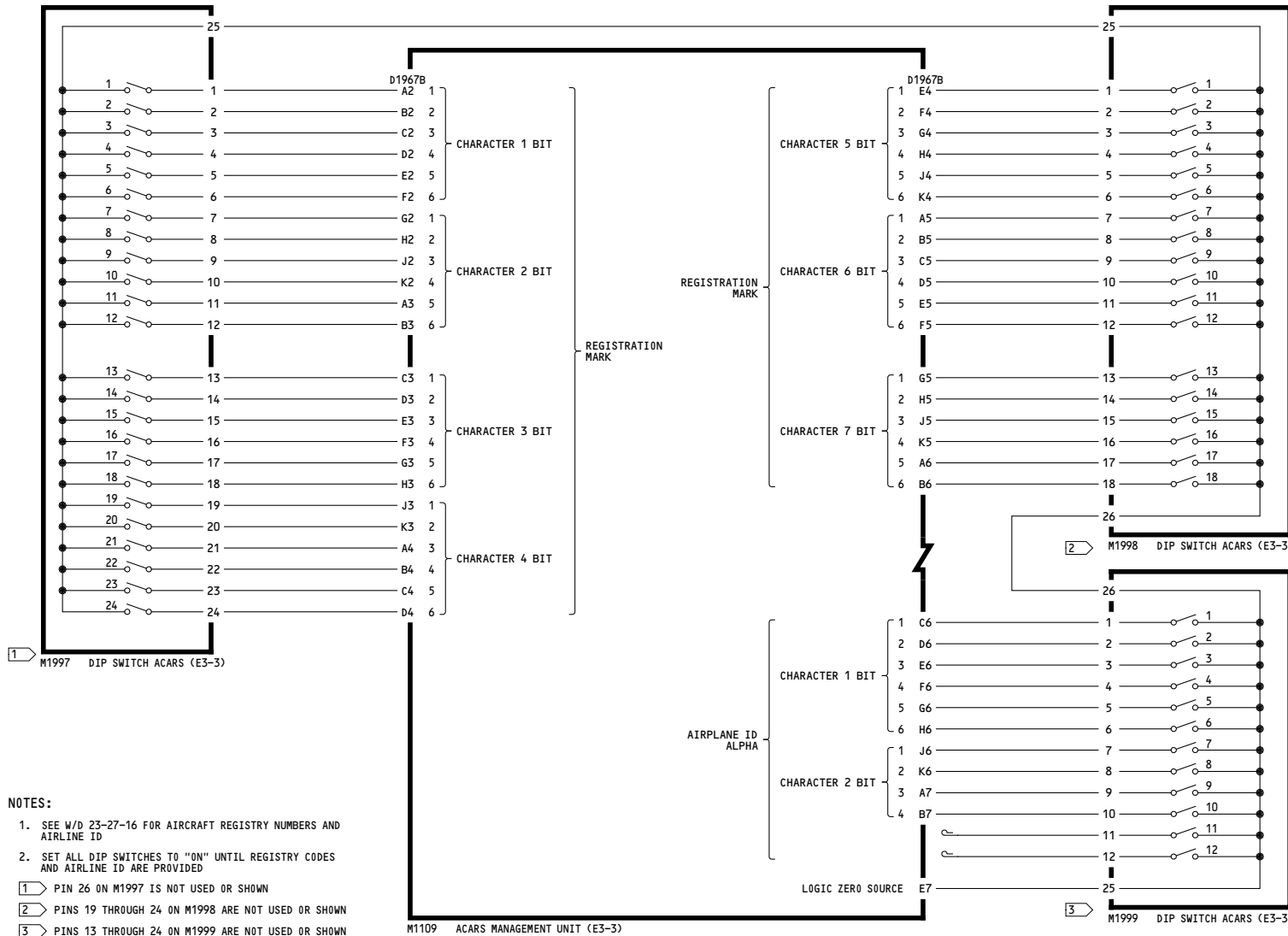

NOTES:

- SEE W/D 23-27-16 FOR AIRCRAFT REGISTRY NUMBERS AND AIRLINE ID
 - SET ALL DIP SWITCHES TO "ON" UNTIL REGISTRY CODES AND AIRLINE ID ARE PROVIDED
- 1 PIN 26 ON M1997 IS NOT USED OR SHOWN
- 2 PINS 19 THROUGH 24 ON M1998 ARE NOT USED OR SHOWN
- 3 PINS 13 THROUGH 24 ON M1999 ARE NOT USED OR SHOWN

YC001-YC030

ACARS (724B) REGISTRY AND AIRLINE ID CODING

Incorporates
EO 23-80059-6

D280A203

23-27-16

Page 101A

Oct 15/2007

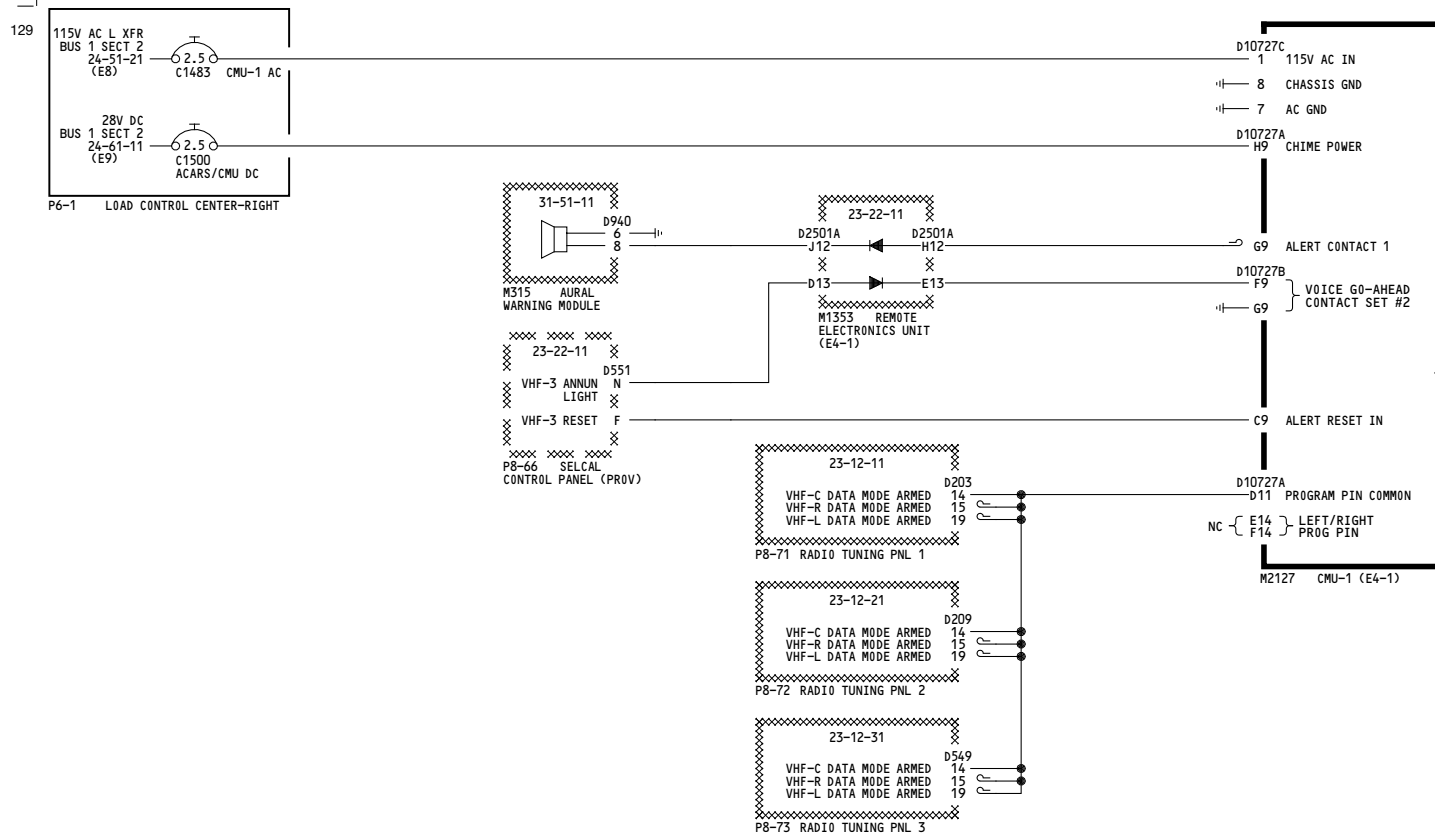

NOTES:
1. ALL GROUNDS = NON-CRITICAL

YK901-YK906	<p align="center">ACARS/CMU - POWER & CONTROL</p> <p align="center">D280A203</p>
-------------	---

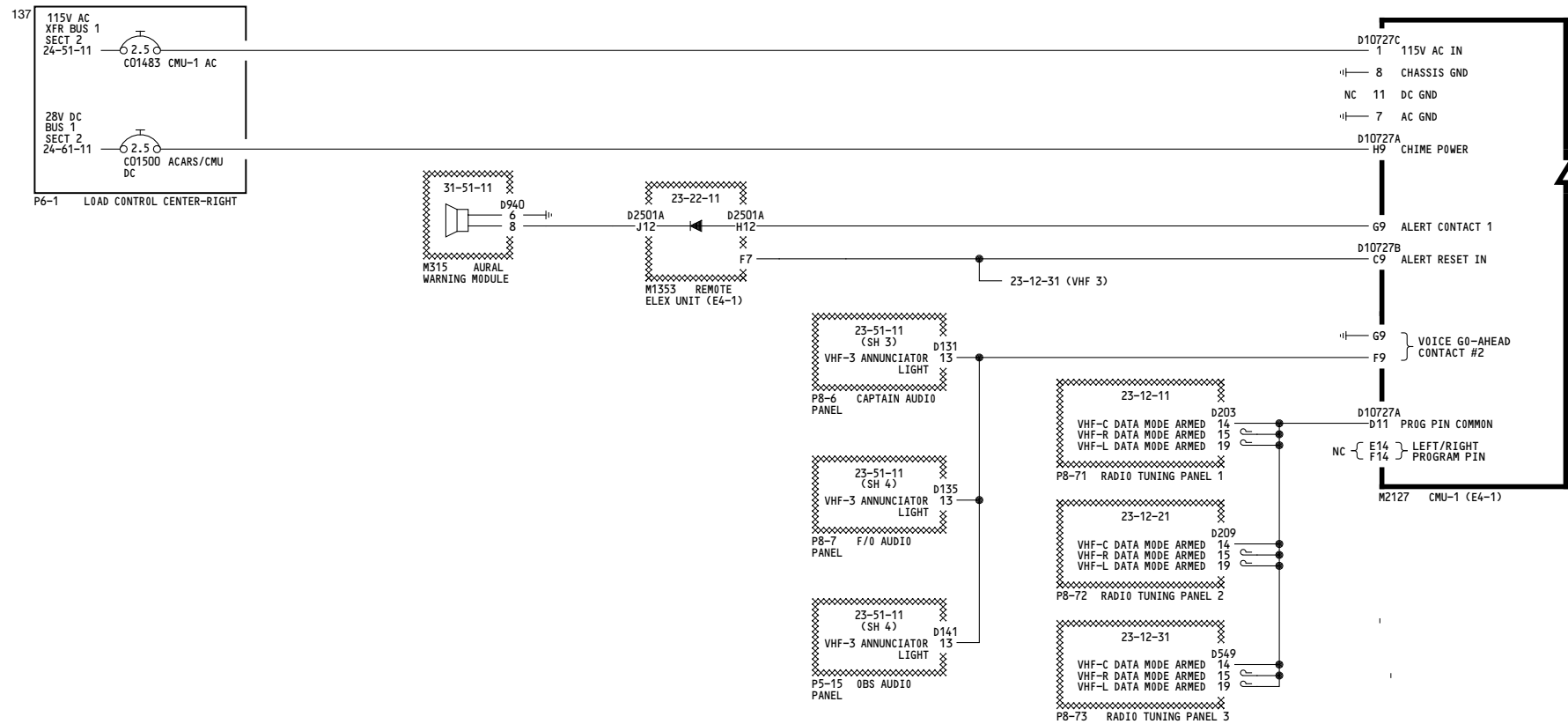

YK907-YL430	<p>ACARS/CMU - POWER & CONTROL</p> <p>D280A203</p>
-------------	---

23-27-31

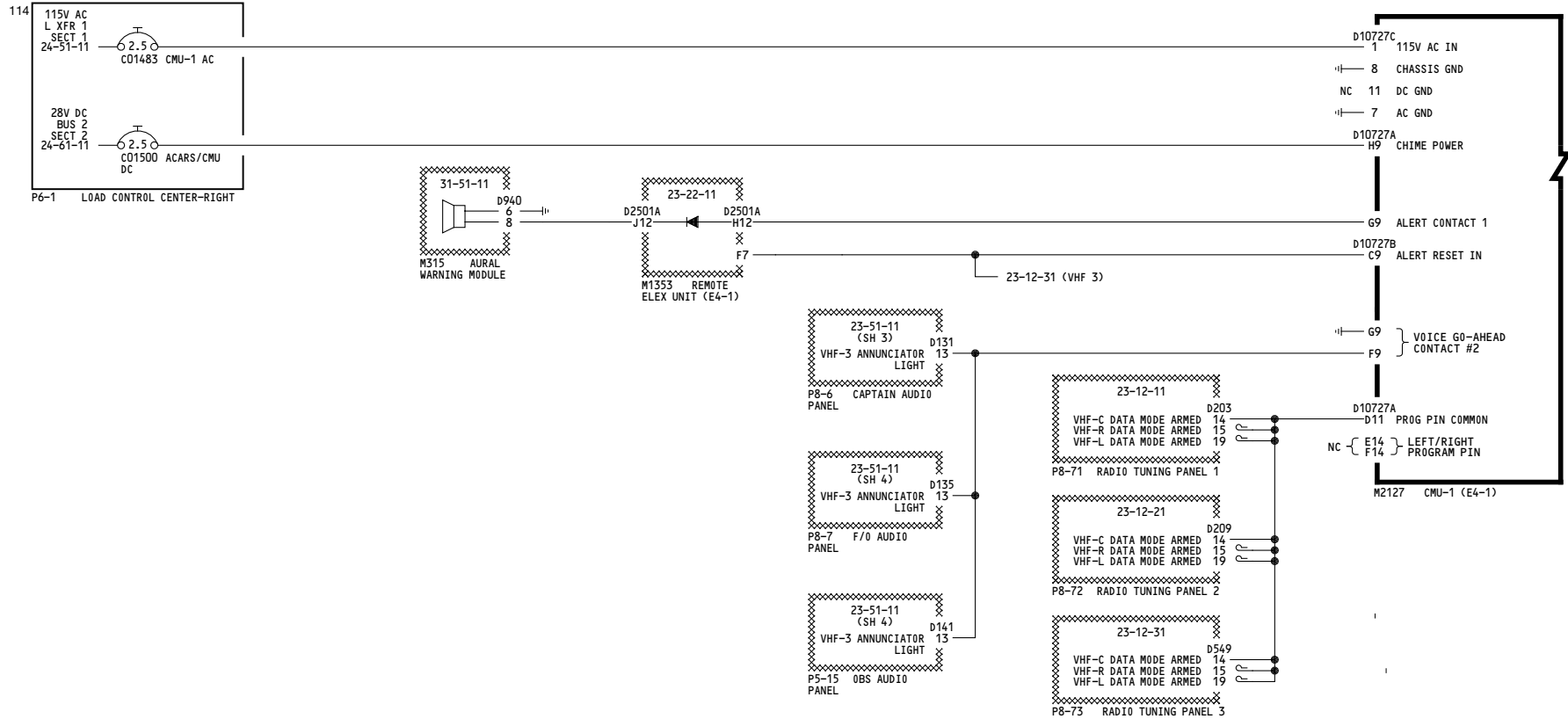

YM643-YM670

**ACARS/CMU -
POWER & CONTROL**

D280A203

23-27-31

Page 103

Feb 12/2008

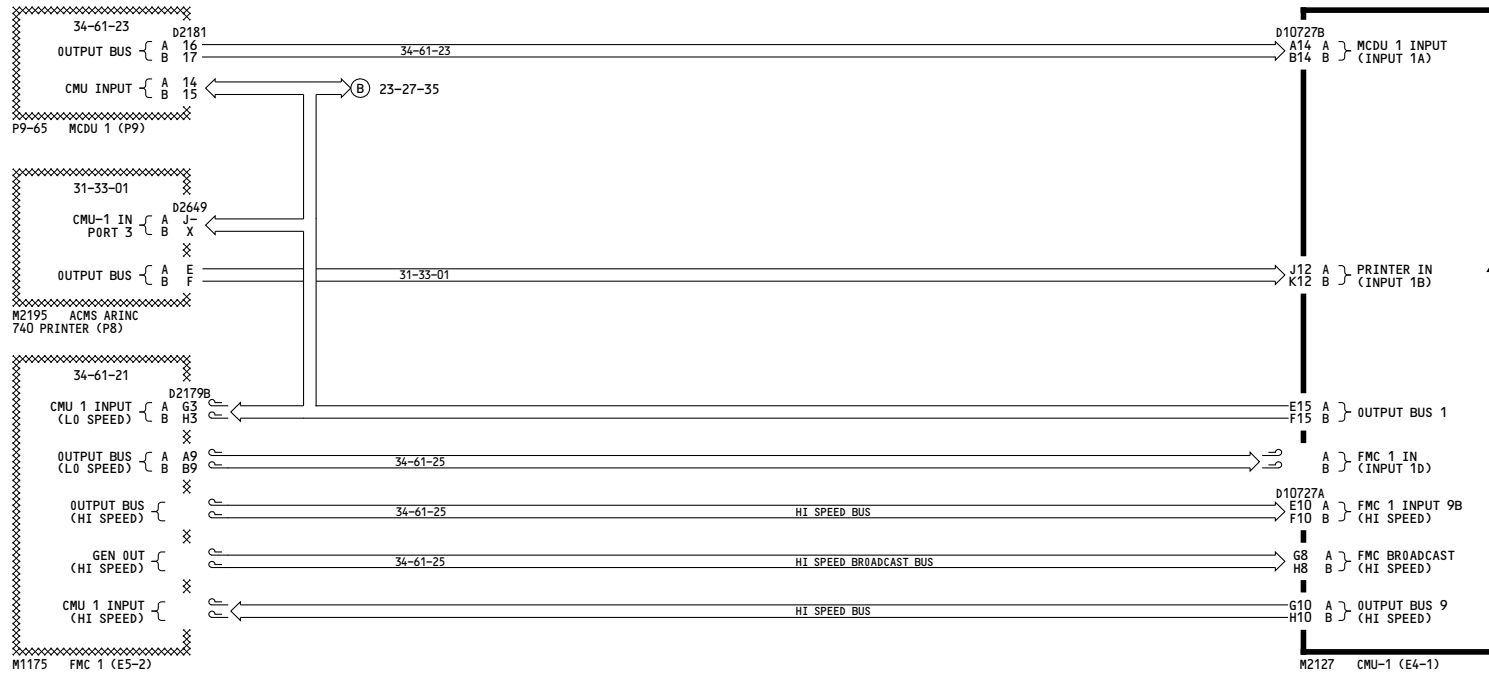

YK901-YK906	<p align="center">ACARS/CMU - OUTPUT BUS 1 INTERFACES</p> <p align="center">D280A203</p>
-------------	---

23-27-32

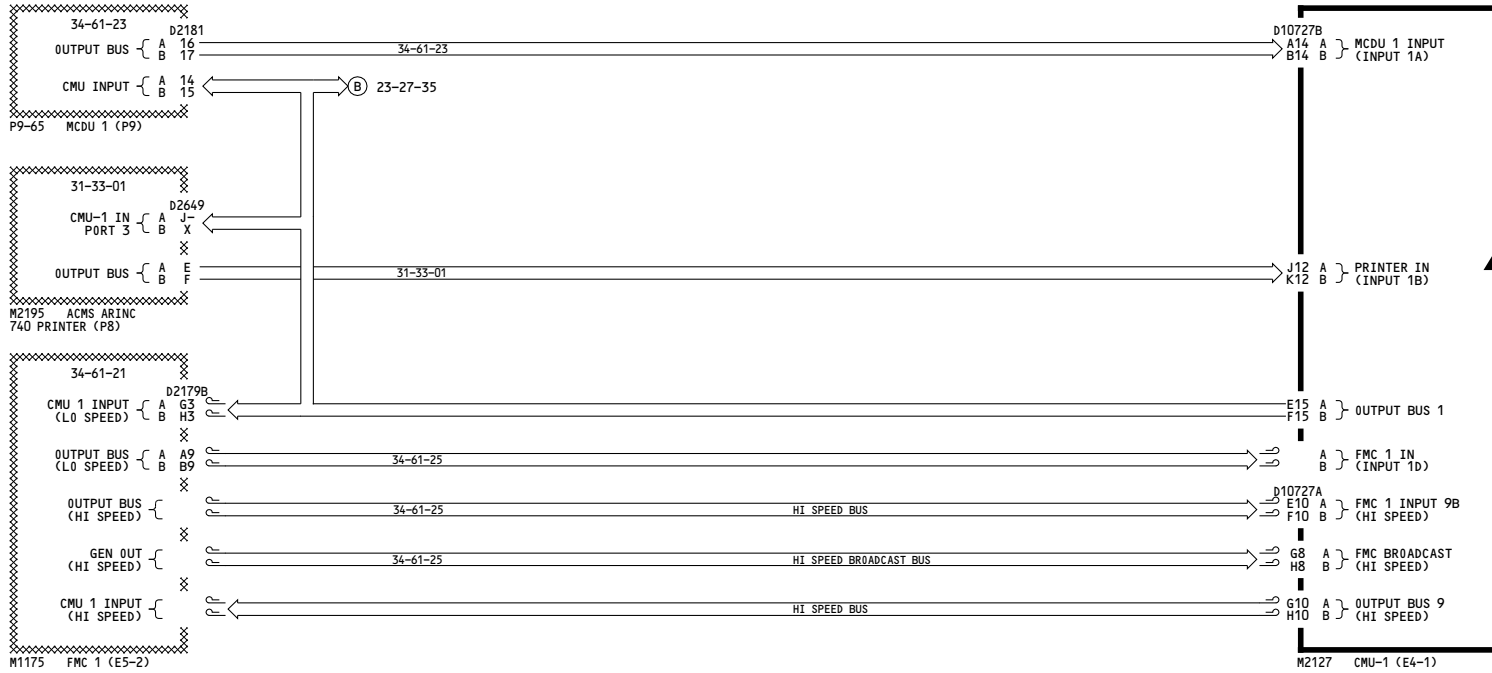

YK907-YM670	<p align="center">ACARS/CMU - OUTPUT BUS 1 INTERFACES</p> <p align="center">D280A203</p>
-------------	---

78

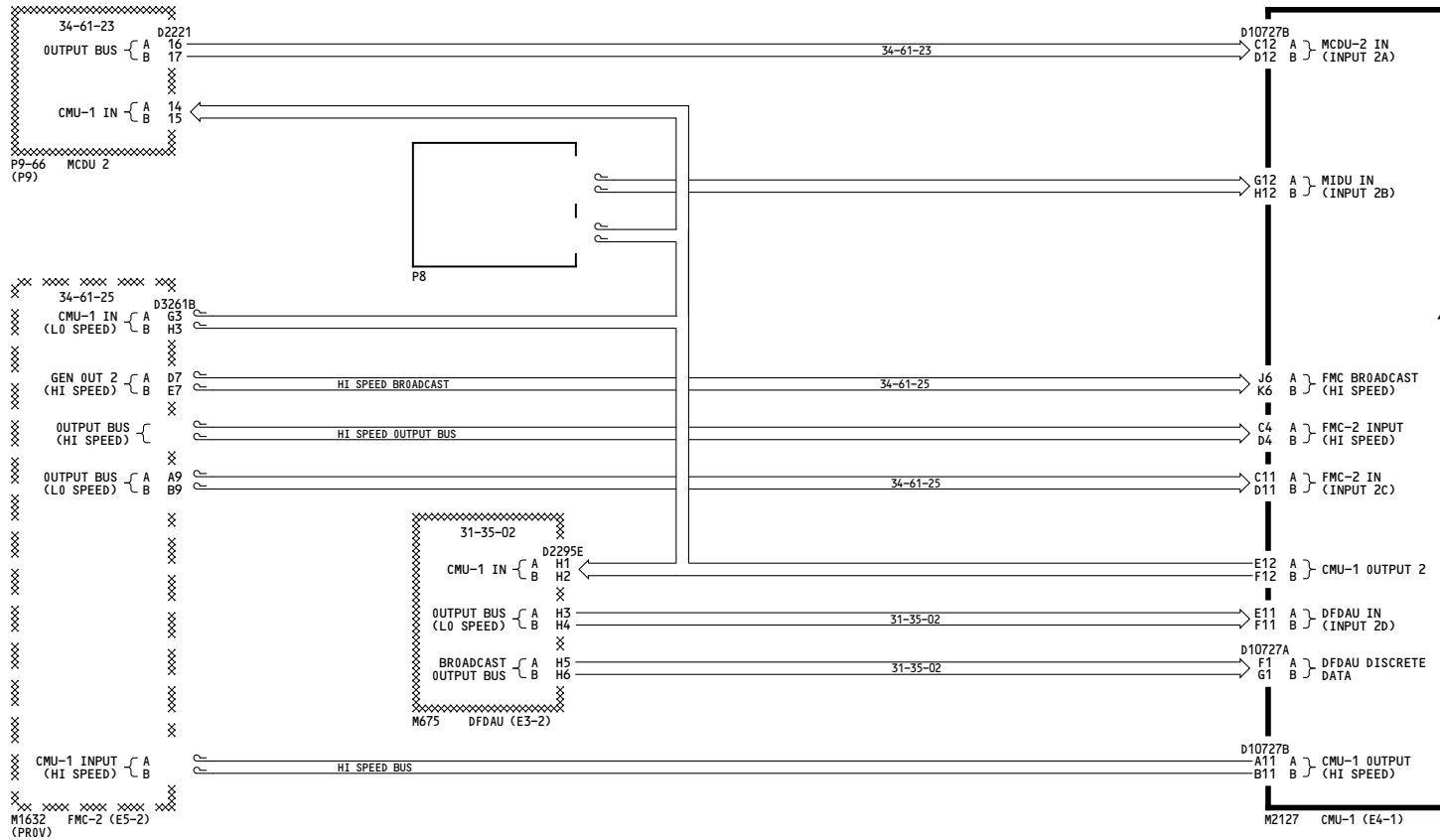

YK901-YK906	<p>ACARS/CMU - OUTPUT BUS 2 INTERFACES</p> <p>D280A203</p>
-------------	---

23-27-33

Page 101

Oct 20/2006

-A

94

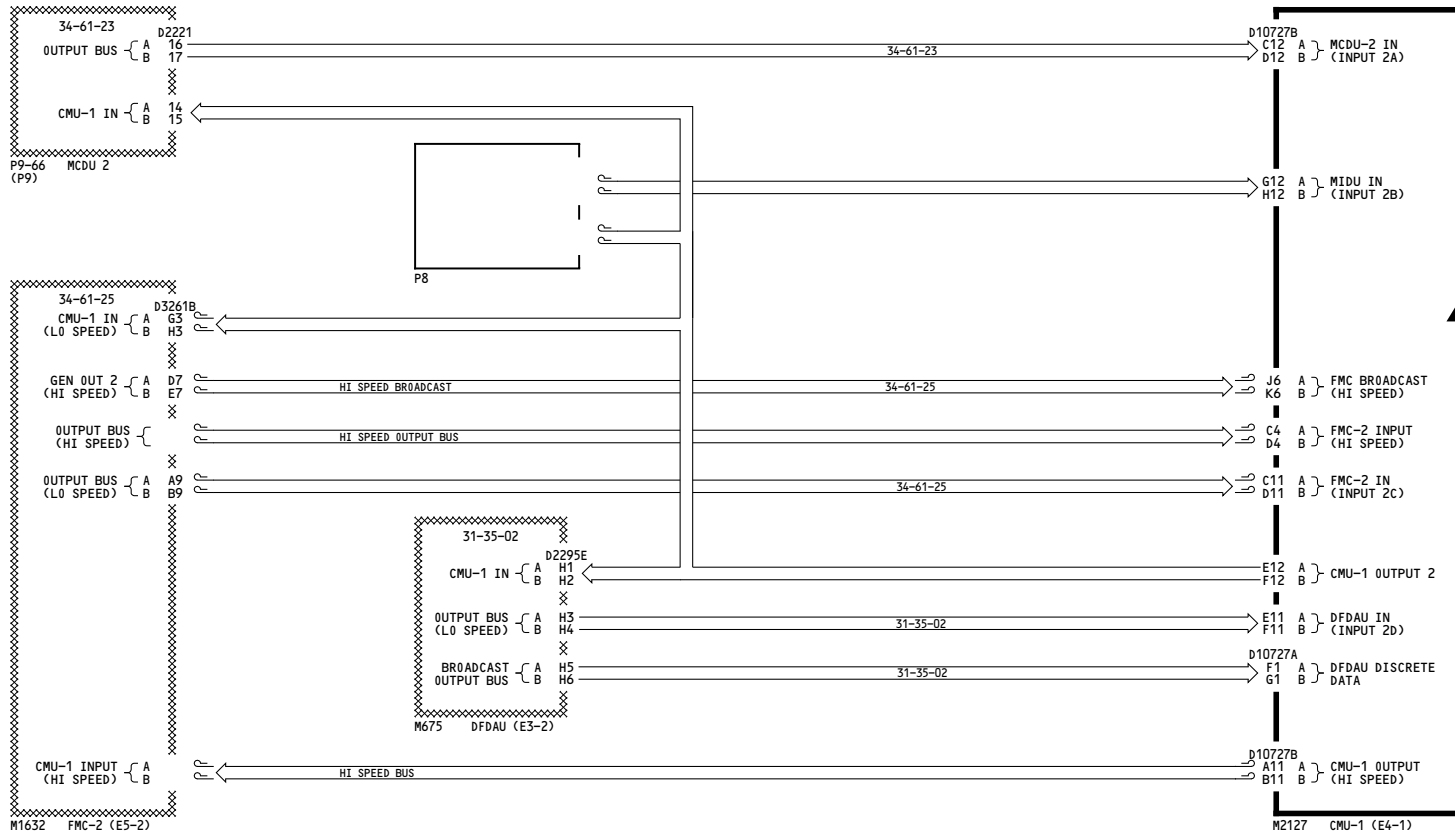

<p>YK907-YK920, YL421-YM670</p>	<p>ACARS/CMU - OUTPUT BUS 2 INTERFACES</p> <p>D280A203</p>
---------------------------------	---

23-27-33

Page 102

Feb 09/2009

114

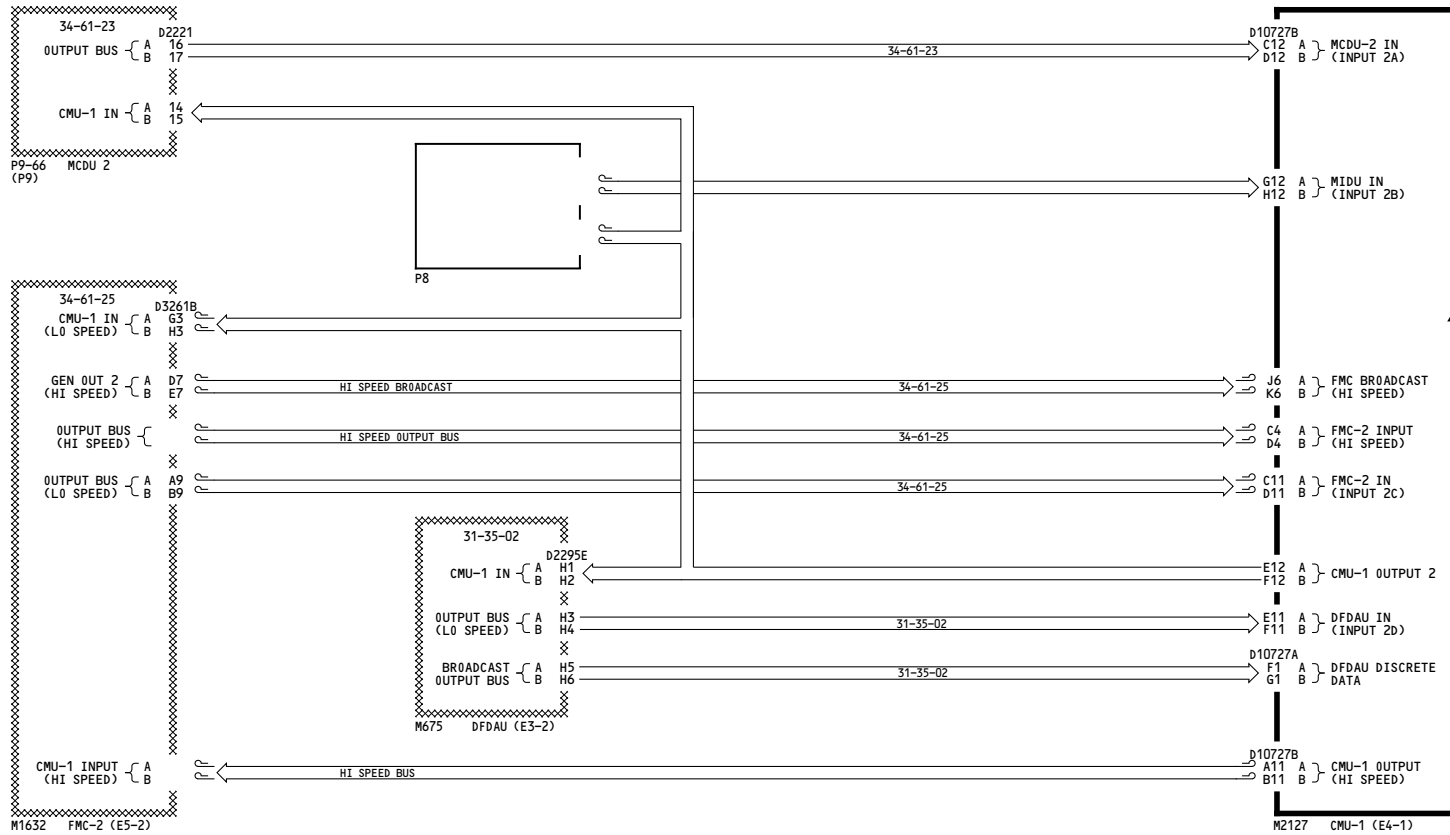

YL401	<p align="center">ACARS/CMU - OUTPUT BUS 2 INTERFACES</p> <p align="center">D280A203</p>
-------	---

23-27-33

Page 103

Aug 13/2008

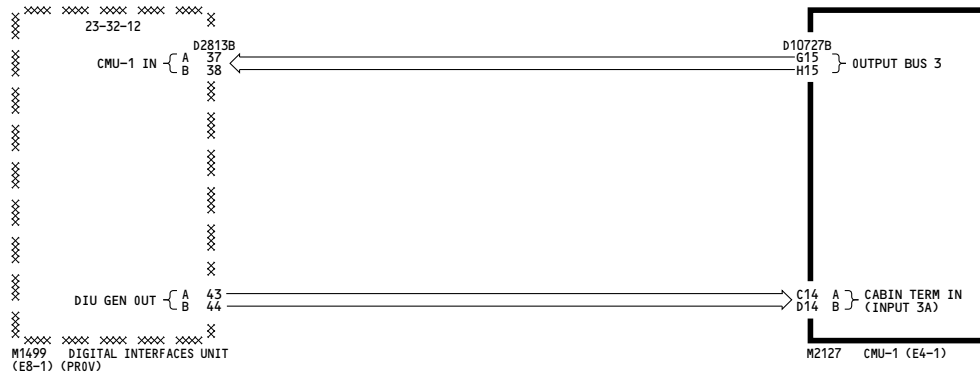

YK901-YK909, YM643-YM646	<p align="center">ACARS/CMU - OUTPUT BUS 3 INTERFACES</p> <p align="center">D280A203</p>
--------------------------	---

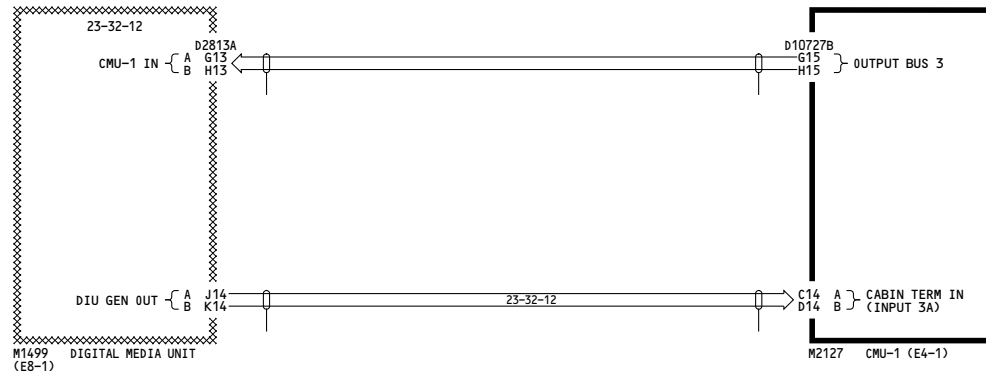

NOTES:

YK910-YL430, YM647-YM670	ACARS/CMU - OUTPUT BUS 3 INTERFACES D280A203
--------------------------	--

23-27-34

Page 102

Feb 09/2009

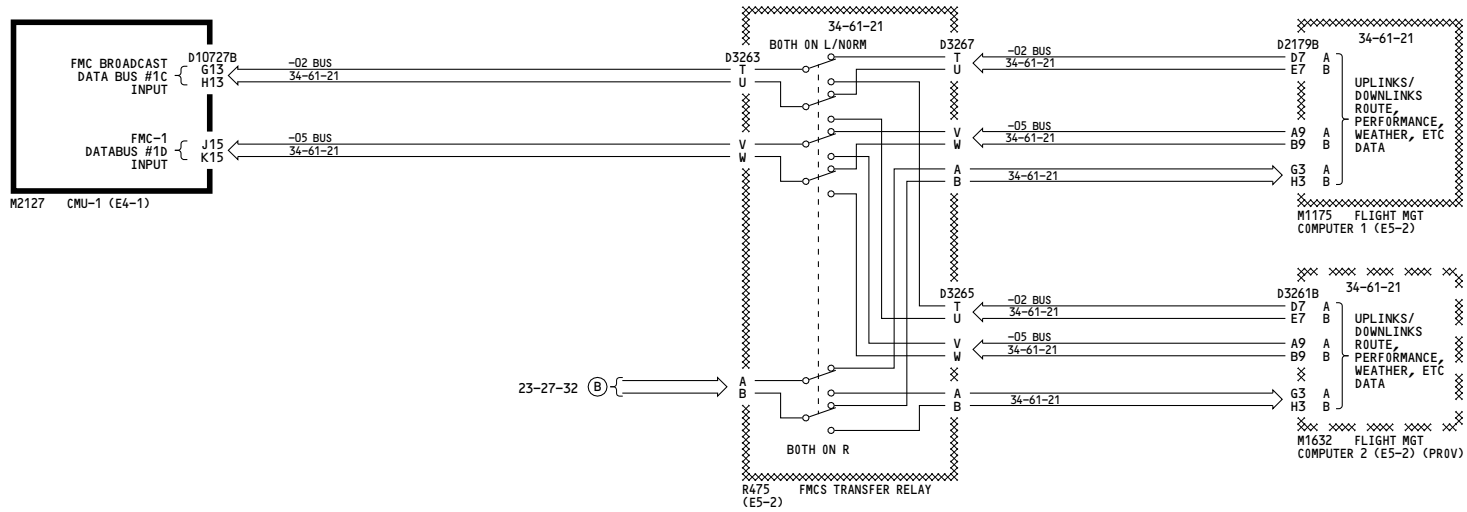

YK901-YK906	<p align="center">ACARS/CMU - 716 VHF AND FMC INTERFACES</p> <p align="center">D280A203</p>
-------------	--

23-27-35

Page 101

Oct 20/2006

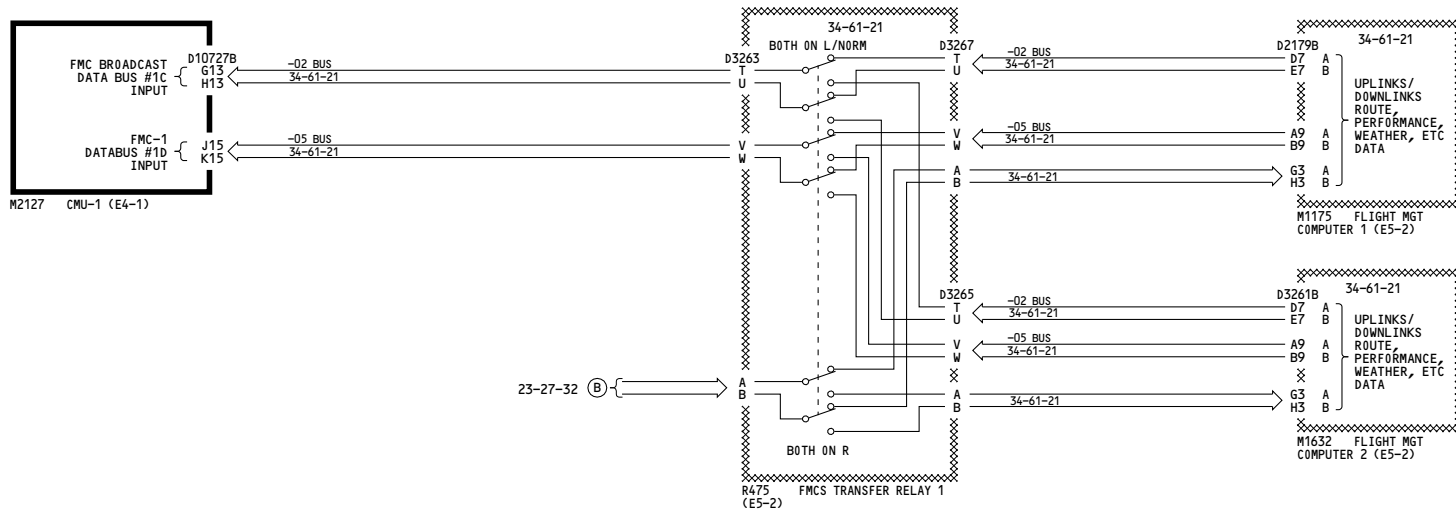

<p>YK907-YM670</p>	<p>ACARS/CMU - 716 VHF AND FMC INTERFACES</p> <p>D280A203</p>
--------------------	--

23-27-35

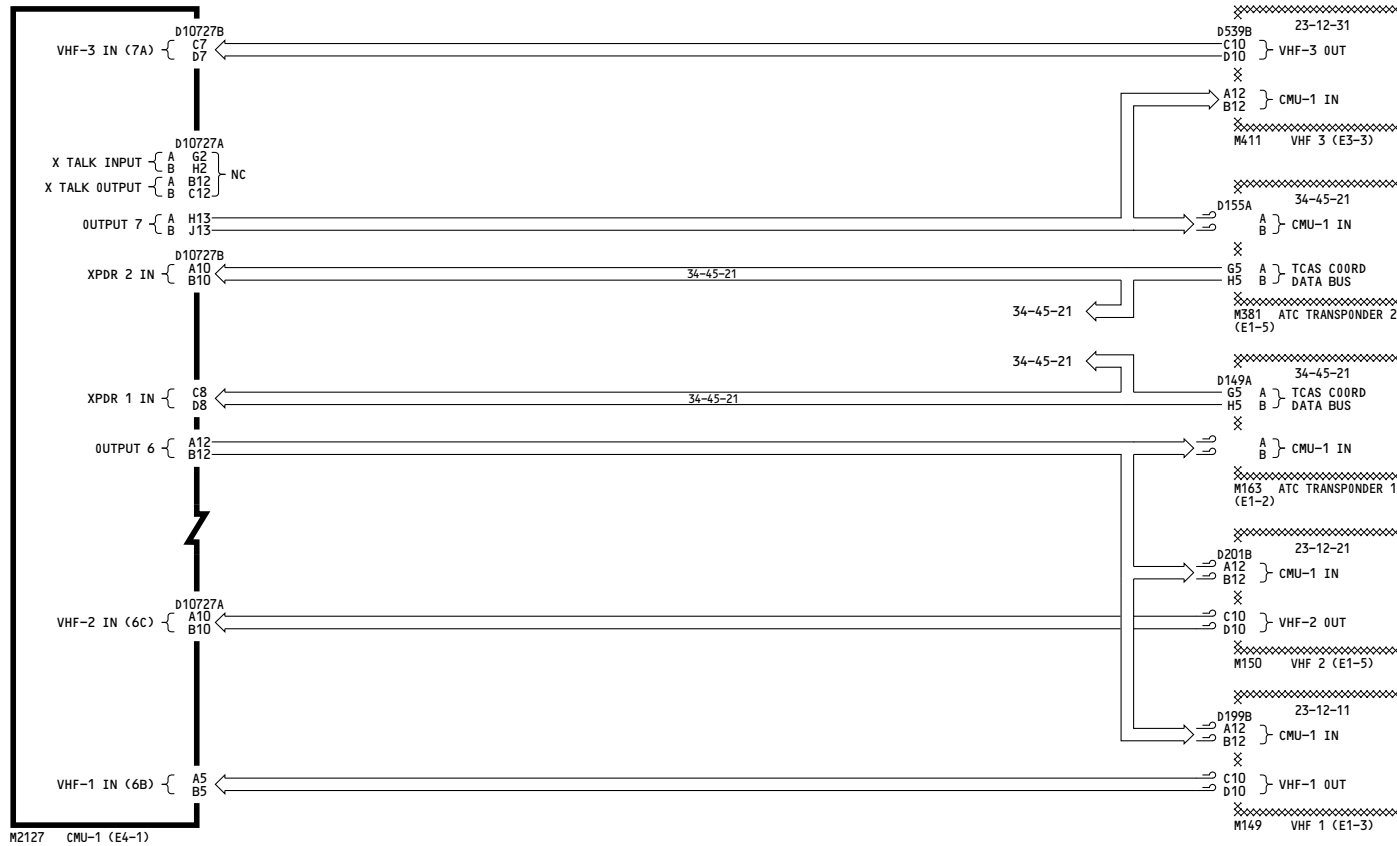

YK901-YM670	<p>CMU - OUTPUT BUS 6 AND BUS 7 INTERFACES</p> <p>D280A203</p>
-------------	---



NOTES:
 1 > PROVISIONS FOR DEU MESSAGING

YK901-YL426, YM643-YM670	ACARS/CMU - OOOI, CREW ADVISORIES AND OUTPUT 8 D280A203
--------------------------	---



NOTES:
 1 PROVISIONS FOR DEU MESSAGING

YL427-YL430	<p>ACARS/CMU - OOOI, CREW ADVISORIES AND OUTPUT 8</p> <p>D280A203</p>
-------------	--

23-27-38

Page 102

Nov 11/2008

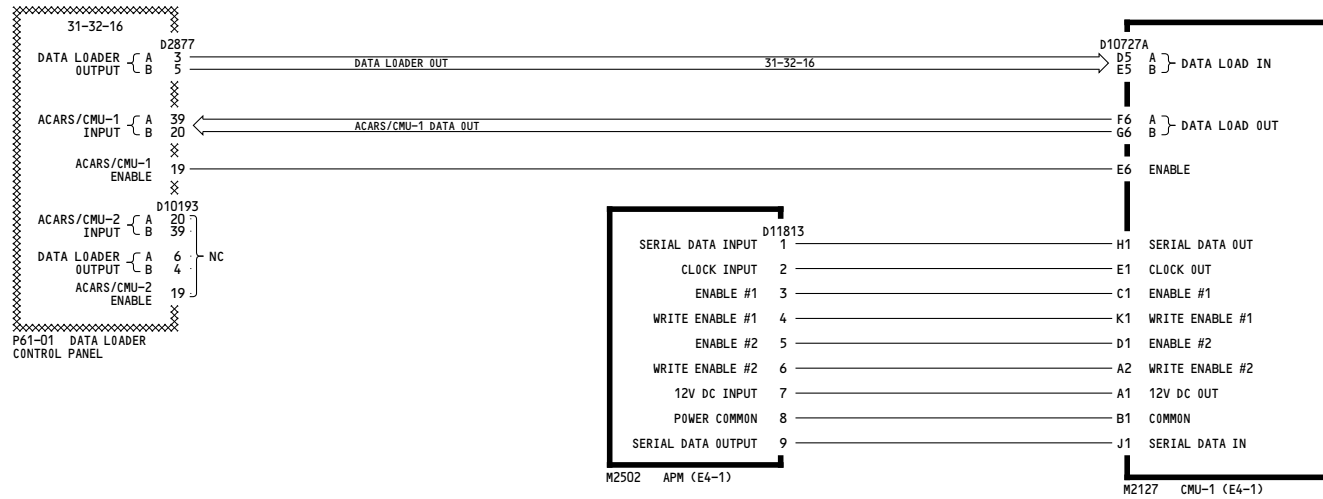

YK901-YM670	<p>ACARS/CMU - DATA LOADER AND PROGRAM PINS</p> <p>D280A203</p>
-------------	--

WIRING DIAGRAMS
 23-31-01
 23-31-02
 23-31-03

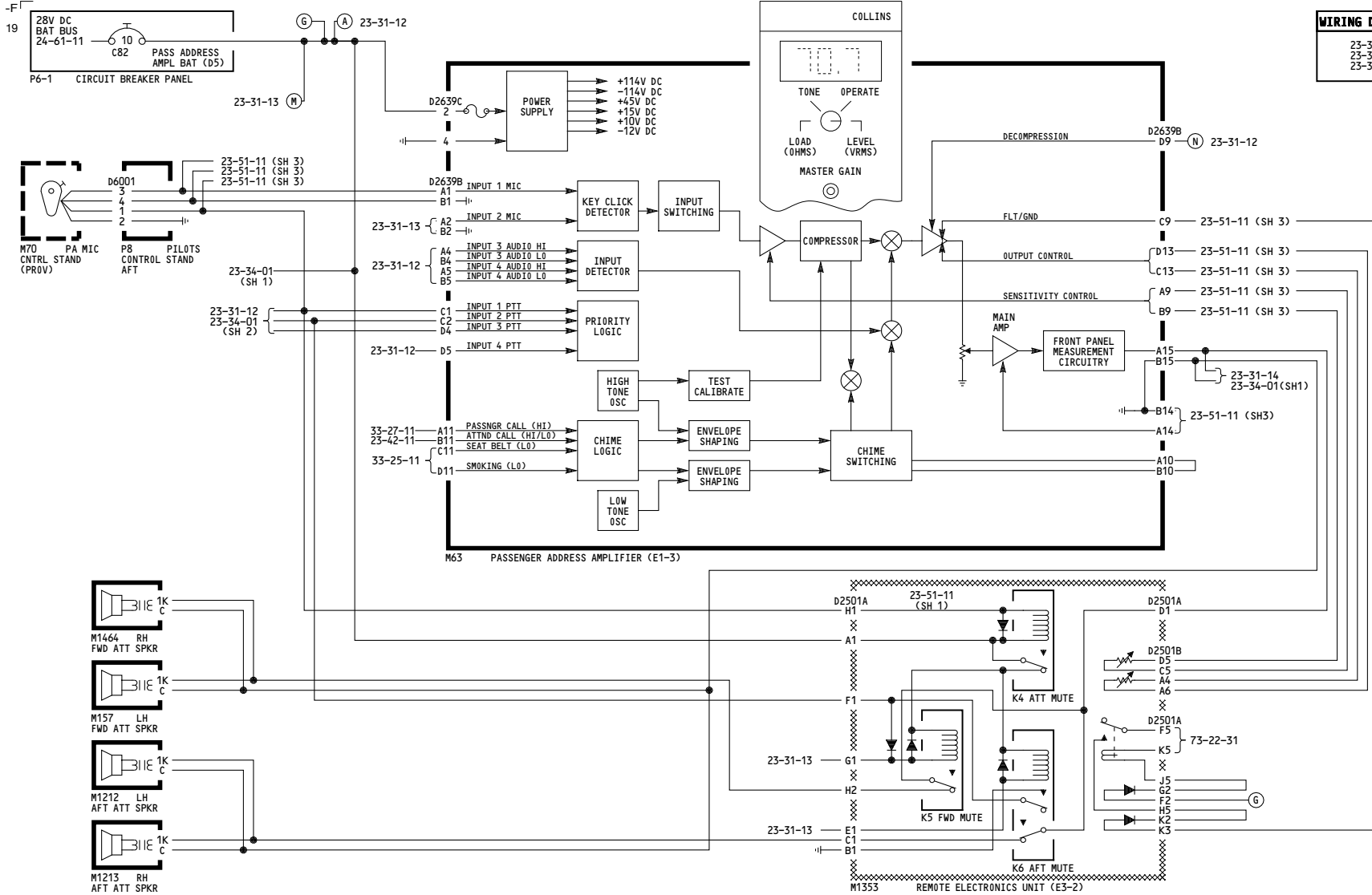

YC001-YC013

PASSENGER ADDRESS SYSTEM

D280A203

23-31-11

WIRING DIAGRAMS
23-31-01
23-31-02
23-31-03

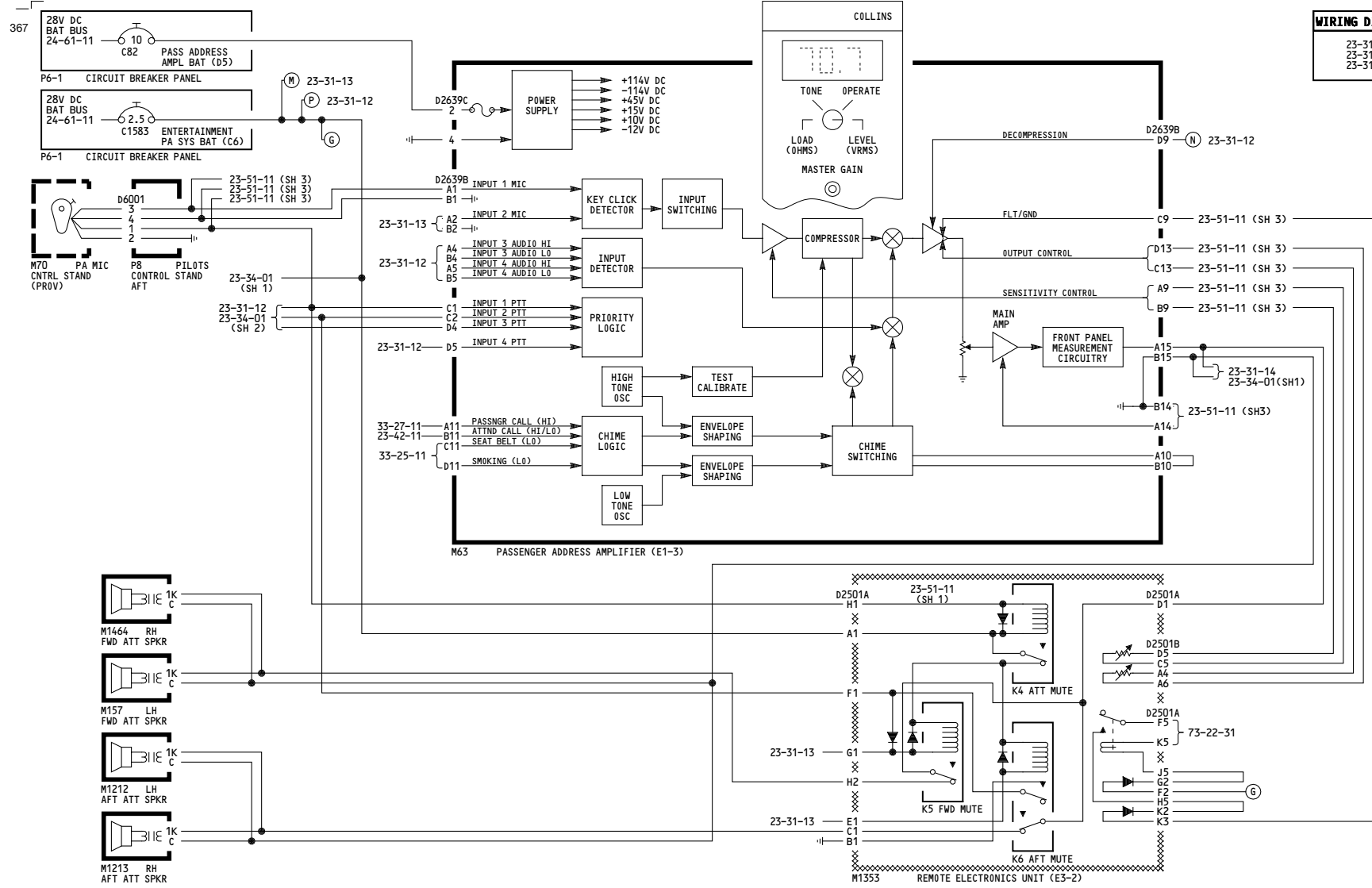

YC001-YC013	PASSENGER ADDRESS SYSTEM
	D280A203

Incorporates
23-1139 R01

23-31-11

WIRING DIAGRAMS
 23-31-01
 23-31-02
 23-31-03

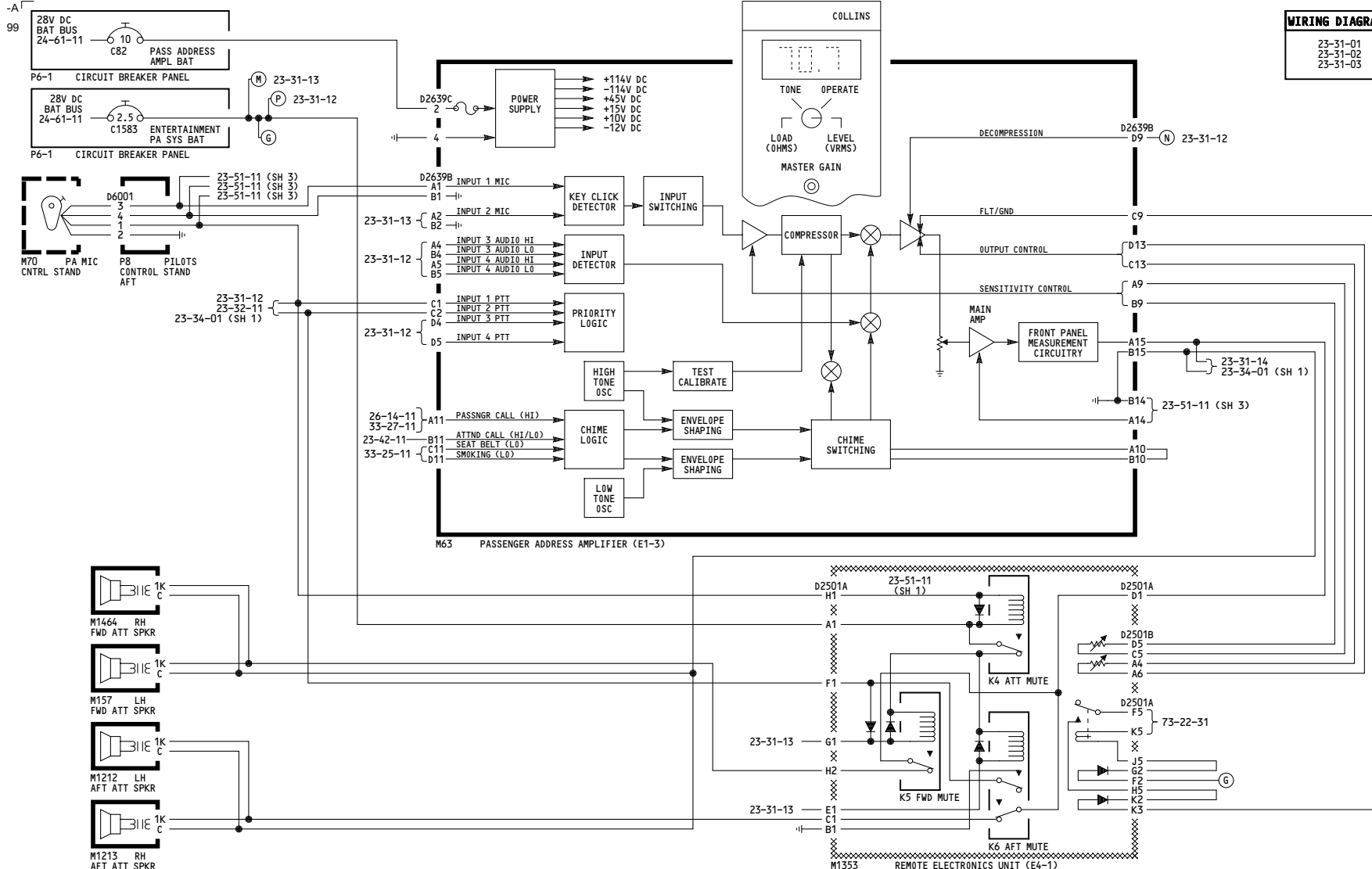

YC015-YC050	PASSENGER ADDRESS SYSTEM
	D280A203

23-31-11

WIRING DIAGRAMS
23-31-01
23-31-02
23-31-03

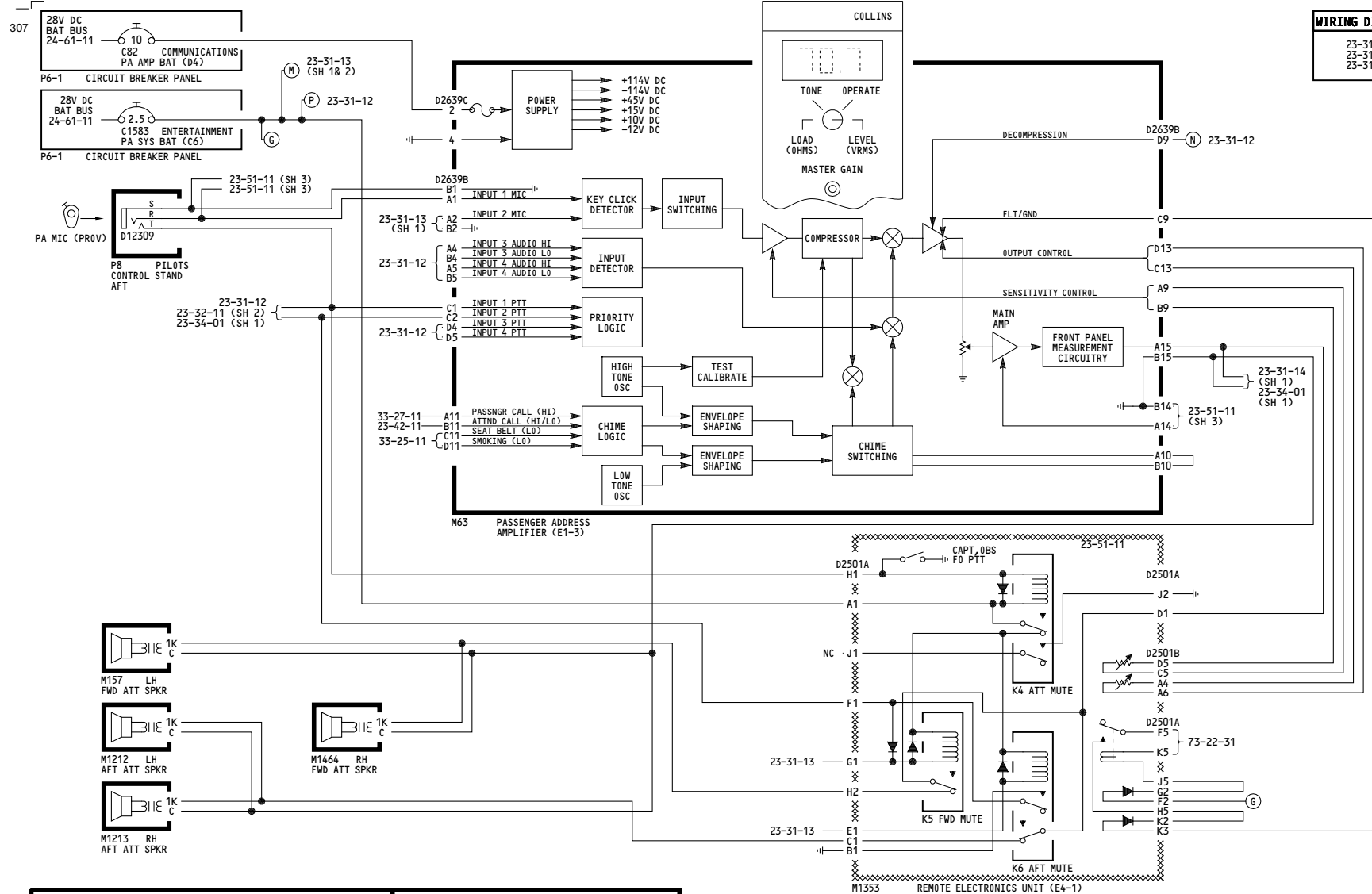

YK901-YL430	<p align="center">PASSENGER ADDRESS SYSTEM</p> <p align="center">D280A203</p>
-------------	--

23-31-11

WIRING DIAGRAMS
 23-31-01
 23-31-02
 23-31-03

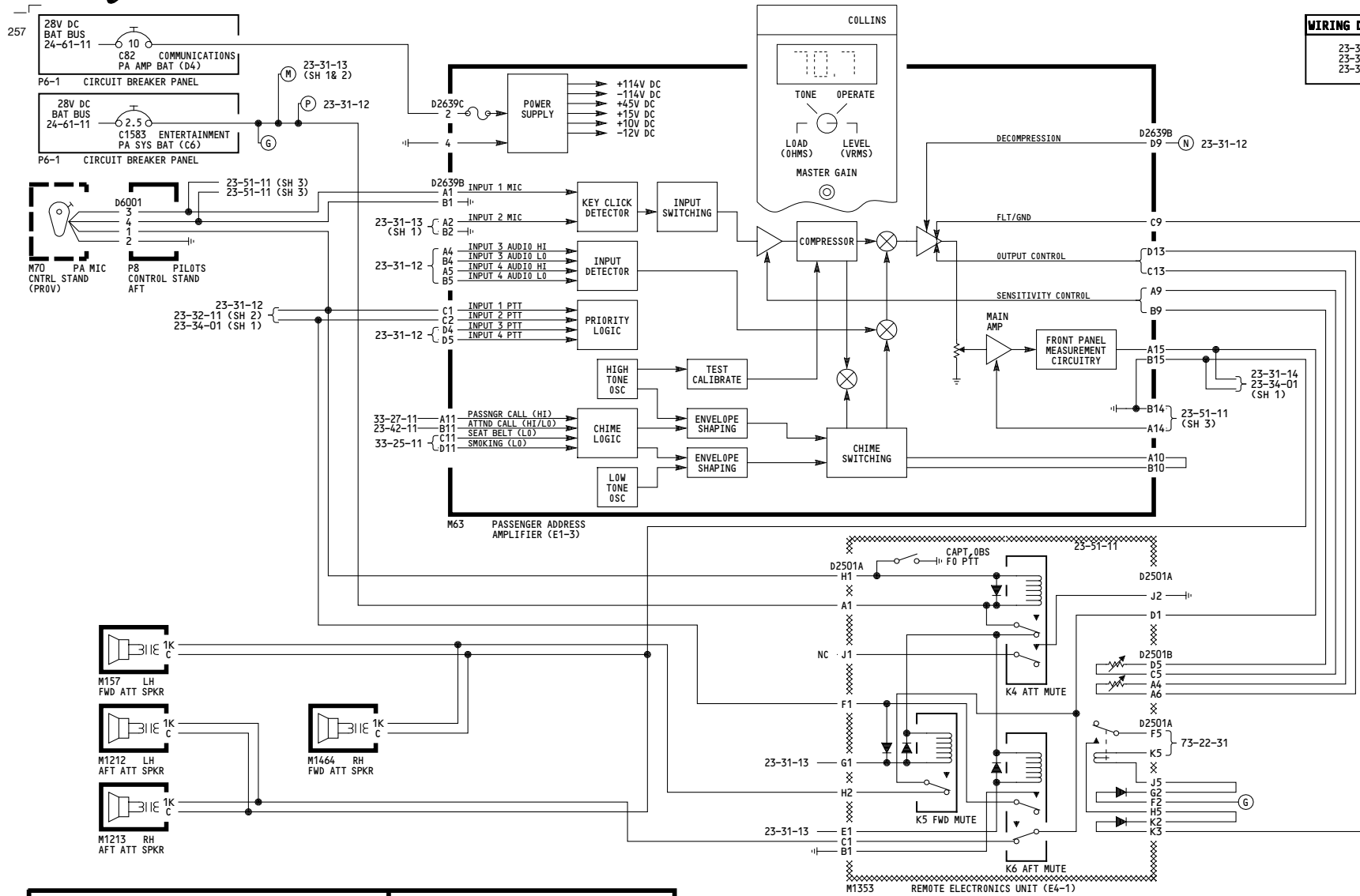

YM643-YM670

PASSENGER ADDRESS SYSTEM

D280A203

23-31-11

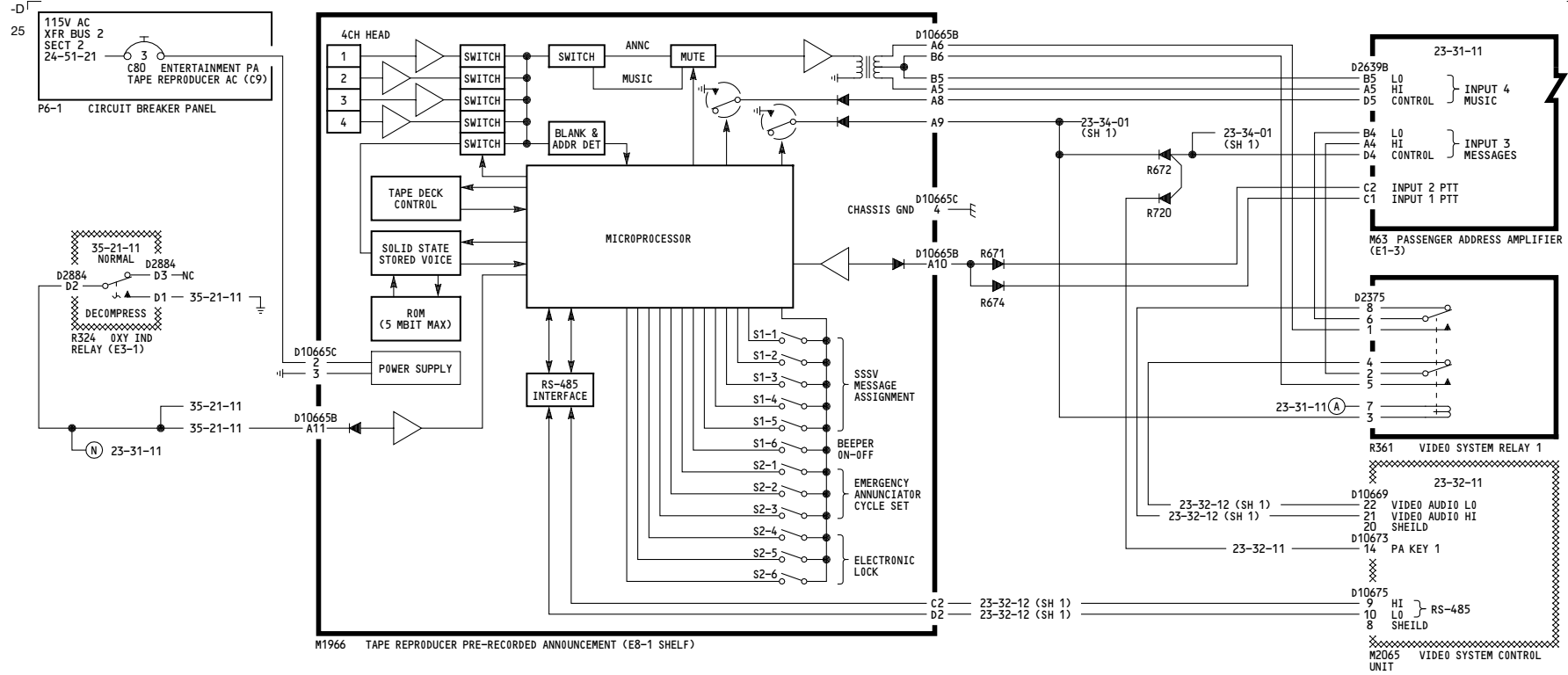

WIRING DIAGRAMS
23-31-06

<p>YC001-YC030</p>	<p>PRE-RECORDER ANNOUNCEMENT MACHINE</p> <p>D280A203</p>
--------------------	---

23-31-12

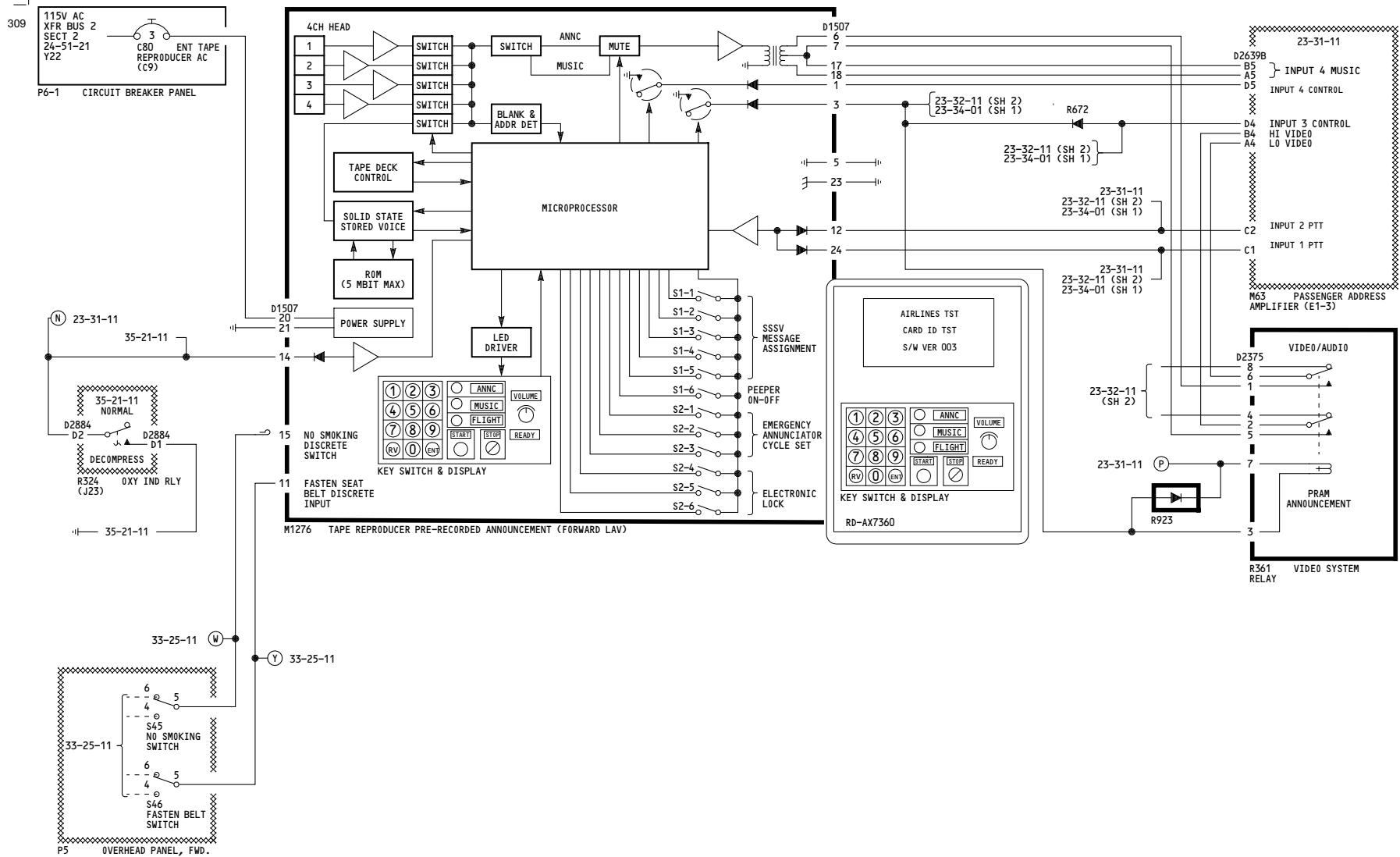

YK901-YM670 **PRE-RECORDER ANNOUNCEMENT MACHINE**
D280A203

-E1
5

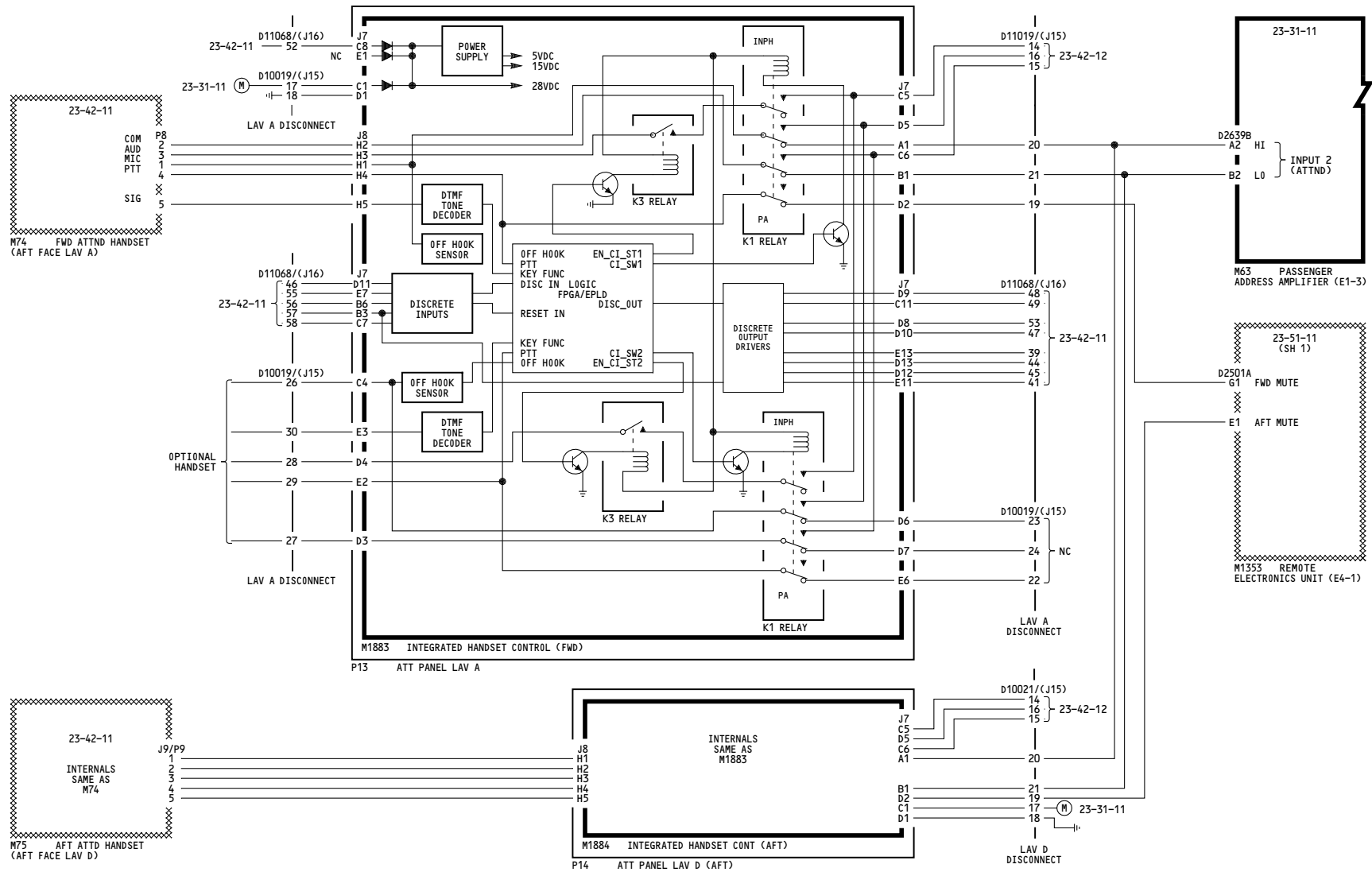

<p>YC001-YC050</p>	<p>INTEGRATED HANDSET CONTROLLER</p> <p>D280A203</p>
--------------------	---

THIS PAGE INTENTIONALLY LEFT BLANK

-G
61

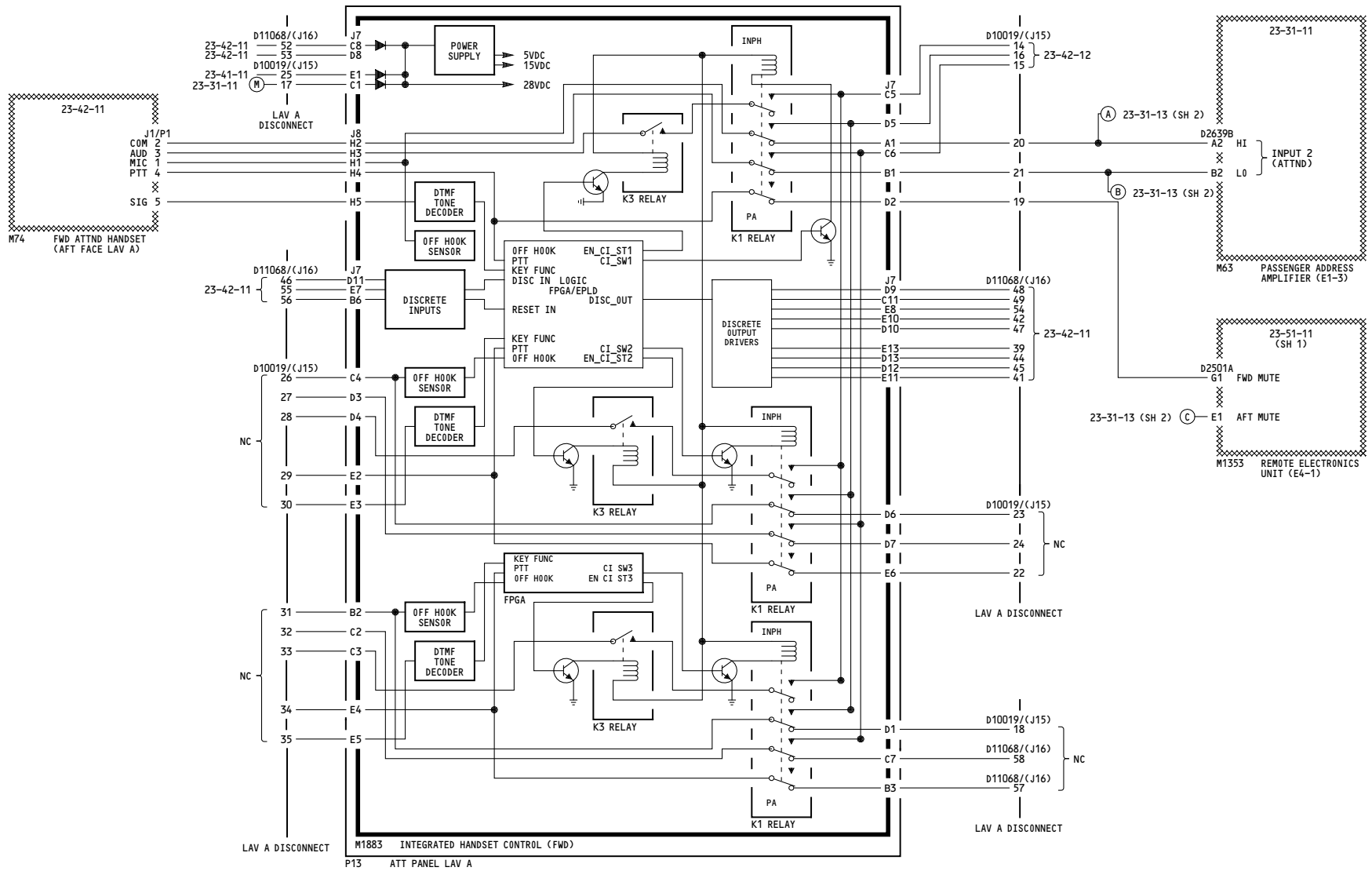

<p>YK901-YL430</p>	<p>INTEGRATED HANDSET CONTROLLER</p> <p>D280A203</p>
--------------------	---

-F
37

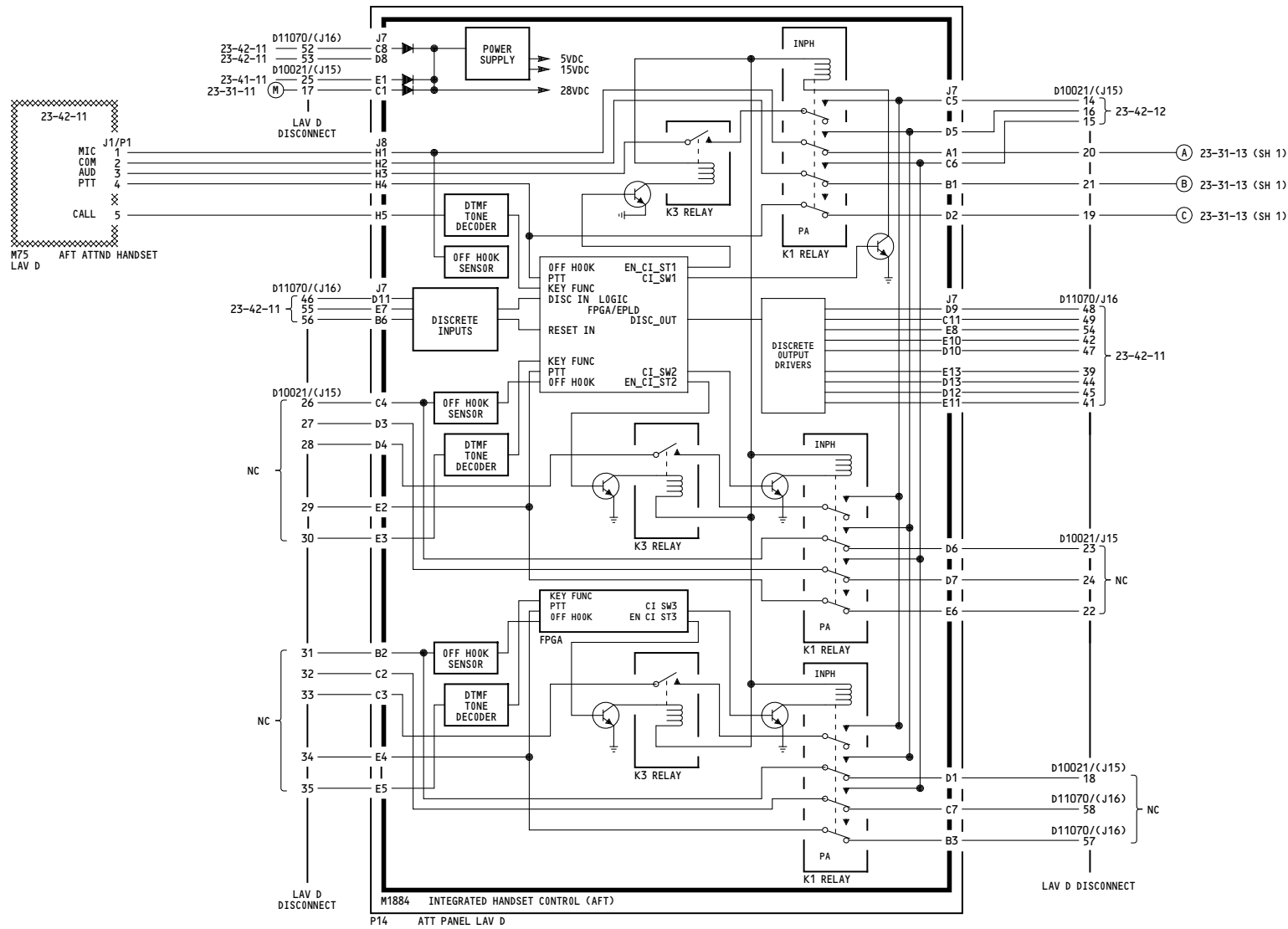

YK901-YL430

**INTEGRATED HANDSET
CONTROLLER**

D280A203

23-31-13

Page 102
Sheet 2
Feb 09/2009

-G
61

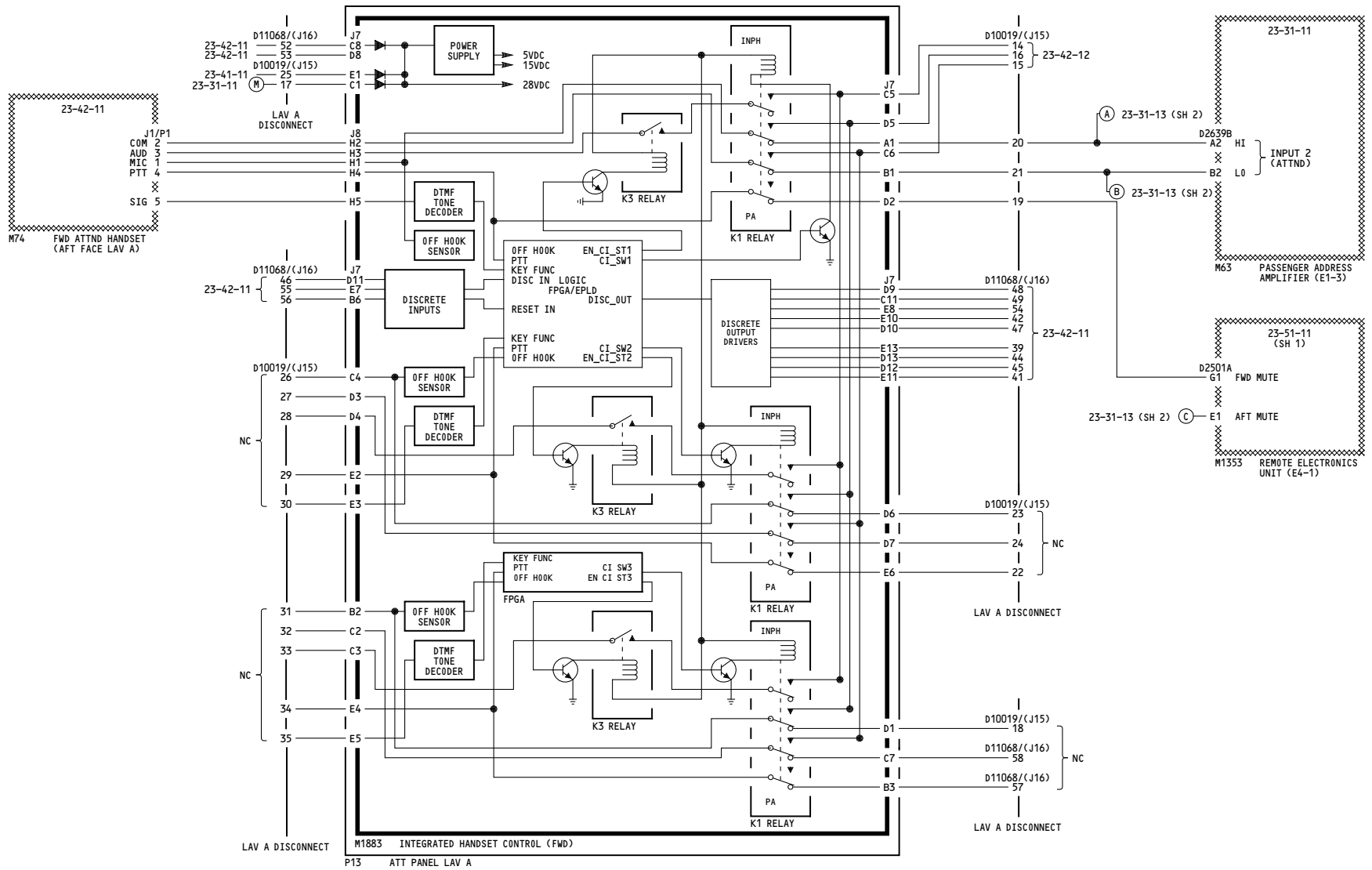

YM643-YM670

INTEGRATED HANDSET CONTROLLER

D280A203

23-31-13

Page 103
Sheet 1
Jan 14/2008

-D
61

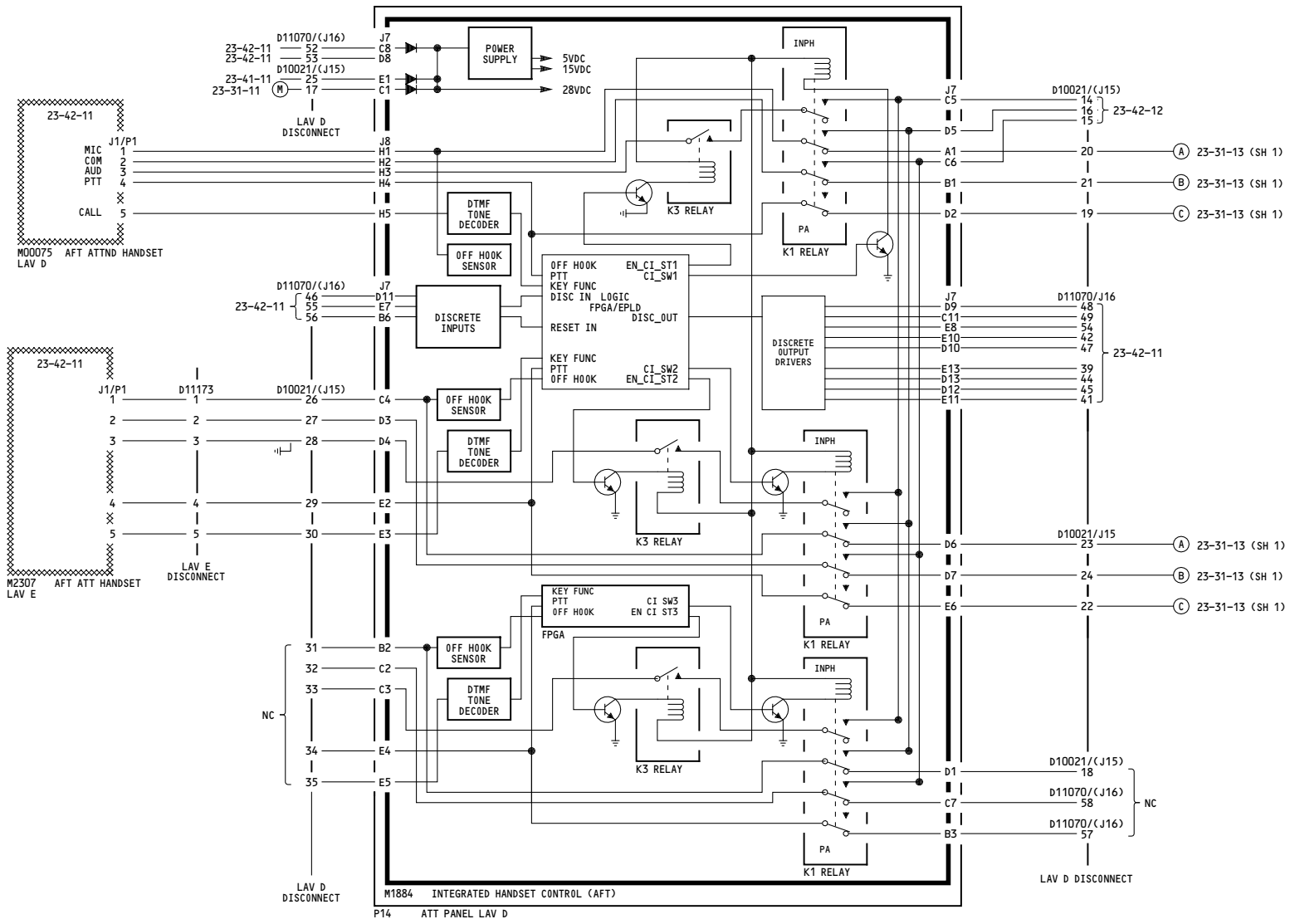

YM643-YM670	INTEGRATED HANDSET CONTROLLER
	D280A203

23-31-13

Page 103
Sheet 2
Jan 14/2008

-D
8

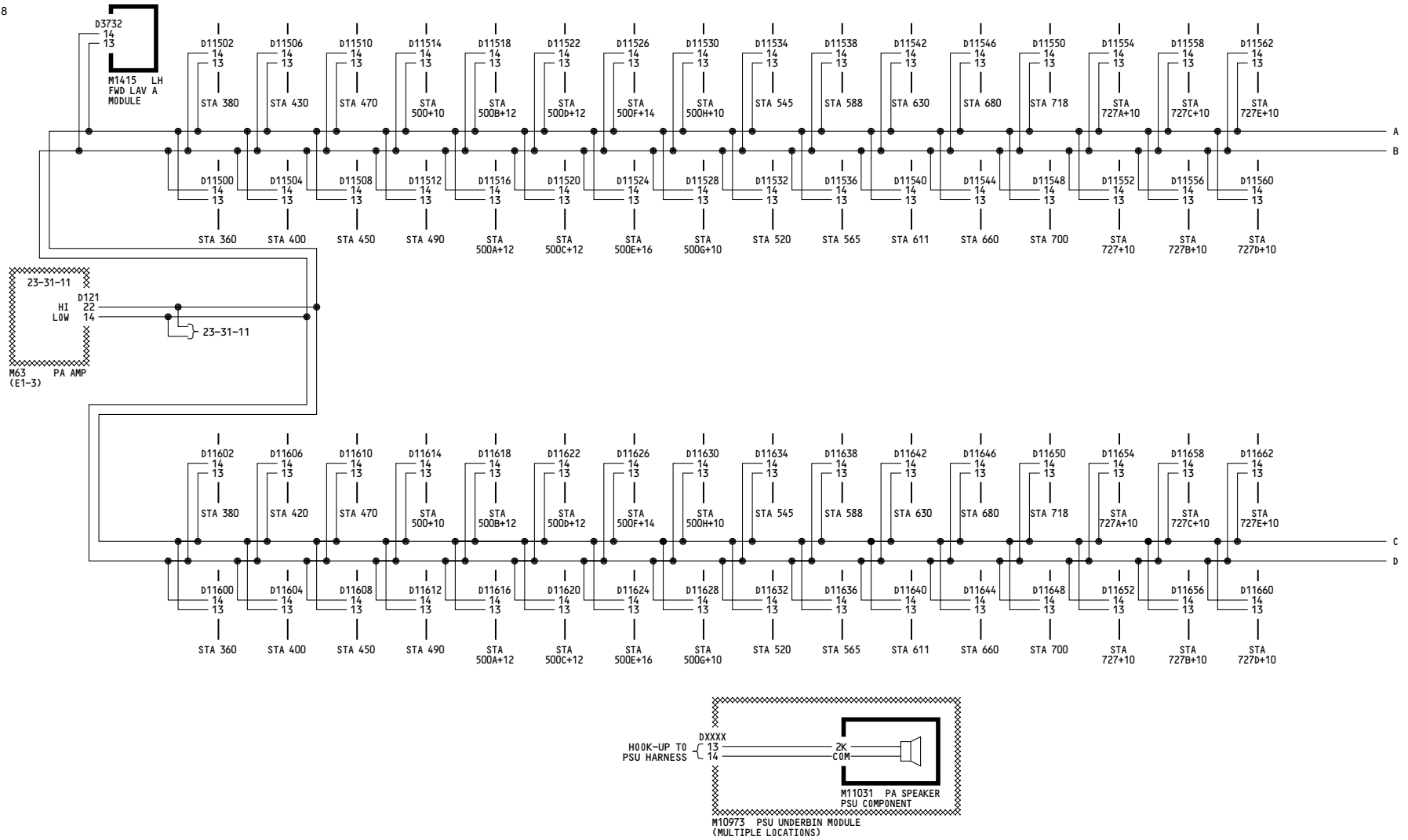

<p>YC001-YC050</p>	<p align="center">PASSENGER ADDRESS SYSTEM SPEAKERS</p> <p align="center">D280A203</p>
--------------------	---

23-31-14

Page 101
Sheet 1
Jul 17/2007

-G
1

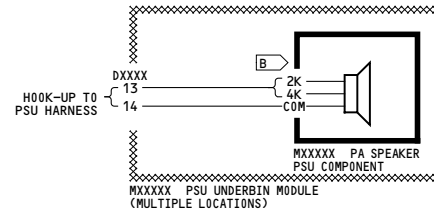
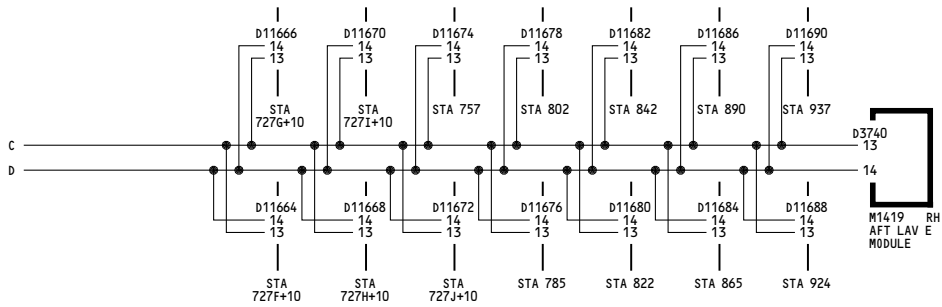
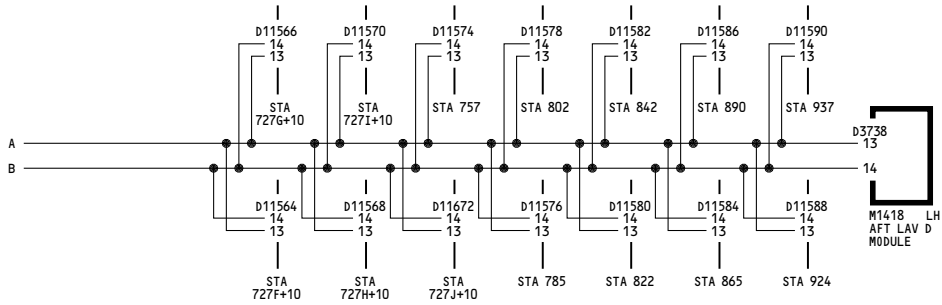

B "2K" OR "4K" CONNECTIONS VARIES WITH LOCATION

YC001-YC050	<p align="center">PASSENGER ADDRESS SYSTEM SPEAKERS</p> <p align="center">D280A203</p>
-------------	---

98

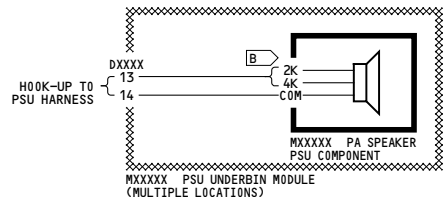
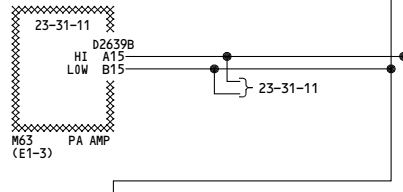
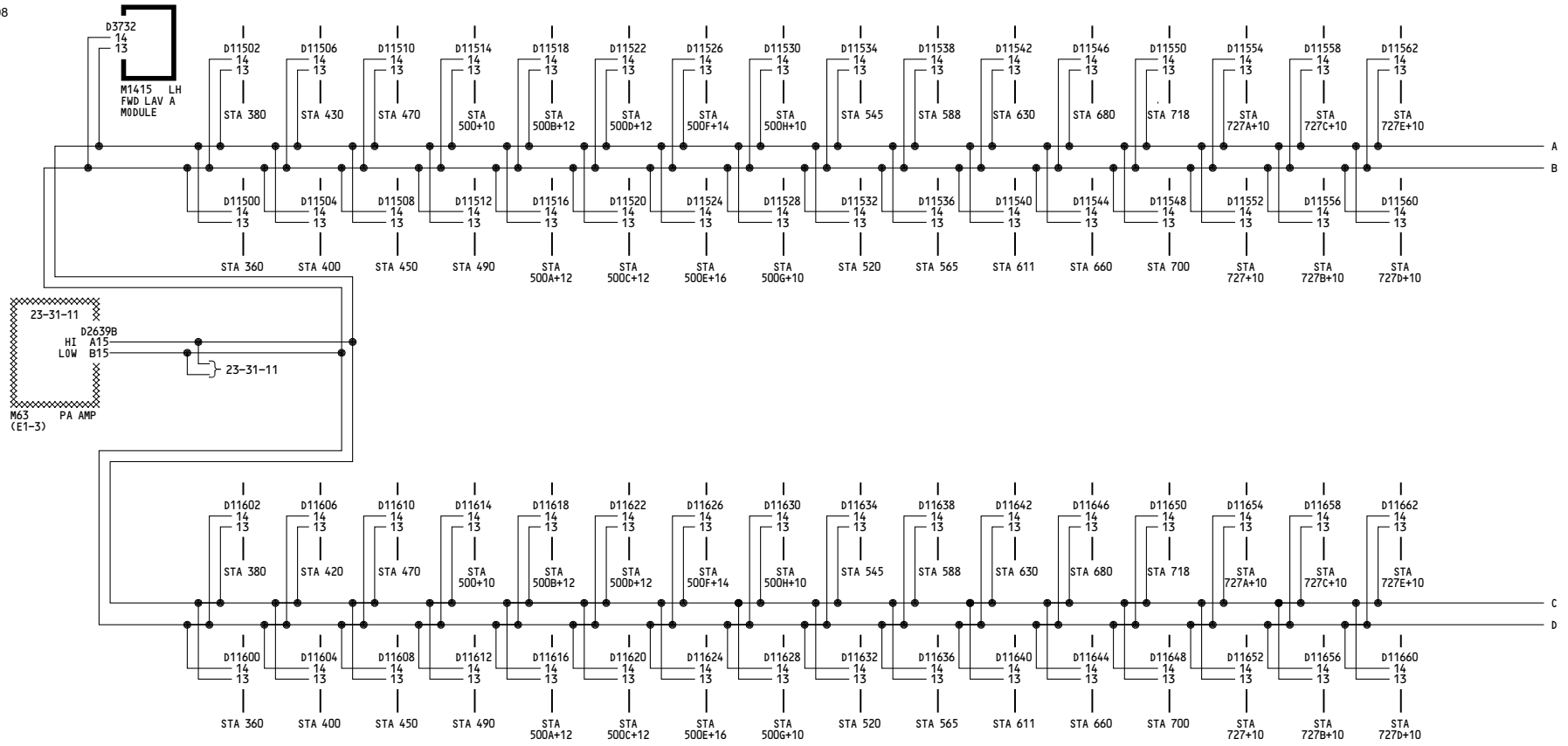

B ALL PSU INSTALLATIONS REQUIRE 2K TAPPED SPEAKERS

YK901-YL430	PASSENGER ADDRESS SYSTEM SPEAKERS D280A203
-------------	--

23-31-14

Page 102
Sheet 1
Feb 09/2009

-A
43

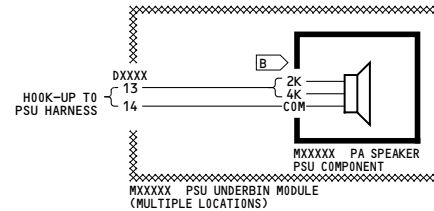
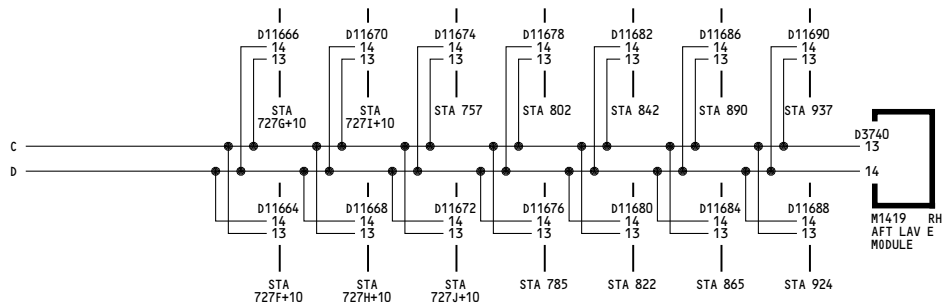
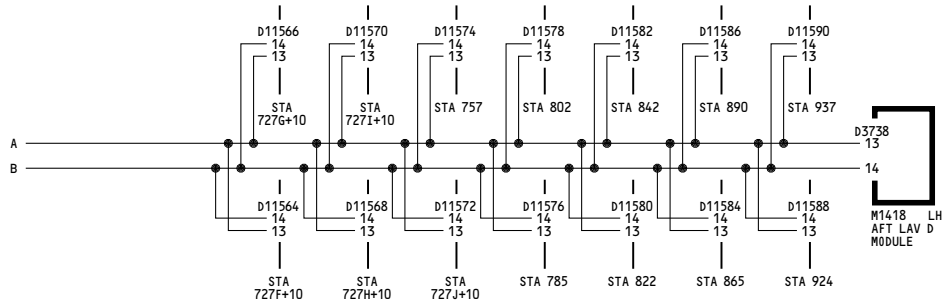

B ALL PSU INSTALLATIONS REQUIRE 2K TAPPED SPEAKERS

YK901-YL430

**PASSENGER ADDRESS SYSTEM
SPEAKERS**

D280A203

23-31-14

Page 102
Sheet 2
Feb 09/2009

-A
99

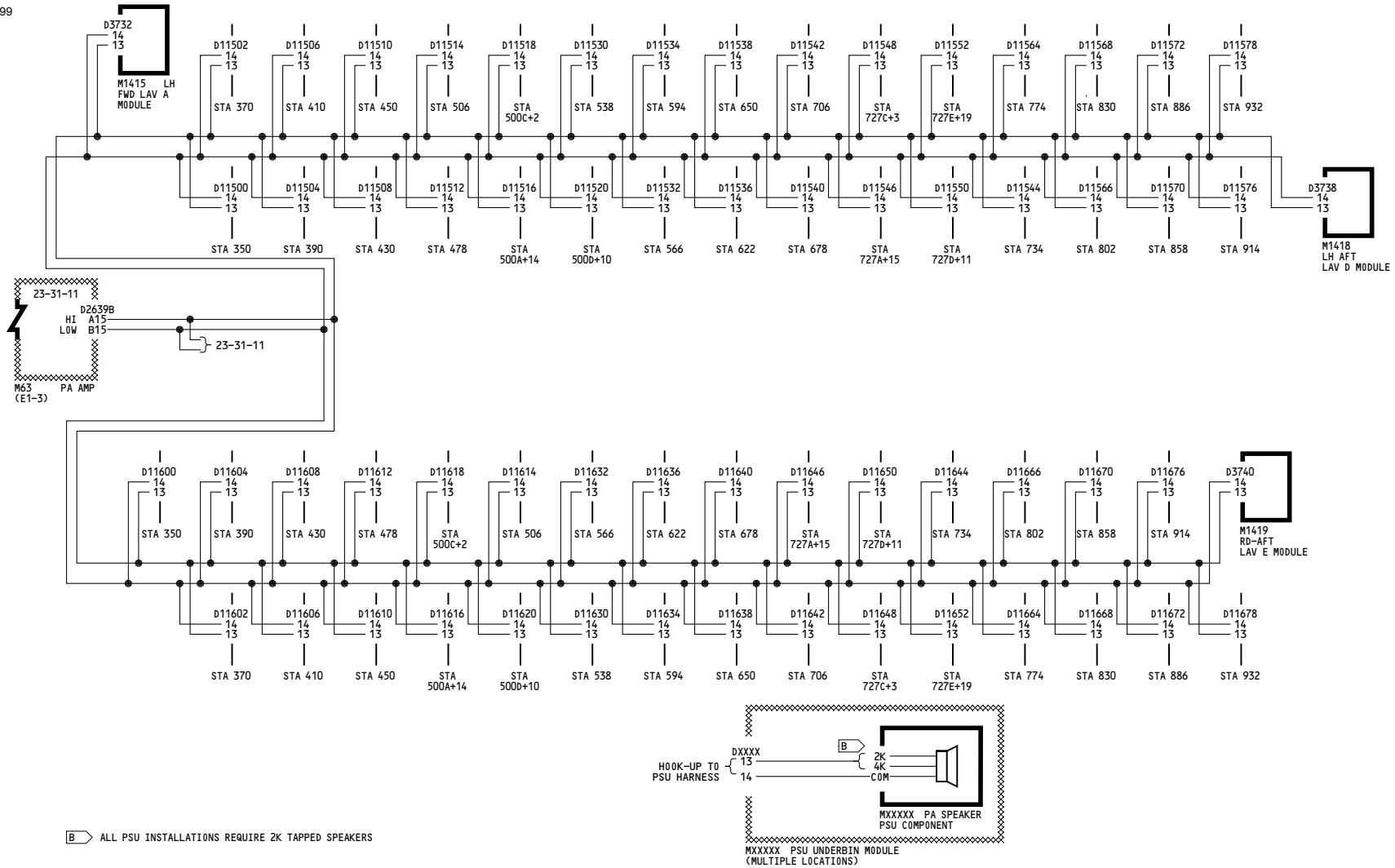

<p>YM643-YM670</p>	<p align="center">PASSENGER ADDRESS SYSTEM SPEAKERS</p> <p align="center">D280A203</p>
--------------------	---

23-31-14

Page 103

Jan 14/2008

THIS PAGE INTENTIONALLY LEFT BLANK

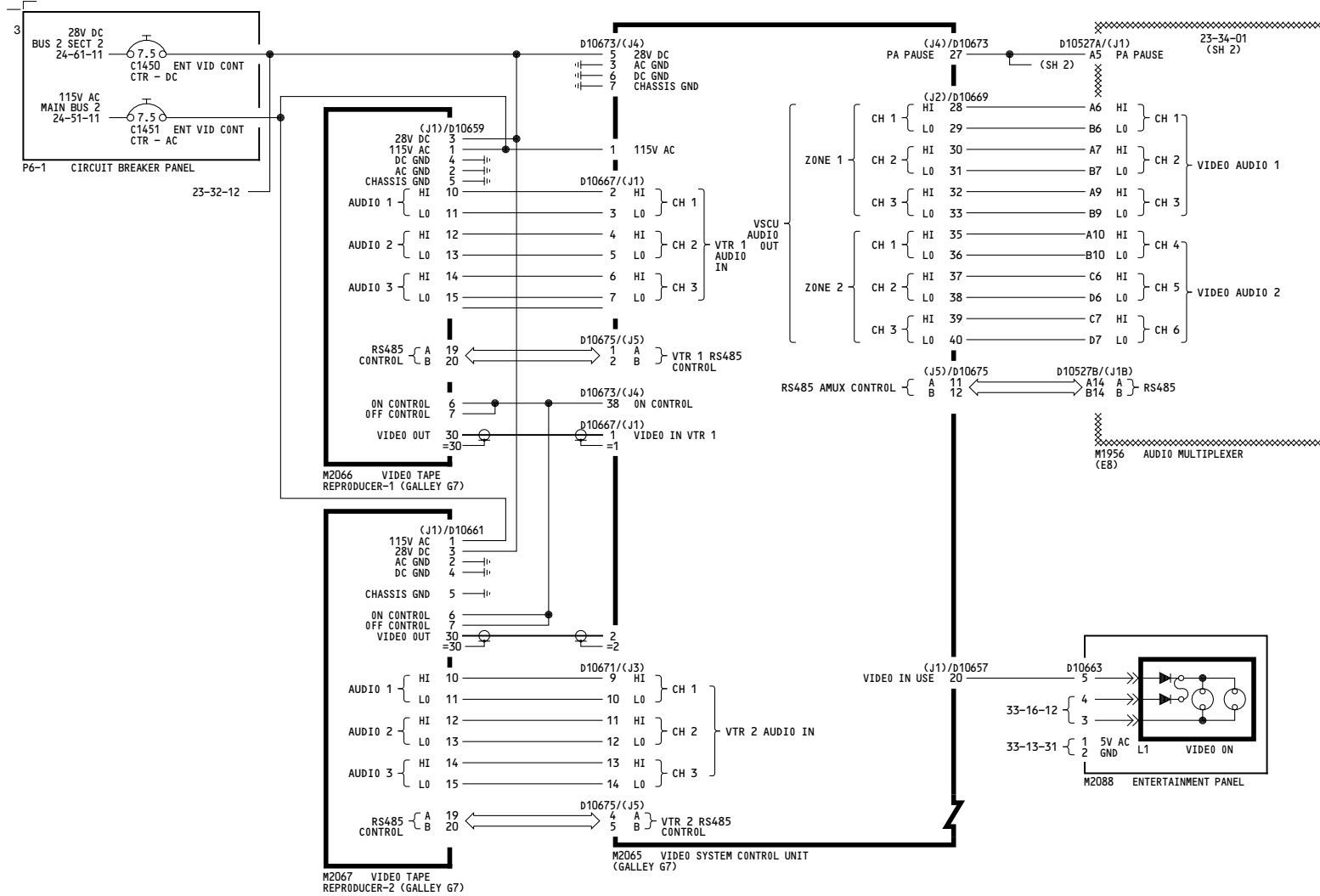

YC001-YC011	VIDEO CONTROL CENTER
D280A203	

23-32-11

Page 101
Sheet 1
Mar 31/2005

WIRING DIAGRAMS	
23-32-11	
23-32-12	
23-32-13	

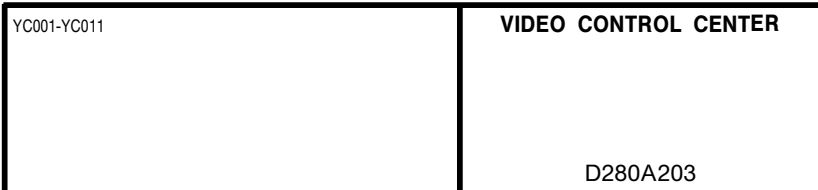
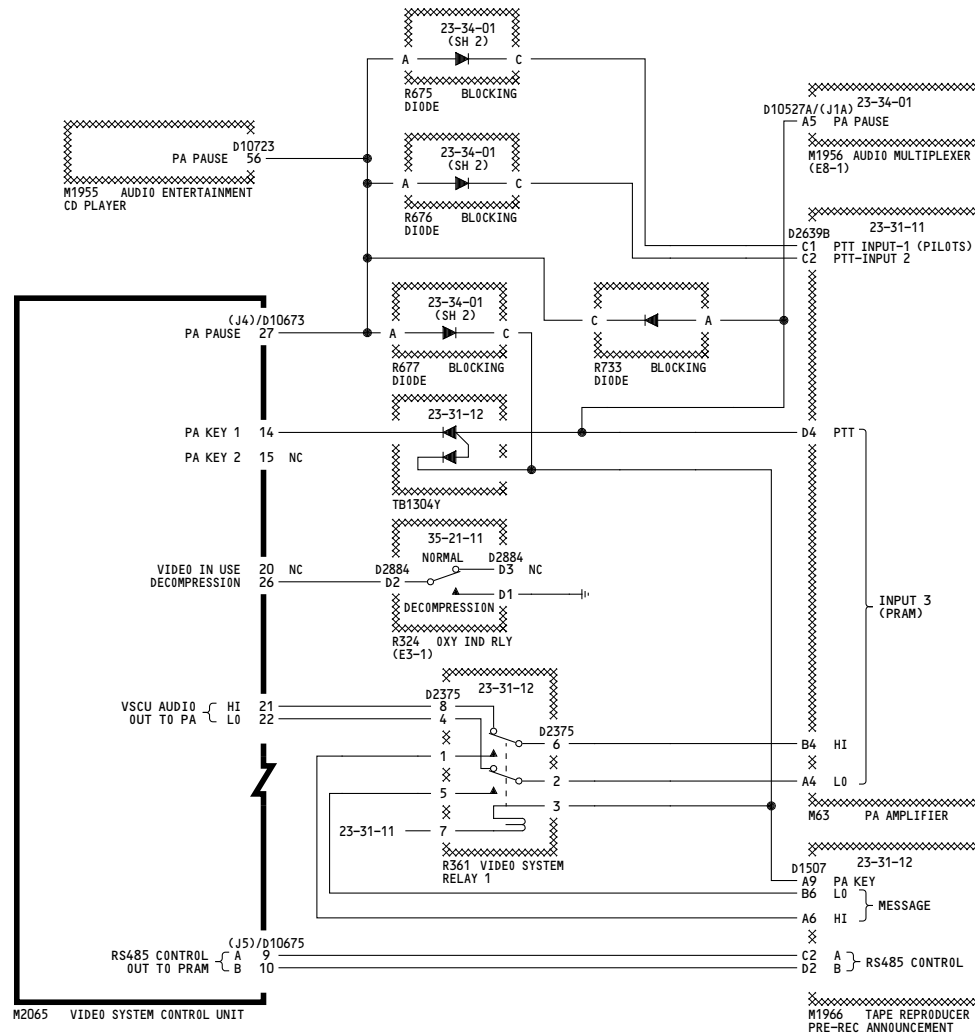

23-32-11

2

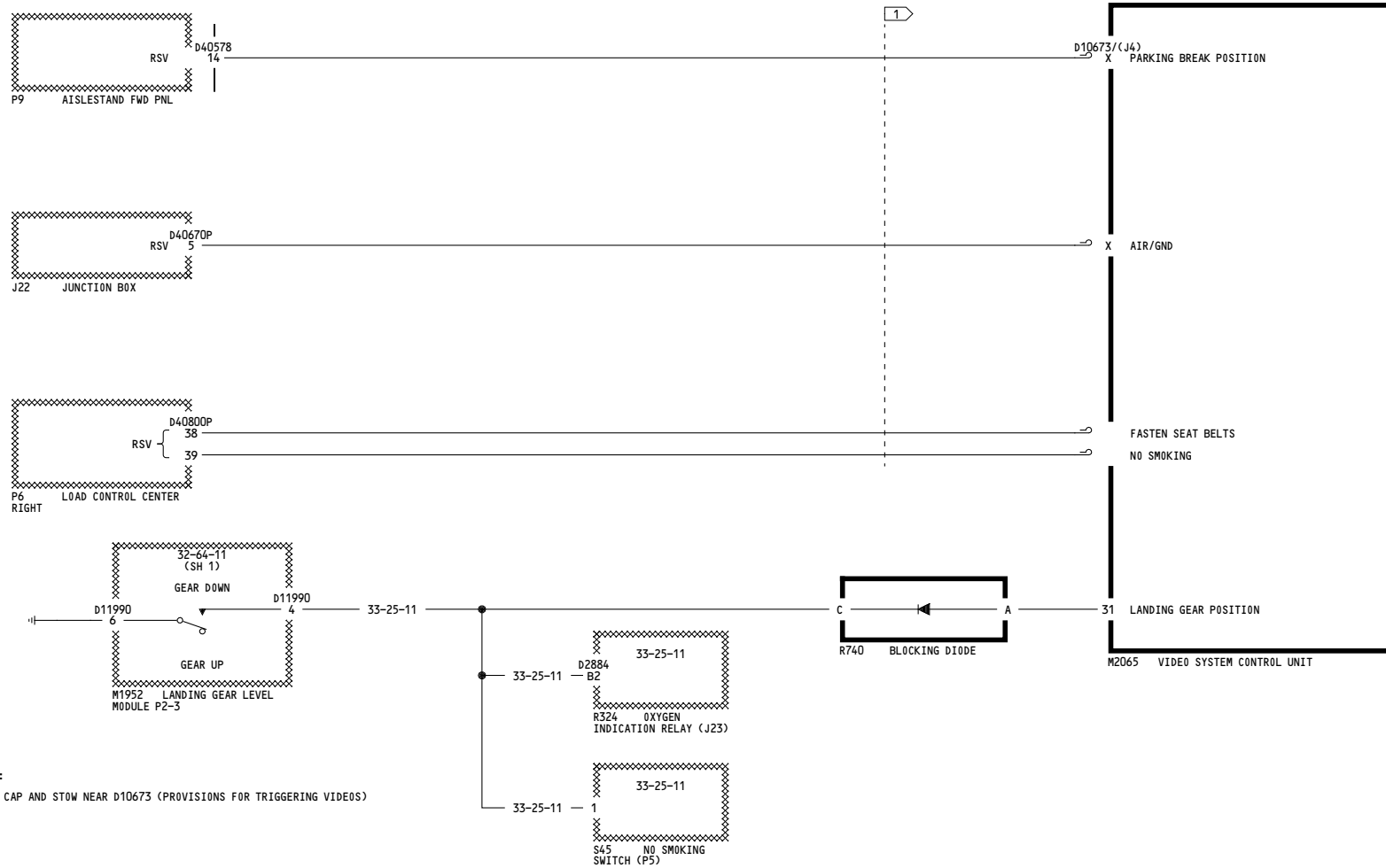

NOTES:

1 CAP AND STOW NEAR D10673 (PROVISIONS FOR TRIGGERING VIDEOS)

<p>YC001-YC011</p>	<p>VIDEO CONTROL CENTER</p> <p>D280A203</p>
--------------------	--

23-32-11

Page 101
Sheet 3
Mar 31/2005

THIS PAGE INTENTIONALLY LEFT BLANK

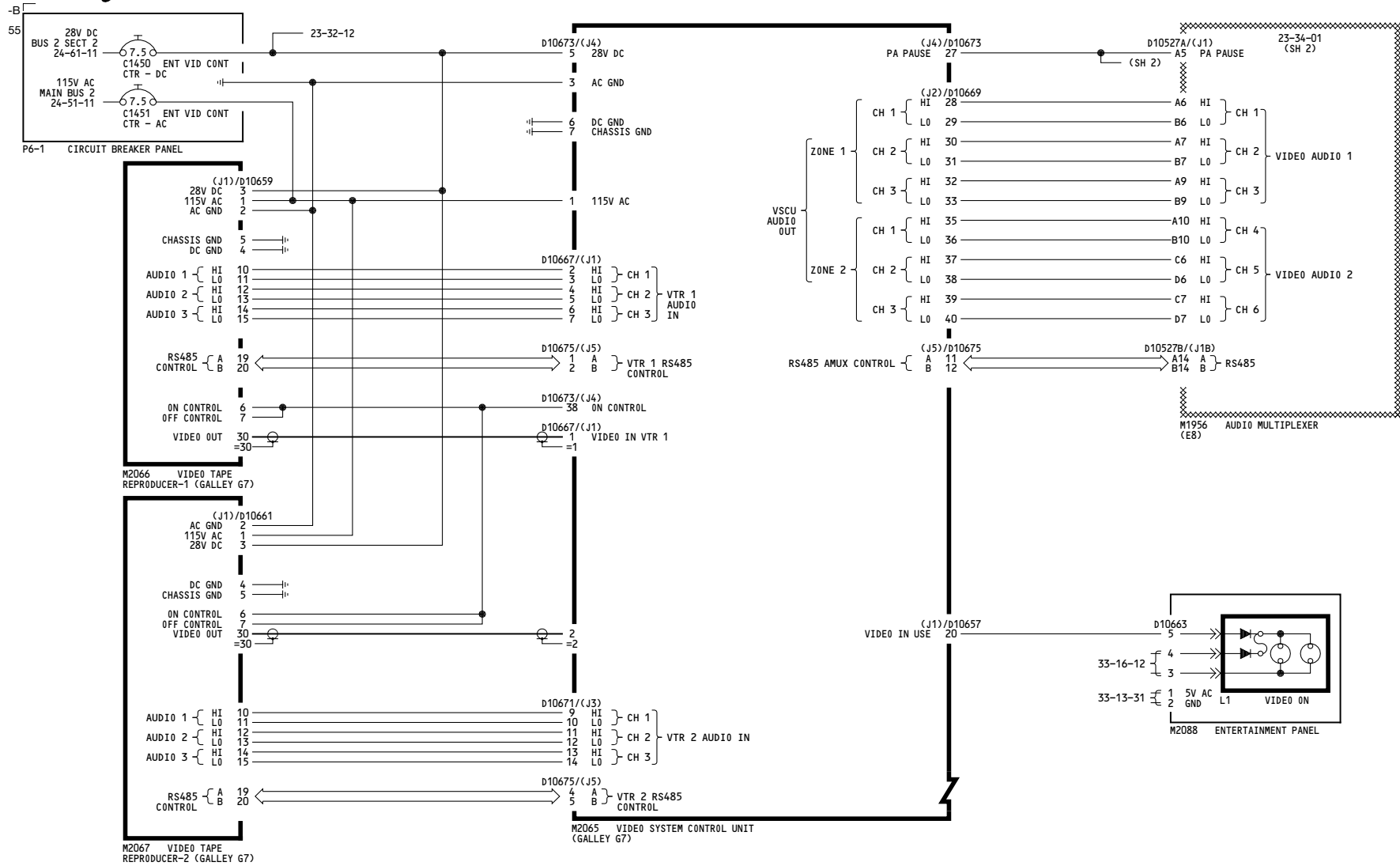

YC012-YC026	VIDEO CONTROL CENTER
D280A203	

23-32-11

WIRING DIAGRAMS	
23-32-11	
23-32-12	
23-32-13	

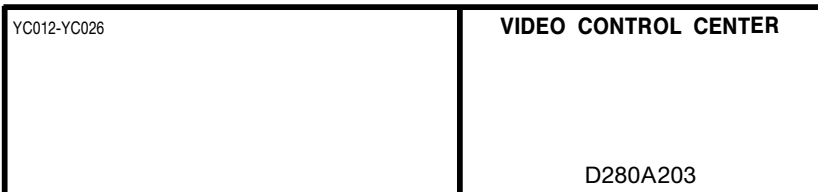
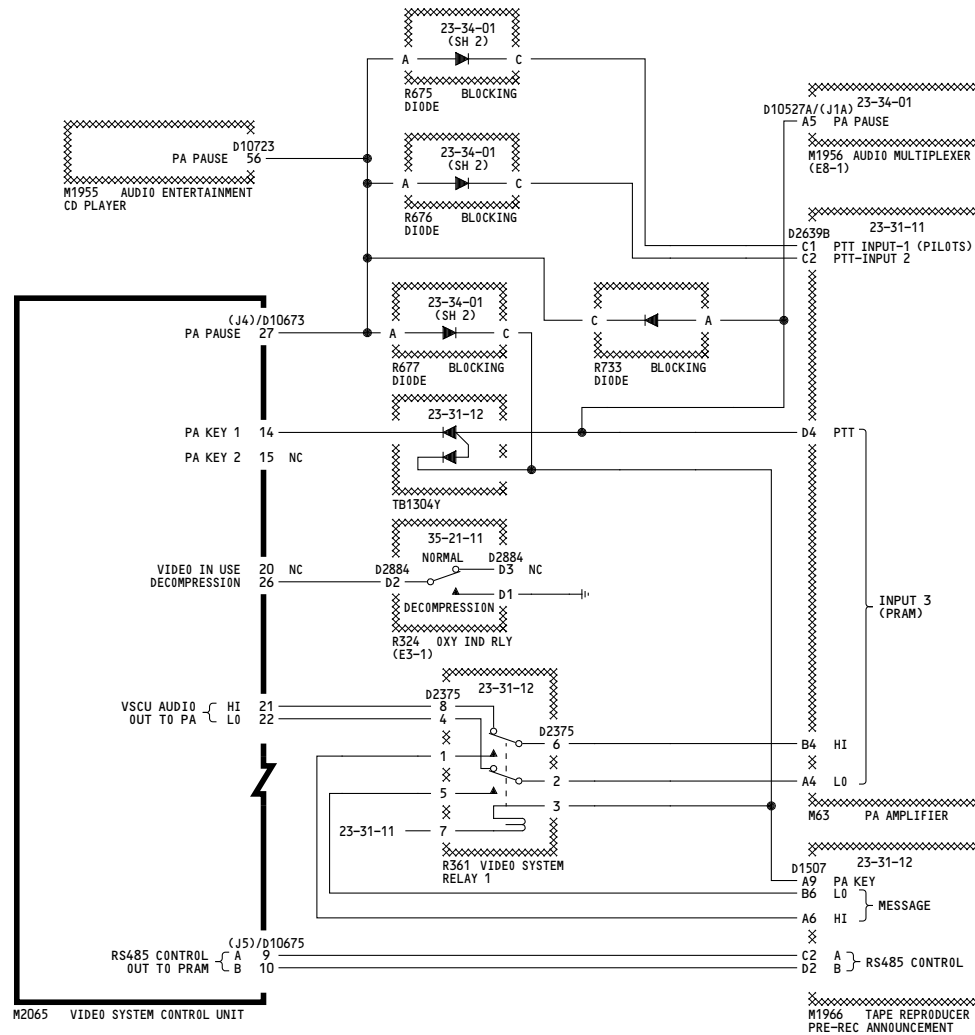

23-32-11

2

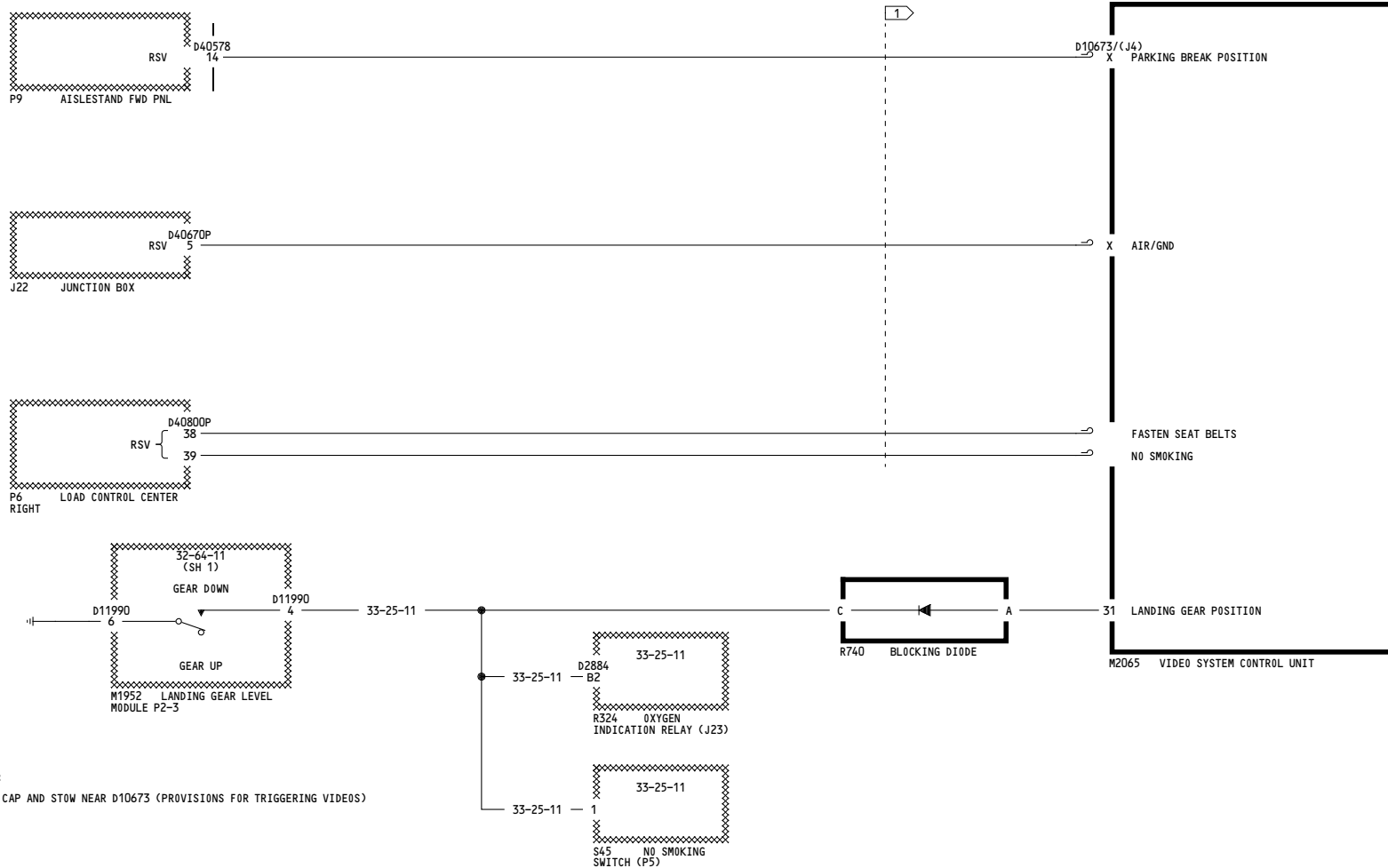

NOTES:

① CAP AND STOW NEAR D10673 (PROVISIONS FOR TRIGGERING VIDEOS)

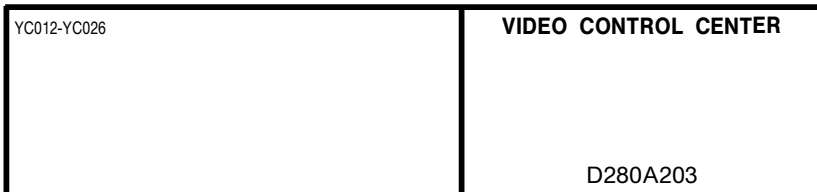

23-32-11

Page 102
Sheet 3
Jul 17/2007

THIS PAGE INTENTIONALLY LEFT BLANK

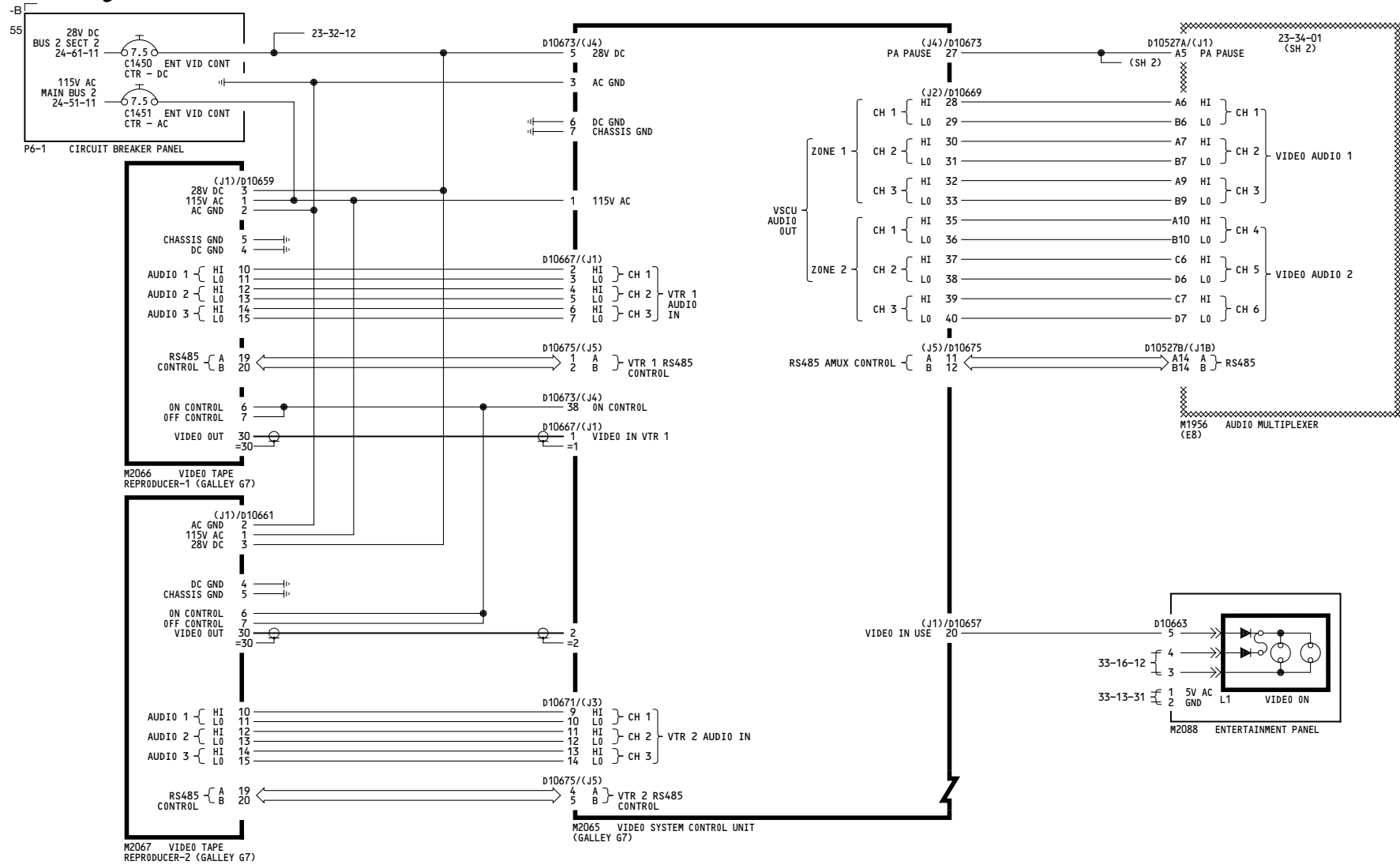

YC028-YC030	VIDEO CONTROL CENTER
D280A203	

23-32-11

WIRING DIAGRAMS	
23-32-11	
23-32-12	
23-32-13	

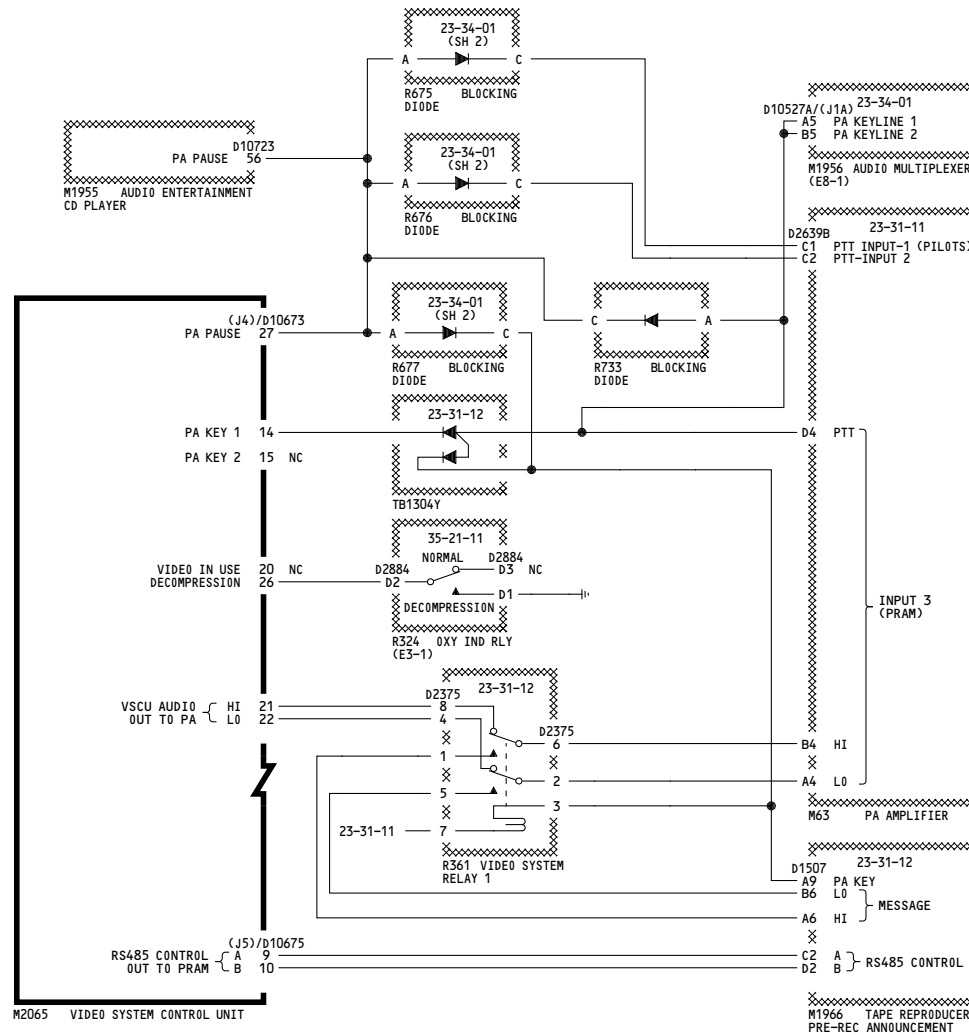

YC028-YC030	VIDEO CONTROL CENTER
	D280A203

23-32-11

Page 103
 Sheet 2
 Mar 31/2005

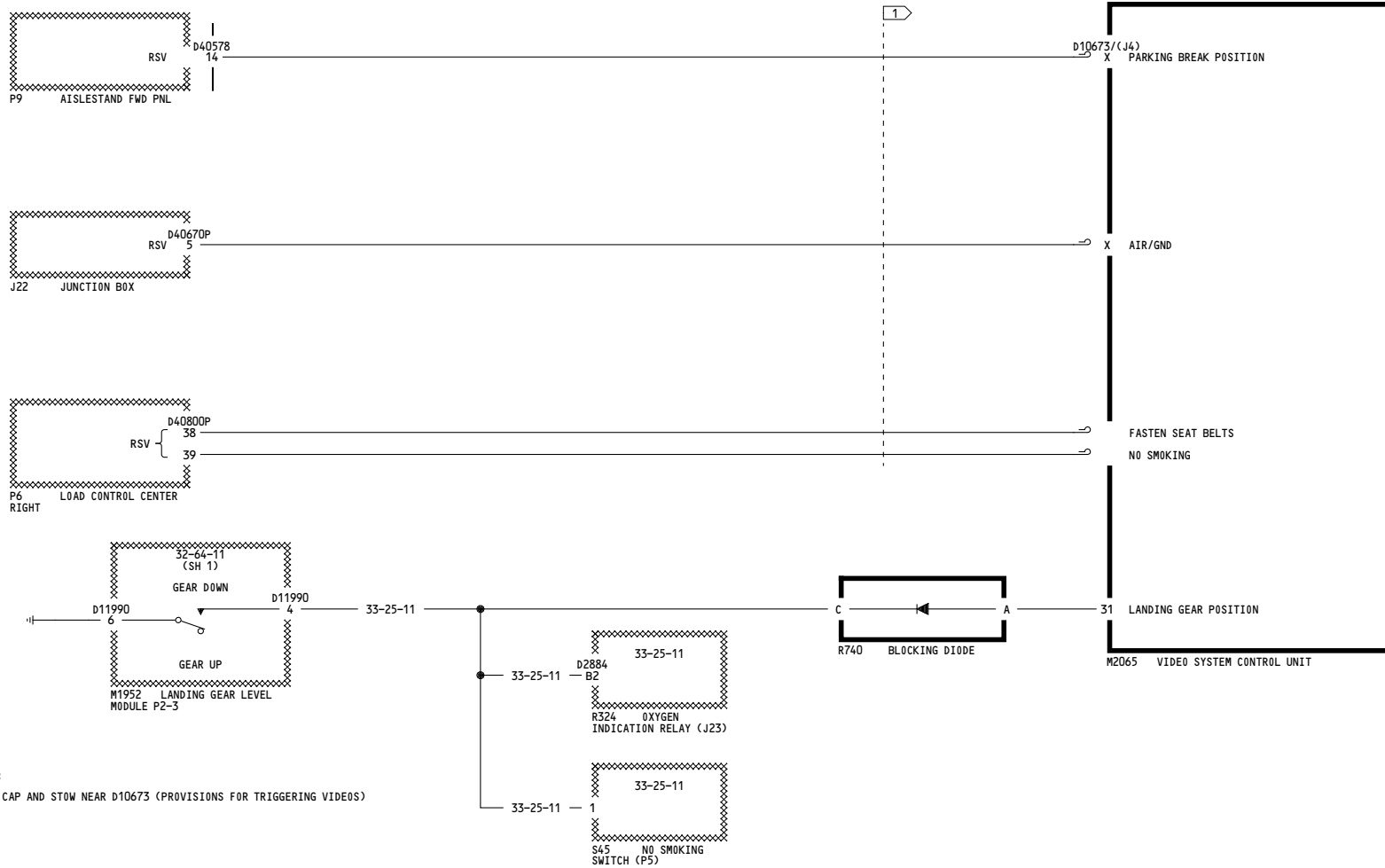

NOTES:

1 CAP AND STOW NEAR D10673 (PROVISIONS FOR TRIGGERING VIDEOS)

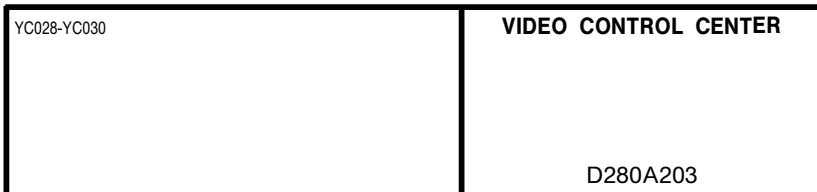

23-32-11

Page 103
Sheet 3
Mar 31/2005

THIS PAGE INTENTIONALLY LEFT BLANK

WIRING DIAGRAMS
23-32-11
23-32-12
23-32-13

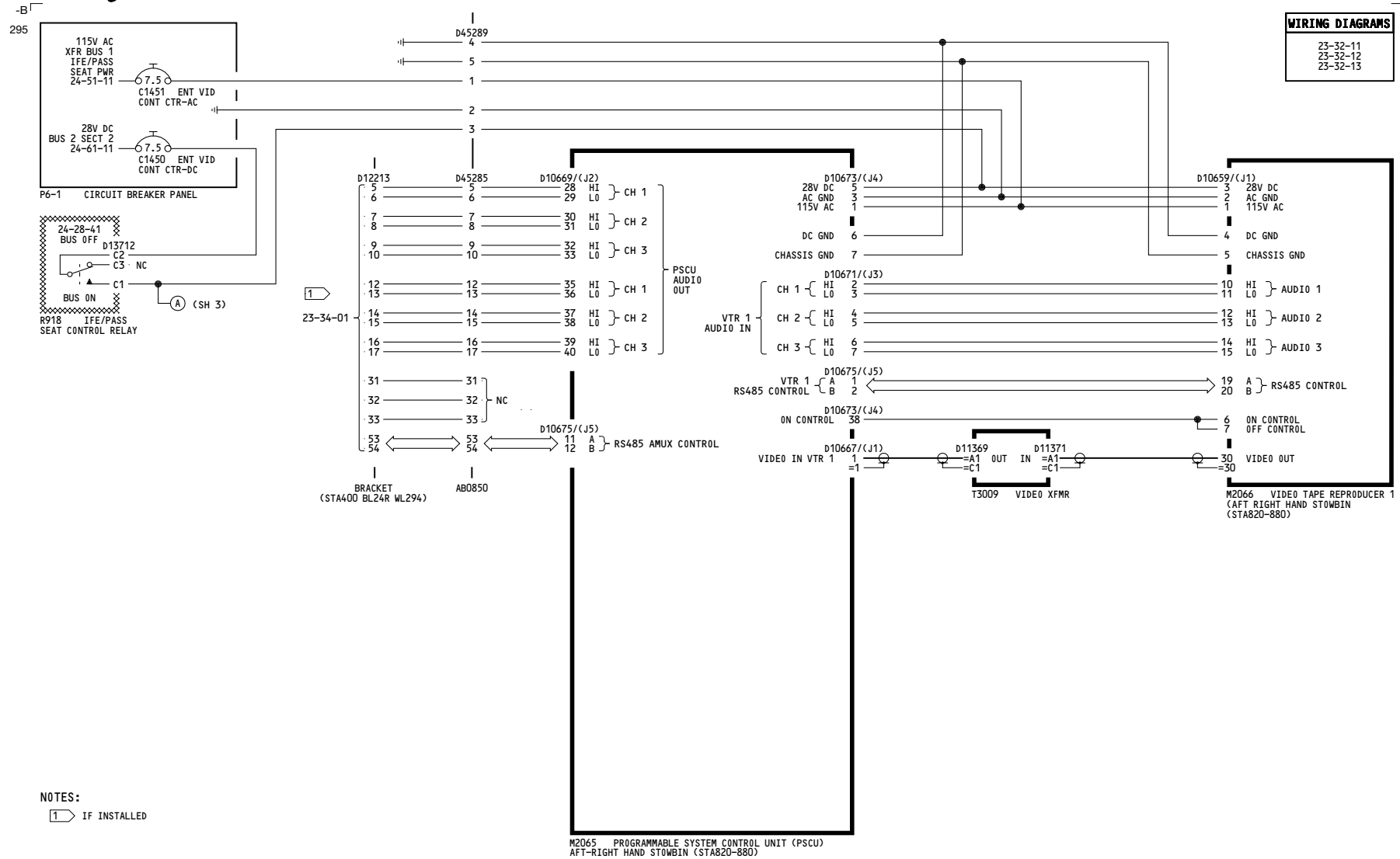

NOTES:
1 IF INSTALLED

YK901-YL401	<p>VIDEO CONTROL CENTER</p> <p>D280A203</p>
-------------	--

23-32-11

WIRING DIAGRAMS
 23-31-06
 23-32-12
 23-34-01

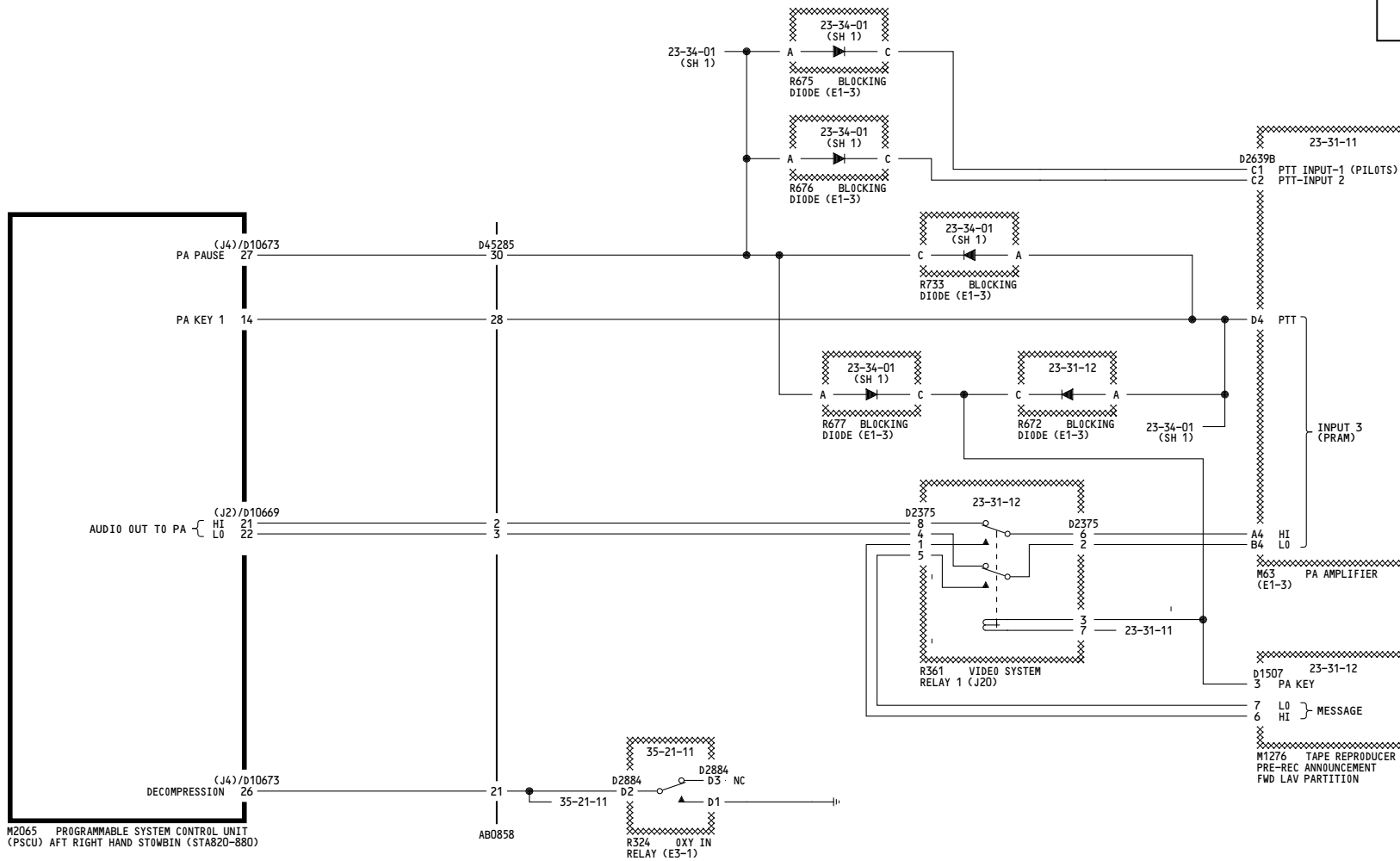

YK901-YL401	VIDEO CONTROL CENTER D280A203
-------------	---

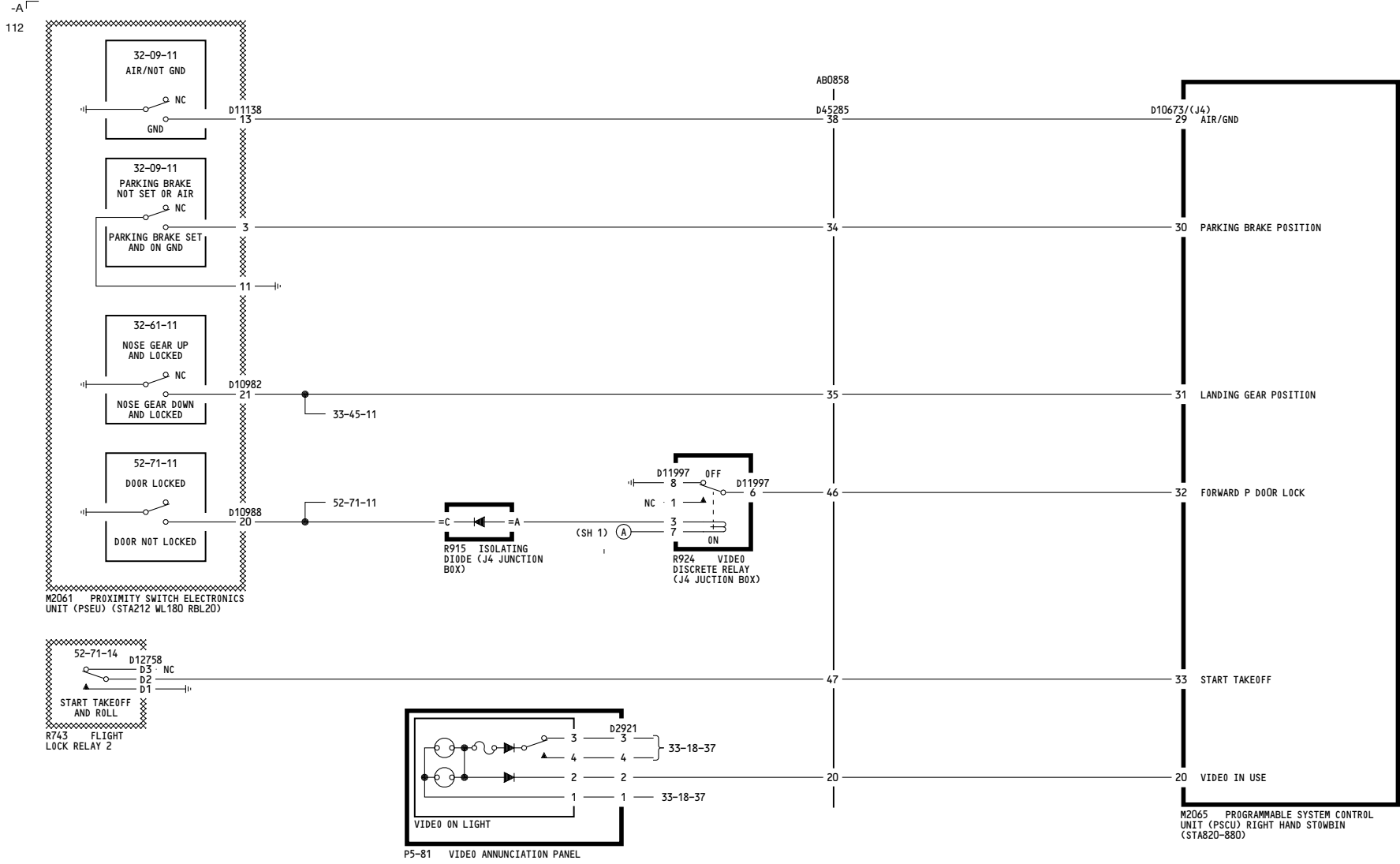

YK901-YL401	VIDEO CONTROL CENTER
D280A203	

23-32-11

THIS PAGE INTENTIONALLY LEFT BLANK

WIRING DIAGRAMS
23-32-11
23-32-12
23-32-13

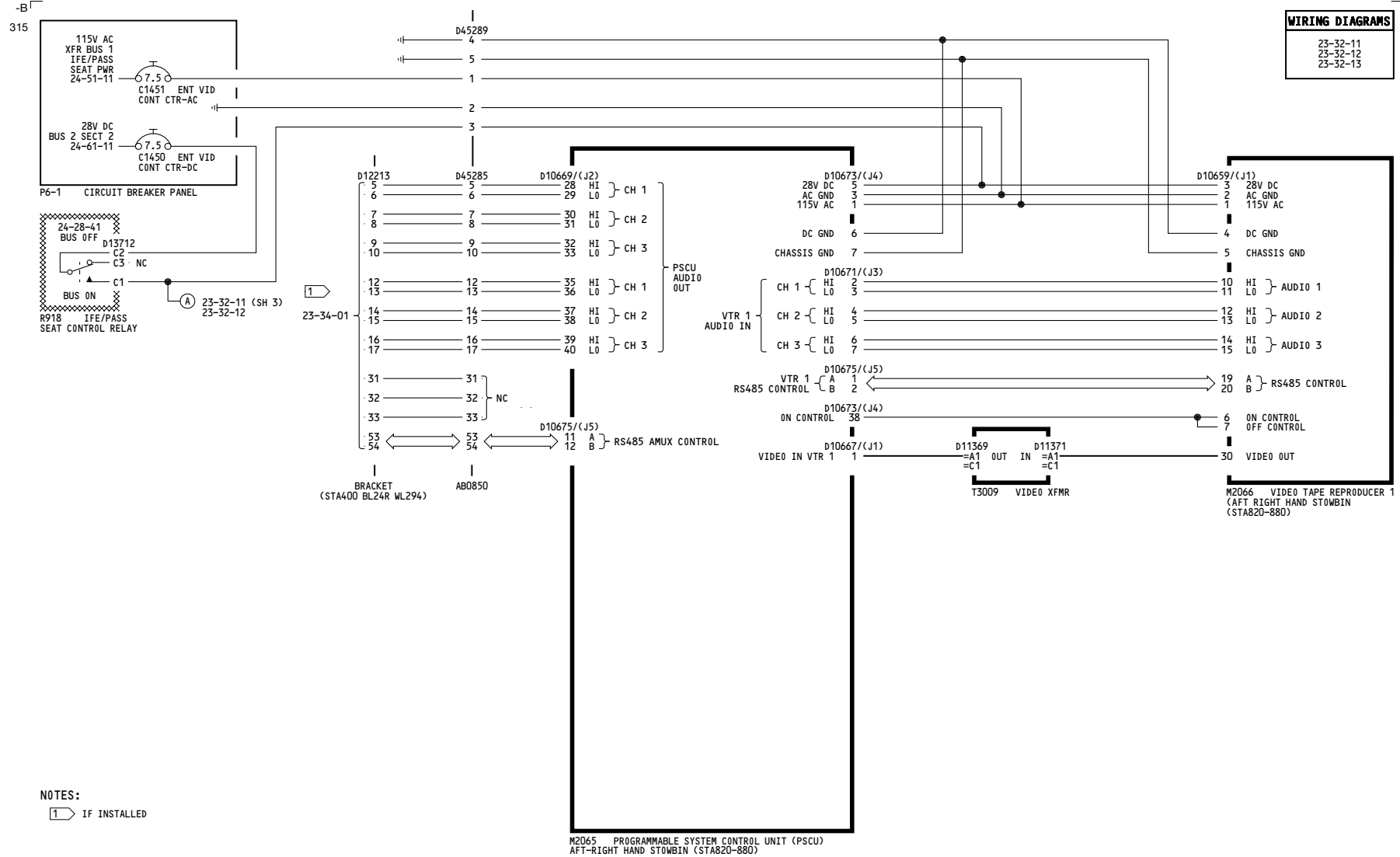

NOTES:
1 IF INSTALLED

YL421-YL425	VIDEO CONTROL CENTER
D280A203	

23-32-11

Page 105
Sheet 1
Nov 11/2008

WIRING DIAGRAMS
 23-31-06
 23-32-12
 23-34-01

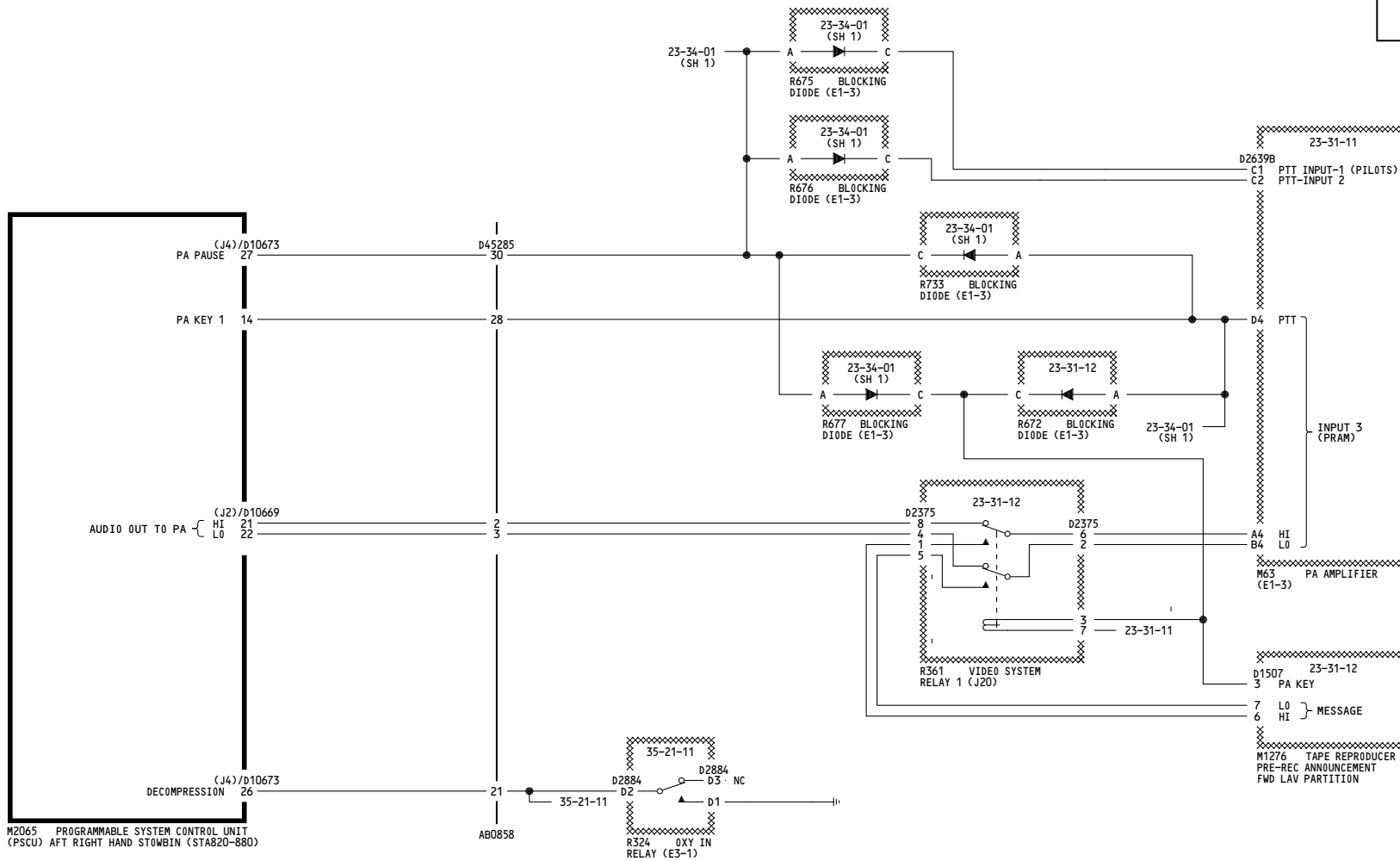

YL421-YL425	VIDEO CONTROL CENTER
	D280A203

23-32-11

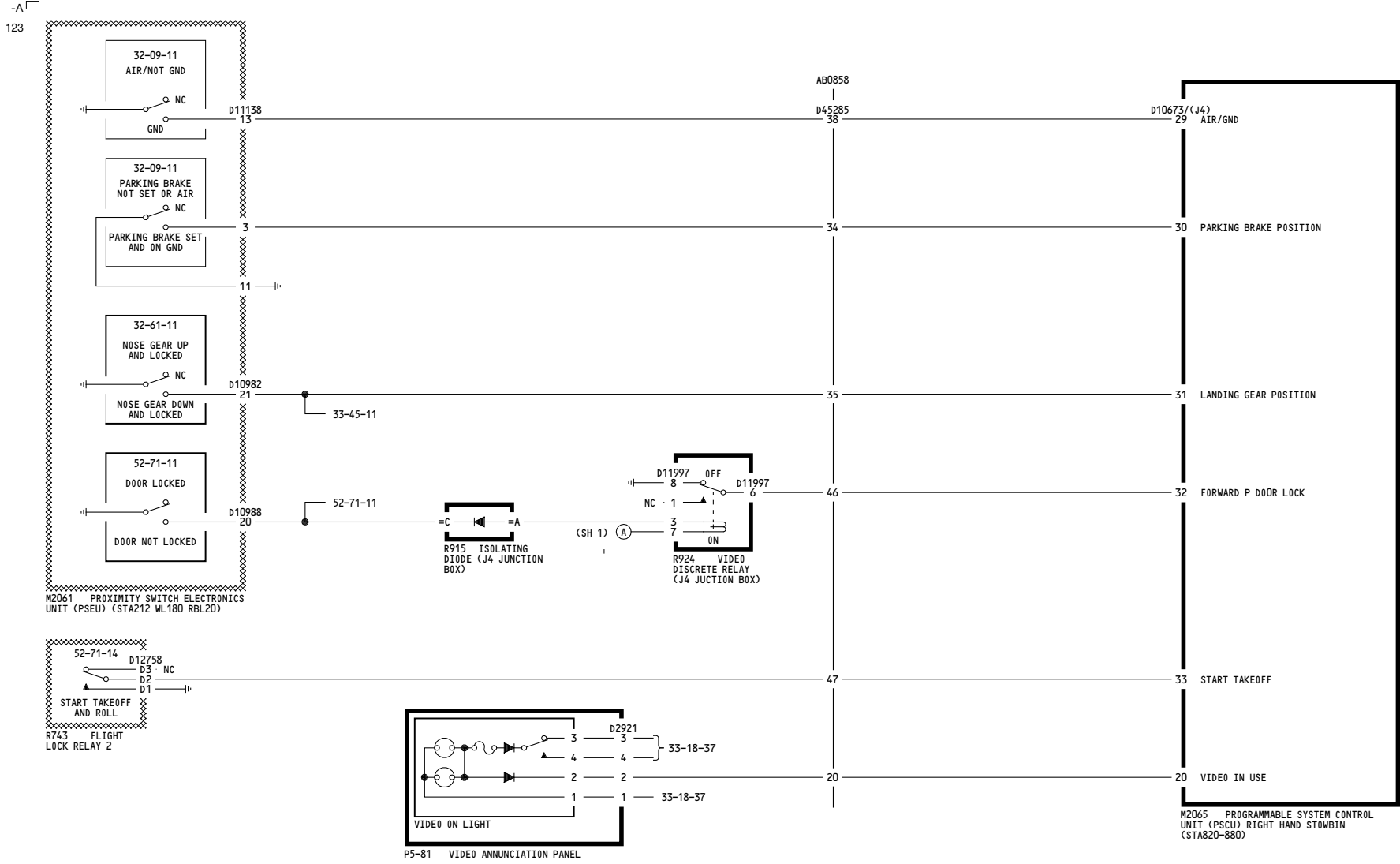

YL421-YL425	VIDEO CONTROL CENTER
D280A203	

23-32-11

Page 105
Sheet 3
Jan 14/2008

THIS PAGE INTENTIONALLY LEFT BLANK

WIRING DIAGRAMS
23-32-11
23-32-12
23-32-13

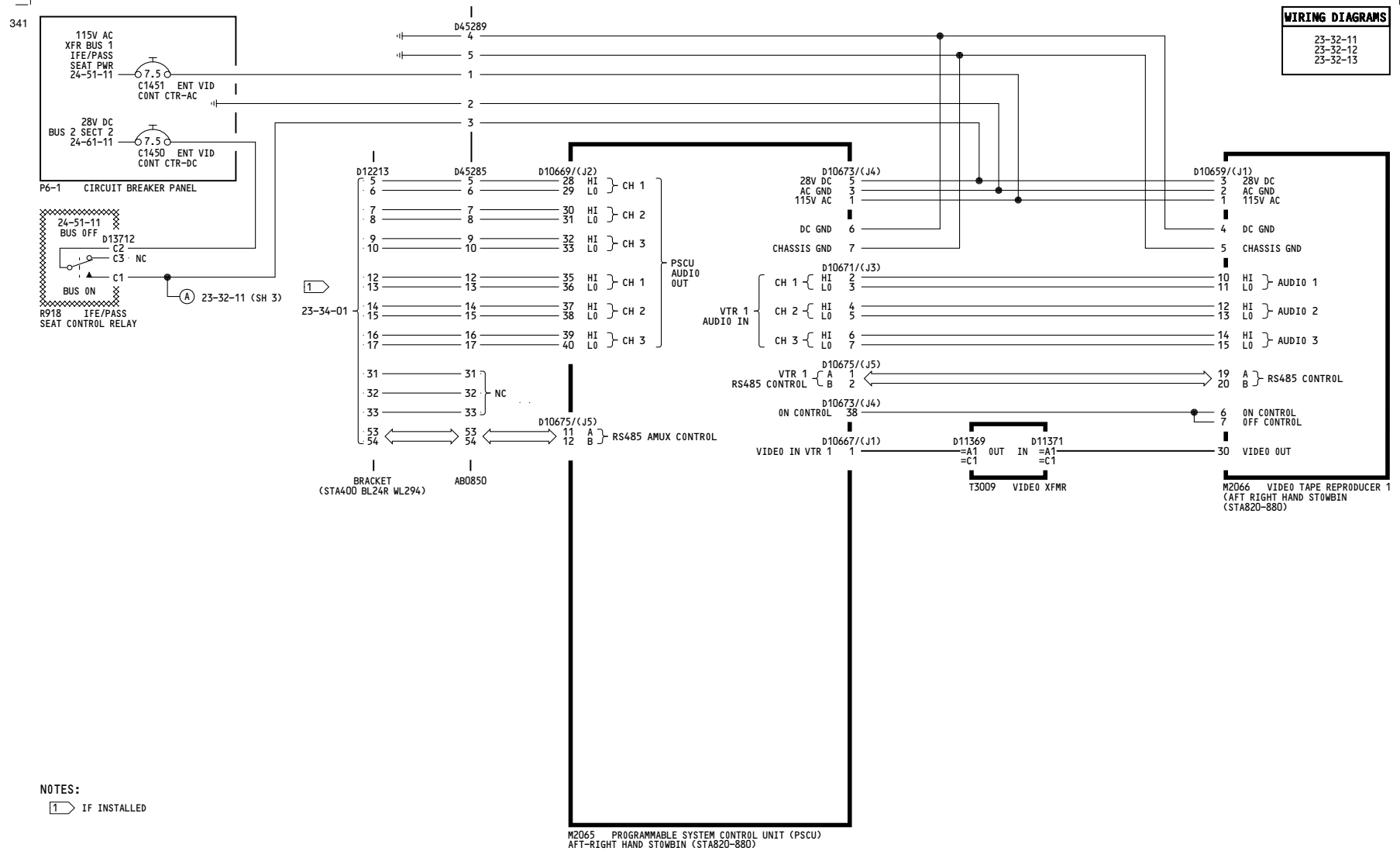

YL426-YL430	VIDEO CONTROL CENTER
D280A203	

23-32-11

WIRING DIAGRAMS
 23-31-06
 23-32-12
 23-34-01

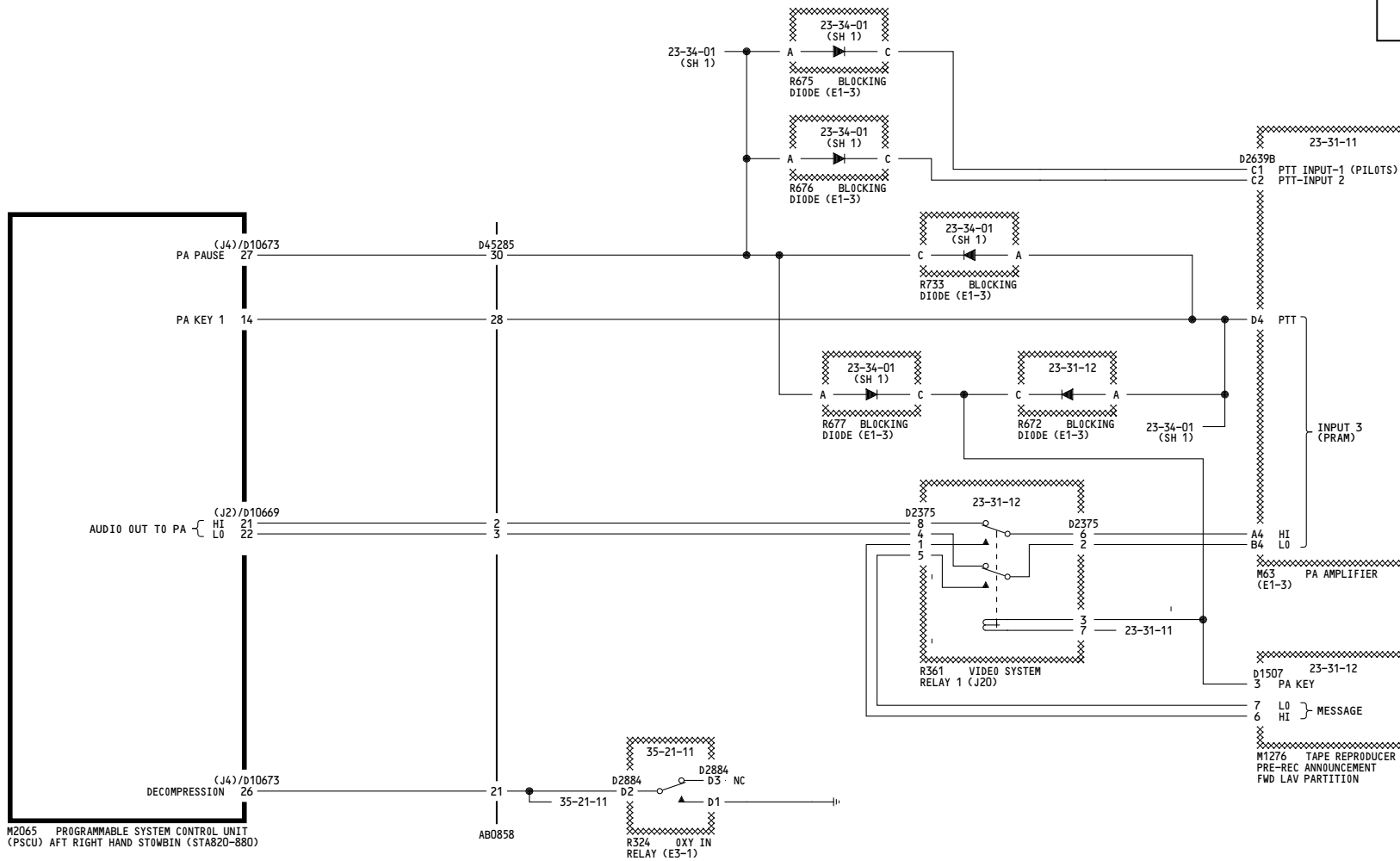

YL426-YL430	<p>VIDEO CONTROL CENTER</p> <p>D280A203</p>
-------------	--

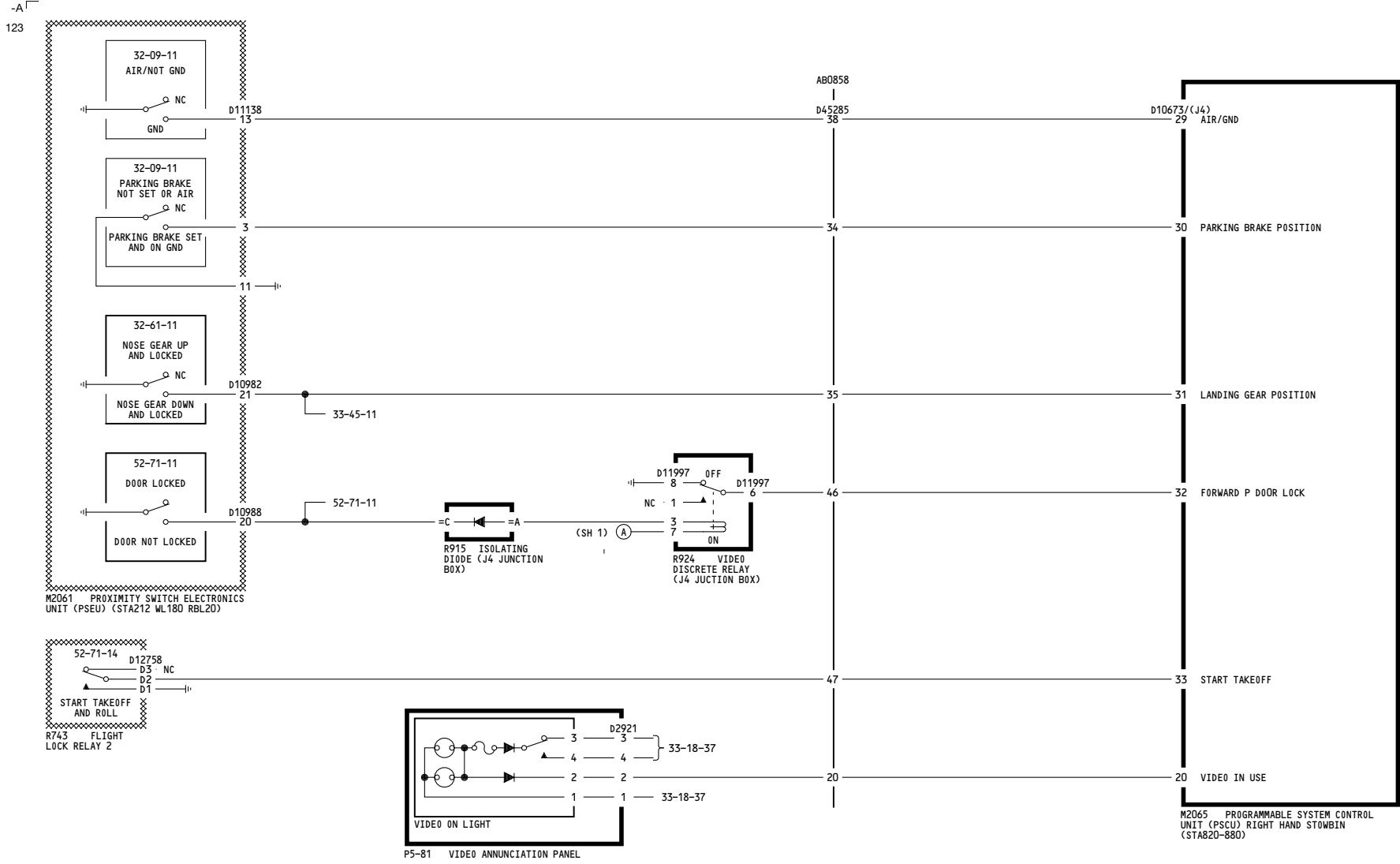

YL426-YL430	VIDEO CONTROL CENTER
D280A203	

23-32-11

Page 106
Sheet 3
Jan 14/2008

THIS PAGE INTENTIONALLY LEFT BLANK

WIRING DIAGRAMS
23-32-11
23-32-12
23-32-13

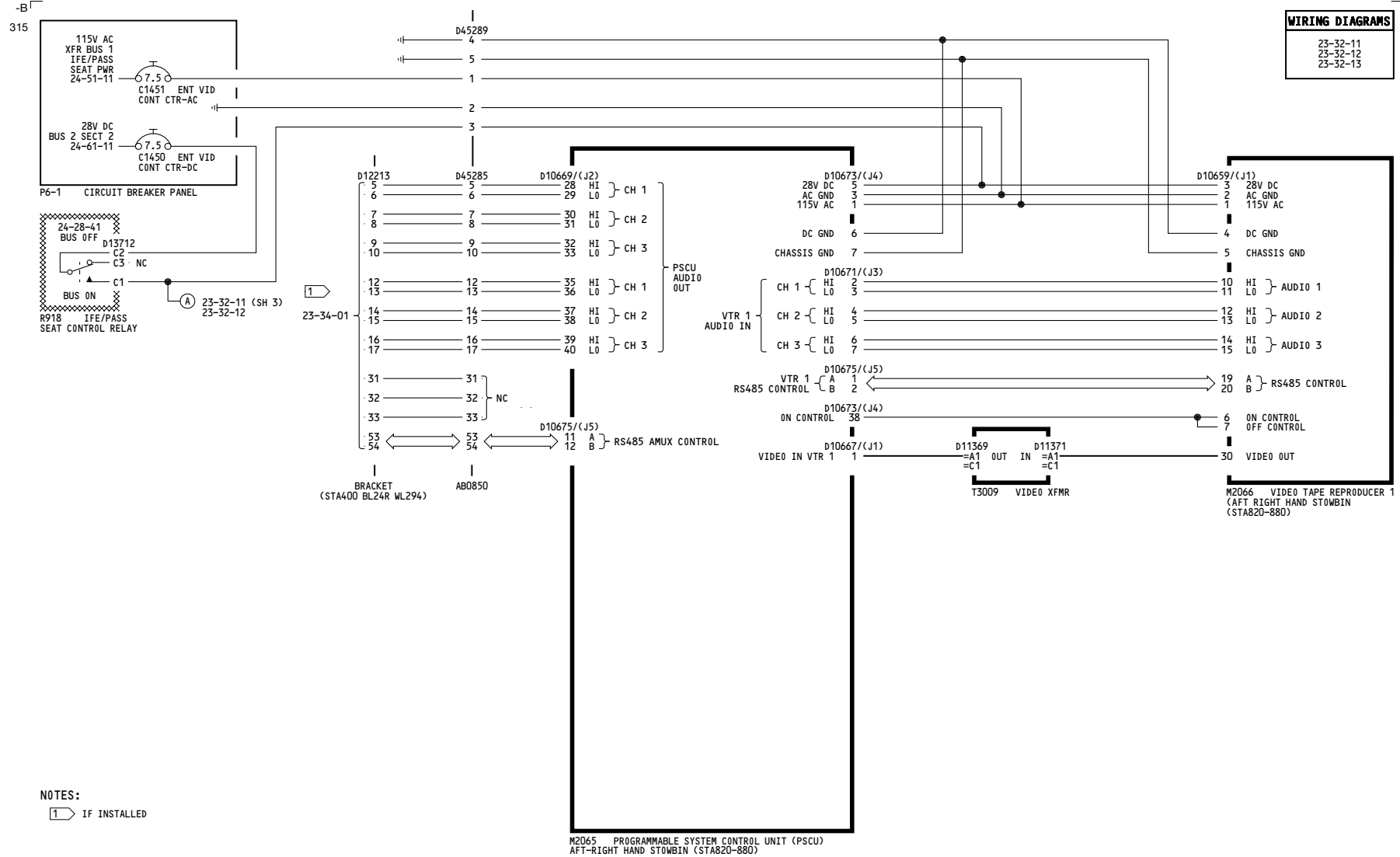

YM643-YM646

VIDEO CONTROL CENTER

D280A203

23-32-11

Page 107
Sheet 1
Nov 11/2008

WIRING DIAGRAMS
 23-31-06
 23-32-12
 23-34-01

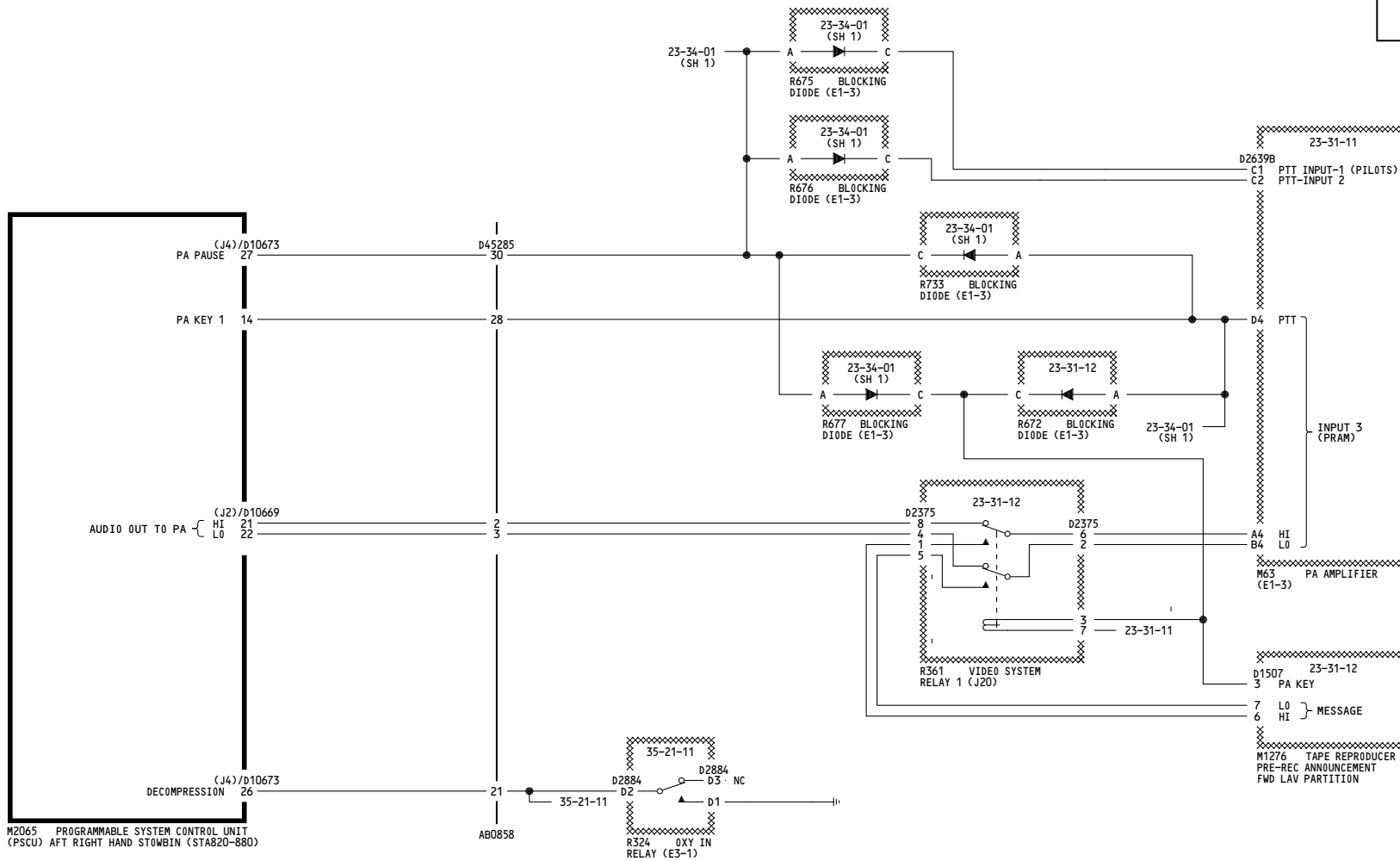

YM643-YM646	VIDEO CONTROL CENTER D280A203
-------------	---

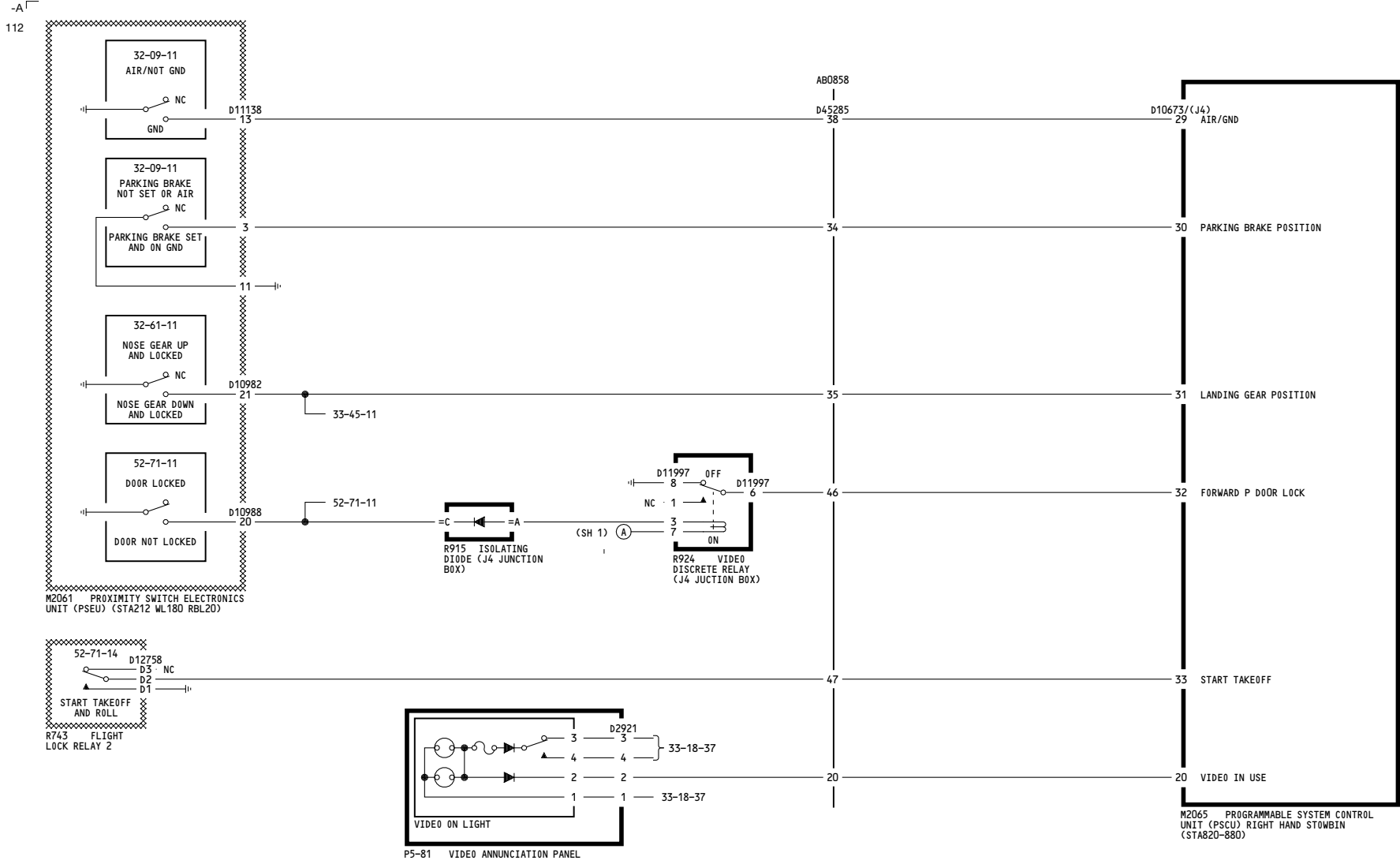

YM643-YM646	VIDEO CONTROL CENTER
D280A203	

23-32-11

THIS PAGE INTENTIONALLY LEFT BLANK

WIRING DIAGRAMS
23-32-11
23-32-12
23-32-13

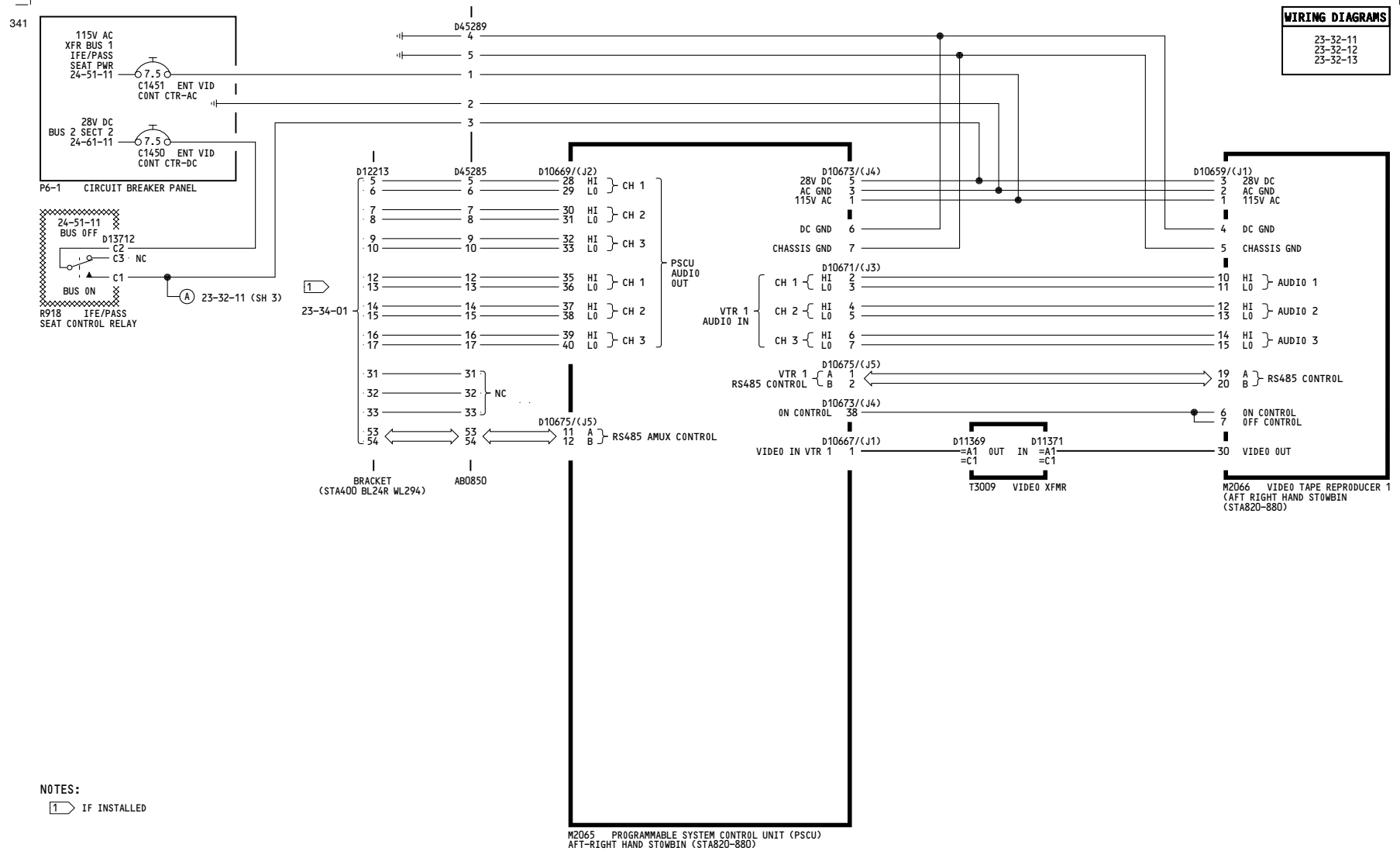

NOTES:
1 IF INSTALLED

YM647-YM670	<p>VIDEO CONTROL CENTER</p> <p>D280A203</p>
-------------	--

23-32-11

WIRING DIAGRAMS
 23-31-06
 23-32-12
 23-34-01

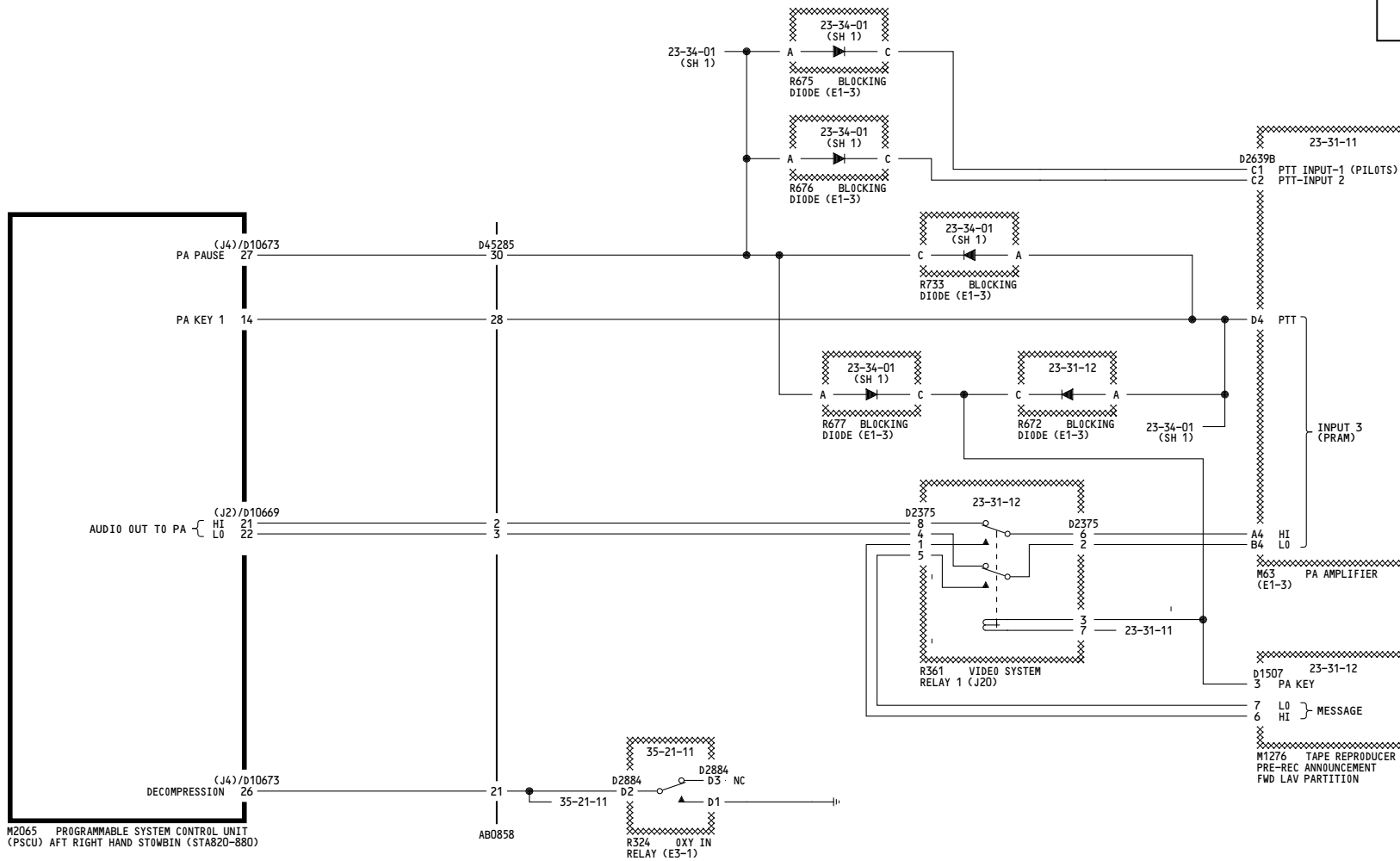

YM647-YM670	VIDEO CONTROL CENTER D280A203
-------------	---

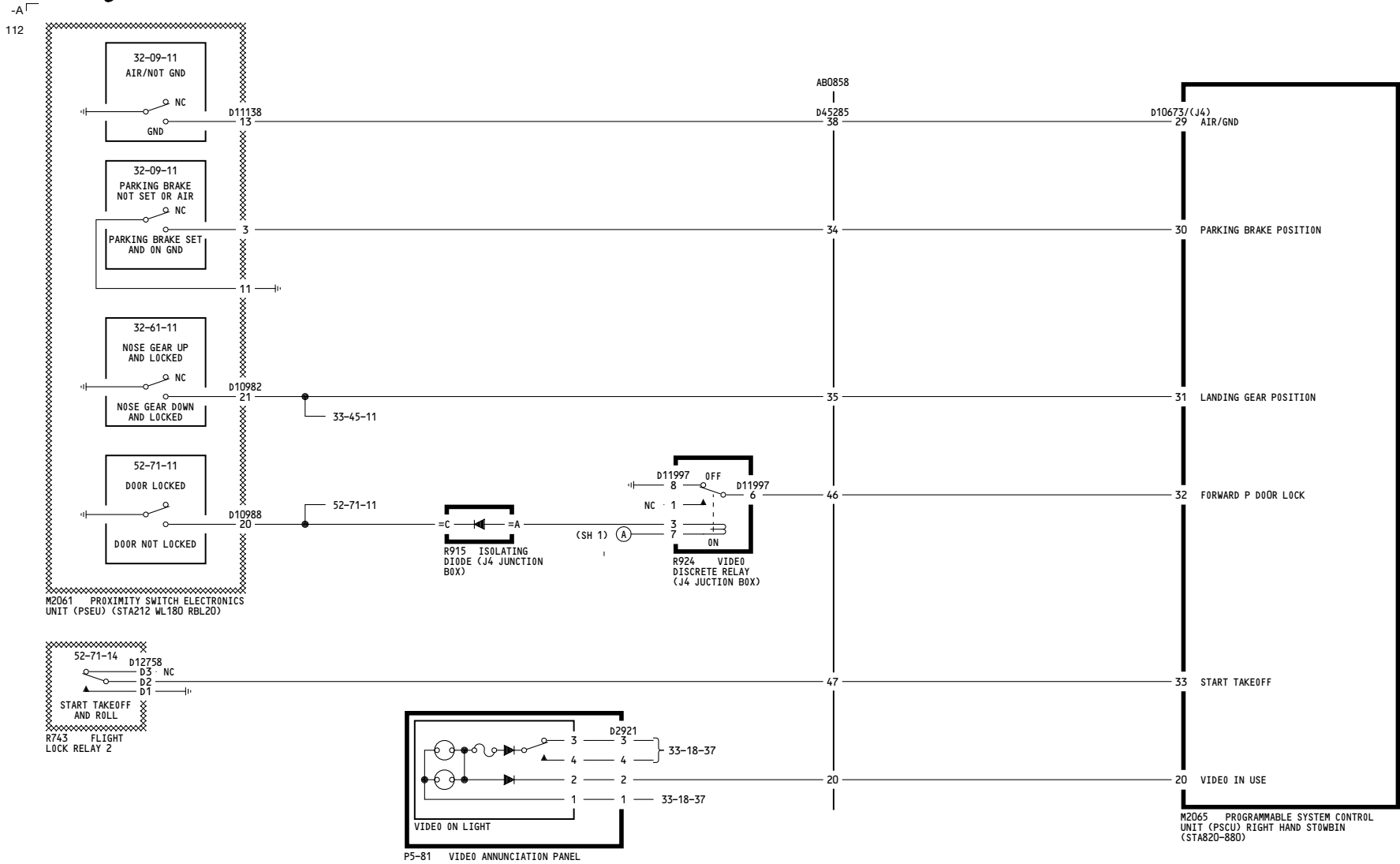

YM647-YM670	VIDEO CONTROL CENTER
D280A203	

23-32-11

Page 108
Sheet 3
Feb 12/2008

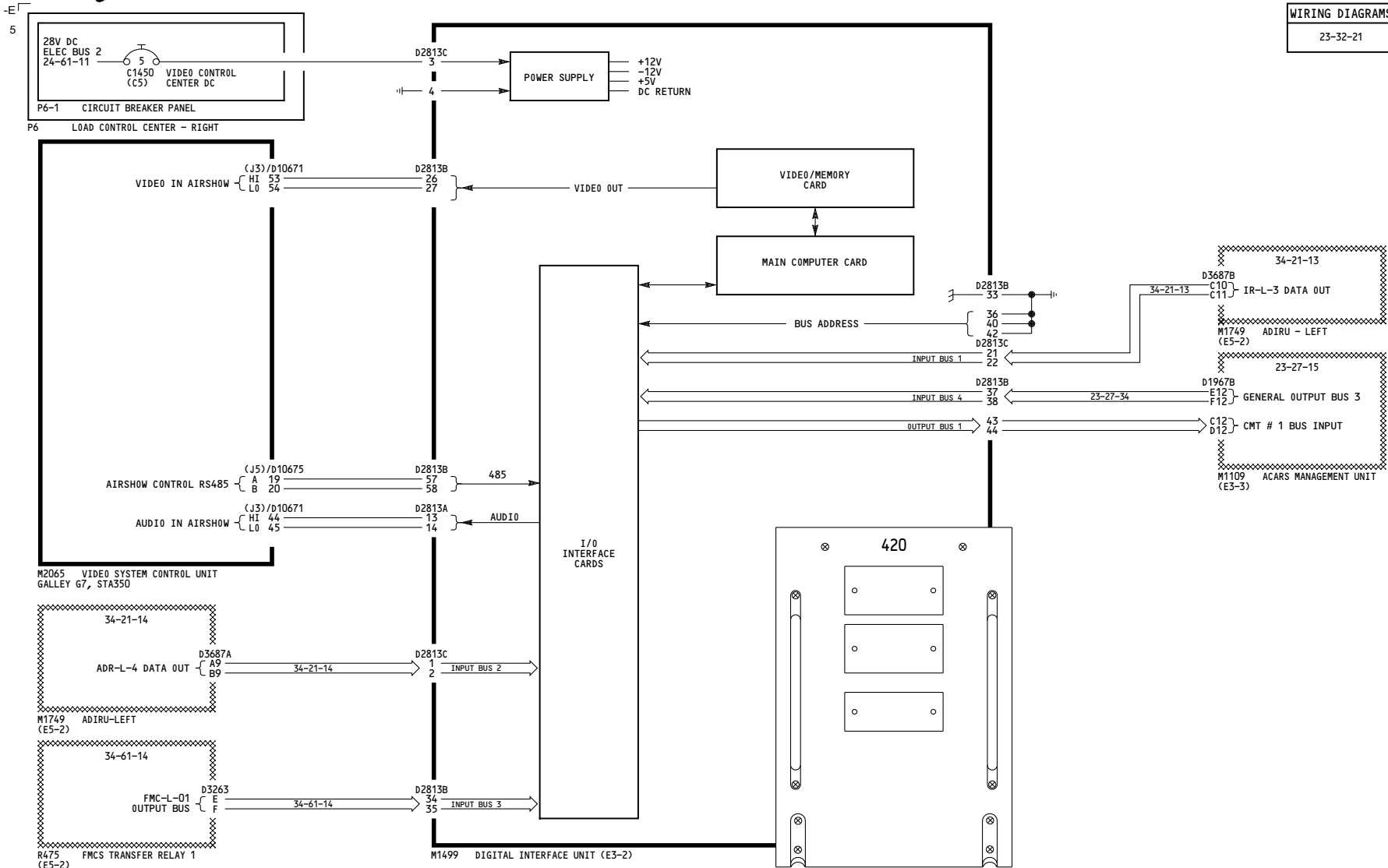

YC001-YC030

PASSENGER FLIGHT INFORMATION SYSTEM

D280A203

23-32-12

160

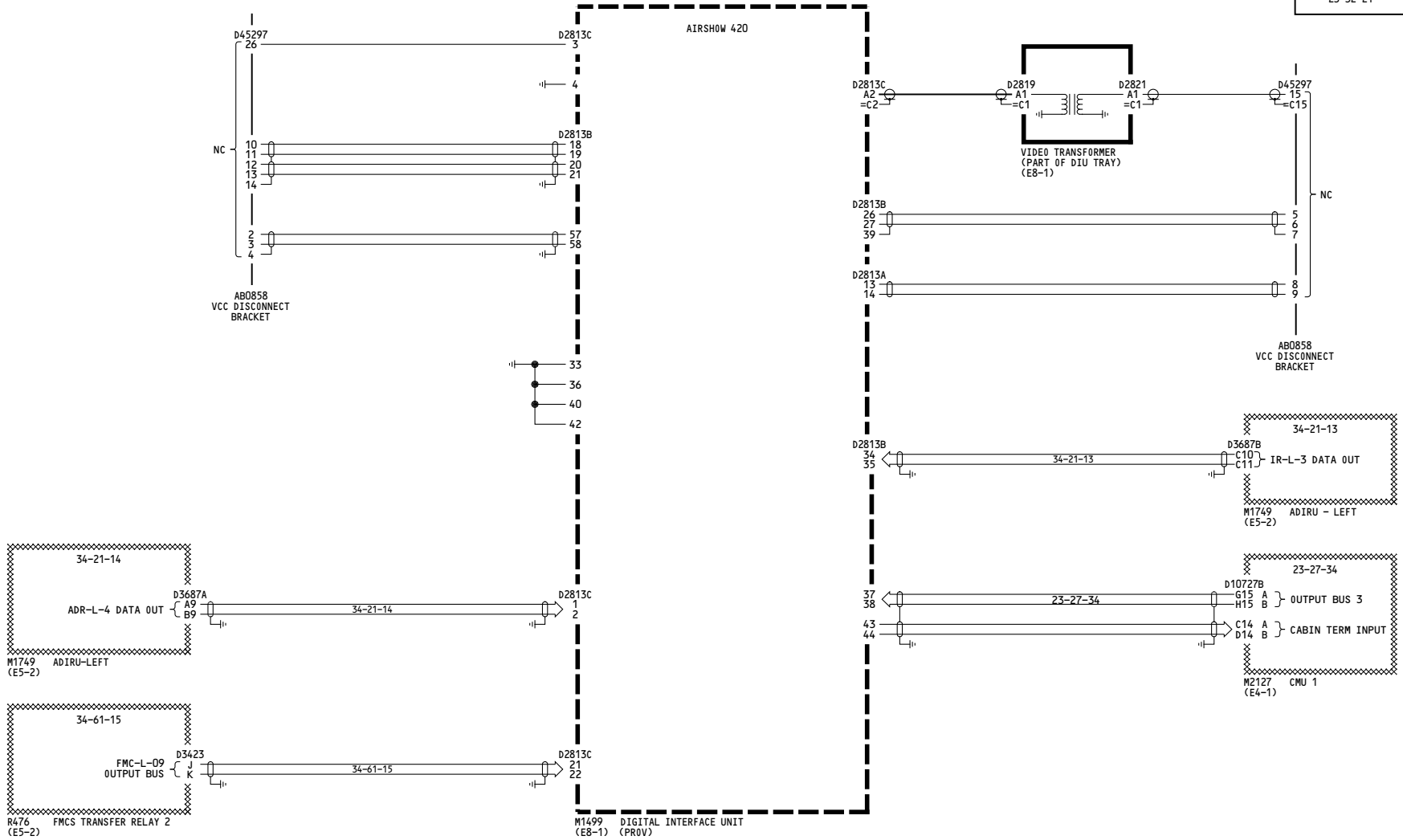

<p>YK901-YK906</p>	<p>PASSENGER FLIGHT INFORMATION SYSTEM</p> <p>D280A203</p>
--------------------	---

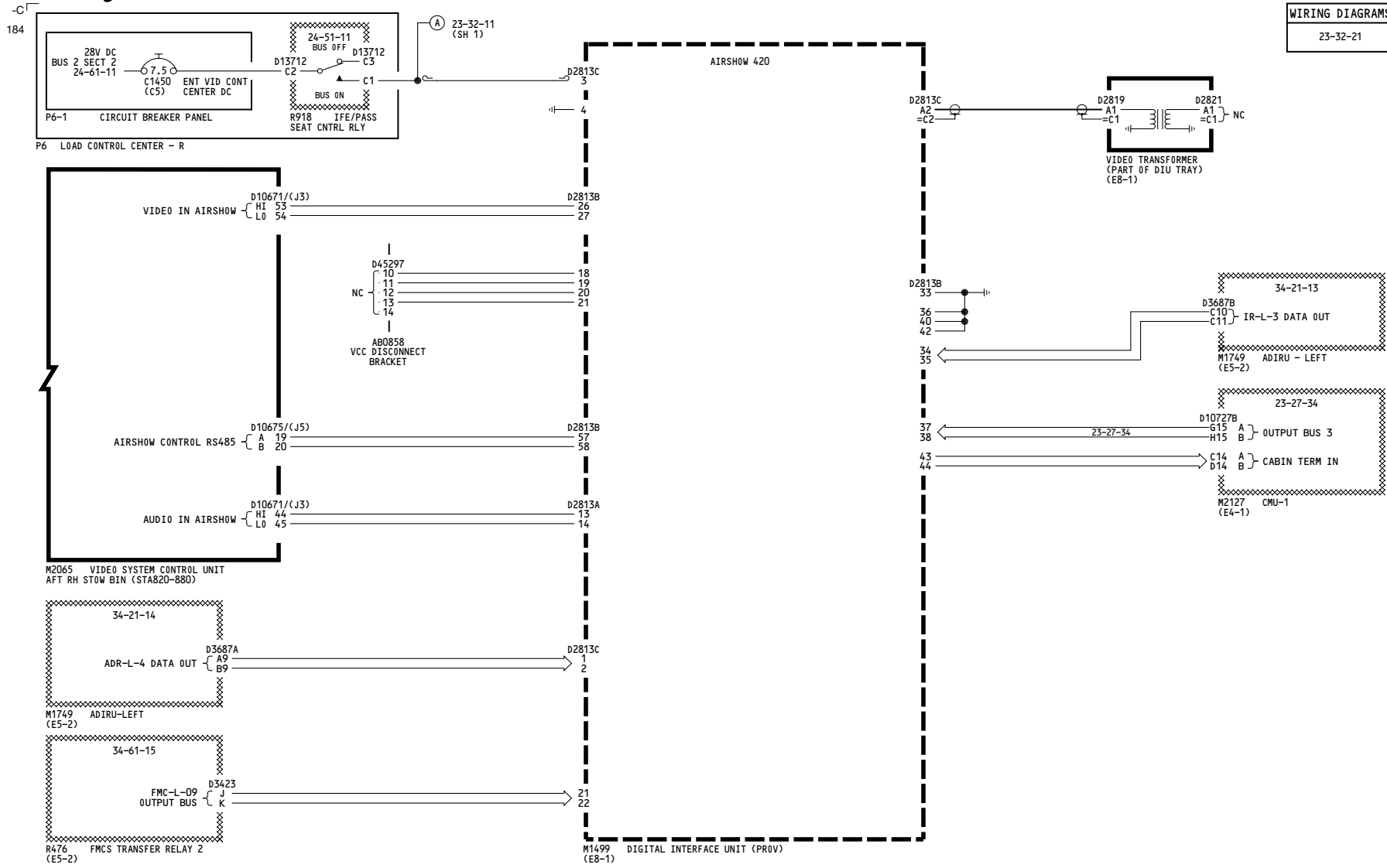

YK907-YK909, YM643-YM646	PASSENGER FLIGHT INFORMATION SYSTEM
D280A203	

23-32-12

186

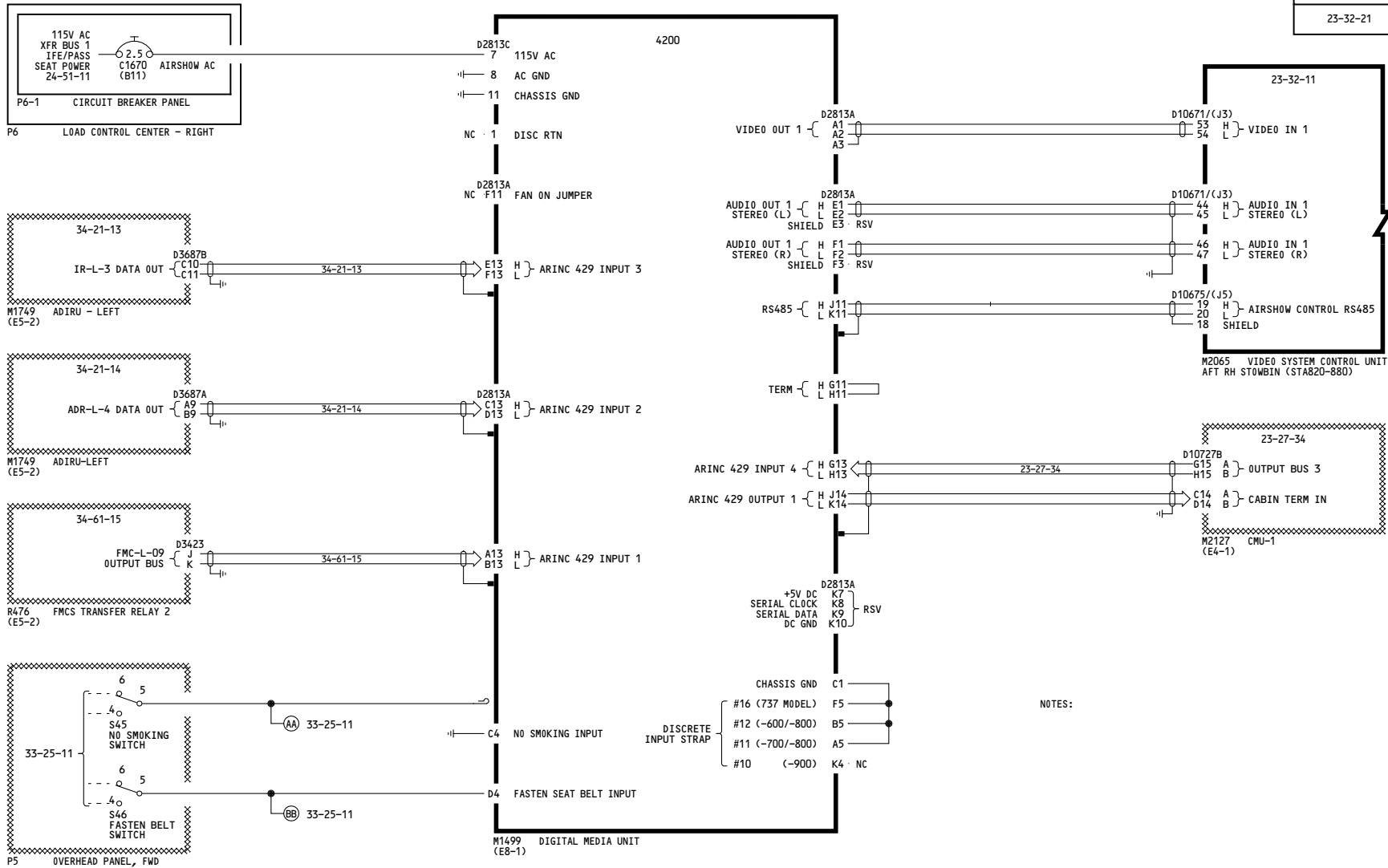

NOTES:

YK910, YK918, YL426

PASSENGER FLIGHT INFORMATION SYSTEM

23-32-12

Page 104

Feb 09/2009

D280A203

215

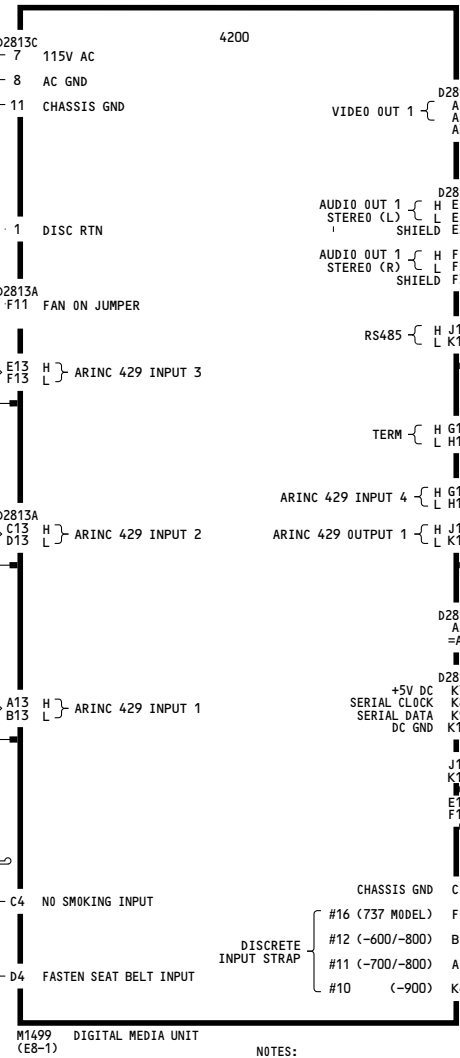
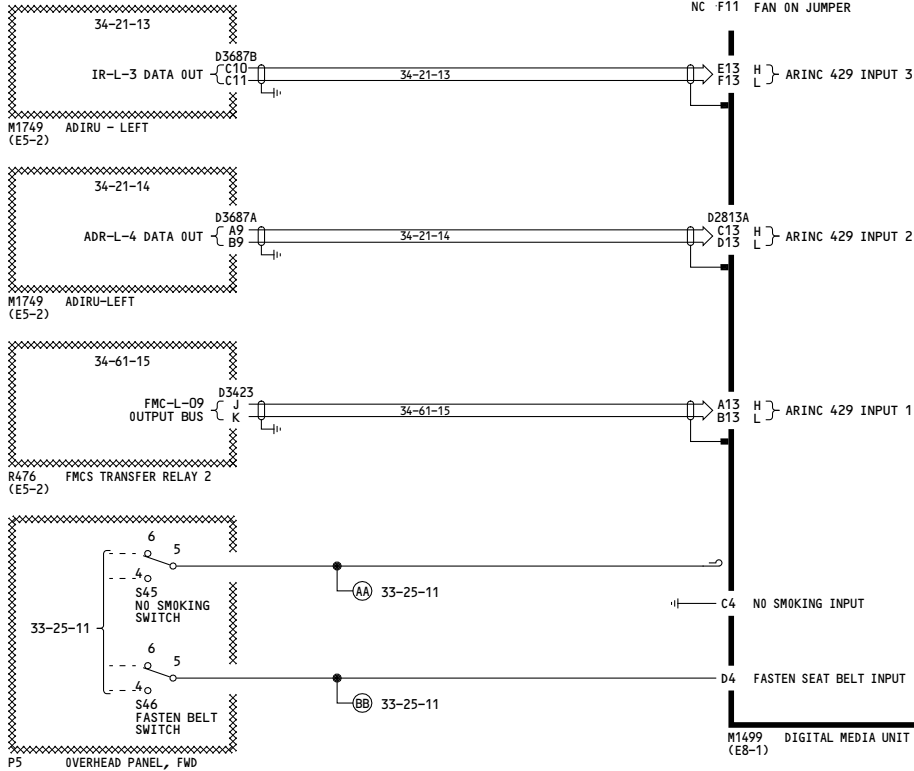
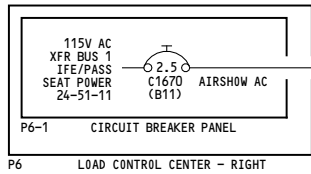

NOTES:

- DISCRETE INPUT STRAP
- #16 (737 MODEL)
 - #12 (-600/-800)
 - #11 (-700/-800)
 - #10 (-900)

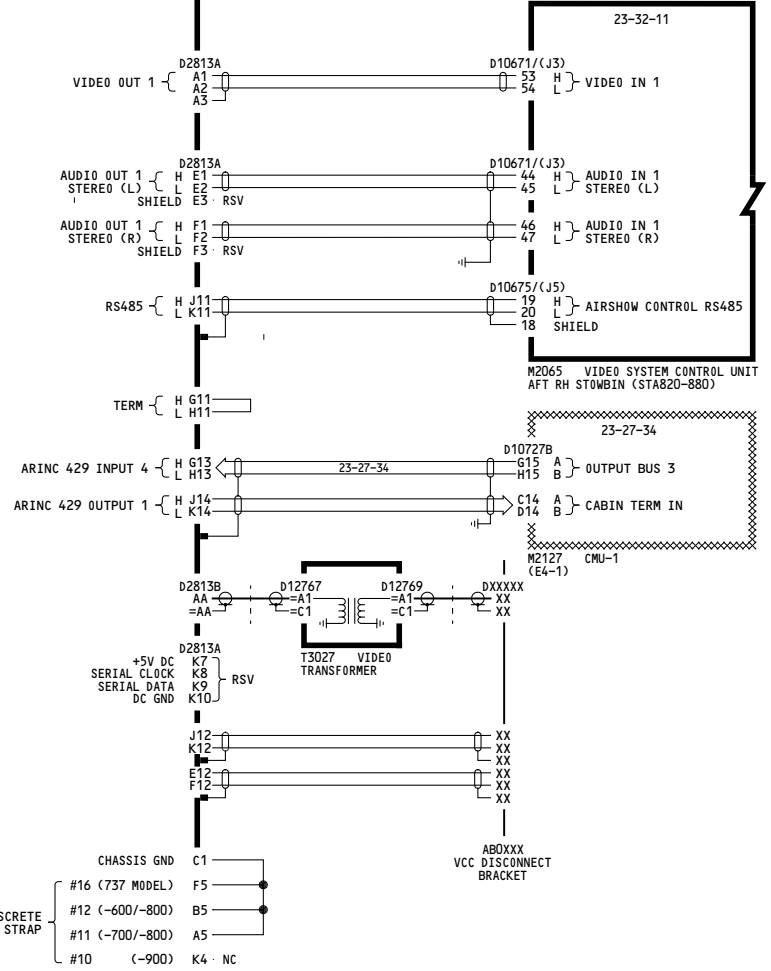

YK911-YK917, YK919-YL401, YL427-YL430

PASSENGER FLIGHT INFORMATION SYSTEM

D280A203

-B-
180

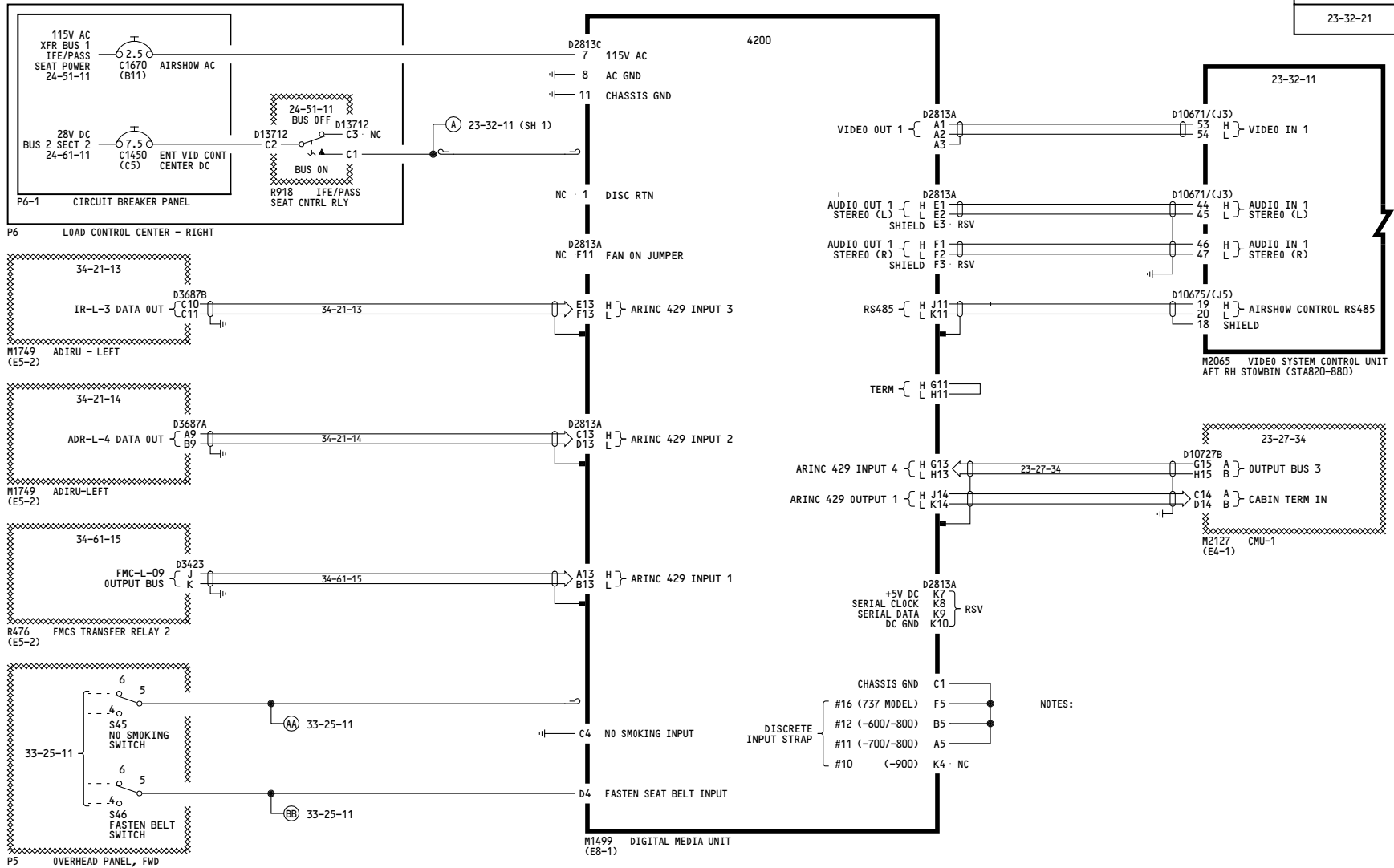

YL421-YL425

PASSENGER FLIGHT INFORMATION SYSTEM

D280A203

23-32-12

Page 106

May 13/2008

231

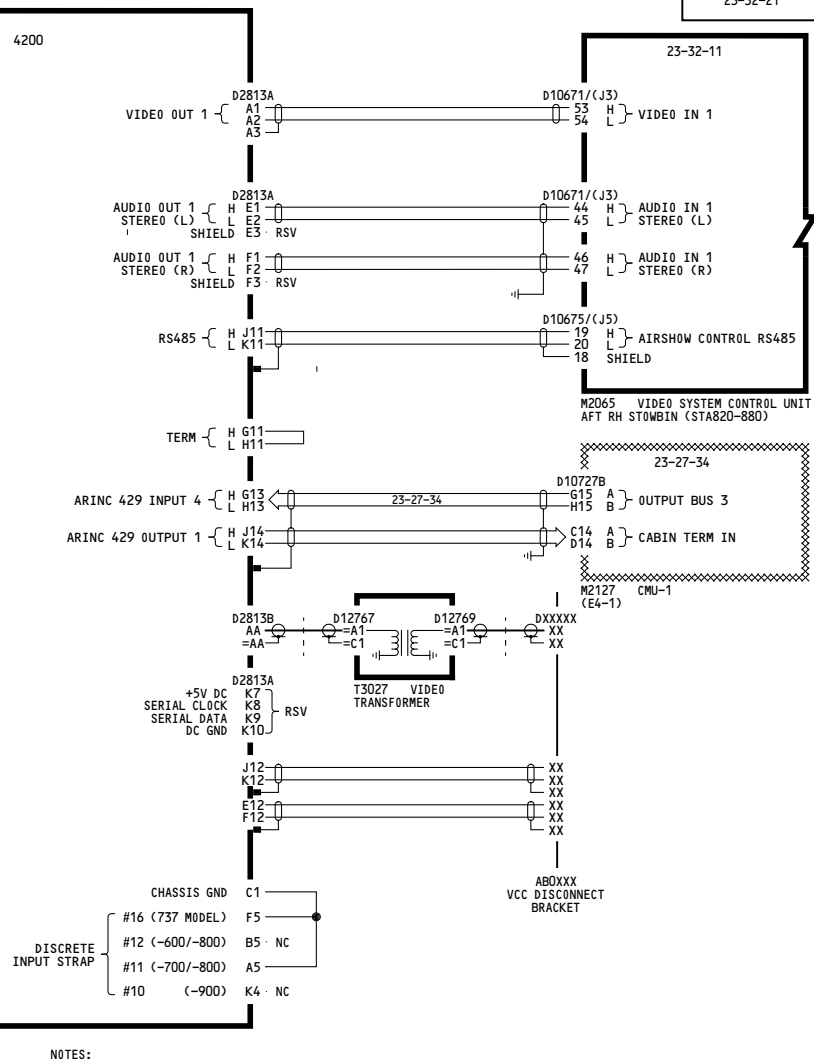
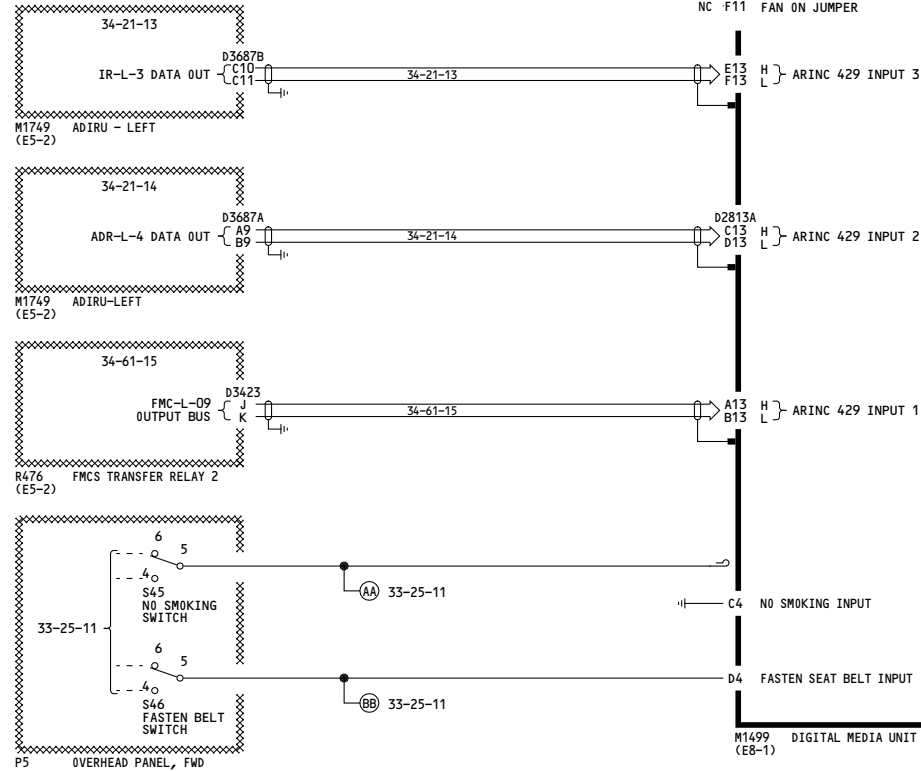
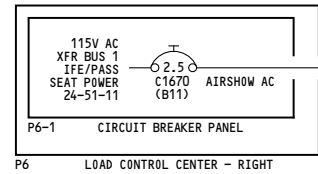

DISCRETE INPUT STRAP

#16 (737 MODEL)	C1
#12 (-600/-800)	F5
#11 (-700/-800)	B5 · NC
#10 (-900)	A5 · NC

NOTES:

YM647-YM670

PASSENGER FLIGHT INFORMATION SYSTEM

D280A203

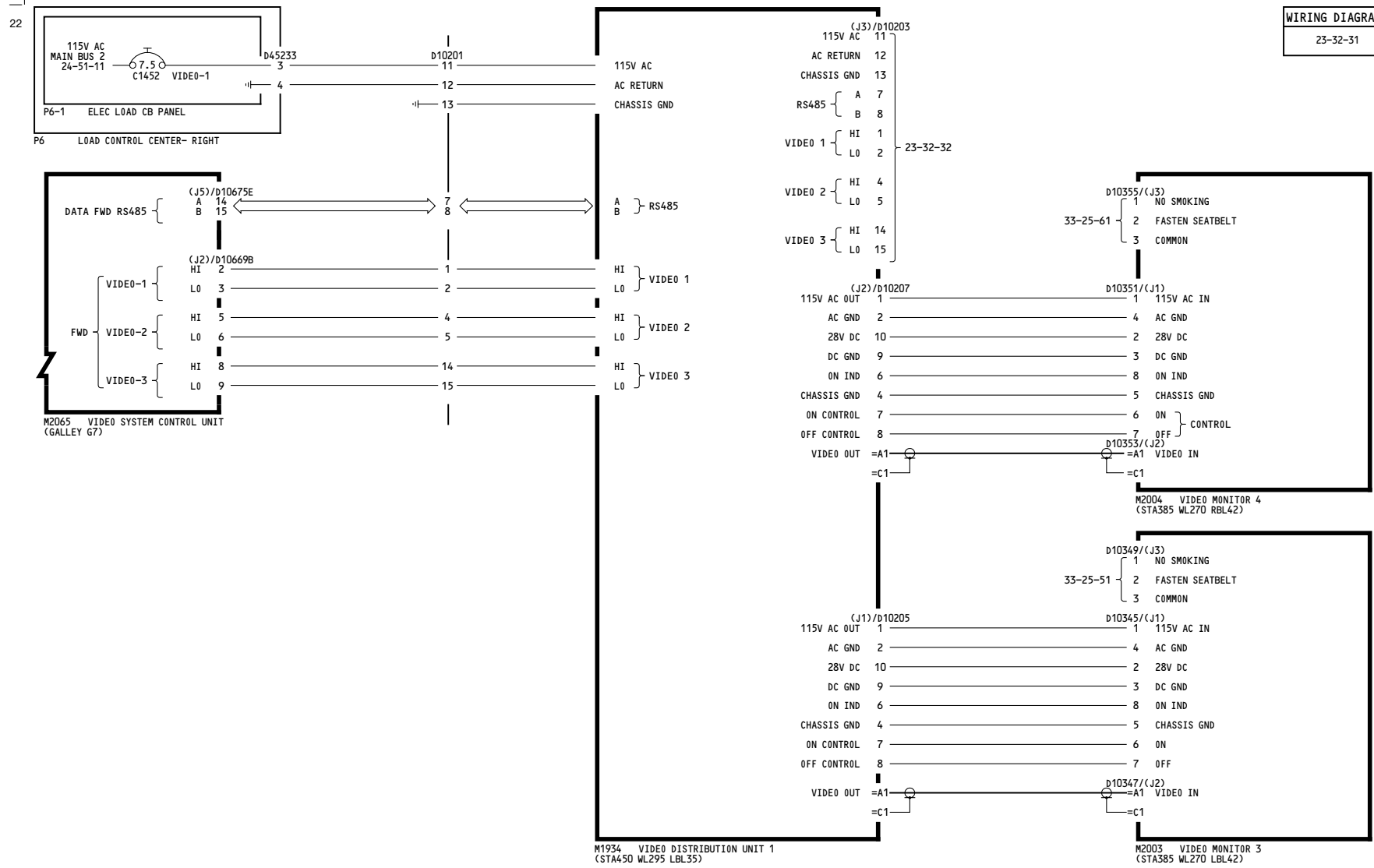

YC001-YC007	VIDEO ENTERTAINMENT SYSTEM TRAY 1 VDU 1 D280A203
-------------	--

23-32-31

36

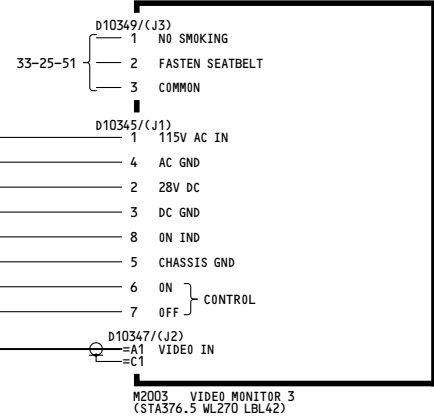
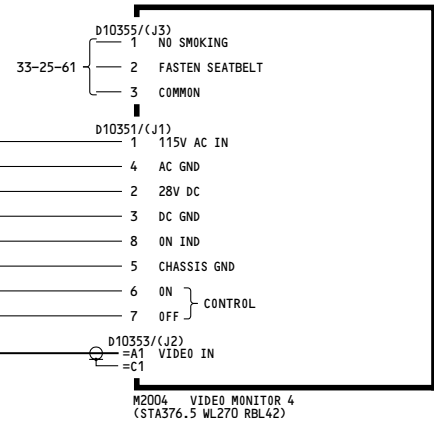
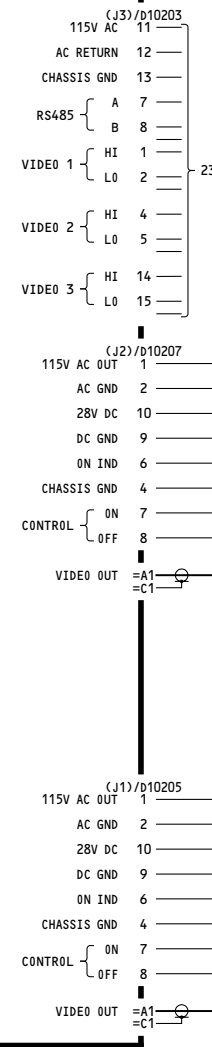
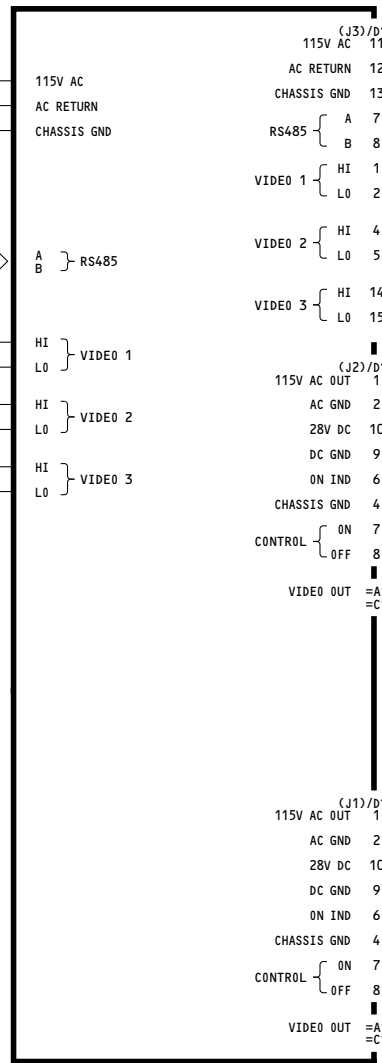
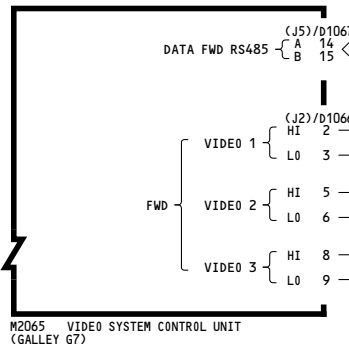
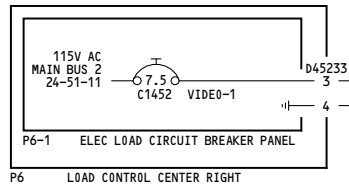

YC008-YC011

VIDEO ENTERTAINMENT SYSTEM TRAY 1 VDU 1

D280A203

23-32-31

Page 102

Mar 31/2005

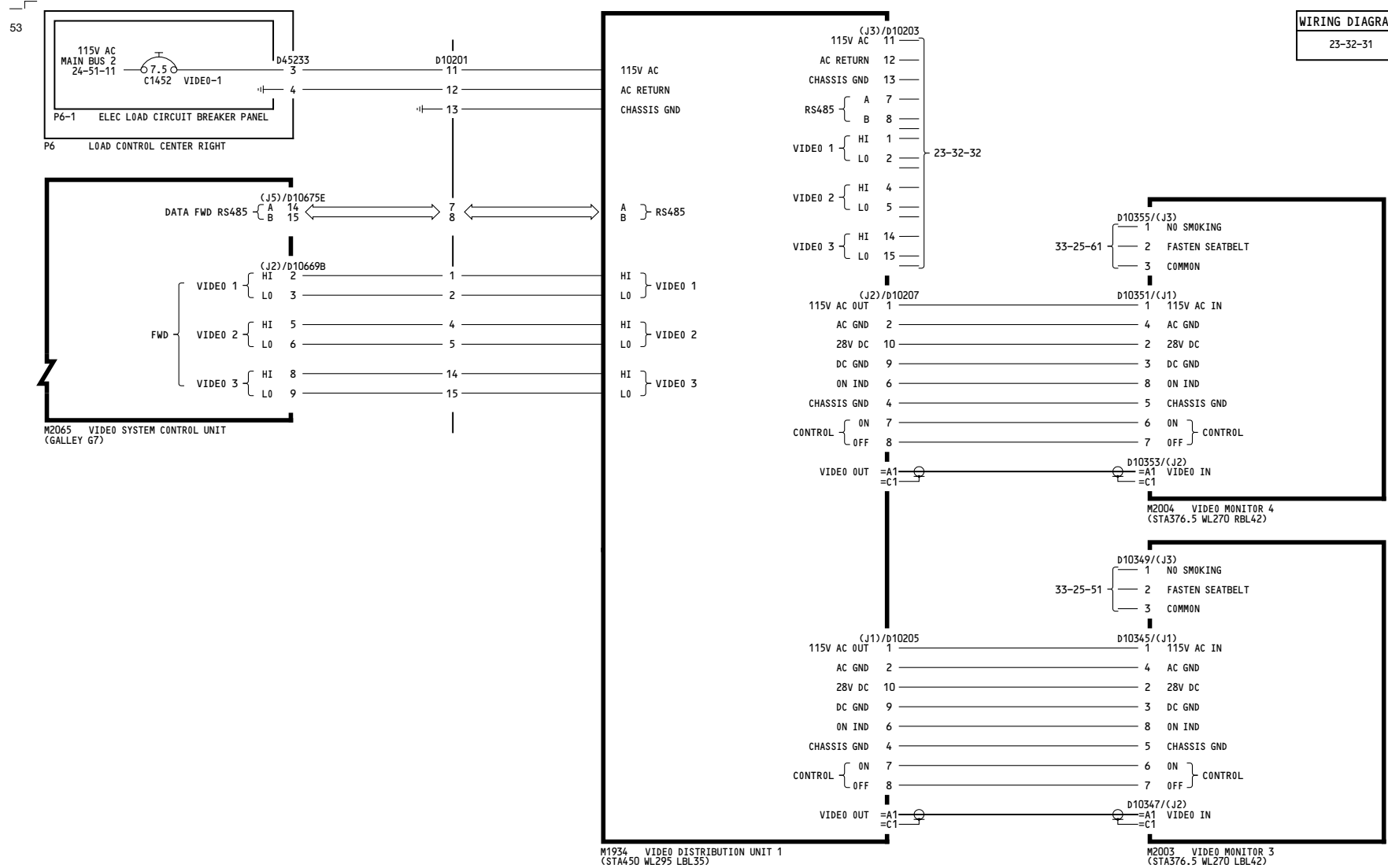

YC012-YC030	VIDEO ENTERTAINMENT SYSTEM TRAY 1 VDU 1 D280A203
-------------	--

WIRING DIAGRAMS
23-32-31

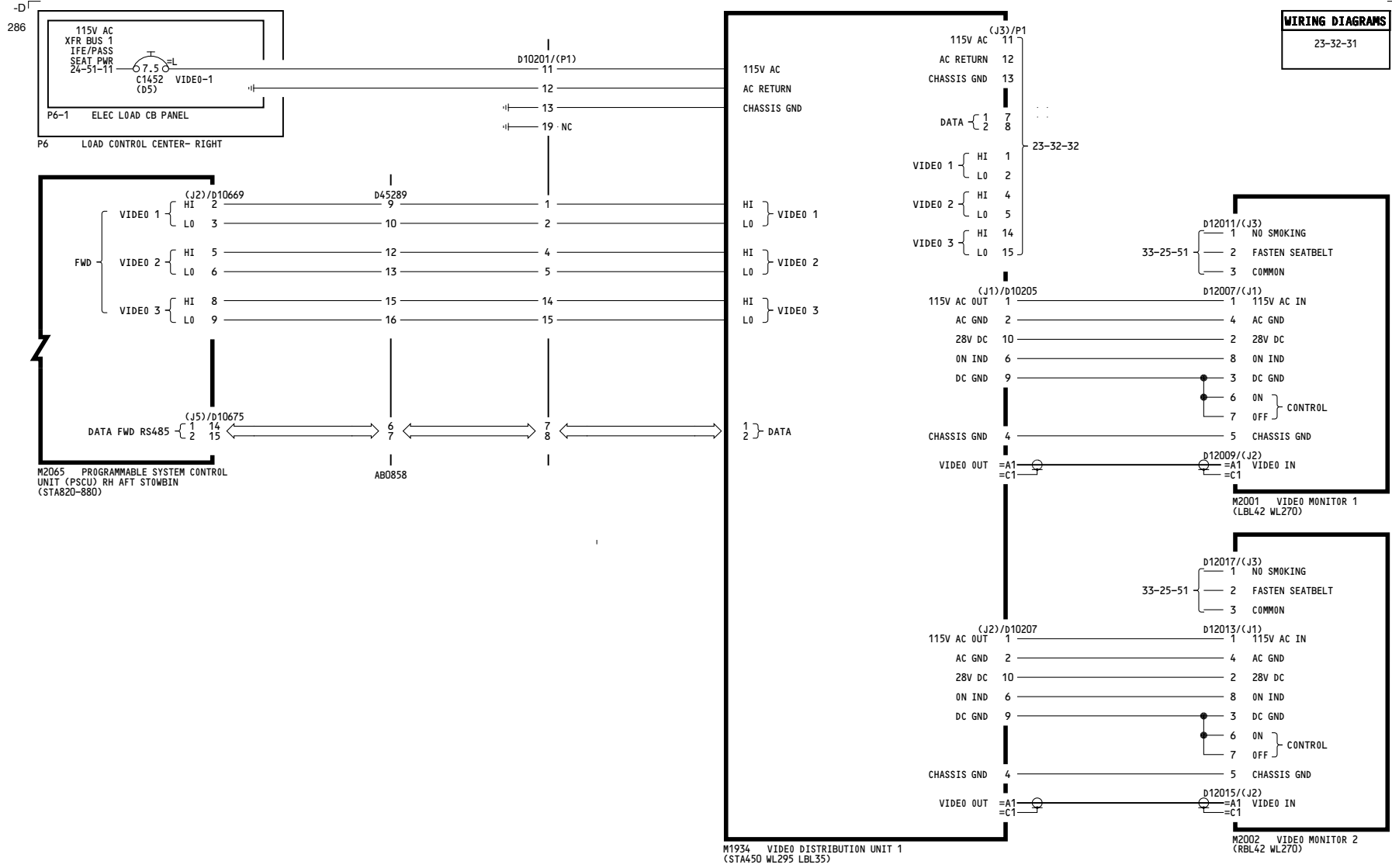

YK901-YL430	<p>VIDEO ENTERTAINMENT SYSTEM TRAY 1 VDU 1</p> <p>D280A203</p>
-------------	---

23-32-31

WIRING DIAGRAMS
23-32-31

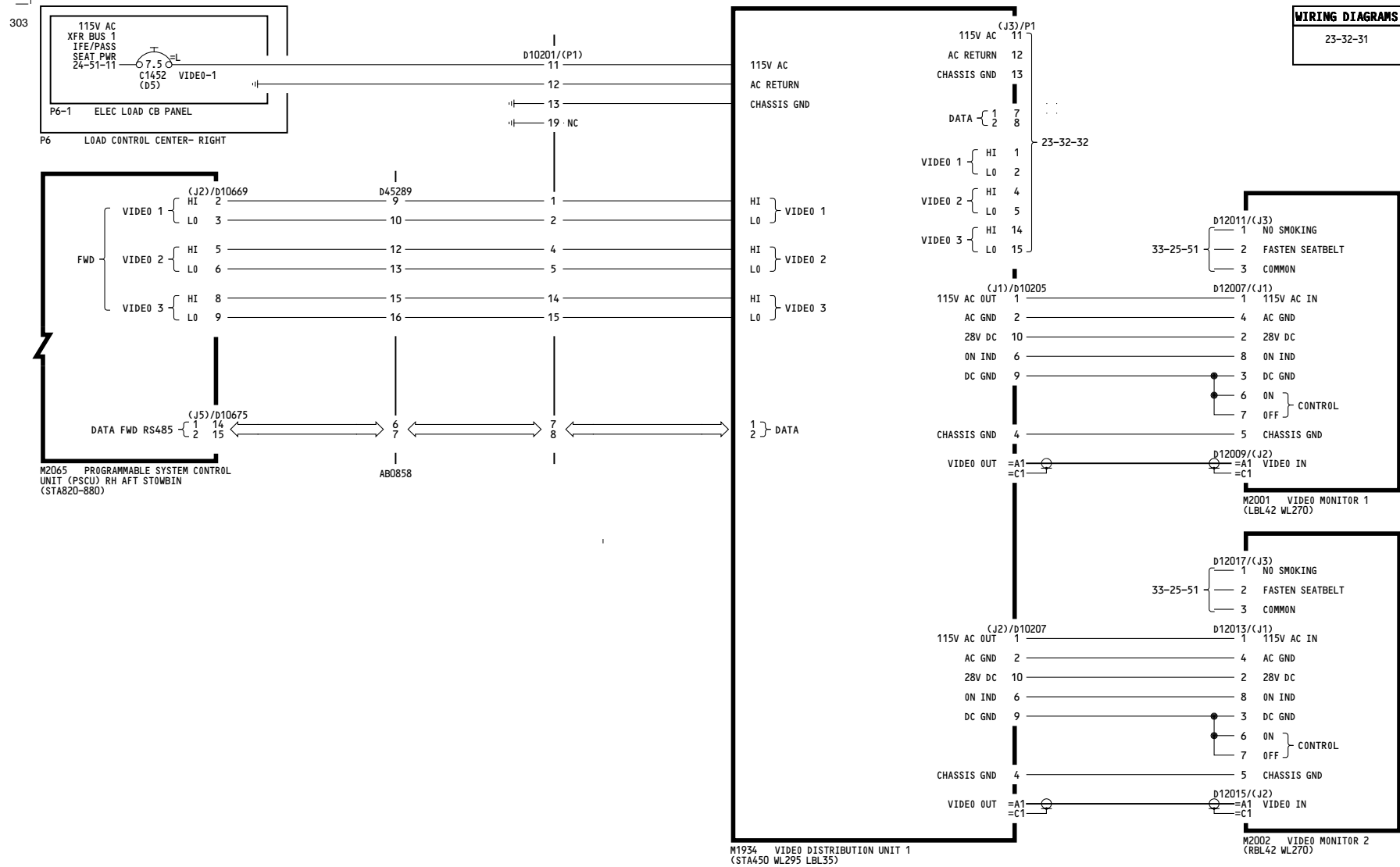

YM643-YM670	<p>VIDEO ENTERTAINMENT SYSTEM TRAY 1 VDU 1</p> <p>D280A203</p>
-------------	---

23-32-31

-D
1

WIRING DIAGRAMS
23-32-32

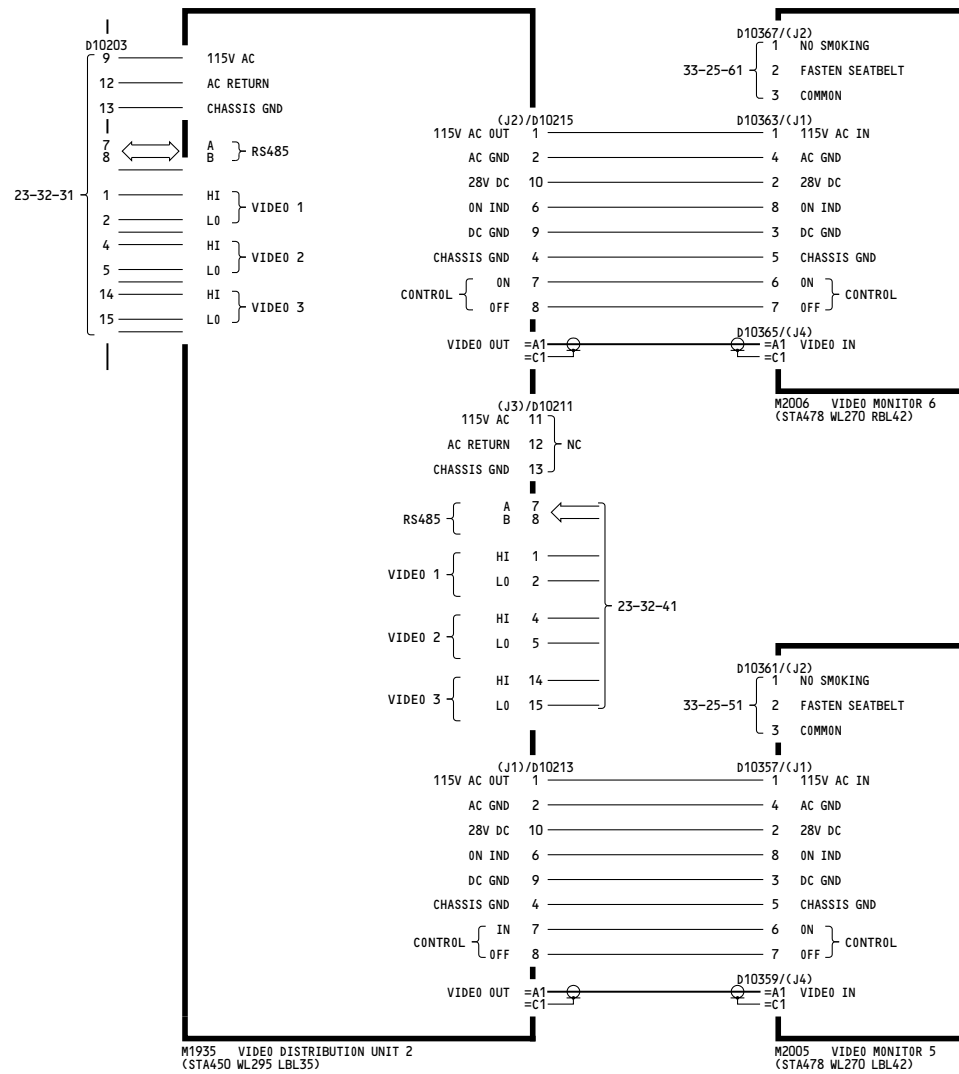

YC001-YC011	<p>VIDEO ENTERTAINMENT SYSTEM</p> <p>TRAY 1 VDU 2</p> <p>D280A203</p>
-------------	---

23-32-32

Page 101

Mar 31/2005

WIRING DIAGRAMS
23-32-32

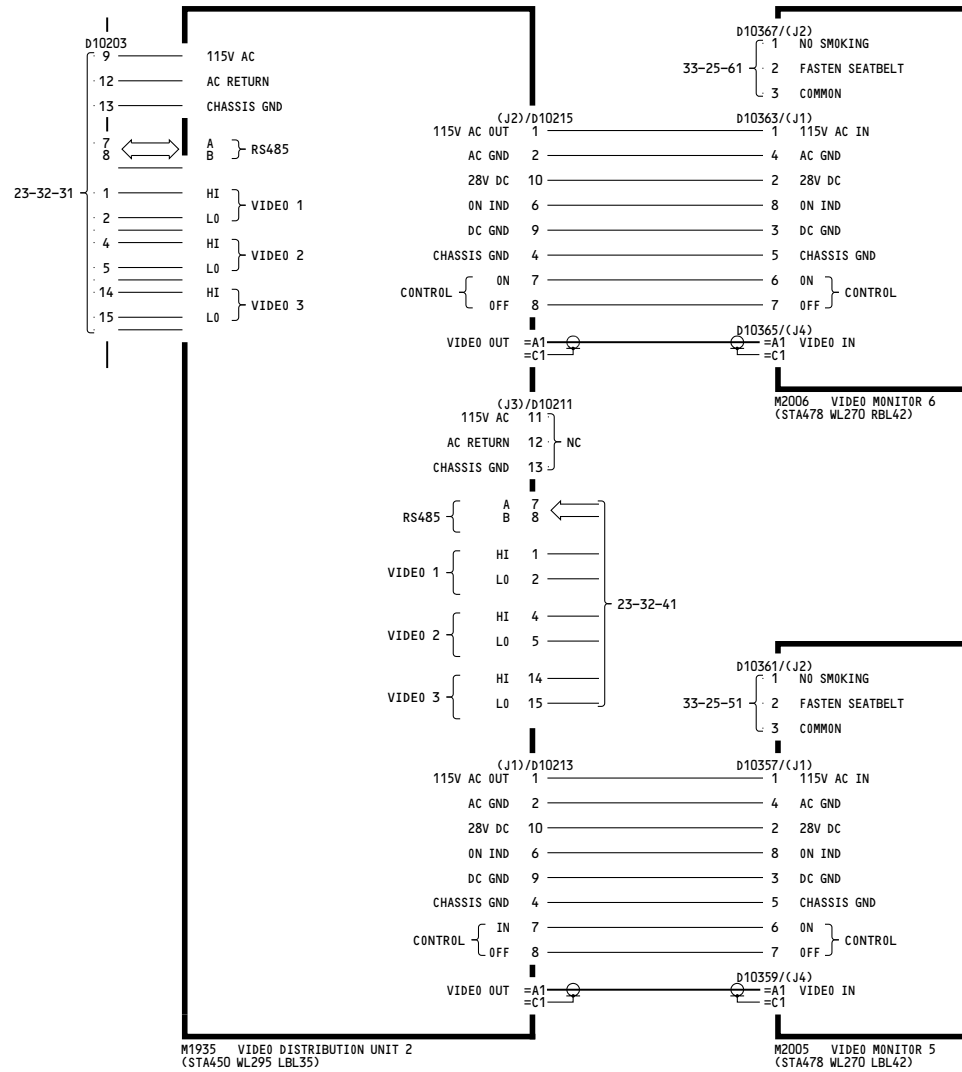

YC012-YC050	<p>VIDEO ENTERTAINMENT SYSTEM</p> <p>TRAY 1 VDU 2</p> <p>D280A203</p>
-------------	--

23-32-32

Page 102

Jul 17/2007

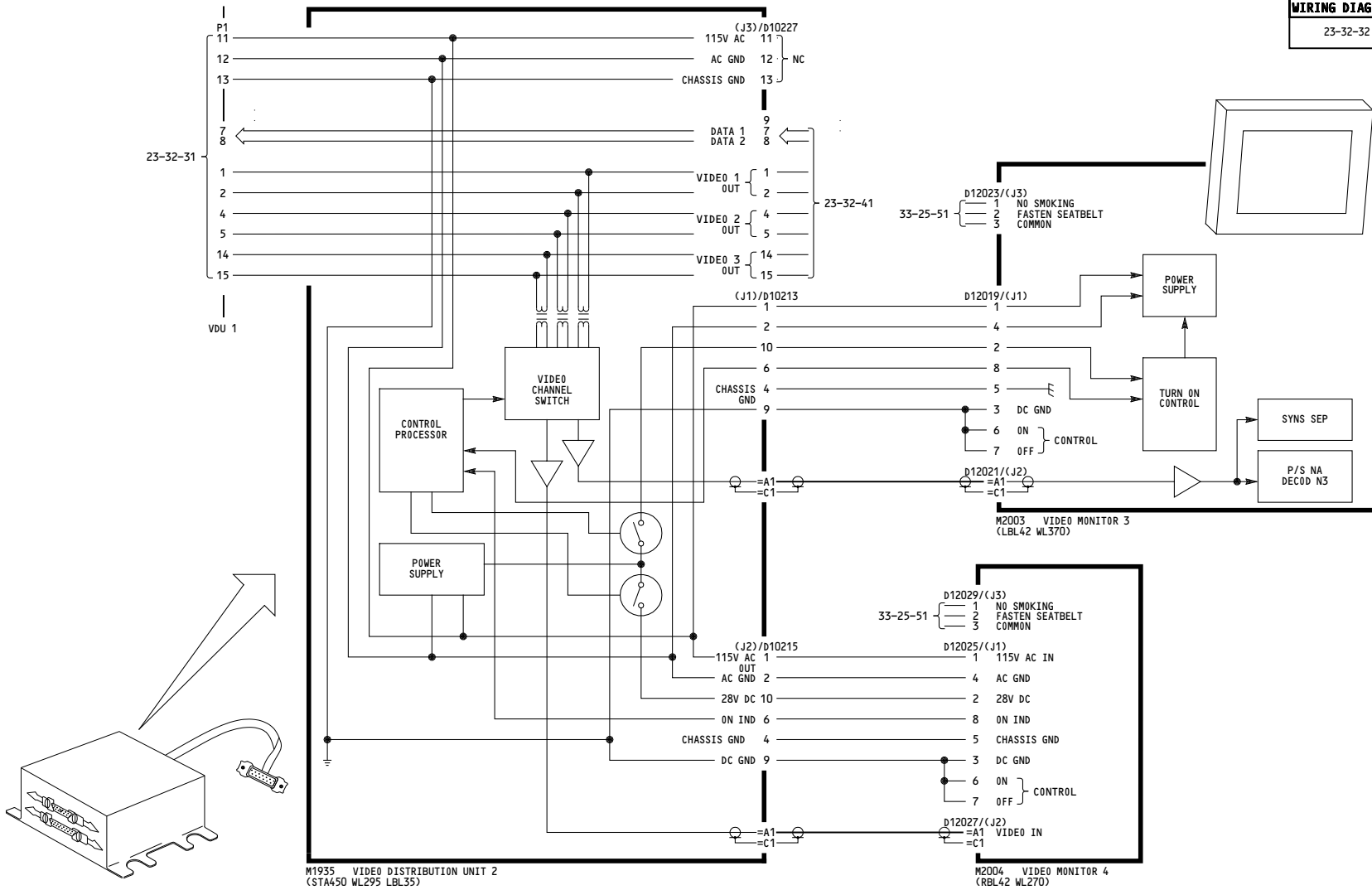

YK901-YL430

VIDEO ENTERTAINMENT SYSTEM TRAY 1 VDU 2

D280A203

23-32-32

Page 103

Feb 09/2009

WIRING DIAGRAMS
23-32-32

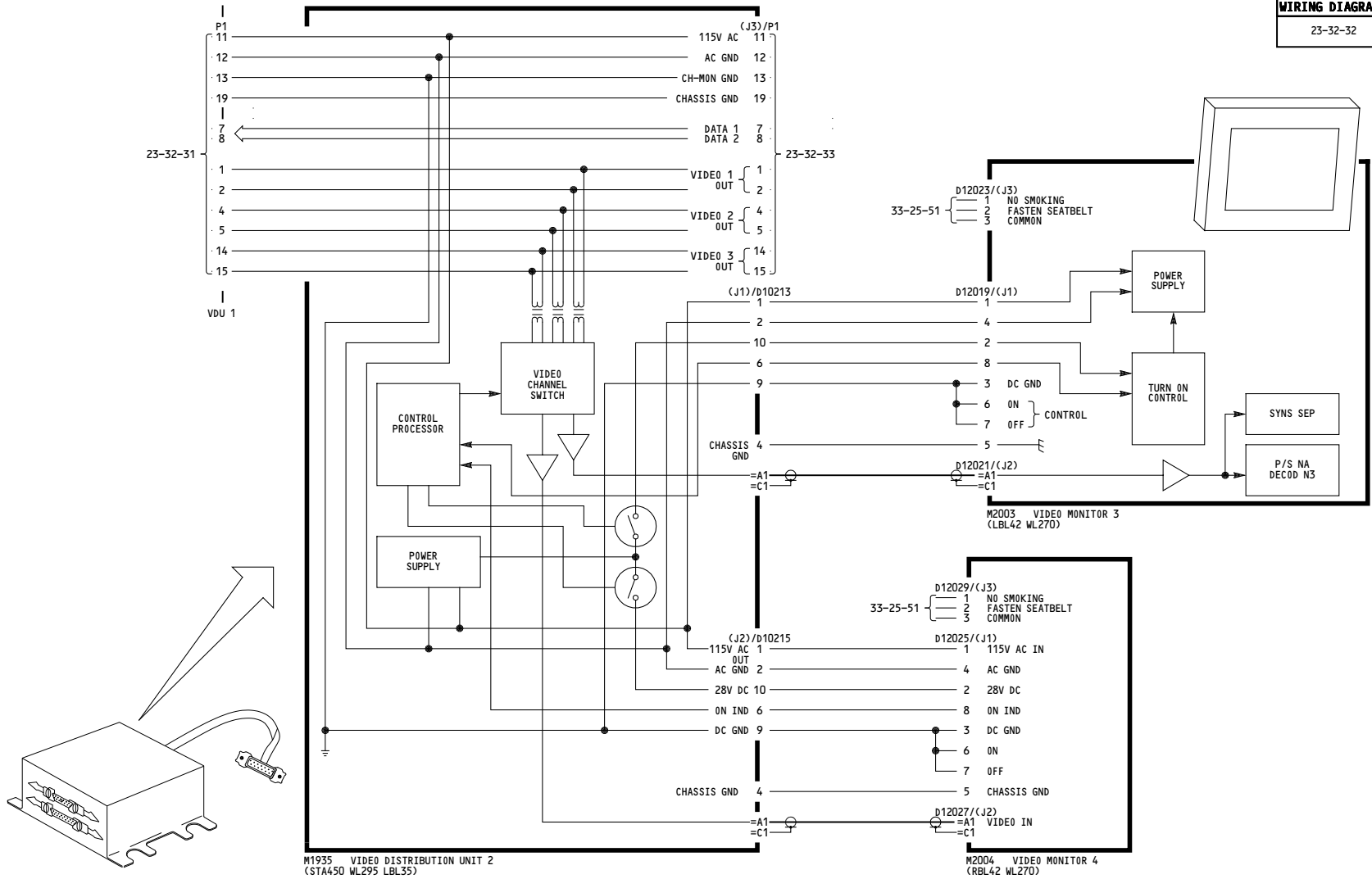

<p>YM643-YM670</p>	<p>VIDEO ENTERTAINMENT SYSTEM TRAY 1 VDU 2</p> <p>D280A203</p>
--------------------	---

23-32-32

WIRING DIAGRAMS
23-32-42

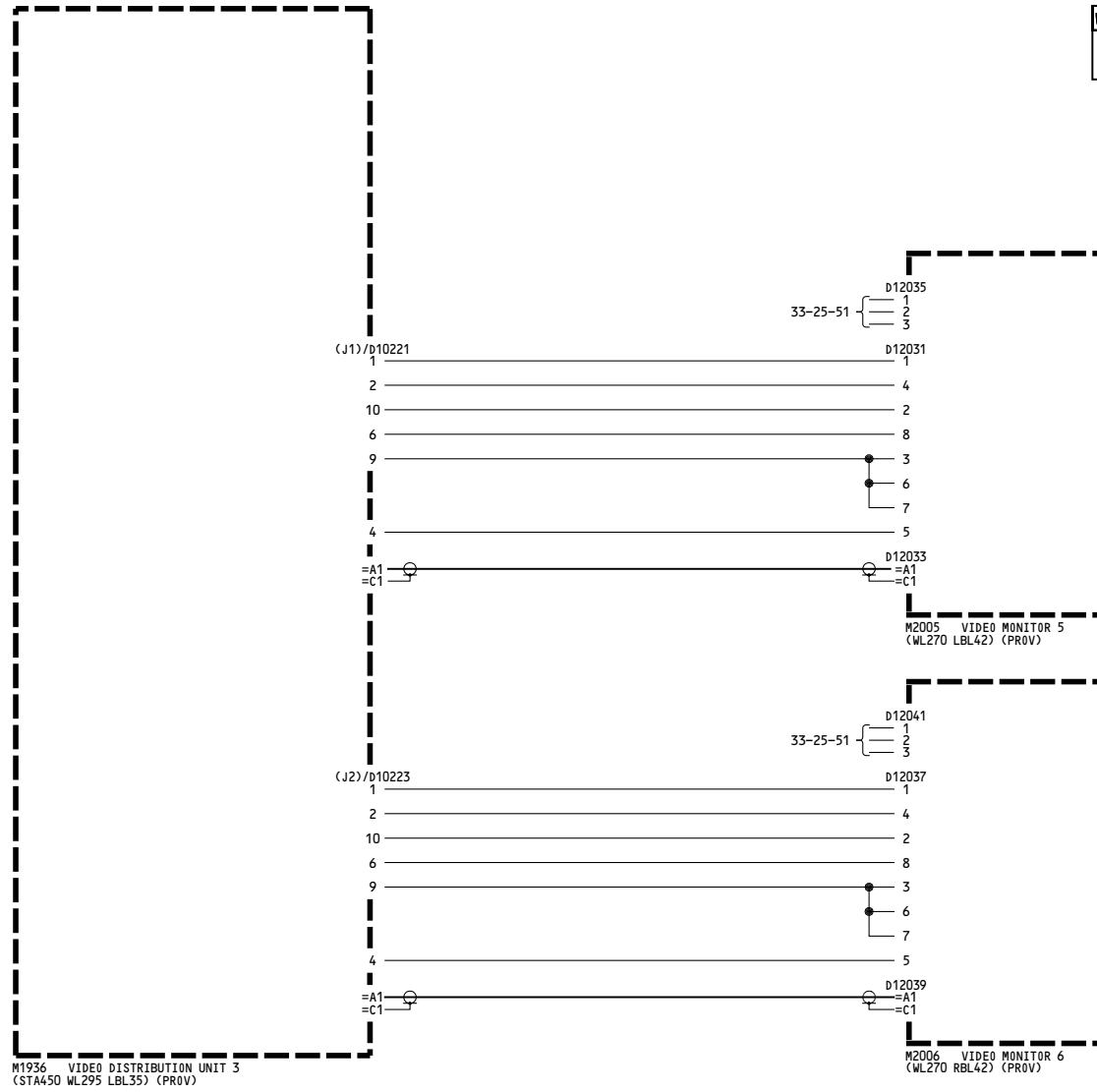

YK901-YL430	<p align="center">VIDEO ENTERTAINMENT SYSTEM TRAY 1 VDU 3</p> <p align="center">D280A203</p>
-------------	---

23-32-33

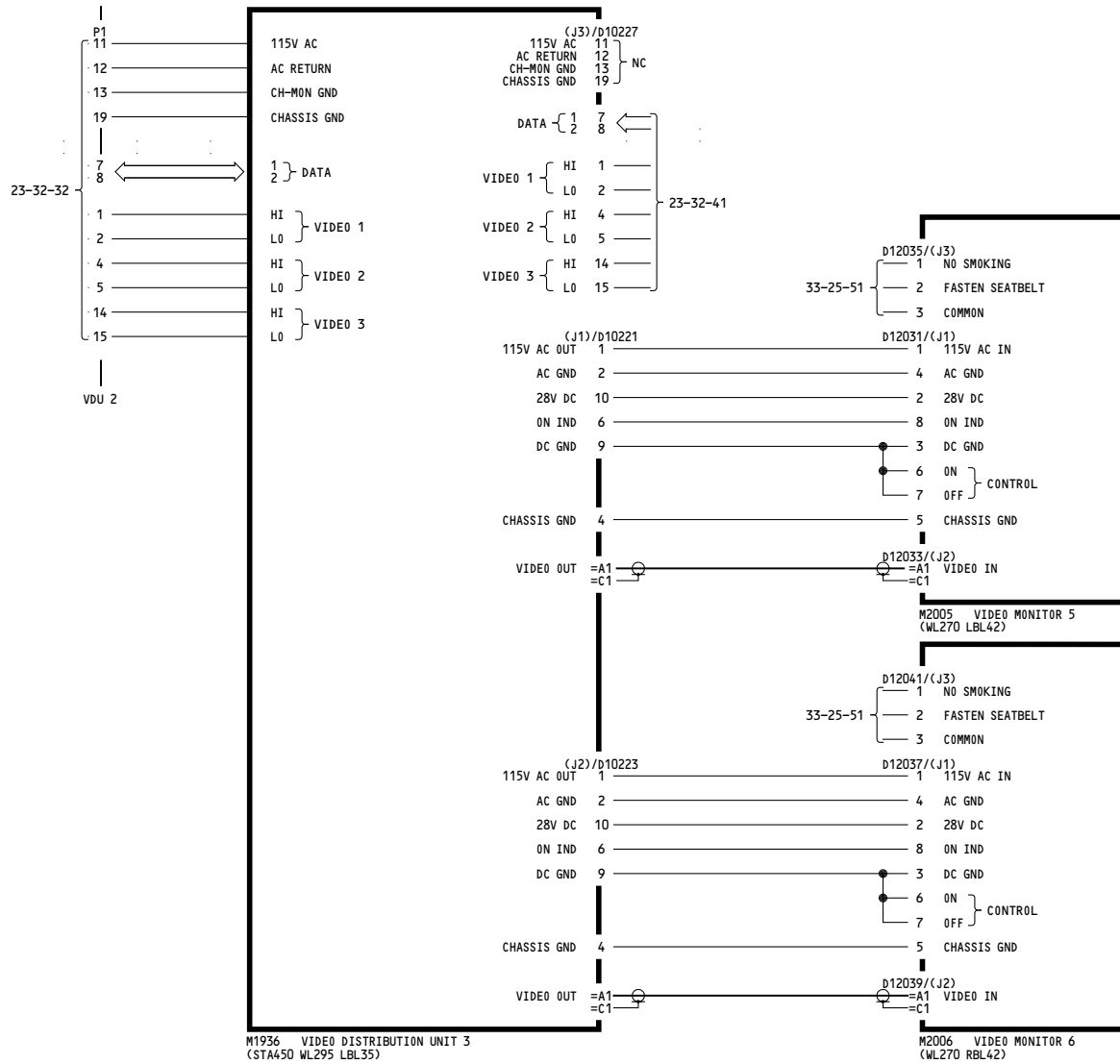

YM643-YM670	<p>VIDEO ENTERTAINMENT SYSTEM TRAY 1 VDU 3</p> <p>D280A203</p>
-------------	---

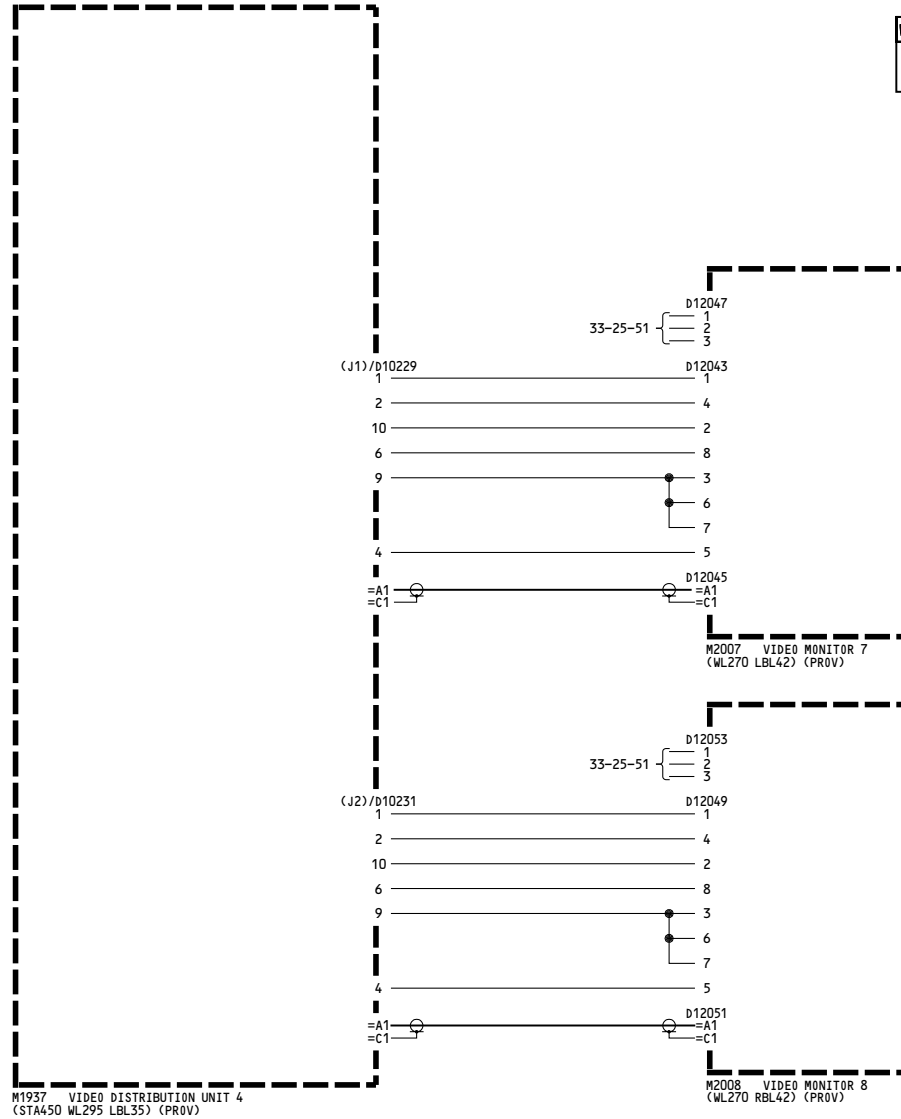

YK901-YL430	<p>VIDEO ENTERTAINMENT SYSTEM TRAY 1 VDU 4</p> <p>D280A203</p>
-------------	---

WIRING DIAGRAMS
23-32-41

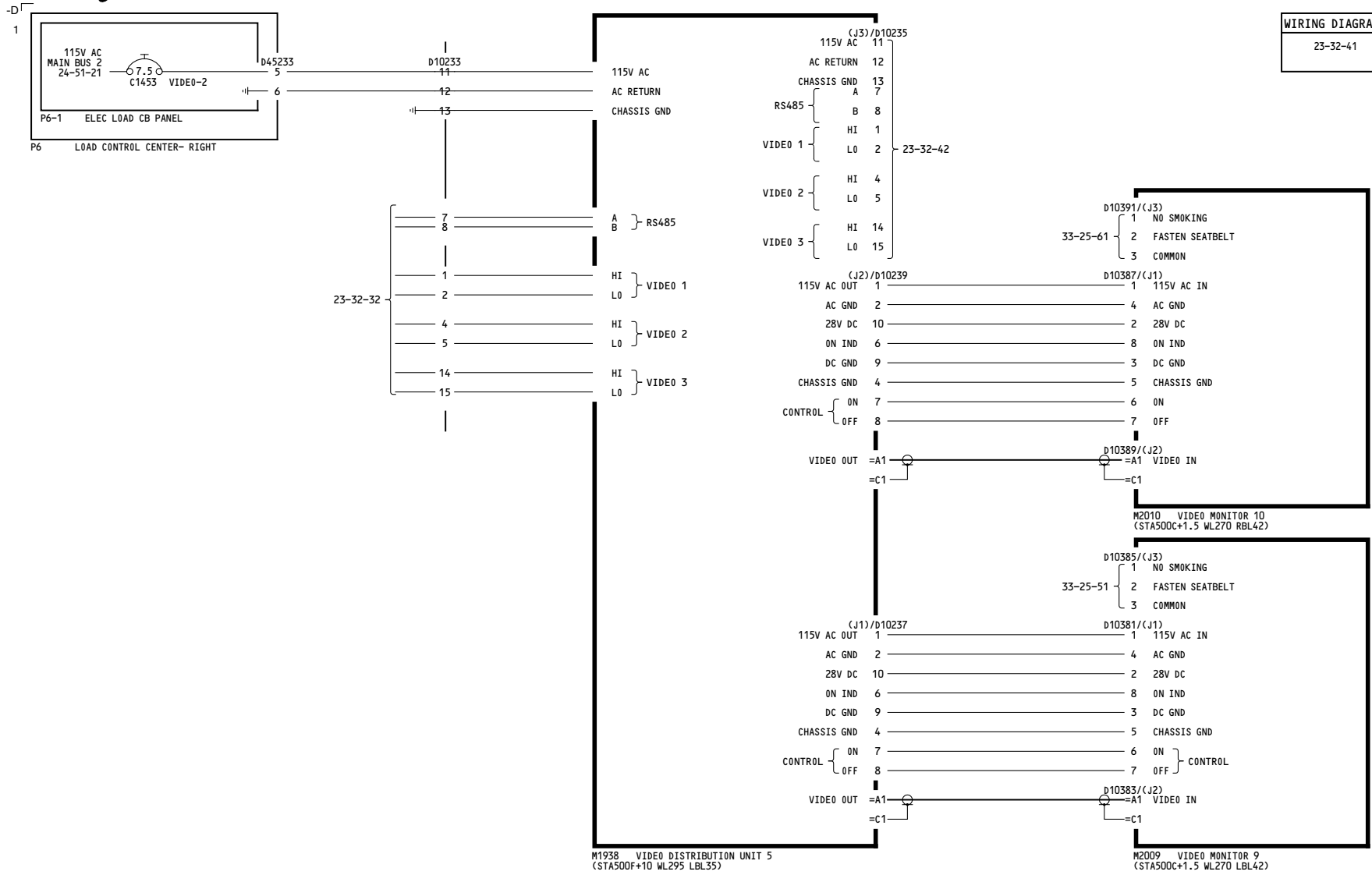

YC001-YC011	<p>VIDEO ENTERTAINMENT SYSTEM</p> <p>TRAY 2 VDU 5</p> <p>D280A203</p>
-------------	---

23-32-41

WIRING DIAGRAMS
23-32-41

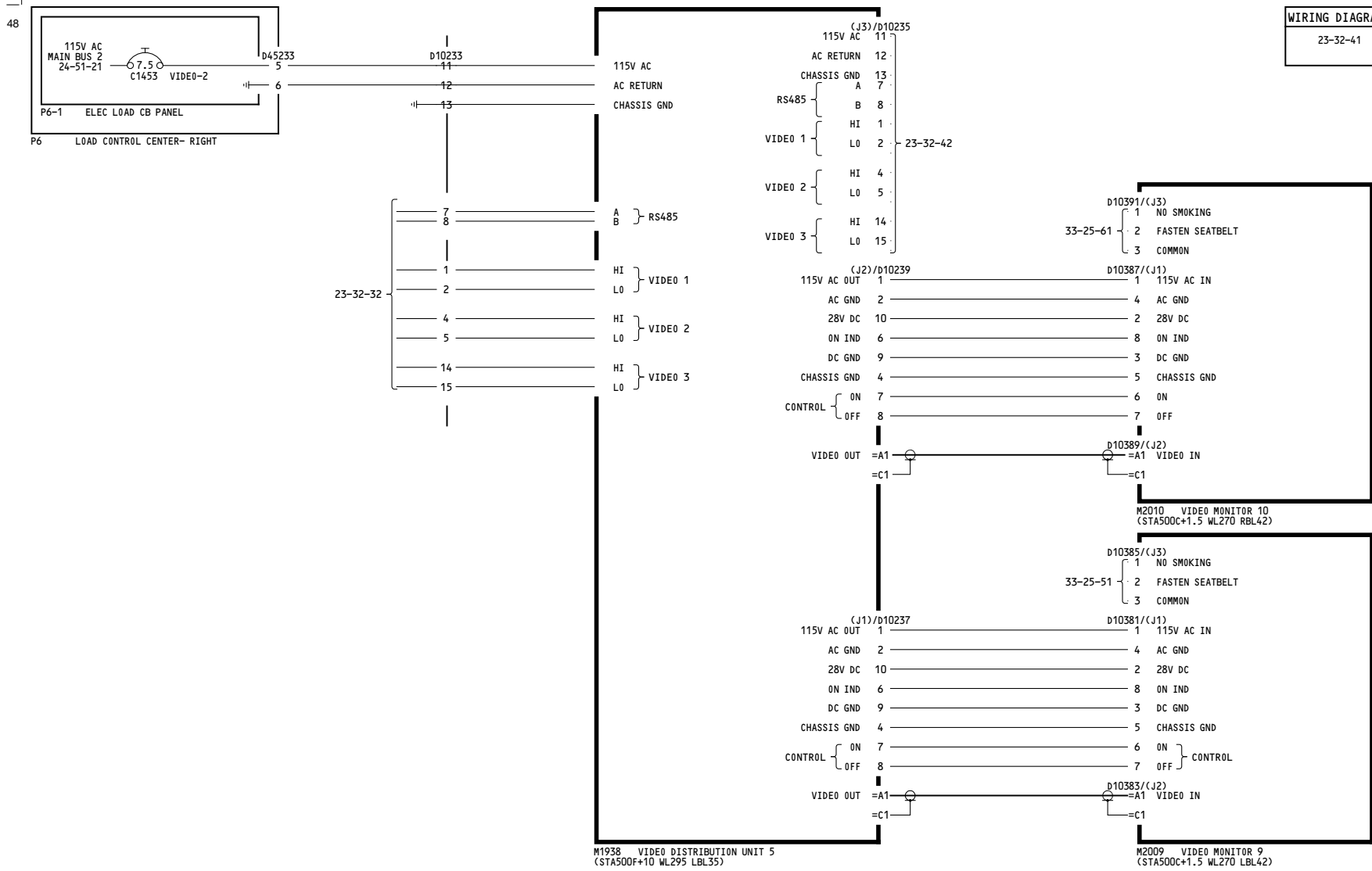

YC012-YC030	<p>VIDEO ENTERTAINMENT SYSTEM</p> <p>TRAY 2 VDU 5</p> <p>D280A203</p>
-------------	---

23-32-41

WIRING DIAGRAMS
23-32-41

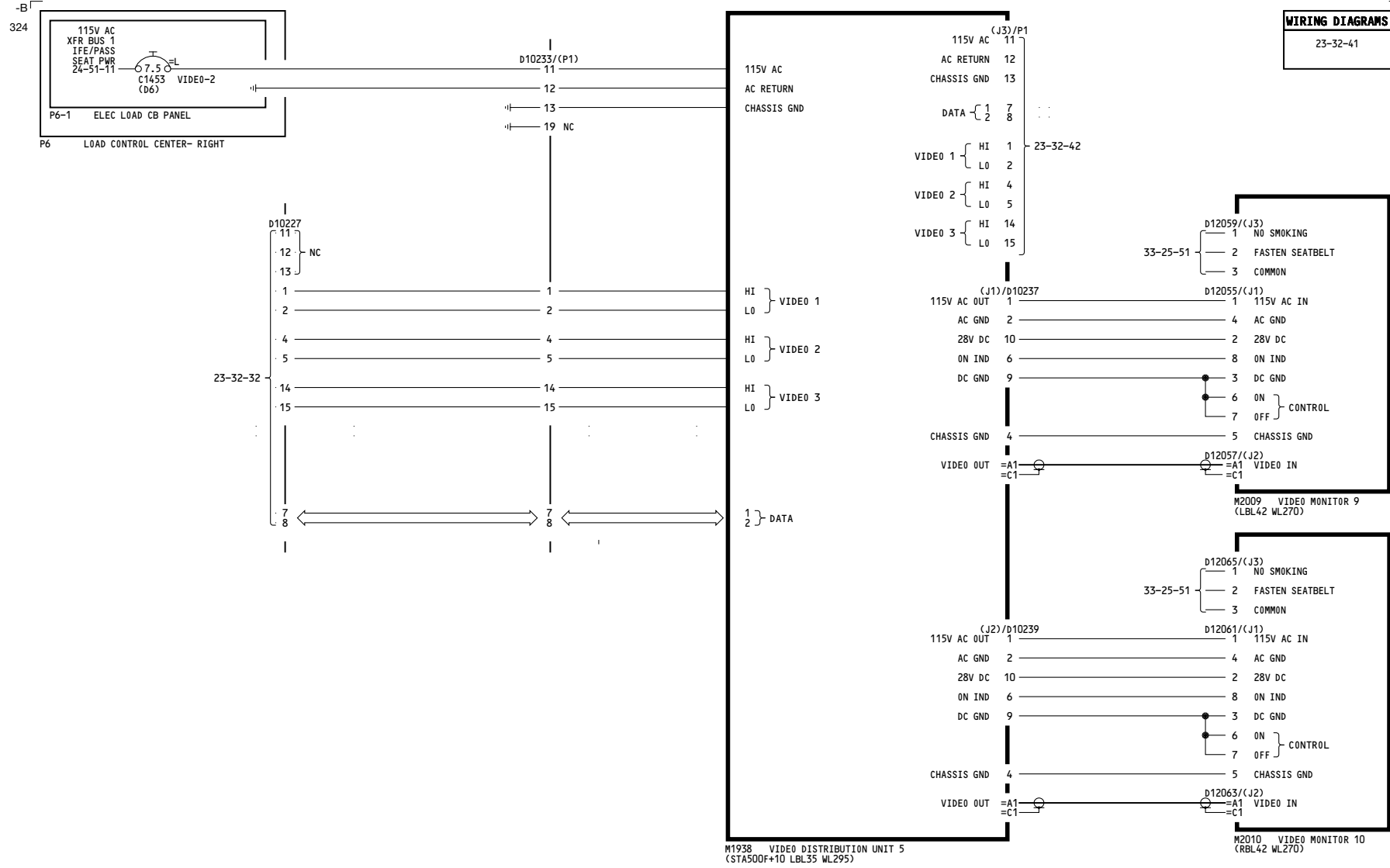

<p>YK901-YL430</p>	<p>VIDEO ENTERTAINMENT SYSTEM TRAY 2 VDU 5</p> <p>D280A203</p>
--------------------	---

23-32-41

WIRING DIAGRAMS
23-32-41

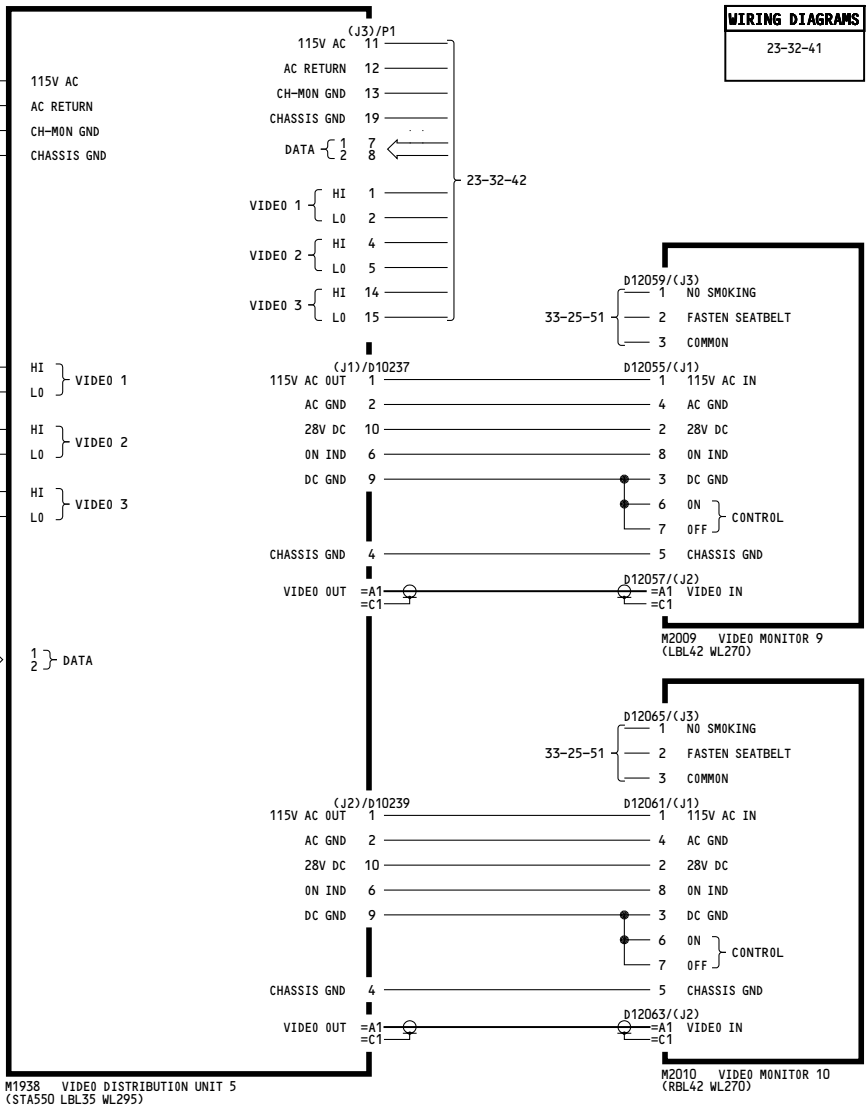
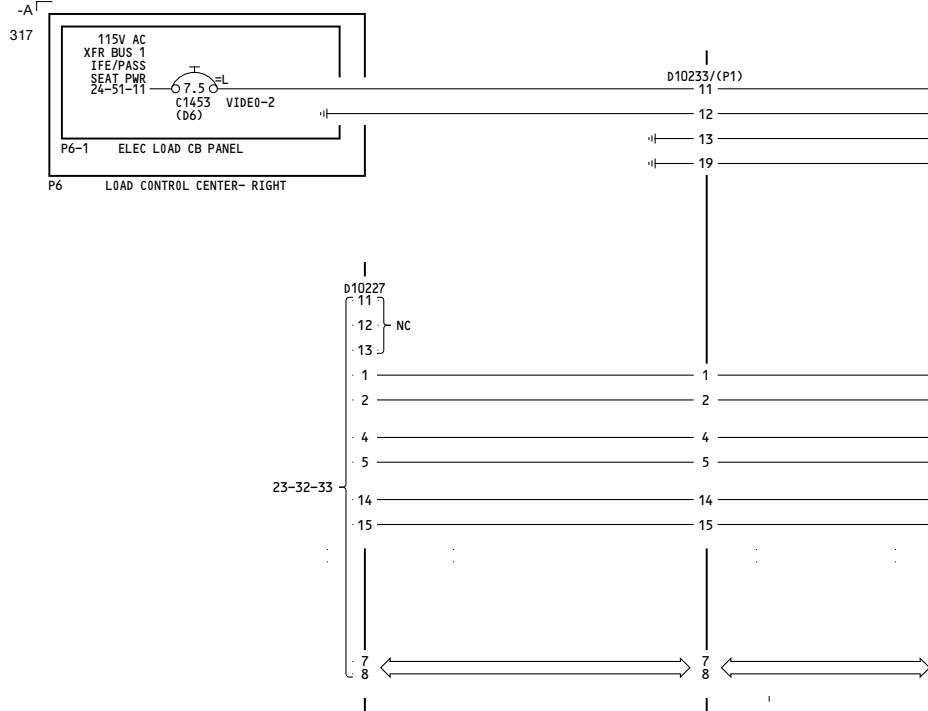

YM643-YM670	<p>VIDE0 ENTERTAINMENT SYSTEM TRAY 2 VDU 5</p> <p>D280A203</p>
-------------	---

23-32-41

-D
1

WIRING DIAGRAMS
23-32-42

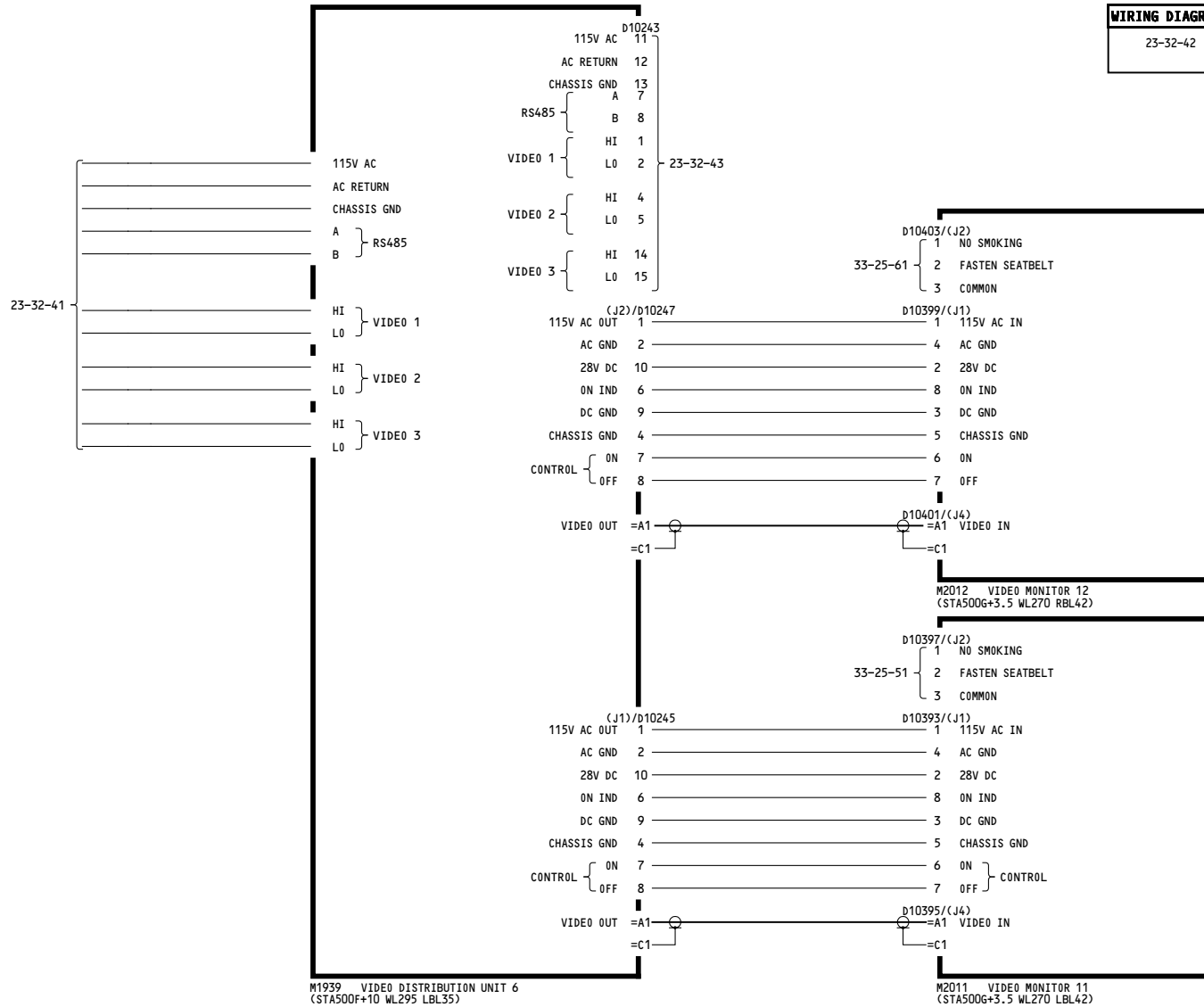

YC001-YC011

**VIDEO ENTERTAINMENT
SYSTEM
TRAY 2 VDU 6**

D280A203

23-32-42

Page 101

Mar 31/2005

WIRING DIAGRAMS
23-32-42

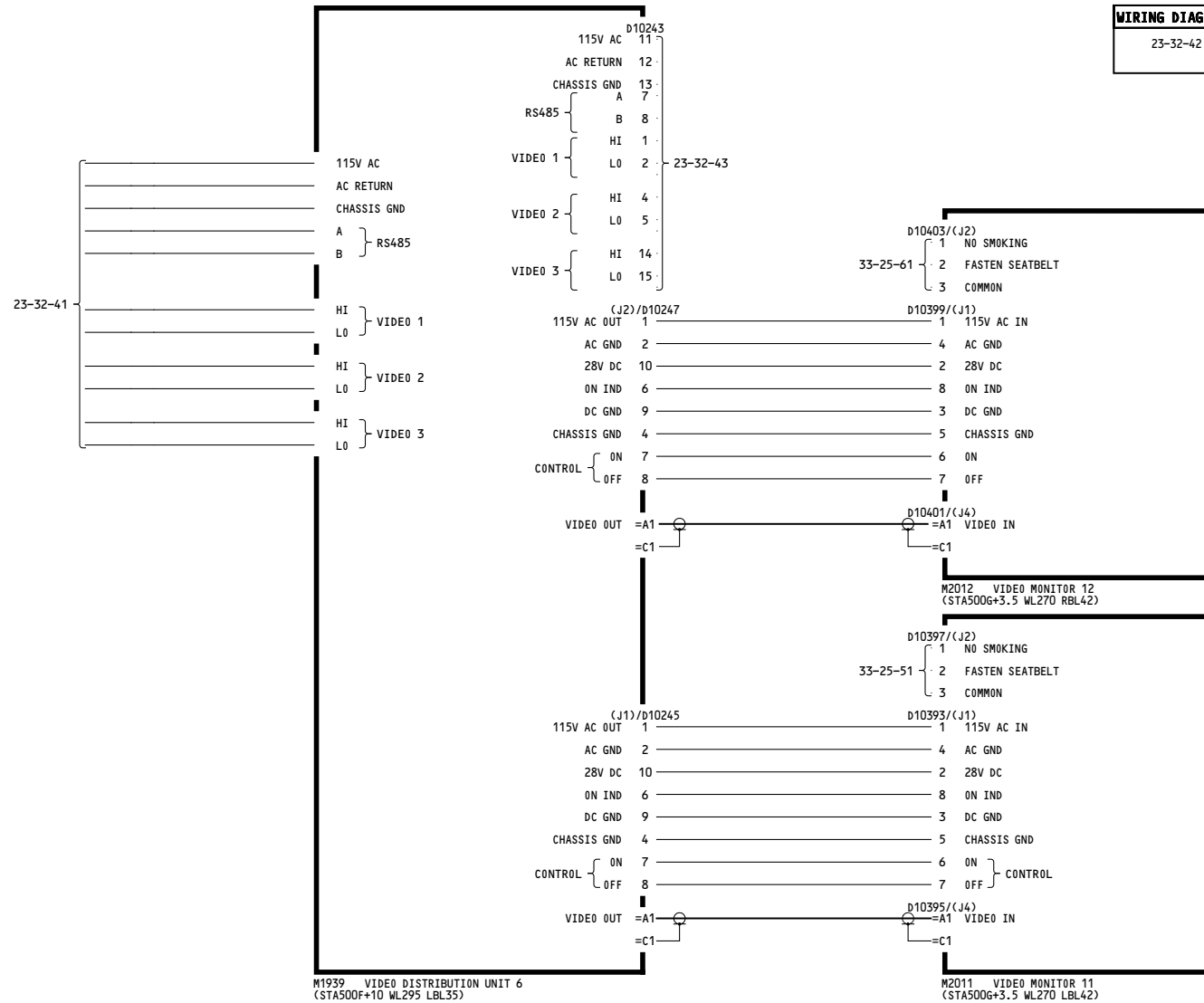

YC012-YC050	VIDEO ENTERTAINMENT SYSTEM TRAY 2 VDU 6 D280A203
-------------	--

23-32-42

WIRING DIAGRAMS
23-32-42

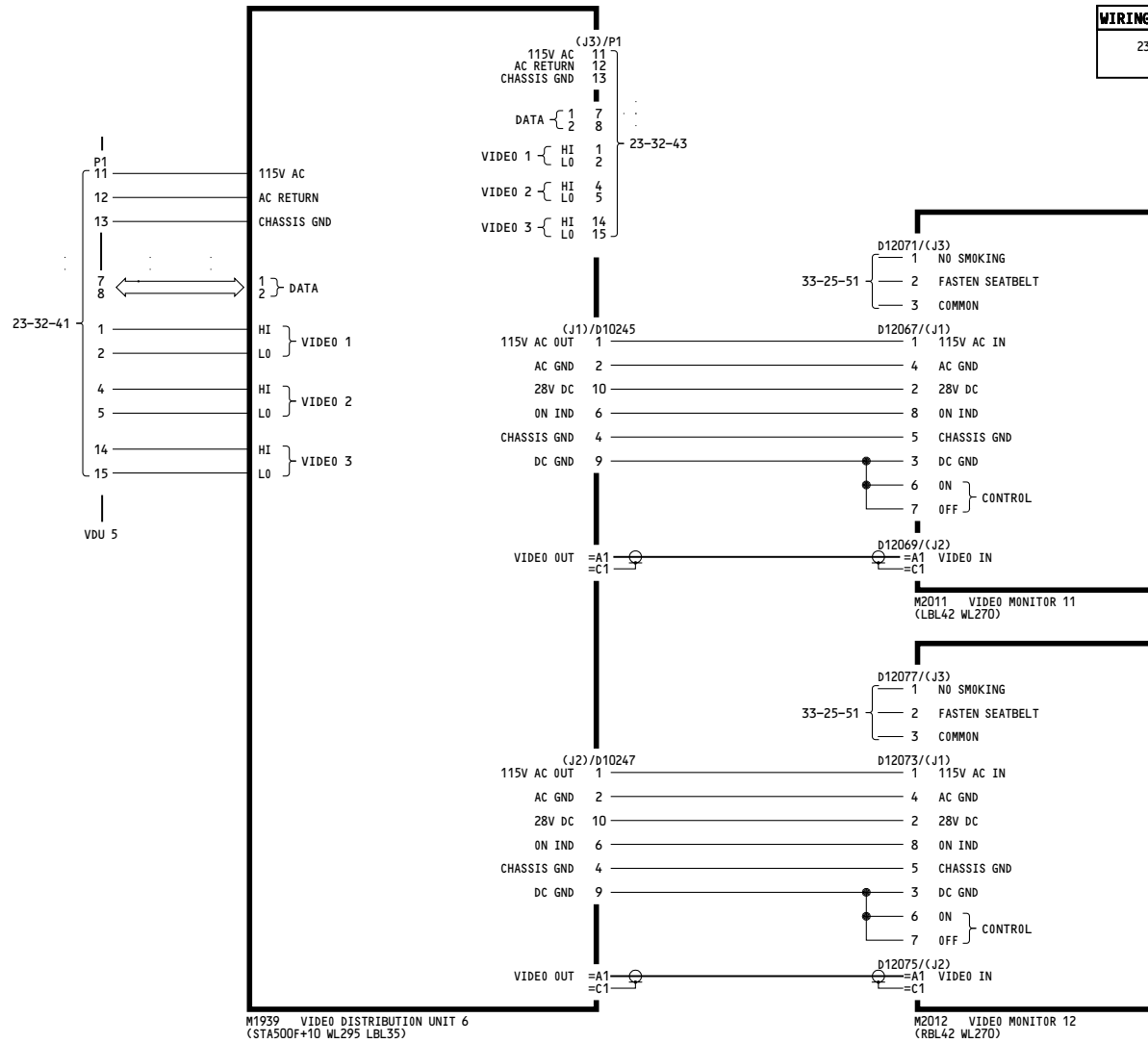

YK901-YL430	VIDEO ENTERTAINMENT SYSTEM TRAY 2 VDU 6 D280A203
-------------	--

23-32-42

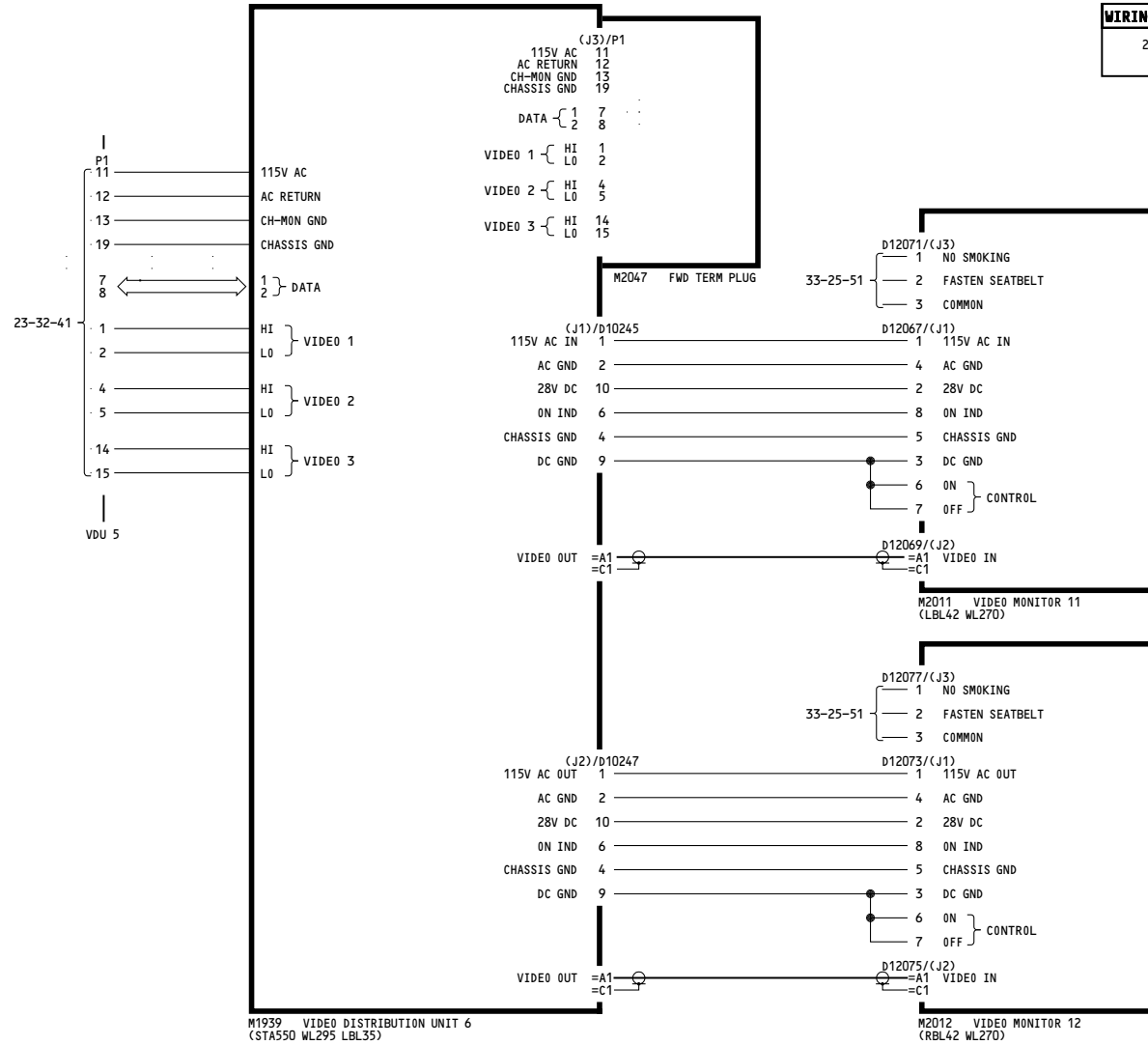

YM643-YM670	<p>VIDEO ENTERTAINMENT SYSTEM TRAY 2 VDU 6</p> <p>D280A203</p>
-------------	---

WIRING DIAGRAMS
23-32-43

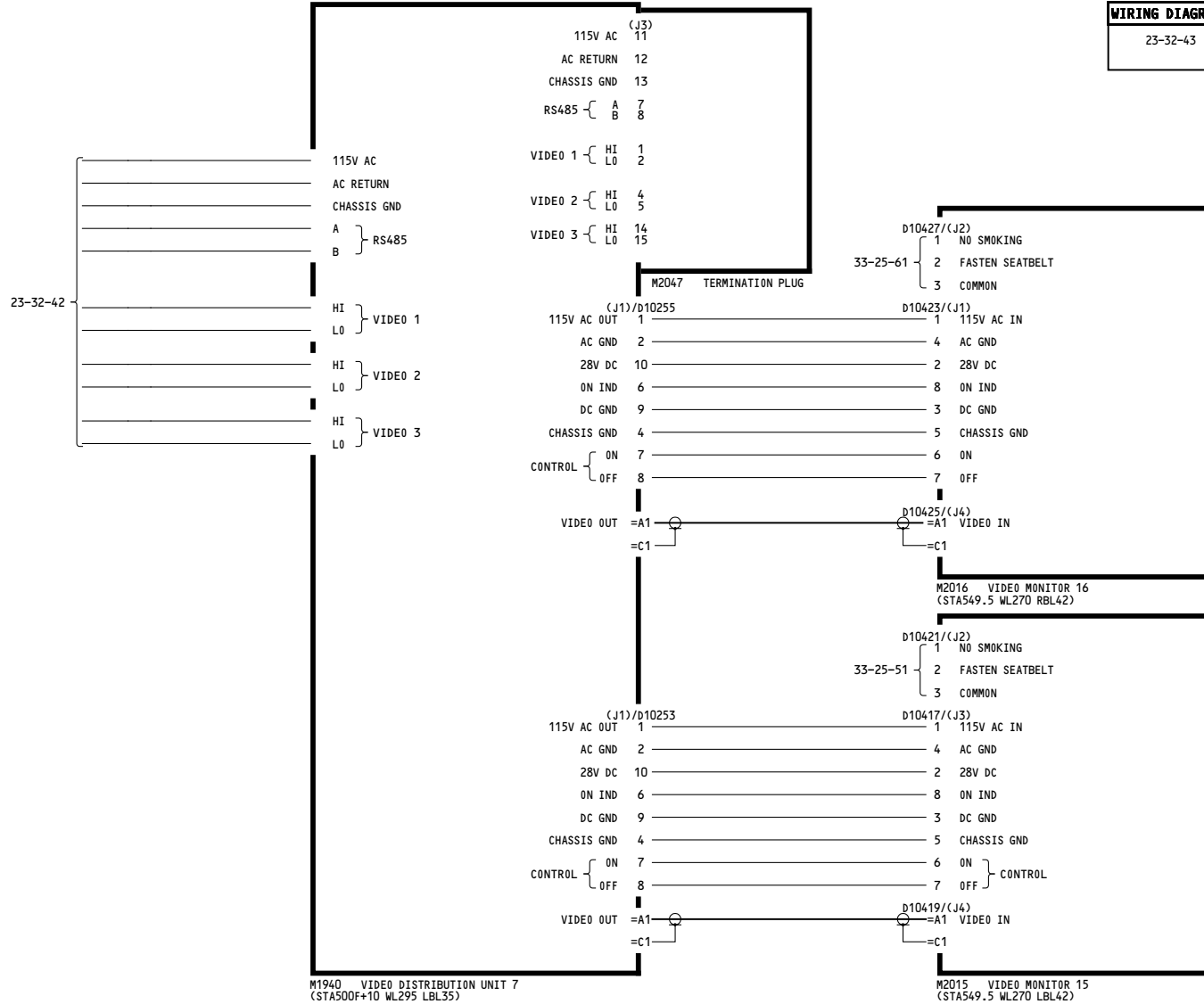

YC001-YC011

**VIDEO ENTERTAINMENT
SYSTEM
TRAY 2 VDU 7**

D280A203

23-32-43

WIRING DIAGRAMS
23-32-43

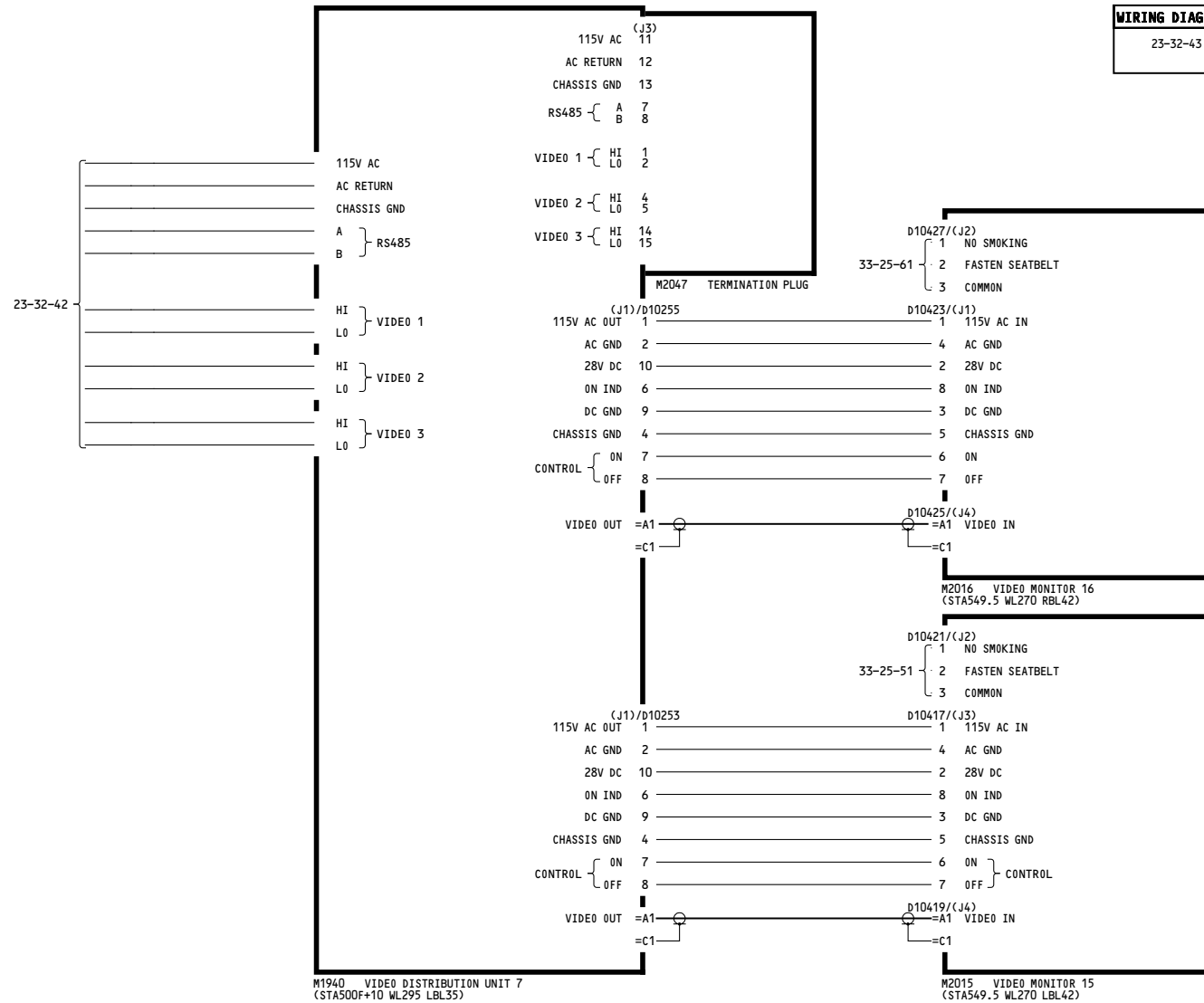

YC012-YC050	VIDEO ENTERTAINMENT SYSTEM TRAY 2 VDU 7
	D280A203

WIRING DIAGRAMS
23-32-43

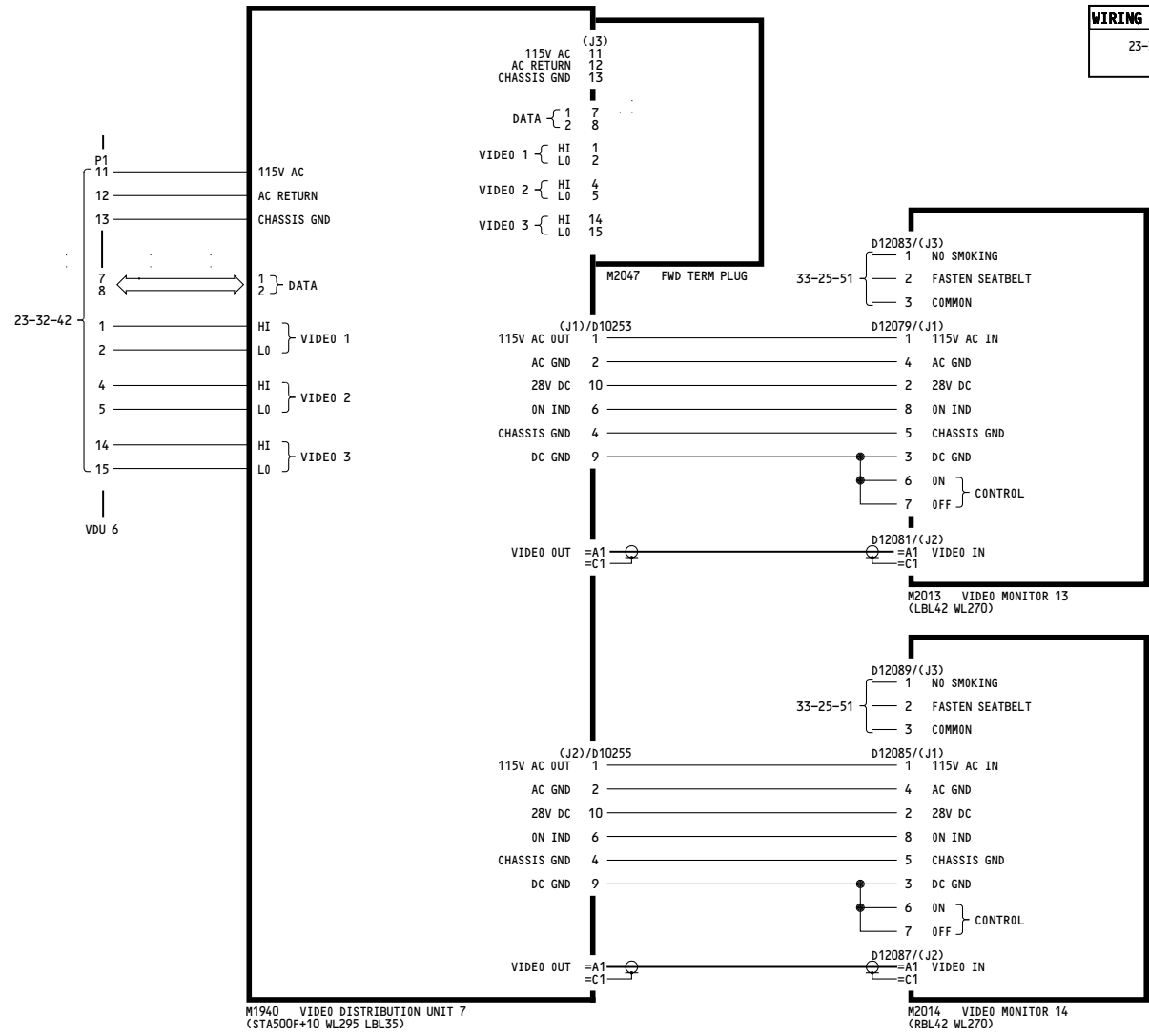

<p>YK901-YL430</p>	<p>VIDEO ENTERTAINMENT SYSTEM TRAY 2 VDU 7</p> <p>D280A203</p>
--------------------	---

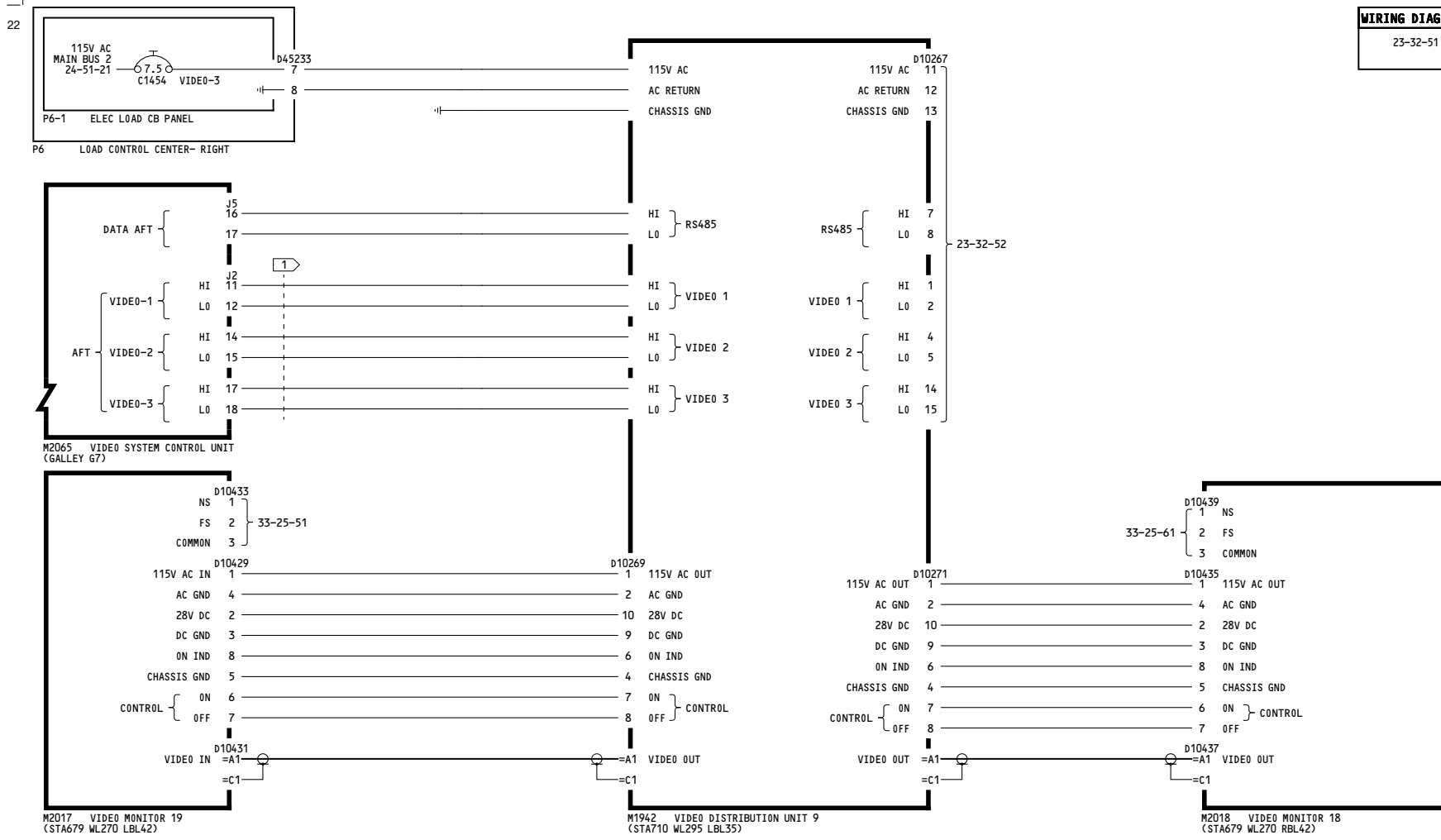

NOTES:
 1 CHAMPLAIN CABLE P/N 51-04570 OR EQUIVALENT

YC001-YC011	VIDEO ENTERTAINMENT SYSTEM TRAY 3 VDU 9 D280A203
-------------	--

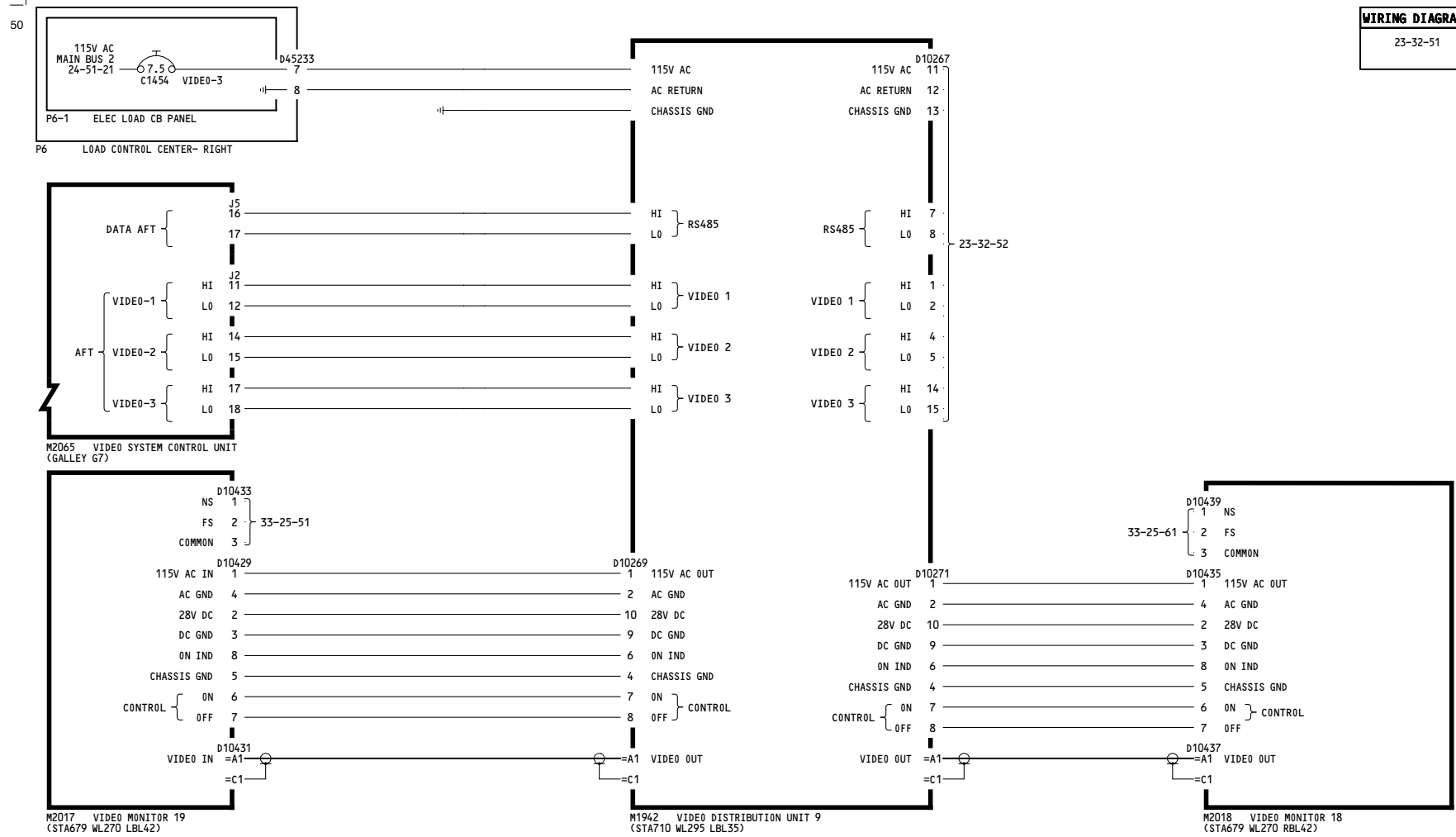

YC012-YC030	VIDEO ENTERTAINMENT SYSTEM TRAY 3 VDU 9 D280A203
-------------	--

NOTES:

272

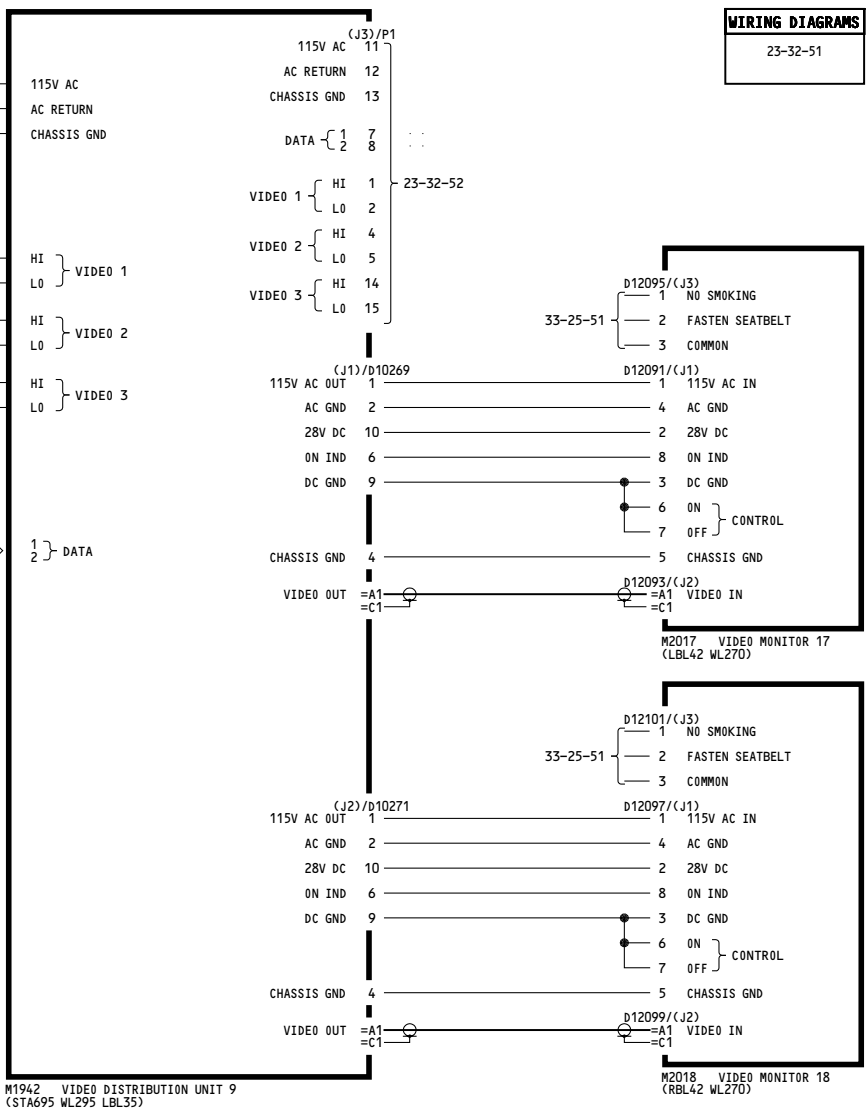
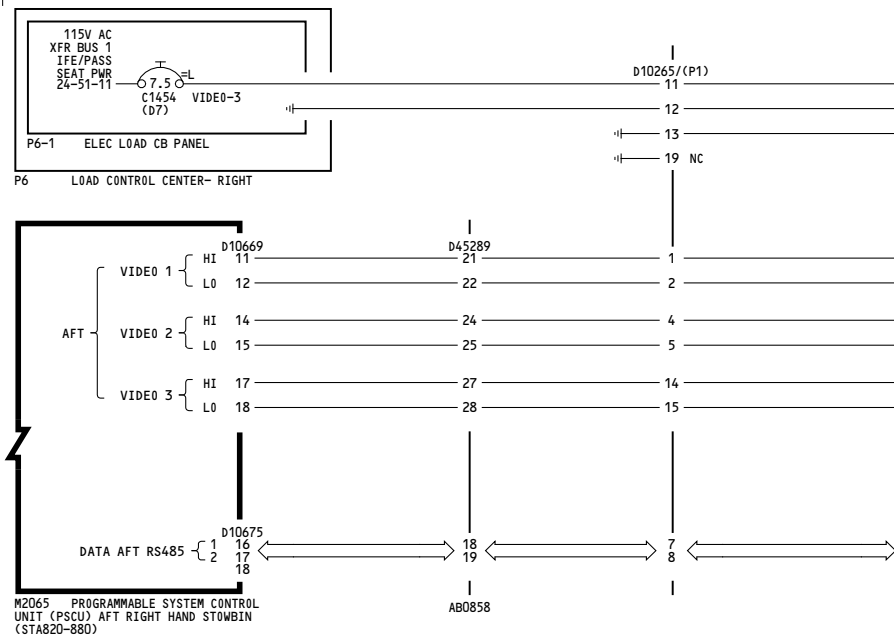

WIRING DIAGRAMS
23-32-51

YK901-YL430	<p>VIDEO ENTERTAINMENT SYSTEM TRAY 3 VDU 9</p> <p>D280A203</p>
-------------	---

23-32-51

288

WIRING DIAGRAMS
23-32-51

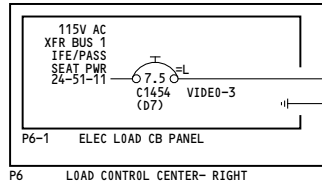

P6 LOAD CONTROL CENTER- RIGHT

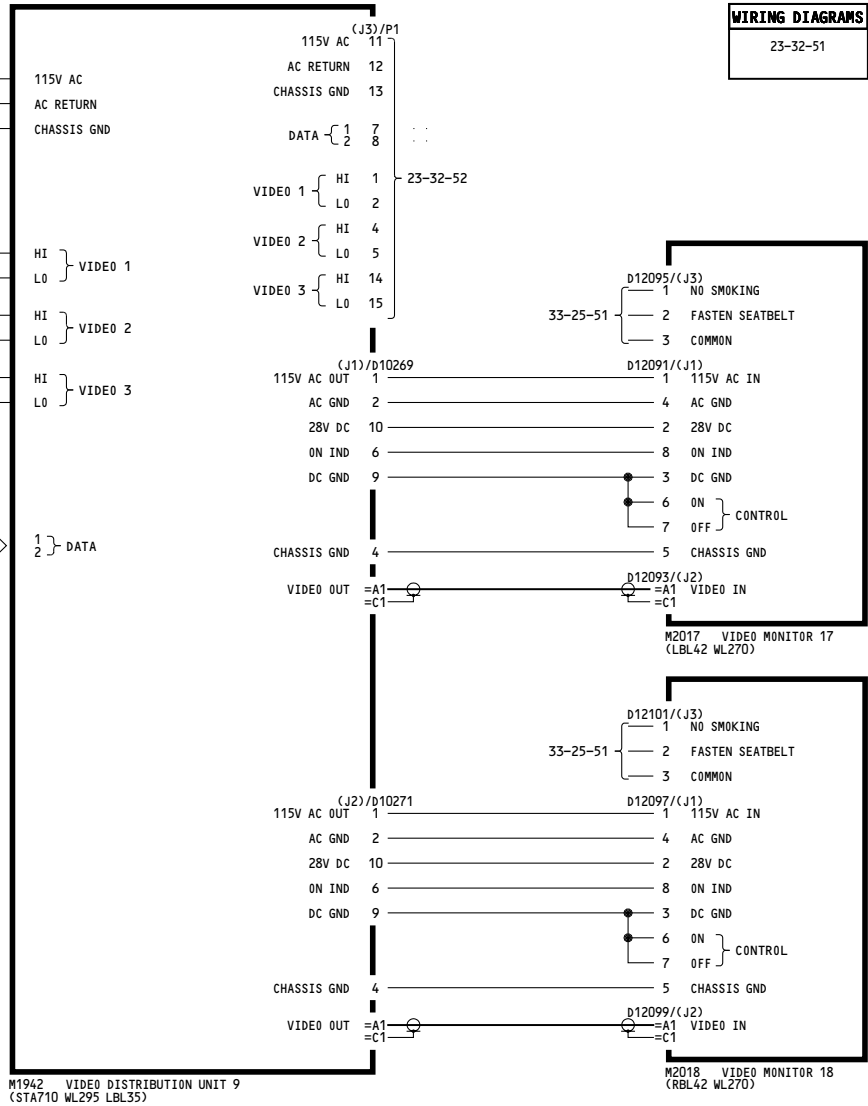
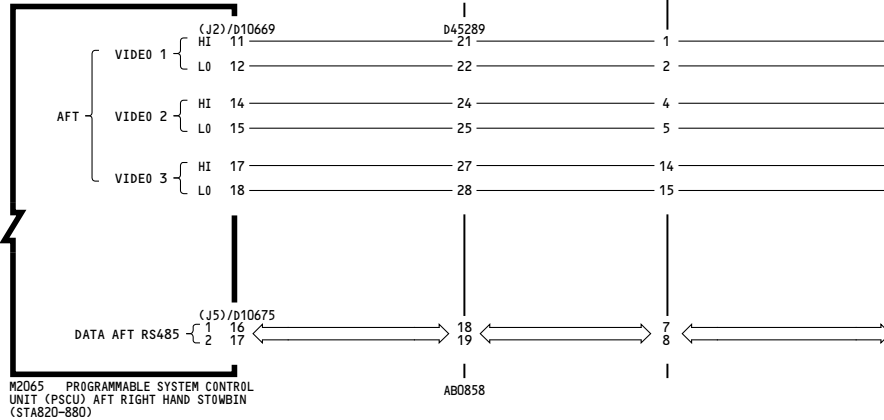

YM643-YM670	VIDEO ENTERTAINMENT SYSTEM TRAY 3 VDU 9 D280A203
-------------	--

23-32-51

Page 104

Jan 14/2008

WIRING DIAGRAMS
23-32-52

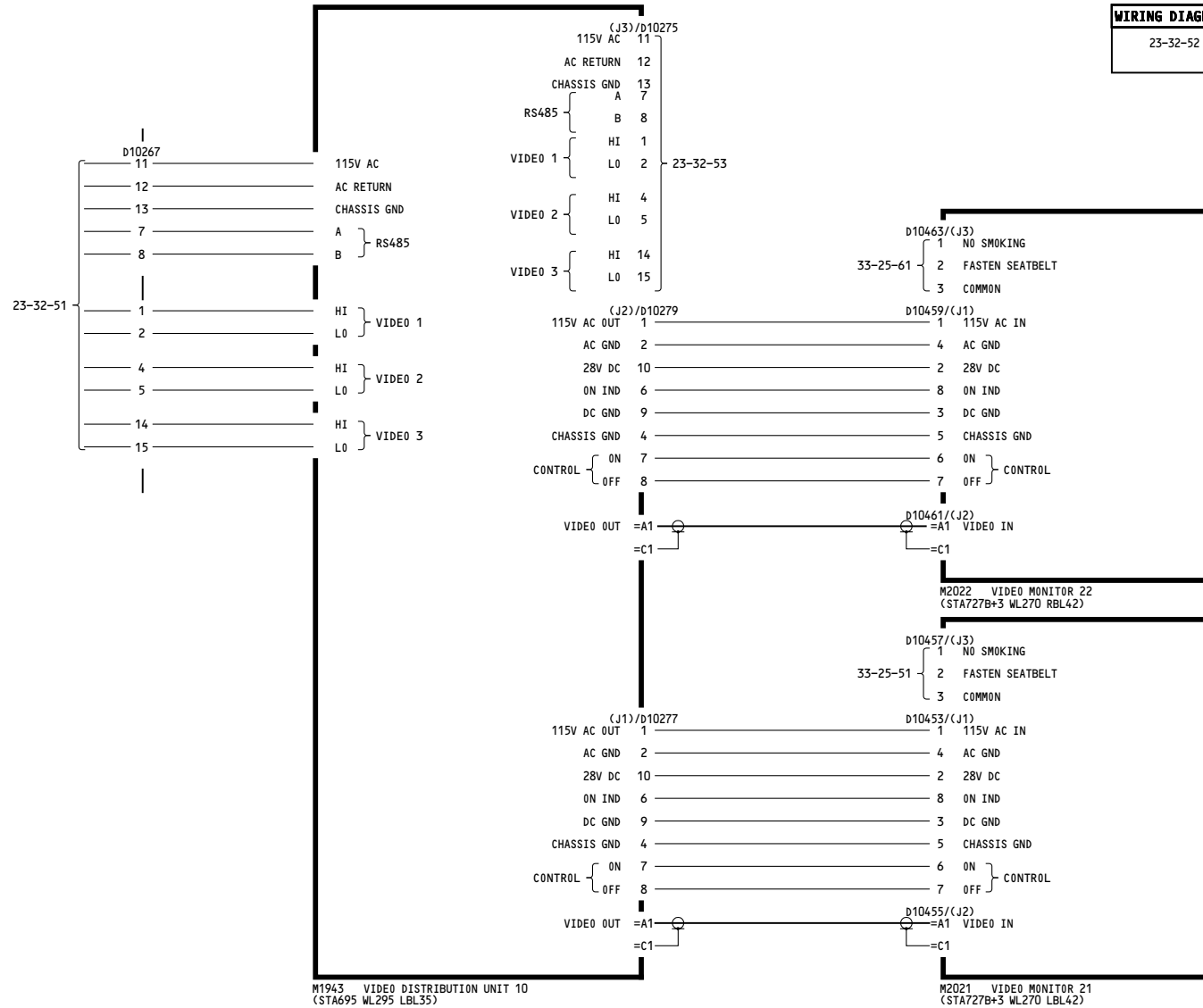

YC001-YC011

VIDEO ENTERTAINMENT SYSTEM TRAY 3 VDU 10

D280A203

23-32-52

WIRING DIAGRAMS
23-32-52

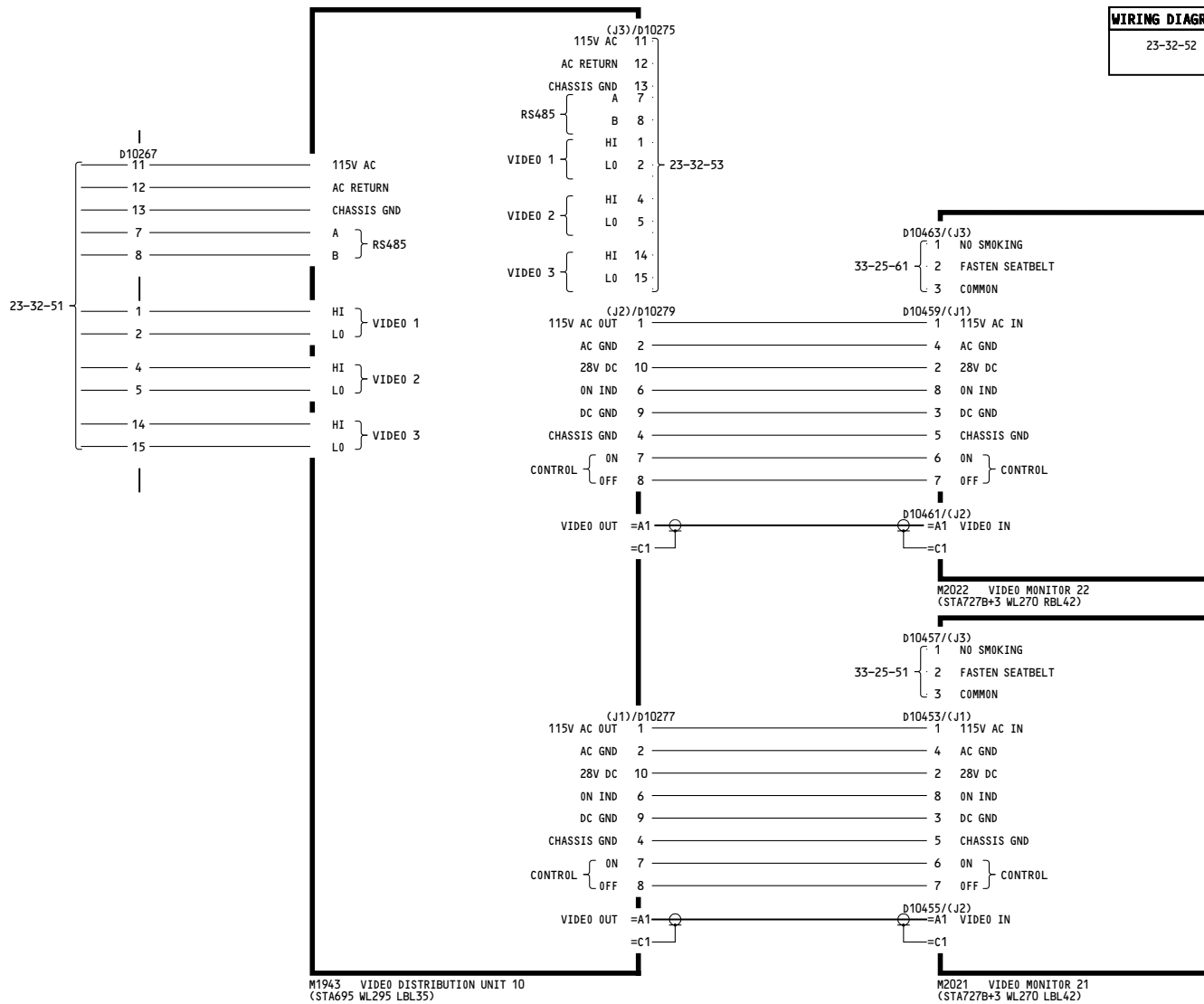

YC012-YC050	<p>VIDEO ENTERTAINMENT SYSTEM TRAY 3 VDU 10</p> <p>D280A203</p>
-------------	---

23-32-52

WIRING DIAGRAMS
23-32-52

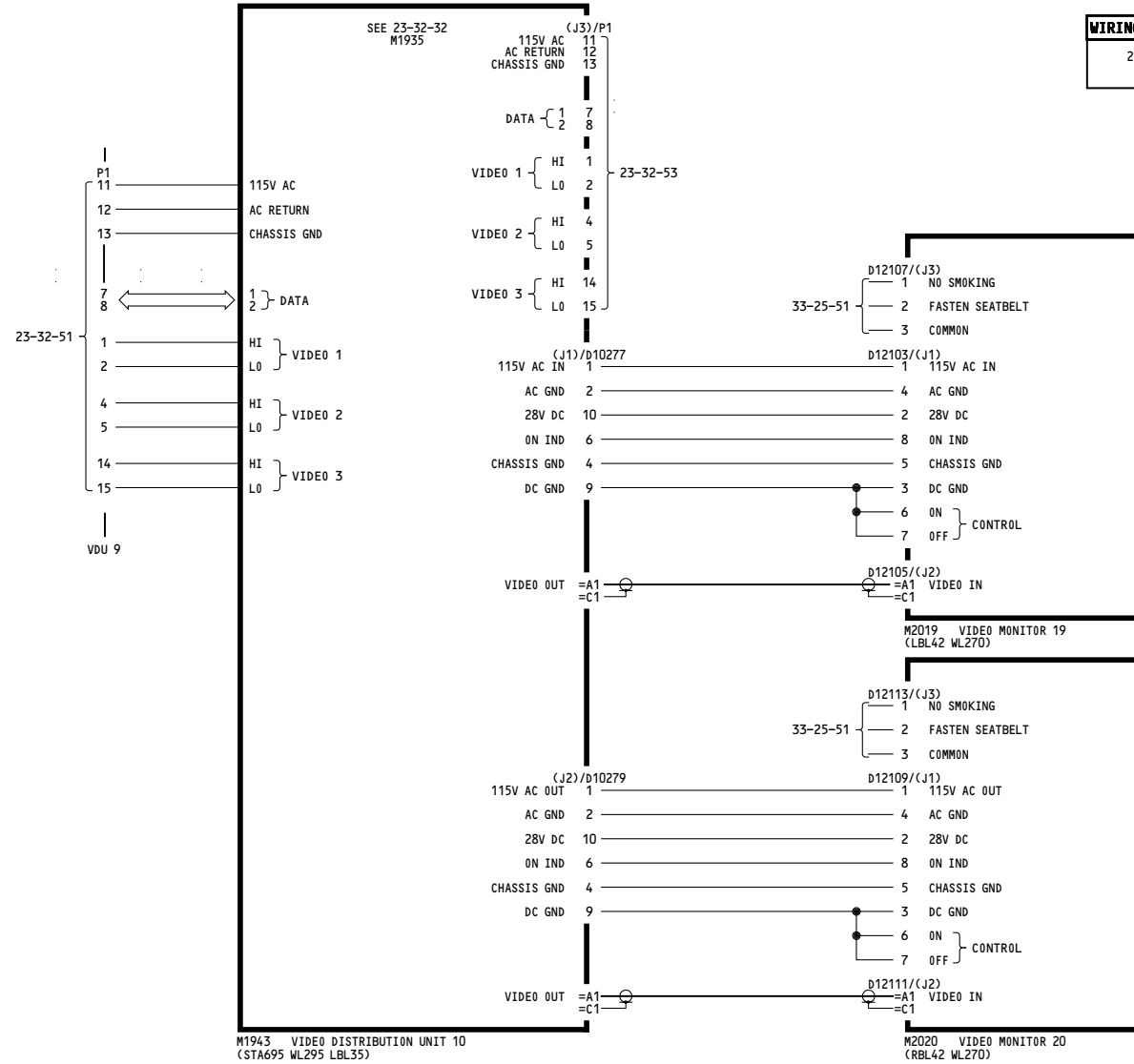

YK901-YL430

**VIDEO ENTERTAINMENT
SYSTEM
TRAY 3 VDU 10**

D280A203

23-32-52

Page 103

Feb 09/2009

WIRING DIAGRAMS
23-32-52

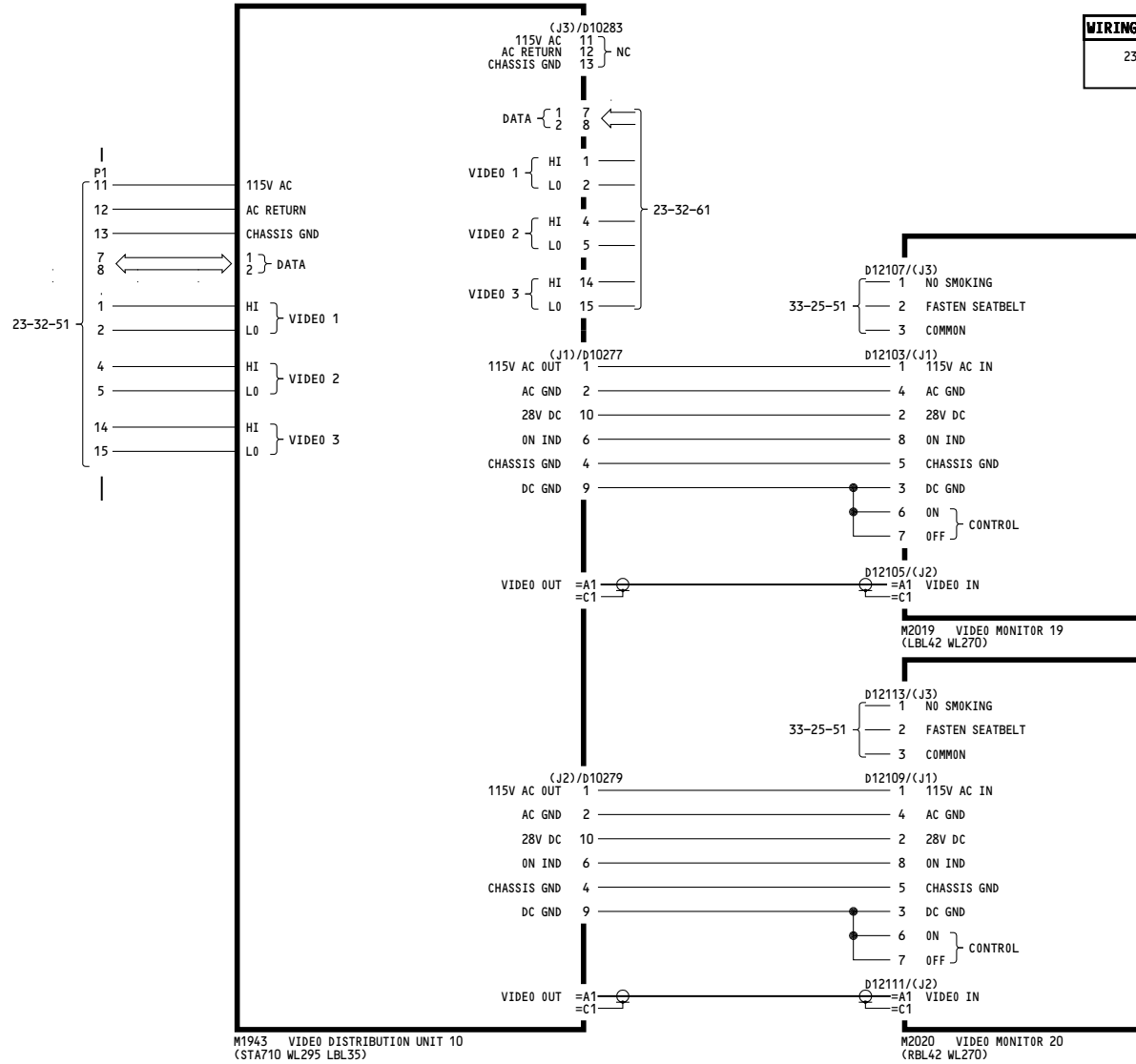

YM643-YM670

**VIDEO ENTERTAINMENT
SYSTEM
TRAY 3 VDU 10**

D280A203

23-32-52

Page 104

Jan 14/2008

WIRING DIAGRAMS
23-32-52

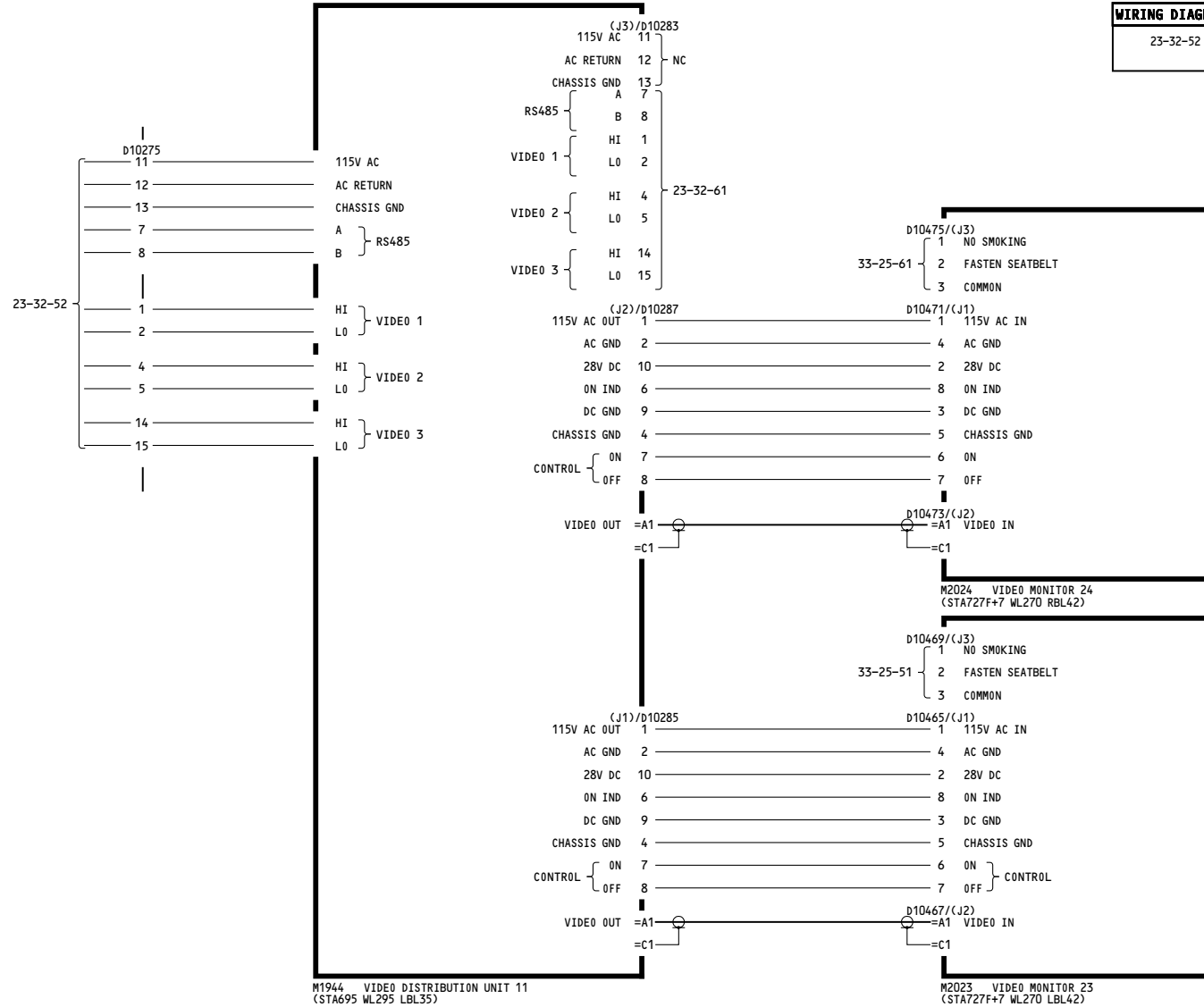

YC001-YC011

**VIDEO ENTERTAINMENT
SYSTEM
TRAY 3 VDU 11**

D280A203

23-32-53

WIRING DIAGRAMS
23-32-52

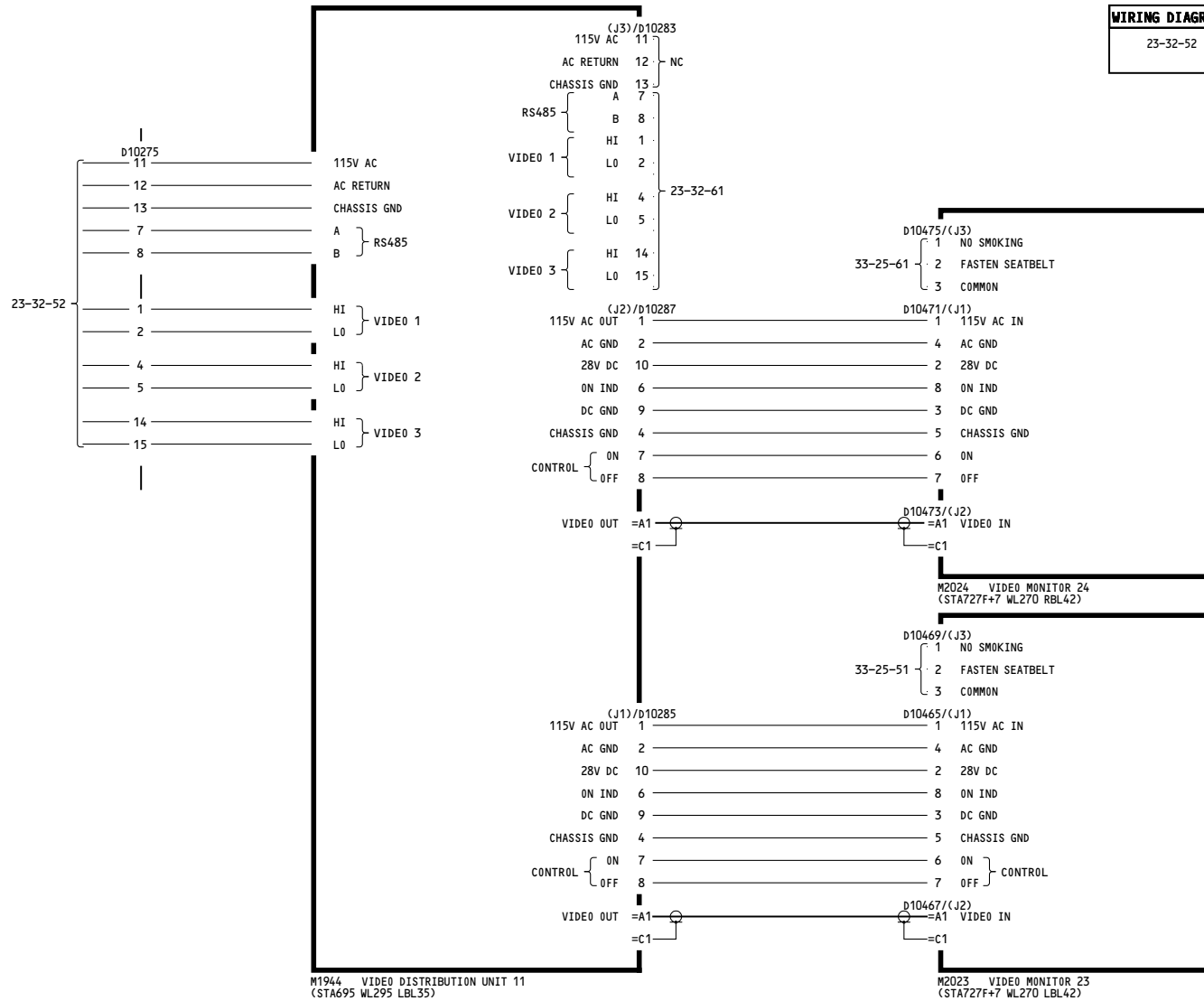

YC012-YC050	<p>VIDEO ENTERTAINMENT SYSTEM TRAY 3 VDU 11</p> <p>D280A203</p>
-------------	---

WIRING DIAGRAMS
23-32-53

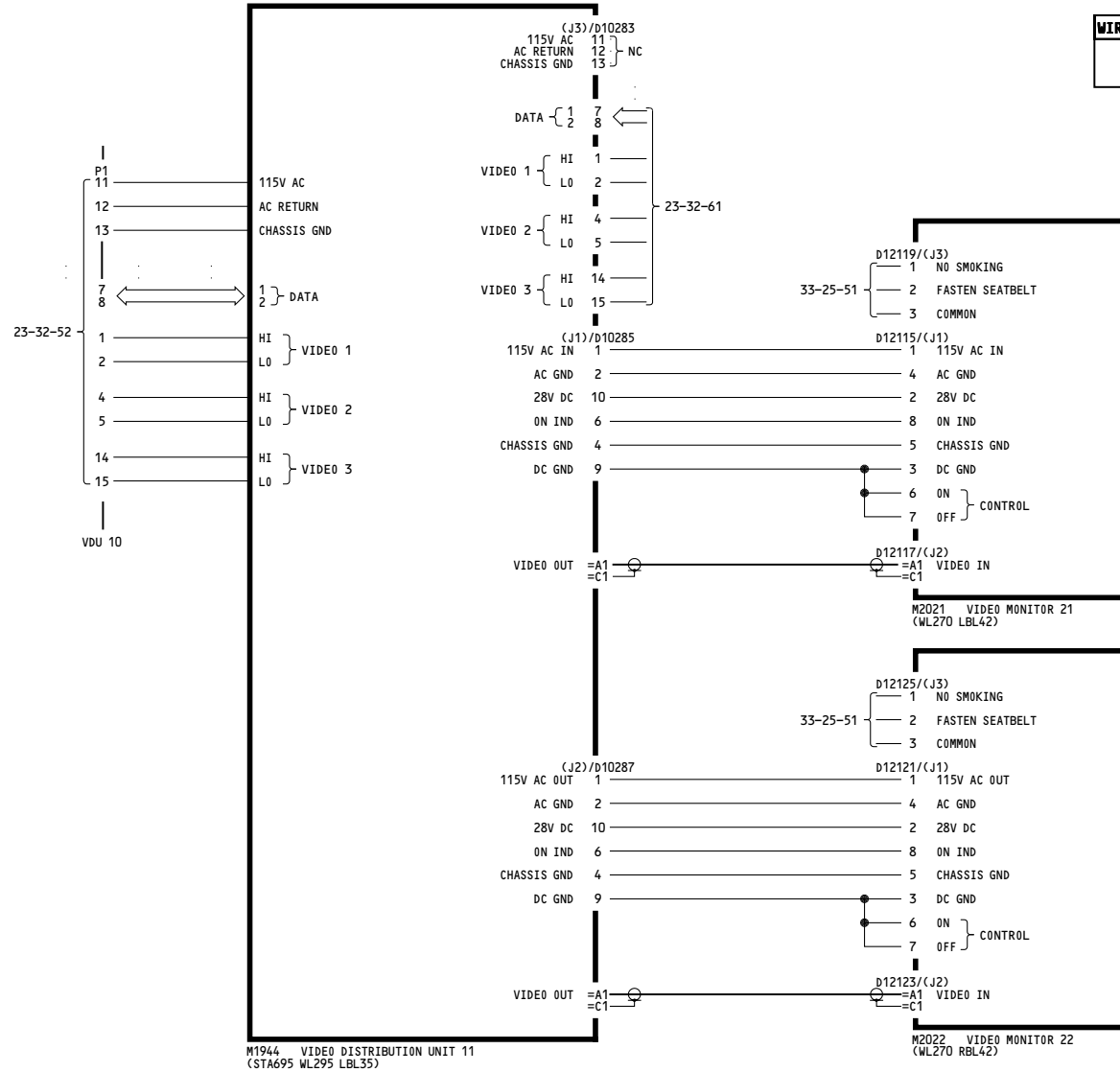

YK901-YL430	<p>VIDEO ENTERTAINMENT SYSTEM TRAY 3 VDU 11</p> <p>D280A203</p>
-------------	---

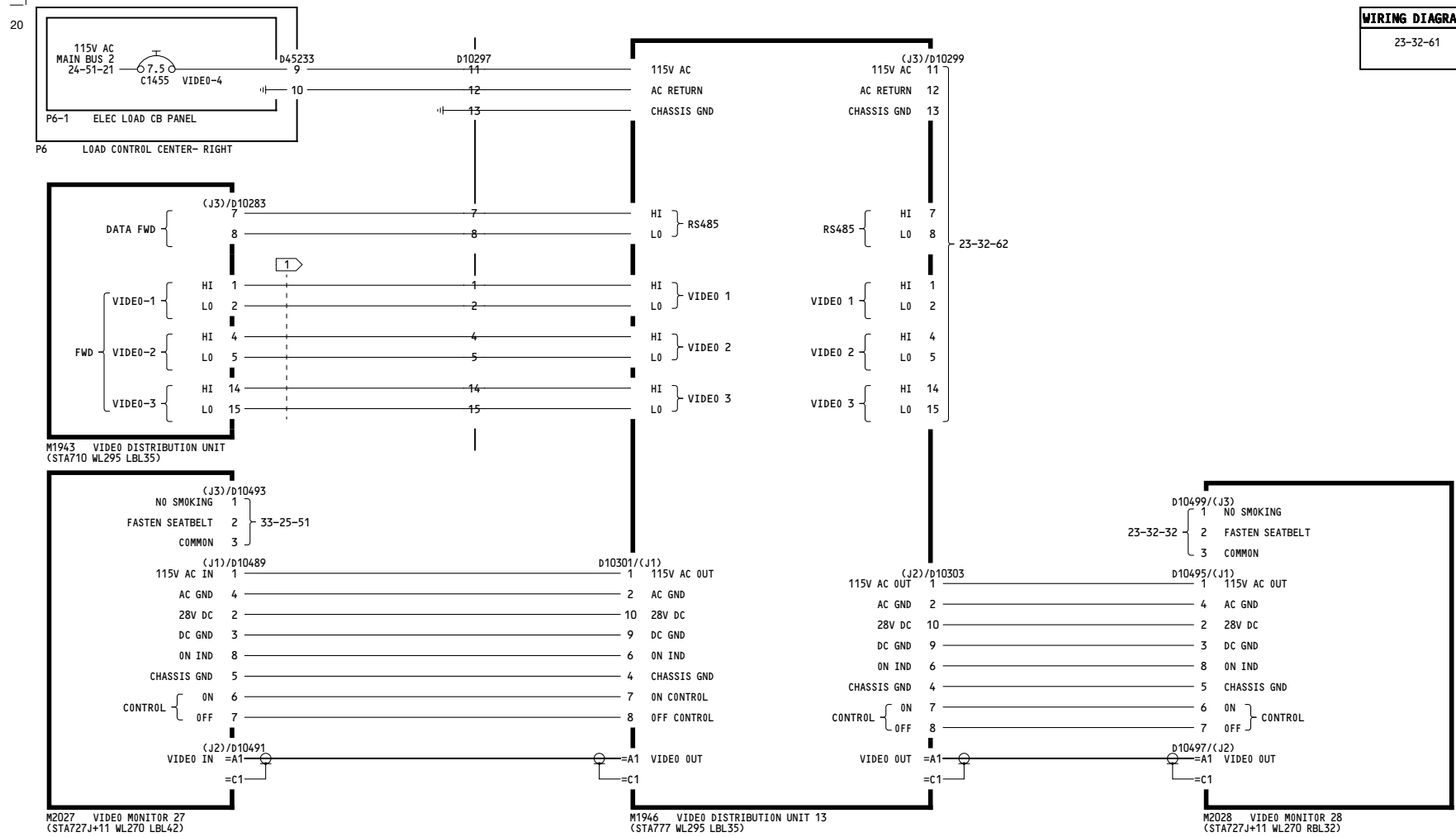

NOTES:

1 CHAMPLAIN CABLE P/N 51-04570 OR EQUIVALENT

YC001-YC011	VIDEO ENTERTAINMENT SYSTEM TRAY 4 VDU 13 D280A203
-------------	---

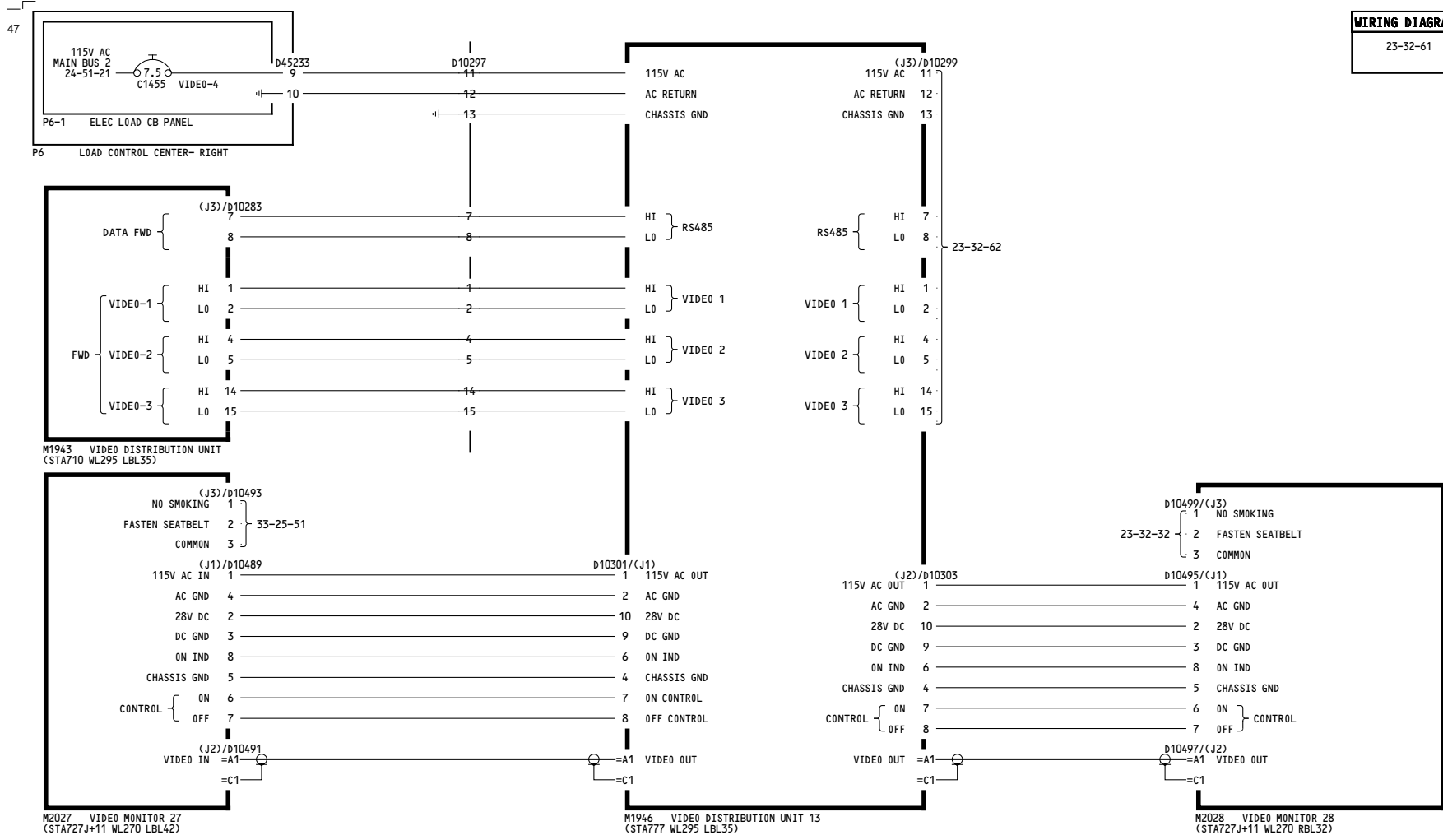

YC012-YC030	VIDEO ENTERTAINMENT SYSTEM TRAY 4 VDU 13 D280A203
-------------	---

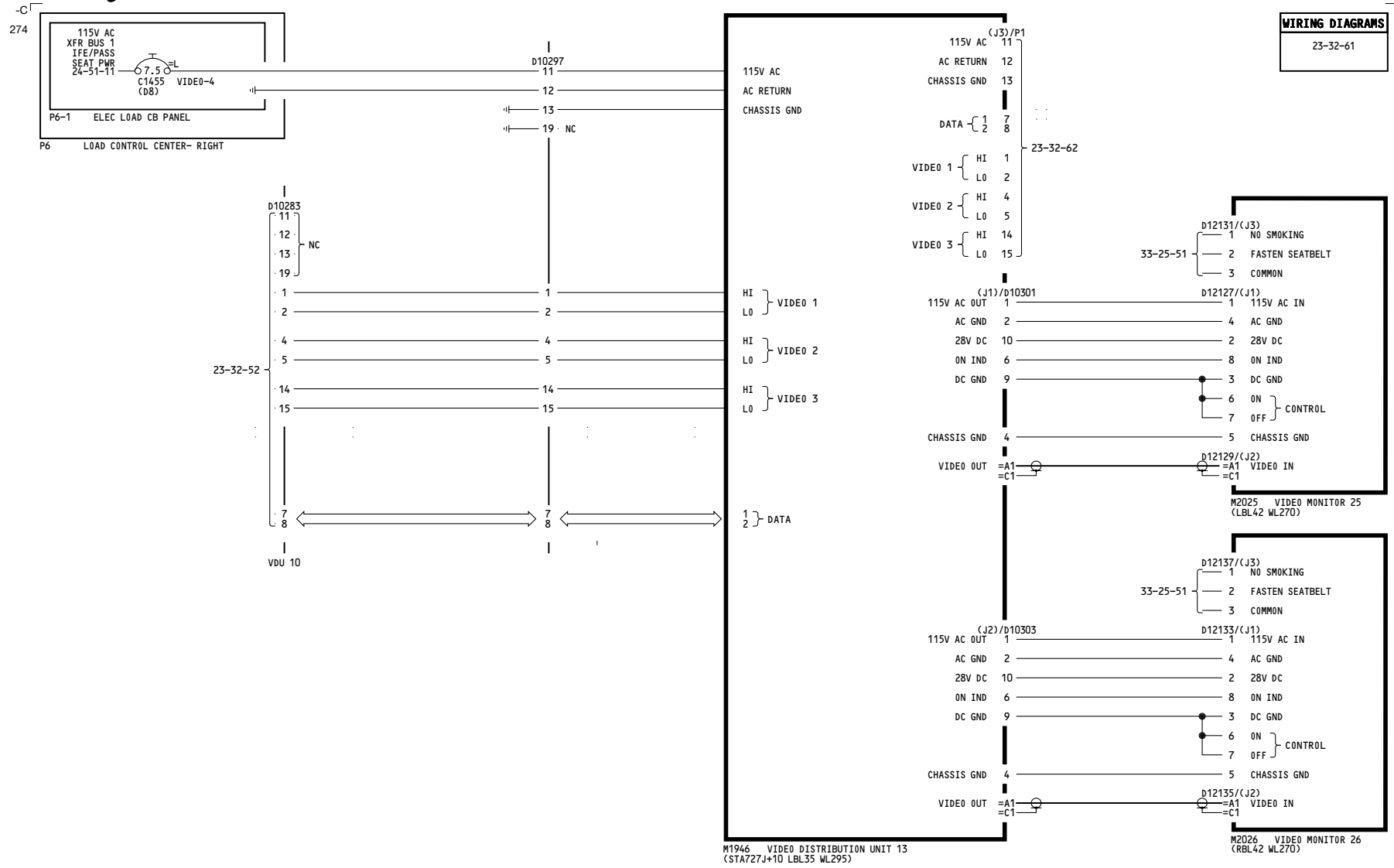

YK901-YK909, YL401-YL430	VIDEO ENTERTAINMENT SYSTEM TRAY 4 VDU 13 D280A203
--------------------------	---

23-32-61

WIRING DIAGRAMS
23-32-61

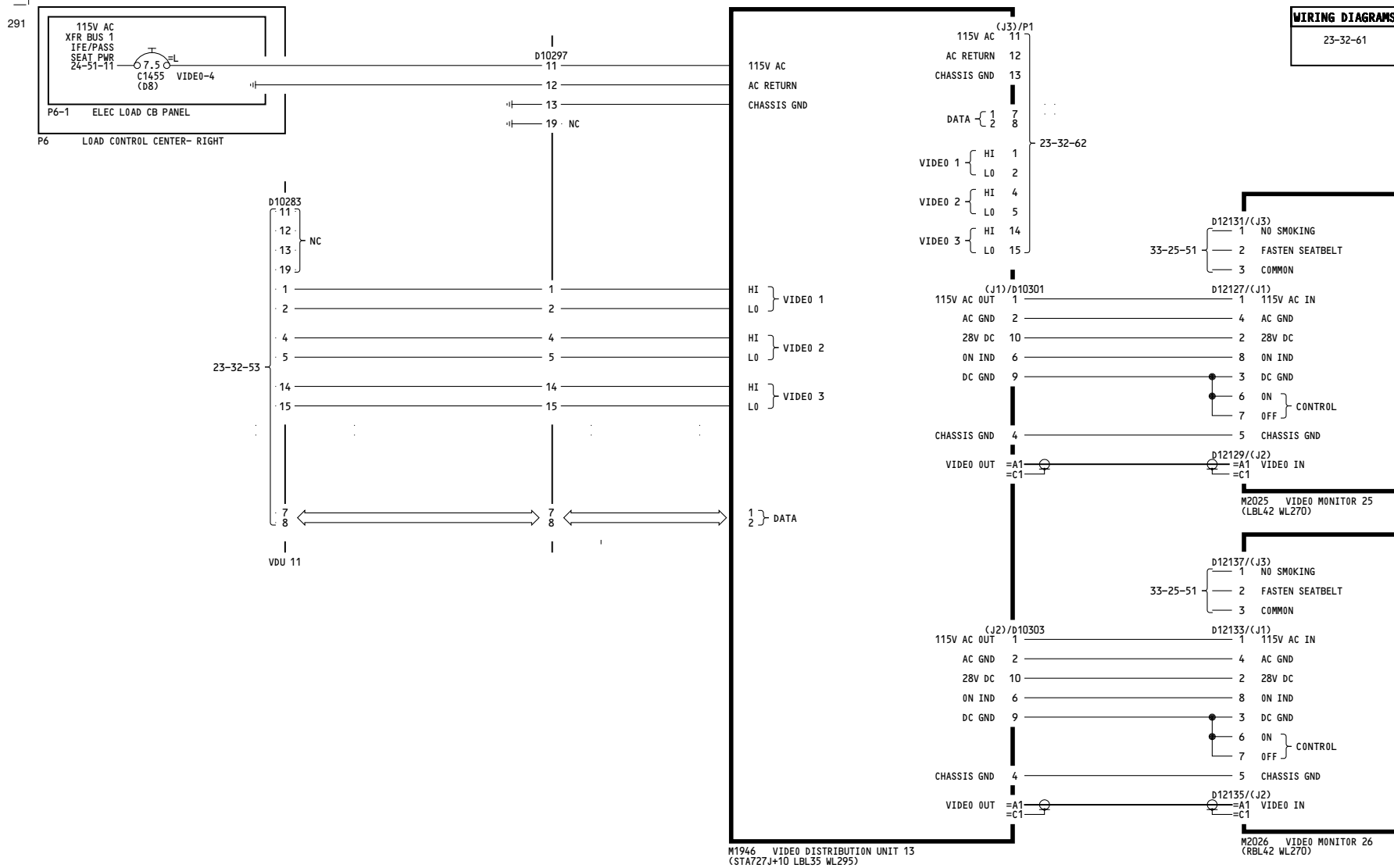

YK910-YK920	<p align="center">VIDEO ENTERTAINMENT SYSTEM TRAY 4 VDU 13</p> <p align="center">D280A203</p>
-------------	--

23-32-61

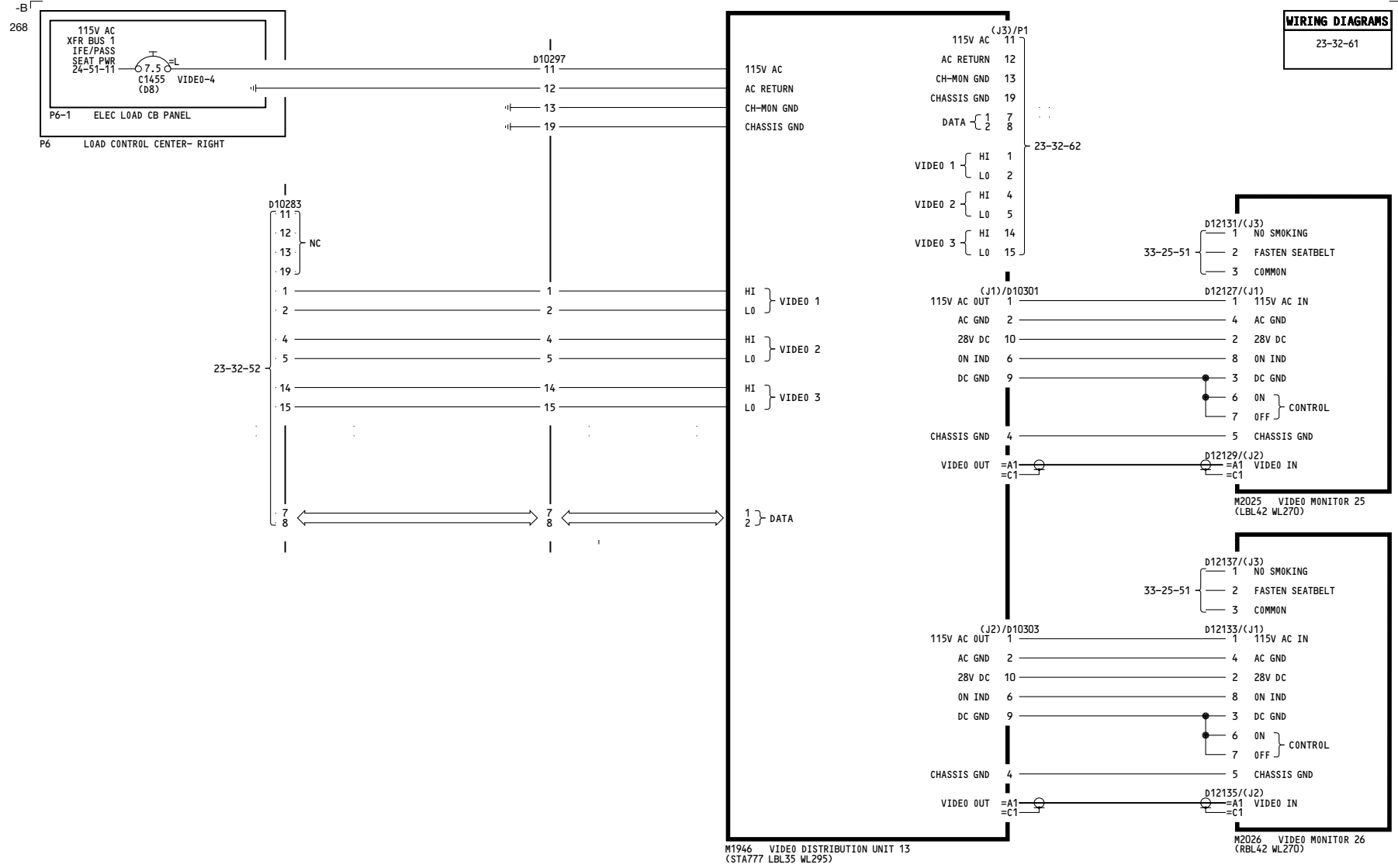

WIRING DIAGRAMS
23-32-61

YM643-YM670	<p>VIDEO ENTERTAINMENT SYSTEM TRAY 4 VDU 13</p> <p>D280A203</p>
-------------	---

23-32-61

WIRING DIAGRAMS
23-32-62

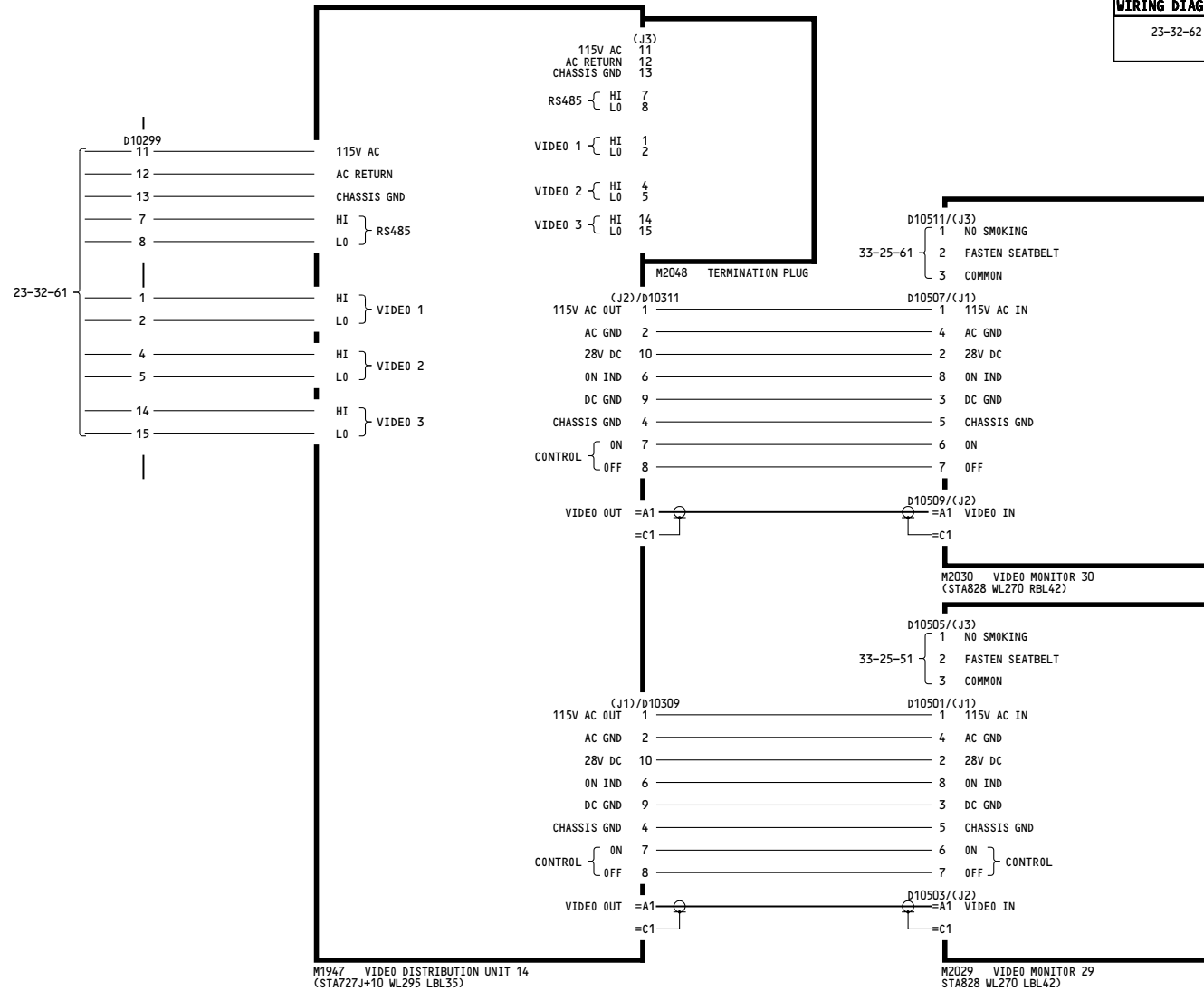

YC001-YC011	<p align="center">VIDEO ENTERTAINMENT SYSTEM TRAY 4 VDU 14</p> <p align="center">D280A203</p>
-------------	---

23-32-62

WIRING DIAGRAMS
23-32-62

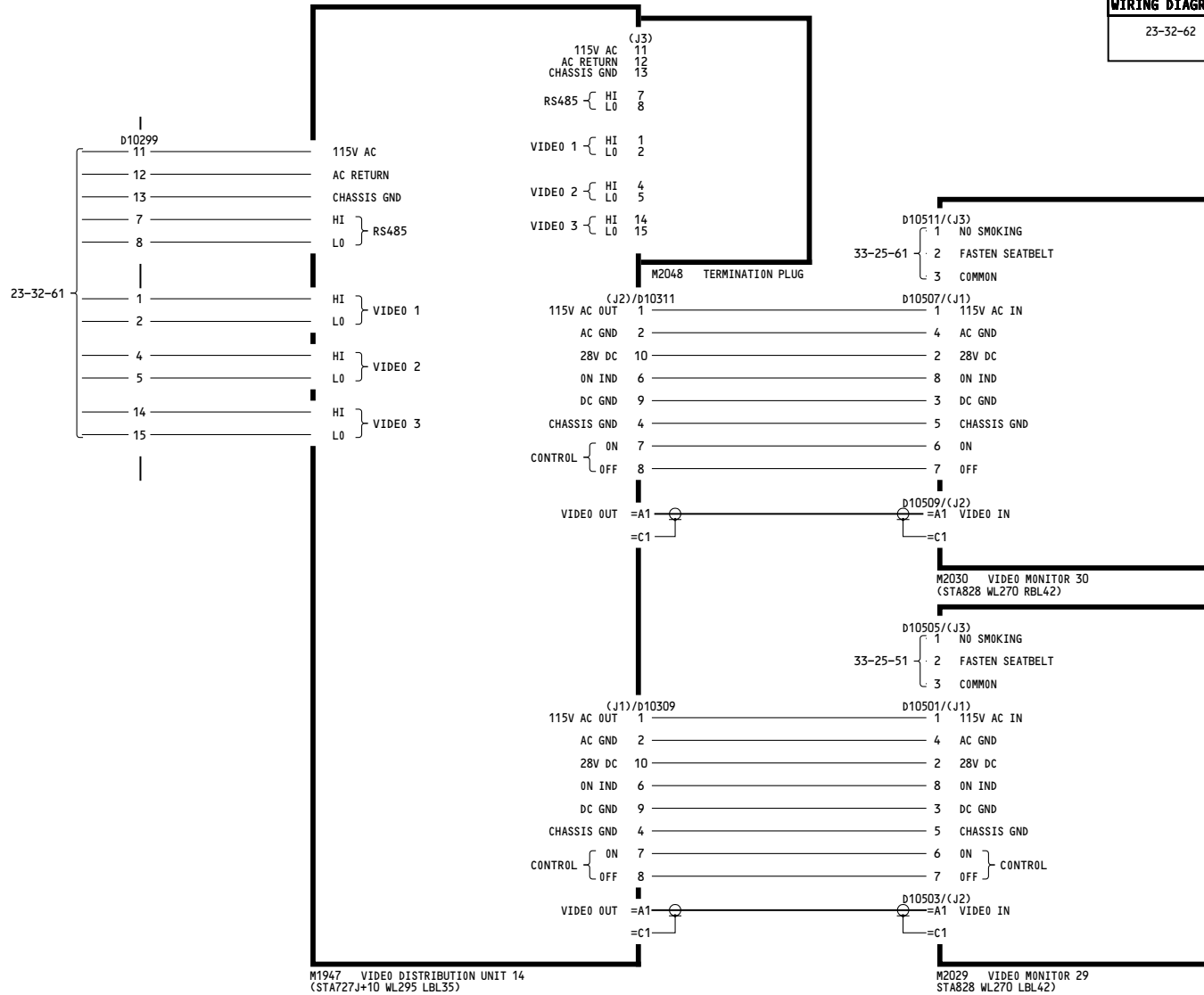

YC012-YC050	VIDEO ENTERTAINMENT SYSTEM TRAY 4 VDU 14
	D280A203

23-32-62

WIRING DIAGRAMS
23-32-63

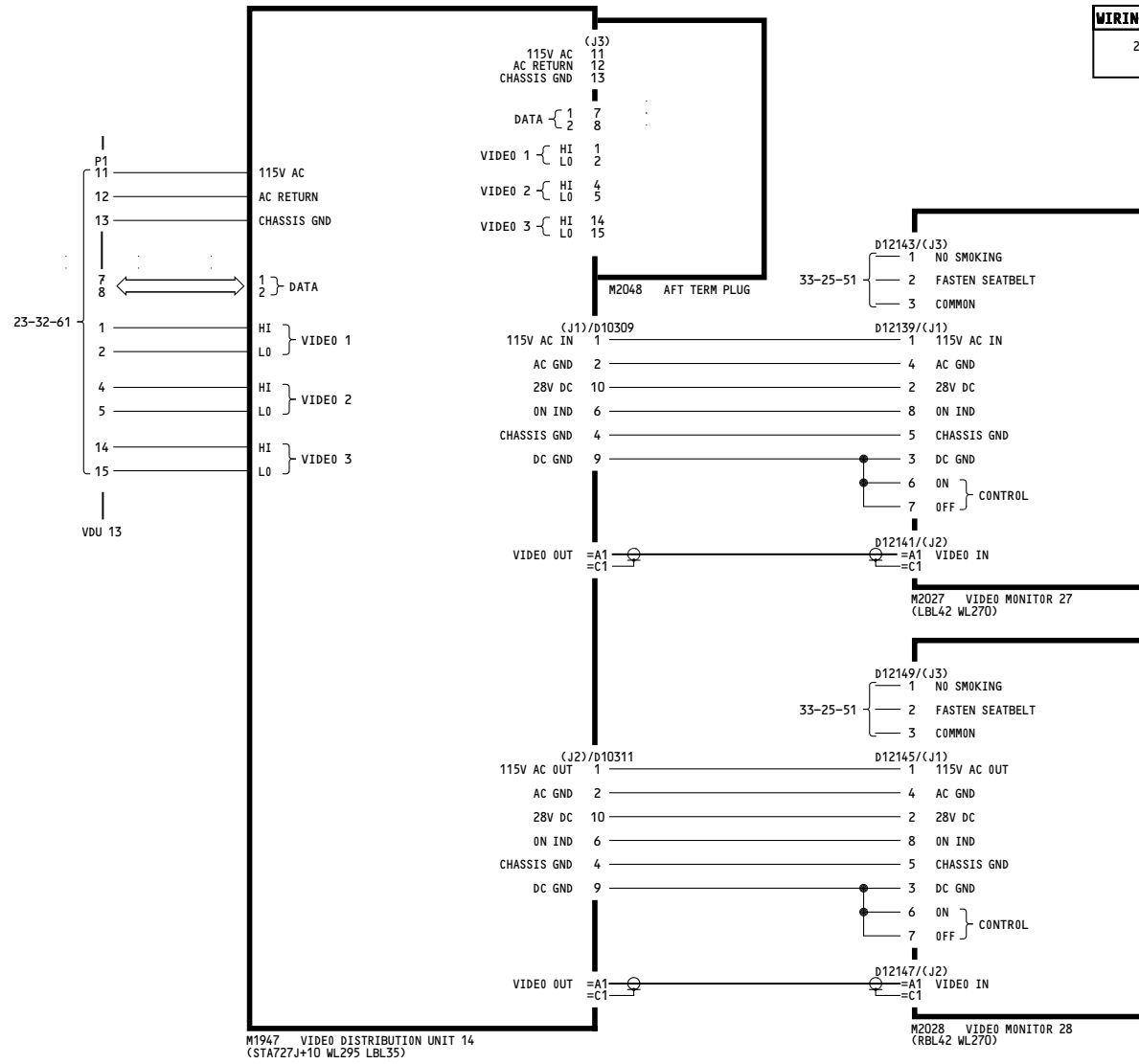

YK901-YL430	<p>VIDEO ENTERTAINMENT SYSTEM TRAY 4 VDU 14</p> <p>D280A203</p>
-------------	---

WIRING DIAGRAMS
23-32-63

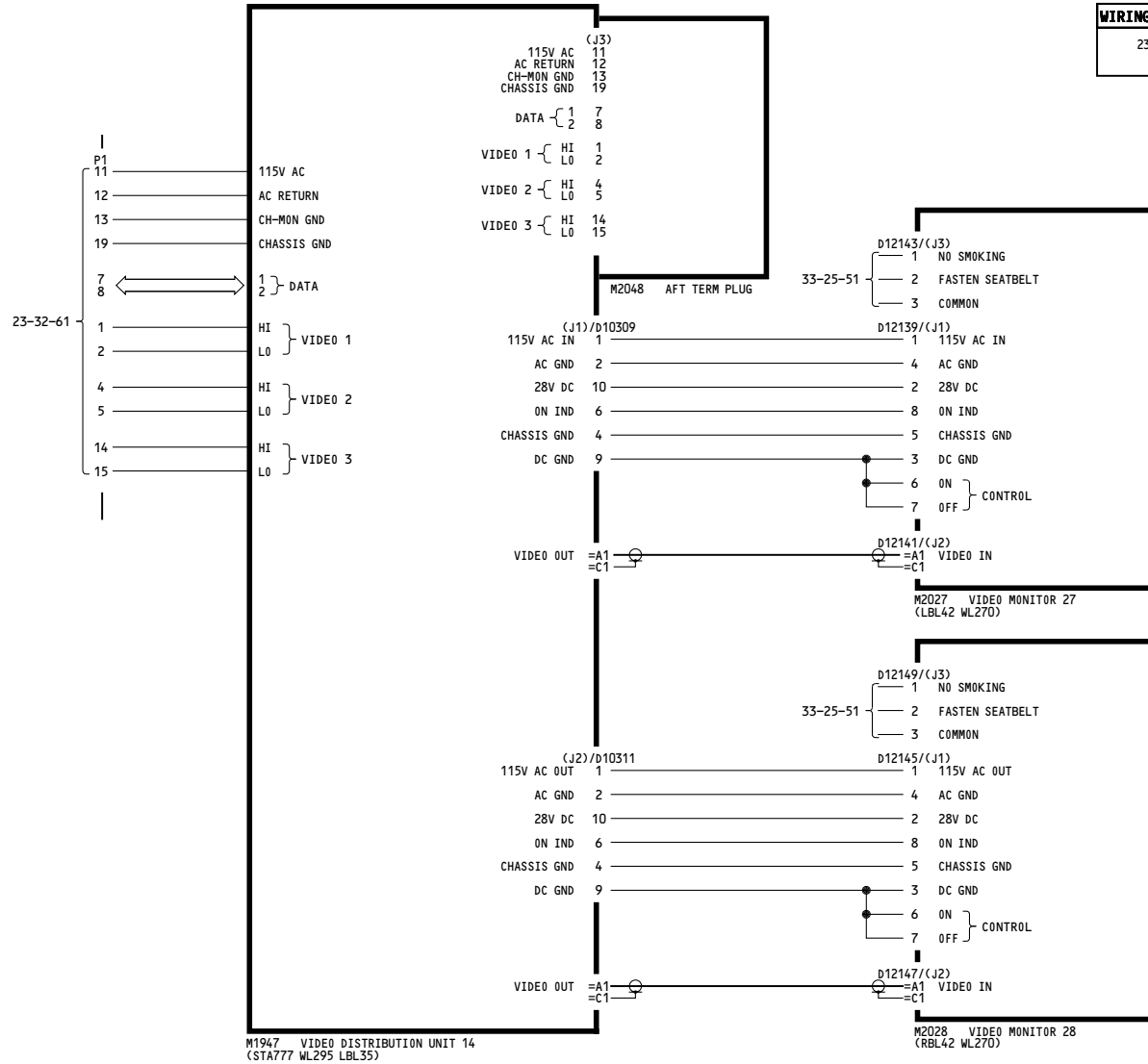

YM643-YM670

VIDEO ENTERTAINMENT SYSTEM TRAY 4 VDU 14

D280A203

23-32-62

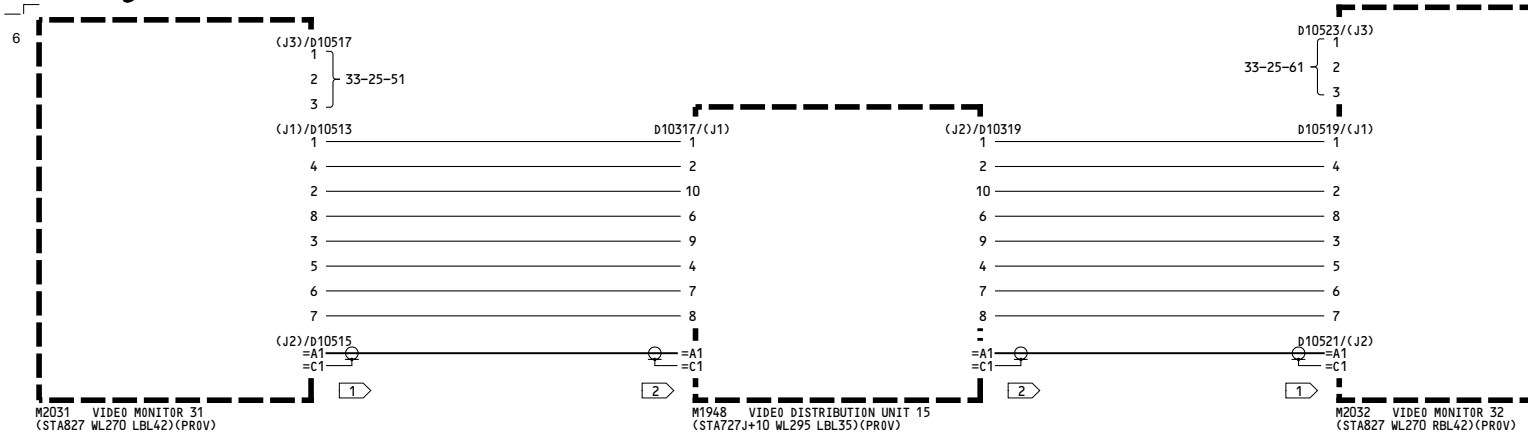

WIRING DIAGRAMS
23-32-62

- NOTES:
- 1** COIL CAP AND STOW AT STA886
 - 2** CAP AND STOW NEAR VDU 15

YC001-YC011	VIDEO ENTERTAINMENT SYSTEM TRAY 4 VDU 15
	D280A203

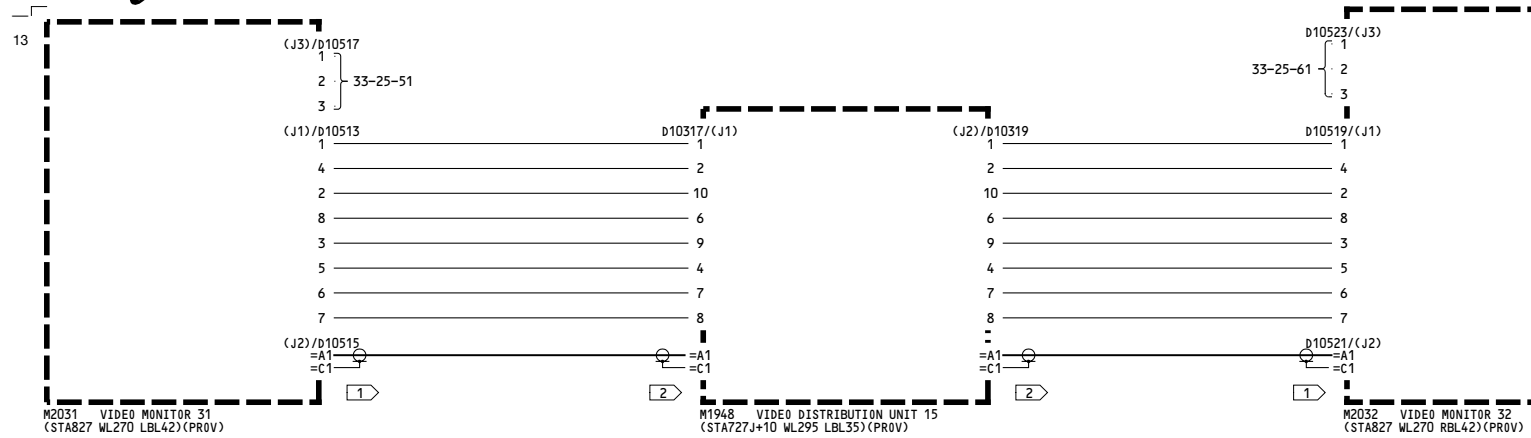

NOTES:

[1] COIL CAP AND STOW AT STA886

[2] CAP AND STOW NEAR VDU 15

YC012-YC050	<p align="center">VIDEO ENTERTAINMENT SYSTEM TRAY 4 VDU 15</p> <p align="center">D280A203</p>
-------------	--

WIRING DIAGRAMS
23-32-63

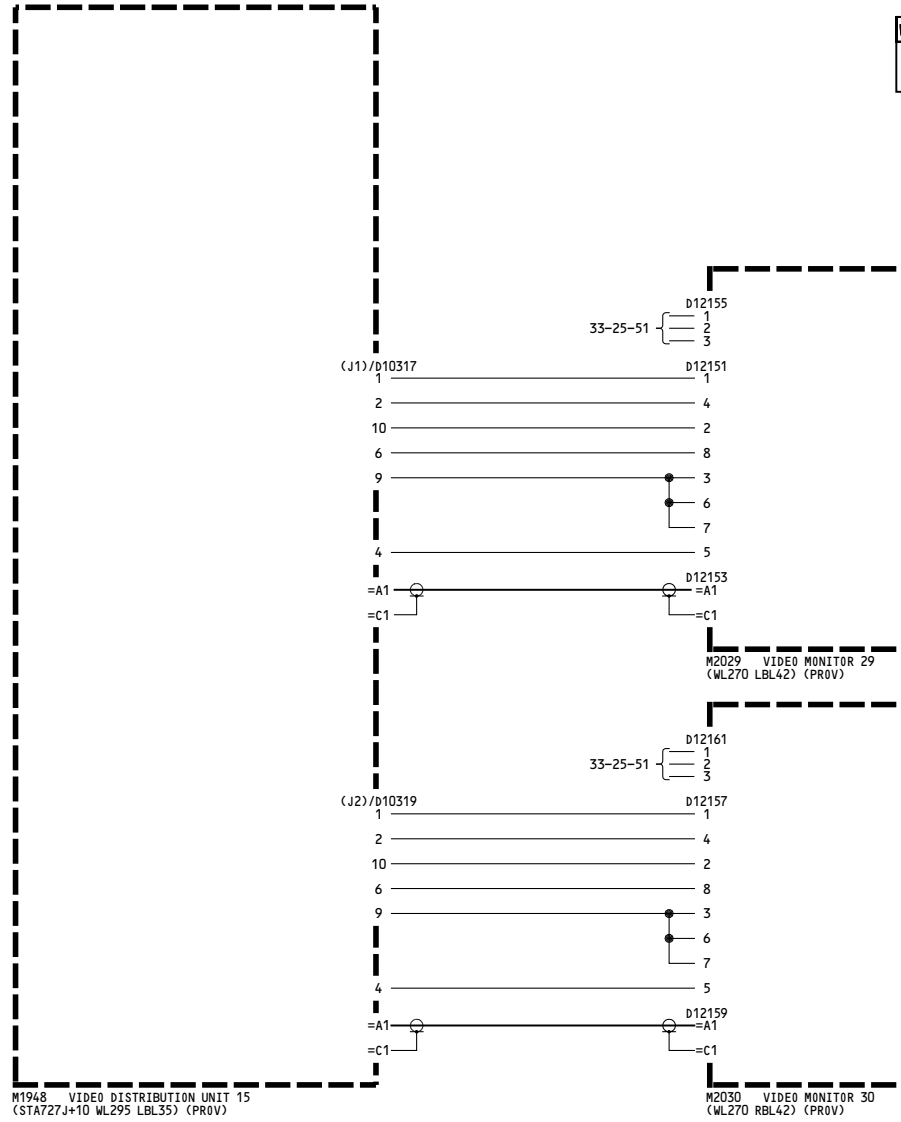

YK901-YL430	<p align="center">VIDEO ENTERTAINMENT SYSTEM TRAY 4 VDU 15</p> <p align="center">D280A203</p>
-------------	---

23-32-63

WIRING DIAGRAMS
23-34-01
23-34-02

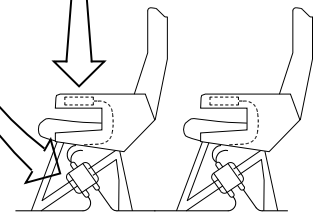
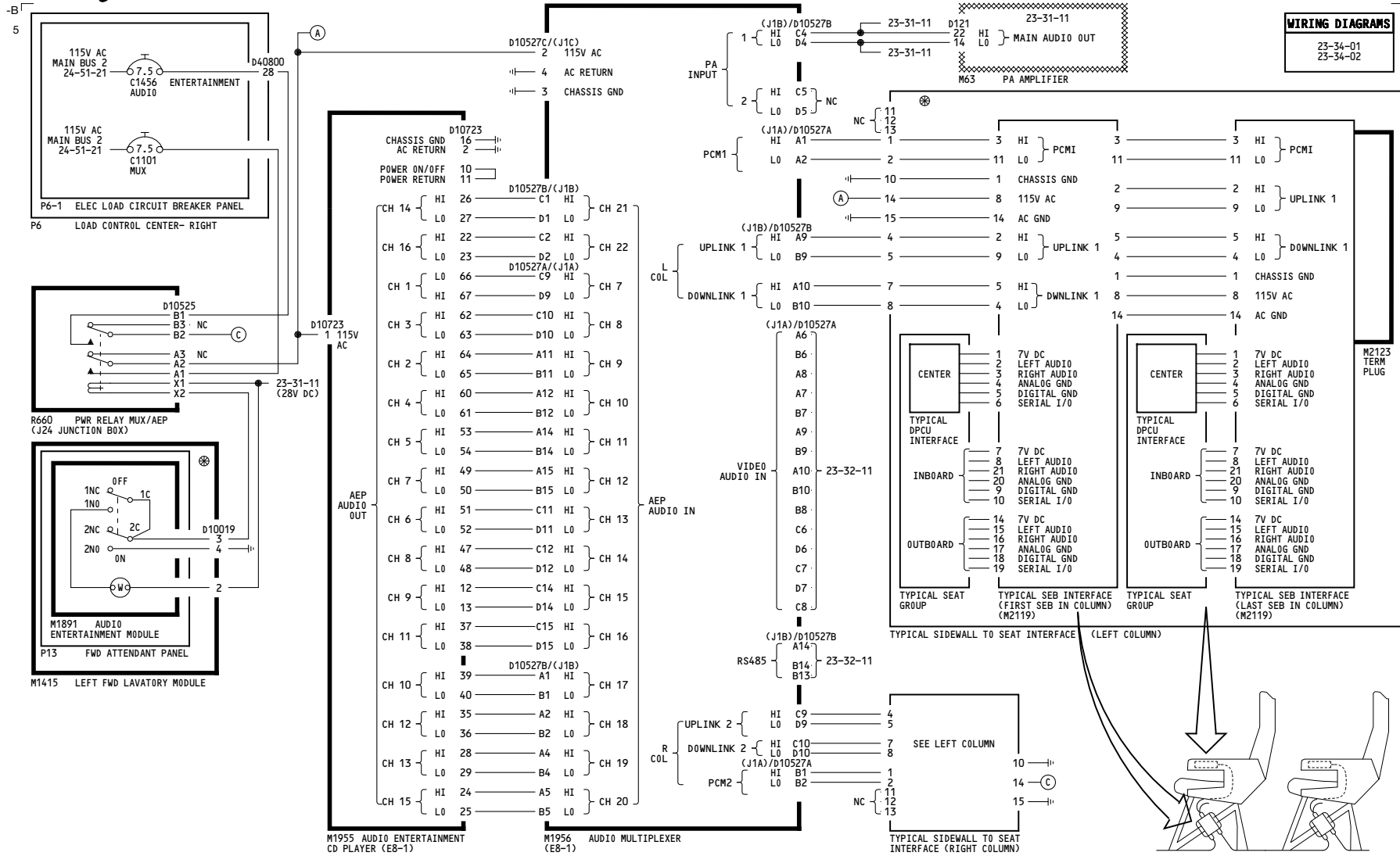

YC001-YC013	AUDIO ENTERTAINMENT SYSTEM
D280A203	

23-34-01

WIRING DIAGRAMS	
23-32-11	
23-32-12	
23-32-13	

-C
2

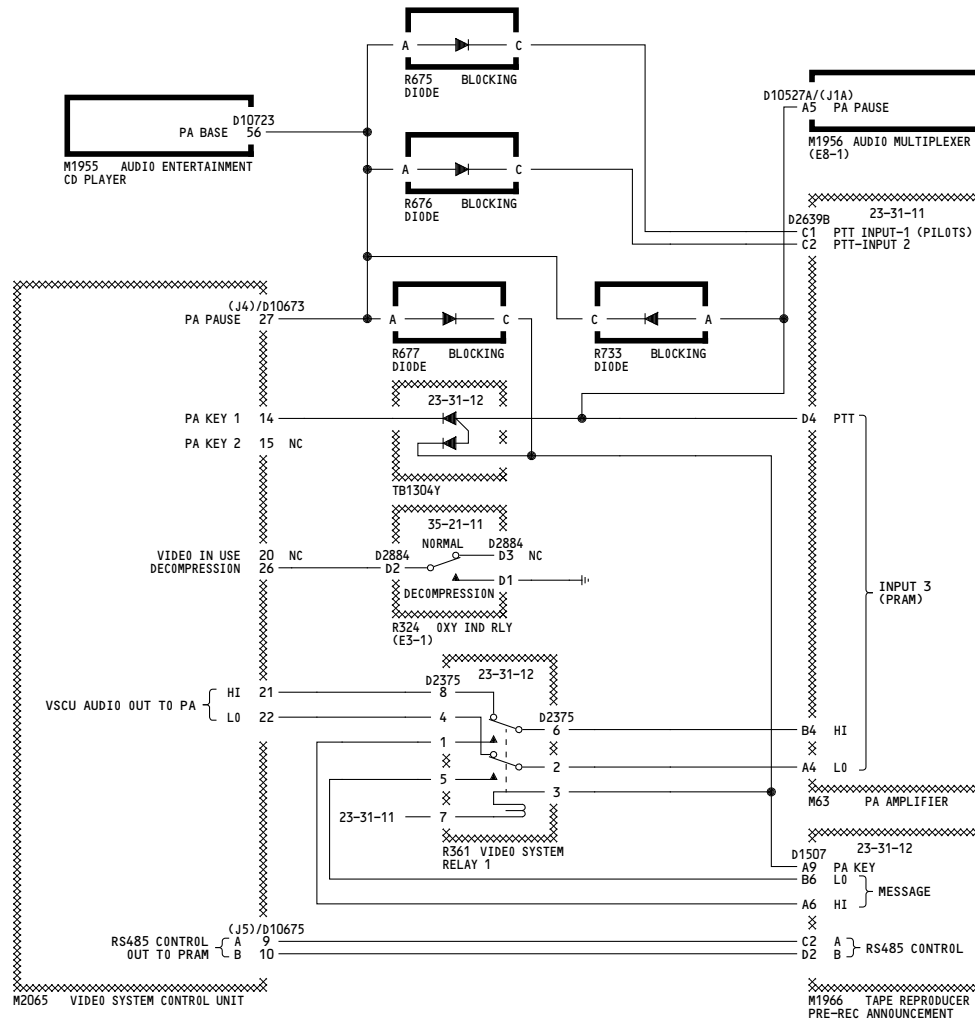

YC001-YC013	AUDIO ENTERTAINMENT SYSTEM
	D280A203

23-34-01

Page 101
Sheet 2
Mar 31/2005

WIRING DIAGRAMS
23-34-01
23-34-02

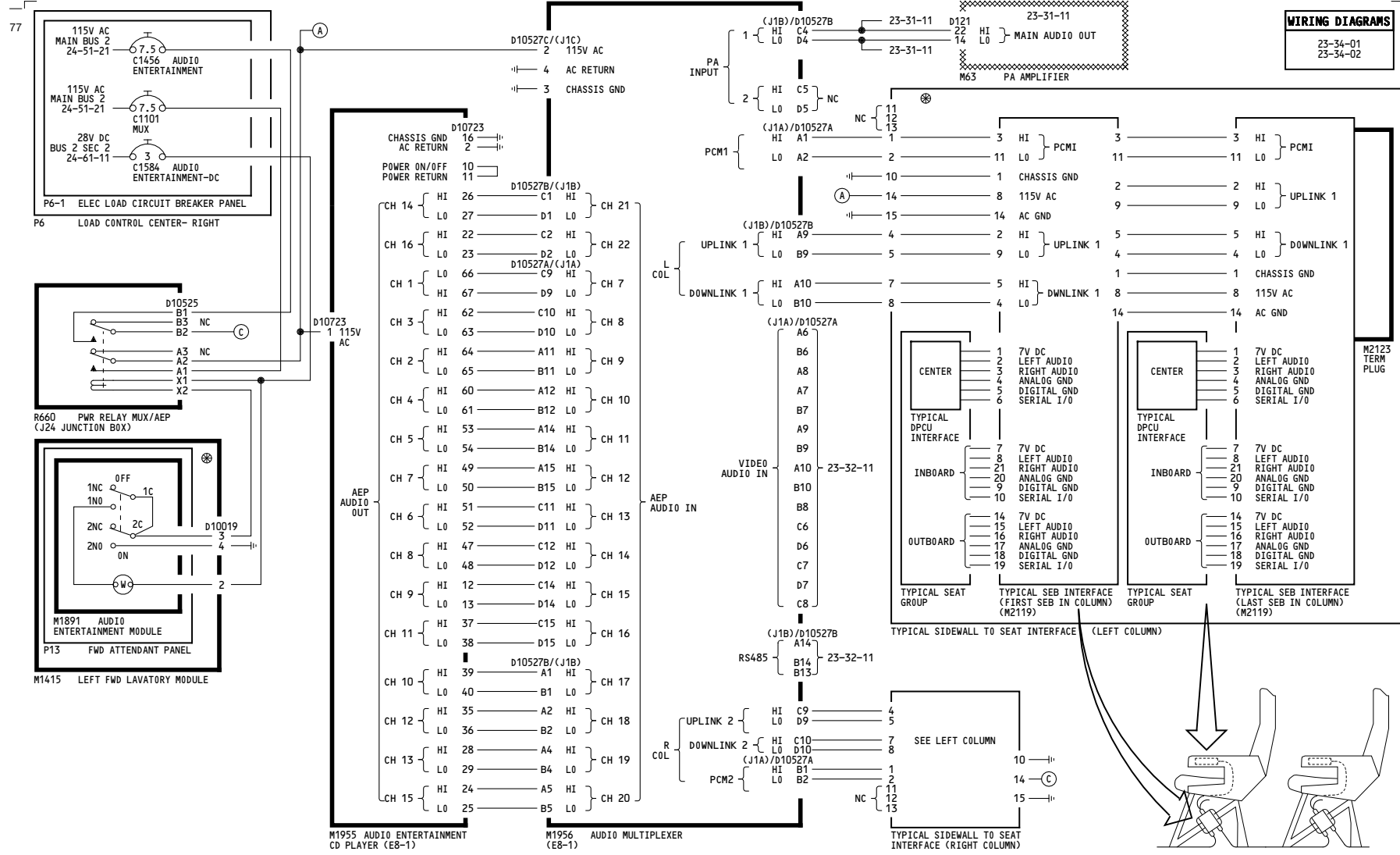

YC001-YC013	AUDIO ENTERTAINMENT SYSTEM
	D280A203

Incorporates
23-1139 R01

23-34-01

Page 101.1
Sheet 1
May 13/2008

WIRING DIAGRAMS	
23-32-11	
23-32-12	
23-32-13	

-C
2

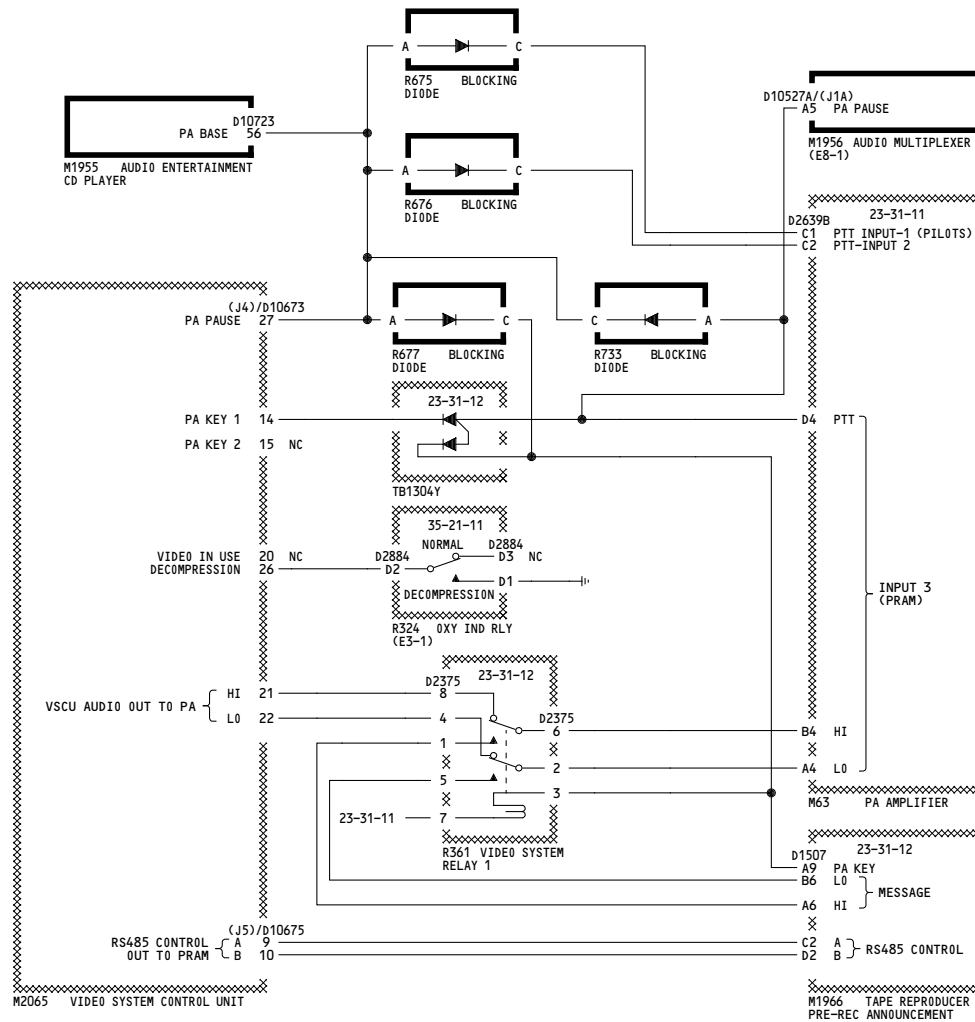

YC001-YC013	AUDIO ENTERTAINMENT SYSTEM
	D280A203

23-34-01

Page 101.1
Sheet 2
May 13/2008

WIRING DIAGRAMS
23-34-01
23-34-02

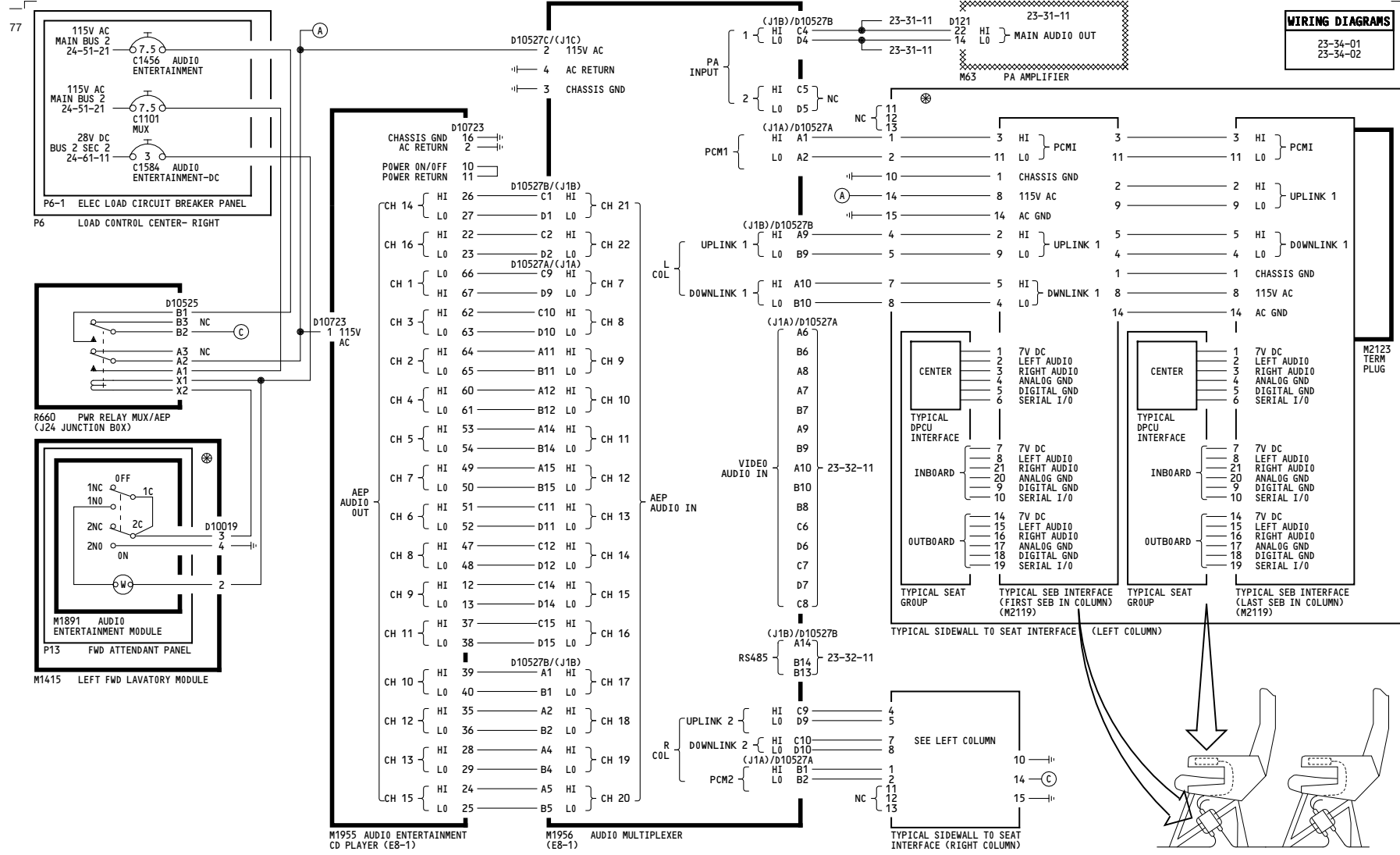

YC015-YC026	AUDIO ENTERTAINMENT SYSTEM D280A203
-------------	---

23-34-01

WIRING DIAGRAMS	
23-32-11	
23-32-12	
23-32-13	

-C
2

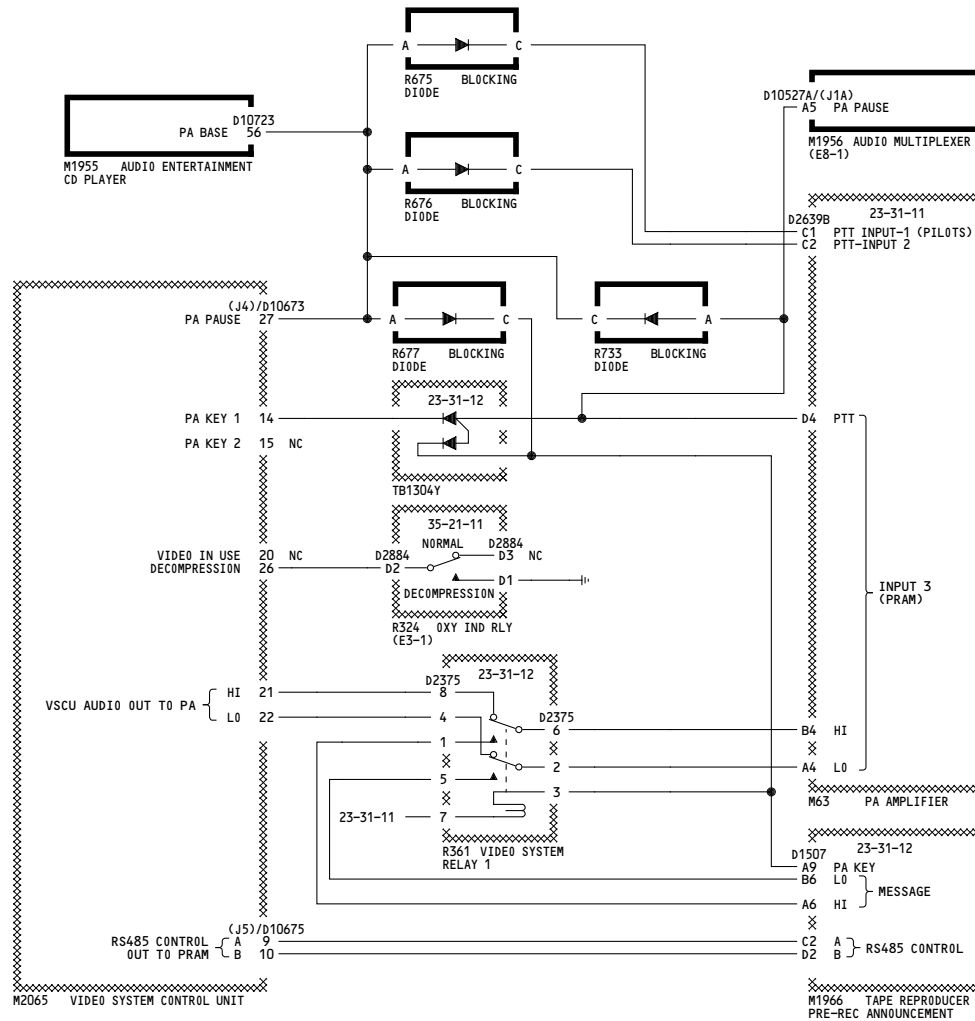

YC015-YC026	AUDIO ENTERTAINMENT SYSTEM
	D280A203

23-34-01

WIRING DIAGRAMS
23-34-01
23-34-02

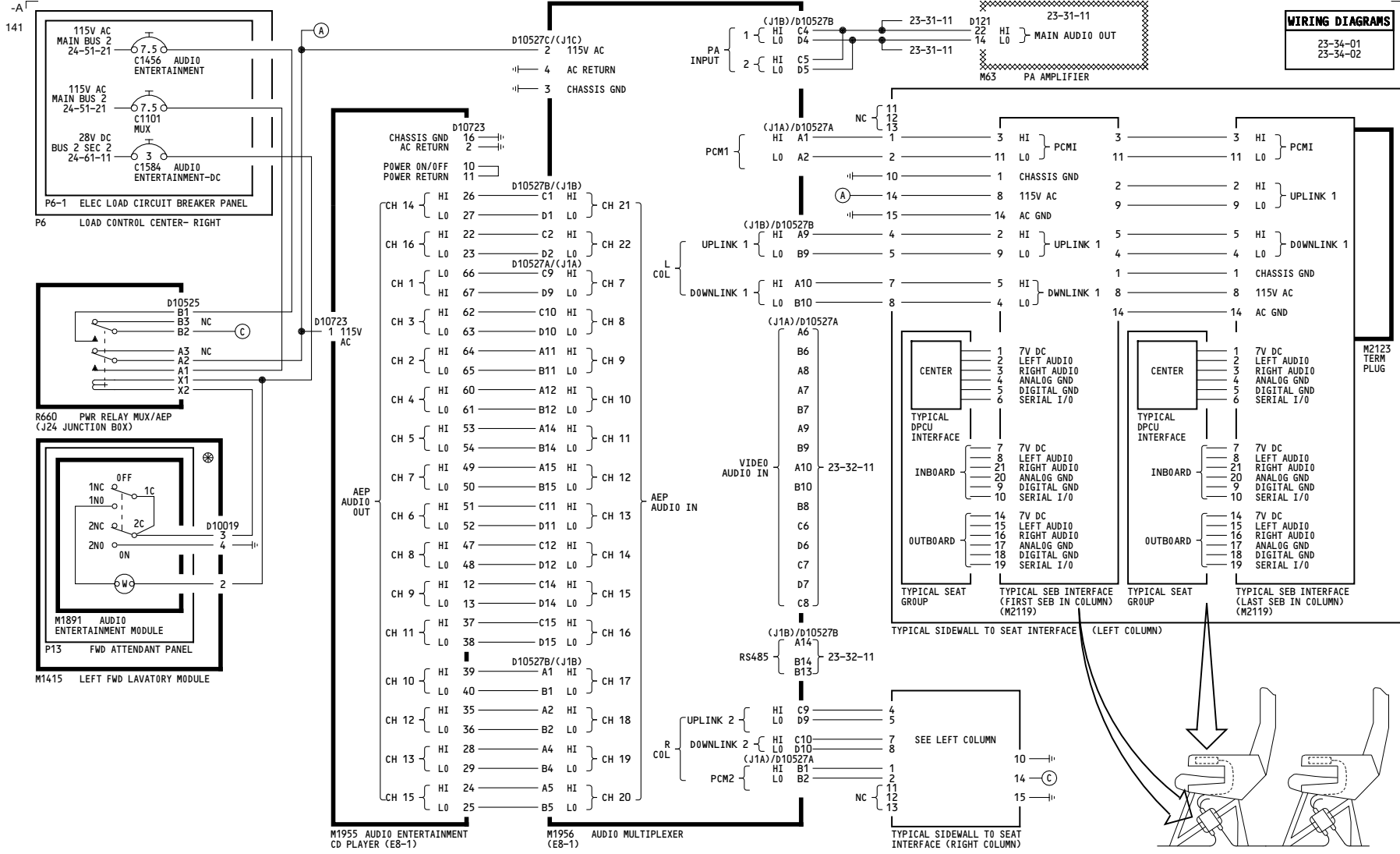

YC028-YC030

AUDIO ENTERTAINMENT SYSTEM

D280A203

23-34-01

WIRING DIAGRAMS	
23-32-11	
23-32-12	
23-32-13	

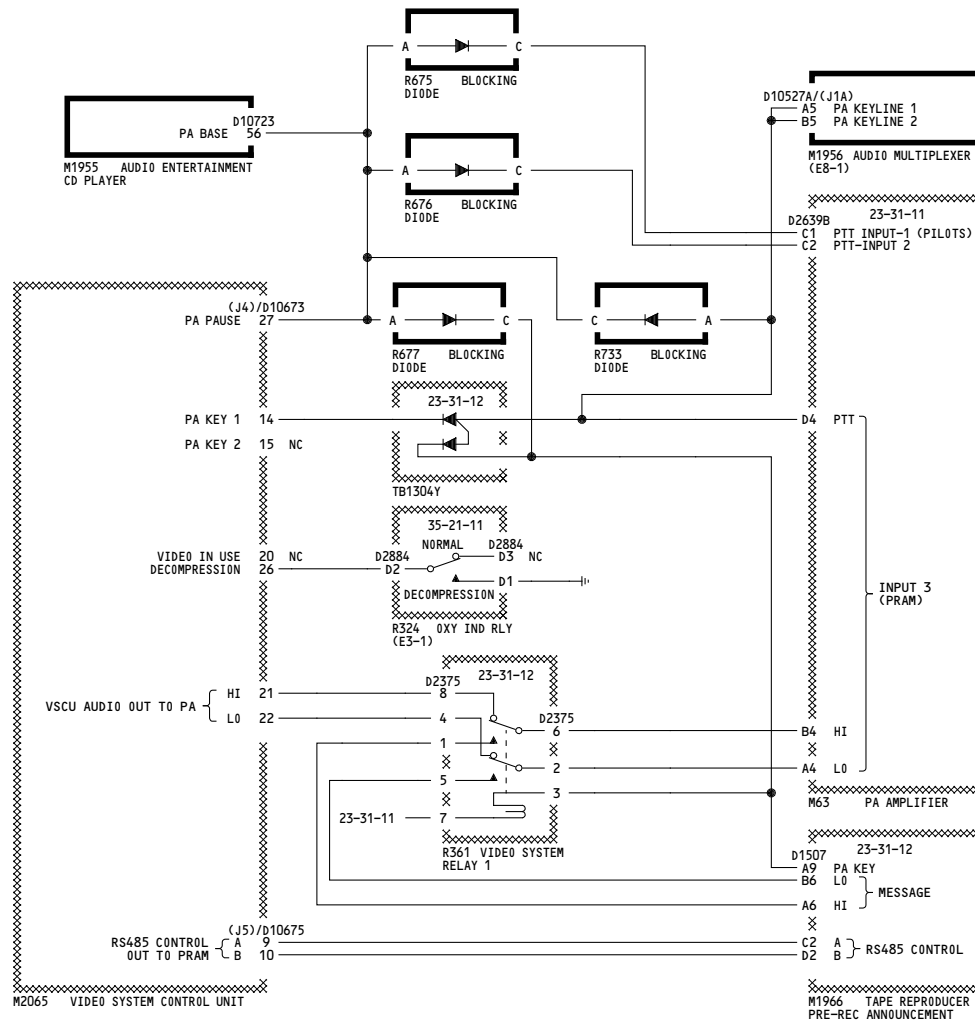

YC028-YC030	AUDIO ENTERTAINMENT SYSTEM
	D280A203

WIRING DIAGRAMS
23-34-01
23-34-02

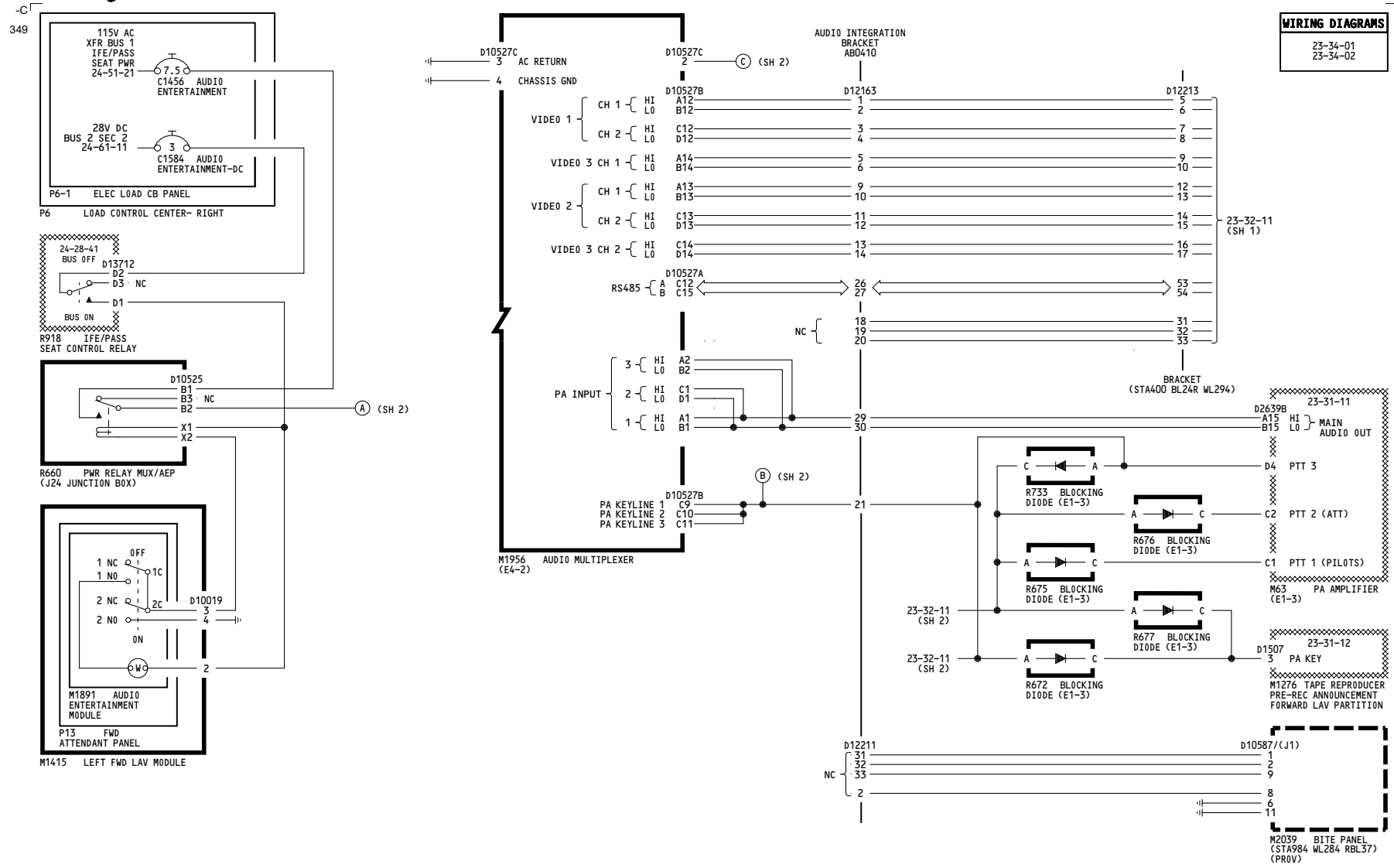

YK901-YM670	<p>AUDIO ENTERTAINMENT SYSTEM</p> <p>D280A203</p>
-------------	--

23-34-01

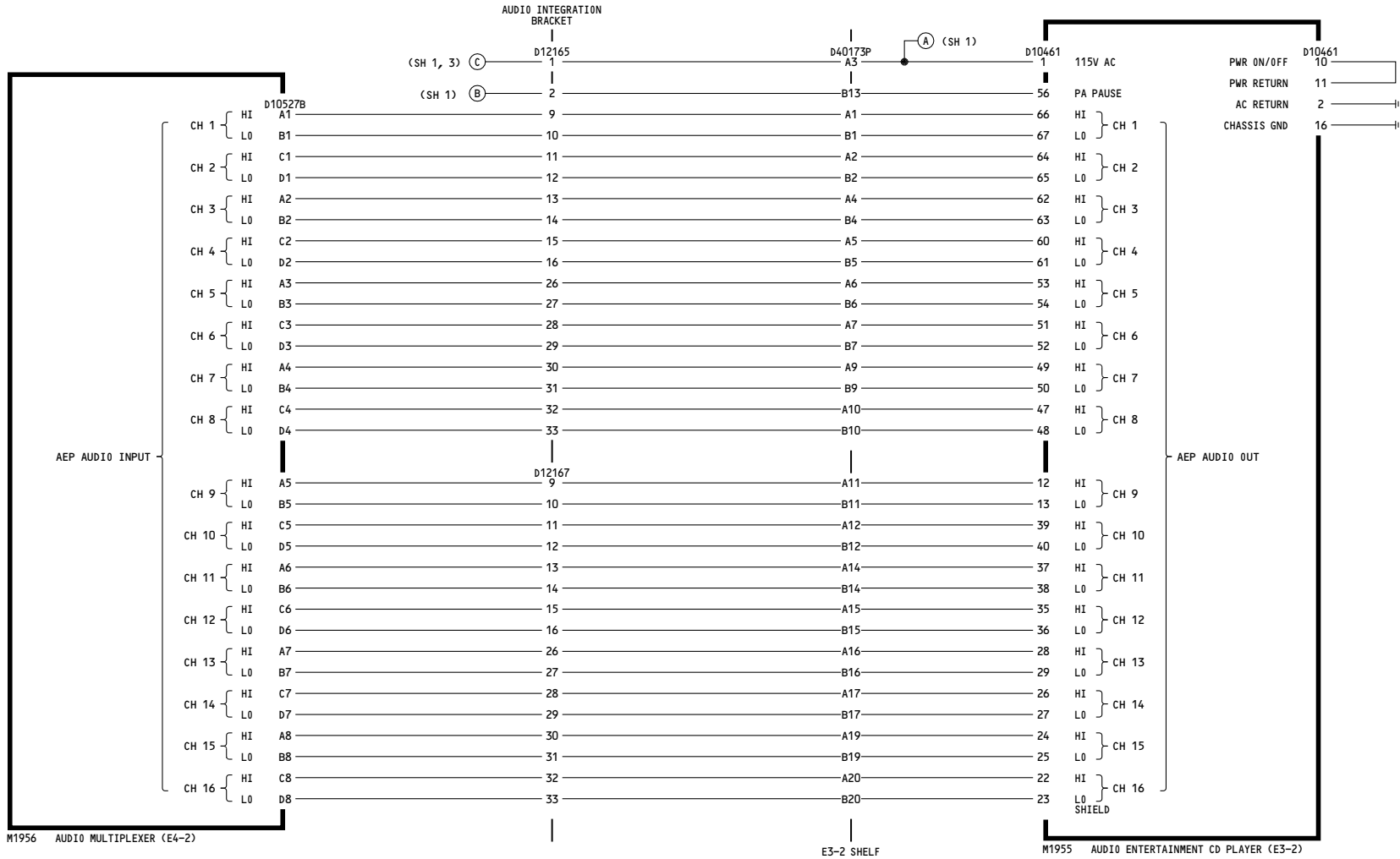

YK901-YM670	AUDIO ENTERTAINMENT SYSTEM
	D280A203

23-34-01

19

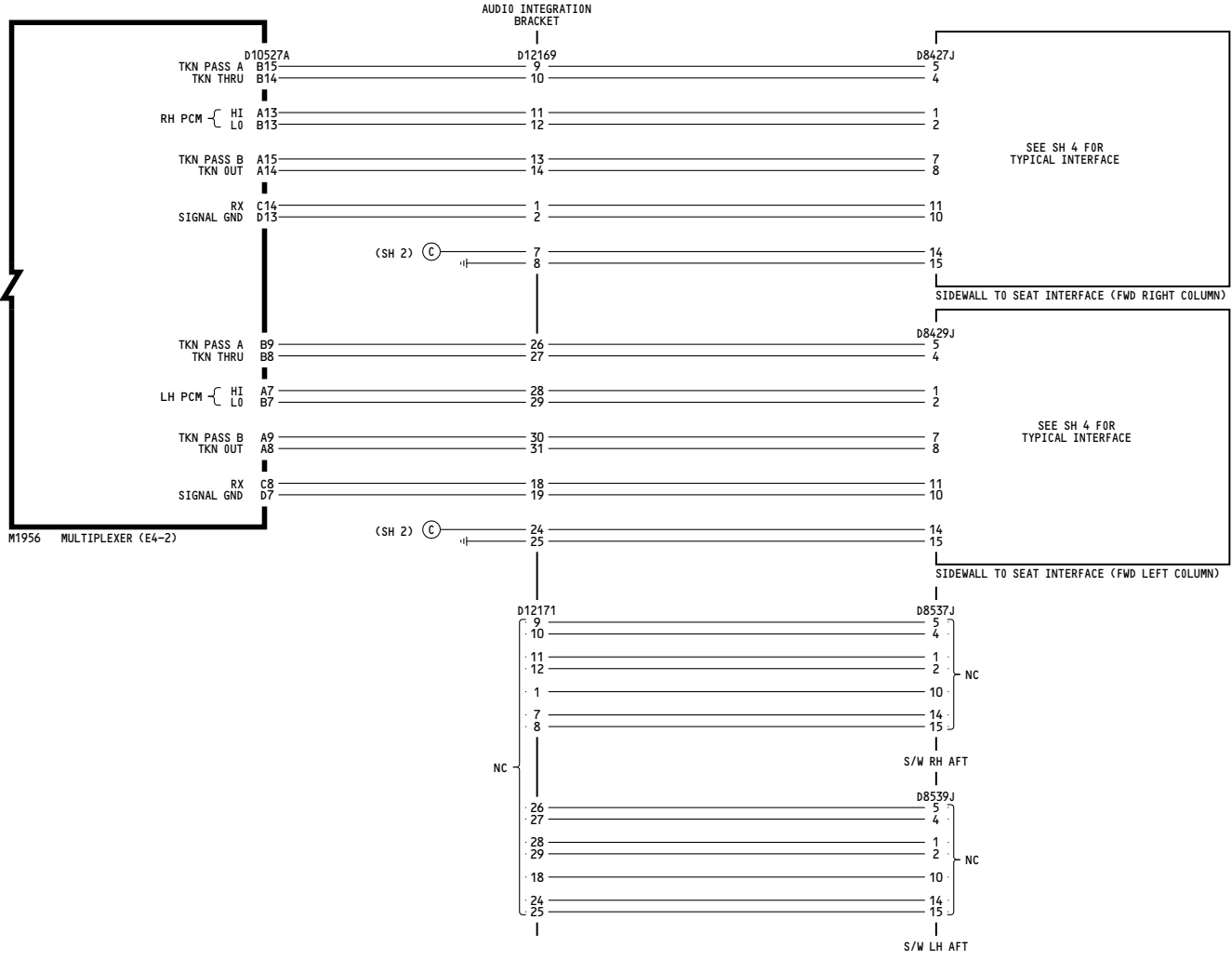

YK901-YM670	<p>AUDIO ENTERTAINMENT SYSTEM</p> <p>D280A203</p>
-------------	--

23-34-01

Page 104
Sheet 3
Feb 09/2009

2

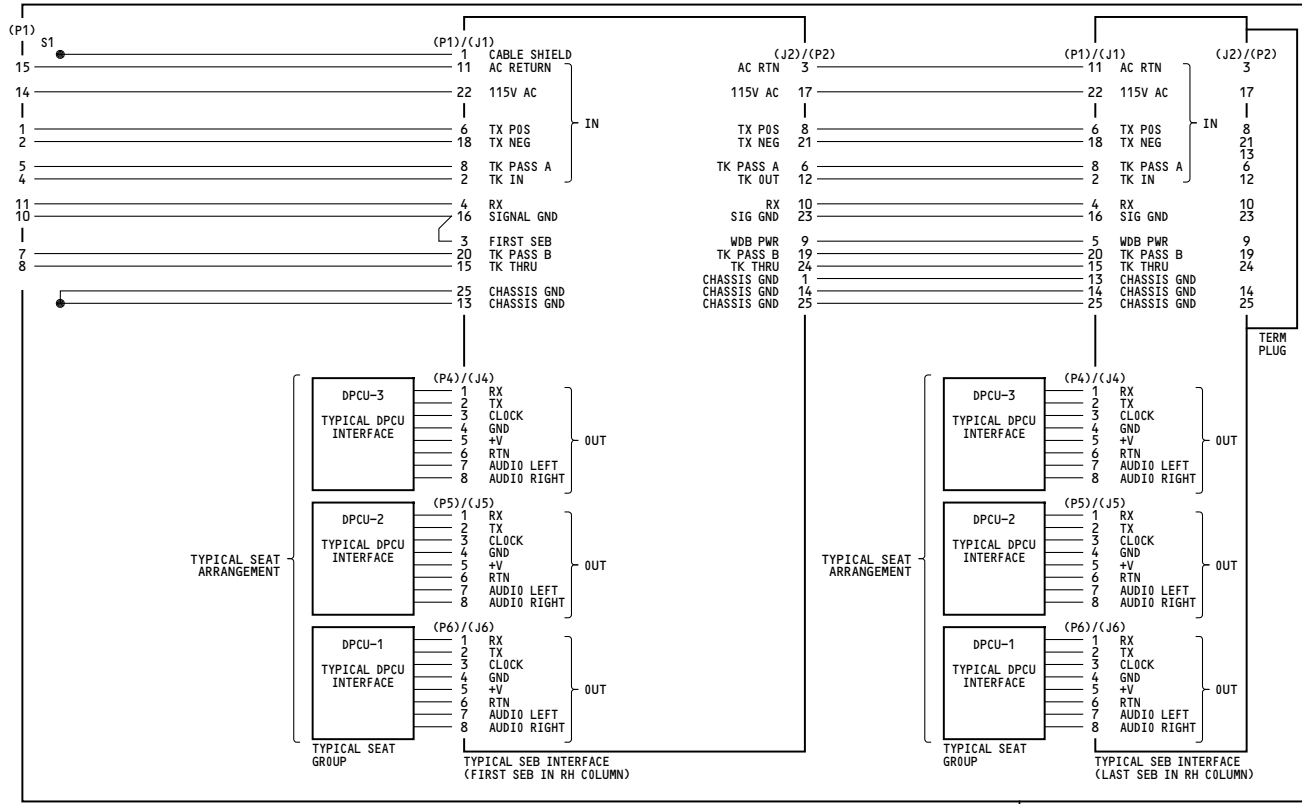

WIRING DIAGRAMS
23-34-01
23-34-02

TYPICAL SIDEWALL TO SEAT INTERFACE (FOR LEFT AND RIGHT COLUMNS)

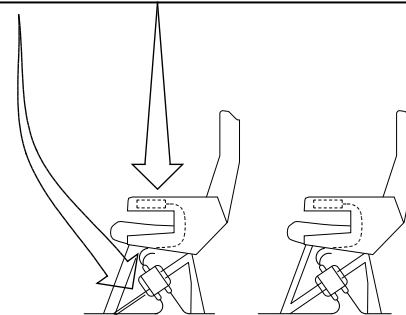

YK901-YM670	<p>AUDIO ENTERTAINMENT SYSTEM</p> <p>D280A203</p>
-------------	--

23-34-01

Page 104
Sheet 4
Feb 09/2009

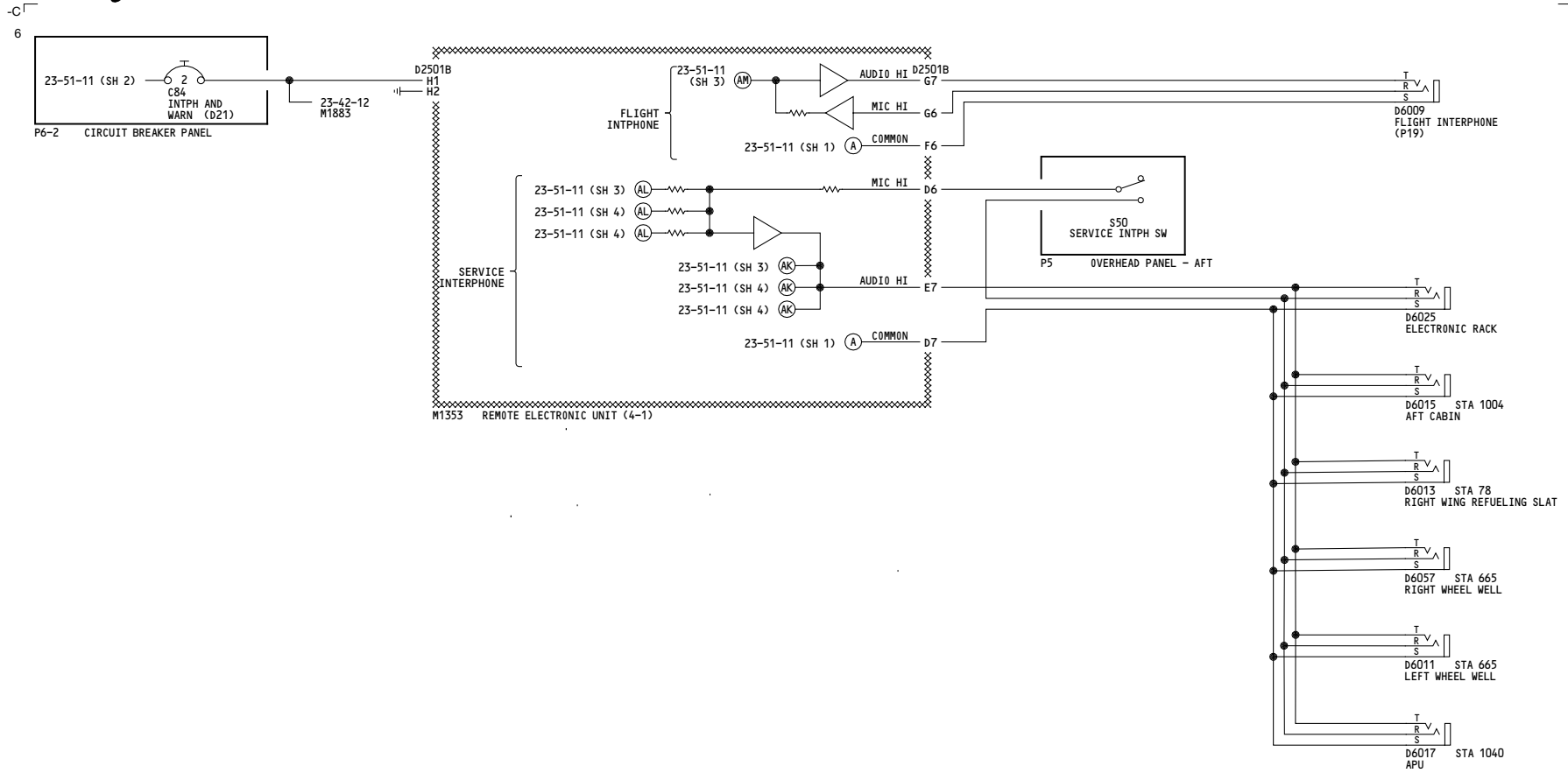

ALL	<p>INTERPHONE ATTENDANT AND SERVICE</p> <p>D280A203</p>
-----	--

23-41-11

Page 101

Feb 09/2009

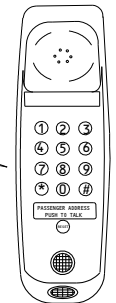
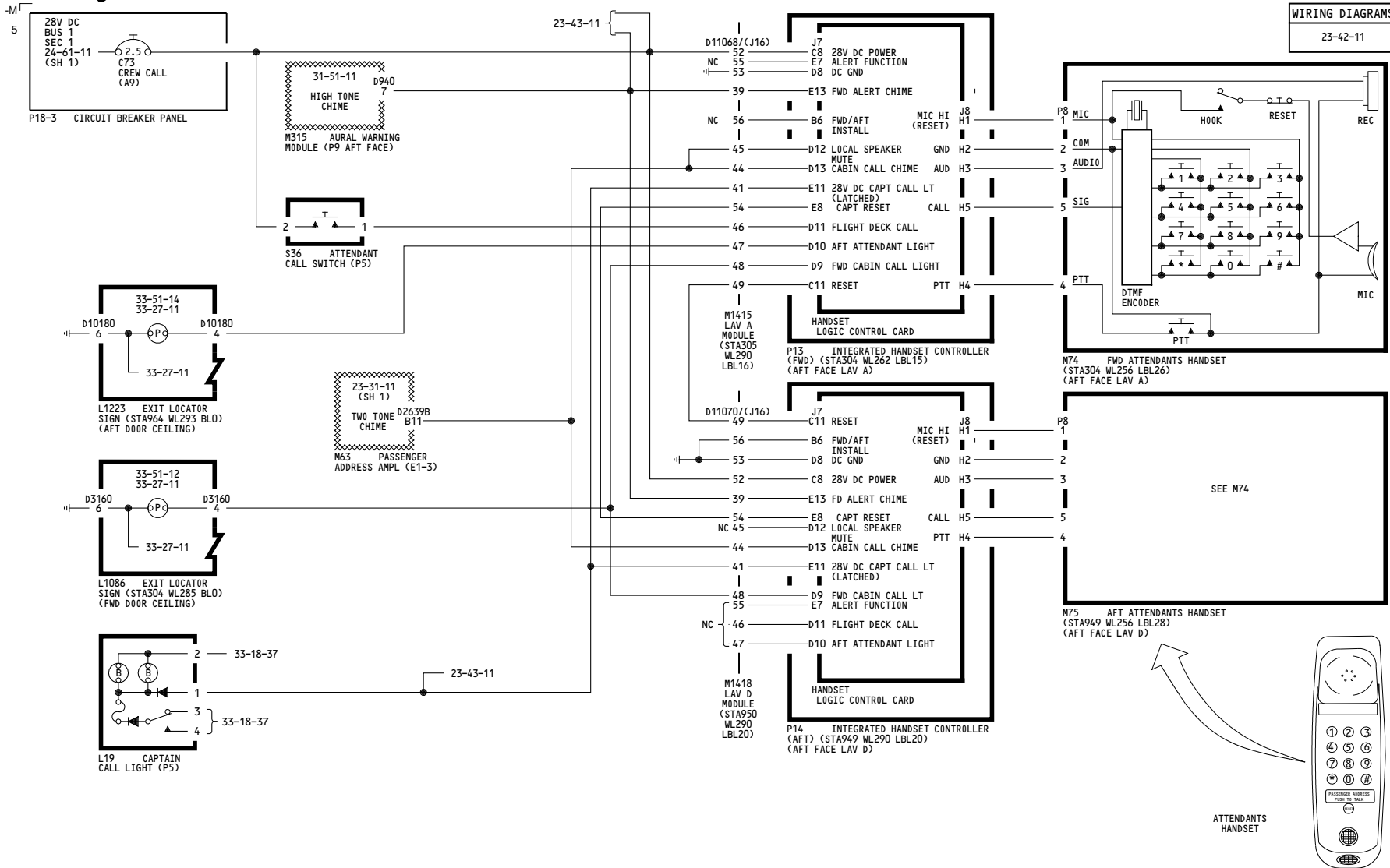

YC001-YC050

CABIN INTERPHONE - IHC CONNECTIONS

D280A203

23-42-11

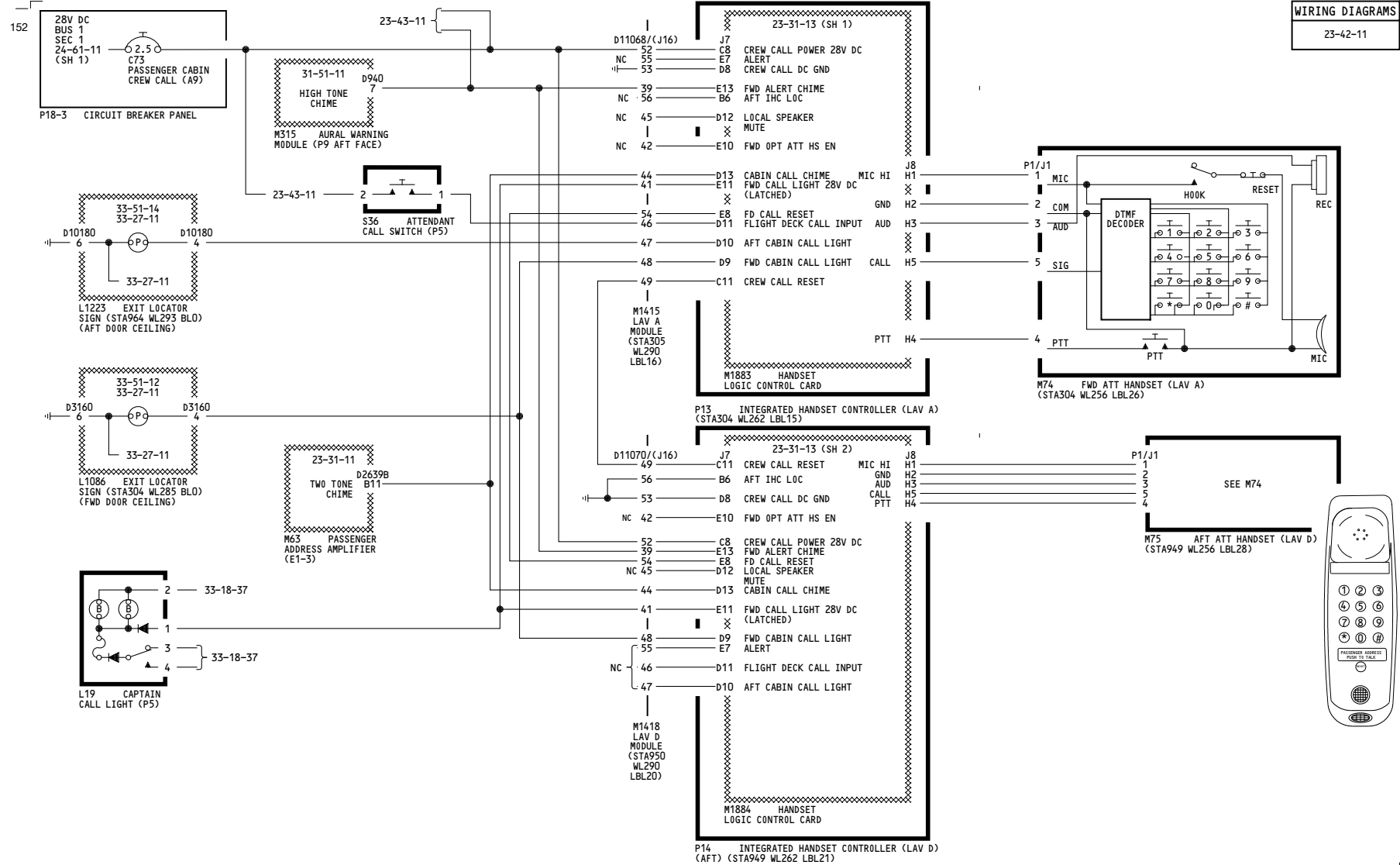

YK901-YK906

FLIGHT AND GROUND CREW CALL

D280A203

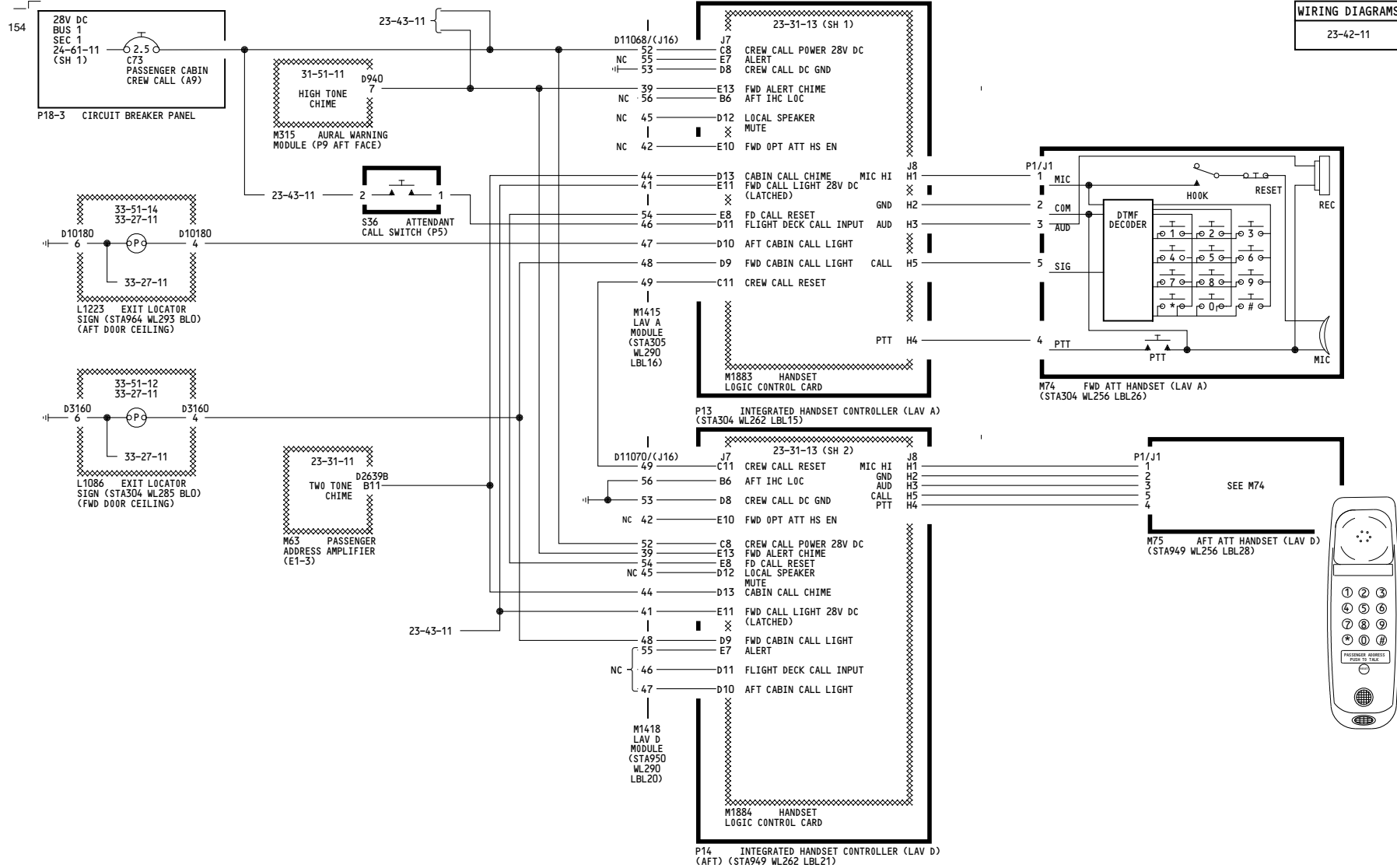

YK907-YL430

FLIGHT AND GROUND CREW CALL

D280A203

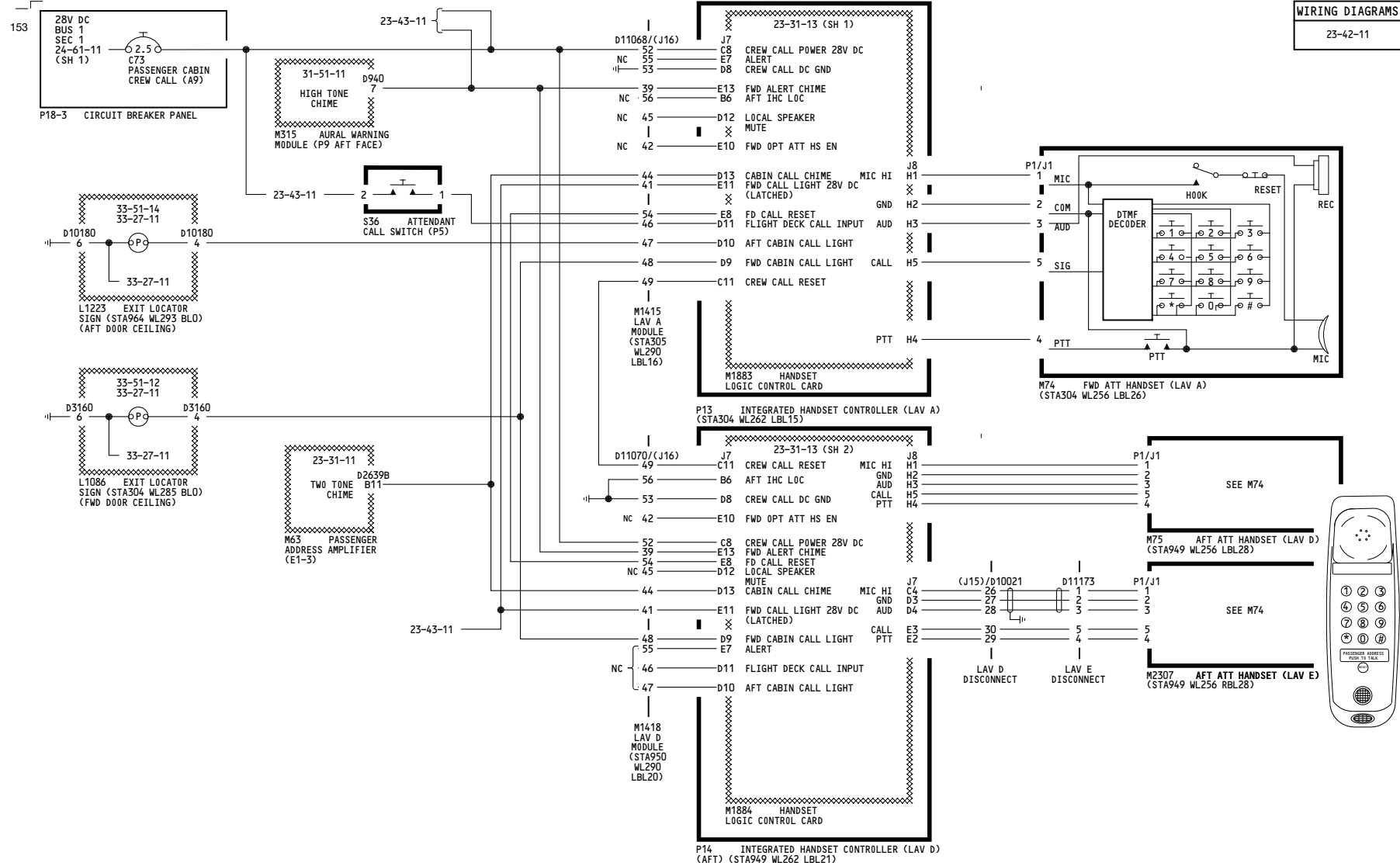

<p>YM643-YM670</p>	<p>FLIGHT AND GROUND CREW CALL</p> <p>D280A203</p>
--------------------	---

-G
1

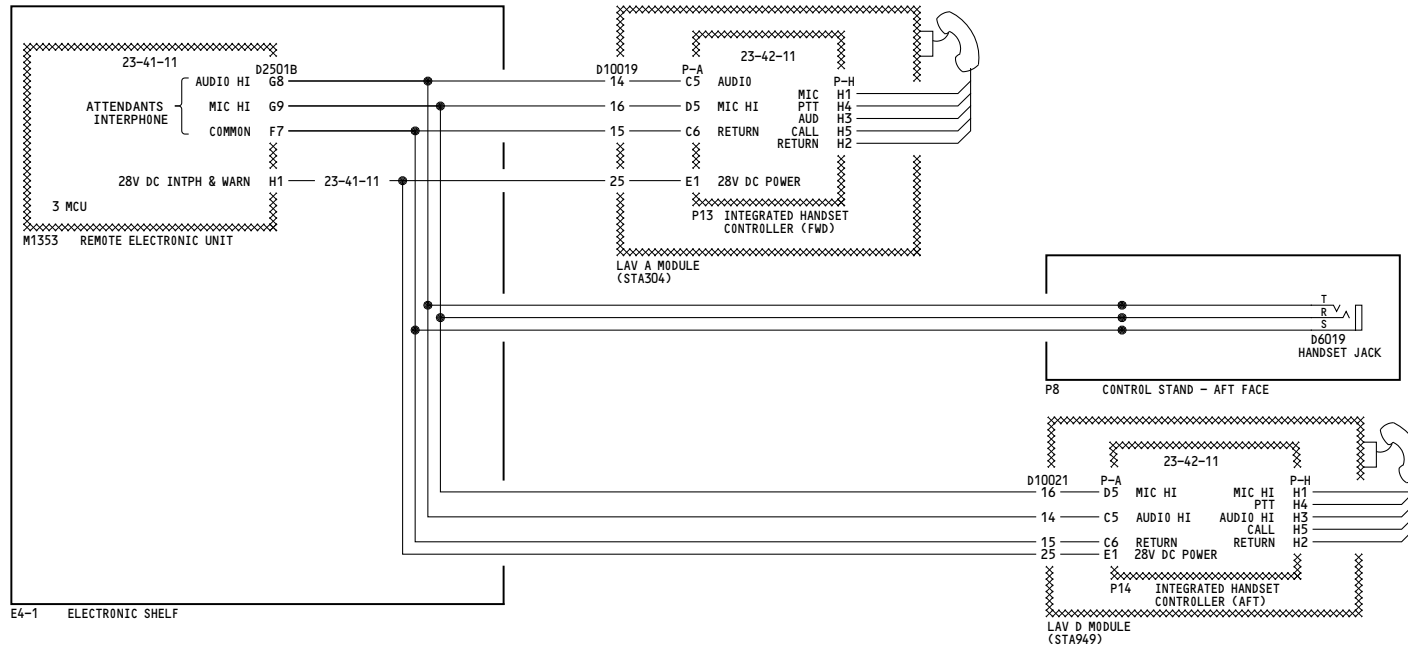

YC001-YC050	<p>CABIN INTERPHONE - BASELINE HANDSETS</p> <p>D280A203</p>
-------------	--

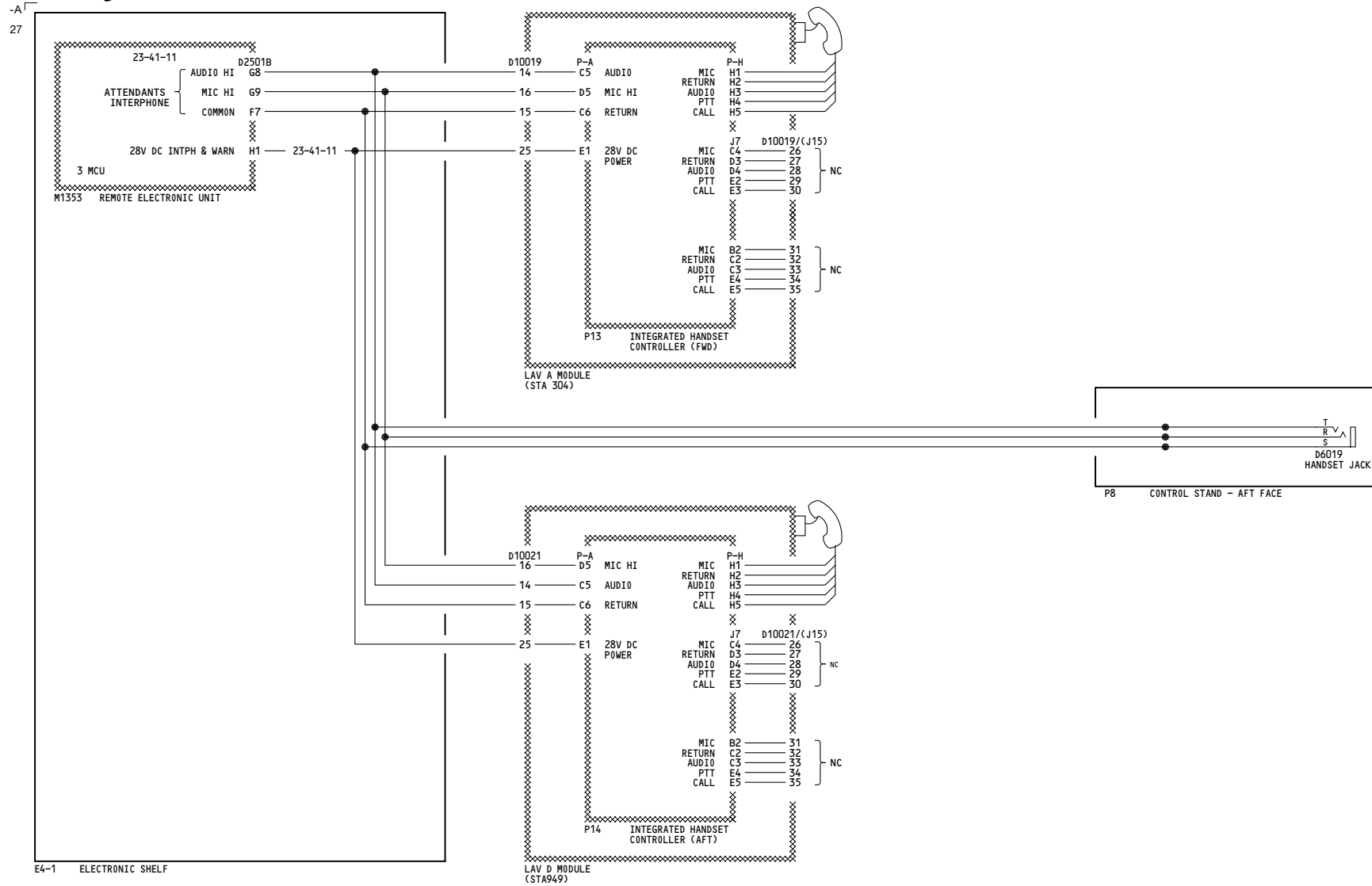

YK901-YL430

**CABIN INTERPHONE -
BASELINE HANDSETS**

D280A203

23-42-12

Page 102

Feb 09/2009

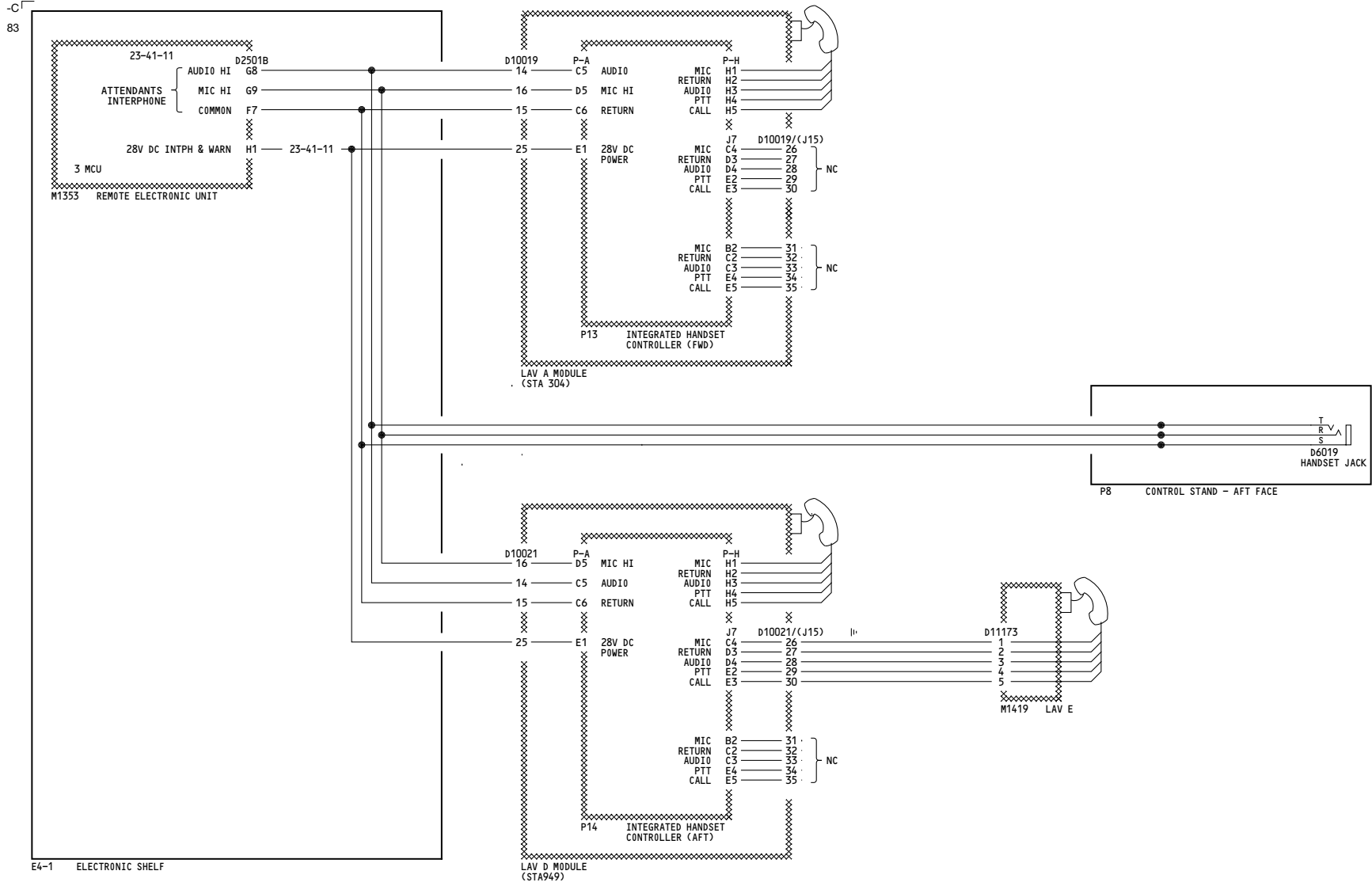

YM643-YM670

**CABIN INTERPHONE -
BASELINE HANDSETS**

D280A203

23-42-12

Page 103

Jan 14/2008

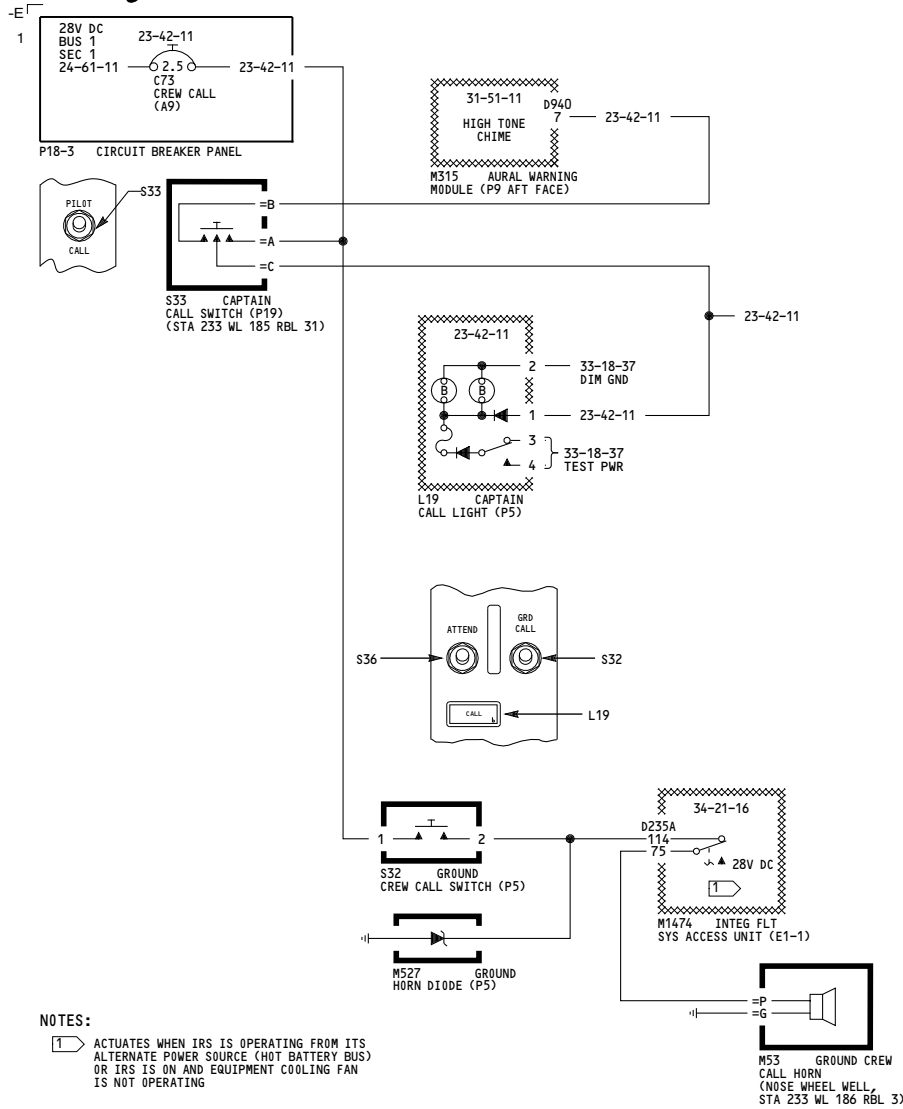

<p>YC001-YK906</p>	<p>GROUND CREW CALL</p> <p>D280A203</p>
--------------------	--

23-43-11

Page 101

Jul 17/2007

WIRING DIAGRAMS
23-42-11
23-43-11

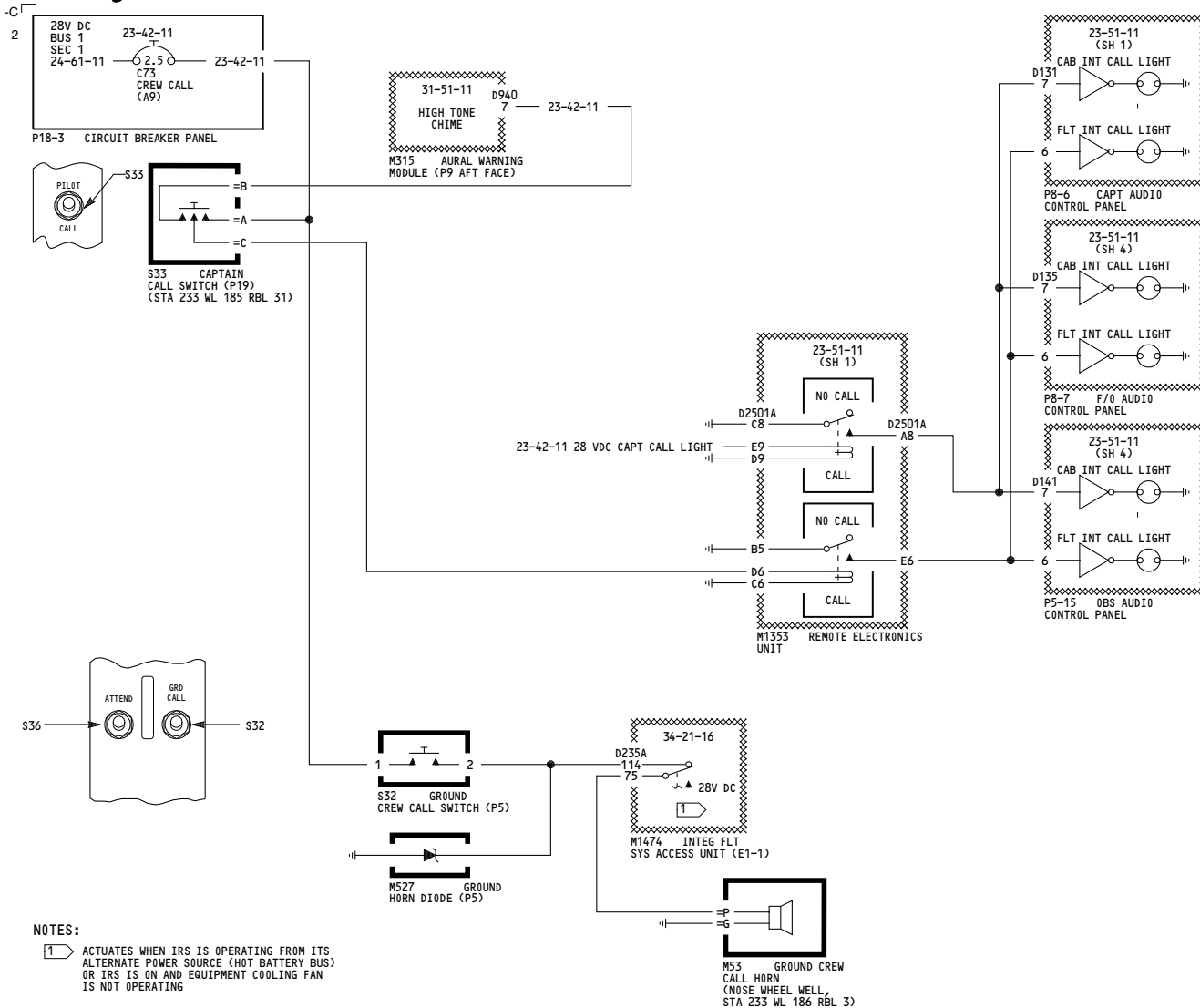

NOTES:
 1 ACTUATES WHEN IRS IS OPERATING FROM ITS ALTERNATE POWER SOURCE (HOT BATTERY BUS) OR IRS IS ON AND EQUIPMENT COOLING FAN IS NOT OPERATING

YK907-YM670	<p align="center">GROUND CREW CALL</p> <p align="center">D280A203</p>
-------------	--

-D
2

WIRING DIAGRAMS
23-51-01
23-51-02
23-51-03
23-71-01

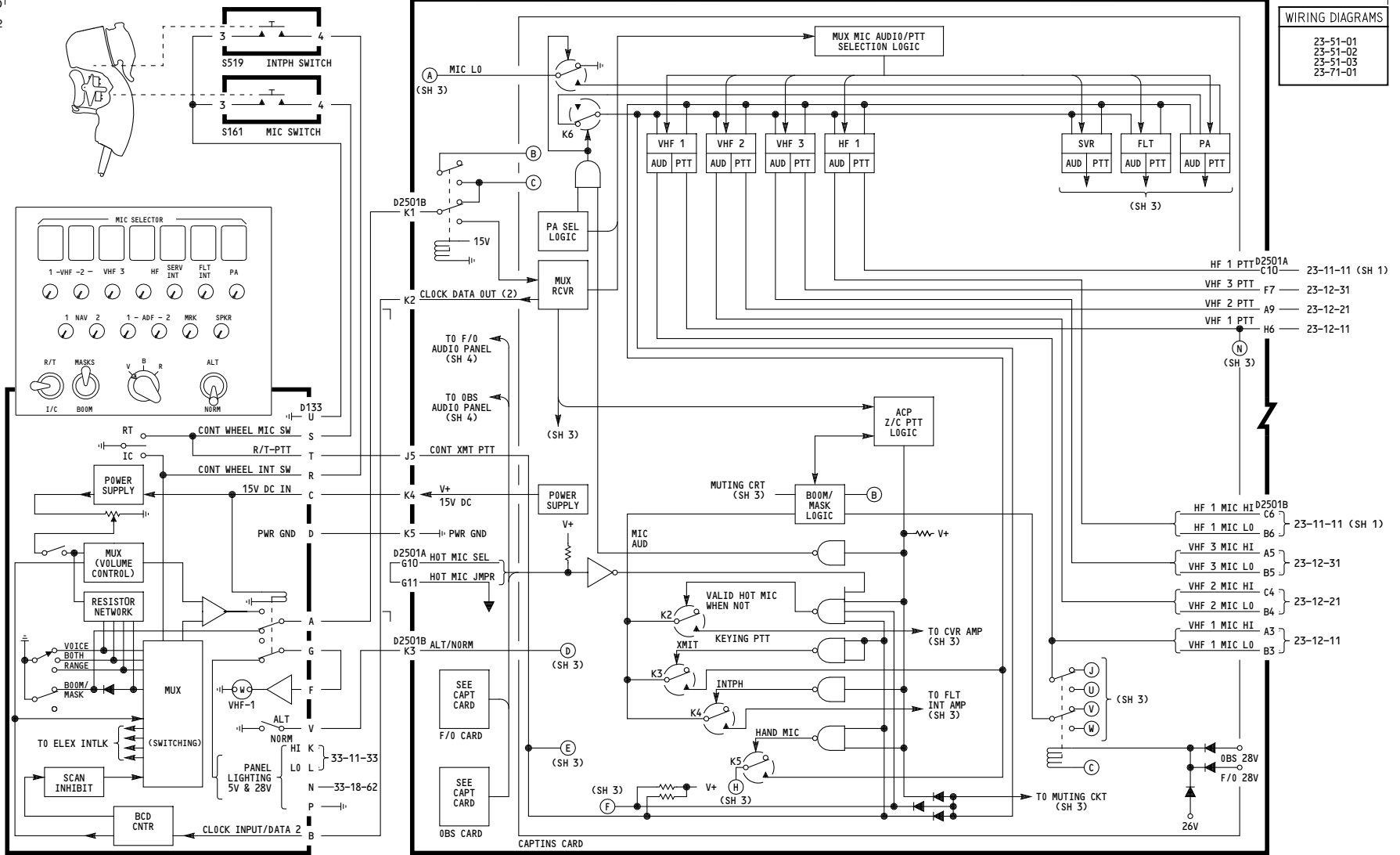

P8-6 CAPT AUDIO CONTROL PANEL

M1353 REMOTE ELECTRONIC UNIT (E4-1)

YC001-YC009

FLIGHT INTERPHONE

D280A203

23-51-11

Page 101
Sheet 1
Mar 31/2005

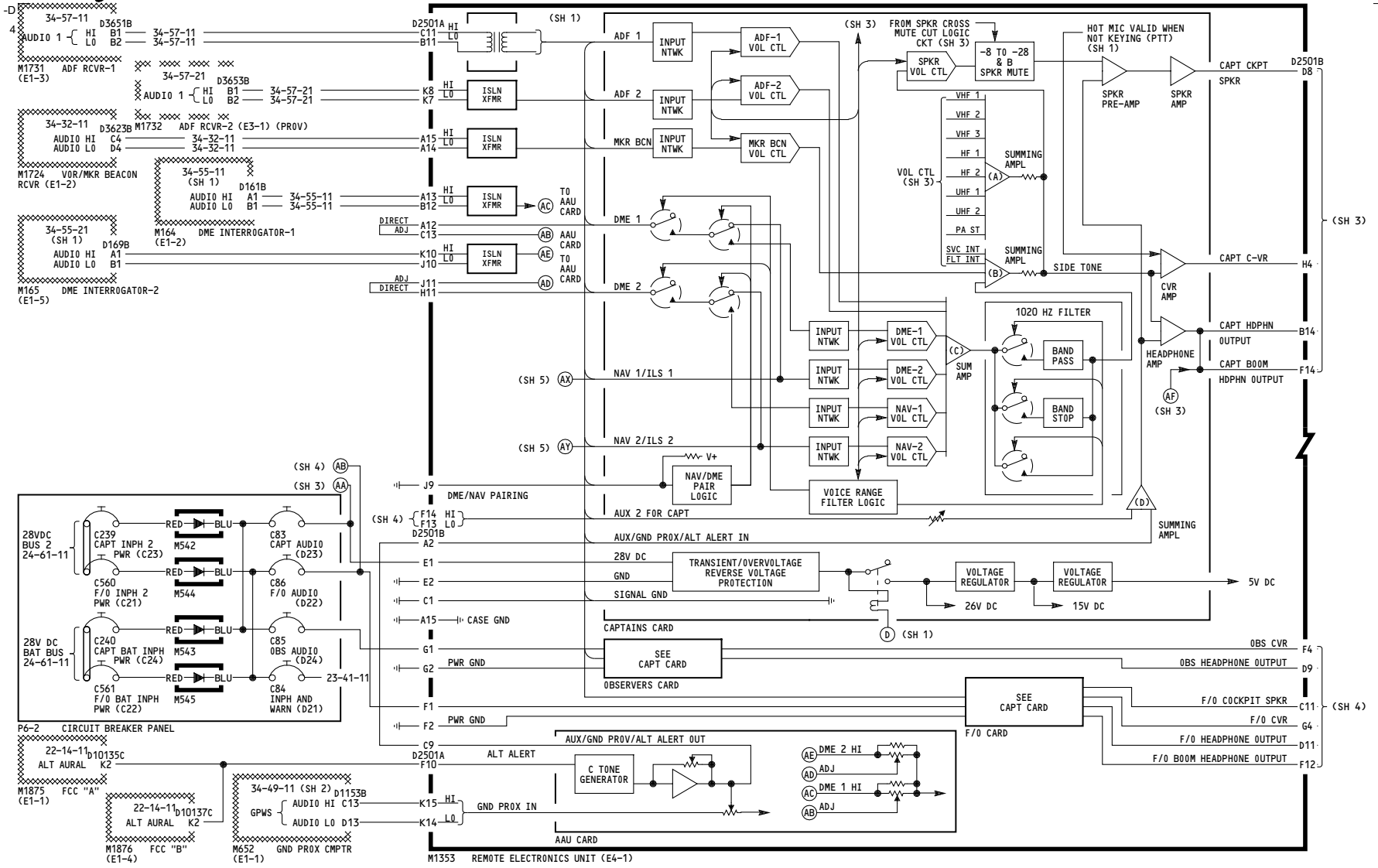

YC001-YC009

FLIGHT INTERPHONE

23-51-11

D280A203

-B
29

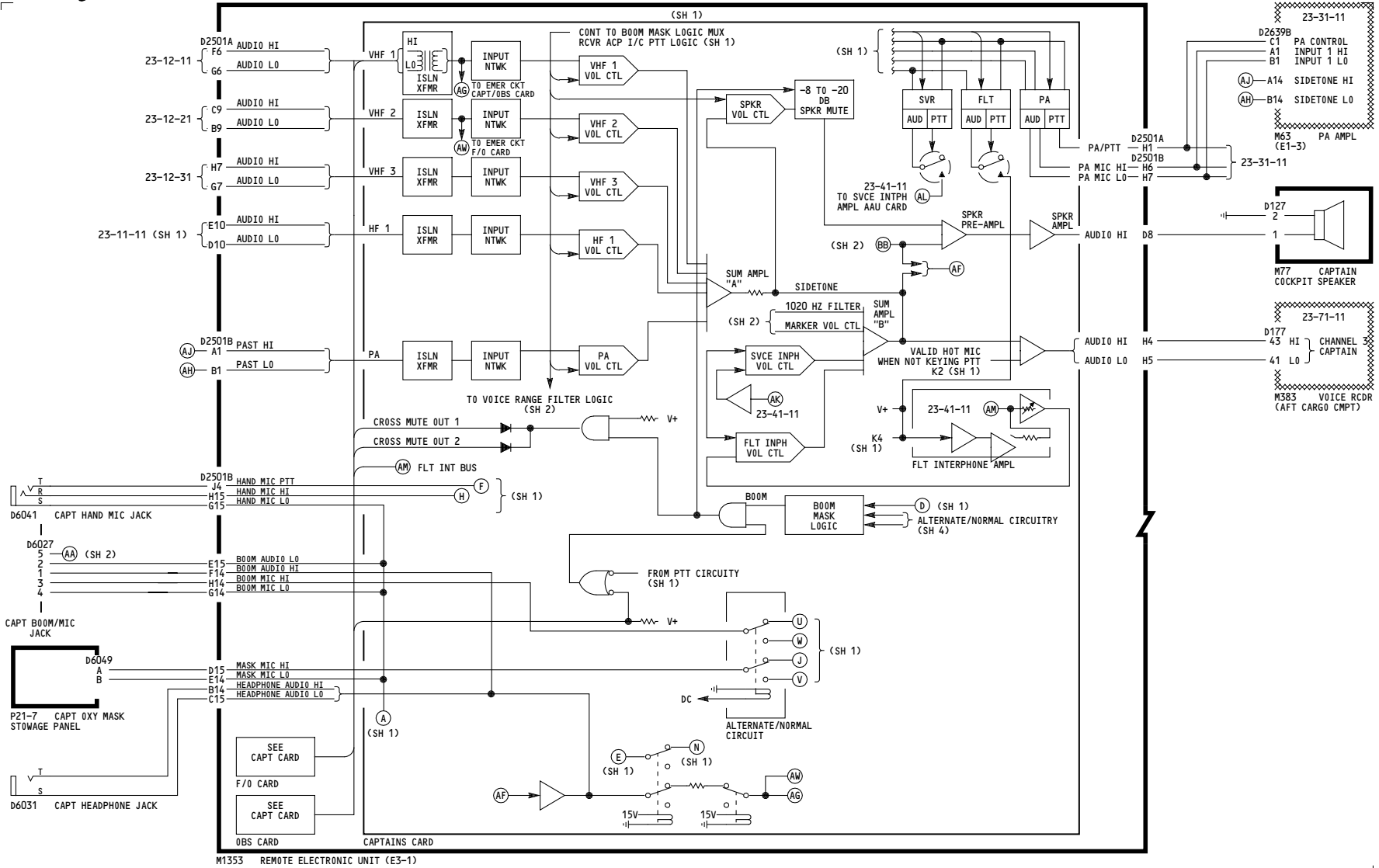

YCO01-YCO09	FLIGHT INTERPHONE
D280A203	

23-51-11

Page 101
Sheet 3
Mar 31/2005

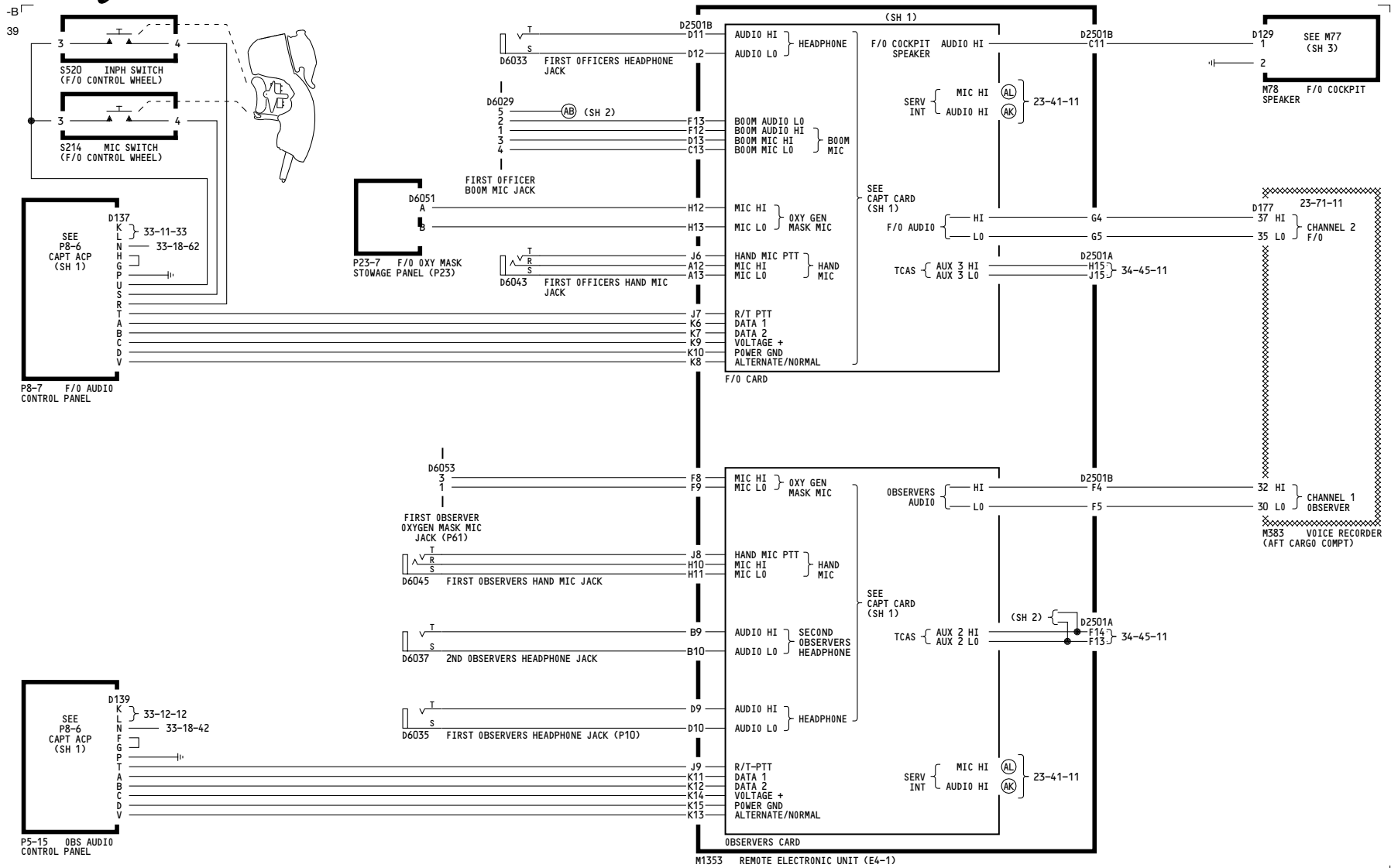

YC001-YC009	FLIGHT INTERPHONE
D280A203	

23-51-11

-D
1

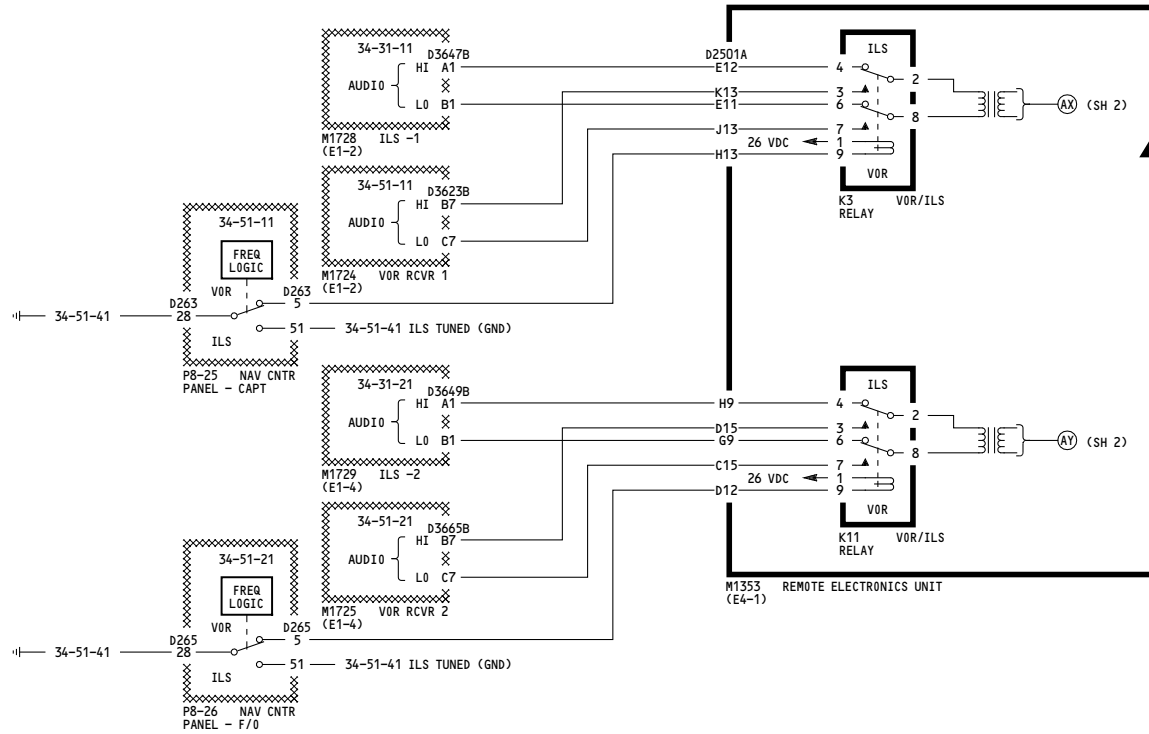

<p>YC001-YC009</p>	<p>FLIGHT INTERPHONE</p> <p>D280A203</p>
--------------------	---

23-51-11

Page 101
Sheet 5
Mar 31/2005

THIS PAGE INTENTIONALLY LEFT BLANK

-B
46

WIRING DIAGRAMS
23-51-01
23-51-02
23-51-03
23-71-01

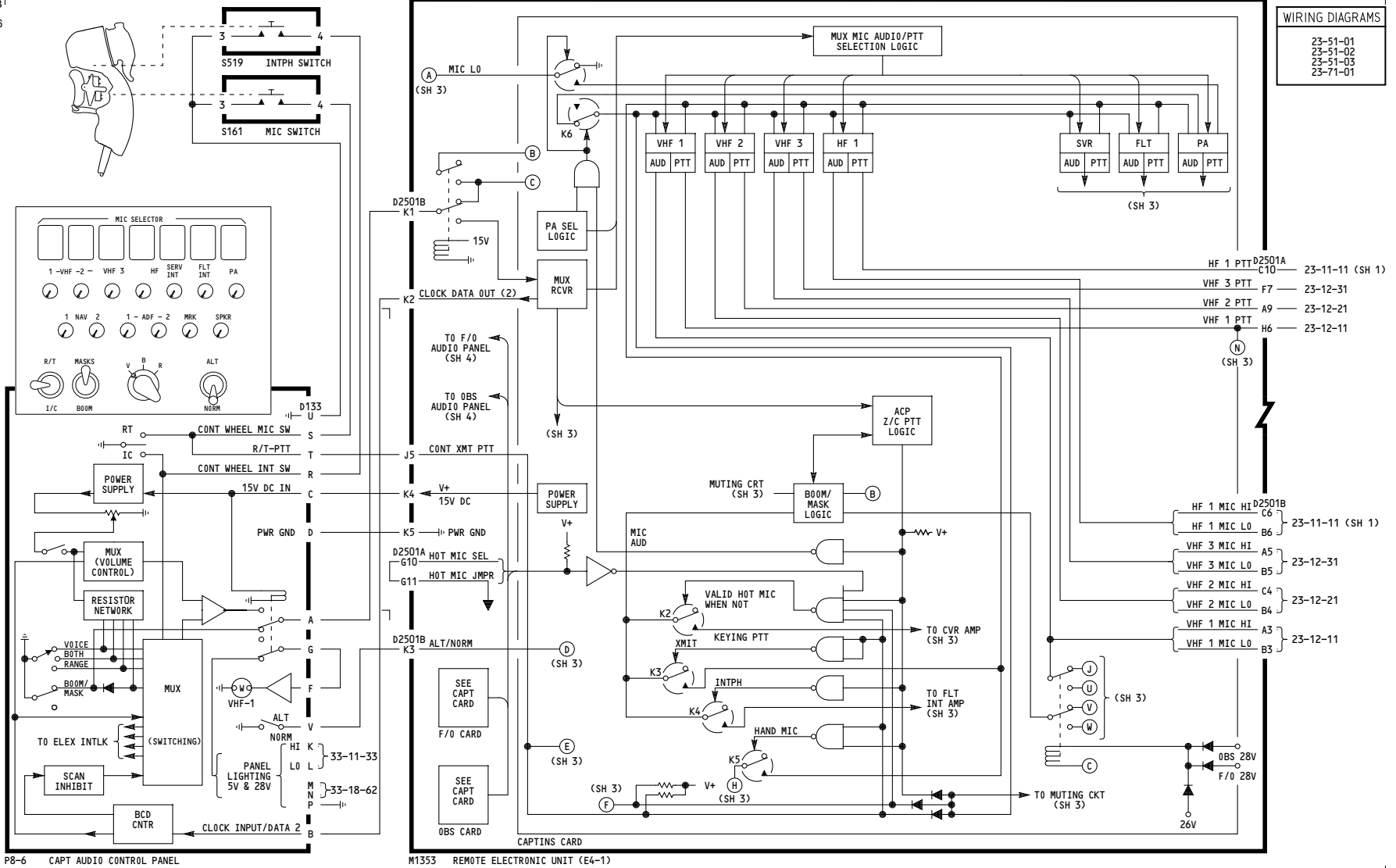

YC010-YC050

FLIGHT INTERPHONE

23-51-11

Page 102
Sheet 1
Jul 17/2007

D280A203

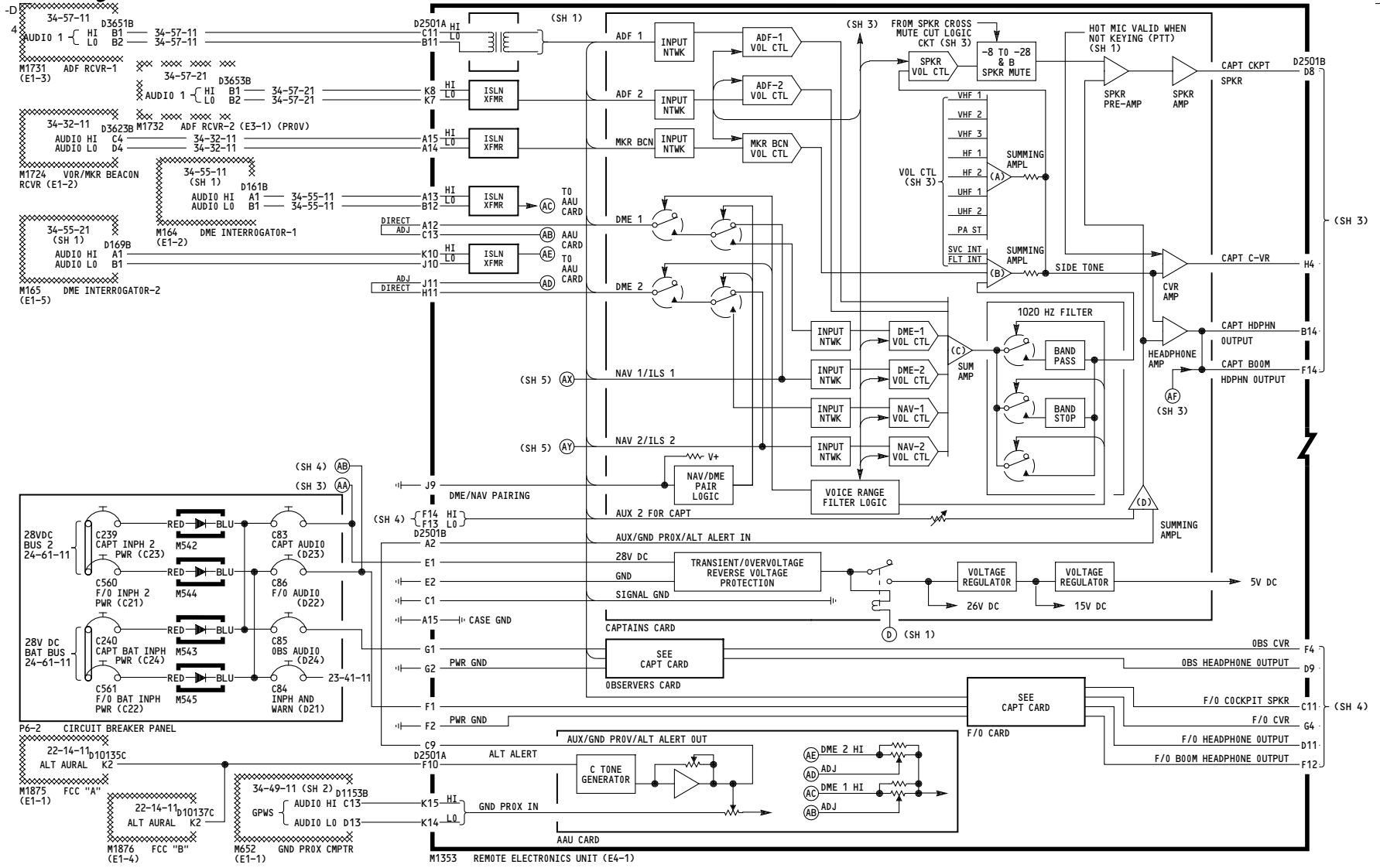

YC010-YC050

FLIGHT INTERPHONE

23-51-11

D280A203

-B
29

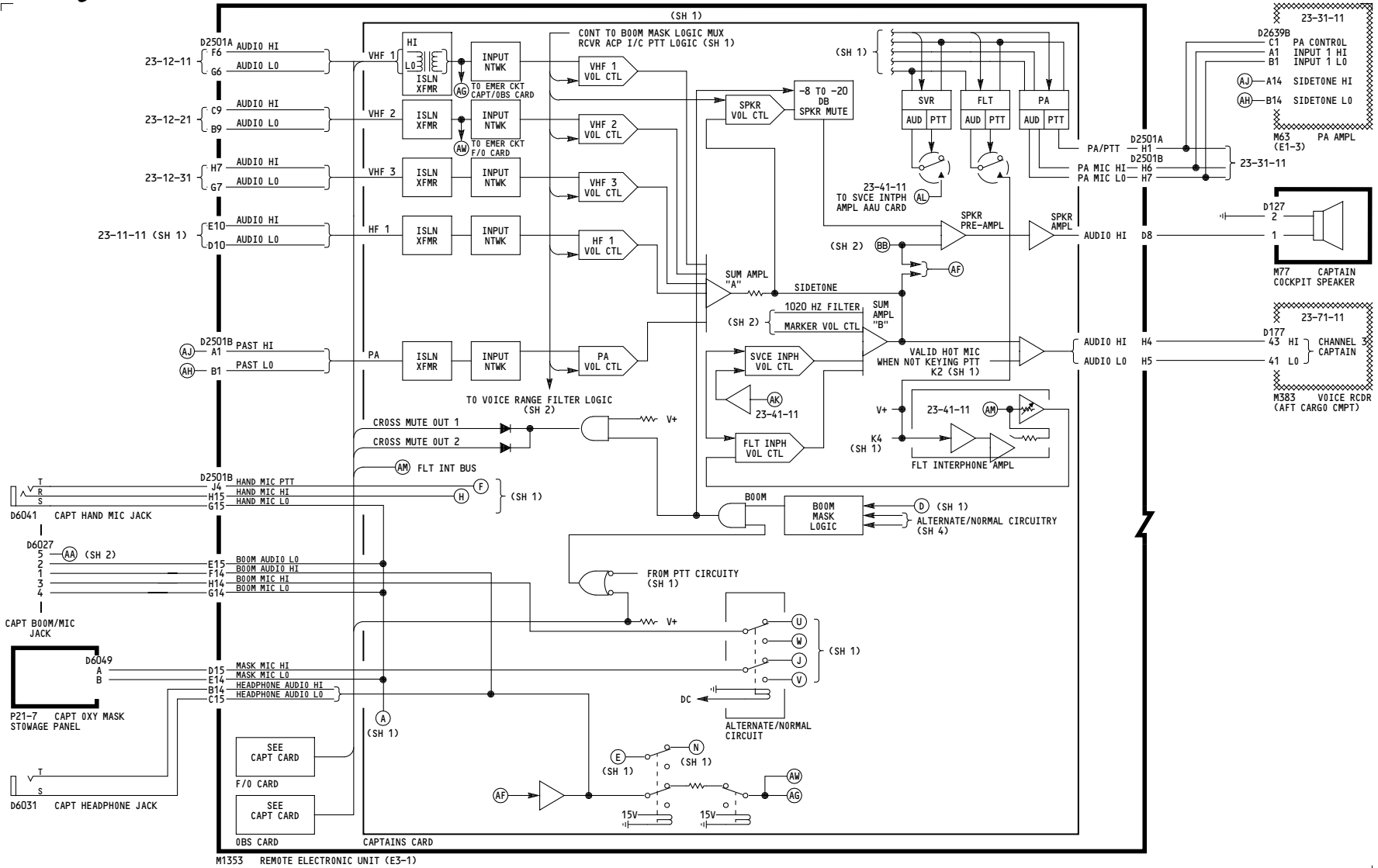

YC010-YC050

FLIGHT INTERPHONE

D280A203

23-51-11

Page 102
Sheet 3
Jul 17/2007

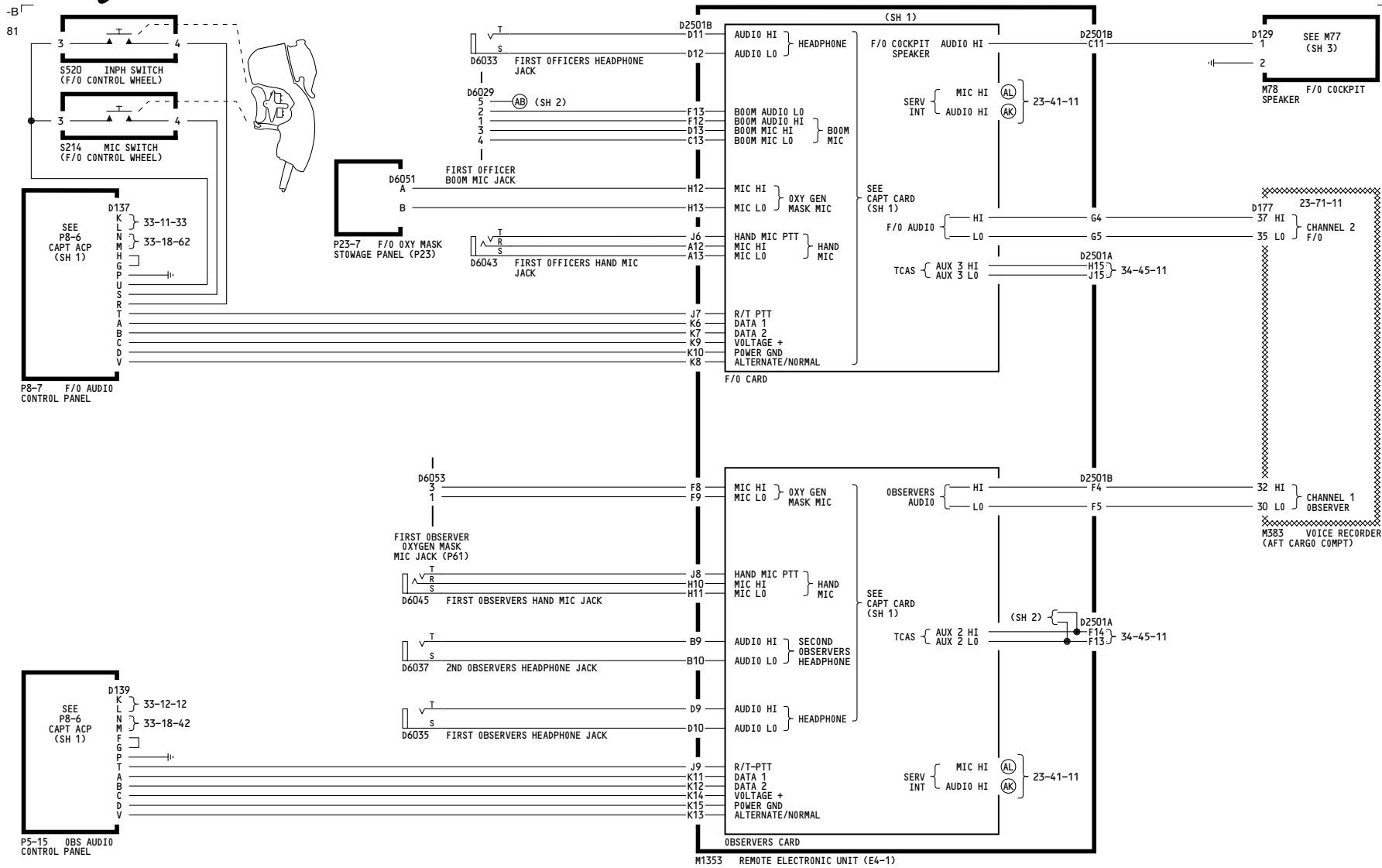

YC010-YC050	FLIGHT INTERPHONE
D280A203	

23-51-11

-D
1

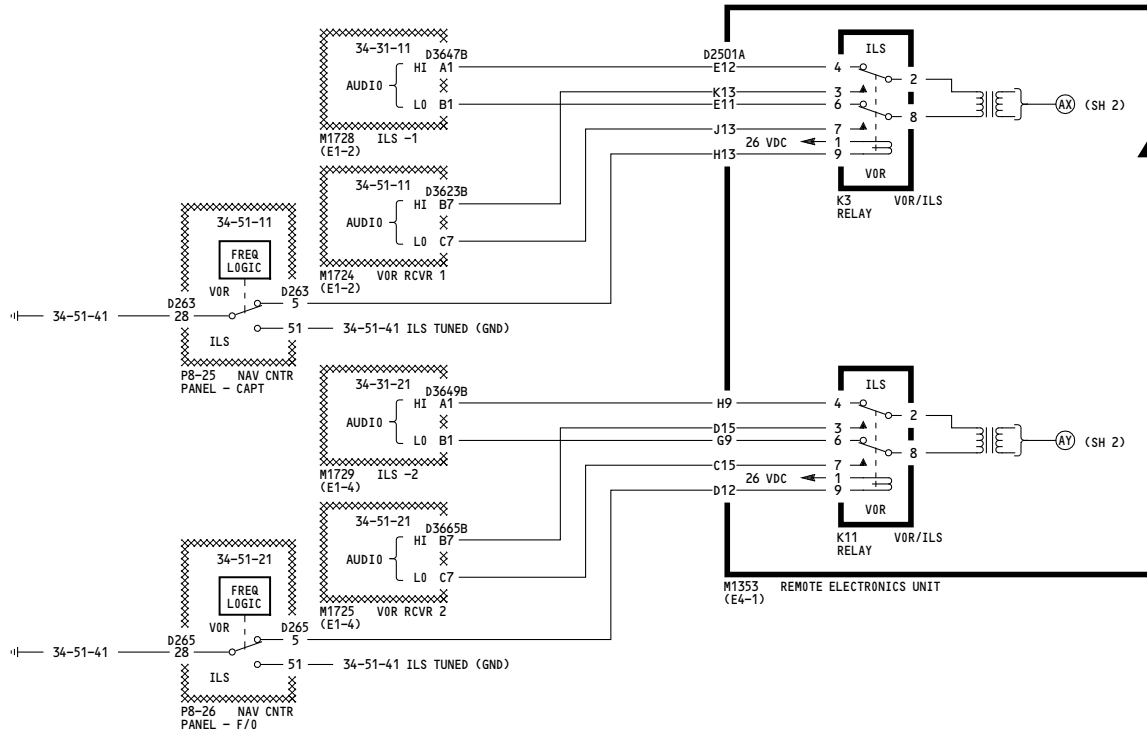

<p>YC010-YC050</p>	<p>FLIGHT INTERPHONE</p> <p>D280A203</p>
--------------------	---

23-51-11

Page 102
Sheet 5
Jul 17/2007

THIS PAGE INTENTIONALLY LEFT BLANK

-B
46

WIRING DIAGRAMS
23-51-01
23-51-02
23-51-03
23-71-01

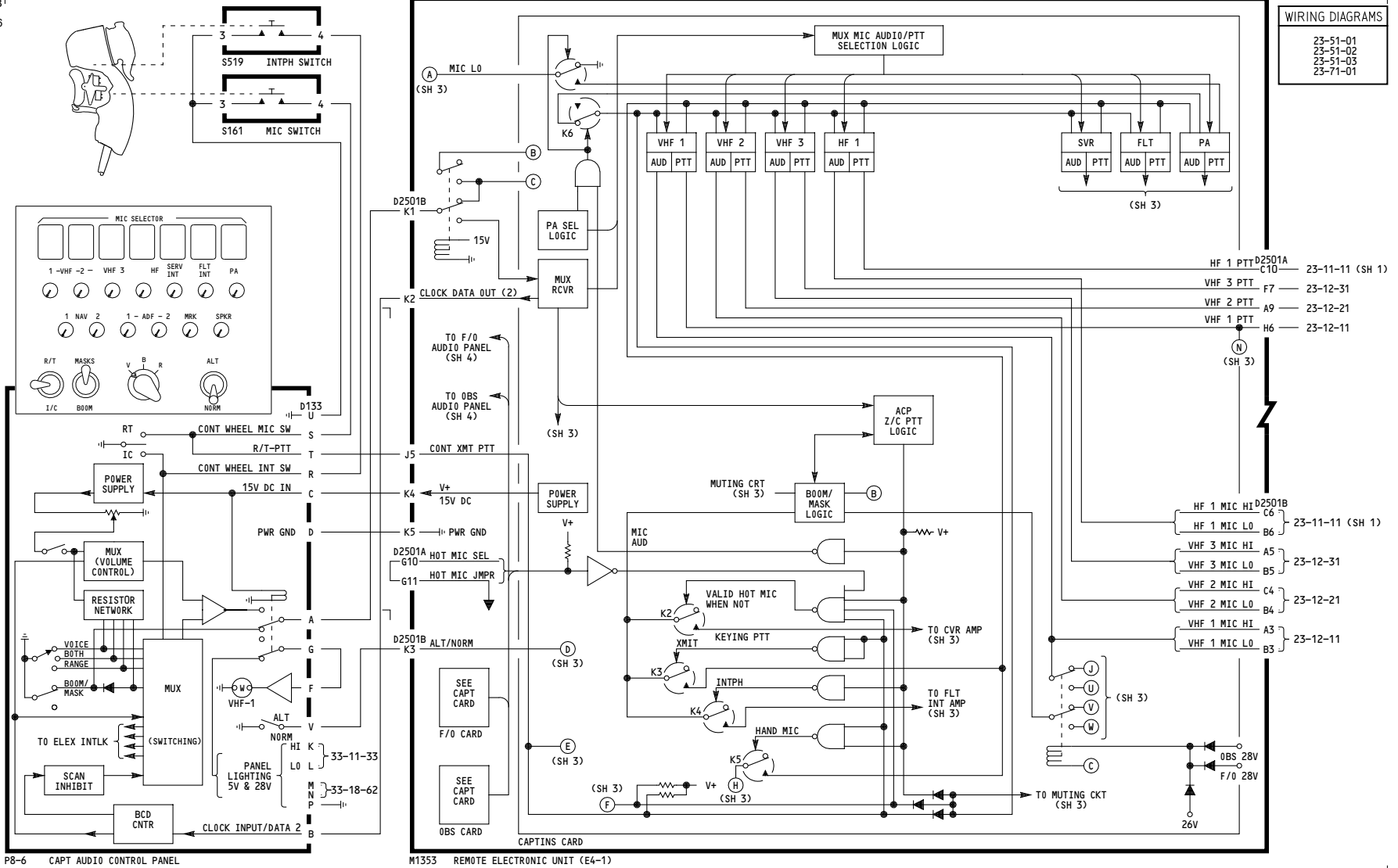

P8-6 CAPT AUDIO CONTROL PANEL

M1353 REMOTE ELECTRONIC UNIT (E4-1)

YC028-YC029

FLIGHT INTERPHONE

D280A203

23-51-11

Page 102.1
Sheet 1
Aug 10/2009

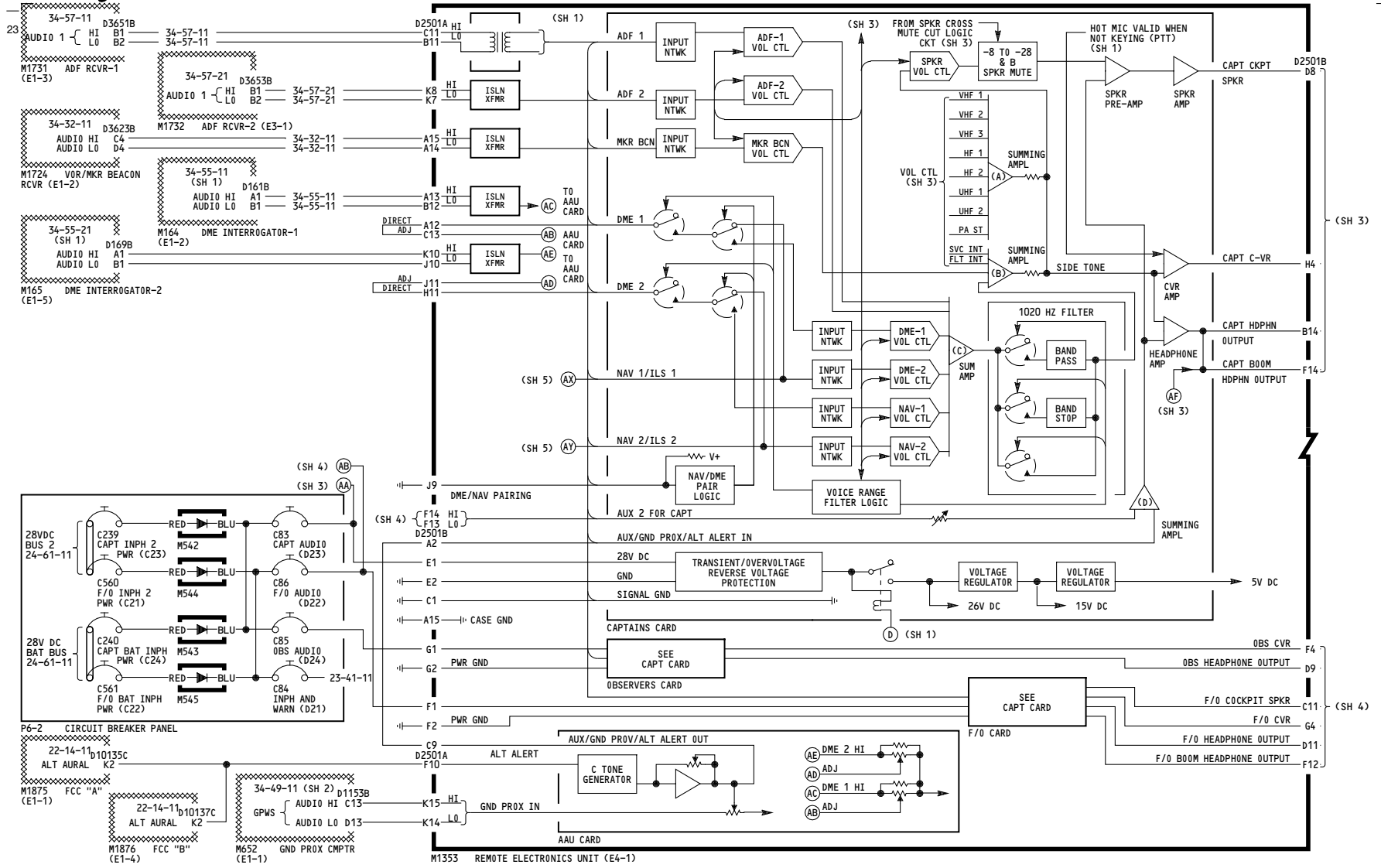

YC028-YC029

FLIGHT INTERPHONE

Incorporates
34-2194

D280A203

23-51-11

Page 102.1
Sheet 2
Aug 10/2009

-B
29

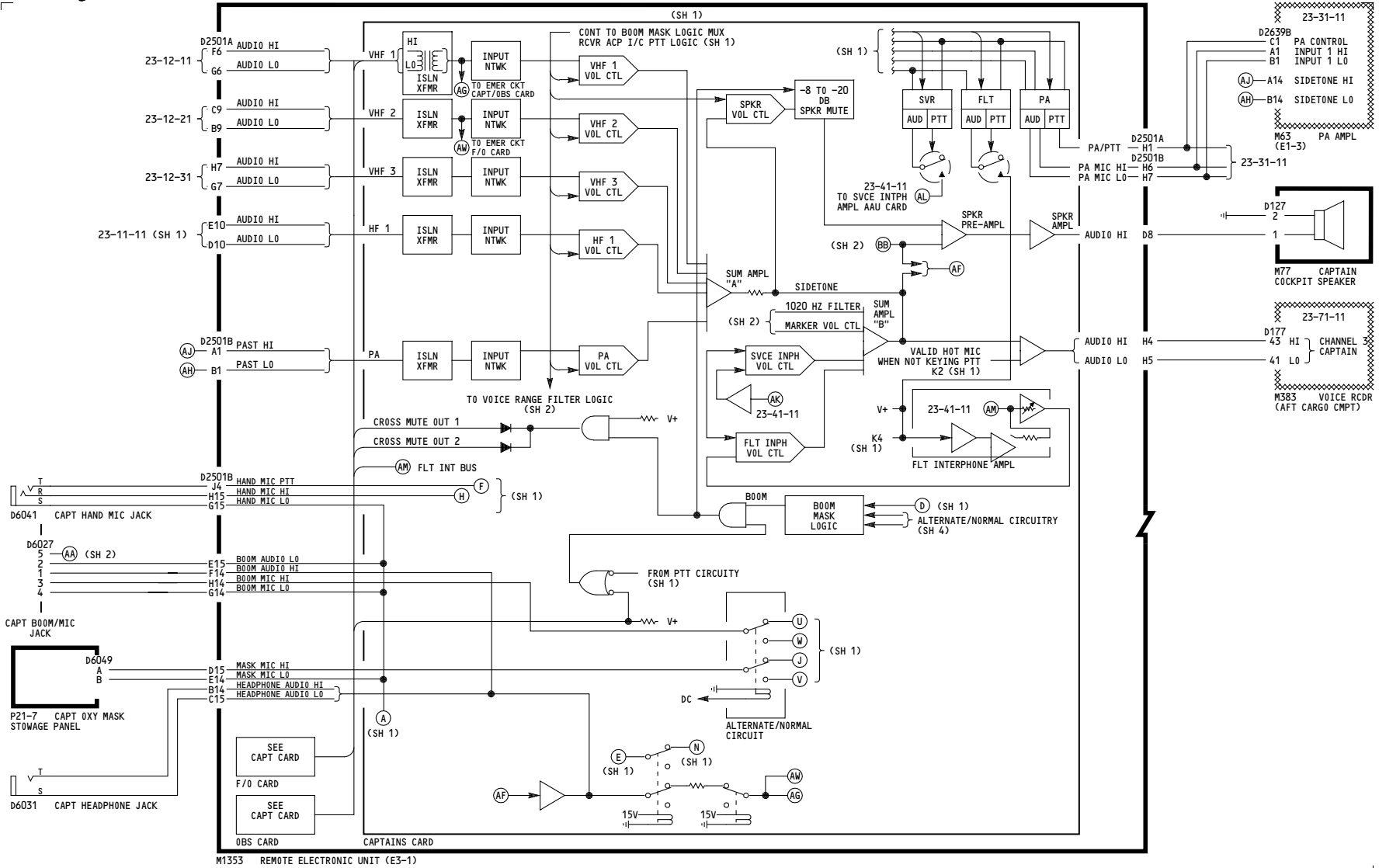

YC028-YC029

FLIGHT INTERPHONE

D280A203

23-51-11

Page 102.1
Sheet 3
Aug 10/2009

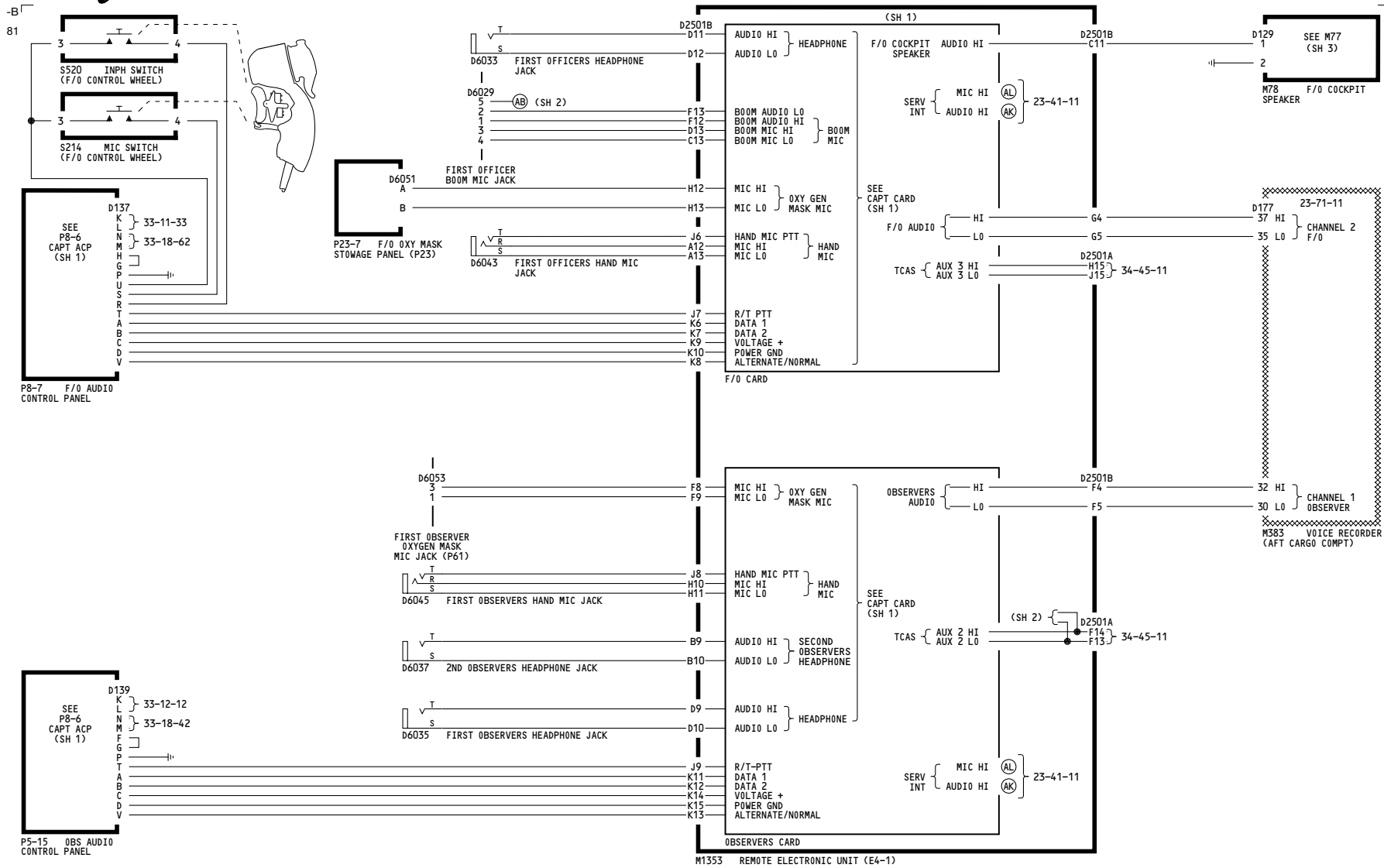

YC028-YC029	FLIGHT INTERPHONE D280A203
-------------	--

23-51-11

Page 102.1
 Sheet 4
 Aug 10/2009

-D
1

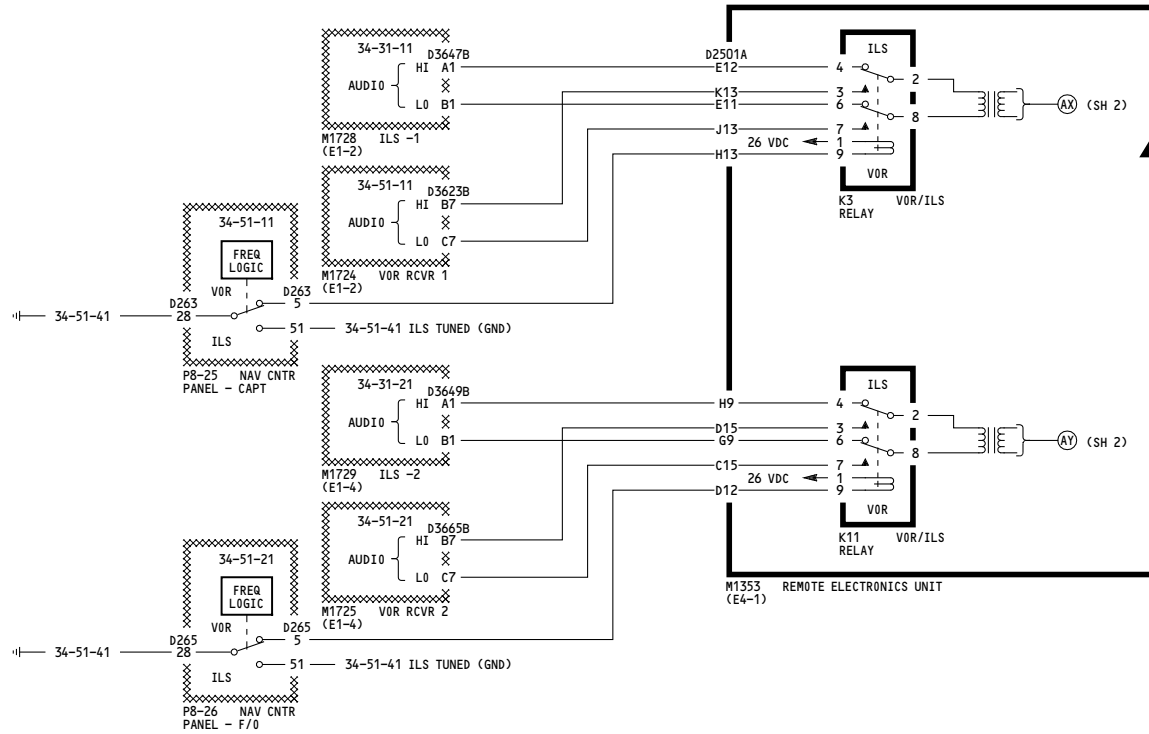

<p>YC028-YC029</p>	<p>FLIGHT INTERPHONE</p> <p>D280A203</p>
--------------------	---

23-51-11

Page 102.1
Sheet 5
Aug 10/2009

THIS PAGE INTENTIONALLY LEFT BLANK

-D
14

WIRING DIAGRAMS	
23-51-01	
23-51-02	
23-51-03	
23-71-01	

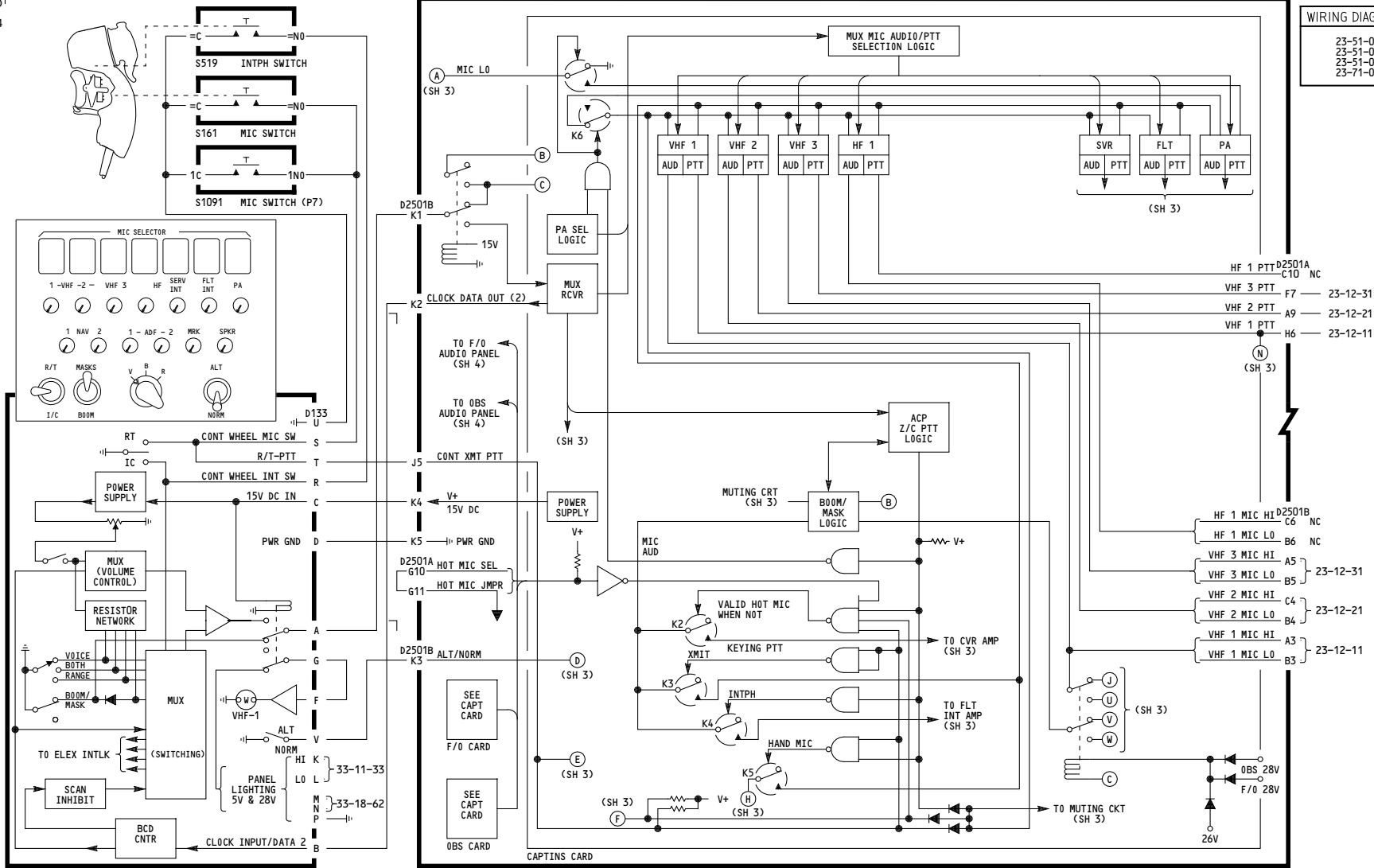

P8-6 CAPT AUDIO CONTROL PANEL

M1353 REMOTE ELECTRONIC UNIT (E4-1)

YK901-YK906

FLIGHT INTERPHONE

D280A203

23-51-11

-D
11

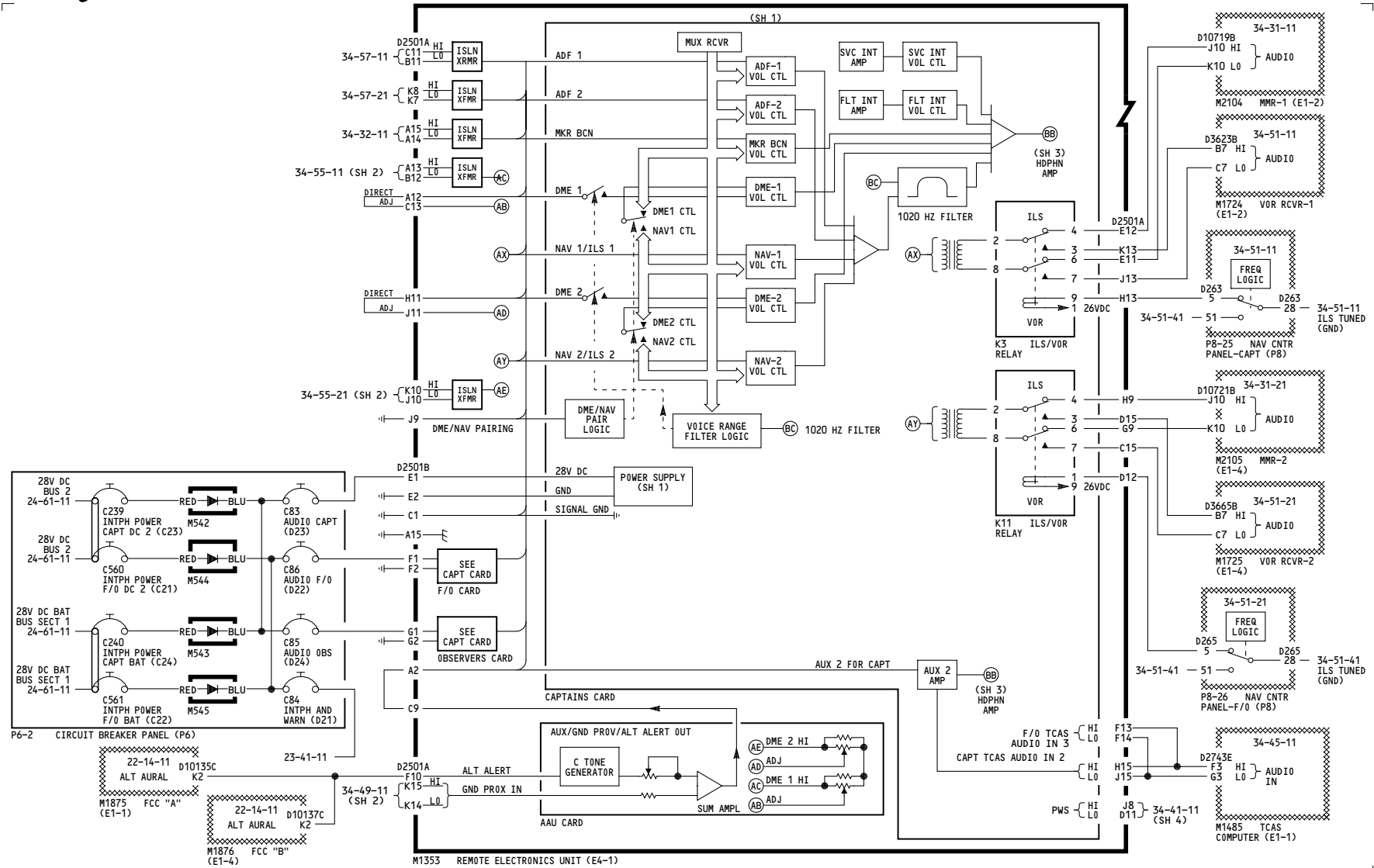

YK901-YK906

FLIGHT INTERPHONE

D280A203

23-51-11

Page 103
Sheet 2
Oct 20/2006

-B
71

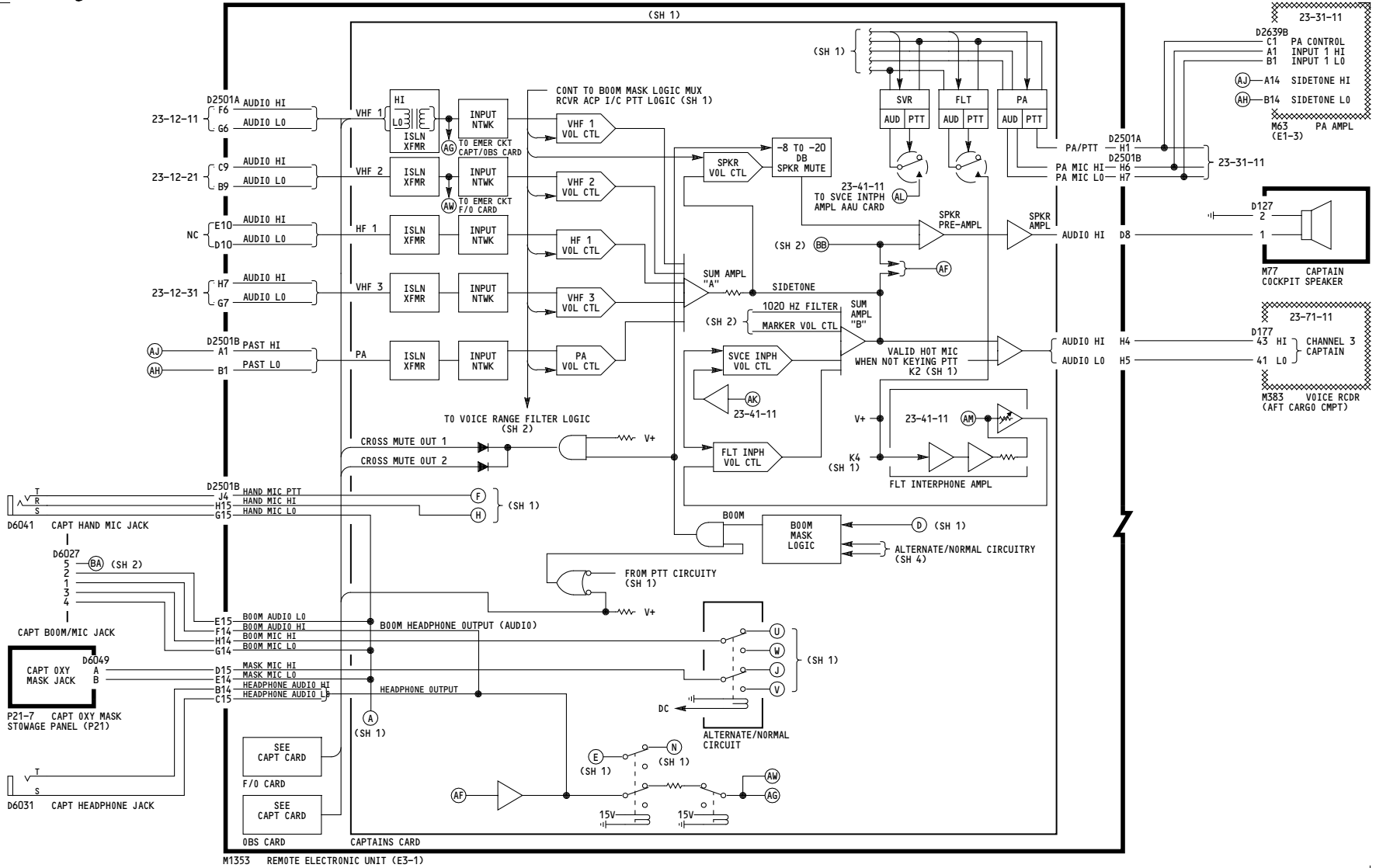

YK901-YK906

FLIGHT INTERPHONE

23-51-11

D280A203

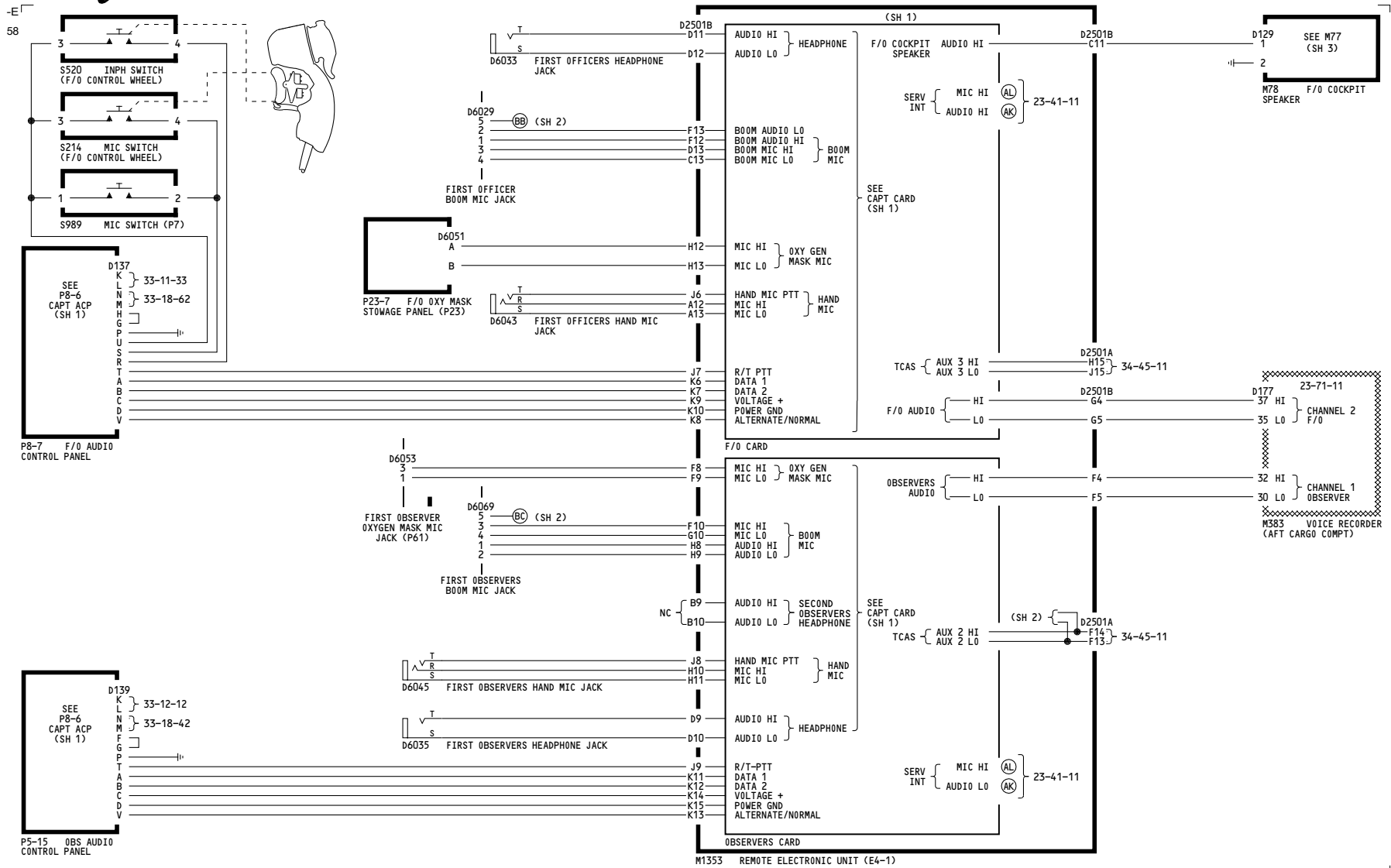

YK901-YK906	FLIGHT INTERPHONE
D280A203	

23-51-11

17

WIRING DIAGRAMS
23-51-01
23-51-02
23-51-03
23-71-01

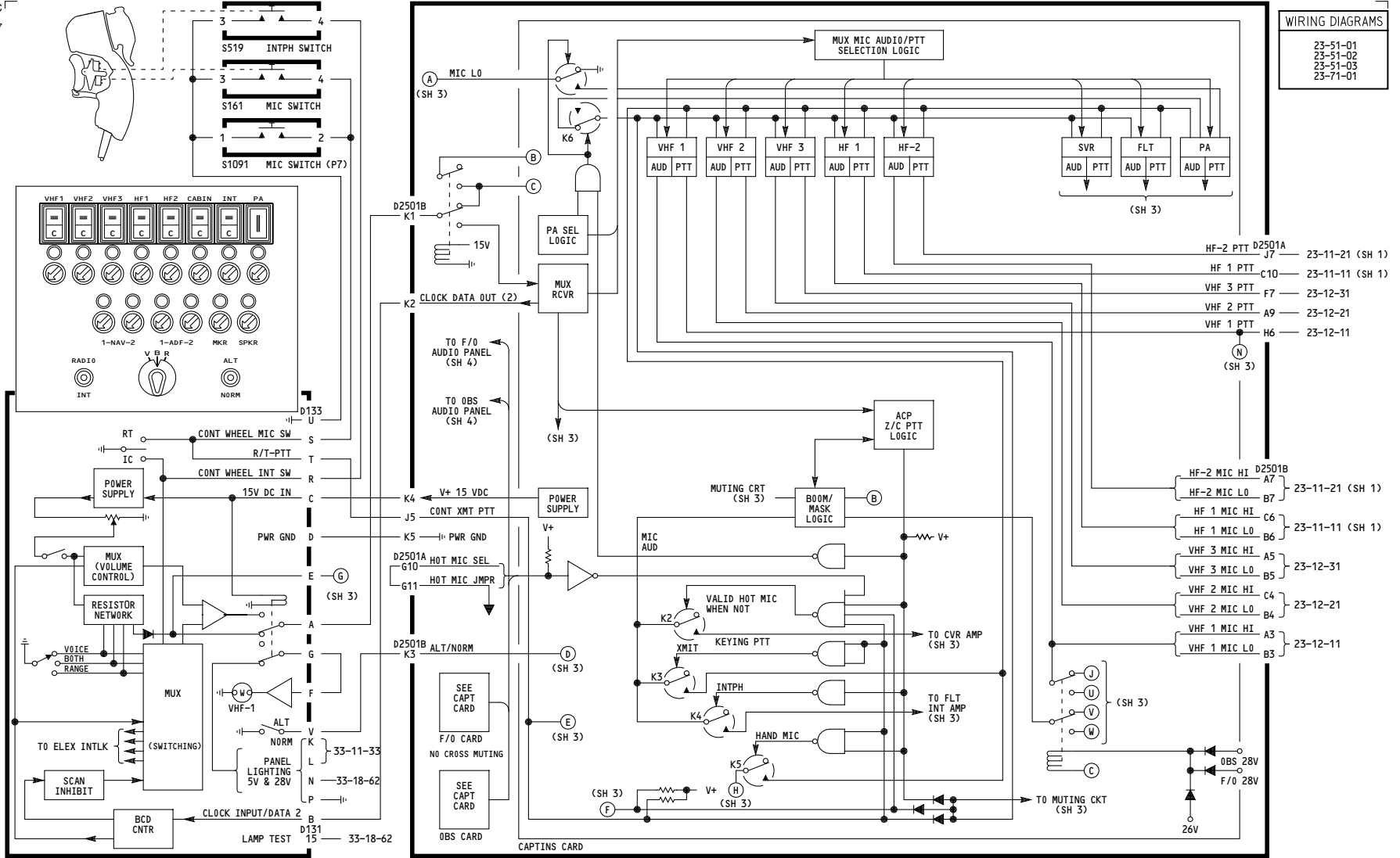

P8-6 CAPT AUDIO CONTROL PANEL

M1353 REMOTE ELECTRONIC UNIT (E4-1)

YK907-YK909, YL401-YM670

FLIGHT INTERPHONE

D280A203

23-51-11

-H
3

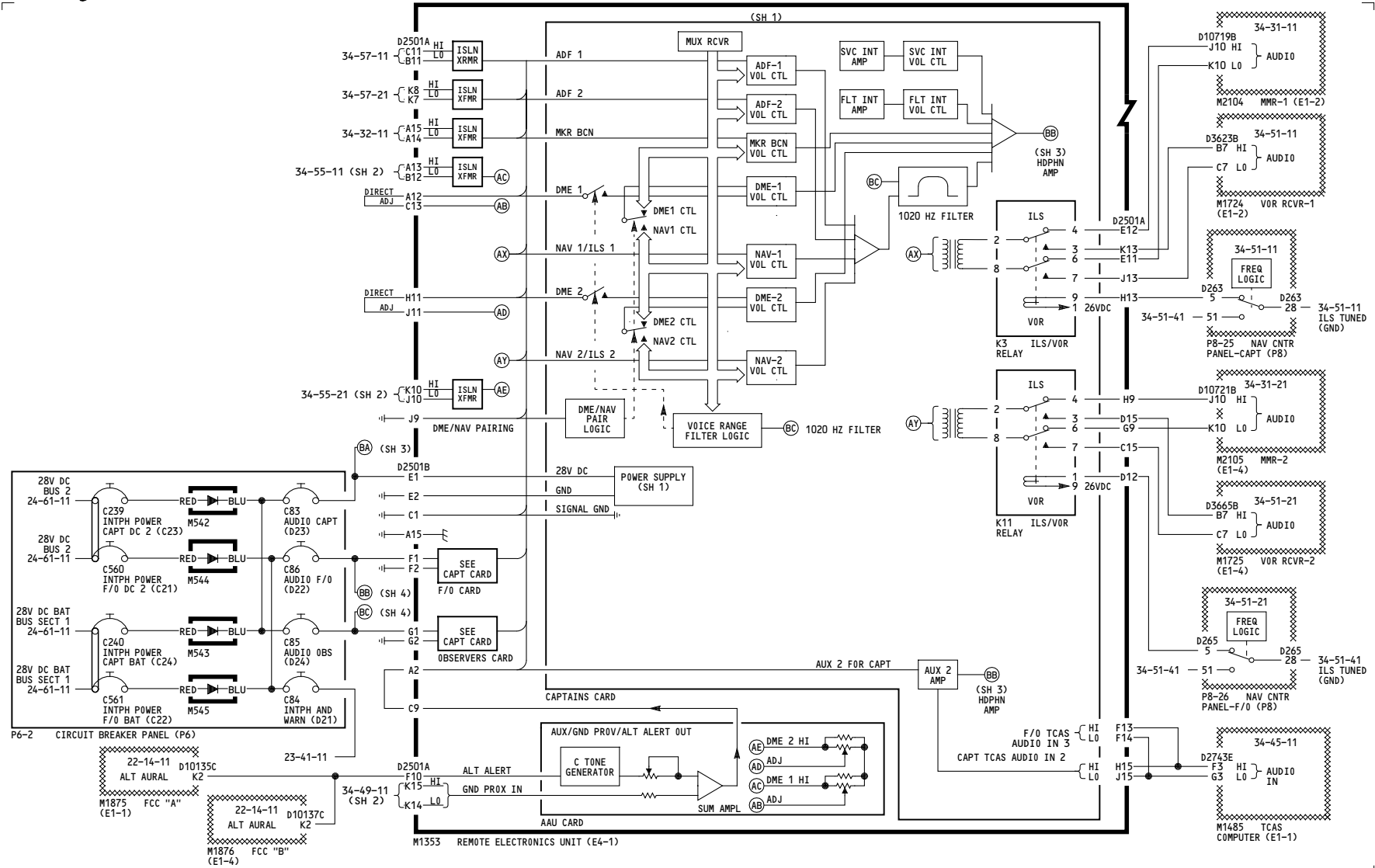

YK907-YK909, YL401-YM670

FLIGHT INTERPHONE

D280A203

23-51-11

Page 104
Sheet 2
Aug 13/2008

-C
55

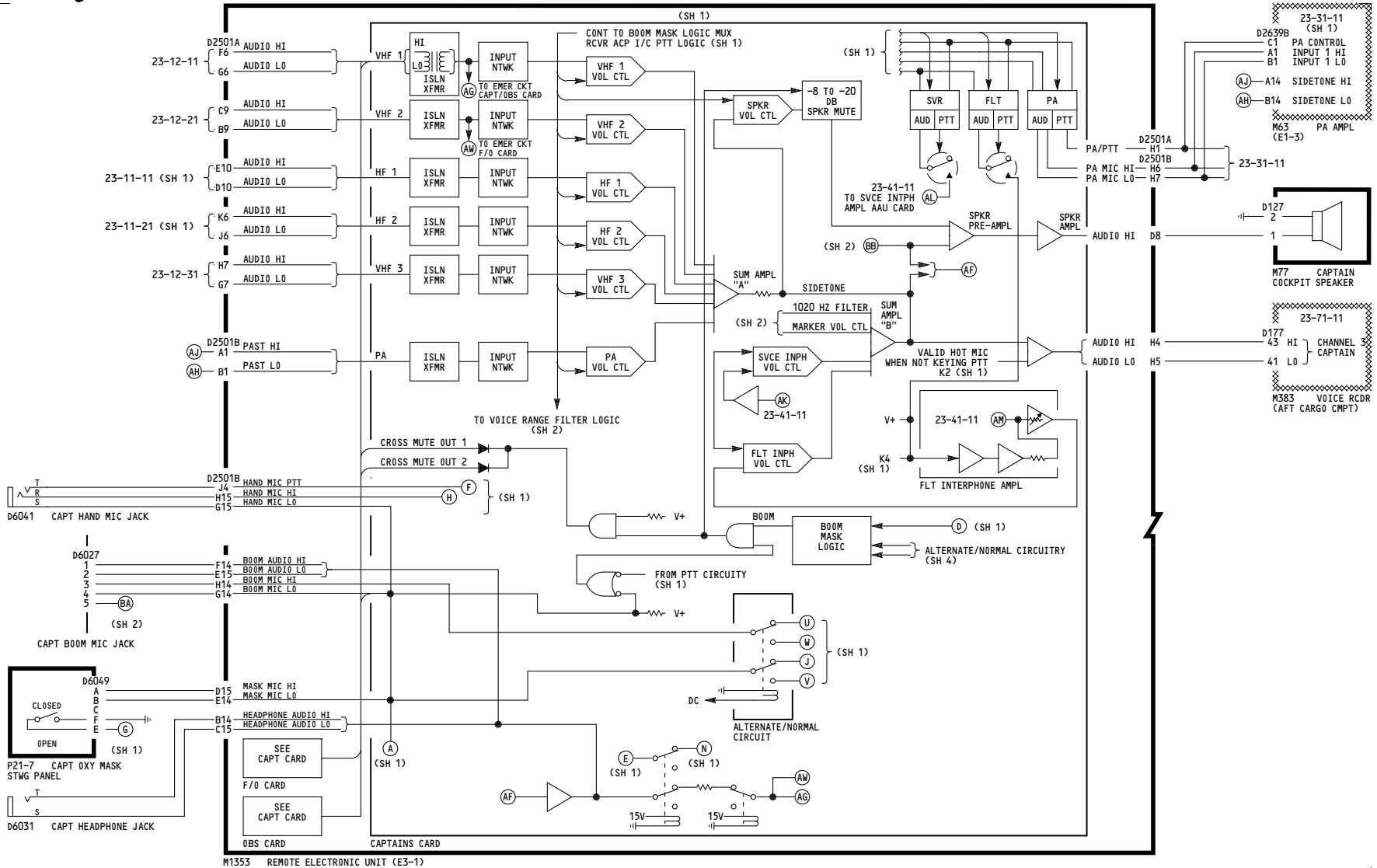

YK907-YK909, YL401-YM670

FLIGHT INTERPHONE

D280A203

23-51-11

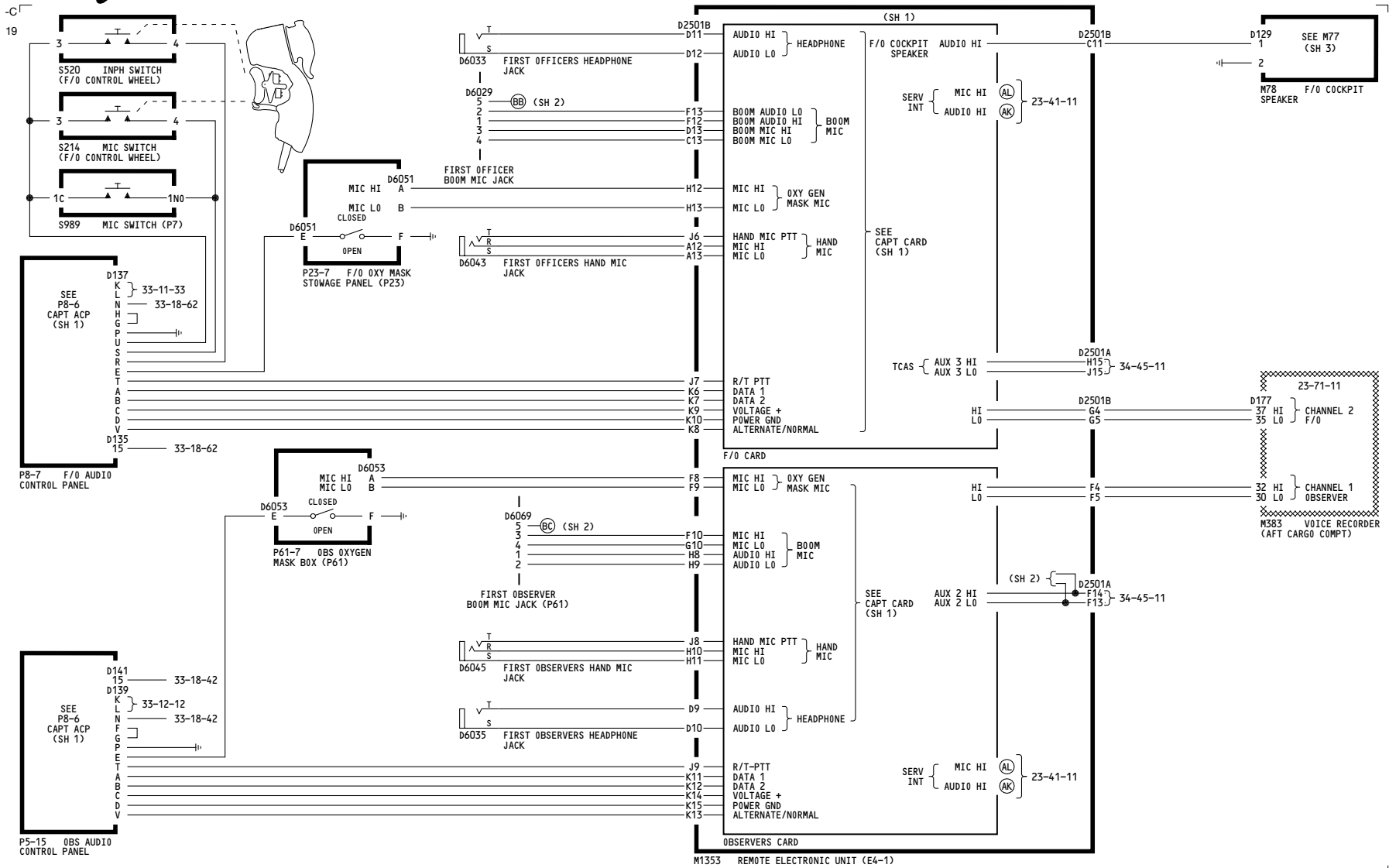

YK907-YK909, YL401-YM670

FLIGHT INTERPHONE

D280A203

23-51-11

Page 104
Sheet 4
Aug 13/2008

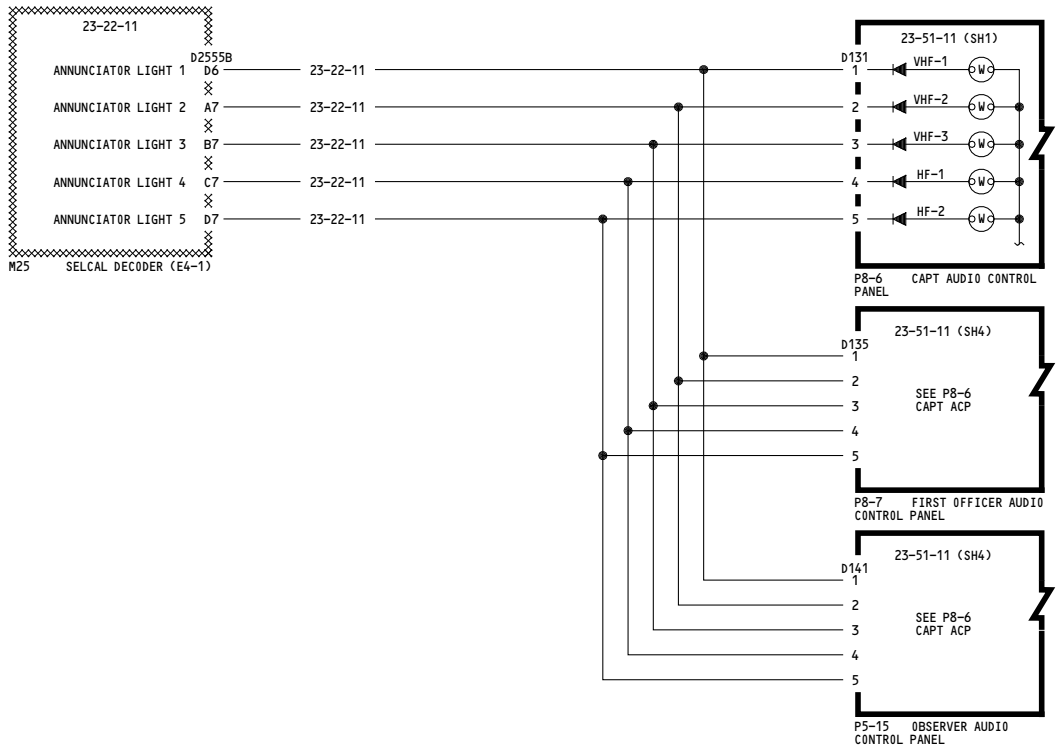

<p>YK907-YK909, YL401-YM670</p>	<p>FLIGHT INTERPHONE</p> <p>D280A203</p>
---------------------------------	---

THIS PAGE INTENTIONALLY LEFT BLANK

17

WIRING DIAGRAMS
23-51-01
23-51-02
23-51-03
23-71-01

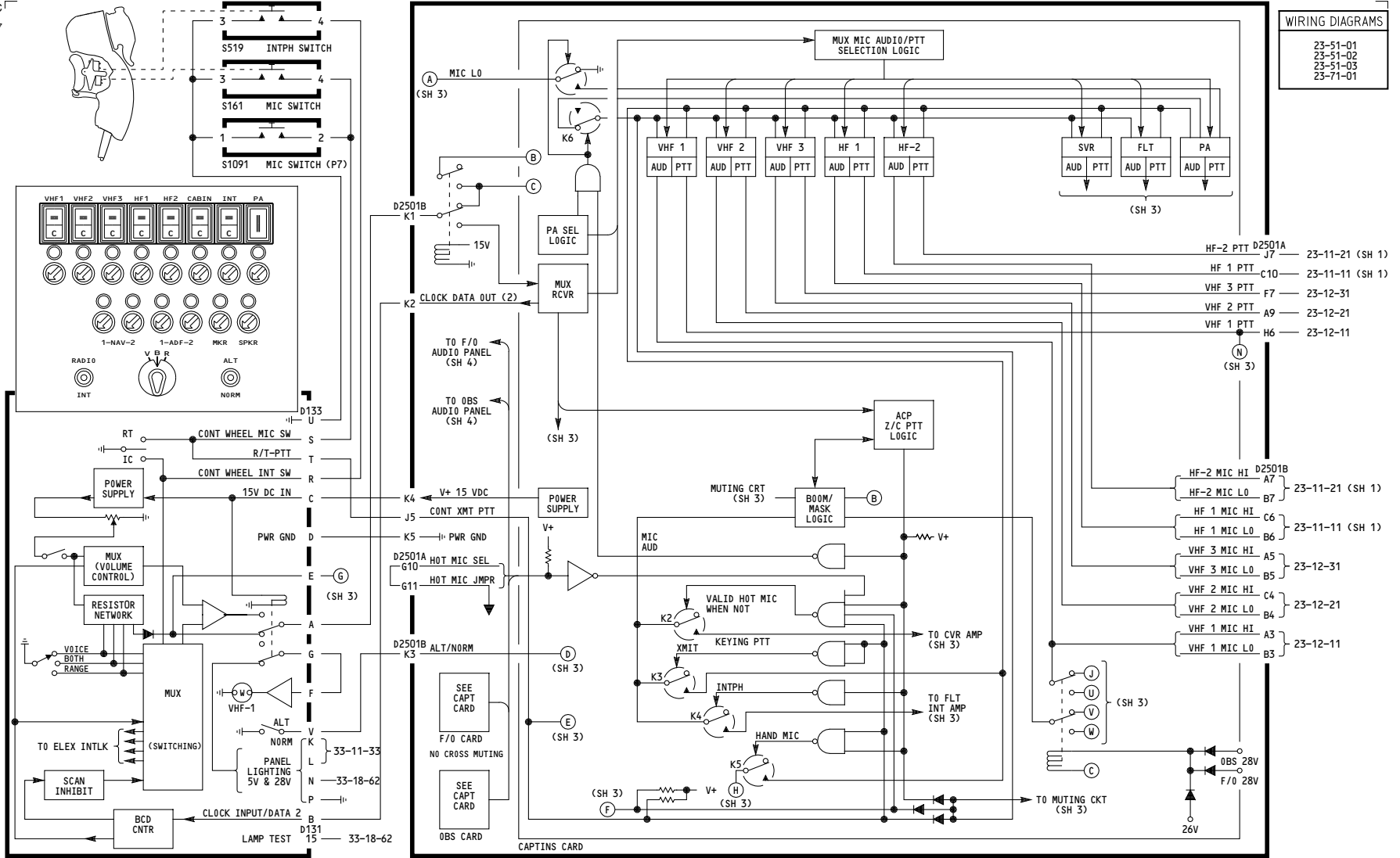

P8-6 CAPT AUDIO CONTROL PANEL

M1353 REMOTE ELECTRONIC UNIT (E4-1)

YK910-YK920

FLIGHT INTERPHONE

D280A203

23-51-11

-H
3

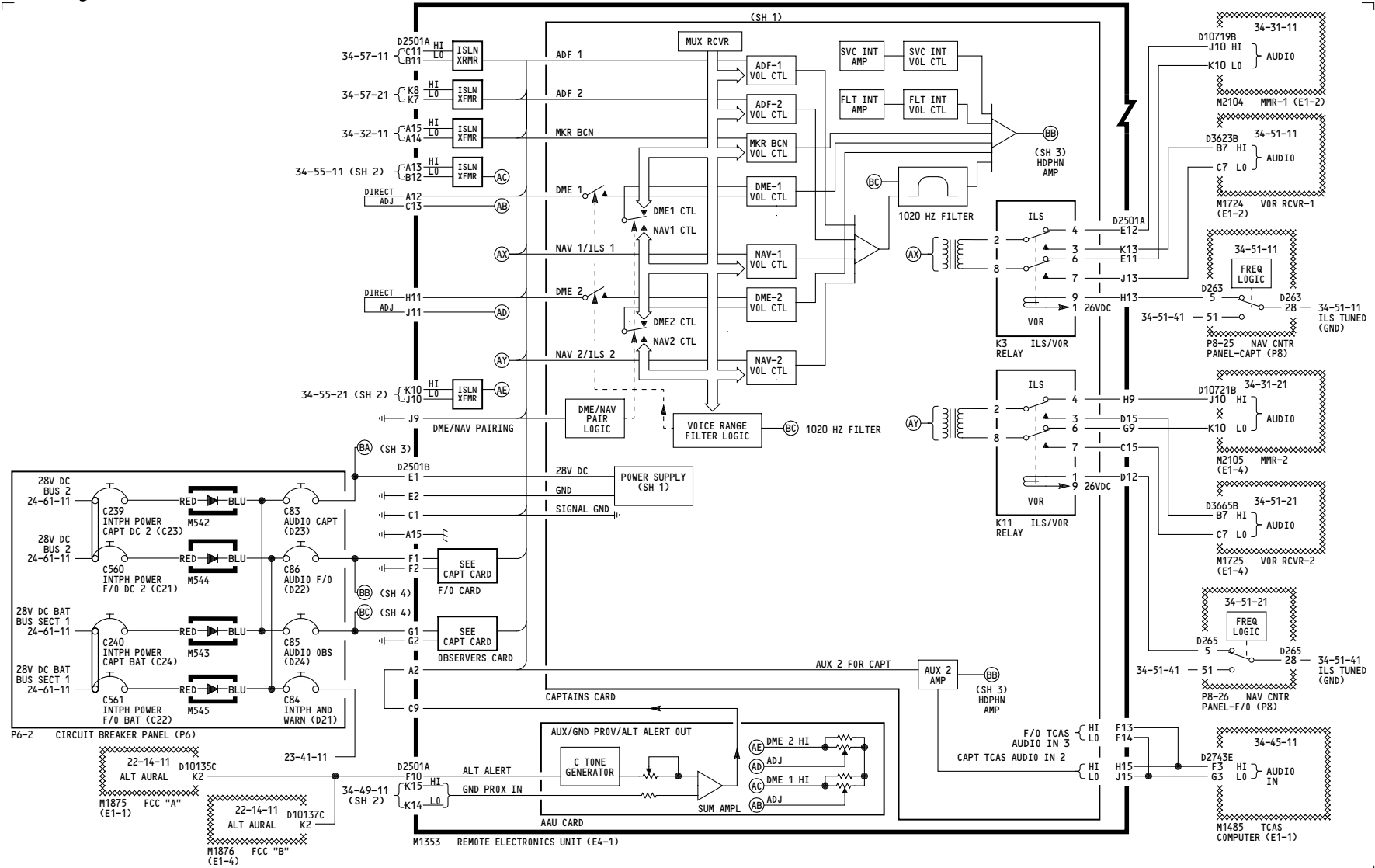

YK910-YK920

FLIGHT INTERPHONE

D280A203

23-51-11

Page 105
Sheet 2
Feb 09/2009

-C
55

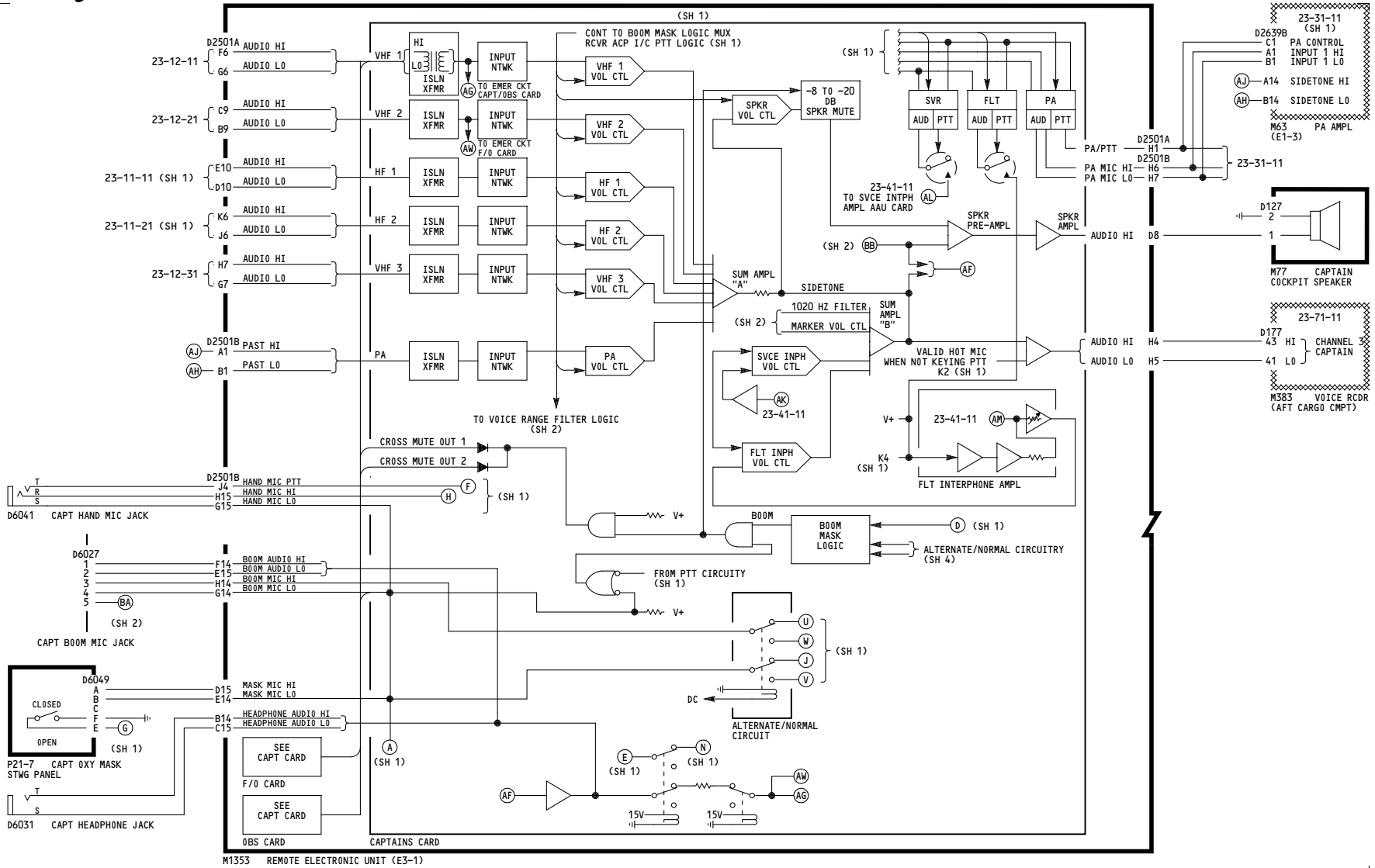

YK910-YK920

FLIGHT INTERPHONE

D280A203

23-51-11

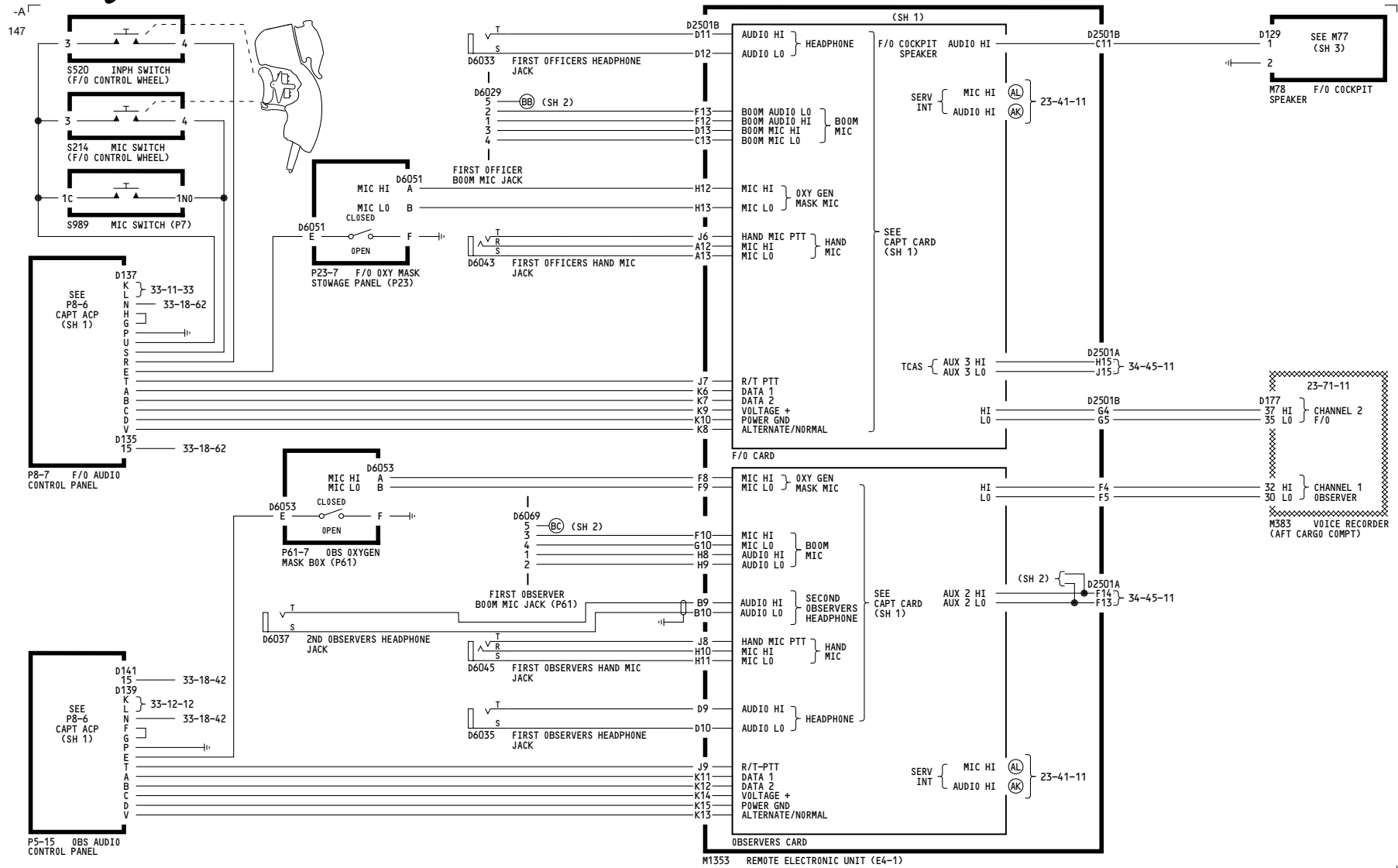

YK910-YK920	FLIGHT INTERPHONE
D280A203	

23-51-11

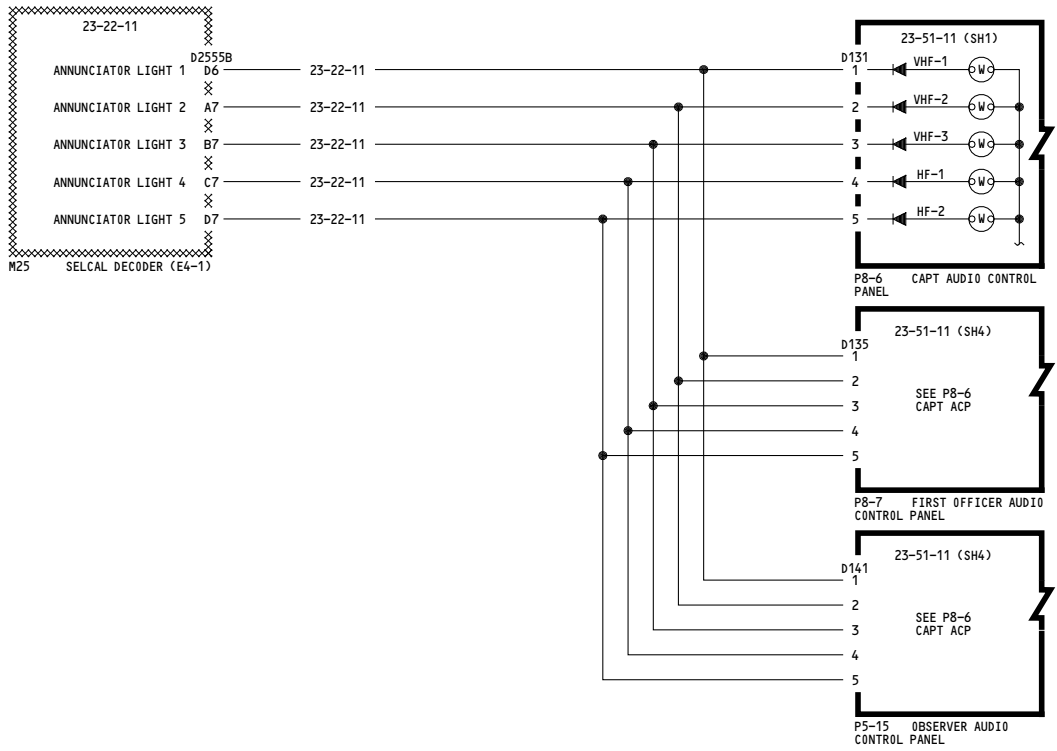

YK910-YK920	<p align="center">FLIGHT INTERPHONE</p> <p align="center">D280A203</p>
-------------	---

THIS PAGE INTENTIONALLY LEFT BLANK

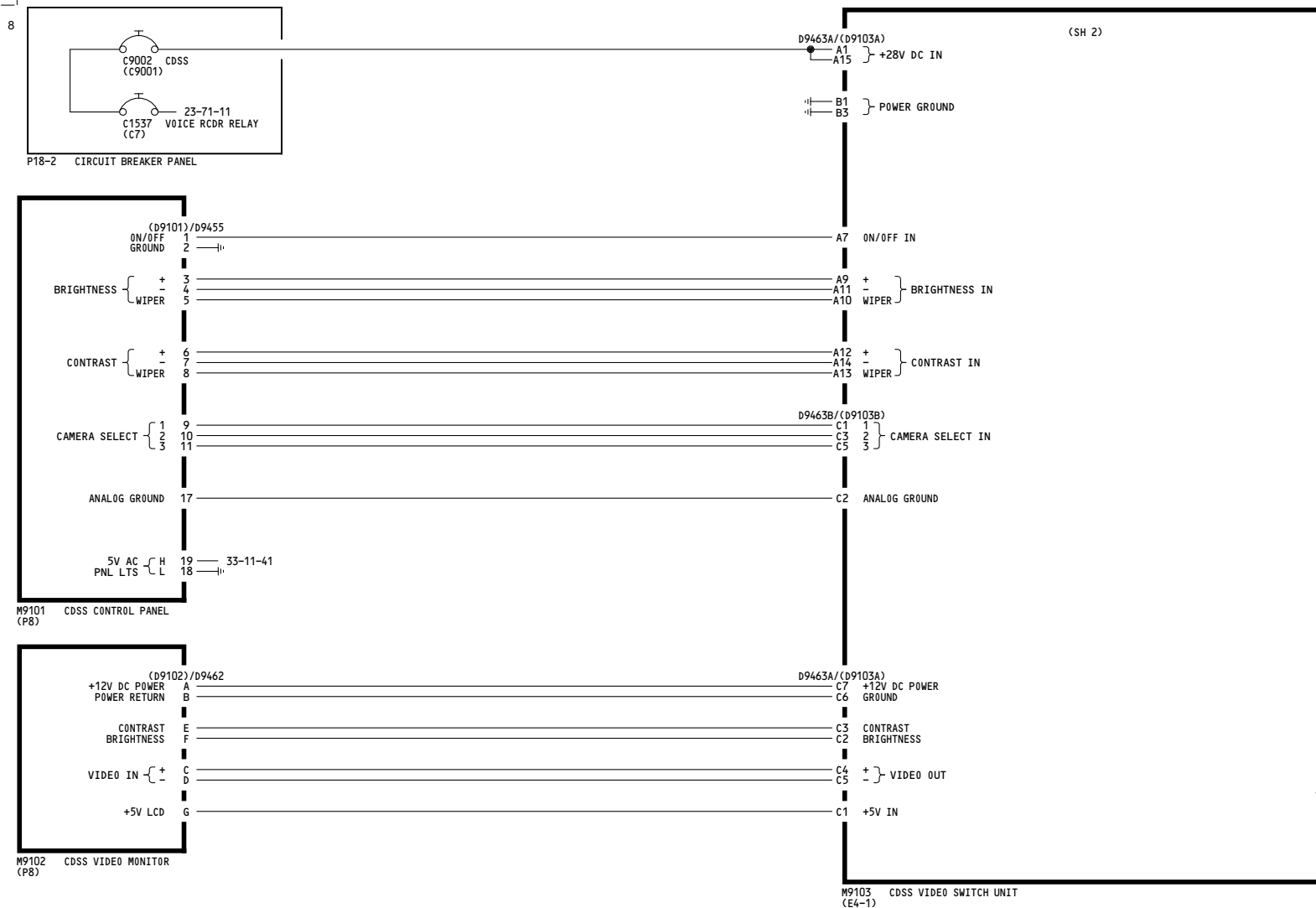

YC001-YC030	VIDEO SURVEILLANCE SYSTEM
	D280A203

Incorporates
230106

23-70-11

Page 101A
Sheet 1
Jul 17/2007

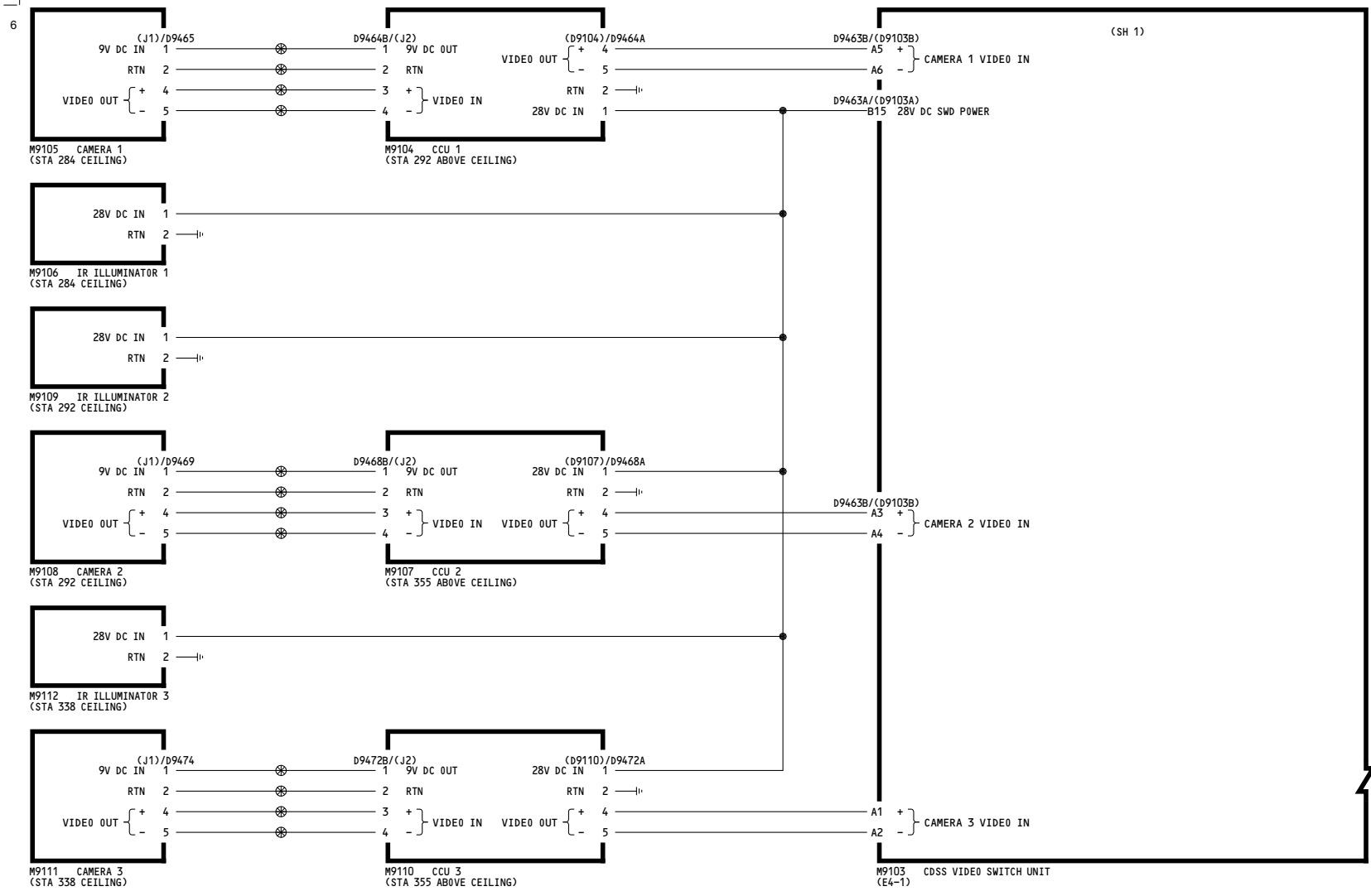

YC001-YC030	VIDEO SURVEILLANCE SYSTEM
	D280A203

Incorporates
▶ 230106

23-70-11

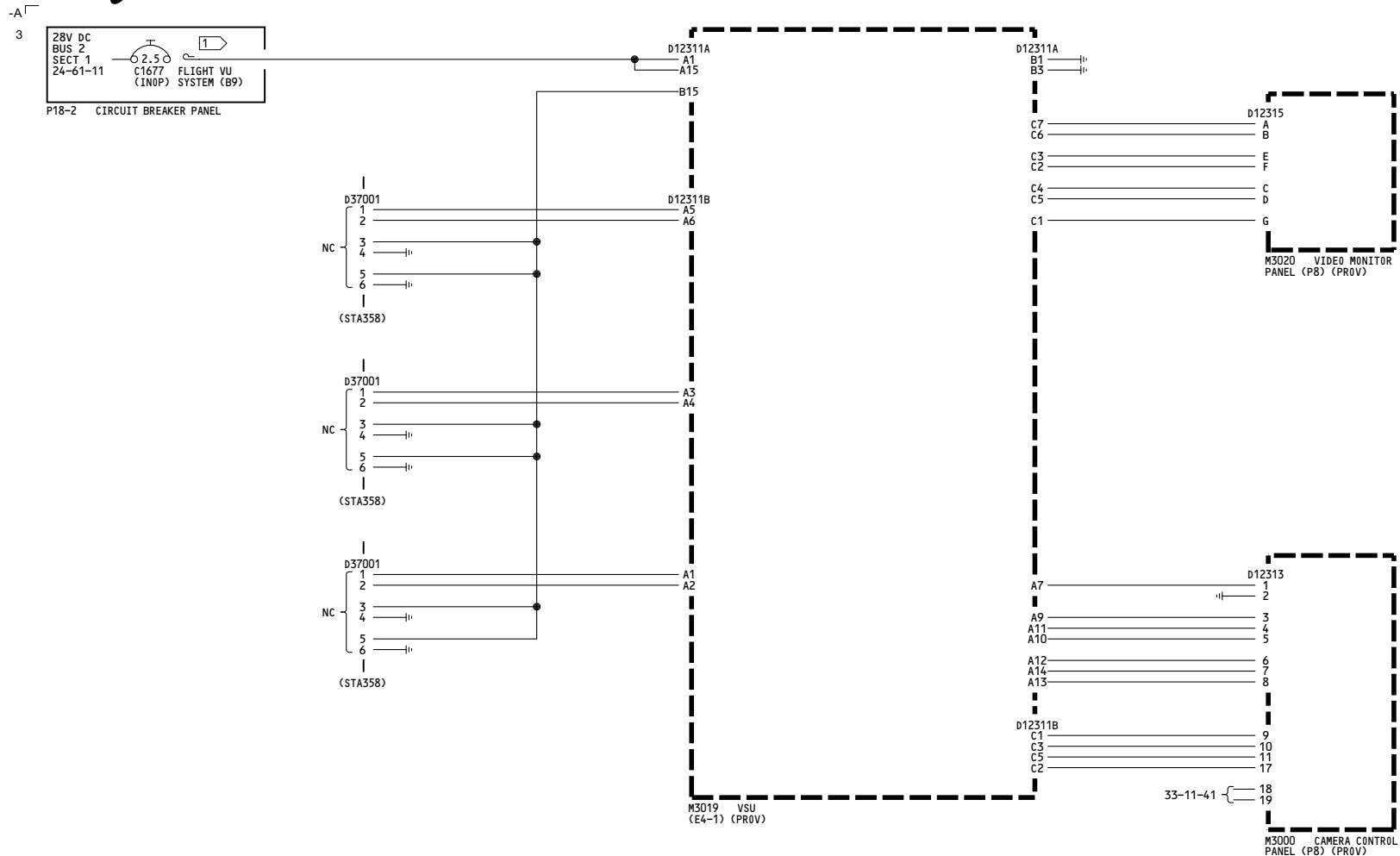

WIRING DIAGRAMS
23-70-11

NOTES:
1 CAP AND STOW, COLLAR AND LABEL (INOP).

YK901-YK906	<p>VIDEO SURVEILLANCE SYSTEM</p> <p>D280A203</p>
-------------	---

23-70-11

Page 102

Oct 20/2006

THIS PAGE INTENTIONALLY LEFT BLANK

WIRING DIAGRAMS
23-70-11

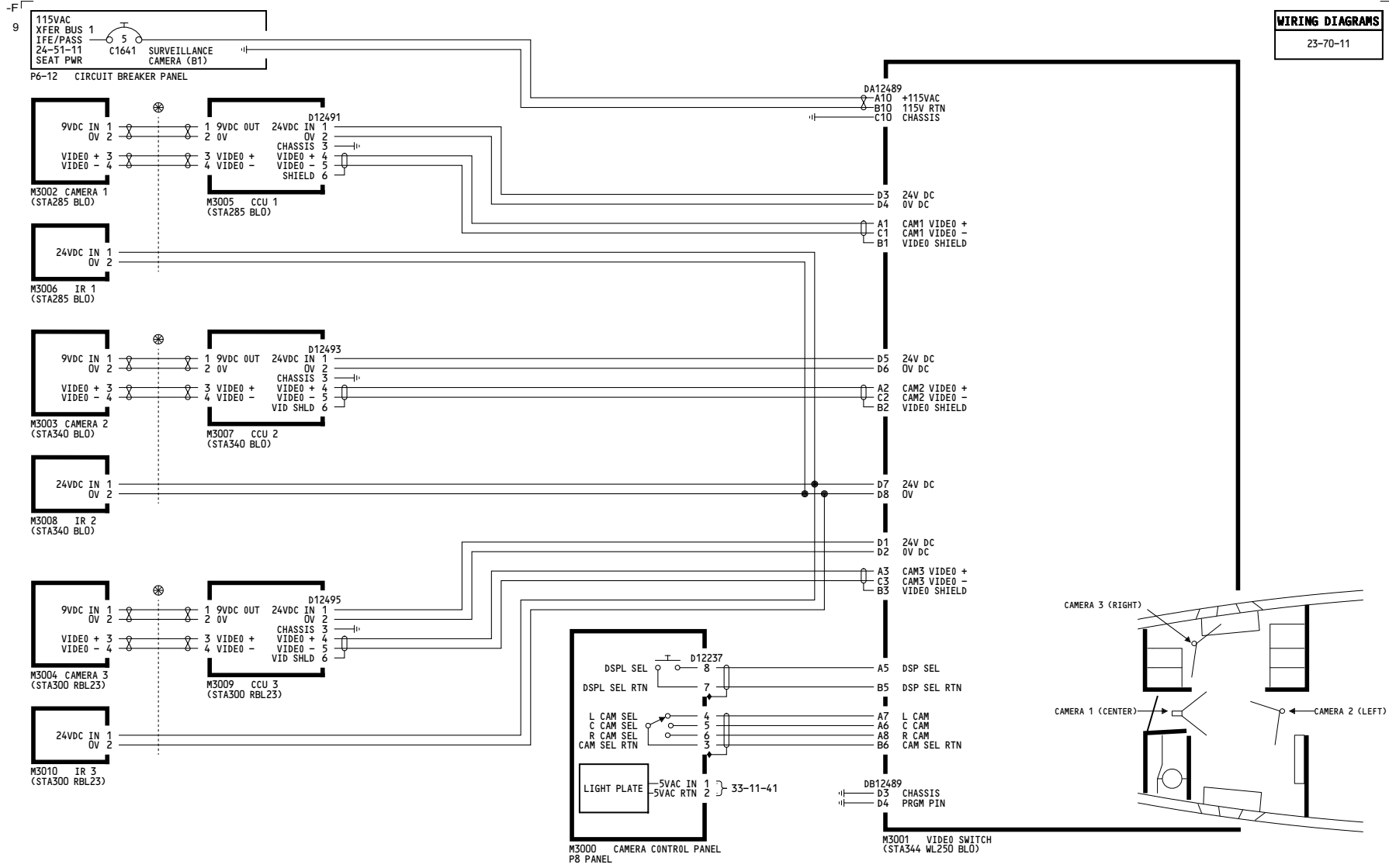

YK907-YM670	VIDEO SURVEILLANCE SYSTEM
	D280A203

23-70-11

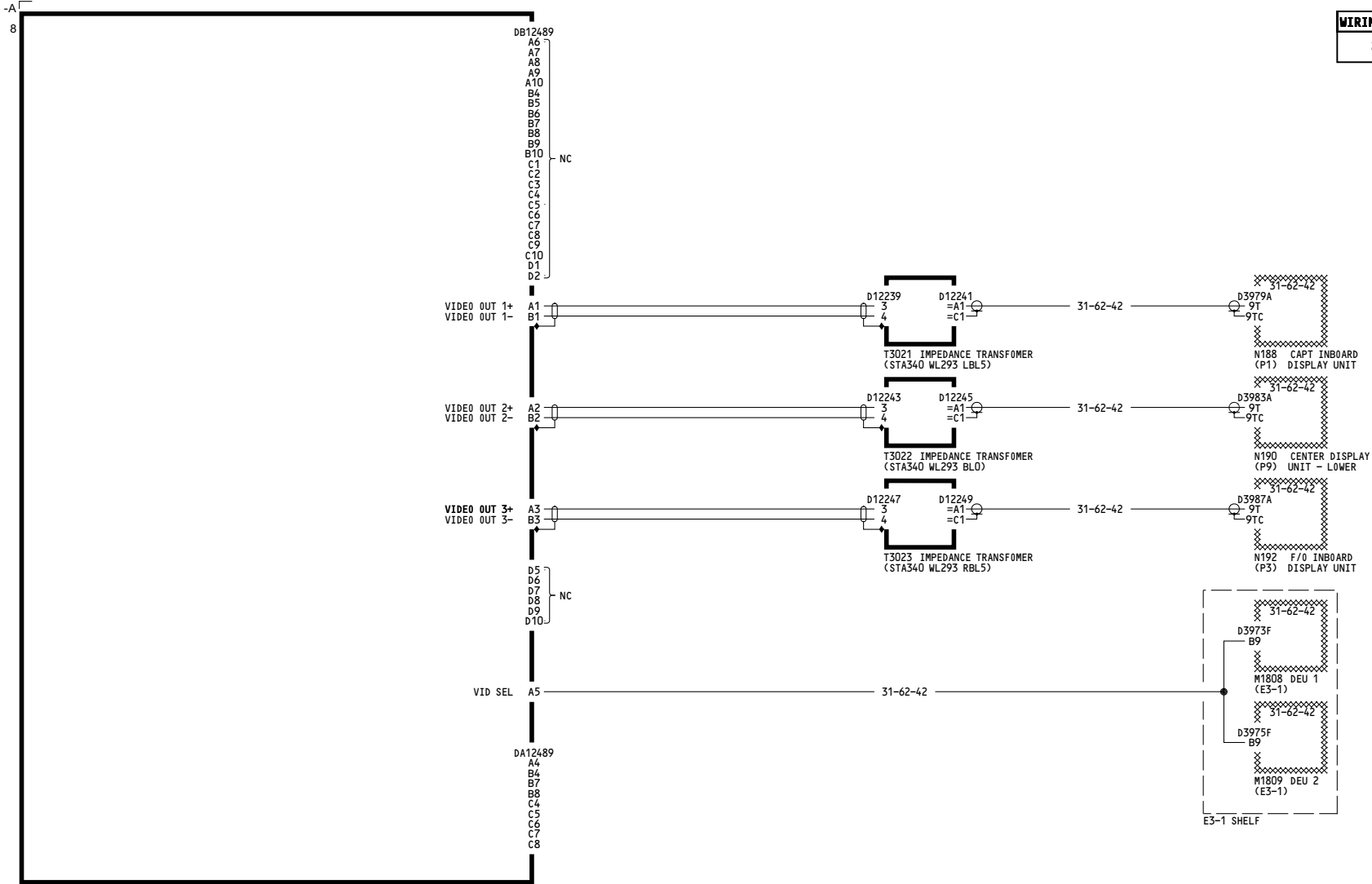

M3001 VIDEO SWITCH
(STA344 WL250 BLO)

YK907-YM670

VIDEO SURVEILLANCE SYSTEM

D280A203

23-70-11

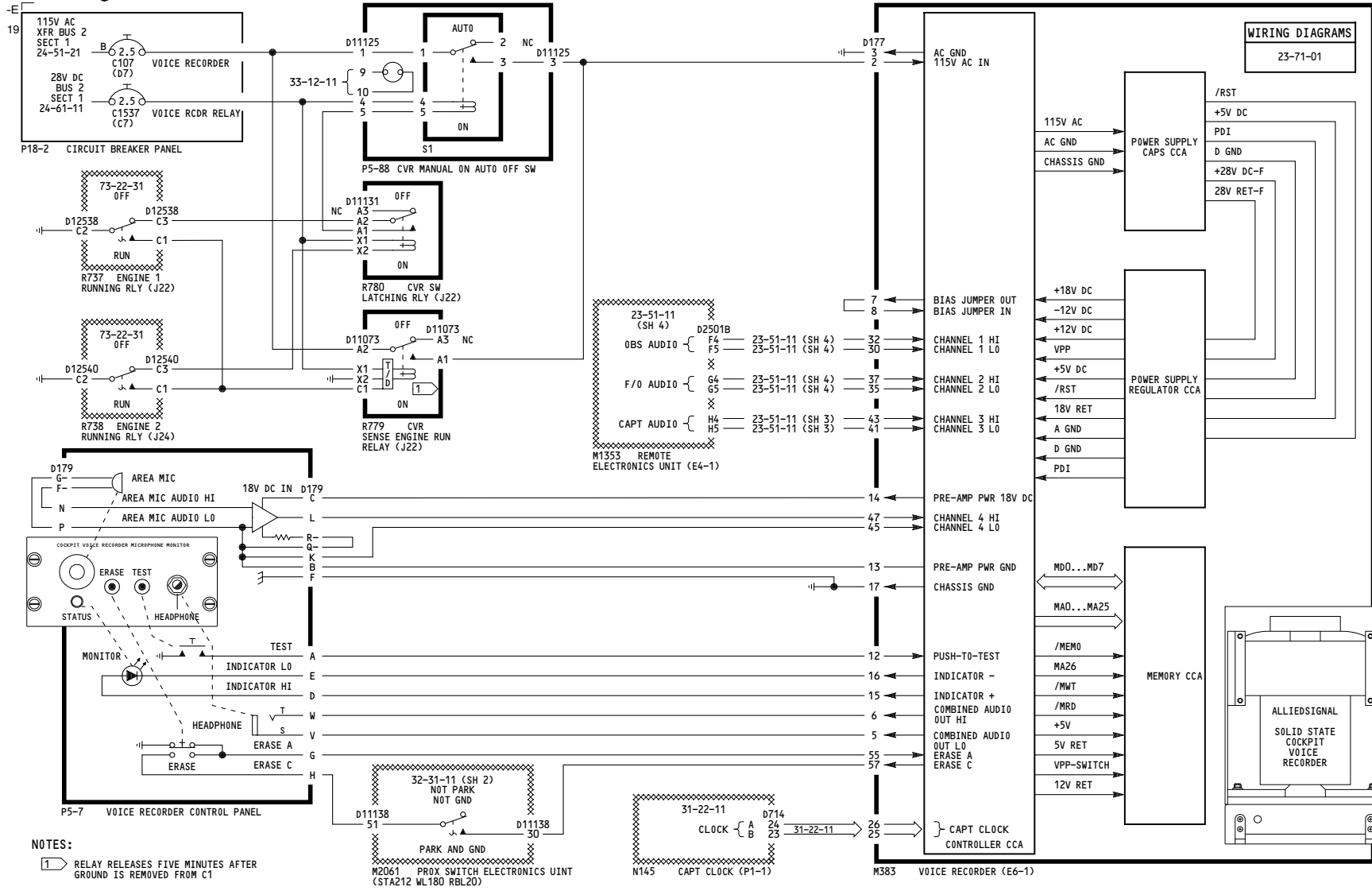

NOTES:
 1 RELAY RELEASES FIVE MINUTES AFTER GROUND IS REMOVED FROM C1

YC001-YC007	VOICE RECORDER
	D280A203

Incorporates
 23-1107

23-71-11

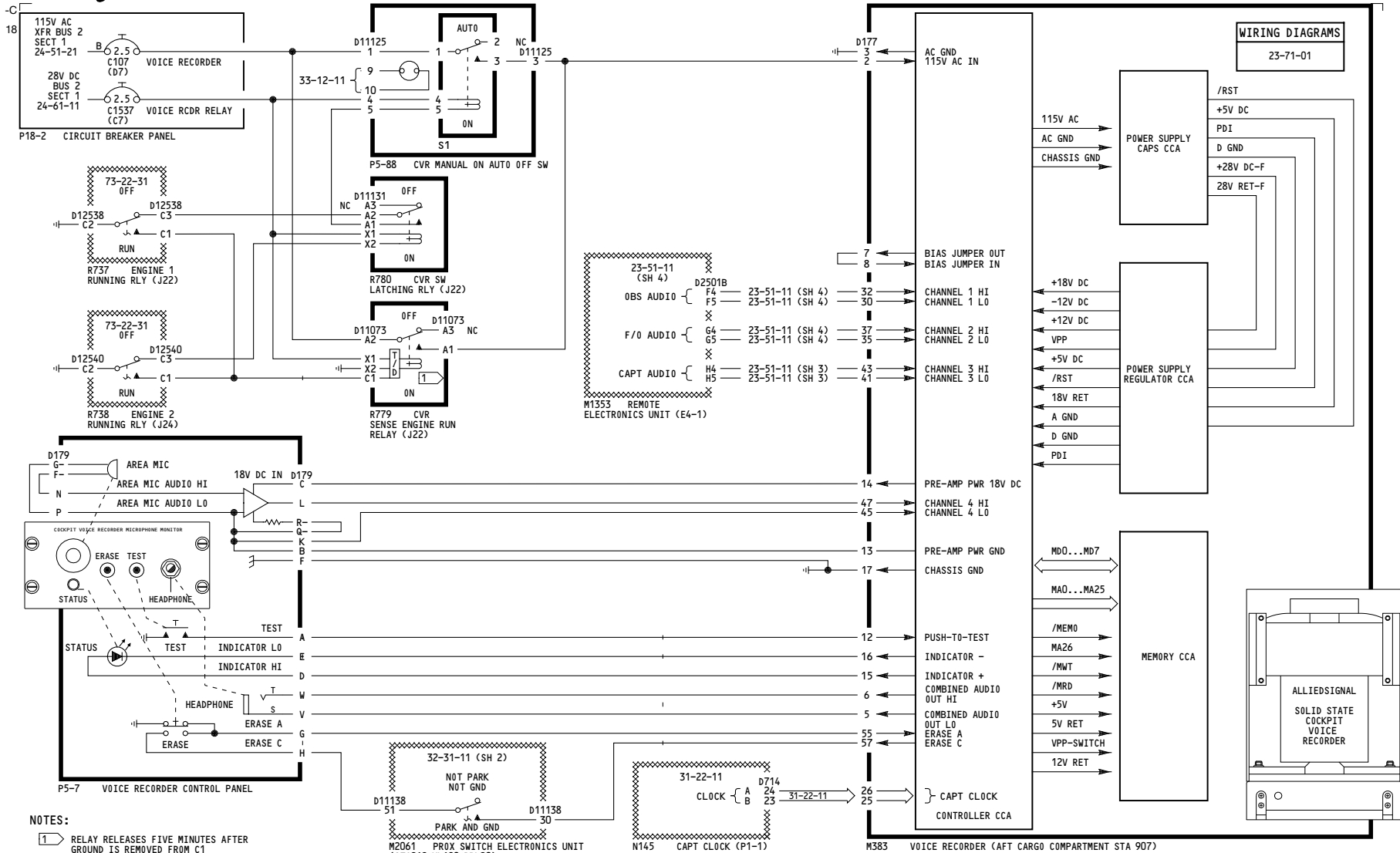

YC008-YK910, YL401-YL430

VOICE RECORDER

D280A203

23-71-11

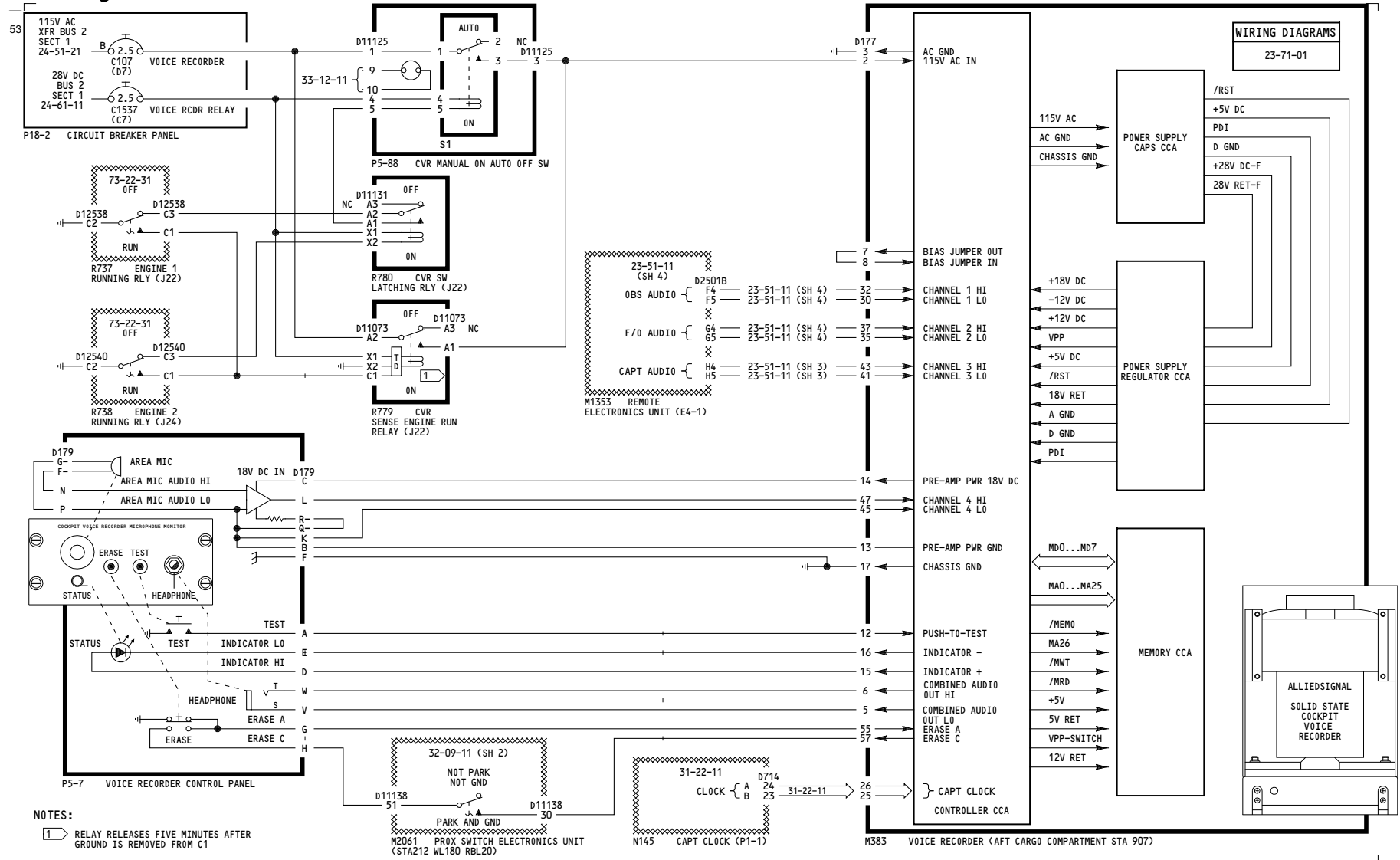

<p>YK911-YK920</p>	<p align="center">VOICE RECORDER</p> <p align="center">D280A203</p>
--------------------	--

23-71-11

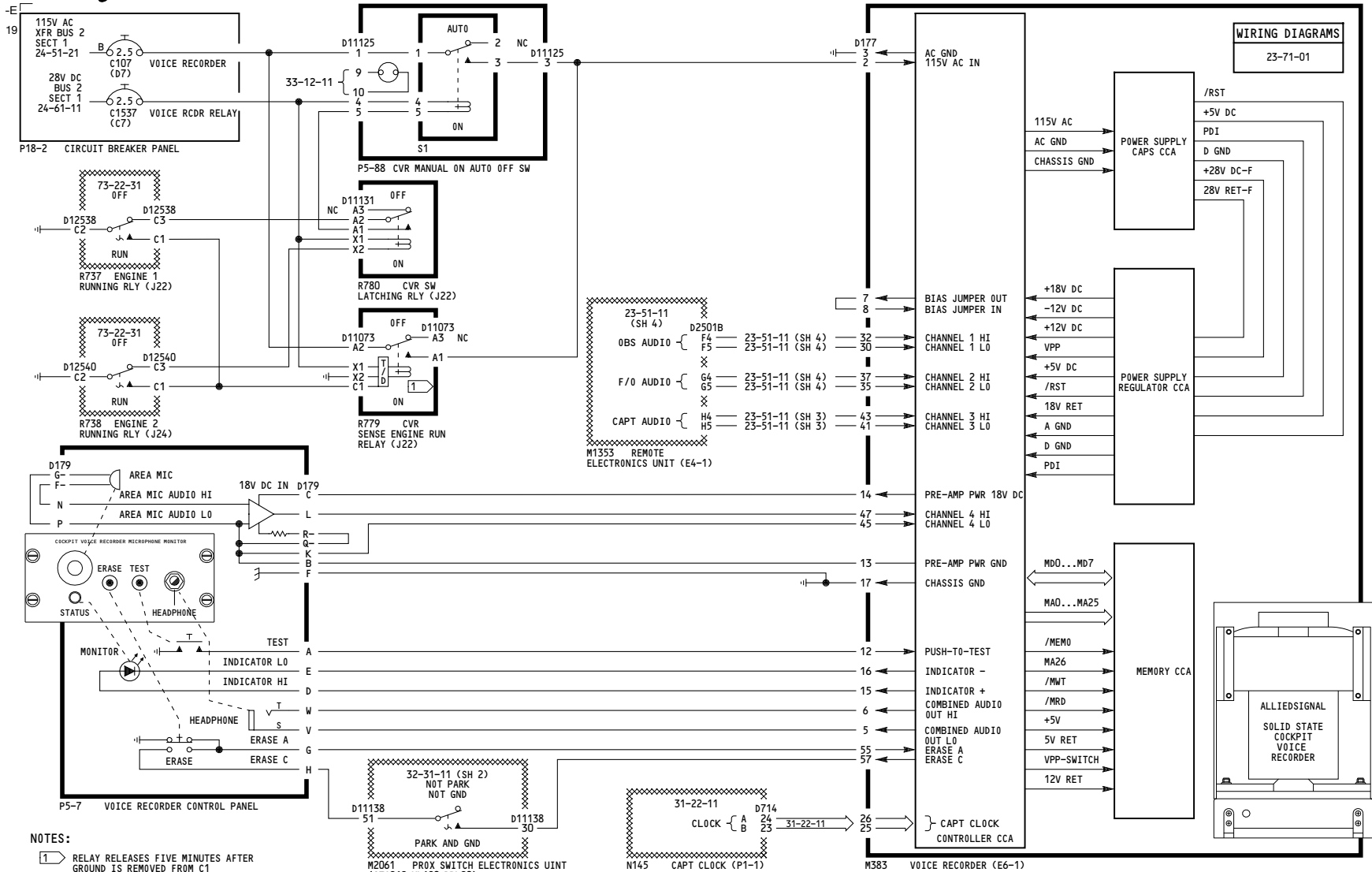

NOTES:
1 RELAY RELEASES FIVE MINUTES AFTER GROUND IS REMOVED FROM C1

YM643-YM670	VOICE RECORDER
	D280A203