

**CHAPTER**

**26**

**FIRE PROTECTION**



CHAPTER 26  
FIRE PROTECTION

CH-SC-SU	Schem	Page	Sheet	Date	CH-SC-SU	Schem	Page	Sheet	Date
26-EFFECTIVE PAGES		1 thru 2		Aug 10/2009	26-11-31 (cont.)		101.1		
26-CONTENTS								2	Aug 13/2008
		1		Feb 09/2009		102		1	Feb 09/2009
		2		Feb 09/2009				2	Feb 09/2009
		3		Feb 09/2009	26-12-11				
		4		BLANK		101		1	Jul 17/2007
26-ALPHABETICAL INDEX								2	Jul 17/2007
		1		Jan 18/2007		102		1	Feb 09/2009
		2		BLANK				2	Feb 09/2009
26-00-01					26-14-11				
		101		Feb 09/2009		101			Feb 09/2009
26-00-05					26-16-21				
		101		Feb 09/2009		101.1		1	Aug 13/2008
26-11-11								2	Aug 13/2008
		101	1	Feb 09/2009		102		1	Aug 13/2008
			2	Feb 09/2009				2	Aug 13/2008
26-11-21						103		1	Aug 13/2008
		101.1	1	Aug 13/2008				2	Aug 13/2008
			2	Aug 13/2008		104		1	Feb 09/2009
		102	1	Feb 09/2009				2	Feb 09/2009
			2	Feb 09/2009		105		1	Aug 13/2008
26-11-31								2	Aug 13/2008
		101.1	1	Aug 13/2008		106		1	Aug 13/2008
								2	Aug 13/2008

A = Added, R = Revised, D = Deleted, O = Overflow

**26-EFFECTIVE PAGES**

Page 1  
Aug 10/2009

D280A203



CHAPTER 26  
FIRE PROTECTION

CH-SC-SU	Schem	Page	Sheet	Date	CH-SC-SU	Schem	Page	Sheet	Date
26-16-22									
		101.1	1	Aug 13/2008					
			2	Aug 13/2008					
	102		1	Aug 13/2008					
			2	Aug 13/2008					
	103		1	Feb 09/2009					
			2	Feb 09/2009					
	104		1	Aug 13/2008					
			2	Aug 13/2008					
26-21-11									
		101	1	Feb 09/2009					
			2	Feb 09/2009					
			3	Feb 09/2009					
26-23-11									
		101.1		Aug 13/2008					
		102		Nov 11/2008					
		103		Feb 09/2009					

A = Added, R = Revised, D = Deleted, O = Overflow

**26-EFFECTIVE PAGES**

Page 2  
Aug 10/2009

D280A203

CHAPTER 26  
FIRE PROTECTION

Title	CH-SC-SU	Schem	Page	Sheet	Date	Effectivity
<b><u>FIRE PROTECTION</u></b>						
ENGINE AND APU FIRE/OVERHEAT DETECTION-SIMPLIFIED	26-00-01		101		Feb 09/2009	ALL
FIRE/OVERHEAT DETECTOR LOCATIONS	26-00-05		101		Feb 09/2009	ALL
<b><u>ENGINE FIRE DETECTION</u></b>						
ENGINE NO.1 FIRE DETECTION	26-11-11		101	1	Feb 09/2009	ALL
				2	Feb 09/2009	ALL
ENGINE NO.2 FIRE DETECTION	26-11-21		101.1	1	Aug 13/2008	YC001-YC007
				2	Aug 13/2008	YC001-YC007
			102	1	Feb 09/2009	YC008-YM670
				2	Feb 09/2009	YC008-YM670
APU FIRE DETECTION	26-11-31		101.1	1	Aug 13/2008	YC001-YC007
				2	Aug 13/2008	YC001-YC007
			102	1	Feb 09/2009	YC008-YM670
				2	Feb 09/2009	YC008-YM670
<b><u>OVERHEAT DETECTION SYSTEM</u></b>						
WHEEL WELL, WING AND LOWER AFT BODY OVERHEAT DETECTION	26-12-11		101	1	Jul 17/2007	YC001-YC030
				2	Jul 17/2007	YC001-YC030
			102	1	Feb 09/2009	YC031-YM670
				2	Feb 09/2009	YC031-YM670
<b><u>LAVATORY SMOKE DETECTION</u></b>						
LAVATORY SMOKE DETECTORS	26-14-11		101		Feb 09/2009	ALL



CHAPTER 26  
FIRE PROTECTION

Title	CH-SC-SU	Schem	Page	Sheet	Date	Effectivity			
<b><u>CARGO COMPARTMENT SMOKE DETECTION SYSTEM</u></b>									
FORWARD CARGO COMPARTMENT SMOKE DETECTION	26-16-21		101.1	1	Aug 13/2008	YC001-YC007			
				2	Aug 13/2008	YC001-YC007			
			102	1	Aug 13/2008	YC008-YC026			
				2	Aug 13/2008	YC008-YC026			
			103	1	Aug 13/2008	YC028-YC030			
				2	Aug 13/2008	YC028-YC030			
			104	1	Feb 09/2009	YC031-YC050 YK906-YL430			
				2	Feb 09/2009	YC031-YC050 YK906-YL430			
			105	1	Aug 13/2008	YK901-YK905			
				2	Aug 13/2008	YK901-YK905			
			106	1	Aug 13/2008	YM643-YM670			
				2	Aug 13/2008	YM643-YM670			
			AFT CARGO COMPARTMENT SMOKE DETECTION	26-16-22		101.1	1	Aug 13/2008	YC001-YC007
							2	Aug 13/2008	YC001-YC007
102	1	Aug 13/2008				YC008-YC030			
	2	Aug 13/2008				YC008-YC030			
103	1	Feb 09/2009				YC031-YL430			
	2	Feb 09/2009				YC031-YL430			
104	1	Aug 13/2008				YM643-YM670			
	2	Aug 13/2008				YM643-YM670			

CHAPTER 26  
FIRE PROTECTION

Title	CH-SC-SU	Schem	Page	Sheet	Date	Effectivity
<b><u>ENGINE FIRE EXTINGUISHING</u></b>						
ENGINE AND APU FIRE EXTINGUISHING SYSTEM	26-21-11		101	1	Feb 09/2009	ALL
				2	Feb 09/2009	ALL
				3	Feb 09/2009	ALL
<b><u>CARGO COMPARTMENT FIRE EXTINGUISHING</u></b>						
CARGO COMPARTMENT FIRE EXTINGUISHERS	26-23-11		101.1		Aug 13/2008	YC001-YC007
			102		Nov 11/2008	YC008-YK917 YL421-YL428 YL430-YM670
			103		Feb 09/2009	YK918-YL401 YL429

**CHAPTER 26  
FIRE PROTECTION**

CH-SC-SU	Title
26-16-22	AFT CARGO COMPARTMENT SMOKE DETECTION
26-11-31	APU FIRE DETECTION
26-23-11	CARGO COMPARTMENT FIRE EXTINGUISHERS
26-21-11	ENGINE AND APU FIRE EXTINGUISHING SYSTEM
26-00-01	ENGINE AND APU FIRE/OVERHEAT DETECTION-SIMPLIFIED
26-11-11	ENGINE NO.1 FIRE DETECTION
26-11-21	ENGINE NO.2 FIRE DETECTION
26-00-05	FIRE/OVERHEAT DETECTOR LOCATIONS
26-16-21	FORWARD CARGO COMPARTMENT SMOKE DETECTION
26-14-11	LAVATORY SMOKE DETECTORS
26-12-11	WHEEL WELL, WING AND LOWER AFT BODY OVERHEAT DETECTION

CH-SC-SU	Title

**26-ALPHABETICAL INDEX**

-E-  
1

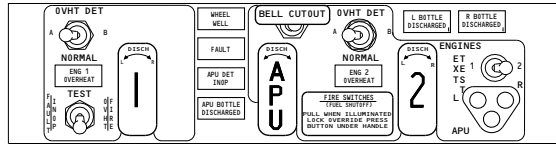
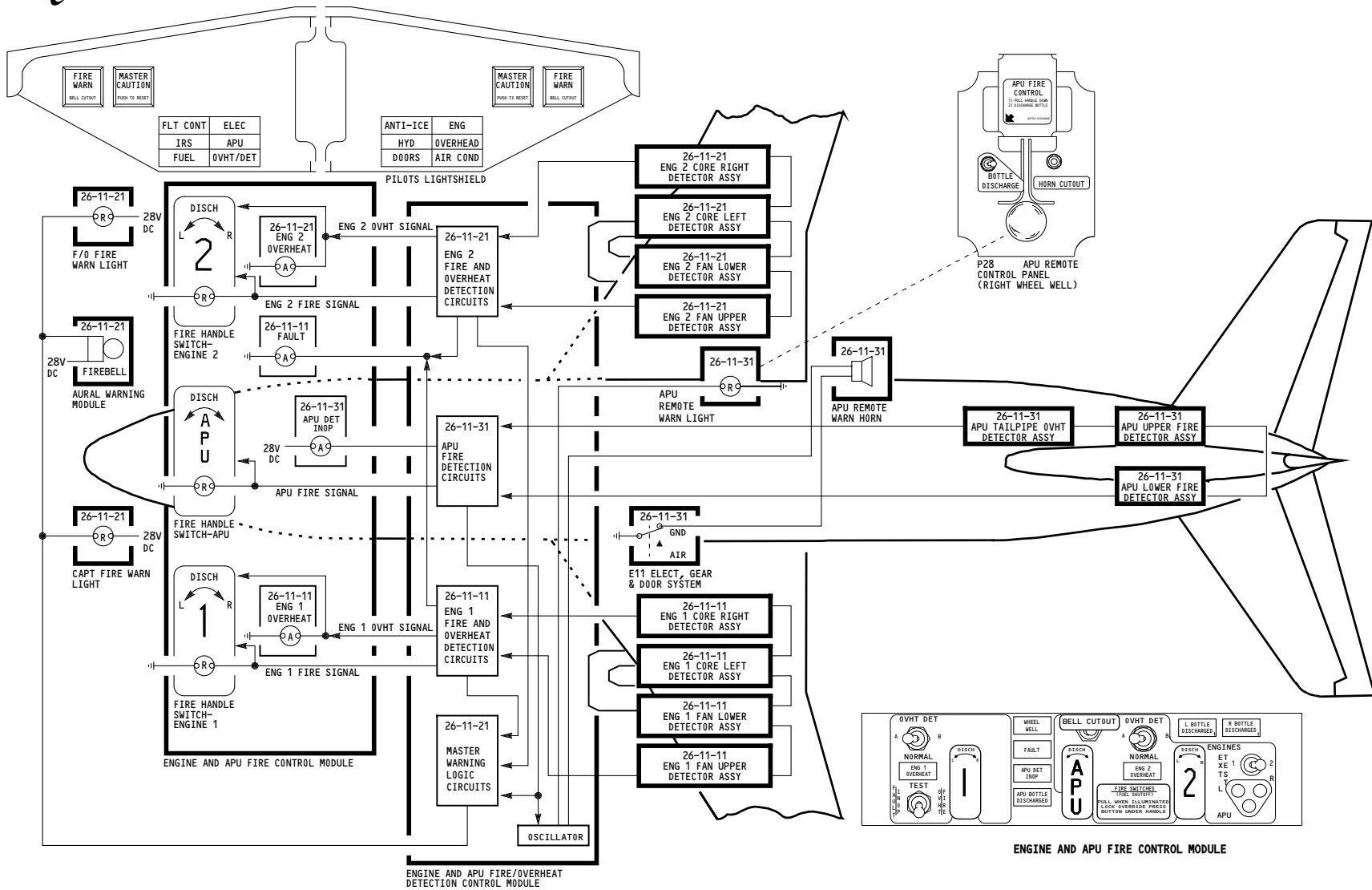

ENGINE AND APU FIRE CONTROL MODULE

ALL

**ENGINE AND APU  
FIRE/OVERHEAT DETECTION-  
SIMPLIFIED**

D280A203

**26-00-01**

Page 101

Feb 09/2009



1

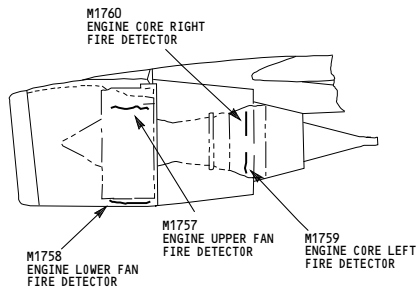

ENGINE FIRE DETECTORS  
(26-11-11, 26-11-21)

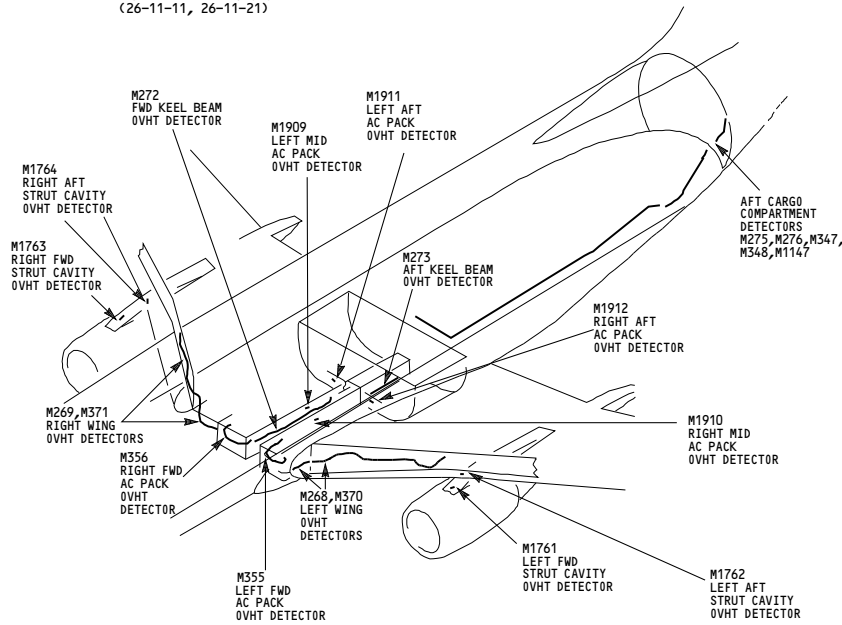

COMPARTMENT OVERHEAT DETECTORS  
(26-12-11)

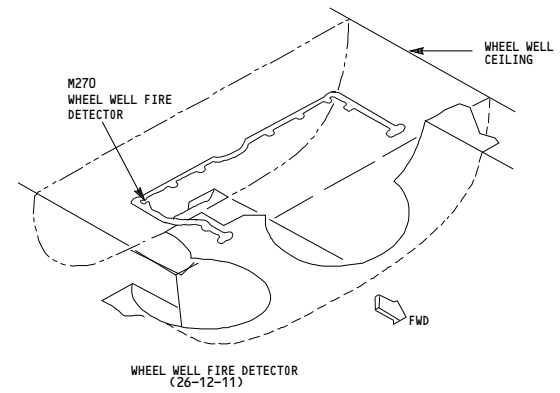

ALL	<p align="center"><b>FIRE/OVERHEAT DETECTOR LOCATIONS</b></p> <p align="center">D280A203</p>
-----	--

26-00-05

Page 101

Feb 09/2009

THIS PAGE INTENTIONALLY LEFT BLANK



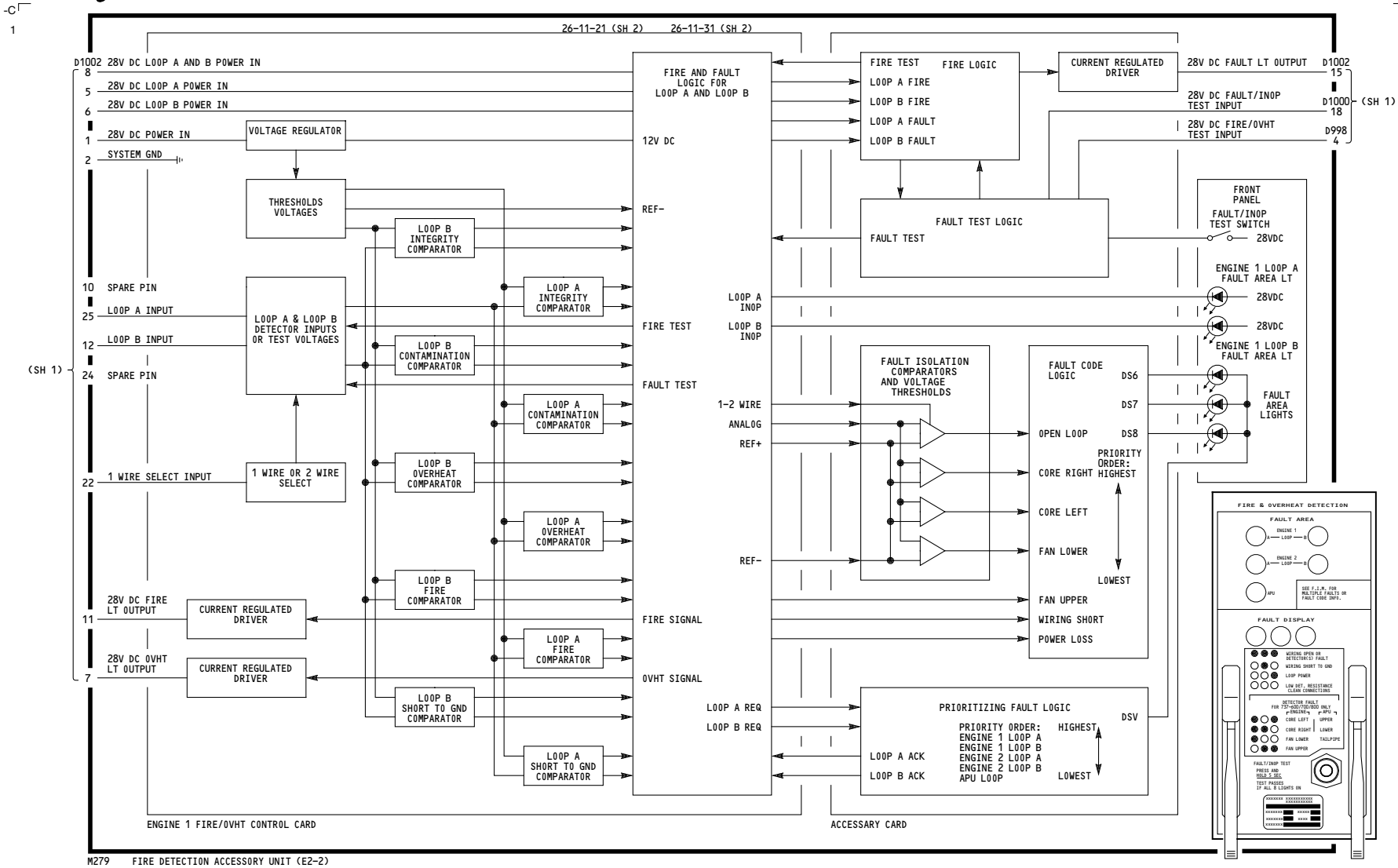

M279 FIRE DETECTION ACCESSORY UNIT (E2-2)

ALL

**ENGINE NO.1  
FIRE DETECTION**

D280A203

**26-11-11**

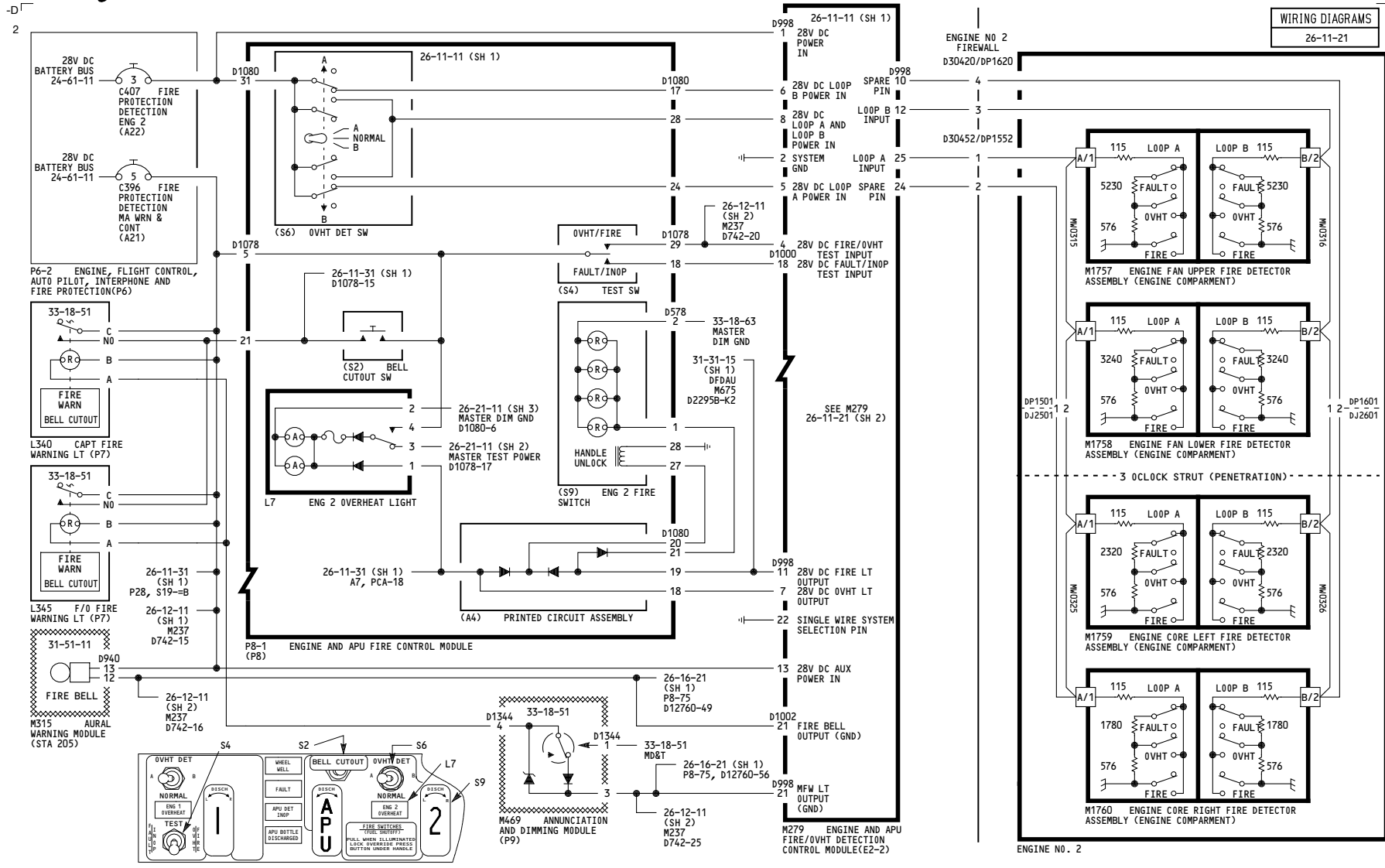

YC001-YC007

**ENGINE NO.2  
FIRE DETECTION**

Incorporates  
26A1083 R01

D280A203

**26-11-21**

Page 101.1  
Sheet 1  
Aug 13/2008

1

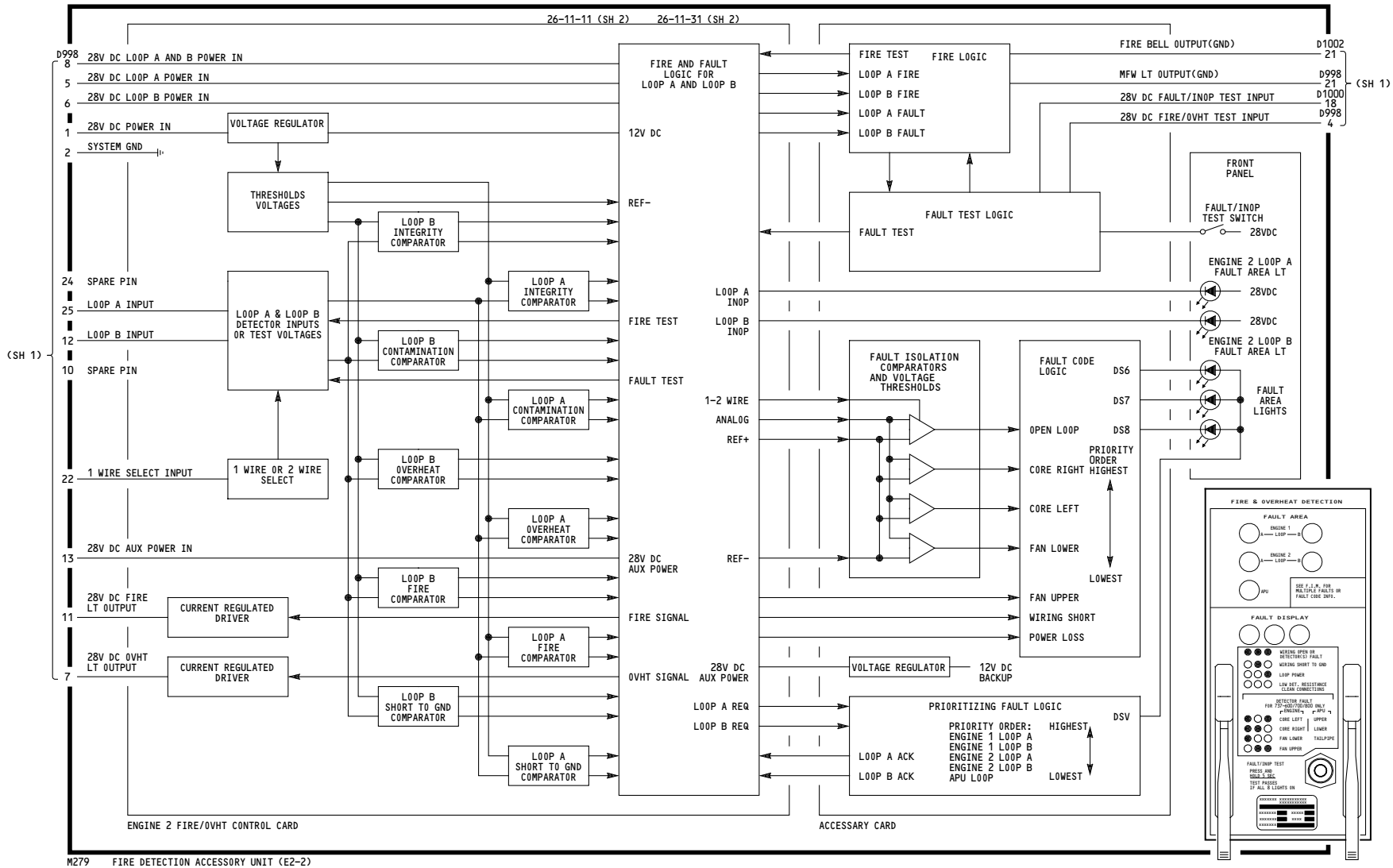

YC001-YC007

**ENGINE NO.2  
FIRE DETECTION**

D280A203

**26-11-21**

Page 101.1  
Sheet 2  
Aug 13/2008

WIRING DIAGRAMS  
26-11-21

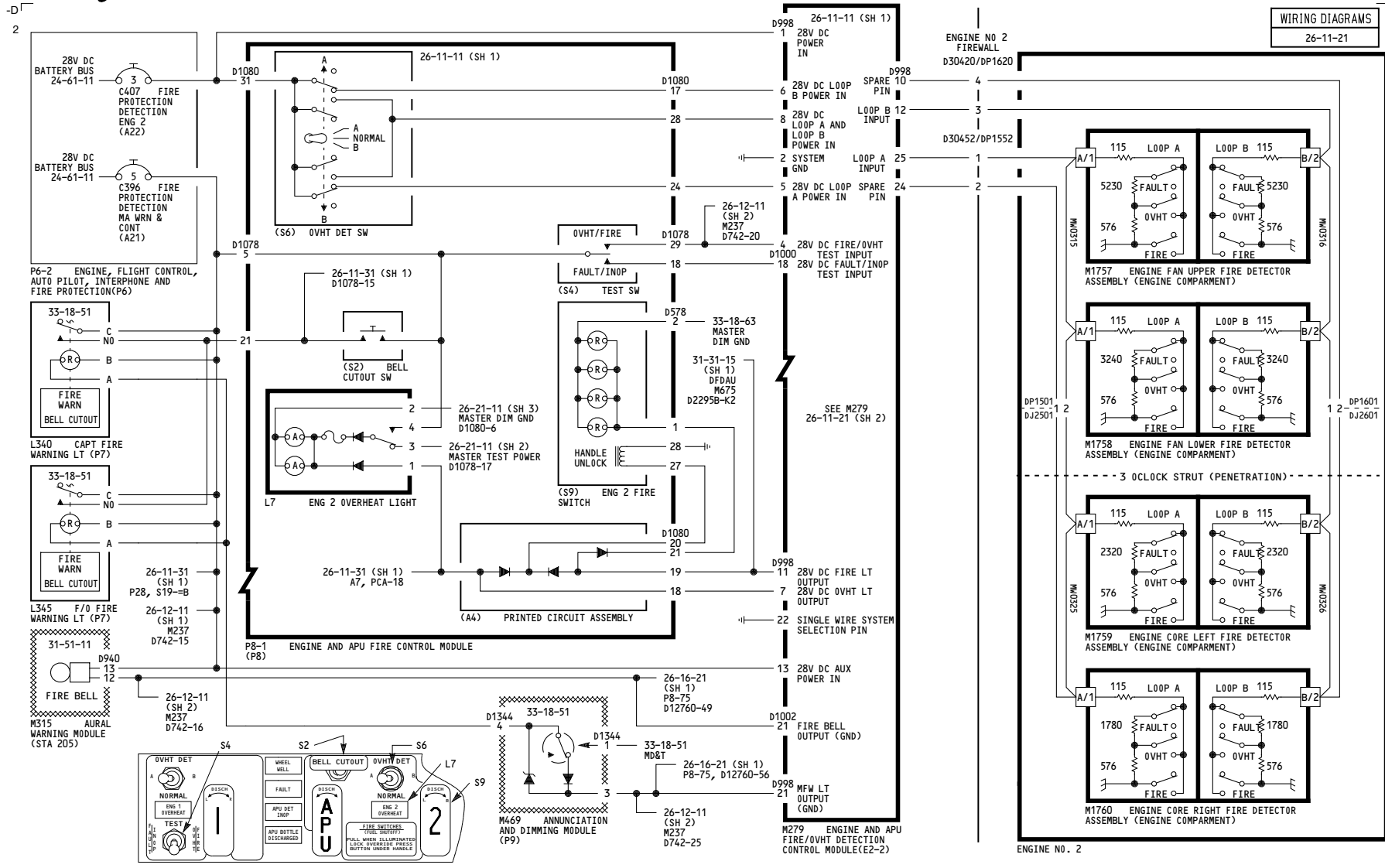

YC008-YM670

**ENGINE NO.2  
FIRE DETECTION**

D280A203

**26-11-21**

1

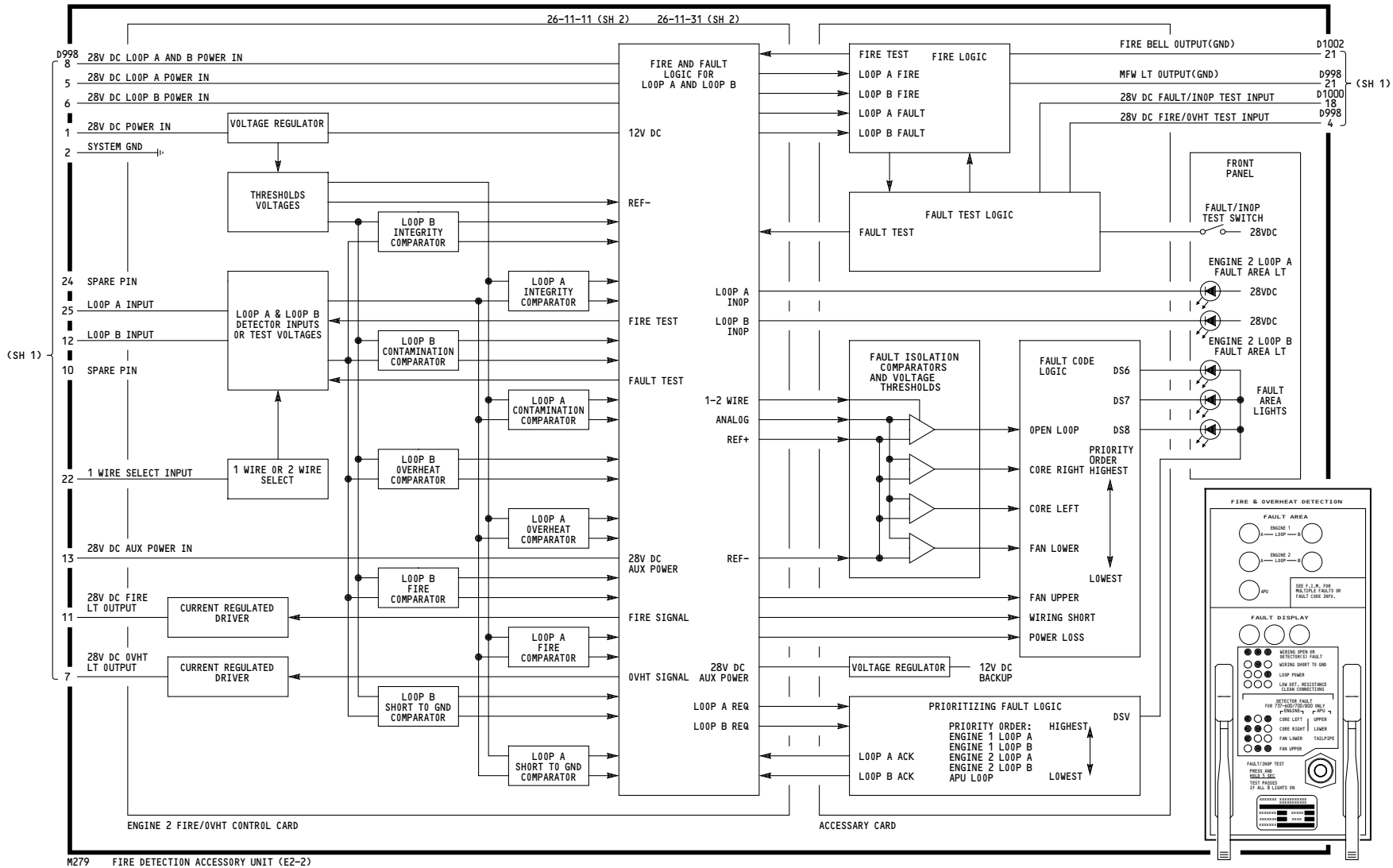

YC008-YM670

**ENGINE NO.2  
FIRE DETECTION**

D280A203

**26-11-21**



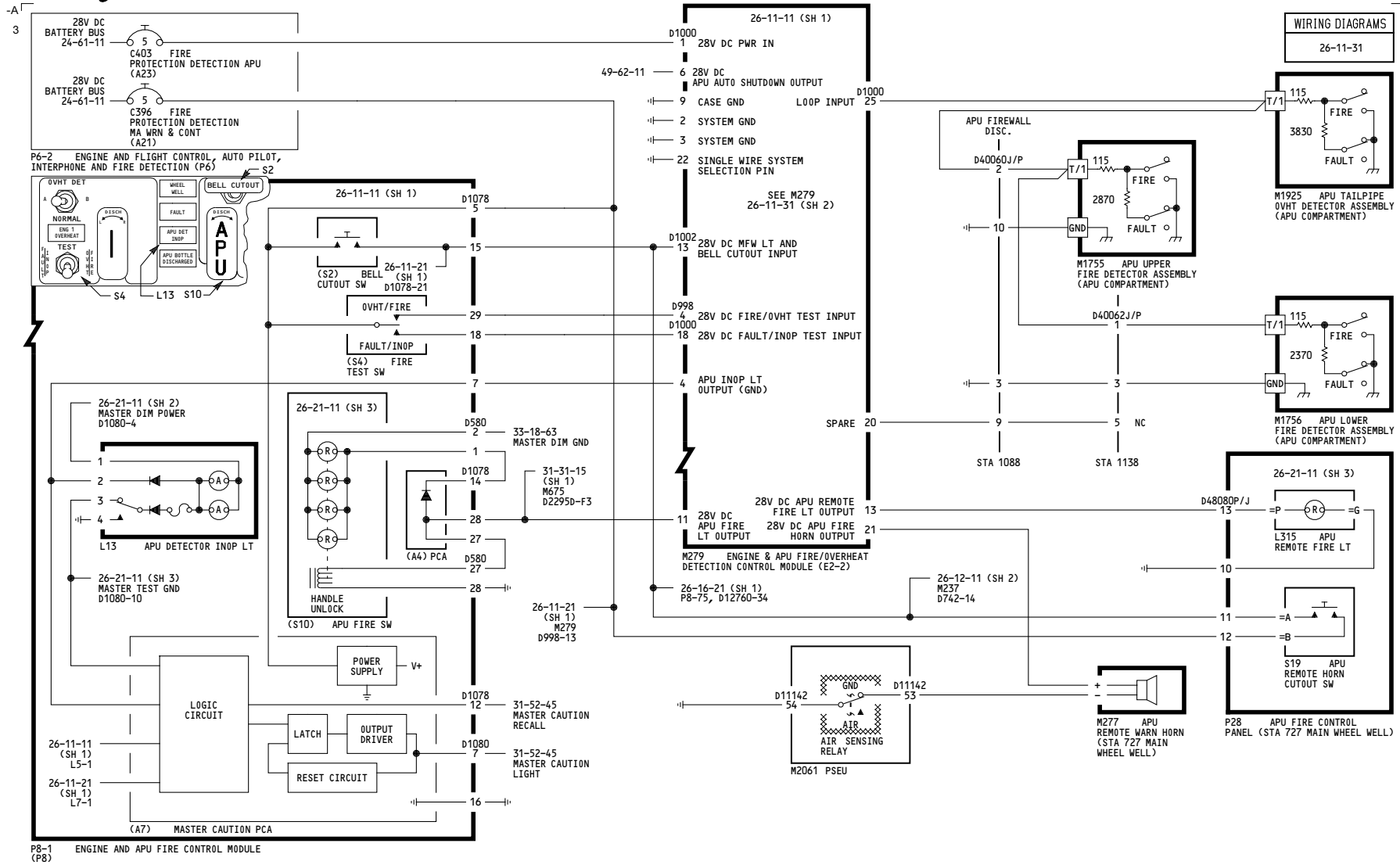

YC001-YC007

**APU  
FIRE DETECTION**

Incorporates  
26A1083 R01

D280A203

**26-11-31**

Page 101.1  
Sheet 1  
Aug 13/2008

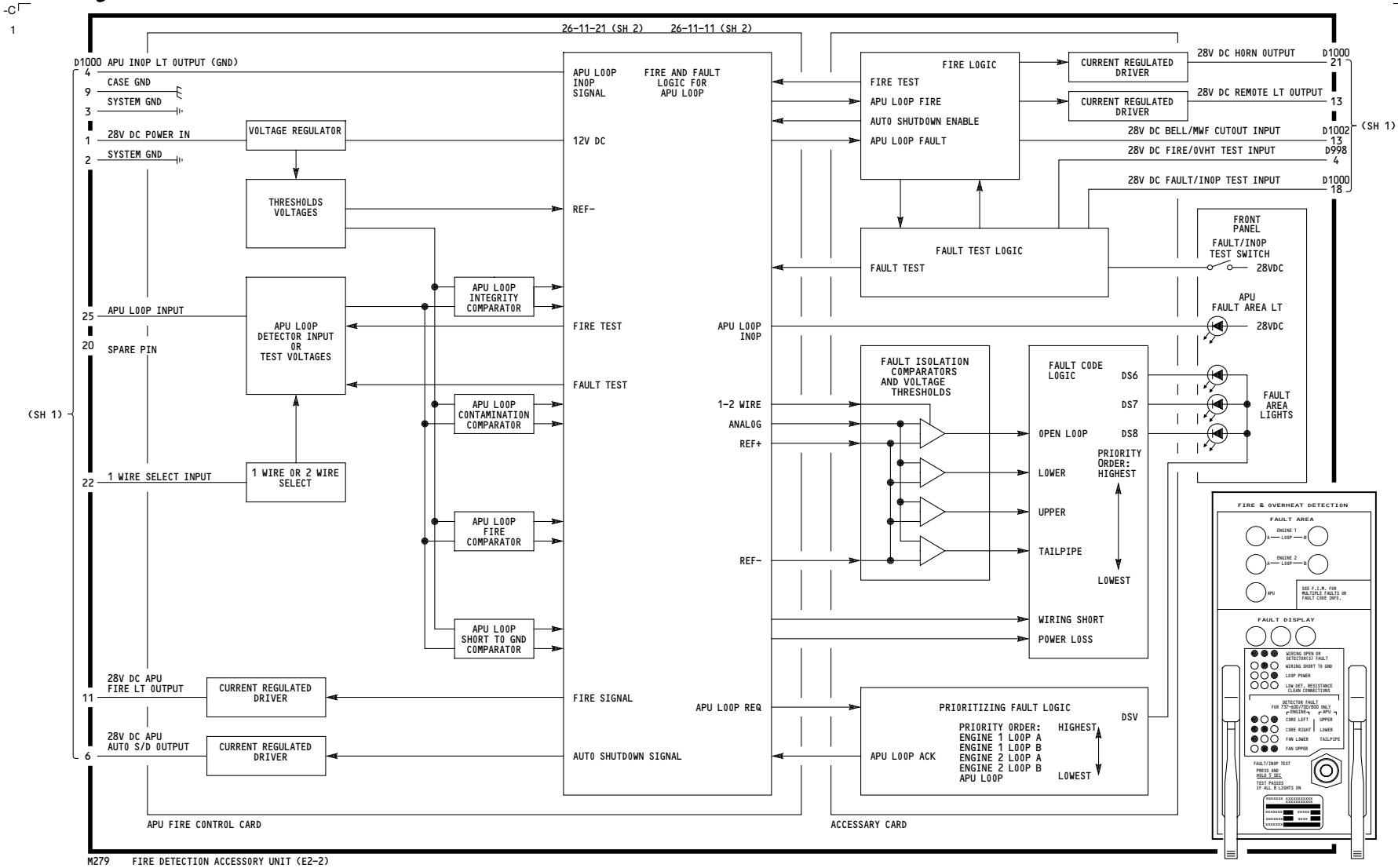

M279 FIRE DETECTION ACCESSORY UNIT (E2-2)

<p>YC001-YC007</p>	<p><b>APU FIRE DETECTION</b></p> <p>D280A203</p>
--------------------	--

**26-11-31**

Page 101.1  
Sheet 2  
Aug 13/2008

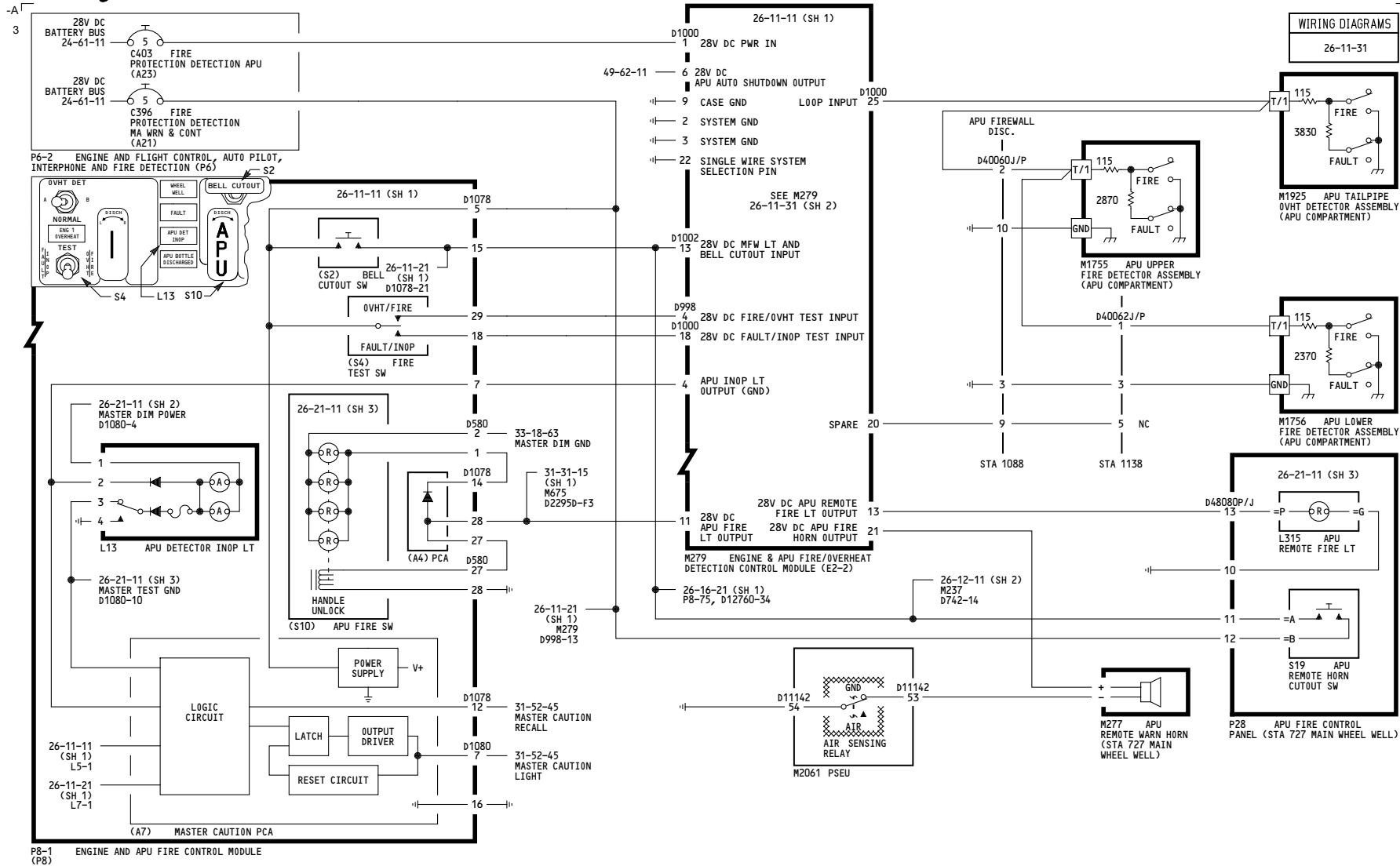

YC008-YM670

**APU FIRE DETECTION**

D280A203

**26-11-31**Page 102  
Sheet 1  
Feb 09/2009

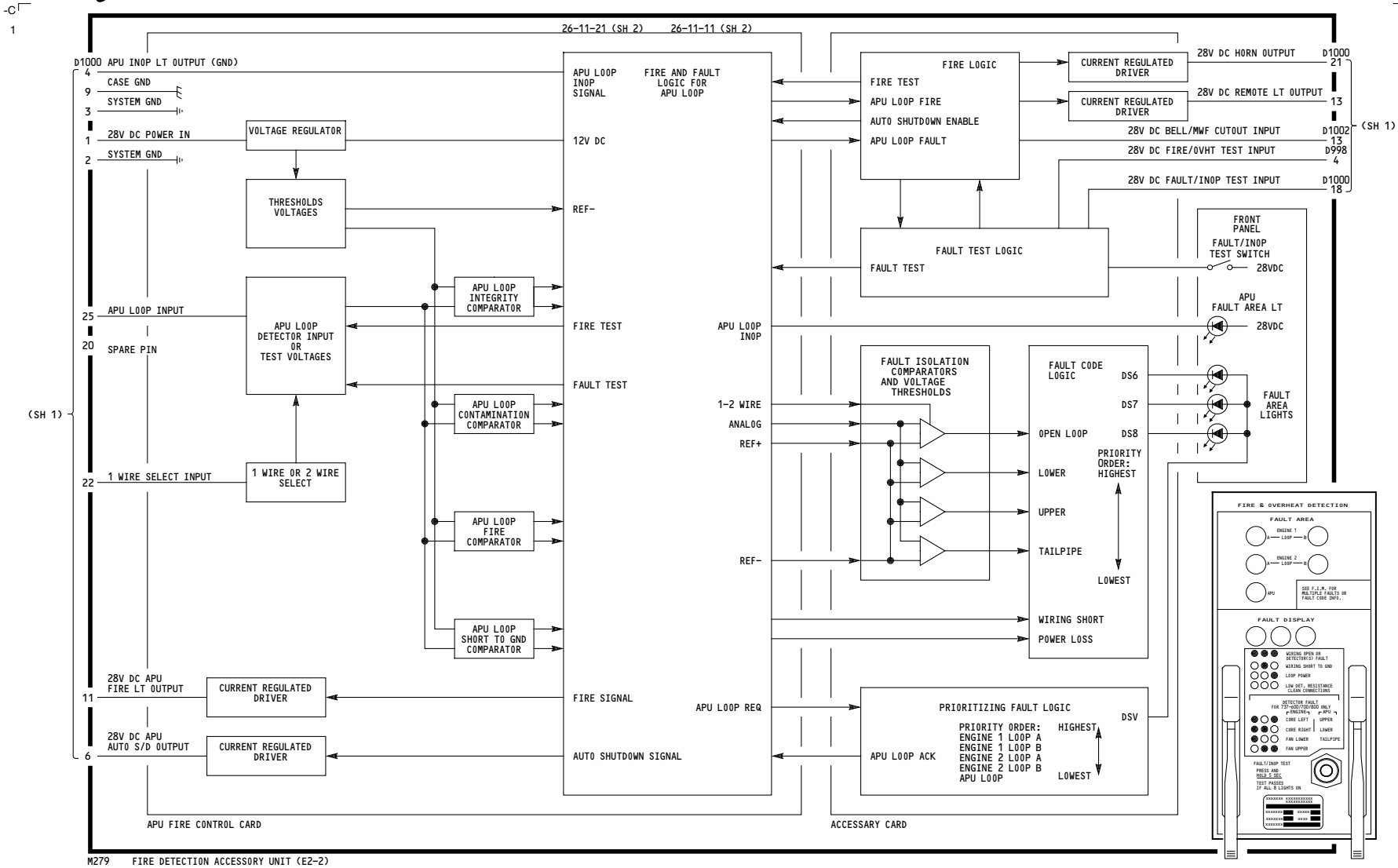

M279 FIRE DETECTION ACCESSORY UNIT (E2-2)

<p>YC008-YM670</p>	<p><b>APU FIRE DETECTION</b></p> <p>D280A203</p>
--------------------	--

**26-11-31**

WIRING DIAGRAMS  
26-12-11

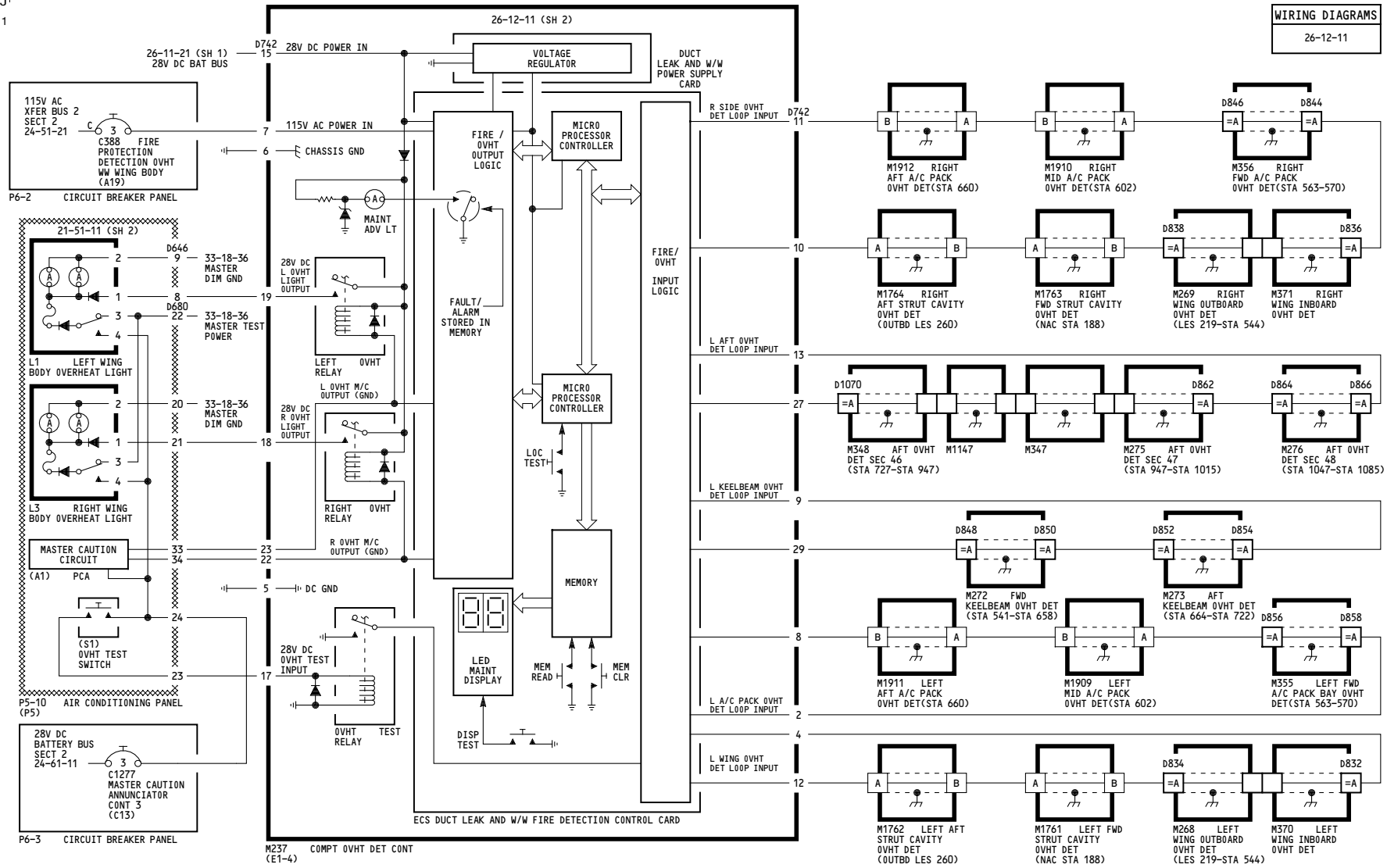

YC001-YC030

**WHEEL WELL, WING AND LOWER AFT BODY OVERHEAT DETECTION**

D280A203

**26-12-11**

Page 101  
Sheet 1  
Jul 17/2007

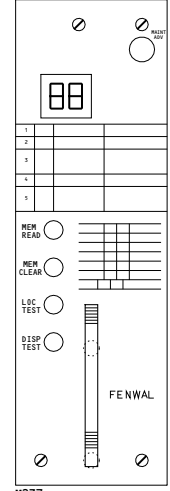
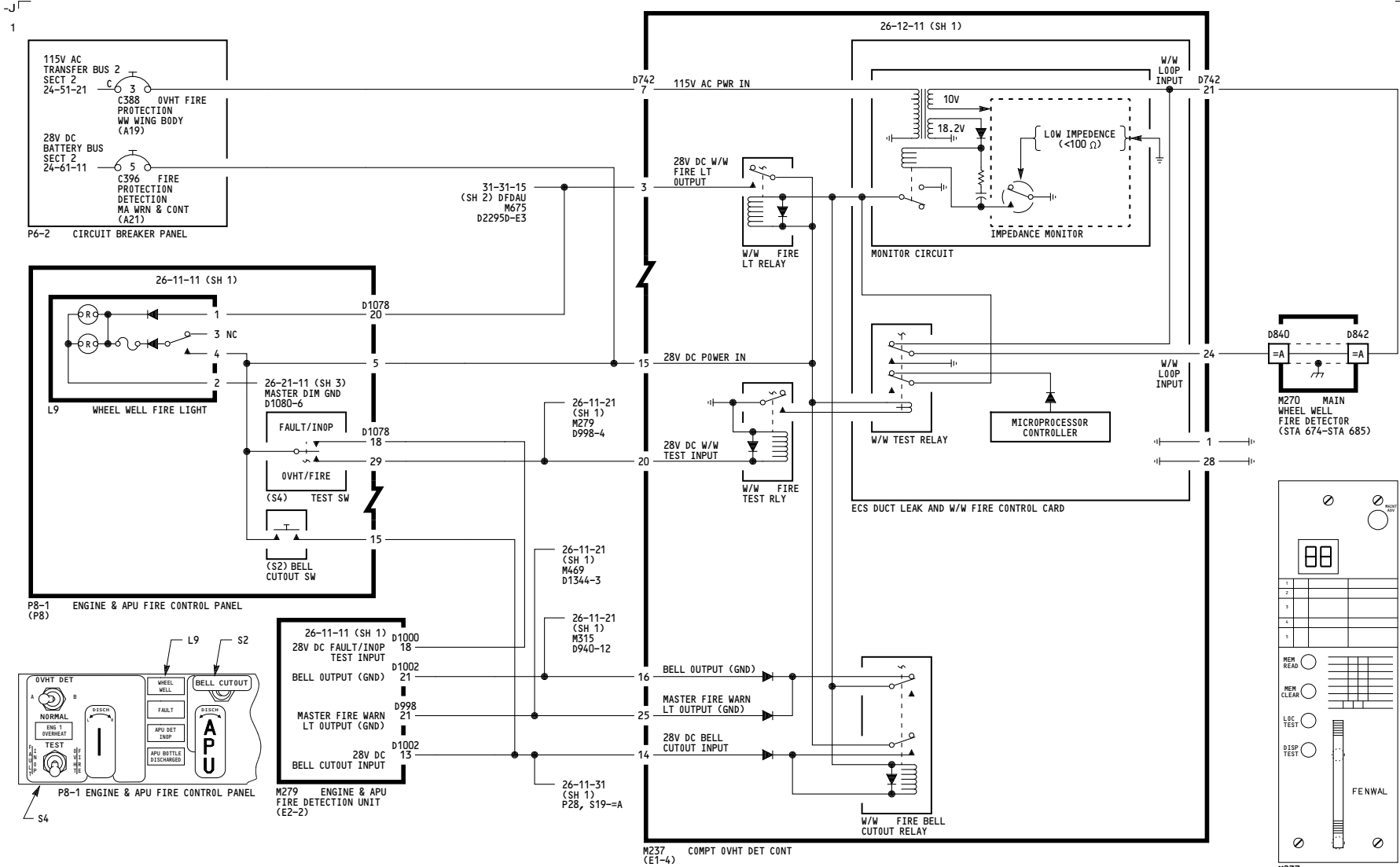

YC001-YC030

**WHEEL WELL, WING AND LOWER AFT BODY OVERHEAT DETECTION**

D280A203

**26-12-11**

WIRING DIAGRAMS  
26-12-11

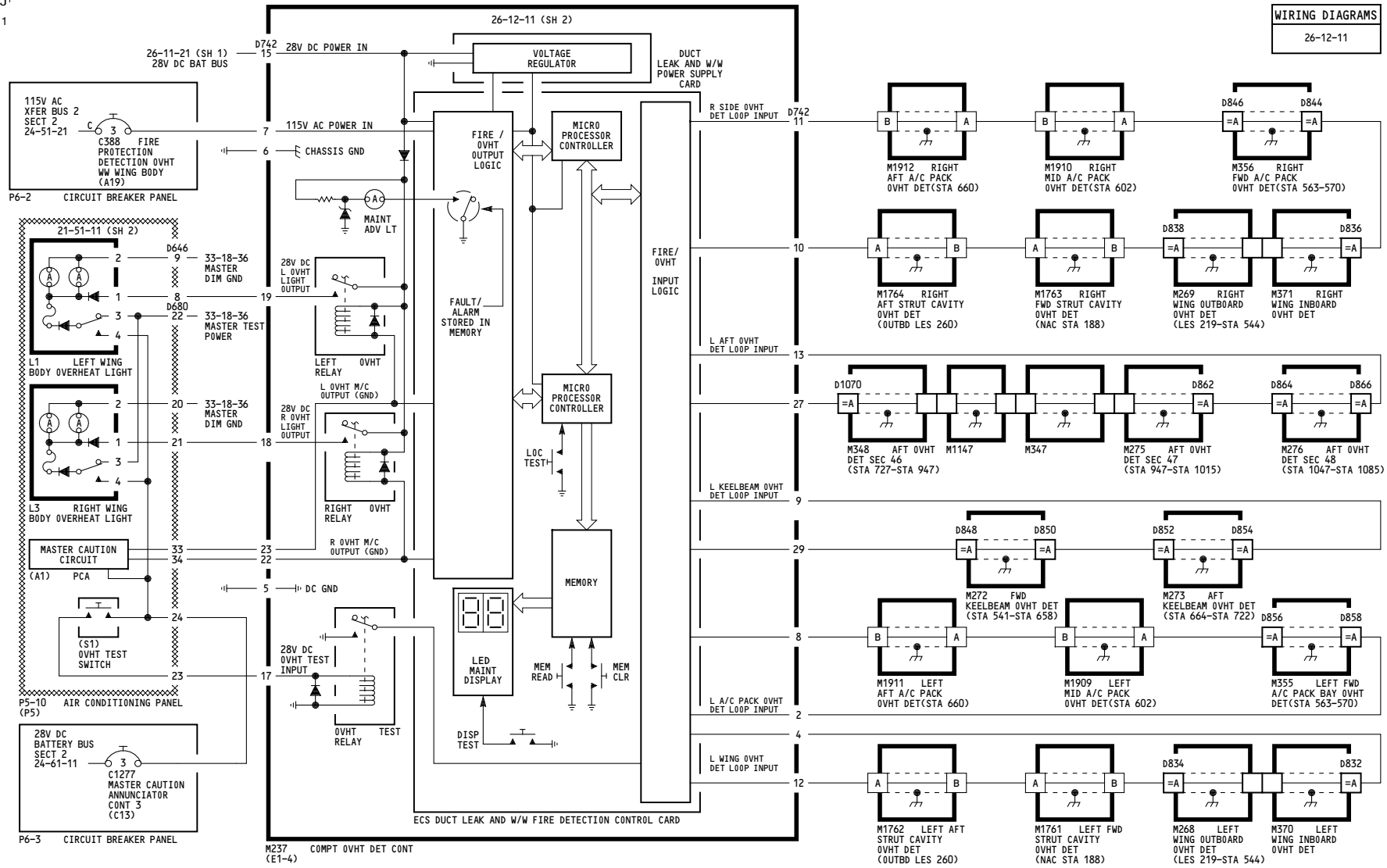

YC031-YM670

**WHEEL WELL, WING AND LOWER AFT BODY OVERHEAT DETECTION**

D280A203

**26-12-11**

-A-  
2

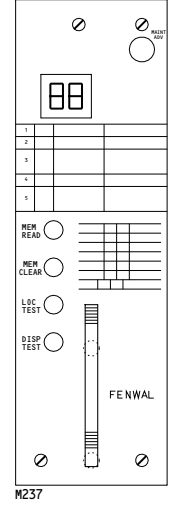
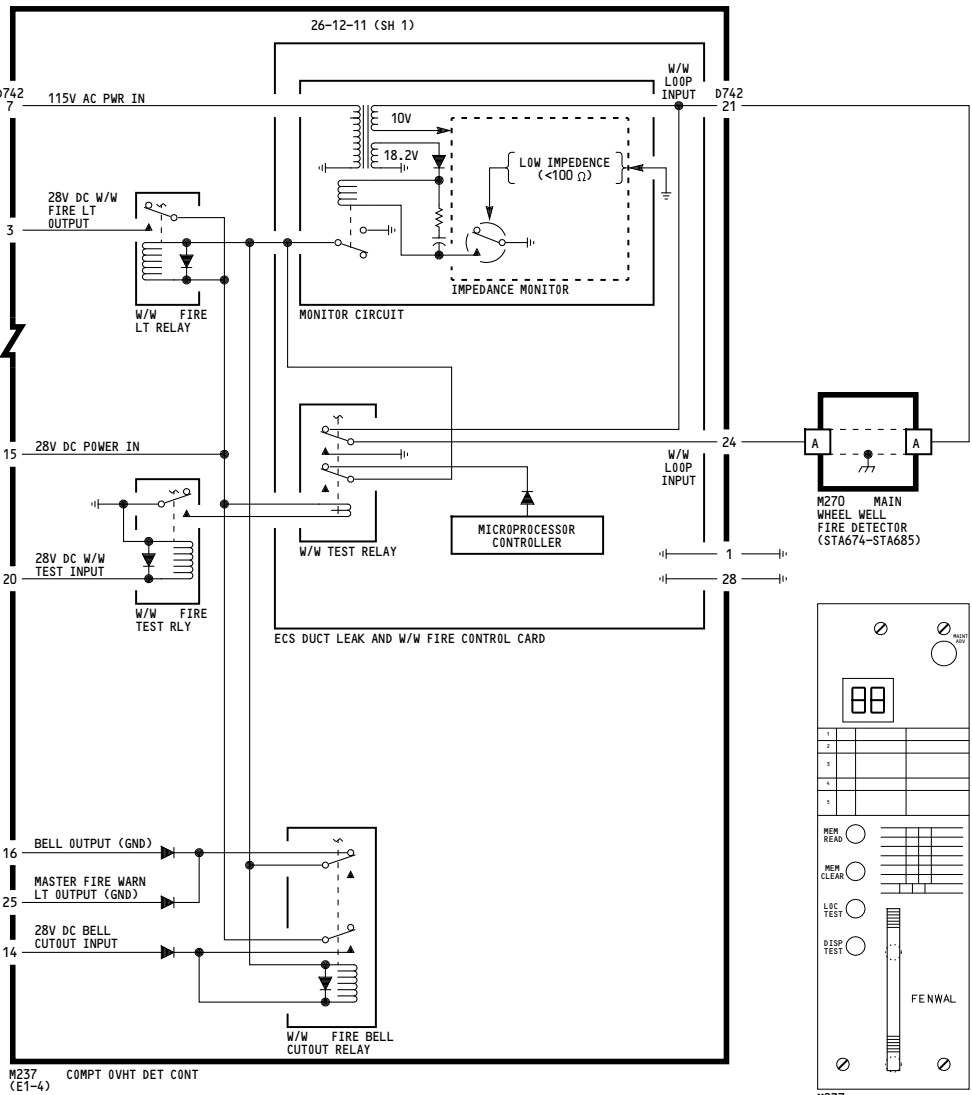
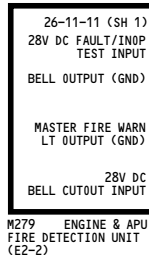
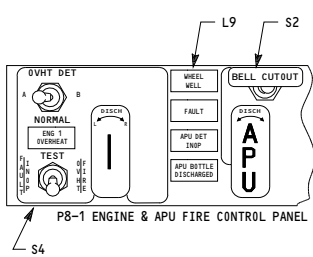
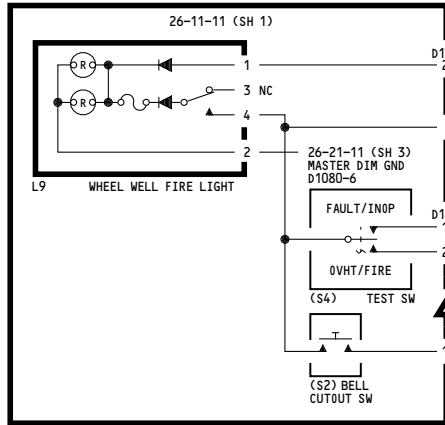
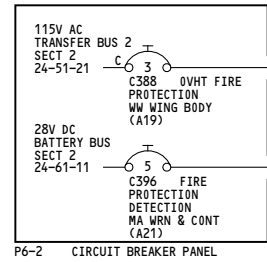

YC031-YM670

**WHEEL WELL, WING AND LOWER AFT BODY OVERHEAT DETECTION**

D280A203

**26-12-11**



WIRING DIAGRAMS  
26-14-11

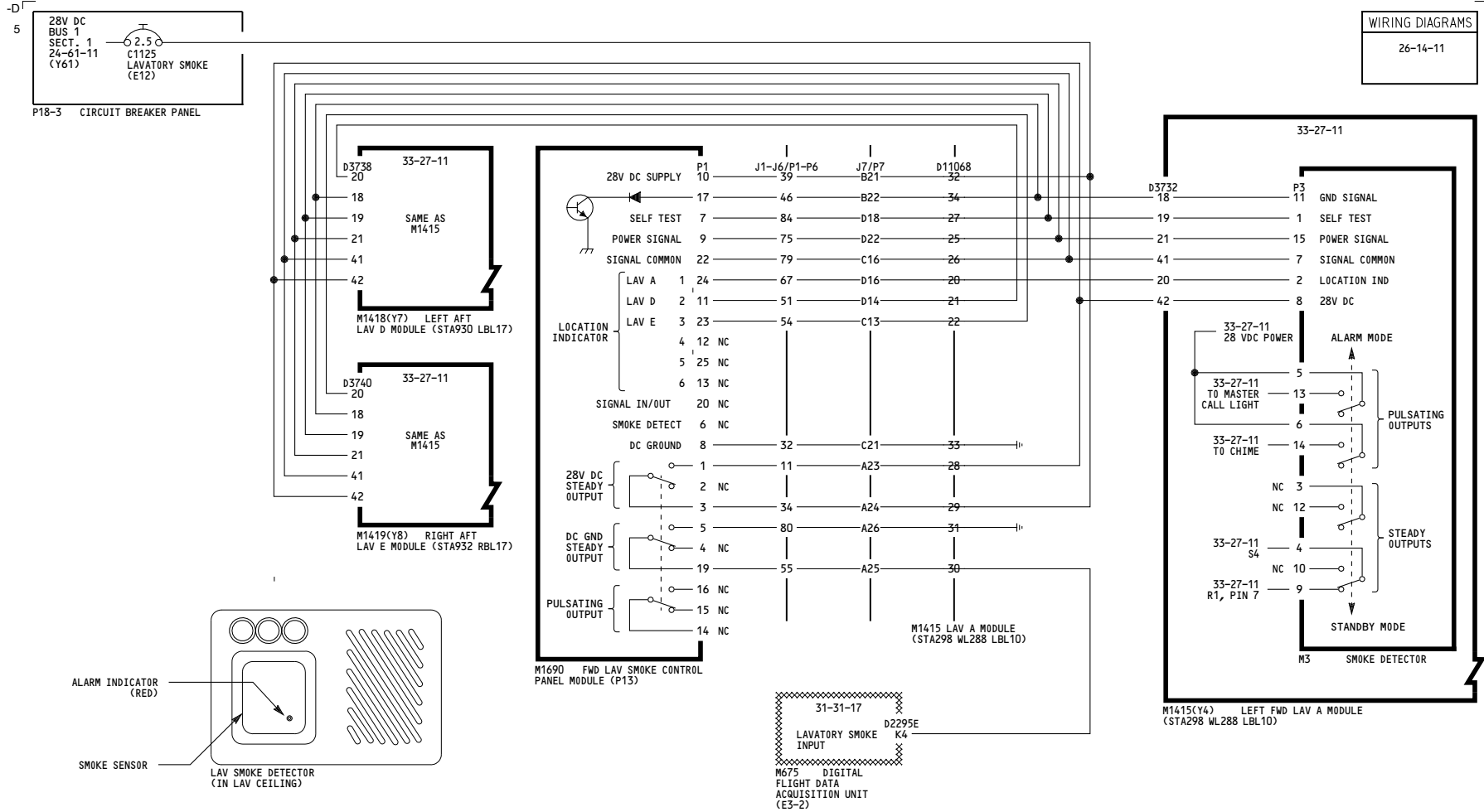

ALL	LAVATORY SMOKE DETECTORS
	D280A203

THIS PAGE INTENTIONALLY LEFT BLANK

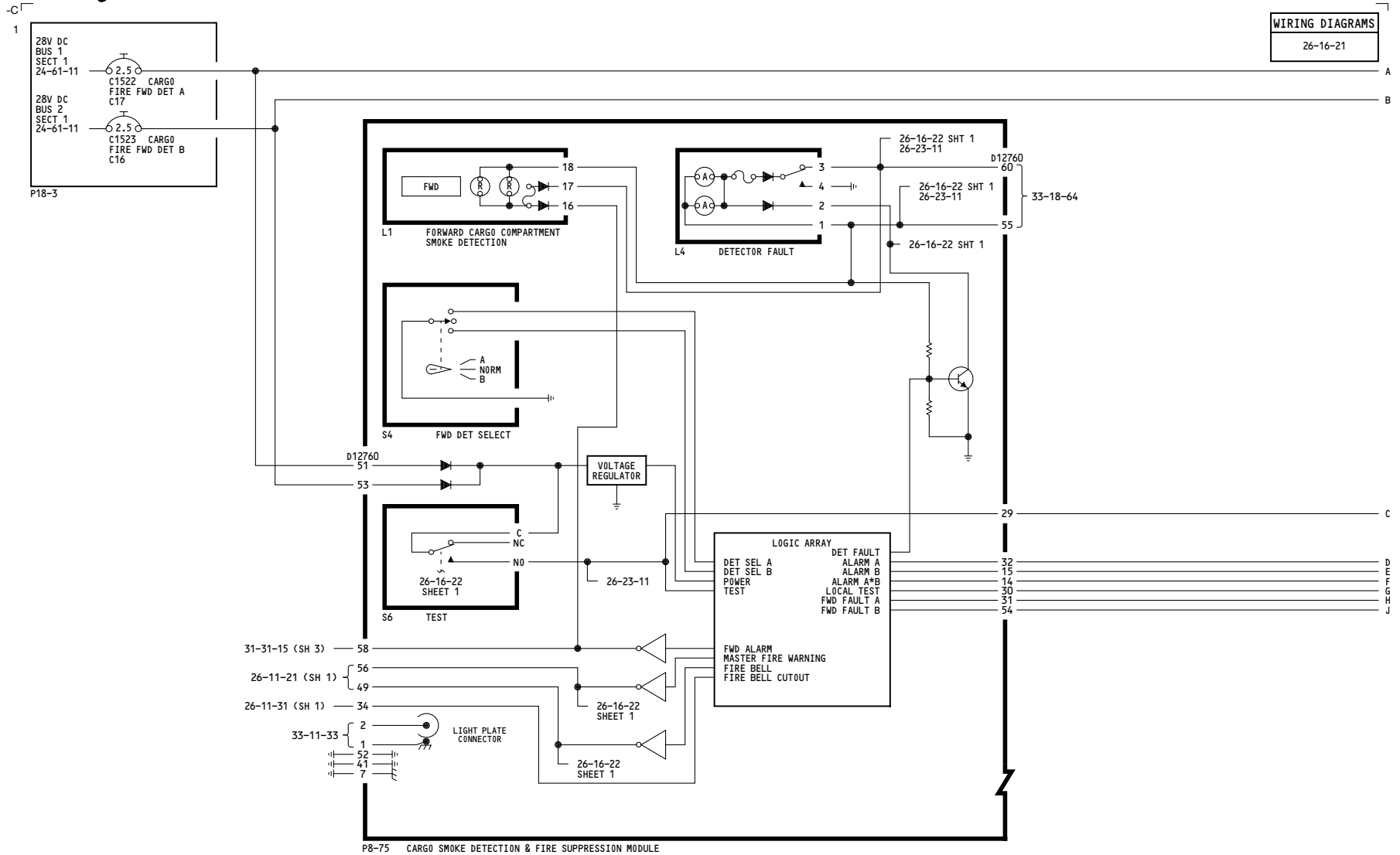

YC001-YC007

**FORWARD CARGO COMPARTMENT SMOKE DETECTION**

D280A203

Incorporates  
26A1083 R01

**26-16-21**

Page 101.1  
Sheet 1  
Aug 13/2008

**WIRING DIAGRAMS**  
26-16-21

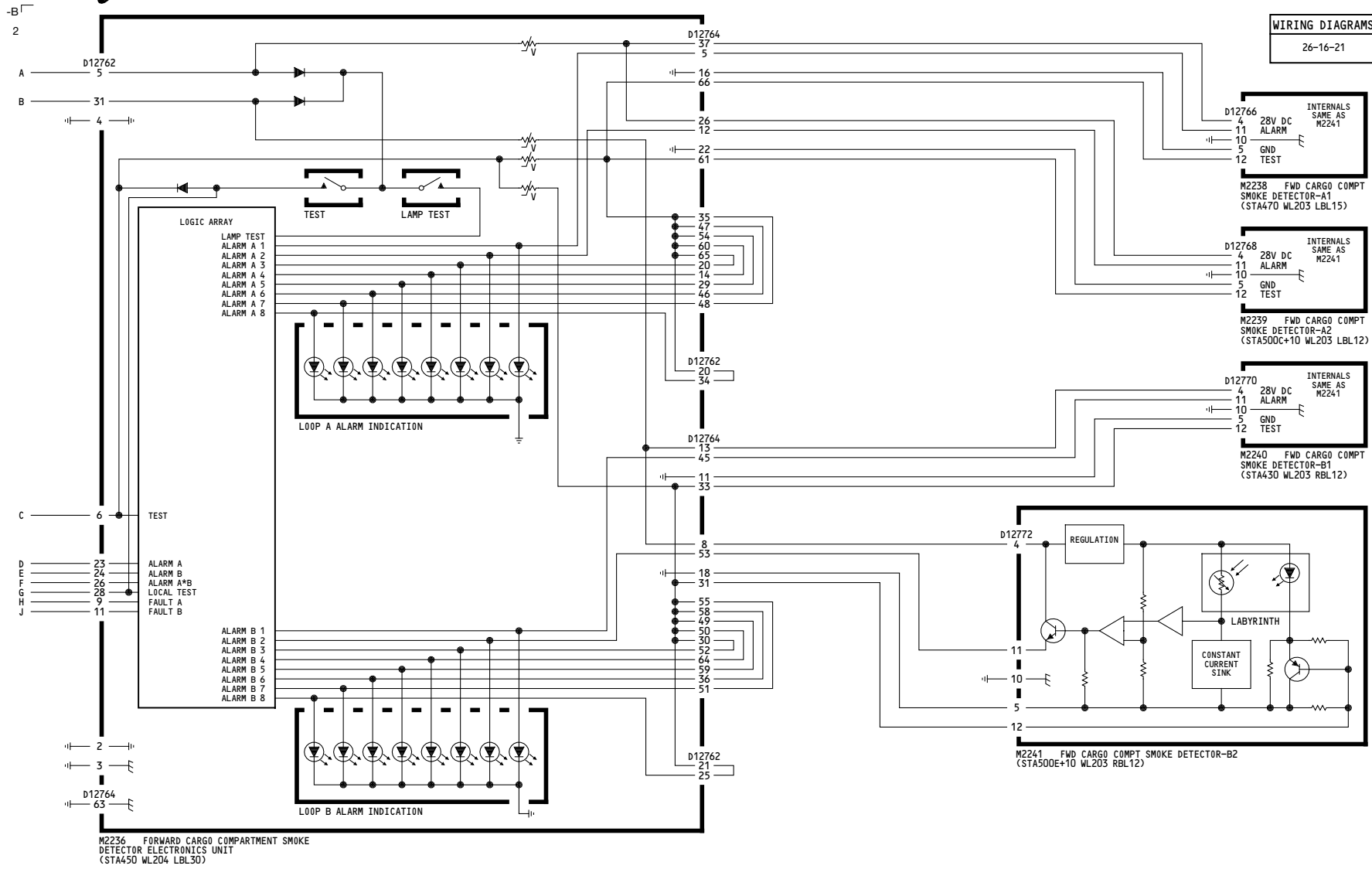

YC001-YC007

**FORWARD CARGO COMPARTMENT SMOKE DETECTION**

D280A203

Incorporates  
26A1083 R01

**26-16-21**

Page 101.1  
Sheet 2  
Aug 13/2008

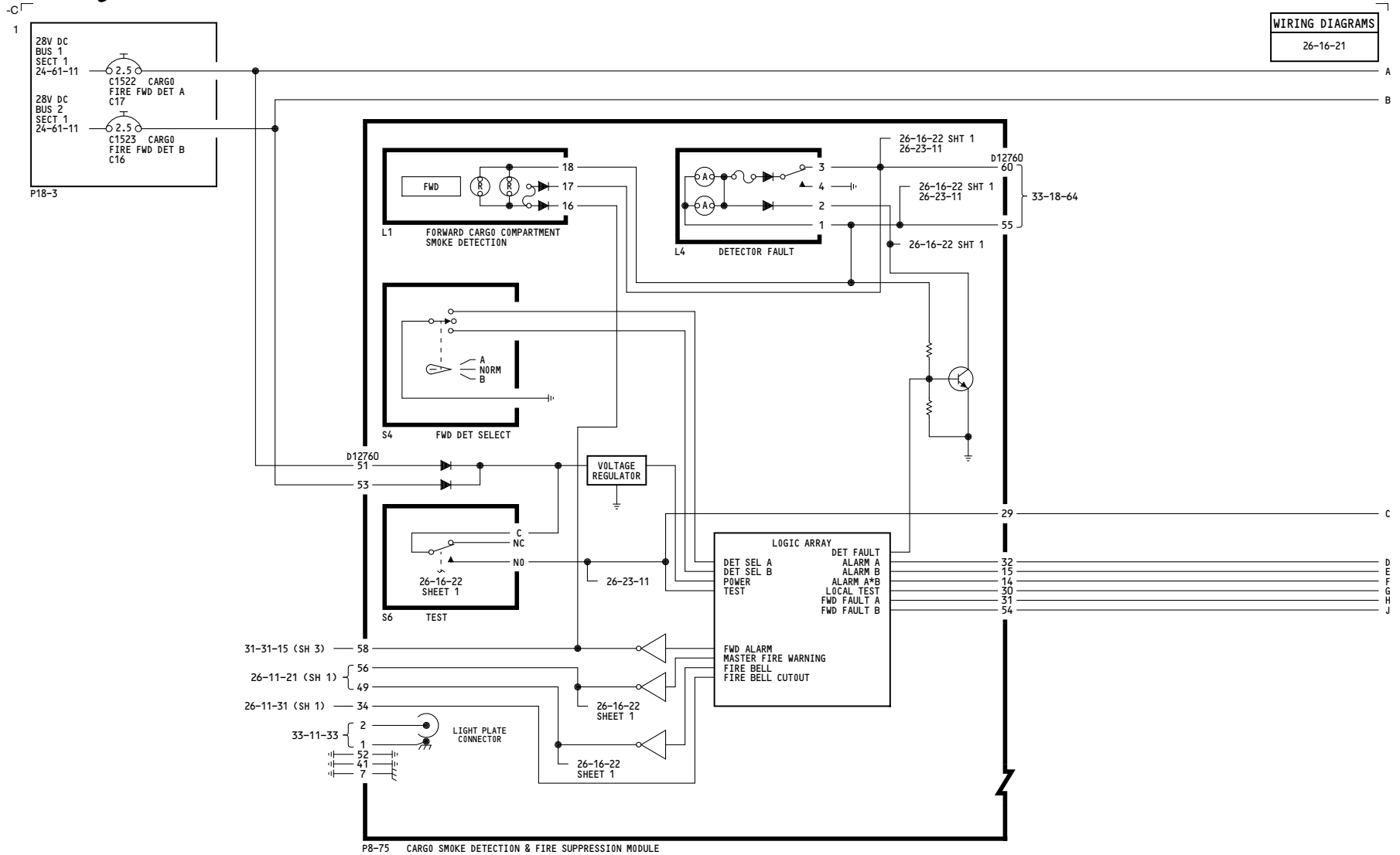

YC008-YC026

**FORWARD CARGO COMPARTMENT SMOKE DETECTION**

D280A203

**26-16-21**

**WIRING DIAGRAMS**  
26-16-21

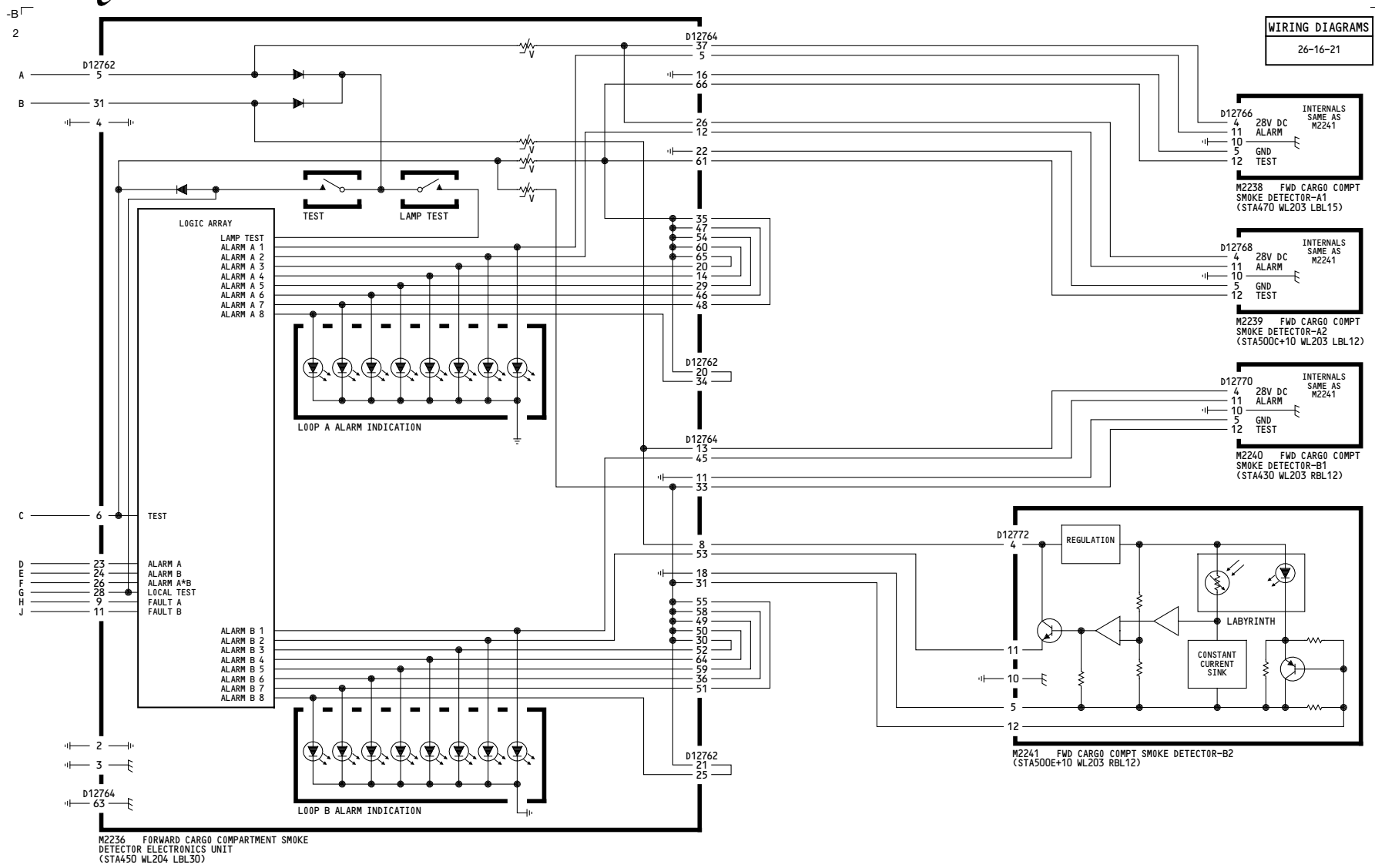

<p>YC008-YC026</p>	<p><b>FORWARD CARGO COMPARTMENT SMOKE DETECTION</b></p> <p>D280A203</p>
--------------------	---

**26-16-21**

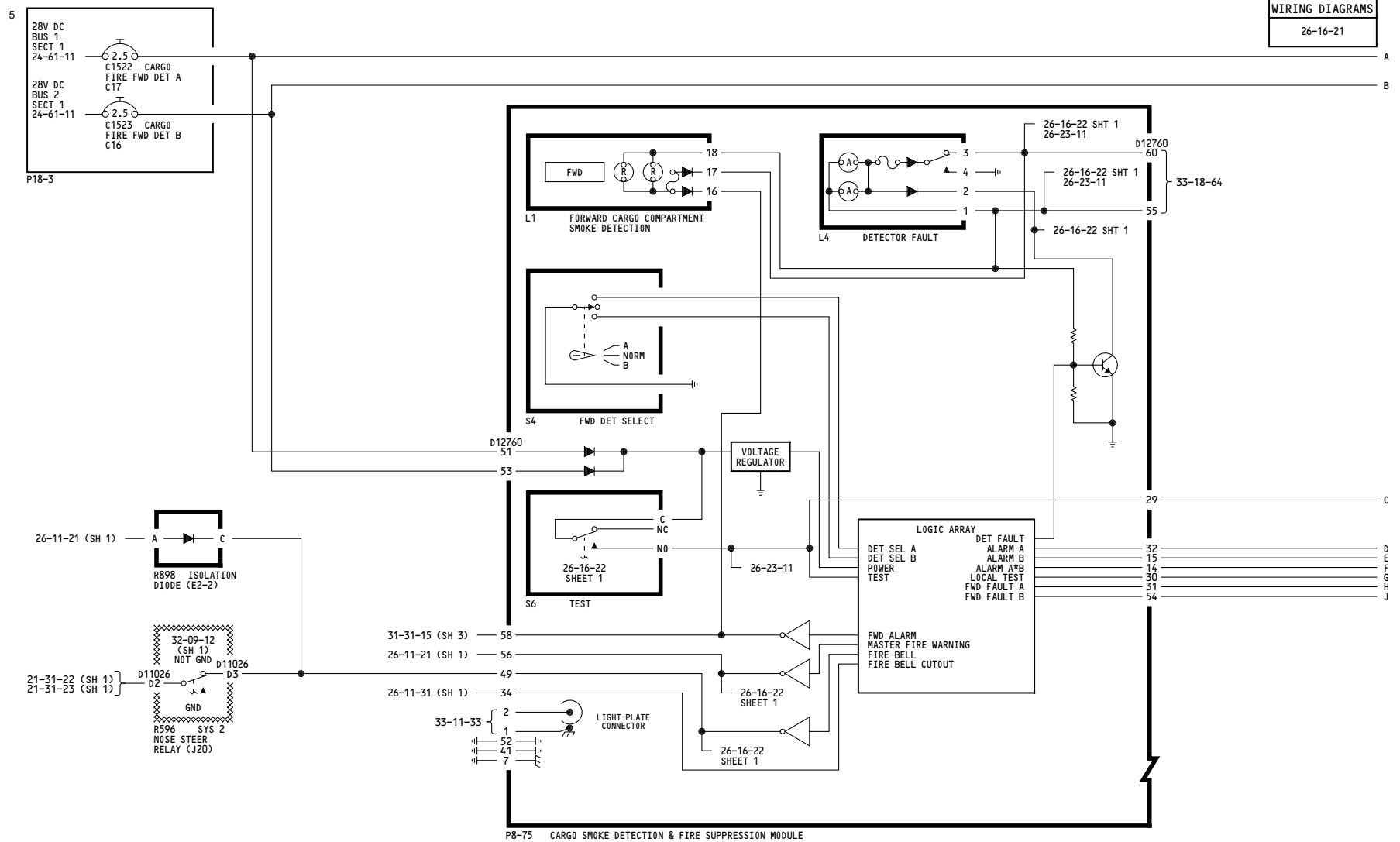

P8-75 CARGO SMOKE DETECTION & FIRE SUPPRESSION MODULE

YC028-YC030	<b>FORWARD CARGO COMPARTMENT SMOKE DETECTION</b>
	D280A203

**26-16-21**

**WIRING DIAGRAMS**  
26-16-21

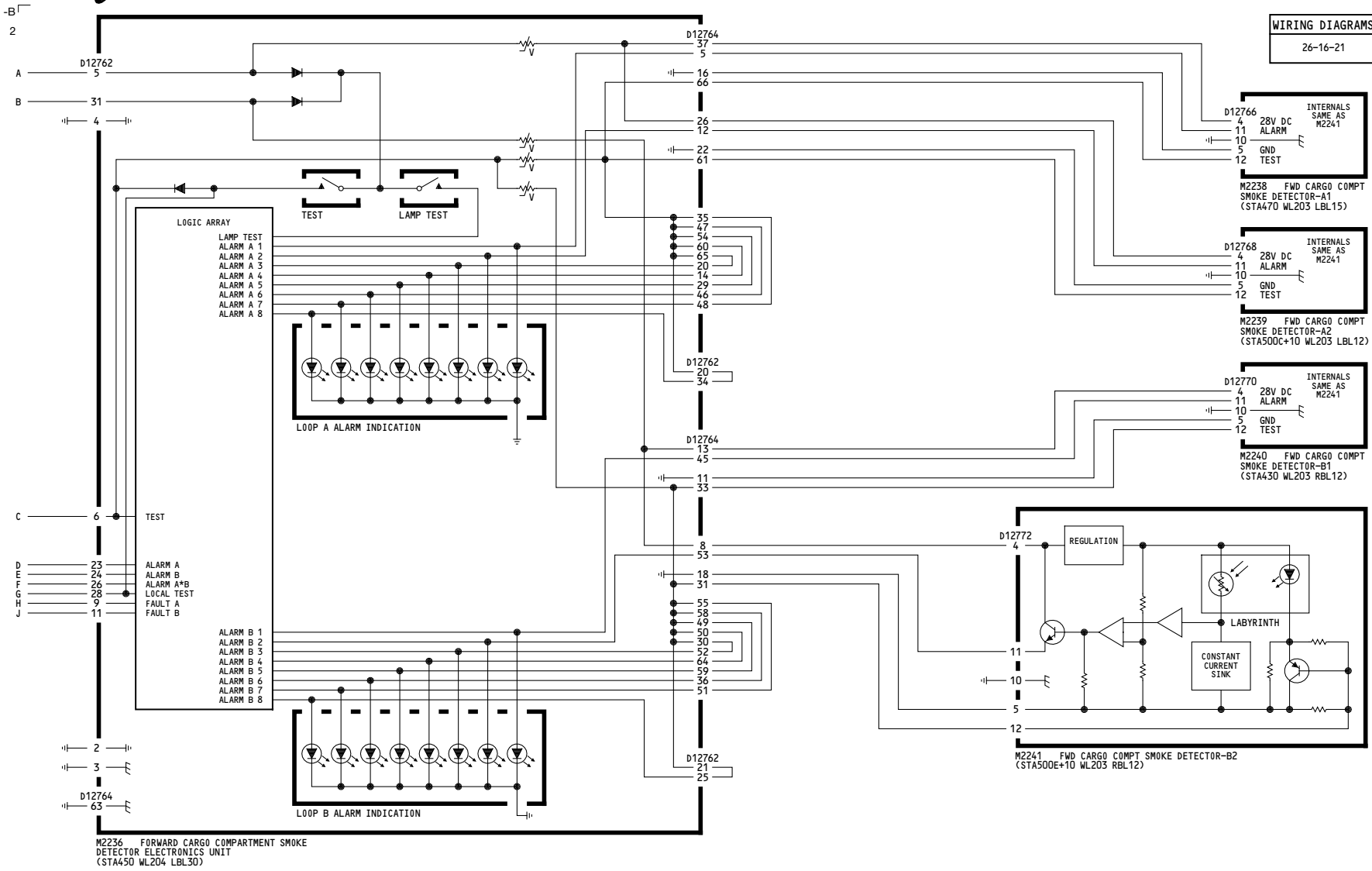

YC028-YC030

**FORWARD CARGO COMPARTMENT SMOKE DETECTION**

D280A203

**26-16-21**



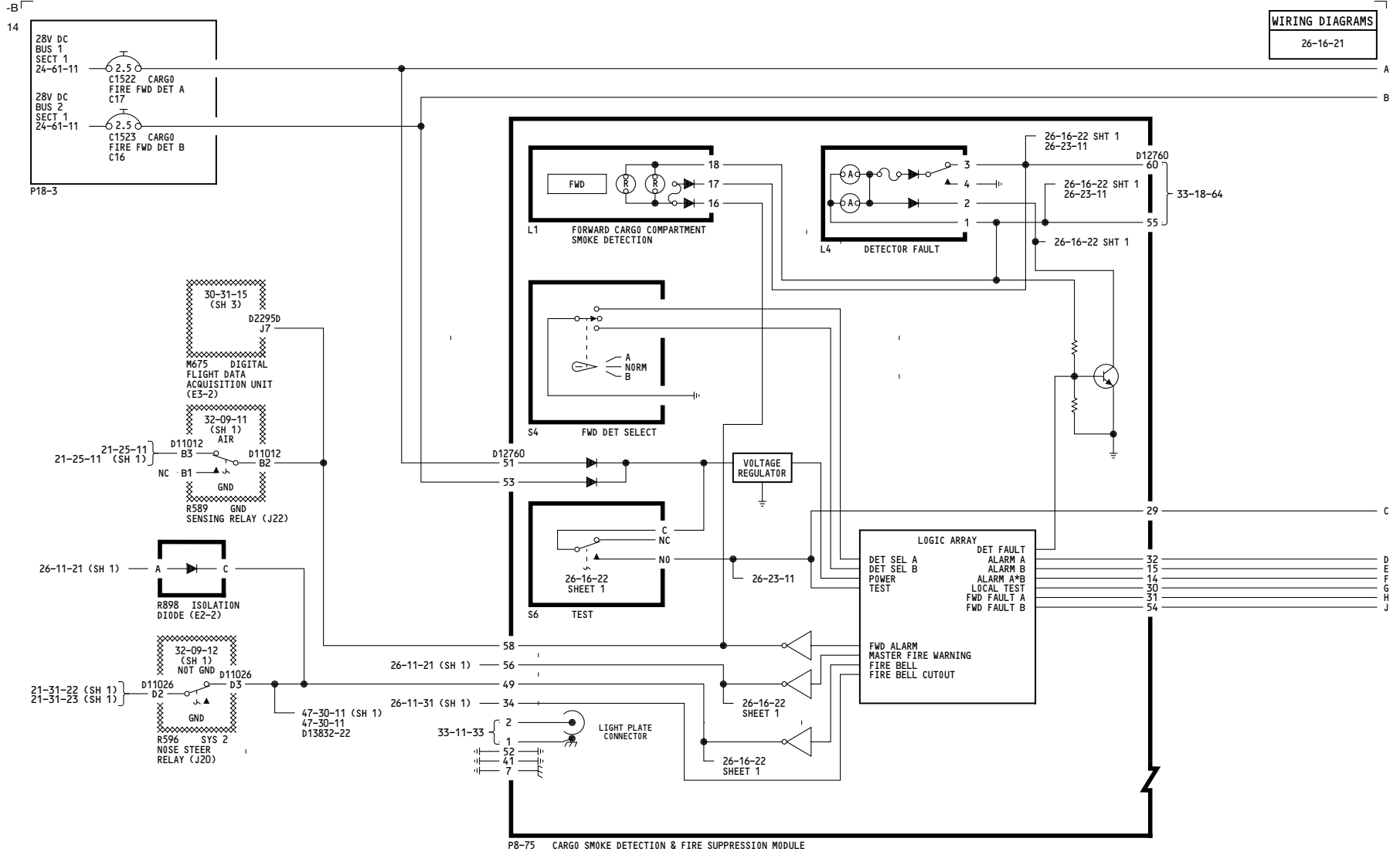

P8-75 CARGO SMOKE DETECTION & FIRE SUPPRESSION MODULE

YC031-YC050, YK906-YL430	<b>FORWARD CARGO COMPARTMENT SMOKE DETECTION</b>
	D280A203

**26-16-21**

**WIRING DIAGRAMS**  
26-16-21

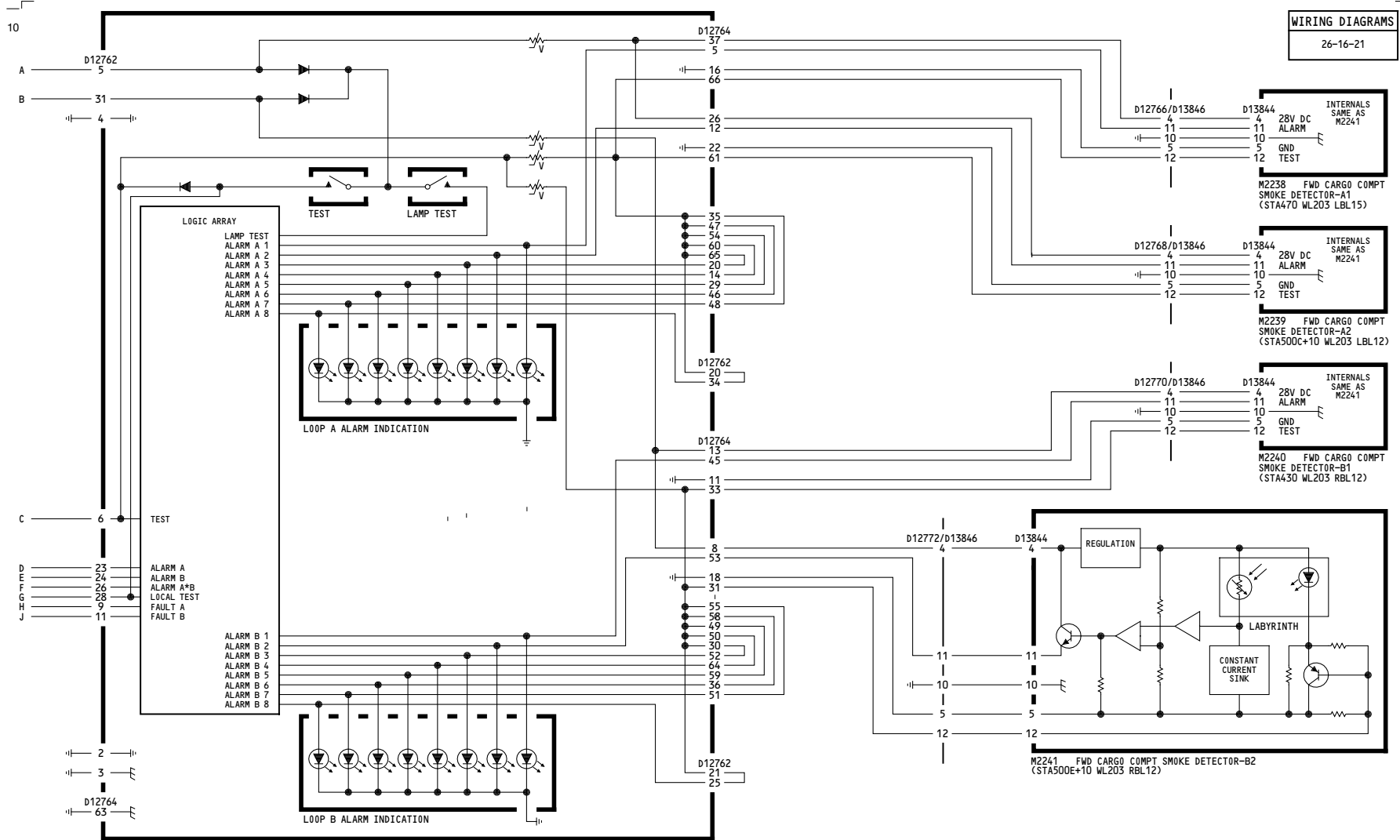

M2236 FORWARD CARGO COMPARTMENT SMOKE DETECTOR ELECTRONICS UNIT (STA450 WL204 LBL30)

YC031-YC050, YK906-YL430	<b>FORWARD CARGO COMPARTMENT SMOKE DETECTION</b>  D280A203
--------------------------	--

**26-16-21**

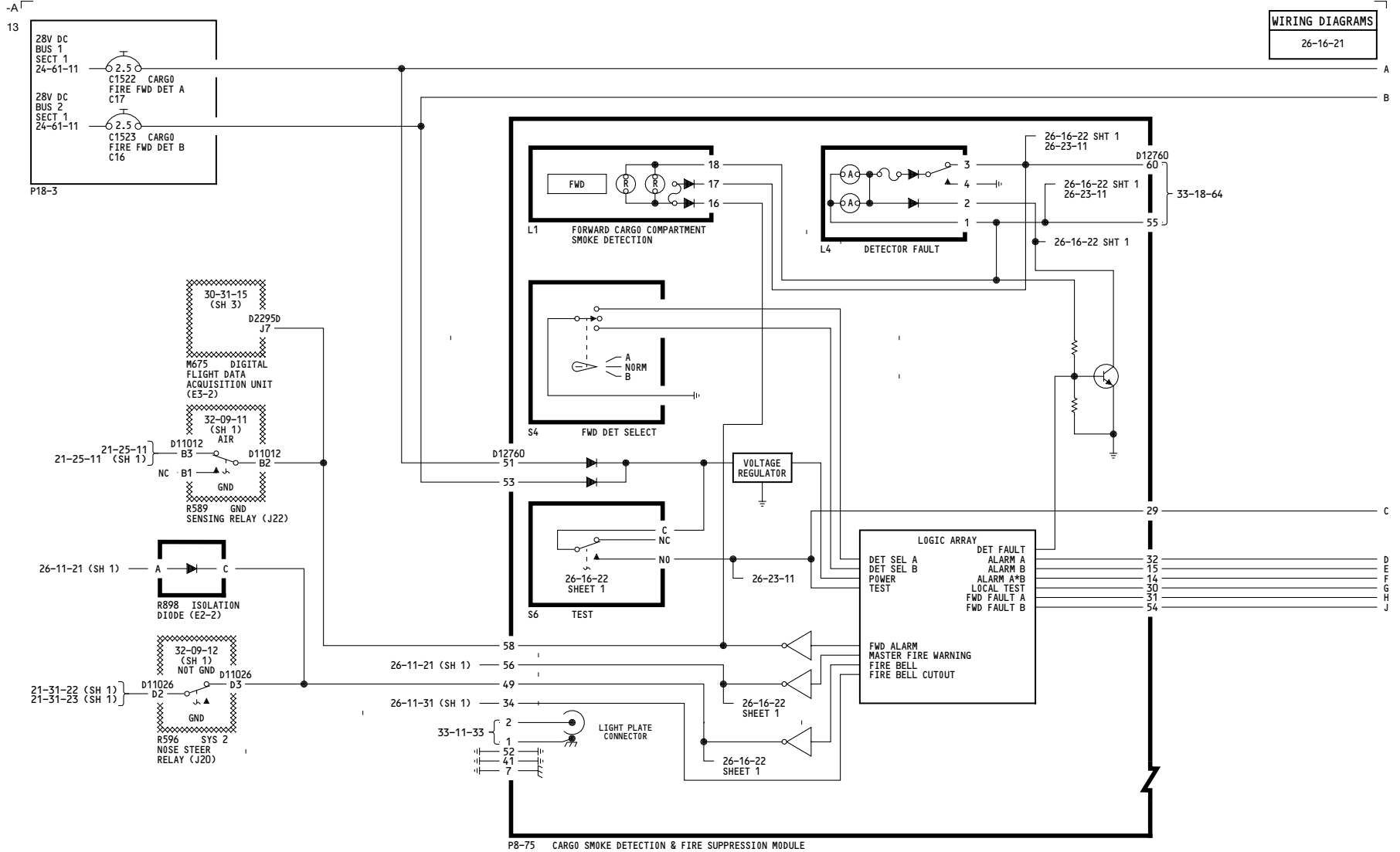

YK901-YK905	<b>FORWARD CARGO COMPARTMENT SMOKE DETECTION</b>
D280A203	

**26-16-21**

**WIRING DIAGRAMS**  
26-16-21

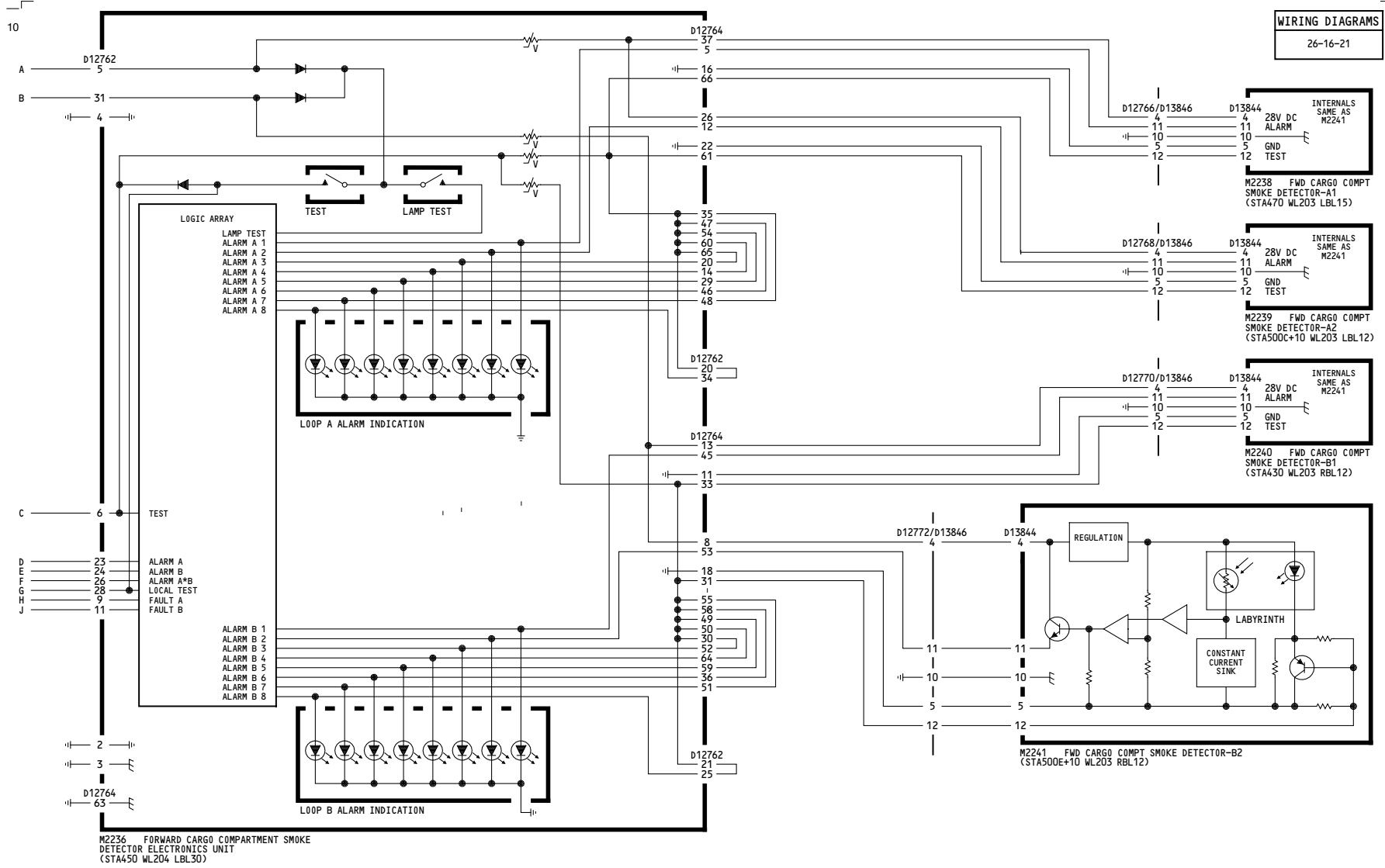

YK901-YK905	<b>FORWARD CARGO COMPARTMENT SMOKE DETECTION</b>  D280A203
-------------	--

**26-16-21**

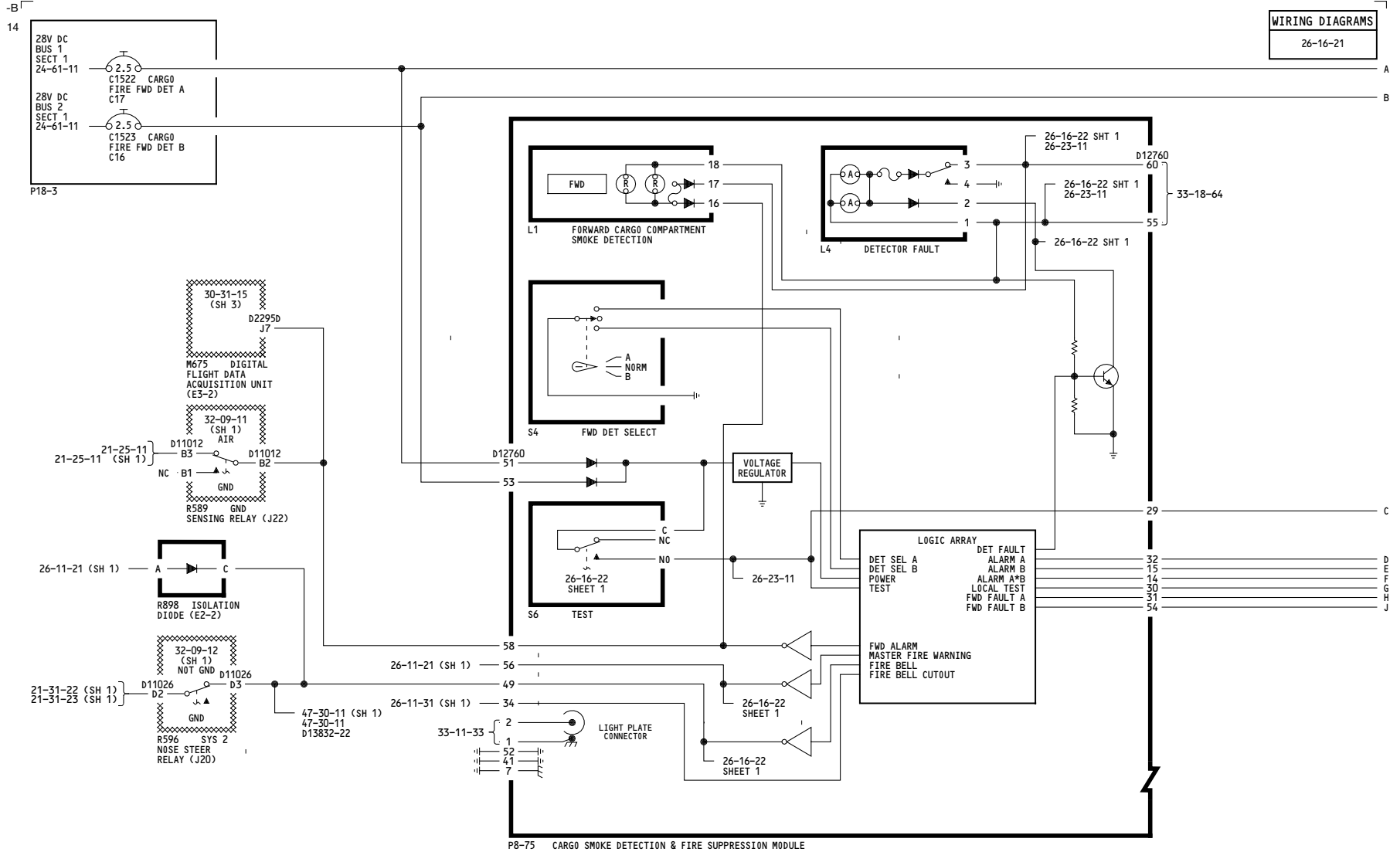

YM643-YM670	<b>FORWARD CARGO COMPARTMENT SMOKE DETECTION</b>  D280A203
-------------	--

**26-16-21**

Page 106  
Sheet 1  
Aug 13/2008

**WIRING DIAGRAMS**  
26-16-21

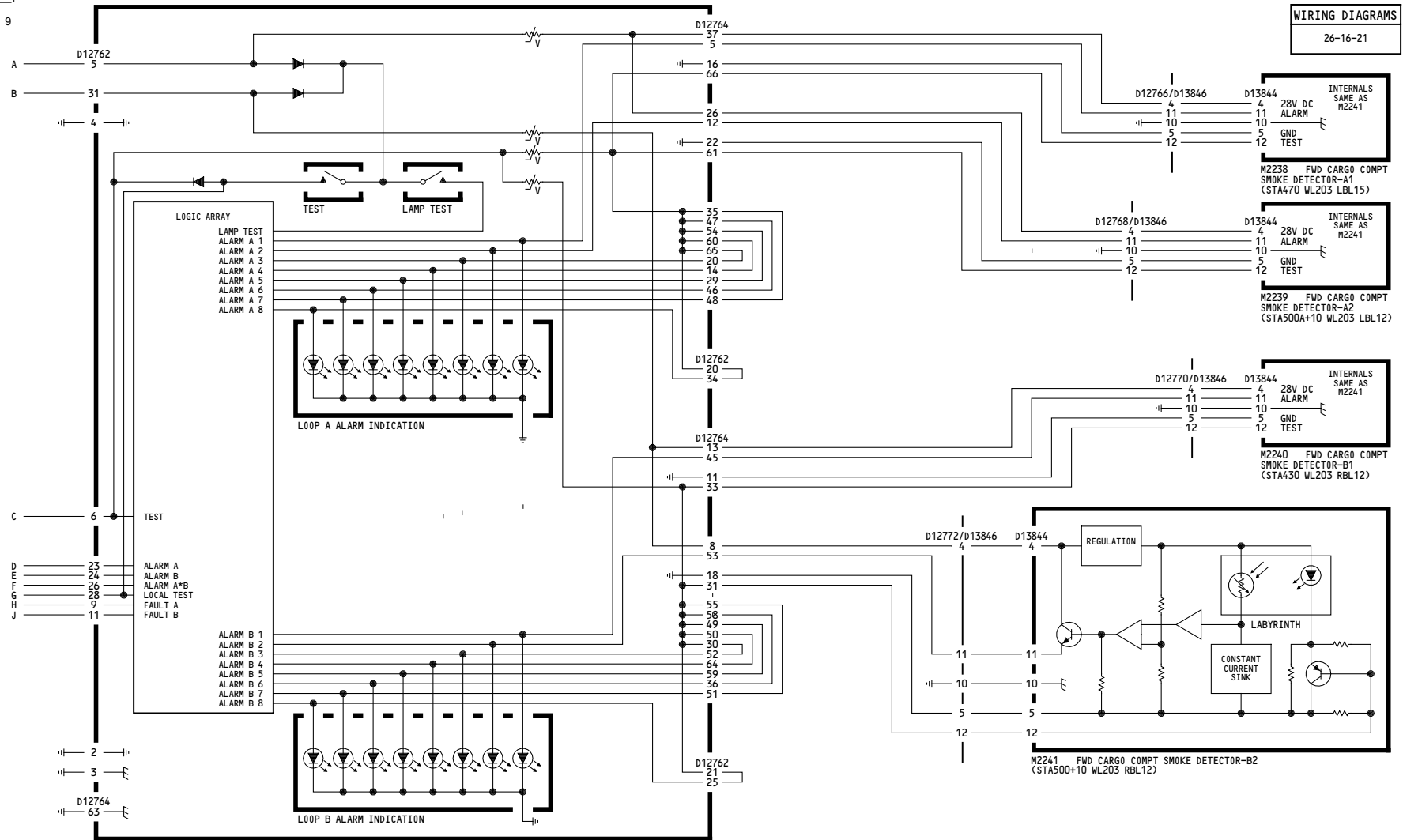

M2236 FORWARD CARGO COMPARTMENT SMOKE DETECTOR ELECTRONICS UNIT (STA450 WL204 LBL30)

<p>YM643-YM670</p>	<p><b>FORWARD CARGO COMPARTMENT SMOKE DETECTION</b></p> <p>D280A203</p>
--------------------	---

**26-16-21**

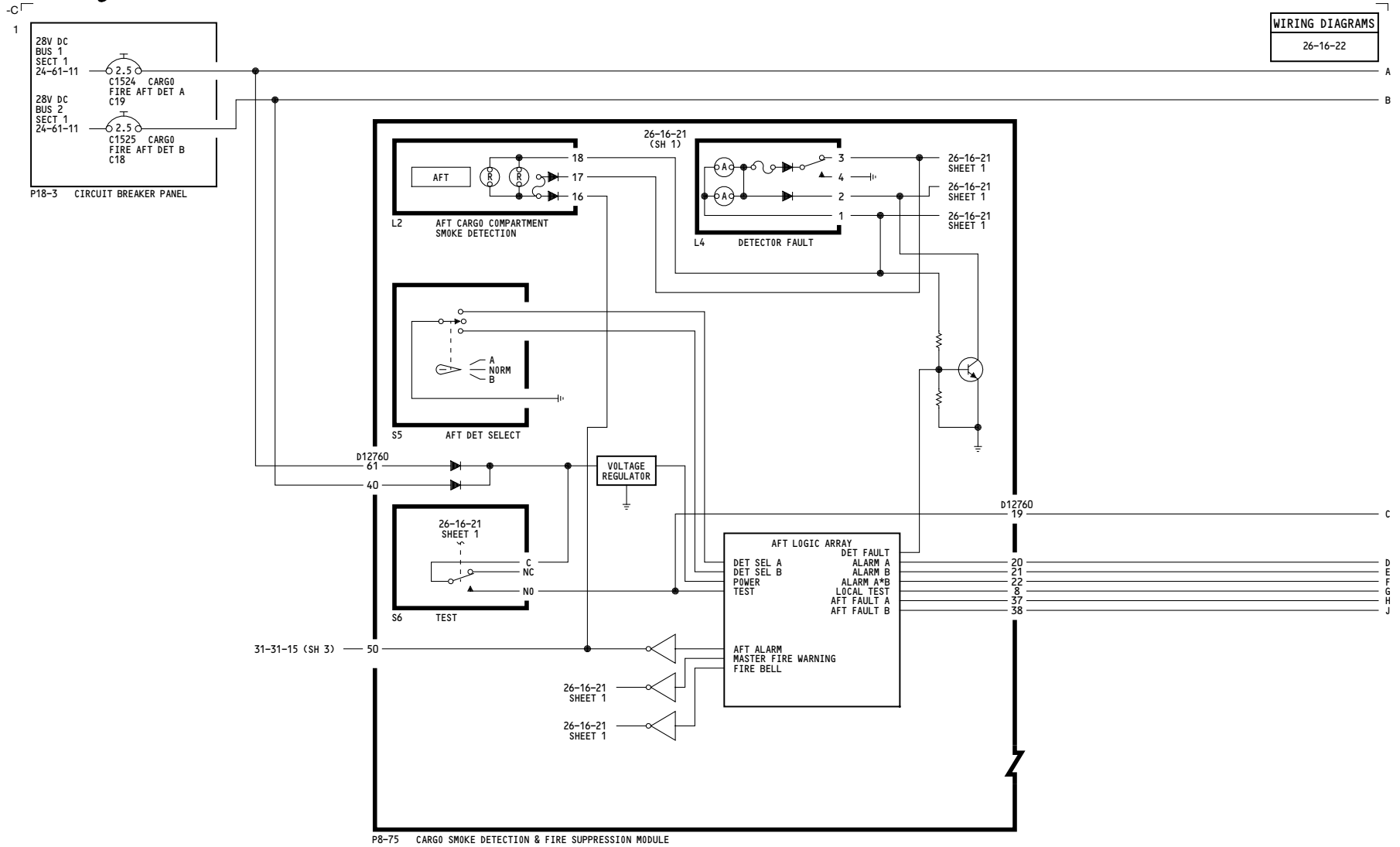

P8-75 CARGO SMOKE DETECTION & FIRE SUPPRESSION MODULE

<p>YC001-YC007</p>	<p><b>AFT CARGO COMPARTMENT SMOKE DETECTION</b></p> <p>D280A203</p>
--------------------	---

Incorporates  
26A1083 R01

**26-16-22**

**WIRING DIAGRAMS**  
26-16-22

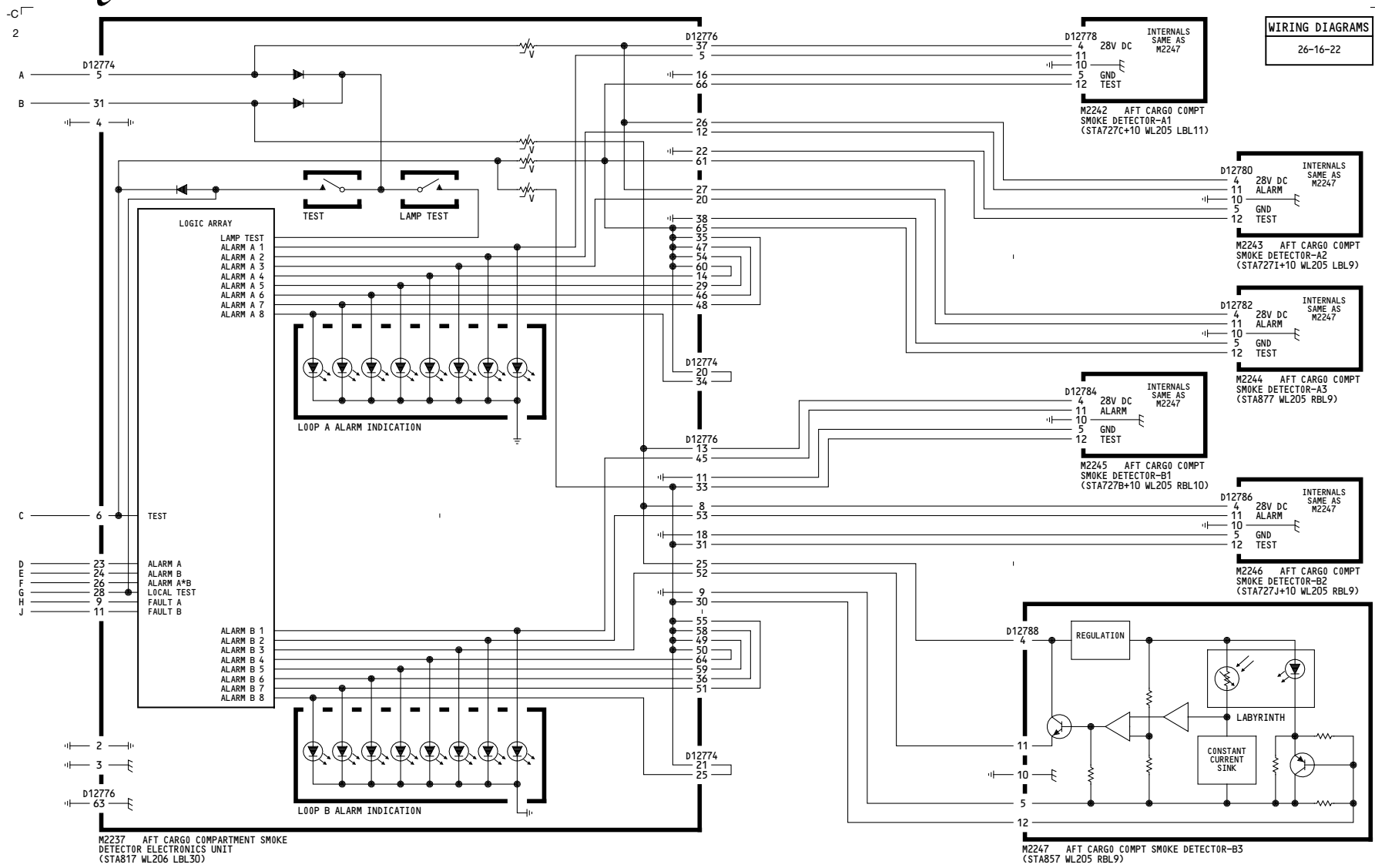

YC001-YC007	<p align="center"><b>AFT CARGO COMPARTMENT SMOKE DETECTION</b></p> <p align="center">D280A203</p>
-------------	---

Incorporates  
26A1083 R01

**26-16-22**

Page 101.1  
Sheet 2  
Aug 13/2008





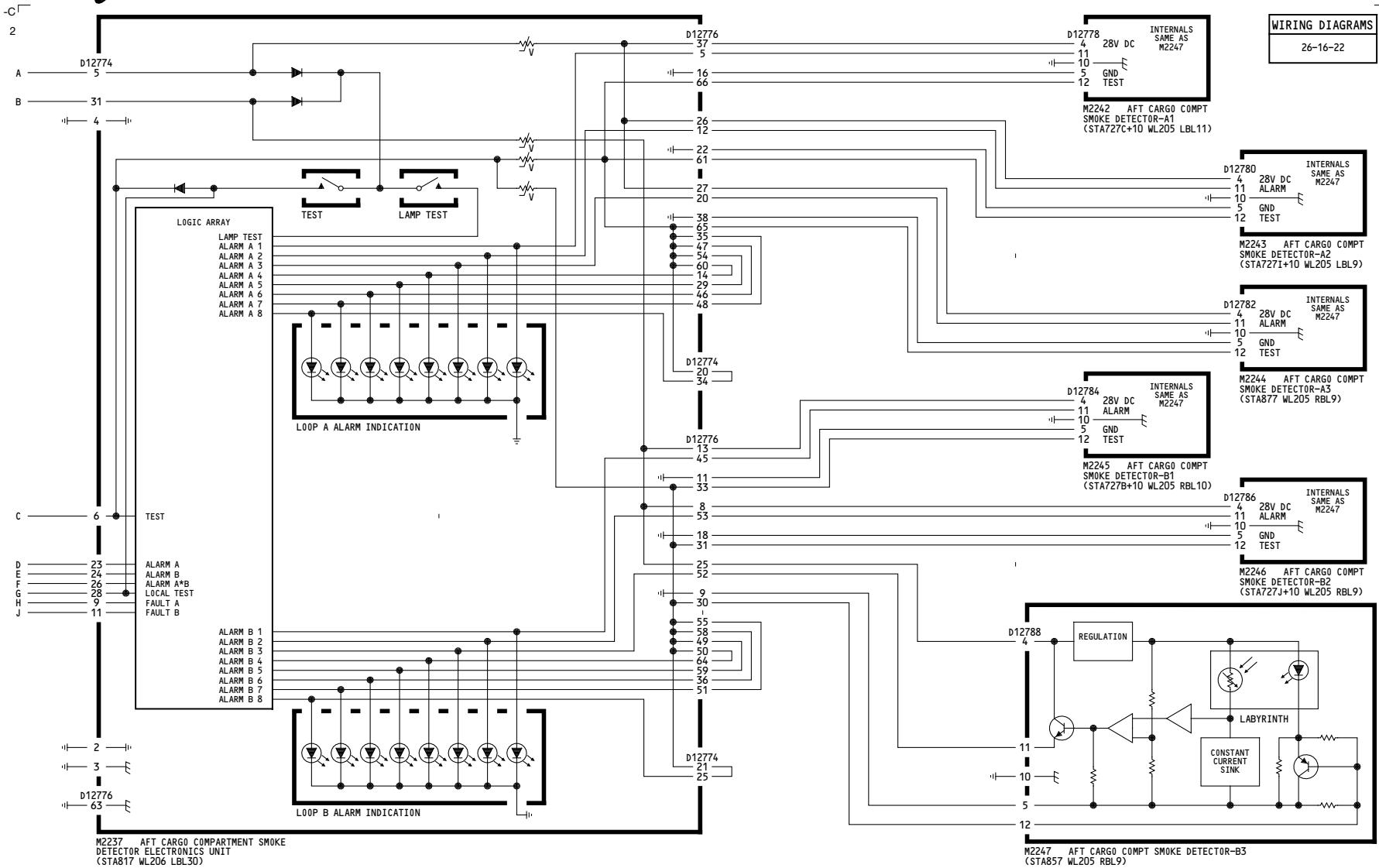

YC008-YC030

**AFT CARGO COMPARTMENT SMOKE DETECTION**

D280A203

**26-16-22**

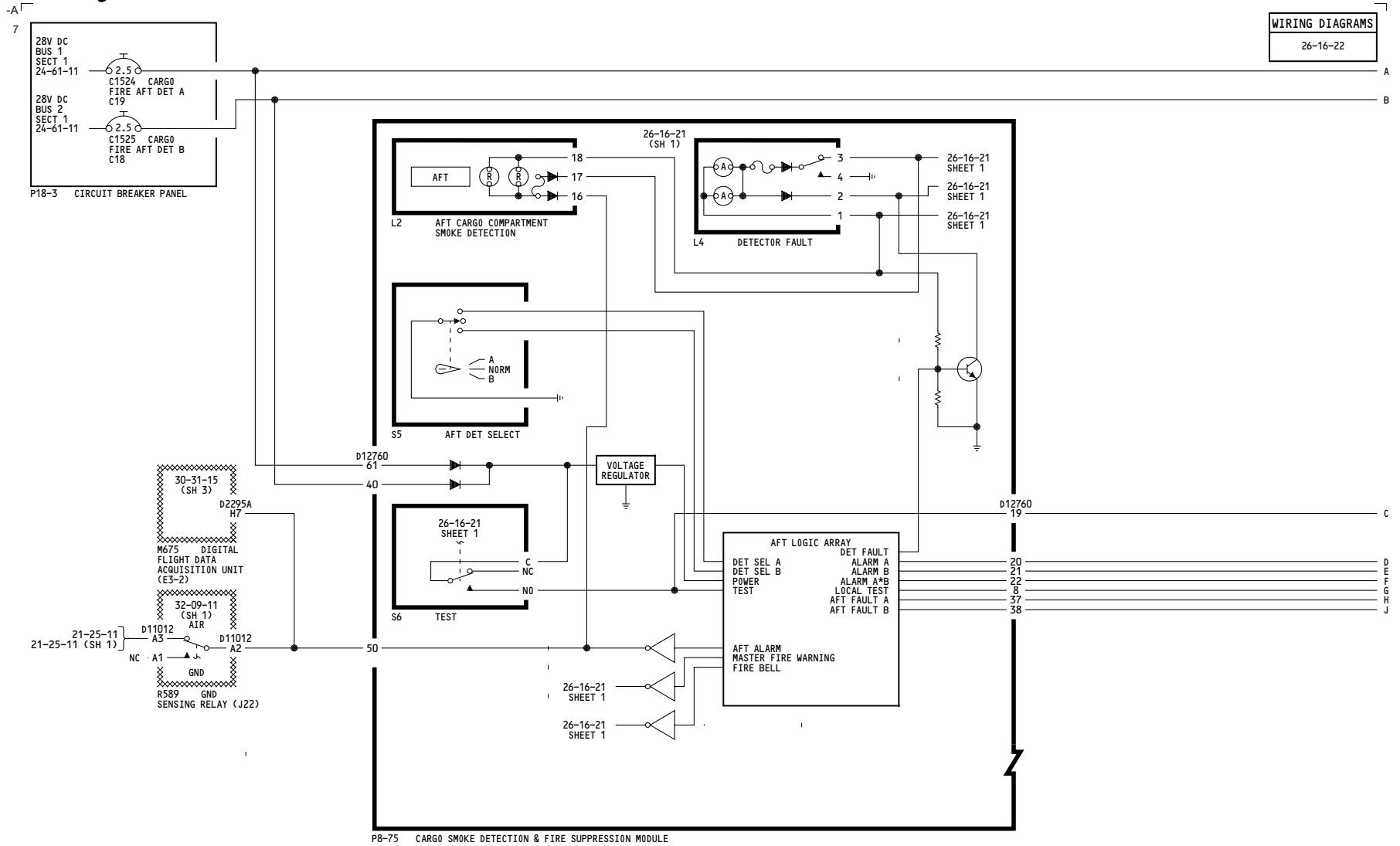

YC031-YL430	<b>AFT CARGO COMPARTMENT SMOKE DETECTION</b>  D280A203
-------------	--

**26-16-22**

**WIRING DIAGRAMS**  
26-16-22

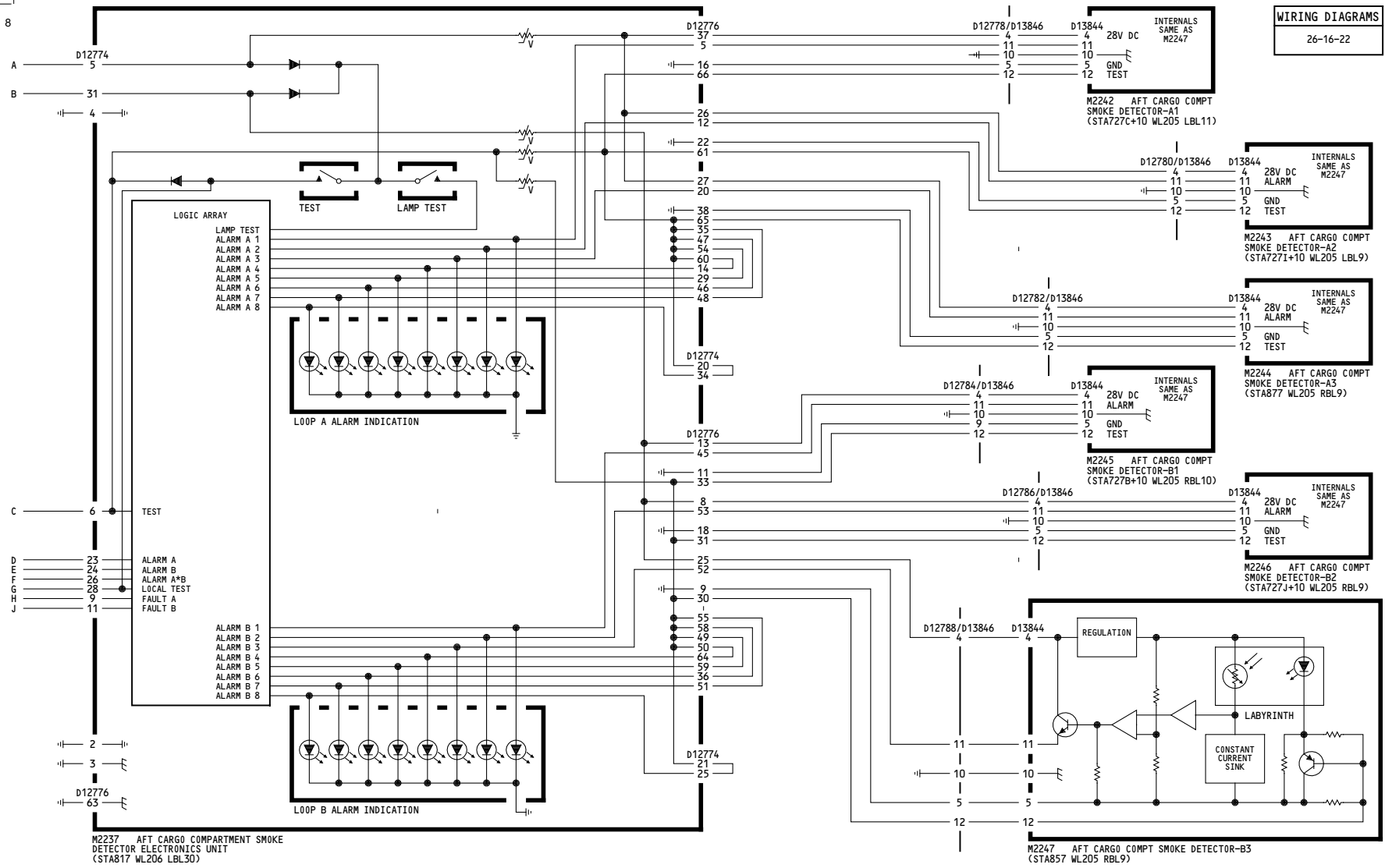

YC031-YL430	<b>AFT CARGO COMPARTMENT SMOKE DETECTION</b>
	D280A203

**26-16-22**

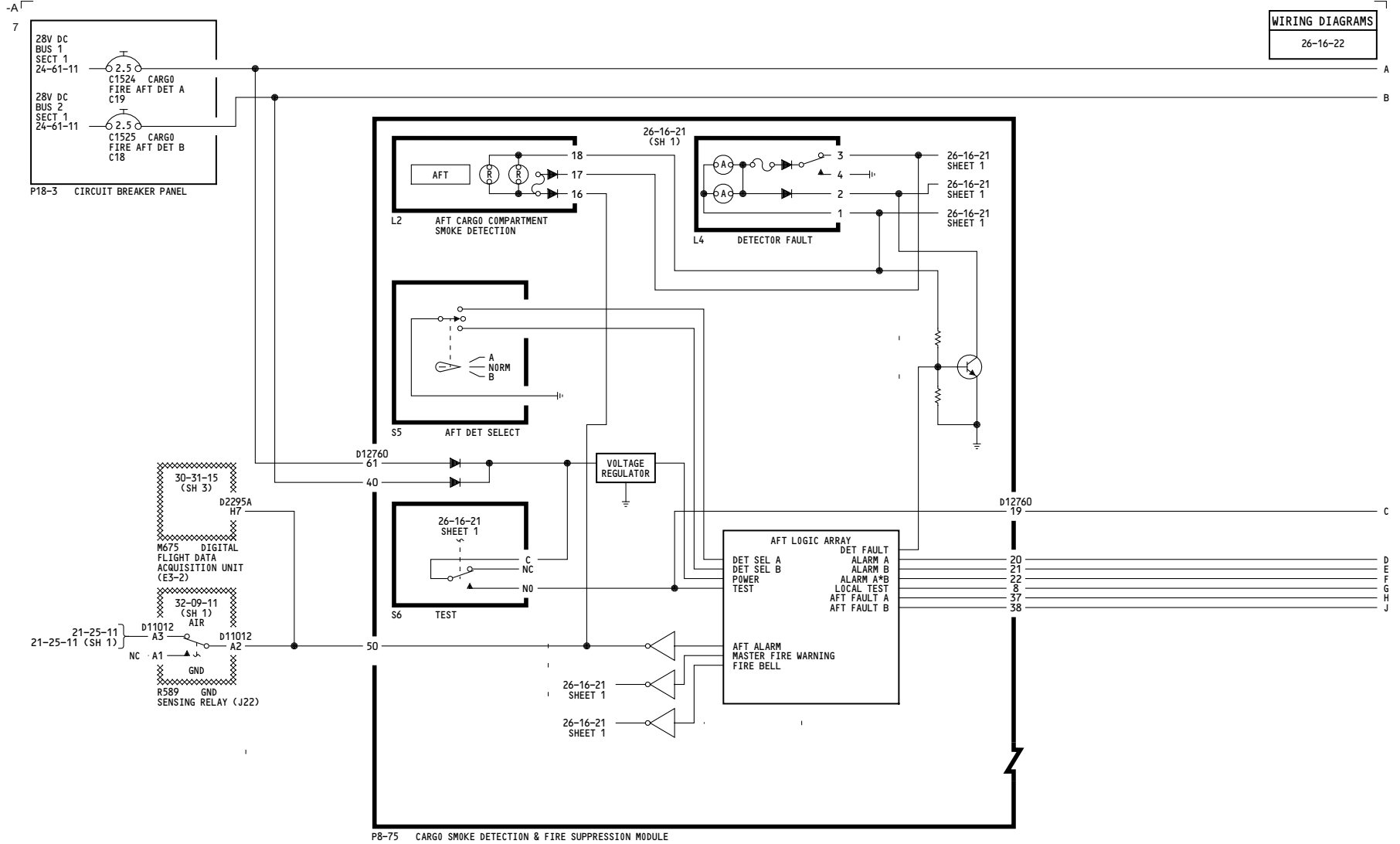

YM643-YM670	<b>AFT CARGO COMPARTMENT SMOKE DETECTION</b>
	D280A203

**26-16-22**

**WIRING DIAGRAMS**  
26-16-22

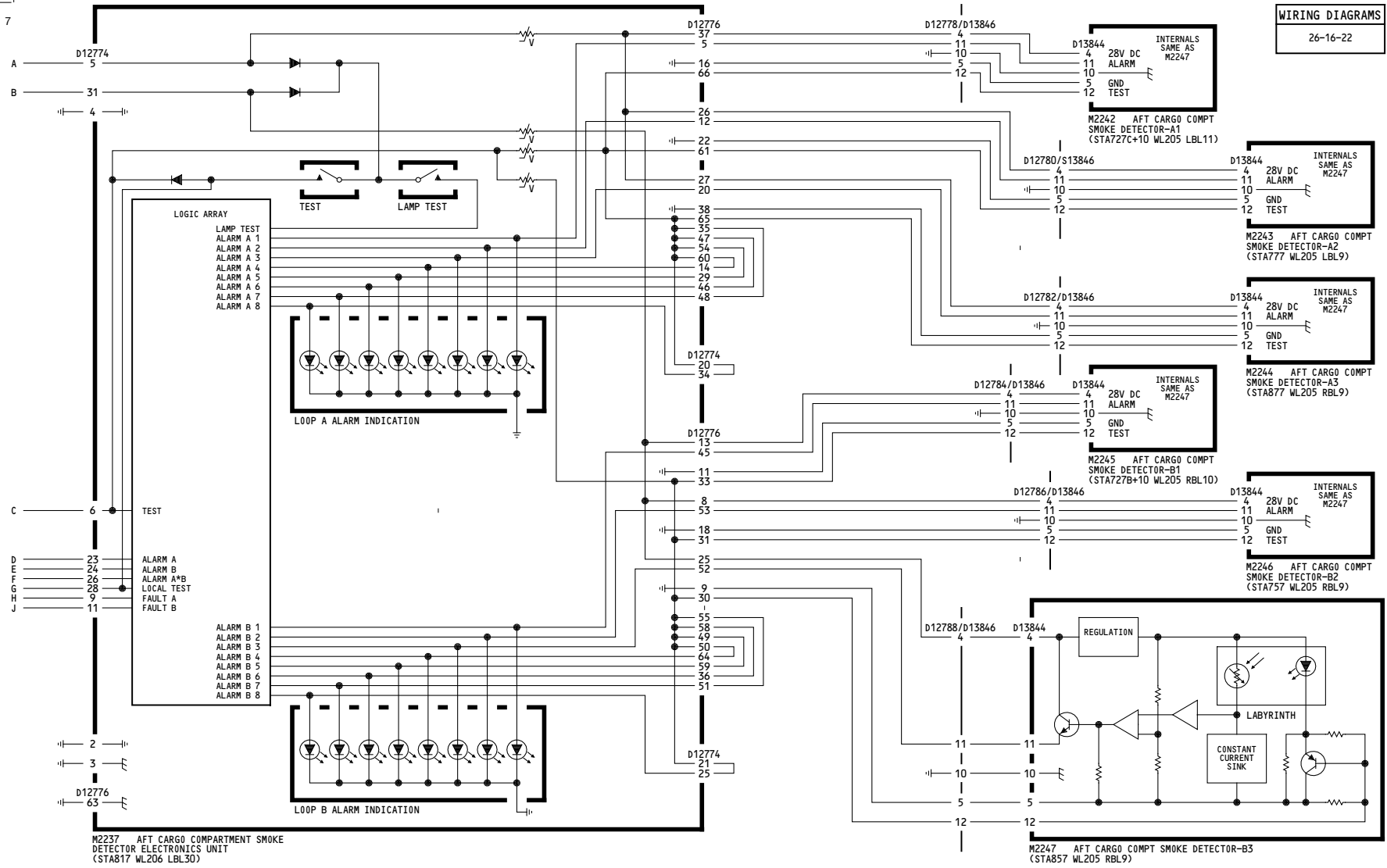

YM643-YM670

**AFT CARGO COMPARTMENT SMOKE DETECTION**

D280A203

**26-16-22**

WIRING DIAGRAMS  
26-21-01

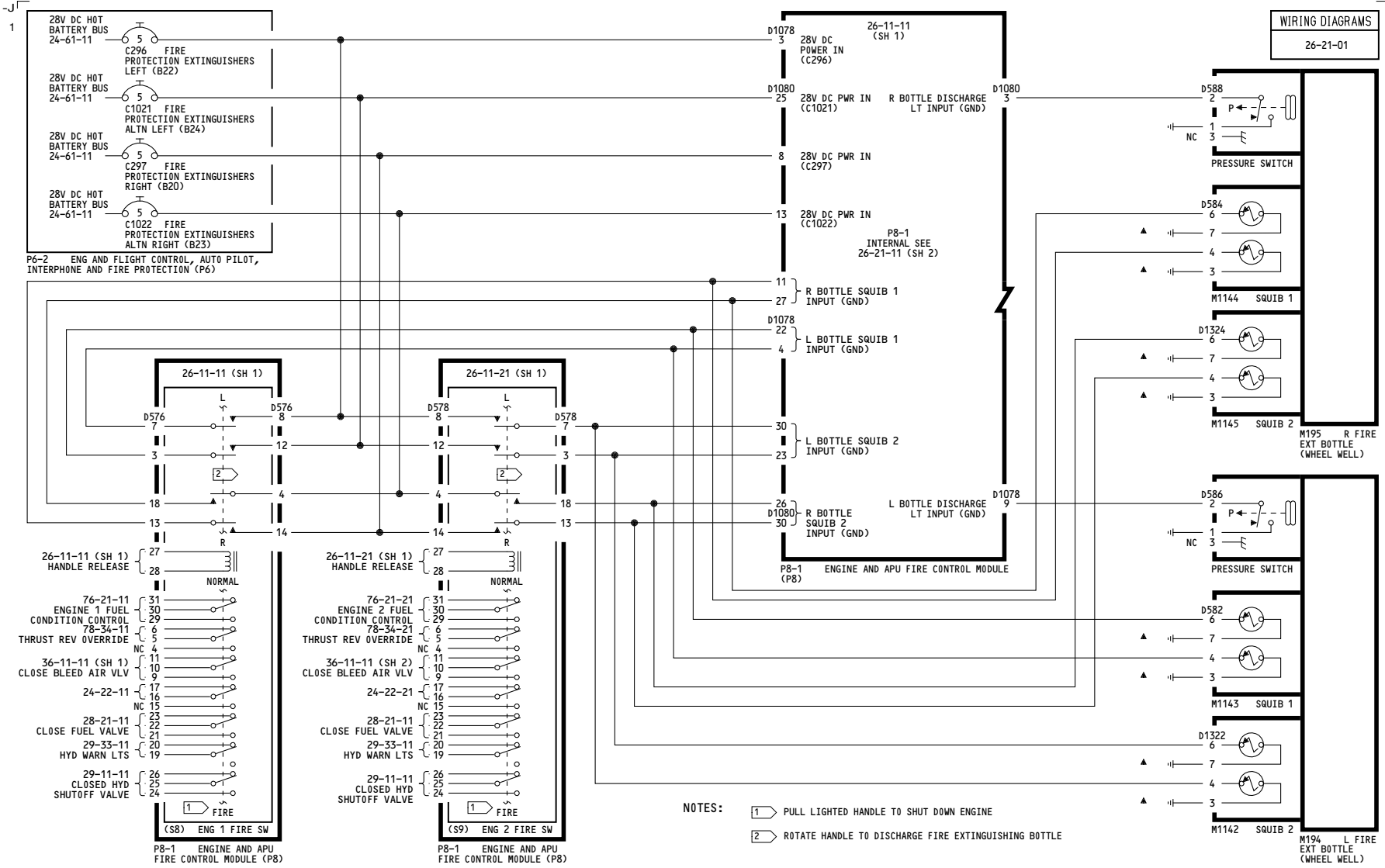

- NOTES:
- 1 PULL LIGHTED HANDLE TO SHUT DOWN ENGINE
  - 2 ROTATE HANDLE TO DISCHARGE FIRE EXTINGUISHING BOTTLE

ALL	<p><b>ENGINE AND APU FIRE EXTINGUISHING SYSTEM</b></p> <p>D280A203</p>
-----	--

**26-21-11**

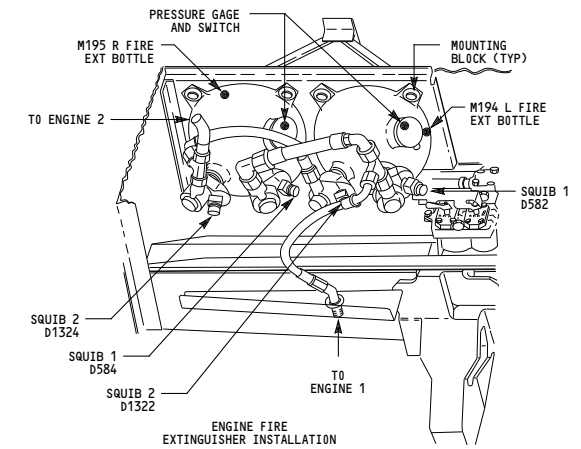
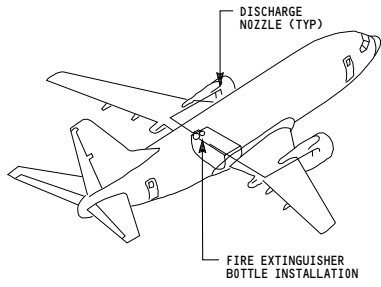
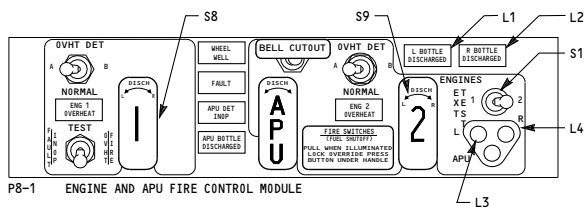
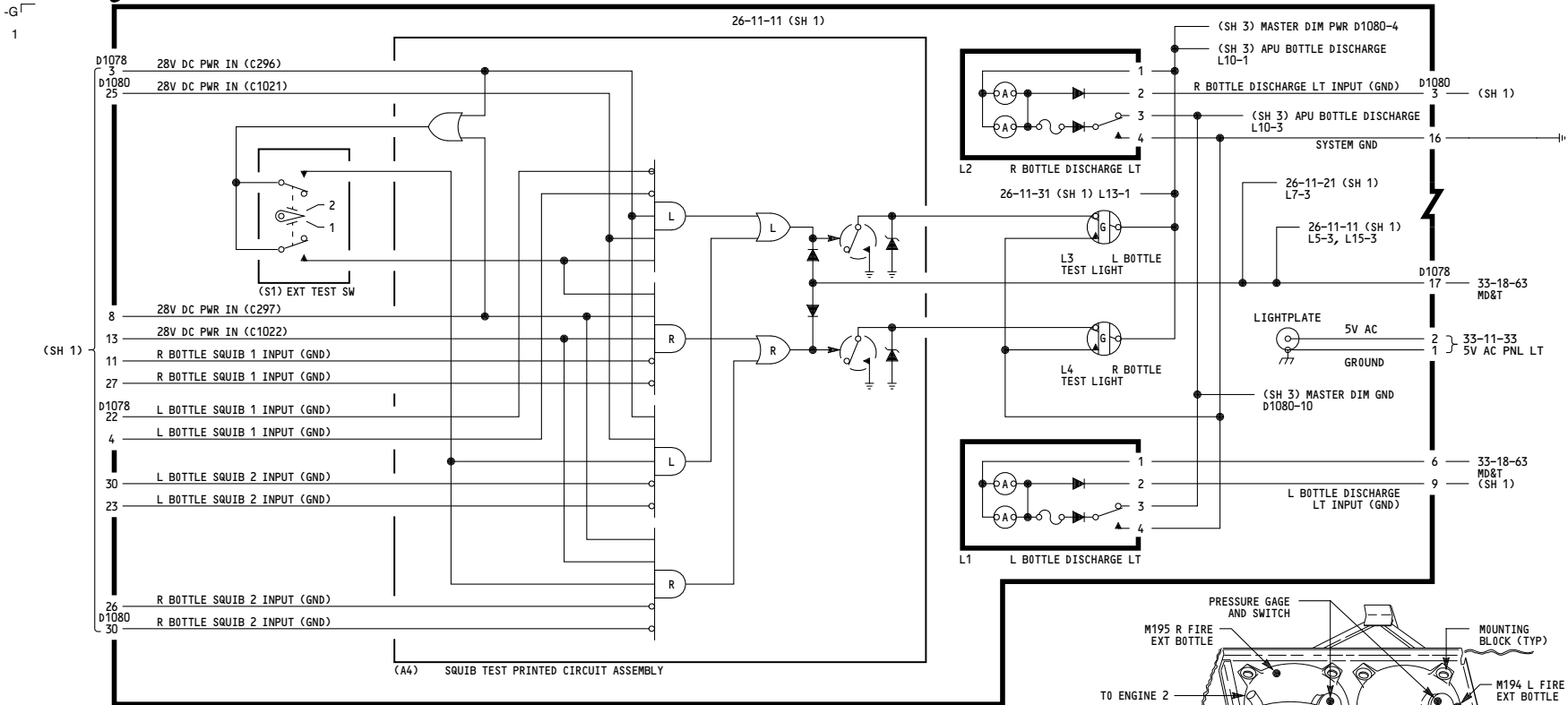

ALL

**ENGINE AND APU  
FIRE EXTINGUISHING  
SYSTEM**

D280A203

**26-21-11**

Page 101  
Sheet 2  
Feb 09/2009



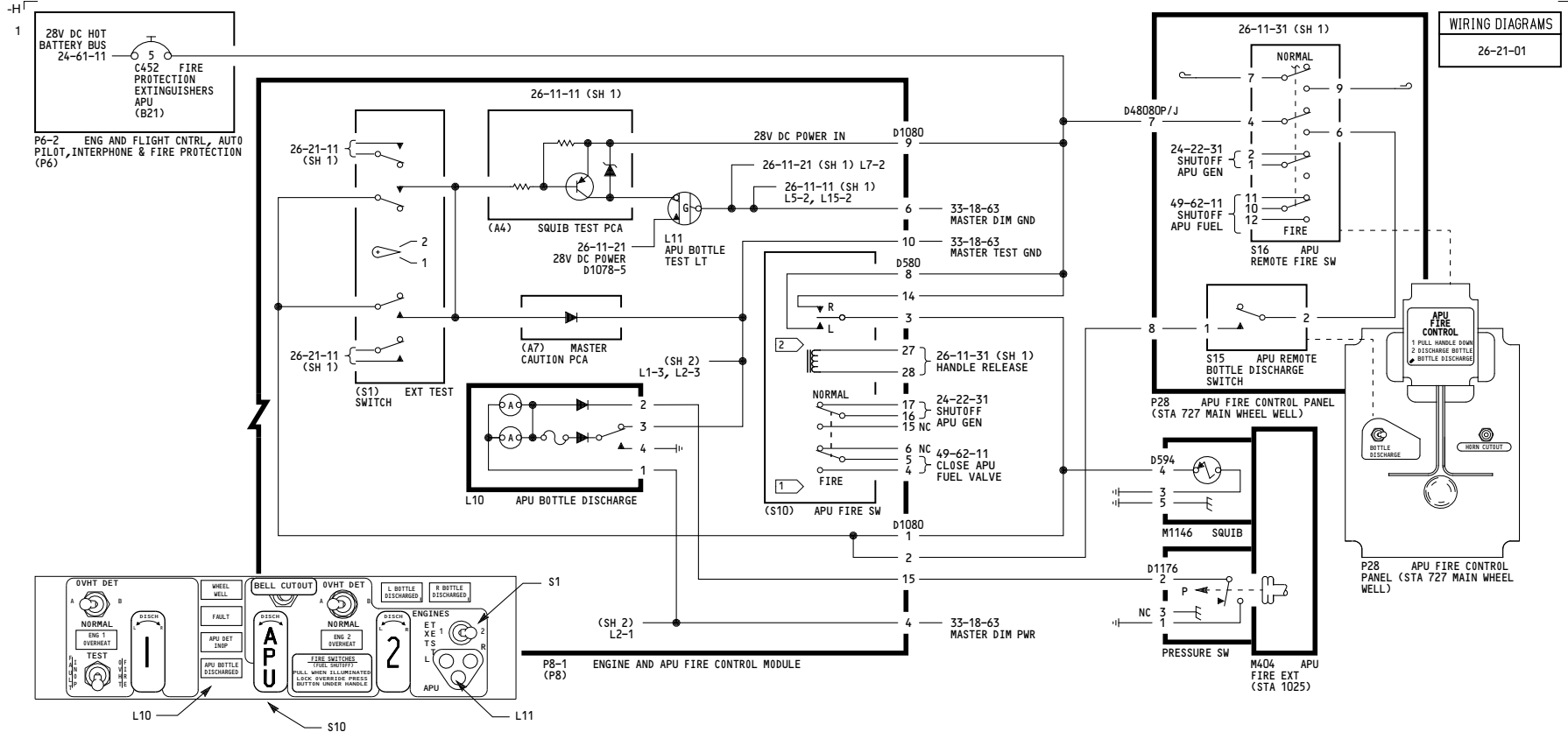

**NOTES:**

- 1 PULL LIGHTED HANDLE TO SHUTDOWN APU
- 2 ROTATE HANDLE TO DISCHARGE FIRE EXTINGUISHING BOTTLE

ALL	<p><b>ENGINE AND APU FIRE EXTINGUISHING SYSTEM</b></p> <p>D280A203</p>
-----	--

-H  
1

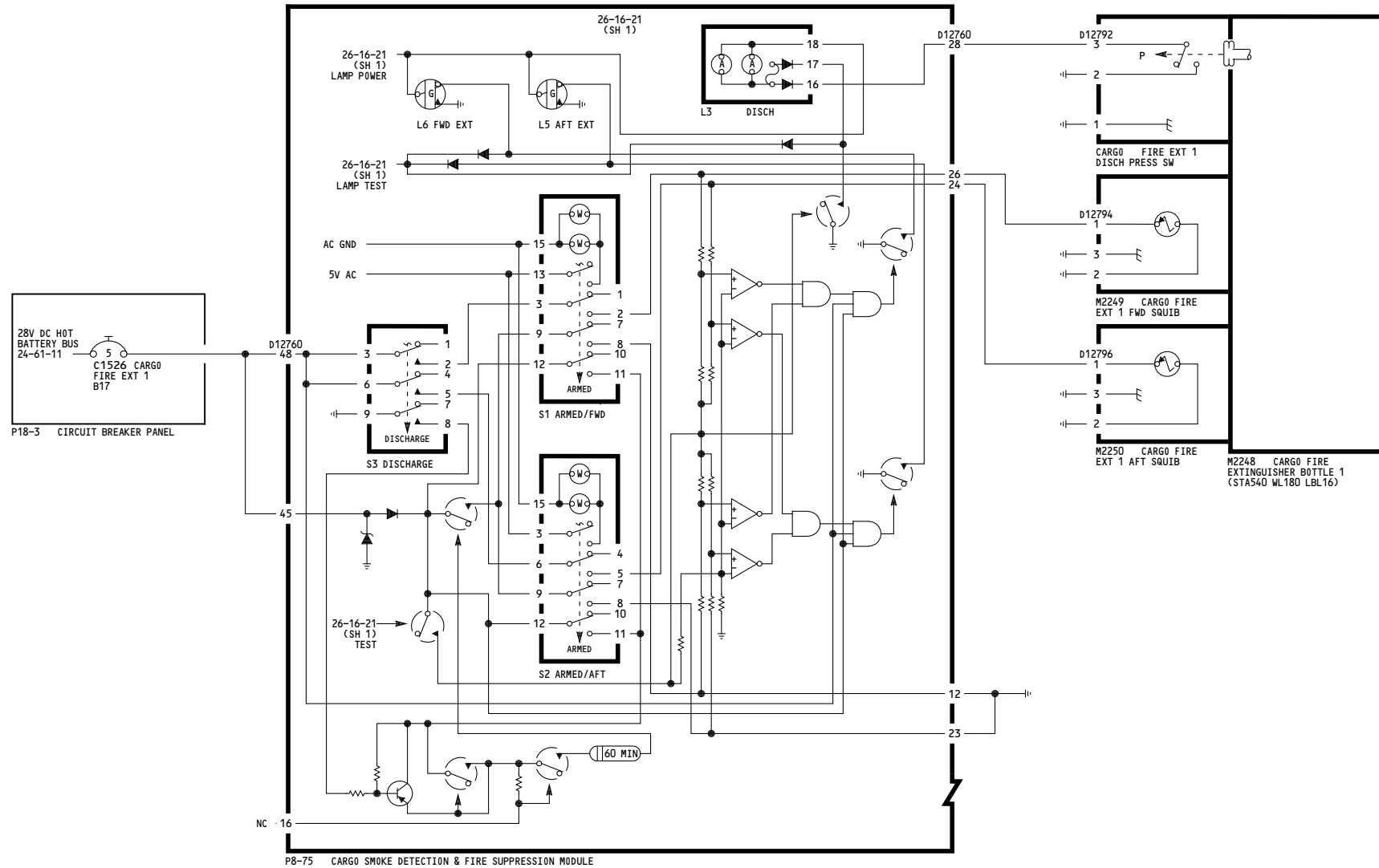

<p>YC001-YC007</p>	<p><b>CARGO COMPARTMENT FIRE EXTINGUISHERS</b></p> <p>D280A203</p>
--------------------	--

Incorporates  
26A1083 R01

**26-23-11**

Page 101.1

Aug 13/2008

-H  
1

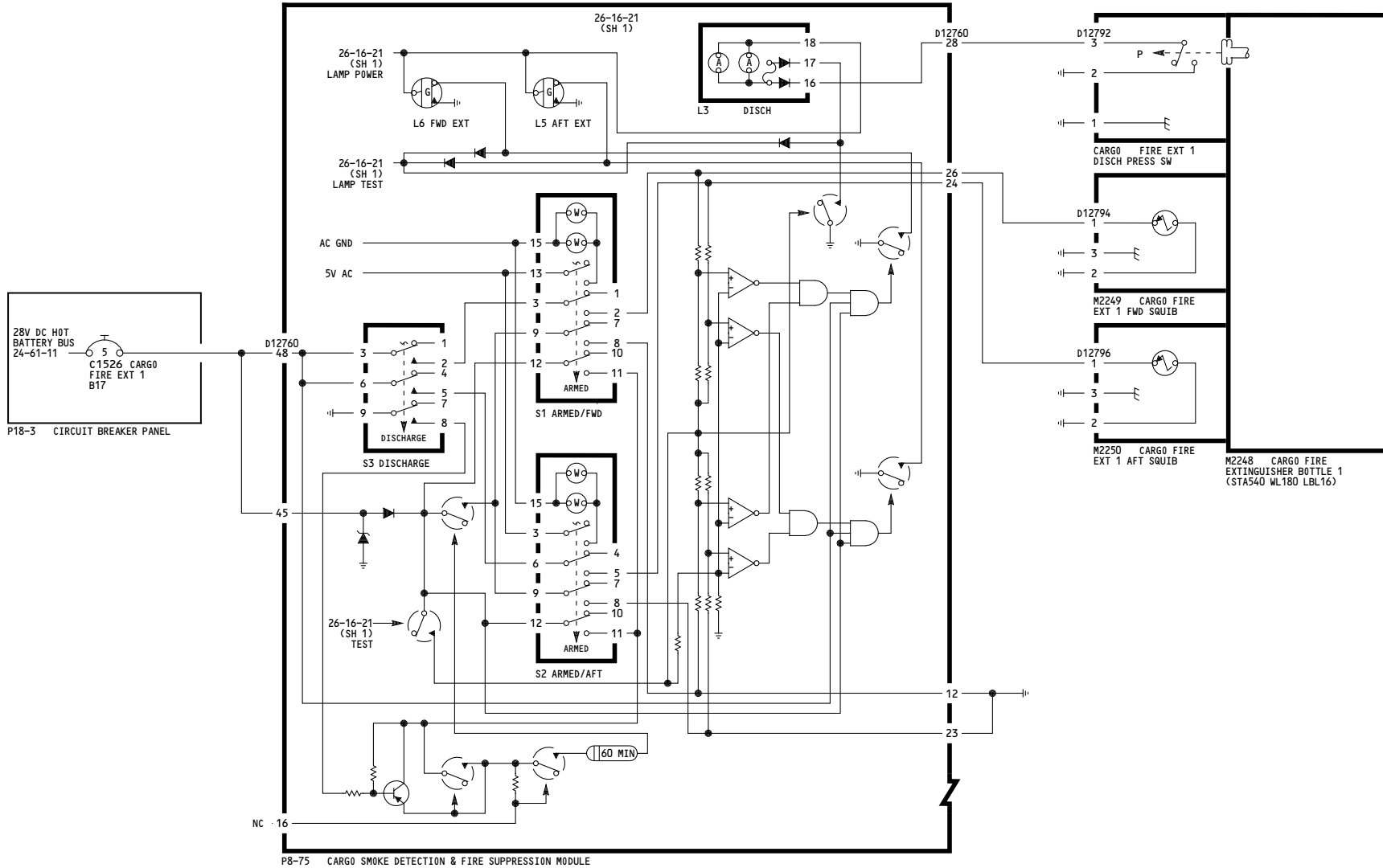

<p>YC008-YK917, YL421-YL428, YL430-YM670</p>	<p><b>CARGO COMPARTMENT FIRE EXTINGUISHERS</b></p> <p>D280A203</p>
--	--

**26-23-11**

Page 102

Nov 11/2008

-L-  
2

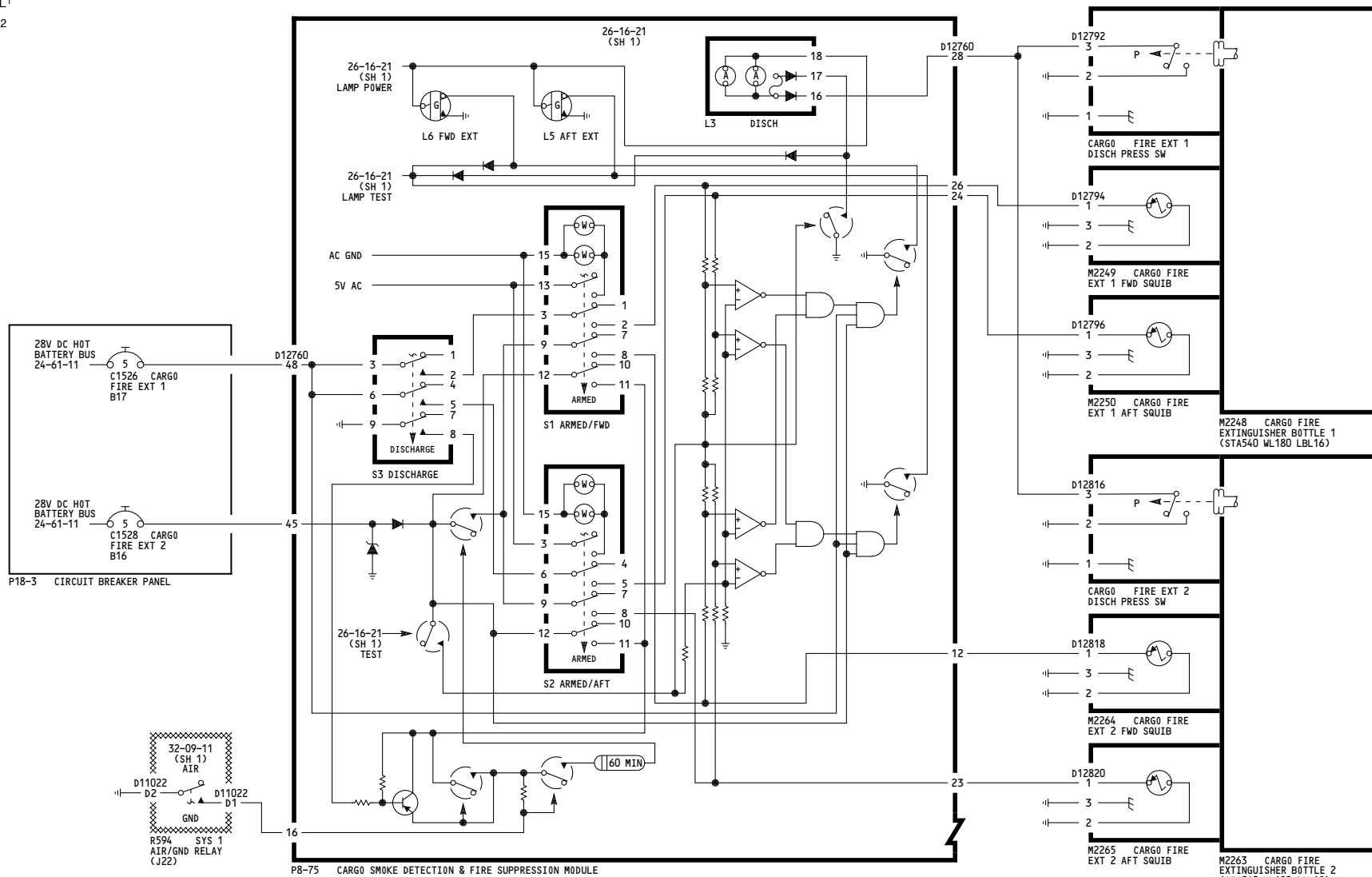

YK918-YL401, YL429

**CARGO COMPARTMENT FIRE EXTINGUISHERS**

D280A203

**26-23-11**

Page 103

Feb 09/2009