

CHAPTER

33

LIGHTS



CHAPTER 33
LIGHTS

CH-SC-SU	Schem	Page	Sheet	Date	CH-SC-SU	Schem	Page	Sheet	Date
33-EFFECTIVE PAGES					33-11-21 (cont.)				
		1 thru 6		Aug 10/2009			102		Feb 09/2009
33-CONTENTS					33-11-31				
		1		Feb 09/2009			101		Jul 17/2007
		2		Feb 09/2009			102		Feb 09/2009
R		3		Aug 10/2009	33-11-32				
R		4		Aug 10/2009			101		Jul 17/2007
R		5		Aug 10/2009			102		Feb 09/2009
		6		May 11/2009	33-11-33				
R		7		Aug 10/2009			101.1		Aug 13/2008
		8		Feb 09/2009			102		Jul 17/2007
		9		May 11/2009			103		Feb 09/2009
		10		May 11/2009	33-11-41				
33-ALPHABETICAL INDEX							101A		Jul 17/2007
		1		Jan 18/2007			102		Jul 17/2007
		2		Jan 18/2007			103		Feb 09/2009
		3		Jan 18/2007	33-12-11				
		4		BLANK			101.1		Mar 31/2005
33-00-01							102		Feb 09/2009
		101		Feb 09/2009			103		Jan 14/2008
33-11-11					33-12-12				
		101		Feb 09/2009			101		Feb 09/2009
33-11-21					33-14-11				
		101		Jul 17/2007			101		Feb 09/2009

A = Added, R = Revised, D = Deleted, O = Overflow

33-EFFECTIVE PAGES

Page 1
Aug 10/2009

D280A203



CHAPTER 33
LIGHTS

CH-SC-SU	Schem	Page	Sheet	Date	CH-SC-SU	Schem	Page	Sheet	Date
33-14-12		101		Feb 09/2009	33-18-32		101		Feb 09/2009
33-17-11		101		Jul 17/2007	33-18-33		101		Feb 09/2009
		102		Feb 09/2009	33-18-34		101.1		Mar 31/2005
		103		Aug 13/2008			102		Feb 09/2009
33-18-11		101		Jul 17/2007	33-18-35		101		Feb 09/2009
		102		Mar 31/2005			102		Jan 14/2008
		103		Feb 09/2009	33-18-36		101		Feb 09/2009
33-18-21		101		Jul 17/2007			102		Jan 14/2008
		102		Feb 09/2009	33-18-37		101		Jul 17/2007
33-18-22		101		Jul 17/2007			102		Oct 20/2006
		102		Feb 09/2009			103		Feb 09/2009
33-18-23		101		Feb 09/2009	33-18-41		101		Jul 17/2007
33-18-24		101		Feb 09/2009			102		Feb 09/2009
33-18-31		101		Jul 17/2007	33-18-42	R	101		Aug 10/2009
		102		Feb 09/2009		R	102		Aug 10/2009
						R	103		Aug 10/2009

A = Added, R = Revised, D = Deleted, O = Overflow

33-EFFECTIVE PAGES

Page 2
Aug 10/2009

D280A203



CHAPTER 33
LIGHTS

CH-SC-SU	Schem	Page	Sheet	Date	CH-SC-SU	Schem	Page	Sheet	Date
R	33-18-42 (cont.)	104		Aug 10/2009	R	33-21-12	101		Aug 10/2009
	33-18-51	101		Jul 17/2007			101.1		Jul 17/2007
		102		Feb 09/2009			102		Feb 09/2009
	33-18-61						103		Jan 14/2008
		101		Jul 17/2007		33-22-11	101		Jul 17/2007
		102		Mar 31/2005			102		Feb 09/2009
		103		Oct 20/2006			103		Jan 14/2008
		104		Feb 09/2009		33-22-12			
	33-18-62						101		Jul 17/2007
		101.1		Aug 13/2008			102		Feb 09/2009
		102		Mar 31/2005			103		Jan 14/2008
		103		Jul 17/2007		33-23-11			
R		104		Aug 10/2009	R		101		Aug 10/2009
R		105		Aug 10/2009			102		Jan 14/2008
R		106		Aug 10/2009		33-23-12			
	33-18-63				R		101		Aug 10/2009
		101		Feb 09/2009			102		Jan 14/2008
	33-18-64					33-23-21			
		101.1		Aug 13/2008			101		Feb 09/2009
		102		Feb 09/2009			102		Jan 14/2008
	33-21-11					33-23-22			
		101		Feb 09/2009			101		Feb 09/2009

A = Added, R = Revised, D = Deleted, O = Overflow

33-EFFECTIVE PAGES

Page 3
Aug 10/2009

D280A203



CHAPTER 33
LIGHTS

CH-SC-SU	Schem	Page	Sheet	Date	CH-SC-SU	Schem	Page	Sheet	Date
33-23-22 (cont.)		102		Jan 14/2008	33-25-31 (cont.)		102		Jan 14/2008
33-23-31		101		Feb 09/2009	33-25-32		101		Feb 09/2009
33-25-11		101		Jul 17/2007			102		Jan 14/2008
		102		Jan 14/2008	33-25-41		101		Feb 09/2009
		103		Apr 18/2007	33-25-51		101		Jul 17/2007
		104		May 11/2009			102		Feb 09/2009
		105		May 11/2009			103		Jan 14/2008
33-25-12		101		Mar 31/2005	33-26-11		101		Feb 09/2009
		102		Jul 17/2007	33-26-21	R	101		Aug 10/2009
		103		Oct 20/2006	33-26-31		101		Jul 17/2007
		104		Feb 09/2009			102		Feb 09/2009
		105		Feb 09/2009	33-27-11		101		Jul 17/2007
33-25-21		101		Feb 09/2009			102		Feb 09/2009
		102		Jan 14/2008	33-27-21		101		Jul 17/2007
33-25-22		101		Feb 09/2009			102		Feb 09/2009
		102		Jan 14/2008	33-27-21		101		Feb 09/2009
33-25-31		101		Feb 09/2009			102		Jan 14/2008

A = Added, R = Revised, D = Deleted, O = Overflow

33-EFFECTIVE PAGES

Page 4
Aug 10/2009

D280A203



CHAPTER 33
LIGHTS

CH-SC-SU	Schem	Page	Sheet	Date	CH-SC-SU	Schem	Page	Sheet	Date
33-27-22		101		Feb 09/2009	33-36-11		101		Feb 09/2009
		102		Jan 14/2008			102		Jan 14/2008
33-27-31		101		Feb 09/2009	33-36-12		101		Feb 09/2009
		102		Jan 14/2008			102		Jan 14/2008
33-27-32		101		Feb 09/2009	33-41-11		101		Feb 09/2009
		102		Jan 14/2008			102		Jan 14/2008
33-27-41		101		Feb 09/2009	33-42-11		101		Feb 09/2009
33-29-11		101		Jul 17/2007	33-43-11		101		Jul 17/2007
		102		Feb 09/2009			101.1		May 13/2008
		103		Jan 14/2008			102		Feb 09/2009
33-32-11		101		Feb 09/2009	33-44-11		101		Feb 09/2009
33-33-11		101		Feb 09/2009	33-44-12		101		Jul 17/2007
33-34-11		101		Feb 09/2009			101.1		May 13/2008
33-35-11		101		Nov 11/2008			102		May 11/2009
		102		Feb 09/2009	33-45-11		101		Jul 17/2007
							102		May 11/2009

A = Added, R = Revised, D = Deleted, O = Overflow

33-EFFECTIVE PAGES

Page 5
Aug 10/2009

D280A203



CHAPTER 33
LIGHTS

CH-SC-SU	Schem	Page	Sheet	Date	CH-SC-SU	Schem	Page	Sheet	Date
33-49-11		101		Feb 09/2009	33-51-21 (cont.)		102		Feb 09/2009
33-51-11		101	1	Jul 17/2007			103		Feb 09/2009
			2	Jul 17/2007			104		Nov 11/2008
		102	1	Feb 09/2009			105		Nov 11/2008
			2	Feb 09/2009					
		103	1	Jan 14/2008					
			2	Jan 14/2008					
33-51-12		101		Jul 17/2007					
		102		Feb 09/2009					
		103		Jan 14/2008					
33-51-13		101		Jul 17/2007					
		102		May 11/2009					
		103		May 11/2009					
		104		Nov 11/2008					
33-51-14		101		Jul 17/2007					
		102		Feb 09/2009					
		103		Jan 14/2008					
33-51-21		101		Jul 17/2007					

A = Added, R = Revised, D = Deleted, O = Overflow

33-EFFECTIVE PAGES

Page 6
Aug 10/2009

D280A203

CHAPTER 33
LIGHTS

Title	CH-SC-SU	Schem	Page	Sheet	Date	Effectivity
<u>LIGHTS</u>						
SPARE BULB STOWAGE	33-00-01		101		Feb 09/2009	ALL
<u>INSTRUMENT AND PANEL LIGHTS</u>						
CAPTAIN'S INSTRUMENT PANEL LIGHTING	33-11-11		101		Feb 09/2009	ALL
FIRST OFFICER'S INSTRUMENT PANEL LIGHTING	33-11-21		101		Jul 17/2007	YC001-YC050
			102		Feb 09/2009	YK901-YM670
CAPTAIN'S & FIRST OFFICER'S CENTER INSTRUMENT PANEL	33-11-31		101		Jul 17/2007	YC001-YC050
			102		Feb 09/2009	YK901-YM670
STANDBY INSTRUMENT AND PANEL LIGHTS - CAPT, F/O, CENTER PANELS	33-11-32		101		Jul 17/2007	YC001-YC050
			102		Feb 09/2009	YK901-YM670
STANDBY INSTRUMENT AND PANEL LIGHTS - CONTROL STAND	33-11-33		101.1		Aug 13/2008	YC001-YC007
			102		Jul 17/2007	YC008-YC050
			103		Feb 09/2009	YK901-YM670
PILOTS CONTROL STAND LIGHTING	33-11-41		101A		Jul 17/2007	YC001-YC030
			102		Jul 17/2007	YK901-YK906
			103		Feb 09/2009	YK907-YM670
<u>OVERHEAD INSTRUMENT PANEL</u>						
OVERHEAD INSTRUMENT PANEL LIGHTS PART ONE	33-12-11		101.1		Mar 31/2005	YC001-YC007
			102		Feb 09/2009	YC008-YL430
			103		Jan 14/2008	YM643-YM670
OVERHEAD INSTRUMENT PANEL LIGHTS PART TWO	33-12-12		101		Feb 09/2009	ALL

**CHAPTER 33
LIGHTS**

Title	CH-SC-SU	Schem	Page	Sheet	Date	Effectivity
<u>FLIGHT COMPARTMENT LIGHTS</u>						
PILOT'S BACKGROUND LIGHTS	33-14-11		101		Feb 09/2009	ALL
DOME LTG, CONTROL STAND FLOOD LTG, STBY COMPASS LTG, & C/B PNL LTG	33-14-12		101		Feb 09/2009	ALL
<u>FLIGHT CREW LIGHTS</u>						
MAP, FLIGHT KIT AND READING LIGHTS	33-17-11		101		Jul 17/2007	YC001-YC026
			102		Feb 09/2009	YC028-YC050 YK910-YK920
			103		Aug 13/2008	YK901-YK909 YL401-YM670
<u>MASTER DIM AND TEST SYSTEM</u>						
MASTER DIM & TEST SYSTEM- POWER & CONTROL	33-18-11		101		Jul 17/2007	YC001-YC026
			102		Mar 31/2005	YC028-YC030
			103		Feb 09/2009	YK901-YM670
MASTER DIM & TEST SYSTEM- MAIN INSTRUMENT PANEL, CAPT	33-18-21		101		Jul 17/2007	YC001-YK910 YL421-YL423 YM643
			102		Feb 09/2009	YK911-YL401 YL424-YL430 YM645-YM670
MASTER DIM & TEST SYSTEM- MAIN INSTRUMENT PANEL, F/O	33-18-22		101		Jul 17/2007	YC001-YK910 YL421-YL423 YM643
			102		Feb 09/2009	YK911-YL401 YL424-YL430 YM645-YM670
MASTER DIM & TEST SYSTEM- MAIN INSTRUMENT PANEL, CTR LEFT	33-18-23		101		Feb 09/2009	ALL
MASTER DIM & TEST SYSTEM- MAIN INSTRUMENT PANEL, CTR RIGHT	33-18-24		101		Feb 09/2009	ALL
MASTER DIM & TEST SYSTEM- FWD OVERHEAD PANEL, GROUP 1	33-18-31		101		Jul 17/2007	YC001-YC030



CHAPTER 33
LIGHTS

Title	CH-SC-SU	Schem	Page	Sheet	Date	Effectivity
MASTER DIM & TEST SYSTEM- FWD OVERHEAD PANEL, GROUP 1 (cont.)	33-18-31		102		Feb 09/2009	YC031-YM670
MASTER DIM & TEST SYSTEM- FWD OVERHEAD PANEL, GROUP 2	33-18-32		101		Feb 09/2009	ALL
MASTER DIM & TEST SYSTEM- FWD OVERHEAD PANEL, GROUP 3	33-18-33		101		Feb 09/2009	ALL
MASTER DIM & TEST SYSTEM- FWD OVERHEAD PANEL, GROUP 4	33-18-34		101.1		Mar 31/2005	YC001-YC007
			102		Feb 09/2009	YC008-YM670
MASTER DIM & TEST SYSTEM- FWD OVERHEAD PANEL, GROUP 5	33-18-35		101		Feb 09/2009	YC001-YL430
			102		Jan 14/2008	YM643-YM670
MASTER DIM & TEST SYSTEM- FWD OVERHEAD PANEL, GROUP 6	33-18-36		101		Feb 09/2009	YC001-YL430
			102		Jan 14/2008	YM643-YM670
MASTER DIM & TEST SYSTEM- FWD OVERHEAD PANEL, GROUP 7	33-18-37		101		Jul 17/2007	YC001-YC050
			102		Oct 20/2006	YK901-YK906
			103		Feb 09/2009	YK907-YM670
MASTER DIM & TEST SYSTEM- AFT OVERHEAD PANEL, GROUP 1	33-18-41		101		Jul 17/2007	YC001-YK906
			102		Feb 09/2009	YK907-YM670
MASTER DIM & TEST SYSTEM- AFT OVERHEAD PANEL, GROUP 2	33-18-42		101		Aug 10/2009	YC001-YC011
			102		Aug 10/2009	YC012-YC050
			103		Aug 10/2009	YK901-YK906

**CHAPTER 33
LIGHTS**

	Title	CH-SC-SU	Schem	Page	Sheet	Date	Effectivity
I	MASTER DIM & TEST SYSTEM- AFT OVERHEAD PANEL, GROUP 2 (cont.)	33-18-42		104		Aug 10/2009	YK907-YM670
	MASTER DIM & TEST SYSTEM- GLARESHIELD PANEL	33-18-51		101		Jul 17/2007	YC001-YC050
				102		Feb 09/2009	YK901-YM670
	MASTER DIM & TEST SYSTEM- AISLE STAND PANEL, GROUP 1	33-18-61		101		Jul 17/2007	YC001-YC026
				102		Mar 31/2005	YC028-YC030
				103		Oct 20/2006	YC031-YK906
				104		Feb 09/2009	YK907-YM670
	MASTER DIM & TEST SYSTEM- AISLE STAND PANEL, GROUP 2	33-18-62		101.1		Aug 13/2008	YC001-YC007
				102		Mar 31/2005	YC008-YC011
				103		Jul 17/2007	YC012-YC026
I				104		Aug 10/2009	YC028-YC050
I				105		Aug 10/2009	YK901-YK906
I				106		Aug 10/2009	YK907-YM670
	MASTER DIM & TEST SYSTEM- AISLE STAND PANEL, GROUP 3	33-18-63		101		Feb 09/2009	ALL
	MASTER DIM & TEST SYSTEM- AISLE STAND PANEL, GROUP 4	33-18-64		101.1		Aug 13/2008	YC001-YC007
				102		Feb 09/2009	YC008-YM670
	<u>WINDOW LIGHTS</u>						
	WINDOW LIGHTS CONTROL	33-21-11		101		Feb 09/2009	ALL
I	WINDOW LIGHTS	33-21-12		101		Aug 10/2009	YC001-YC050
				101.1		Jul 17/2007	YC021-YC026

CHAPTER 33
LIGHTS

Title	CH-SC-SU	Schem	Page	Sheet	Date	Effectivity
WINDOW LIGHTS (cont.)	33-21-12		102		Feb 09/2009	YK901-YL430
			103		Jan 14/2008	YM643-YM670
<u>CEILING LIGHTS</u>						
CEILING LIGHTS CONTROL	33-22-11		101		Jul 17/2007	YC001-YK906
			102		Feb 09/2009	YK907-YL430
			103		Jan 14/2008	YM643-YM670
CEILING LIGHTS	33-22-12		101		Jul 17/2007	YC001-YC030
			102		Feb 09/2009	YC031-YL430
			103		Jan 14/2008	YM643-YM670
<u>READING LIGHTS</u>						
■ PASS READING LTS - LEFT FWD	33-23-11		101		Aug 10/2009	YC001-YL430
			102		Jan 14/2008	YM643-YM670
■ PASS READING LTS - LEFT AFT	33-23-12		101		Aug 10/2009	YC001-YL430
			102		Jan 14/2008	YM643-YM670
PASS READING LTS - RIGHT FWD	33-23-21		101		Feb 09/2009	YC001-YL430
			102		Jan 14/2008	YM643-YM670
PASS READING LTS - RIGHT AFT	33-23-22		101		Feb 09/2009	YC001-YL430
			102		Jan 14/2008	YM643-YM670
READING LTS - PASS SERVICE UNIT	33-23-31		101		Feb 09/2009	ALL
<u>PASSENGER SIGNS</u>						
PASS SIGN - CONTROL	33-25-11		101		Jul 17/2007	YC001-YC050
			102		Jan 14/2008	YK901-YK906 YM643-YM646
			103		Apr 18/2007	YK907-YK909

**CHAPTER 33
LIGHTS**

Title	CH-SC-SU	Schem	Page	Sheet	Date	Effectivity
PASS SIGN - CONTROL (cont.)	33-25-11		104		May 11/2009	YK910-YK912 YK918-YK919 YL401-YL429
			105		May 11/2009	YM647-YM652
PASS SIGNS - MISC	33-25-12		101		Mar 31/2005	YC001-YC002
			102		Jul 17/2007	YC003-YC030
			103		Oct 20/2006	YC031-YK906
			104		Feb 09/2009	YK907-YK911 YK918 YM643-YM651 YM653-YM670
			105		Feb 09/2009	YK912-YK917 YK919-YL430 YM652
PASS SIGNS - PSU LEFT FWD	33-25-21		101		Feb 09/2009	YC001-YL430
			102		Jan 14/2008	YM643-YM670
PASS SIGNS - PSU LEFT AFT	33-25-22		101		Feb 09/2009	YC001-YL430
			102		Jan 14/2008	YM643-YM670
PASS SIGNS - PSU RIGHT FWD	33-25-31		101		Feb 09/2009	YC001-YL430
			102		Jan 14/2008	YM643-YM670
PASS SIGNS - PSU RIGHT AFT	33-25-32		101		Feb 09/2009	YC001-YL430
			102		Jan 14/2008	YM643-YM670
NO SMOKING/FASTEN SEAT BELT SIGNS - PASS SERVICE UNIT	33-25-41		101		Feb 09/2009	ALL
PASSENGER NS/FSB SIGNS - VIDEO MONITOR, LEFT AND RIGHT	33-25-51		101		Jul 17/2007	YC001-YC050
			102		Feb 09/2009	YK901-YL430
			103		Jan 14/2008	YM643-YM670

**CHAPTER 33
LIGHTS**

Title	CH-SC-SU	Schem	Page	Sheet	Date	Effectivity
<u>WORK LIGHTS</u>						
ATTENDANT WORK LIGHTS	33-26-11		101		Feb 09/2009	ALL
GALLEY LIGHTS	33-26-21		101		Aug 10/2009	ALL
LAVATORY LIGHTS AND SIGNS	33-26-31		101		Jul 17/2007	YC001-YC030
			102		Feb 09/2009	YC031-YM670
<u>PASSENGER AND LAVATORY CALL LIGHTS</u>						
PASSENGER AND LAVATORY CALL CONTROL	33-27-11		101		Jul 17/2007	YC001-YC030
			102		Feb 09/2009	YK901-YM670
PASSENGER AND LAVATORY CALL - LEFT FWD	33-27-21		101		Feb 09/2009	YC001-YL430
			102		Jan 14/2008	YM643-YM670
PASSENGER AND LAVATORY CALL - LEFT AFT	33-27-22		101		Feb 09/2009	YC001-YL430
			102		Jan 14/2008	YM643-YM670
PASSENGER AND LAVATORY CALL - RIGHT FWD	33-27-31		101		Feb 09/2009	YC001-YL430
			102		Jan 14/2008	YM643-YM670
PASSENGER AND LAVATORY CALL - RIGHT AFT	33-27-32		101		Feb 09/2009	YC001-YL430
			102		Jan 14/2008	YM643-YM670
PASSENGER AND LAVATORY CALL - PSU	33-27-41		101		Feb 09/2009	ALL
<u>ENTRY LIGHTS</u>						
ENTRY LIGHTS	33-29-11		101		Jul 17/2007	YC001-YK906
			102		Feb 09/2009	YK907-YL430
			103		Jan 14/2008	YM643-YM670
<u>WHEEL WELL LIGHTS</u>						
SERVICE LIGHTING - WHEEL WELLS	33-32-11		101		Feb 09/2009	ALL

**CHAPTER 33
LIGHTS**

Title	CH-SC-SU	Schem	Page	Sheet	Date	Effectivity
<u>AIR CONDITIONING COMPARTMENT LIGHTS</u>						
SERVICE LIGHTING - AIR CONDITIONING COMPARTMENT	33-33-11		101		Feb 09/2009	ALL
<u>ELECTRONIC EQUIPMENT COMPARTMENT LIGHTS</u>						
SERVICE LIGHTING - EQUIPMENT RACK FORWARD LOWER COMPARTMENT	33-34-11		101		Feb 09/2009	ALL
<u>ACCESSORY COMPARTMENT LIGHTS</u>						
SERVICE LIGHTING - ACCESSORY COMPARTMENT	33-35-11		101		Nov 11/2008	YC001-YC026
			102		Feb 09/2009	YC028-YM670
<u>CARGO COMPARTMENT LIGHTS</u>						
SERVICE LIGHTING - CARGO COMPARTMENT - FWD	33-36-11		101		Feb 09/2009	YC001-YL430
			102		Jan 14/2008	YM643-YM670
SERVICE LIGHTING - CARGO COMPARTMENT - AFT	33-36-12		101		Feb 09/2009	YC001-YL430
			102		Jan 14/2008	YM643-YM670
<u>WING ILLUMINATION LIGHTS</u>						
EXTERIOR LIGHTS - WING SCANNING	33-41-11		101		Feb 09/2009	YC001-YL430
			102		Jan 14/2008	YM643-YM670
<u>LANDING LIGHTS</u>						
EXTERIOR LIGHTS - LANDING	33-42-11		101		Feb 09/2009	ALL
<u>POSITION LIGHTS</u>						
EXTERIOR LIGHTS - POSITION	33-43-11		101		Jul 17/2007	YC001-YC050
			101.1		May 13/2008	YC001-YC010 YC012-YC030
			102		Feb 09/2009	YK901-YM670

CHAPTER 33
LIGHTS

Title	CH-SC-SU	Schem	Page	Sheet	Date	Effectivity
<u>ANTI-COLLISION LIGHTS</u>						
EXTERIOR LIGHTS - ANTICOLLISION - RED	33-44-11		101		Feb 09/2009	ALL
EXTERIOR LIGHTS - ANTICOLLISION - WHITE	33-44-12		101		Jul 17/2007	YC001-YC050
			101.1		May 13/2008	YC001-YC010 YC012-YC030
			102		May 11/2009	YK901-YK912 YK918-YK919 YL401-YL429 YM643-YM652
<u>TAXI AND RUNWAY TURNOFF LIGHTS</u>						
EXTERIOR LIGHTS - TAXI AND RUNWAY TURNOFF	33-45-11		101		Jul 17/2007	YC001-YC050
			102		May 11/2009	YK901-YM670
<u>LOGO LIGHTS</u>						
EXTERIOR LIGHTS - STABILIZER (LOGO) FLOOD LIGHTS	33-49-11		101		Feb 09/2009	ALL
<u>EMERGENCY LIGHTS</u>						
EMERGENCY EXIT LIGHTS - CONTROL	33-51-11		101	1	Jul 17/2007	YC001-YC050
				2	Jul 17/2007	YC001-YC050
			102	1	Feb 09/2009	YK901-YL430
				2	Feb 09/2009	YK901-YL430
			103	1	Jan 14/2008	YM643-YM670
				2	Jan 14/2008	YM643-YM670
EMERGENCY EXIT LIGHTS - FORWARD	33-51-12		101		Jul 17/2007	YC001-YC050
			102		Feb 09/2009	YK901-YL430
			103		Jan 14/2008	YM643-YM670
EMERGENCY EXIT LIGHTS - MID	33-51-13		101		Jul 17/2007	YC001-YC050

**CHAPTER 33
LIGHTS**

Title	CH-SC-SU	Schem	Page	Sheet	Date	Effectivity
EMERGENCY EXIT LIGHTS - MID (cont.)	33-51-13		102		May 11/2009	YK901-YK910 YK918 YL421-YL426
			103		May 11/2009	YK911-YK917 YK919-YL401 YL427-YL430
			104		Nov 11/2008	YM643-YM652
EMERGENCY EXIT LIGHTS - AFT	33-51-14		101		Jul 17/2007	YC001-YC050
			102		Feb 09/2009	YK901-YL430
			103		Jan 14/2008	YM643-YM670
EMERGENCY EXIT LIGHTS - FLOOR PROXIMITY	33-51-21		101		Jul 17/2007	YC001-YC050
			102		Feb 09/2009	YK901-YK911 YK918
			103		Feb 09/2009	YK912-YK917 YK919-YL430
			104		Nov 11/2008	YM643-YM651 YM653-YM670
			105		Nov 11/2008	YM652

**CHAPTER 33
LIGHTS**

CH-SC-SU	Title
33-26-11	ATTENDANT WORK LIGHTS
33-11-31	CAPTAIN'S & FIRST OFFICER'S CENTER INSTRUMENT PANEL
33-11-11	CAPTAIN'S INSTRUMENT PANEL LIGHTING
33-22-12	CEILING LIGHTS
33-22-11	CEILING LIGHTS CONTROL
33-14-12	DOME LTG, CONTROL STAND FLOOD LTG, STBY COMPASS LTG, & C/B PNL LTG
33-51-14	EMERGENCY EXIT LIGHTS - AFT
33-51-11	EMERGENCY EXIT LIGHTS - CONTROL
33-51-21	EMERGENCY EXIT LIGHTS - FLOOR PROXIMITY
33-51-12	EMERGENCY EXIT LIGHTS - FORWARD
33-51-13	EMERGENCY EXIT LIGHTS - MID
33-29-11	ENTRY LIGHTS
33-44-11	EXTERIOR LIGHTS - ANTICOLLISION - RED
33-44-12	EXTERIOR LIGHTS - ANTICOLLISION - WHITE
33-42-11	EXTERIOR LIGHTS - LANDING
33-43-11	EXTERIOR LIGHTS - POSITION
33-49-11	EXTERIOR LIGHTS - STABILIZER (LOGO) FLOOD LIGHTS
33-45-11	EXTERIOR LIGHTS - TAXI AND RUNWAY TURNOFF

CH-SC-SU	Title
33-41-11	EXTERIOR LIGHTS - WING SCANNING
33-11-21	FIRST OFFICER'S INSTRUMENT PANEL LIGHTING
33-26-21	GALLEY LIGHTS
33-26-31	LAVATORY LIGHTS AND SIGNS
33-17-11	MAP, FLIGHT KIT AND READING LIGHTS
33-18-41	MASTER DIM & TEST SYSTEM- AFT OVERHEAD PANEL, GROUP 1
33-18-42	MASTER DIM & TEST SYSTEM- AFT OVERHEAD PANEL, GROUP 2
33-18-61	MASTER DIM & TEST SYSTEM- AISLE STAND PANEL, GROUP 1
33-18-62	MASTER DIM & TEST SYSTEM- AISLE STAND PANEL, GROUP 2
33-18-63	MASTER DIM & TEST SYSTEM- AISLE STAND PANEL, GROUP 3
33-18-64	MASTER DIM & TEST SYSTEM- AISLE STAND PANEL, GROUP 4
33-18-31	MASTER DIM & TEST SYSTEM- FWD OVERHEAD PANEL, GROUP 1
33-18-32	MASTER DIM & TEST SYSTEM- FWD OVERHEAD PANEL, GROUP 2
33-18-33	MASTER DIM & TEST SYSTEM- FWD OVERHEAD PANEL, GROUP 3

33-ALPHABETICAL INDEX

**CHAPTER 33
LIGHTS**

CH-SC-SU	Title
33-18-34	MASTER DIM & TEST SYSTEM- FWD OVERHEAD PANEL, GROUP 4
33-18-35	MASTER DIM & TEST SYSTEM- FWD OVERHEAD PANEL, GROUP 5
33-18-36	MASTER DIM & TEST SYSTEM- FWD OVERHEAD PANEL, GROUP 6
33-18-37	MASTER DIM & TEST SYSTEM- FWD OVERHEAD PANEL, GROUP 7
33-18-51	MASTER DIM & TEST SYSTEM- GLARESHIELD PANEL
33-18-21	MASTER DIM & TEST SYSTEM- MAIN INSTRUMENT PANEL, CAPT
33-18-23	MASTER DIM & TEST SYSTEM- MAIN INSTRUMENT PANEL, CTR LEFT
33-18-24	MASTER DIM & TEST SYSTEM- MAIN INSTRUMENT PANEL, CTR RIGHT
33-18-22	MASTER DIM & TEST SYSTEM- MAIN INSTRUMENT PANEL, F/O
33-18-11	MASTER DIM & TEST SYSTEM- POWER & CONTROL
33-25-41	NO SMOKING/FASTEN SEAT BELT SIGNS - PASS SERVICE UNIT
33-12-11	OVERHEAD INSTRUMENT PANEL LIGHTS PART ONE
33-12-12	OVERHEAD INSTRUMENT PANEL LIGHTS PART TWO
33-23-12	PASS READING LTS - LEFT AFT

CH-SC-SU	Title
33-23-11	PASS READING LTS - LEFT FWD
33-23-22	PASS READING LTS - RIGHT AFT
33-23-21	PASS READING LTS - RIGHT FWD
33-25-11	PASS SIGN - CONTROL
33-25-12	PASS SIGNS - MISC
33-25-22	PASS SIGNS - PSU LEFT AFT
33-25-21	PASS SIGNS - PSU LEFT FWD
33-25-32	PASS SIGNS - PSU RIGHT AFT
33-25-31	PASS SIGNS - PSU RIGHT FWD
33-27-22	PASSENGER AND LAVATORY CALL - LEFT AFT
33-27-21	PASSENGER AND LAVATORY CALL - LEFT FWD
33-27-41	PASSENGER AND LAVATORY CALL - PSU
33-27-32	PASSENGER AND LAVATORY CALL - RIGHT AFT
33-27-31	PASSENGER AND LAVATORY CALL - RIGHT FWD
33-27-11	PASSENGER AND LAVATORY CALL CONTROL
33-25-51	PASSENGER NS/FSB SIGNS - VIDEO MONITOR, LEFT AND RIGHT
33-14-11	PILOT'S BACKGROUND LIGHTS
33-11-41	PILOTS CONTROL STAND LIGHTING
33-23-31	READING LTS - PASS SERVICE UNIT

33-ALPHABETICAL INDEX

CHAPTER 33
LIGHTS

CH-SC-SU	Title
33-35-11	SERVICE LIGHTING - ACCESSORY COMPARTMENT
33-33-11	SERVICE LIGHTING - AIR CONDITIONING COMPARTMENT
33-36-12	SERVICE LIGHTING - CARGO COMPARTMENT - AFT
33-36-11	SERVICE LIGHTING - CARGO COMPARTMENT - FWD
33-34-11	SERVICE LIGHTING - EQUIPMENT RACK FORWARD LOWER COMPARTMENT
33-32-11	SERVICE LIGHTING - WHEEL WELLS
33-00-01	SPARE BULB STOWAGE
33-11-32	STANDBY INSTRUMENT AND PANEL LIGHTS - CAPT, F/O, CENTER PANELS
33-11-33	STANDBY INSTRUMENT AND PANEL LIGHTS - CONTROL STAND
33-21-12	WINDOW LIGHTS
33-21-11	WINDOW LIGHTS CONTROL

CH-SC-SU	Title
----------	-------

33-ALPHABETICAL INDEX

LAMP NO.	USAGE	SPARE QTY
303	P6 FLOOD LT (OVHD)	1
3051F	THRESHOLD LT	1
327	STANDBY COMPASS LIGHTED PUSH BUTTON SW LAVATORY CALL LT	1
387AS15	ANNUNCIATOR LT LIGHTED PUSH BUTTON SW ASP MIC SELECT SW FIRE HANDLE LT NS/FSB SIGN	6
737AS15	MASTER CAUTION DISPLAY	1
767 ***	EXTERIOR EMERGENCY LT	1
1251	LAVATORY LT	1
1308	MAP LT ATTENDANT WORK LT	1
1317	PASS CABIN EMERGENCY LT CONT CABIN EMERGENCY LT	1
1665	CONT CABIN DOME LT WHEEL WELL LT AIR CONDITIONING COMPARTMENT LT ASSESSORY COMPARTMENT LT E/E BAY RACK LT CARGO COMPARTMENT LT	2
1691	P6 FLOOD LT (FLOOR)	1
1864	MASTER CAUTION ANNUNCIATOR FIRE WARNING ANNUNCIATOR FLIGHT KIT LT P6/P18 PANEL FLOOD LT PASS CABIN NIGHT LT CABIN ENTRY LT (DIM) RETURN TO SEAT SIGN (LAV)	1

LAMP NO.	USAGE	SPARE QTY
3011	WHEEL WELL LT	1
0L-3071BPE GPL	FLOOR PROXIMITY LT EMERGENCY EXIT SIGN	4
7387	PASS CABIN ATTENDANT CALL LT	1
9204 ***	FLIGHT CREW CHART LT PASSENGER READING LT	4
H342AA55	STANDBY ATTITUDE IND LT	1
HLX64621 ***	WING SCANNING LT POSITION LT LOGO LT	1

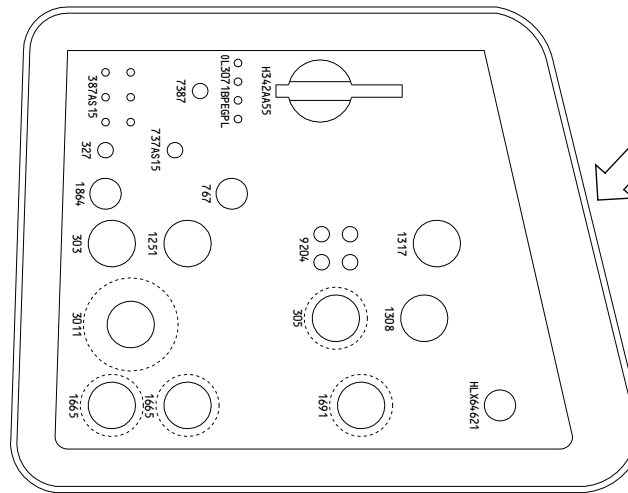
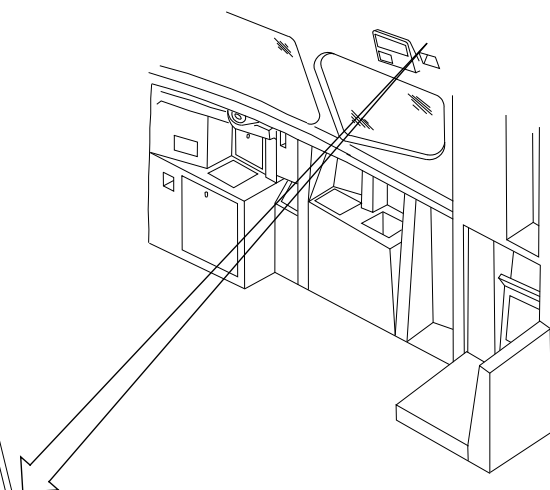

THIS CHART DOES NOT SHOW ALL BULBS USED ON AIRCRAFT.

*** SPECIAL HANDLING REQUIRED:- LEAVE SHIPPING SLEEVE ON UNTIL INSTALLED IN ASSEMBLY. FINGERPRINTS WILL SHORTEN LAMP LIFE.

ALL	<p>SPARE BULB STOWAGE</p> <p>D280A203</p>
-----	---

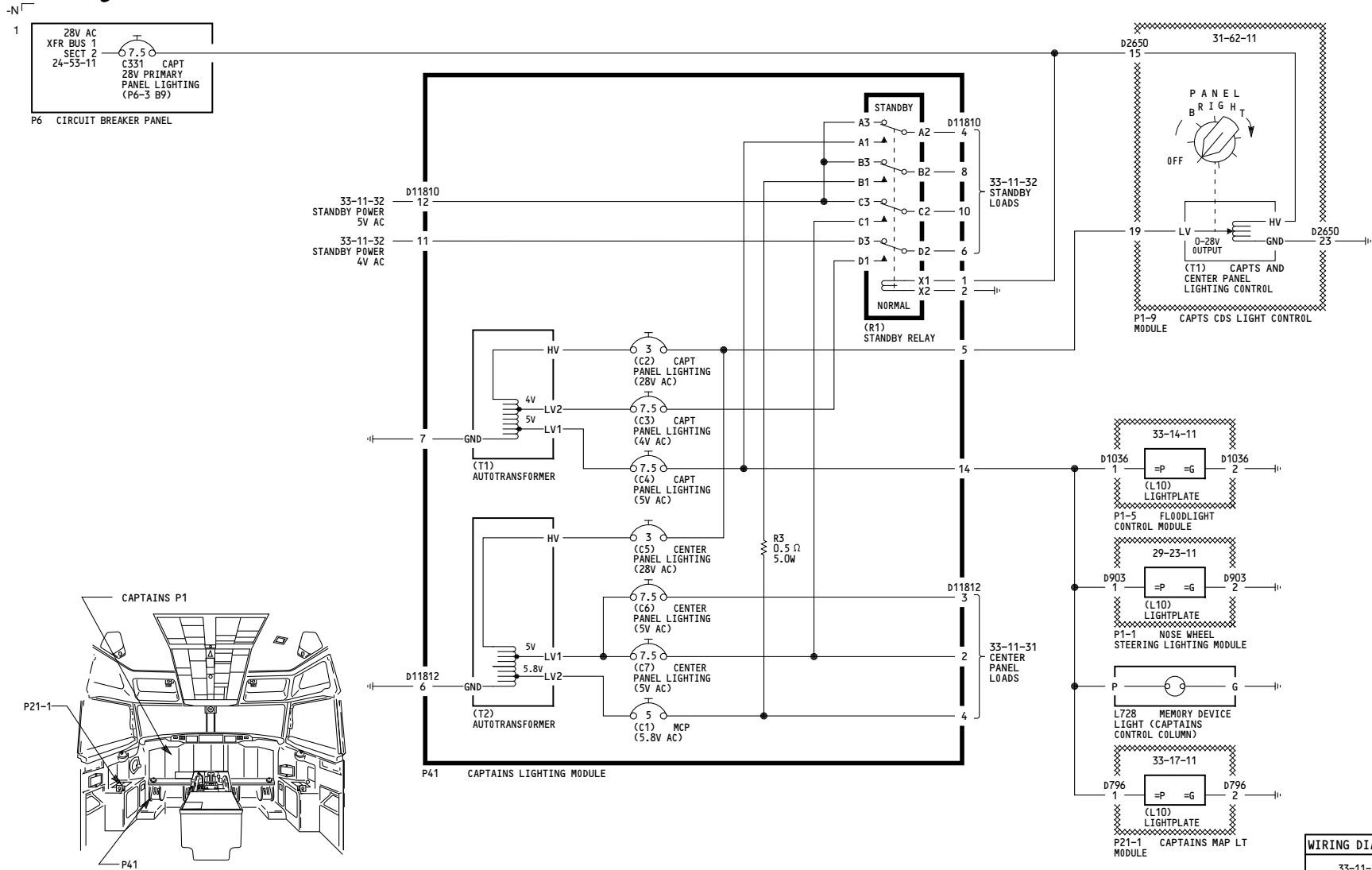

WIRING DIAGRAMS
 33-11-11

ALL	CAPTAIN'S INSTRUMENT PANEL LIGHTING D280A203
-----	---

33-11-11

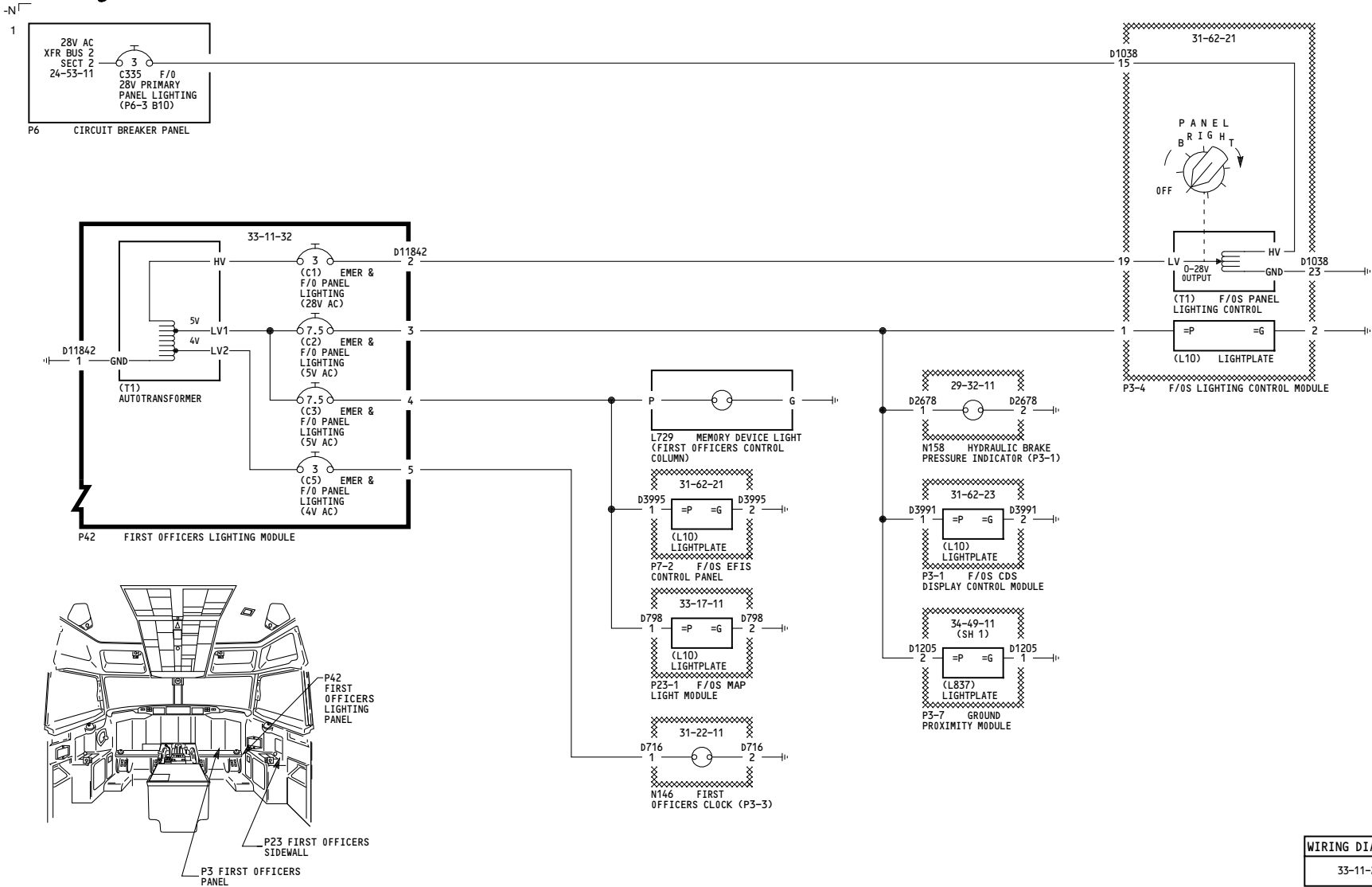

YC001-YC050	FIRST OFFICER'S INSTRUMENT PANEL LIGHTING D280A203
-------------	--

33-11-21

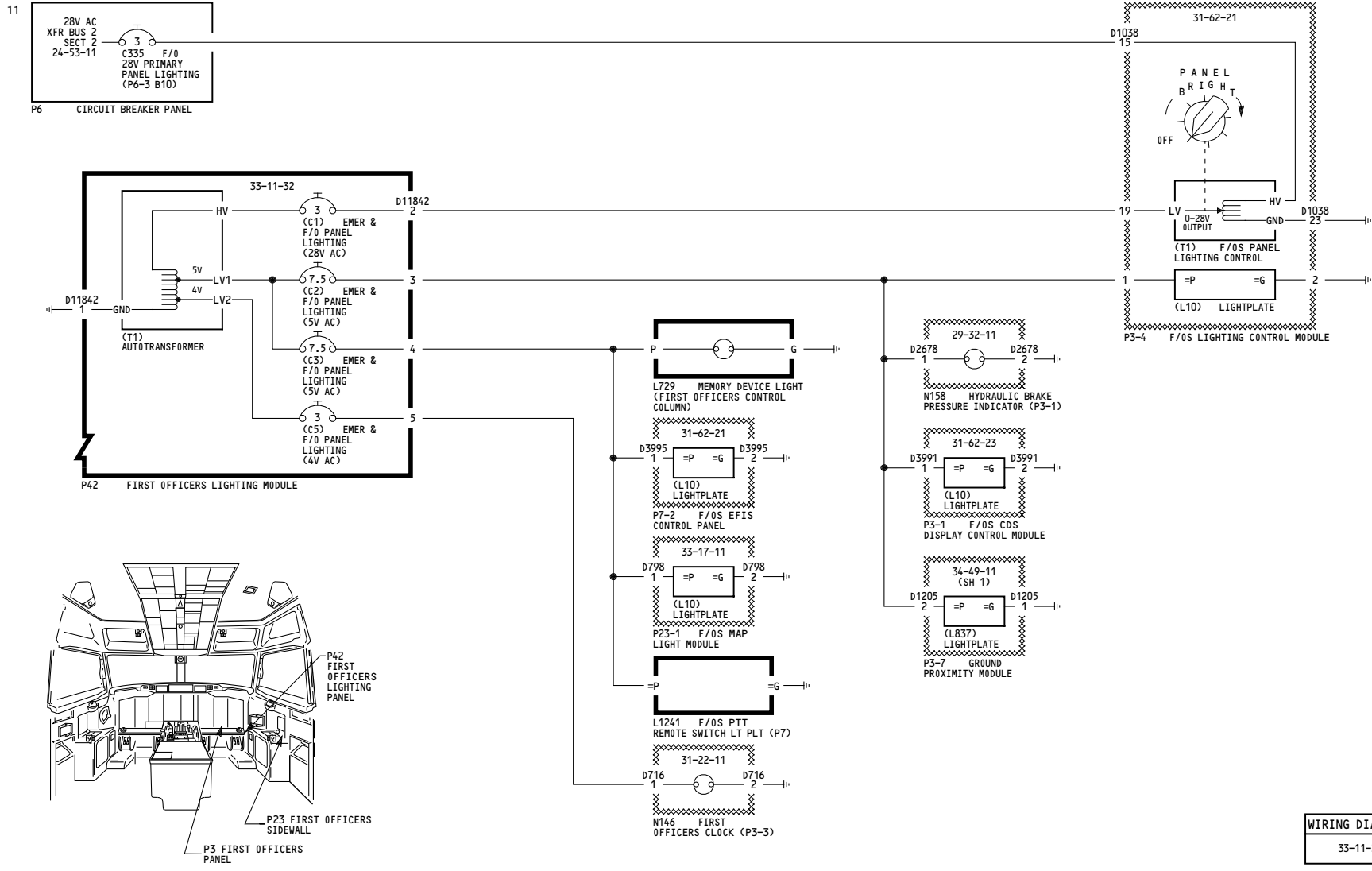

YK901-YM670

FIRST OFFICER'S INSTRUMENT PANEL LIGHTING

D280A203

33-11-21

Page 102

Feb 09/2009

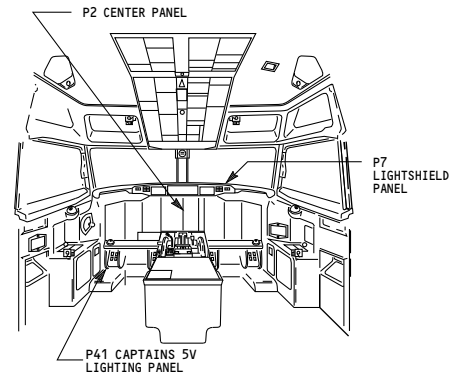
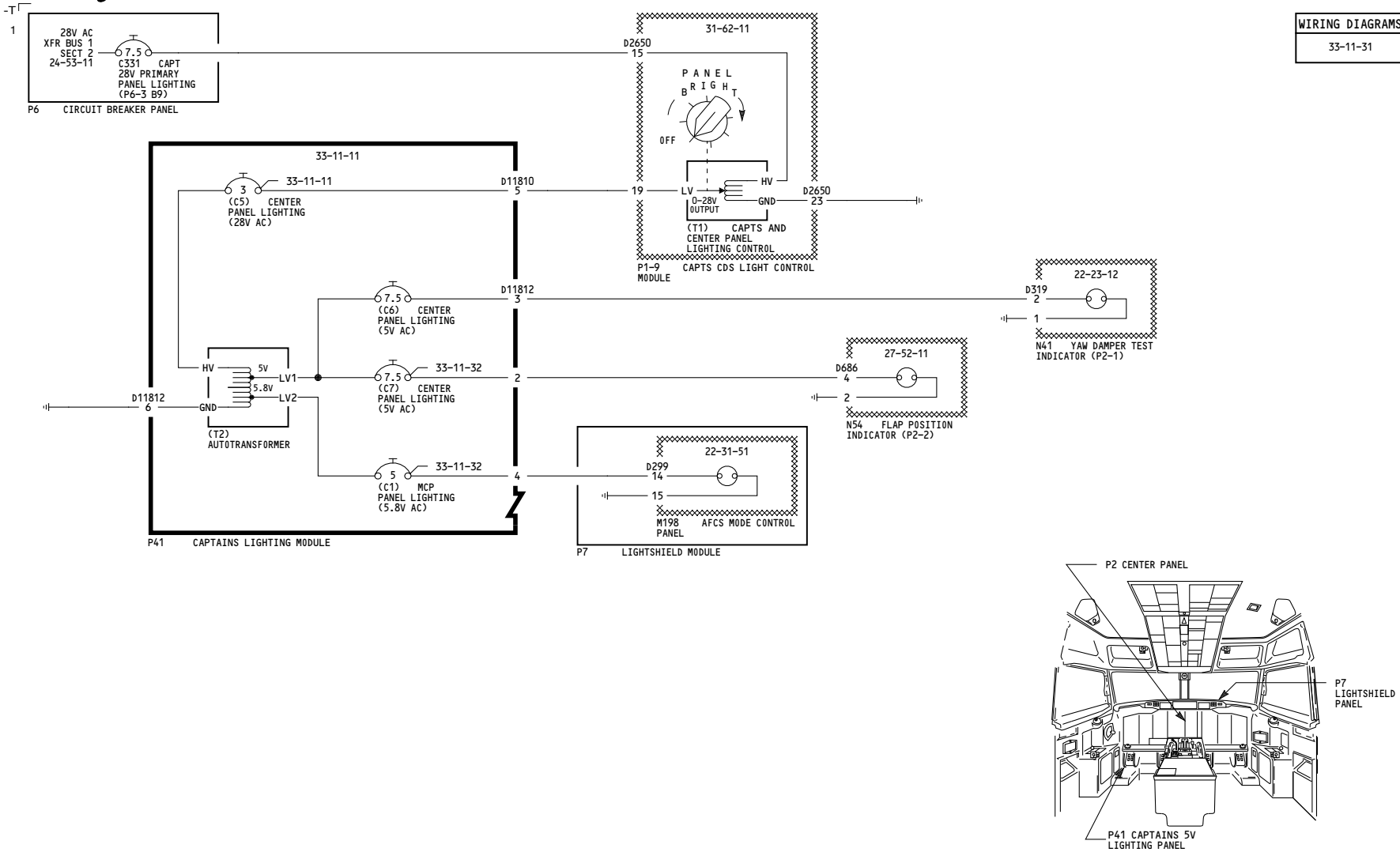

<p>YC001-YC050</p>	<p>CAPTAIN'S & FIRST OFFICER'S CENTER INSTRUMENT PANEL</p> <p>D280A203</p>
--------------------	---

33-11-31

Page 101

Jul 17/2007

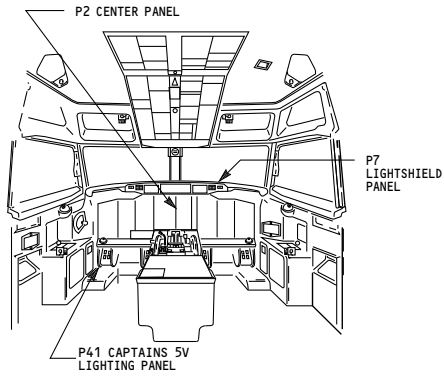
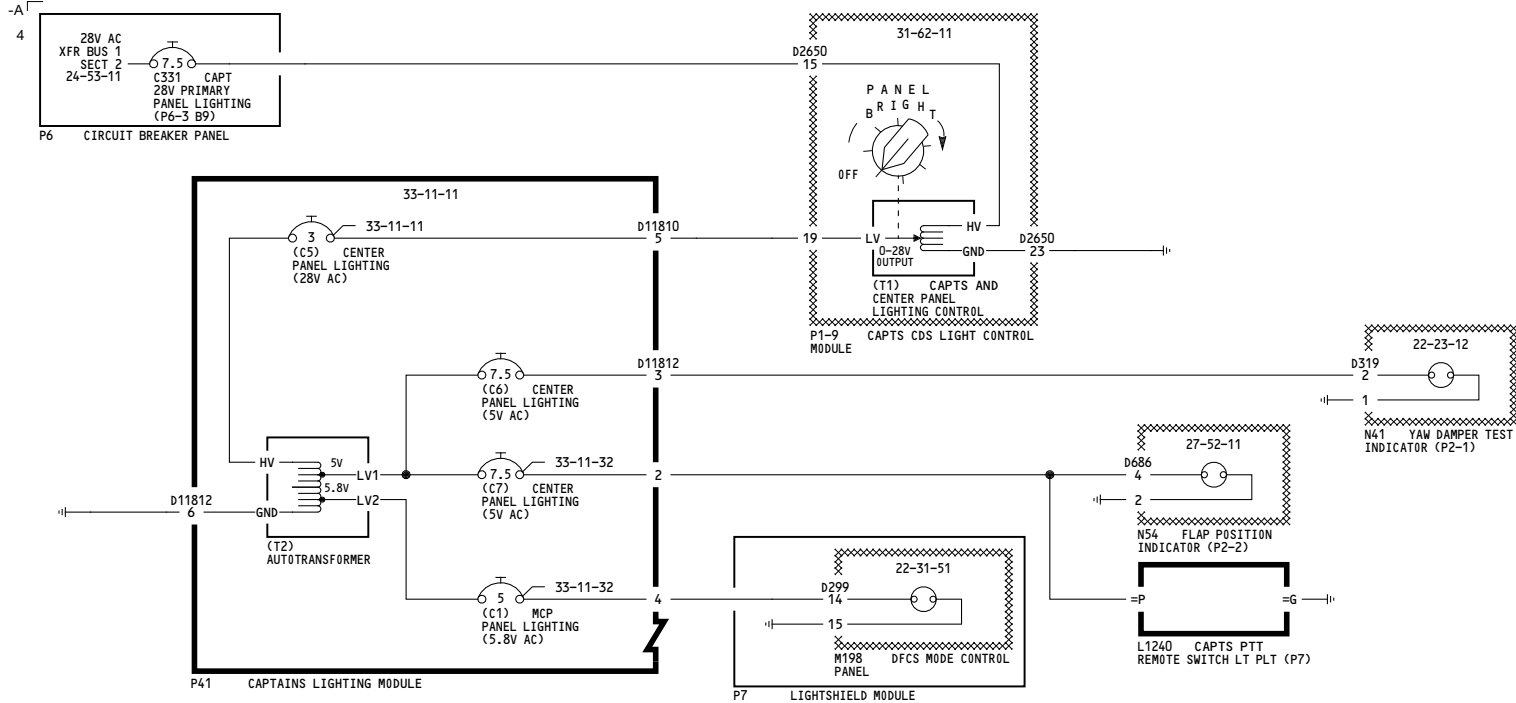

<p>YK901-YM670</p>	<p>CAPTAIN'S & FIRST OFFICER'S CENTER INSTRUMENT PANEL</p> <p>D280A203</p>
--------------------	---

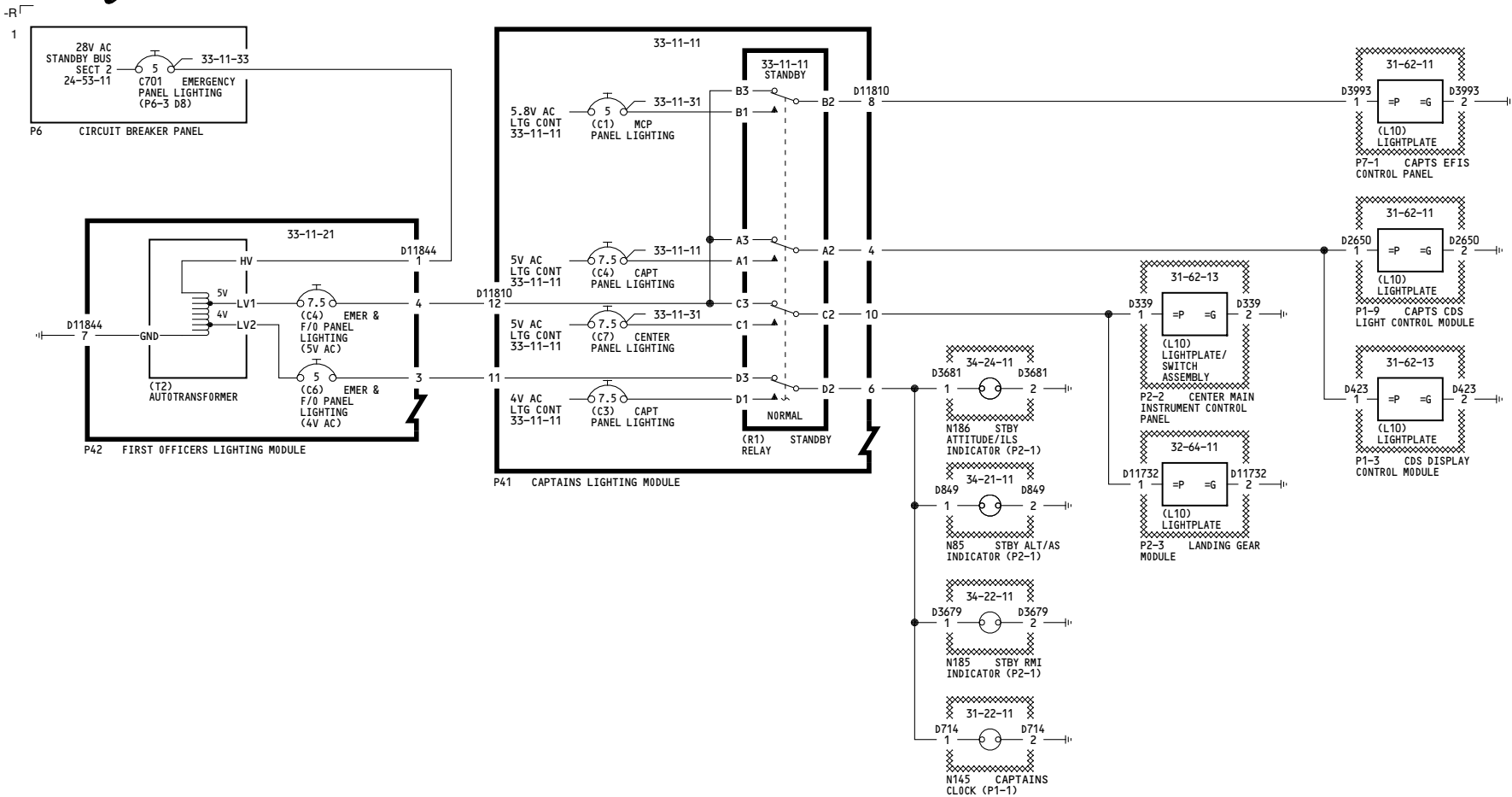

WIRING DIAGRAMS
33-11-32

YC001-YC050

STANDBY INSTRUMENT AND PANEL LIGHTS - CAPT, F/O, CENTER PANELS

D280A203

33-11-32

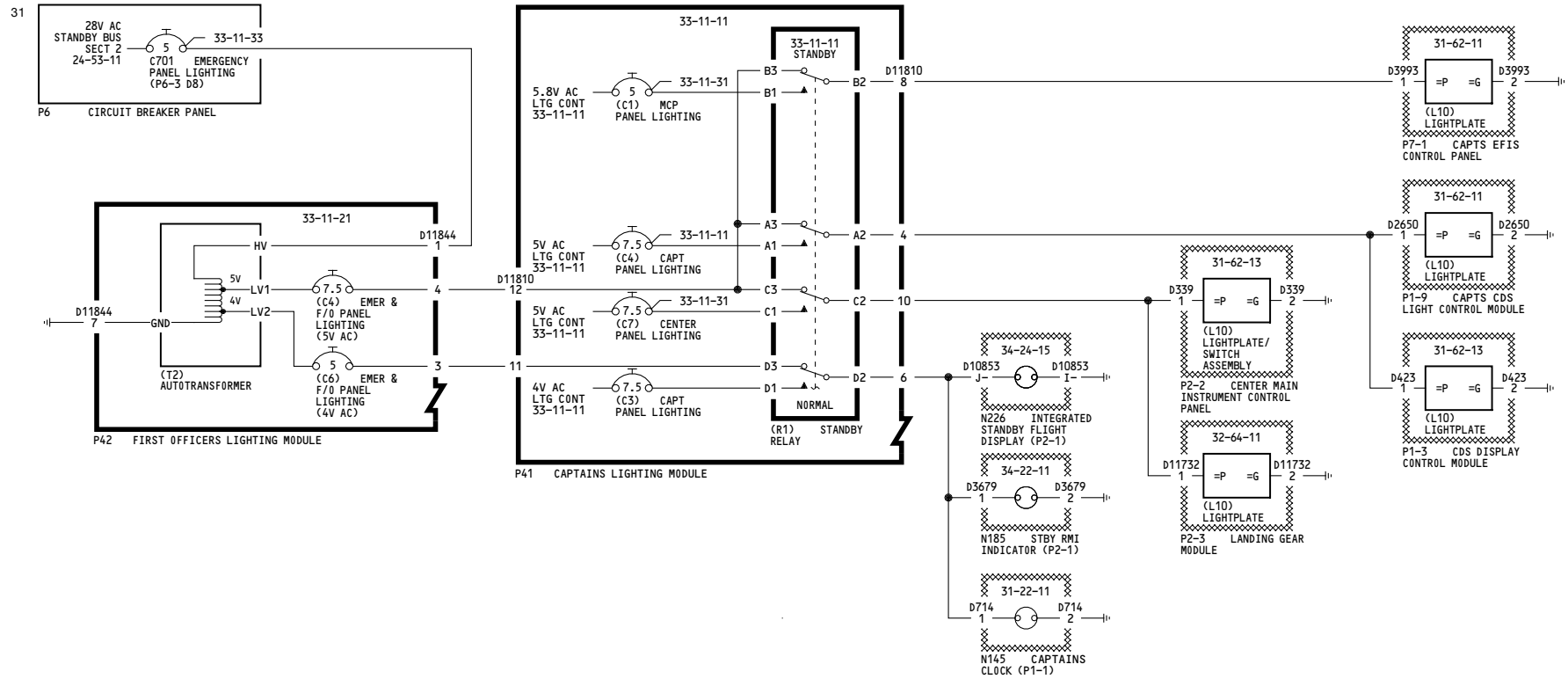

WIRING DIAGRAMS
33-11-32

<p>YK901-YM670</p>	<p>STANDBY INSTRUMENT AND PANEL LIGHTS - CAPT, F/O, CENTER PANELS</p> <p>D280A203</p>
--------------------	--

33-11-32

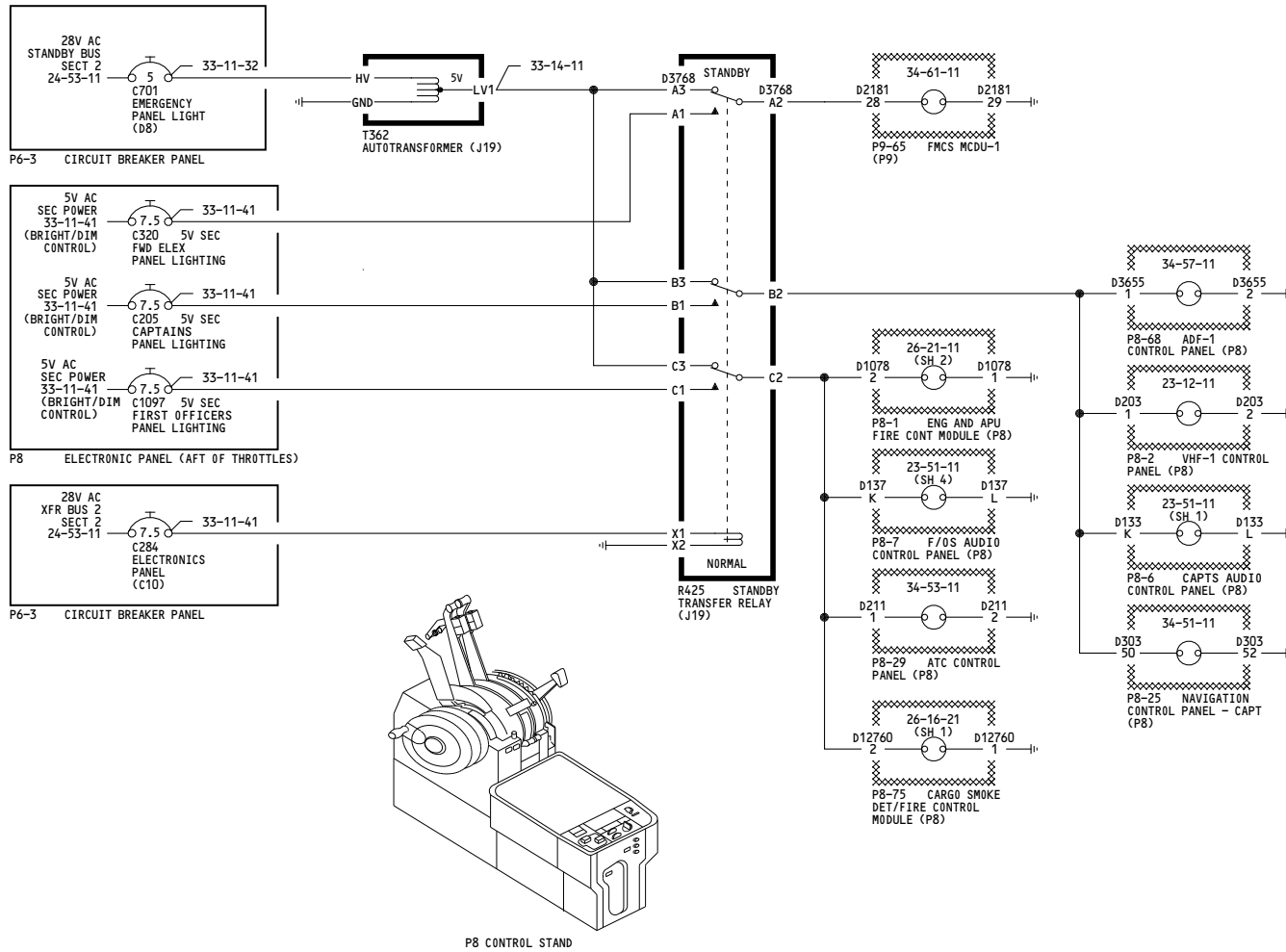

<p>YC001-YC007</p>	<p>STANDBY INSTRUMENT AND PANEL LIGHTS - CONTROL STAND</p> <p>Incorporates 26A1083 R01</p> <p>D280A203</p>
--------------------	---

43

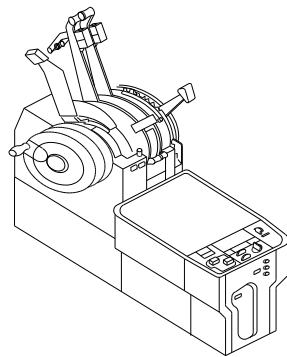
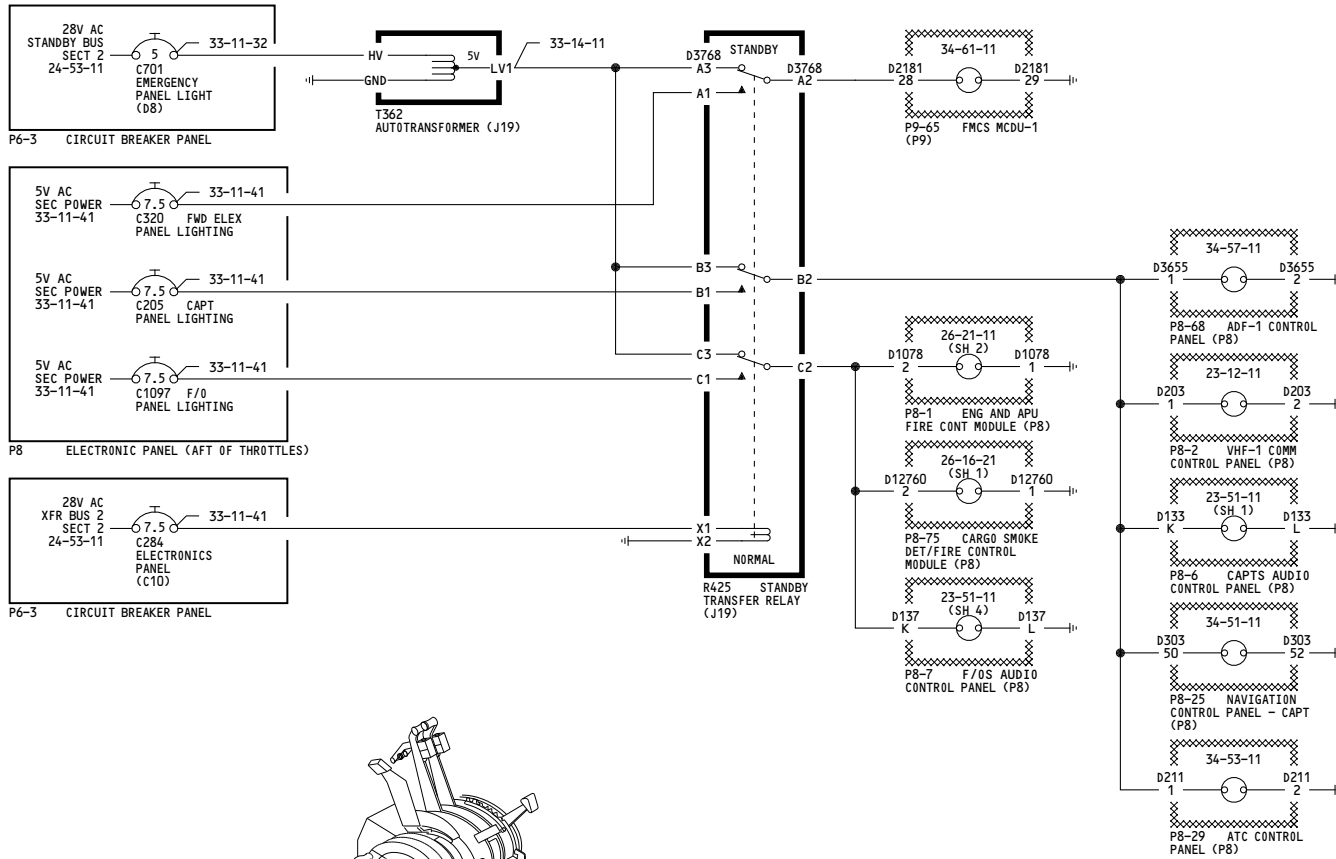

P8 CONTROL STAND

<p>YC008-YC050</p>	<p>STANDBY INSTRUMENT AND PANEL LIGHTS - CONTROL STAND</p> <p>D280A203</p>
--------------------	---

WIRING DIAGRAMS
33-11-33

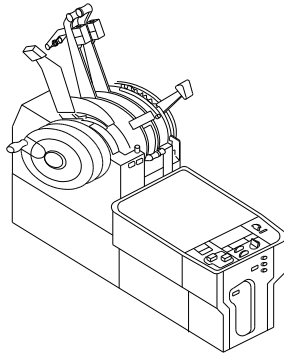
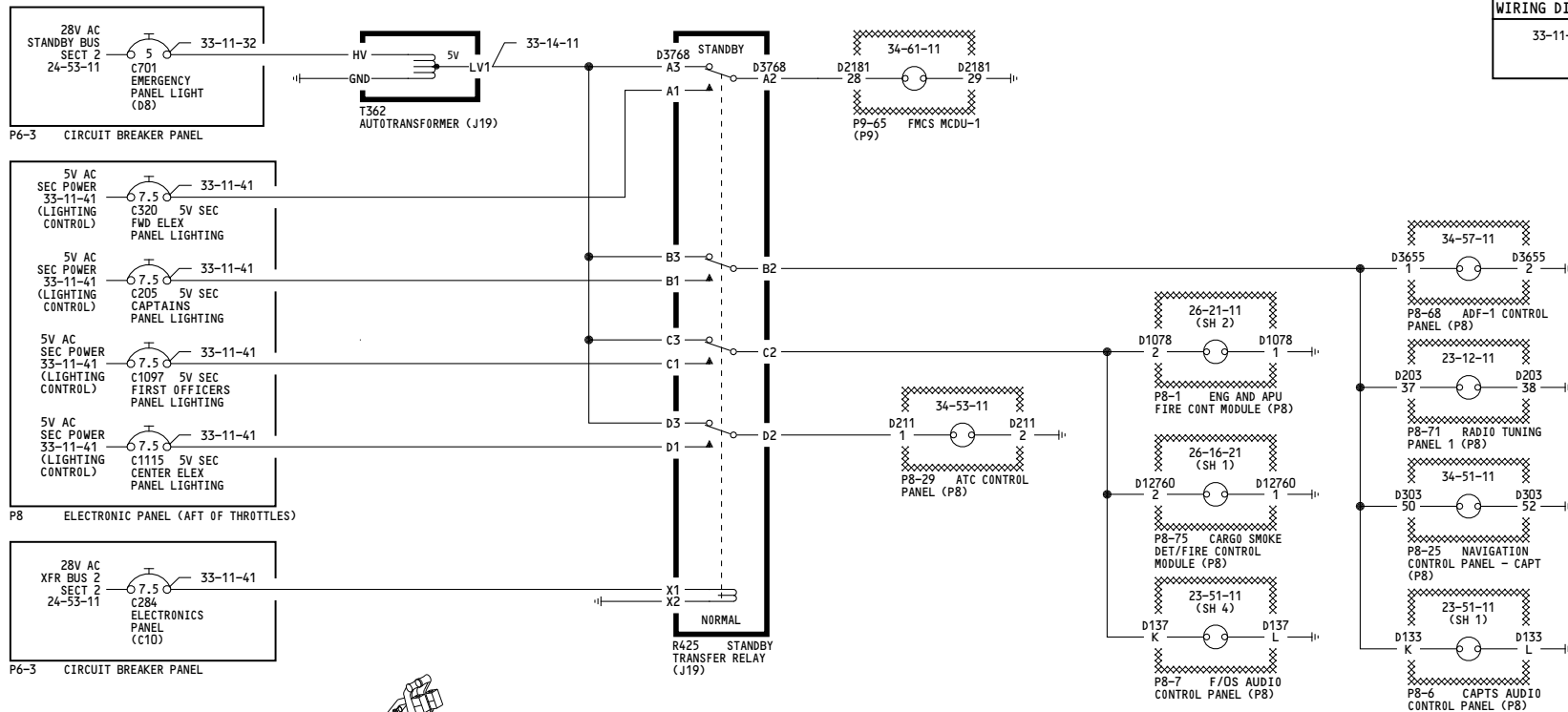

P8 CONTROL STAND

YK901-YM670

**STANDBY INSTRUMENT AND
PANEL LIGHTS -
CONTROL STAND**

D280A203

33-11-33

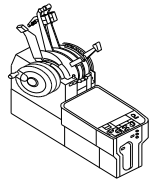
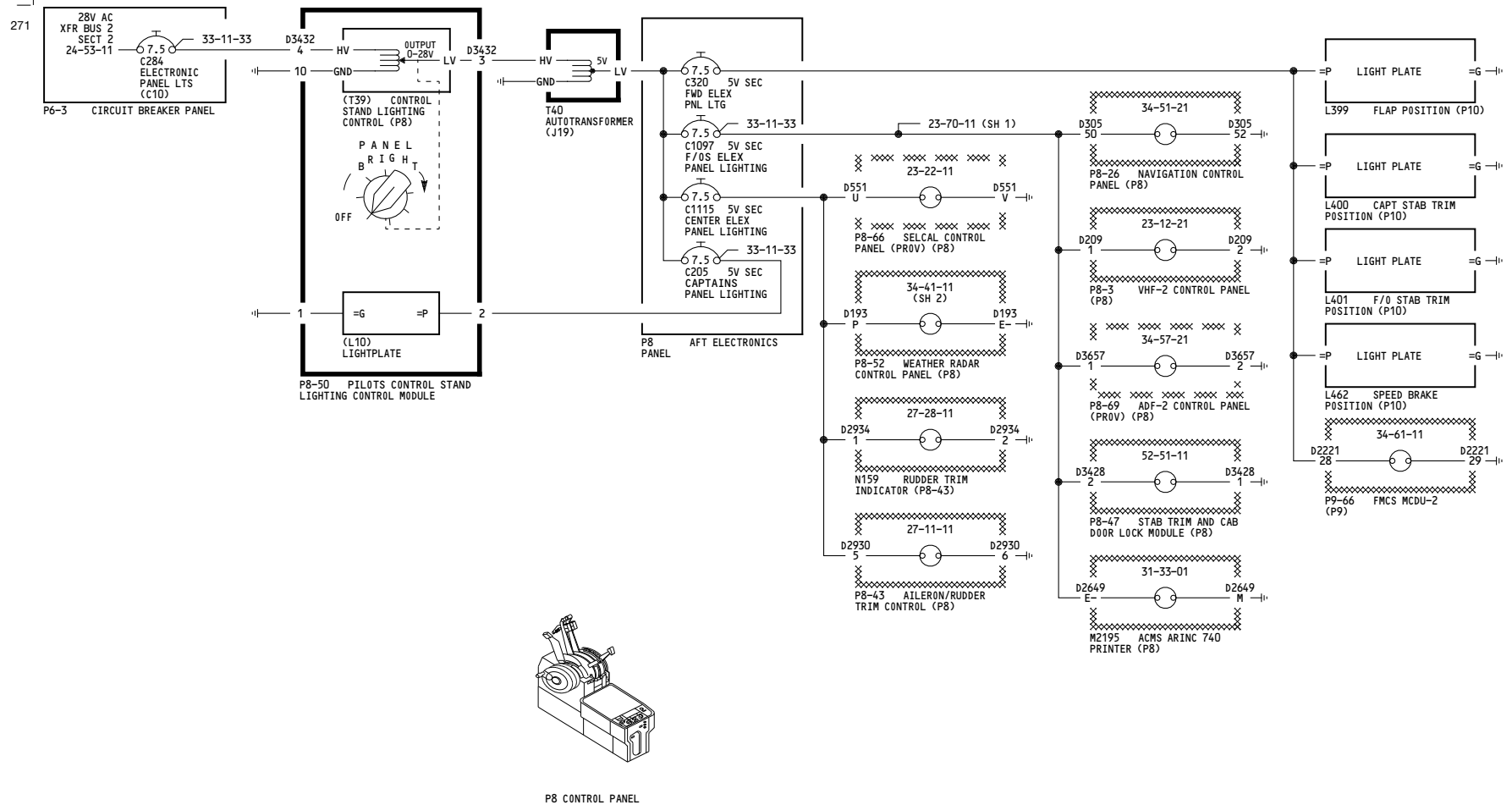

P8 CONTROL PANEL

WIRING DIAGRAMS
33-11-41

<p>YC001-YC030</p>	<p>PILOTS CONTROL STAND LIGHTING</p> <p>D280A203</p>
--------------------	---

Incorporates
230106

33-11-41

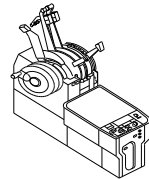
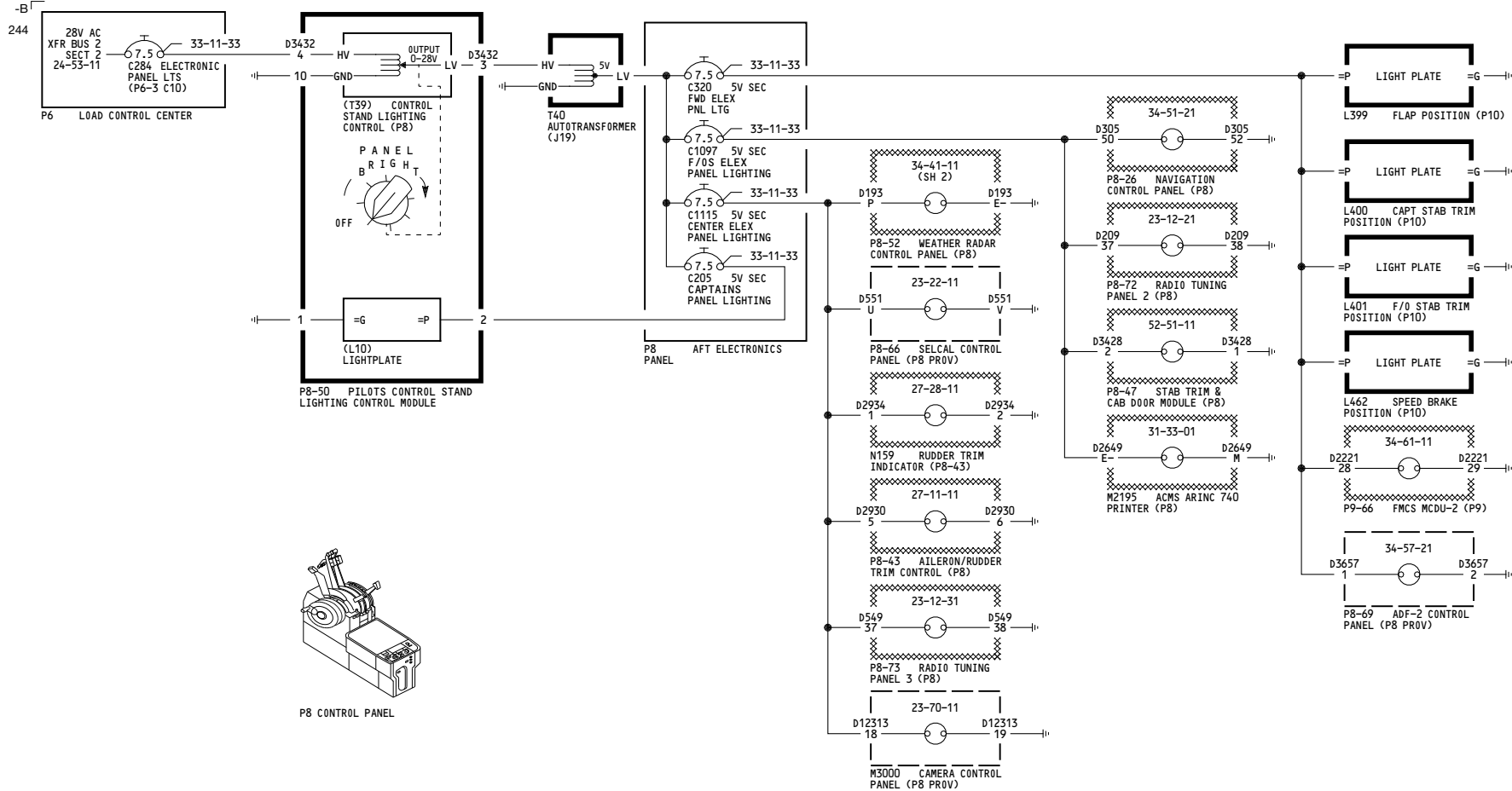

P8 CONTROL PANEL

<p>YK901-YK906</p>	<p>PILOTS CONTROL STAND LIGHTING</p> <p>D280A203</p>
--------------------	---

WIRING DIAGRAMS
33-11-41

33-11-41

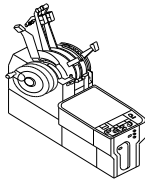
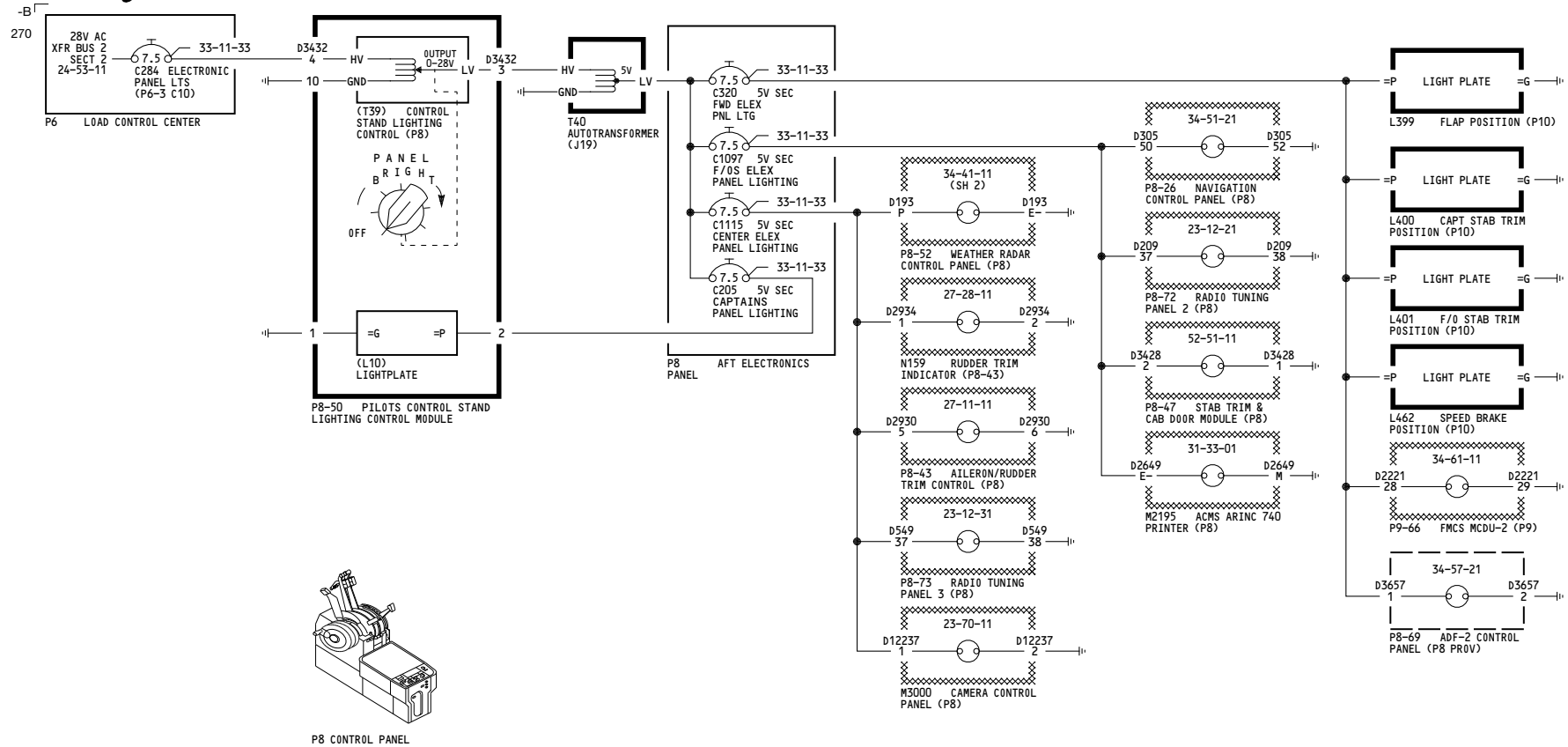

P8 CONTROL PANEL

WIRING DIAGRAMS
33-11-41

33-11-41

<p>YK907-YM670</p>	<p>PILOTS CONTROL STAND LIGHTING</p> <p>D280A203</p>
--------------------	---

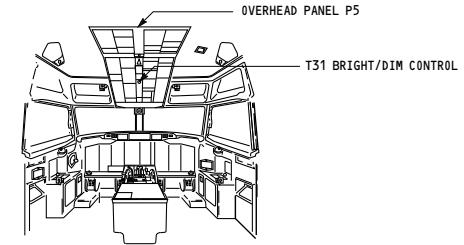
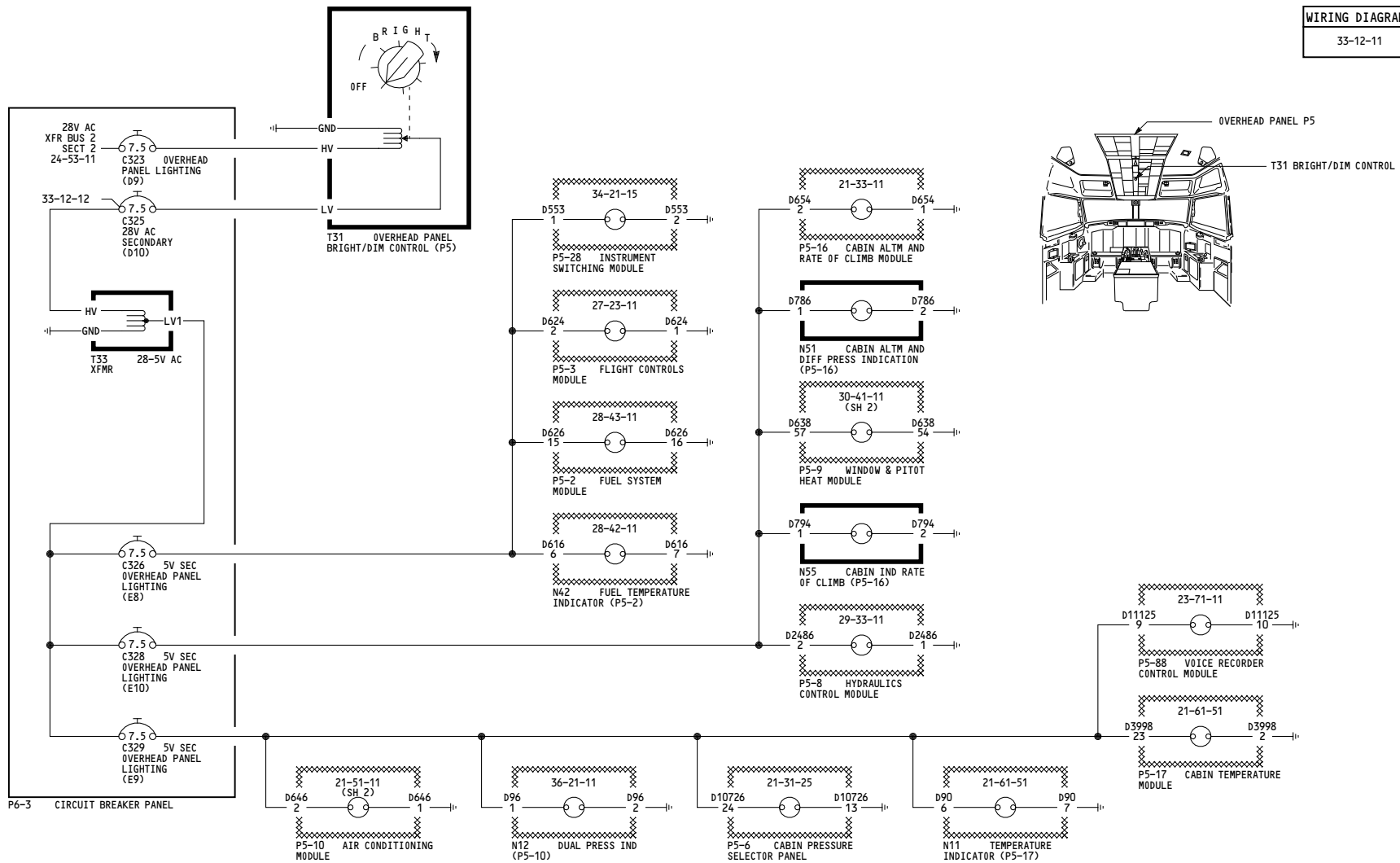

YC001-YC007	<p align="center">OVERHEAD INSTRUMENT PANEL LIGHTS PART ONE</p> <p align="center">D280A203</p>
-------------	---

Incorporates
23-1107

33-12-11

Page 101.1

Mar 31/2005

8

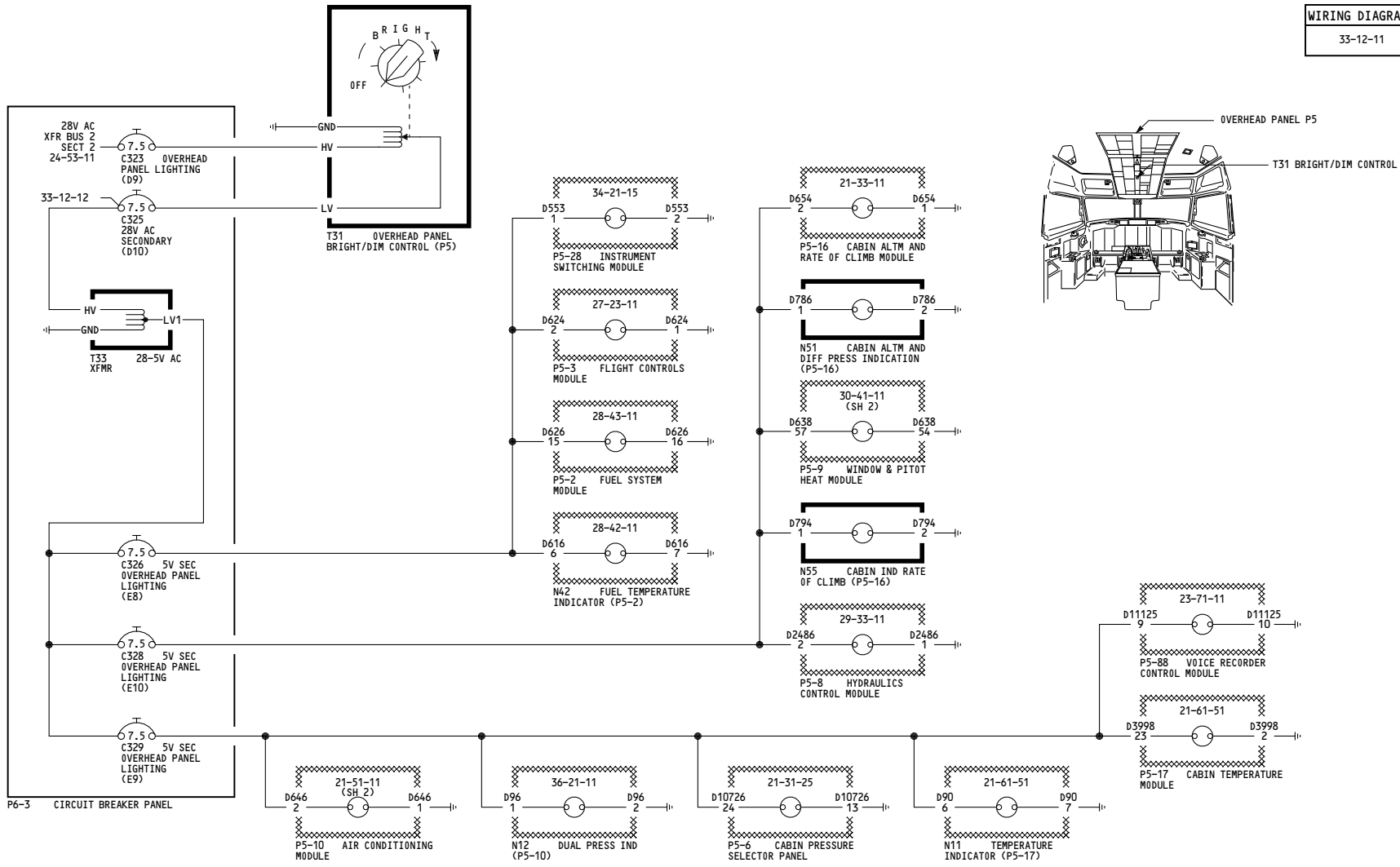

<p>YC008-YL430</p>	<p>OVERHEAD INSTRUMENT PANEL LIGHTS PART ONE</p> <p>D280A203</p>
--------------------	---

33-12-11

Page 102

Feb 09/2009

7

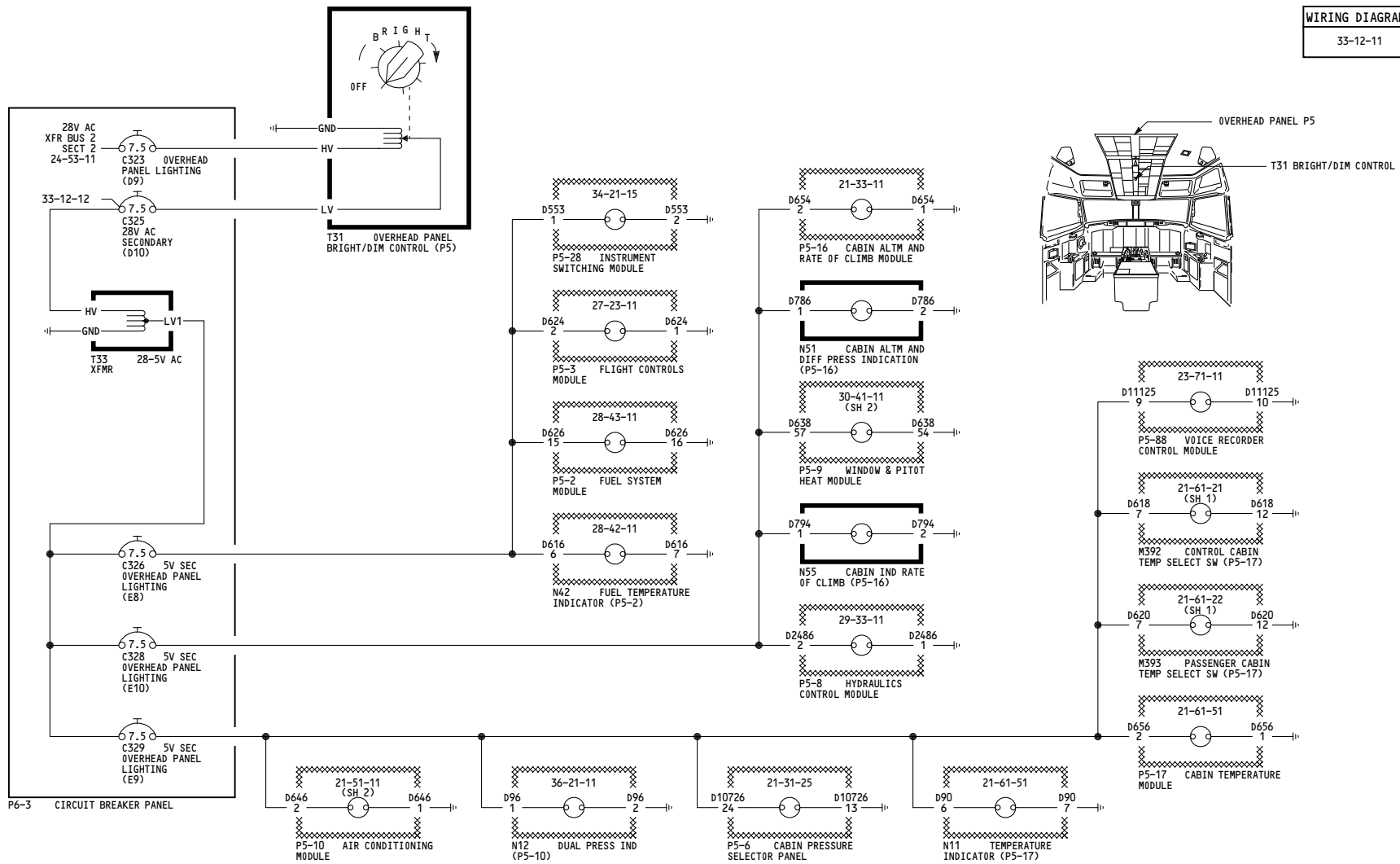

YM643-YM670	OVERHEAD INSTRUMENT PANEL LIGHTS PART ONE D280A203
-------------	--

33-12-11

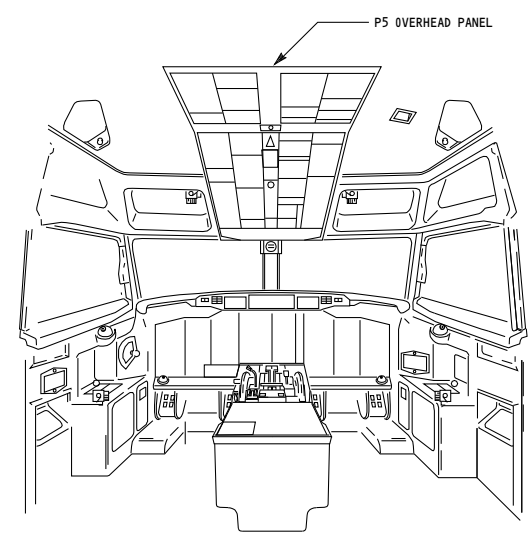
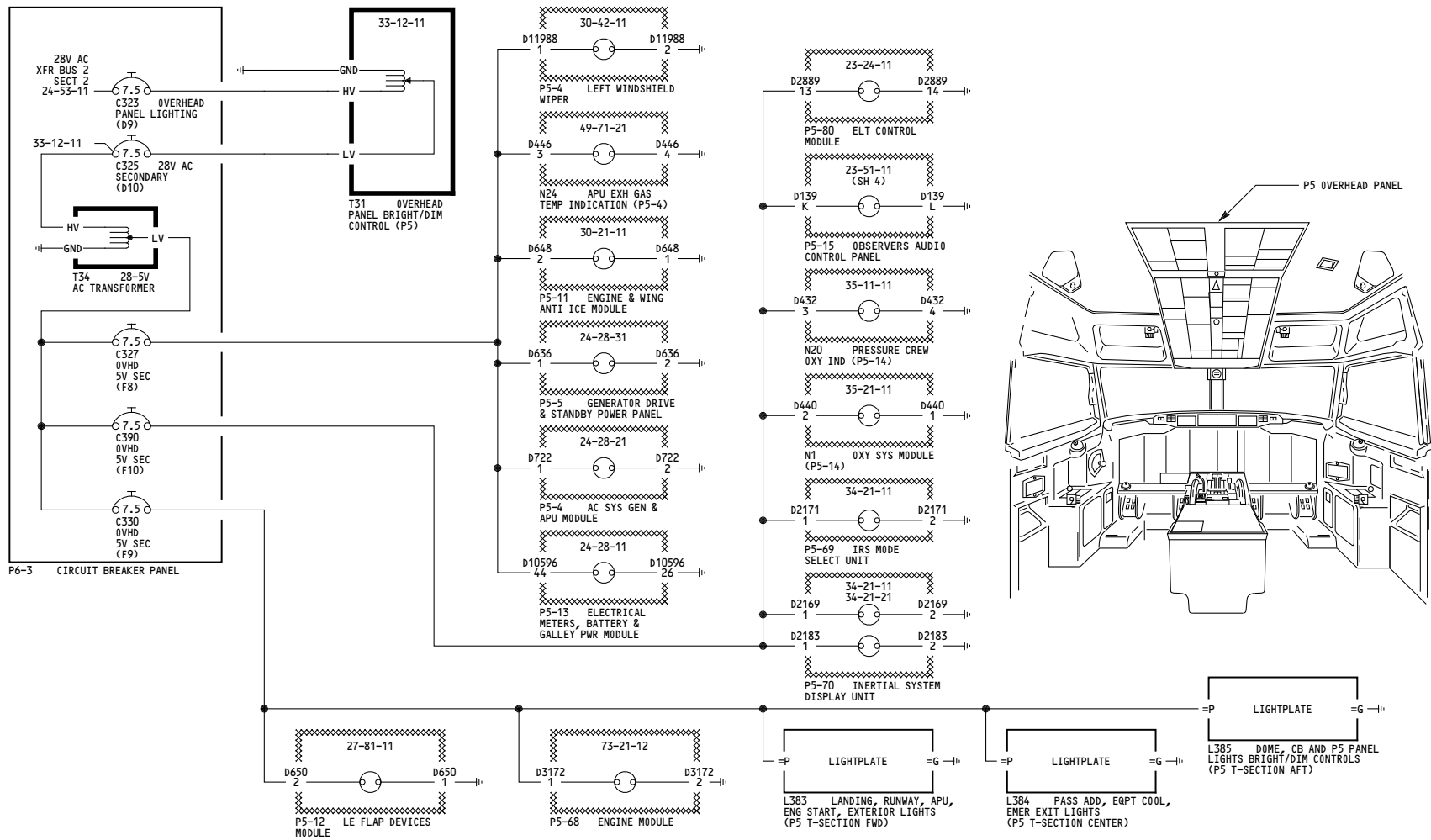

ALL	<p>OVERHEAD INSTRUMENT PANEL LIGHTS PART TWO</p> <p>D280A203</p>
-----	---

33-12-12

Page 101

Feb 09/2009

WIRING DIAGRAMS
33-14-11

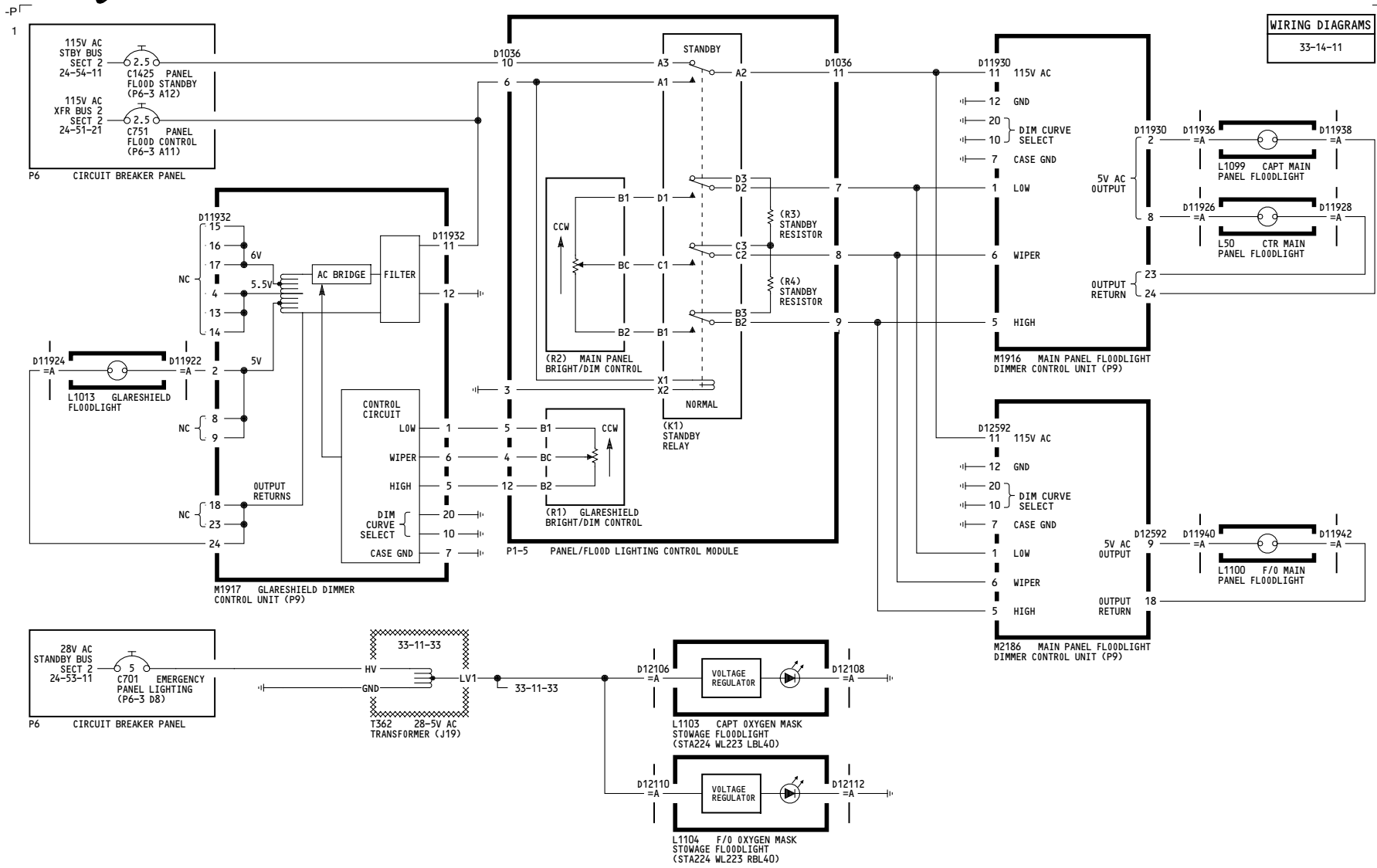

ALL PILOT'S BACKGROUND LIGHTS

D280A203

33-14-11

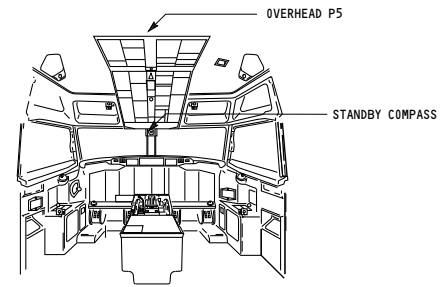
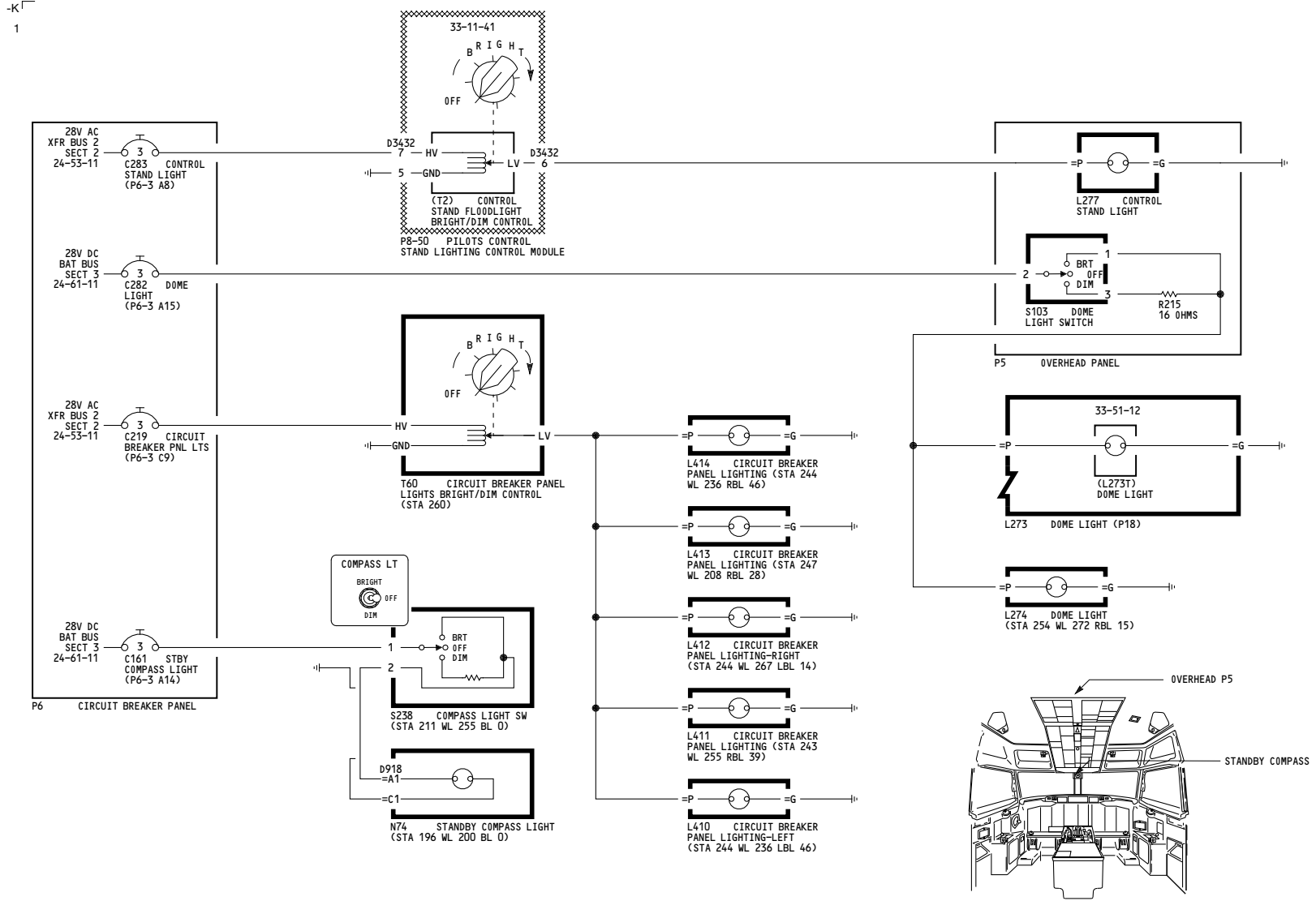

ALL

DOME LTG, CONTROL STAND FLOOD LTG, STBY COMPASS LTG, & C/B PNL LTG

D280A203

33-14-12

Page 101

Feb 09/2009

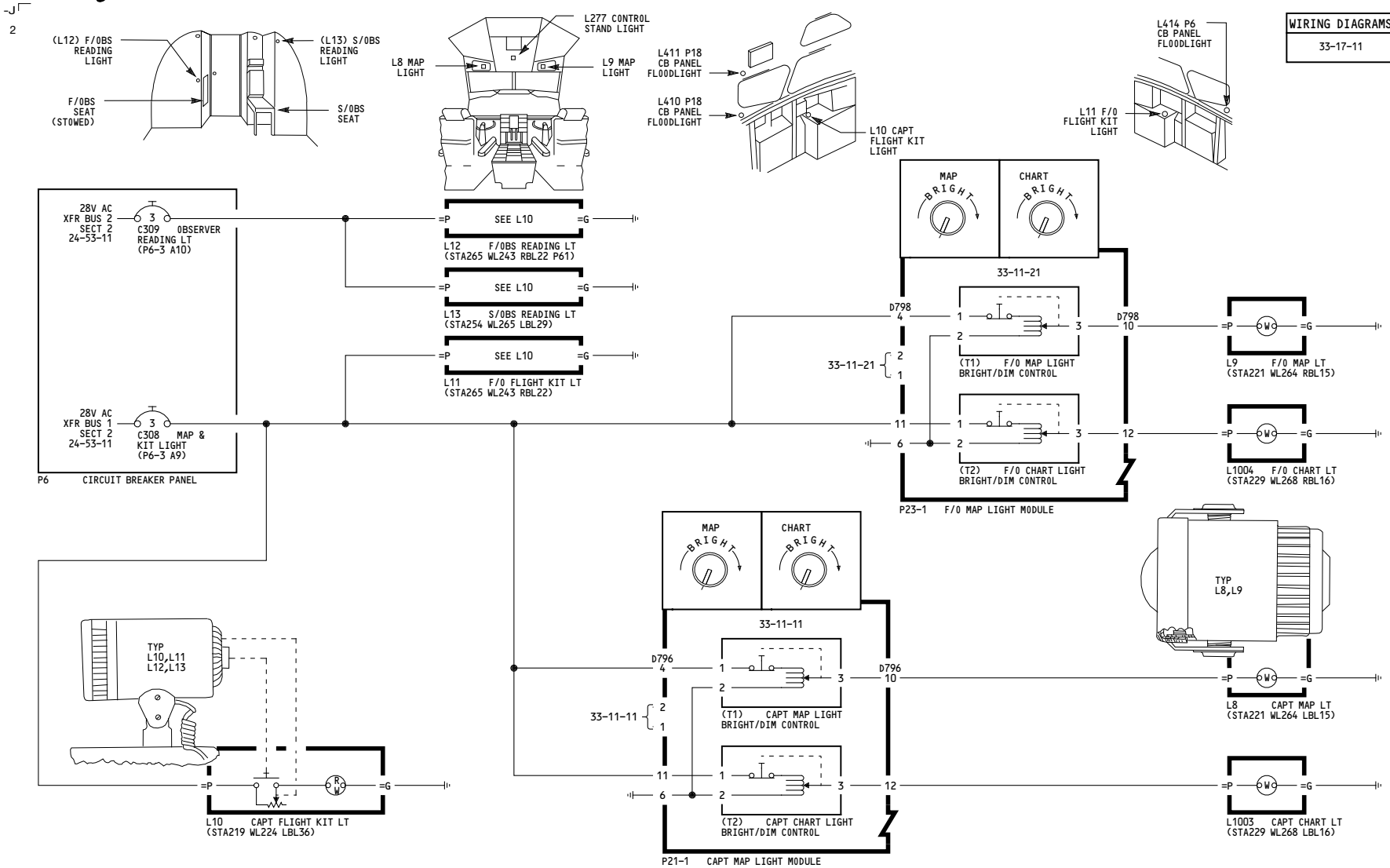

YC001-YC026

MAP, FLIGHT KIT AND READING LIGHTS

D280A203

33-17-11

Page 101

Jul 17/2007

WIRING DIAGRAMS
33-17-11

-B
11

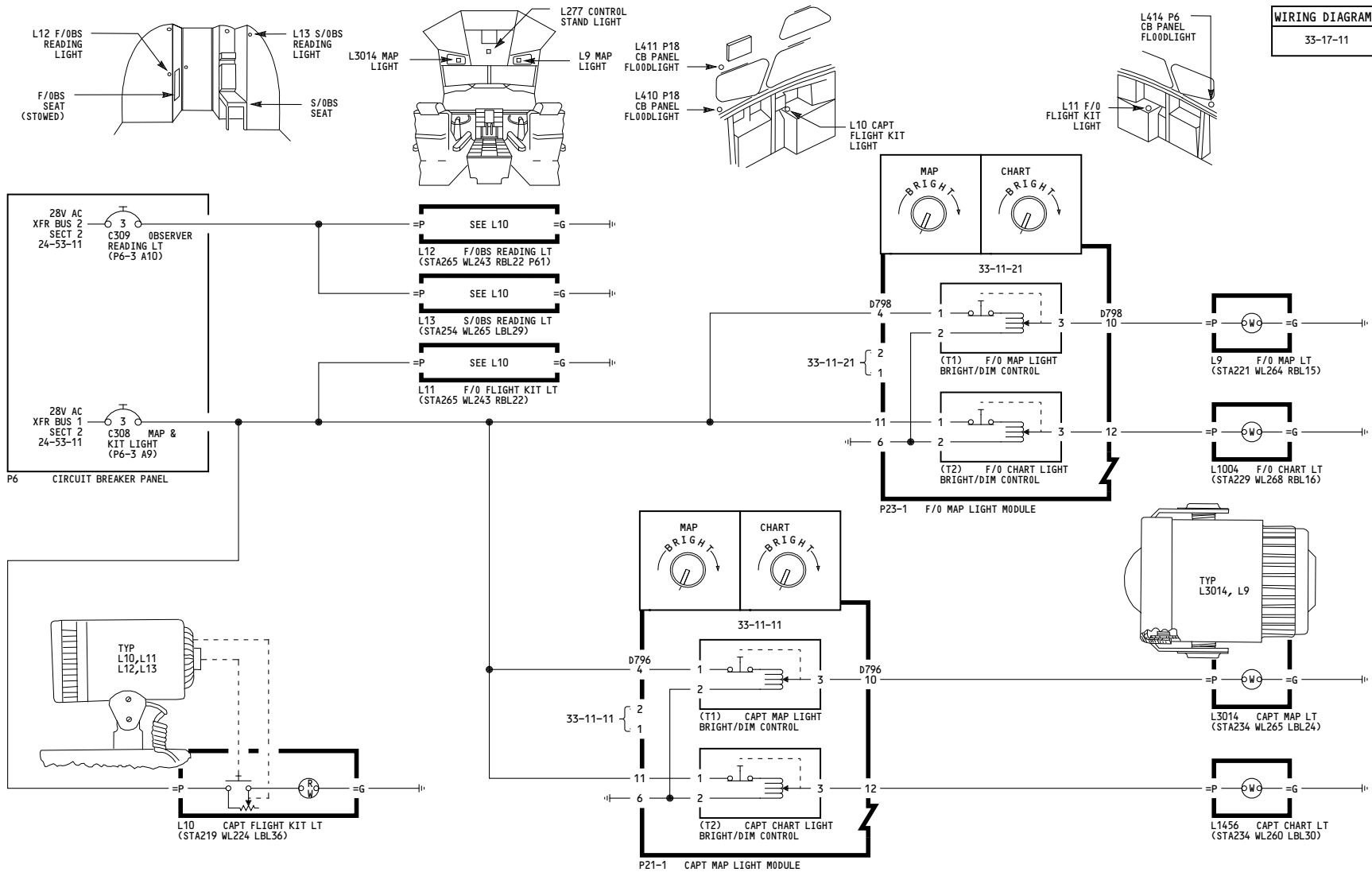

YC028-YC050, YK910-YK920

MAP, FLIGHT KIT AND READING LIGHTS

D280A203

33-17-11

Page 102

Feb 09/2009

-B
10

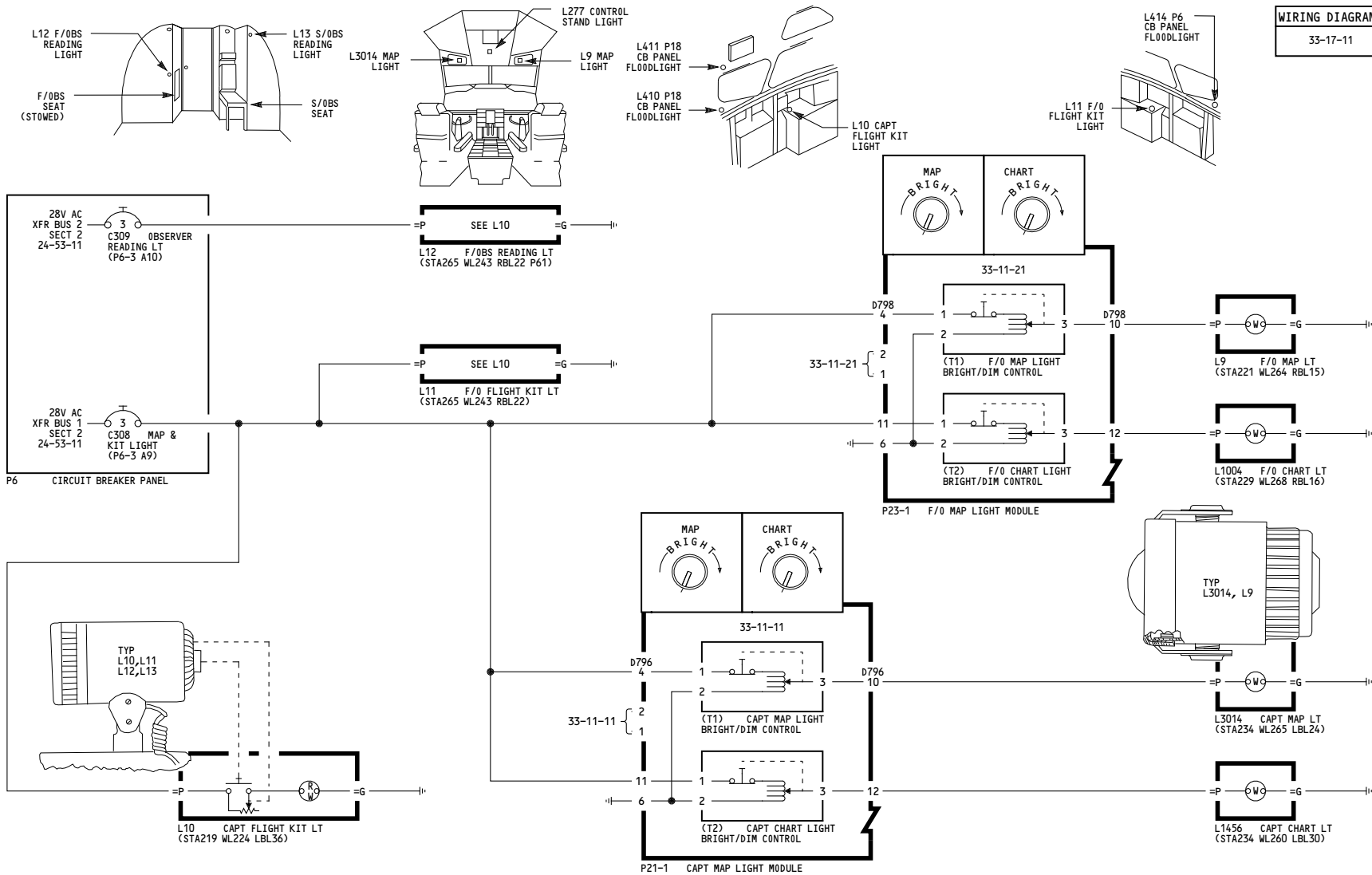

YK901-YK909, YL401-YM670

MAP, FLIGHT KIT AND READING LIGHTS

D280A203

33-17-11

Page 103

Aug 13/2008

-D
3

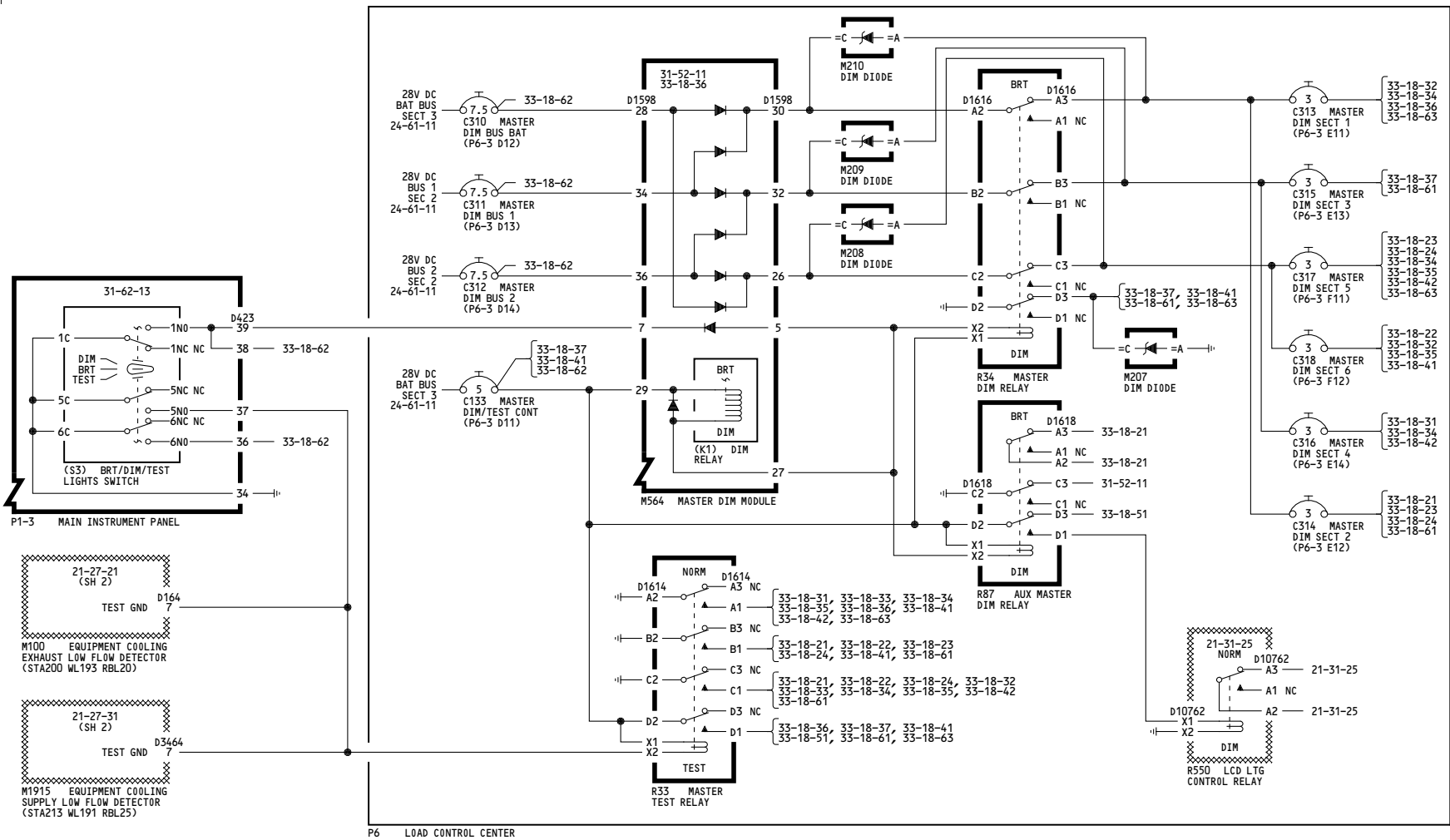

WIRING DIAGRAMS
33-18-11

YC001-YC026	MASTER DIM & TEST SYSTEM- POWER & CONTROL
	D280A203

33-18-11

Page 101

Jul 17/2007

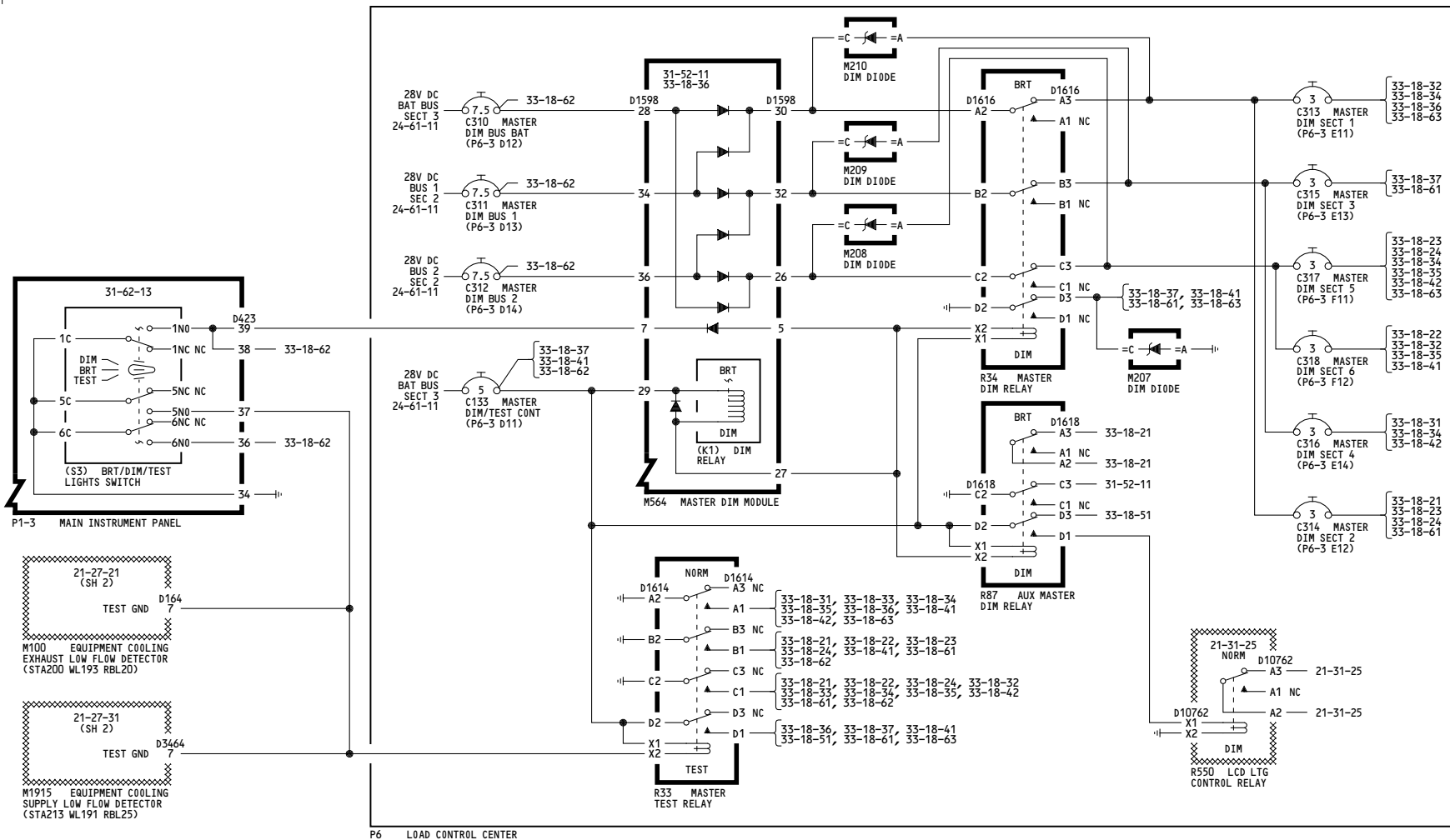

WIRING DIAGRAMS
33-18-11

YC028-YC030

**MASTER DIM & TEST SYSTEM-
POWER & CONTROL**

33-18-11

D280A203

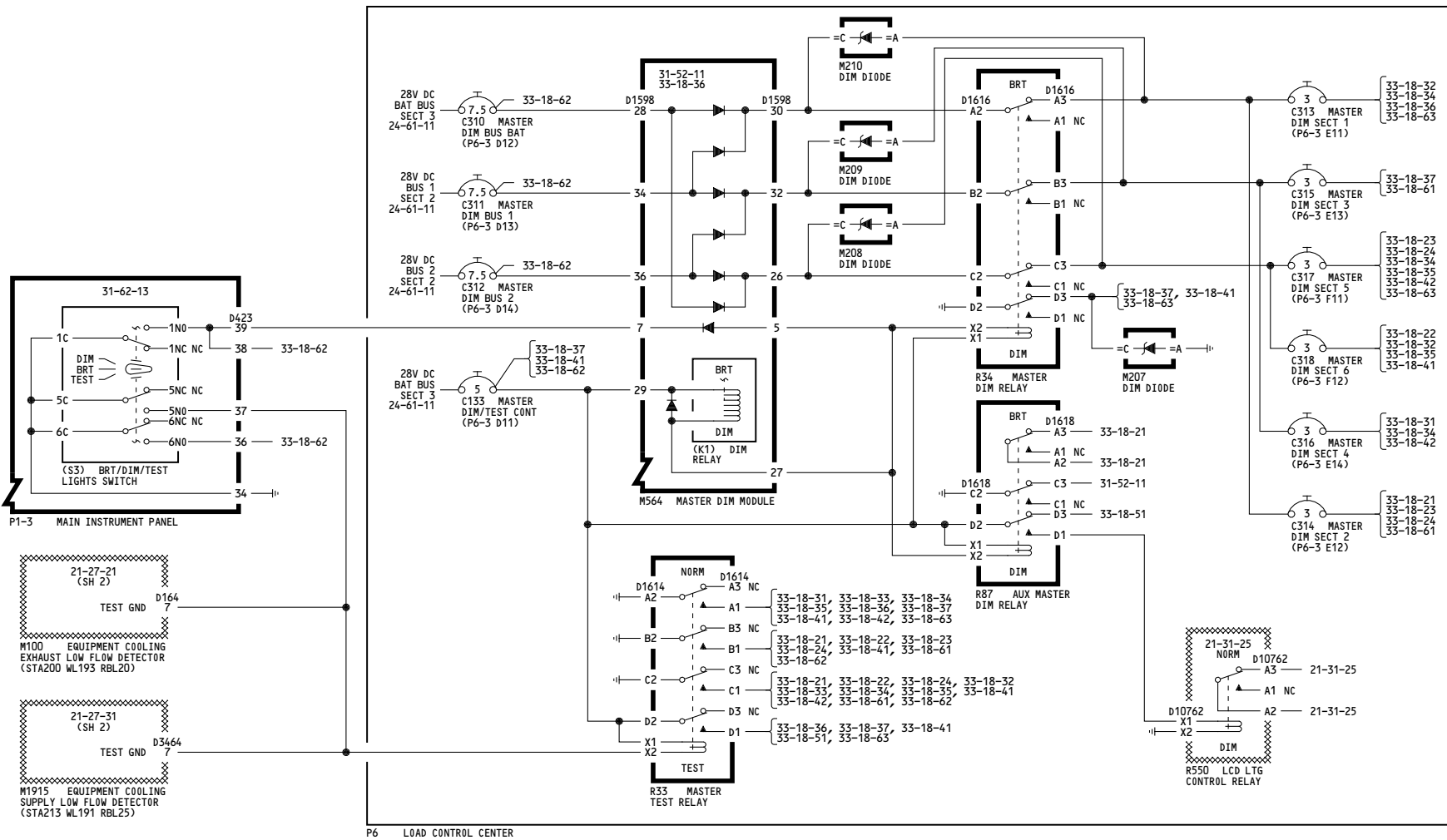

YK901-YM670

**MASTER DIM & TEST SYSTEM-
POWER & CONTROL**

D280A203

WIRING DIAGRAMS

33-18-11

33-18-11

Page 103

Feb 09/2009

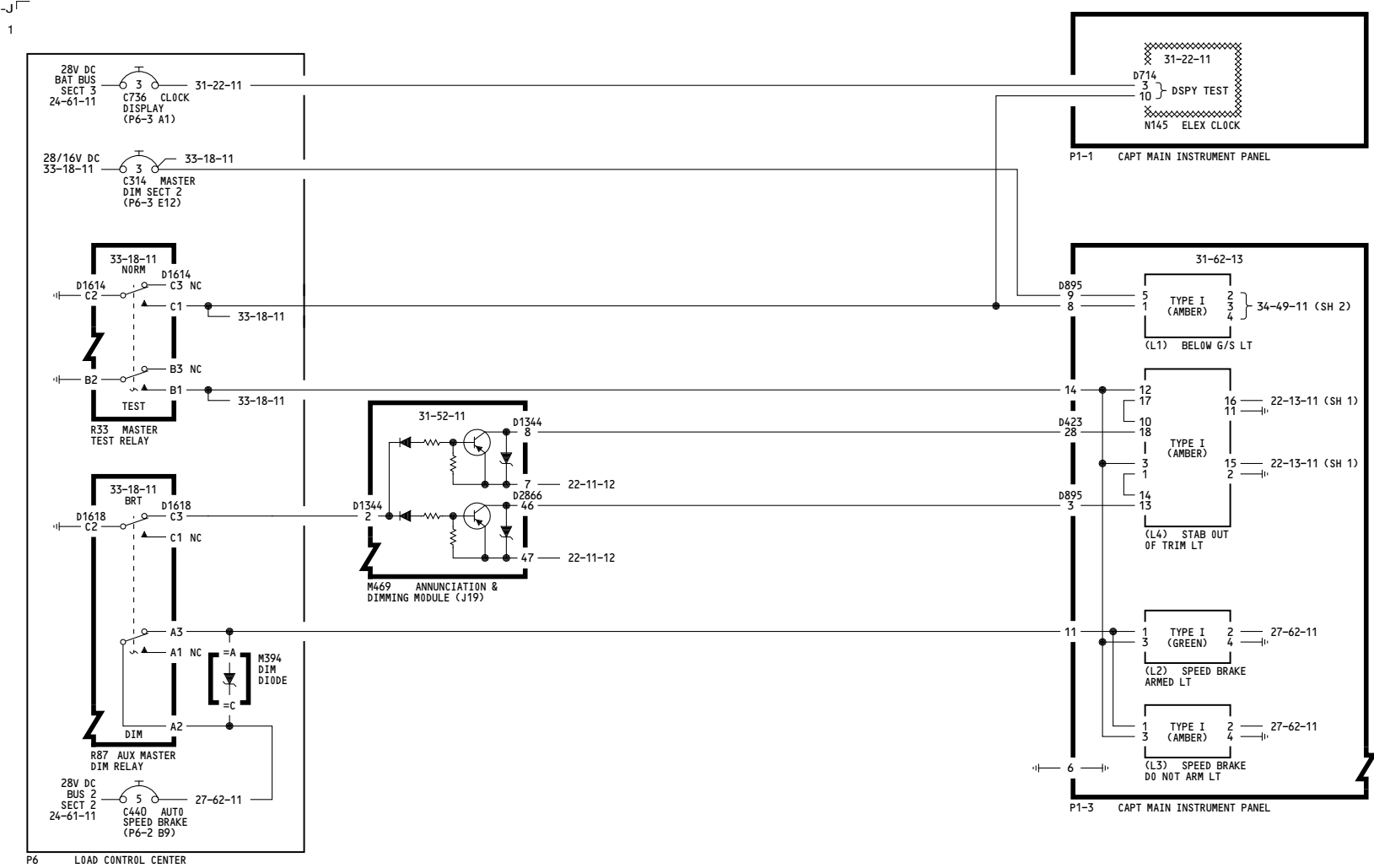

WIRING DIAGRAMS
33-18-11

YC001-YK910, YL421-YL423, YM643

**MASTER DIM & TEST SYSTEM-
MAIN INSTRUMENT PANEL,
CAPT**

D280A203

33-18-21

Page 101

Jul 17/2007

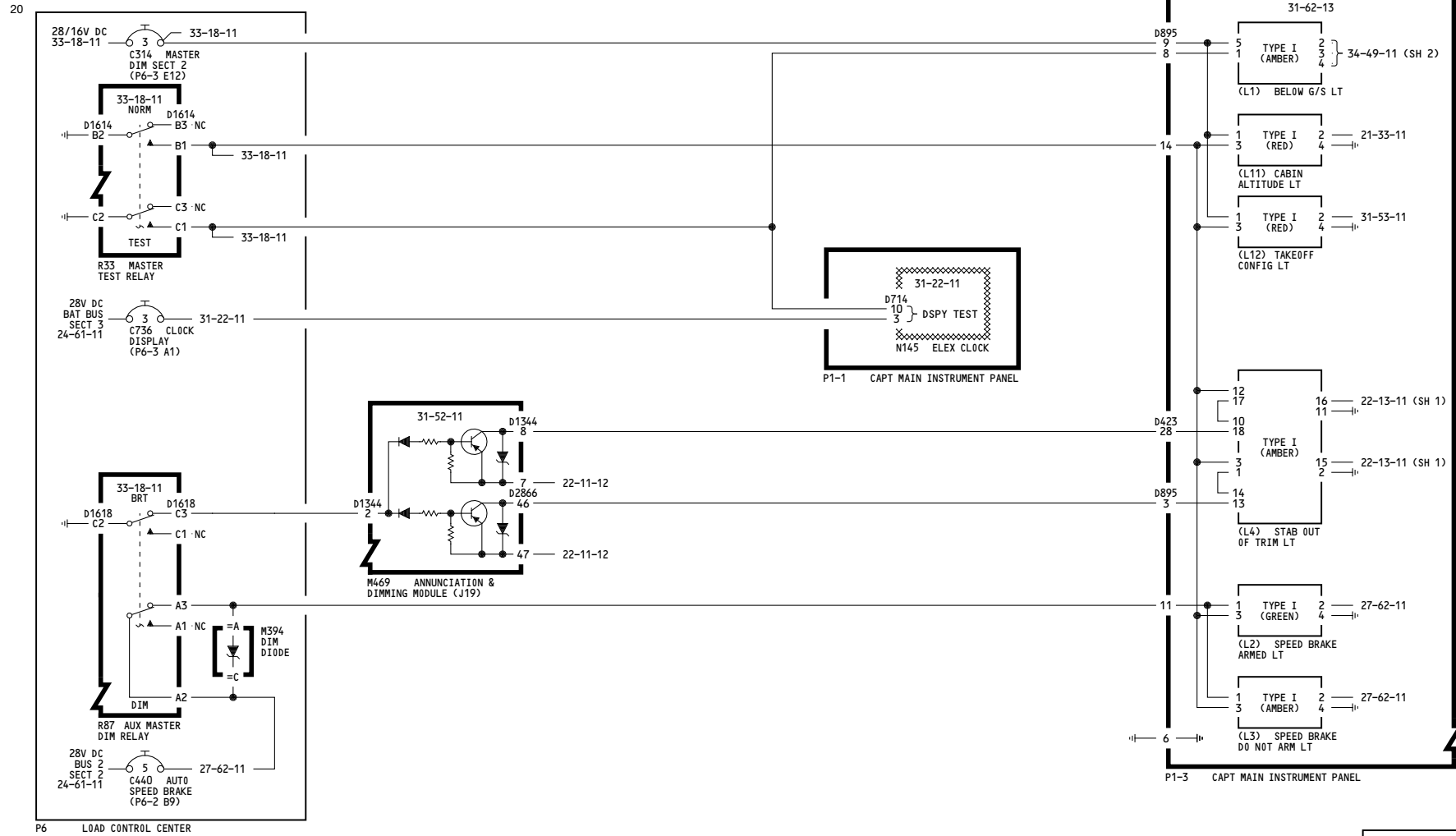

WIRING DIAGRAMS
33-18-21

33-18-21

YK911-YL401, YL424-YL430, YM645-YM670

**MASTER DIM & TEST SYSTEM-
MAIN INSTRUMENT PANEL,
CAPT**

D280A203

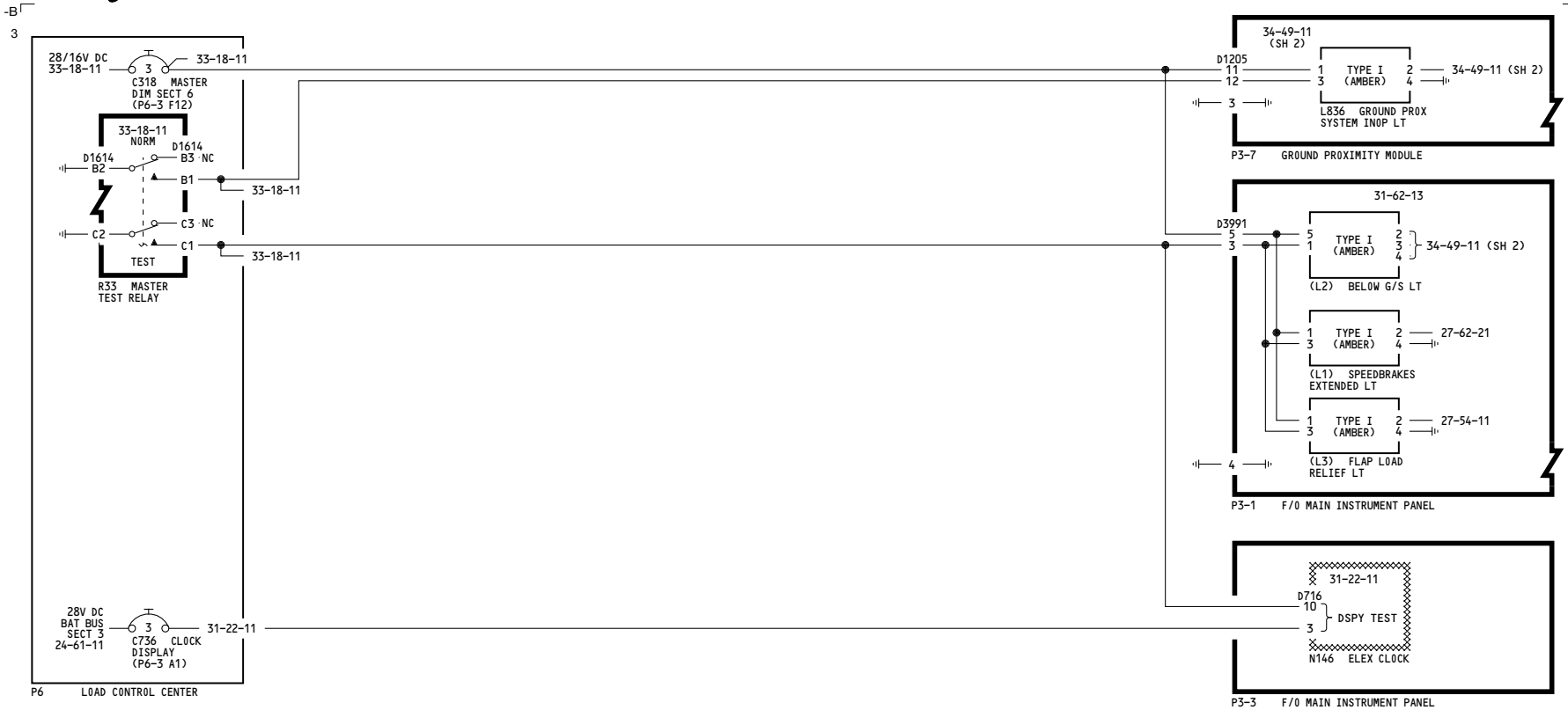

WIRING DIAGRAMS

33-18-22

33-18-22

Page 101

Jul 17/2007

YC001-YK910, YL421-YL423, YM643

**MASTER DIM & TEST SYSTEM-
MAIN INSTRUMENT PANEL,
F/O**

D280A203

54

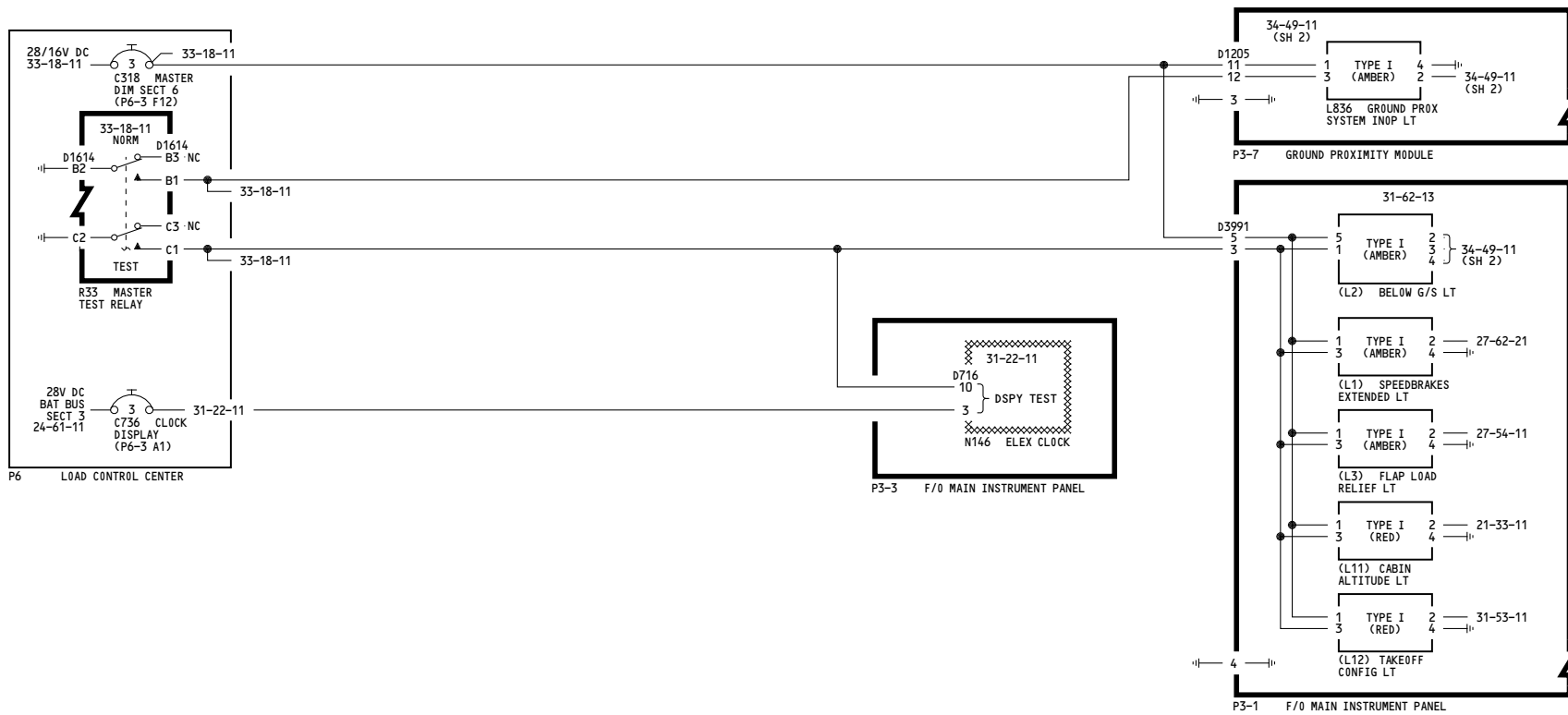

WIRING DIAGRAMS
33-18-22

33-18-22

Page 102

Feb 09/2009

YK911-YL401, YL424-YL430, YM645-YM670

**MASTER DIM & TEST SYSTEM-
MAIN INSTRUMENT PANEL,
F/O**

D280A203

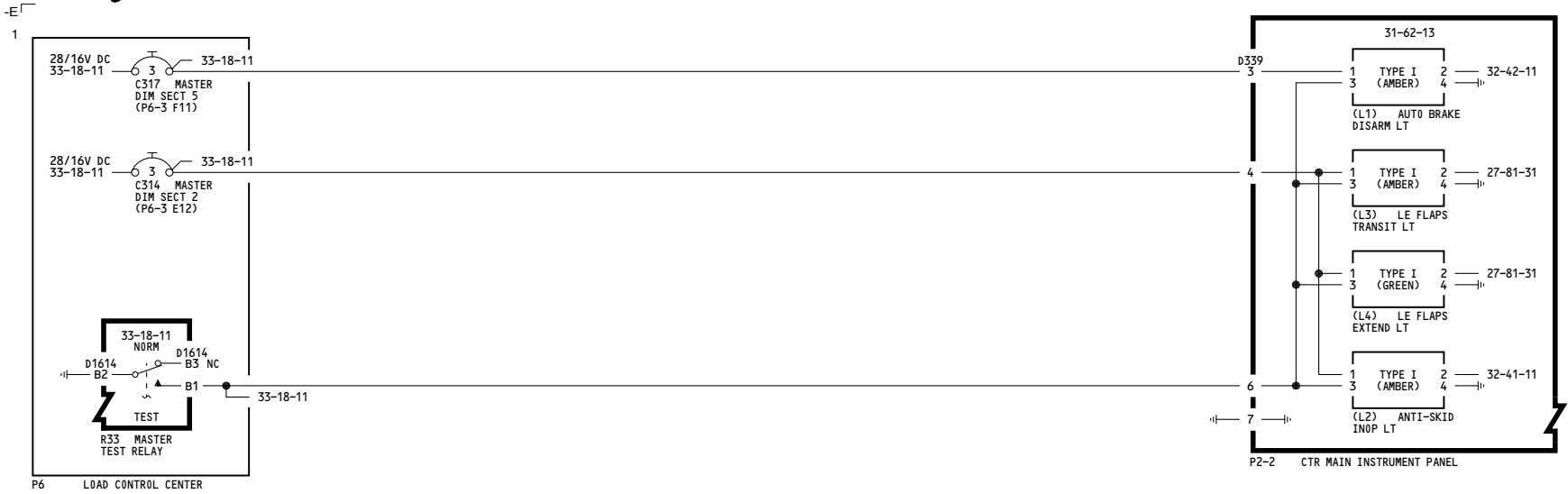

P6 LOAD CONTROL CENTER

P2-2 CTR MAIN INSTRUMENT PANEL

WIRING DIAGRAMS
33-18-23

33-18-23

Page 101

Feb 09/2009

ALL	<p>MASTER DIM & TEST SYSTEM- MAIN INSTRUMENT PANEL, CTR LEFT</p> <p>D280A203</p>
-----	---



WIRING DIAGRAMS
33-18-24

33-18-24

ALL	<p>MASTER DIM & TEST SYSTEM- MAIN INSTRUMENT PANEL, CTR RIGHT</p> <p>D280A203</p>
-----	--

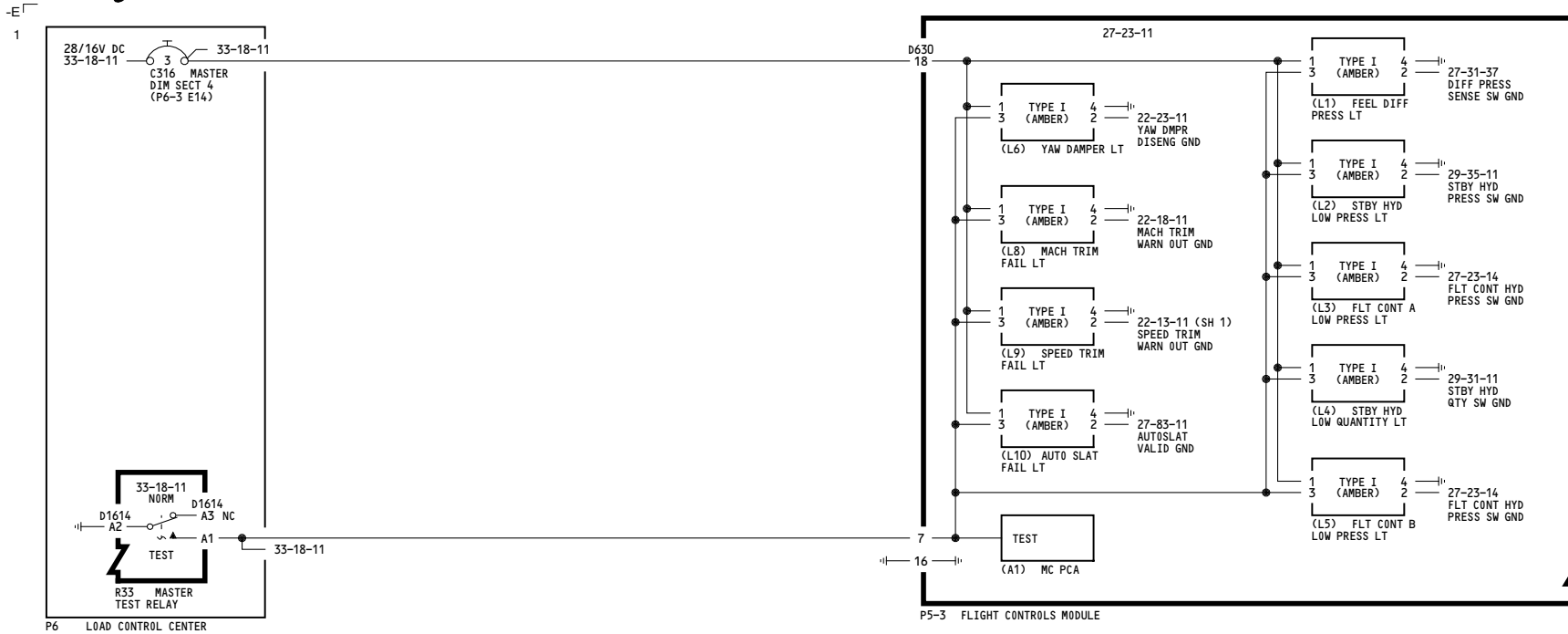

WIRING DIAGRAMS
33-18-31

YC001-YC030	MASTER DIM & TEST SYSTEM- FWD OVERHEAD PANEL, GROUP 1
	D280A203

33-18-31

Page 101

Jul 17/2007

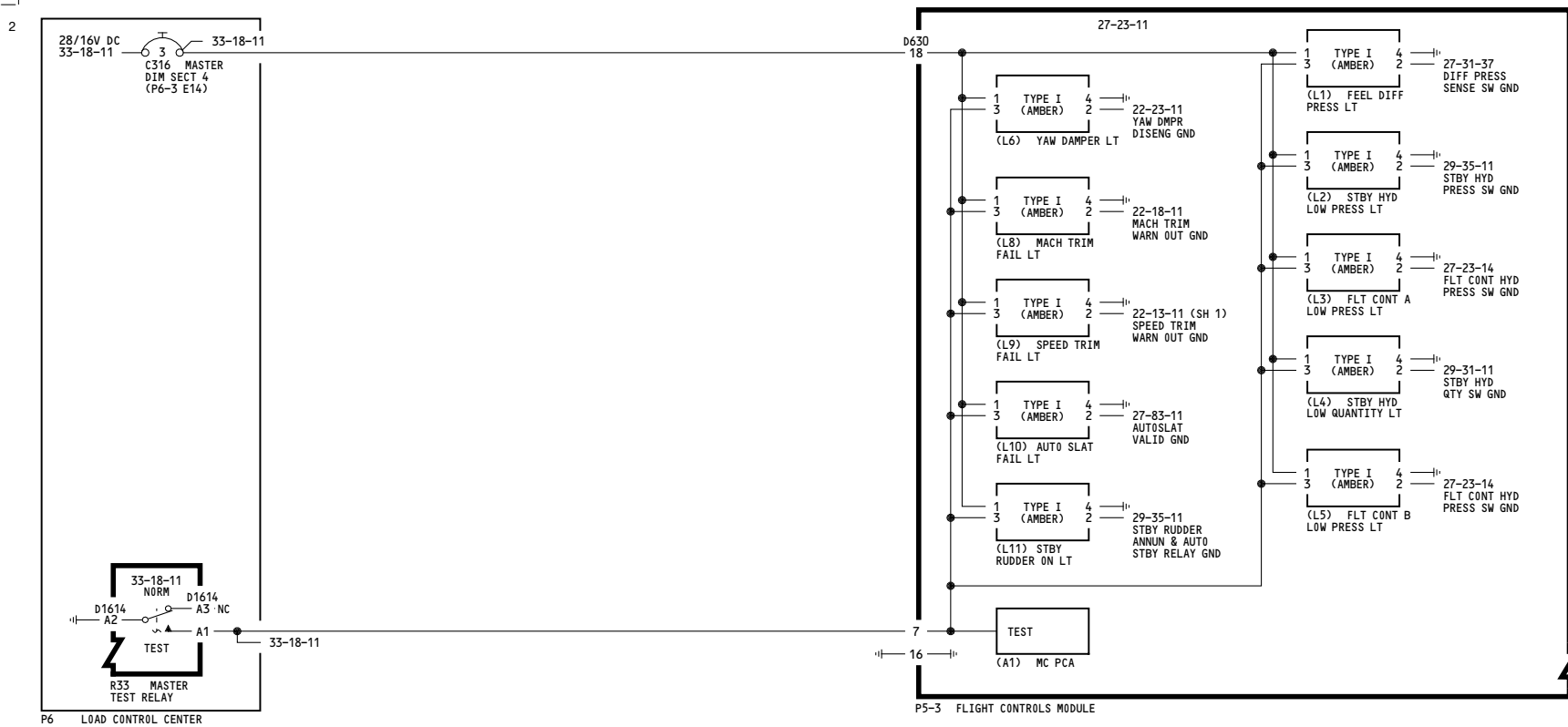

WIRING DIAGRAMS
33-18-31

33-18-31

Page 102

Feb 09/2009

YC031-YM670

**MASTER DIM & TEST SYSTEM-
FWD OVERHEAD PANEL,
GROUP 1**

D280A203

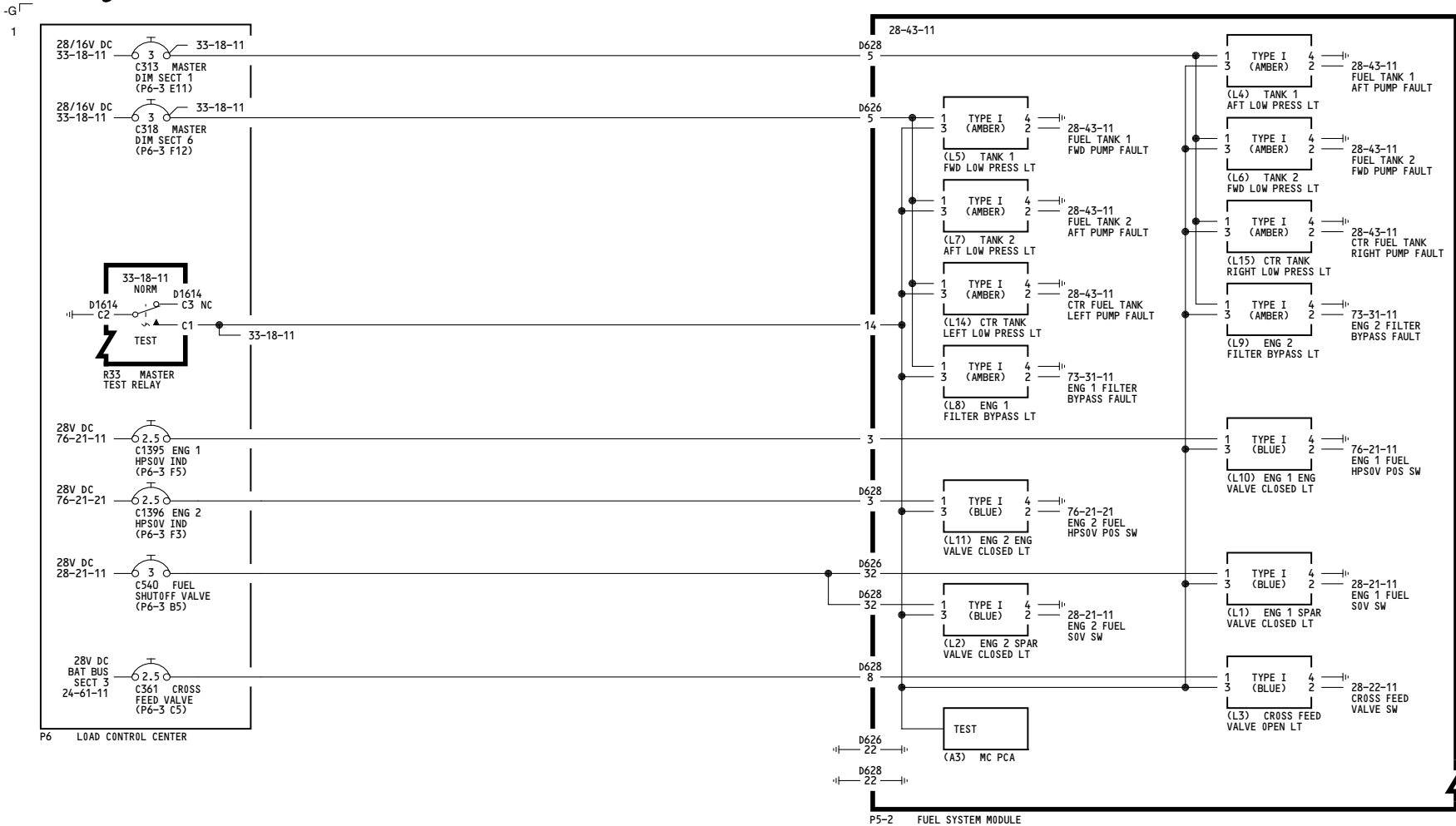

WIRING DIAGRAMS
33-18-32

33-18-32

ALL	<p>MASTER DIM & TEST SYSTEM- FWD OVERHEAD PANEL, GROUP 2</p> <p>D280A203</p>
-----	---

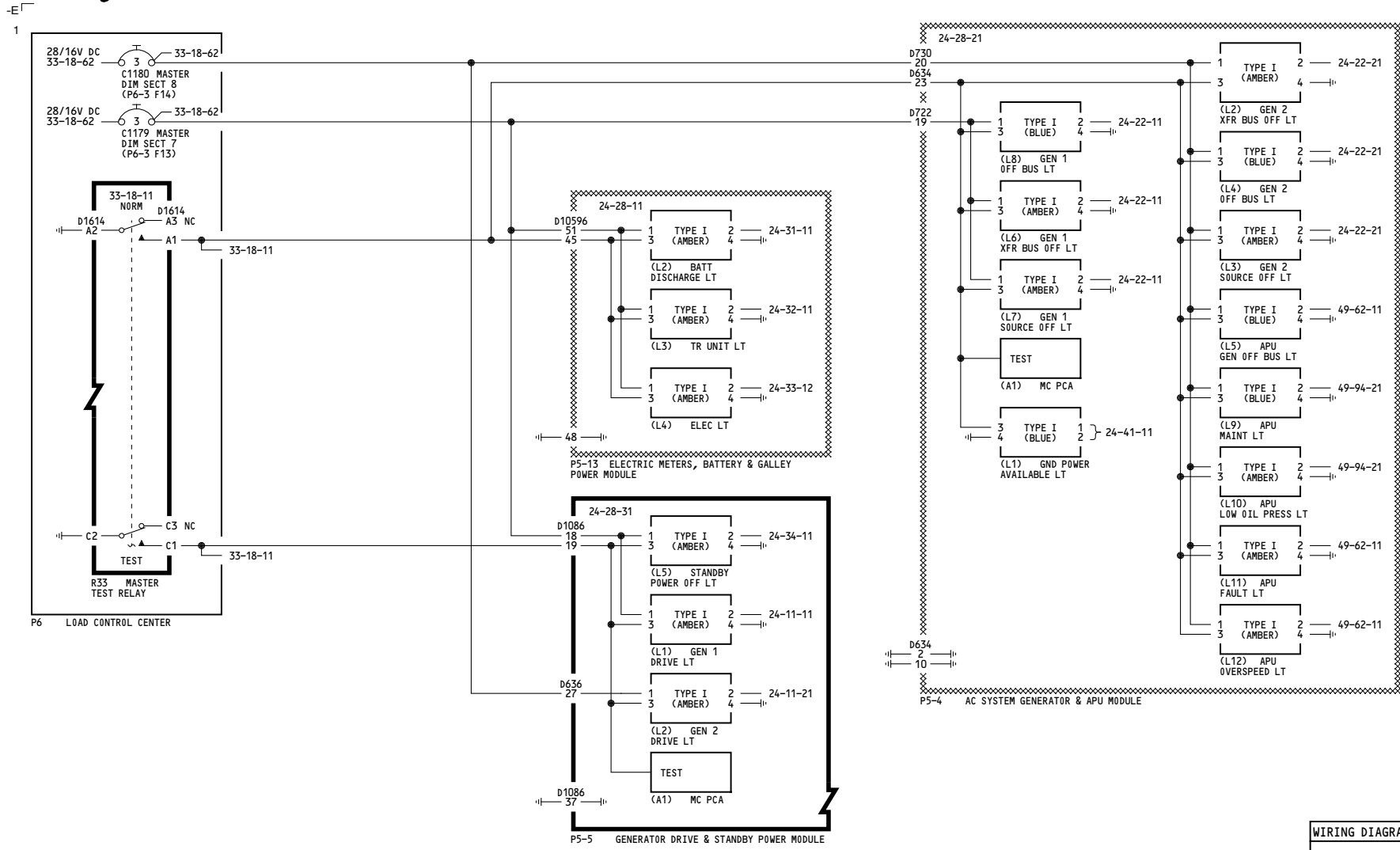

WIRING DIAGRAMS
33-18-33

33-18-33

ALL	<p>MASTER DIM & TEST SYSTEM- FWD OVERHEAD PANEL, GROUP 3</p> <p>D280A203</p>
-----	---

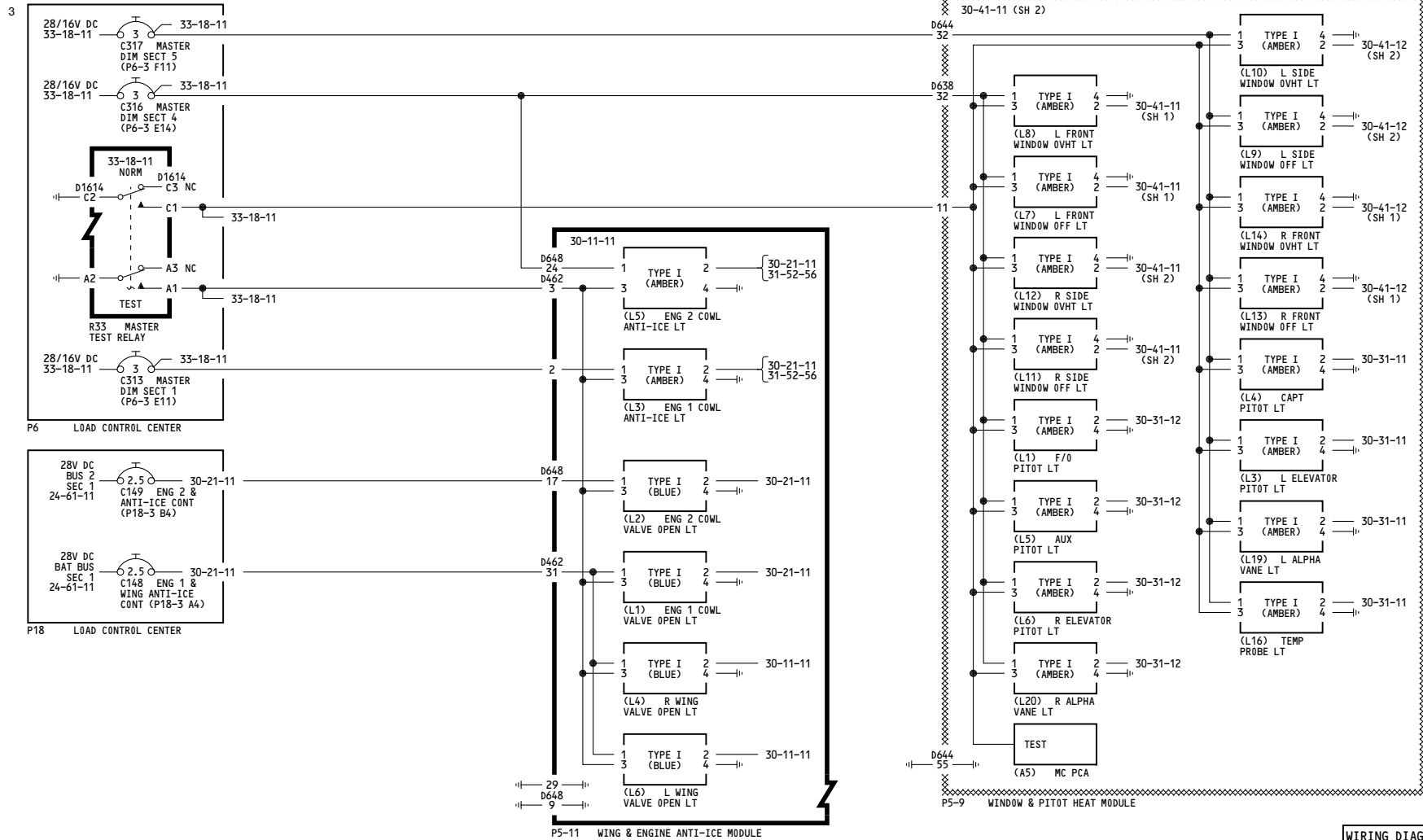

WIRING DIAGRAMS
33-18-34

YC001-YC007

MASTER DIM & TEST SYSTEM-FWD OVERHEAD PANEL, GROUP 4

D280A203

Incorporates
30-1047

33-18-34

Page 101.1

Mar 31/2005

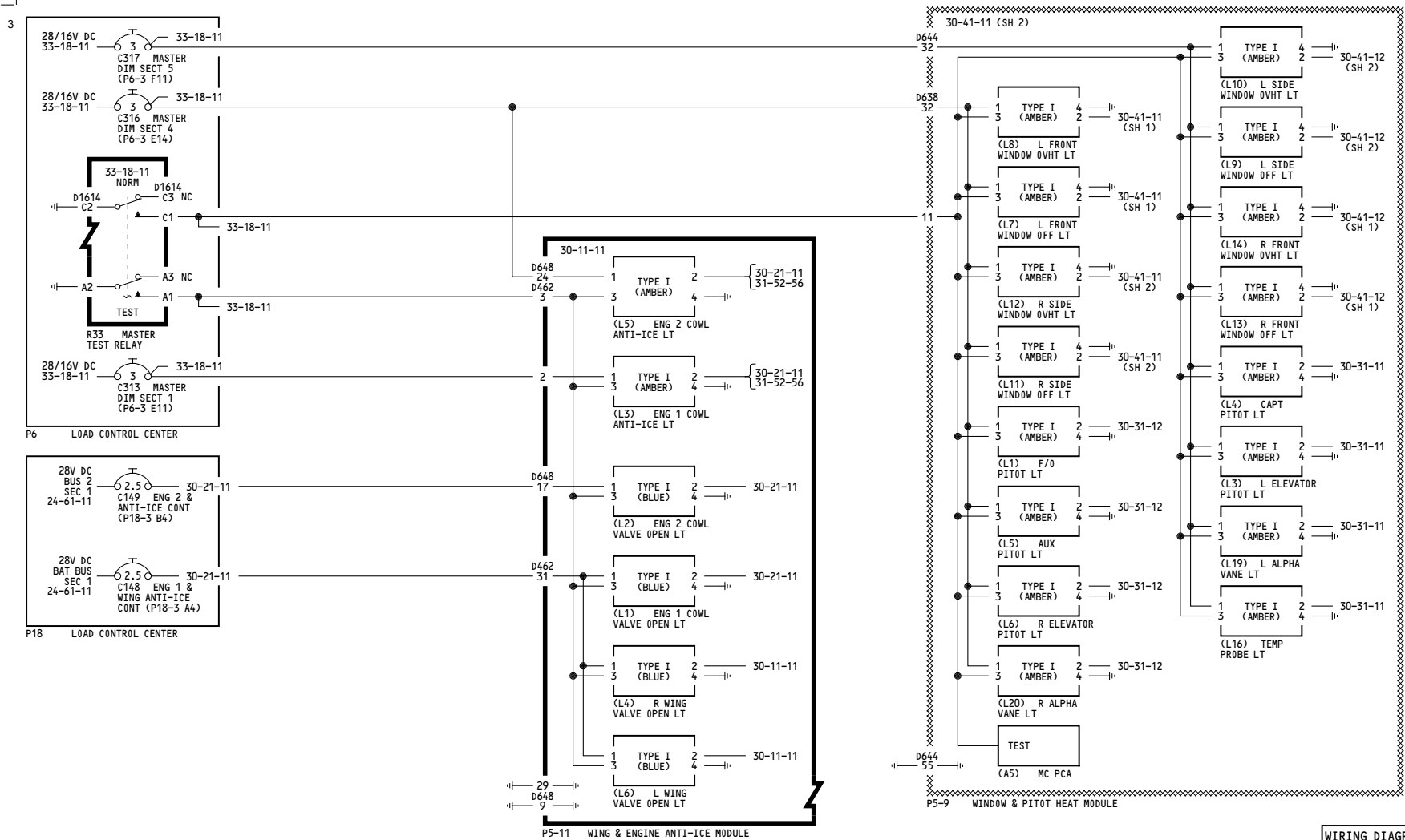

WIRING DIAGRAMS
33-18-34

33-18-34

<p>YC008-YM670</p>	<p>MASTER DIM & TEST SYSTEM- FWD OVERHEAD PANEL, GROUP 4</p> <p>D280A203</p>
--------------------	---

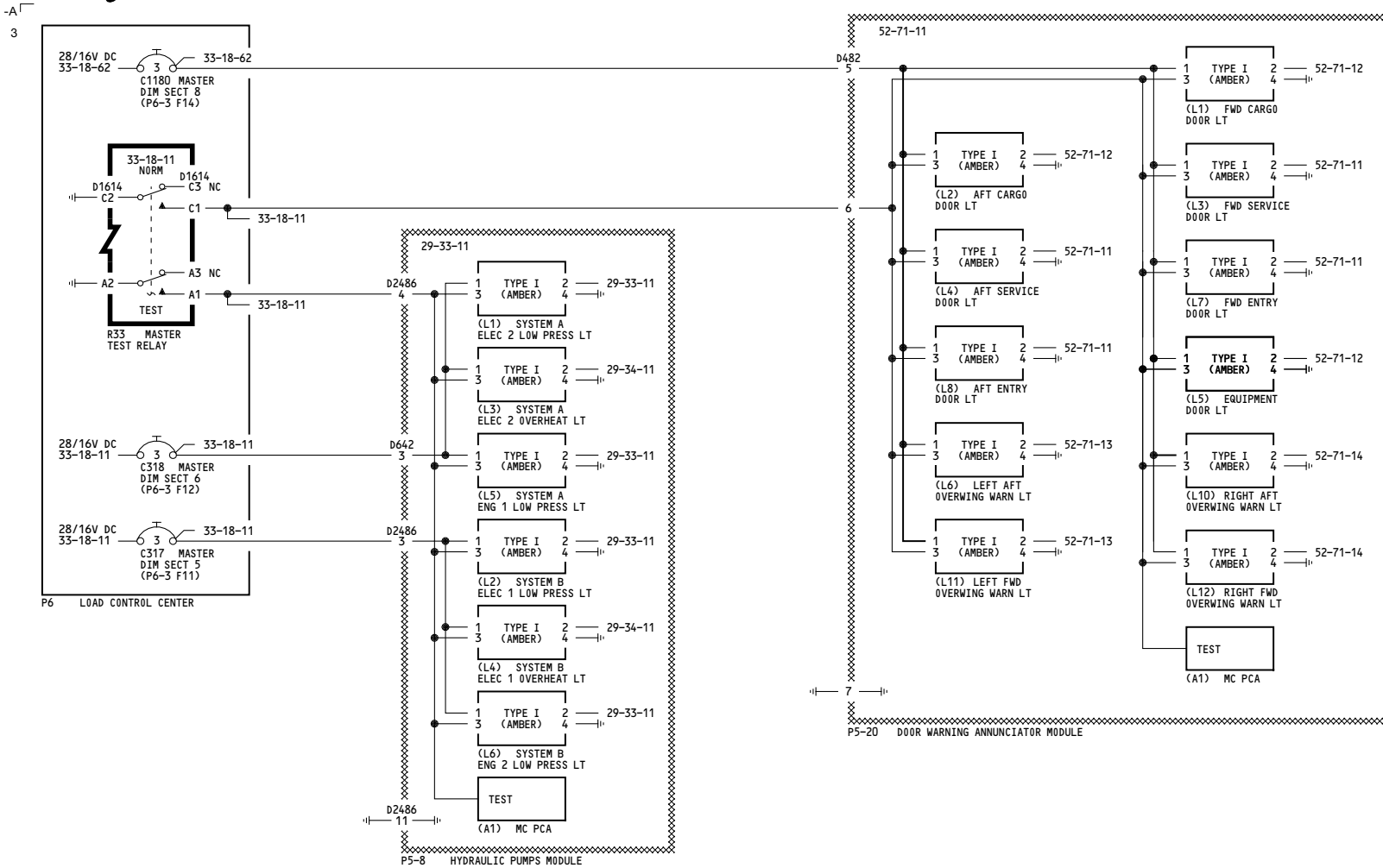

YC001-YL430

**MASTER DIM & TEST SYSTEM-
FWD OVERHEAD PANEL,
GROUP 5**

D280A203

WIRING DIAGRAMS
33-18-35

33-18-35

Page 101

Feb 09/2009

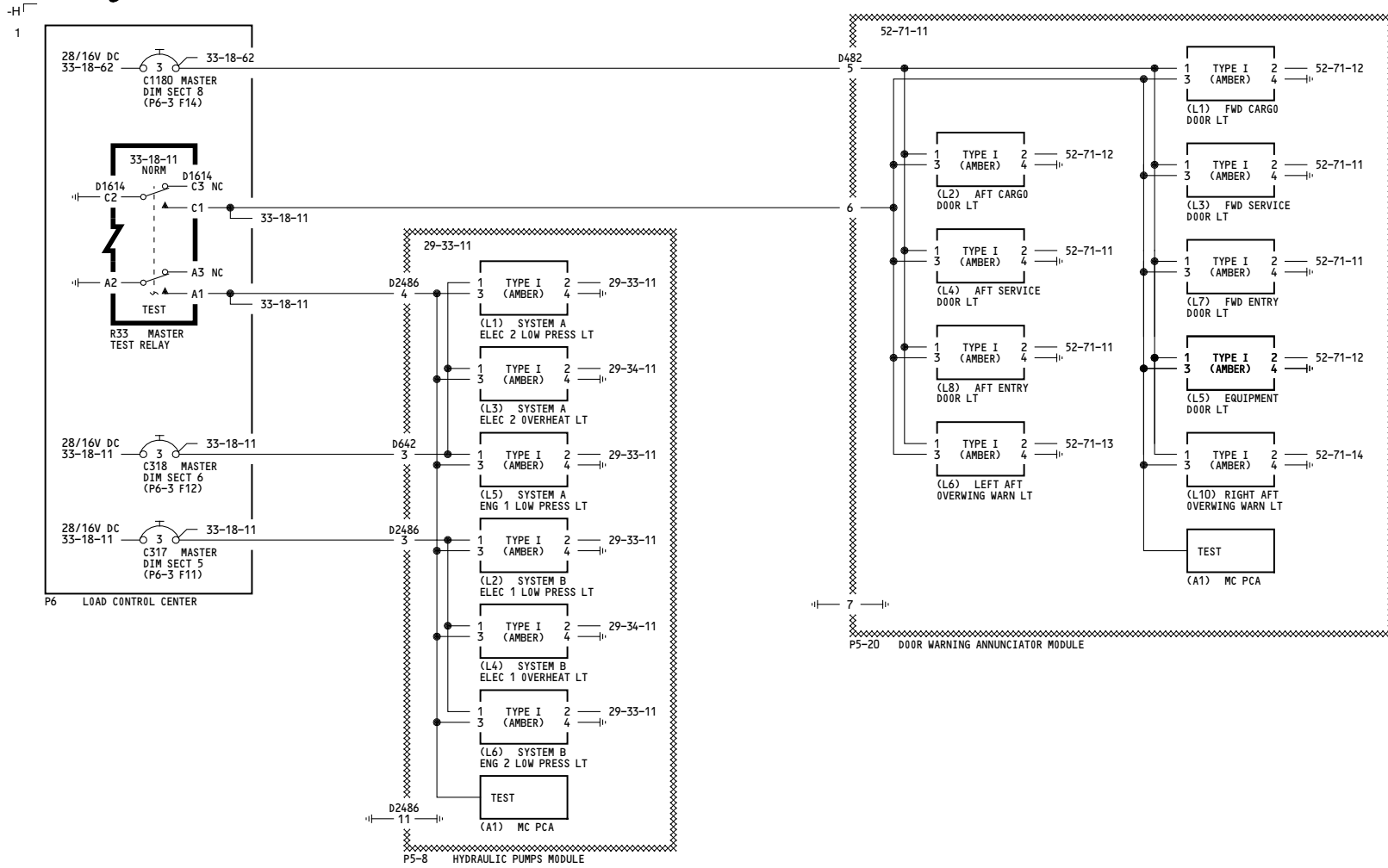

WIRING DIAGRAMS
33-18-35

33-18-35

<p>YM643-YM670</p>	<p>MASTER DIM & TEST SYSTEM- FWD OVERHEAD PANEL, GROUP 5</p> <p>D280A203</p>
--------------------	---

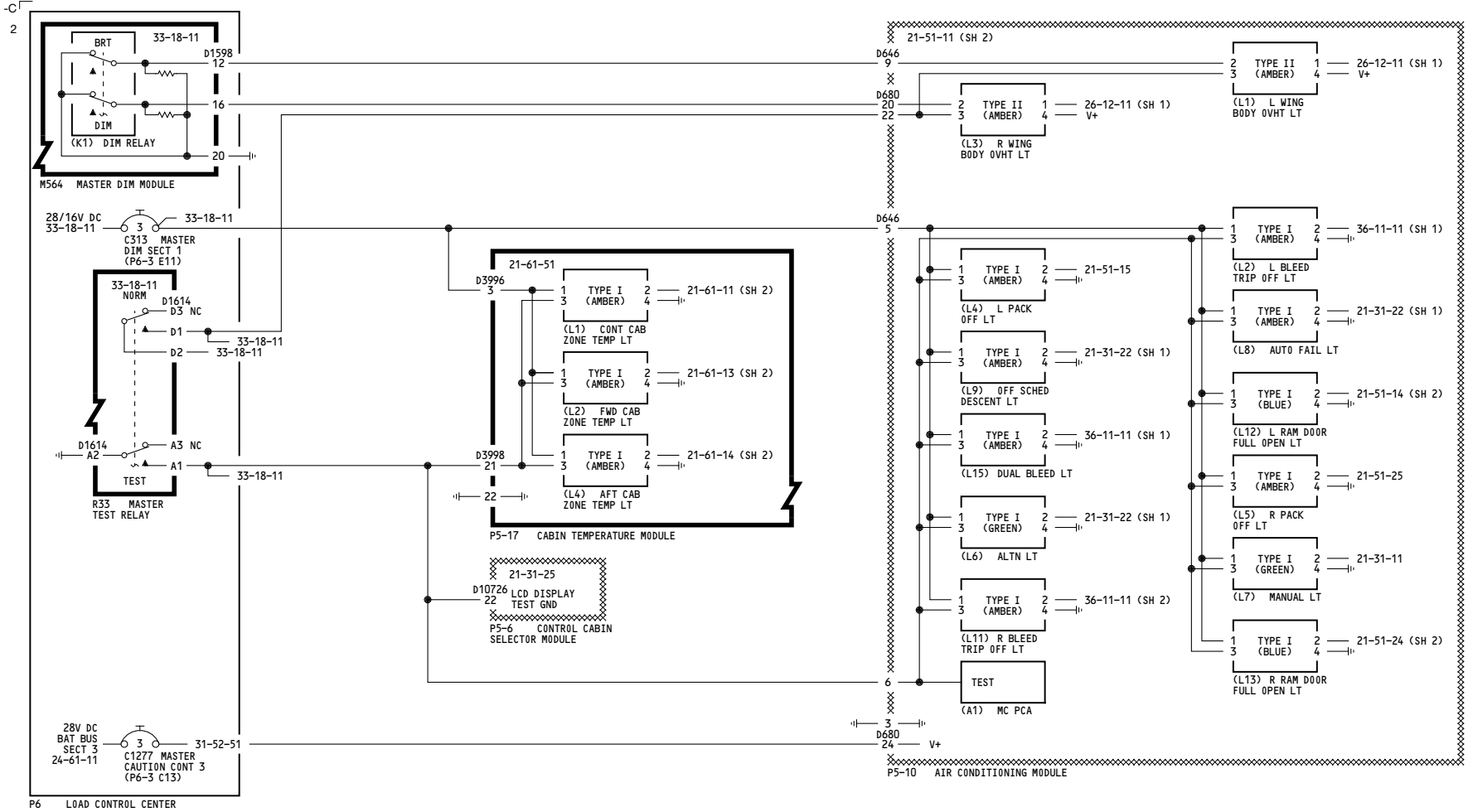

WIRING DIAGRAMS
33-18-36

YC001-YL430

**MASTER DIM & TEST SYSTEM-
FWD OVERHEAD PANEL,
GROUP 6**

D280A203

33-18-36

Page 101

Feb 09/2009

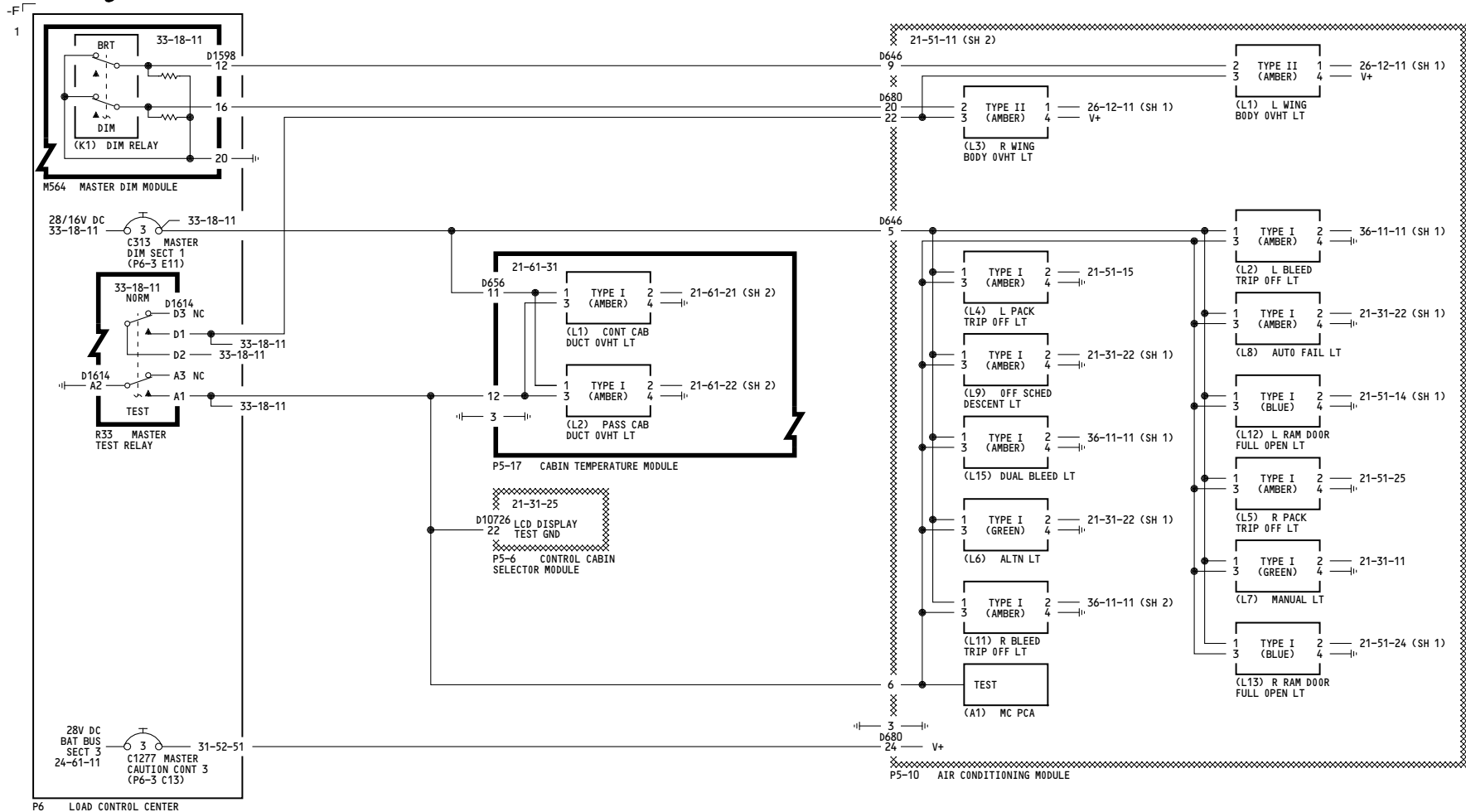

YM643-YM670

**MASTER DIM & TEST SYSTEM-
FWD OVERHEAD PANEL,
GROUP 6**

D280A203

WIRING DIAGRAMS
33-18-36

33-18-36

Page 102

Jan 14/2008



WIRING DIAGRAMS
33-18-37

YC001-YC050	<p>MASTER DIM & TEST SYSTEM- FWD OVERHEAD PANEL, GROUP 7</p> <p>D280A203</p>
-------------	---

33-18-37

15

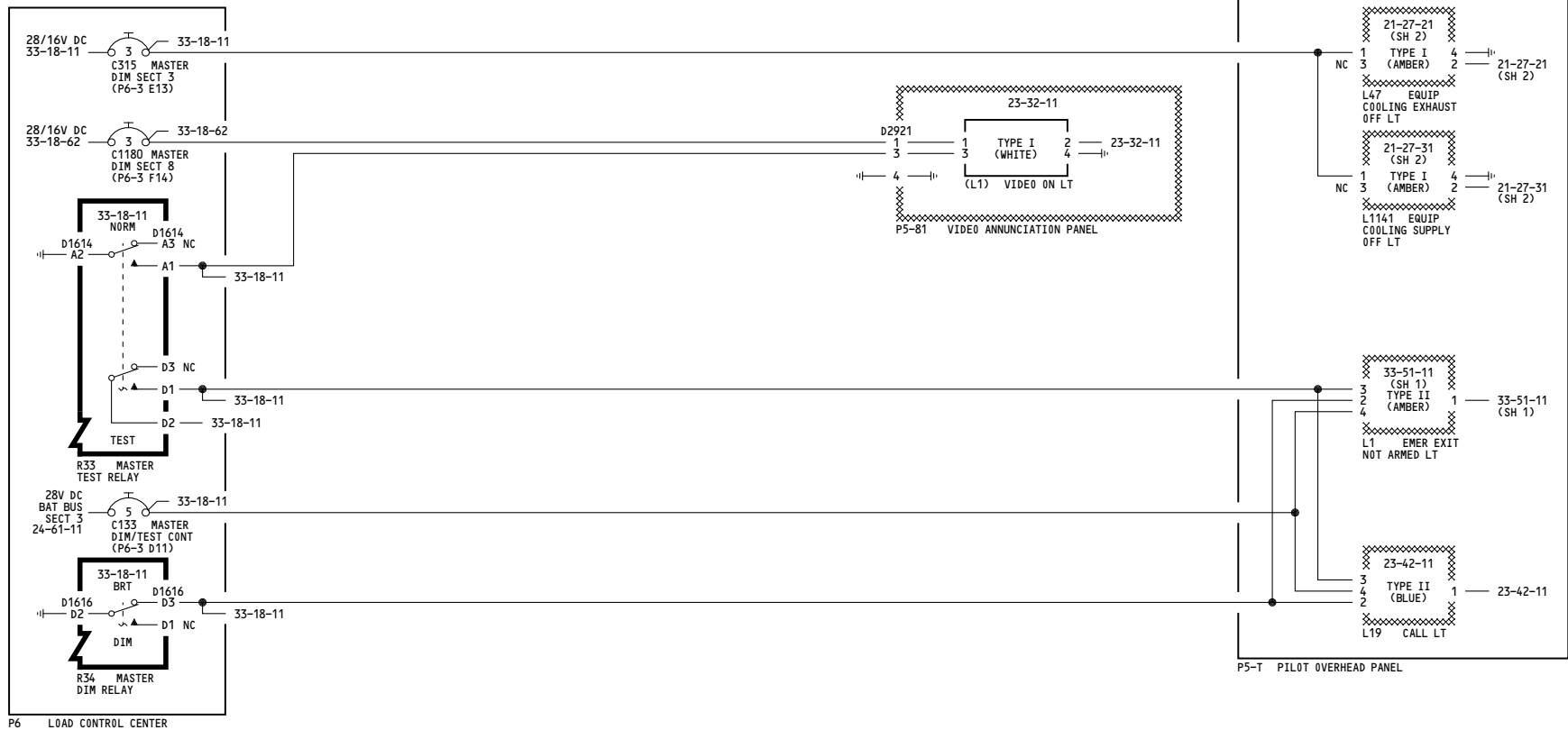

YK901-YK906

**MASTER DIM & TEST SYSTEM-
FWD OVERHEAD PANEL,
GROUP 7**

D280A203

WIRING DIAGRAMS

33-18-37

33-18-37

Page 102

Oct 20/2006

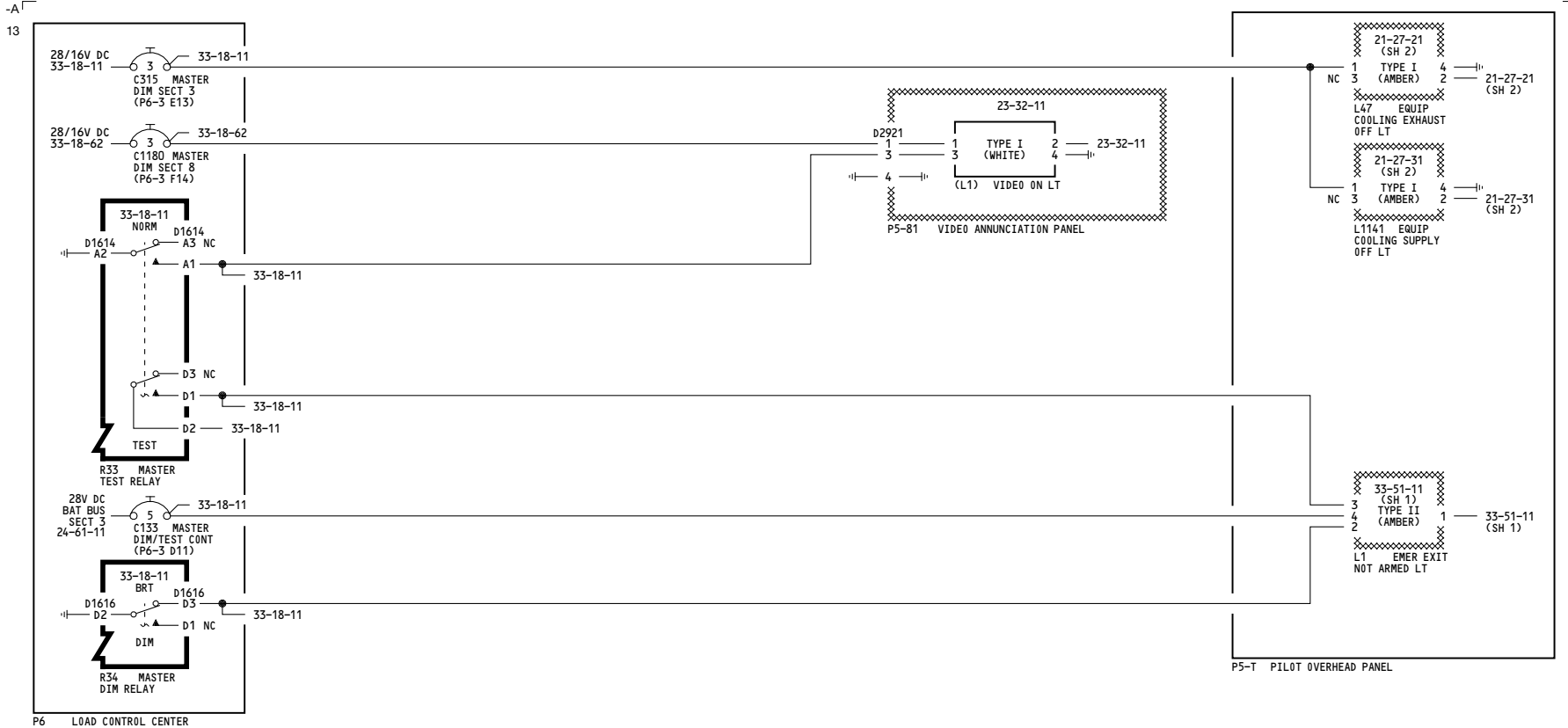

WIRING DIAGRAMS
33-18-37

YK907-YM670	<p align="center">MASTER DIM & TEST SYSTEM- FWD OVERHEAD PANEL, GROUP 7</p> <p align="center">D280A203</p>
-------------	---

33-18-37

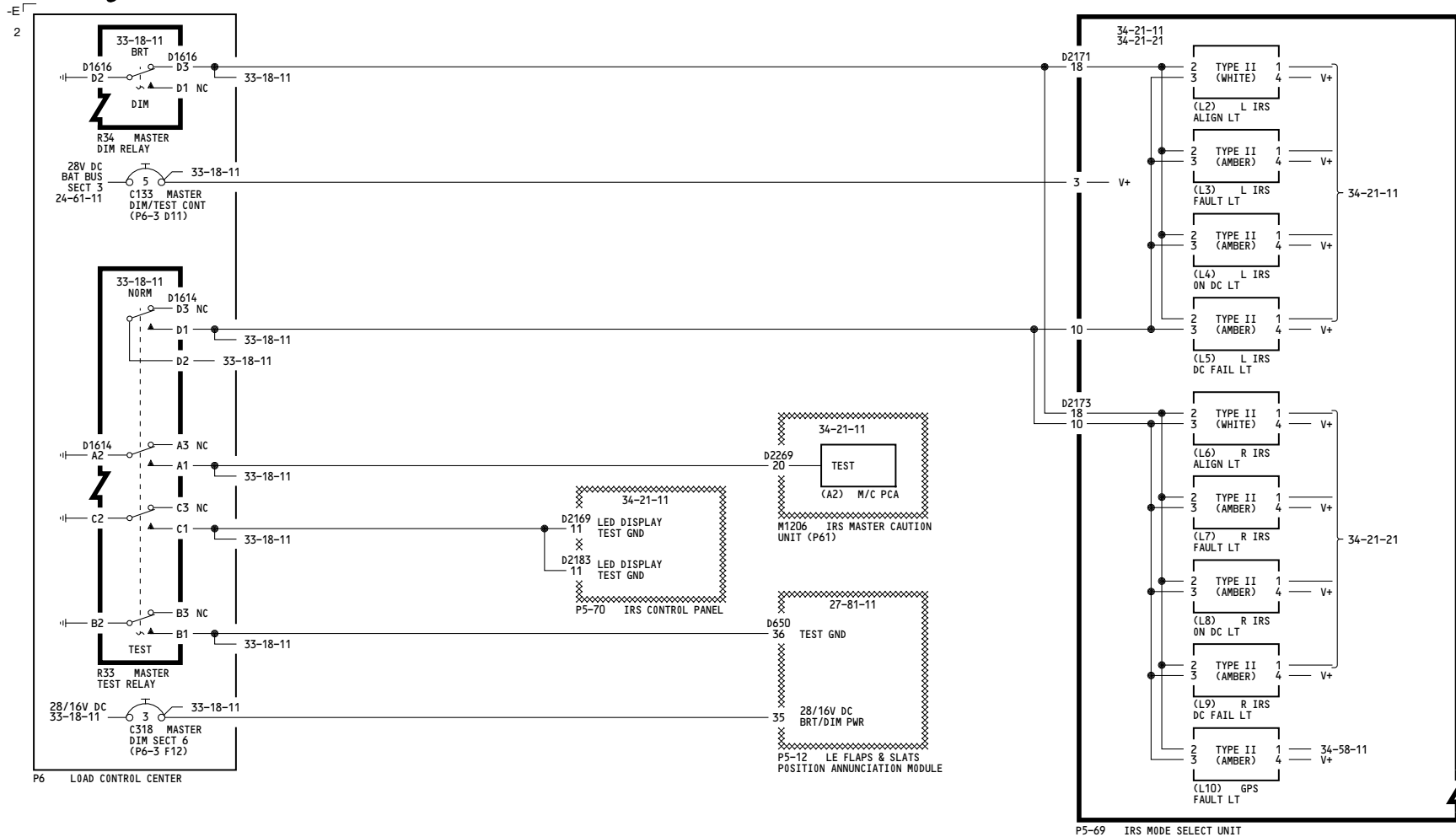

WIRING DIAGRAMS
33-18-41

33-18-41

<p>YC001-YK906</p>	<p>MASTER DIM & TEST SYSTEM- AFT OVERHEAD PANEL, GROUP 1</p> <p>D280A203</p>
--------------------	---

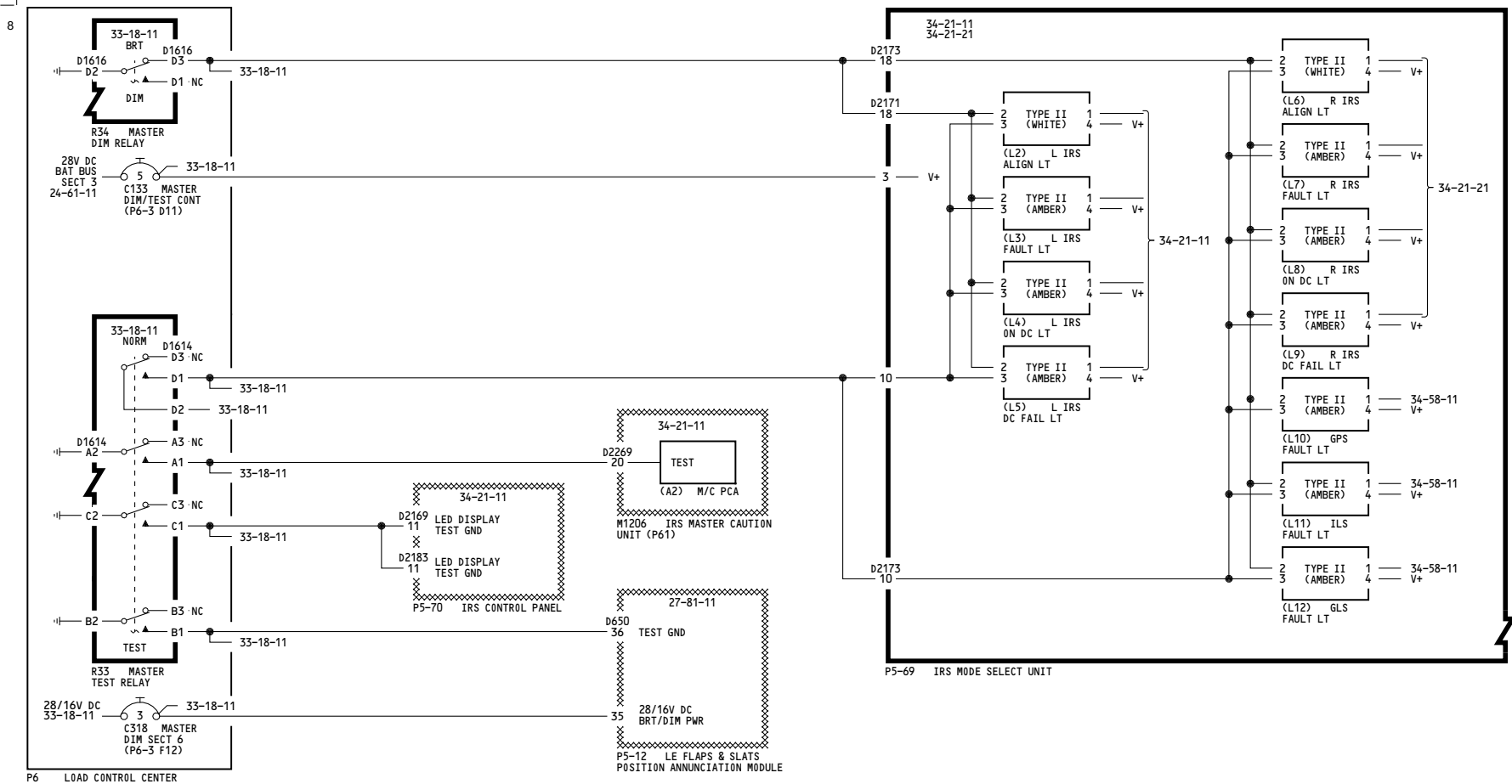

WIRING DIAGRAMS
33-18-41

YK907-YM670

**MASTER DIM & TEST SYSTEM-
AFT OVERHEAD PANEL,
GROUP 1**

D280A203

33-18-41

Page 102

Feb 09/2009

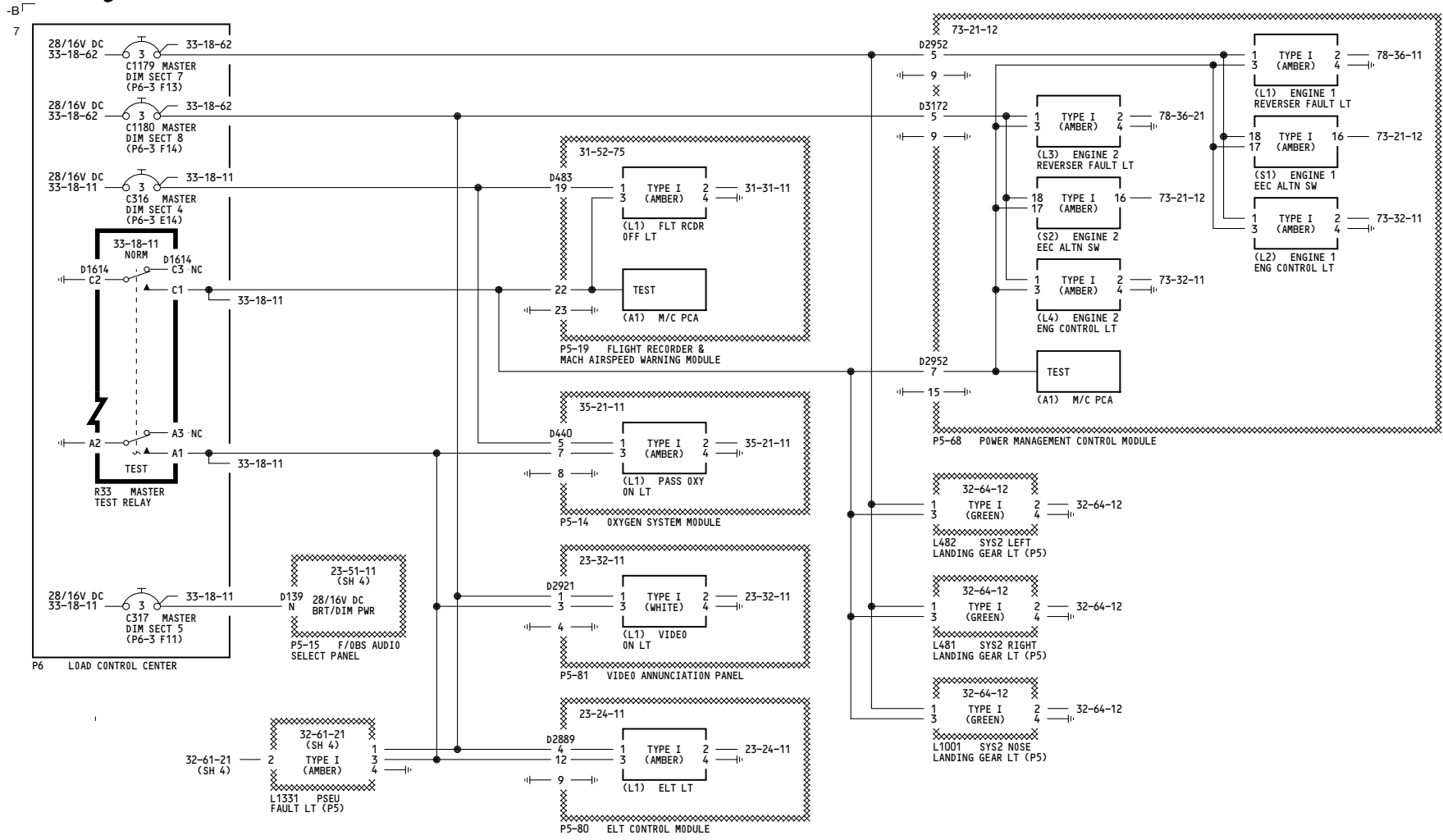

WIRING DIAGRAMS
33-18-42

33-18-42

<p>YC001-YC011</p>	<p>MASTER DIM & TEST SYSTEM- AFT OVERHEAD PANEL, GROUP 2</p> <p>D280A203</p>
--------------------	---

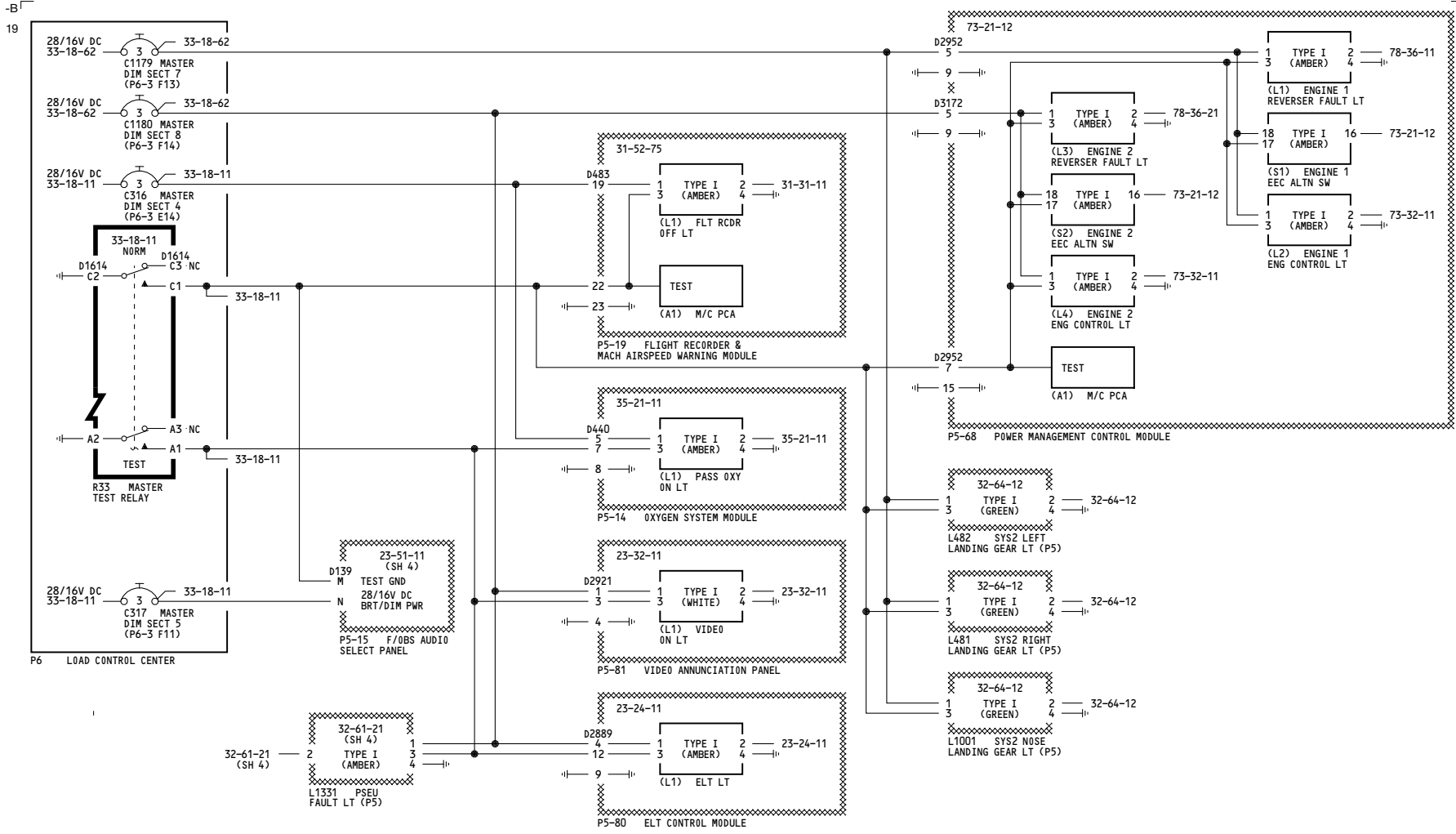

WIRING DIAGRAMS
33-18-42

<p>YC012-YC050</p>	<p>MASTER DIM & TEST SYSTEM- AFT OVERHEAD PANEL, GROUP 2</p> <p>D280A203</p>
--------------------	---

33-18-42

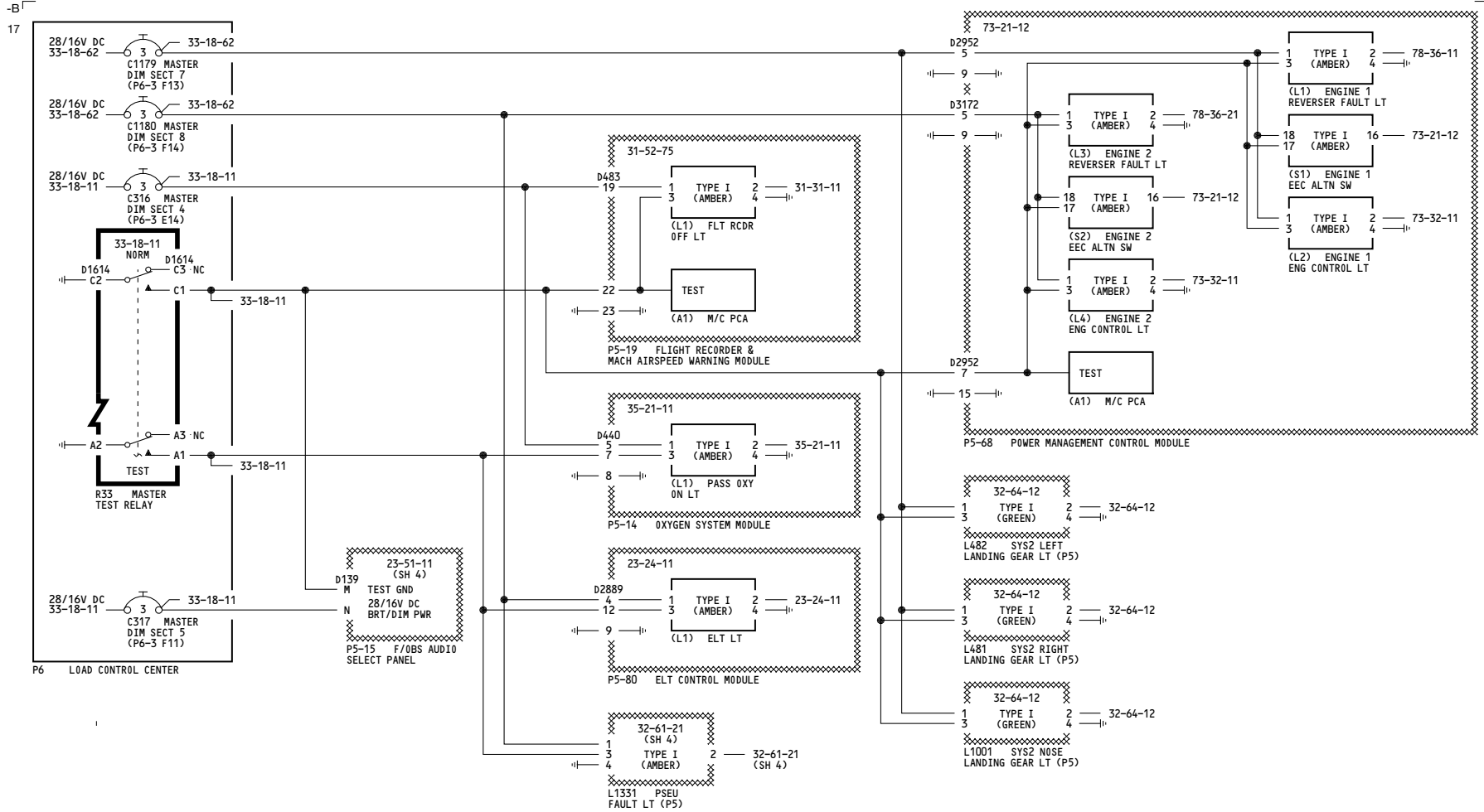

WIRING DIAGRAMS
33-18-42

33-18-42

<p>YK901-YK906</p>	<p>MASTER DIM & TEST SYSTEM- AFT OVERHEAD PANEL, GROUP 2</p> <p>D280A203</p>
--------------------	---

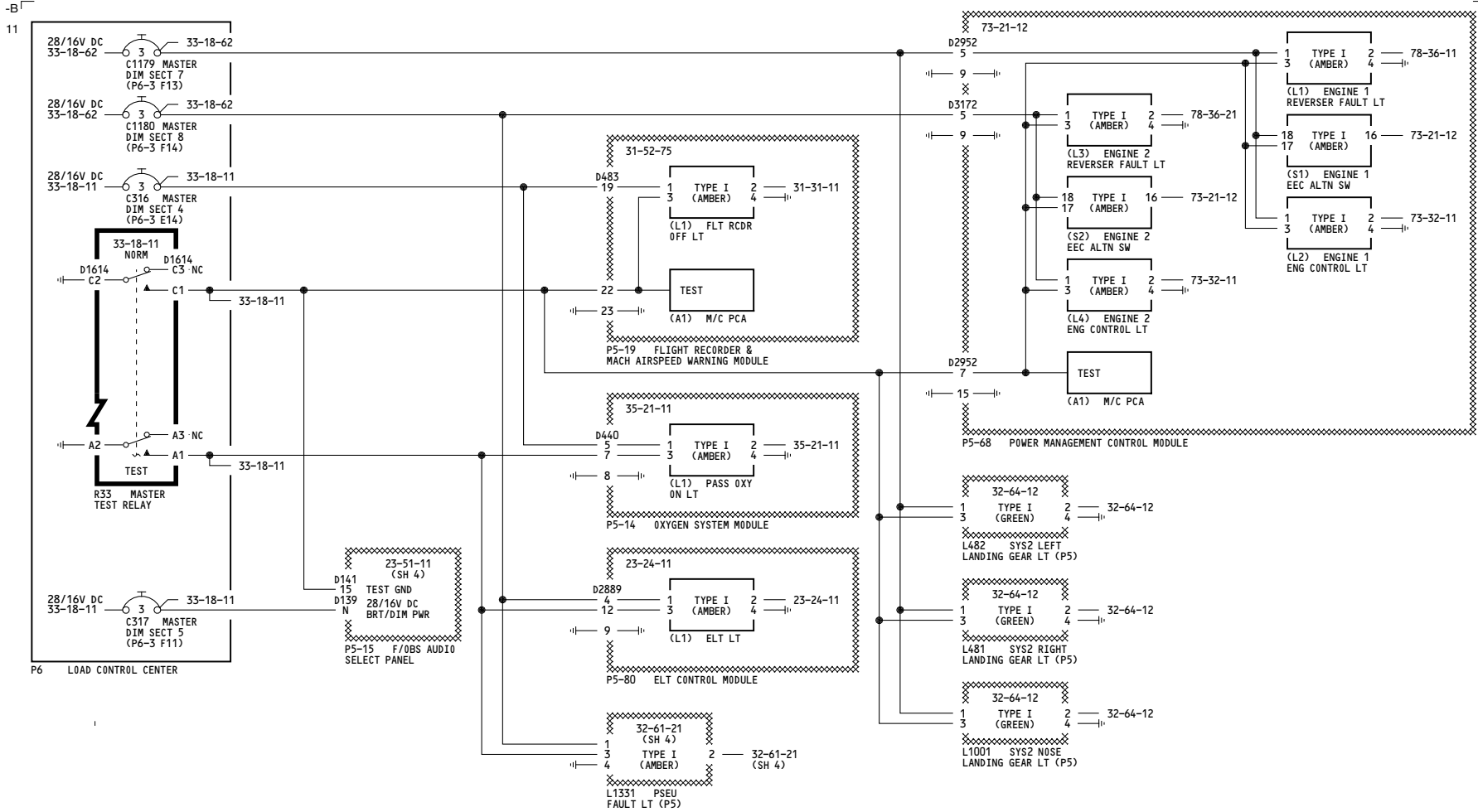

WIRING DIAGRAMS
33-18-42

<p>YK907-YM670</p>	<p>MASTER DIM & TEST SYSTEM- AFT OVERHEAD PANEL, GROUP 2</p> <p>D280A203</p>
--------------------	---

33-18-42

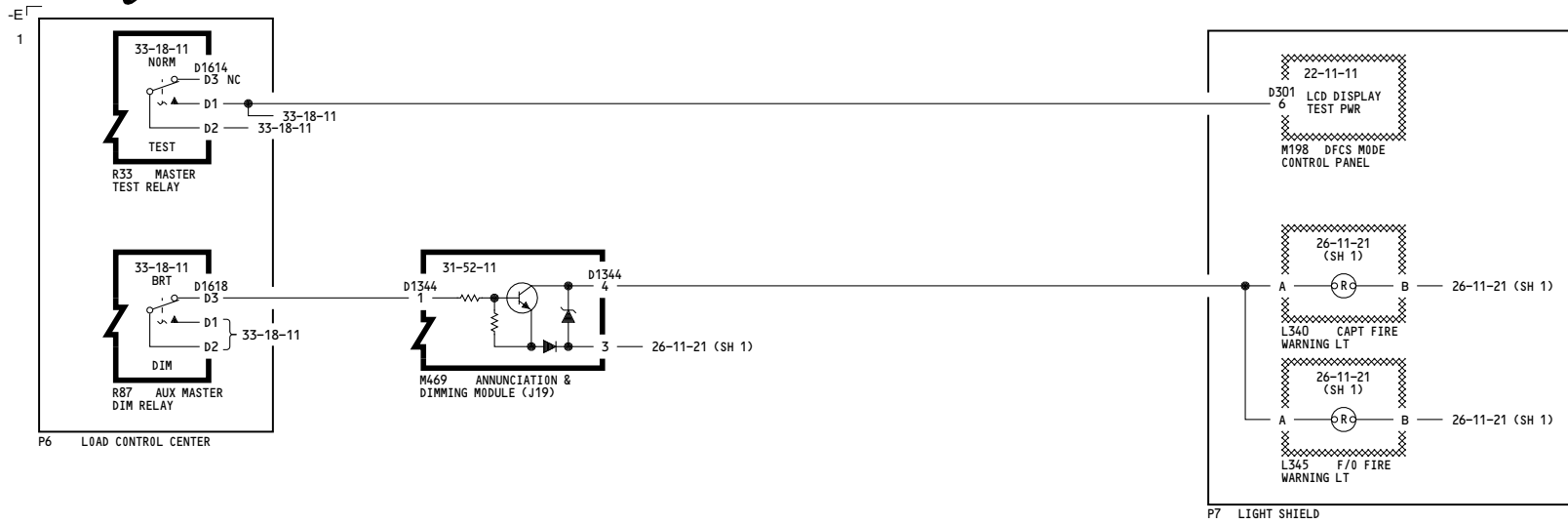

WIRING DIAGRAMS
33-18-51

YC001-YC050	<p align="center">MASTER DIM & TEST SYSTEM- GLARESHIELD PANEL</p> <p align="center">D280A203</p>
-------------	---

33-18-51

Page 101

Jul 17/2007

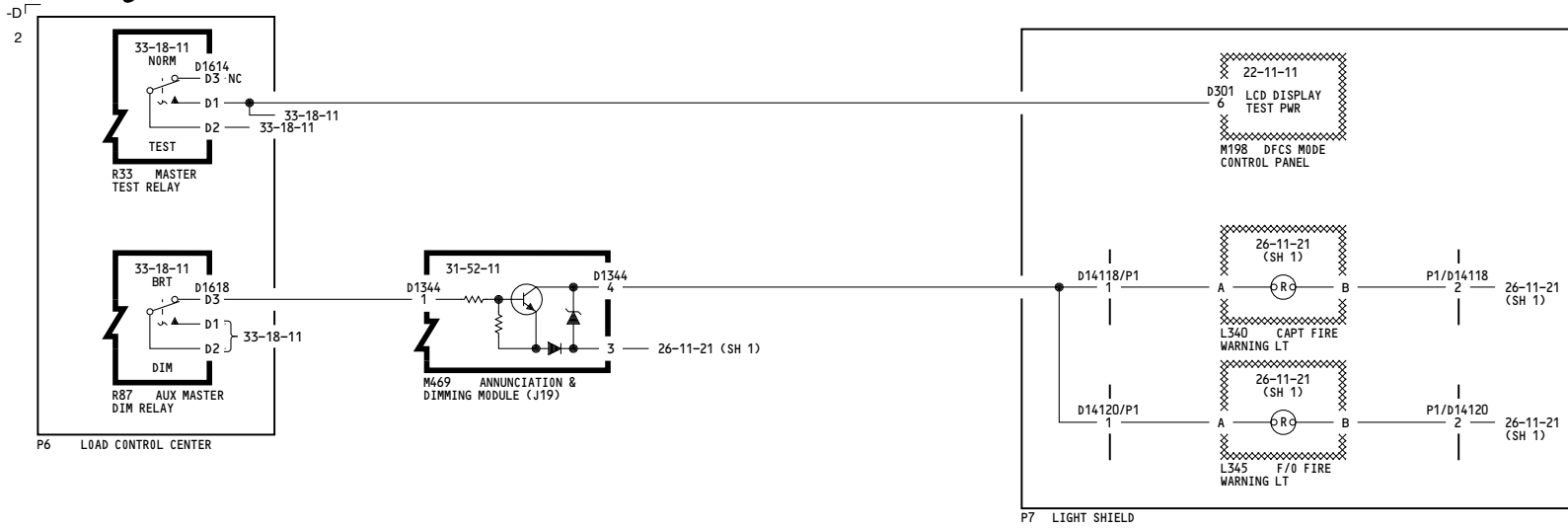

YK901-YM670

**MASTER DIM & TEST SYSTEM-
GLARESHIELD PANEL**

D280A203

WIRING DIAGRAMS

33-18-51

33-18-51

Page 102

Feb 09/2009

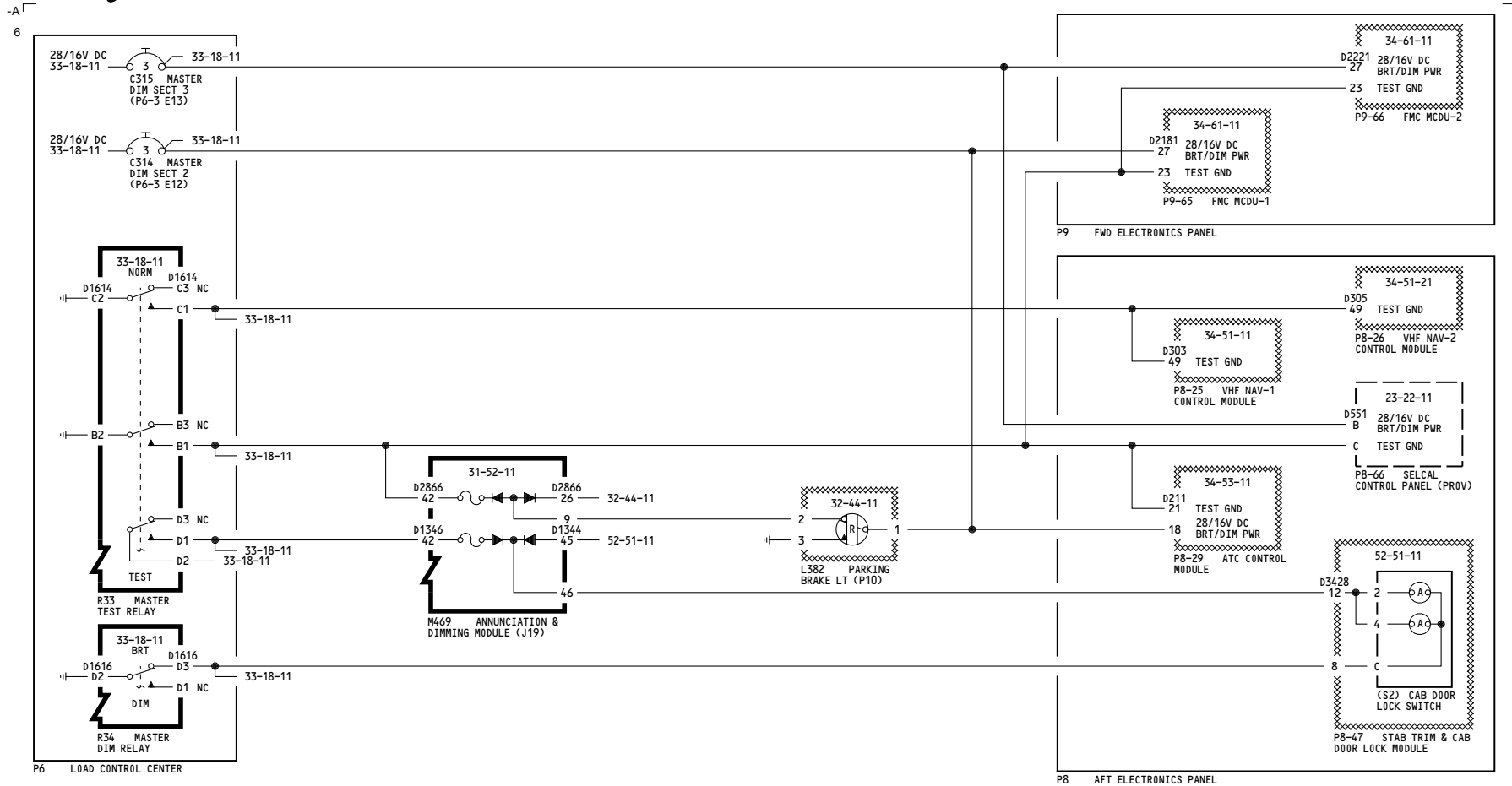

WIRING DIAGRAMS
33-18-61

33-18-61

<p>YC001-YC026</p>	<p>MASTER DIM & TEST SYSTEM- AISLE STAND PANEL, GROUP 1</p> <p>D280A203</p>
--------------------	--

25

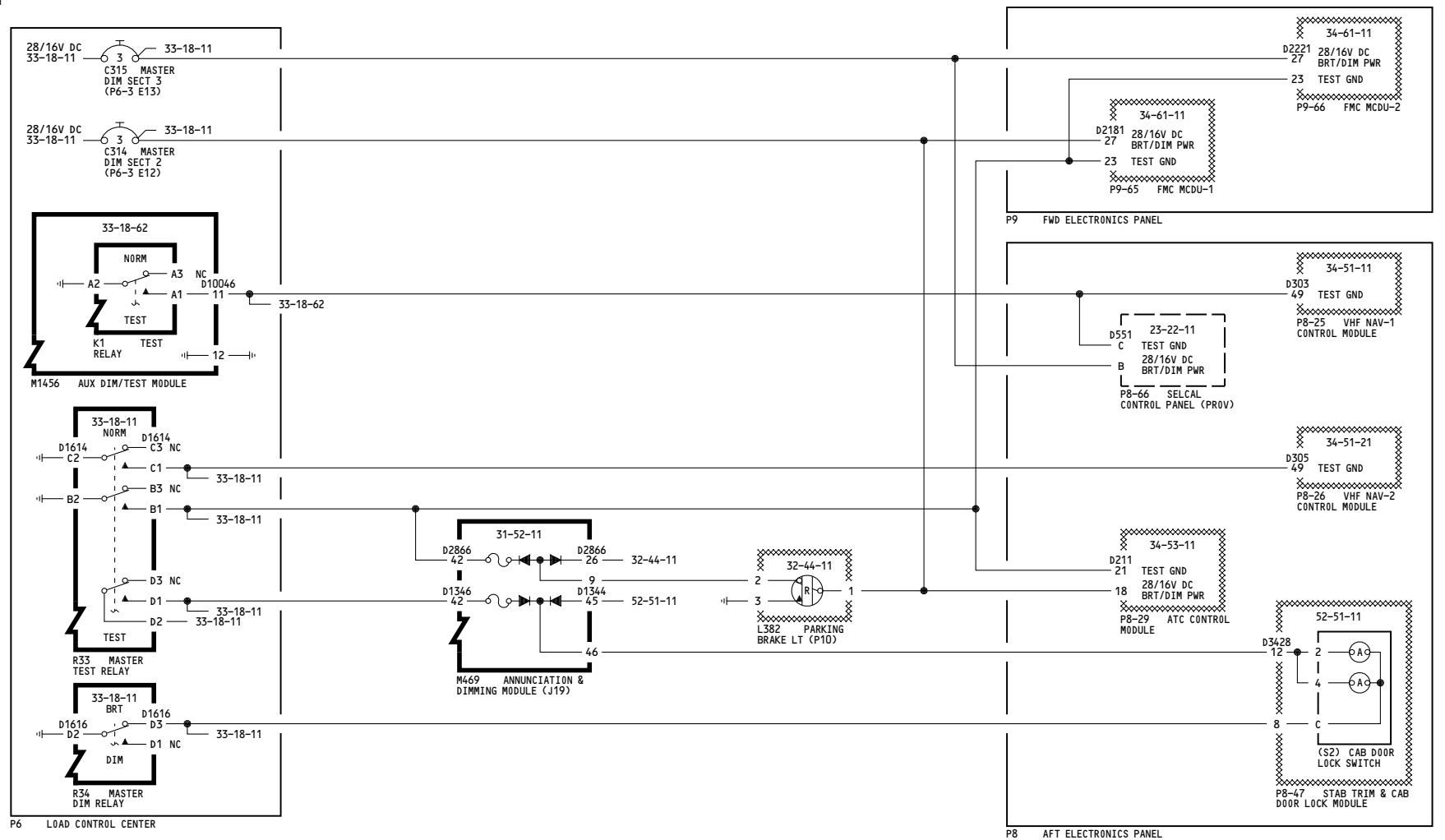

WIRING DIAGRAMS
33-18-61

<p>YC028-YC030</p>	<p>MASTER DIM & TEST SYSTEM- AISLE STAND PANEL, GROUP 1</p> <p>D280A203</p>
--------------------	--

33-18-61

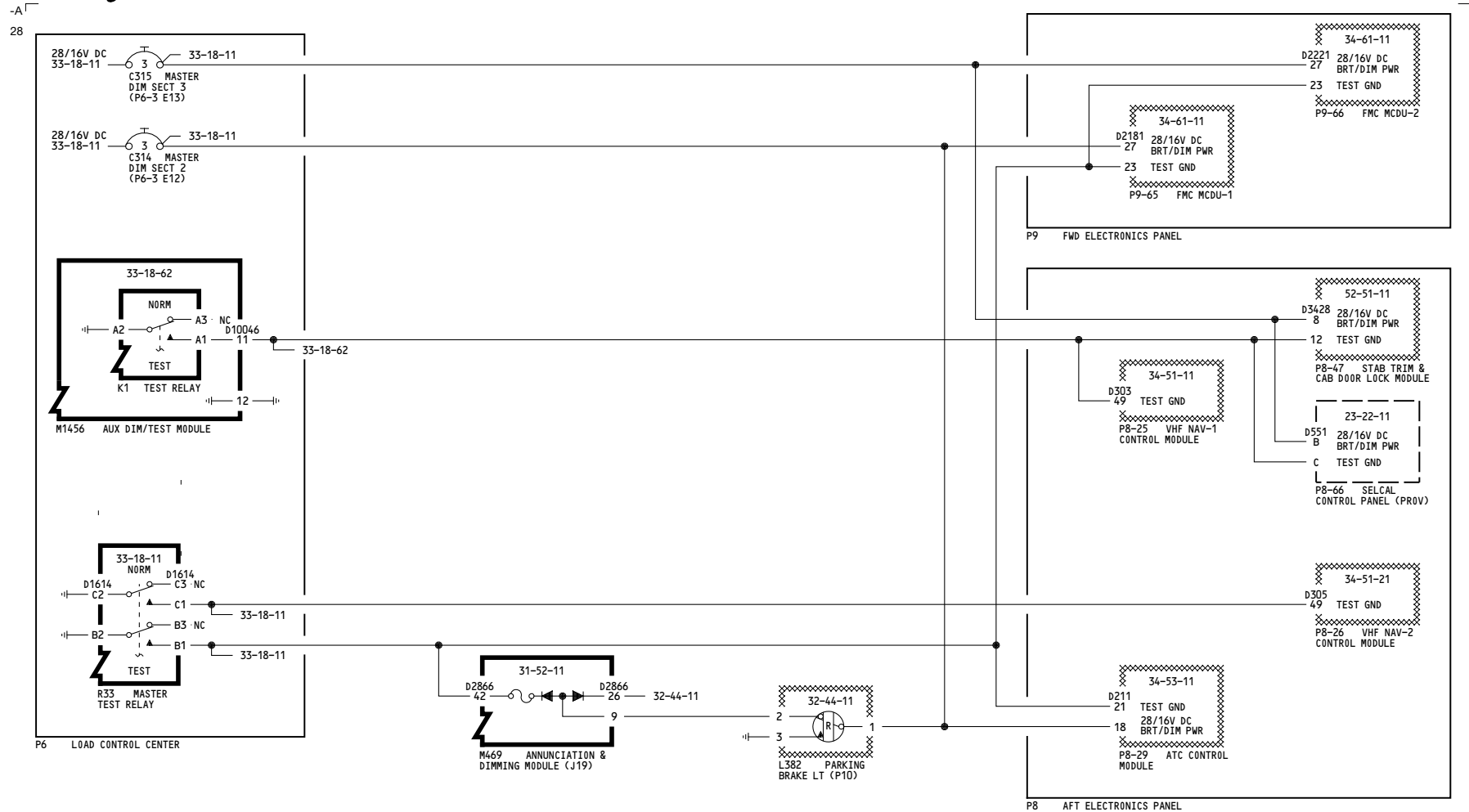

WIRING DIAGRAMS
33-18-61

33-18-61

<p>YC031-YK906</p>	<p>MASTER DIM & TEST SYSTEM- AISLE STAND PANEL, GROUP 1</p> <p>D280A203</p>
--------------------	--

31

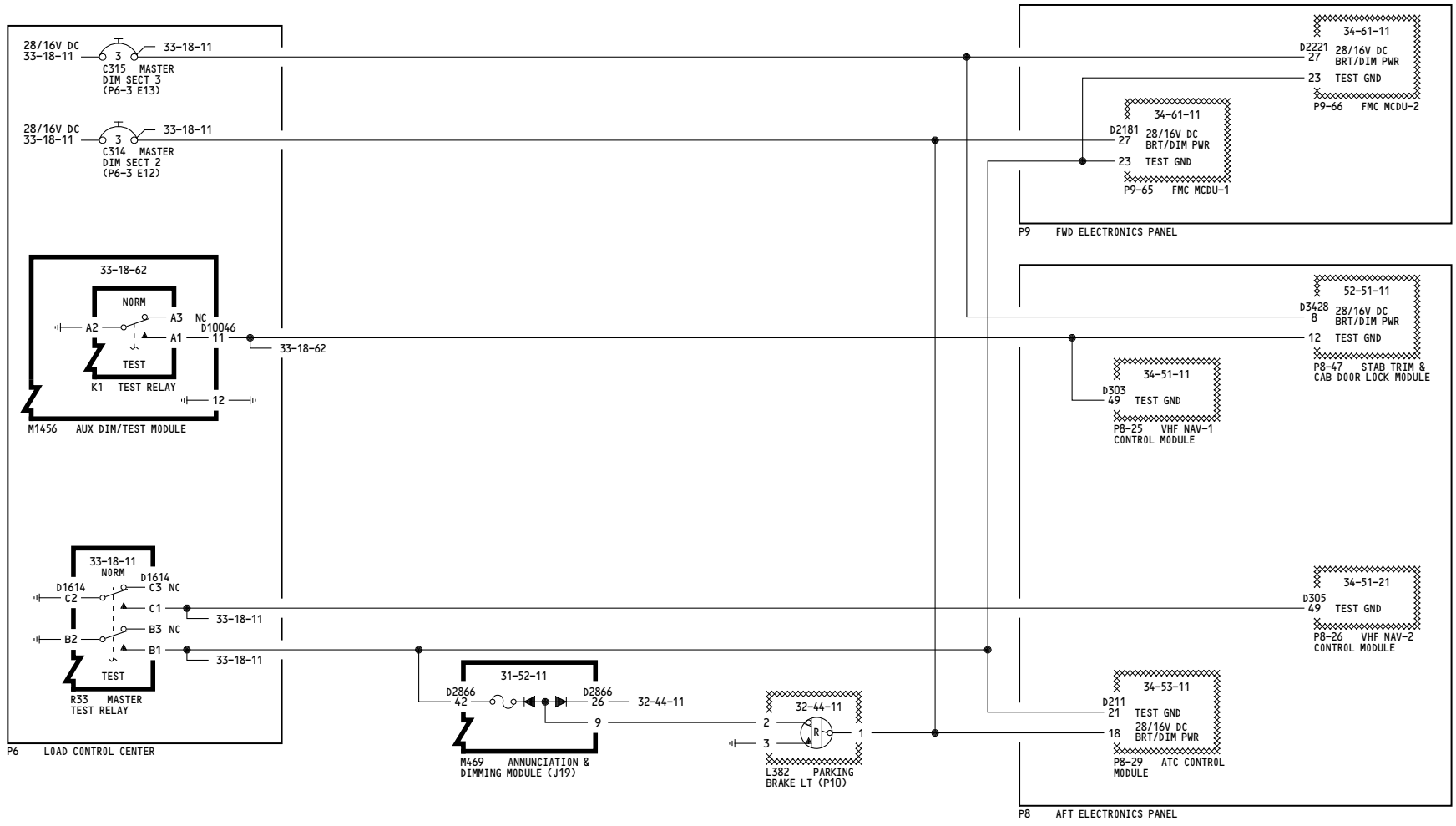

WIRING DIAGRAMS
33-18-61

YK907-YM670

MASTER DIM & TEST SYSTEM- AISLE STAND PANEL, GROUP 1

D280A203

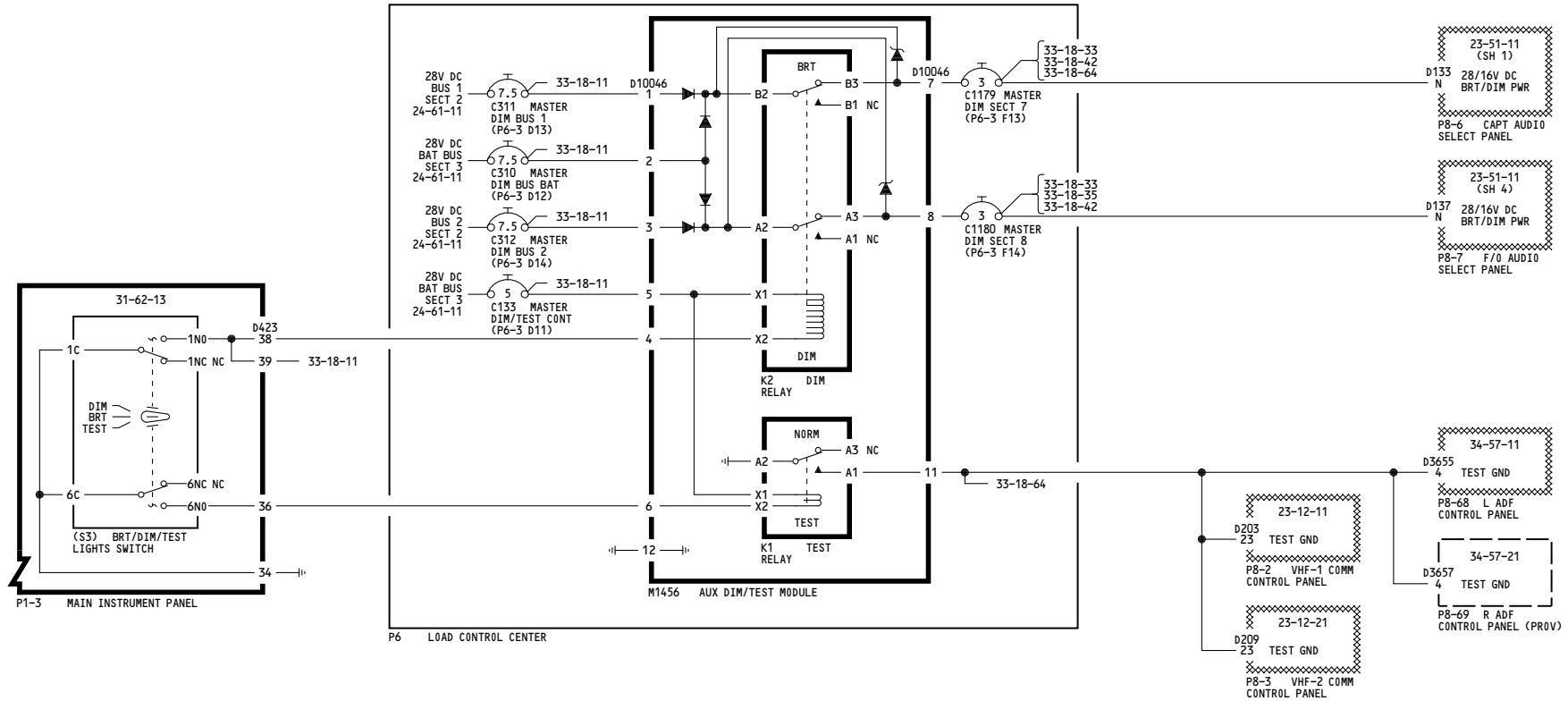

YC001-YC007

**MASTER DIM & TEST SYSTEM-
AISLE STAND PANEL,
GROUP 2**

Incorporates
26A1083 R01

D280A203

WIRING DIAGRAMS
33-18-62

33-18-62

Page 101.1

Aug 13/2008

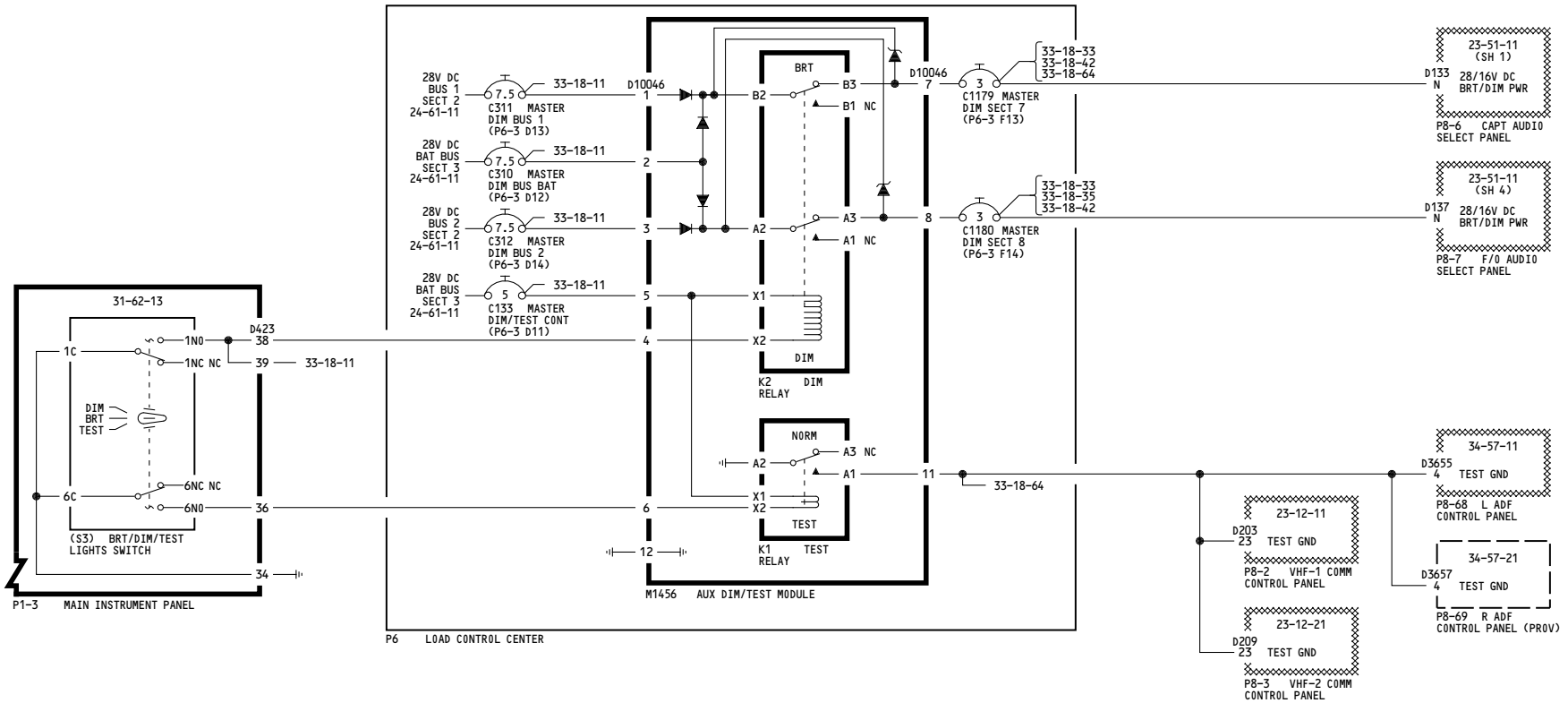

YC008-YC011

**MASTER DIM & TEST SYSTEM-
AISLE STAND PANEL,
GROUP 2**

D280A203

WIRING DIAGRAMS
33-18-62

33-18-62

Page 102

Mar 31/2005

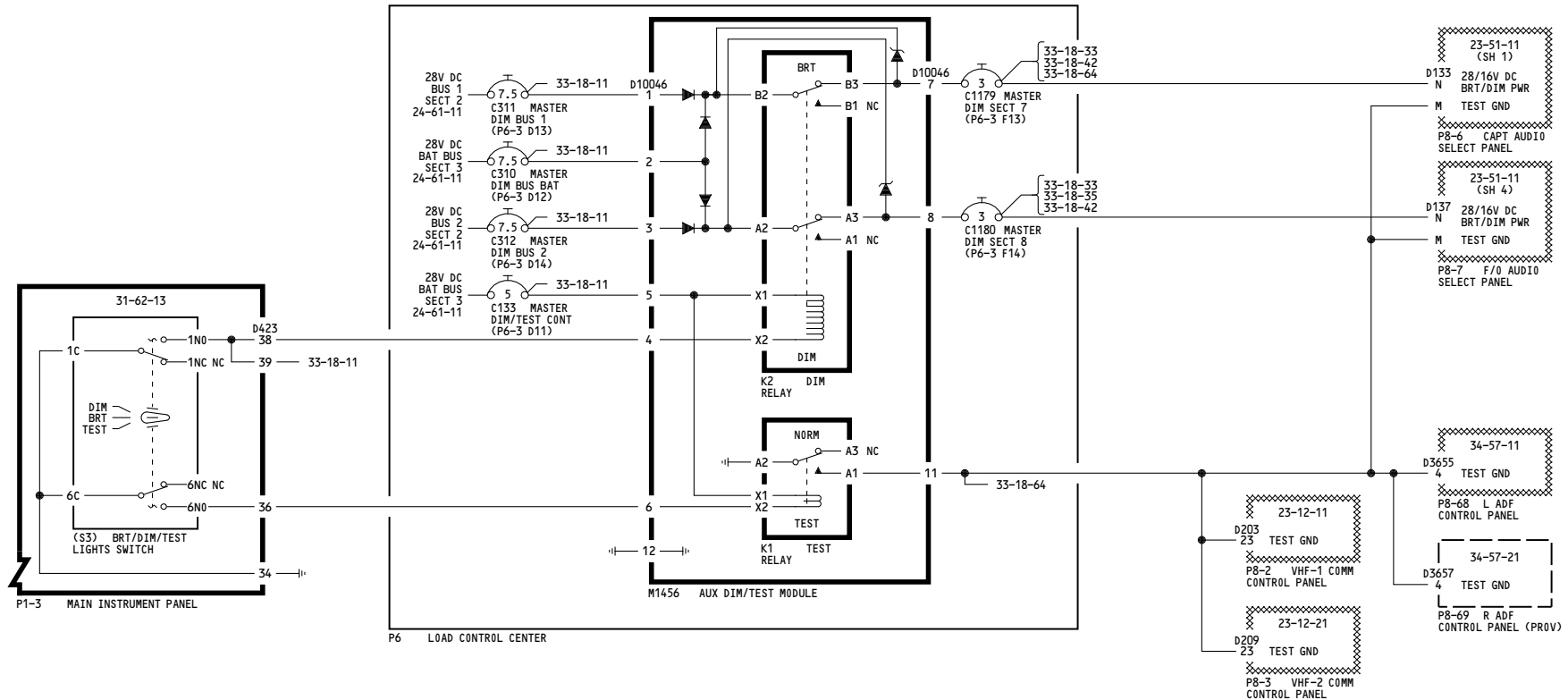

YC012-YC026

**MASTER DIM & TEST SYSTEM-
AISLE STAND PANEL,
GROUP 2**

D280A203

WIRING DIAGRAMS
33-18-62

33-18-62

Page 103

Jul 17/2007

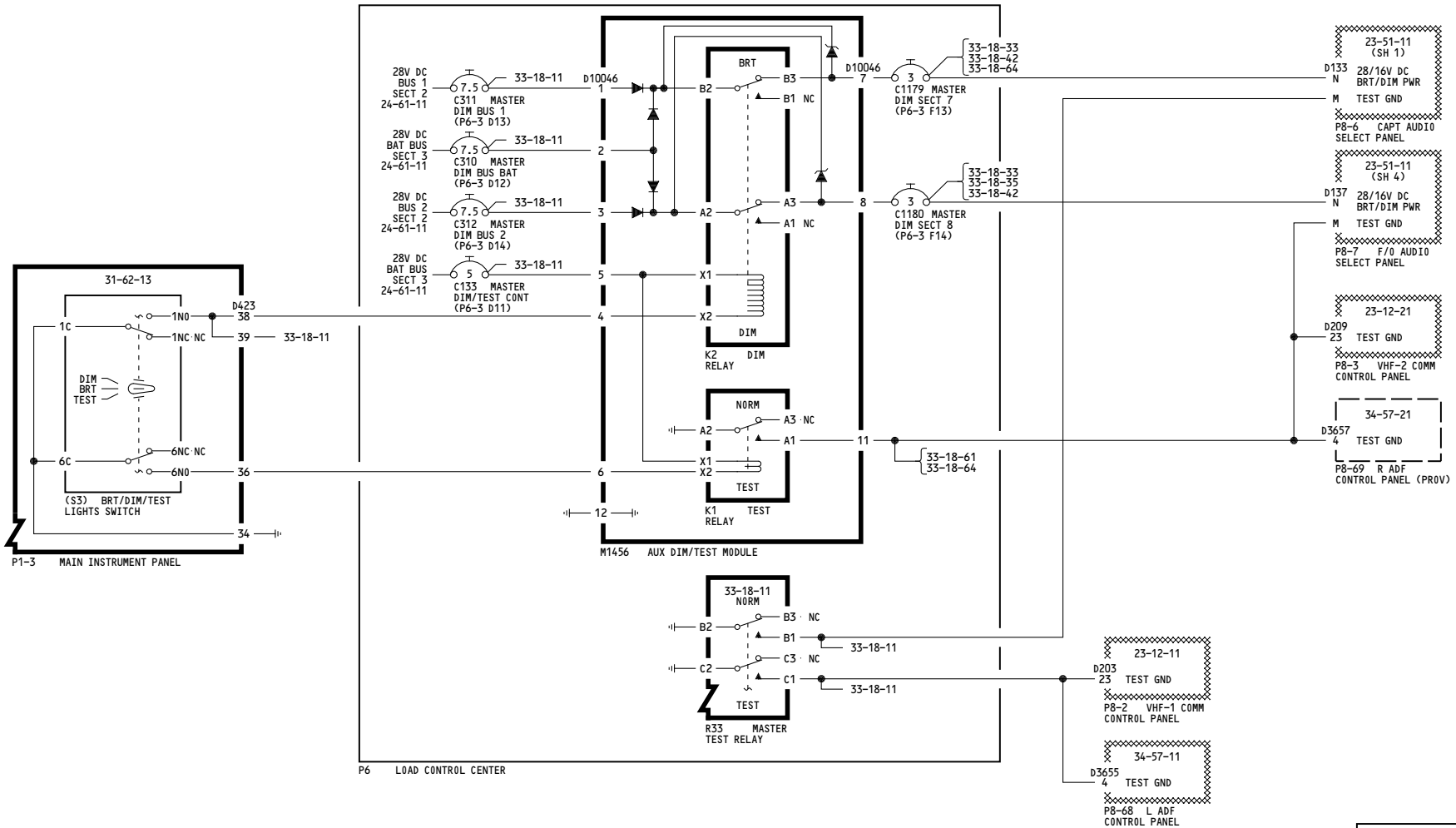

WIRING DIAGRAMS
33-18-62

YC028-YC050

**MASTER DIM & TEST SYSTEM-
AISLE STAND PANEL,
GROUP 2**

D280A203

33-18-62

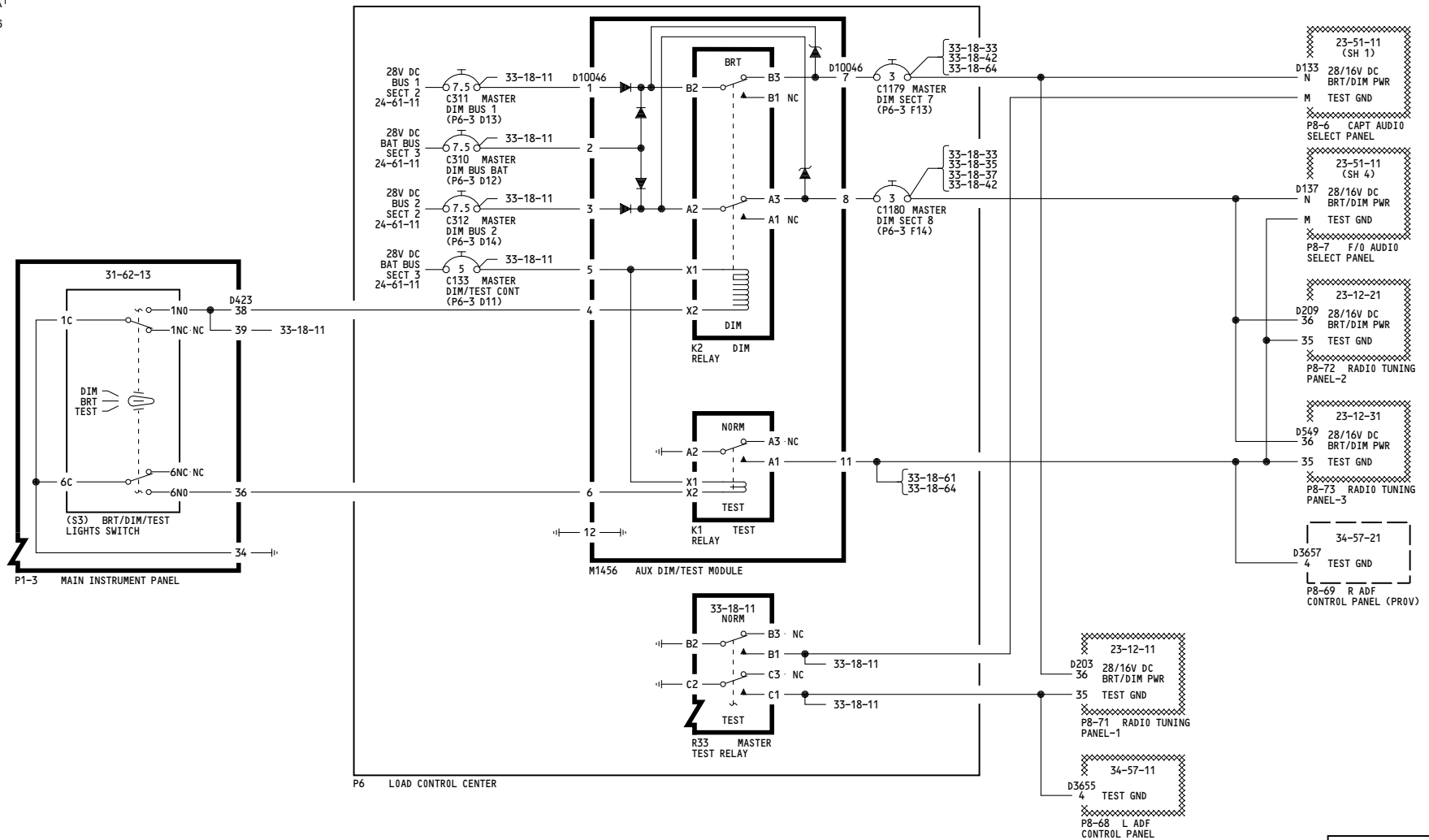

WIRING DIAGRAMS
33-18-62

33-18-62

<p>YK901-YK906</p>	<p>MASTER DIM & TEST SYSTEM- AISLE STAND PANEL, GROUP 2</p> <p>D280A203</p>
--------------------	--

-A
230

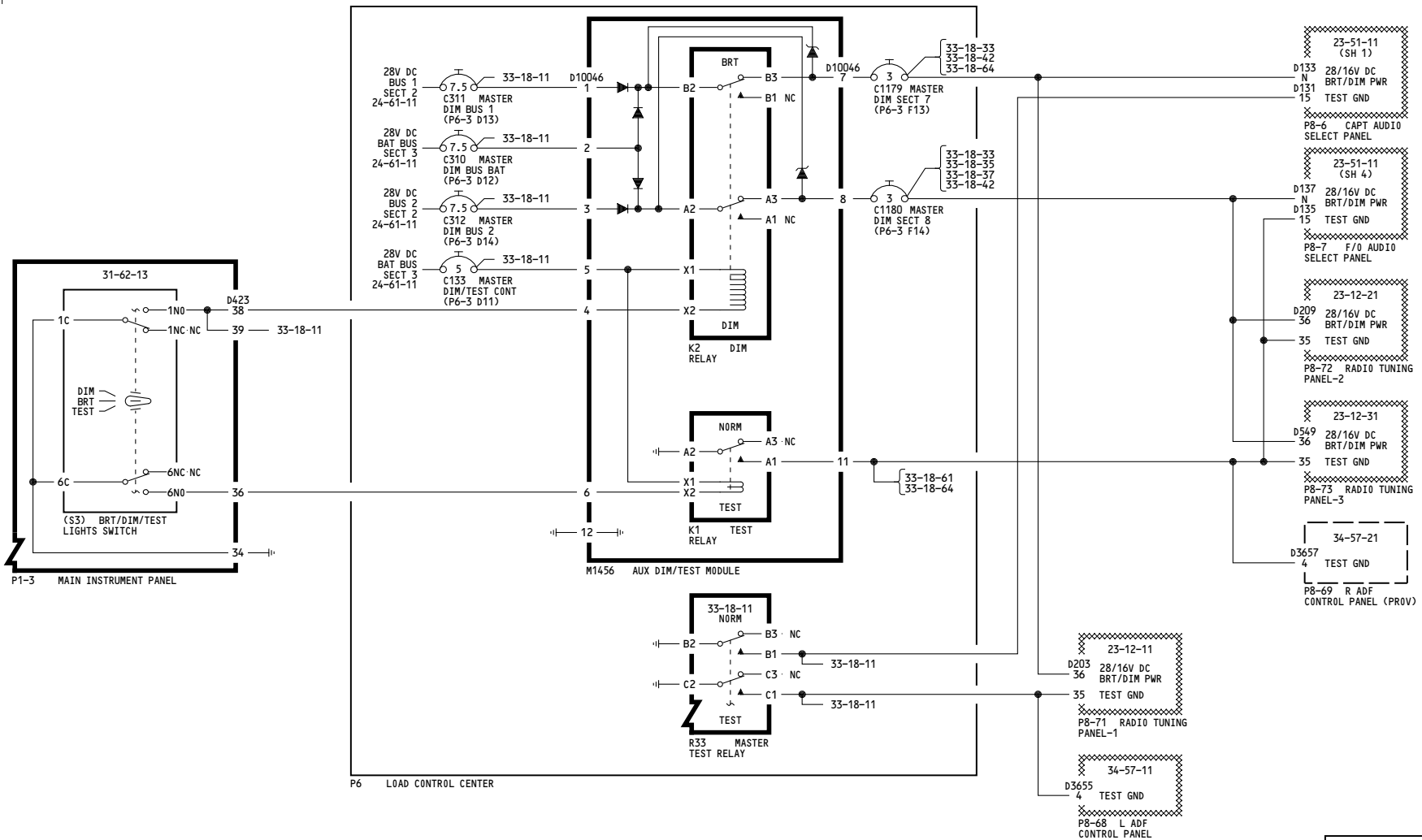

WIRING DIAGRAMS
33-18-62

YK907-YM670

**MASTER DIM & TEST SYSTEM-
AISLE STAND PANEL,
GROUP 2**

D280A203

33-18-62

Page 106

Aug 10/2009

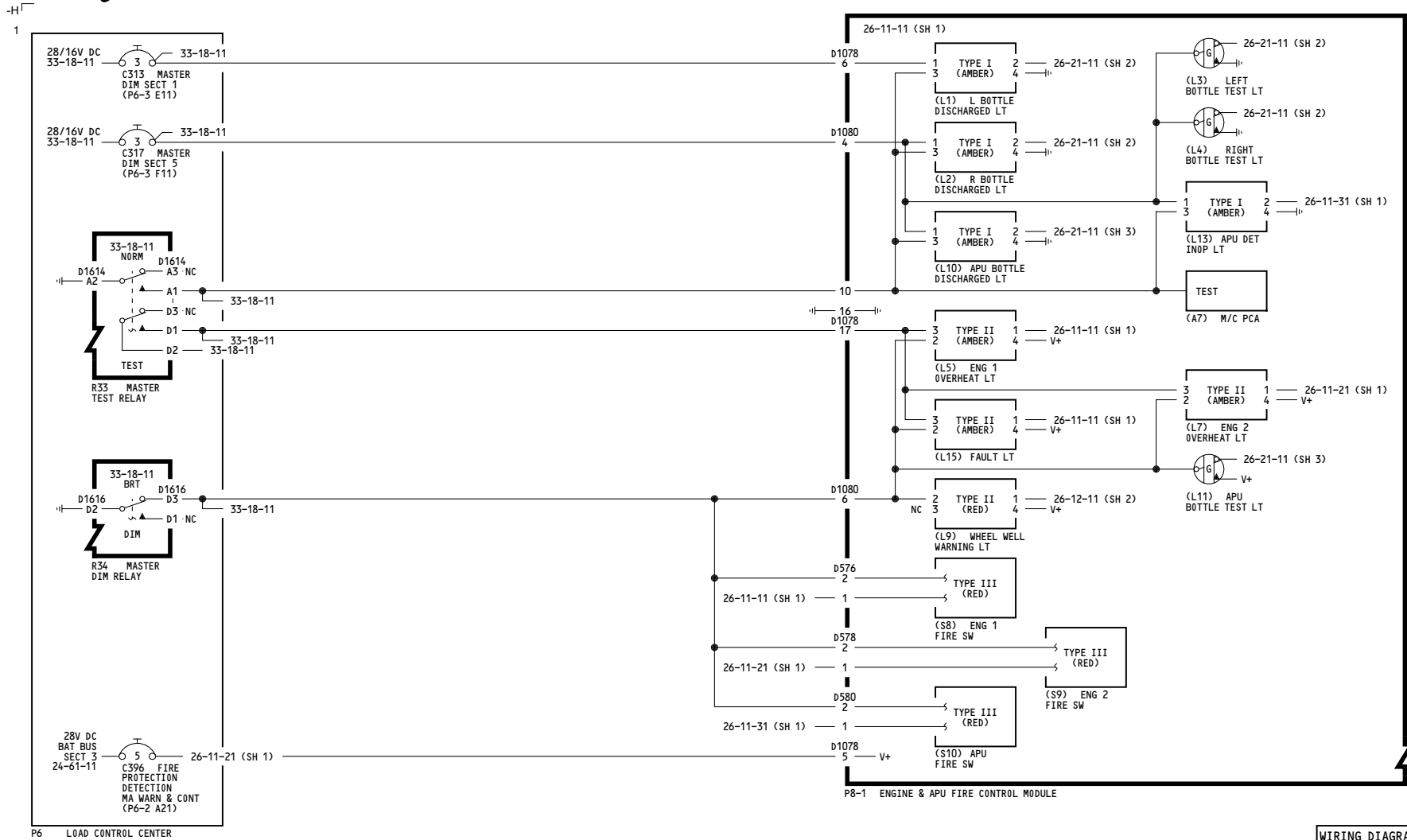

P6 LOAD CONTROL CENTER

P8-1 ENGINE & APU FIRE CONTROL MODULE

WIRING DIAGRAMS
33-18-63

33-18-63

Page 101

Feb 09/2009

ALL

**MASTER DIM & TEST SYSTEM-
AISLE STAND PANEL,
GROUP 3**

D280A203

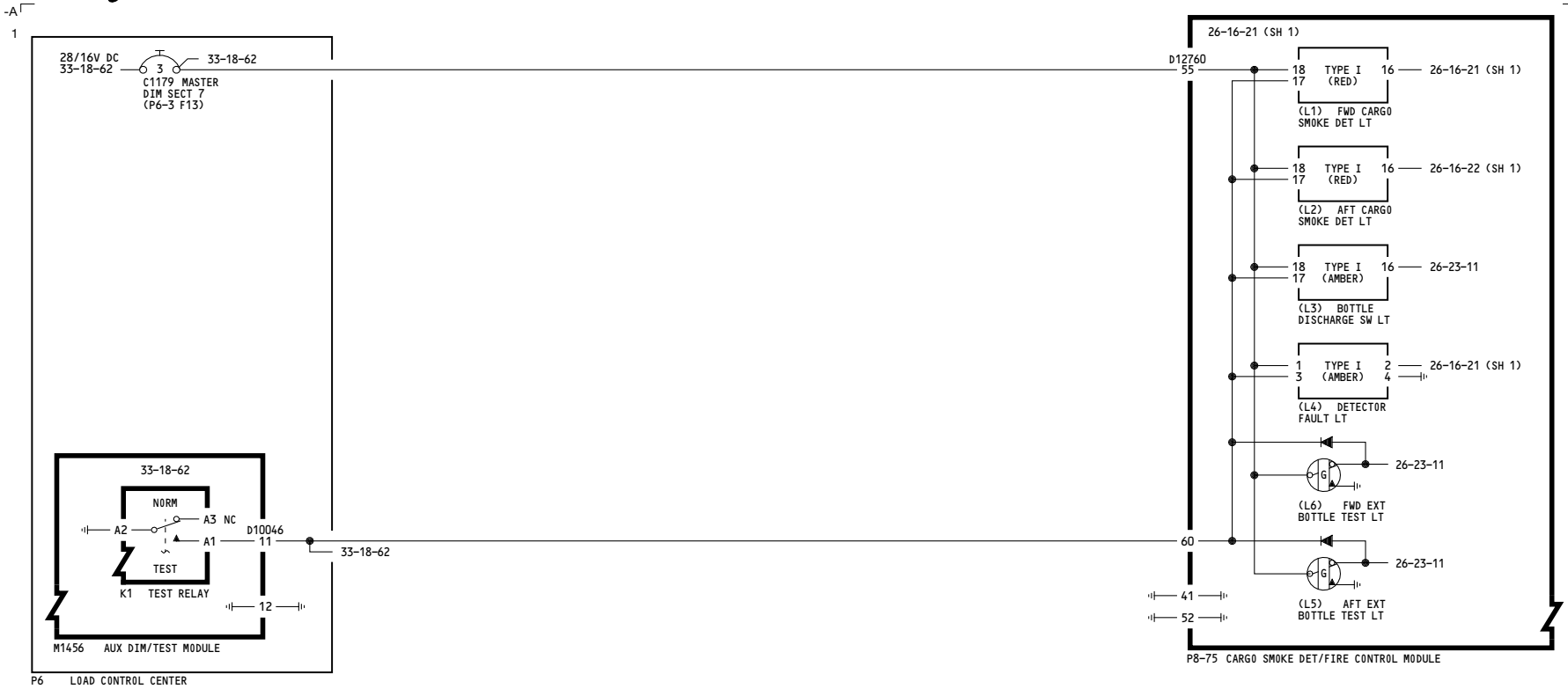

P6 LOAD CONTROL CENTER

P8-75 CARGO SMOKE DET/FIRE CONTROL MODULE

WIRING DIAGRAMS
33-18-64

YC001-YC007

MASTER DIM & TEST SYSTEM- AISLE STAND PANEL, GROUP 4

D280A203

Incorporates
26A1083 R01

33-18-64

Page 101.1

Aug 13/2008

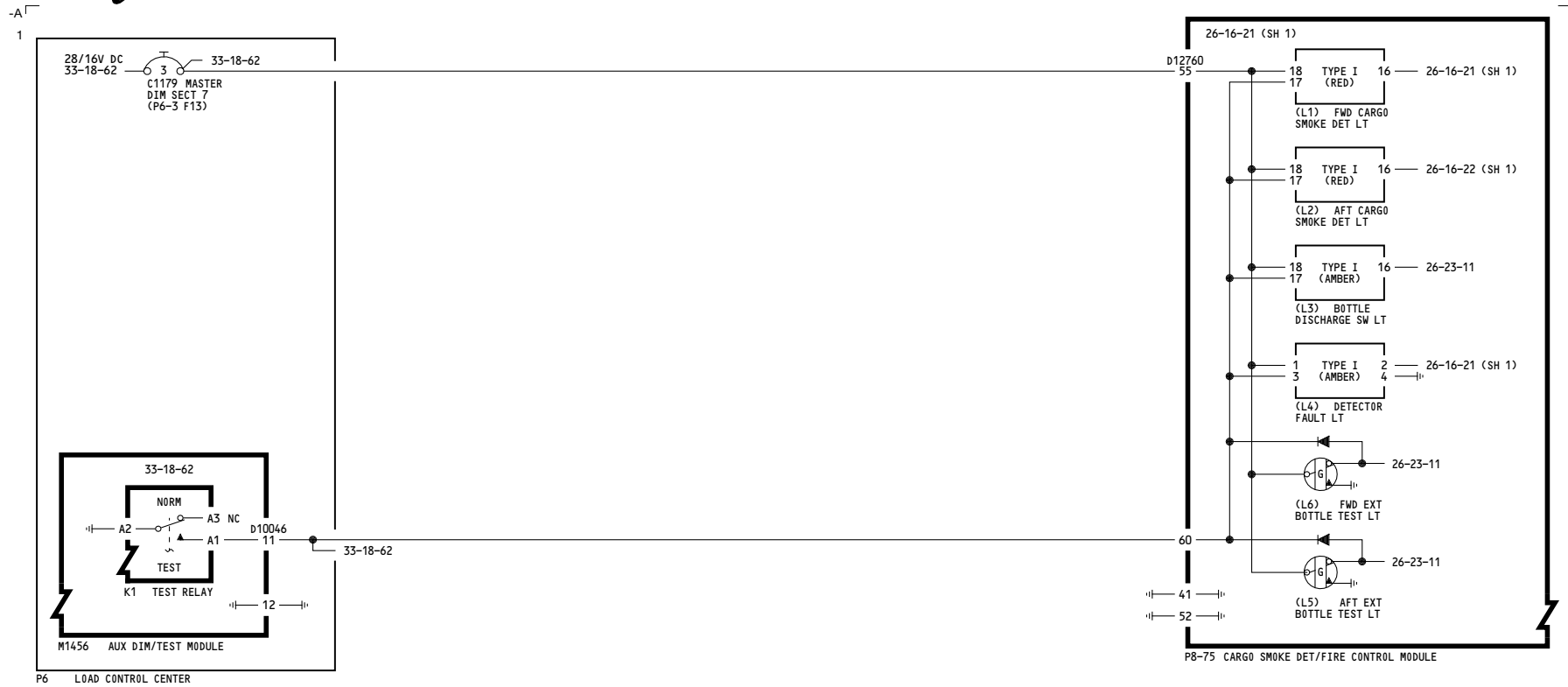

P6 LOAD CONTROL CENTER

<p>YC008-YM670</p>	<p>MASTER DIM & TEST SYSTEM- AISLE STAND PANEL, GROUP 4</p> <p>D280A203</p>
--------------------	--

WIRING DIAGRAMS
33-18-64

33-18-64

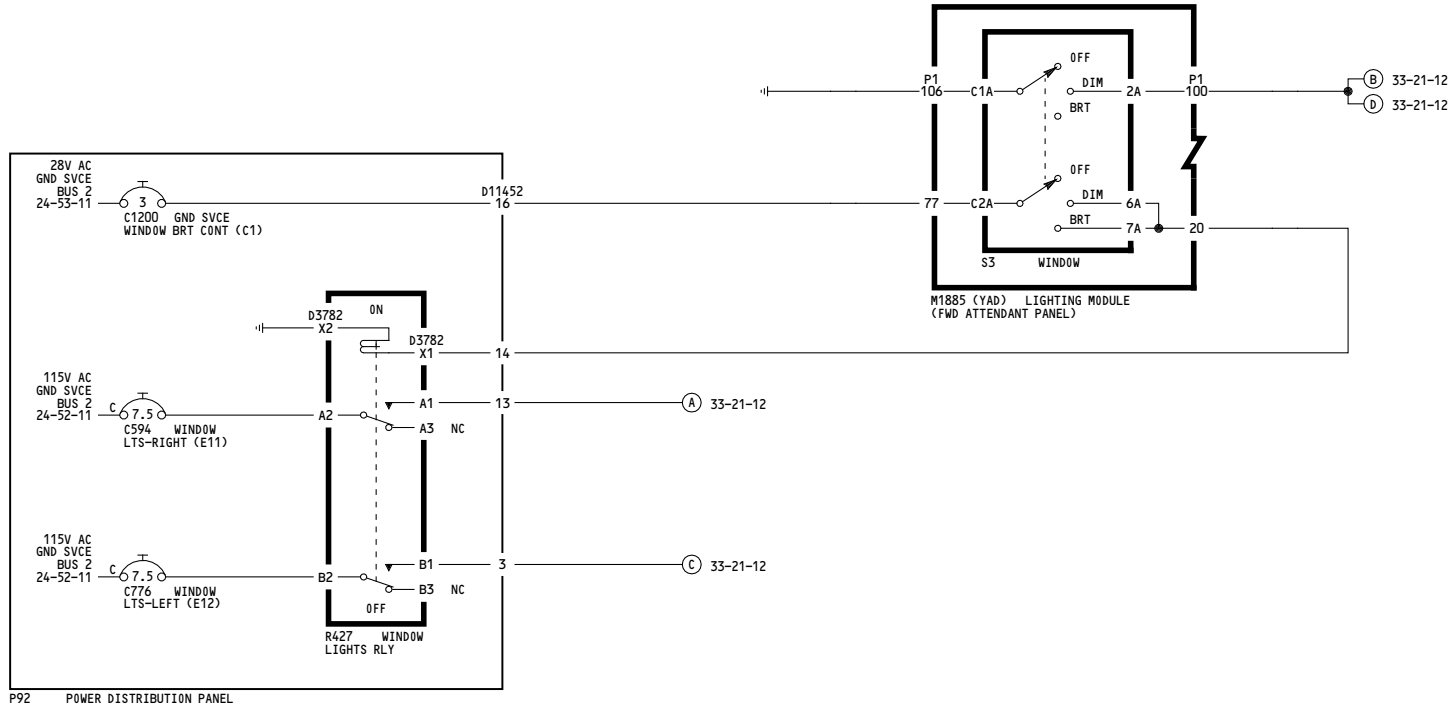

ALL	<p>WINDOW LIGHTS CONTROL</p> <p>D280A203</p>
-----	---

33-21-11

-B
33

WIRING DIAGRAMS
33-21-12

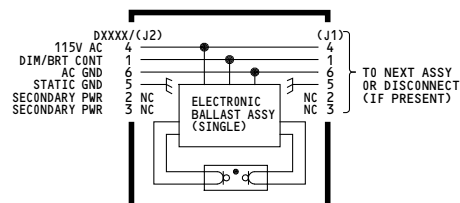
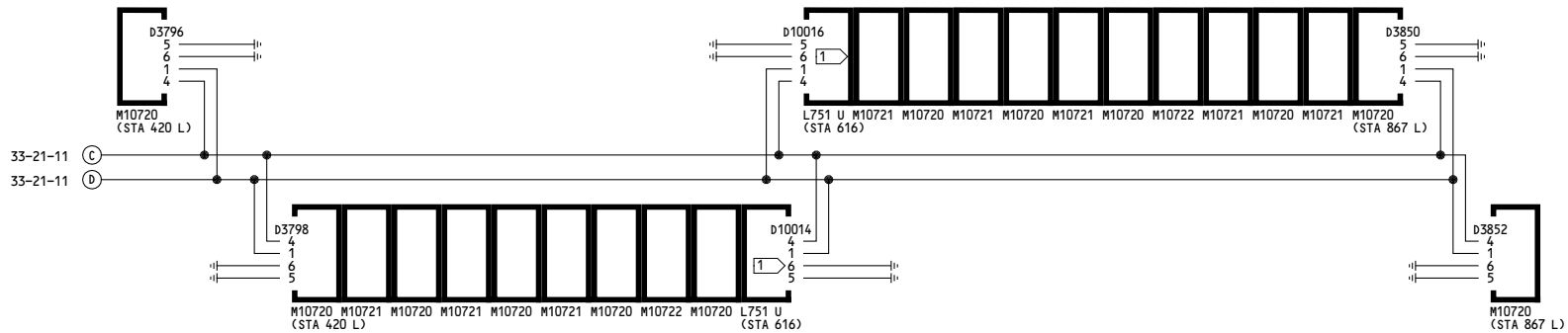
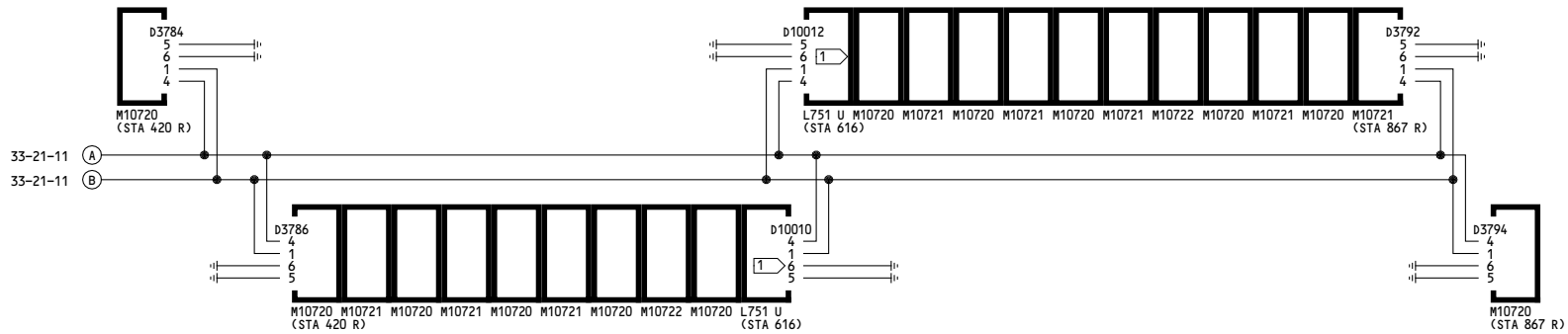

M10722 SHORT LIGHT ASSY⁻³
M10766 MEDIUM LIGHT ASSY⁻⁴
(STAXXX WL272 BL57L&R)

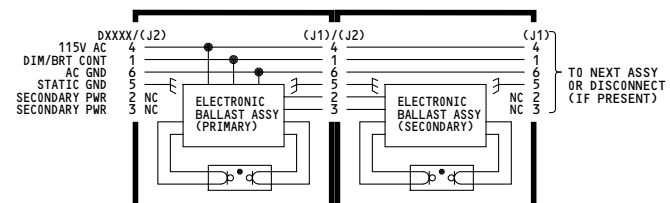

M10720 LONG LIGHT ASSY⁻¹ (PRIMARY)
(STAXXX WL272 BL57L&R)
M10721 LONG LIGHT ASSY⁻² (SECONDARY)

NOTES

1 L751 U IS A BALLAST OPERATING A LAMP IN THE OVERWING EXIT ASSY (L751).

YC001-YC050	<p>WINDOW LIGHTS</p> <p>D280A203</p>
-------------	--

WIRING DIAGRAMS
33-21-12

96

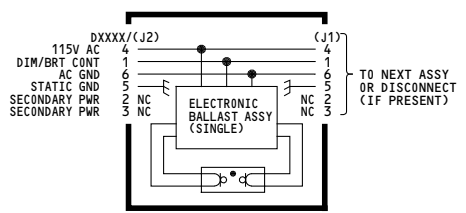
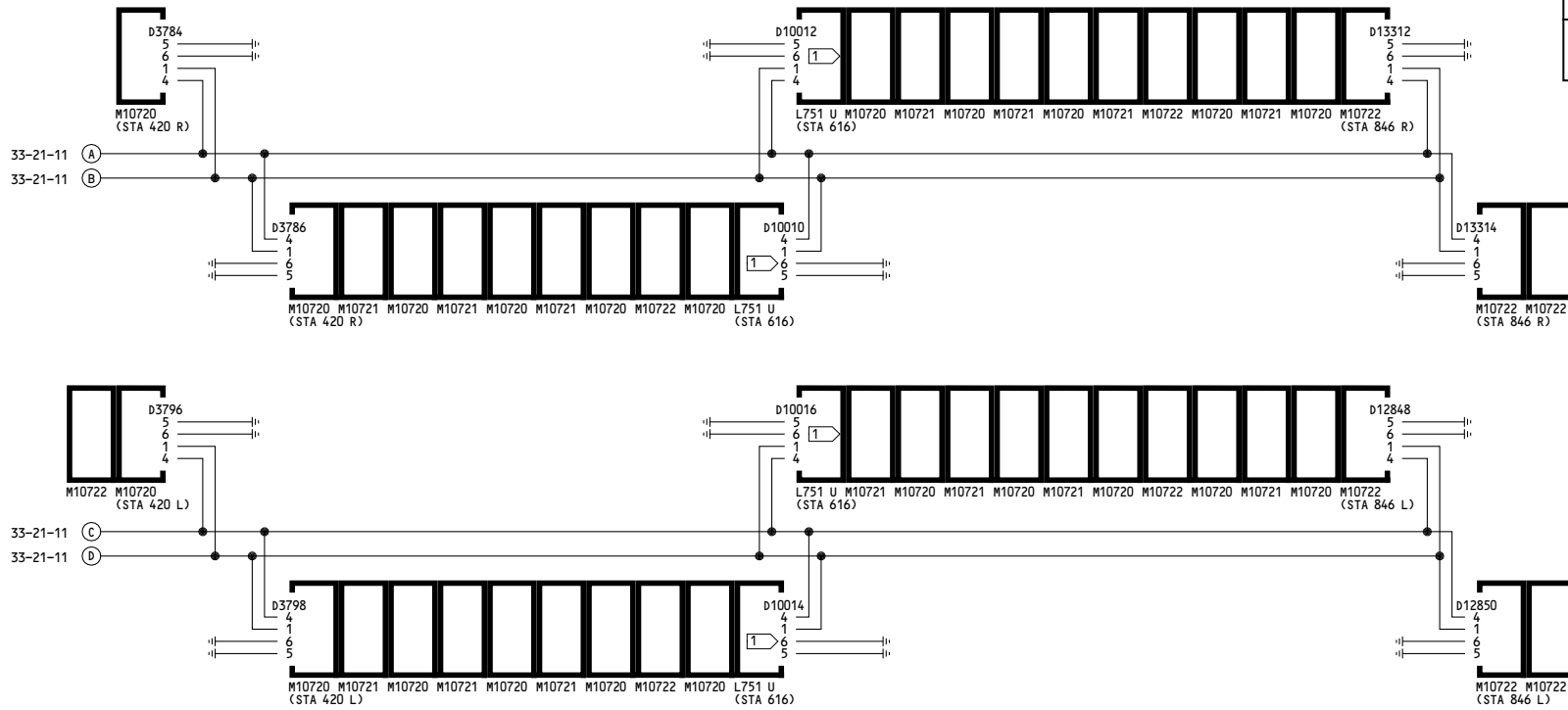

M10722 SHORT LIGHT ASSY
M10766 MEDIUM LIGHT ASSY
(STAXXX WL272 BL57L&R)

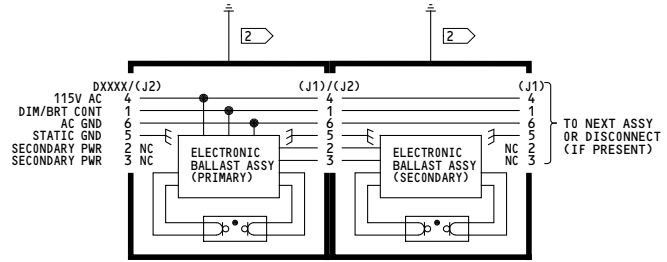

M10720 LONG LIGHT ASSY (PRIMARY)
(STAXXX WL272 BL57L&R)
M10721 LONG LIGHT ASSY (SECONDARY)

- NOTES**
- ① L751 U IS A BALLAST OPERATING A LAMP IN THE OVERWING EXIT ASSY (L751).
 - ② CASE GROUND ADDED, SEE 737-SL-33-042 FOR DETAILS.

YC021-YC026	WINDOW LIGHTS
	Incorporates SL-33-042
	D280A203

33-21-12

Page 101.1

Jul 17/2007

-B
18

WIRING DIAGRAMS
33-21-12

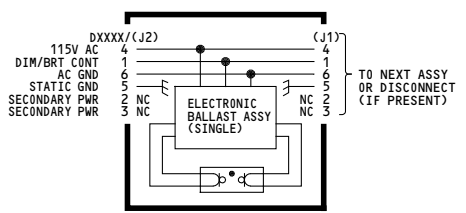
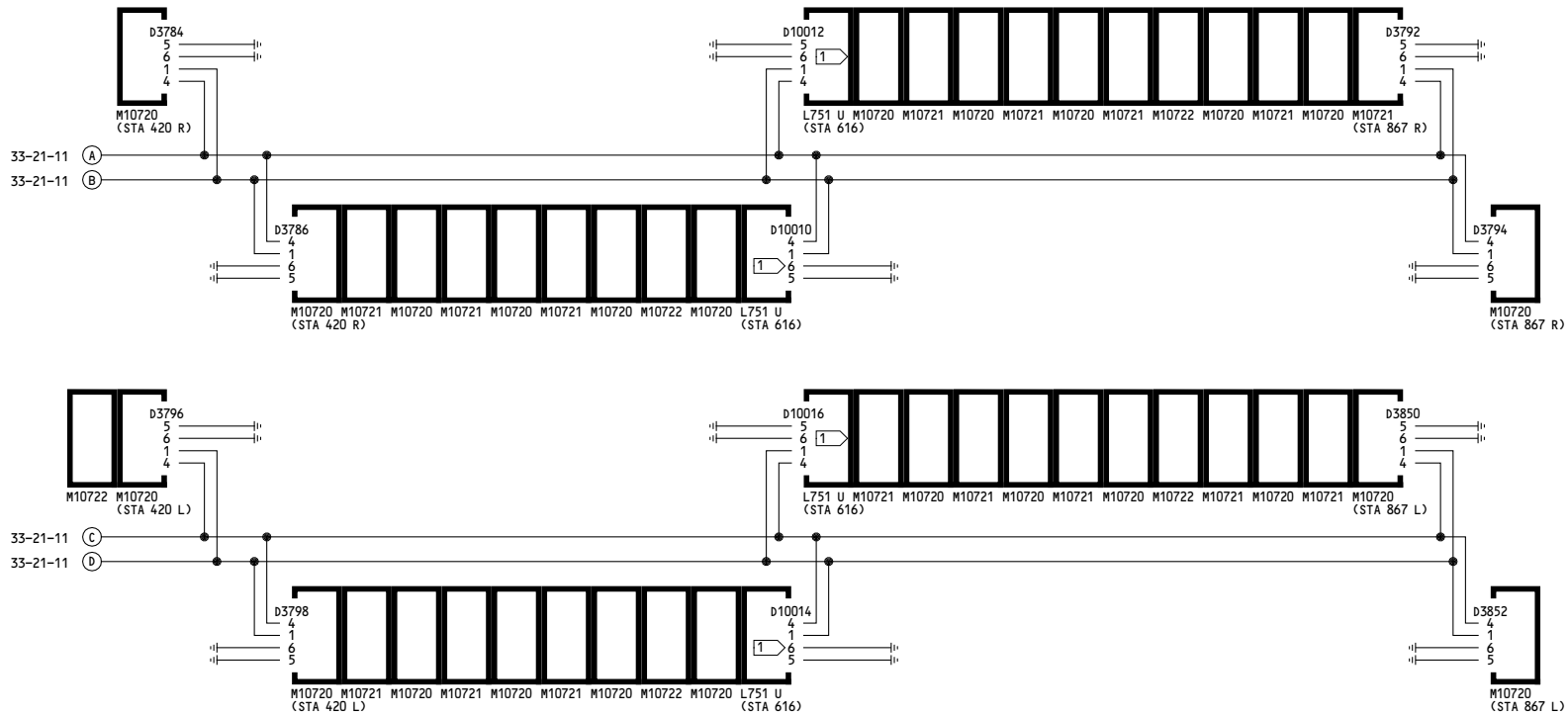

M10722 SHORT LIGHT ASSY
M10766 MEDIUM LIGHT ASSY
(STAXXX WL272 BL57L&R)

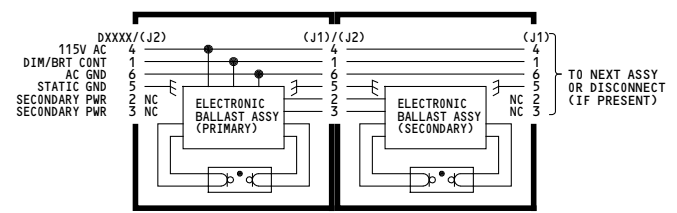

M10720 LONG LIGHT ASSY (PRIMARY)
(STAXXX WL272 BL57L&R)
M10721 LONG LIGHT ASSY (SECONDARY)

NOTES
1 L751 U IS A BALLAST OPERATING A LAMP IN THE OVERWING EXIT ASSY (L751).

YK901-YL430	<p>WINDOW LIGHTS</p> <p>D280A203</p>
-------------	---

WIRING DIAGRAMS
33-21-12

-E
3

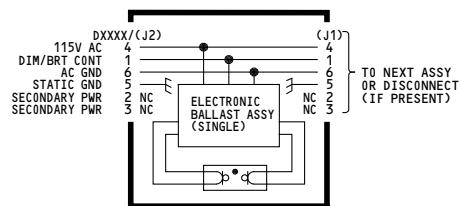
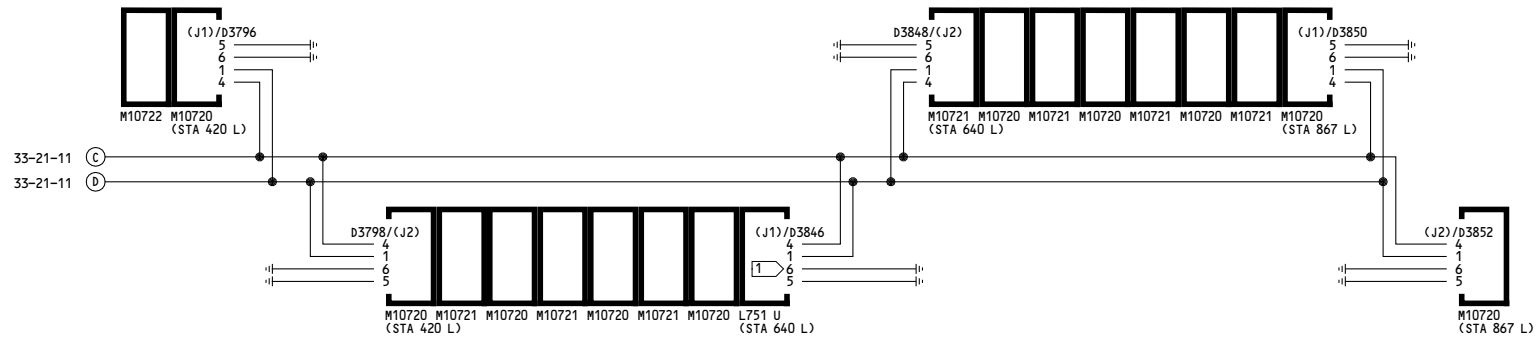
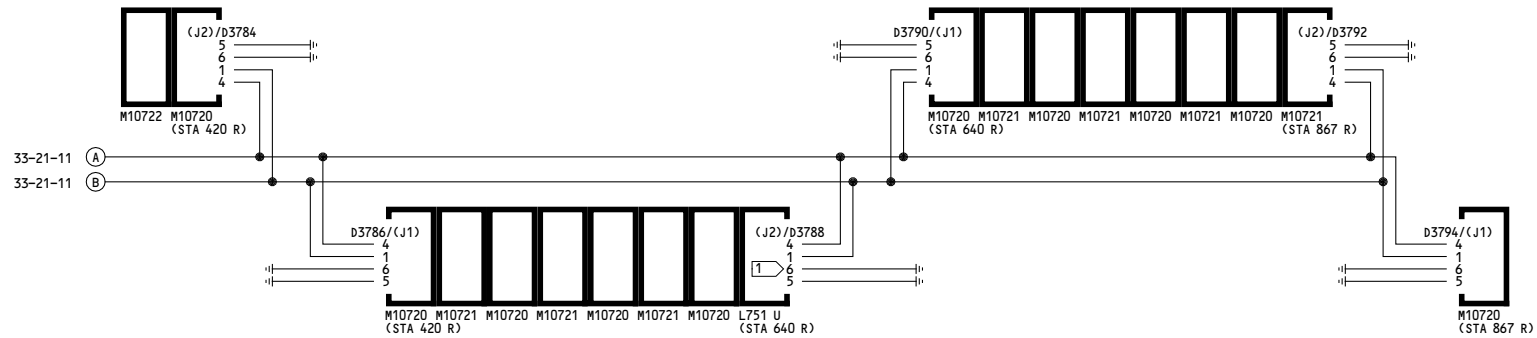

M10722 SHORT LIGHT ASSY
M10766 MEDIUM LIGHT ASSY
(STAXXX WL272 BL57L&R)

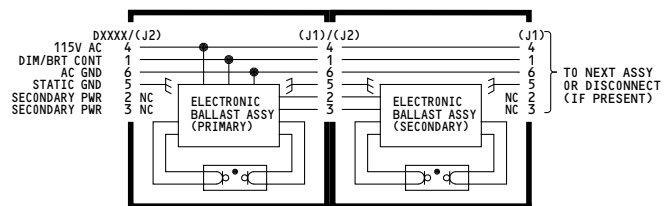

M10720 LONG LIGHT ASSY (PRIMARY)
(STAXXX WL272 BL57L&R)

M10721 LONG LIGHT ASSY (SECONDARY)

NOTES

1 L751 U IS A BALLAST OPERATING A LAMP IN THE OVERWING EXIT ASSY (L751).

YM643-YM670	WINDOW LIGHTS
	D280A203

WIRING DIAGRAMS
33-22-11

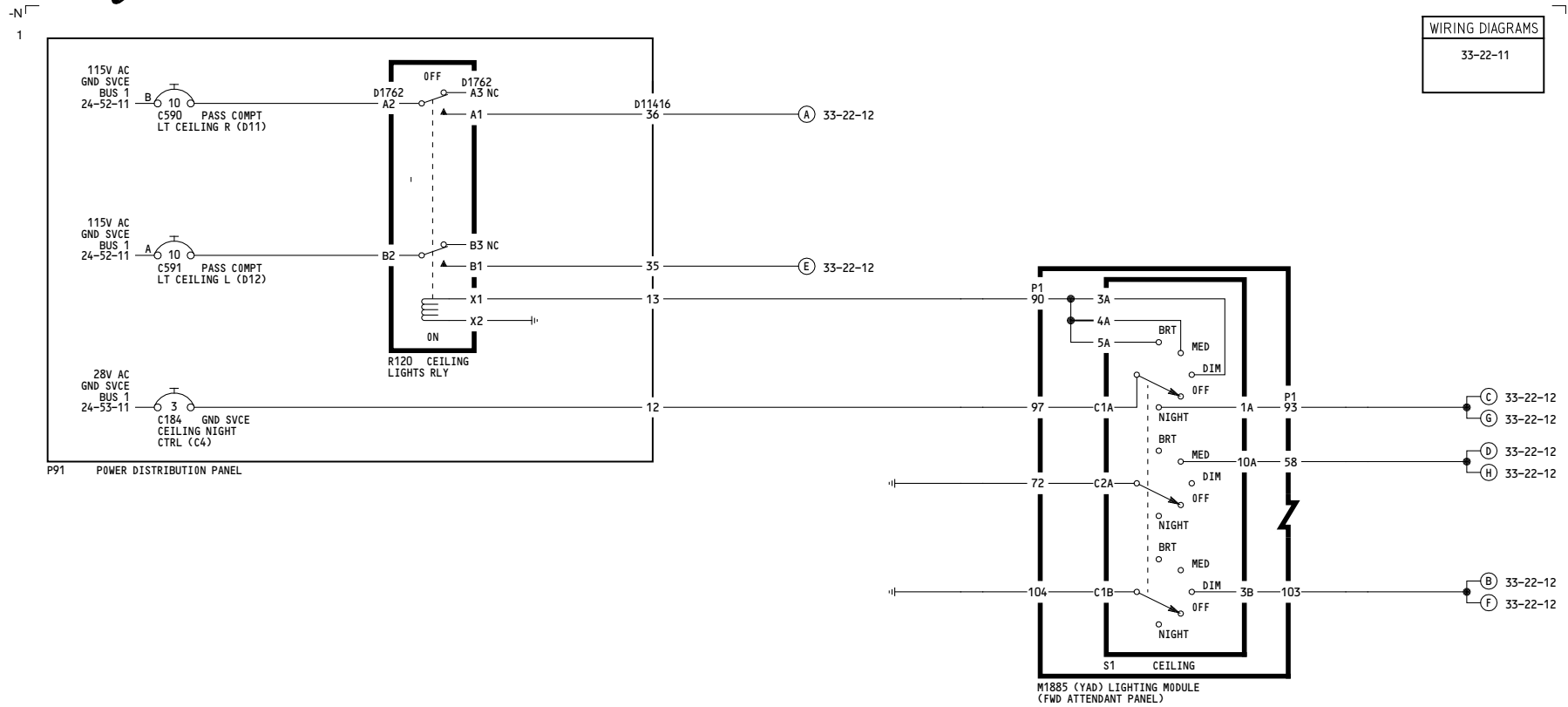

YC001-YK906	<p align="center">CEILING LIGHTS CONTROL</p> <p align="center">D280A203</p>
-------------	--

33-22-11

Page 101

Jul 17/2007

WIRING DIAGRAMS
33-22-11

24

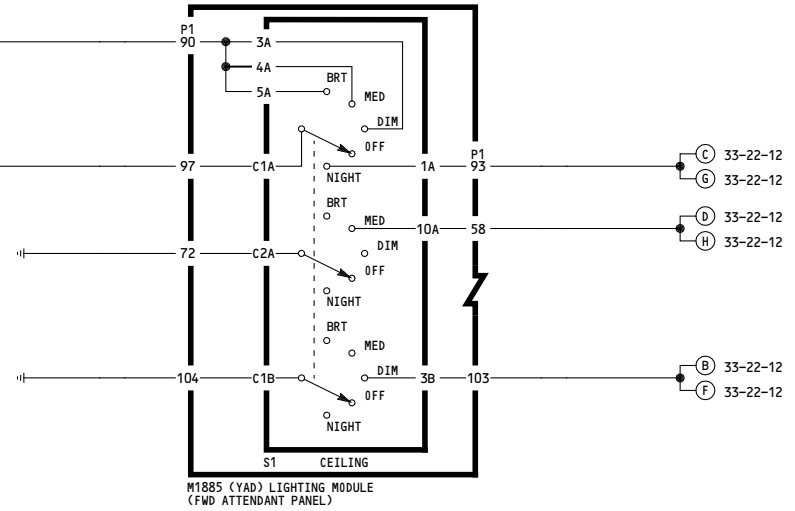
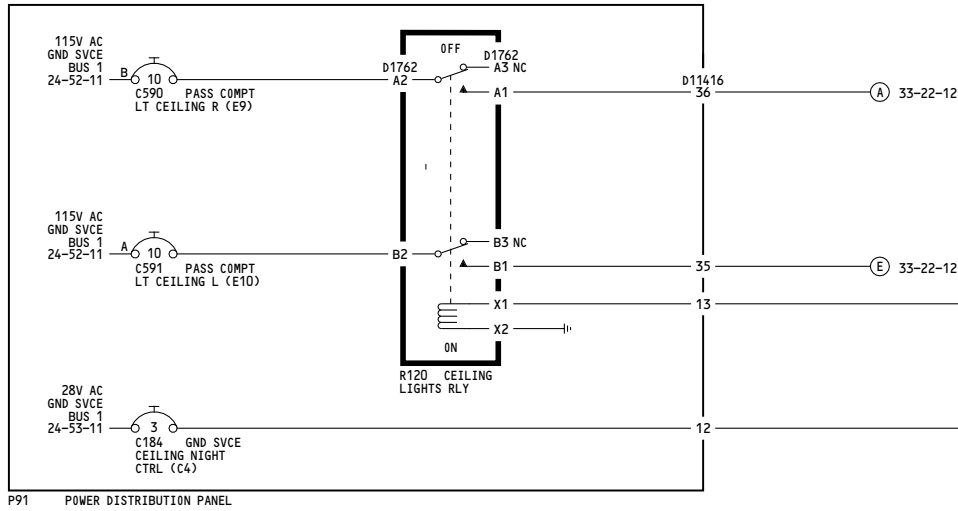

YK907-YL430	<p align="center">CEILING LIGHTS CONTROL</p> <p align="center">D280A203</p>
-------------	--

33-22-11

Page 102

Feb 09/2009

23

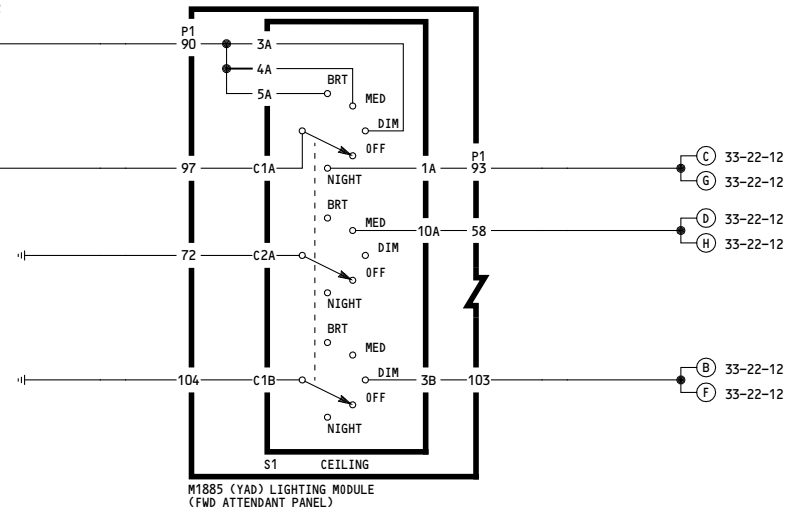
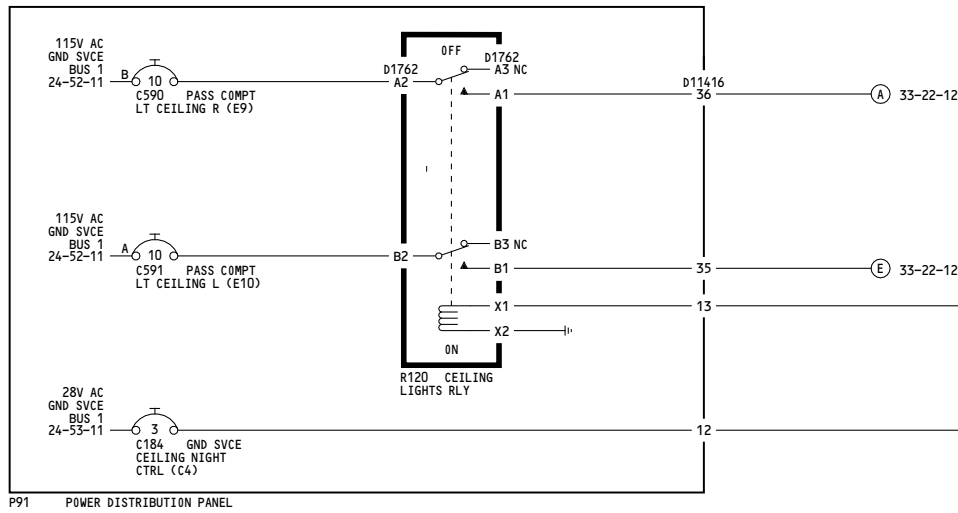

YM643-YM670	<p align="center">CEILING LIGHTS CONTROL</p> <p align="center">D280A203</p>
-------------	--

33-22-11

Page 103

Jan 14/2008

WIRING DIAGRAMS
33-22-21 33-22-22
33-22-31 33-22-32

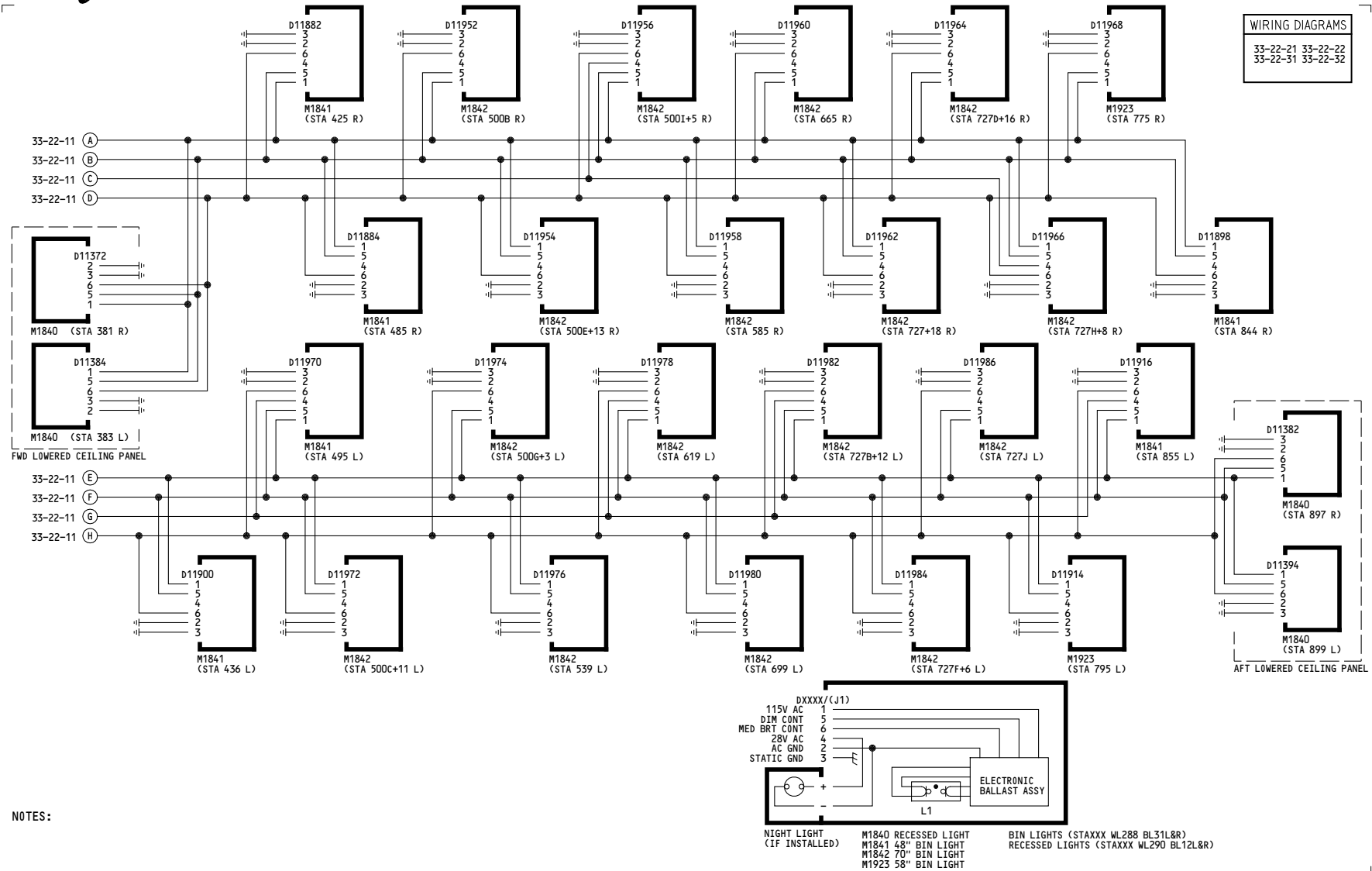

NOTES:

YC001-YC030	<p align="center">CEILING LIGHTS</p> <p align="center">D280A203</p>
-------------	--

-B
24

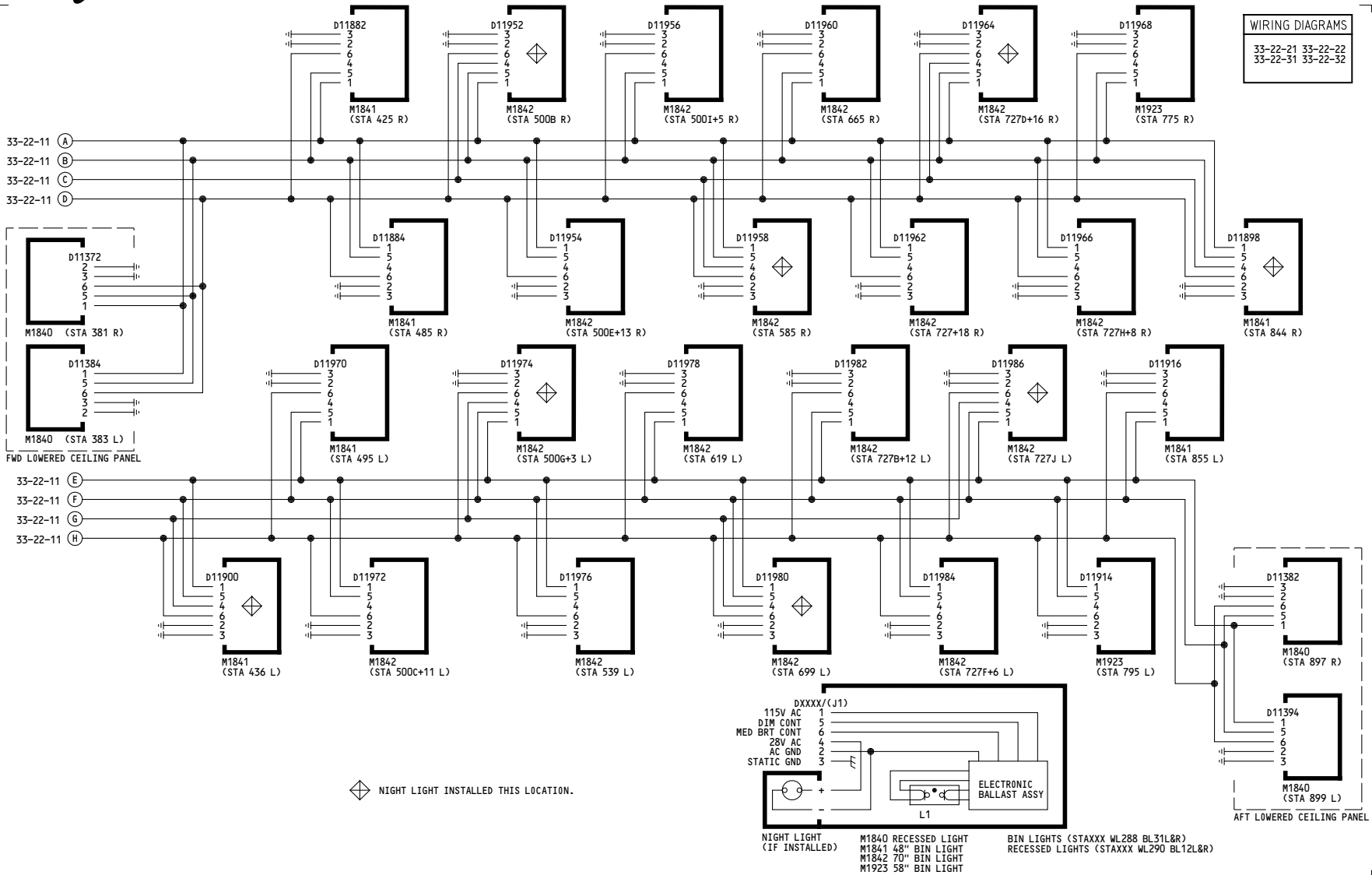

YC031-YL430	CEILING LIGHTS
	D280A203

33-22-12

Page 102

Feb 09/2009

WIRING DIAGRAMS
33-22-21 33-22-22
33-22-31 33-22-32

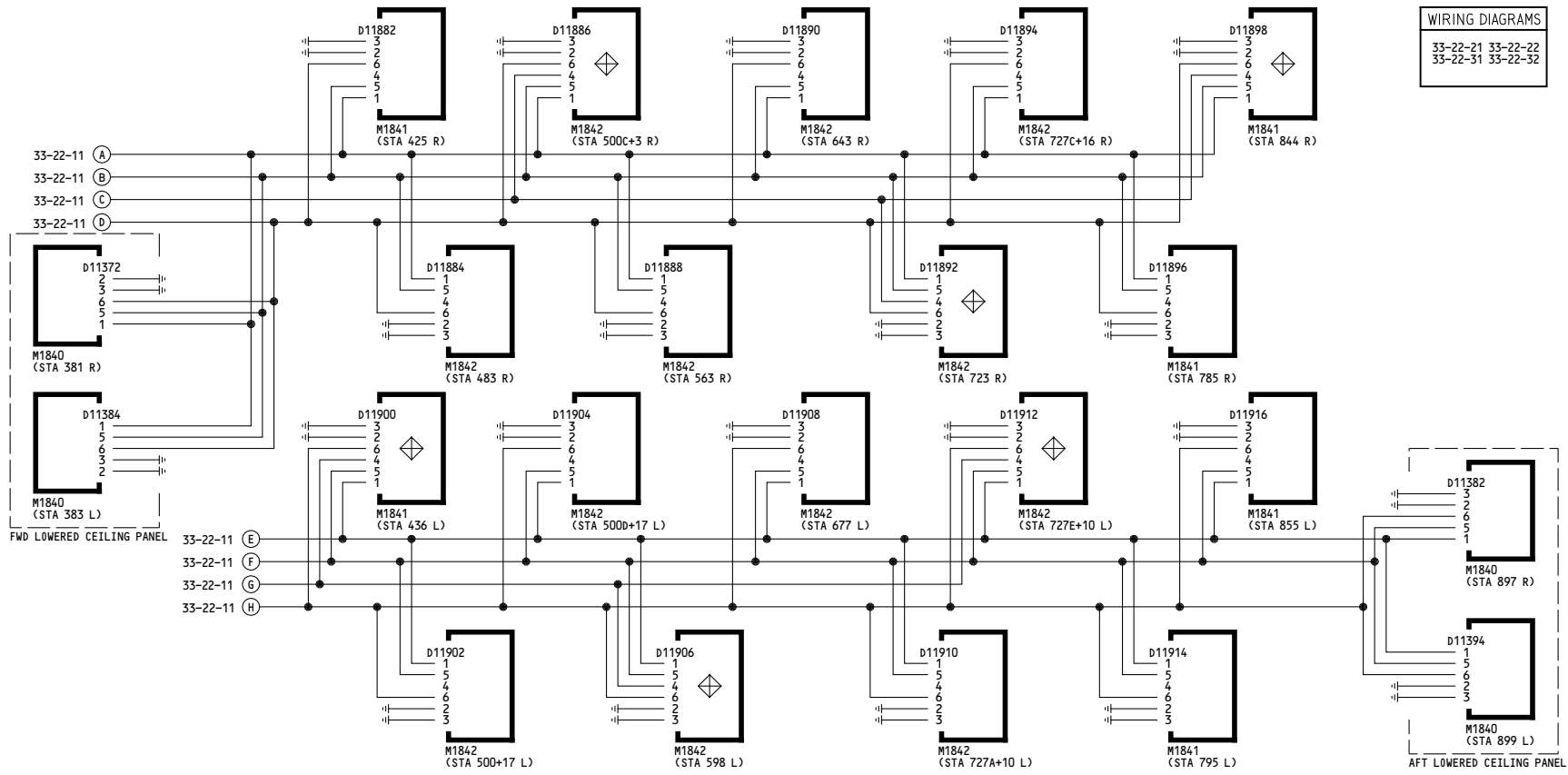

◆ NIGHT LIGHT INSTALLED THIS LOCATION.

NOTES:

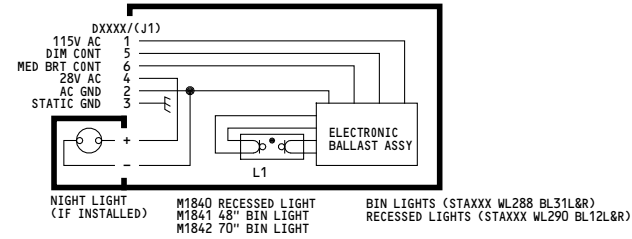

YM643-YM670	<p align="center">CEILING LIGHTS</p> <p align="center">D280A203</p>
-------------	--

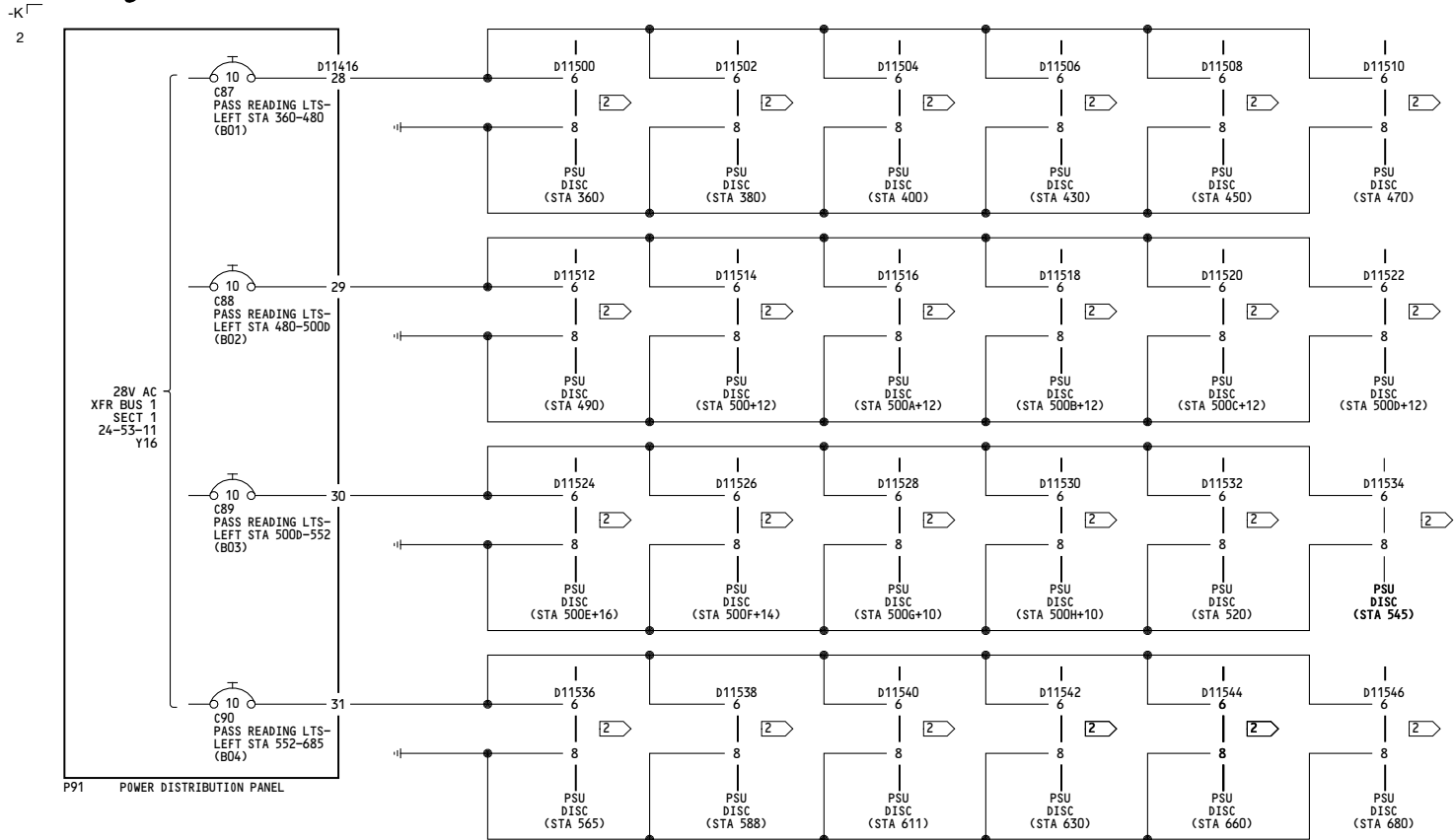

NOTES

- 1 PSU: PASSENGER SERVICE UNIT
- 2 MATE WITH PSU IF INSTALLED
- 3 ALL PSU DISCONNECTS LOCATED AT: WL 274, LBL 51

YC001-YL430	PASS READING LTS - LEFT FWD D280A203
-------------	--

33-23-11

Page 101

Aug 10/2009

-W
1

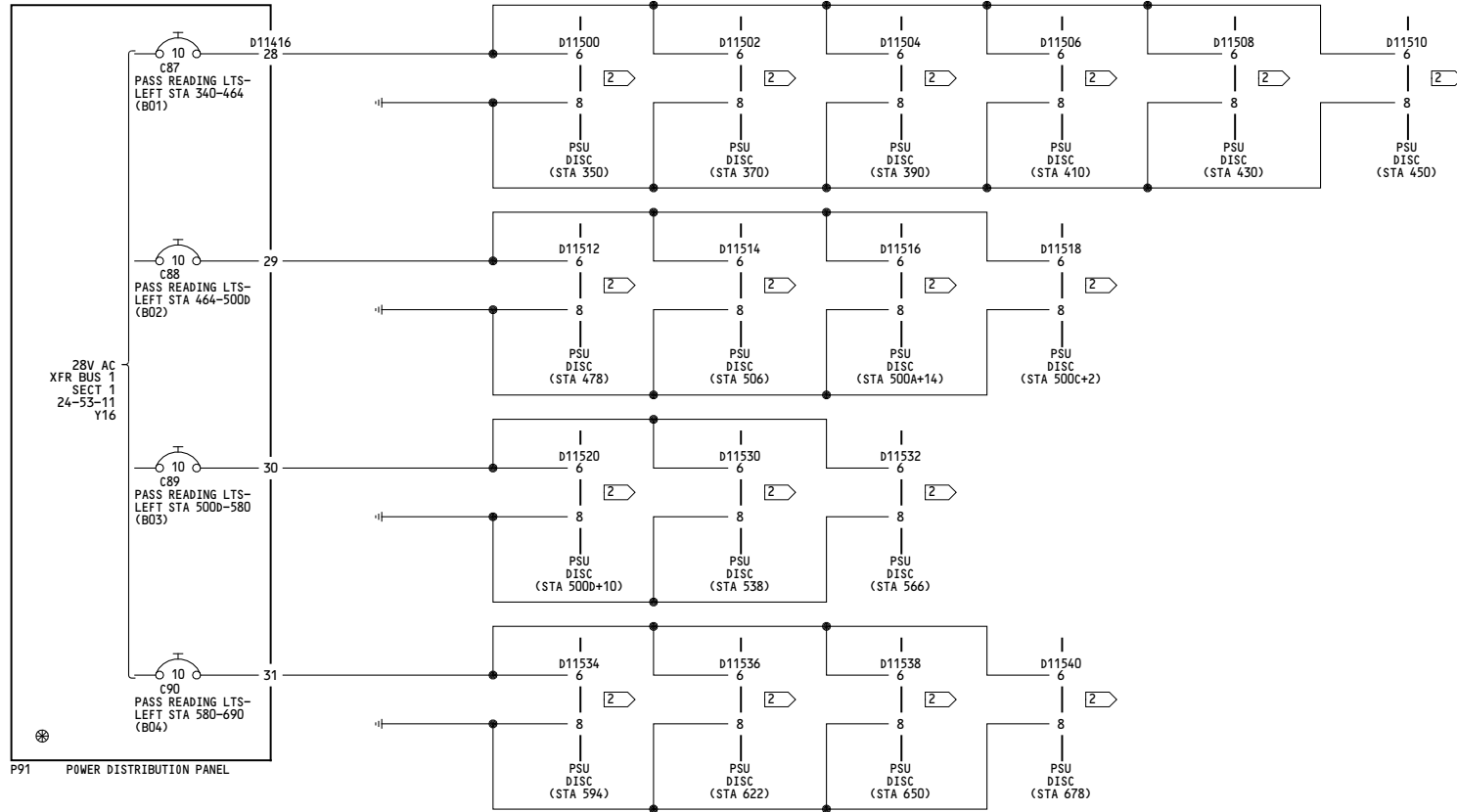

NOTES

- 1 PSU: PASSENGER SERVICE UNIT
- 2 MATE WITH PSU IF INSTALLED
- 3 ALL PSU DISCONNECTS LOCATED AT: WL 274 LBL 51

YM643-YM670	PASS READING LTS - LEFT FWD
	D280A203

33-23-11

Page 102

Jan 14/2008

WIRING DIAGRAMS
33-23-12

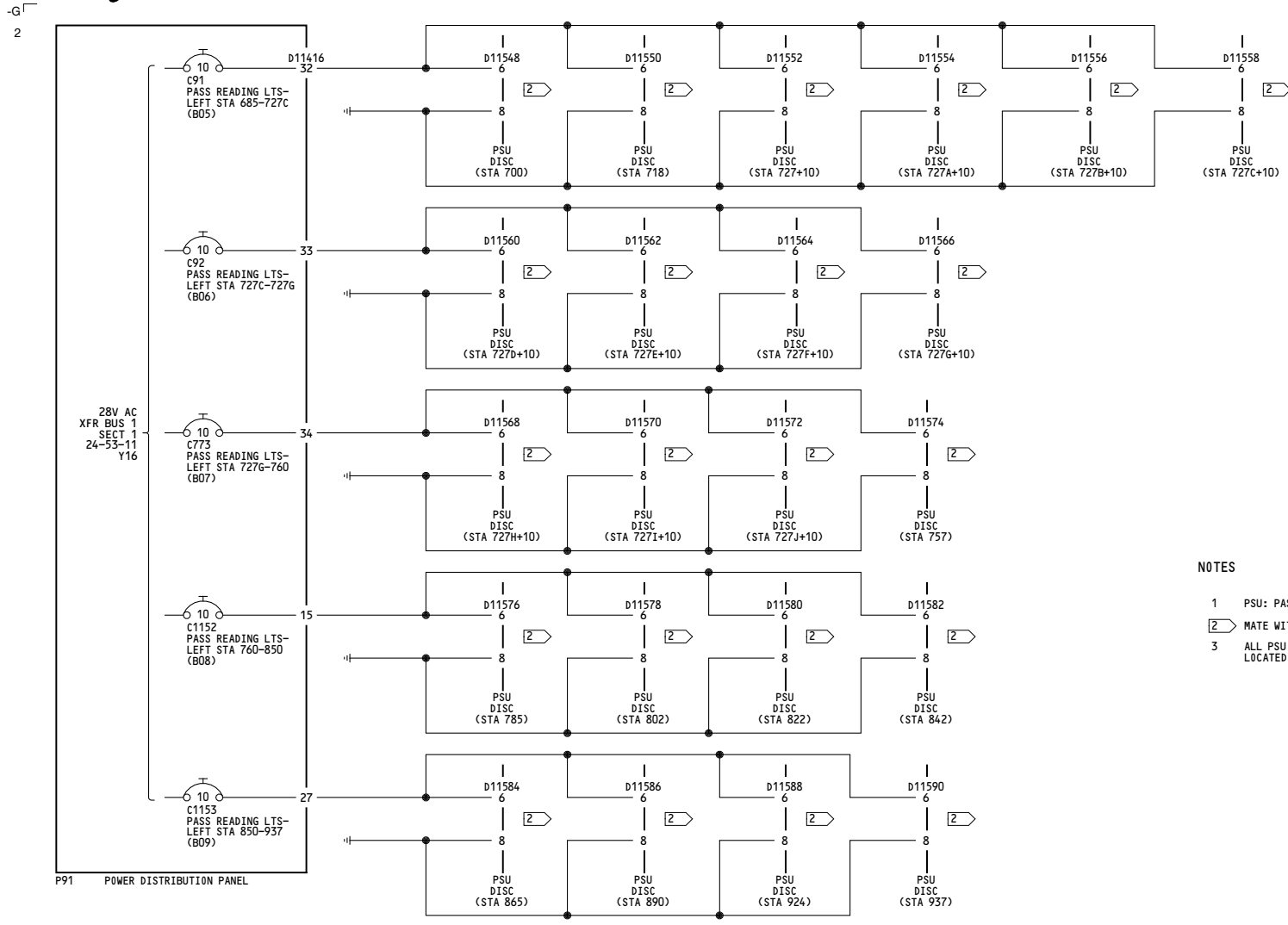

- NOTES
- 1 PSU: PASSENGER SERVICE UNIT
 - 2 MATE WITH PSU IF INSTALLED
 - 3 ALL PSU DISCONNECTS LOCATED AT: WL 274, LBL 51

YC001-YL430	PASS READING LTS - LEFT AFT
D280A203	

33-23-12

Page 101

Aug 10/2009

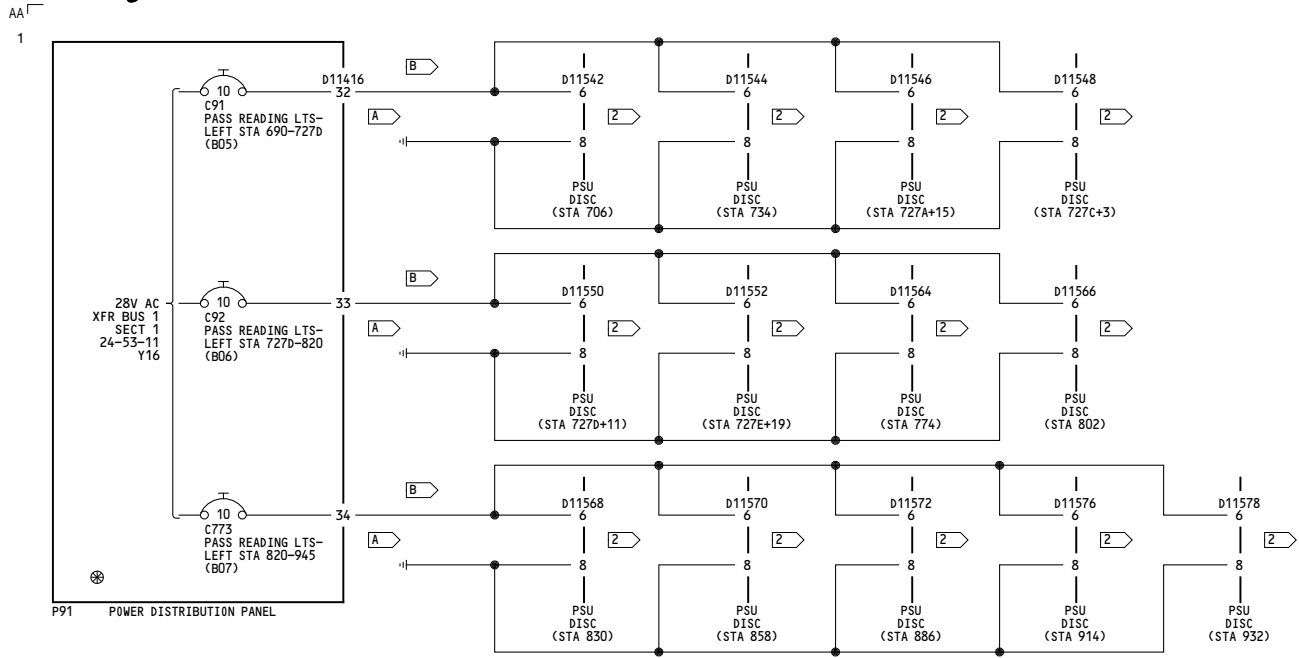

NOTES

- 1 PSU: PASSENGER SERVICE UNIT
- 2 MATE WITH PSU IF INSTALLED OR CAP & STOW CONNECTOR WHEN PSU IS NOT INSTALLED.
- 3 ALL PSU DISCONNECTS LOCATED AT: WL 274 LBL 51

YM643-YM670	<p align="center">PASS READING LTS - LEFT AFT</p> <p align="center">D280A203</p>
-------------	---

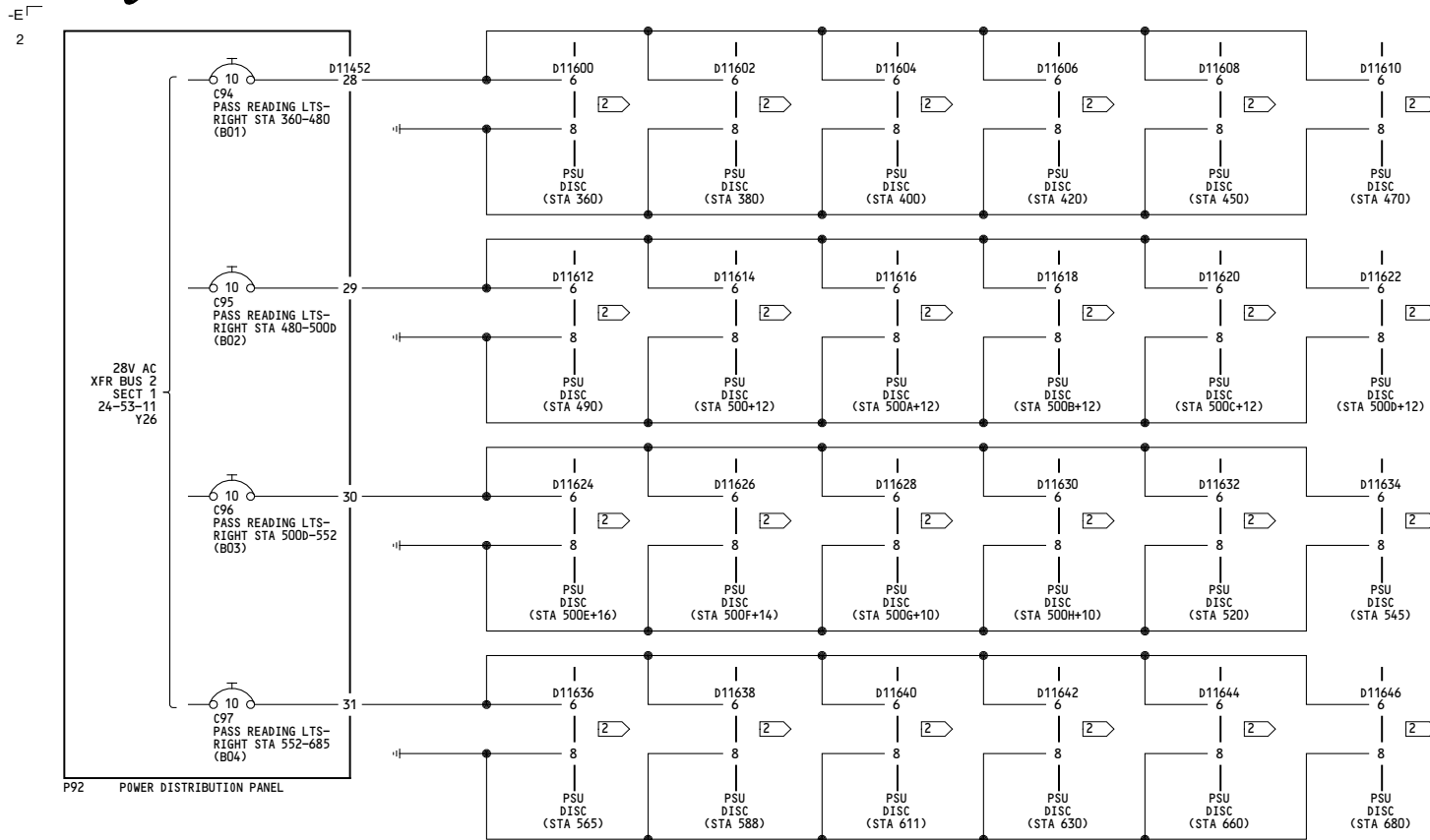

NOTES

- 1 PSU: PASSENGER SERVICE UNIT
- 2 MATE WITH PSU IF INSTALLED
- 3 ALL PSU DISCONNECTS LOCATED AT: WL 274, LBL 51

YC001-YL430	PASS READING LTS - RIGHT FWD
	D280A203

33-23-21

-T-
1

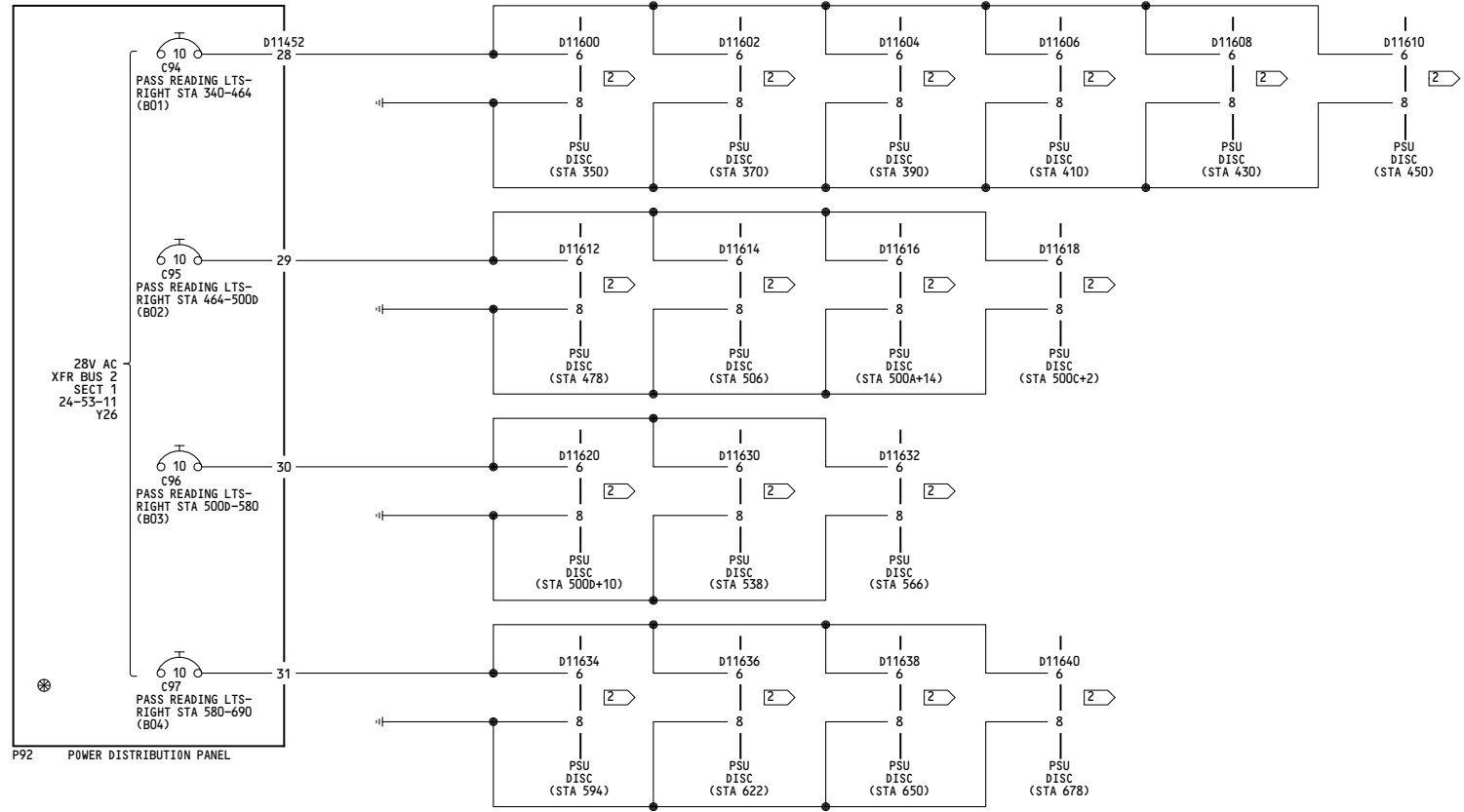

- NOTES**
- 1 PSU: PASSENGER SERVICE UNIT
 - 2 MATE WITH PSU IF INSTALLED OR CAP & STOW CONNECTOR WHEN PSU IS NOT INSTALLED.
 - 3 ALL PSU DISCONNECTS LOCATED AT: WL 274 LBL 51

YM643-YM670	PASS READING LTS - RIGHT FWD
	D280A203

33-23-21

Page 102

Jan 14/2008

WIRING DIAGRAMS
33-23-22

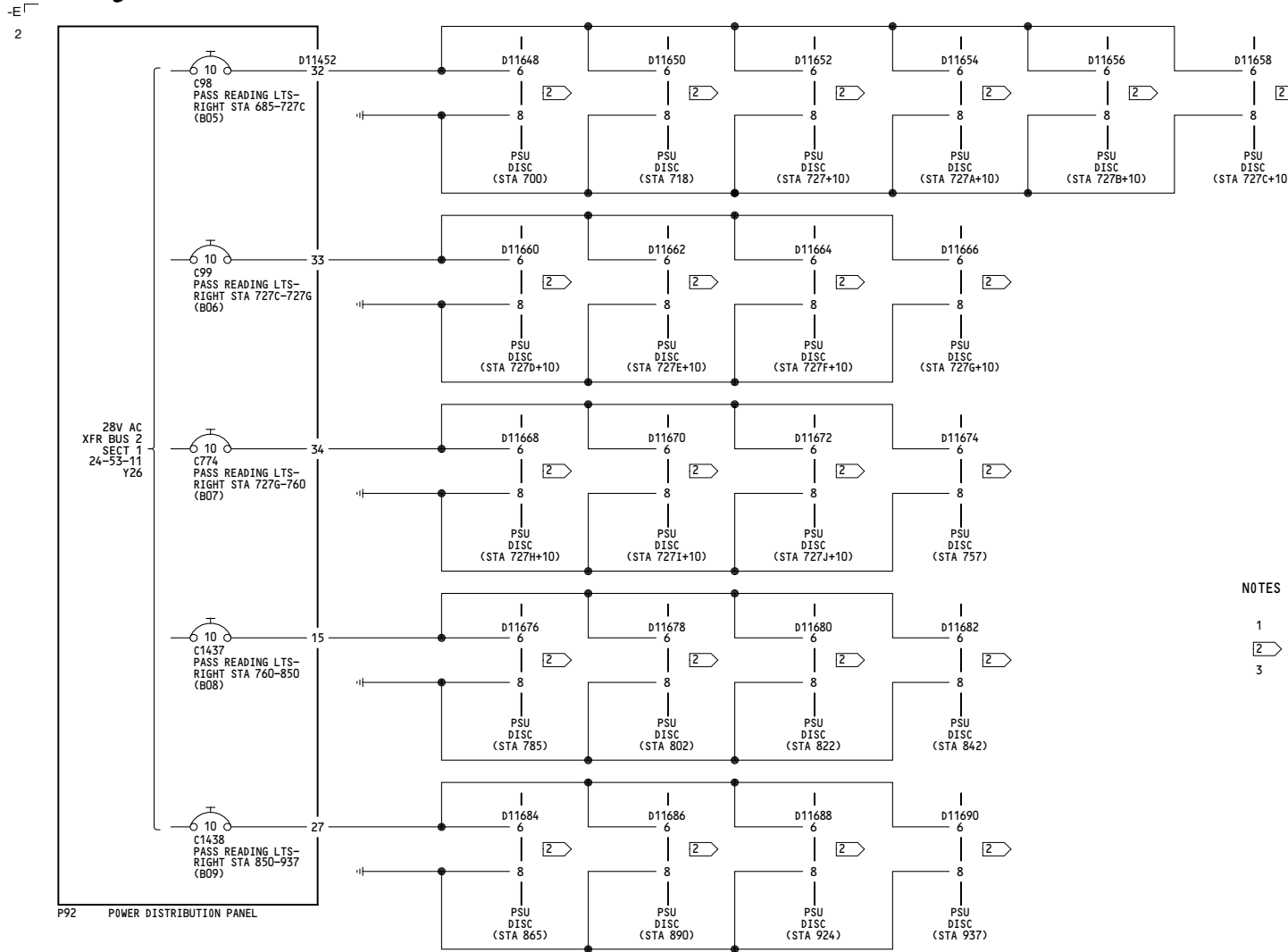

- NOTES**
- 1 PSU: PASSENGER SERVICE UNIT
 - 2 MATE WITH PSU IF INSTALLED
 - 3 ALL PSU DISCONNECTS LOCATED AT: WL 274, LBL 51

YC001-YL430

PASS READING LTS - RIGHT AFT

D280A203

33-23-22

Page 101

Feb 09/2009

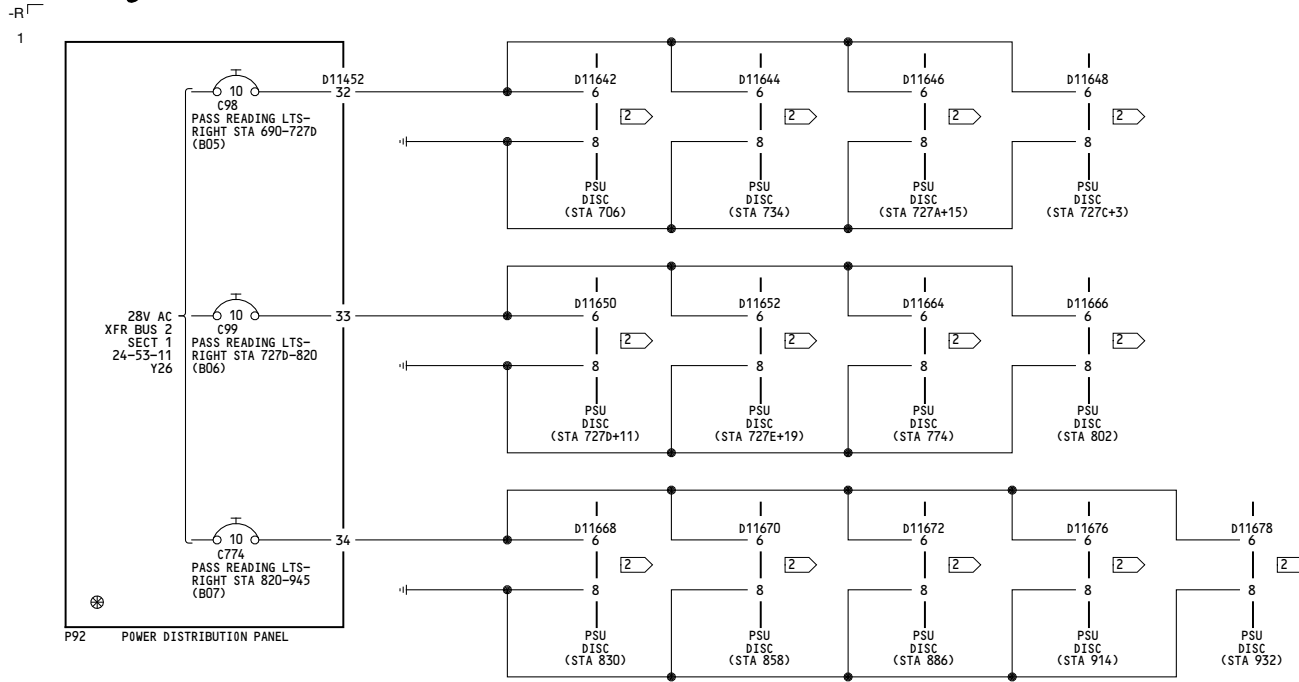

- NOTES**
- 1 PSU: PASSENGER SERVICE UNIT
 - 2 MATE WITH PSU IF INSTALLED OR CAP & STOW CONNECTOR WHEN PSU IS NOT INSTALLED.
 - 3 ALL PSU DISCONNECTS LOCATED AT: WL 274 LBL 51

YM643-YM670	<p align="center">PASS READING LTS - RIGHT AFT</p> <p align="center">D280A203</p>
-------------	--

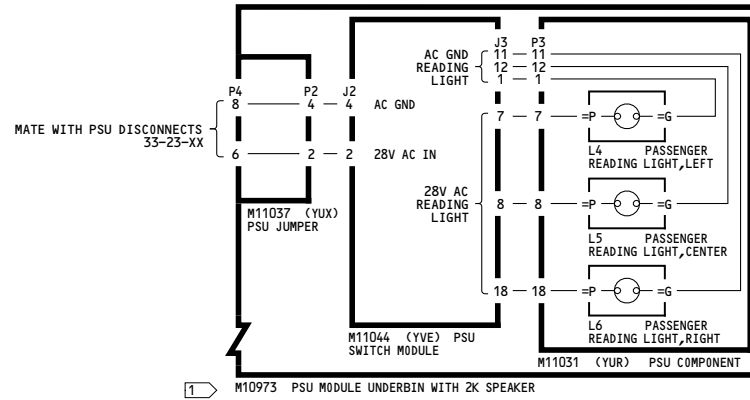
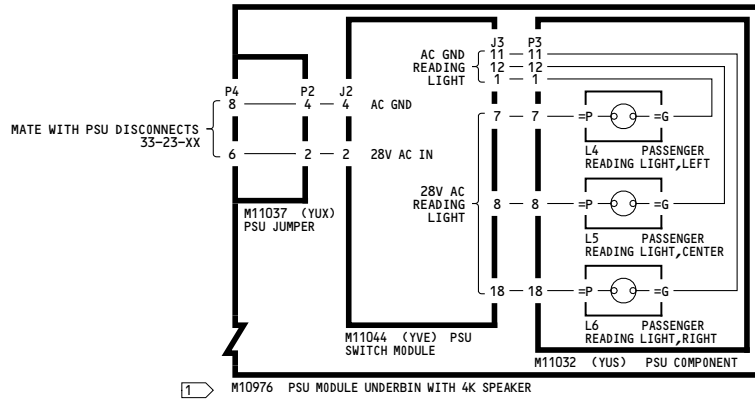

NOTES:

1 EITHER THE M10973, M10976 OR A COMBINATION OF BOTH PSU MODULES WILL BE INSTALLED, ACCORDING TO THE INTERIOR ARRANGEMENT OF EACH AIRPLANE.

ALL	<p>READING LTS - PASS SERVICE UNIT</p> <p>D280A203</p>
-----	---

WIRING DIAGRAMS
33-25-11

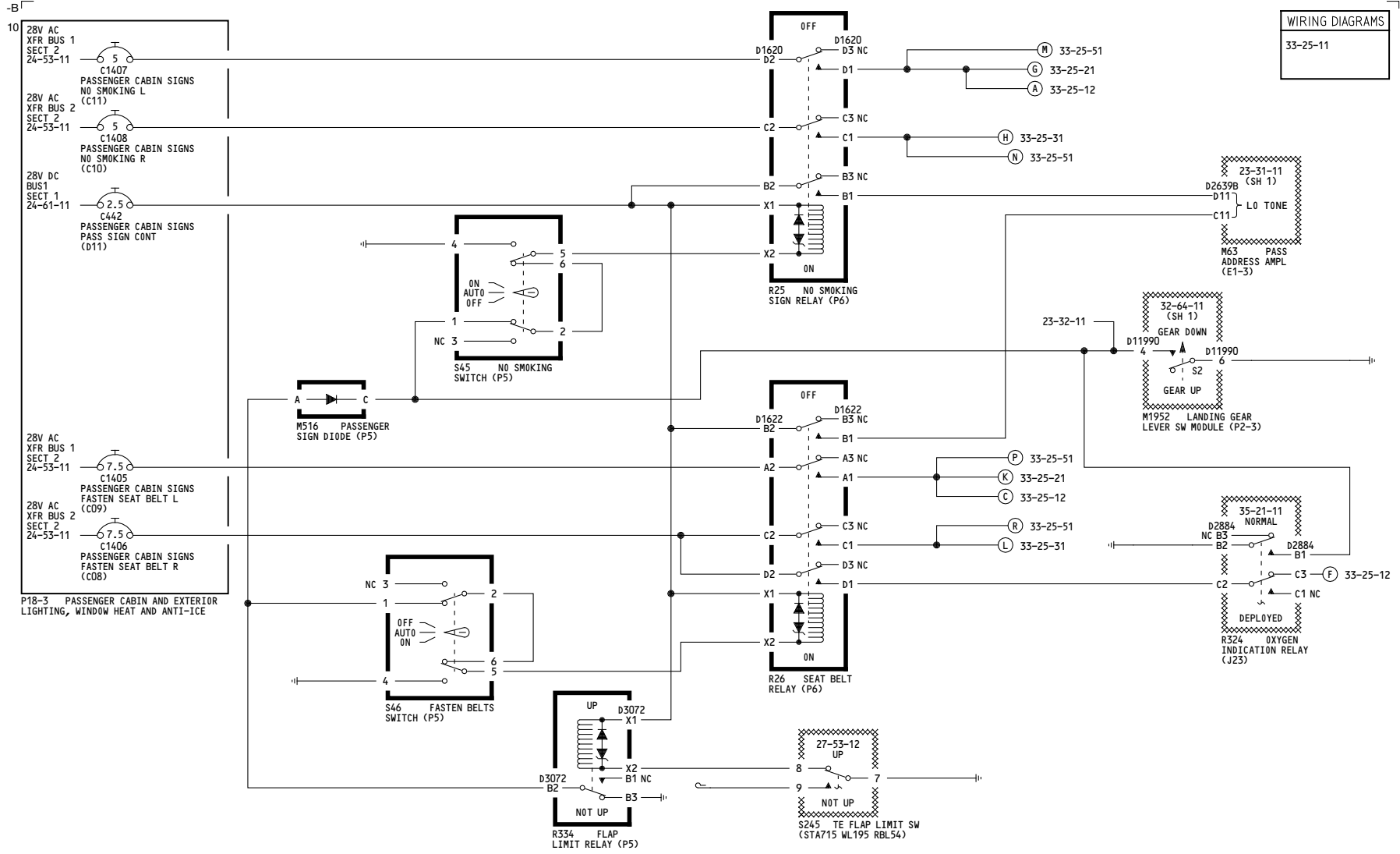

YC001-YC050

PASS SIGN - CONTROL

D280A203

WIRING DIAGRAMS
33-25-11

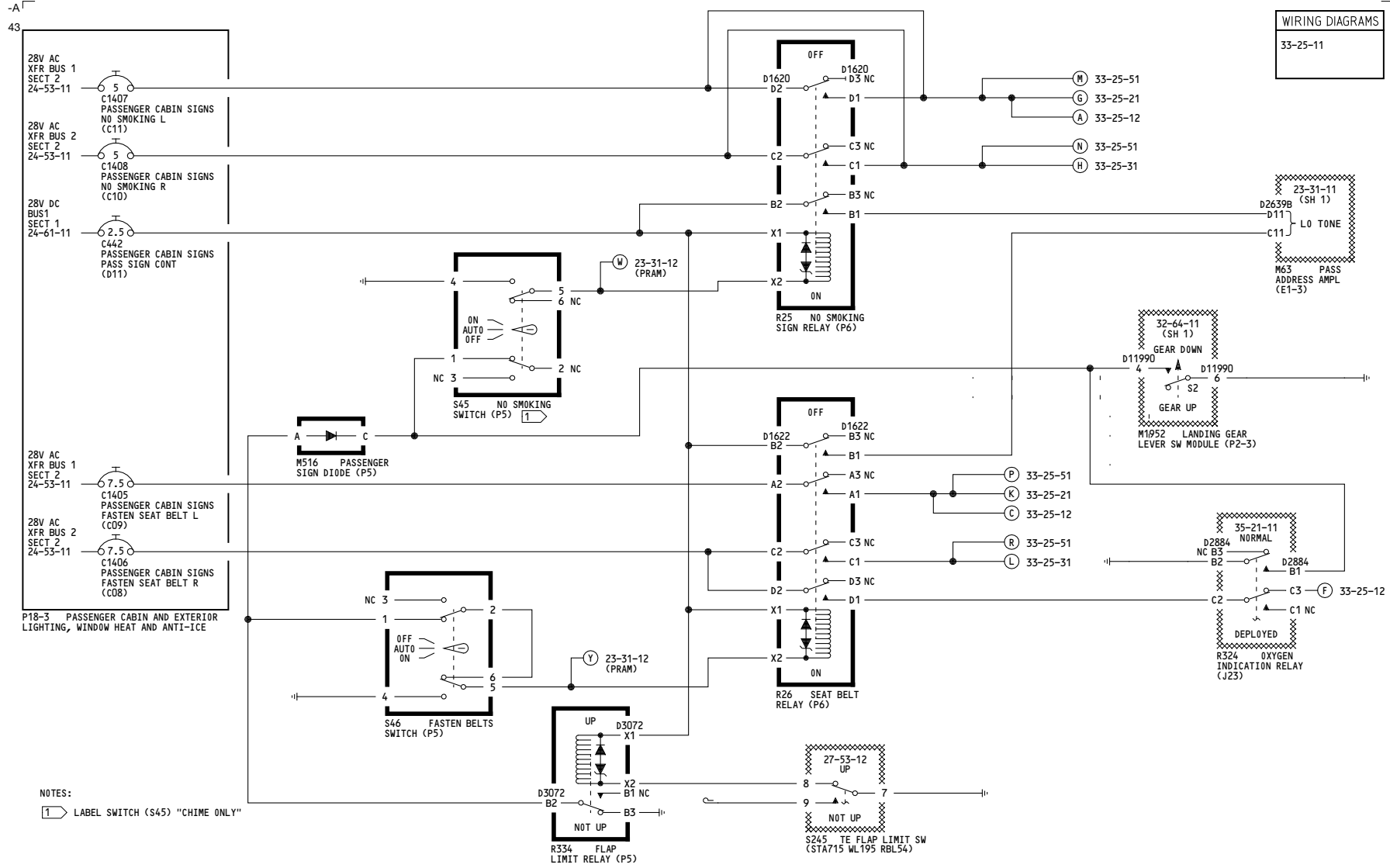

YK901-YK906, YM643-YM646	PASS SIGN - CONTROL D280A203
--------------------------	--

33-25-11

WIRING DIAGRAMS
33-25-11

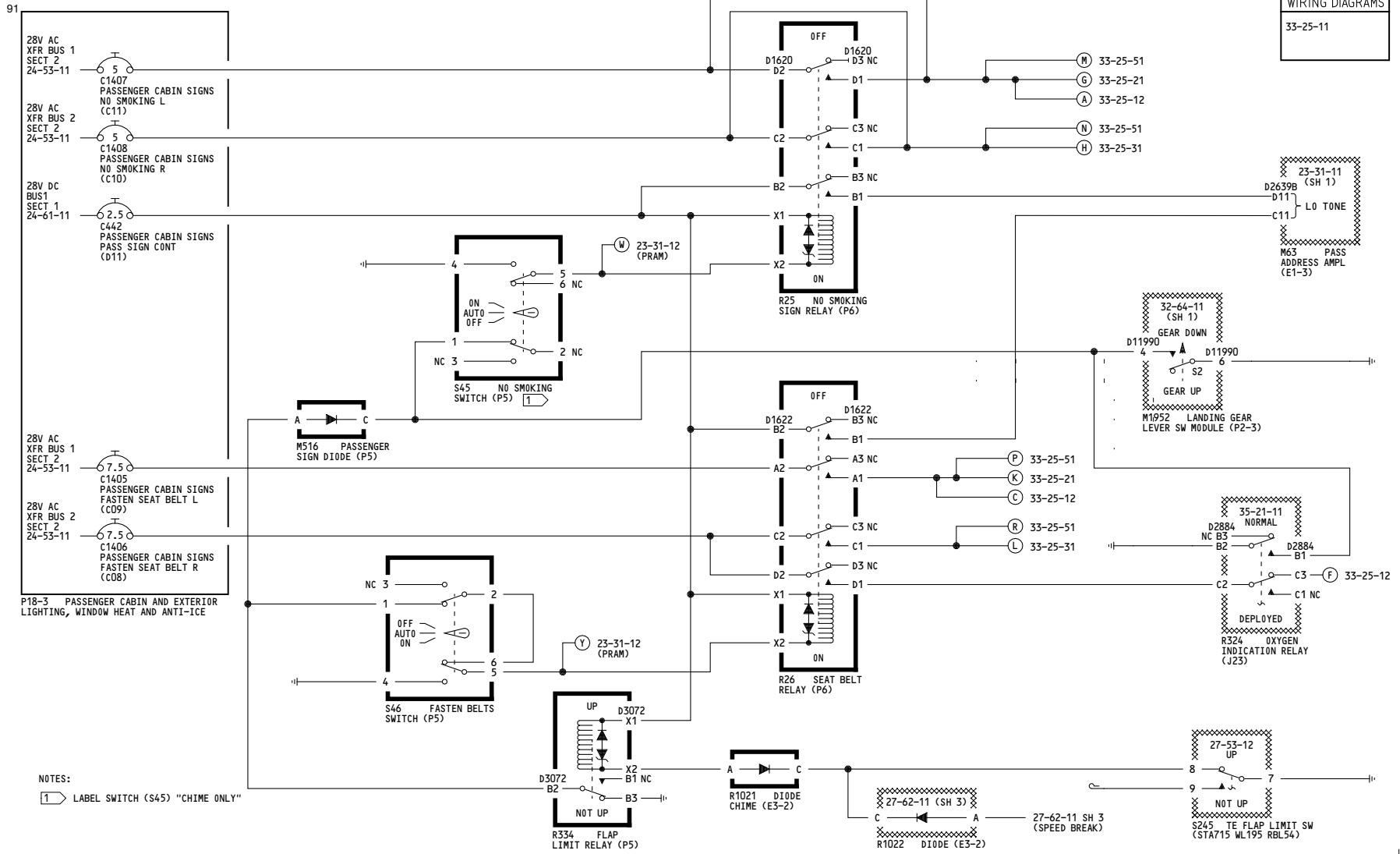

NOTES:
1 LABEL SWITCH (S45) "CHIME ONLY"

YK907-YK909	PASS SIGN - CONTROL
	D280A203

33-25-11

WIRING DIAGRAMS
33-25-11

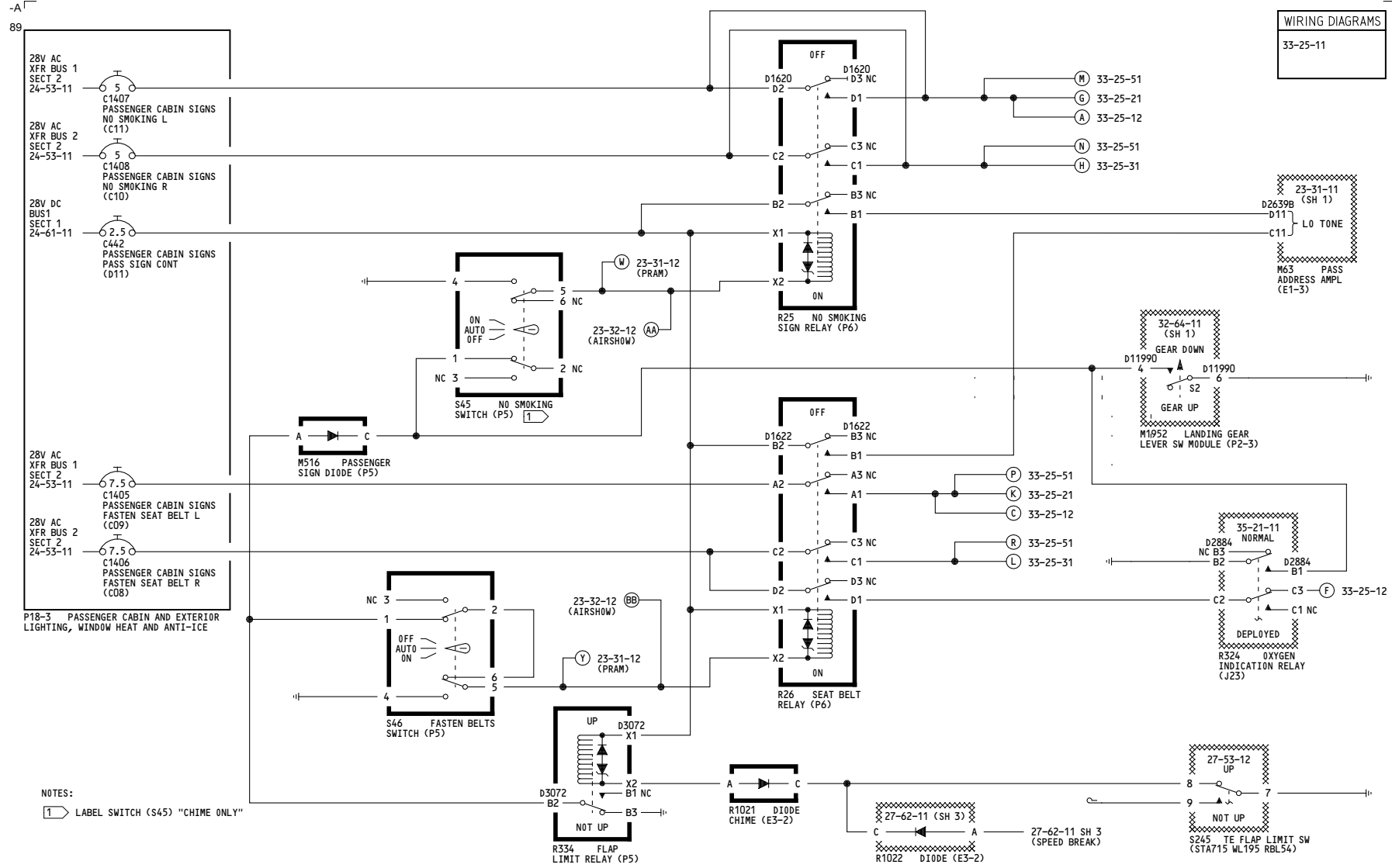

YK910-YK912, YK918-YK919, YL401-YL429	PASS SIGN - CONTROL D280A203
---------------------------------------	--

33-25-11

WIRING DIAGRAMS
33-25-11

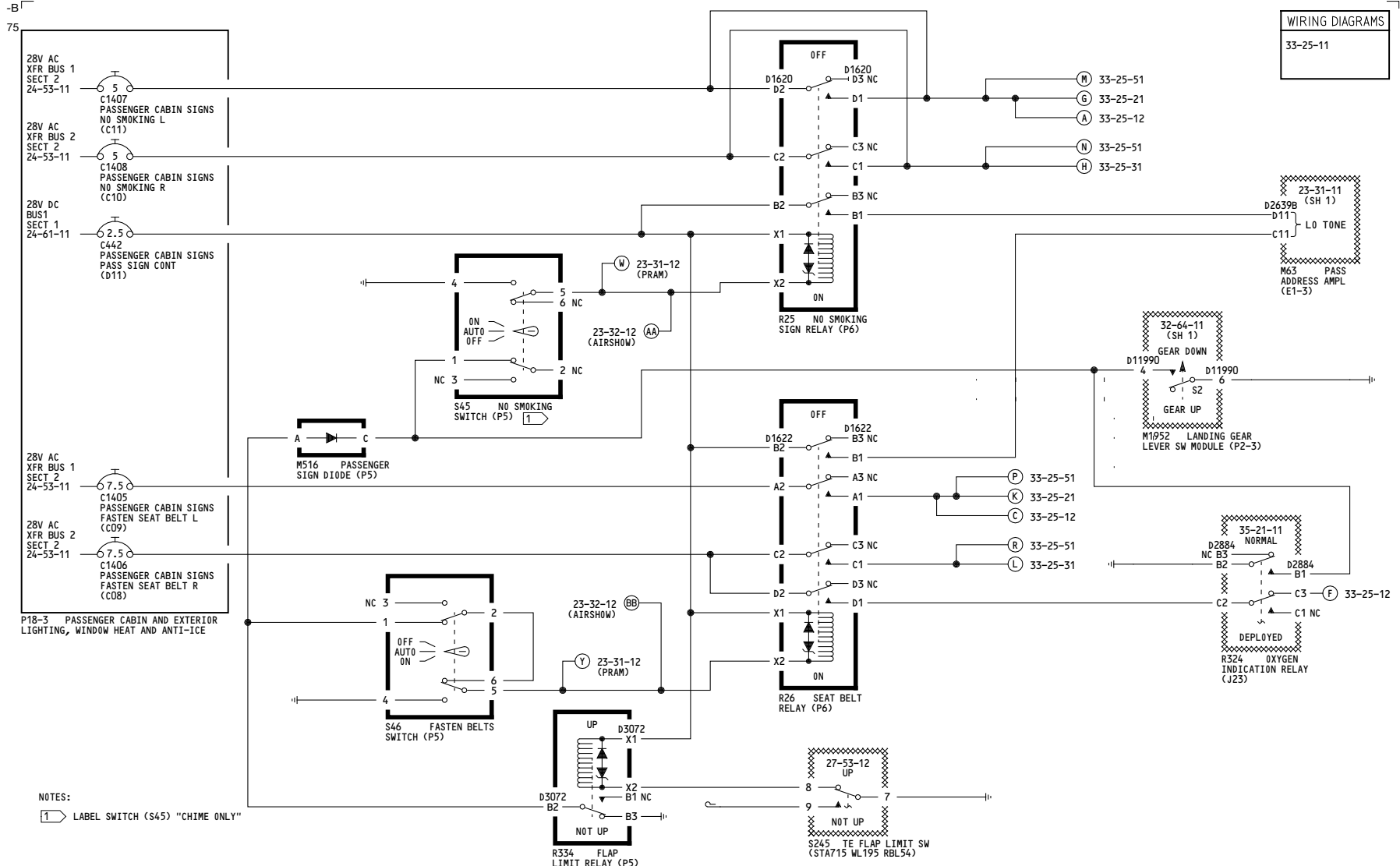

NOTES:
1 LABEL SWITCH (S45) "CHIME ONLY"

YM647-YM652	<p>PASS SIGN - CONTROL</p> <p>D280A203</p>
-------------	---

33-25-11

-G
5

WIRING DIAGRAMS
33-25-11
33-25-21
33-25-22

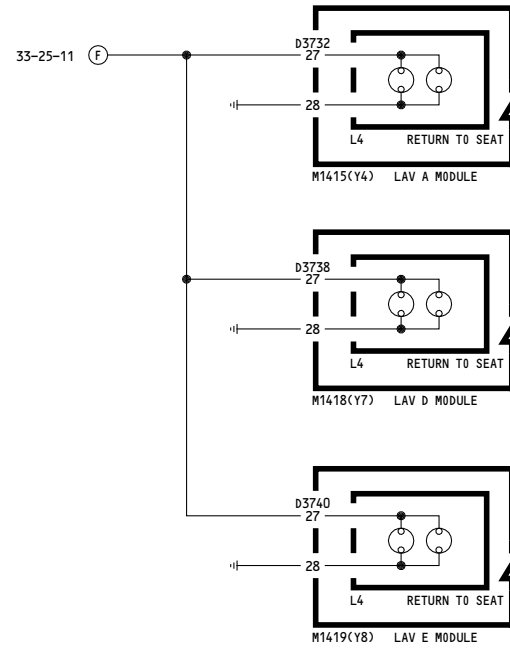
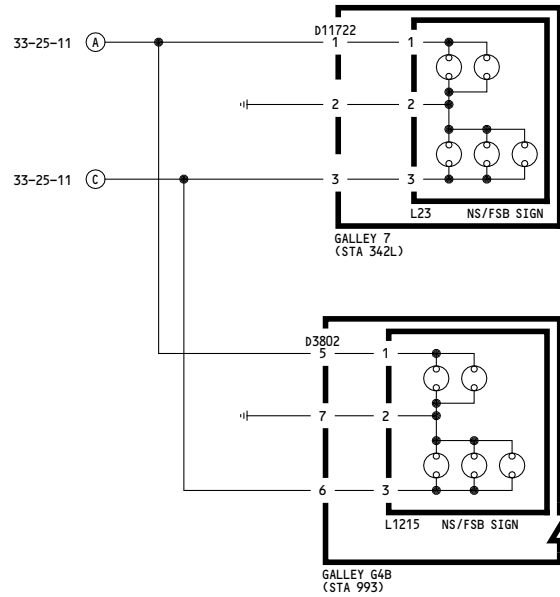

YC001-YC002	<p>PASS SIGNS - MISC</p> <p>D280A203</p>
-------------	---

WIRING DIAGRAMS
33-25-11
33-25-21
33-25-32

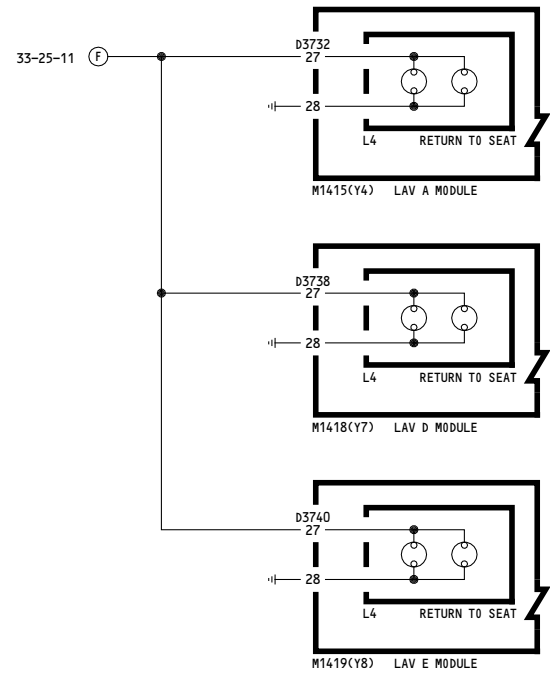
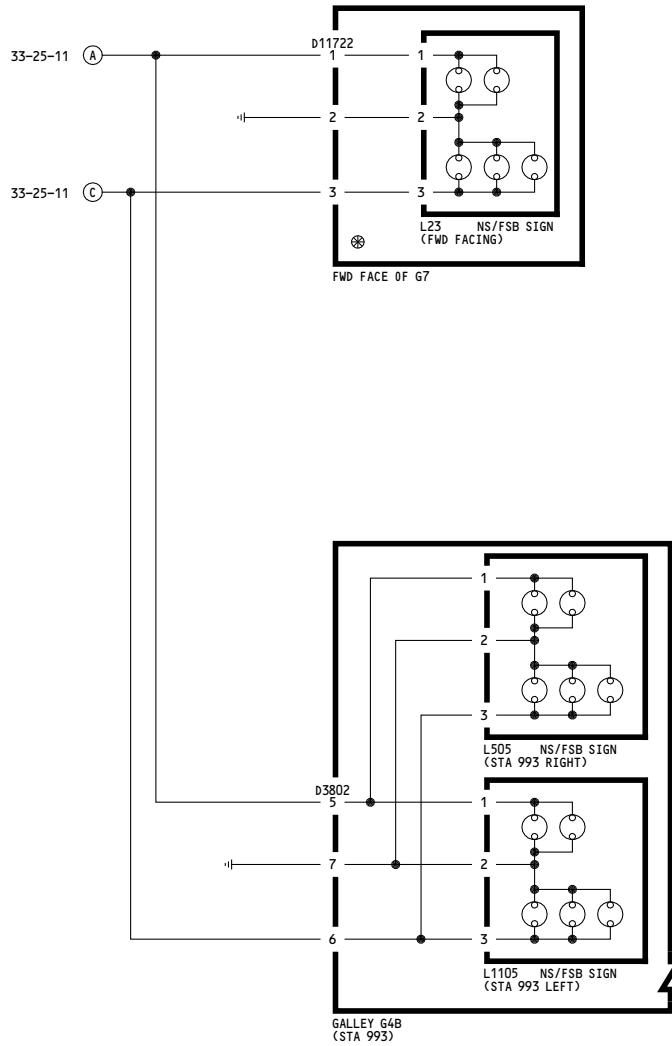

YC003-YC030	<p align="center">PASS SIGNS - MISC</p> <p align="center">D280A203</p>
-------------	---

WIRING DIAGRAMS
33-25-11
33-25-21
33-25-22

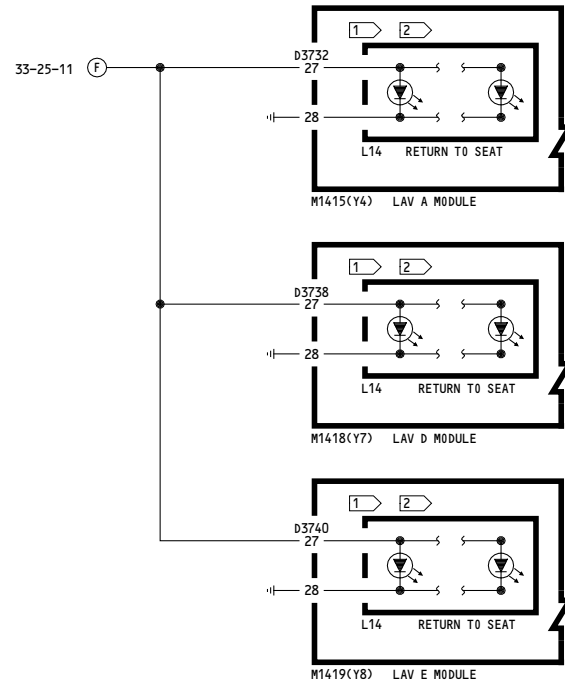
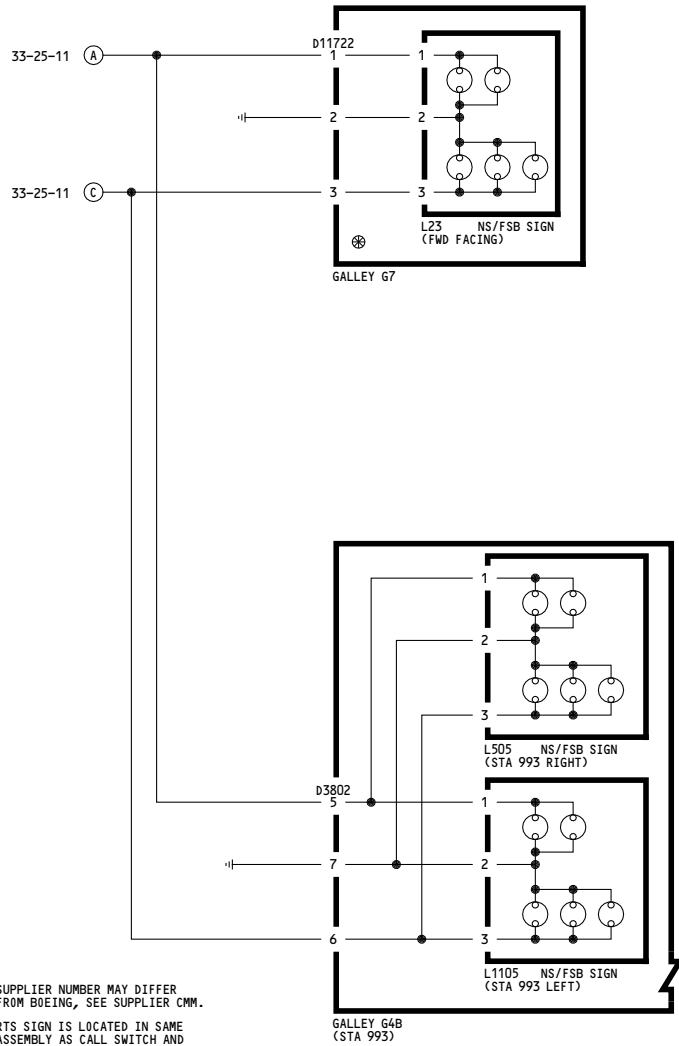

NOTES:

- 1 SUPPLIER NUMBER MAY DIFFER FROM BOEING, SEE SUPPLIER CMM.
- 2 RTS SIGN IS LOCATED IN SAME ASSEMBLY AS CALL SWITCH AND DIODES R5 & R6 SHOWN ON 33-27-11.

YC031-YK906	PASS SIGNS - MISC
	D280A203

WIRING DIAGRAMS
33-25-11
33-25-21
33-25-22

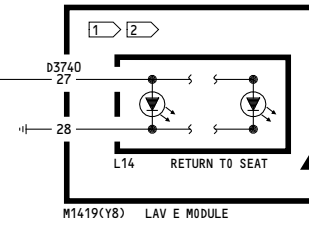
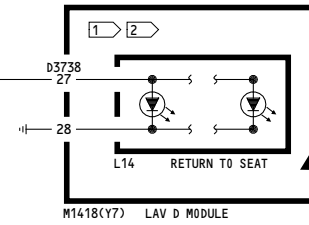
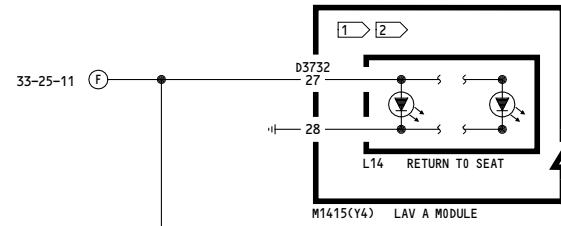
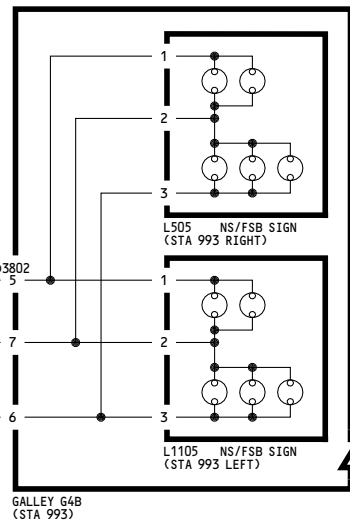
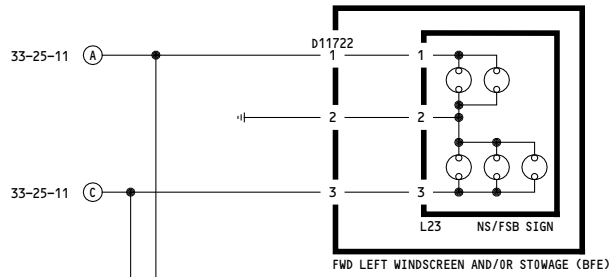

NOTES:

- 1 SUPPLIER NUMBER MAY DIFFER FROM BOEING. SEE SUPPLIER CMM.
- 2 RTS SIGN, CALL SWITCH AND DIODES R5 & R6 ARE LOCATED IN SAME ASSEMBLY.

YK907-YK911, YK918, YM643-YM651, YM653-YM670

PASS SIGNS - MISC

D280A203

WIRING DIAGRAMS
33-25-11
33-25-21
33-25-22

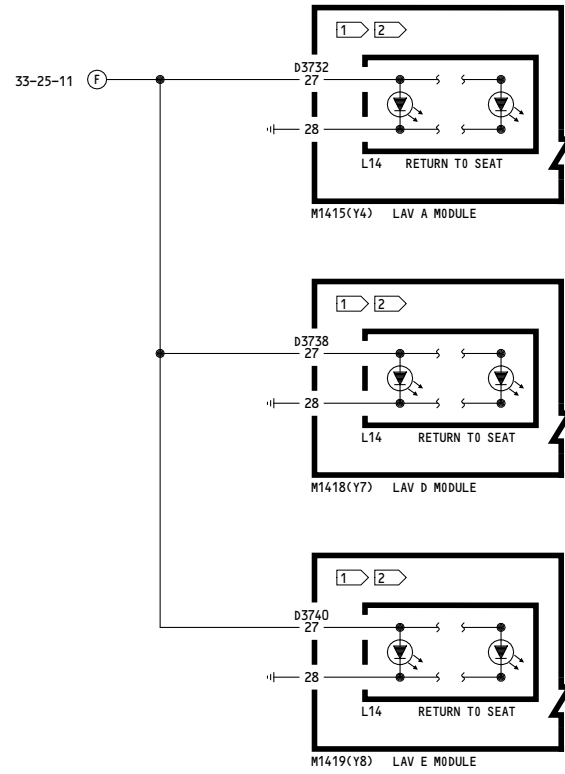
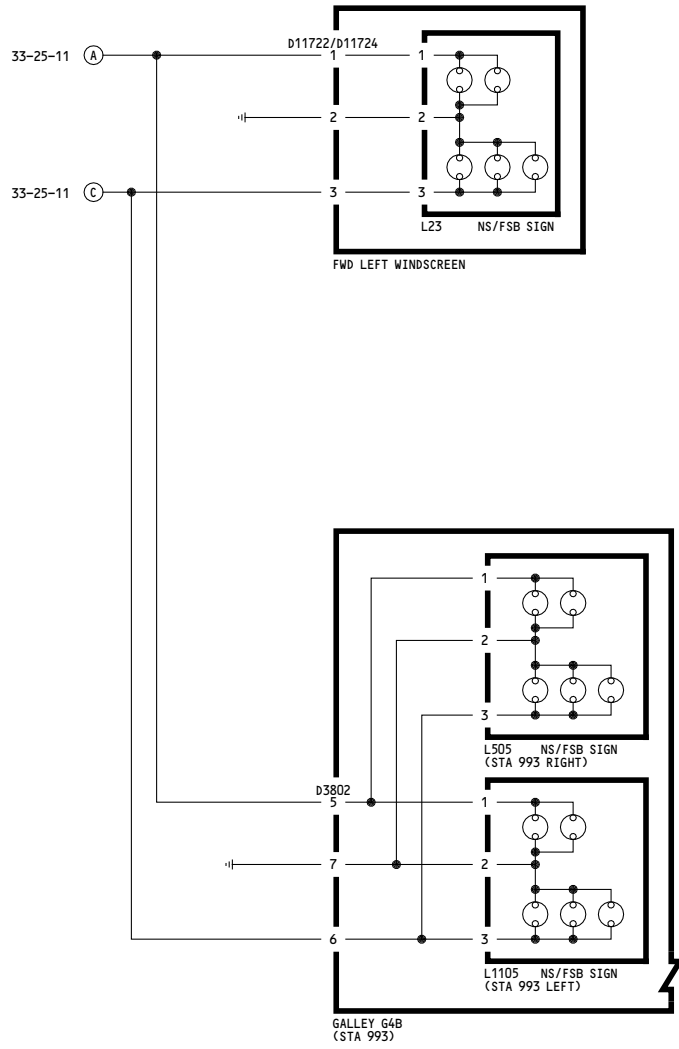

NOTES:

- ① SUPPLIER NUMBER MAY DIFFER FROM BOEING. SEE SUPPLIER CHM.
- ② RTS SIGN, CALL SWITCH AND DIODES R5 & R6 ARE LOCATED IN SAME ASSEMBLY.

YK912-YK917, YK919-YL430, YM652

PASS SIGNS - MISC

D280A203

-D
2

WIRING DIAGRAMS
33-25-21

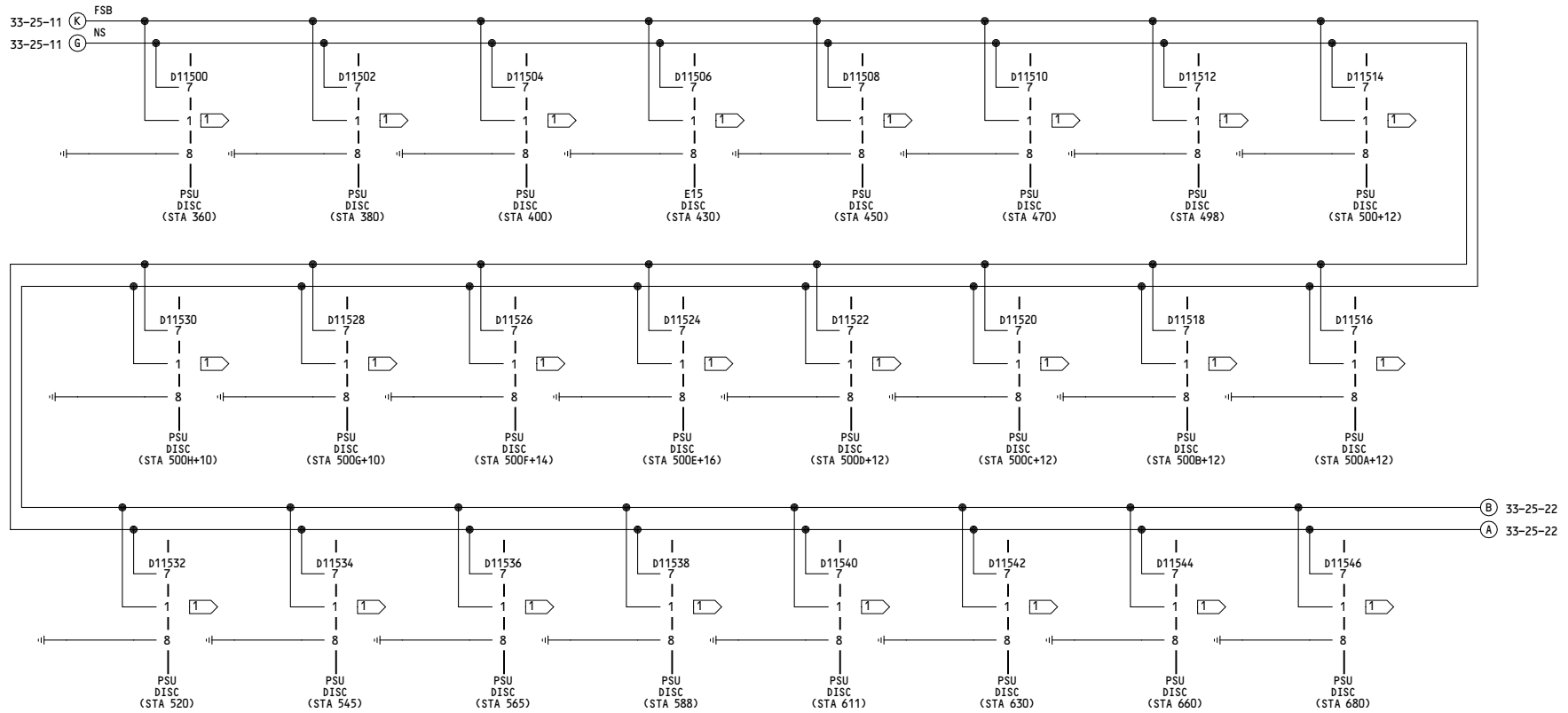

NOTES

1 MATE WITH PASSENGER SERVICE UNIT IF INSTALLED

<p>YC001-YL430</p>	<p>PASS SIGNS - PSU LEFT FWD</p> <p>D280A203</p>
--------------------	---

33-25-21

Page 101

Feb 09/2009

-F-
1

WIRING DIAGRAMS
33-25-21

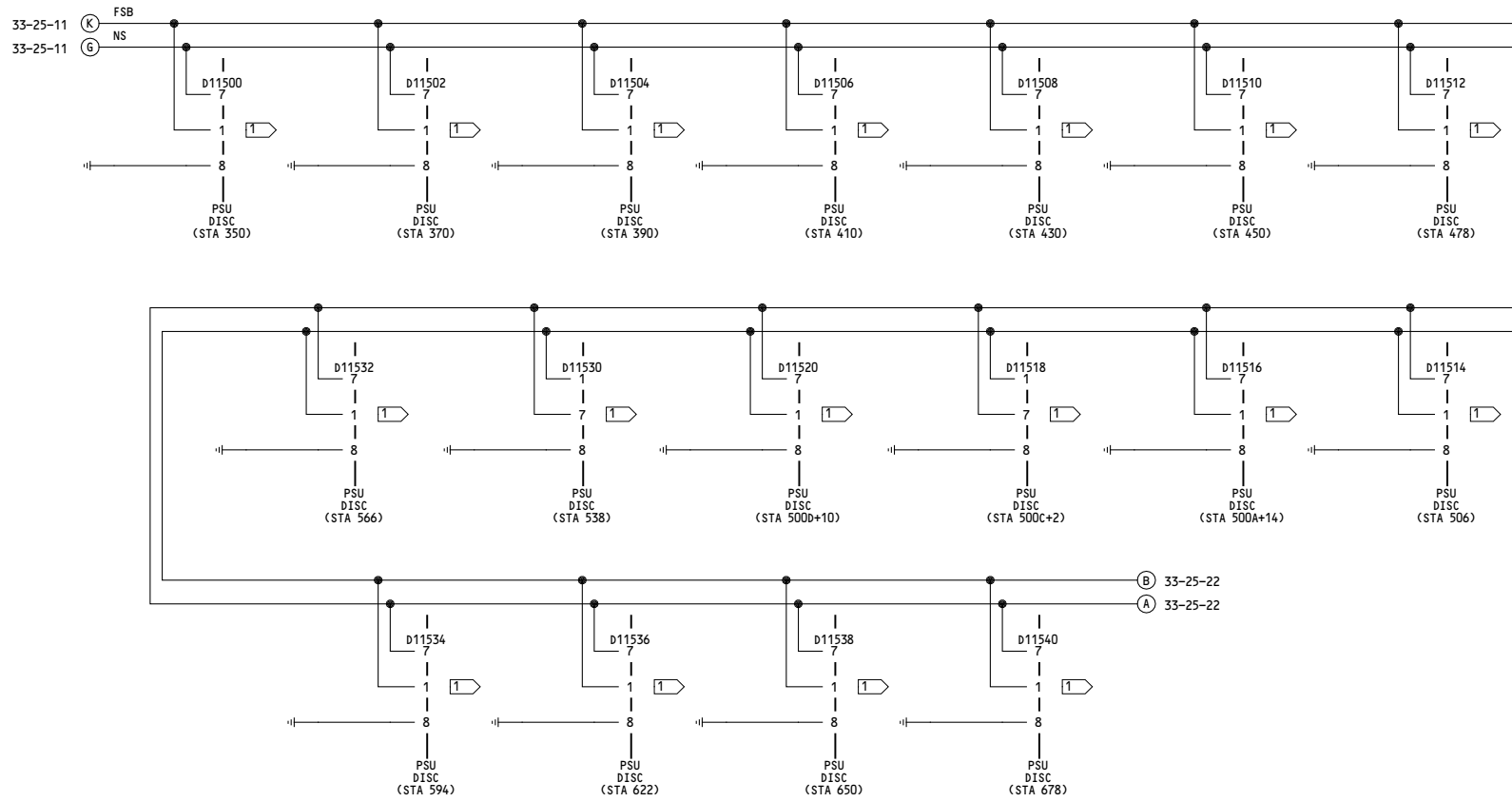

NOTES

1 MATE WITH PASSENGER SERVICE UNIT IF INSTALLED

YM643-YM670	PASS SIGNS - PSU LEFT FWD
	D280A203

33-25-21

Page 102

Jan 14/2008

-E
2

WIRING DIAGRAMS
33-25-22

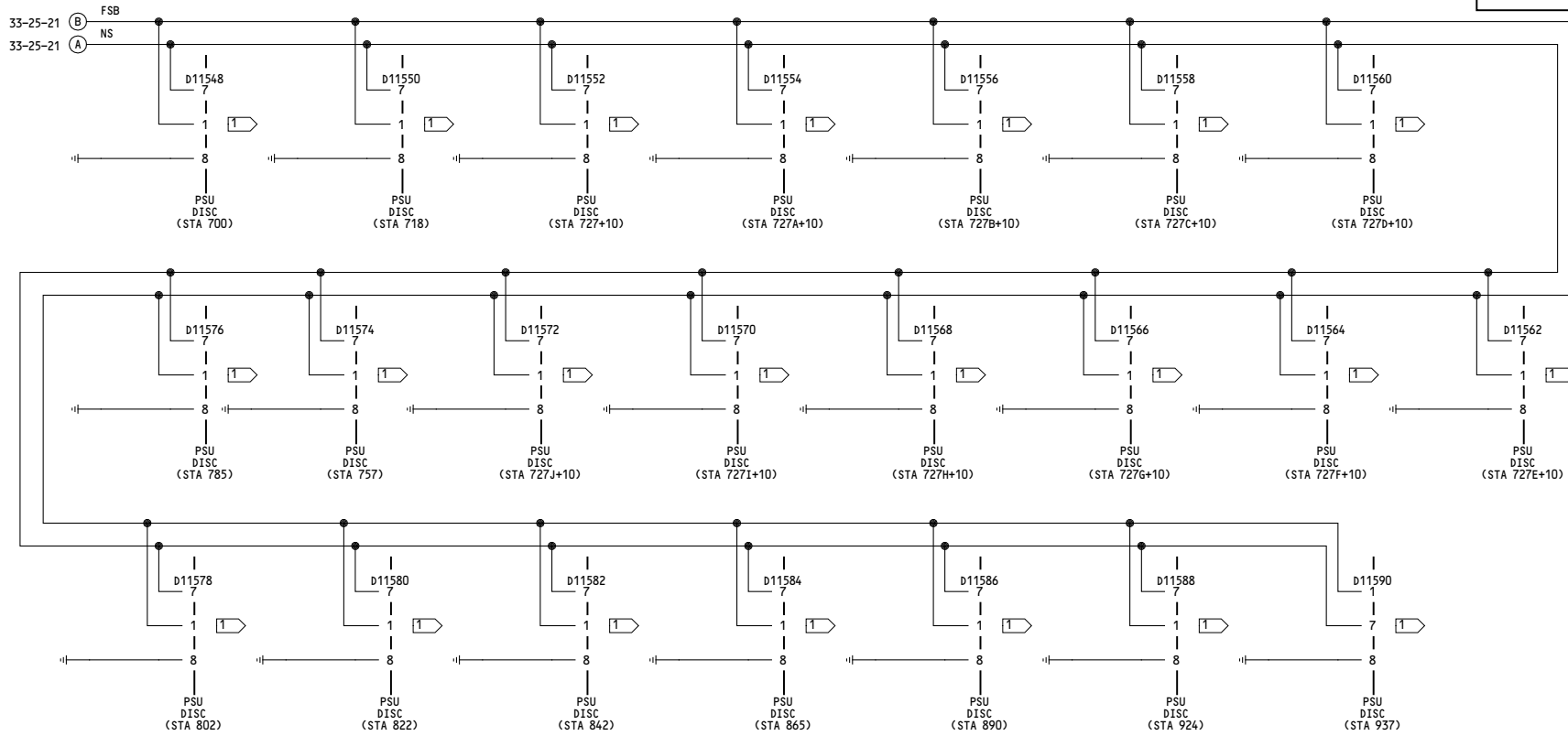

NOTES
 [1] MATE WITH PASSENGER SERVICE UNIT IF INSTALLED

YC001-YL430	PASS SIGNS - PSU LEFT AFT D280A203
-------------	--

33-25-22

Page 101

Feb 09/2009

-G
1

WIRING DIAGRAMS
33-25-22

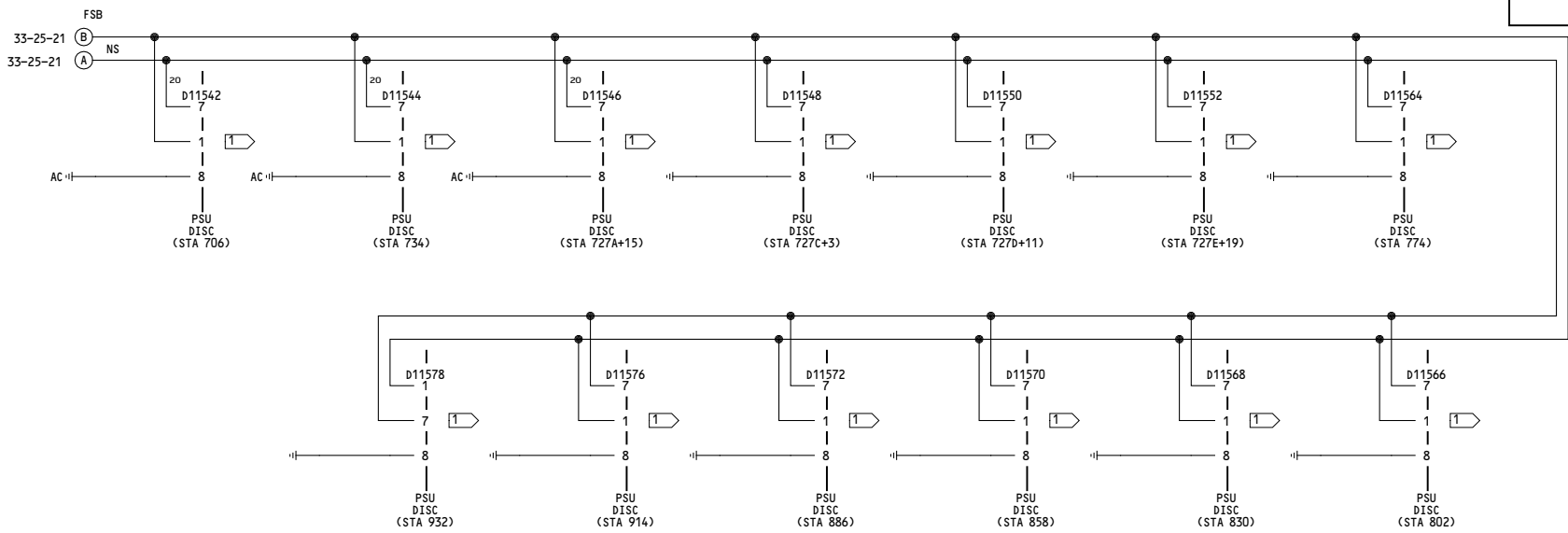

NOTES

1 MATE WITH PSU IF INSTALLED OR CAP & STOW CONNECTOR WHEN PSU IS NOT INSTALLED.

2 PSU: PASSENGER SERVICE UNIT

YM643-YM670	<p align="center">PASS SIGNS - PSU LEFT AFT</p> <p align="center">D280A203</p>
-------------	---

33-25-22

Page 102

Jan 14/2008

-D
2

WIRING DIAGRAMS
33-25-31

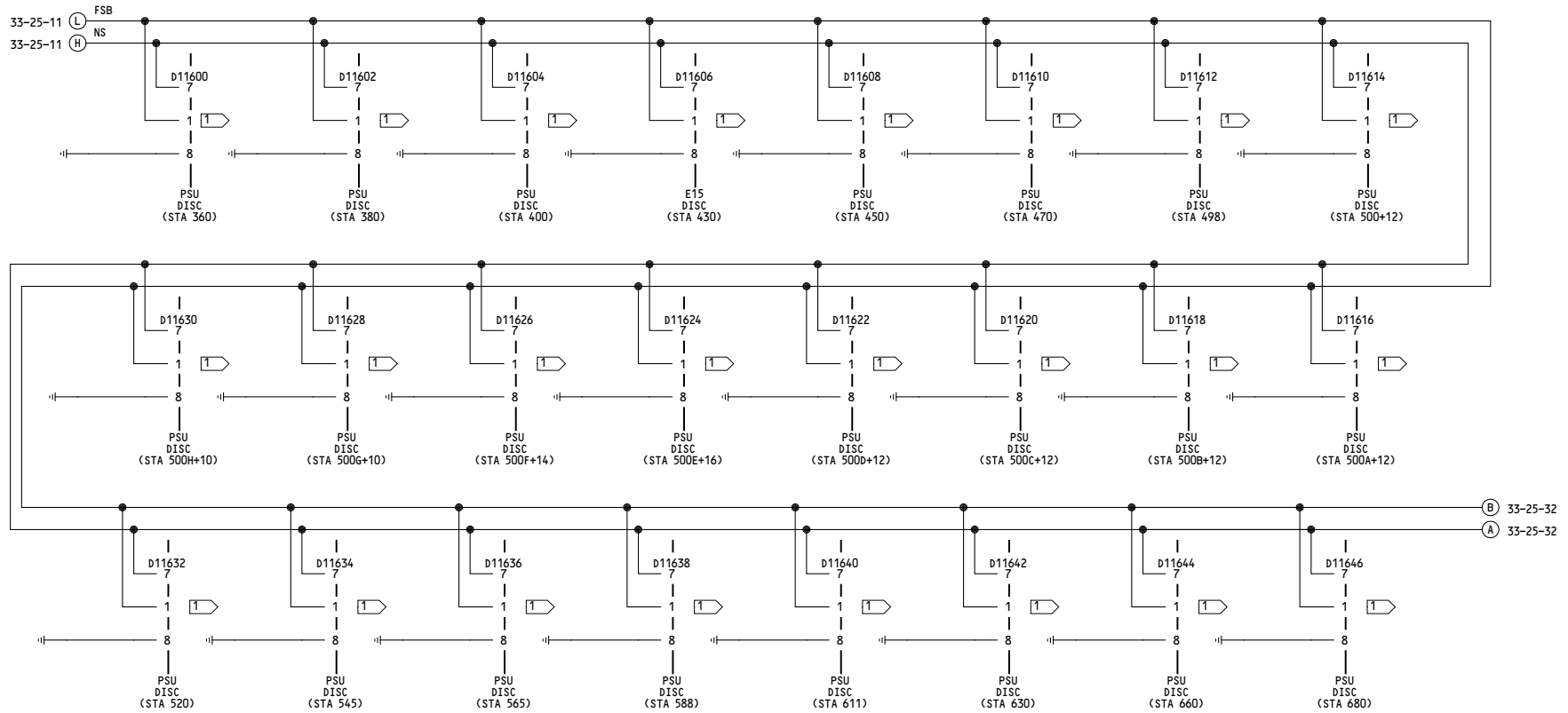

NOTES

1 → MATE WITH PASSENGER SERVICE UNIT IF INSTALLED

YC001-YL430	<p>PASS SIGNS - PSU RIGHT FWD</p> <p>D280A203</p>
-------------	--

33-25-31

Page 101

Feb 09/2009

-B
5

WIRING DIAGRAMS
33-25-31

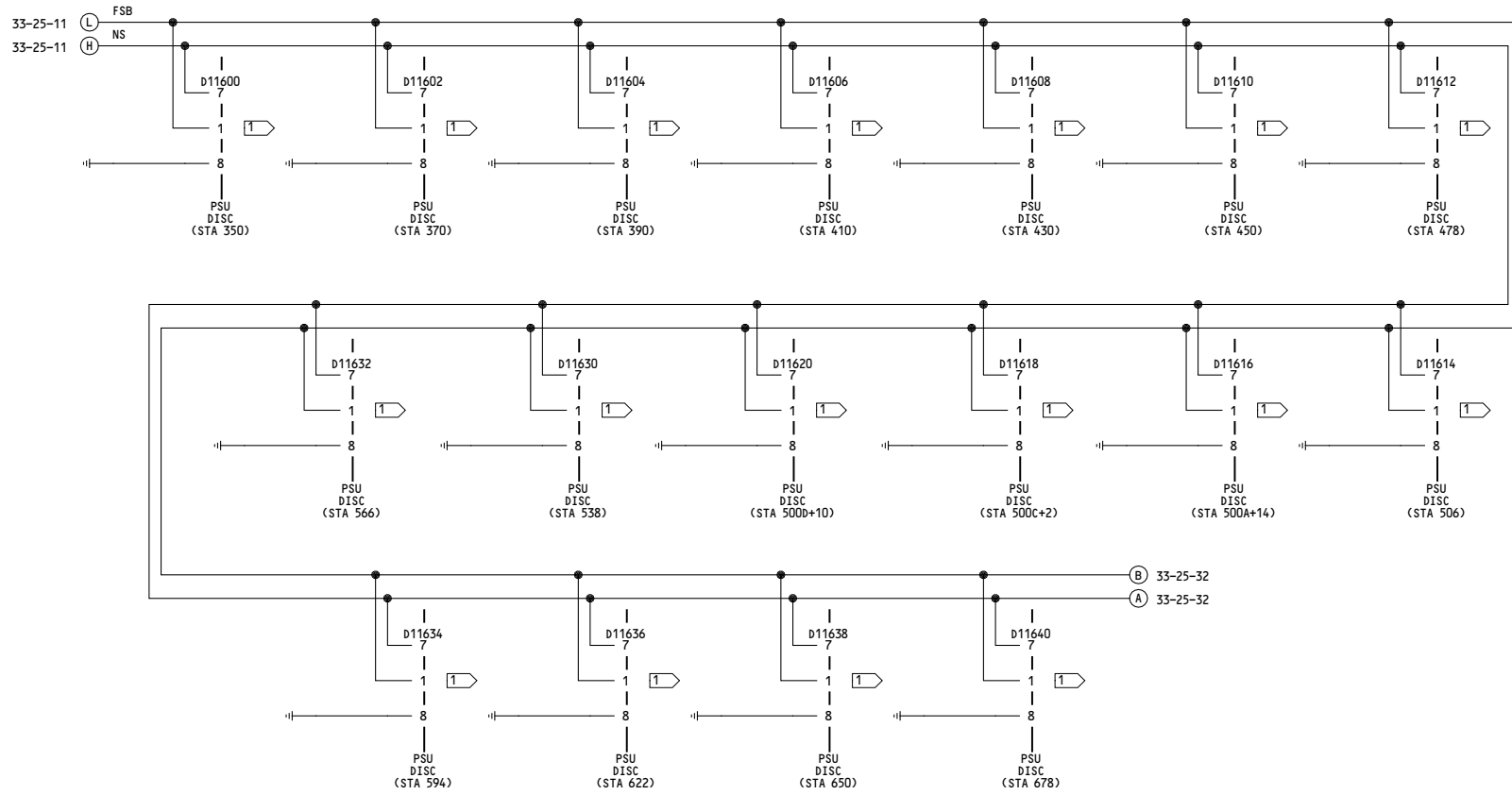

NOTES

- 1 MATE WITH PSU IF INSTALLED OR CAP & STOW CONNECTOR WHEN PSU IS NOT INSTALLED.
- 2 PSU: PASSENGER SERVICE UNIT

YM643-YM670	PASS SIGNS - PSU RIGHT FWD
	D280A203

33-25-31

Page 102

Jan 14/2008

-F
2

WIRING DIAGRAMS
33-25-32

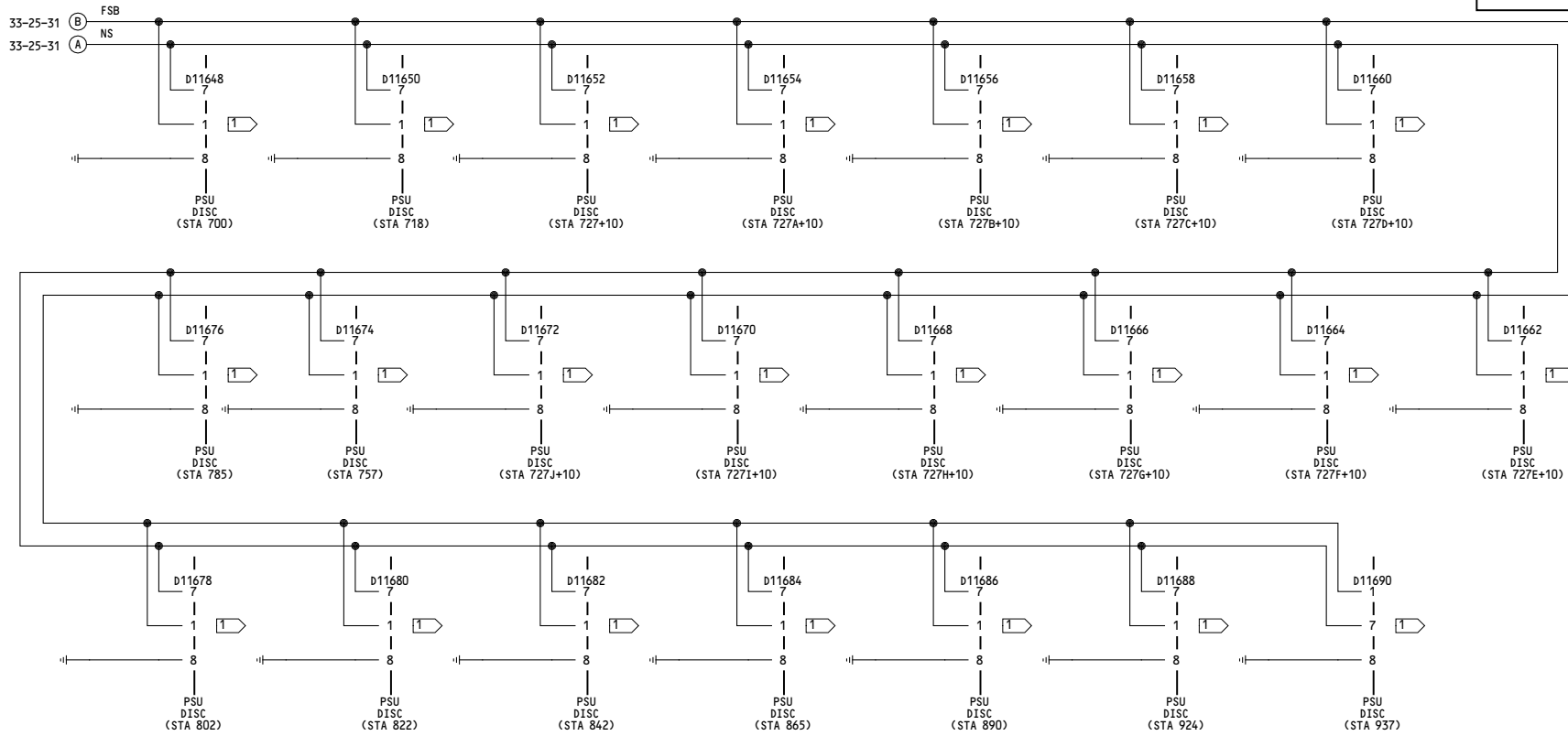

NOTES
 [1] MATE WITH PASSENGER SERVICE UNIT IF INSTALLED

YC001-YL430	<p align="center">PASS SIGNS - PSU RIGHT AFT</p> <p align="center">D280A203</p>
-------------	--

33-25-32

Page 101

Feb 09/2009

-A
5

WIRING DIAGRAMS
33-25-32

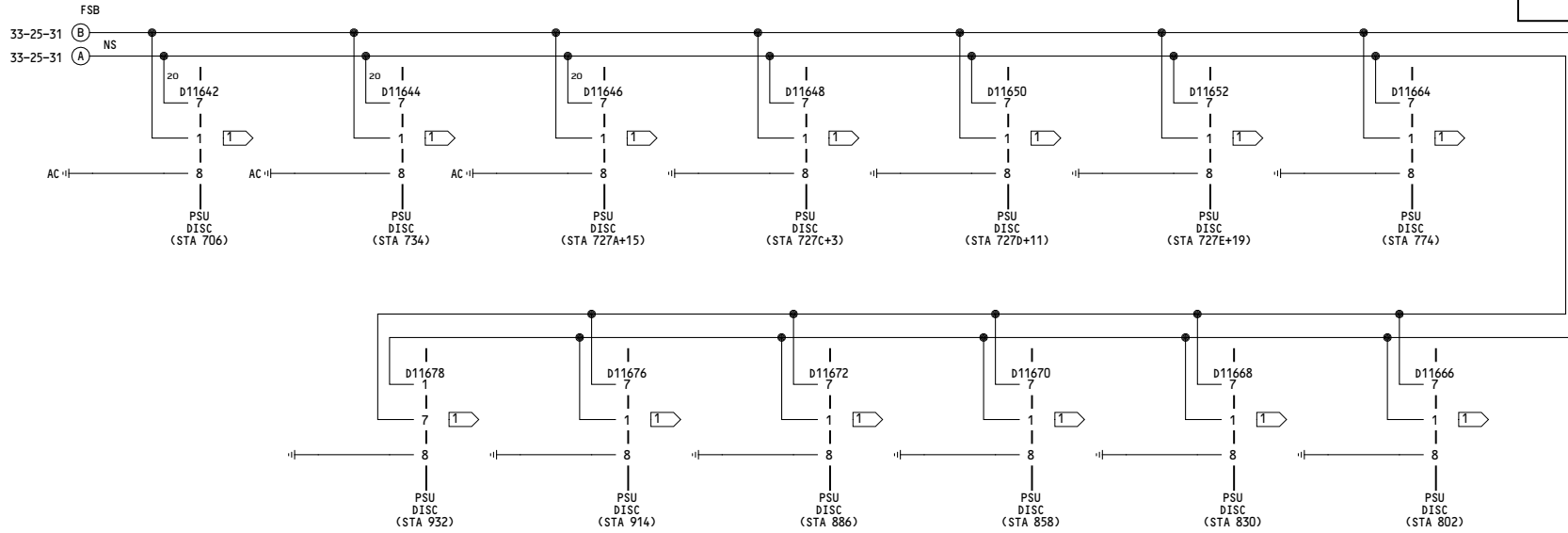

NOTES

- 1 MATE WITH PSU IF INSTALLED OR CAP & STOW CONNECTOR WHEN PSU IS NOT INSTALLED.
- 2 PSU: PASSENGER SERVICE UNIT

YM643-YM670	PASS SIGNS - PSU RIGHT AFT
	D280A203

33-25-32

Page 102

Jan 14/2008

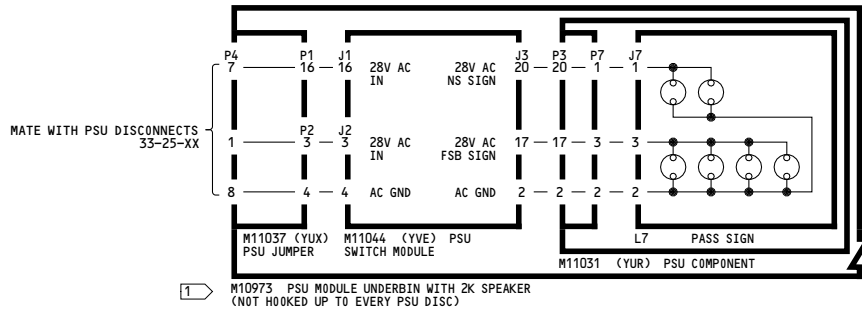
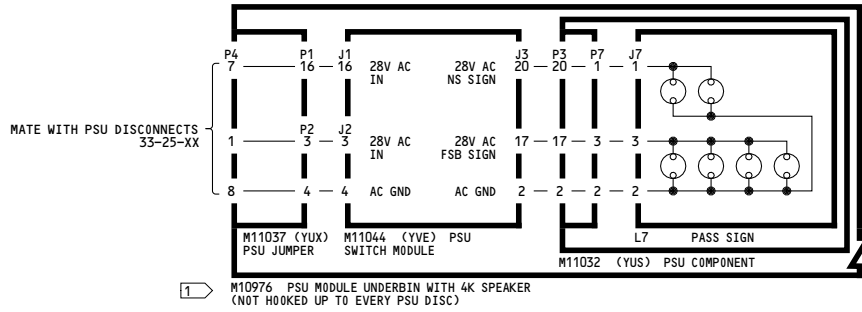

NOTES:

1 EITHER THE M10973, M10976 OR A COMBINATION OF BOTH PSU MODULES WILL BE INSTALLED, ACCORDING TO THE INTERIOR ARRANGEMENT OF EACH AIRPLANE.

ALL	<p>NO SMOKING/FASTEN SEAT BELT SIGNS - PASS SERVICE UNIT</p> <p>D280A203</p>
-----	---

-D
4

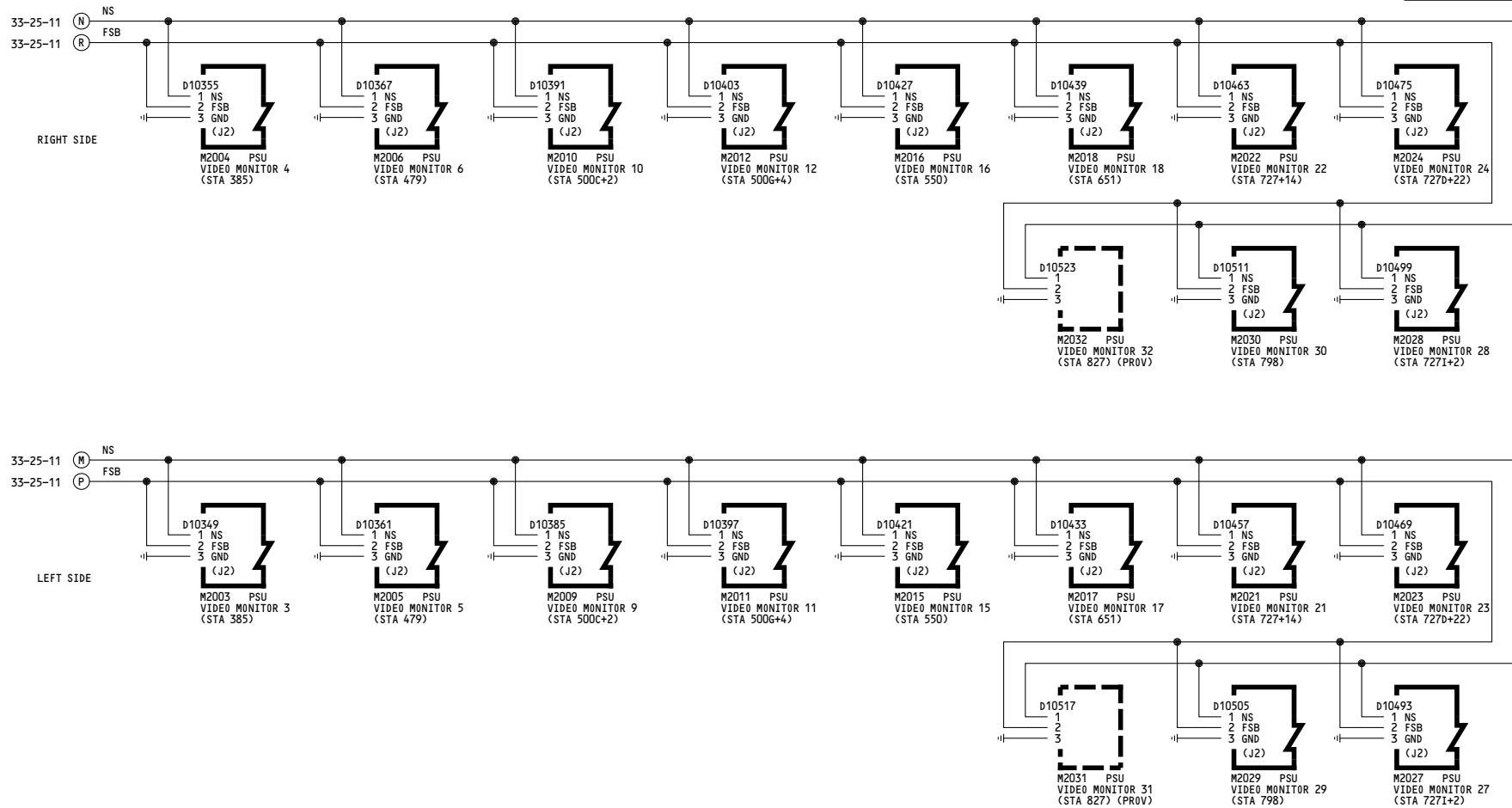

YC001-YC050

PASSENGER NS/FSB SIGNS - VIDEO MONITOR, LEFT AND RIGHT

D280A203

WIRING DIAGRAMS
33-25-51
33-25-61

151

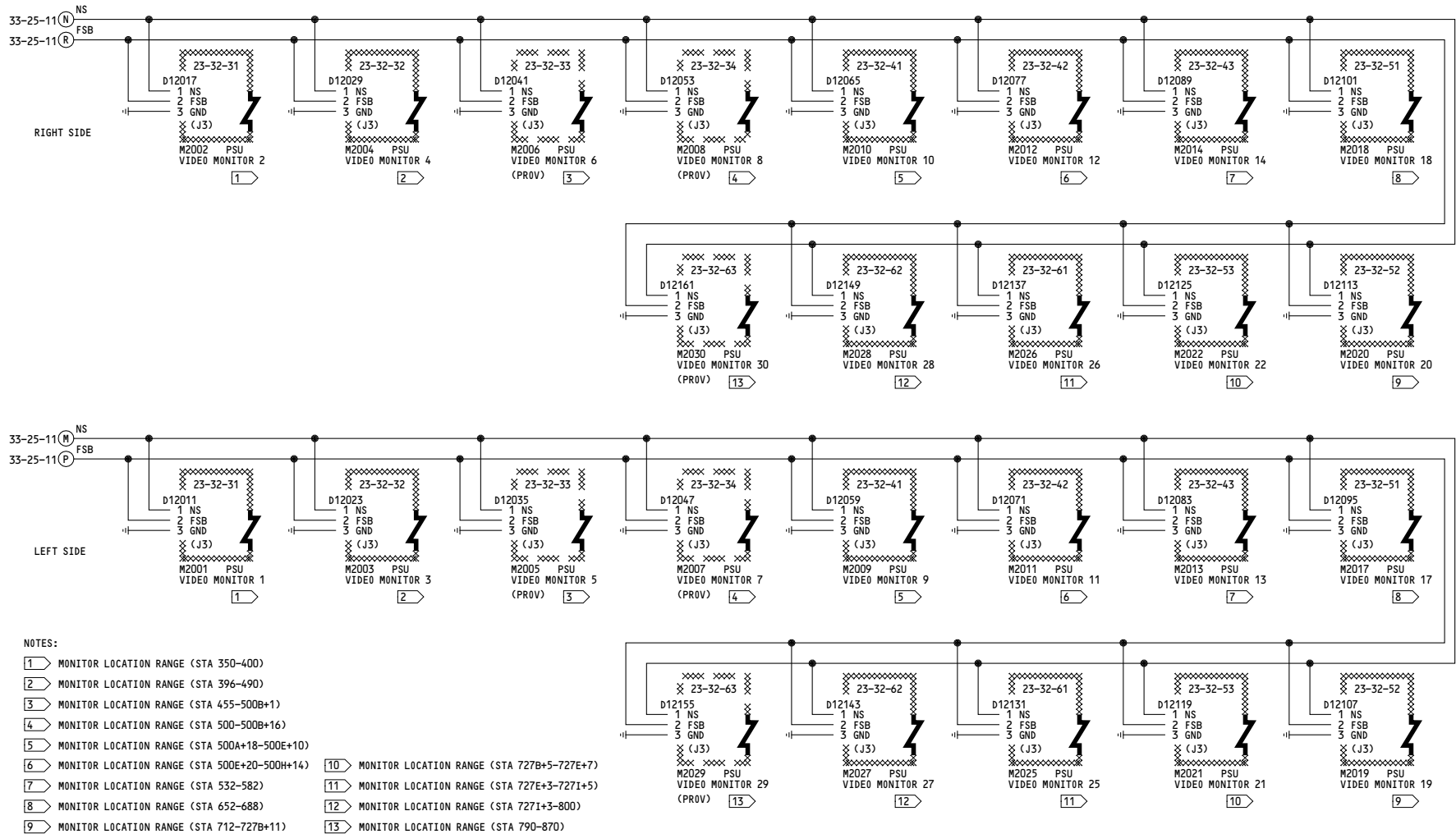

YK901-YL430

33-25-51

Page 102

Feb 09/2009

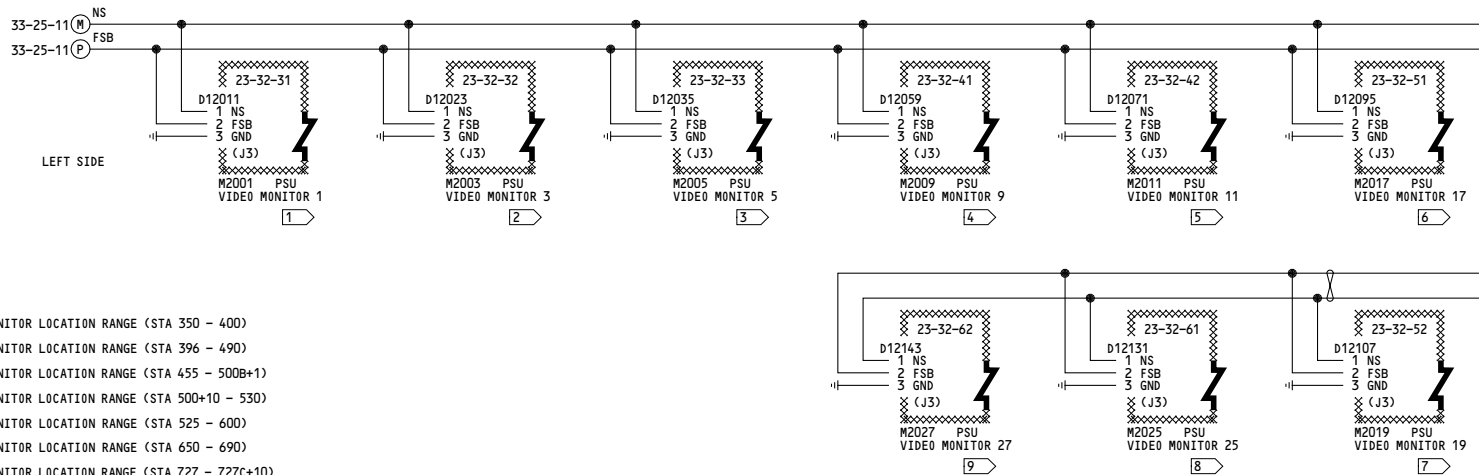
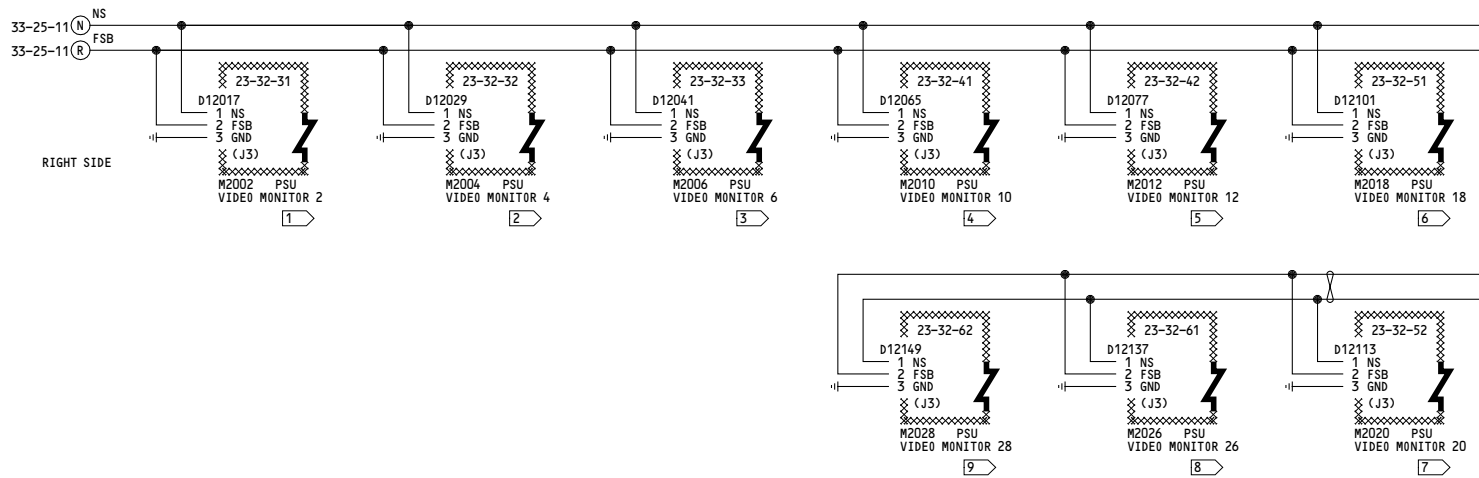

NOTES:

- 1 MONITOR LOCATION RANGE (STA 350 - 400)
- 2 MONITOR LOCATION RANGE (STA 396 - 490)
- 3 MONITOR LOCATION RANGE (STA 455 - 500B+1)
- 4 MONITOR LOCATION RANGE (STA 500+10 - 530)
- 5 MONITOR LOCATION RANGE (STA 525 - 600)
- 6 MONITOR LOCATION RANGE (STA 650 - 690)
- 7 MONITOR LOCATION RANGE (STA 727 - 727C+10)
- 8 MONITOR LOCATION RANGE (STA 727D - 780)
- 9 MONITOR LOCATION RANGE (STA 790 - 870)

YM643-YM670	PASSENGER NS/FSB SIGNS - VIDEO MONITOR, LEFT AND RIGHT
D280A203	

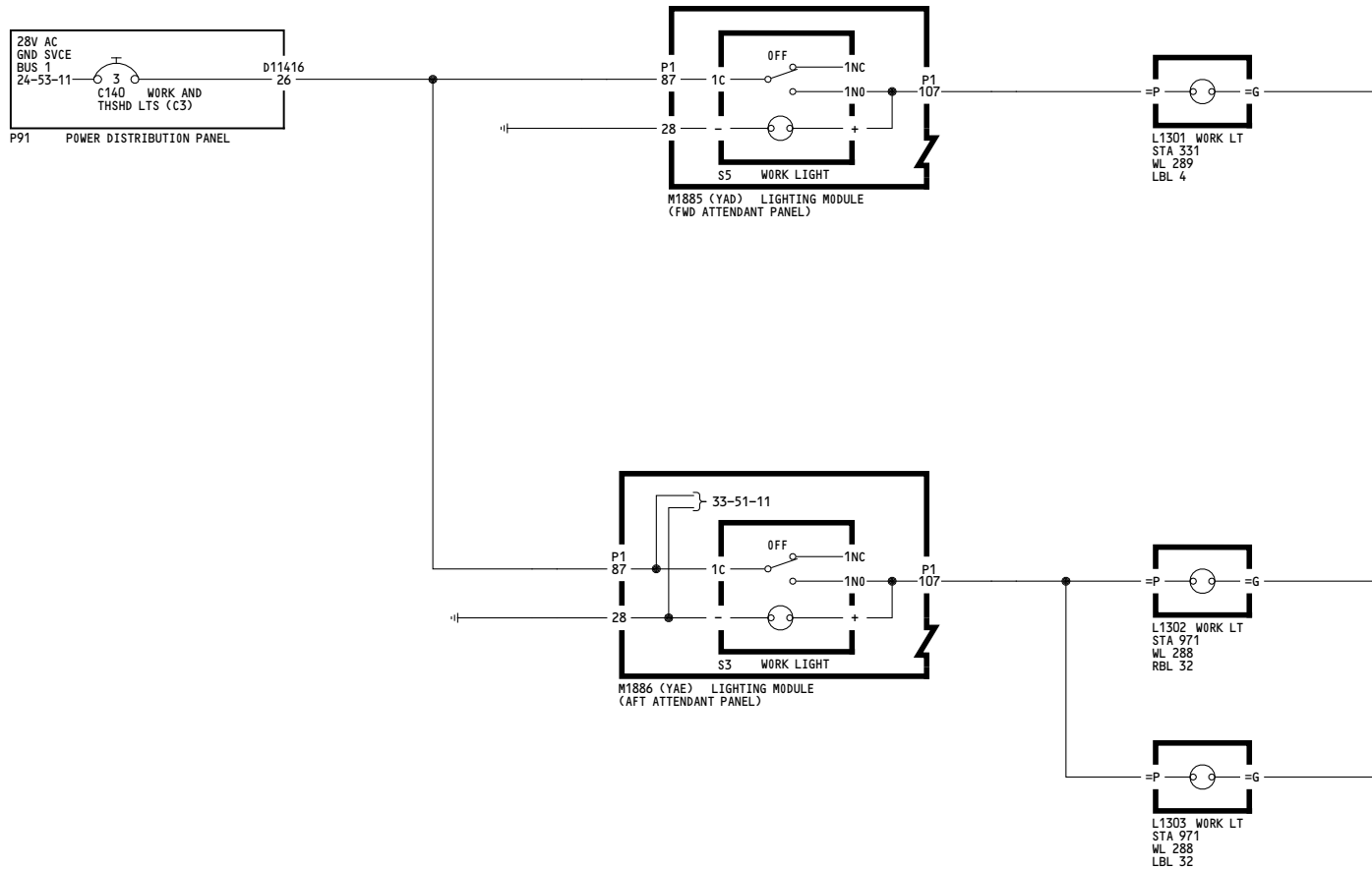

ALL	ATTENDANT WORK LIGHTS D280A203
-----	---------------------------------------

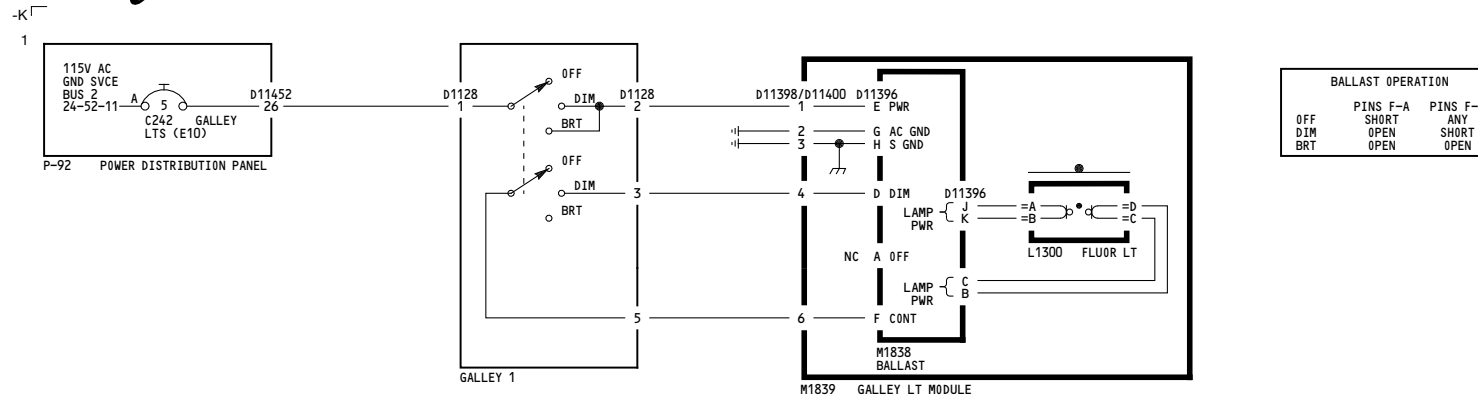

ALL	<p>GALLEY LIGHTS</p> <p>D280A203</p>
-----	---

WIRING DIAGRAMS
33-26-31

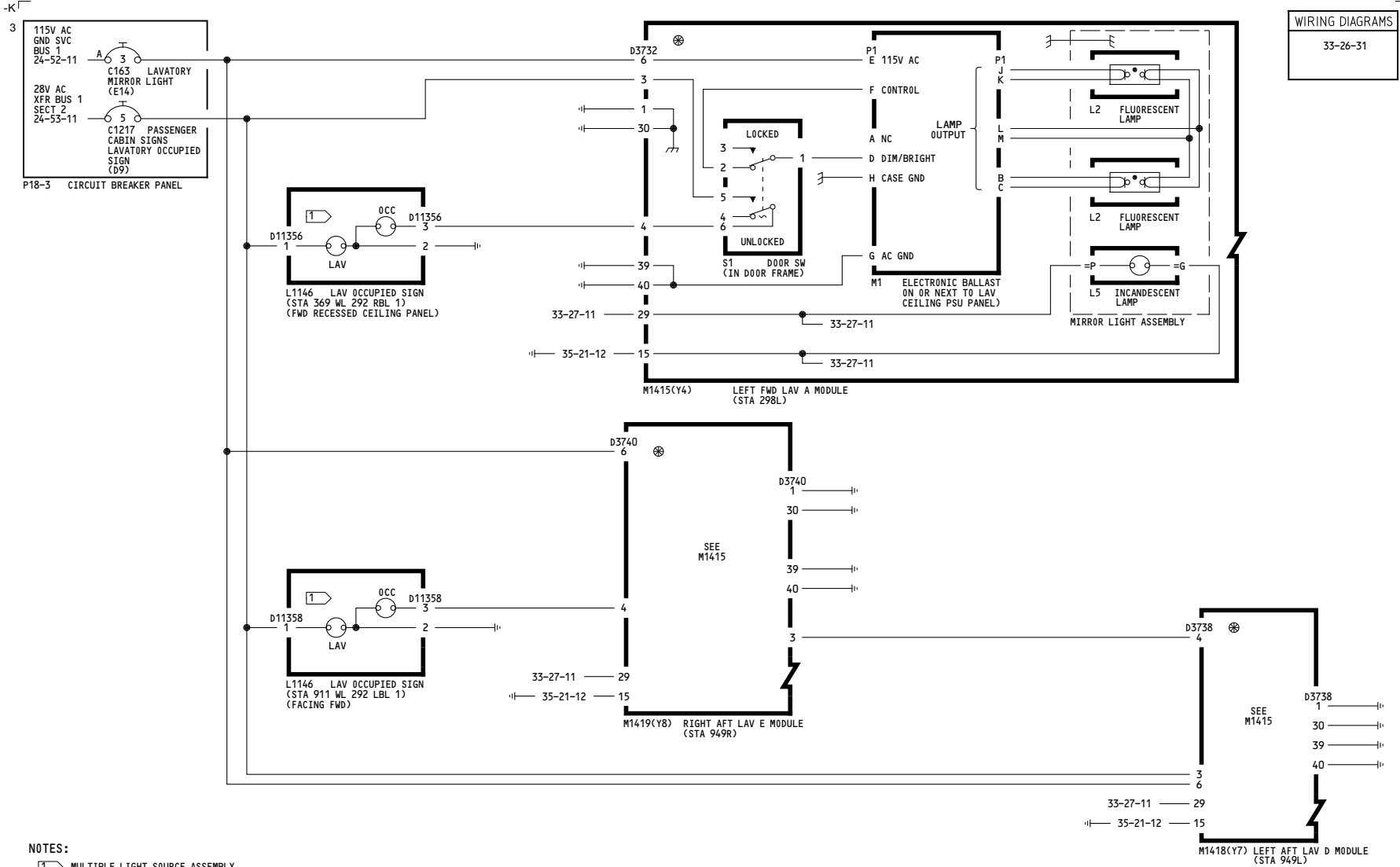

NOTES:
1 MULTIPLE LIGHT SOURCE ASSEMBLY

YC001-YC030	LAVATORY LIGHTS AND SIGNS
	D280A203

33-26-31

WIRING DIAGRAMS
33-26-31

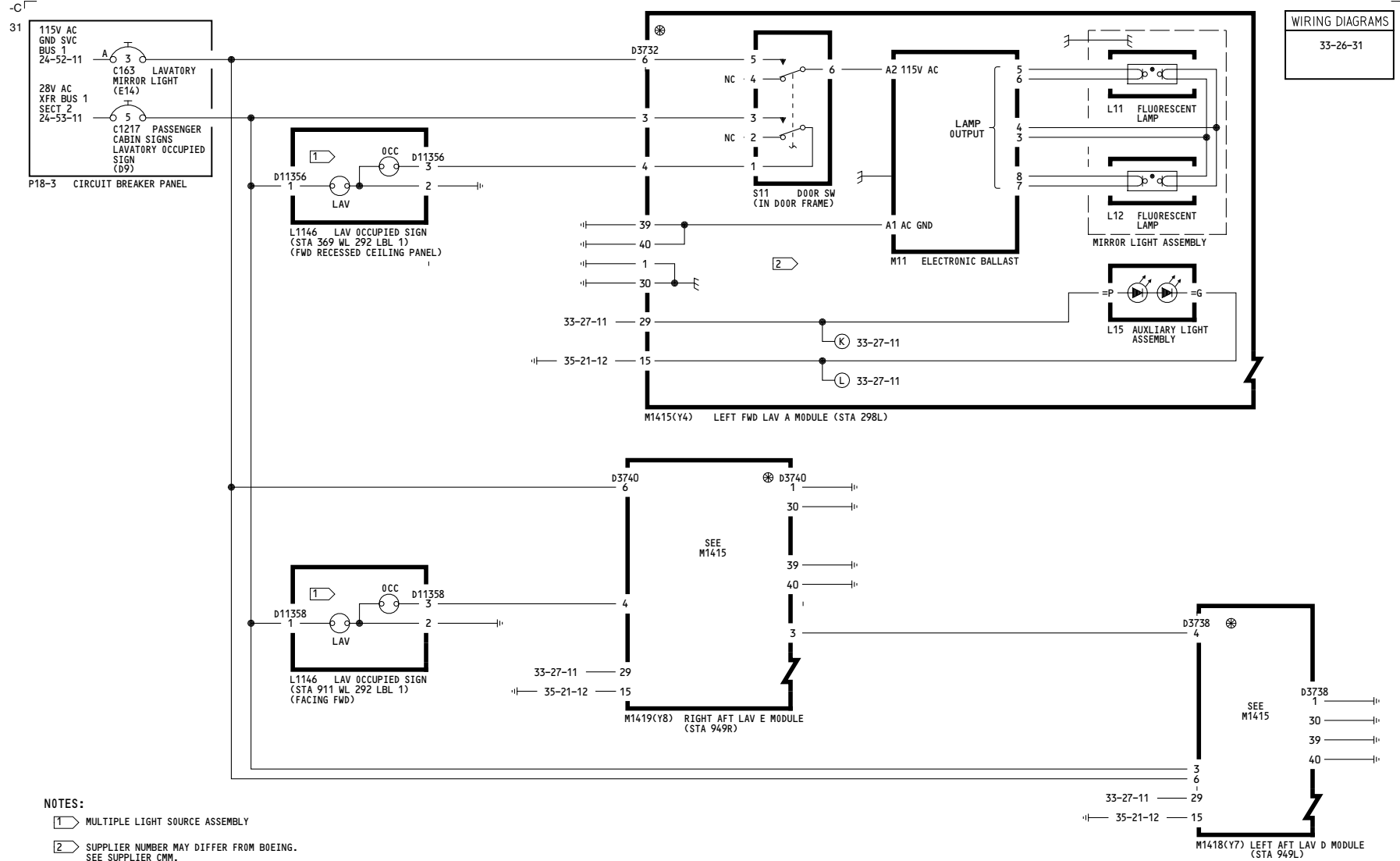

- NOTES:**
- 1 MULTIPLE LIGHT SOURCE ASSEMBLY
 - 2 SUPPLIER NUMBER MAY DIFFER FROM BOEING. SEE SUPPLIER CMM.

YC031-YM670	LAVATORY LIGHTS AND SIGNS
	D280A203

33-26-31

Page 102

Feb 09/2009

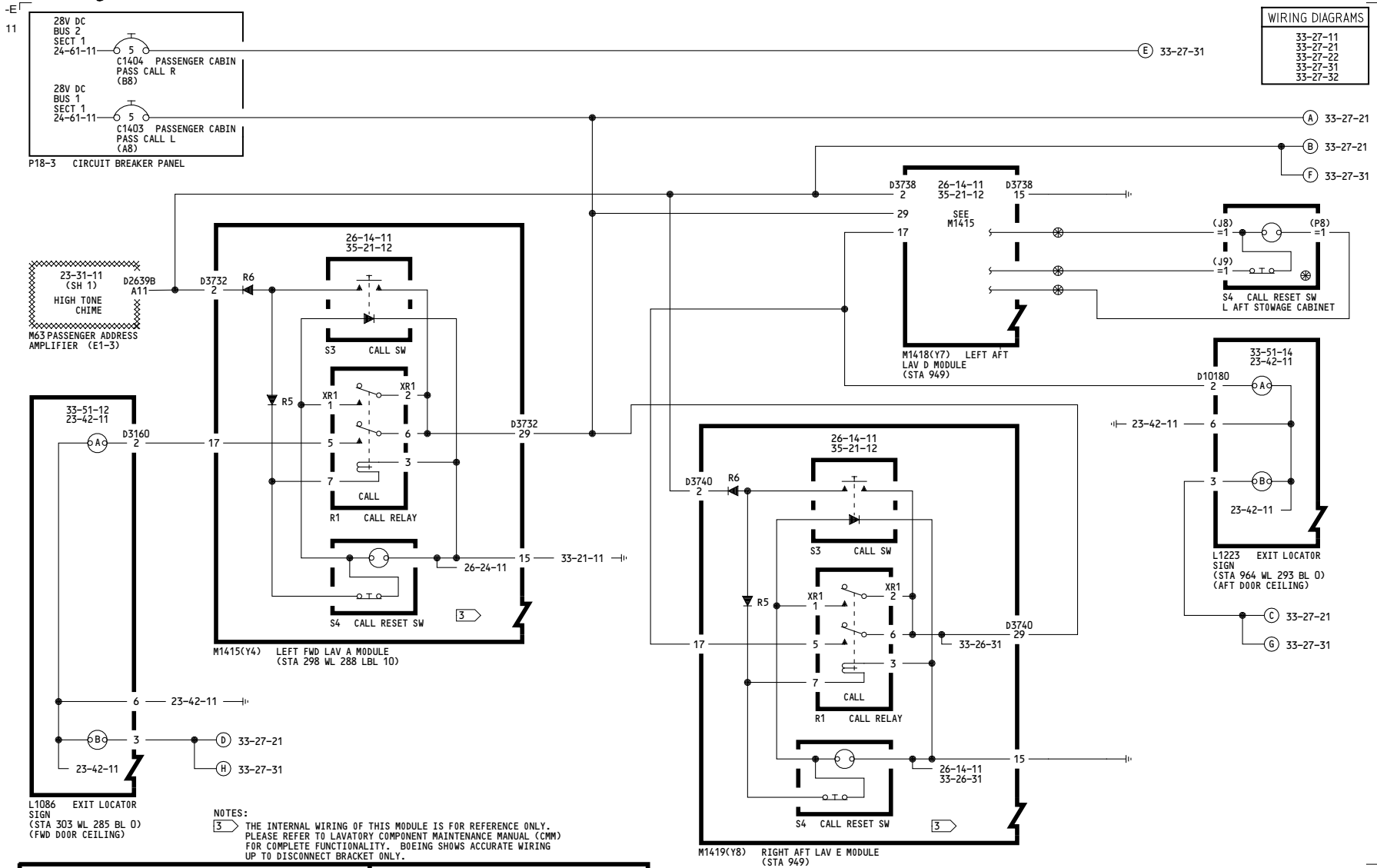

YC001-YC030	PASSENGER AND LAVATORY CALL CONTROL
	D280A203

33-27-11

WIRING DIAGRAMS	
33-27-11	
33-27-21	
33-27-22	
33-27-31	
33-27-32	

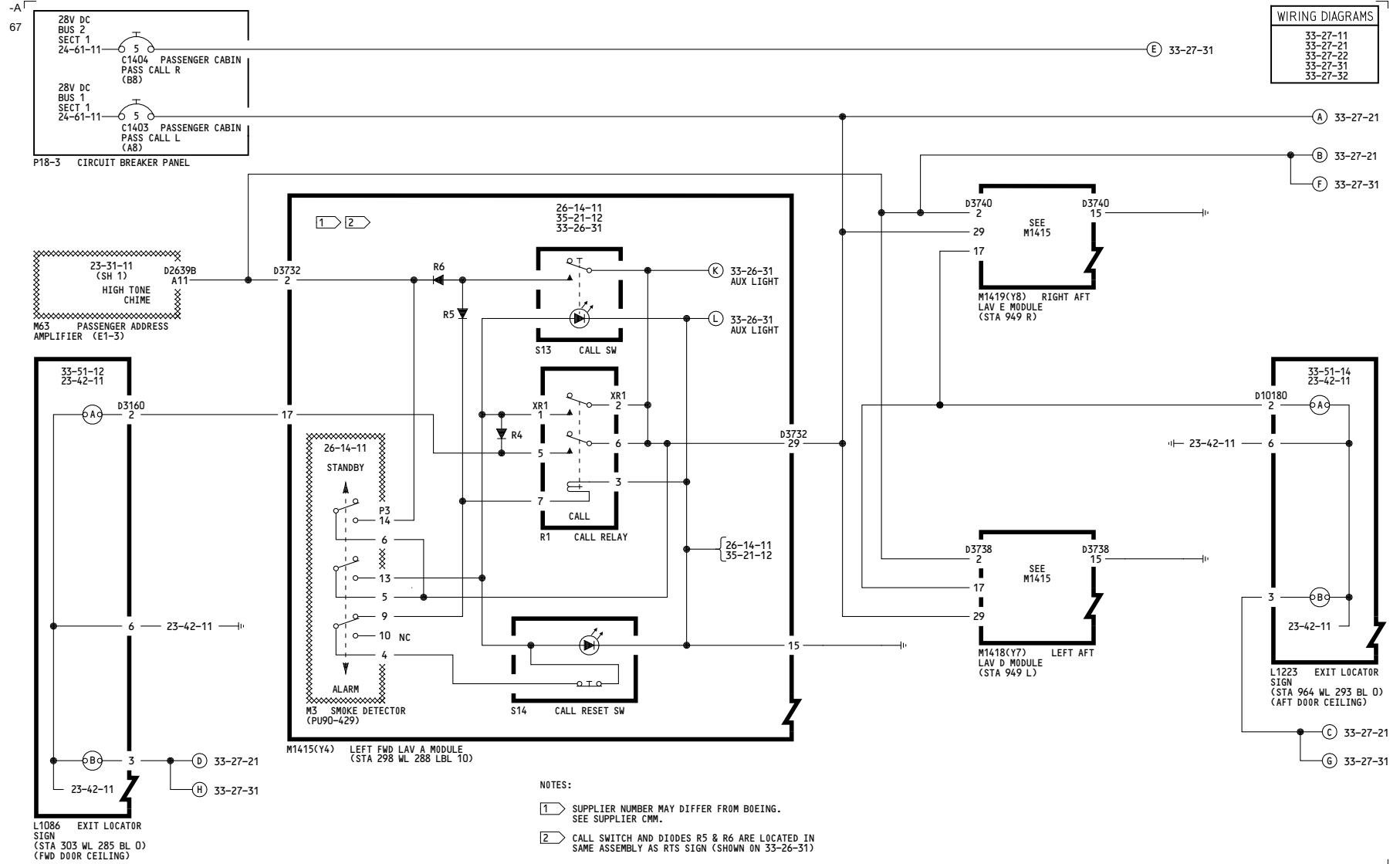

YK901-YM670	PASSENGER AND LAVATORY CALL CONTROL
	D280A203

33-27-11

Page 102

Feb 09/2009

WIRING DIAGRAMS
33-27-21

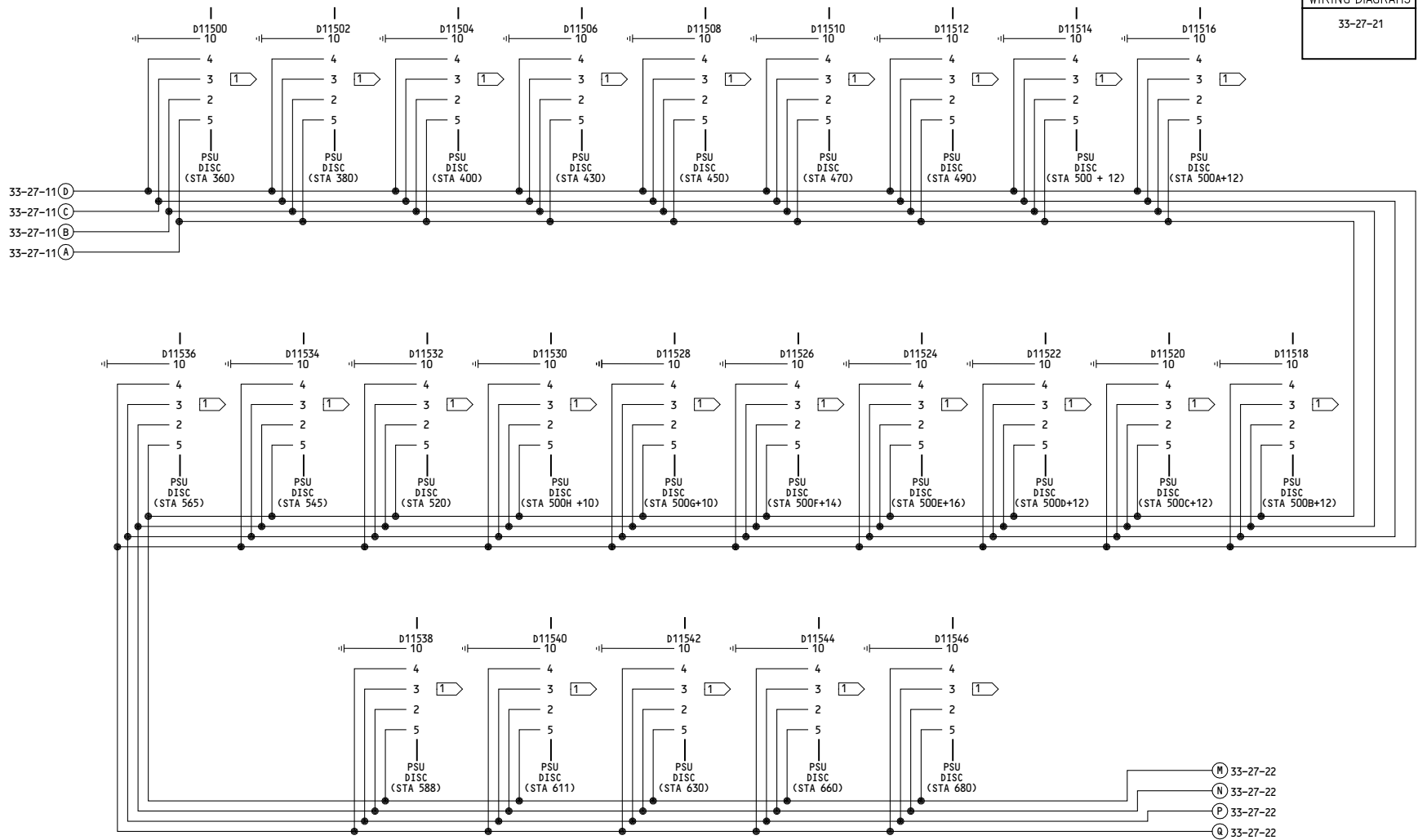

YC001-YL430

**PASSENGER AND LAVATORY
CALL - LEFT FWD**

D280A203

33-27-21

-F-
1

WIRING DIAGRAMS
33-27-21
33-27-22

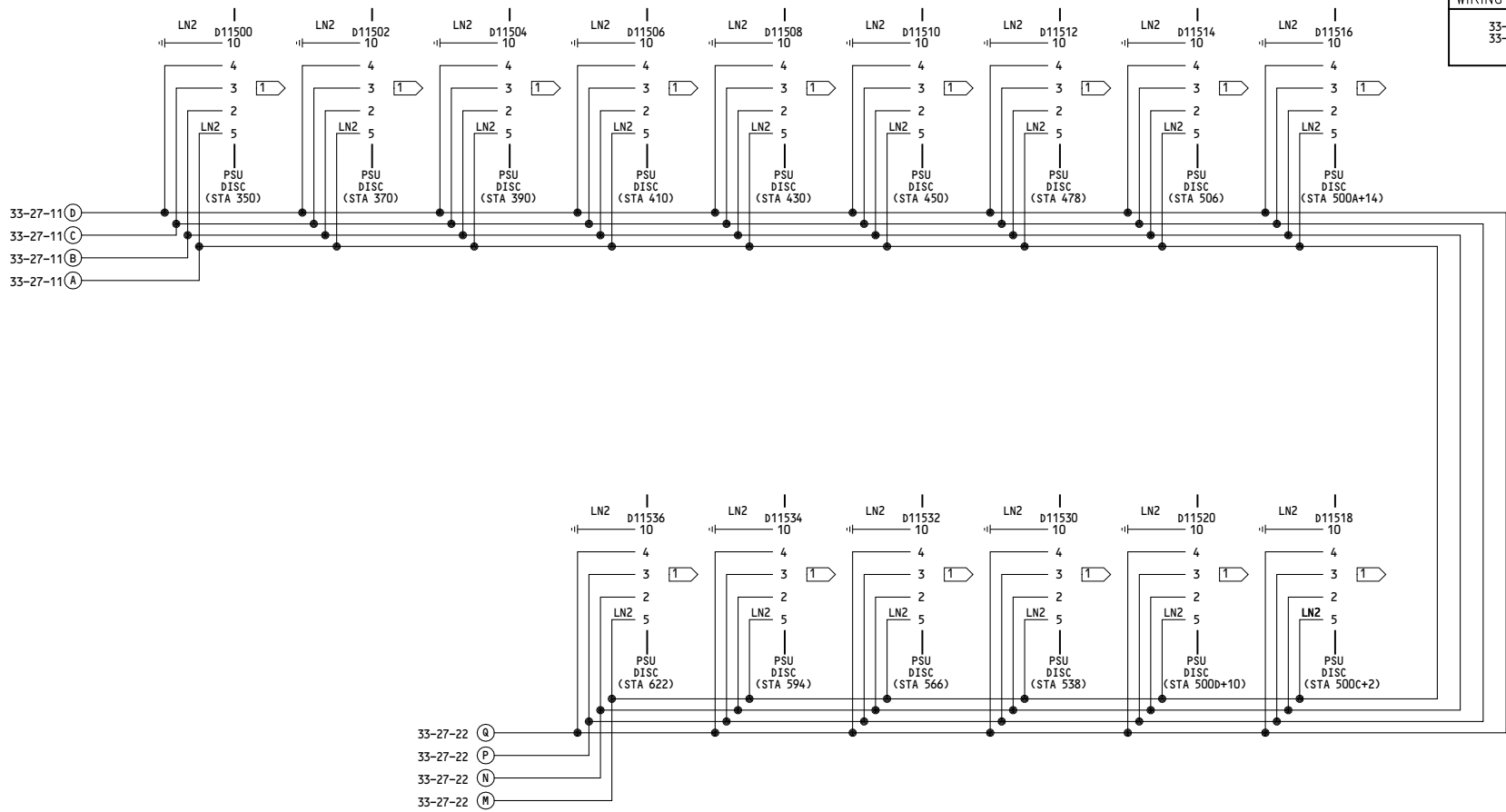

NOTES:

1 MATES WITH PSU DISCONNECT P4
IF INSTALLED, SEE 33-27-41

<p>YM643-YM670</p>	<p>PASSENGER AND LAVATORY CALL - LEFT FWD</p> <p>D280A203</p>
--------------------	--

33-27-21

Page 102

Jan 14/2008

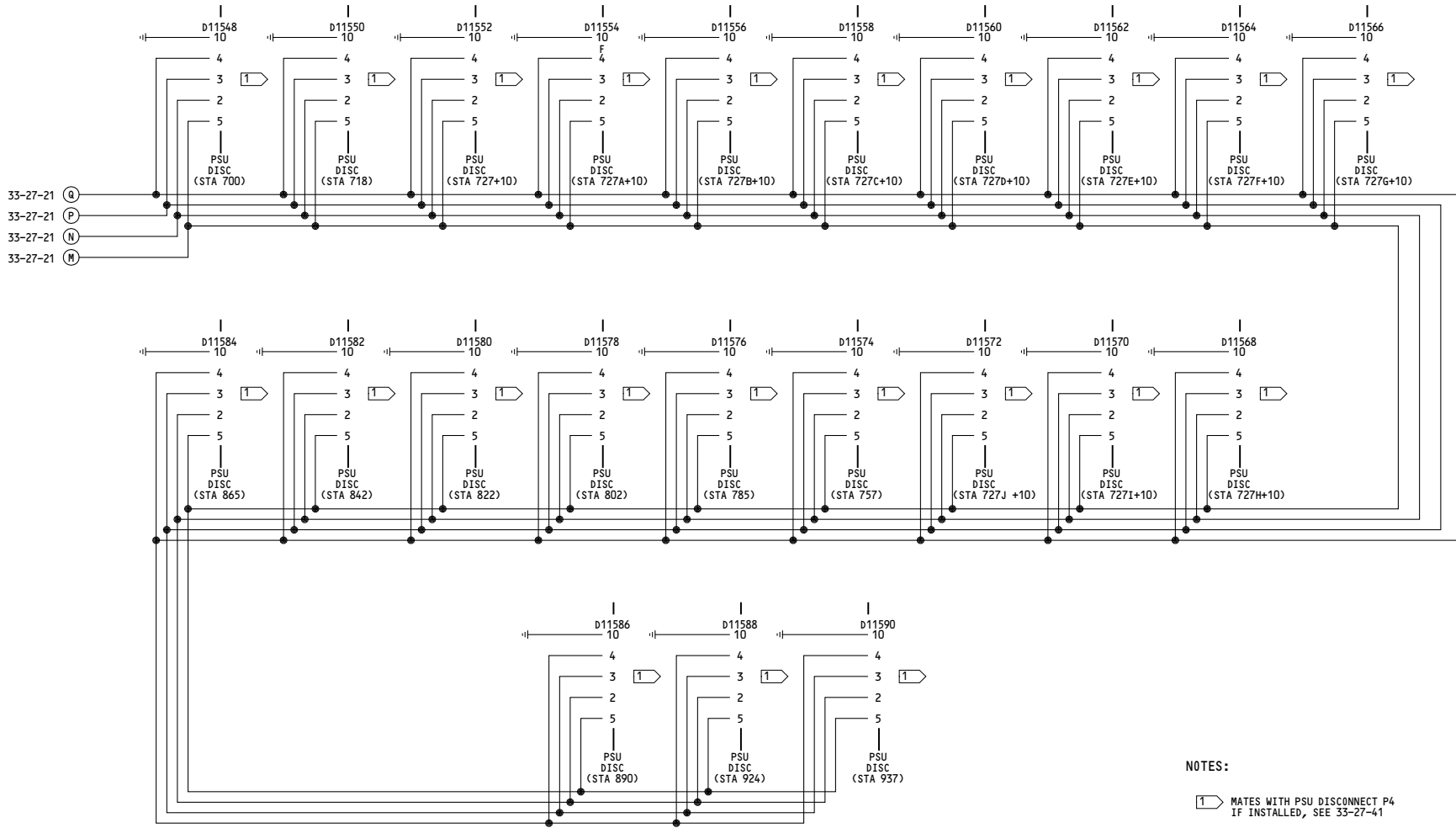

NOTES:

1 MATES WITH PSU DISCONNECT P4 IF INSTALLED, SEE 33-27-41

YC001-YL430

**PASSENGER AND LAVATORY
CALL - LEFT AFT**

D280A203

33-27-22

Page 101

Feb 09/2009

-C
1

WIRING DIAGRAMS
33-27-21
33-27-22

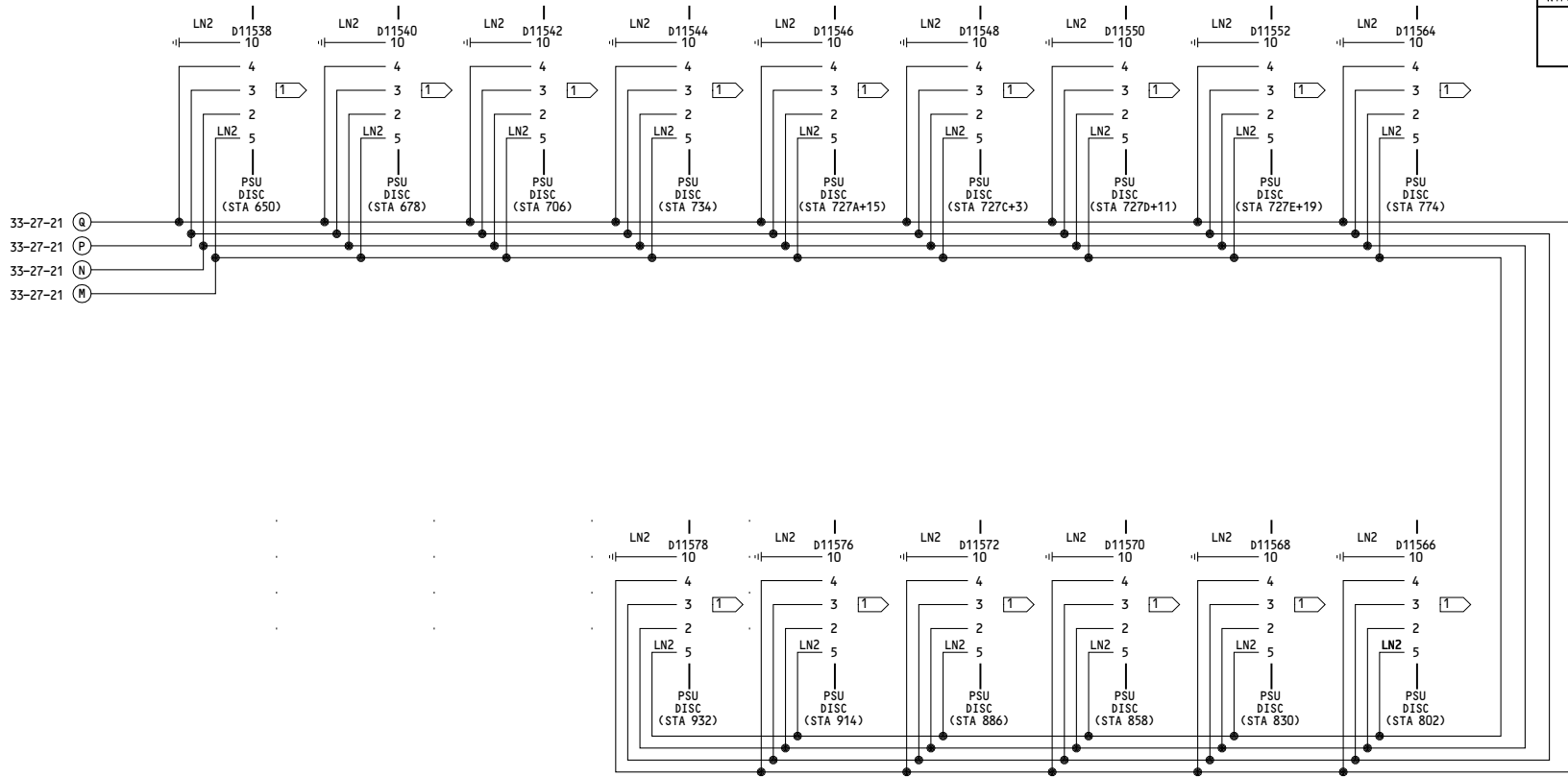

NOTES:

1 MATES WITH PSU DISCONNECT P4
IF INSTALLED, SEE 33-27-41
IF NOT INSTALLED, CAP & STOW CONNECTOR.

YM643-YM670	<p align="center">PASSENGER AND LAVATORY CALL - LEFT AFT</p> <p align="center">D280A203</p>
-------------	--

33-27-22

Page 102

Jan 14/2008

-H
2

WIRING DIAGRAMS
33-27-31

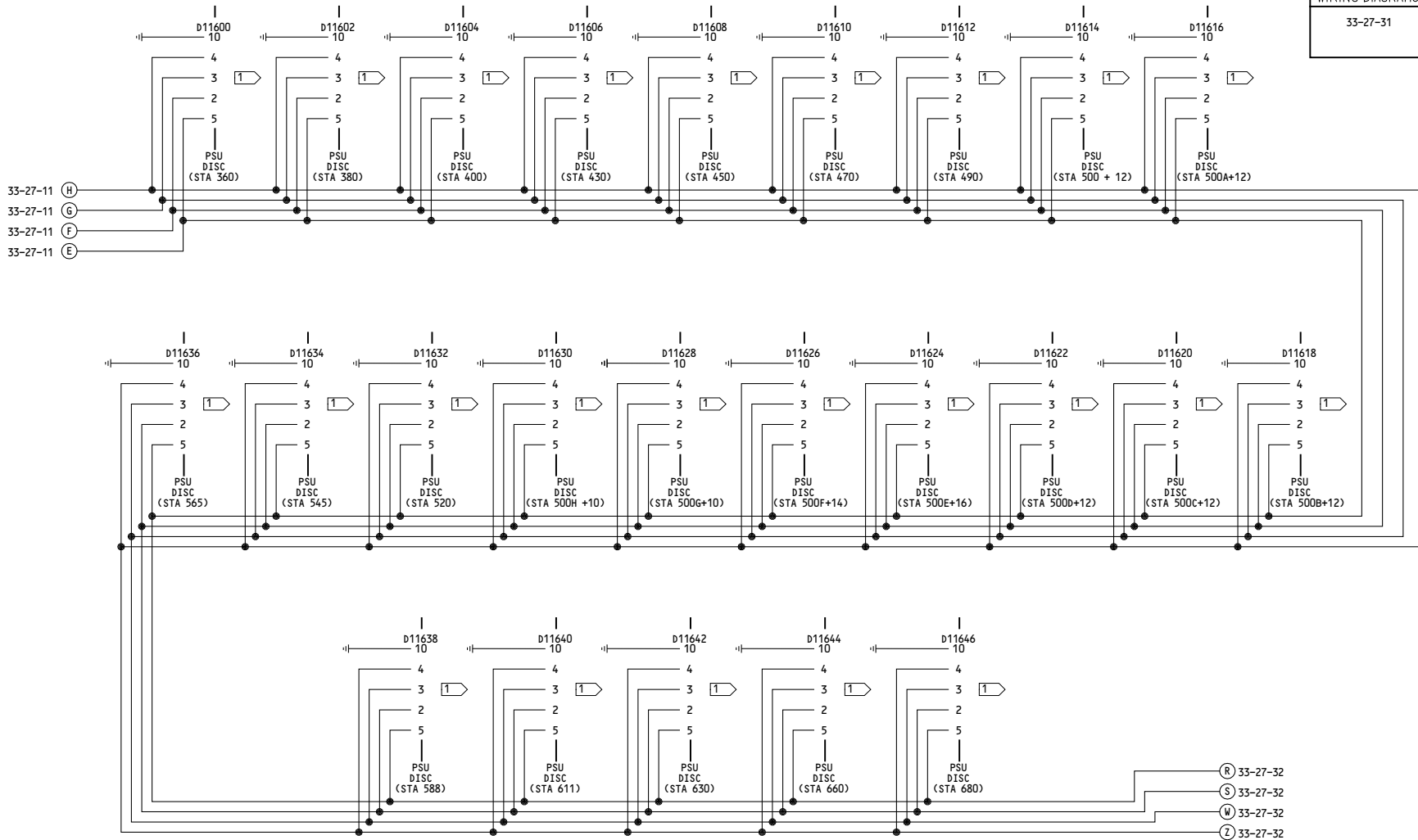

YC001-YL430

**PASSENGER AND LAVATORY
CALL - RIGHT FWD**

D280A203

33-27-31

Page 101

Feb 09/2009

WIRING DIAGRAMS
33-27-31
33-27-32

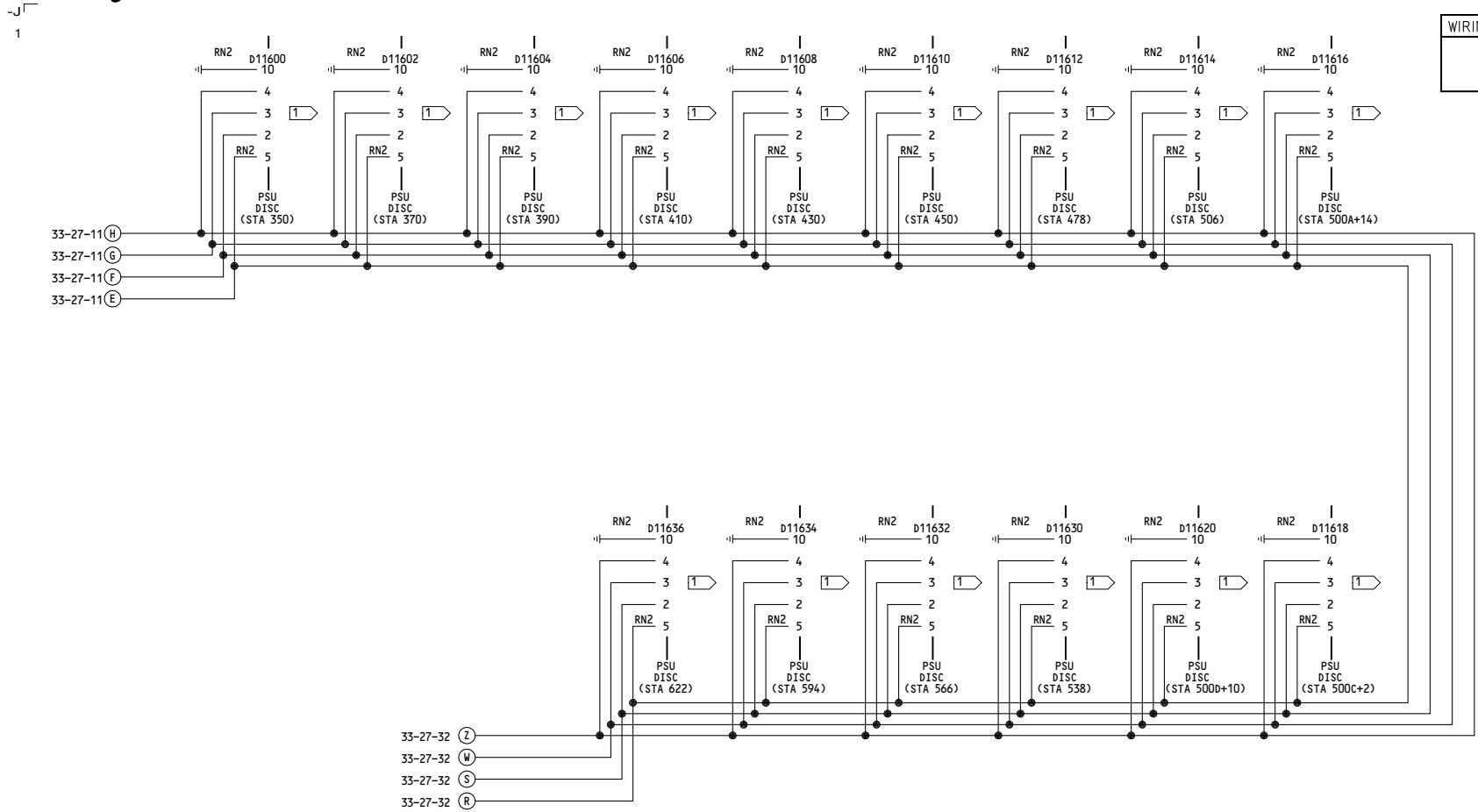

NOTES:

1 MATES WITH PSU DISCONNECT P4
IF INSTALLED, SEE 33-27-41
IF NOT INSTALLED, CAP & STOW CONNECTOR.

YM643-YM670	<p align="center">PASSENGER AND LAVATORY CALL - RIGHT FWD</p> <p align="center">D280A203</p>
-------------	---

-D
2

WIRING DIAGRAMS
33-27-32

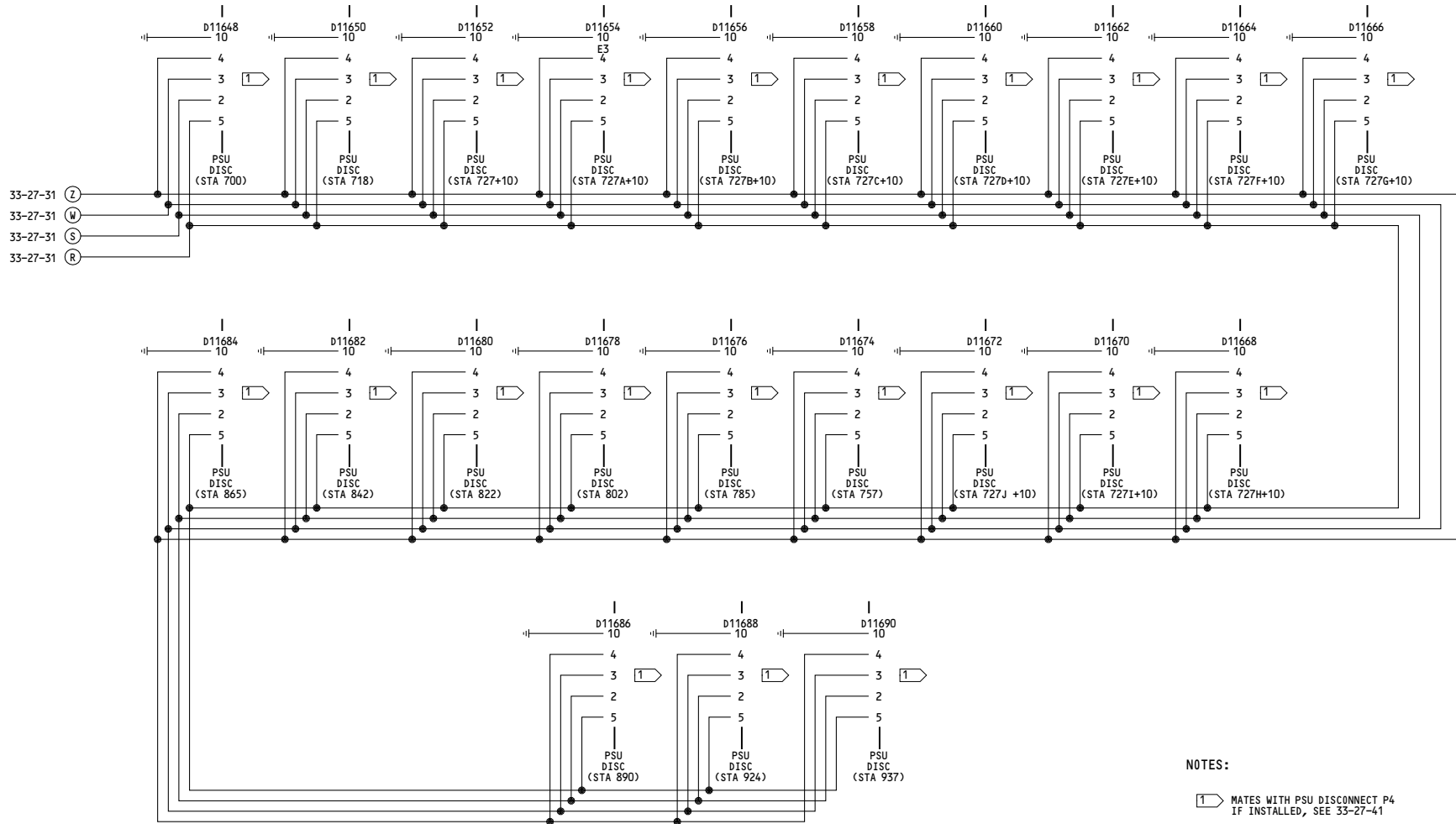

NOTES:

➤ MATES WITH PSU DISCONNECT P4 IF INSTALLED, SEE 33-27-41

YC001-YL430

**PASSENGER AND LAVATORY
CALL - RIGHT AFT**

D280A203

33-27-32

Page 101

Feb 09/2009

-B
1

WIRING DIAGRAMS
33-27-31
33-27-32

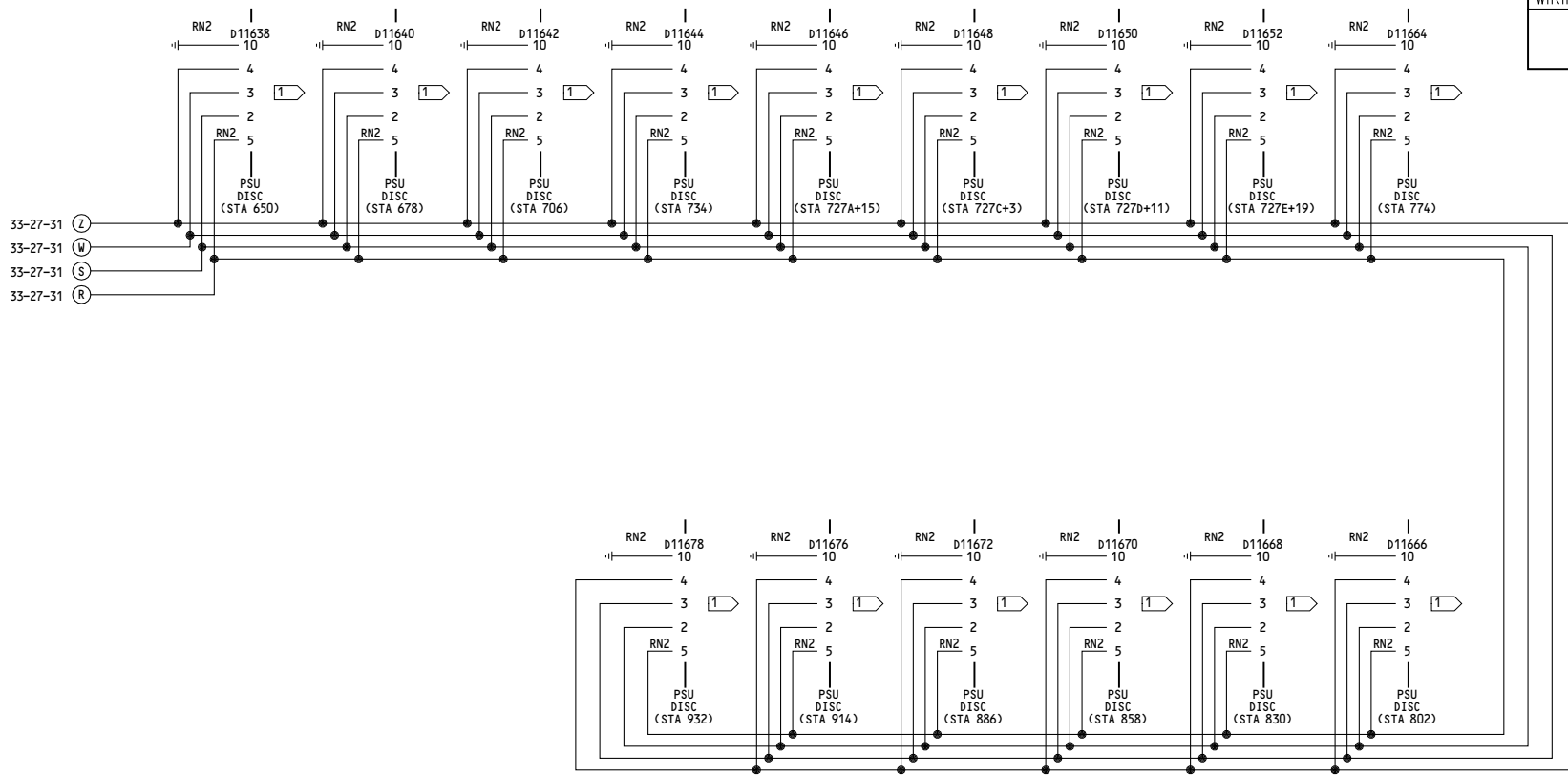

NOTES:

1 MATES WITH PSU DISCONNECT P4
IF INSTALLED, SEE 33-27-41
IF NOT INSTALLED, CAP & STOW CONNECTOR.

YM643-YM670	<p>PASSENGER AND LAVATORY CALL - RIGHT AFT</p> <p>D280A203</p>
-------------	---

33-27-32

Page 102

Jan 14/2008

3

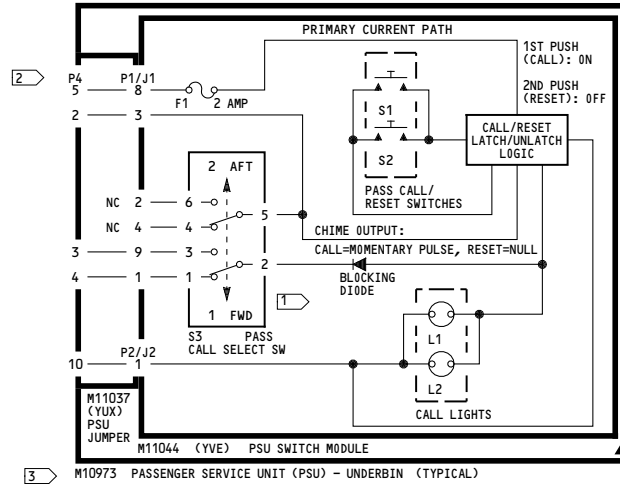
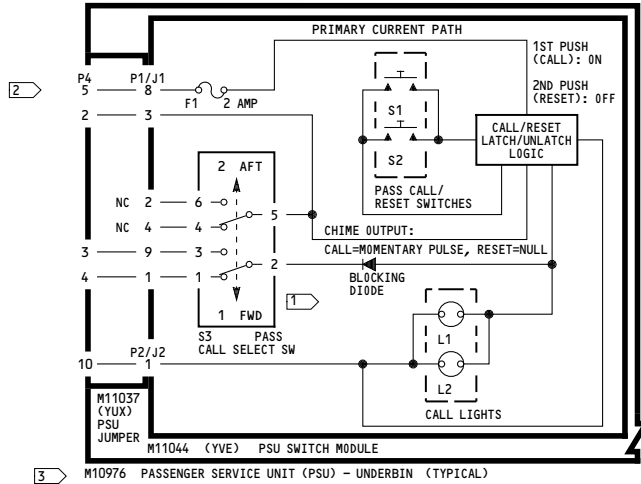

NOTES:

- 1 FOR MULTI CLASS CONFIGURATION:
 MOVE SWITCH S3 TO POSITION 1 FOR PSUS FWD OF CLASS PARTITION
 MOVE SWITCH S3 TO POSITION 2 FOR PSUS AFT OF CLASS PARTITION
 FOR SINGLE CLASS CONFIGURATION:
 MOVE SWITCH S3 TO POSITION 1 FOR FWD HALF OF PSUS
 MOVE SWITCH S3 TO POSITION 2 FOR AFT HALF OF PSUS
- 2 P4 MATES WITH PSU DISCONNECT DXXXXX (SEE 33-27-2X AND 33-27-3X)
- 3 EITHER THE M10973, M10976 OR A COMBINATION OF BOTH PSU MODULES WILL BE INSTALLED, ACCORDING TO THE INTERIOR ARRANGEMENT OF EACH AIRPLANE.

ALL	PASSENGER AND LAVATORY CALL - PSU D280A203
-----	--

-U
1

	BALLAST PINS F-A	OPERATION PINS F-D
OFF	SHORT	ANY
DIM	OPEN	SHORT
BRT	OPEN	OPEN

WIRING DIAGRAMS	
33-29-11	

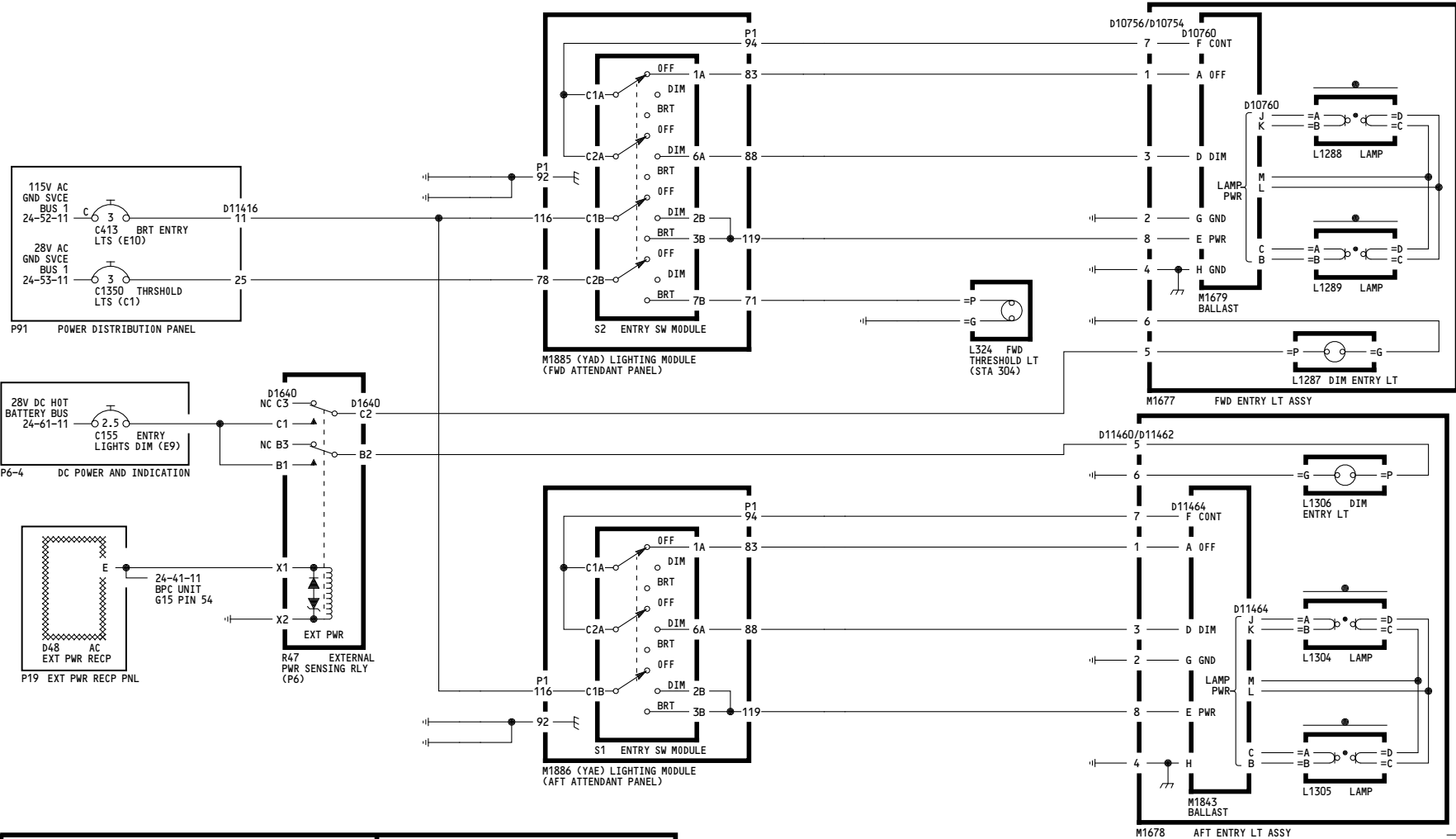

YC001-YK906	ENTRY LIGHTS
	D280A203

33-29-11

	BALLAST PINS F-A	OPERATION PINS F-D
OFF	SHORT	ANY
DIM	OPEN	SHORT
BRT	OPEN	OPEN

WIRING DIAGRAMS
33-29-11

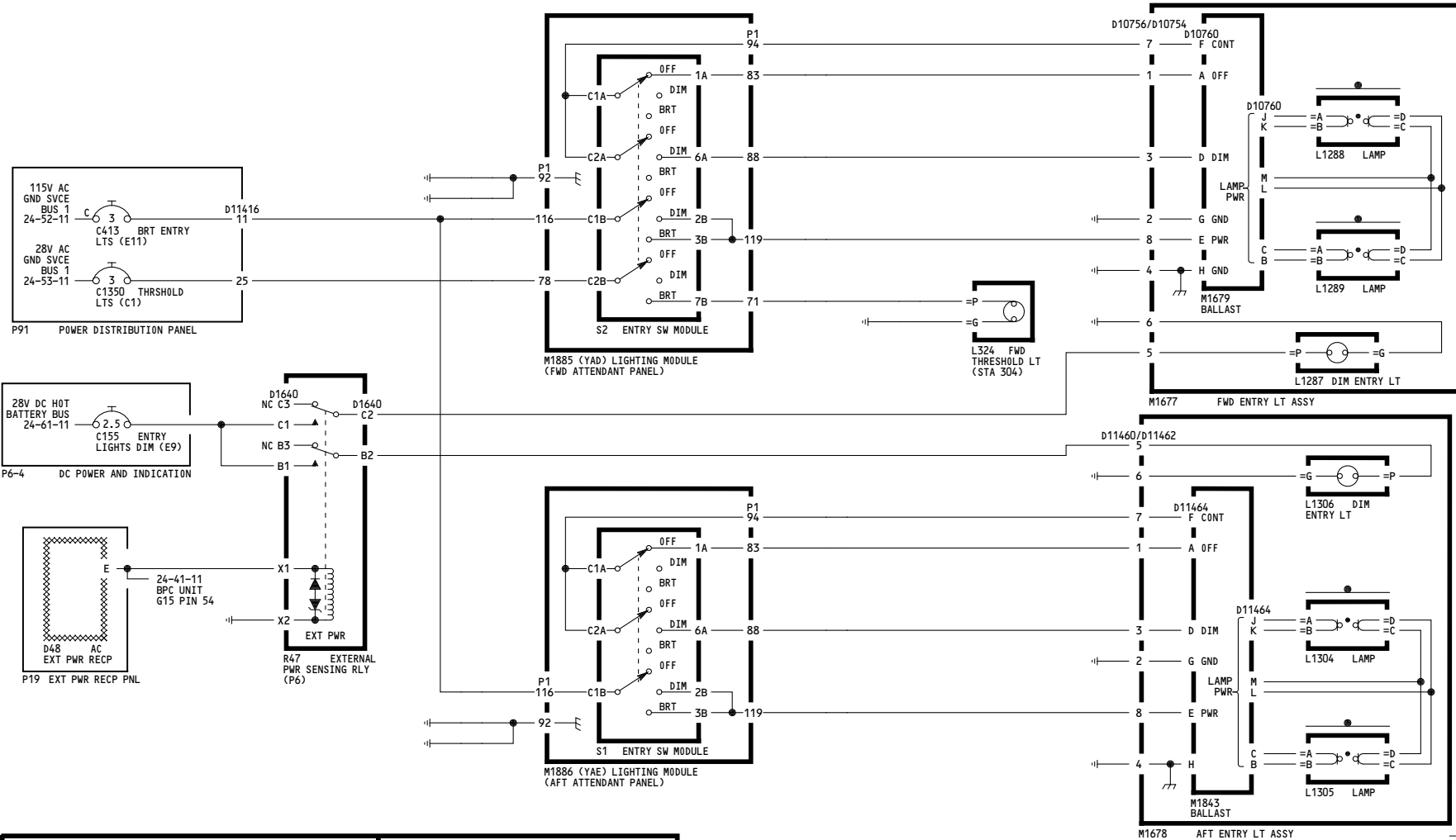

YK907-YL430	ENTRY LIGHTS
	D280A203

33-29-11

	BALLAST PINS F-A	OPERATION PINS F-D
OFF	SHORT	ANY
DIM	OPEN	SHORT
BRT	OPEN	OPEN

WIRING DIAGRAMS
33-29-11

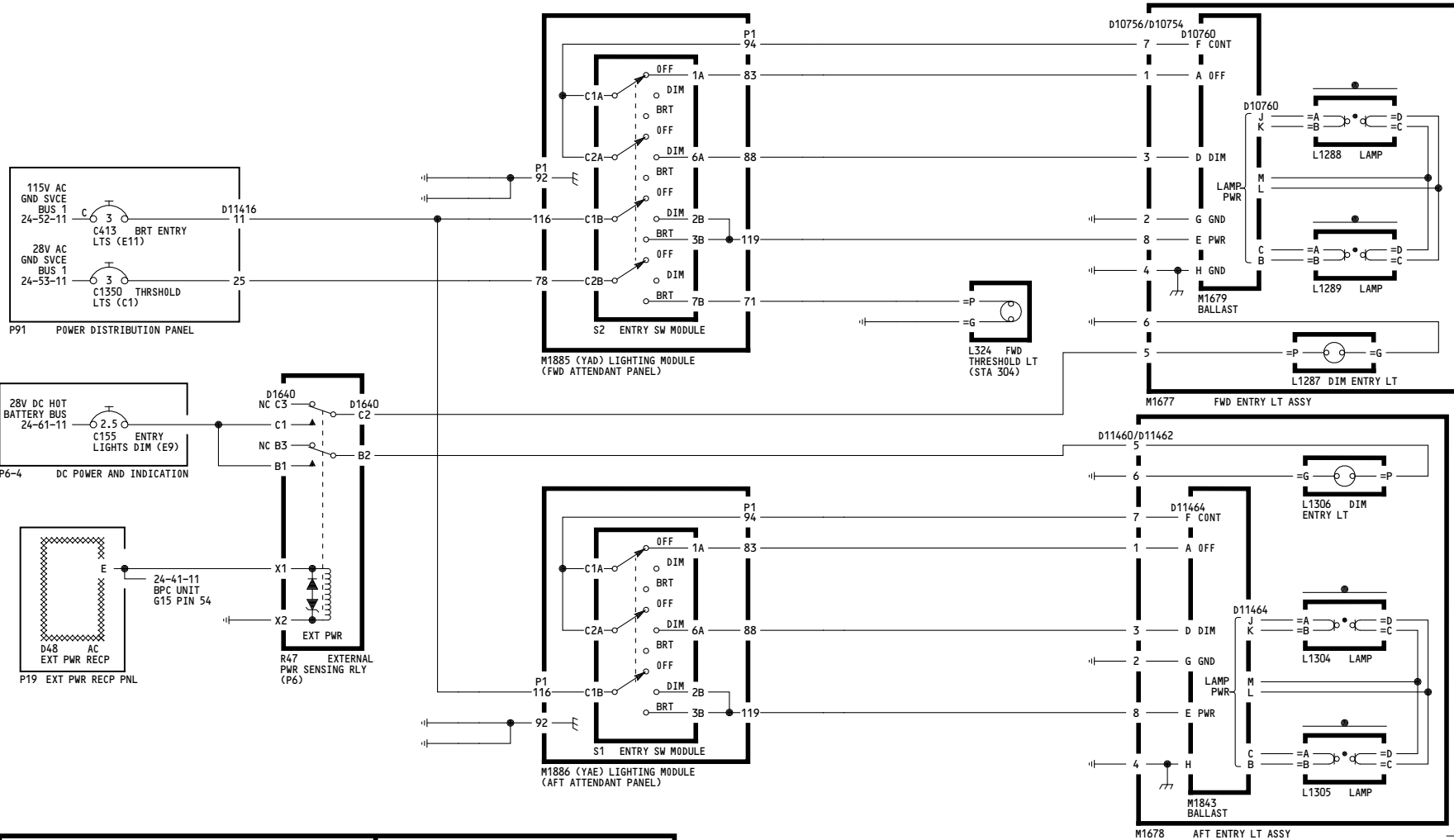

YM643-YM670	ENTRY LIGHTS
	D280A203

33-29-11

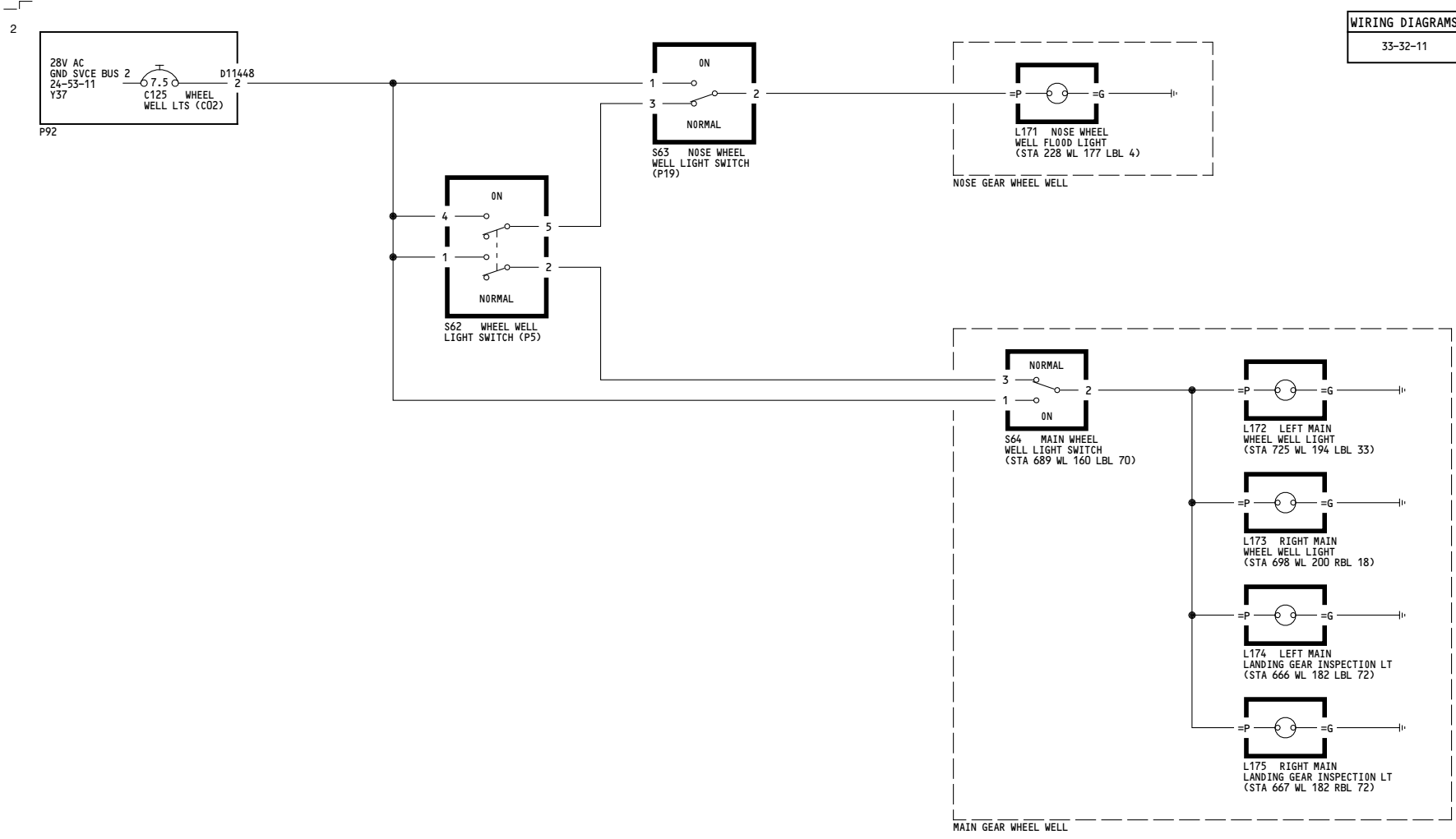

ALL	<p>SERVICE LIGHTING - WHEEL WELLS</p> <p>D280A203</p>
-----	--

-M
1

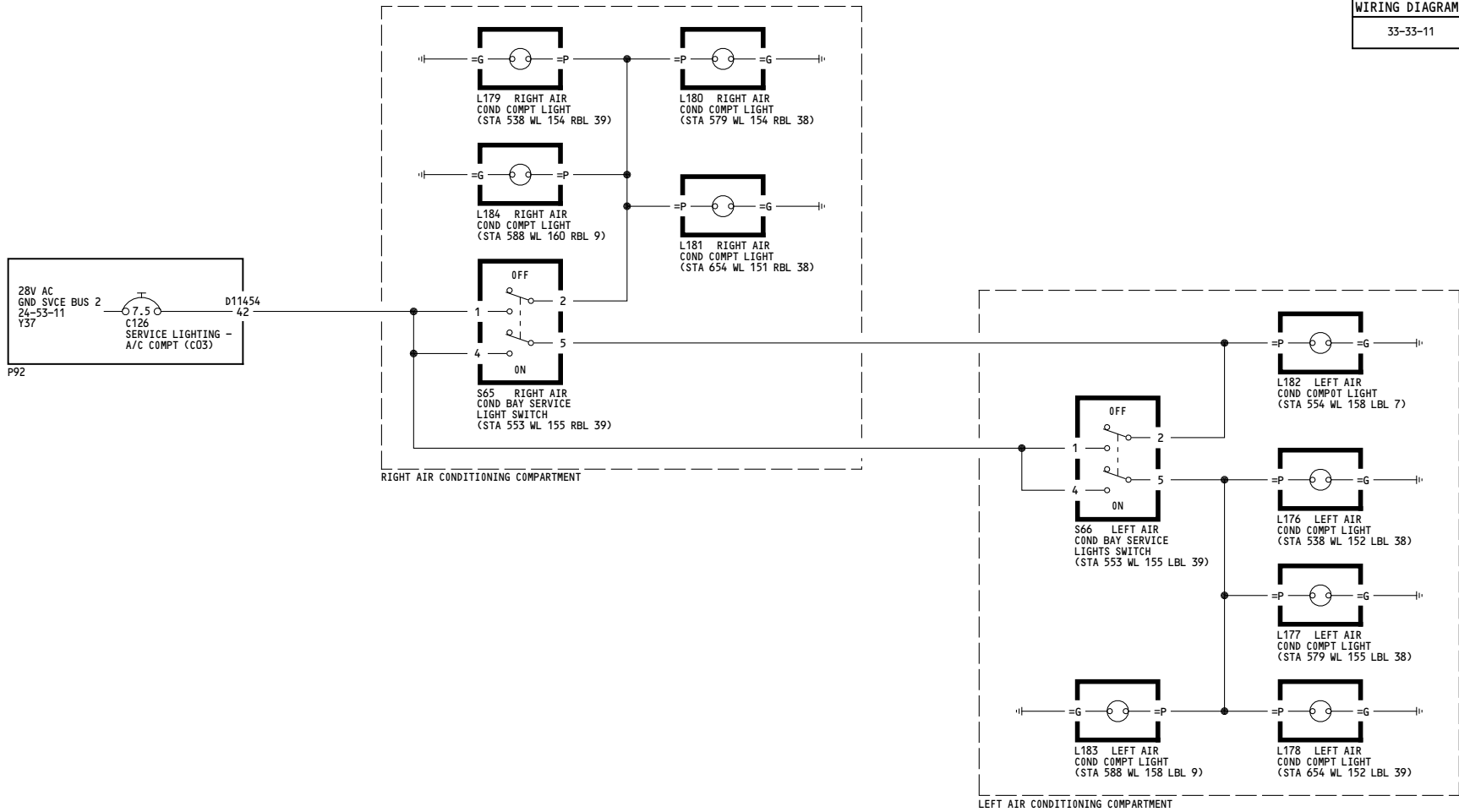

ALL	<p>SERVICE LIGHTING - AIR CONDITIONING COMPARTMENT</p> <p>D280A203</p>
-----	---

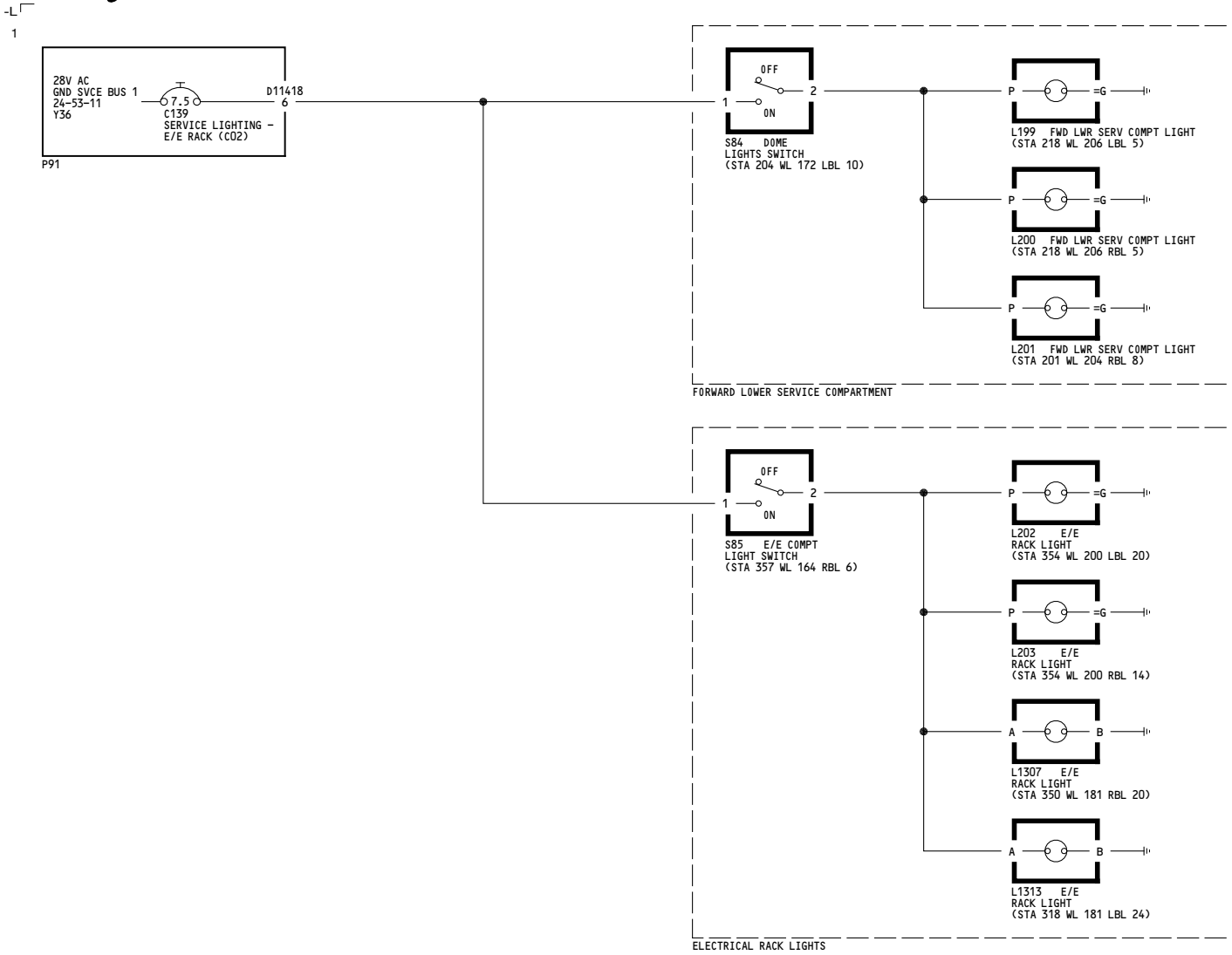

ALL	<p>SERVICE LIGHTING - EQUIPMENT RACK FORWARD LOWER COMPARTMENT</p> <p>D280A203</p>
-----	---

-A
3

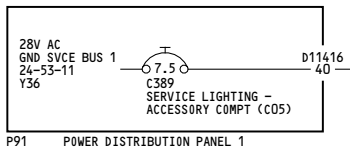

SAME AS SHEET CONFIGURATION 1

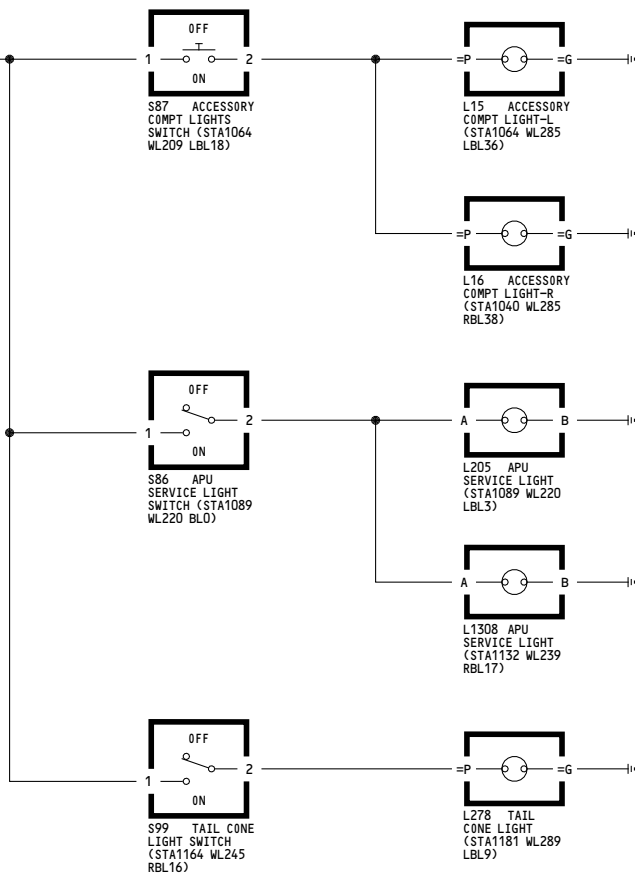

<p>YC001-YC026</p>	<p>SERVICE LIGHTING - ACCESSORY COMPARTMENT</p> <p>D280A203</p>
--------------------	--

-A
4

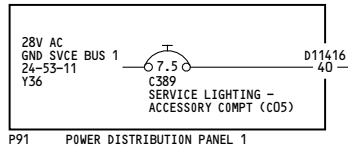

SAME AS SHEET CONFIGURATION 2

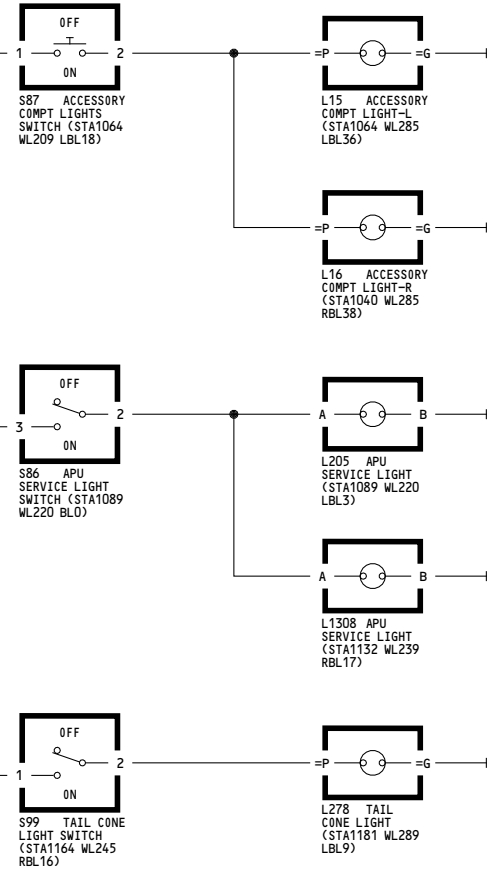

YC028-YM670

**SERVICE LIGHTING -
ACCESSORY COMPARTMENT**

D280A203

33-35-11

Page 102

Feb 09/2009

-E-
2

WIRING DIAGRAMS
33-36-11

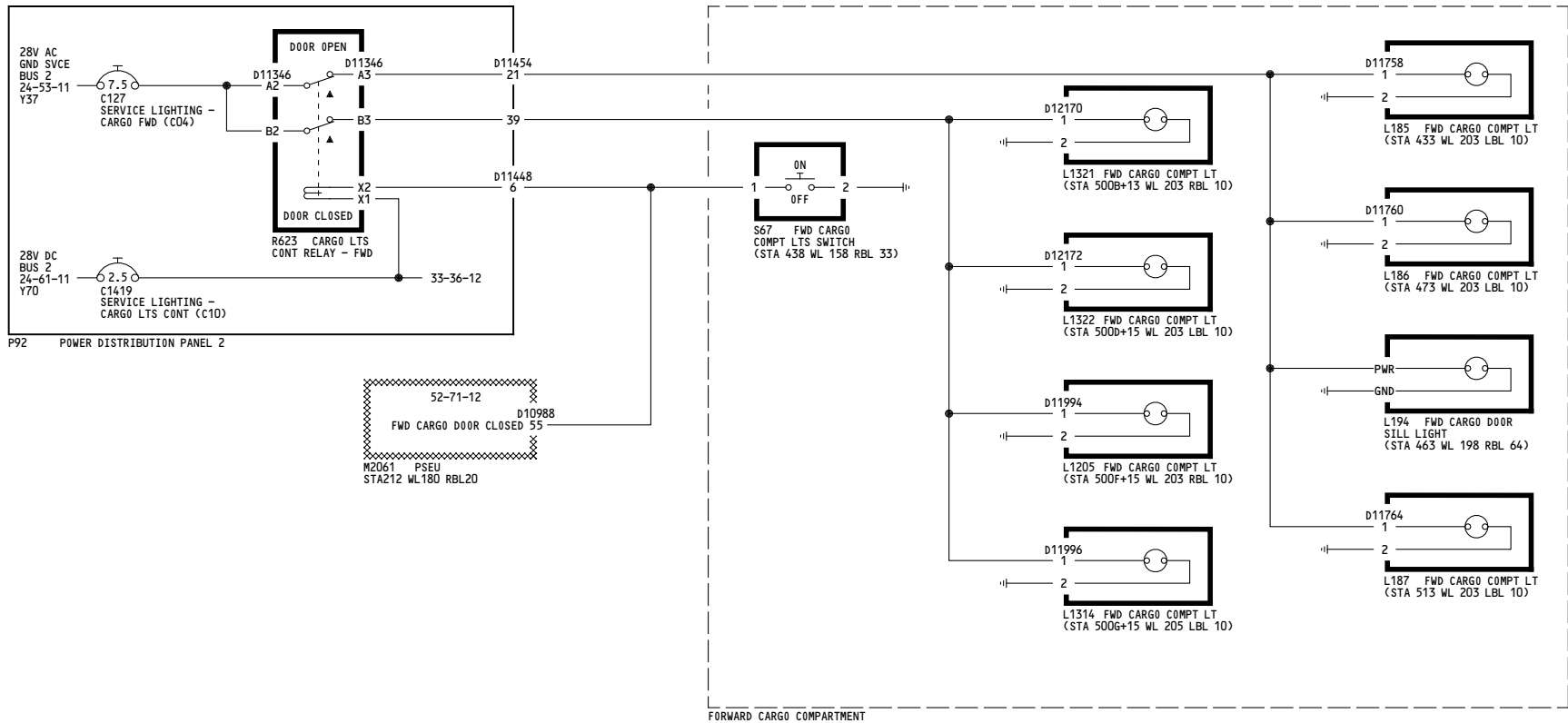

YC001-YL430	<p align="center">SERVICE LIGHTING - CARGO COMPARTMENT - FWD</p> <p align="center">D280A203</p>
-------------	--

33-36-11

Page 101

Feb 09/2009

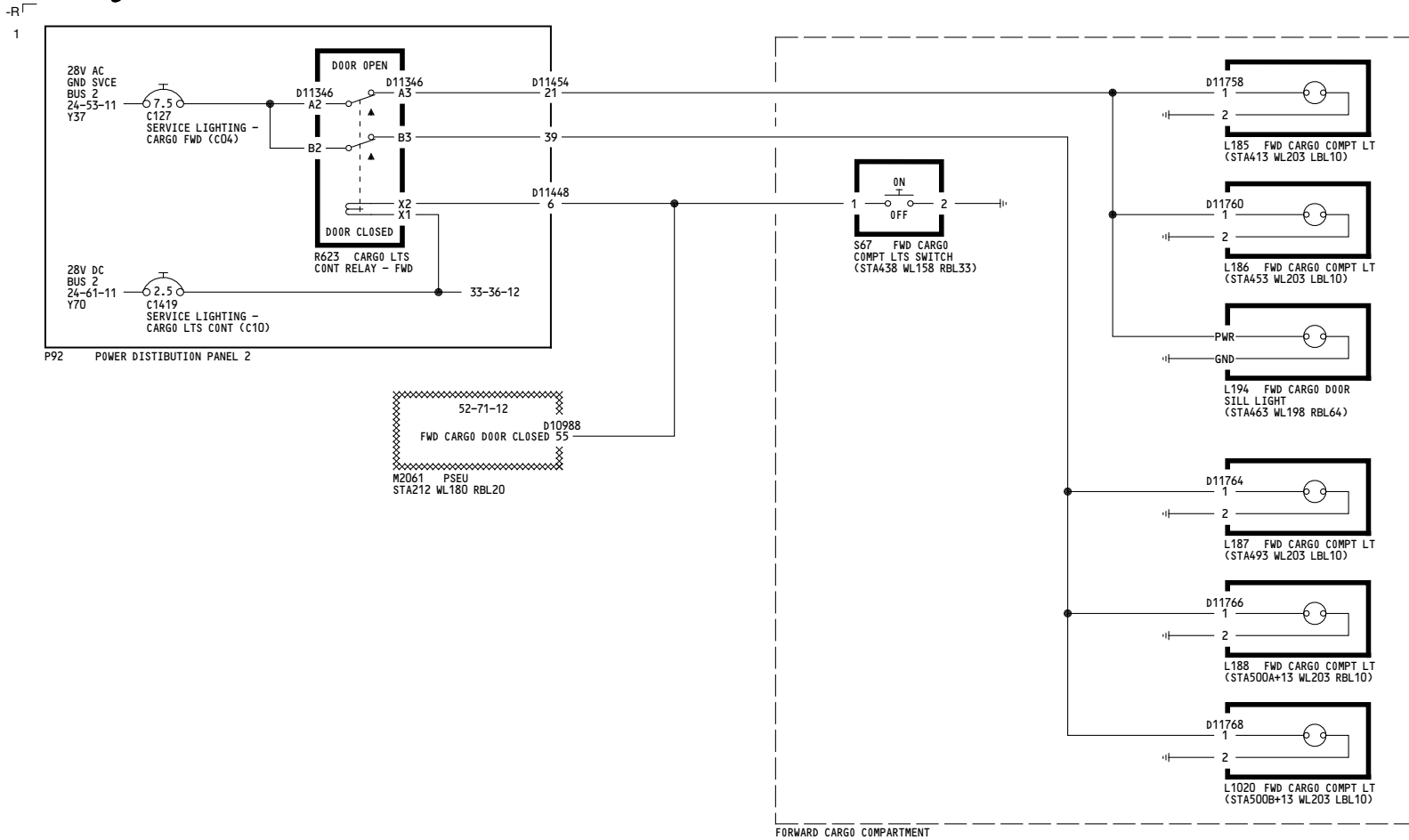

YM643-YM670	<p align="center">SERVICE LIGHTING - CARGO COMPARTMENT - FWD</p> <p align="center">D280A203</p>
-------------	--

-G
2

WIRING DIAGRAMS
33-36-11

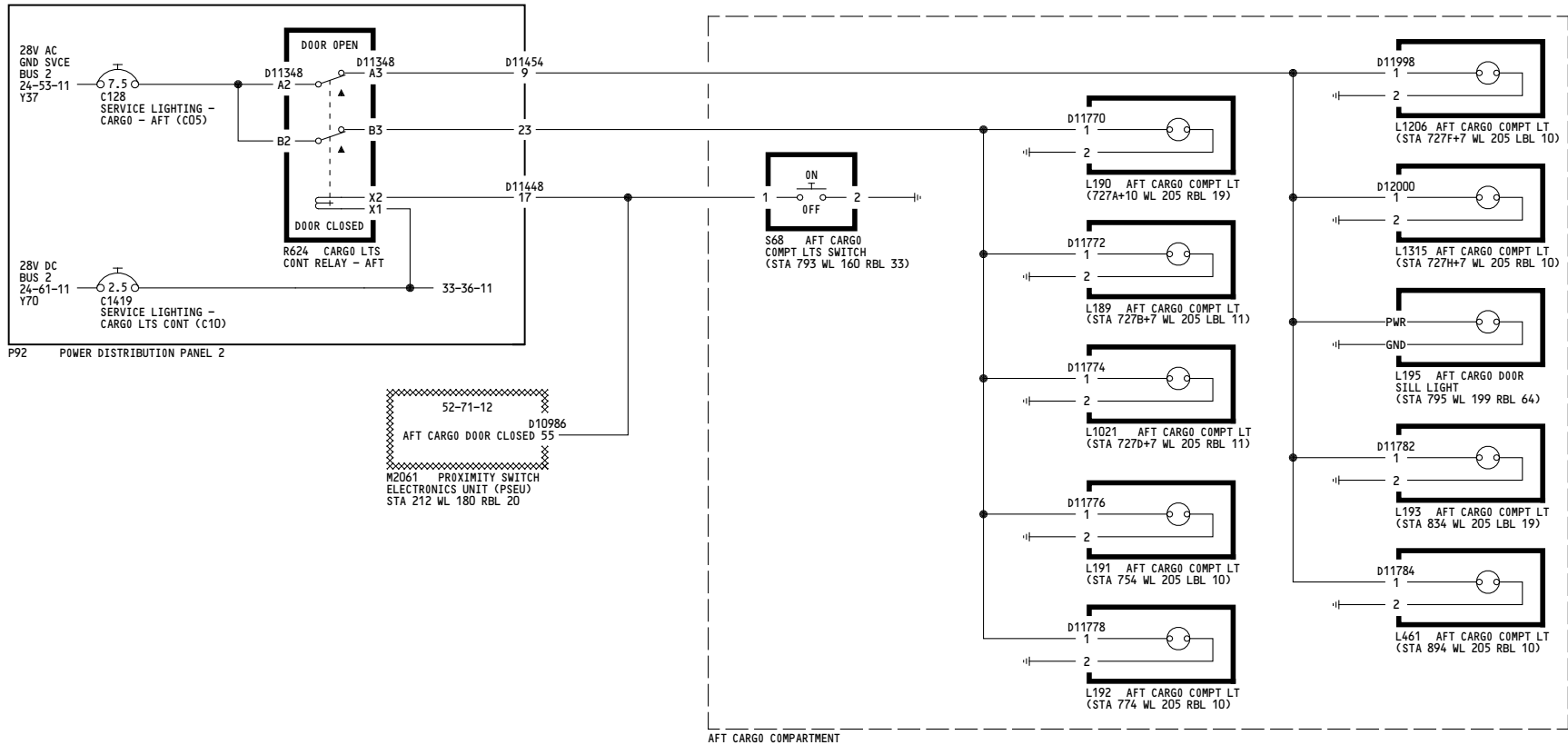

YC001-YL430	<p align="center">SERVICE LIGHTING - CARGO COMPARTMENT - AFT</p> <p align="center">D280A203</p>
-------------	--

33-36-12

Page 101

Feb 09/2009

-N
1

WIRING DIAGRAMS
33-36-11

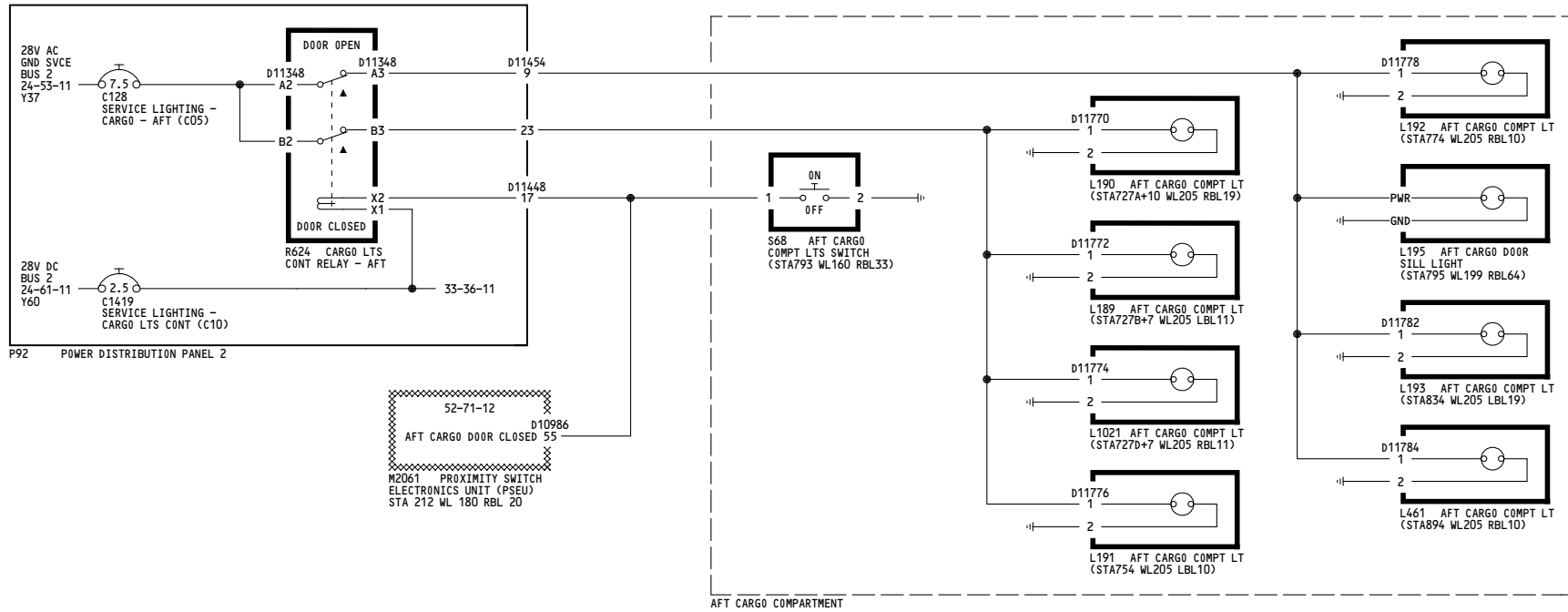

YM643-YM670

SERVICE LIGHTING - CARGO COMPARTMENT - AFT

D280A203

33-36-12

Page 102

Jan 14/2008

5

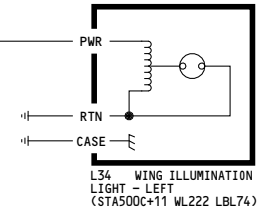
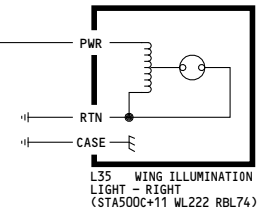
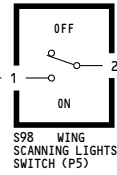
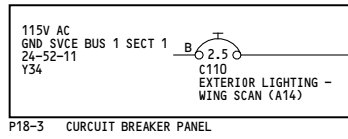

YC001-YL430	<p>EXTERIOR LIGHTS - WING SCANNING</p> <p>D280A203</p>
-------------	---

-G
1

WIRING DIAGRAMS
33-41-11

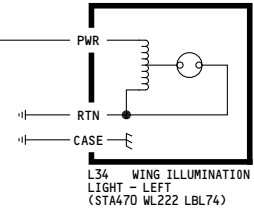
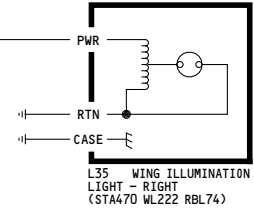
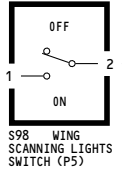
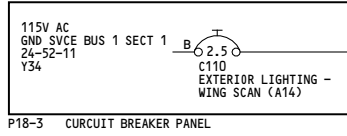

YM643-YM670	<p>EXTERIOR LIGHTS - WING SCANNING</p> <p>D280A203</p>
-------------	---

33-41-11

Page 102

Jan 14/2008

WIRING DIAGRAMS
33-42-11

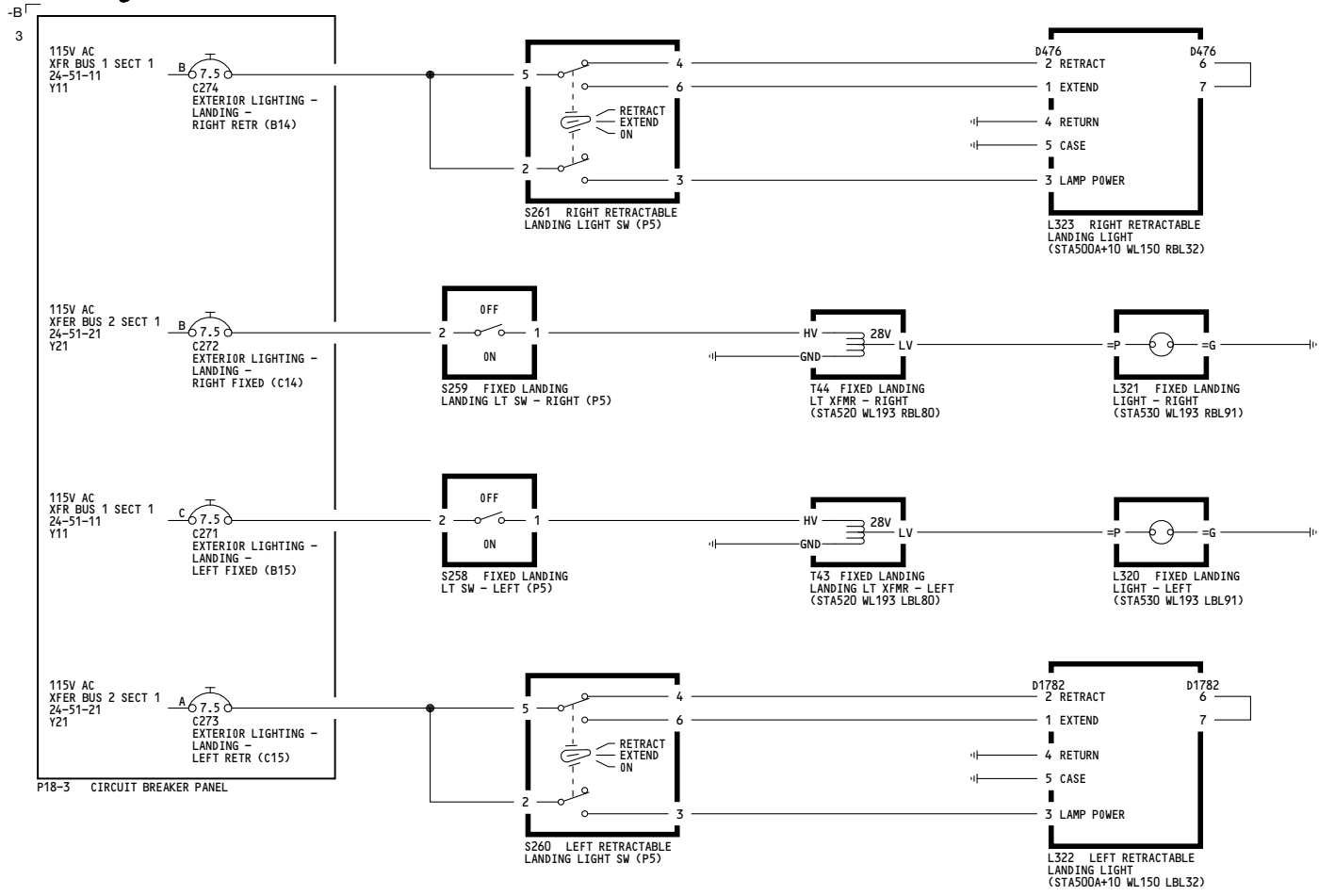

ALL	<p>EXTERIOR LIGHTS - LANDING</p> <p>D280A203</p>
-----	---

33-42-11

Page 101

Feb 09/2009

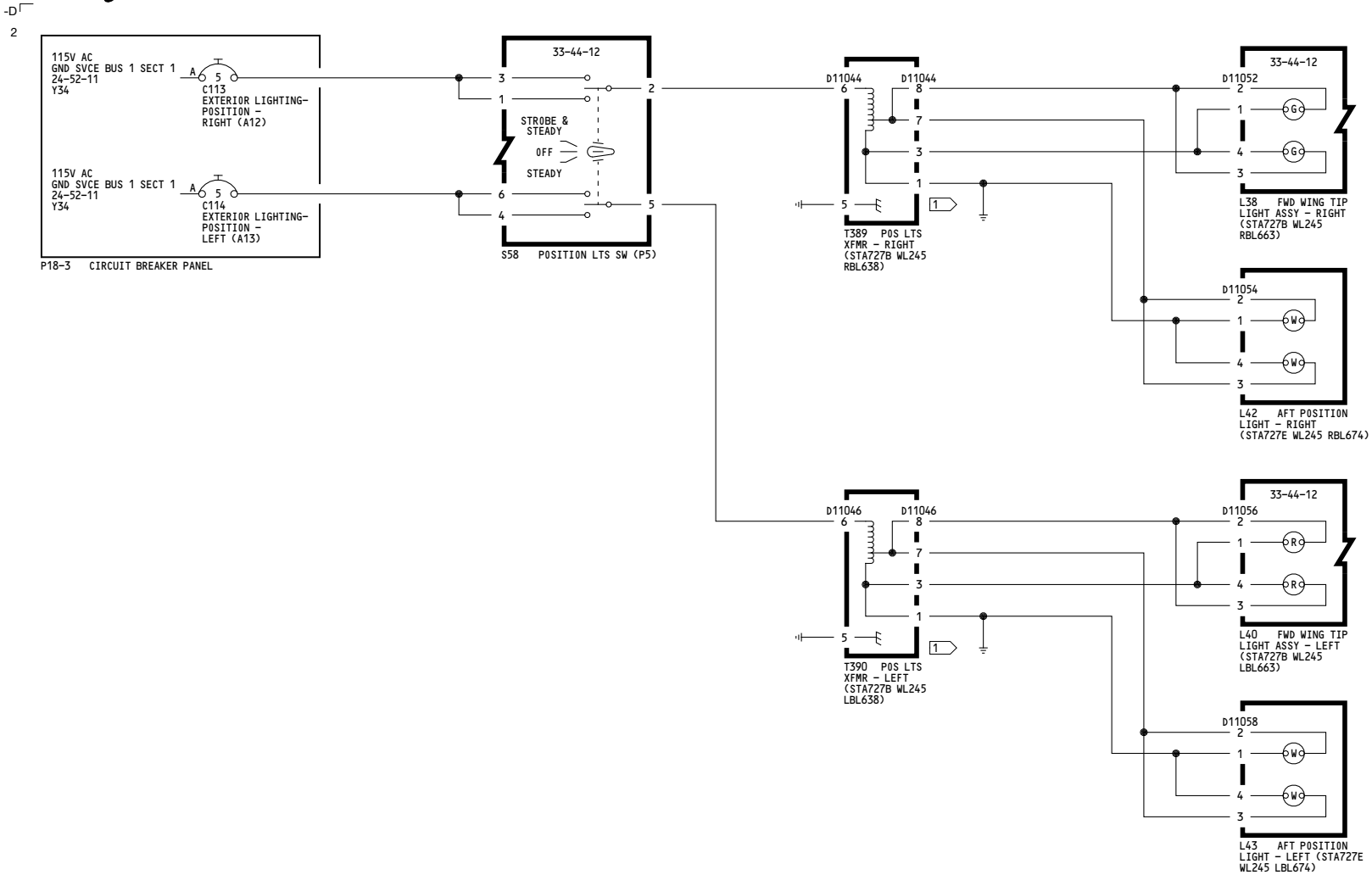

NOTES:
 1 TRANSFORMER FT1246 OUTPUT VOLTAGE IS (10V) AND PRR38275-14 CHANGES TRANSFORMER TO FT1348 OUTPUT VOLTAGE IS (9V)

YC001-YC050	EXTERIOR LIGHTS - POSITION D280A203
-------------	---

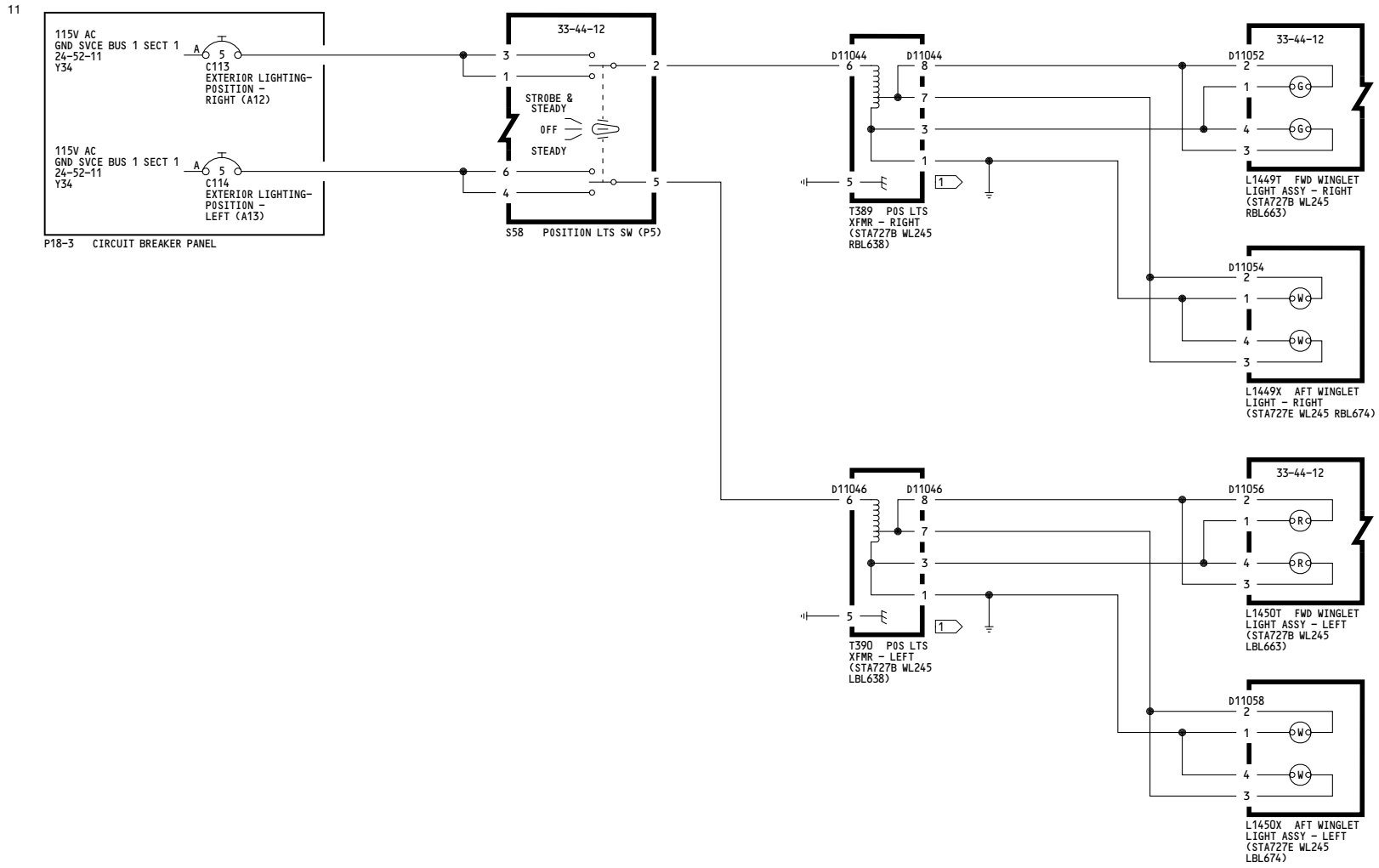

NOTES:

1 TRANSFORMER FT1246 OUTPUT VOLTAGE IS (10V) AND PRR38275-14 CHANGES TRANSFORMER TO FT1348 OUTPUT VOLTAGE IS (9V)

YC001-YC010, YC012-YC030	<p align="center">EXTERIOR LIGHTS - POSITION</p> <p align="center">D280A203</p>
--------------------------	--

Incorporates
PD 0802664

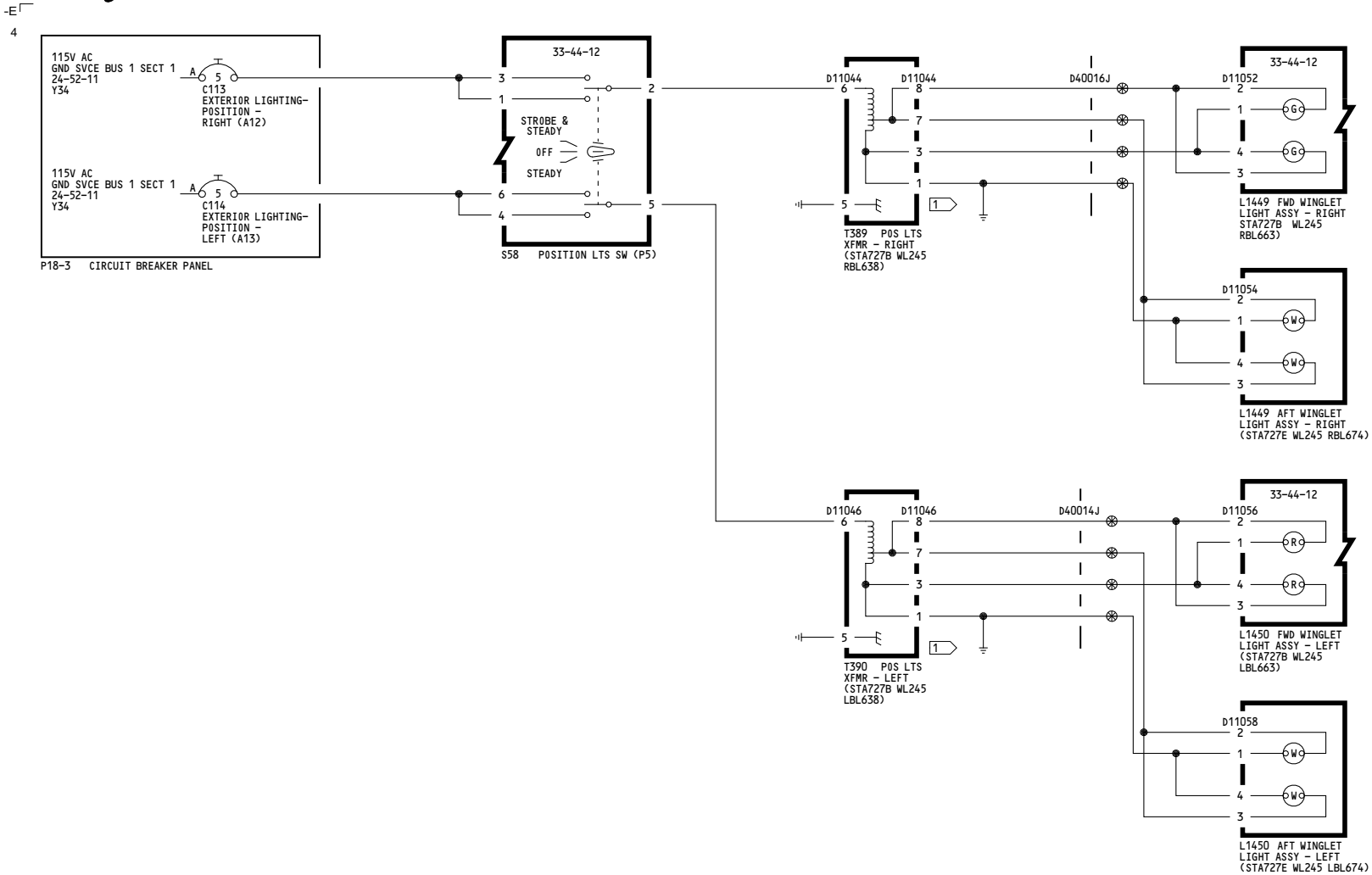

NOTES:
 1 TRANSFORMER FT1246 OUTPUT VOLTAGE IS (10V) AND PRR38275-14 CHANGES TRANSFORMER TO FT1348 OUTPUT VOLTAGE IS (9V)

YK901-YM670	EXTERIOR LIGHTS - POSITION D280A203
-------------	---

-K
1

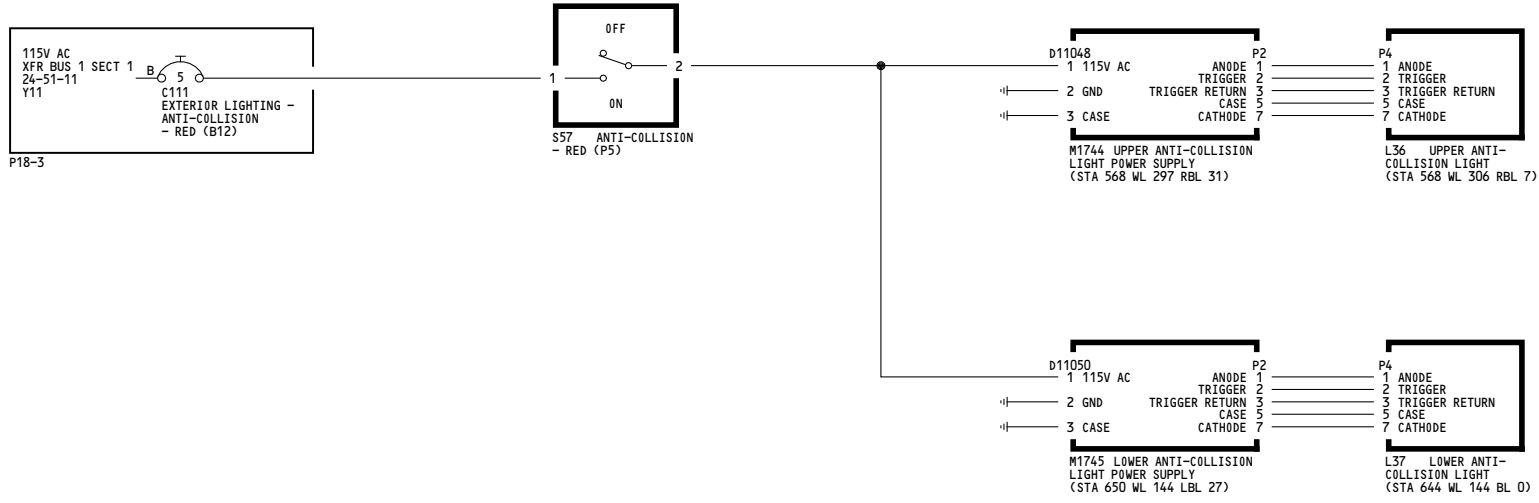

ALL	EXTERIOR LIGHTS - ANTICOLLISION - RED
	D280A203

33-44-11

Page 101

Feb 09/2009

-B
3

WIRING DIAGRAMS
33-44-12

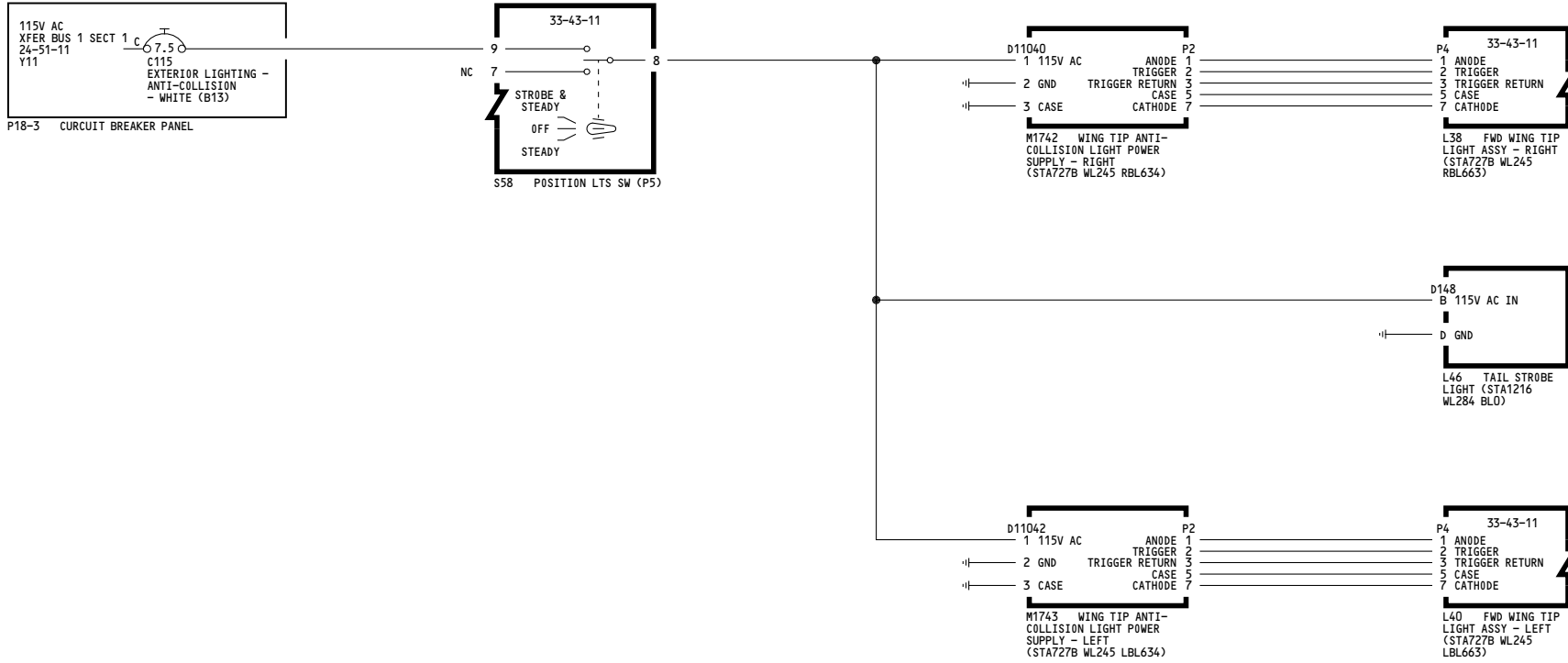

YC001-YC050	<p align="center">EXTERIOR LIGHTS - ANTICOLLISION - WHITE</p> <p align="center">D280A203</p>
-------------	---

33-44-12

Page 101

Jul 17/2007

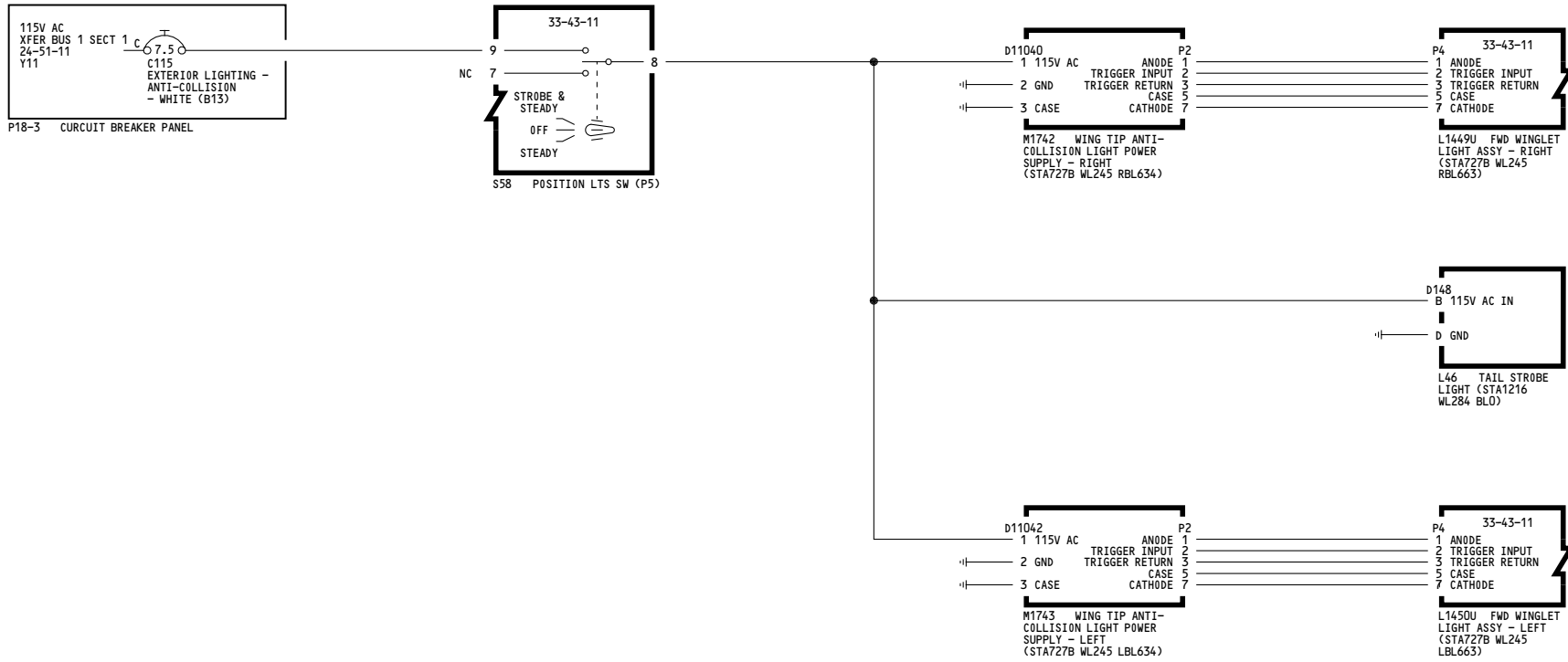

YC001-YC010, YC012-YC030	<p>EXTERIOR LIGHTS - ANTICOLLISION - WHITE</p> <p>D280A203</p>
--------------------------	---

Incorporates
PD 0802664

33-44-12

Page 101.1

May 13/2008

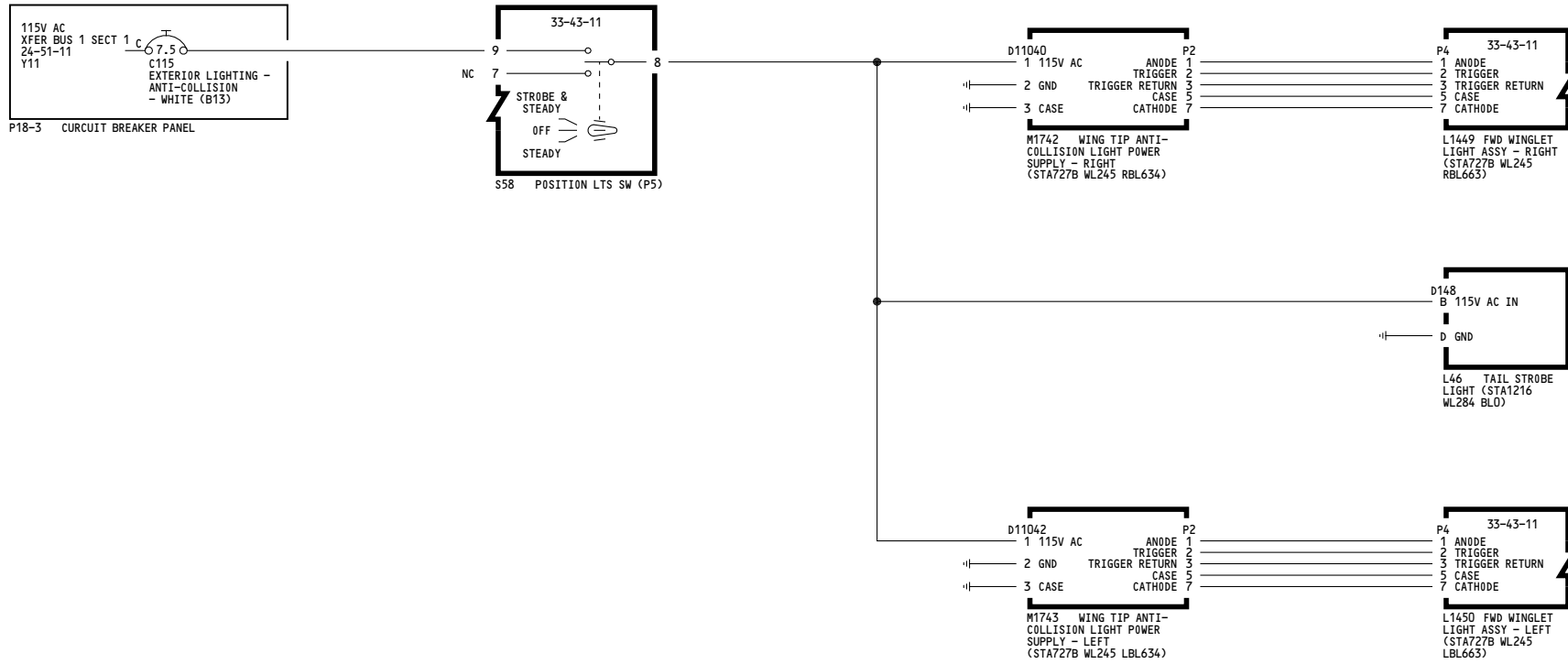

YK901-YK912, YK918-YK919, YL401-YL429, YM643-YM652	EXTERIOR LIGHTS - ANTICOLLISION - WHITE
	D280A203

1

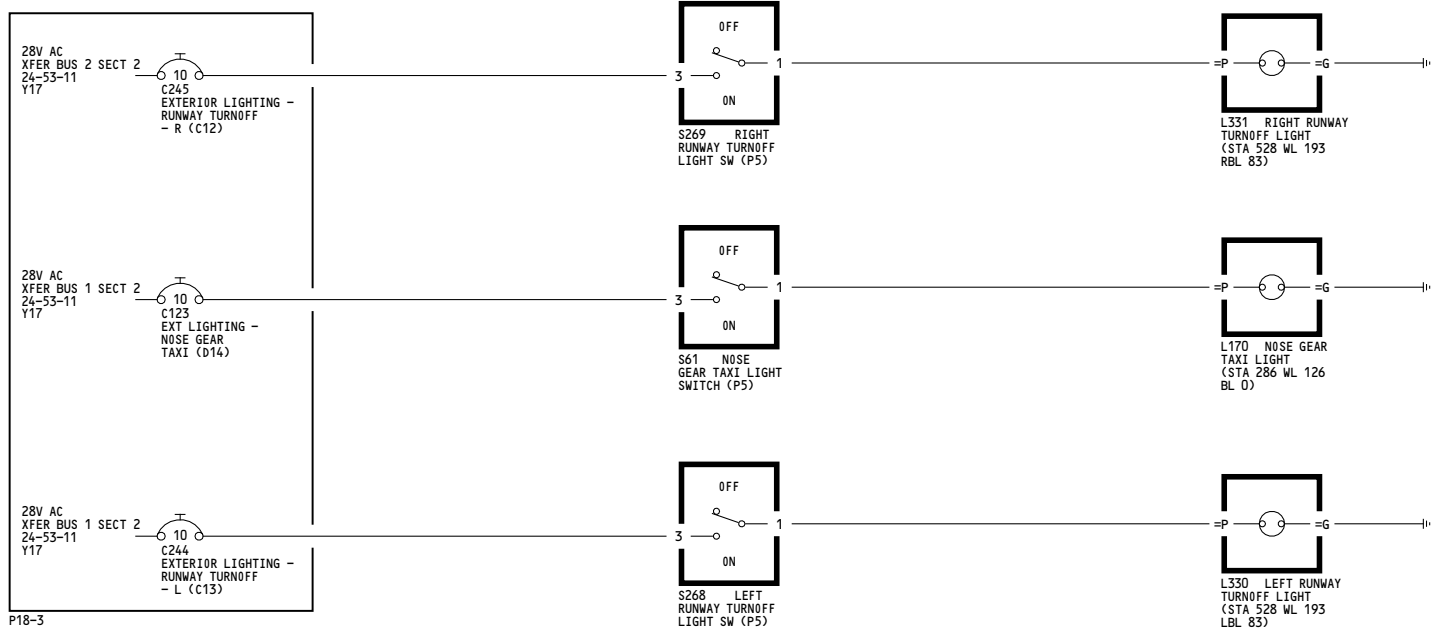

P18-3

<p>YC001-YC050</p>	<p>EXTERIOR LIGHTS - TAXI AND RUNWAY TURNOFF</p> <p>D280A203</p>
--------------------	---

33-45-11

Page 101

Jul 17/2007

-A
9

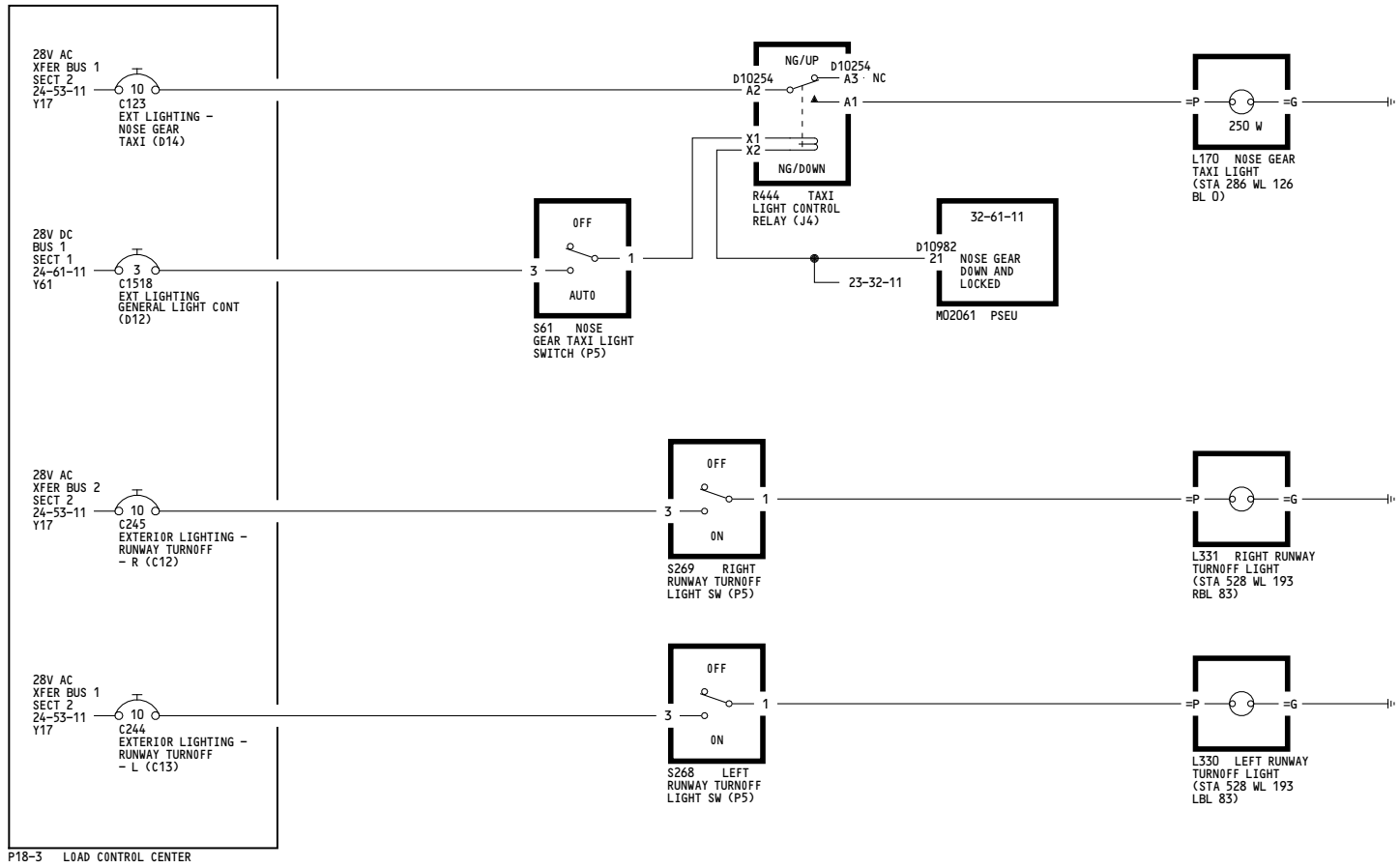

YK901-YM670	<p>EXTERIOR LIGHTS - TAXI AND RUNWAY TURNOFF</p> <p>D280A203</p>
-------------	---

-L
1

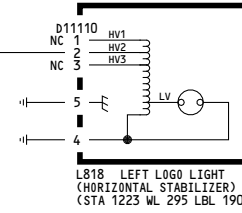
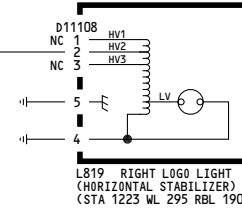
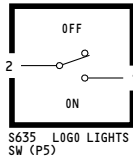
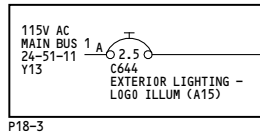

115V INTO	LV	LAMP LIFE	LIGHT OUTPUT
HV1	11.5	LONGER	DIMMER
HV2	12.0	NOMINAL	NOMINAL
HV3	12.5	SHORTER	BRIGHTER

ALL	<p>EXTERIOR LIGHTS - STABILIZER (LOGO) FLOOD LIGHTS</p> <p>D280A203</p>
-----	--

THIS PAGE INTENTIONALLY LEFT BLANK

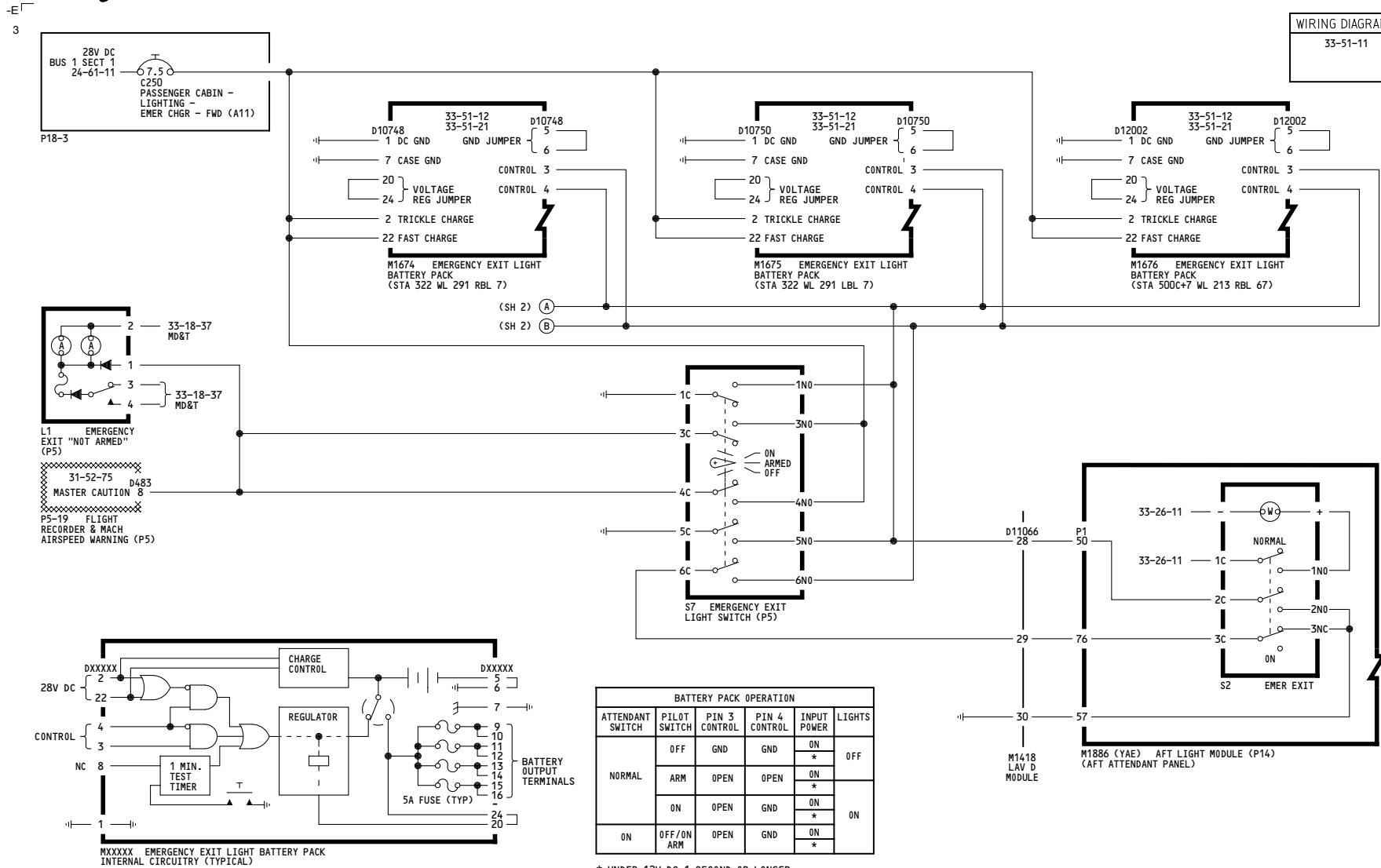

YC001-YC050

EMERGENCY EXIT LIGHTS - CONTROL

D280A203

33-51-11

-D
2

WIRING DIAGRAMS
33-51-11

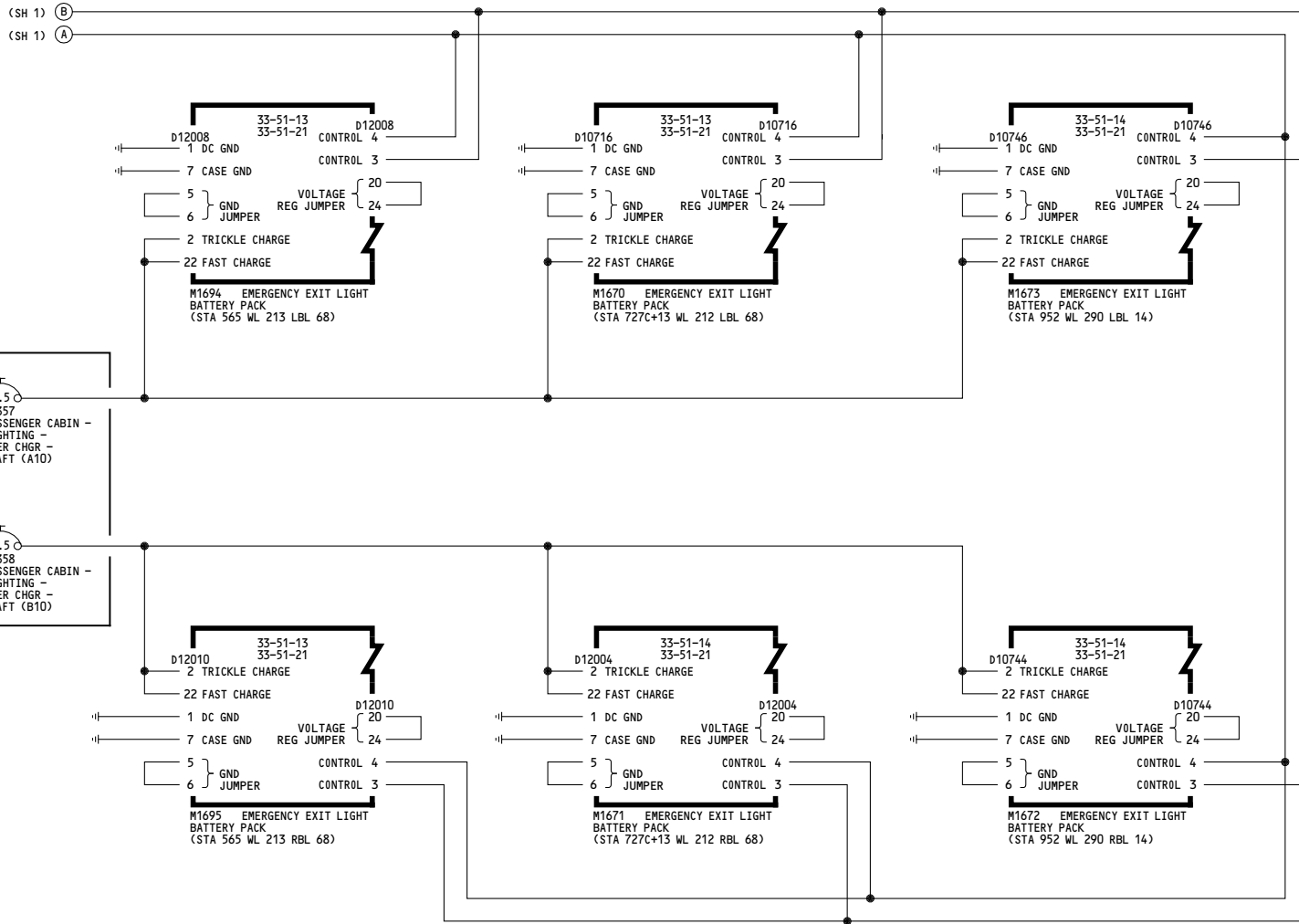

YC001-YC050

**EMERGENCY EXIT LIGHTS -
CONTROL**

D280A203

33-51-11

Page 101
Sheet 2
Jul 17/2007

WIRING DIAGRAMS
33-51-11

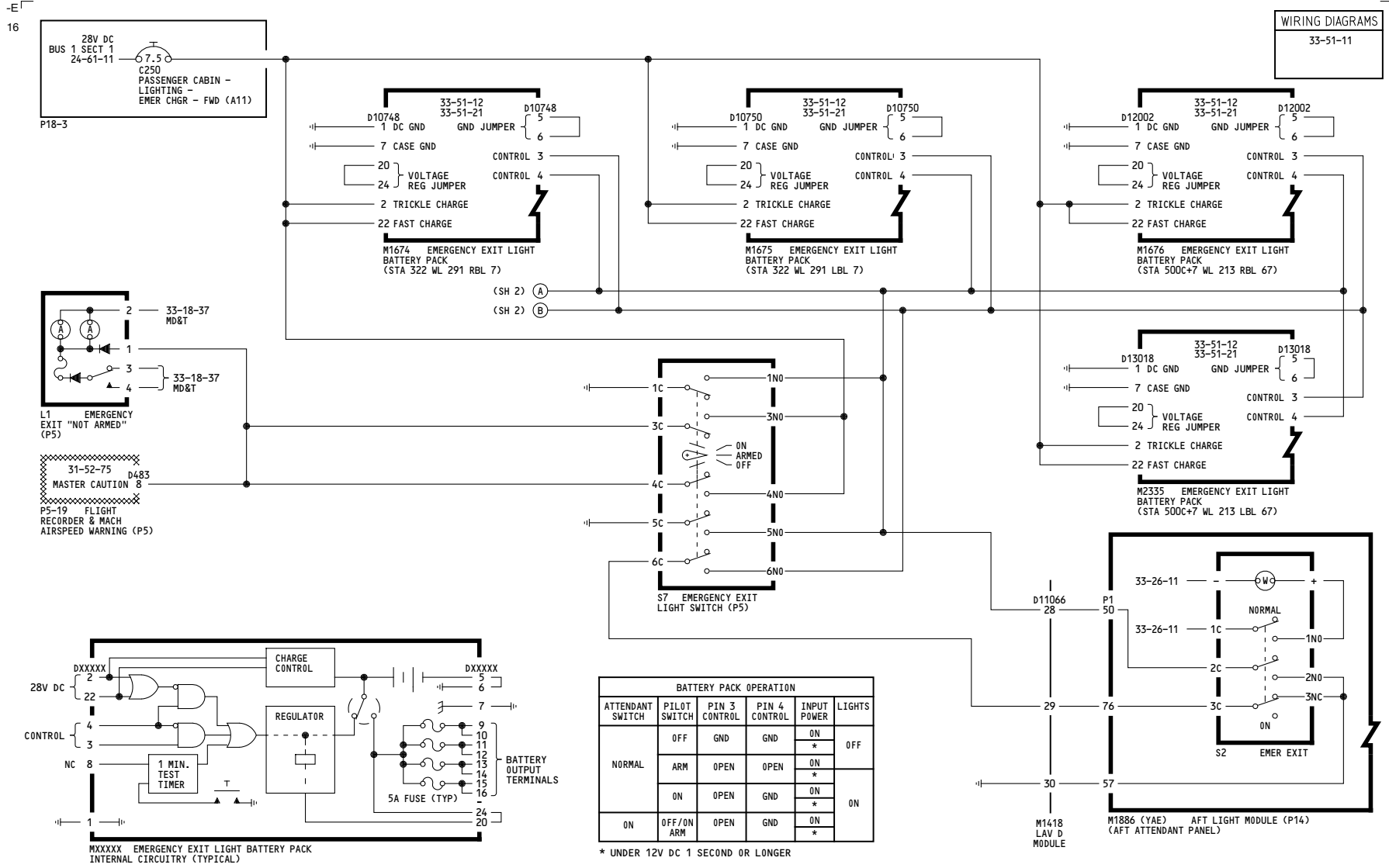

YK901-YL430

EMERGENCY EXIT LIGHTS - CONTROL

D280A203

33-51-11

-D
2

WIRING DIAGRAMS
33-51-11

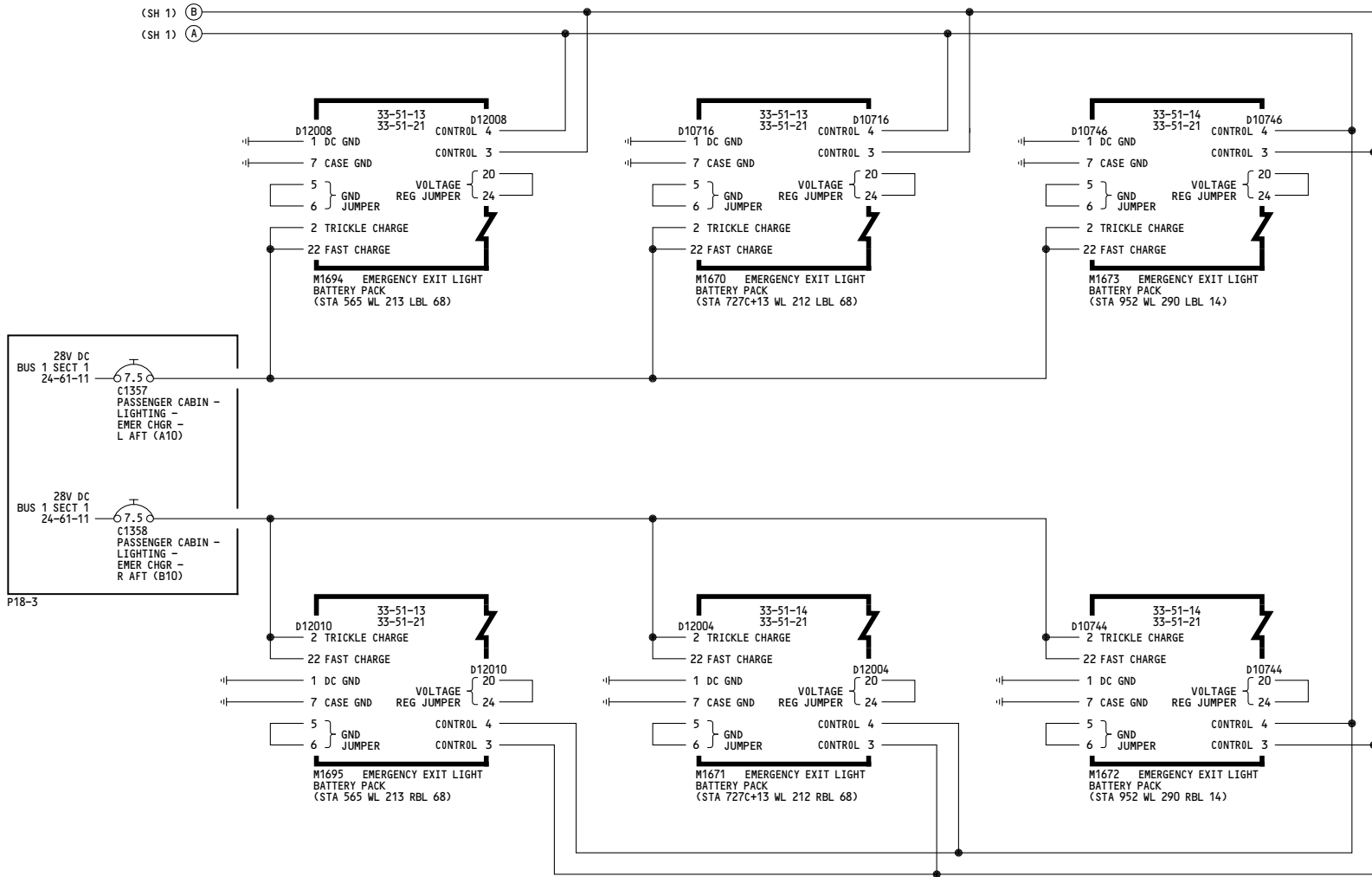

YK901-YL430

EMERGENCY EXIT LIGHTS - CONTROL

D280A203

33-51-11

Page 102
Sheet 2
Feb 09/2009

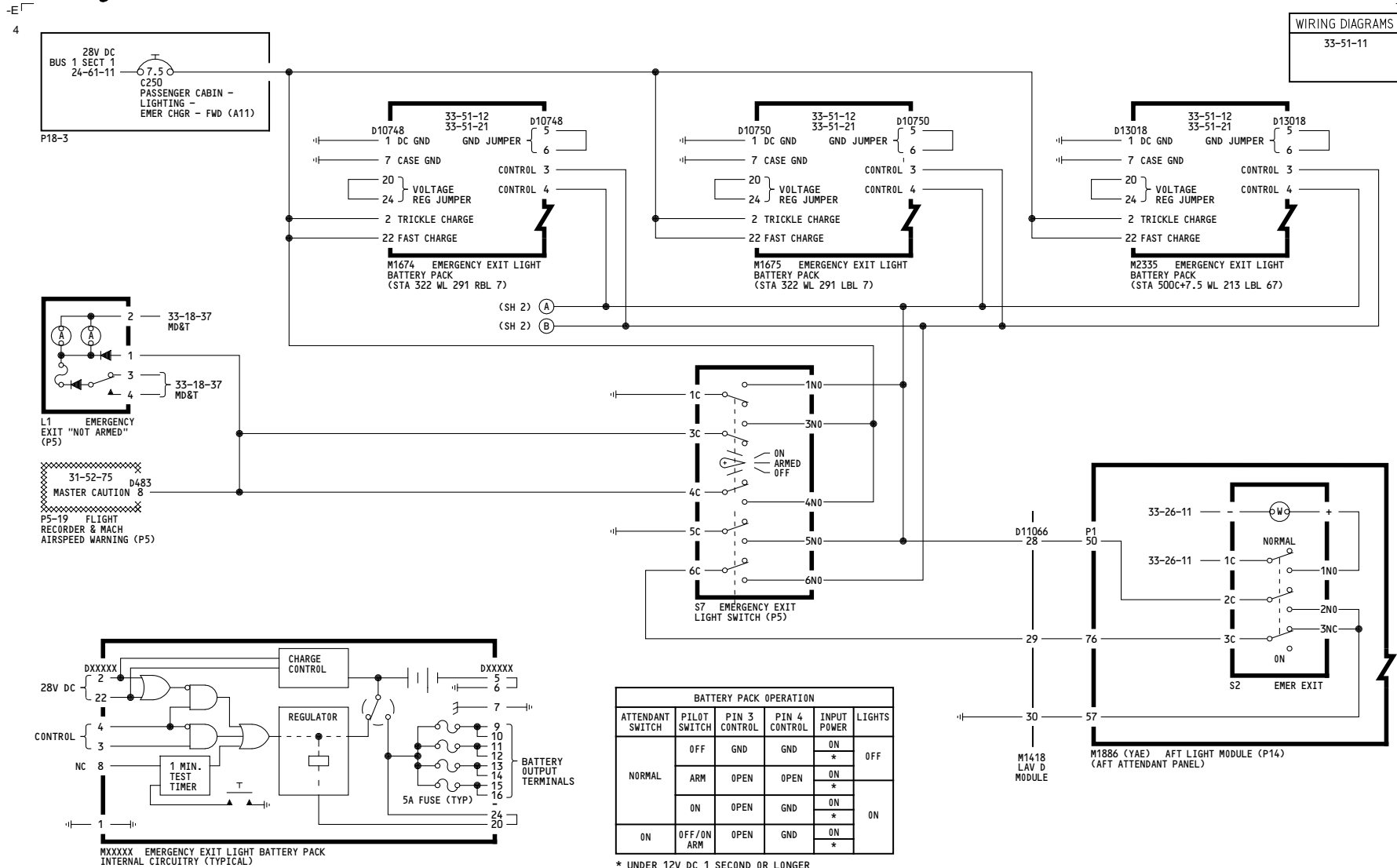

BATTERY PACK OPERATION					
ATTENDANT SWITCH	PILOT SWITCH	PIN 3 CONTROL	PIN 4 CONTROL	INPUT POWER	LIGHTS
NORMAL	OFF	GND	GND	ON	OFF
	ARM	OPEN	OPEN	ON	*
	ON	OPEN	GND	ON	*
ON	OFF/ON ARM	OPEN	GND	ON	ON

* UNDER 12V DC 1 SECOND OR LONGER

YM643-YM670

EMERGENCY EXIT LIGHTS - CONTROL

D280A203

33-51-11

-K
1

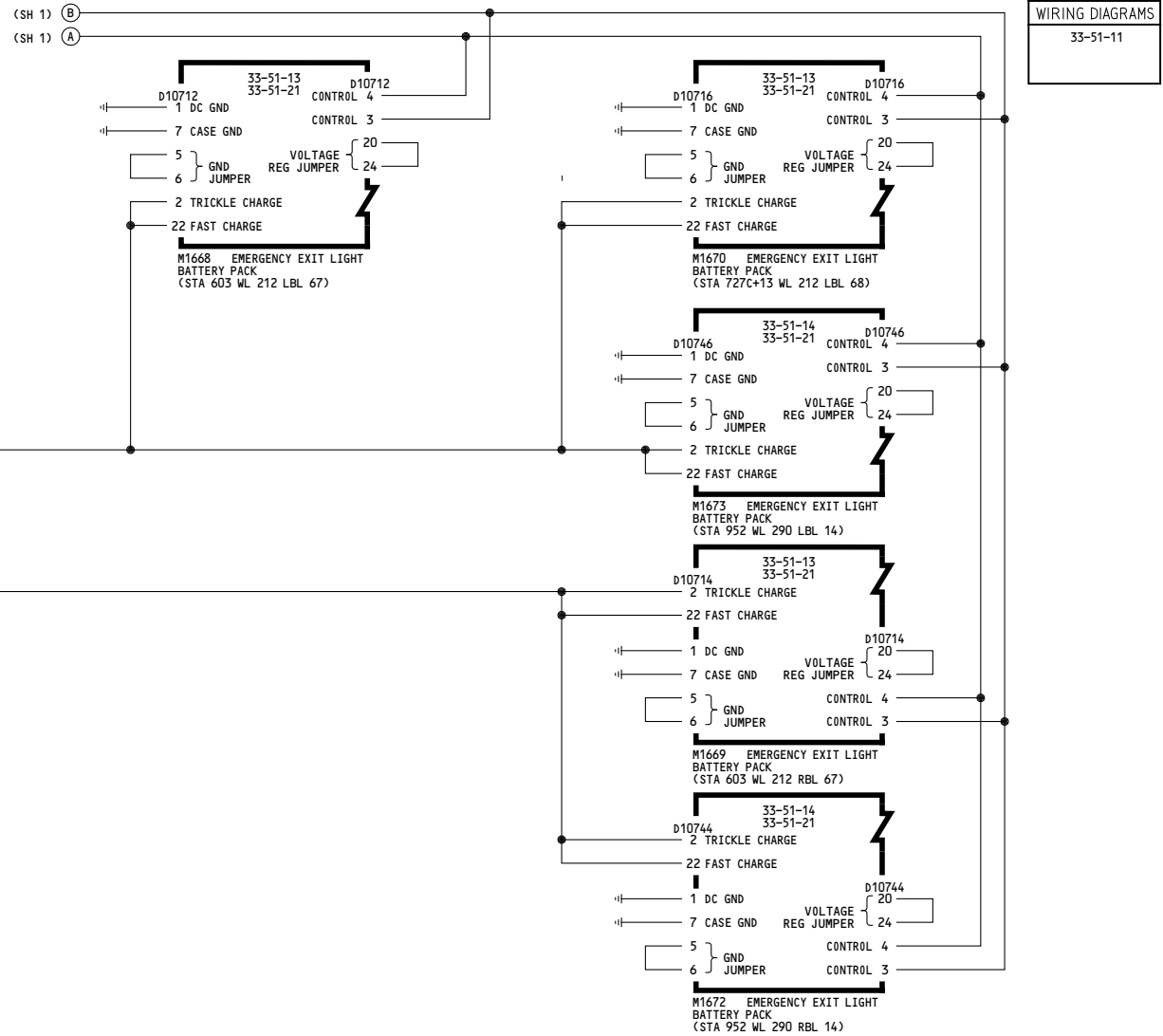

YM643-YM670	<p align="center">EMERGENCY EXIT LIGHTS - CONTROL</p> <p align="center">D280A203</p>
-------------	---

33-51-11

-G
2

WIRING DIAGRAMS
33-51-12

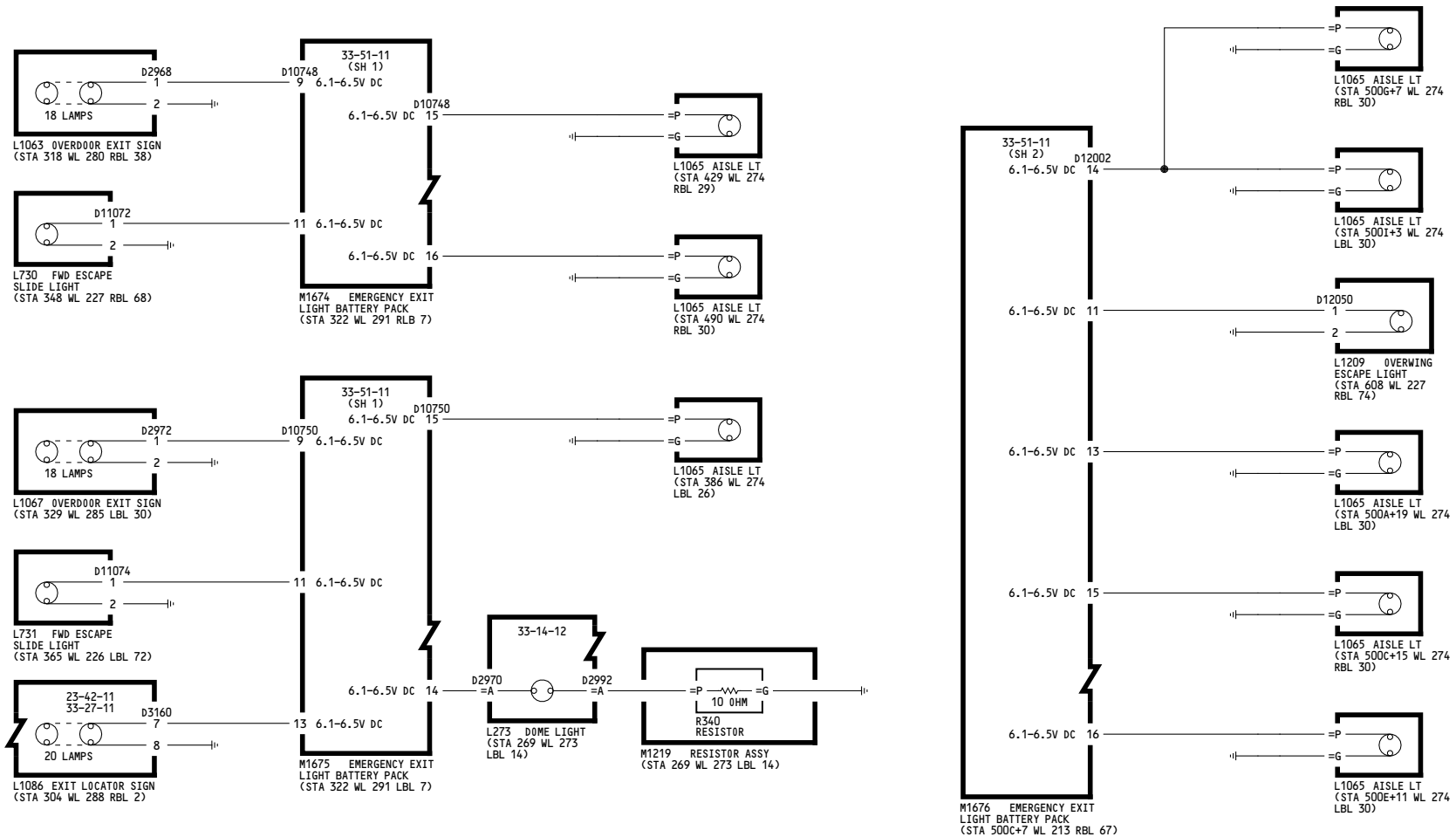

<p>YC001-YC050</p>	<p>EMERGENCY EXIT LIGHTS - FORWARD</p> <p>D280A203</p>
--------------------	---

33-51-12

Page 101

Jul 17/2007

-D
58

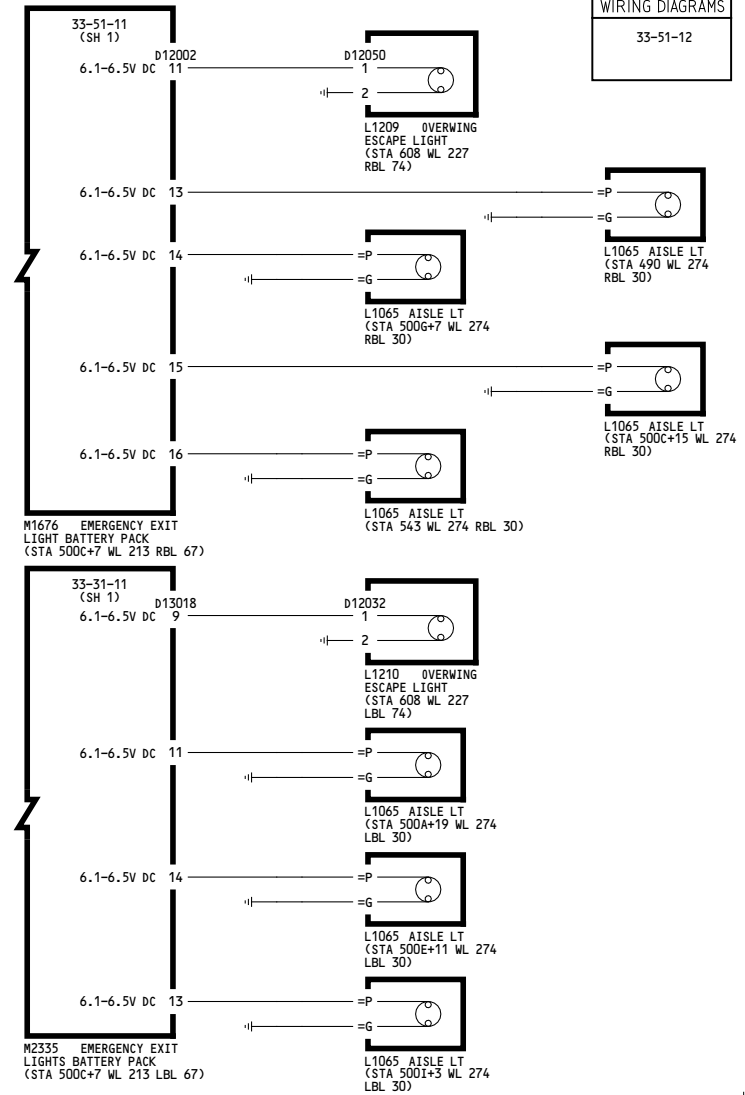
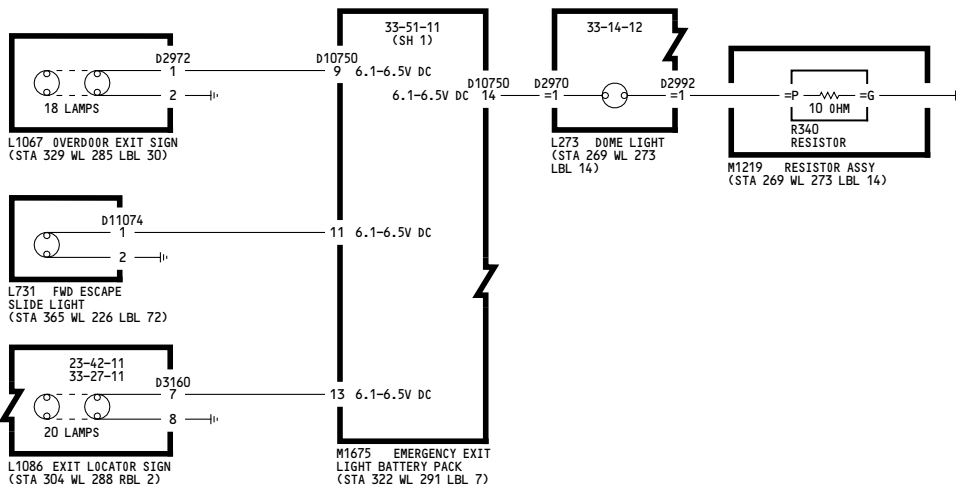
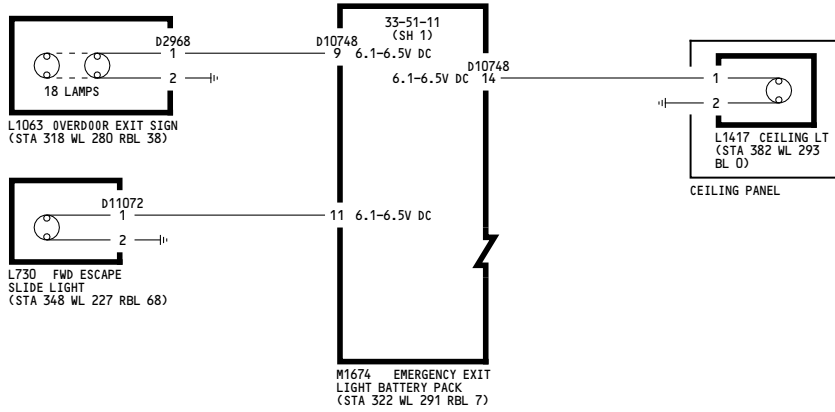

WIRING DIAGRAMS
33-51-12

YK901-YL430

EMERGENCY EXIT LIGHTS - FORWARD

D280A203

33-51-12

Page 102

Feb 09/2009

73

WIRING DIAGRAMS
33-51-12

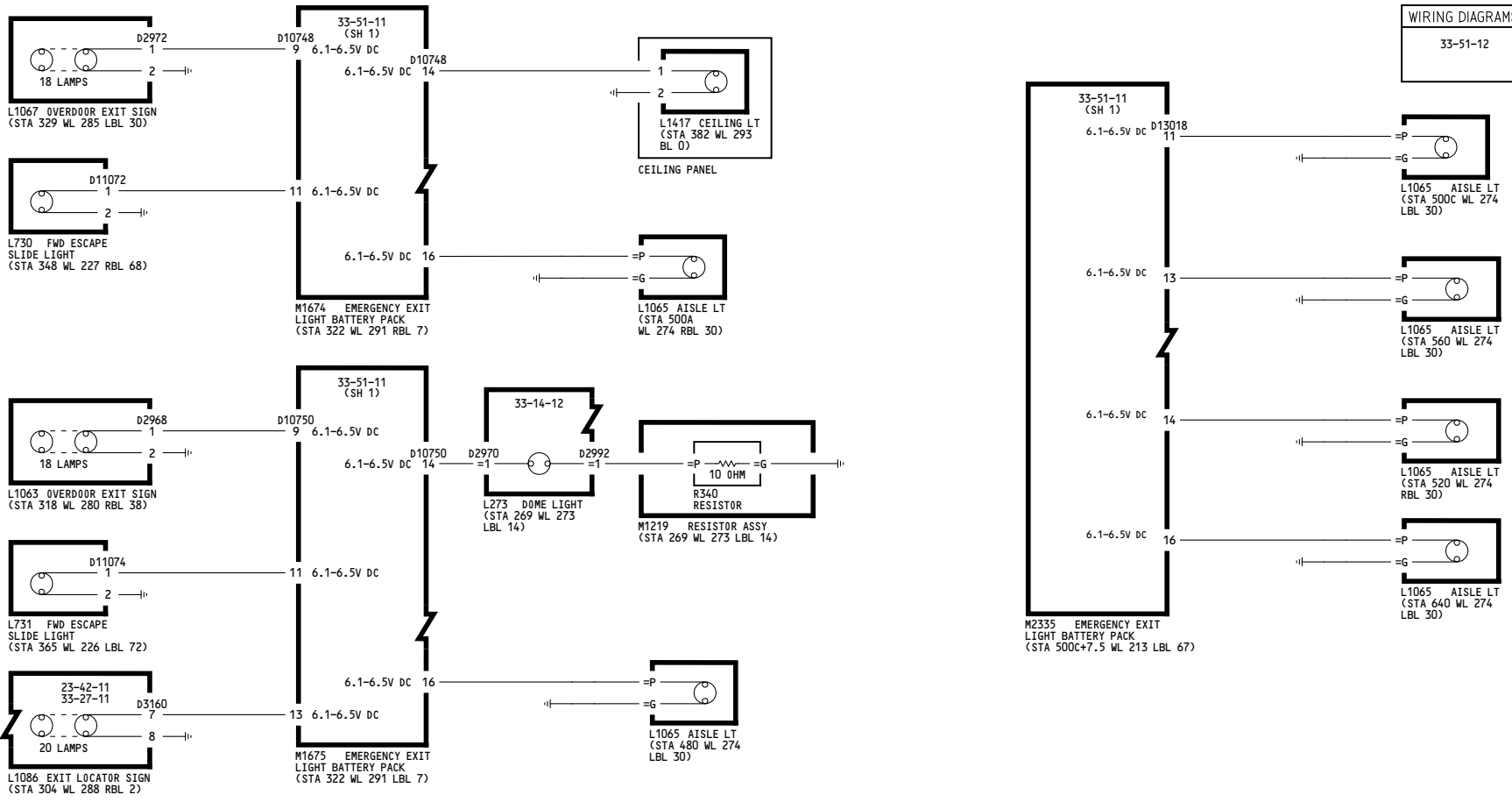

YM643-YM670	<p>EMERGENCY EXIT LIGHTS - FORWARD</p> <p>D280A203</p>
-------------	---

33-51-12

Page 103

Jan 14/2008

-G
12

WIRING DIAGRAMS
33-51-13

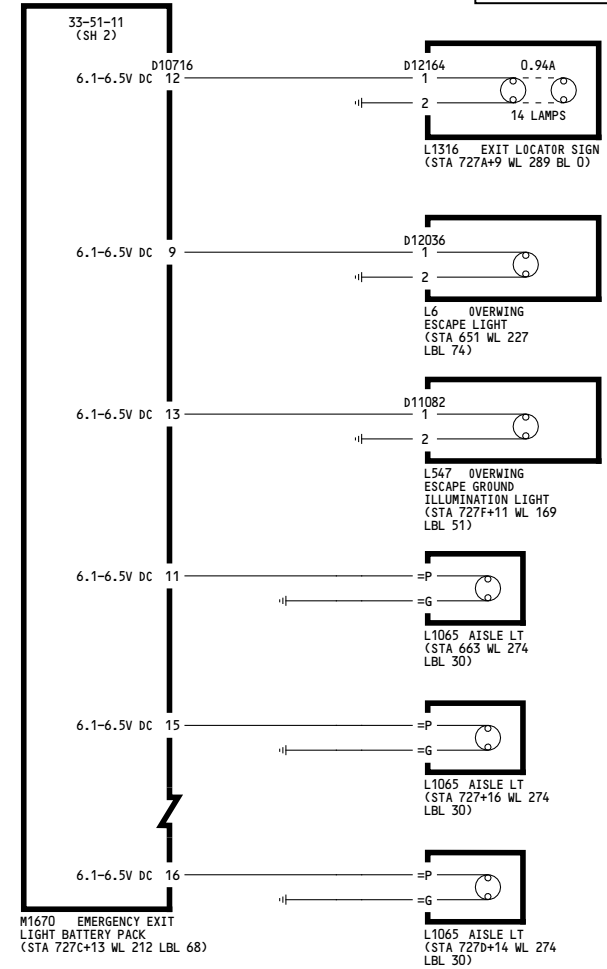
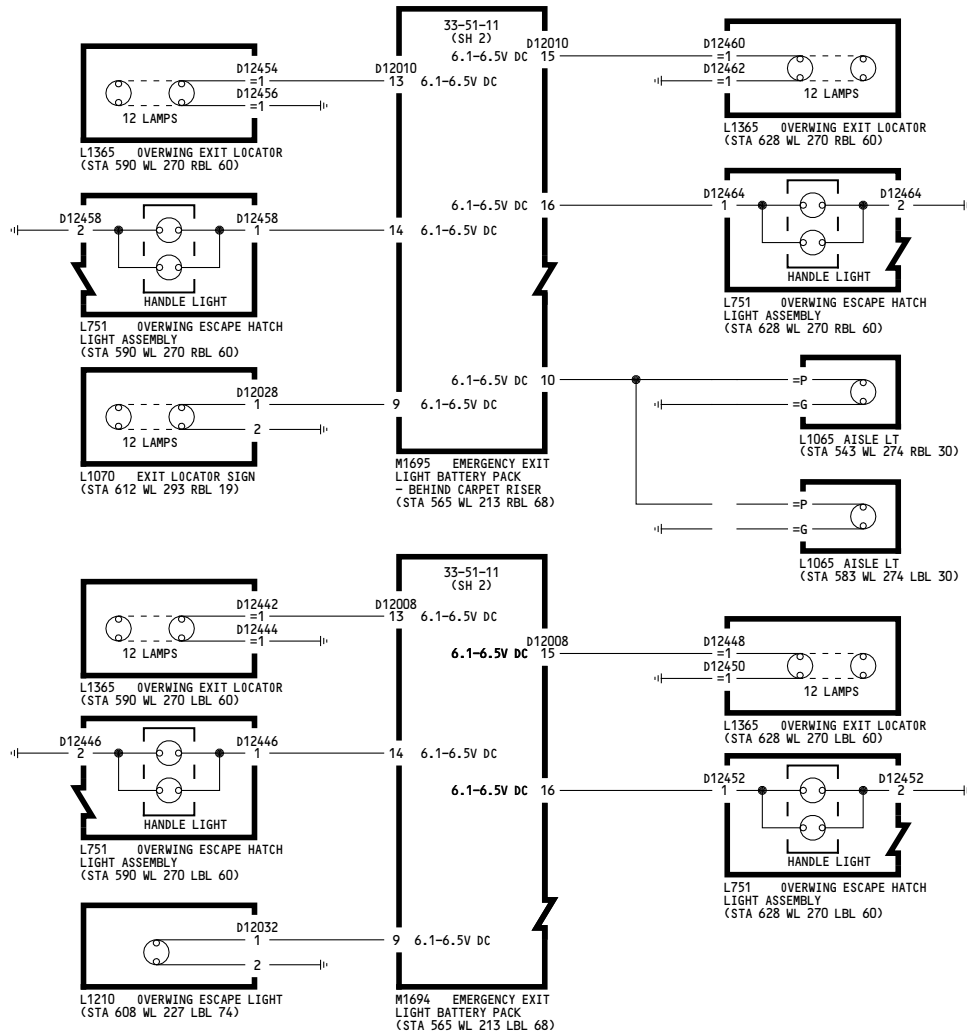

YC001-YC050	<p align="center">EMERGENCY EXIT LIGHTS - MID</p> <p align="center">D280A203</p>
-------------	---

33-51-13

Page 101

Jul 17/2007

-B
71

WIRING DIAGRAMS
33-51-13

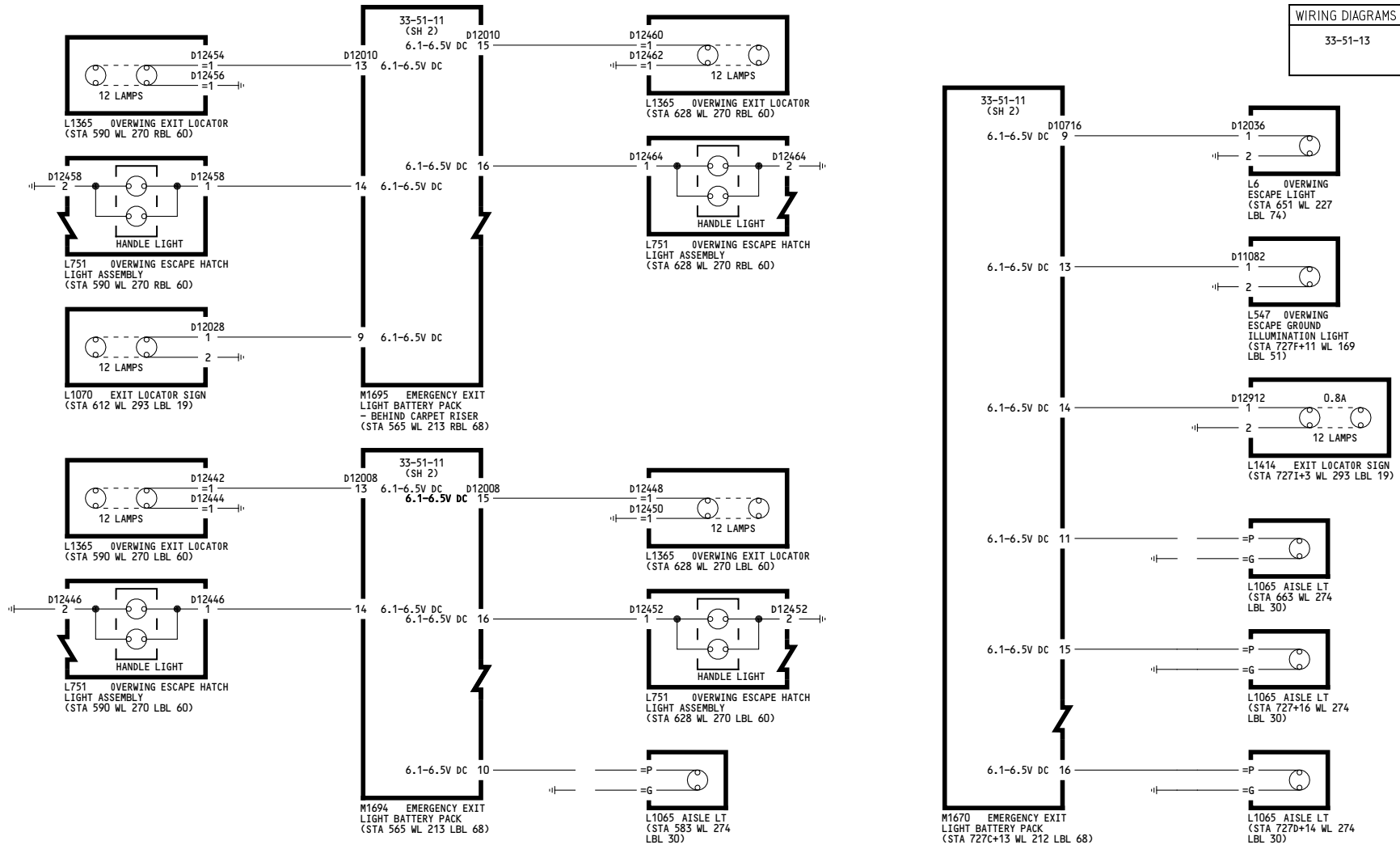

YK901-YK910, YK918, YL421-YL426

EMERGENCY EXIT LIGHTS - MID

D280A203

33-51-13

Page 102

May 11/2009

WIRING DIAGRAMS
33-51-13

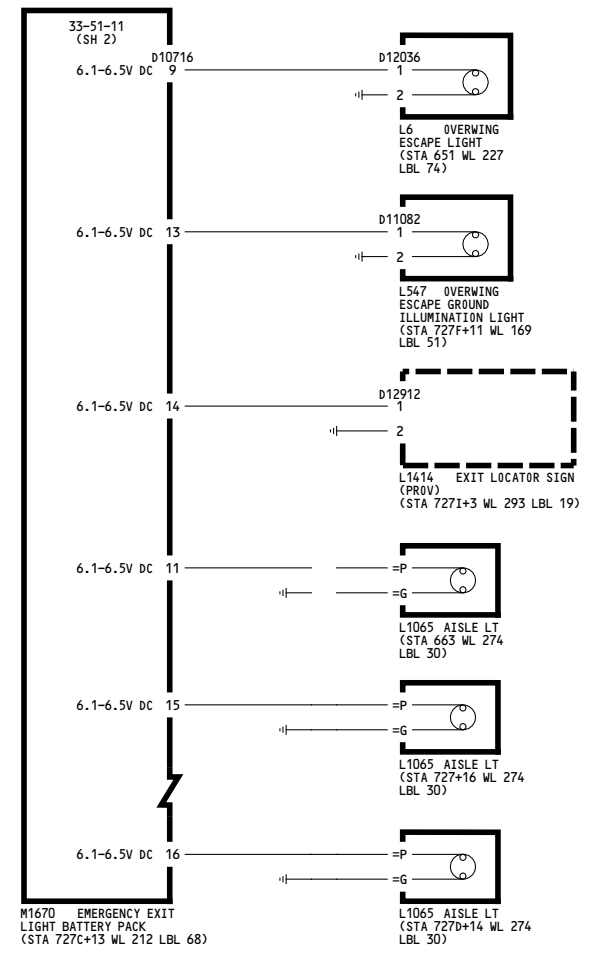
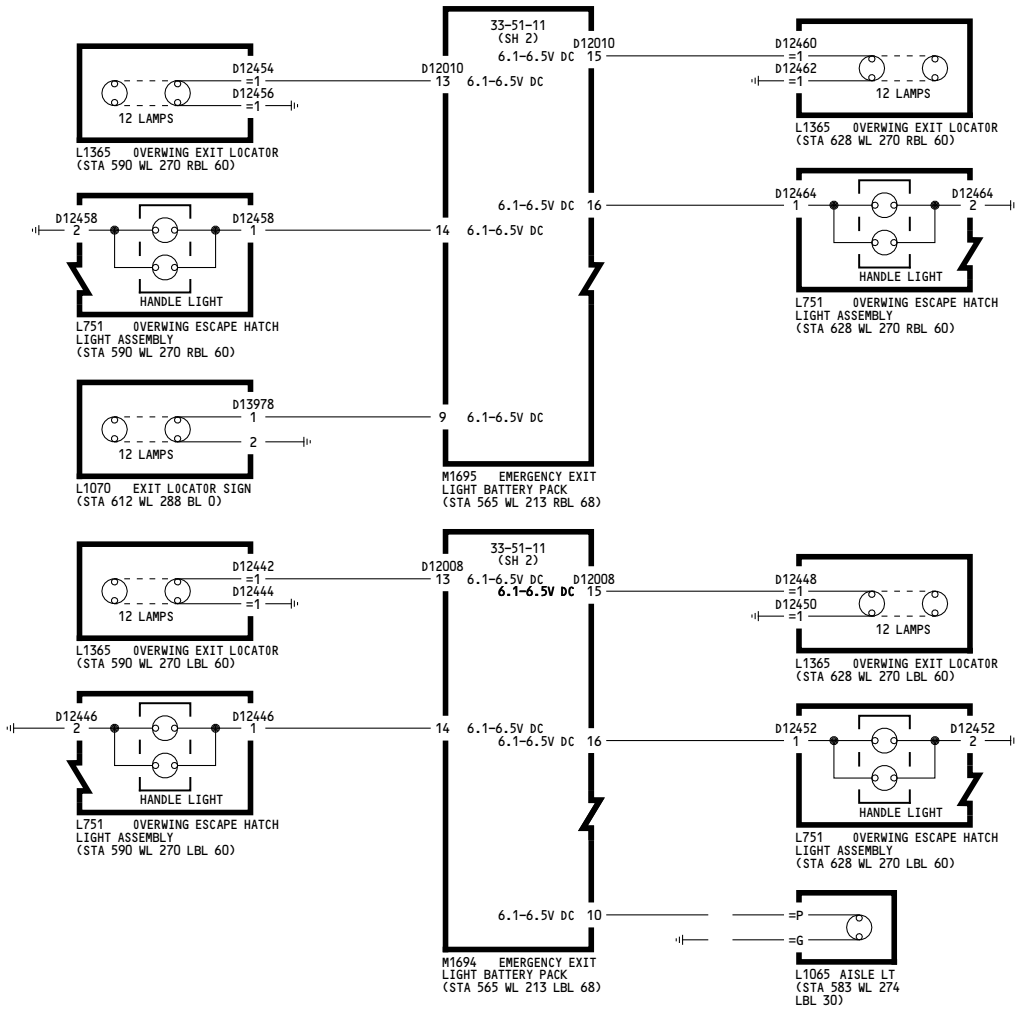

YK911-YK917, YK919-YL401, YL427-YL430

EMERGENCY EXIT LIGHTS - MID

D280A203

33-51-13

WIRING DIAGRAMS
33-51-13

-B
67

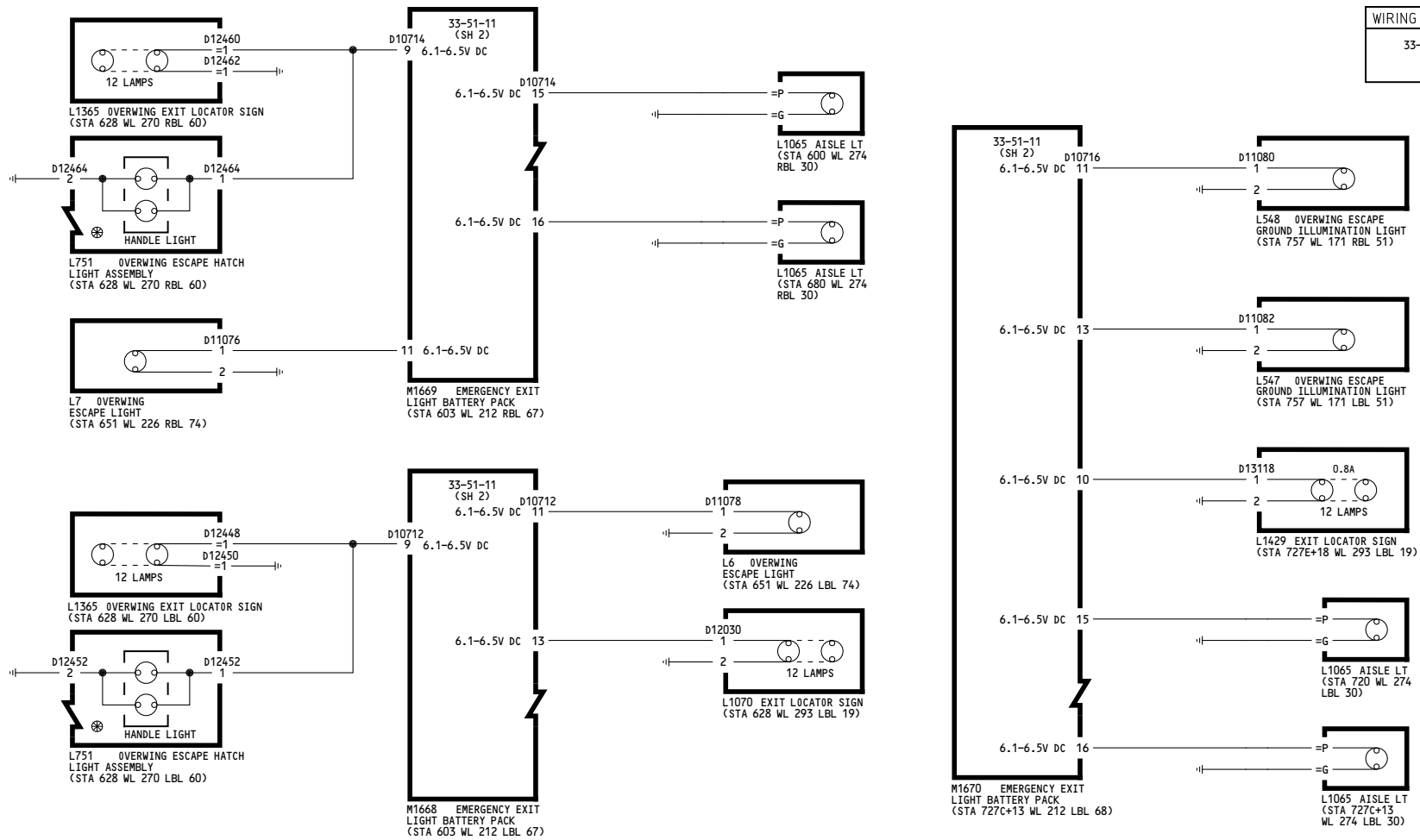

YM643-YM652	<p align="center">EMERGENCY EXIT LIGHTS - MID</p> <p align="center">D280A203</p>
-------------	---

33-51-13

Page 104

Nov 11/2008

WIRING DIAGRAMS
33-51-14

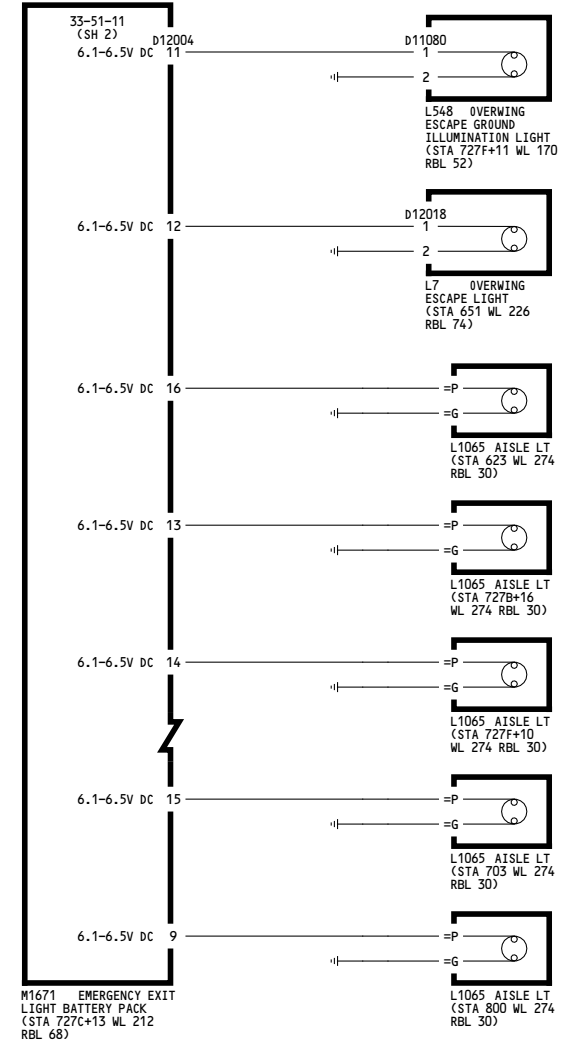
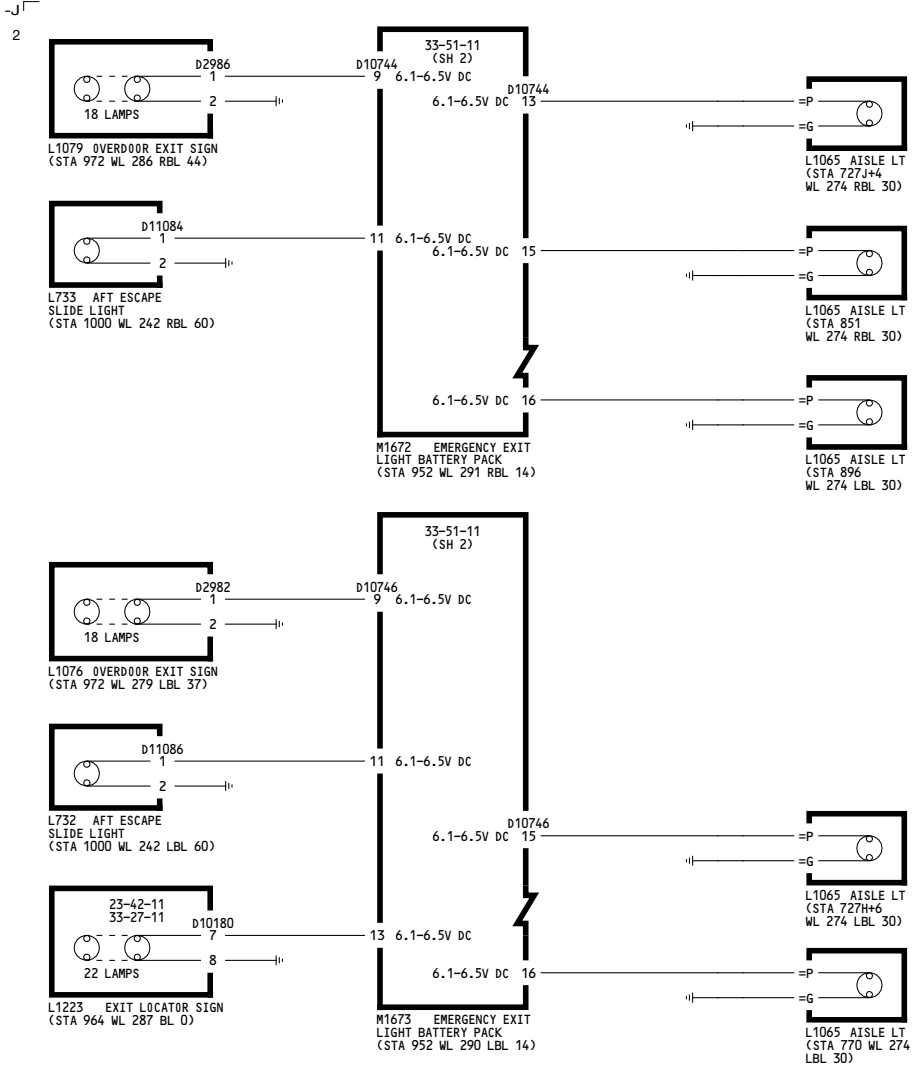

YC001-YC050

EMERGENCY EXIT LIGHTS - AFT

D280A203

33-51-14

WIRING DIAGRAMS
33-51-14

-B
47

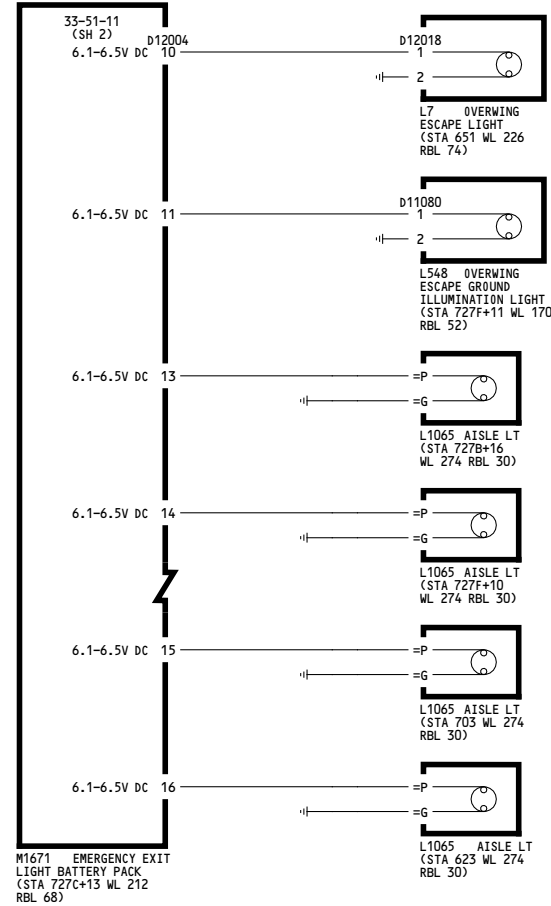
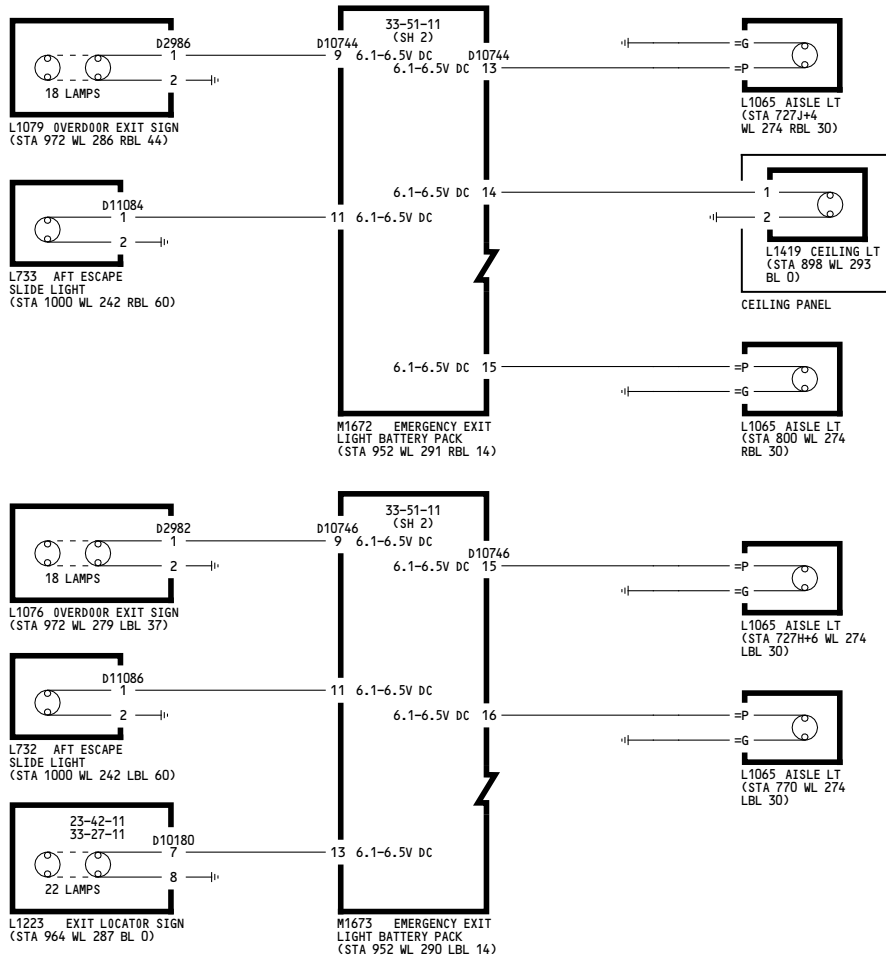

YK901-YL430	<p align="center">EMERGENCY EXIT LIGHTS - AFT</p> <p align="center">D280A203</p>
-------------	---

33-51-14

Page 102

Feb 09/2009

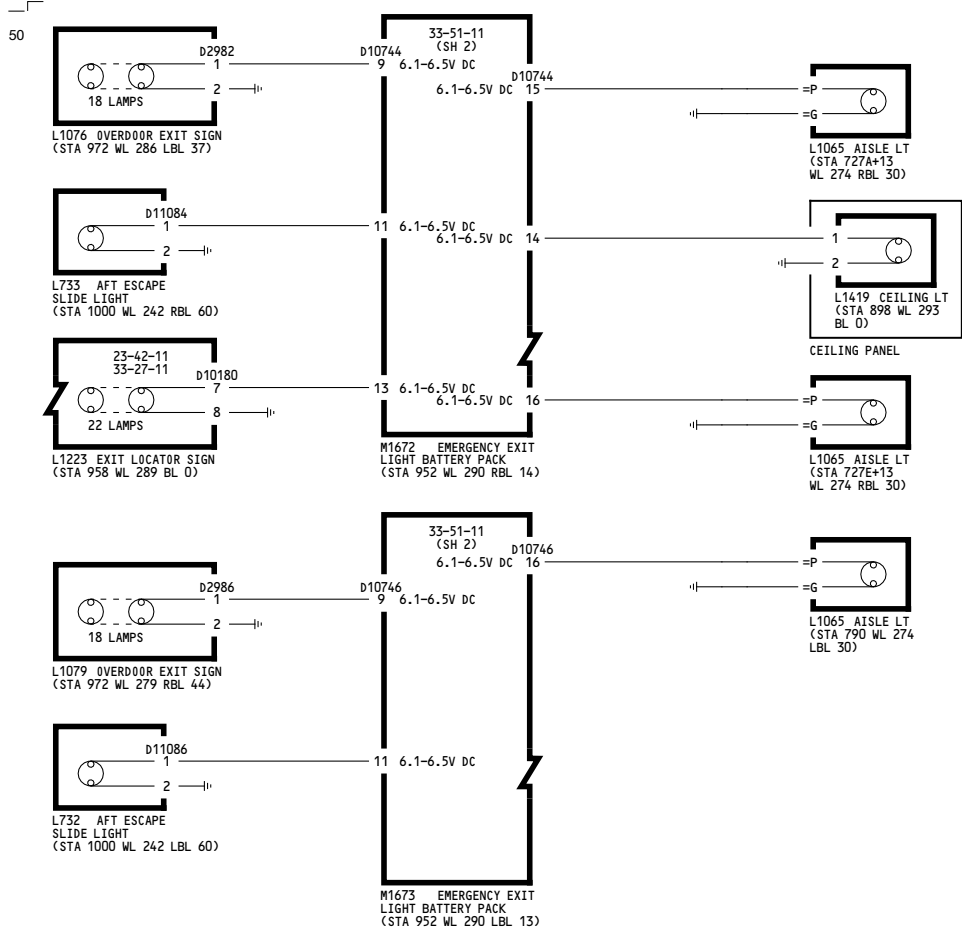

YM643-YM670	<p align="center">EMERGENCY EXIT LIGHTS - AFT</p> <p align="center">D280A203</p>
-------------	---

WIRING DIAGRAMS
33-51-21

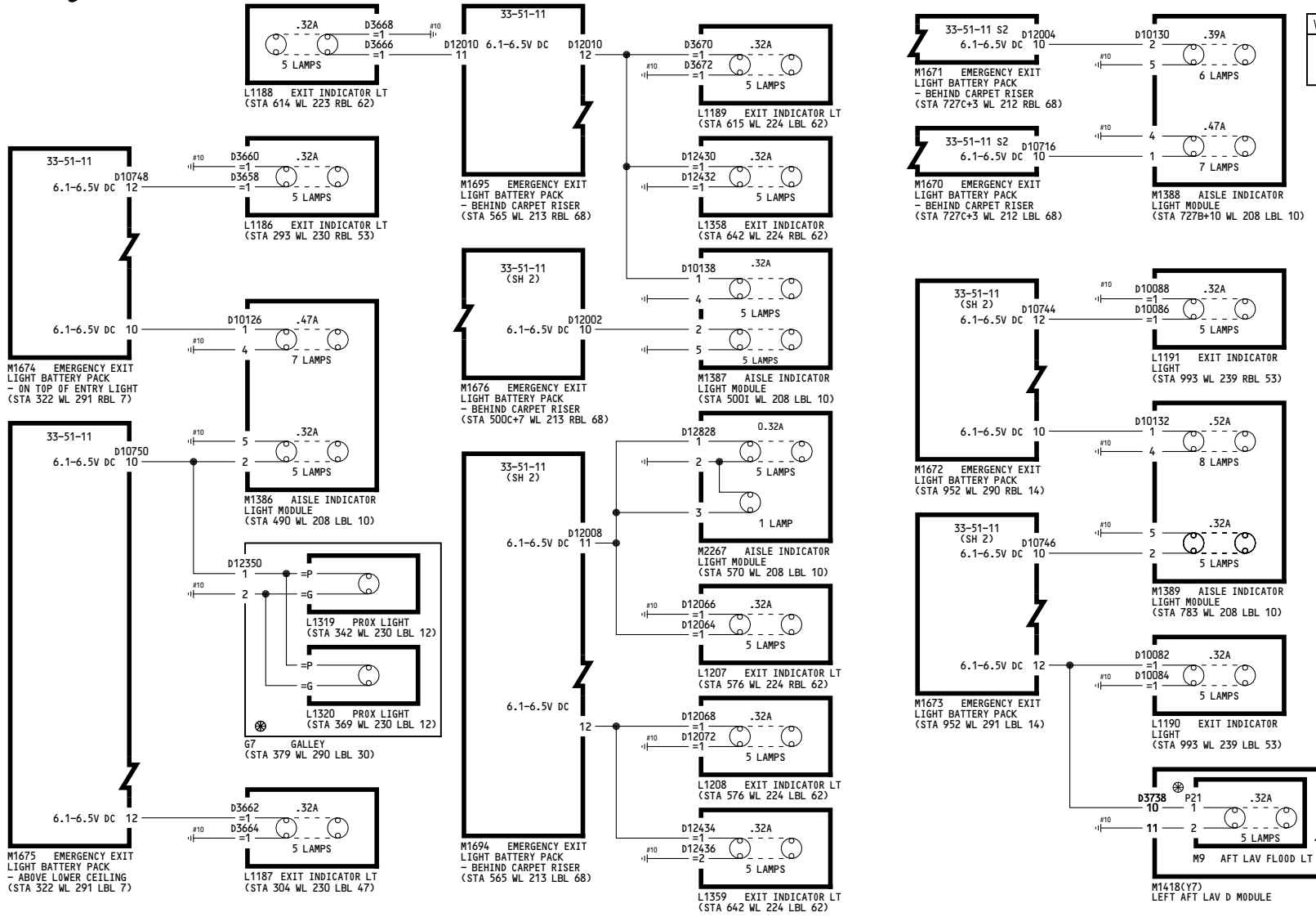

YCO01-YCO50

EMERGENCY EXIT LIGHTS - FLOOR PROXIMITY

D280A203

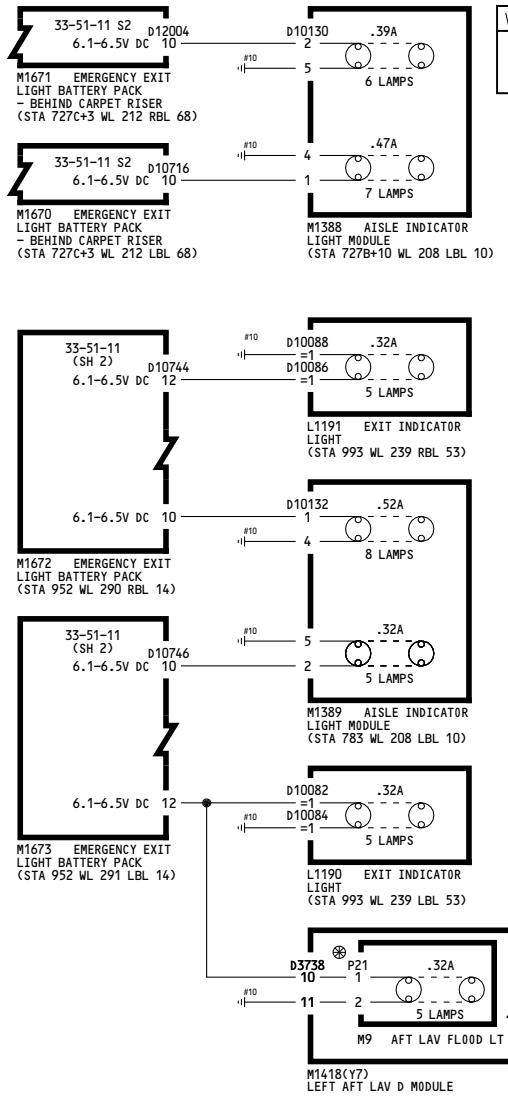

33-51-21

301

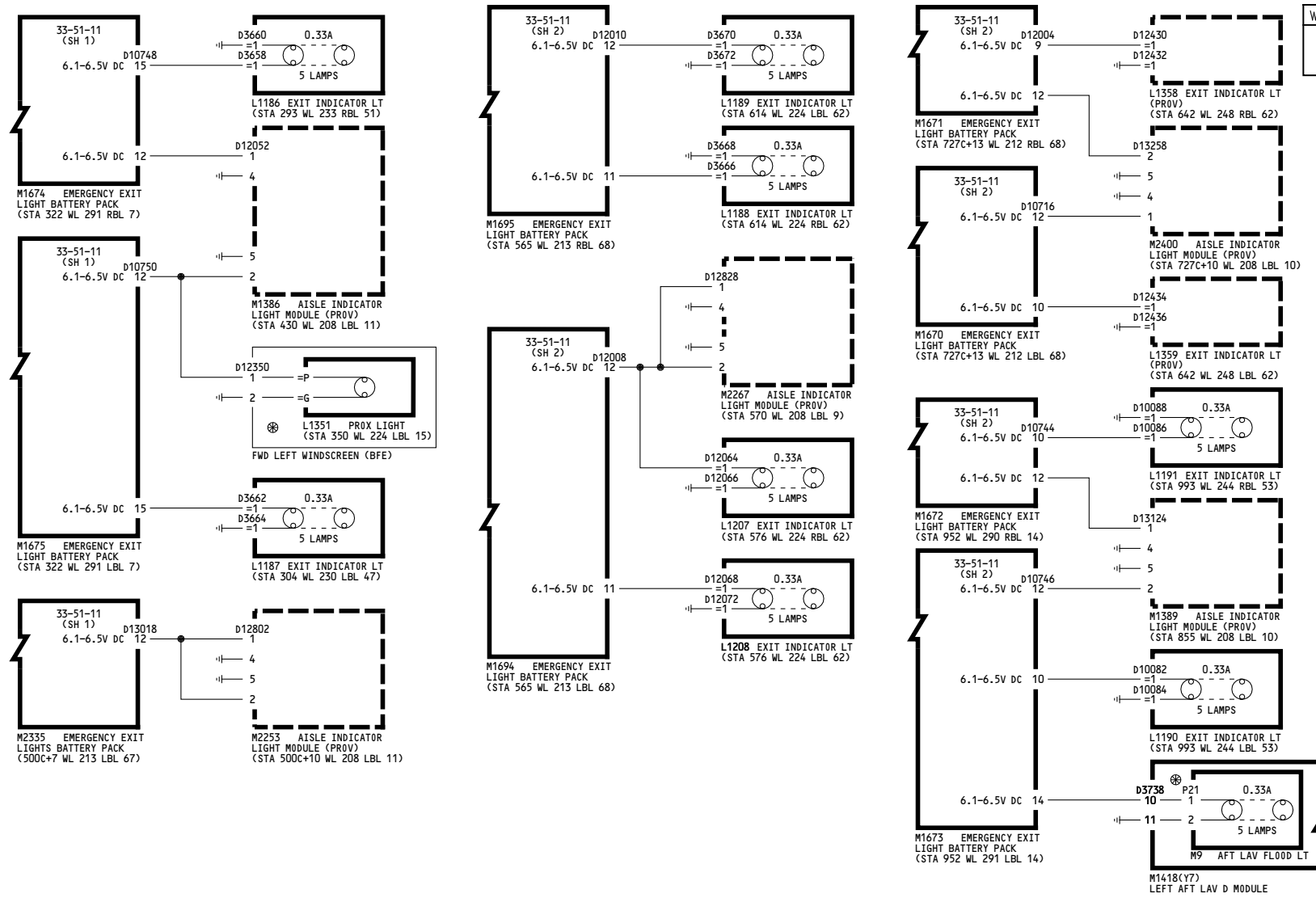

WIRING DIAGRAMS
33-51-21
33-51-22

YK901-YK911, YK918	EMERGENCY EXIT LIGHTS - FLOOR PROXIMITY D280A203
--------------------	--

33-51-21

-E-
277

WIRING DIAGRAMS
33-51-21
33-51-22

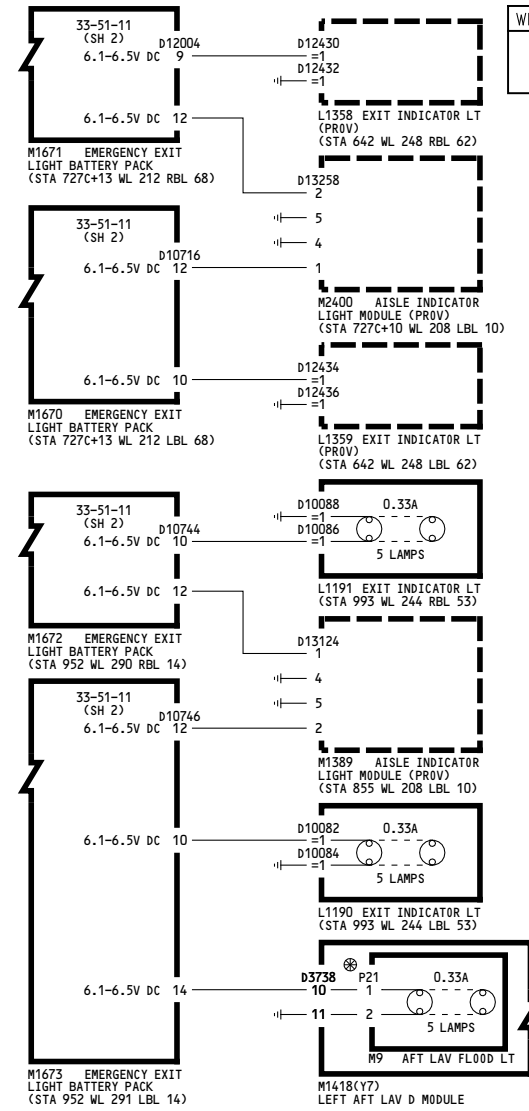
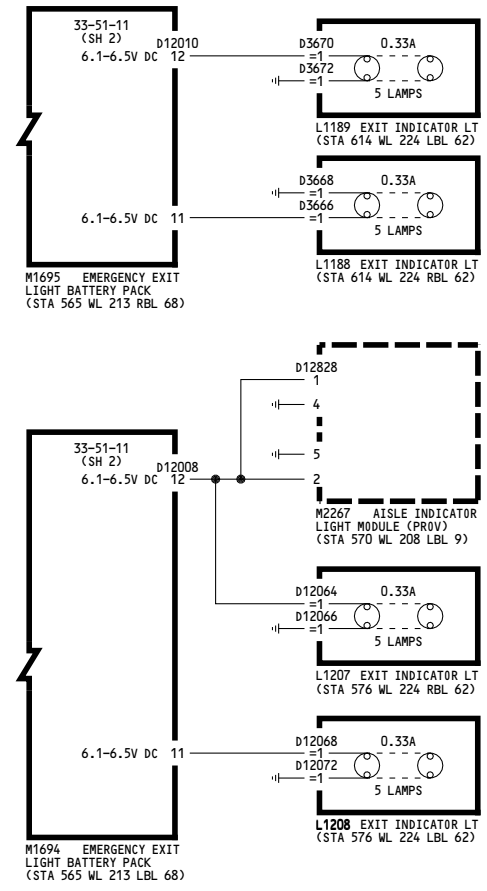
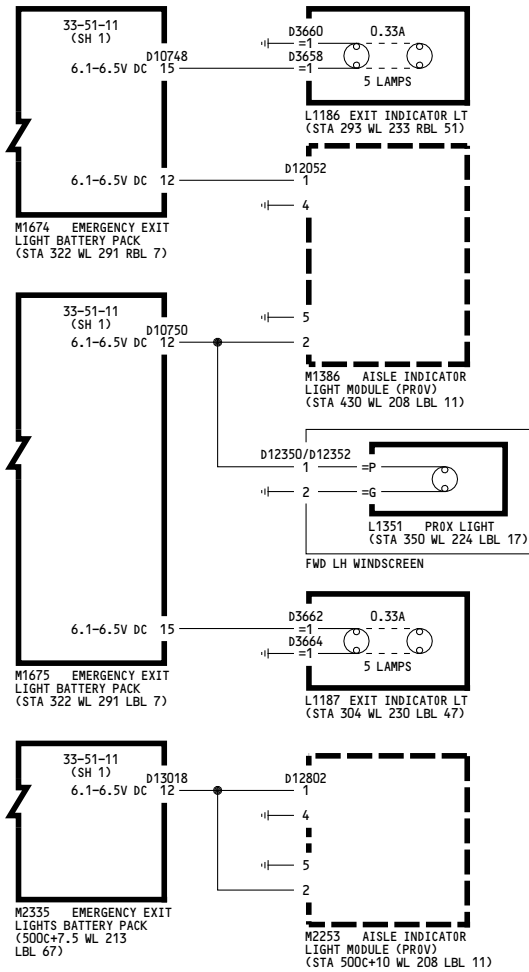

YK912-YK917, YK919-YL430

EMERGENCY EXIT LIGHTS - FLOOR PROXIMITY

D280A203

33-51-21

318

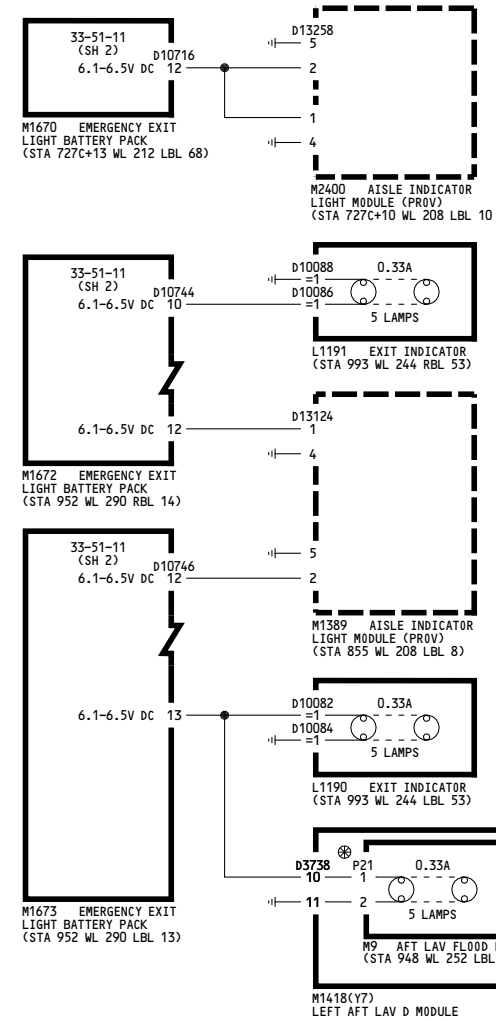
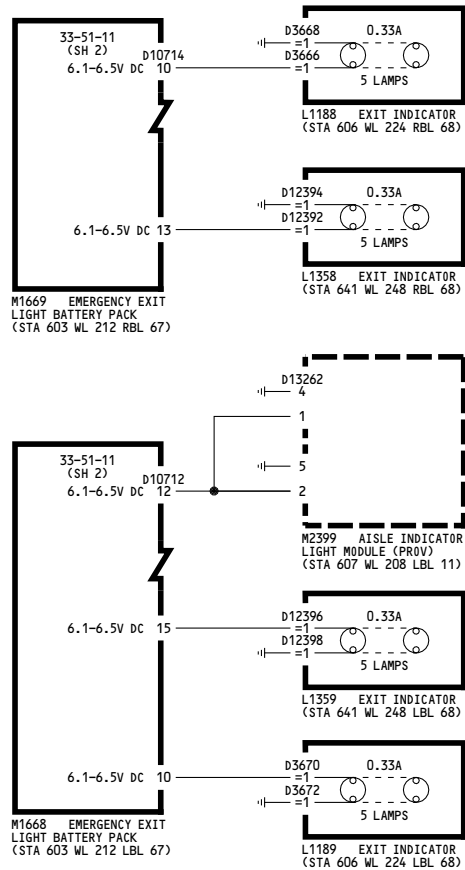
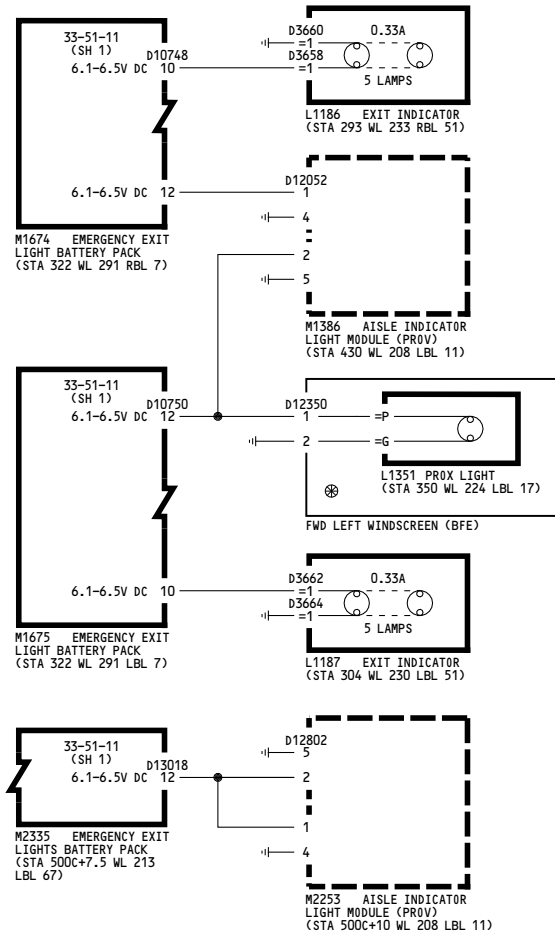

WIRING DIAGRAMS

33-51-21
33-51-22

YM643-YM651, YM653-YM670	EMERGENCY EXIT LIGHTS - FLOOR PROXIMITY
	D280A203

33-51-21

317

WIRING DIAGRAMS
33-51-21
33-51-22

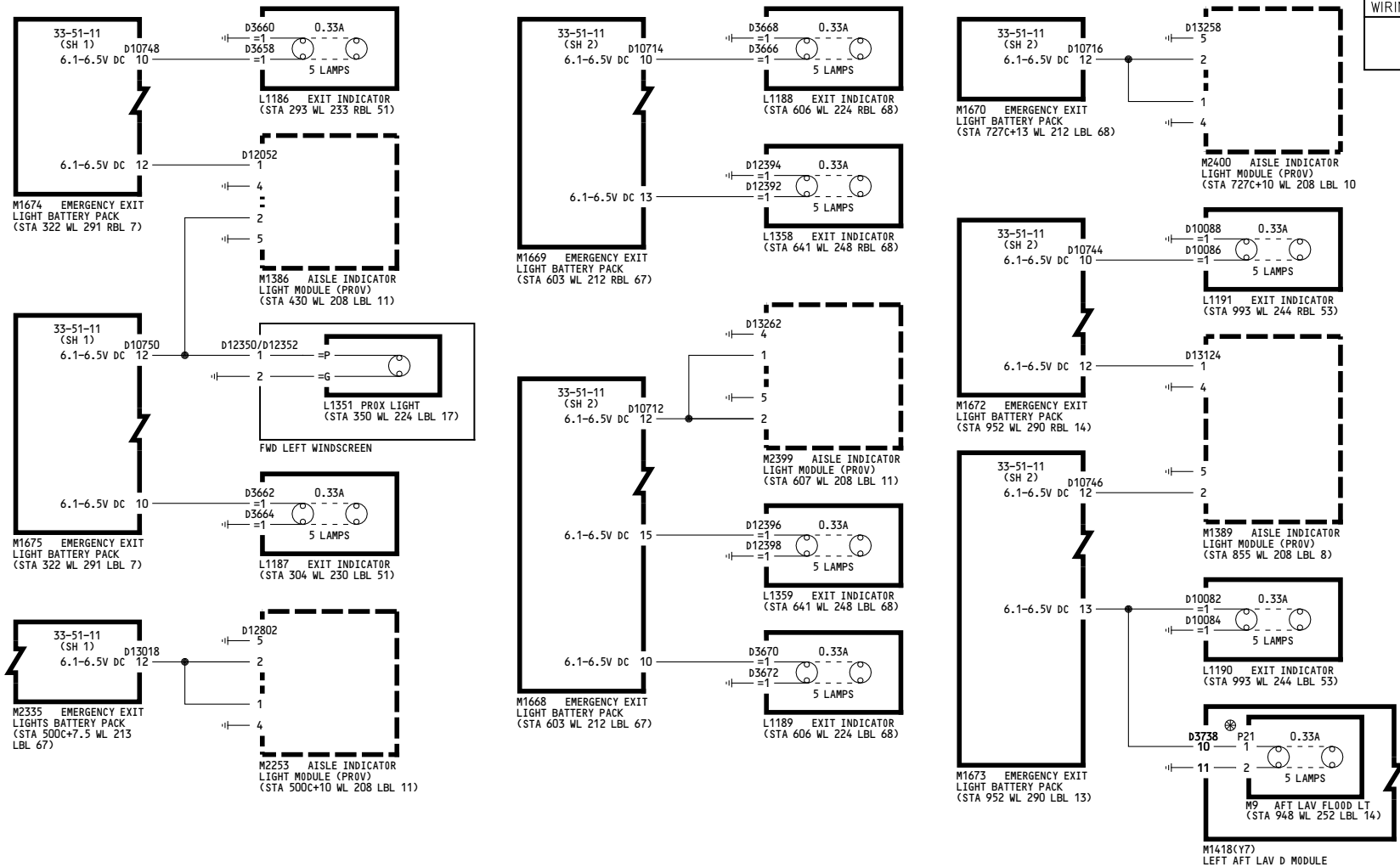

<p>YM652</p>	<p>EMERGENCY EXIT LIGHTS - FLOOR PROXIMITY</p> <p>D280A203</p>
--------------	---

33-51-21

Page 105

Nov 11/2008