

CHAPTER
80
STARTING



CHAPTER 80
STARTING

CH-SC-SU	Schem	Page	Sheet	Date	CH-SC-SU	Schem	Page	Sheet	Date
80-EFFECTIVE PAGES									
		1		Aug 10/2009					
		2		BLANK					
80-CONTENTS									
		1		Feb 09/2009					
		2		BLANK					
80-ALPHABETICAL INDEX									
		1		Jan 18/2007					
		2		BLANK					
80-00-00		101		Feb 09/2009					
		102		Jan 14/2008					
80-11-11		101		Feb 09/2009					

A = Added, R = Revised, D = Deleted, O = Overflow

80-EFFECTIVE PAGES

CHAPTER 80
STARTING

Title	CH-SC-SU	Schem	Page	Sheet	Date	Effectivity
<u>STARTING</u>						
ENGINE STARTING SYSTEM GENERAL ARRANGEMENT	80-00-00		101		Feb 09/2009	YC001-YL430
			102		Jan 14/2008	YM643-YM670
<u>ENGINE STARTING SYSTEM</u>						
ENGINE STARTING SYSTEM	80-11-11		101		Feb 09/2009	ALL

CHAPTER 80
STARTING

CH-SC-SU	Title
80-11-11	ENGINE STARTING SYSTEM
80-00-00	ENGINE STARTING SYSTEM GENERAL ARRANGEMENT

CH-SC-SU	Title
----------	-------

80-ALPHABETICAL INDEX

-A
4

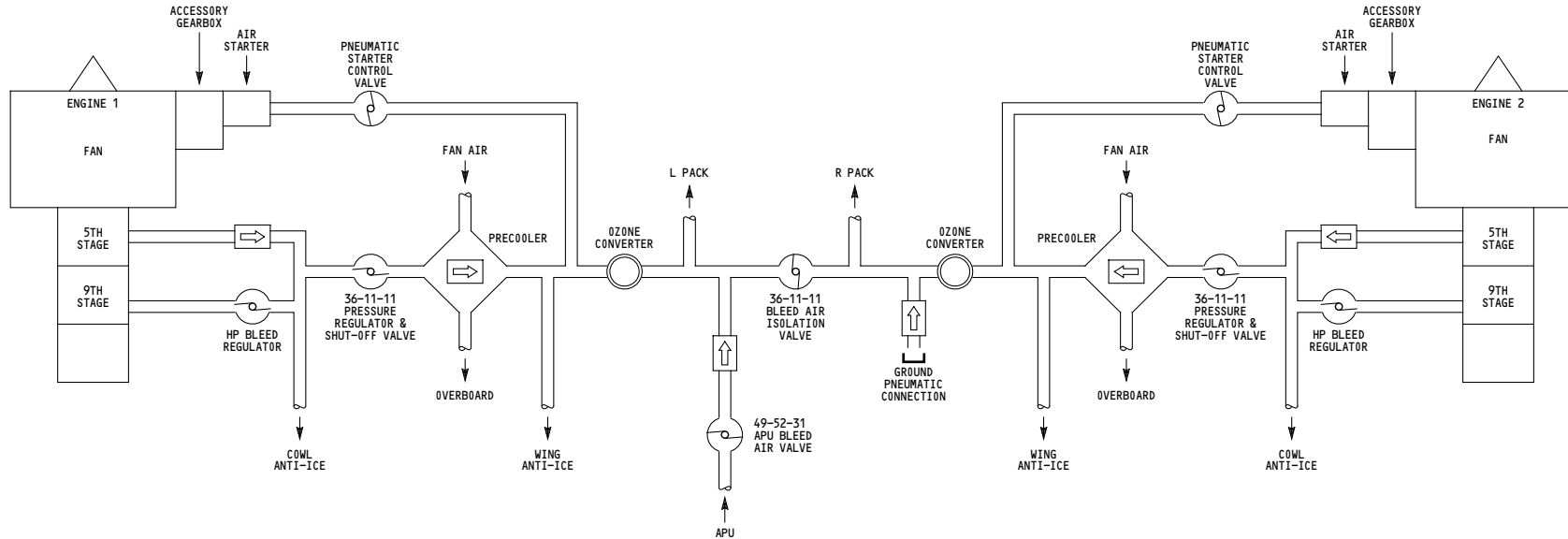
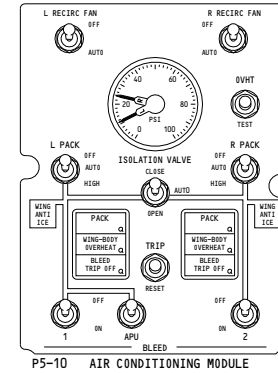
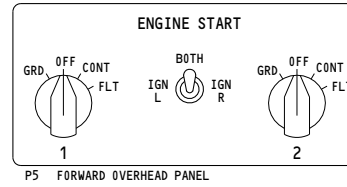
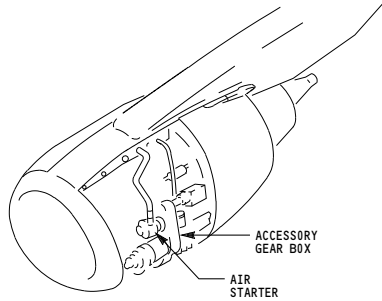

<p>YC001-YL430</p>	<p>ENGINE STARTING SYSTEM GENERAL ARRANGEMENT</p> <p>D280A203</p>
--------------------	--

80-00-00

Page 101

Feb 09/2009

1

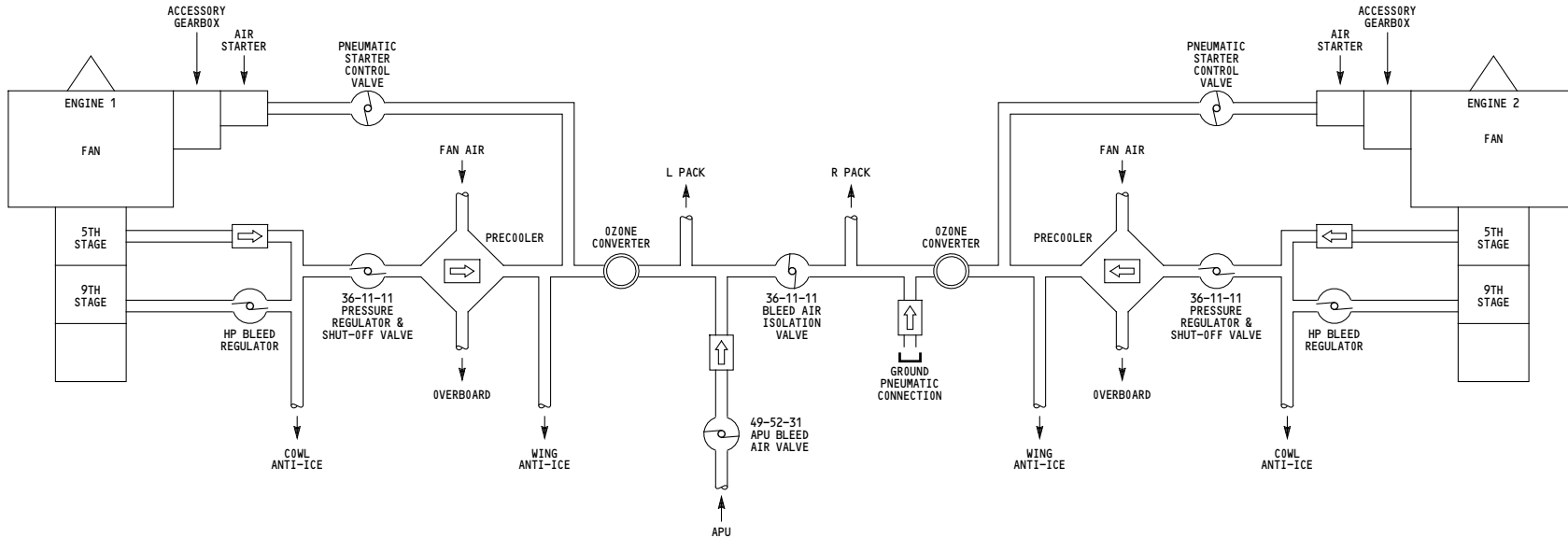
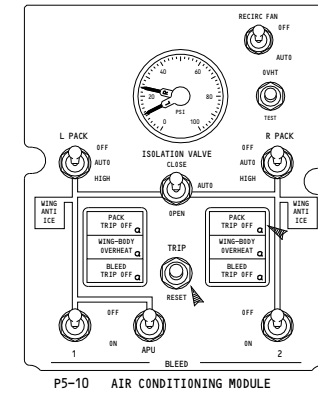
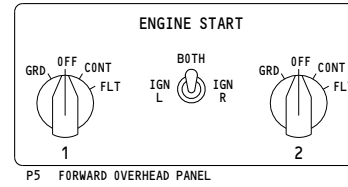
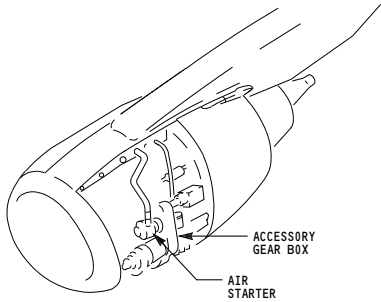

<p>YM643-YM670</p>	<p>ENGINE STARTING SYSTEM GENERAL ARRANGEMENT</p> <p>D280A203</p>
--------------------	--

80-00-00

Page 102

Jan 14/2008

-G
1

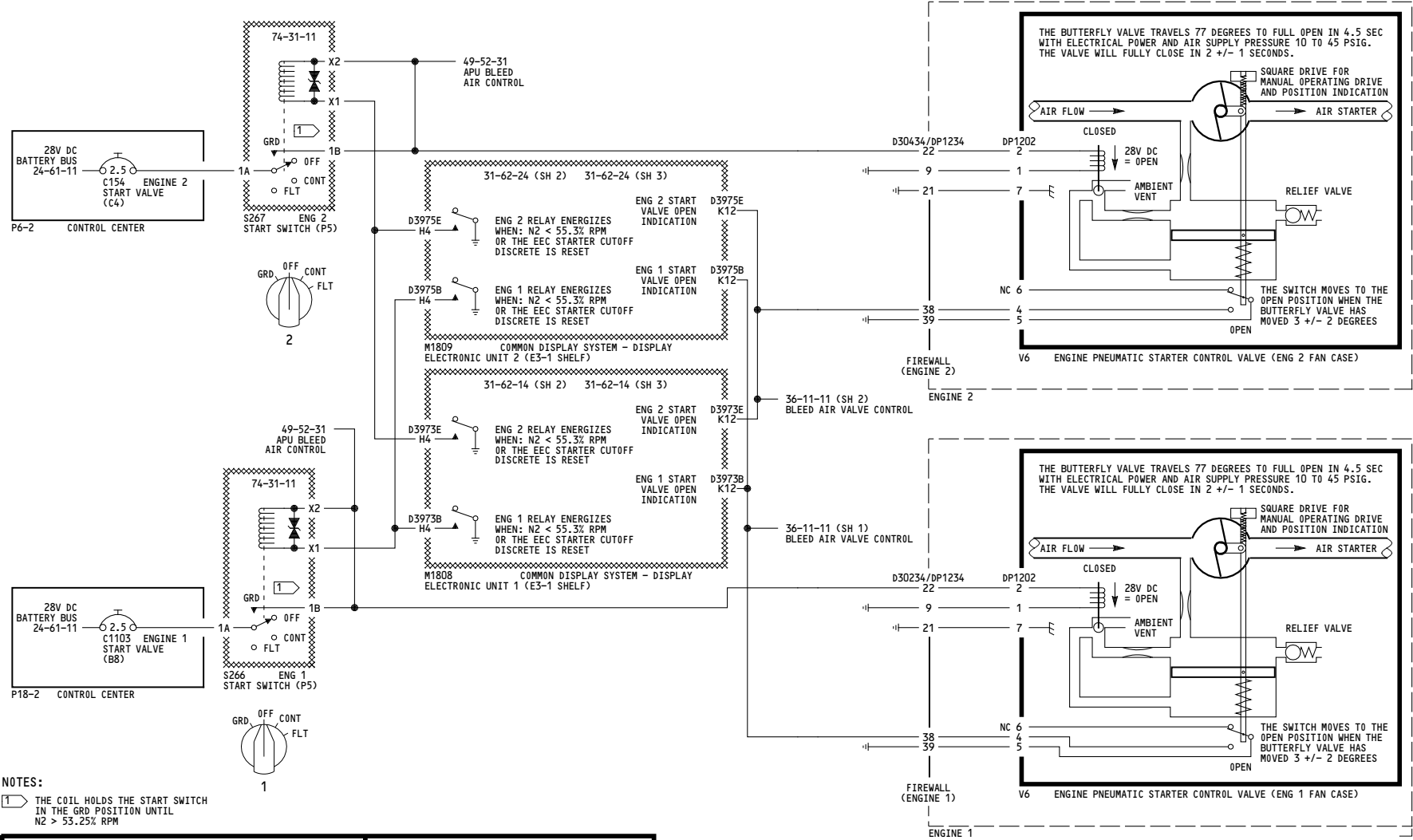

NOTES:
1 THE COIL HOLDS THE START SWITCH IN THE GRD POSITION UNTIL N2 > 53.25% RPM

ALL	ENGINE STARTING SYSTEM
	D280A203

80-11-11