

CHAPTER

21

AIR CONDITIONING



737-700/800

WIRING DIAGRAM MANUAL

CHAPTER 21
AIR CONDITIONING

CH-SC-SU	Schem	Page	Sheet	Date	CH-SC-SU	Schem	Page	Sheet	Date
21-EFFECTIVE PAGES		1 thru 2		Aug 10/2009	21-31-23 (cont.)		3		Jul 17/2007
21-CONTENTS		1		Feb 09/2009		4	1		Oct 20/2006
		2		Feb 09/2009			2		Mar 31/2005
		3		Feb 09/2009		5	1		Feb 09/2009
		4		May 11/2009			2		Feb 09/2009
		5		Feb 09/2009	21-31-24		1		Jul 17/2007
		6		BLANK			2		Feb 09/2009
21-ALPHABETICAL INDEX		1		Jan 18/2007	21-31-25		1		Feb 09/2009
		2		Jan 18/2007	21-33-11		1		Mar 31/2005
21-25-11		1	1	Mar 31/2005		2			Jul 17/2007
			2	Mar 31/2005		3			Aug 13/2008
		2	1	Mar 31/2005		4			Feb 09/2009
			2	Mar 31/2005		5			Feb 09/2009
		3	1	Jul 17/2007	21-42-11		1	1	Jul 26/2006
			2	Jul 17/2007				2	Mar 31/2005
		4	1	Feb 09/2009				3	Mar 31/2005
			2	Feb 09/2009				2	Jul 17/2007
		5		Jan 14/2008			2	1	Jul 17/2007
21-27-21		1	1	Jul 26/2006				2	Jul 17/2007
			2	Mar 31/2005			3	1	Jul 17/2007
		2	1	Jul 26/2006				3	Feb 09/2009
			2	Jan 18/2006				2	Feb 09/2009
		3	1	Jul 17/2007			4	1	Jan 14/2008
			2	Jul 17/2007				2	Jan 14/2008
		4	1	Feb 09/2009	21-43-21		1		Jul 26/2006
			2	Feb 09/2009			2		Jul 26/2006
21-27-31		1	1	Mar 31/2005			3		Jul 17/2007
			2	Mar 31/2005			4		Feb 09/2009
		2	1	Mar 31/2005	21-51-11		1		Mar 31/2005
			2	Mar 31/2005			2		Mar 31/2005
		3	1	Jul 17/2007			3		Jul 17/2007
			2	Jul 17/2007			4	1	Mar 31/2005
		4	1	Feb 09/2009				2	Mar 31/2005
			2	Feb 09/2009			5	1	Feb 09/2009
21-31-11		1		Jul 26/2006				2	Feb 09/2009
		2		Jul 17/2007			6	1	Jan 18/2006
		3		Feb 09/2009				2	Jan 18/2006
21-31-22		1		Oct 20/2006			7	1	Jan 14/2008
		2		Jul 17/2007				2	Jan 14/2008
		3	1	Feb 09/2009	21-51-12		1		Mar 31/2005
			2	Feb 09/2009			1.1		Apr 18/2007
21-31-23		1		Oct 20/2006			2		Mar 31/2005
		2		Oct 20/2006			2.1		Apr 18/2007
							3		Jul 17/2007

A = Added, R = Revised, D = Deleted, O = Overflow

21-EFFECTIVE PAGES

Page 1
Aug 10/2009

D280A103



737-700/800

WIRING DIAGRAM MANUAL

CHAPTER 21
AIR CONDITIONING

CH-SC-SU	Schem	Page	Sheet	Date	CH-SC-SU	Schem	Page	Sheet	Date
21-51-12 (cont.)		4		Feb 09/2009	21-61-14 (cont.)		3		Feb 09/2009
21-51-13		1		Feb 09/2009	21-61-15		1		Feb 09/2009
21-51-14		1		May 11/2009	21-61-21		1	1	Jan 14/2008
		2		May 11/2009				2	Jan 14/2008
		3		May 11/2009	21-61-22				
		4		May 11/2009			1	1	Jan 14/2008
		5		May 11/2009				2	Jan 14/2008
21-51-15		1		Mar 31/2005	21-61-51		1		Mar 31/2005
		2		Jul 17/2007			2		Feb 09/2009
		3		Feb 09/2009			3		Jan 14/2008
		4		Jan 14/2008					
21-51-16		1		Jan 14/2008					
21-51-21		1		Jul 17/2007					
		2	1	Mar 31/2005					
			2	Jan 18/2006					
		3	1	Feb 09/2009					
			2	Feb 09/2009					
		4	1	Jan 14/2008					
			2	Jan 14/2008					
21-51-22		1		Mar 31/2005					
		1.1		Mar 31/2005					
		2		Jul 17/2007					
		3		Feb 09/2009					
21-51-23		1		Feb 09/2009					
21-51-24		1		May 11/2009					
		2		May 11/2009					
21-51-25		1		Feb 09/2009					
		2		Jan 14/2008					
21-51-26		1		Jan 14/2008					
21-61-11		1		Jul 26/2006					
		2		Jul 17/2007					
		3		Feb 09/2009					
21-61-12		1		Feb 09/2009					
21-61-13		1		Jul 17/2007					
		2		Feb 09/2009					
21-61-14		1		Jul 26/2006					
		2		Jul 17/2007					

A = Added, R = Revised, D = Deleted, O = Overflow

21-EFFECTIVE PAGES

Page 2
Aug 10/2009

D280A103



737-700/800

WIRING DIAGRAM MANUAL

CHAPTER 21 AIR CONDITIONING

Title	CH-SC-SU	Schem	Page	Sheet	Date	Effectivity			
<u>RECIRCULATION SYSTEM</u>									
CABIN AIR RECIRCULATION SYSTEM	21-25-11		1	1	Mar 31/2005	YC001-YC003			
				2	Mar 31/2005	YC001-YC003			
			2	1	Mar 31/2005	YC004-YC007			
				2	Mar 31/2005	YC004-YC007			
			3	1	Jul 17/2007	YC008-YC030			
				2	Jul 17/2007	YC008-YC030			
			4	1	Feb 09/2009	YC031-YL430			
				2	Feb 09/2009	YC031-YL430			
			5		Jan 14/2008	YM643-YM670			
			<u>EQUIPMENT COOLING SYSTEM</u>						
EQUIPMENT COOLING EXHAUST	21-27-21		1	1	Jul 26/2006	YC001-YC003			
				2	Mar 31/2005	YC001-YC003			
			2	1	Jul 26/2006	YC004-YC007			
				2	Jan 18/2006	YC004-YC007			
			3	1	Jul 17/2007	YC008-YC030			
				2	Jul 17/2007	YC008-YC030			
			4	1	Feb 09/2009	YC031-YM670			
				2	Feb 09/2009	YC031-YM670			
			EQUIPMENT COOLING SUPPLY	21-27-31		1	1	Mar 31/2005	YC001-YC003
							2	Mar 31/2005	YC001-YC003
2	1	Mar 31/2005				YC004-YC007			
	2	Mar 31/2005				YC004-YC007			
3	1	Jul 17/2007				YC008-YC030			
	2	Jul 17/2007				YC008-YC030			
4	1	Feb 09/2009				YC031-YM670			
	2	Feb 09/2009				YC031-YM670			
<u>PRESSURIZATION CONTROL SYSTEM</u>									
PRESSURIZATION CONTROL MANUAL MODE	21-31-11					1		Jul 26/2006	YC001-YC007
			2		Jul 17/2007	YC008-YC030			
			3		Feb 09/2009	YC031-YM670			

21-CONTENTS

Page 1
Feb 09/2009

D280A103



737-700/800

WIRING DIAGRAM MANUAL

CHAPTER 21
AIR CONDITIONING

Title	CH-SC-SU	Schem	Page	Sheet	Date	Effectivity
PRESSURIZATION CONTROL AUTO 1	21-31-22		1		Oct 20/2006	YC001-YC007
			2		Jul 17/2007	YC008-YC026
			3	1	Feb 09/2009	YC028-YM670
				2	Feb 09/2009	YC028-YM670
			1		Oct 20/2006	YC001-YC004
PRESSURIZATION CONTROL AUTO 2	21-31-23		2		Oct 20/2006	YC005-YC007
			3		Jul 17/2007	YC008-YC026
			4	1	Oct 20/2006	YC028-YC030
				2	Mar 31/2005	YC028-YC030
			5	1	Feb 09/2009	YC031-YM670
				2	Feb 09/2009	YC031-YM670
PRESSURIZATION CONTROL - AUTO CHANNEL INTERFACES	21-31-24		1		Jul 17/2007	YC001-YC030
			2		Feb 09/2009	YC031-YM670
PRESSURIZATION CONTROL LCD LIGHTING	21-31-25		1		Feb 09/2009	ALL
CABIN PRESSURE INDICATION AND WARNING SYSTEM						
CABIN PRESSURE WARNING	21-33-11		1		Mar 31/2005	YC001-YC003
			2		Jul 17/2007	YC004-YK910 YL421-YL423 YM643
			3		Aug 13/2008	YK911 YM651
			4		Feb 09/2009	YK912-YK917 YK919-YL401 YL427-YL430 YM652-YM670
			5		Feb 09/2009	YK918 YL424-YL426 YM645-YM649
SUPPLEMENTAL HEATING SYSTEMS						
DOOR AREA HEATERS	21-42-11		1	1	Jul 26/2006	YC001-YC003
				2	Mar 31/2005	YC001-YC003
				3	Mar 31/2005	YC001-YC003
			2	1	Jul 17/2007	YC004-YC028
				2	Jul 17/2007	YC004-YC028

21-CONTENTS



737-700/800

WIRING DIAGRAM MANUAL

**CHAPTER 21
AIR CONDITIONING**

Title	CH-SC-SU	Schem	Page	Sheet	Date	Effectivity	
DOOR AREA HEATERS (cont.)	21-42-11			3	Jul 17/2007	YC004-YC028	
			3	1	Feb 09/2009	YC029-YL430	
				2	Feb 09/2009	YC029-YL430	
				3	Feb 09/2009	YC029-YL430	
			4	1	Jan 14/2008	YM643-YM670	
				2	Jan 14/2008	YM643-YM670	
<u>FORWARD CARGO COMPARTMENT HEATING SYSTEM</u>							
OVERBOARD EXHAUST VALVE CONTROL	21-43-21		1		Jul 26/2006	YC001-YC003	
				2	Jul 26/2006	YC004-YC007	
				3	Jul 17/2007	YC008-YC030	
				4	Feb 09/2009	YC031-YM670	
<u>PACK FLOW CONTROL AND PACK COOLING SYSTEM</u>							
LEFT PACK VALVE CONTROL	21-51-11		1		Mar 31/2005	YC001-YC003	
				2	Mar 31/2005	YC004-YC007	
				3	Jul 17/2007	YC008-YC028	
				4	1	Mar 31/2005	YC029-YC030
					2	Mar 31/2005	YC029-YC030
				5	1	Feb 09/2009	YC031-YC050 YK906-YL430
					2	Feb 09/2009	YC031-YC050 YK906-YL430
				6	1	Jan 18/2006	YK901-YK905
					2	Jan 18/2006	YK901-YK905
				7	1	Jan 14/2008	YM643-YM670
					2	Jan 14/2008	YM643-YM670
LEFT AIR CONDITIONING PACK CONTROL - AUTO	21-51-12		1		Mar 31/2005	YC001-YC007	
				1.1	Apr 18/2007	YC001-YC007	
				2	Mar 31/2005	YC008-YC022	
				2.1	Apr 18/2007	YC008-YC022	
				3	Jul 17/2007	YC023-YC030	
				4	Feb 09/2009	YC031-YL430	

21-CONTENTS

Page 3
Feb 09/2009

D280A103



737-700/800

WIRING DIAGRAM MANUAL

**CHAPTER 21
AIR CONDITIONING**

Title	CH-SC-SU	Schem	Page	Sheet	Date	Effectivity
LEFT AIR CONDITIONING PACK CONTROL STANDBY	21-51-13		1		Feb 09/2009	YC001-YL430
LEFT RAM MODULATION CONTROL	21-51-14		1		May 11/2009	YC001-YC030 YK901-YK905
			2		May 11/2009	YC031-YC050 YK906-YK910 YK918 YL421-YL426
			3		May 11/2009	YK911-YK912 YK919 YL401 YL427-YL429
			4		May 11/2009	YM643-YM649
			5		May 11/2009	YM651-YM652
LEFT PACK PROTECTION	21-51-15		1		Mar 31/2005	YC001-YC007
			2		Jul 17/2007	YC008-YC030
			3		Feb 09/2009	YC031-YL430
			4		Jan 14/2008	YM643-YM670
LEFT WATER SEPARATOR 35 DEGREES FAHRENHEIT CONTROL	21-51-16		1		Jan 14/2008	YM643-YM670
RIGHT PACK VALVE CONTROL	21-51-21		1		Jul 17/2007	YC001-YC028
			2	1	Mar 31/2005	YC029-YC030
				2	Jan 18/2006	YC029-YC030
			3	1	Feb 09/2009	YK901-YL430
				2	Feb 09/2009	YK901-YL430
			4	1	Jan 14/2008	YM643-YM670
				2	Jan 14/2008	YM643-YM670
RIGHT AIR CONDITIONING PACK CONTROL - AUTO	21-51-22		1		Mar 31/2005	YC001-YC022
			1.1		Mar 31/2005	YC001-YC022
			2		Jul 17/2007	YC023-YC030
			3		Feb 09/2009	YC031-YL430
RIGHT AIR CONDITIONING PACK CONTROL STANDBY	21-51-23		1		Feb 09/2009	YC001-YL430
RIGHT RAM MODULATION CONTROL	21-51-24		1		May 11/2009	YC001-YL430
			2		May 11/2009	YM643-YM670
RIGHT PACK PROTECTION	21-51-25		1		Feb 09/2009	YC001-YL430

21-CONTENTS

Page 4

May 11/2009

D280A103



737-700/800

WIRING DIAGRAM MANUAL

CHAPTER 21
AIR CONDITIONING

Title	CH-SC-SU	Schem	Page	Sheet	Date	Effectivity
RIGHT PACK PROTECTION (cont.)	21-51-25		2		Jan 14/2008	YM643-YM670
RIGHT WATER SEPARATOR 35 DEGREES FAHRENHEIT CONTROL	21-51-26		1		Jan 14/2008	YM643-YM670
<u>ZONE TEMPERATURE CONTROL AND INDICATION</u>						
TEMPERATURE CONTROL - FLIGHT DECK ZONE (PRIMARY)	21-61-11		1		Jul 26/2006	YC001-YC007
			2		Jul 17/2007	YC008-YC030
			3		Feb 09/2009	YC031-YL430
TEMPERATURE CONTROL - FLIGHT DECK ZONE (BACKUP)	21-61-12		1		Feb 09/2009	YC001-YL430
TEMPERATURE CONTROL - FWD PASSENGER ZONE	21-61-13		1		Jul 17/2007	YC001-YC030
			2		Feb 09/2009	YC031-YL430
TEMPERATURE CONTROL AFT PASSENGER ZONE	21-61-14		1		Jul 26/2006	YC001-YC007
			2		Jul 17/2007	YC008-YC030
			3		Feb 09/2009	YC031-YL430
TEMPERATURE CONTROL - TRIP PRESSURE REGULATION	21-61-15		1		Feb 09/2009	YC001-YL430
TEMPERATURE CONTROL - CONTROL CABIN	21-61-21		1	1	Jan 14/2008	YM643-YM670
				2	Jan 14/2008	YM643-YM670
TEMPERATURE CONTROL - PASSENGER CABIN	21-61-22		1	1	Jan 14/2008	YM643-YM670
				2	Jan 14/2008	YM643-YM670
AIR CONDITIONING TEMPERATURE INDICATION	21-61-51		1		Mar 31/2005	YC001-YC011
			2		Feb 09/2009	YC012-YL430
			3		Jan 14/2008	YM643-YM670

21-CONTENTS

Page 5
Feb 09/2009

D280A103



737-700/800

WIRING DIAGRAM MANUAL

CHAPTER 21 AIR CONDITIONING

CH-SC-SU	Title
21-61-51	AIR CONDITIONING TEMPERATURE INDICATION
21-25-11	CABIN AIR RECIRCULATION SYSTEM
21-33-11	CABIN PRESSURE WARNING
21-42-11	DOOR AREA HEATERS
21-27-21	EQUIPMENT COOLING EXHAUST
21-27-31	EQUIPMENT COOLING SUPPLY
21-51-12	LEFT AIR CONDITIONING PACK CONTROL - AUTO
21-51-13	LEFT AIR CONDITIONING PACK CONTROL STANDBY
21-51-15	LEFT PACK PROTECTION
21-51-11	LEFT PACK VALVE CONTROL
21-51-14	LEFT RAM MODULATION CONTROL
21-51-16	LEFT WATER SEPARATOR 35 DEGREES FAHRENHEIT CONTROL
21-43-21	OVERBOARD EXHAUST VALVE CONTROL
21-31-24	PRESSURIZATION CONTROL - AUTO CHANNEL INTERFACES
21-31-22	PRESSURIZATION CONTROL AUTO 1
21-31-23	PRESSURIZATION CONTROL AUTO 2
21-31-25	PRESSURIZATION CONTROL LCD LIGHTING
21-31-11	PRESSURIZATION CONTROL MANUAL MODE
21-51-22	RIGHT AIR CONDITIONING PACK CONTROL - AUTO
21-51-23	RIGHT AIR CONDITIONING PACK CONTROL STANDBY
21-51-25	RIGHT PACK PROTECTION
21-51-21	RIGHT PACK VALVE CONTROL
21-51-24	RIGHT RAM MODULATION CONTROL
21-51-26	RIGHT WATER SEPARATOR 35 DEGREES FAHRENHEIT CONTROL
21-61-21	TEMPERATURE CONTROL - CONTROL CABIN
21-61-12	TEMPERATURE CONTROL - FLIGHT DECK ZONE (BACKUP)
21-61-11	TEMPERATURE CONTROL - FLIGHT DECK ZONE (PRIMARY)
21-61-13	TEMPERATURE CONTROL - FWD PASSENGER ZONE

21-ALPHABETICAL INDEX

D280A103

Page 1
Jan 18/2007



737-700/800

WIRING DIAGRAM MANUAL

CHAPTER 21 AIR CONDITIONING

CH-SC-SU	Title
21-61-22	TEMPERATURE CONTROL - PASSENGER CABIN
21-61-15	TEMPERATURE CONTROL - TRIP PRESSURE REGULATION
21-61-14	TEMPERATURE CONTROL AFT PASSENGER ZONE

21-ALPHABETICAL INDEX

D280A103

Page 2
Jan 18/2007

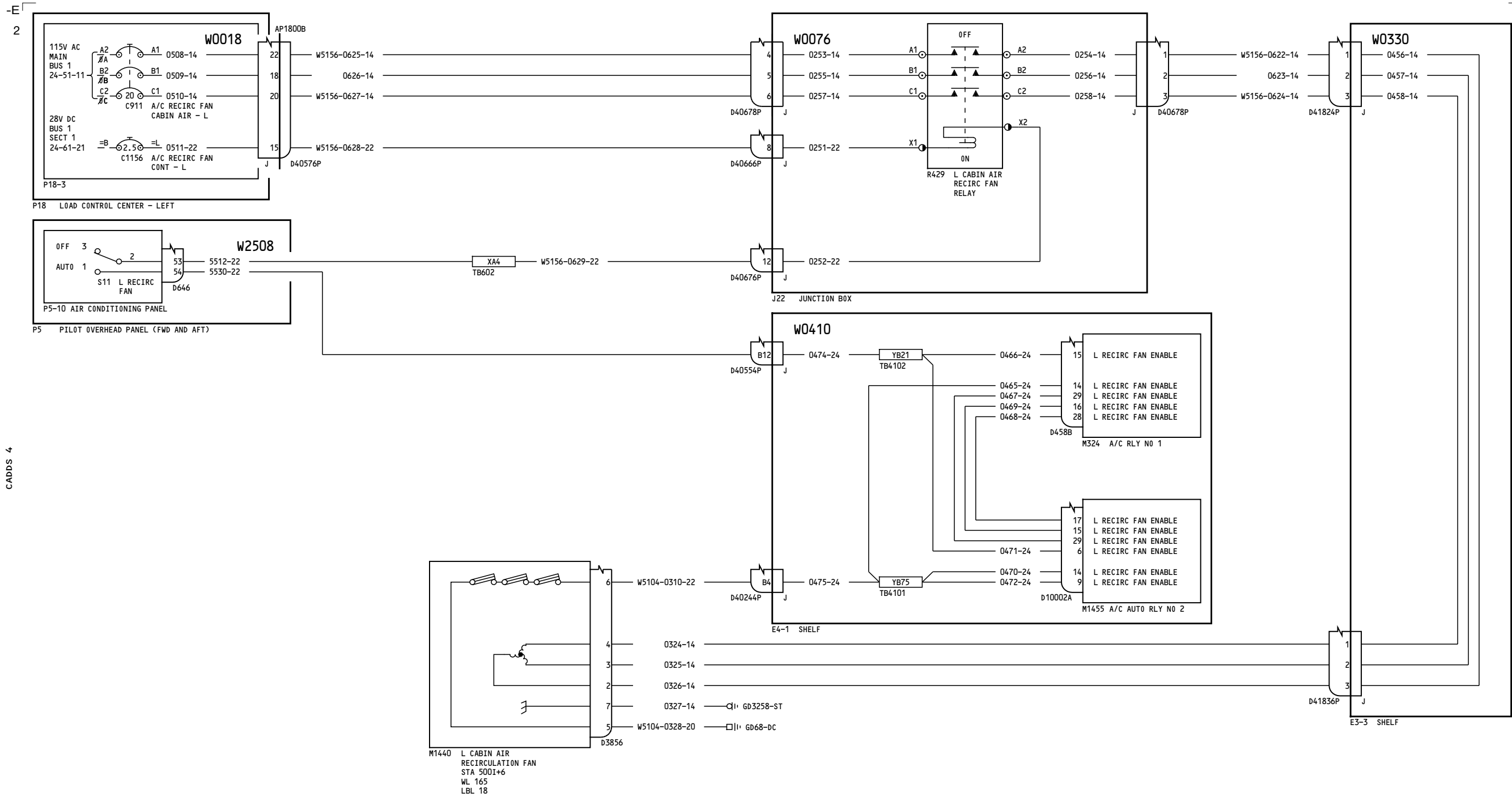

CADDS 4

YC001-YC003

CABIN AIR RECIRCULATION SYSTEM

D280A103

21-25-11

Page 1
Sheet 1
Mar 31/2005

21-25-11

Page 1
Sheet 1
Mar 31/2005

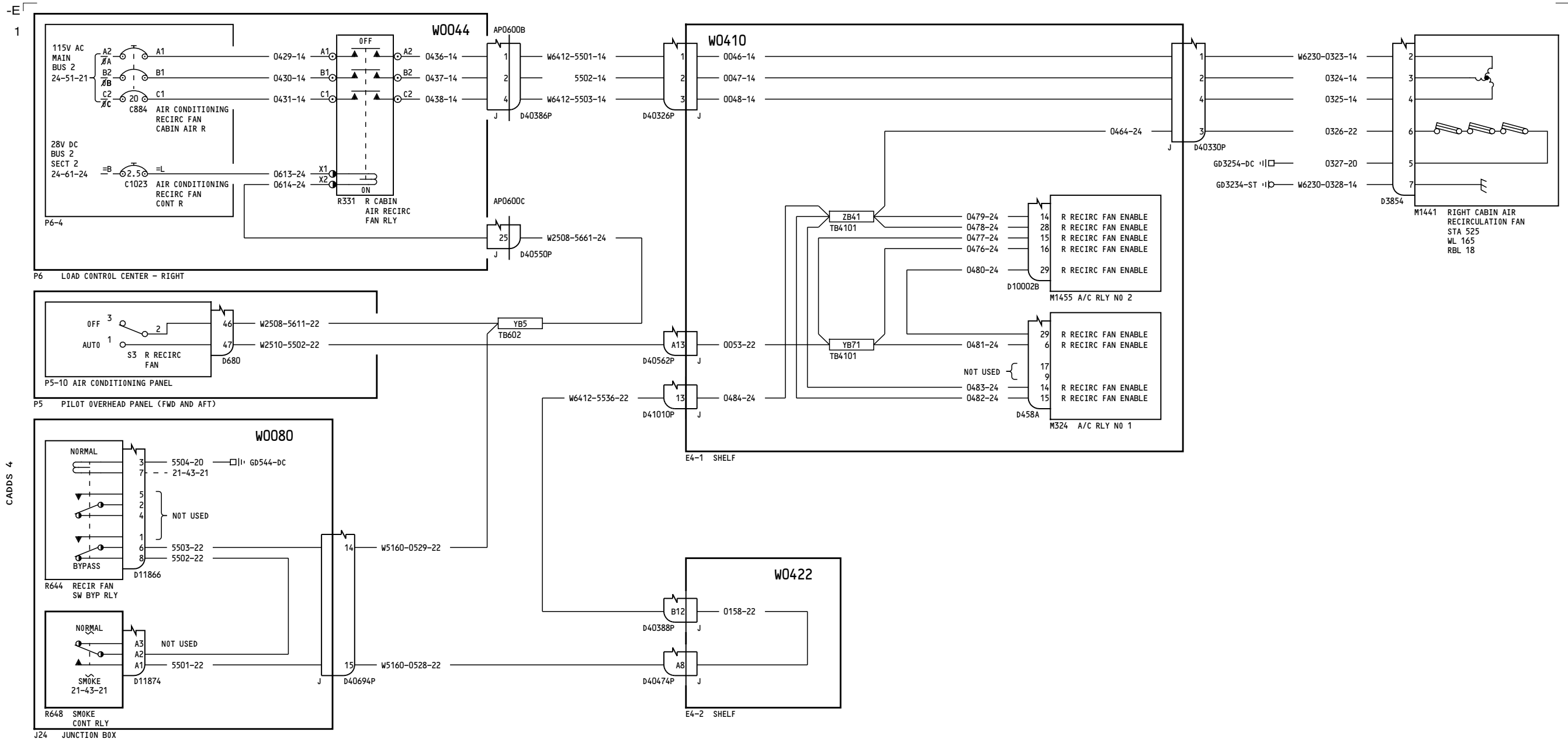

YC001-YC003

**CABIN AIR
RECIRCULATION SYSTEM**

21-25-11

Page 1
Sheet 2
Mar 31/2005

D280A103

21-25-11

Page 1
Sheet 2
Mar 31/2005

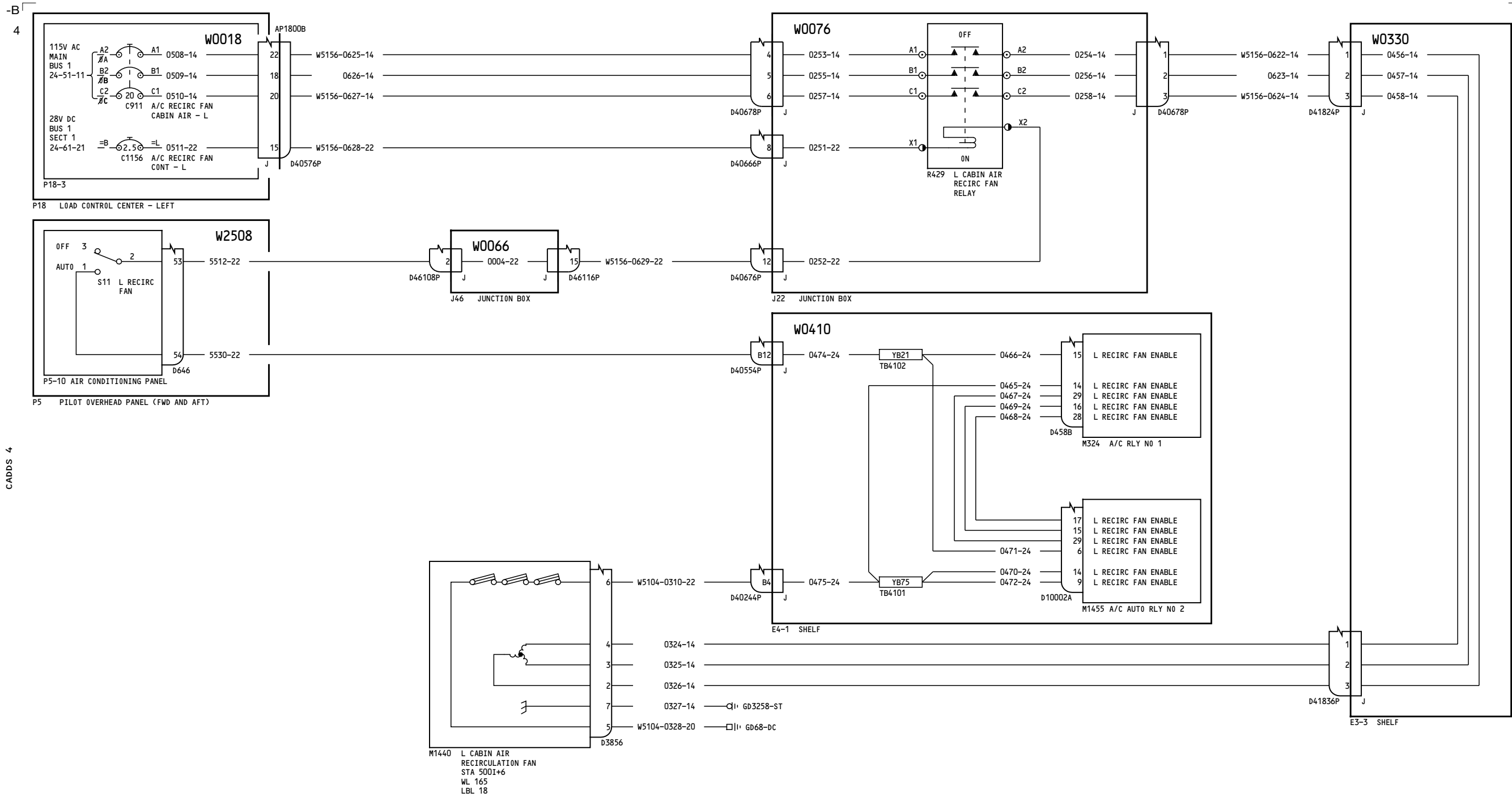

CADDs 4

YC004-YC007

CABIN AIR RECIRCULATION SYSTEM

D280A103

21-25-11

Page 2
Sheet 1
Mar 31/2005

21-25-11

Page 2
Sheet 1
Mar 31/2005

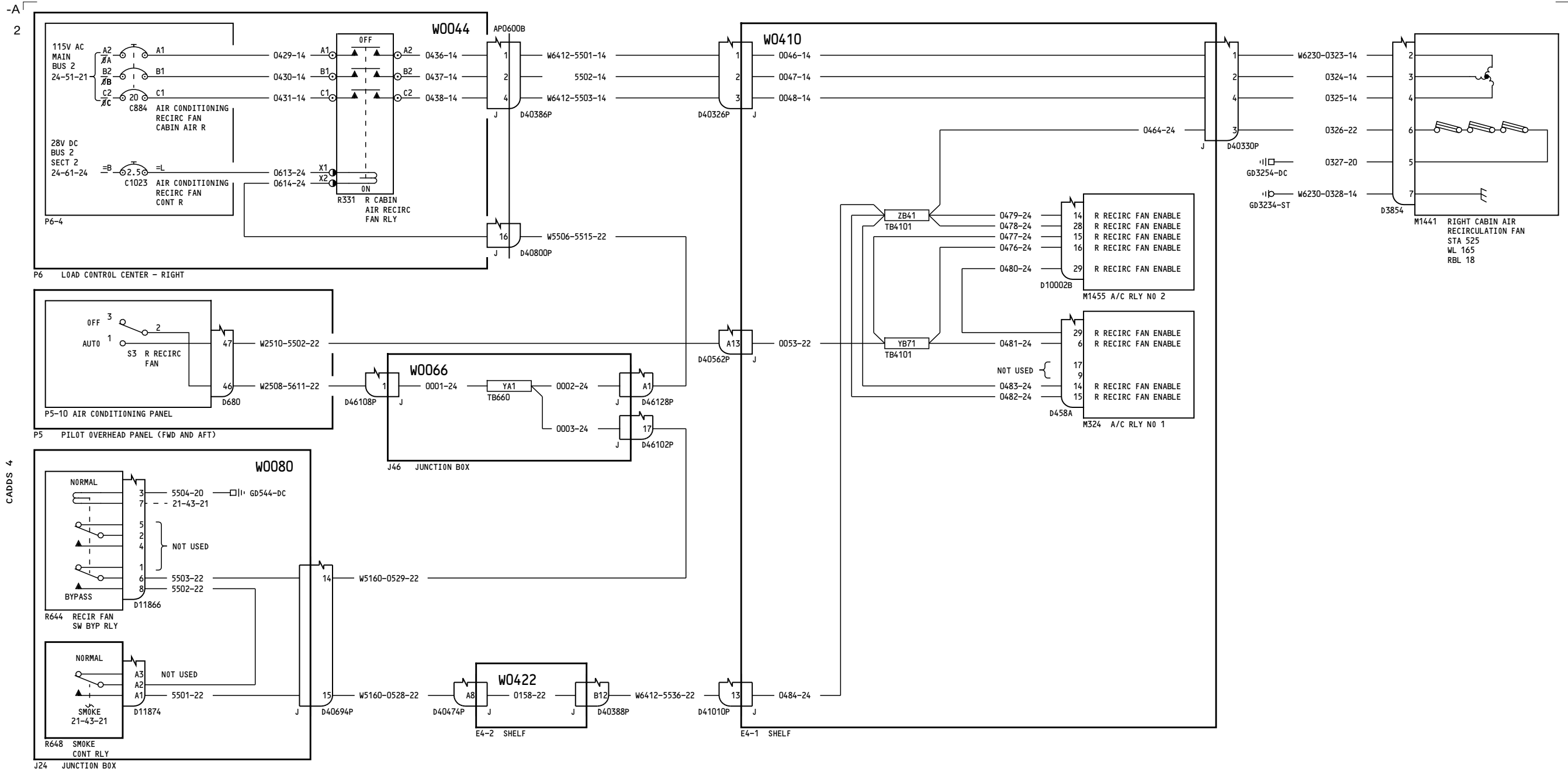

YC004-YC007

**CABIN AIR
RECIRCULATION SYSTEM**

D280A103

21-25-11

Page 2
Sheet 2
Mar 31/2005

21-25-11

Page 2
Sheet 2
Mar 31/2005

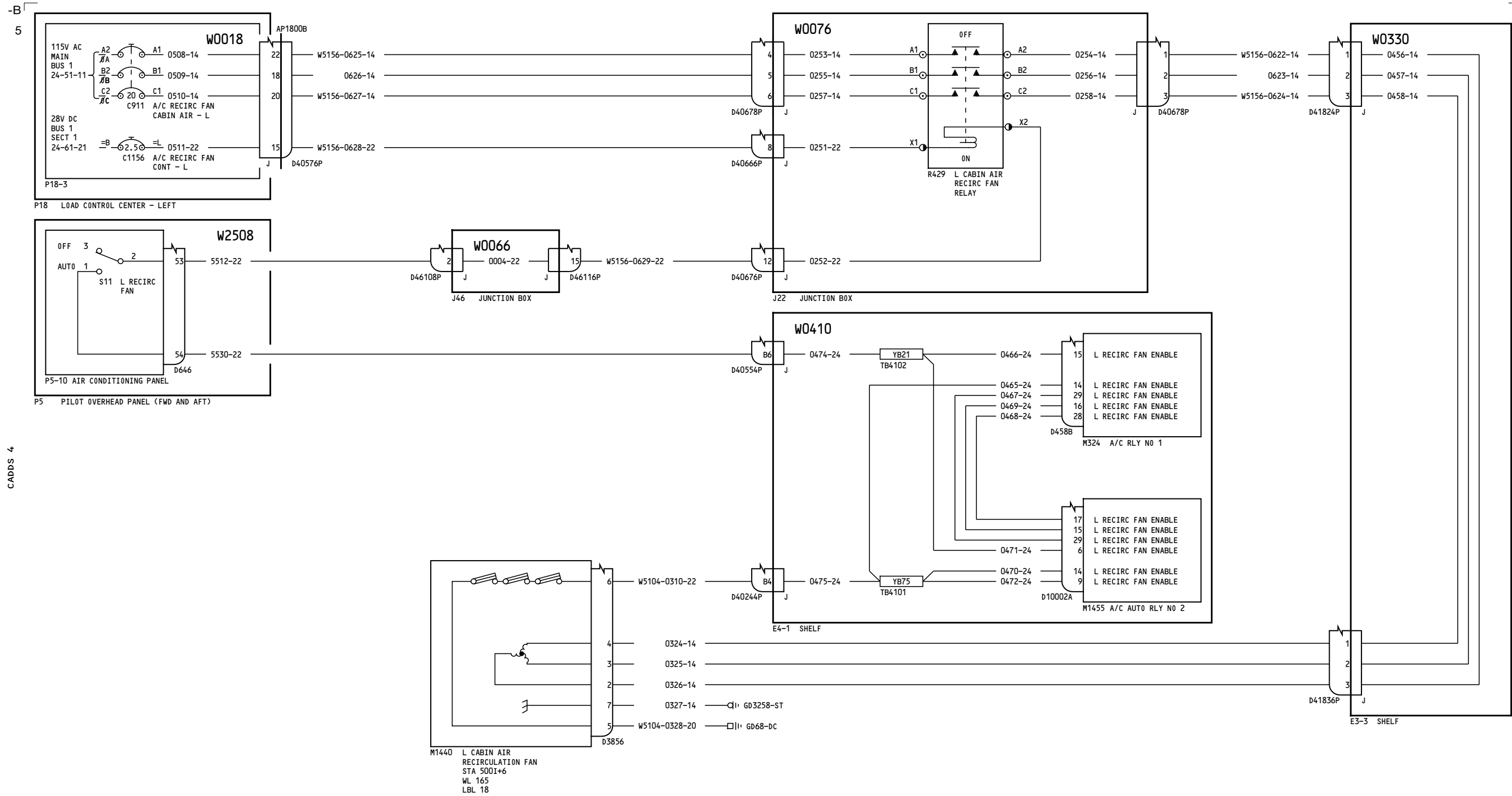

CADDs 4

YC008-YC030

CABIN AIR RECIRCULATION SYSTEM

D280A103

21-25-11

Page 3
Sheet 1
Jul 17/2007

21-25-11

Page 3
Sheet 1
Jul 17/2007

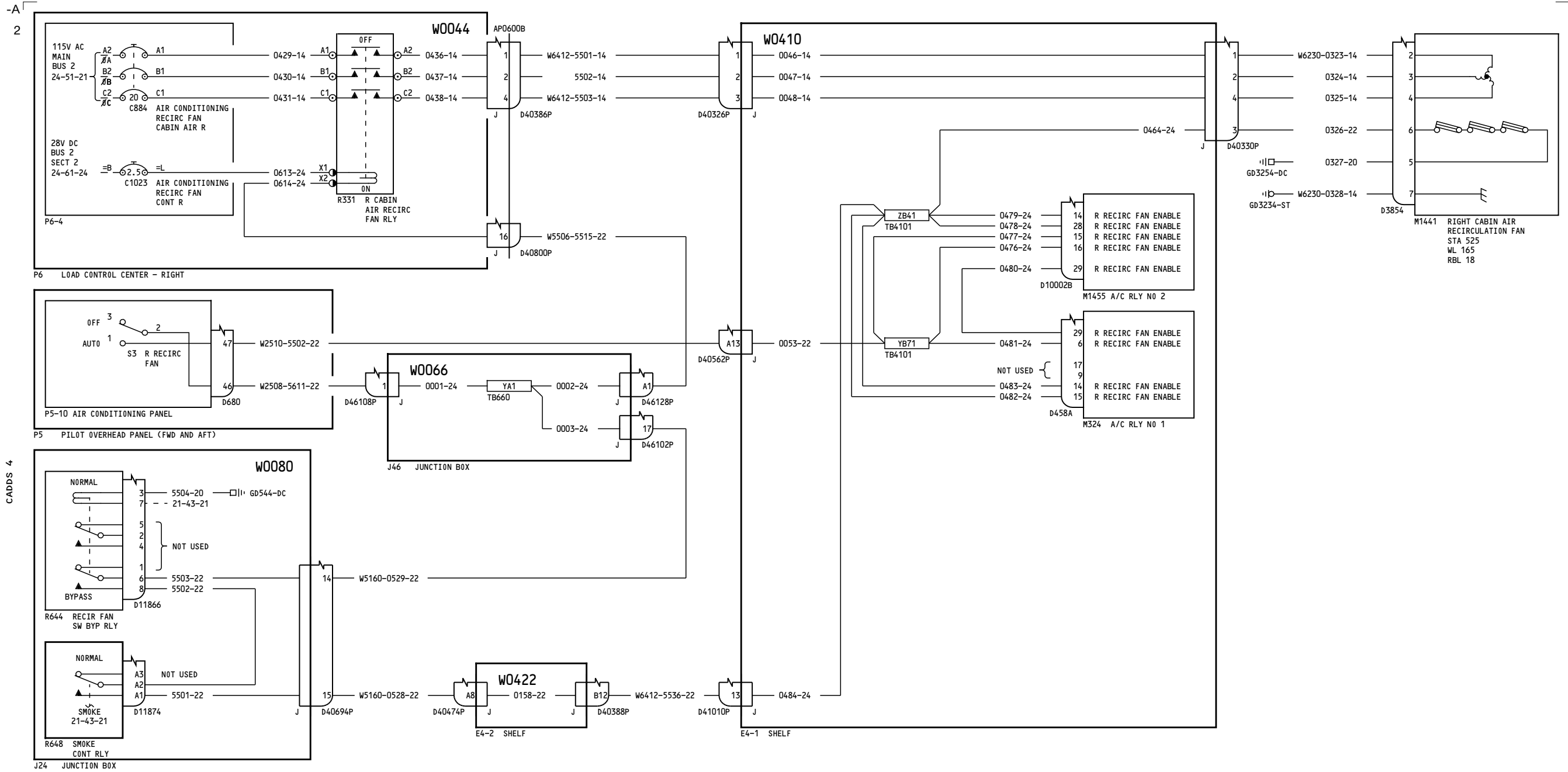

YC008-YC030

**CABIN AIR
RECIRCULATION SYSTEM****21-25-11**Page 3
Sheet 2
Jul 17/2007

D280A103

21-25-11Page 3
Sheet 2
Jul 17/2007

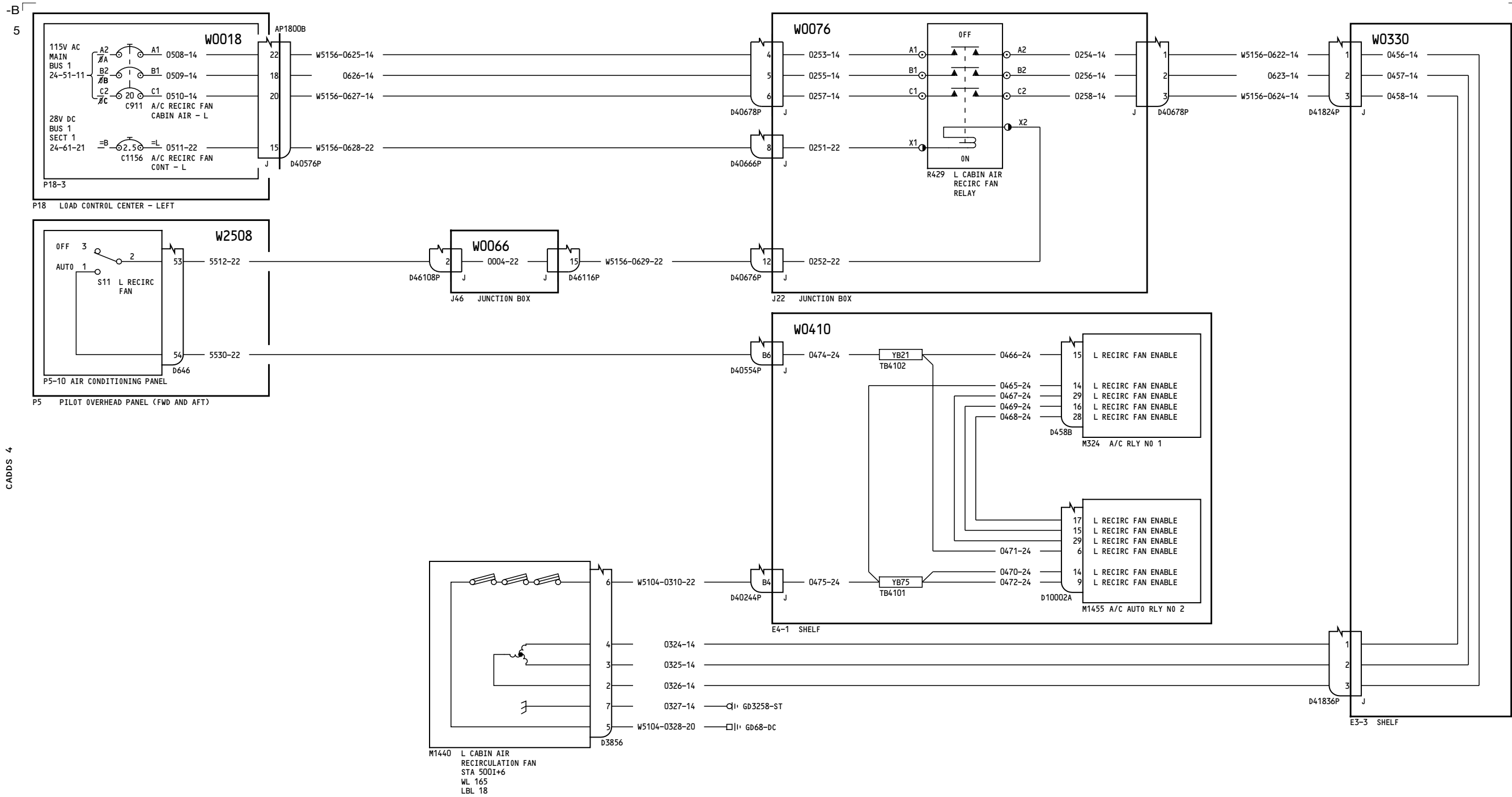

CADDS 4

YC031-YL430

**CABIN AIR
RECIRCULATION SYSTEM**

D280A103

21-25-11

Page 4
Sheet 1
Feb 09/2009

21-25-11

Page 4
Sheet 1
Feb 09/2009

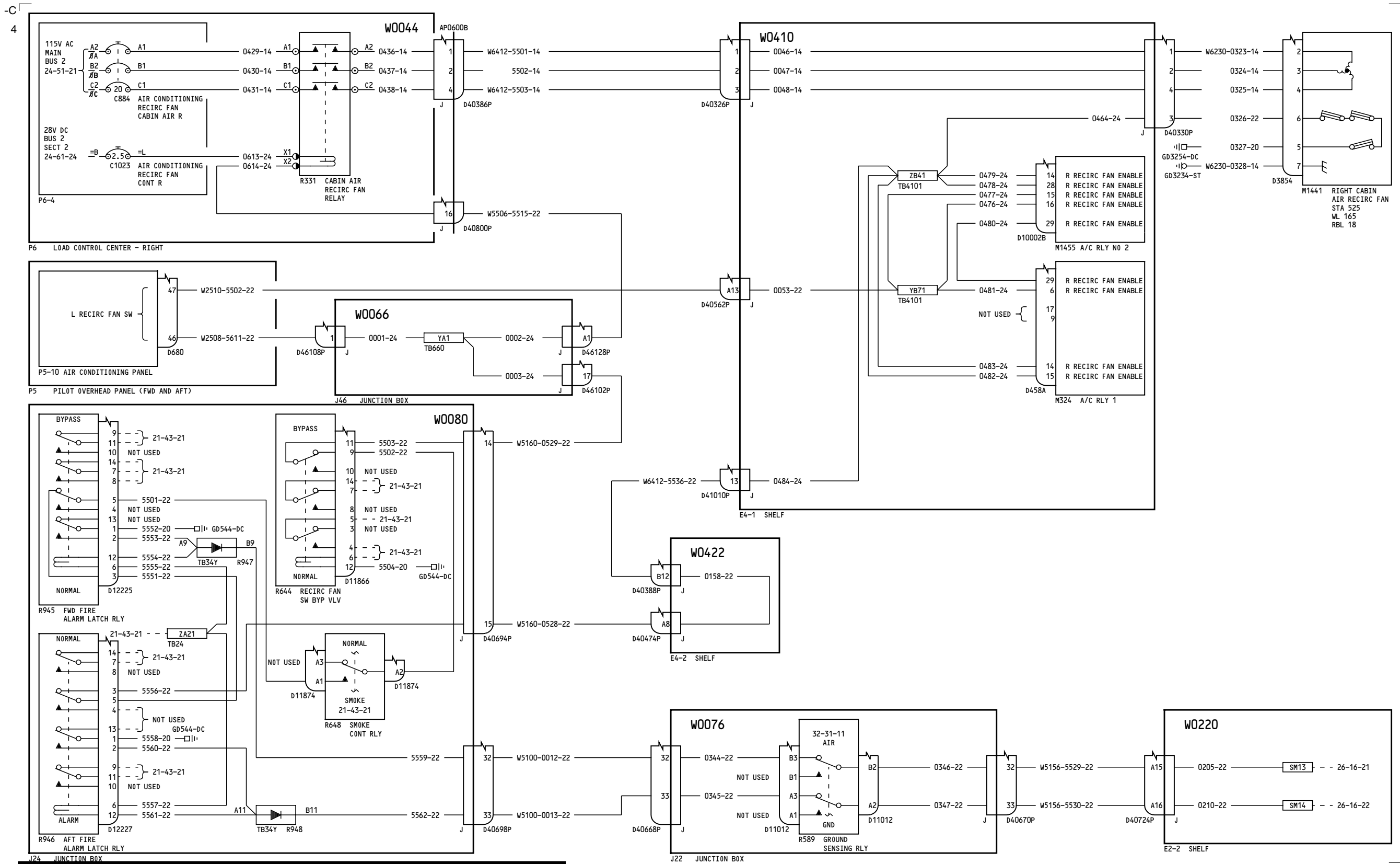

YC031-YL430

CABIN AIR RECIRCULATION SYSTEM

D280A103

21-25-11

Page 4
Sheet 2
Feb 09/2009

21-25-11

Page 4
Sheet 2
Feb 09/2009

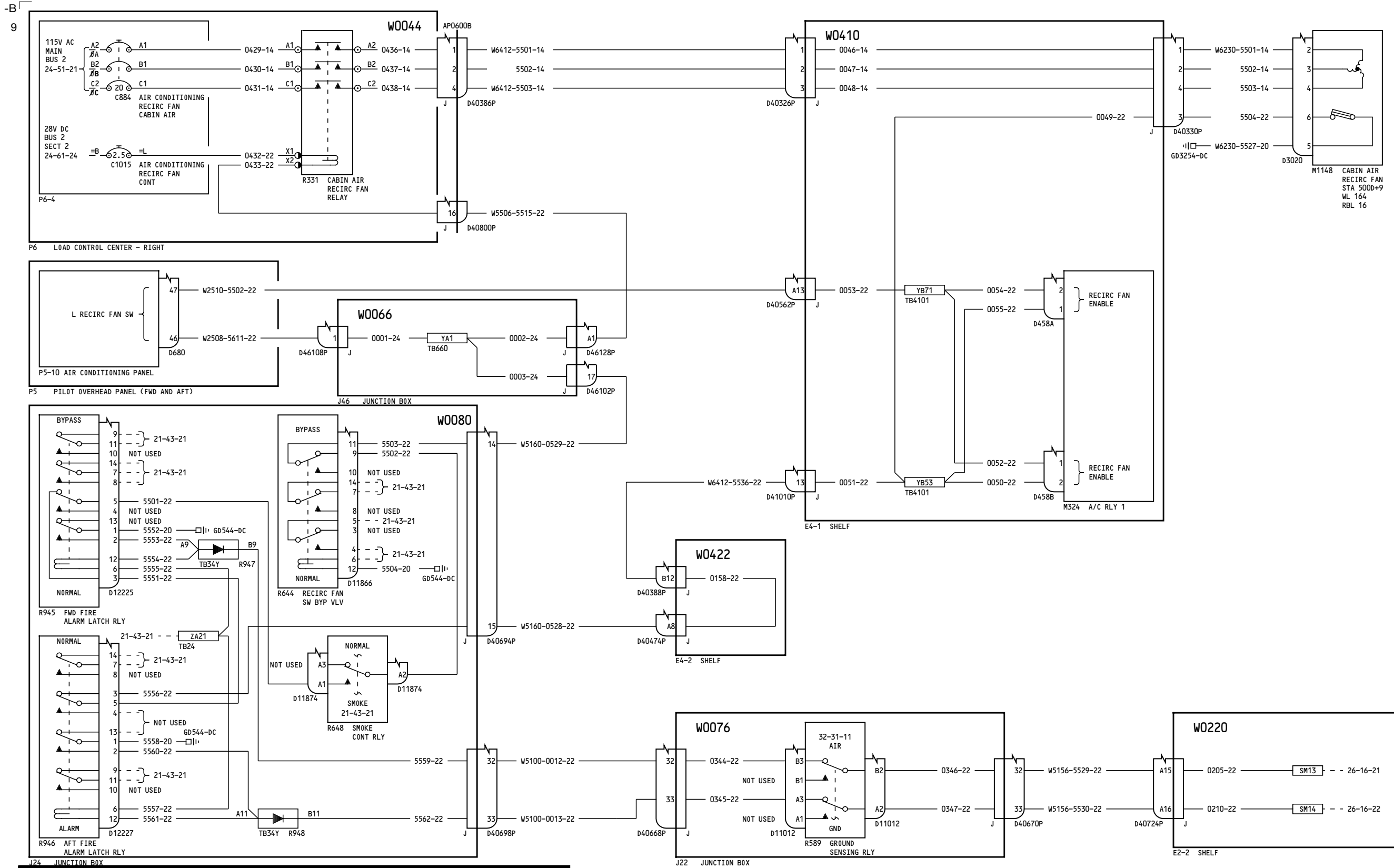

YM643-YM670

CABIN AIR RECIRCULATION SYSTEM

D280A103

21-25-11

Page 5

Jan 14/2008

21-25-11

Page 5

Jan 14/2008

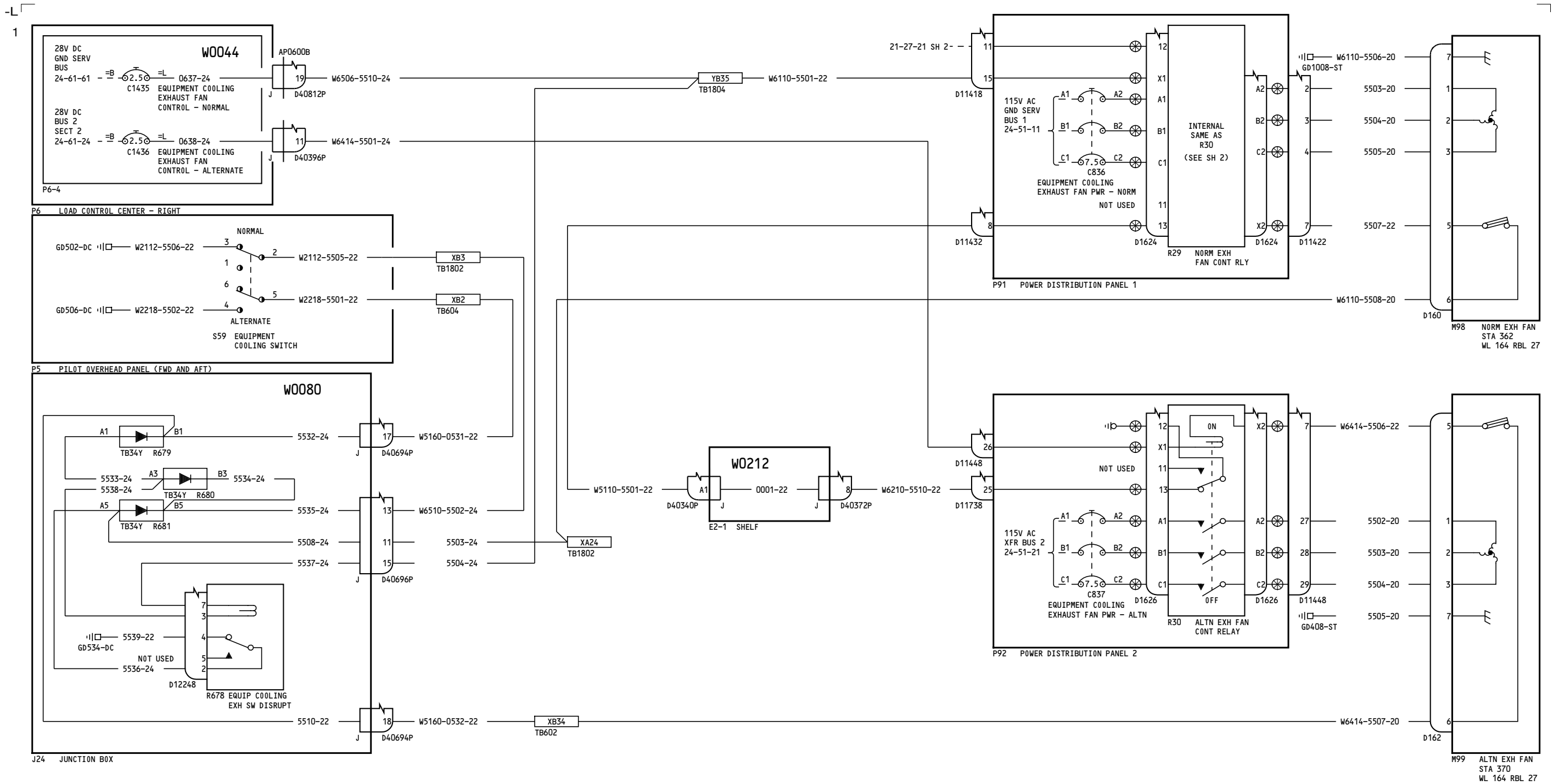

YC001-YC003

EQUIPMENT COOLING EXHAUST

21-27-21

Page 1
Sheet 1
Jul 26/2006

D280A103

21-27-21

Page 1
Sheet 1
Jul 26/2006

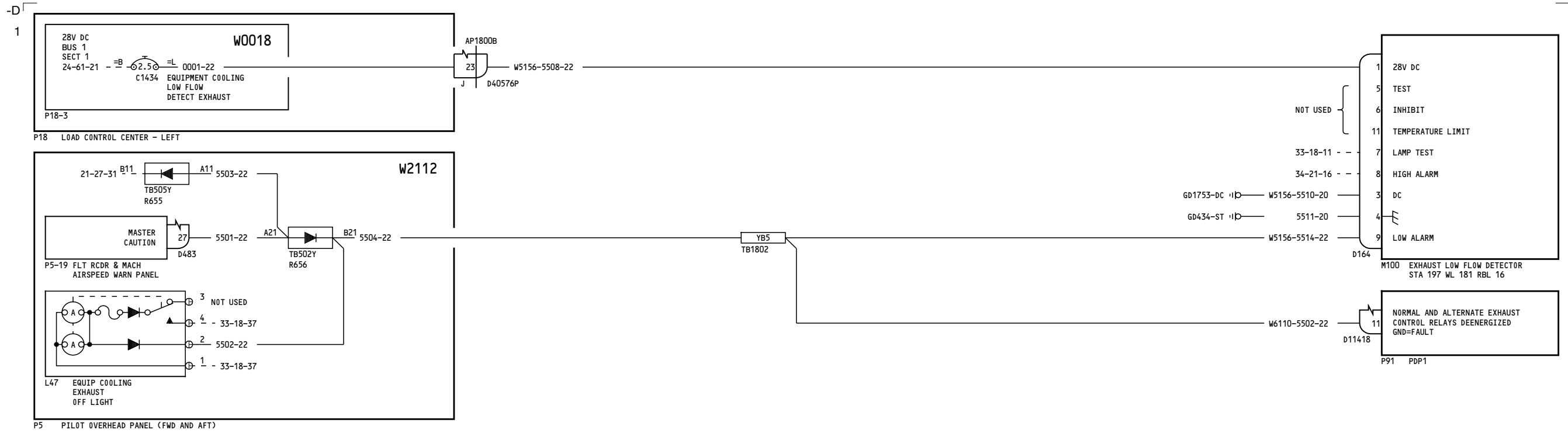

YC001-YC003

EQUIPMENT COOLING EXHAUST

21-27-21

Page 1
 Sheet 2
 Mar 31/2005

D280A103

21-27-21

Page 1
 Sheet 2
 Mar 31/2005

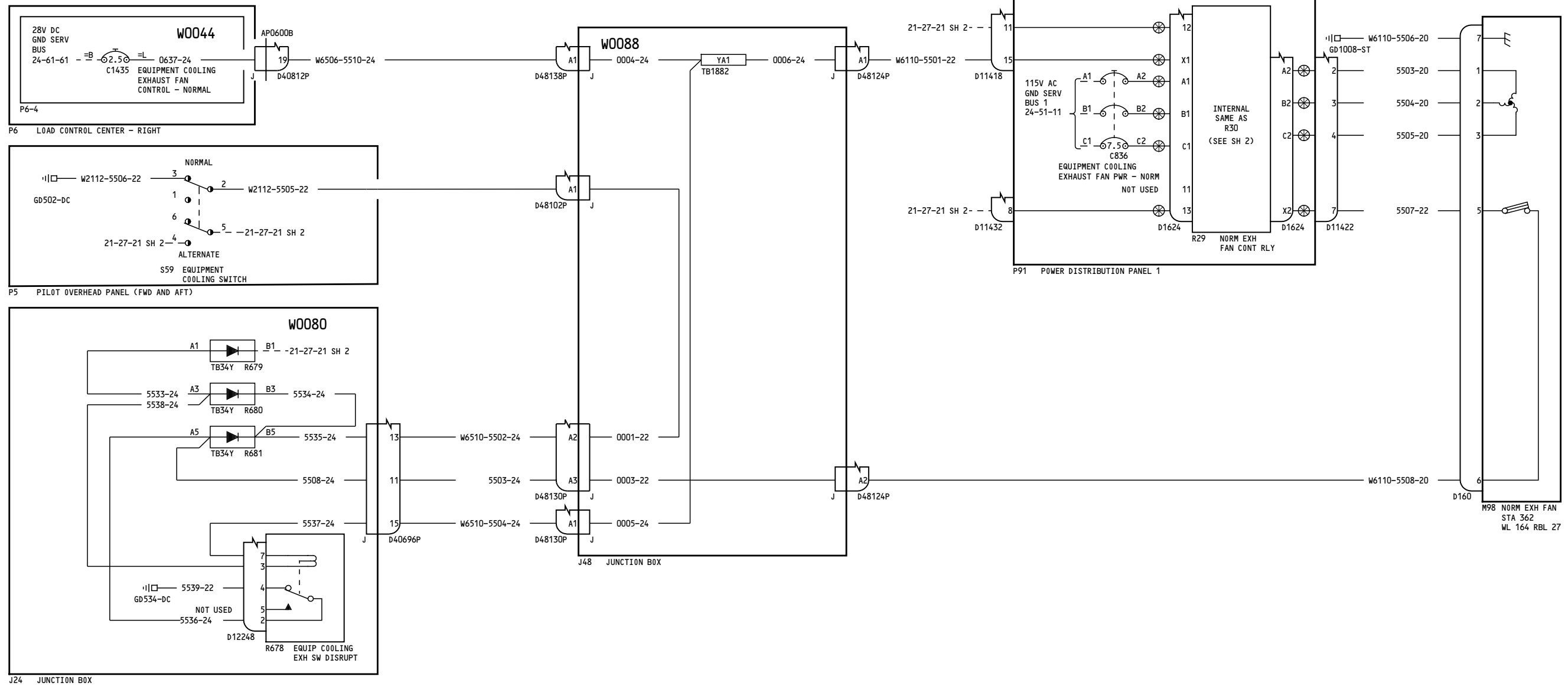

YC004-YC007

EQUIPMENT COOLING EXHAUST

D280A103

21-27-21

Page 2
Sheet 1
Jul 26/2006

21-27-21

Page 2
Sheet 1
Jul 26/2006

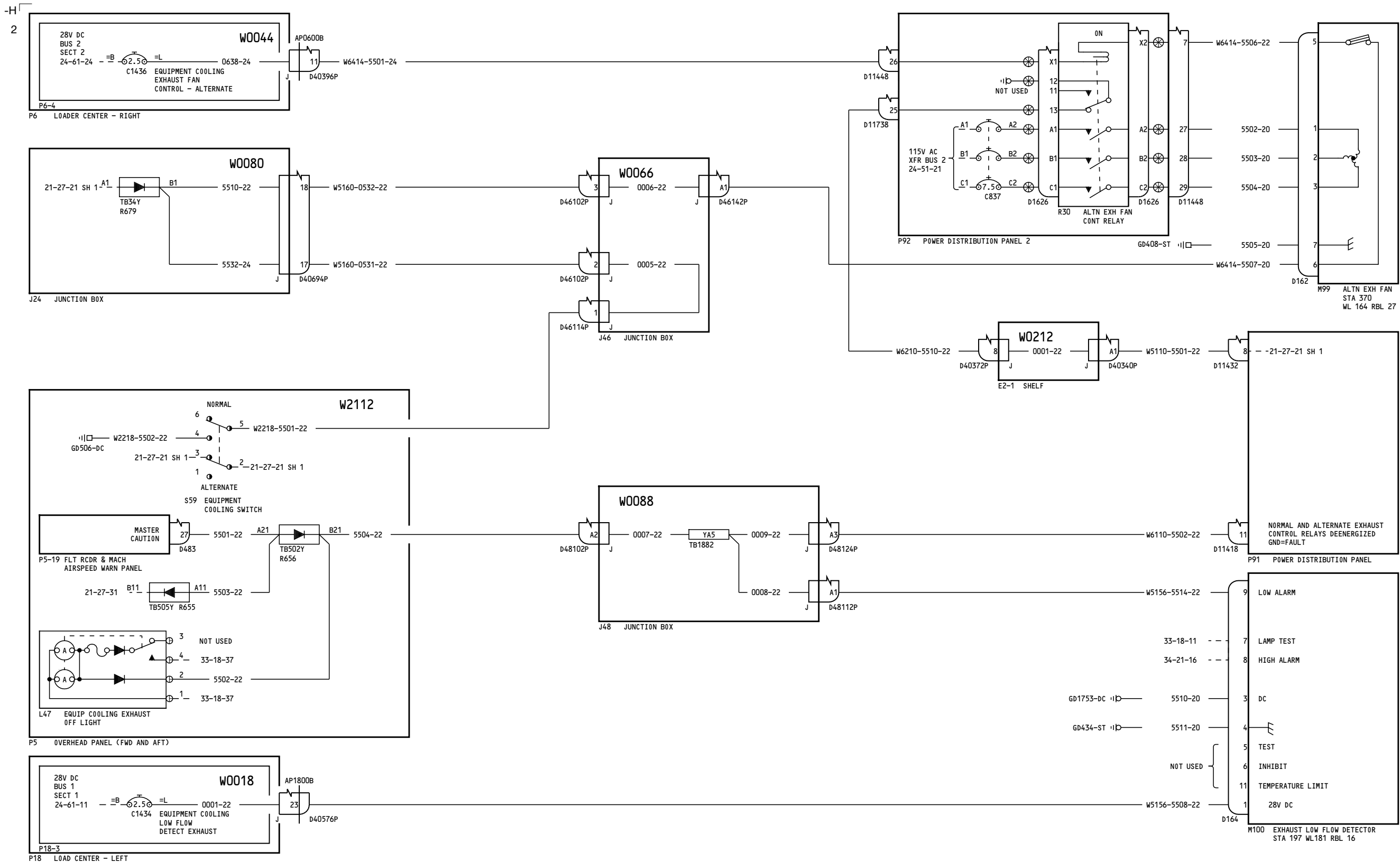

YC004-YC007

EQUIPMENT COOLING EXHAUST

21-27-21

Page 2
Sheet 2
Jan 18/2006

D280A103

21-27-21

Page 2
Sheet 2
Jan 18/2006

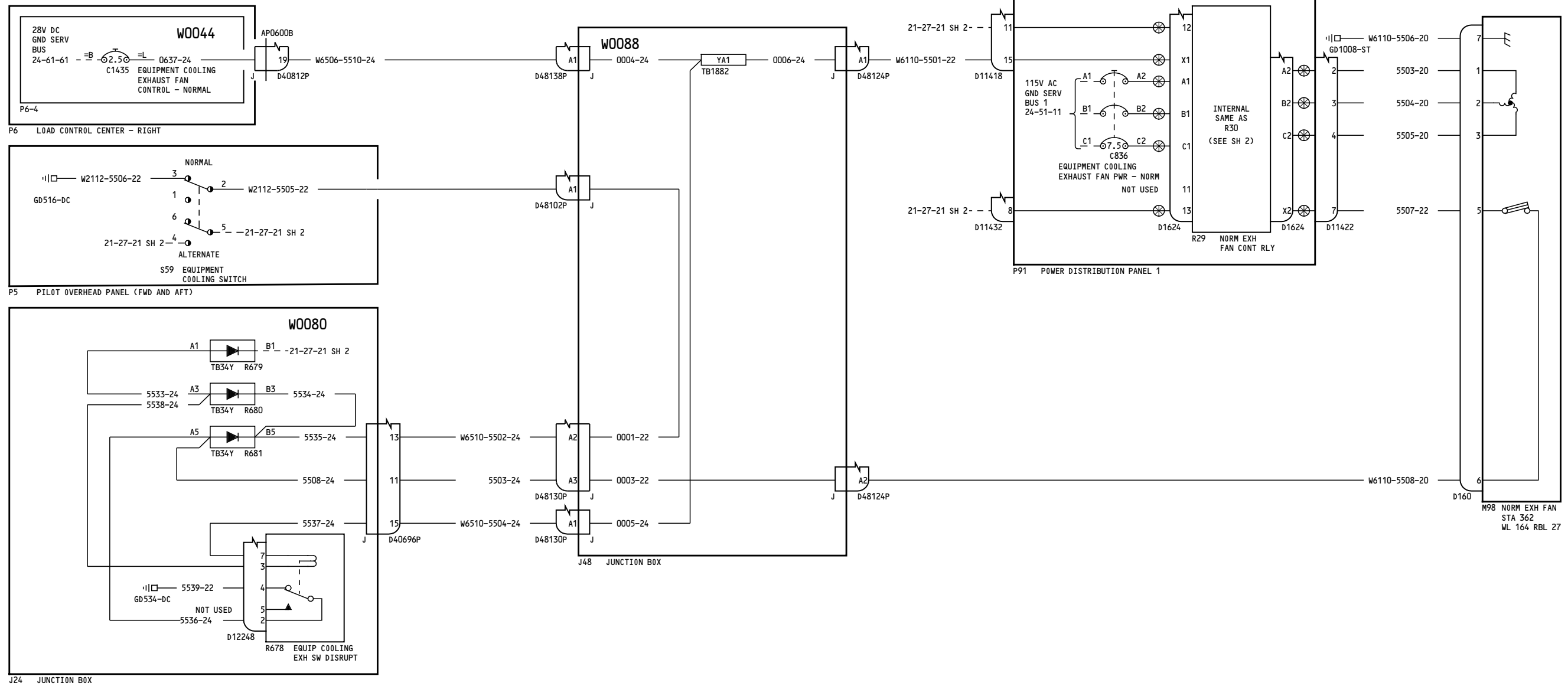

YC008-YC030

EQUIPMENT COOLING EXHAUST

21-27-21

Page 3
Sheet 1
Jul 17/2007

D280A103

21-27-21

Page 3
Sheet 1
Jul 17/2007

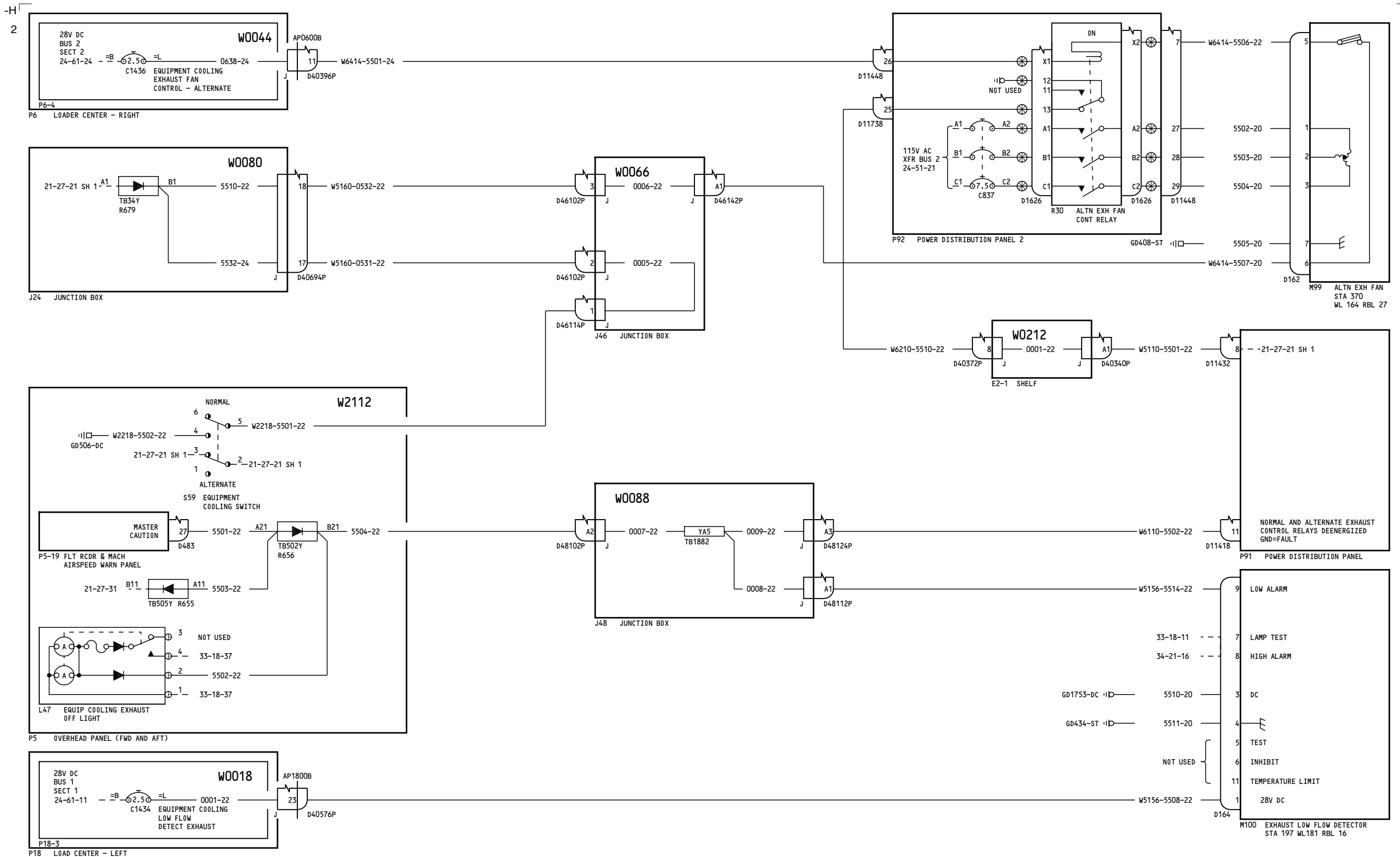

YC008-YC030

EQUIPMENT COOLING EXHAUST

21-27-21

Page 3
Sheet 2
Jul 17/2007

D280A103

21-27-21

Page 3
Sheet 2
Jul 17/2007

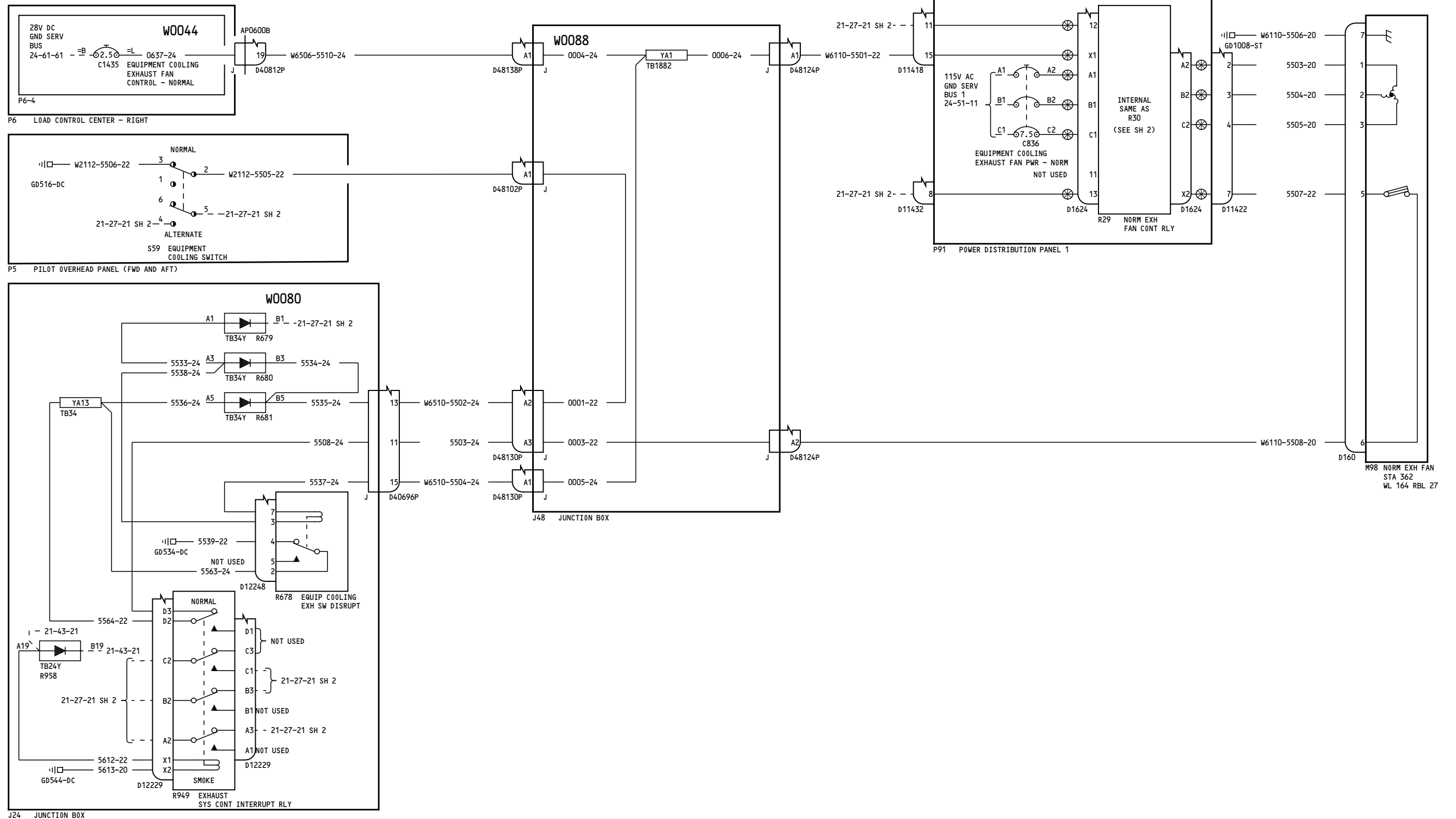

YC031-YM670

EQUIPMENT COOLING EXHAUST

21-27-21

Page 4
Sheet 1
Feb 09/2009

D280A103

21-27-21

Page 4
Sheet 1
Feb 09/2009

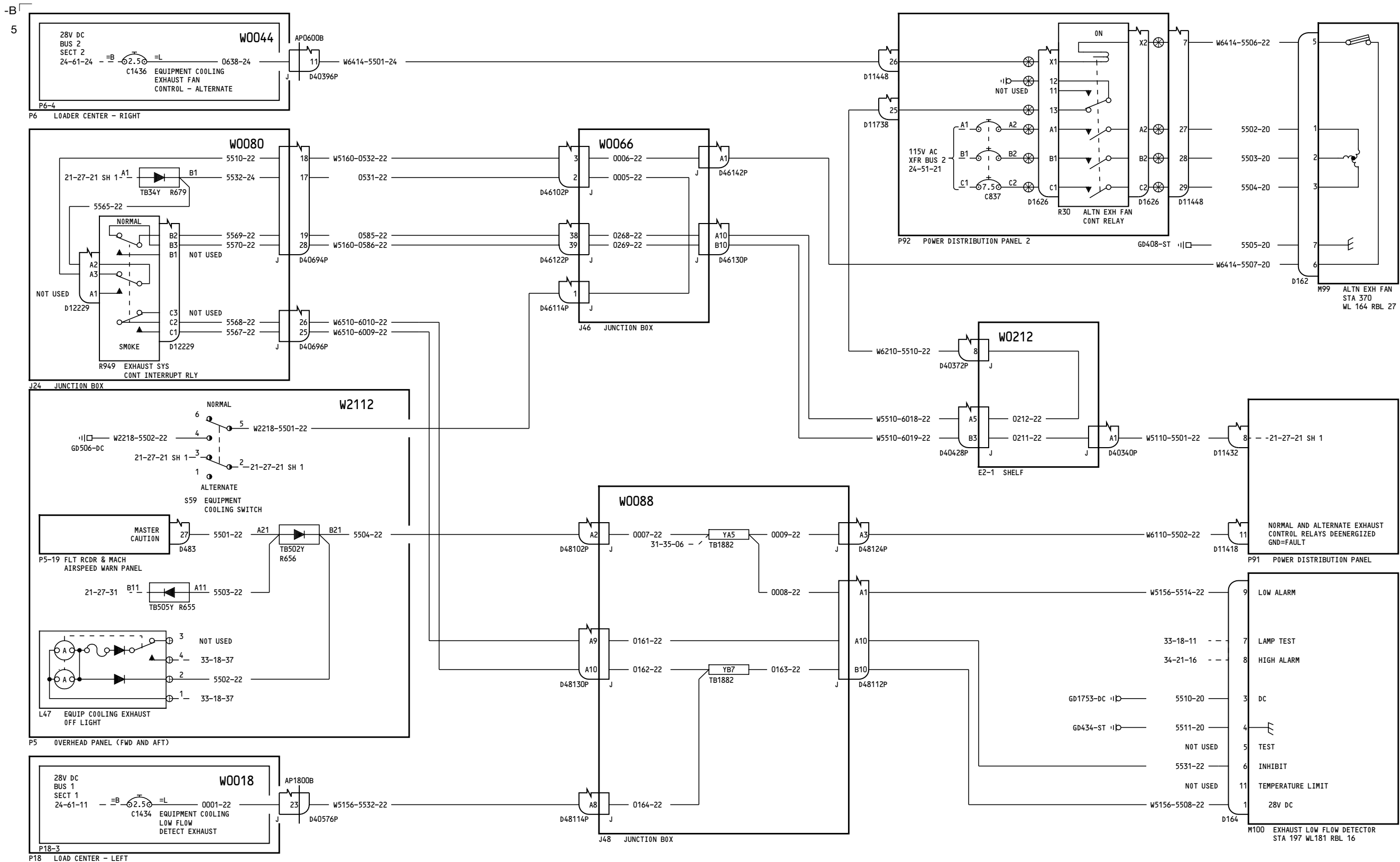

YC031-YM670

EQUIPMENT COOLING EXHAUST

21-27-21

Page 4
Sheet 2
Feb 09/2009

D280A103

21-27-21

Page 4
Sheet 2
Feb 09/2009

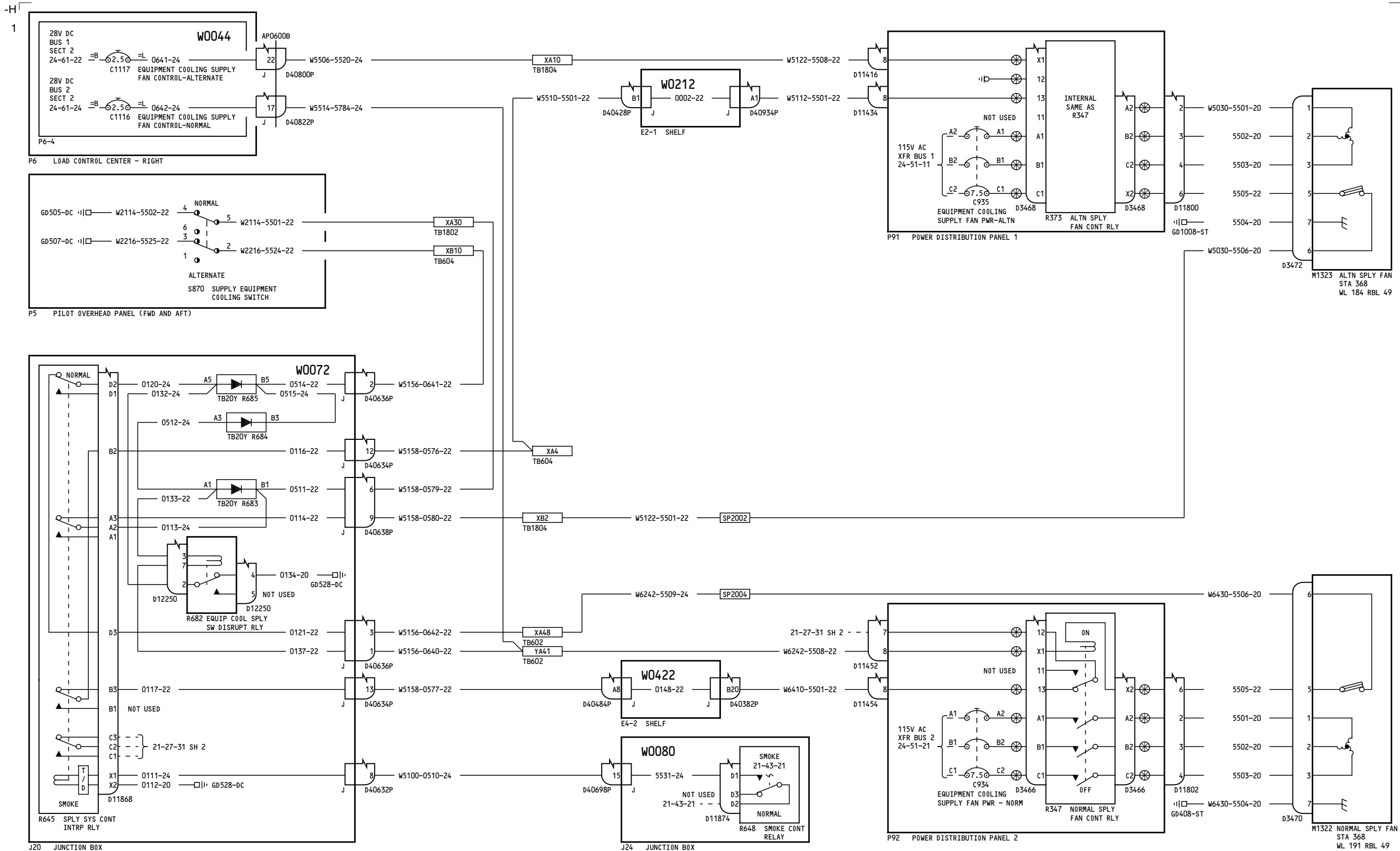

YC001-YC003

EQUIPMENT COOLING SUPPLY

21-27-31

Page 1
Sheet 1
Mar 31/2005

D280A103

21-27-31

Page 1
Sheet 1
Mar 31/2005

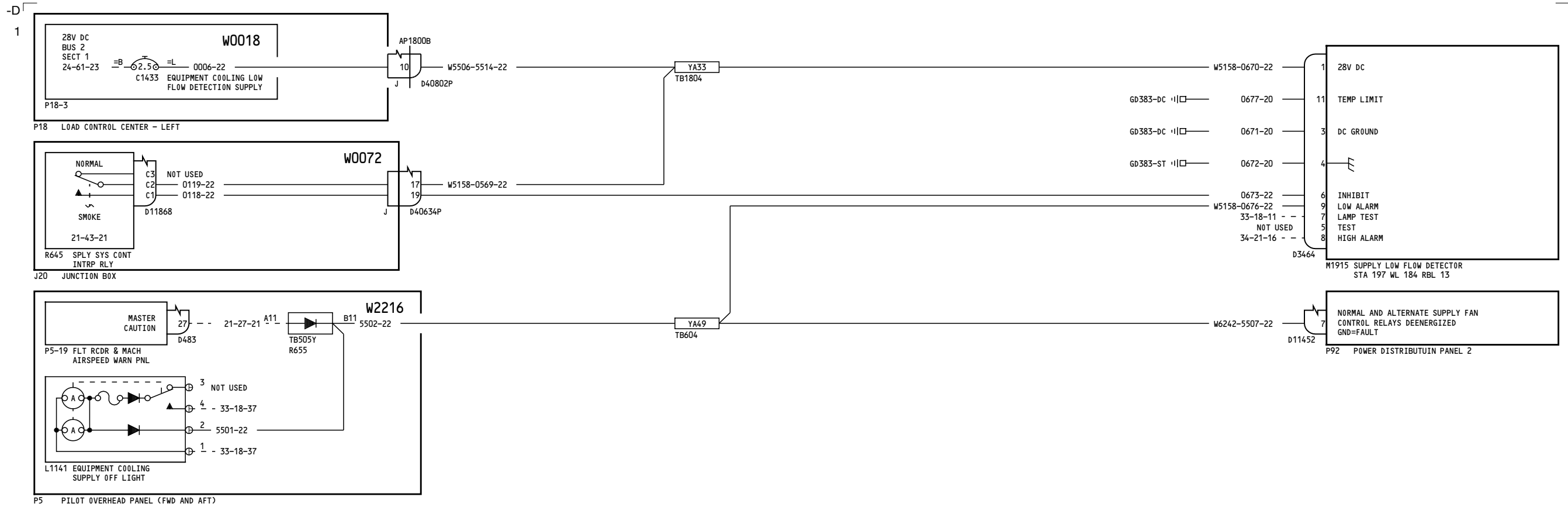

YC001-YC003

EQUIPMENT COOLING SUPPLY

21-27-31

Page 1
Sheet 2
Mar 31/2005

D280A103

21-27-31

Page 1
Sheet 2
Mar 31/2005

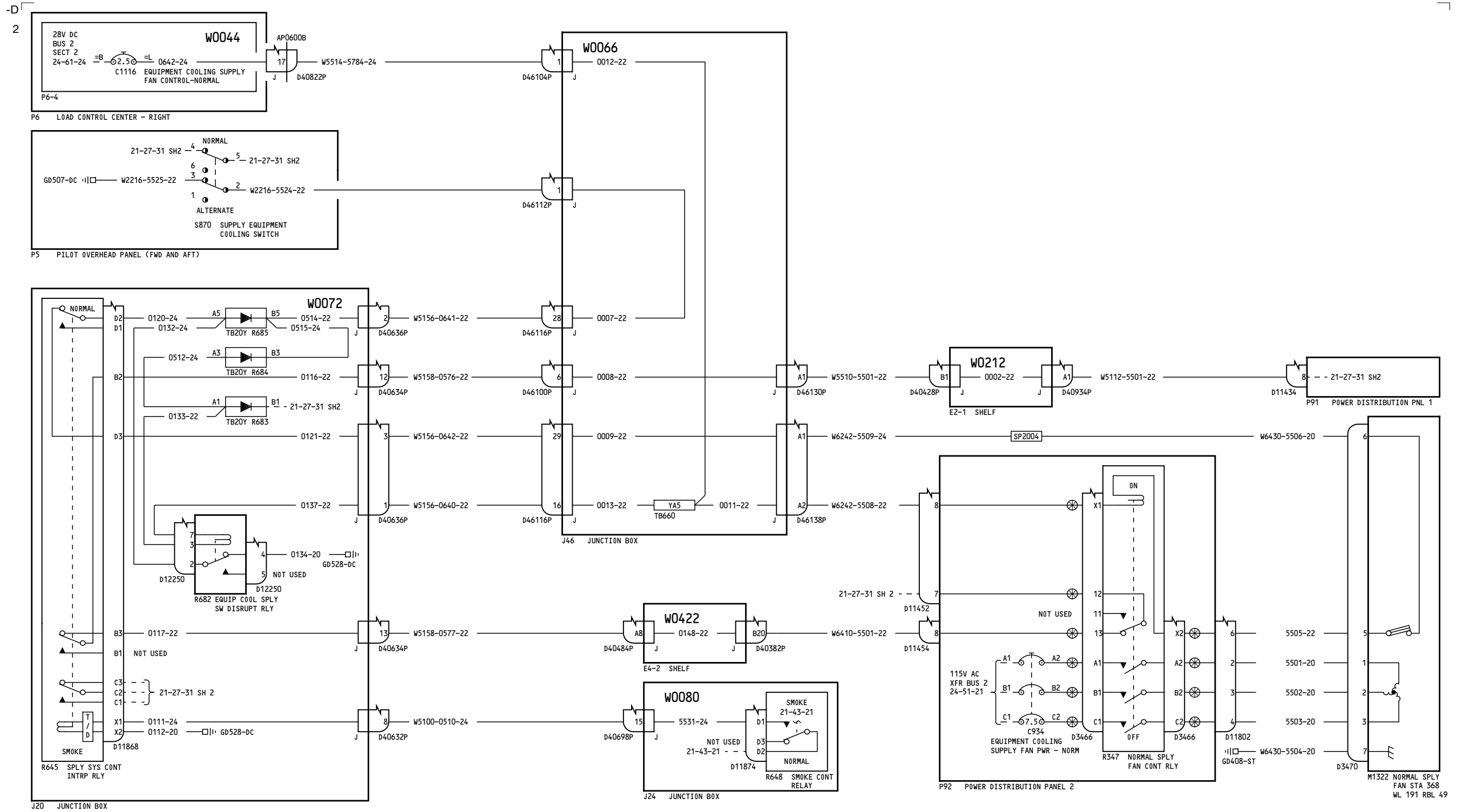

YC004-YC007

EQUIPMENT COOLING SUPPLY

21-27-31

Page 2
Sheet 1
Mar 31/2005

D280A103

21-27-31

Page 2
Sheet 1
Mar 31/2005

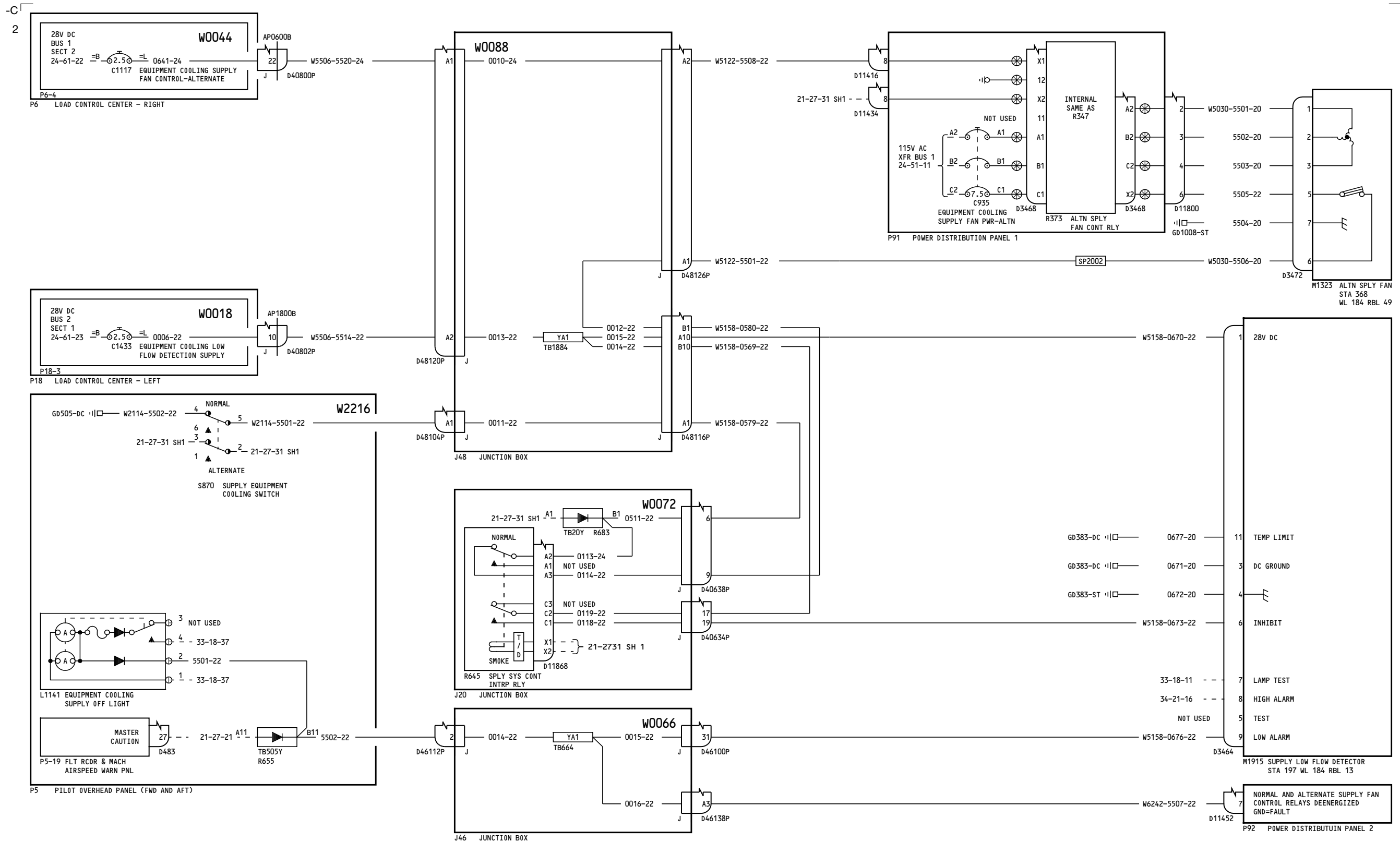

YC004-YC007

EQUIPMENT COOLING SUPPLY

21-27-31

Page 2
Sheet 2
Mar 31/2005

D280A103

21-27-31

Page 2
Sheet 2
Mar 31/2005

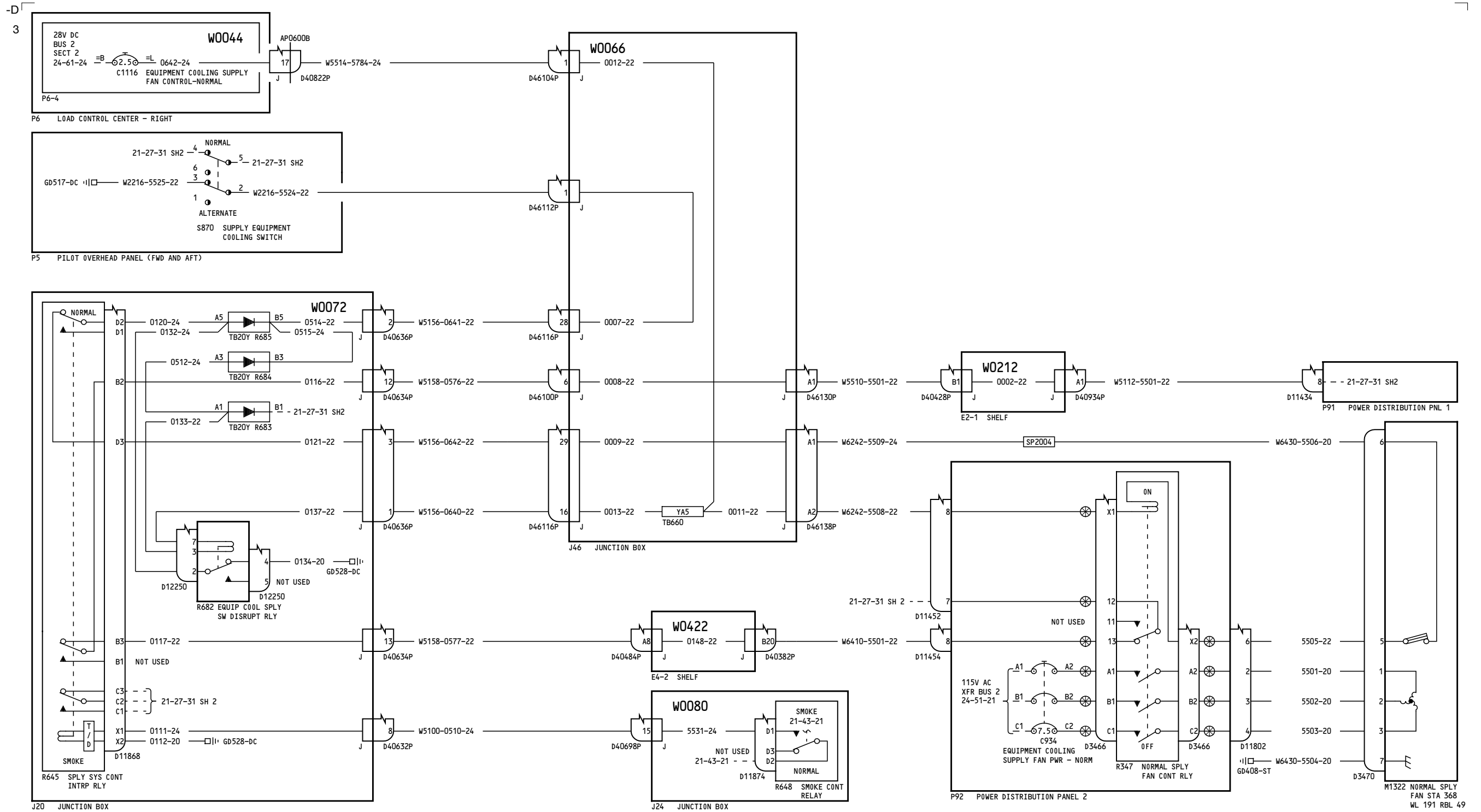

YC008-YC030

EQUIPMENT COOLING SUPPLY

21-27-31

Page 3
Sheet 1
Jul 17/2007

D280A103

21-27-31

Page 3
Sheet 1
Jul 17/2007

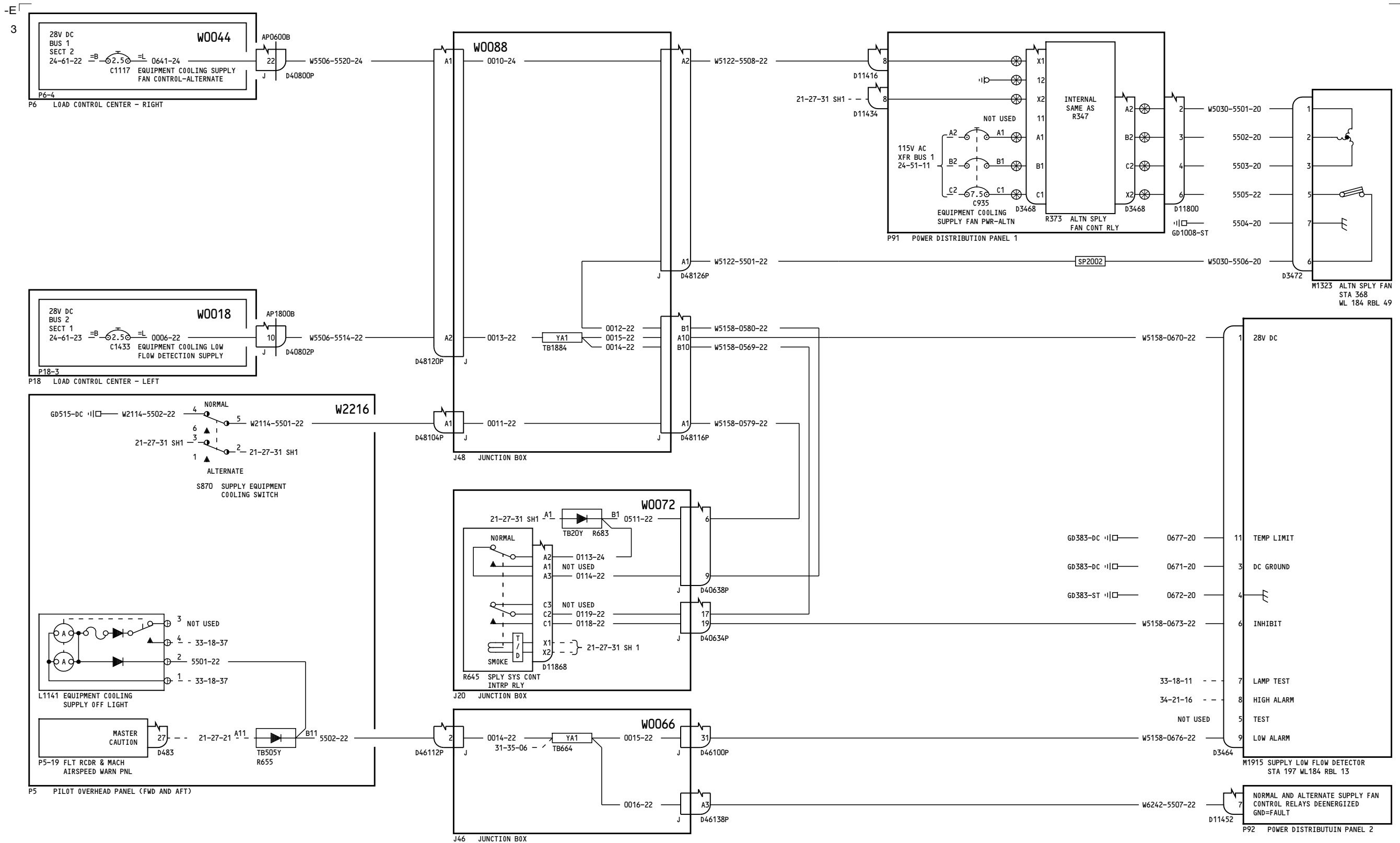

YC008-YC030

EQUIPMENT COOLING SUPPLY

21-27-31

Page 3
Sheet 2
Jul 17/2007

D280A103

21-27-31

Page 3
Sheet 2
Jul 17/2007

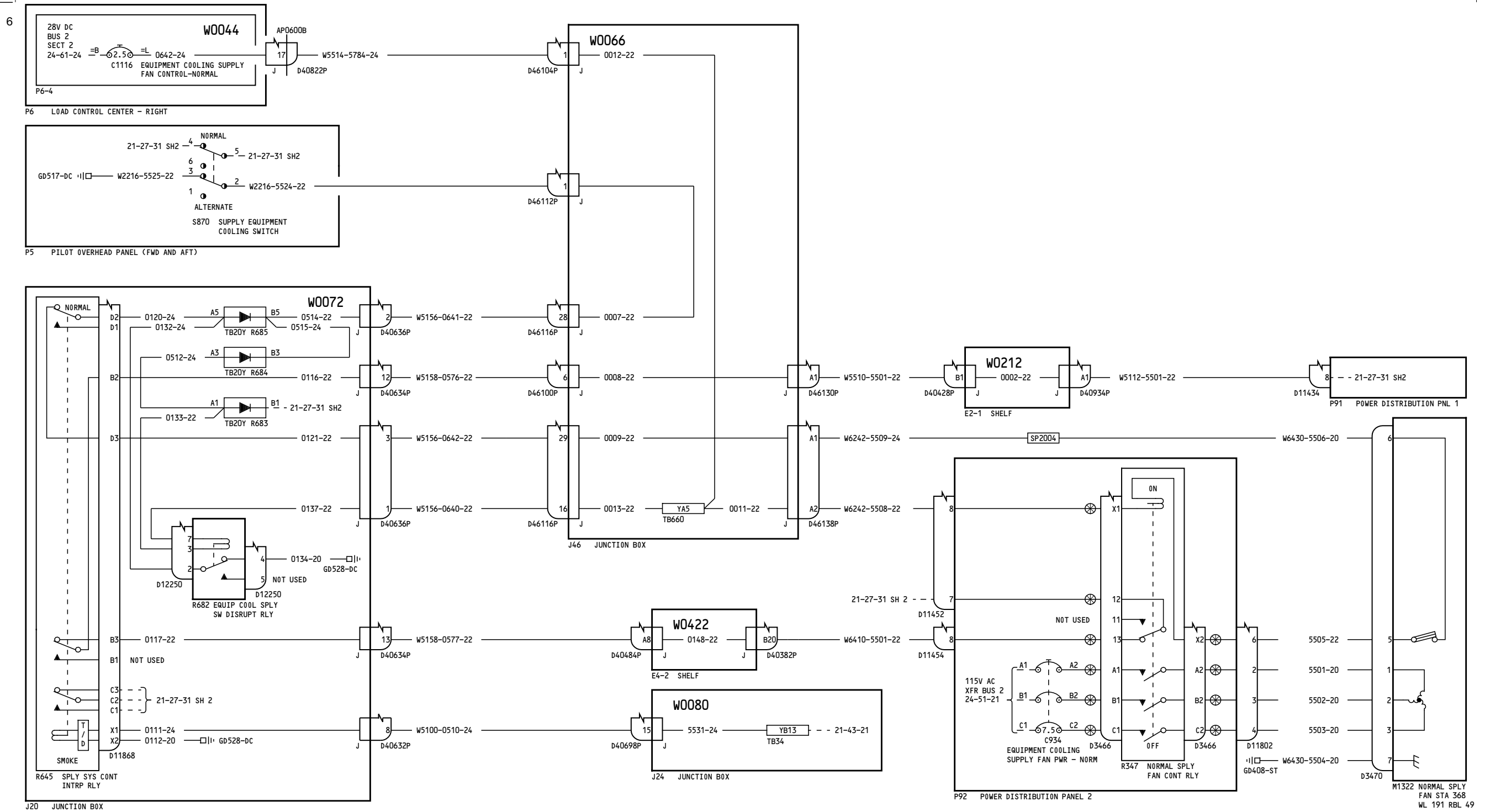

YC031-YM670

EQUIPMENT COOLING SUPPLY

21-27-31

Page 4
Sheet 1
Feb 09/2009

D280A103

21-27-31

Page 4
Sheet 1
Feb 09/2009

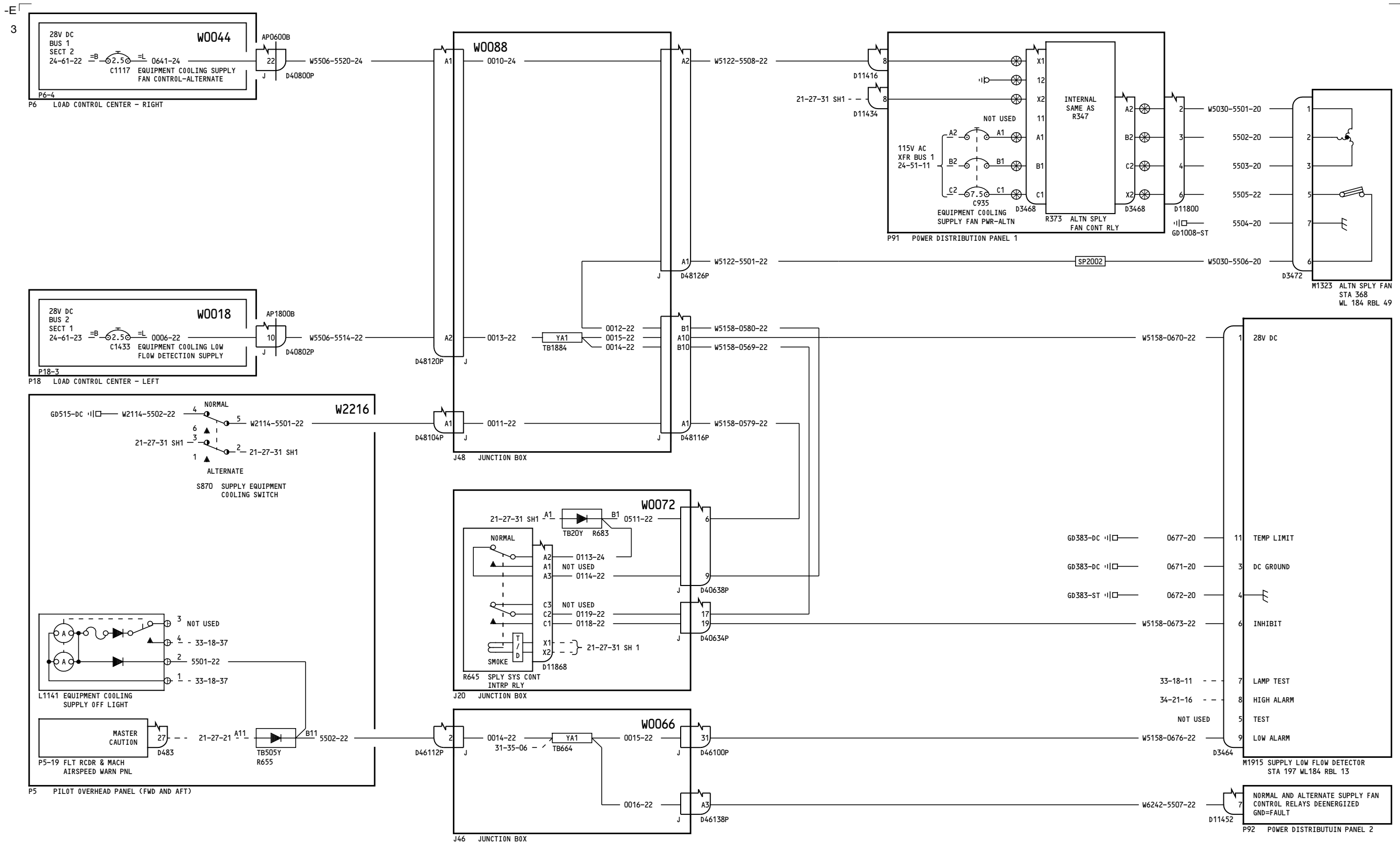

YC031-YM670

EQUIPMENT COOLING SUPPLY

21-27-31

Page 4
Sheet 2
Feb 09/2009

D280A103

21-27-31

Page 4
Sheet 2
Feb 09/2009

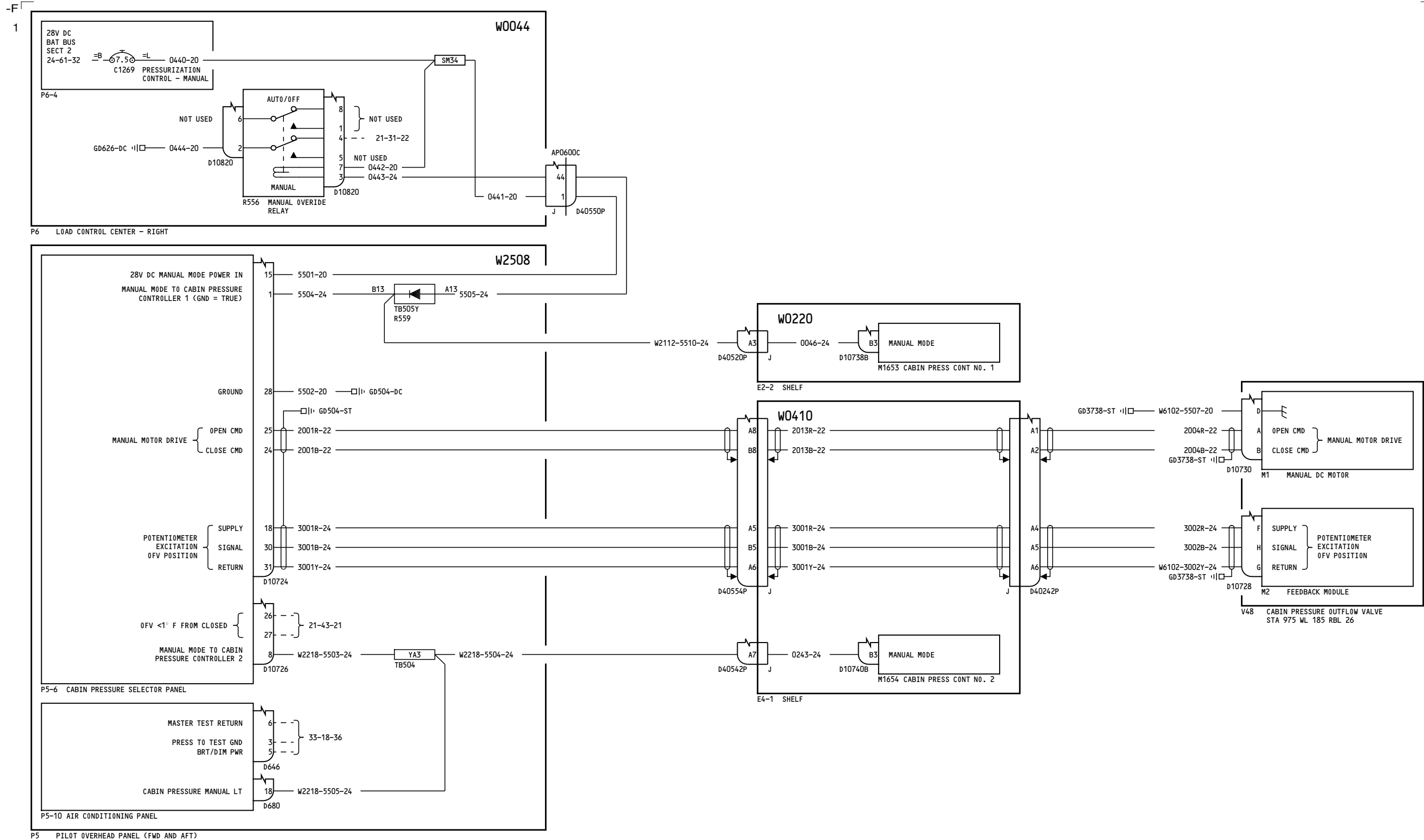

YC001-YC007

**PRESSURIZATION CONTROL
MANUAL MODE**

21-31-11

Page 1

D280A103

Jul 26/2006

21-31-11

Page 1

Jul 26/2006

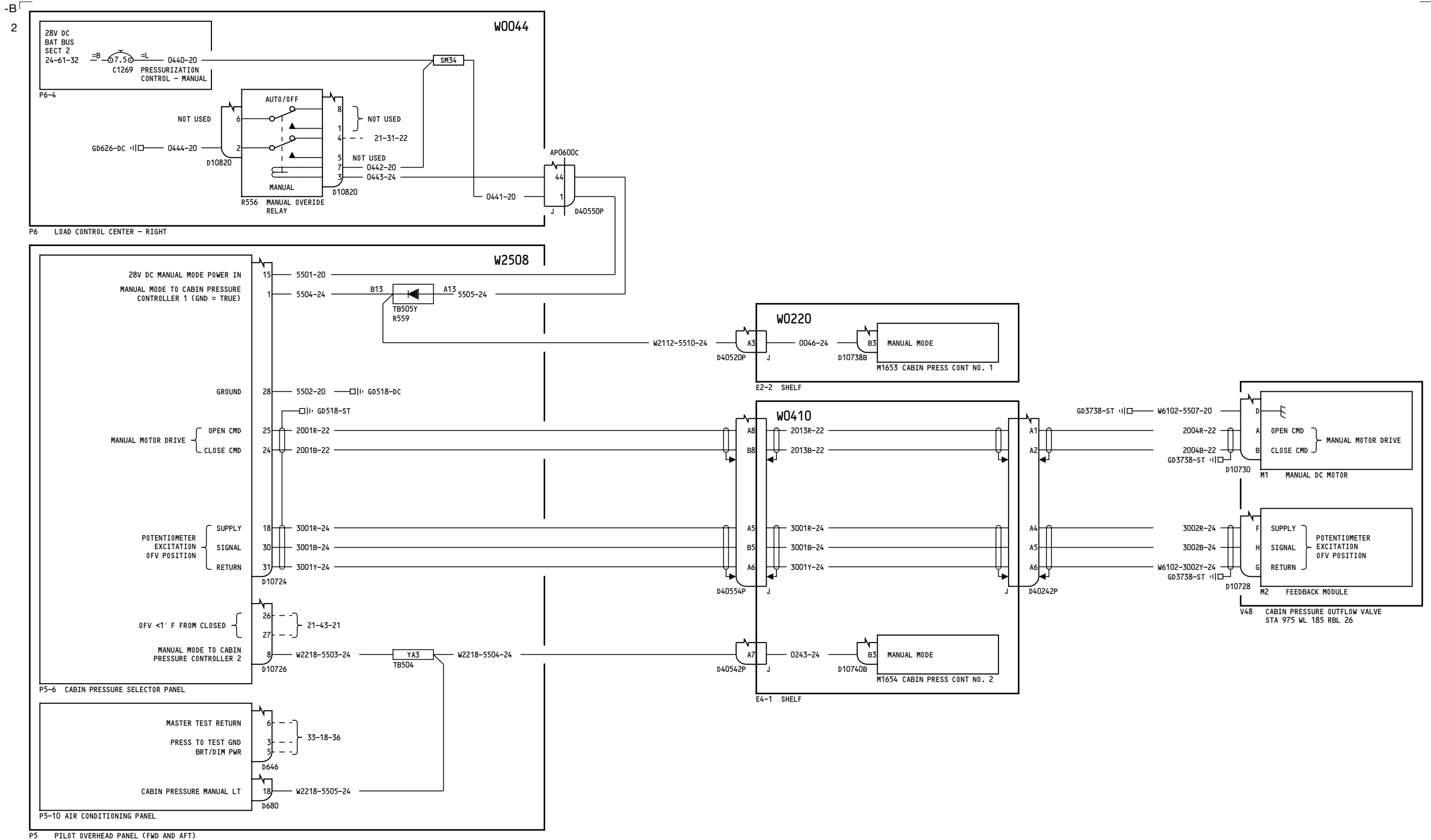

YC008-YC030

PRESSURIZATION CONTROL
MANUAL MODE

21-31-11

Page 2

D280A103

Jul 17/2007

21-31-11

Page 2

Jul 17/2007

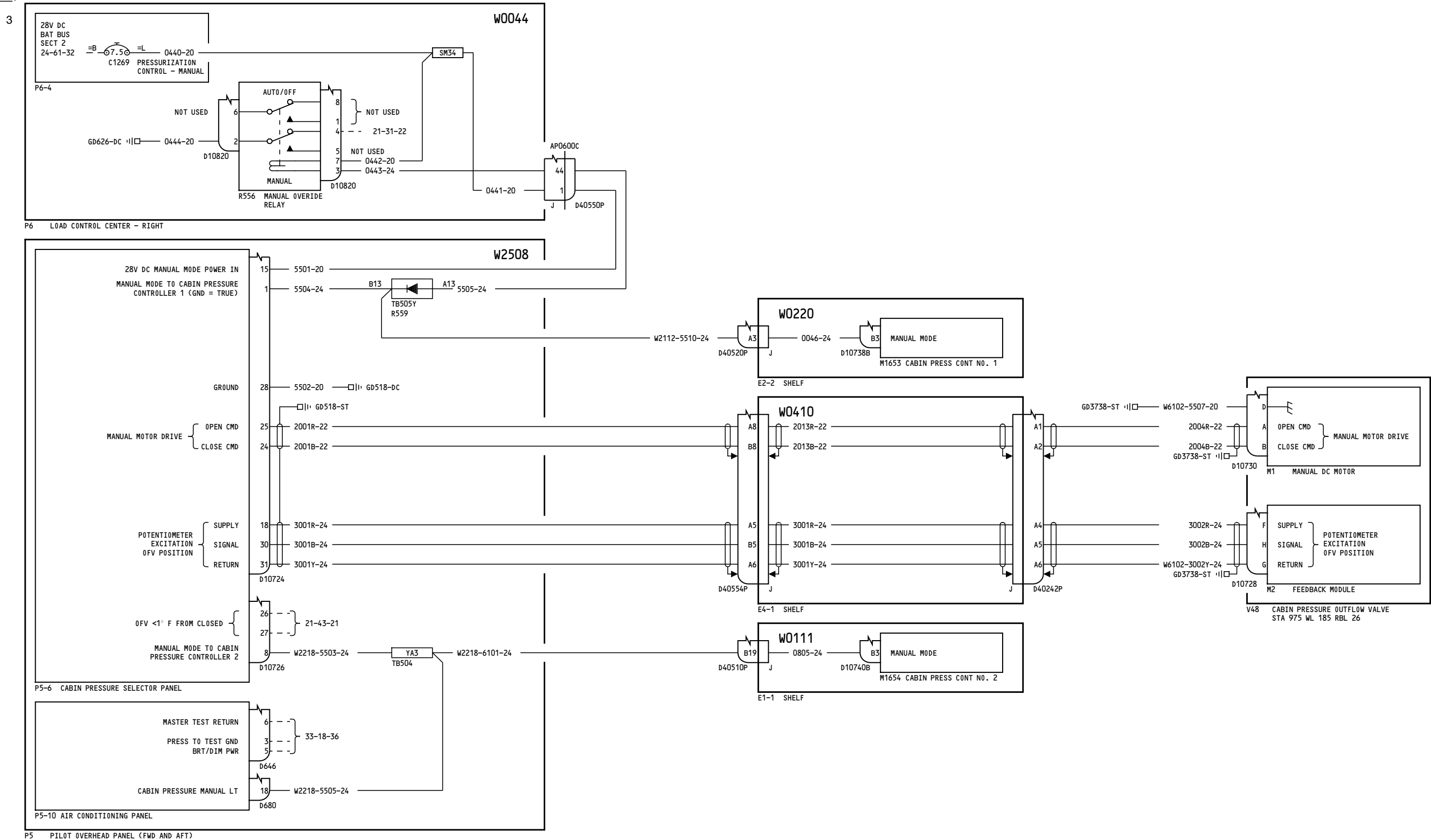

YC031-YM670

**PRESSURIZATION CONTROL
MANUAL MODE**

21-31-11

Page 3

D280A103

Feb 09/2009

21-31-11

Page 3

Feb 09/2009

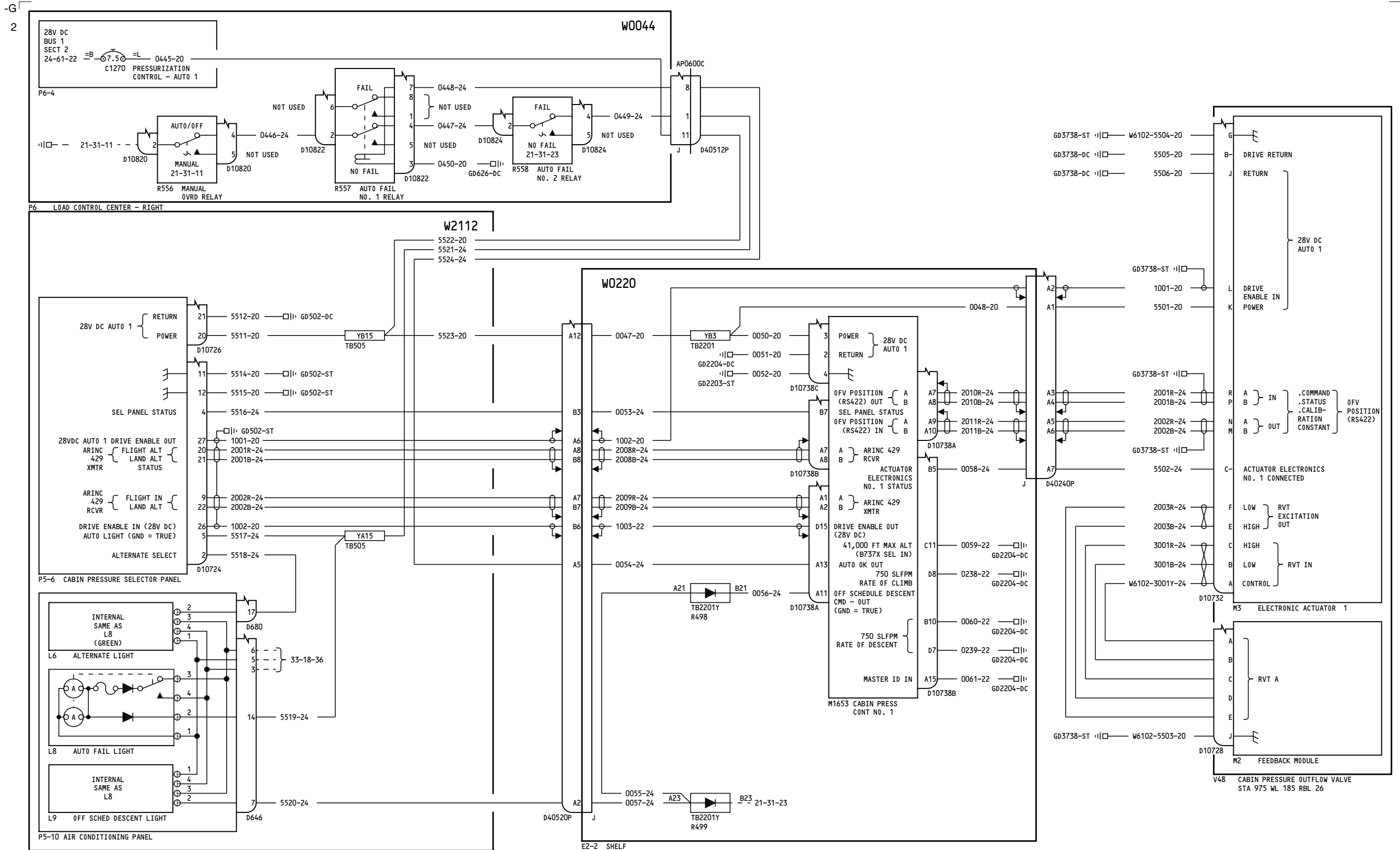

YC001-YC007

**PRESSURIZATION CONTROL
AUTO 1**

21-31-22

Page 1

D280A103

Oct 20/2006

21-31-22

Page 1

Oct 20/2006

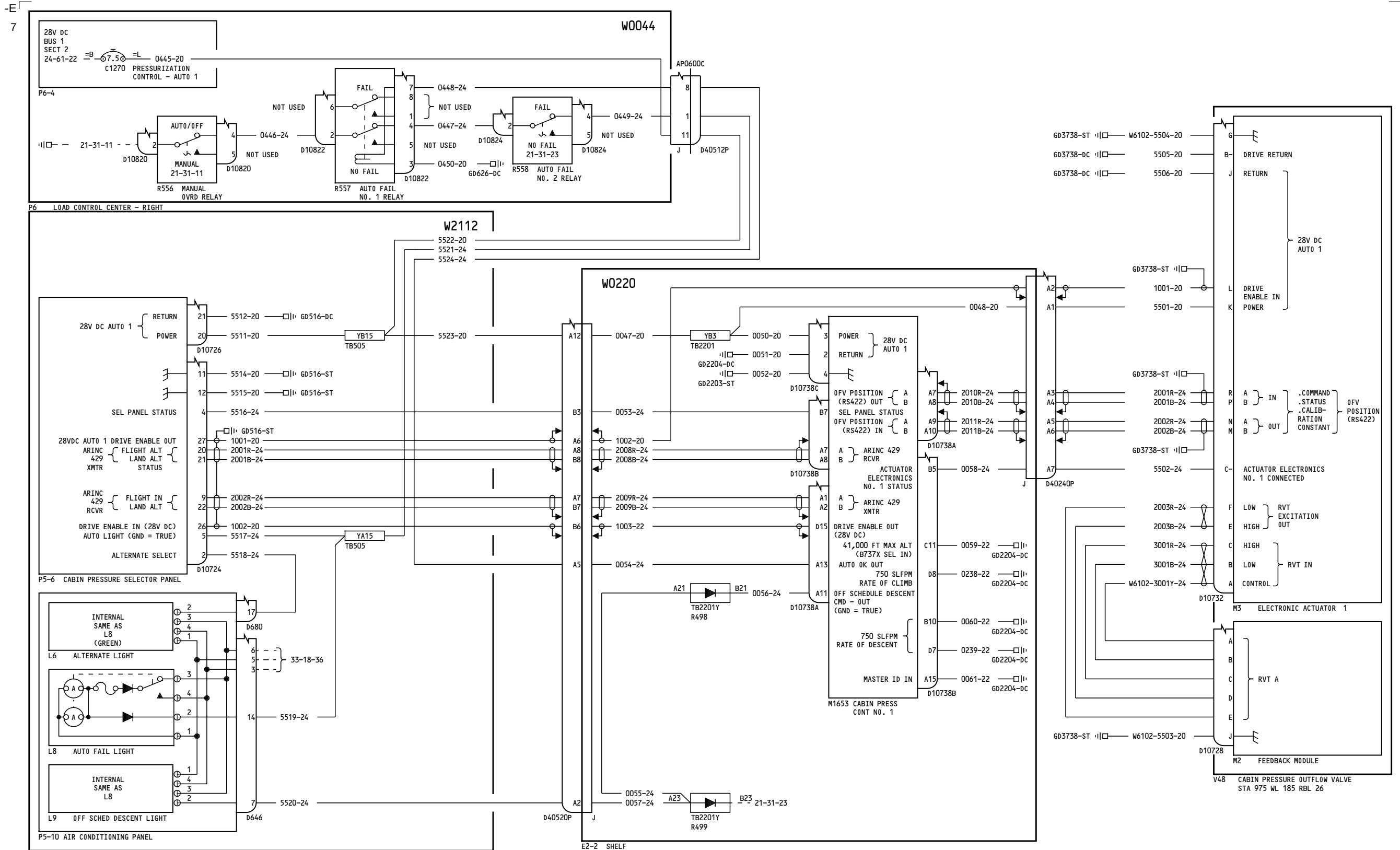

YC008-YC026

PRESSURIZATION CONTROL AUTO 1

21-31-22

Page 2

D280A103

Jul 17/2007

21-31-22

Page 2

Jul 17/2007

-C
12

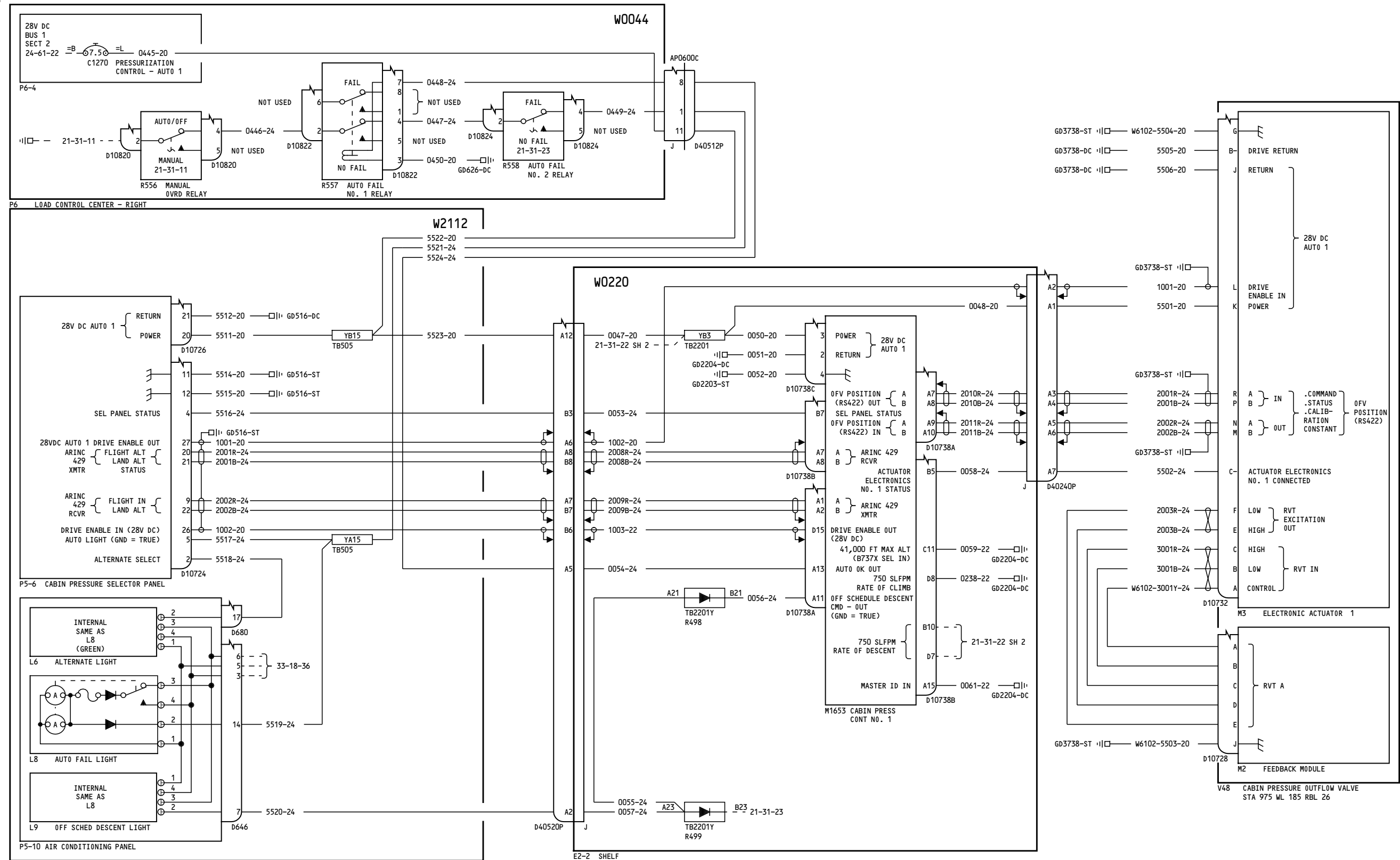

YC028-YM670

**PRESSURIZATION CONTROL
AUTO 1**

D280A103

21-31-22

Page 3
Sheet 1
Feb 09/2009

21-31-22

Page 3
Sheet 1
Feb 09/2009

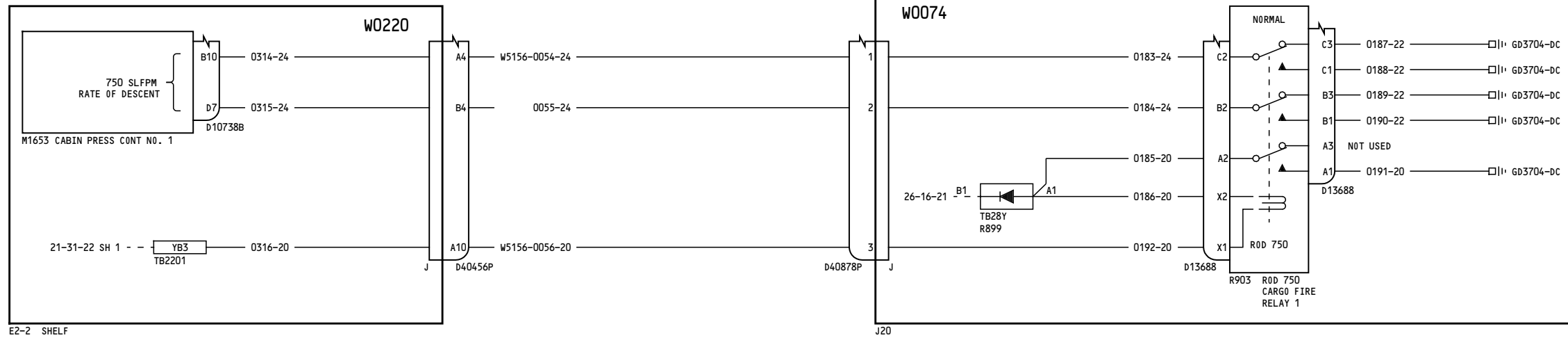

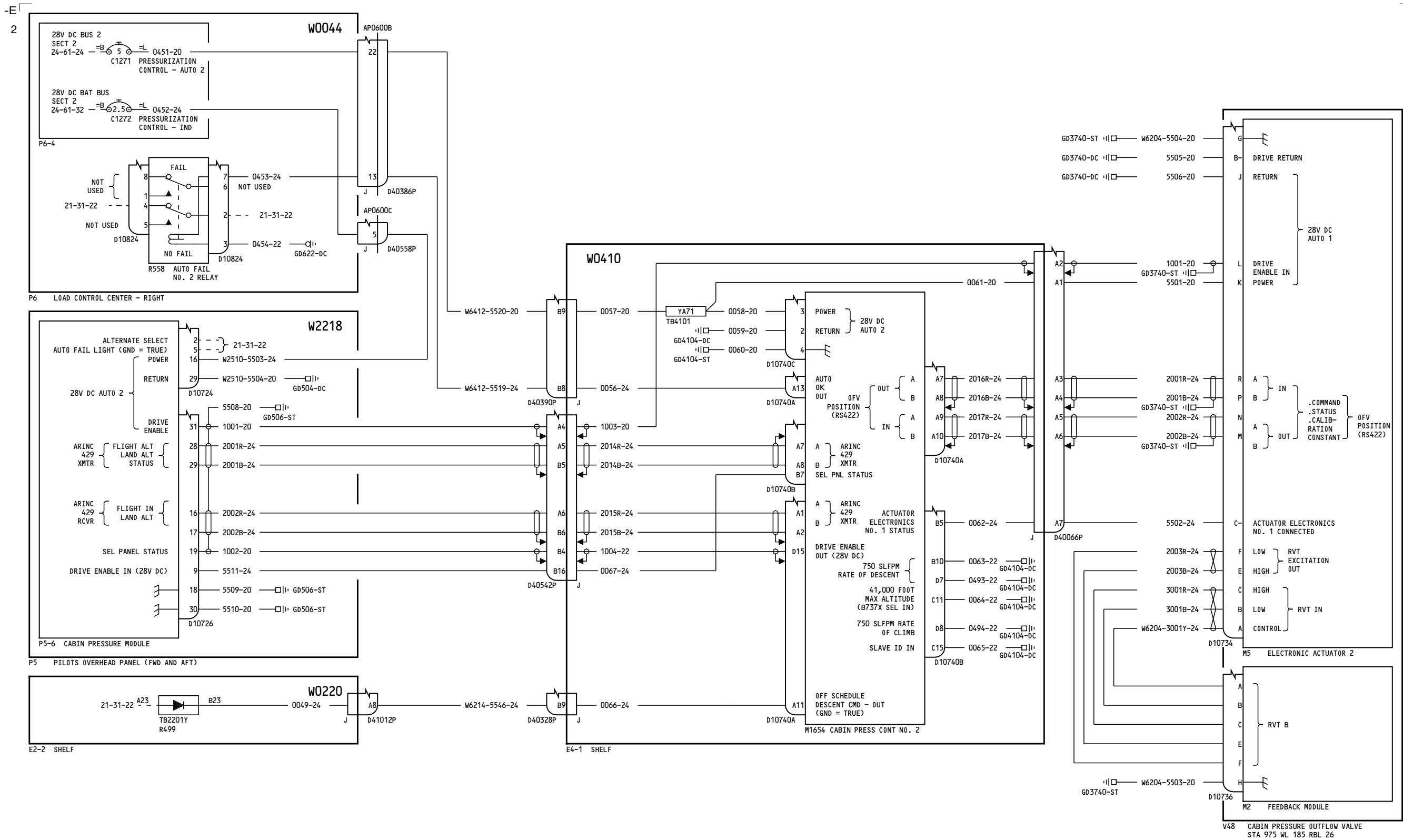

YC001-YC004

PRESSURIZATION CONTROL AUTO 2

21-31-23

Page 1

D280A103

Oct 20/2006

21-31-23

Page 1

Oct 20/2006

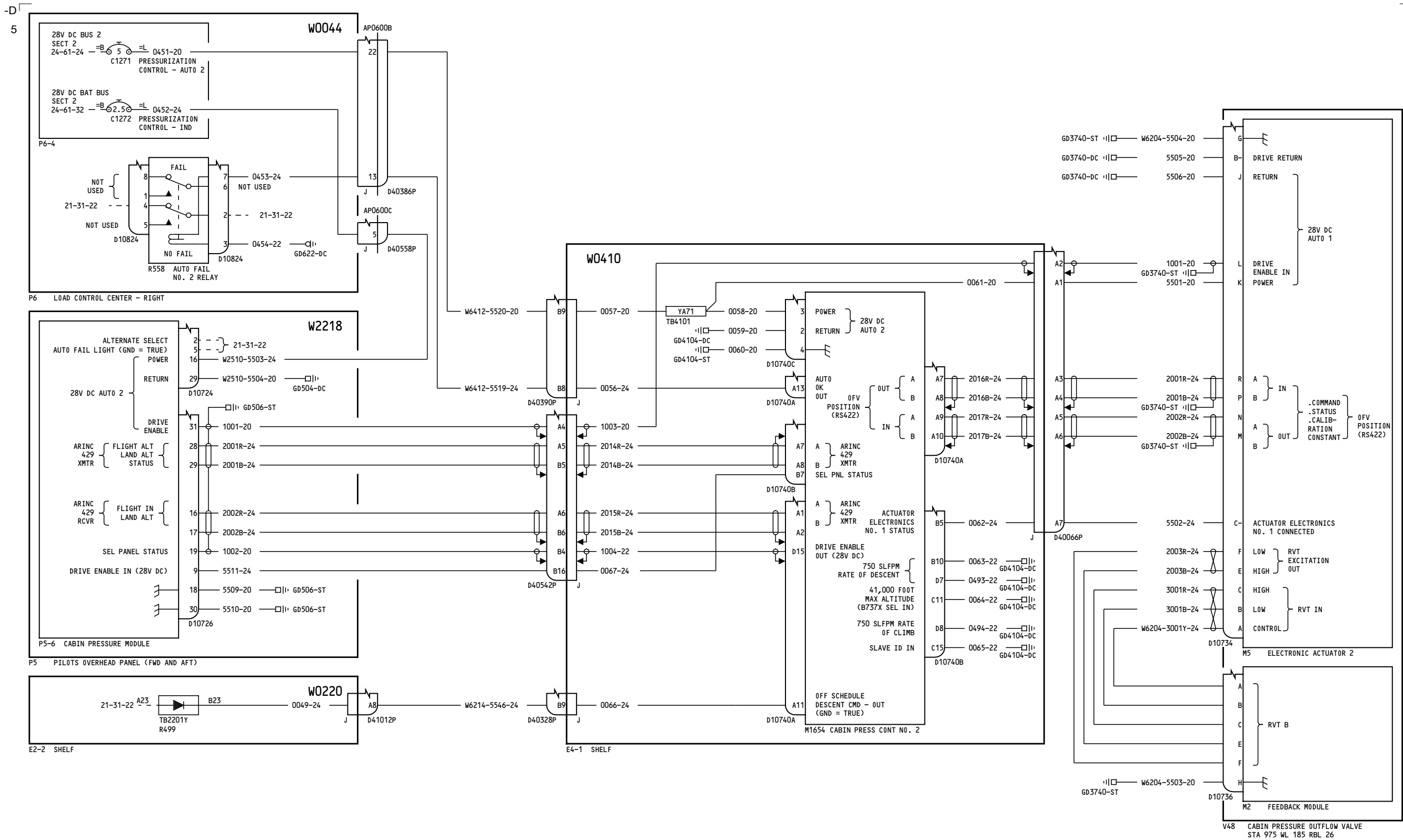

YC005-YC007

PRESSURIZATION CONTROL AUTO 2

21-31-23

Page 2

D280A103

Oct 20/2006

21-31-23

Page 2

Oct 20/2006

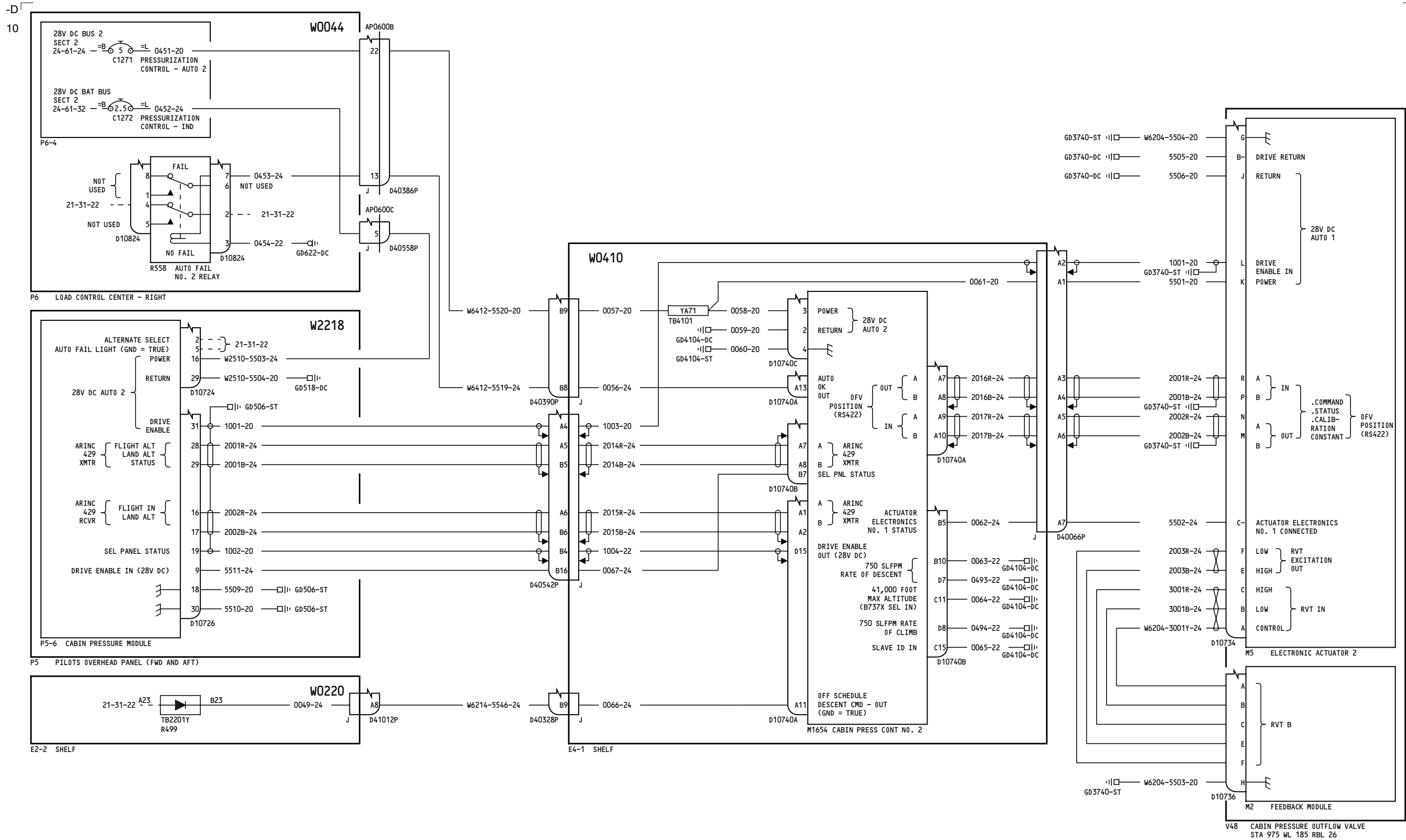

YC008-YC026

**PRESSURIZATION CONTROL
AUTO 2**

21-31-23

Page 3

D280A103

Jul 17/2007

21-31-23

Page 3

Jul 17/2007

-B
17

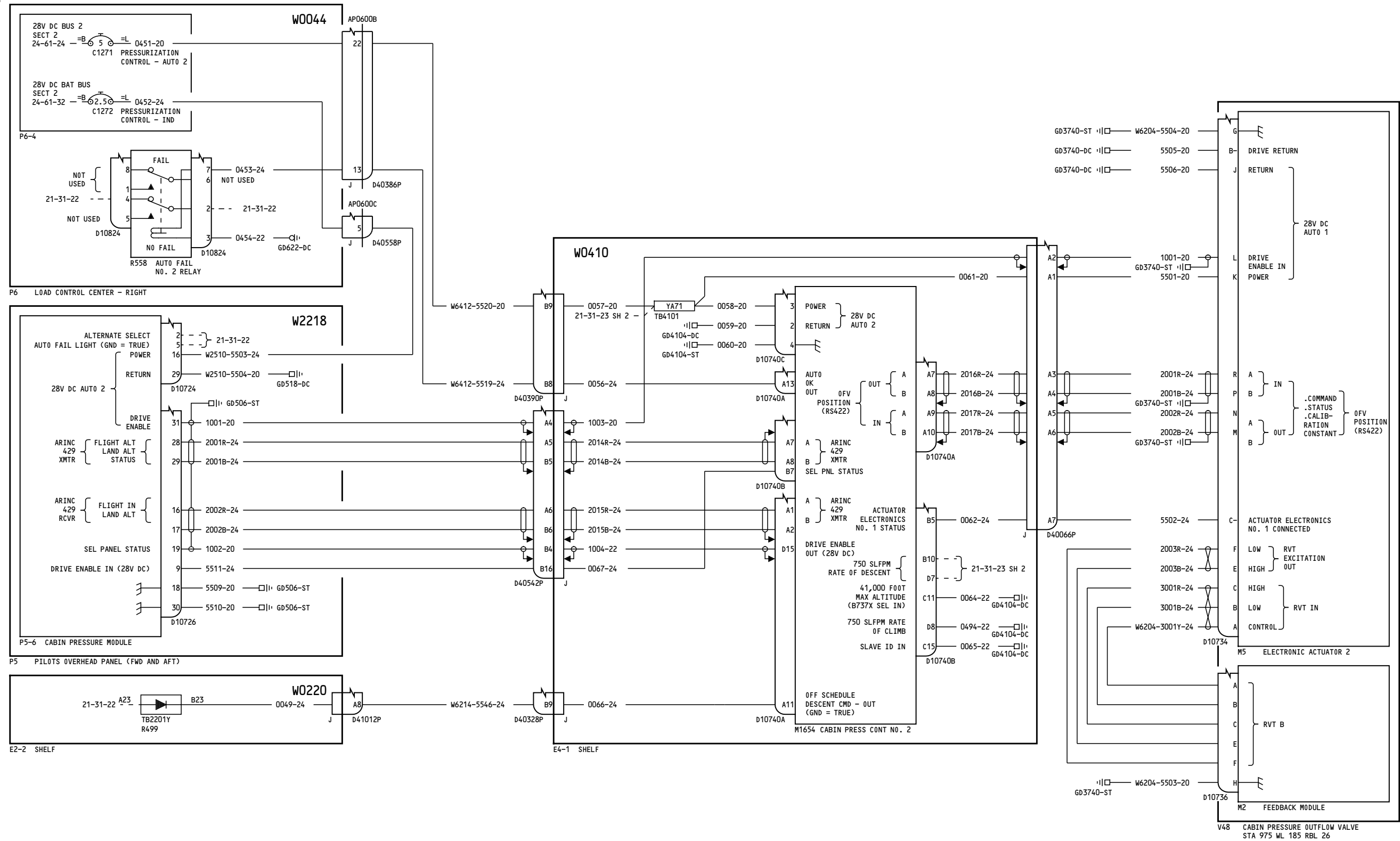

YC028-YC030

**PRESSURIZATION CONTROL
AUTO 2**

21-31-23

Page 4
Sheet 1
Oct 20/2006

D280A103

21-31-23

Page 4
Sheet 1
Oct 20/2006

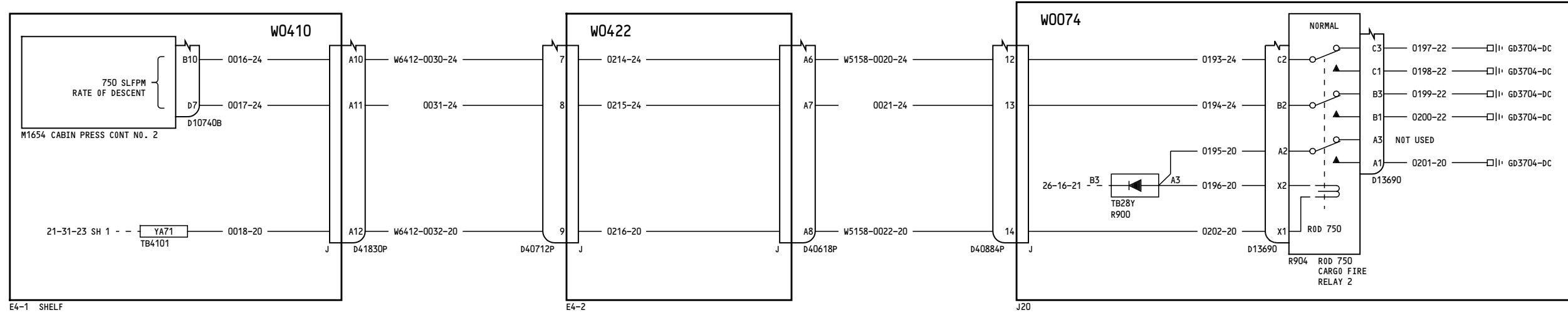

YC028-YC030

**PRESSURIZATION CONTROL
AUTO 2**

D280A103

21-31-23

Page 4
Sheet 2
Mar 31/2005

21-31-23

Page 4
Sheet 2
Mar 31/2005

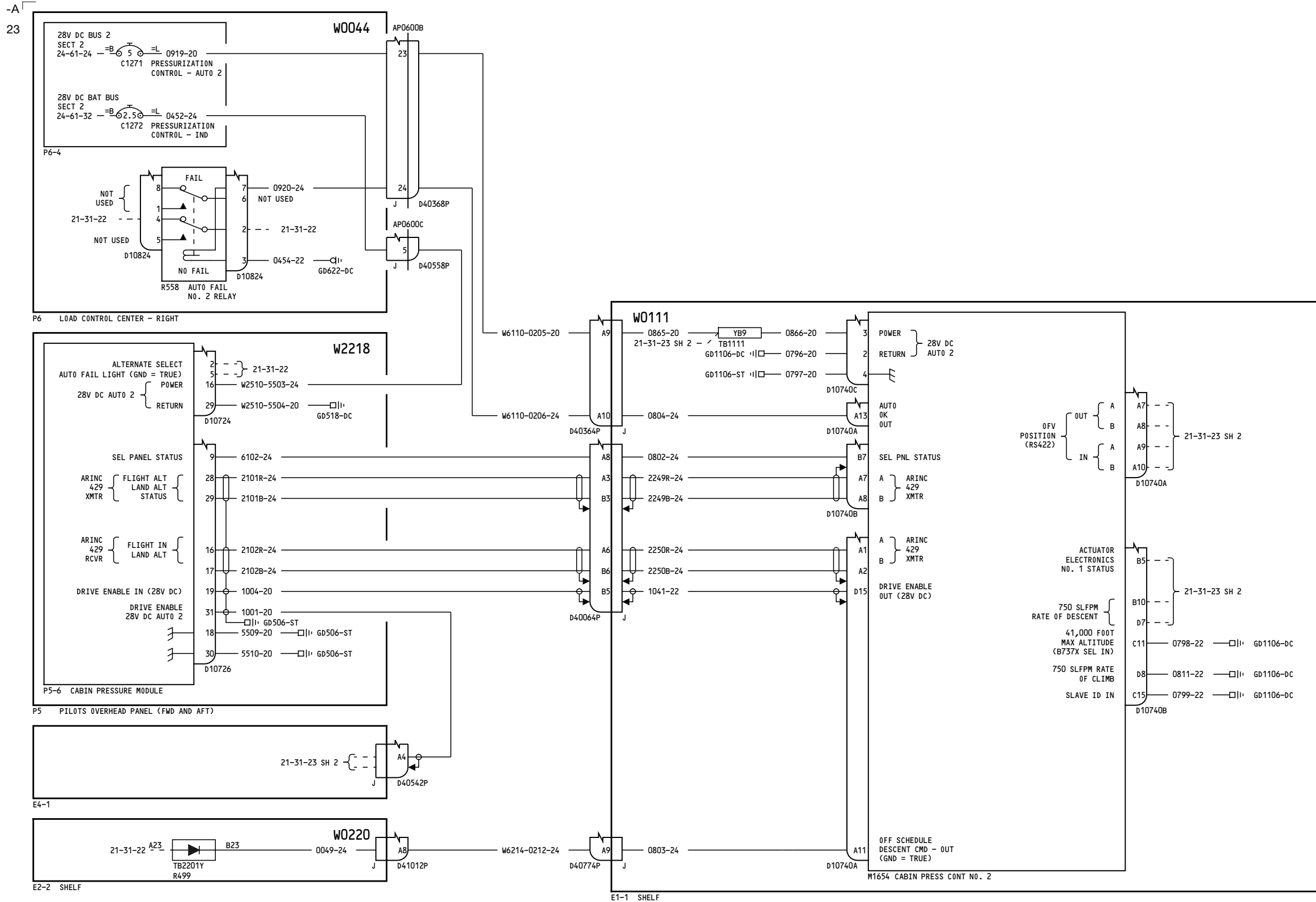

YC031-YM670

**PRESSURIZATION CONTROL
AUTO 2**

21-31-23

Page 5
Sheet 1
Feb 09/2009

D280A103

21-31-23

Page 5
Sheet 1
Feb 09/2009

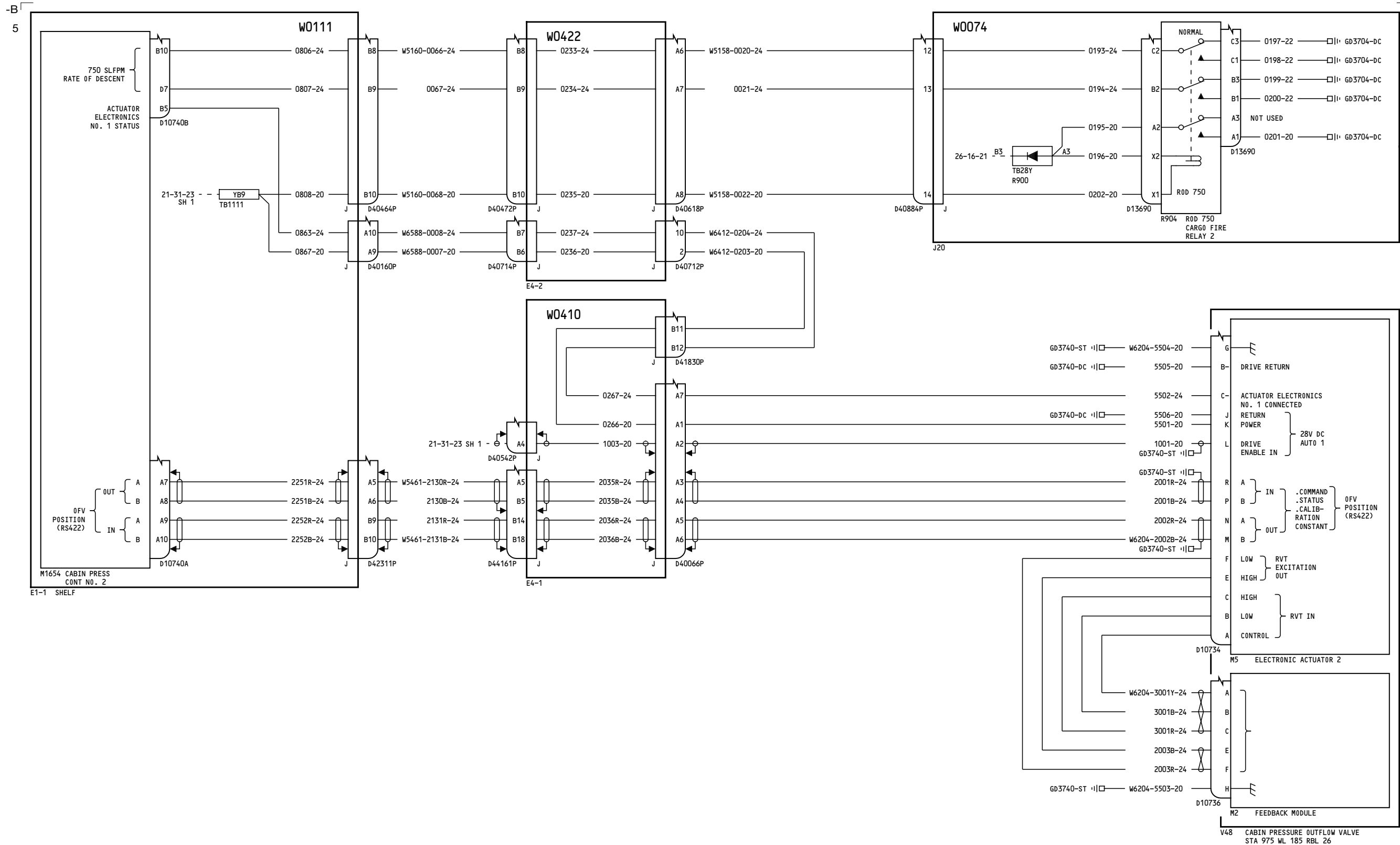

YC031-YM670

**PRESSURIZATION CONTROL
AUTO 2**

21-31-23

Page 5
Sheet 2
Feb 09/2009

D280A103

21-31-23

Page 5
Sheet 2
Feb 09/2009

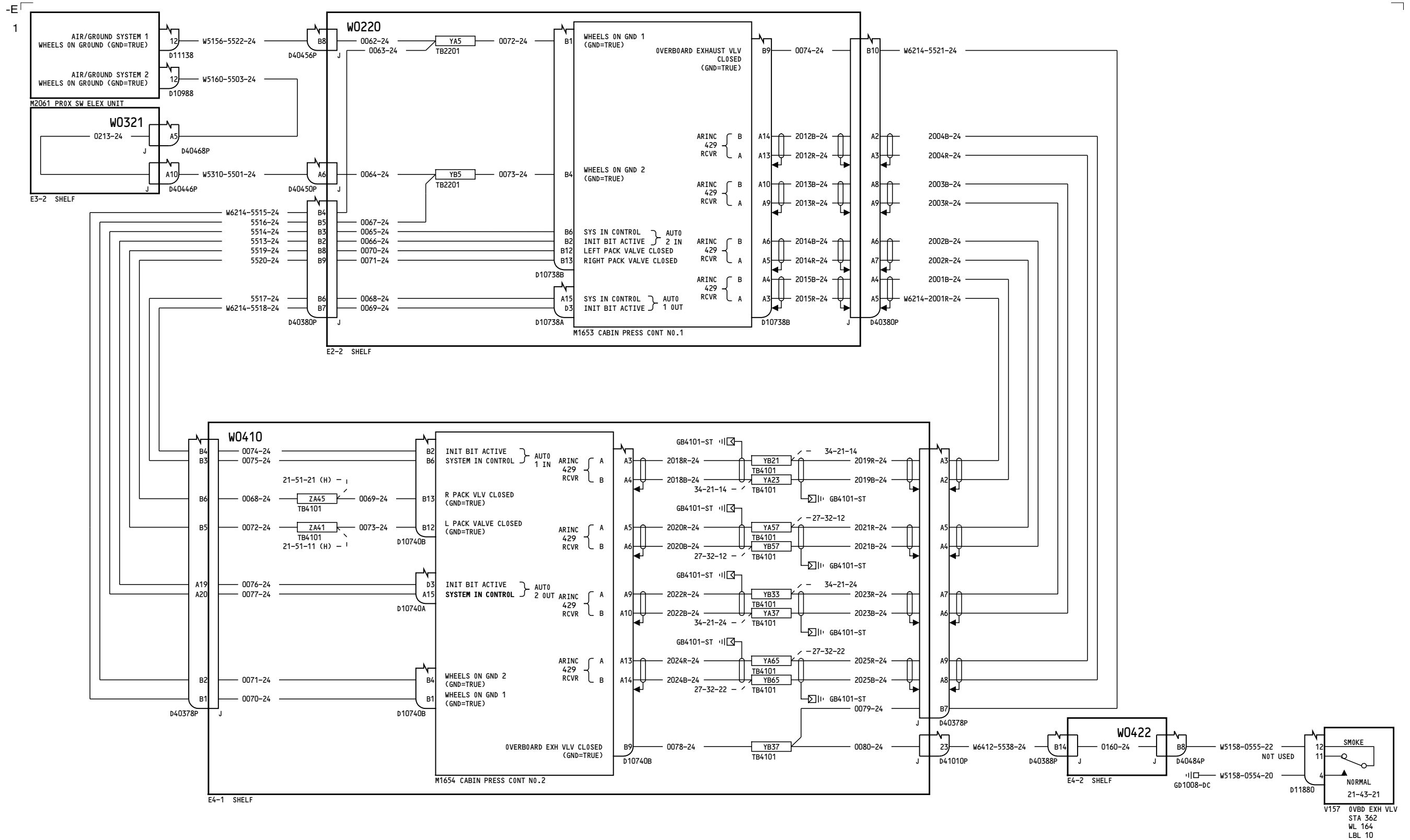

YC001-YC030

**PRESSURIZATION CONTROL -
AUTO CHANNEL INTERFACES**

21-31-24

Page 1

D280A103

Jul 17/2007

21-31-24

Page 1

Jul 17/2007

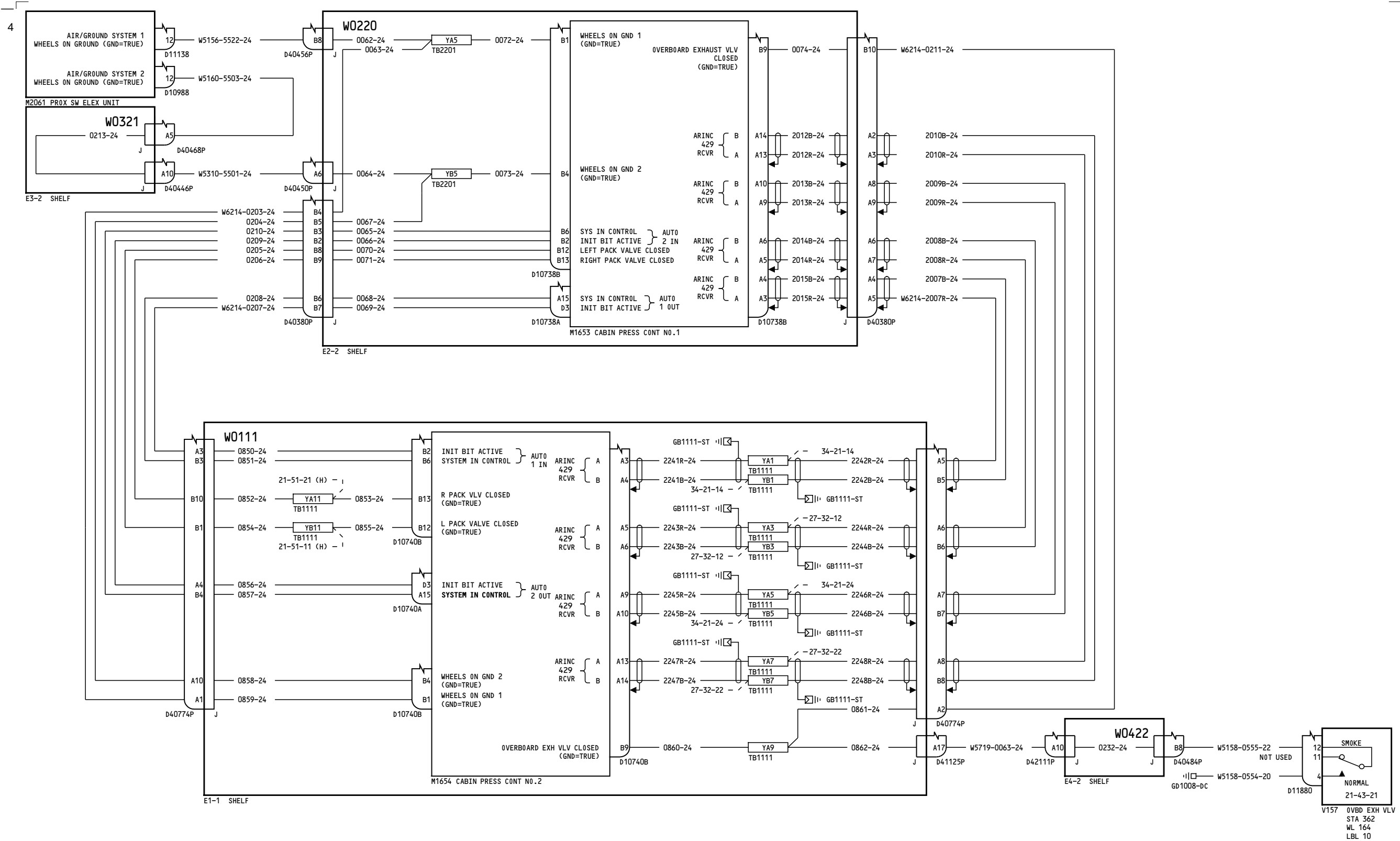

YC031-YM670

**PRESSURIZATION CONTROL -
AUTO CHANNEL INTERFACES**

21-31-24

Page 2

D280A103

Feb 09/2009

21-31-24

Page 2

Feb 09/2009

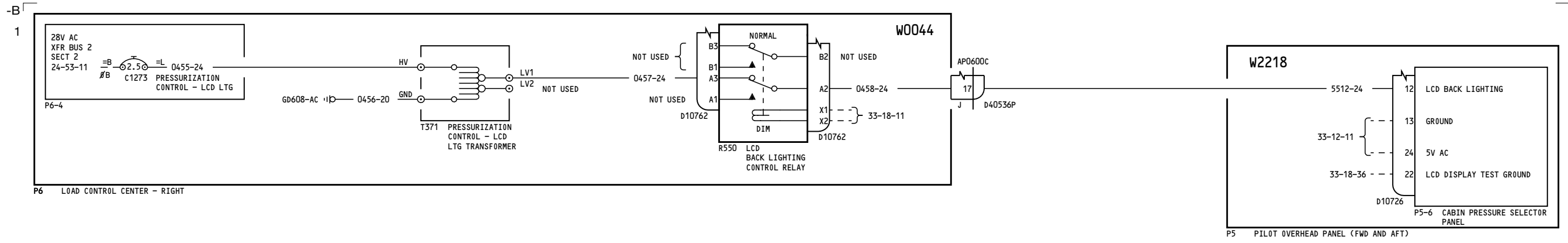

ALL

**PRESSURIZATION CONTROL
LCD LIGHTING**

D280A103

21-31-25

Page 1

Feb 09/2009

21-31-25

Page 1

Feb 09/2009

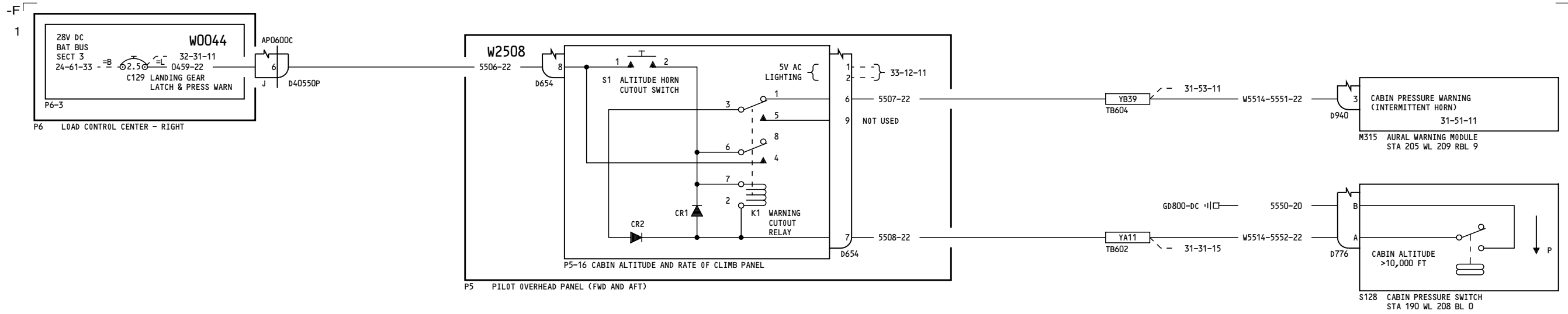

YC001-YC003

CABIN PRESSURE WARNING

21-33-11

Page 1

D280A103

Mar 31/2005

21-33-11

Page 1

Mar 31/2005

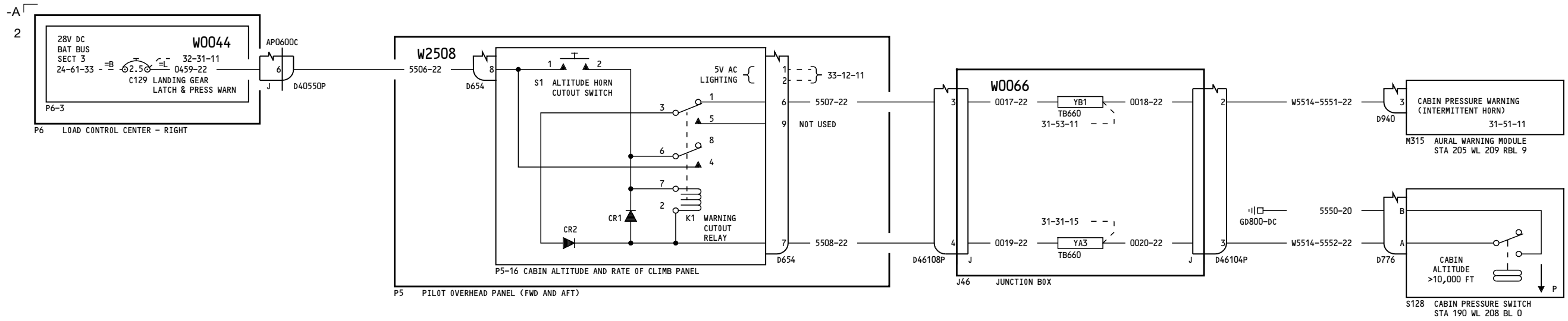

YC004-YK910, YL421-YL423, YM643

CABIN PRESSURE WARNING

21-33-11

Page 2

D280A103

Jul 17/2007

21-33-11

Page 2

Jul 17/2007

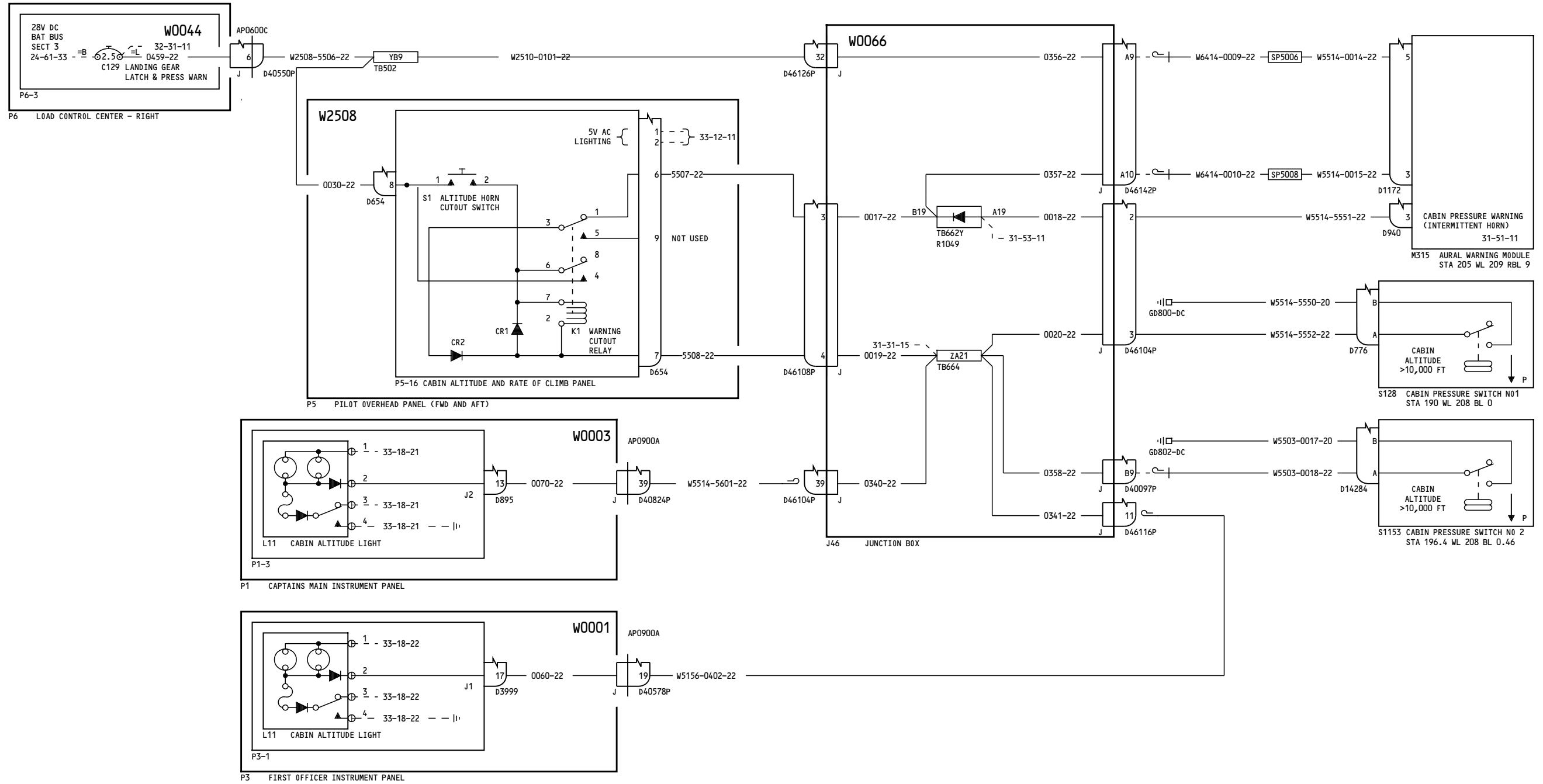

YK911, YM651

CABIN PRESSURE WARNING

21-33-11

Page 3

Aug 13/2008

D280A103

21-33-11

Page 3

Aug 13/2008

-A
27

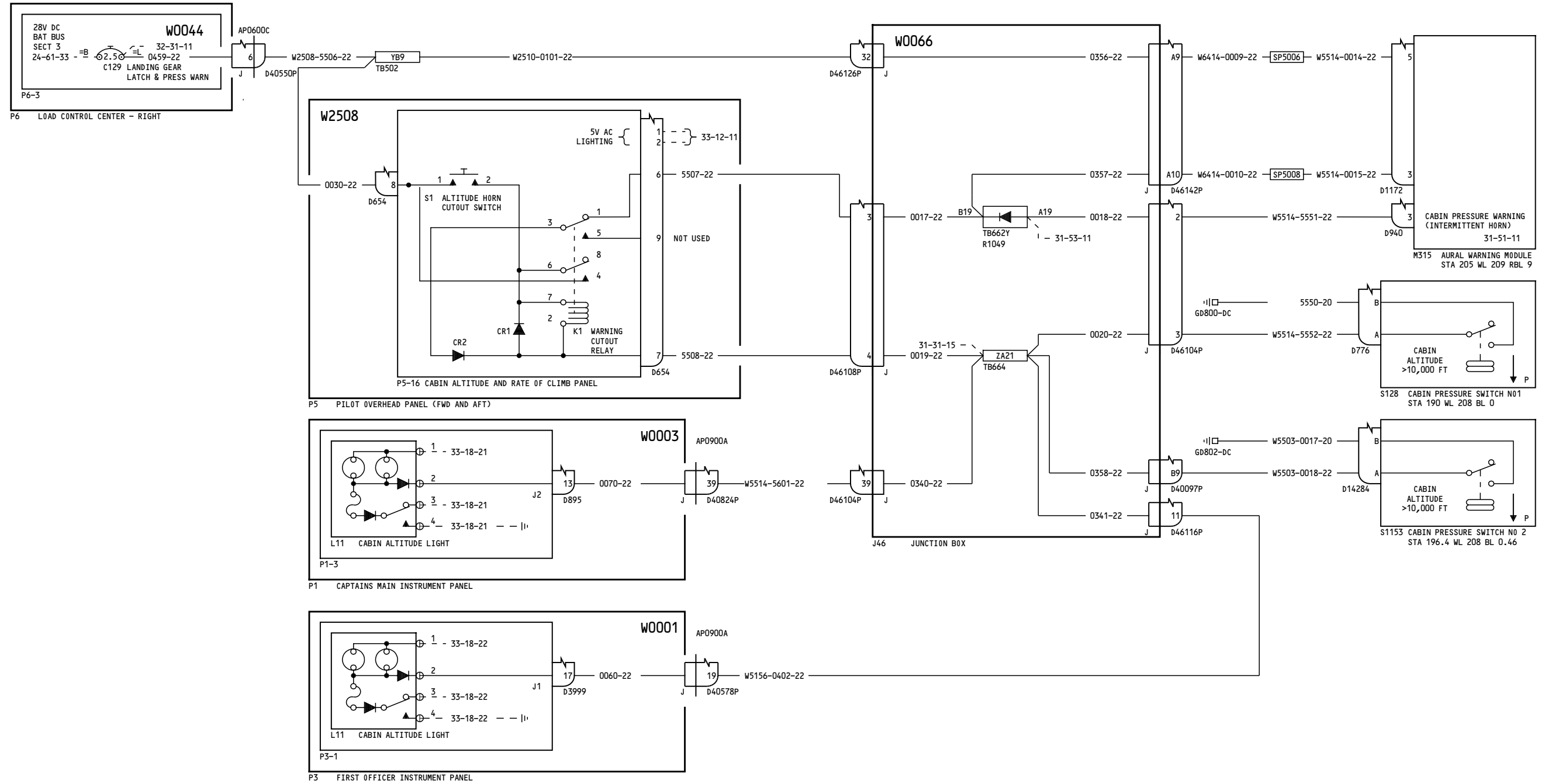

YK912-YK917, YK919-YL401, YL427-YL430, YM652-YM670

CABIN PRESSURE WARNING

21-33-11

Page 4

D280A103

Feb 09/2009

21-33-11

Page 4

Feb 09/2009

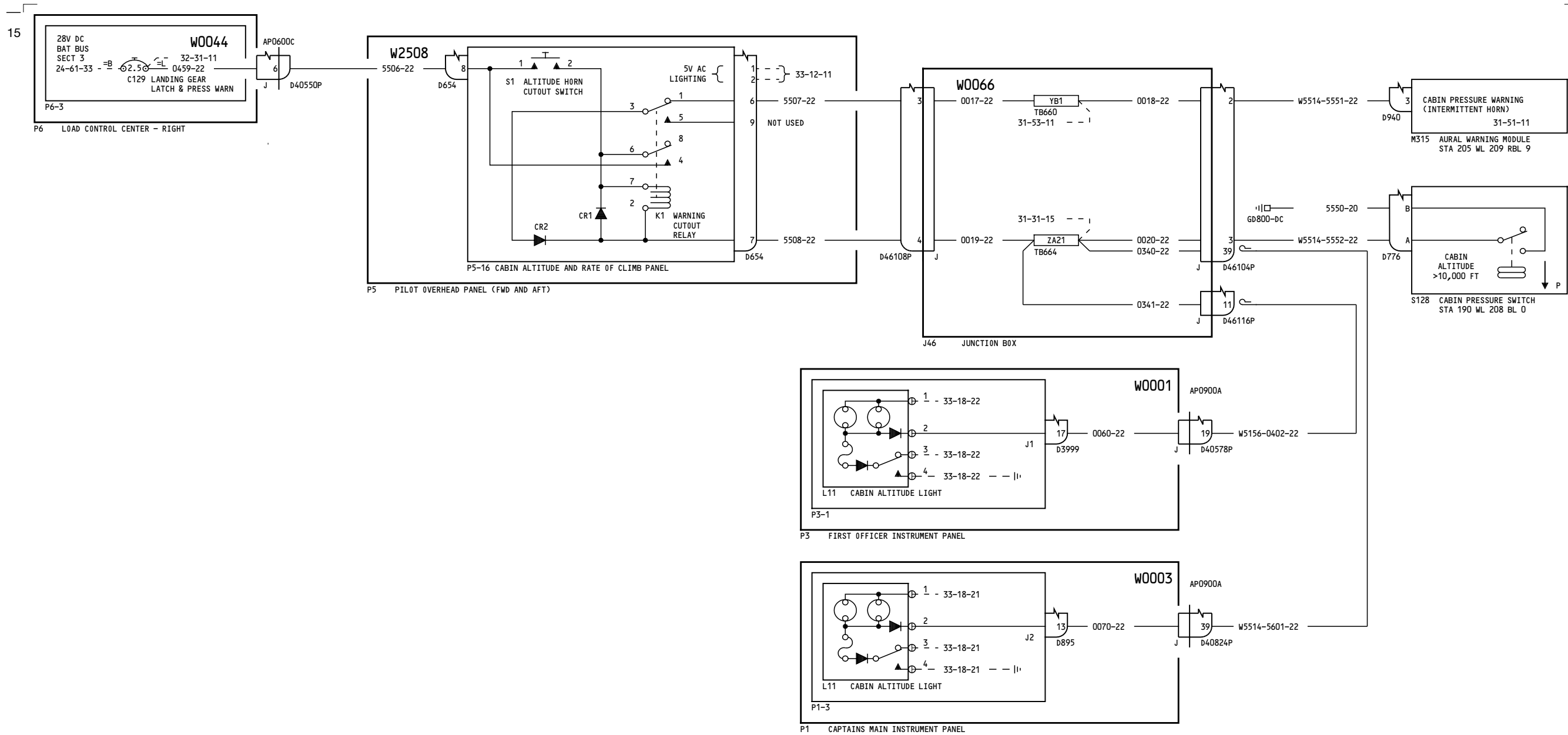

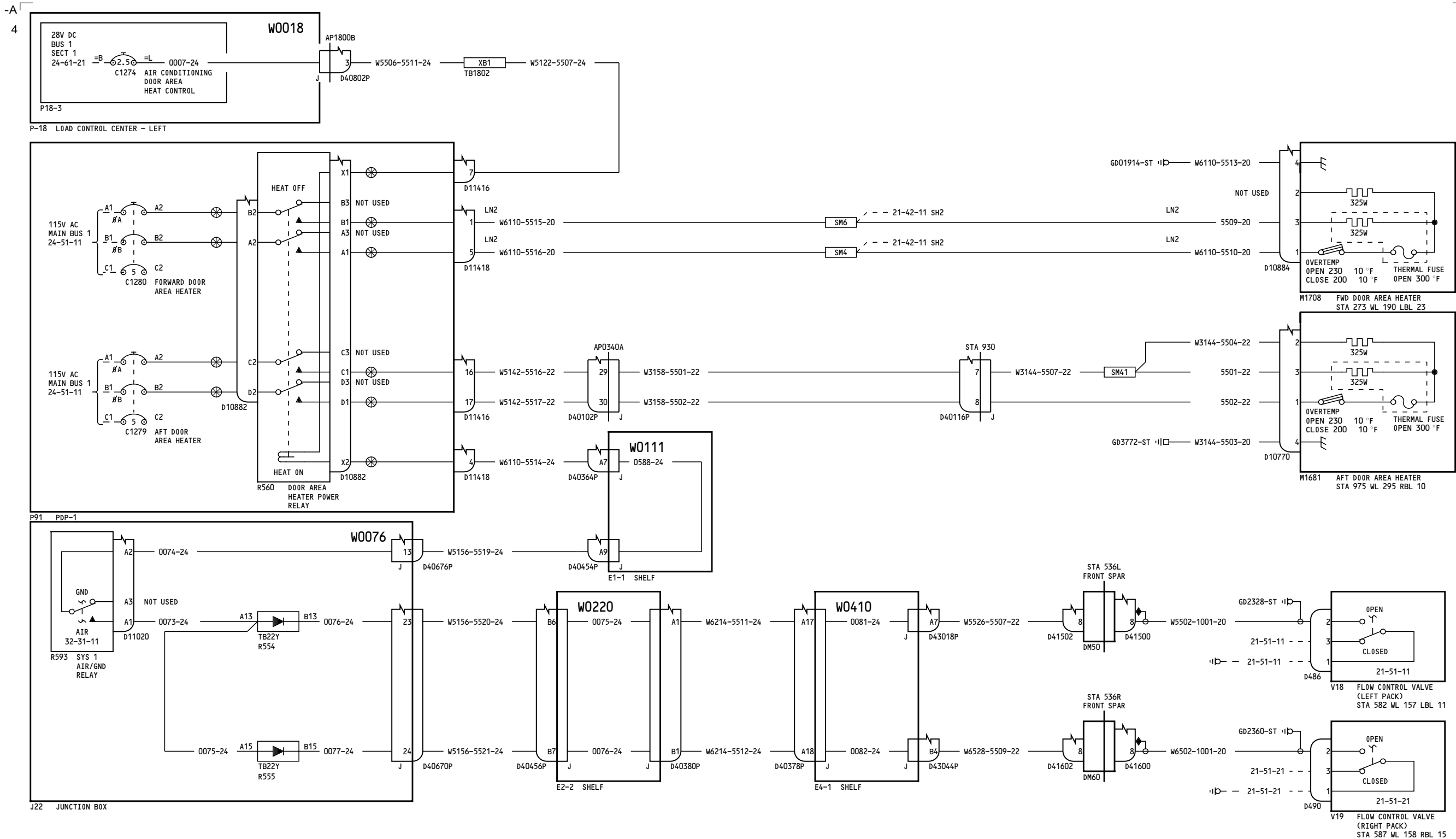

YC001-YC003

DOOR AREA HEATERS

21-42-11

Page 1
Sheet 1
Jul 26/2006

D280A103

21-42-11

Page 1
Sheet 1
Jul 26/2006

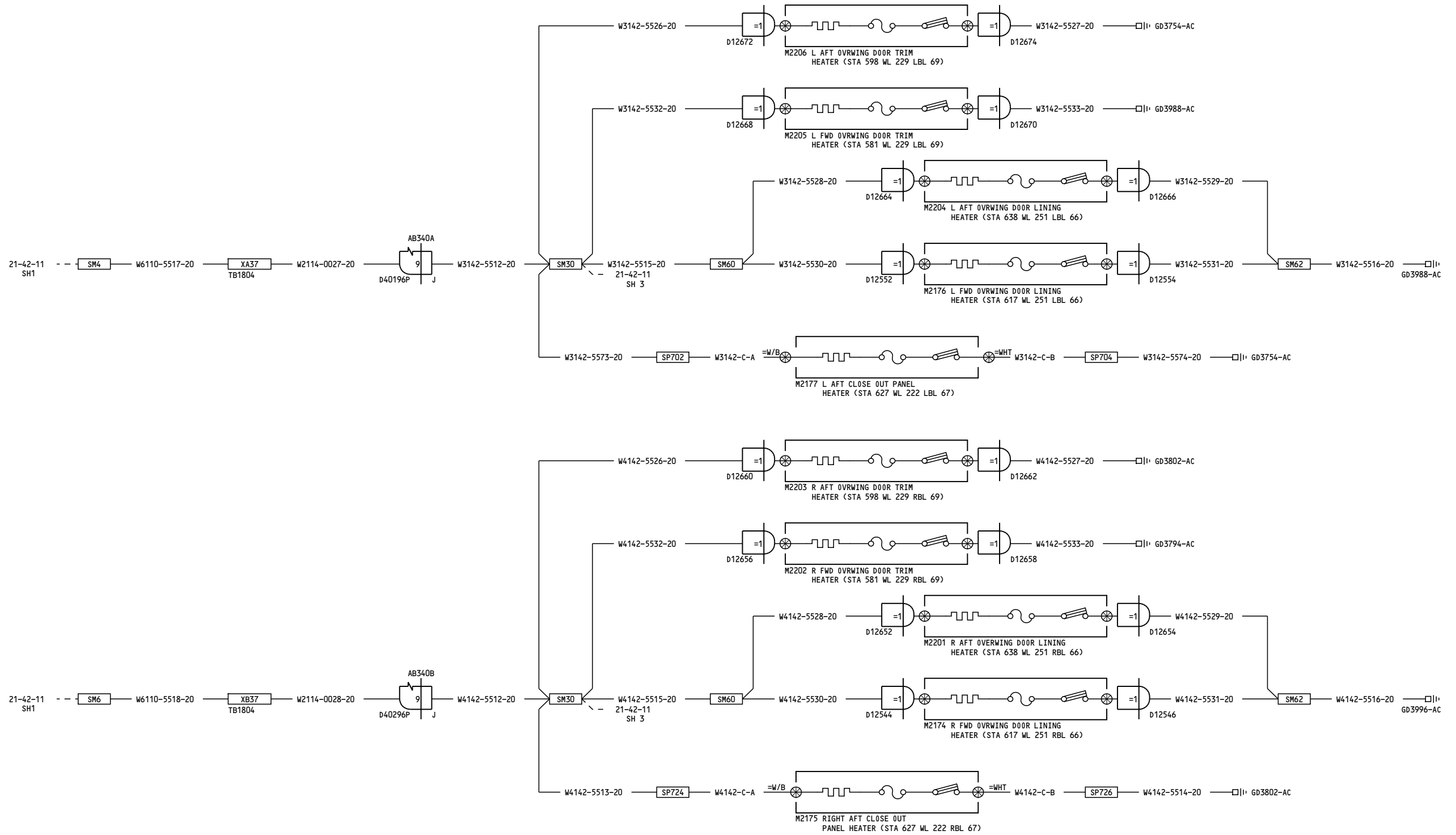

YC001-YC003

DOOR AREA HEATERS

D280A103

21-42-11

Page 1
Sheet 2
Mar 31/2005

21-42-11

Page 1
Sheet 2
Mar 31/2005

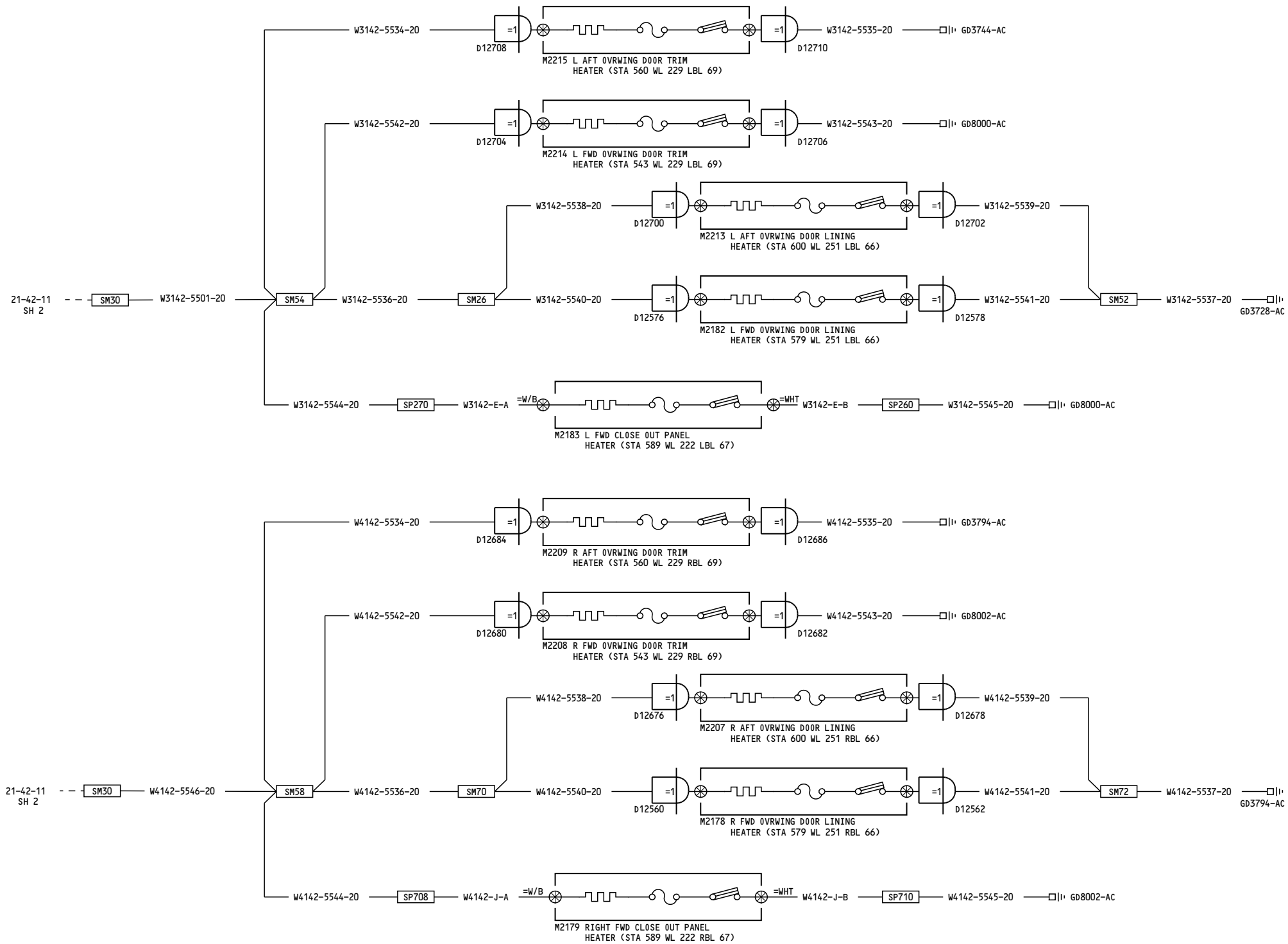

YC001-YC003

DOOR AREA HEATERS

D280A103

21-42-11

Page 1
Sheet 3
Mar 31/2005

21-42-11

Page 1
Sheet 3
Mar 31/2005

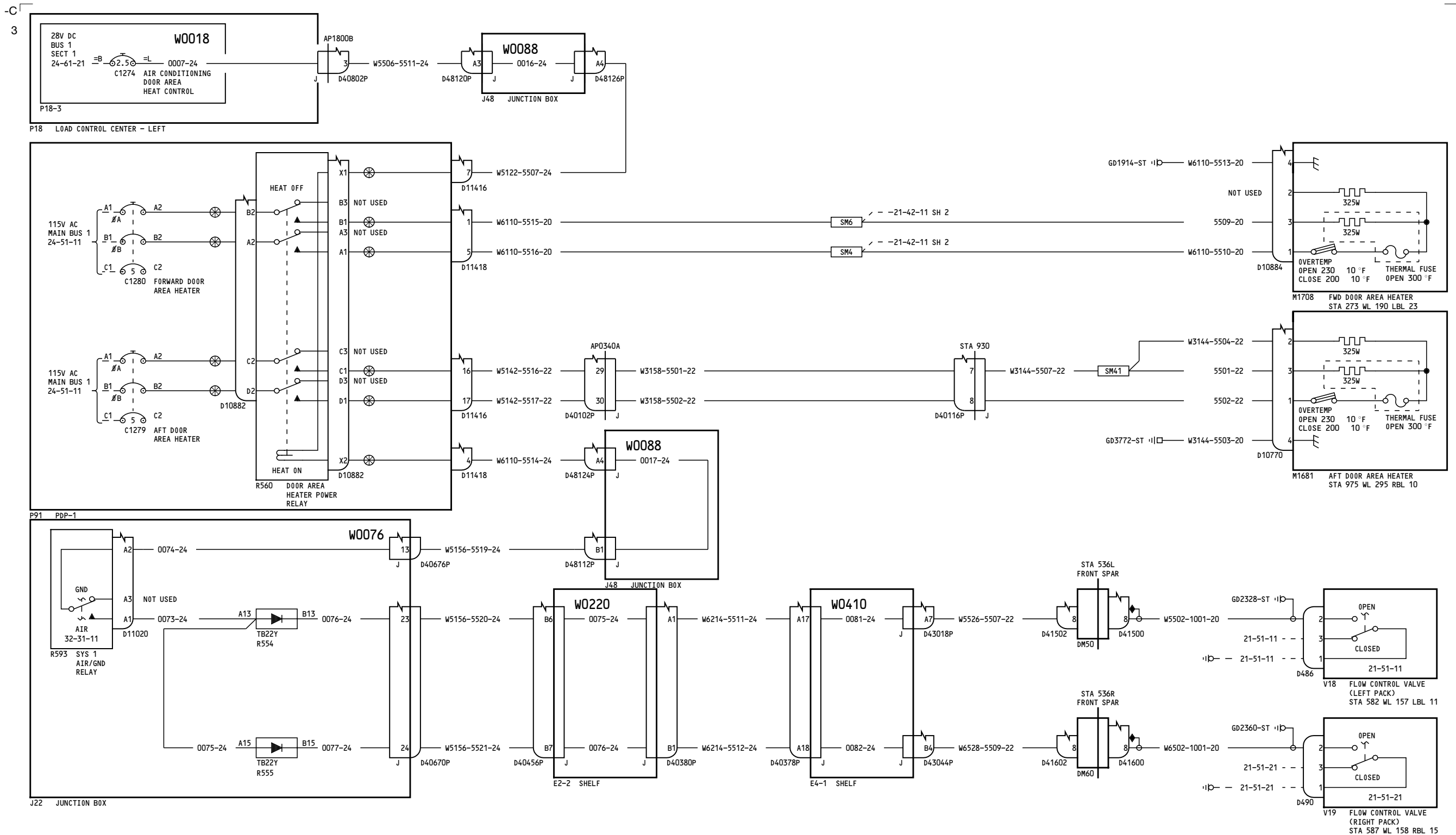

YC004-YC028

DOOR AREA HEATERS

21-42-11

Page 2
Sheet 1
Jul 17/2007

D280A103

21-42-11

Page 2
Sheet 1
Jul 17/2007

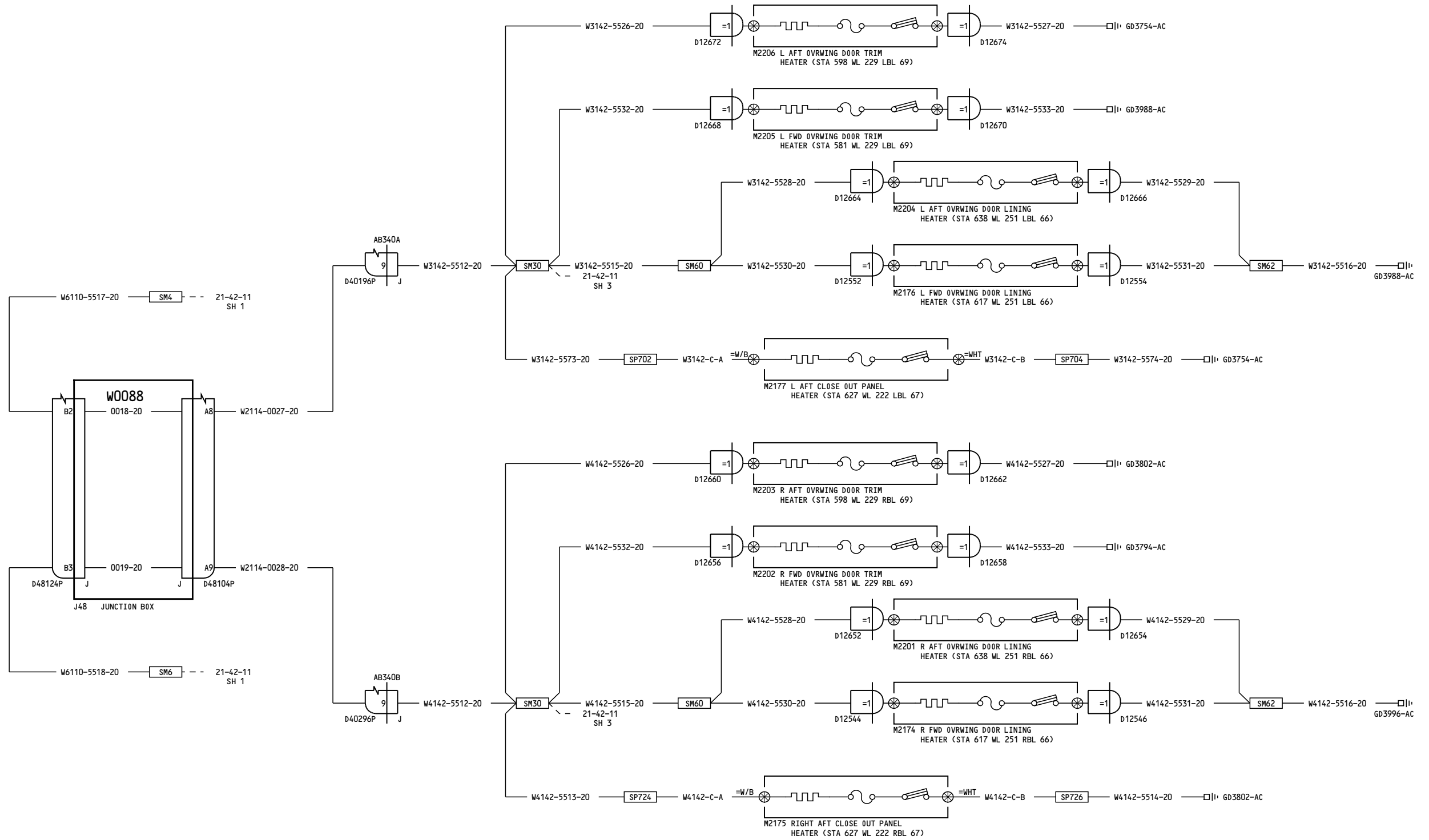

YC004-YC028

DOOR AREA HEATERS

21-42-11

Page 2
Sheet 2
Jul 17/2007

D280A103

21-42-11

Page 2
Sheet 2
Jul 17/2007

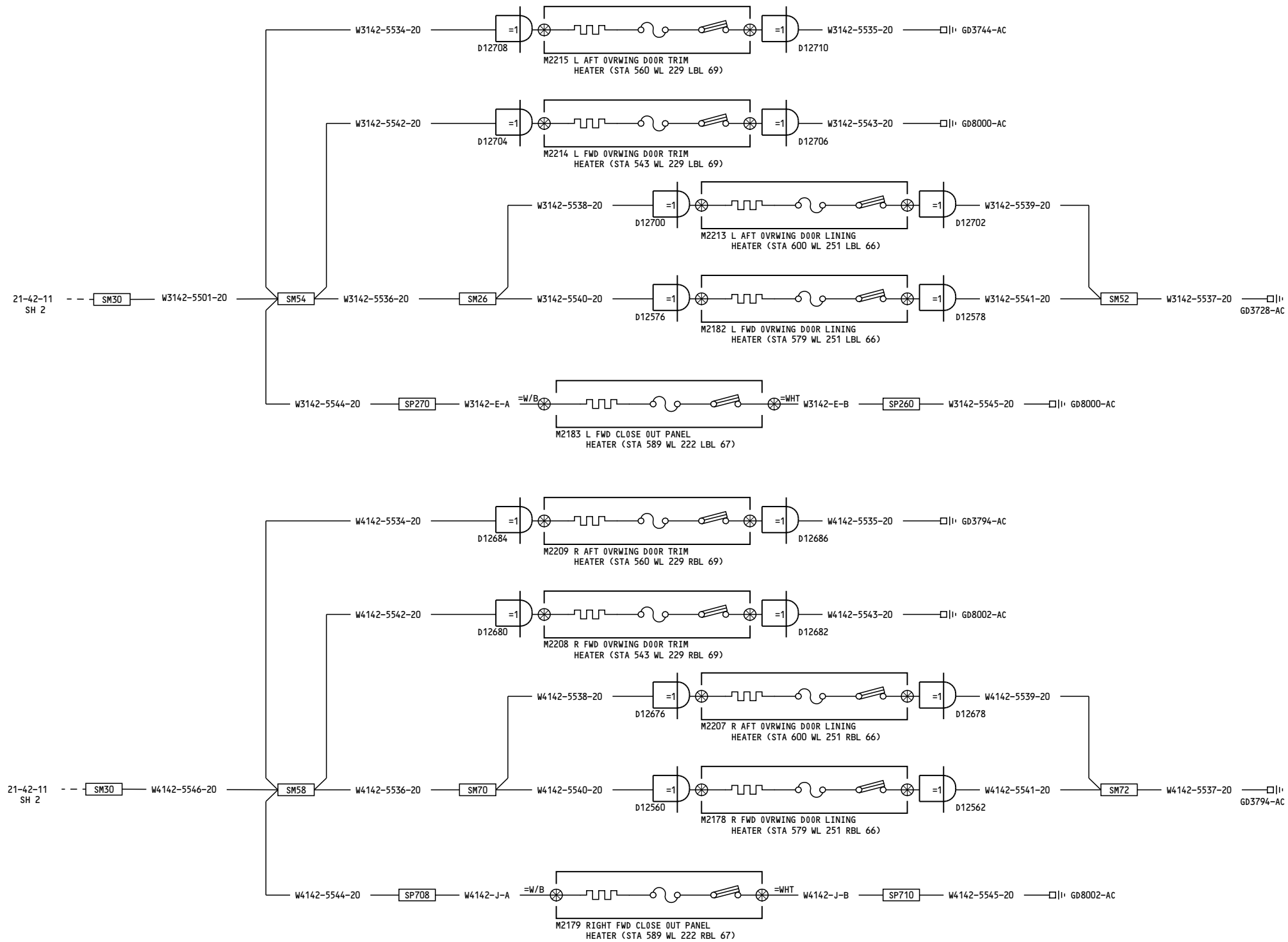

YC004-YC028

DOOR AREA HEATERS

D280A103

21-42-11

Page 2
Sheet 3
Jul 17/2007

21-42-11

Page 2
Sheet 3
Jul 17/2007

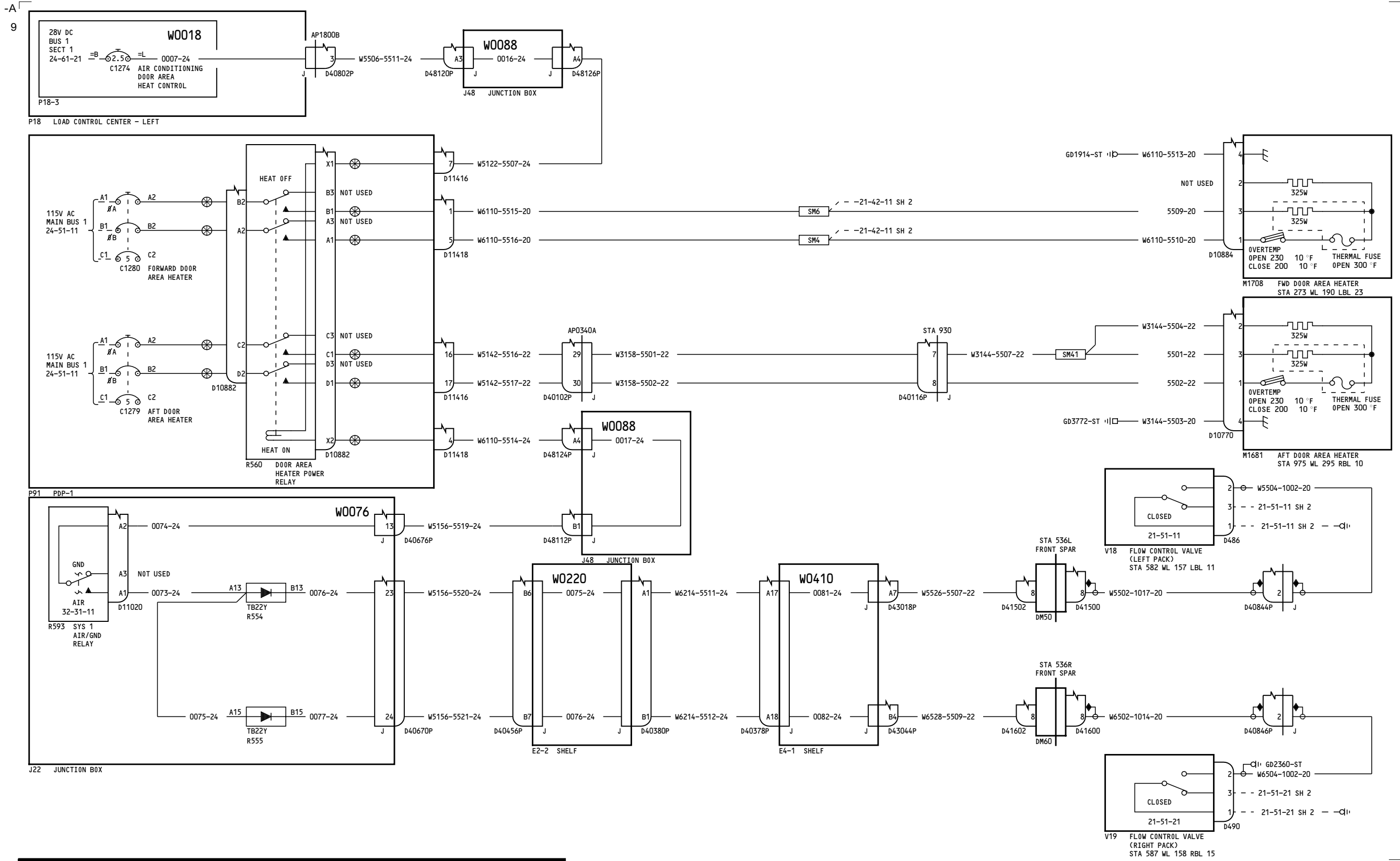

YC029-YL430

DOOR AREA HEATERS

21-42-11

Page 3
Sheet 1
Feb 09/2009

D280A103

21-42-11

Page 3
Sheet 1
Feb 09/2009

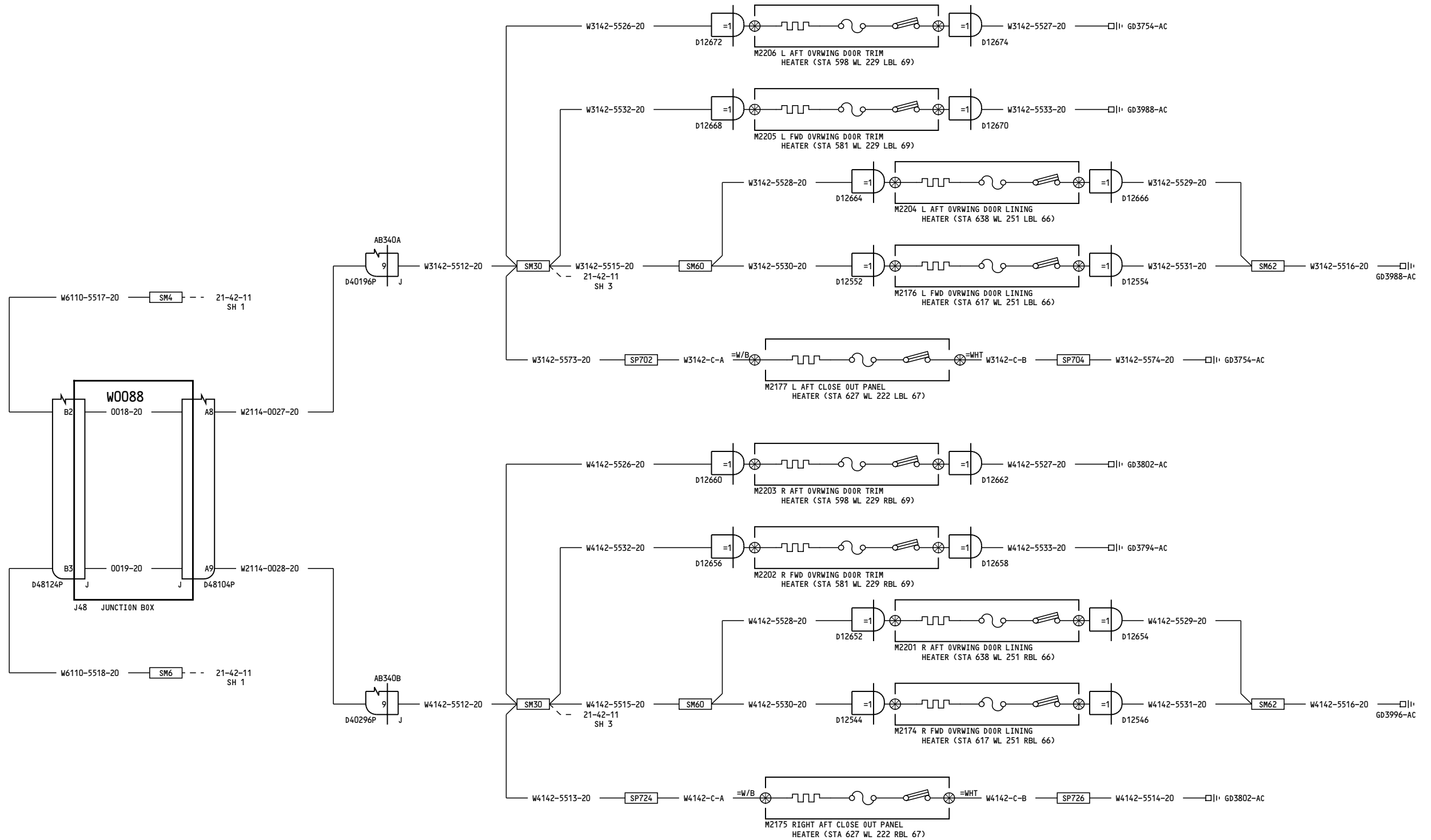

YC029-YL430

DOOR AREA HEATERS

21-42-11

Page 3
Sheet 2
Feb 09/2009

D280A103

21-42-11

Page 3
Sheet 2
Feb 09/2009

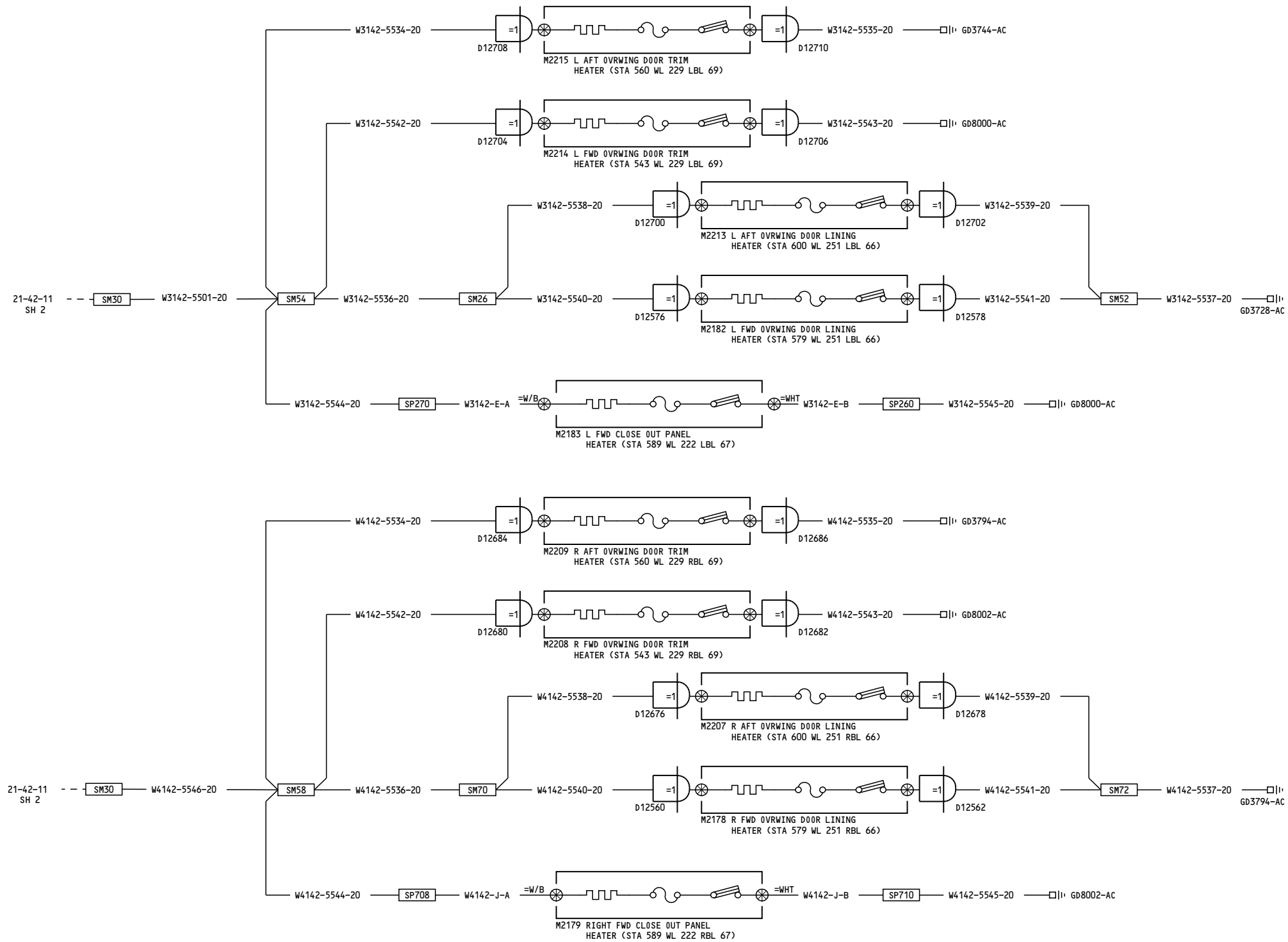

YC029-YL430

DOOR AREA HEATERS

D280A103

21-42-11

Page 3
Sheet 3
Feb 09/2009

21-42-11

Page 3
Sheet 3
Feb 09/2009

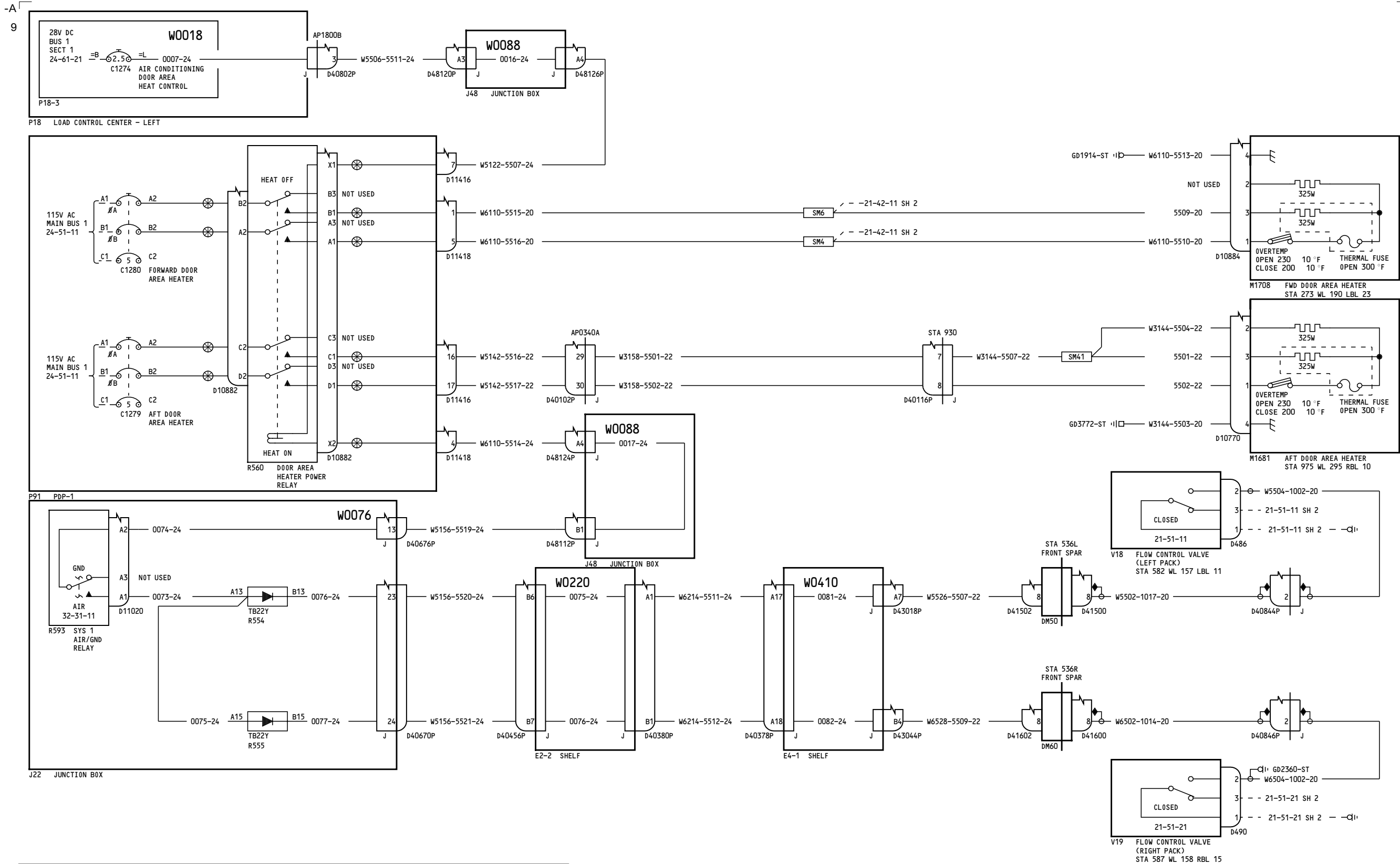

YM643-YM670

DOOR AREA HEATERS

21-42-11

Page 4
Sheet 1
Jan 14/2008

D280A103

21-42-11

Page 4
Sheet 1
Jan 14/2008

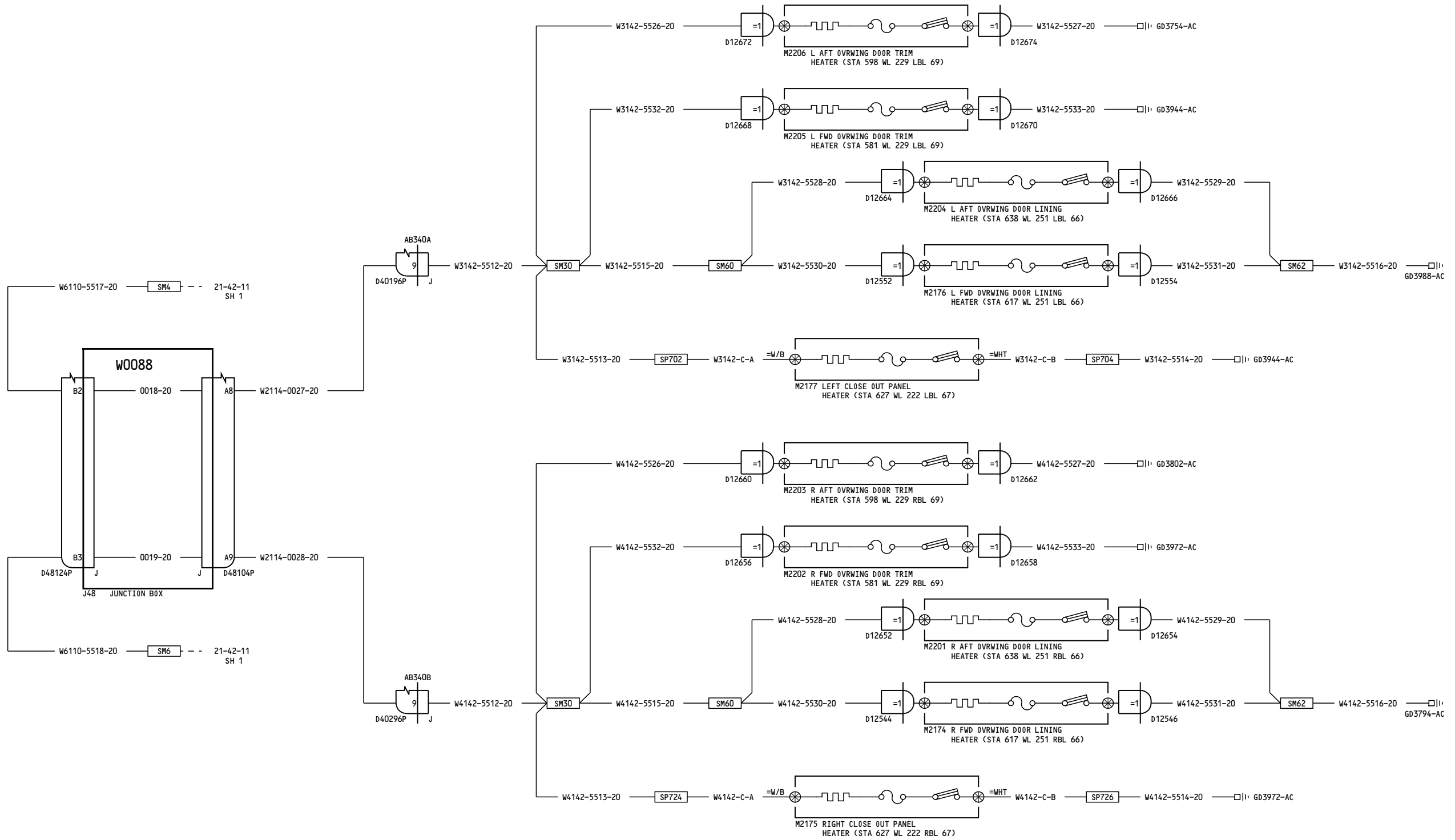

YM643-YM670

DOOR AREA HEATERS

21-42-11

Page 4
Sheet 2
Jan 14/2008

D280A103

21-42-11

Page 4
Sheet 2
Jan 14/2008

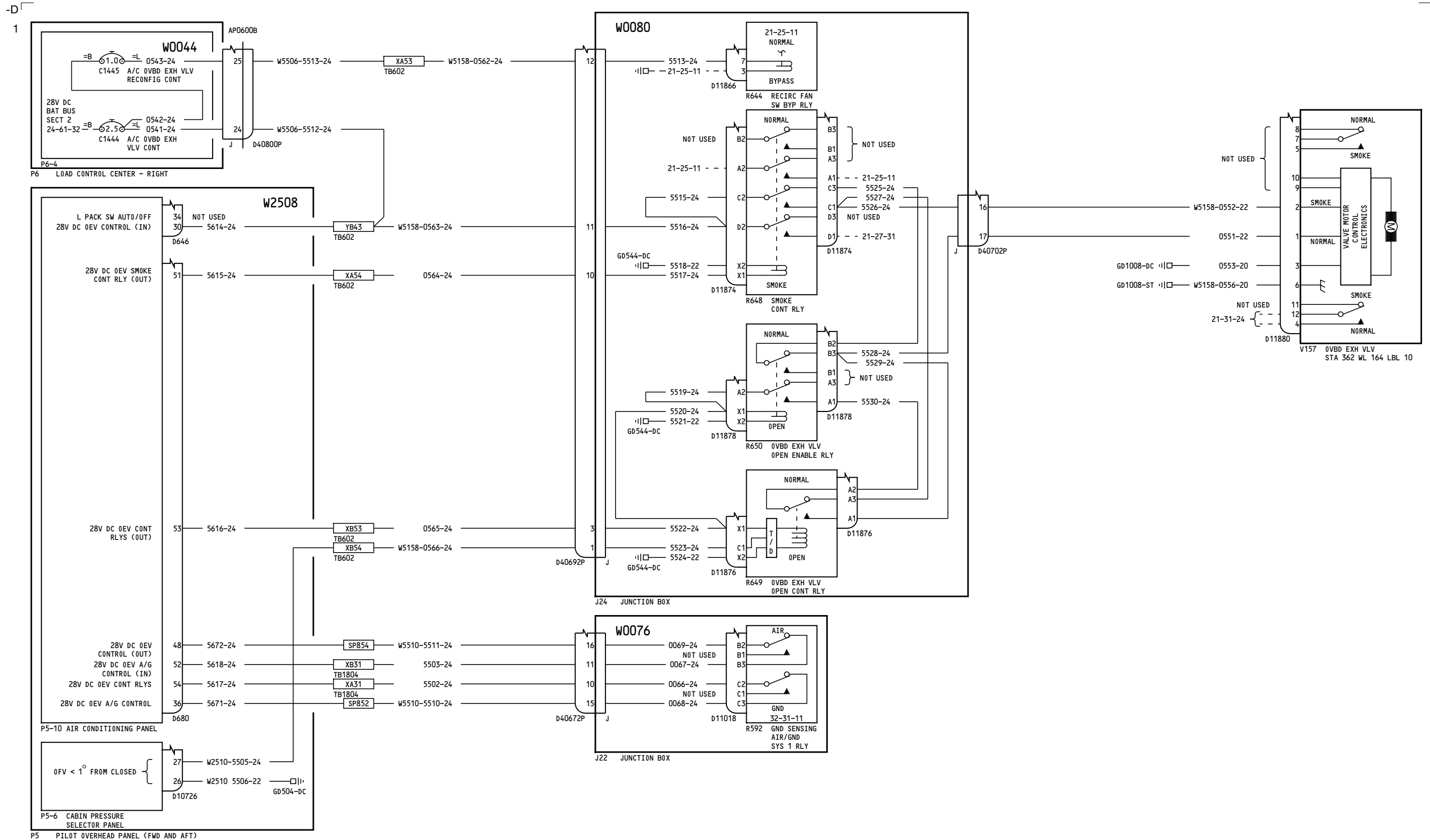

YC001-YC003

OVERBOARD EXHAUST VALVE CONTROL

21-43-21

Page 1

D280A103

Jul 26/2006

21-43-21

Page 1

Jul 26/2006

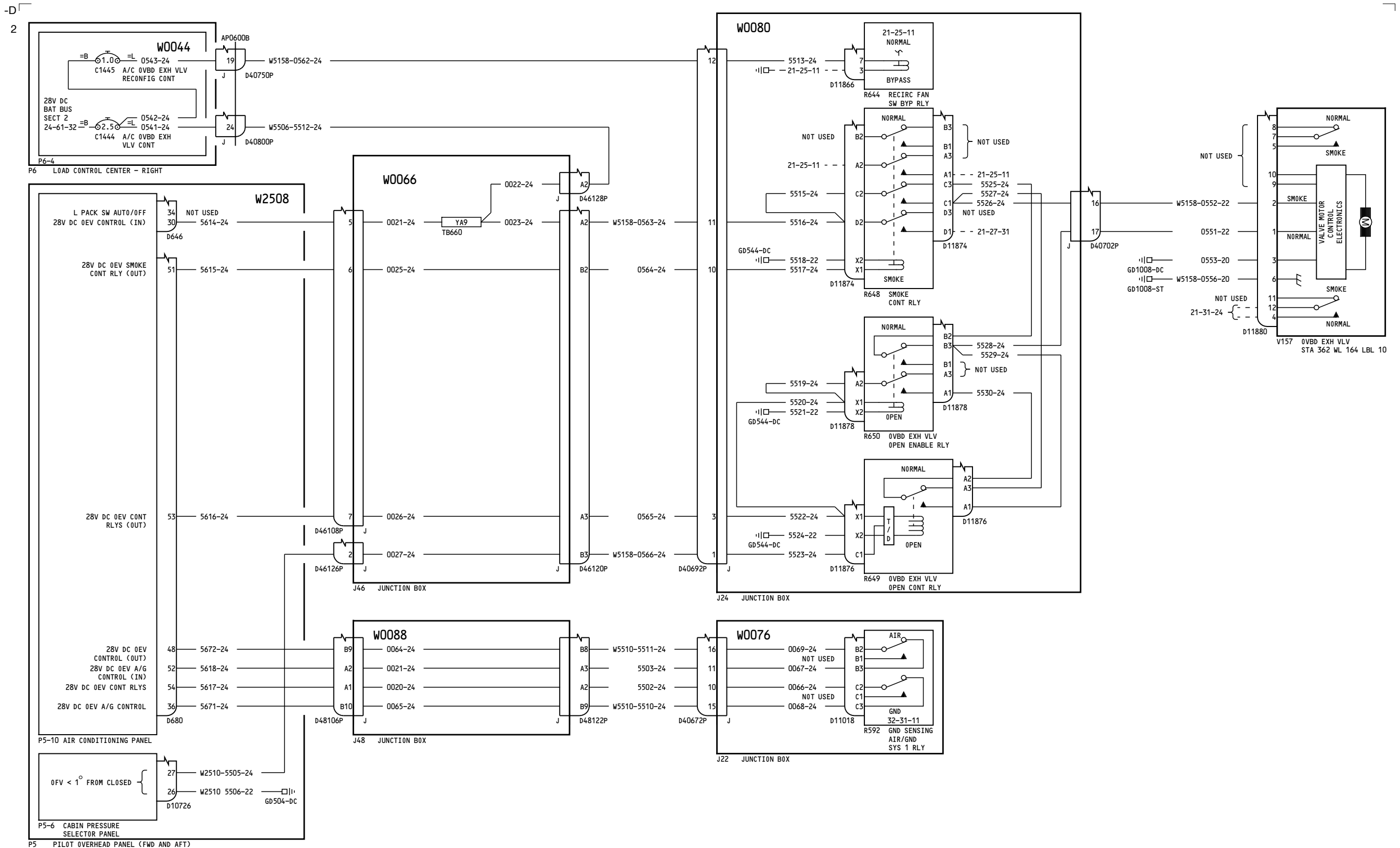

YC004-YC007

OVERBOARD EXHAUST VALVE CONTROL

21-43-21

Page 2

D280A103

Jul 26/2006

21-43-21

Page 2

Jul 26/2006

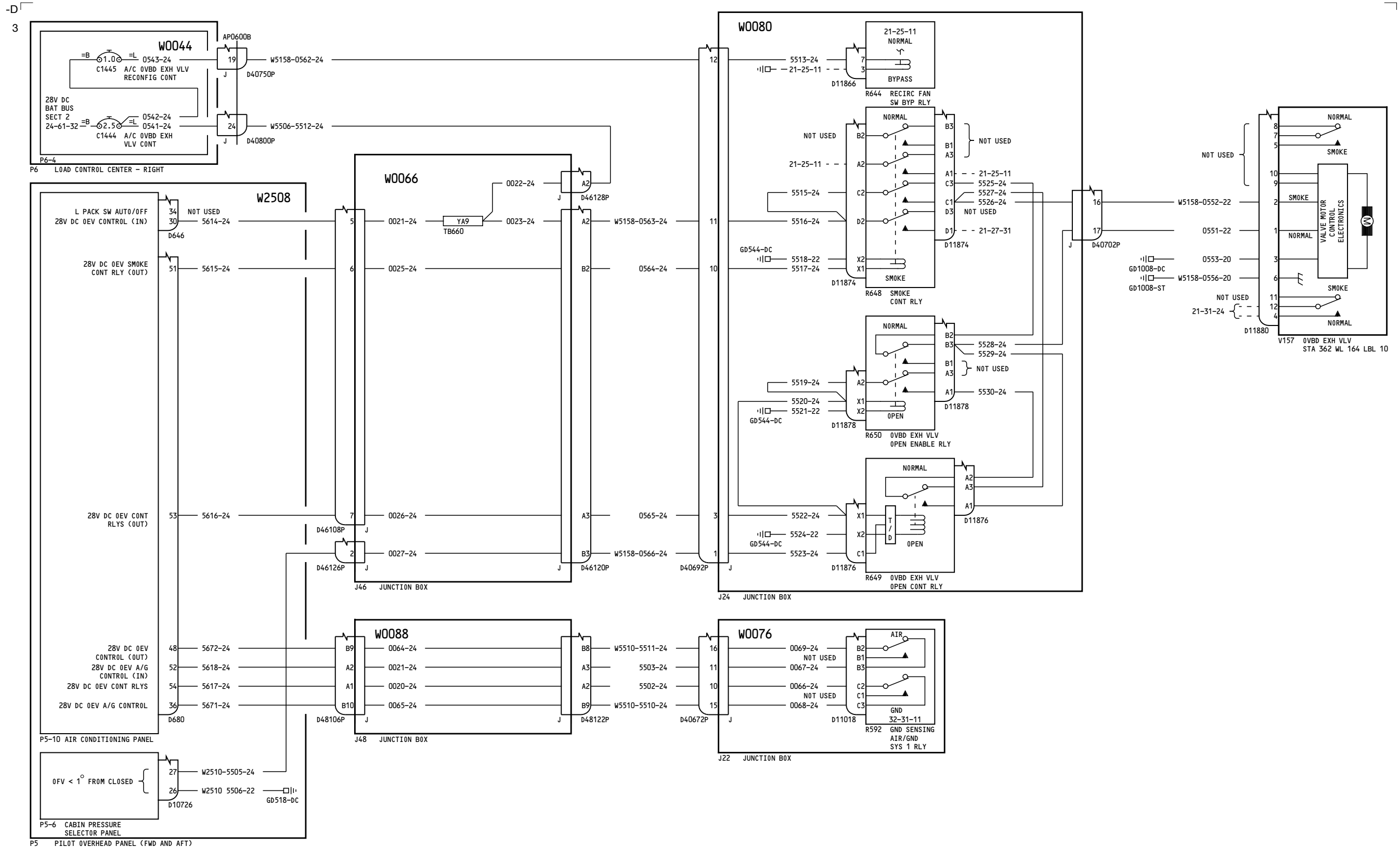

YC008-YC030

OVERBOARD EXHAUST VALVE CONTROL

21-43-21

Page 3

D280A103

Jul 17/2007

21-43-21

Page 3

Jul 17/2007

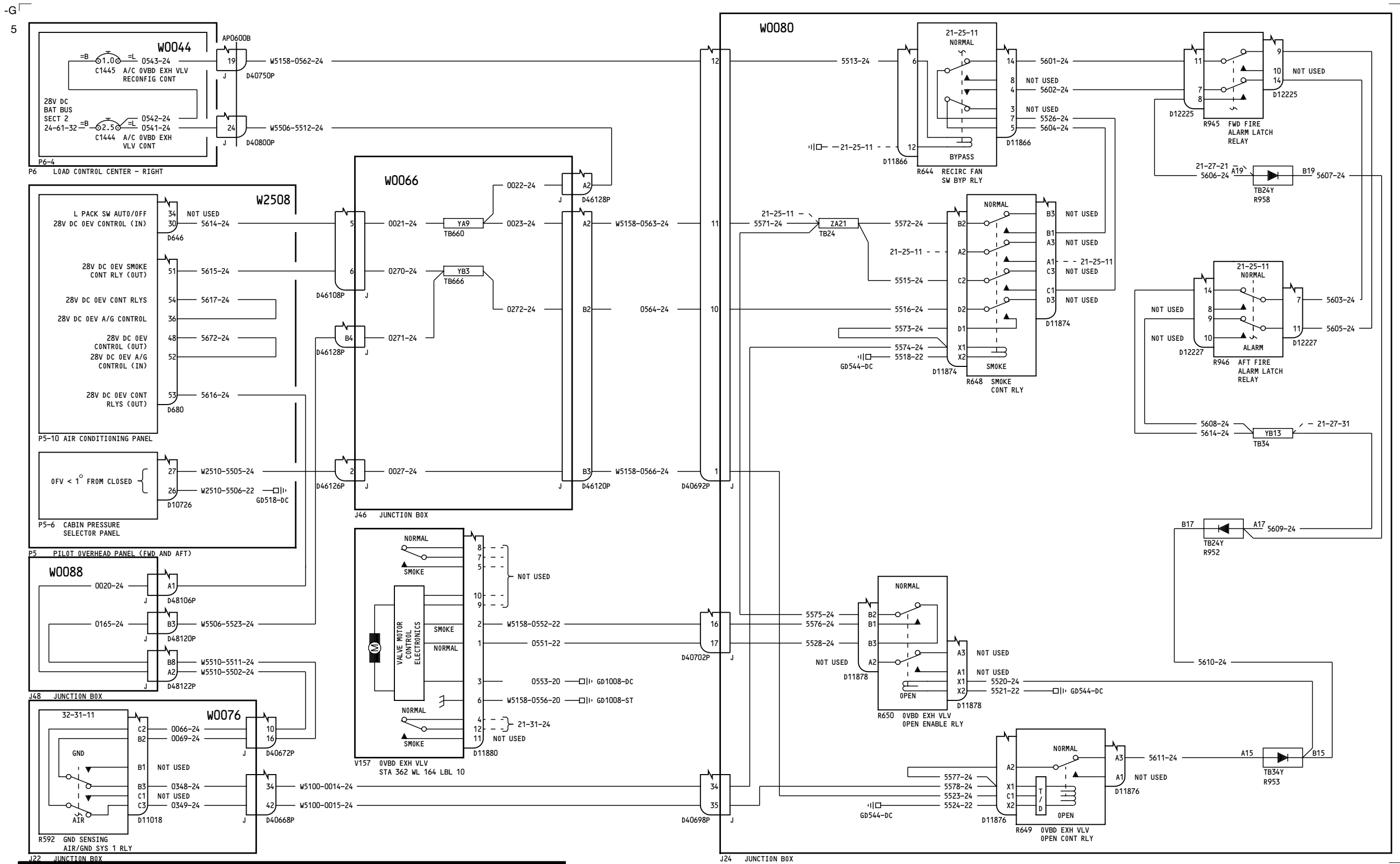

YC031-YM670

OVERBOARD EXHAUST VALVE CONTROL

D280A103

21-43-21

Page 4
Feb 09/2009

21-43-21

Page 4
Feb 09/2009

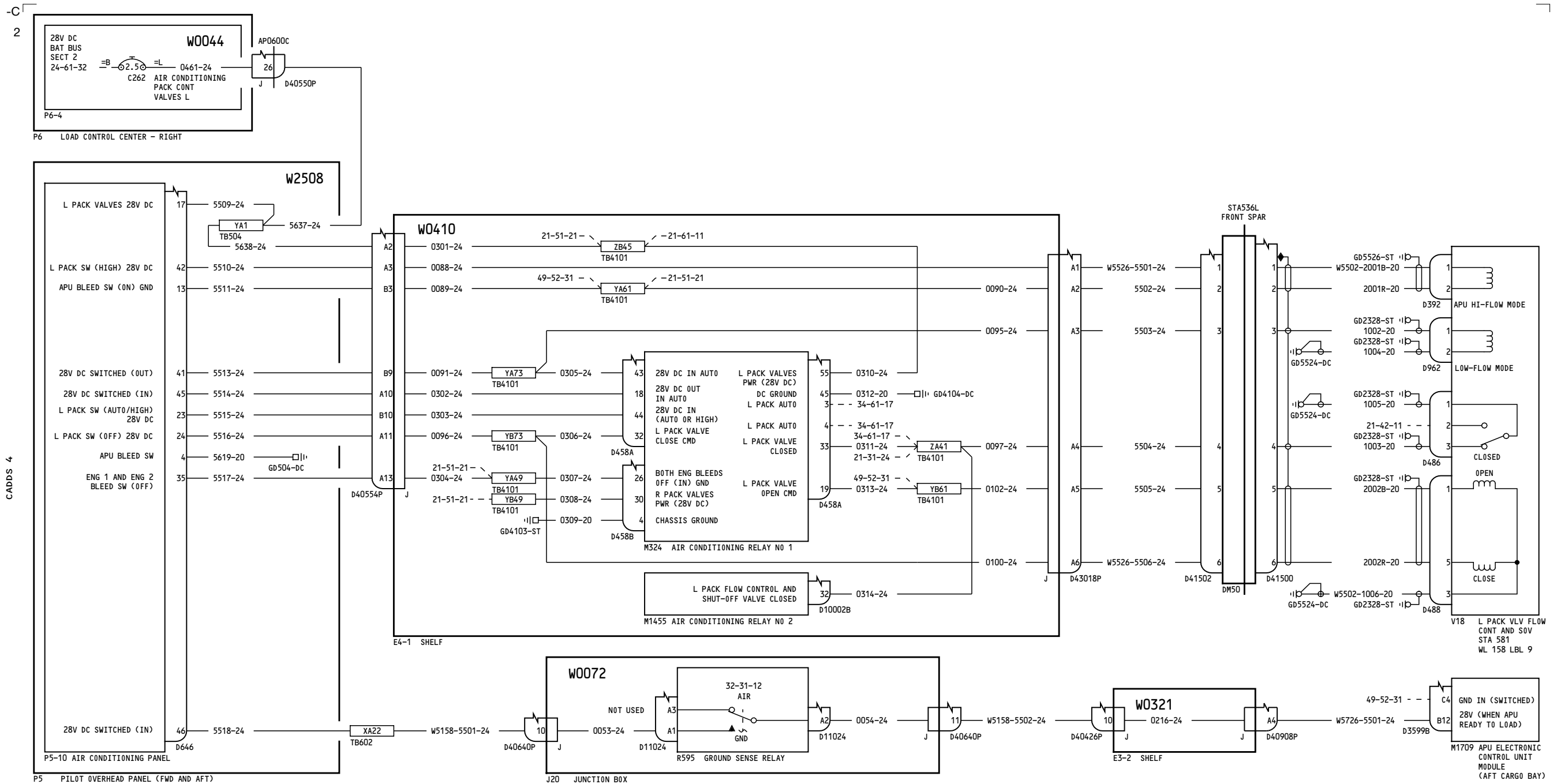

YC001-YC003

LEFT PACK VALVE CONTROL

21-51-11

Page 1

D280A103

Mar 31/2005

21-51-11

Page 1

Mar 31/2005

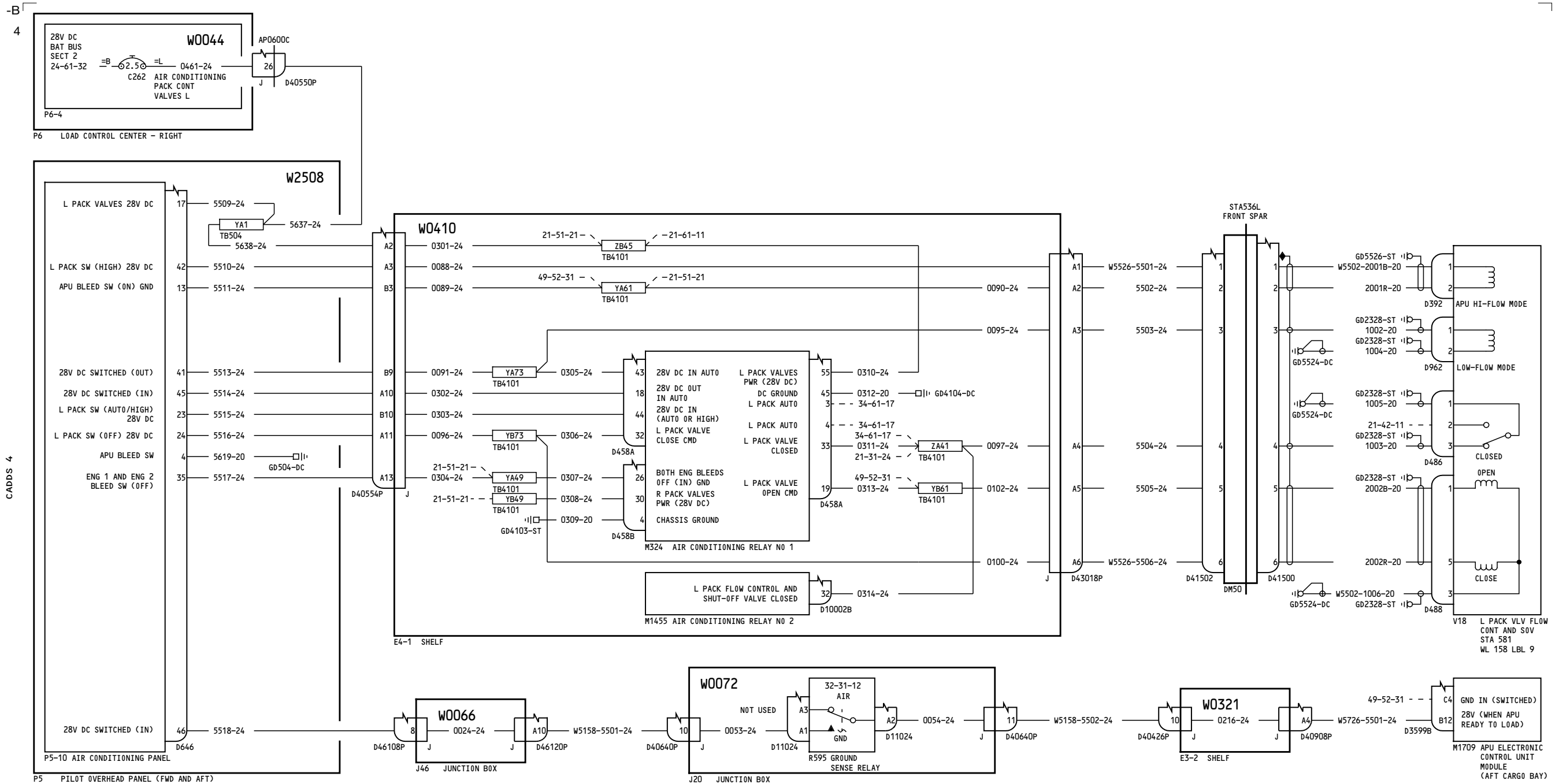

YC004-YC007

LEFT PACK VALVE CONTROL

21-51-11

Page 2

D280A103

Mar 31/2005

21-51-11

Page 2

Mar 31/2005

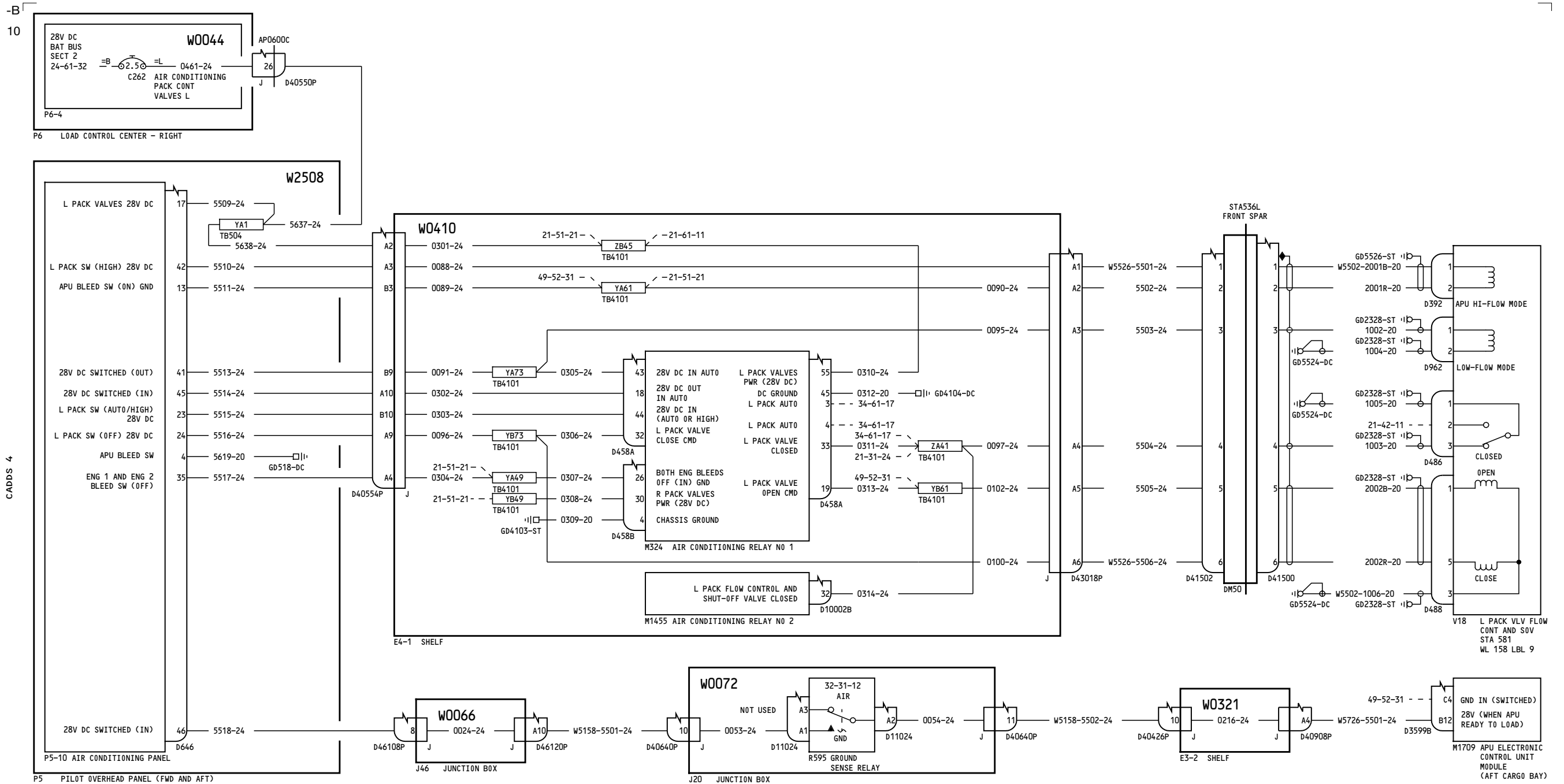

YC008-YC028

LEFT PACK VALVE CONTROL

21-51-11

Page 3

D280A103

Jul 17/2007

21-51-11

Page 3

Jul 17/2007

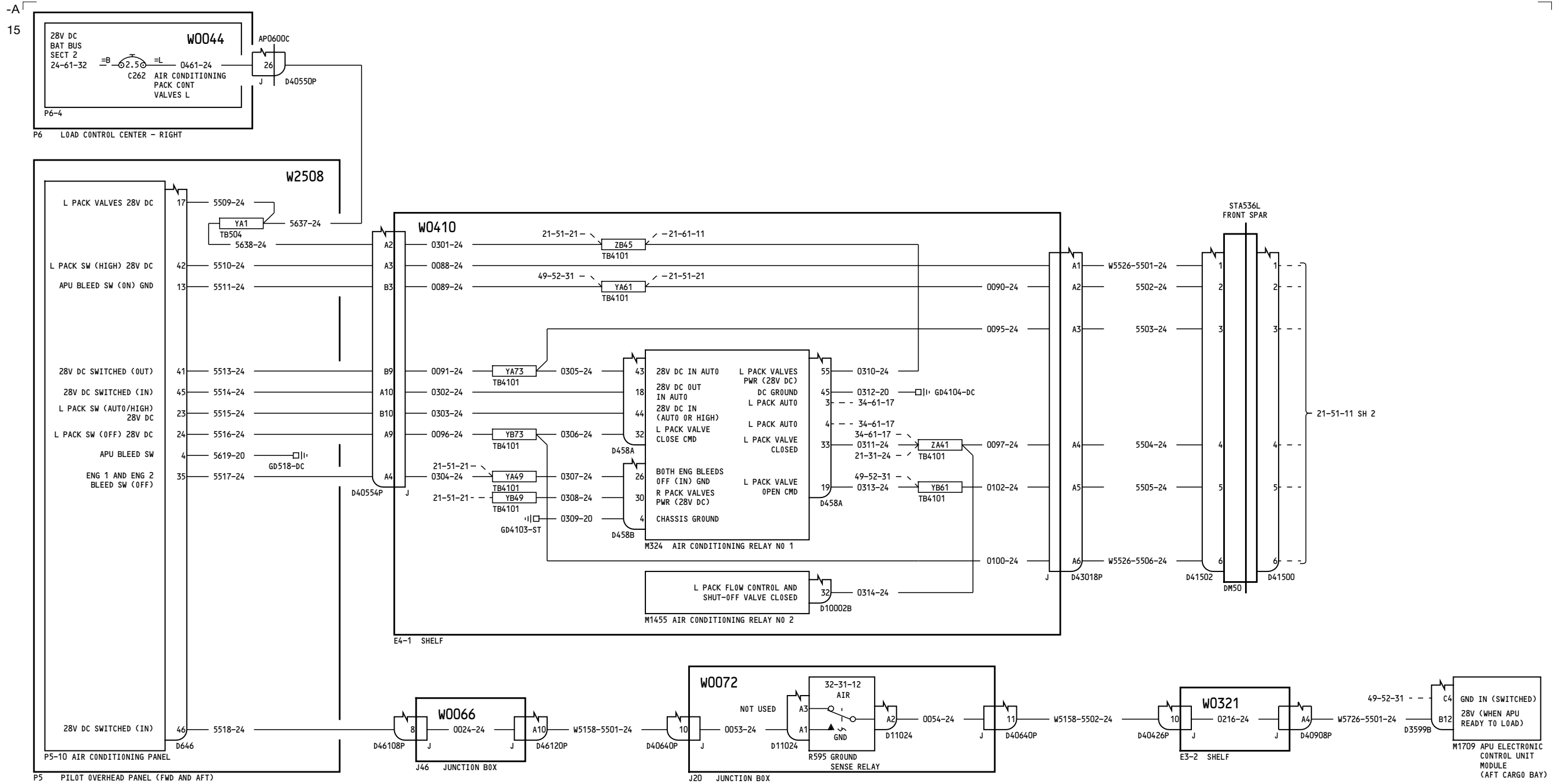

YC029-YC030

LEFT PACK VALVE CONTROL

21-51-11

Page 4
Sheet 1
Mar 31/2005

D280A103

21-51-11

Page 4
Sheet 1
Mar 31/2005

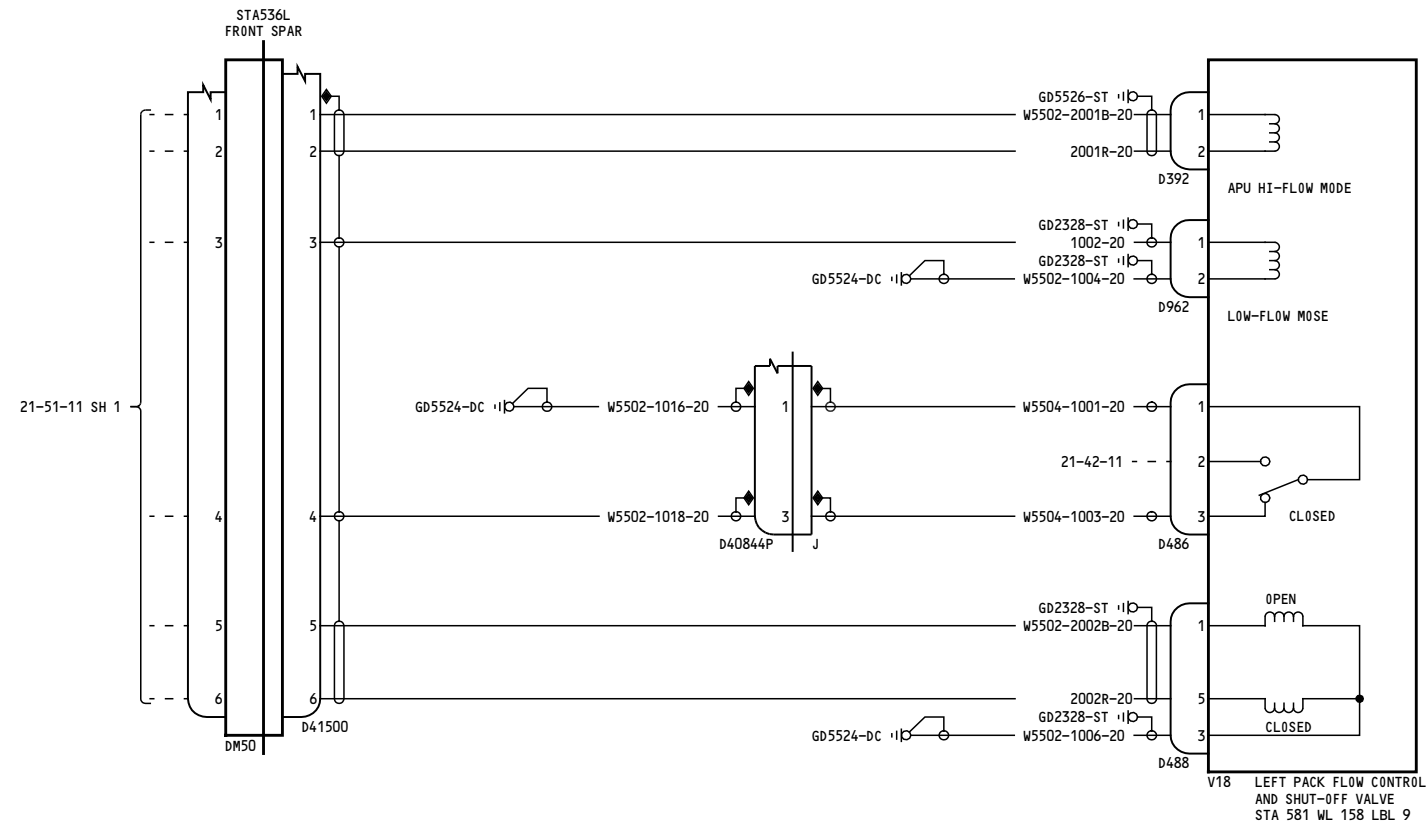

YC029-YC030

LEFT PACK VALVE CONTROL

D280A103

21-51-11

Page 4
Sheet 2
Mar 31/2005

21-51-11

Page 4
Sheet 2
Mar 31/2005

32

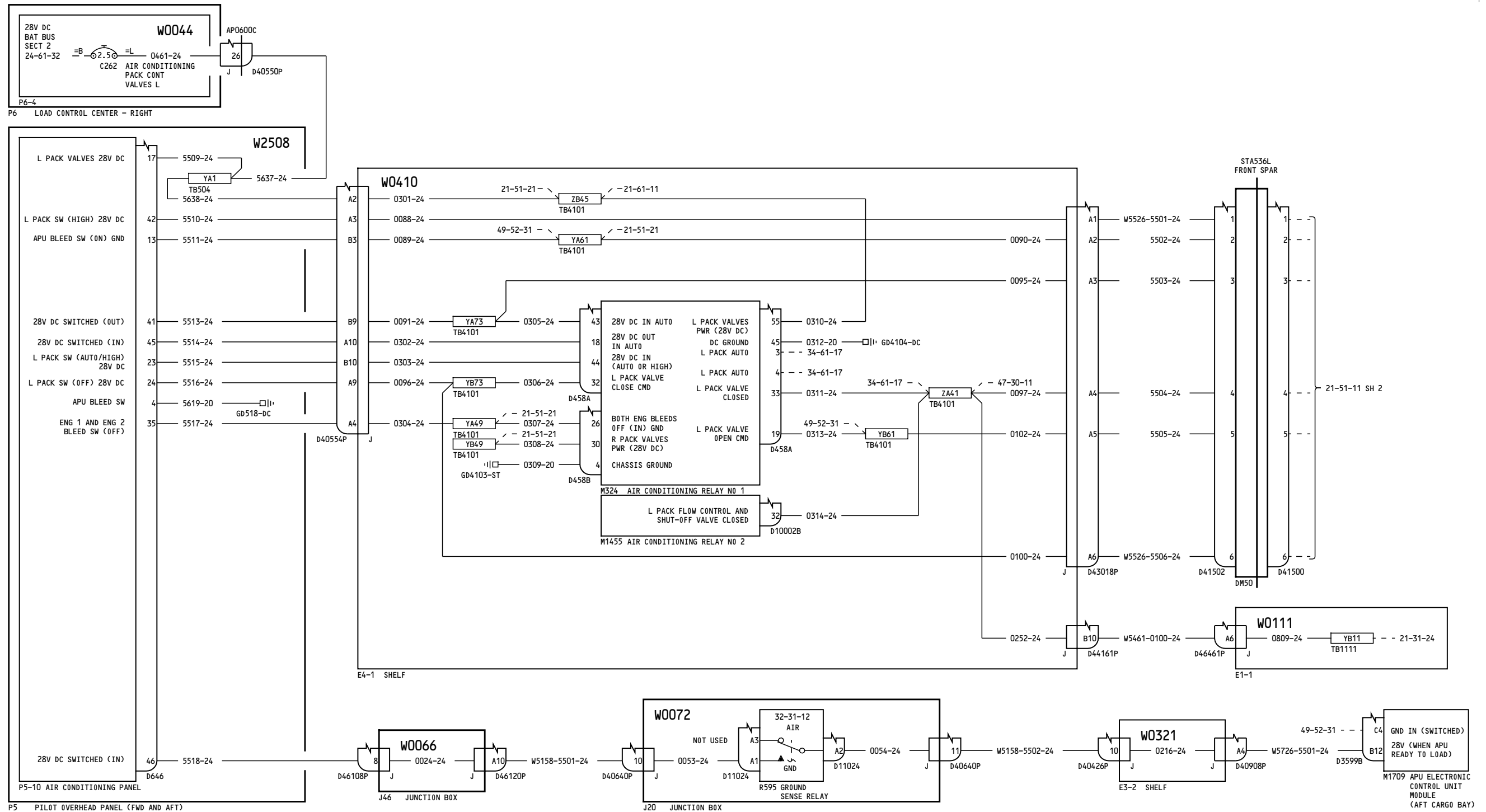

YC031-YC050, YK906-YL430

LEFT PACK VALVE CONTROL

21-51-11

Page 5
Sheet 1
Feb 09/2009

D280A103

21-51-11

Page 5
Sheet 1
Feb 09/2009

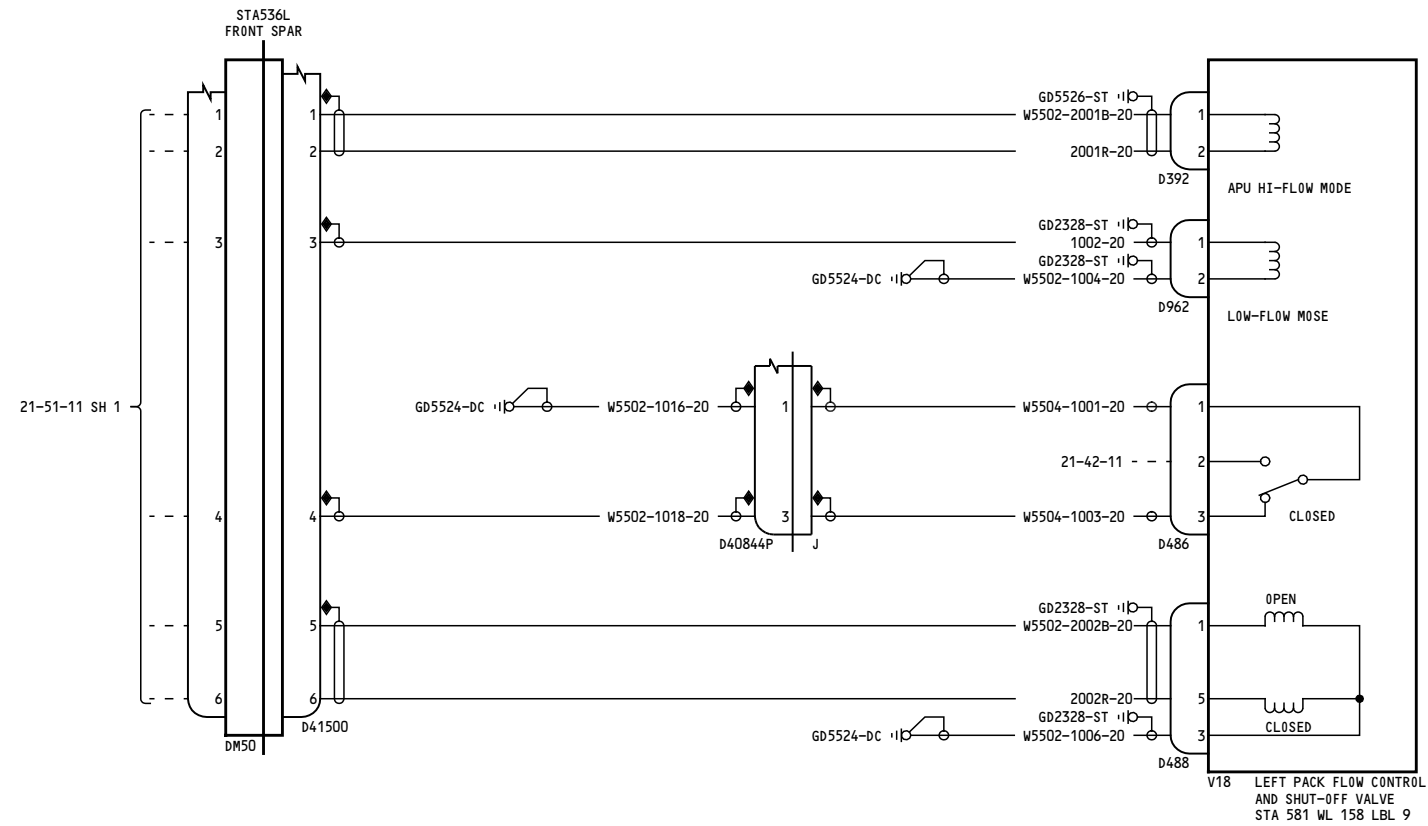

24

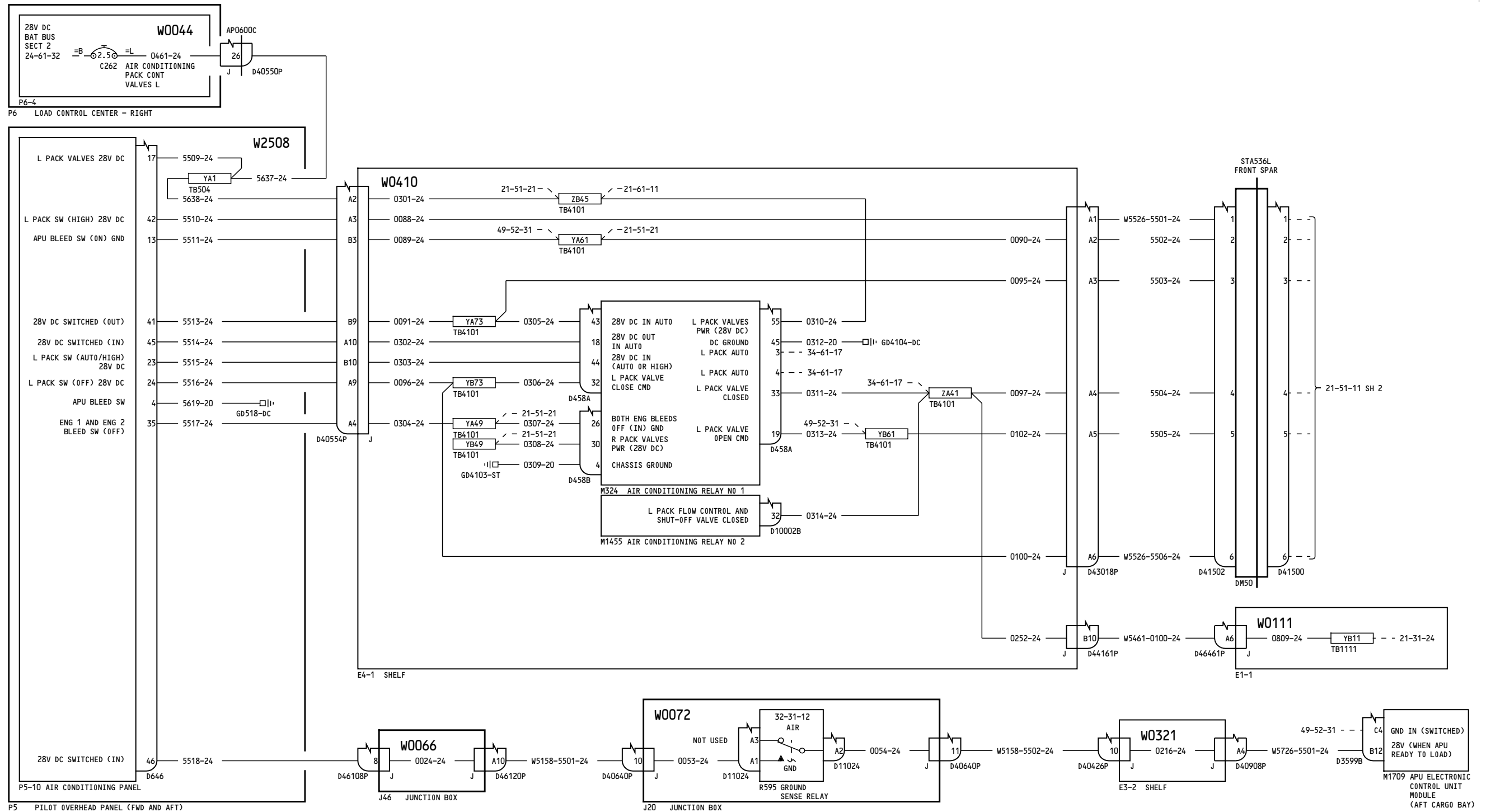

YK901-YK905

LEFT PACK VALVE CONTROL

21-51-11

Page 6
Sheet 1
Jan 18/2006

D280A103

21-51-11

Page 6
Sheet 1
Jan 18/2006

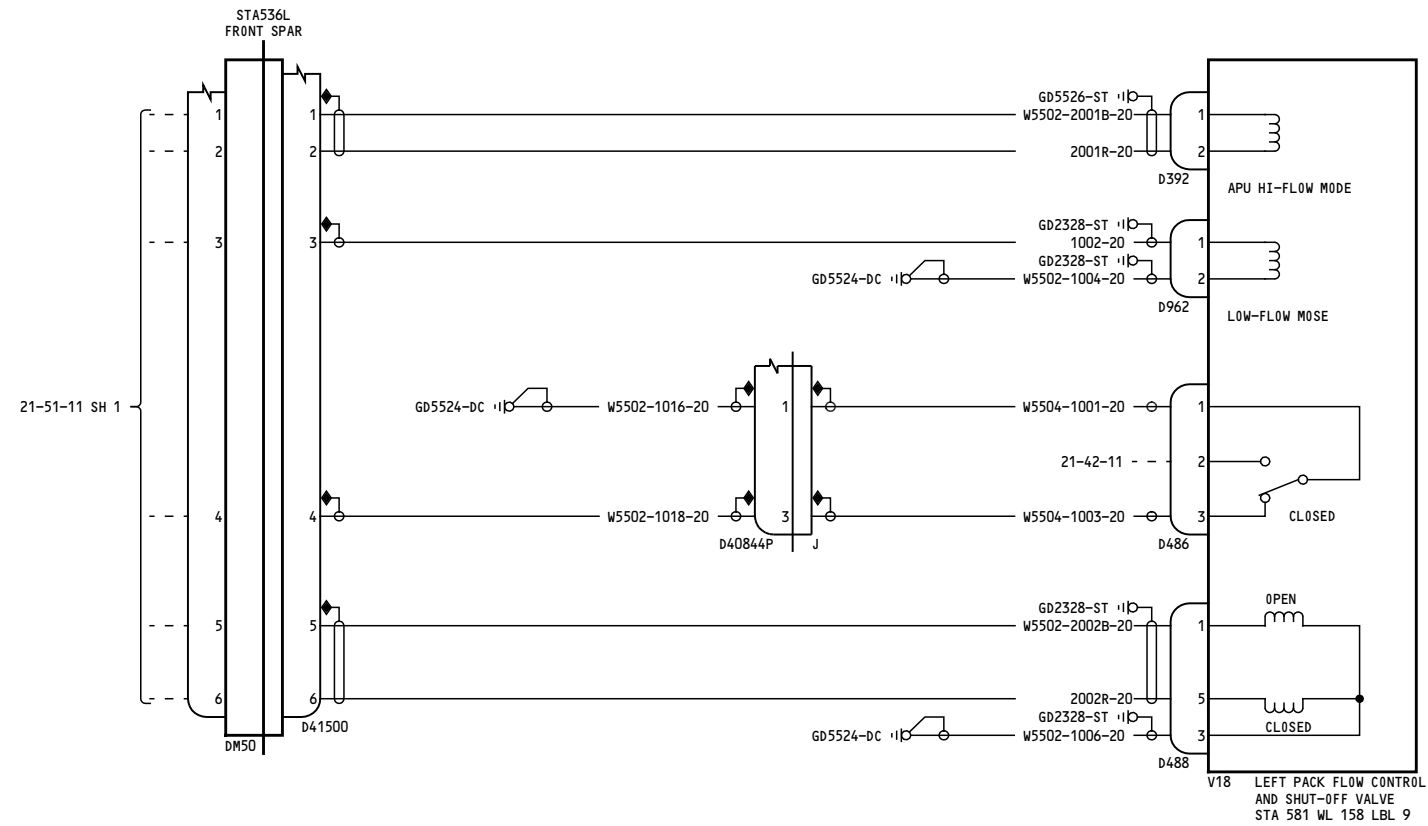

YK901-YK905

LEFT PACK VALVE CONTROL

D280A103

21-51-11

Page 6
Sheet 2
Jan 18/2006

21-51-11

Page 6
Sheet 2
Jan 18/2006

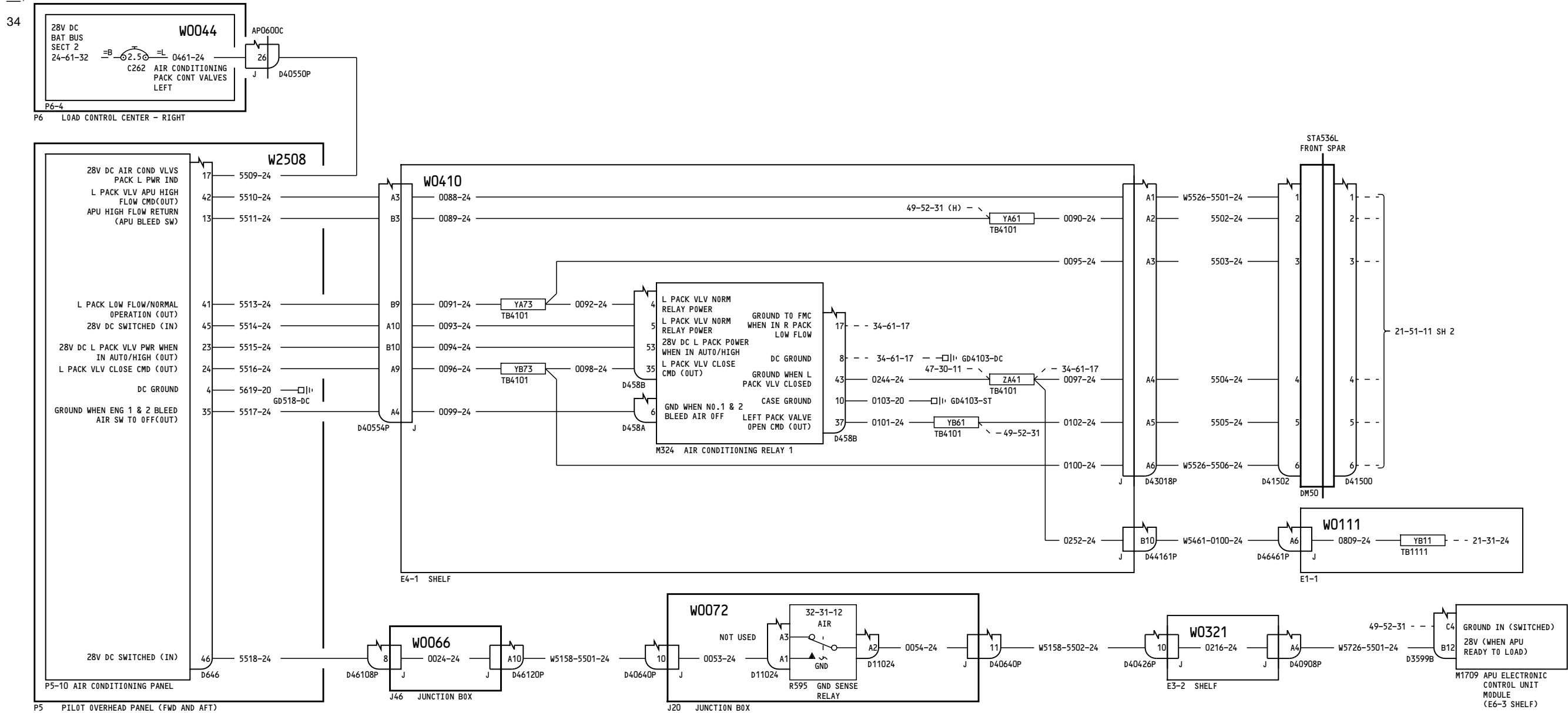

YM643-YM670

LEFT PACK VALVE CONTROL

21-51-11

Page 7
Sheet 1
Jan 14/2008

D280A103

21-51-11

Page 7
Sheet 1
Jan 14/2008

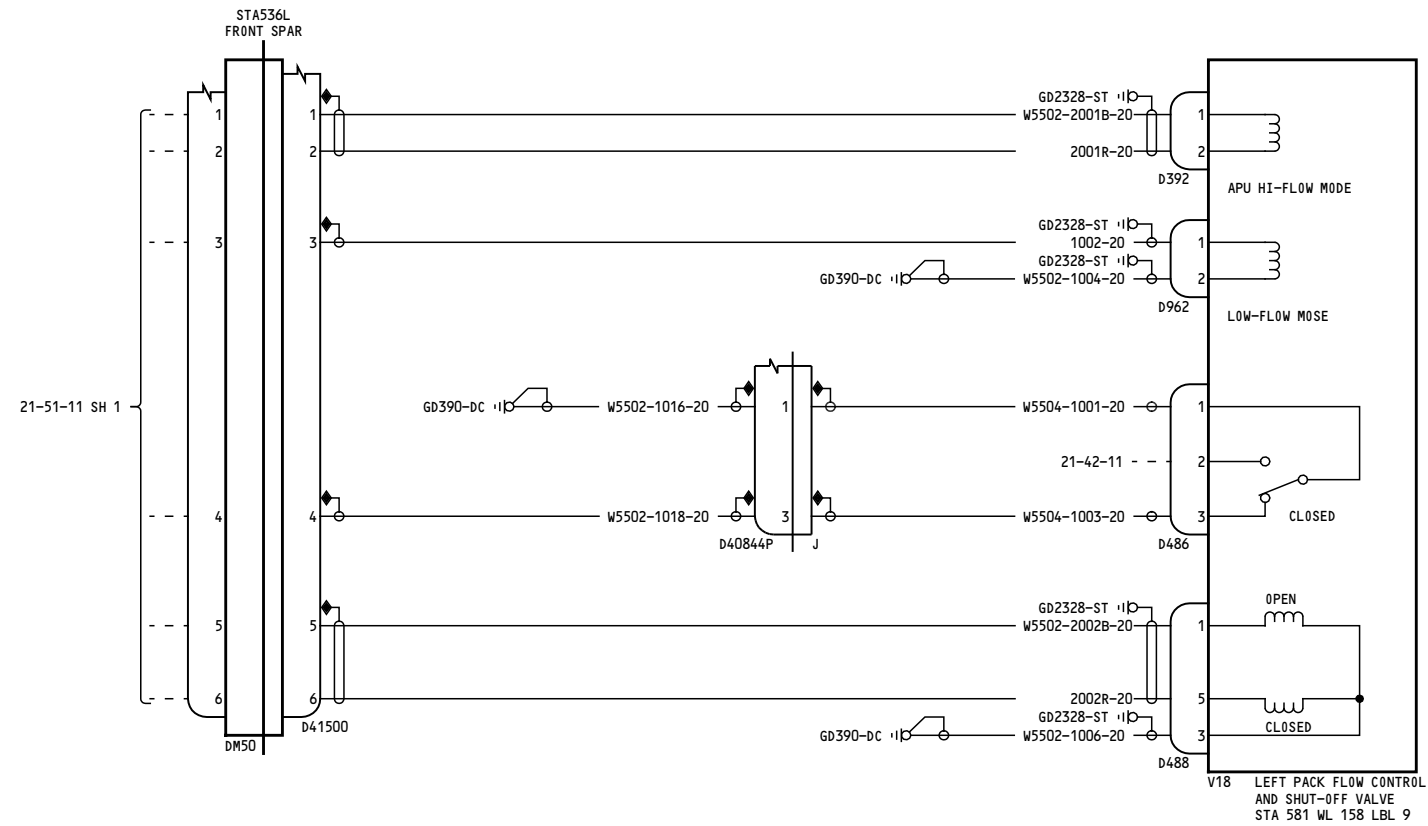

YM643-YM670

LEFT PACK VALVE CONTROL

D280A103

21-51-11

Page 7
Sheet 2
Jan 14/2008

21-51-11

Page 7
Sheet 2
Jan 14/2008

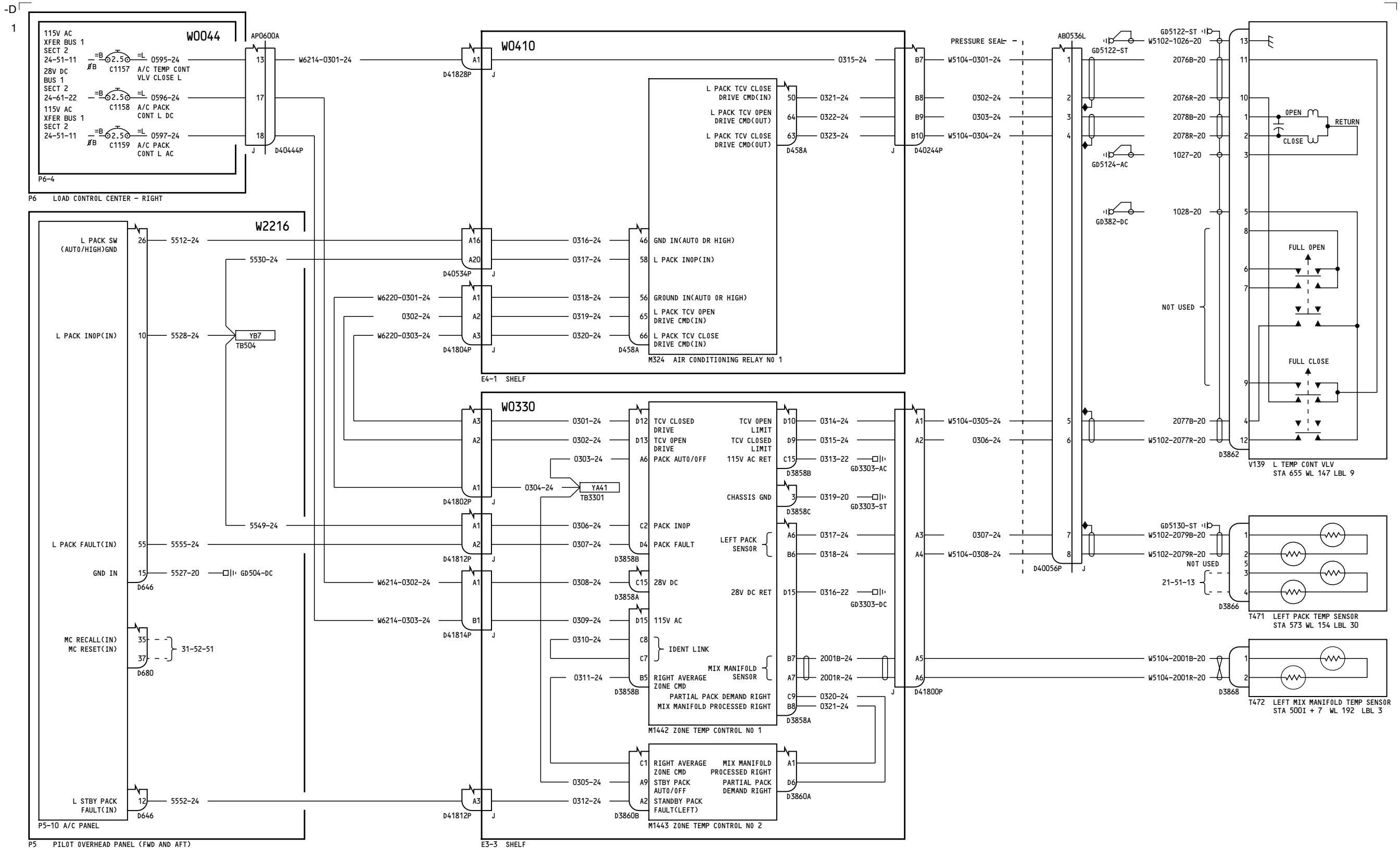

YC001-YC007

LEFT AIR CONDITIONING PACK CONTROL - AUTO

21-51-12

Page 1

D280A103

Mar 31/2005

21-51-12

Page 1

Mar 31/2005

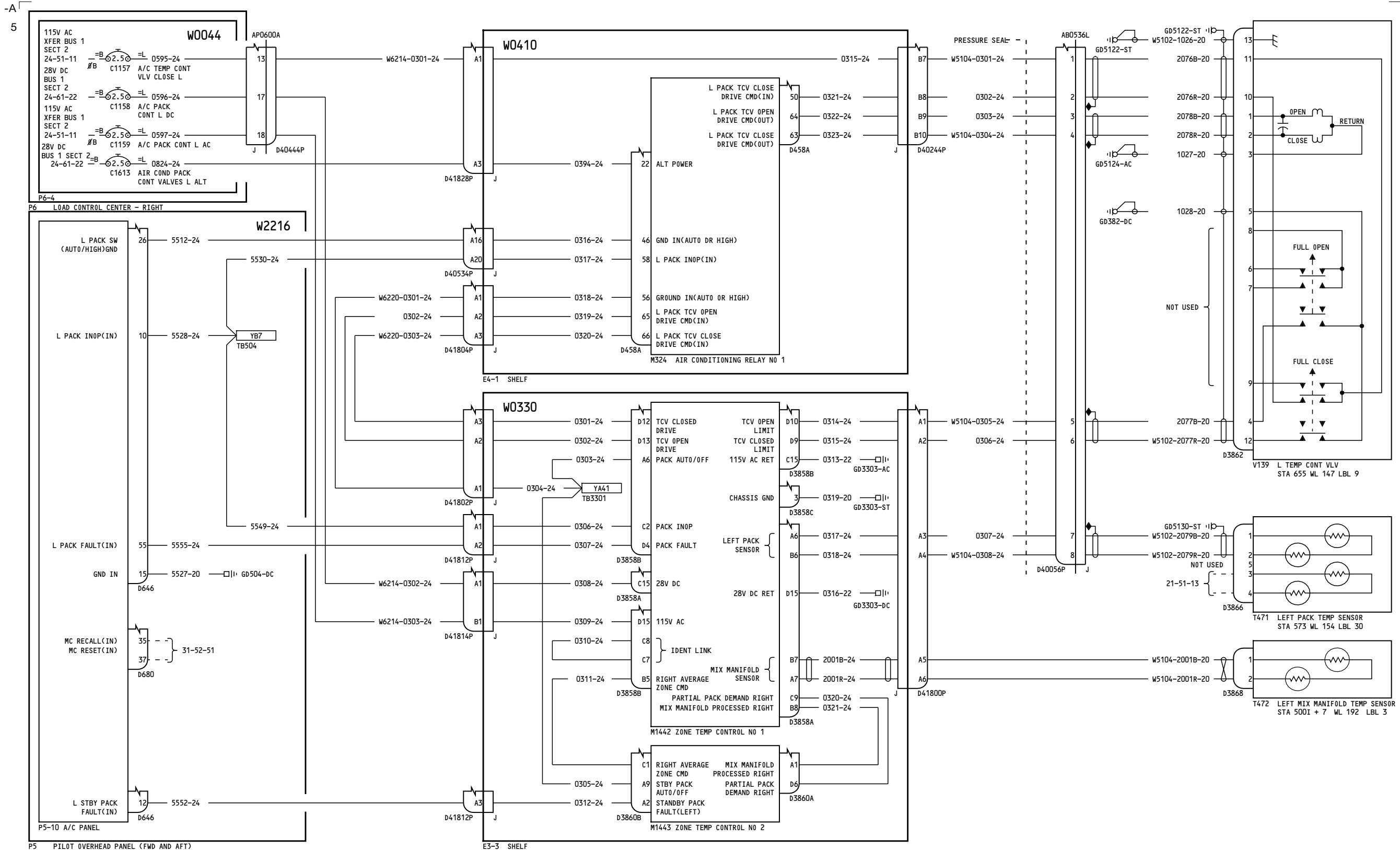

YC001-YC007

LEFT AIR CONDITIONING PACK CONTROL - AUTO

21-51-12

Incorporates 21-1133

21-51-12

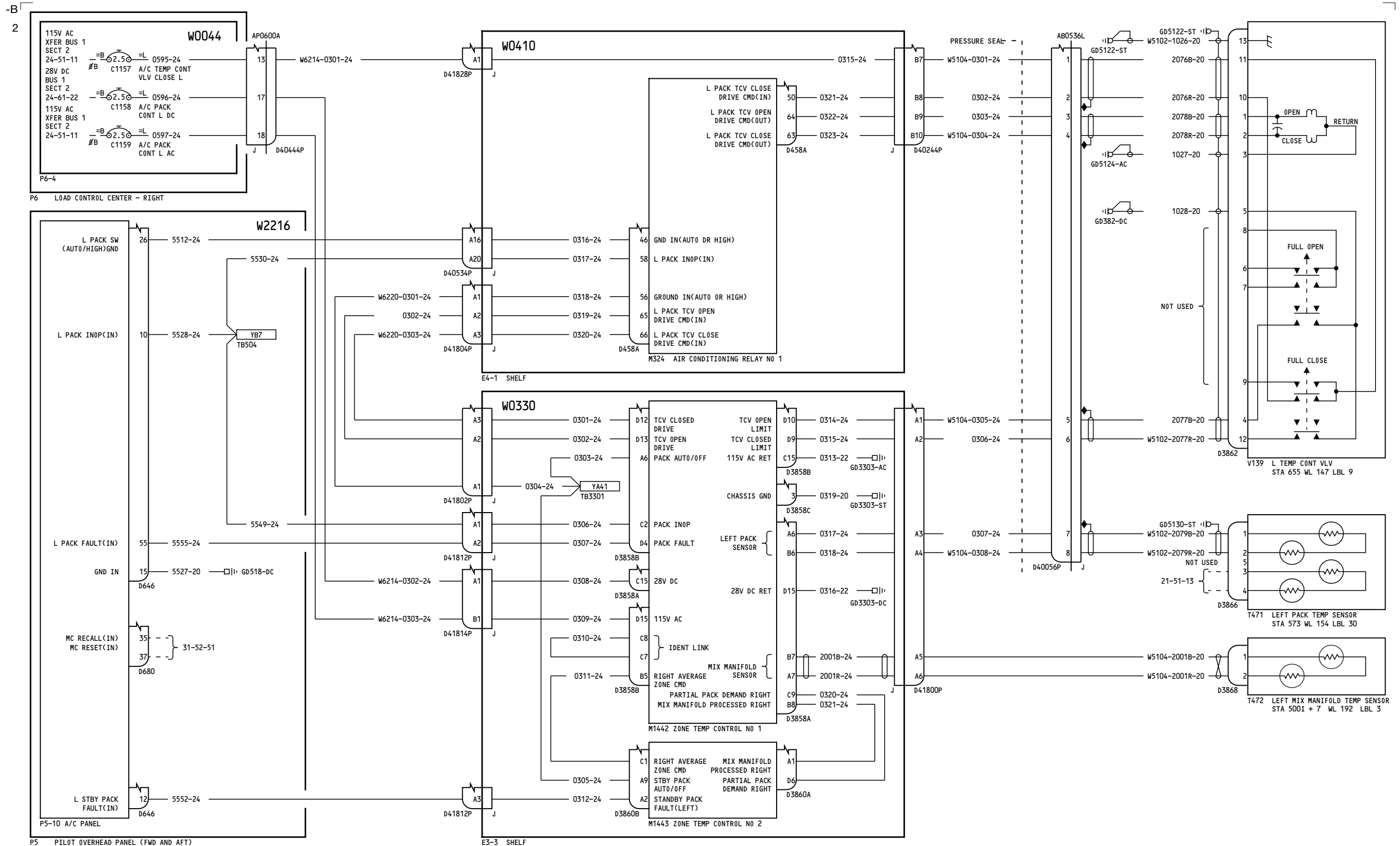

YC008-YC022

LEFT AIR CONDITIONING PACK CONTROL - AUTO

21-51-12

Page 2

D280A103

Mar 31/2005

21-51-12

Page 2

Mar 31/2005

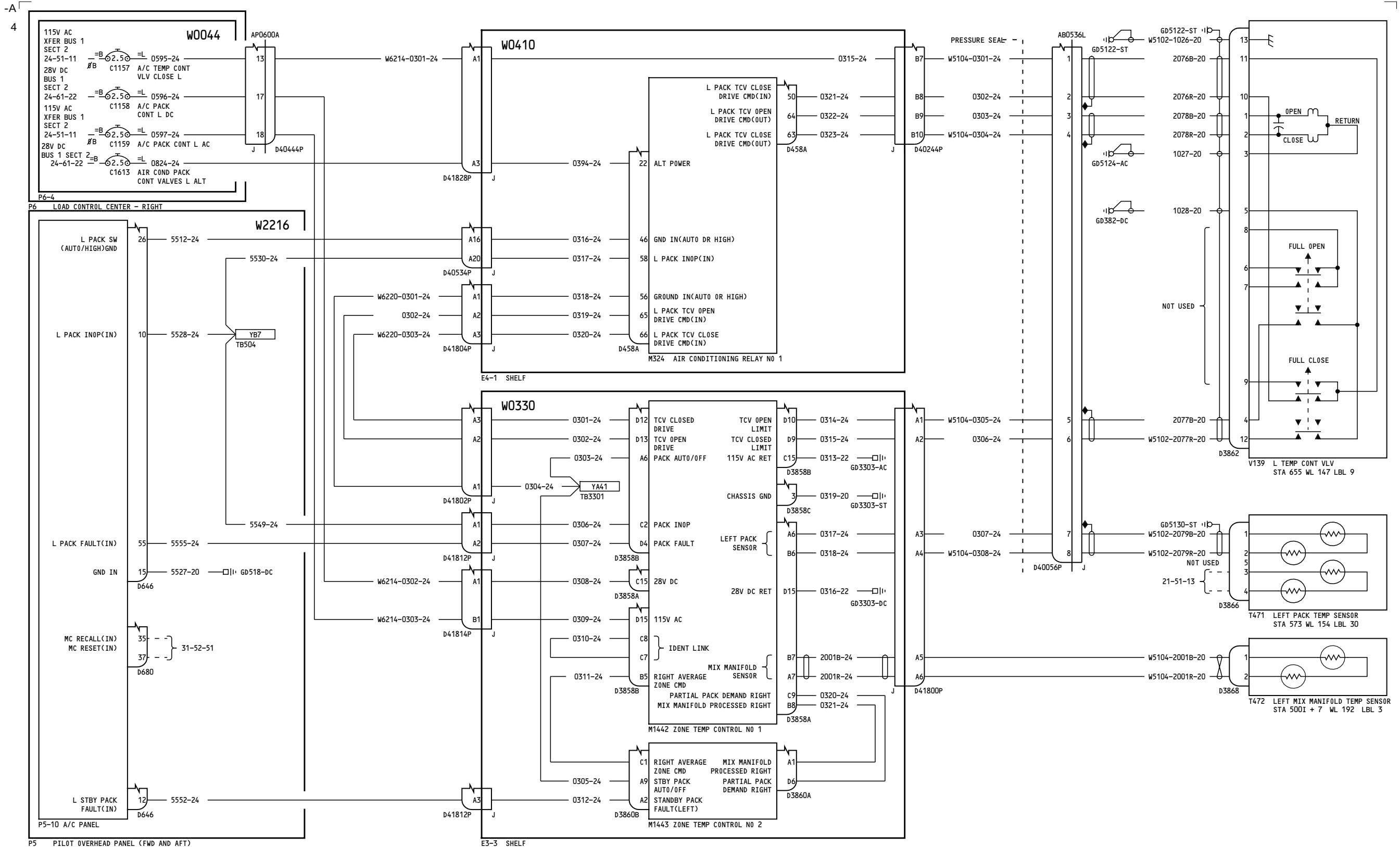

YC008-YC022

LEFT AIR CONDITIONING PACK CONTROL - AUTO

21-51-12

Incorporates 21-1133

Page 2.1

D280A103

Apr 18/2007

21-51-12

Page 2.1

Apr 18/2007

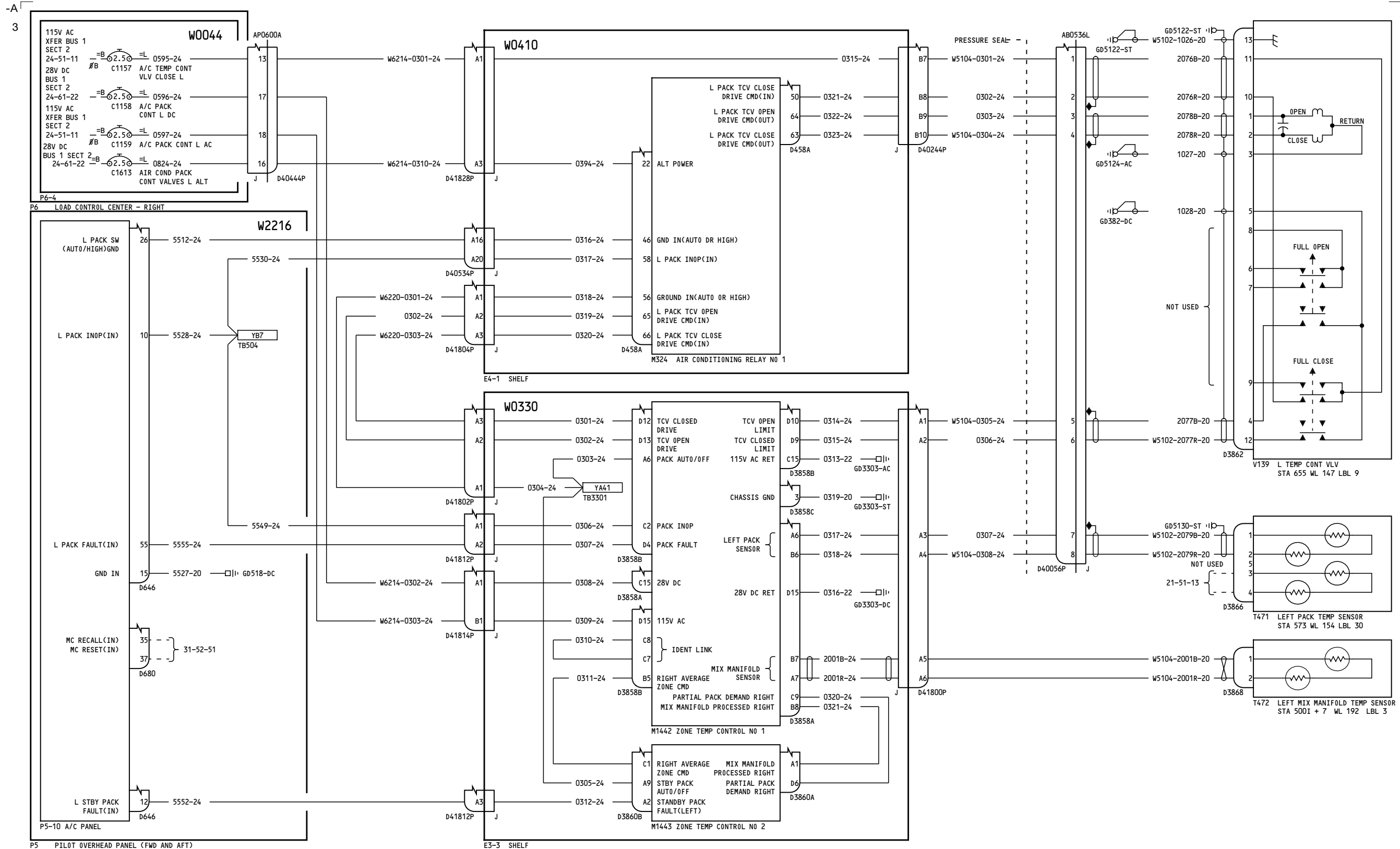

YC023-YC030

LEFT AIR CONDITIONING PACK CONTROL - AUTO

21-51-12

Page 3

D280A103

Jul 17/2007

21-51-12

Page 3

Jul 17/2007

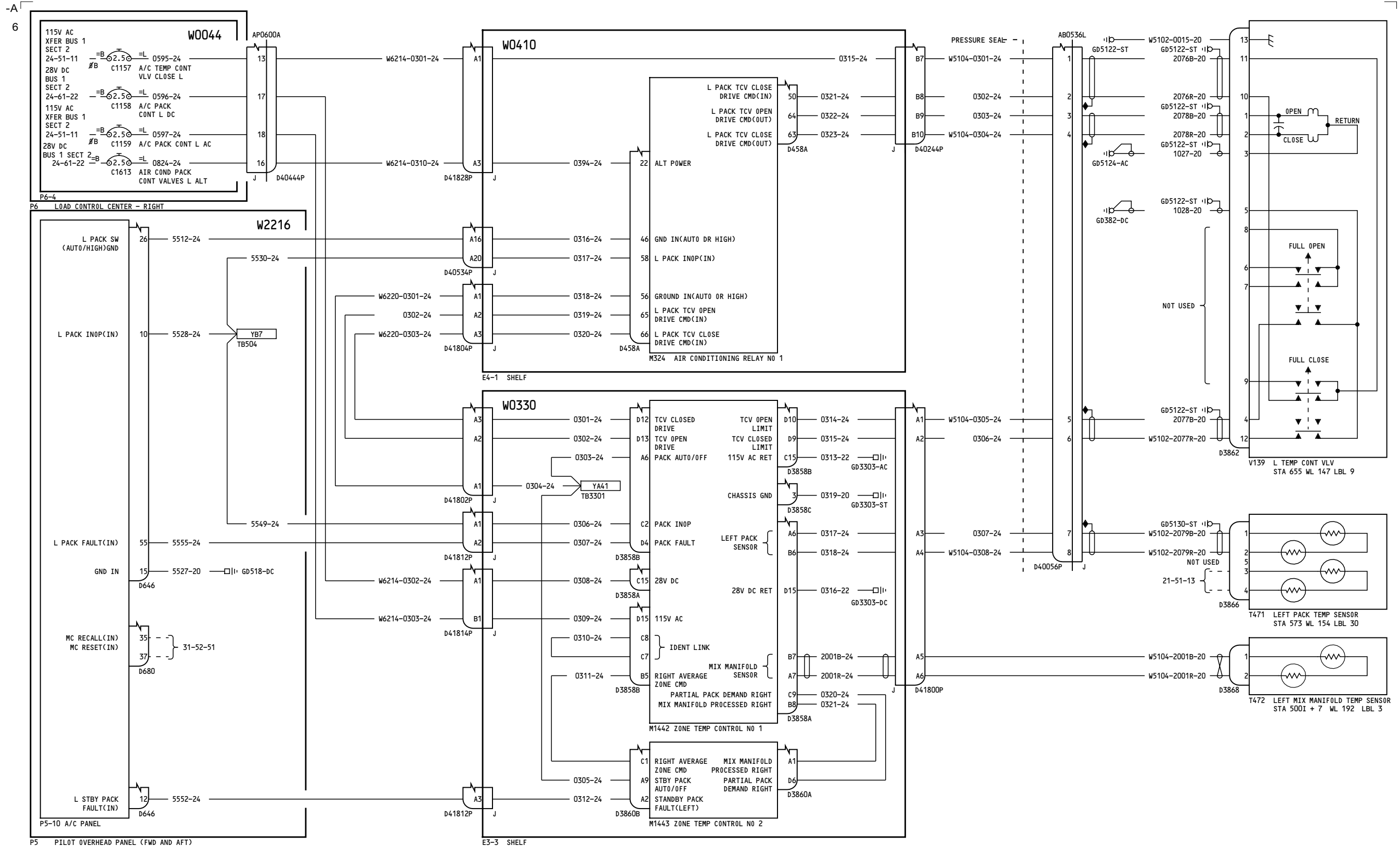

YC031-YL430

**LEFT AIR CONDITIONING
PACK CONTROL - AUTO**

21-51-12

Page 4

D280A103

Feb 09/2009

21-51-12

Page 4

Feb 09/2009

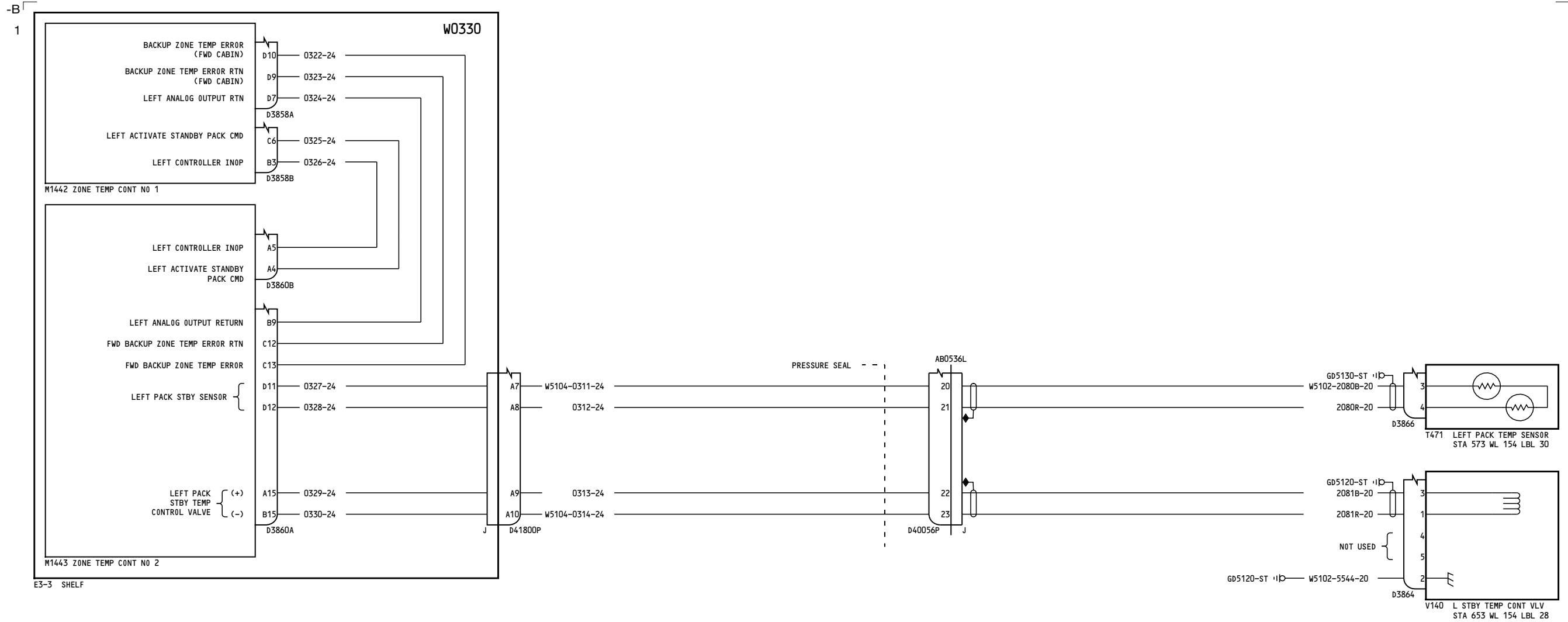

YC001-YL430

**LEFT AIR CONDITIONING
PACK CONTROL STANDBY**

21-51-13

Page 1

D280A103

Feb 09/2009

21-51-13

Page 1

Feb 09/2009

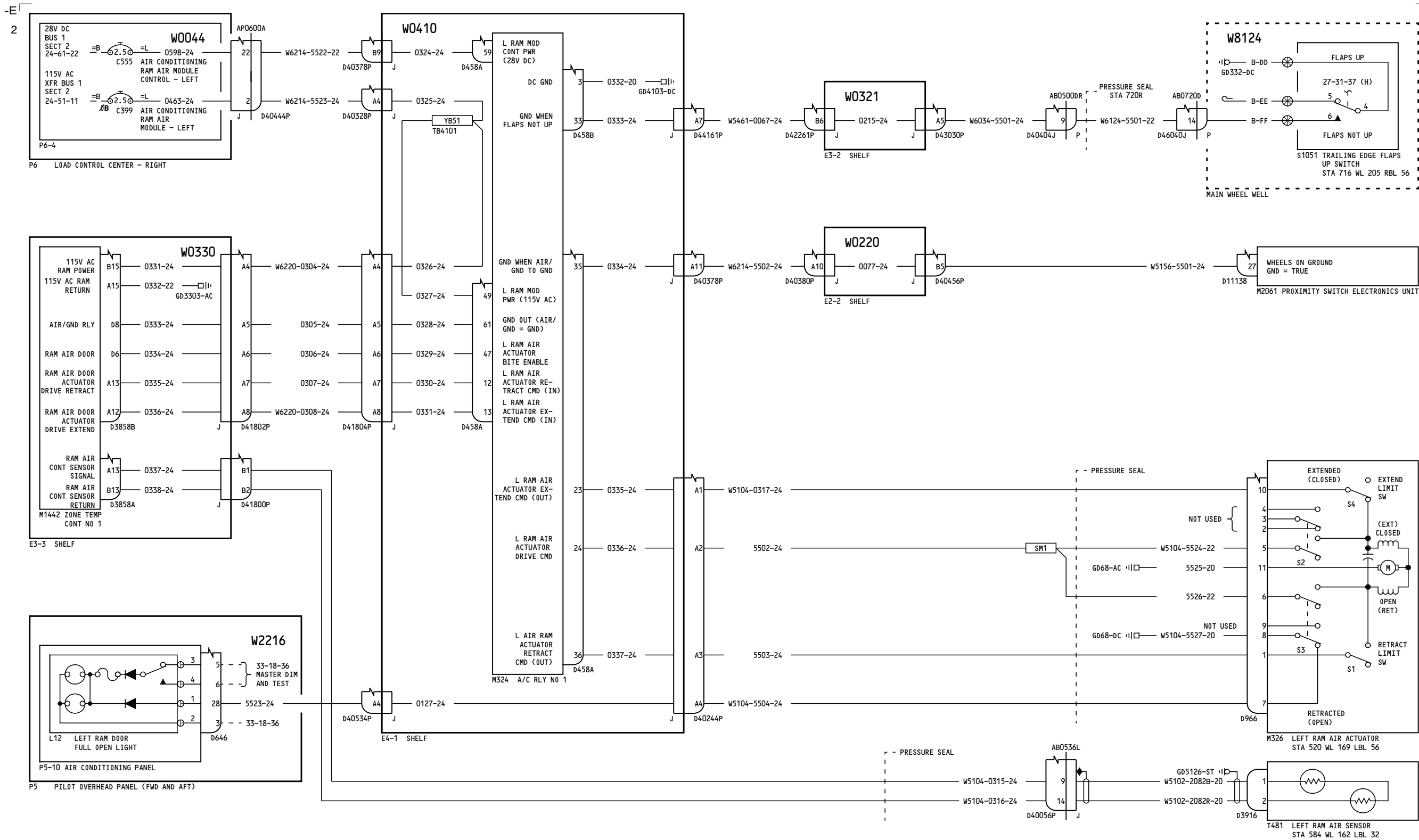

YC001-YC030, YK901-YK905

LEFT RAM MODULATION CONTROL

21-51-14

Page 1

D280A103

May 11/2009

21-51-14

Page 1

May 11/2009

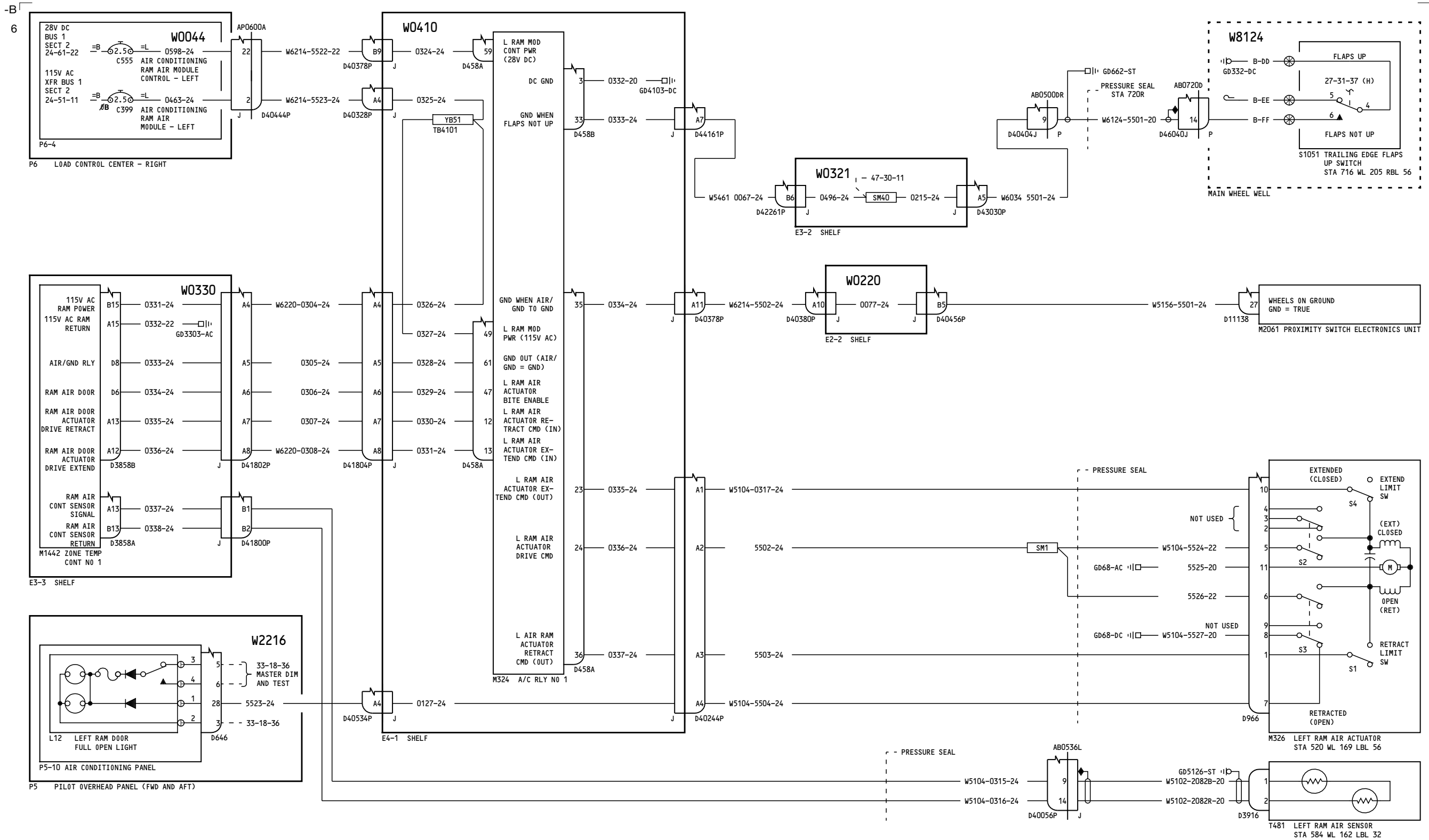

YC031-YC050, YK906-YK910, YK918, YL421-YL426

LEFT RAM MODULATION CONTROL

21-51-14

Page 2

D280A103

May 11/2009

21-51-14

Page 2

May 11/2009

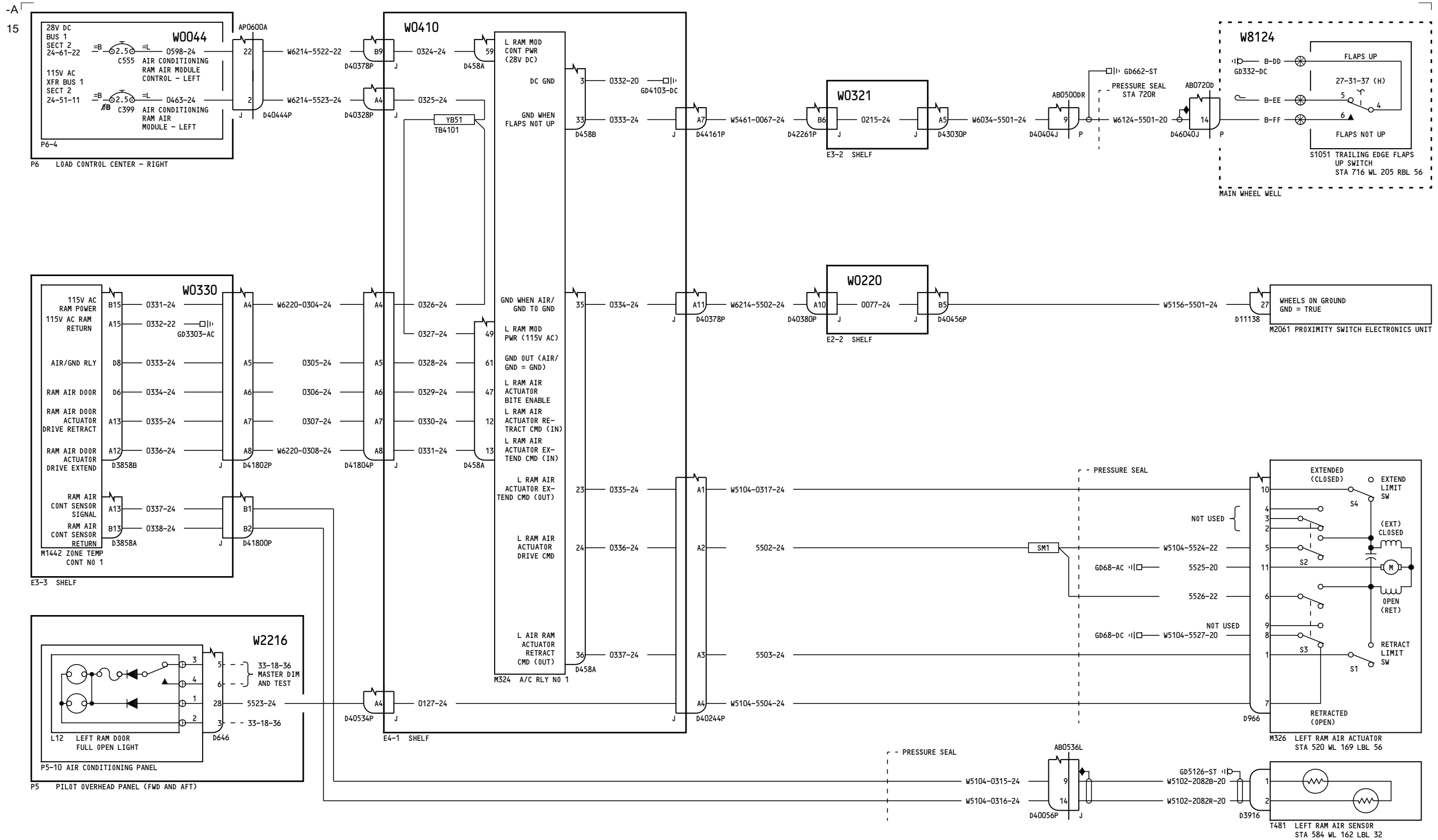

YK911-YK912, YK919, YL401, YL427-YL429

LEFT RAM MODULATION CONTROL

21-51-14

Page 3

D280A103

May 11/2009

21-51-14

Page 3

May 11/2009

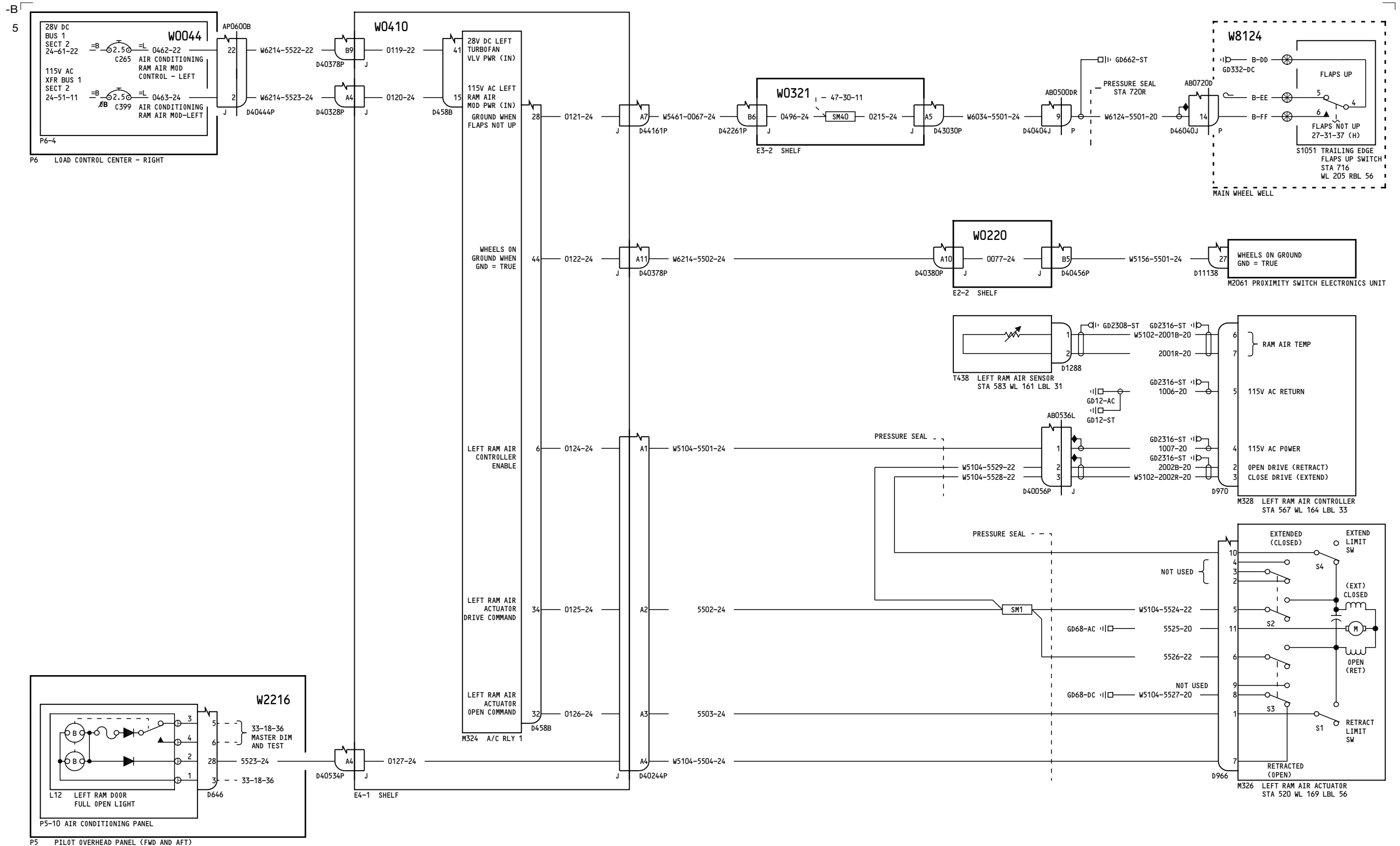

YM643-YM649

LEFT RAM MODULATION CONTROL

21-51-14

Page 4

D280A103

May 11/2009

21-51-14

Page 4

May 11/2009

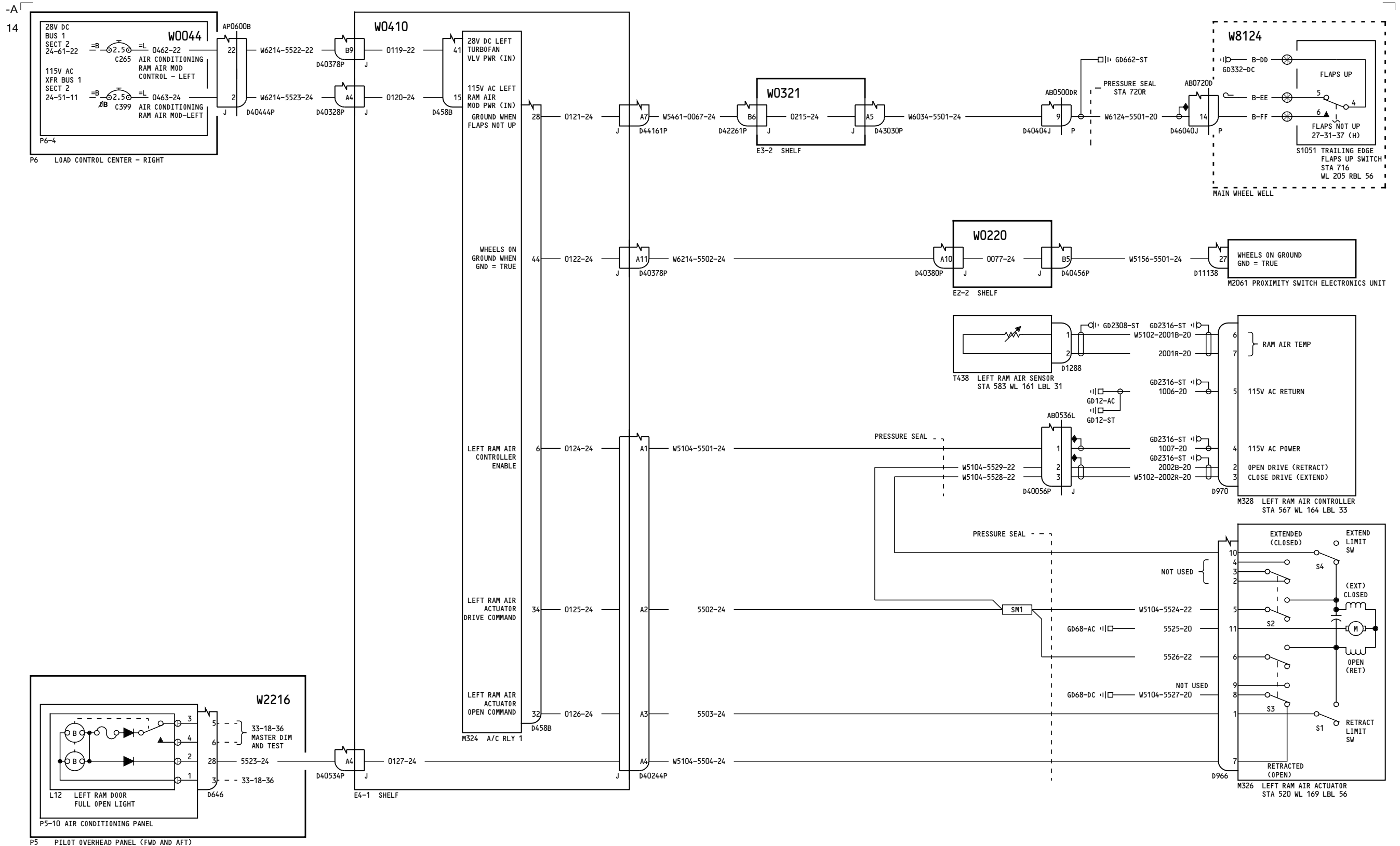

YM651-YM652

LEFT RAM MODULATION CONTROL

21-51-14

Page 5

D280A103

May 11/2009

21-51-14

Page 5

May 11/2009

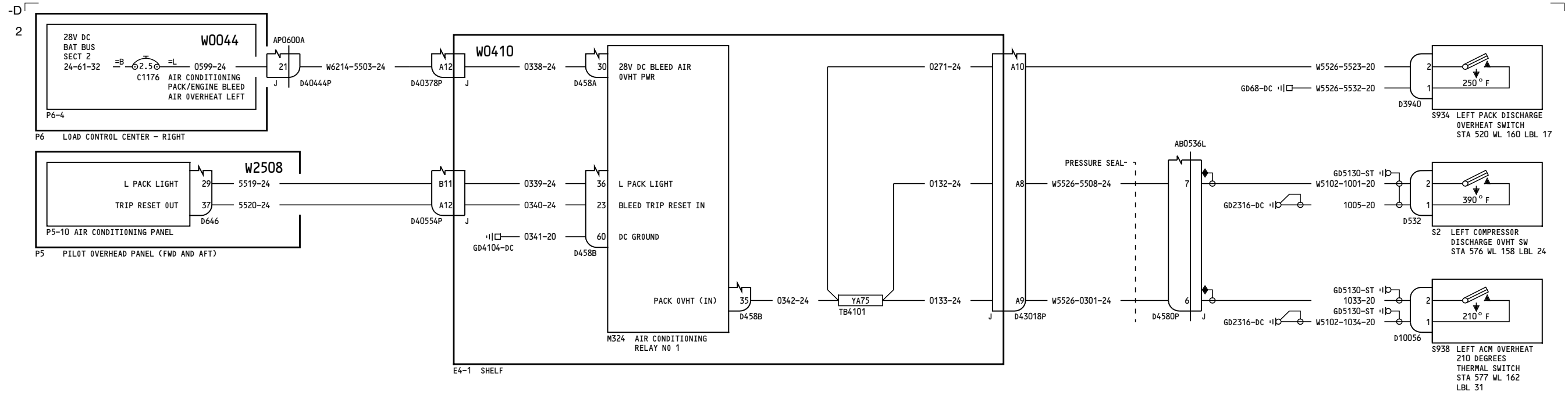

YC001-YC007

LEFT PACK PROTECTION

D280A103

21-51-15

Page 1

Mar 31/2005

21-51-15

Page 1

Mar 31/2005

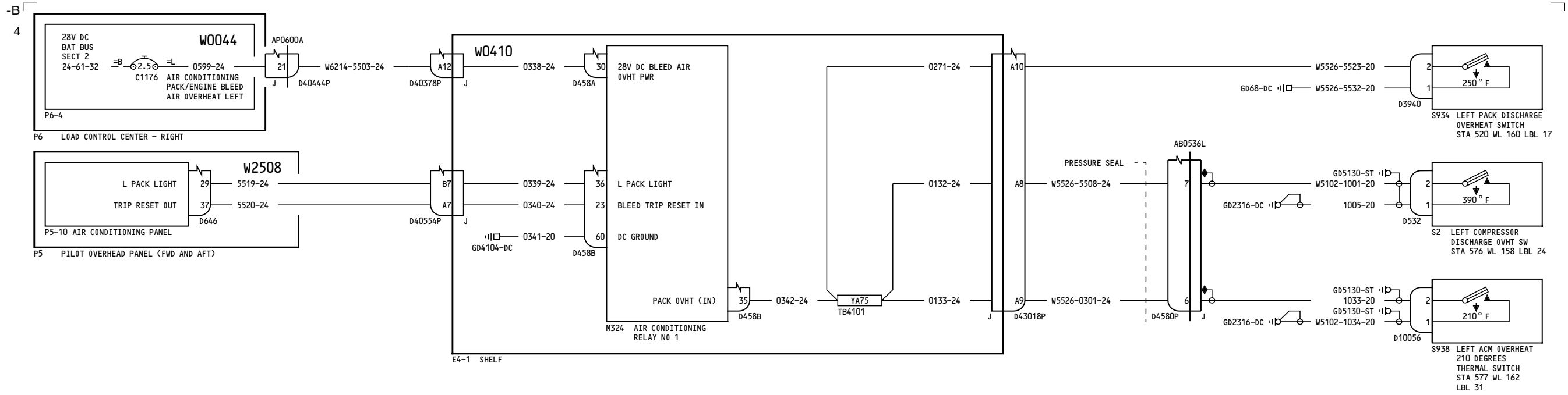

YC008-YC030

LEFT PACK PROTECTION

D280A103

21-51-15

Page 2

Jul 17/2007

21-51-15

Page 2

Jul 17/2007

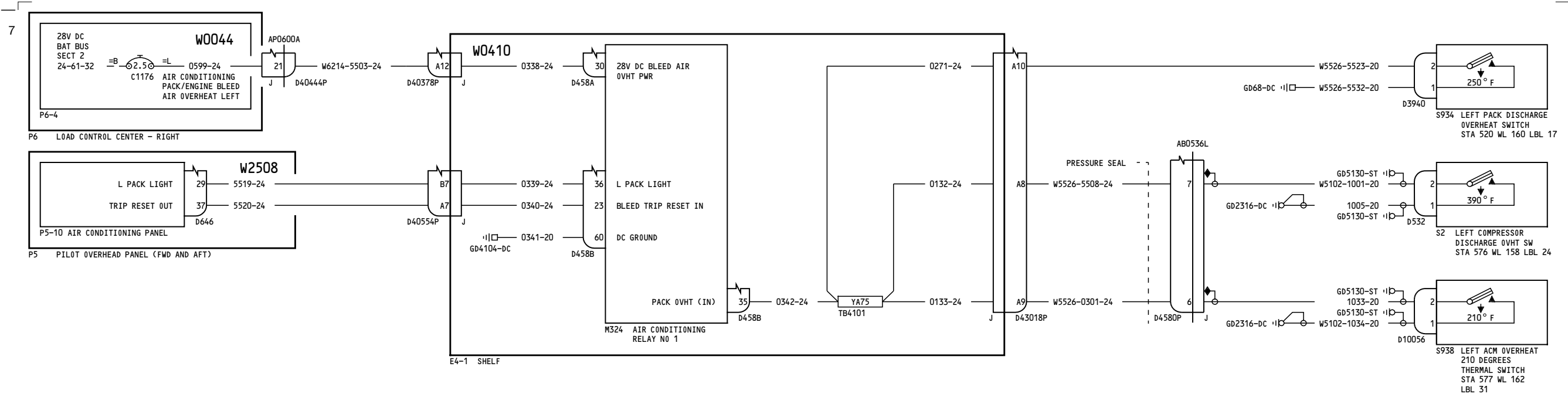

YC031-YL430

LEFT PACK PROTECTION

21-51-15

Page 3

Feb 09/2009

D280A103

21-51-15

Page 3

Feb 09/2009

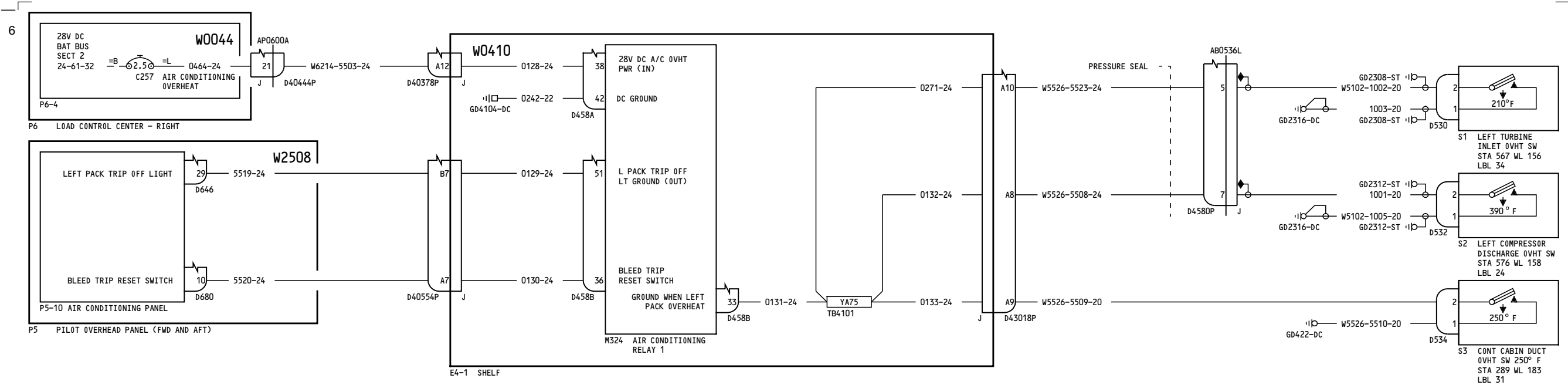

YM643-YM670

LEFT PACK PROTECTION

21-51-15

Page 4

Jan 14/2008

D280A103

21-51-15

Page 4

Jan 14/2008

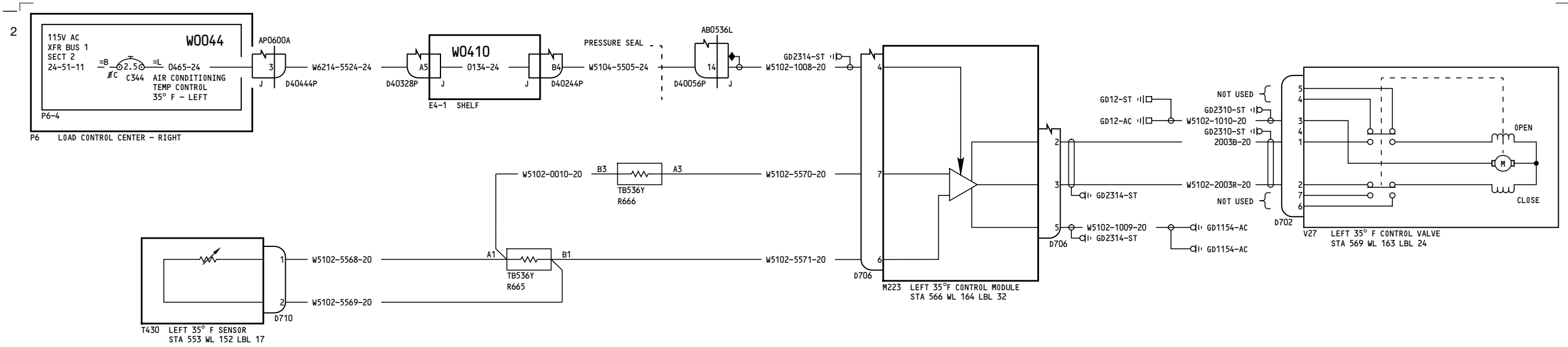

CADDs 4

YM643-YM670

**LEFT WATER SEPARATOR
35 DEGREES FAHRENHEIT
CONTROL**

D280A103

21-51-16

Page 1

Jan 14/2008

21-51-16

Page 1

Jan 14/2008

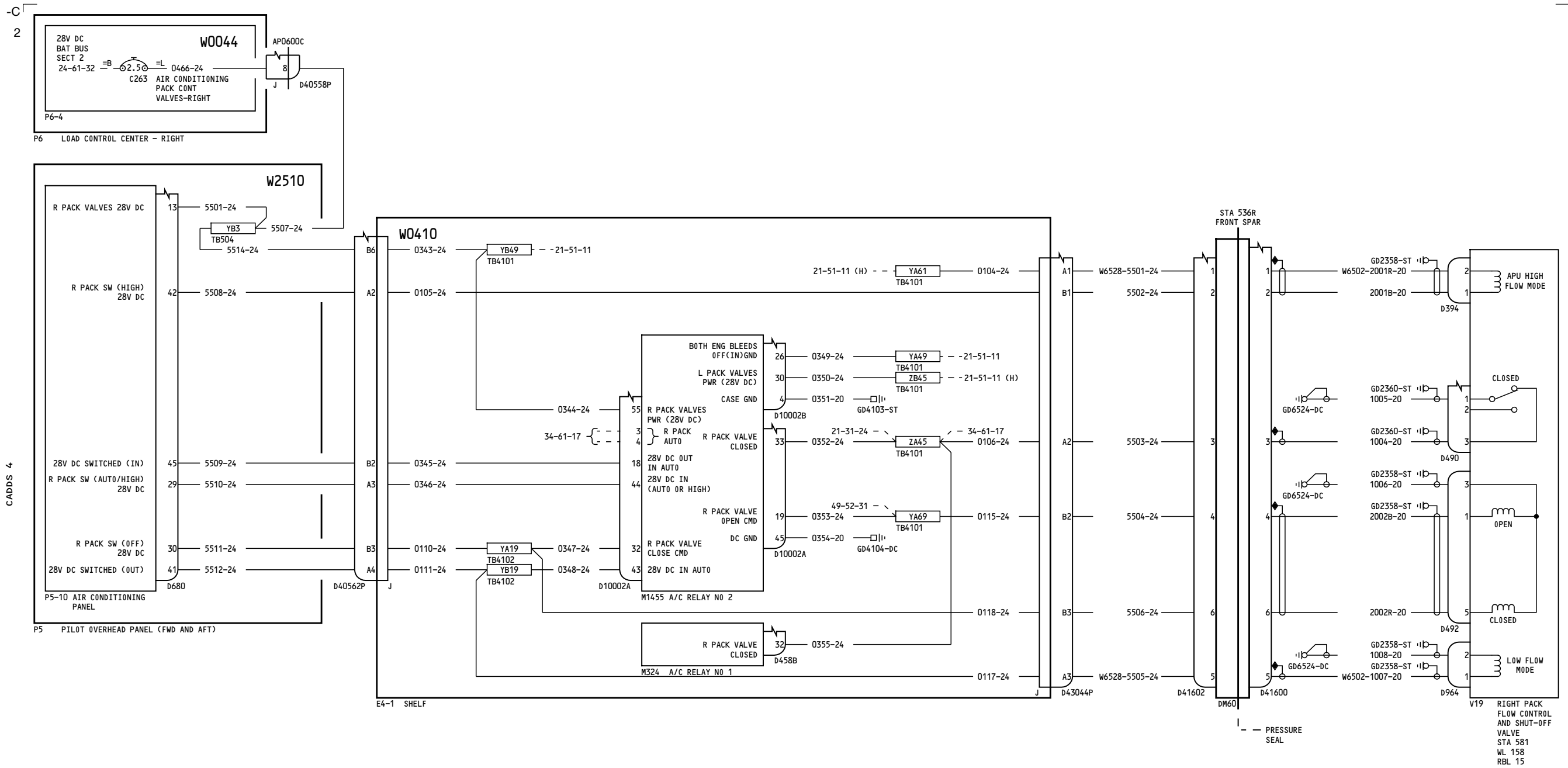

YC001-YC028

RIGHT PACK VALVE CONTROL

21-51-21

Page 1

D280A103

Jul 17/2007

21-51-21

Page 1

Jul 17/2007

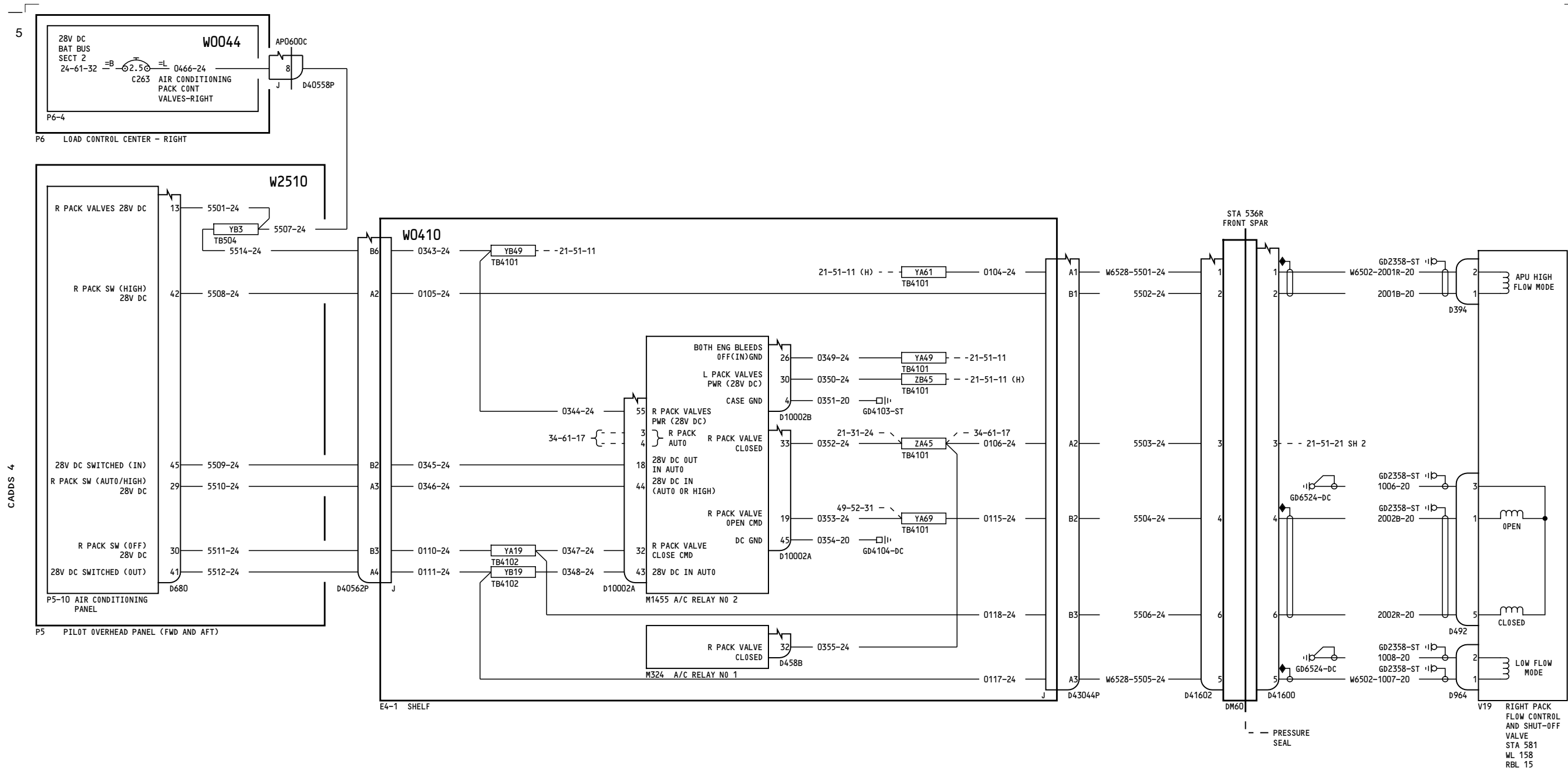

YC029-YC030

RIGHT PACK VALVE CONTROL

21-51-21

Page 2
Sheet 1
Mar 31/2005

D280A103

21-51-21

Page 2
Sheet 1
Mar 31/2005

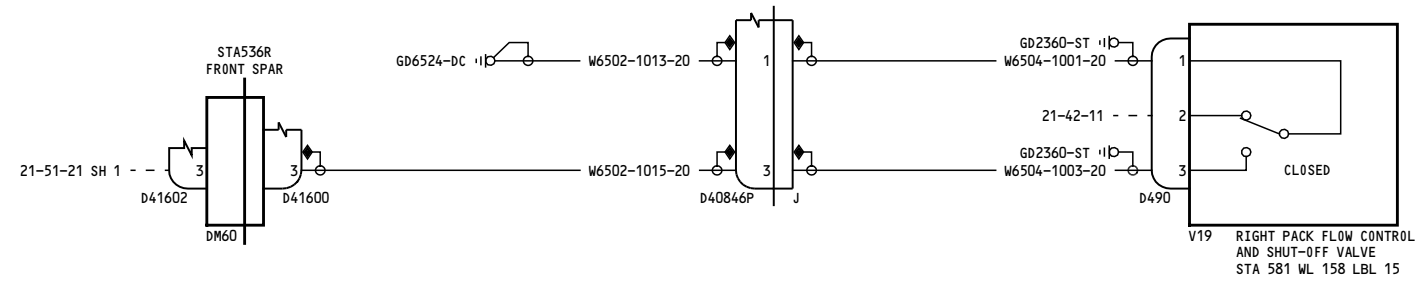

YC029-YC030

RIGHT PACK VALVE CONTROL

D280A103

21-51-21

Page 2
Sheet 2
Jan 18/2006

21-51-21

Page 2
Sheet 2
Jan 18/2006

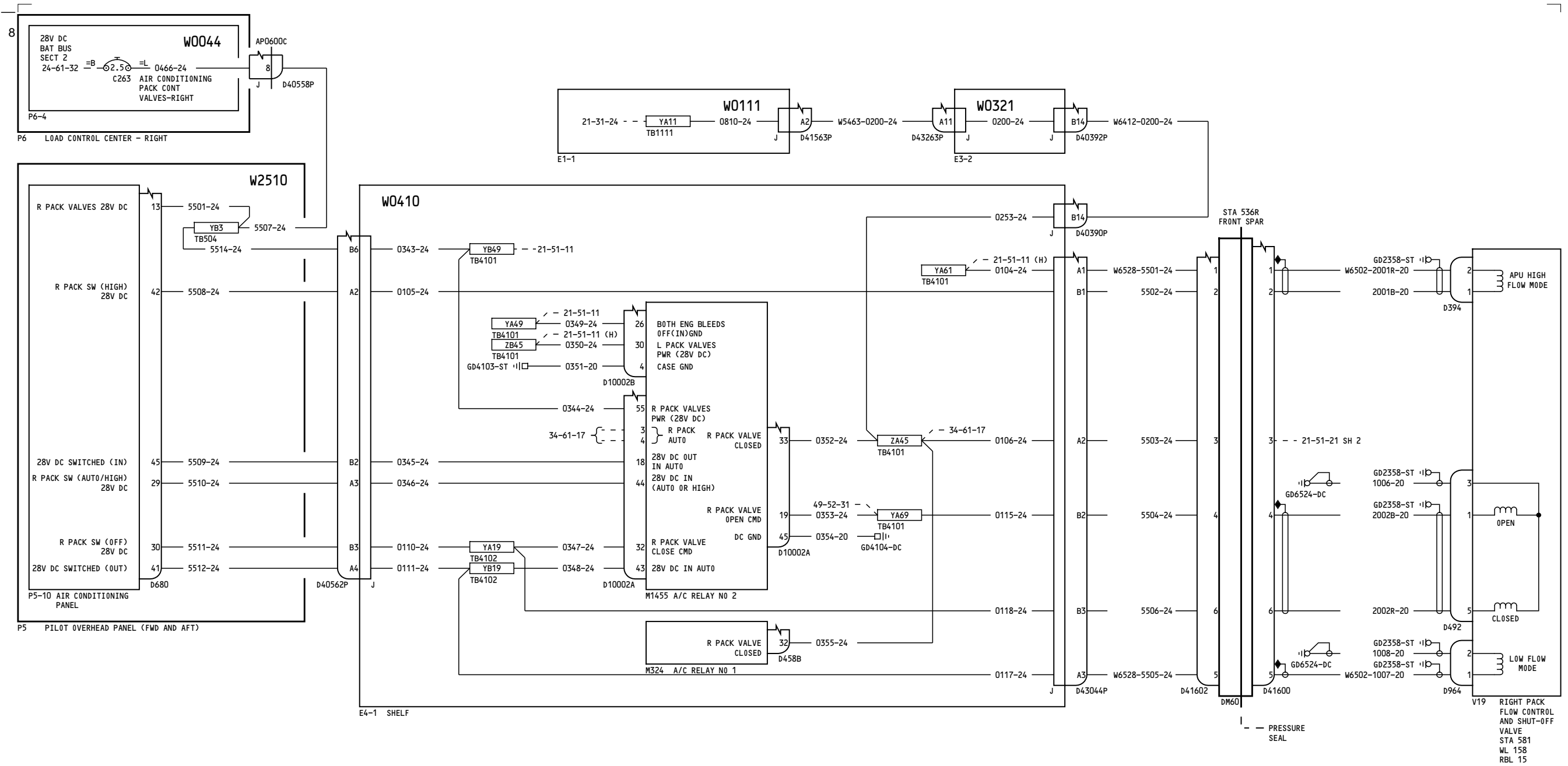

YK901-YL430

RIGHT PACK VALVE CONTROL

21-51-21

Page 3
Sheet 1
Feb 09/2009

D280A103

21-51-21

Page 3
Sheet 1
Feb 09/2009

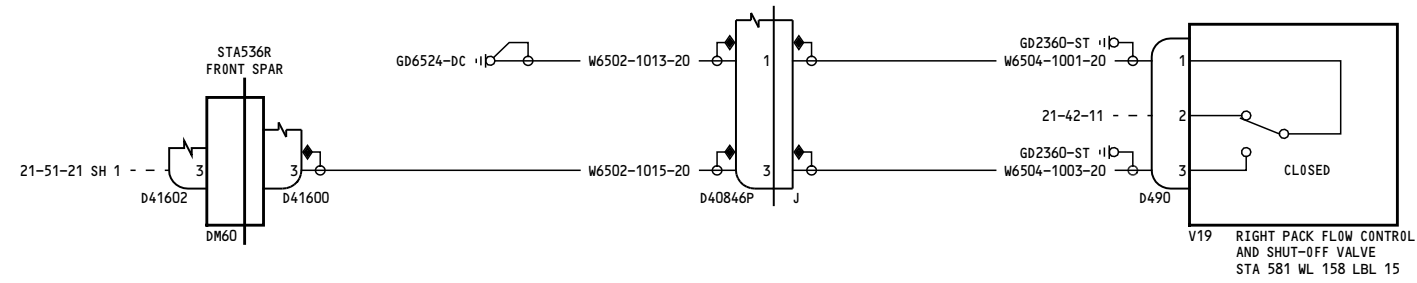

YK901-YL430

RIGHT PACK VALVE CONTROL

D280A103

21-51-21

Page 3
Sheet 2
Feb 09/2009

21-51-21

Page 3
Sheet 2
Feb 09/2009

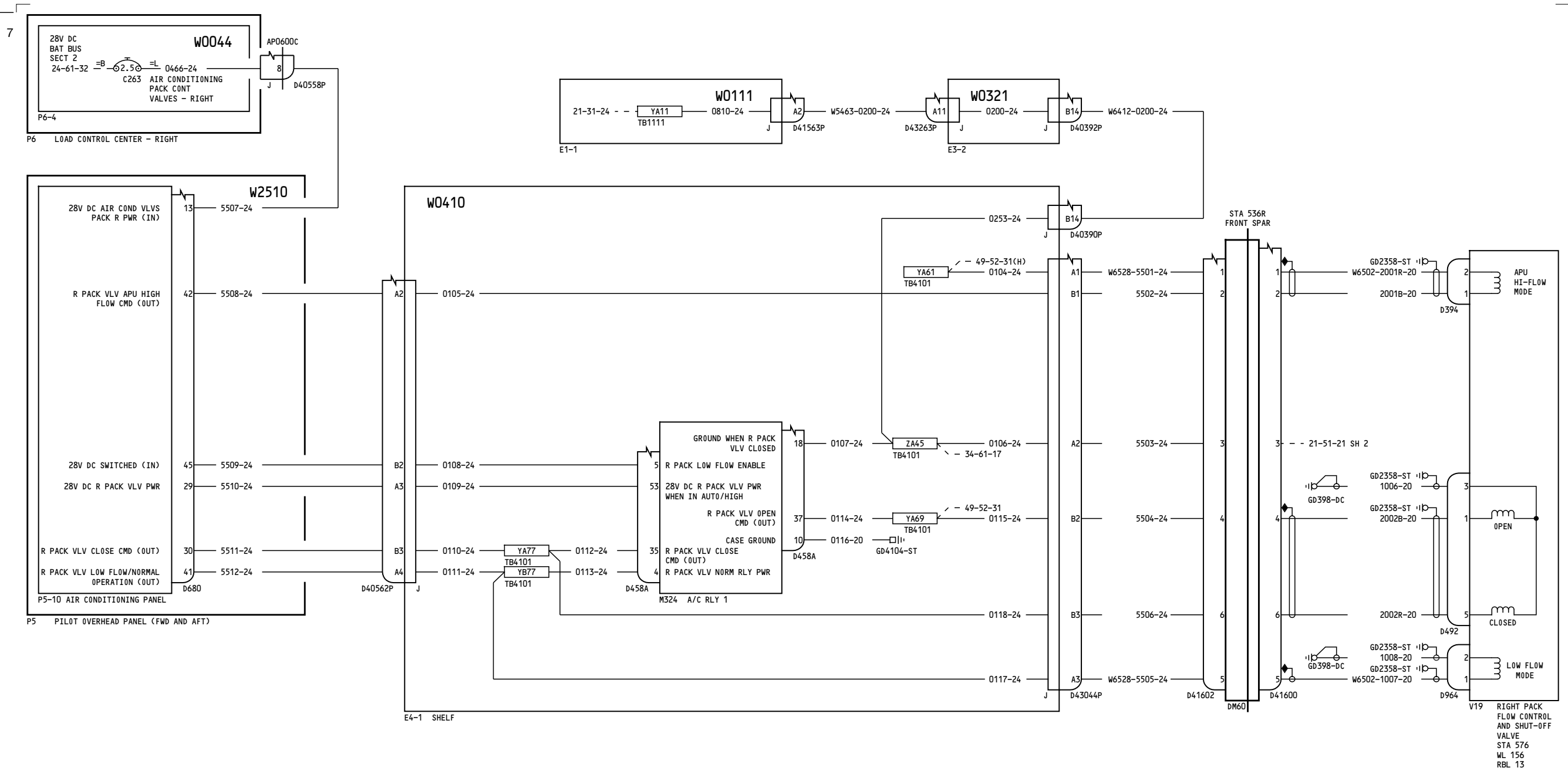

YM643-YM670

RIGHT PACK VALVE CONTROL

21-51-21

Page 4
Sheet 1
Jan 14/2008

D280A103

21-51-21

Page 4
Sheet 1
Jan 14/2008

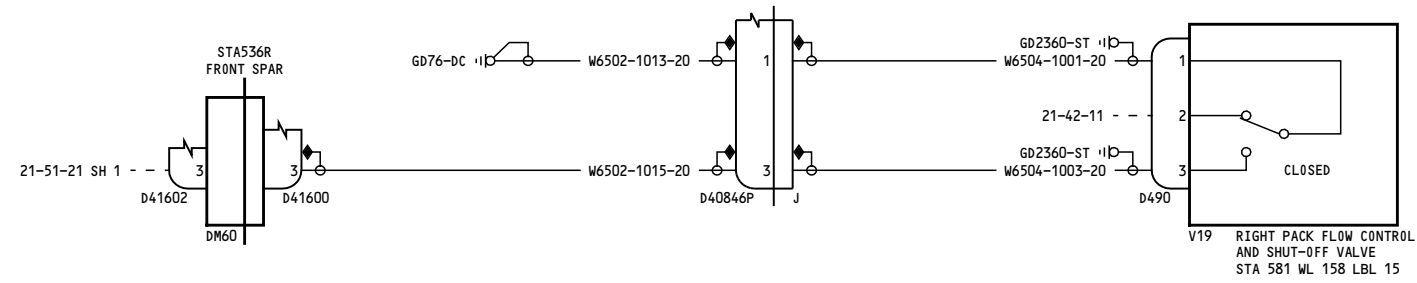

YM643-YM670

RIGHT PACK VALVE CONTROL

D280A103

21-51-21

Page 4
Sheet 2
Jan 14/2008

21-51-21

Page 4
Sheet 2
Jan 14/2008

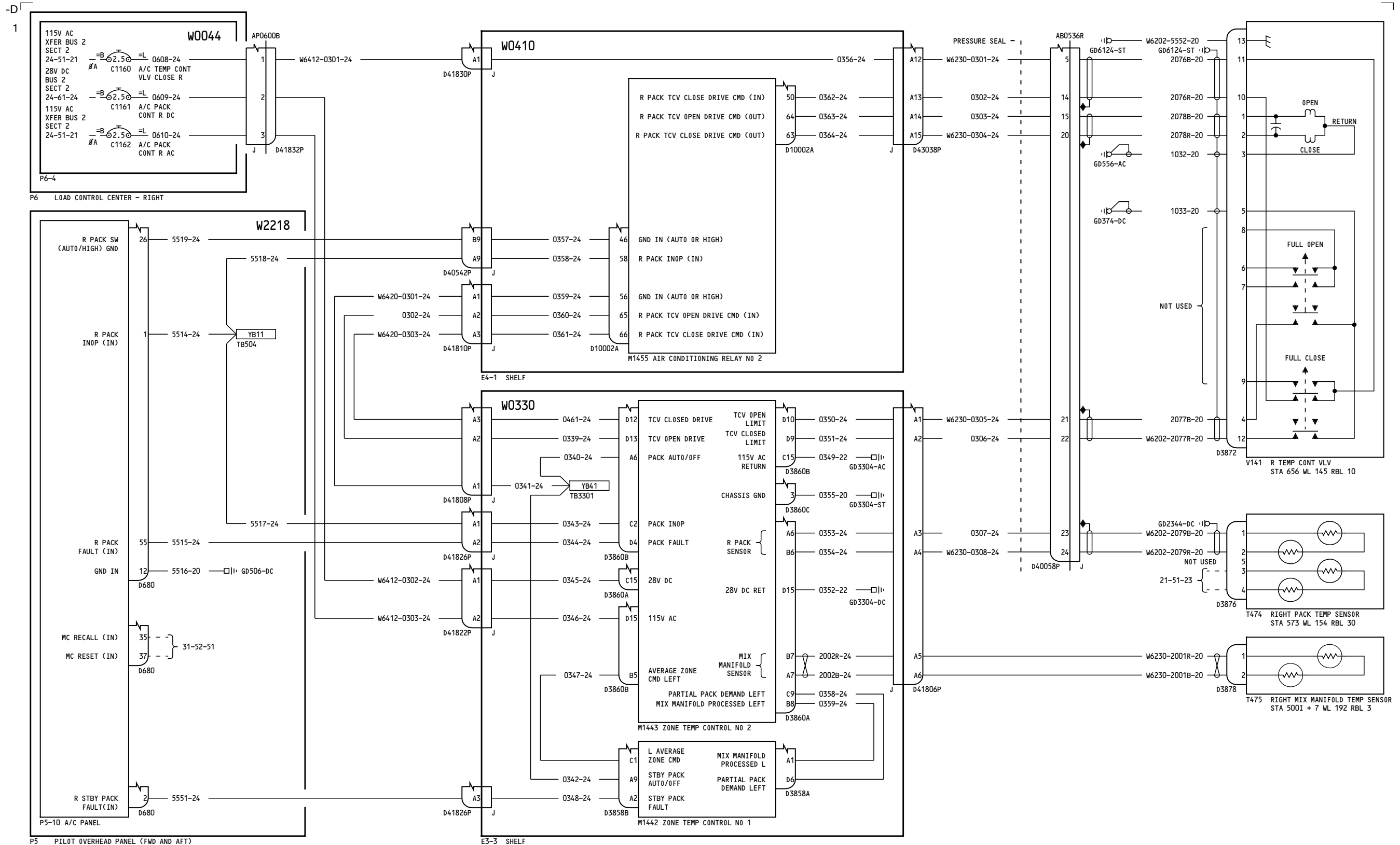

YC001-YC022

RIGHT AIR CONDITIONING PACK CONTROL - AUTO

21-51-22

Page 1

D280A103

Mar 31/2005

21-51-22

Page 1

Mar 31/2005

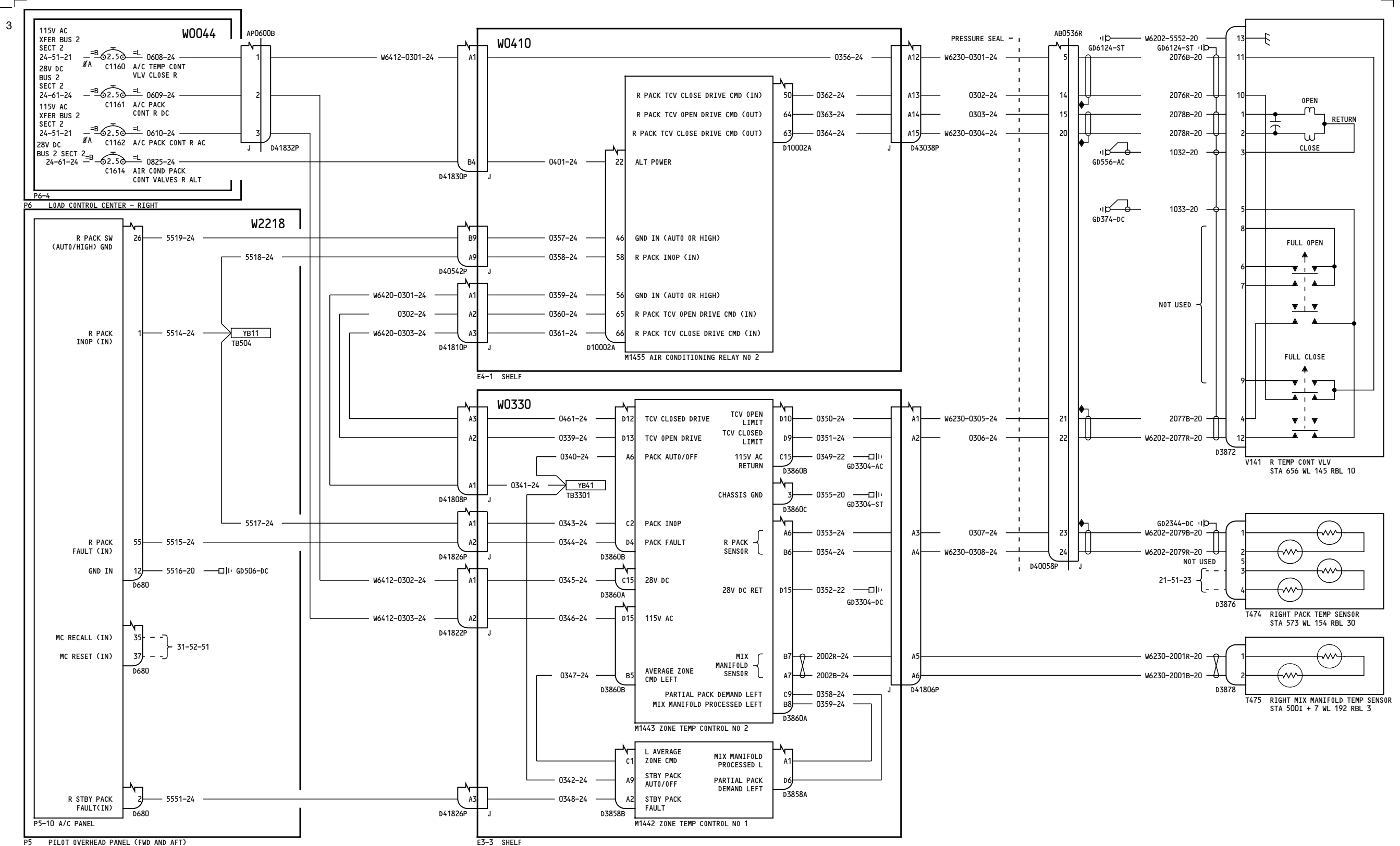

YC001-YC022

RIGHT AIR CONDITIONING PACK CONTROL - AUTO

21-51-22

Incorporates 21-1133

21-51-22

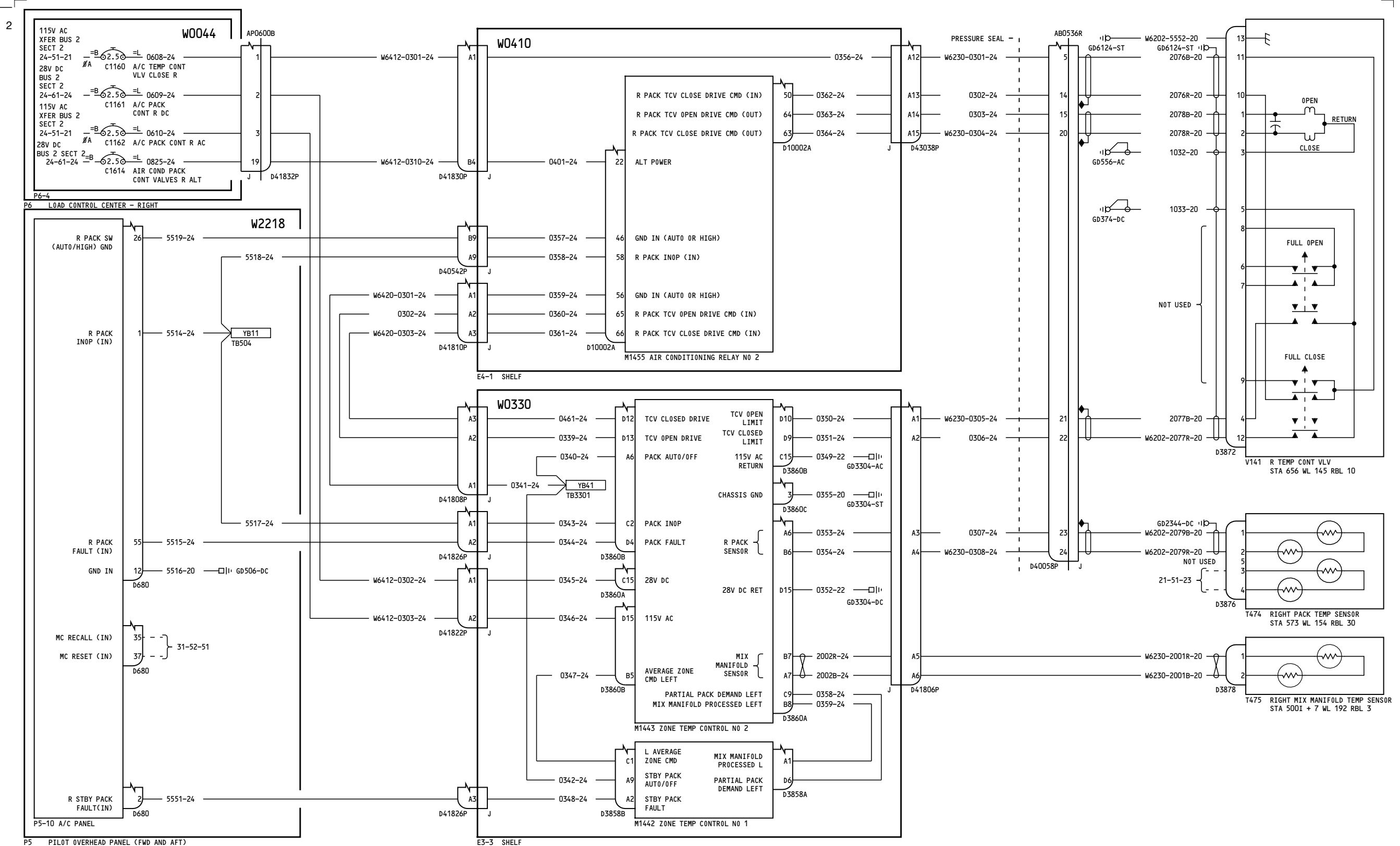

YC023-YC030

RIGHT AIR CONDITIONING PACK CONTROL - AUTO

21-51-22

Page 2

D280A103

Jul 17/2007

21-51-22

Page 2

Jul 17/2007

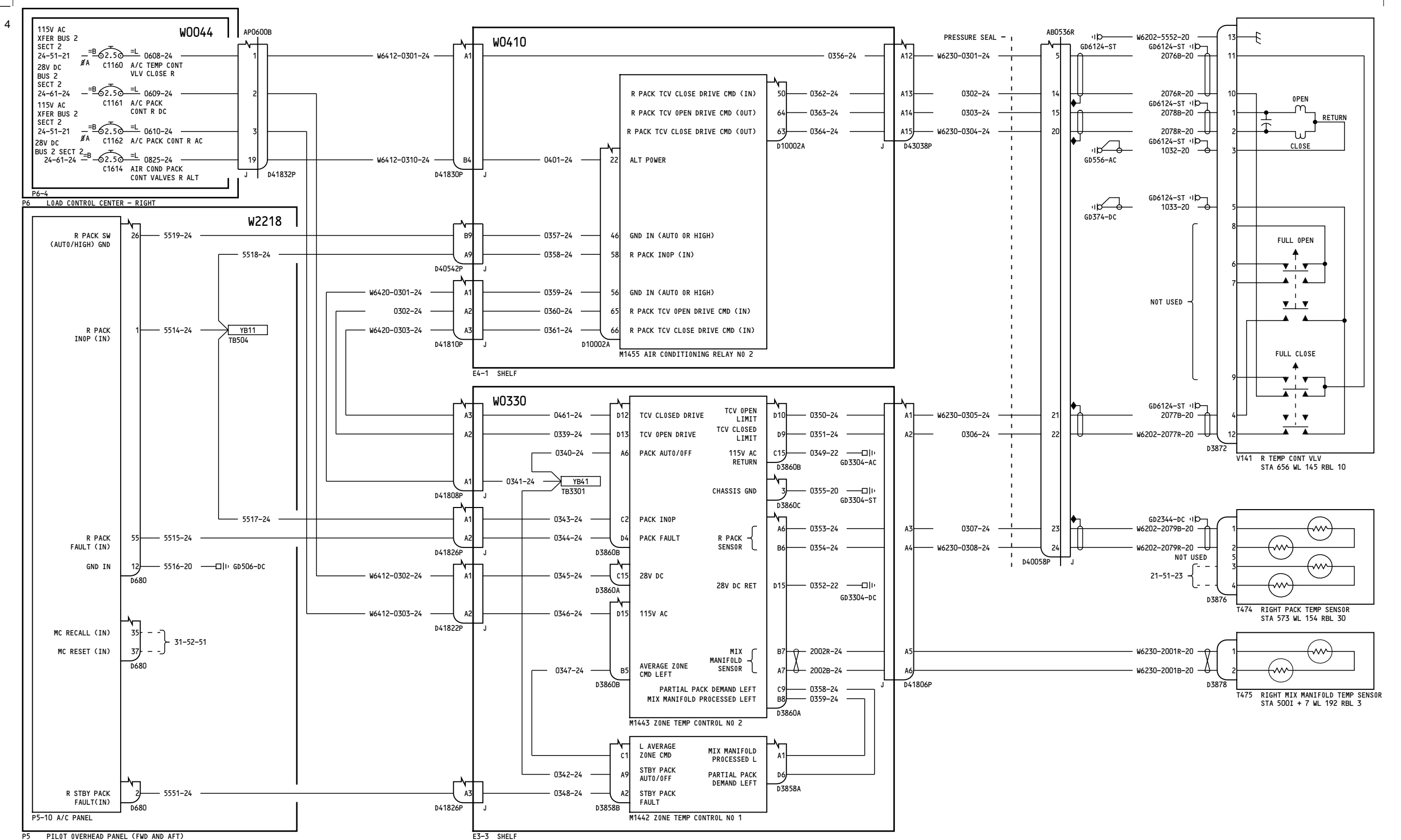

YC031-YL430

**RIGHT AIR CONDITIONING
PACK CONTROL - AUTO**

21-51-22

Page 3

D280A103

Feb 09/2009

21-51-22

Page 3

Feb 09/2009

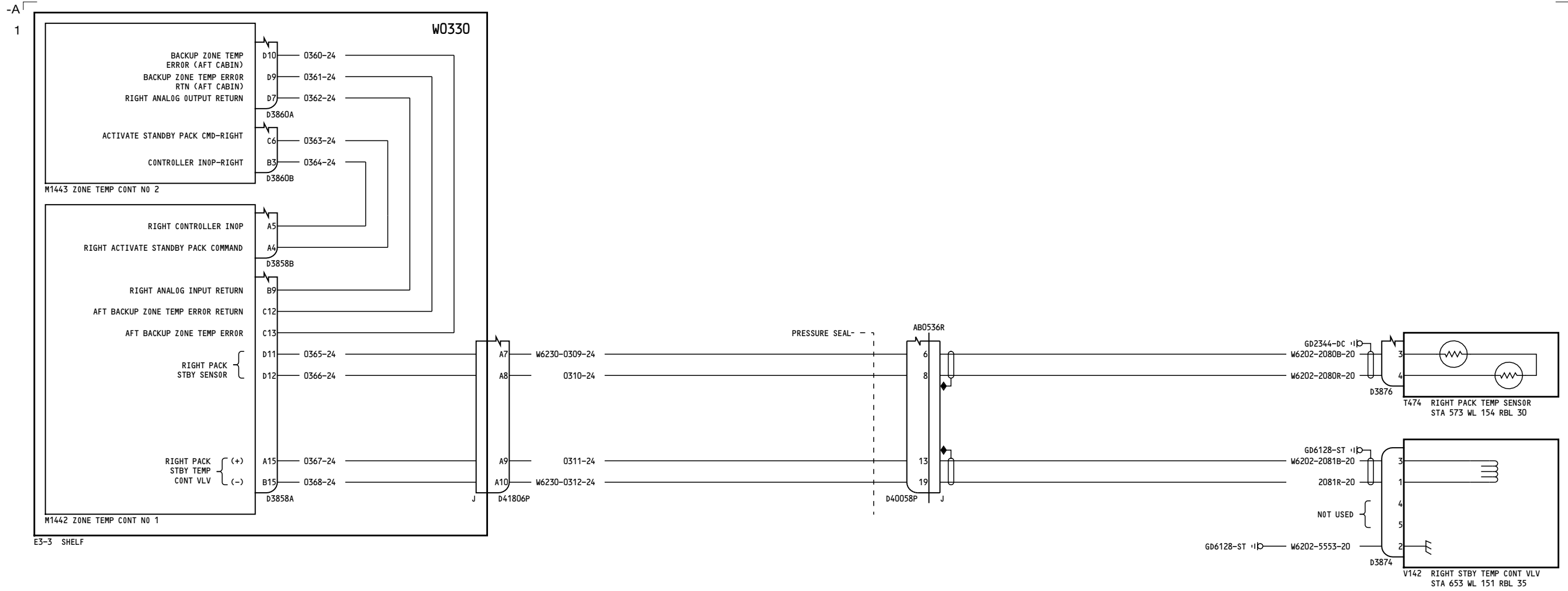

YC001-YL430

**RIGHT AIR CONDITIONING
PACK CONTROL STANDBY**

D280A103

21-51-23

Page 1

Feb 09/2009

21-51-23

Page 1

Feb 09/2009

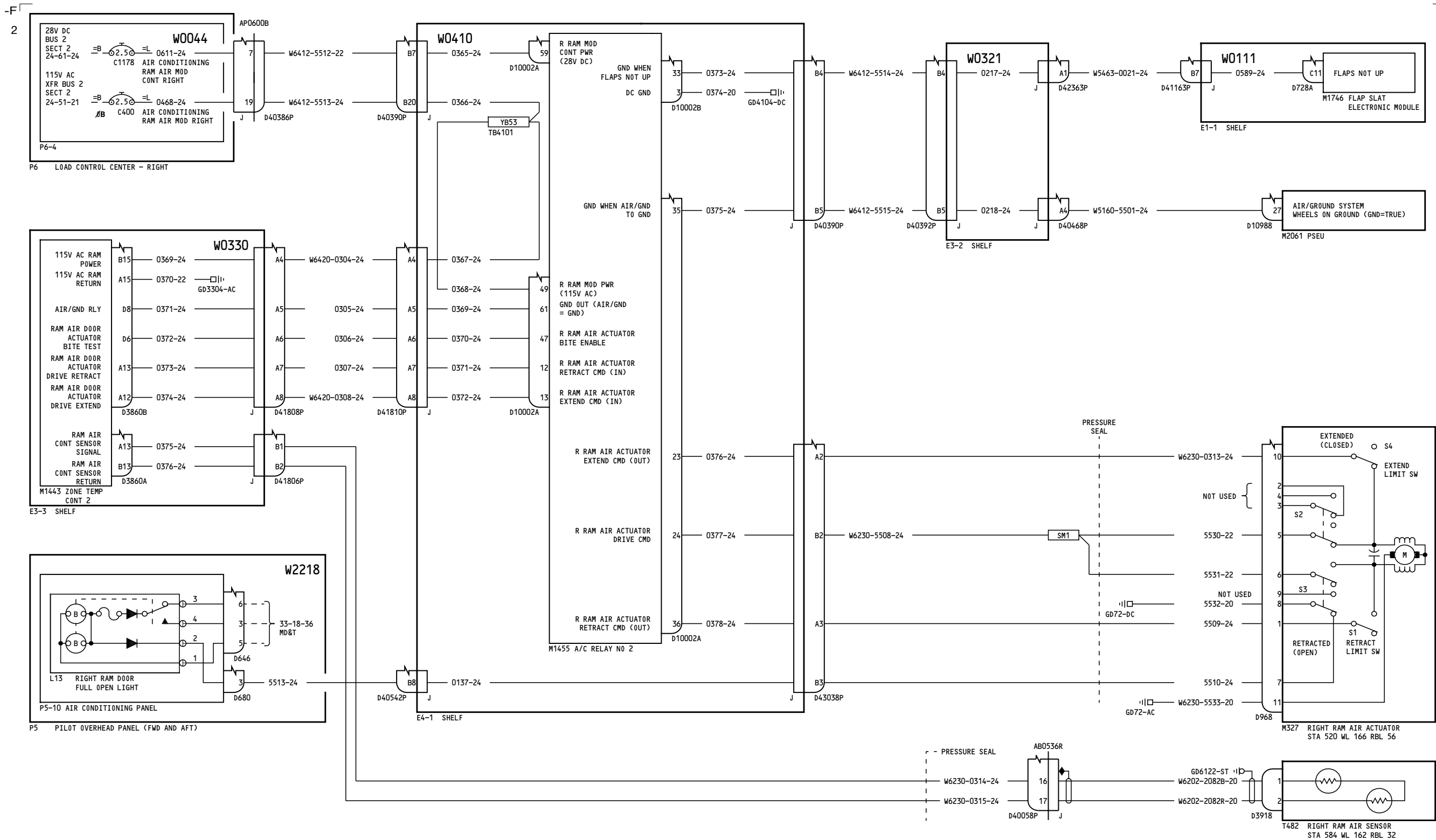

YC001-YL430

RIGHT RAM MODULATION CONTROL

21-51-24

Page 1

D280A103

May 11/2009

21-51-24

Page 1

May 11/2009

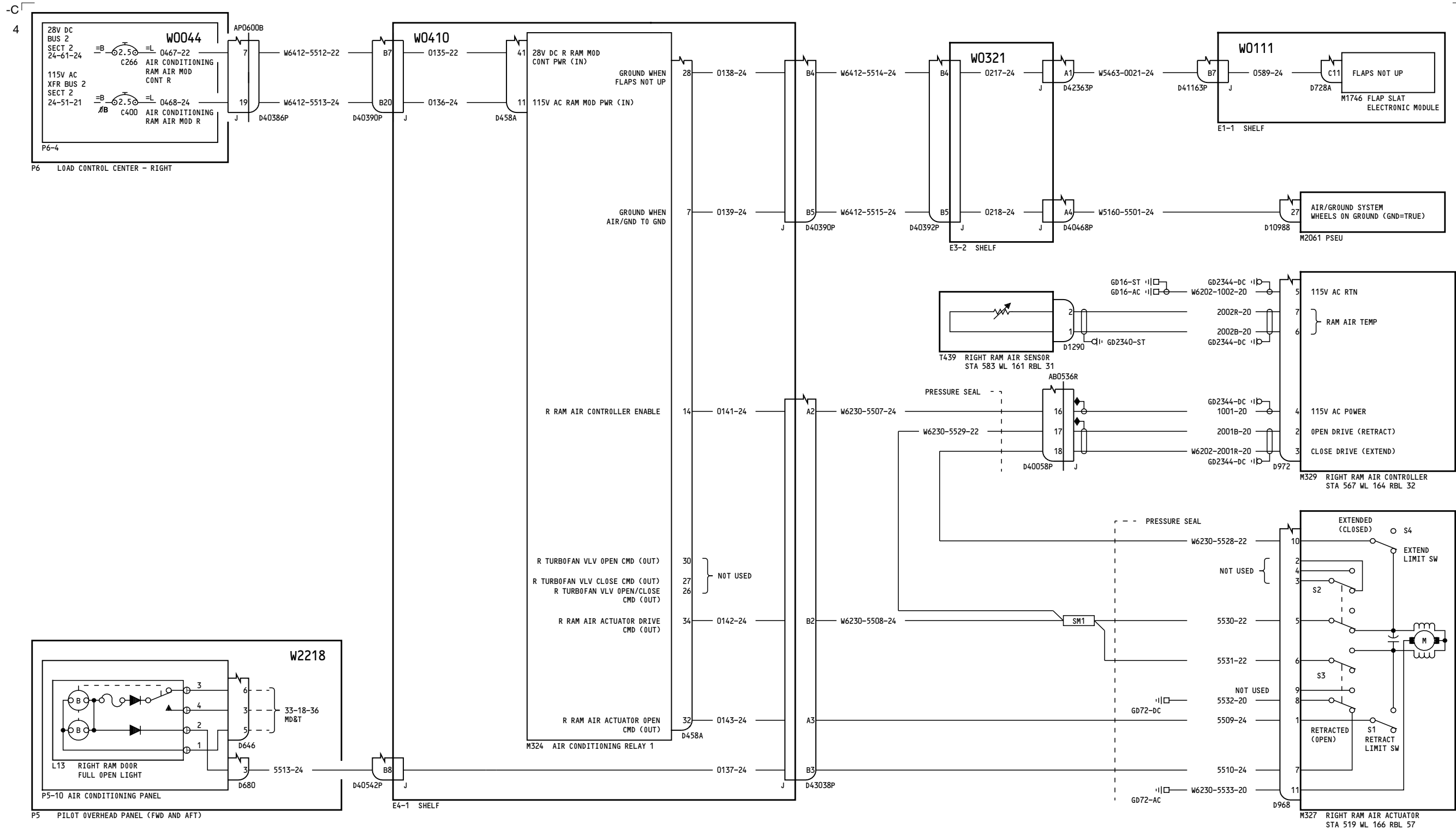

YM643-YM670

RIGHT RAM MODULATION CONTROL

21-51-24

Page 2

D280A103

May 11/2009

21-51-24

Page 2

May 11/2009

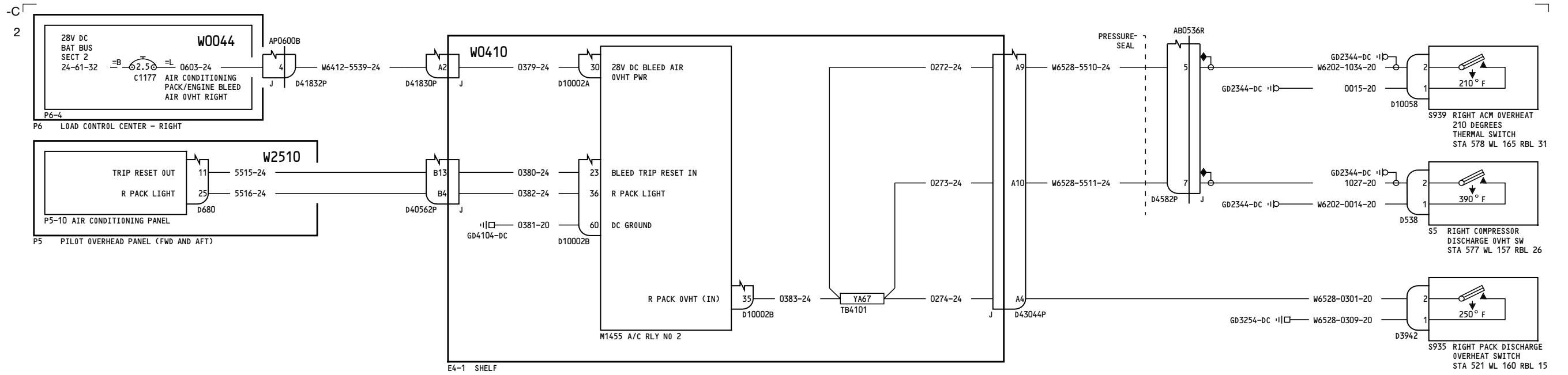

YC001-YL430

RIGHT PACK PROTECTION

21-51-25

Page 1

Feb 09/2009

D280A103

21-51-25

Page 1

Feb 09/2009

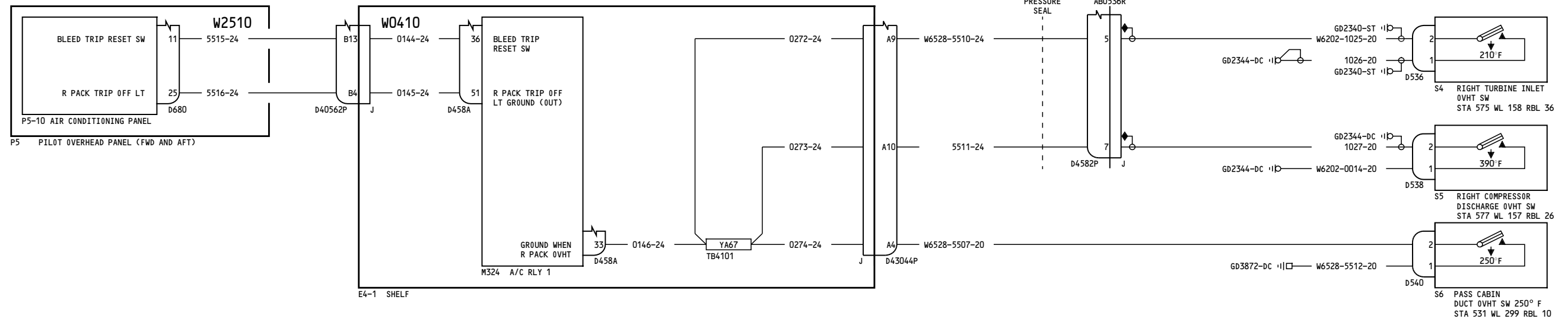

YM643-YM670

RIGHT PACK PROTECTION

D280A103

21-51-25

Page 2

Jan 14/2008

21-51-25

Page 2

Jan 14/2008

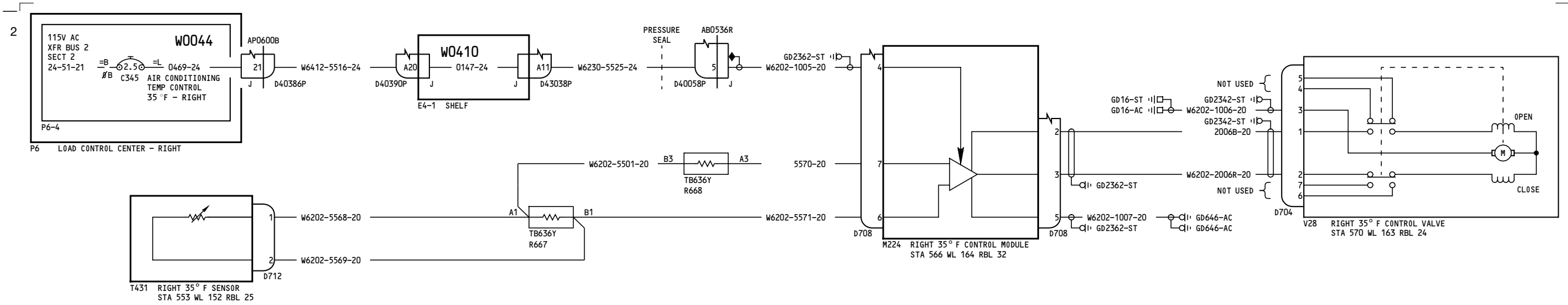

CADDs 4

YM643-YM670

**RIGHT WATER SEPARATOR
35 DEGREES FAHRENHEIT
CONTROL**

D280A103

21-51-26

Page 1

Jan 14/2008

21-51-26

Page 1

Jan 14/2008

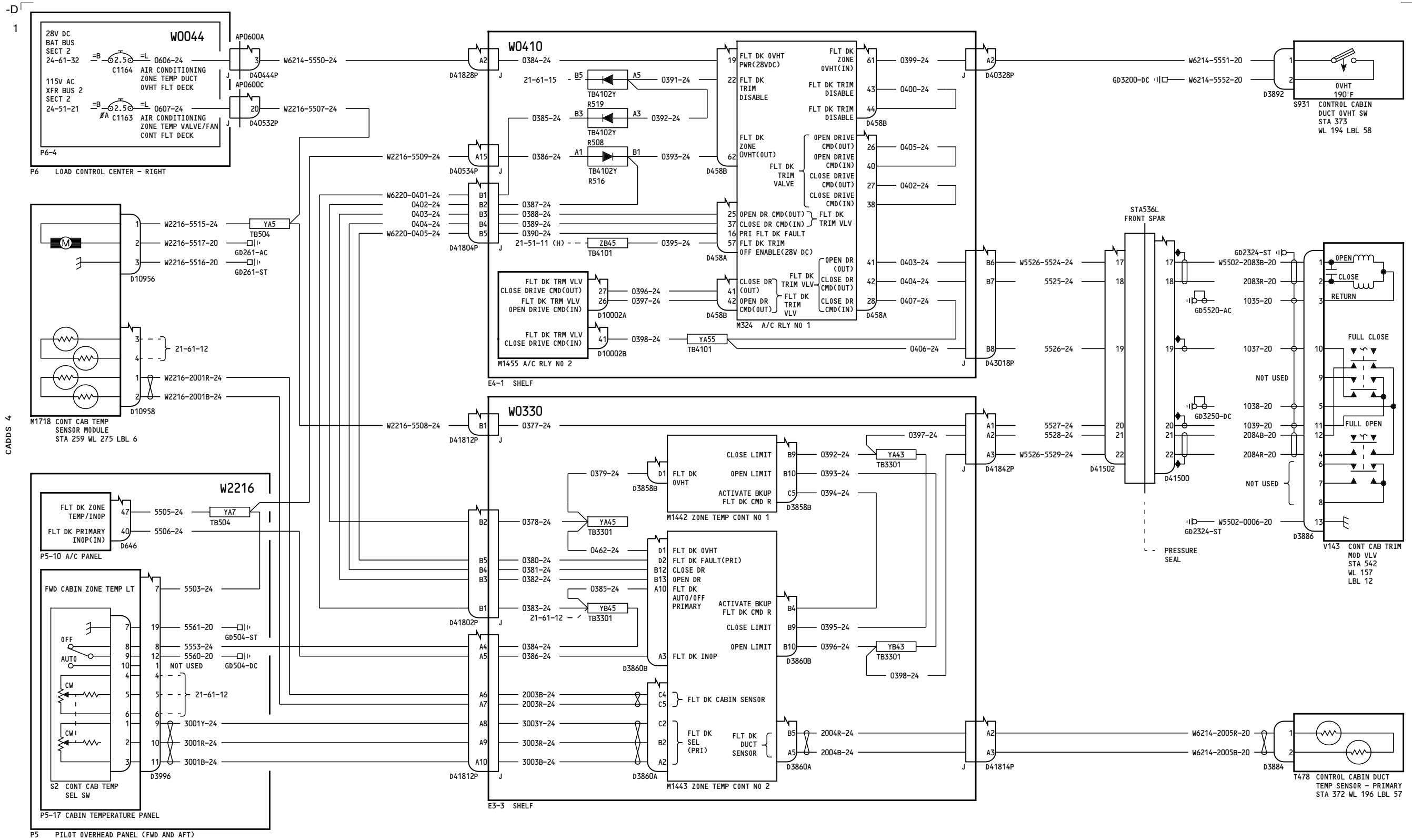

YC001-YC007

**TEMPERATURE CONTROL -
FLIGHT DECK ZONE
(PRIMARY)**

21-61-11

Page 1

D280A103

Jul 26/2006

21-61-11

Page 1

Jul 26/2006

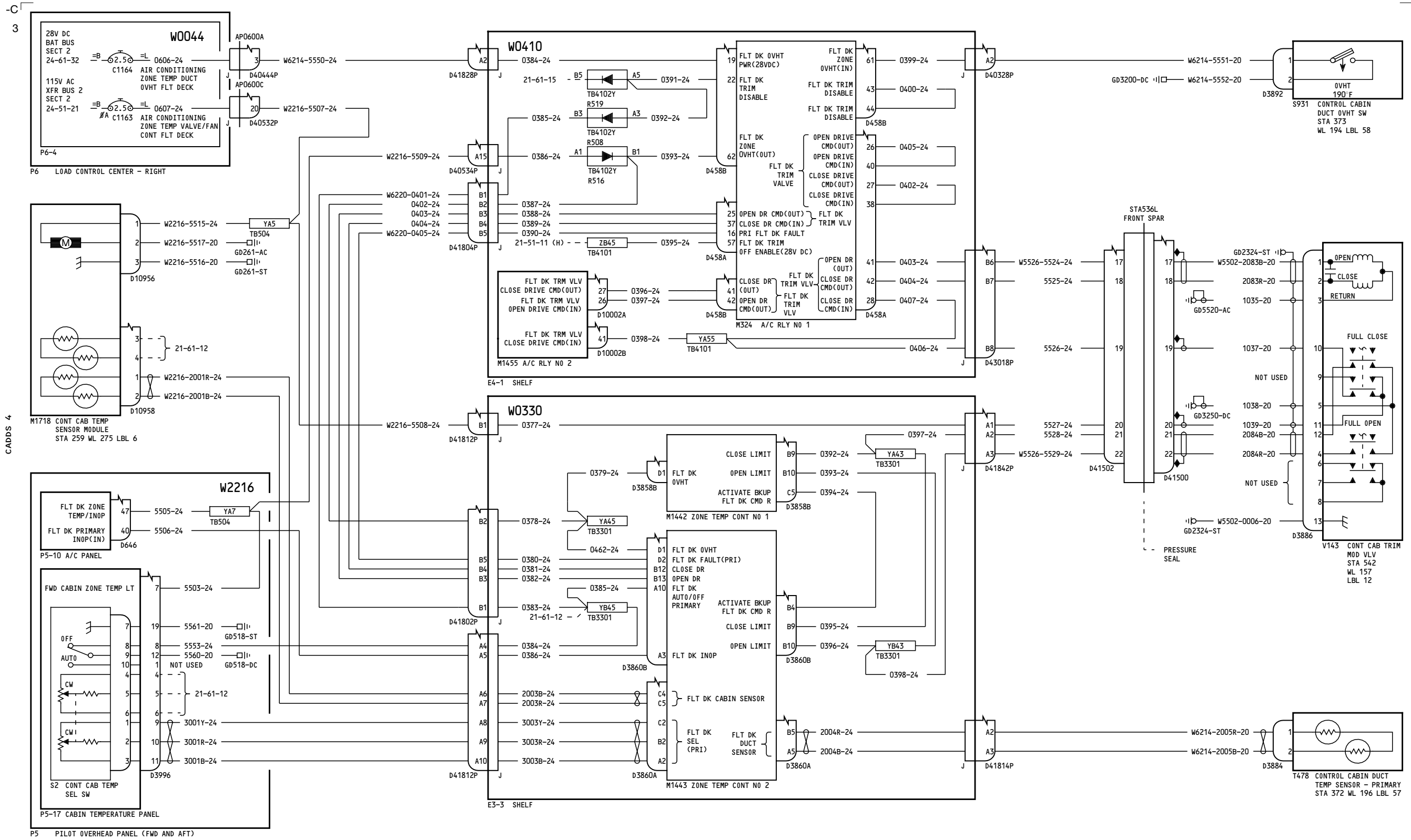

YC008-YC030

**TEMPERATURE CONTROL -
FLIGHT DECK ZONE
(PRIMARY)**

21-61-11

Page 2

D280A103

Jul 17/2007

21-61-11

Page 2

Jul 17/2007

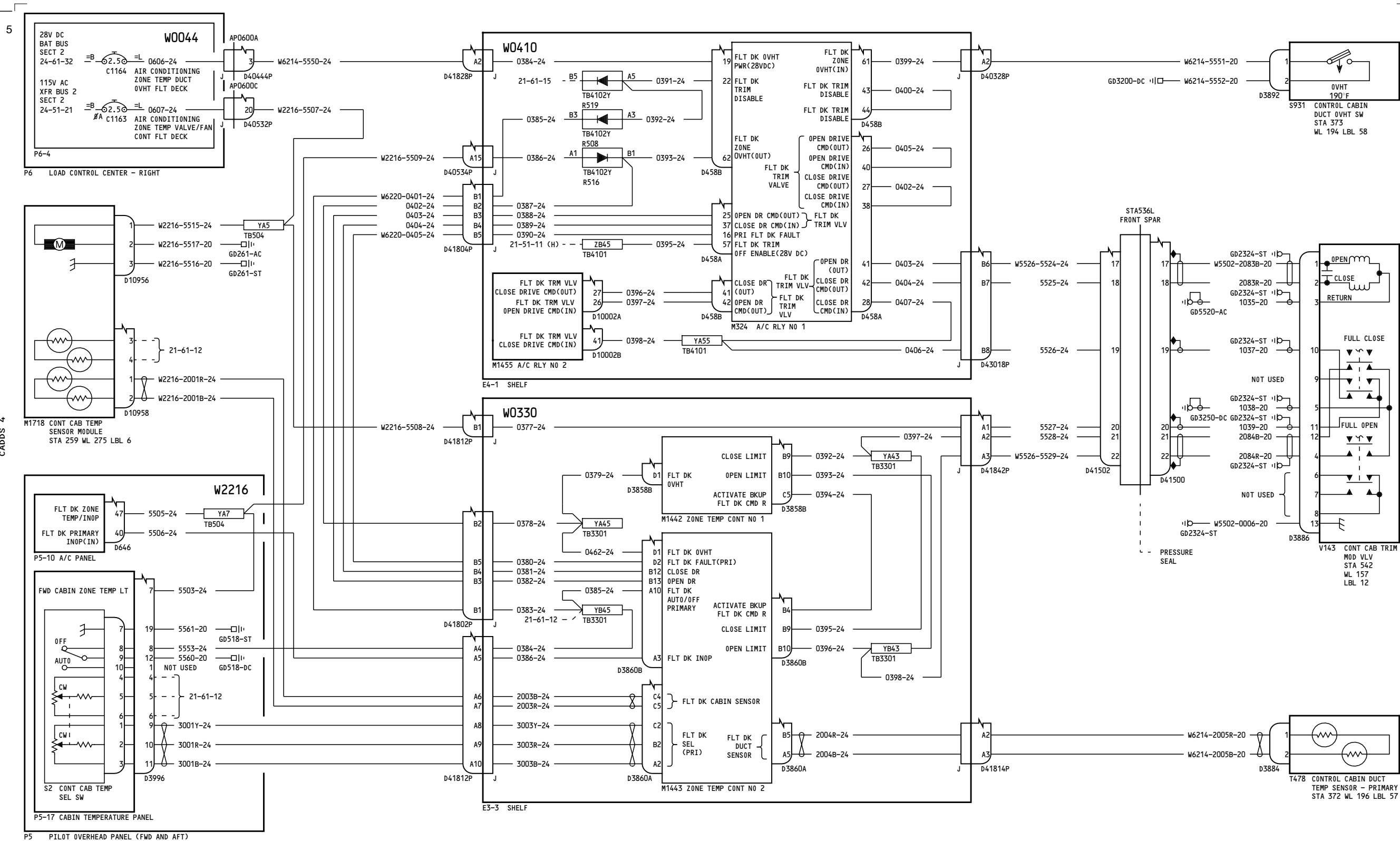

YC031-YL430

TEMPERATURE CONTROL - FLIGHT DECK ZONE (PRIMARY)

21-61-11

Page 3

D280A103

Feb 09/2009

21-61-11

Page 3

Feb 09/2009

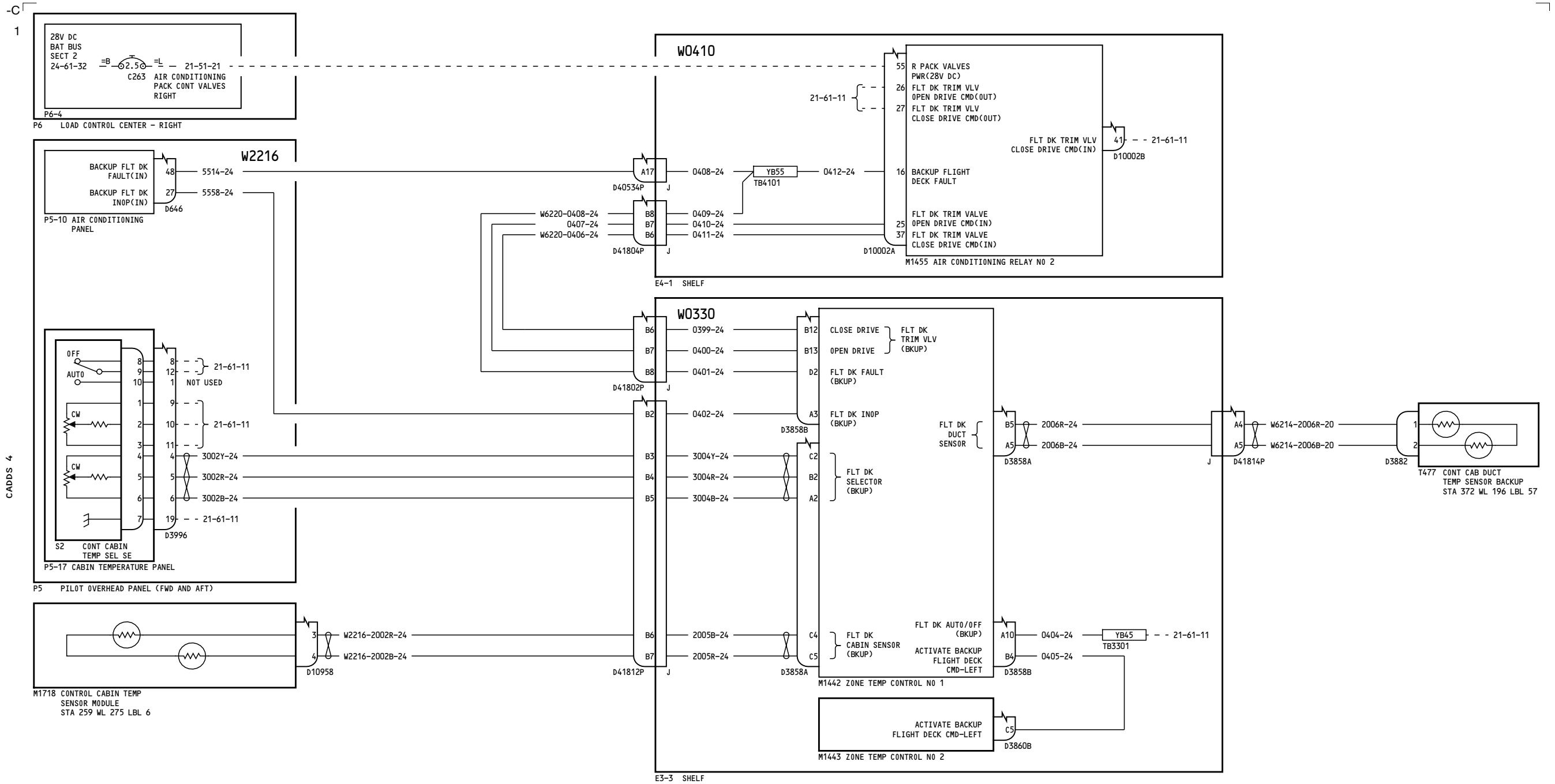

YC001-YL430

**TEMPERATURE CONTROL -
FLIGHT DECK ZONE
(BACKUP)**

21-61-12

Page 1

Feb 09/2009

D280A103

21-61-12

Page 1

Feb 09/2009

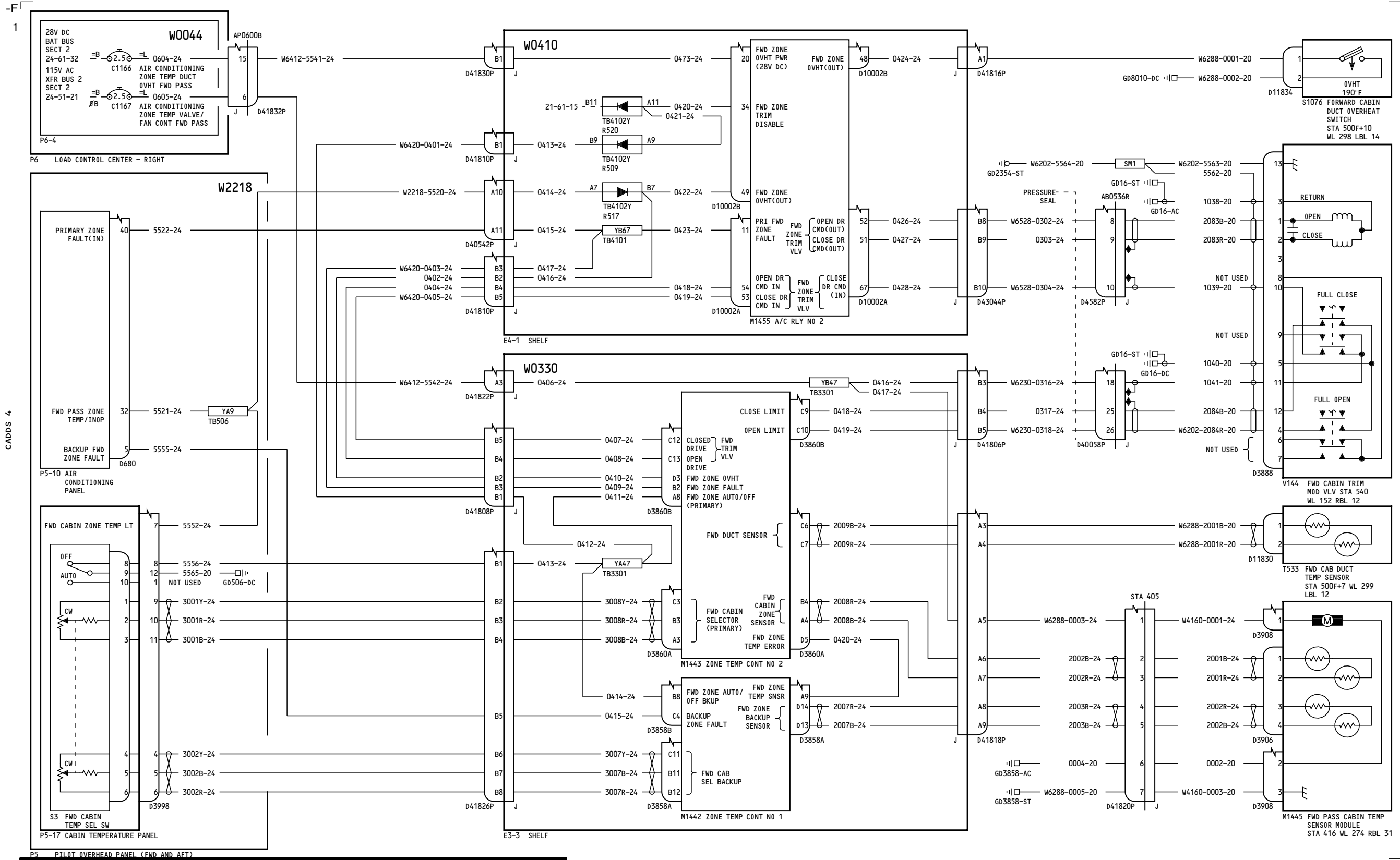

YC001-YC030

TEMPERATURE CONTROL - FWD PASSENGER ZONE

21-61-13

Page 1

D280A103

Jul 17/2007

21-61-13

Page 1

Jul 17/2007

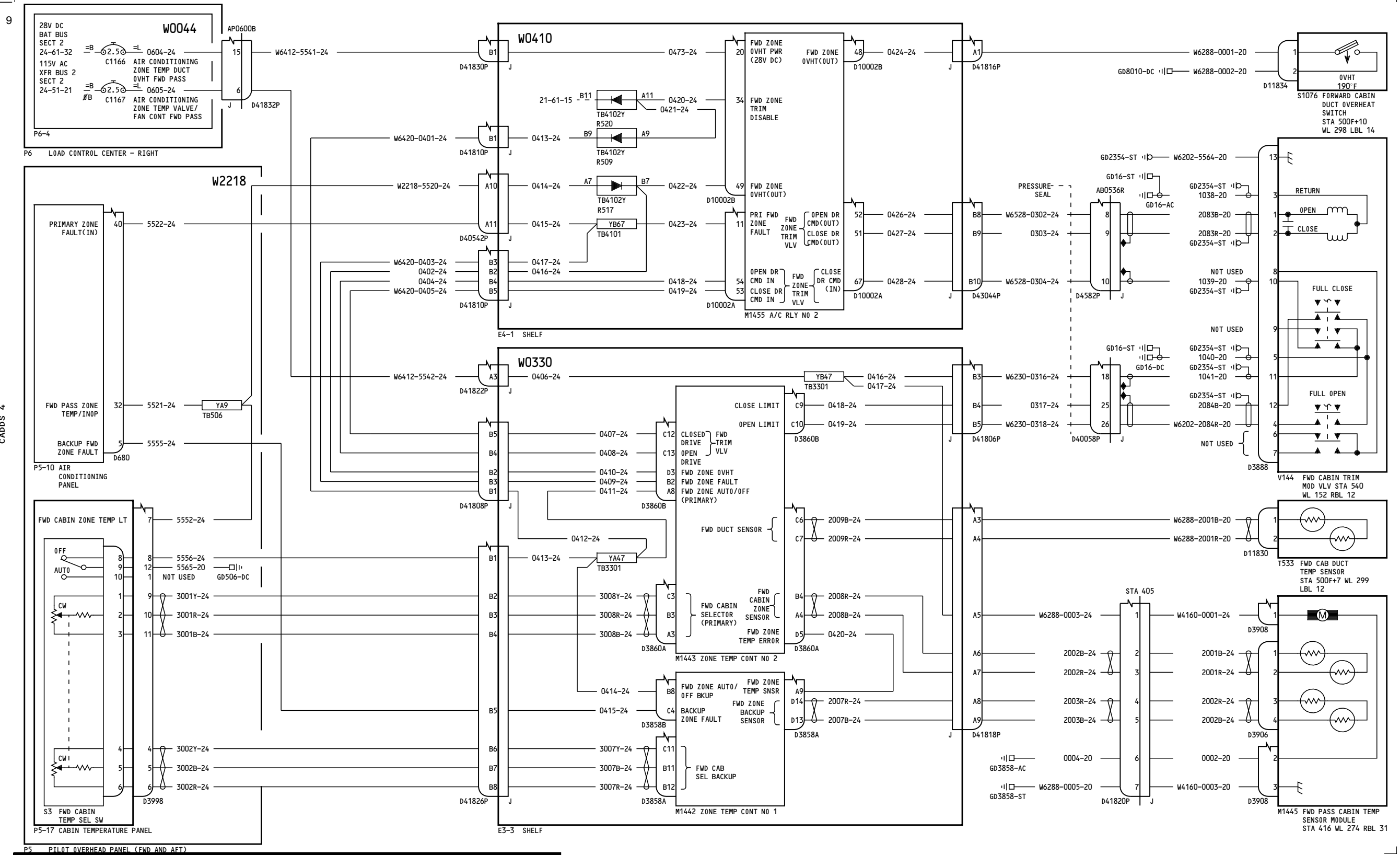

YC031-YL430

TEMPERATURE CONTROL - FWD PASSENGER ZONE

21-61-13

Page 2

D280A103

Feb 09/2009

21-61-13

Page 2

Feb 09/2009

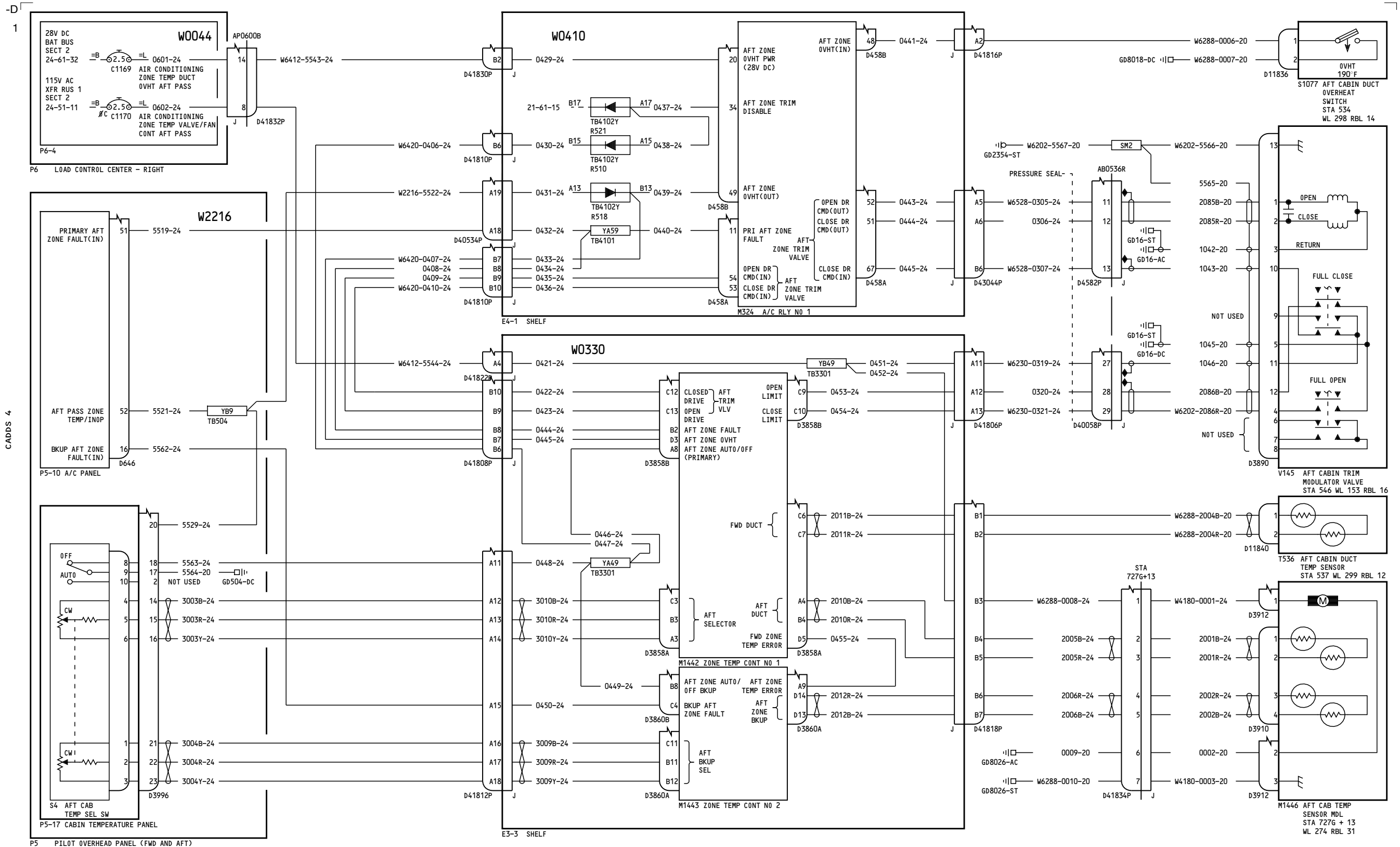

YC001-YC007

**TEMPERATURE CONTROL
AFT PASSENGER ZONE**

21-61-14

Page 1

D280A103

Jul 26/2006

21-61-14

Page 1

Jul 26/2006

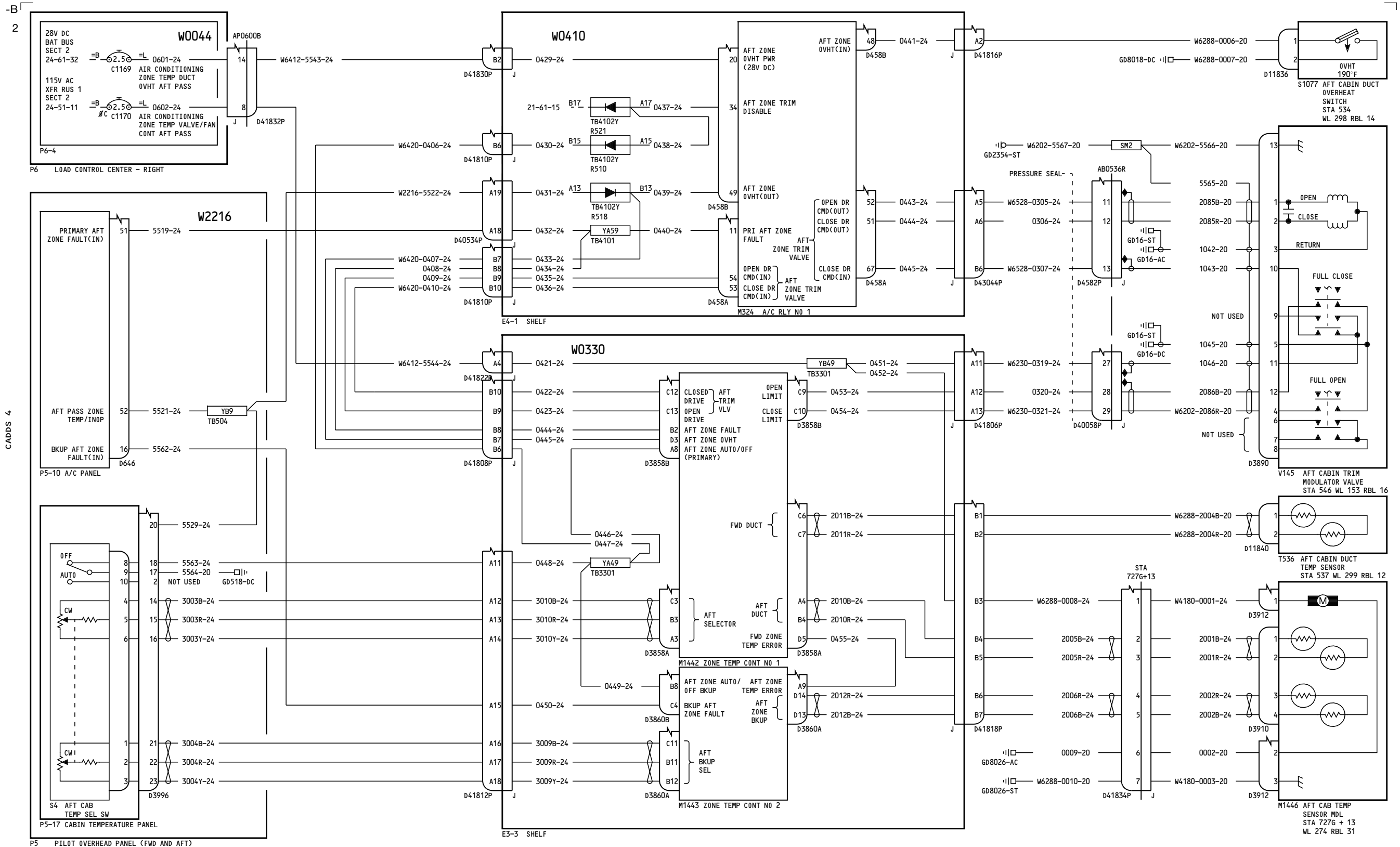

YC008-YC030

TEMPERATURE CONTROL
AFT PASSENGER ZONE

21-61-14

Page 2

D280A103

Jul 17/2007

21-61-14

Page 2

Jul 17/2007

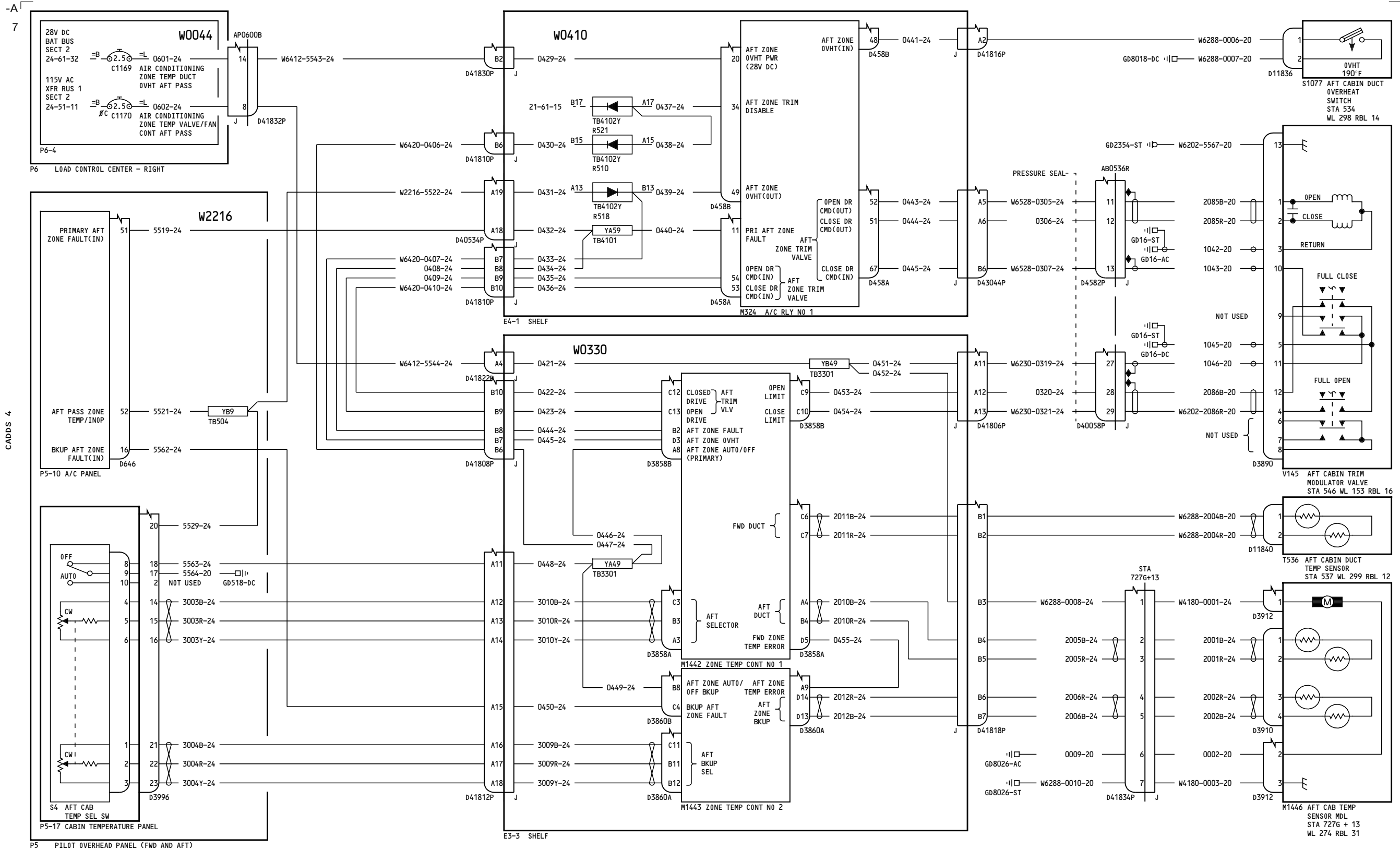

YC031-YL430

TEMPERATURE CONTROL AFT PASSENGER ZONE

21-61-14

Page 3

D280A103

Feb 09/2009

21-61-14

Page 3

Feb 09/2009

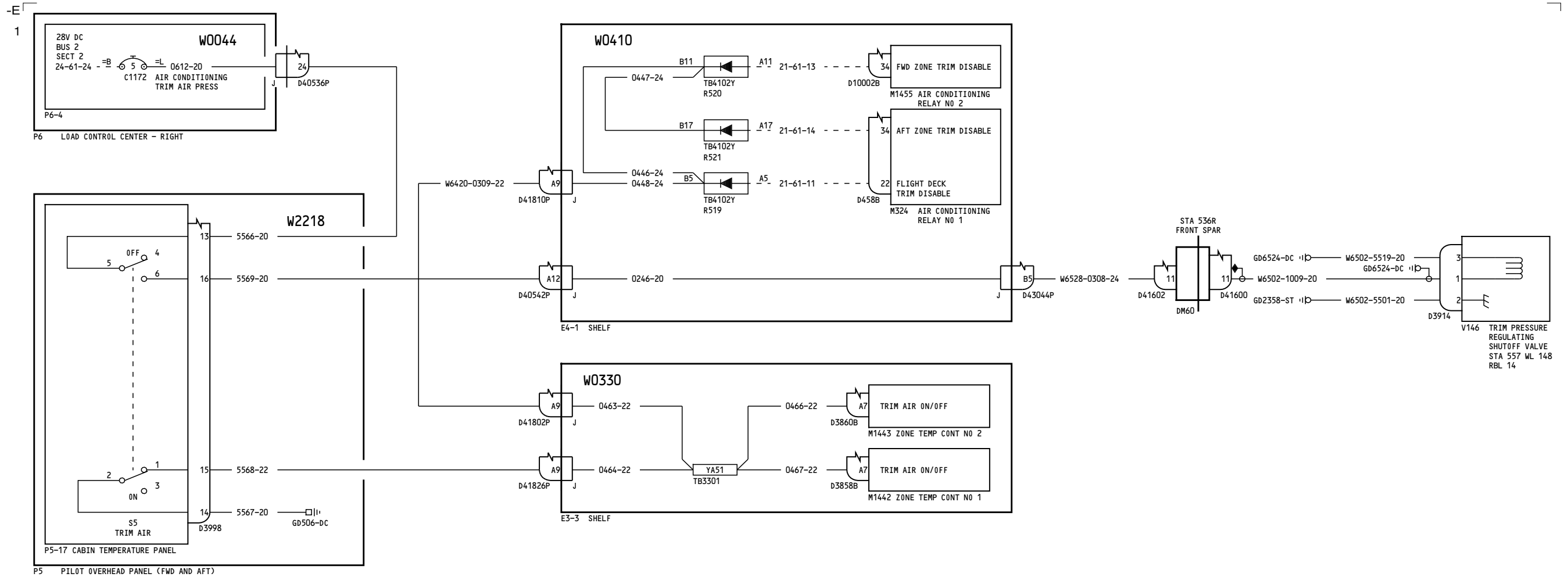

YC001-YL430

TEMPERATURE CONTROL - TRIP PRESSURE REGULATION

21-61-15

Page 1

D280A103

Feb 09/2009

21-61-15

Page 1

Feb 09/2009

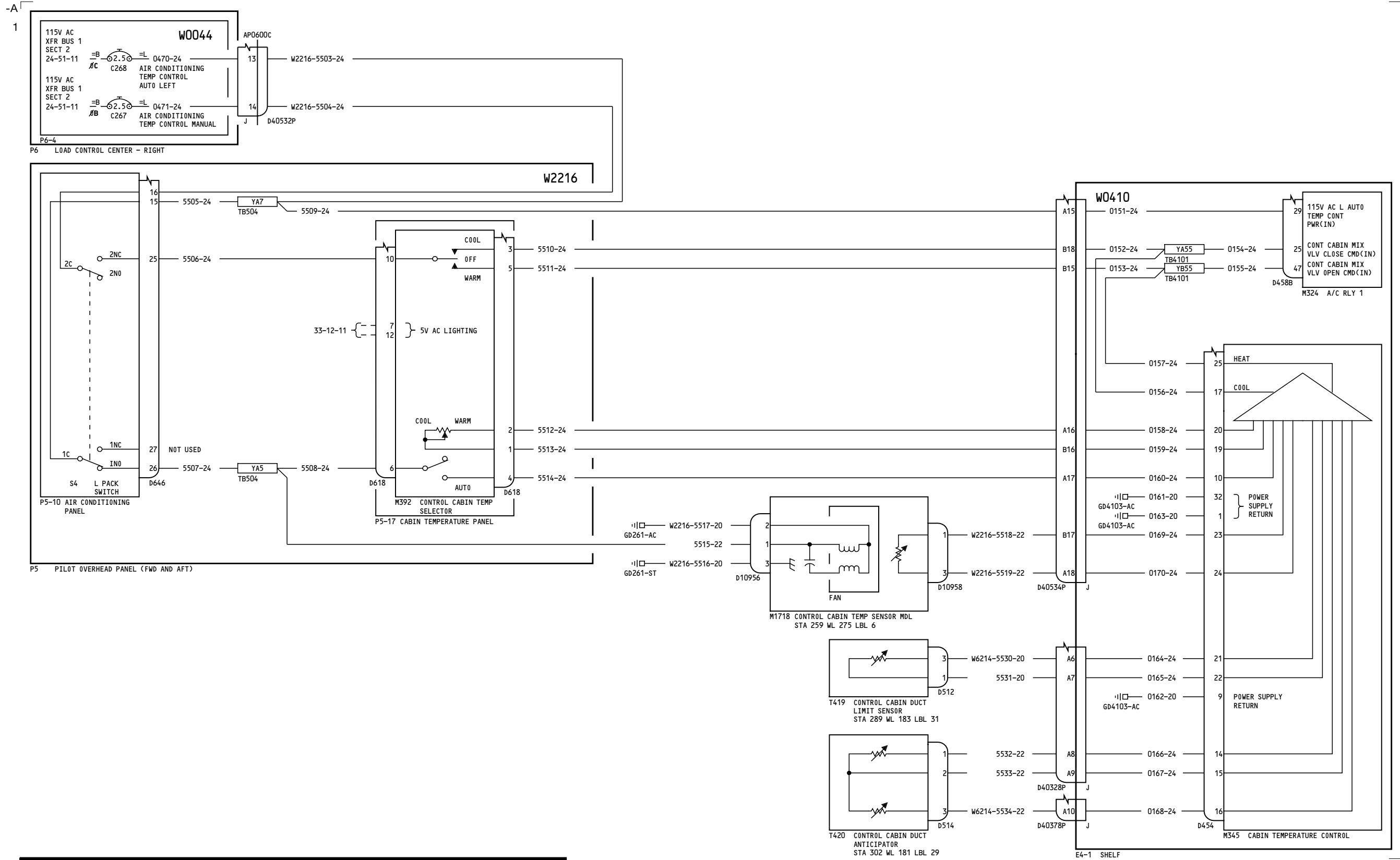

YM643-YM670

TEMPERATURE CONTROL - CONTROL CABIN

21-61-21

Page 1
Sheet 1
Jan 14/2008

D280A103

21-61-21

Page 1
Sheet 1
Jan 14/2008

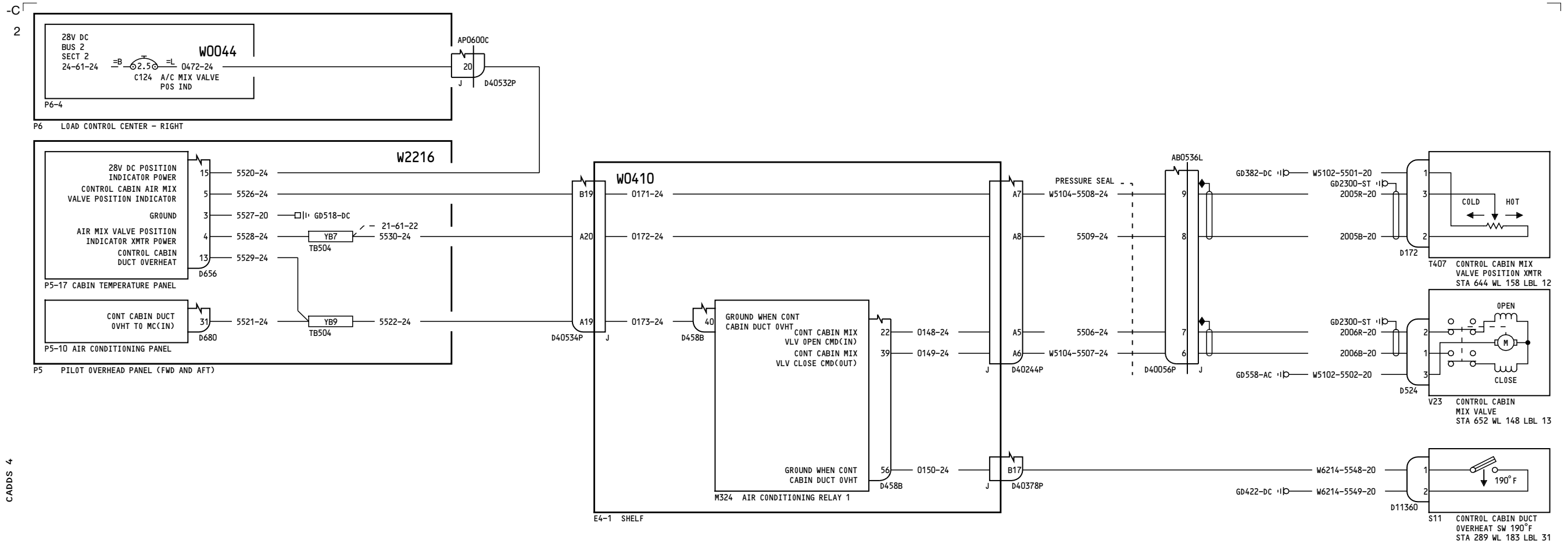

YM643-YM670

TEMPERATURE CONTROL - CONTROL CABIN

D280A103

21-61-21

Page 1
Sheet 2
Jan 14/2008

21-61-21

Page 1
Sheet 2
Jan 14/2008

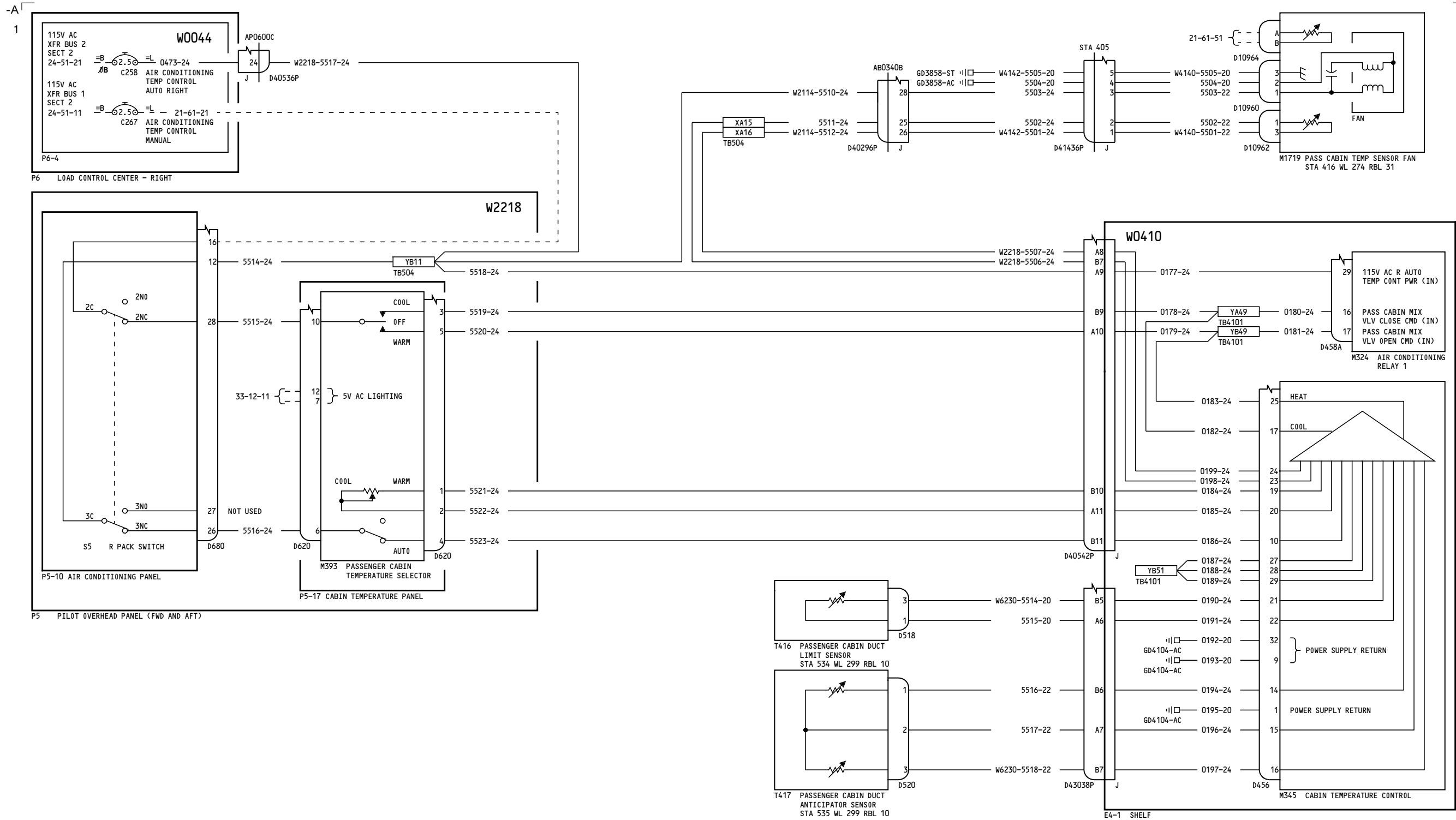

YM643-YM670

TEMPERATURE CONTROL - PASSENGER CABIN

21-61-22

Page 1
Sheet 1
Jan 14/2008

D280A103

21-61-22

Page 1
Sheet 1
Jan 14/2008

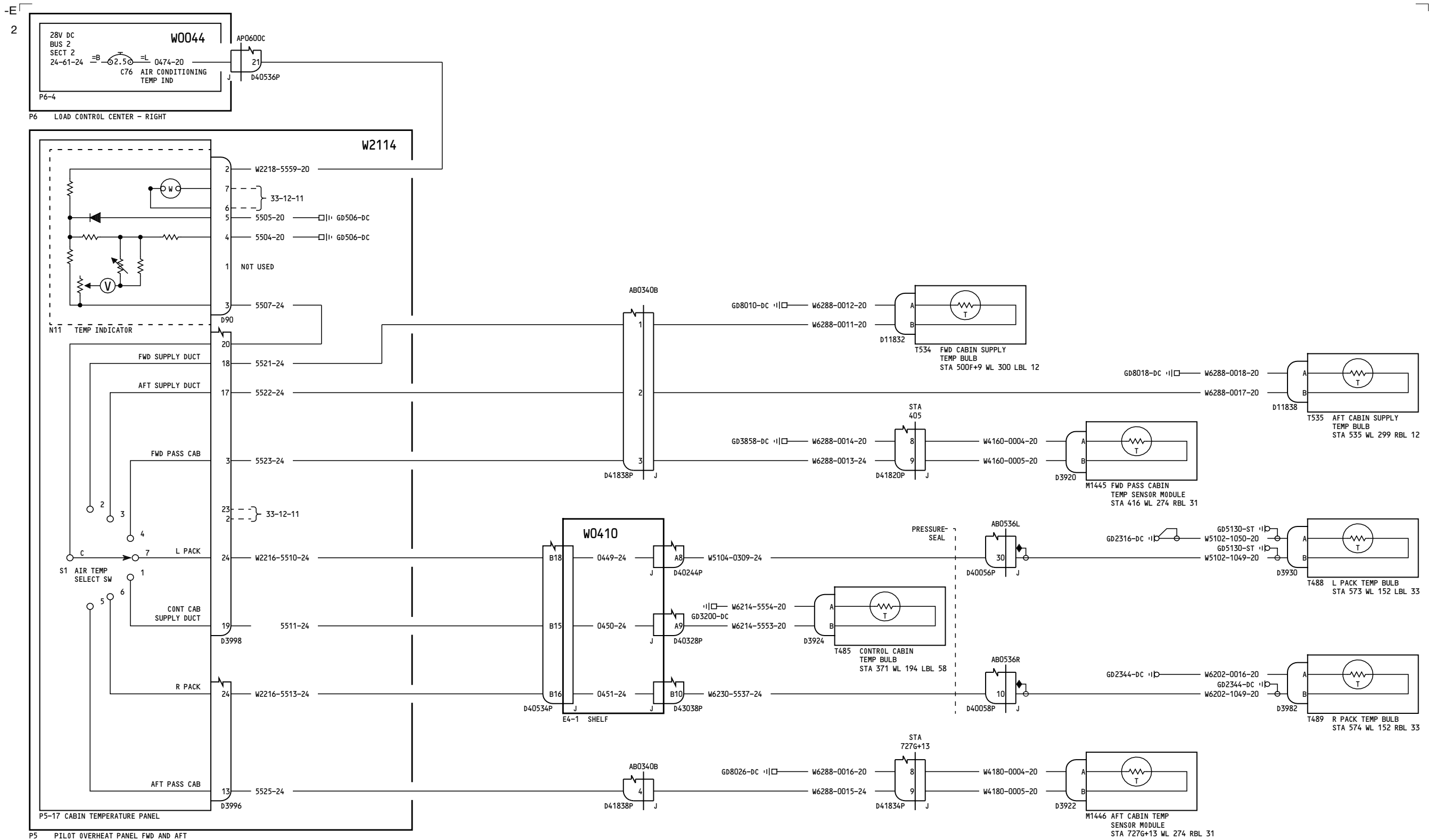

YC001-YC011

AIR CONDITIONING TEMPERATURE INDICATION

21-61-51

Page 1

D280A103

Mar 31/2005

21-61-51

Page 1

Mar 31/2005

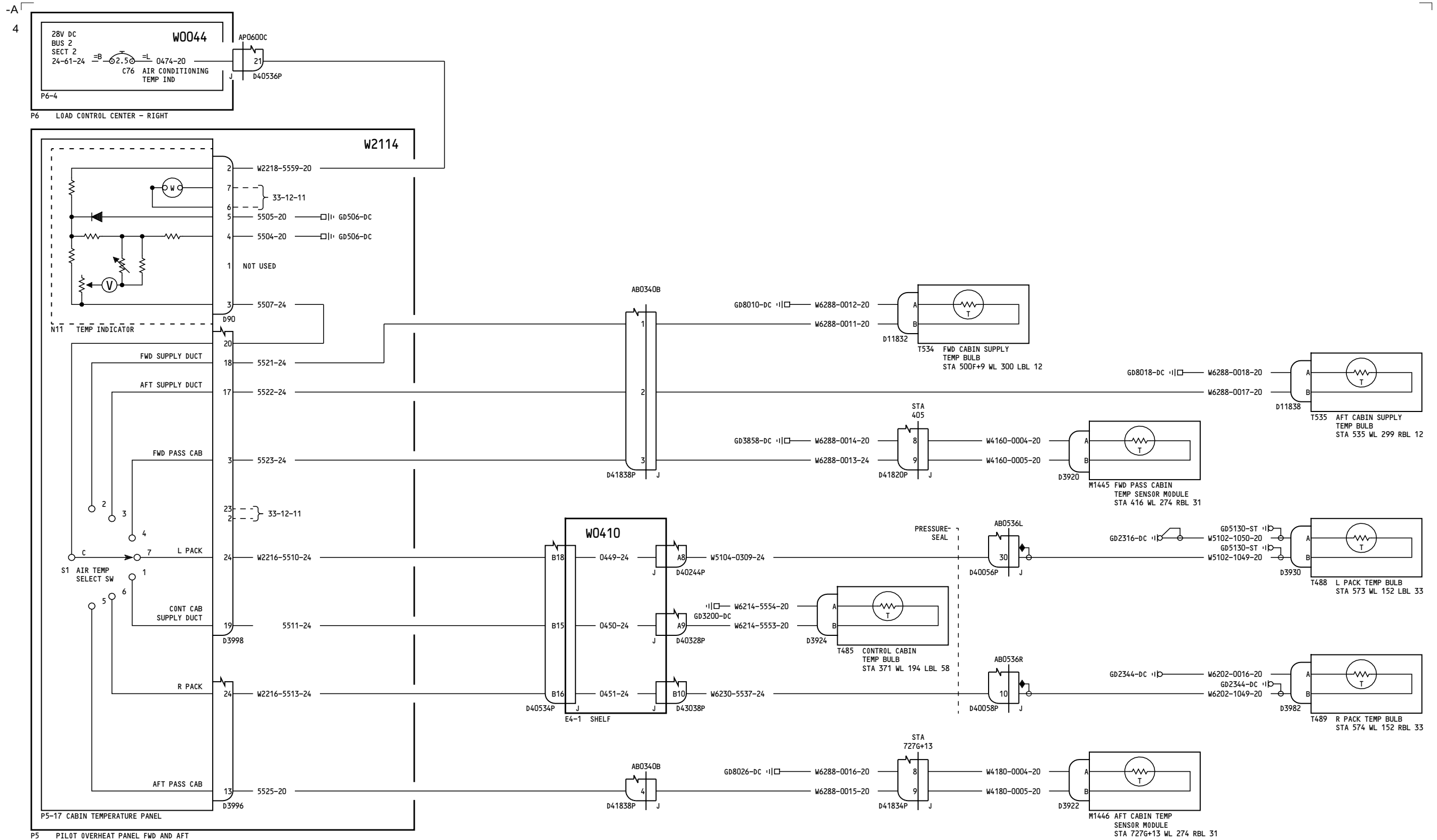

YC012-YL430

AIR CONDITIONING TEMPERATURE INDICATION

21-61-51

Page 2

D280A103

Feb 09/2009

21-61-51

Page 2

Feb 09/2009

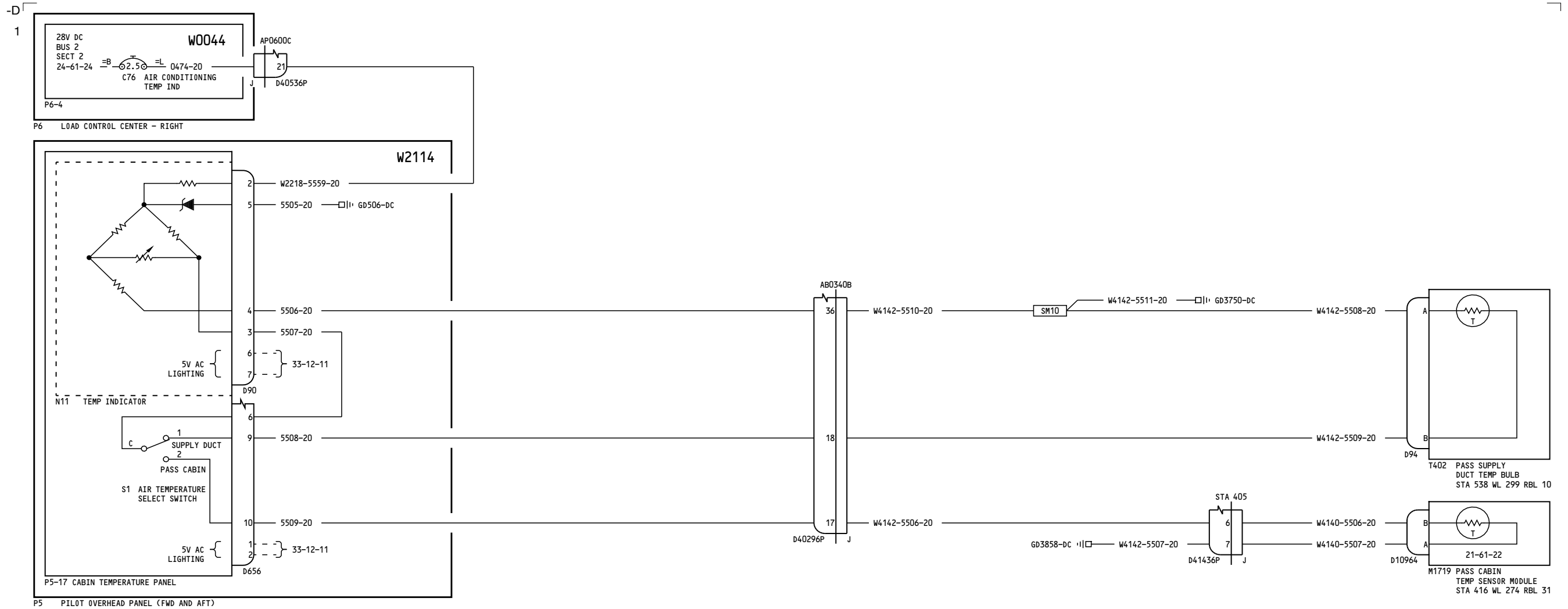

YM643-YM670

**AIR CONDITIONING
TEMPERATURE INDICATION**

21-61-51

Page 3

Jan 14/2008

D280A103

21-61-51

Page 3

Jan 14/2008