

CHAPTER

26

FIRE PROTECTION



737-700/800

WIRING DIAGRAM MANUAL

CHAPTER 26
FIRE PROTECTION

CH-SC-SU	Schem	Page	Sheet	Date	CH-SC-SU	Schem	Page	Sheet	Date
26-EFFECTIVE PAGES					26-16-21 (cont.)				
		1		Aug 10/2009			3		Aug 13/2008
		2		BLANK			4		Feb 09/2009
26-CONTENTS							5		Aug 13/2008
		1		Feb 09/2009			6		Aug 13/2008
		2		Feb 09/2009	26-16-22				
		3		Feb 09/2009			1.1		Aug 13/2008
		4		BLANK			2		Aug 13/2008
26-ALPHABETICAL INDEX							3		Feb 09/2009
		1		Jan 18/2007			4		Aug 13/2008
		2		BLANK	26-21-11				
26-11-11		1		Feb 09/2009			1	1	Apr 18/2007
26-11-21		1.1	1	Aug 13/2008			2	2	Mar 31/2005
			2	Feb 12/2008			2	1	Apr 18/2007
		2.1	1	Feb 12/2008			3	2	Apr 18/2007
			2	Feb 12/2008			3	3	Mar 31/2005
		3.1	1	Feb 12/2008			4	1	Jul 17/2007
			2	Feb 12/2008				2	Jul 17/2007
		4	1	Feb 09/2009				3	Jul 17/2007
			2	Feb 09/2009	26-23-11				
26-11-31		1.1		Aug 13/2008			1.1		Aug 13/2008
		2		Jul 17/2007			2		Feb 09/2009
		3		Feb 09/2009			3		Feb 09/2009
26-12-11		1	1	Jul 26/2006					
			2	Mar 31/2005					
		1.1	1	Oct 15/2007					
			2	Oct 15/2007					
		2	1	Jul 26/2006					
			2	Mar 31/2005					
		2.1	1	Oct 15/2007					
			2	Oct 15/2007					
		3	1	Jul 17/2007					
			2	Jul 17/2007					
		3.1	1	Oct 15/2007					
			2	Oct 15/2007					
		4	1	Apr 18/2007					
			2	Apr 18/2007					
		5	1	Apr 18/2007					
			2	Apr 18/2007					
		6	1	Feb 09/2009					
			2	Feb 09/2009					
		7	1	Jan 14/2008					
			2	Jan 14/2008					
26-14-11		1		Feb 09/2009					
26-16-21		1.1		Aug 13/2008					
		2		Aug 13/2008					

A = Added, R = Revised, D = Deleted, O = Overflow

26-EFFECTIVE PAGES

Page 1
Aug 10/2009

D280A103



737-700/800

WIRING DIAGRAM MANUAL

CHAPTER 26
FIRE PROTECTION

Title	CH-SC-SU	Schem	Page	Sheet	Date	Effectivity
<u>ENGINE FIRE DETECTION</u>						
ENGINE 1 FIRE DETECTION	26-11-11		1		Feb 09/2009	ALL
ENGINE 2 FIRE DETECTION	26-11-21		1.1	1	Aug 13/2008	YC001-YC007
				2	Feb 12/2008	YC001-YC007
			2.1	1	Feb 12/2008	YC008-YC026
				2	Feb 12/2008	YC008-YC026
			3.1	1	Feb 12/2008	YC028-YC030
				2	Feb 12/2008	YC028-YC030
			4	1	Feb 09/2009	YK901-YM670
				2	Feb 09/2009	YK901-YM670
APU FIRE DETECTION	26-11-31		1.1		Aug 13/2008	YC001-YC007
			2		Jul 17/2007	YC008-YC030
			3		Feb 09/2009	YC031-YM670
<u>OVERHEAT DETECTION SYSTEM</u>						
WHEEL WELL, WING AND LOWER AFT BODY OVERHEAT DETECTION	26-12-11		1	1	Jul 26/2006	YC001-YC003
				2	Mar 31/2005	YC001-YC003
			1.1	1	Oct 15/2007	YC001-YC003
				2	Oct 15/2007	YC001-YC003
			2	1	Jul 26/2006	YC004-YC007
				2	Mar 31/2005	YC004-YC007
			2.1	1	Oct 15/2007	YC004-YC007
				2	Oct 15/2007	YC004-YC007
			3	1	Jul 17/2007	YC008-YC030
				2	Jul 17/2007	YC008-YC030
			3.1	1	Oct 15/2007	YC008-YC030
				2	Oct 15/2007	YC008-YC030
			4	1	Apr 18/2007	YC031-YK906
				2	Apr 18/2007	YC031-YK906
			5	1	Apr 18/2007	YK907 YL421
				2	Apr 18/2007	YK907 YL421
			6	1	Feb 09/2009	YK908-YL401 YL422-YL430

26-CONTENTS



737-700/800

WIRING DIAGRAM MANUAL

CHAPTER 26
FIRE PROTECTION

Title	CH-SC-SU	Schem	Page	Sheet	Date	Effectivity
WHEEL WELL, WING AND LOWER AFT BODY OVERHEAT DETECTION (cont.)	26-12-11			2	Feb 09/2009	YK908-YL401 YL422-YL430
			7	1	Jan 14/2008	YM643-YM670
				2	Jan 14/2008	YM643-YM670
<u>LAVATORY SMOKE DETECTION</u>						
LAVATORY SMOKE DETECTORS	26-14-11		1		Feb 09/2009	ALL
<u>CARGO COMPARTMENT SMOKE DETECTION SYSTEM</u>						
FORWARD CARGO COMPARTMENT SMOKE DETECTION	26-16-21		1.1		Aug 13/2008	YC001-YC007
				2	Aug 13/2008	YC008-YC026
				3	Aug 13/2008	YC028-YC030
				4	Feb 09/2009	YC031-YC050 YK906-YL430
				5	Aug 13/2008	YK901-YK905
				6	Aug 13/2008	YM643-YM670
AFT CARGO COMPARTMENT SMOKE DETECTION	26-16-22		1.1		Aug 13/2008	YC001-YC007
				2	Aug 13/2008	YC008-YC030
				3	Feb 09/2009	YC031-YL430
				4	Aug 13/2008	YM643-YM670
<u>ENGINE FIRE EXTINGUISHING</u>						
ENGINE AND APU FIRE EXTINGUISHING SYSTEM	26-21-11		1	1	Apr 18/2007	YC001-YC003
				2	Mar 31/2005	YC001-YC003
			2	1	Apr 18/2007	YC004-YC007
				2	Apr 18/2007	YC004-YC007
				3	Mar 31/2005	YC004-YC007
			3	1	Jul 17/2007	YC008-YC030
				2	Jul 17/2007	YC008-YC030
				3	Jul 17/2007	YC008-YC030
			4	1	Feb 09/2009	YC031-YM670
				2	Feb 09/2009	YC031-YM670



737-700/800

WIRING DIAGRAM MANUAL

CHAPTER 26 FIRE PROTECTION

Title	CH-SC-SU	Schem	Page	Sheet	Date	Effectivity
ENGINE AND APU FIRE EXTINGUISHING SYSTEM (cont.)	26-21-11			3	Feb 09/2009	YC031-YM670
<u>CARGO COMPARTMENT FIRE EXTINGUISHING</u>						
CARGO COMPARTMENT FIRE EXTINGUISHERS	26-23-11		1.1		Aug 13/2008	YC001-YC007
			2		Feb 09/2009	YC008-YK917 YL421-YL428 YL430-YM670
			3		Feb 09/2009	YK918-YL401 YL429

26-CONTENTS

Page 3
Feb 09/2009

D280A103



737-700/800

WIRING DIAGRAM MANUAL

CHAPTER 26 FIRE PROTECTION

CH-SC-SU	Title
26-16-22	AFT CARGO COMPARTMENT SMOKE DETECTION
26-11-31	APU FIRE DETECTION
26-23-11	CARGO COMPARTMENT FIRE EXTINGUISHERS
26-11-11	ENGINE 1 FIRE DETECTION
26-11-21	ENGINE 2 FIRE DETECTION
26-21-11	ENGINE AND APU FIRE EXTINGUISHING SYSTEM
26-16-21	FORWARD CARGO COMPARTMENT SMOKE DETECTION
26-14-11	LAVATORY SMOKE DETECTORS
26-12-11	WHEEL WELL, WING AND LOWER AFT BODY OVERHEAT DETECTION

26-ALPHABETICAL INDEX

D280A103

Page 1
Jan 18/2007

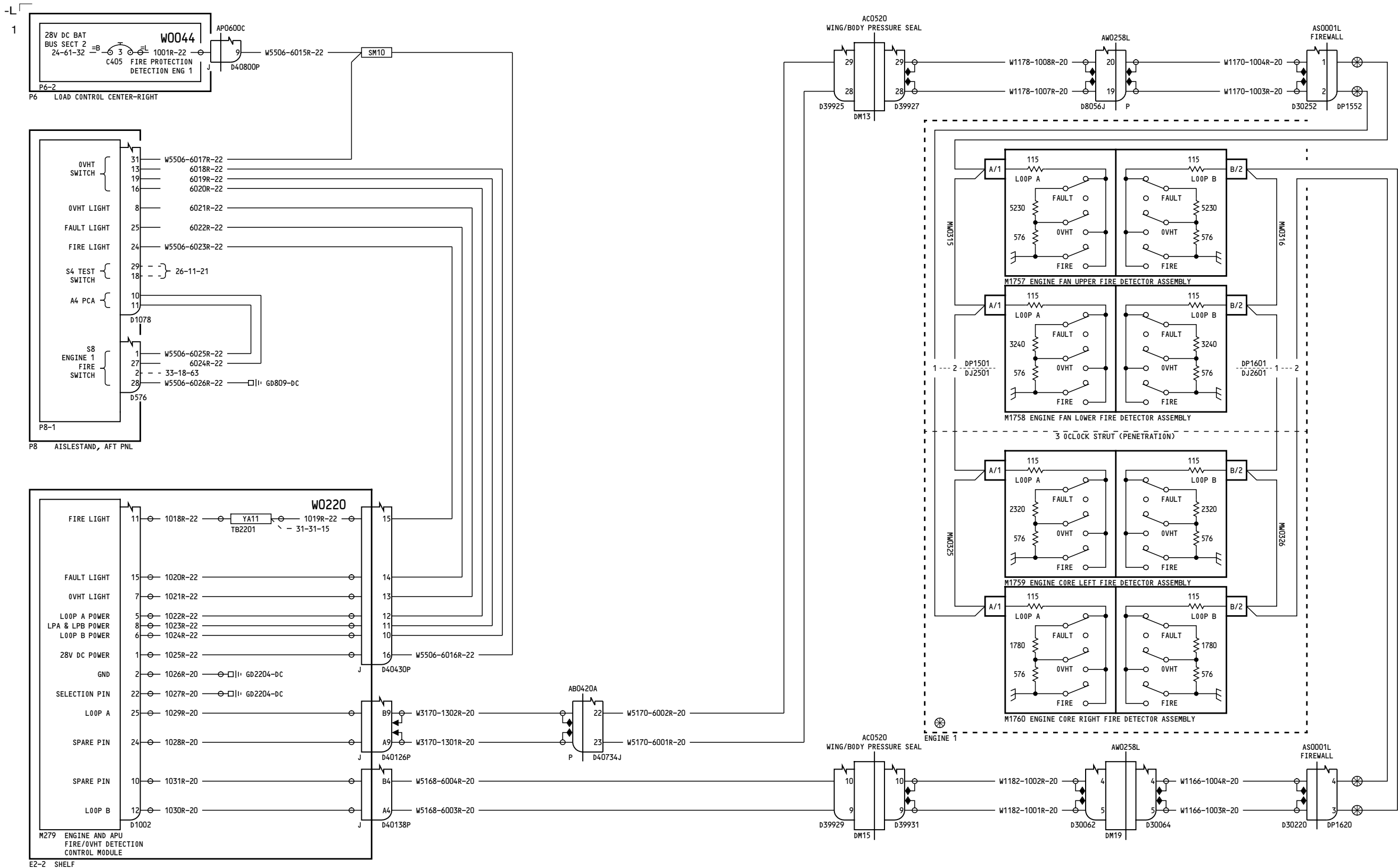

ALL

ENGINE 1 FIRE DETECTION

D280A103

26-11-11

Page 1

Feb 09/2009

26-11-11

Page 1

Feb 09/2009

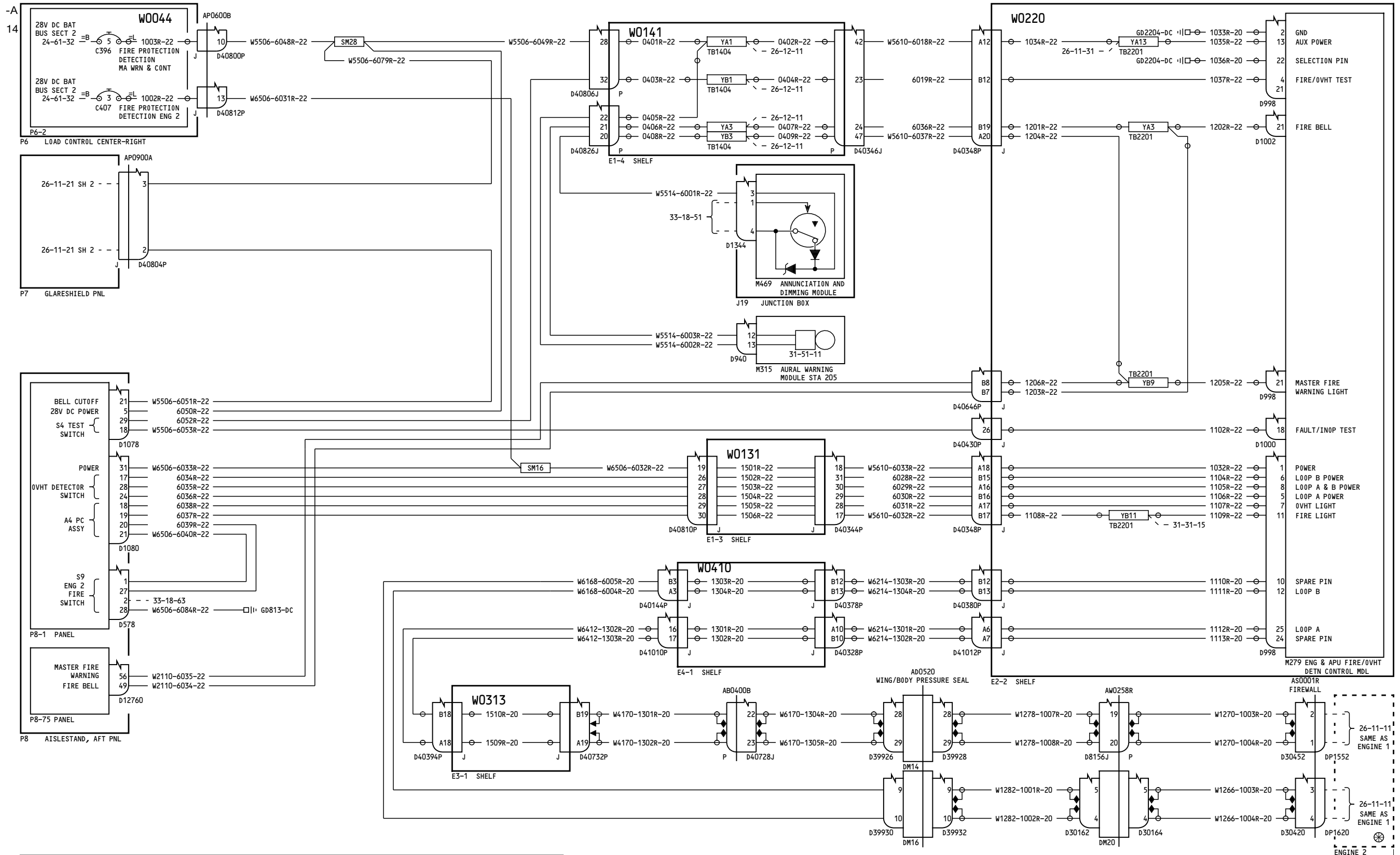

YC001-YC007

ENGINE 2 FIRE DETECTION

26-11-21

Incorporates 26A1083 R01 31-1284

26-11-21

D280A103

Page 1.1 Sheet 1 Aug 13/2008

Page 1.1 Sheet 1 Aug 13/2008

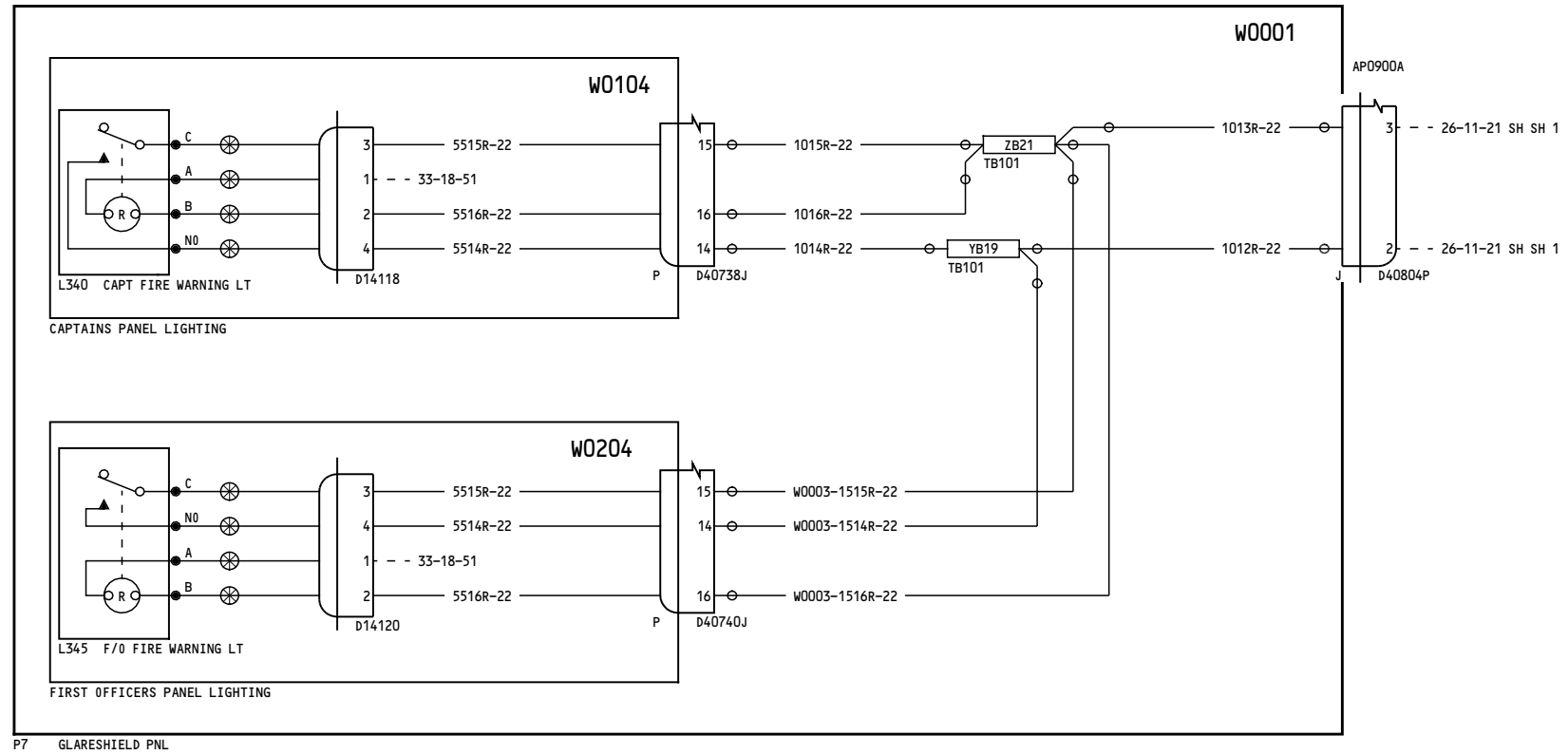

YC001-YC007

ENGINE 2 FIRE DETECTION

D280A103

26-11-21

Page 1.1
Sheet 2
Feb 12/2008

Incorporates
▶ 31-1284

26-11-21

Page 1.1
Sheet 2
Feb 12/2008

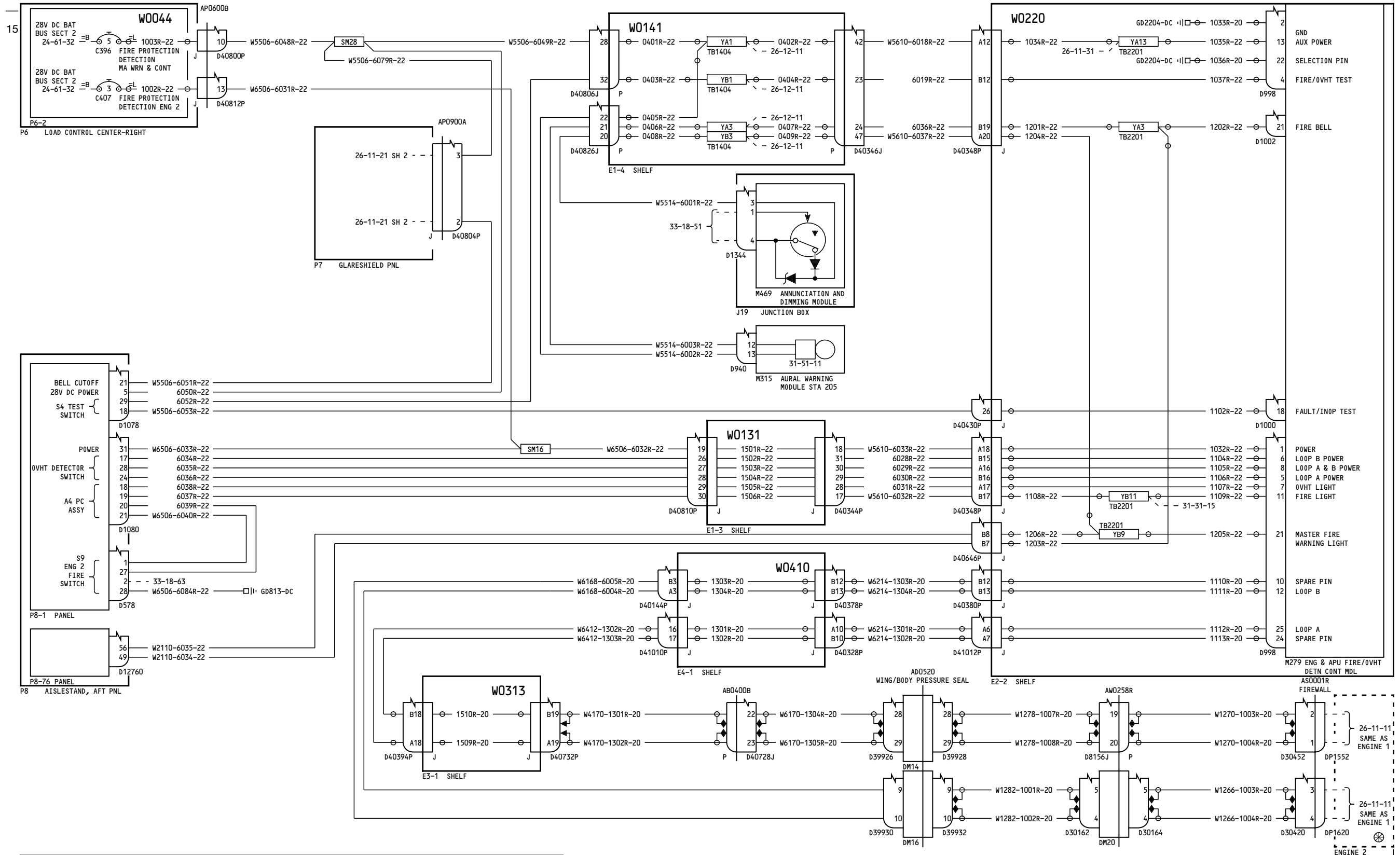

YC008-YC026

ENGINE 2 FIRE DETECTION

26-11-21

Page 2.1
Sheet 1
Feb 12/2008

D280A103

Incorporates
31-1284

26-11-21

Page 2.1
Sheet 1
Feb 12/2008

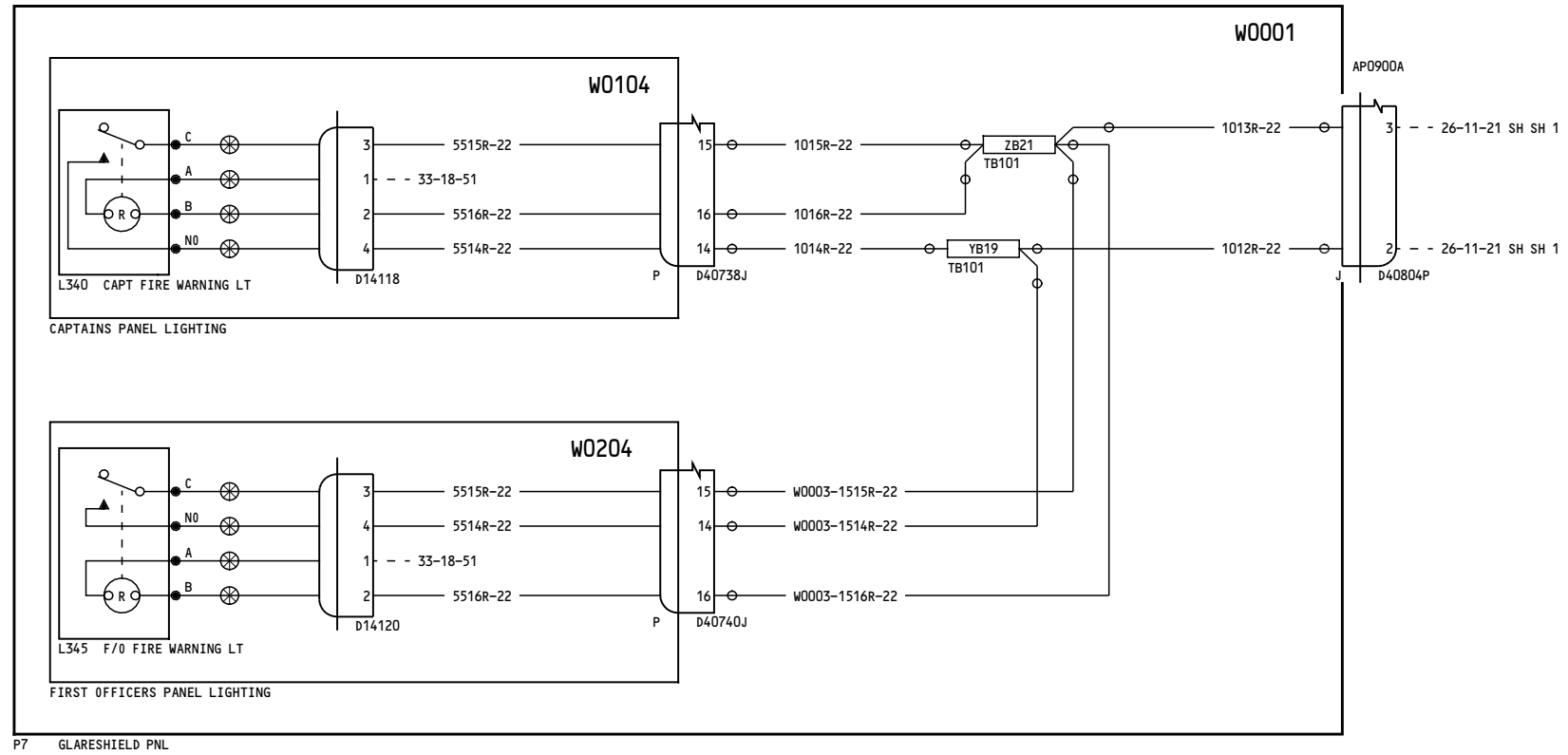

YC008-YC026

ENGINE 2 FIRE DETECTION

D280A103

26-11-21

Page 2.1
Sheet 2
Feb 12/2008

Incorporates
31-1284

26-11-21

Page 2.1
Sheet 2
Feb 12/2008

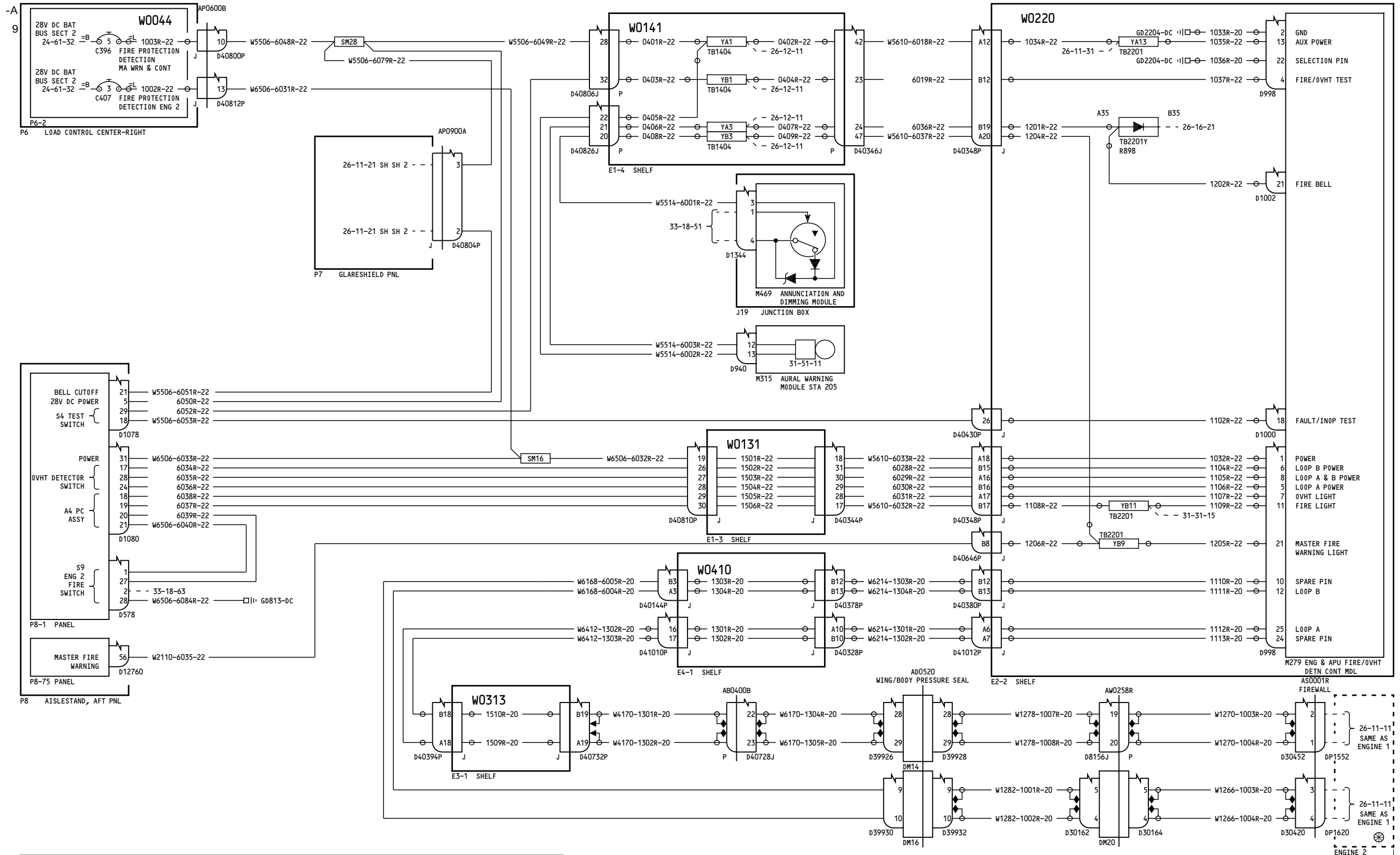

YC028-YC030

ENGINE 2 FIRE DETECTION

26-11-21

Page 3.1
Sheet 1
Feb 12/2008

D280A103

Incorporates
31-1284

26-11-21

Page 3.1
Sheet 1
Feb 12/2008

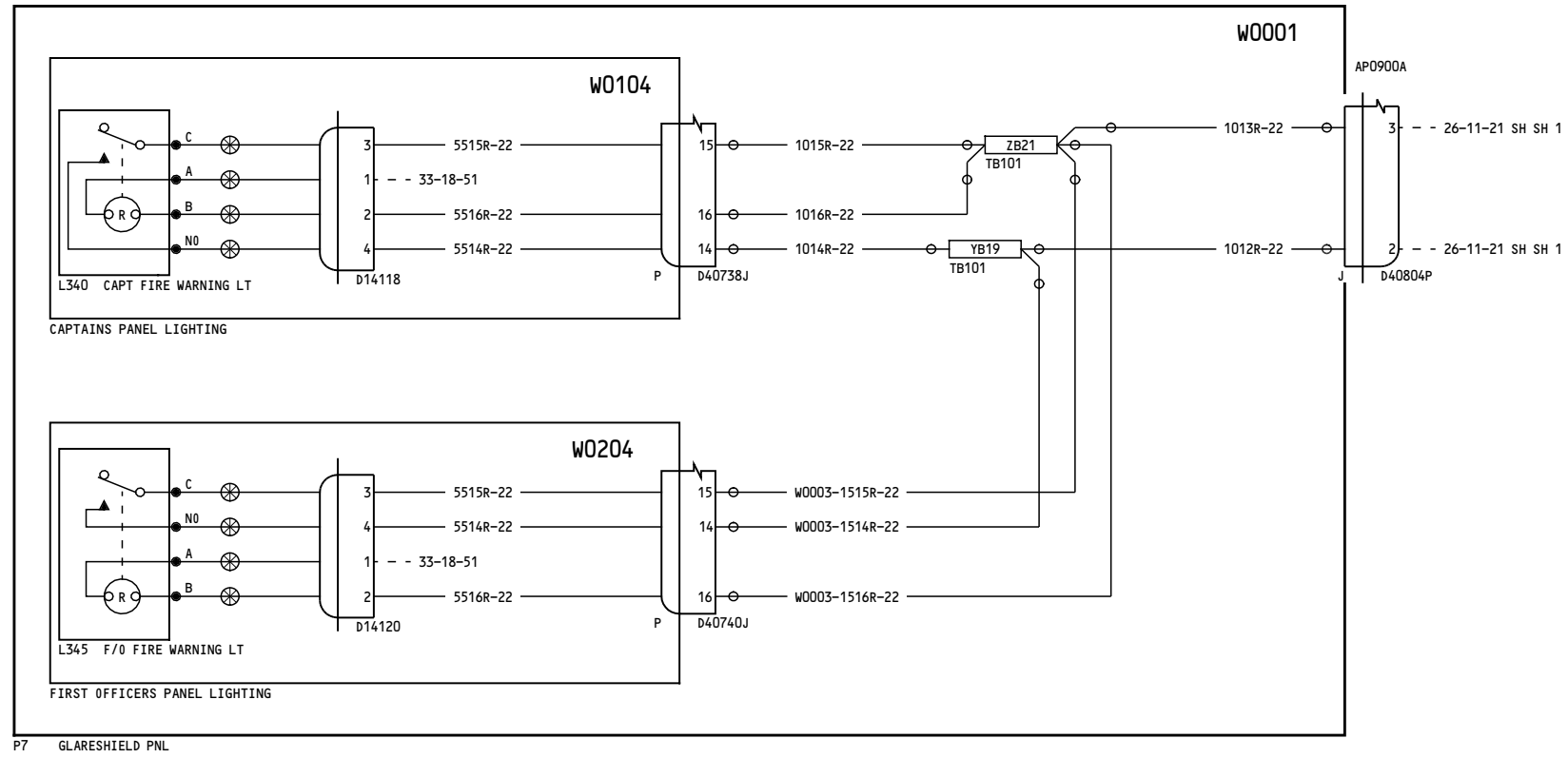

YC028-YC030

ENGINE 2 FIRE DETECTION

D280A103

26-11-21

Page 3.1
Sheet 2
Feb 12/2008

Incorporates
▶ 31-1284

26-11-21

Page 3.1
Sheet 2
Feb 12/2008

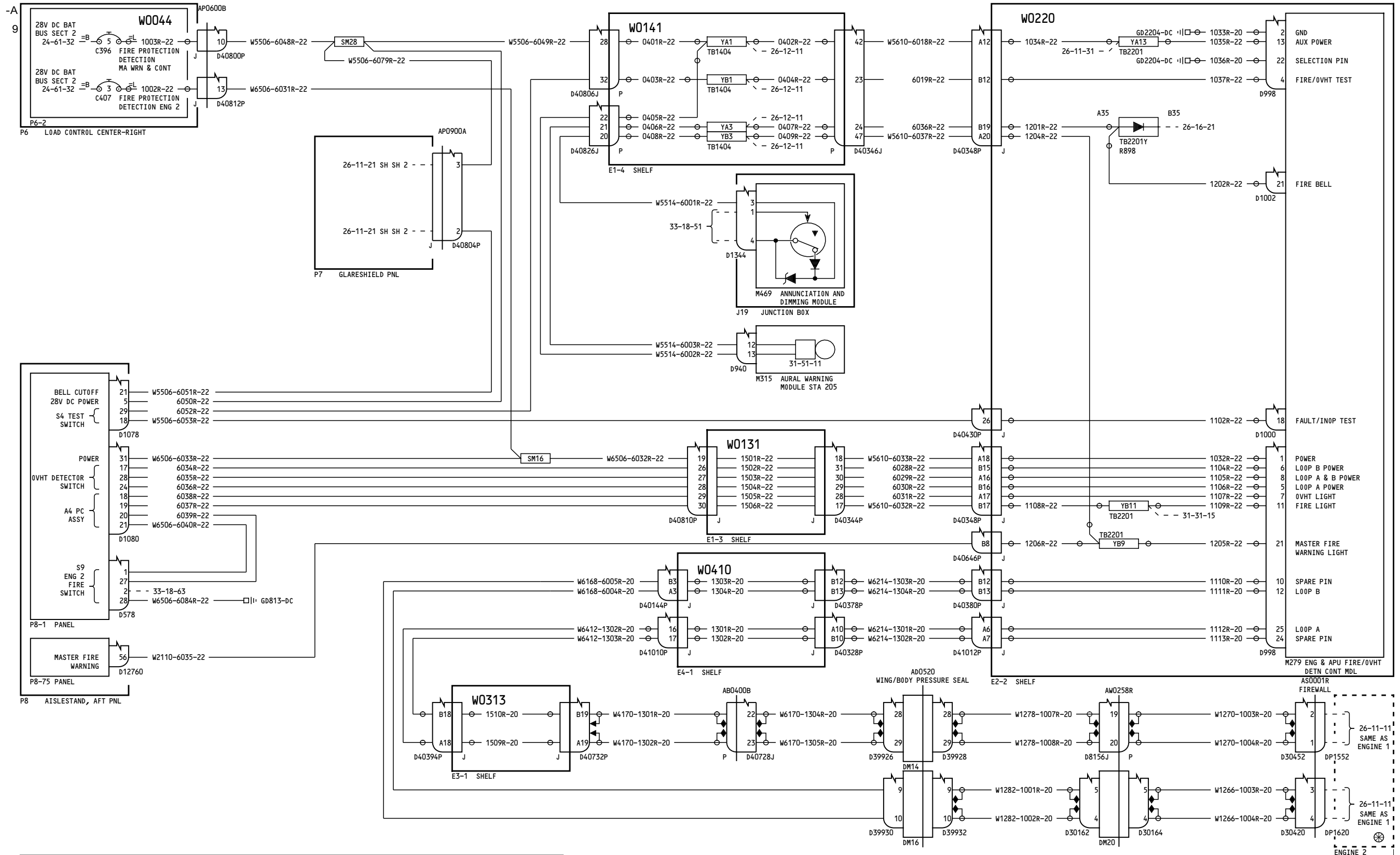

YK901-YM670

ENGINE 2 FIRE DETECTION

26-11-21

Page 4
Sheet 1
Feb 09/2009

D280A103

26-11-21

Page 4
Sheet 1
Feb 09/2009

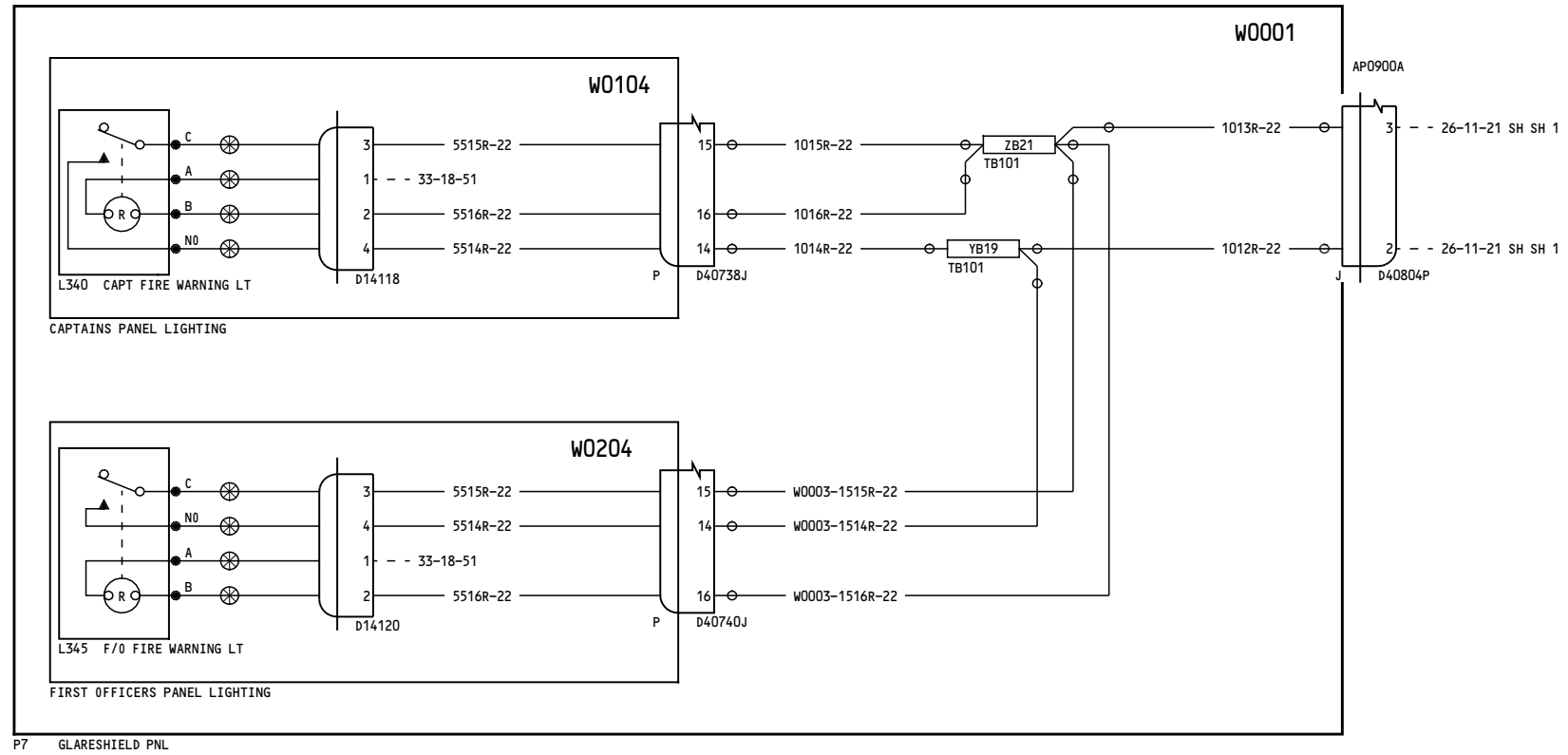

YK901-YM670

ENGINE 2 FIRE DETECTION

D280A103

26-11-21

Page 4
Sheet 2
Feb 09/2009

26-11-21

Page 4
Sheet 2
Feb 09/2009

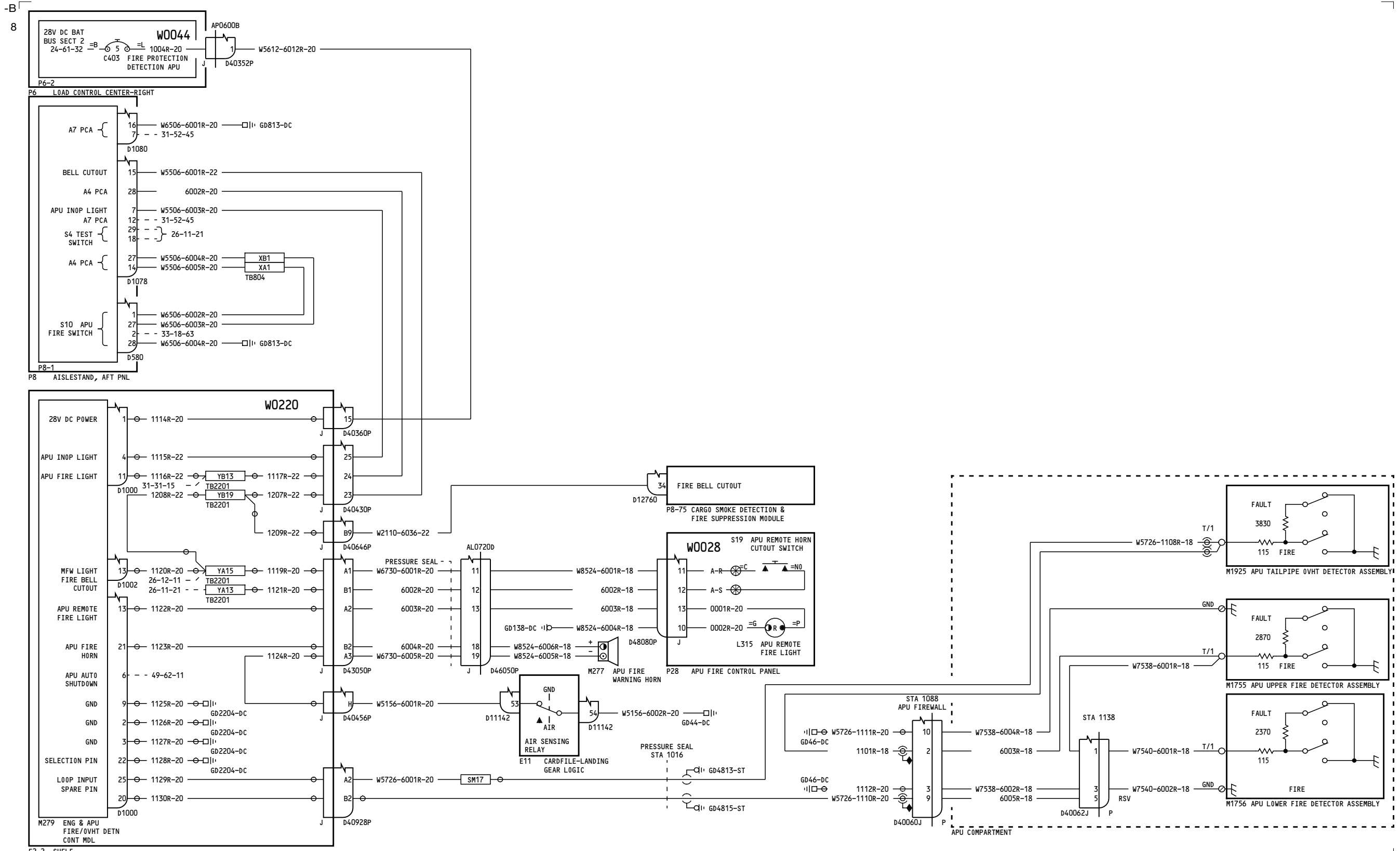

YC001-YC007

APU FIRE DETECTION

26-11-31

Incorporates 26A1083 R01

D280A103

26-11-31

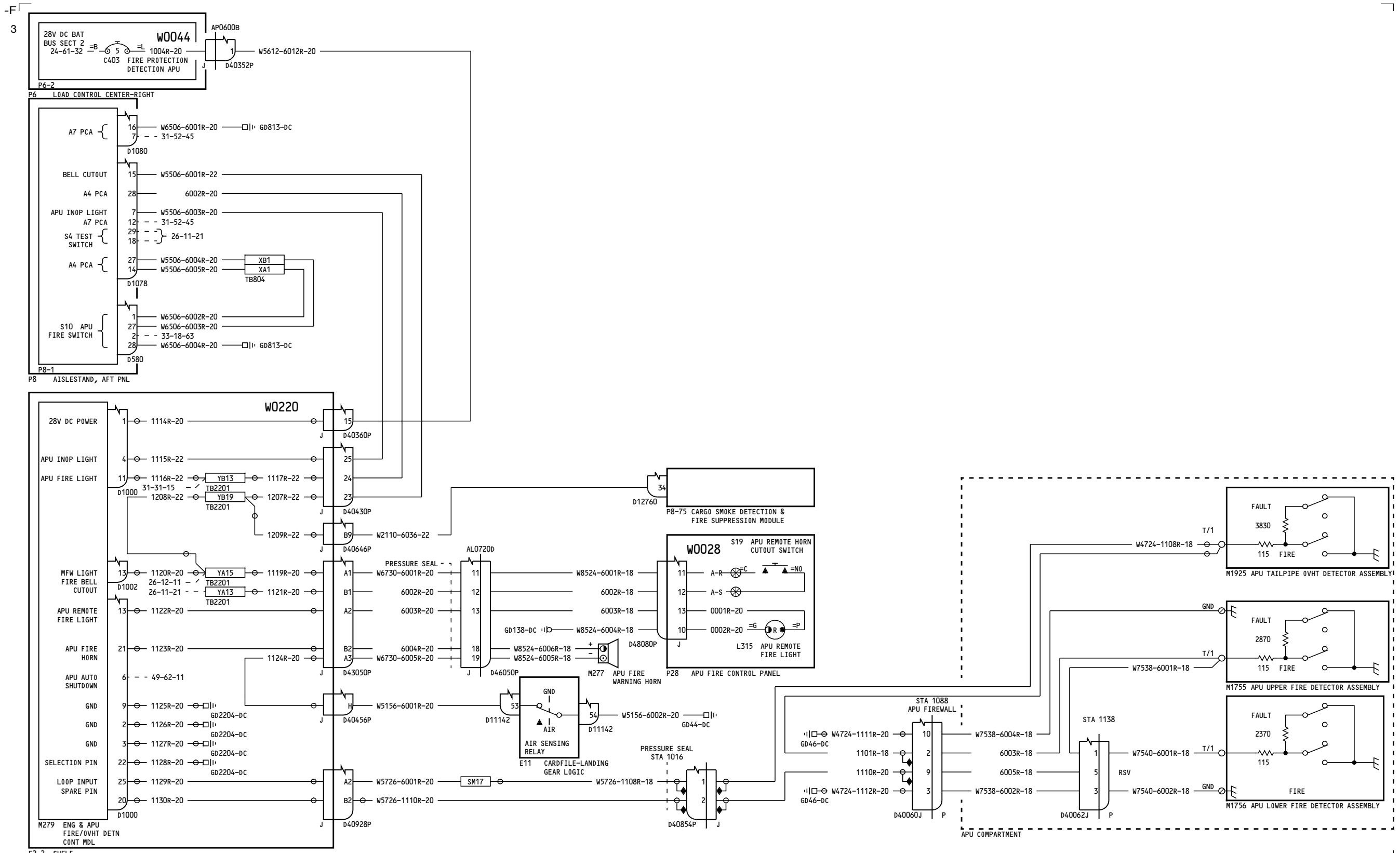

YC008-YC030

APU FIRE DETECTION

26-11-31

Page 2

D280A103

Jul 17/2007

26-11-31

Page 2

Jul 17/2007

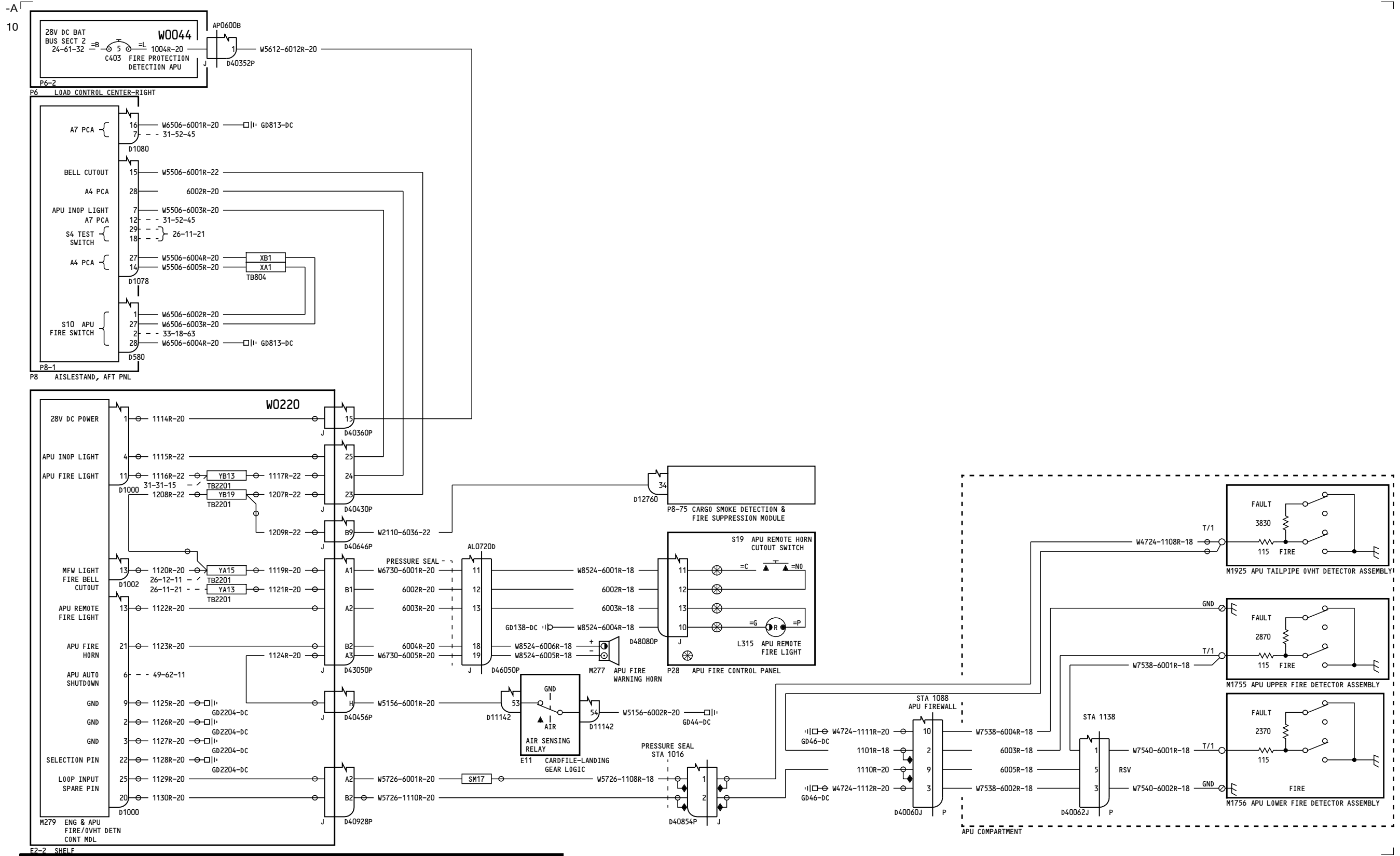

YC031-YM670

APU FIRE DETECTION

26-11-31

Page 3

D280A103

Feb 09/2009

26-11-31

Page 3

Feb 09/2009

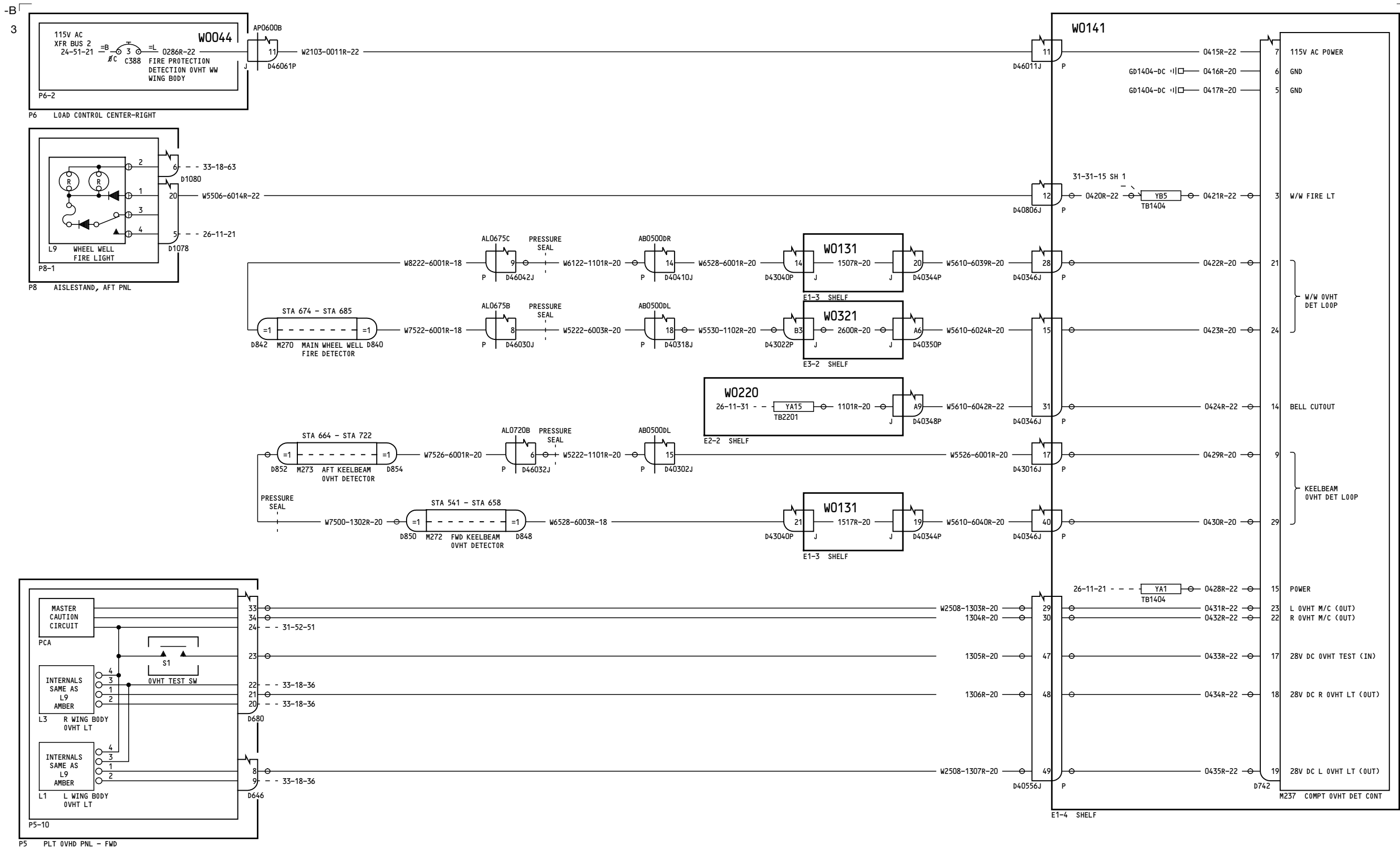

YC001-YC003

WHEEL WELL, WING AND LOWER AFT BODY OVERHEAT DETECTION

26-12-11

Page 1
Sheet 1
Jul 26/2006

D280A103

26-12-11

Page 1
Sheet 1
Jul 26/2006

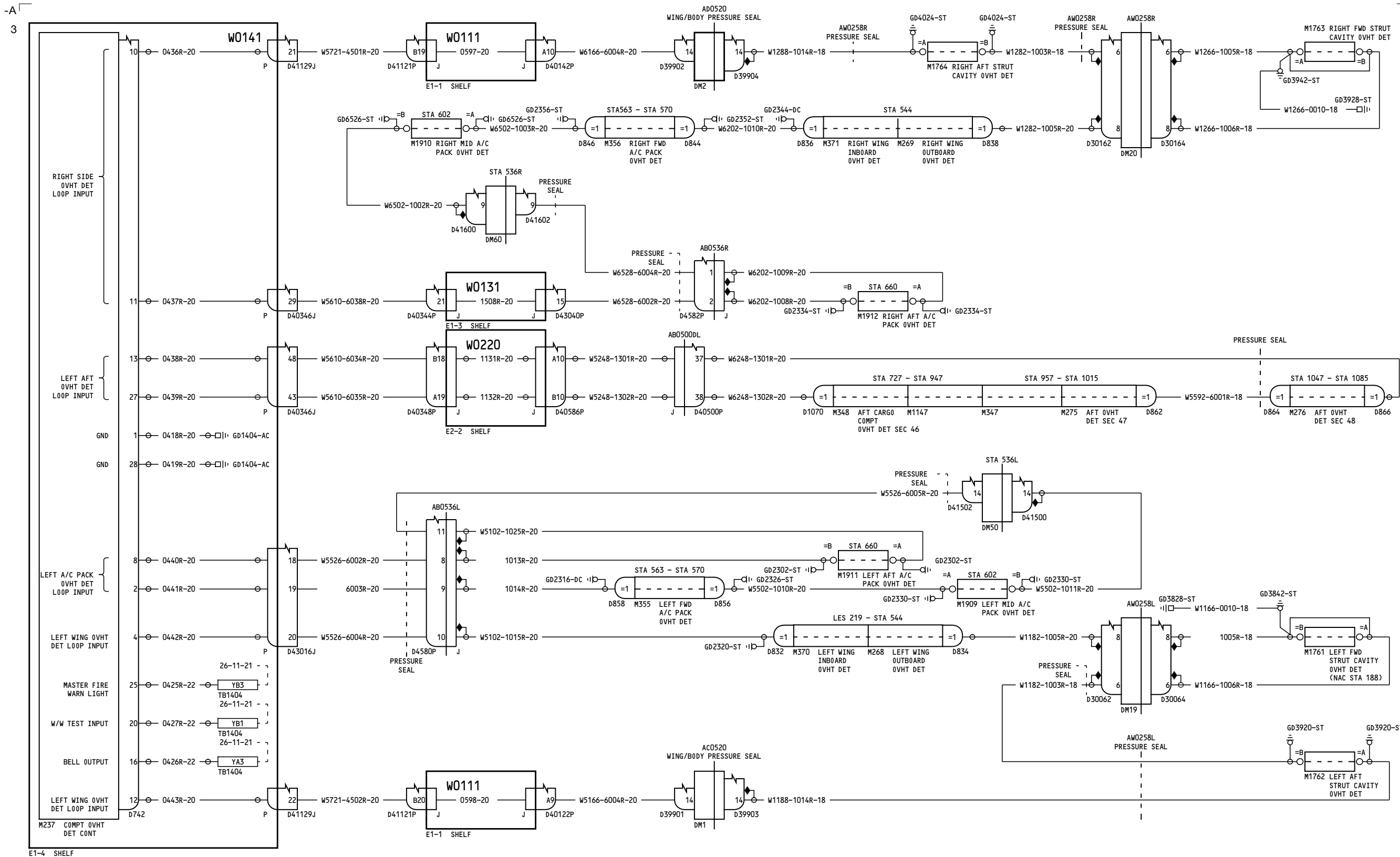

YC001-YC003

WHEEL WELL, WING AND LOWER AFT BODY OVERHEAT DETECTION

D280A103

26-12-11

Page 1
Sheet 2
Mar 31/2005

26-12-11

Page 1
Sheet 2
Mar 31/2005

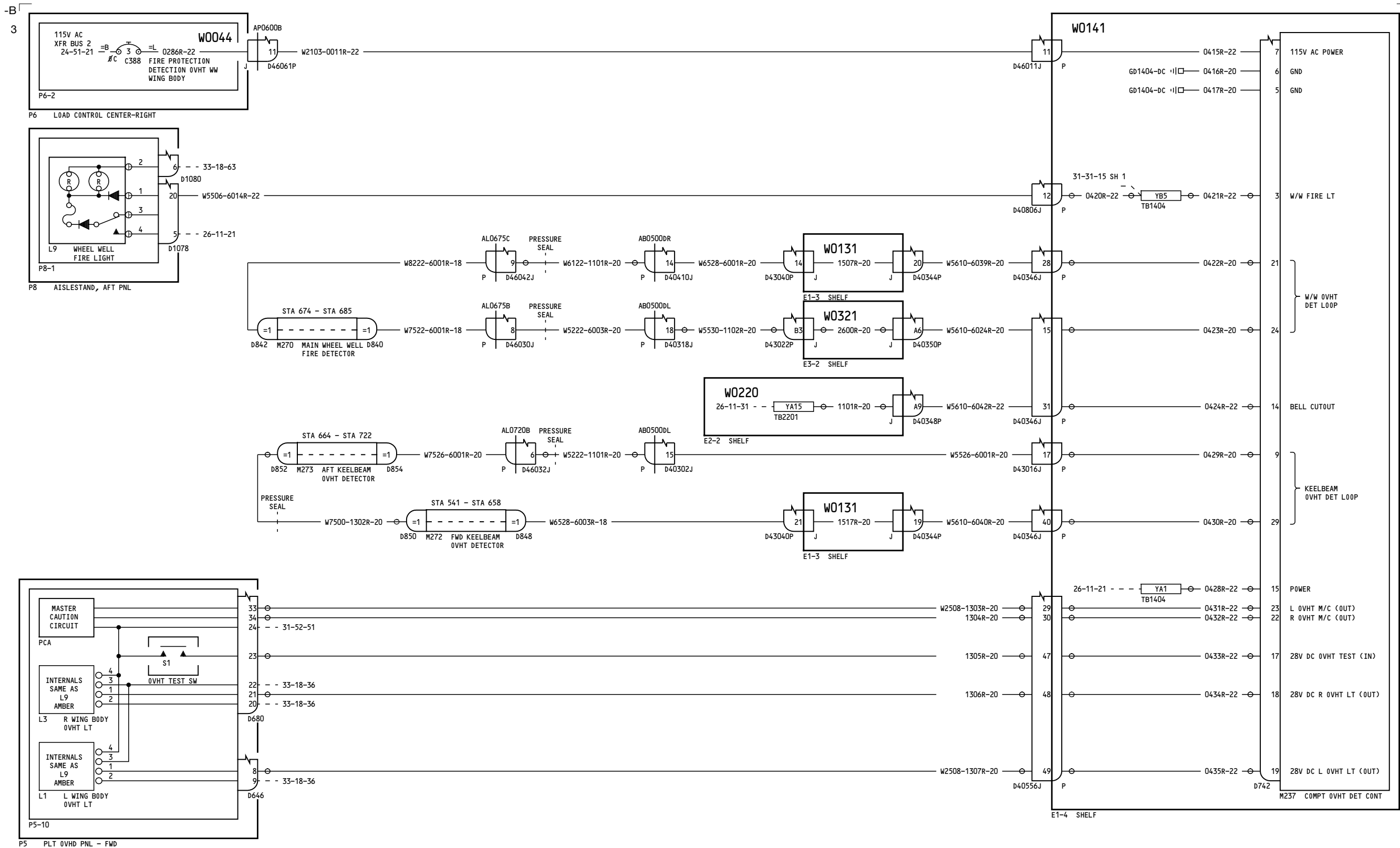

YC001-YC003

WHEEL WELL, WING AND LOWER AFT BODY OVERHEAT DETECTION

D280A103

26-12-11

Page 1.1
Sheet 1
Oct 15/2007

26-12-11

Page 1.1
Sheet 1
Oct 15/2007

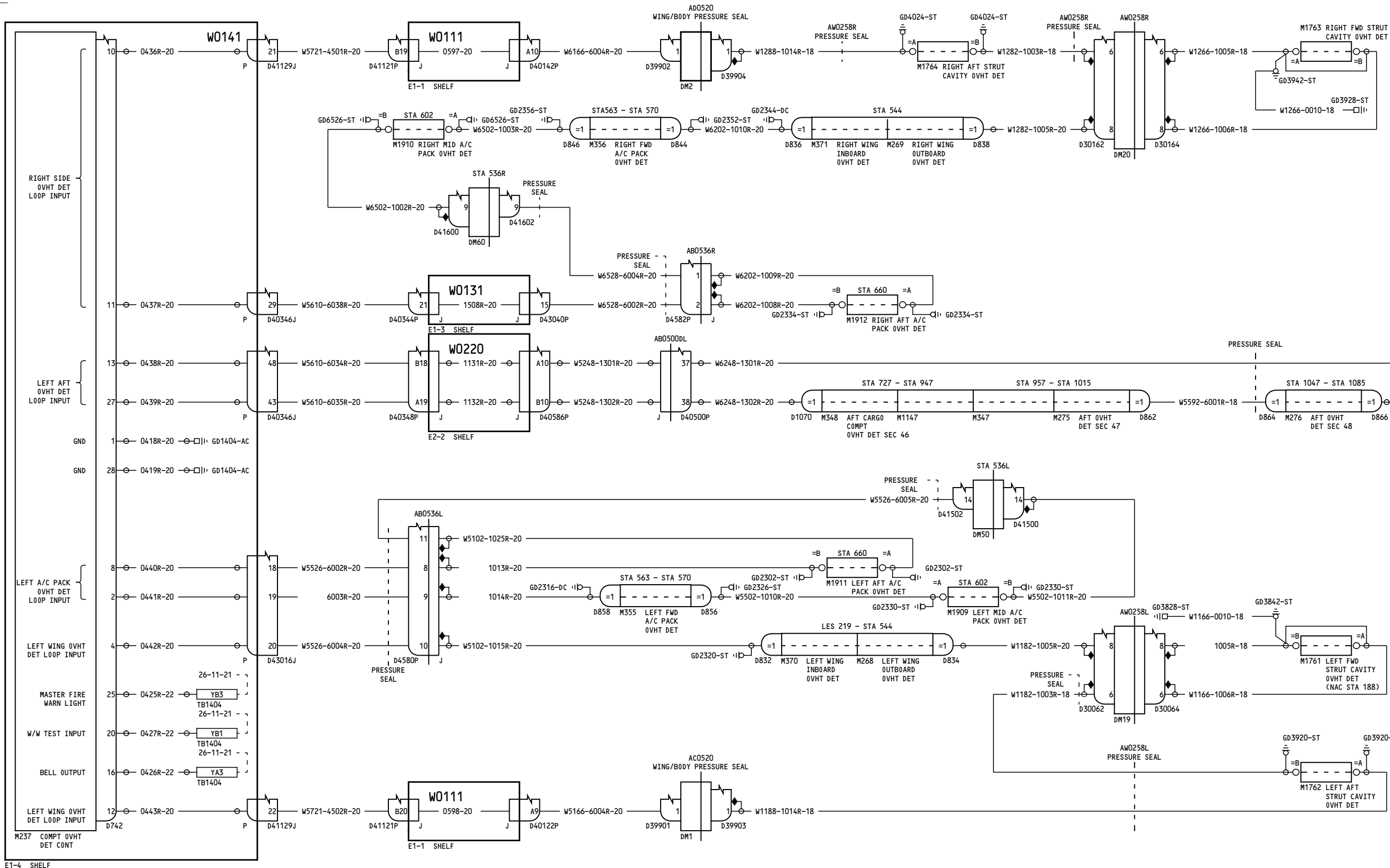

YC001-YC003

WHEEL WELL, WING AND LOWER AFT BODY OVERHEAT DETECTION

D280A103

26-12-11

Page 1.1
Sheet 2
Oct 15/2007

Incorporates
28-1194 R02

26-12-11

Page 1.1
Sheet 2
Oct 15/2007

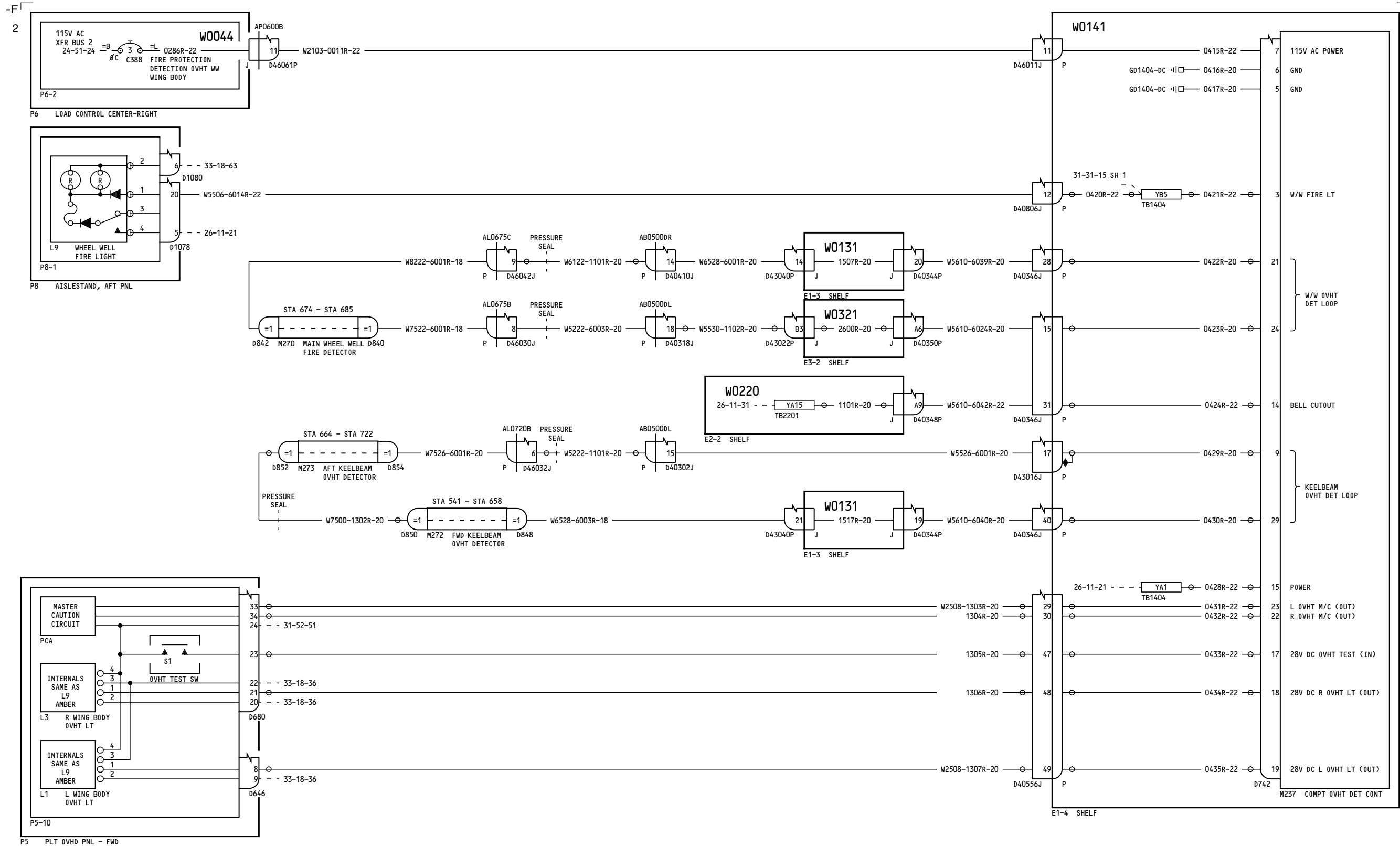

YC004-YC007

WHEEL WELL, WING AND LOWER AFT BODY OVERHEAT DETECTION

26-12-11

Page 2
Sheet 1
Jul 26/2006

D280A103

26-12-11

Page 2
Sheet 1
Jul 26/2006

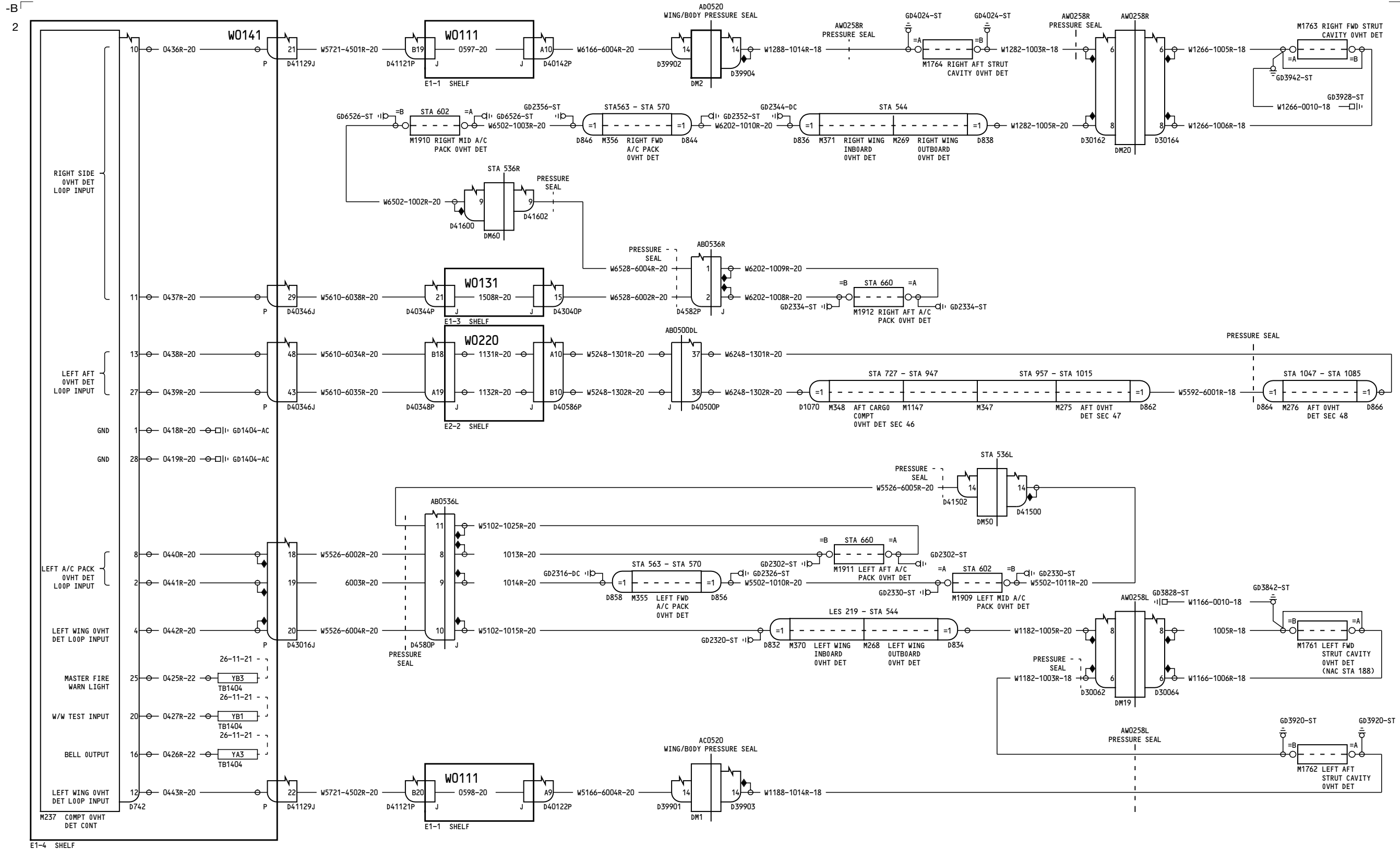

YC004-YC007

WHEEL WELL, WING AND LOWER AFT BODY OVERHEAT DETECTION

D280A103

26-12-11

Page 2
Sheet 2
Mar 31/2005

26-12-11

Page 2
Sheet 2
Mar 31/2005

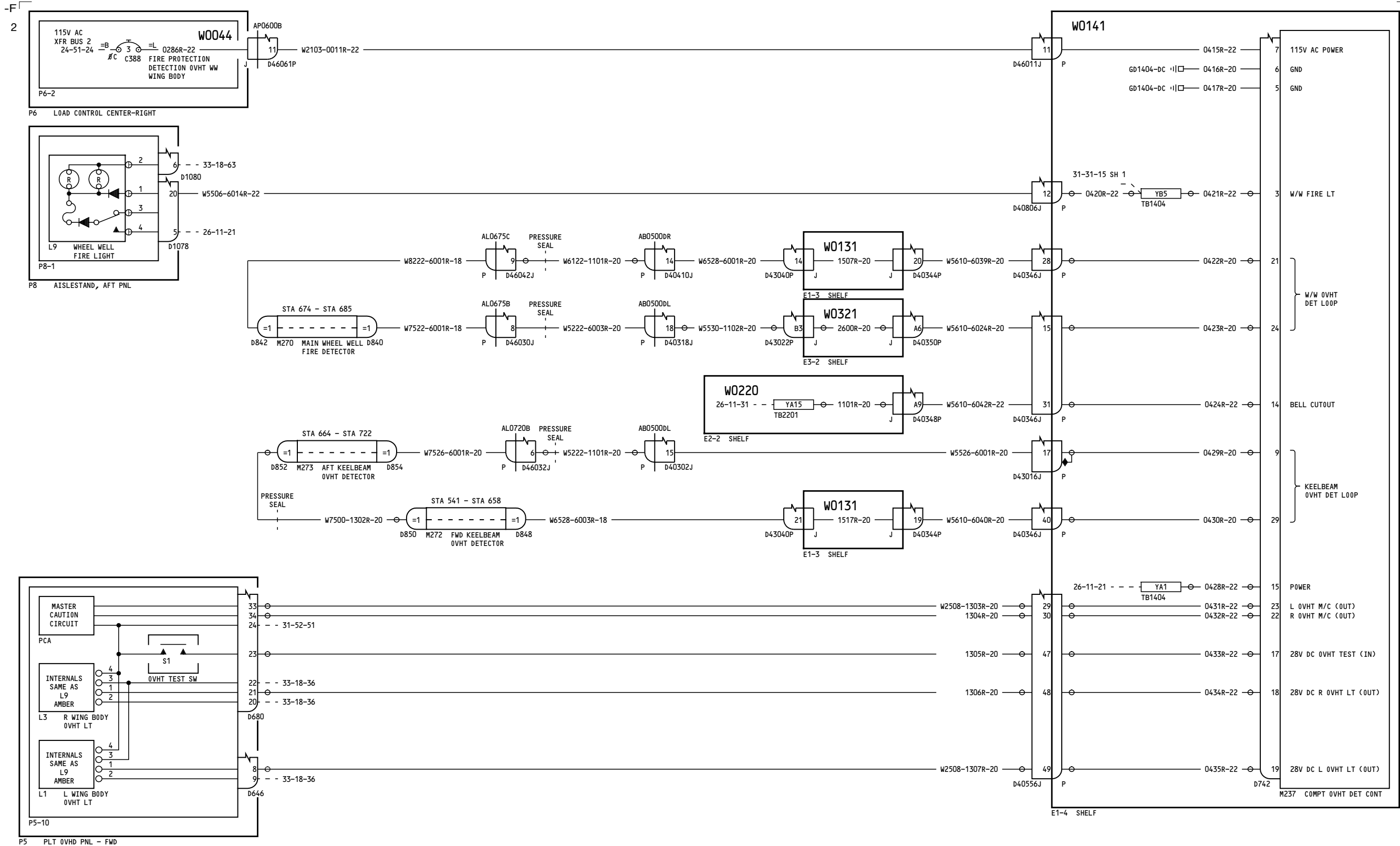

YC004-YC007

WHEEL WELL, WING AND LOWER AFT BODY OVERHEAT DETECTION

D280A103

26-12-11

Page 2.1
Sheet 1
Oct 15/2007

26-12-11

Page 2.1
Sheet 1
Oct 15/2007

12

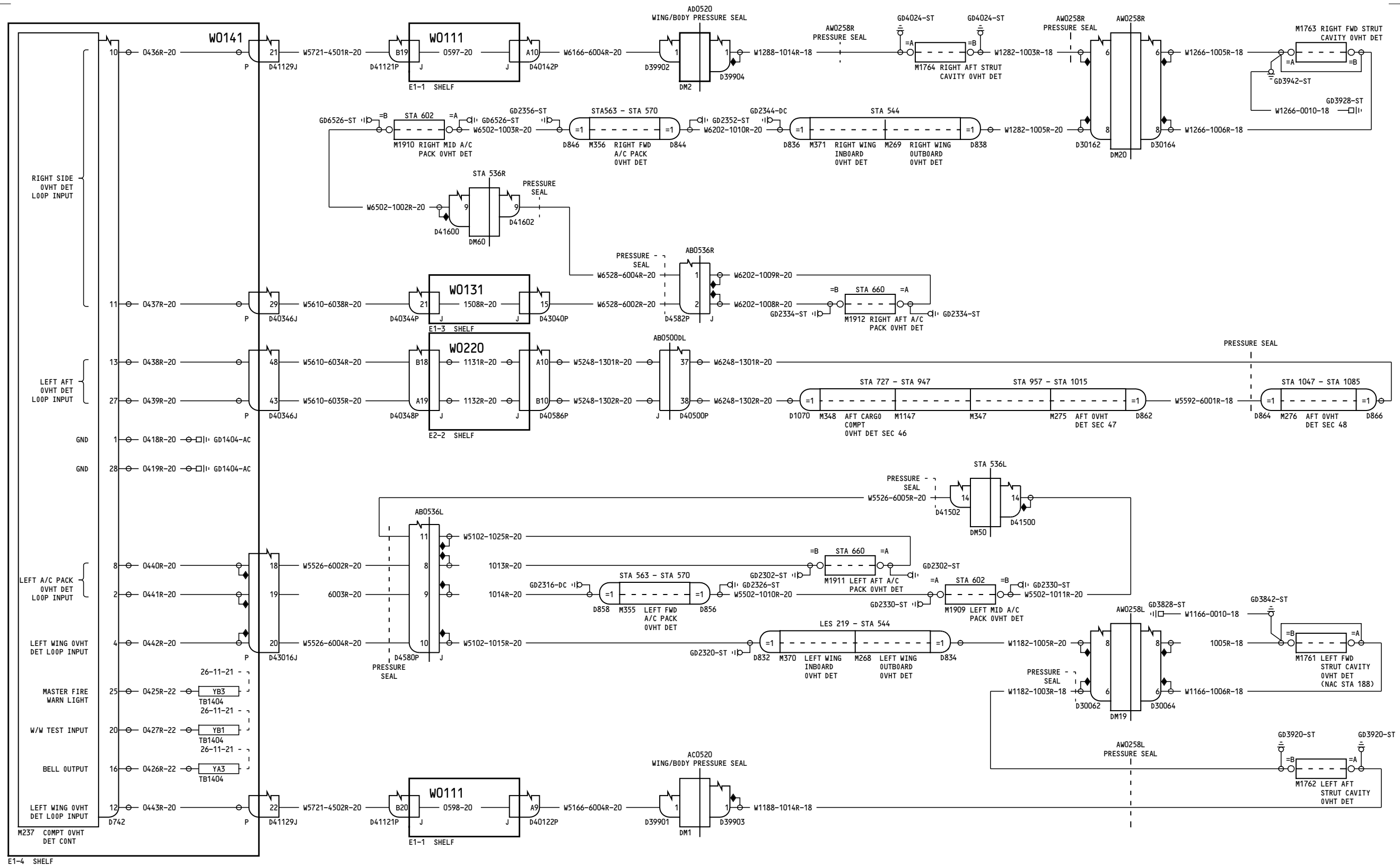

YC004-YC007

WHEEL WELL, WING AND LOWER AFT BODY OVERHEAT DETECTION

D280A103

26-12-11

Page 2.1
Sheet 2
Oct 15/2007

Incorporates
28-1194 R02

26-12-11

Page 2.1
Sheet 2
Oct 15/2007

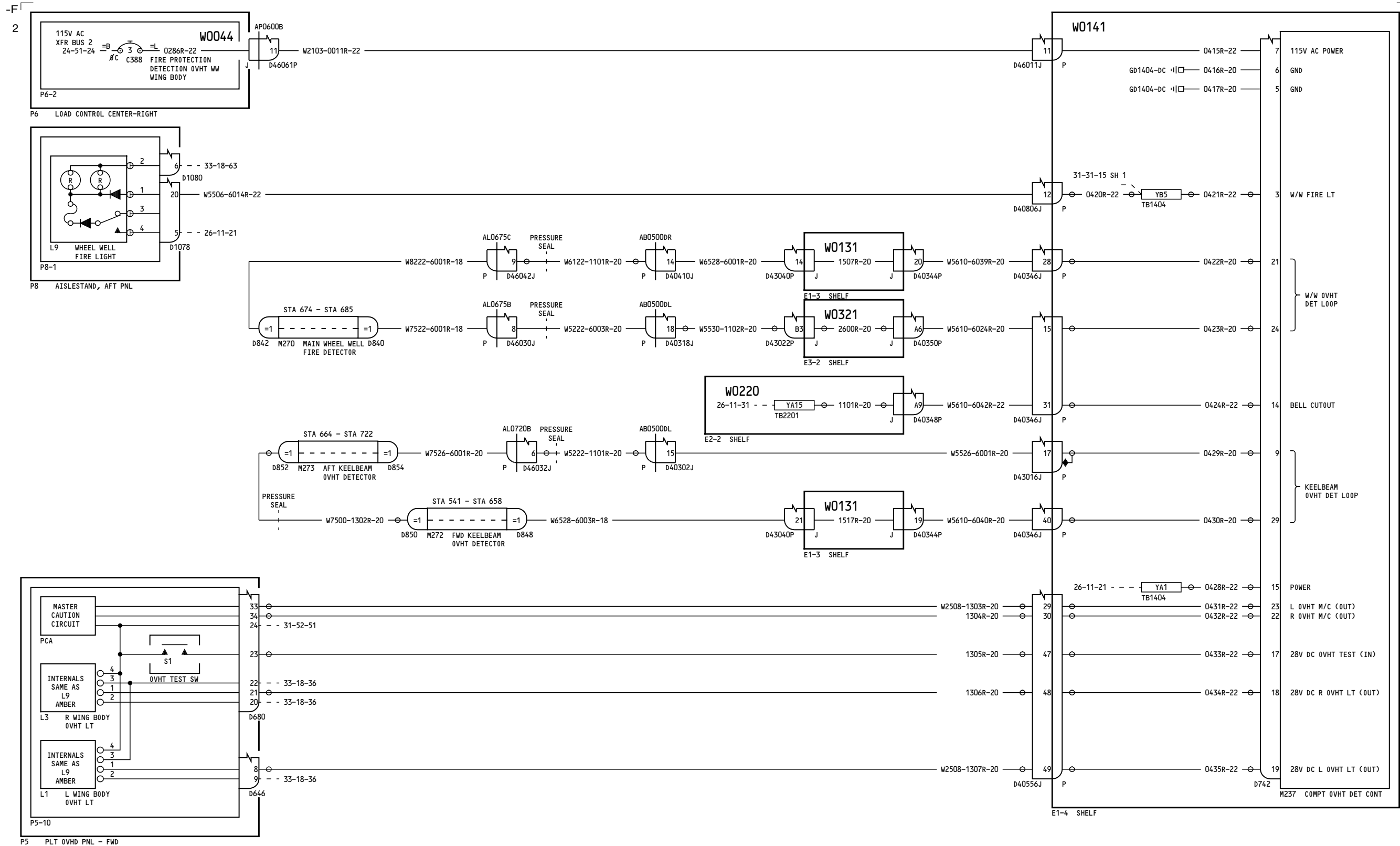

YC008-YC030

WHEEL WELL, WING AND LOWER AFT BODY OVERHEAT DETECTION

D280A103

26-12-11

Page 3
Sheet 1
Jul 17/2007

26-12-11

Page 3
Sheet 1
Jul 17/2007

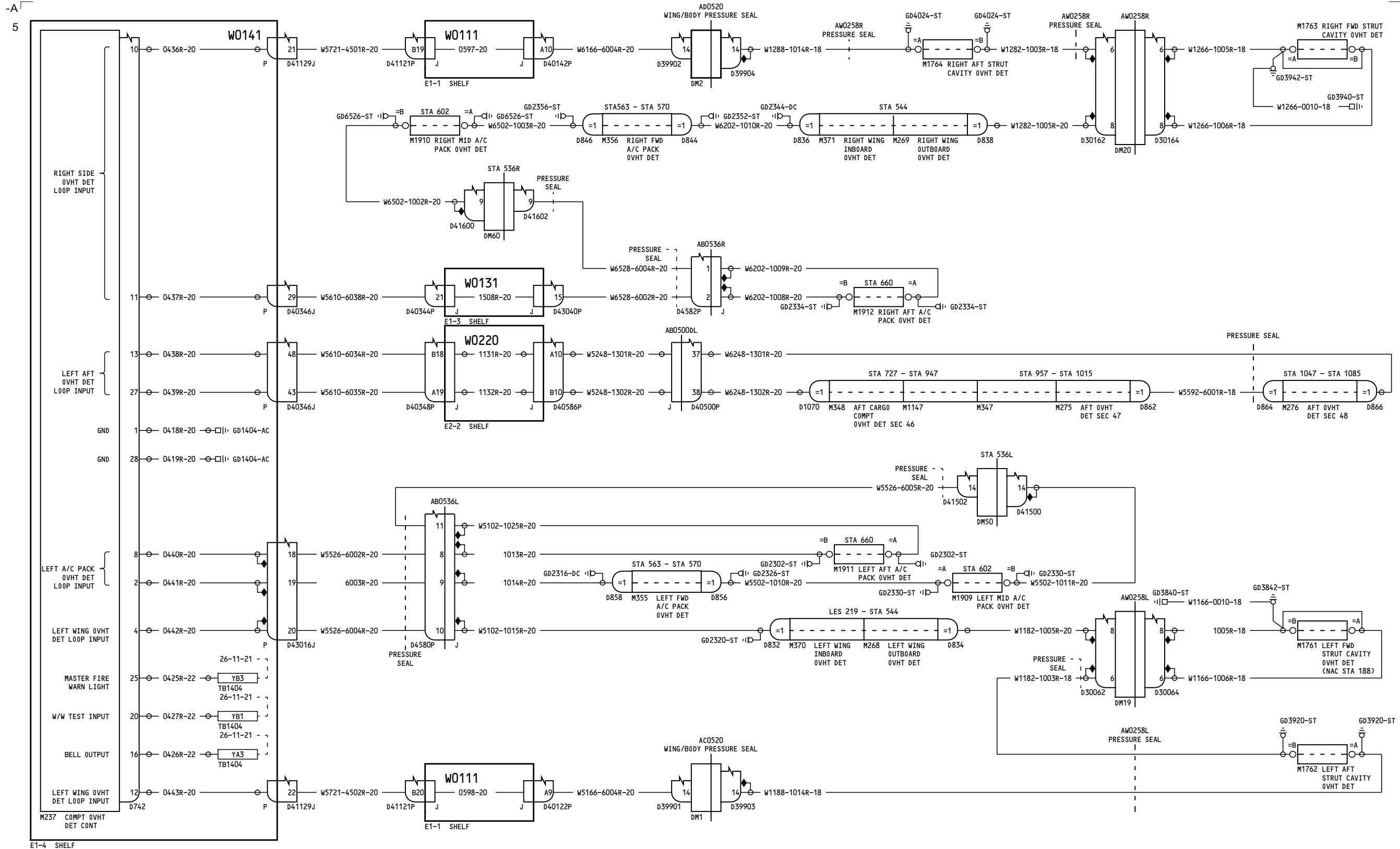

YC008-YC030

WHEEL WELL, WING AND LOWER AFT BODY OVERHEAT DETECTION

D280A103

26-12-11

Page 3
Sheet 2
Jul 17/2007

26-12-11

Page 3
Sheet 2
Jul 17/2007

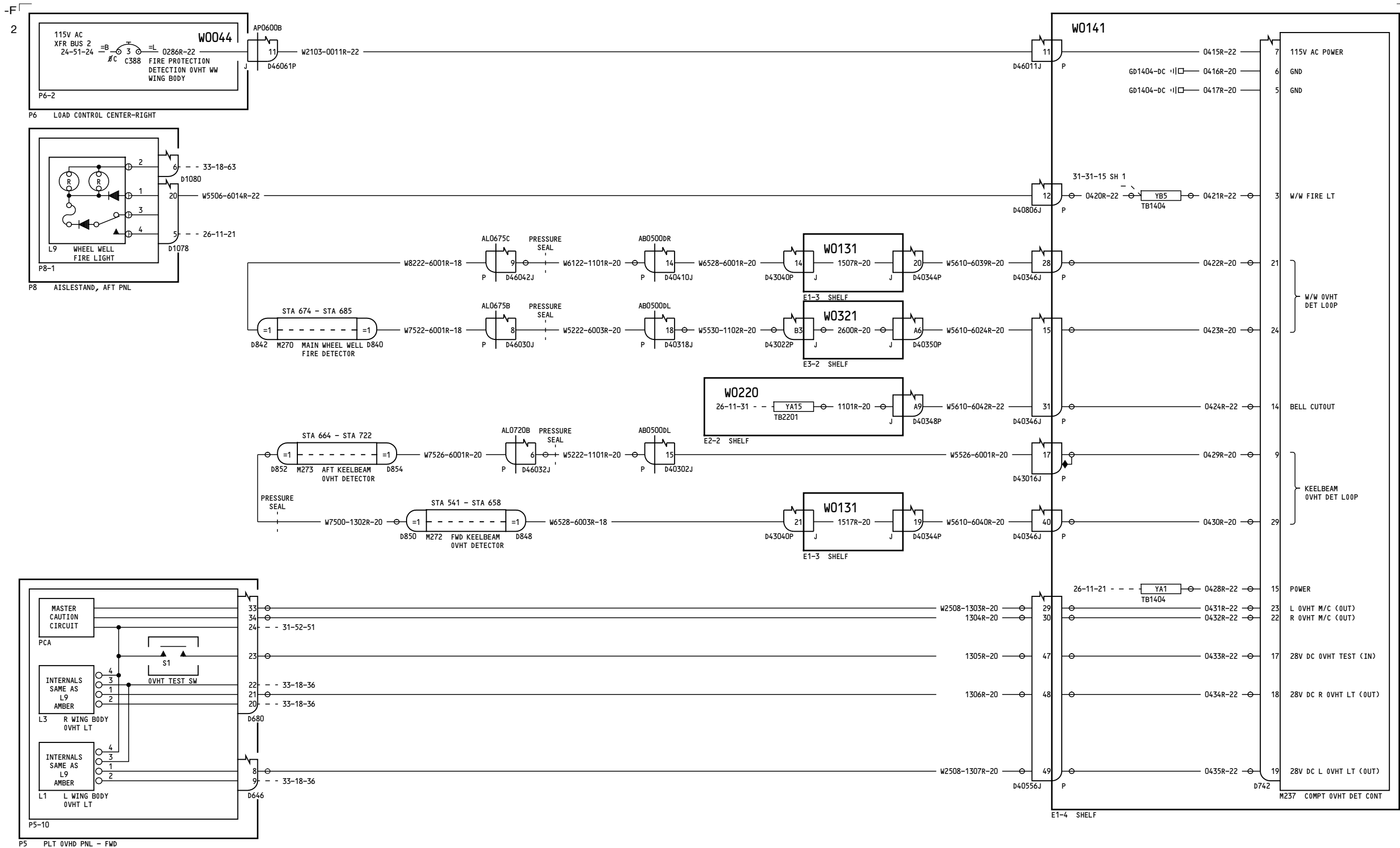

YC008-YC030

WHEEL WELL, WING AND LOWER AFT BODY OVERHEAT DETECTION

D280A103

26-12-11

Page 3.1
Sheet 1
Oct 15/2007

26-12-11

Page 3.1
Sheet 1
Oct 15/2007

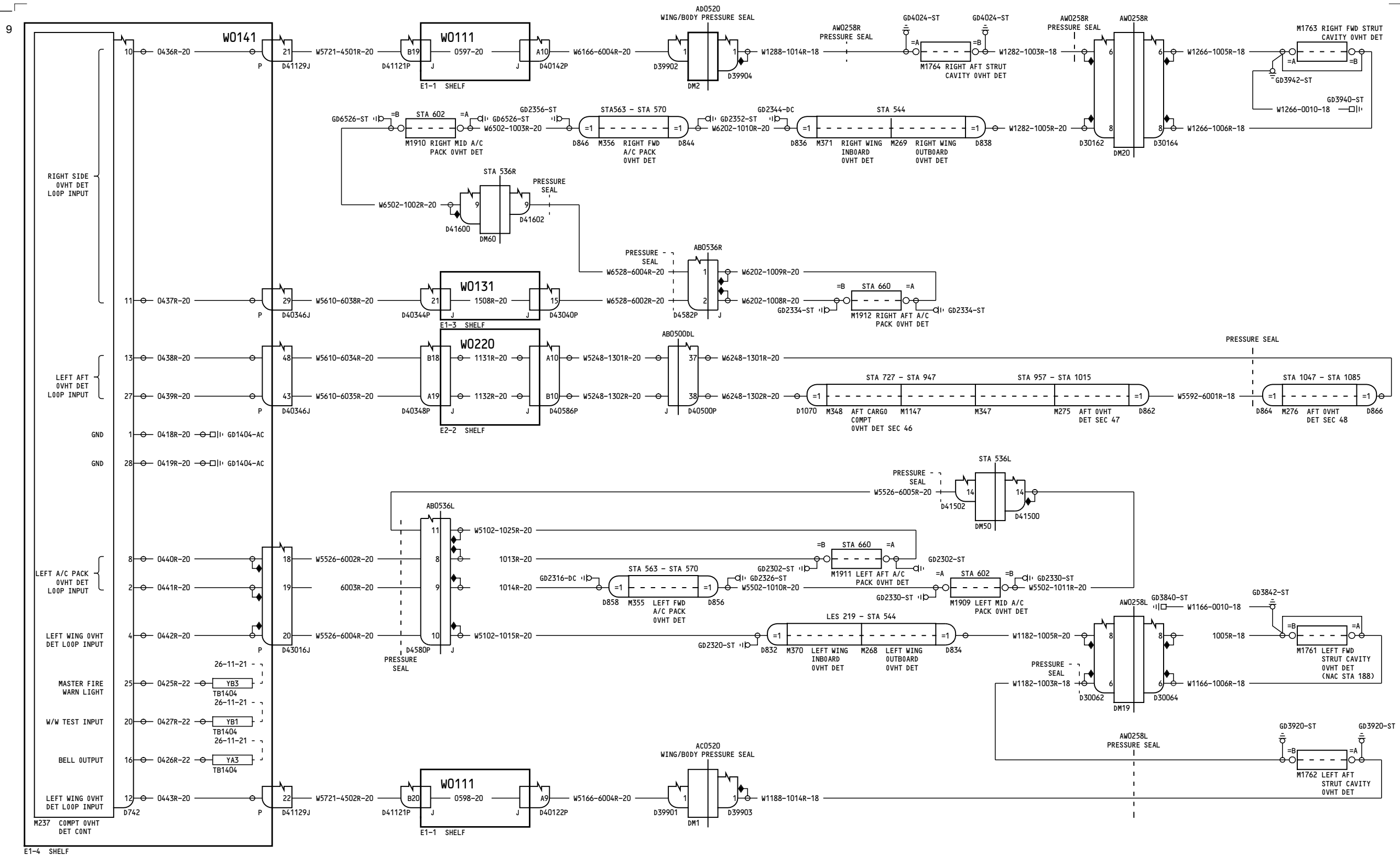

YC008-YC030

WHEEL WELL, WING AND LOWER AFT BODY OVERHEAT DETECTION

D280A103

26-12-11

Page 3.1
Sheet 2
Oct 15/2007

Incorporates
28-1194 R02

26-12-11

Page 3.1
Sheet 2
Oct 15/2007

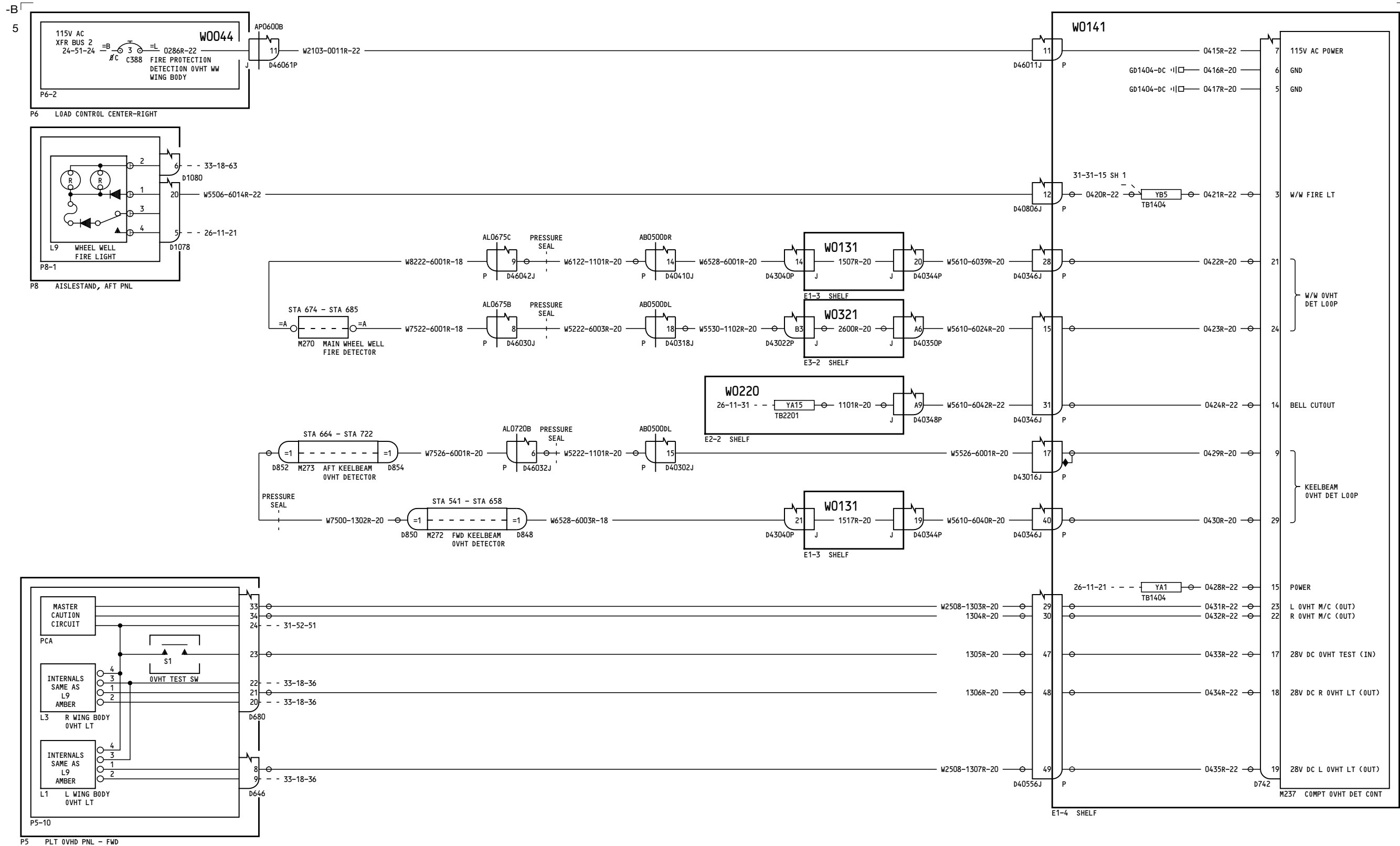

YC031-YK906

WHEEL WELL, WING AND LOWER AFT BODY OVERHEAT DETECTION

D280A103

26-12-11

Page 4
Sheet 1
Apr 18/2007

26-12-11

Page 4
Sheet 1
Apr 18/2007

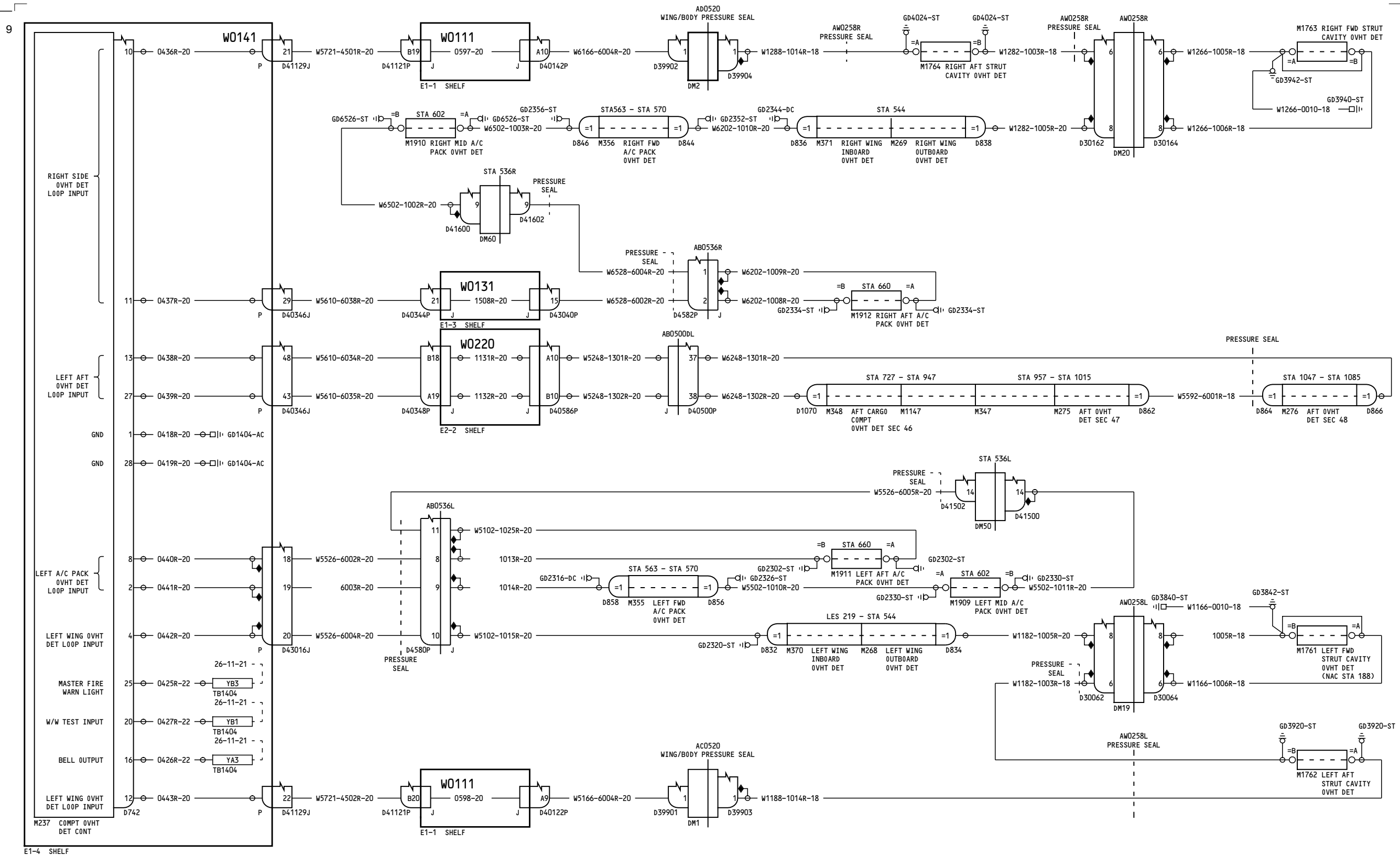

YC031-YK906

WHEEL WELL, WING AND LOWER AFT BODY OVERHEAT DETECTION

D280A103

26-12-11

Page 4
Sheet 2
Apr 18/2007

26-12-11

Page 4
Sheet 2
Apr 18/2007

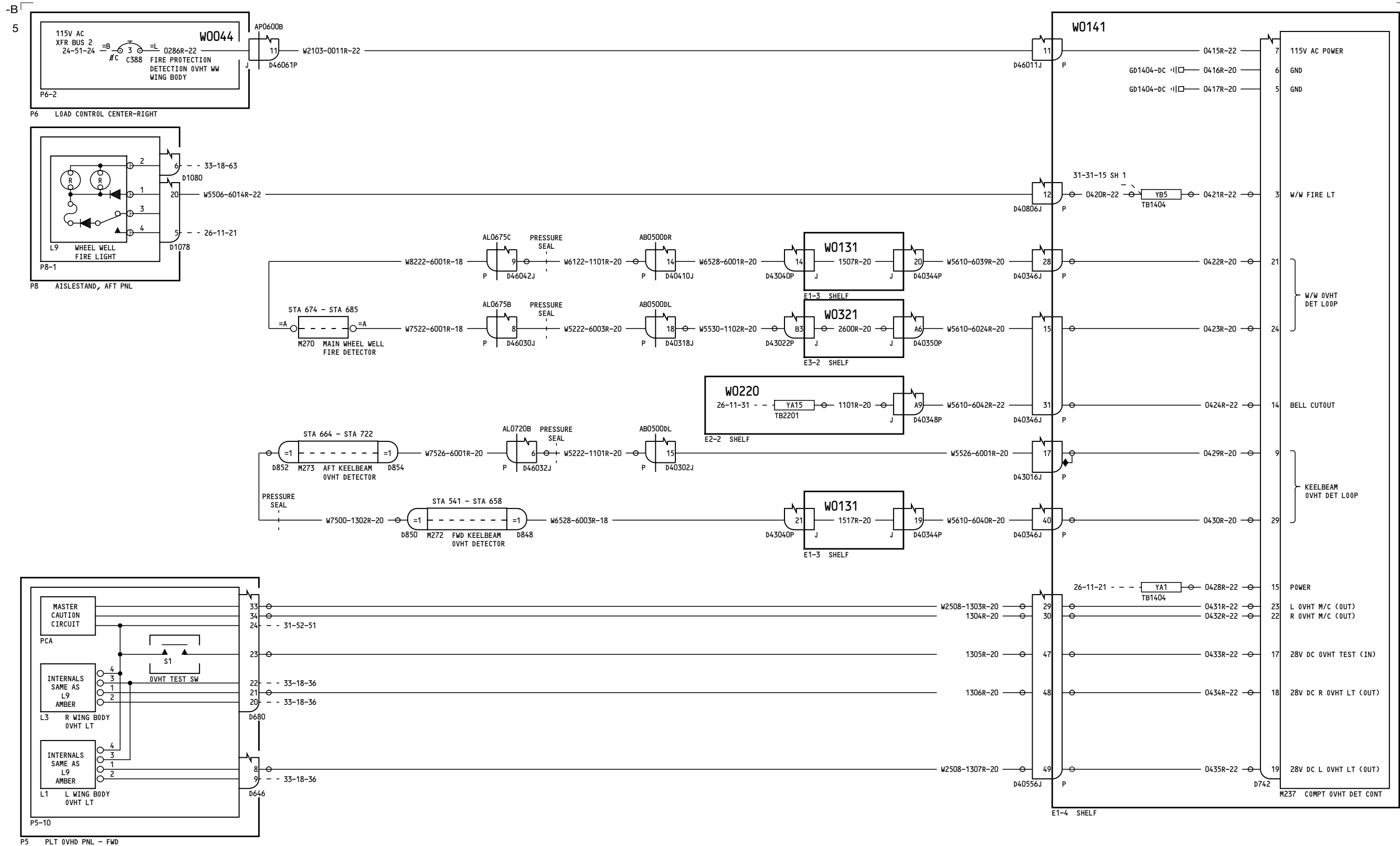

YK907, YL421

WHEEL WELL, WING AND LOWER AFT BODY OVERHEAT DETECTION

D280A103

26-12-11

Page 5
Sheet 1
Apr 18/2007

26-12-11

Page 5
Sheet 1
Apr 18/2007

24

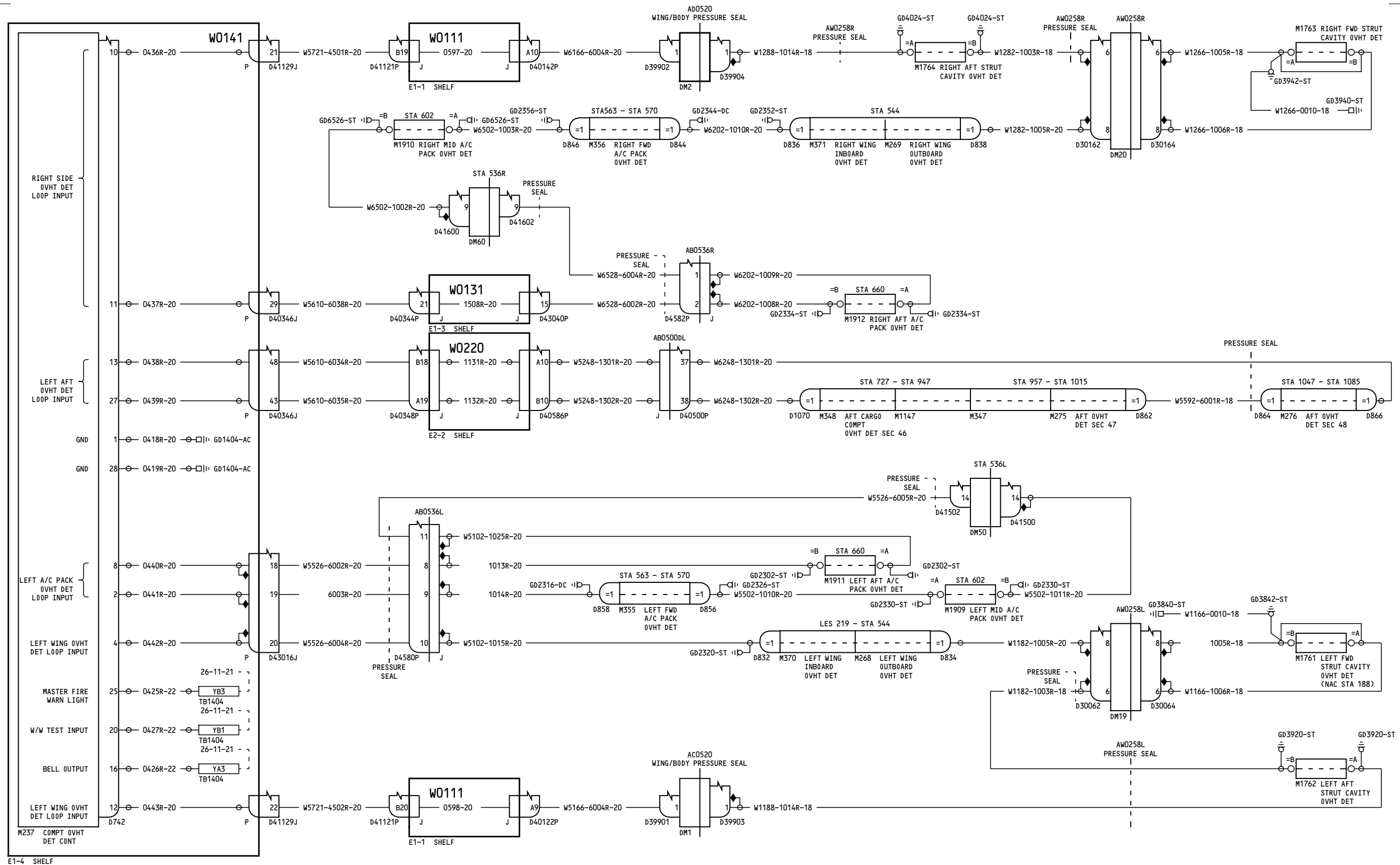

YK907, YL421

WHEEL WELL, WING AND LOWER AFT BODY OVERHEAT DETECTION

D280A103

26-12-11

Page 5
Sheet 2
Apr 18/2007

26-12-11

Page 5
Sheet 2
Apr 18/2007

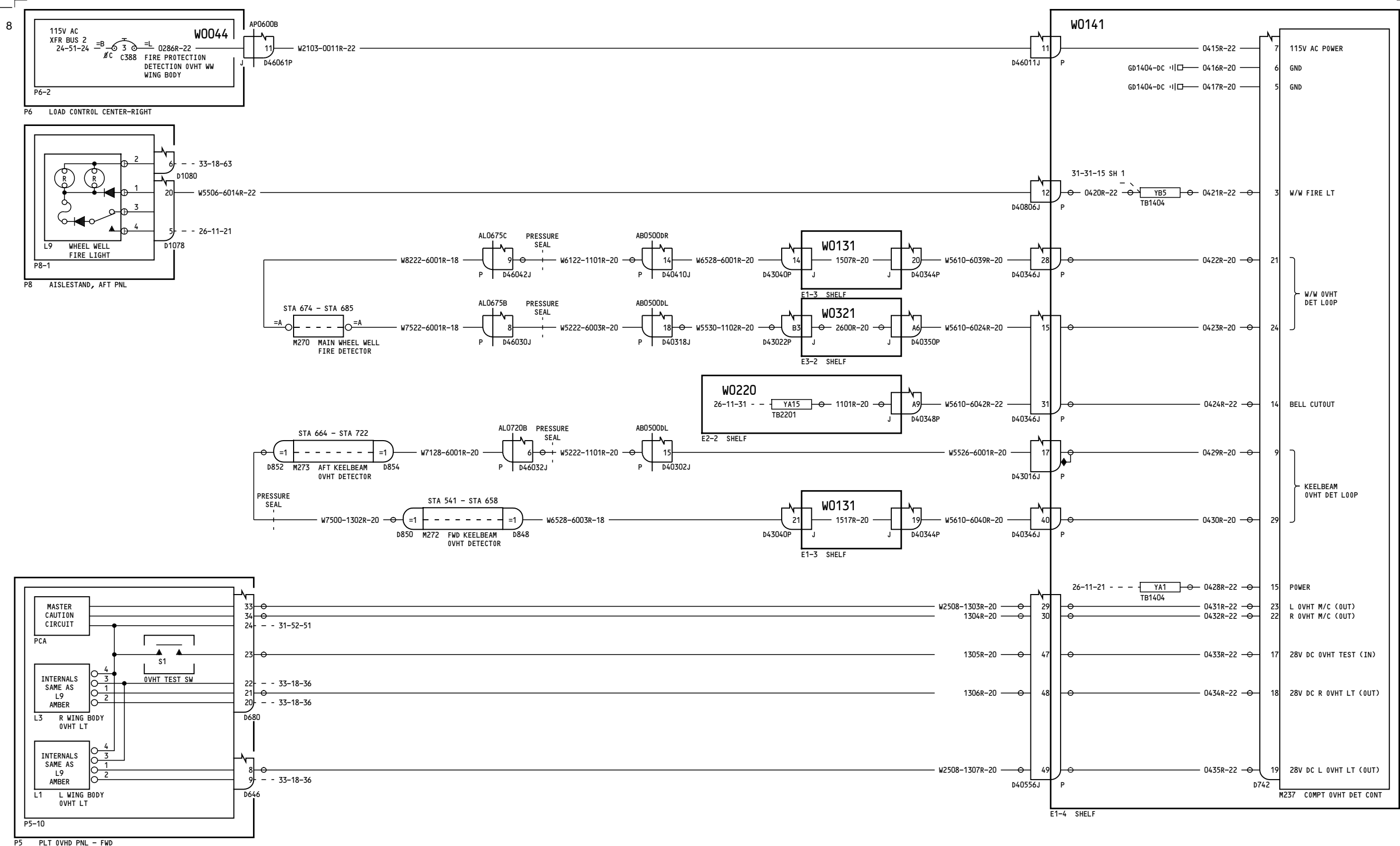

YK908-YL401, YL422-YL430

WHEEL WELL, WING AND LOWER AFT BODY OVERHEAT DETECTION

D280A103

26-12-11

Page 6
Sheet 1
Feb 09/2009

26-12-11

Page 6
Sheet 1
Feb 09/2009

24

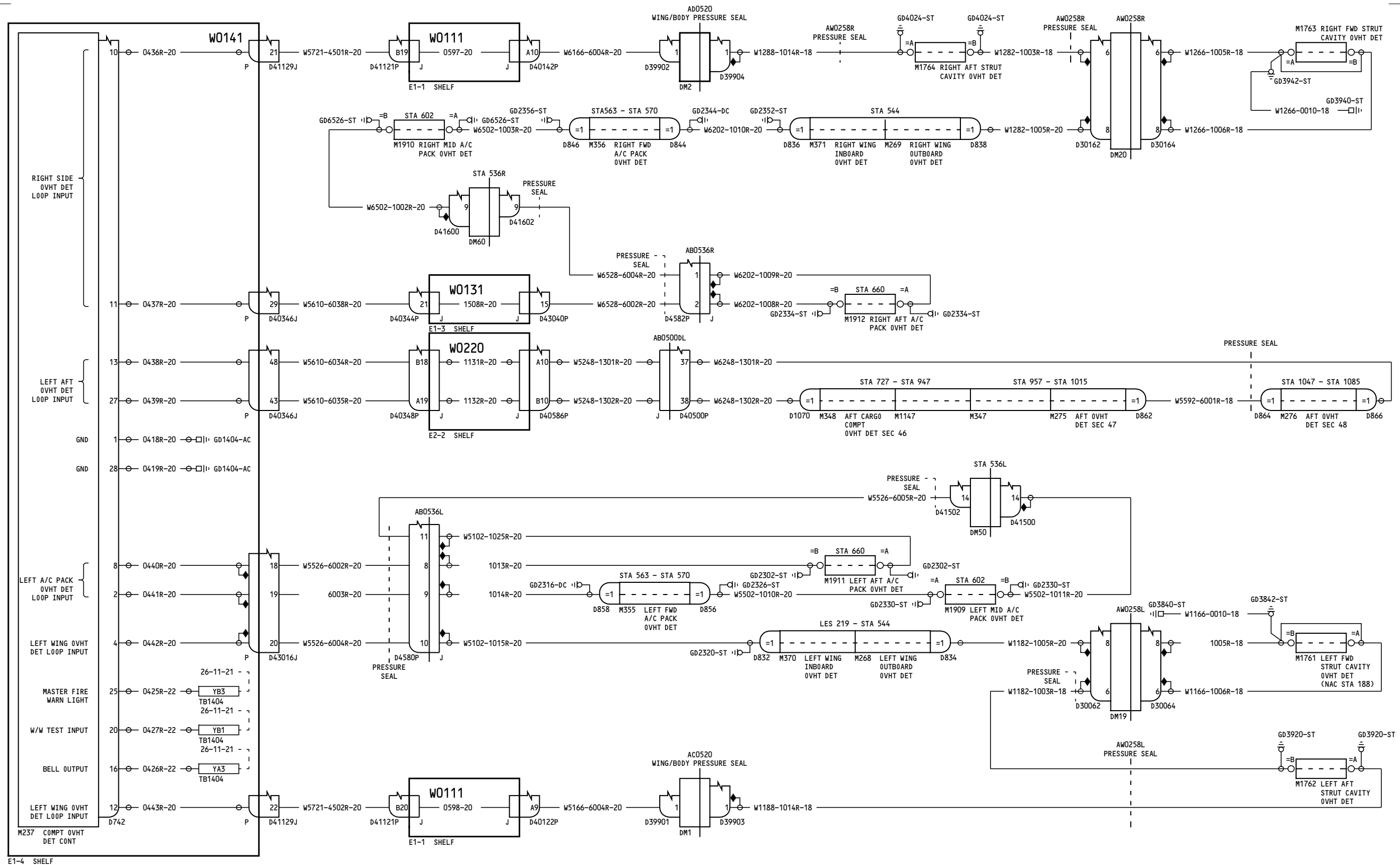

YK908-YL401, YL422-YL430

WHEEL WELL, WING AND LOWER AFT BODY OVERHEAT DETECTION

D280A103

26-12-11

Page 6
Sheet 2
Feb 09/2009

26-12-11

Page 6
Sheet 2
Feb 09/2009

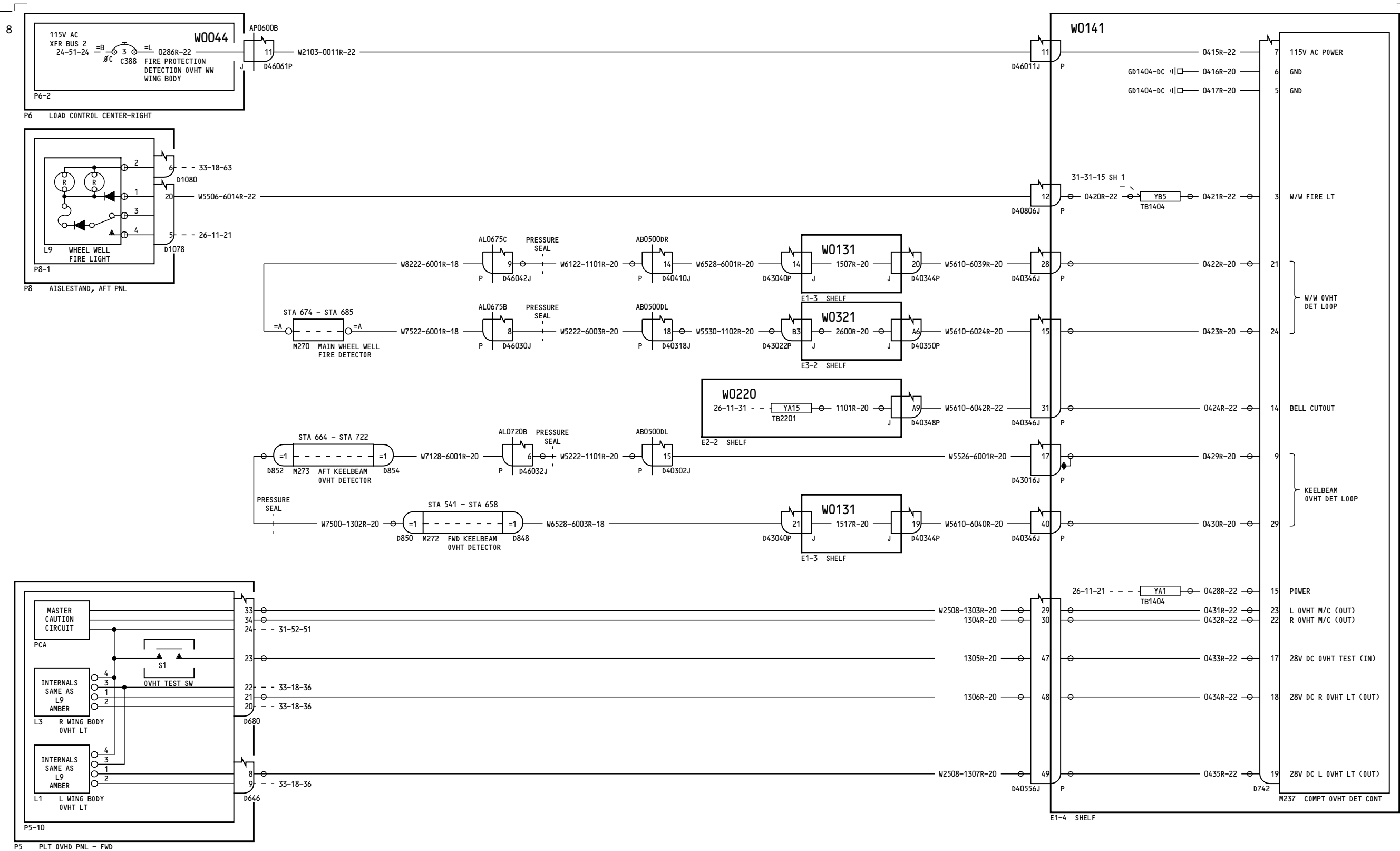

YM643-YM670

WHEEL WELL, WING AND LOWER AFT BODY OVERHEAT DETECTION

D280A103

26-12-11

Page 7
Sheet 1
Jan 14/2008

26-12-11

Page 7
Sheet 1
Jan 14/2008

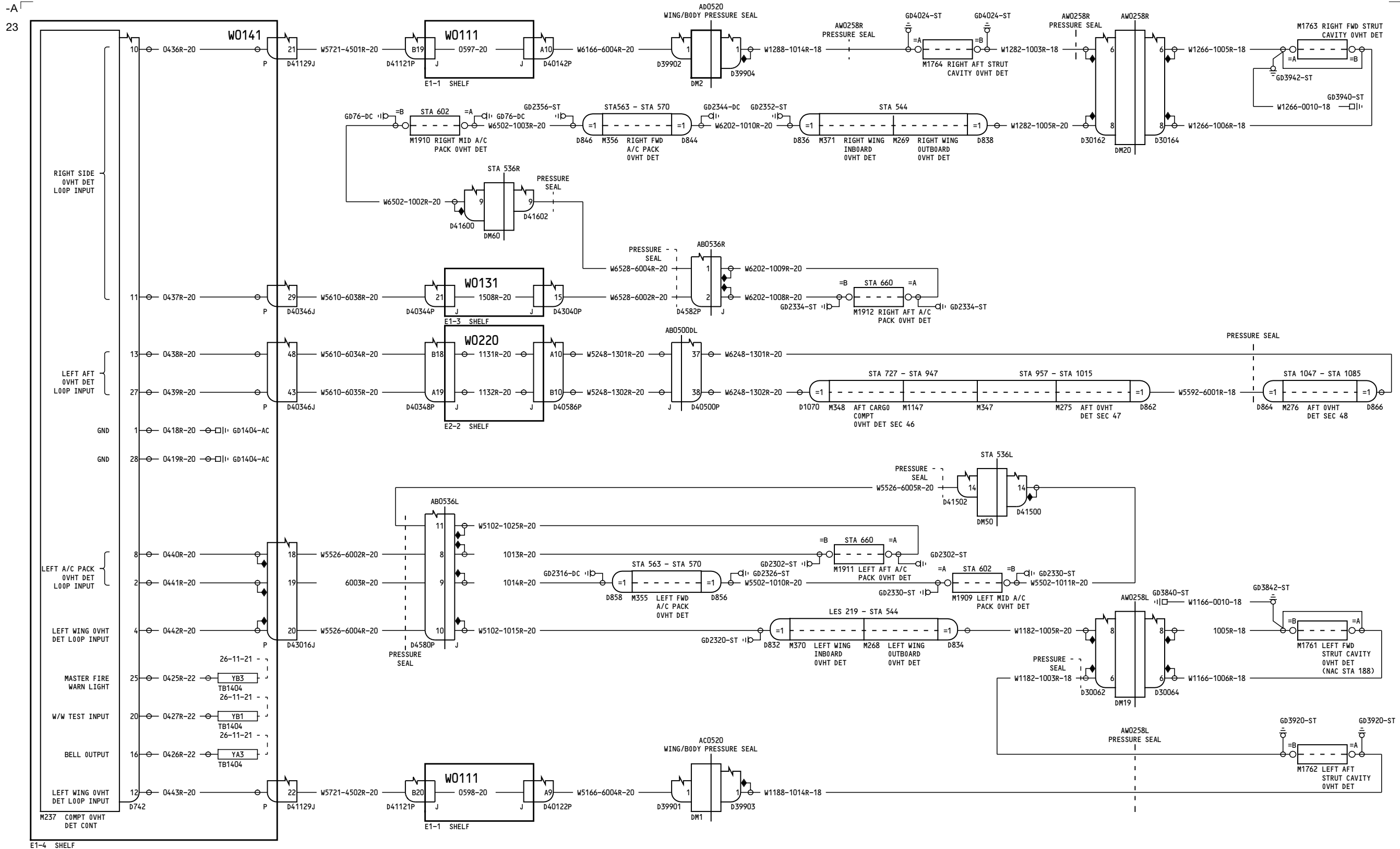

YM643-YM670

WHEEL WELL, WING AND LOWER AFT BODY OVERHEAT DETECTION

D280A103

26-12-11

Page 7
Sheet 2
Jan 14/2008

26-12-11

Page 7
Sheet 2
Jan 14/2008

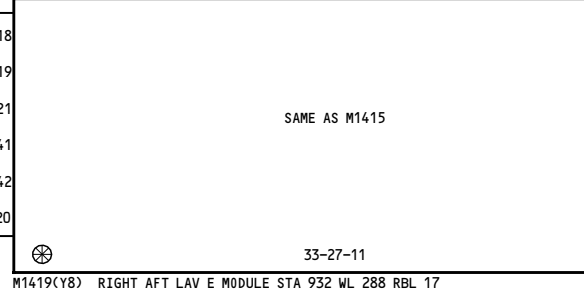
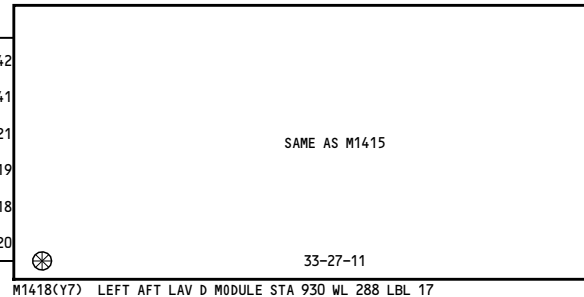
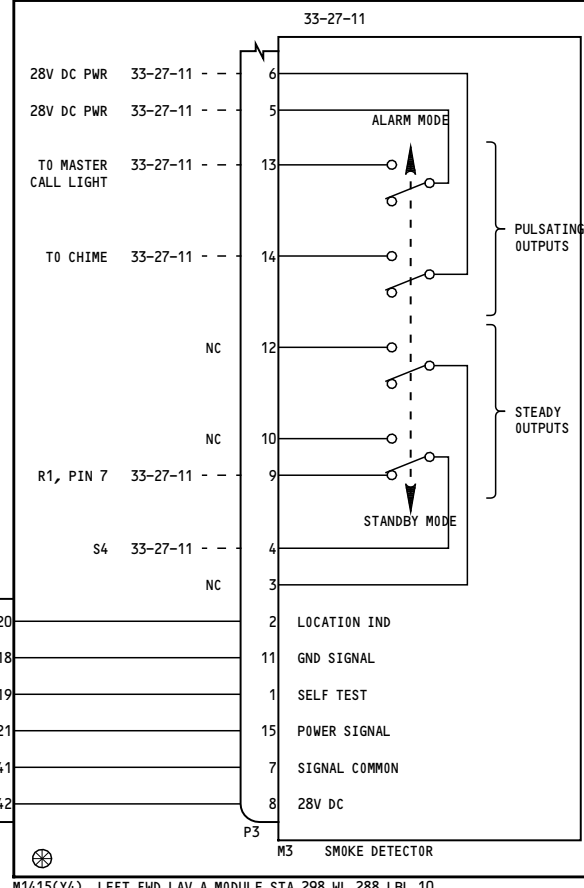
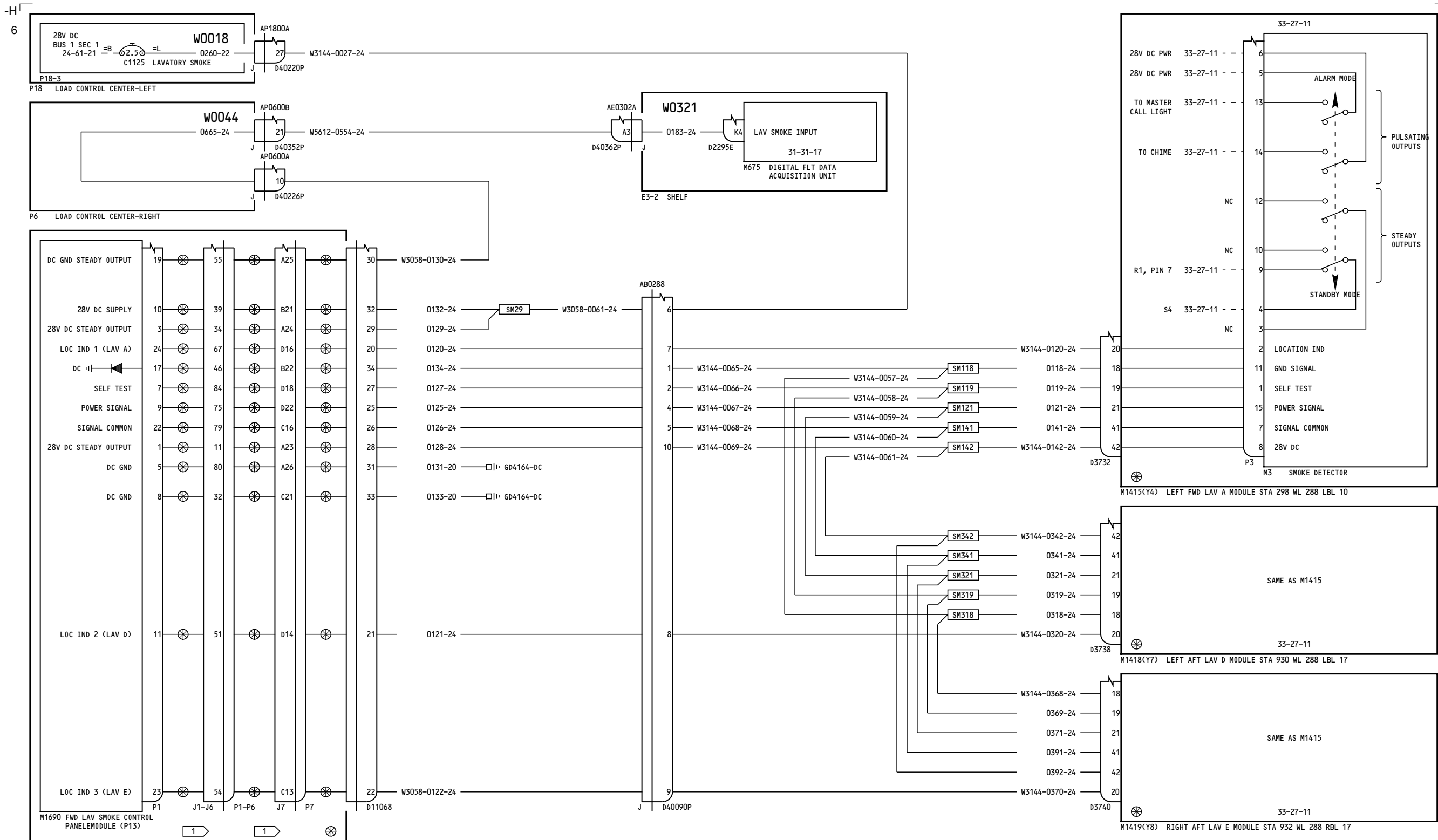

NOTE:
THE INTERNAL WIRING OF THE LAVATORY MODULE IS FOR REFERENCE ONLY.
PLEASE REFER TO LAVATORY COMPONENT MAINTENANCE MANUAL (CMM) FOR COMPLETE FUNCTIONALITY.
BOEING SHOWS ACCURATE WIRING UP TO DISCONNECT BRACKET ONLY.

1 SEE DWG. NO 417A1010 AND DWG. 285A1780 FOR MORE INFO.

ALL	LAVATORY SMOKE DETECTORS
	26-14-11
	Page 1
	Feb 09/2009
	D280A103

26-14-11

Page 1

Feb 09/2009

21

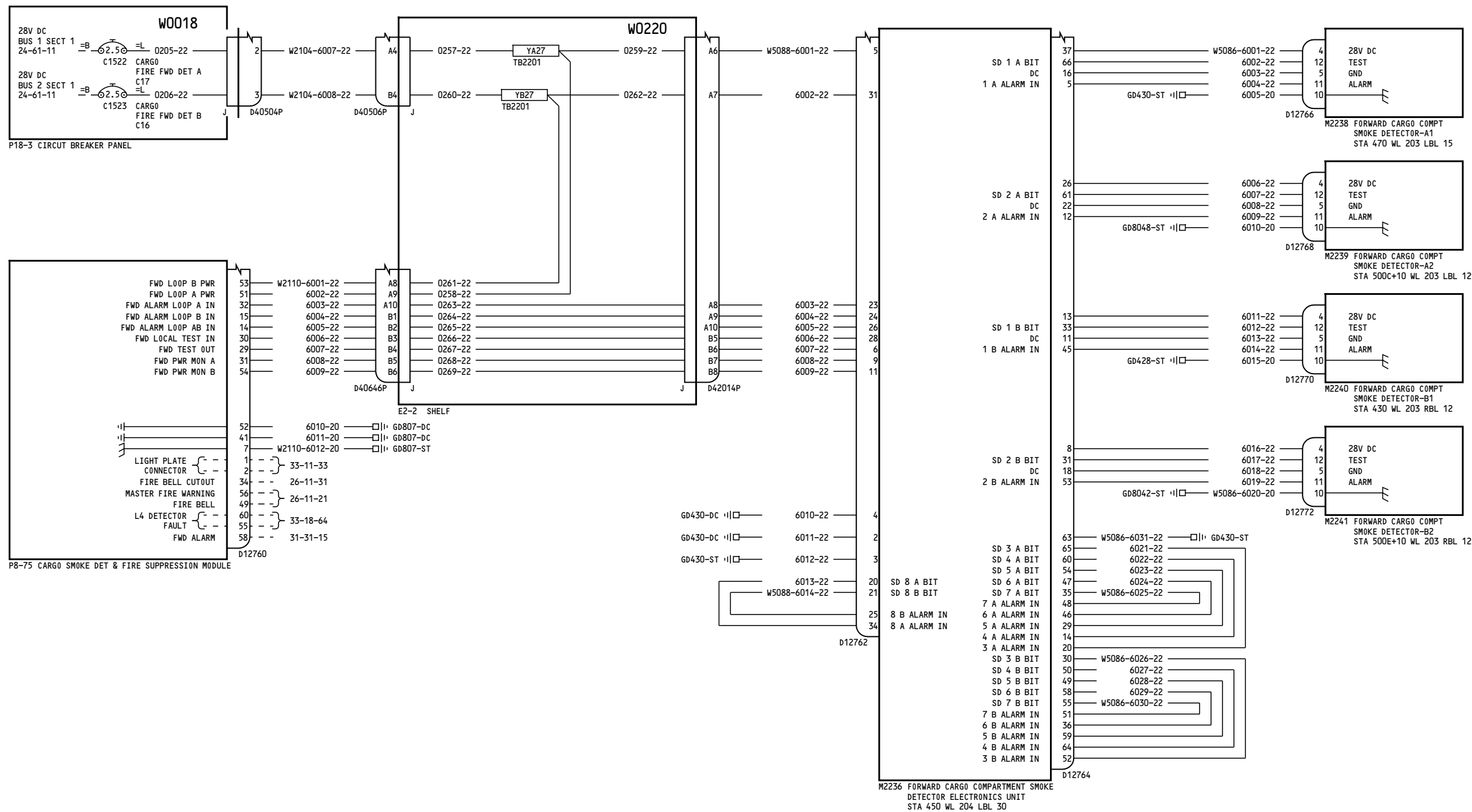

YC001-YC007

FORWARD CARGO COMPARTMENT SMOKE DETECTION

D280A103

26-16-21

Page 1.1

Aug 13/2008

Incorporates 26A1083 R01

26-16-21

Page 1.1

Aug 13/2008

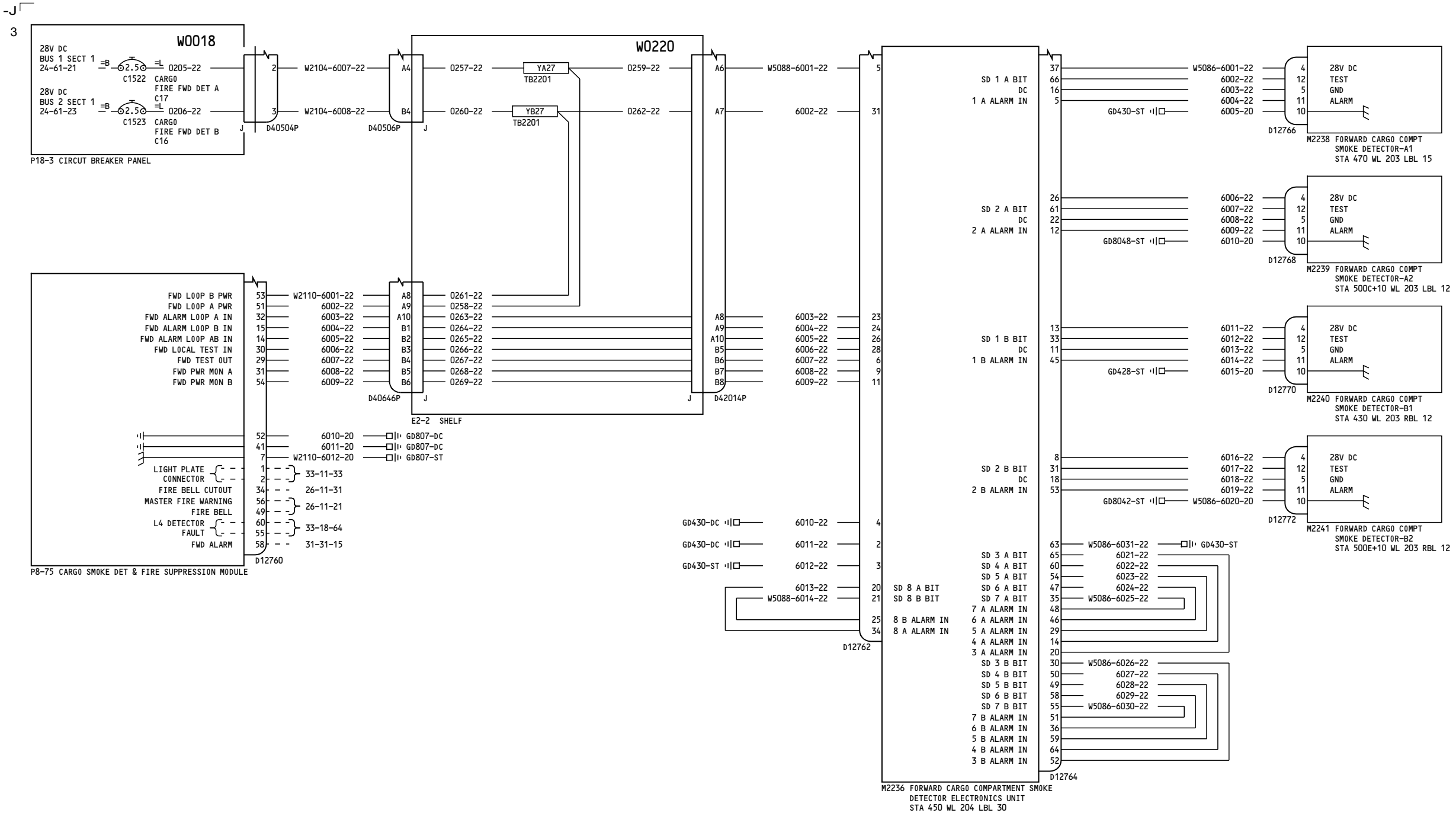

YC008-YC026

FORWARD CARGO COMPARTMENT SMOKE DETECTION

26-16-21

Page 2

D280A103

Aug 13/2008

26-16-21

Page 2

Aug 13/2008

-A
11

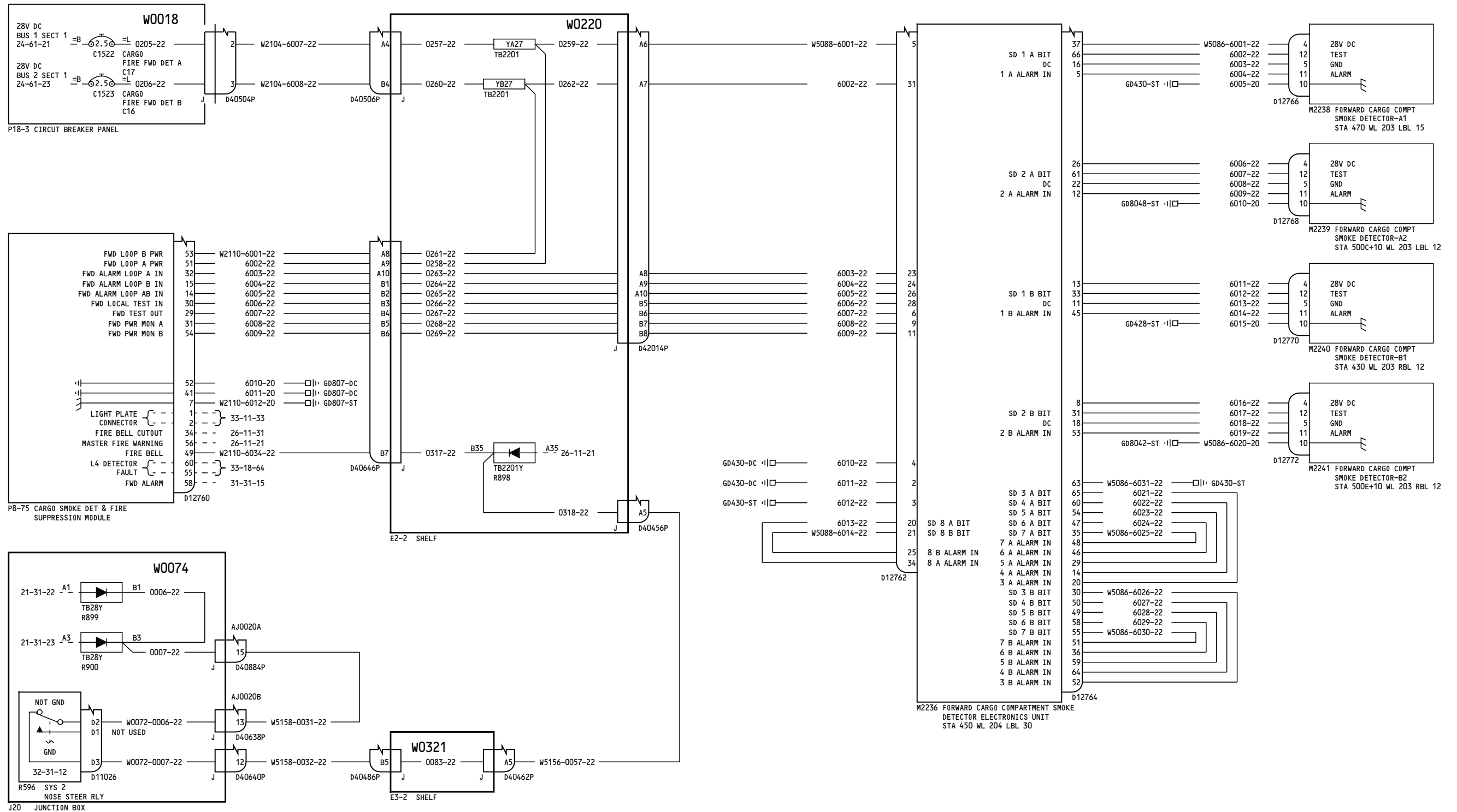

YC028-YC030

FORWARD CARGO COMPARTMENT SMOKE DETECTION

26-16-21

Page 3

D280A103

Aug 13/2008

26-16-21

Page 3

Aug 13/2008

-A

39

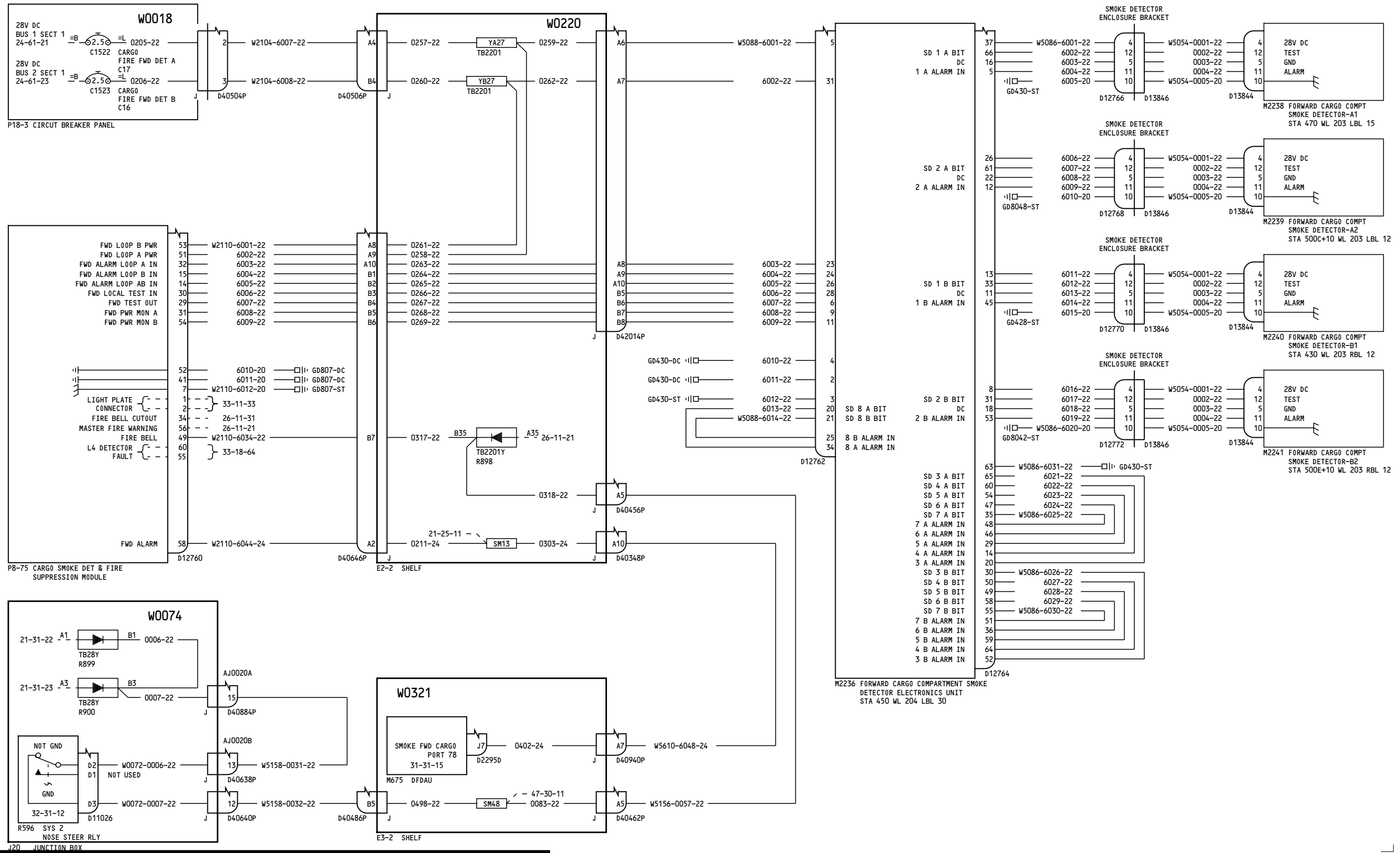

YC031-YC050, YK906-YL430

FORWARD CARGO COMPARTMENT SMOKE DETECTION

D280A103

26-16-21

Page 4

Feb 09/2009

26-16-21

Page 4

Feb 09/2009

-C
28

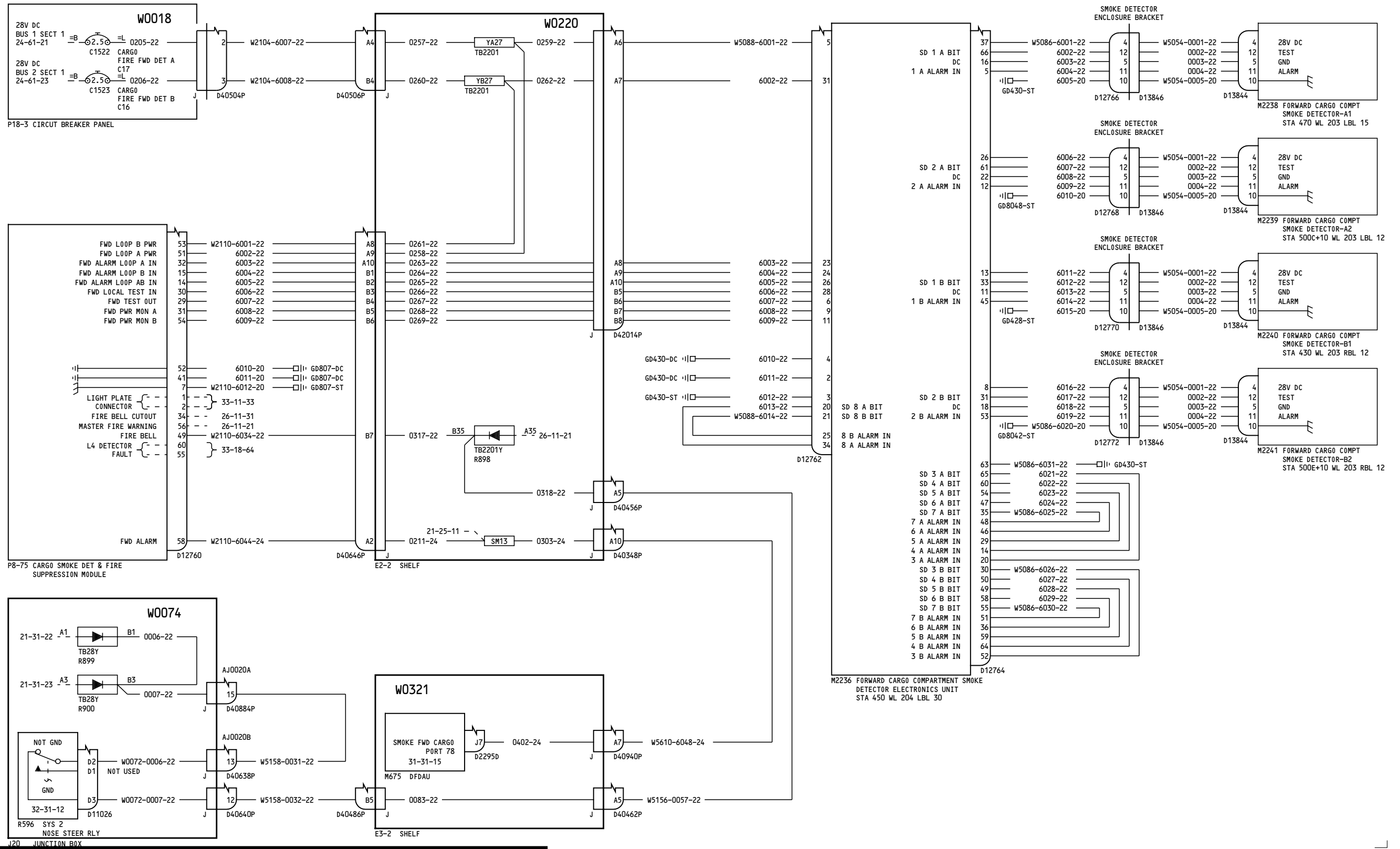

YK901-YK905

FORWARD CARGO COMPARTMENT SMOKE DETECTION

26-16-21

Page 5

D280A103

Aug 13/2008

26-16-21

Page 5

Aug 13/2008

-A
35

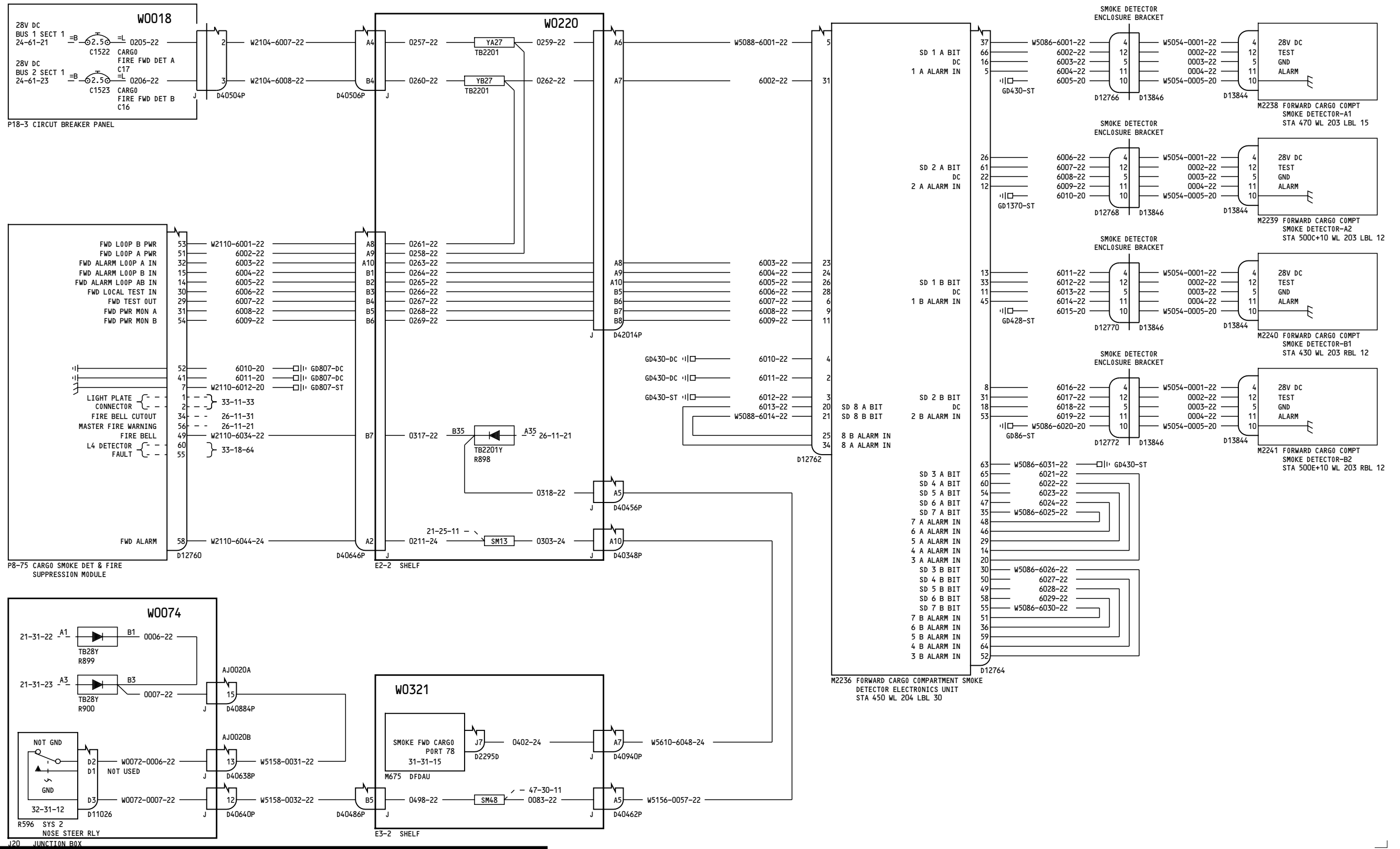

YM643-YM670

FORWARD CARGO COMPARTMENT SMOKE DETECTION

D280A103

26-16-21

Page 6

Aug 13/2008

26-16-21

Page 6

Aug 13/2008

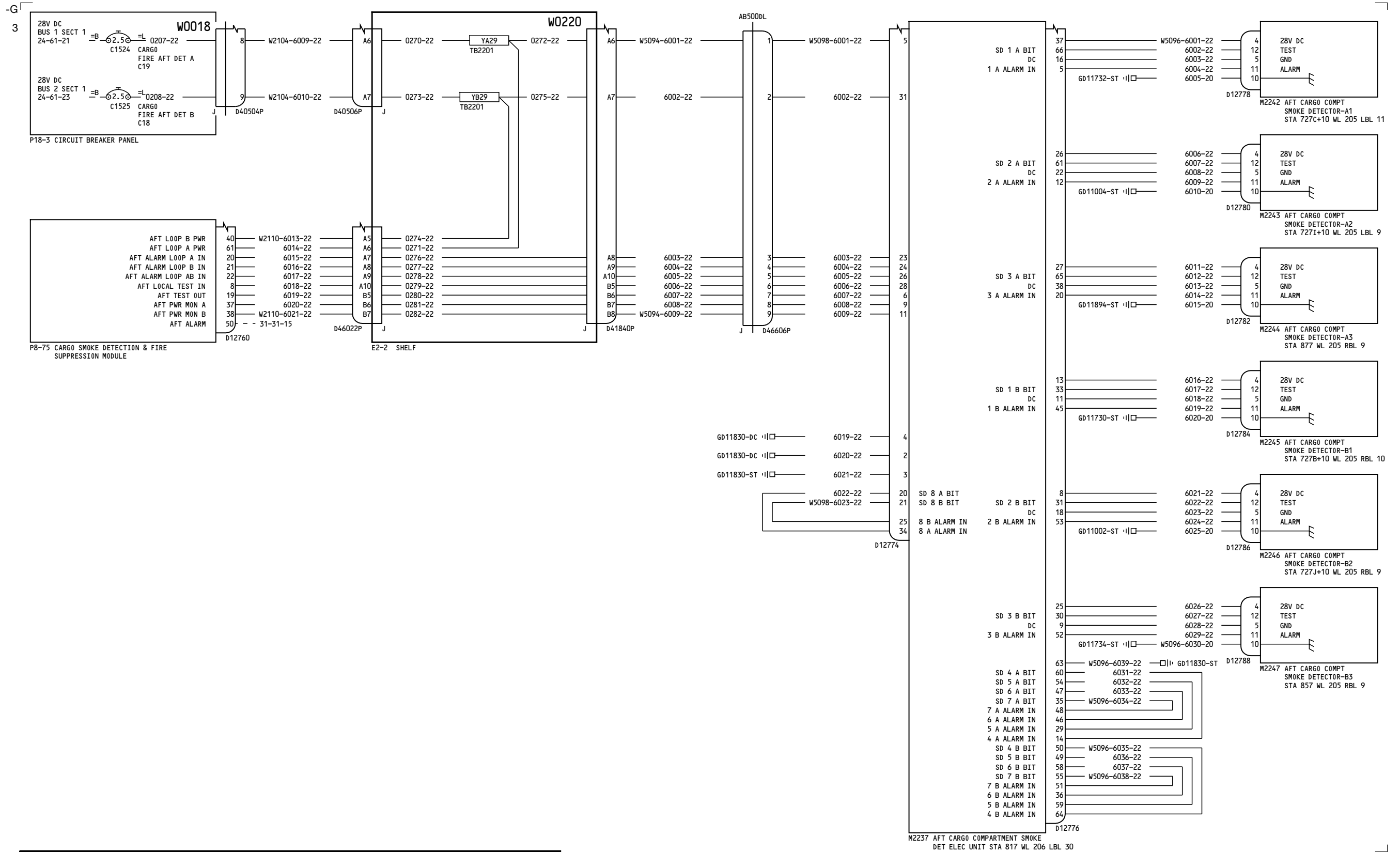

YC001-YC007	AFT CARGO COMPARTMENT SMOKE DETECTION D280A103
-------------	--

26-16-22

Page 1.1

Aug 13/2008

Incorporates
26A1083 R01

26-16-22

Page 1.1

Aug 13/2008

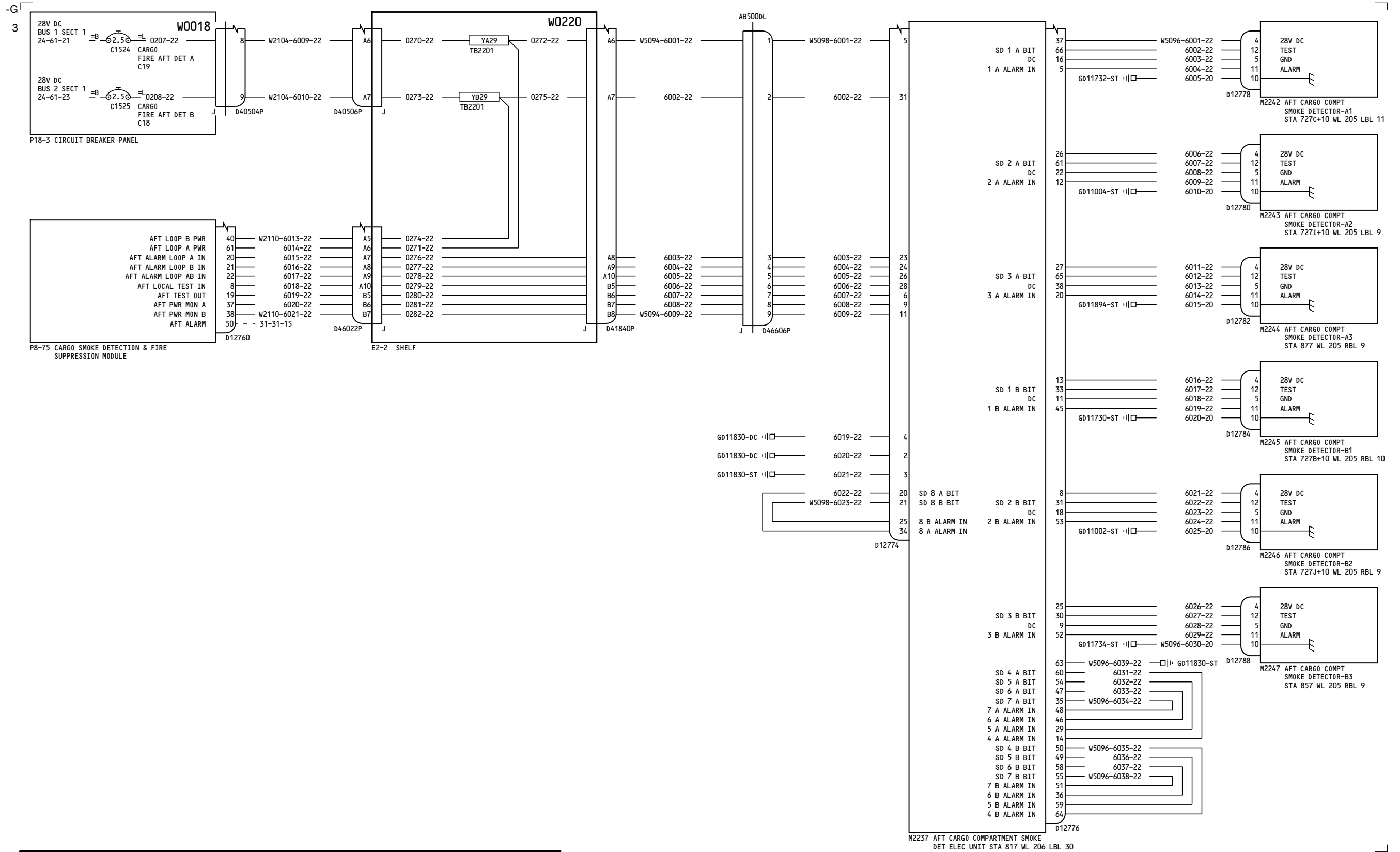

YC008-YC030

**AFT CARGO COMPARTMENT
SMOKE DETECTION**

26-16-22

Page 2

D280A103

Aug 13/2008

26-16-22

Page 2

Aug 13/2008

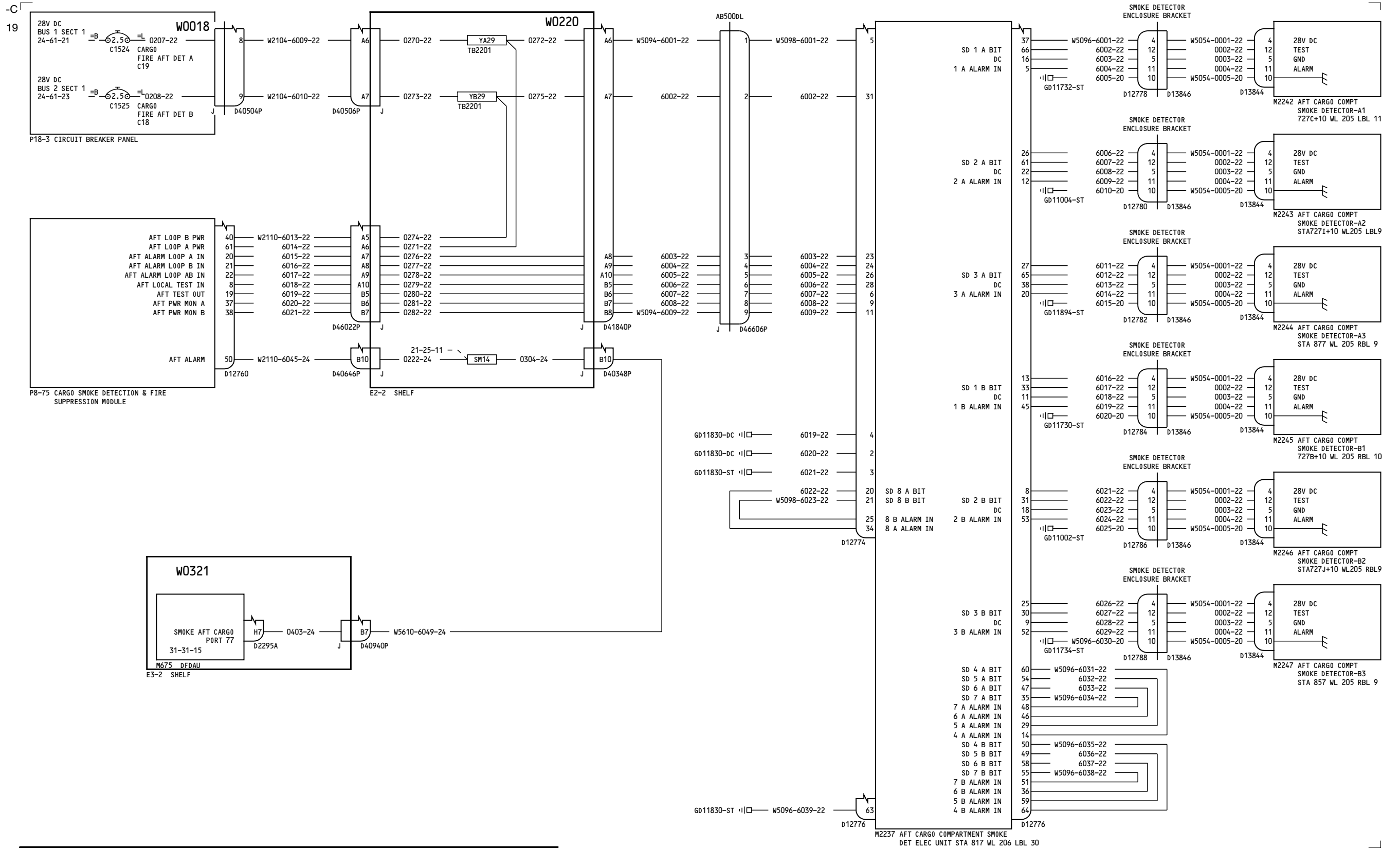

YC031-YL430

AFT CARGO COMPARTMENT SMOKE DETECTION

26-16-22

Page 3

D280A103

Feb 09/2009

26-16-22

Page 3

Feb 09/2009

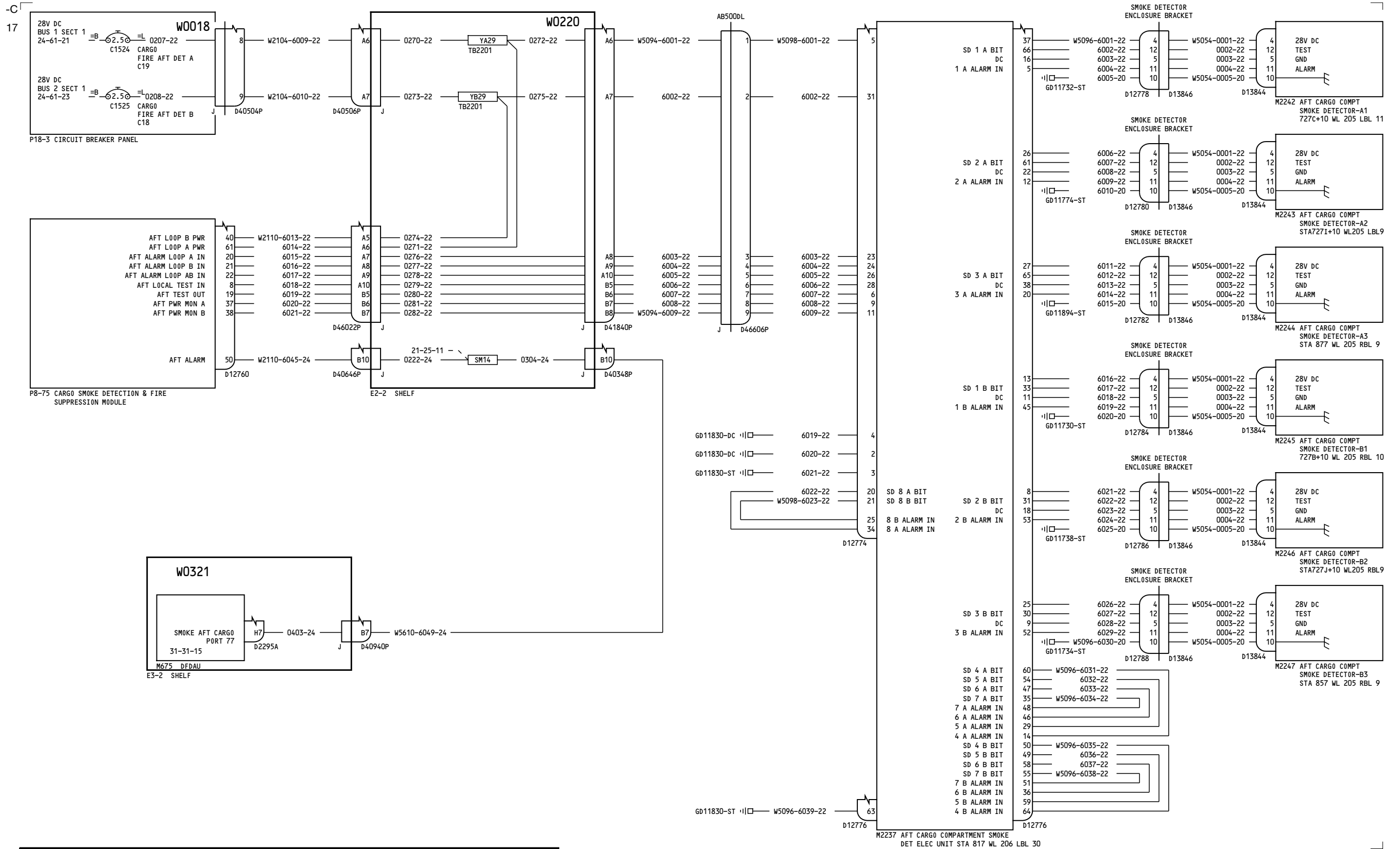

YM643-YM670

AFT CARGO COMPARTMENT SMOKE DETECTION

26-16-22

Page 4

D280A103

Aug 13/2008

26-16-22

Page 4

Aug 13/2008

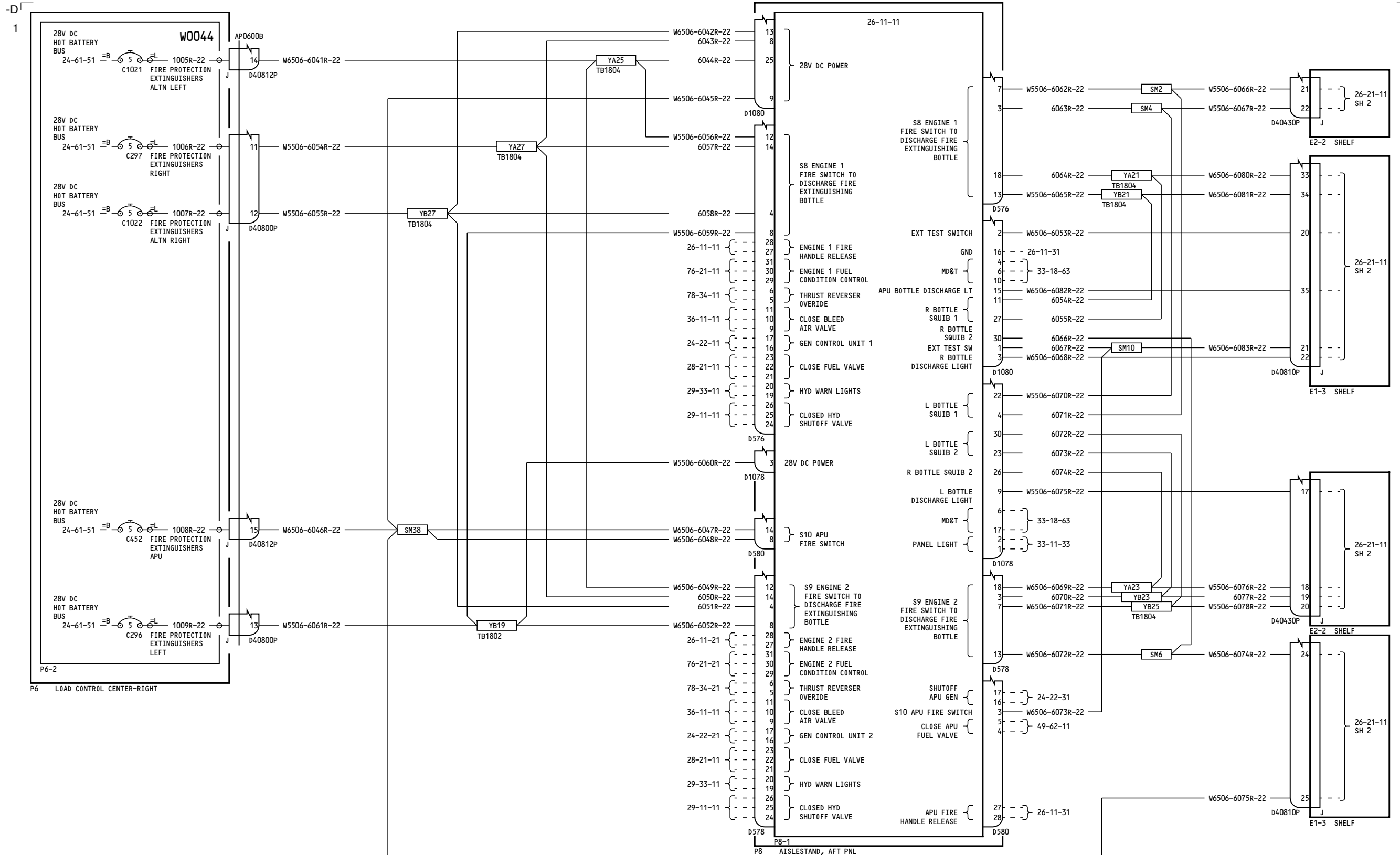

YC001-YC003

ENGINE AND APU FIRE EXTINGUISHING SYSTEM

26-21-11

Page 1
Sheet 1
Apr 18/2007

D280A103

26-21-11

Page 1
Sheet 1
Apr 18/2007

-K
1

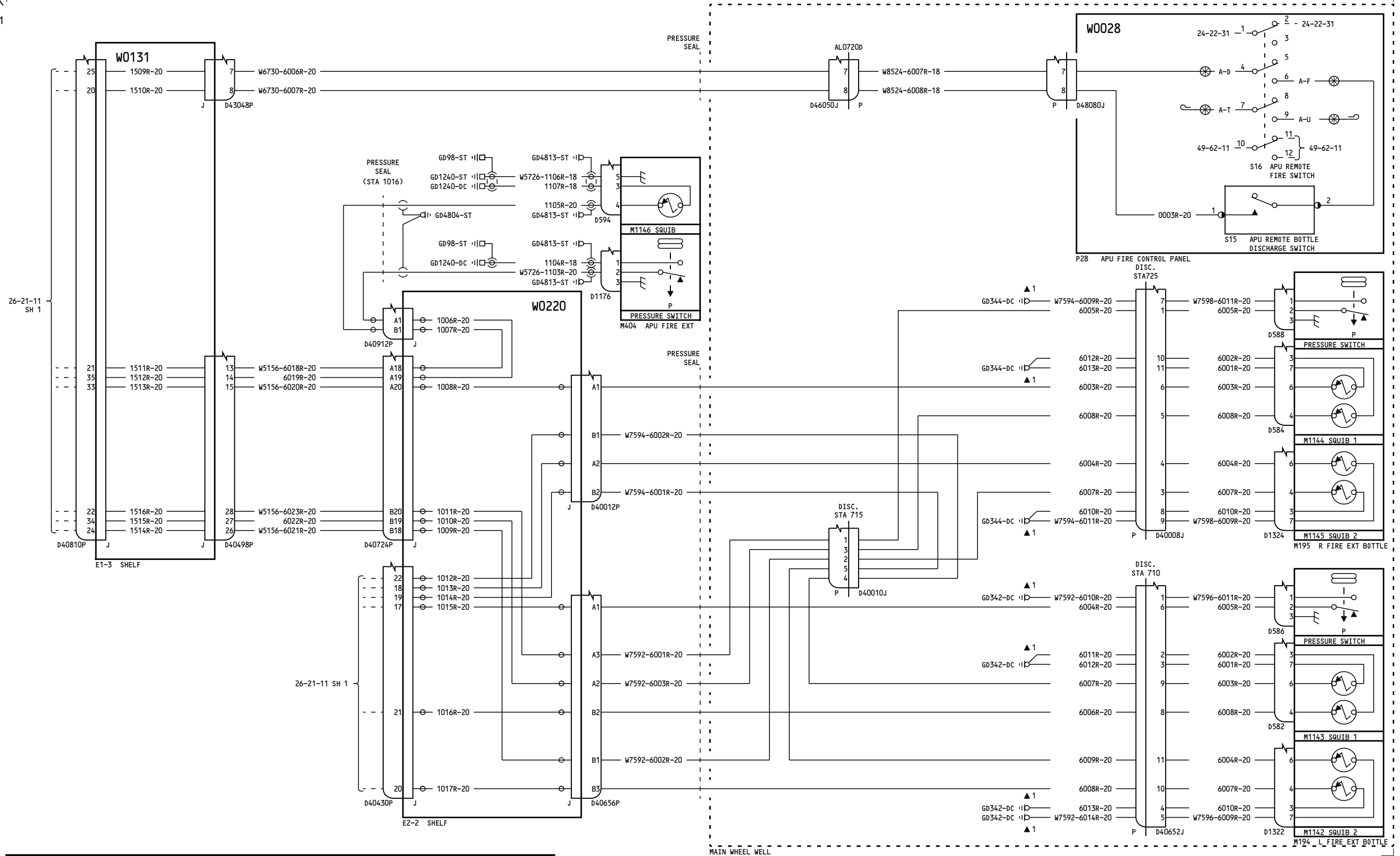

YC001-YC003

ENGINE AND APU FIRE EXTINGUISHING SYSTEM

D280A103

26-21-11

Page 1
Sheet 2
Mar 31/2005

26-21-11

Page 1
Sheet 2
Mar 31/2005

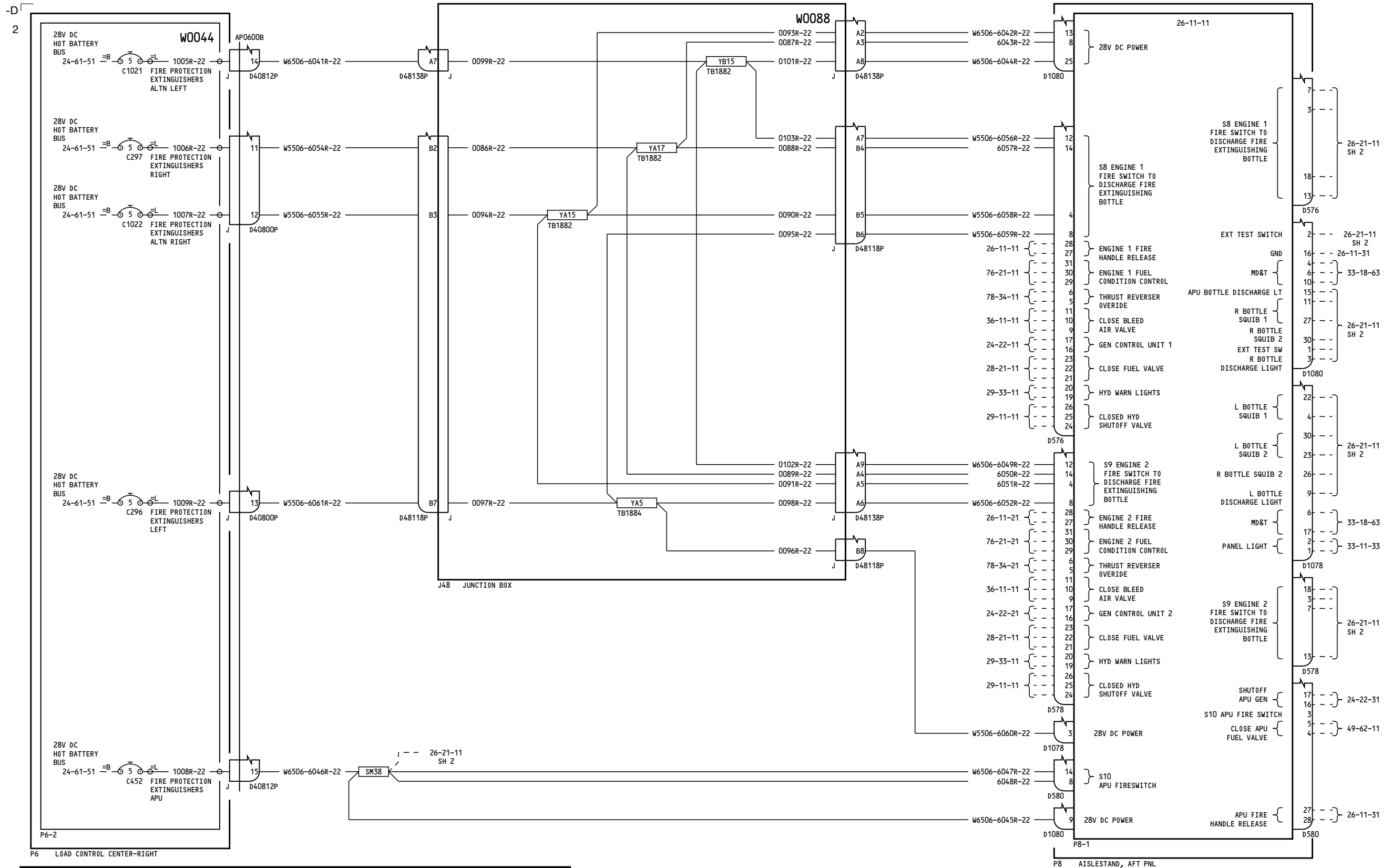

YC004-YC007

ENGINE AND APU FIRE EXTINGUISHING SYSTEM

26-21-11

Page 2
Sheet 1
Apr 18/2007

D280A103

26-21-11

Page 2
Sheet 1
Apr 18/2007

-E
2

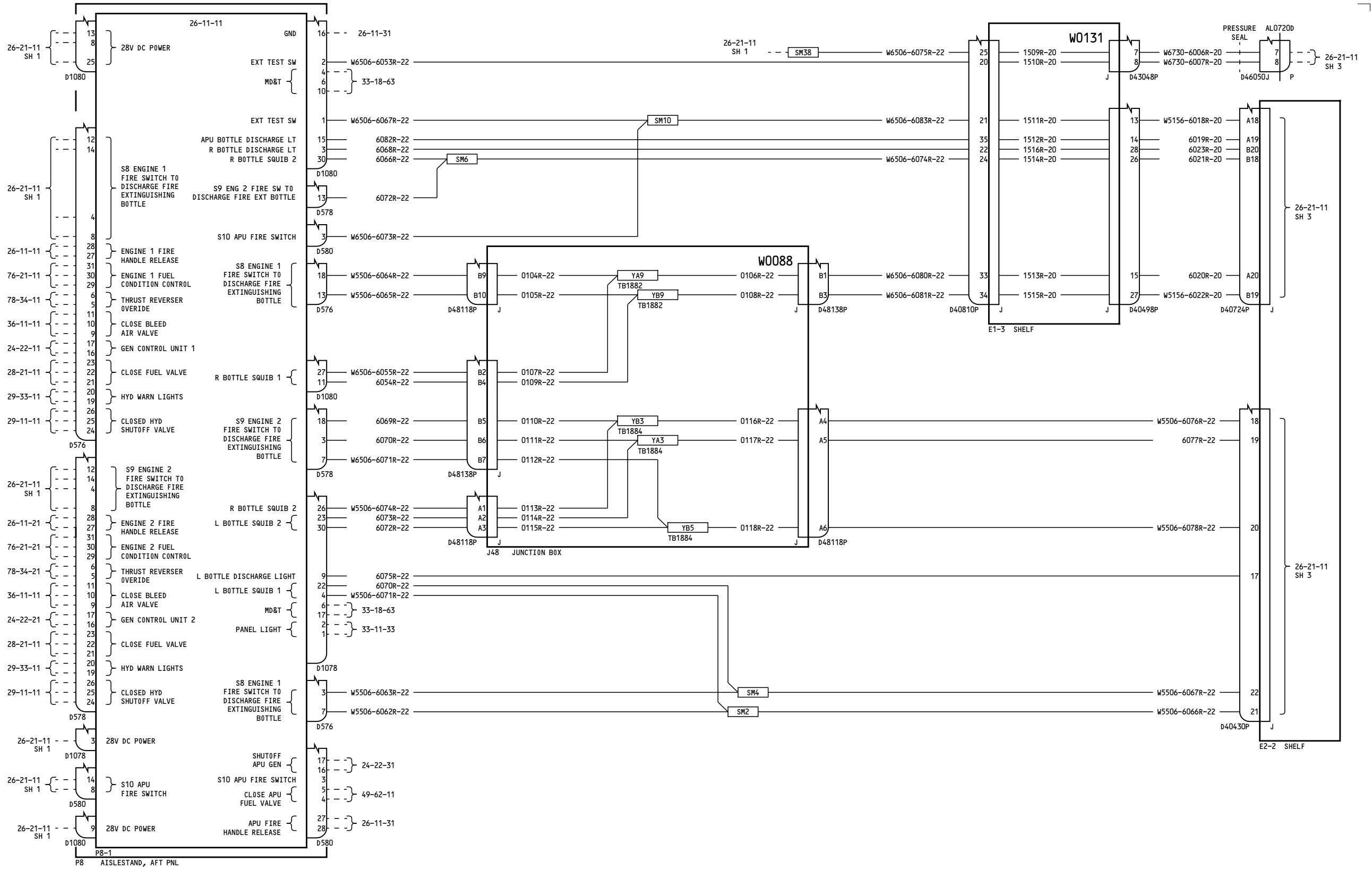

YC004-YC007

ENGINE AND APU FIRE EXTINGUISHING SYSTEM

26-21-11

Page 2
Sheet 2
Apr 18/2007

D280A103

26-21-11

Page 2
Sheet 2
Apr 18/2007

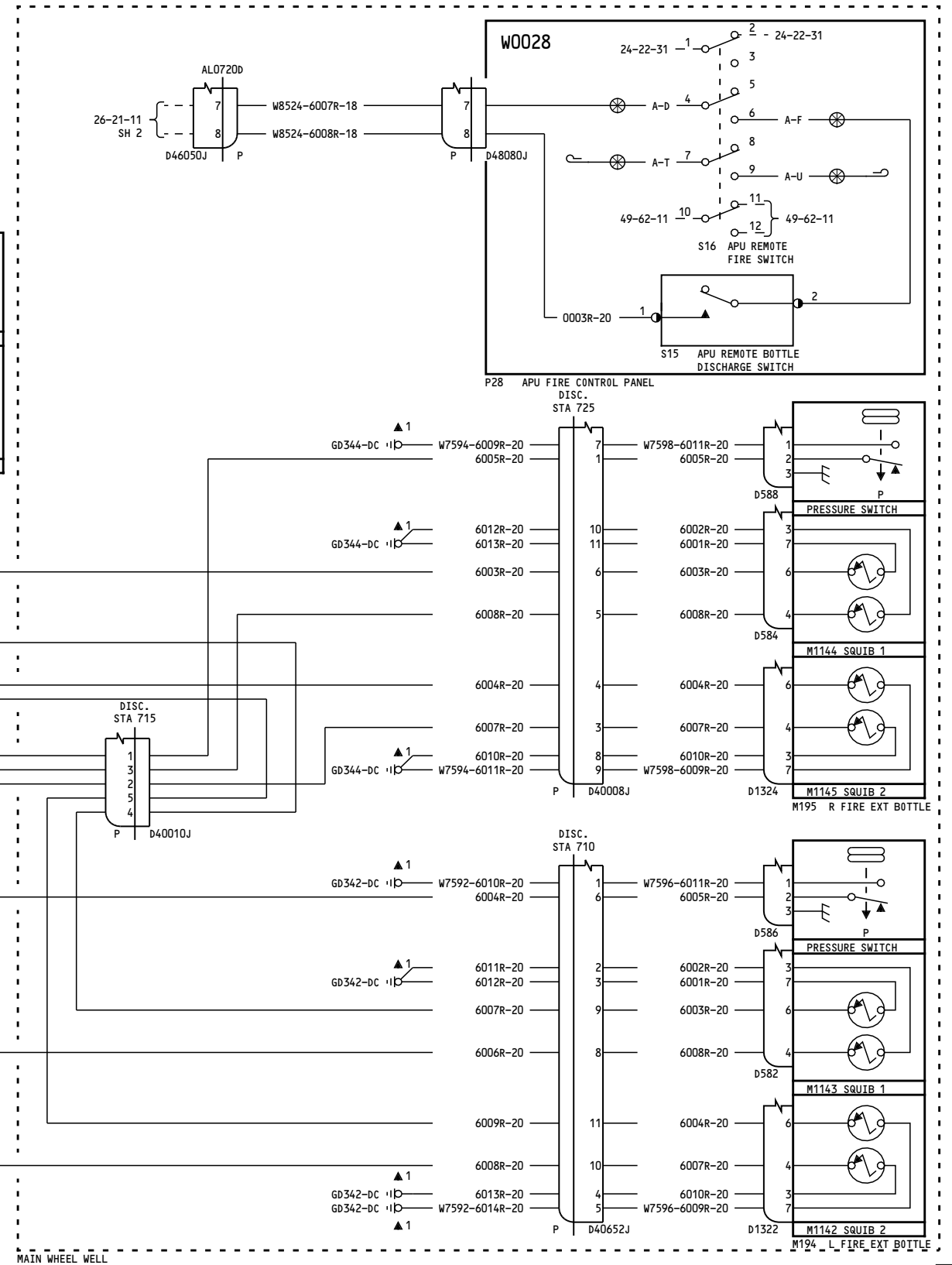
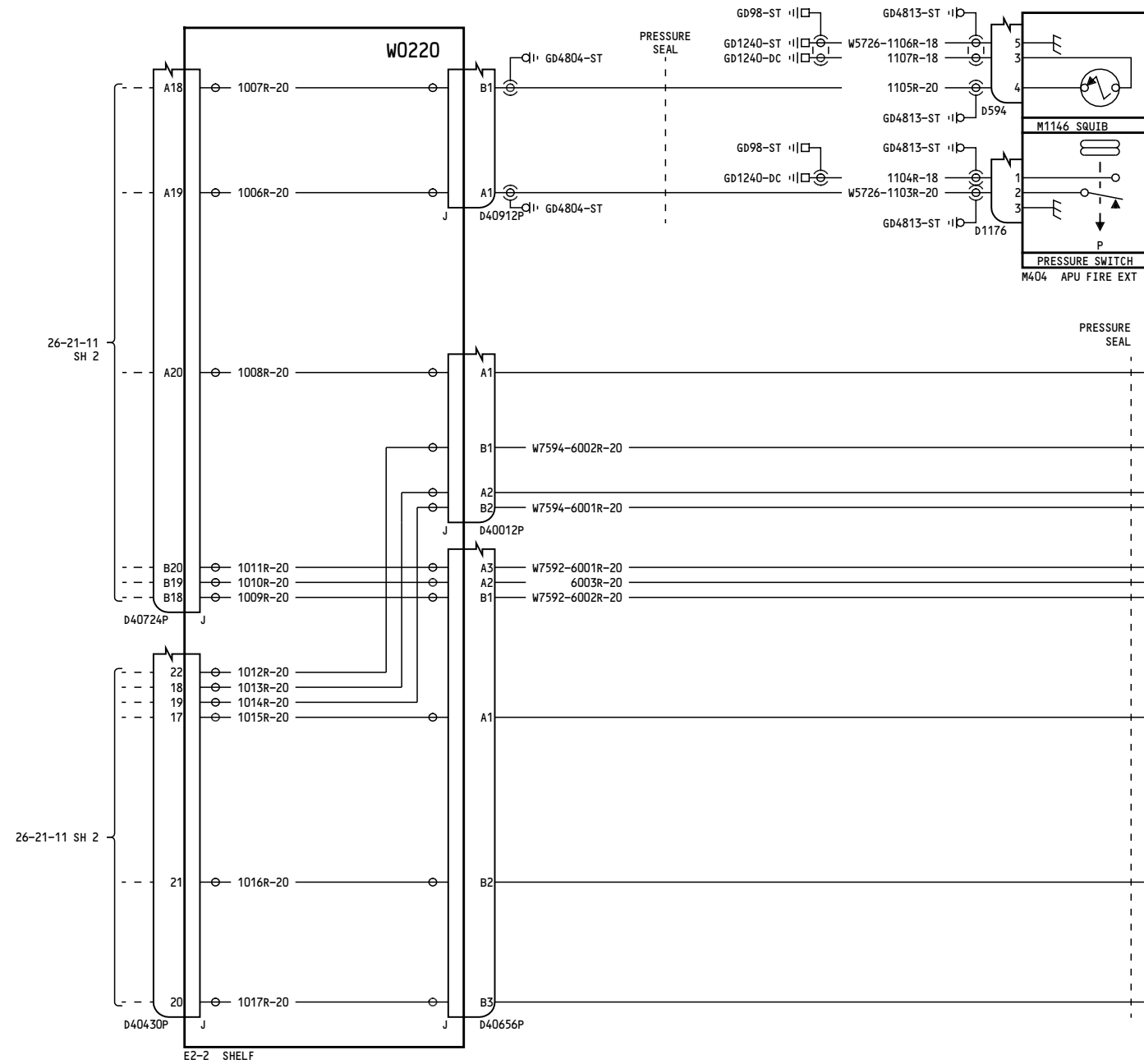

YC004-YC007

ENGINE AND APU FIRE EXTINGUISHING SYSTEM

26-21-11

Page 2
Sheet 3
Mar 31/2005

D280A103

26-21-11

Page 2
Sheet 3
Mar 31/2005

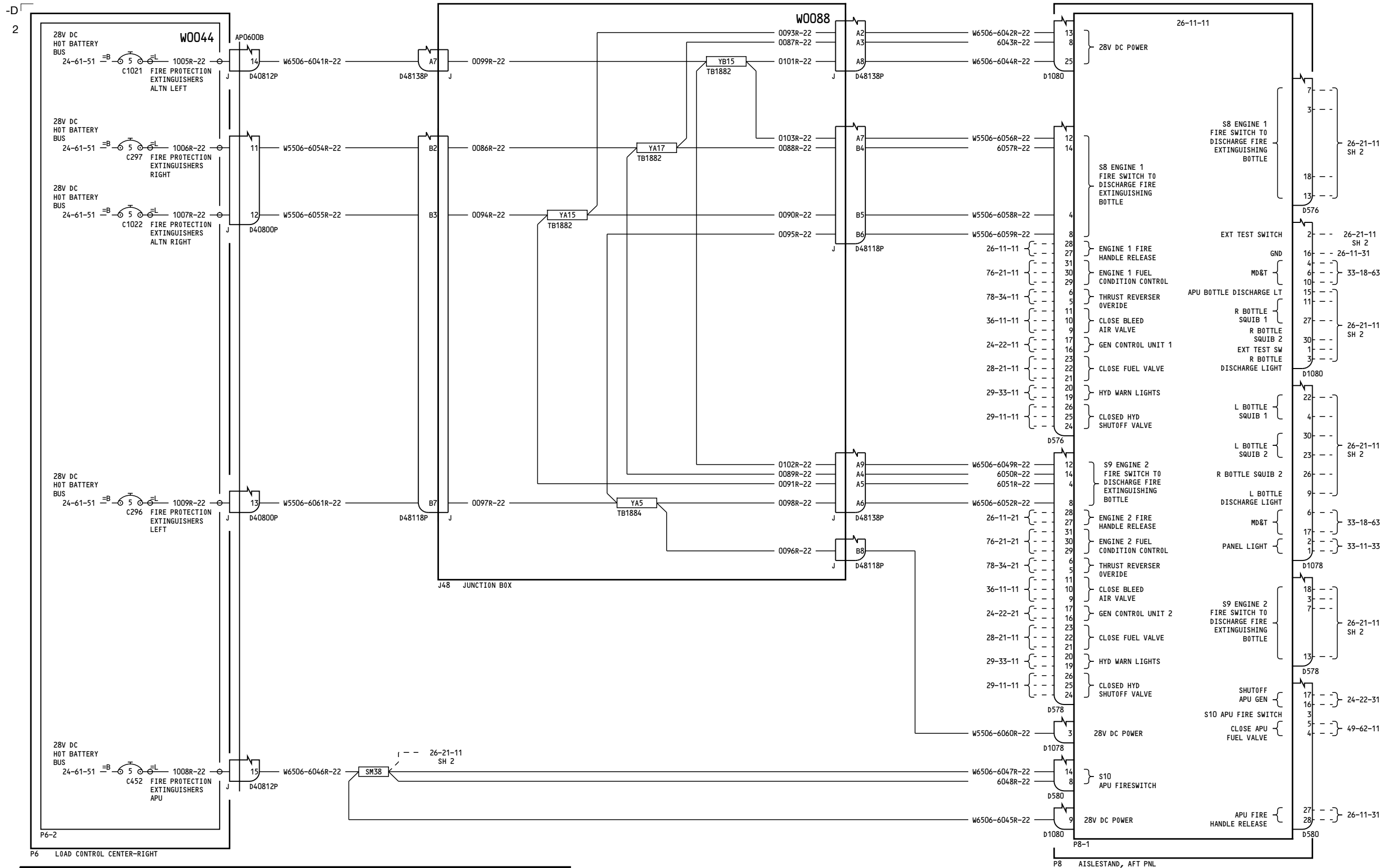

YC008-YC030

ENGINE AND APU FIRE EXTINGUISHING SYSTEM

26-21-11

Page 3
Sheet 1
Jul 17/2007

D280A103

26-21-11

Page 3
Sheet 1
Jul 17/2007

-E
2

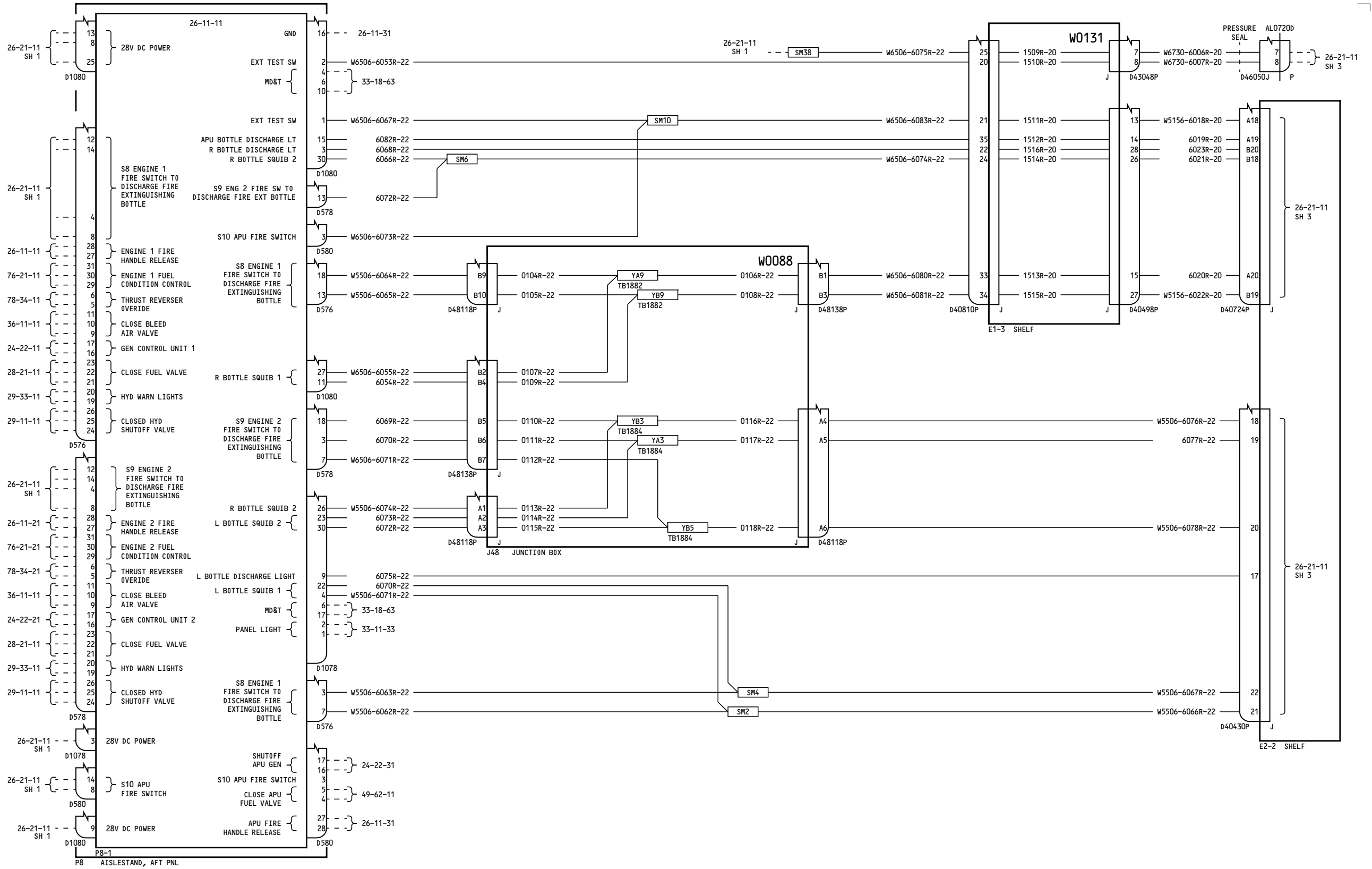

YC008-YC030

ENGINE AND APU FIRE EXTINGUISHING SYSTEM

26-21-11

Page 3
Sheet 2
Jul 17/2007

D280A103

26-21-11

Page 3
Sheet 2
Jul 17/2007

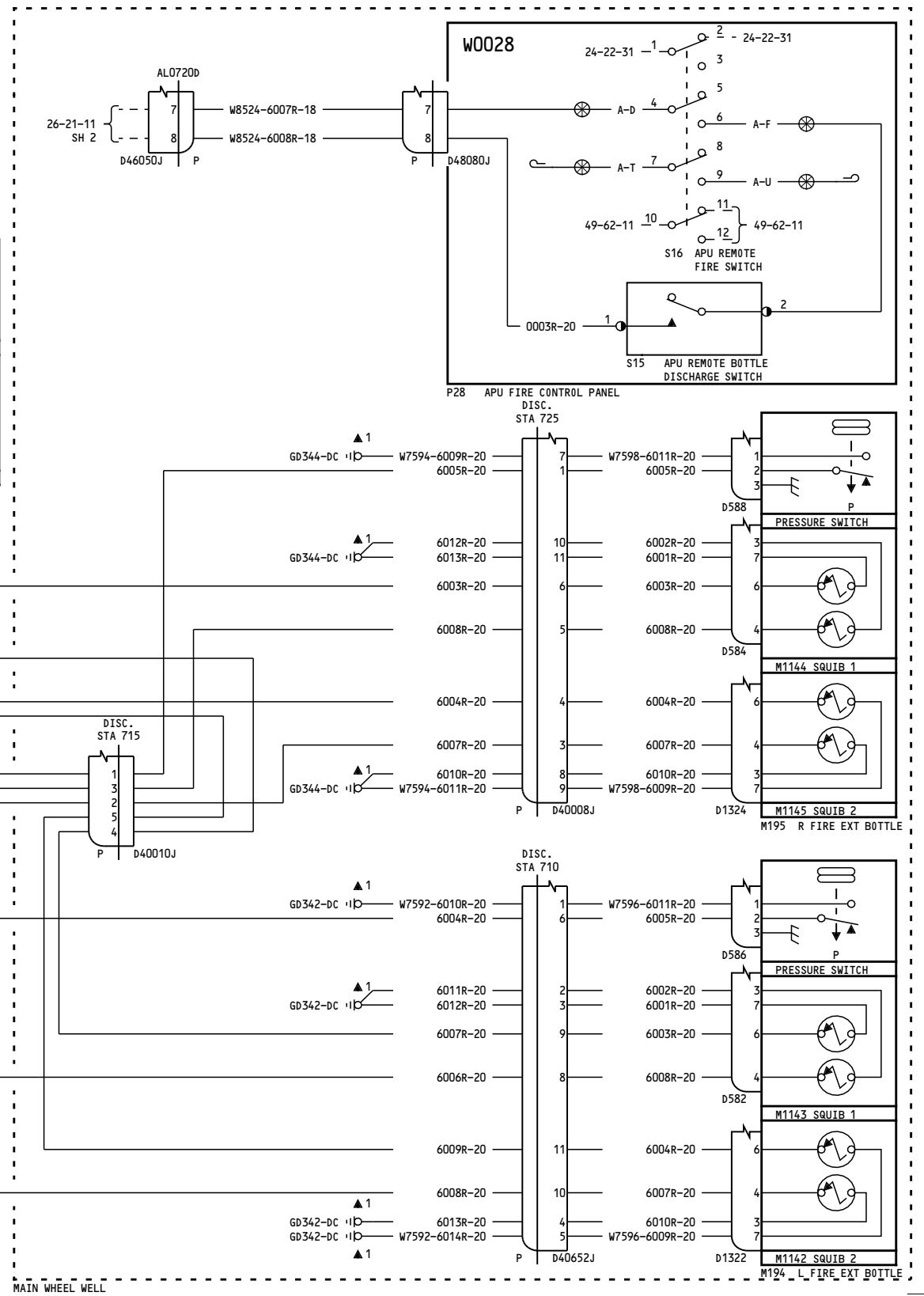
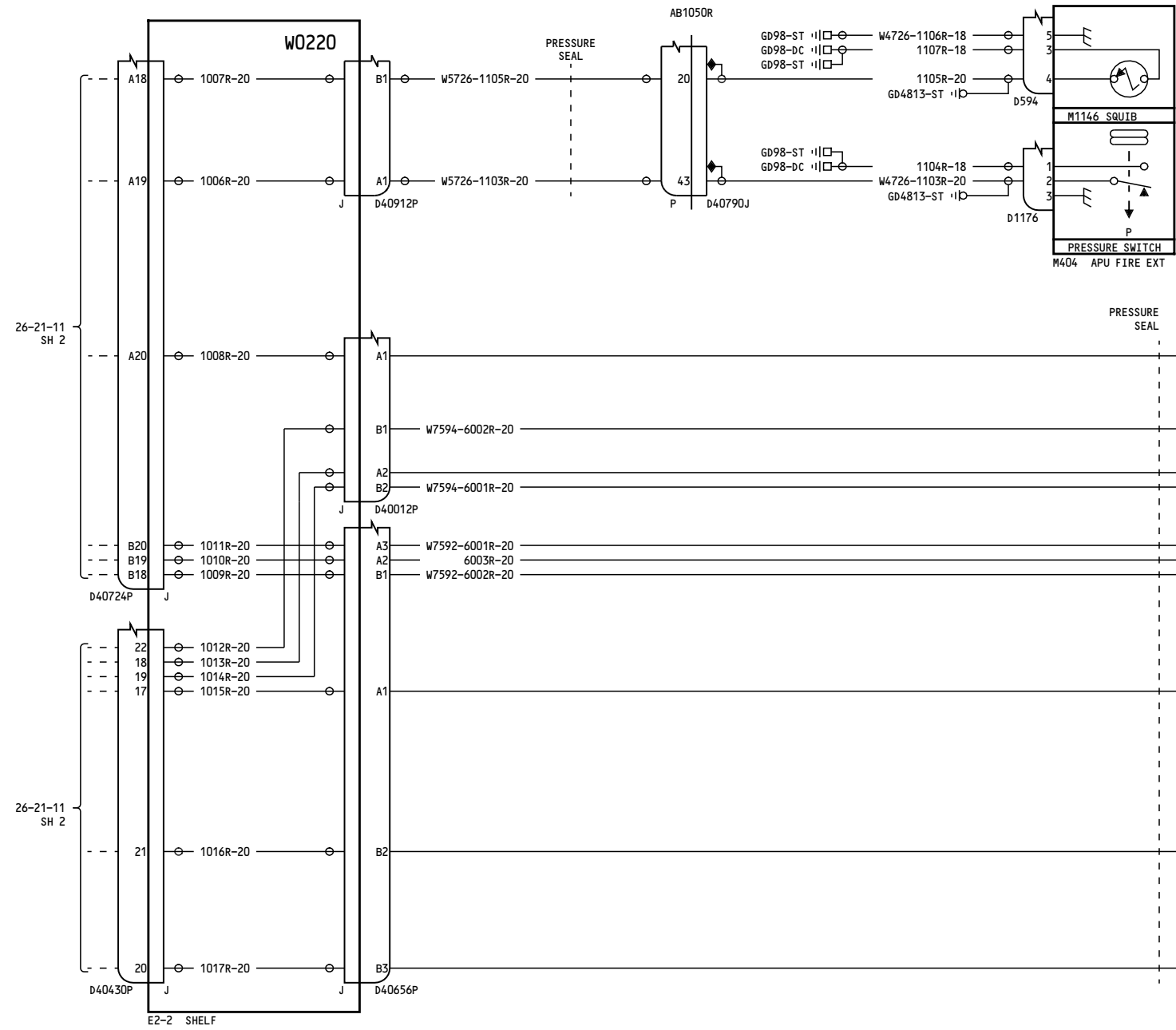

YC008-YC030

ENGINE AND APU FIRE EXTINGUISHING SYSTEM

26-21-11

Page 3
Sheet 3
Jul 17/2007

D280A103

26-21-11

Page 3
Sheet 3
Jul 17/2007

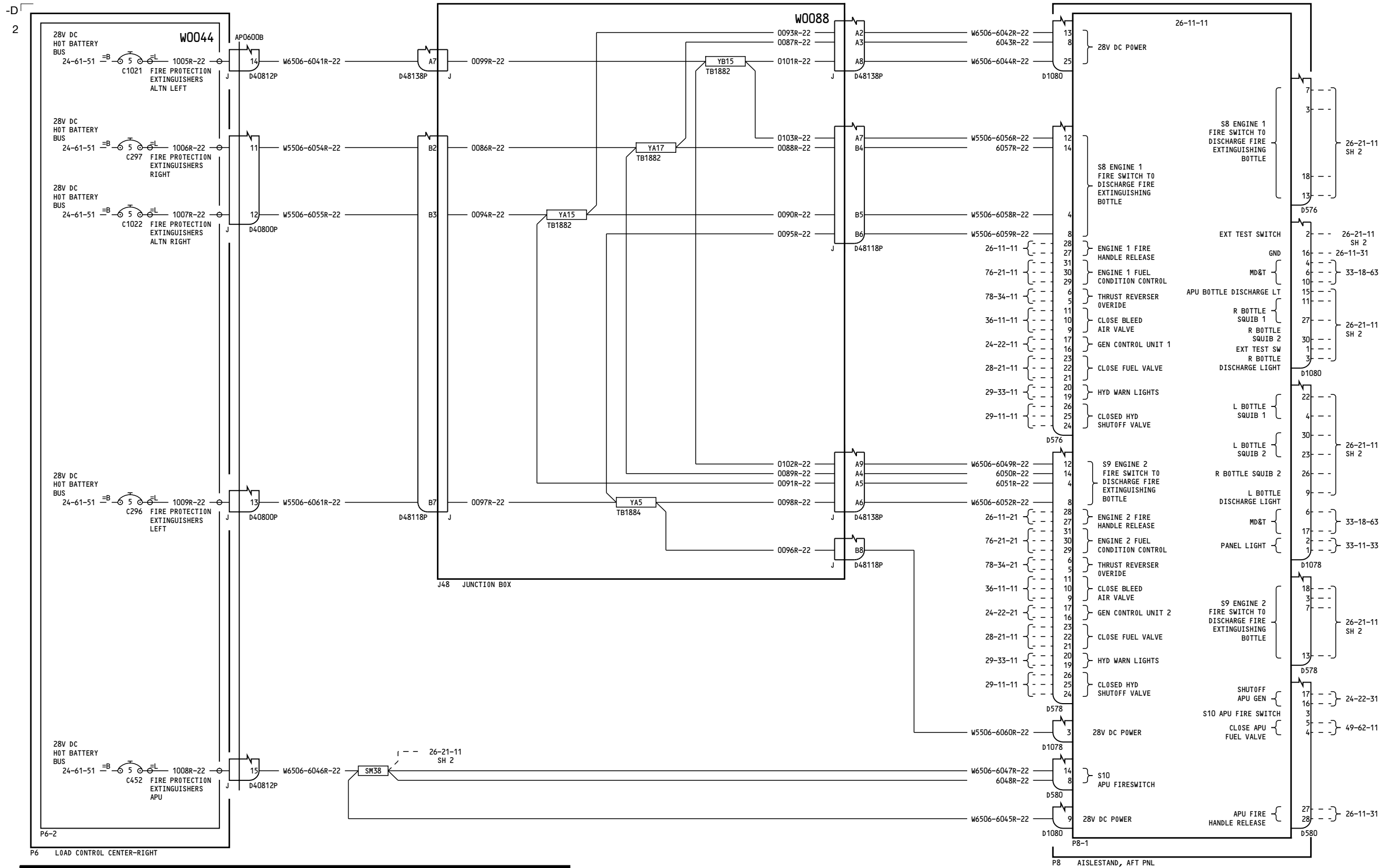

YC031-YM670

ENGINE AND APU FIRE EXTINGUISHING SYSTEM

26-21-11

Page 4
Sheet 1
Feb 09/2009

D280A103

26-21-11

Page 4
Sheet 1
Feb 09/2009

-E
2

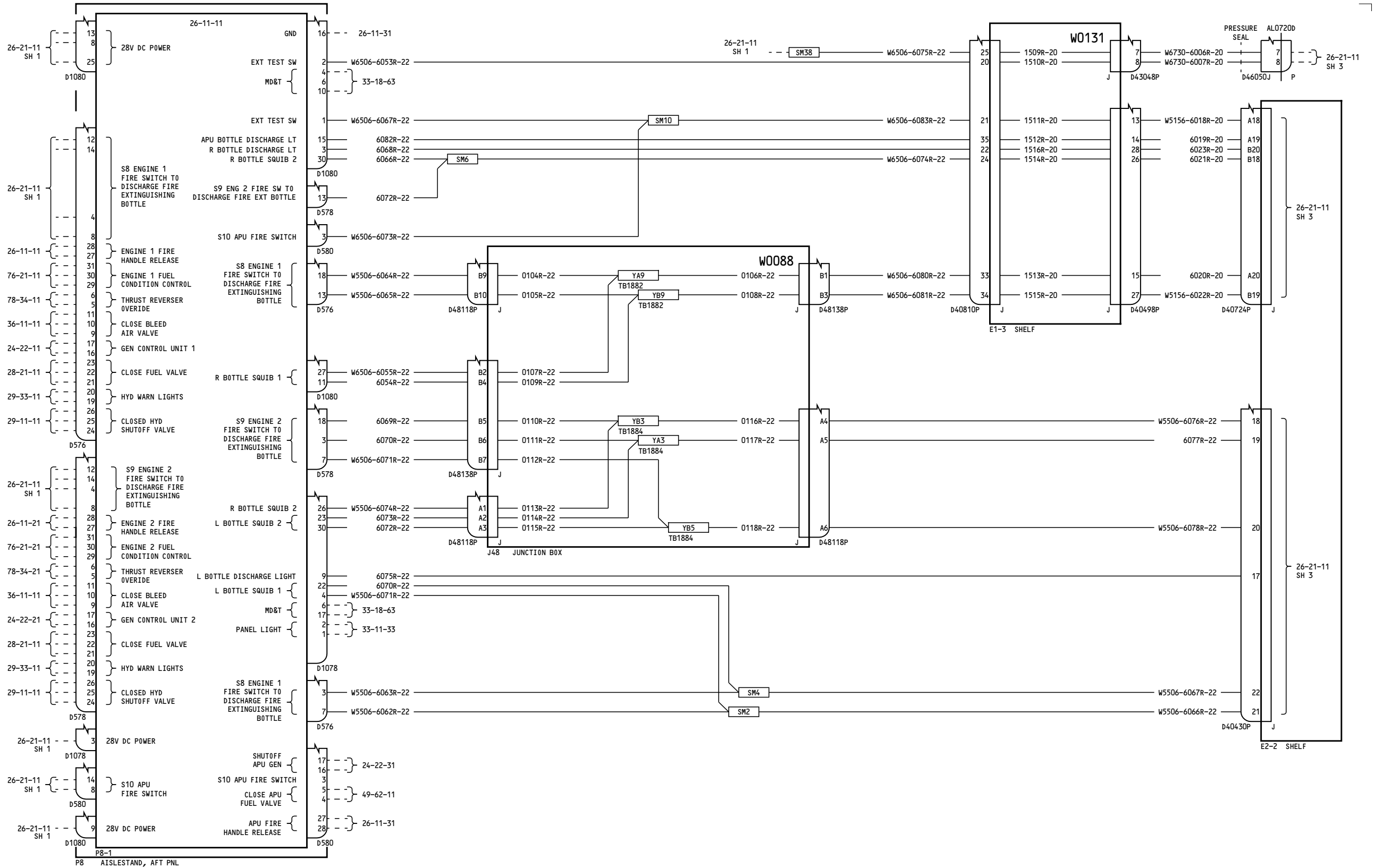

YC031-YM670

ENGINE AND APU FIRE EXTINGUISHING SYSTEM

26-21-11

Page 4
Sheet 2
Feb 09/2009

D280A103

26-21-11

Page 4
Sheet 2
Feb 09/2009

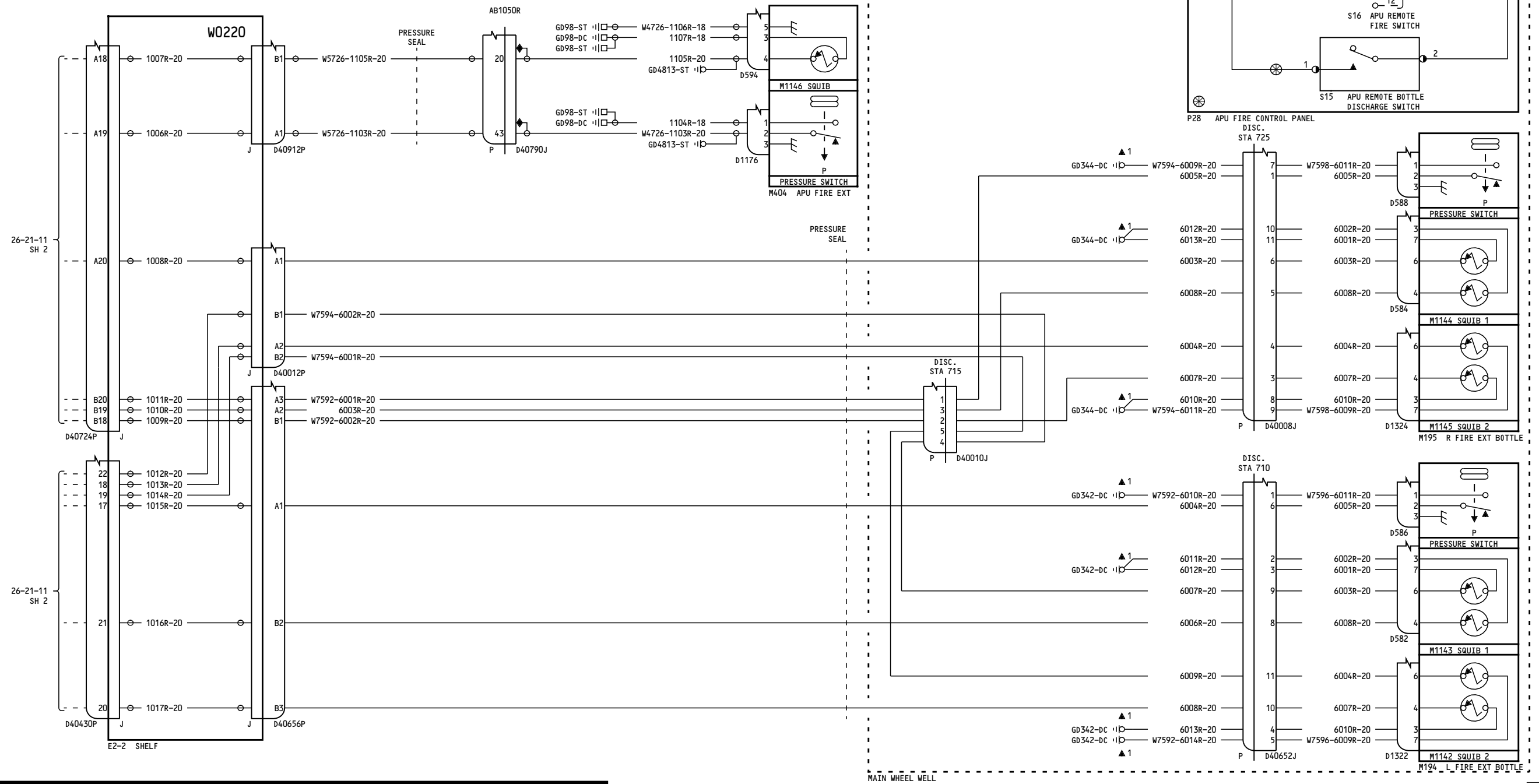

YC031-YM670

ENGINE AND APU FIRE EXTINGUISHING SYSTEM

26-21-11

Page 4
Sheet 3
Feb 09/2009

D280A103

26-21-11

Page 4
Sheet 3
Feb 09/2009

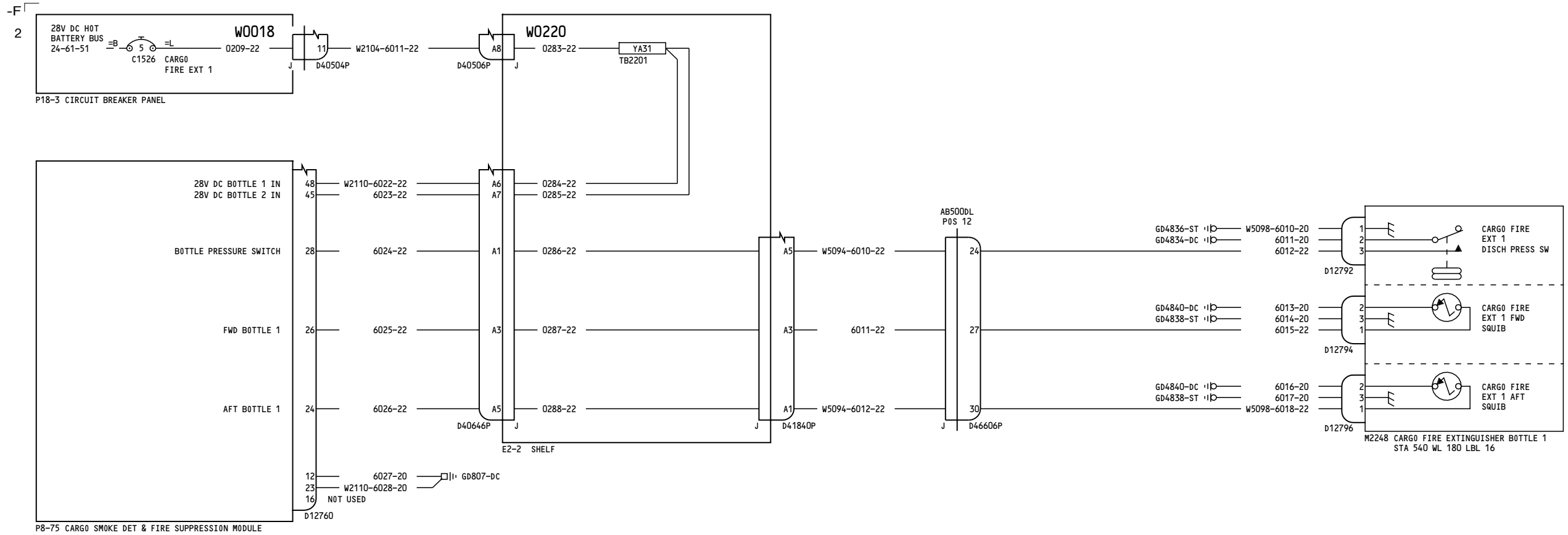

YC001-YC007

CARGO COMPARTMENT FIRE EXTINGUISHERS

D280A103

26-23-11

Page 1.1

Aug 13/2008

Incorporates
26A1083 R01

26-23-11

Page 1.1

Aug 13/2008

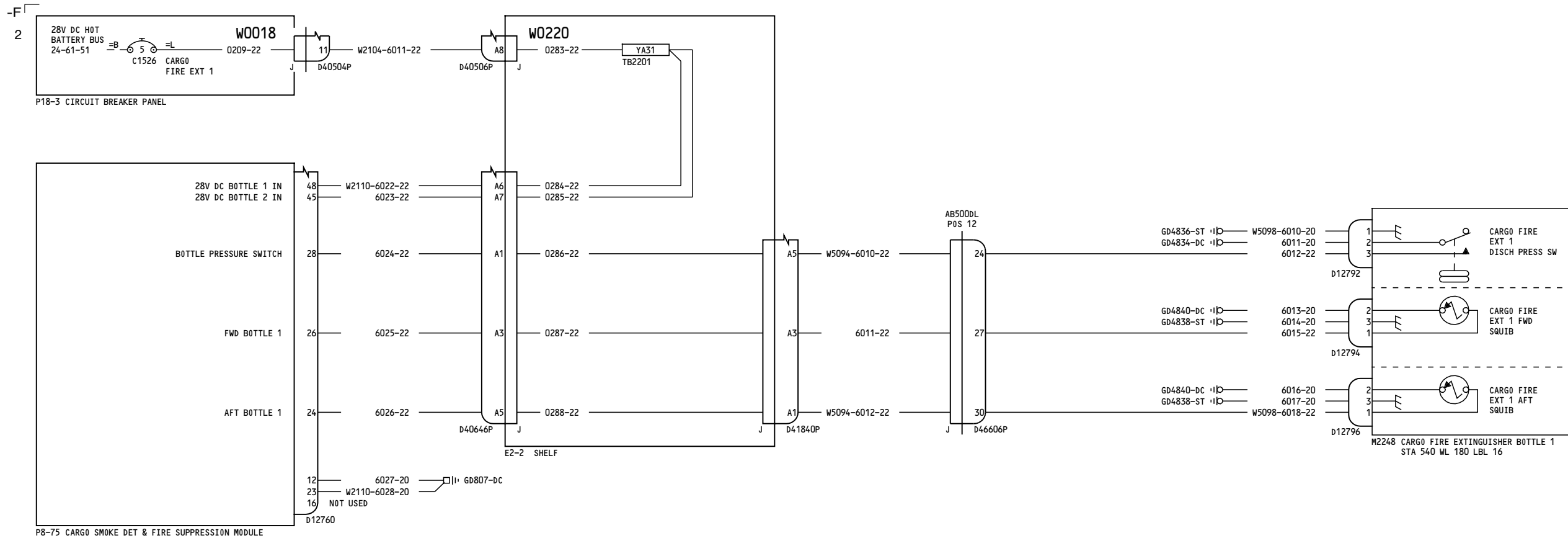

YC008-YK917, YL421-YL428, YL430-YM670

CARGO COMPARTMENT FIRE EXTINGUISHERS

26-23-11

Page 2

Feb 09/2009

D280A103

26-23-11

Page 2

Feb 09/2009

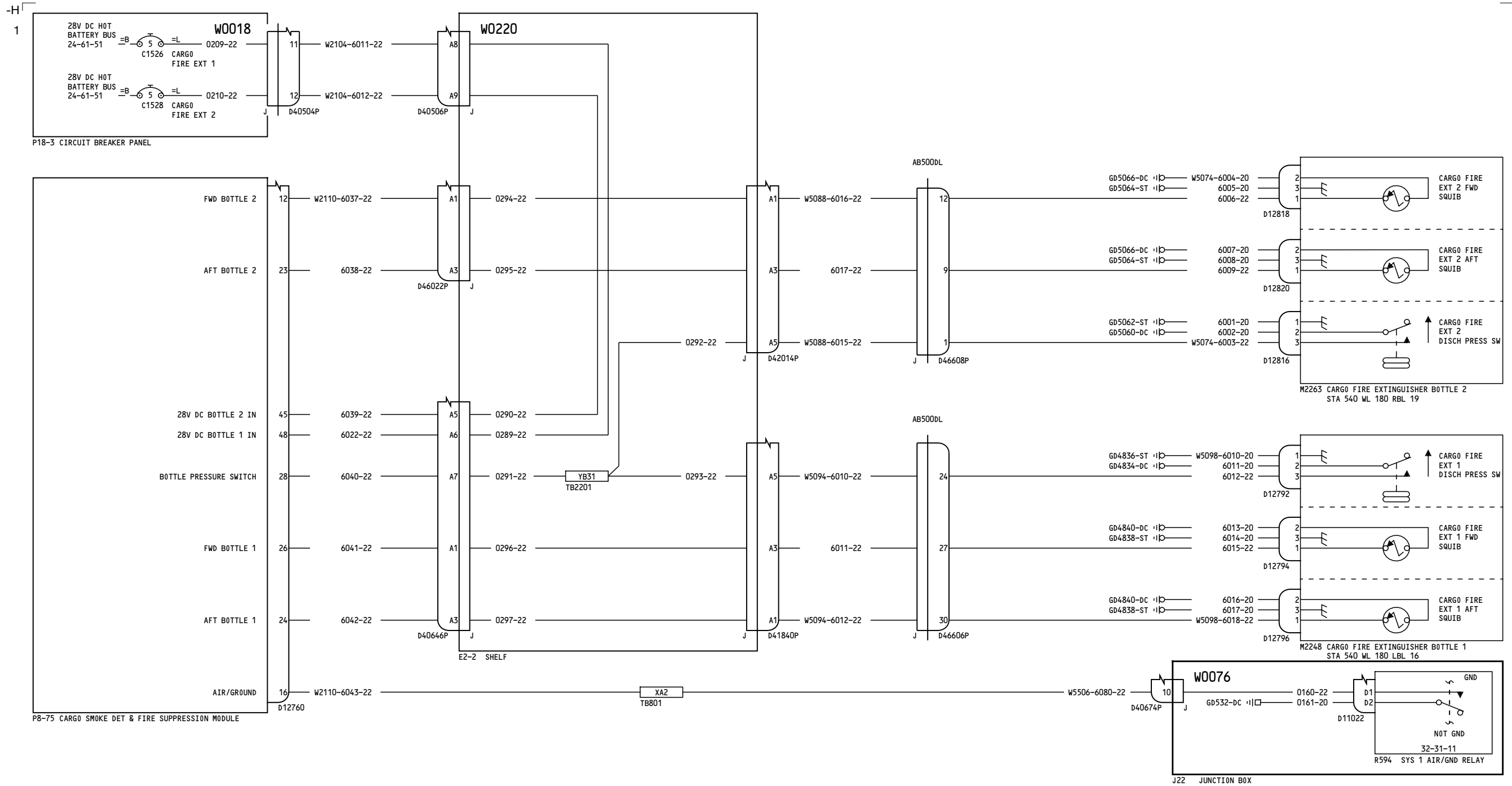

YK918-YL401, YL429

CARGO COMPARTMENT FIRE EXTINGUISHERS

D280A103

26-23-11

Page 3

Feb 09/2009

26-23-11

Page 3

Feb 09/2009