

CHAPTER

28

FUEL



737-700/800

WIRING DIAGRAM MANUAL

CHAPTER 28
FUEL

CH-SC-SU	Schem	Page	Sheet	Date	CH-SC-SU	Schem	Page	Sheet	Date
28-EFFECTIVE PAGES					28-41-11				
		1		Aug 10/2009			1	1	May 11/2009
		2		BLANK				2	May 11/2009
28-CONTENTS							2	1	May 11/2009
R		1		Aug 10/2009				2	May 11/2009
		2		May 11/2009			3	1	May 11/2009
R		3		Aug 10/2009				2	May 11/2009
		4		BLANK	28-42-11				
28-ALPHABETICAL INDEX							1		Mar 31/2005
		1		Jan 18/2007			2		Mar 31/2005
		2		BLANK			3		Feb 09/2009
28-21-11					28-43-11				
		1	1	Mar 31/2005			1		Oct 20/2006
			2	Mar 31/2005			2		Jul 17/2007
		2	1	Mar 31/2005			3		Feb 09/2009
			2	Mar 31/2005	28-44-11				
		3	1	Feb 09/2009			1	1	Jul 17/2007
			2	Feb 09/2009				2	Jul 17/2007
		4	1	Oct 20/2006			2	1	Oct 20/2005
			2	Oct 20/2006				2	Oct 20/2005
28-21-21					R		3	1	Aug 10/2009
		1		Mar 31/2005	R			2	Aug 10/2009
		2		Feb 09/2009			4	1	Jan 18/2006
28-22-11								2	Jan 18/2006
R		1		Aug 10/2009					
		2		Feb 09/2009					
A		3		Aug 10/2009					
28-23-11									
		1	1	May 11/2009					
			2	May 11/2009					
		1.1	1	Oct 15/2007					
			2	Aug 13/2008					
		2	1	Jul 26/2006					
			2	Jul 26/2006					
			3	Jul 26/2006					
			4	Jul 26/2006					
		2.1	1	Aug 13/2008					
			2	Aug 13/2008					
			3	Aug 13/2008					
			4	Aug 13/2008					
		3	1	Jul 26/2006					
			2	Jul 26/2006					
			3	Jul 26/2006					
			4	Jul 26/2006					
		4	1	Jan 18/2007					
			2	Jan 18/2007					
			3	Jan 18/2007					
			4	Jan 18/2007					
		5	1	Feb 09/2009					
			2	Feb 09/2009					
			3	Feb 09/2009					
			4	Feb 09/2009					

A = Added, R = Revised, D = Deleted, O = Overflow

28-EFFECTIVE PAGES

Page 1
Aug 10/2009

D280A103



737-700/800

WIRING DIAGRAM MANUAL

CHAPTER 28
FUEL

Title	CH-SC-SU	Schem	Page	Sheet	Date	Effectivity
<u>ENGINE FUEL SYSTEM</u>						
ENGINE FUEL SHUT-OFF VALVES	28-21-11		1	1	Mar 31/2005	YC001-YC003
				2	Mar 31/2005	YC001-YC003
			2	1	Mar 31/2005	YC004-YC007
				2	Mar 31/2005	YC004-YC007
			3	1	Feb 09/2009	YC008-YK901 YK907-YM670
				2	Feb 09/2009	YC008-YK901 YK907-YM670
			4	1	Oct 20/2006	YK902-YK906
				2	Oct 20/2006	YK902-YK906
BATTERY AND CONTROL POWER ENGINE SPAR AND APU FUEL VALVES	28-21-21		1		Mar 31/2005	YC001-YC006
			2		Feb 09/2009	YC007-YM670
<u>ENGINE FUEL FEED SYSTEM</u>						
FUEL CROSSFEED VALVE	28-22-11		1		Aug 10/2009	YC001-YK901
			2		Feb 09/2009	YK902-YK906
			3		Aug 10/2009	YK907-YM670
<u>FUEL BOOST PUMPS</u>						
FUEL BOOST PUMPS	28-23-11		1	1	May 11/2009	YC001-YC030
				2	May 11/2009	YC001-YC030
			1.1	1	Oct 15/2007	YC001-YC030
				2	Aug 13/2008	YC001-YC030
			2	1	Jul 26/2006	YK901
				2	Jul 26/2006	YK901
				3	Jul 26/2006	YK901
				4	Jul 26/2006	YK901
			2.1	1	Aug 13/2008	YK901
				2	Aug 13/2008	YK901
				3	Aug 13/2008	YK901
				4	Aug 13/2008	YK901
			3	1	Jul 26/2006	YK902-YK906
				2	Jul 26/2006	YK902-YK906

28-CONTENTS



737-700/800

WIRING DIAGRAM MANUAL

**CHAPTER 28
FUEL**

Title	CH-SC-SU	Schem	Page	Sheet	Date	Effectivity		
FUEL BOOST PUMPS (cont.)	28-23-11			3	Jul 26/2006	YK902-YK906		
				4	Jul 26/2006	YK902-YK906		
			4	1	Jan 18/2007	YK907 YL421		
				2	Jan 18/2007	YK907 YL421		
				3	Jan 18/2007	YK907 YL421		
				4	Jan 18/2007	YK907 YL421		
			5	1	Feb 09/2009	YK908-YL401 YL422-YM670		
				2	Feb 09/2009	YK908-YL401 YL422-YM670		
				3	Feb 09/2009	YK908-YL401 YL422-YM670		
				4	Feb 09/2009	YK908-YL401 YL422-YM670		
		<u>FUEL QUANTITY INDICATING SYSTEM</u>						
		FUEL QUANTITY	28-41-11		1	1	May 11/2009	YC001-YC003
				2	May 11/2009	YC001-YC003		
	2			1	May 11/2009	YC004-YK906		
				2	May 11/2009	YC004-YK906		
	3			1	May 11/2009	YK907-YM670		
				2	May 11/2009	YK907-YM670		
<u>FUEL TEMPERATURE INDICATING SYSTEM</u>								
FUEL TEMPERATURE INDICATION	28-42-11		1		Mar 31/2005	YC001-YC003		
				2	Mar 31/2005	YC004-YC007		
				3	Feb 09/2009	YC008-YM670		
<u>FUEL PRESSURE INDICATING SYSTEM</u>								
FUEL BOOST PUMPS LOW PRESSURE WARNING LIGHTS	28-43-11		1		Oct 20/2006	YC001-YC007		
				2	Jul 17/2007	YC008-YC030		
				3	Feb 09/2009	YC031-YM670		
<u>REFUELING INDICATION</u>								
GROUND REFUELING	28-44-11		1	1	Jul 17/2007	YC001-YC026		
				2	Jul 17/2007	YC001-YC026		
				2	1	Oct 20/2005	YC028-YC030	

28-CONTENTS

Page 2
May 11/2009

D280A103



737-700/800

WIRING DIAGRAM MANUAL

CHAPTER 28
FUEL

Title	CH-SC-SU	Schem	Page	Sheet	Date	Effectivity	
GROUND REFUELING (cont.)	28-44-11			2	Oct 20/2005	YC028-YC030	
			3	1	Aug 10/2009	YC031-YC050 YK906-YK912 YK918-YK919 YL401-YL429 YM643-YM652	
				2	Aug 10/2009	YC031-YC050 YK906-YK912 YK918-YK919 YL401-YL429 YM643-YM652	
			4	1	Jan 18/2006	YK901-YK905	
				2	Jan 18/2006	YK901-YK905	

28-CONTENTS



737-700/800

WIRING DIAGRAM MANUAL

CHAPTER 28 FUEL

CH-SC-SU	Title
28-21-21	BATTERY AND CONTROL POWER ENGINE SPAR AND APU FUEL VALVES
28-21-11	ENGINE FUEL SHUT-OFF VALVES
28-23-11	FUEL BOOST PUMPS
28-43-11	FUEL BOOST PUMPS LOW PRESSURE WARNING LIGHTS
28-22-11	FUEL CROSSFEED VALVE
28-41-11	FUEL QUANTITY
28-42-11	FUEL TEMPERATURE INDICATION
28-44-11	GROUND REFUELING

28-ALPHABETICAL INDEX

D280A103

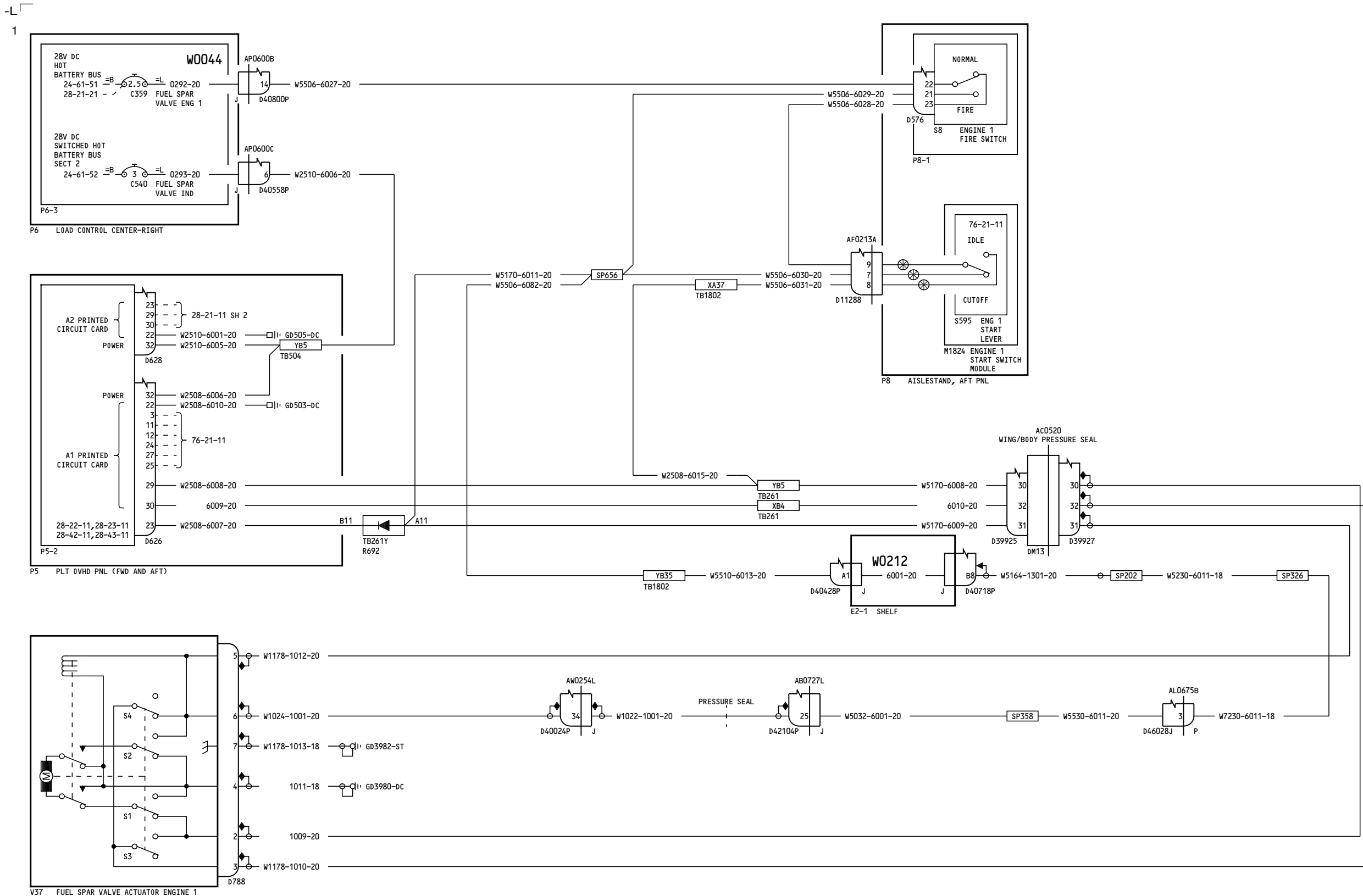

YC001-YC003

ENGINE FUEL SHUT-OFF VALVES

28-21-11

Page 1
Sheet 1
Mar 31/2005

D280A103

28-21-11

Page 1
Sheet 1
Mar 31/2005

-D
2

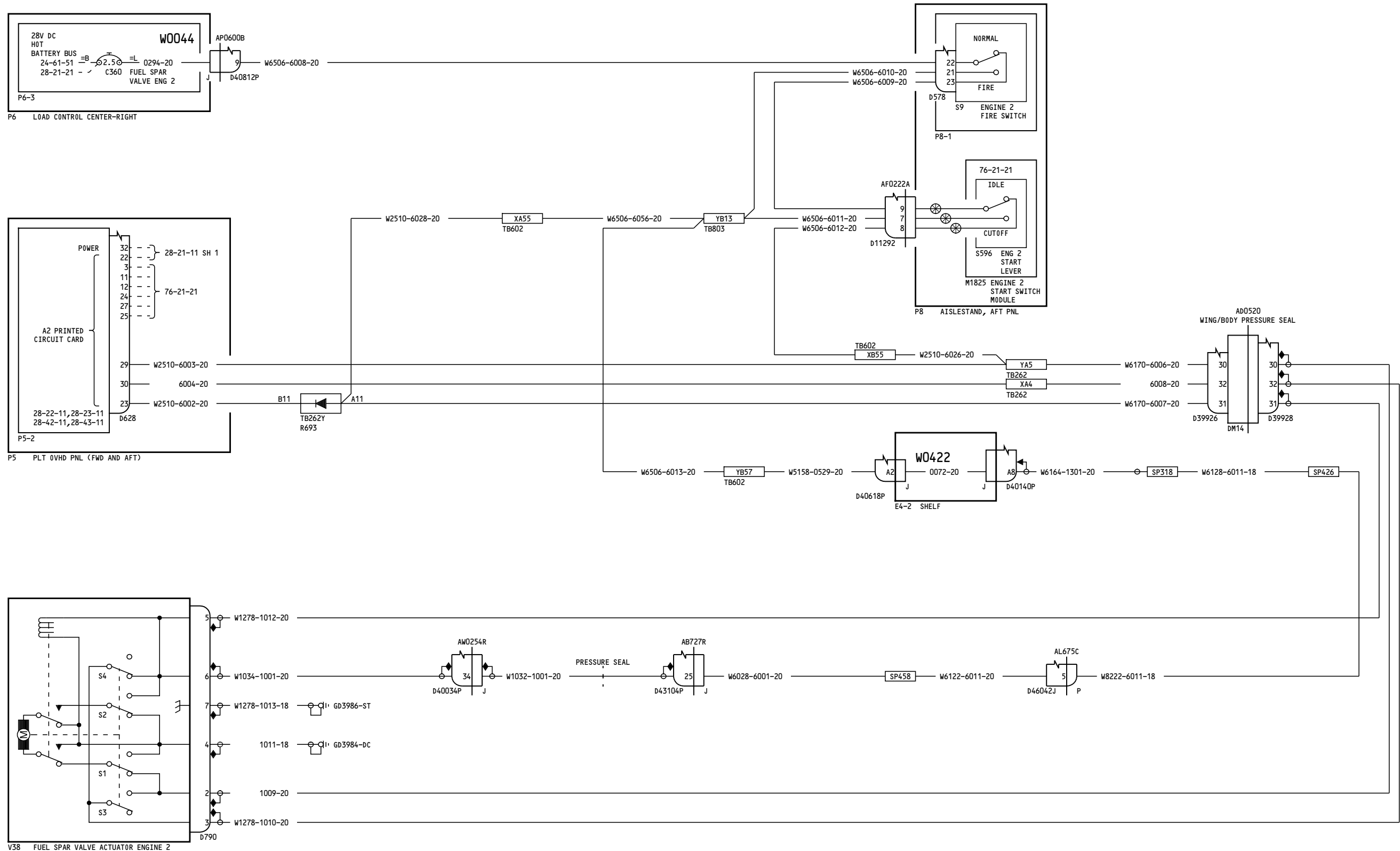

YC001-YC003

ENGINE FUEL SHUT-OFF VALVES

28-21-11

Page 1
Sheet 2
Mar 31/2005

D280A103

28-21-11

Page 1
Sheet 2
Mar 31/2005

-E
2

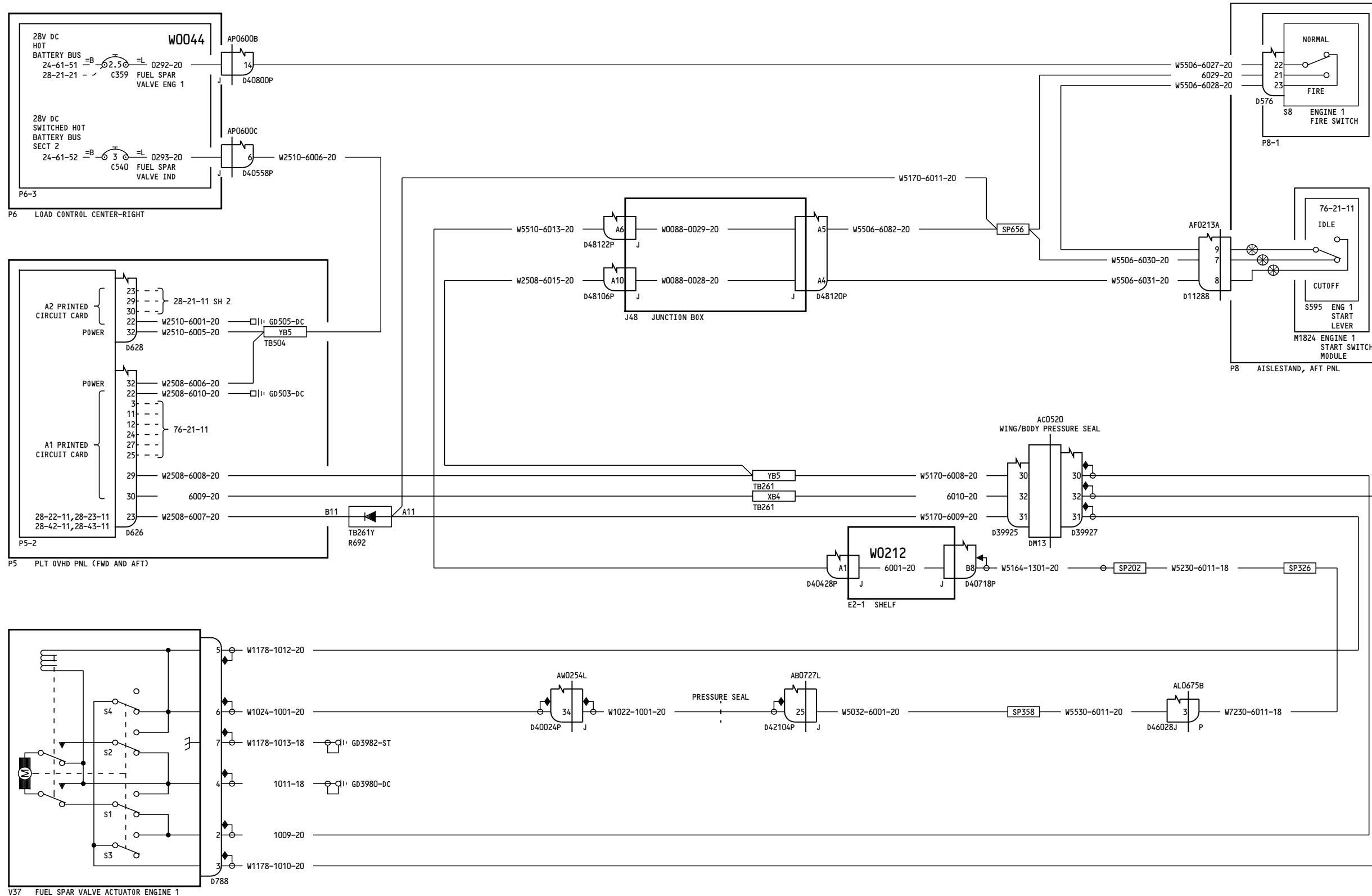

YC004-YC007

ENGINE FUEL SHUT-OFF VALVES

28-21-11

Page 2
Sheet 1
Mar 31/2005

D280A103

28-21-11

Page 2
Sheet 1
Mar 31/2005

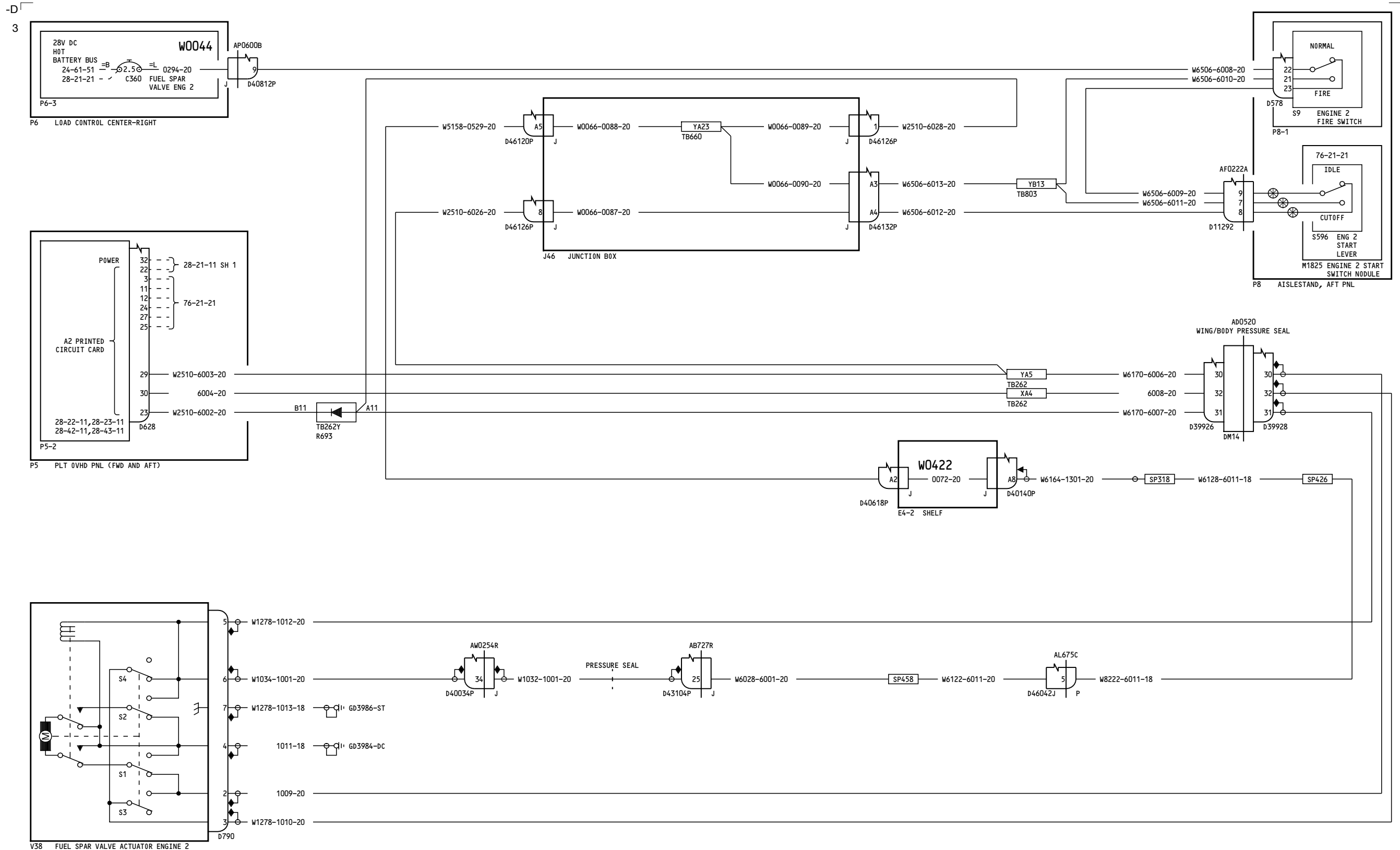

YC004-YC007

ENGINE FUEL SHUT-OFF VALVES

28-21-11

Page 2
Sheet 2
Mar 31/2005

D280A103

28-21-11

Page 2
Sheet 2
Mar 31/2005

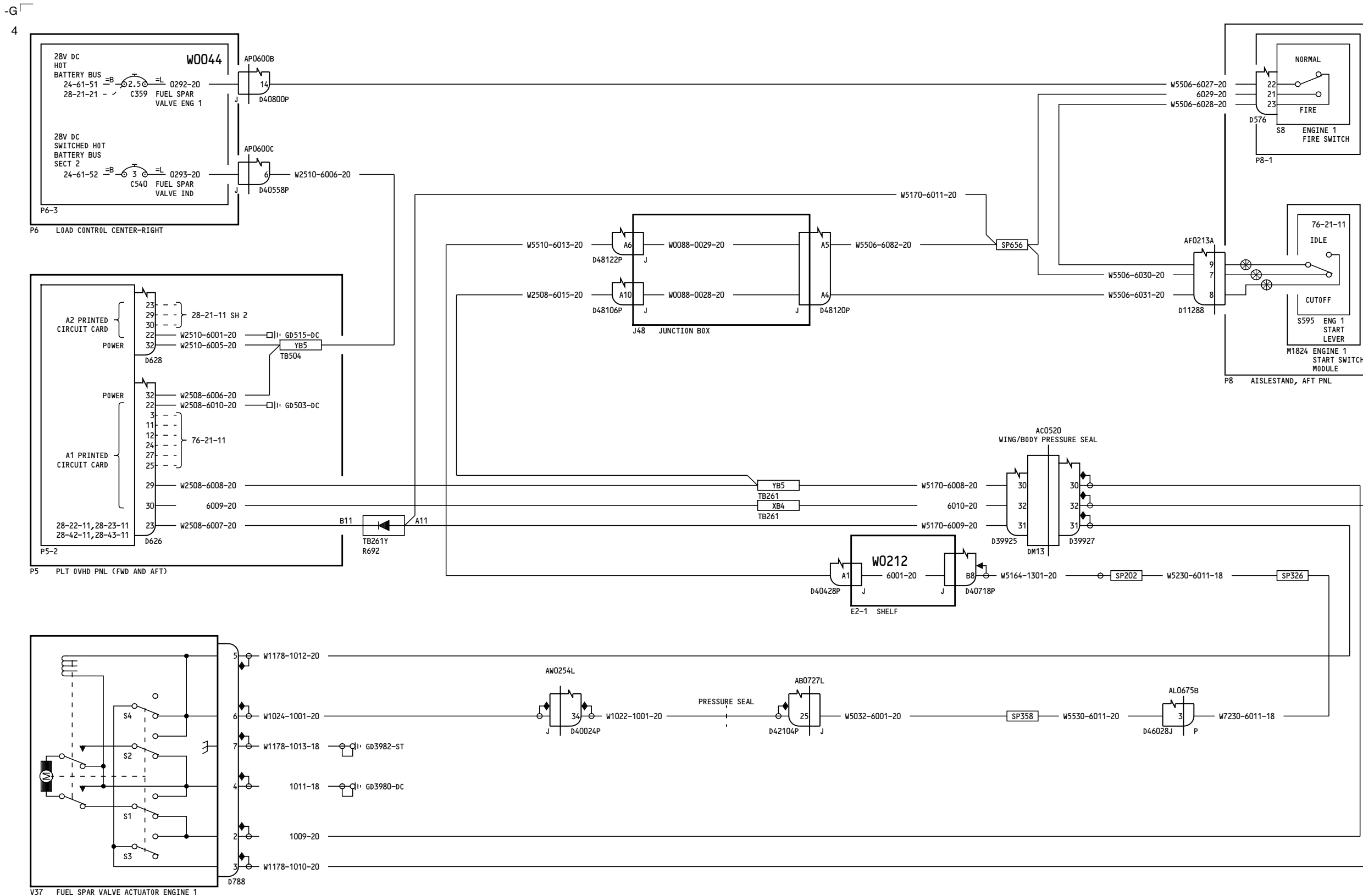

YC008-YK901, YK907-YM670

ENGINE FUEL SHUT-OFF VALVES

28-21-11

Page 3
Sheet 1
Feb 09/2009

D280A103

28-21-11

Page 3
Sheet 1
Feb 09/2009

6

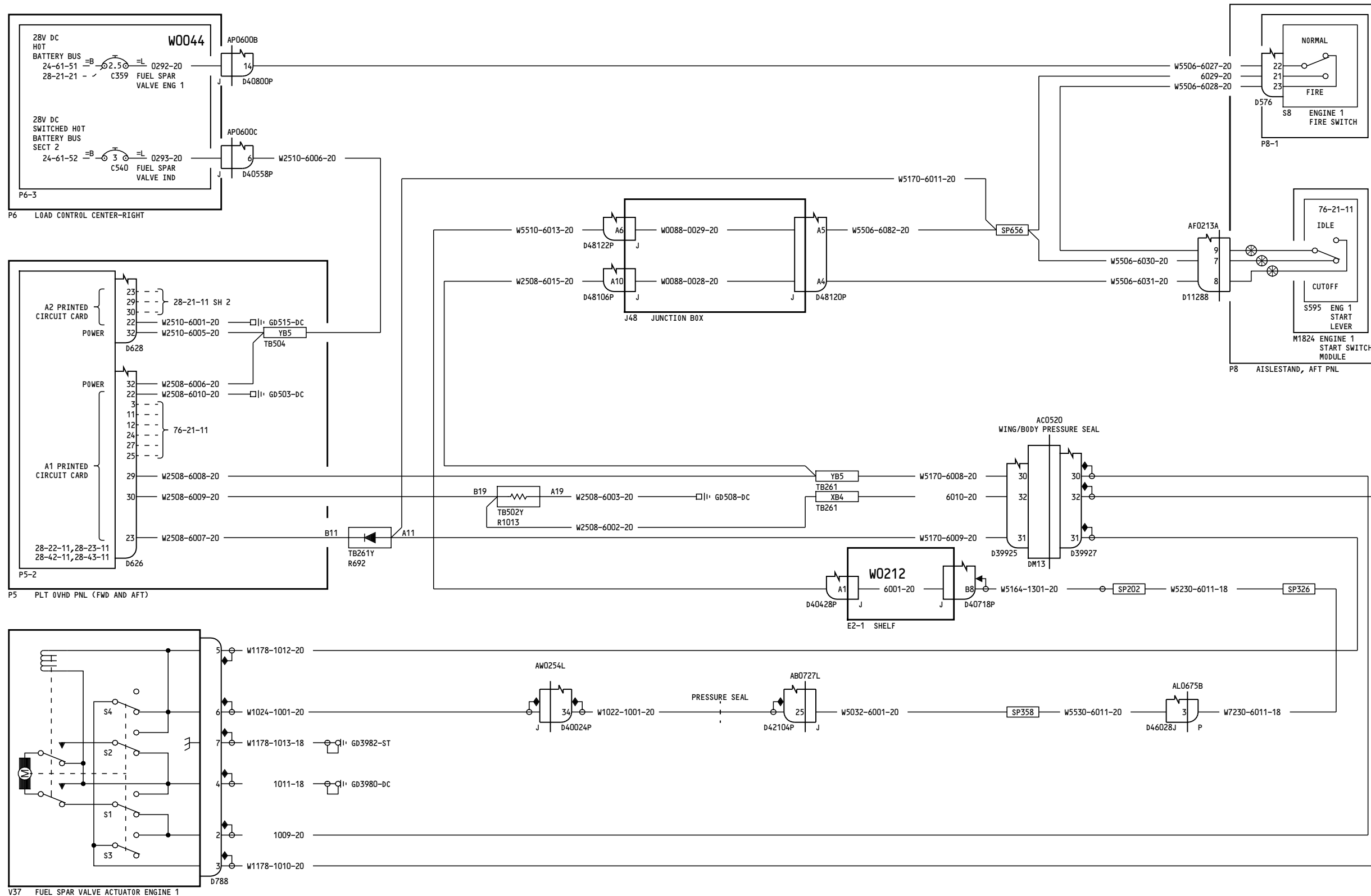

YK902-YK906

ENGINE FUEL SHUT-OFF VALVES

D280A103

28-21-11

Page 4
Sheet 1
Oct 20/2006

28-21-11

Page 4
Sheet 1
Oct 20/2006

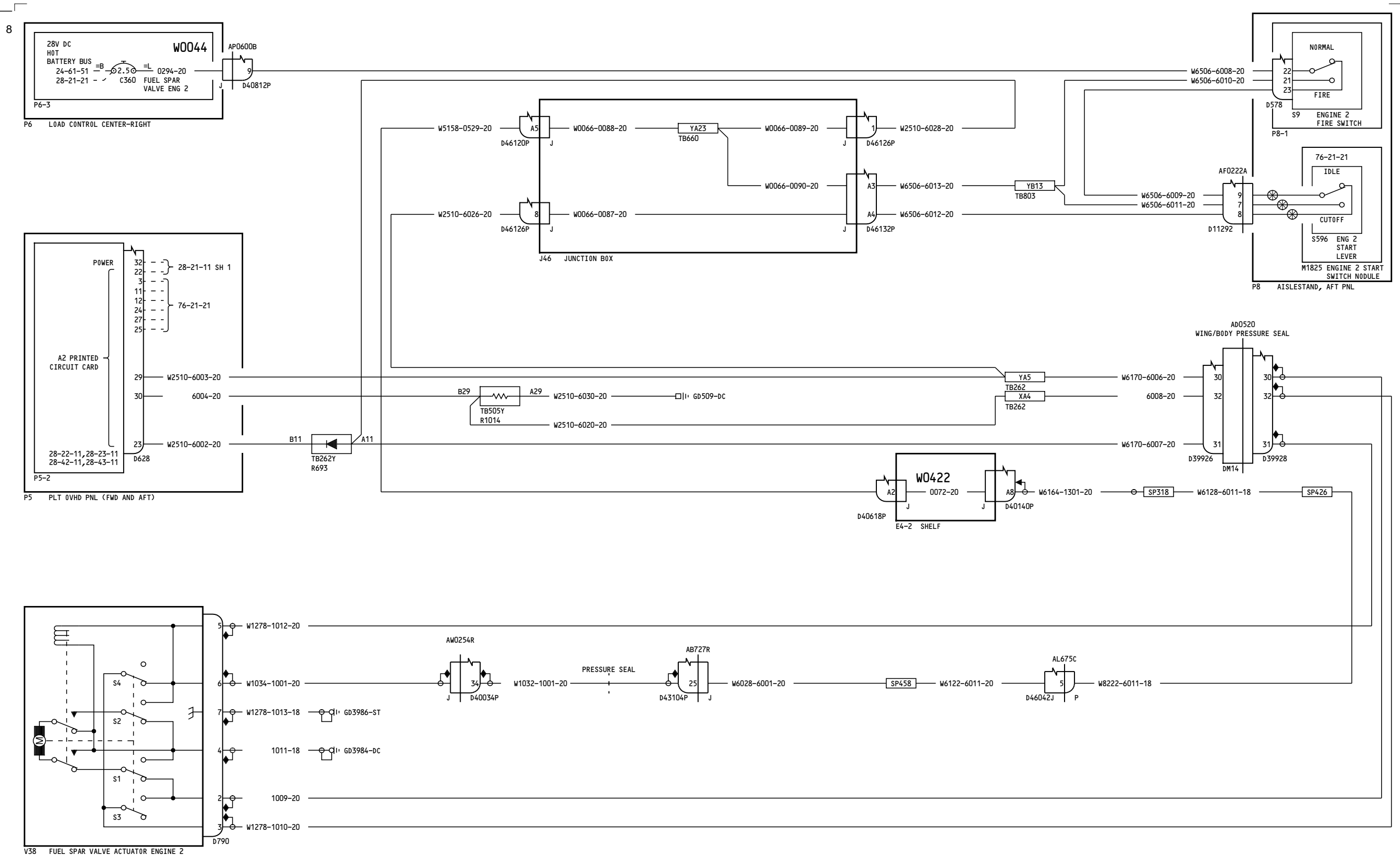

YK902-YK906

ENGINE FUEL SHUT-OFF VALVES

D280A103

28-21-11

Page 4
Sheet 2
Oct 20/2006

28-21-11

Page 4
Sheet 2
Oct 20/2006

-F

1

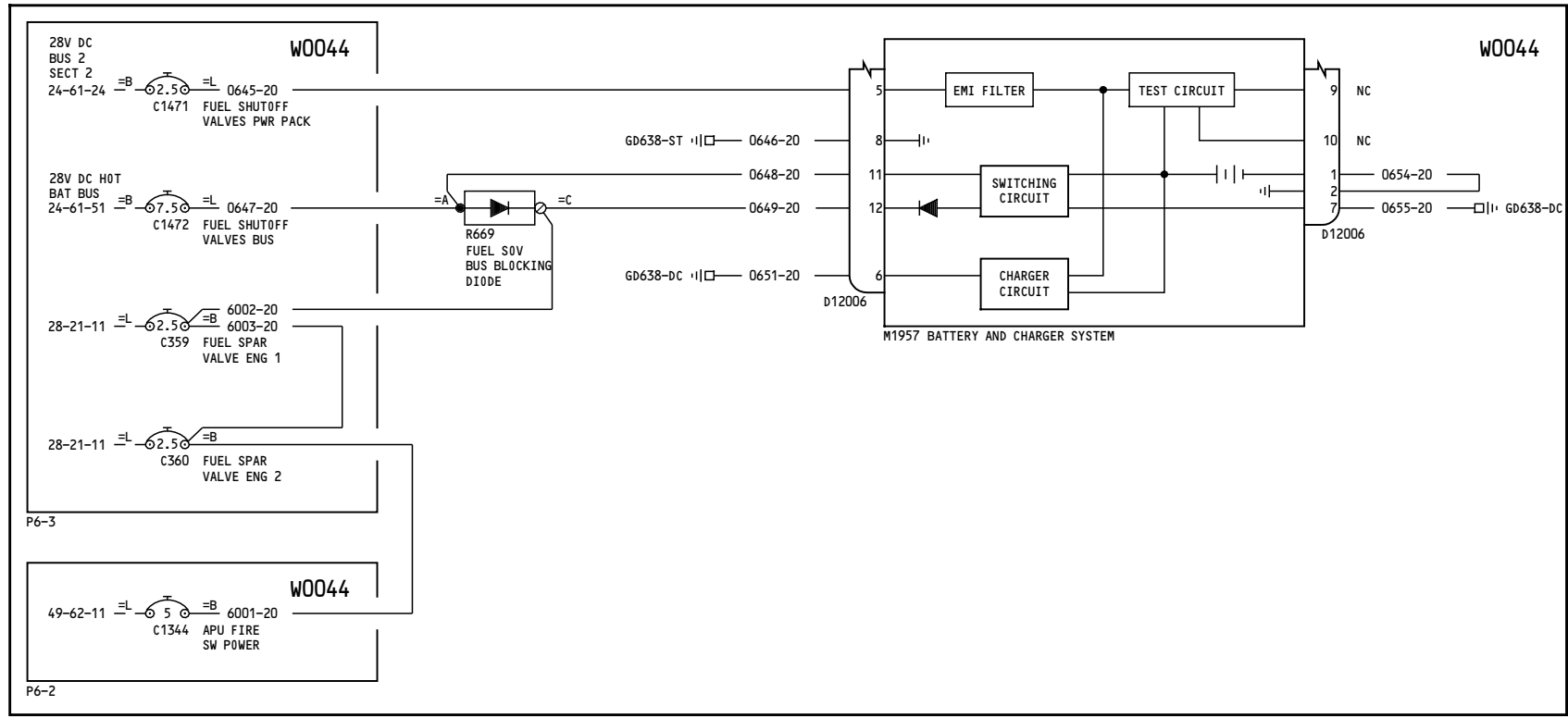

P6 LOAD CONTROL CENTER-RIGHT

YC001-YC006

**BATTERY AND CONTROL POWER
ENGINE SPAR AND APU
FUEL VALVES**

28-21-21

Page 1

Mar 31/2005

D280A103

28-21-21

Page 1

Mar 31/2005

-B
2

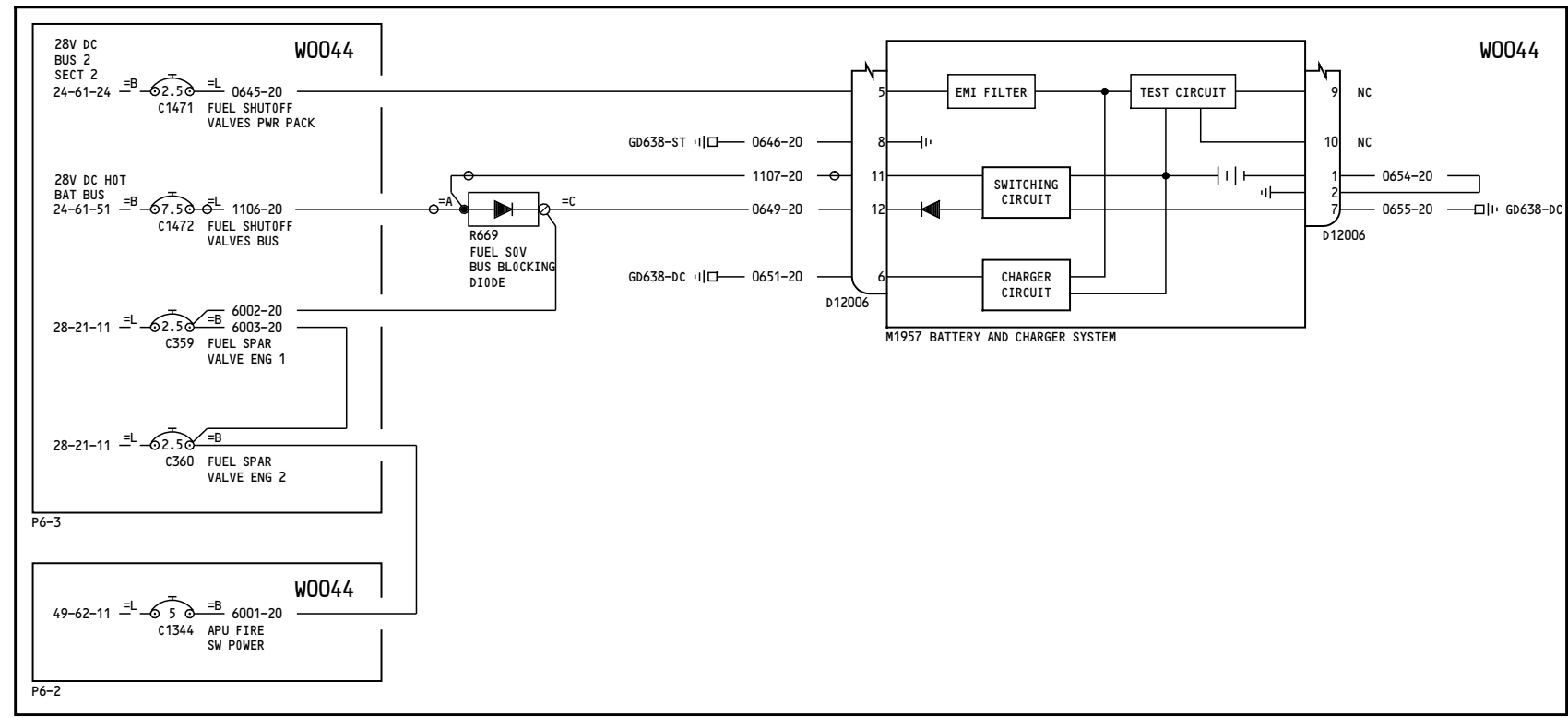

P6 LOAD CONTROL CENTER-RIGHT

YC007-YM670

**BATTERY AND CONTROL POWER
ENGINE SPAR AND APU
FUEL VALVES**

28-21-21

Page 2

Feb 09/2009

D280A103

28-21-21

Page 2

Feb 09/2009

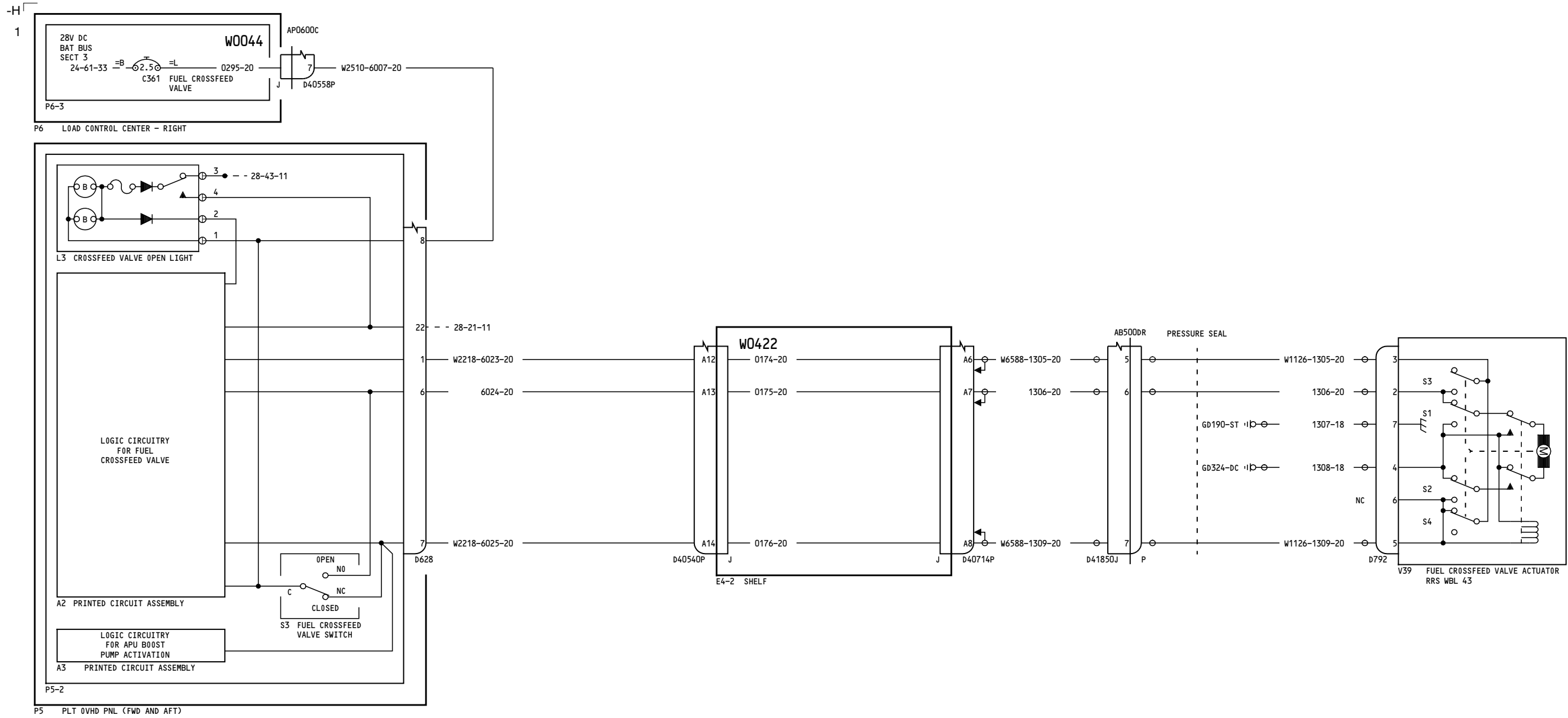

YC001-YK901

FUEL CROSSFEED VALVE

28-22-11

Page 1

Aug 10/2009

D280A103

28-22-11

Page 1

Aug 10/2009

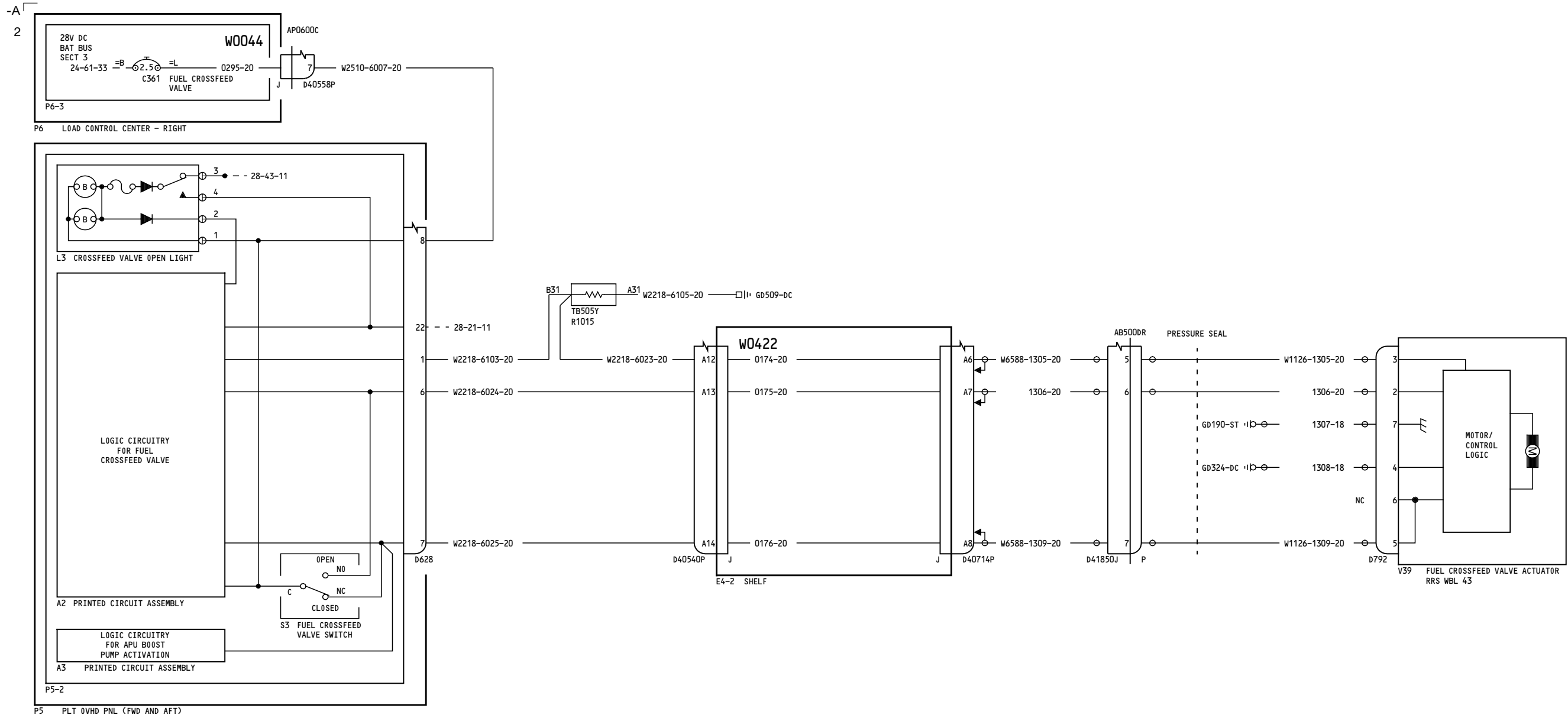

YK902-YK906

FUEL CROSSFEED VALVE

28-22-11

Page 2

D280A103

Feb 09/2009

28-22-11

Page 2

Feb 09/2009

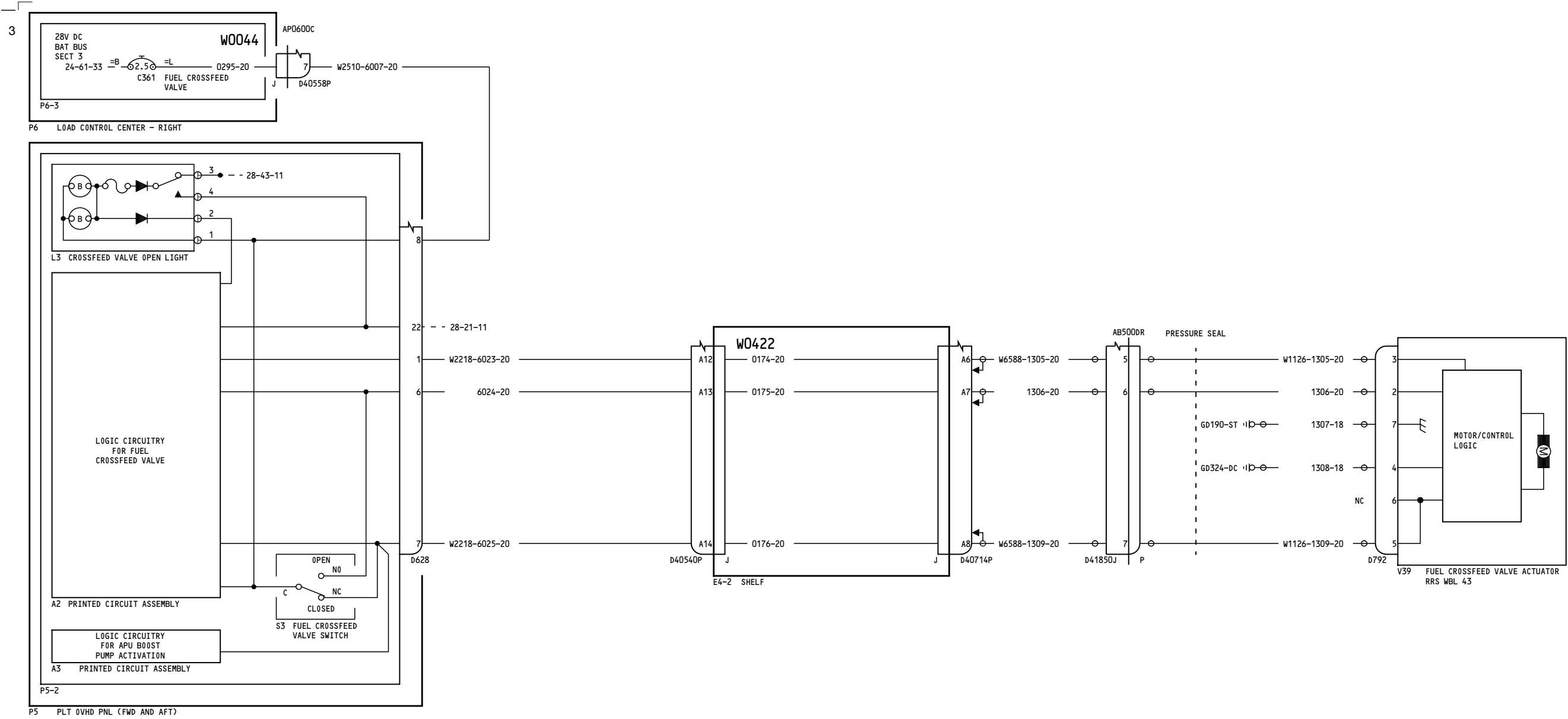

YK907-YM670

FUEL CROSSFEED VALVE

D280A103

28-22-11

Page 3

Aug 10/2009

28-22-11

Page 3

Aug 10/2009

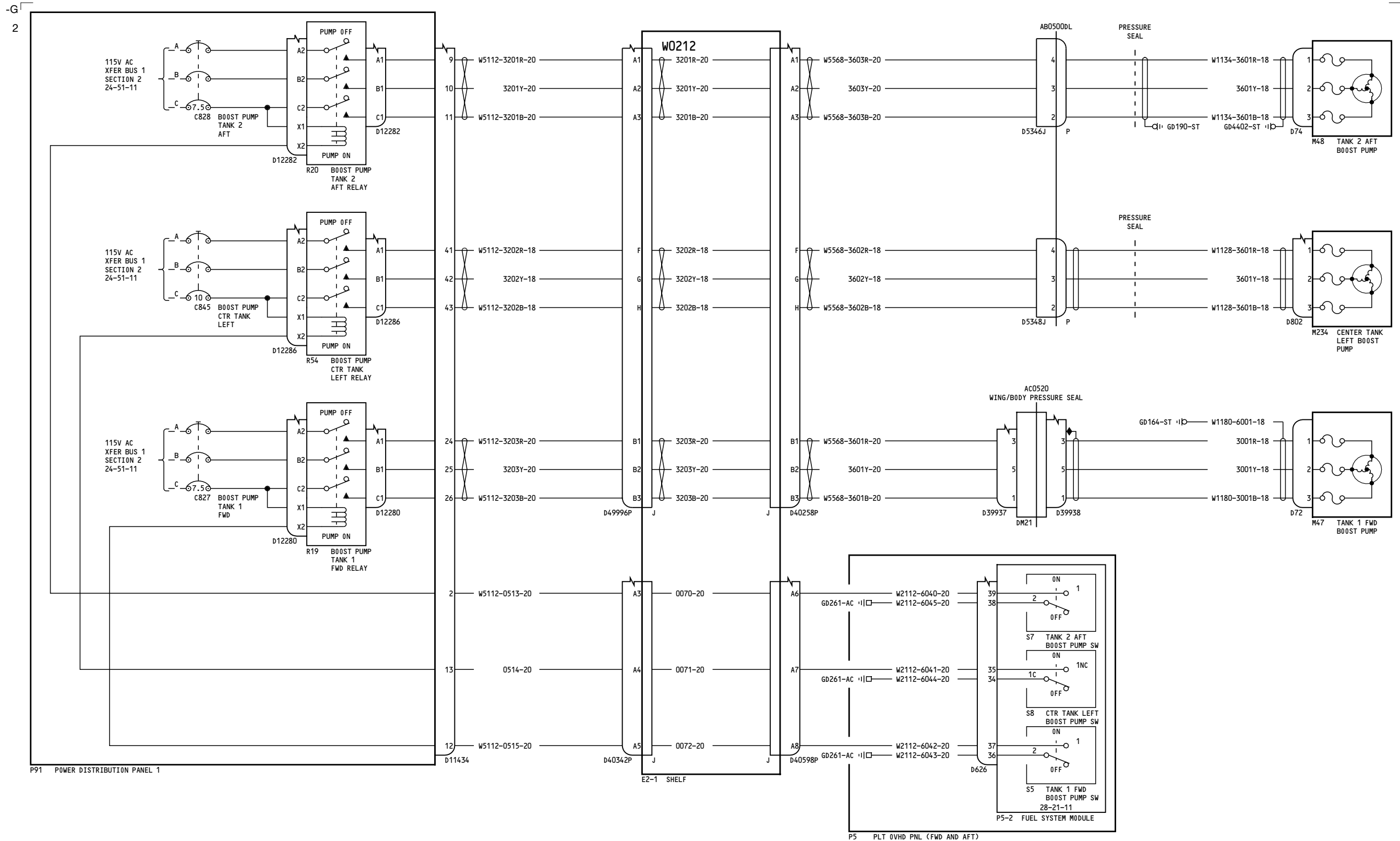

YC001-YC030

FUEL BOOST PUMPS

D280A103

28-23-11

Page 1
Sheet 1
May 11/2009

28-23-11

Page 1
Sheet 1
May 11/2009

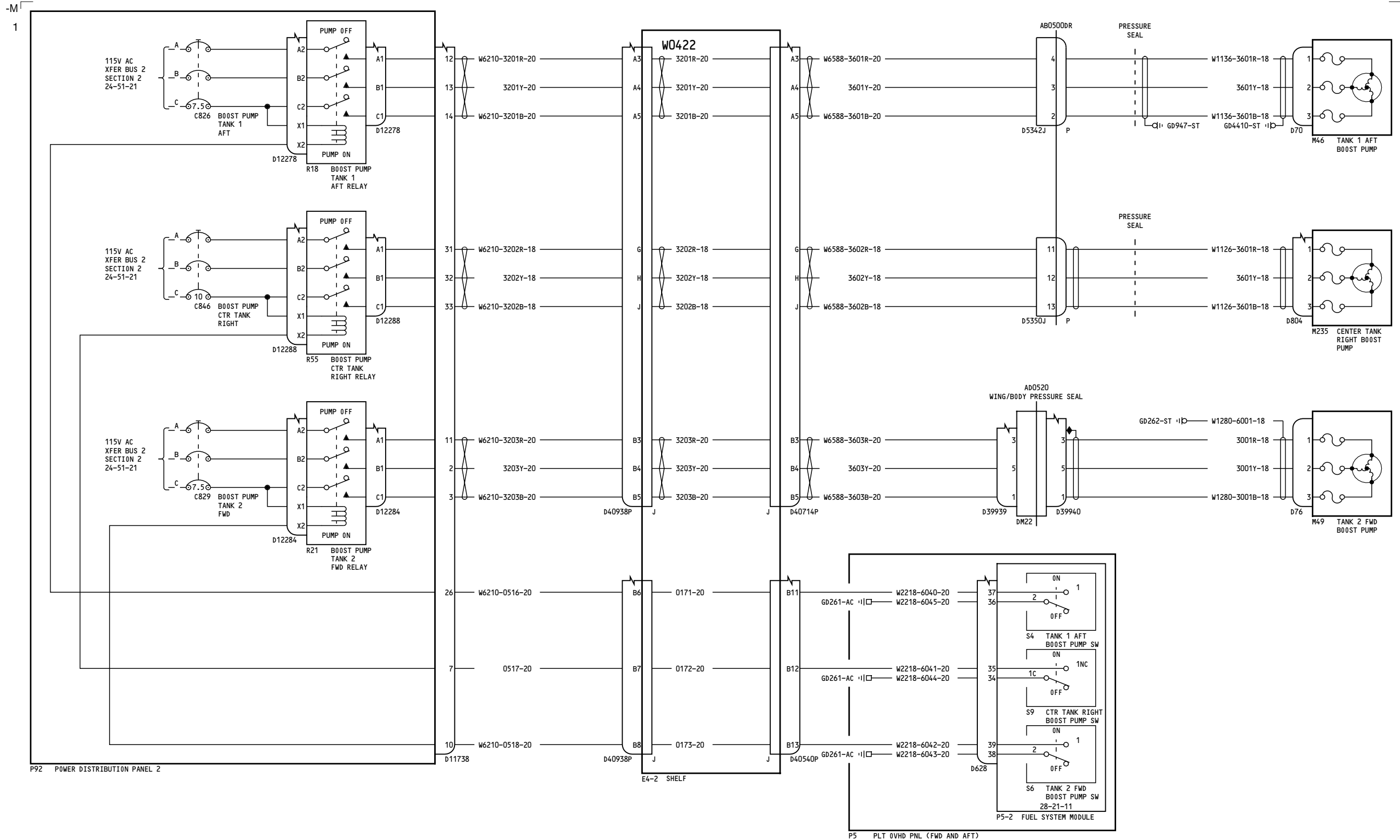

YC001-YC030

FUEL BOOST PUMPS

28-23-11

Page 1
Sheet 2
May 11/2009

D280A103

28-23-11

Page 1
Sheet 2
May 11/2009

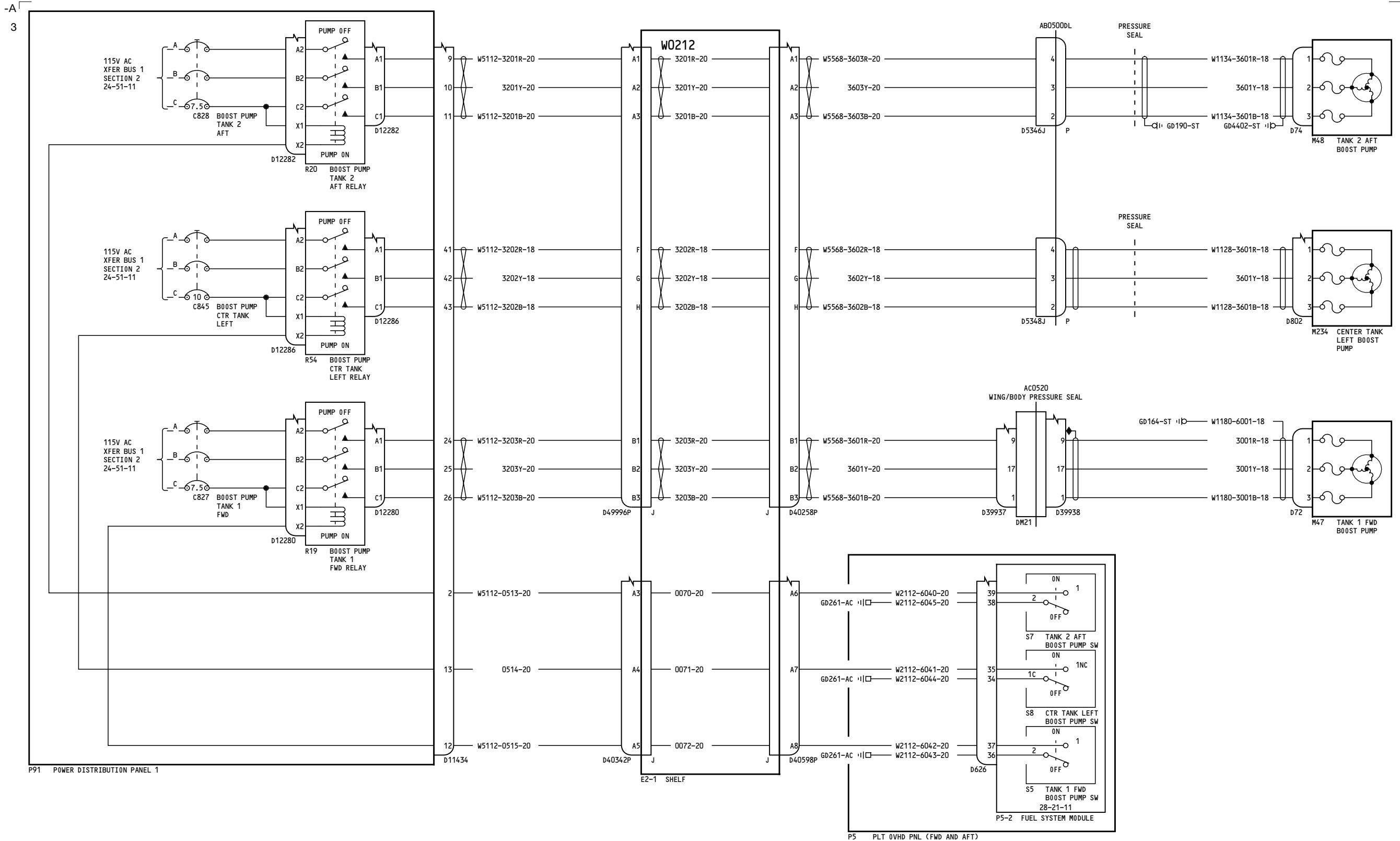

YC001-YC030

FUEL BOOST PUMPS

28-23-11

Incorporates 28-1194 R02

28-23-11

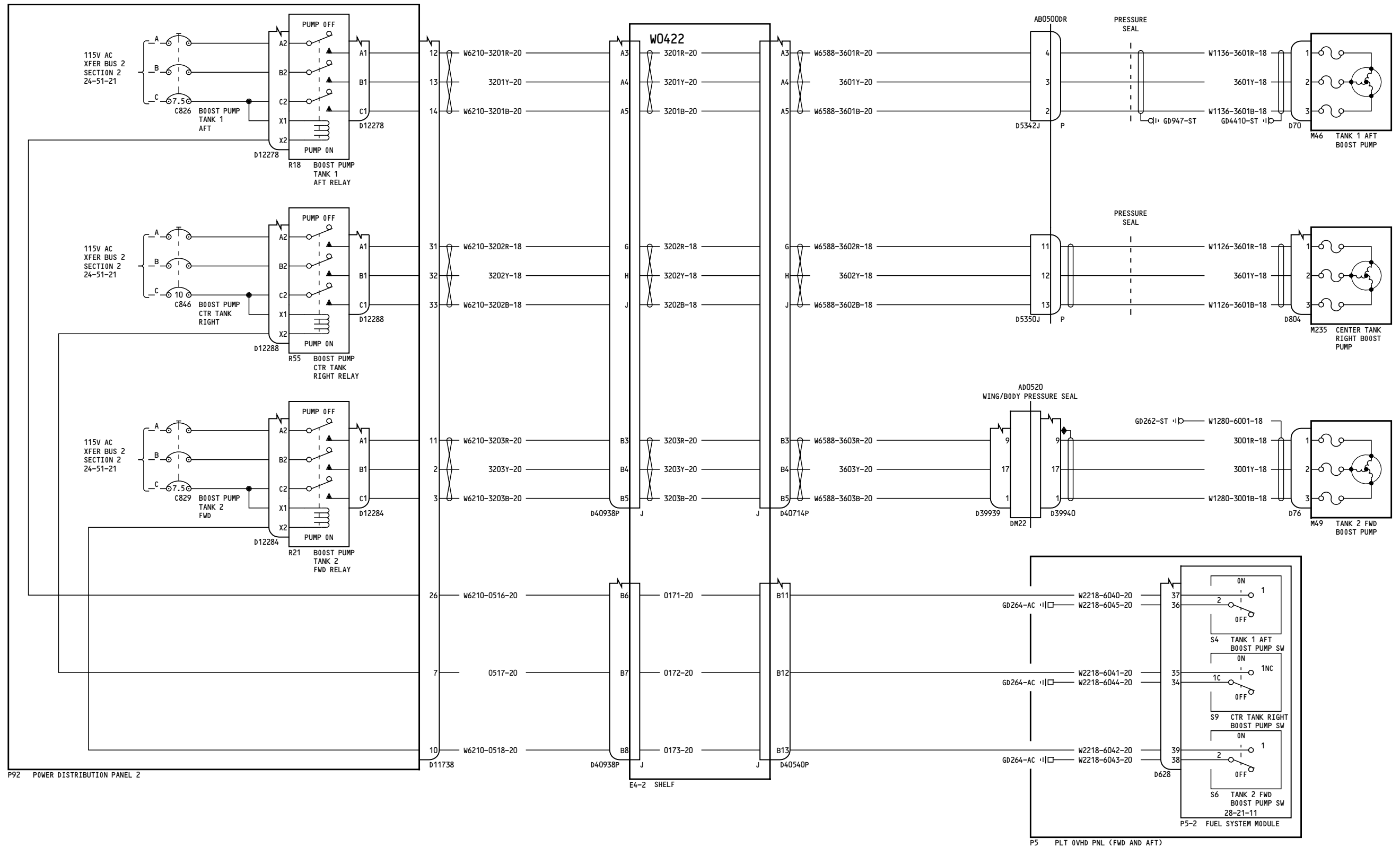

YC001-YC030

FUEL BOOST PUMPS

28-23-11

Page 1.1
Sheet 2
Aug 13/2008

D280A103

Incorporates
28-1194 R02
28-1257 R01

28-23-11

Page 1.1
Sheet 2
Aug 13/2008

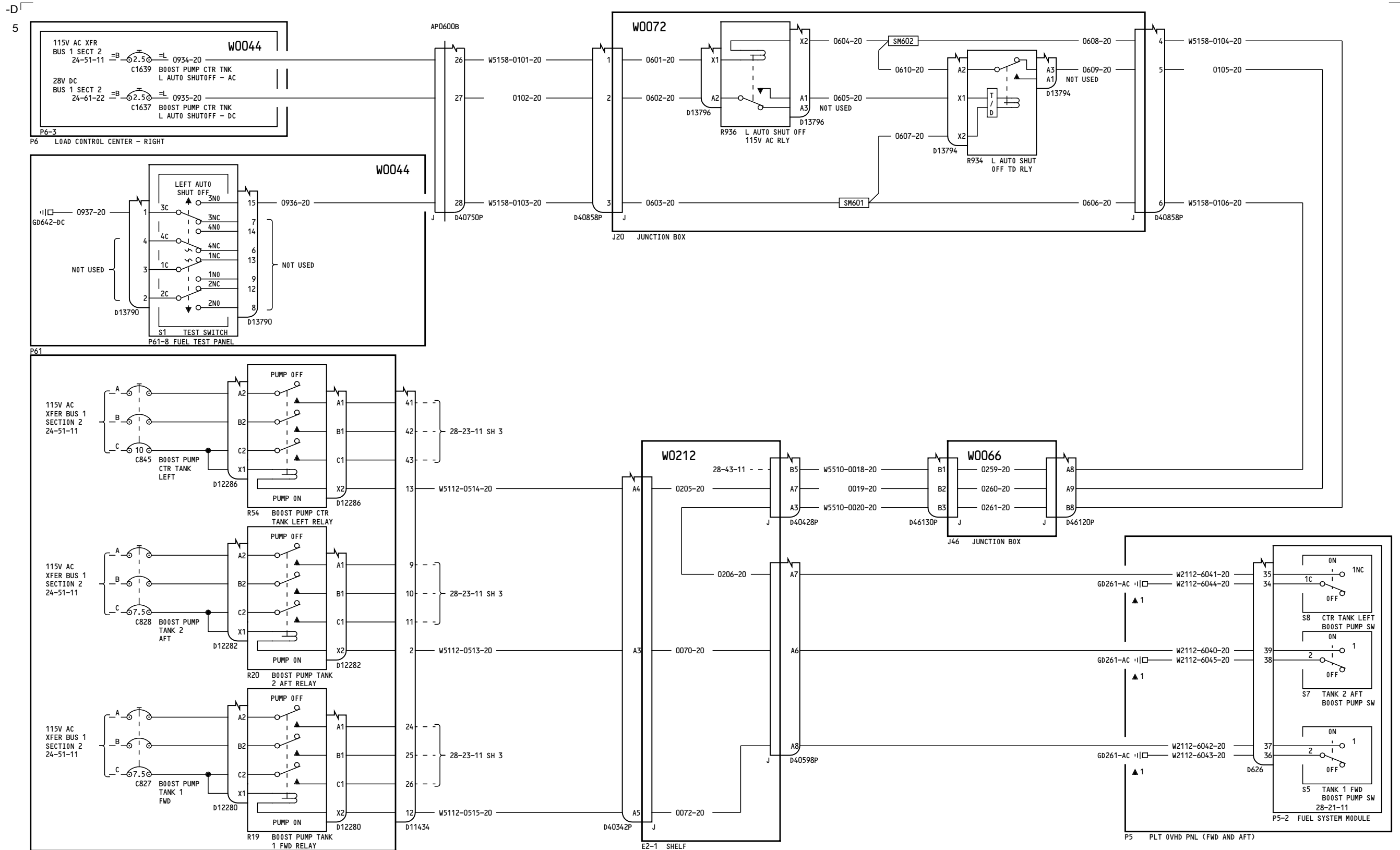

YK901

FUEL BOOST PUMPS

28-23-11

Page 2
Sheet 1
Jul 26/2006

D280A103

28-23-11

Page 2
Sheet 1
Jul 26/2006

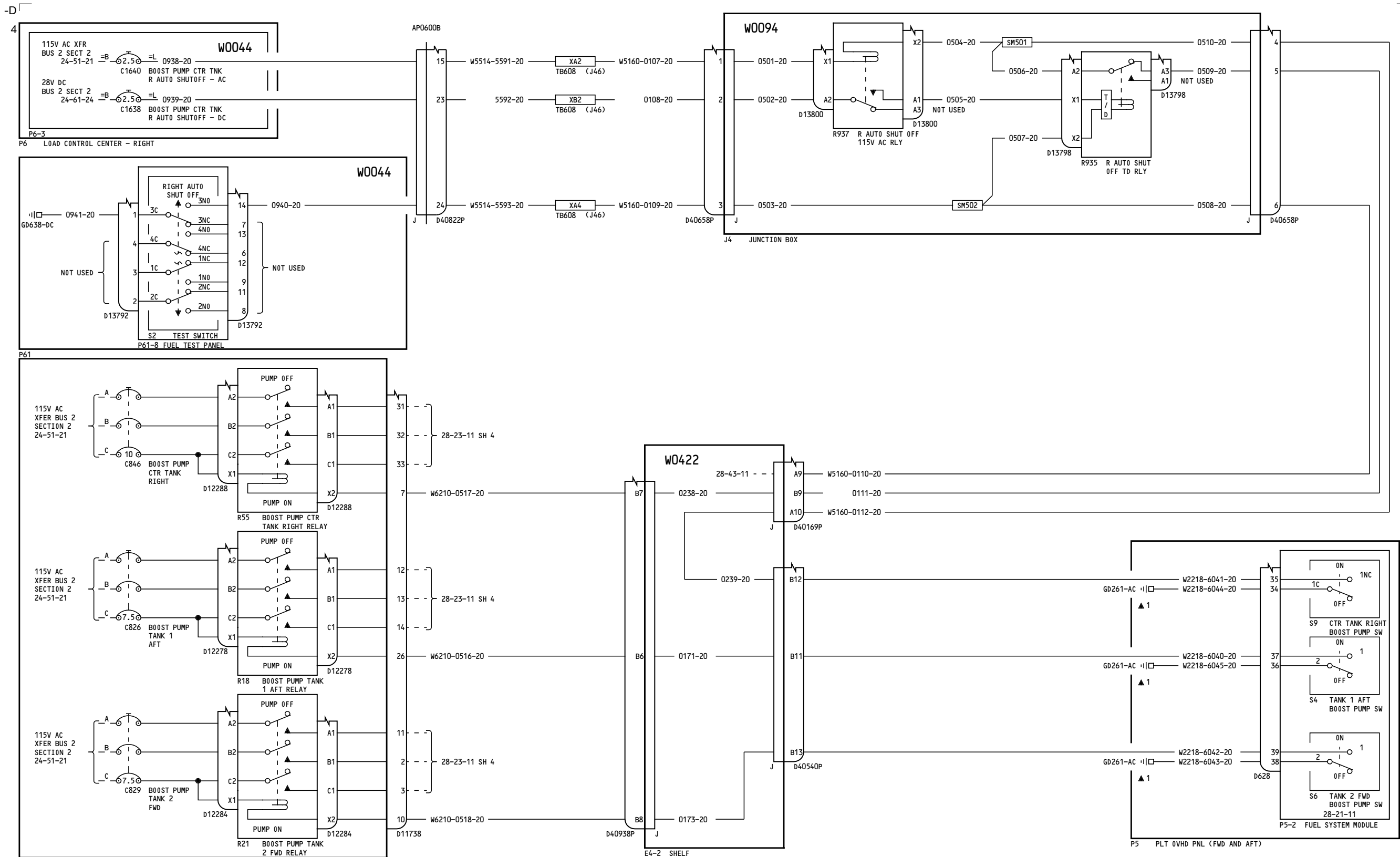

P6-3
LOAD CONTROL CENTER - RIGHT

P61
POWER DISTRIBUTION PANEL 2

YK901

FUEL BOOST PUMPS

28-23-11

Page 2
Sheet 2
Jul 26/2006

D280A103

28-23-11

Page 2
Sheet 2
Jul 26/2006

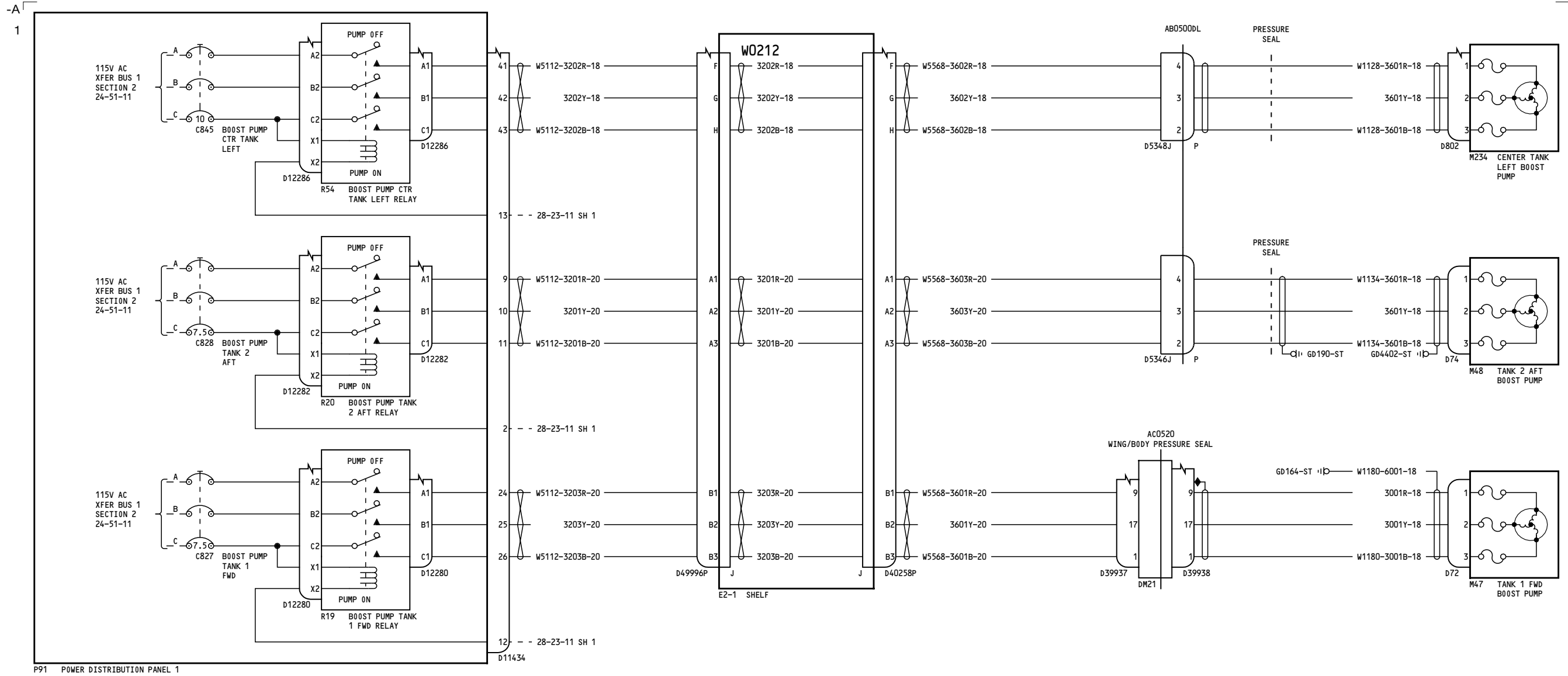

P91 POWER DISTRIBUTION PANEL 1

YK901

FUEL BOOST PUMPS

D280A103

28-23-11

Page 2
Sheet 3
Jul 26/2006

28-23-11

Page 2
Sheet 3
Jul 26/2006

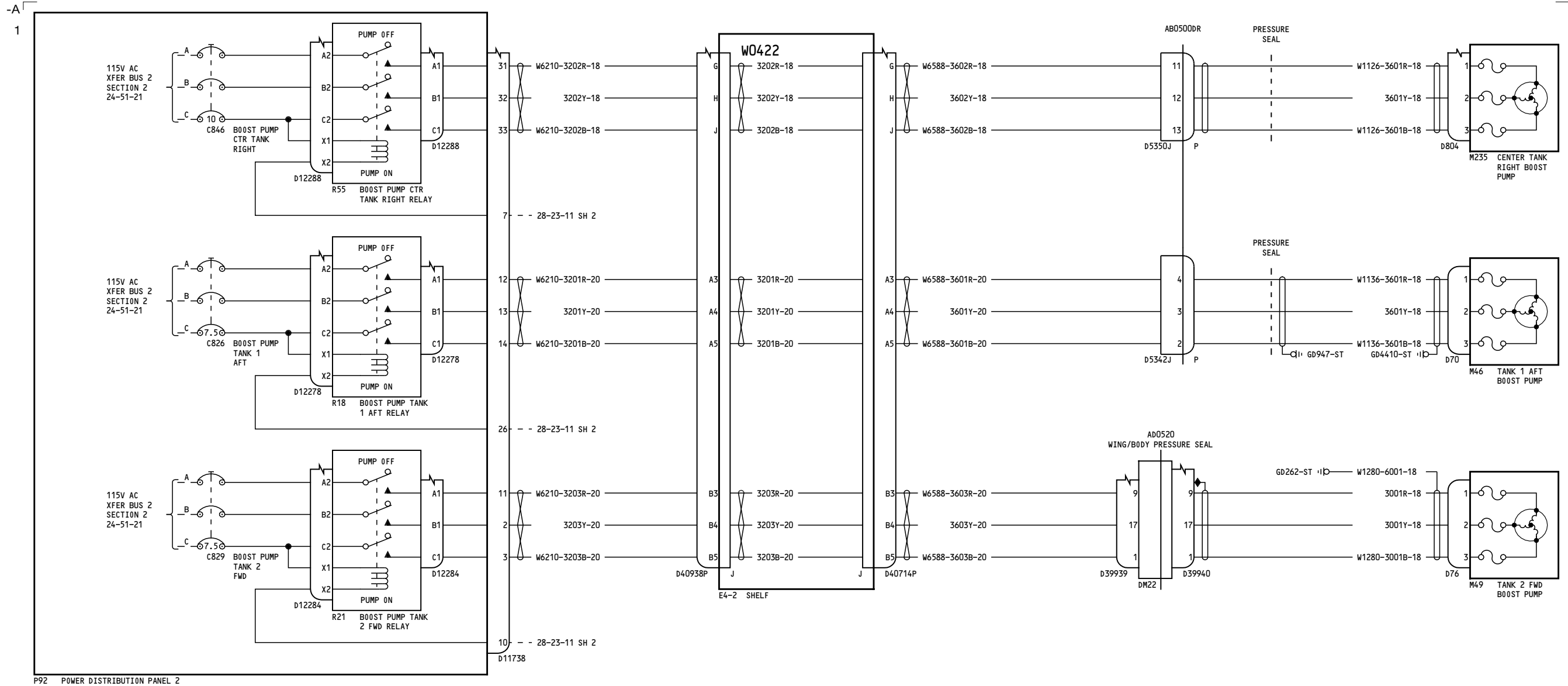

P92 POWER DISTRIBUTION PANEL 2

YK901

FUEL BOOST PUMPS

D280A103

28-23-11

Page 2
Sheet 4
Jul 26/2006

28-23-11

Page 2
Sheet 4
Jul 26/2006

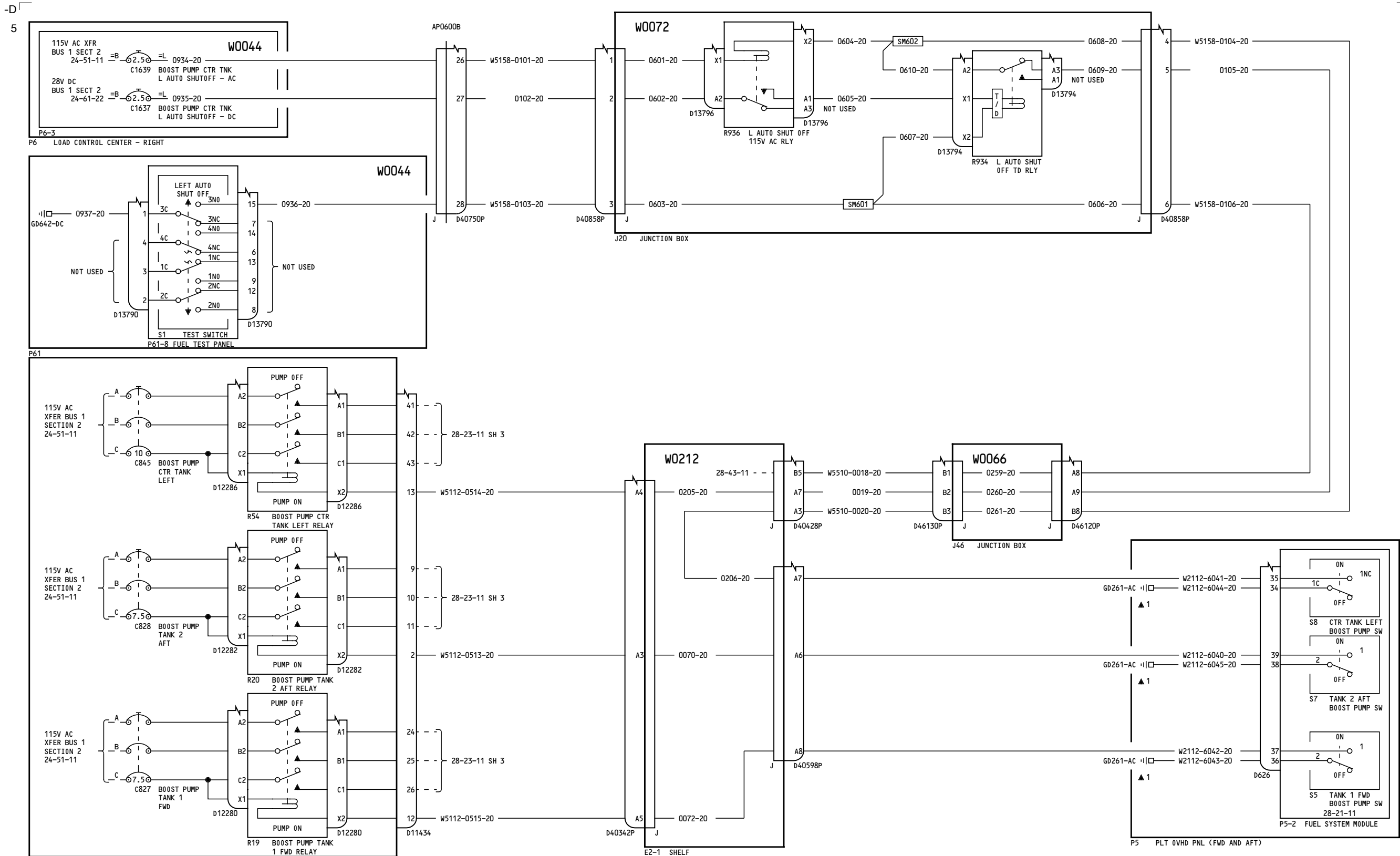

YK901

FUEL BOOST PUMPS

28-23-11

Page 2.1
Sheet 1
Aug 13/2008

D280A103

28-23-11

Page 2.1
Sheet 1
Aug 13/2008

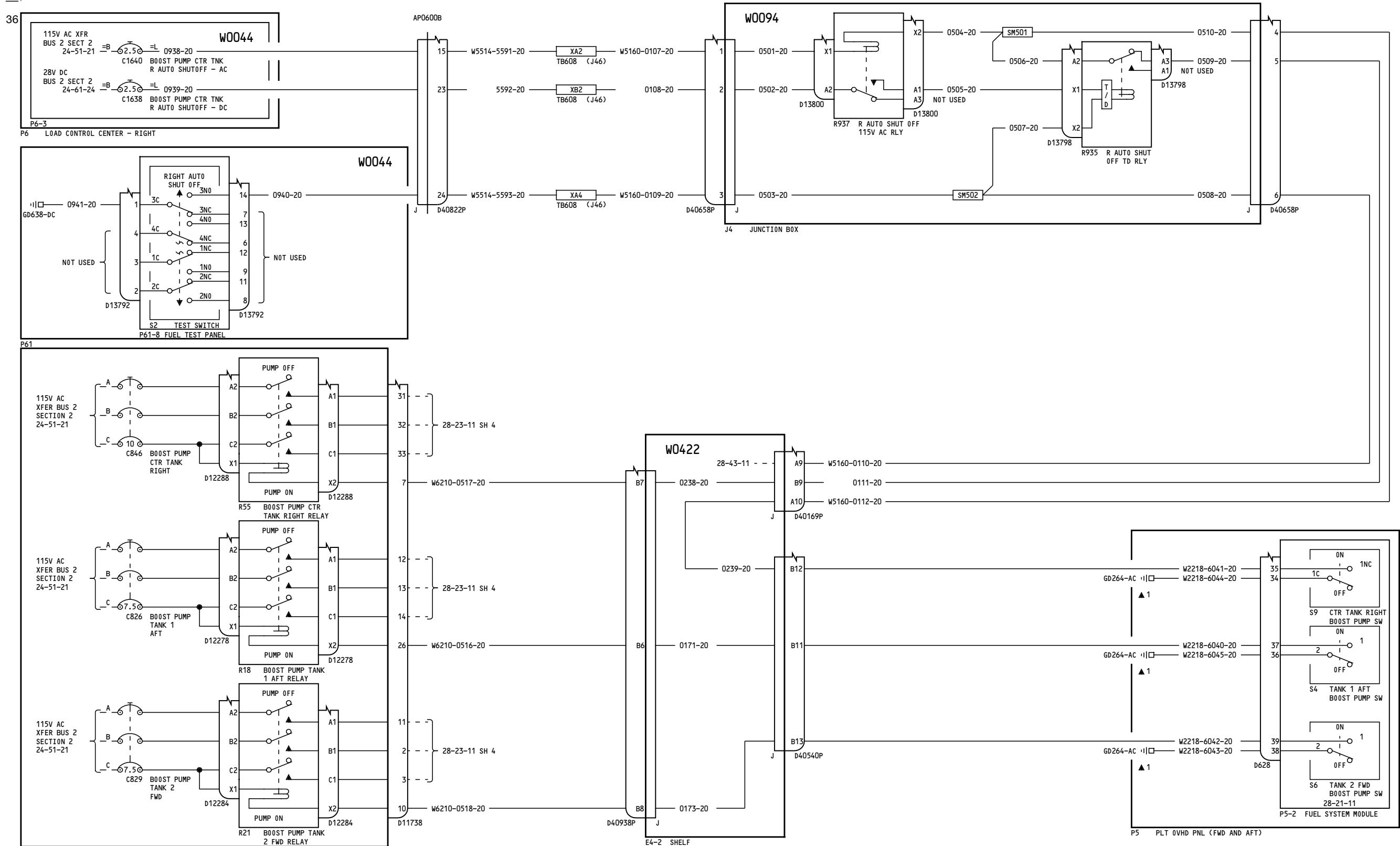

YK901

FUEL BOOST PUMPS

D280A103

28-23-11

Page 2.1
Sheet 2
Aug 13/2008

Incorporates
28-1257 R01

28-23-11

Page 2.1
Sheet 2
Aug 13/2008

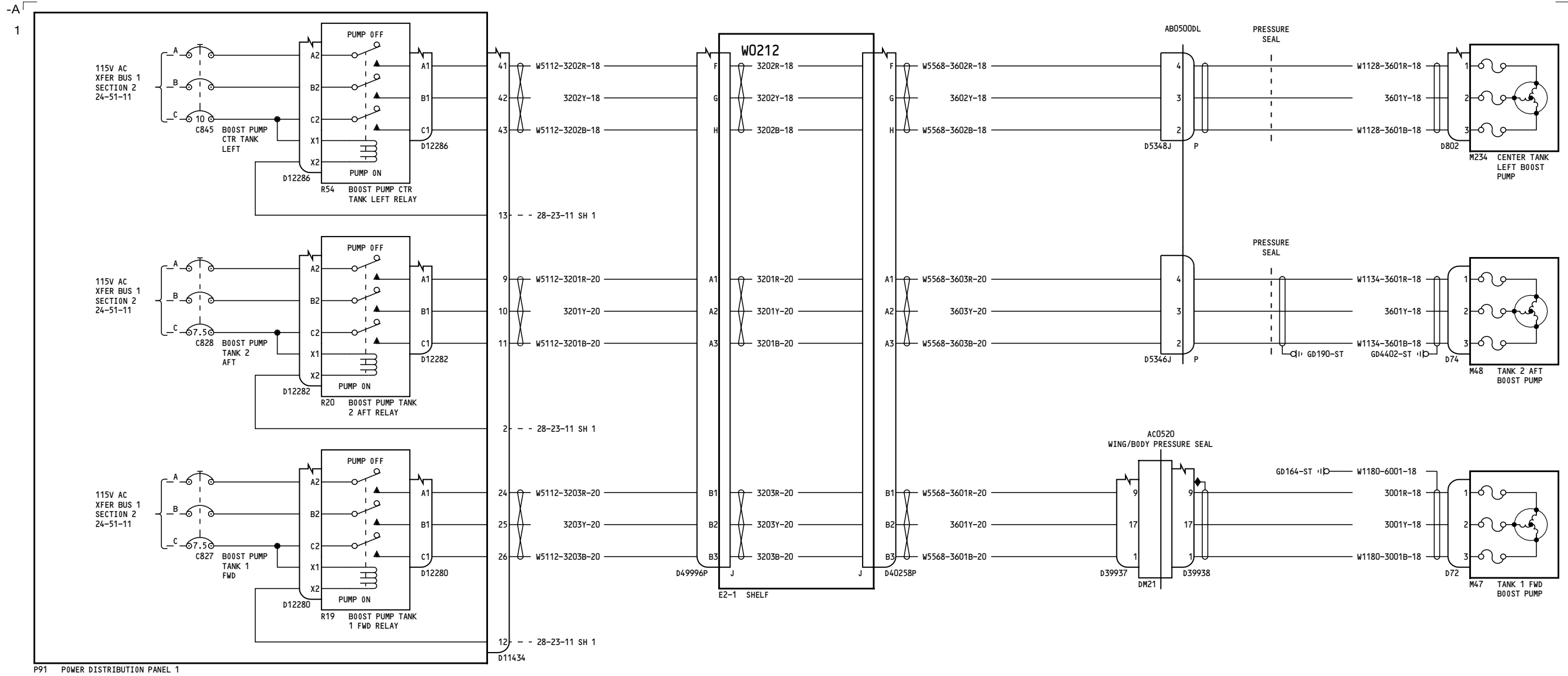

P91 POWER DISTRIBUTION PANEL 1

YK901

FUEL BOOST PUMPS

D280A103

28-23-11

Page 2.1
Sheet 3
Aug 13/2008

28-23-11

Page 2.1
Sheet 3
Aug 13/2008

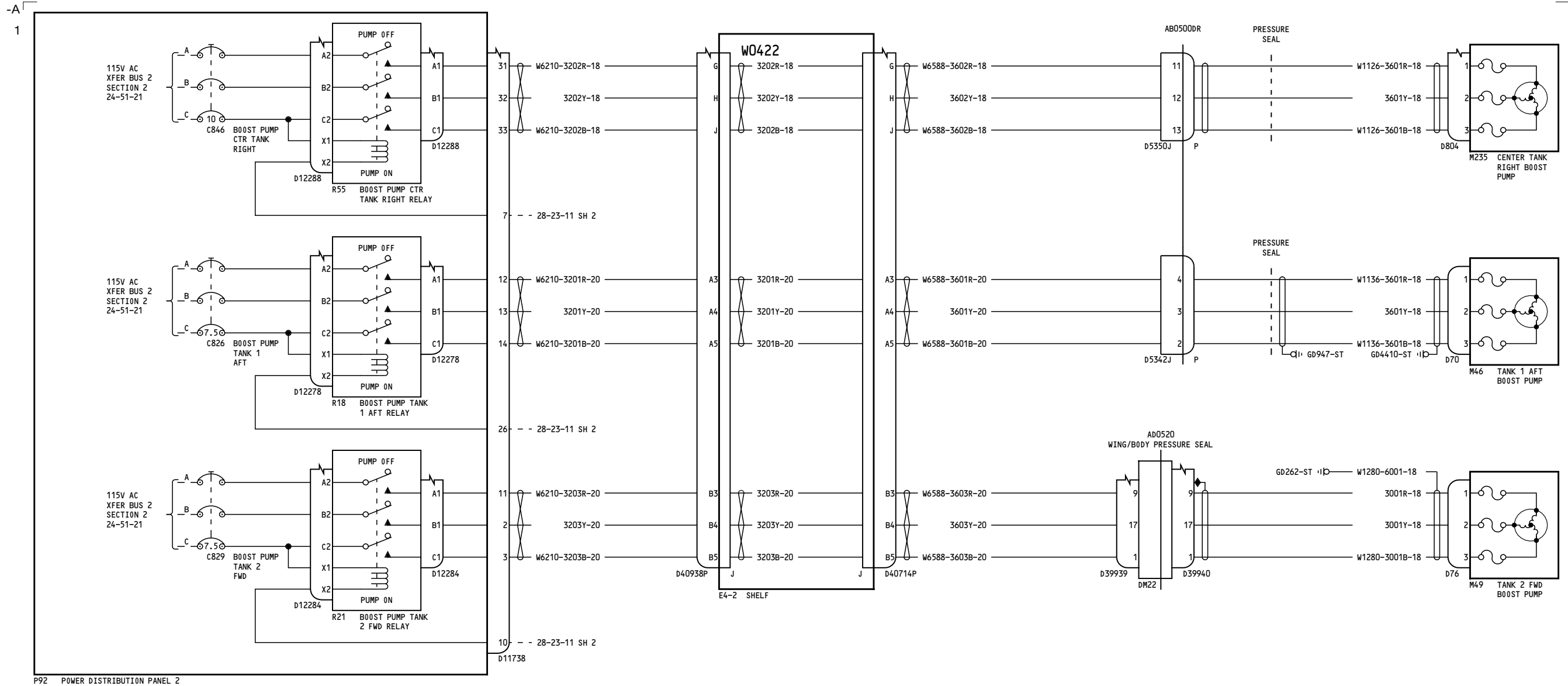

P92 POWER DISTRIBUTION PANEL 2

YK901	<p>FUEL BOOST PUMPS</p> <p>D280A103</p>
-------	--

28-23-11

Page 2.1
Sheet 4
Aug 13/2008

28-23-11

Page 2.1
Sheet 4
Aug 13/2008

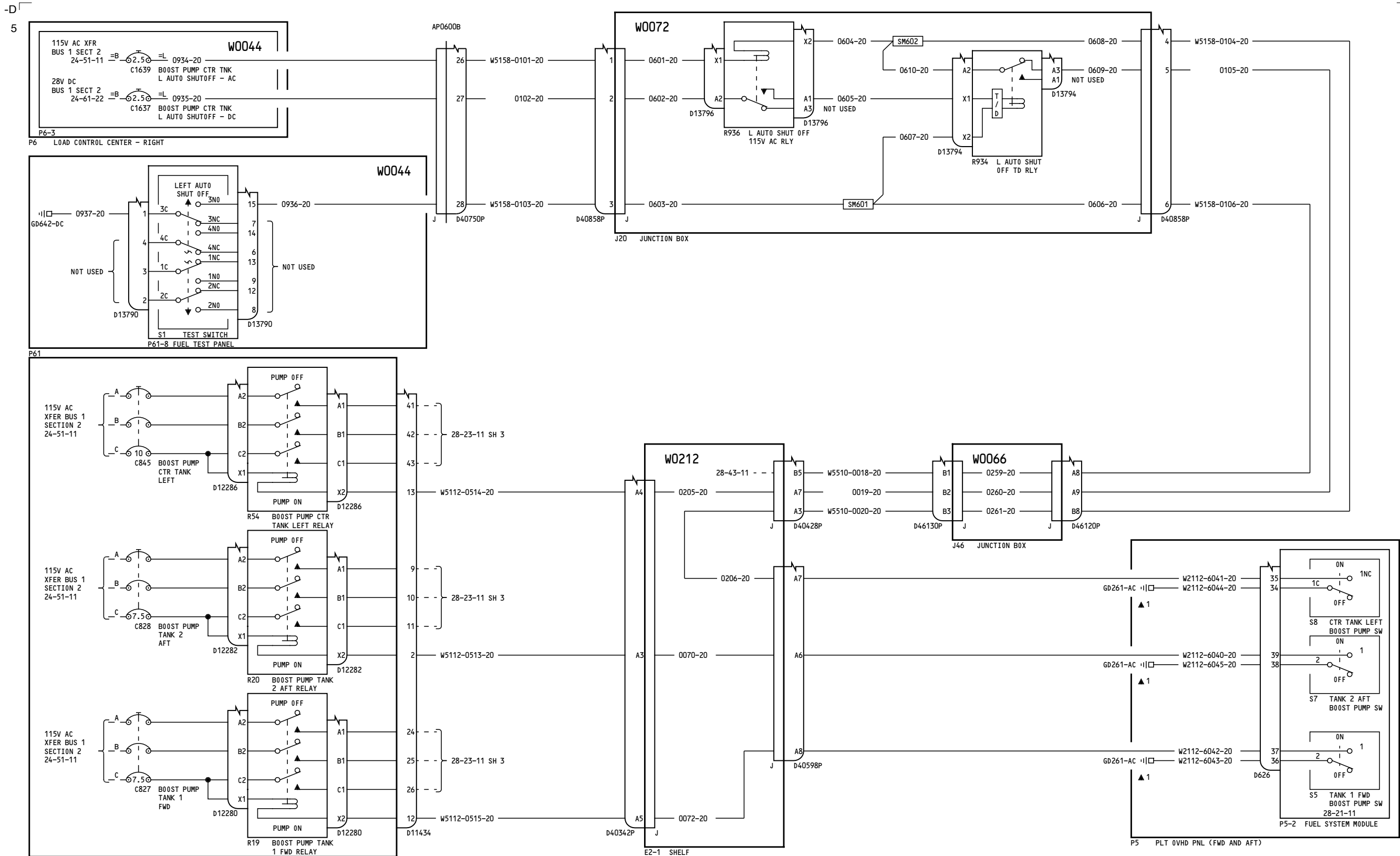

YK902-YK906

FUEL BOOST PUMPS

28-23-11

Page 3
Sheet 1
Jul 26/2006

D280A103

28-23-11

Page 3
Sheet 1
Jul 26/2006

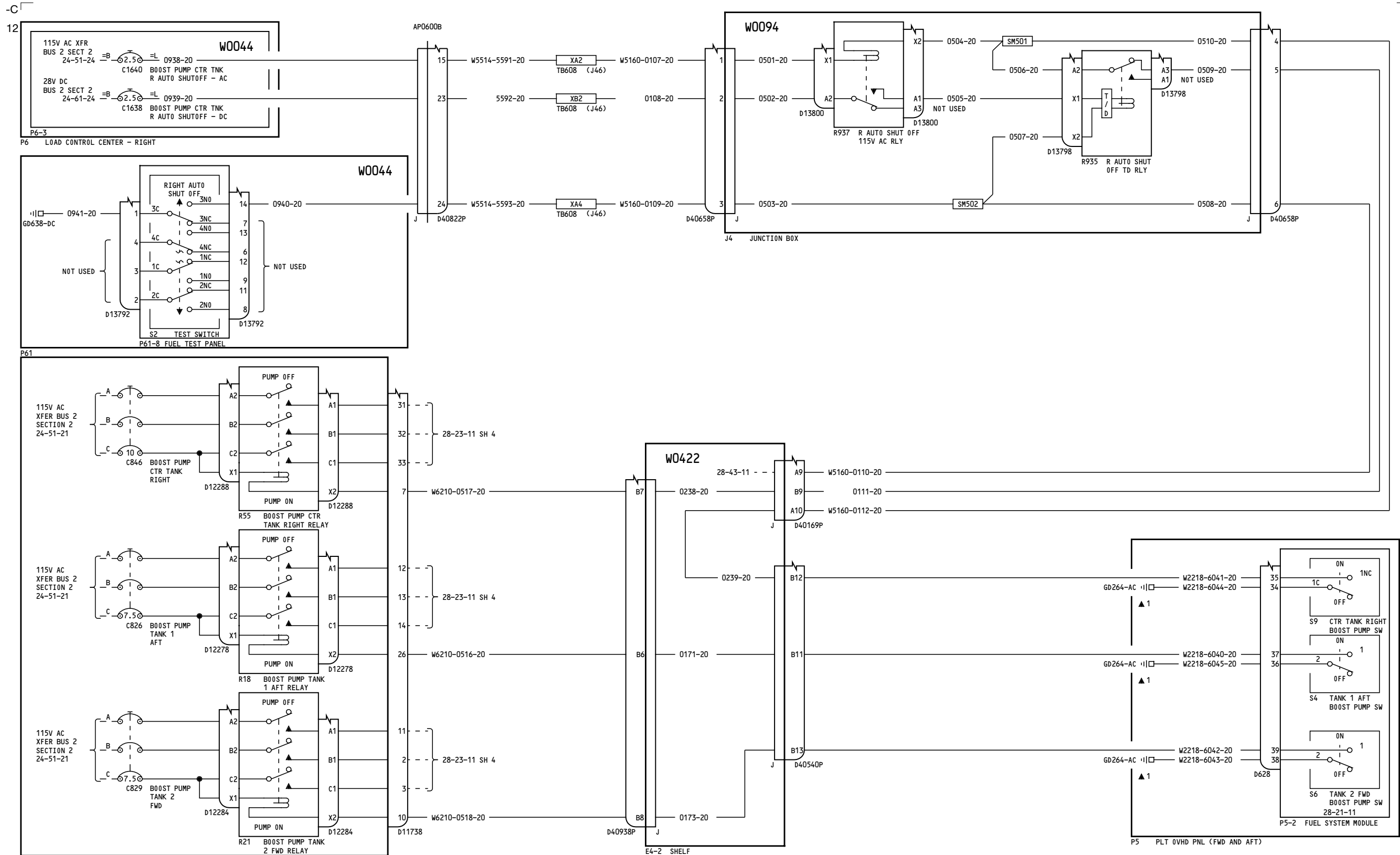

YK902-YK906

FUEL BOOST PUMPS

28-23-11

Page 3
Sheet 2
Jul 26/2006

D280A103

28-23-11

Page 3
Sheet 2
Jul 26/2006

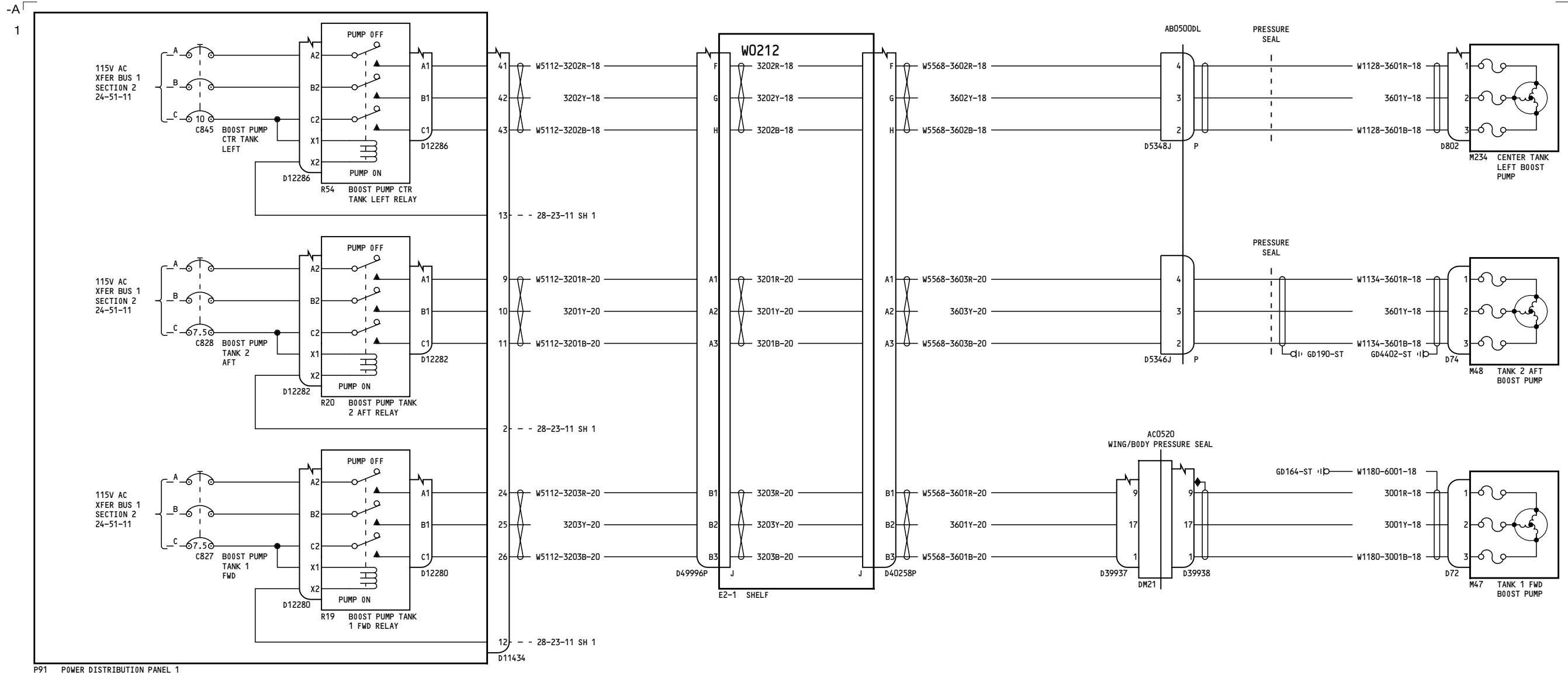

P91 POWER DISTRIBUTION PANEL 1

YK902-YK906

FUEL BOOST PUMPS

D280A103

28-23-11

Page 3
Sheet 3
Jul 26/2006

28-23-11

Page 3
Sheet 3
Jul 26/2006

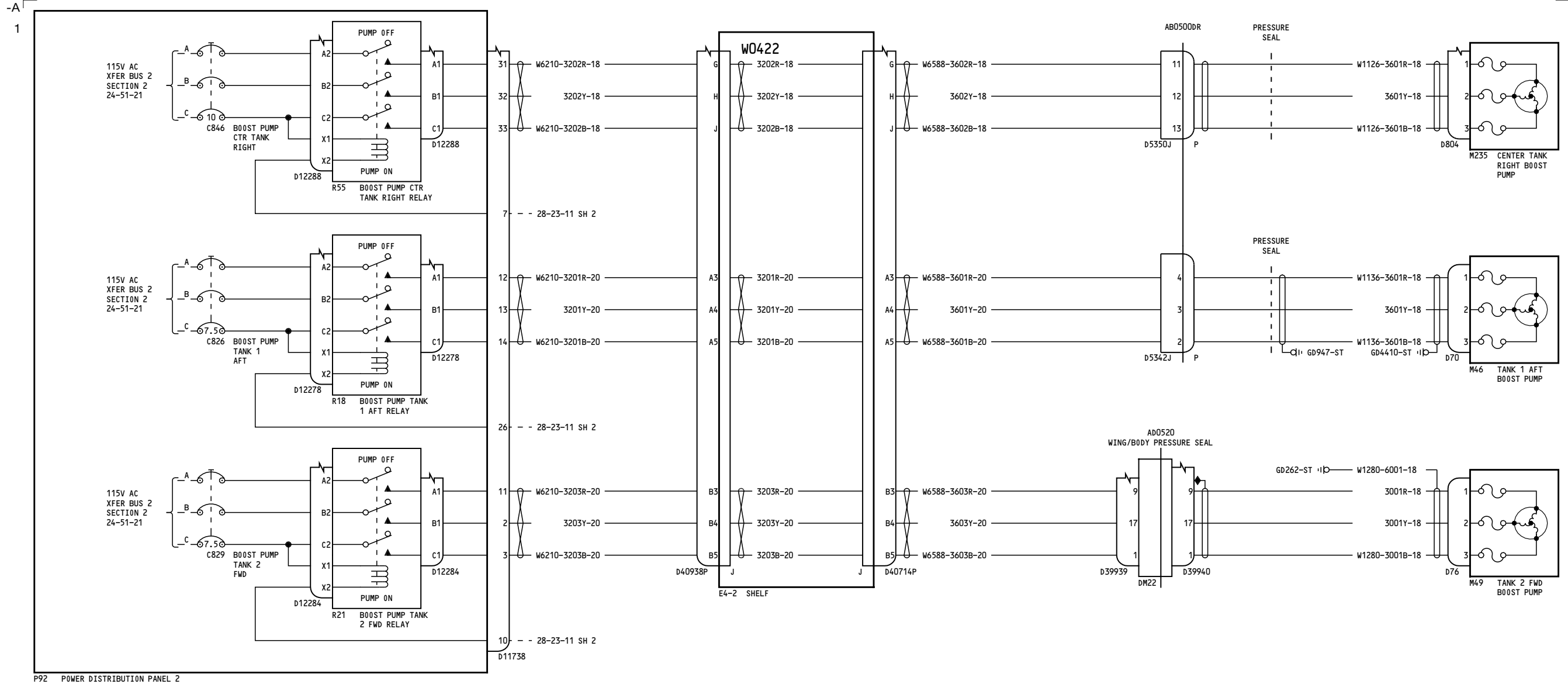

P92 POWER DISTRIBUTION PANEL 2

YK902-YK906

FUEL BOOST PUMPS

D280A103

28-23-11

Page 3
Sheet 4
Jul 26/2006

28-23-11

Page 3
Sheet 4
Jul 26/2006

-A
13

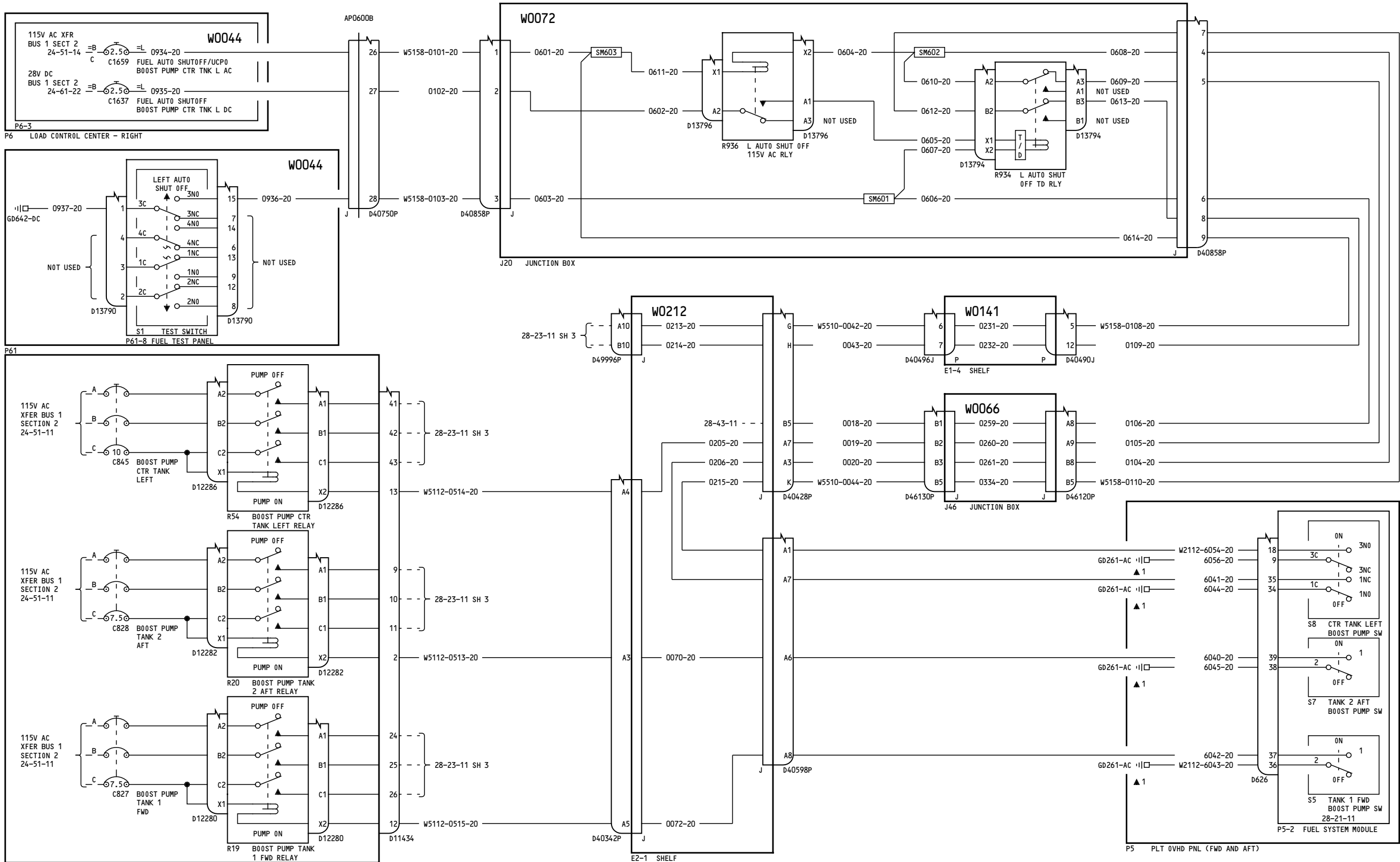

P91 POWER DISTRIBUTION PANEL 1

YK907, YL421

FUEL BOOST PUMPS

D280A103

28-23-11

Page 4
Sheet 1
Jan 18/2007

28-23-11

Page 4
Sheet 1
Jan 18/2007

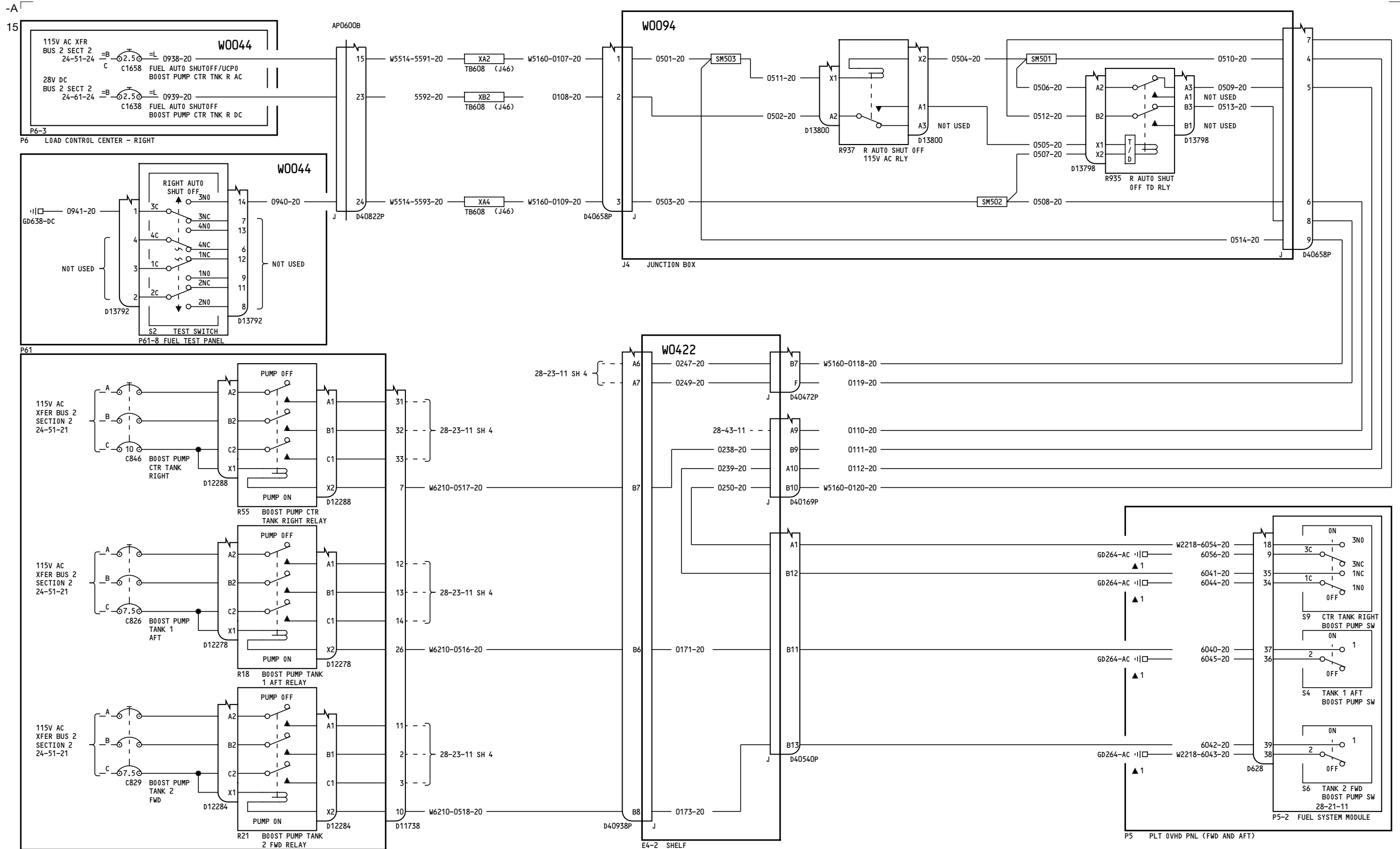

YK907, YL421

FUEL BOOST PUMPS

28-23-11

Page 4
Sheet 2
Jan 18/2007

D280A103

28-23-11

Page 4
Sheet 2
Jan 18/2007

-A
6

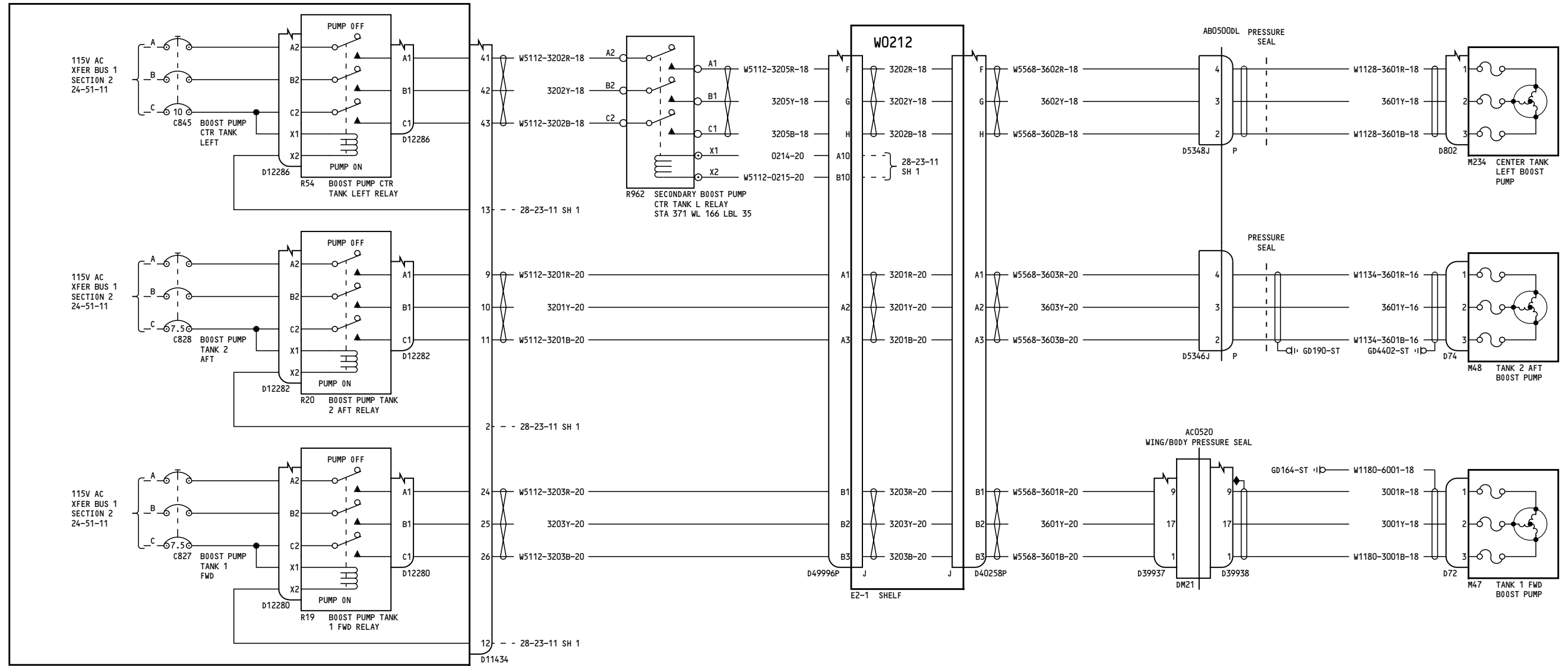

P91 POWER DISTRIBUTION PANEL 1

YK907, YL421

FUEL BOOST PUMPS

D280A103

28-23-11

Page 4
Sheet 3
Jan 18/2007

28-23-11

Page 4
Sheet 3
Jan 18/2007

-A
6

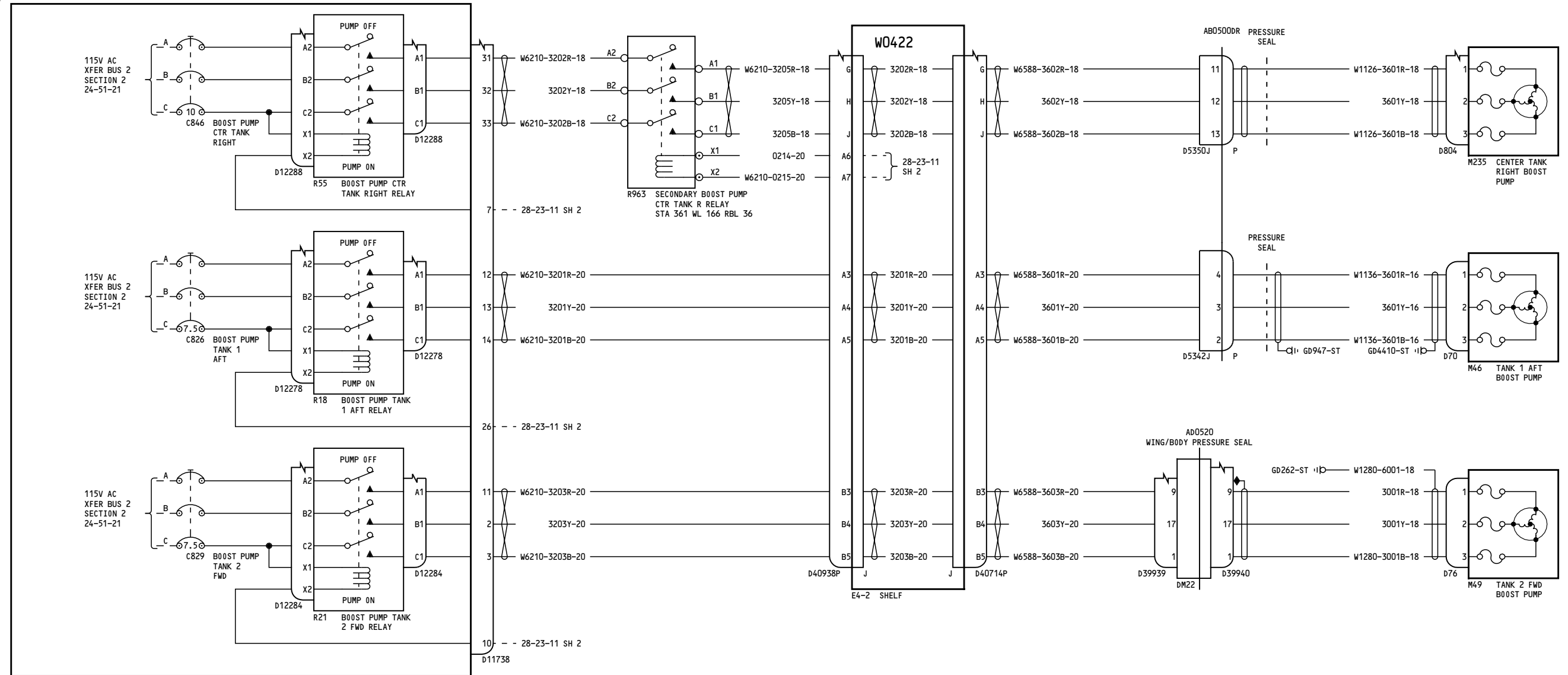

P92 POWER DISTRIBUTION PANEL 2

-A
14

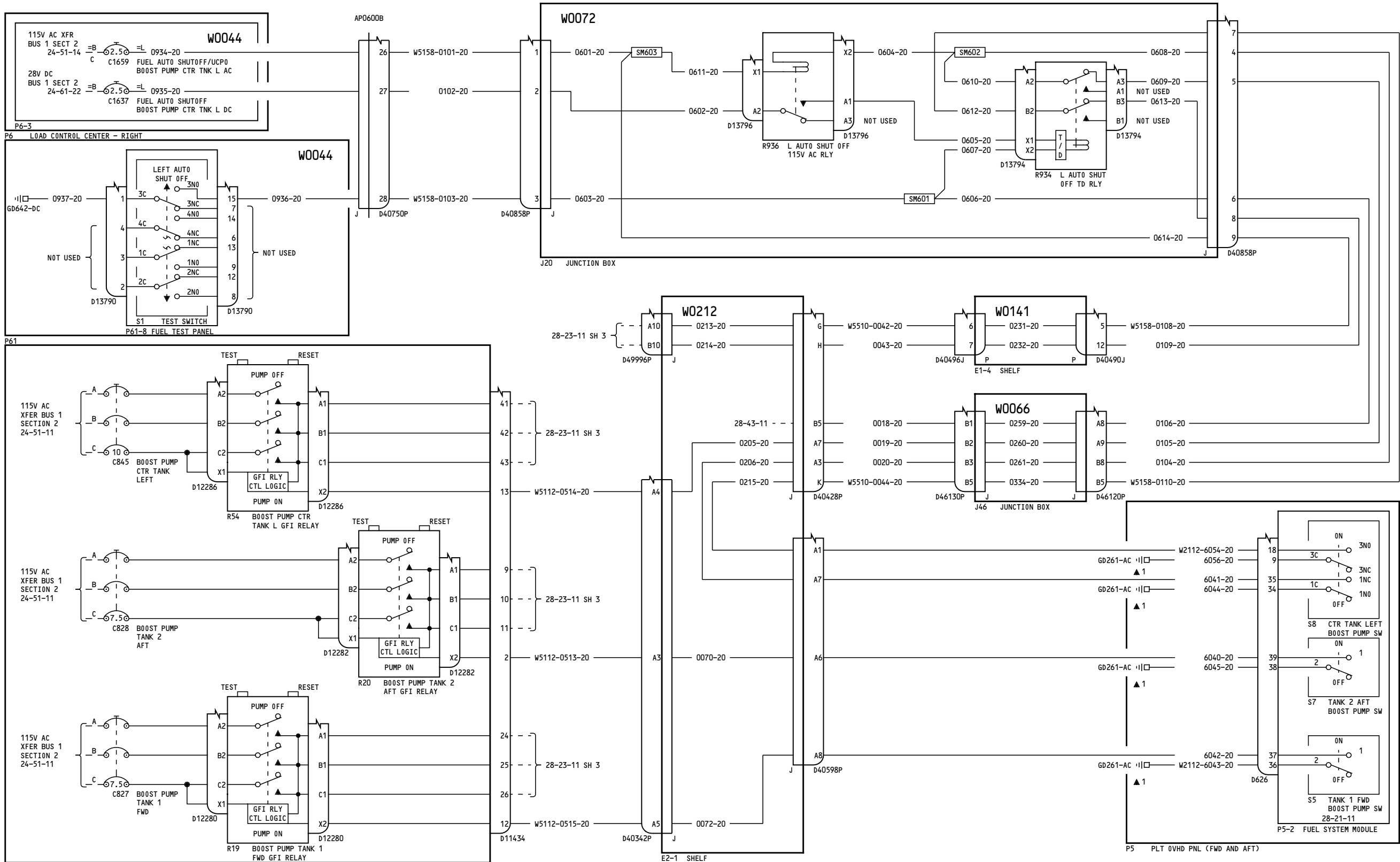

P91 POWER DISTRIBUTION PANEL 1
YK908-YL401, YL422-YM670

FUEL BOOST PUMPS

D280A103

28-23-11

Page 5
Sheet 1
Feb 09/2009

28-23-11

Page 5
Sheet 1
Feb 09/2009

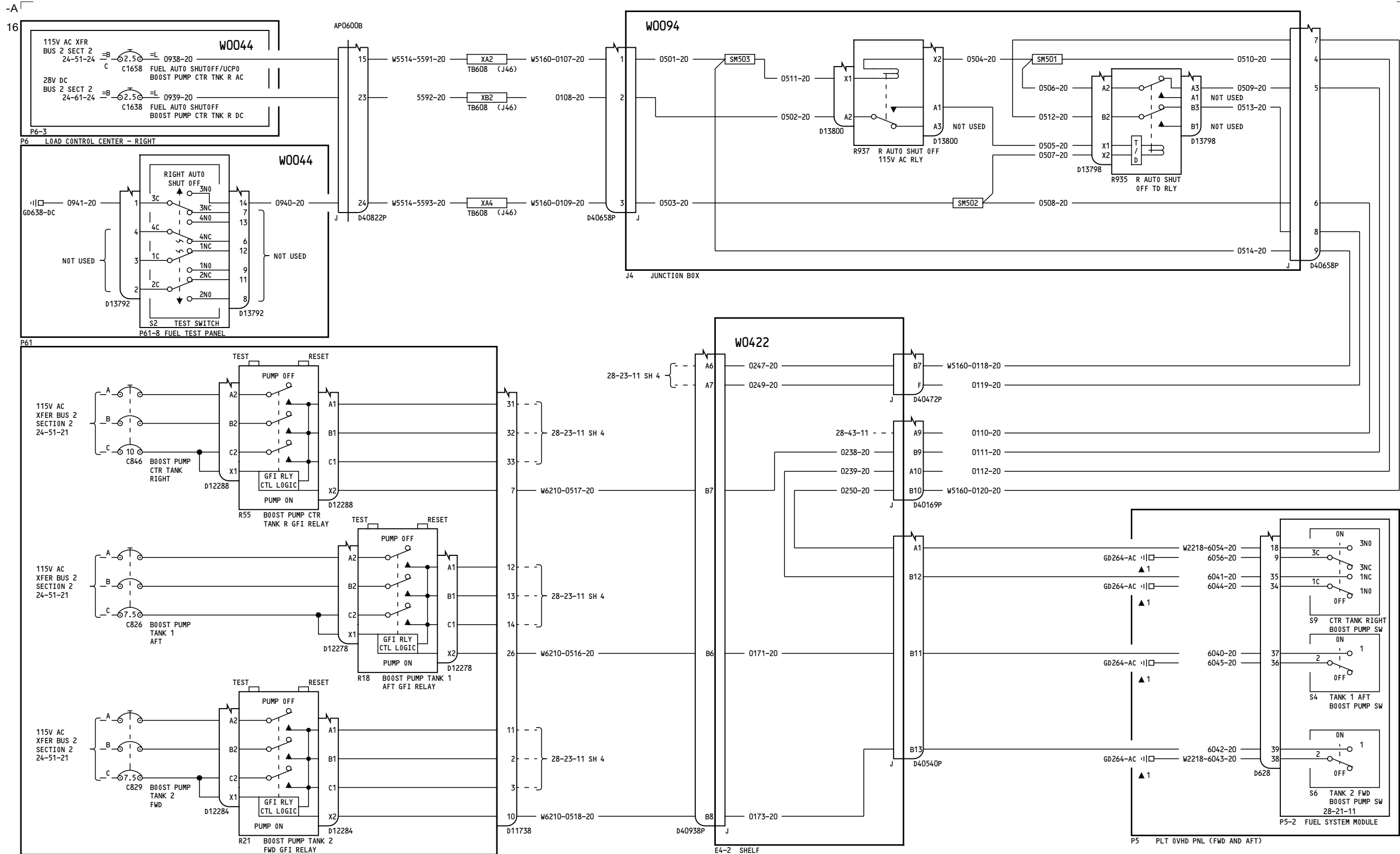

P92 POWER DISTRIBUTION PANEL 2
YK908-YL401, YL422-YM670

FUEL BOOST PUMPS

D280A103

28-23-11

Page 5
Sheet 2
Feb 09/2009

28-23-11

Page 5
Sheet 2
Feb 09/2009

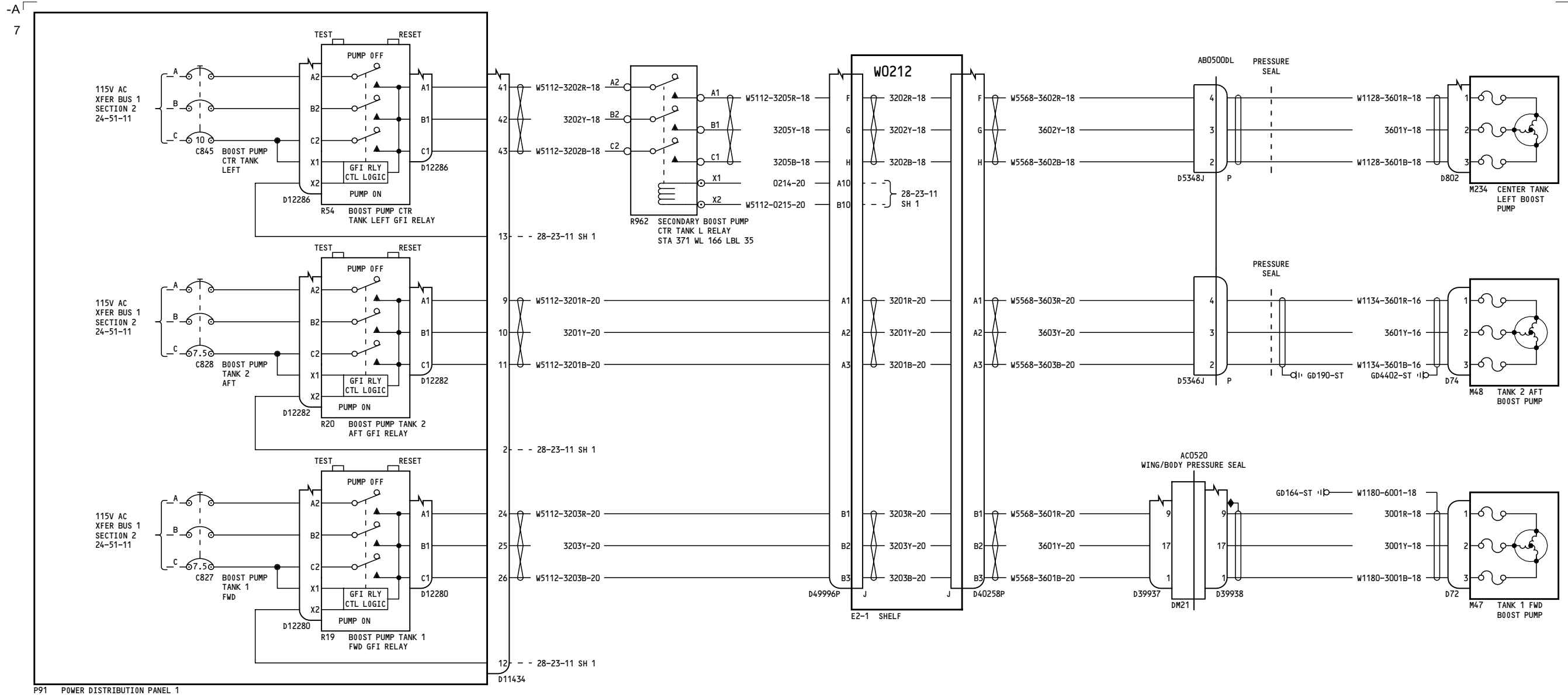

P91 POWER DISTRIBUTION PANEL 1

YK908-YL401, YL422-YM670

FUEL BOOST PUMPS

D280A103

28-23-11

Page 5
Sheet 3
Feb 09/2009

28-23-11

Page 5
Sheet 3
Feb 09/2009

-A
7

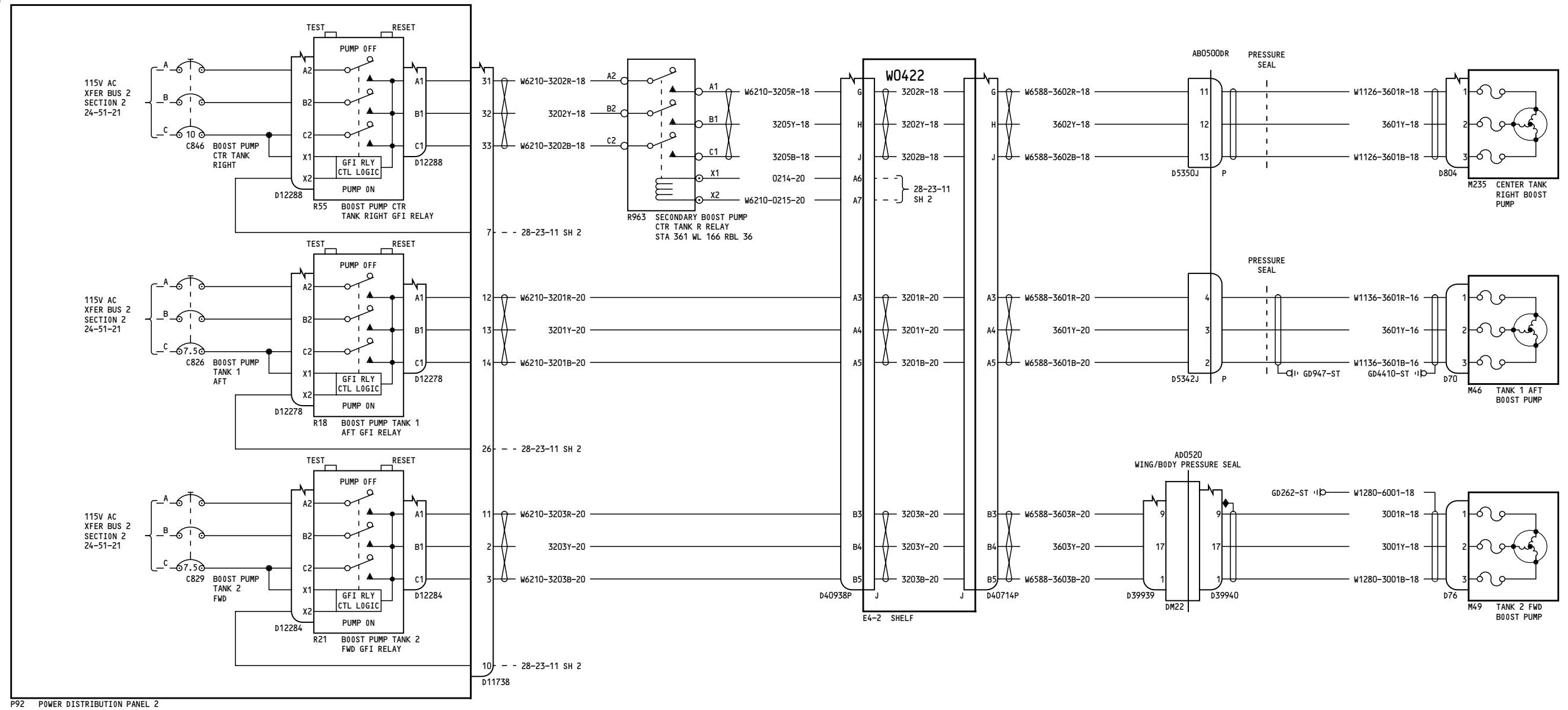

P92 POWER DISTRIBUTION PANEL 2

YK908-YL401, YL422-YM670

FUEL BOOST PUMPS

D280A103

28-23-11

Page 5
Sheet 4
Feb 09/2009

28-23-11

Page 5
Sheet 4
Feb 09/2009

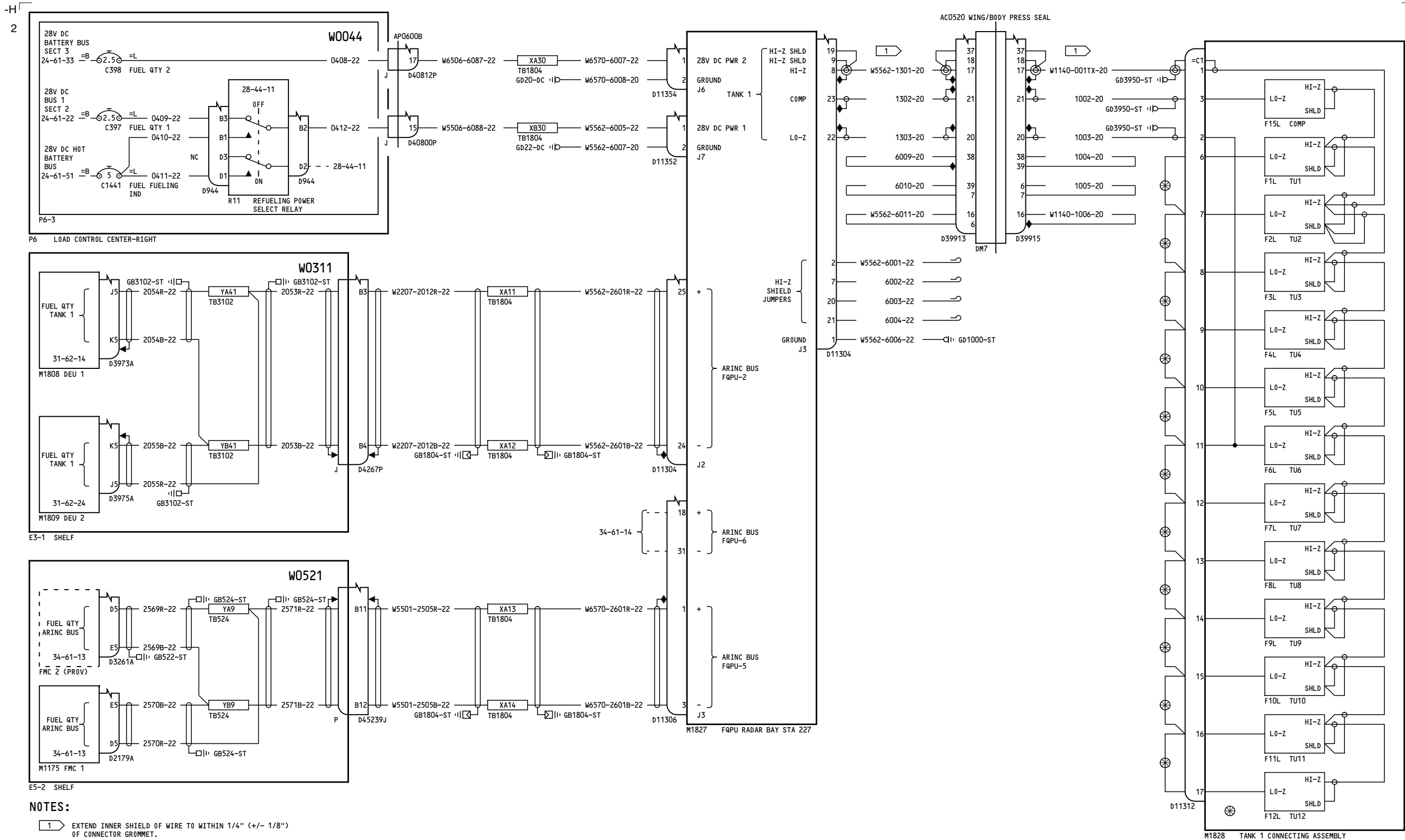

YC001-YC003

FUEL QUANTITY

28-41-11

Page 1
Sheet 1
May 11/2009

D280A103

28-41-11

Page 1
Sheet 1
May 11/2009

-P
2

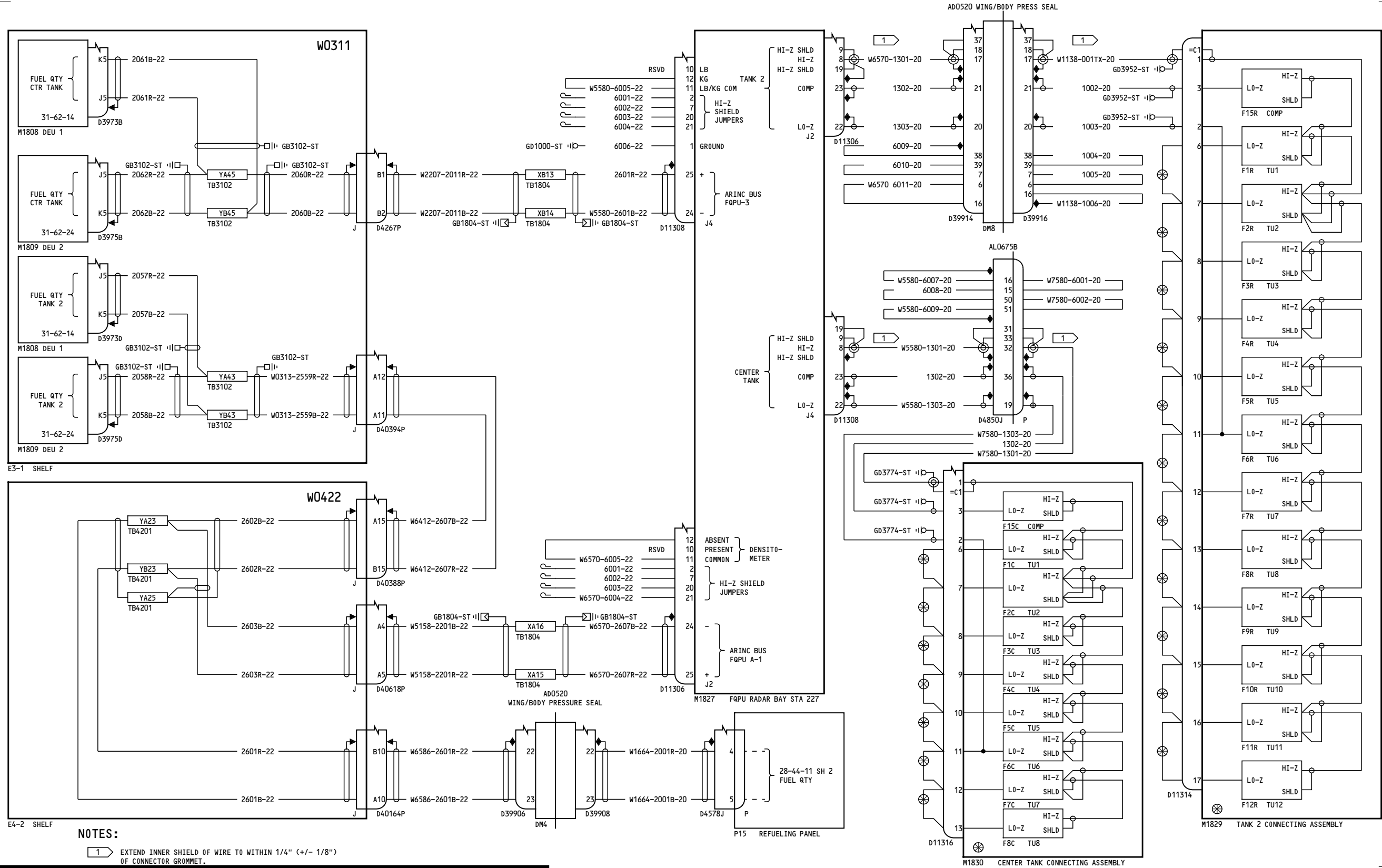

NOTES:

1 EXTEND INNER SHIELD OF WIRE TO WITHIN 1/4" (+/- 1/8") OF CONNECTOR GROMMET.

YC001-YC003

FUEL QUANTITY

28-41-11

Page 1
Sheet 2
May 11/2009

D280A103

28-41-11

Page 1
Sheet 2
May 11/2009

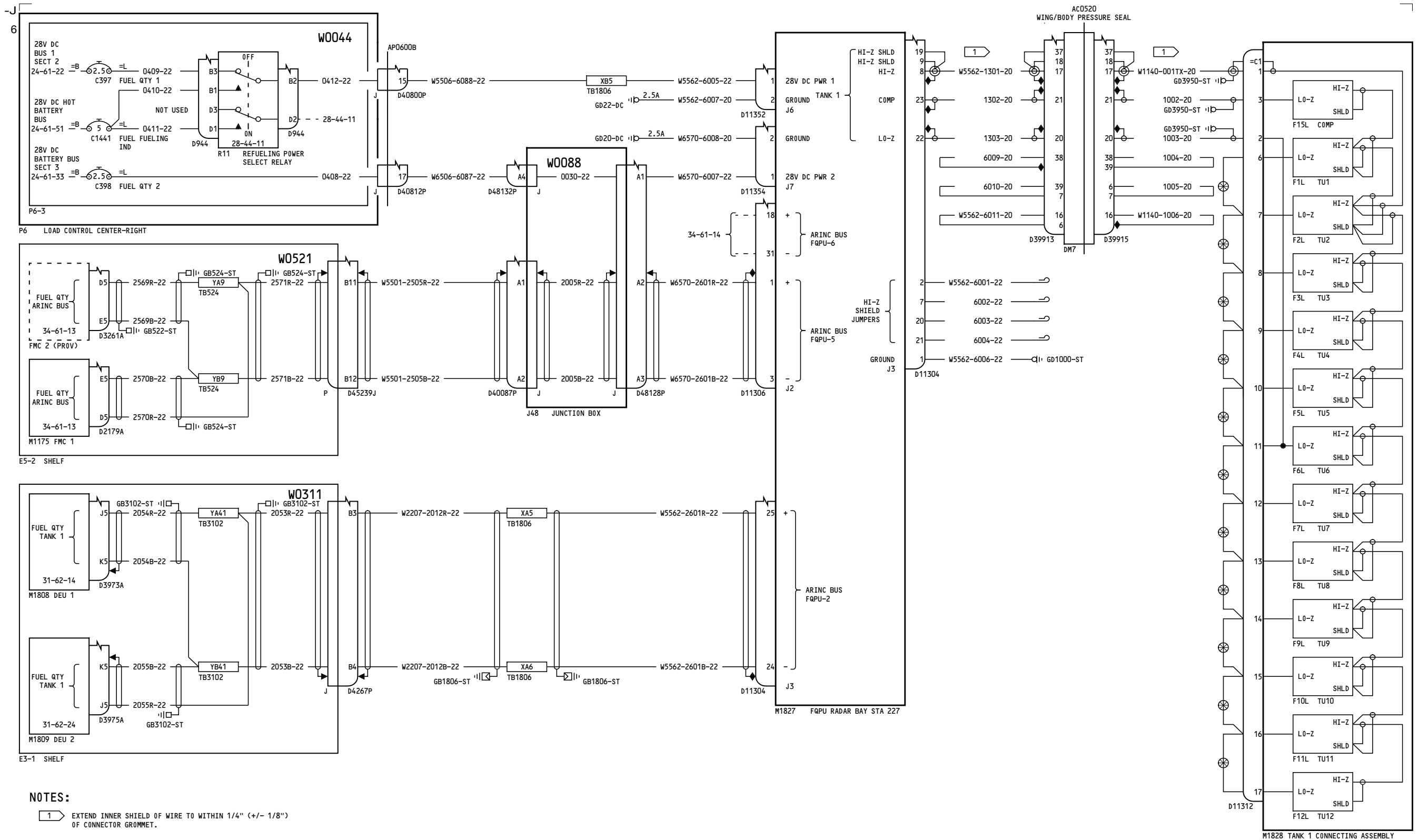

NOTES:
 1 EXTEND INNER SHIELD OF WIRE TO WITHIN 1/4" (+/- 1/8") OF CONNECTOR GROMMET.

YC004-YK906

FUEL QUANTITY

28-41-11

Page 2
 Sheet 1
 May 11/2009

D280A103

28-41-11

Page 2
 Sheet 1
 May 11/2009

-C
5

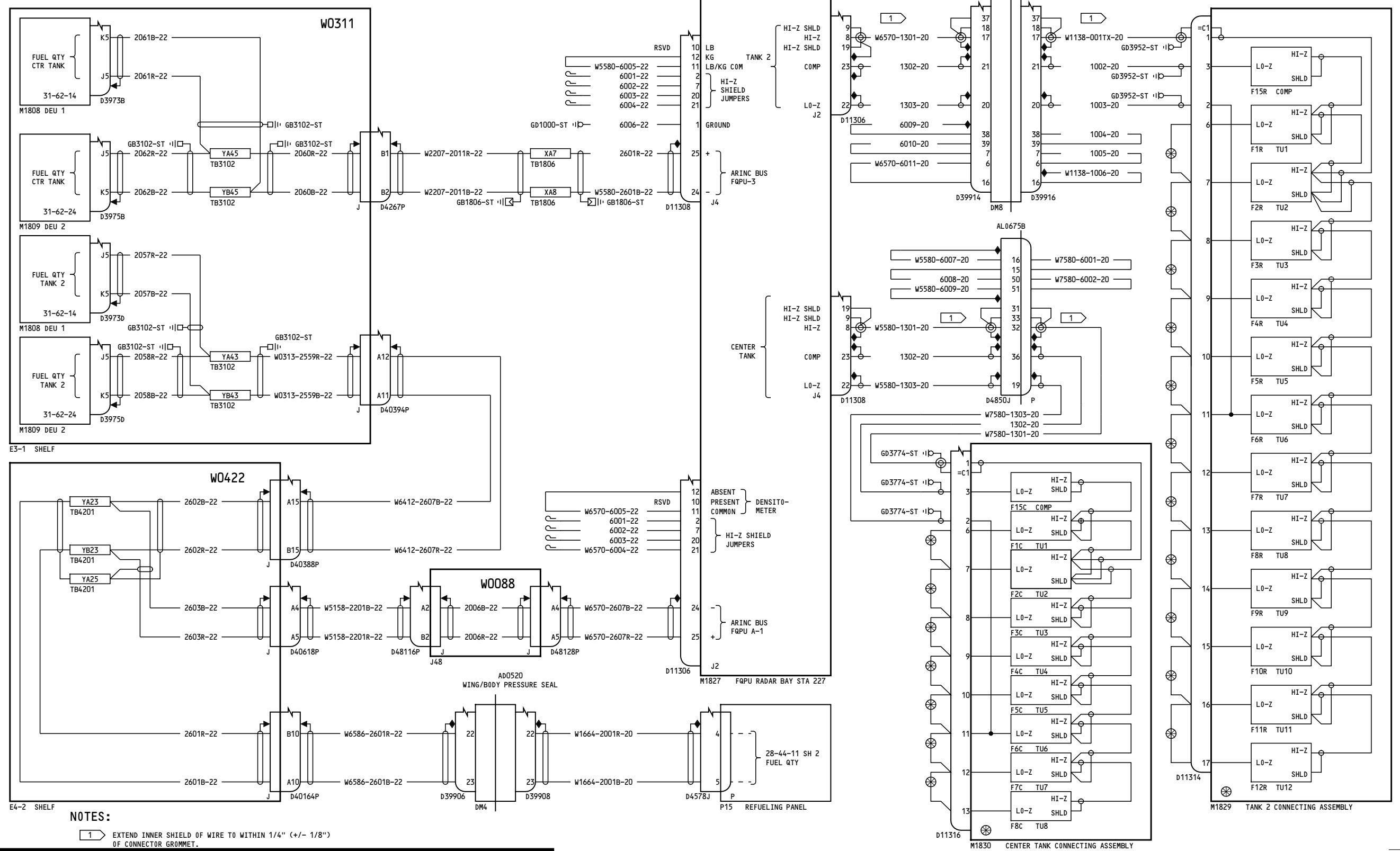

NOTES:

1 EXTEND INNER SHIELD OF WIRE TO WITHIN 1/4" (+/- 1/8") OF CONNECTOR GROMMET.

<p>YC004-YK906</p>	<p>FUEL QUANTITY</p> <p>D280A103</p>
--------------------	---

28-41-11

Page 2
Sheet 2
May 11/2009

28-41-11

Page 2
Sheet 2
May 11/2009

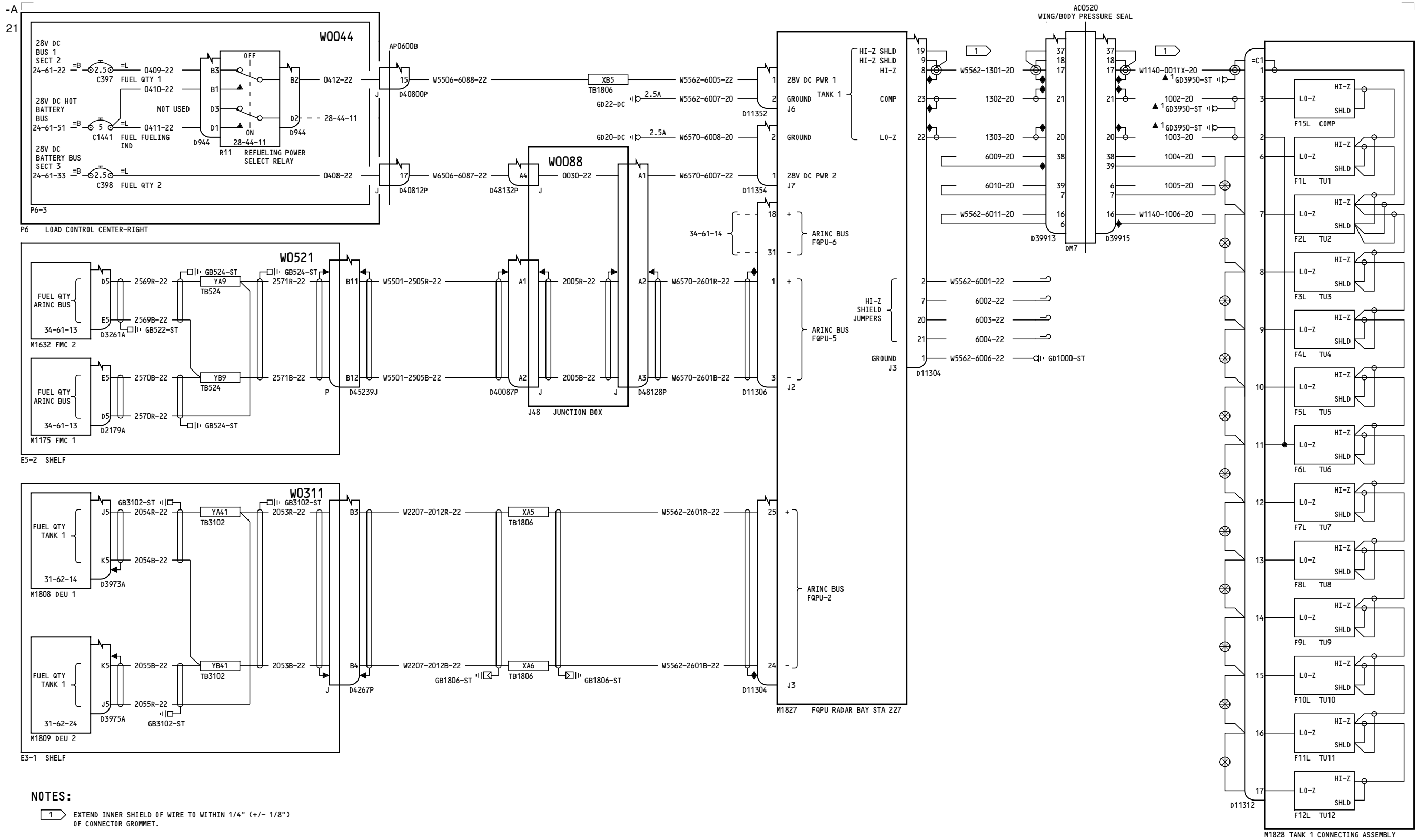

NOTES:
 1 EXTEND INNER SHIELD OF WIRE TO WITHIN 1/4" (+/- 1/8") OF CONNECTOR GROMMET.

YK907-YM670

FUEL QUANTITY

28-41-11

Page 3
 Sheet 1
 May 11/2009

D280A103

28-41-11

Page 3
 Sheet 1
 May 11/2009

-B
26

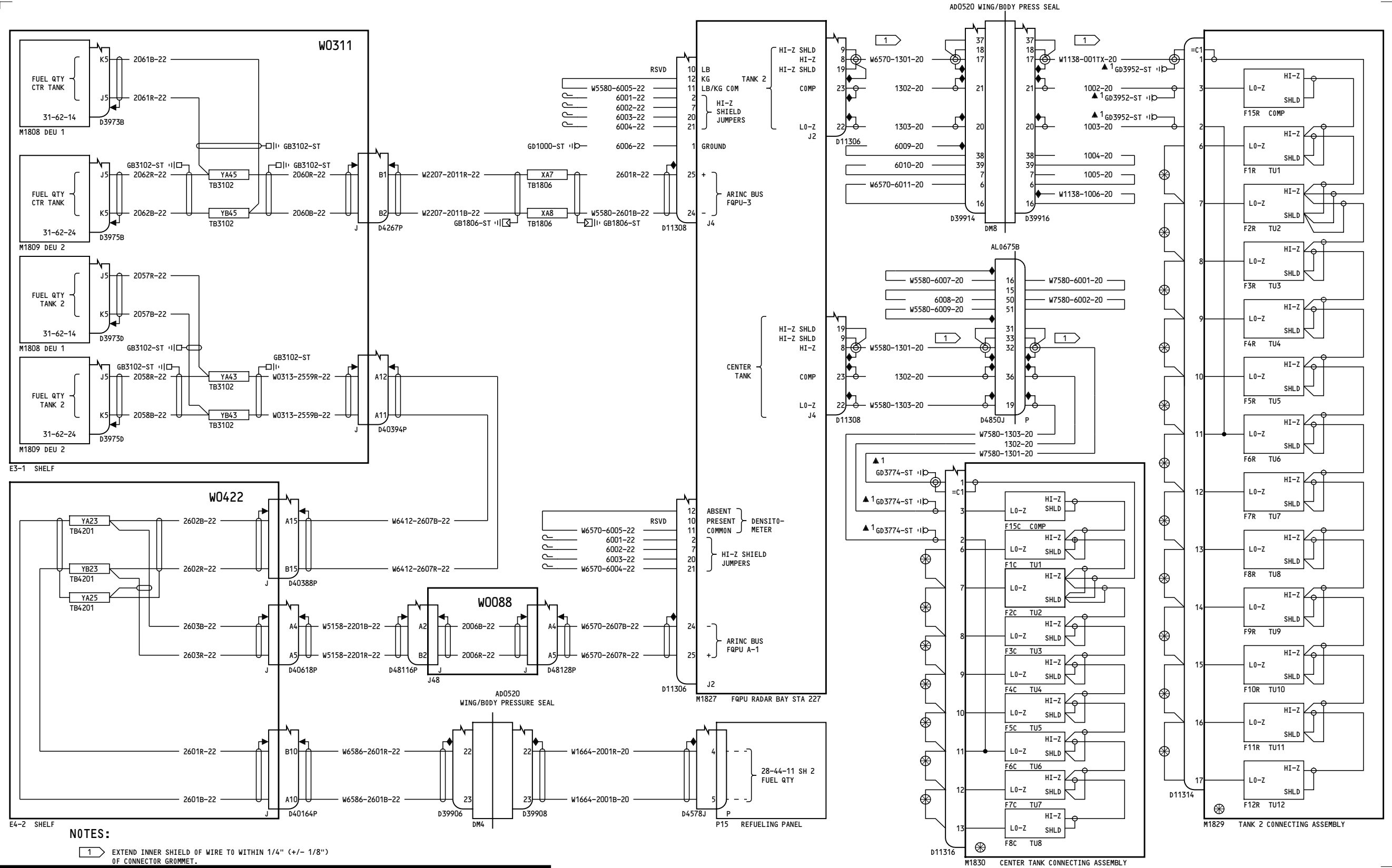

NOTES:

1 EXTEND INNER SHIELD OF WIRE TO WITHIN 1/4" (+/- 1/8") OF CONNECTOR GROMMET.

<p>YK907-YM670</p>	<p>FUEL QUANTITY</p> <p>D280A103</p>
--------------------	---

28-41-11

Page 3
Sheet 2
May 11/2009

28-41-11

Page 3
Sheet 2
May 11/2009

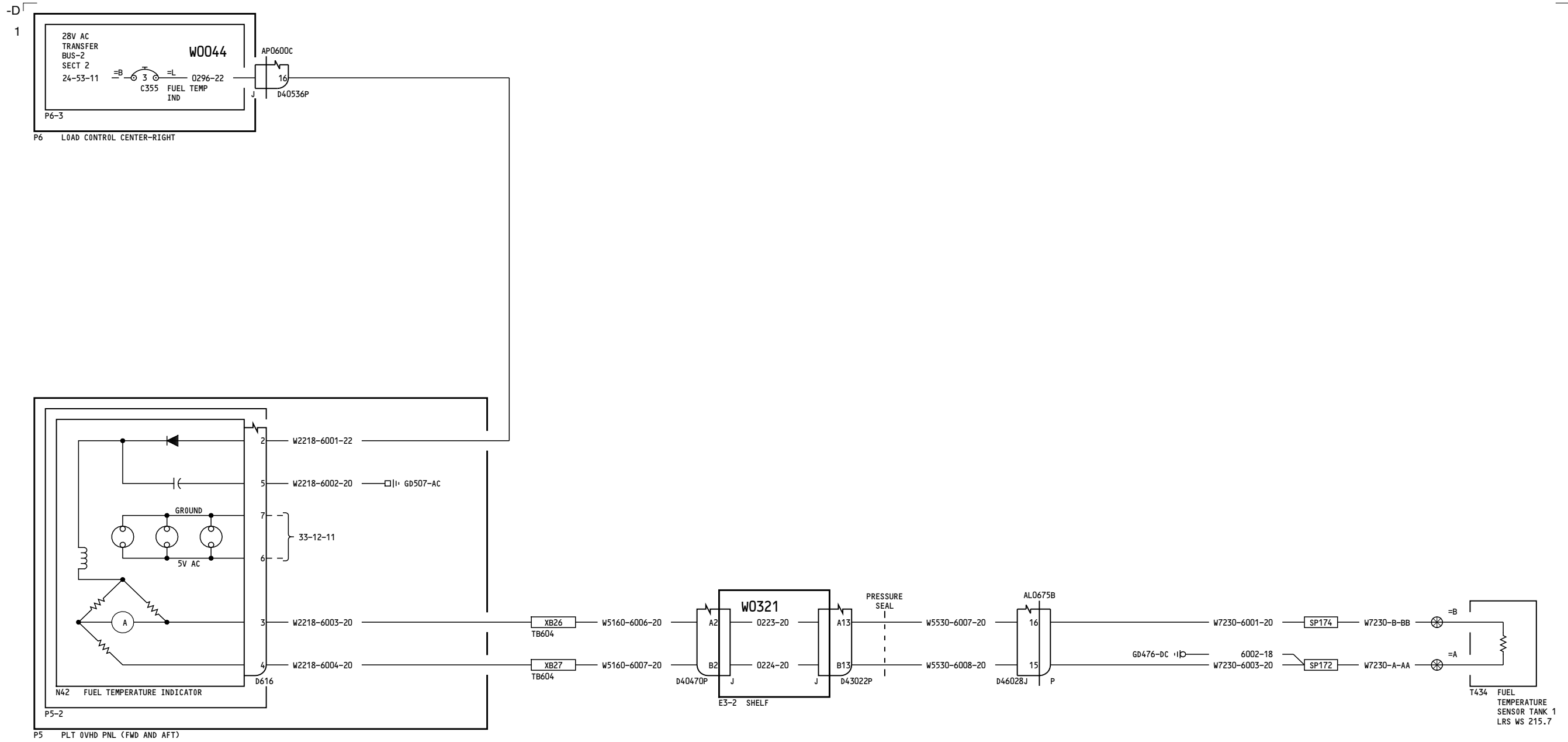

YC001-YC003

FUEL TEMPERATURE INDICATION

28-42-11

Page 1

D280A103

Mar 31/2005

28-42-11

Page 1

Mar 31/2005

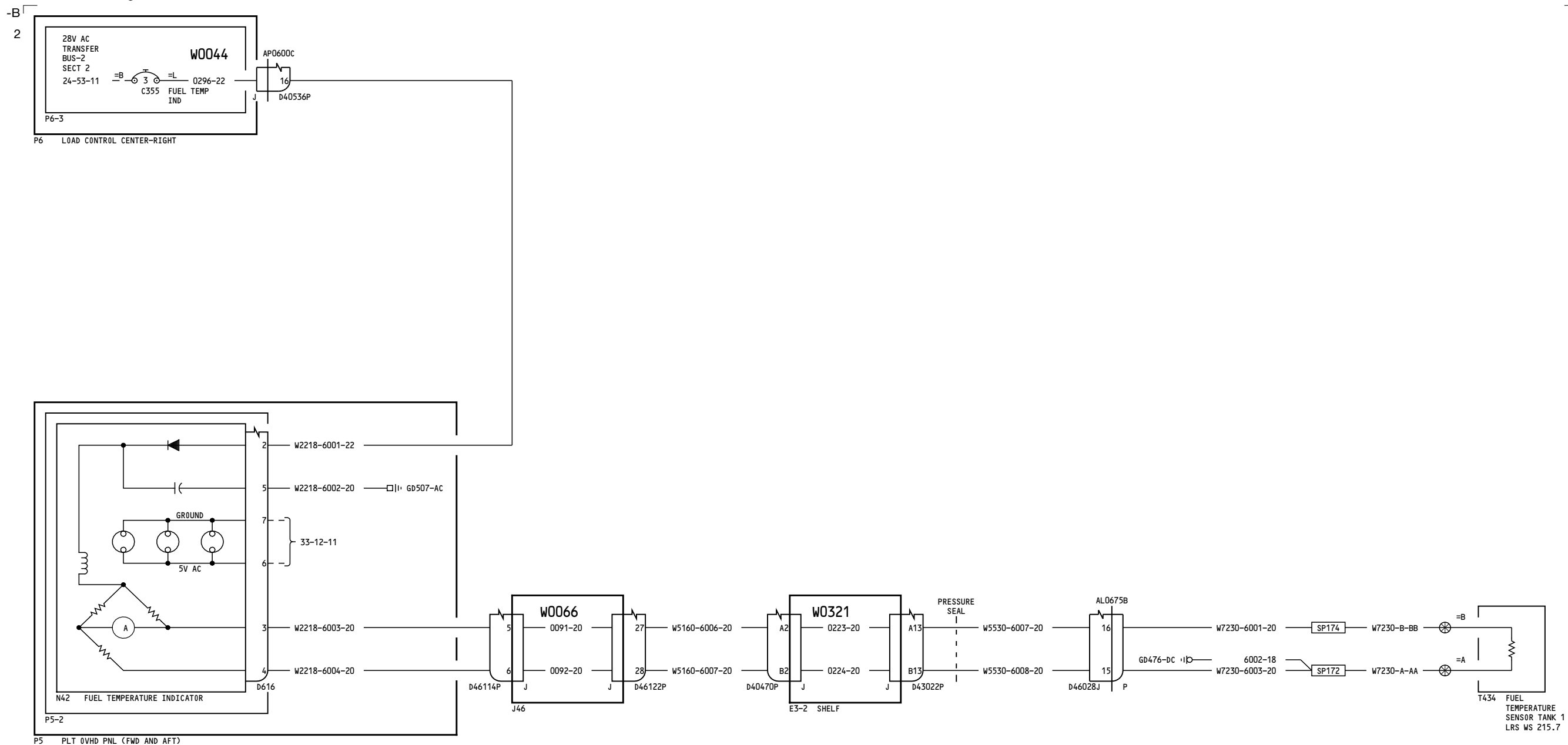

YC004-YC007

FUEL TEMPERATURE INDICATION

28-42-11

Page 2

D280A103

Mar 31/2005

28-42-11

Page 2

Mar 31/2005

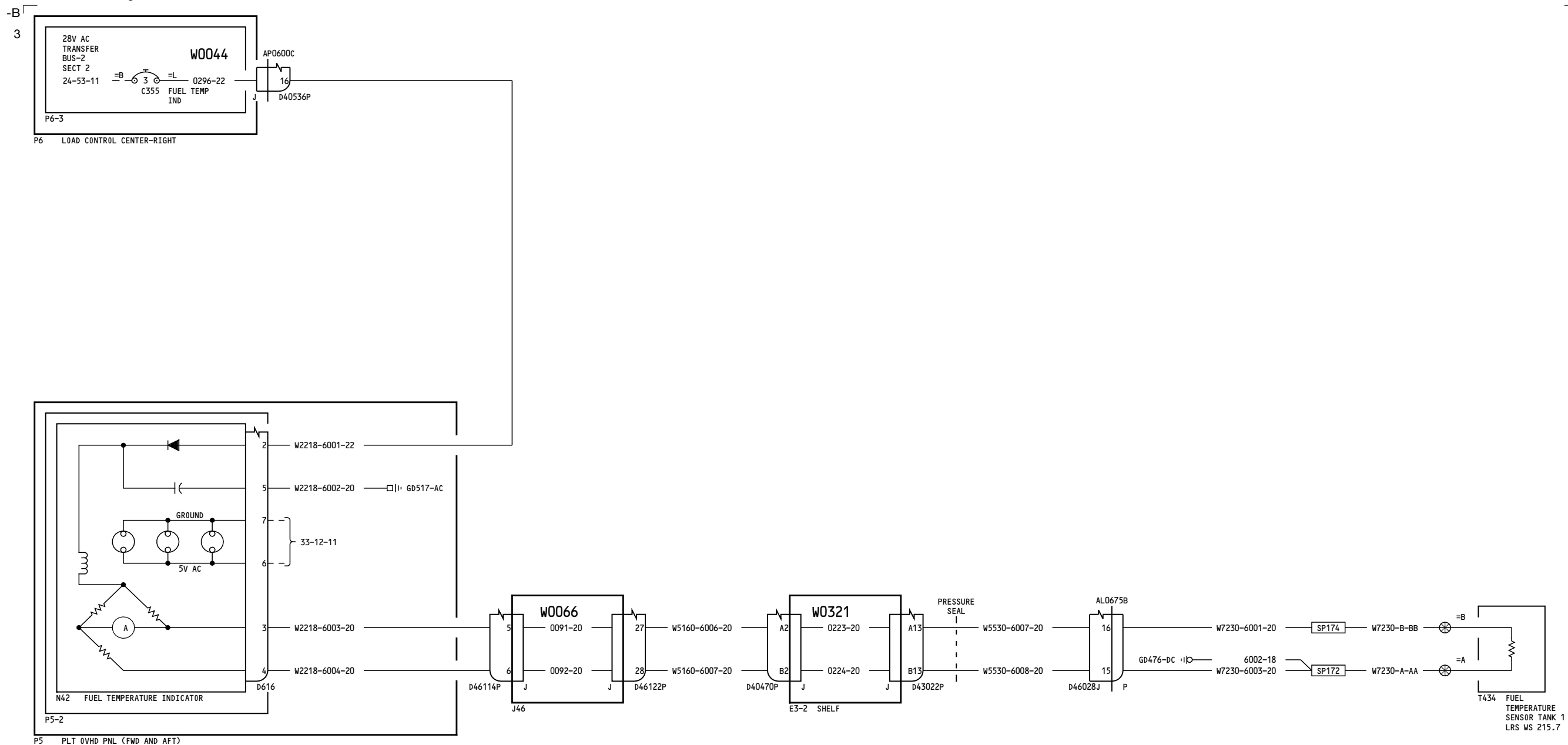

YC008-YM670

FUEL TEMPERATURE INDICATION

28-42-11

Page 3

Feb 09/2009

D280A103

28-42-11

Page 3

Feb 09/2009

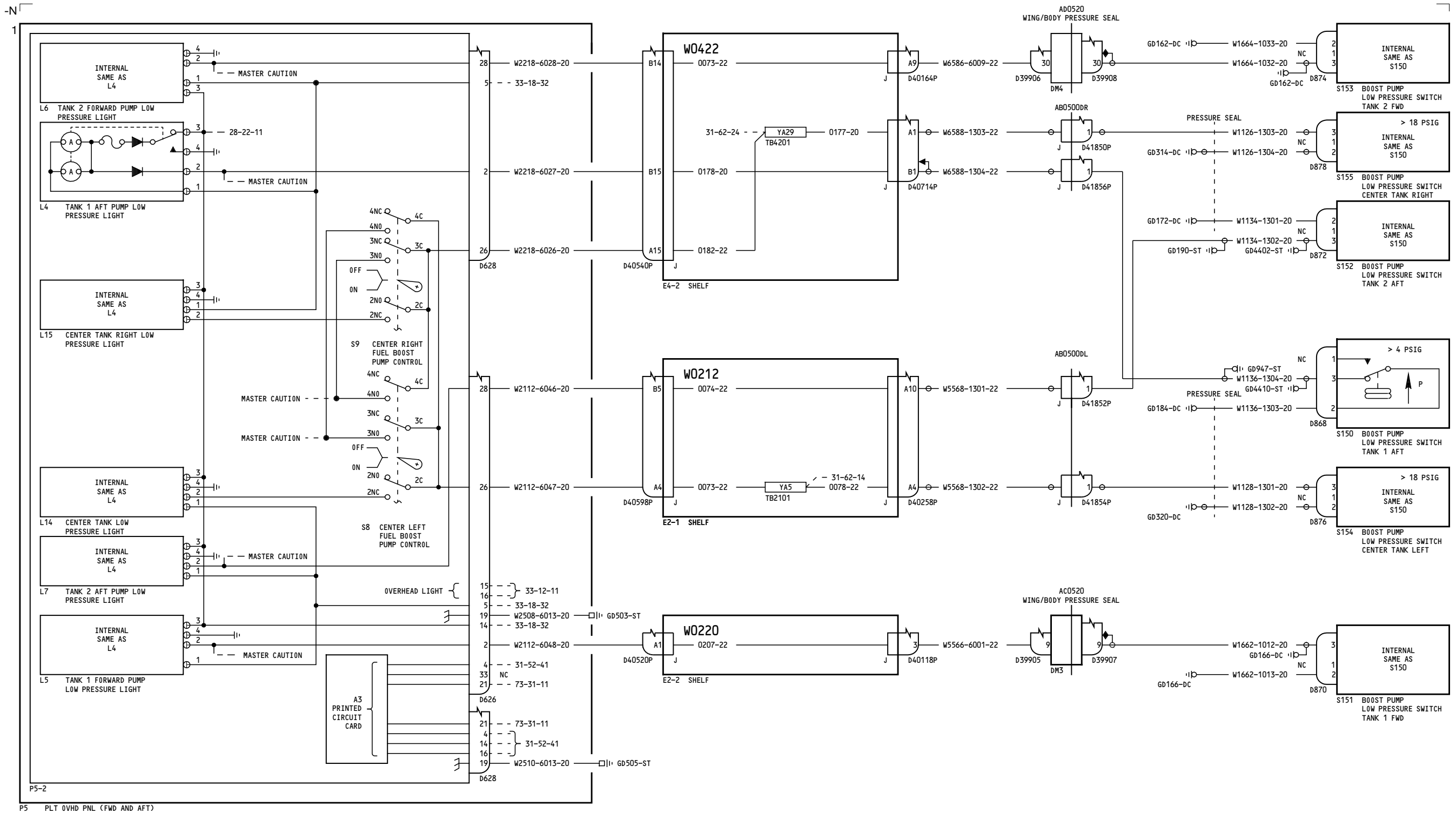

P5 PLT OVHD PNL (FWD AND AFT)

YC001-YC007

FUEL BOOST PUMPS LOW PRESSURE WARNING LIGHTS

D280A103

28-43-11

Page 1

Oct 20/2006

28-43-11

Page 1

Oct 20/2006

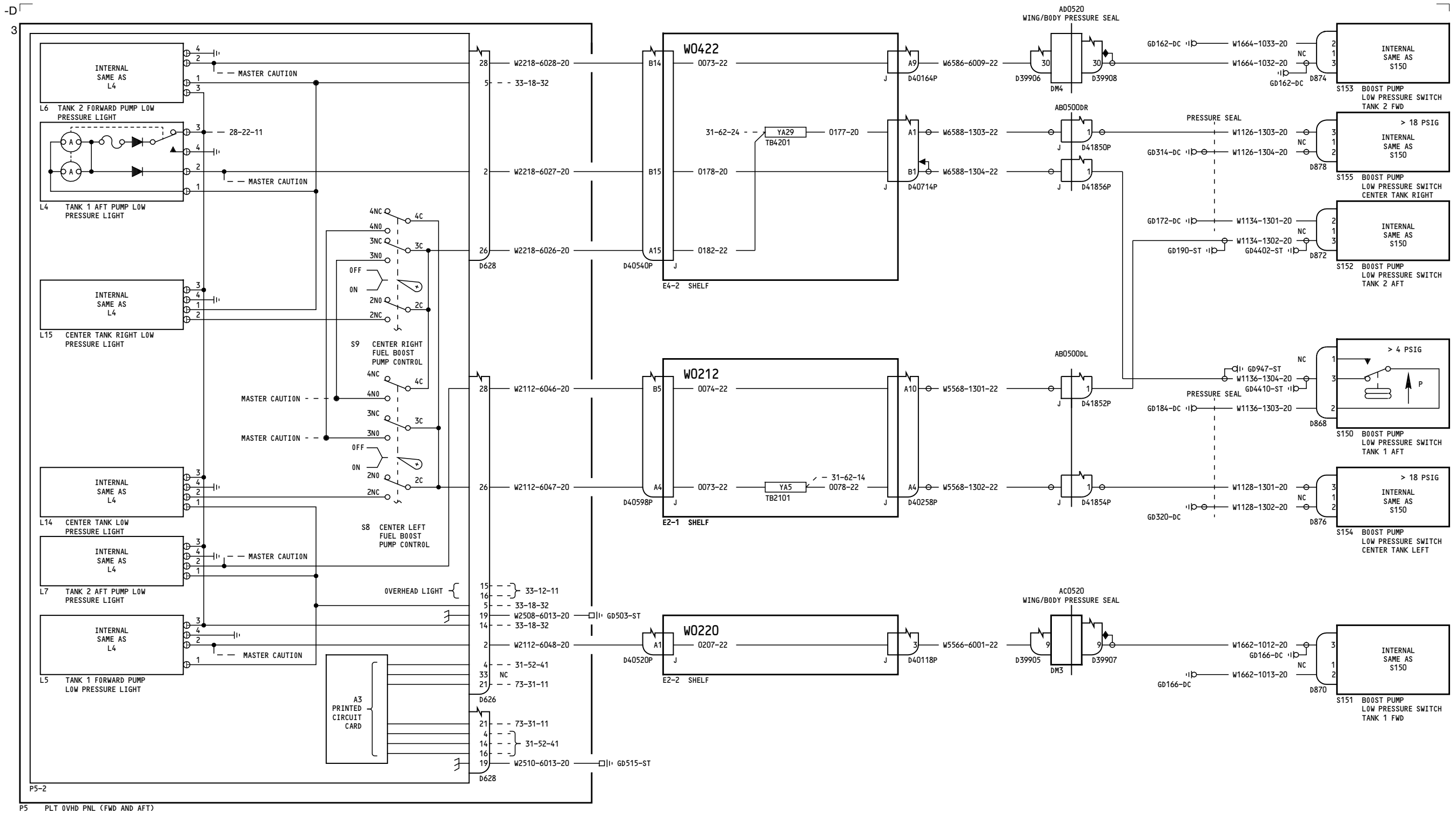

P5 PLT OVHD PNL (FWD AND AFT)

YC008-YC030

**FUEL BOOST PUMPS
LOW PRESSURE
WARNING LIGHTS**

28-43-11

Page 2

D280A103

Jul 17/2007

28-43-11

Page 2

Jul 17/2007

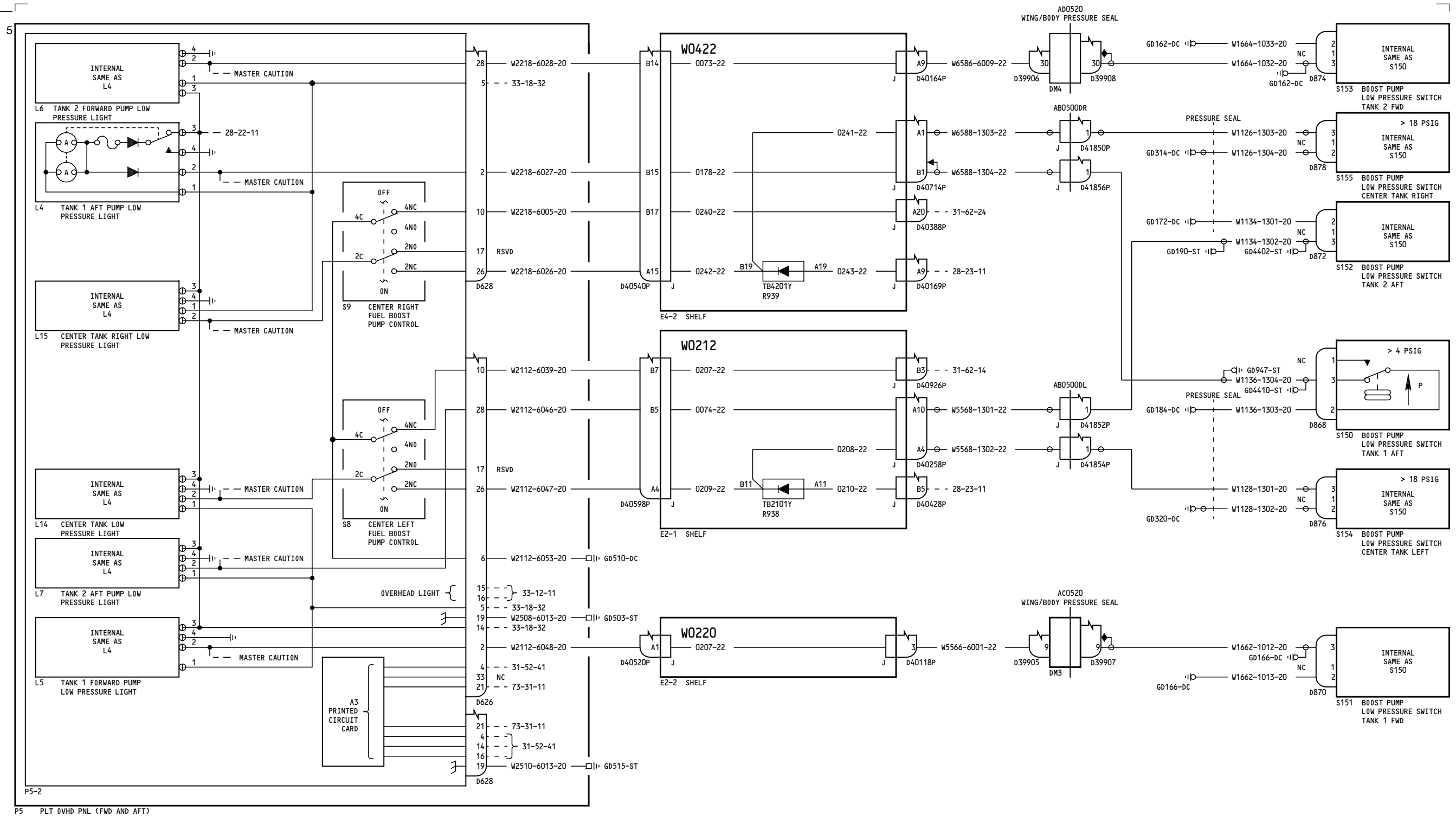

P5-2
P5 PLT OVHD PNL (FWD AND AFT)

YC031-YM670

**FUEL BOOST PUMPS
LOW PRESSURE
WARNING LIGHTS**

D280A103

28-43-11

Page 3

Feb 09/2009

28-43-11

Page 3

Feb 09/2009

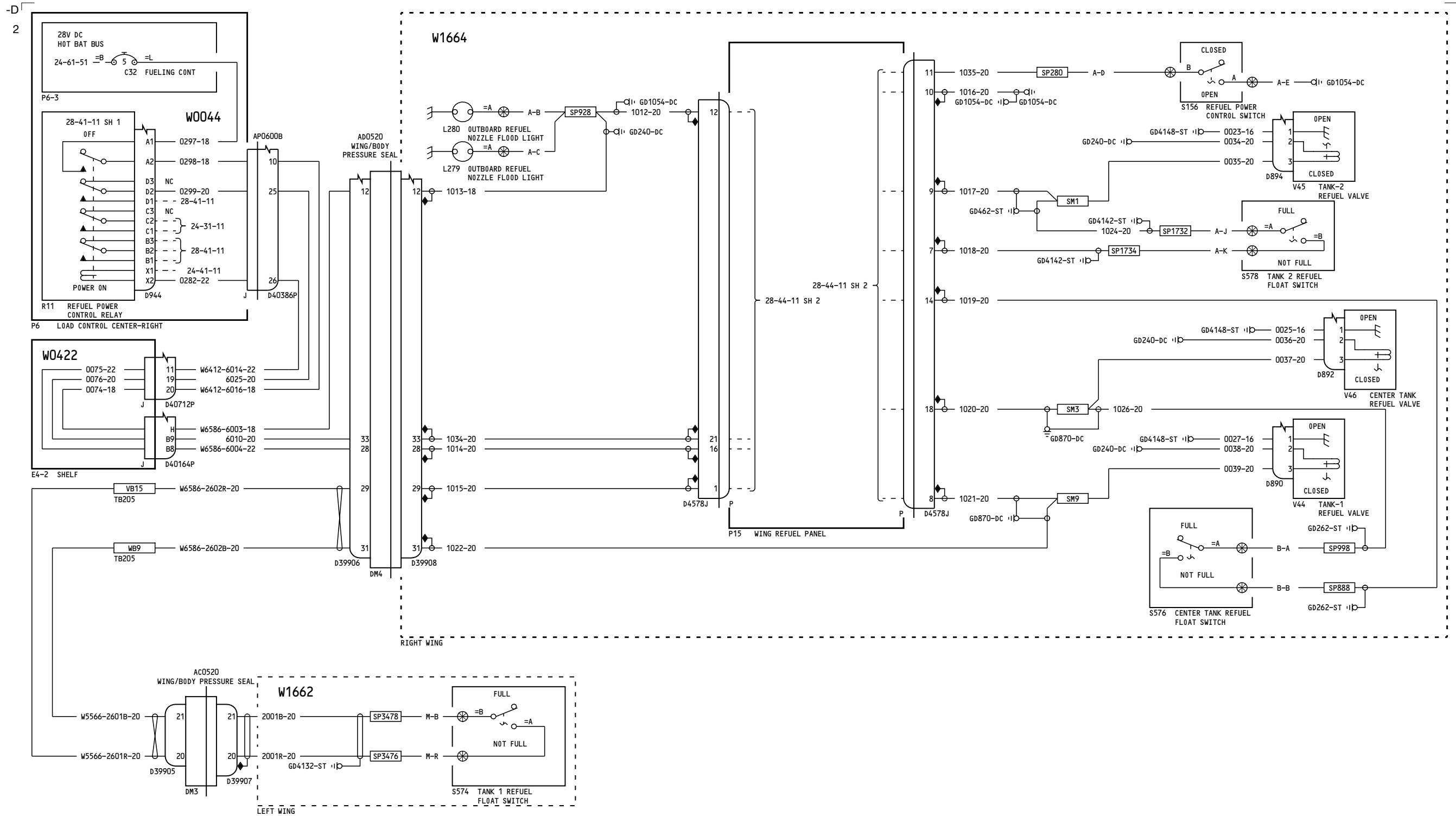

YC001-YC026

GROUND REFUELING

28-44-11

Page 1
Sheet 1
Jul 17/2007

D280A103

28-44-11

Page 1
Sheet 1
Jul 17/2007

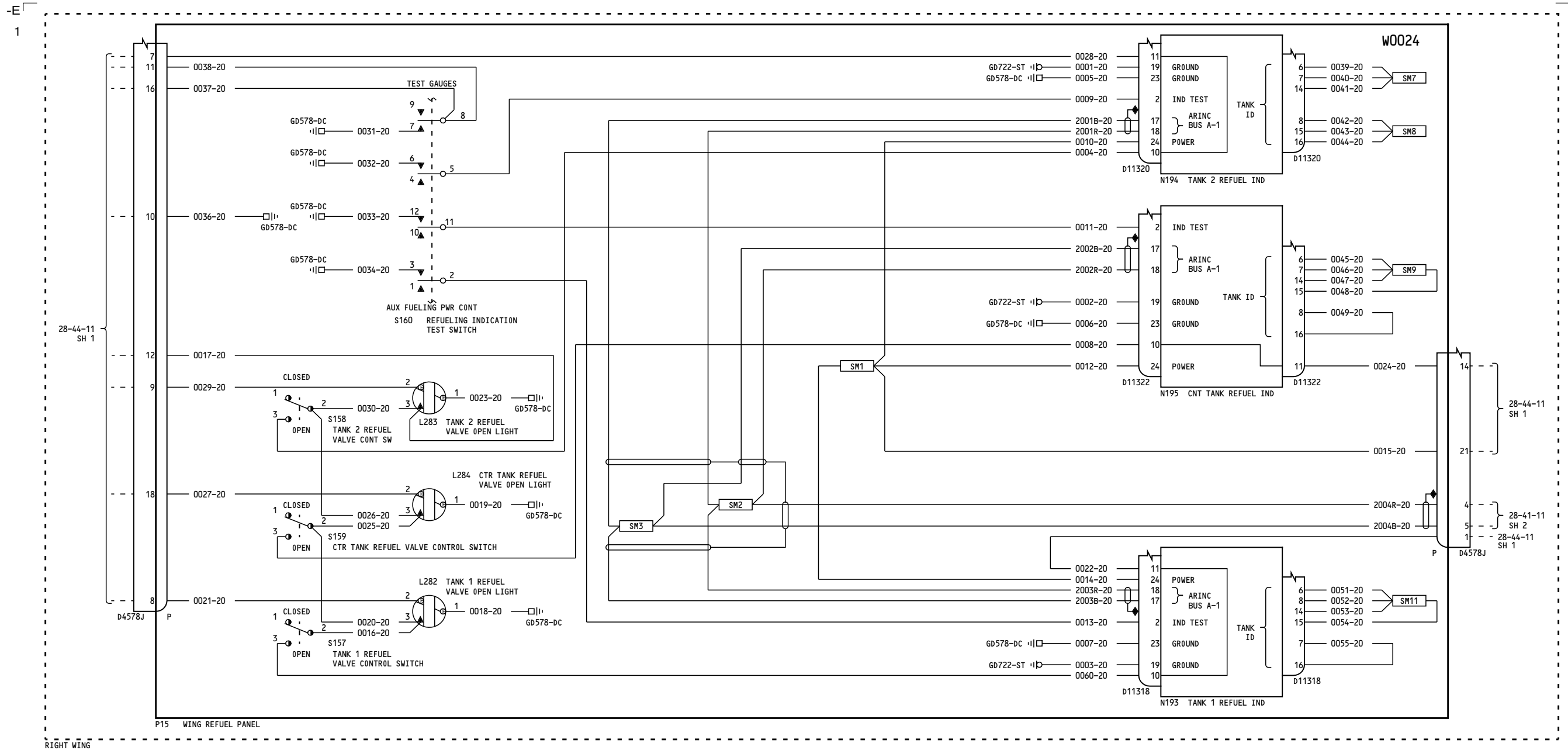

YC001-YC026

GROUND REFUELING

28-44-11

Page 1
Sheet 2
Jul 17/2007

D280A103

28-44-11

Page 1
Sheet 2
Jul 17/2007

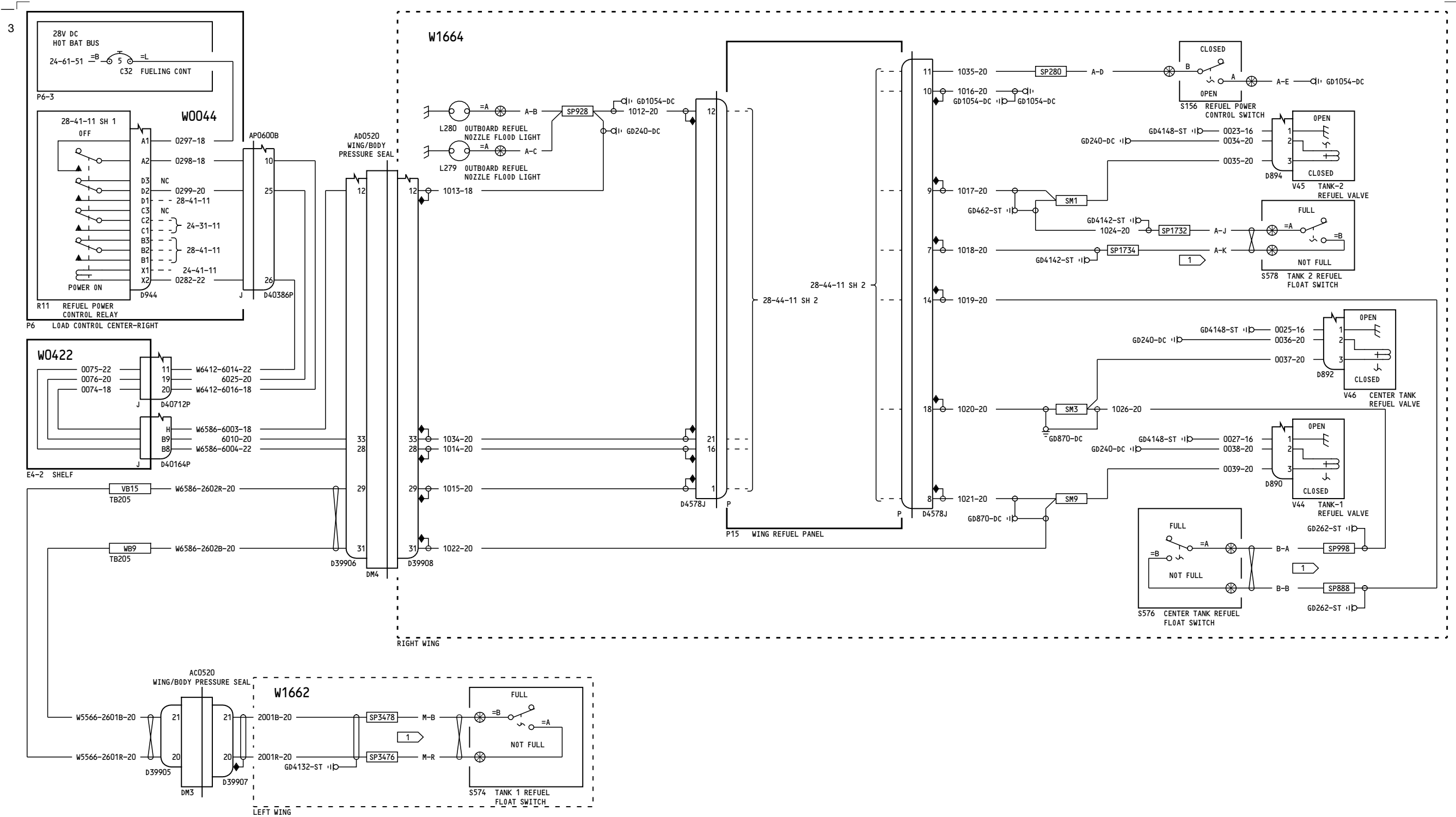

NOTES:

- 1 INSTALL 1 IN. LENGTH DWP-125 SLEEVING OVER END OF CABLE JACKET TO PREVENT MOISTURE INCURSION FROM SPLICE AREA TO FLOAT SWITCH ON FLOAT SWITCHES SUPPLIED WITH JACKETED CABLE PIGTAILS.

YC028-YC030

GROUND REFUELING

D280A103

28-44-11

Page 2
Sheet 1
Oct 20/2005

28-44-11

Page 2
Sheet 1
Oct 20/2005

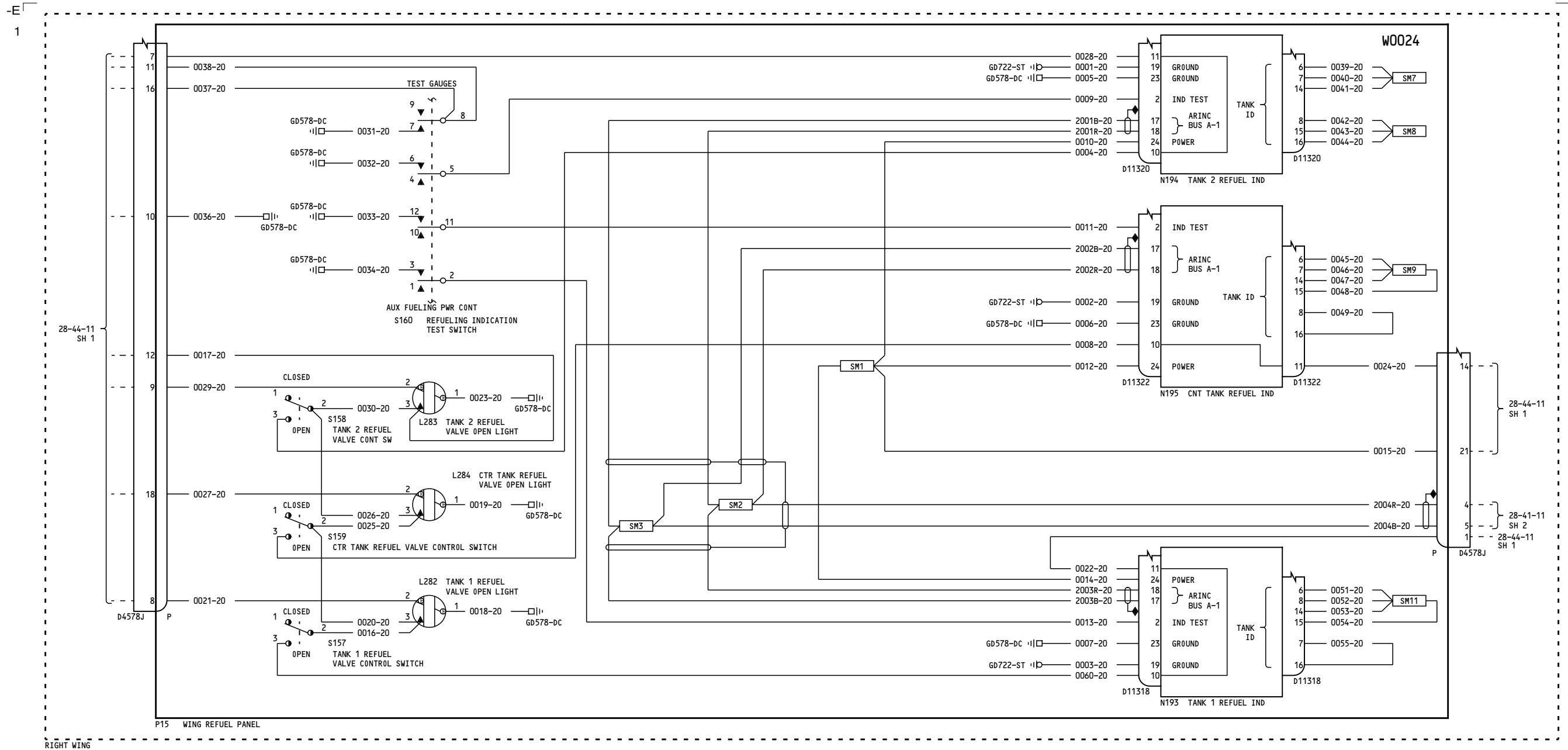

YC028-YC030

GROUND REFUELING

D280A103

28-44-11

Page 2
Sheet 2
Oct 20/2005

28-44-11

Page 2
Sheet 2
Oct 20/2005

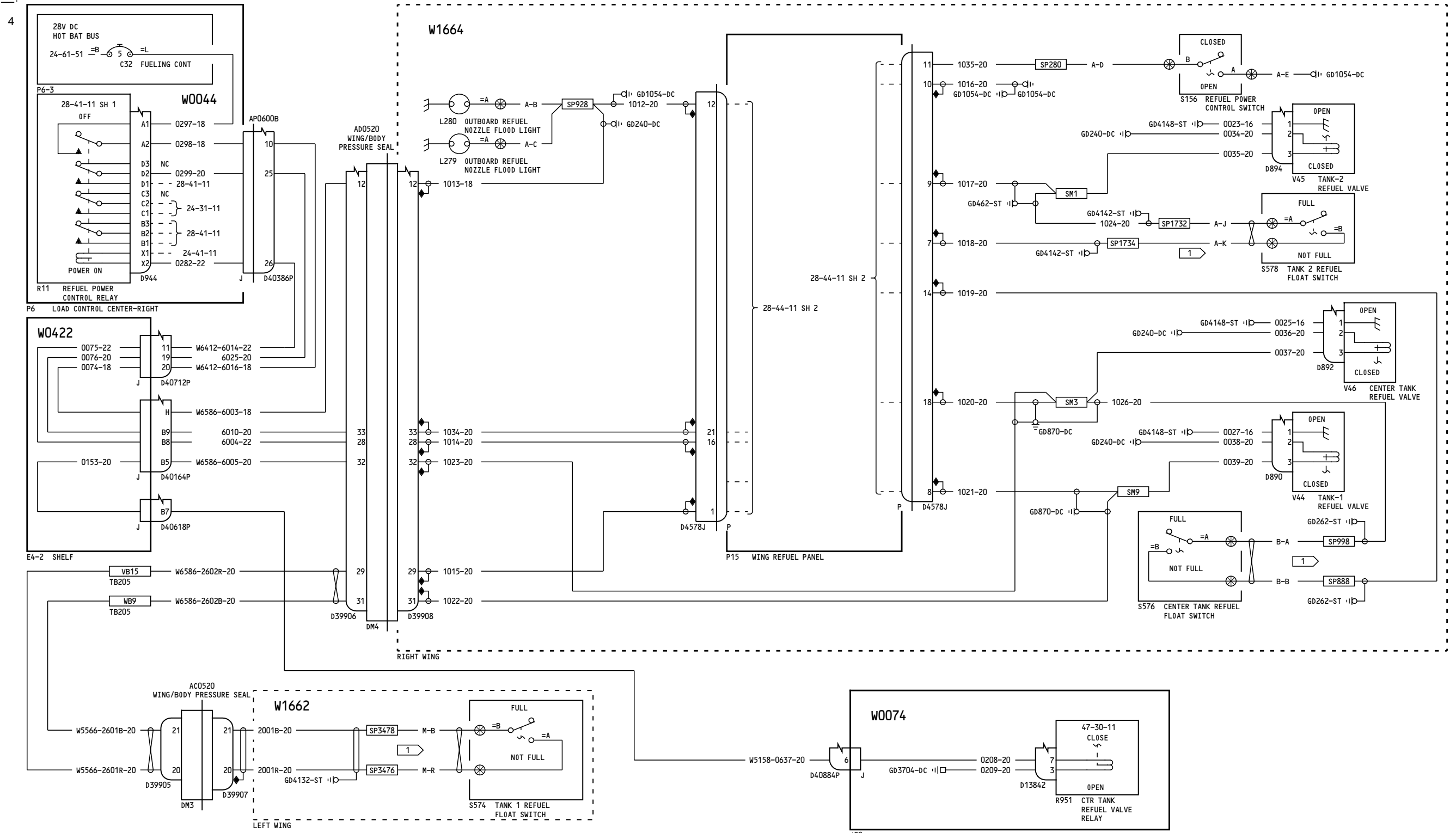

NOTES:

- 1 INSTALL 1 IN. LENGTH DWP-125 SLEEVING OVER END OF CABLE JACKET TO PREVENT MOISTURE INCURSION FROM SPLICE AREA TO FLOAT SWITCH ON FLOAT SWITCHES SUPPLIED WITH JACKETED CABLE PIGTAILS.

YC031-YC050, YK906-YK912, YK918-YK919, YL401-YL429, YM643-YM652

GROUND REFUELING

D280A103

28-44-11

Page 3
Sheet 1
Aug 10/2009

28-44-11

Page 3
Sheet 1
Aug 10/2009

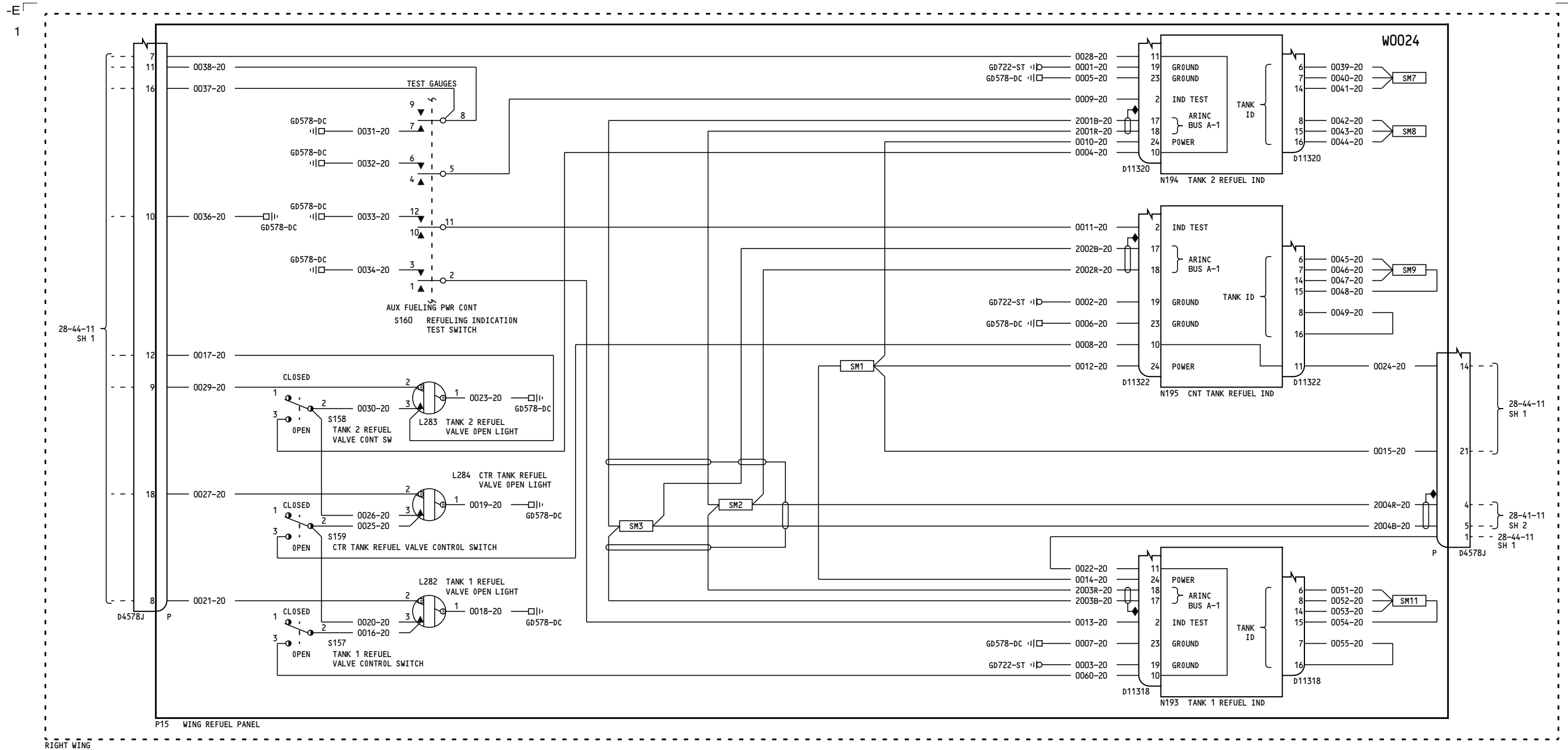

YC031-YC050, YK906-YK912, YK918-YK919, YL401-YL429, YM643-YM652

GROUND REFUELING

28-44-11

Page 3
Sheet 2
Aug 10/2009

D280A103

28-44-11

Page 3
Sheet 2
Aug 10/2009

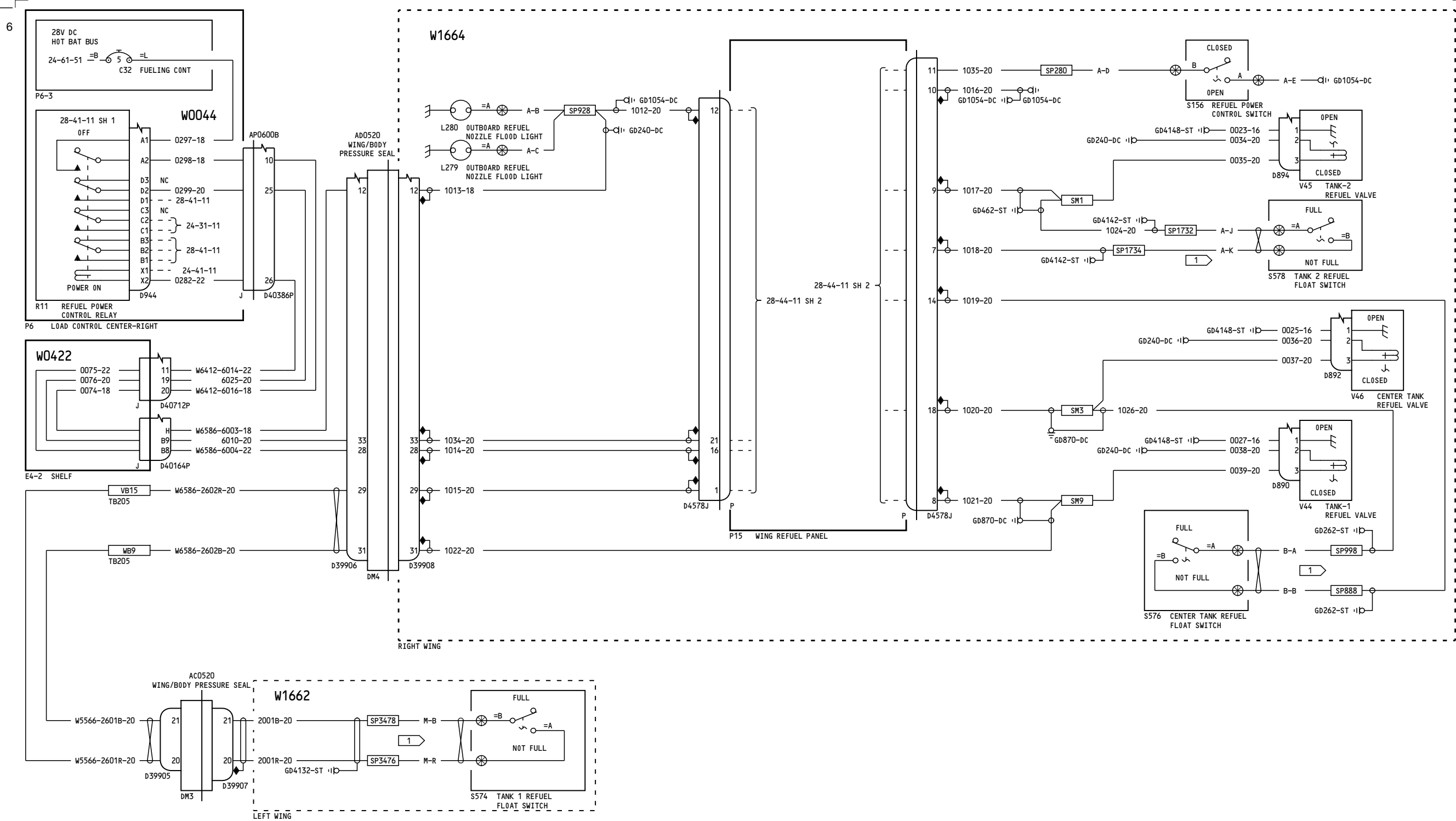

NOTES:

- 1 INSTALL 1 IN. LENGTH DWP-125 SLEEVING OVER END OF CABLE JACKET TO PREVENT MOISTURE INCURSION FROM SPLICE AREA TO FLOAT SWITCH ON FLOAT SWITCHES SUPPLIED WITH JACKETED CABLE PIGTAILS.

YK901-YK905

GROUND REFUELING

D280A103

28-44-11

Page 4
Sheet 1
Jan 18/2006

28-44-11

Page 4
Sheet 1
Jan 18/2006

