

CHAPTER

29

HYDRAULIC POWER



737-700/800

WIRING DIAGRAM MANUAL

CHAPTER 29
HYDRAULIC POWER

CH-SC-SU	Schem	Page	Sheet	Date	CH-SC-SU	Schem	Page	Sheet	Date
29-EFFECTIVE PAGES					29-32-11				
		1		Aug 10/2009			1		Jul 17/2007
		2		BLANK			2		Feb 09/2009
29-CONTENTS					29-33-11				
		1		May 11/2009		1	1		Mar 31/2005
		2		May 11/2009			2		Mar 31/2005
		3		May 11/2009		2	1		Feb 09/2009
		4		BLANK			2		Feb 09/2009
29-ALPHABETICAL INDEX					29-34-11				
		1		Jan 18/2007		1			Feb 09/2009
		2		BLANK	29-35-11				
29-11-11		1	1	Mar 31/2005		1.1			Oct 15/2007
			2	Mar 31/2005		2.1			Feb 09/2009
	1.1	1		Oct 15/2007		3			Feb 09/2009
		2		Oct 15/2007		4			Feb 09/2009
	2	1		Jul 17/2007					
		2		Jul 17/2007					
	2.1	1		Oct 15/2007					
		2		Oct 15/2007					
	3	1		Feb 09/2009					
		2		Feb 09/2009					
29-11-12		1		May 11/2009					
		2		May 11/2009					
29-22-11		1		Mar 31/2005					
		2		Feb 09/2009					
29-23-11		1		Mar 31/2005					
		2		Feb 09/2009					
29-25-11		1	1	Jul 26/2006					
			2	Mar 31/2005					
	2	1		Jul 26/2006					
		2		Mar 31/2005					
	3	1		Jul 17/2007					
		2		Jul 17/2007					
	4	1		May 11/2009					
		2		May 11/2009					
	5	1		May 11/2009					
		2		May 11/2009					
29-31-11		1	1	Jul 17/2007					
			2	Jul 17/2007					
	2	1		Oct 20/2006					
		2		Oct 20/2006					
	3	1		Oct 20/2006					
		2		Oct 20/2006					
	4	1		Feb 09/2009					
		2		Feb 09/2009					

A = Added, R = Revised, D = Deleted, O = Overflow

29-EFFECTIVE PAGES

Page 1
Aug 10/2009

D280A103



737-700/800

WIRING DIAGRAM MANUAL

CHAPTER 29
HYDRAULIC POWER

Title	CH-SC-SU	Schem	Page	Sheet	Date	Effectivity
<u>HYDRAULIC SYSTEMS A AND B</u>						
ENGINE HYDRAULIC PUMP CONTROL	29-11-11		1	1	Mar 31/2005	YC001-YC003
				2	Mar 31/2005	YC001-YC003
			1.1	1	Oct 15/2007	YC001-YC003
				2	Oct 15/2007	YC001-YC003
			2	1	Jul 17/2007	YC004-YC030
				2	Jul 17/2007	YC004-YC030
			2.1	1	Oct 15/2007	YC004-YC030
				2	Oct 15/2007	YC004-YC030
			3	1	Feb 09/2009	YC031-YM670
				2	Feb 09/2009	YC031-YM670
ELECTRIC HYDRAULIC PUMP CONTROL	29-11-12		1		May 11/2009	YC001-YC003
			2		May 11/2009	YC004-YM670
<u>HYDRAULIC STANDBY CONTROL</u>						
STANDBY HYDRAULIC PUMP CONTROL	29-22-11		1		Mar 31/2005	YC001-YC003
			2		Feb 09/2009	YC004-YM670
<u>LANDING GEAR TRANSFER VALVE CONTROL</u>						
LANDING GEAR TRANSFER VALVE CONTROL	29-23-11		1		Mar 31/2005	YC001-YC003
			2		Feb 09/2009	YC004-YM670
<u>HYDRAULIC POWER TRANSFER UNIT CONTROL</u>						
HYDRAULIC POWER TRANSFER UNIT CONTROL	29-25-11		1	1	Jul 26/2006	YC001-YC003
				2	Mar 31/2005	YC001-YC003
			2	1	Jul 26/2006	YC004-YC007
				2	Mar 31/2005	YC004-YC007
			3	1	Jul 17/2007	YC008-YK906
				2	Jul 17/2007	YC008-YK906
			4	1	May 11/2009	YK907-YK912 YK918-YK919 YL401-YL429

29-CONTENTS

Page 1
May 11/2009

D280A103



737-700/800

WIRING DIAGRAM MANUAL

CHAPTER 29
HYDRAULIC POWER

Title	CH-SC-SU	Schem	Page	Sheet	Date	Effectivity
HYDRAULIC POWER TRANSFER UNIT CONTROL (cont.)	29-25-11			2	May 11/2009	YK907-YK912 YK918-YK919 YL401-YL429
				5	May 11/2009	YM643-YM652
				2	May 11/2009	YM643-YM652
<u>HYDRAULIC FLUID QUANTITY INDICATING SYSTEM</u>						
HYDRAULIC FLUID QUANTITY INDICATION	29-31-11			1	Jul 17/2007	YC001-YC028
				2	Jul 17/2007	YC001-YC028
				2	Oct 20/2006	YC029-YC050
				2	Oct 20/2006	YC029-YC050
				3	Oct 20/2006	YK901-YK907 YL421
				2	Oct 20/2006	YK901-YK907 YL421
				4	Feb 09/2009	YK908-YL401 YL422-YM670
				2	Feb 09/2009	YK908-YL401 YL422-YM670
<u>HYDRAULIC FLUID INDICATING SYSTEM</u>						
HYDRAULIC FLUID PRESSURE INDICATION	29-32-11			1	Jul 17/2007	YC001-YC028
				2	Feb 09/2009	YC029-YM670
<u>PUMP LOW PRESSURE WARNING SYSTEM</u>						
HYDRAULIC SYSTEM LOW PRESSURE LIGHTS	29-33-11			1	Mar 31/2005	YC001-YC003
				2	Mar 31/2005	YC001-YC003
				2	Feb 09/2009	YC004-YM670
				2	Feb 09/2009	YC004-YM670
<u>HYDRAULIC FLUID OVERHEAT WARNING SYSTEM</u>						
MAIN HYDRAULIC SYSTEM OVERHEAT LIGHTS	29-34-11			1	Feb 09/2009	ALL
<u>HYDRAULIC PRESSURE INDICATION SYSTEM</u>						
STANDBY HYDRAULIC SYSTEM LOW PRESSURE LIGHTS	29-35-11			1.1	Oct 15/2007	YC001-YC007
				2.1	Feb 09/2009	YC008-YC030
				3	Feb 09/2009	YC031-YK907 YL421

29-CONTENTS

Page 2
May 11/2009

D280A103



737-700/800

WIRING DIAGRAM MANUAL

CHAPTER 29 HYDRAULIC POWER

Title	CH-SC-SU	Schem	Page	Sheet	Date	Effectivity
STANDBY HYDRAULIC SYSTEM LOW PRESSURE LIGHTS (cont.)	29-35-11		4		Feb 09/2009	YK908-YL401 YL422-YM670

29-CONTENTS

Page 3

May 11/2009

D280A103



737-700/800

WIRING DIAGRAM MANUAL

CHAPTER 29 HYDRAULIC POWER

CH-SC-SU	Title
29-11-12	ELECTRIC HYDRAULIC PUMP CONTROL
29-11-11	ENGINE HYDRAULIC PUMP CONTROL
29-32-11	HYDRAULIC FLUID PRESSURE INDICATION
29-31-11	HYDRAULIC FLUID QUANTITY INDICATION
29-25-11	HYDRAULIC POWER TRANSFER UNIT CONTROL
29-33-11	HYDRAULIC SYSTEM LOW PRESSURE LIGHTS
29-23-11	LANDING GEAR TRANSFER VALVE CONTROL
29-34-11	MAIN HYDRAULIC SYSTEM OVERHEAT LIGHTS
29-22-11	STANDBY HYDRAULIC PUMP CONTROL
29-35-11	STANDBY HYDRAULIC SYSTEM LOW PRESSURE LIGHTS

29-ALPHABETICAL INDEX

D280A103

Page 1
Jan 18/2007

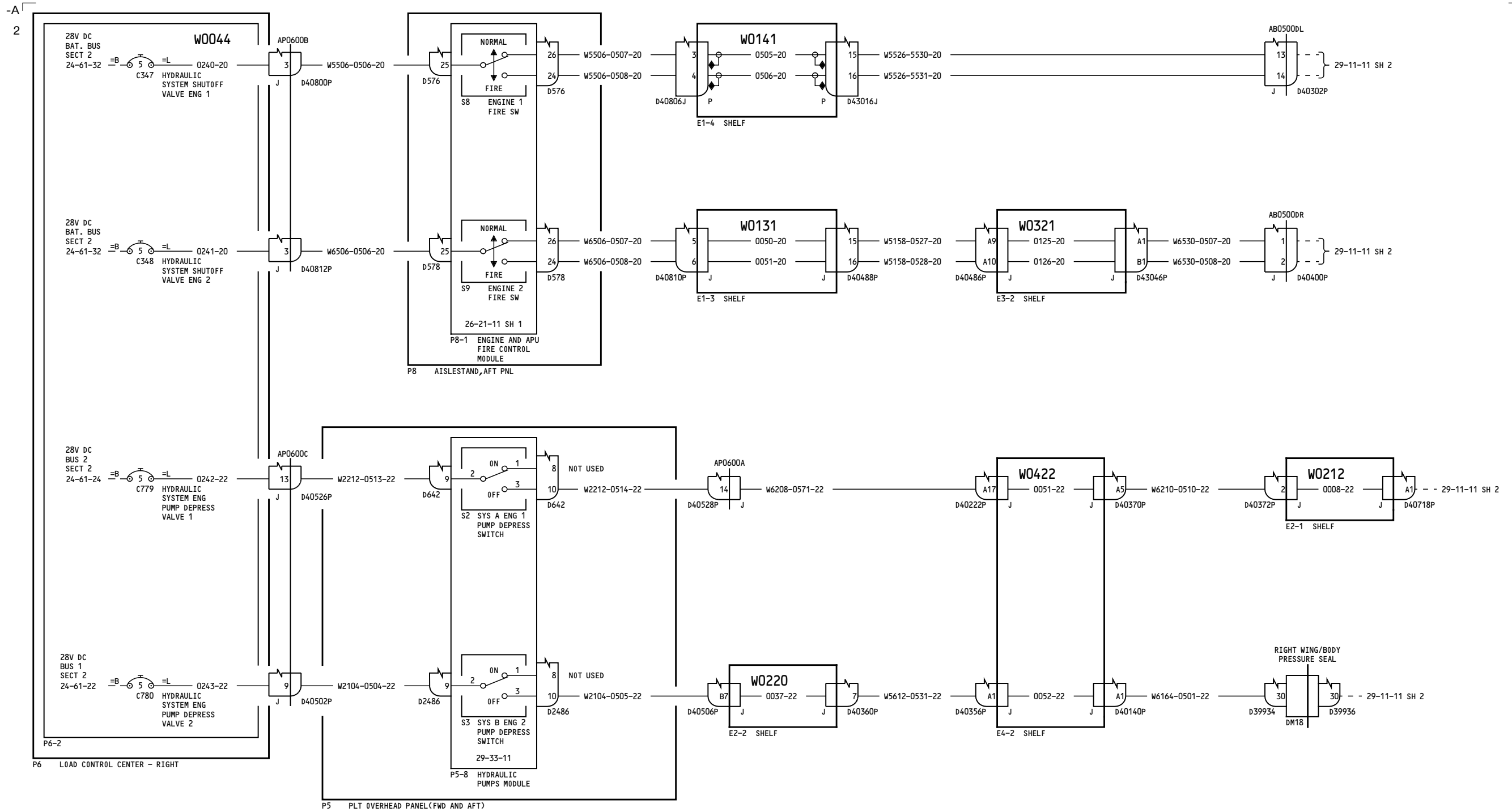

YC001-YC003

ENGINE HYDRAULIC PUMP CONTROL

29-11-11

D280A103

Page 1
Sheet 1
Mar 31/2005

29-11-11

Page 1
Sheet 1
Mar 31/2005

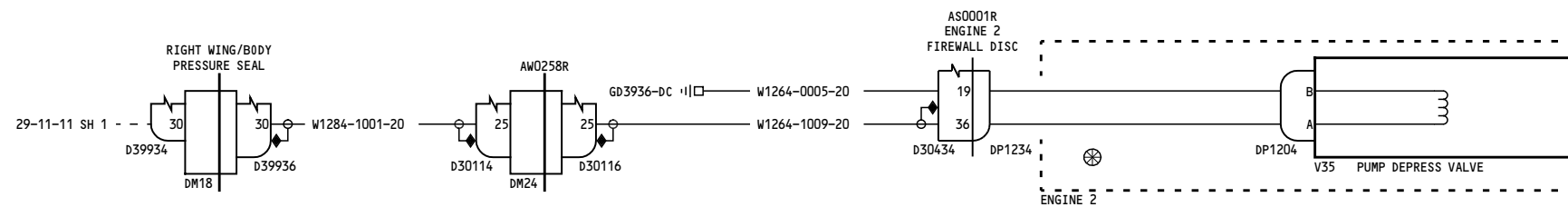
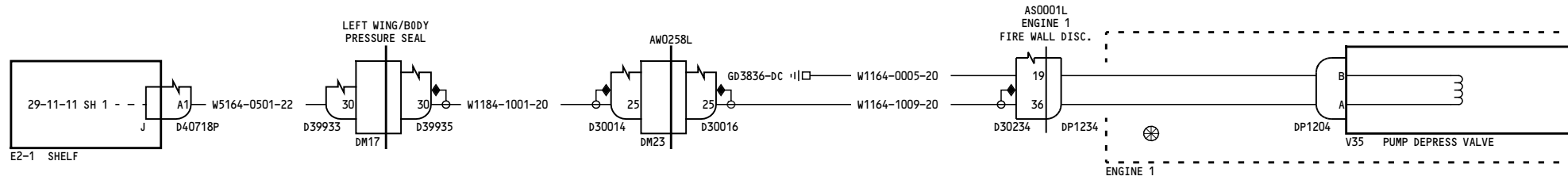
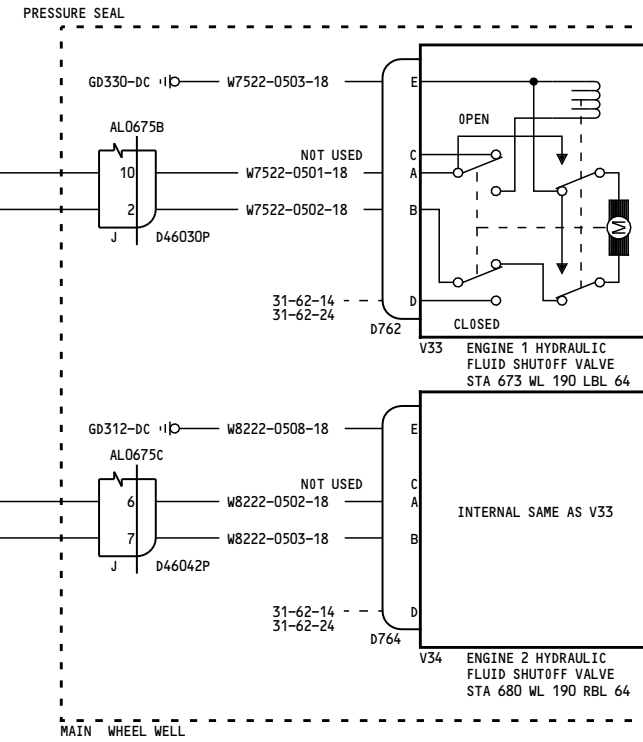
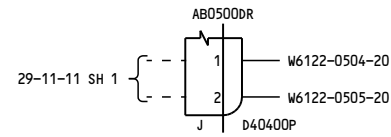
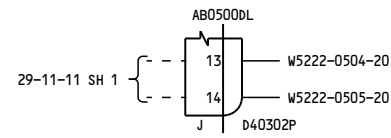

YC001-YC003

ENGINE HYDRAULIC PUMP CONTROL

D280A103

29-11-11

Page 1
Sheet 2
Mar 31/2005

29-11-11

Page 1
Sheet 2
Mar 31/2005

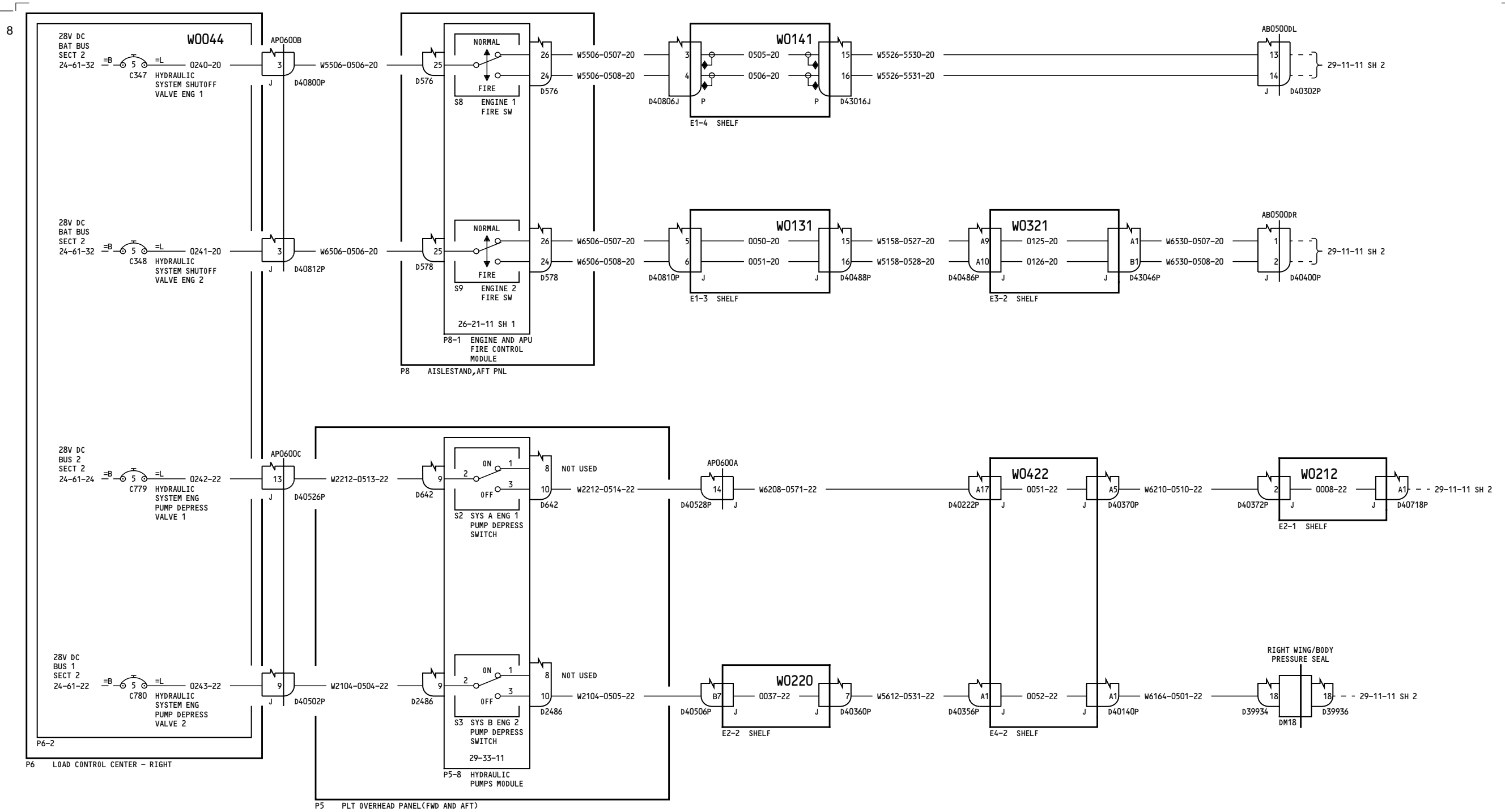

YC001-YC003

ENGINE HYDRAULIC PUMP CONTROL

29-11-11

Incorporates
28-1194 R02

29-11-11

D280A103

Page 1.1
Sheet 1
Oct 15/2007

Page 1.1
Sheet 1
Oct 15/2007

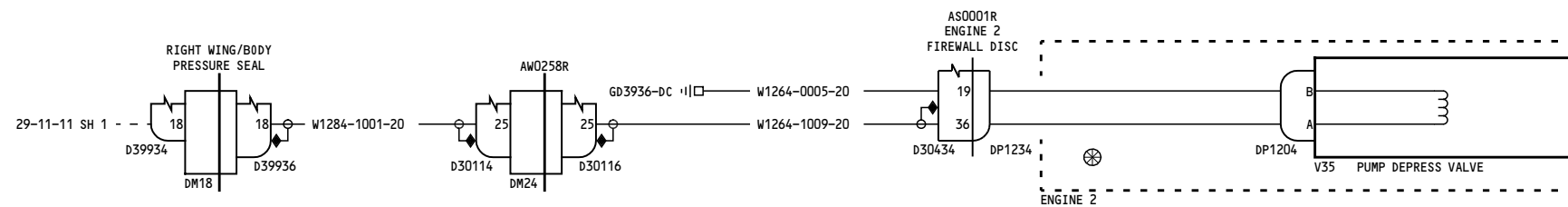
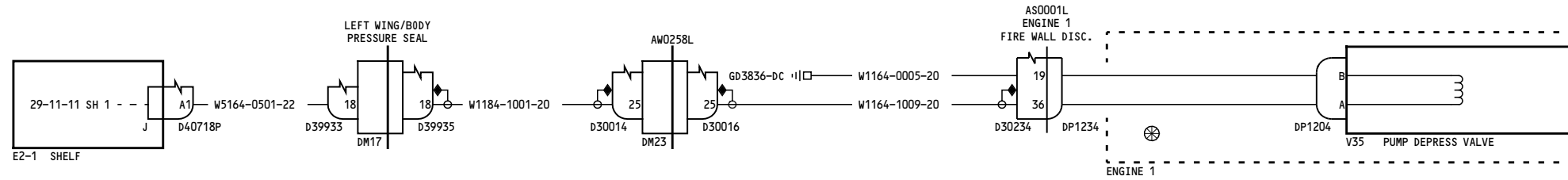
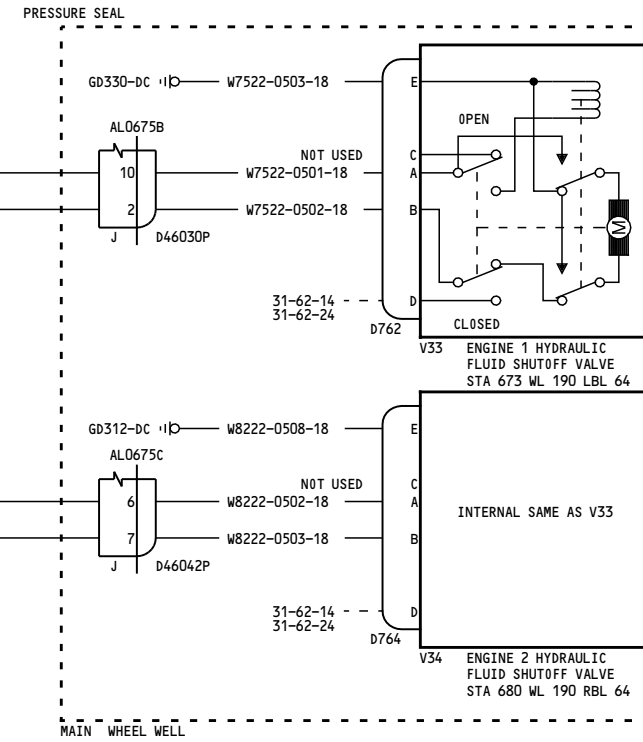
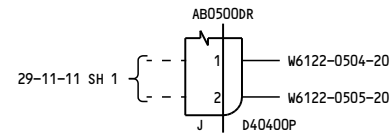
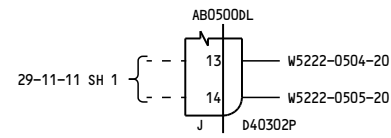

YC001-YC003

ENGINE HYDRAULIC PUMP CONTROL

29-11-11

Page 1.1
Sheet 2
Oct 15/2007

D280A103

Incorporates
28-1194 R02

29-11-11

Page 1.1
Sheet 2
Oct 15/2007

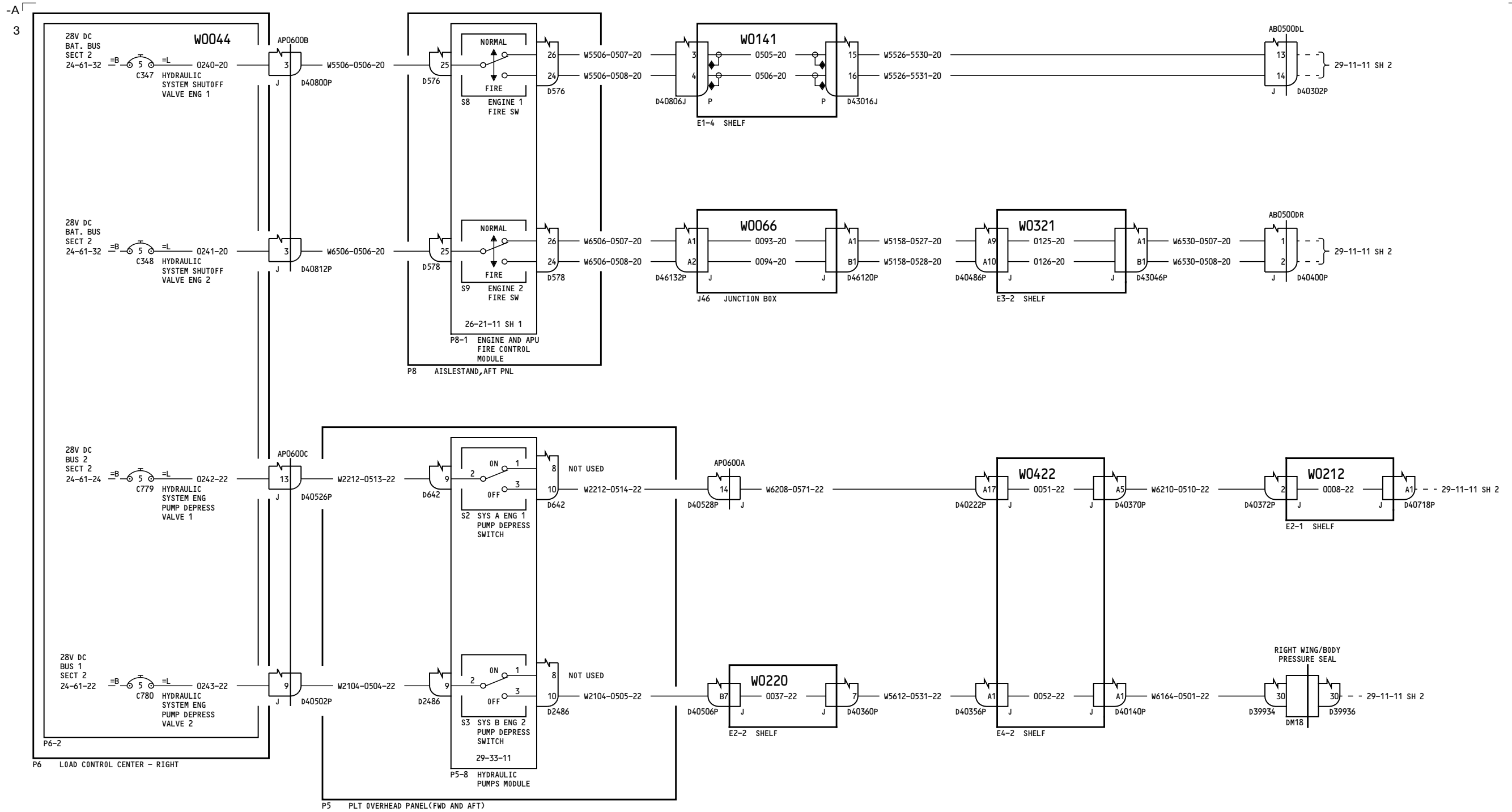

YC004-YC030

ENGINE HYDRAULIC PUMP CONTROL

29-11-11

D280A103

Page 2
Sheet 1
Jul 17/2007

29-11-11

Page 2
Sheet 1
Jul 17/2007

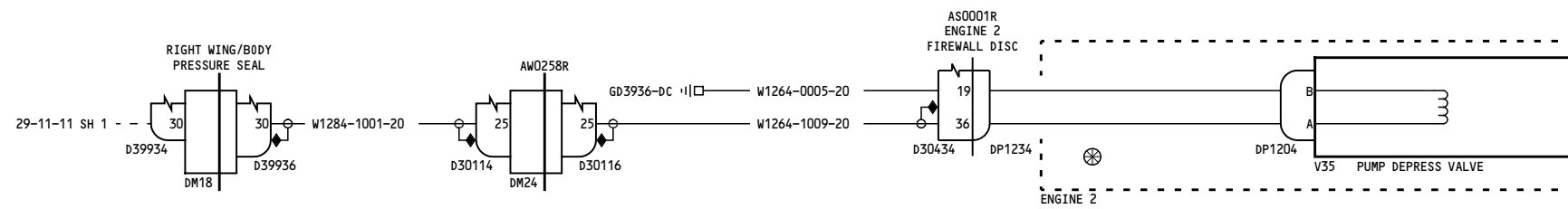
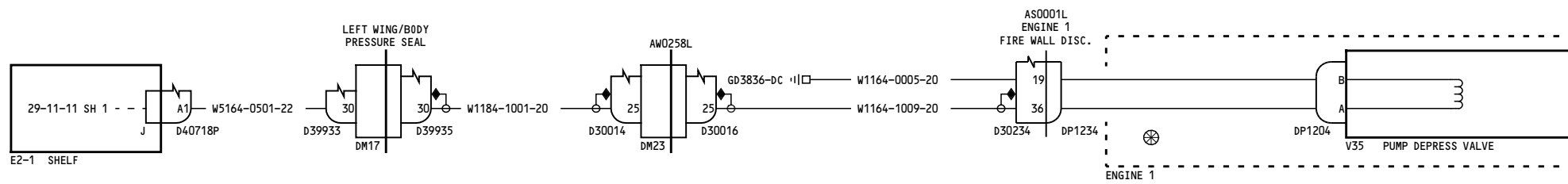
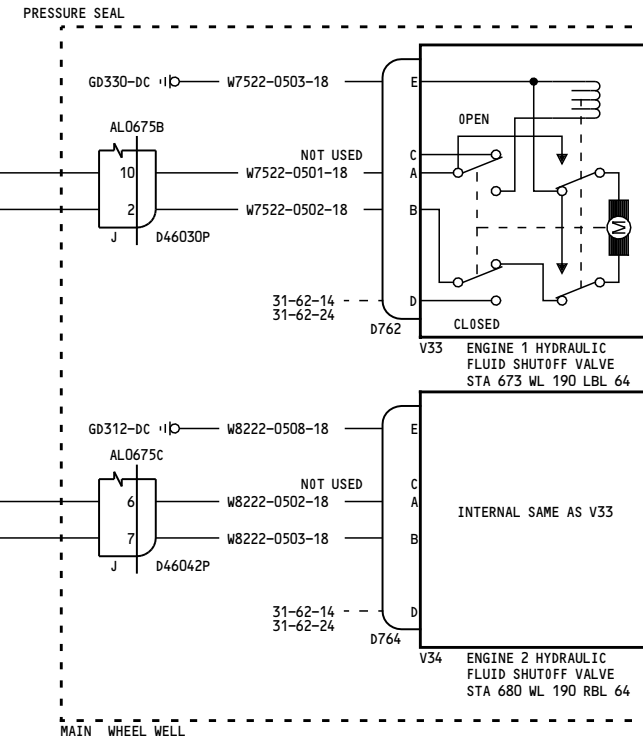
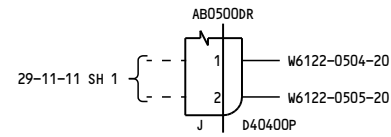
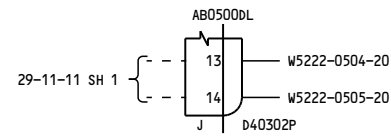

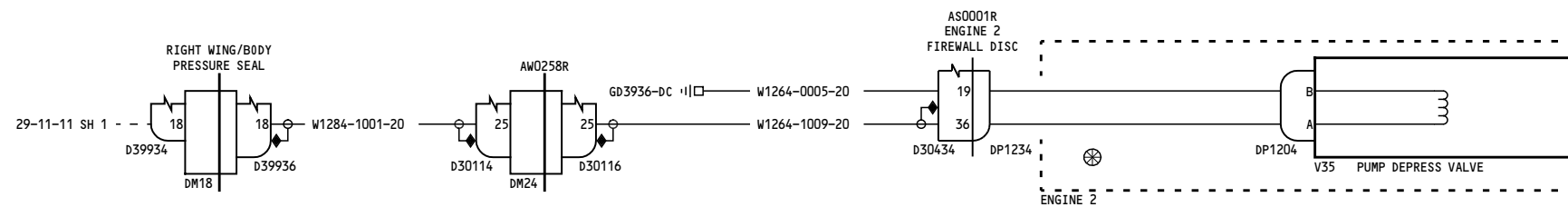
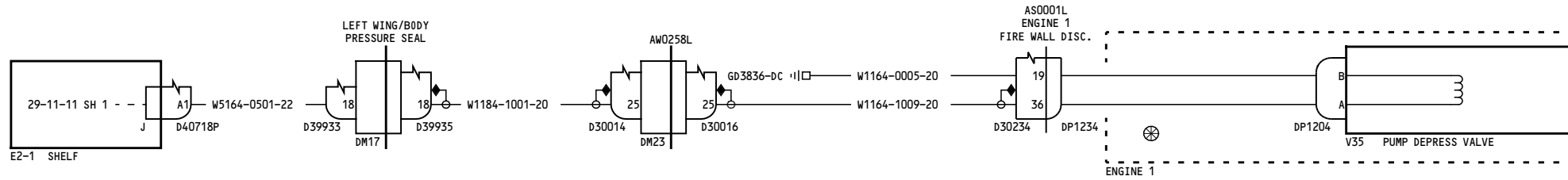
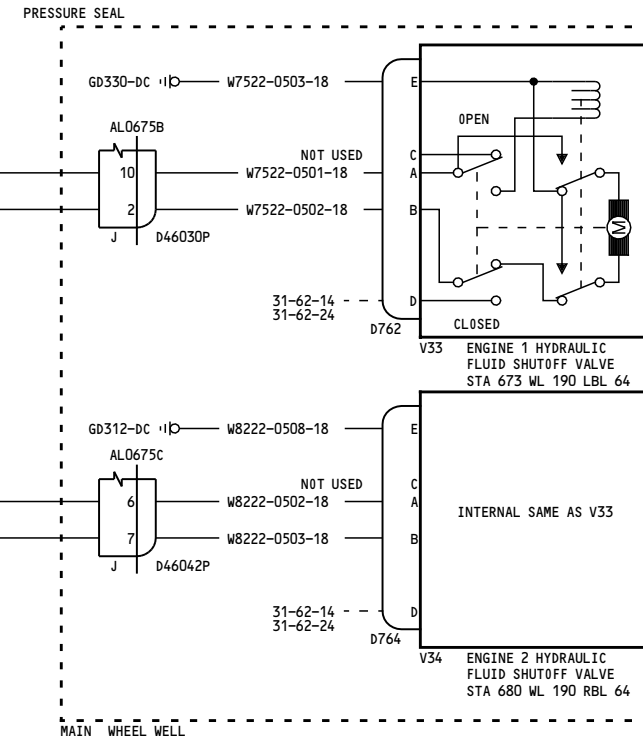
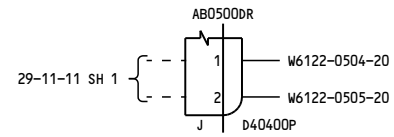
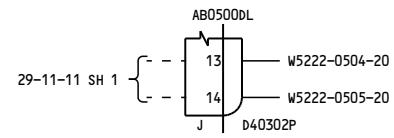

YC004-YC030

ENGINE HYDRAULIC PUMP CONTROL

29-11-11

Page 2.1
Sheet 2
Oct 15/2007

D280A103

Incorporates
28-1194 R02

29-11-11

Page 2.1
Sheet 2
Oct 15/2007

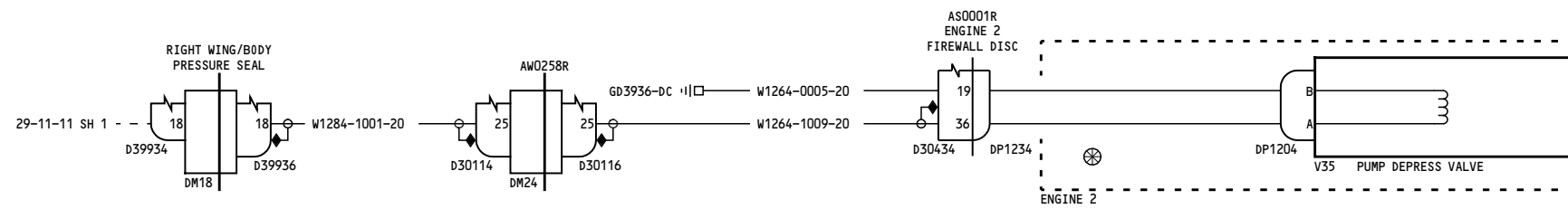
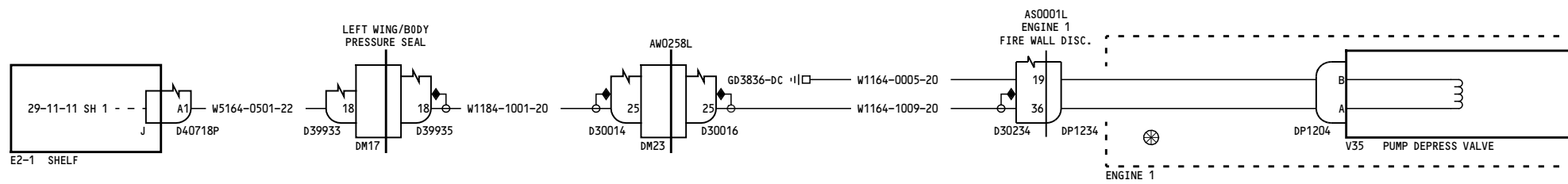
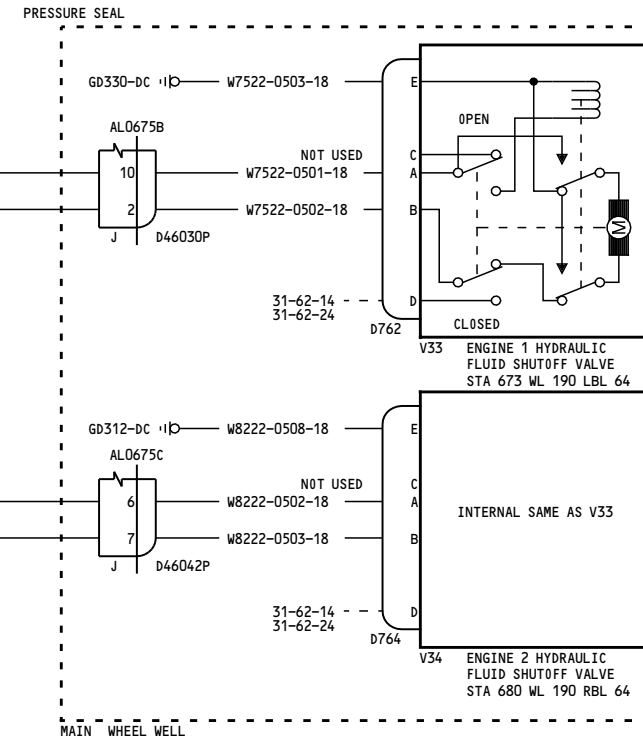
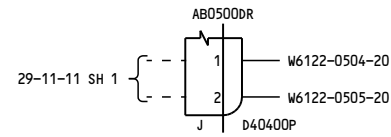
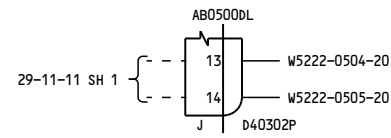

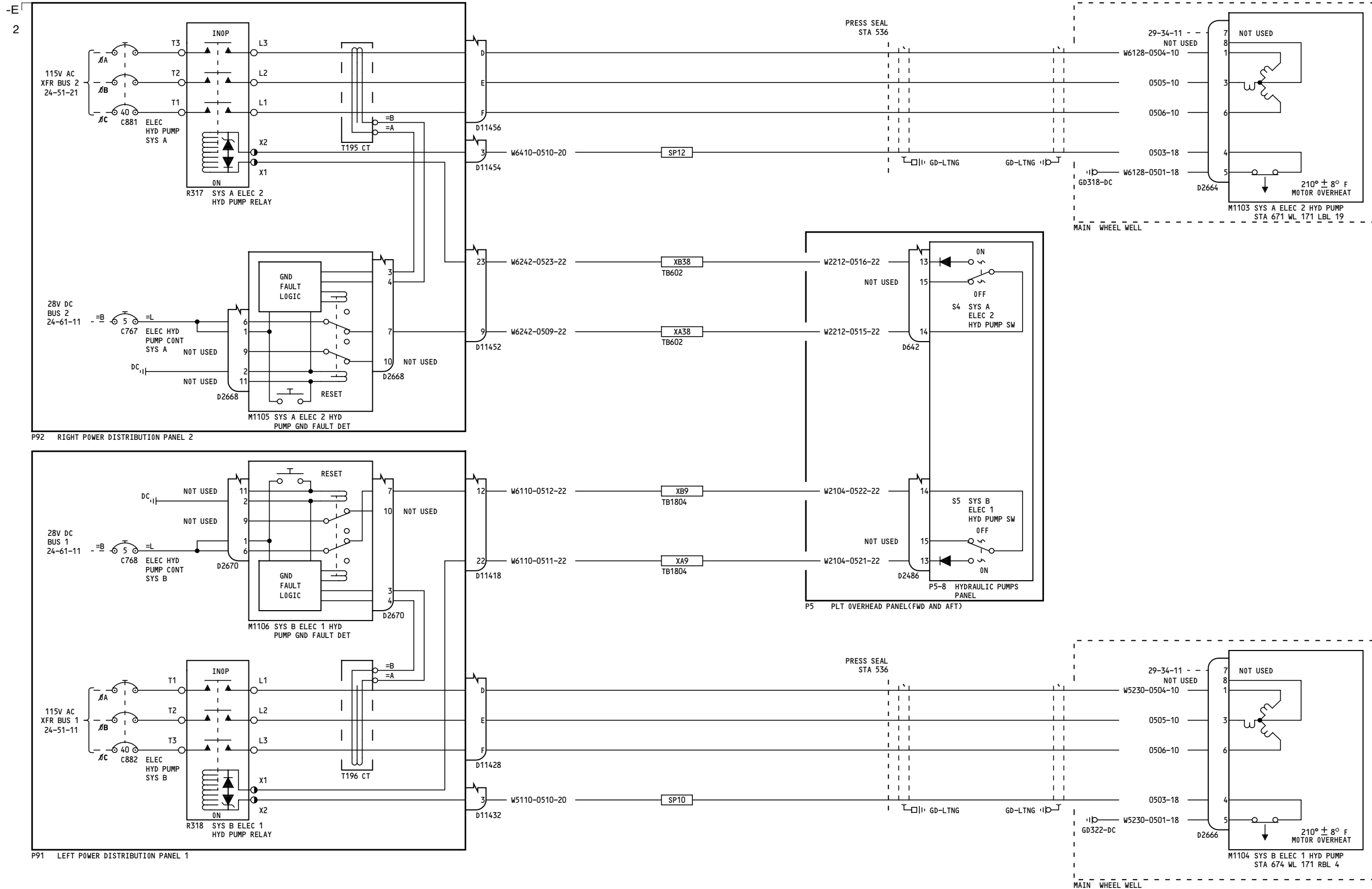

YC001-YC003

ELECTRIC HYDRAULIC PUMP CONTROL

D280A103

29-11-12

Page 1

May 11/2009

29-11-12

Page 1

May 11/2009

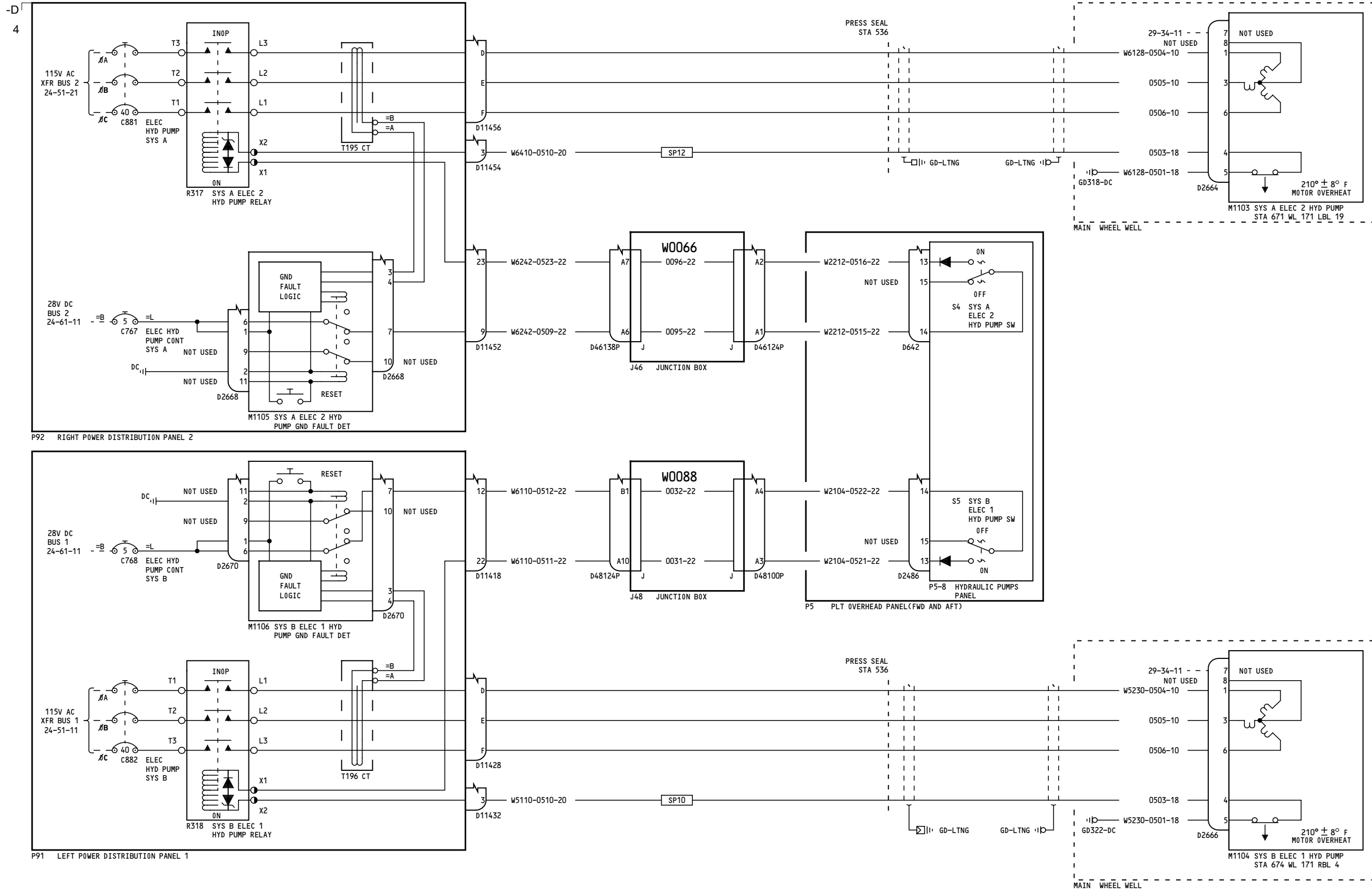

YC004-YM670

ELECTRIC HYDRAULIC PUMP CONTROL

D280A103

29-11-12

Page 2

May 11/2009

29-11-12

Page 2

May 11/2009

-H
1

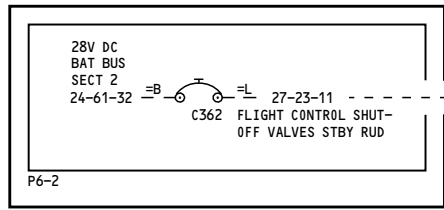

P6 LOAD CONTROL CENTER - RIGHT

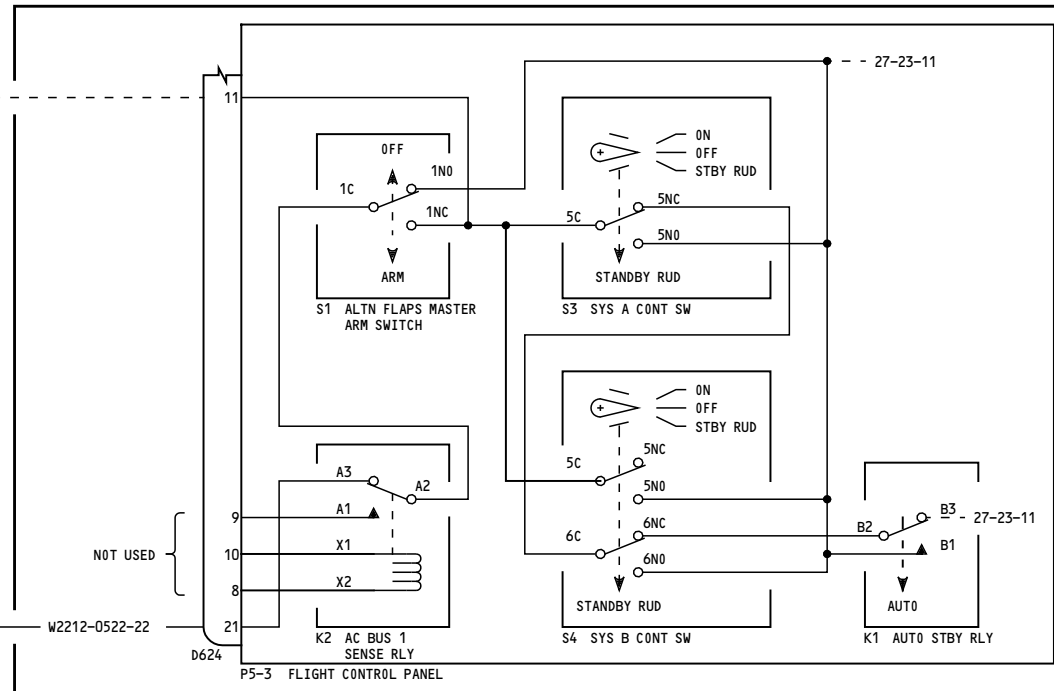

P5 PLT OVERHEAD PANEL (FWD AND AFT)

CADD 4

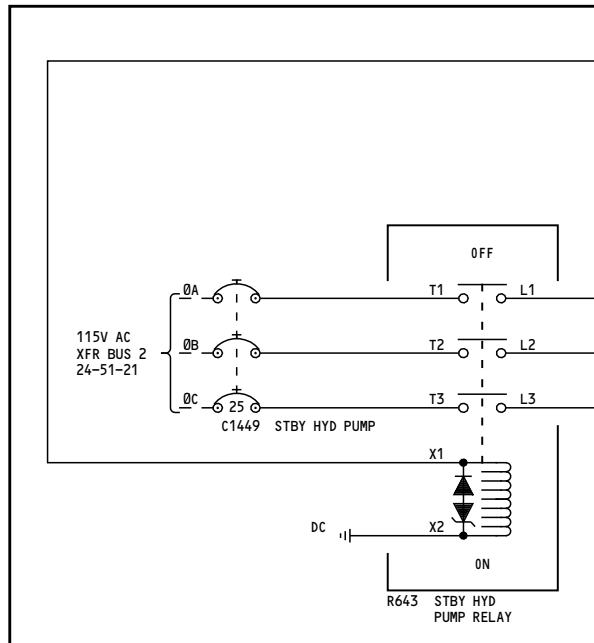

P92 POWER DISTRIBUTION PANEL 2

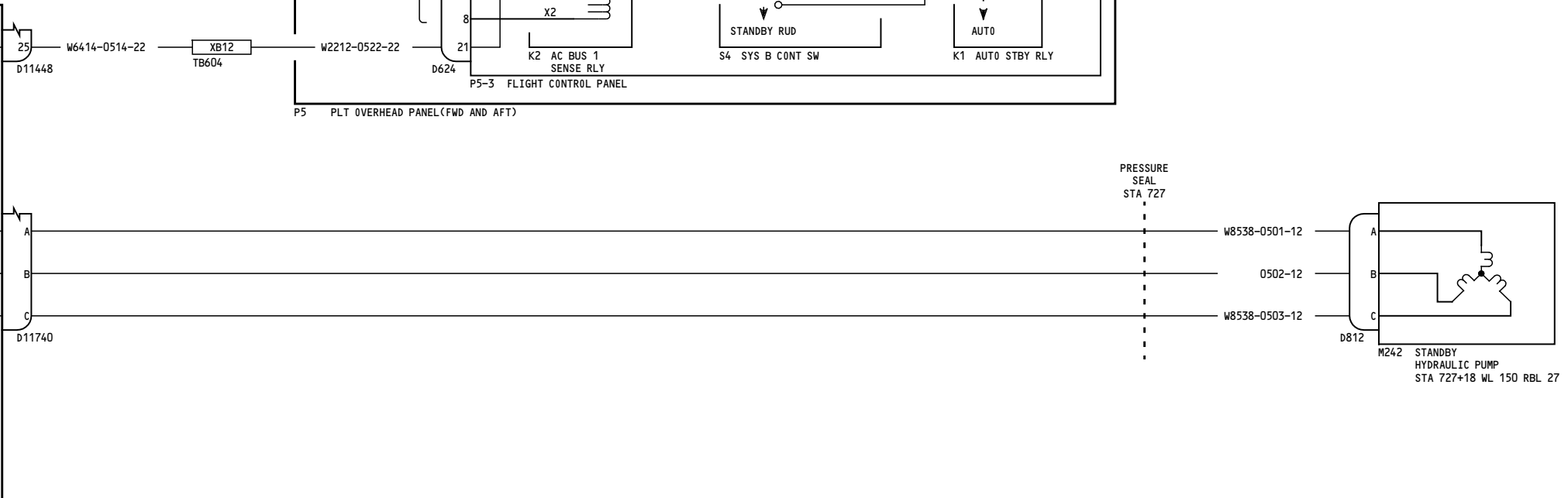

YC001-YC003

STANDBY HYDRAULIC PUMP CONTROL

29-22-11

Page 1

D280A103

Mar 31/2005

29-22-11

Page 1

Mar 31/2005

-A
2

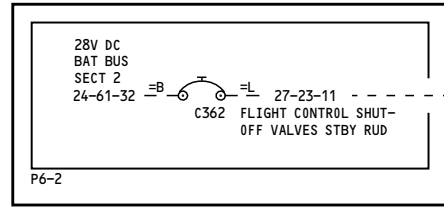

P6 LOAD CONTROL CENTER - RIGHT

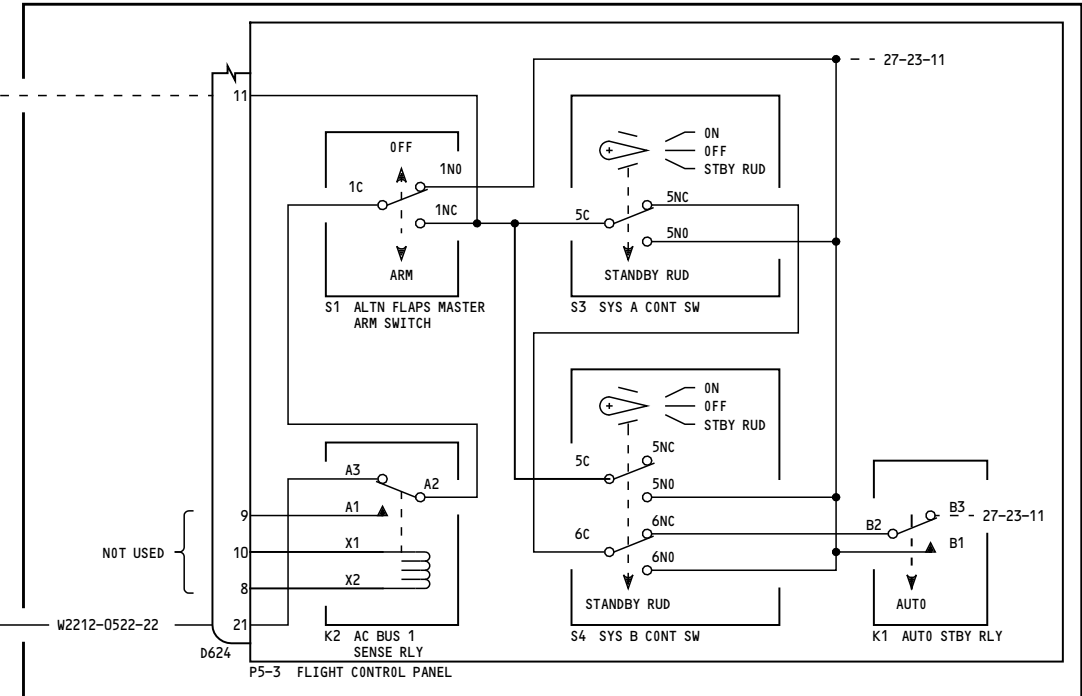

P5 PLT OVERHEAD PANEL (FWD AND AFT)

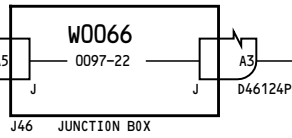

W6414-0514-22

D11448

D46142P

D46124P

W2212-0522-22

D624

CADDS 4

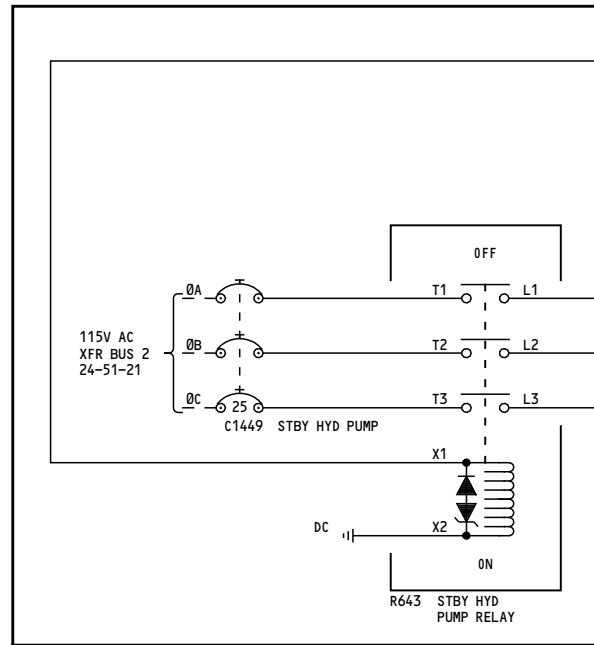

P92 POWER DISTRIBUTION PANEL 2

PRESSURE SEAL STA 727

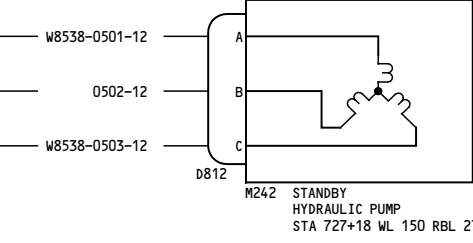

YC004-YM670

STANDBY HYDRAULIC PUMP CONTROL

29-22-11

Page 2

D280A103

Feb 09/2009

29-22-11

Page 2

Feb 09/2009

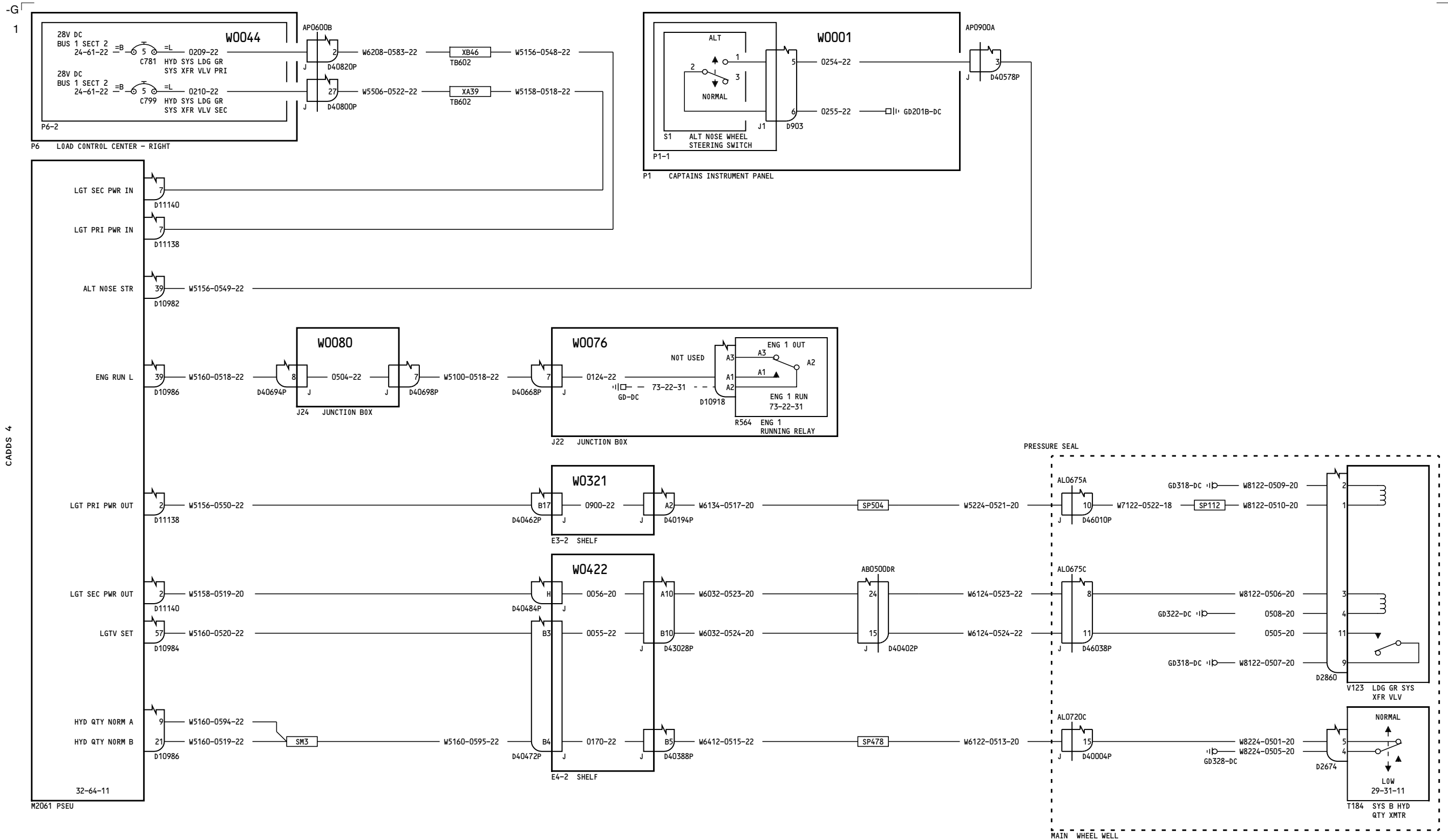

YC001-YC003

LANDING GEAR TRANSFER VALVE CONTROL

29-23-11

Page 1

D280A103

Mar 31/2005

29-23-11

Page 1

Mar 31/2005

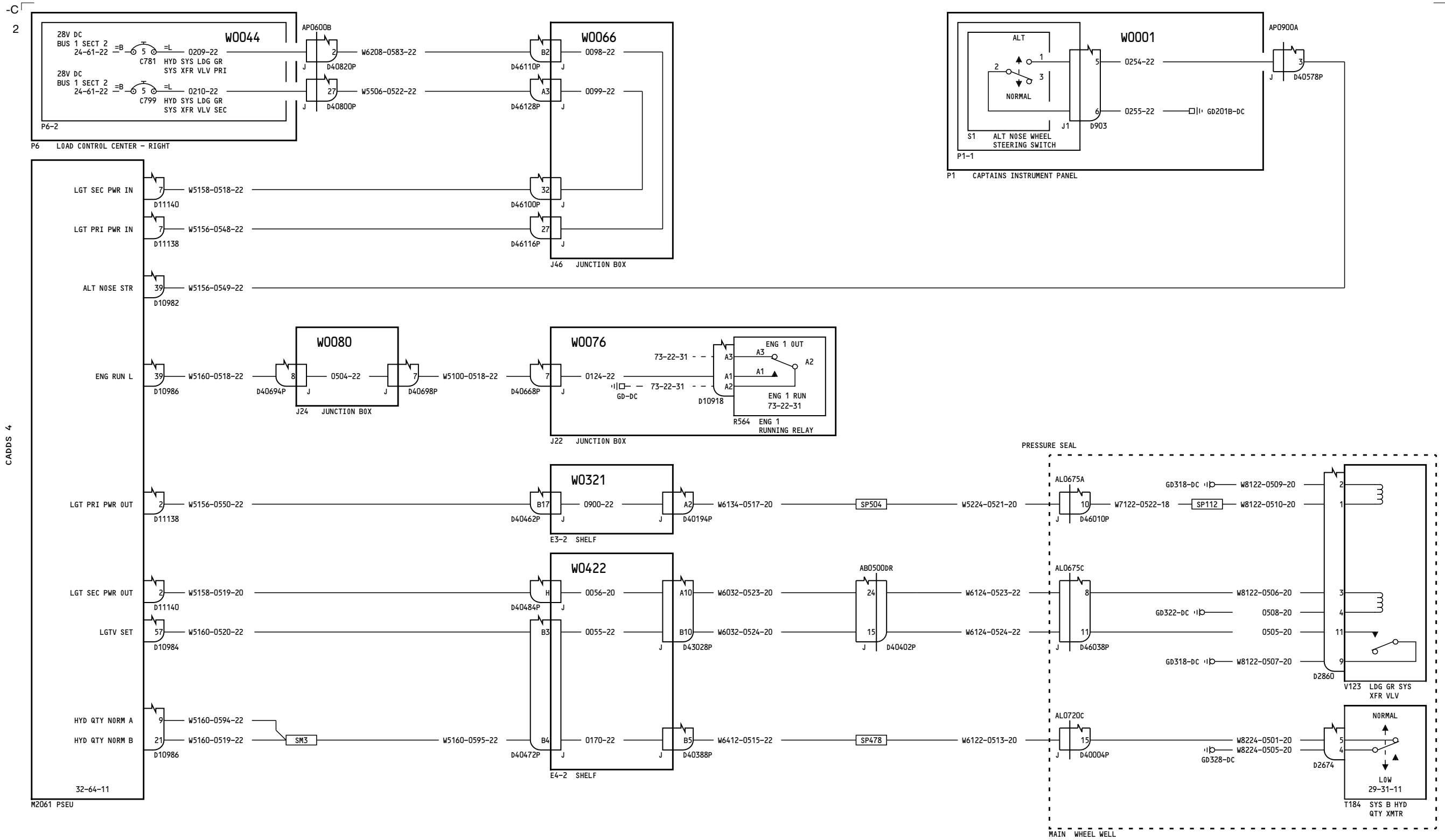

YC004-YM670

LANDING GEAR TRANSFER VALVE CONTROL

29-23-11

Page 2

D280A103

Feb 09/2009

29-23-11

Page 2

Feb 09/2009

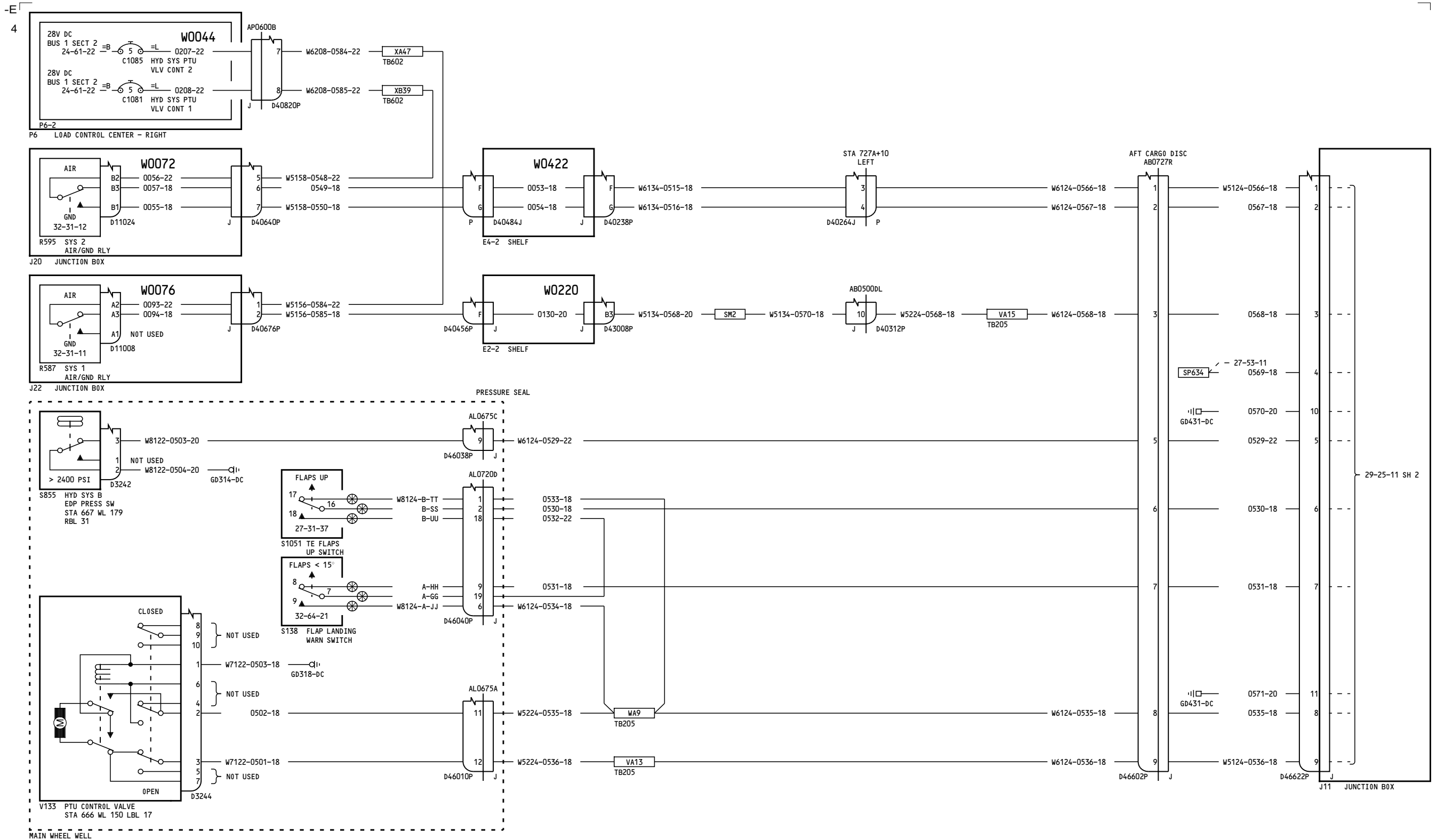

YC001-YC003

HYDRAULIC POWER TRANSFER UNIT CONTROL

29-25-11

Page 1
Sheet 1
Jul 26/2006

D280A103

29-25-11

Page 1
Sheet 1
Jul 26/2006

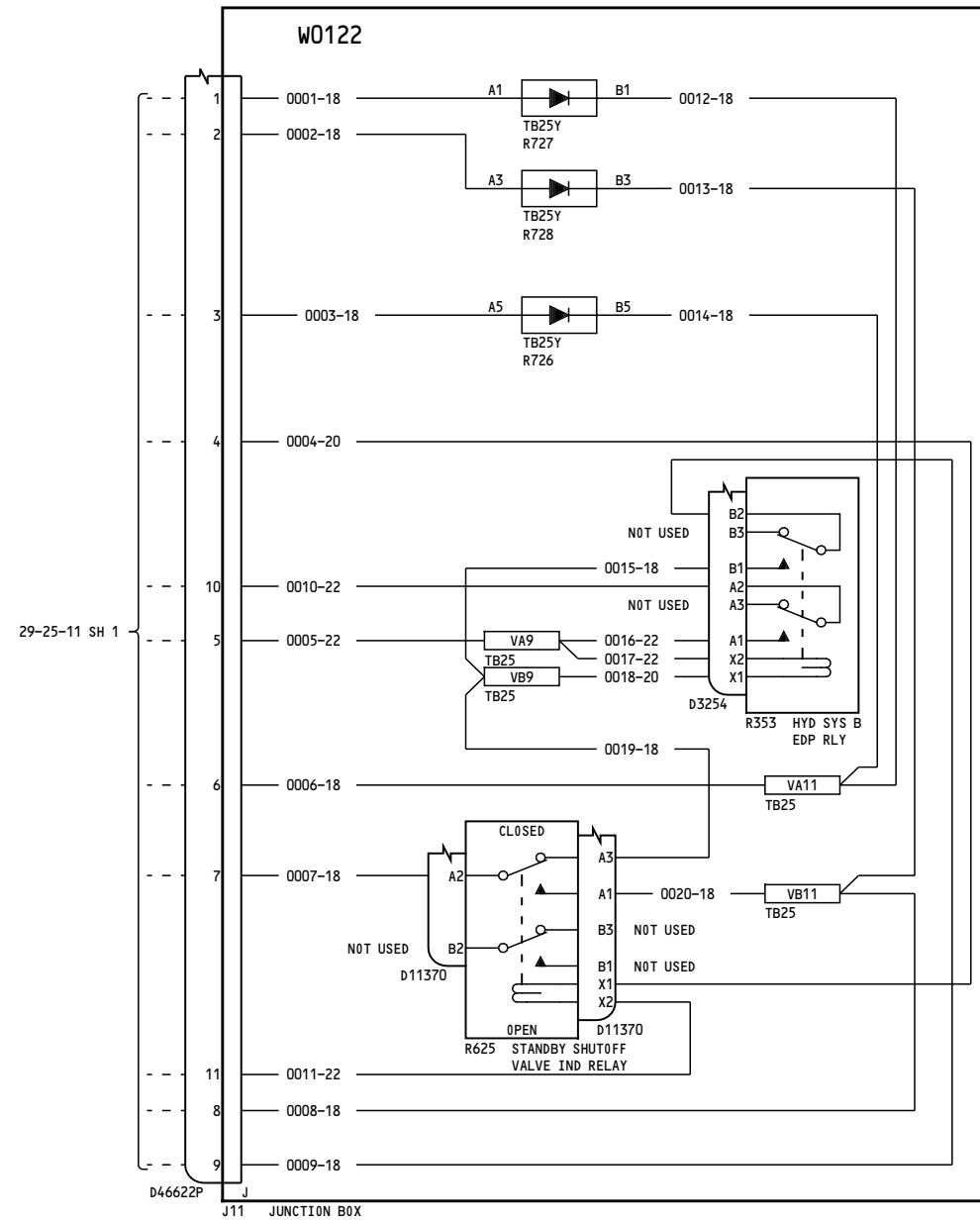

YC001-YC003

**HYDRAULIC POWER TRANSFER
UNIT CONTROL**

D280A103

29-25-11

Page 1
Sheet 2
Mar 31/2005

29-25-11

Page 1
Sheet 2
Mar 31/2005

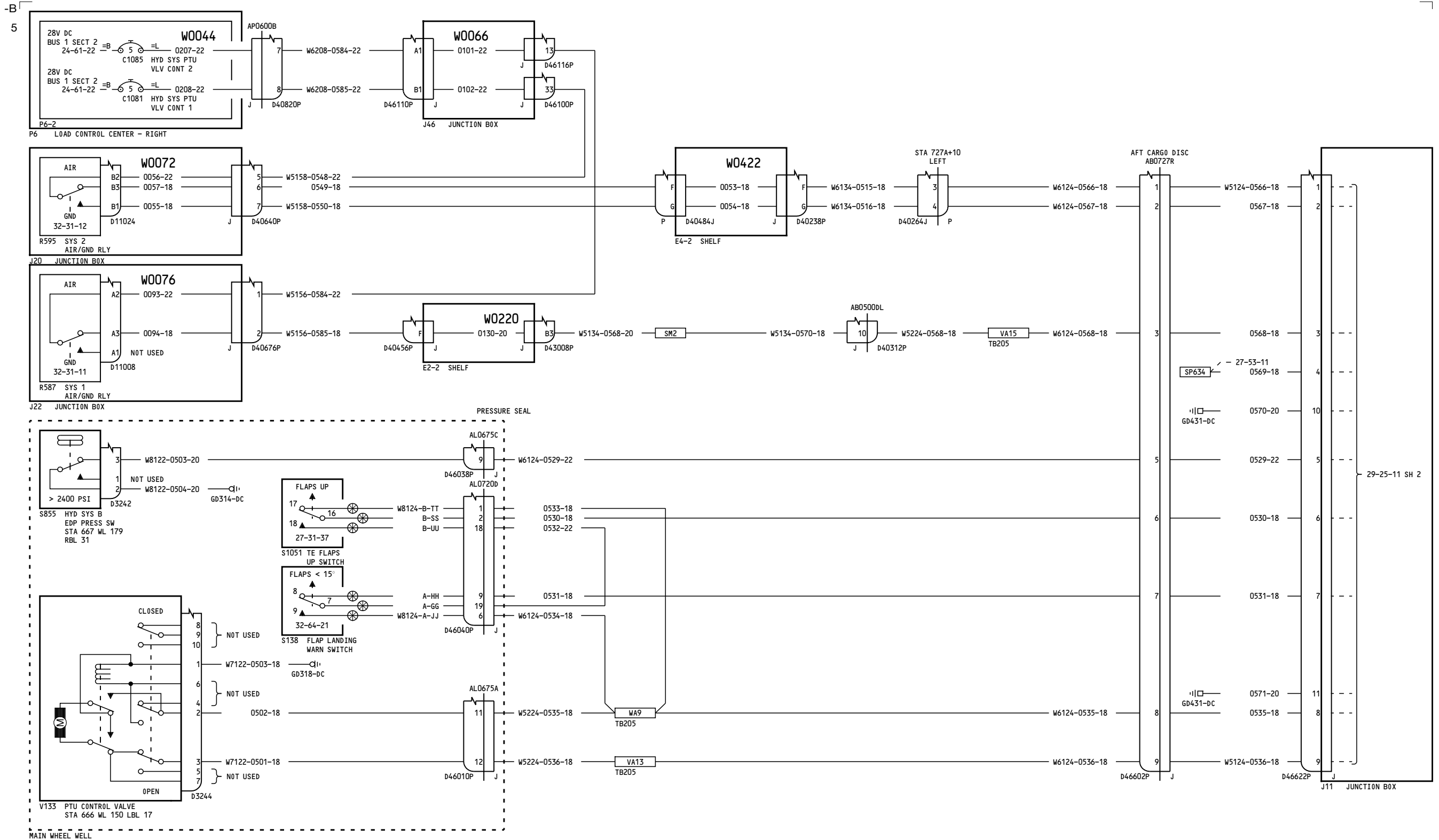

YC004-YC007

HYDRAULIC POWER TRANSFER UNIT CONTROL

29-25-11

Page 2
Sheet 1
Jul 26/2006

D280A103

29-25-11

Page 2
Sheet 1
Jul 26/2006

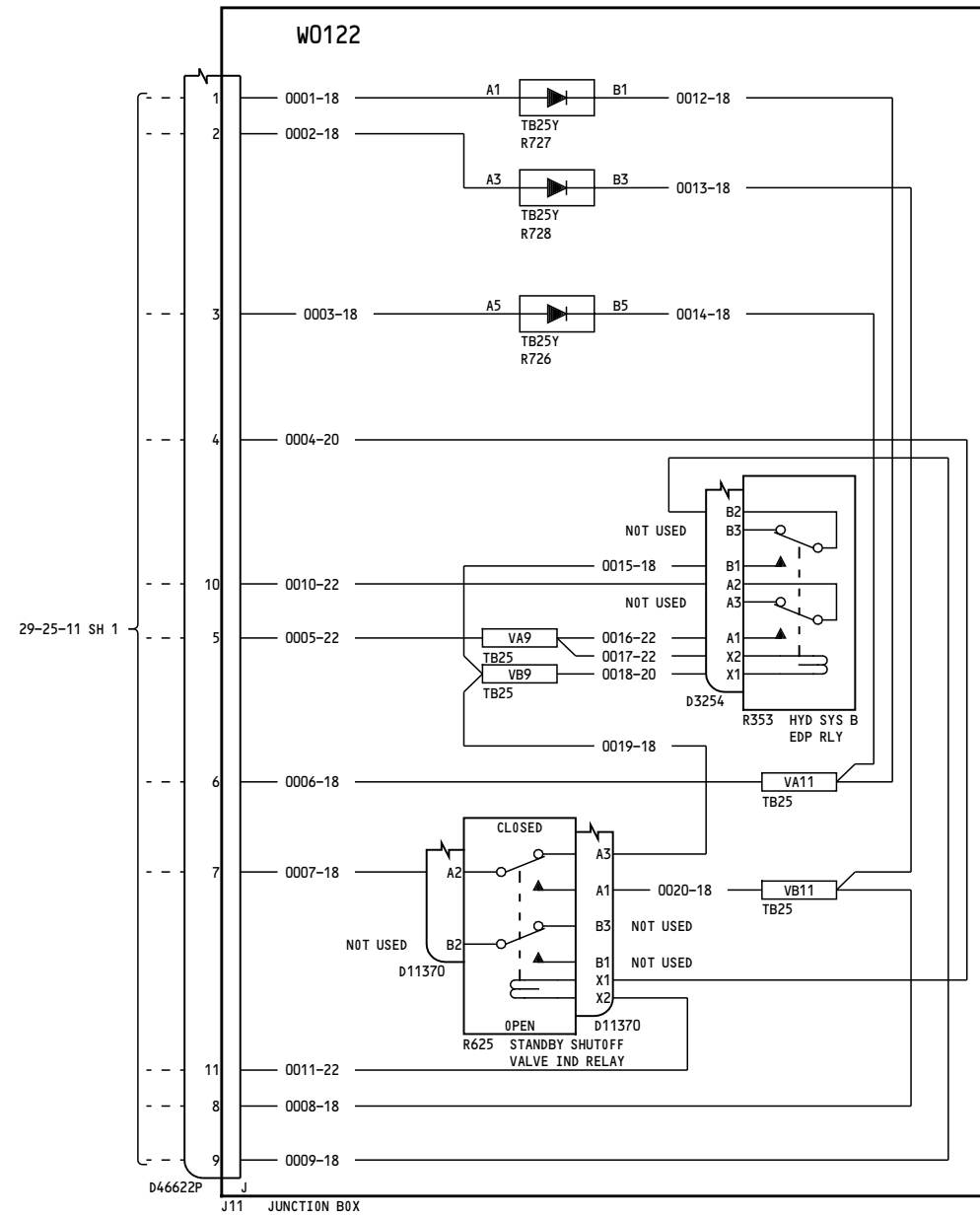

YC004-YC007

HYDRAULIC POWER TRANSFER
UNIT CONTROL

D280A103

29-25-11

Page 2
Sheet 2
Mar 31/2005

29-25-11

Page 2
Sheet 2
Mar 31/2005

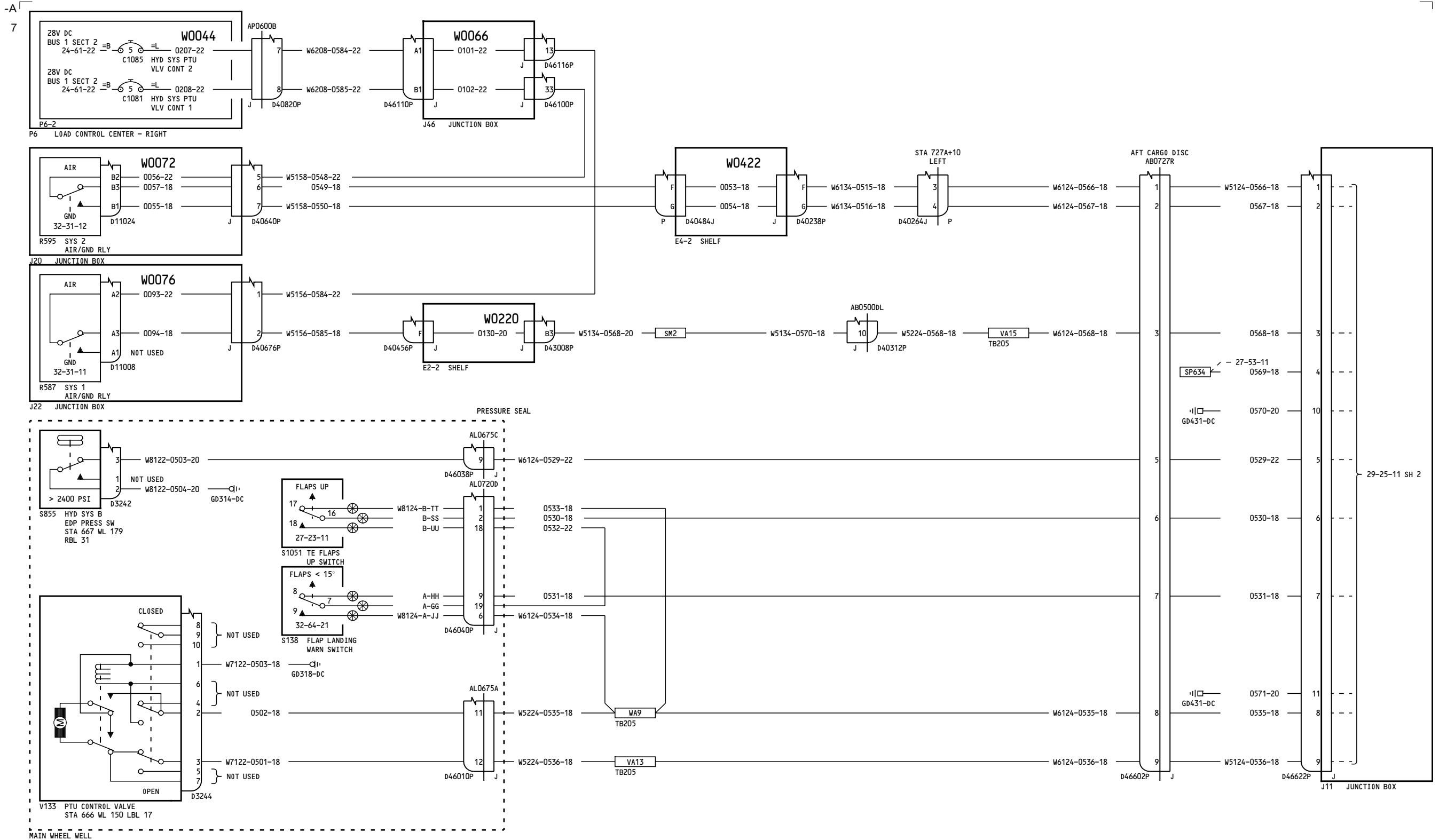

YC008-YK906

HYDRAULIC POWER TRANSFER UNIT CONTROL

29-25-11

Page 3
Sheet 1
Jul 17/2007

D280A103

29-25-11

Page 3
Sheet 1
Jul 17/2007

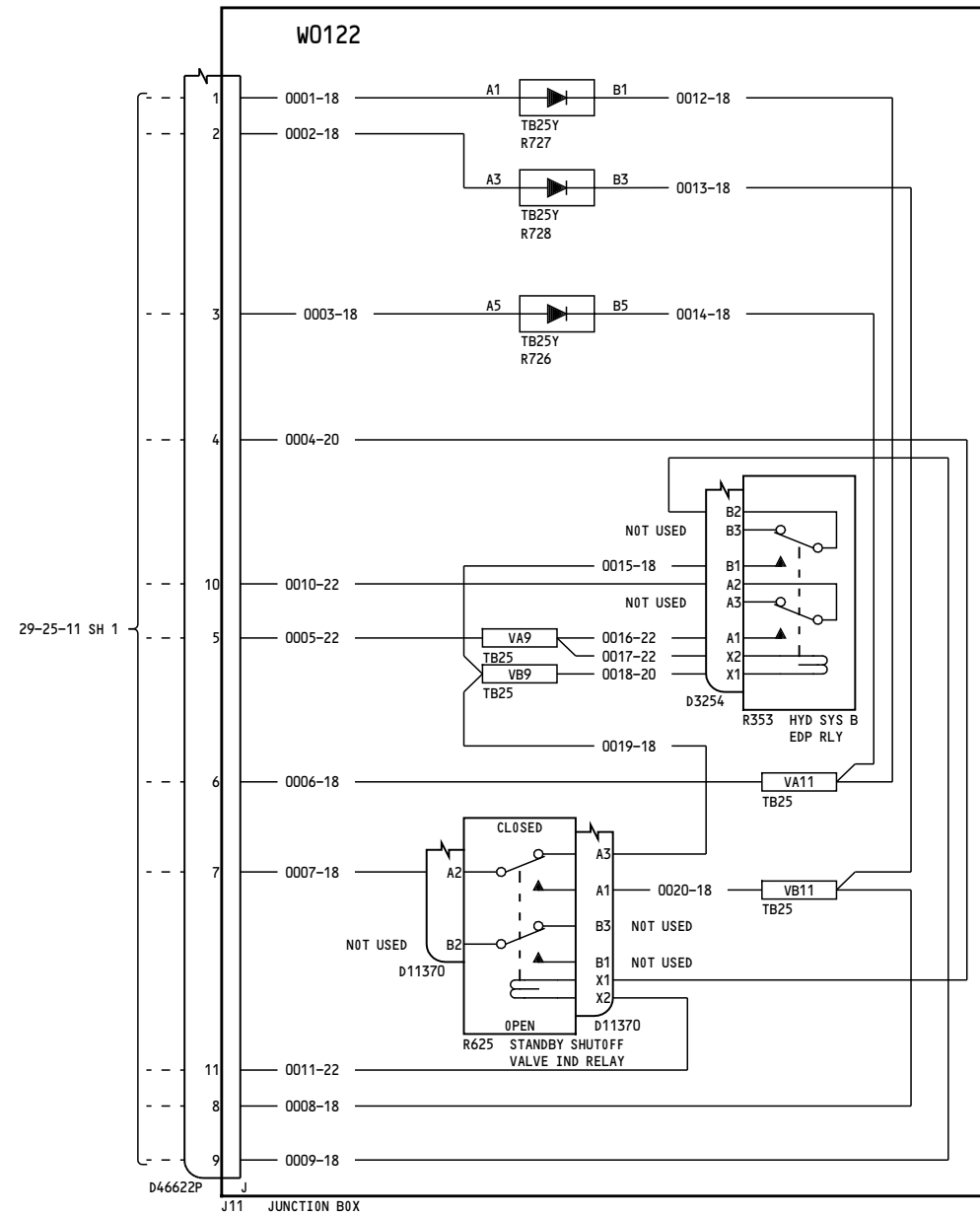

YC008-YK906

**HYDRAULIC POWER TRANSFER
UNIT CONTROL**

D280A103

29-25-11

Page 3
Sheet 2
Jul 17/2007

29-25-11

Page 3
Sheet 2
Jul 17/2007

11

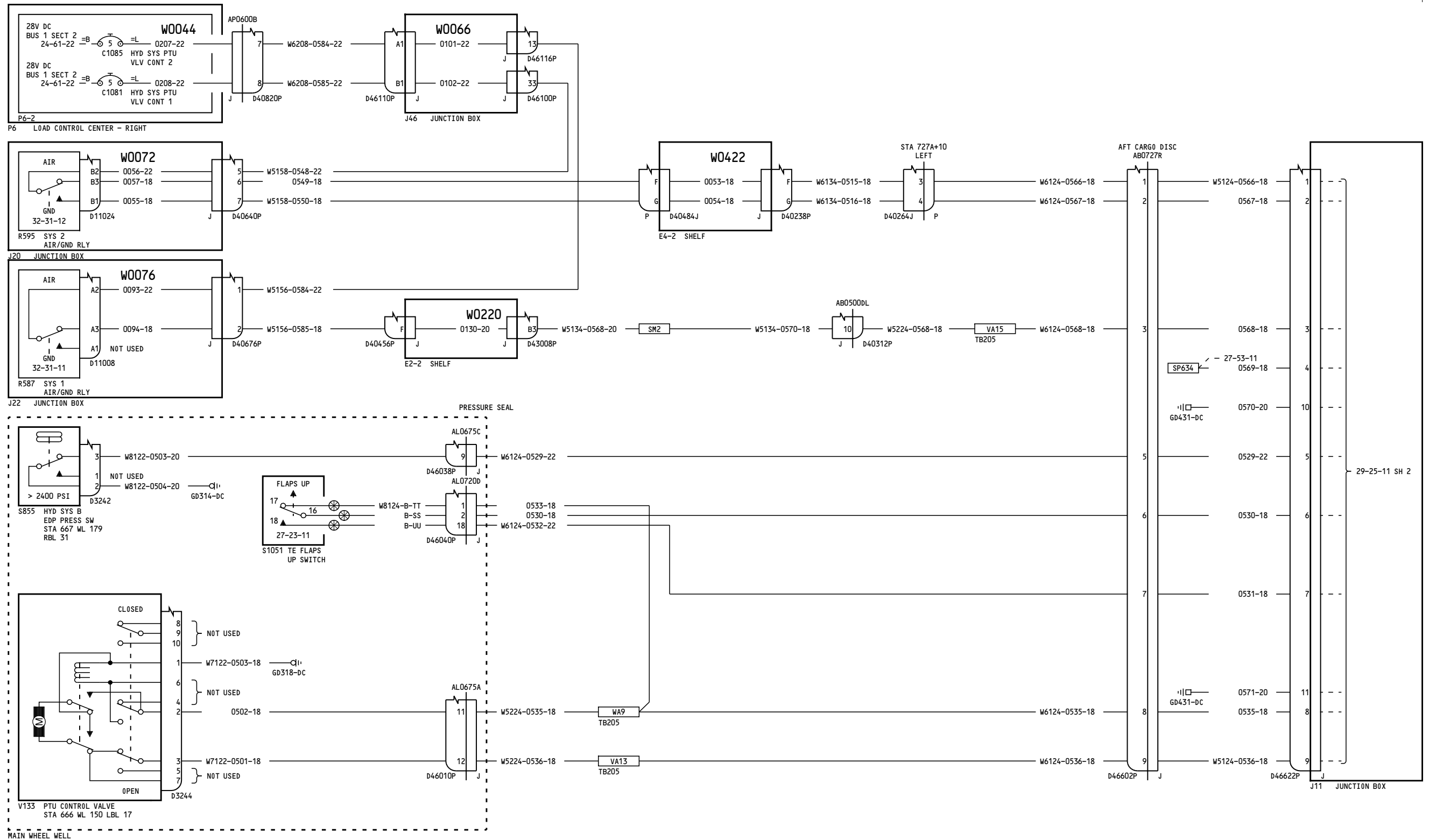

YK907-YK912, YK918-YK919, YL401-YL429

HYDRAULIC POWER TRANSFER UNIT CONTROL

29-25-11

Page 4
Sheet 1
May 11/2009

D280A103

29-25-11

Page 4
Sheet 1
May 11/2009

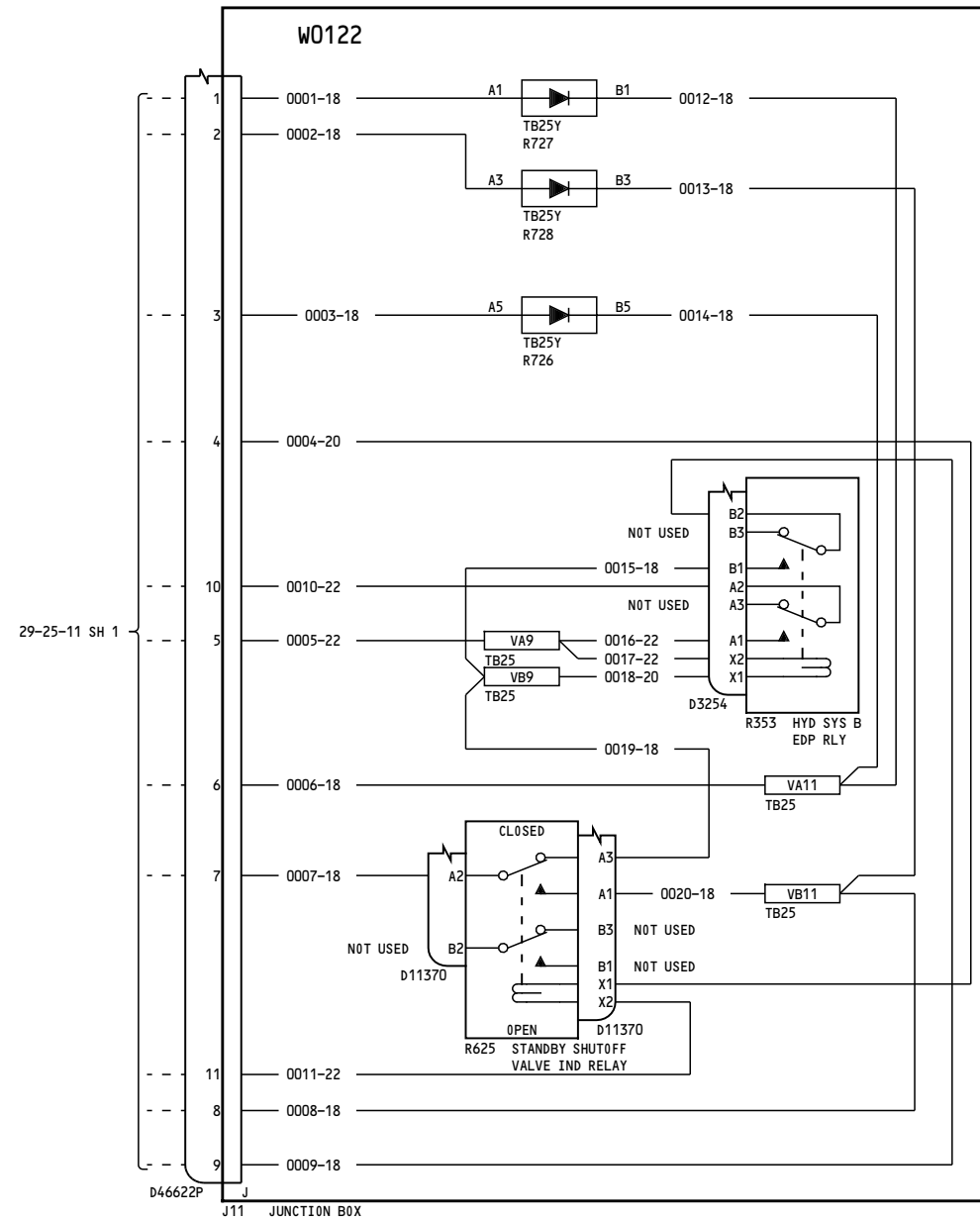

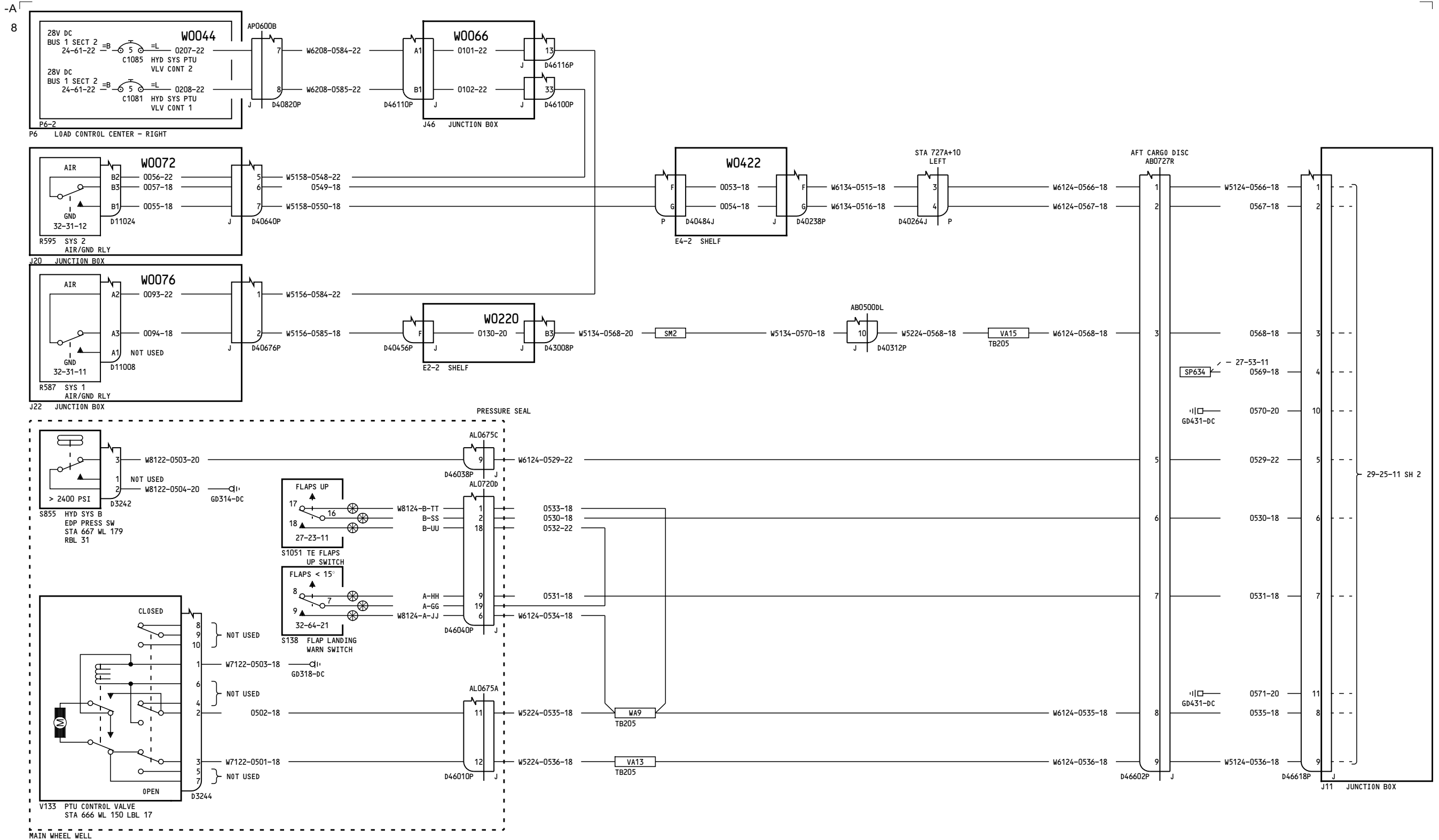

YM643-YM652

HYDRAULIC POWER TRANSFER UNIT CONTROL

29-25-11

Page 5
Sheet 1
May 11/2009

D280A103

29-25-11

Page 5
Sheet 1
May 11/2009

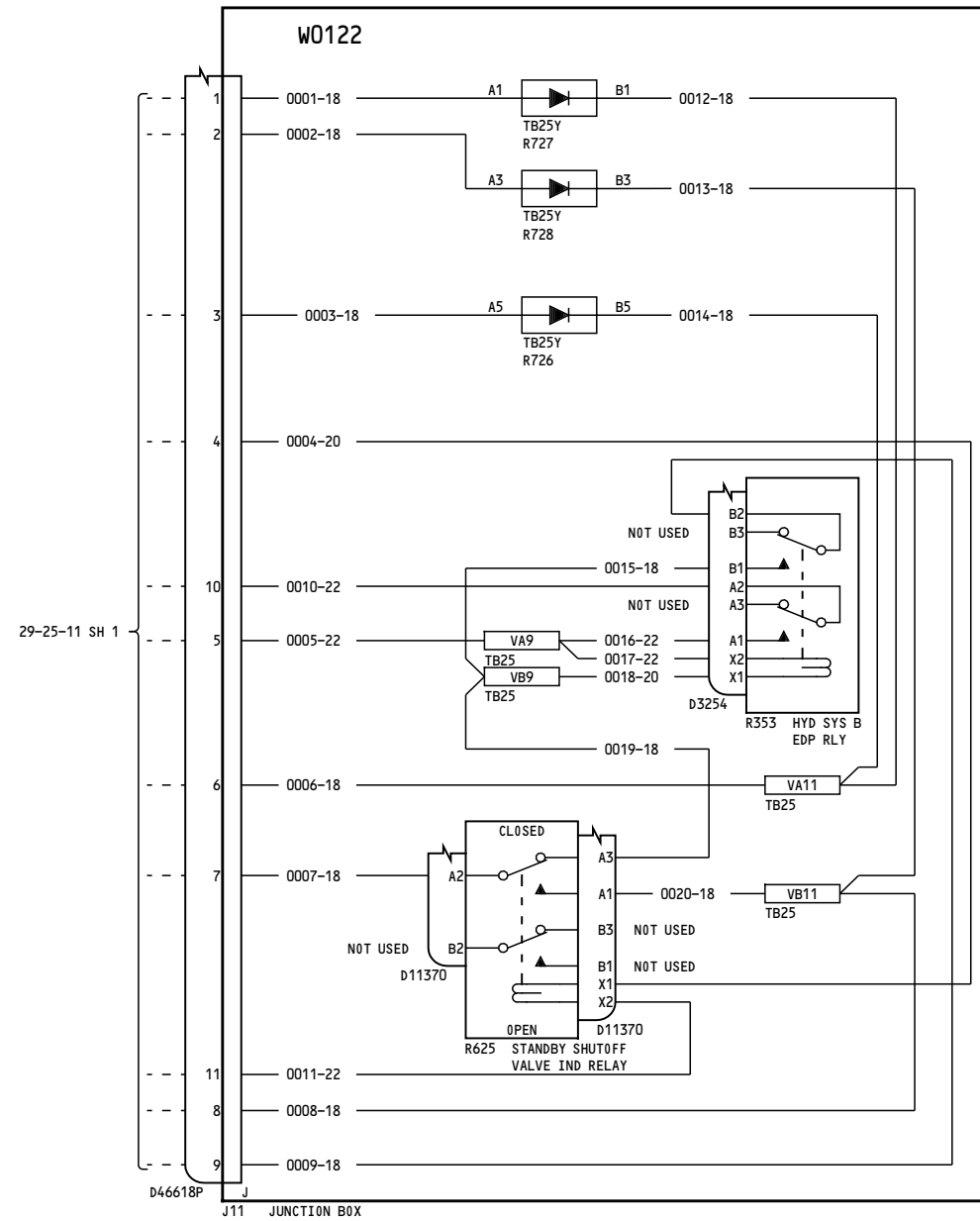

YM643-YM652

**HYDRAULIC POWER TRANSFER
UNIT CONTROL**

D280A103

29-25-11

Page 5
Sheet 2
May 11/2009

29-25-11

Page 5
Sheet 2
May 11/2009

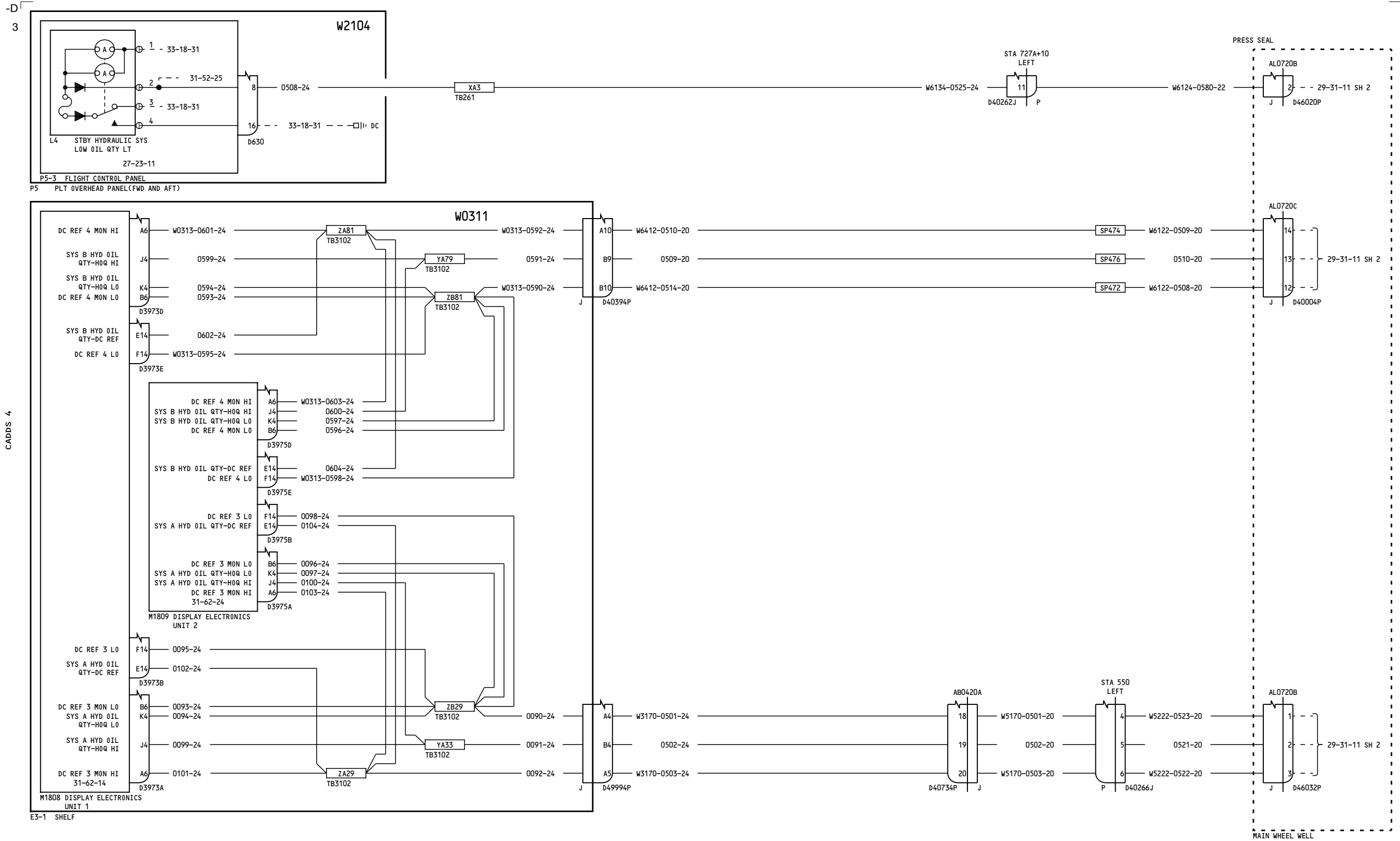

YC001-YC028

HYDRAULIC FLUID QUANTITY INDICATION

29-31-11

Page 1
Sheet 1
Jul 17/2007

D280A103

29-31-11

Page 1
Sheet 1
Jul 17/2007

-D
1

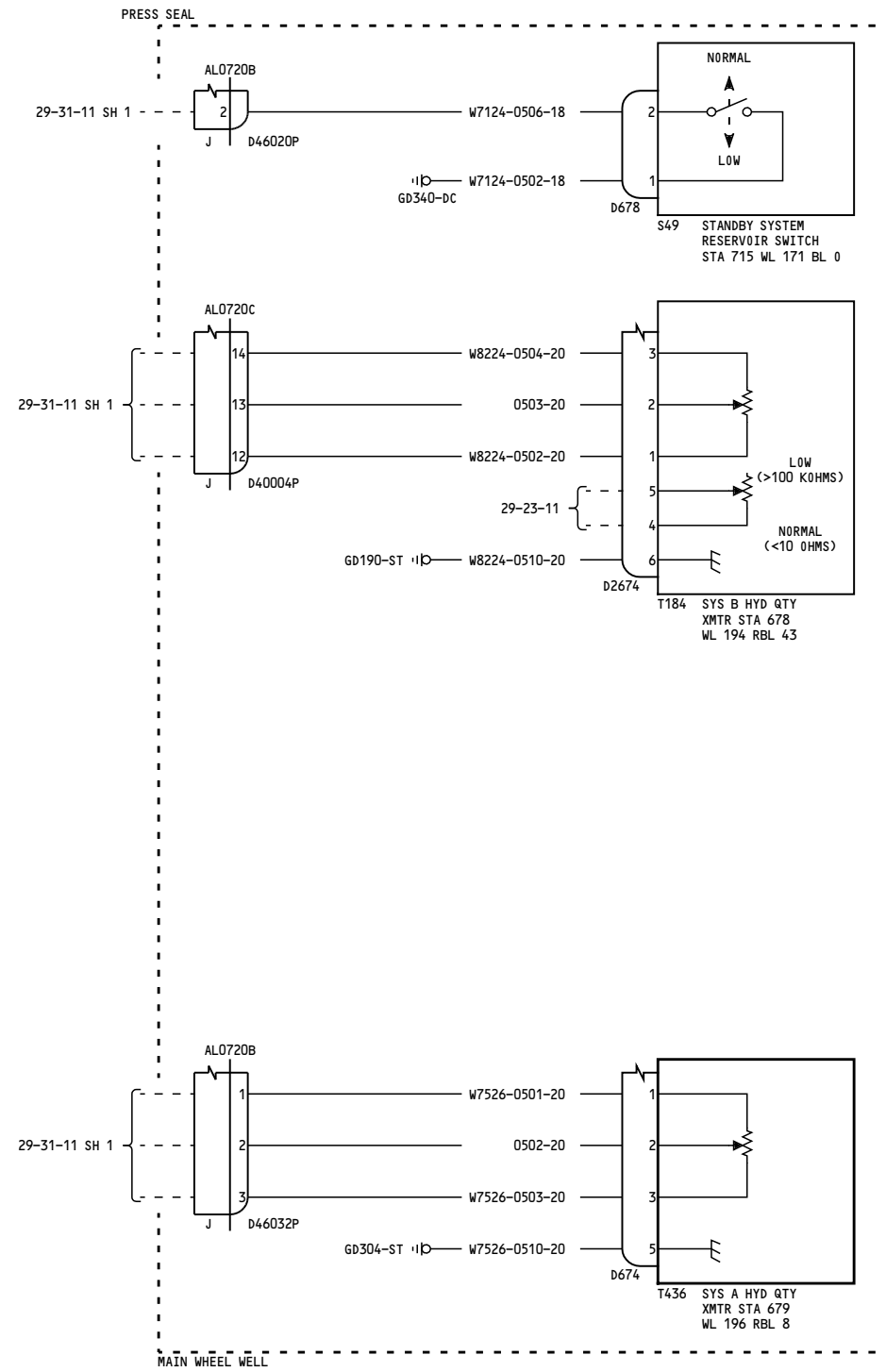

CADDS 4

YC001-YC028

HYDRAULIC FLUID QUANTITY INDICATION

D280A103

29-31-11

Page 1
Sheet 2
Jul 17/2007

29-31-11

Page 1
Sheet 2
Jul 17/2007

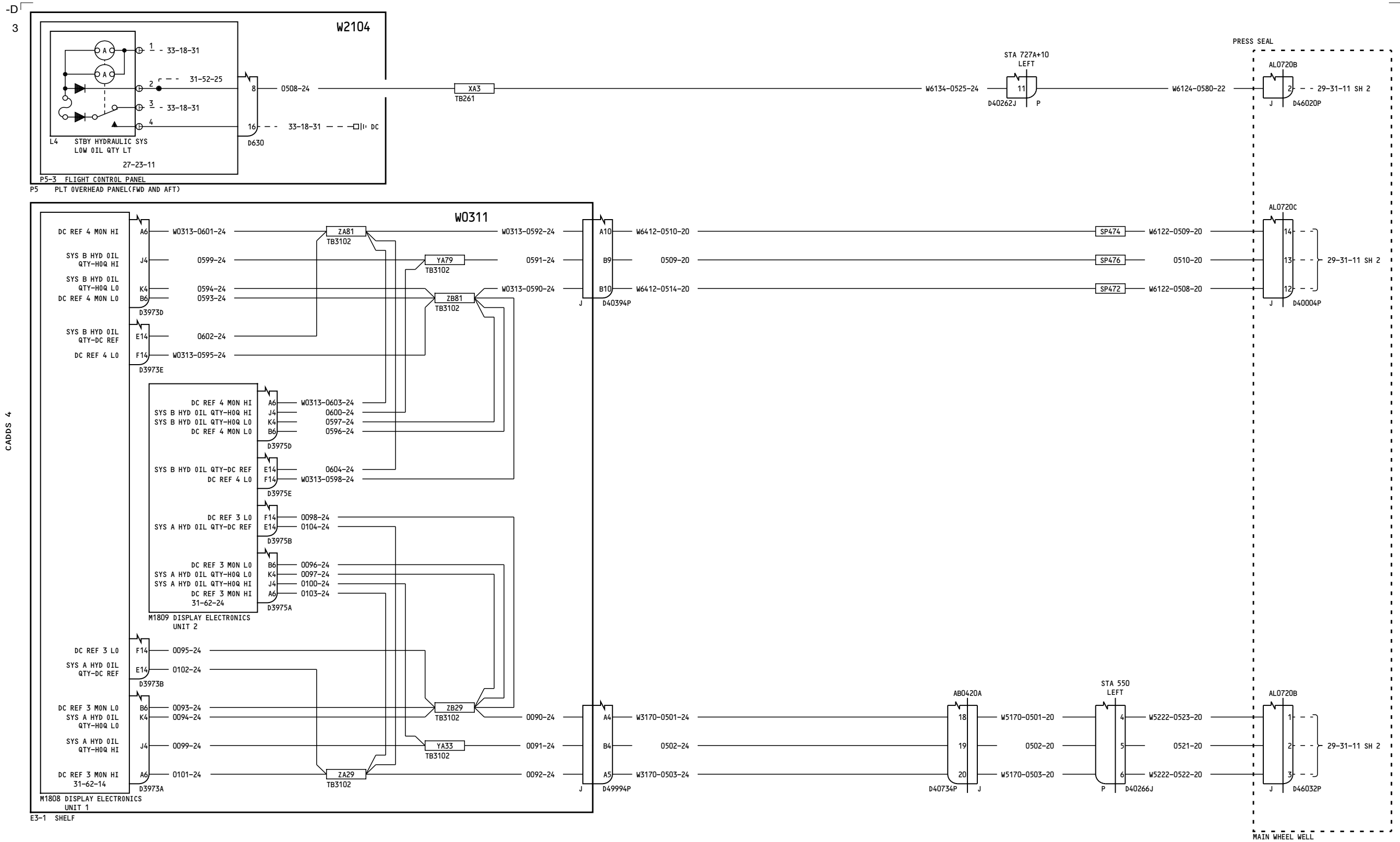

YC029-YC050

HYDRAULIC FLUID QUANTITY INDICATION

29-31-11

Page 2
Sheet 1
Oct 20/2006

D280A103

29-31-11

Page 2
Sheet 1
Oct 20/2006

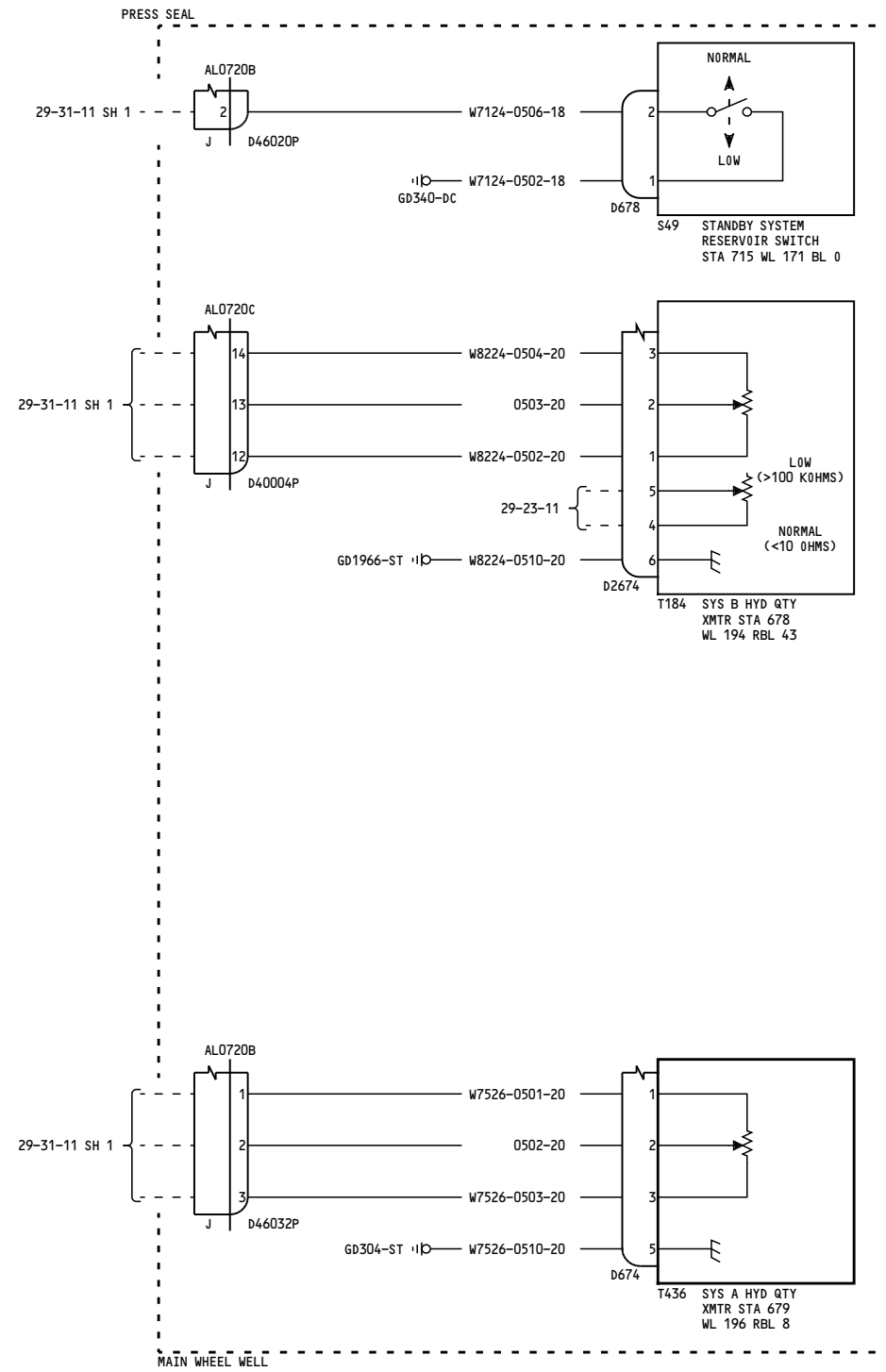

CADDS 4

YC029-YC050

HYDRAULIC FLUID QUANTITY INDICATION

D280A103

29-31-11

Page 2
Sheet 2
Oct 20/2006

29-31-11

Page 2
Sheet 2
Oct 20/2006

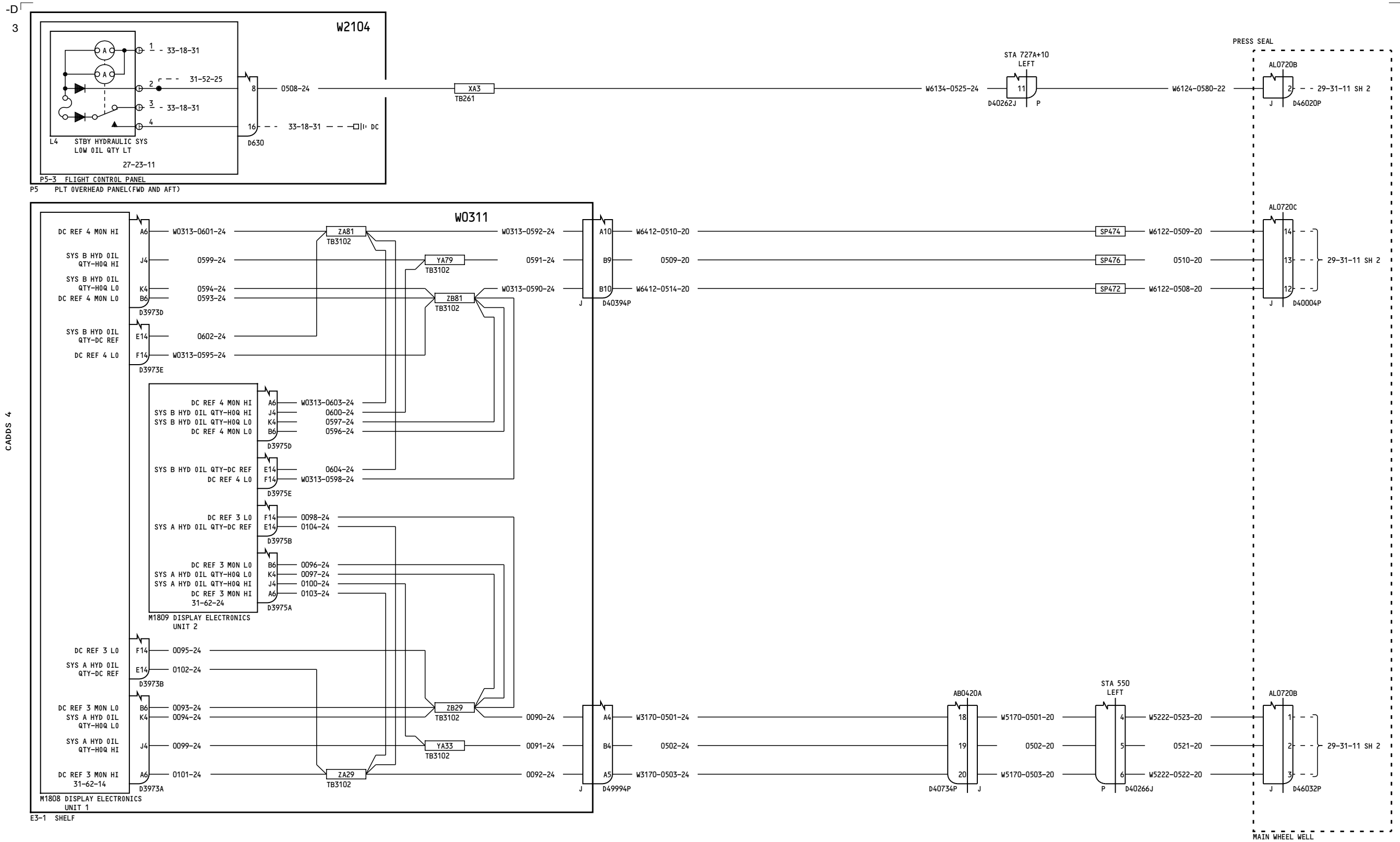

YK901-YK907, YL421

HYDRAULIC FLUID QUANTITY INDICATION

29-31-11

Page 3
Sheet 1
Oct 20/2006

D280A103

29-31-11

Page 3
Sheet 1
Oct 20/2006

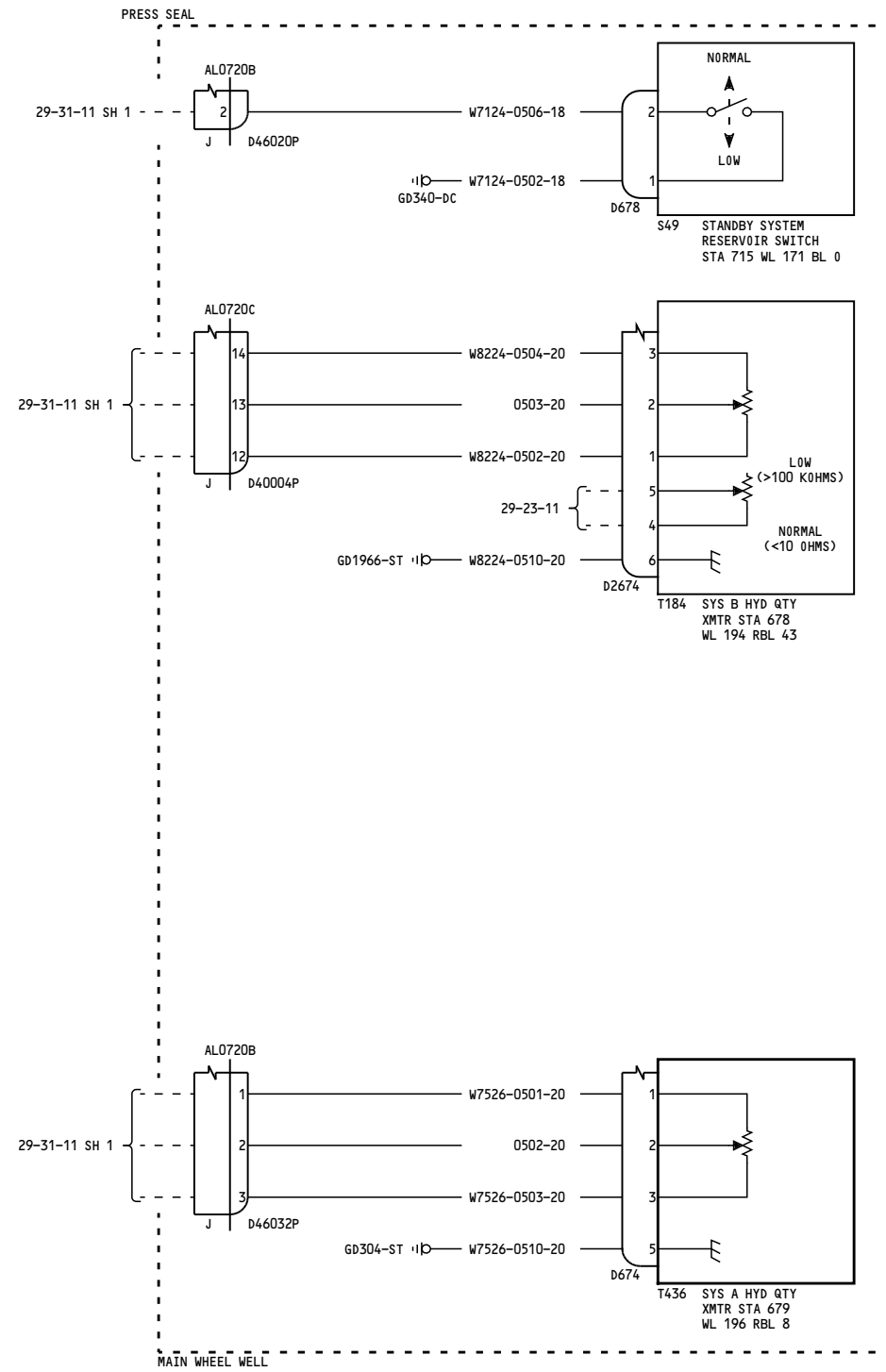

YK901-YK907, YL421

HYDRAULIC FLUID QUANTITY INDICATION

D280A103

29-31-11

Page 3
Sheet 2
Oct 20/2006

29-31-11

Page 3
Sheet 2
Oct 20/2006

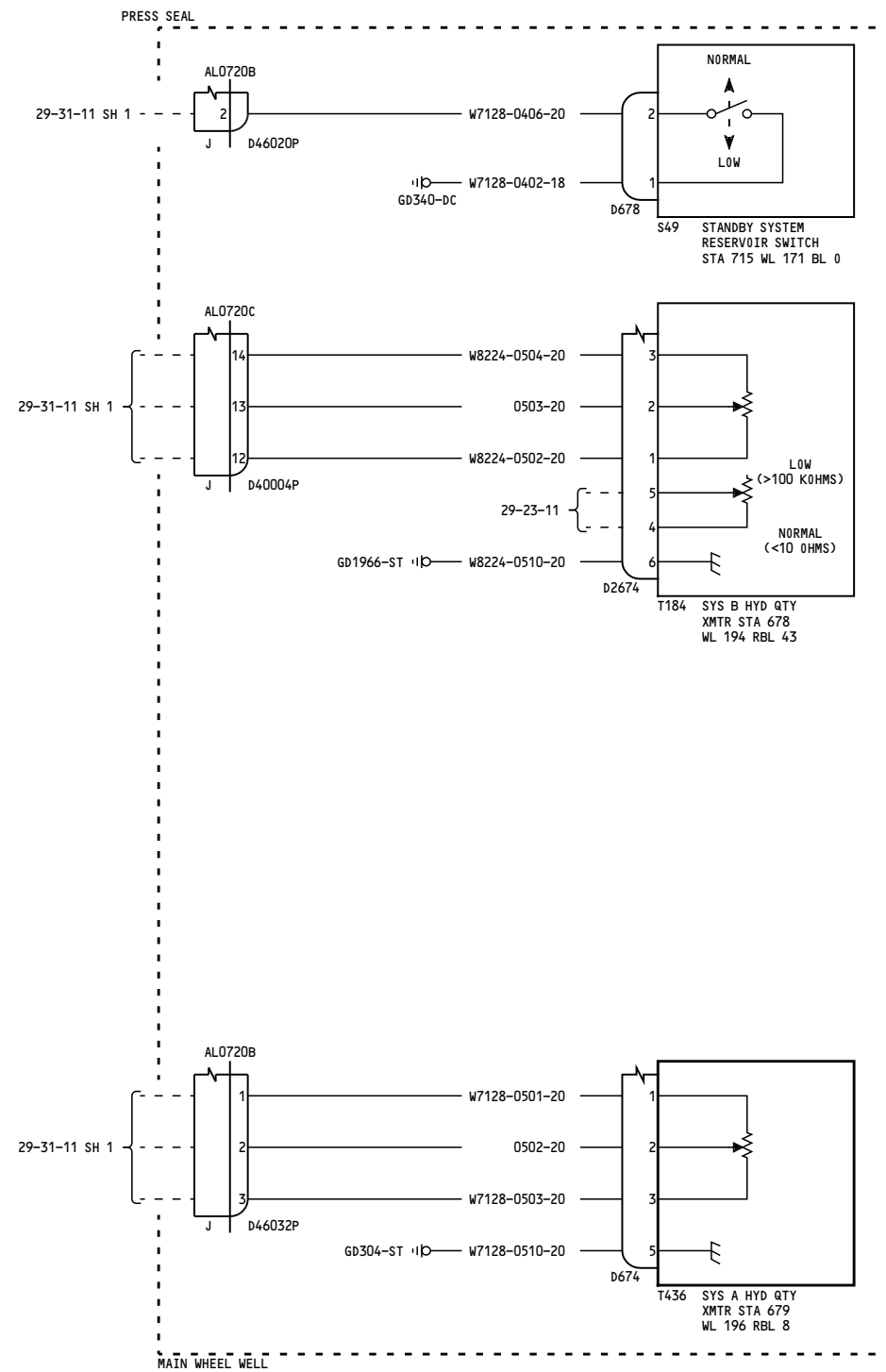

YK908-YL401, YL422-YM670

HYDRAULIC FLUID QUANTITY INDICATION

D280A103

29-31-11

Page 4
Sheet 2
Feb 09/2009

29-31-11

Page 4
Sheet 2
Feb 09/2009

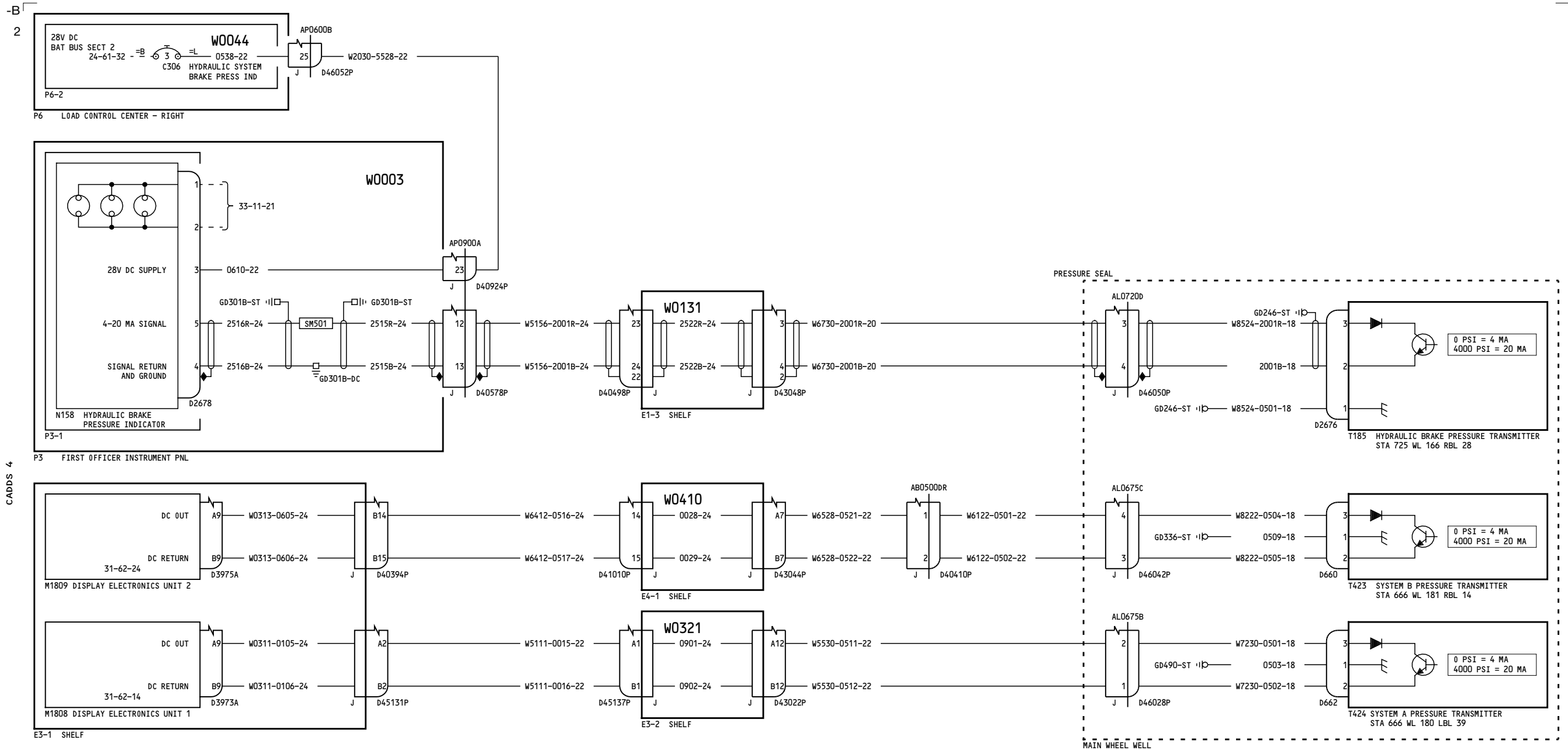

YC001-YC028

HYDRAULIC FLUID PRESSURE INDICATION

29-32-11

Page 1

Jul 17/2007

D280A103

29-32-11

Page 1

Jul 17/2007

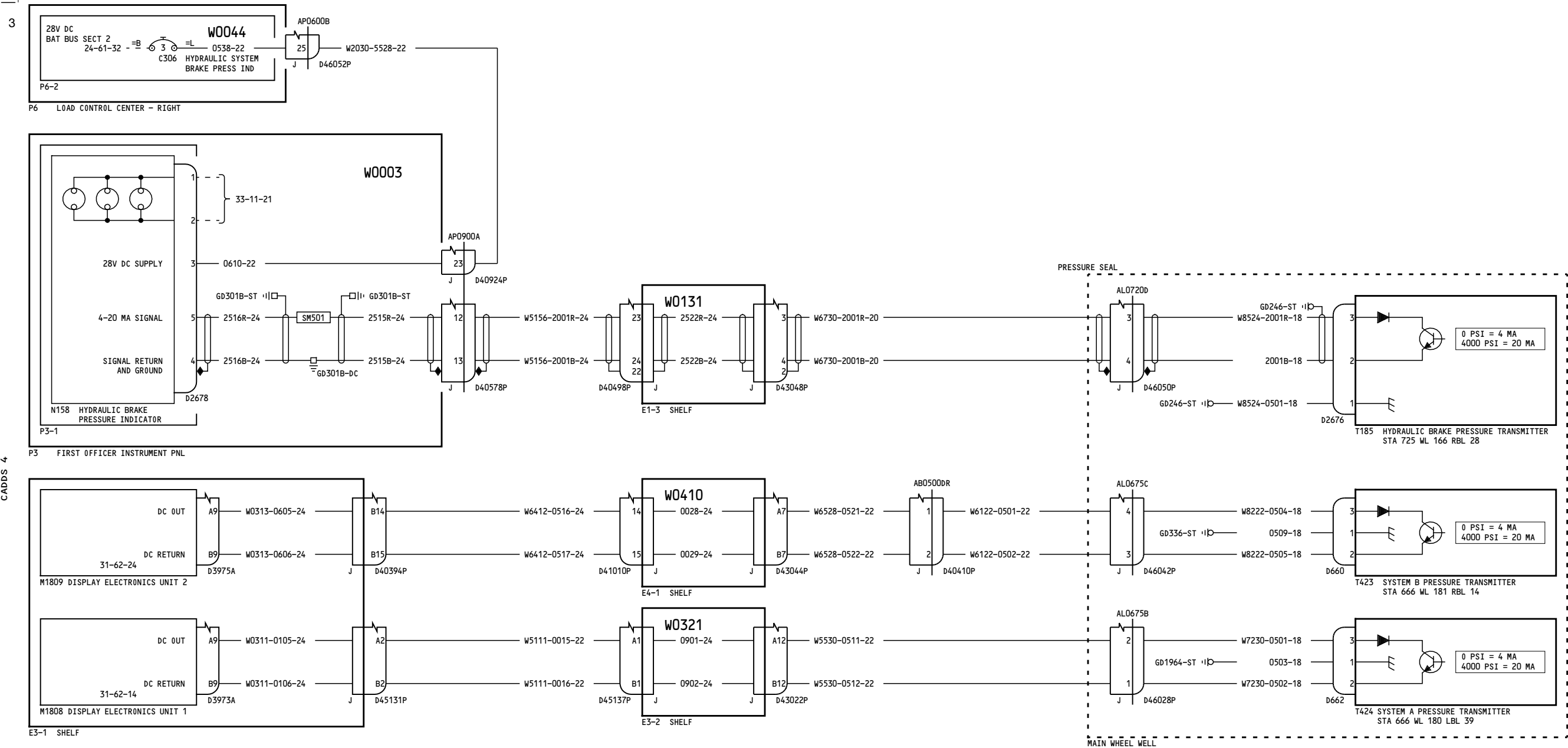

YC029-YM670

HYDRAULIC FLUID PRESSURE INDICATION

29-32-11

Page 2

D280A103

Feb 09/2009

29-32-11

Page 2

Feb 09/2009

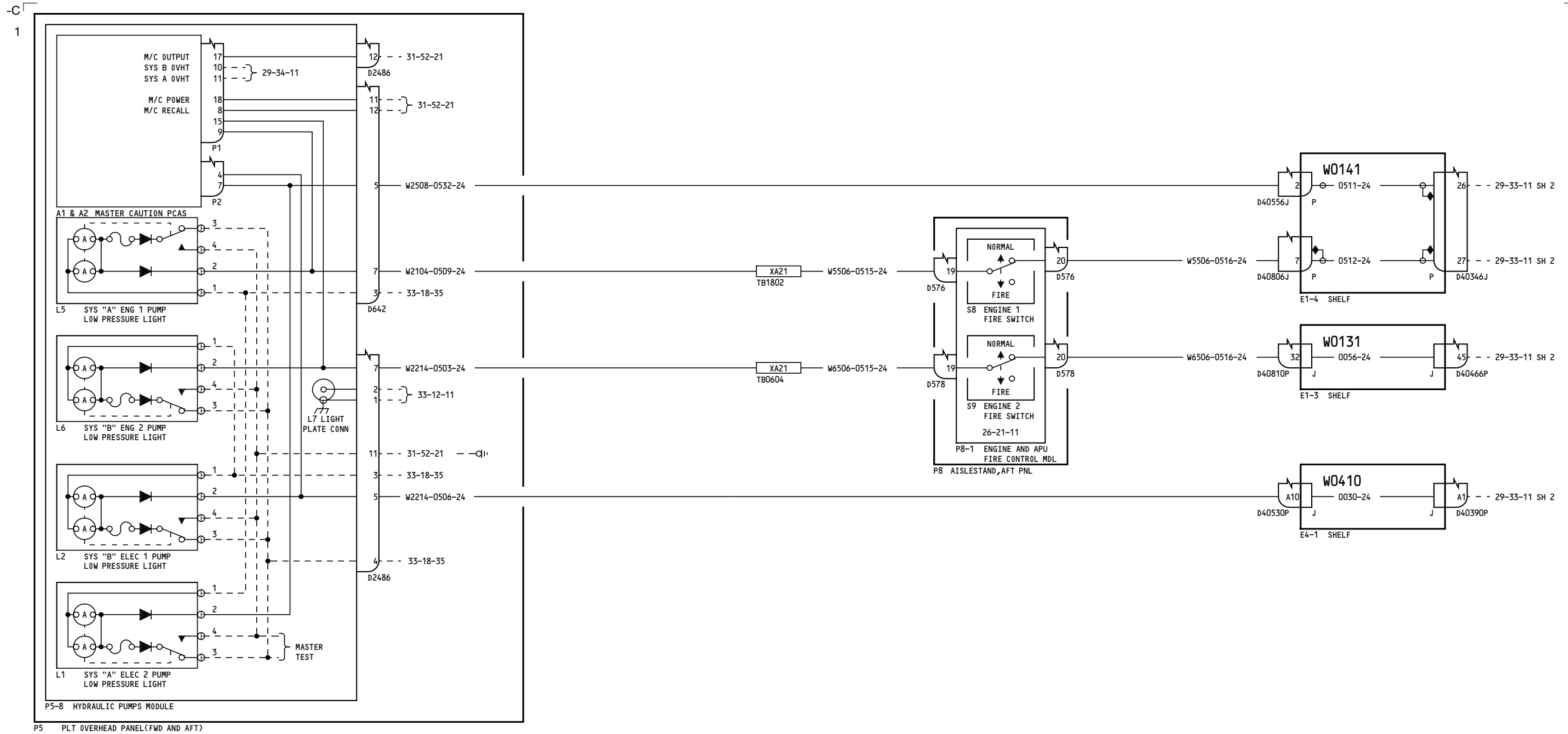

NOTES:

YC001-YC003

HYDRAULIC SYSTEM LOW PRESSURE LIGHTS

29-33-11

Page 1
Sheet 1
Mar 31/2005

D280A103

29-33-11

Page 1
Sheet 1
Mar 31/2005

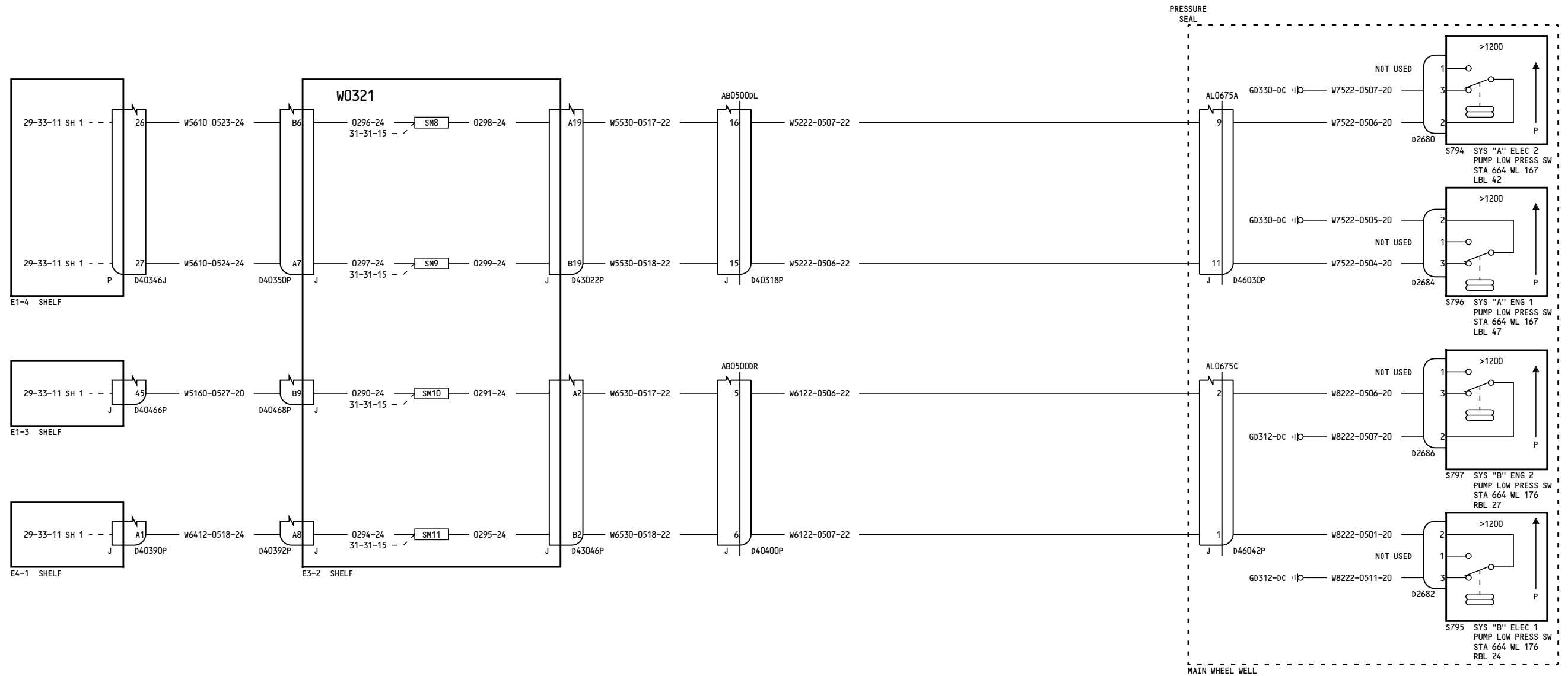

YC001-YC003

HYDRAULIC SYSTEM LOW PRESSURE LIGHTS

D280A103

29-33-11

Page 1
Sheet 2
Mar 31/2005

29-33-11

Page 1
Sheet 2
Mar 31/2005

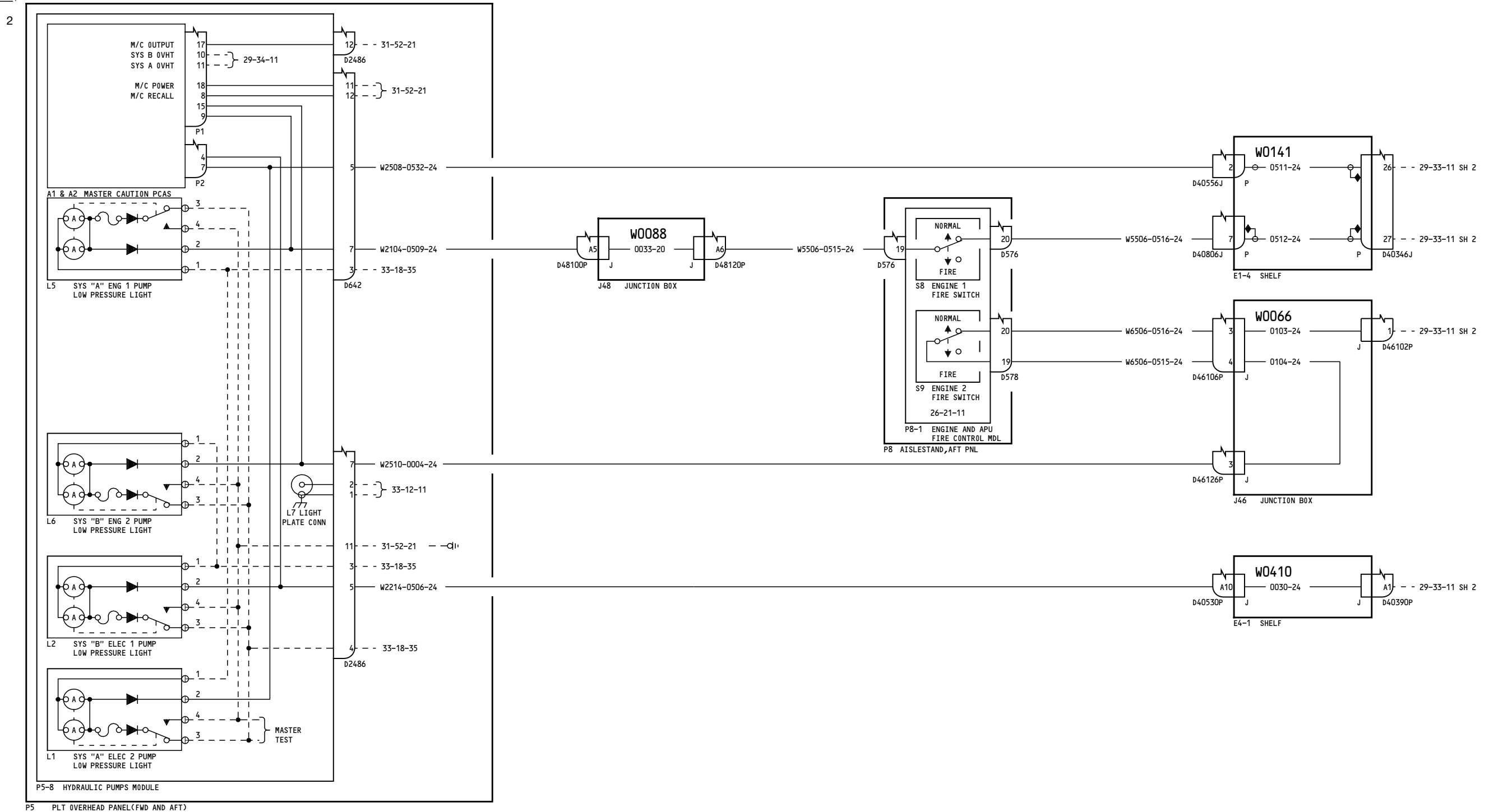

NOTES:

YC004-YM670

HYDRAULIC SYSTEM LOW PRESSURE LIGHTS

29-33-11

Page 2
Sheet 1
Feb 09/2009

D280A103

29-33-11

Page 2
Sheet 1
Feb 09/2009

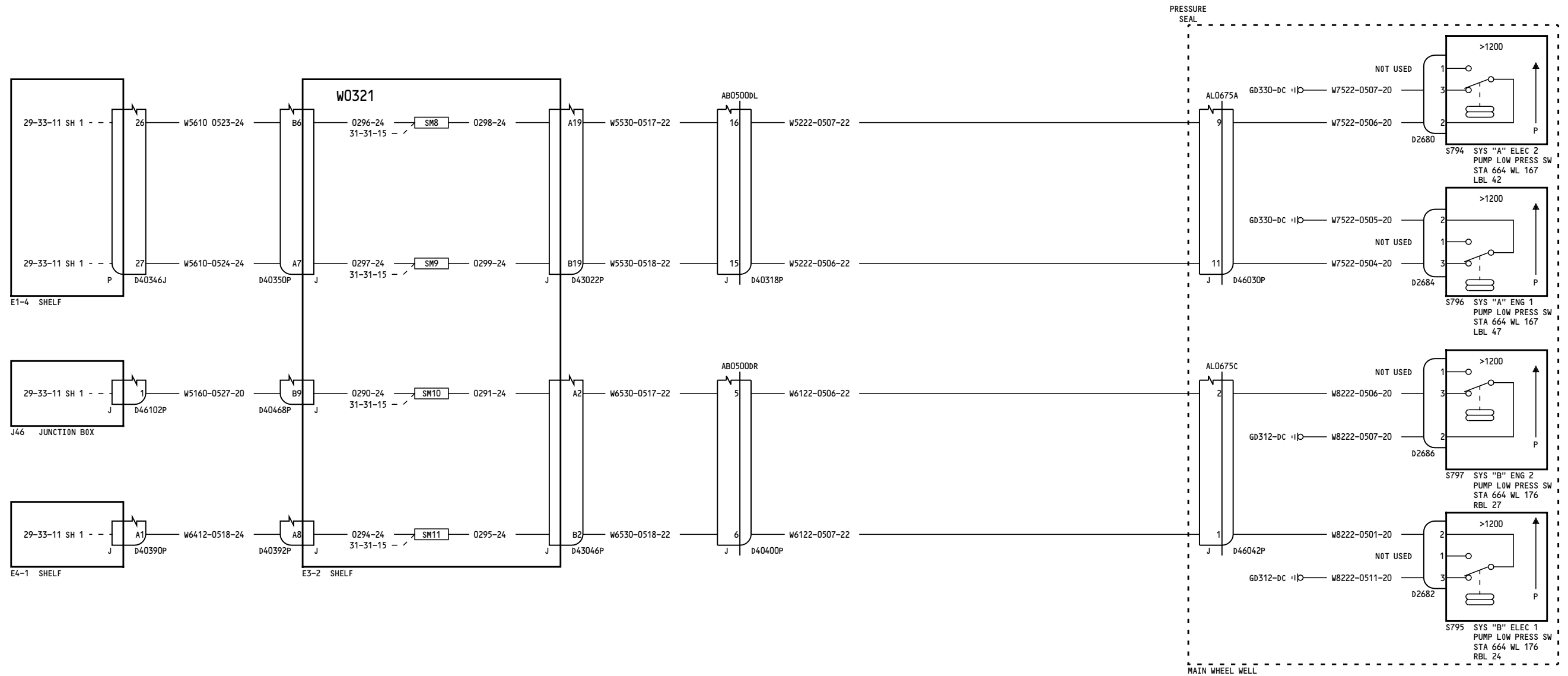

YC004-YM670

HYDRAULIC SYSTEM LOW PRESSURE LIGHTS

D280A103

29-33-11

Page 2
Sheet 2
Feb 09/2009

29-33-11

Page 2
Sheet 2
Feb 09/2009

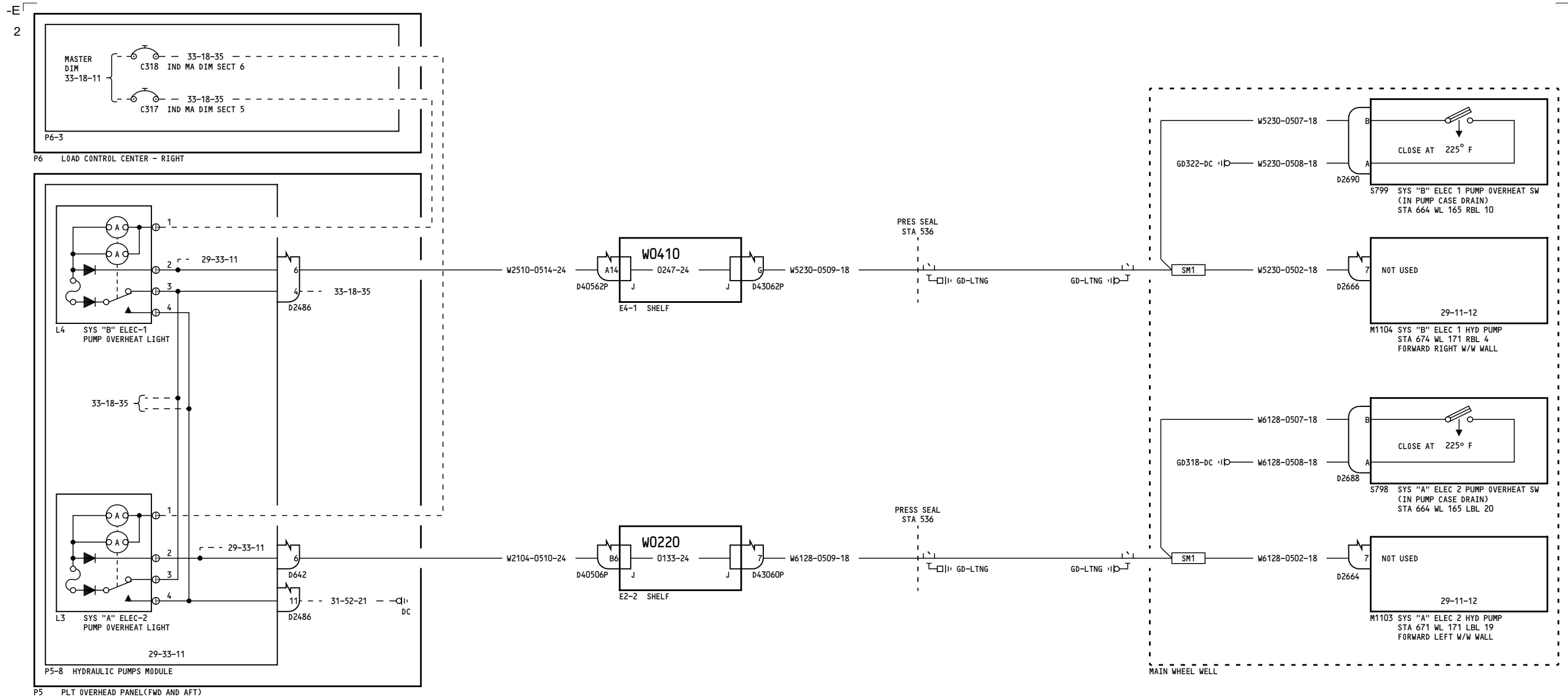

ALL	<p align="center">MAIN HYDRAULIC SYSTEM OVERHEAT LIGHTS</p> <p align="center">D280A103</p>
-----	---

29-34-11

Page 1
Feb 09/2009

29-34-11

Page 1
Feb 09/2009

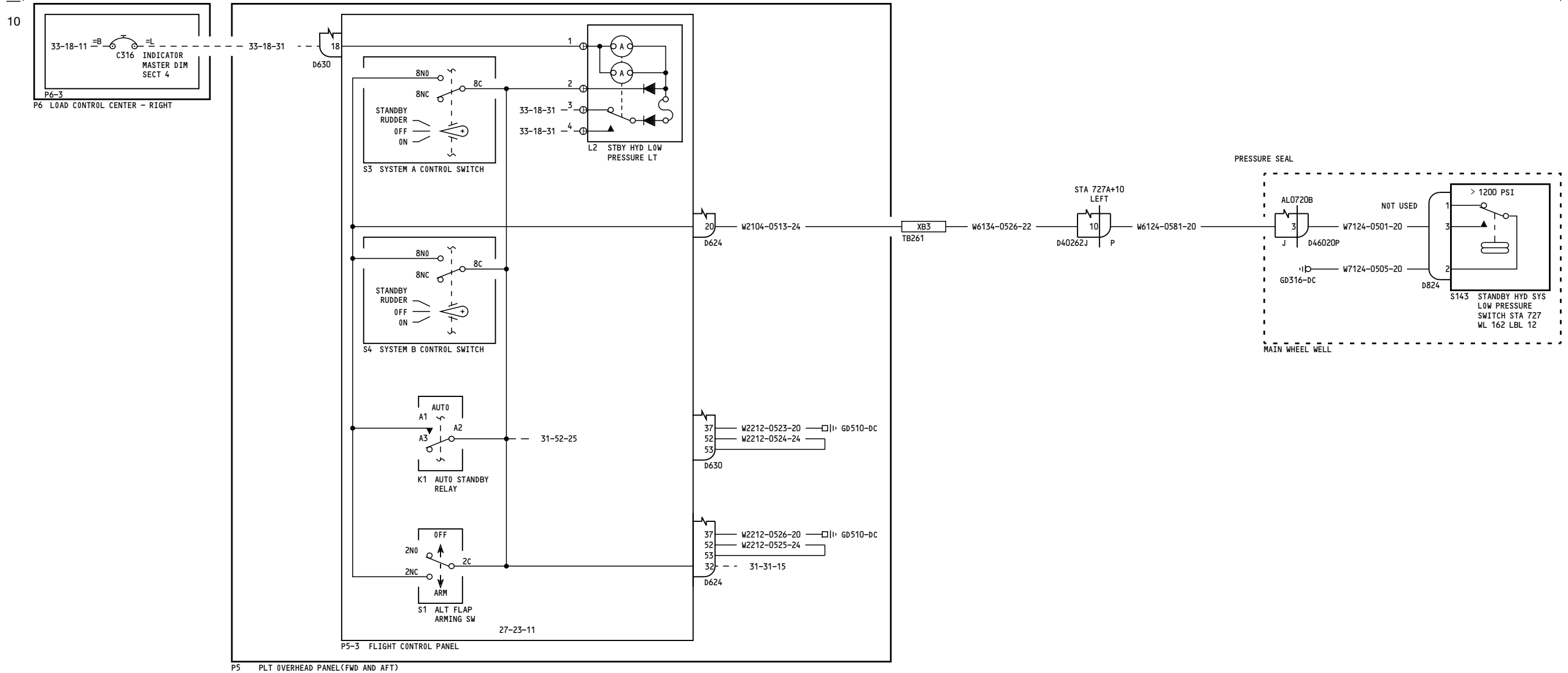

YC001-YC007

**STANDBY HYDRAULIC SYSTEM
LOW PRESSURE LIGHTS**

29-35-11

Page 1.1

D280A103

Oct 15/2007

Incorporates
27-1253 R03

29-35-11

Page 1.1

Oct 15/2007

15

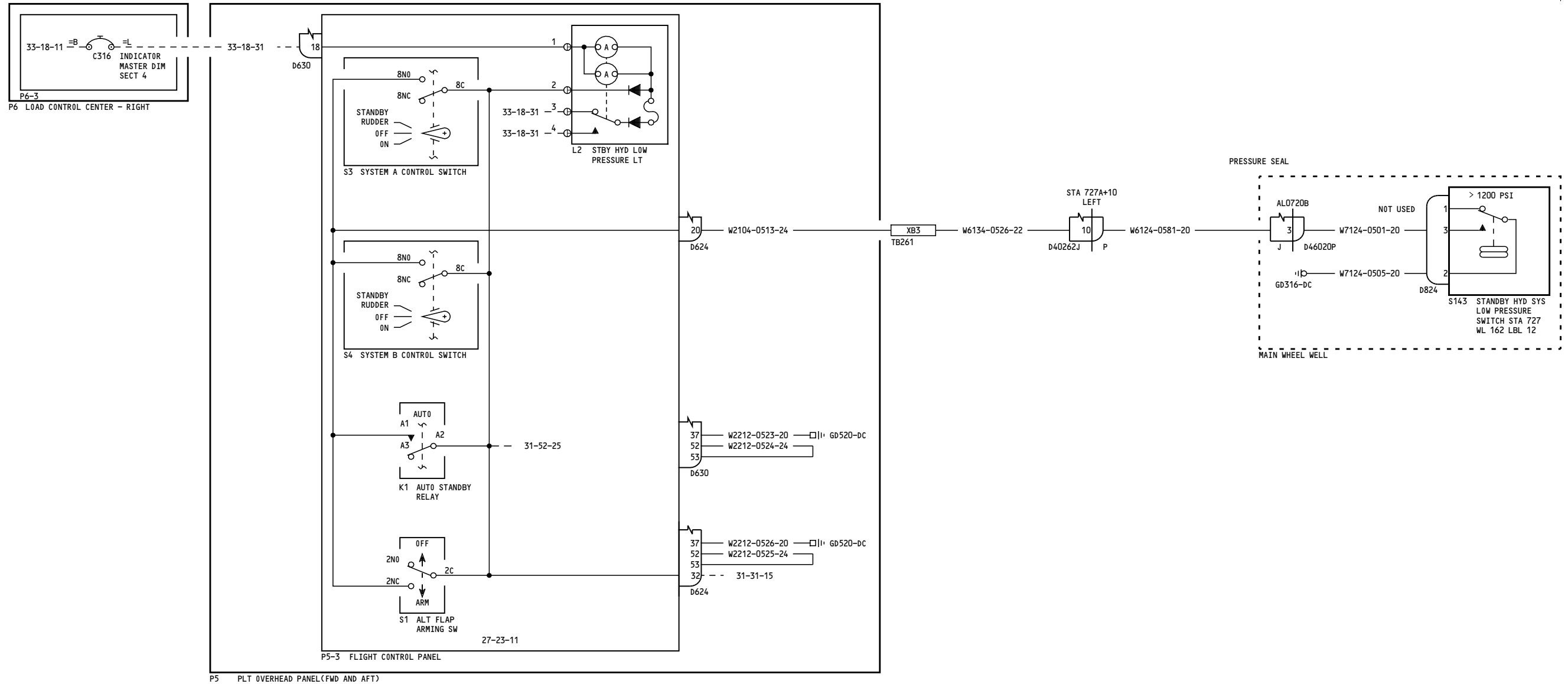

YC008-YC030

**STANDBY HYDRAULIC SYSTEM
LOW PRESSURE LIGHTS**

D280A103

29-35-11

Page 2.1

Feb 09/2009

Incorporates
27-1253 R03

29-35-11

Page 2.1

Feb 09/2009

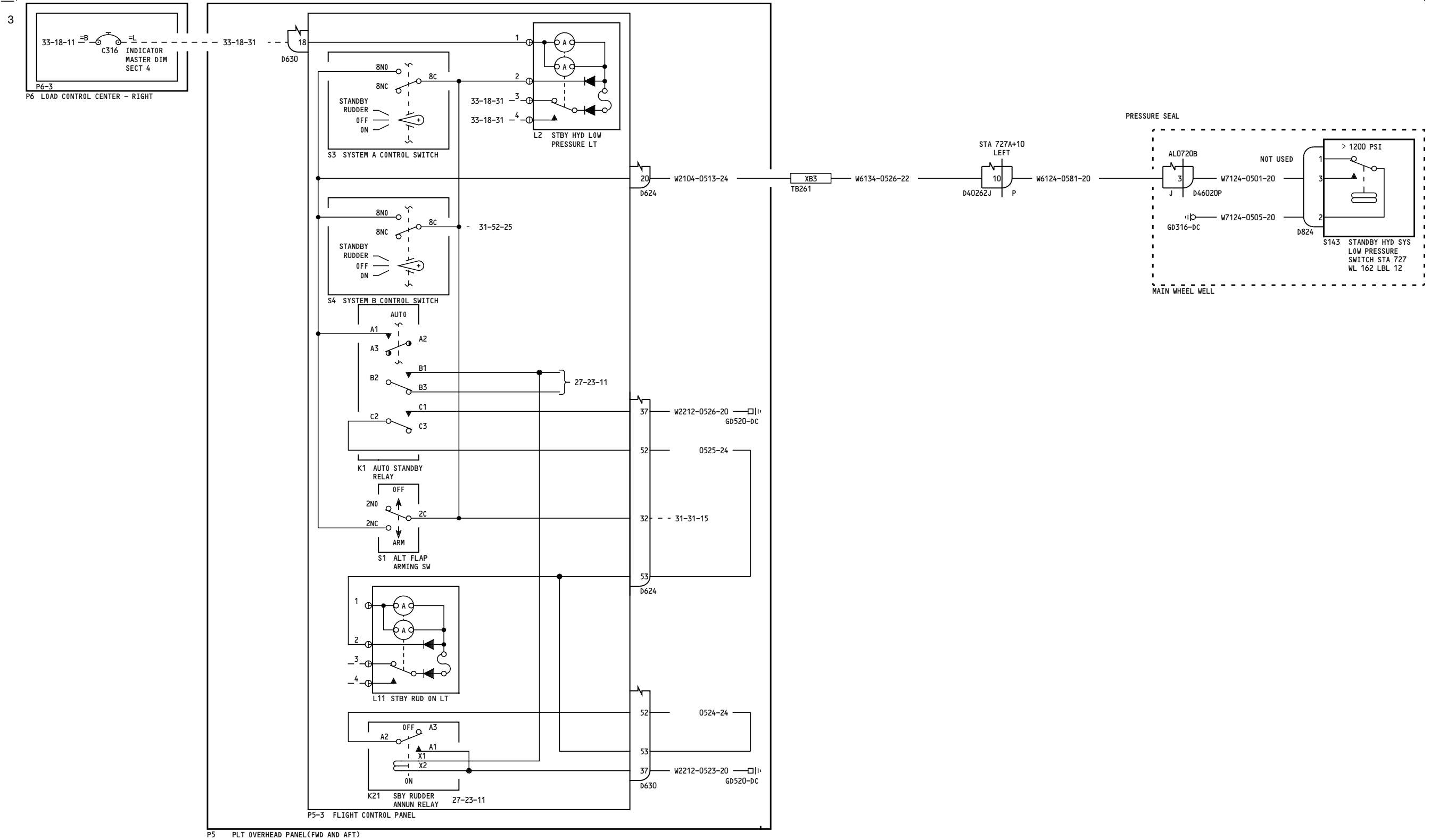

YC031-YK907, YL421

**STANDBY HYDRAULIC SYSTEM
LOW PRESSURE LIGHTS**

29-35-11

Page 3

D280A103

Feb 09/2009

29-35-11

Page 3

Feb 09/2009

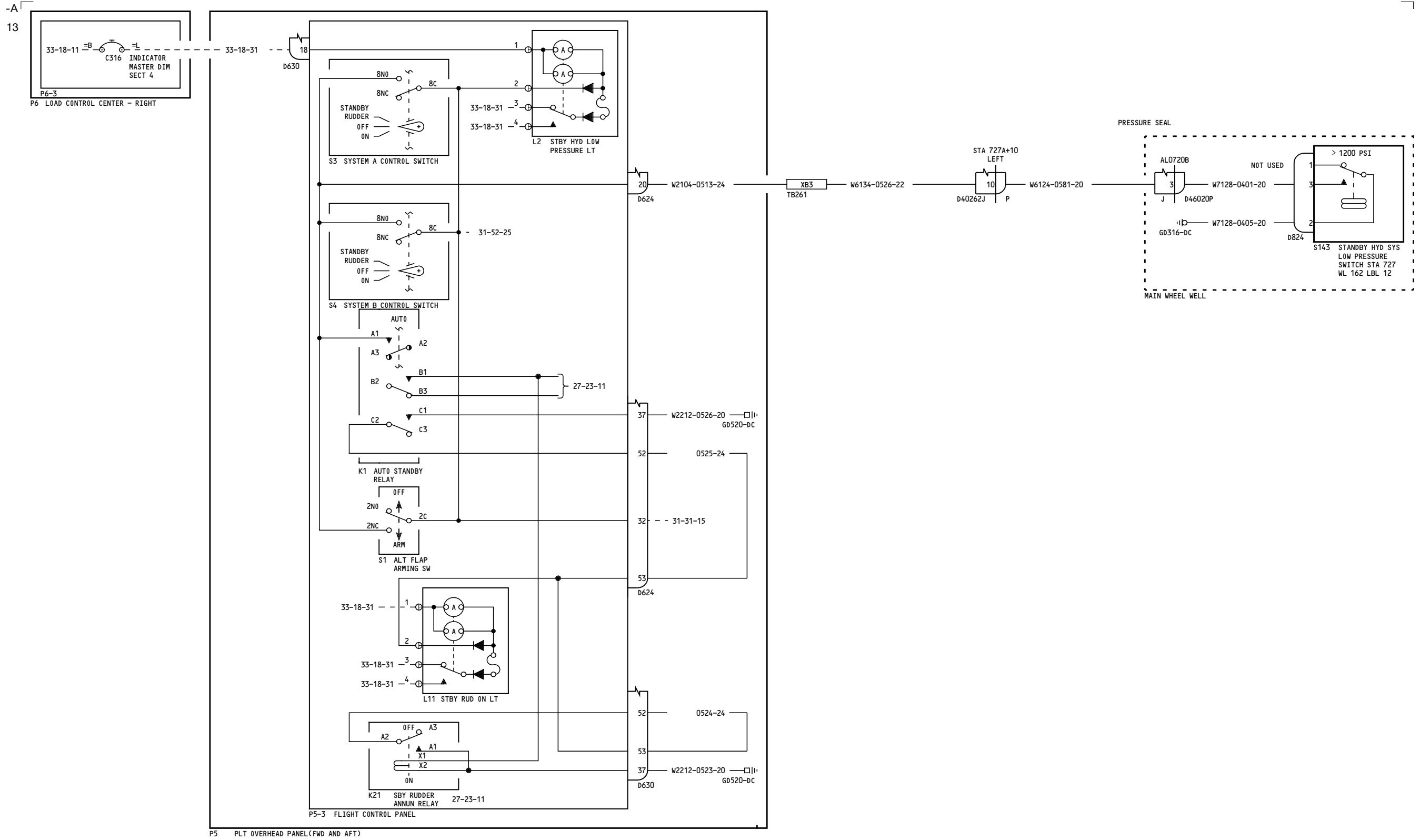

YK908-YL401, YL422-YM670

**STANDBY HYDRAULIC SYSTEM
LOW PRESSURE LIGHTS**

29-35-11

Page 4

D280A103

Feb 09/2009

29-35-11

Page 4

Feb 09/2009