

**CHAPTER**

**30**

**ICE AND RAIN  
PROTECTION**



737-700/800

WIRING DIAGRAM MANUAL

CHAPTER 30  
ICE AND RAIN PROTECTION

CH-SC-SU	Schem	Page	Sheet	Date	CH-SC-SU	Schem	Page	Sheet	Date
30-EFFECTIVE PAGES					30-41-12				
		1		Aug 10/2009			1.1	1	Jul 26/2006
		2		BLANK	R			2	Aug 10/2009
30-CONTENTS					D		1.2	1	Aug 10/2009
R		1		Aug 10/2009	D			2	Aug 10/2009
R		2		Aug 10/2009			2.1	1	Jul 26/2006
O		3		Aug 10/2009	R			2	Aug 10/2009
		4		BLANK	D		2.2	1	Aug 10/2009
30-ALPHABETICAL INDEX					D			2	Aug 10/2009
		1		Jan 18/2007	D		3	1	Aug 10/2009
		2		BLANK	D			2	Aug 10/2009
	30-11-11						3.1	1	May 13/2008
		1		Mar 31/2005				2	Feb 09/2009
		1.1		Oct 15/2007	D		4	1	Aug 10/2009
		2		Mar 31/2005	D			2	Aug 10/2009
		2.1		Oct 15/2007			4.1	1	May 13/2008
		3		Jul 17/2007				2	Feb 09/2009
		3.1		Oct 15/2007			5	1	Jul 26/2006
		4		Feb 09/2009				2	Feb 09/2009
	30-21-11						6	1	Feb 09/2009
		1		Jul 26/2006				2	Feb 09/2009
		2		Feb 09/2009					
	30-21-21						1		Mar 31/2005
		1		Mar 31/2005			2		Mar 31/2005
		2		Feb 09/2009			3		Feb 09/2009
	30-31-11								
		1		Mar 31/2005			1	1	Jul 26/2006
		2		Feb 09/2009				2	Jul 26/2006
								3	Oct 20/2006
	30-31-12						2	1	Feb 09/2009
		1		Mar 31/2005				2	Feb 09/2009
		2		Mar 31/2005				3	Feb 09/2009
		3		Feb 09/2009				3	Feb 09/2009
	30-41-11						3	1	Feb 09/2009
		1.1	1	Jul 26/2006				2	Feb 09/2009
R			2	Aug 10/2009				3	Feb 09/2009
D		1.2	1	Aug 10/2009			4	1	Aug 13/2008
D			2	Aug 10/2009				2	Aug 13/2008
		2.1	1	Jul 26/2006				3	Aug 13/2008
R			2	Aug 10/2009			5	1	Aug 13/2008
D		2.2	1	Aug 10/2009				2	Aug 13/2008
D			2	Aug 10/2009				3	Aug 13/2008
D		3	1	Aug 10/2009					
D			2	Aug 10/2009					
		3.1	1	May 13/2008					
			2	Feb 09/2009					
		4	1	Jul 26/2006					
			2	Feb 09/2009					
		5	1	Jul 26/2006					
			2	Feb 09/2009					
		6	1	Feb 09/2009					
			2	Feb 09/2009					

A = Added, R = Revised, D = Deleted, O = Overflow

30-EFFECTIVE PAGES

Page 1  
Aug 10/2009

D280A103



737-700/800

WIRING DIAGRAM MANUAL

CHAPTER 30  
ICE AND RAIN PROTECTION

Title	CH-SC-SU	Schem	Page	Sheet	Date	Effectivity
<b><u>WING THERMAL ANTI-ICING SYSTEM</u></b>						
WING THERMAL ANTI-ICE SYSTEM	30-11-11		1		Mar 31/2005	YC001-YC003
			1.1		Oct 15/2007	YC001-YC003
			2		Mar 31/2005	YC004-YC007
			2.1		Oct 15/2007	YC004-YC007
			3		Jul 17/2007	YC008-YC030
			3.1		Oct 15/2007	YC008-YC030
			4		Feb 09/2009	YC031-YM670
<b><u>INLET COWL AND NACELLE ANTI-ICING SYSTEM</u></b>						
ENGINE 1 NACELLE ANTI-ICE	30-21-11		1		Jul 26/2006	YC001-YC003
			2		Feb 09/2009	YC004-YM670
ENGINE 2 NACELLE ANTI-ICE	30-21-21		1		Mar 31/2005	YC001-YC003
			2		Feb 09/2009	YC004-YM670
<b><u>PITOT TUBES AND TEMPERATURE PROBE ANTI-ICING SYSTEM</u></b>						
PITOT AND PROBE HEATERS - SYSTEM A	30-31-11		1		Mar 31/2005	YC001-YC003
			2		Feb 09/2009	YC004-YM670
PITOT AND PROBE HEATERS - SYSTEM B	30-31-12		1		Mar 31/2005	YC001-YC003
			2		Mar 31/2005	YC004-YC007
			3		Feb 09/2009	YC008-YM670
<b><u>FLIGHT COMPARTMENT WINDOW ANTI-ICING SYSTEM</u></b>						
WINDSHIELD HEAT SYSTEM - L. FRONT, R. SIDE AND OPTIONAL L3 WINDOW	30-41-11		1.1	1	Jul 26/2006	YC001-YC003
				2	Aug 10/2009	YC001-YC003
			2.1	1	Jul 26/2006	YC004-YC007
				2	Aug 10/2009	YC004-YC007
			3.1	1	May 13/2008	YC008-YC030
				2	Feb 09/2009	YC008-YC030
			4	1	Jul 26/2006	YC031-YK901
				2	Feb 09/2009	YC031-YK901
			5	1	Jul 26/2006	YK902-YK906

30-CONTENTS



737-700/800

**WIRING DIAGRAM MANUAL**

**CHAPTER 30  
ICE AND RAIN PROTECTION**

Title	CH-SC-SU	Schem	Page	Sheet	Date	Effectivity
WINDSHIELD HEAT SYSTEM - L. FRONT, R. SIDE AND OPTIONAL L3 WINDOW (cont.)	30-41-11			2	Feb 09/2009	YK902-YK906
			6	1	Feb 09/2009	YK907-YM670
				2	Feb 09/2009	YK907-YM670
WINDSHIELD HEAT SYSTEM - R. FRONT, L. SIDE AND OPTIONAL R3 WINDOW	30-41-12		1.1	1	Jul 26/2006	YC001-YC003
				2	Aug 10/2009	YC001-YC003
			2.1	1	Jul 26/2006	YC004-YC007
				2	Aug 10/2009	YC004-YC007
			3.1	1	May 13/2008	YC008-YC009
				2	Feb 09/2009	YC008-YC009
			4.1	1	May 13/2008	YC010-YC030
				2	Feb 09/2009	YC010-YC030
			5	1	Jul 26/2006	YC031-YK906
				2	Feb 09/2009	YC031-YK906
			6	1	Feb 09/2009	YK907-YM670
		2	Feb 09/2009	YK907-YM670		
<b><u>WINDSHIELD WIPER SYSTEM</u></b>						
WINDSHIELD WIPERS	30-42-11		1		Mar 31/2005	YC001-YC003
			2		Mar 31/2005	YC004-YC019
			3		Feb 09/2009	YC020-YM670
<b><u>WATER AND TOILET DRAIN ANTI-ICING SYSTEM</u></b>						
DRAIN HEATERS	30-71-11		1	1	Jul 26/2006	YC001-YC007
				2	Jul 26/2006	YC001-YC007
				3	Oct 20/2006	YC001-YC007
			2	1	Feb 09/2009	YC008-YK912 YK918 YL401-YL426
				2	Feb 09/2009	YC008-YK912 YK918 YL401-YL426
				3	Feb 09/2009	YC008-YK912 YK918 YL401-YL426
			3	1	Feb 09/2009	YK913-YK917 YK919-YK920 YL427-YL430

**30-CONTENTS**



737-700/800

# WIRING DIAGRAM MANUAL

## CHAPTER 30 ICE AND RAIN PROTECTION

Title	CH-SC-SU	Schem	Page	Sheet	Date	Effectivity
DRAIN HEATERS (cont.)	30-71-11		2		Feb 09/2009	YK913-YK917 YK919-YK920 YL427-YL430
				3	Feb 09/2009	YK913-YK917 YK919-YK920 YL427-YL430
			4	1	Aug 13/2008	YM643-YM651
				2	Aug 13/2008	YM643-YM651
				3	Aug 13/2008	YM643-YM651
			5	1	Aug 13/2008	YM652-YM670
				2	Aug 13/2008	YM652-YM670
				3	Aug 13/2008	YM652-YM670

### 30-CONTENTS

Page 3  
Aug 10/2009

D280A103



737-700/800

## WIRING DIAGRAM MANUAL

### CHAPTER 30 ICE AND RAIN PROTECTION

CH-SC-SU	Title
30-71-11	DRAIN HEATERS
30-21-11	ENGINE 1 NACELLE ANTI-ICE
30-21-21	ENGINE 2 NACELLE ANTI-ICE
30-31-11	PITOT AND PROBE HEATERS - SYSTEM A
30-31-12	PITOT AND PROBE HEATERS - SYSTEM B
30-41-11	WINDSHIELD HEAT SYSTEM - L. FRONT, R. SIDE AND OPTIONAL L3 WINDOW
30-41-12	WINDSHIELD HEAT SYSTEM - R. FRONT, L. SIDE AND OPTIONAL R3 WINDOW
30-42-11	WINDSHIELD WIPERS
30-11-11	WING THERMAL ANTI-ICE SYSTEM

## 30-ALPHABETICAL INDEX

D280A103

Page 1  
Jan 18/2007

-K

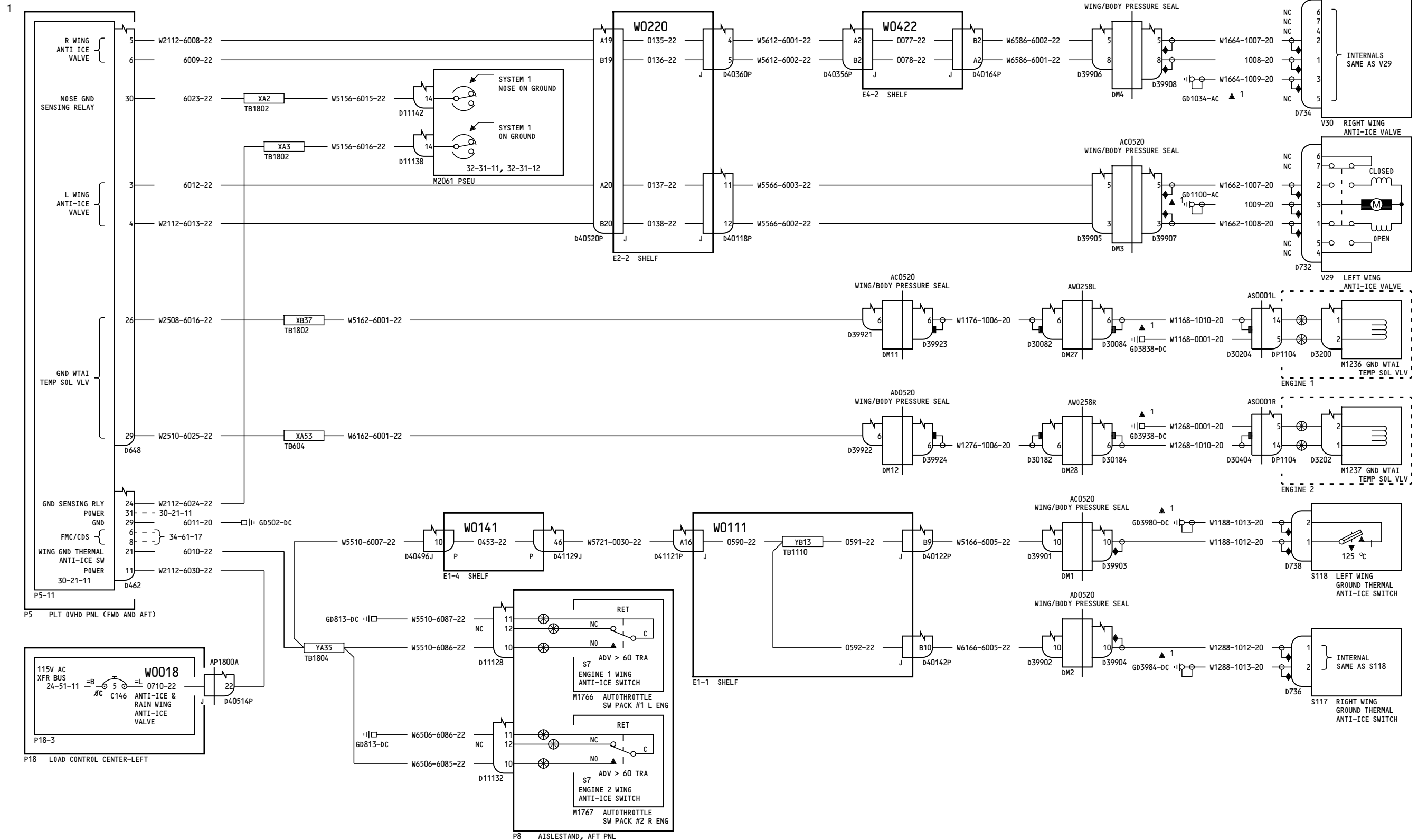

YC001-YC003

**WING THERMAL ANTI-ICE SYSTEM**

**30-11-11**

Page 1

D280A103

Mar 31/2005

**30-11-11**

Page 1

Mar 31/2005

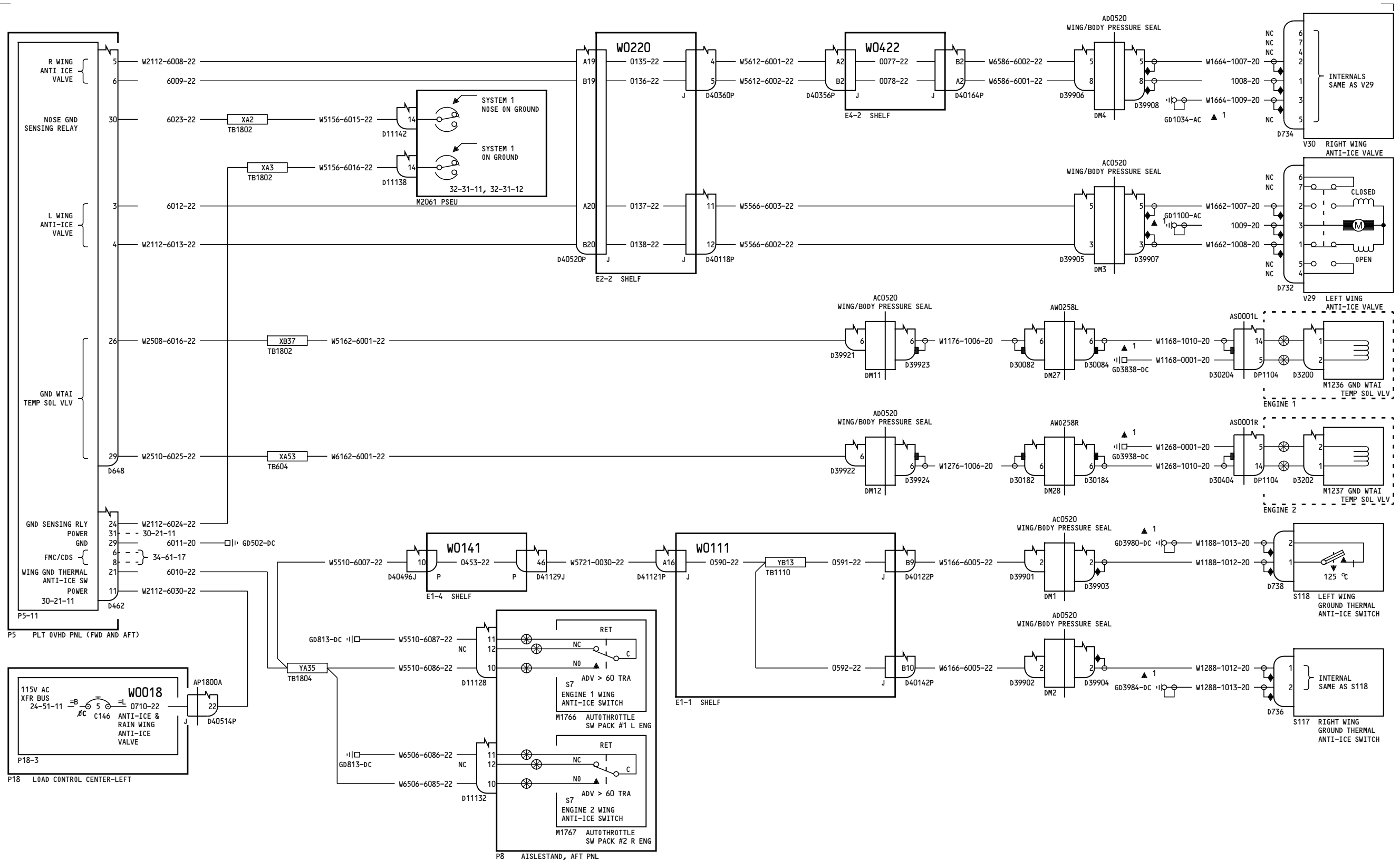

YC001-YC003

WING THERMAL ANTI-ICE SYSTEM

30-11-11

Incorporates 28-1194 R02

30-11-11



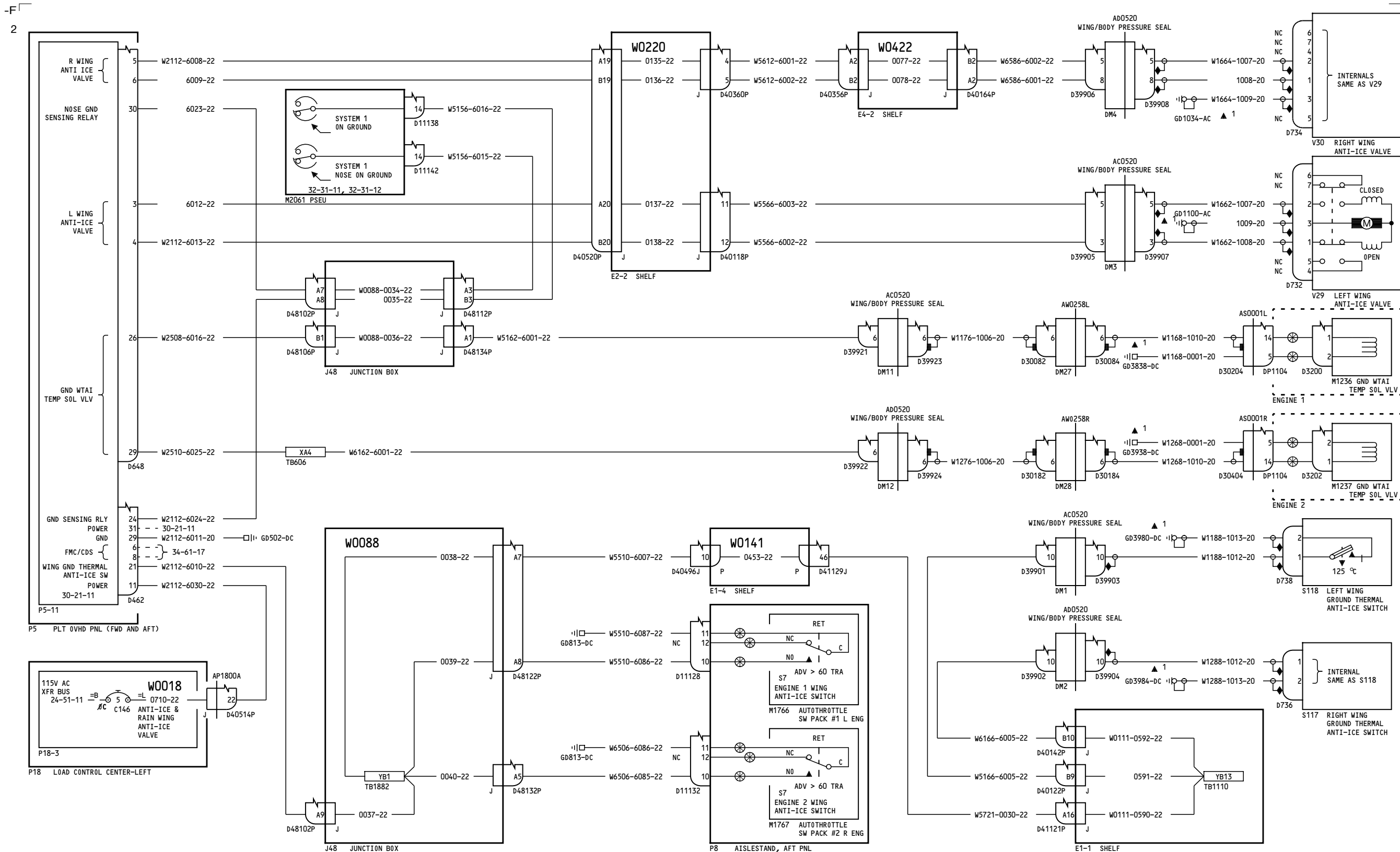

YC004-YC007

**WING THERMAL ANTI-ICE SYSTEM**

D280A103

**30-11-11**

Page 2

Mar 31/2005

**30-11-11**

Page 2

Mar 31/2005

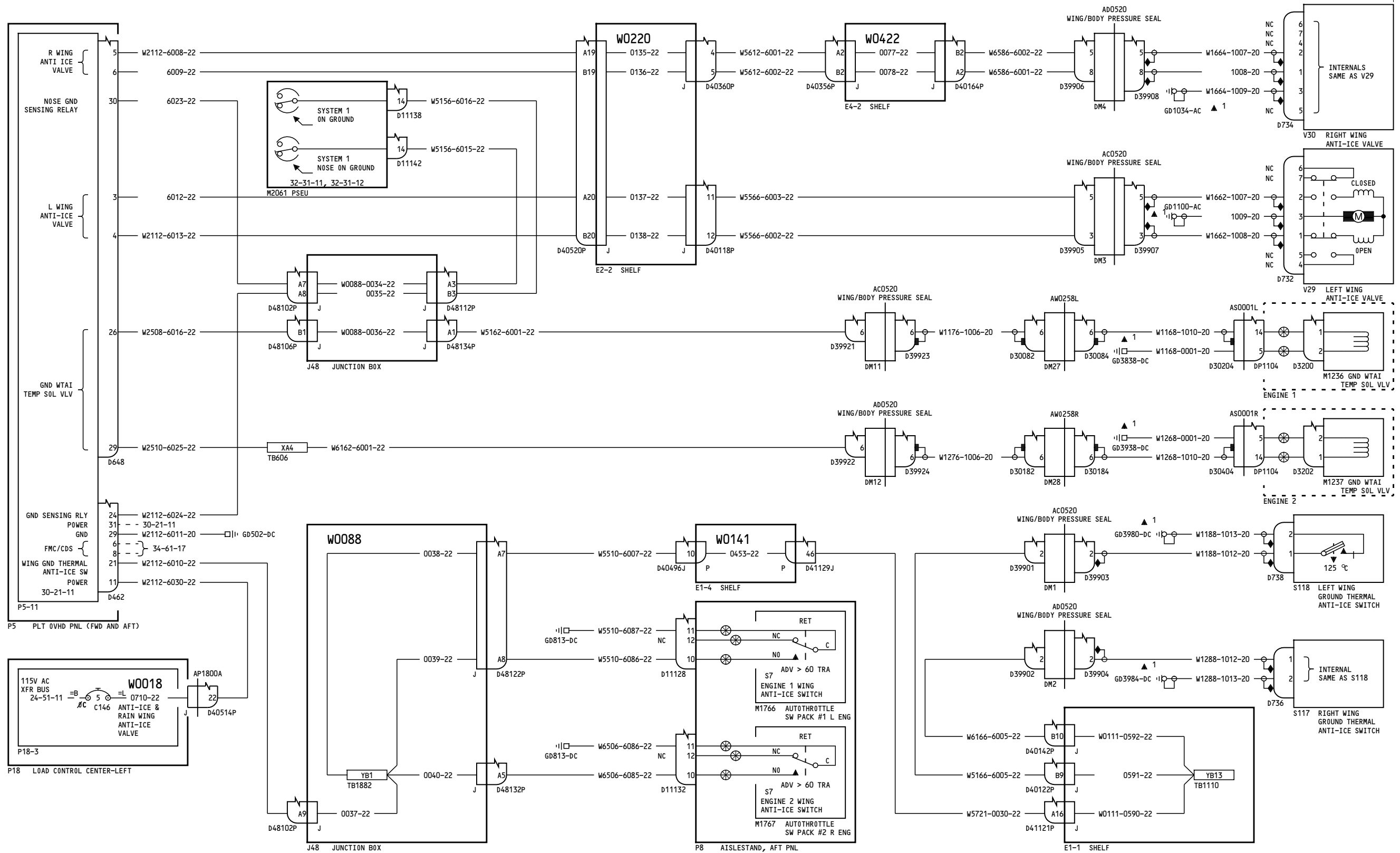

YC004-YC007

WING THERMAL ANTI-ICE SYSTEM

D280A103

30-11-11

Page 2.1

Oct 15/2007

Incorporates 28-1194 R02

BOEING PROPRIETARY - Copyright © - Unpublished Work - See title page for details.

30-11-11

Page 2.1

Oct 15/2007

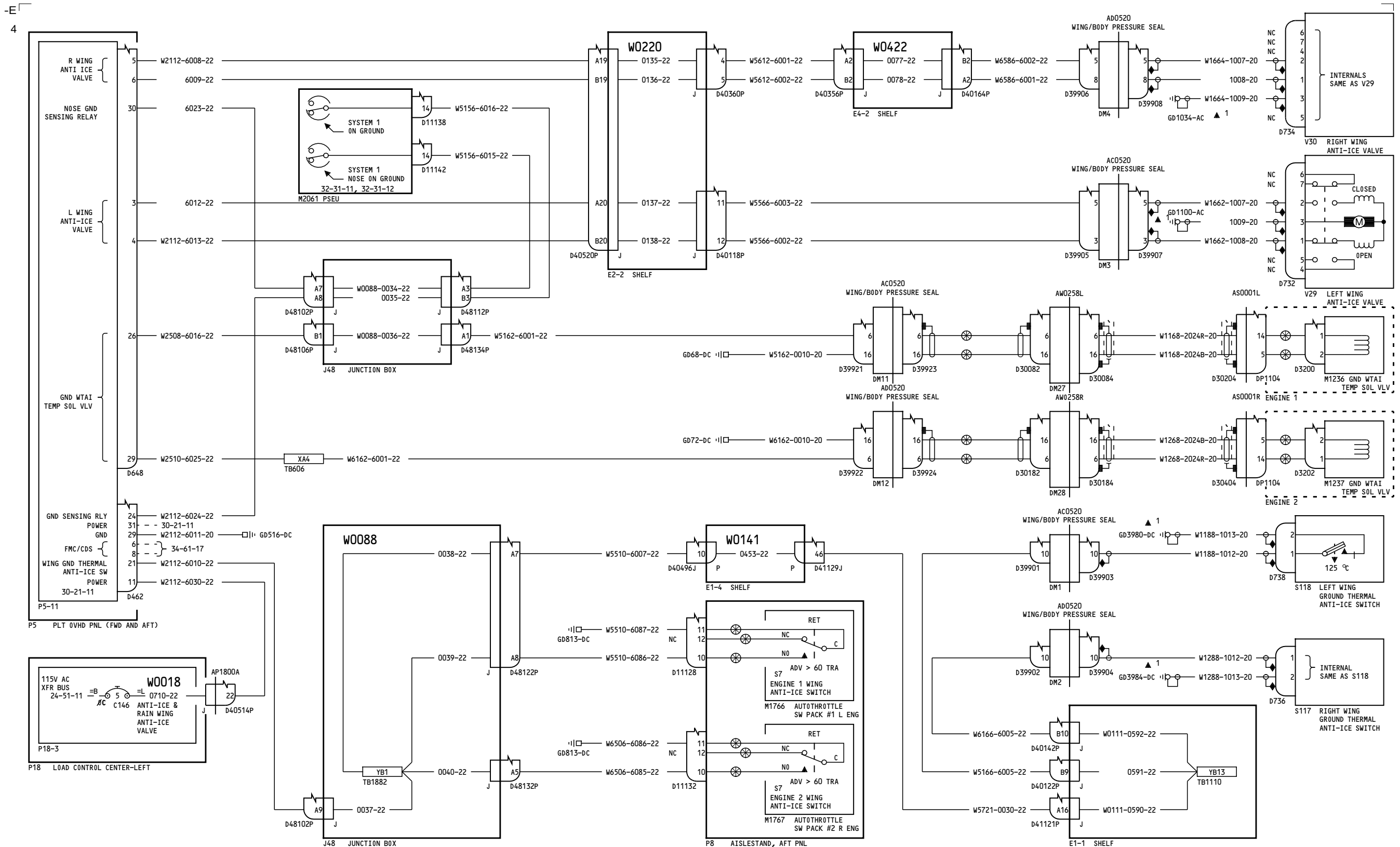

YC008-YC030

WING THERMAL ANTI-ICE SYSTEM

D280A103

30-11-11

Page 3

Jul 17/2007

30-11-11

Page 3

Jul 17/2007

26

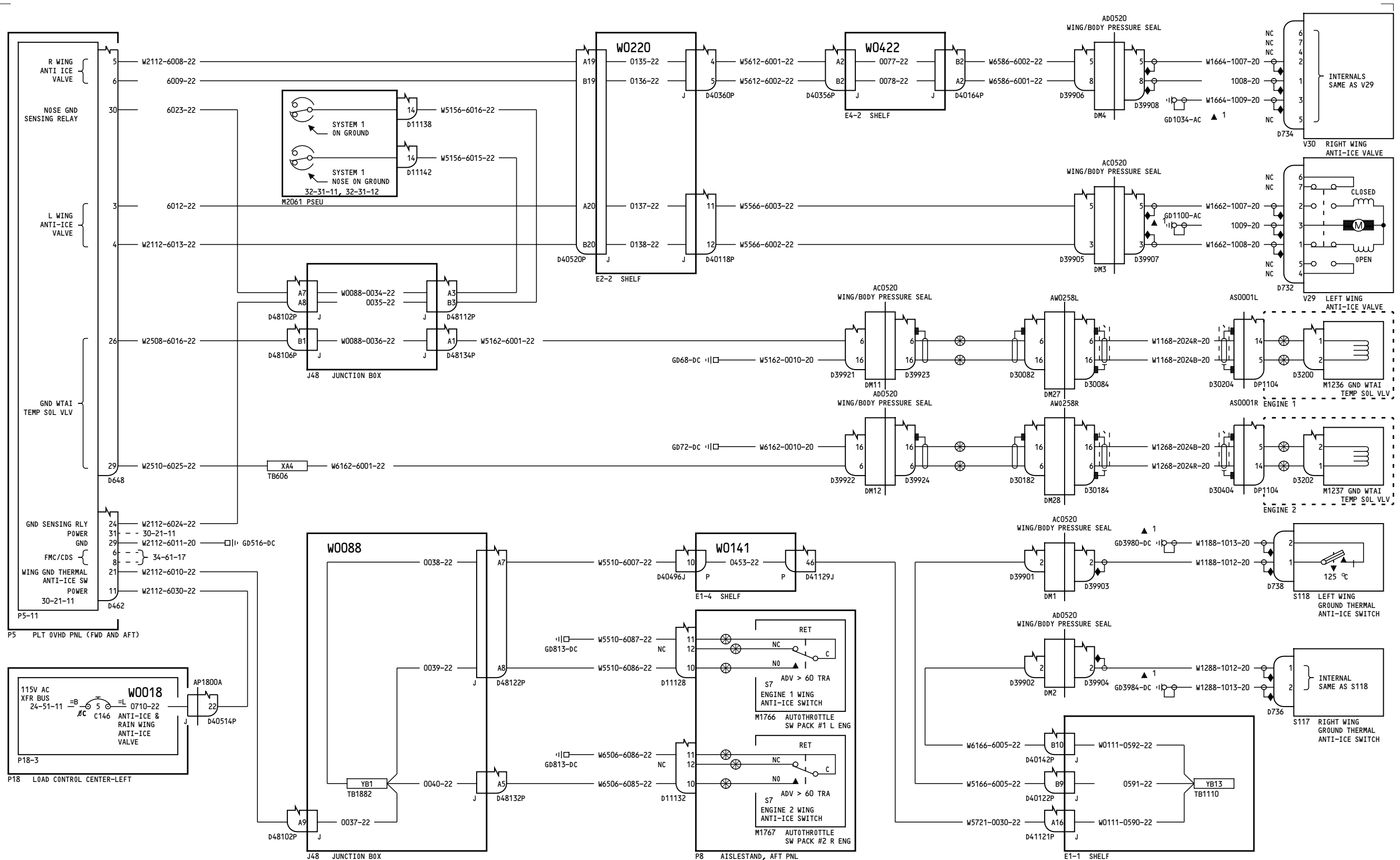

YC008-YC030

**WING THERMAL ANTI-ICE SYSTEM**

D280A103

**30-11-11**

Page 3.1

Oct 15/2007

Incorporates  
28-1194 R02

**30-11-11**

Page 3.1

Oct 15/2007

-B  
13

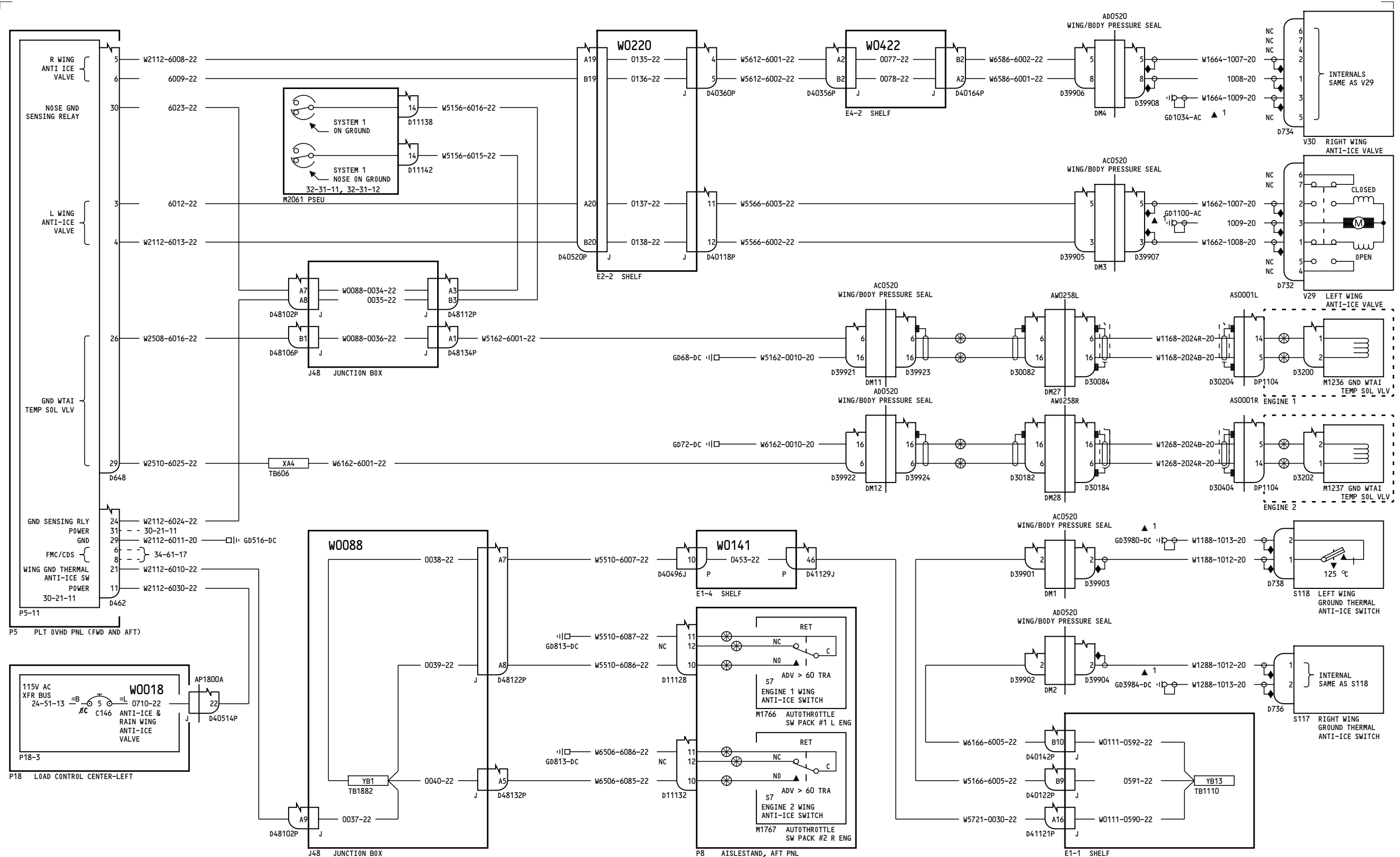

YC031-YM670

**WING THERMAL ANTI-ICE SYSTEM**

30-11-11

Page 4

D280A103

Feb 09/2009

30-11-11

Page 4

Feb 09/2009

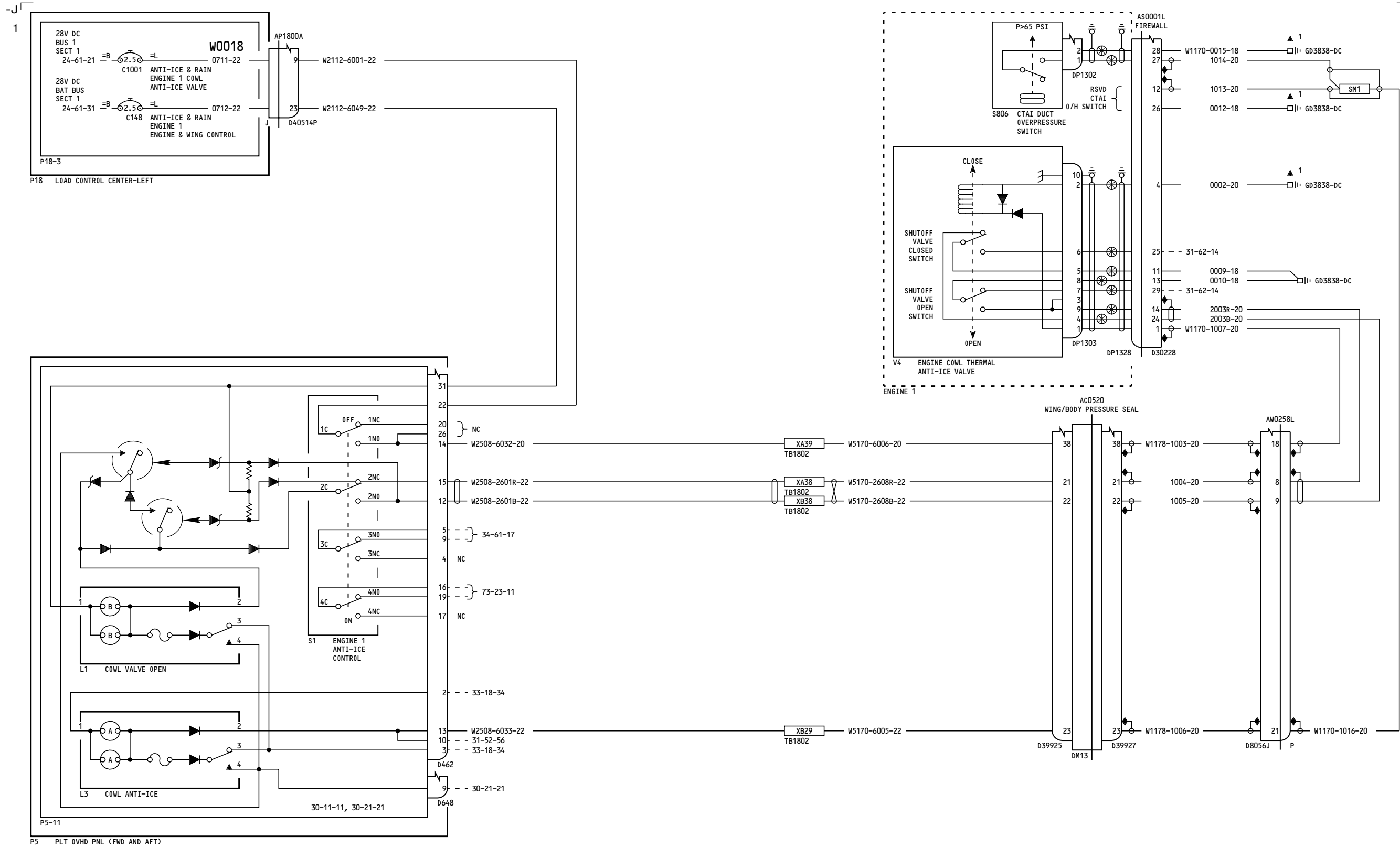

YC001-YC003

**ENGINE 1 NACELLE ANTI-ICE**

**30-21-11**

Page 1

D280A103

Jul 26/2006

**30-21-11**

Page 1

Jul 26/2006

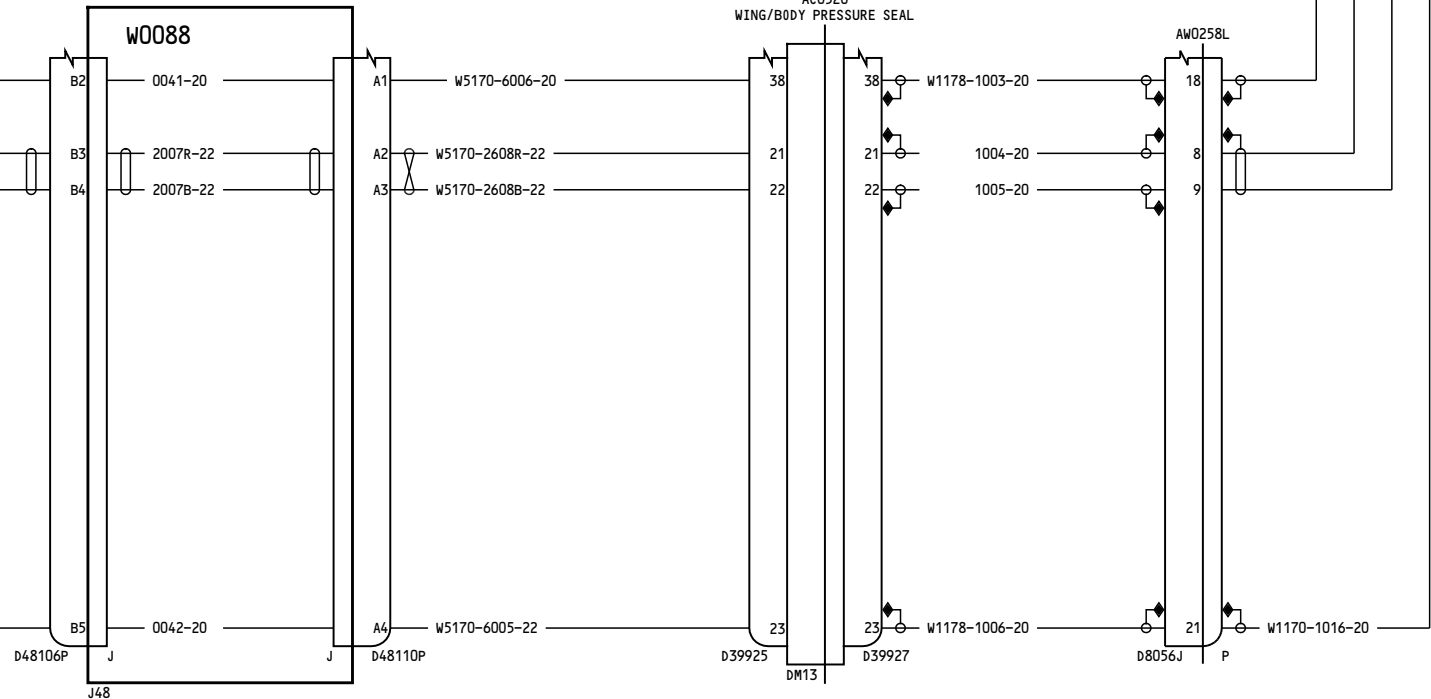
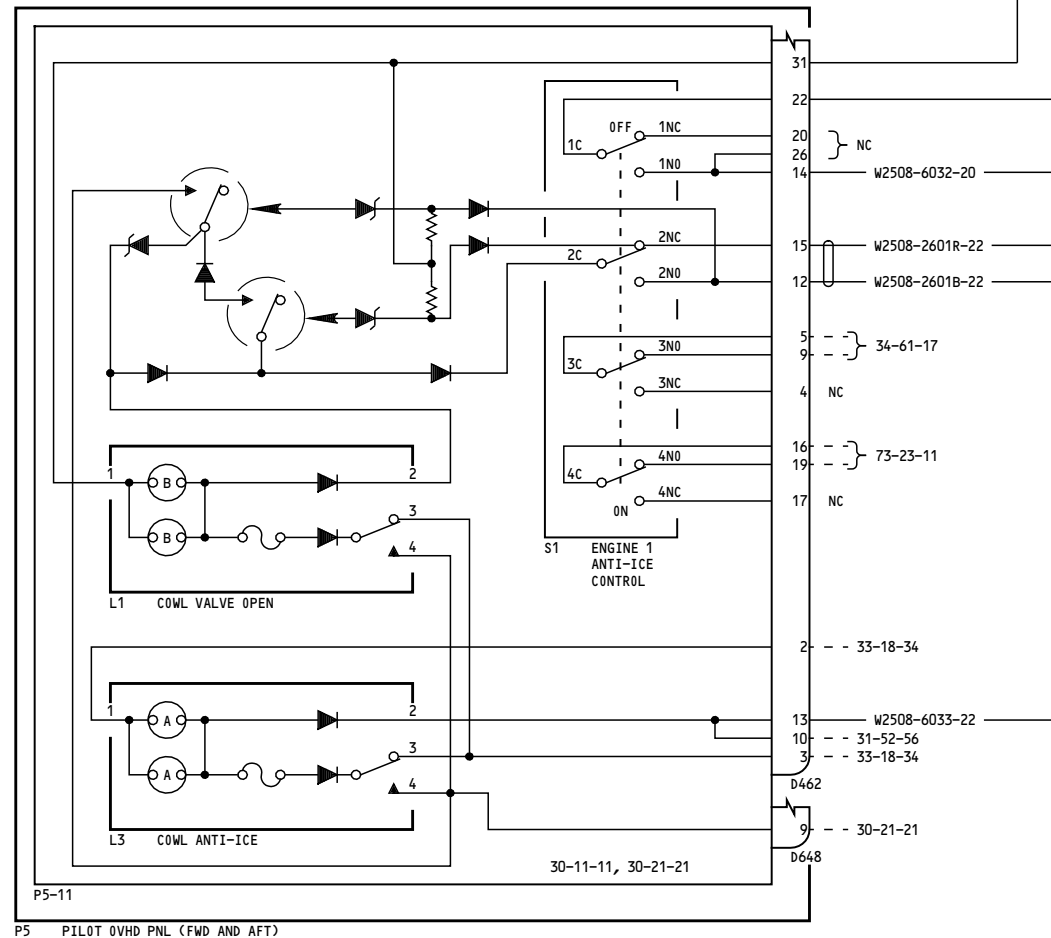
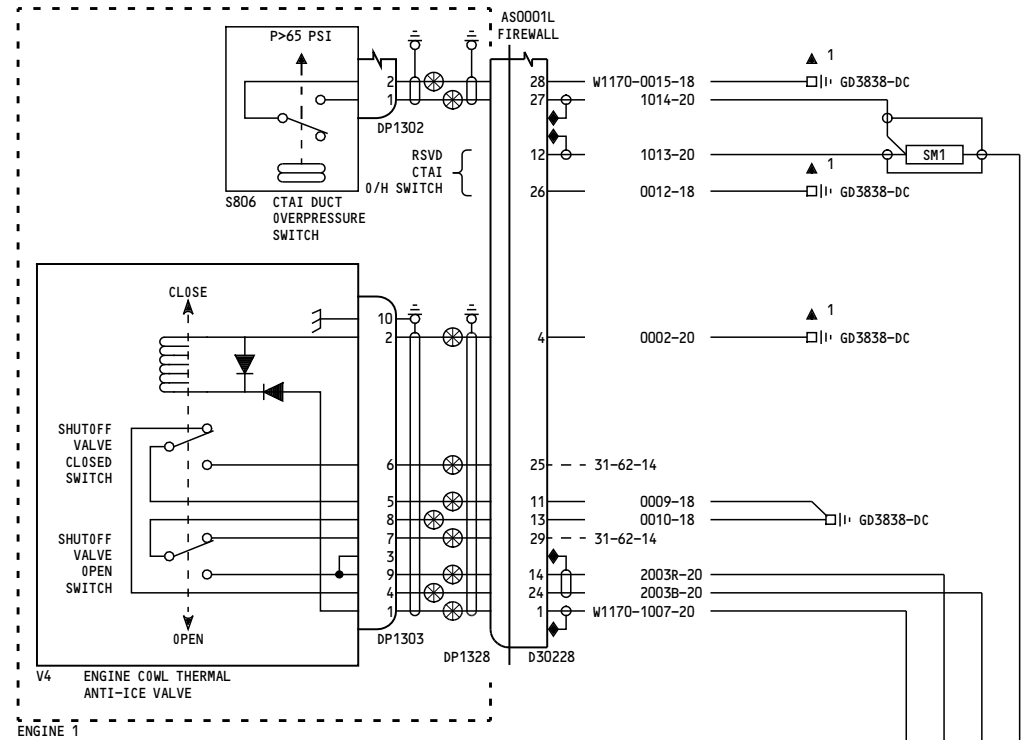
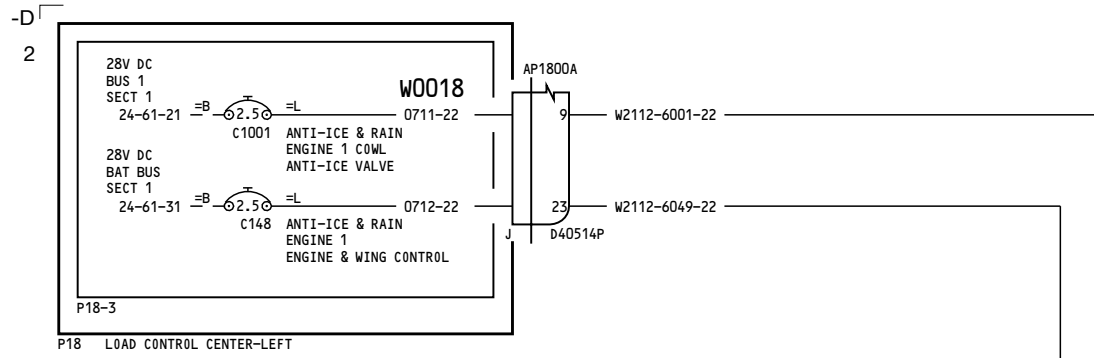

YC004-YM670

**ENGINE 1 NACELLE ANTI-ICE**

**30-21-11**

**30-21-11**

Page 2

Page 2

D280A103

Feb 09/2009

Feb 09/2009

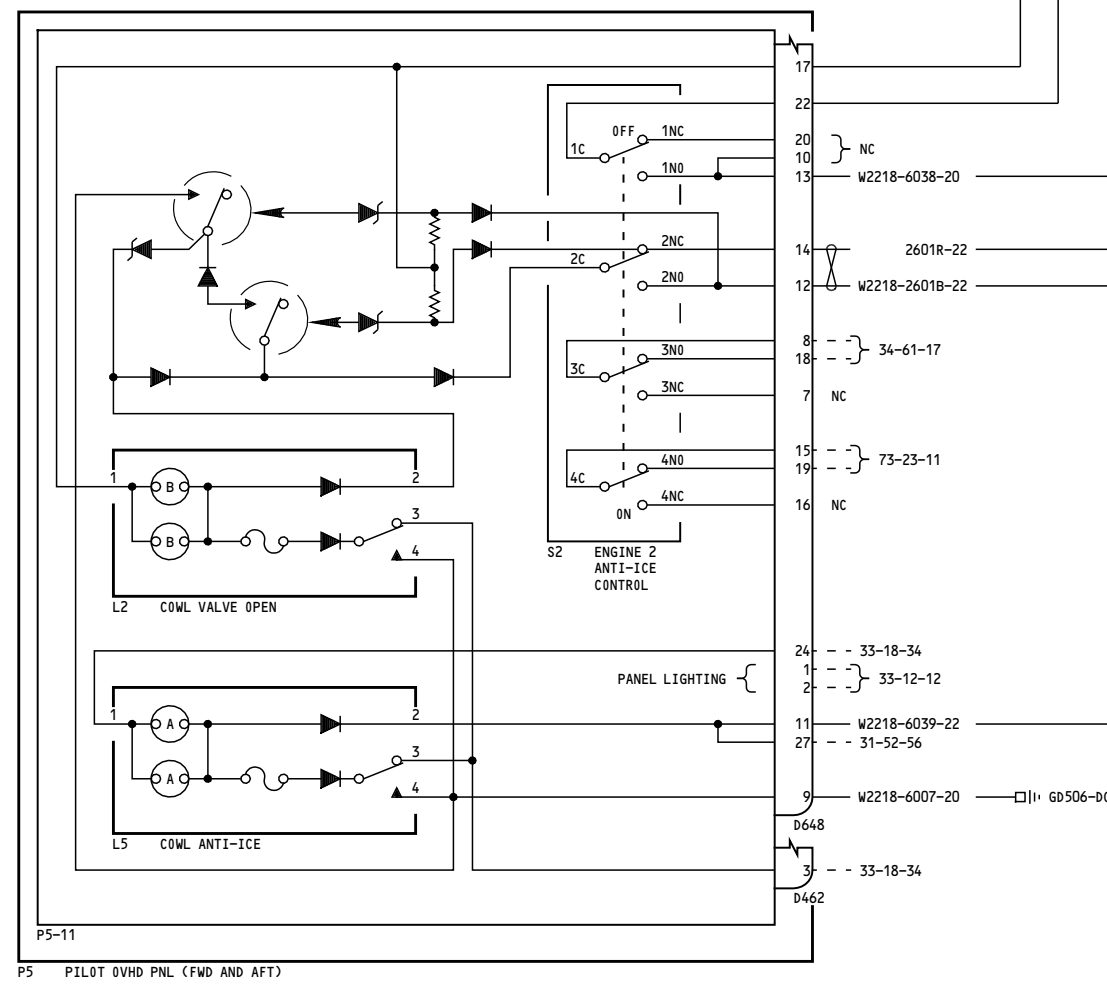
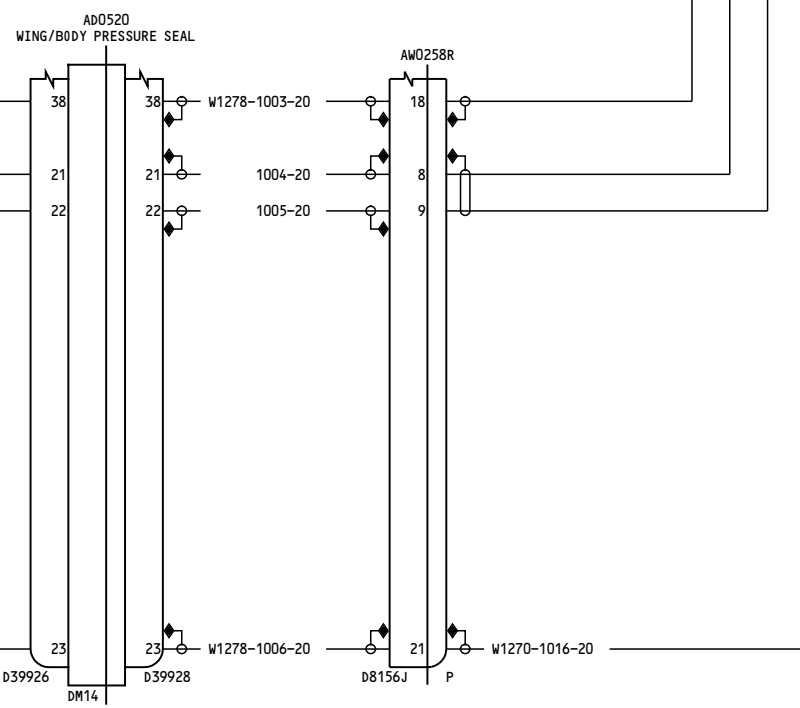
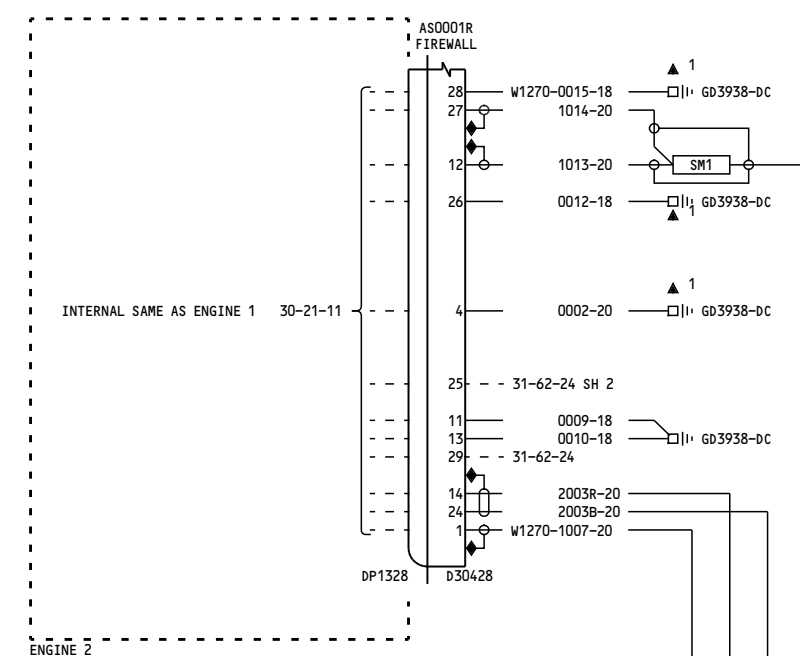
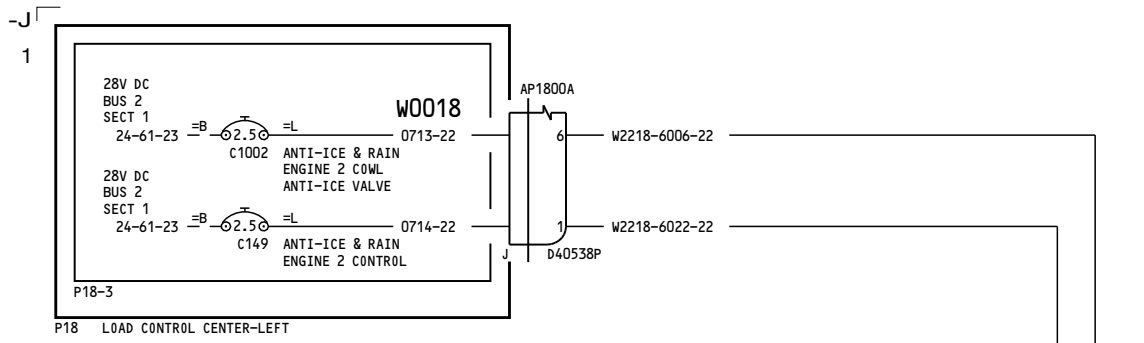

YC001-YC003 ENGINE 2 NACELLE ANTI-ICE D280A103	<b>30-21-21</b> Page 1 Mar 31/2005
--	--

**30-21-21**  
 Page 1  
 Mar 31/2005



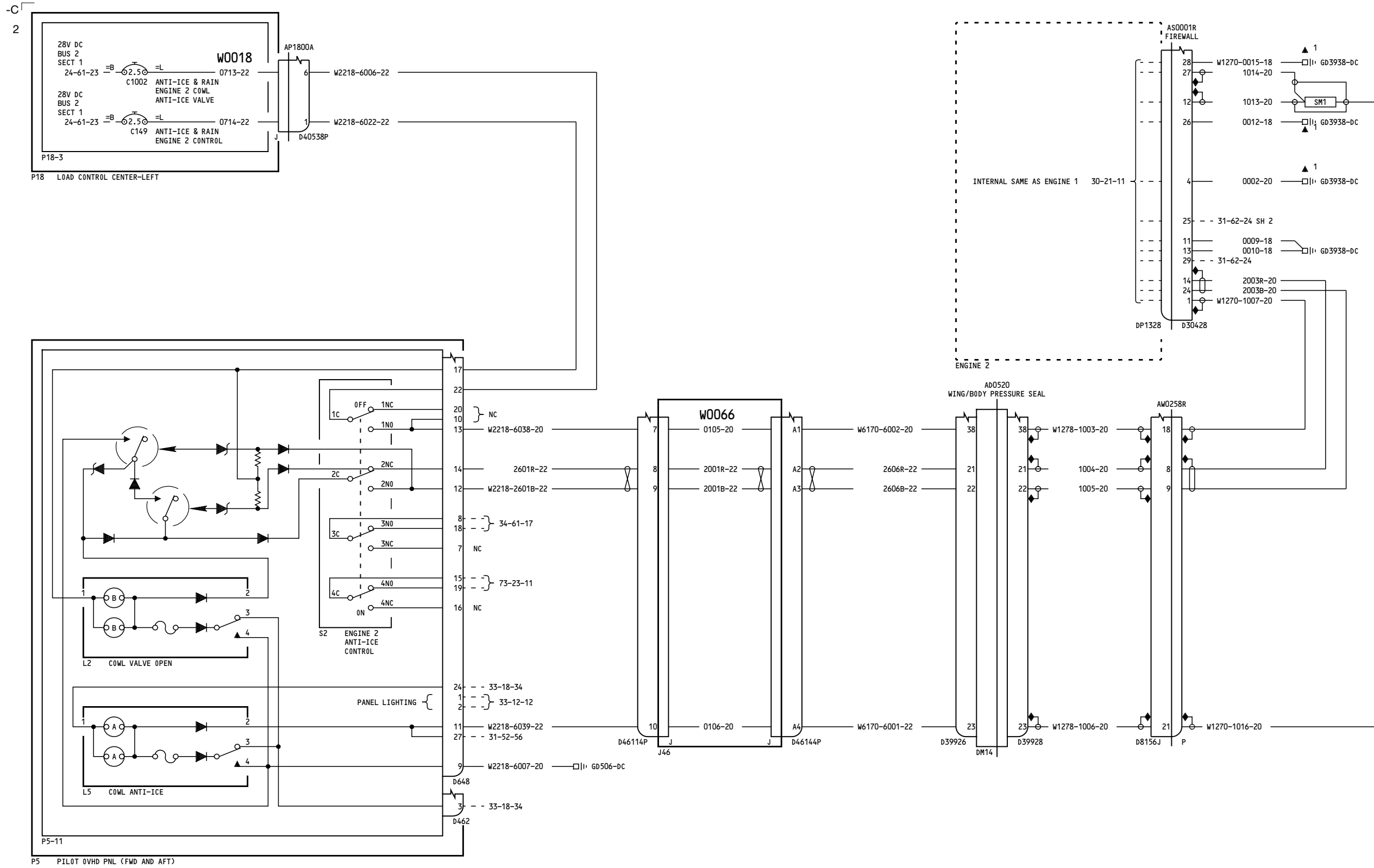

YC004-YM670

**ENGINE 2 NACELLE ANTI-ICE**

**30-21-21**

Page 2

Feb 09/2009

D280A103

**30-21-21**

Page 2

Feb 09/2009

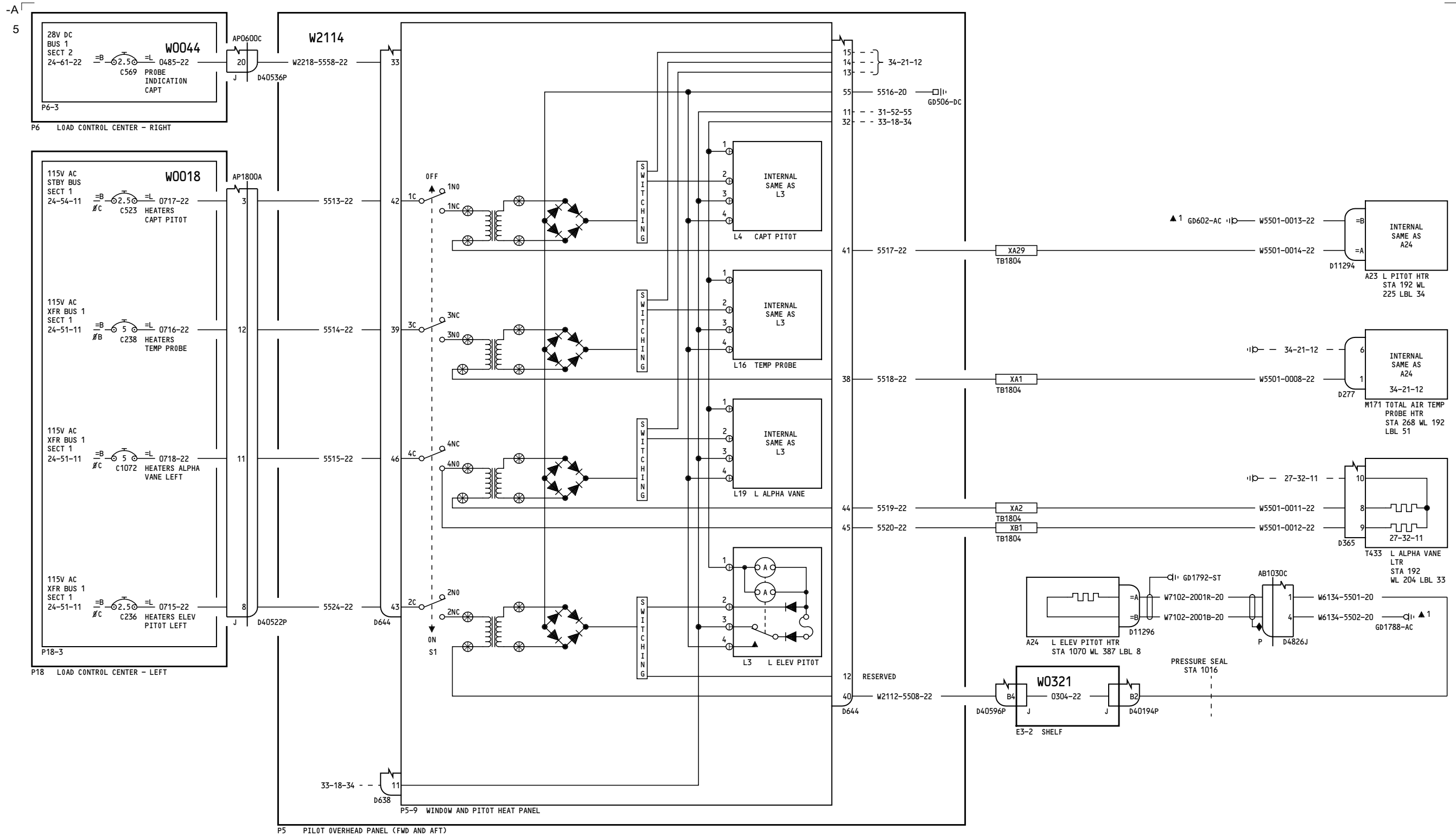

YC001-YC003

PITOT AND PROBE HEATERS - SYSTEM A

30-31-11

Page 1

D280A103

Mar 31/2005

30-31-11

Page 1

Mar 31/2005

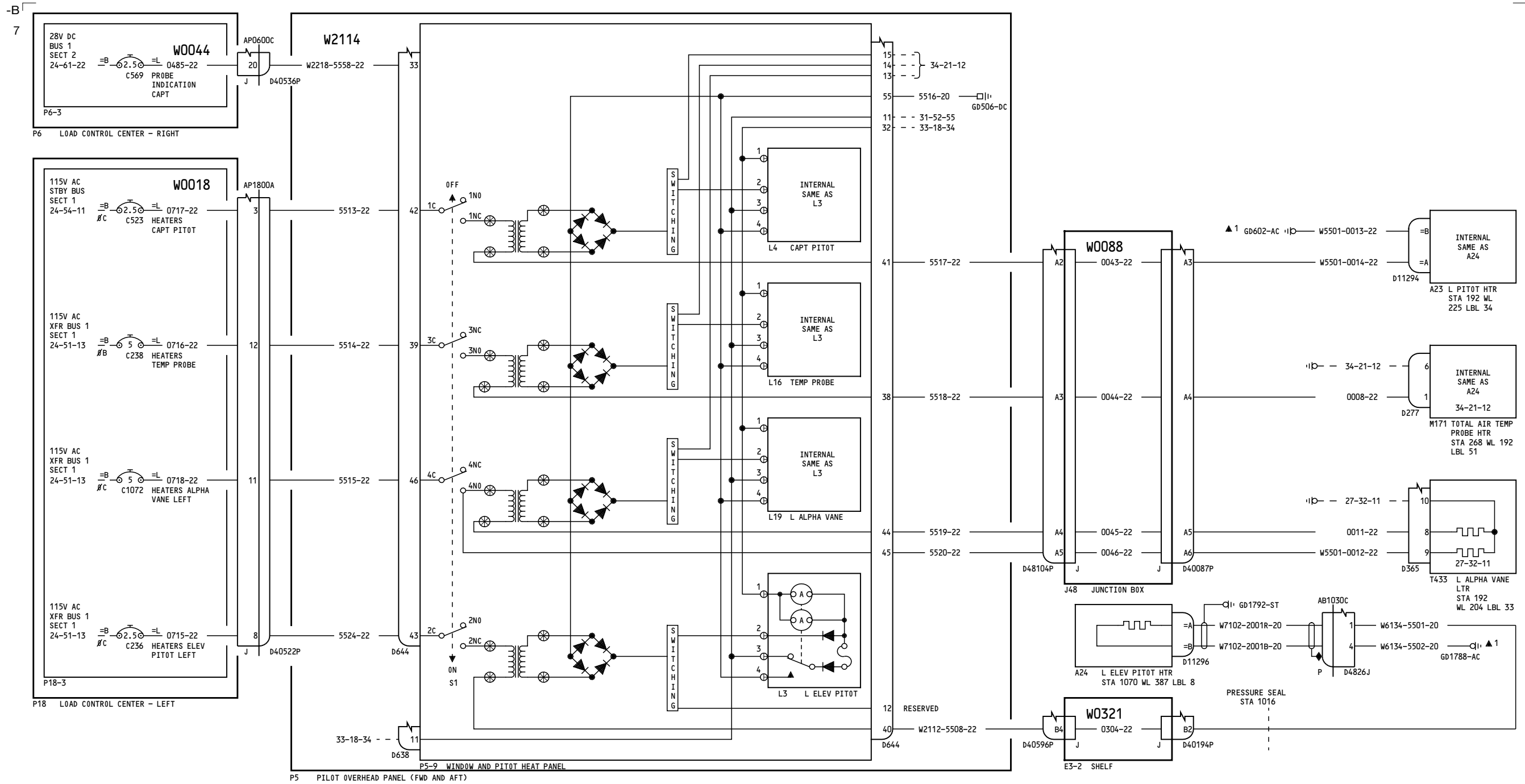

YC004-YM670

**PITOT AND PROBE HEATERS - SYSTEM A**

**30-31-11**

Page 2

D280A103

Feb 09/2009

**30-31-11**

Page 2

Feb 09/2009

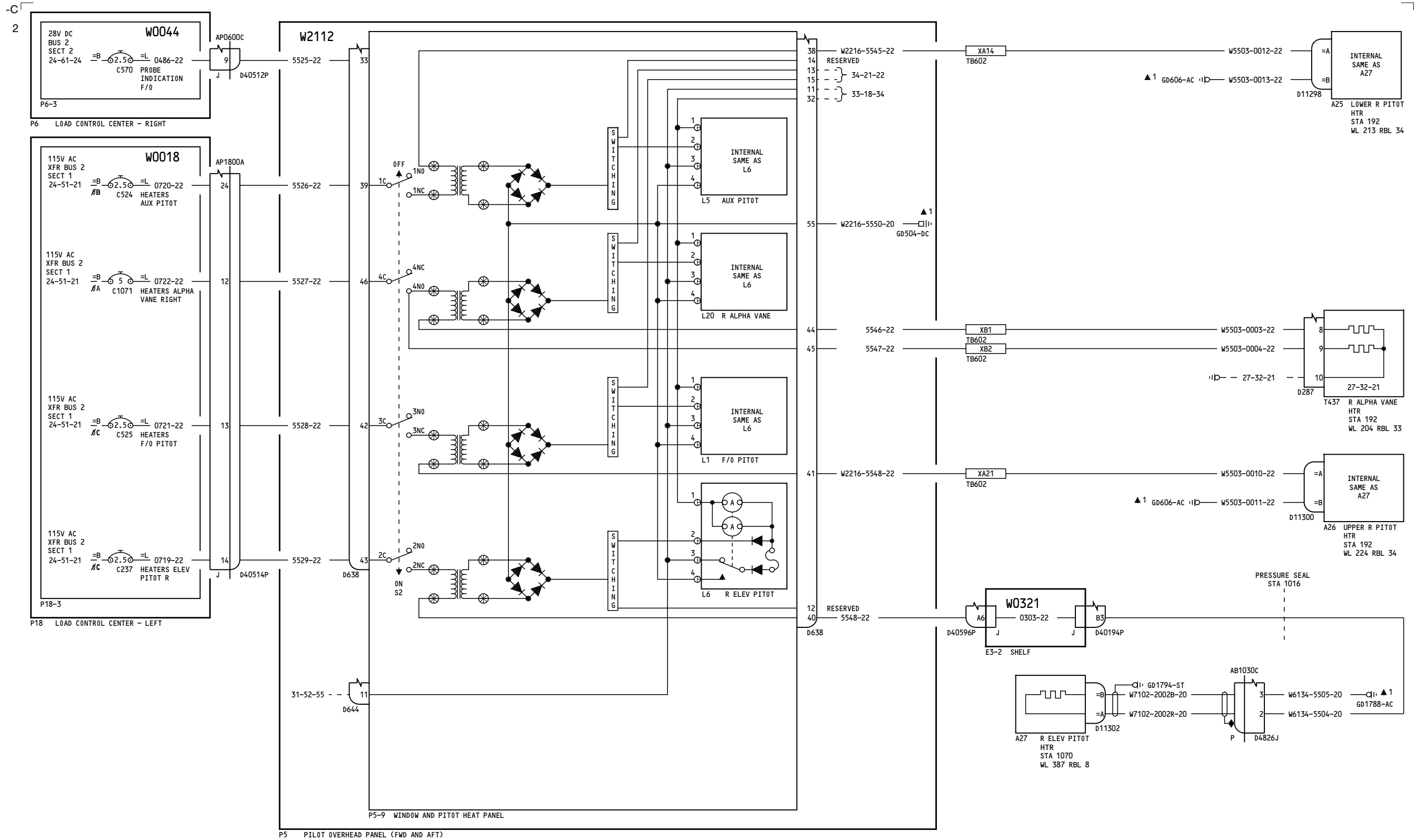

YC001-YC003

**PITOT AND PROBE HEATERS - SYSTEM B**

**30-31-12**

Page 1

D280A103

Mar 31/2005

**30-31-12**

Page 1

Mar 31/2005

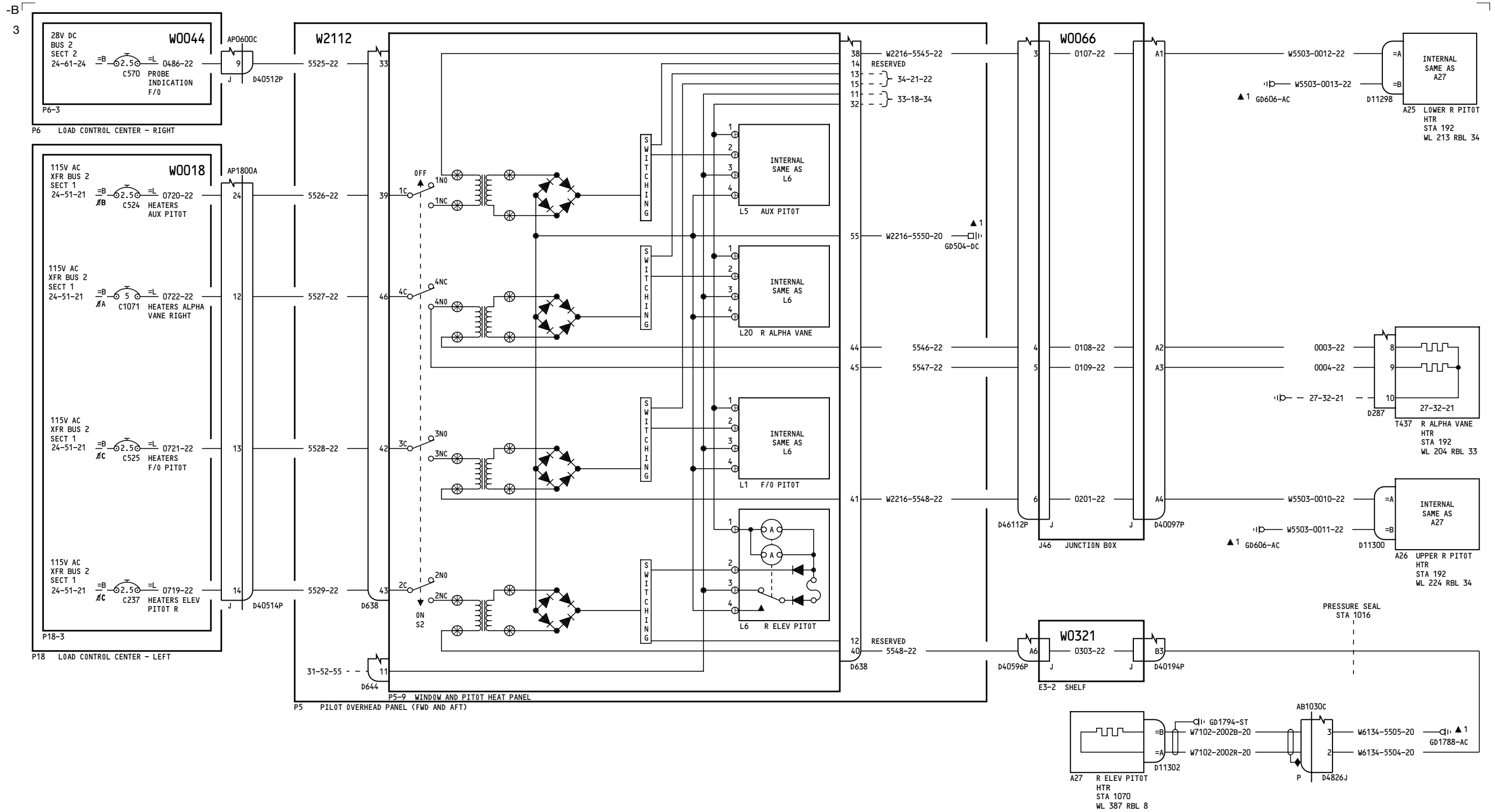

YC004-YC007

**PITOT AND PROBE HEATERS - SYSTEM B**

**30-31-12**

Page 2

Mar 31/2005

D280A103

**30-31-12**

Page 2

Mar 31/2005

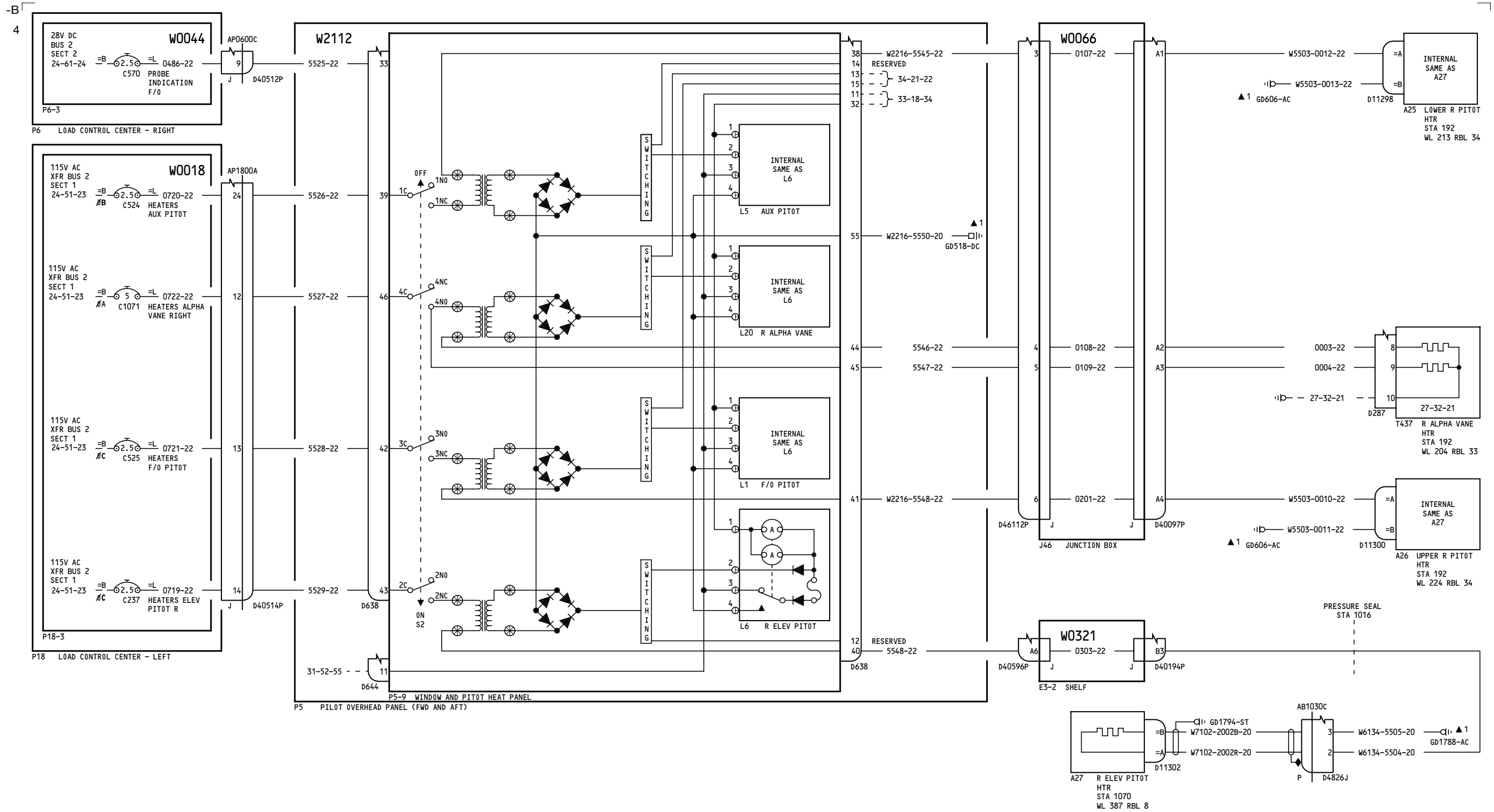

YC008-YM670

**PITOT AND PROBE HEATERS - SYSTEM B**

**30-31-12**

Page 3

Feb 09/2009

D280A103

**30-31-12**

Page 3

Feb 09/2009

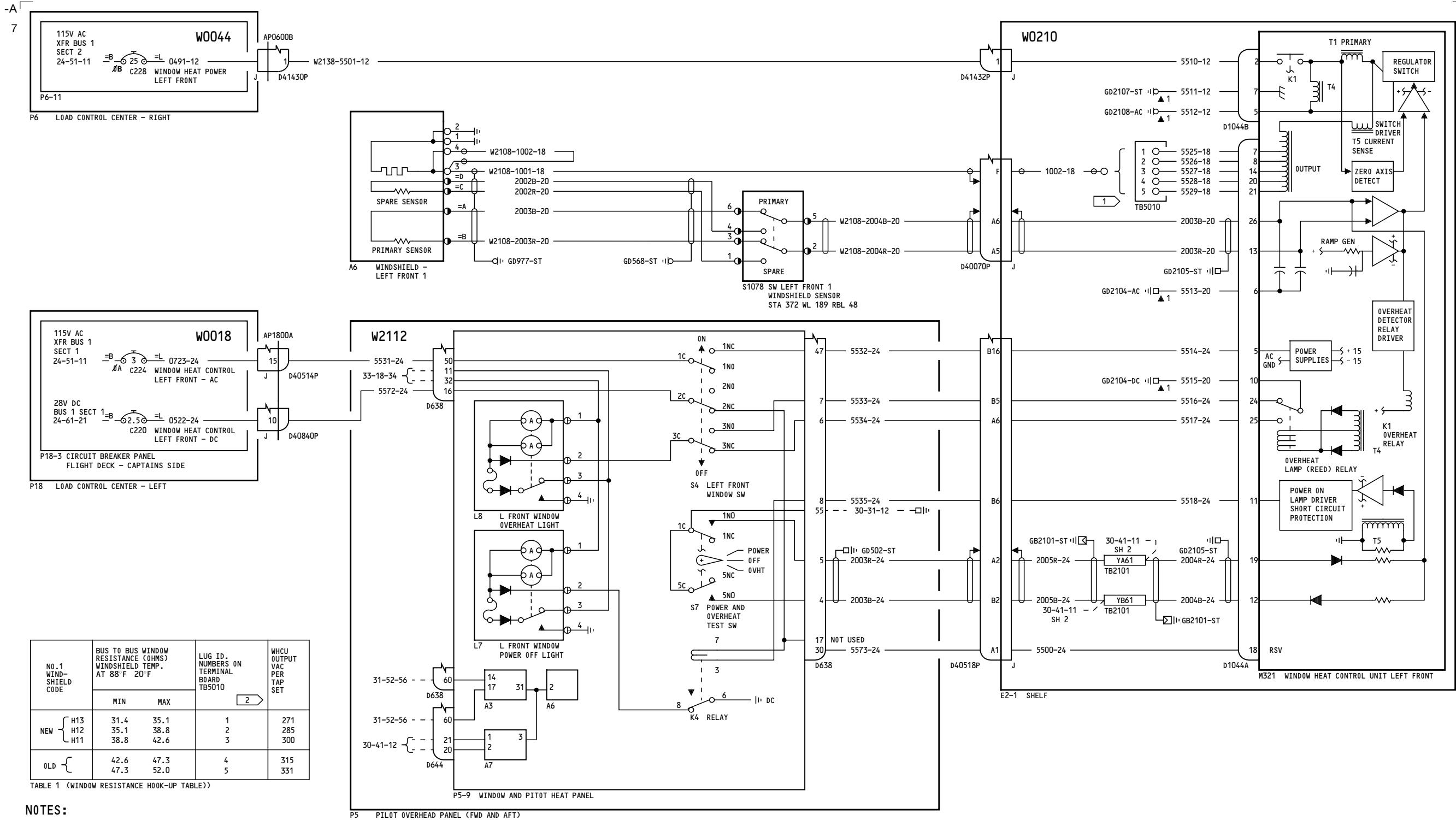

YC001-YC003

**WINDSHIELD HEAT SYSTEM -  
L. FRONT, R. SIDE AND  
OPTIONAL L3 WINDOW**

D280A103

**30-41-11**

Page 1.1  
Sheet 1  
Jul 26/2006

Incorporates  
30-1047

**30-41-11**

Page 1.1  
Sheet 1  
Jul 26/2006

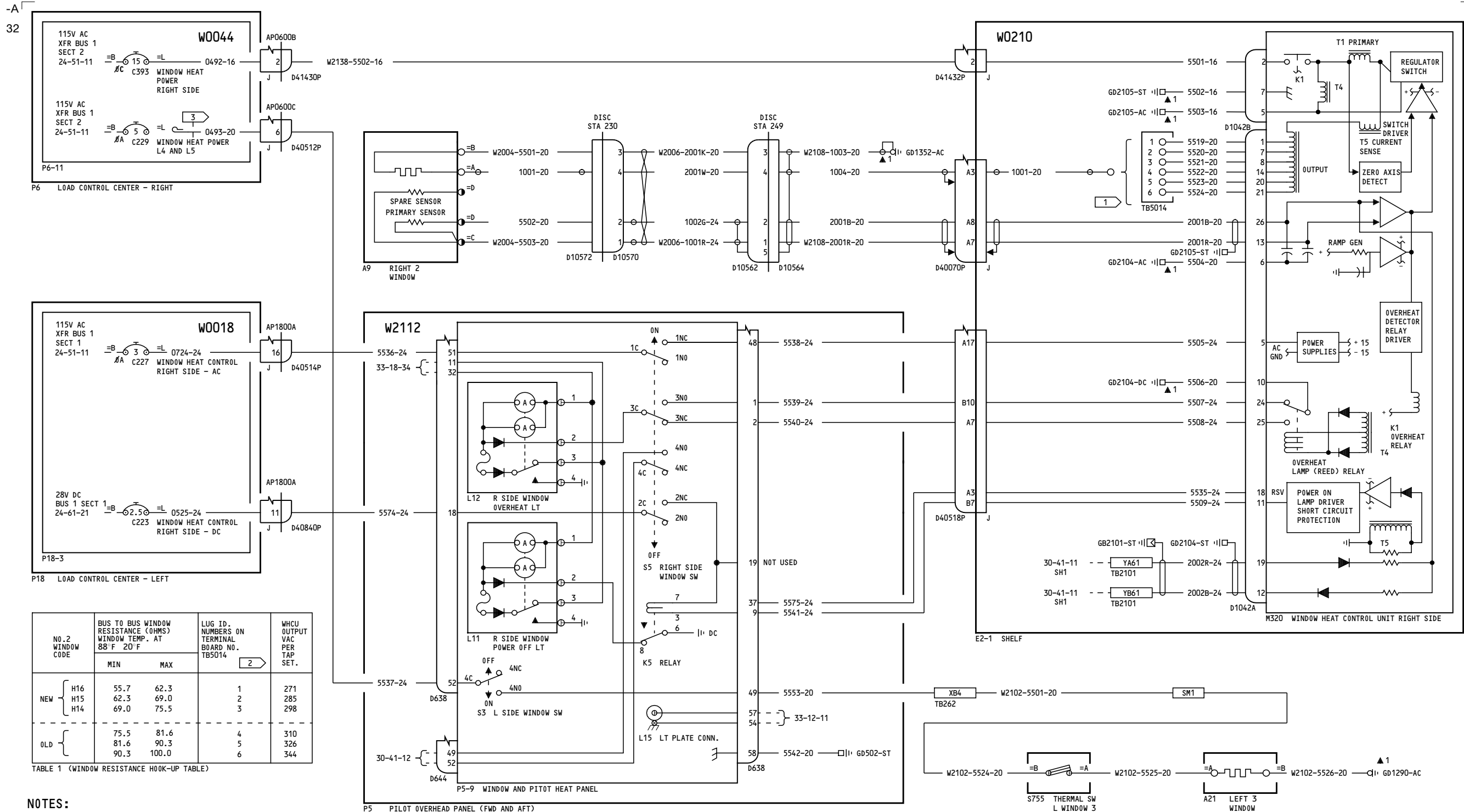

NO. 2 WINDOW CODE	BUS TO BUS WINDOW RESISTANCE (OHMS) WINDOW TEMP. AT 88° F 20° F		LUG ID. NUMBERS ON TERMINAL BOARD NO. TB5014	WHCU OUTPUT VAC PER TAP SET.	
	MIN	MAX			
NEW	H16	55.7	62.3	1	271
	H15	62.3	69.0	2	285
	H14	69.0	75.5	3	298
OLD		75.5	81.6	4	310
		81.6	90.3	5	326
		90.3	100.0	6	344

TABLE 1 (WINDOW RESISTANCE HOOK-UP TABLE)

- NOTES:**
- 1 SEE TABLE 1. HOOKUP DETERMINED BY WINDOW RESISTANCE.
  - 2 TERMINAL BOARD LOCATION AND HOOK UP TABLE.
  - 3 CAP AND STOW NEAR C229

YC001-YC003

**WINDSHIELD HEAT SYSTEM - L. FRONT, R. SIDE AND OPTIONAL L3 WINDOW**

D280A103

Incorporates  
30-1047  
56-1017 R01



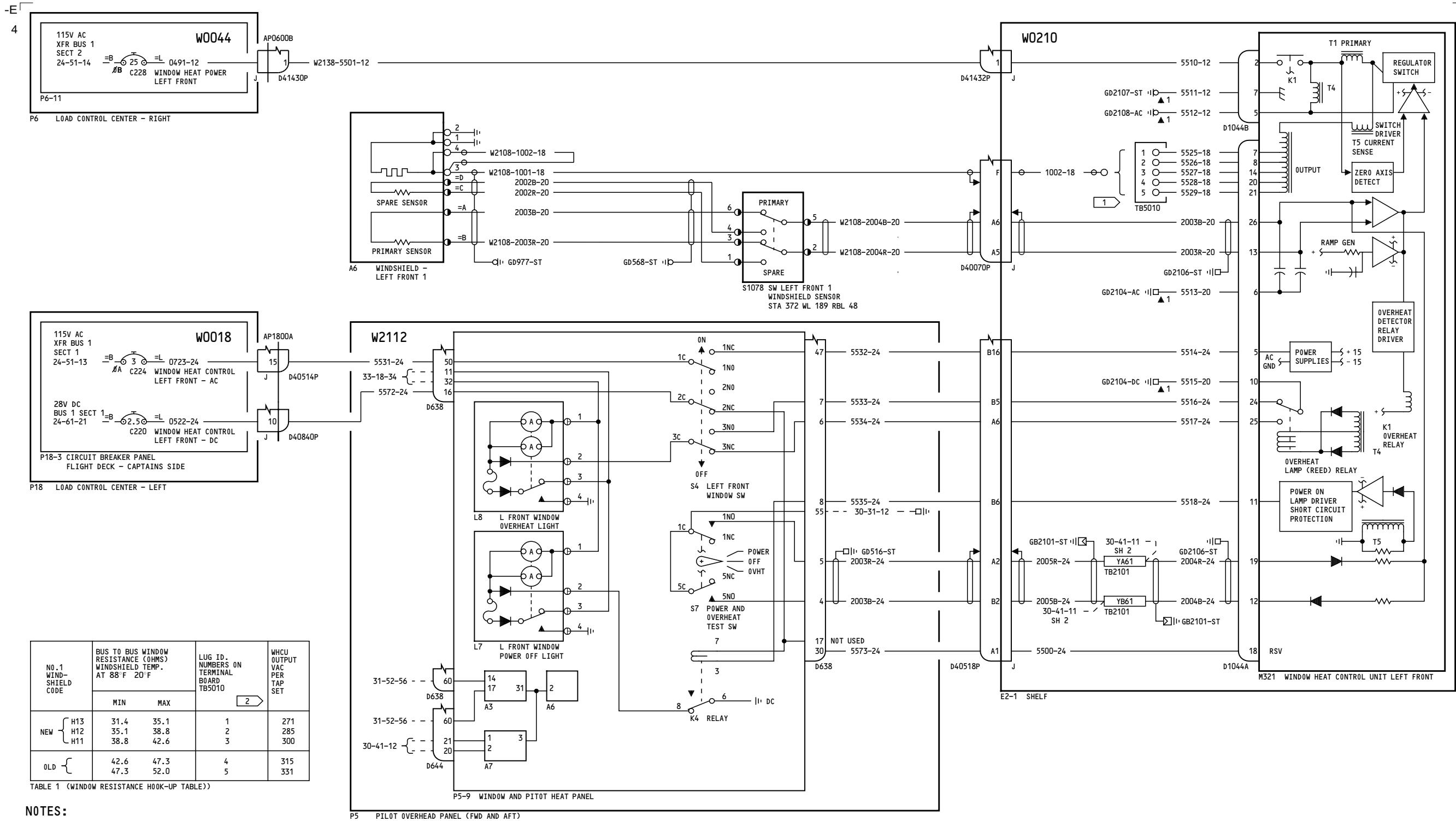

YC004-YC007

**WINDSHIELD HEAT SYSTEM -  
L. FRONT, R. SIDE AND  
OPTIONAL L3 WINDOW**

D280A103

**30-41-11**

Page 2.1  
Sheet 1  
Jul 26/2006

Incorporates  
30-1047

**30-41-11**

Page 2.1  
Sheet 1  
Jul 26/2006

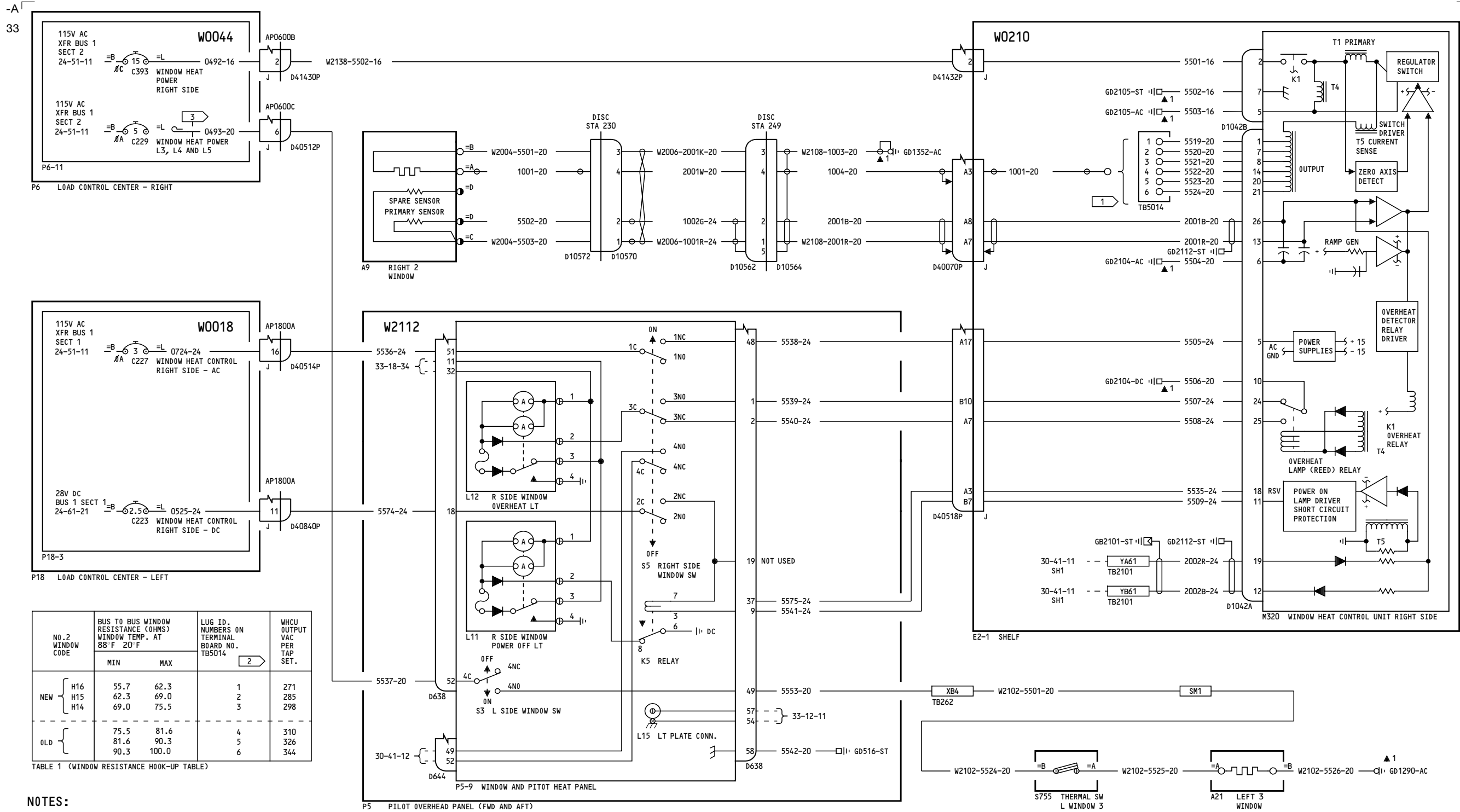

NO. 2 WINDOW CODE	BUS TO BUS WINDOW RESISTANCE (OHMS) WINDOW TEMP. AT 88° F 20° F		LUG ID. NUMBERS ON TERMINAL BOARD NO. TB5014	WHCU OUTPUT VAC PER TAP SET.	
	MIN	MAX			
NEW	H16	55.7	62.3	1	271
	H15	62.3	69.0	2	285
	H14	69.0	75.5	3	298
OLD		75.5	81.6	4	310
		81.6	90.3	5	326
		90.3	100.0	6	344

TABLE 1 (WINDOW RESISTANCE HOOK-UP TABLE)

- NOTES:**
- 1 SEE TABLE 1. HOOKUP DETERMINED BY WINDOW RESISTANCE.
  - 2 TERMINAL BOARD LOCATION AND HOOK UP TABLE.
  - 3 CAP AND STOW NEAR C229

YC004-YC007

**WINDSHIELD HEAT SYSTEM - L. FRONT, R. SIDE AND OPTIONAL L3 WINDOW**

D280A103

**30-41-11**

Page 2.1  
Sheet 2  
Aug 10/2009

Incorporates  
30-1047  
56-1017 R01

**30-41-11**

Page 2.1  
Sheet 2  
Aug 10/2009

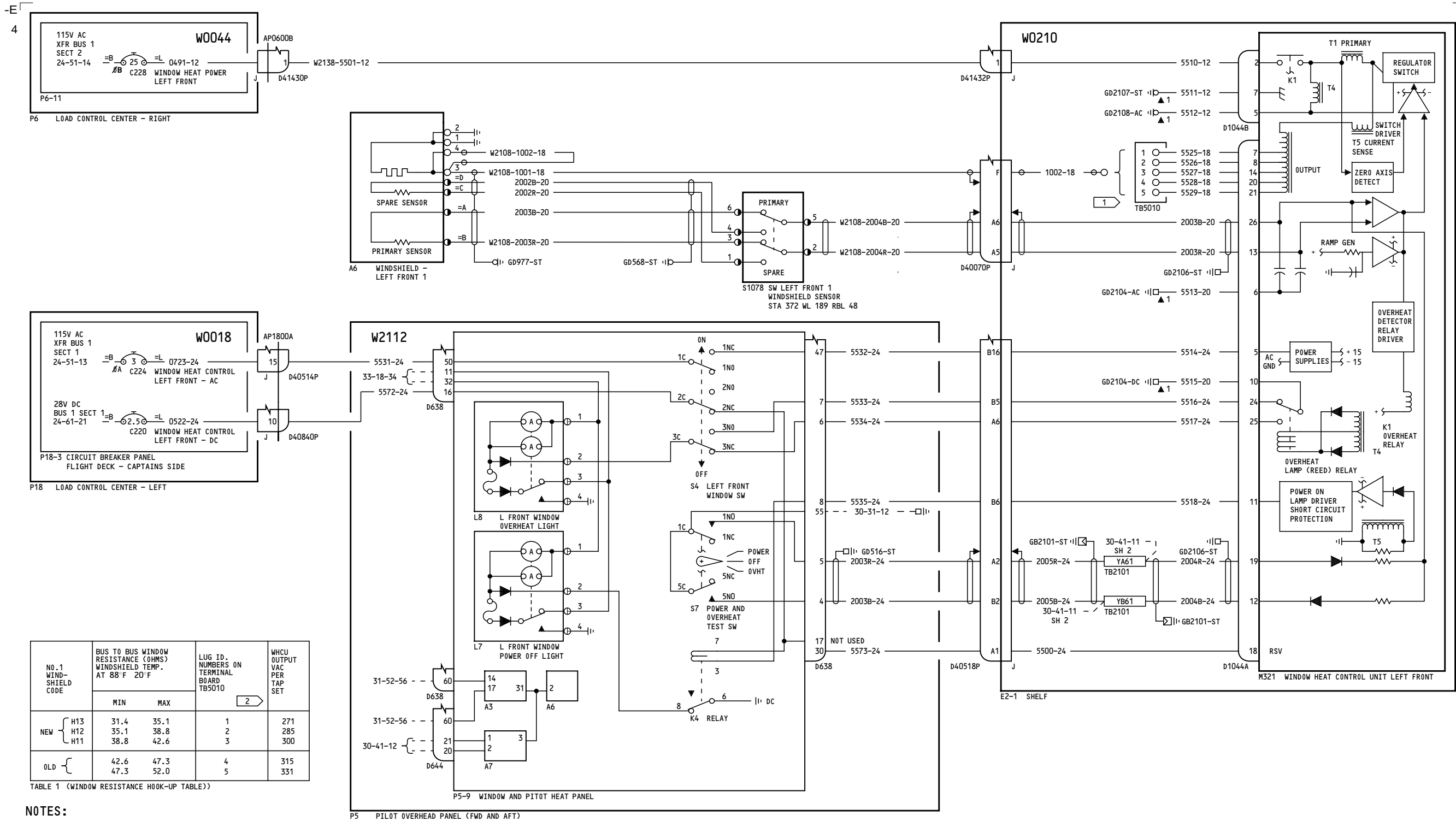

YC008-YC030

**WINDSHIELD HEAT SYSTEM - L. FRONT, R. SIDE AND OPTIONAL L3 WINDOW**

D280A103

**30-41-11**

Page 3.1  
Sheet 1  
May 13/2008

**30-41-11**

Page 3.1  
Sheet 1  
May 13/2008

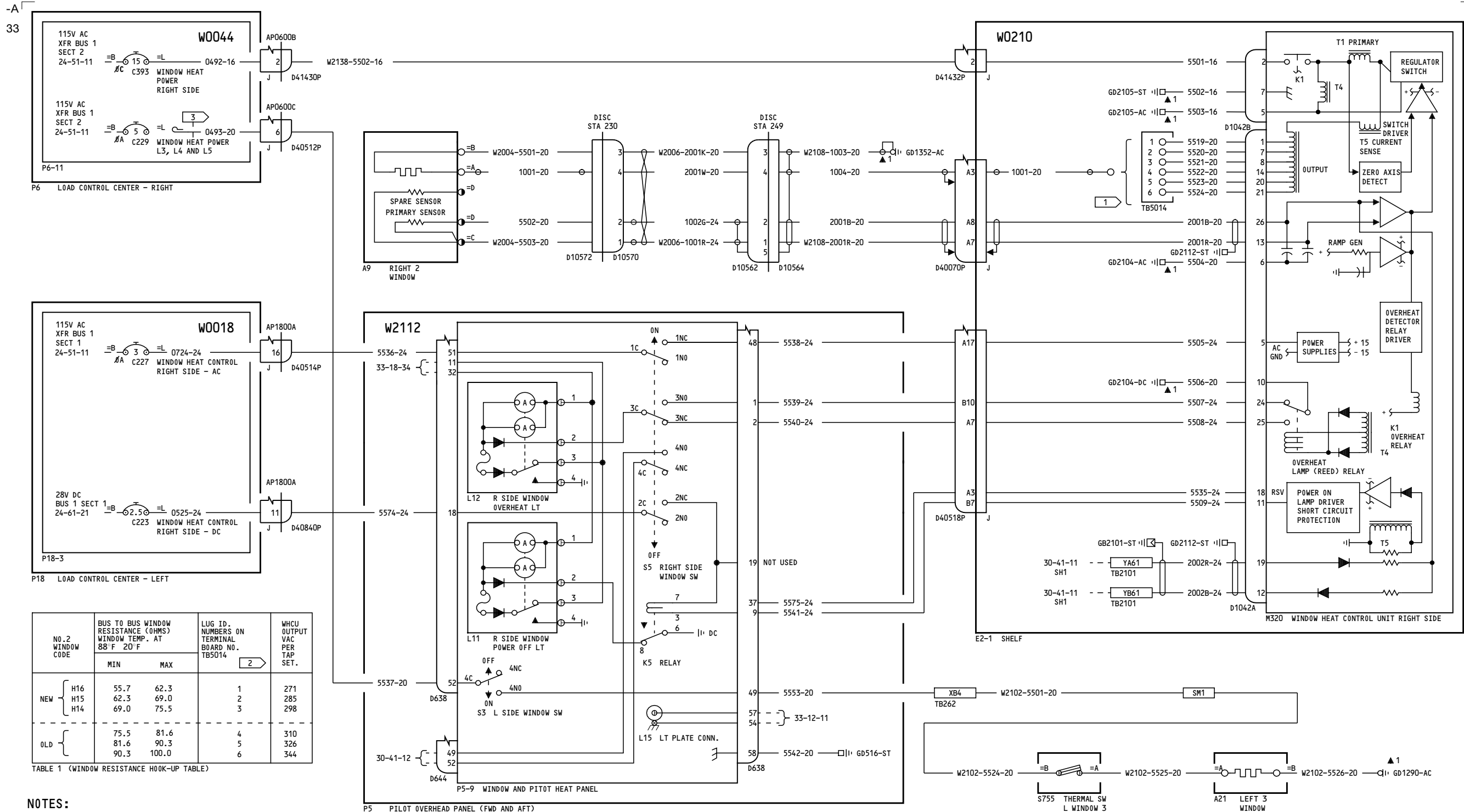

NO. 2 WINDOW CODE	BUS TO BUS WINDOW RESISTANCE (OHMS) WINDOW TEMP. AT 88° F 20° F		LUG ID. NUMBERS ON TERMINAL BOARD NO. TB5014	WHCU OUTPUT VAC PER TAP SET.	
	MIN	MAX			
NEW	H16	55.7	62.3	1	271
	H15	62.3	69.0	2	285
	H14	69.0	75.5	3	298
OLD		75.5	81.6	4	310
		81.6	90.3	5	326
		90.3	100.0	6	344

TABLE 1 (WINDOW RESISTANCE HOOK-UP TABLE)

**NOTES:**

- 1 SEE TABLE 1. HOOKUP DETERMINED BY WINDOW RESISTANCE.
- 2 TERMINAL BOARD LOCATION AND HOOK UP TABLE.
- 3 CAP AND STOW NEAR C229

YC008-YC030

**WINDSHIELD HEAT SYSTEM -  
L. FRONT, R. SIDE AND  
OPTIONAL L3 WINDOW**

**30-41-11**

Incorporates  
56-1017 R01

**30-41-11**

D280A103

Page 3.1  
Sheet 2  
Feb 09/2009

Page 3.1  
Sheet 2  
Feb 09/2009

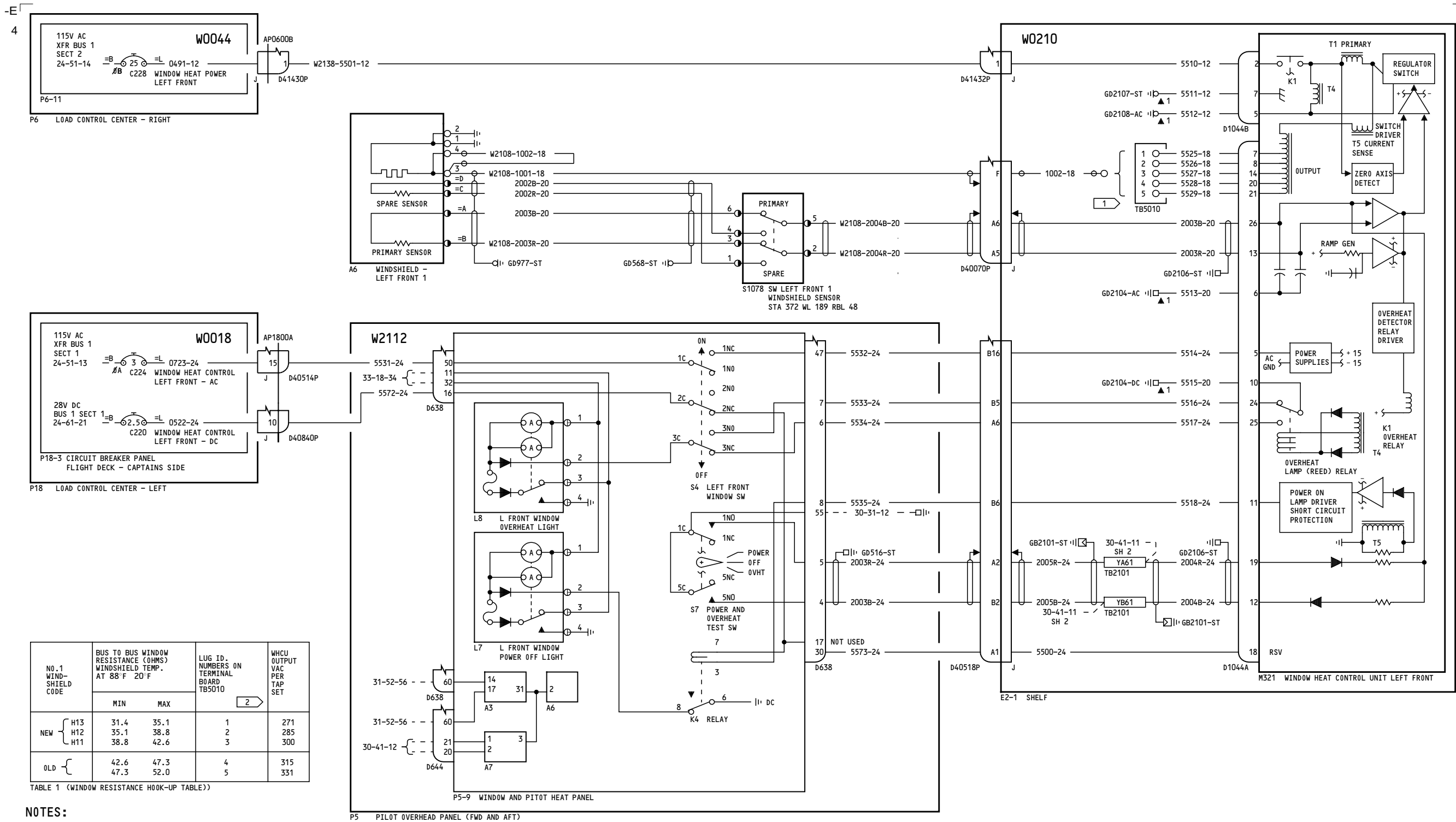

**NOTES:**

1 SEE TABLE 1. HOOKUP DETERMINED BY WINDOW RESISTANCE

2 USE WINDSHIELD CODE AND RESISTANCE VALUES FOR OLD (USED) AND NEW WINDSHIELDS TO DETERMINE TERMINAL CONNECTIONS.

YC031-YK901

**WINDSHIELD HEAT SYSTEM - L. FRONT, R. SIDE AND OPTIONAL L3 WINDOW**

D280A103

**30-41-11**

Page 4  
Sheet 1  
Jul 26/2006

**30-41-11**

Page 4  
Sheet 1  
Jul 26/2006

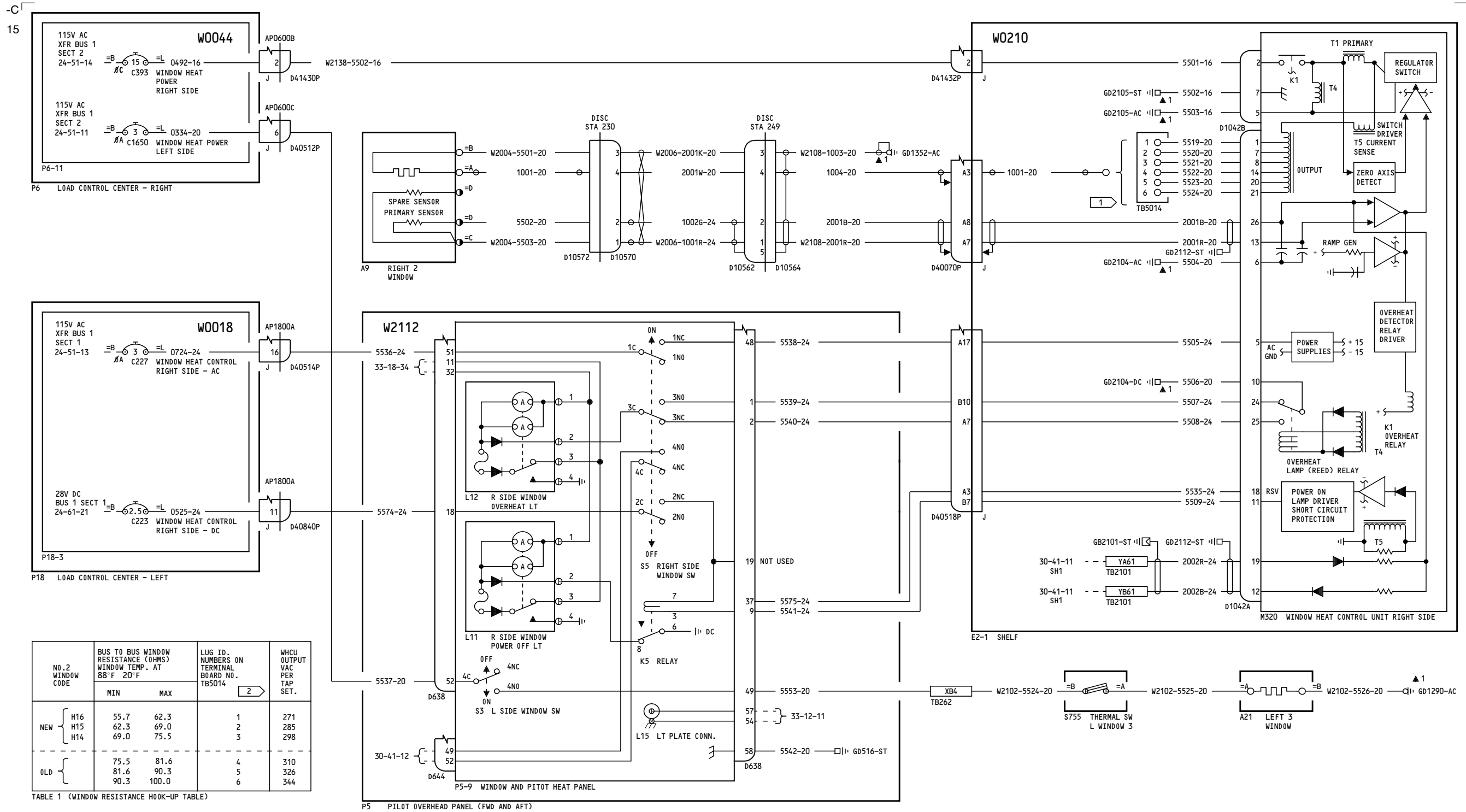

YC031-YK901

**WINDSHIELD HEAT SYSTEM - L. FRONT, R. SIDE AND OPTIONAL L3 WINDOW**

D280A103

**30-41-11**

Page 4  
Sheet 2  
Feb 09/2009

**30-41-11**

Page 4  
Sheet 2  
Feb 09/2009

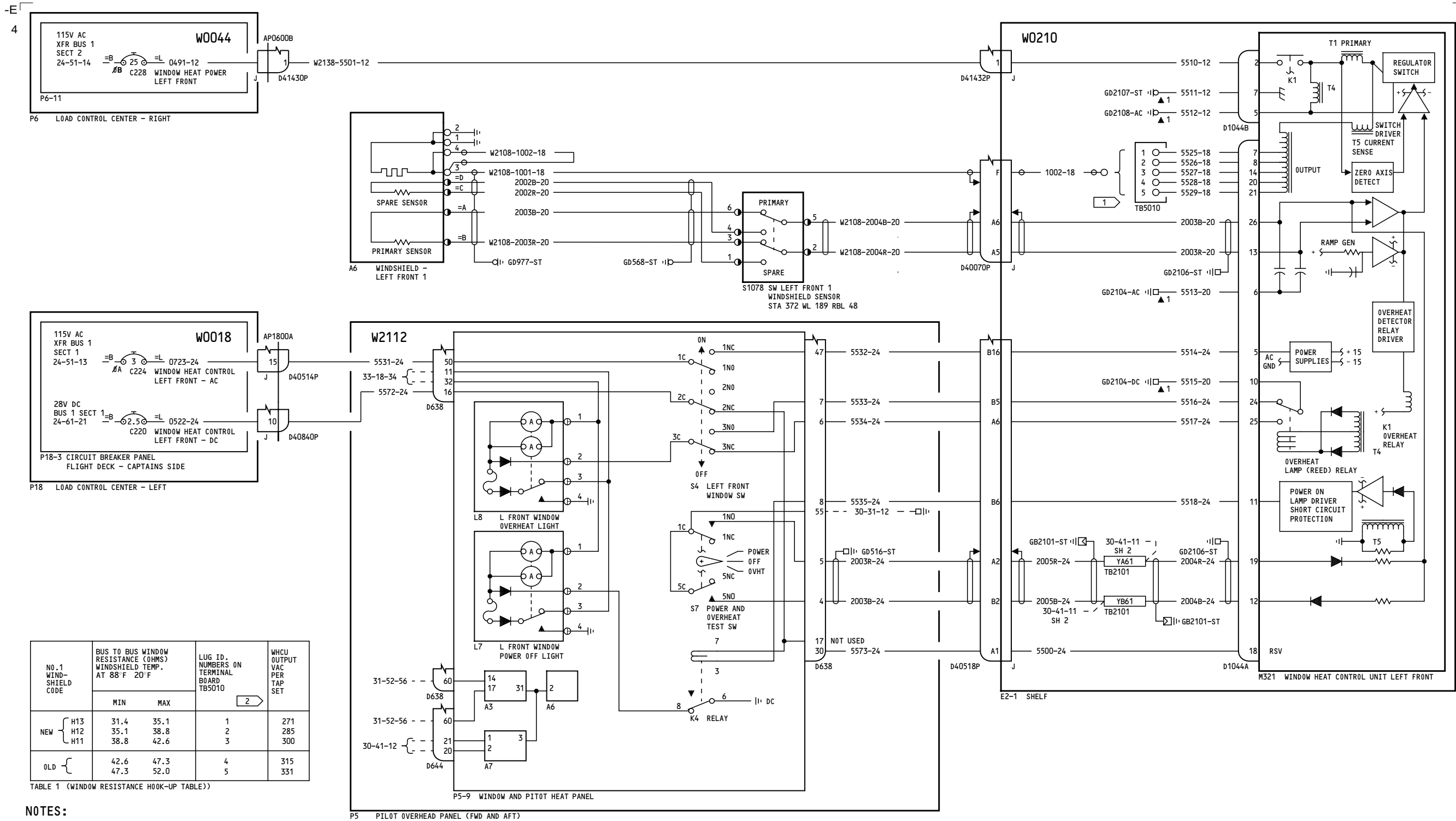

YK902-YK906

**WINDSHIELD HEAT SYSTEM - L. FRONT, R. SIDE AND OPTIONAL L3 WINDOW**

D280A103

**30-41-11**

Page 5  
Sheet 1  
Jul 26/2006

**30-41-11**

Page 5  
Sheet 1  
Jul 26/2006

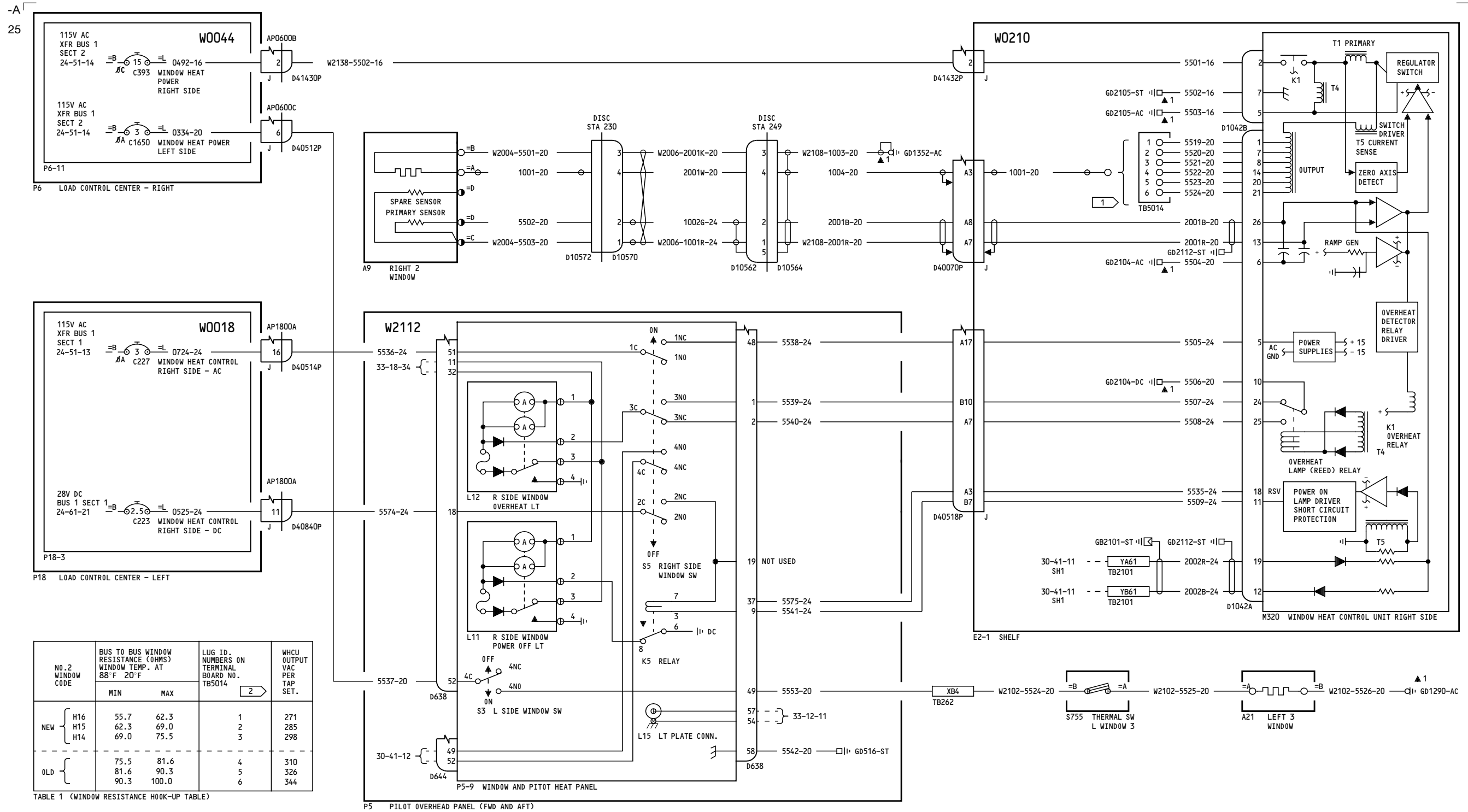

YK902-YK906

**WINDSHIELD HEAT SYSTEM - L. FRONT, R. SIDE AND OPTIONAL L3 WINDOW**

**30-41-11**

Page 5  
Sheet 2  
Feb 09/2009

D280A103

**30-41-11**

Page 5  
Sheet 2  
Feb 09/2009



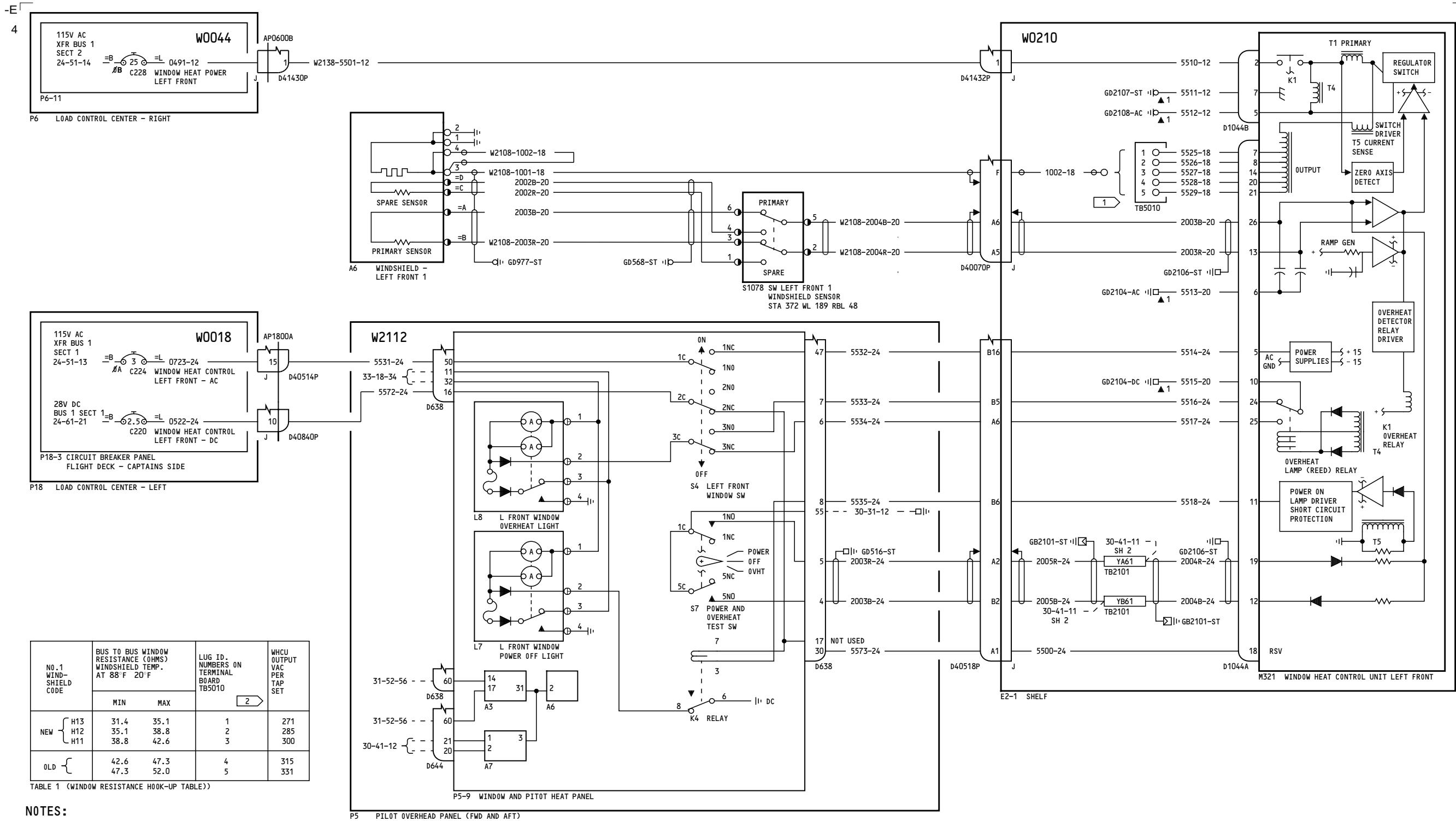

YK907-YM670

**WINDSHIELD HEAT SYSTEM - L. FRONT, R. SIDE AND OPTIONAL L3 WINDOW**

D280A103

**30-41-11**

Page 6  
Sheet 1  
Feb 09/2009

**30-41-11**

Page 6  
Sheet 1  
Feb 09/2009

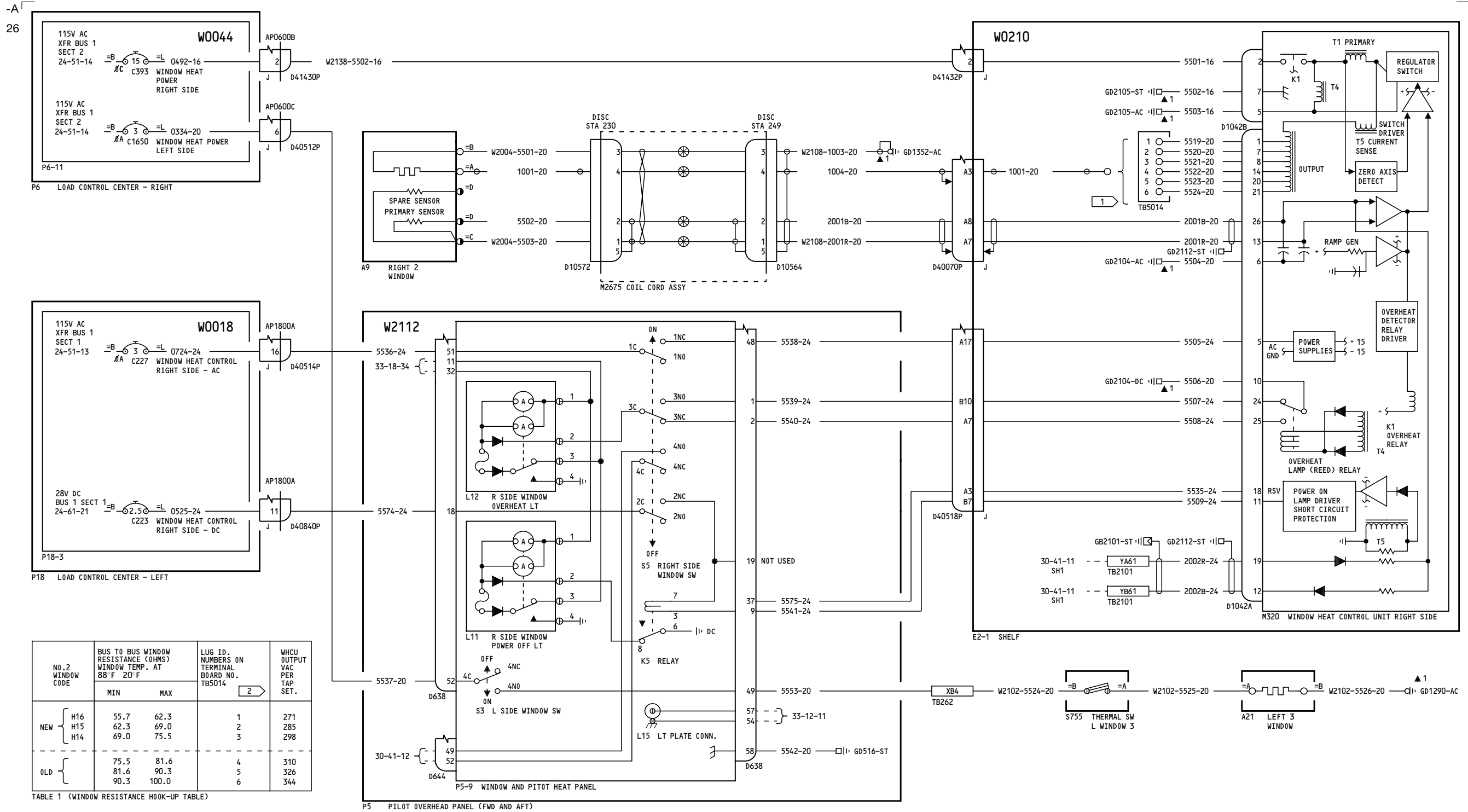

YK907-YM670

**WINDSHIELD HEAT SYSTEM - L. FRONT, R. SIDE AND OPTIONAL L3 WINDOW**

**30-41-11**

Page 6  
Sheet 2  
Feb 09/2009

D280A103

**30-41-11**

Page 6  
Sheet 2  
Feb 09/2009

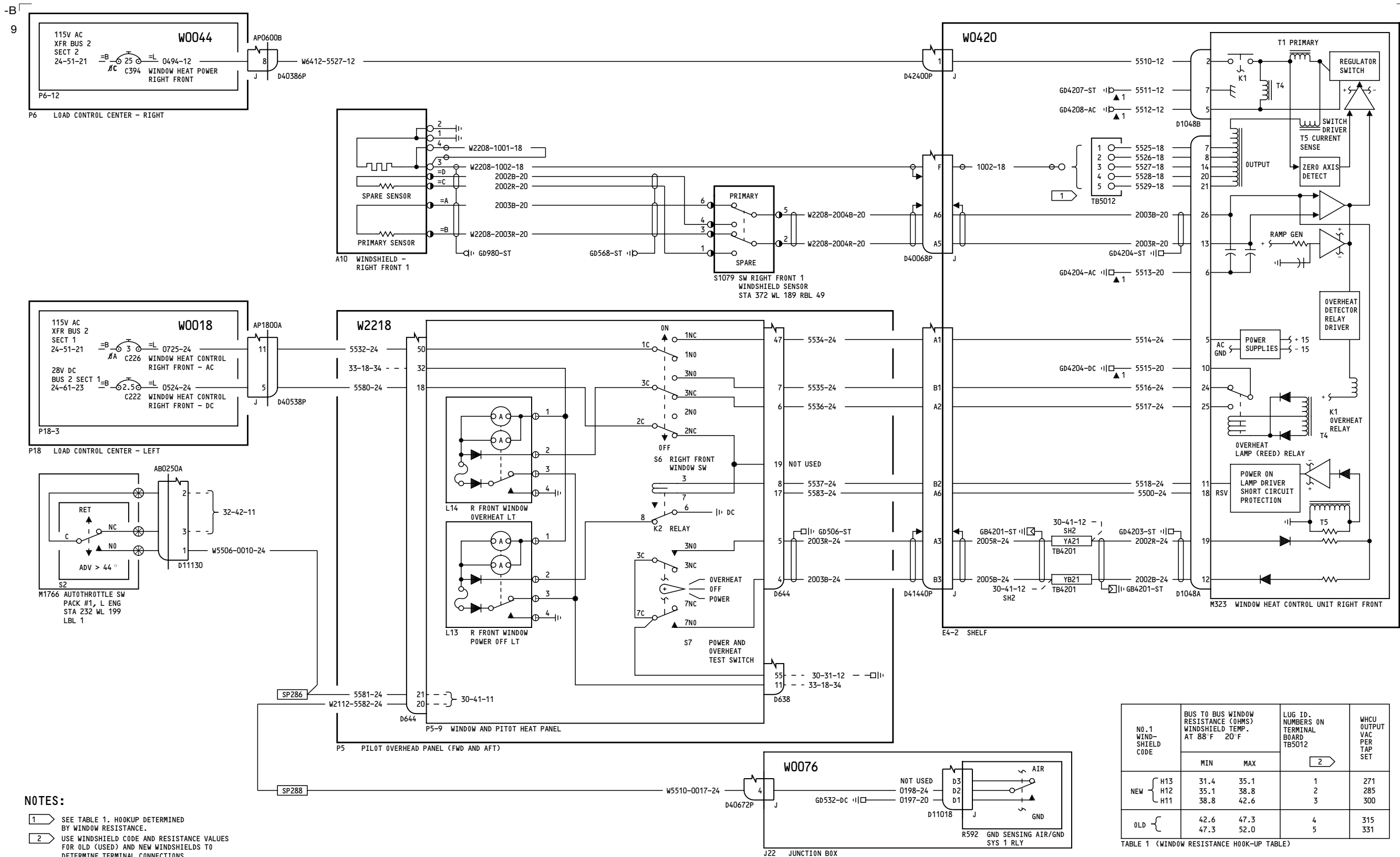

**NOTES:**

1 SEE TABLE 1. HOOKUP DETERMINED BY WINDOW RESISTANCE.

2 USE WINDSHIELD CODE AND RESISTANCE VALUES FOR OLD (USED) AND NEW WINDSHIELDS TO DETERMINE TERMINAL CONNECTIONS.

NO. 1 WINDSHIELD CODE	BUS TO BUS WINDOW RESISTANCE (OHMS) WINDSHIELD TEMP. AT 88° F 20° F		LUG ID. NUMBERS ON TERMINAL BOARD TB5012	WHCU OUTPUT VAC PER TAP SET
	MIN	MAX		
NEW { H13, H12, H11 }	31.4	35.1	1	271
	35.1	38.8	2	285
	38.8	42.6	3	300
OLD { }	42.6	47.3	4	315
	47.3	52.0	5	331

TABLE 1 (WINDOW RESISTANCE HOOK-UP TABLE)

YC001-YC003

**WINDSHIELD HEAT SYSTEM - R. FRONT, L. SIDE AND OPTIONAL R3 WINDOW**

D280A103

**30-41-12**

Page 1.1  
Sheet 1  
Jul 26/2006

Incorporates  
30-1047

**30-41-12**

Page 1.1  
Sheet 1  
Jul 26/2006

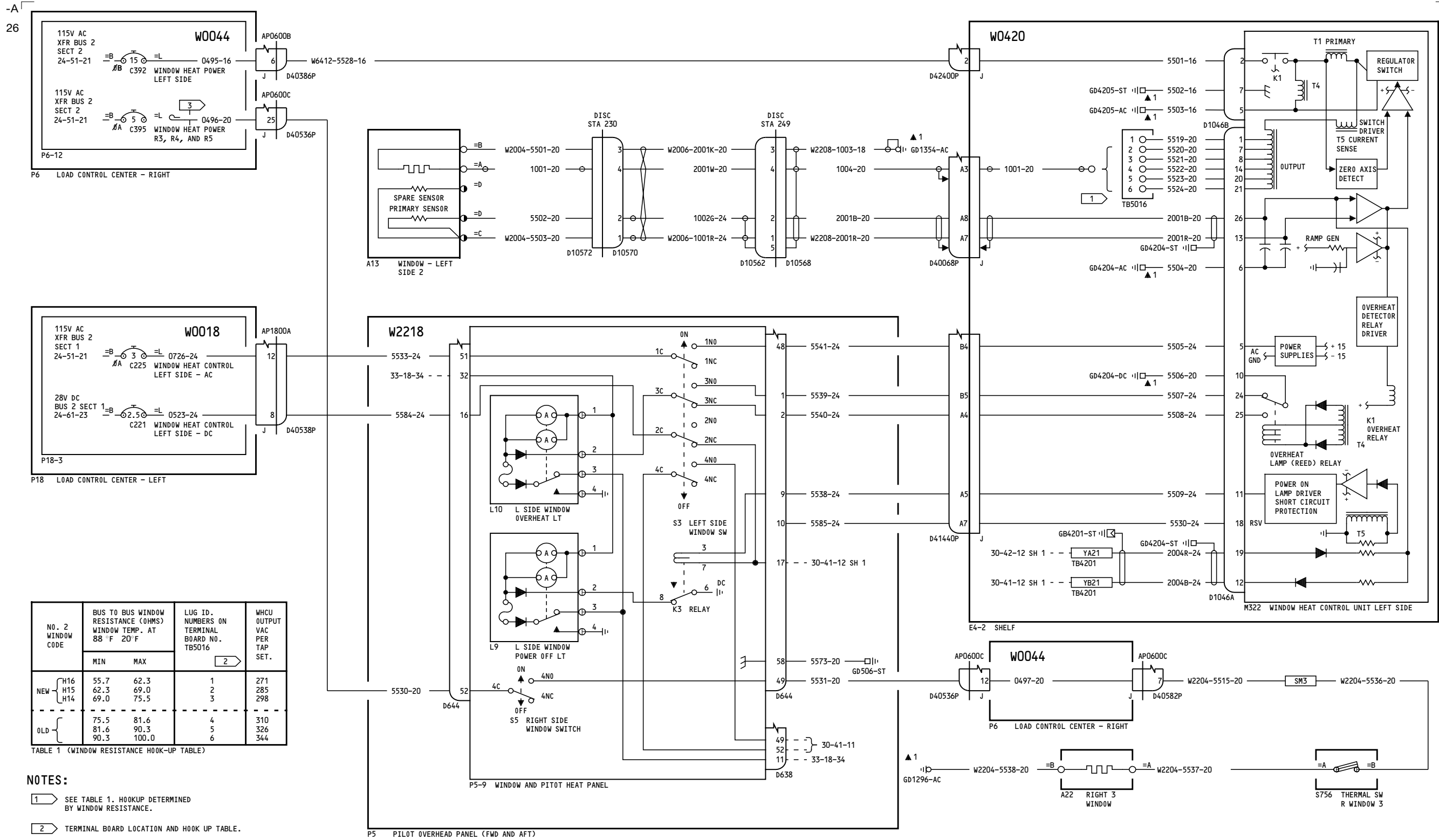

YC001-YC003

**WINDSHIELD HEAT SYSTEM - R. FRONT, L. SIDE AND OPTIONAL R3 WINDOW**

**30-41-12**

Incorporates  
30-1047  
56-1017 R01

**30-41-12**

D280A103

Page 1.1  
Sheet 2  
Aug 10/2009

Page 1.1  
Sheet 2  
Aug 10/2009

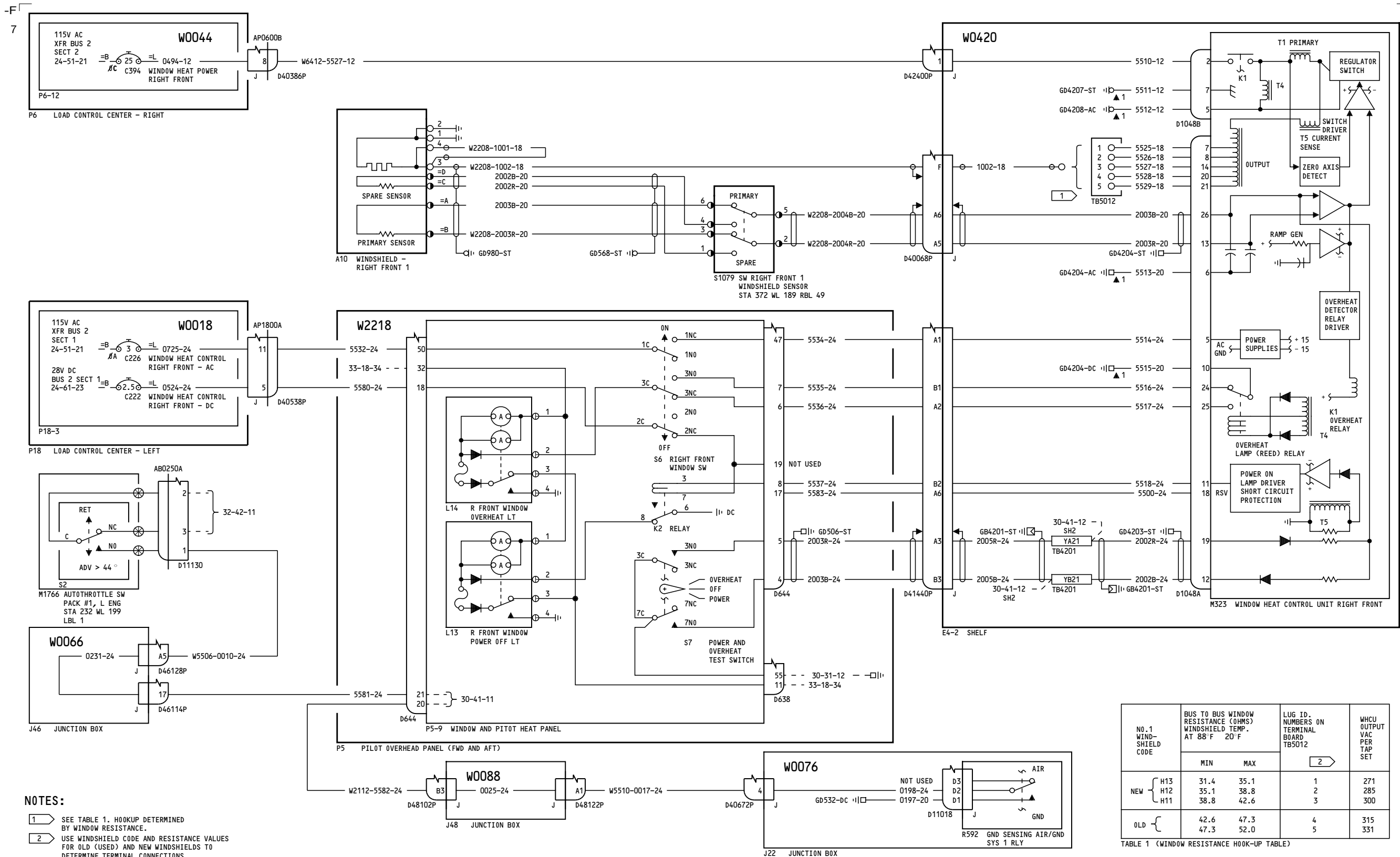

**NOTES:**

1 SEE TABLE 1. HOOKUP DETERMINED BY WINDOW RESISTANCE.

2 USE WINDSHIELD CODE AND RESISTANCE VALUES FOR OLD (USED) AND NEW WINDSHIELDS TO DETERMINE TERMINAL CONNECTIONS.

NO. 1 WINDSHIELD CODE	BUS TO BUS WINDOW RESISTANCE (OHMS) WINDSHIELD TEMP. AT 88° F 20° F		LUG ID. NUMBERS ON TERMINAL BOARD TB5012	WHCU OUTPUT VAC PER TAP SET
	MIN	MAX		
NEW { H13, H12, H11	31.4	35.1	1	271
	35.1	38.8	2	285
	38.8	42.6	3	300
OLD {	42.6	47.3	4	315
	47.3	52.0	5	331

TABLE 1 (WINDOW RESISTANCE HOOK-UP TABLE)

YC004-YC007

**WINDSHIELD HEAT SYSTEM - R. FRONT, L. SIDE AND OPTIONAL R3 WINDOW**

D280A103

**30-41-12**

Page 2.1  
Sheet 1  
Jul 26/2006

Incorporates  
30-1047

**30-41-12**

Page 2.1  
Sheet 1  
Jul 26/2006

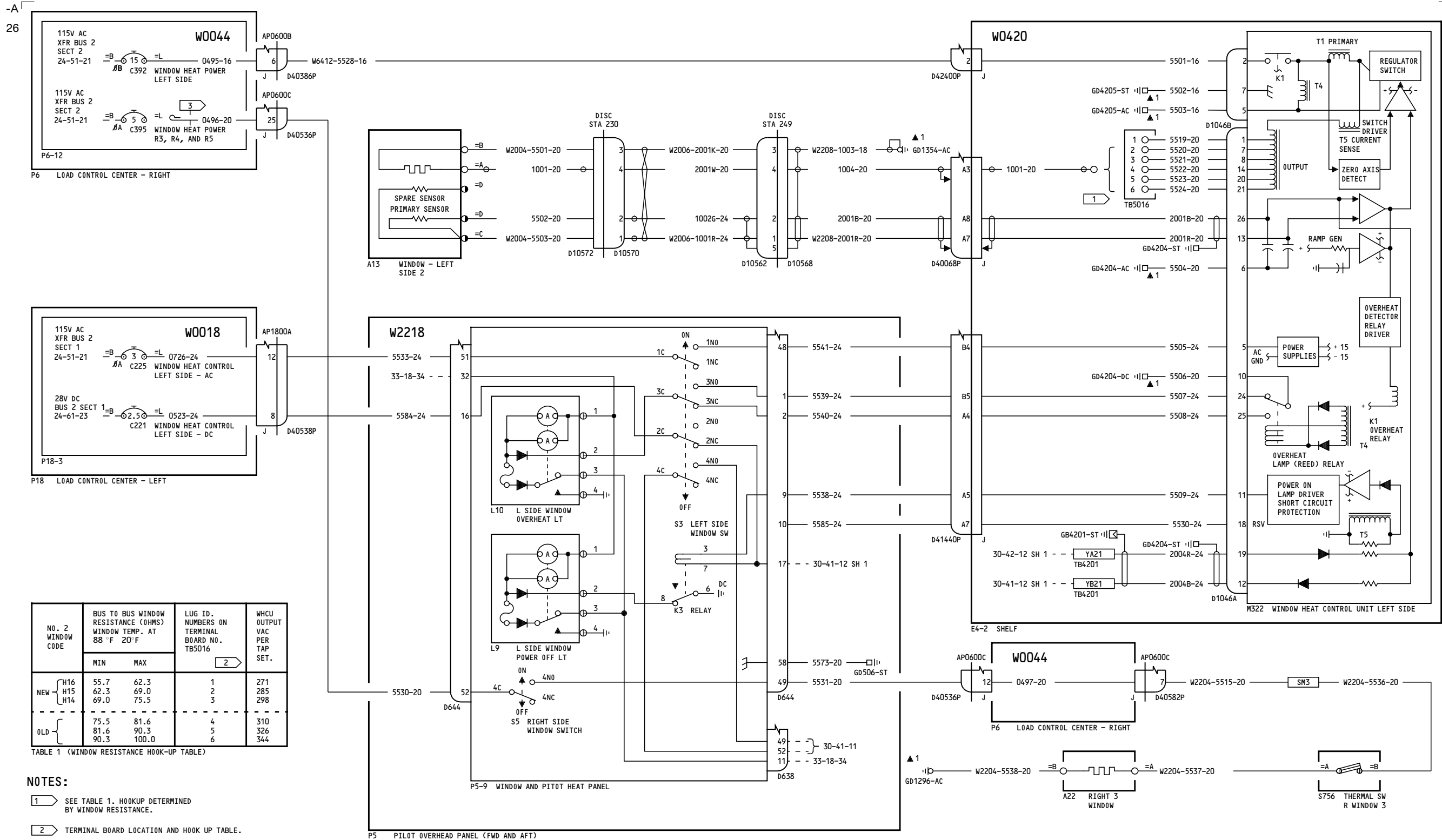

NO. 2 WINDOW CODE	BUS TO BUS WINDOW RESISTANCE (OHMS) WINDOW TEMP. AT 88 °F 20 °F		LUG ID. NUMBERS ON TERMINAL BOARD NO. TB5016	WHCU OUTPUT VAC PER TAP SET.	
	MIN	MAX			
NEW	H16	55.7	62.3	1	271
	H15	62.3	69.0	2	285
	H14	69.0	75.5	3	298
OLD		75.5	81.6	4	310
		81.6	90.3	5	326
		90.3	100.0	6	344

TABLE 1 (WINDOW RESISTANCE HOOK-UP TABLE)

- NOTES:**
- 1 SEE TABLE 1. HOOKUP DETERMINED BY WINDOW RESISTANCE.
  - 2 TERMINAL BOARD LOCATION AND HOOK UP TABLE.
  - 3 CAP AND STOW NEAR C395

YC004-YC007

**WINDSHIELD HEAT SYSTEM - R. FRONT, L. SIDE AND OPTIONAL R3 WINDOW**

**30-41-12**

Page 2.1  
Sheet 2  
Aug 10/2009

D280A103

Incorporates  
30-1047  
56-1017 R01

**30-41-12**

Page 2.1  
Sheet 2  
Aug 10/2009

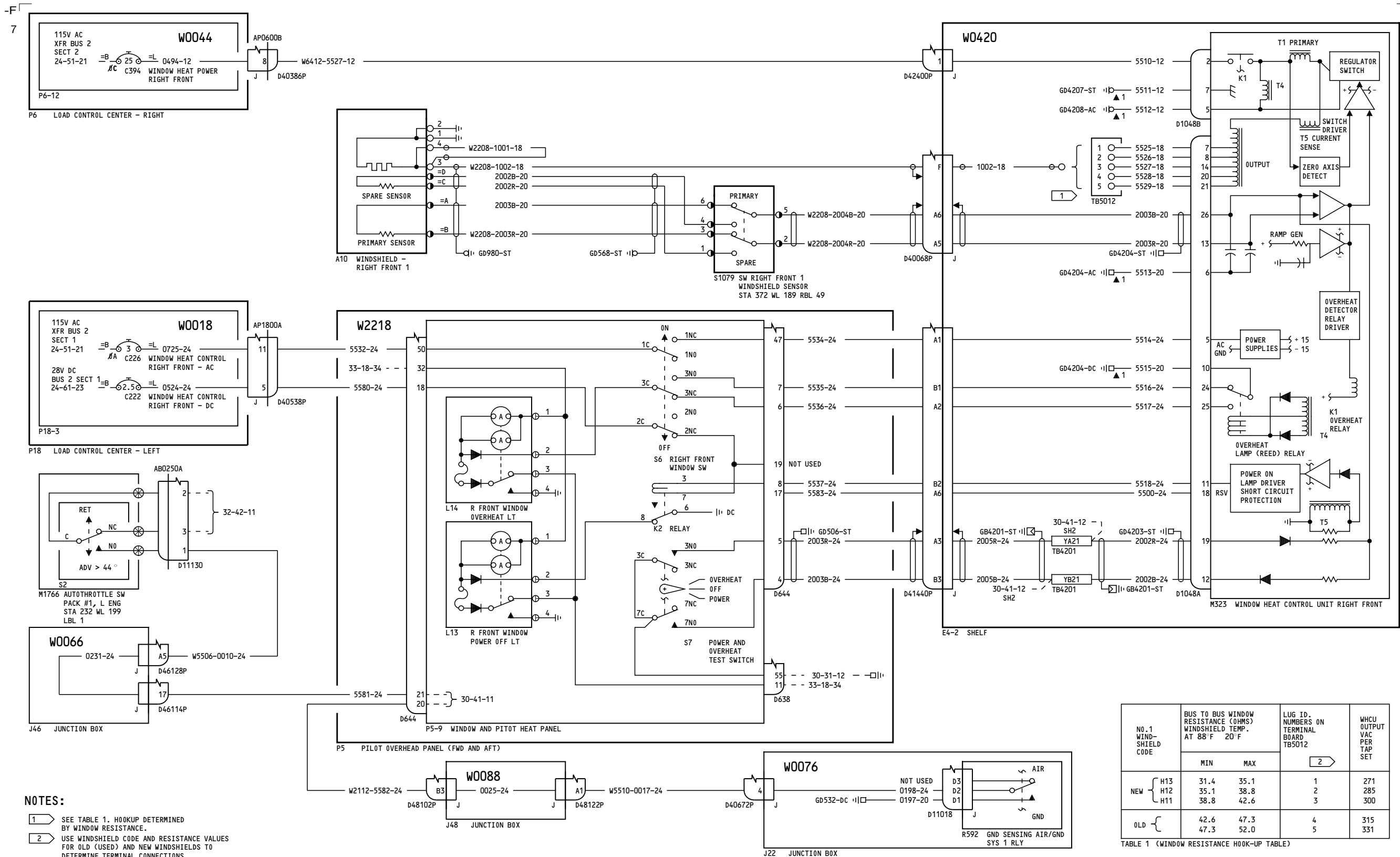

**NOTES:**

1 SEE TABLE 1. HOOKUP DETERMINED BY WINDOW RESISTANCE.

2 USE WINDSHIELD CODE AND RESISTANCE VALUES FOR OLD (USED) AND NEW WINDSHIELDS TO DETERMINE TERMINAL CONNECTIONS.

NO. 1 WINDSHIELD CODE	BUS TO BUS WINDOW RESISTANCE (OHMS) WINDSHIELD TEMP. AT 88° F 20° F		LUG ID. NUMBERS ON TERMINAL BOARD TB5012	WHCU OUTPUT VAC PER TAP SET
	MIN	MAX		
NEW { H13 H12 H11	31.4	35.1	1	271
	35.1	38.8	2	285
	38.8	42.6	3	300
OLD {	42.6	47.3	4	315
	47.3	52.0	5	331

TABLE 1 (WINDOW RESISTANCE HOOK-UP TABLE)

YC008-YC009

**WINDSHIELD HEAT SYSTEM - R. FRONT, L. SIDE AND OPTIONAL R3 WINDOW**

D280A103

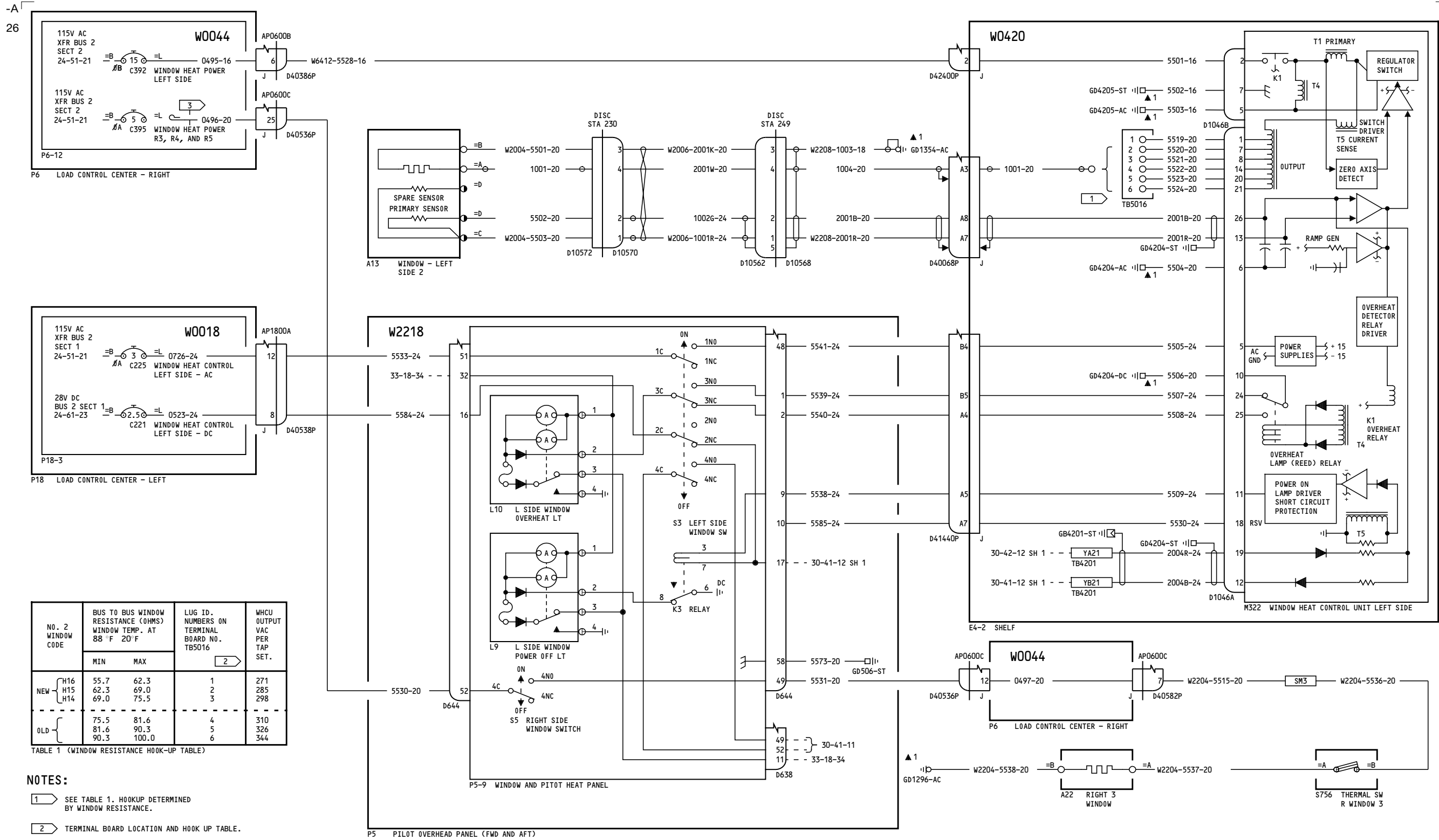

NO. 2 WINDOW CODE	BUS TO BUS WINDOW RESISTANCE (OHMS) WINDOW TEMP. AT 88 °F 20 °F		LUG ID. NUMBERS ON TERMINAL BOARD NO. TB5016	WHCU OUTPUT VAC PER TAP SET.	
	MIN	MAX			
NEW	H16	55.7	62.3	1	271
	H15	62.3	69.0	2	285
	H14	69.0	75.5	3	298
OLD		75.5	81.6	4	310
		81.6	90.3	5	326
		90.3	100.0	6	344

TABLE 1 (WINDOW RESISTANCE HOOK-UP TABLE)

- NOTES:**
- 1 SEE TABLE 1. HOOKUP DETERMINED BY WINDOW RESISTANCE.
  - 2 TERMINAL BOARD LOCATION AND HOOK UP TABLE.
  - 3 CAP AND STOW NEAR C395

YC008-YC009

**WINDSHIELD HEAT SYSTEM - R. FRONT, L. SIDE AND OPTIONAL R3 WINDOW**

D280A103

**30-41-12**

Page 3.1  
Sheet 2  
Feb 09/2009

Incorporates  
56-1017 R01

**30-41-12**

Page 3.1  
Sheet 2  
Feb 09/2009



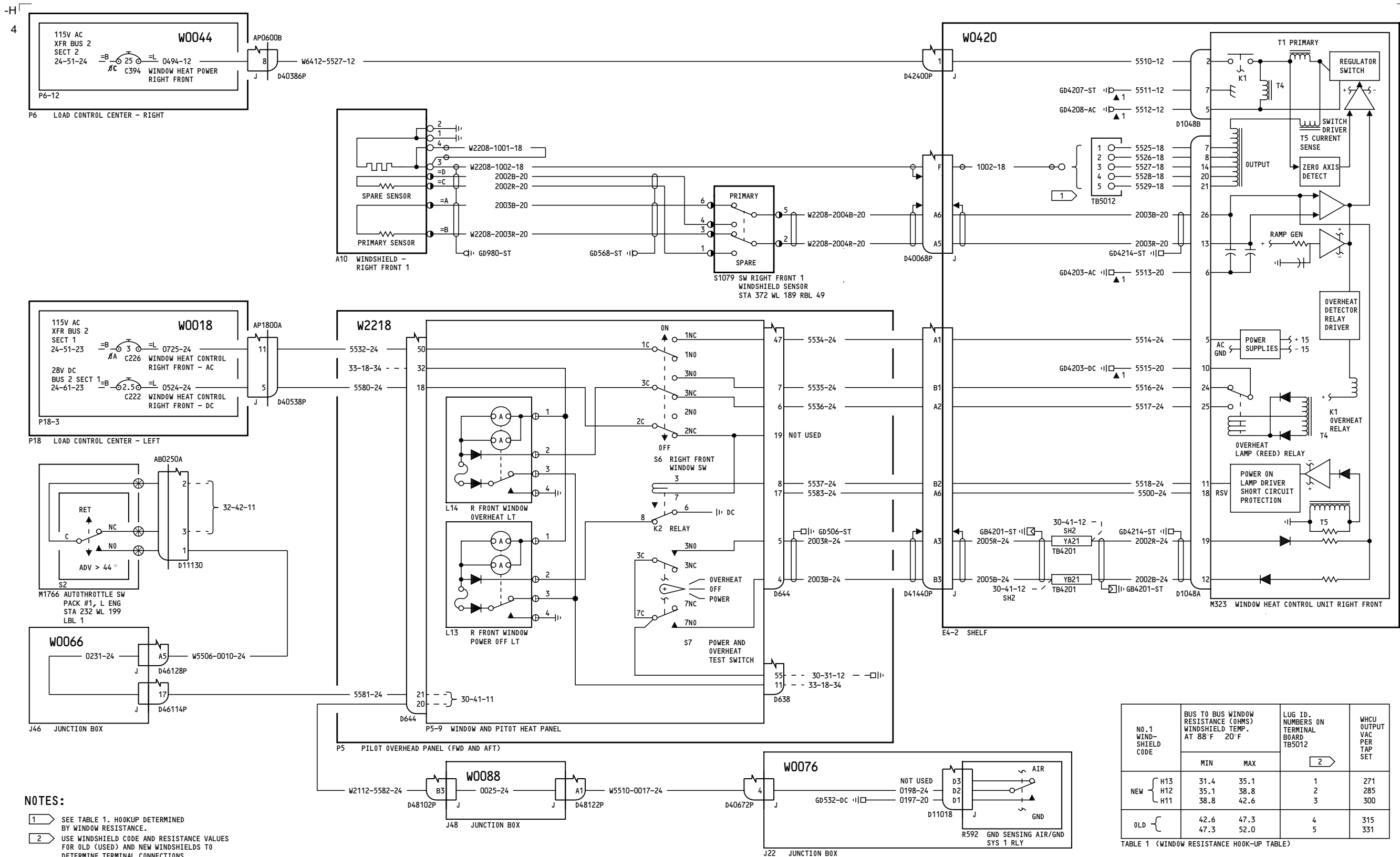

**NOTES:**

1 SEE TABLE 1. HOOKUP DETERMINED BY WINDOW RESISTANCE.

2 USE WINDSHIELD CODE AND RESISTANCE VALUES FOR OLD (USED) AND NEW WINDSHIELDS TO DETERMINE TERMINAL CONNECTIONS.

NO. 1 WINDSHIELD CODE	BUS TO BUS WINDOW RESISTANCE (OHMS) WINDSHIELD TEMP. AT 88° F 20° F		LUG ID. NUMBERS ON TERMINAL BOARD TB5012	WHCU OUTPUT VAC PER TAP SET
	MIN	MAX		
NEW { H13, H12, H11	31.4	35.1	1	271
	35.1	38.8	2	285
	38.8	42.6	3	300
OLD {	42.6	47.3	4	315
	47.3	52.0	5	331

TABLE 1 (WINDOW RESISTANCE HOOK-UP TABLE)

YC010-YC030

**WINDSHIELD HEAT SYSTEM - R. FRONT, L. SIDE AND OPTIONAL R3 WINDOW**

**30-41-12**

D280A103

Page 4.1  
Sheet 1  
May 13/2008

**30-41-12**

Page 4.1  
Sheet 1  
May 13/2008

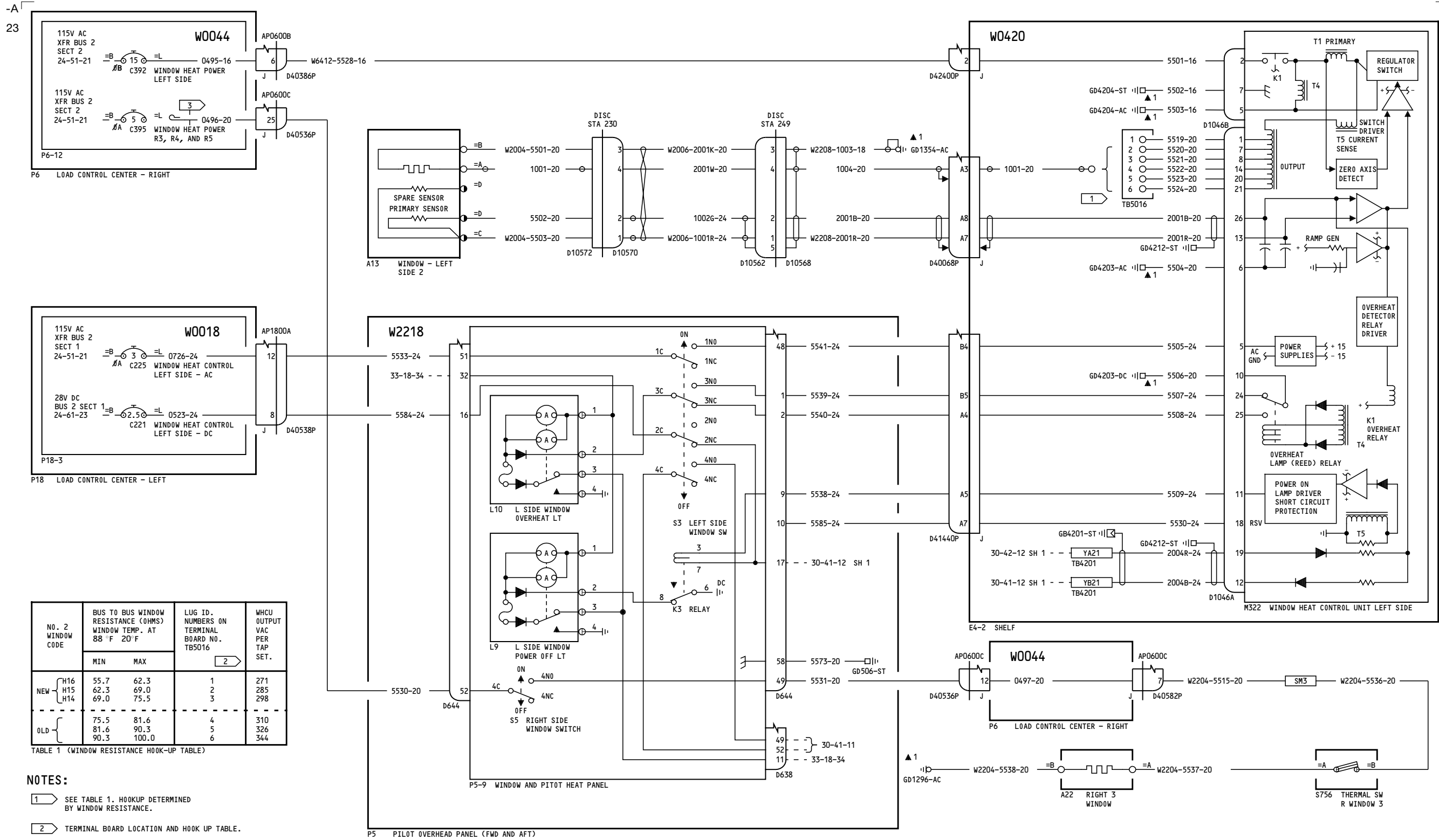

YC010-YC030

**WINDSHIELD HEAT SYSTEM - R. FRONT, L. SIDE AND OPTIONAL R3 WINDOW**

**30-41-12**

Incorporates  
56-1017 R01

**30-41-12**

D280A103

Page 4.1  
Sheet 2  
Feb 09/2009

Page 4.1  
Sheet 2  
Feb 09/2009

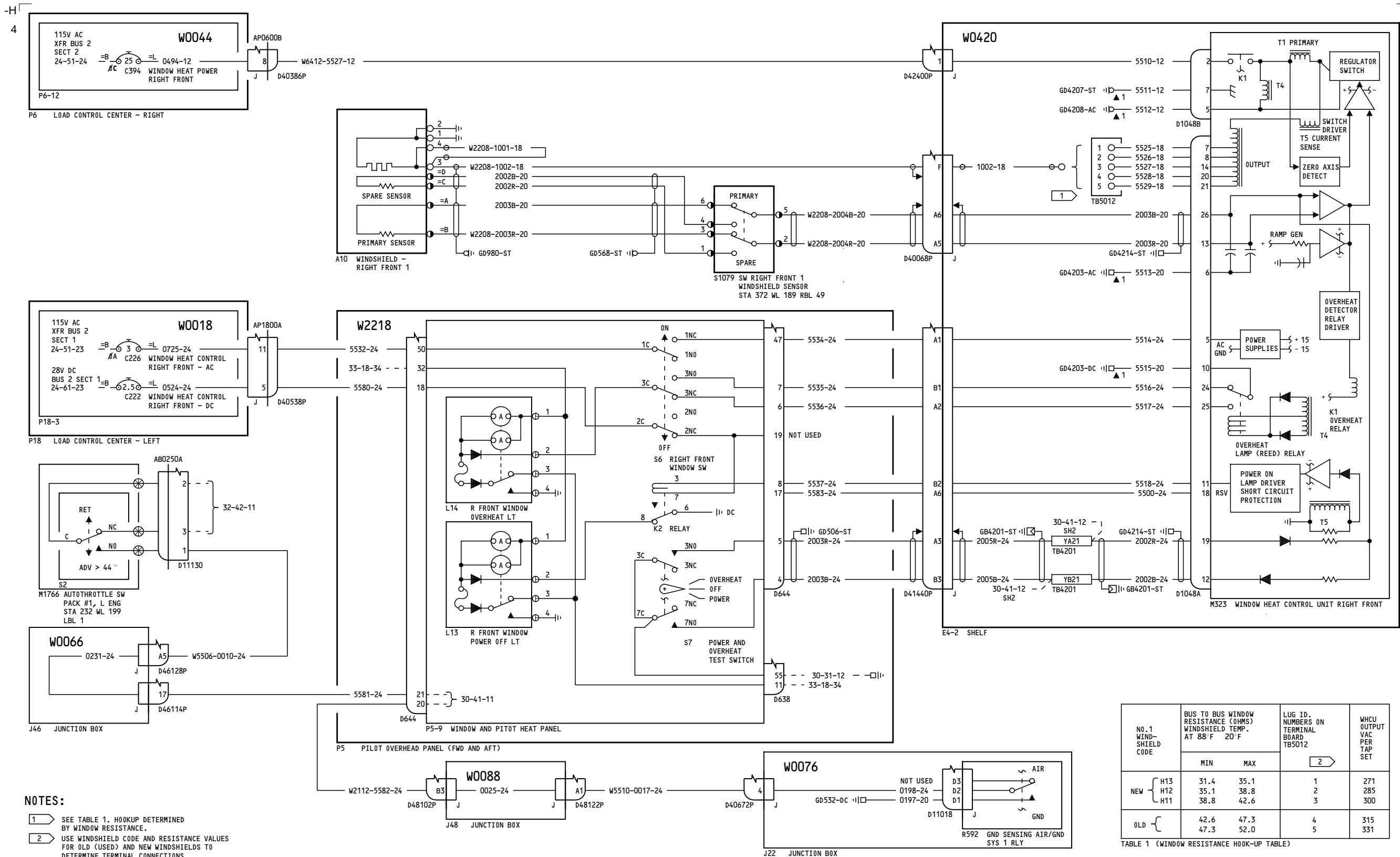

**NOTES:**

1 SEE TABLE 1. HOOKUP DETERMINED BY WINDOW RESISTANCE.

2 USE WINDSHIELD CODE AND RESISTANCE VALUES FOR OLD (USED) AND NEW WINDSHIELDS TO DETERMINE TERMINAL CONNECTIONS.

NO. 1 WINDSHIELD CODE	BUS TO BUS WINDOW RESISTANCE (OHMS) WINDSHIELD TEMP. AT 88° F 20° F		LUG ID. NUMBERS ON TERMINAL BOARD TB5012	WHCU OUTPUT VAC PER TAP SET
	MIN	MAX		
NEW { H13 H12 H11	31.4	35.1	1	271
	35.1	38.8	2	285
	38.8	42.6	3	300
OLD {	42.6	47.3	4	315
	47.3	52.0	5	331

TABLE 1 (WINDOW RESISTANCE HOOK-UP TABLE)

YC031-YK906

**WINDSHIELD HEAT SYSTEM - R. FRONT, L. SIDE AND OPTIONAL R3 WINDOW**

**30-41-12**

D280A103

Page 5  
Sheet 1  
Jul 26/2006

**30-41-12**

Page 5  
Sheet 1  
Jul 26/2006

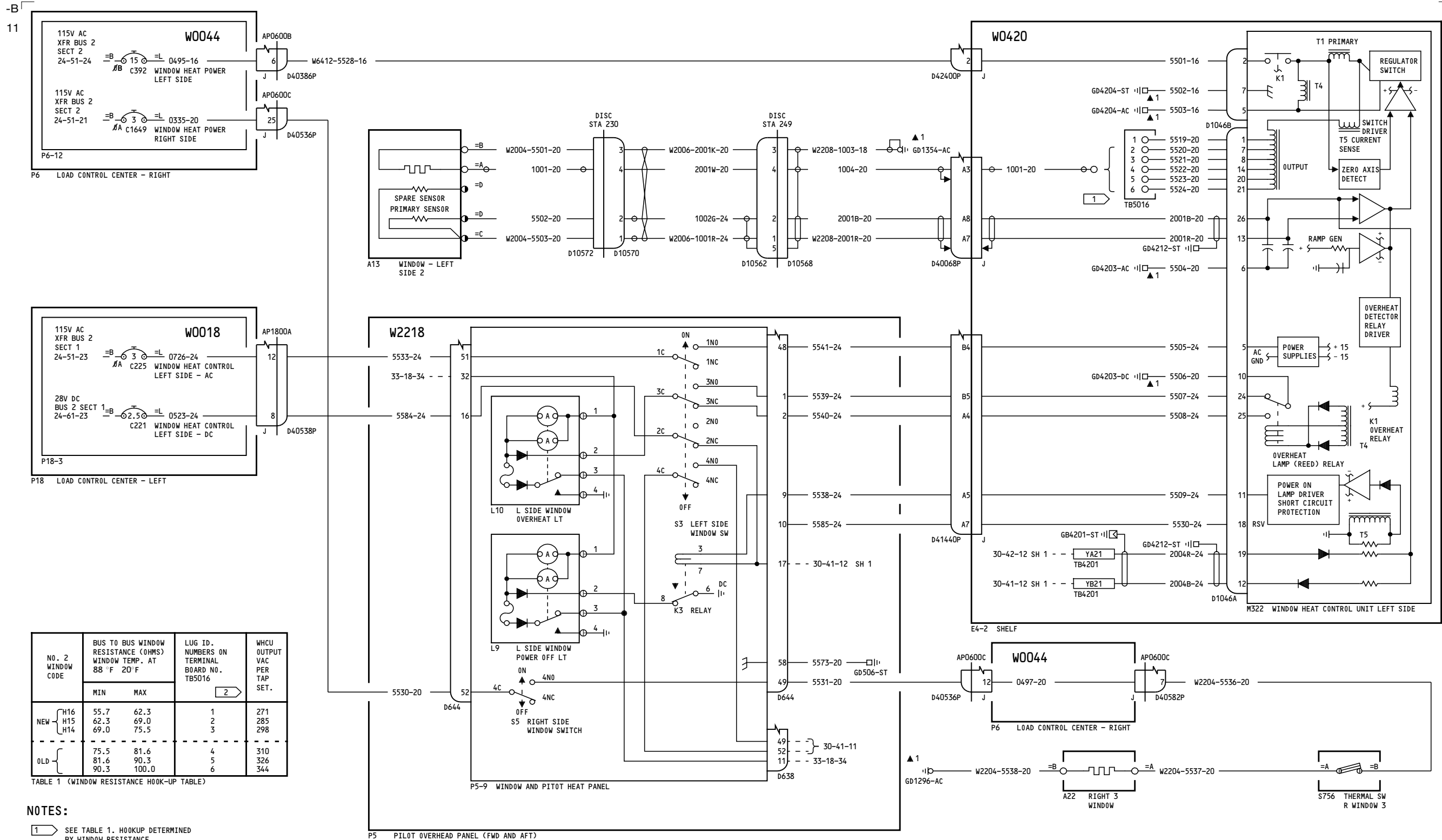

YC031-YK906

**WINDSHIELD HEAT SYSTEM - R. FRONT, L. SIDE AND OPTIONAL R3 WINDOW**

D280A103

**30-41-12**

Page 5  
Sheet 2  
Feb 09/2009

**30-41-12**

Page 5  
Sheet 2  
Feb 09/2009

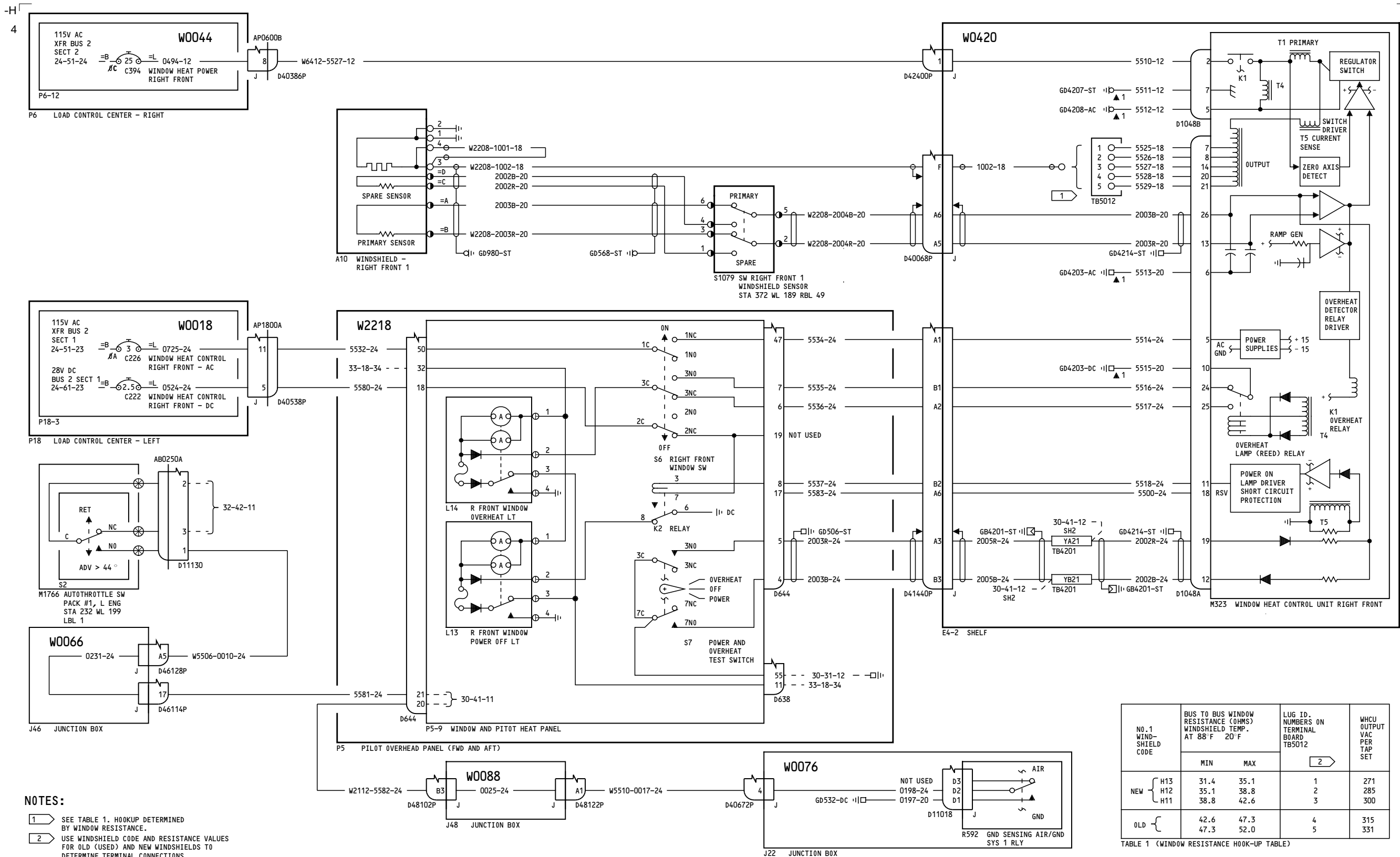

**NOTES:**

1 SEE TABLE 1. HOOKUP DETERMINED BY WINDOW RESISTANCE.

2 USE WINDSHIELD CODE AND RESISTANCE VALUES FOR OLD (USED) AND NEW WINDSHIELDS TO DETERMINE TERMINAL CONNECTIONS.

NO. 1 WINDSHIELD CODE	BUS TO BUS WINDOW RESISTANCE (OHMS) WINDSHIELD TEMP. AT 88° F 20° F		LUG ID. NUMBERS ON TERMINAL BOARD TB5012	WHCU OUTPUT VAC PER TAP SET
	MIN	MAX		
NEW { H13 H12 H11	31.4	35.1	1	271
	35.1	38.8	2	285
	38.8	42.6	3	300
OLD {	42.6	47.3	4	315
	47.3	52.0	5	331

TABLE 1 (WINDOW RESISTANCE HOOK-UP TABLE)

YK907-YM670

**WINDSHIELD HEAT SYSTEM - R. FRONT, L. SIDE AND OPTIONAL R3 WINDOW**

**30-41-12**

D280A103

Page 6  
Sheet 1  
Feb 09/2009

**30-41-12**

Page 6  
Sheet 1  
Feb 09/2009

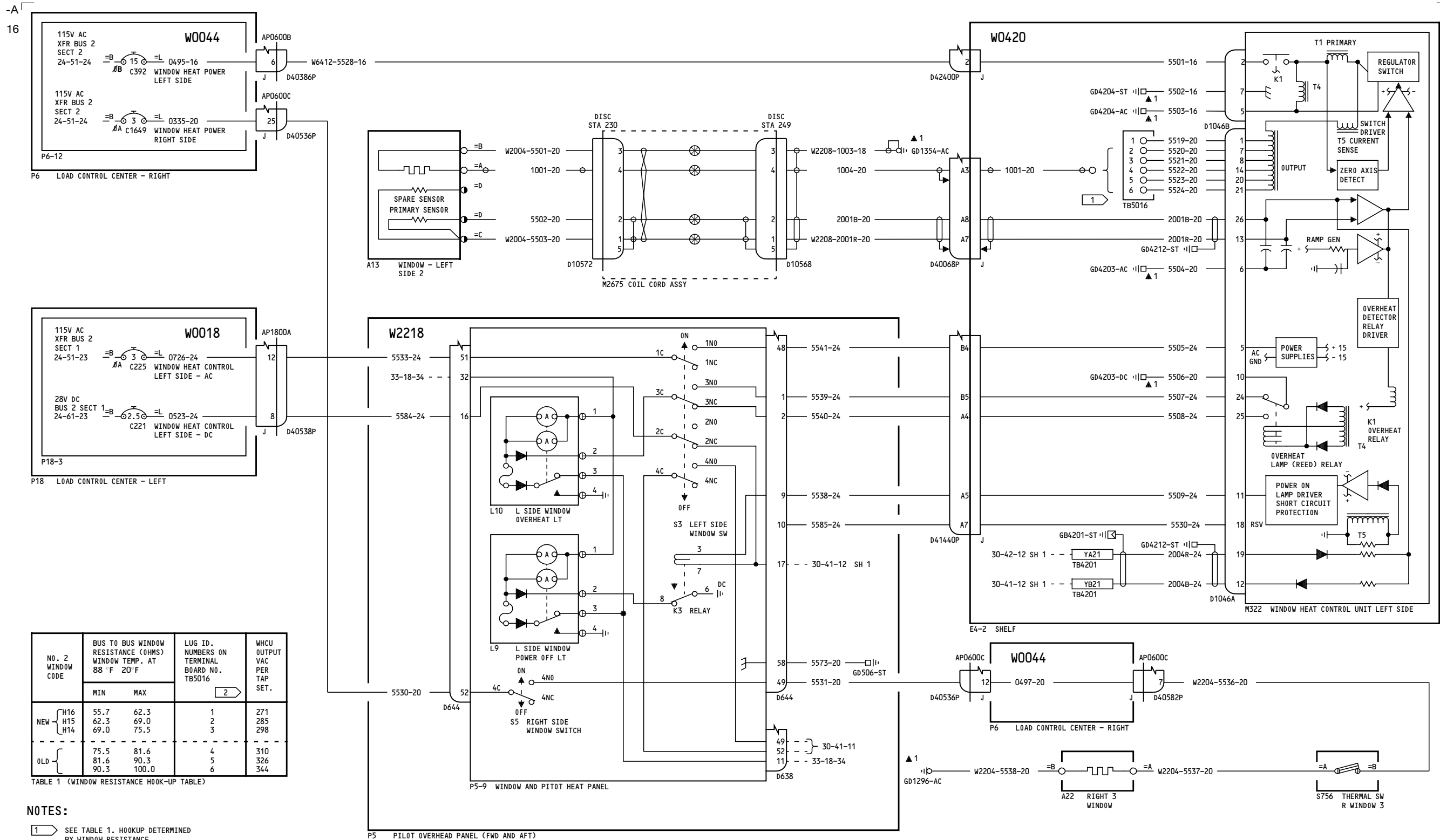

YK907-YM670

**WINDSHIELD HEAT SYSTEM - R. FRONT, L. SIDE AND OPTIONAL R3 WINDOW**

D280A103

**30-41-12**

Page 6  
Sheet 2  
Feb 09/2009

**30-41-12**

Page 6  
Sheet 2  
Feb 09/2009

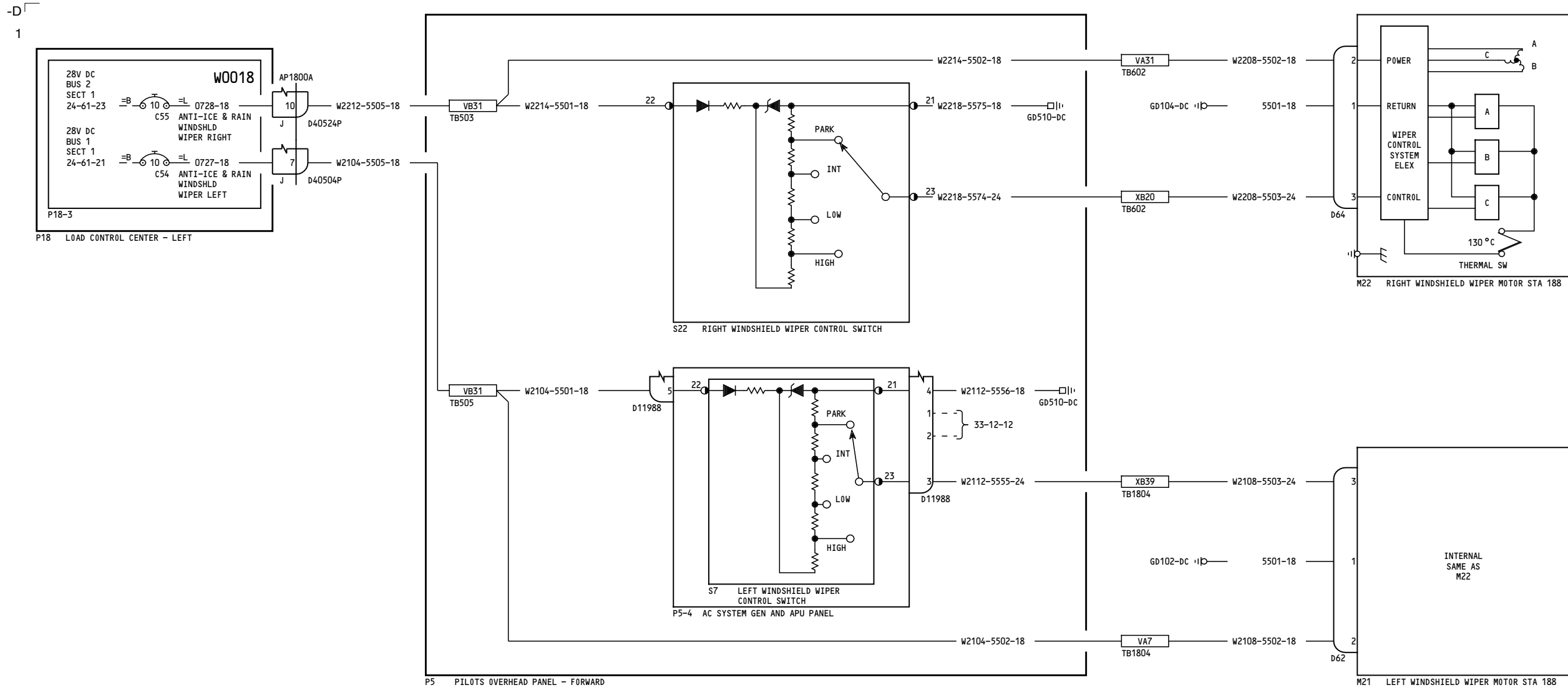

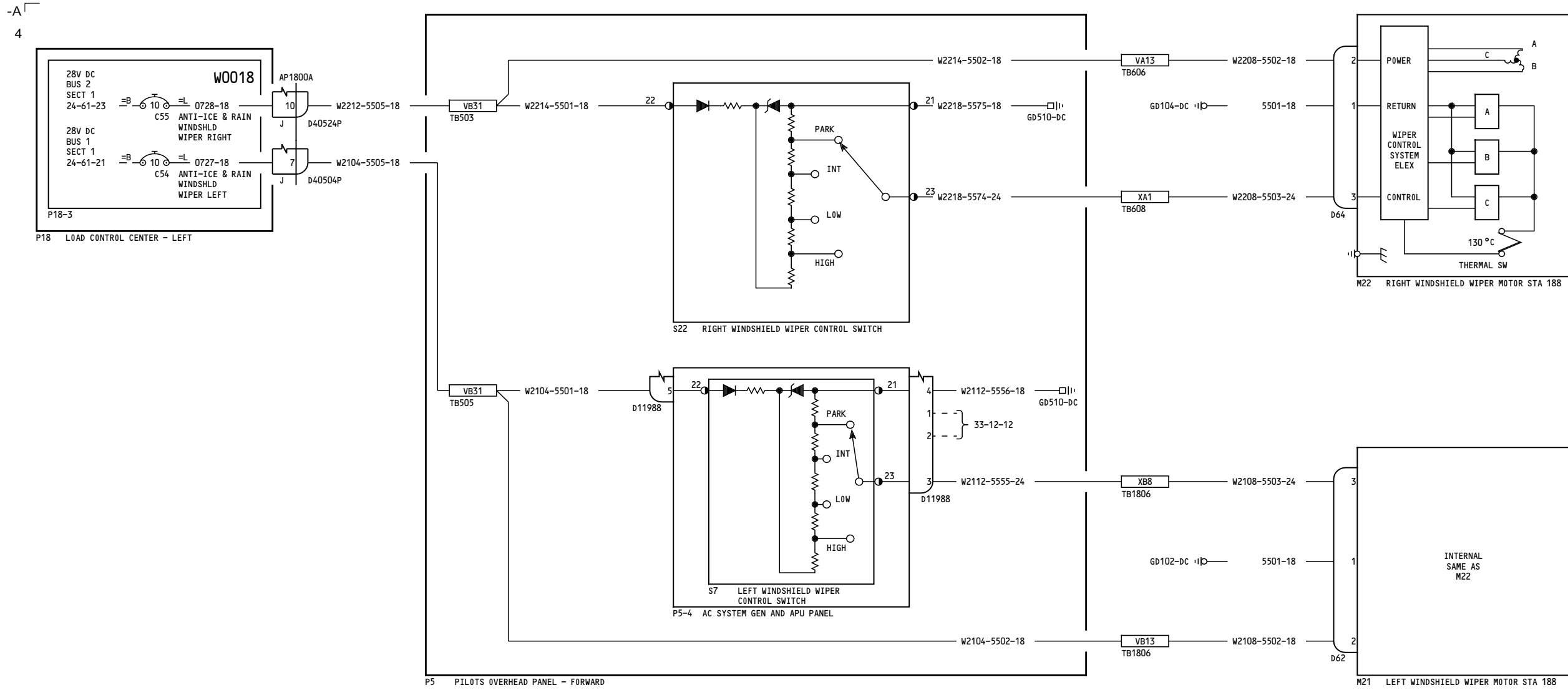



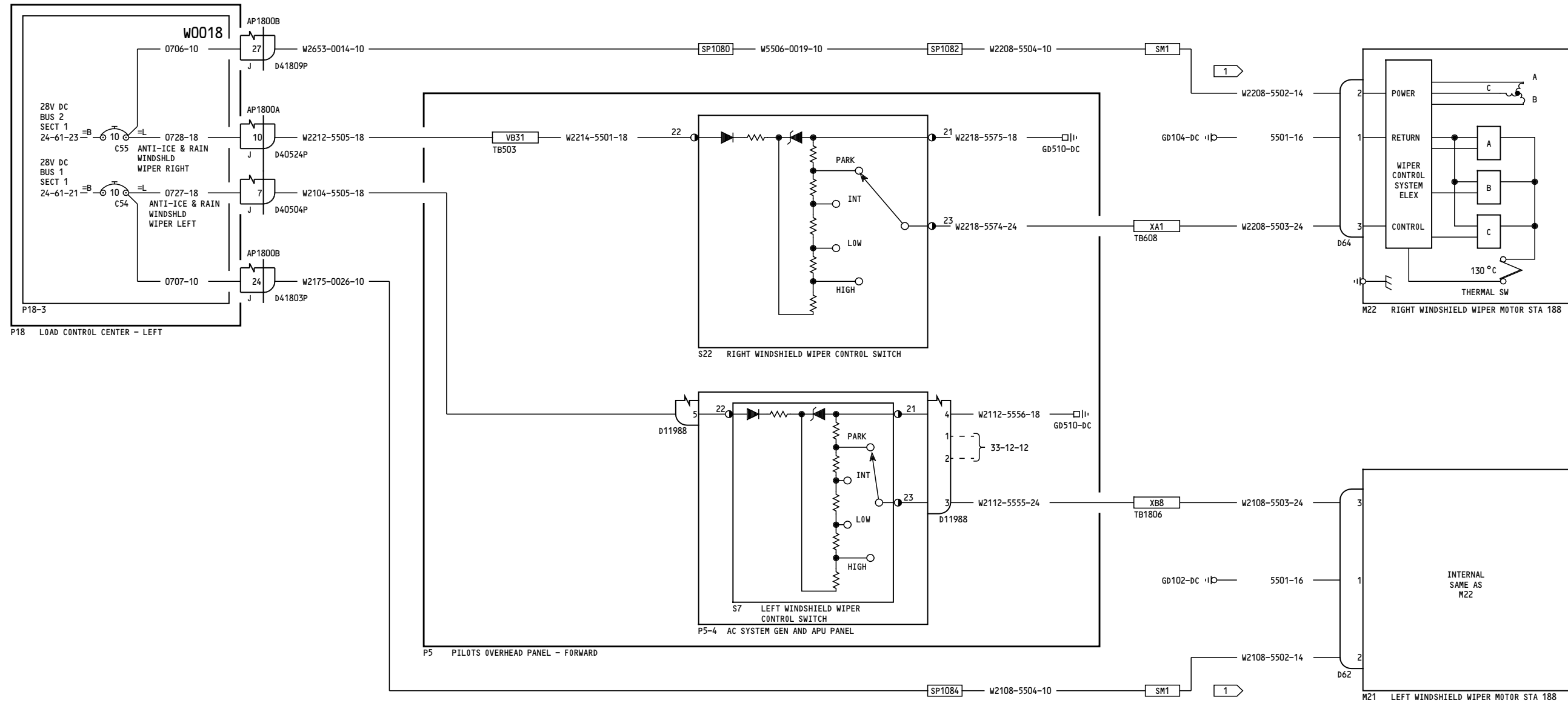

**NOTES:**

① WIRE GAGE REDUCED TO MEET CONNECTOR REQUIREMENTS. MAINTAIN 1 FT MAXIMUM LENGTH.

YC020-YM670

**WINDSHIELD WIPERS**

**30-42-11**

Page 3

Feb 09/2009

D280A103

**30-42-11**

Page 3

Feb 09/2009

-N  
6

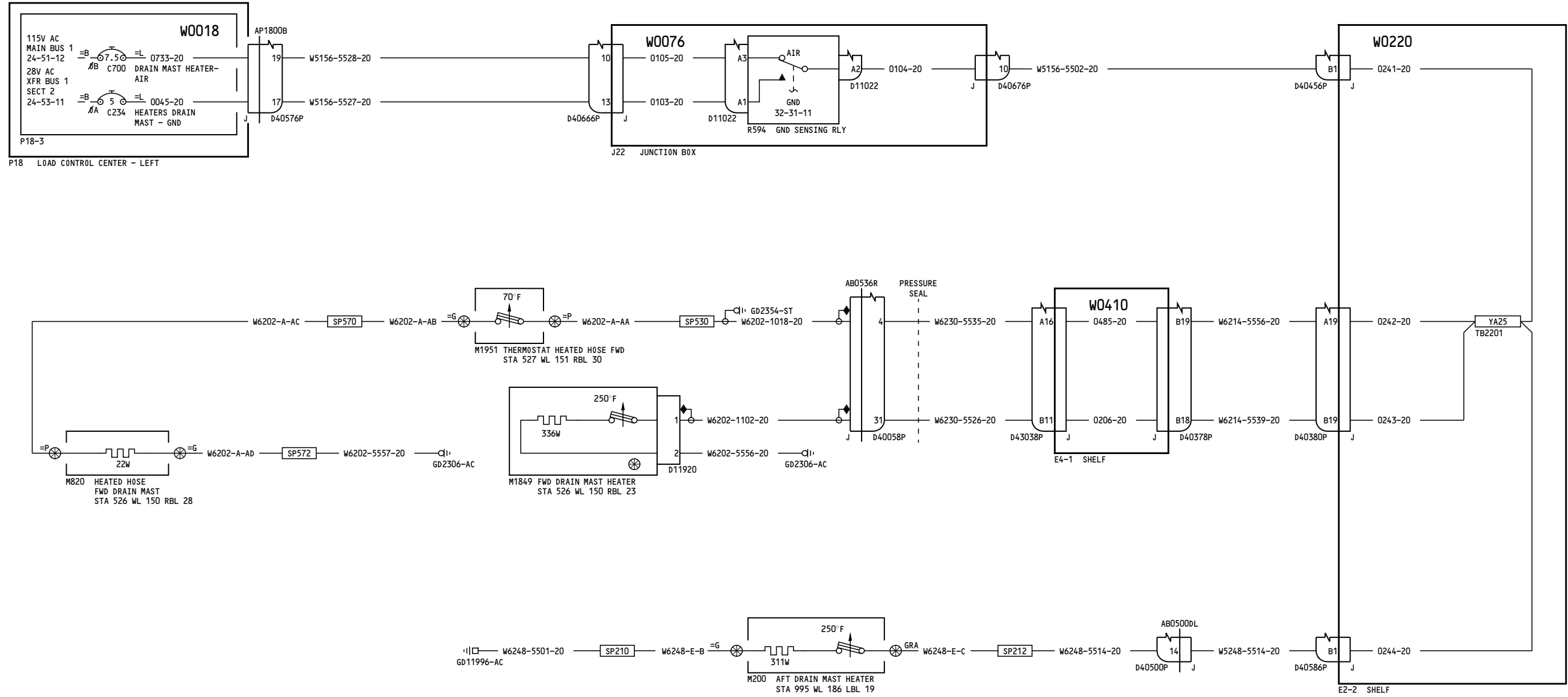

YC001-YC007

**DRAIN HEATERS**

D280A103

**30-71-11**

Page 1  
Sheet 1  
Jul 26/2006

**30-71-11**

Page 1  
Sheet 1  
Jul 26/2006

-T  
1

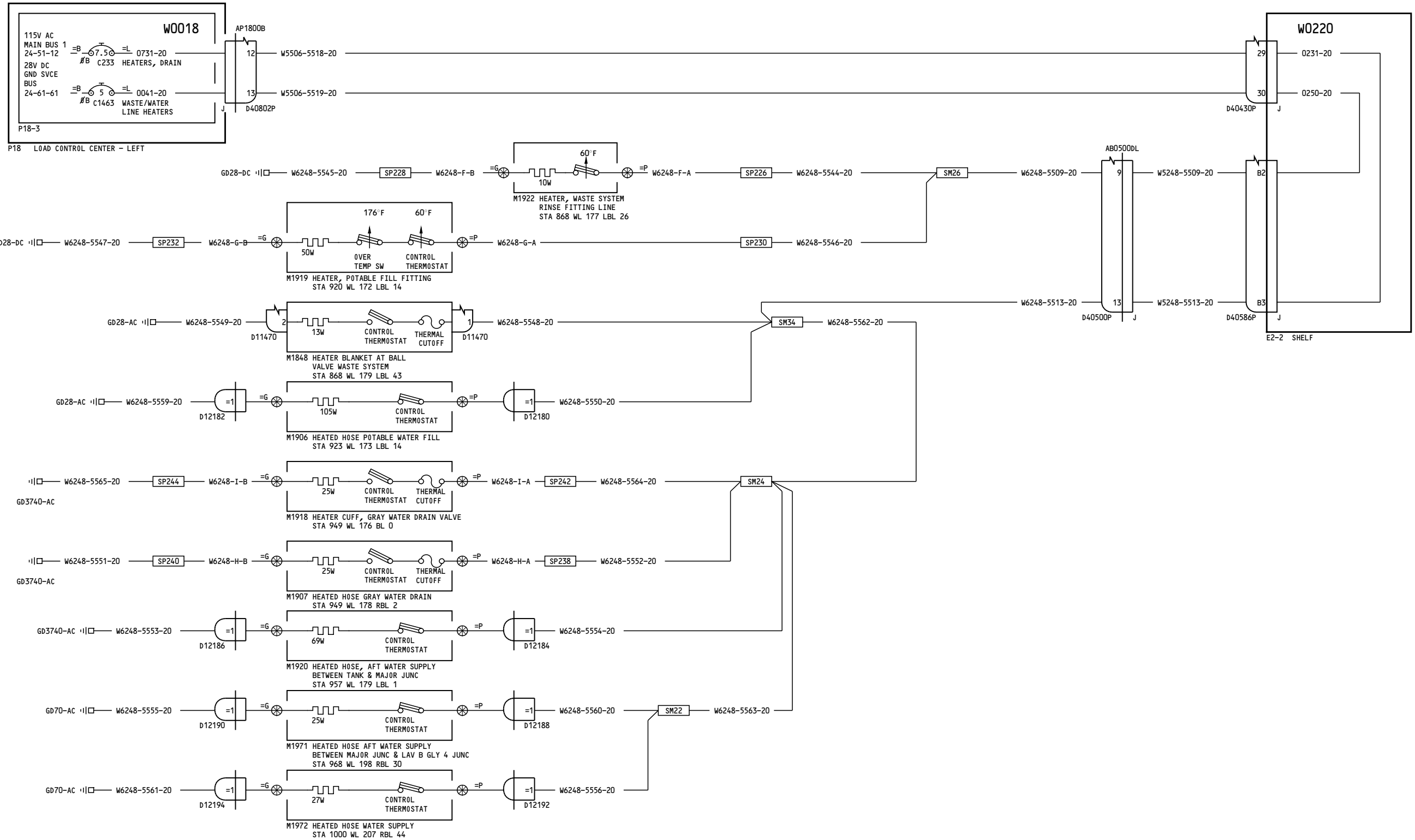

YC001-YC007

**DRAIN HEATERS**

**30-71-11**

Page 1  
Sheet 2  
Jul 26/2006

D280A103

**30-71-11**

Page 1  
Sheet 2  
Jul 26/2006

-H  
10

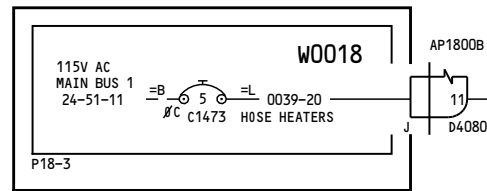

P18 LOAD CONTROL CENTER - LEFT

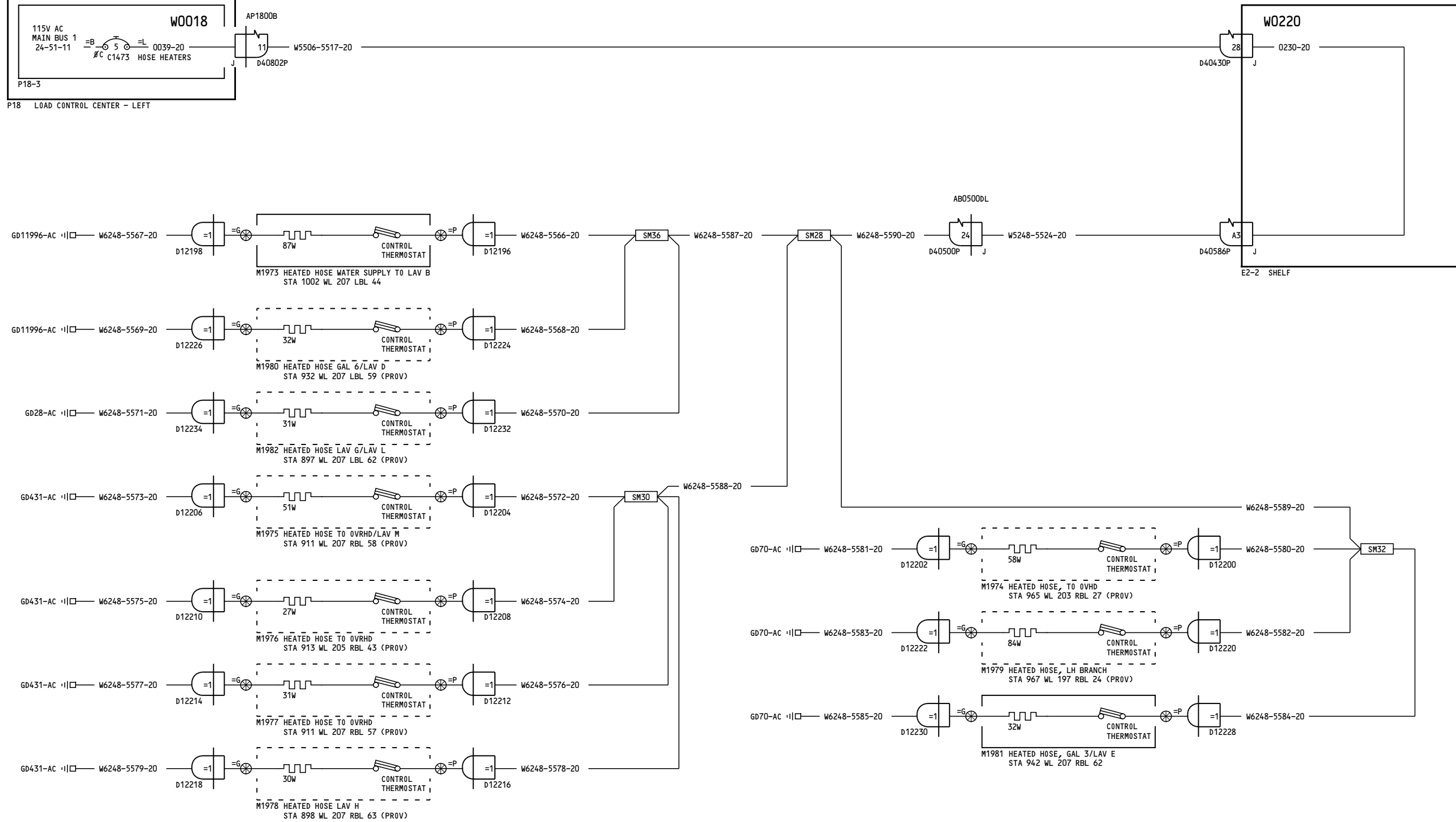

YC001-YC007

**DRAIN HEATERS**

**30-71-11**

Page 1  
Sheet 3  
Oct 20/2006

D280A103

**30-71-11**

Page 1  
Sheet 3  
Oct 20/2006

-N  
6

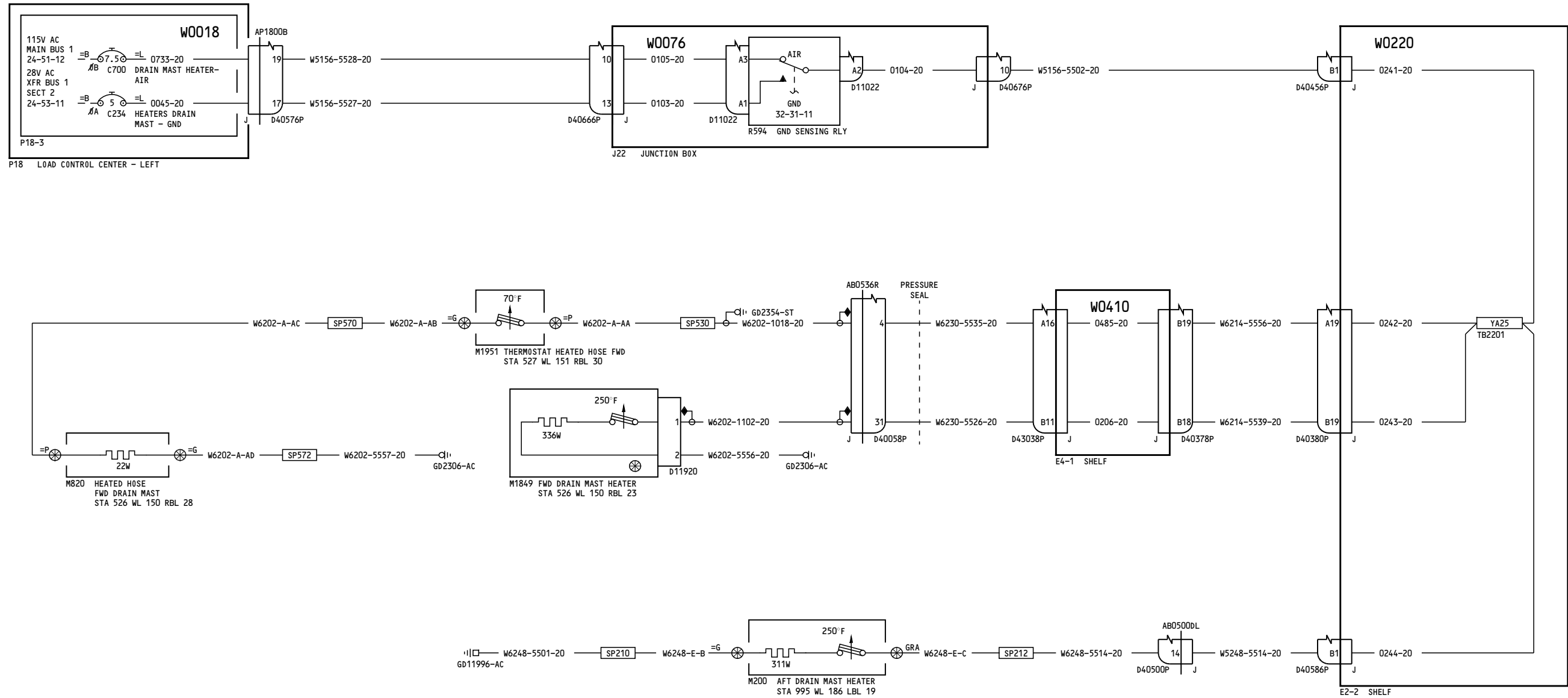

YC008-YK912, YK918, YL401-YL426

**DRAIN HEATERS**

D280A103

**30-71-11**

Page 2  
Sheet 1  
Feb 09/2009

**30-71-11**

Page 2  
Sheet 1  
Feb 09/2009

-T  
1

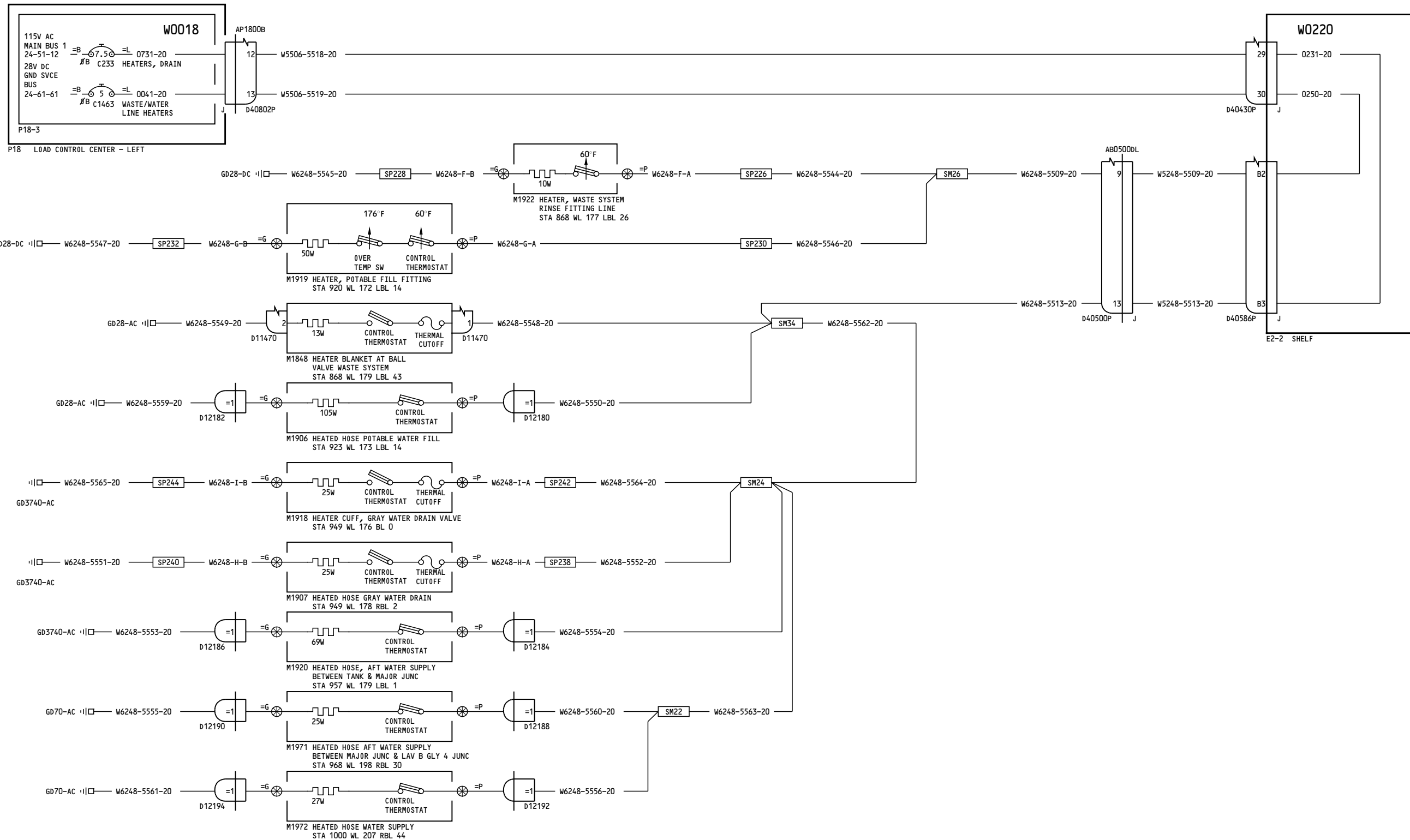

YC008-YK912, YK918, YL401-YL426

**DRAIN HEATERS**

D280A103

**30-71-11**

Page 2  
Sheet 2  
Feb 09/2009

**30-71-11**

Page 2  
Sheet 2  
Feb 09/2009

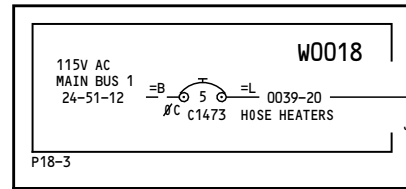

P18 LOAD CONTROL CENTER - LEFT

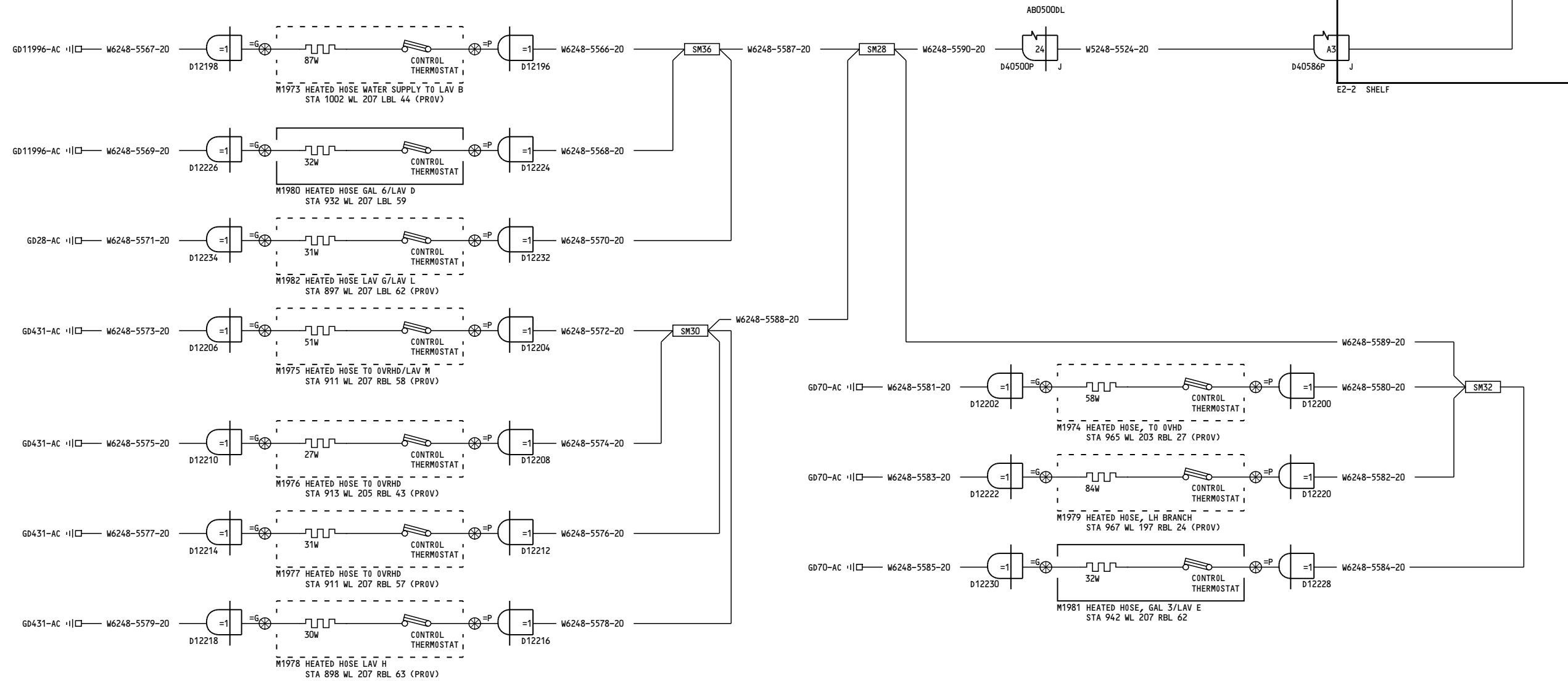

YC008-YK912, YK918, YL401-YL426

**DRAIN HEATERS**

**30-71-11**

Page 2  
Sheet 3  
Feb 09/2009

D280A103

**30-71-11**

Page 2  
Sheet 3  
Feb 09/2009

-N  
6

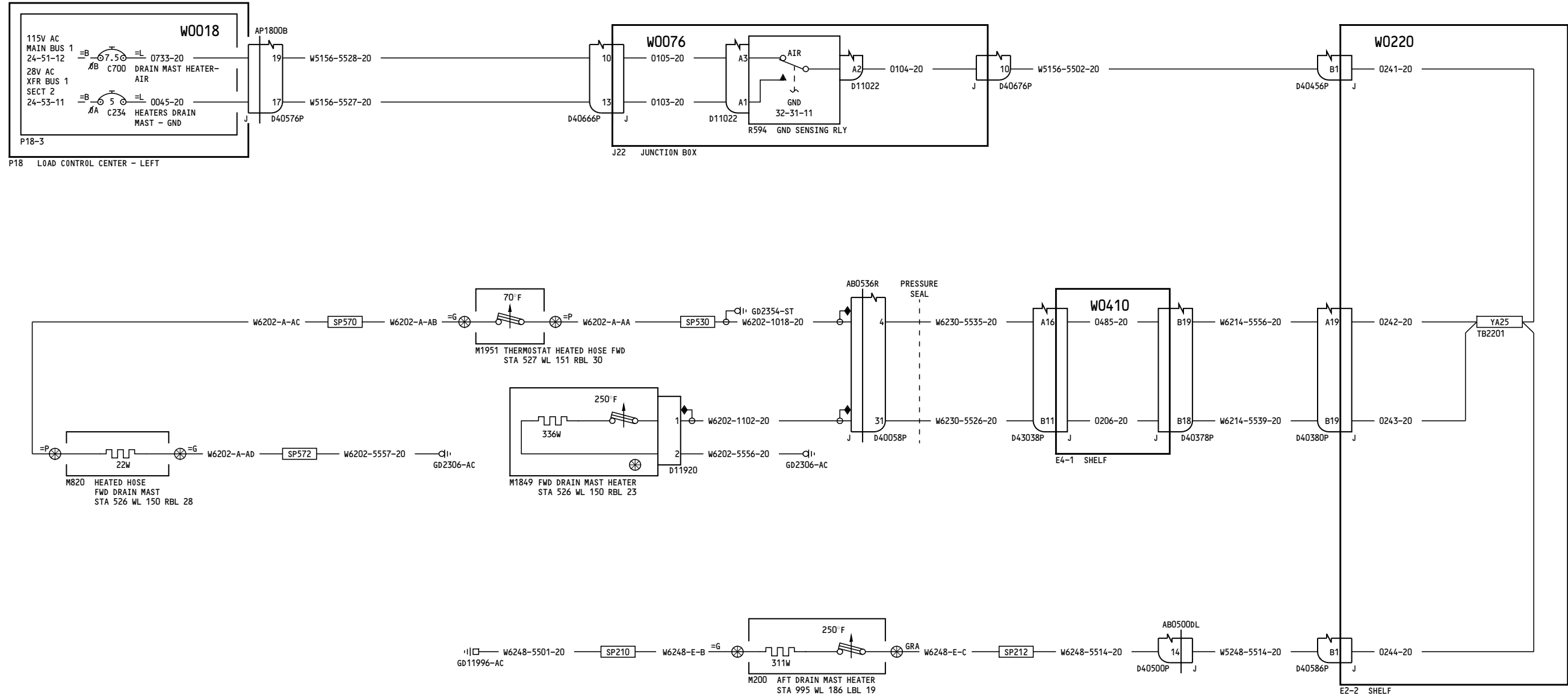

YK913-YK917, YK919-YK920, YL427-YL430

**DRAIN HEATERS**

D280A103

**30-71-11**

Page 3  
Sheet 1  
Feb 09/2009

**30-71-11**

Page 3  
Sheet 1  
Feb 09/2009



-A  
9

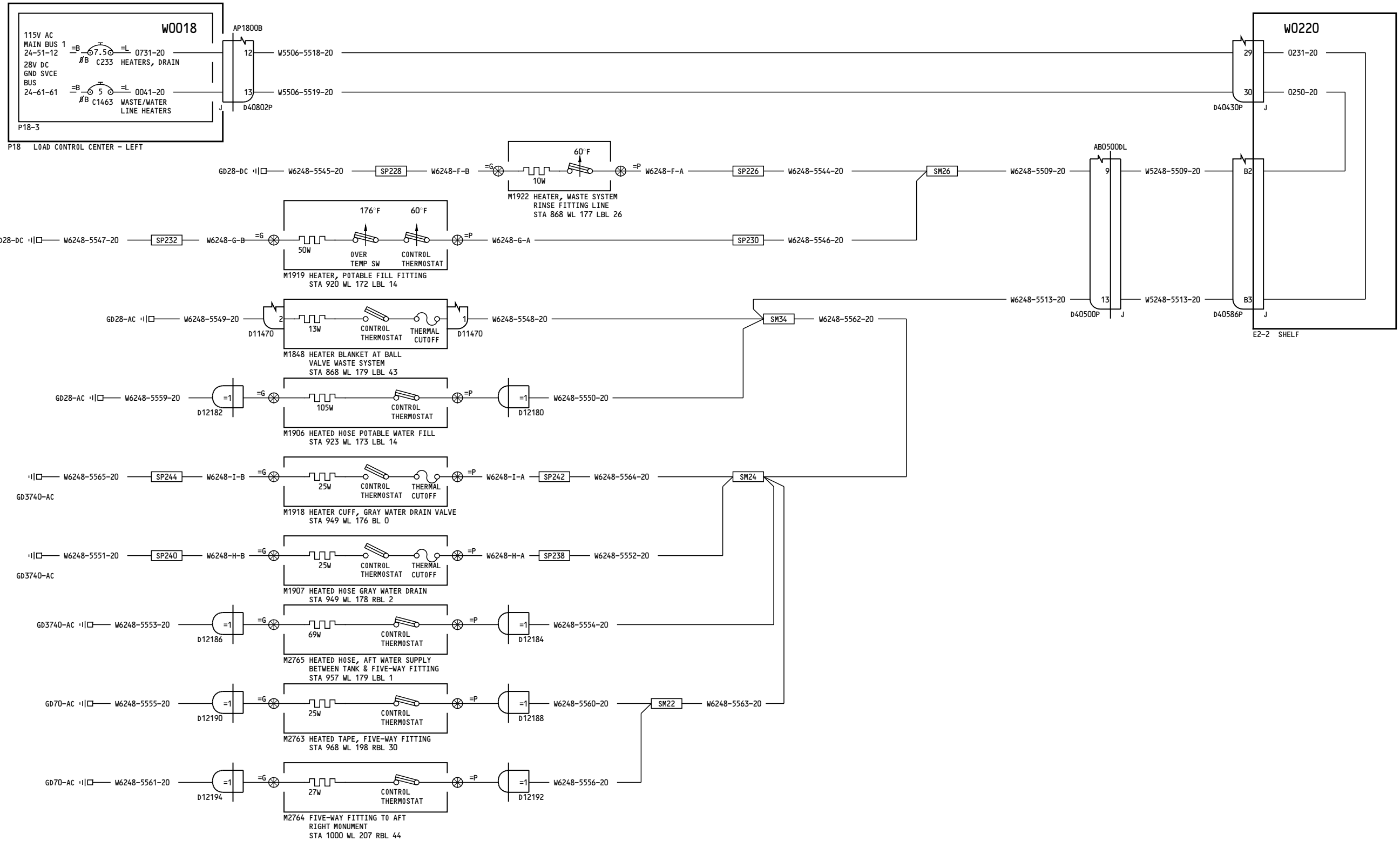

YK913-YK917, YK919-YK920, YL427-YL430

**DRAIN HEATERS**

D280A103

**30-71-11**

Page 3  
Sheet 2  
Feb 09/2009

**30-71-11**

Page 3  
Sheet 2  
Feb 09/2009

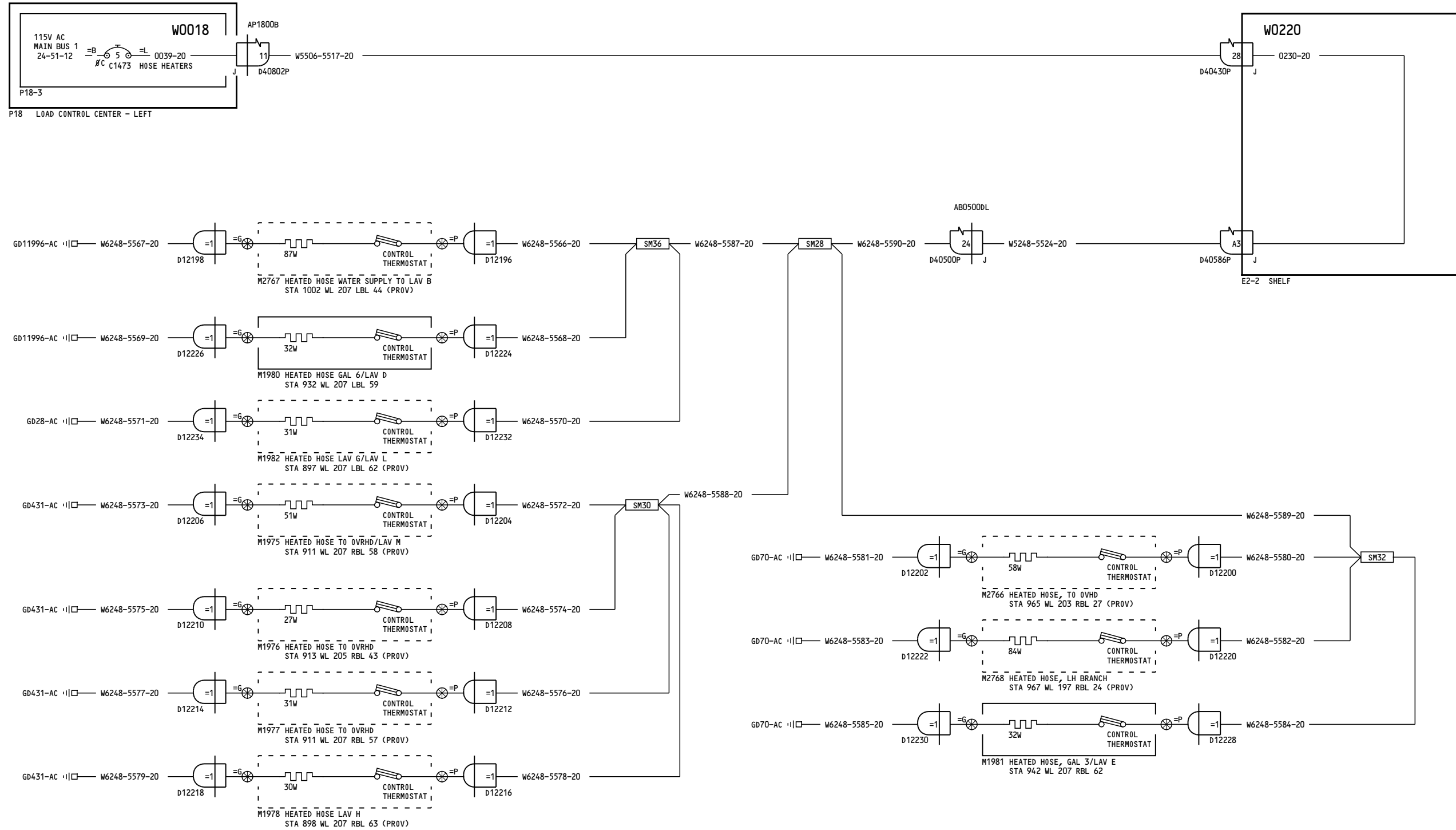

YK913-YK917, YK919-YK920, YL427-YL430

**DRAIN HEATERS**

D280A103

**30-71-11**

Page 3  
Sheet 3  
Feb 09/2009

**30-71-11**

Page 3  
Sheet 3  
Feb 09/2009

-M  
7

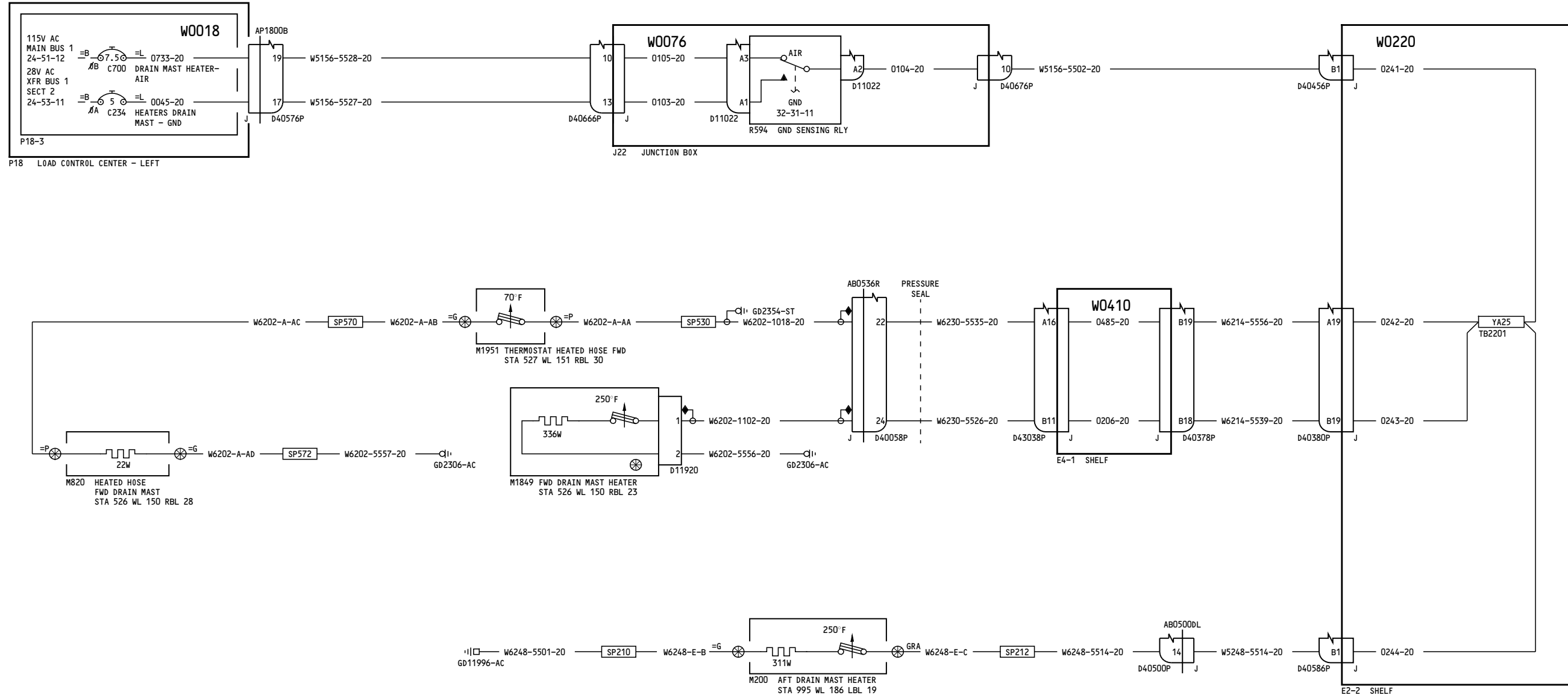

YM643-YM651

**DRAIN HEATERS**

D280A103

**30-71-11**

Page 4  
Sheet 1  
Aug 13/2008

**30-71-11**

Page 4  
Sheet 1  
Aug 13/2008

-T  
1

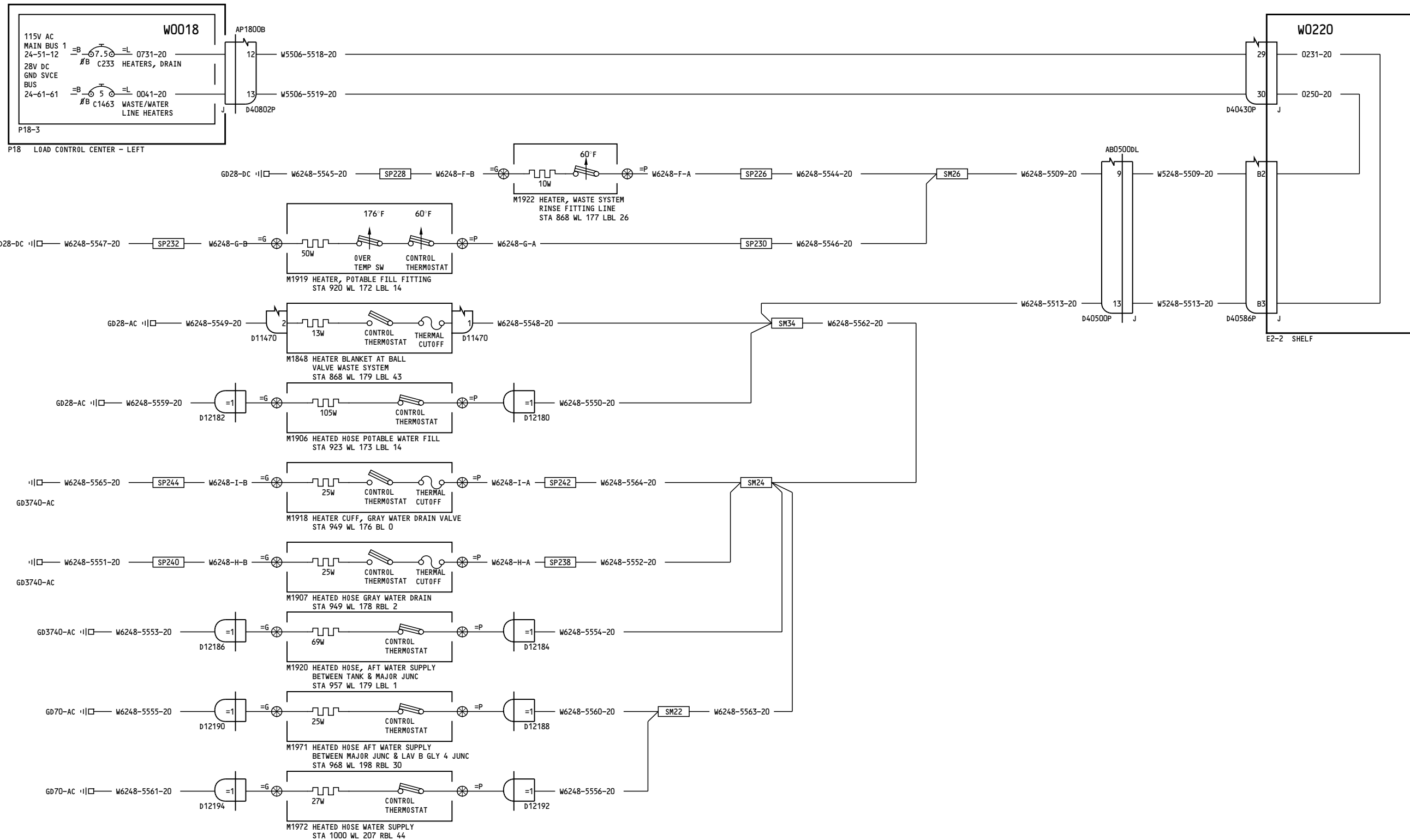

YM643-YM651

**DRAIN HEATERS**

**30-71-11**

Page 4  
Sheet 2  
Aug 13/2008

D280A103

**30-71-11**

Page 4  
Sheet 2  
Aug 13/2008

17

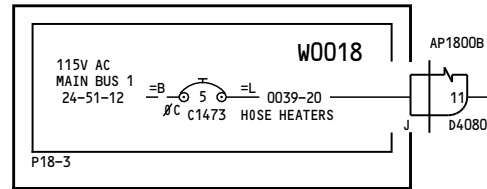

P18 LOAD CONTROL CENTER - LEFT

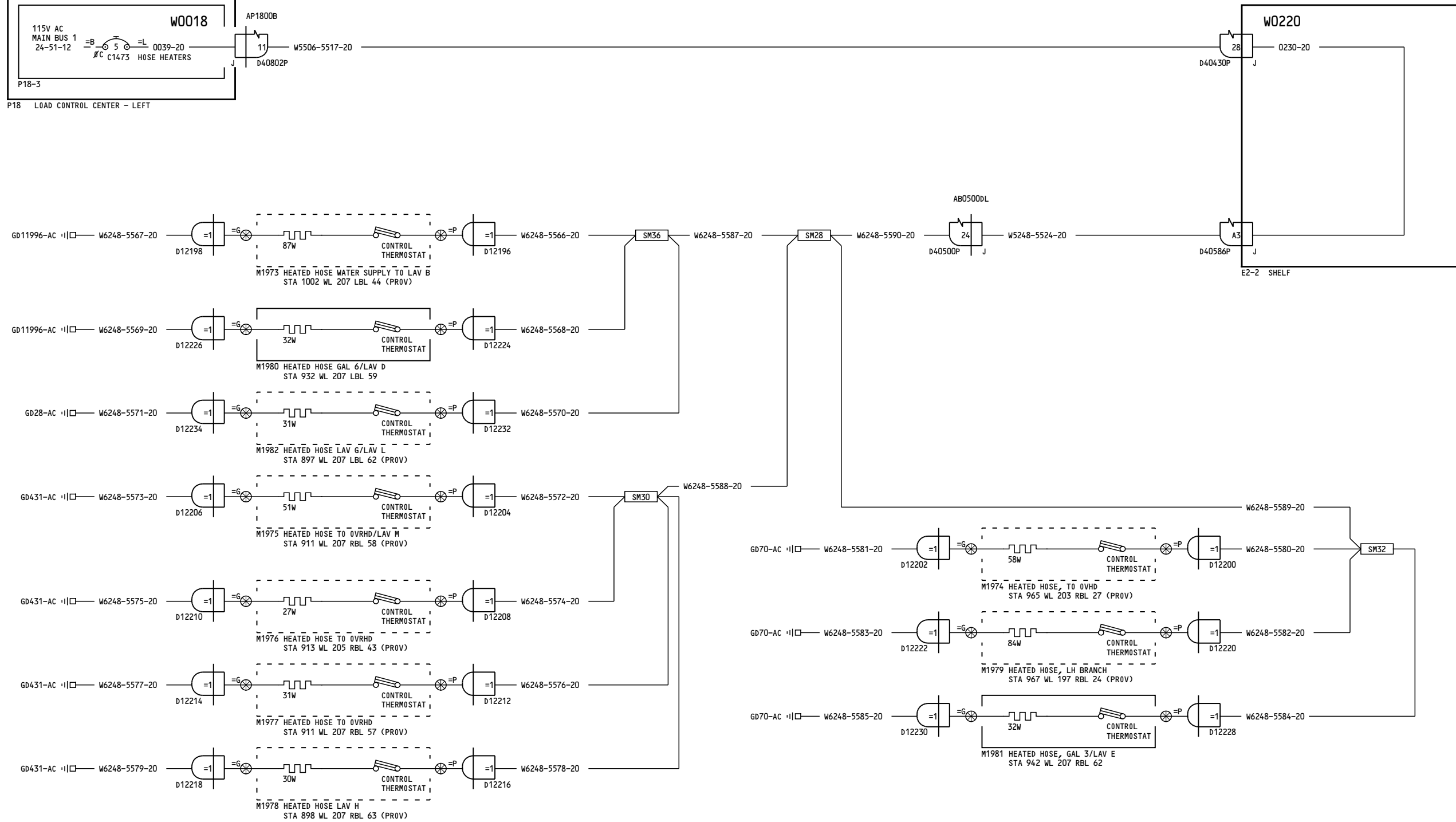

YM643-YM651

**DRAIN HEATERS**

**30-71-11**

Page 4  
Sheet 3  
Aug 13/2008

D280A103

**30-71-11**

Page 4  
Sheet 3  
Aug 13/2008

-M  
7

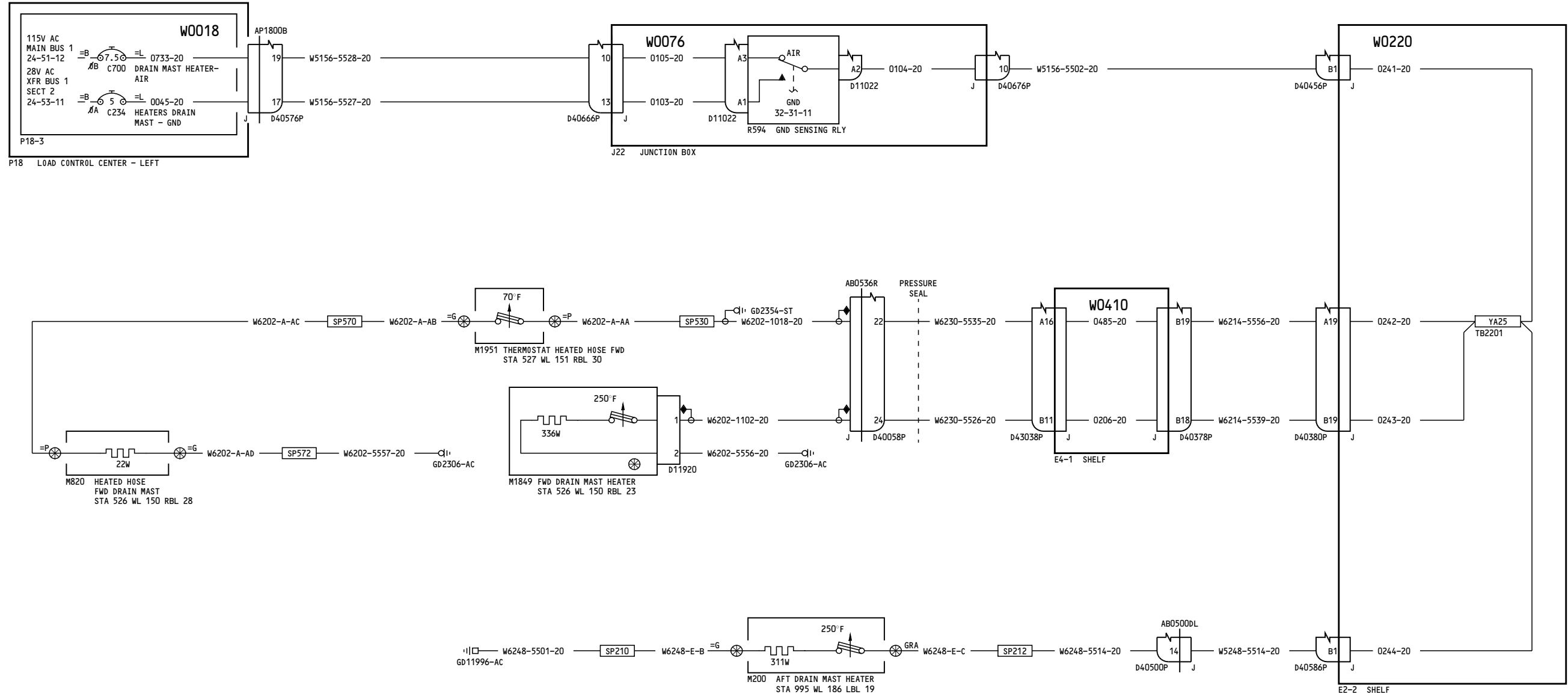

YM652-YM670

**DRAIN HEATERS**

**30-71-11**

Page 5  
Sheet 1  
Aug 13/2008

D280A103

**30-71-11**

Page 5  
Sheet 1  
Aug 13/2008

-A  
9

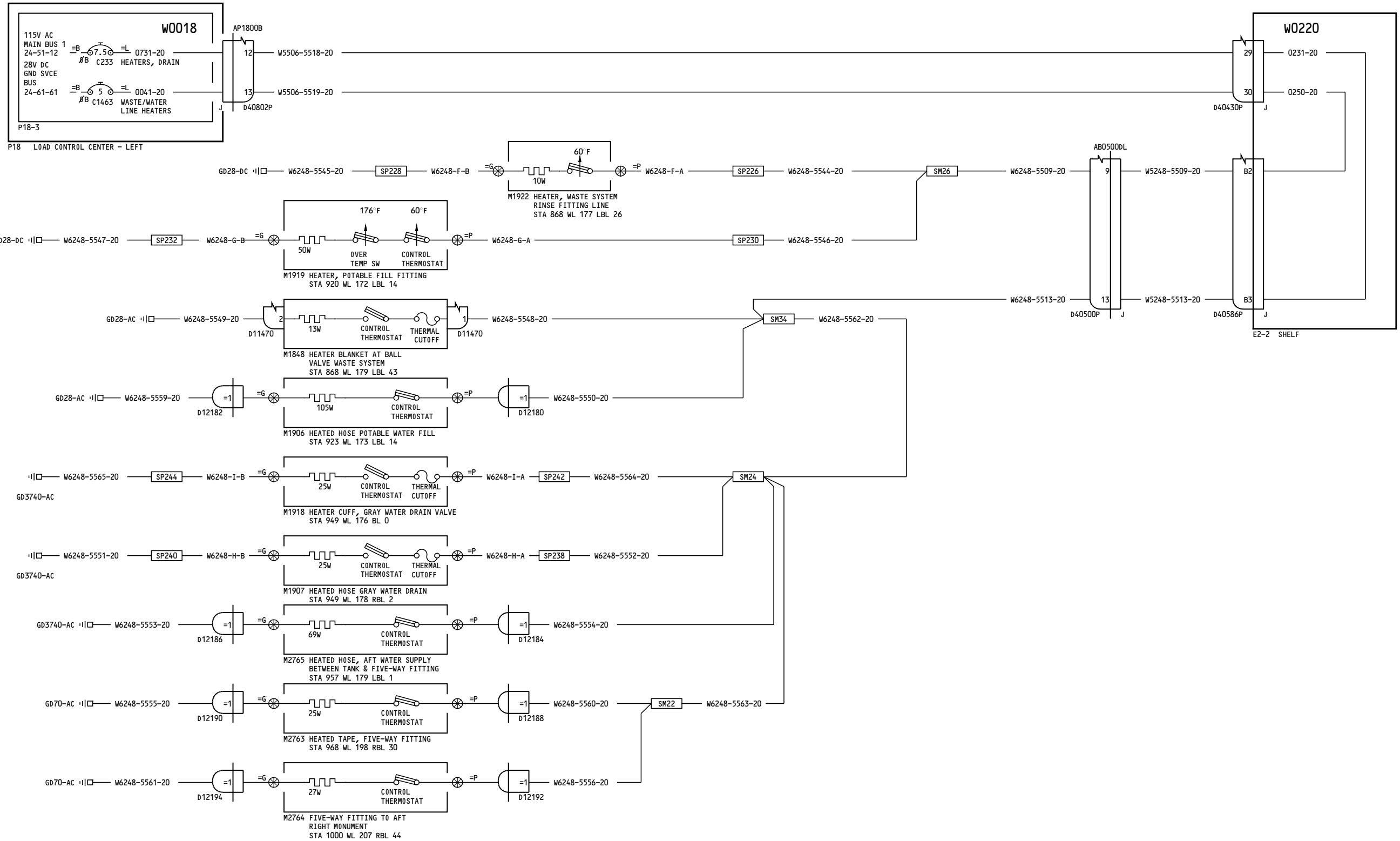

YM652-YM670

**DRAIN HEATERS**

D280A103

**30-71-11**

Page 5  
Sheet 2  
Aug 13/2008

**30-71-11**

Page 5  
Sheet 2  
Aug 13/2008

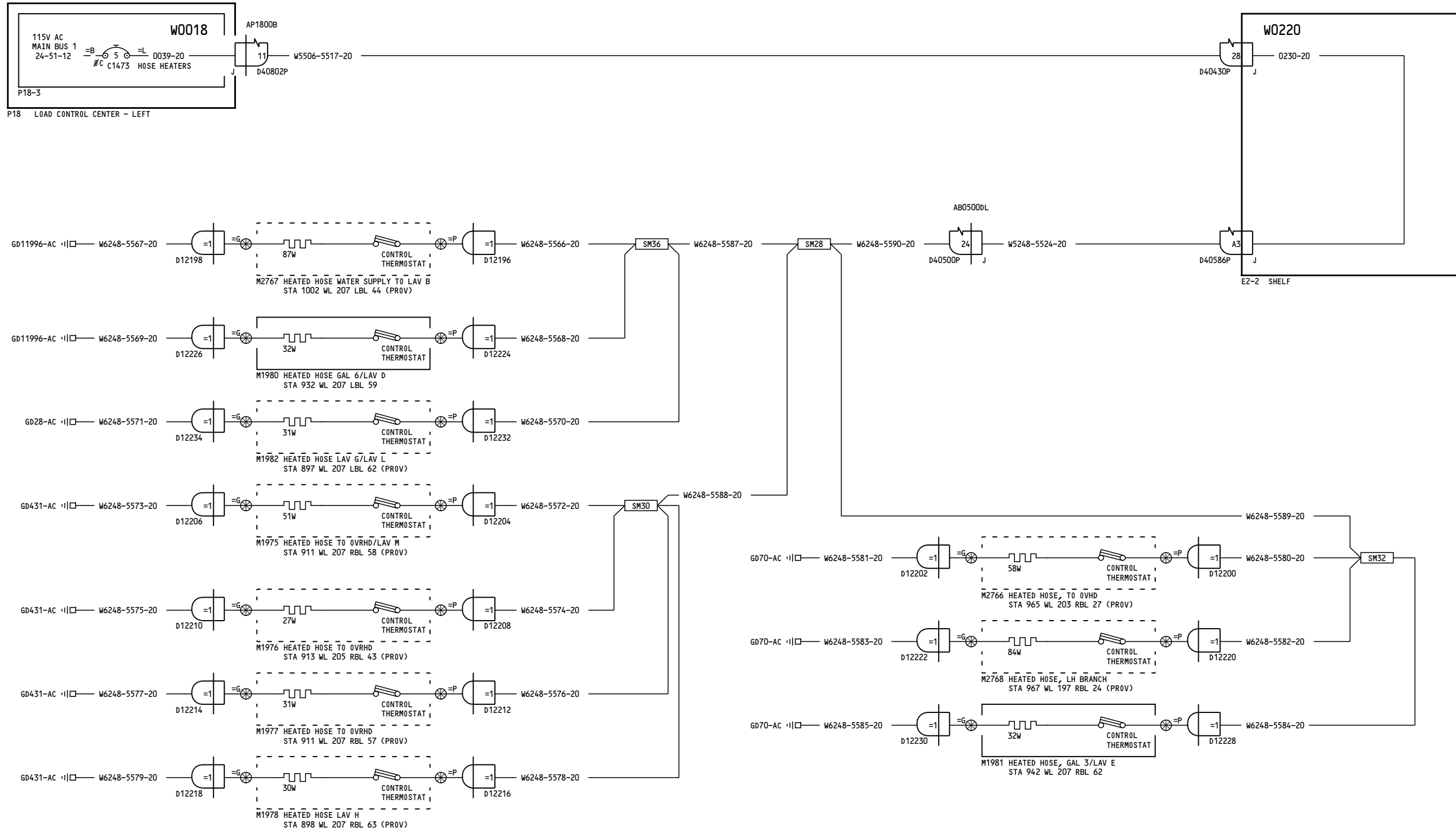

YM652-YM670

**DRAIN HEATERS**

**30-71-11**

Page 5  
Sheet 3  
Aug 13/2008

D280A103

**30-71-11**

Page 5  
Sheet 3  
Aug 13/2008