

CHAPTER

31

INDICATING /

RECORDING SYSTEMS



737-700/800

WIRING DIAGRAM MANUAL

CHAPTER 31
INDICATING / RECORDING SYSTEMS

CH-SC-SU	Schem	Page	Sheet	Date	CH-SC-SU	Schem	Page	Sheet	Date
31-EFFECTIVE PAGES		1 thru 4		Aug 10/2009	31-31-15 (cont.)		2.1		
31-CONTENTS								3	Aug 13/2008
		1		Feb 09/2009				1	Mar 31/2005
		2		May 11/2009				2	Apr 18/2006
		3		May 11/2009				3	Mar 31/2005
R		4		Aug 10/2009		4		1	Jul 17/2007
		5		May 11/2009				2	Jul 17/2007
R		6		Aug 10/2009				3	Jul 17/2007
R		7		Aug 10/2009		5		4	Jul 17/2007
R		8		Aug 10/2009				1	Apr 18/2007
R		9		Aug 10/2009				2	Apr 18/2007
O		10		Aug 10/2009				3	Apr 18/2007
O		11		Aug 10/2009				4	Apr 18/2007
D		12		Aug 10/2009		6		1	Aug 13/2008
D				BLANK				2	Apr 18/2007
31-ALPHABETICAL INDEX								3	Apr 18/2007
		1		Jan 18/2007				4	Apr 18/2007
		2		Jan 18/2007				7	May 11/2009
31-22-11								1	May 11/2009
		1		May 13/2008				2	May 11/2009
		2		Feb 09/2009				3	May 11/2009
		3		May 13/2008				4	May 11/2009
31-31-11						8		1	Aug 13/2008
		1		Apr 18/2006				2	Aug 13/2008
		2		Feb 09/2009				3	Aug 13/2008
31-31-13								4	Aug 13/2008
		1	1	Jul 17/2007	31-31-16		1		Jul 17/2007
			2	Jul 17/2007			2		Feb 09/2009
		2	1	Feb 09/2009			3		Nov 11/2008
			2	Feb 09/2009			4		Nov 11/2008
31-31-14					31-31-17				
		1	1	Jan 18/2007			1		Mar 31/2005
			2	Apr 18/2006			2		Jul 17/2007
			3	Apr 18/2006			3		Jan 18/2007
		2	1	Jul 17/2007			3.1		May 13/2008
			2	Jul 17/2007			4		Feb 09/2009
			3	Jul 17/2007			5		Feb 09/2009
		3	1	Jan 18/2007			6		Aug 13/2008
			2	Oct 20/2006	31-32-15				
			3	Oct 20/2006			1.1	1	Mar 31/2005
		4	1	Feb 09/2009				2	Mar 31/2005
			2	Feb 09/2009				3	Mar 31/2005
			3	Feb 09/2009			2	1	Jul 17/2007
		5	1	Jan 14/2008				2	Jul 17/2007
			2	Jan 14/2008				3	Jul 17/2007
			3	Jan 14/2008			3	1	Feb 09/2009
31-31-15								2	Feb 09/2009
		1.1	1	Aug 13/2008				3	Feb 09/2009
			2	Aug 13/2008	31-33-01				
			3	Aug 13/2008			1		Jul 17/2007
		2.1	1	Aug 13/2008				2	Oct 20/2006
			2	Aug 13/2008				3	Feb 09/2009

A = Added, R = Revised, D = Deleted, O = Overflow

31-EFFECTIVE PAGES

Page 1
Aug 10/2009

D280A103



737-700/800

WIRING DIAGRAM MANUAL

CHAPTER 31
INDICATING / RECORDING SYSTEMS

CH-SC-SU	Schem	Page	Sheet	Date	CH-SC-SU	Schem	Page	Sheet	Date
31-33-01 (cont.)		4		May 11/2009	31-52-35 (cont.)		3		May 13/2008
31-35-01		1.1		Oct 20/2006			4		Feb 09/2009
		2		Feb 09/2009	31-52-41		1		Mar 31/2005
31-35-02		1		Jul 17/2007			2		Mar 31/2005
		2		Feb 09/2009			3		Jul 17/2007
31-35-03							4		Feb 09/2009
		1		Jul 17/2007	31-52-45		1		May 13/2008
R		2		Aug 10/2009			2		May 13/2008
		2.1		Feb 09/2009			3		Feb 09/2009
		3		May 11/2009	31-52-51		1		Mar 31/2005
		4		May 11/2009			2		Mar 31/2005
		5		May 11/2009			3		Jul 17/2007
31-35-04							4		Feb 09/2009
		1		Feb 09/2009			5		Jan 14/2008
31-51-11					31-52-52		1		Feb 09/2009
		1		Jul 17/2007					
		2		Feb 09/2009	31-52-55		1		Mar 31/2005
		3		Feb 09/2009			2		Mar 31/2005
		4		Nov 11/2008			3		Jul 17/2007
		5		Nov 11/2008			4		Feb 09/2009
31-52-11		1.1	1	Feb 12/2008					
			2	Feb 12/2008	31-52-56		1.1		Oct 20/2005
		2.1	1	Feb 12/2008			2		Feb 09/2009
			2	Feb 12/2008					
			3	Feb 09/2009	31-52-61	R	1		Aug 10/2009
			2	Feb 09/2009		R	2		Aug 10/2009
			4	Nov 11/2008			3		Jul 17/2007
			5	Nov 11/2008			4		Feb 09/2009
		4	1	Jan 14/2008					
			2	Jan 14/2008	31-52-65		1		Mar 31/2005
31-52-21							2		Mar 31/2005
		1		Mar 31/2005			3		Jul 17/2007
		2		Mar 31/2005			4		Feb 09/2009
		3		Jul 17/2007			5		Jan 14/2008
		4		Feb 09/2009	31-52-71		1		Mar 31/2005
31-52-25							2		Jul 17/2007
		1		Mar 31/2005			3		Jan 18/2007
		2		Mar 31/2005			4		Feb 09/2009
		3		Jul 17/2007					
		4		Feb 09/2009					
31-52-31					31-52-75		1		Mar 31/2005
		1		May 13/2008			2		Mar 31/2005
		2		May 13/2008			3		Jul 17/2007
		3		May 13/2008			4		Feb 09/2009
		4		Feb 09/2009					
31-52-32									
		1		Feb 09/2009	31-53-11		1	1	Mar 31/2005
31-52-35								2	May 11/2009
		1		May 13/2008					
		2		May 13/2008					

A = Added, R = Revised, D = Deleted, O = Overflow

31-EFFECTIVE PAGES

Page 2
Aug 10/2009

D280A103



737-700/800

WIRING DIAGRAM MANUAL

CHAPTER 31
INDICATING / RECORDING SYSTEMS

CH-SC-SU	Schem	Page	Sheet	Date	CH-SC-SU	Schem	Page	Sheet	Date
31-53-11 (cont.)		2	1	Mar 31/2005	31-62-15 (cont.)		3	1	Jul 17/2007
			2	May 11/2009				2	Jul 17/2007
		3	1	Jul 17/2007				3	Jul 17/2007
			2	May 11/2009				4	Jul 17/2007
		4	1	May 11/2009		4	1	1	Oct 20/2006
			2	May 11/2009				2	May 13/2008
		5	1	May 11/2009				3	Oct 20/2006
			2	May 11/2009				4	Oct 20/2006
			3	May 11/2009		5	1	1	Feb 09/2009
R		6	1	Aug 10/2009				2	Feb 09/2009
R			2	Aug 10/2009				3	Feb 09/2009
R			3	Aug 10/2009				4	Feb 09/2009
			1	May 11/2009	31-62-21		1	1	Feb 09/2009
			2	May 11/2009				2	Feb 09/2009
			3	May 11/2009					
		8	1	May 11/2009	31-62-22		1	1	Feb 09/2009
			2	May 11/2009				2	Feb 09/2009
		9	1	May 11/2009					
			2	May 11/2009	31-62-23		1		Mar 31/2005
			3	May 11/2009				2	Mar 31/2005
		10	1	May 11/2009				3	Mar 31/2005
			2	May 11/2009				4	Feb 09/2009
			3	May 11/2009				5	Aug 13/2008
R		11	1	Aug 10/2009	31-62-24		1	1	Jul 17/2007
R			2	Aug 10/2009				2	Jul 17/2007
R			3	Aug 10/2009				2	Feb 09/2009
	31-62-11		1	Feb 09/2009				2	Feb 09/2009
			2	Feb 09/2009					
	31-62-12		1	Feb 09/2009	31-62-25		1.1A	1	Mar 31/2005
			2	Feb 09/2009				2	Mar 31/2005
	31-62-13		1	Mar 31/2005				3	Mar 31/2005
			2	Mar 31/2005		2.1	1	1	Mar 31/2005
			3	Mar 31/2005				2	Mar 31/2005
			4	Feb 09/2009				3	Mar 31/2005
			5	Aug 13/2008				4	Mar 31/2005
	31-62-14		1	Jul 17/2007			3	1	Jul 17/2007
			2	Jul 17/2007				2	Jul 17/2007
		2	1	Feb 09/2009				3	Jul 17/2007
			2	Feb 09/2009		4	1	1	Oct 20/2006
	31-62-15		1.1A	1	Mar 31/2005			2	Oct 20/2006
				2	Mar 31/2005			3	Jan 18/2007
				3	Mar 31/2005			4	Oct 20/2006
			2.1	1	Mar 31/2005		5	1	Feb 09/2009
				2	Mar 31/2005			2	Feb 09/2009
				3	Mar 31/2005			3	Feb 09/2009
				4	Mar 31/2005			4	Feb 09/2009
				4	Mar 31/2005	31-62-41		1.1	Jul 17/2007

A = Added, R = Revised, D = Deleted, O = Overflow

31-EFFECTIVE PAGES

Page 3
Aug 10/2009

D280A103



737-700/800

WIRING DIAGRAM MANUAL

CHAPTER 31
INDICATING / RECORDING SYSTEMS

CH-SC-SU	Schem	Page	Sheet	Date	CH-SC-SU	Schem	Page	Sheet	Date
31-62-41 (cont.)		2		Feb 09/2009					
31-62-42		1		Feb 09/2009					
		2		Feb 09/2009					

A = Added, R = Revised, D = Deleted, O = Overflow

31-EFFECTIVE PAGES

D280A103

Page 4
Aug 10/2009



737-700/800

WIRING DIAGRAM MANUAL

**CHAPTER 31
INDICATING / RECORDING SYSTEMS**

Title	CH-SC-SU	Schem	Page	Sheet	Date	Effectivity
<u>CLOCK</u>						
ELECTRONIC CLOCK	31-22-11		1		May 13/2008	YC001-YC007
			2		Feb 09/2009	YC008-YC050 YK907-YM670
			3		May 13/2008	YK901-YK906
<u>FLIGHT DATA RECORDER SYSTEM</u>						
DIGITAL FLIGHT DATA RECORDER SYSTEM - INTERFACE	31-31-11		1		Apr 18/2006	YC001-YC003
			2		Feb 09/2009	YC004-YM670
DIGITAL FLIGHT DATA RECORDER SYSTEM - DIGITAL INTERFACE	31-31-13		1	1	Jul 17/2007	YC001-YC030
				2	Jul 17/2007	YC001-YC030
			2	1	Feb 09/2009	YC031-YM670
			2	2	Feb 09/2009	YC031-YM670
DIGITAL FLIGHT DATA RECORDER SYSTEM - ANALOG INTERFACE	31-31-14		1	1	Jan 18/2007	YC001-YC007
				2	Apr 18/2006	YC001-YC007
				3	Apr 18/2006	YC001-YC007
			2	1	Jul 17/2007	YC008-YC030
				2	Jul 17/2007	YC008-YC030
				3	Jul 17/2007	YC008-YC030
			3	1	Jan 18/2007	YK901-YK907 YL421
				2	Oct 20/2006	YK901-YK907 YL421
				3	Oct 20/2006	YK901-YK907 YL421
			4	1	Feb 09/2009	YK908-YL401 YL422-YL430
				2	Feb 09/2009	YK908-YL401 YL422-YL430
				3	Feb 09/2009	YK908-YL401 YL422-YL430
				5	1	Jan 14/2008
			2	Jan 14/2008	YM643-YM670	
			3	Jan 14/2008	YM643-YM670	

31-CONTENTS

Page 1
Feb 09/2009

D280A103



737-700/800

WIRING DIAGRAM MANUAL

CHAPTER 31
INDICATING / RECORDING SYSTEMS

Title	CH-SC-SU	Schem	Page	Sheet	Date	Effectivity
DIGITAL FLIGHT DATA RECORDER SYSTEM DISCRETE INTERFACE	31-31-15		1.1	1	Aug 13/2008	YC001-YC003
				2	Aug 13/2008	YC001-YC003
				3	Aug 13/2008	YC001-YC003
			2.1	1	Aug 13/2008	YC004-YC007
				2	Aug 13/2008	YC004-YC007
				3	Aug 13/2008	YC004-YC007
			3	1	Mar 31/2005	YC008-YC019
				2	Apr 18/2006	YC008-YC019
				3	Mar 31/2005	YC008-YC019
			4	1	Jul 17/2007	YC020-YC030
				2	Jul 17/2007	YC020-YC030
				3	Jul 17/2007	YC020-YC030
				4	Jul 17/2007	YC020-YC030
			5	1	Apr 18/2007	YC031-YK909
				2	Apr 18/2007	YC031-YK909
				3	Apr 18/2007	YC031-YK909
				4	Apr 18/2007	YC031-YK909
			6	1	Aug 13/2008	YK910 YL421-YL423 YM643
				2	Apr 18/2007	YK910 YL421-YL423 YM643
				3	Apr 18/2007	YK910 YL421-YL423 YM643
				4	Apr 18/2007	YK910 YL421-YL423 YM643
			7	1	May 11/2009	YK911-YK912 YK918-YK919 YL424-YL429 YM645-YM652
				2	May 11/2009	YK911-YK912 YK918-YK919 YL424-YL429 YM645-YM652
				3	May 11/2009	YK911-YK912 YK918-YK919 YL424-YL429 YM645-YM652

31-CONTENTS

Page 2

May 11/2009

D280A103



737-700/800

WIRING DIAGRAM MANUAL

**CHAPTER 31
INDICATING / RECORDING SYSTEMS**

Title	CH-SC-SU	Schem	Page	Sheet	Date	Effectivity
DIGITAL FLIGHT DATA RECORDER SYSTEM DISCRETE INTERFACE (cont.)	31-31-15			4	May 11/2009	YK911-YK912 YK918-YK919 YL424-YL429 YM645-YM652
				8	Aug 13/2008	YL401
					Aug 13/2008	YL401
					Aug 13/2008	YL401
					Aug 13/2008	YL401
DIGITAL FLIGHT DATA RECORDER SYSTEM AIRPLANE CODING	31-31-16		1		Jul 17/2007	YC001-YC050
				2	Feb 09/2009	YK901-YK920
				3	Nov 11/2008	YL401-YL430
				4	Nov 11/2008	YM643-YM670
DIGITAL FLIGHT DATA RECORDER SYSTEM MANDATORY OPTIONS	31-31-17		1		Mar 31/2005	YC001-YC007
				2	Jul 17/2007	YC008-YK906
				3	Jan 18/2007	YK907-YK909
				3.1	May 13/2008	YK907-YK909
				4	Feb 09/2009	YK910-YK920 YL421-YL430
				5	Feb 09/2009	YL401
	Aug 13/2008	YM643-YM670				
<u>DATA LOADING AND RECORDING SYSTEM</u>						
DATA LOADER INTERFACE	31-32-15			1.1	Mar 31/2005	YC001-YC011
					Mar 31/2005	YC001-YC011
					Mar 31/2005	YC001-YC011
				2	Jul 17/2007	YC012-YC050
					Jul 17/2007	YC012-YC050
					Jul 17/2007	YC012-YC050
				3	Feb 09/2009	YK901-YM670
					Feb 09/2009	YK901-YM670
					Feb 09/2009	YK901-YM670
<u>FLIGHT COMPARTMENT PRINTING</u>						
PRINTER INTERFACE	31-33-01			1	Jul 17/2007	YC001-YC050

31-CONTENTS



737-700/800

WIRING DIAGRAM MANUAL

CHAPTER 31
INDICATING / RECORDING SYSTEMS

Title	CH-SC-SU	Schem	Page	Sheet	Date	Effectivity
PRINTER INTERFACE (cont.)	31-33-01		2		Oct 20/2006	YK901-YK906
			3		Feb 09/2009	YK907-YL401
			4		May 11/2009	YL421-YM670
<u>AIRCRAFT INTEGRATED DATA SYSTEM</u>						
DIGITAL FLIGHT DATA RECORDER SYSTEM - DATA LOADER INTERFACE	31-35-01		1.1		Oct 20/2006	YC001-YC011
			2		Feb 09/2009	YC012-YM670
DIGITAL FLIGHT DATA RECORDER SYSTEM - ACMS INTERFACE	31-35-02		1		Jul 17/2007	YC001-YC050
			2		Feb 09/2009	YK901-YM670
DIGITAL FLIGHT DATA RECORDER SYSTEM - ACMS INTERFACE 3	31-35-03		1		Jul 17/2007	YK910 YM643
			2		Aug 10/2009	YK911 YK918 YL421-YL423
			2.1		Feb 09/2009	YK918 YL421-YL423 YM645-YM646
			3		May 11/2009	YK912-YK917 YK919-YK920
			4		May 11/2009	YL424-YL430 YM647-YM651 YM653-YM670
			5		May 11/2009	YM652
DIGITAL FLIGHT DATA RECORDER SYSTEM - ACMS INTERFACE	31-35-04		1		Feb 09/2009	YK901-YM670
<u>AURAL WARNING SYSTEM</u>						
AURAL WARNING SYSTEM	31-51-11		1		Jul 17/2007	YC001-YC030
			2		Feb 09/2009	YK901-YK910 YK918 YL421-YL426
			3		Feb 09/2009	YK911-YK917 YK919-YL401 YL427-YL430
			4		Nov 11/2008	YM643-YM649
			5		Nov 11/2008	YM651-YM670



737-700/800

WIRING DIAGRAM MANUAL

CHAPTER 31
INDICATING / RECORDING SYSTEMS

Title	CH-SC-SU	Schem	Page	Sheet	Date	Effectivity
MASTER CAUTION						
MASTER CAUTION SYSTEM- POWER & CONTROL	31-52-11		1.1	1	Feb 12/2008	YC001-YC003
				2	Feb 12/2008	YC001-YC003
			2.1	1	Feb 12/2008	YC004-YC030
				2	Feb 12/2008	YC004-YC030
			3	1	Feb 09/2009	YK901-YL430
				2	Feb 09/2009	YK901-YL430
			4	1	Jan 14/2008	YM643-YM670
				2	Jan 14/2008	YM643-YM670
MASTER CAUTION SYSTEM - HYDRAULIC CONTROL	31-52-21		1		Mar 31/2005	YC001-YC003
			2		Mar 31/2005	YC004-YC007
			3		Jul 17/2007	YC008-YC030
			4		Feb 09/2009	YC031-YM670
MASTER CAUTION SYSTEM - FLIGHT CONTROLS	31-52-25		1		Mar 31/2005	YC001-YC003
			2		Mar 31/2005	YC004-YC007
			3		Jul 17/2007	YC008-YC030
			4		Feb 09/2009	YC031-YM670
MASTER CAUTION SYSTEM - ELECTRICAL CONTROL, GENERATOR	31-52-31		1		May 13/2008	YC001-YC003
			2		May 13/2008	YC004-YC007
			3		May 13/2008	YC008-YC030
			4		Feb 09/2009	YC031-YM670
MASTER CAUTION SYSTEM - ELECTRICAL CONTROL, POWER BUS	31-52-32		1		Feb 09/2009	ALL
MASTER CAUTION SYSTEM - APU CONTROL	31-52-35		1		May 13/2008	YC001-YC003
			2		May 13/2008	YC004-YC007
			3		May 13/2008	YC008-YC030
			4		Feb 09/2009	YC031-YM670
MASTER CAUTION SYSTEM - FUEL CONTROL	31-52-41		1		Mar 31/2005	YC001-YC003

31-CONTENTS

Page 5

May 11/2009

D280A103



737-700/800

WIRING DIAGRAM MANUAL

CHAPTER 31
INDICATING / RECORDING SYSTEMS

Title	CH-SC-SU	Schem	Page	Sheet	Date	Effectivity
MASTER CAUTION SYSTEM - FUEL CONTROL (cont.)	31-52-41		2		Mar 31/2005	YC004-YC007
			3		Jul 17/2007	YC008-YC030
			4		Feb 09/2009	YC031-YM670
			1		May 13/2008	YC001-YC003
MASTER CAUTION SYSTEM - OVERHEAT DETECTION	31-52-45		2		May 13/2008	YC004-YC030
			3		Feb 09/2009	YC031-YM670
			1		Mar 31/2005	YC001-YC003
MASTER CAUTION SYSTEM - AIR CONDITIONG CONTROL, PACK & TEMP	31-52-51		2		Mar 31/2005	YC004-YC007
			3		Jul 17/2007	YC008-YC030
			4		Feb 09/2009	YC031-YL430
			5		Jan 14/2008	YM643-YM670
			1		Feb 09/2009	ALL
MASTER CAUTION SYSTEM - AIR CONDITIONG CONTROL, BLEED AIR	31-52-52		1		Mar 31/2005	YC001-YC003
			2		Mar 31/2005	YC004-YC007
			3		Jul 17/2007	YC008-YC030
			4		Feb 09/2009	YC031-YM670
MASTER CAUTION SYSTEM - ANTI-ICE CONTROL, PITOT HEAT	31-52-55		4		Feb 09/2009	YC031-YM670
			1.1		Oct 20/2005	YC001-YC007
			2		Feb 09/2009	YC008-YM670
MASTER CAUTION SYSTEM - ANTI-ICE CONTROL, WINDOW/COWL HEAT	31-52-56		1		Aug 10/2009	YC001-YC003
			2		Aug 10/2009	YC004-YC007
			3		Jul 17/2007	YC008-YC030
			4		Feb 09/2009	YC031-YM670
MASTER CAUTION SYSTEM - ENGINE CONTROL	31-52-61		1		Mar 31/2005	YC001-YC003
			2		Mar 31/2005	YC004-YC007
			3		Jul 17/2007	YC008-YC030
			4		Feb 09/2009	YC031-YL430
MASTER CAUTION SYSTEM - DOOR WARNING	31-52-65		1		Mar 31/2005	YC001-YC003
			2		Mar 31/2005	YC004-YC007
			3		Jul 17/2007	YC008-YC030
			4		Feb 09/2009	YC031-YL430

31-CONTENTS



737-700/800

WIRING DIAGRAM MANUAL

CHAPTER 31
INDICATING / RECORDING SYSTEMS

Title	CH-SC-SU	Schem	Page	Sheet	Date	Effectivity
MASTER CAUTION SYSTEM - DOOR WARNING (cont.)	31-52-65		5		Jan 14/2008	YM643-YM670
MASTER CAUTION SYSTEM - IRS CONTROL	31-52-71		1		Mar 31/2005	YC001-YC003
			2		Jul 17/2007	YC004-YC030
			3		Jan 18/2007	YK901-YK906
			4		Feb 09/2009	YK907-YM670
MASTER CAUTION SYSTEM - OVERHEAD CONTROL	31-52-75		1		Mar 31/2005	YC001-YC003
			2		Mar 31/2005	YC004-YC007
			3		Jul 17/2007	YC008-YC030
			4		Feb 09/2009	YC031-YM670
AURAL WARNING - TAKEOFF WARNING						
AURAL WARNING - TAKEOFF WARNING	31-53-11		1	1	Mar 31/2005	YC001-YC003
			2		May 11/2009	YC001-YC003
			2	1	Mar 31/2005	YC004-YC007
				2	May 11/2009	YC004-YC007
			3	1	Jul 17/2007	YC008-YC030
				2	May 11/2009	YC008-YC030
			4	1	May 11/2009	YC031-YK910 YL421-YL423
				2	May 11/2009	YC031-YK910 YL421-YL423
			5	1	May 11/2009	YK911
				2	May 11/2009	YK911
				3	May 11/2009	YK911
			6	1	Aug 10/2009	YK912 YK919 YL401 YL427-YL429
				2	Aug 10/2009	YK912 YK919 YL401 YL427-YL429
				3	Aug 10/2009	YK912 YK919 YL401 YL427-YL429
			7	1	May 11/2009	YK918 YL424-YL426
				2	May 11/2009	YK918 YL424-YL426
				3	May 11/2009	YK918 YL424-YL426

31-CONTENTS

Page 7
Aug 10/2009

D280A103



737-700/800

WIRING DIAGRAM MANUAL

CHAPTER 31
INDICATING / RECORDING SYSTEMS

Title	CH-SC-SU	Schem	Page	Sheet	Date	Effectivity
AURAL WARNING - TAKEOFF WARNING (cont.)	31-53-11		8	1	May 11/2009	YM643
				2	May 11/2009	YM643
			9	1	May 11/2009	YM645-YM649
				2	May 11/2009	YM645-YM649
				3	May 11/2009	YM645-YM649
			10	1	May 11/2009	YM651
				2	May 11/2009	YM651
				3	May 11/2009	YM651
			11	1	Aug 10/2009	YM652
				2	Aug 10/2009	YM652
				3	Aug 10/2009	YM652
COMMON DISPLAY SYSTEM						
CDS - POWER DISTRIBUTION AND INSTRUMENT LIGHTING CAPTAINS	31-62-11		1	1	Feb 09/2009	ALL
				2	Feb 09/2009	ALL
CDS - VIDEO COAX SPLITTERS 1 AND 3 DU STATUS	31-62-12		1	1	Feb 09/2009	ALL
				2	Feb 09/2009	ALL
CDS - CONTROL PANEL INTERFACES - CAPTAINS	31-62-13		1		Mar 31/2005	YC001-YC002 YC007
			2		Mar 31/2005	YC003
			3		Mar 31/2005	YC004-YC006
			4		Feb 09/2009	YC008-YK920 YM643-YM646
			5		Aug 13/2008	YL401-YL430 YM647-YM670
CDS - DEU 1 ENGINE HYDRAULIC, APU AND FUEL INTERFACES	31-62-14		1	1	Jul 17/2007	YC001-YC030
				2	Jul 17/2007	YC001-YC030
			2	1	Feb 09/2009	YC031-YM670
				2	Feb 09/2009	YC031-YM670
CDS - DEU 1 AVIONICS INTERFACES	31-62-15		1.1A	1	Mar 31/2005	YC001-YC007

31-CONTENTS

Page 8
Aug 10/2009

D280A103



737-700/800

WIRING DIAGRAM MANUAL

CHAPTER 31
INDICATING / RECORDING SYSTEMS

Title	CH-SC-SU	Schem	Page	Sheet	Date	Effectivity	
CDS - DEU 1 AVIONICS INTERFACES (cont.)	31-62-15			2	Mar 31/2005	YC001-YC007	
				3	Mar 31/2005	YC001-YC007	
		2.1		1	Mar 31/2005	YC008-YC011	
				2	Mar 31/2005	YC008-YC011	
				3	Mar 31/2005	YC008-YC011	
				4	Mar 31/2005	YC008-YC011	
			3		1	Jul 17/2007	YC012-YC030
					2	Jul 17/2007	YC012-YC030
					3	Jul 17/2007	YC012-YC030
					4	Jul 17/2007	YC012-YC030
				4	1	Oct 20/2006	YK901-YK906
					2	May 13/2008	YK901-YK906
					3	Oct 20/2006	YK901-YK906
					4	Oct 20/2006	YK901-YK906
				5	1	Feb 09/2009	YK907-YM670
					2	Feb 09/2009	YK907-YM670
					3	Feb 09/2009	YK907-YM670
			4	Feb 09/2009	YK907-YM670		
CDS - POWER DISTRIBUTION AND INSTRUMENT LIGHTING FIRST OFFICER	31-62-21		1	1	Feb 09/2009	ALL	
				2	Feb 09/2009	ALL	
CDS - VIDEO COAX SPLITTERS 2 AND 4 DU STATUS	31-62-22		1	1	Feb 09/2009	ALL	
				2	Feb 09/2009	ALL	
CDS - CONTROL PANEL INTERFACES - F/O	31-62-23		1		Mar 31/2005	YC001-YC002 YC007	
				2	Mar 31/2005	YC003	
				3	Mar 31/2005	YC004-YC006	
				4	Feb 09/2009	YC008-YK920 YM643-YM646	
				5	Aug 13/2008	YL401-YL430 YM647-YM670	

31-CONTENTS



737-700/800

WIRING DIAGRAM MANUAL

CHAPTER 31
INDICATING / RECORDING SYSTEMS

Title	CH-SC-SU	Schem	Page	Sheet	Date	Effectivity	
CDS - DEU 2 ENGINE HYDRAULIC, APU AND FUEL INTERFACES	31-62-24		1	1	Jul 17/2007	YC001-YC030	
				2	Jul 17/2007	YC001-YC030	
			2	1	Feb 09/2009	YC031-YM670	
				2	Feb 09/2009	YC031-YM670	
CDS - DEU 2 AVIONICS INTERFACES	31-62-25		1.1A	1	Mar 31/2005	YC001-YC007	
				2	Mar 31/2005	YC001-YC007	
				3	Mar 31/2005	YC001-YC007	
			2.1	1	Mar 31/2005	YC008-YC011	
				2	Mar 31/2005	YC008-YC011	
				3	Mar 31/2005	YC008-YC011	
				4	Mar 31/2005	YC008-YC011	
			3	1	Jul 17/2007	YC012-YC030	
				2	Jul 17/2007	YC012-YC030	
				3	Jul 17/2007	YC012-YC030	
				4	Jul 17/2007	YC012-YC030	
			4	1	Oct 20/2006	YK901-YK906	
				2	Oct 20/2006	YK901-YK906	
				3	Jan 18/2007	YK901-YK906	
				4	Oct 20/2006	YK901-YK906	
				5	1	Feb 09/2009	YK907-YM670
					2	Feb 09/2009	YK907-YM670
		3	Feb 09/2009	YK907-YM670			
		4	Feb 09/2009	YK907-YM670			
CDS - DEU SELECT AND PROGRAM PINS	31-62-41		1.1		Jul 17/2007	YC001-YC030	
				2	Feb 09/2009	YC031-YM670	
CDS - VIDEO MONITORING	31-62-42		1		Feb 09/2009	YK907-YK911 YK918 YL421-YL426 YM643-YM651	
				2	Feb 09/2009	YK912-YK917 YK919-YL401 YL427-YL430 YM652-YM670	

31-CONTENTS

Page 10
Aug 10/2009

D280A103



737-700/800

WIRING DIAGRAM MANUAL

CHAPTER 31 INDICATING / RECORDING SYSTEMS

CH-SC-SU	Title
31-53-11	AURAL WARNING - TAKEOFF WARNING
31-51-11	AURAL WARNING SYSTEM
31-62-13	CDS - CONTROL PANEL INTERFACES - CAPTAINS
31-62-23	CDS - CONTROL PANEL INTERFACES - F/O
31-62-15	CDS - DEU 1 AVIONICS INTERFACES
31-62-14	CDS - DEU 1 ENGINE HYDRAULIC, APU AND FUEL INTERFACES
31-62-25	CDS - DEU 2 AVIONICS INTERFACES
31-62-24	CDS - DEU 2 ENGINE HYDRAULIC, APU AND FUEL INTERFACES
31-62-41	CDS - DEU SELECT AND PROGRAM PINS
31-62-11	CDS - POWER DISTRIBUTION AND INSTRUMENT LIGHTING CAPTAINS
31-62-21	CDS - POWER DISTRIBUTION AND INSTRUMENT LIGHTING FIRST OFFICER
31-62-12	CDS - VIDEO COAX SPLITTERS 1 AND 3 DU STATUS
31-62-22	CDS - VIDEO COAX SPLITTERS 2 AND 4 DU STATUS
31-62-42	CDS - VIDEO MONITORING
31-32-15	DATA LOADER INTERFACE
31-35-02	DIGITAL FLIGHT DATA RECORDER SYSTEM - ACMS INTERFACE
31-35-04	DIGITAL FLIGHT DATA RECORDER SYSTEM - ACMS INTERFACE
31-35-03	DIGITAL FLIGHT DATA RECORDER SYSTEM - ACMS INTERFACE 3
31-31-14	DIGITAL FLIGHT DATA RECORDER SYSTEM - ANALOG INTERFACE
31-35-01	DIGITAL FLIGHT DATA RECORDER SYSTEM - DATA LOADER INTERFACE
31-31-13	DIGITAL FLIGHT DATA RECORDER SYSTEM - DIGITAL INTERFACE
31-31-11	DIGITAL FLIGHT DATA RECORDER SYSTEM - INTERFACE
31-31-16	DIGITAL FLIGHT DATA RECORDER SYSTEM AIRPLANE CODING
31-31-15	DIGITAL FLIGHT DATA RECORDER SYSTEM DISCRETE INTERFACE
31-31-17	DIGITAL FLIGHT DATA RECORDER SYSTEM MANDATORY OPTIONS
31-22-11	ELECTRONIC CLOCK
31-52-52	MASTER CAUTION SYSTEM - AIR CONDITIONG CONTROL, BLEED AIR
31-52-51	MASTER CAUTION SYSTEM - AIR CONDITIONG CONTROL, PACK & TEMP

31-ALPHABETICAL INDEX

D280A103

Page 1
Jan 18/2007



737-700/800

WIRING DIAGRAM MANUAL

CHAPTER 31 INDICATING / RECORDING SYSTEMS

CH-SC-SU	Title
31-52-55	MASTER CAUTION SYSTEM - ANTI-ICE CONTROL, PITOT HEAT
31-52-56	MASTER CAUTION SYSTEM - ANTI-ICE CONTROL, WINDOW/COWL HEAT
31-52-35	MASTER CAUTION SYSTEM - APU CONTROL
31-52-65	MASTER CAUTION SYSTEM - DOOR WARNING
31-52-31	MASTER CAUTION SYSTEM - ELECTRICAL CONTROL, GENERATOR
31-52-32	MASTER CAUTION SYSTEM - ELECTRICAL CONTROL, POWER BUS
31-52-61	MASTER CAUTION SYSTEM - ENGINE CONTROL
31-52-25	MASTER CAUTION SYSTEM - FLIGHT CONTROLS
31-52-41	MASTER CAUTION SYSTEM - FUEL CONTROL
31-52-21	MASTER CAUTION SYSTEM - HYDRAULIC CONTROL
31-52-71	MASTER CAUTION SYSTEM - IRS CONTROL
31-52-75	MASTER CAUTION SYSTEM - OVERHEAD CONTROL
31-52-45	MASTER CAUTION SYSTEM - OVERHEAT DETECTION
31-52-11	MASTER CAUTION SYSTEM- POWER & CONTROL
31-33-01	PRINTER INTERFACE

31-ALPHABETICAL INDEX

D280A103

Page 2
Jan 18/2007

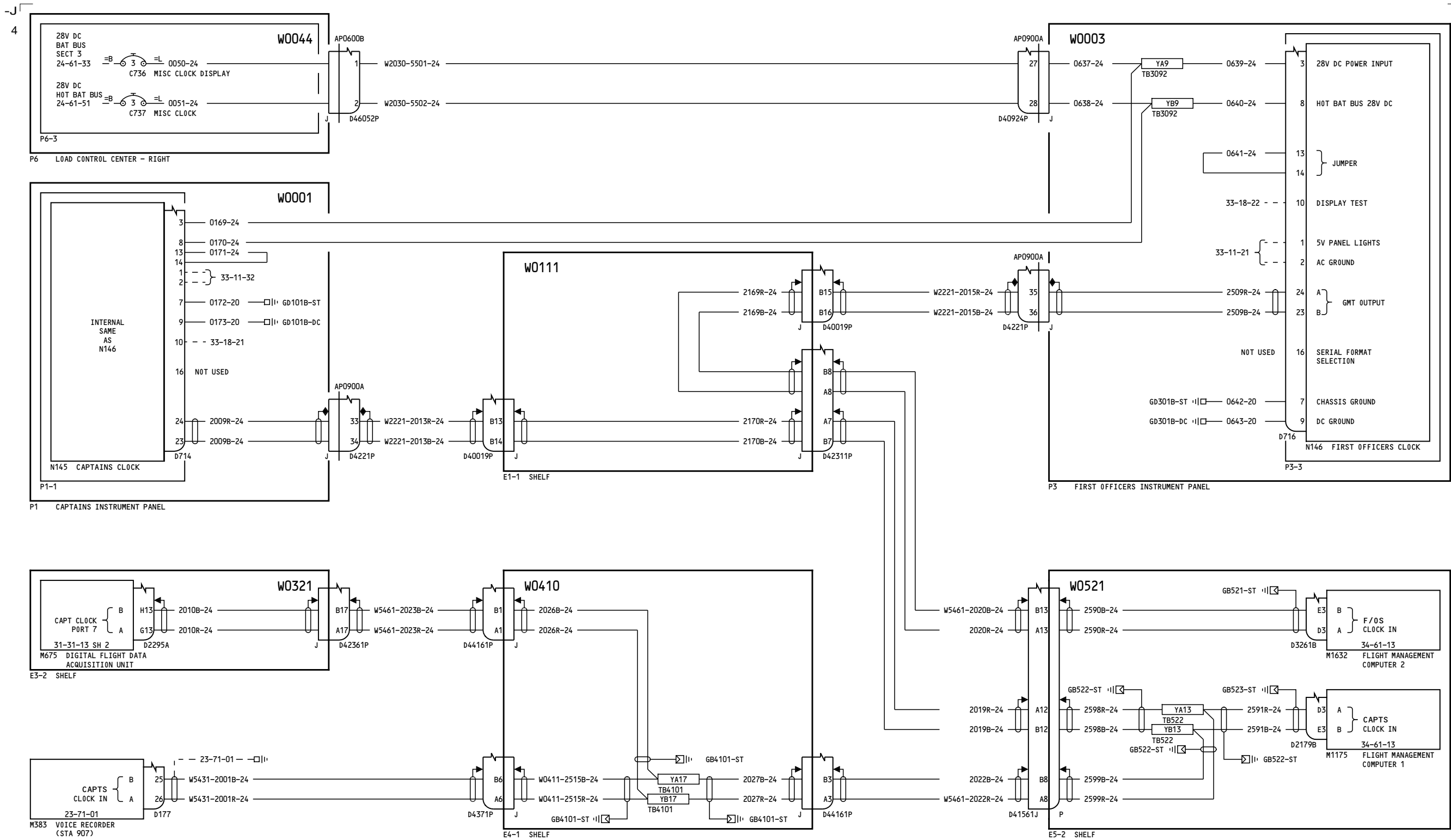

YC001-YC007

ELECTRONIC CLOCK

31-22-11

Page 1

D280A103

May 13/2008

31-22-11

Page 1

May 13/2008

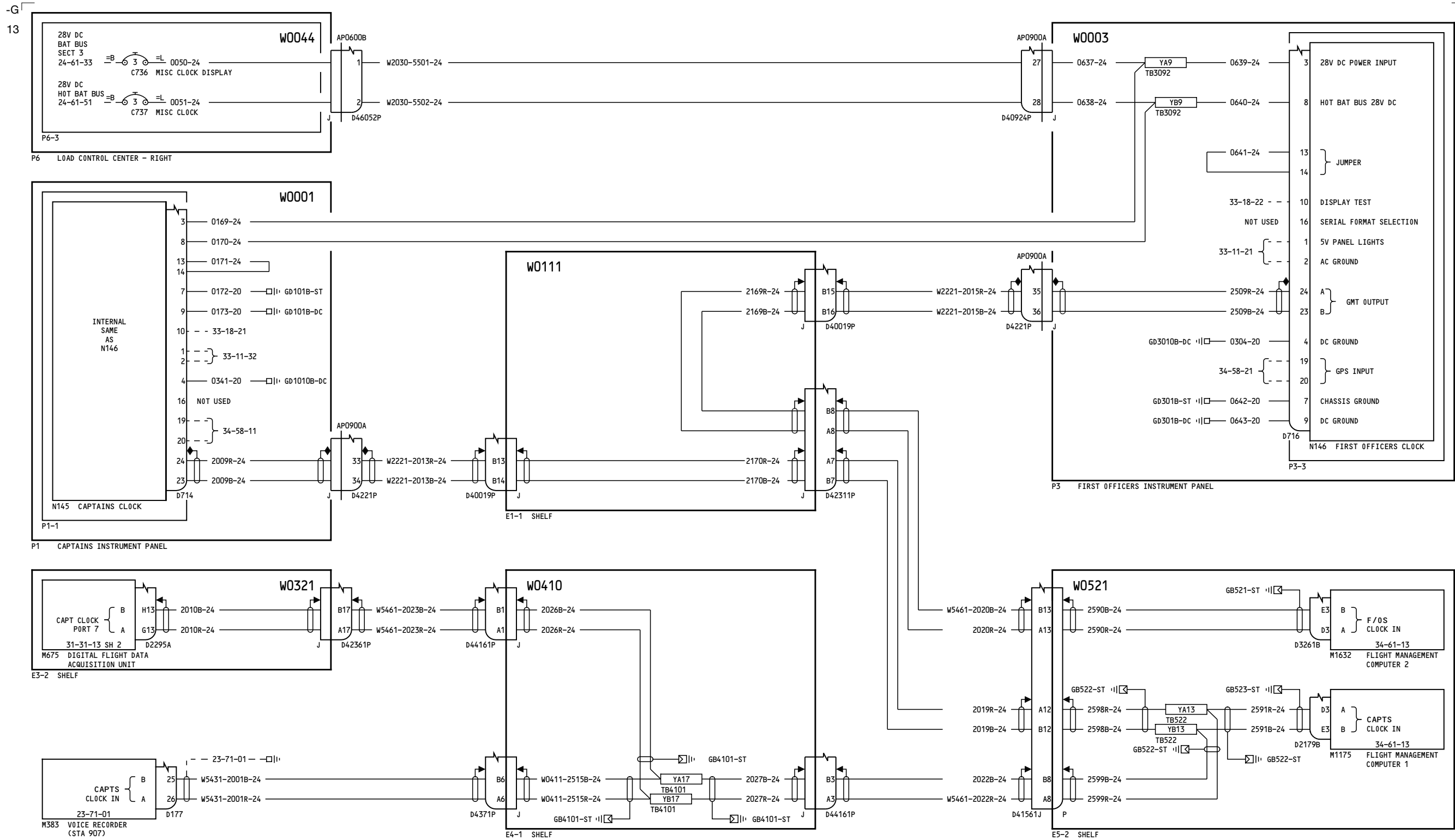

YC008-YC050, YK907-YM670

ELECTRONIC CLOCK

31-22-11

Page 2

D280A103

Feb 09/2009

31-22-11

Page 2

Feb 09/2009

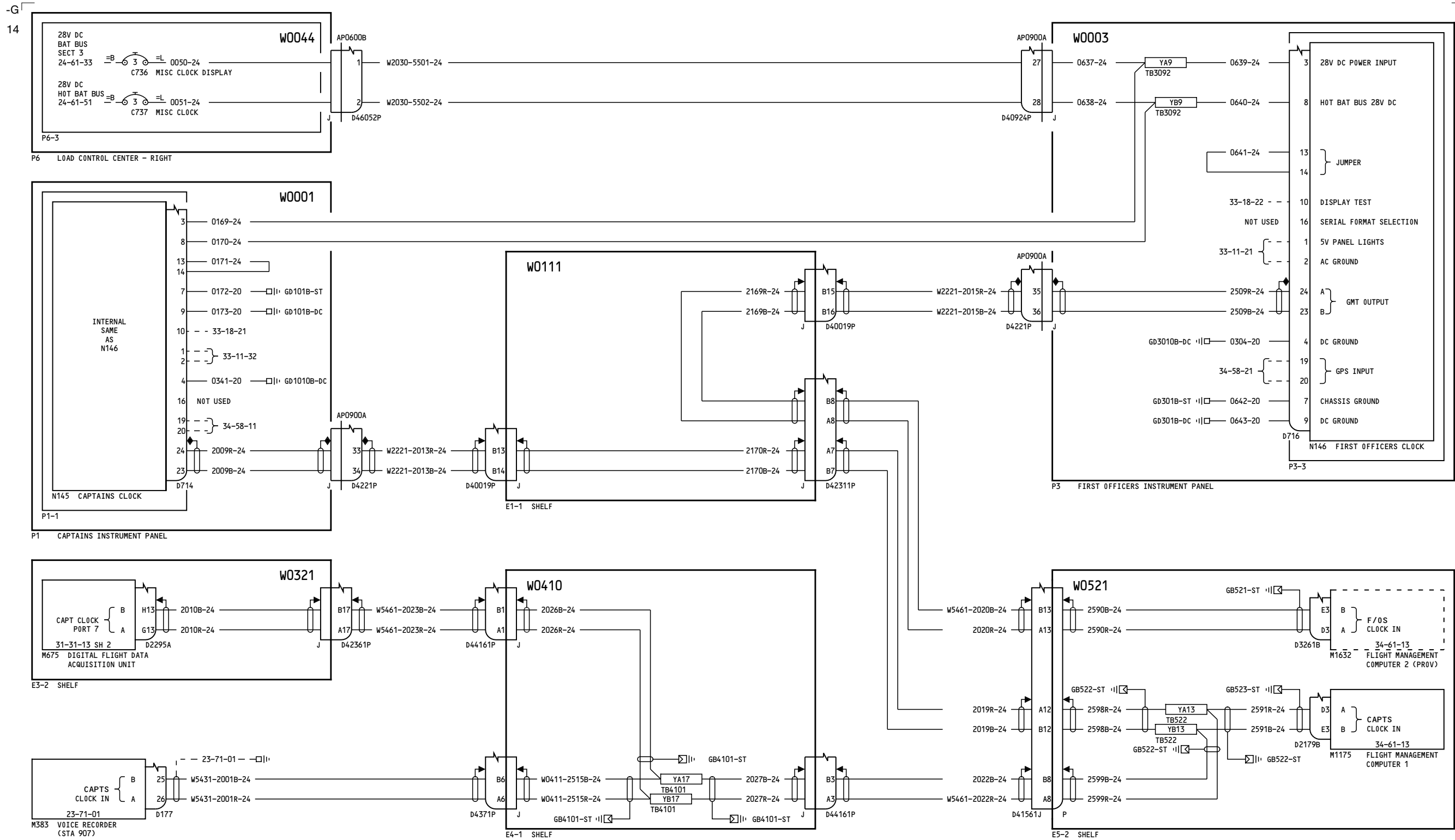

YK901-YK906

ELECTRONIC CLOCK

31-22-11

Page 3

D280A103

May 13/2008

31-22-11

Page 3

May 13/2008

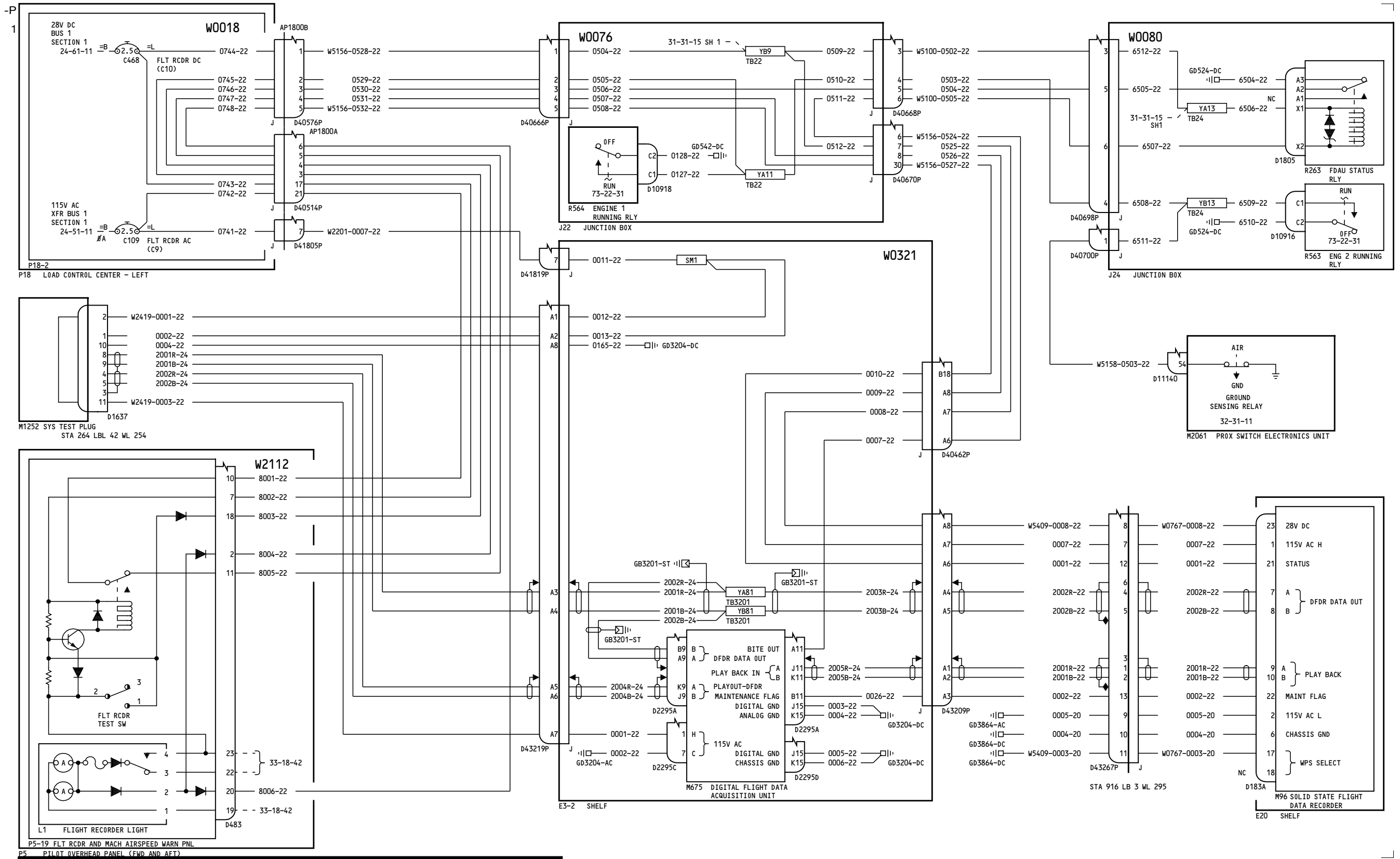

YC001-YC003

DIGITAL FLIGHT DATA RECORDER SYSTEM - INTERFACE

31-31-11

Page 1

D280A103

Apr 18/2006

31-31-11

Page 1

Apr 18/2006

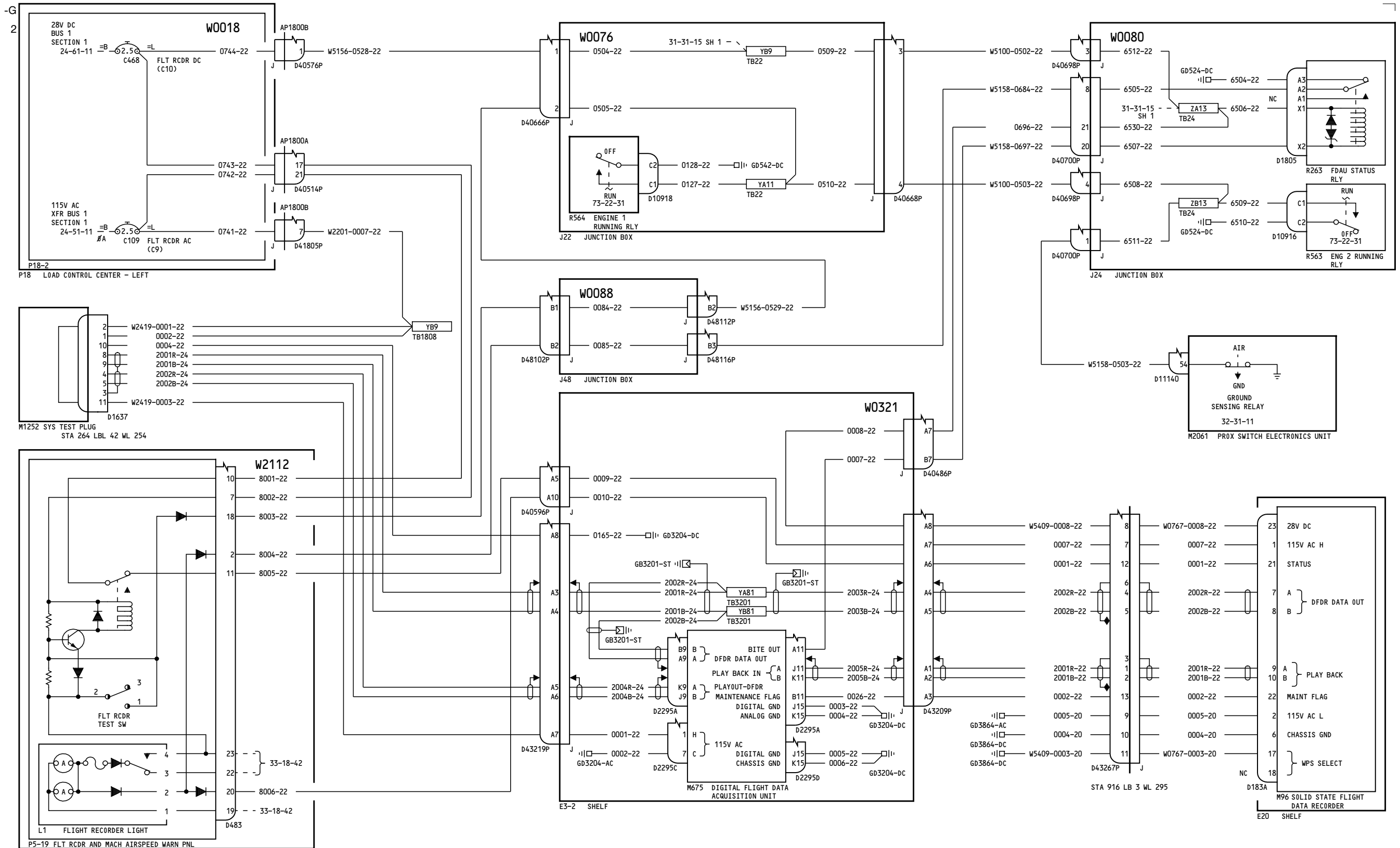

YC004-YM670

DIGITAL FLIGHT DATA RECORDER SYSTEM - INTERFACE

31-31-11

Page 2

D280A103

Feb 09/2009

31-31-11

Page 2

Feb 09/2009

-B
2

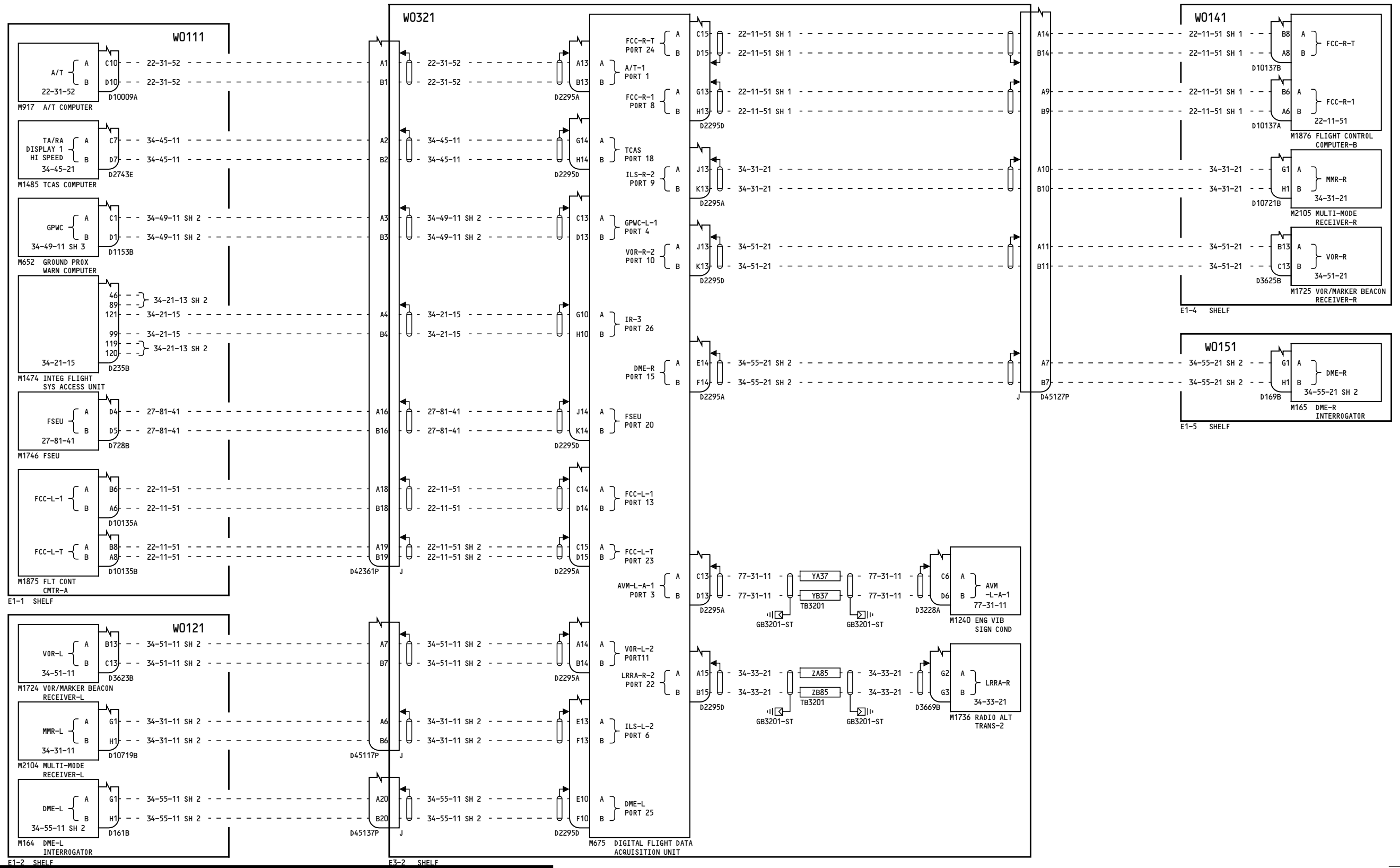

YC001-YC030

**DIGITAL FLIGHT DATA
RECORDER SYSTEM - DIGITAL
INTERFACE**

D280A103

31-31-13

Page 1
Sheet 1
Jul 17/2007

31-31-13

Page 1
Sheet 1
Jul 17/2007

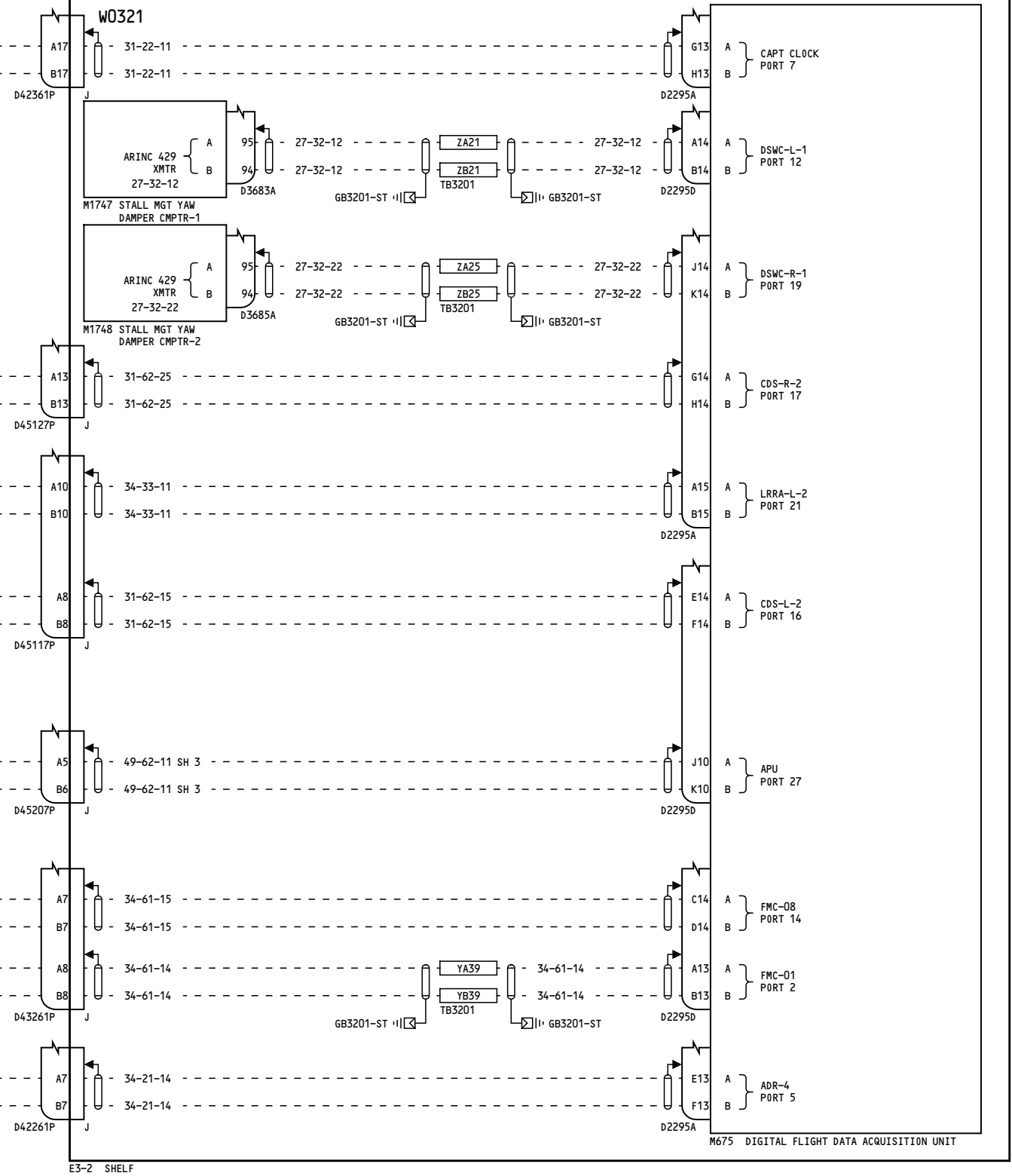
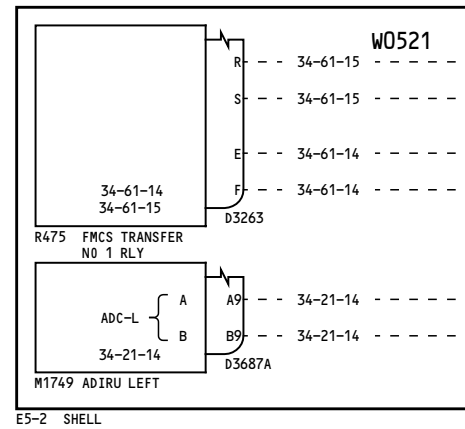
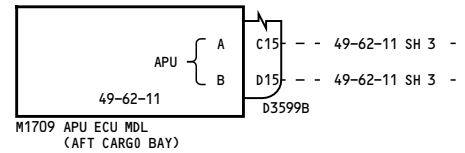
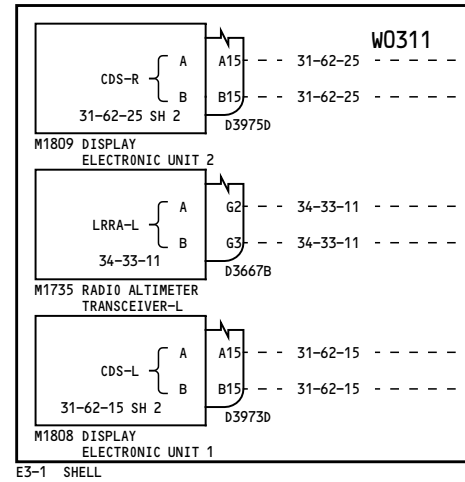
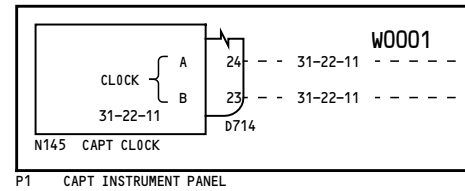

YC001-YC030

DIGITAL FLIGHT DATA RECORDER SYSTEM - DIGITAL INTERFACE

D280A103

31-31-13

Page 1
Sheet 2
Jul 17/2007

31-31-13

Page 1
Sheet 2
Jul 17/2007

3

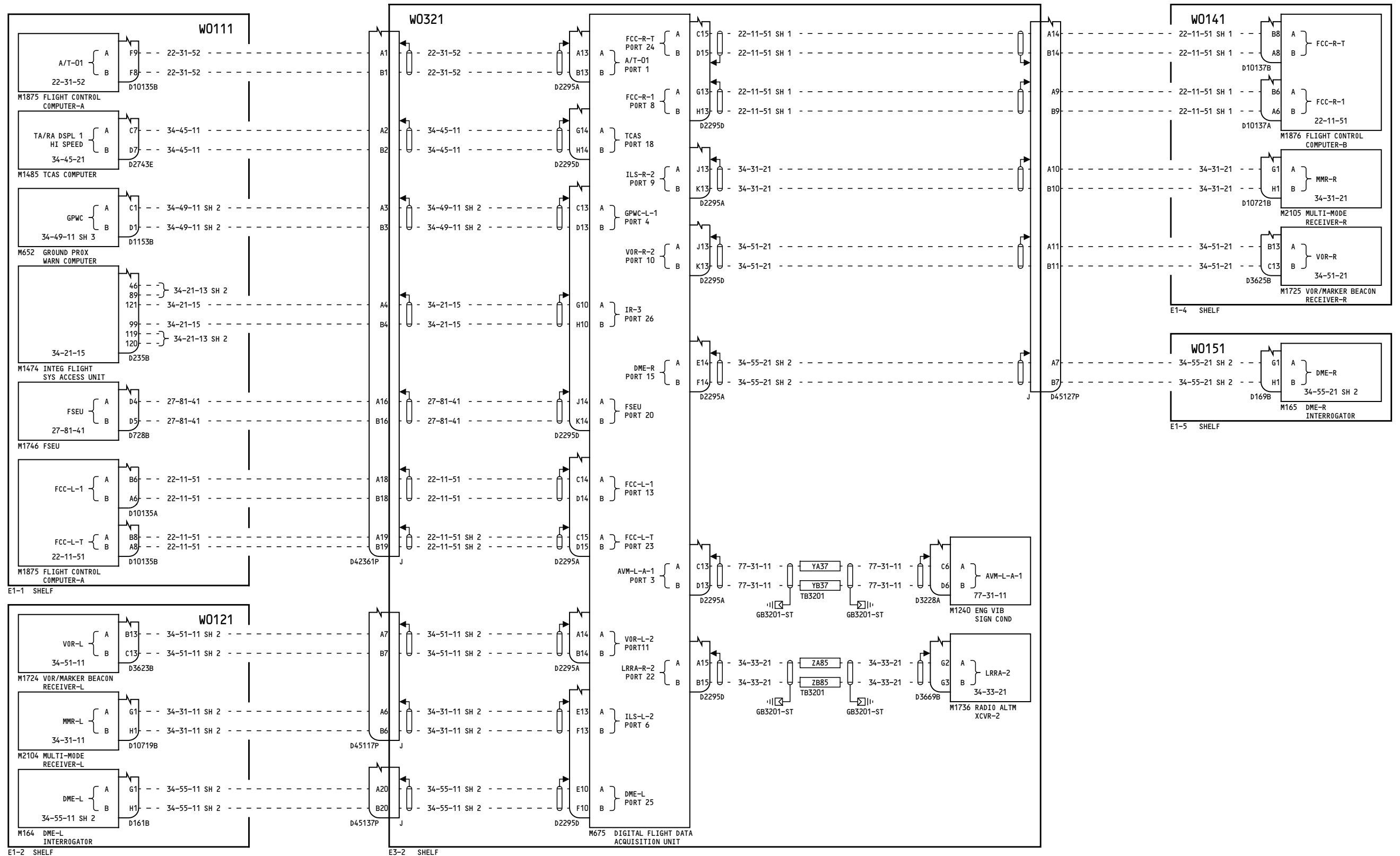

YC031-YM670

DIGITAL FLIGHT DATA RECORDER SYSTEM - DIGITAL INTERFACE

31-31-13

Page 2
Sheet 1
Feb 09/2009

D280A103

31-31-13

Page 2
Sheet 1
Feb 09/2009

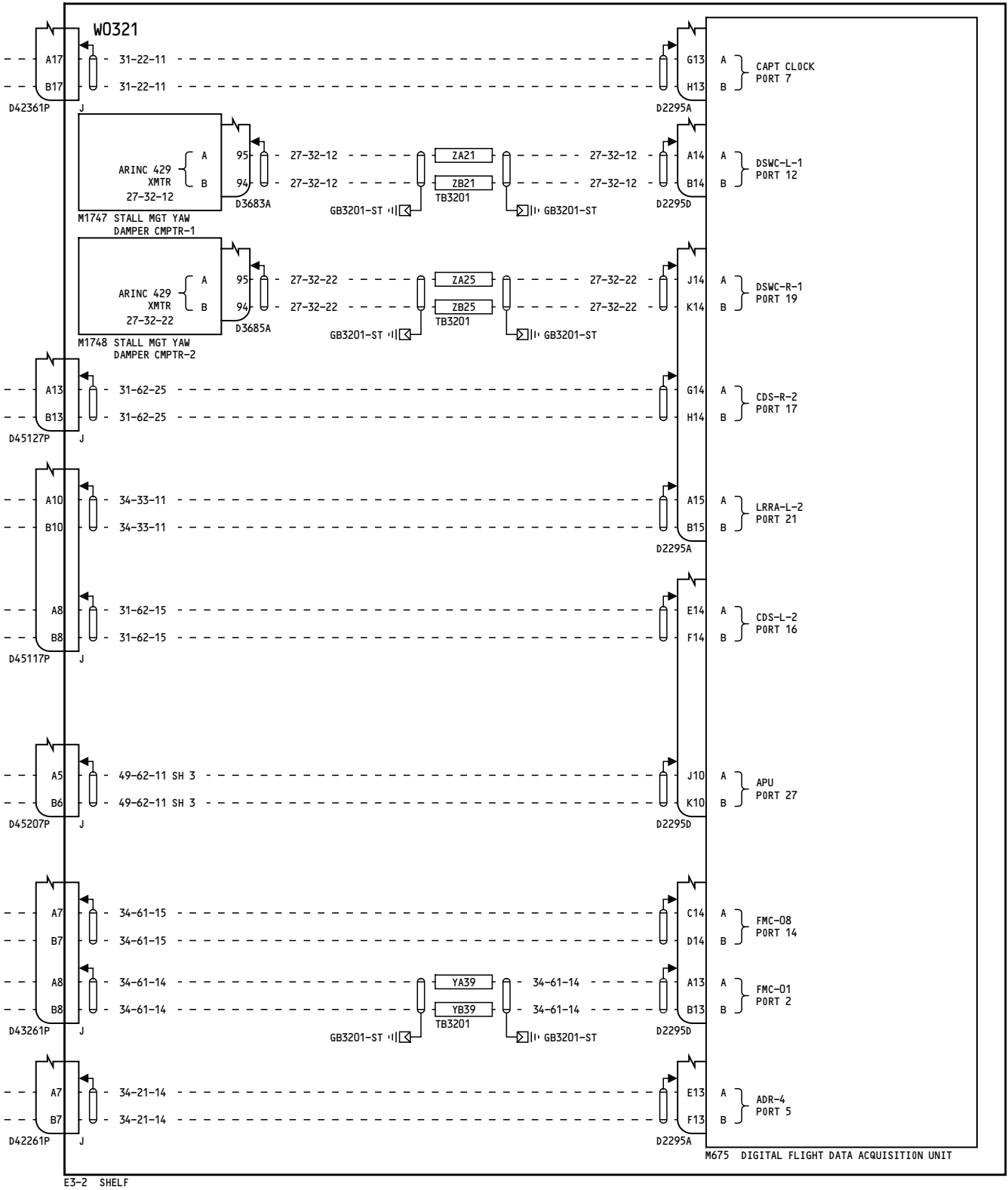
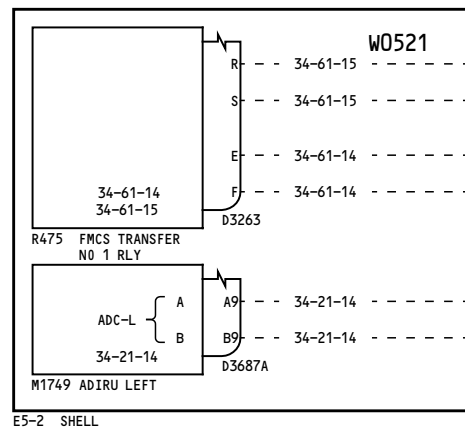
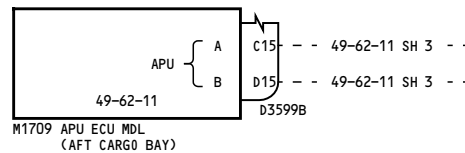
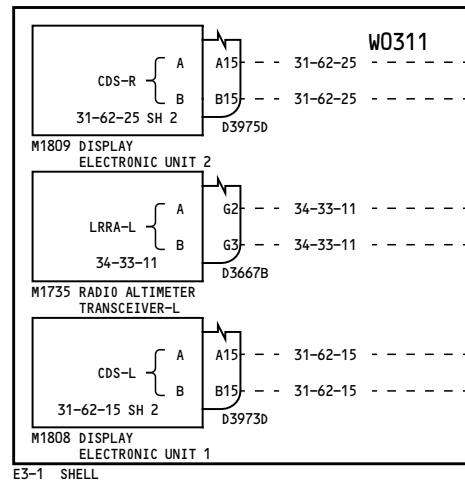
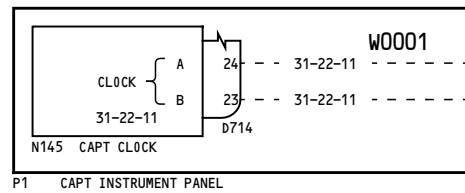

YC031-YM670

**DIGITAL FLIGHT DATA
RECORDER SYSTEM - DIGITAL
INTERFACE**

D280A103

31-31-13

Page 2
Sheet 2
Feb 09/2009

31-31-13

Page 2
Sheet 2
Feb 09/2009

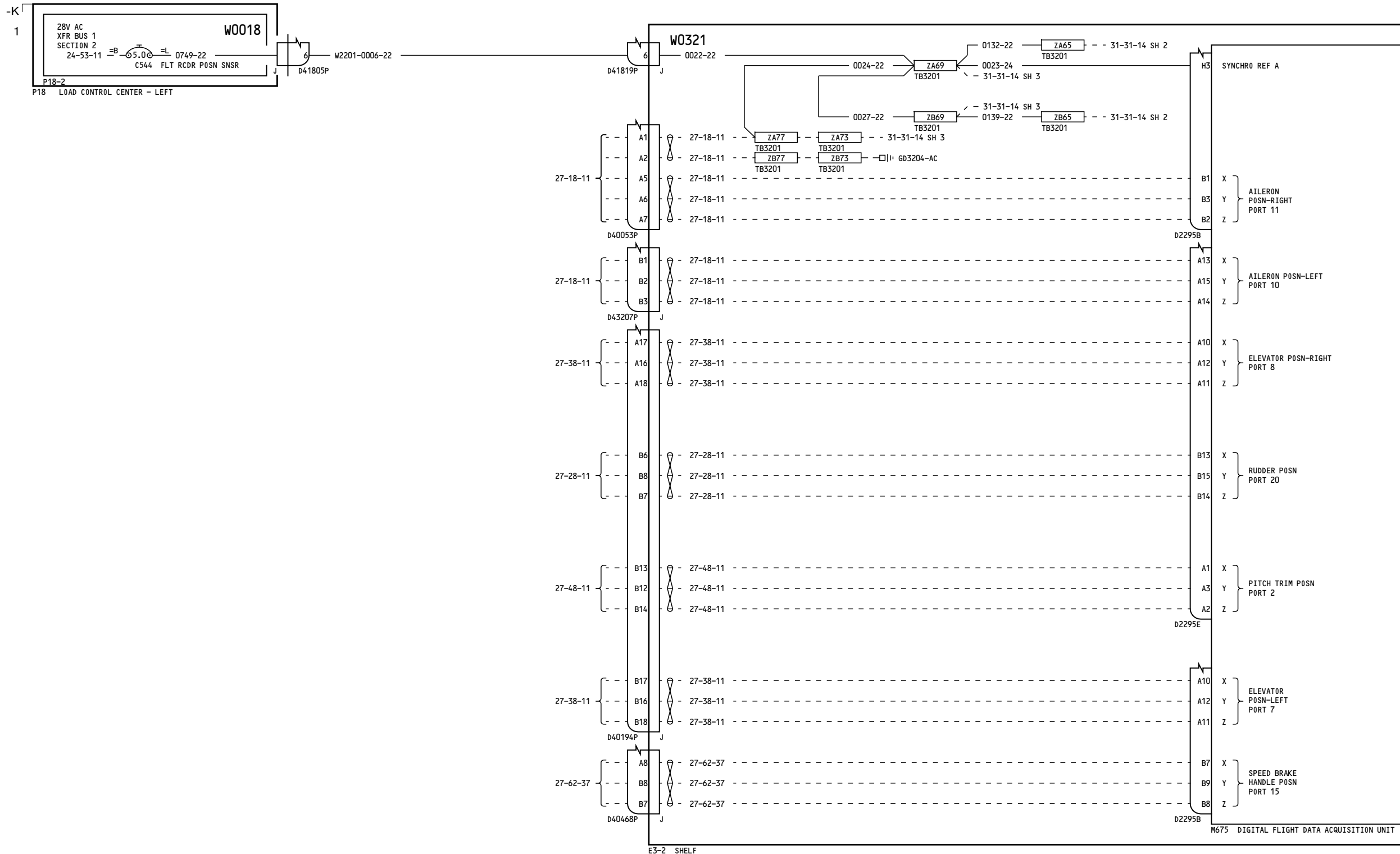

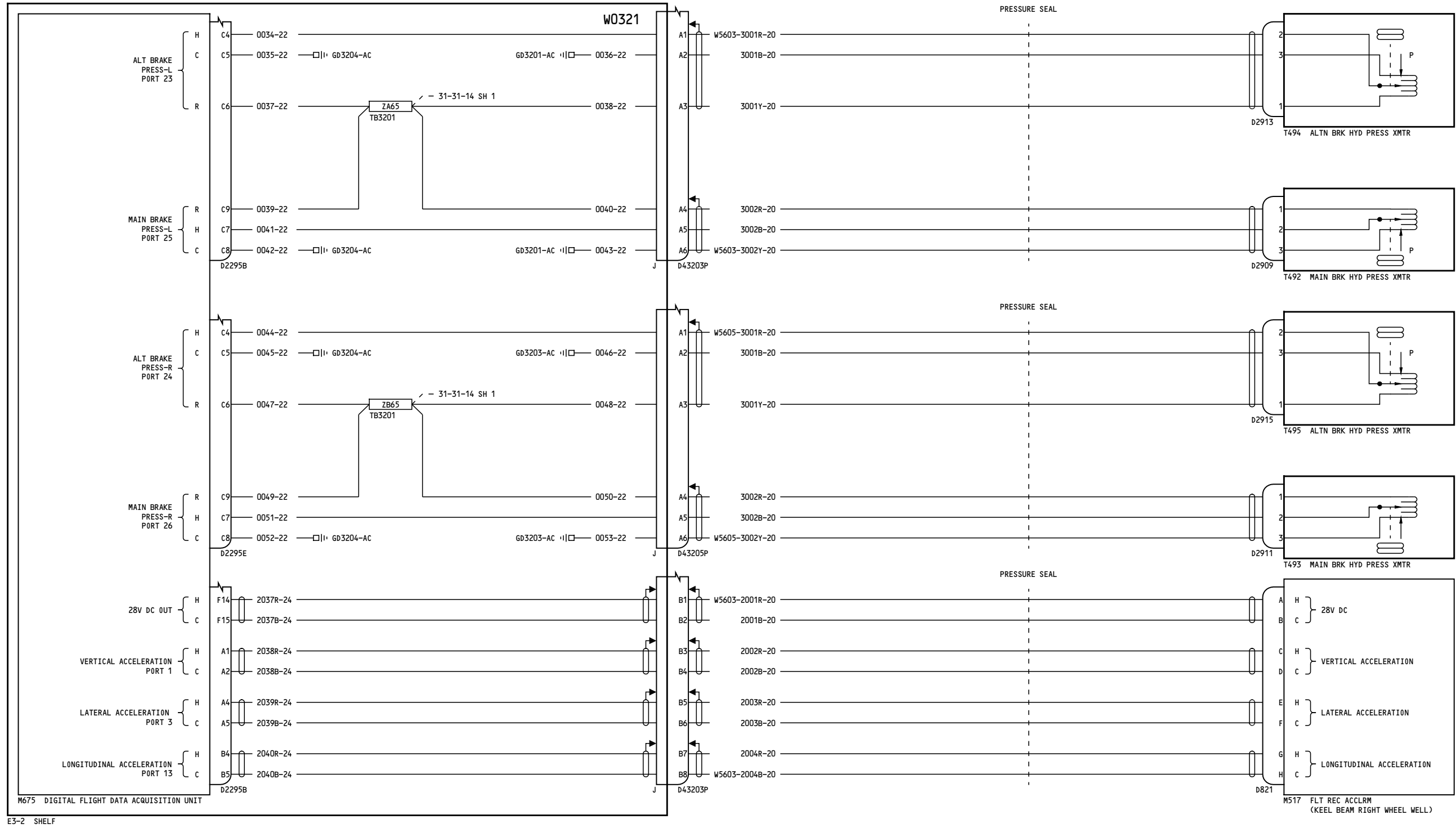

YC001-YC007

**DIGITAL FLIGHT DATA
RECORDER SYSTEM - ANALOG
INTERFACE**

31-31-14

Page 1
Sheet 2
Apr 18/2006

D280A103

31-31-14

Page 1
Sheet 2
Apr 18/2006

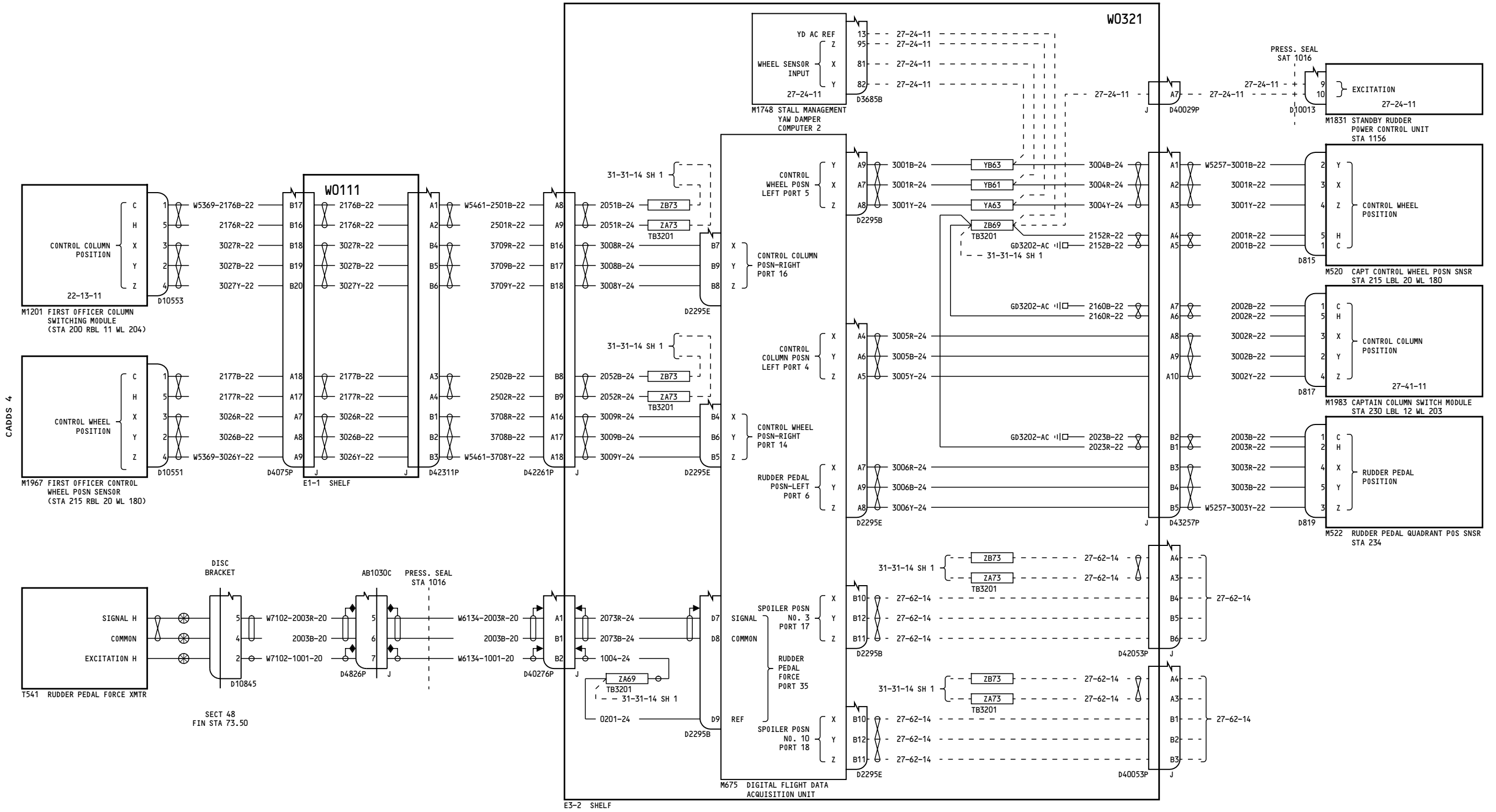

YC001-YC007

DIGITAL FLIGHT DATA RECORDER SYSTEM - ANALOG INTERFACE

31-31-14

Page 1
Sheet 3
Apr 18/2006

D280A103

31-31-14

Page 1
Sheet 3
Apr 18/2006

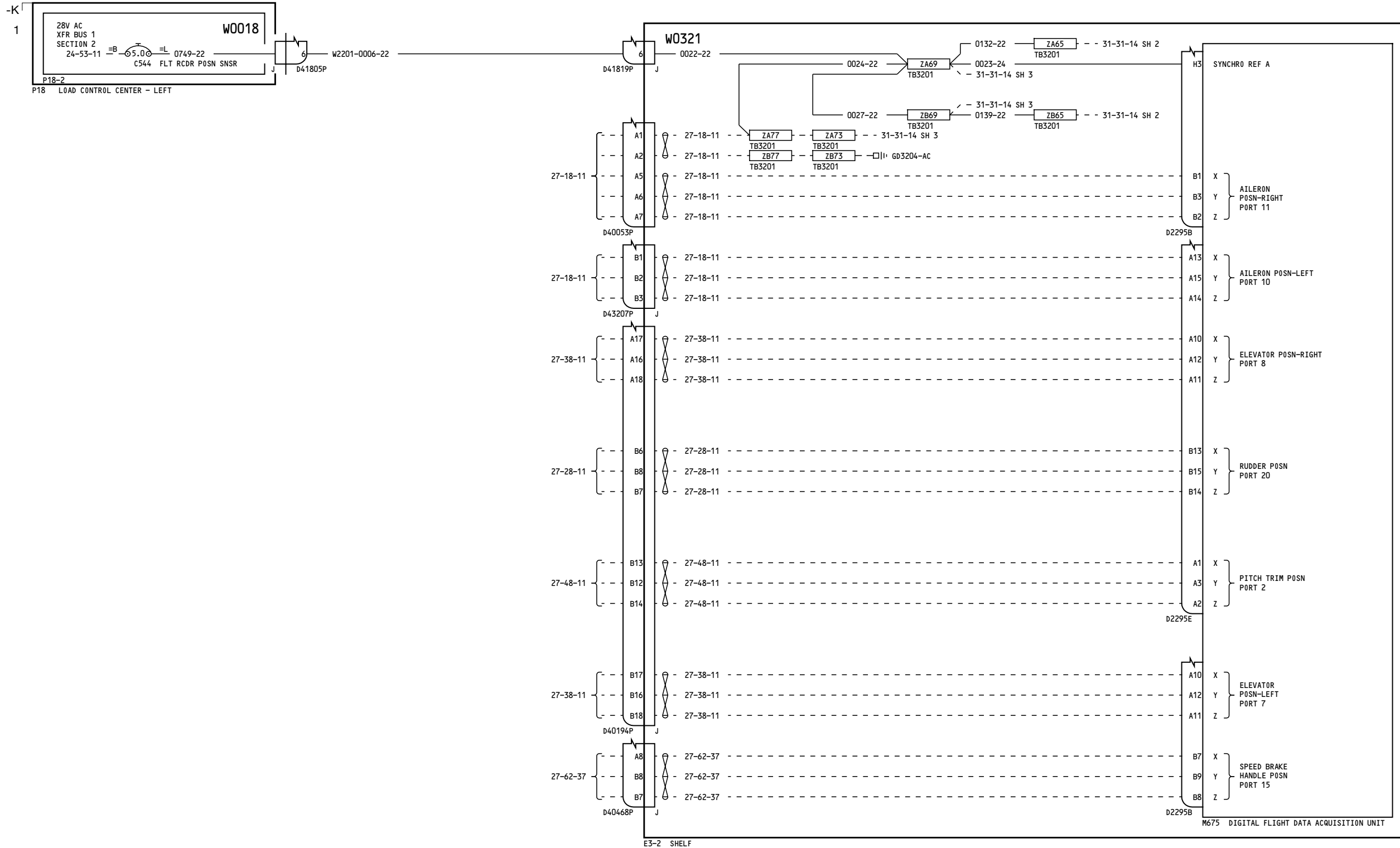

YC008-YC030

**DIGITAL FLIGHT DATA
RECORDER SYSTEM - ANALOG
INTERFACE**

D280A103

31-31-14

Page 2
Sheet 1
Jul 17/2007

31-31-14

Page 2
Sheet 1
Jul 17/2007

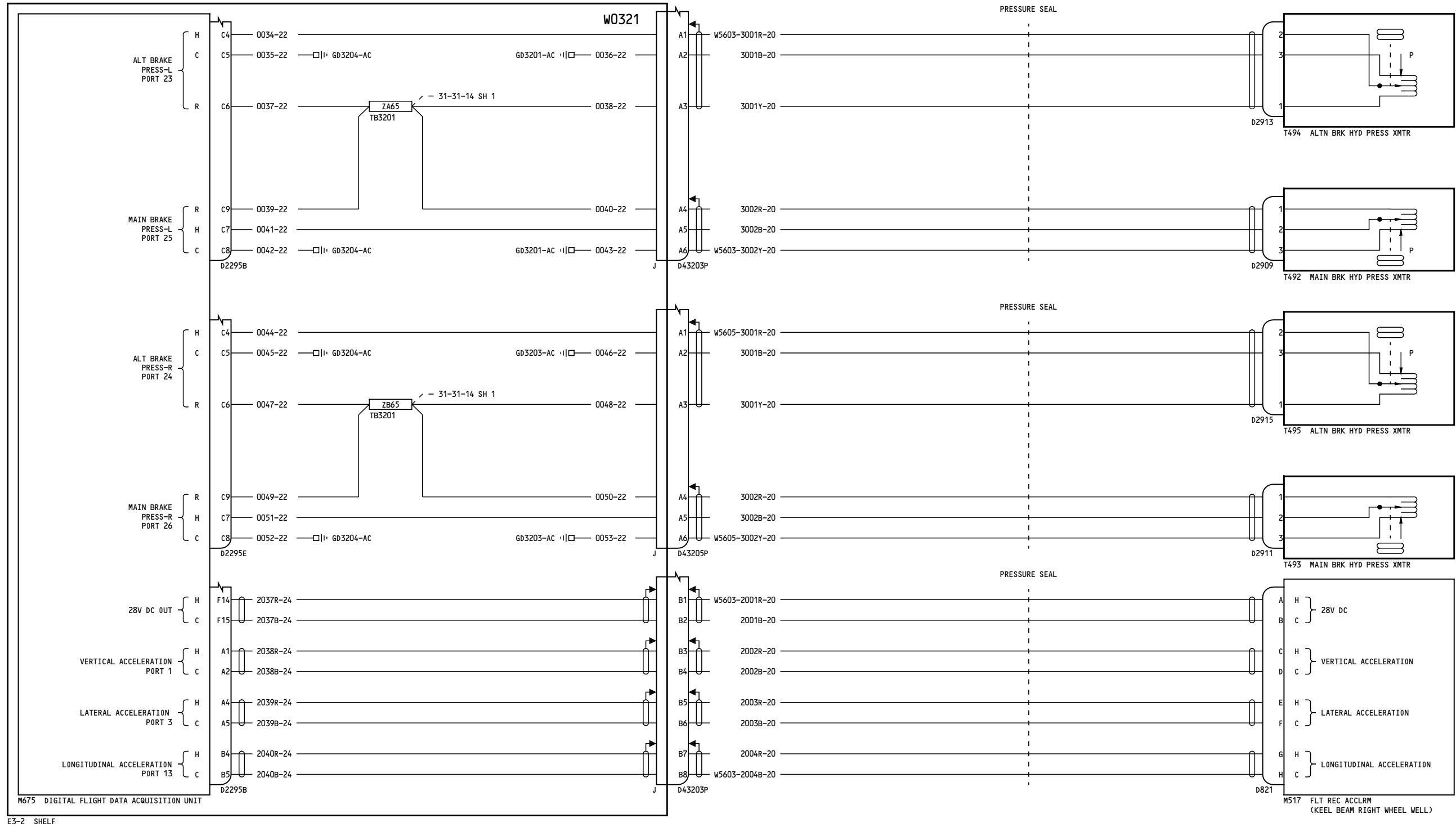

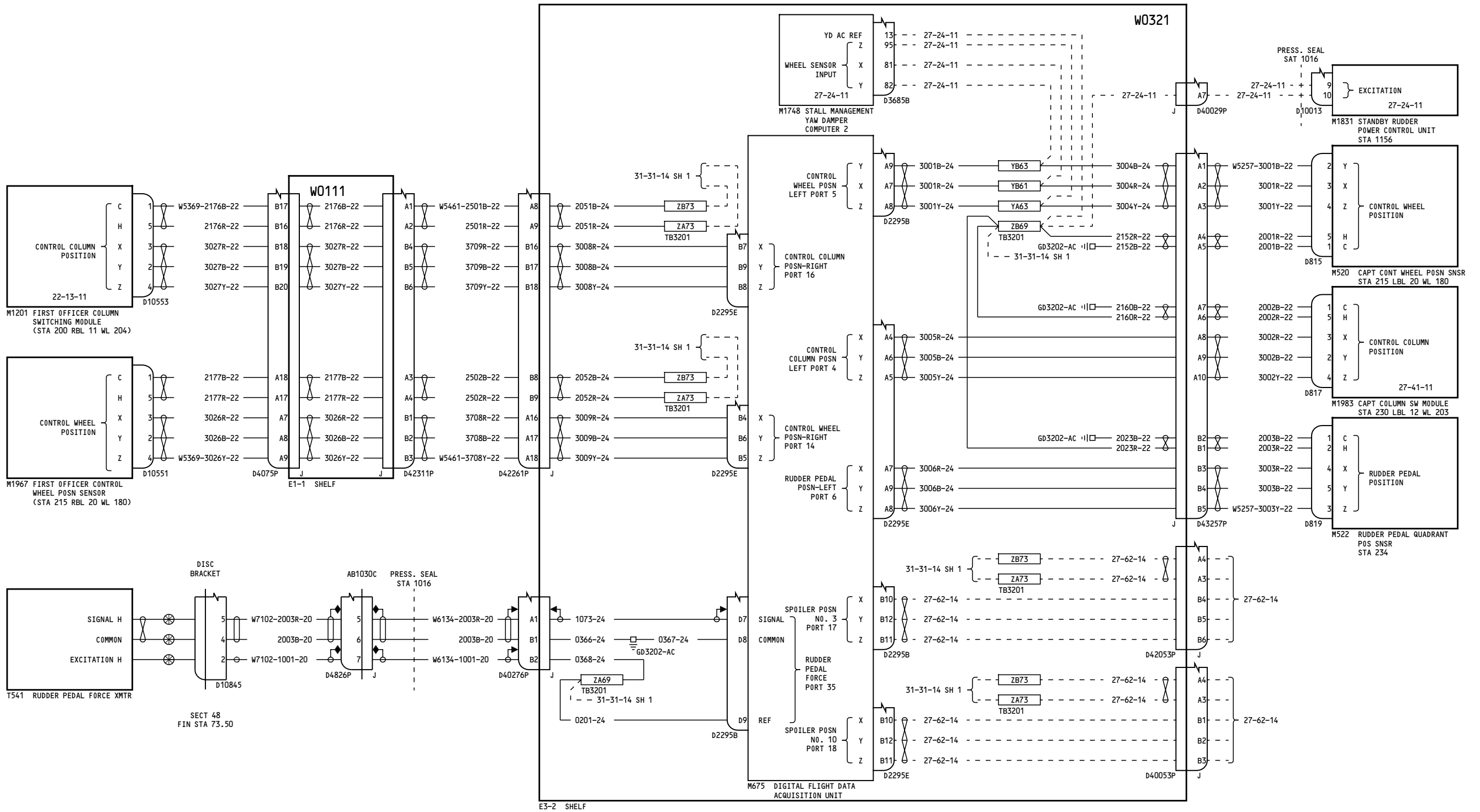

YC008-YC030

DIGITAL FLIGHT DATA RECORDER SYSTEM - ANALOG INTERFACE

31-31-14

D280A103

Page 2
Sheet 3
Jul 17/2007

31-31-14

Page 2
Sheet 3
Jul 17/2007

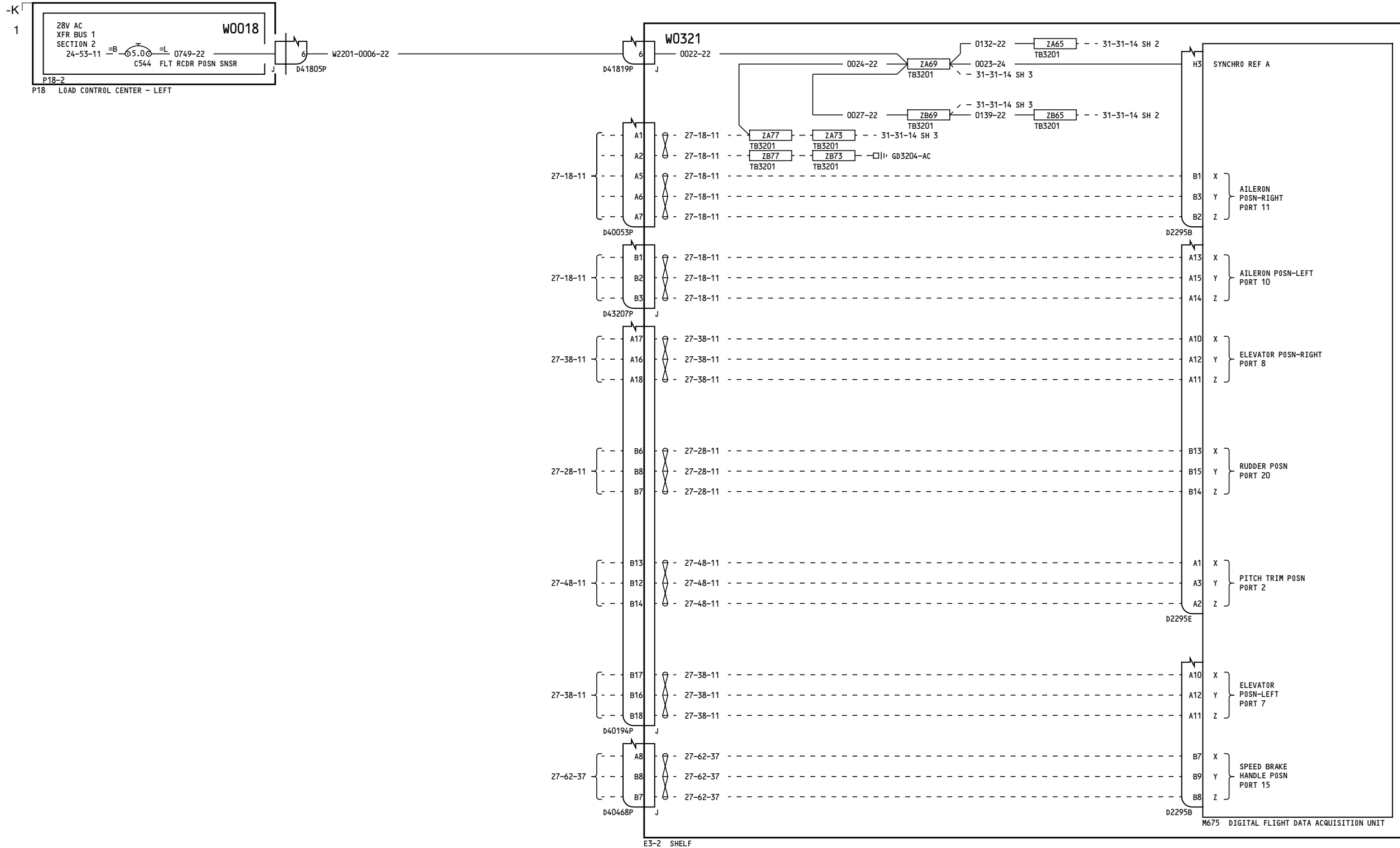

YK901-YK907, YL421

**DIGITAL FLIGHT DATA
RECORDER SYSTEM - ANALOG
INTERFACE**

D280A103

31-31-14

Page 3
Sheet 1
Jan 18/2007

31-31-14

Page 3
Sheet 1
Jan 18/2007

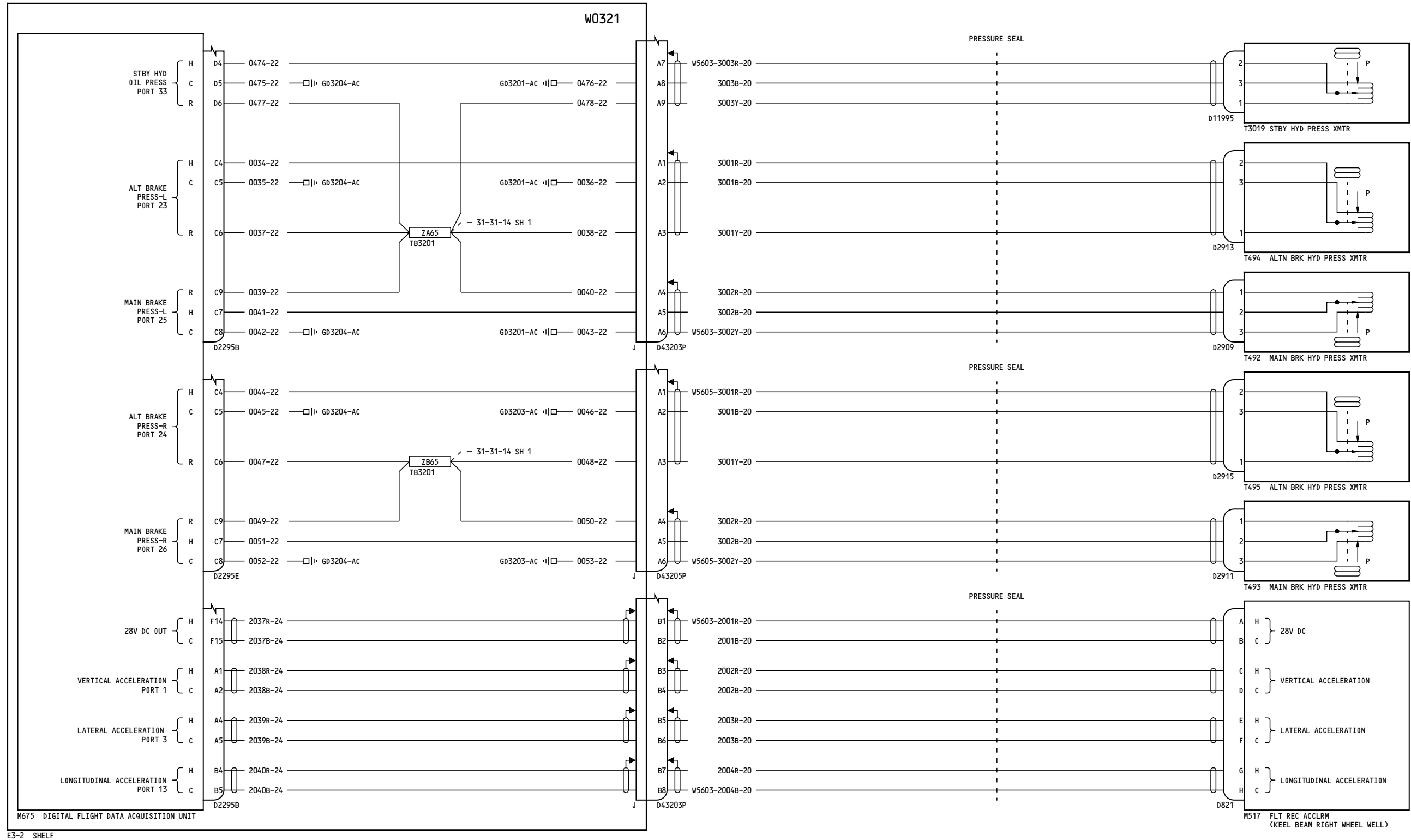

YK901-YK907, YL421

DIGITAL FLIGHT DATA RECORDER SYSTEM - ANALOG INTERFACE

31-31-14

Page 3
Sheet 2
Oct 20/2006

D280A103

31-31-14

Page 3
Sheet 2
Oct 20/2006

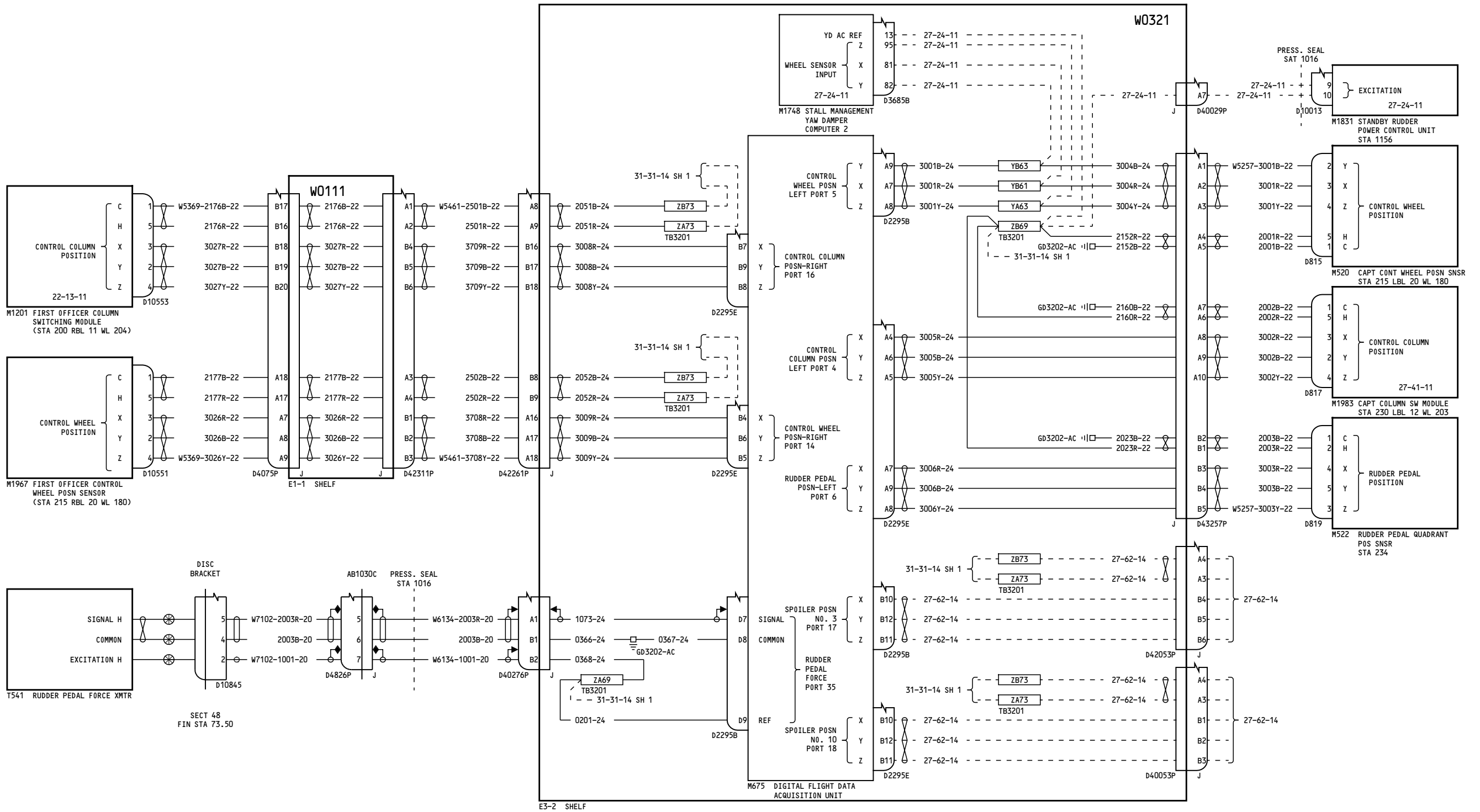

YK901-YK907, YL421

DIGITAL FLIGHT DATA RECORDER SYSTEM - ANALOG INTERFACE

31-31-14

Page 3
Sheet 3
Oct 20/2006

D280A103

31-31-14

Page 3
Sheet 3
Oct 20/2006

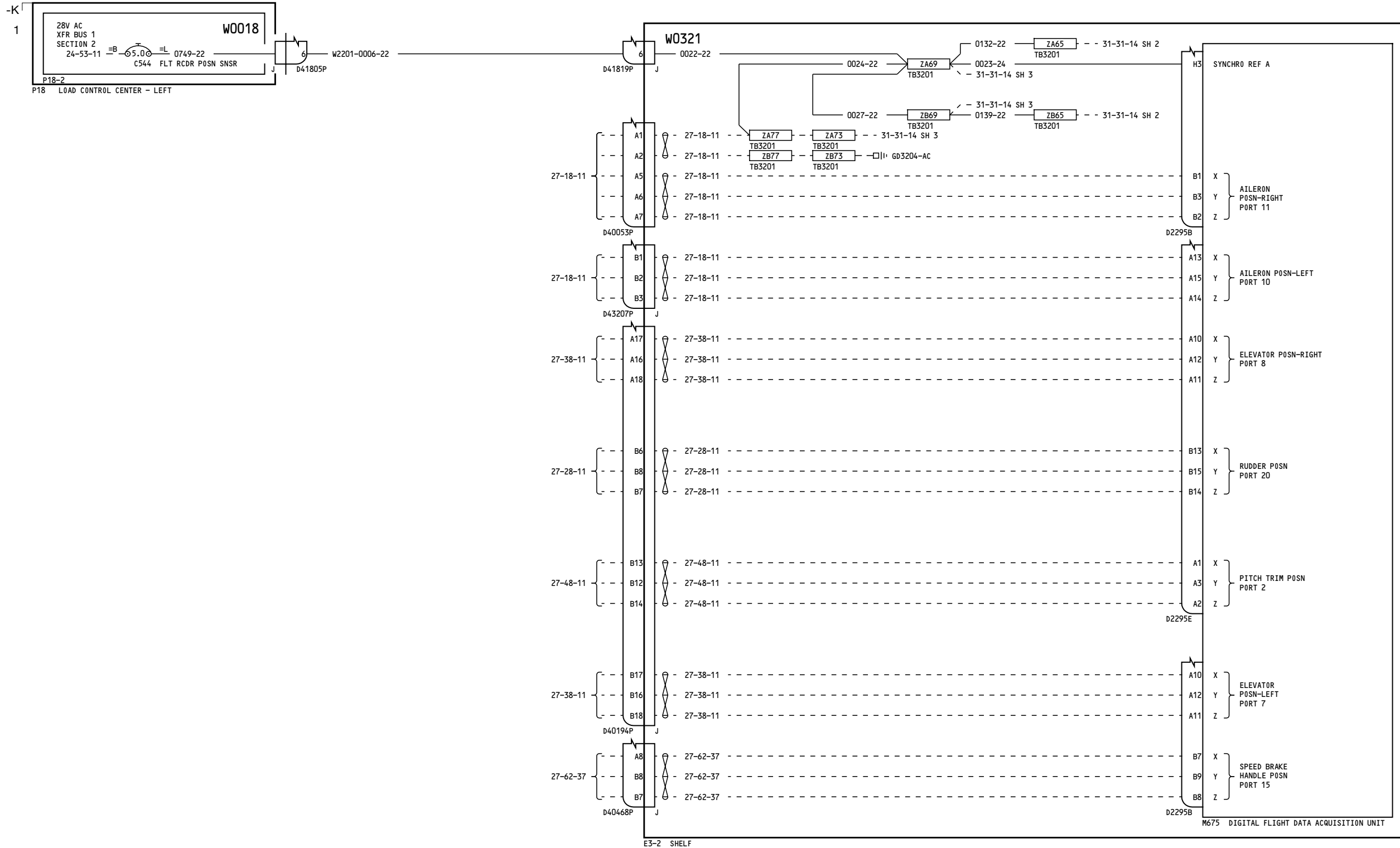

YK908-YL401, YL422-YL430

**DIGITAL FLIGHT DATA
RECORDER SYSTEM - ANALOG
INTERFACE**

D280A103

31-31-14

Page 4
Sheet 1
Feb 09/2009

31-31-14

Page 4
Sheet 1
Feb 09/2009

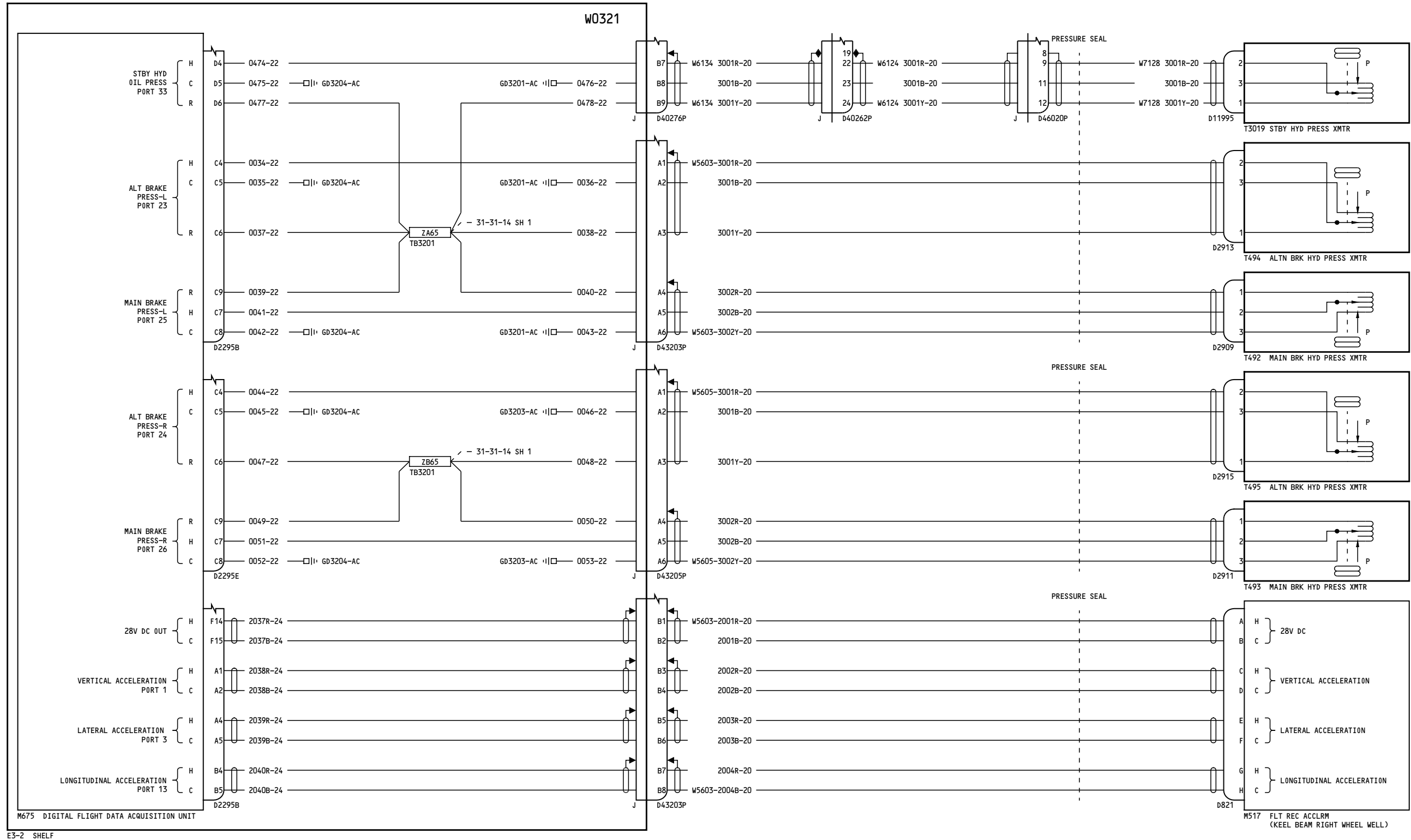

YK908-YL401, YL422-YL430

DIGITAL FLIGHT DATA RECORDER SYSTEM - ANALOG INTERFACE

D280A103

31-31-14

Page 4
Sheet 2
Feb 09/2009

31-31-14

Page 4
Sheet 2
Feb 09/2009

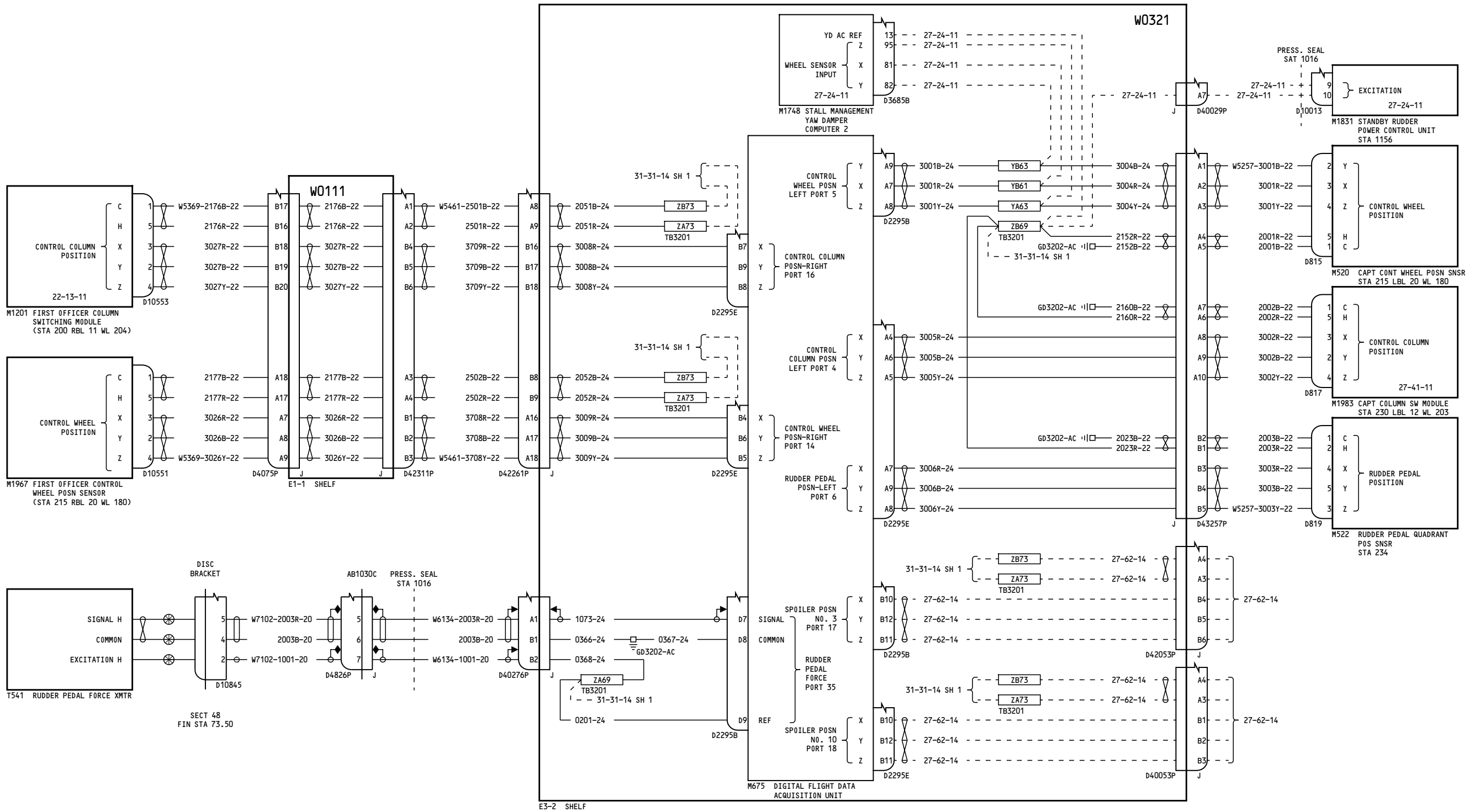

YK908-YL401, YL422-YL430

DIGITAL FLIGHT DATA RECORDER SYSTEM - ANALOG INTERFACE

31-31-14

Page 4
Sheet 3
Feb 09/2009

D280A103

31-31-14

Page 4
Sheet 3
Feb 09/2009

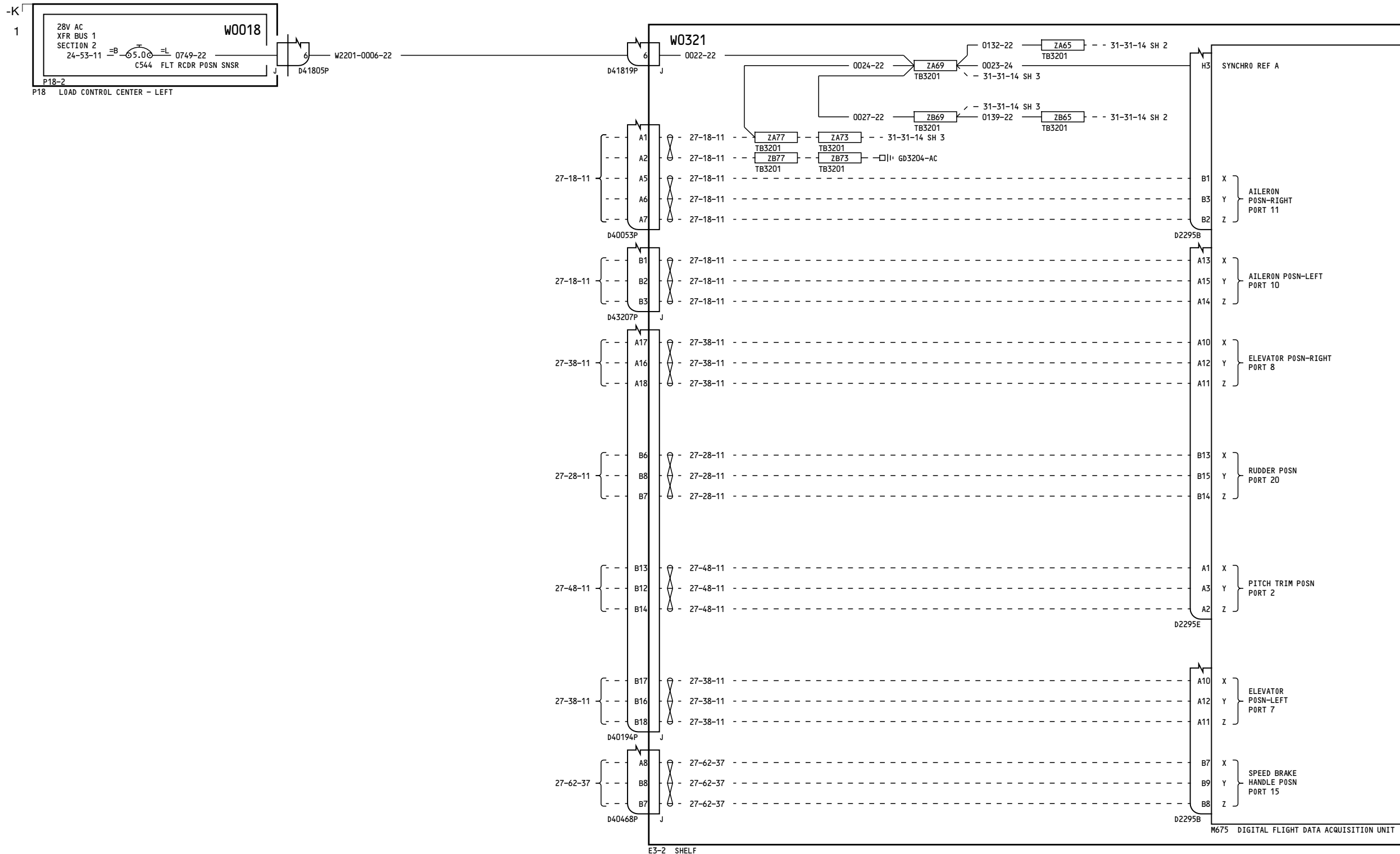

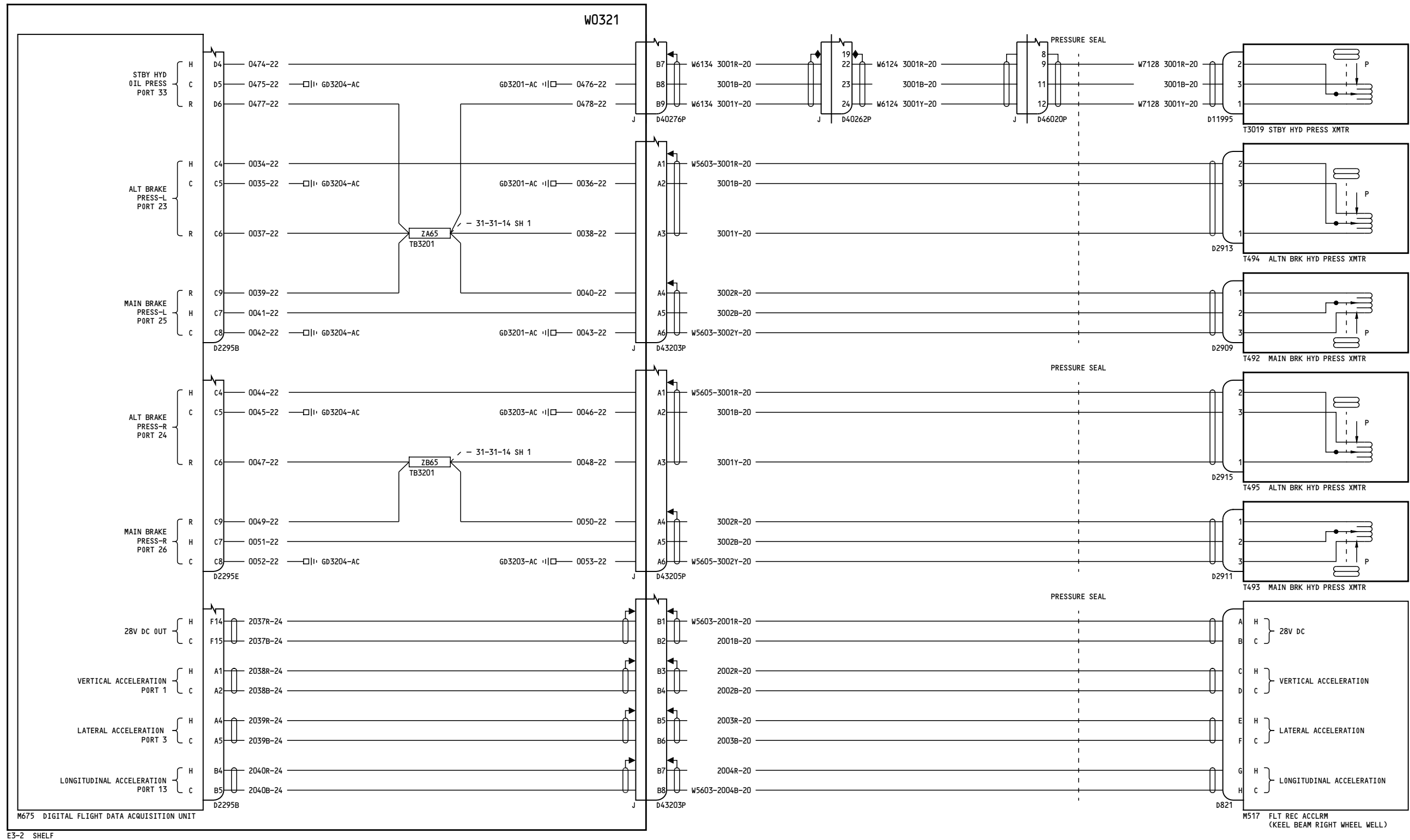

YM643-YM670

DIGITAL FLIGHT DATA RECORDER SYSTEM - ANALOG INTERFACE

31-31-14

D280A103

Page 5
Sheet 2
Jan 14/2008

31-31-14

Page 5
Sheet 2
Jan 14/2008

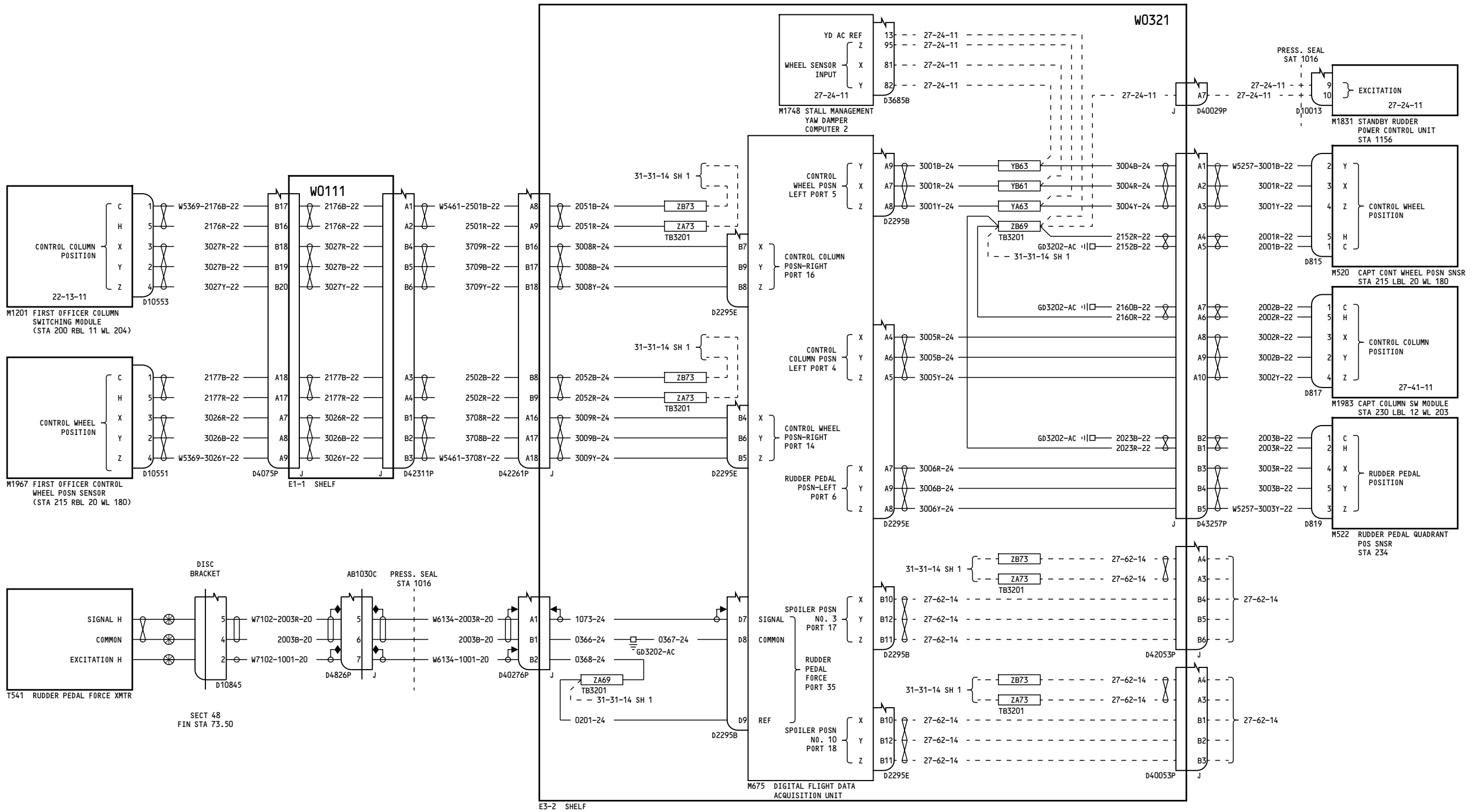

YM643-YM670

DIGITAL FLIGHT DATA RECORDER SYSTEM - ANALOG INTERFACE

D280A103

31-31-14

Page 5
Sheet 3
Jan 14/2008

31-31-14

Page 5
Sheet 3
Jan 14/2008

-C
2

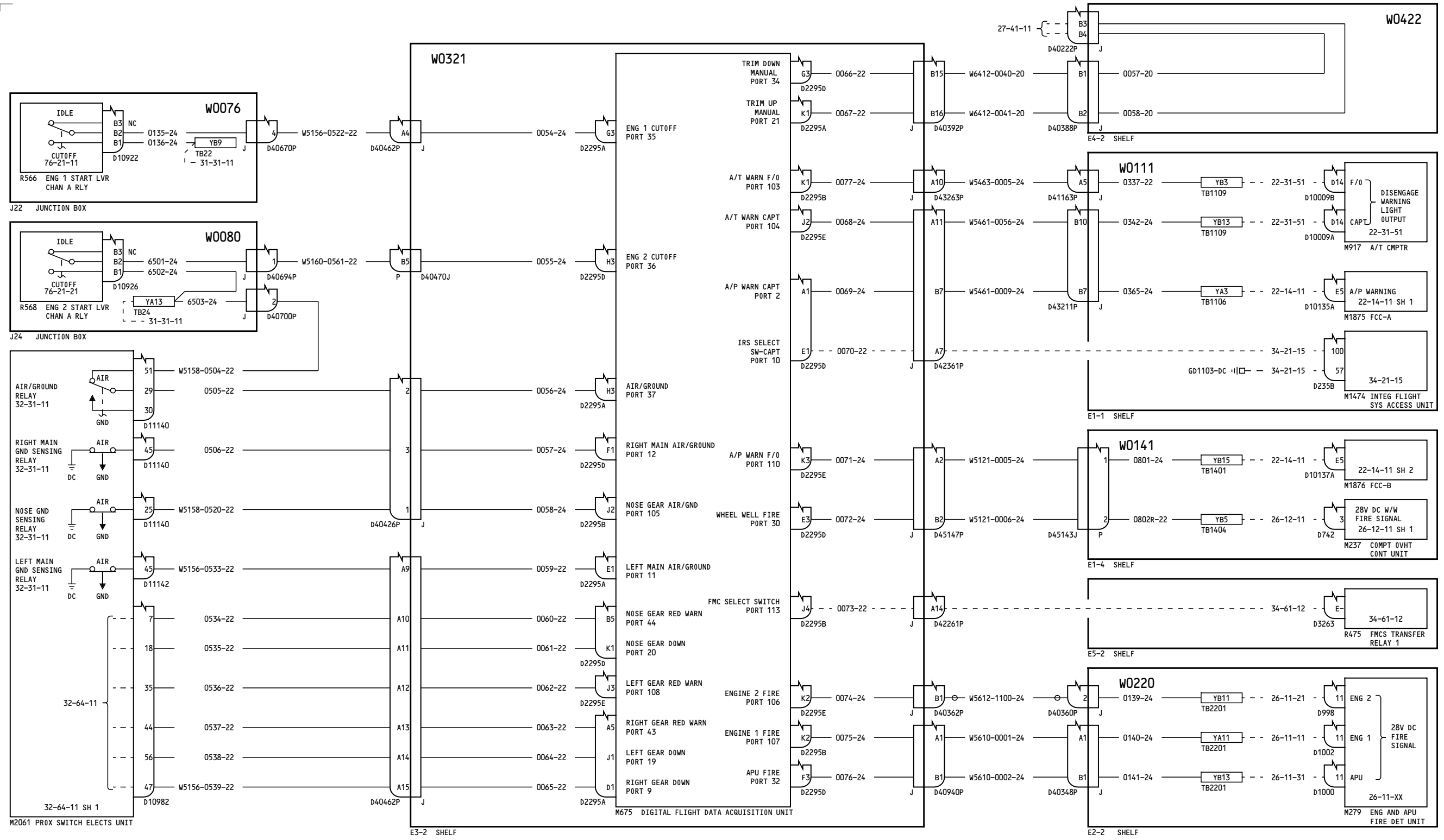

NOTES: EMC TYPE 1* WIRES MAY BE ROUTED NO MORE THAN 50 FEET WITH TYPE 2 WIRES.

YC001-YC003

DIGITAL FLIGHT DATA RECORDER SYSTEM DISCRETE INTERFACE

31-31-15

Page 1.1
Sheet 1
Aug 13/2008

D280A103

31-31-15

Page 1.1
Sheet 1
Aug 13/2008

-D
1

CADD 4

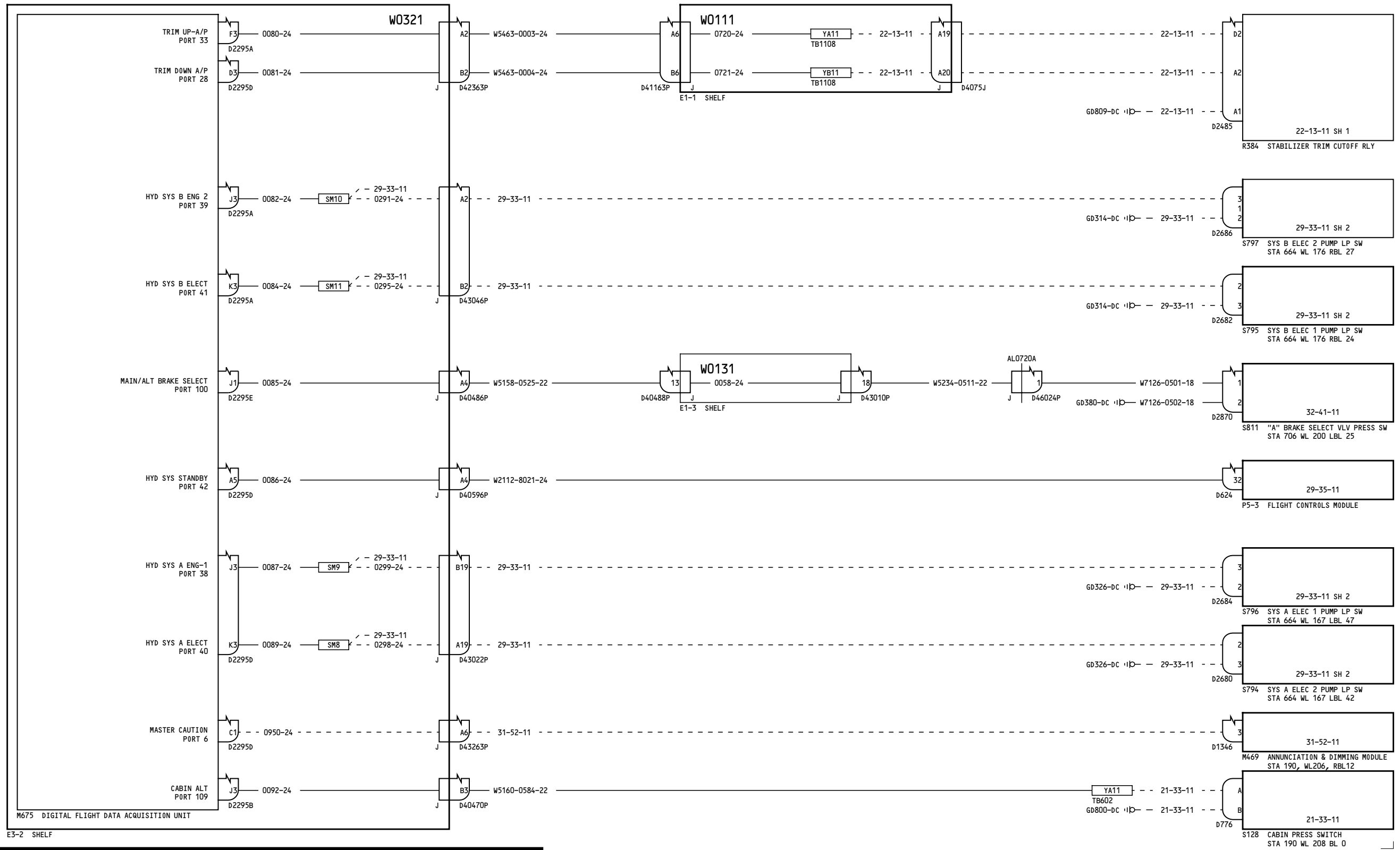

YC001-YC003

DIGITAL FLIGHT DATA RECORDER SYSTEM DISCRETE INTERFACE

D280A103

31-31-15

Page 1.1
Sheet 2
Aug 13/2008

31-31-15

Page 1.1
Sheet 2
Aug 13/2008

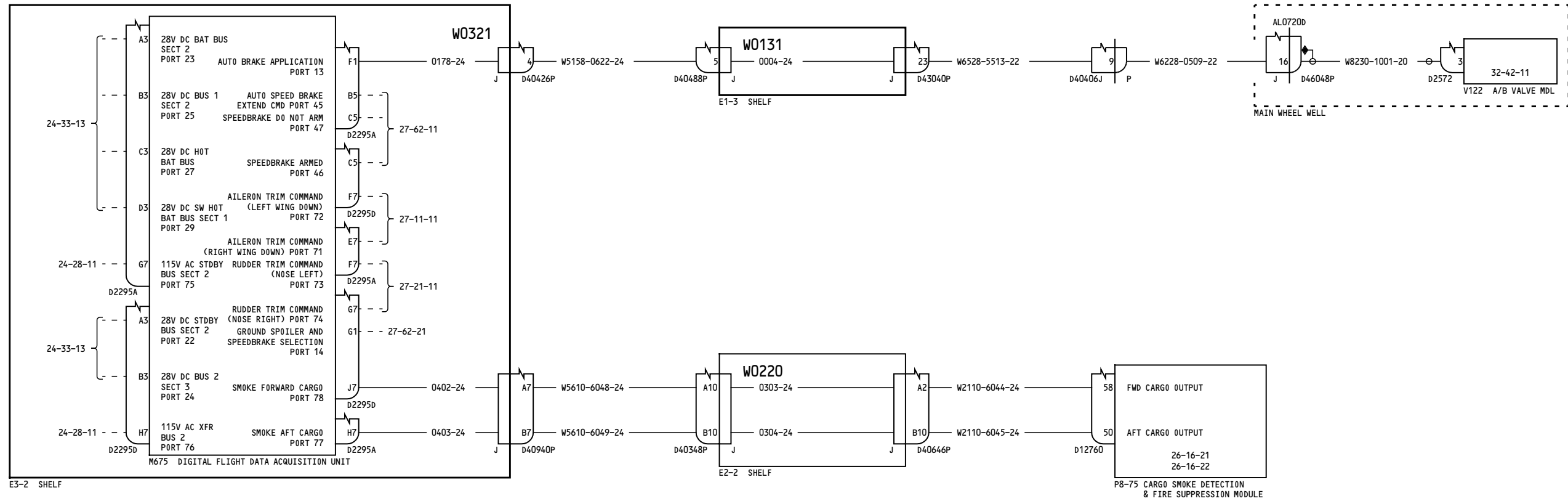

YC001-YC003

**DIGITAL FLIGHT DATA
RECORDER SYSTEM DISCRETE
INTERFACE**

D280A103

31-31-15

Page 1.1
Sheet 3
Aug 13/2008

Incorporates
26A1083 R01

31-31-15

Page 1.1
Sheet 3
Aug 13/2008

-C-
3

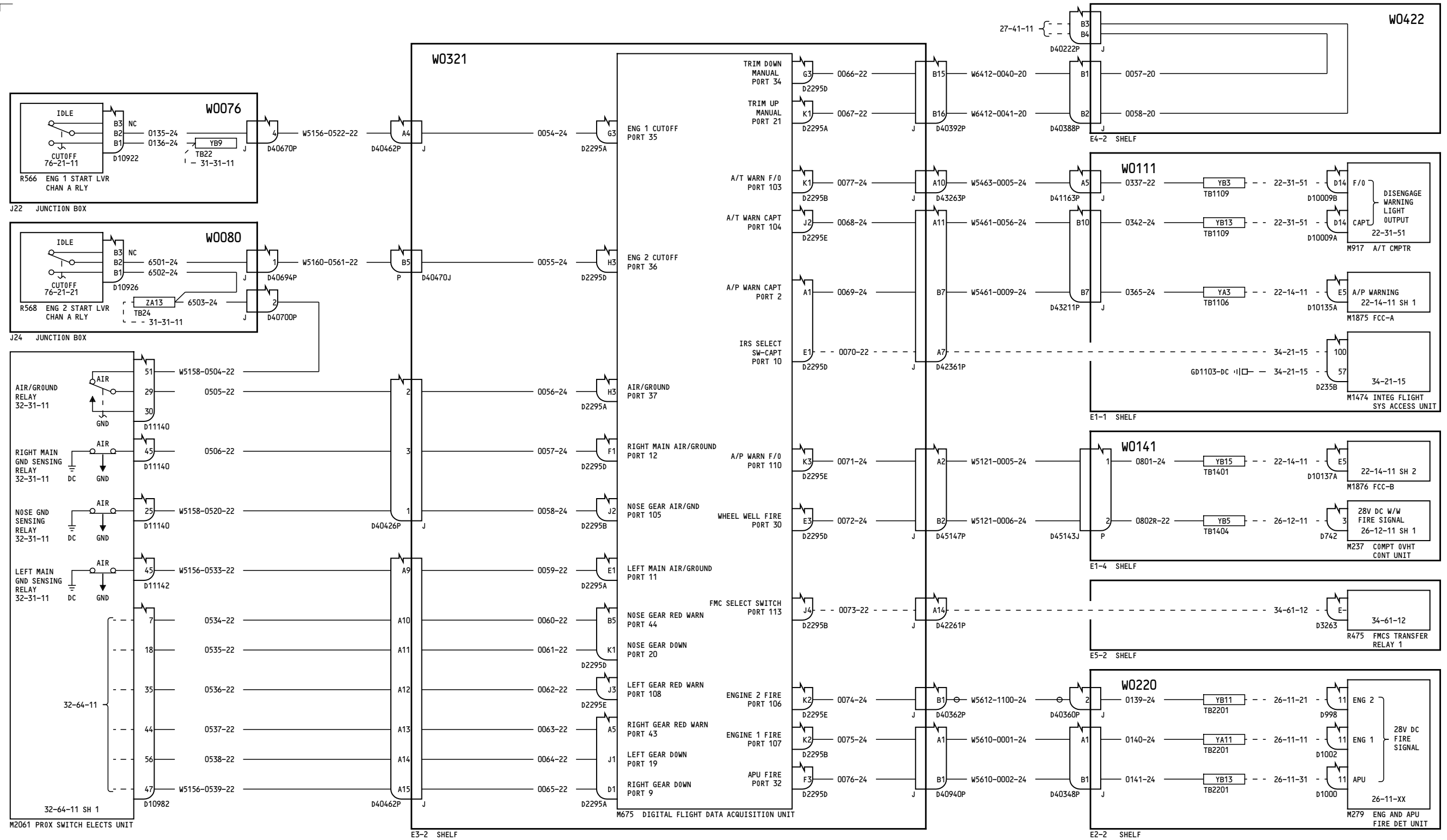

NOTES: EMC TYPE 1* WIRES MAY BE ROUTED NO MORE THAN 50 FEET WITH TYPE 2 WIRES.

YC004-YC007

DIGITAL FLIGHT DATA RECORDER SYSTEM DISCRETE INTERFACE

31-31-15

Page 2.1
Sheet 1
Aug 13/2008

D280A103

31-31-15

Page 2.1
Sheet 1
Aug 13/2008

-C
2

CADD5 4

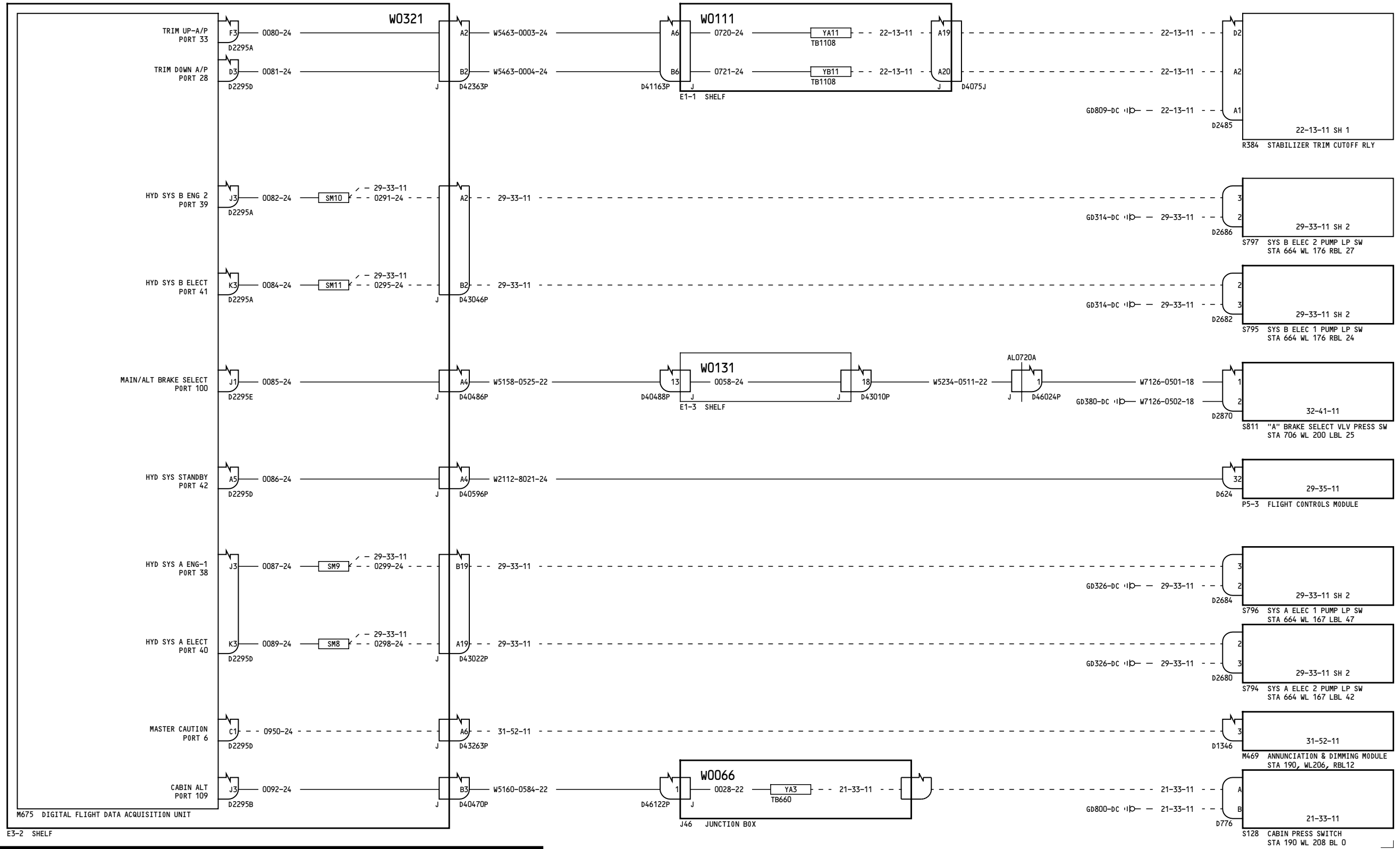

YC004-YC007

DIGITAL FLIGHT DATA
RECORDER SYSTEM DISCRETE
INTERFACE

D280A103

31-31-15

Page 2.1
Sheet 2
Aug 13/2008

31-31-15

Page 2.1
Sheet 2
Aug 13/2008

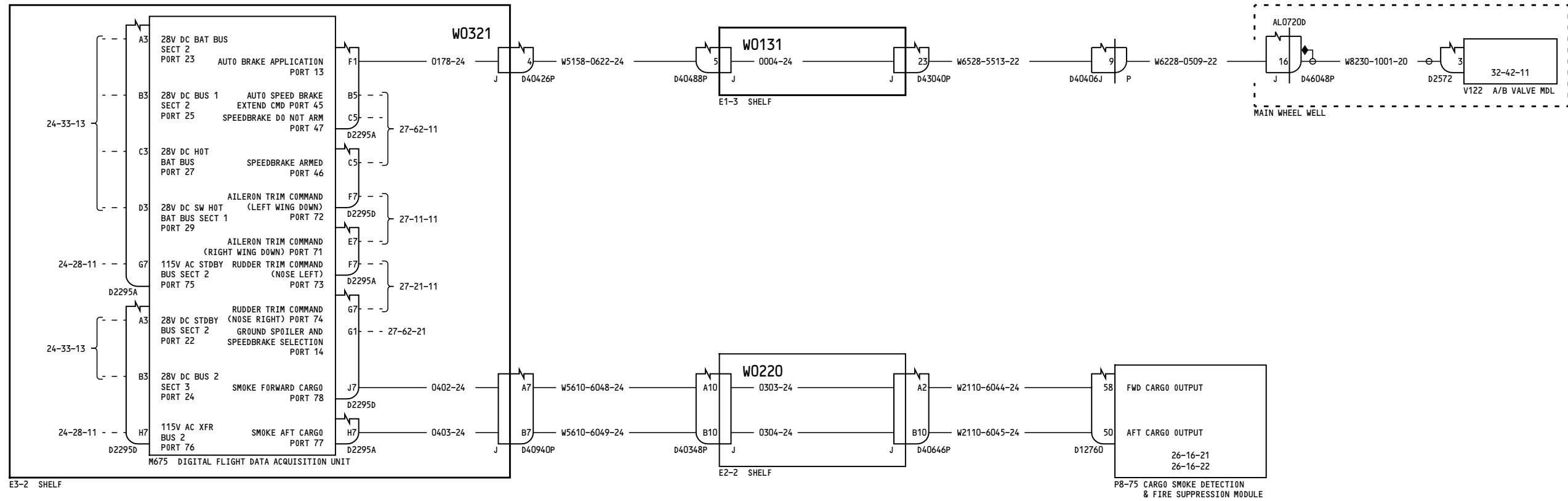

YC004-YC007

**DIGITAL FLIGHT DATA
RECORDER SYSTEM DISCRETE
INTERFACE**

D280A103

31-31-15

Page 2.1
Sheet 3
Aug 13/2008

Incorporates
26A1083 R01

31-31-15

Page 2.1
Sheet 3
Aug 13/2008

-C
3

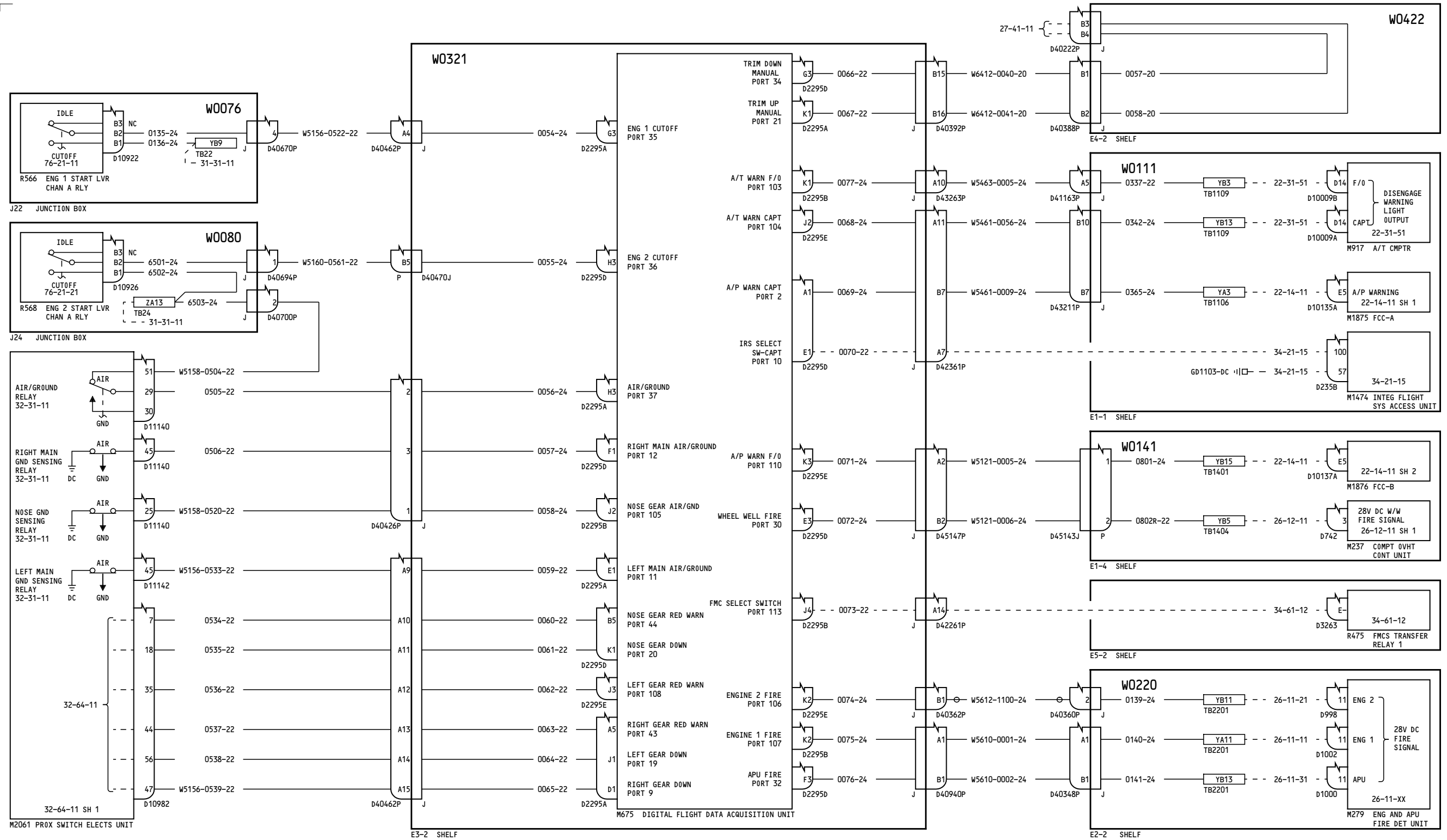

NOTES: EMC TYPE 1* WIRES MAY BE ROUTED NO MORE THAN 50 FEET WITH TYPE 2 WIRES.

YC008-YC019

DIGITAL FLIGHT DATA RECORDER SYSTEM DISCRETE INTERFACE

31-31-15

Page 3
Sheet 1
Mar 31/2005

D280A103

31-31-15

Page 3
Sheet 1
Mar 31/2005

-C
2

CADD5 4

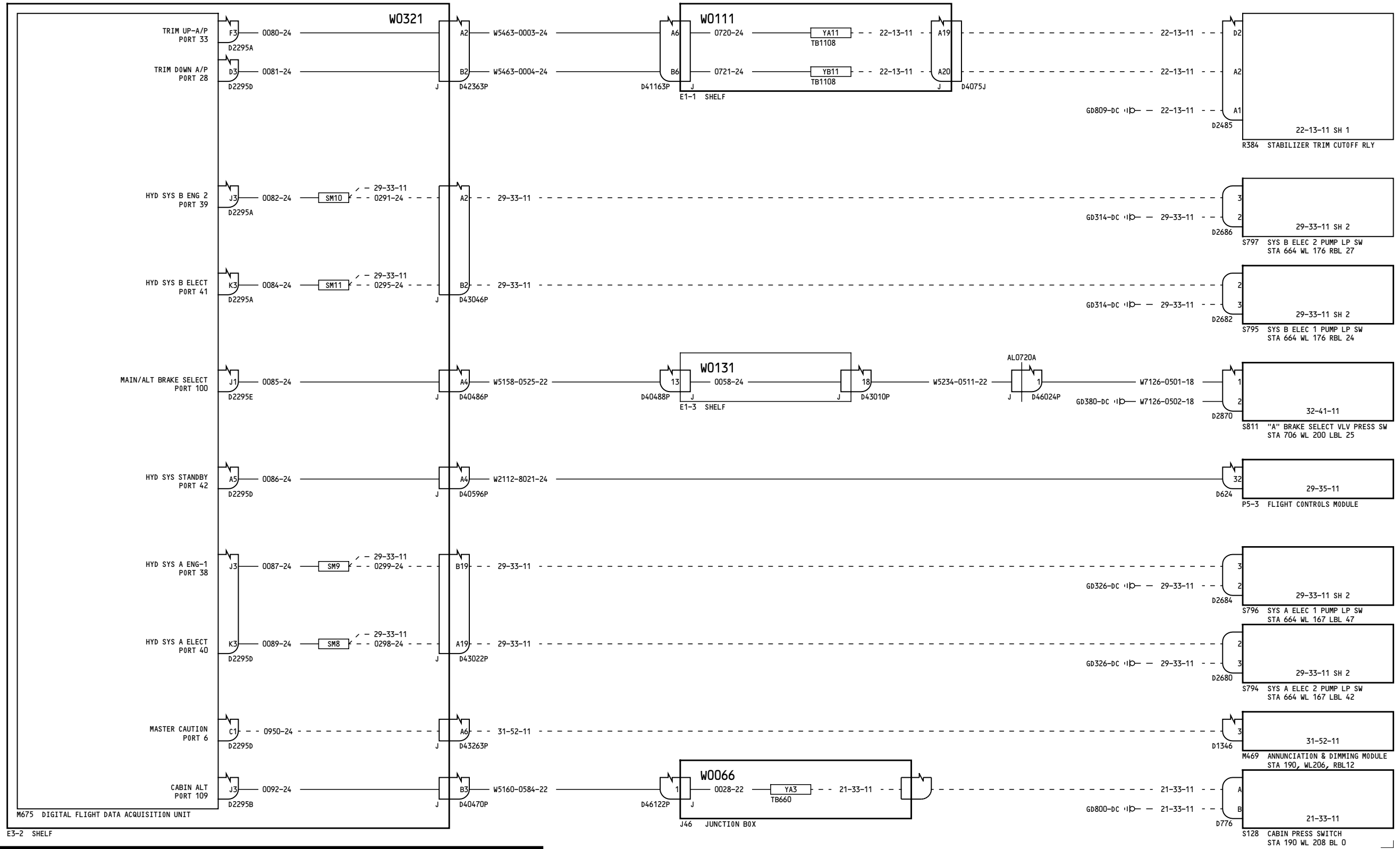

YC008-YC019

DIGITAL FLIGHT DATA RECORDER SYSTEM DISCRETE INTERFACE

D280A103

31-31-15

Page 3
Sheet 2
Apr 18/2006

31-31-15

Page 3
Sheet 2
Apr 18/2006

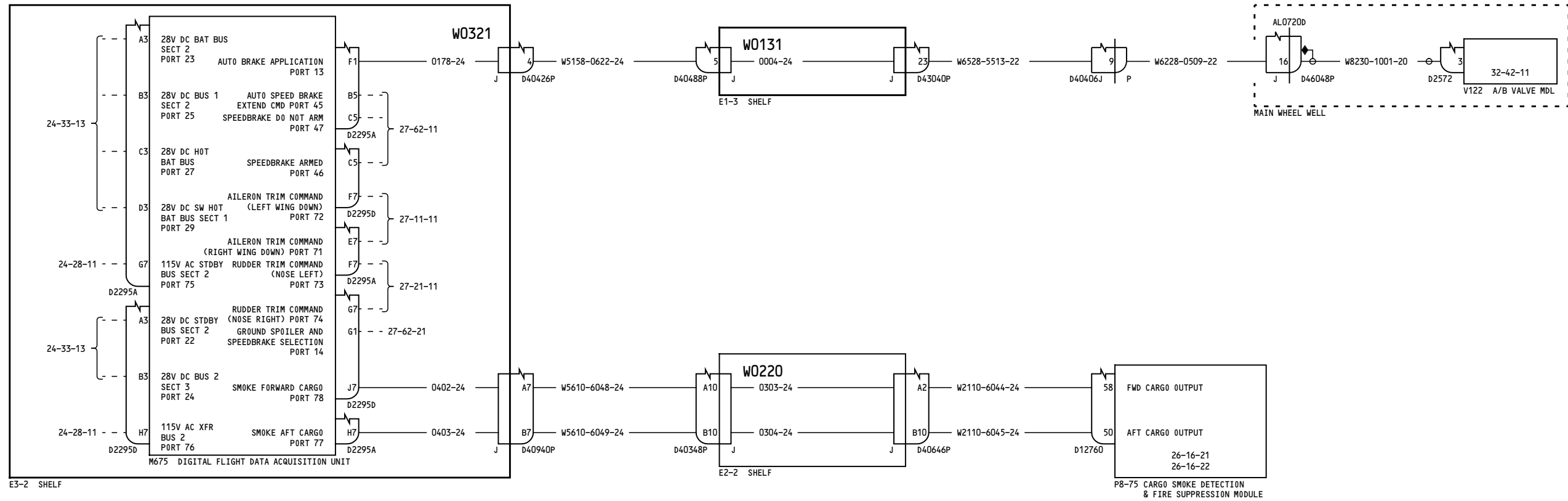

YC008-YC019

**DIGITAL FLIGHT DATA
RECORDER SYSTEM DISCRETE
INTERFACE**

D280A103

31-31-15

Page 3
Sheet 3
Mar 31/2005

31-31-15

Page 3
Sheet 3
Mar 31/2005

-C
3

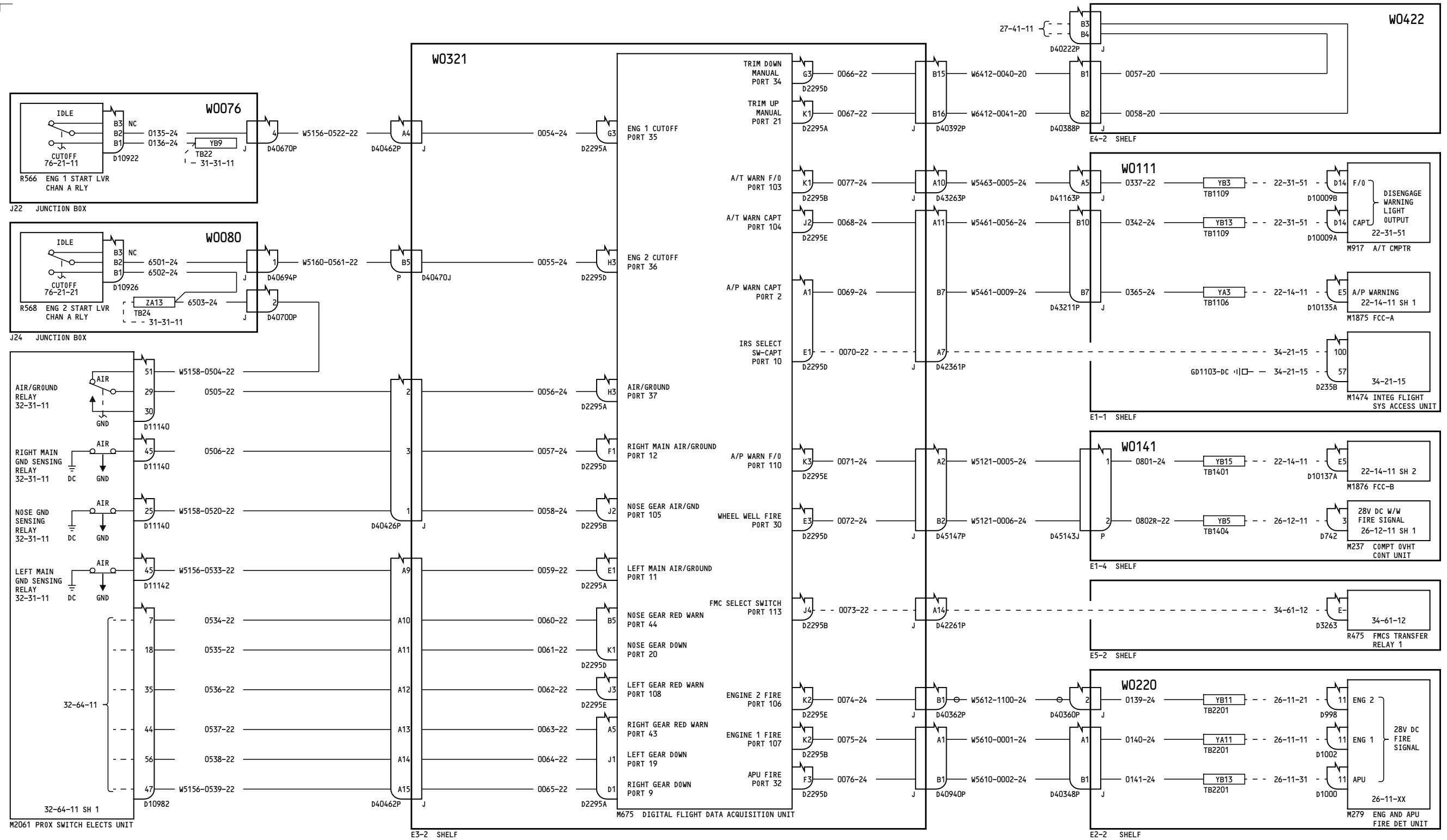

NOTES: EMC TYPE 1* WIRES MAY BE ROUTED NO MORE THAN 50 FEET WITH TYPE 2 WIRES.

YC020-YC030

DIGITAL FLIGHT DATA RECORDER SYSTEM DISCRETE INTERFACE

31-31-15

Page 4
Sheet 1
Jul 17/2007

D280A103

31-31-15

Page 4
Sheet 1
Jul 17/2007

-C
2

CADD5 4

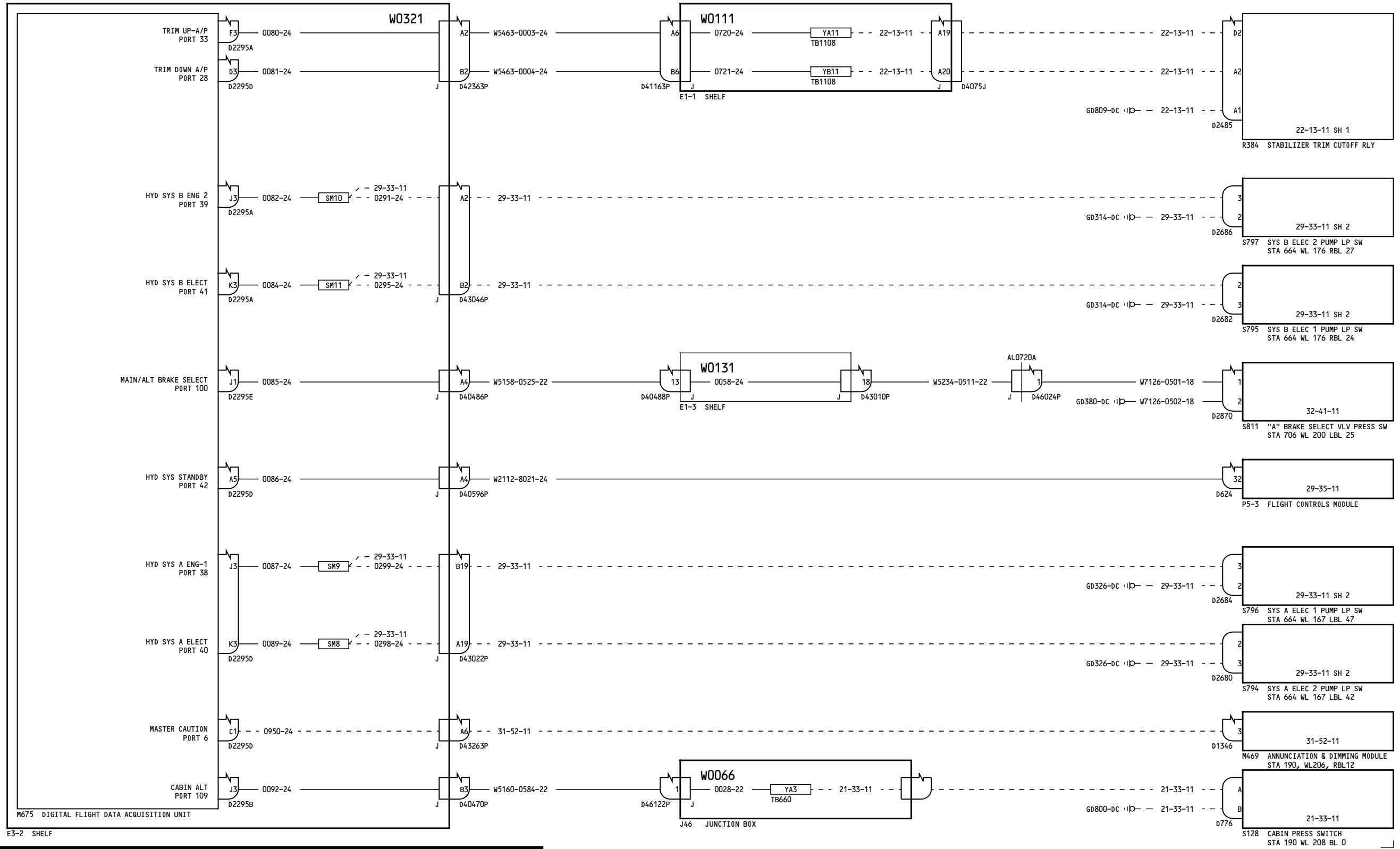

YC020-YC030

**DIGITAL FLIGHT DATA
RECORDER SYSTEM DISCRETE
INTERFACE**

D280A103

31-31-15

Page 4
Sheet 2
Jul 17/2007

31-31-15

Page 4
Sheet 2
Jul 17/2007

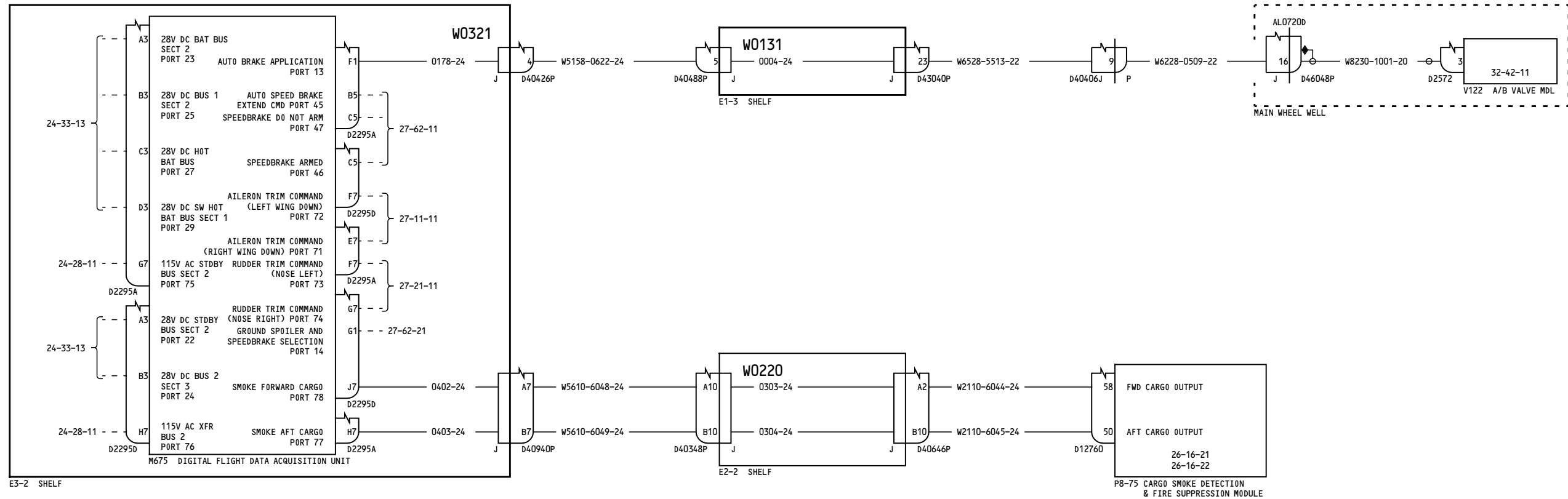

YC020-YC030

**DIGITAL FLIGHT DATA
RECORDER SYSTEM DISCRETE
INTERFACE**

D280A103

31-31-15

Page 4
Sheet 3
Jul 17/2007

31-31-15

Page 4
Sheet 3
Jul 17/2007

1

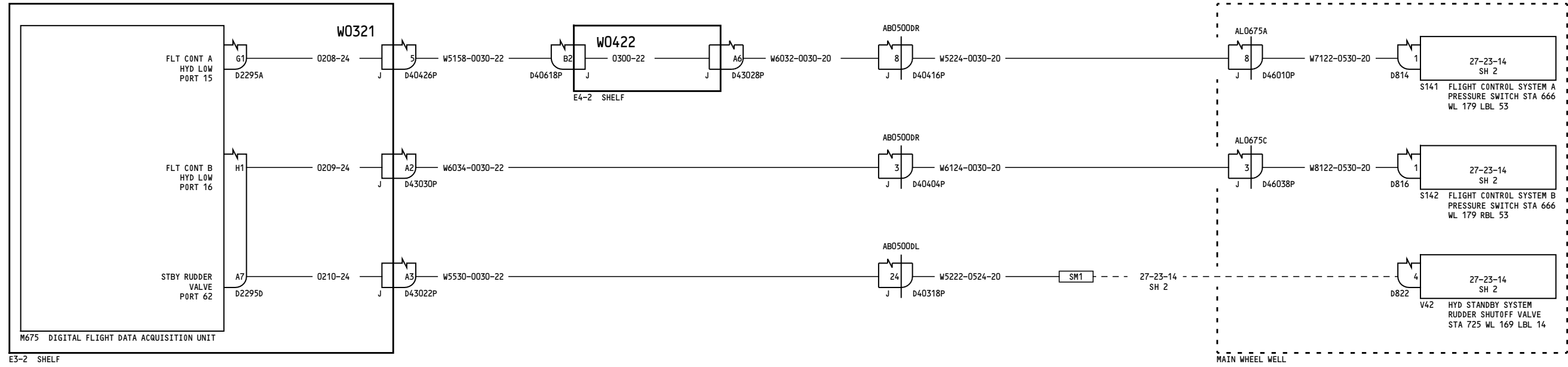

NOTES: * EMC TYPE 1* WIRES MAY BE ROUTED NO MORE THAN 80 FEET WITH TYPE 2 WIRES.

YC020-YC030	<p align="center">DIGITAL FLIGHT DATA RECORDER SYSTEM DISCRETE INTERFACE</p> <p align="center">D280A103</p>
-------------	--

31-31-15

Page 4
Sheet 4
Jul 17/2007

31-31-15

Page 4
Sheet 4
Jul 17/2007

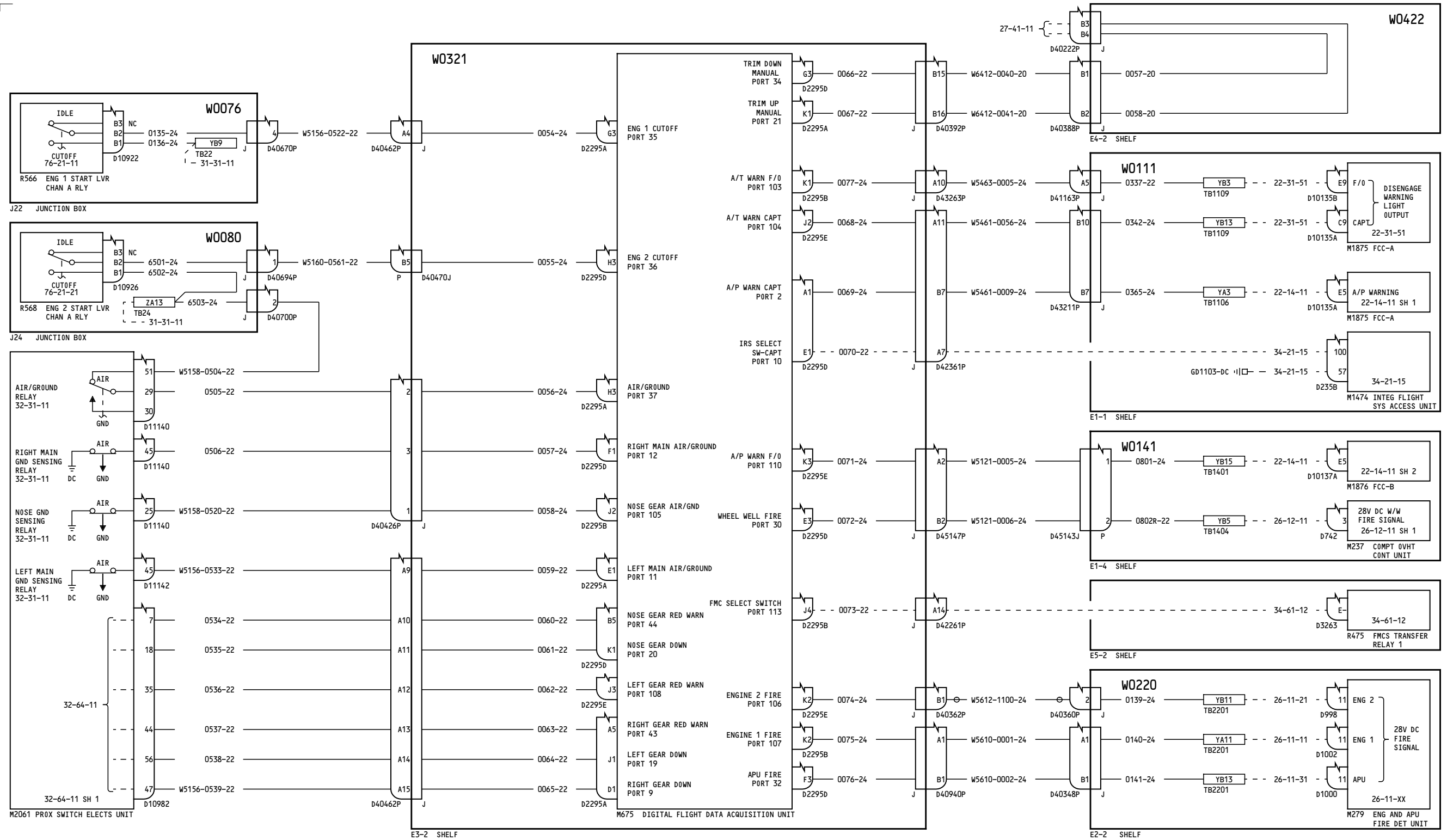

NOTES: EMC TYPE 1* WIRES MAY BE ROUTED NO MORE THAN 50 FEET WITH TYPE 2 WIRES.

YC031-YK909

DIGITAL FLIGHT DATA RECORDER SYSTEM DISCRETE INTERFACE

31-31-15

Page 5
Sheet 1
Apr 18/2007

D280A103

31-31-15

Page 5
Sheet 1
Apr 18/2007

-C
2

CADD 4

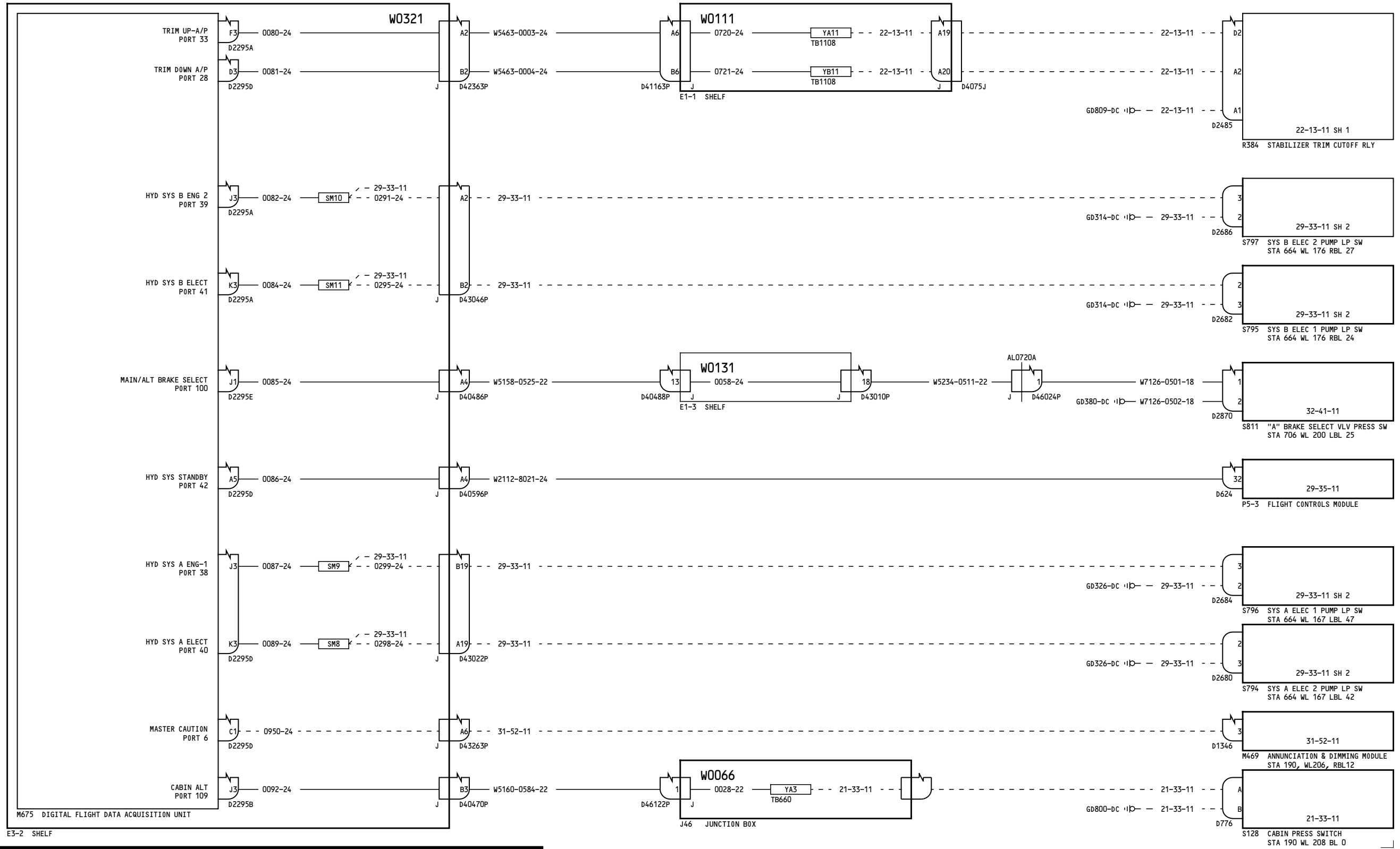

YC031-YK909

**DIGITAL FLIGHT DATA
RECORDER SYSTEM DISCRETE
INTERFACE**

D280A103

31-31-15

Page 5
Sheet 2
Apr 18/2007

31-31-15

Page 5
Sheet 2
Apr 18/2007

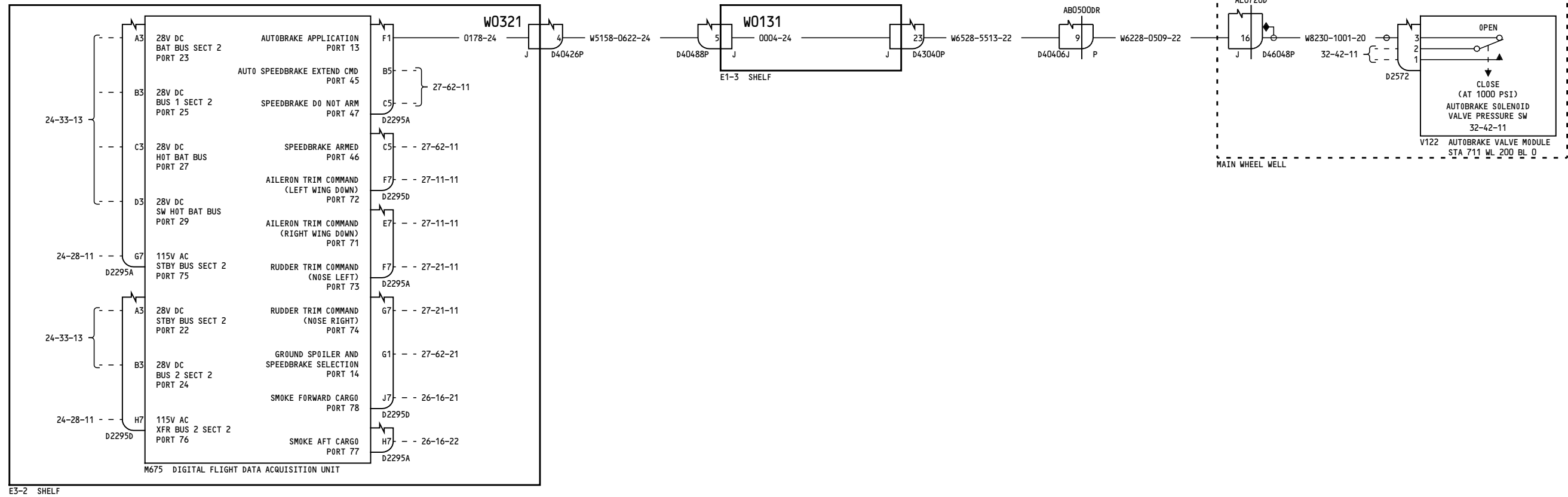

YC031-YK909

**DIGITAL FLIGHT DATA
RECORDER SYSTEM DISCRETE
INTERFACE**

D280A103

31-31-15

Page 5
Sheet 3
Apr 18/2007

31-31-15

Page 5
Sheet 3
Apr 18/2007

1

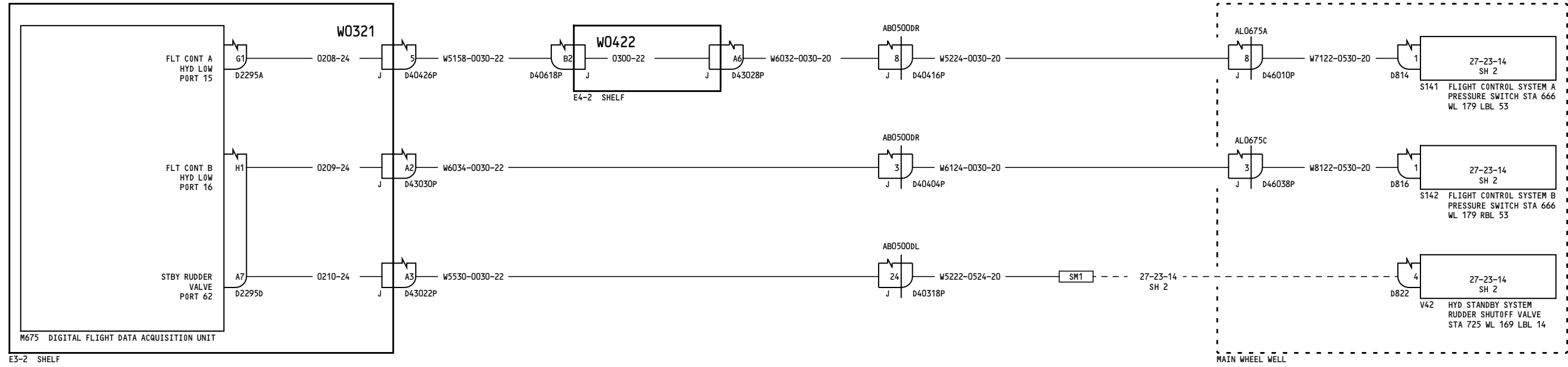

NOTES: * EMC TYPE 1* WIRES MAY BE ROUTED NO MORE THAN 80 FEET WITH TYPE 2 WIRES.

YC031-YK909

**DIGITAL FLIGHT DATA
RECORDER SYSTEM DISCRETE
INTERFACE**

D280A103

31-31-15

Page 5
Sheet 4
Apr 18/2007

31-31-15

Page 5
Sheet 4
Apr 18/2007

-A
15

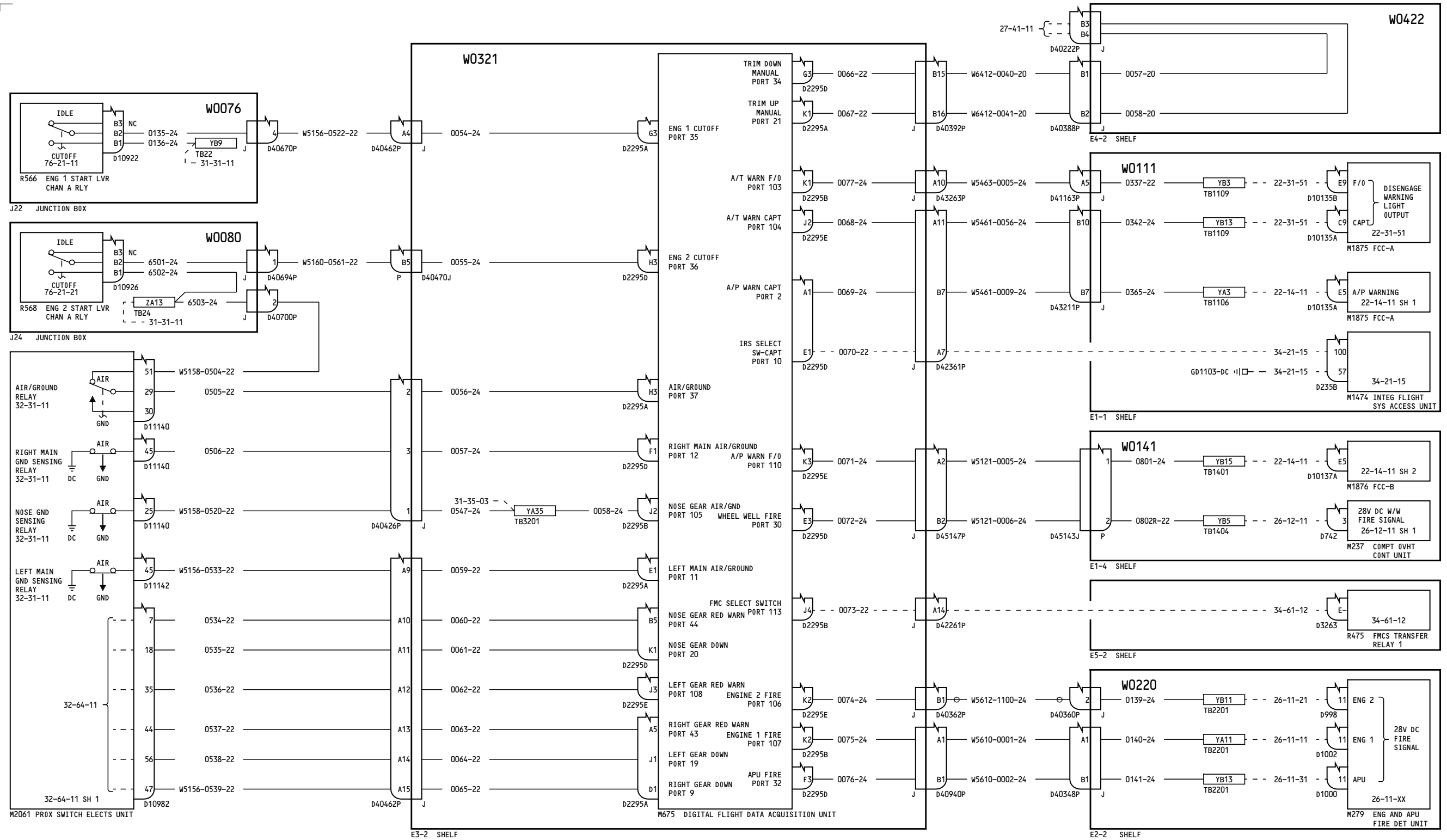

NOTES: EMC TYPE 1* WIRES MAY BE ROUTED NO MORE THAN 50 FEET WITH TYPE 2 WIRES.

YK910, YL421-YL423, YM643

DIGITAL FLIGHT DATA RECORDER SYSTEM DISCRETE INTERFACE

31-31-15

Page 6
Sheet 1
Aug 13/2008

D280A103

31-31-15

Page 6
Sheet 1
Aug 13/2008

-C
2

CADD5 4

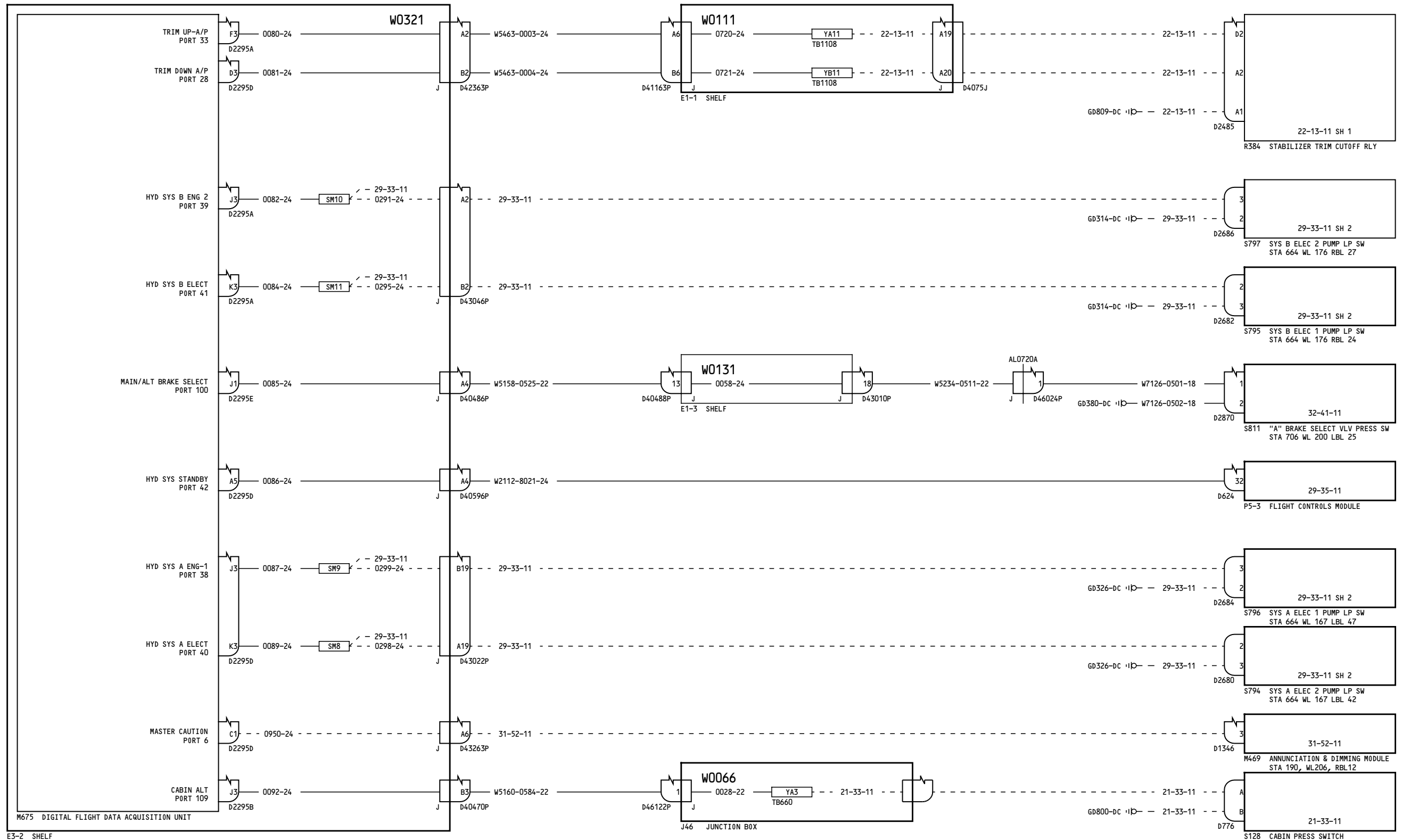

YK910, YL421-YL423, YM643

DIGITAL FLIGHT DATA RECORDER SYSTEM DISCRETE INTERFACE

D280A103

31-31-15

Page 6
Sheet 2
Apr 18/2007

31-31-15

Page 6
Sheet 2
Apr 18/2007

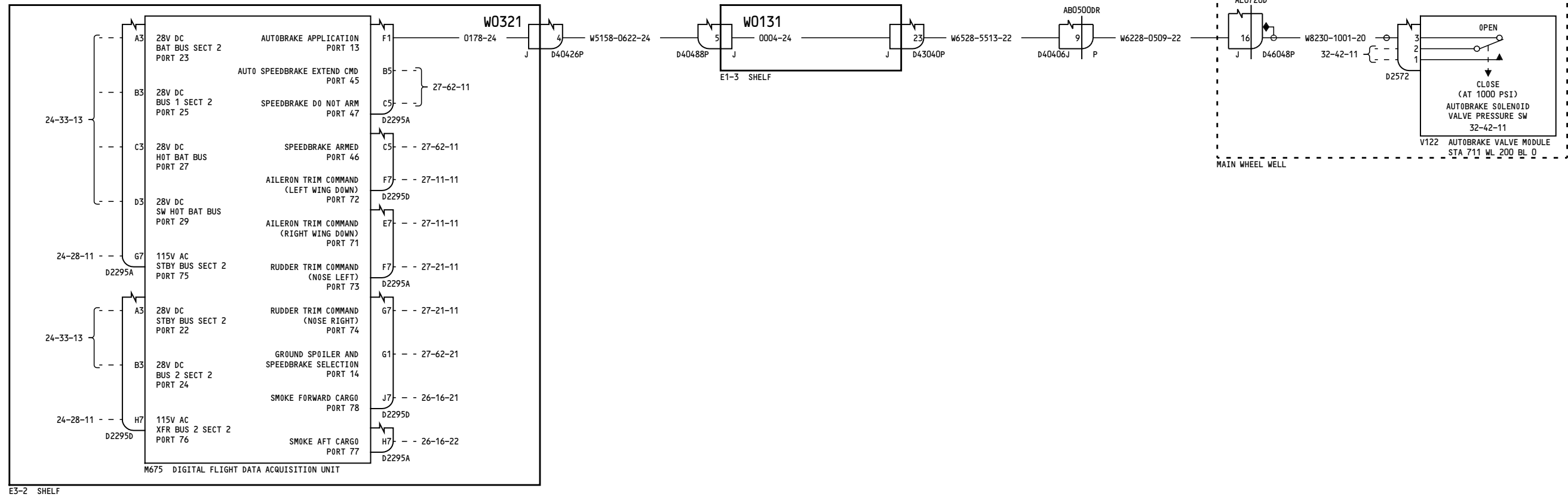

YK910, YL421-YL423, YM643

**DIGITAL FLIGHT DATA
RECORDER SYSTEM DISCRETE
INTERFACE**

D280A103

31-31-15

Page 6
Sheet 3
Apr 18/2007

31-31-15

Page 6
Sheet 3
Apr 18/2007

1

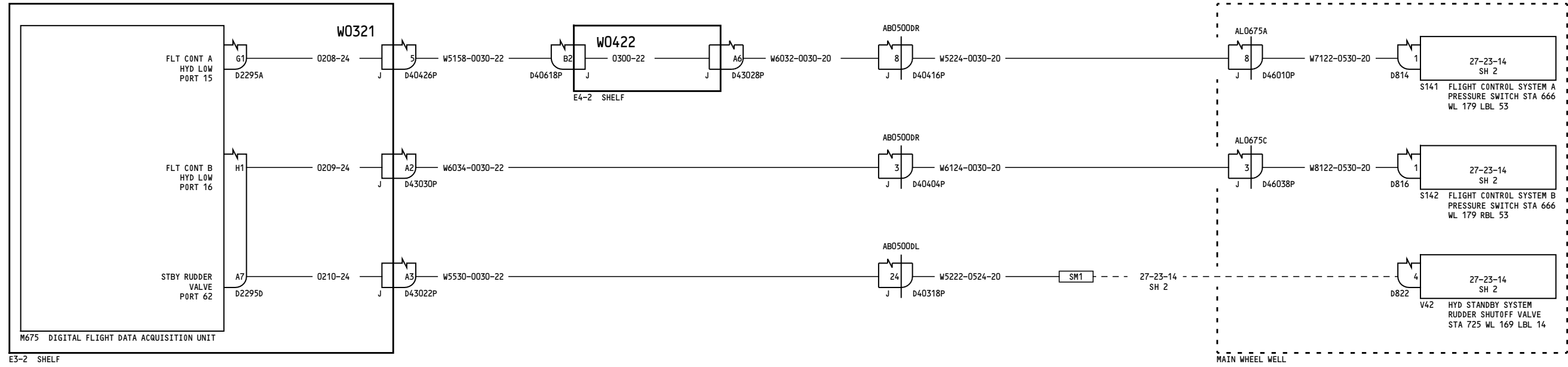

NOTES: * EMC TYPE 1* WIRES MAY BE ROUTED NO MORE THAN 80 FEET WITH TYPE 2 WIRES.

YK910, YL421-YL423, YM643	DIGITAL FLIGHT DATA RECORDER SYSTEM DISCRETE INTERFACE D280A103
---------------------------	---

31-31-15
 Page 6
 Sheet 4
 Apr 18/2007

31-31-15
 Page 6
 Sheet 4
 Apr 18/2007

-A
15

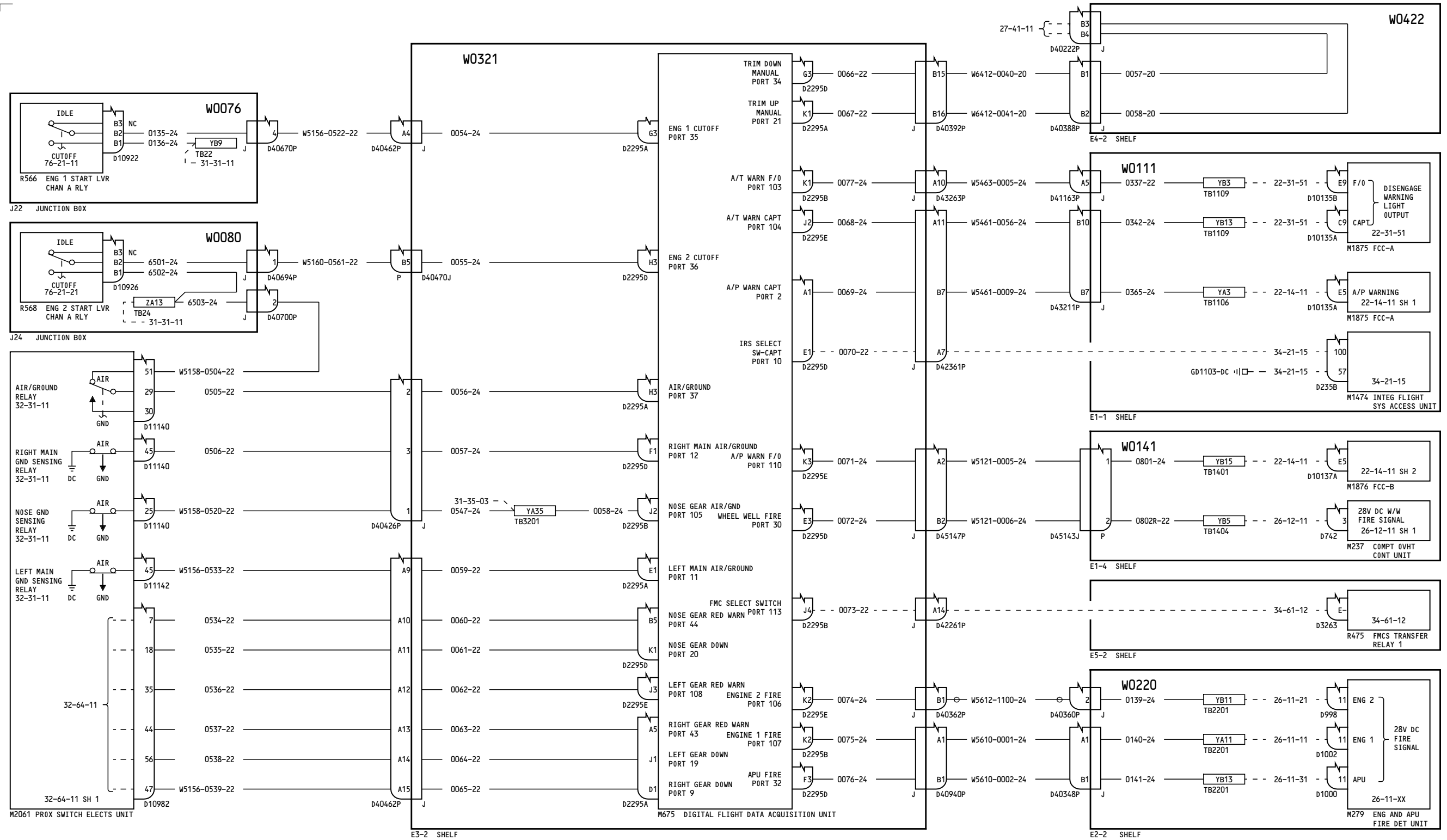

NOTES: EMC TYPE 1* WIRES MAY BE ROUTED NO MORE THAN 50 FEET WITH TYPE 2 WIRES.

YK911-YK912, YK918-YK919, YL424-YL429, YM645-YM652

DIGITAL FLIGHT DATA RECORDER SYSTEM DISCRETE INTERFACE
D280A103

31-31-15
Page 7
Sheet 1
May 11/2009

31-31-15
Page 7
Sheet 1
May 11/2009

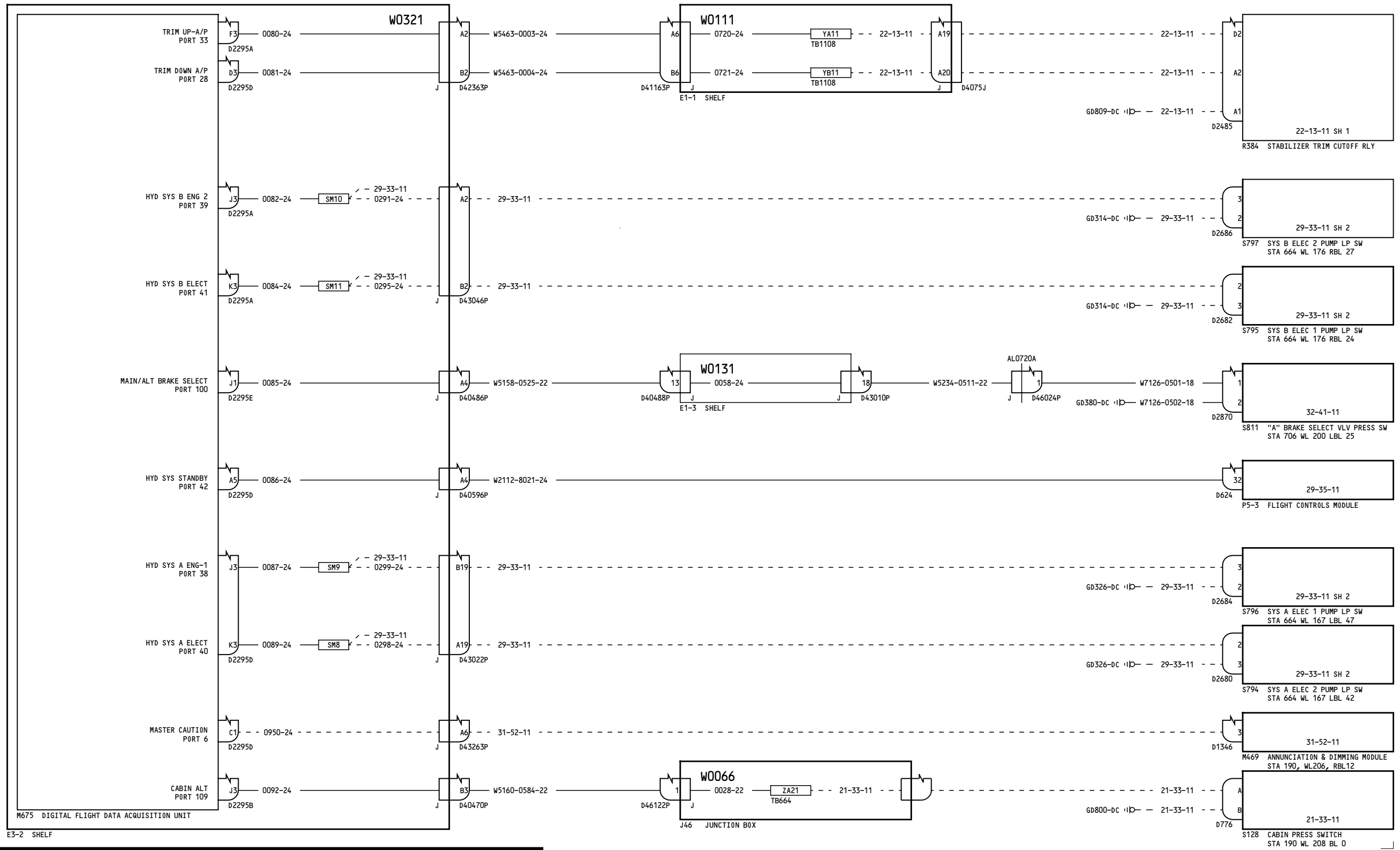

YK911-YK912, YK918-YK919, YL424-YL429, YM645-YM652

**DIGITAL FLIGHT DATA
RECORDER SYSTEM DISCRETE
INTERFACE**

D280A103

31-31-15

Page 7
Sheet 2
May 11/2009

31-31-15

Page 7
Sheet 2
May 11/2009

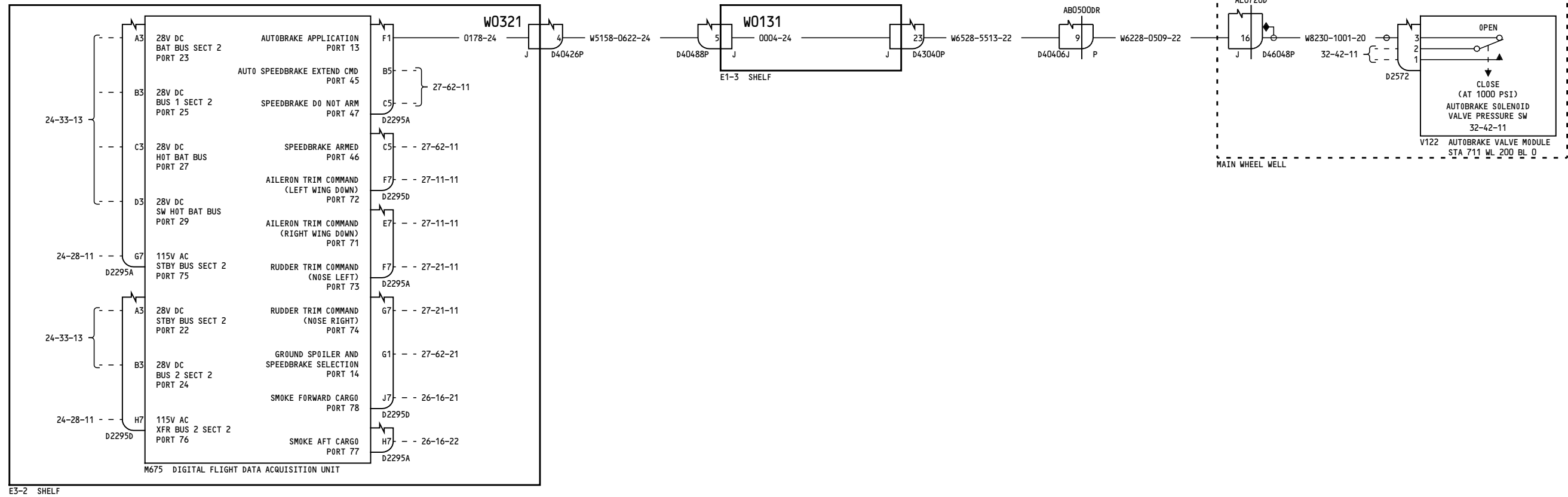

YK911-YK912, YK918-YK919, YL424-YL429, YM645-YM652

DIGITAL FLIGHT DATA RECORDER SYSTEM DISCRETE INTERFACE

D280A103

31-31-15

Page 7
Sheet 3
May 11/2009

31-31-15

Page 7
Sheet 3
May 11/2009

1

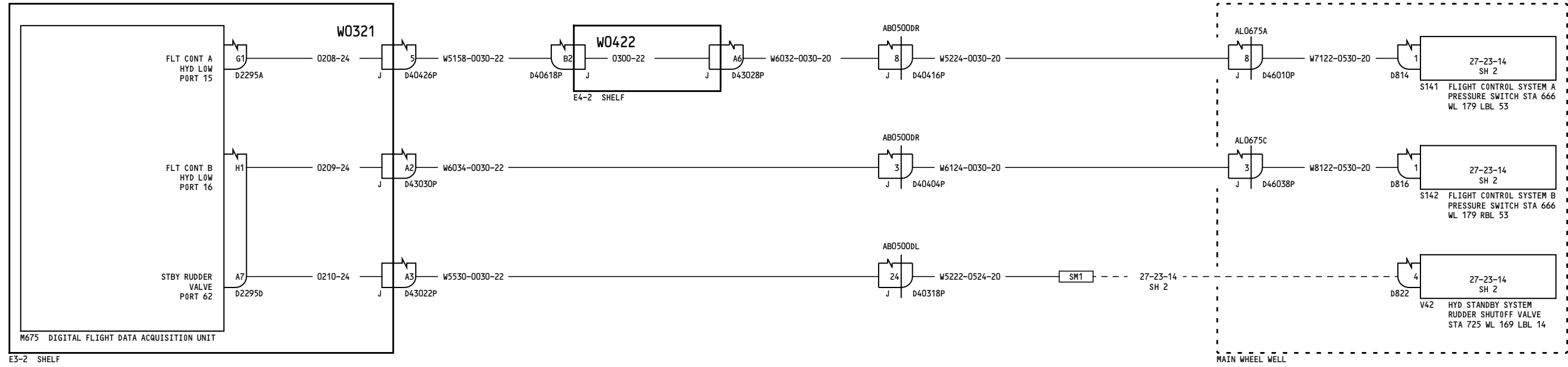

NOTES: * EMC TYPE 1* WIRES MAY BE ROUTED NO MORE THAN 80 FEET WITH TYPE 2 WIRES.

YK911-YK912, YK918-YK919, YL424-YL429, YM645-YM652

**DIGITAL FLIGHT DATA
RECORDER SYSTEM DISCRETE
INTERFACE**

D280A103

31-31-15

Page 7
Sheet 4
May 11/2009

31-31-15

Page 7
Sheet 4
May 11/2009

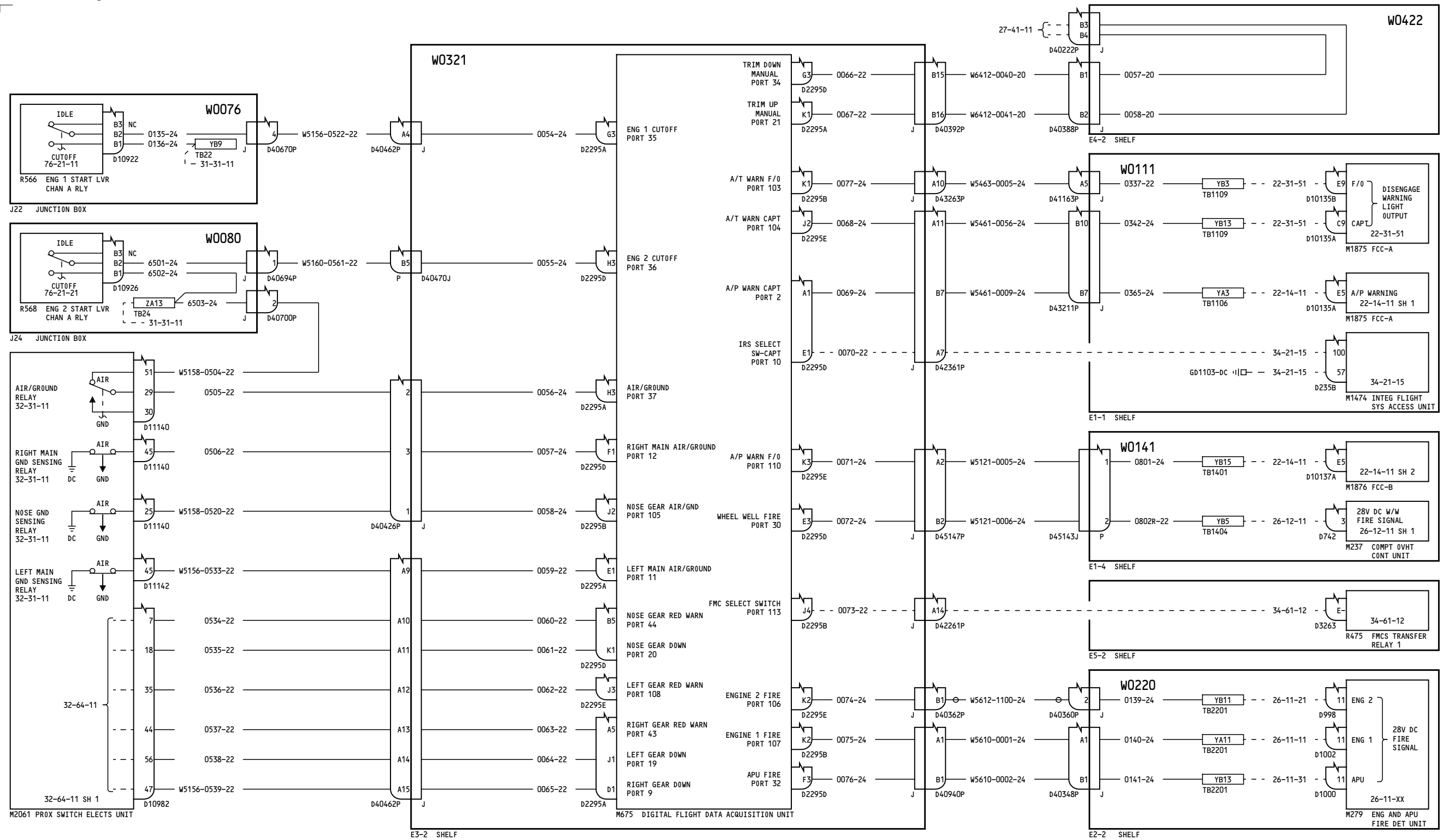

NOTES: EMC TYPE 1* WIRES MAY BE ROUTED NO MORE THAN 50 FEET WITH TYPE 2 WIRES.

YL401

DIGITAL FLIGHT DATA RECORDER SYSTEM DISCRETE INTERFACE

31-31-15

Page 8
Sheet 1
Aug 13/2008

D280A103

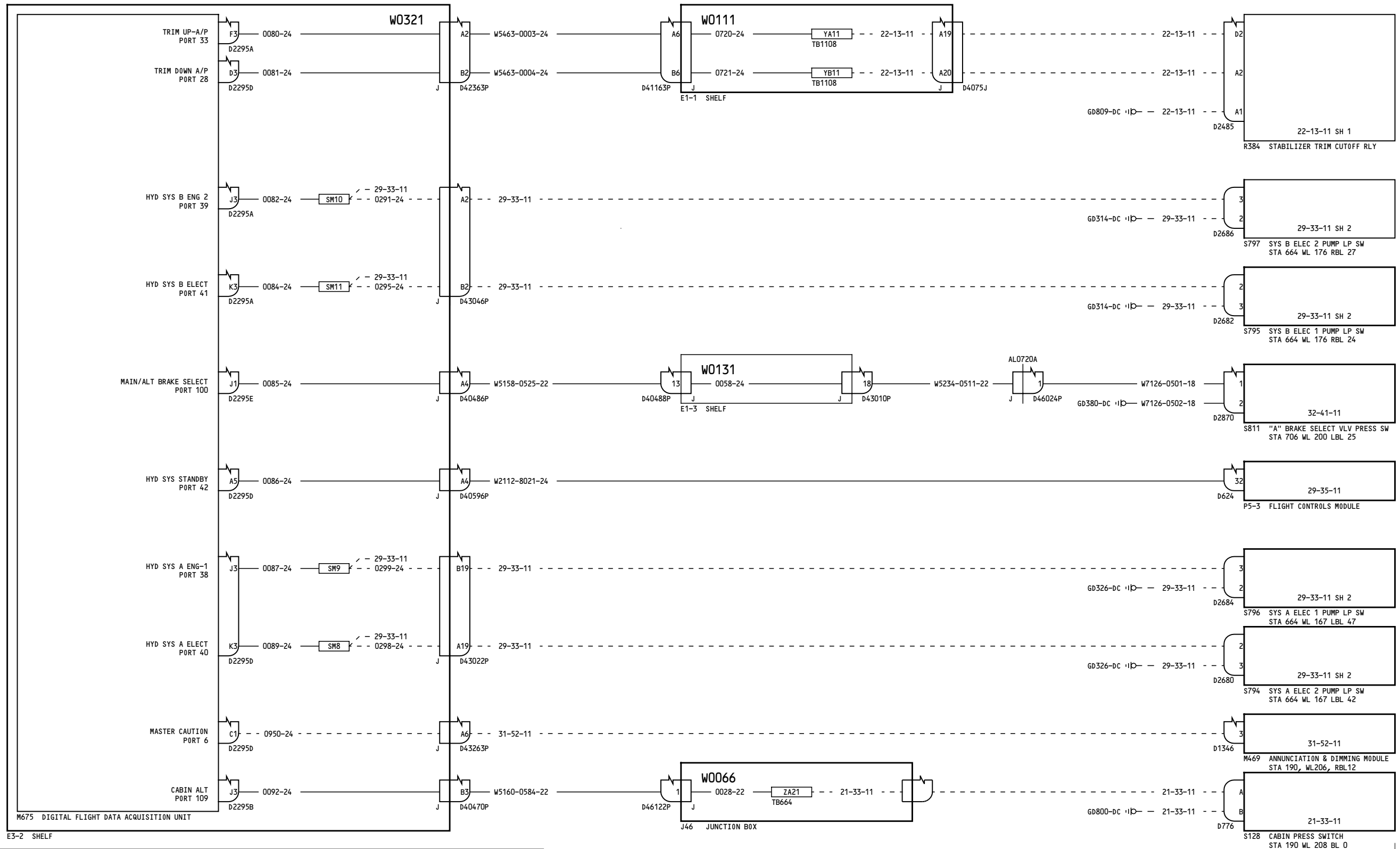

YL401

**DIGITAL FLIGHT DATA
RECORDER SYSTEM DISCRETE
INTERFACE**

D280A103

31-31-15

Page 8
Sheet 2
Aug 13/2008

31-31-15

Page 8
Sheet 2
Aug 13/2008

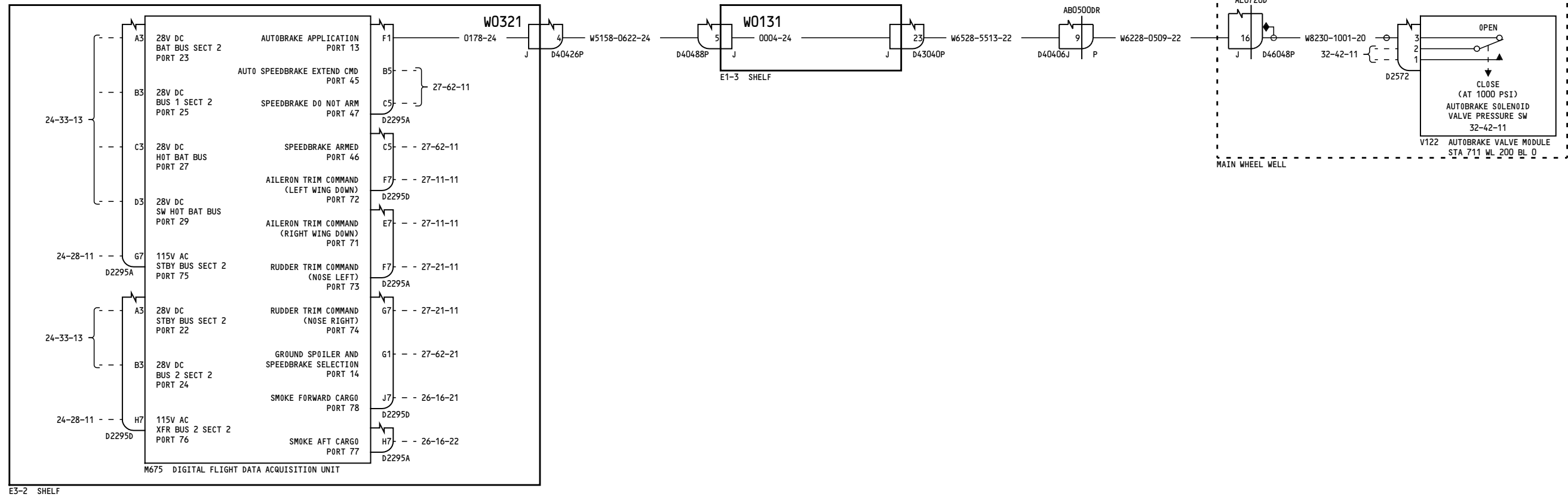

YL401

**DIGITAL FLIGHT DATA
RECORDER SYSTEM DISCRETE
INTERFACE**

D280A103

31-31-15

Page 8
Sheet 3
Aug 13/2008

31-31-15

Page 8
Sheet 3
Aug 13/2008

1

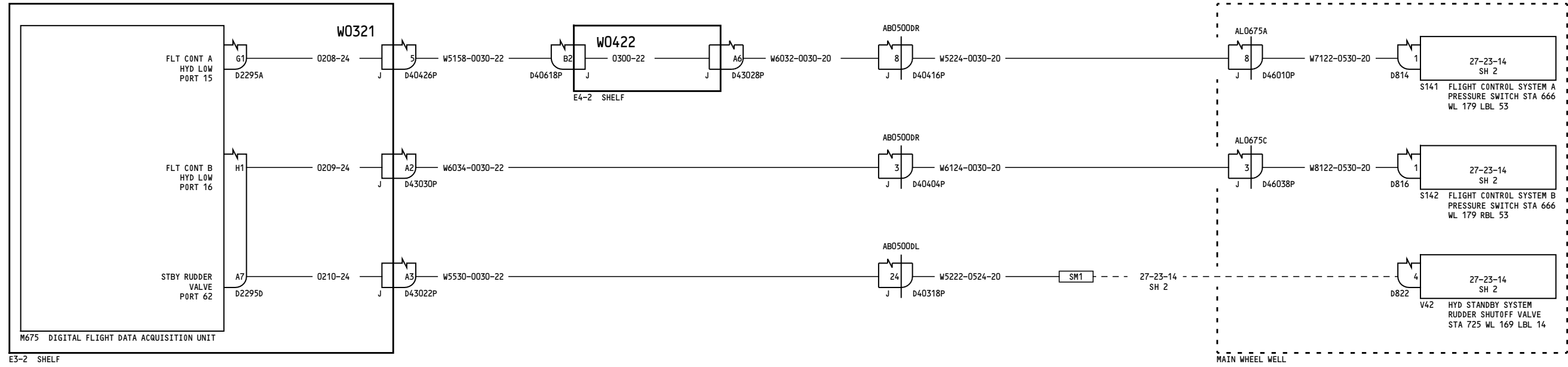

NOTES: * EMC TYPE 1* WIRES MAY BE ROUTED NO MORE THAN 80 FEET WITH TYPE 2 WIRES.

YL401

**DIGITAL FLIGHT DATA
RECORDER SYSTEM DISCRETE
INTERFACE**

D280A103

31-31-15

Page 8
Sheet 4
Aug 13/2008

31-31-15

Page 8
Sheet 4
Aug 13/2008

-C
5

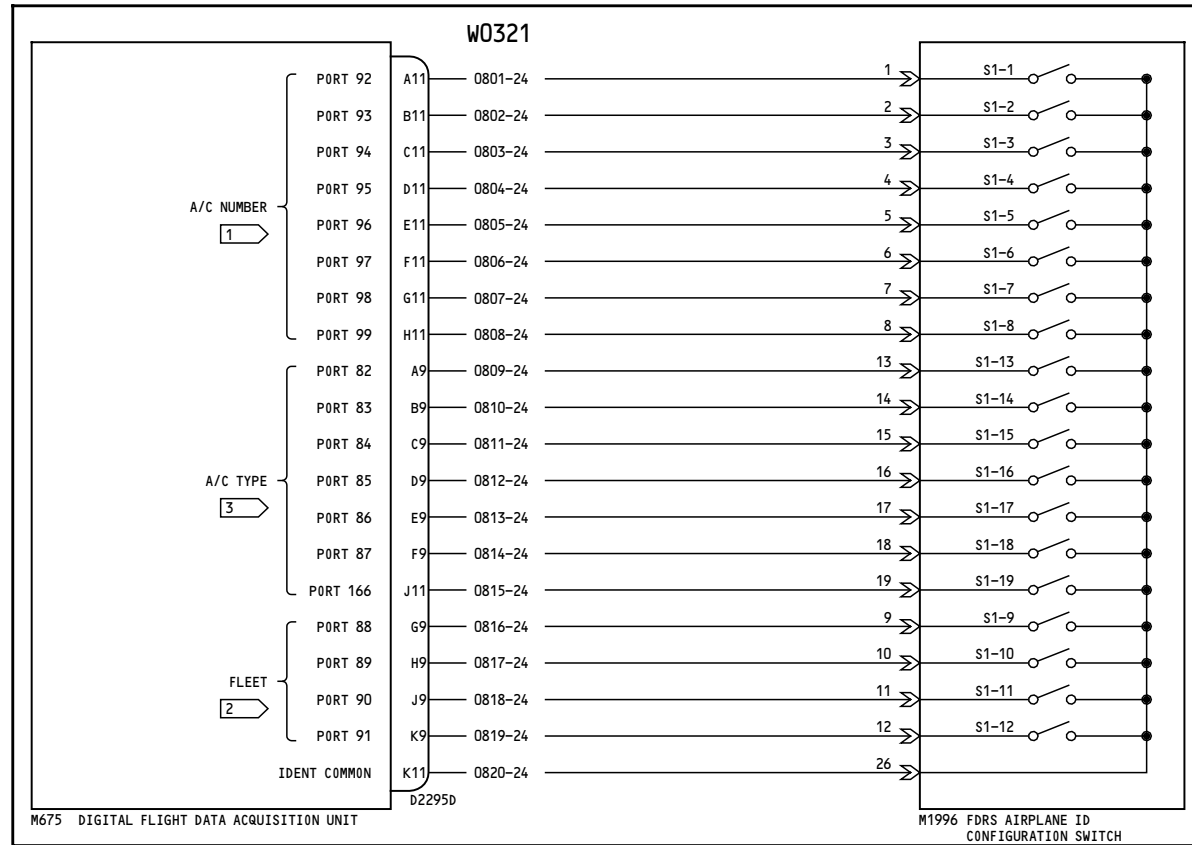

A/C EFF	A/C NUMBER 1							
	99	98	97	96	95	94	93	92
YC001	0	0	0	0	0	0	0	1
YC002	0	0	0	0	0	0	1	0
YC003	0	0	0	0	0	0	1	1
YC004	0	0	0	0	0	1	0	0
YC005	0	0	0	0	0	1	0	1
YC006	0	0	0	0	0	1	1	0
YC007	0	0	0	0	0	1	1	1
YC008	0	0	0	0	1	0	0	0
YC009	0	0	0	0	1	0	0	1
YC010	0	0	0	0	1	0	1	0
YC011	0	0	0	0	1	0	1	1
YC012	0	0	0	0	1	1	0	0
YC013	0	0	0	0	1	1	0	1
YC014	0	0	0	0	1	1	1	0
YC015	0	0	0	0	1	1	1	1
YC016	0	0	0	1	0	0	0	0
YC017	0	0	0	1	0	0	0	1
YC018	0	0	0	1	0	0	1	0
YC019	0	0	0	1	0	0	1	1
YC020	0	0	0	1	0	1	0	0
YC021	0	0	0	1	0	1	0	1
YC022	0	0	0	1	0	1	1	0
YC023	0	0	0	1	0	1	1	1
YC024	0	0	0	1	1	0	0	0
YC025	0	0	0	1	1	0	0	1
YC026	0	0	0	1	1	0	1	0
YC027	0	0	0	1	1	0	1	1
YC028	0	0	0	1	1	1	0	0
YC029	0	0	0	1	1	1	0	1
YC030	0	0	0	1	1	1	1	0
YC031	0	0	0	1	1	1	1	1
YC032	0	0	1	0	0	0	0	0
YC033	0	0	1	0	0	0	0	1
YC034	0	0	1	0	0	0	1	0
YC035	0	0	1	0	0	0	1	1
YC036	0	0	1	0	0	1	0	0
YC037	0	0	1	0	0	1	0	1
YC038	0	0	1	0	0	1	1	0
YC039	0	0	1	0	0	1	1	1
YC040	0	0	1	0	1	0	0	0
YC041	0	0	1	0	1	0	0	1
YC042	0	0	1	0	1	0	1	0
YC043	0	0	1	0	1	0	1	1
YC044	0	0	1	0	1	1	0	0
YC045	0	0	1	0	1	1	0	1
YC046	0	0	1	0	1	1	1	0
YC047	0	0	1	0	1	1	1	1
YC048	0	0	1	1	0	0	0	0
YC049	0	0	1	1	0	0	0	1
YC050	0	0	1	1	0	0	1	0

1 - M1996 SELECTED TO "ON"
0 - M1996 SELECTED TO "OFF"

A/C EFF	FLEET 2			
	91	90	89	88
YC001-YC050	0	0	0	1

1 - M1996 SELECTED TO "ON"
0 - M1996 SELECTED TO "OFF"

A/C EFF	A/C TYPE 3						
	166	87	86	85	84	83	82
YC001-YC050	1	0	0	0	0	0	1

1 - M1996 SELECTED TO "ON"
0 - M1996 SELECTED TO "OFF"

NOTES:

- 1 AIRCRAFT NUMBER
- 2 FLEET IDENTIFICATION
- 3 AIRCRAFT TYPE

YC001-YC050

DIGITAL FLIGHT DATA RECORDER SYSTEM AIRPLANE CODING

D280A103

31-31-16

Page 1

Jul 17/2007

31-31-16

Page 1

Jul 17/2007

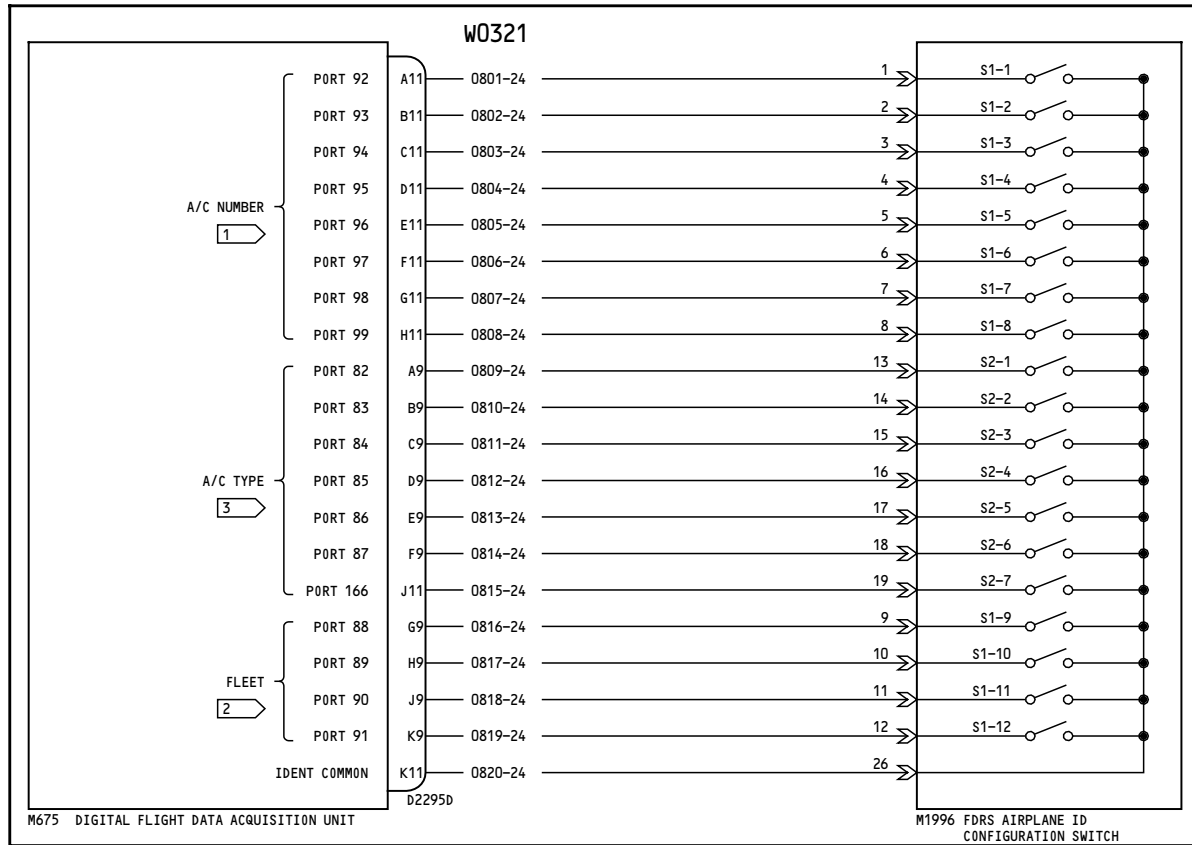

A/C EFF	A/C NUMBER 1								FLEET 2				A/C TYPE 3							
	99	98	97	96	95	94	93	92	91	90	89	88	166	87	86	85	84	83	82	
YK901	0	0	0	0	0	0	0	1	0	0	0	0	1	0	0	0	0	0	1	
YK902	0	0	0	0	0	0	1	0	0	0	0	0	1	0	0	0	0	0	1	
YK903	0	0	0	0	0	0	1	1	0	0	0	0	1	0	0	0	0	0	1	
YK904	0	0	0	0	0	1	0	0	0	0	0	0	1	0	0	0	0	0	1	
YK905	0	0	0	0	0	1	0	1	0	0	0	0	1	0	0	0	0	0	1	
YK906	0	0	0	0	0	1	1	0	0	0	0	0	1	0	0	0	0	0	1	
YK907	0	0	0	0	0	1	1	1	0	0	0	0	1	0	0	0	0	0	1	
YK908	0	0	0	0	1	0	0	0	0	0	0	0	1	0	0	0	0	0	1	
YK909	0	0	0	0	1	0	0	1	0	0	0	0	1	0	0	0	0	0	1	
YK910	0	0	0	0	1	0	1	0	0	0	0	0	1	0	0	0	0	0	1	
YK911	0	0	0	0	1	0	1	1	0	0	0	0	1	0	0	0	0	0	1	
YK912	0	0	0	0	1	1	0	0	0	0	0	0	1	0	0	0	0	0	1	
YK913	0	0	0	0	1	1	0	1	0	0	0	0	1	0	0	0	0	0	1	
YK914	0	0	0	0	1	1	1	1	0	0	0	0	1	0	0	0	0	0	1	
YK915	0	0	0	0	1	1	1	1	0	0	0	0	1	0	0	0	0	0	1	
YK916	0	0	0	1	0	0	0	0	0	0	0	0	1	0	0	0	0	0	1	
YK917	0	0	0	1	0	0	0	1	0	0	0	0	1	0	0	0	0	0	1	
YK918	0	0	0	1	0	0	1	0	0	0	0	0	1	0	0	0	0	0	1	
YK919	0	0	0	1	0	0	1	1	0	0	0	0	1	0	0	0	0	0	1	
YK920	0	0	0	1	0	1	0	0	0	0	0	0	1	0	0	0	0	0	1	
YL941	0	0	1	0	1	0	0	1	0	0	0	0	1	0	0	0	0	0	1	
YL942	0	0	1	0	1	0	1	0	0	0	0	0	1	0	0	0	0	0	1	
YL943	0	0	1	0	1	0	1	1	0	0	0	0	1	0	0	0	0	0	1	
YL944	0	0	1	0	1	1	0	0	0	0	0	0	1	0	0	0	0	0	1	
YL945	0	0	1	0	1	1	0	1	0	0	0	0	1	0	0	0	0	0	1	
YL946	0	0	1	0	1	1	1	0	0	0	0	0	1	0	0	0	0	0	1	
YL947	0	0	1	0	1	1	1	1	0	0	0	0	1	0	0	0	0	0	1	
YL948	0	0	1	1	0	0	0	0	0	0	0	0	1	0	0	0	0	0	1	
YL949	0	0	1	1	0	0	0	1	0	0	0	0	1	0	0	0	0	0	1	
YL950	0	0	1	1	0	0	1	0	0	0	0	0	1	0	0	0	0	0	1	

1 - M1996 SELECTED TO "ON"
0 - M1996 SELECTED TO "OFF"

NOTES:

- 1 AIRCRAFT NUMBER
- 2 FLEET IDENTIFICATION
- 3 AIRCRAFT TYPE

YK901-YK920

DIGITAL FLIGHT DATA RECORDER SYSTEM AIRPLANE CODING

D280A103

31-31-16

Page 2

Feb 09/2009

31-31-16

Page 2

Feb 09/2009

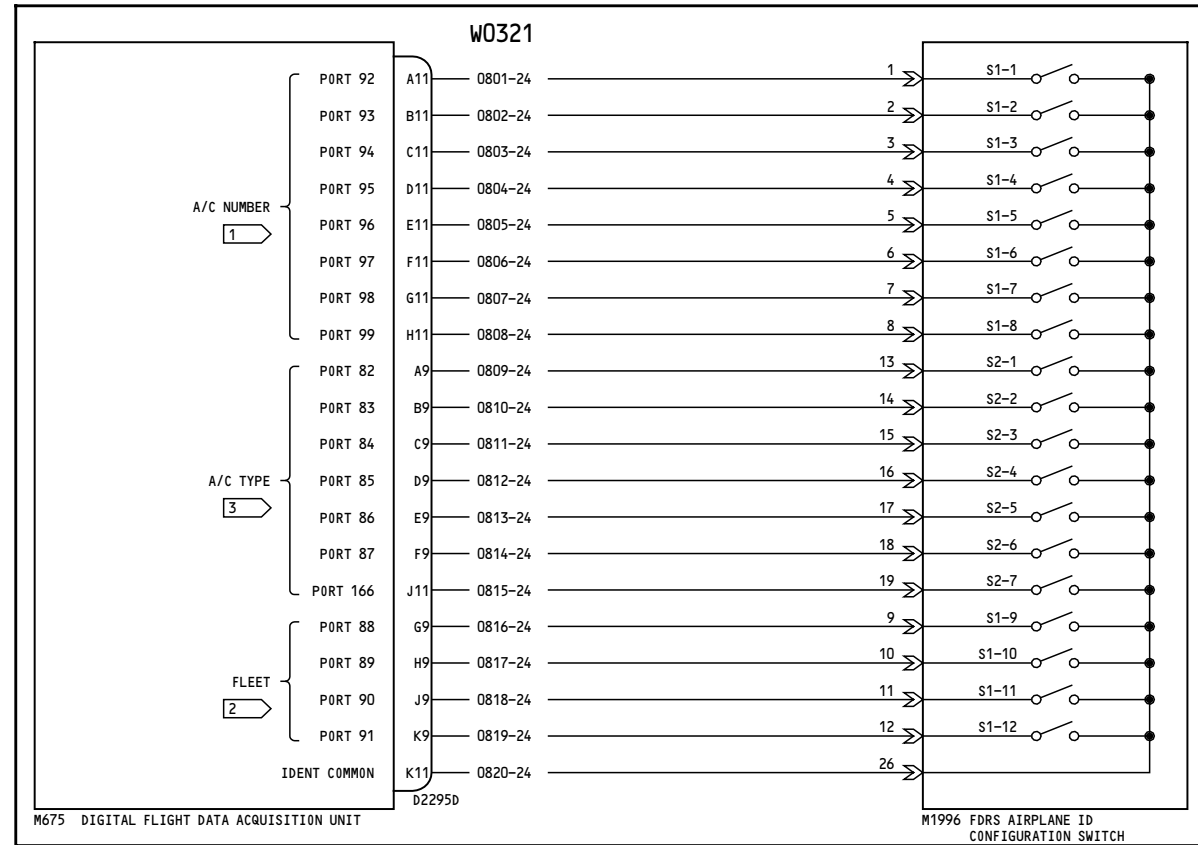

A/C EFF	A/C NUMBER 1								FLEET 2				A/C TYPE 3							
	99	98	97	96	95	94	93	92	91	90	89	88	166	87	86	85	84	83	82	
YL401	0	0	0	1	0	1	0	1	0	0	0	0	1	0	0	0	0	0	1	
YL402	0	0	0	1	0	1	1	0	0	0	0	0	1	0	0	0	0	0	1	
YL403	0	0	0	1	0	1	1	1	0	0	0	0	1	0	0	0	0	0	1	
YL404	0	0	0	1	1	0	0	0	0	0	0	0	1	0	0	0	0	0	1	
YL405	0	0	0	1	1	0	0	1	0	0	0	0	1	0	0	0	0	0	1	
YL406	0	0	0	1	1	0	1	0	0	0	0	0	1	0	0	0	0	0	1	
YL407	0	0	0	1	1	0	1	1	0	0	0	0	1	0	0	0	0	0	1	
YL408	0	0	0	1	1	1	0	0	0	0	0	0	1	0	0	0	0	0	1	
YL409	0	0	0	1	1	1	0	1	0	0	0	0	1	0	0	0	0	0	1	
YL410	0	0	0	1	1	1	1	0	0	0	0	0	1	0	0	0	0	0	1	
YL411	0	0	0	1	1	1	1	1	0	0	0	0	1	0	0	0	0	0	1	
YL412	0	0	1	0	0	0	0	0	0	0	0	0	1	0	0	0	0	0	1	
YL413	0	0	1	0	0	0	0	1	0	0	0	0	1	0	0	0	0	0	1	
YL414	0	0	1	0	0	0	1	0	0	0	0	0	1	0	0	0	0	0	1	
YL415	0	0	1	0	0	0	1	1	0	0	0	0	1	0	0	0	0	0	1	
YL416	0	0	1	0	0	1	0	0	0	0	0	0	1	0	0	0	0	0	1	
YL417	0	0	1	0	0	1	0	1	0	0	0	0	1	0	0	0	0	0	1	
YL418	0	0	1	0	0	1	1	0	0	0	0	0	1	0	0	0	0	0	1	
YL419	0	0	1	0	0	1	1	1	0	0	0	0	1	0	0	0	0	0	1	
YL420	0	0	1	0	1	0	0	0	0	0	0	0	1	0	0	0	0	0	1	
YL421	0	0	1	0	1	0	0	1	0	0	0	0	1	0	0	0	0	0	1	
YL422	0	0	1	0	1	0	1	0	0	0	0	0	1	0	0	0	0	0	1	
YL423	0	0	1	0	1	0	1	1	0	0	0	0	1	0	0	0	0	0	1	
YL424	0	0	1	0	1	1	0	0	0	0	0	0	1	0	0	0	0	0	1	
YL425	0	0	1	0	1	1	0	1	0	0	0	0	1	0	0	0	0	0	1	
YL426	0	0	1	0	1	1	1	0	0	0	0	0	1	0	0	0	0	0	1	
YL427	0	0	1	0	1	1	1	1	0	0	0	0	1	0	0	0	0	0	1	
YL428	0	0	1	1	0	0	0	0	0	0	0	0	1	0	0	0	0	0	1	
YL429	0	0	1	1	0	0	0	1	0	0	0	0	1	0	0	0	0	0	1	
YL430	0	0	1	1	0	0	1	0	0	0	0	0	1	0	0	0	0	0	1	

1 - M1996 SELECTED TO "ON"
0 - M1996 SELECTED TO "OFF"

NOTES:

- 1 AIRCRAFT NUMBER
- 2 FLEET IDENTIFICATION
- 3 AIRCRAFT TYPE

YL401-YL430

DIGITAL FLIGHT DATA RECORDER SYSTEM AIRPLANE CODING

D280A103

31-31-16

Page 3

Nov 11/2008

31-31-16

Page 3

Nov 11/2008

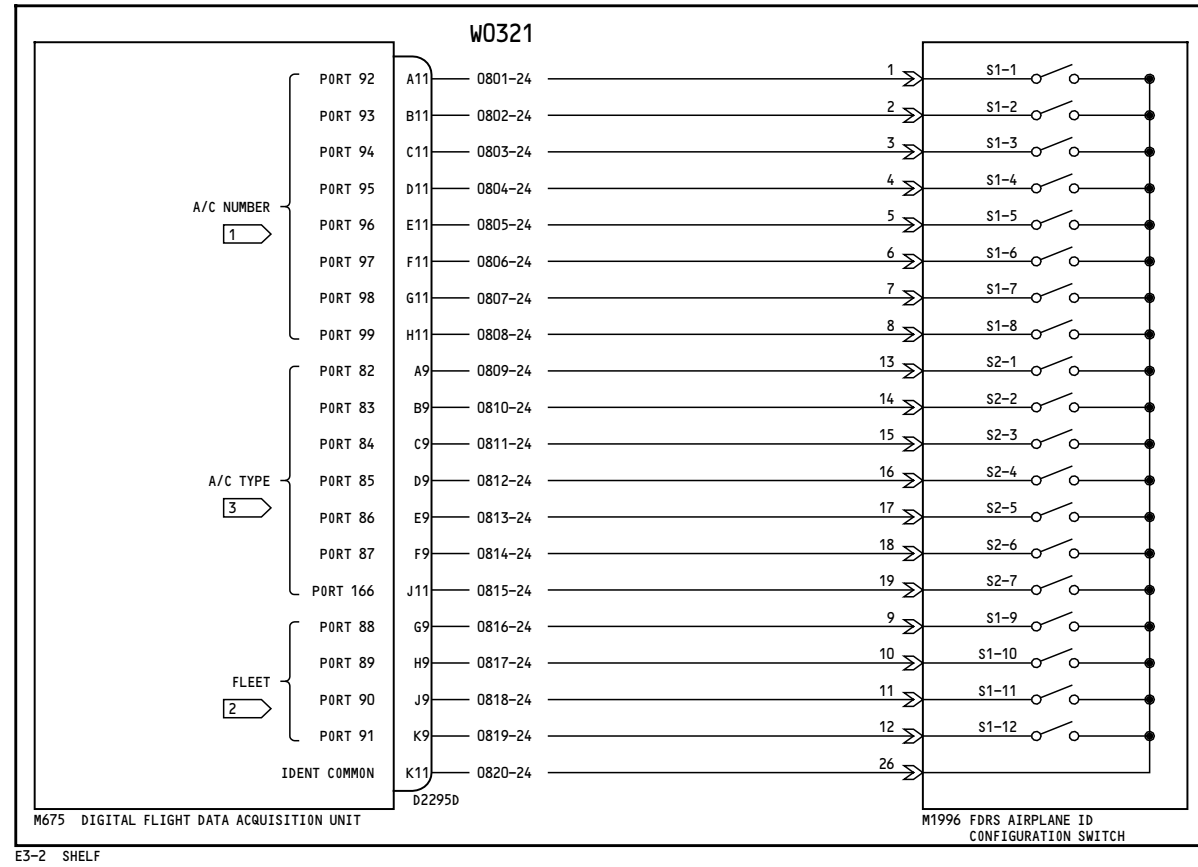

A/C EFF	A/C NUMBER 1								FLEET 2				A/C TYPE 3							
	99	98	97	96	95	94	93	92	91	90	89	88	166	87	86	85	84	83	82	
YM641	0	0	0	0	0	0	0	1	0	0	0	1	1	0	0	0	0	0	0	
YM642	0	0	0	0	0	0	1	0	0	0	1	1	0	0	0	0	0	0	0	
YM643	0	0	0	0	0	0	1	1	0	0	1	1	0	0	0	0	0	0	0	
YM644	0	0	0	0	0	1	0	0	0	0	1	1	0	0	0	0	0	0	0	
YM645	0	0	0	0	0	1	0	1	0	0	1	1	0	0	0	0	0	0	0	
YM646	0	0	0	0	0	1	1	0	0	0	1	1	0	0	0	0	0	0	0	
YM647	0	0	0	0	0	1	1	1	0	0	1	1	0	0	0	0	0	0	0	
YM648	0	0	0	0	1	0	0	0	0	0	1	1	0	0	0	0	0	0	0	
YM649	0	0	0	0	1	0	0	1	0	0	1	1	0	0	0	0	0	0	0	
YM650	0	0	0	0	1	0	1	0	0	0	1	1	0	0	0	0	0	0	0	
YM651	0	0	0	0	1	0	1	1	0	0	1	1	0	0	0	0	0	0	0	
YM652	0	0	0	0	1	1	0	0	0	0	1	1	0	0	0	0	0	0	0	
YM653	0	0	0	0	1	1	0	1	0	0	1	1	0	0	0	0	0	0	0	
YM654	0	0	0	0	1	1	1	1	0	0	1	1	0	0	0	0	0	0	0	
YM655	0	0	0	0	1	1	1	1	0	0	1	1	0	0	0	0	0	0	0	
YM656	0	0	0	1	0	0	0	0	0	0	1	1	0	0	0	0	0	0	0	
YM657	0	0	0	1	0	0	0	1	0	0	1	1	0	0	0	0	0	0	0	
YM658	0	0	0	1	0	0	1	0	0	0	1	1	0	0	0	0	0	0	0	
YM659	0	0	0	1	0	0	1	1	0	0	1	1	0	0	0	0	0	0	0	
YM660	0	0	0	1	0	1	0	0	0	0	1	1	0	0	0	0	0	0	0	
YM661	0	0	0	1	0	1	0	1	0	0	1	1	0	0	0	0	0	0	0	
YM662	0	0	0	1	0	1	1	0	0	0	1	1	0	0	0	0	0	0	0	
YM663	0	0	0	1	0	1	1	1	0	0	1	1	0	0	0	0	0	0	0	
YM664	0	0	0	1	1	0	0	0	0	0	1	1	0	0	0	0	0	0	0	
YM665	0	0	0	1	1	0	0	1	0	0	1	1	0	0	0	0	0	0	0	
YM666	0	0	0	1	1	0	1	0	0	0	1	1	0	0	0	0	0	0	0	
YM667	0	0	0	1	1	0	1	1	0	0	1	1	0	0	0	0	0	0	0	
YM668	0	0	0	1	1	1	0	0	0	0	1	1	0	0	0	0	0	0	0	
YM669	0	0	0	1	1	1	0	1	0	0	1	1	0	0	0	0	0	0	0	
YM670	0	0	0	1	1	1	1	0	0	0	1	1	0	0	0	0	0	0	0	

1 - M1996 SELECTED TO "ON"
0 - M1996 SELECTED TO "OFF"

NOTES:

- 1** AIRCRAFT NUMBER
- 2** FLEET IDENTIFICATION
- 3** AIRCRAFT TYPE

YM643-YM670

DIGITAL FLIGHT DATA RECORDER SYSTEM AIRPLANE CODING

D280A103

31-31-16

Page 4

Nov 11/2008

31-31-16

Page 4

Nov 11/2008

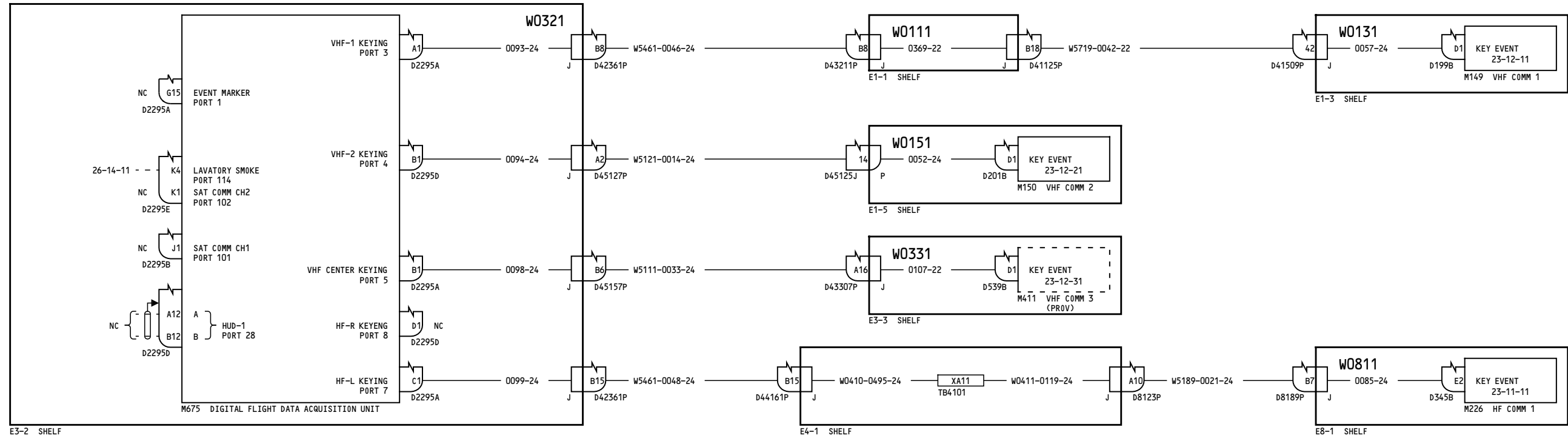

YC001-YC007

**DIGITAL FLIGHT DATA
RECORDER SYSTEM MANDATORY
OPTIONS**

D280A103

31-31-17

Page 1

Mar 31/2005

31-31-17

Page 1

Mar 31/2005

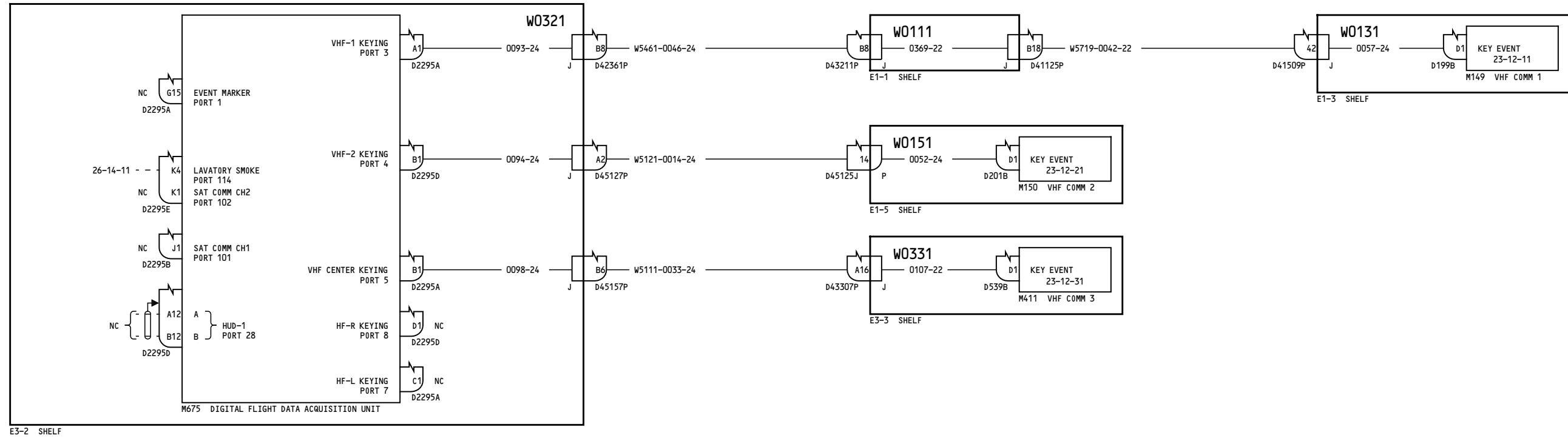

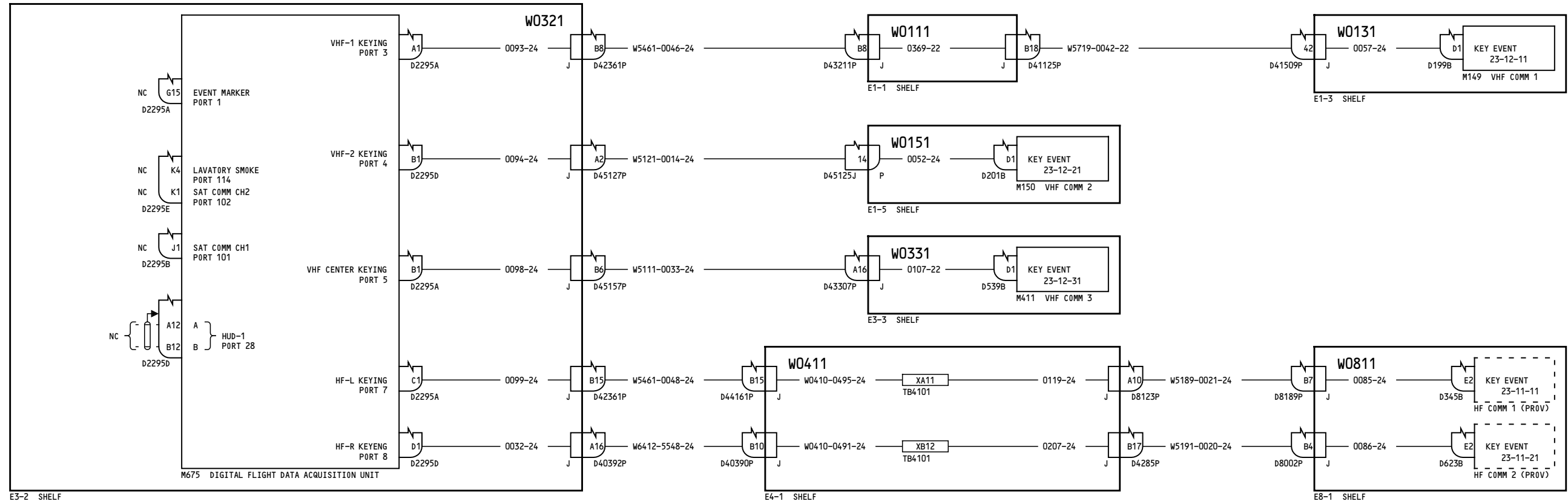

YK907-YK909

**DIGITAL FLIGHT DATA
RECORDER SYSTEM MANDATORY
OPTIONS**

D280A103

31-31-17

Page 3

Jan 18/2007

31-31-17

Page 3

Jan 18/2007

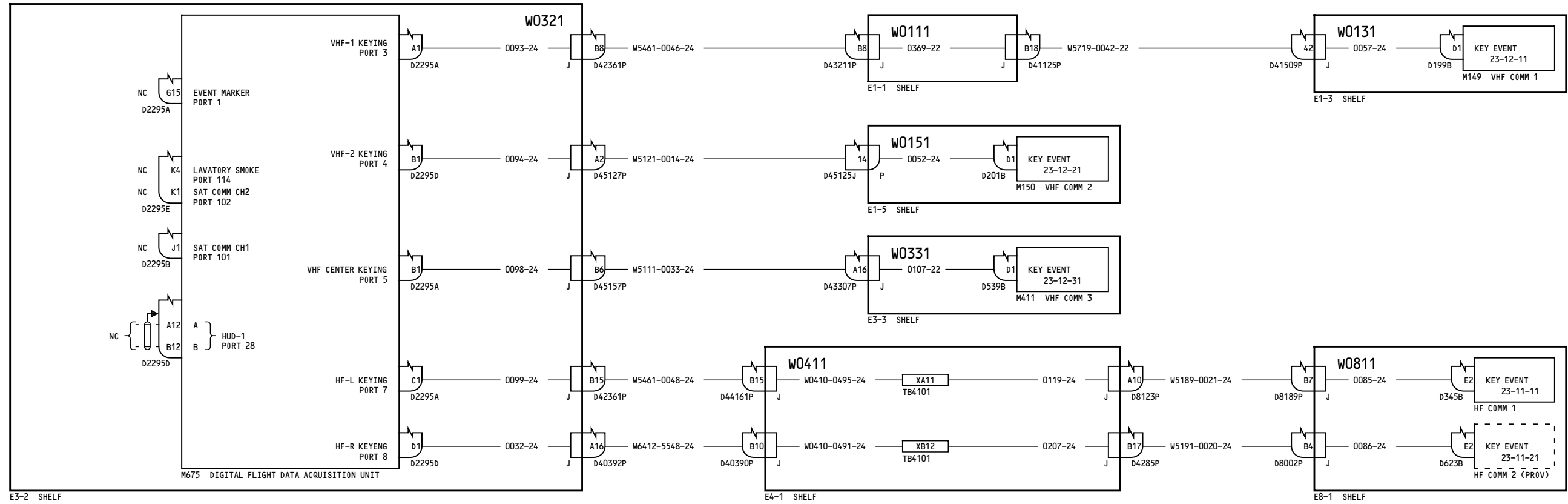

YK907-YK909

**DIGITAL FLIGHT DATA
RECORDER SYSTEM MANDATORY
OPTIONS**

D280A103

31-31-17

Page 3.1

May 13/2008

Incorporates
23-1299

31-31-17

Page 3.1

May 13/2008

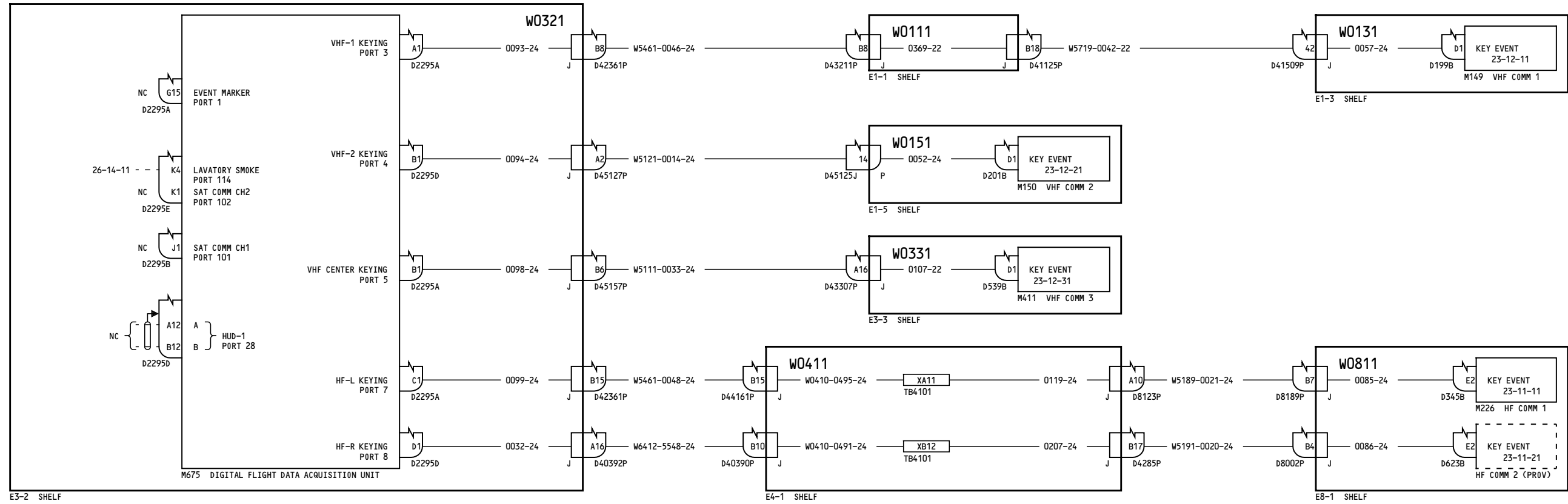

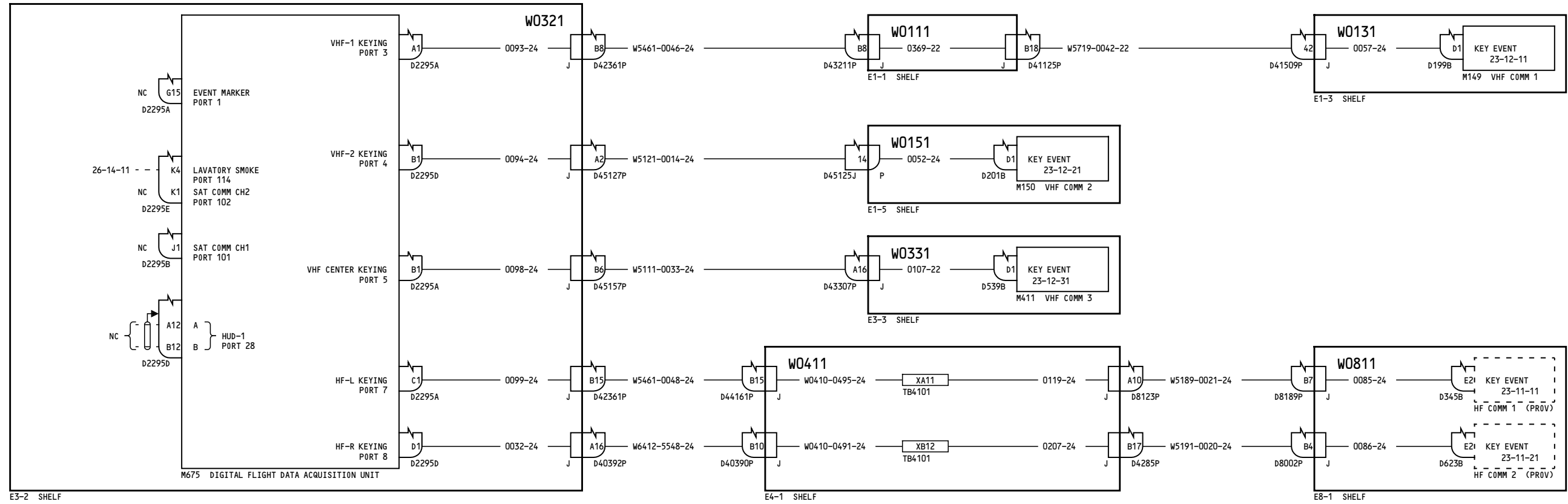

YL401

**DIGITAL FLIGHT DATA
RECORDER SYSTEM MANDATORY
OPTIONS**

D280A103

31-31-17

Page 5

Feb 09/2009

31-31-17

Page 5

Feb 09/2009

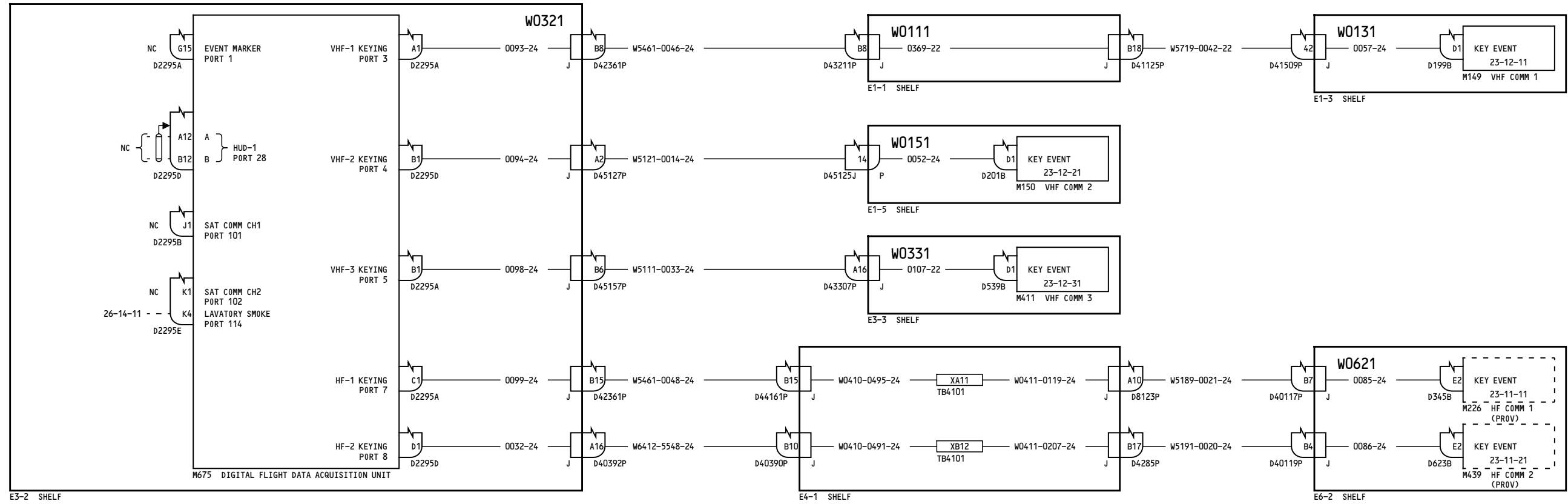

YM643-YM670

**DIGITAL FLIGHT DATA
RECORDER SYSTEM MANDATORY
OPTIONS**

D280A103

31-31-17

Page 6

Aug 13/2008

31-31-17

Page 6

Aug 13/2008

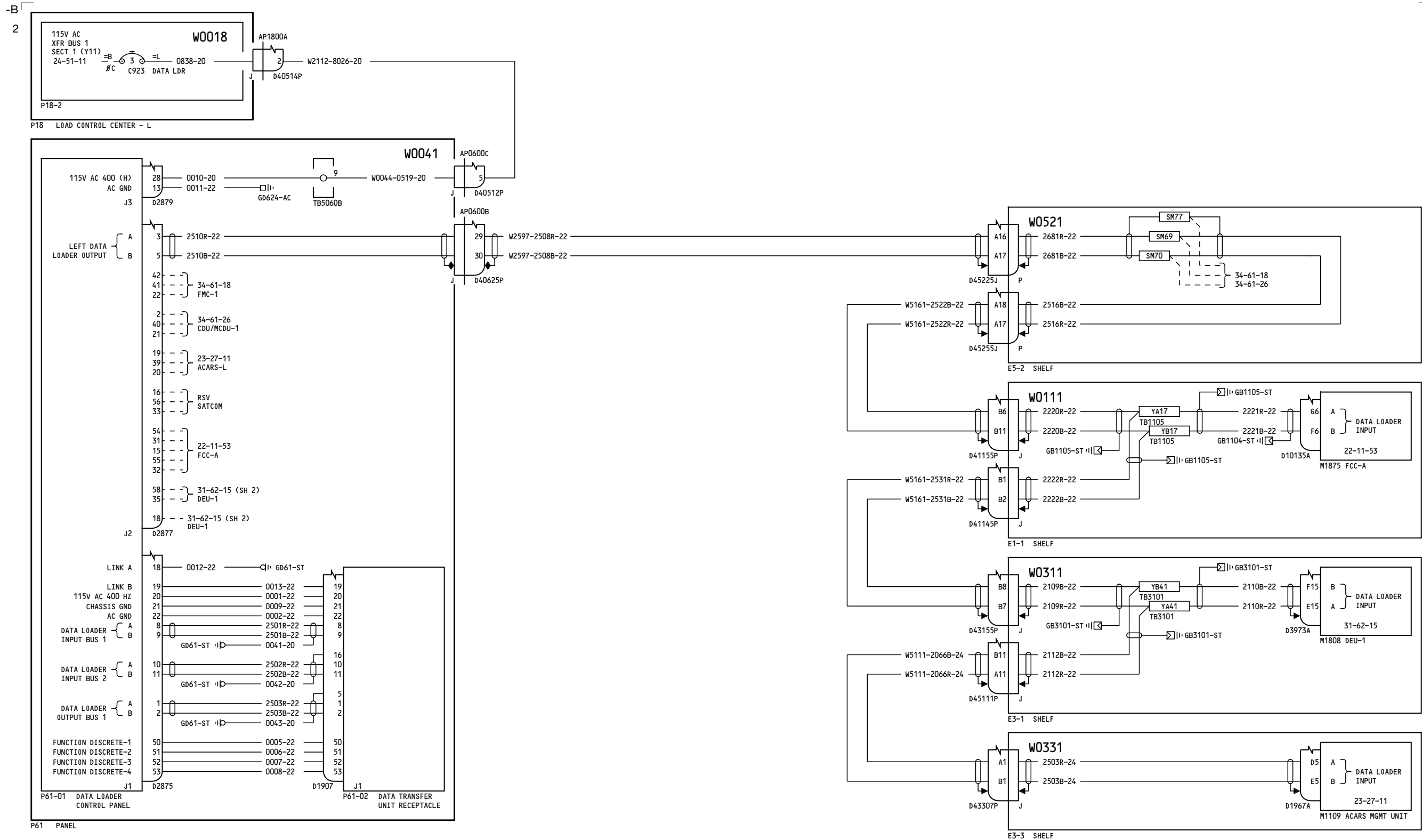

YC001-YC011

DATA LOADER INTERFACE

31-32-15

Page 1.1
Sheet 1
Mar 31/2005

D280A103

Incorporates
31-1136

31-32-15

Page 1.1
Sheet 1
Mar 31/2005

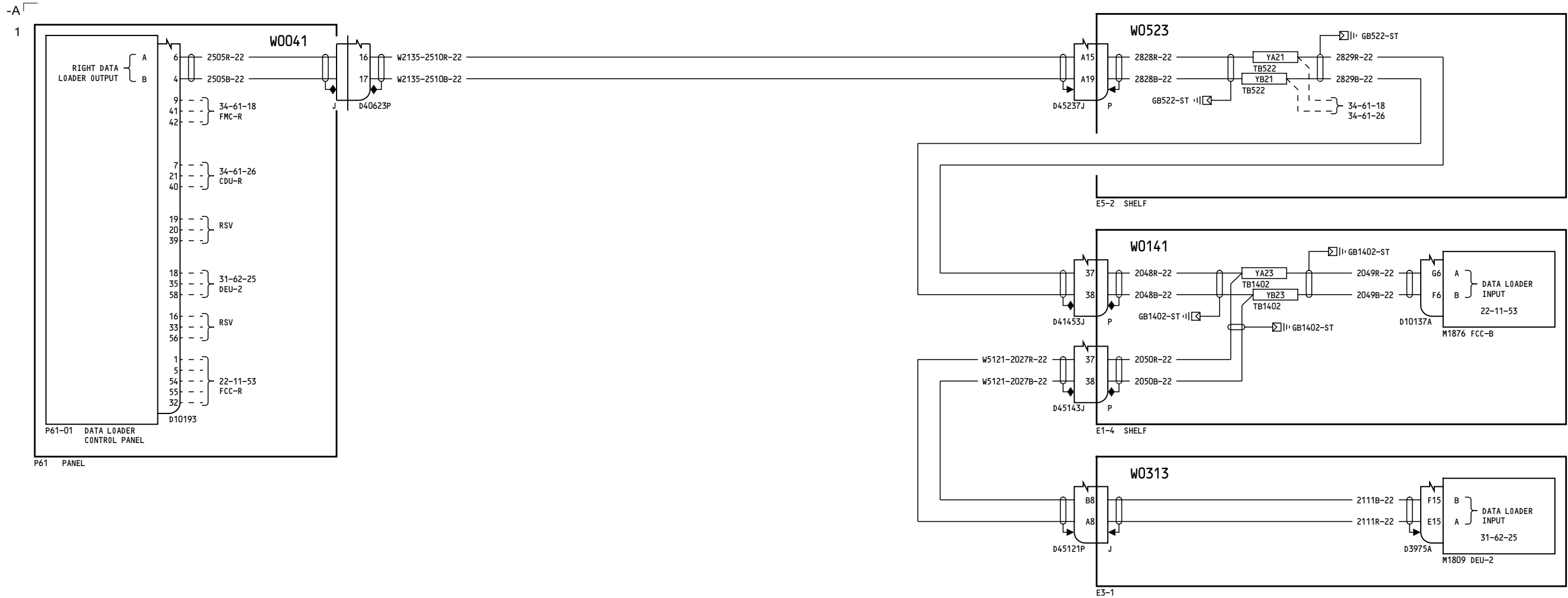

YC001-YC011

DATA LOADER INTERFACE

31-32-15

Page 1.1
Sheet 2
Mar 31/2005

D280A103

Incorporates
31-1136

31-32-15

Page 1.1
Sheet 2
Mar 31/2005

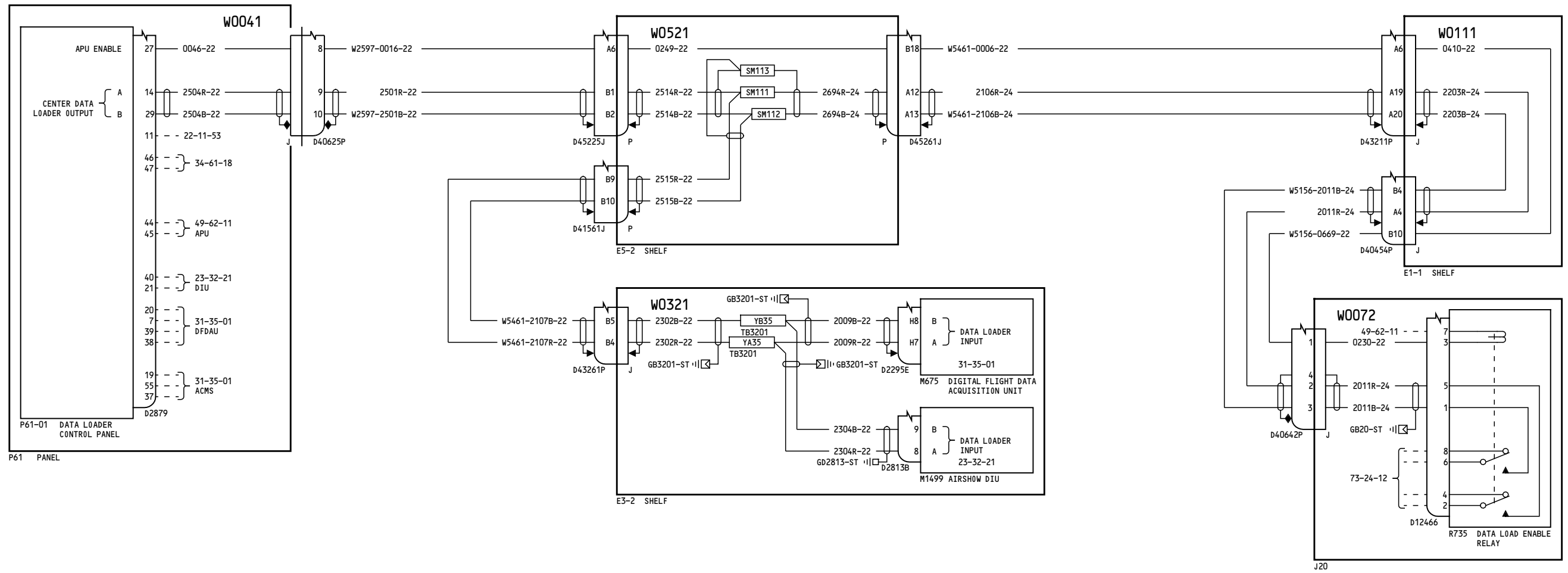

YC001-YC011

DATA LOADER INTERFACE

31-32-15

Page 1.1
Sheet 3
Mar 31/2005

D280A103

Incorporates
31-1136

31-32-15

Page 1.1
Sheet 3
Mar 31/2005

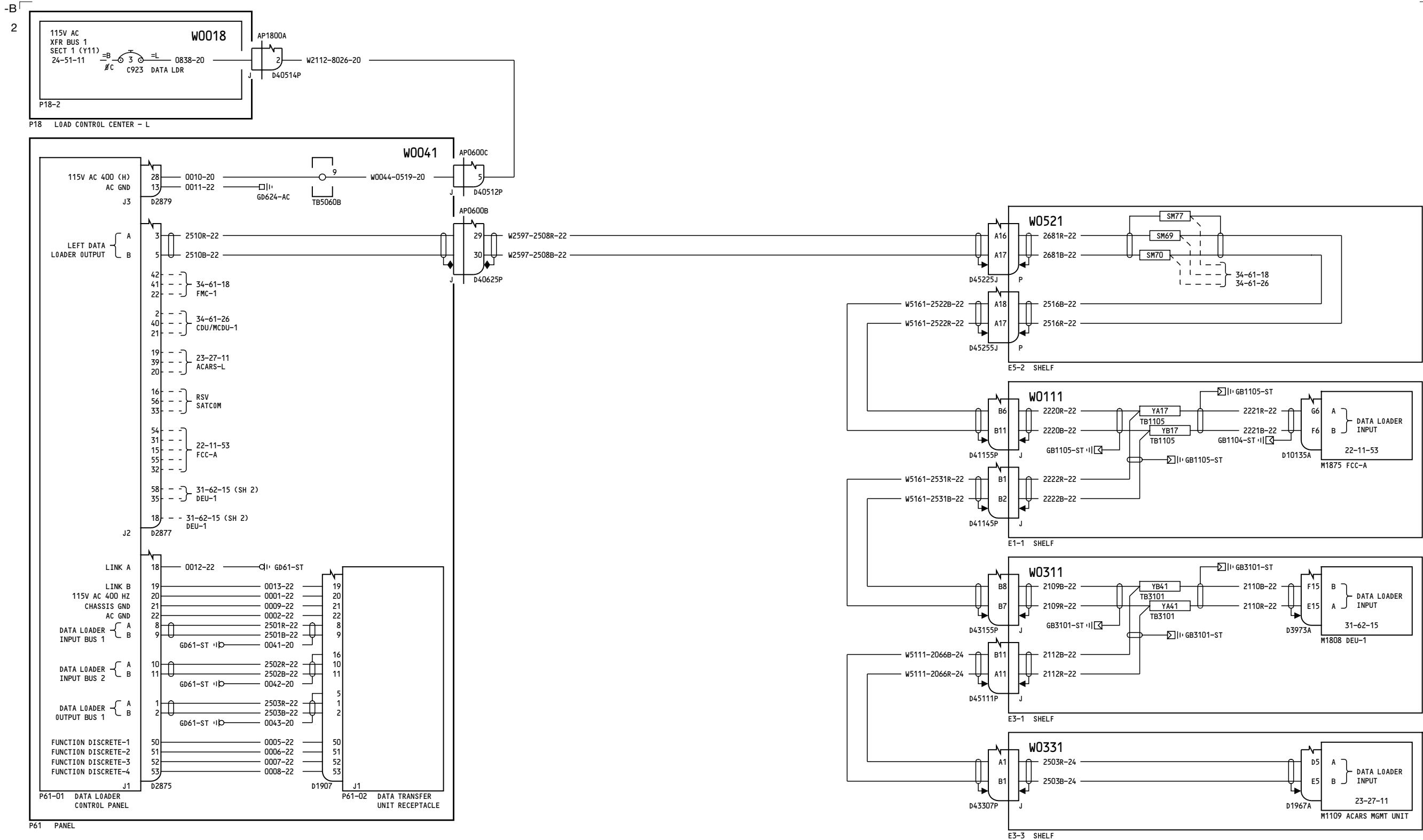

YC012-YC050

DATA LOADER INTERFACE

31-32-15

Page 2
Sheet 1
Jul 17/2007

D280A103

31-32-15

Page 2
Sheet 1
Jul 17/2007

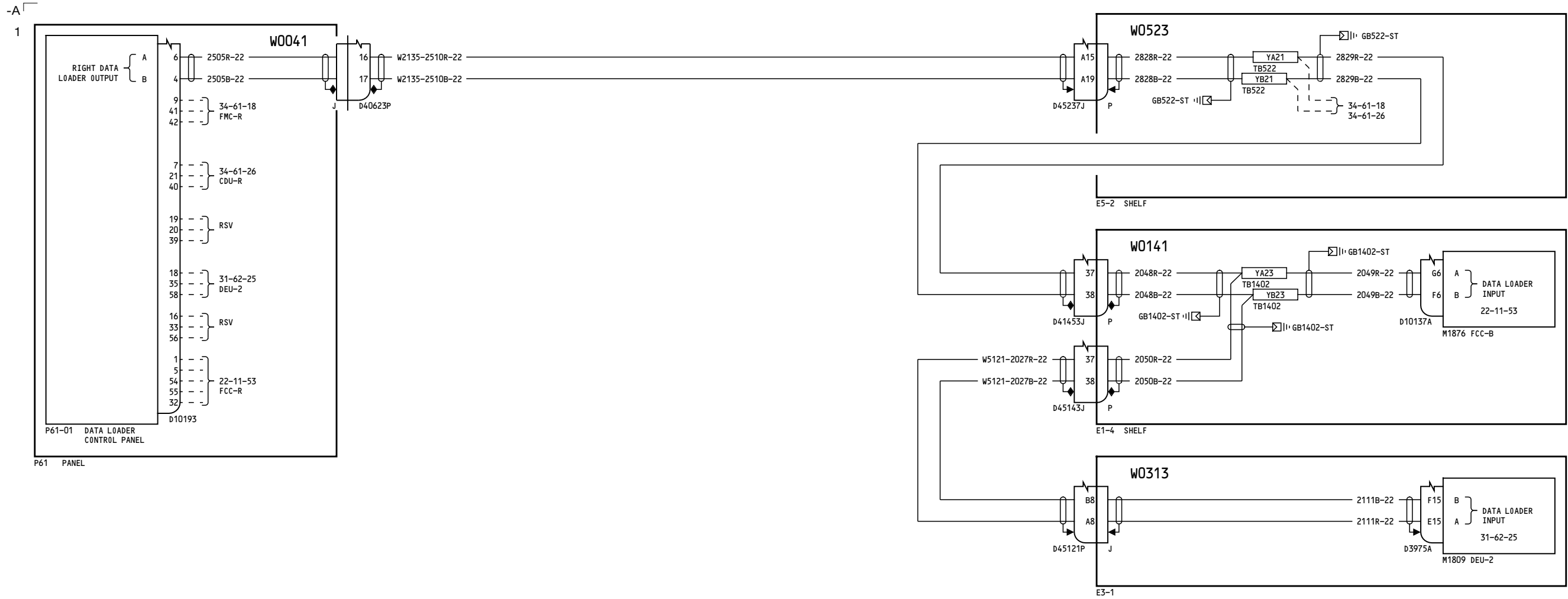

YC012-YC050

DATA LOADER INTERFACE

31-32-15

Page 2
Sheet 2
Jul 17/2007

D280A103

31-32-15

Page 2
Sheet 2
Jul 17/2007

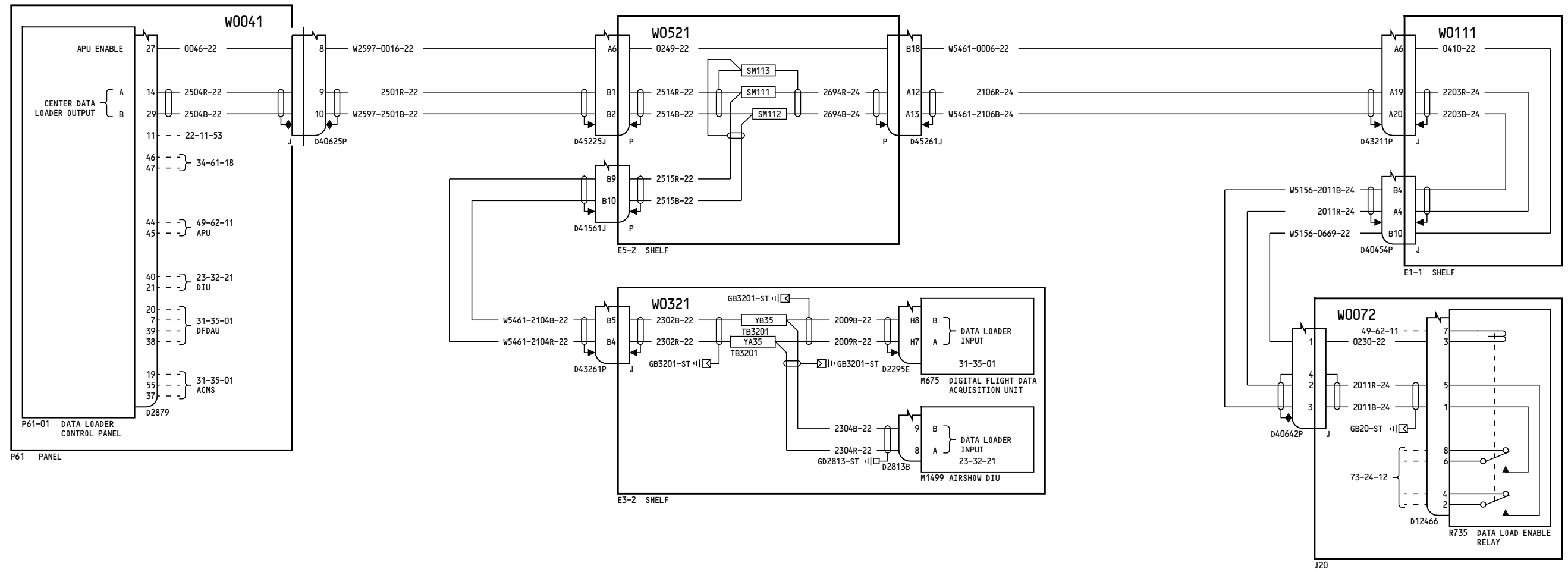

YC012-YC050

DATA LOADER INTERFACE

31-32-15

Page 2
Sheet 3
Jul 17/2007

D280A103

31-32-15

Page 2
Sheet 3
Jul 17/2007

-A
31

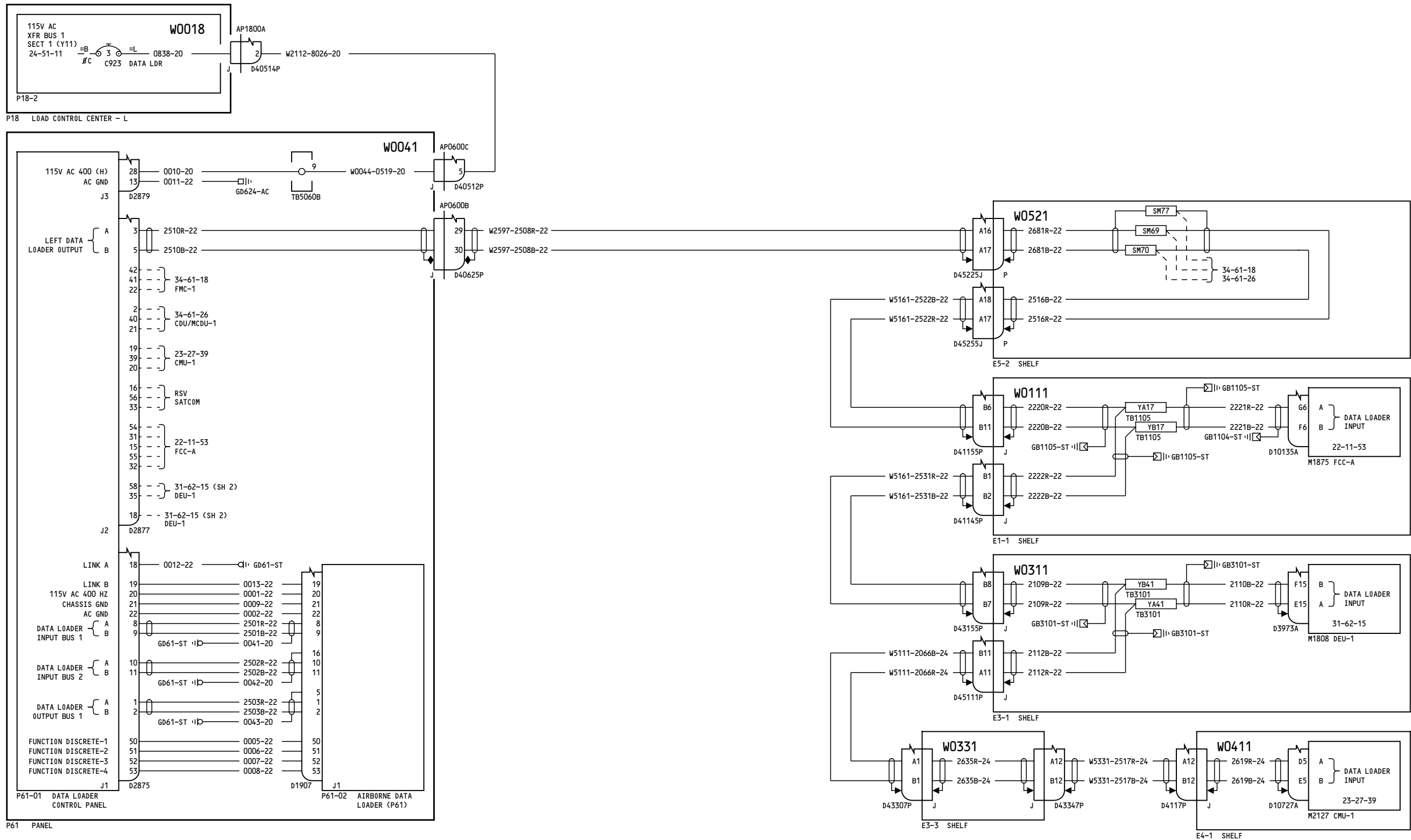

YK901-YM670

DATA LOADER INTERFACE

31-32-15

Page 3
Sheet 1
Feb 09/2009

D280A103

31-32-15

Page 3
Sheet 1
Feb 09/2009

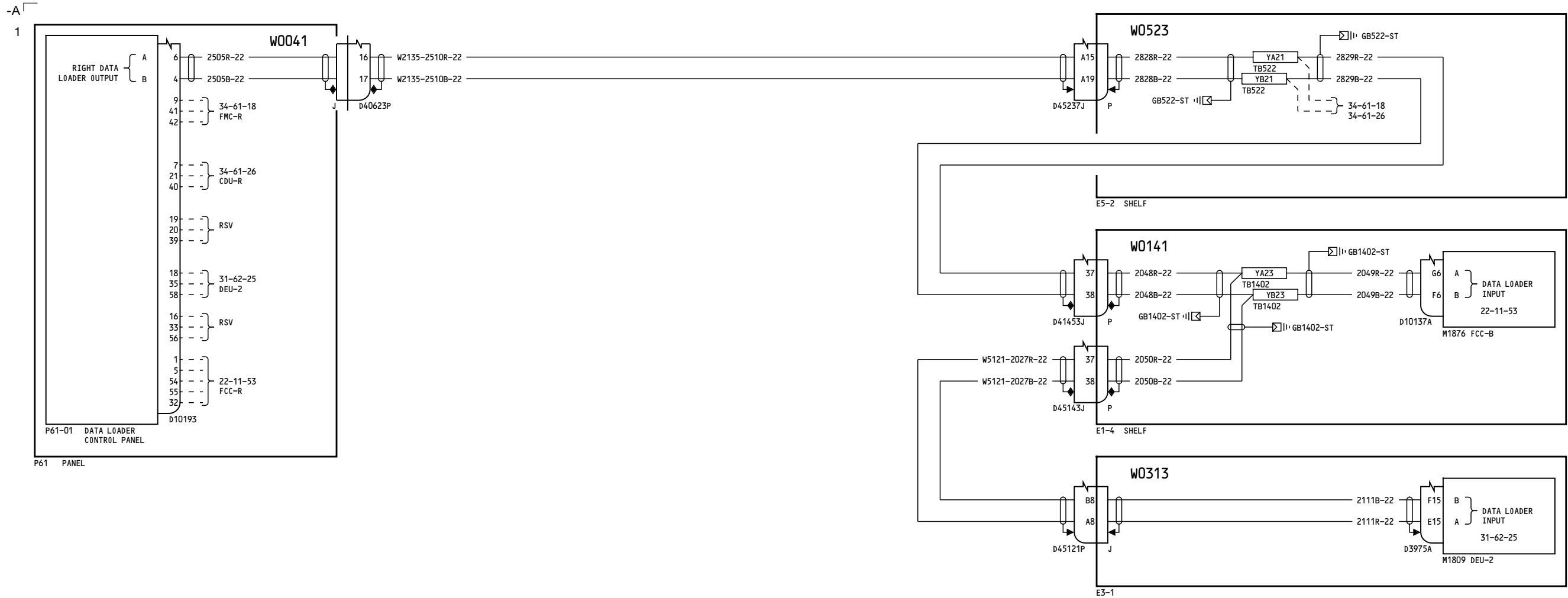

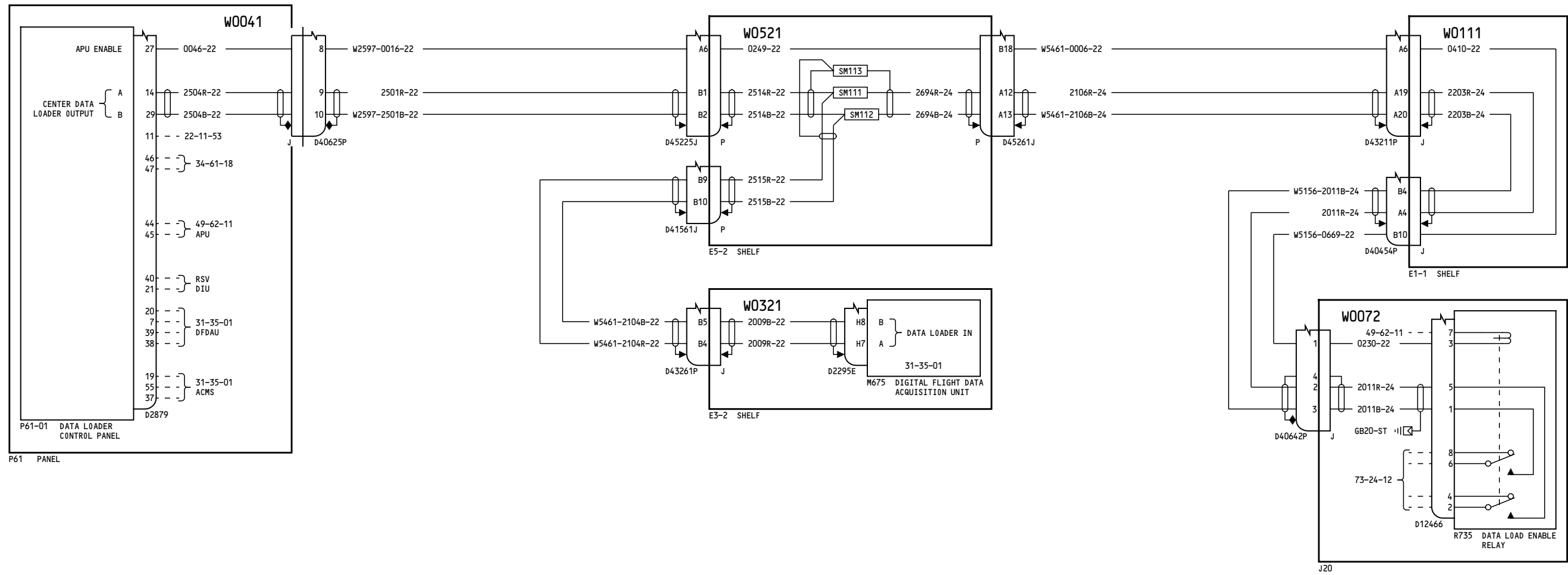

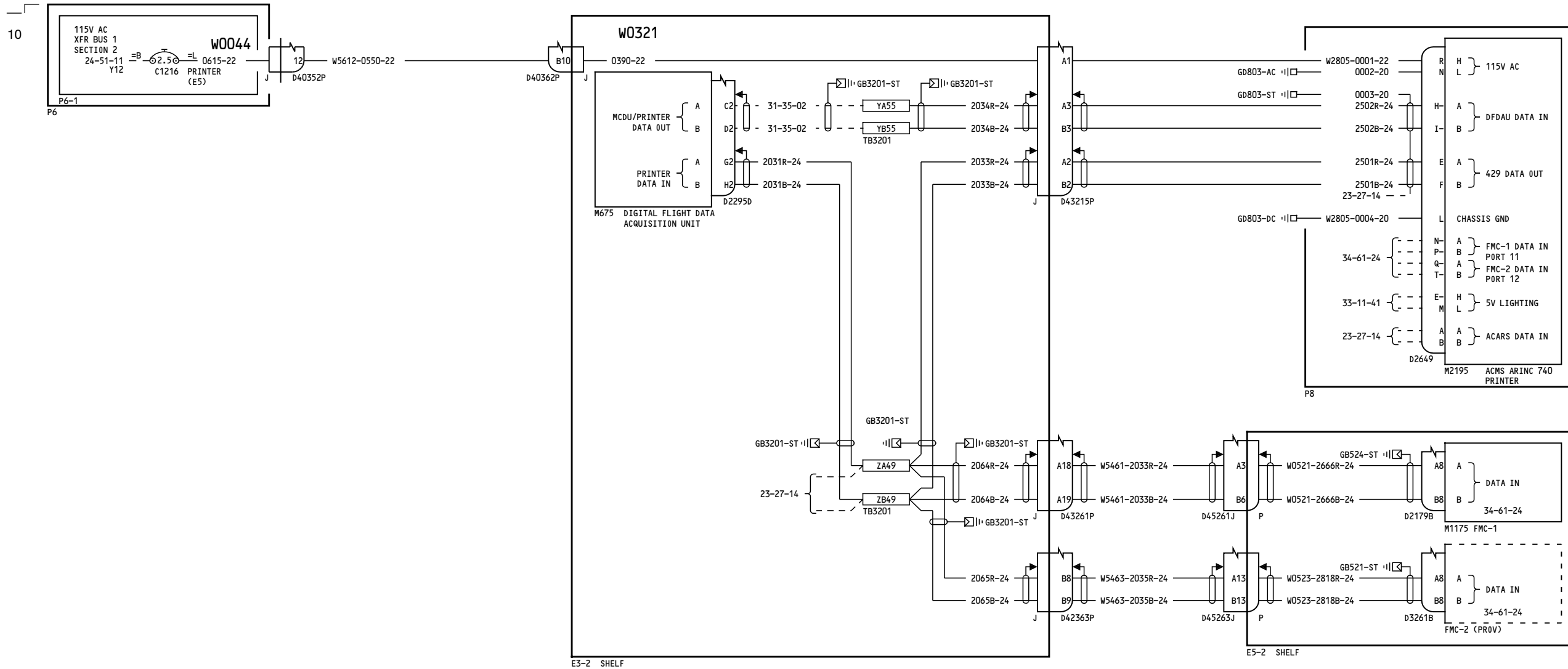

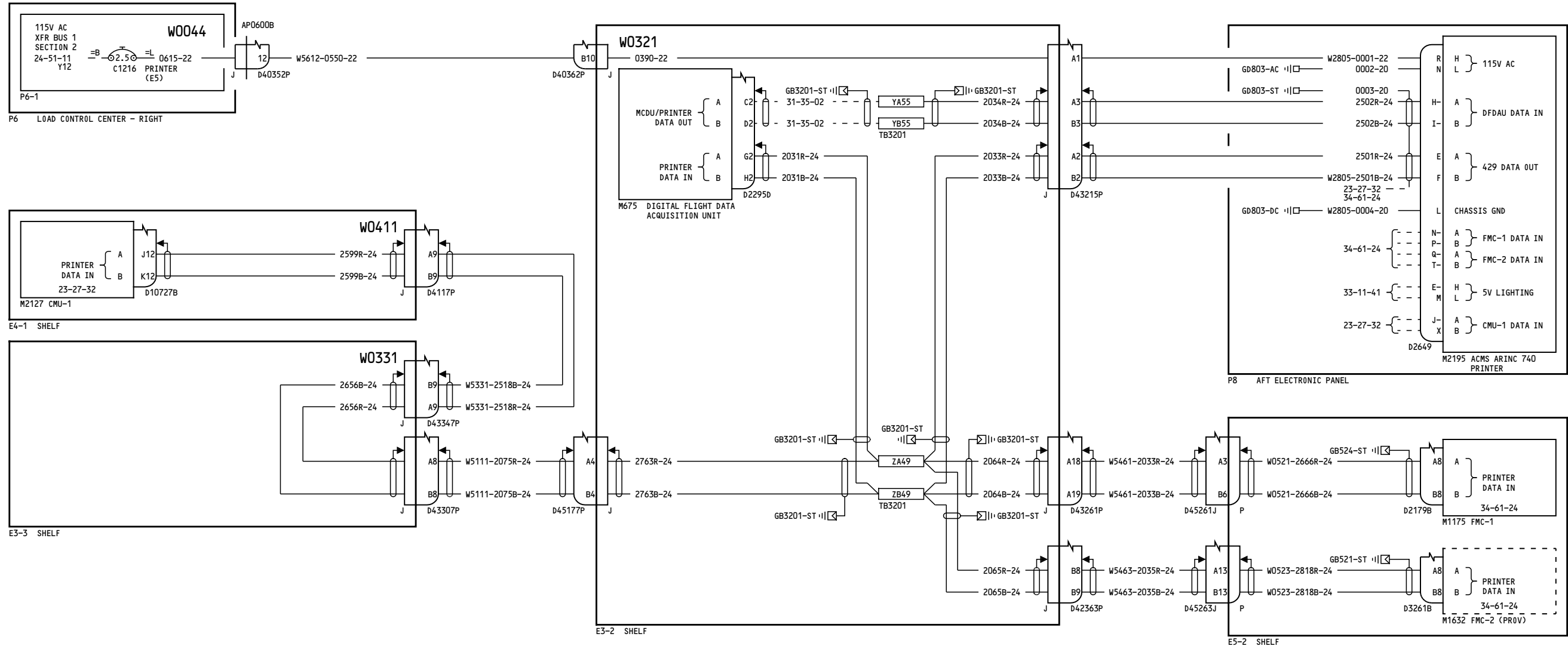

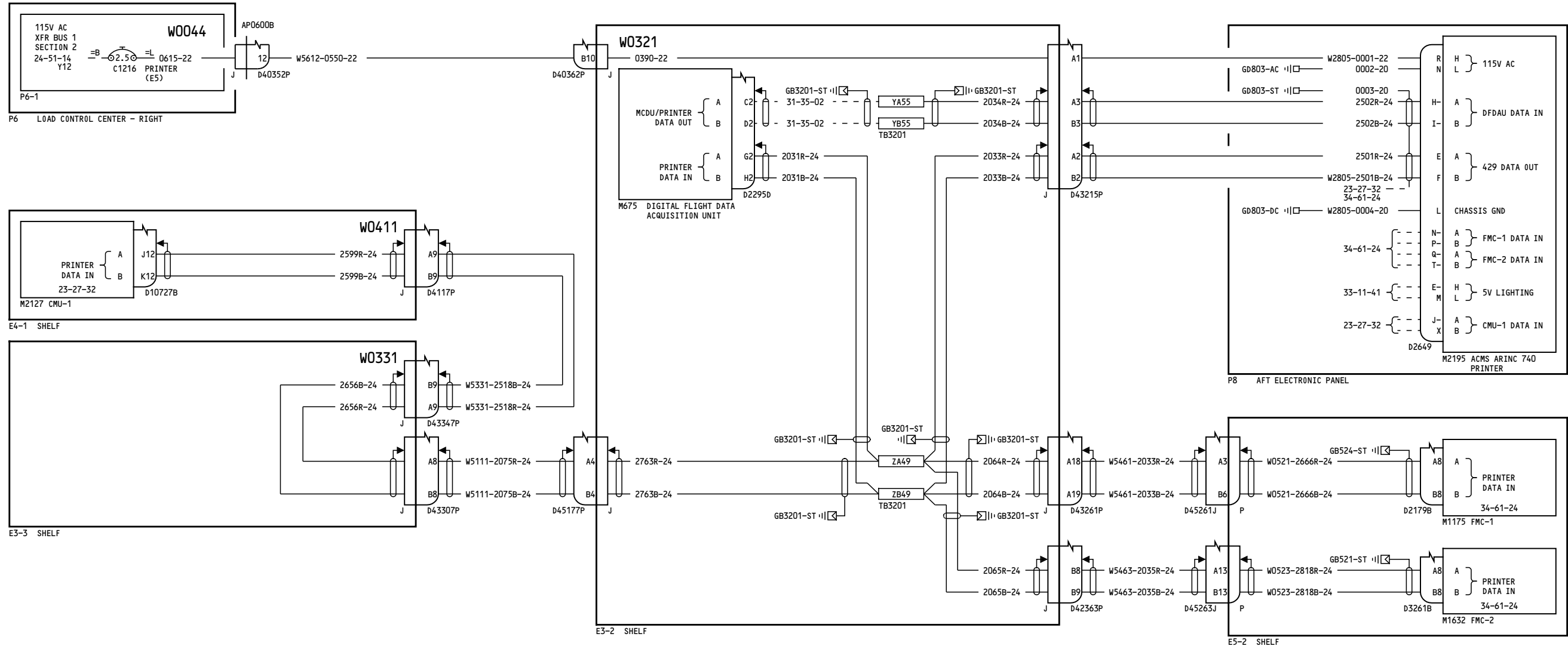

-A
171

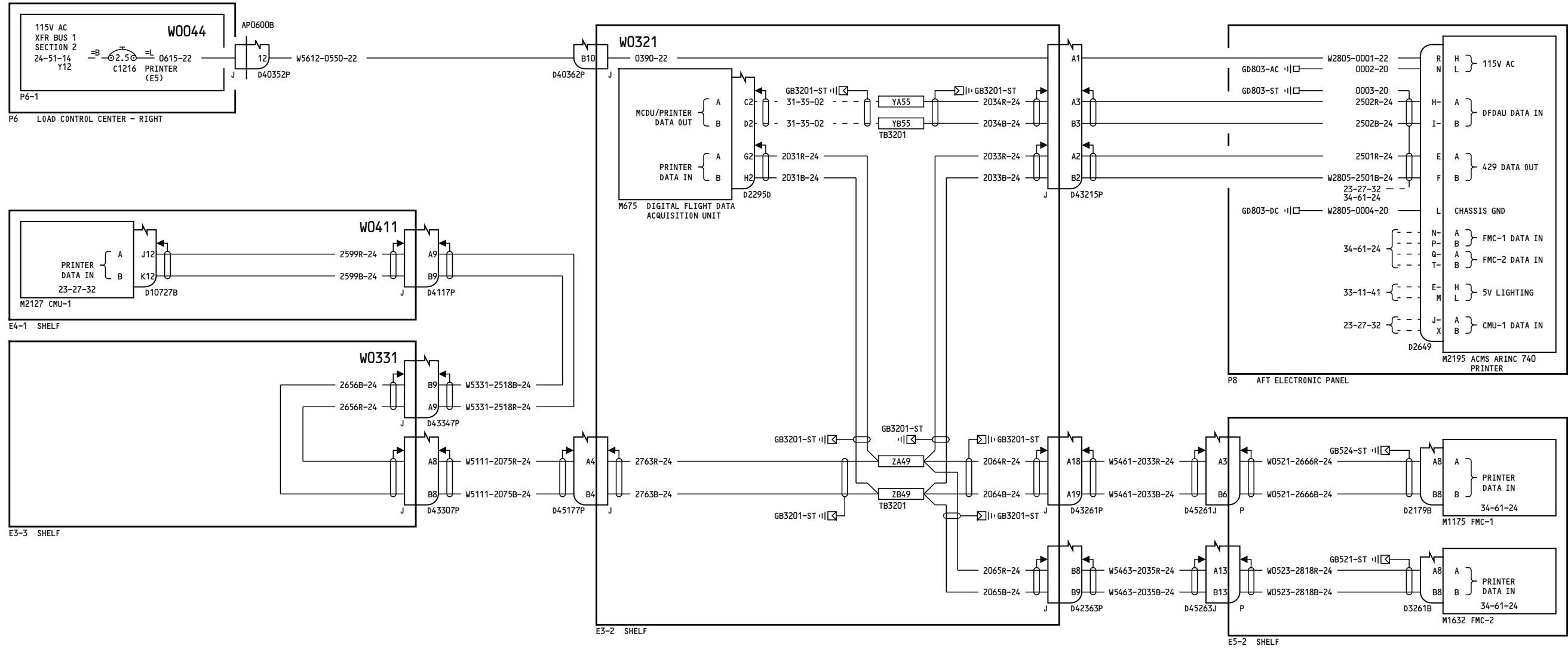

YL421-YM670

PRINTER INTERFACE

31-33-01

Page 4

May 11/2009

D280A103

31-33-01

Page 4

May 11/2009

-C
7

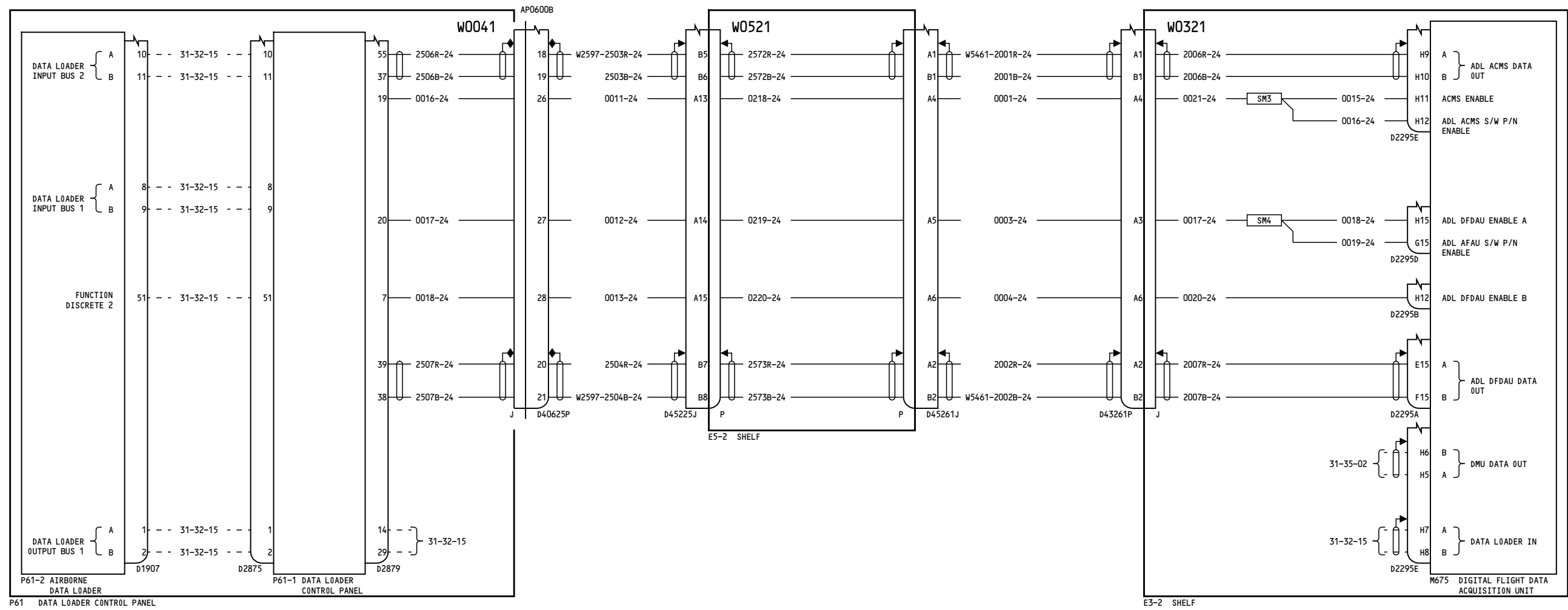

YC001-YC011

**DIGITAL FLIGHT DATA
RECORDER SYSTEM - DATA
LOADER INTERFACE**

D280A103

31-35-01

Page 1.1

Oct 20/2006

Incorporates
▶ 31-1136

31-35-01

Page 1.1

Oct 20/2006

-C
7

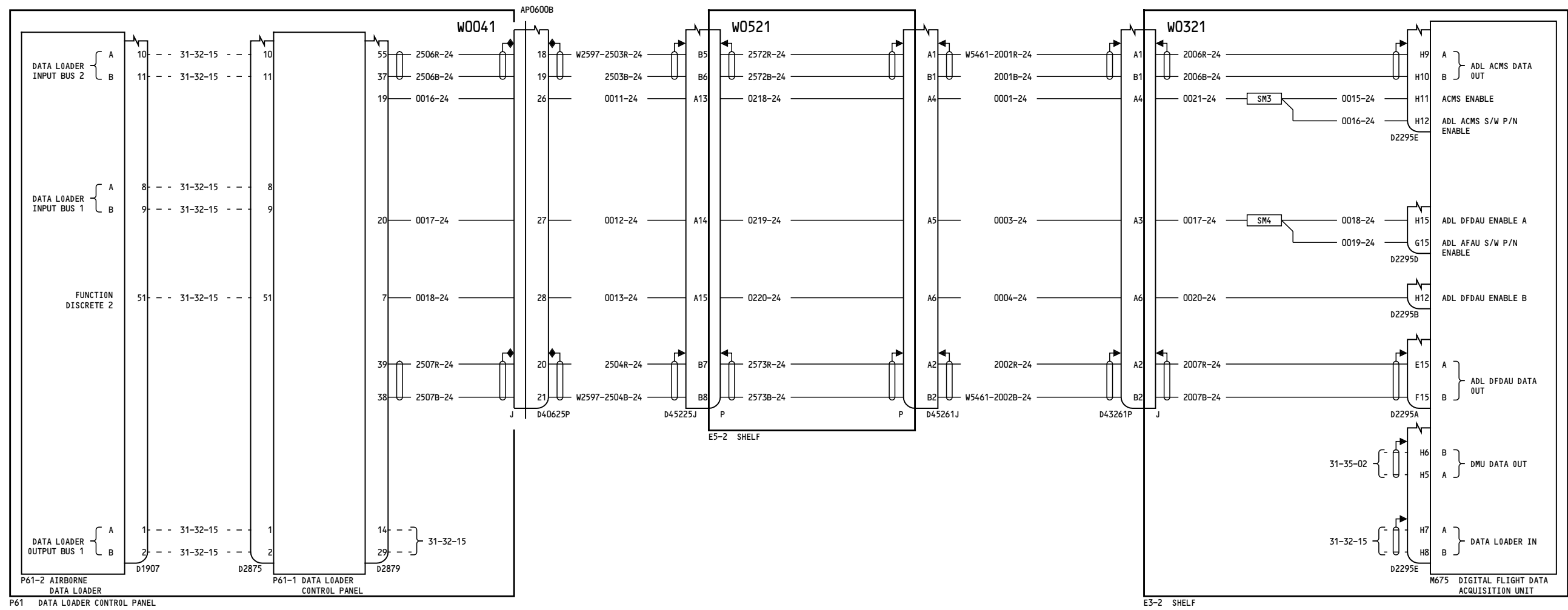

YC012-YM670

**DIGITAL FLIGHT DATA
RECORDER SYSTEM - DATA
LOADER INTERFACE**

31-35-01

Page 2

D280A103

Feb 09/2009

31-35-01

Page 2

Feb 09/2009

-B
3

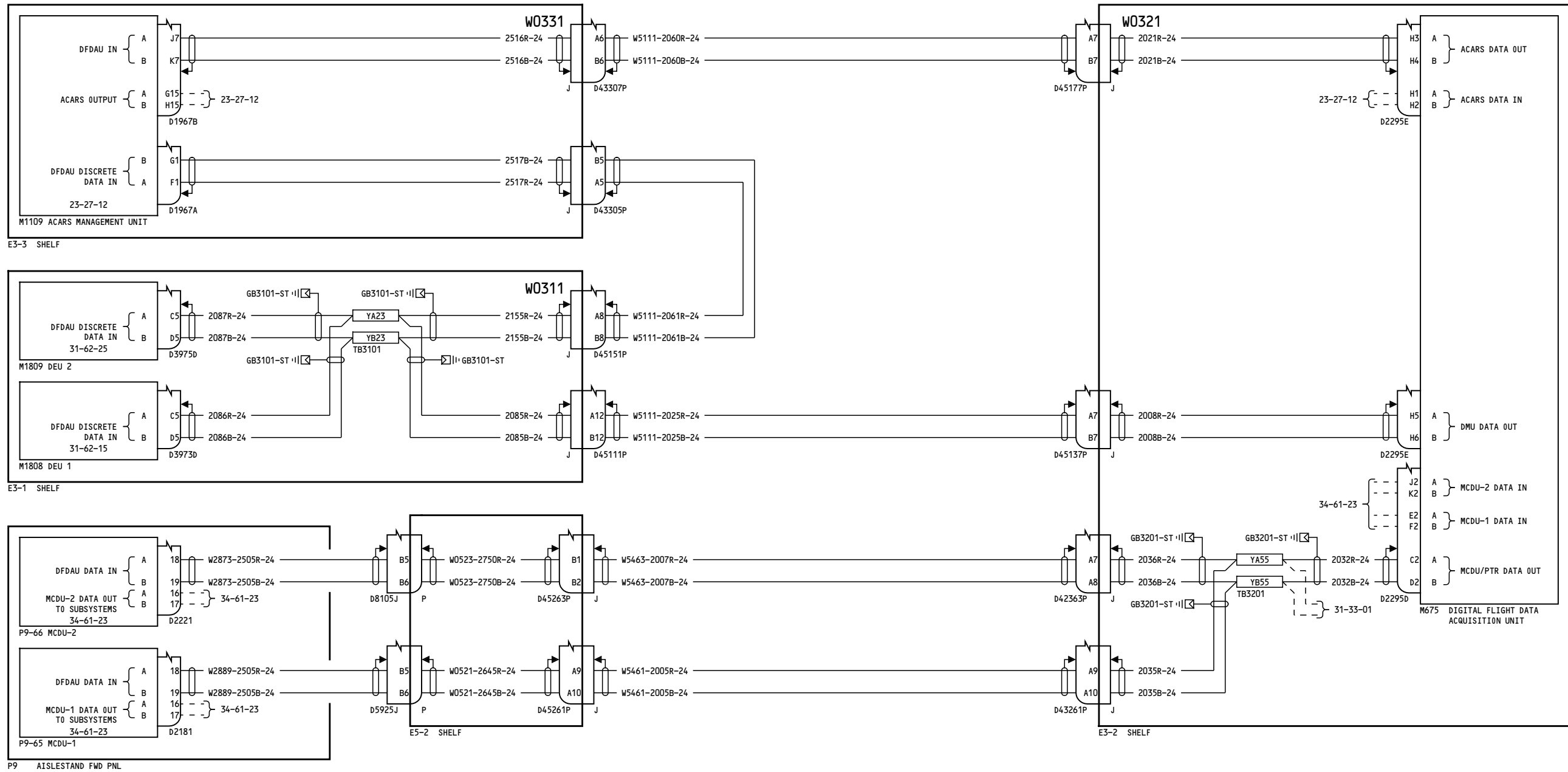

YC001-YC050

**DIGITAL FLIGHT DATA
RECORDER SYSTEM - ACMS
INTERFACE**

31-35-02

Page 1

D280A103

Jul 17/2007

31-35-02

Page 1

Jul 17/2007

81

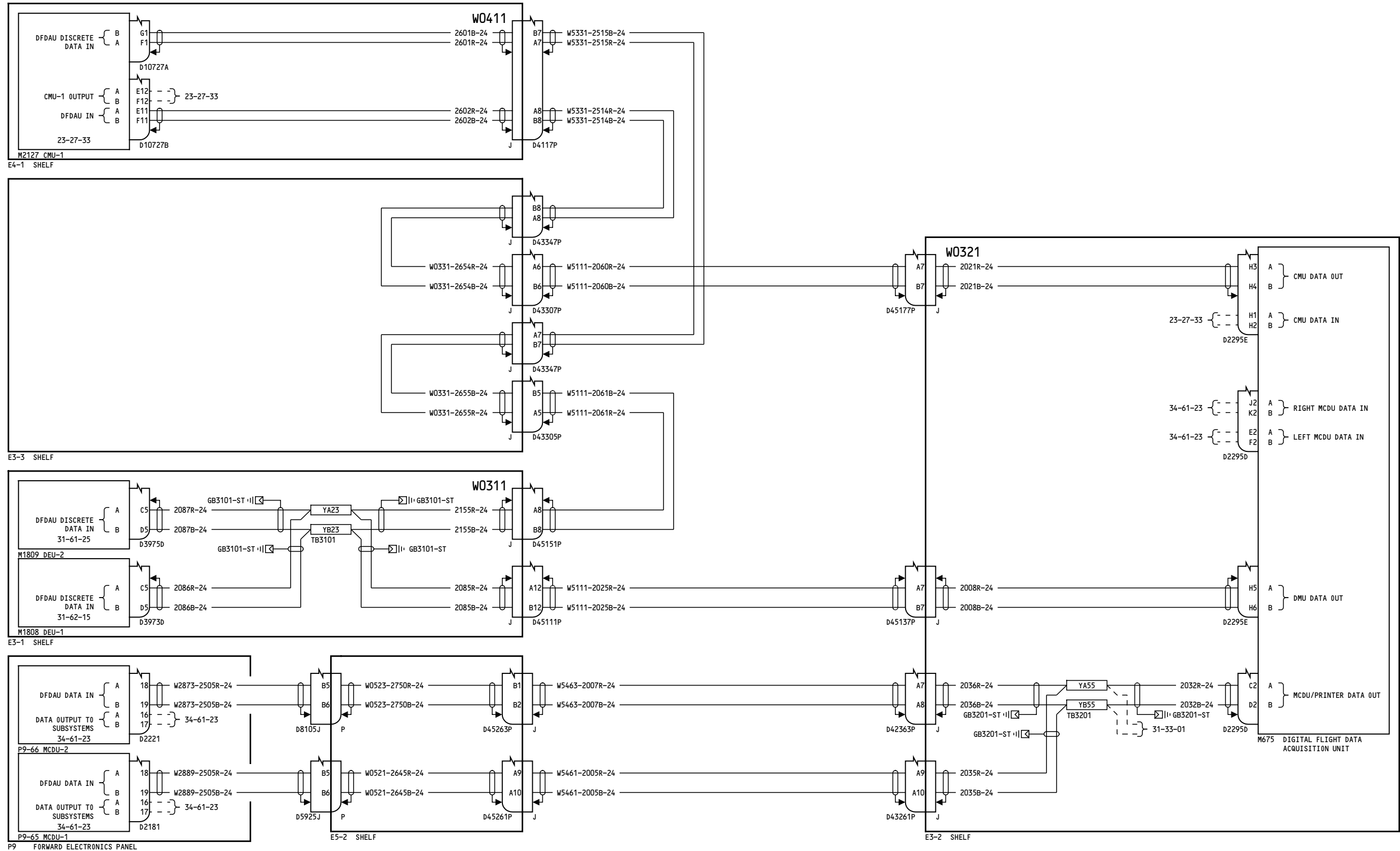

YK901-YM670

DIGITAL FLIGHT DATA RECORDER SYSTEM - ACMS INTERFACE

31-35-02

Page 2

D280A103

Feb 09/2009

31-35-02

Page 2

Feb 09/2009

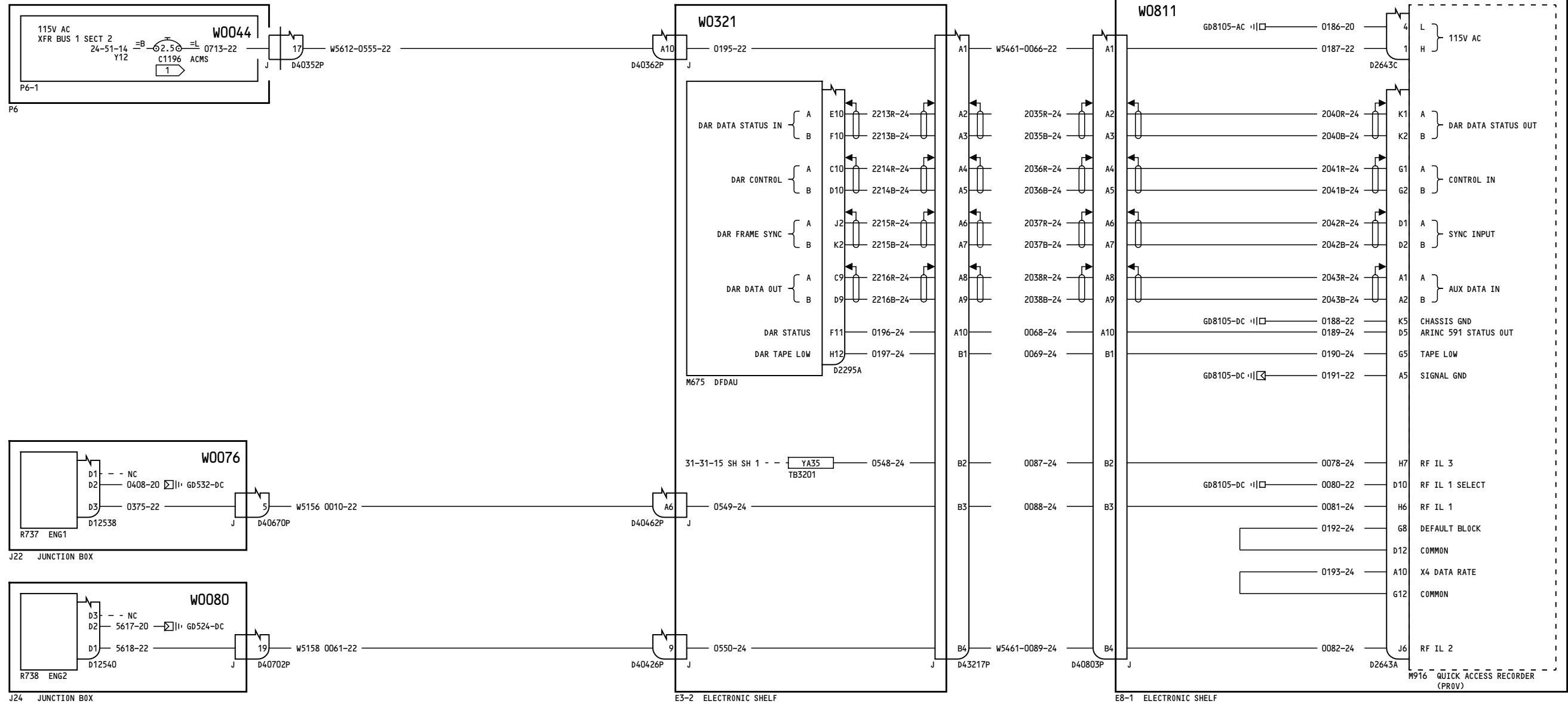

NOTES:

1 COLLAR AND LABEL "INOP"

YK910, YM643

**DIGITAL FLIGHT DATA
RECORDER SYSTEM - ACMS
INTERFACE 3**

D280A103

31-35-03

Page 1

Jul 17/2007

31-35-03

Page 1

Jul 17/2007

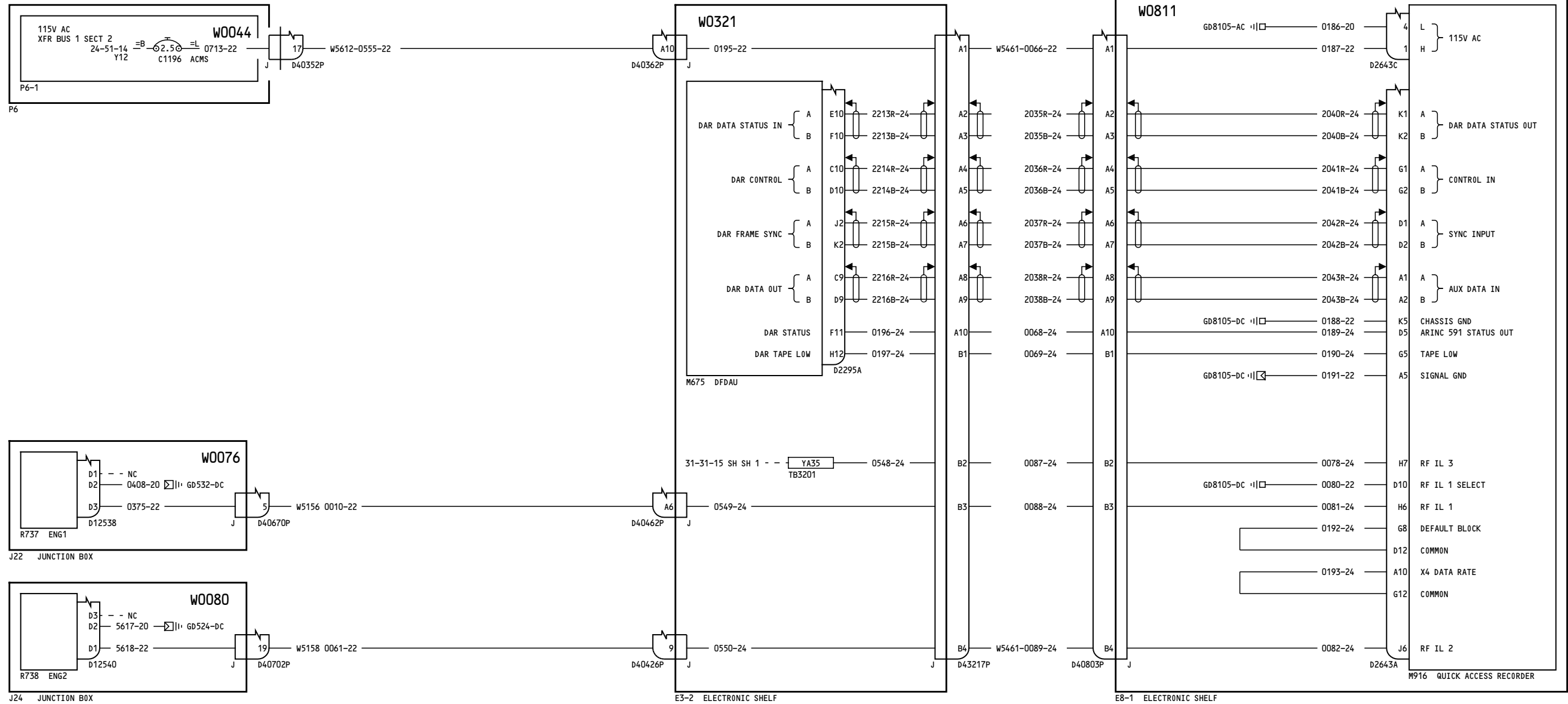

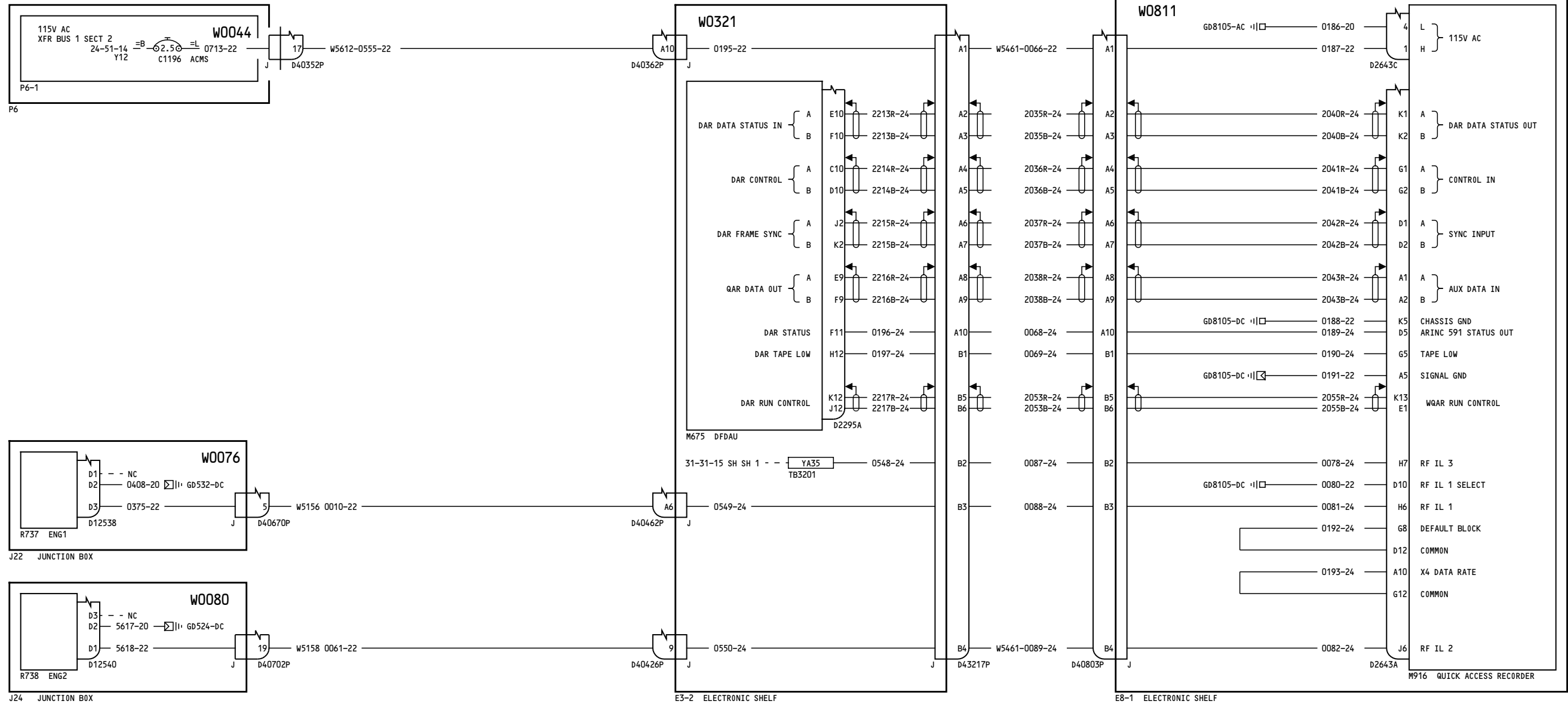

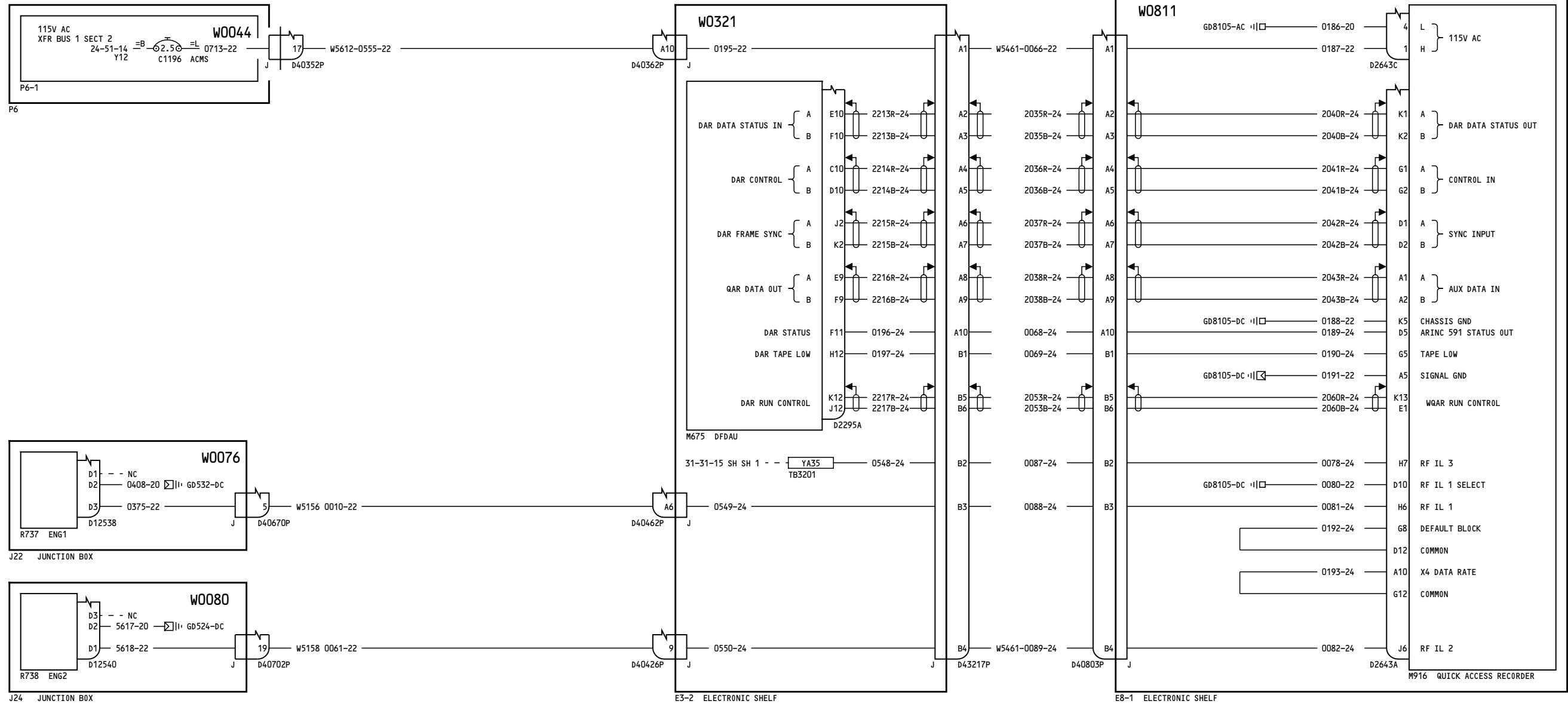

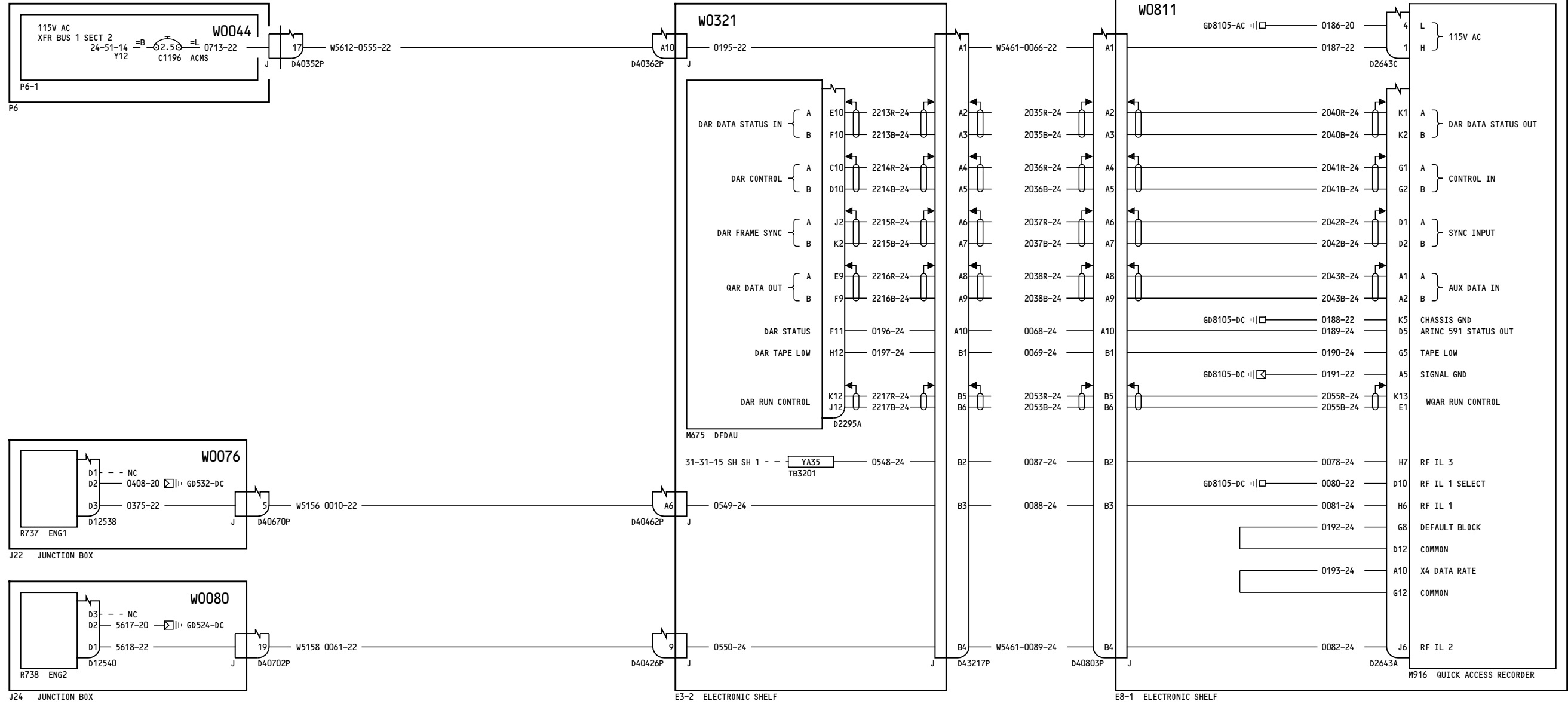

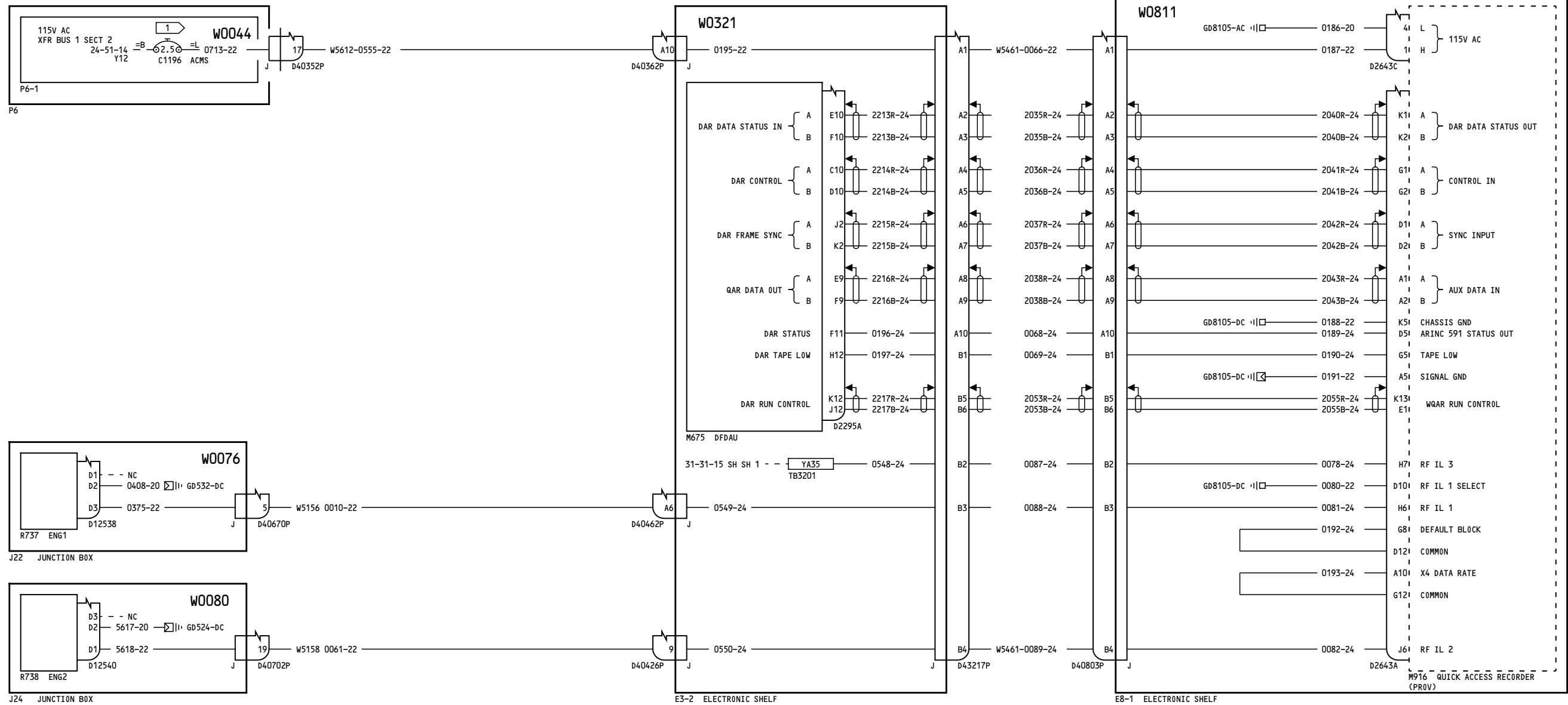

NOTES:

1 COLLAR AND LABEL "INOP"

YM652

**DIGITAL FLIGHT DATA
RECORDER SYSTEM - ACMS
INTERFACE 3**

31-35-03

Page 5

May 11/2009

D280A103

31-35-03

Page 5

May 11/2009

-D

1

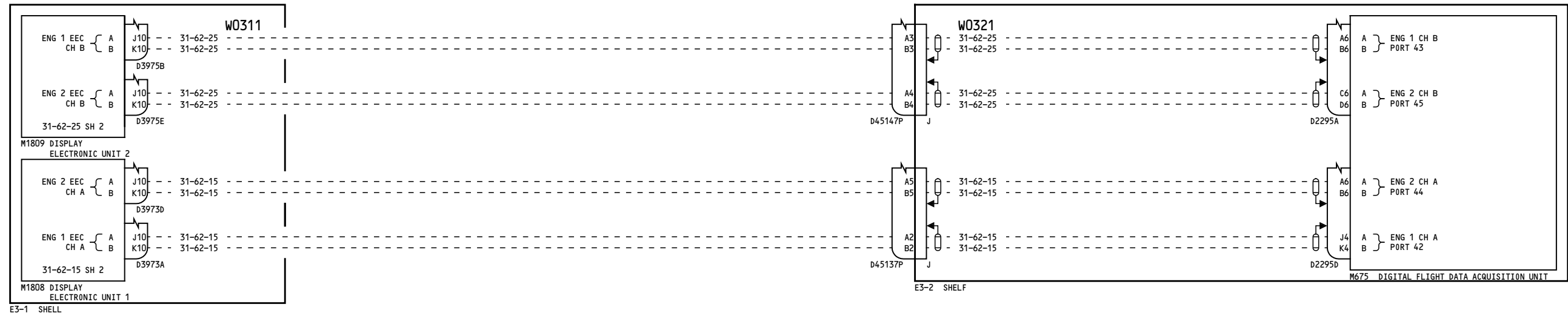

YK901-YM670

**DIGITAL FLIGHT DATA
RECORDER SYSTEM - ACMS
INTERFACE**

D280A103

31-35-04

Page 1

Feb 09/2009

31-35-04

Page 1

Feb 09/2009

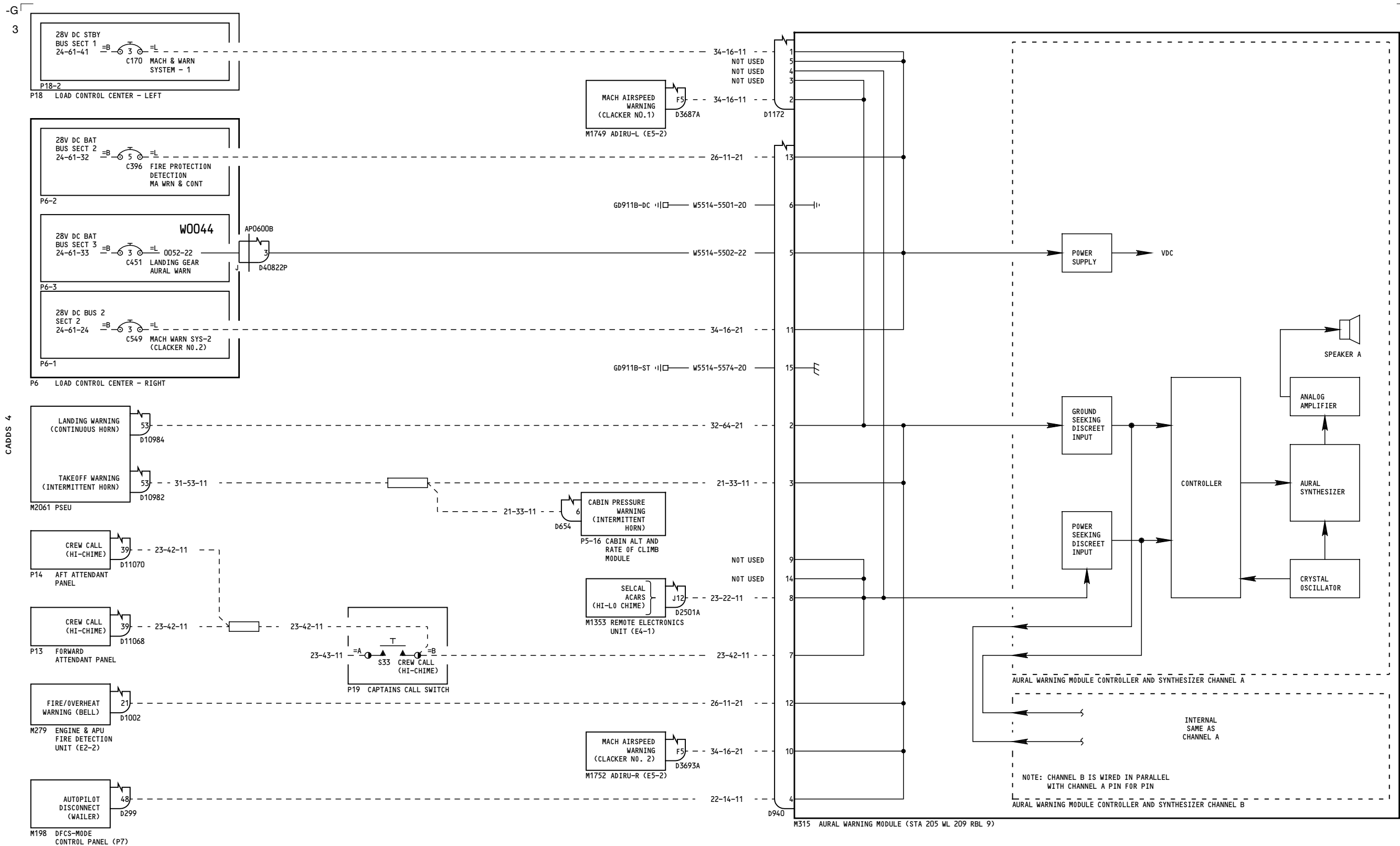

YC001-YC030

AURAL WARNING SYSTEM

31-51-11

Page 1

D280A103

Jul 17/2007

31-51-11

Page 1

Jul 17/2007

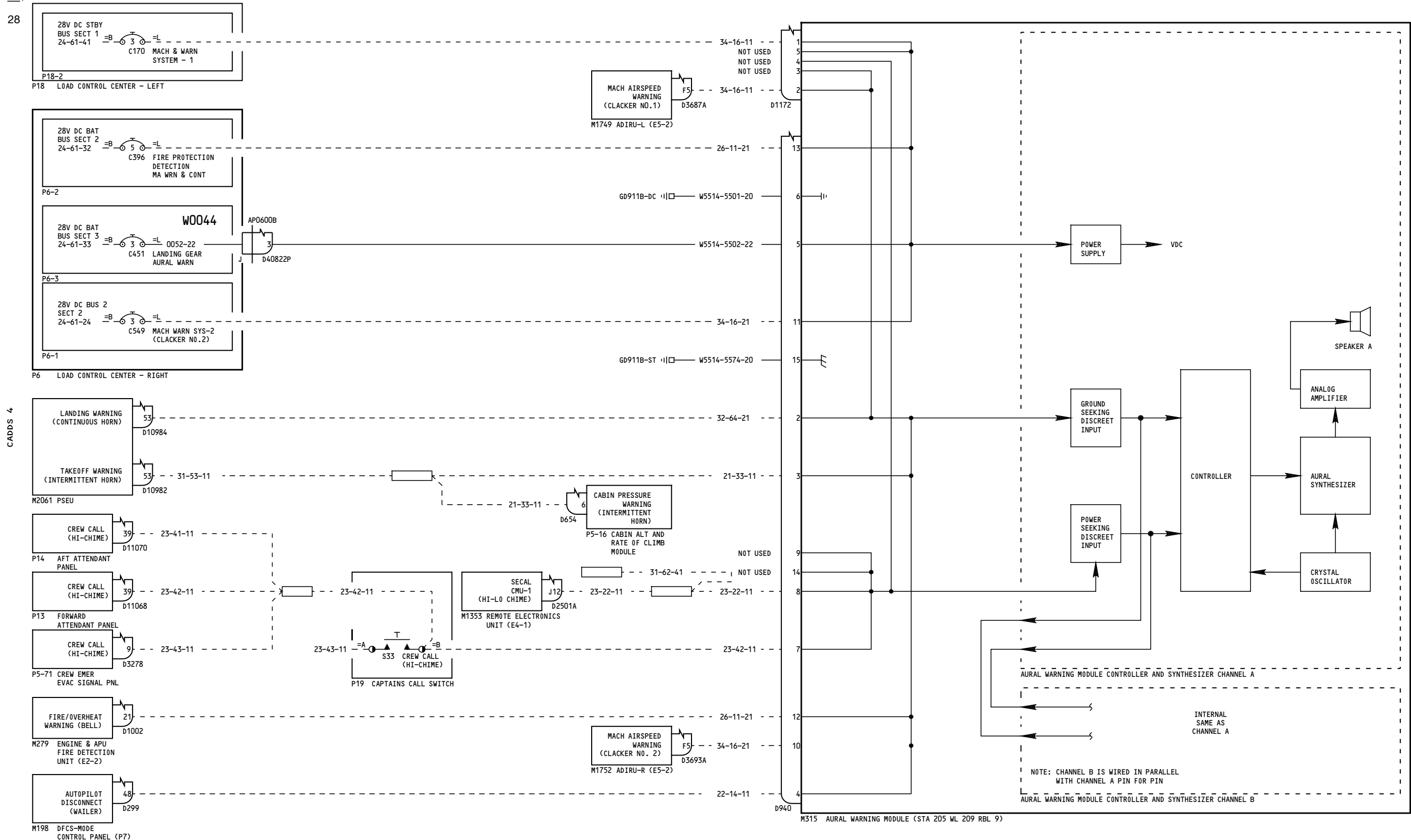

YK901-YK910, YK918, YL421-YL426

AURAL WARNING SYSTEM

31-51-11

Page 2

D280A103

Feb 09/2009

31-51-11

Page 2

Feb 09/2009

43

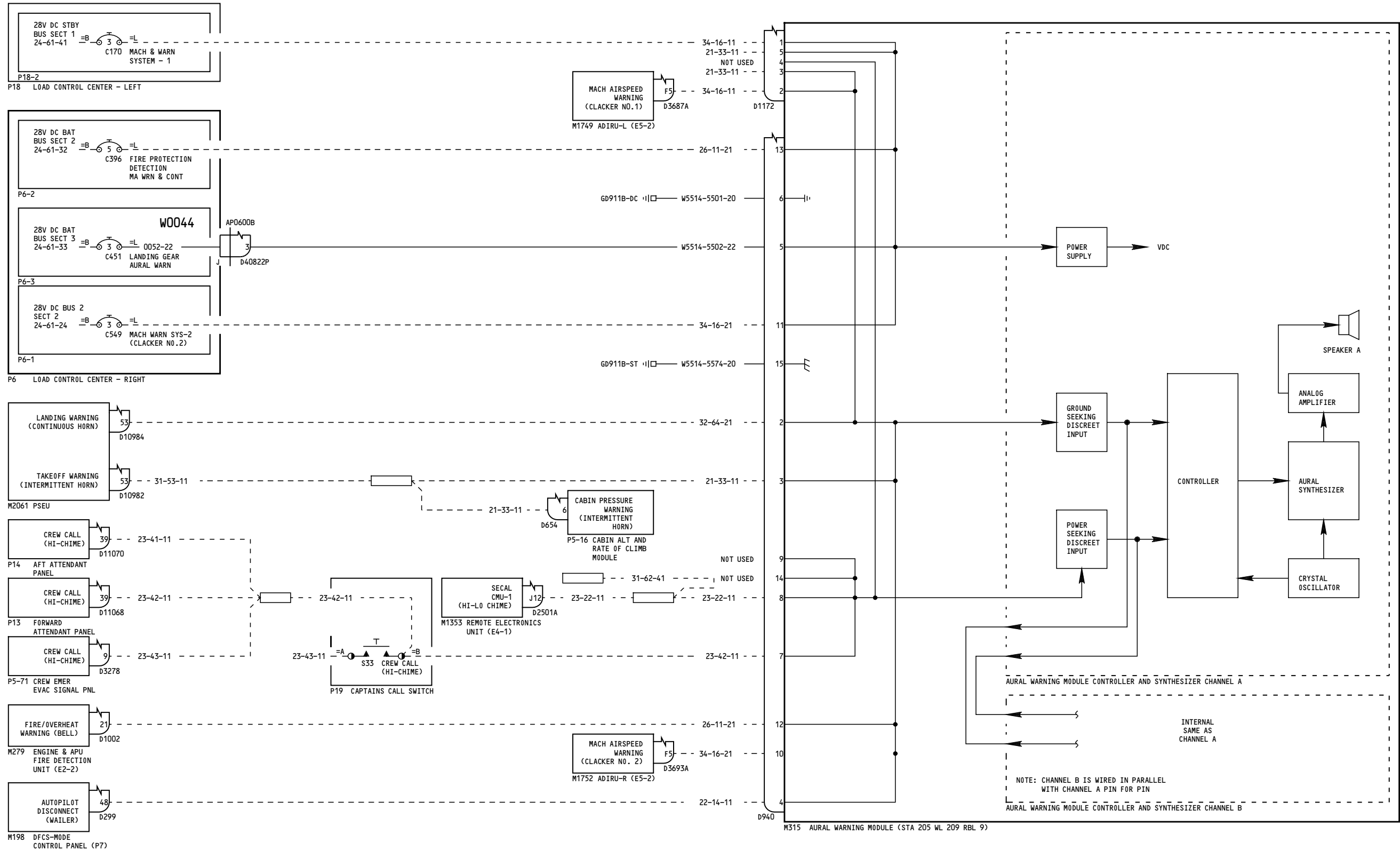

YK911-YK917, YK919-YL401, YL427-YL430

AURAL WARNING SYSTEM

31-51-11

Page 3

D280A103

Feb 09/2009

31-51-11

Page 3

Feb 09/2009

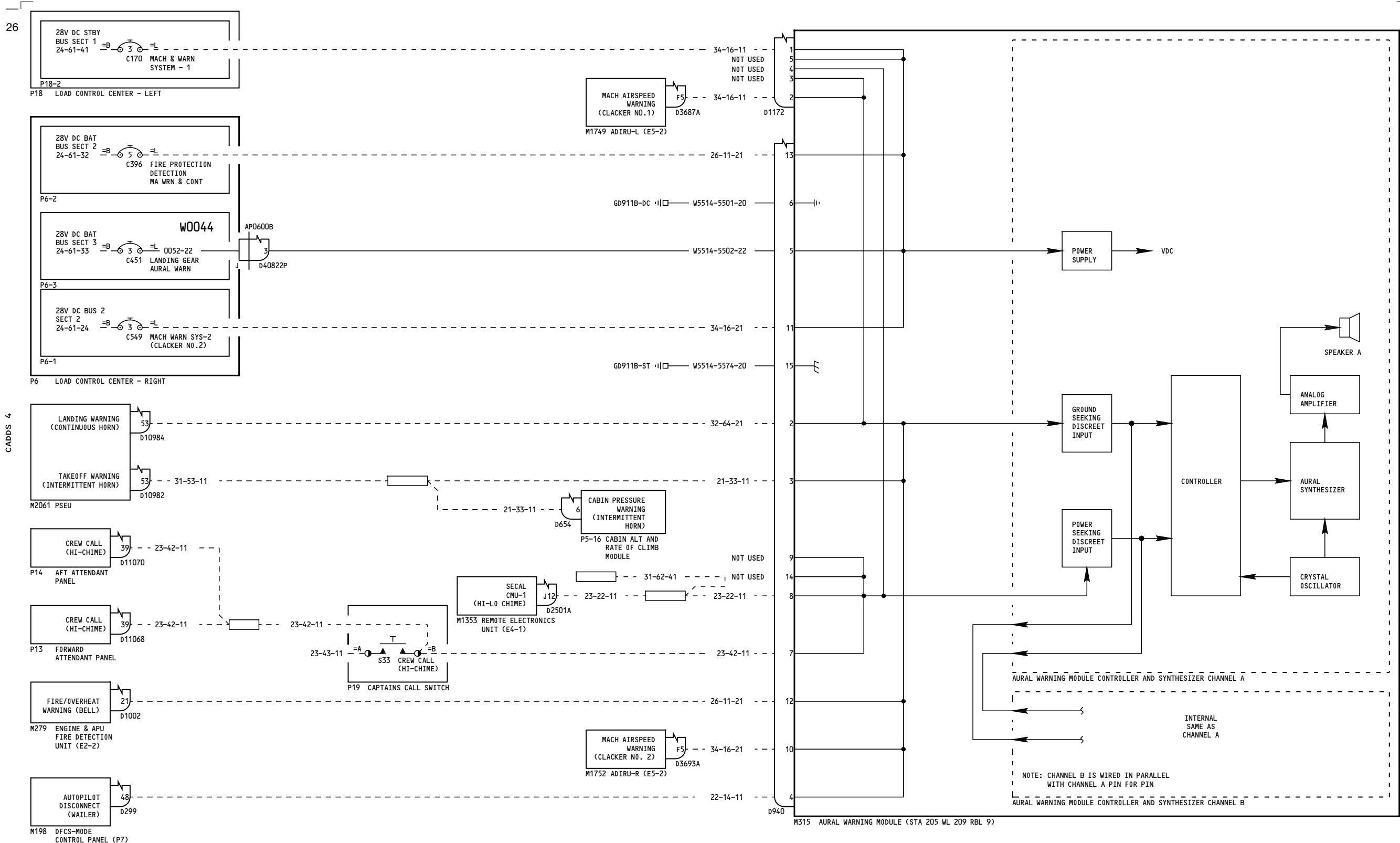

YM643-YM649

AURAL WARNING SYSTEM

31-51-11

Page 4

D280A103

Nov 11/2008

31-51-11

Page 4

Nov 11/2008

36

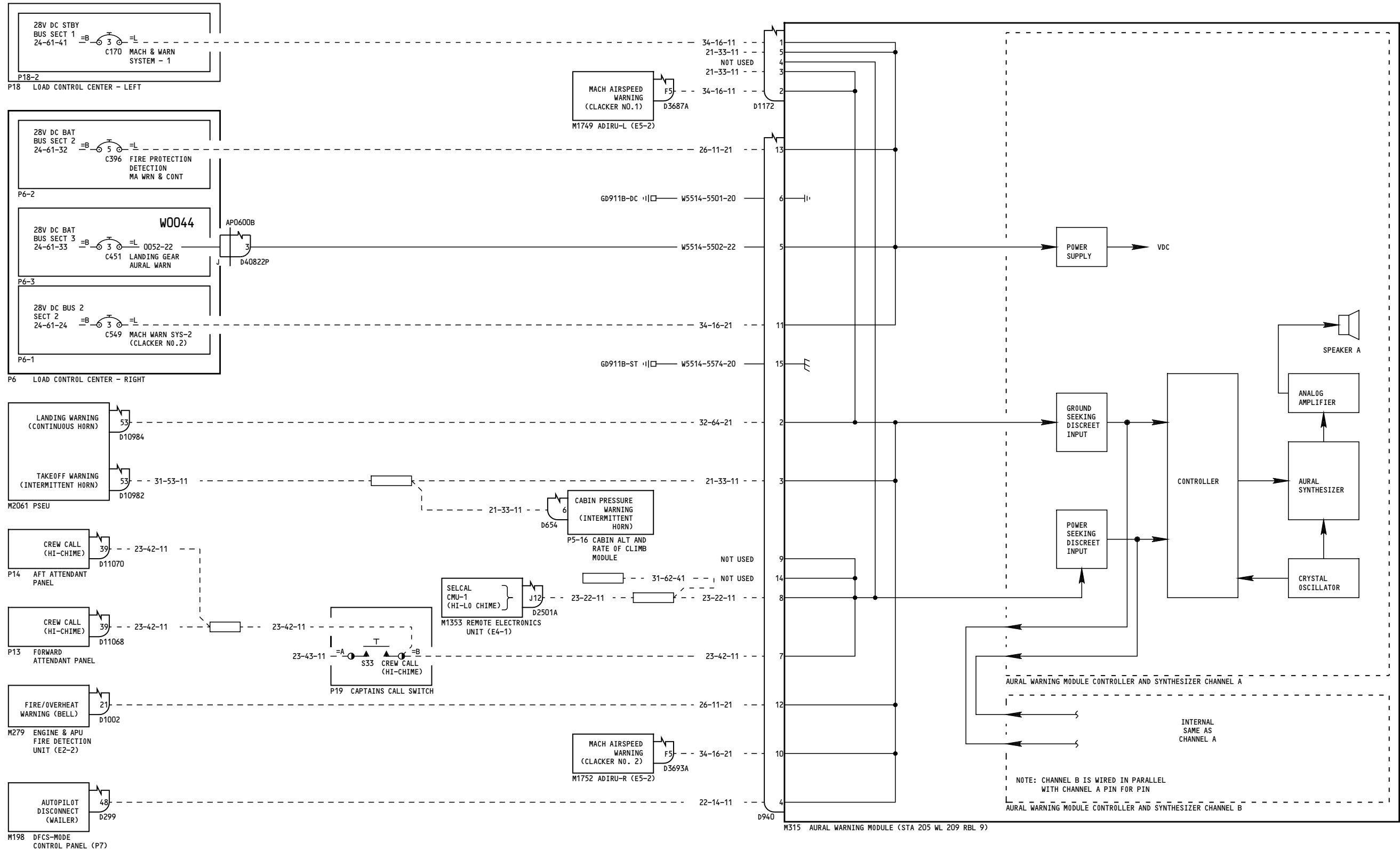

YM651-YM670

AURAL WARNING SYSTEM

31-51-11

Page 5

D280A103

Nov 11/2008

31-51-11

Page 5

Nov 11/2008

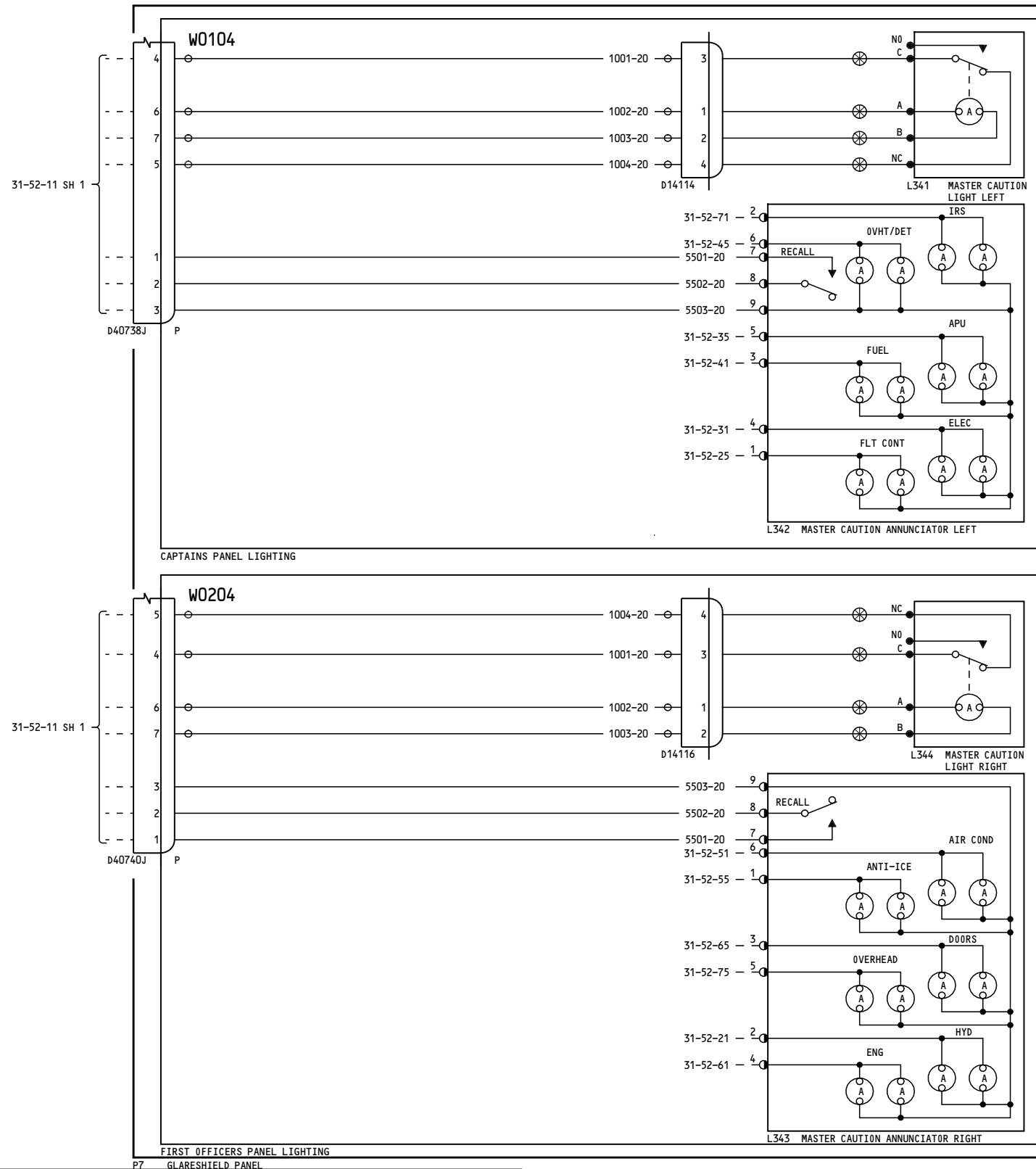

YC001-YC003

**MASTER CAUTION SYSTEM-
POWER & CONTROL**

31-52-11

Incorporates
31-1284

31-52-11

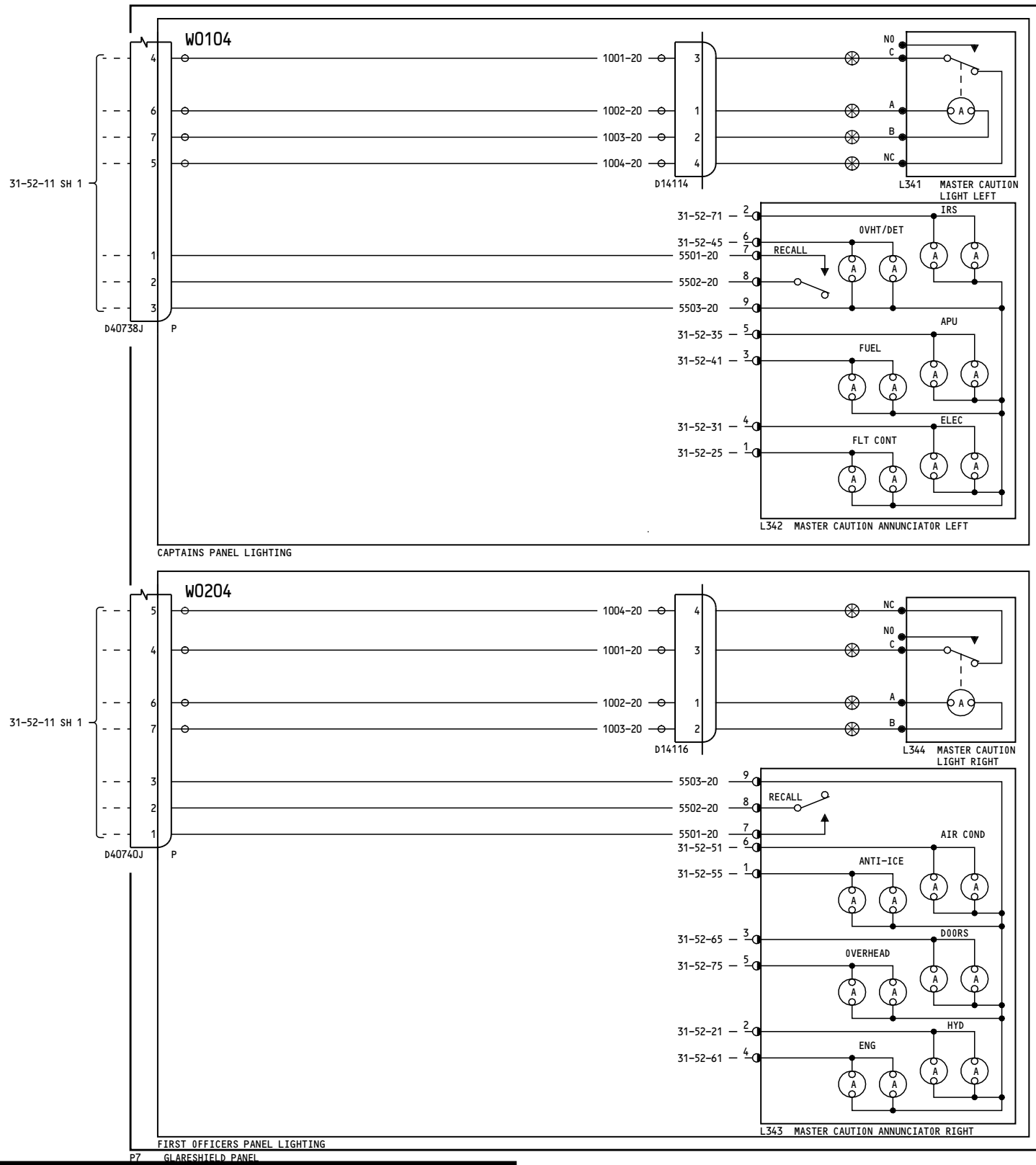

YC004-YC030

**MASTER CAUTION SYSTEM-
POWER & CONTROL**

31-52-11

Page 2.1
Sheet 2
Feb 12/2008

D280A103

Incorporates
31-1284

31-52-11

Page 2.1
Sheet 2
Feb 12/2008

13

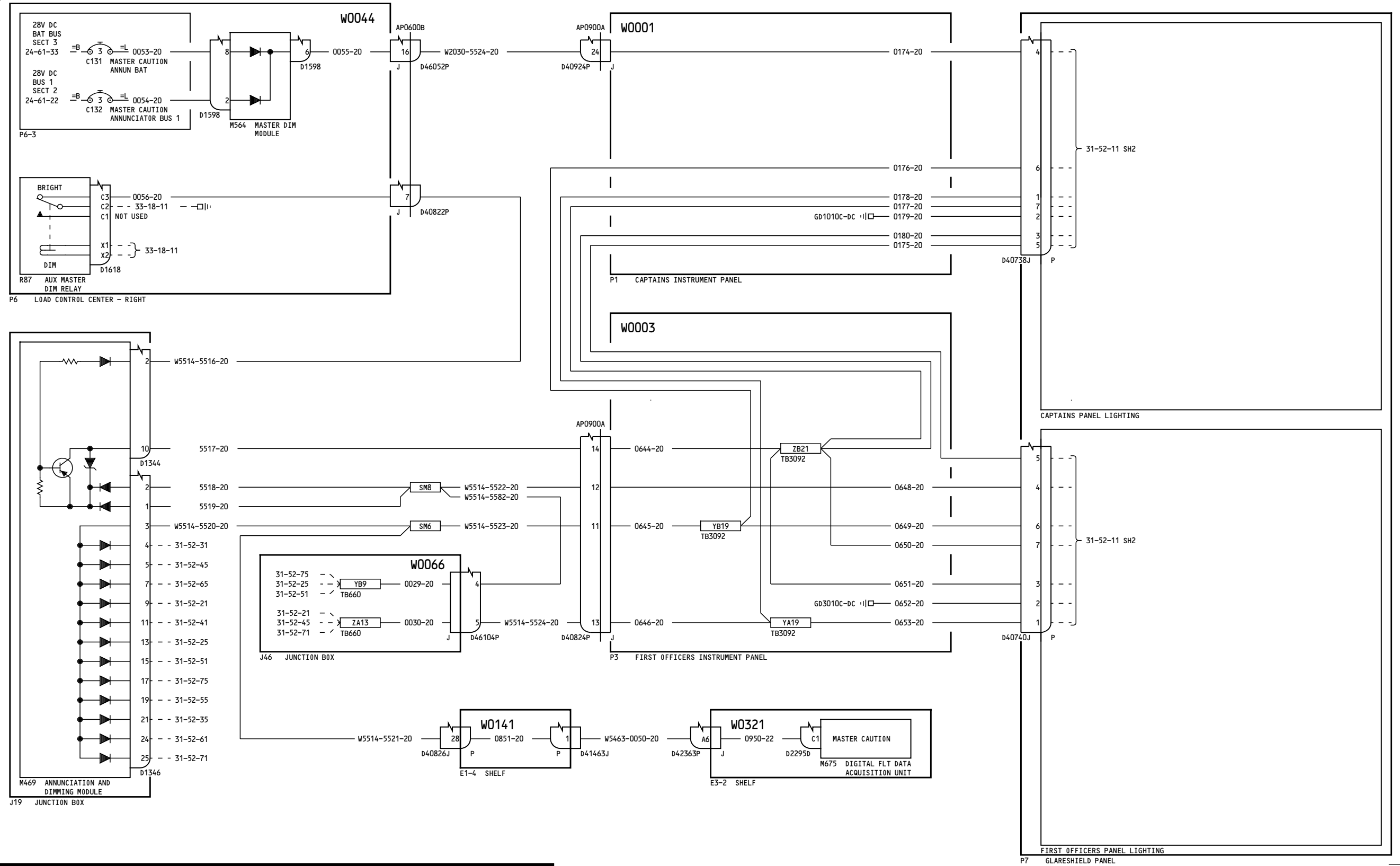

YK901-YL430

**MASTER CAUTION SYSTEM-
POWER & CONTROL**

D280A103

31-52-11

Page 3
Sheet 1
Feb 09/2009

31-52-11

Page 3
Sheet 1
Feb 09/2009

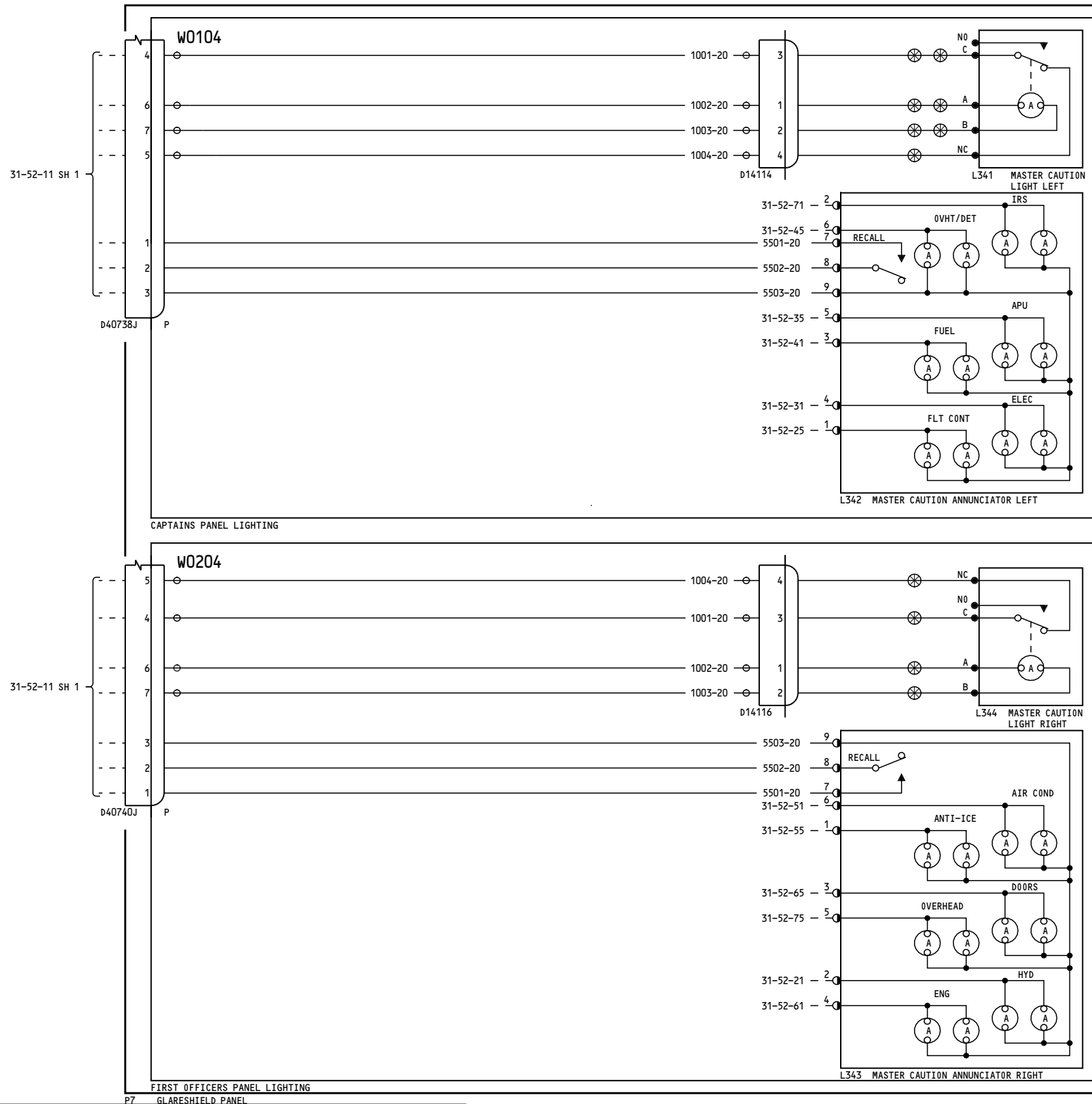

YK901-YL430

**MASTER CAUTION SYSTEM-
POWER & CONTROL**

D280A103

31-52-11

Page 3
Sheet 2
Feb 09/2009

31-52-11

Page 3
Sheet 2
Feb 09/2009

12

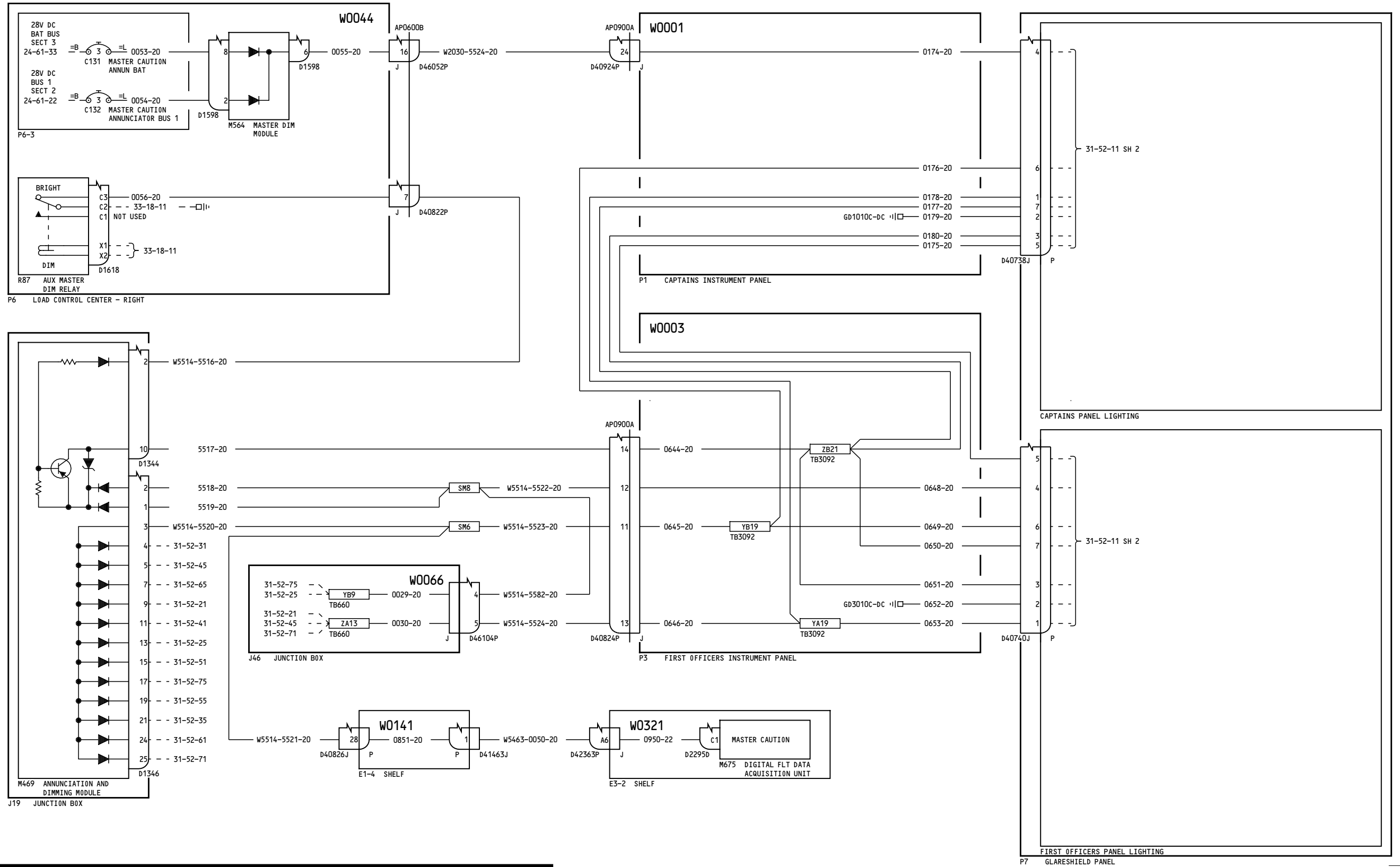

YM643-YM670

MASTER CAUTION SYSTEM- POWER & CONTROL

D280A103

31-52-11

Page 4
Sheet 1
Jan 14/2008

31-52-11

Page 4
Sheet 1
Jan 14/2008

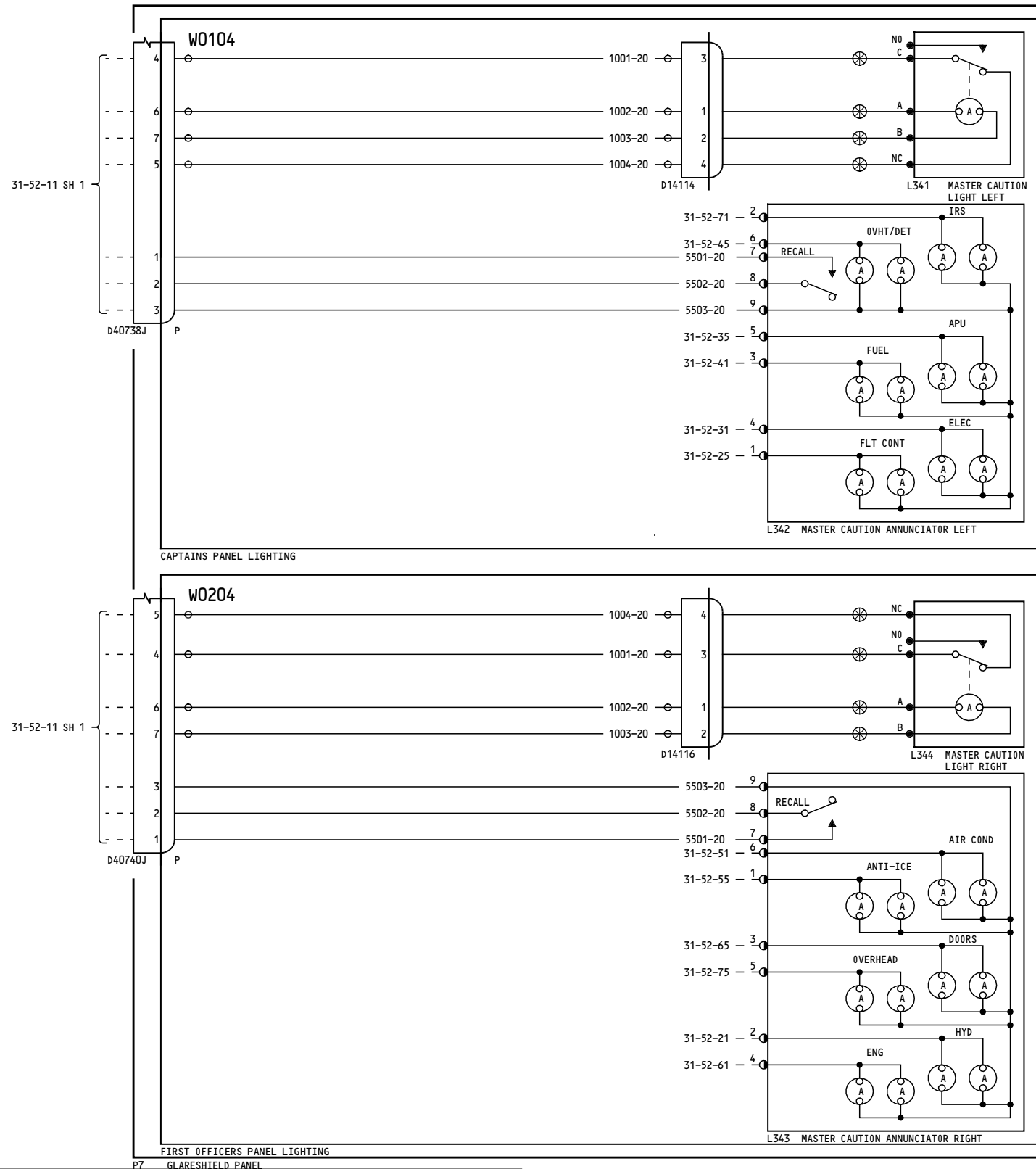

YM643-YM670

**MASTER CAUTION SYSTEM-
POWER & CONTROL**

31-52-11

Page 4
Sheet 2
Jan 14/2008

D280A103

31-52-11

Page 4
Sheet 2
Jan 14/2008

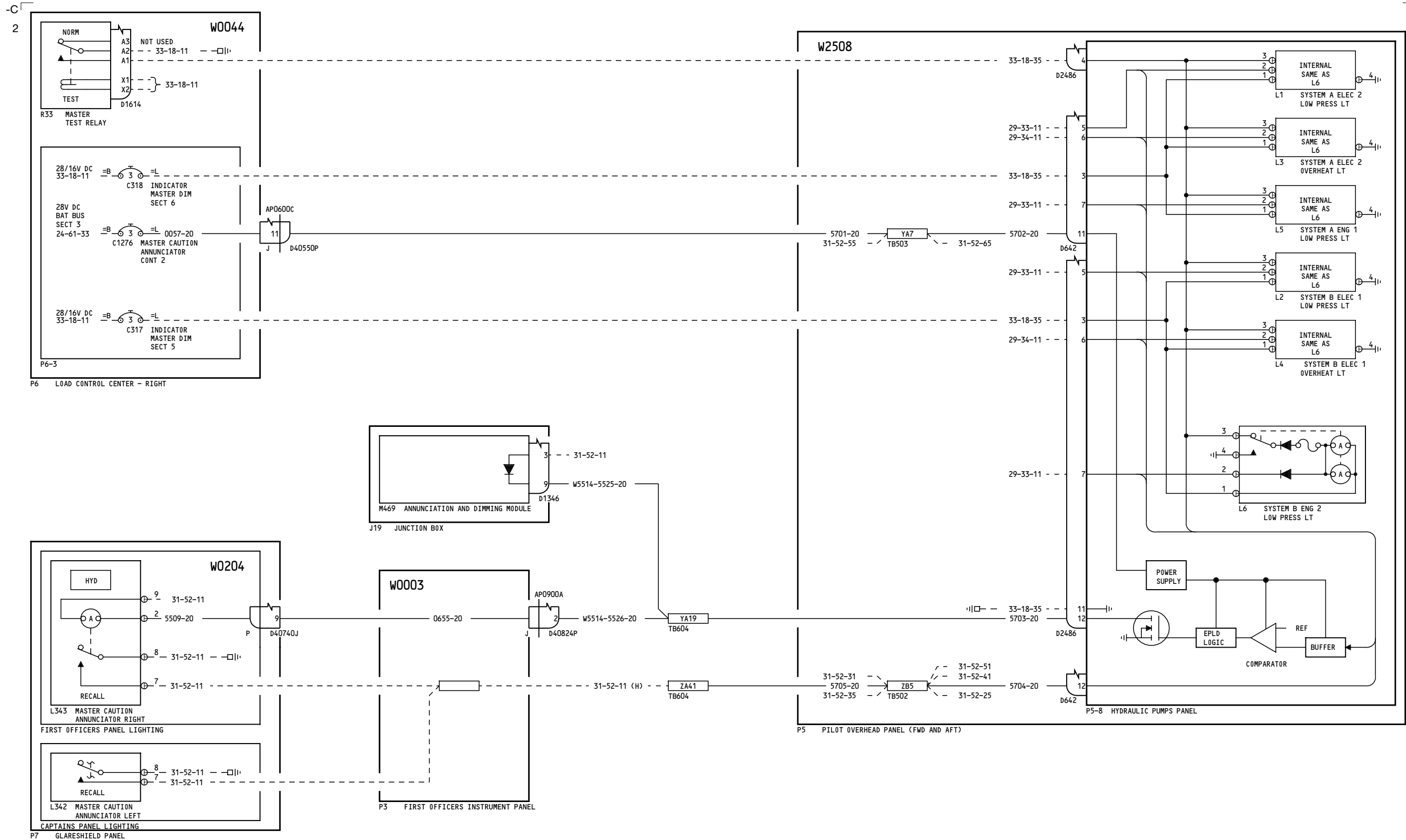

YC001-YC003

**MASTER CAUTION SYSTEM -
HYDRAULIC CONTROL**

31-52-21

Page 1

D280A103

Mar 31/2005

31-52-21

Page 1

Mar 31/2005

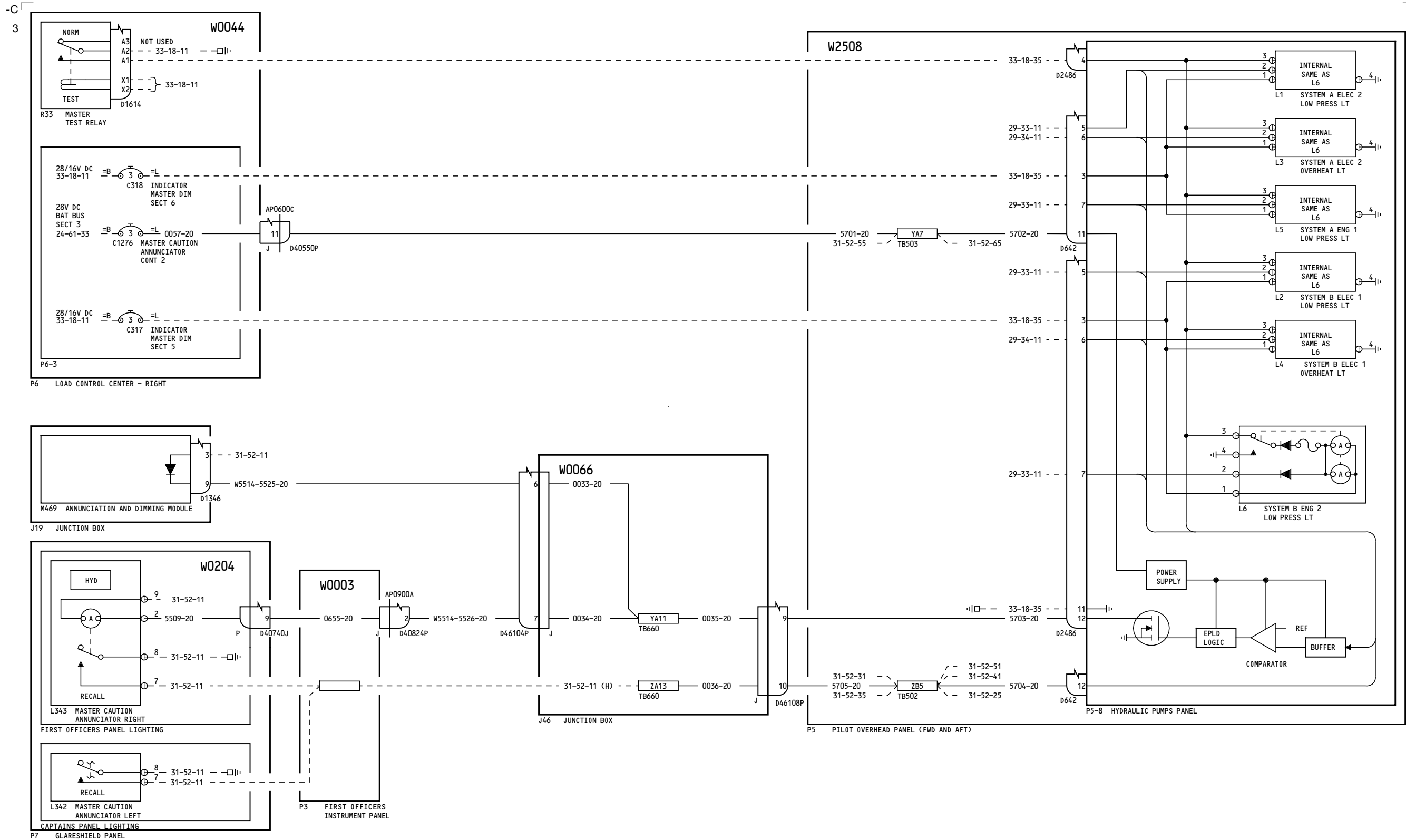

YC004-YC007

**MASTER CAUTION SYSTEM -
HYDRAULIC CONTROL**

31-52-21

Page 2

D280A103

Mar 31/2005

31-52-21

Page 2

Mar 31/2005

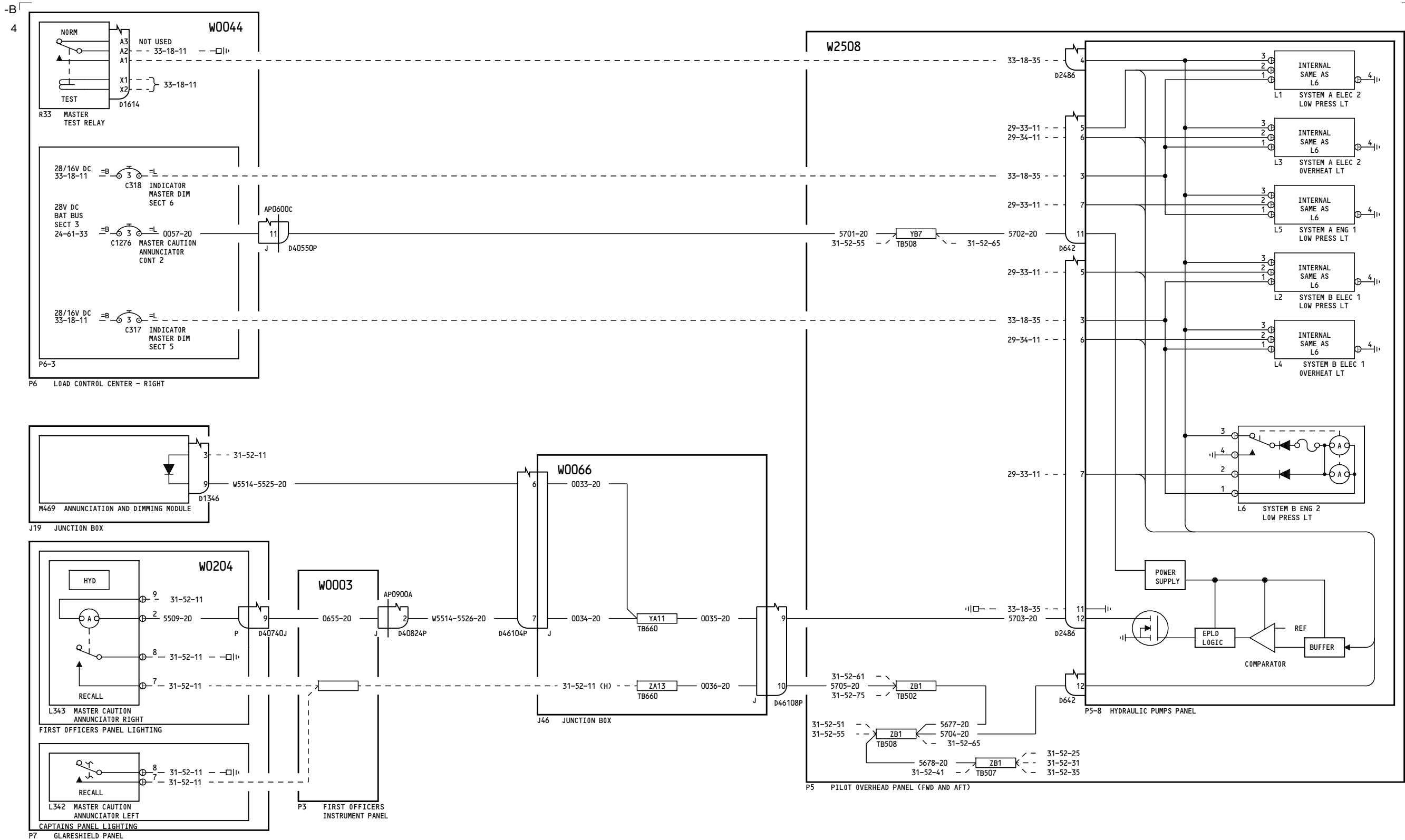

YC008-YC030

**MASTER CAUTION SYSTEM -
HYDRAULIC CONTROL**

31-52-21

Page 3

D280A103

Jul 17/2007

31-52-21

Page 3

Jul 17/2007

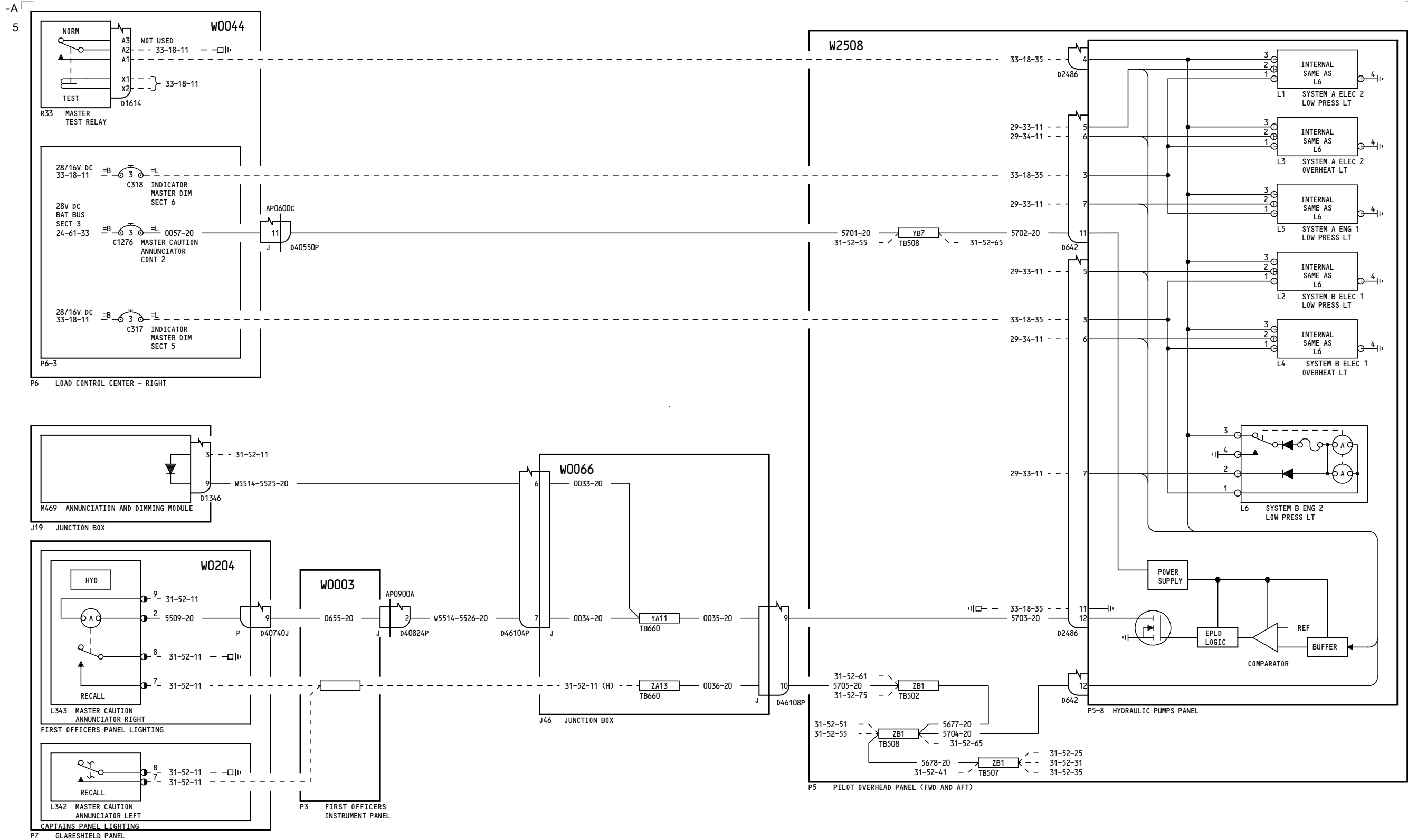

YC031-YM670

MASTER CAUTION SYSTEM - HYDRAULIC CONTROL

31-52-21

Page 4

D280A103

Feb 09/2009

31-52-21

Page 4

Feb 09/2009

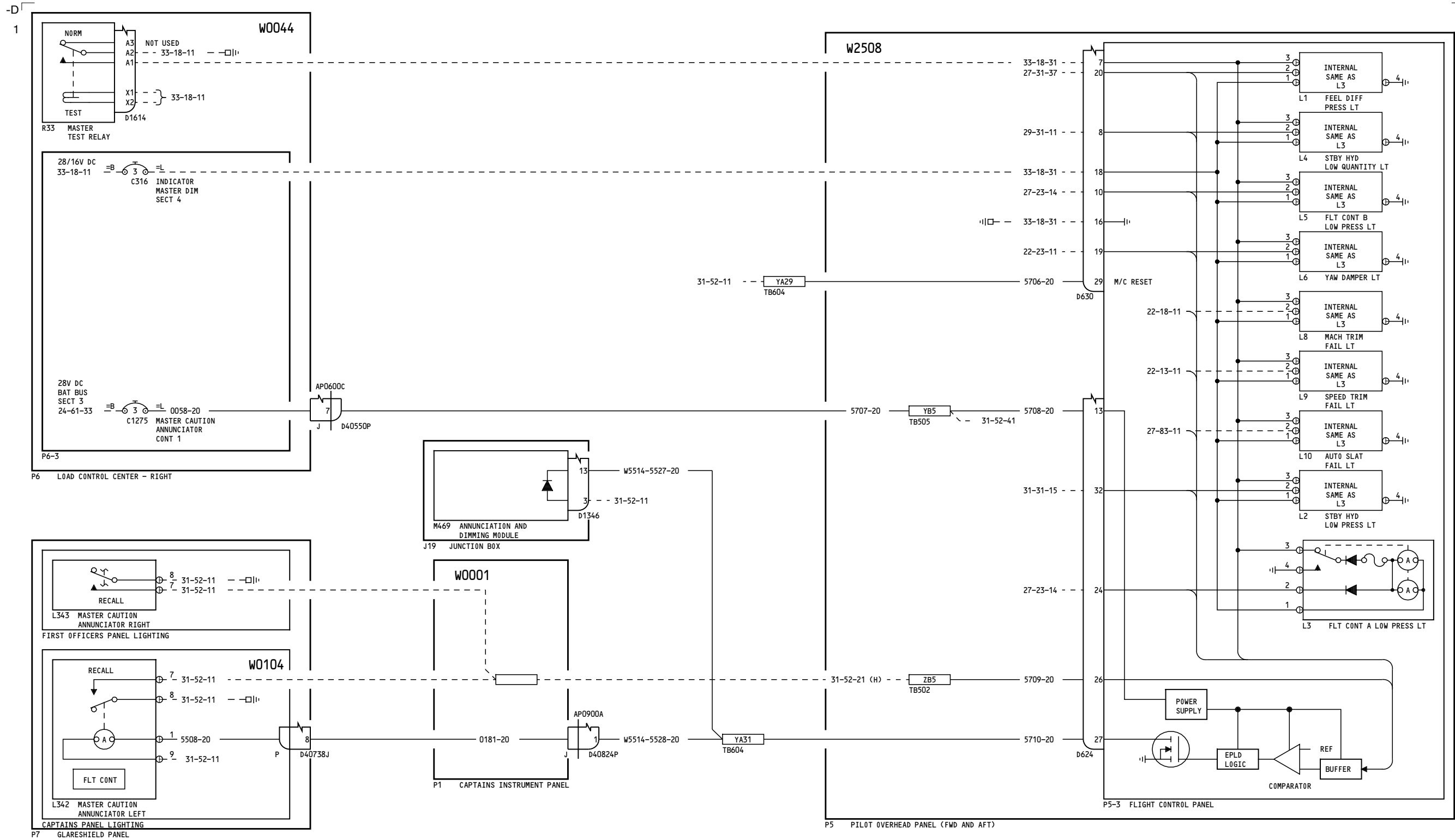

YC001-YC003

MASTER CAUTION SYSTEM - FLIGHT CONTROLS

31-52-25

Page 1

D280A103

Mar 31/2005

31-52-25

Page 1

Mar 31/2005

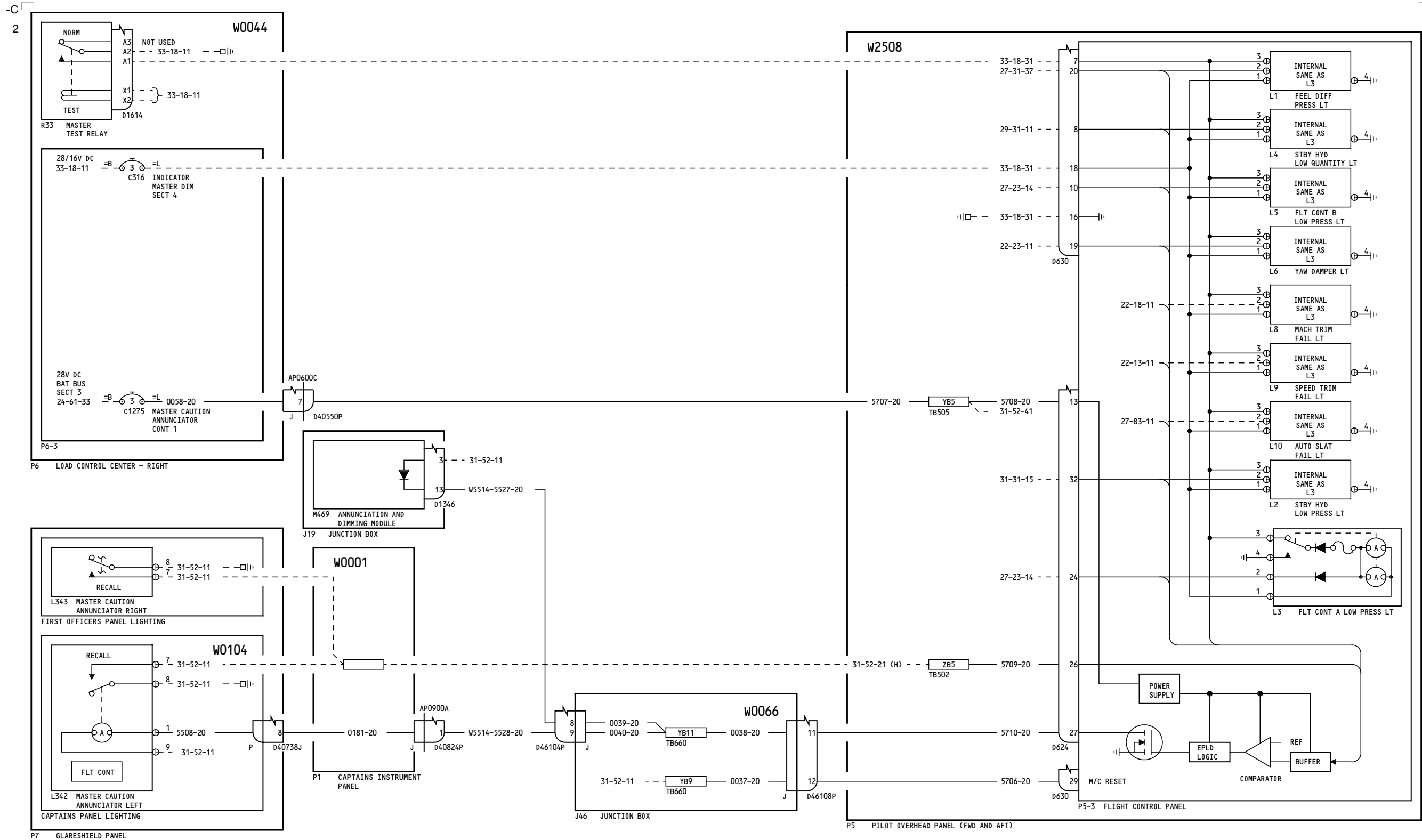

YC004-YC007

MASTER CAUTION SYSTEM - FLIGHT CONTROLS

31-52-25

Page 2

D280A103

Mar 31/2005

31-52-25

Page 2

Mar 31/2005

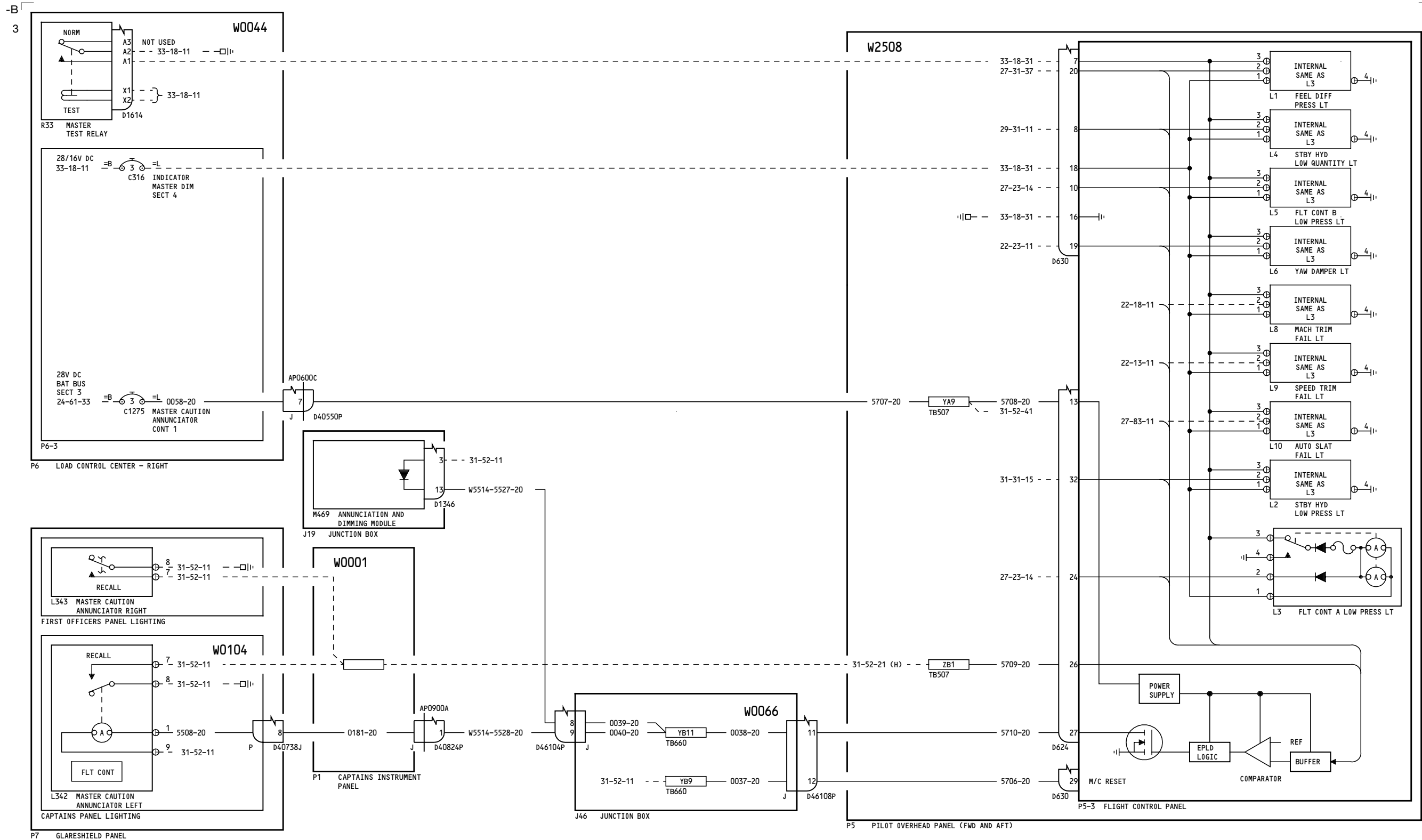

YC008-YC030

MASTER CAUTION SYSTEM - FLIGHT CONTROLS

31-52-25

Page 3

D280A103

Jul 17/2007

31-52-25

Page 3

Jul 17/2007

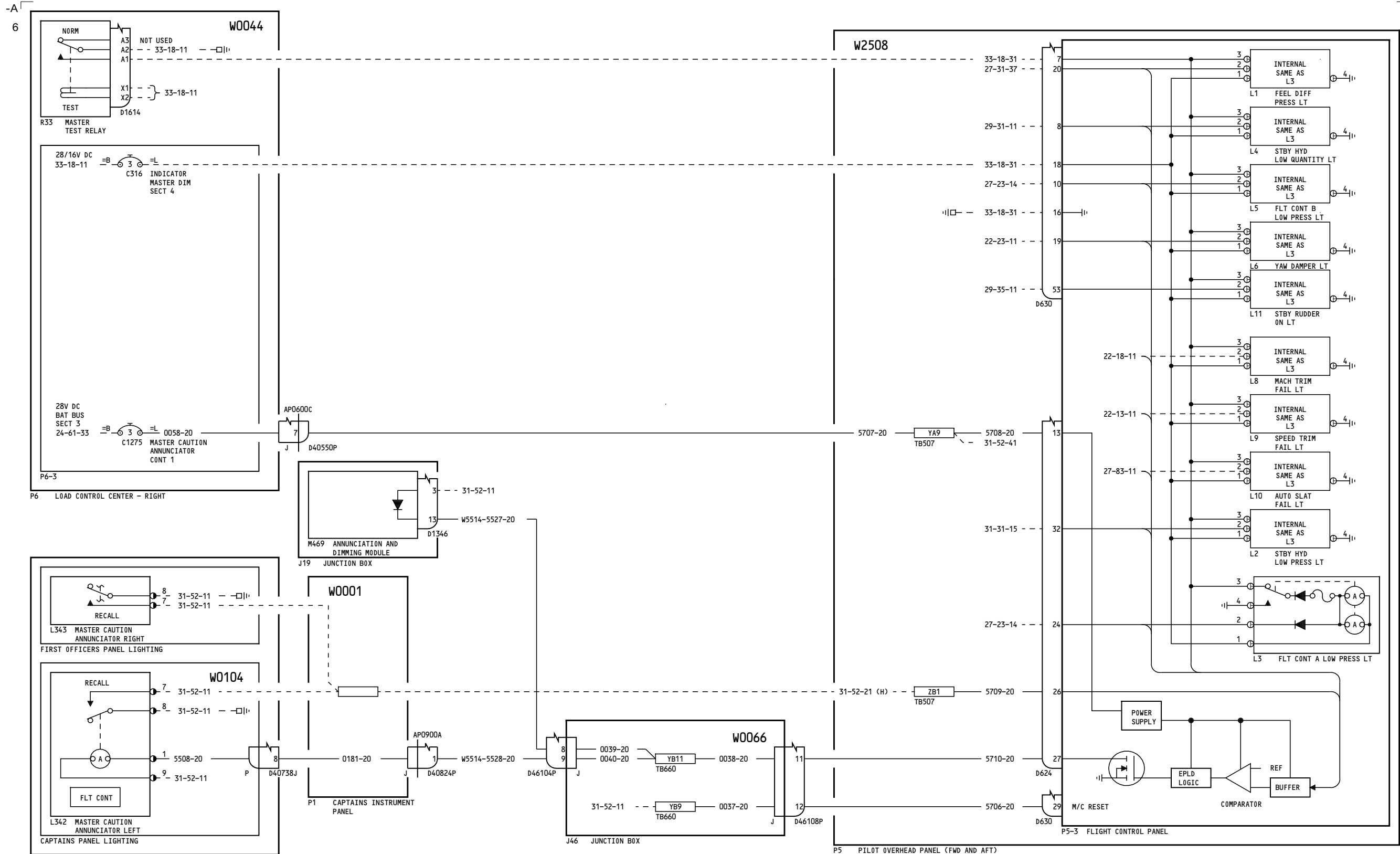

YC031-YM670

MASTER CAUTION SYSTEM - FLIGHT CONTROLS

31-52-25

Page 4

D280A103

Feb 09/2009

31-52-25

Page 4

Feb 09/2009

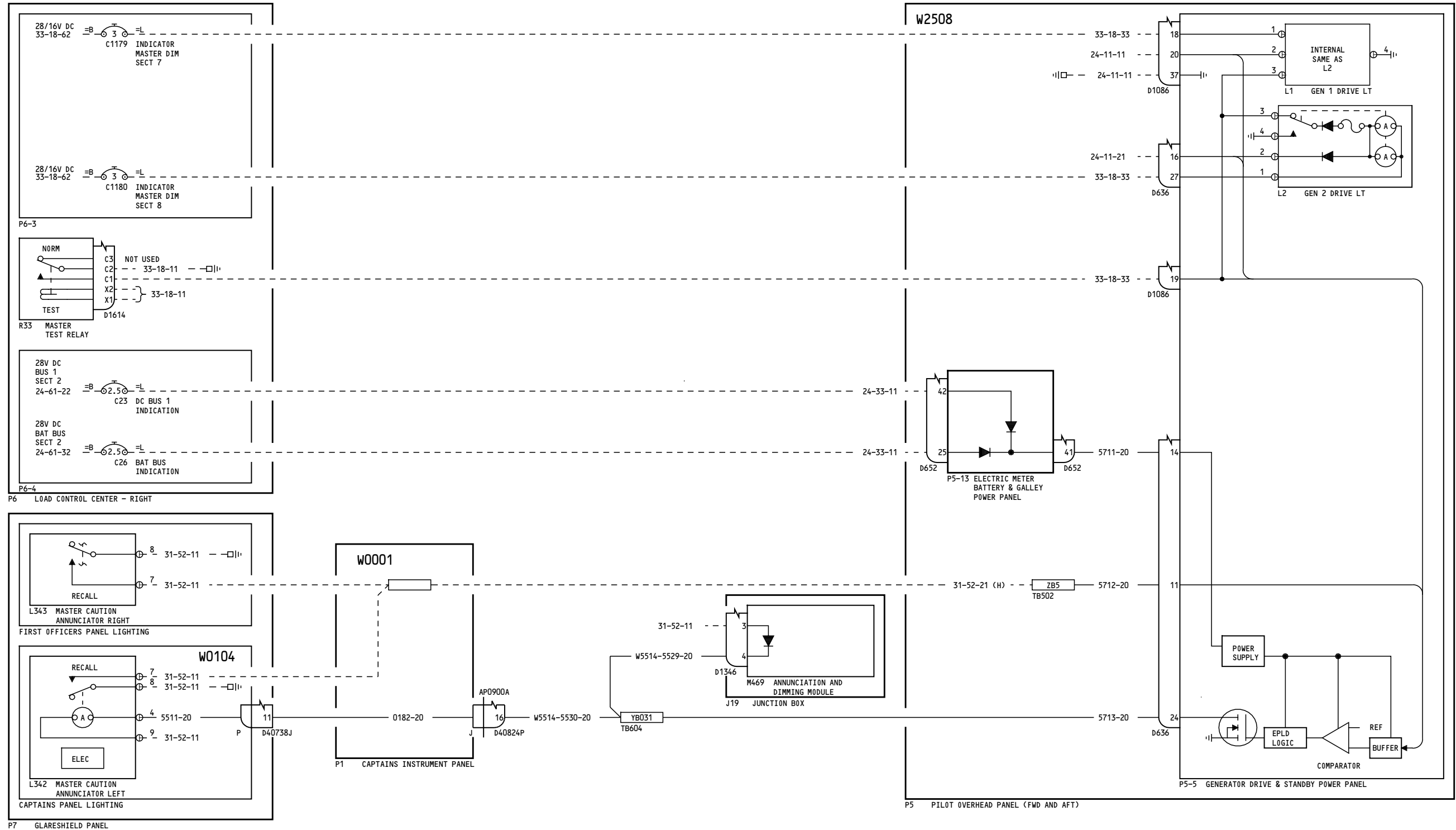

YC001-YC003

**MASTER CAUTION SYSTEM -
ELECTRICAL CONTROL,
GENERATOR**

31-52-31

Page 1

May 13/2008

D280A103

31-52-31

Page 1

May 13/2008

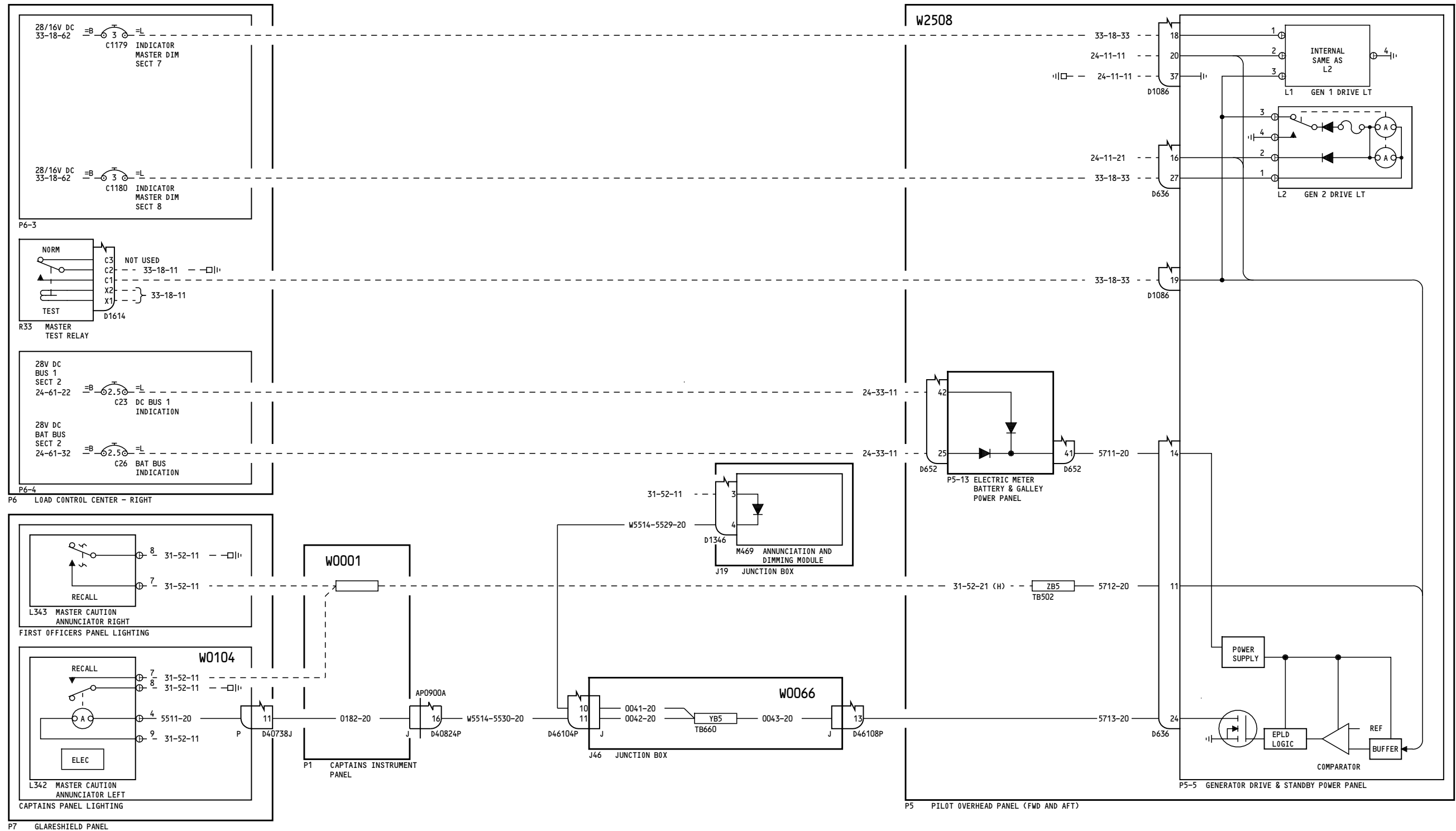

YC004-YC007

**MASTER CAUTION SYSTEM -
ELECTRICAL CONTROL,
GENERATOR**

31-52-31

Page 2

May 13/2008

D280A103

31-52-31

Page 2

May 13/2008

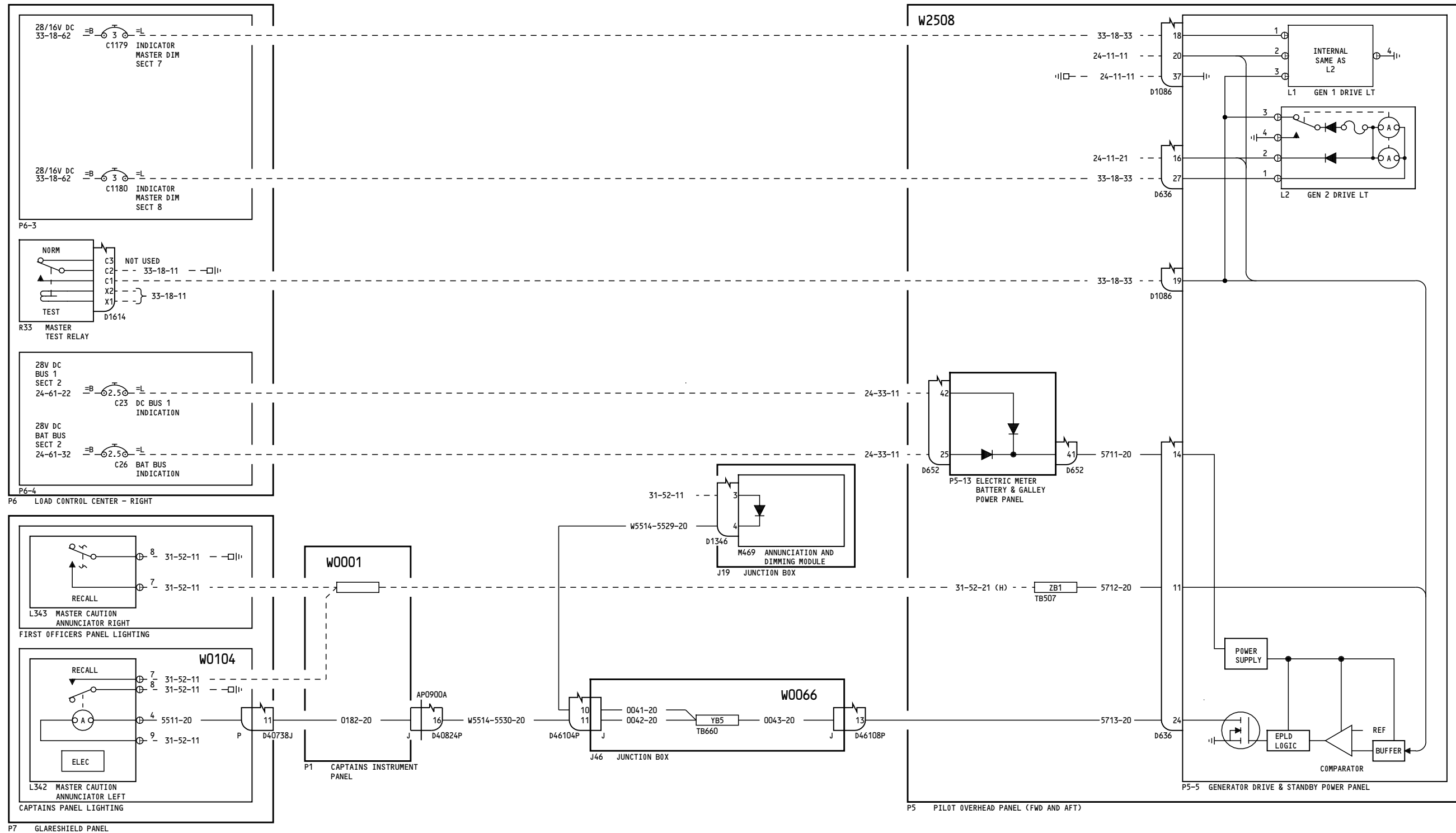

YC008-YC030

**MASTER CAUTION SYSTEM -
ELECTRICAL CONTROL,
GENERATOR**

31-52-31

Page 3

May 13/2008

D280A103

31-52-31

Page 3

May 13/2008

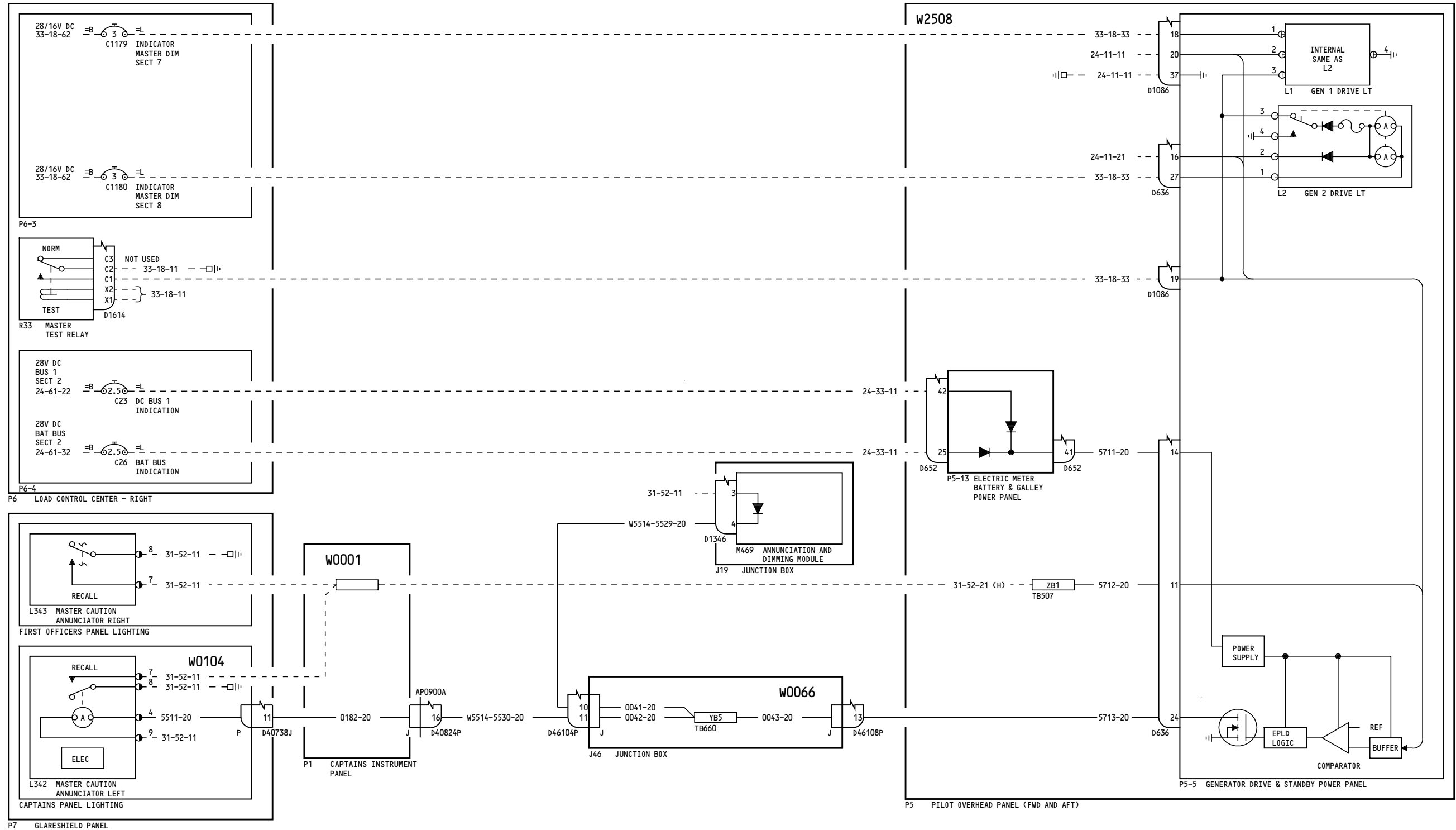

YC031-YM670

**MASTER CAUTION SYSTEM -
ELECTRICAL CONTROL,
GENERATOR**

31-52-31

Page 4

Feb 09/2009

D280A103

31-52-31

Page 4

Feb 09/2009

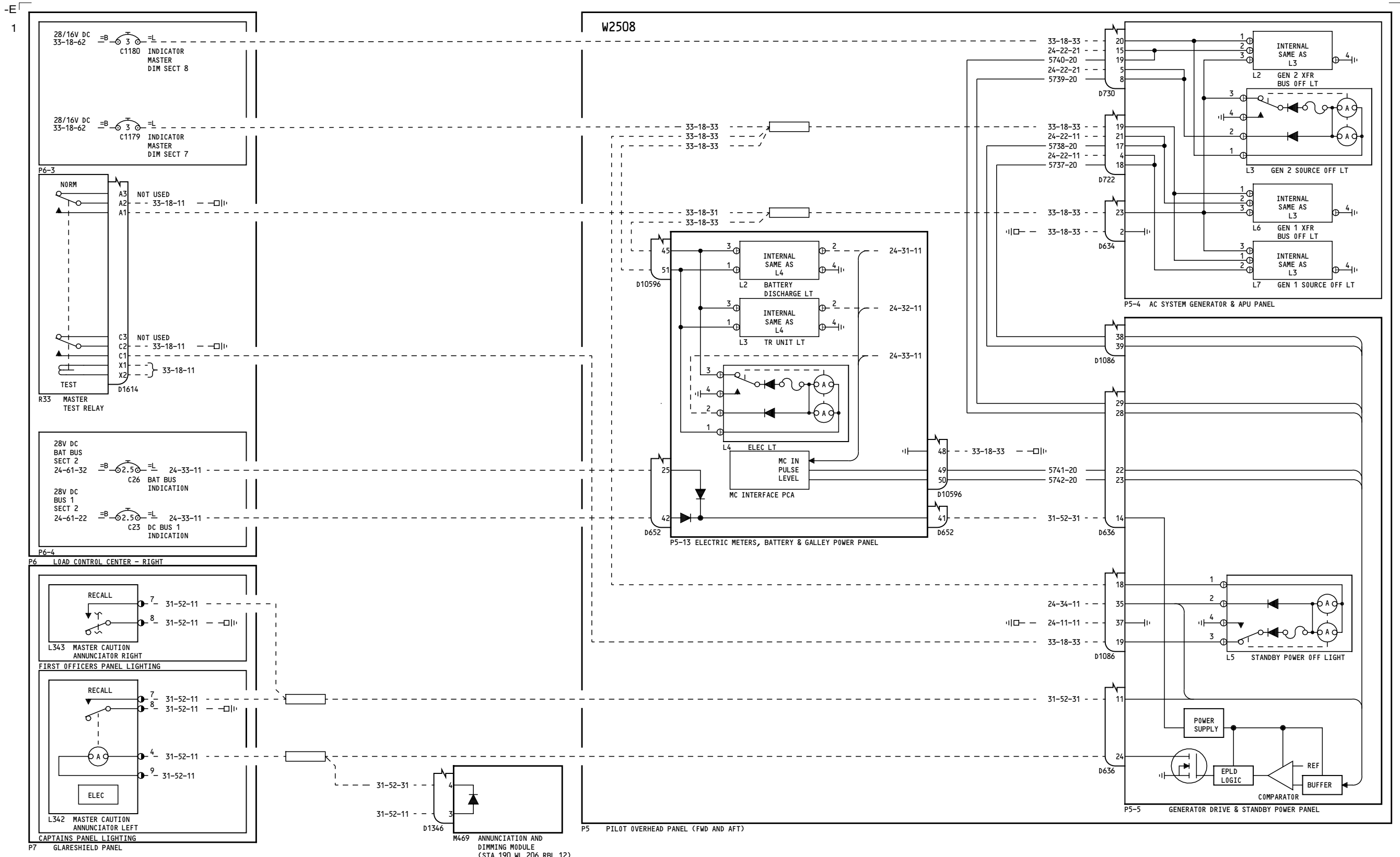

ALL

MASTER CAUTION SYSTEM - ELECTRICAL CONTROL, POWER BUS

31-52-32

Page 1

Feb 09/2009

D280A103

31-52-32

Page 1

Feb 09/2009

-E

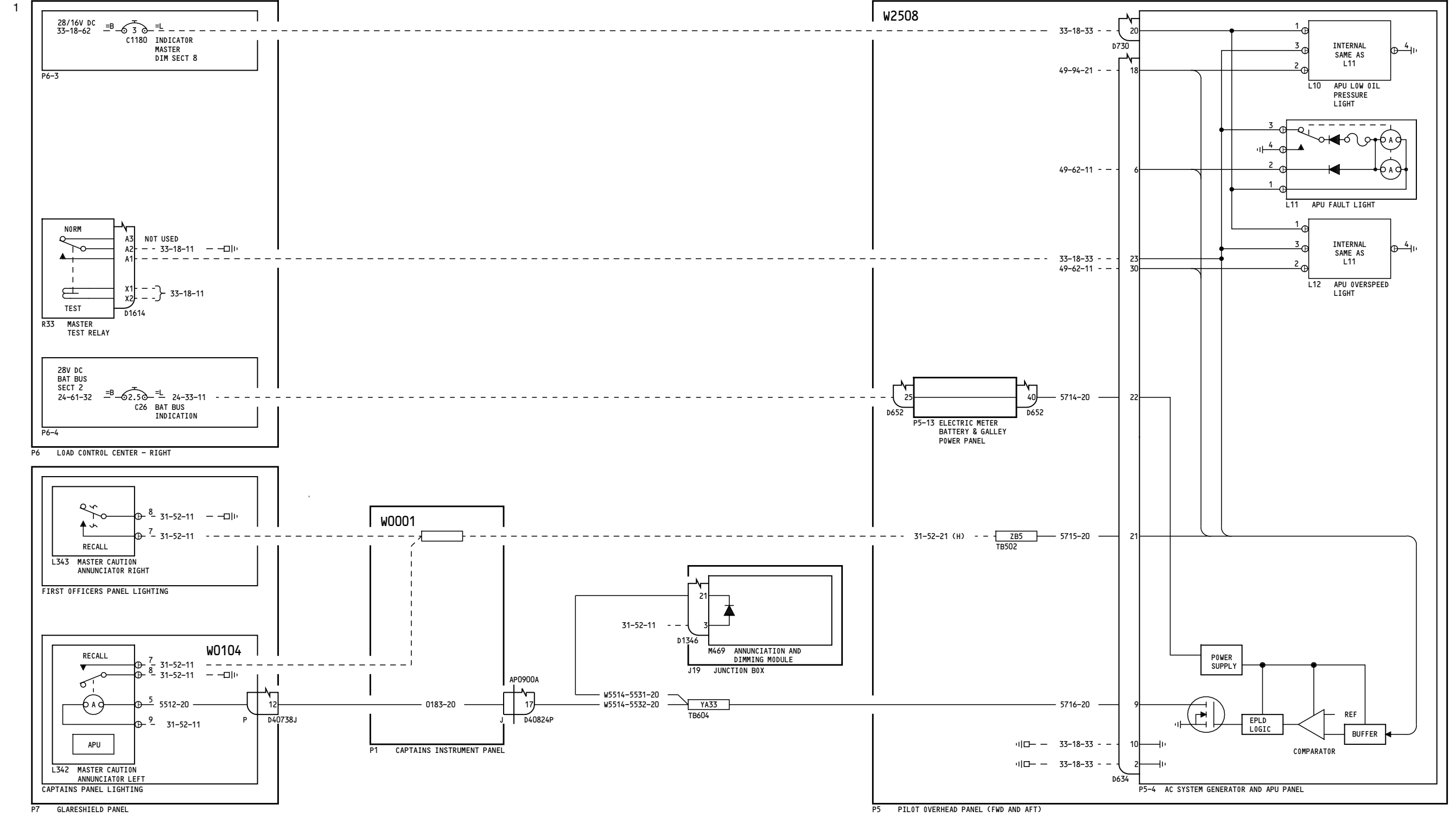

YC001-YC003

**MASTER CAUTION SYSTEM -
APU CONTROL**

31-52-35

Page 1

May 13/2008

D280A103

31-52-35

Page 1

May 13/2008

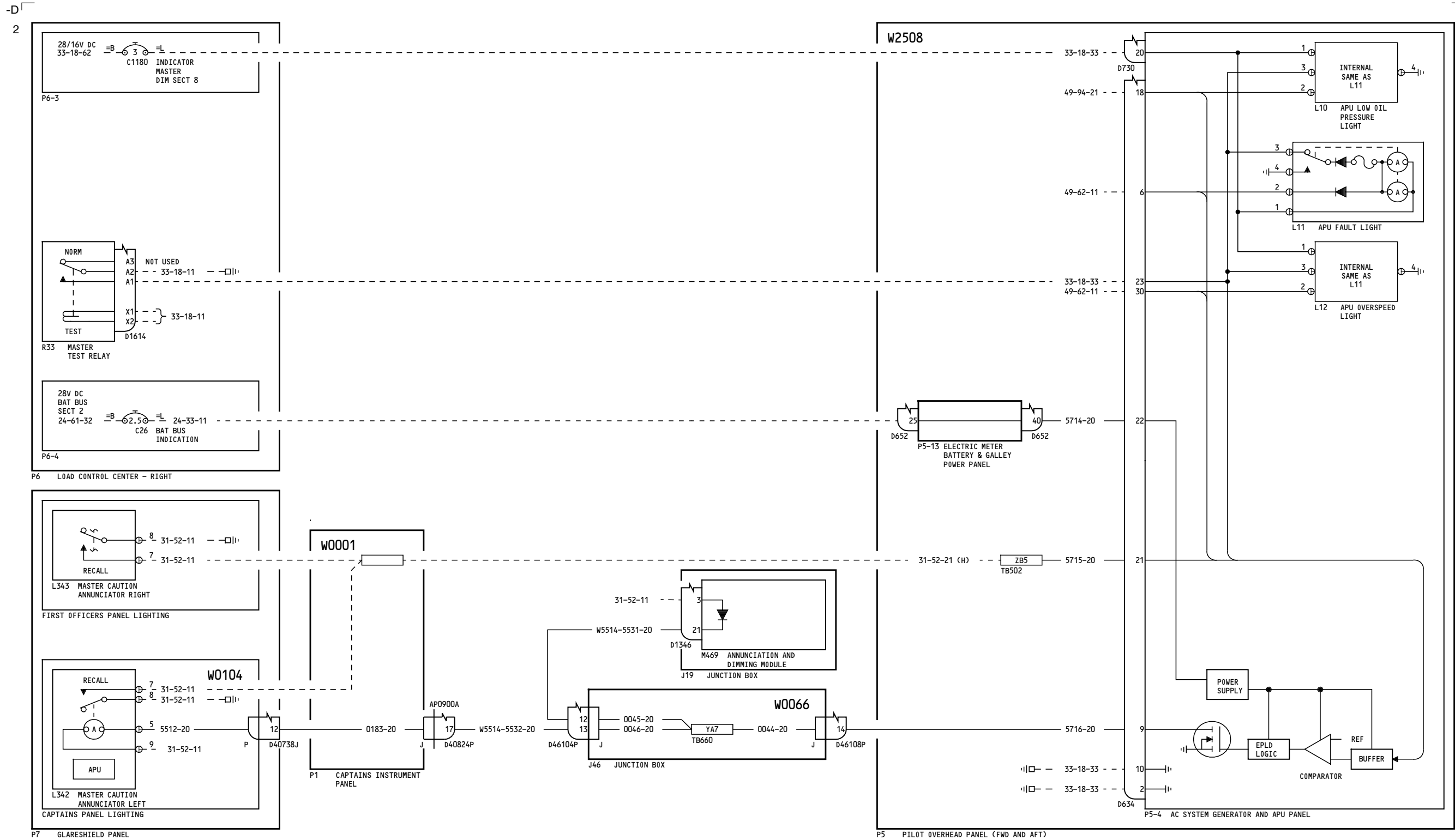

YC004-YC007

**MASTER CAUTION SYSTEM -
APU CONTROL**

31-52-35

Page 2

D280A103

May 13/2008

31-52-35

Page 2

May 13/2008

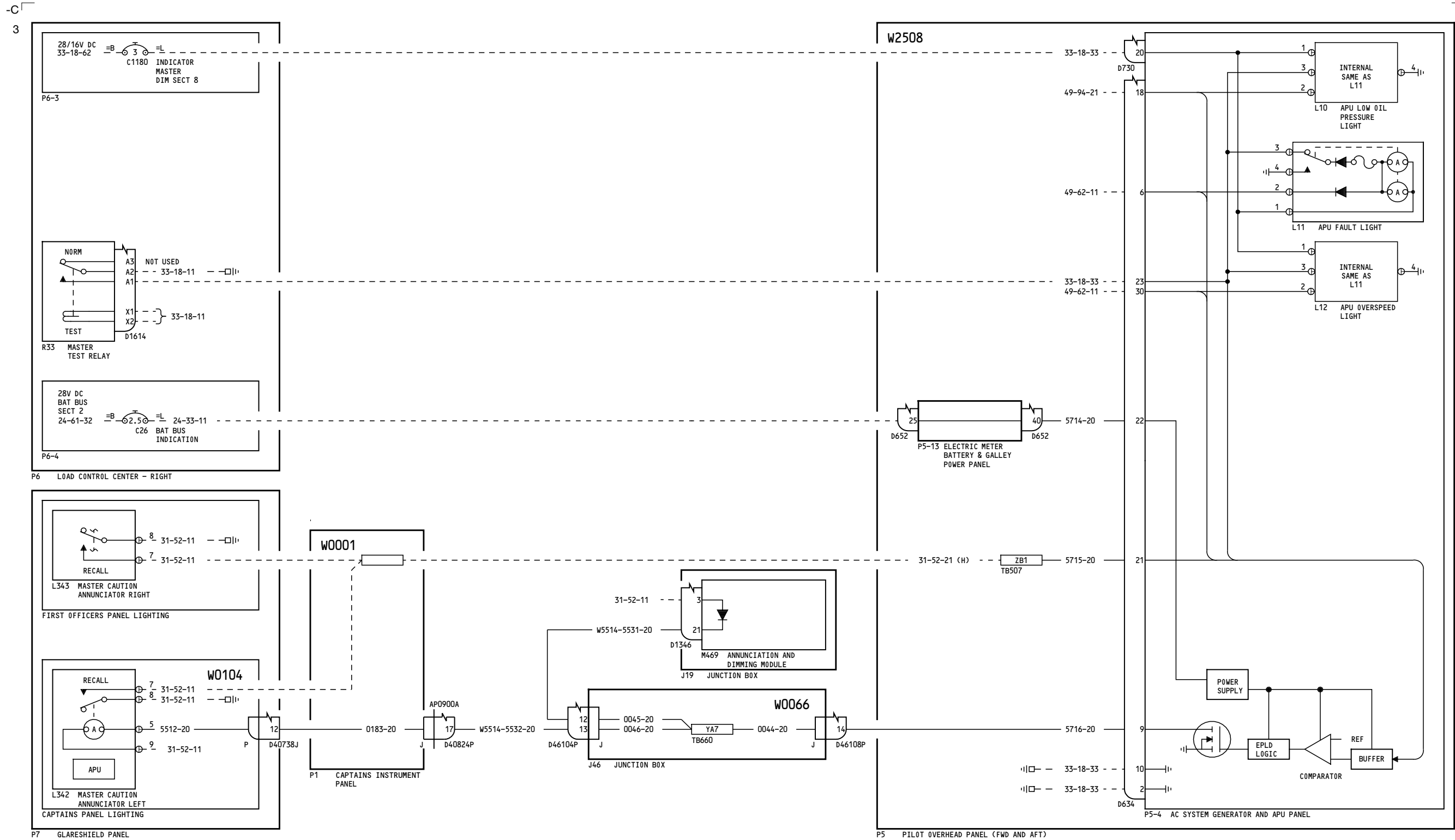

YC008-YC030

**MASTER CAUTION SYSTEM -
APU CONTROL**

31-52-35

Page 3

D280A103

May 13/2008

31-52-35

Page 3

May 13/2008

-B

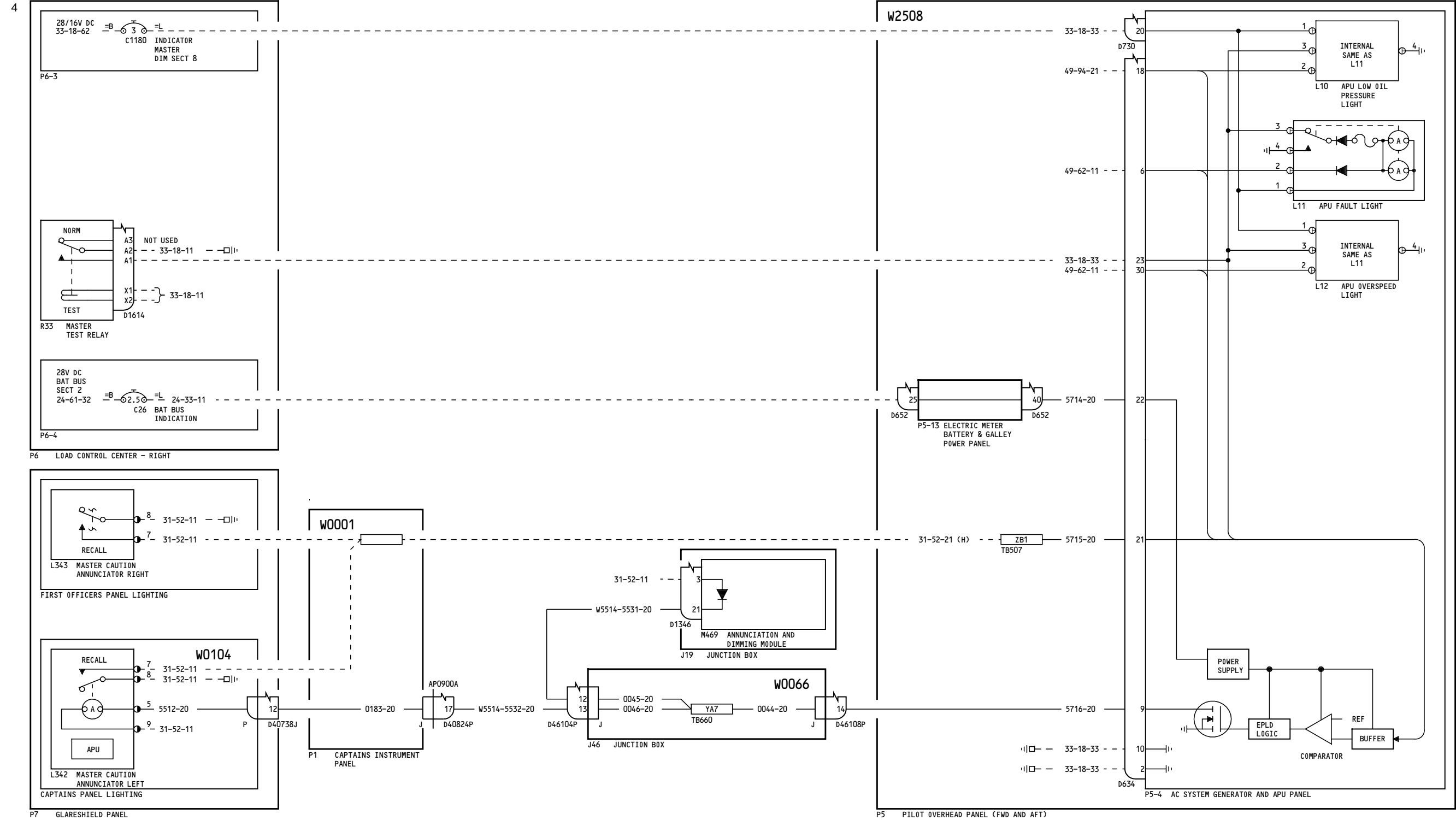

YC031-YM670

**MASTER CAUTION SYSTEM -
APU CONTROL**

31-52-35

Page 4

D280A103

Feb 09/2009

31-52-35

Page 4

Feb 09/2009

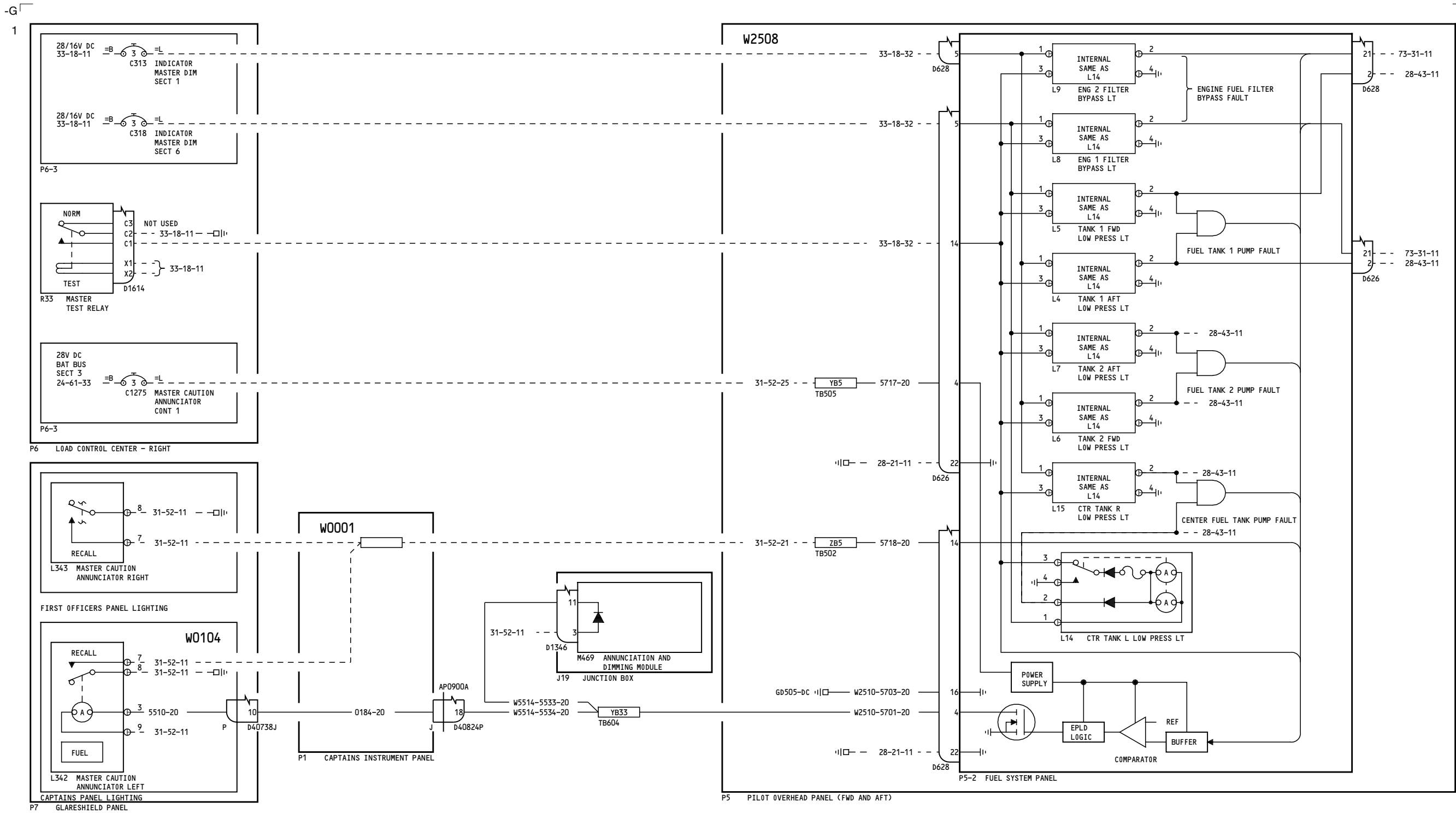

YC001-YC003

MASTER CAUTION SYSTEM - FUEL CONTROL

31-52-41

Page 1

D280A103

Mar 31/2005

31-52-41

Page 1

Mar 31/2005

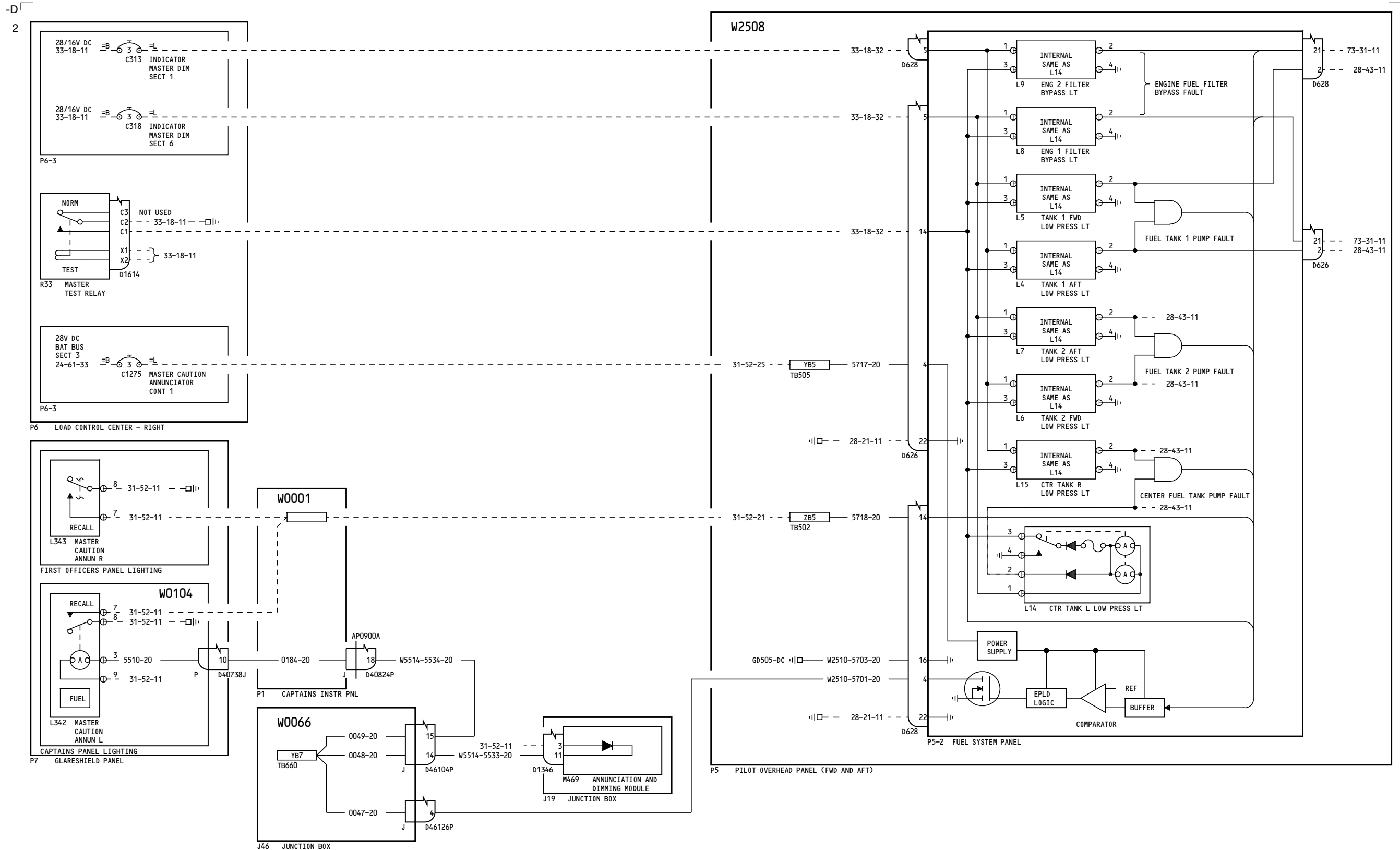

YC004-YC007

MASTER CAUTION SYSTEM - FUEL CONTROL

31-52-41

Page 2

D280A103

Mar 31/2005

31-52-41

Page 2

Mar 31/2005

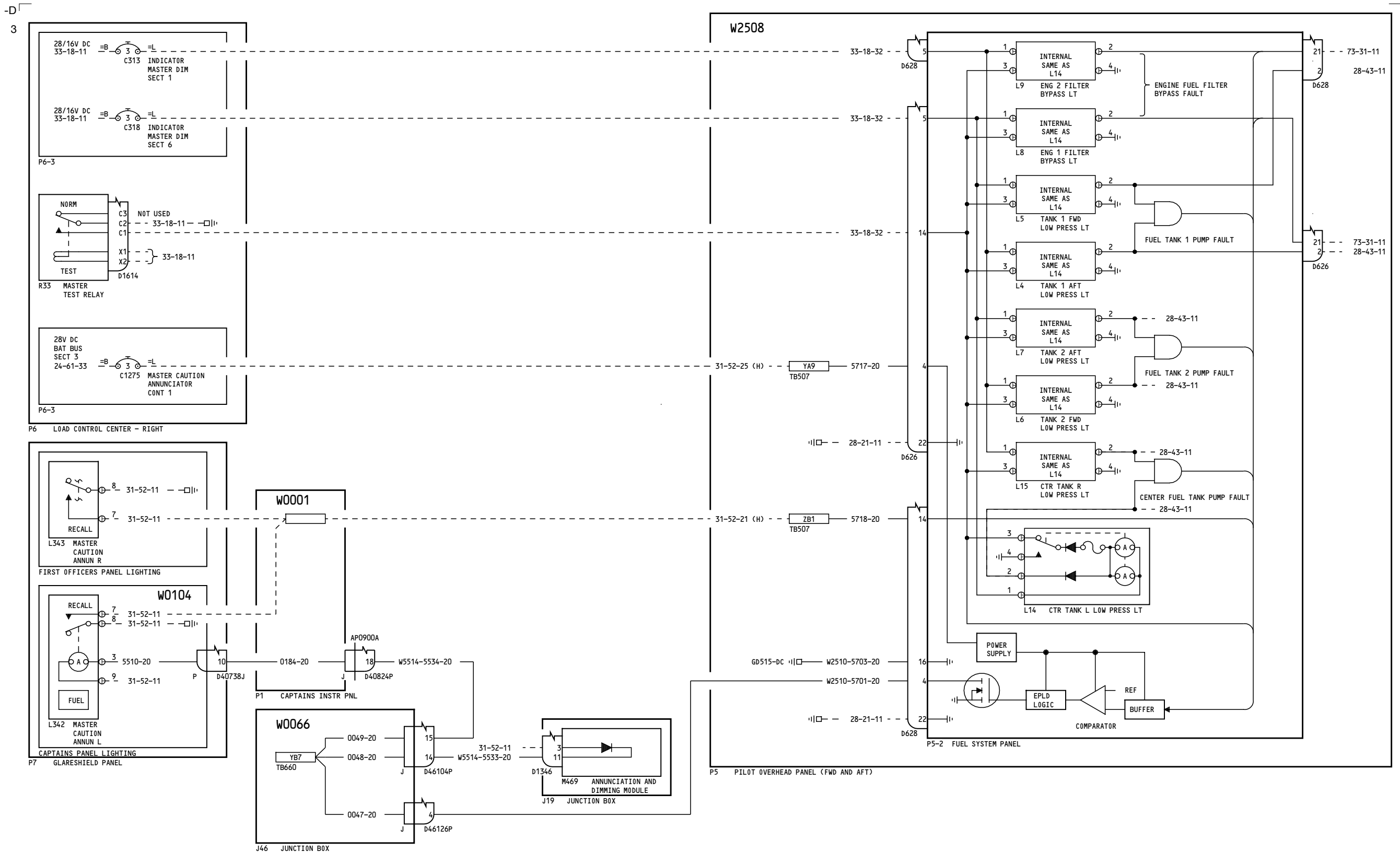

YC008-YC030

MASTER CAUTION SYSTEM - FUEL CONTROL

31-52-41

Page 3

D280A103

Jul 17/2007

31-52-41

Page 3

Jul 17/2007

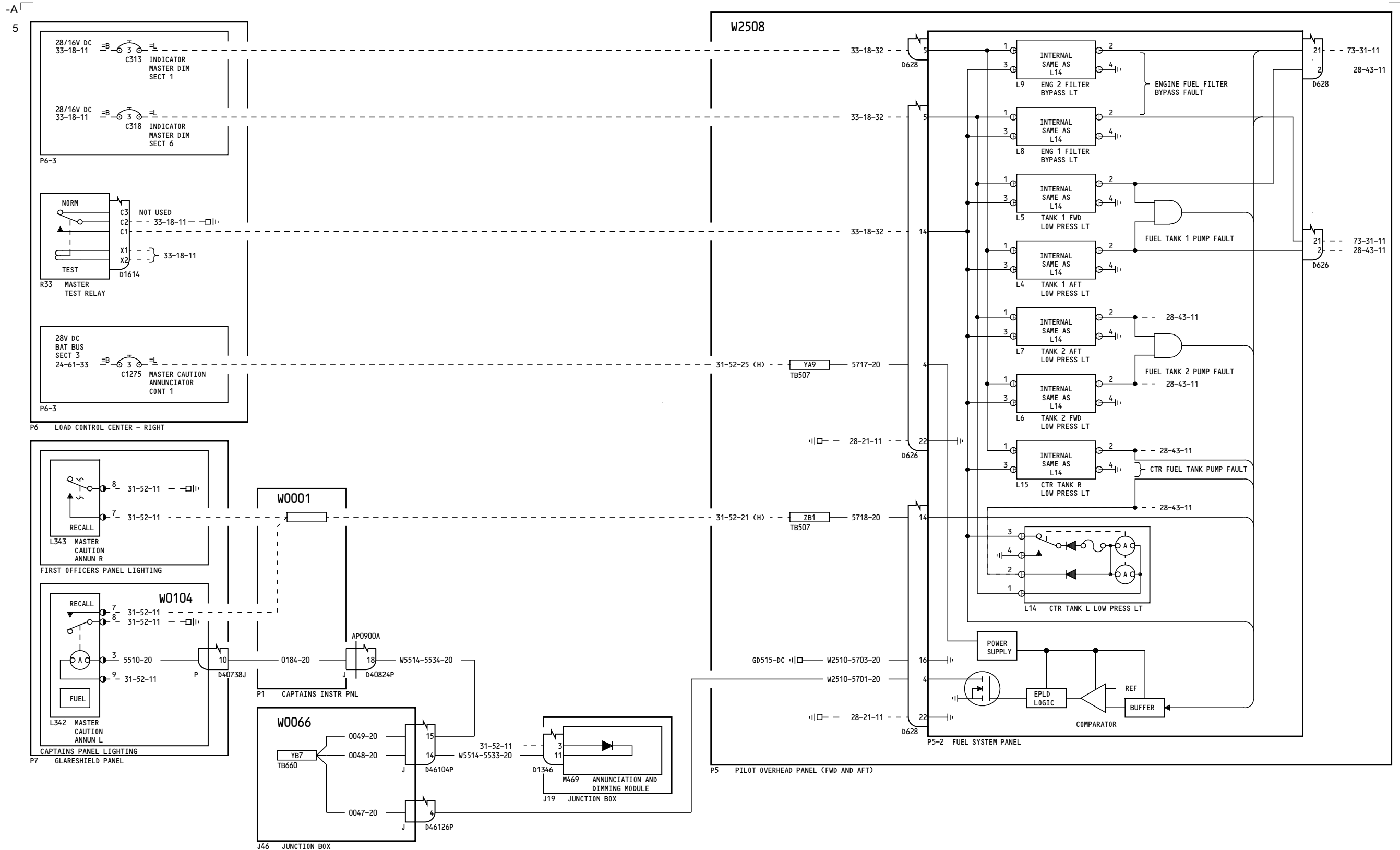

YC031-YM670

MASTER CAUTION SYSTEM - FUEL CONTROL

31-52-41

Page 4

D280A103

Feb 09/2009

31-52-41

Page 4

Feb 09/2009

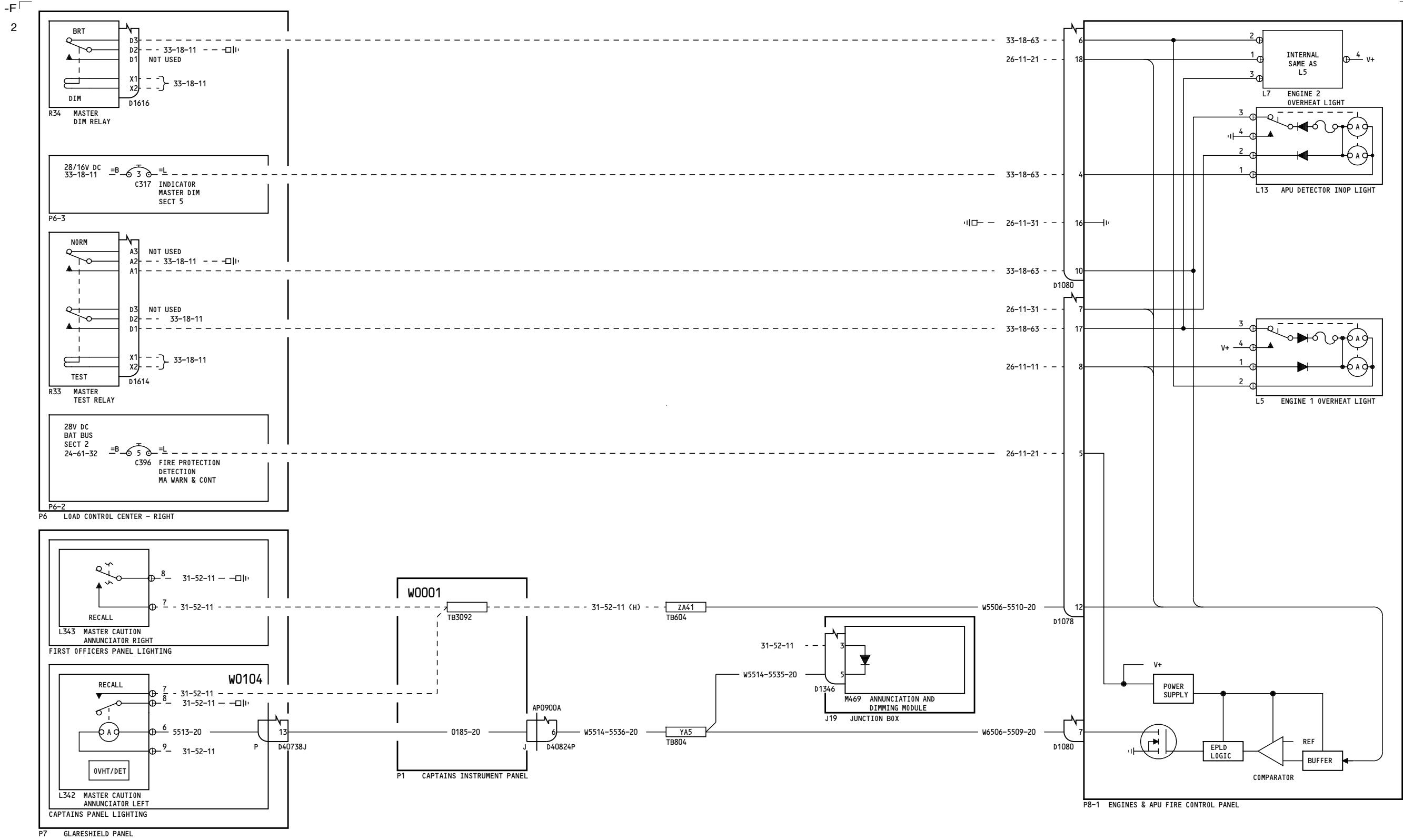

YC001-YC003

MASTER CAUTION SYSTEM - OVERHEAT DETECTION

31-52-45

Page 1

D280A103

May 13/2008

31-52-45

Page 1

May 13/2008

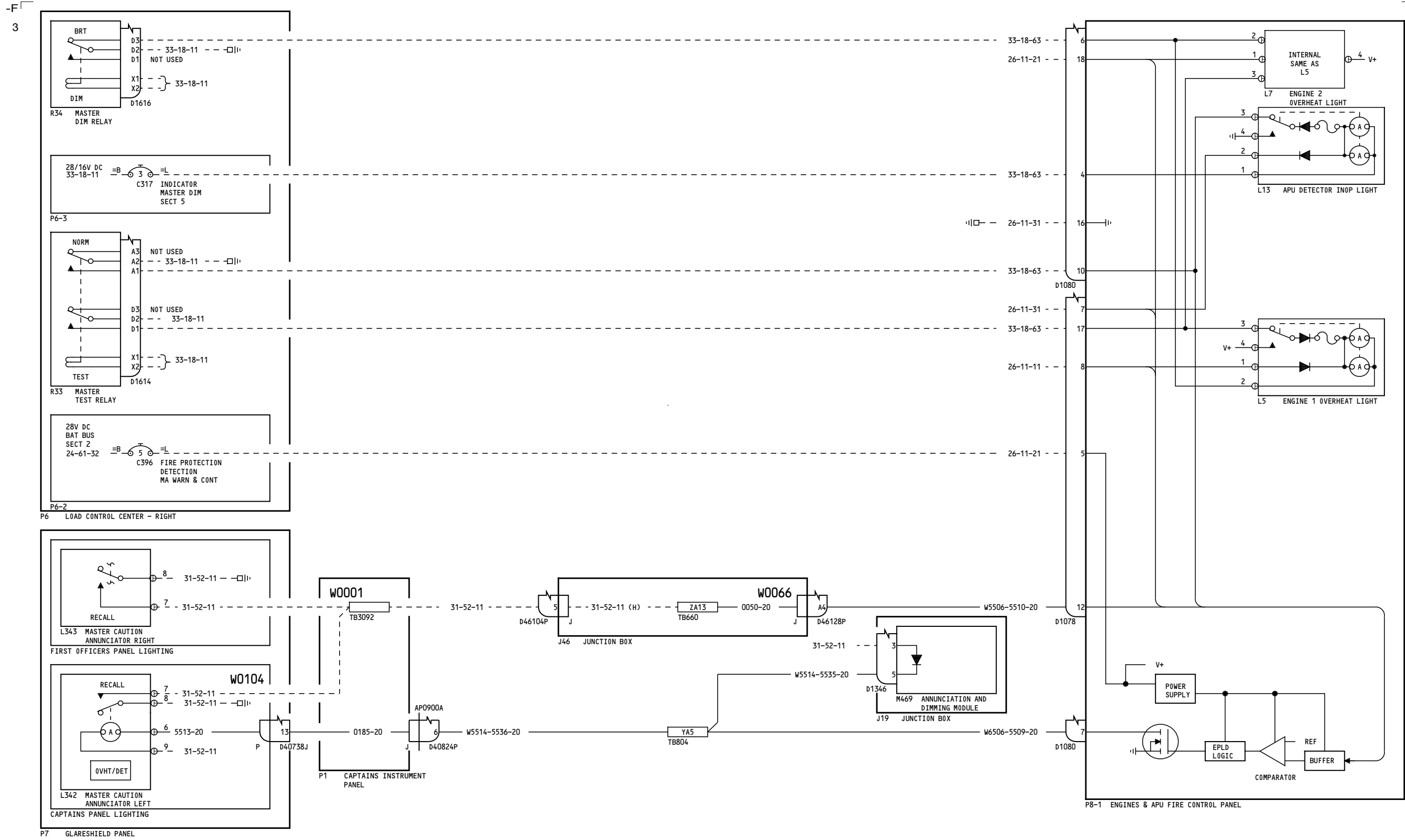

YC004-YC030

**MASTER CAUTION SYSTEM -
OVERHEAT DETECTION**

31-52-45

Page 2

D280A103

May 13/2008

31-52-45

Page 2

May 13/2008

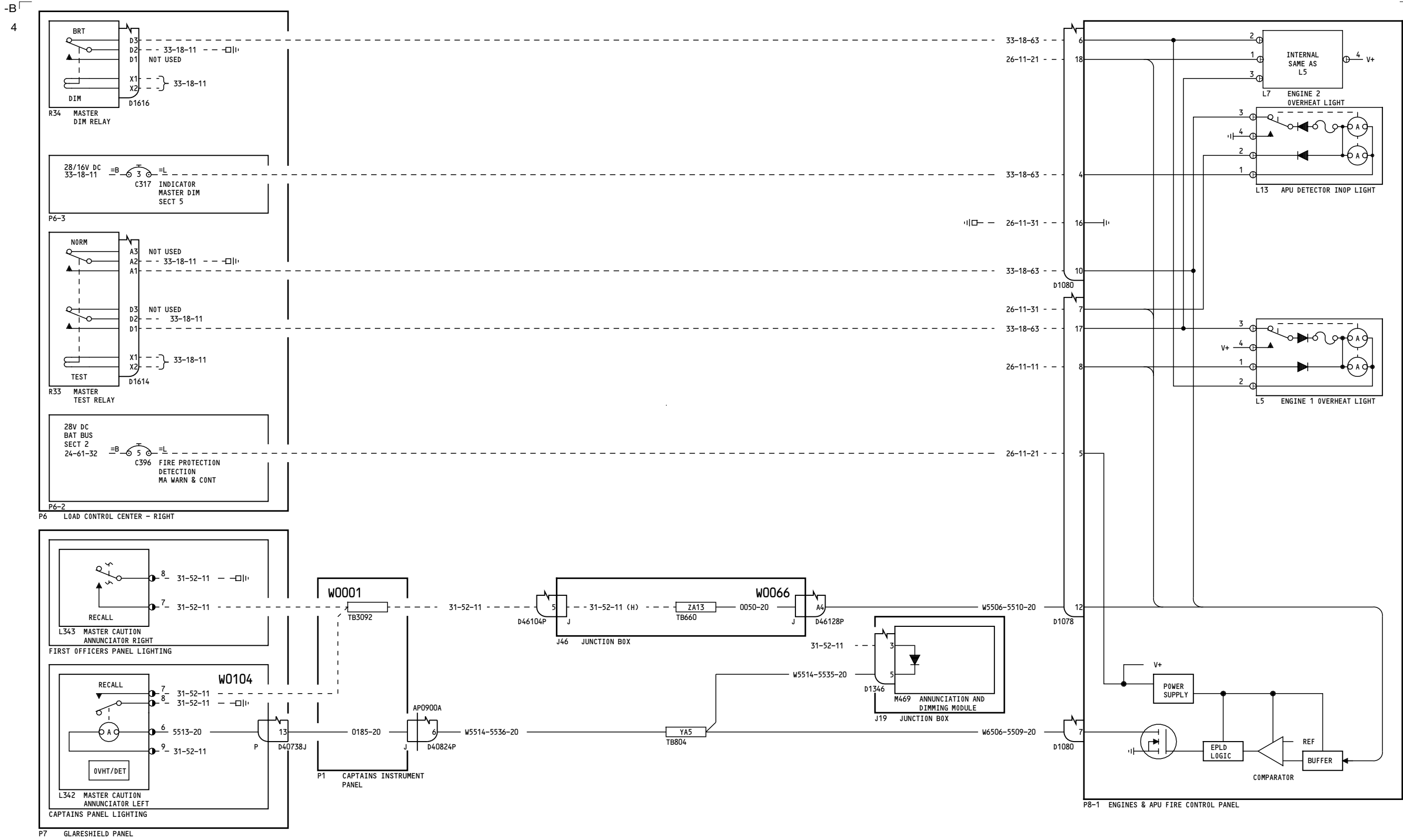

YC031-YM670

**MASTER CAUTION SYSTEM -
OVERHEAT DETECTION**

31-52-45

Page 3

D280A103

Feb 09/2009

31-52-45

Page 3

Feb 09/2009

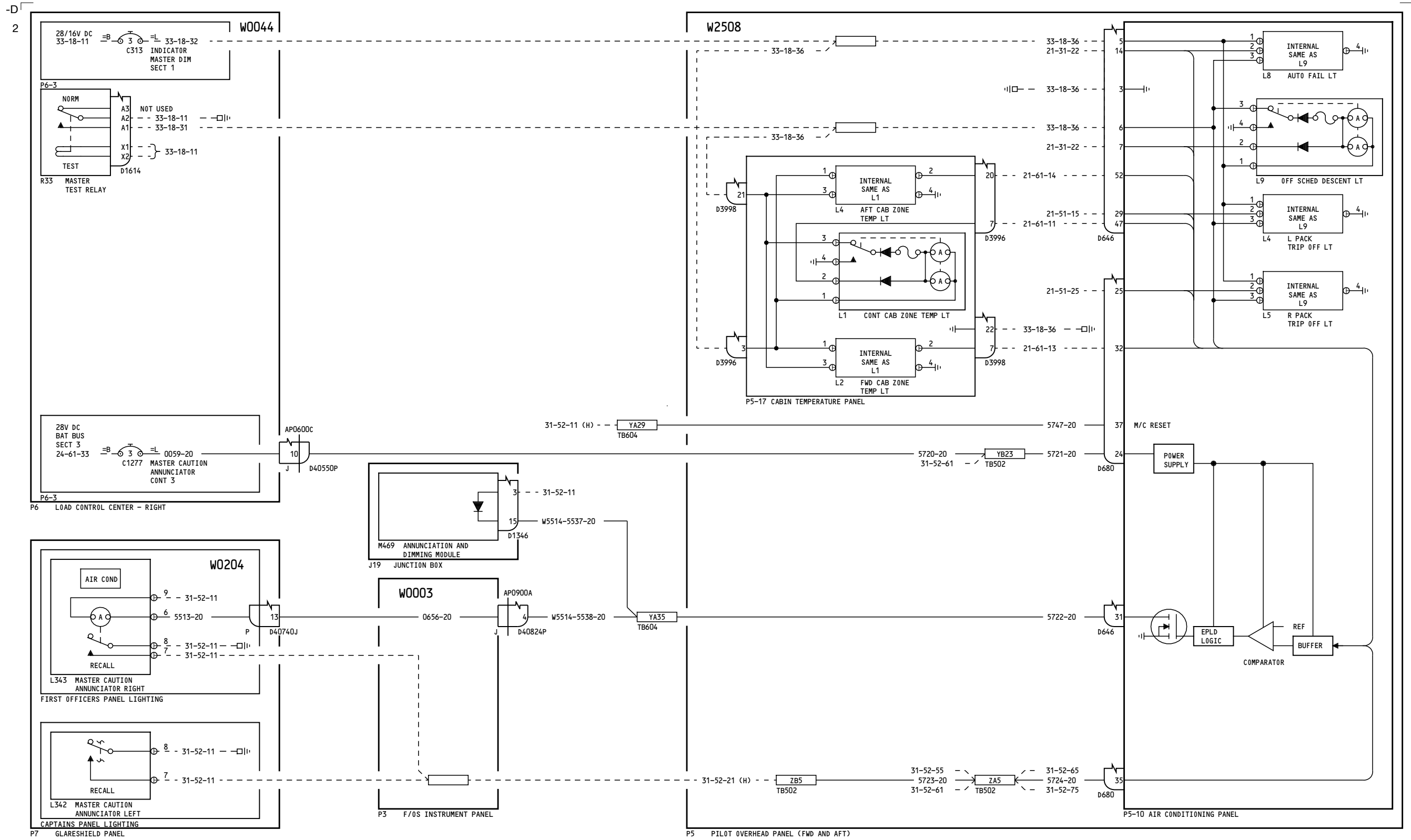

YC001-YC003

MASTER CAUTION SYSTEM - AIR CONDITIONING CONTROL, PACK & TEMP

31-52-51

Page 1

D280A103

Mar 31/2005

31-52-51

Page 1

Mar 31/2005

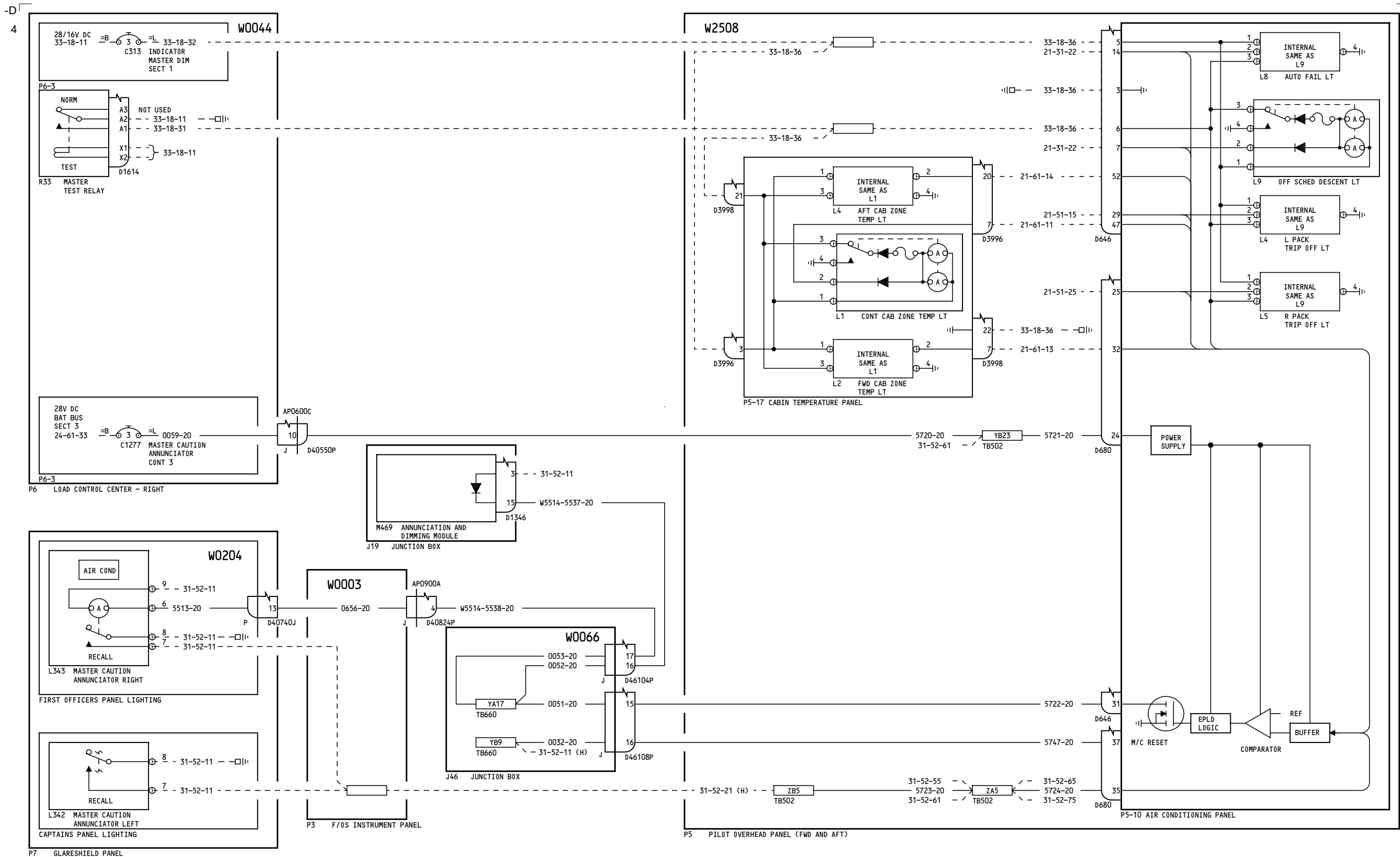

YC004-YC007

MASTER CAUTION SYSTEM - AIR CONDITIONING CONTROL, PACK & TEMP

31-52-51

Page 2

D280A103

Mar 31/2005

31-52-51

Page 2

Mar 31/2005

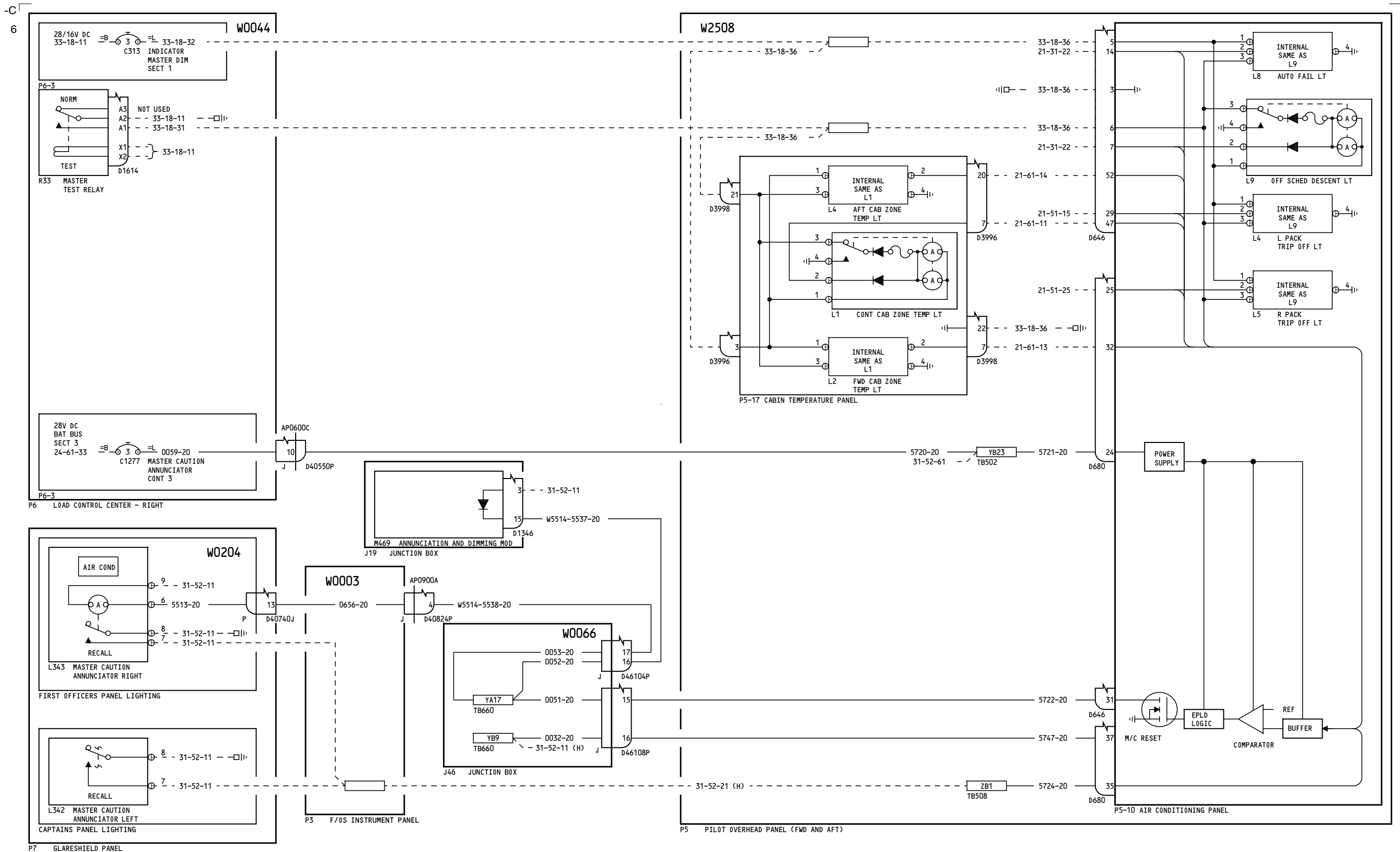

YC008-YC030

MASTER CAUTION SYSTEM - AIR CONDITIONING CONTROL, PACK & TEMP

31-52-51

Page 3

D280A103

Jul 17/2007

31-52-51

Page 3

Jul 17/2007

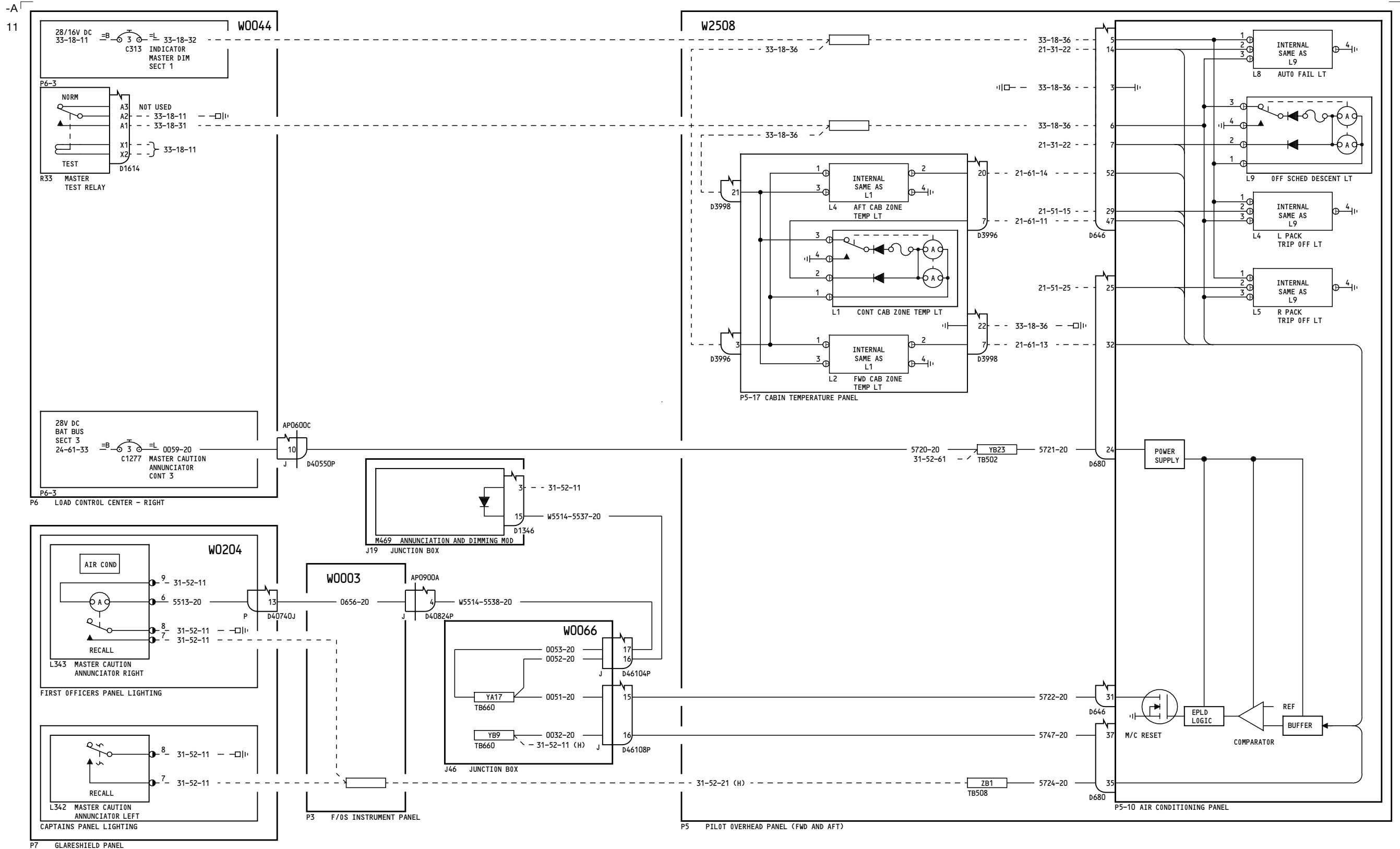

YC031-YL430

MASTER CAUTION SYSTEM - AIR CONDITIONING CONTROL, PACK & TEMP

31-52-51

Page 4

D280A103

Feb 09/2009

31-52-51

Page 4

Feb 09/2009

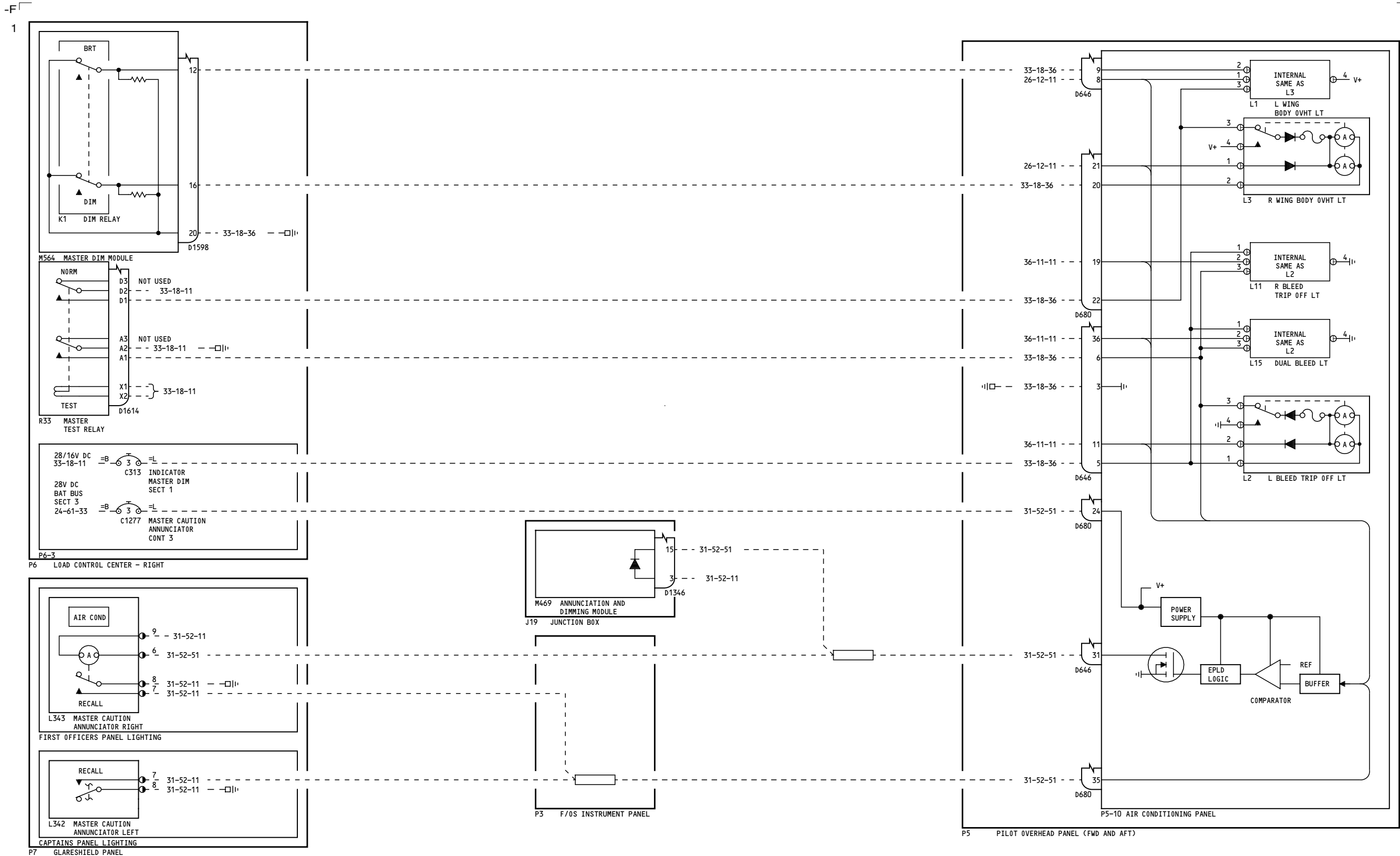

ALL

**MASTER CAUTION SYSTEM -
AIR CONDITIONING CONTROL,
BLEED AIR**

31-52-52

31-52-52

Page 1

Page 1

D280A103

Feb 09/2009

Feb 09/2009

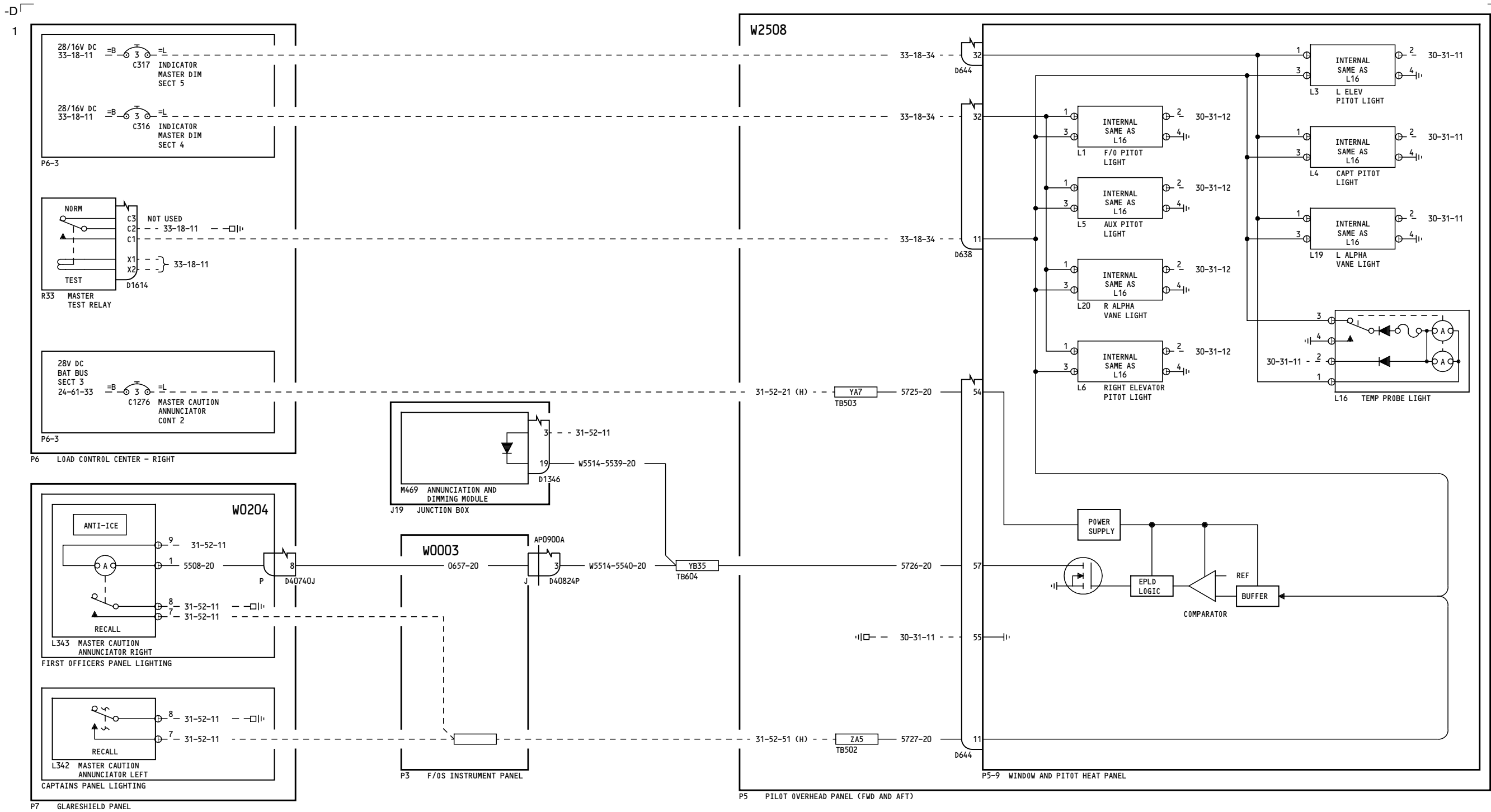

YC001-YC003

**MASTER CAUTION SYSTEM -
ANTI-ICE CONTROL,
PITOT HEAT**

31-52-55

Page 1

D280A103

Mar 31/2005

31-52-55

Page 1

Mar 31/2005

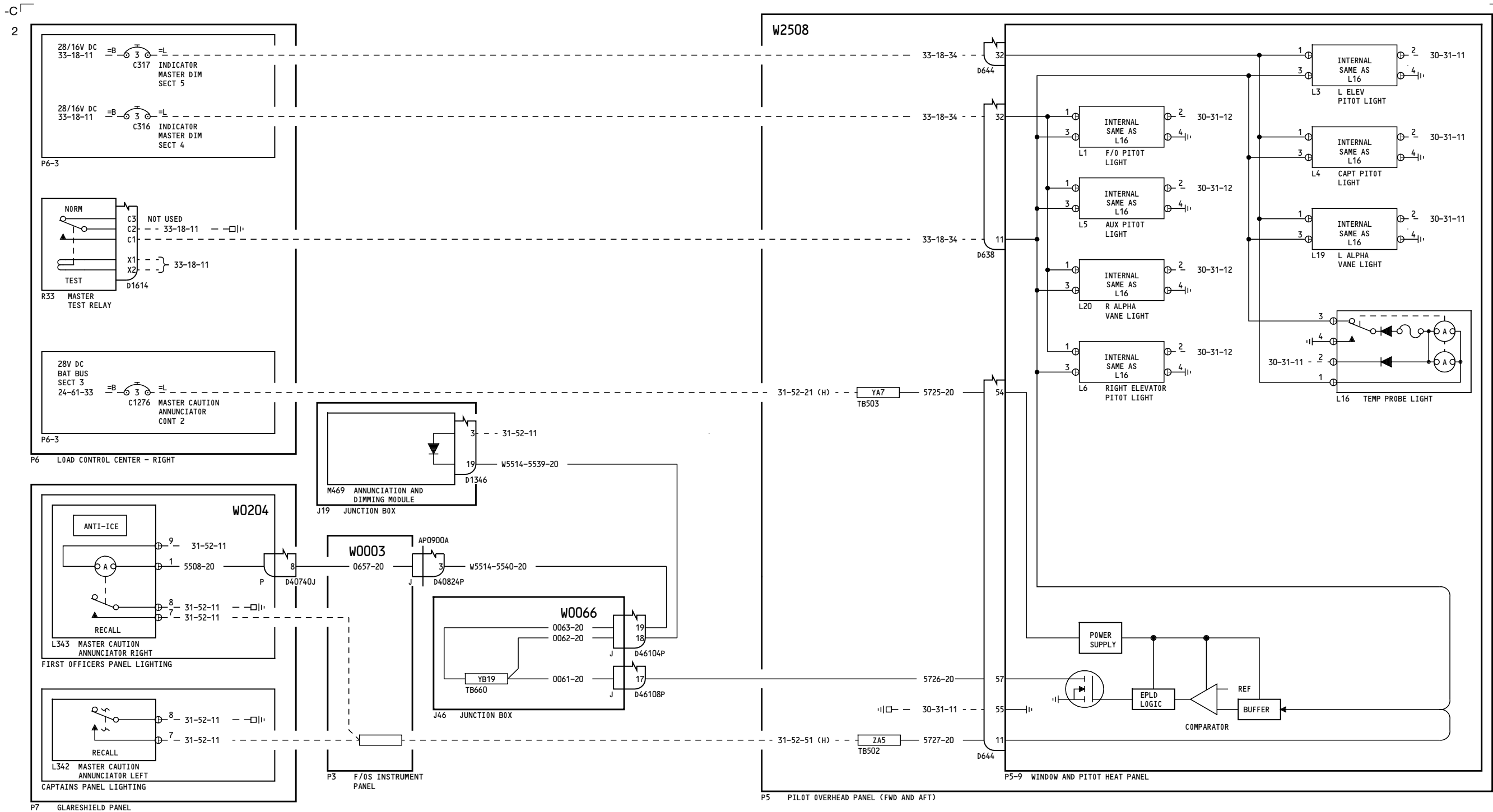

YC004-YC007

**MASTER CAUTION SYSTEM -
ANTI-ICE CONTROL,
PITOT HEAT**

31-52-55

Page 2

D280A103

Mar 31/2005

31-52-55

Page 2

Mar 31/2005

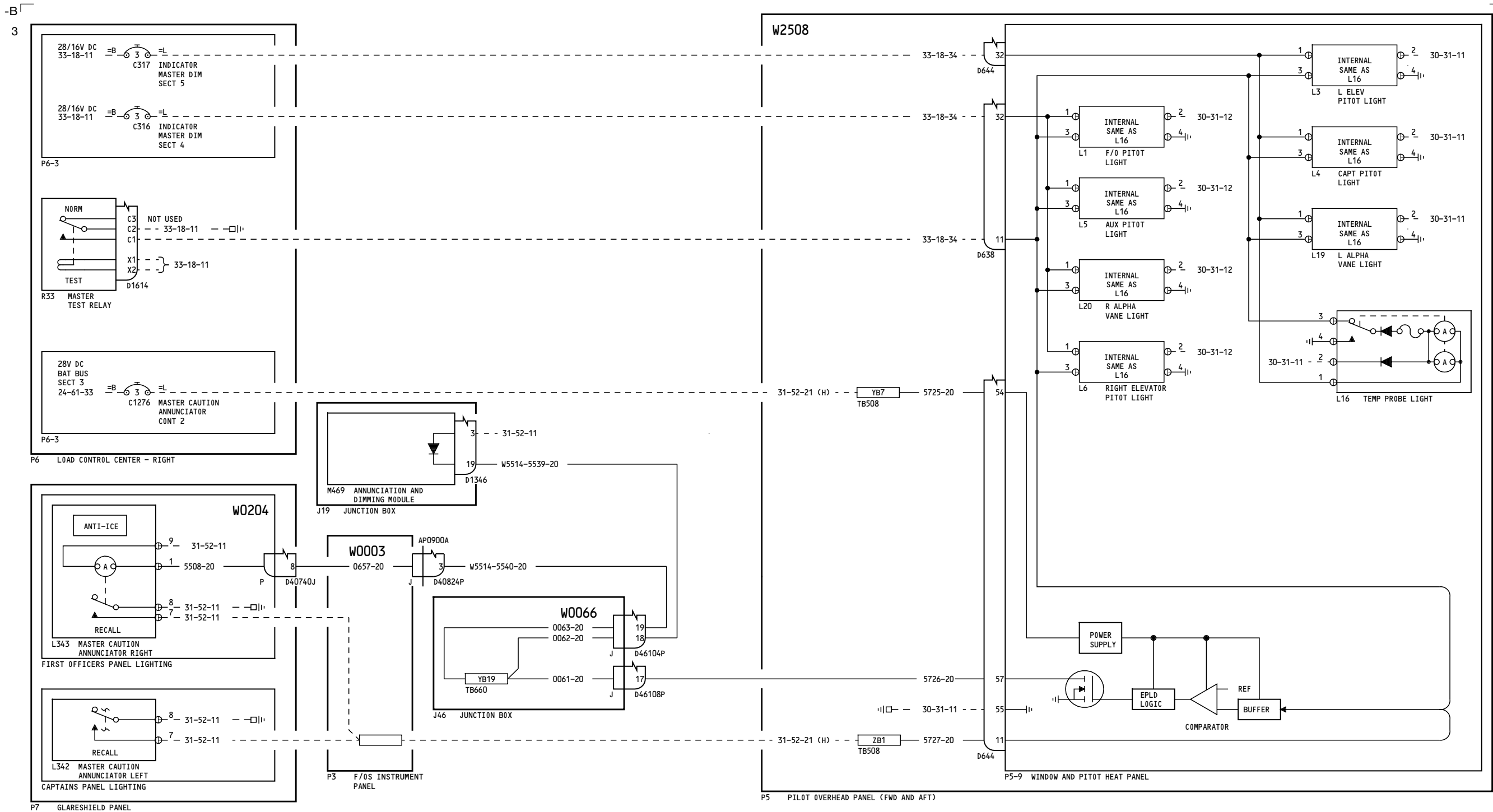

YC008-YC030

**MASTER CAUTION SYSTEM -
ANTI-ICE CONTROL,
PITOT HEAT**

31-52-55

Page 3

D280A103

Jul 17/2007

31-52-55

Page 3

Jul 17/2007

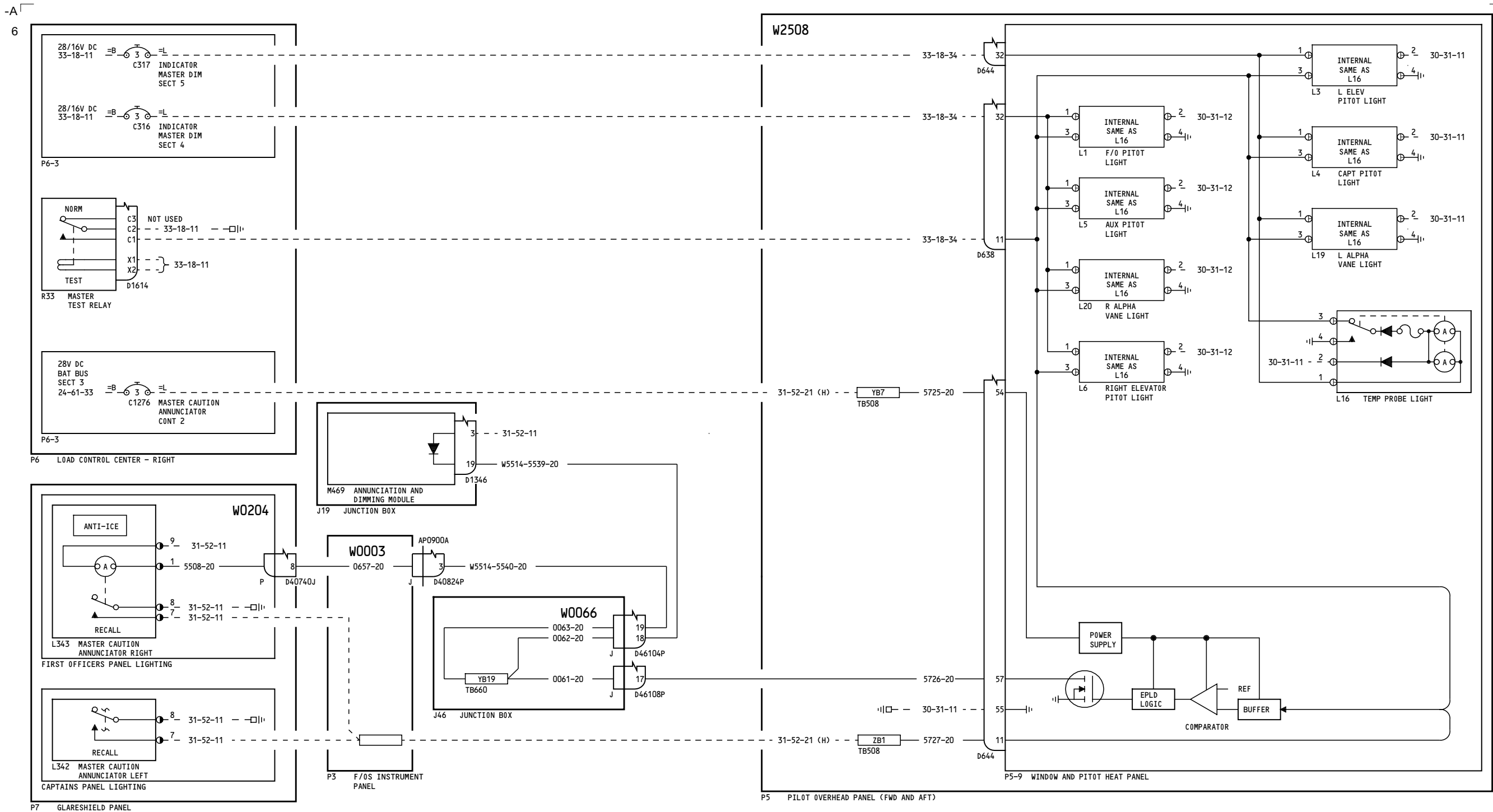

YC031-YM670

**MASTER CAUTION SYSTEM -
ANTI-ICE CONTROL,
PITOT HEAT**

31-52-55

Page 4

D280A103

Feb 09/2009

31-52-55

Page 4

Feb 09/2009

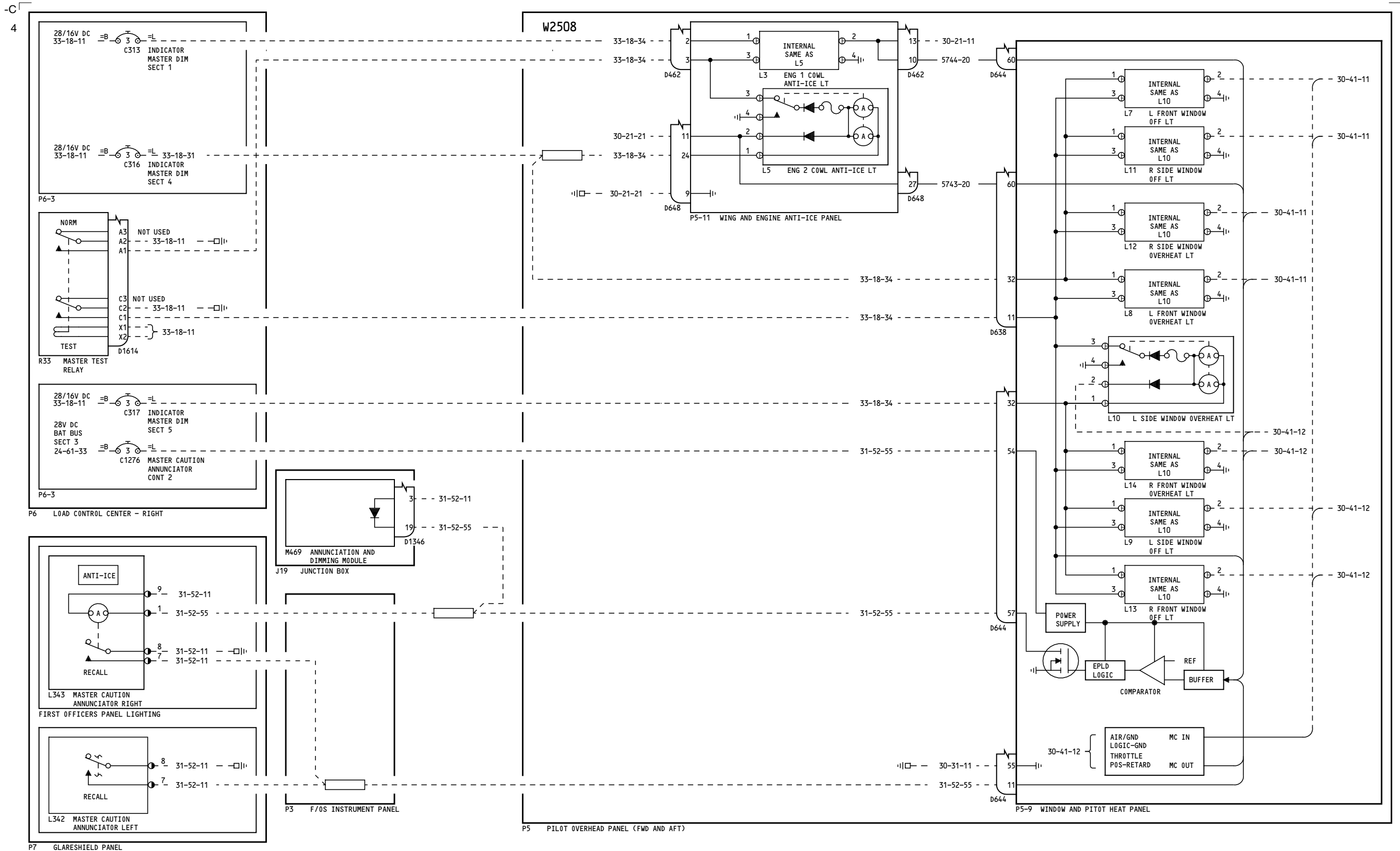

YC001-YC007

**MASTER CAUTION SYSTEM -
ANTI-ICE CONTROL,
WINDOW/COWL HEAT**

31-52-56

Page 1.1

D280A103

Oct 20/2005

Incorporates
30-1047

31-52-56

Page 1.1

Oct 20/2005

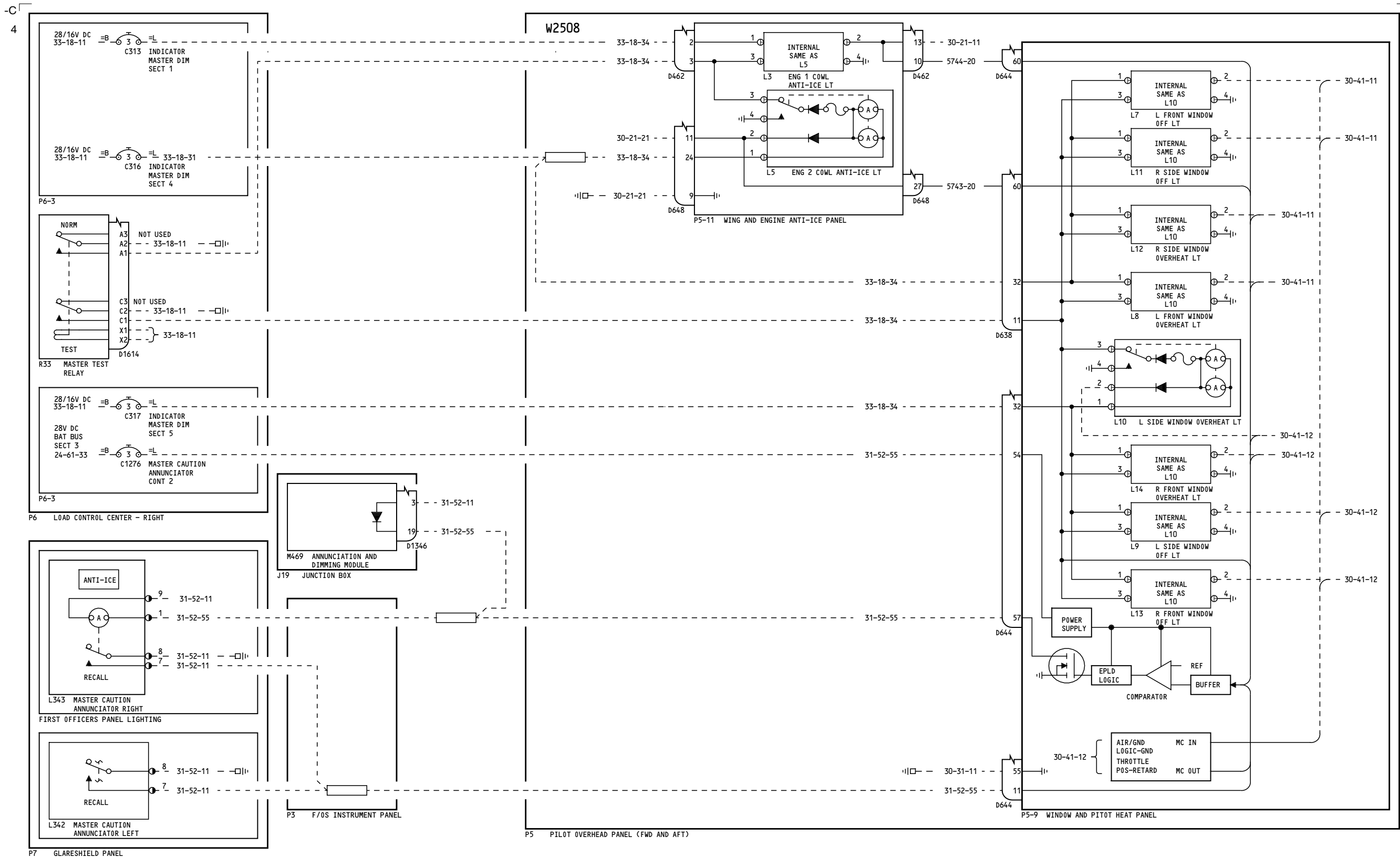

YC008-YM670

**MASTER CAUTION SYSTEM -
ANTI-ICE CONTROL,
WINDOW/COWL HEAT**

31-52-56

Page 2

Feb 09/2009

D280A103

31-52-56

Page 2

Feb 09/2009

-E
1

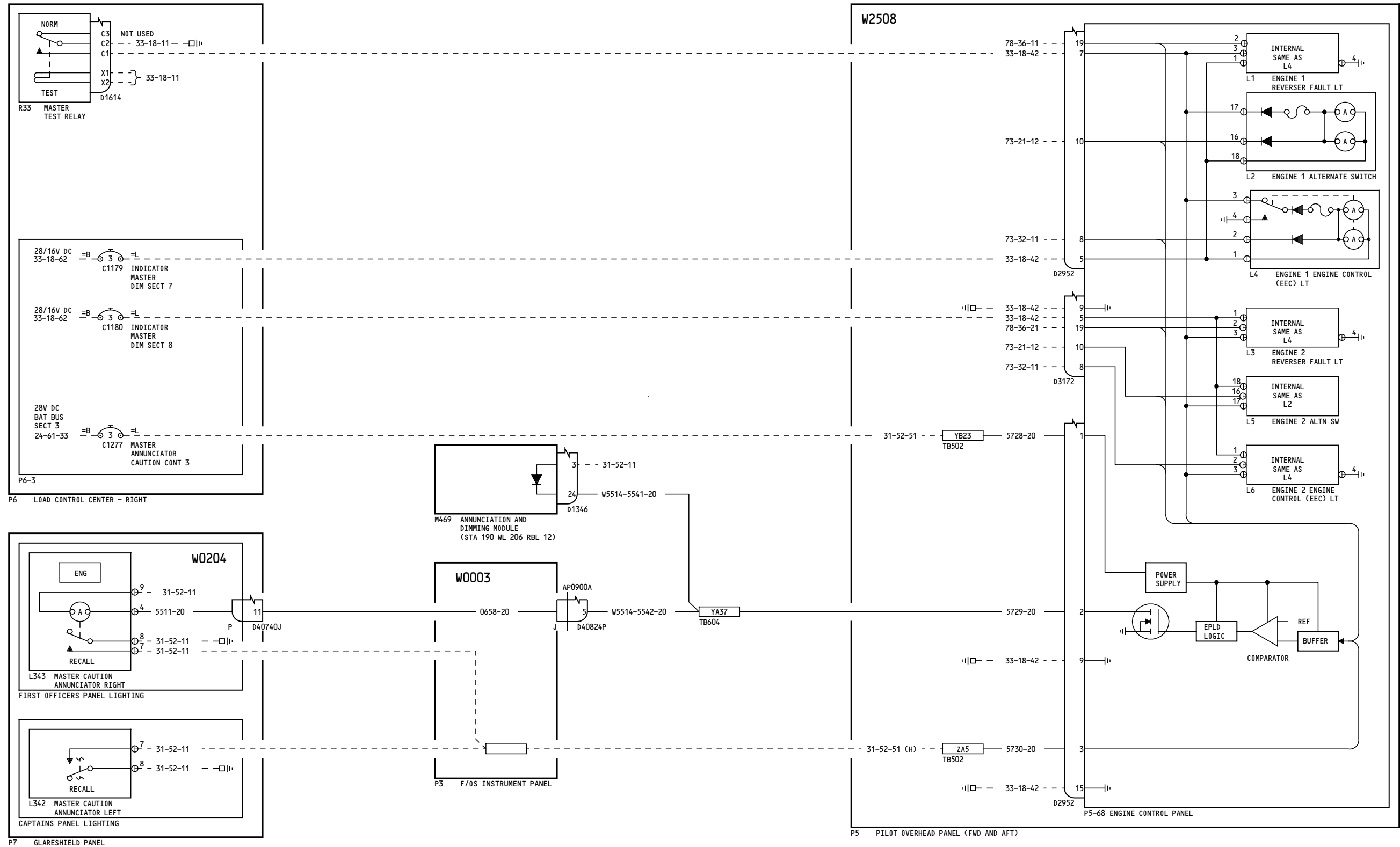

YC001-YC003

**MASTER CAUTION SYSTEM -
ENGINE CONTROL**

31-52-61

Page 1

D280A103

Aug 10/2009

31-52-61

Page 1

Aug 10/2009

-D
2

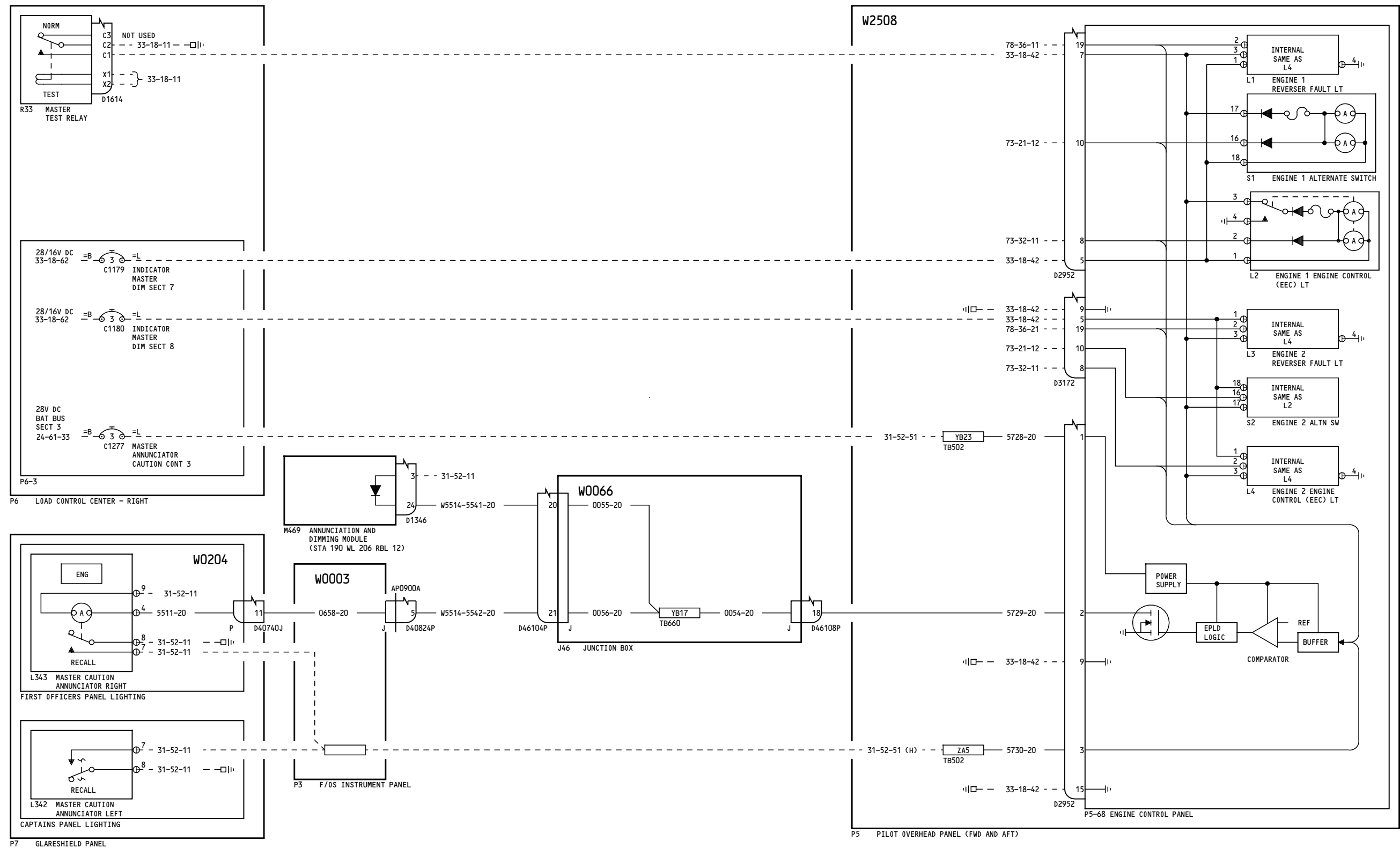

YC004-YC007

MASTER CAUTION SYSTEM - ENGINE CONTROL

31-52-61

Page 2

D280A103

Aug 10/2009

31-52-61

Page 2

Aug 10/2009

-A
4

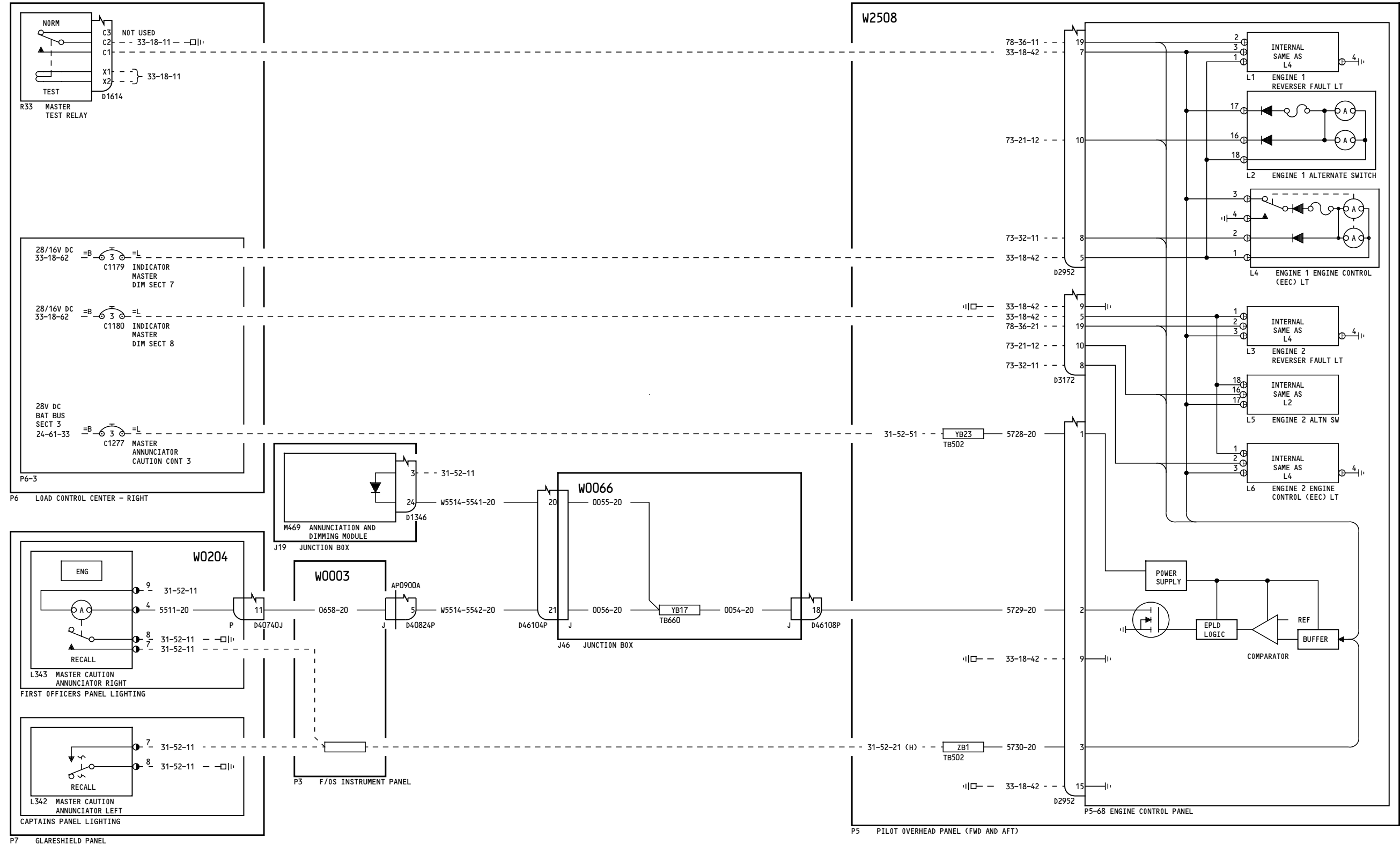

YC031-YM670

**MASTER CAUTION SYSTEM -
ENGINE CONTROL**

31-52-61

Page 4

D280A103

Feb 09/2009

31-52-61

Page 4

Feb 09/2009

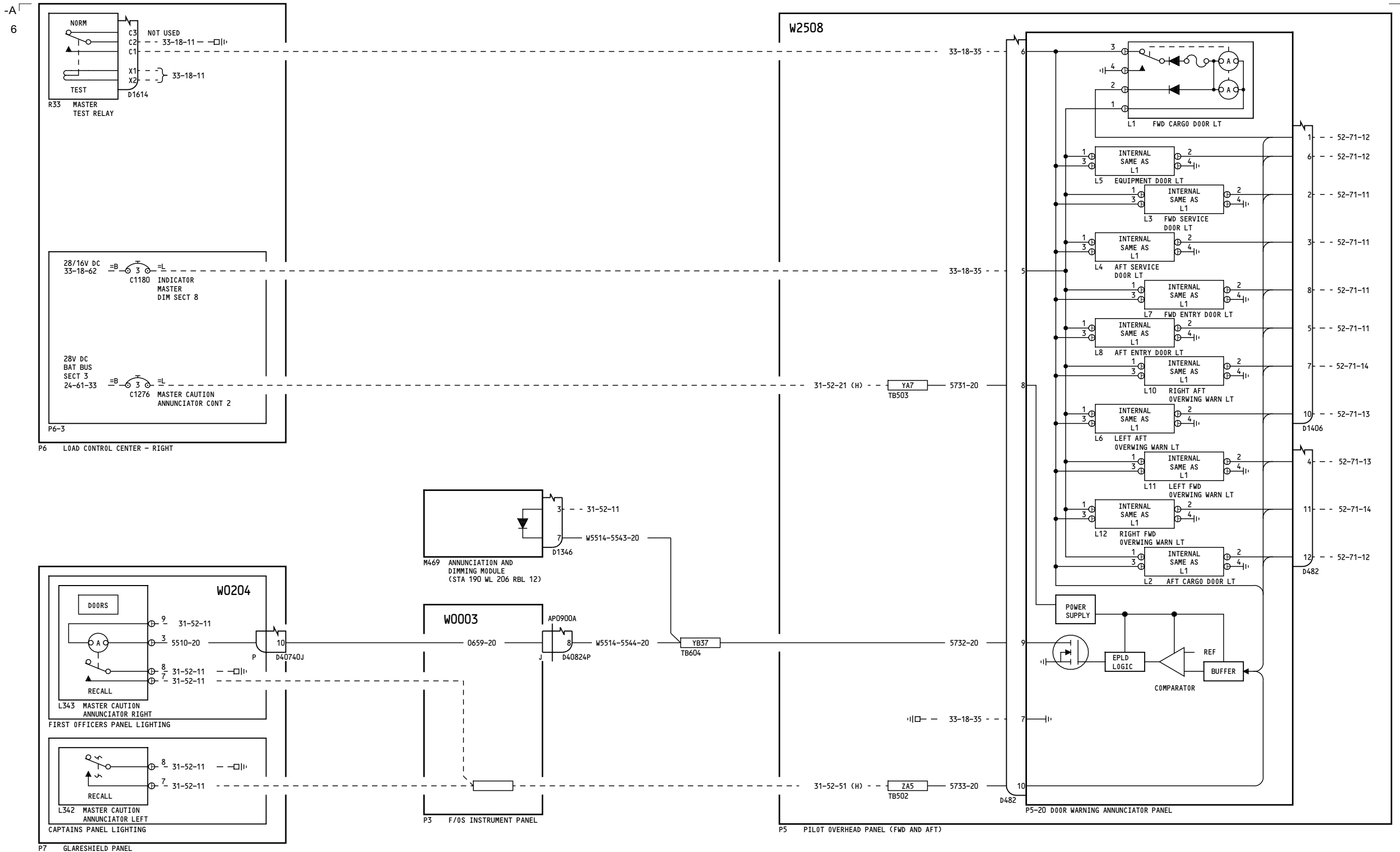

YC001-YC003

**MASTER CAUTION SYSTEM -
DOOR WARNING**

31-52-65

Page 1

D280A103

Mar 31/2005

31-52-65

Page 1

Mar 31/2005

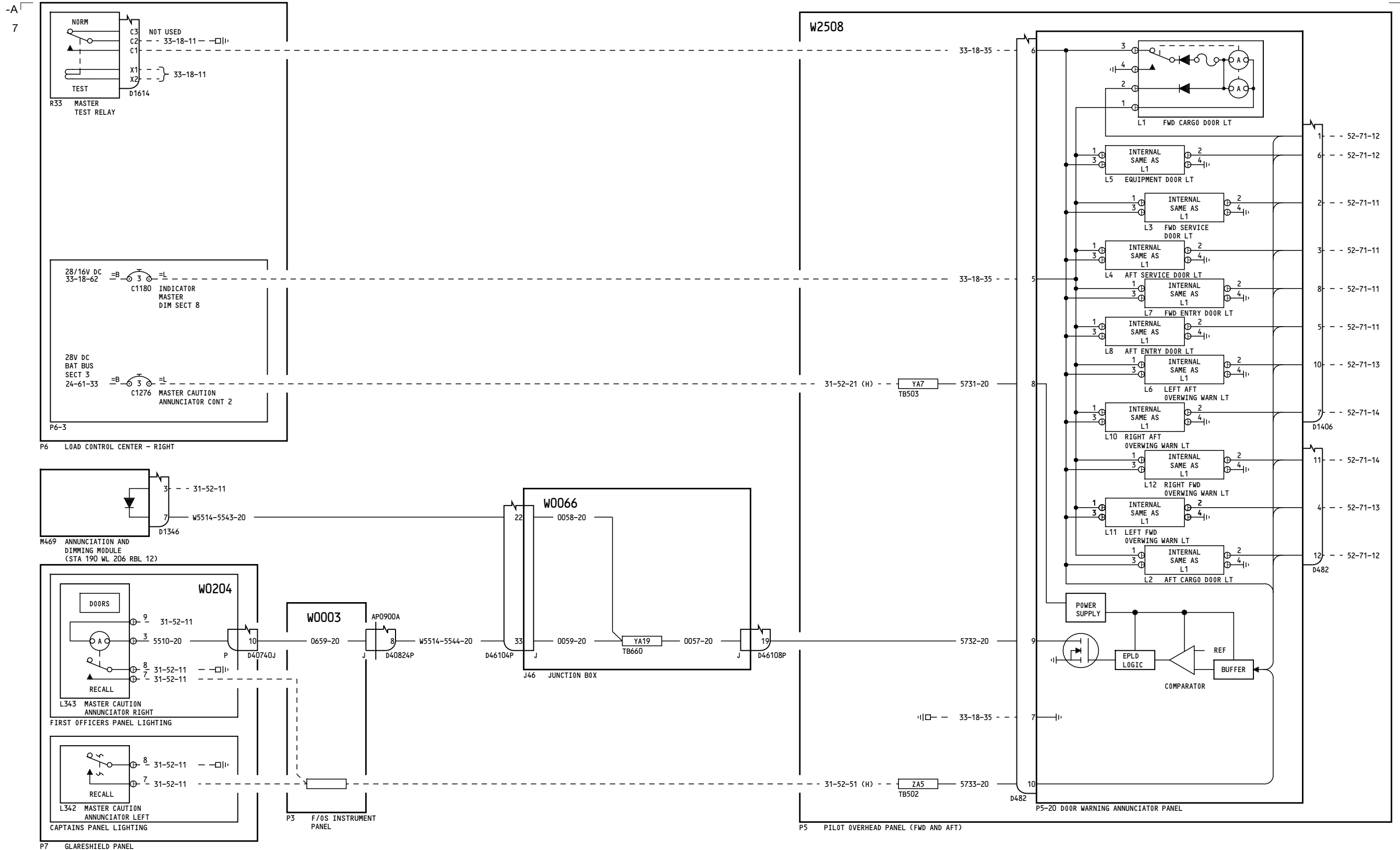

YC004-YC007

**MASTER CAUTION SYSTEM -
DOOR WARNING**

31-52-65

Page 2

D280A103

Mar 31/2005

31-52-65

Page 2

Mar 31/2005

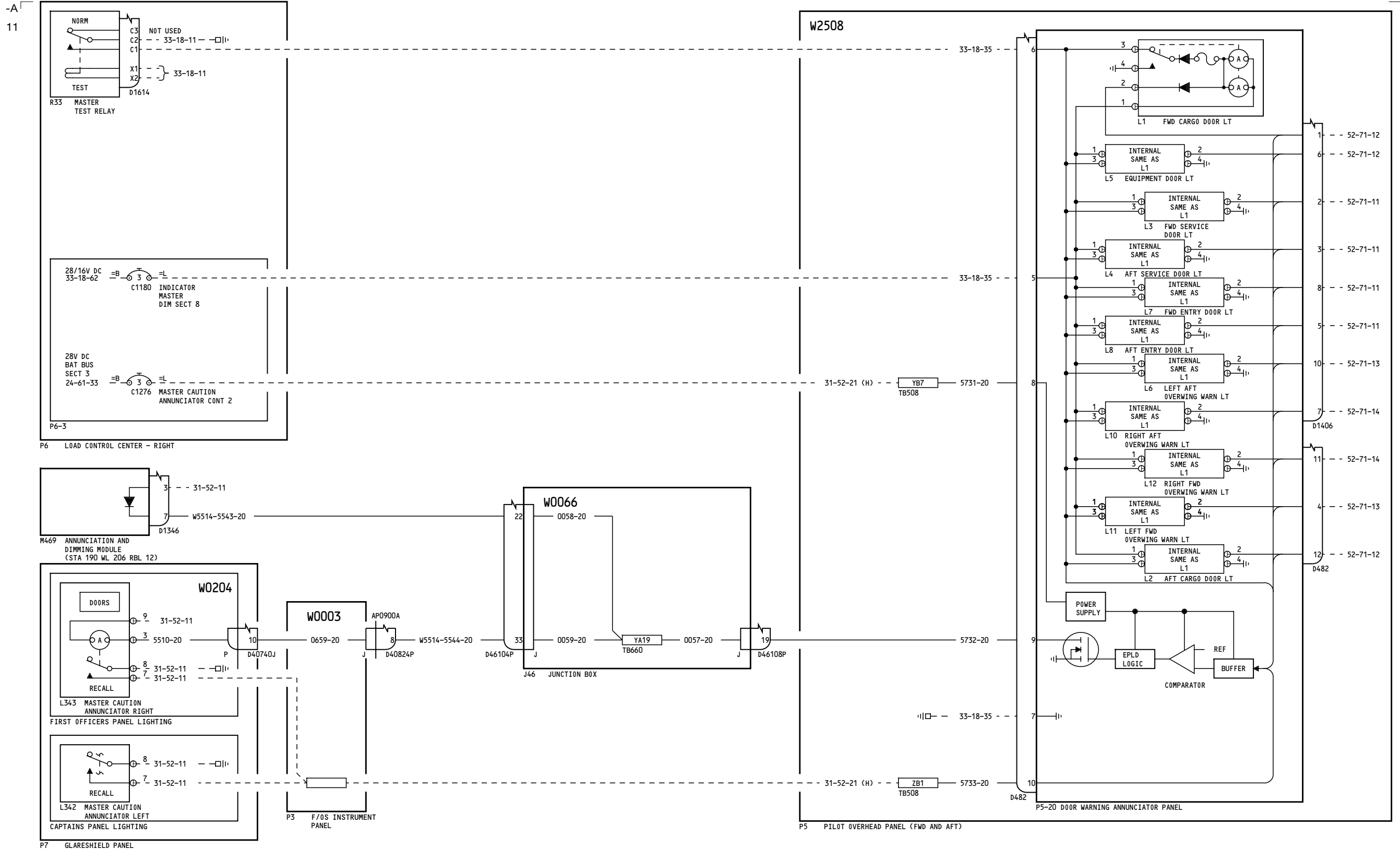

YC008-YC030

MASTER CAUTION SYSTEM - DOOR WARNING

31-52-65

Page 3

D280A103

Jul 17/2007

31-52-65

Page 3

Jul 17/2007

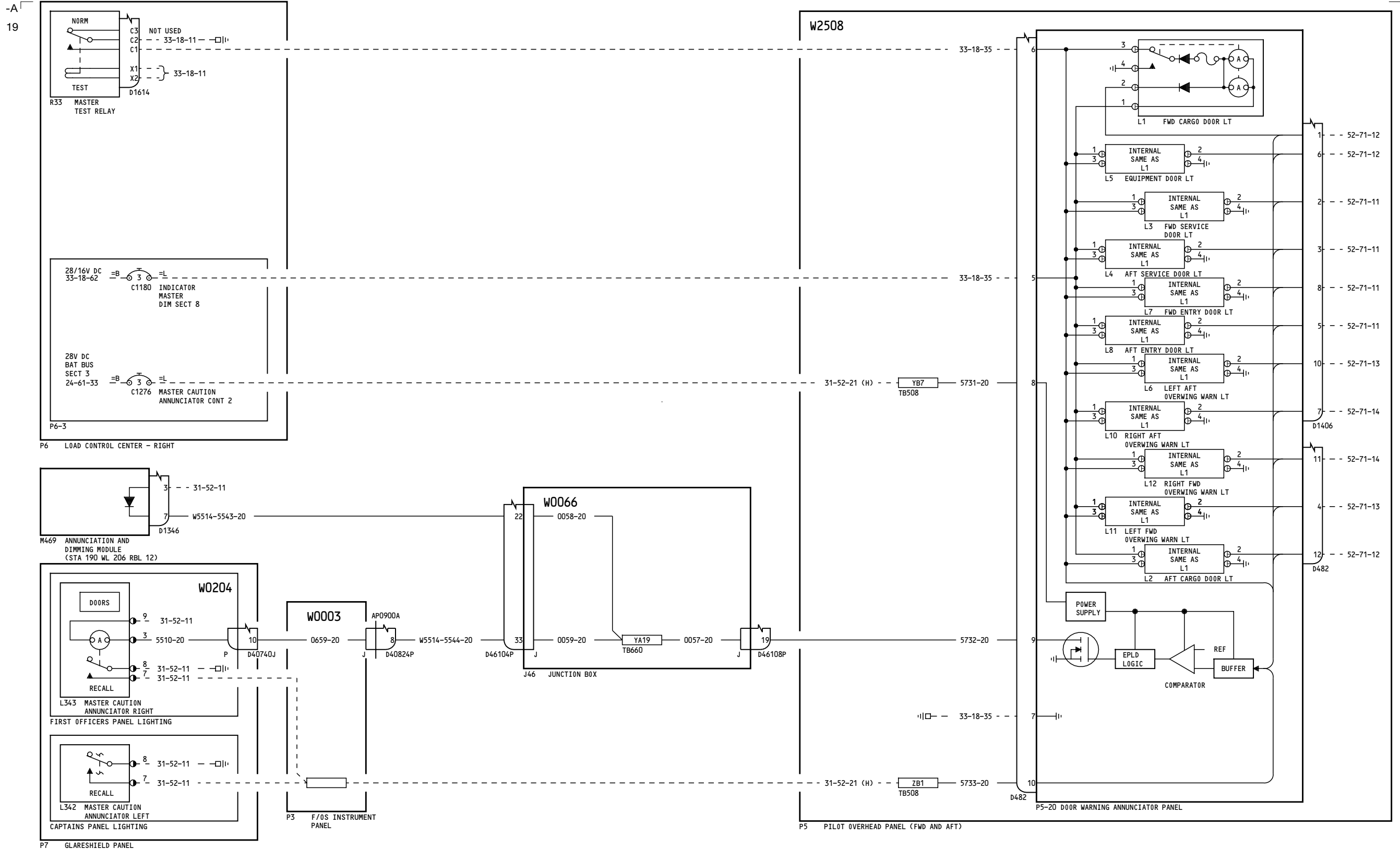

YC031-YL430

MASTER CAUTION SYSTEM - DOOR WARNING

31-52-65

Page 4

D280A103

Feb 09/2009

31-52-65

Page 4

Feb 09/2009

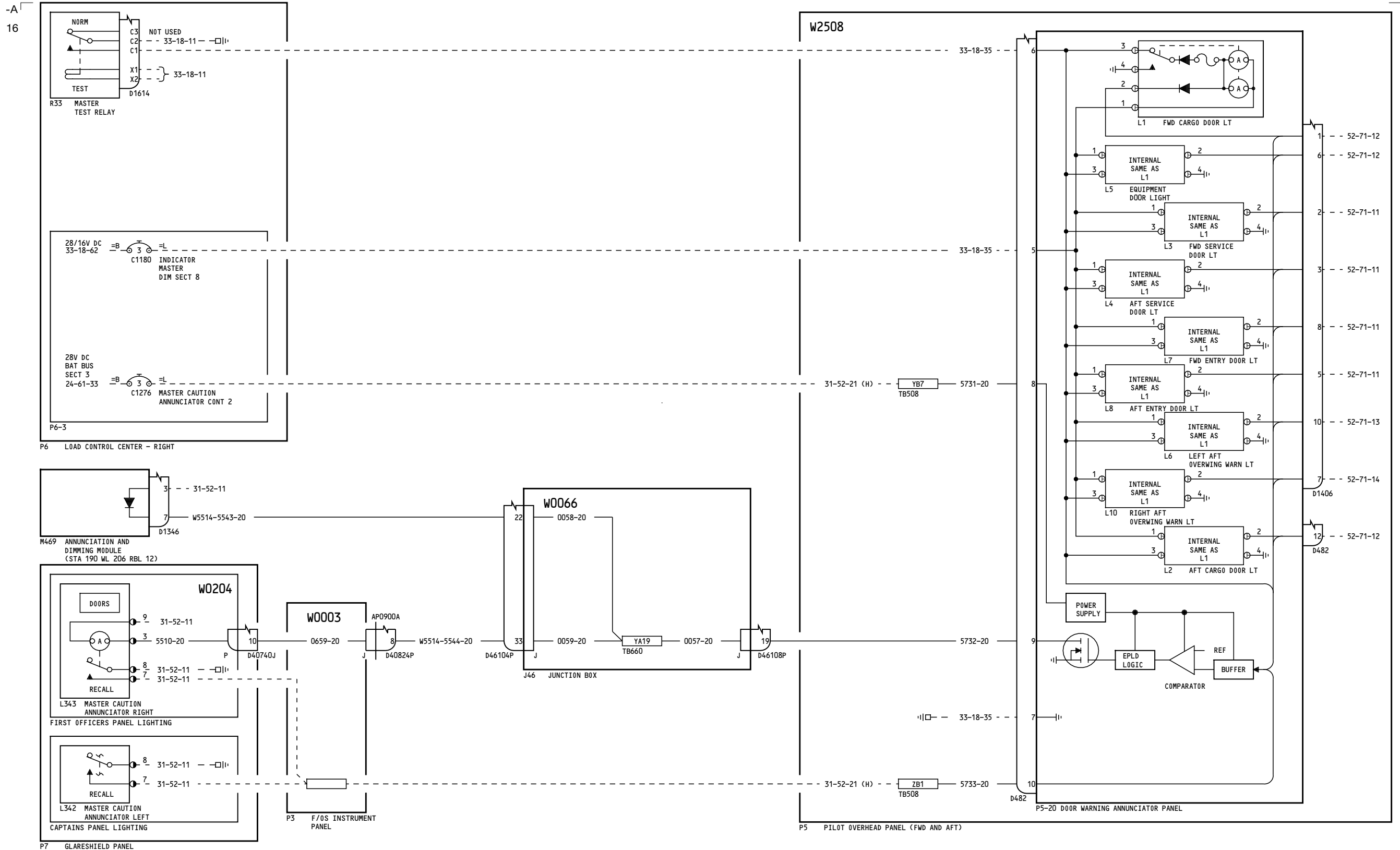

YM643-YM670

MASTER CAUTION SYSTEM - DOOR WARNING

31-52-65

Page 5

D280A103

Jan 14/2008

31-52-65

Page 5

Jan 14/2008

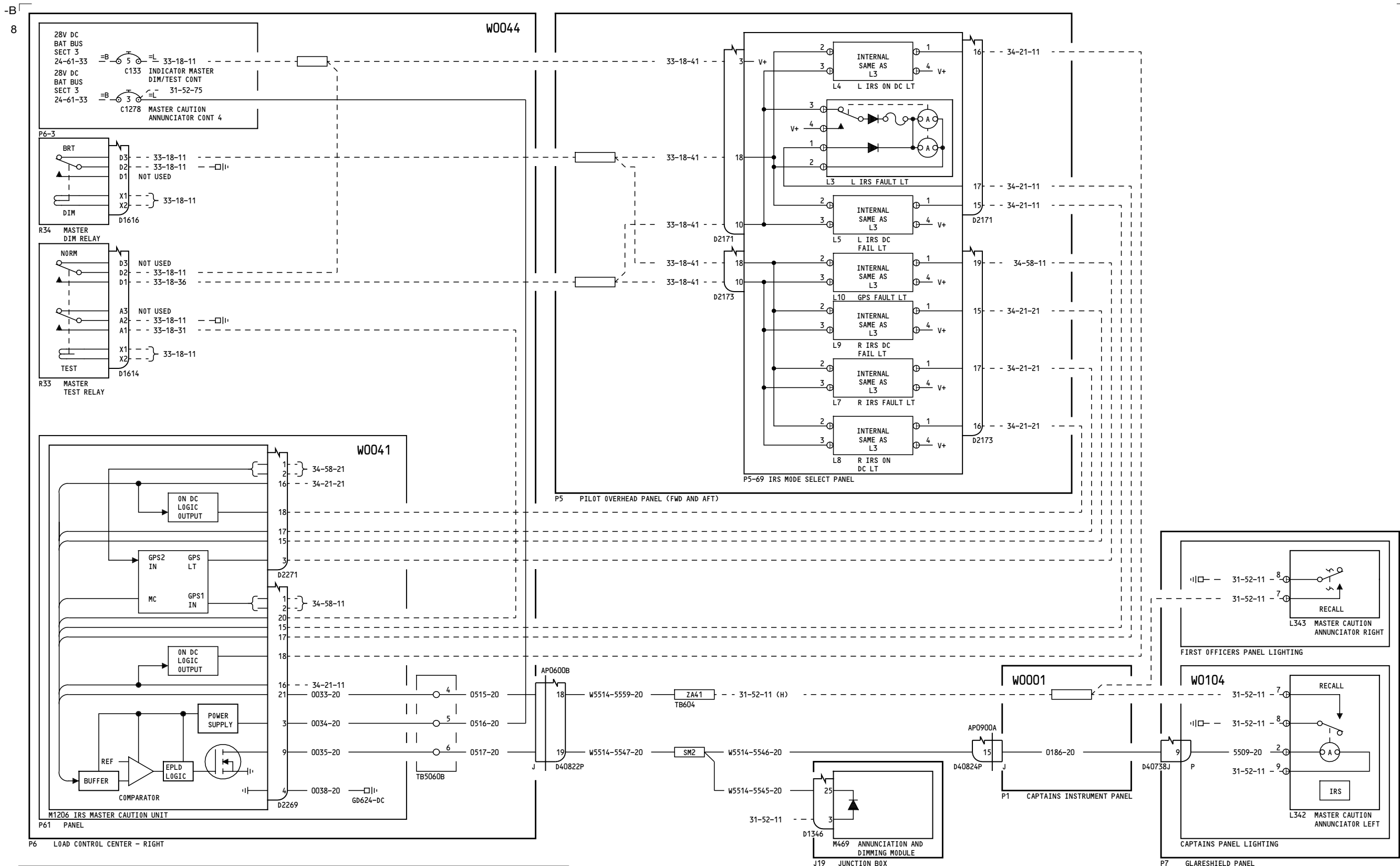

YC001-YC003

MASTER CAUTION SYSTEM - IRS CONTROL

31-52-71

Page 1

D280A103

Mar 31/2005

31-52-71

Page 1

Mar 31/2005

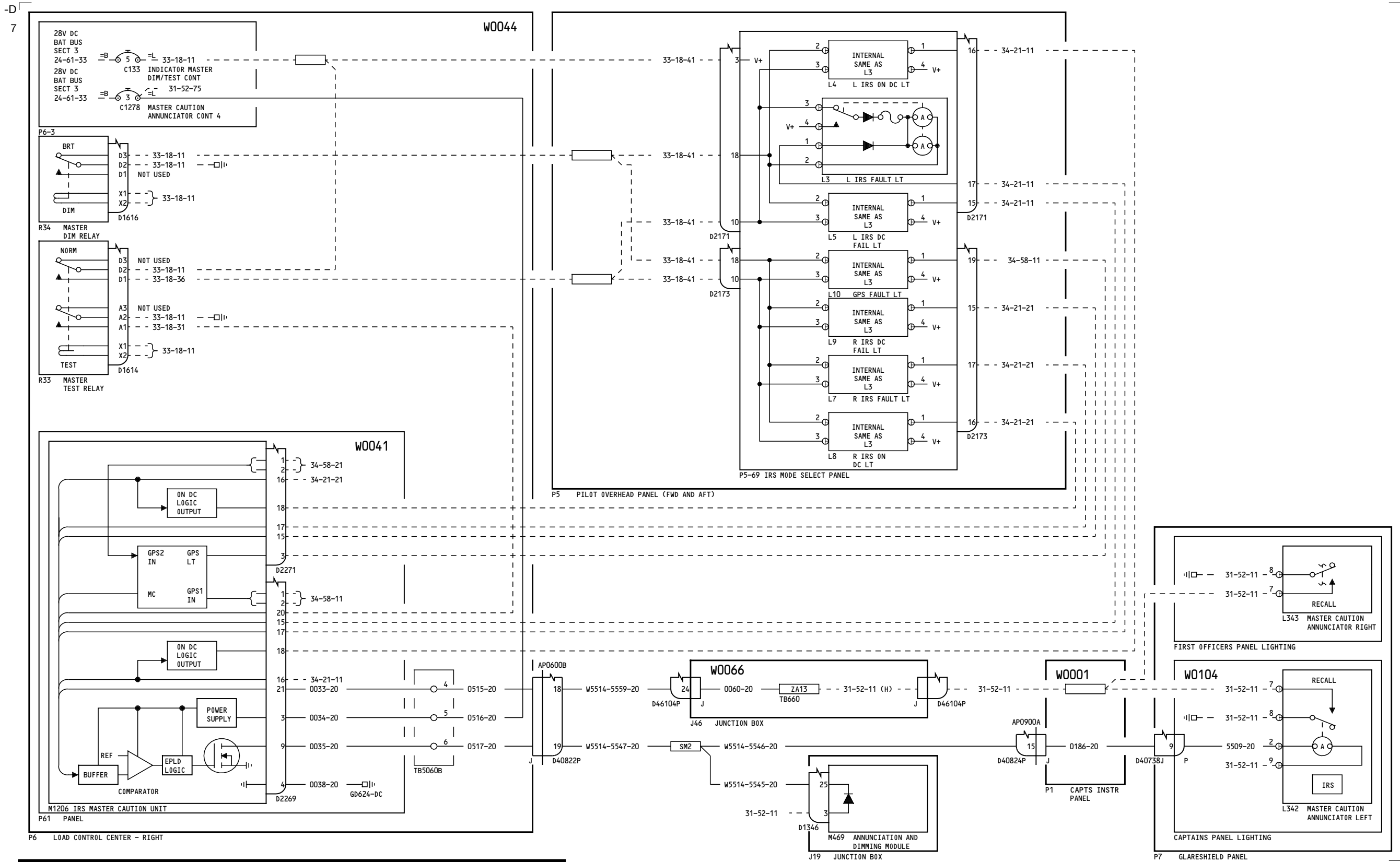

YC004-YC030

MASTER CAUTION SYSTEM - IRS CONTROL

31-52-71

Page 2

D280A103

Jul 17/2007

31-52-71

Page 2

Jul 17/2007

-A
14

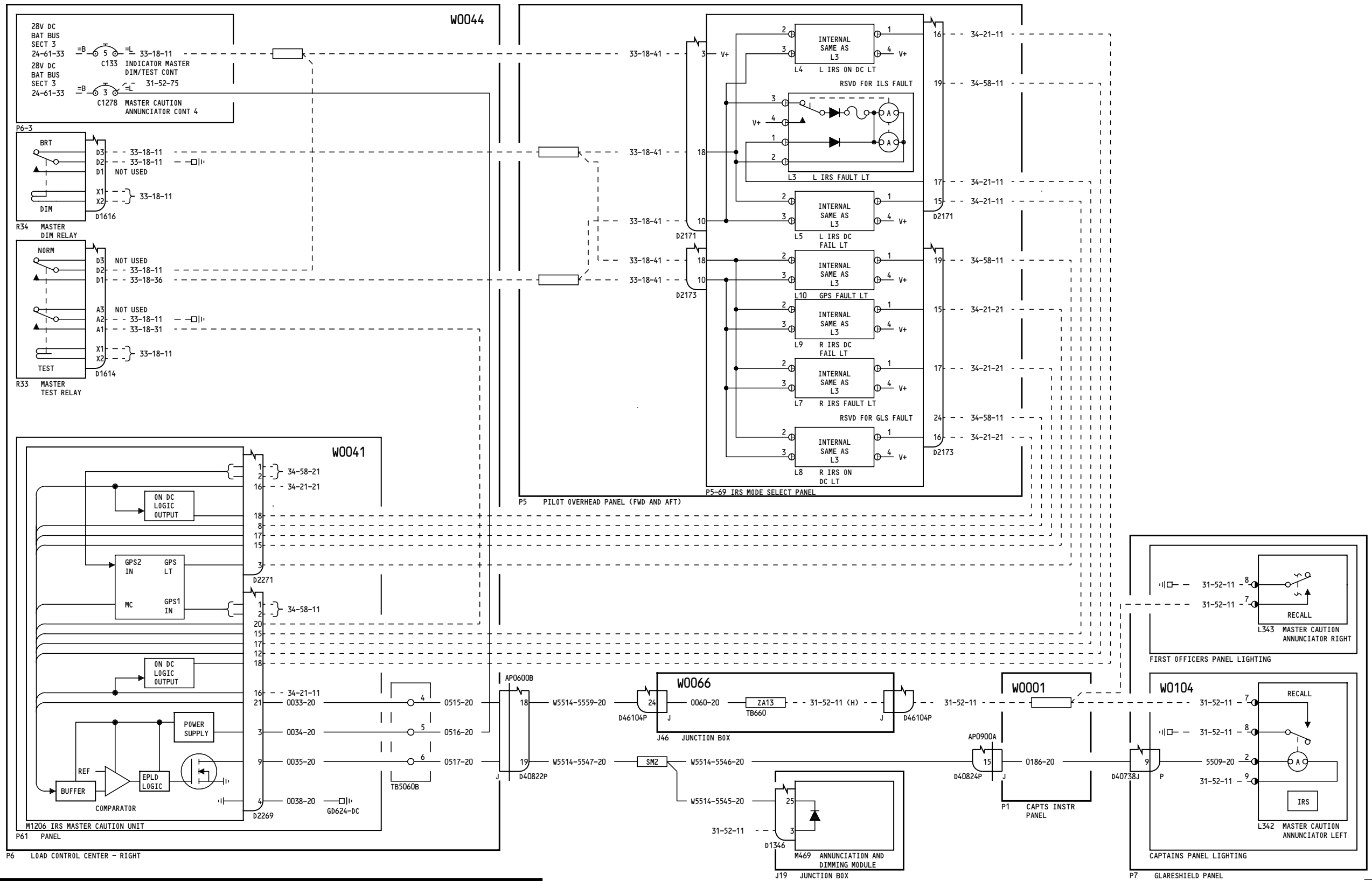

YK901-YK906

**MASTER CAUTION SYSTEM -
IRS CONTROL**

D280A103

31-52-71

Page 3

Jan 18/2007

31-52-71

Page 3

Jan 18/2007

-A
16

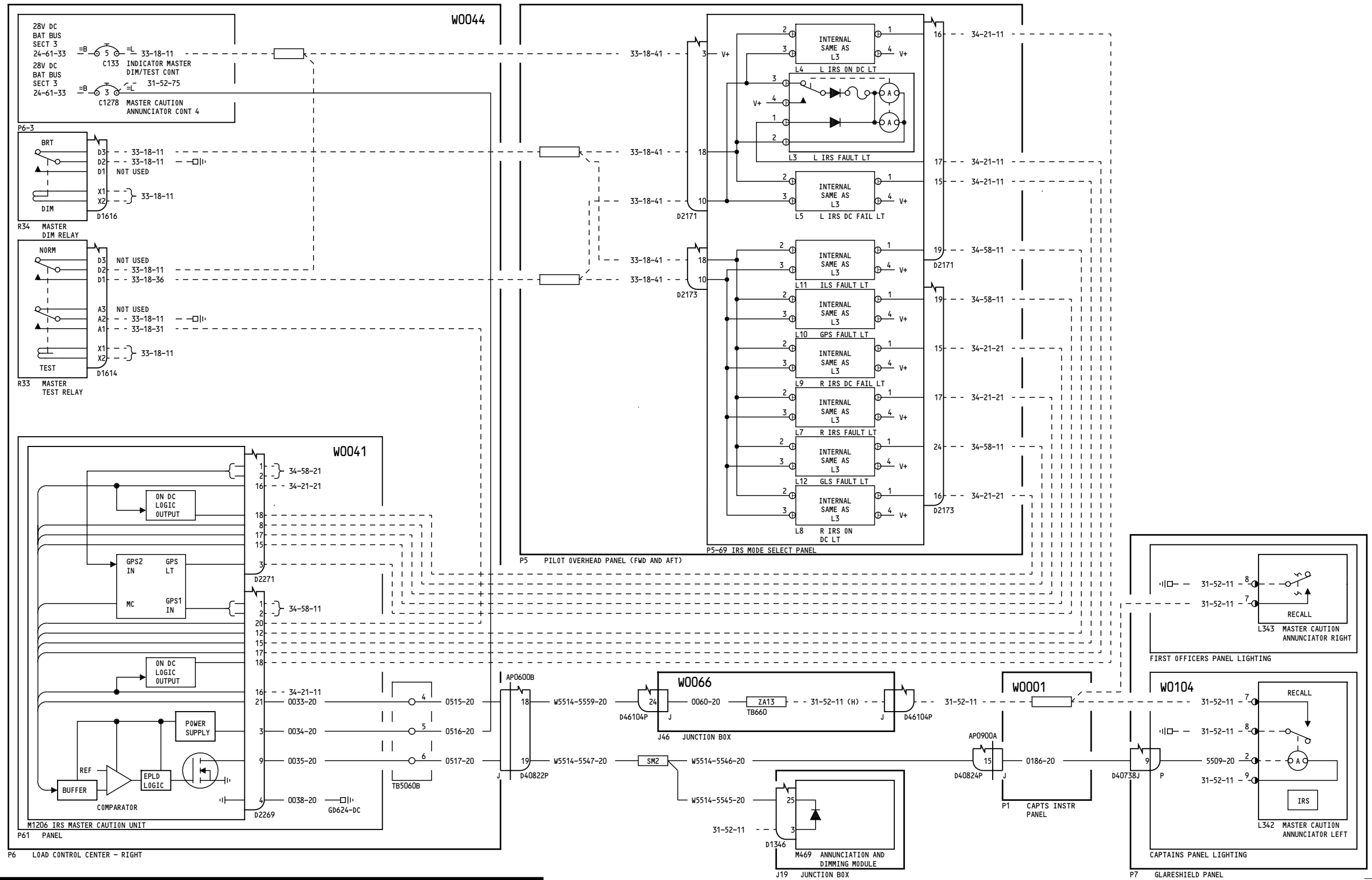

YK907-YM670

**MASTER CAUTION SYSTEM -
IRS CONTROL**

31-52-71

Page 4

Feb 09/2009

D280A103

31-52-71

Page 4

Feb 09/2009

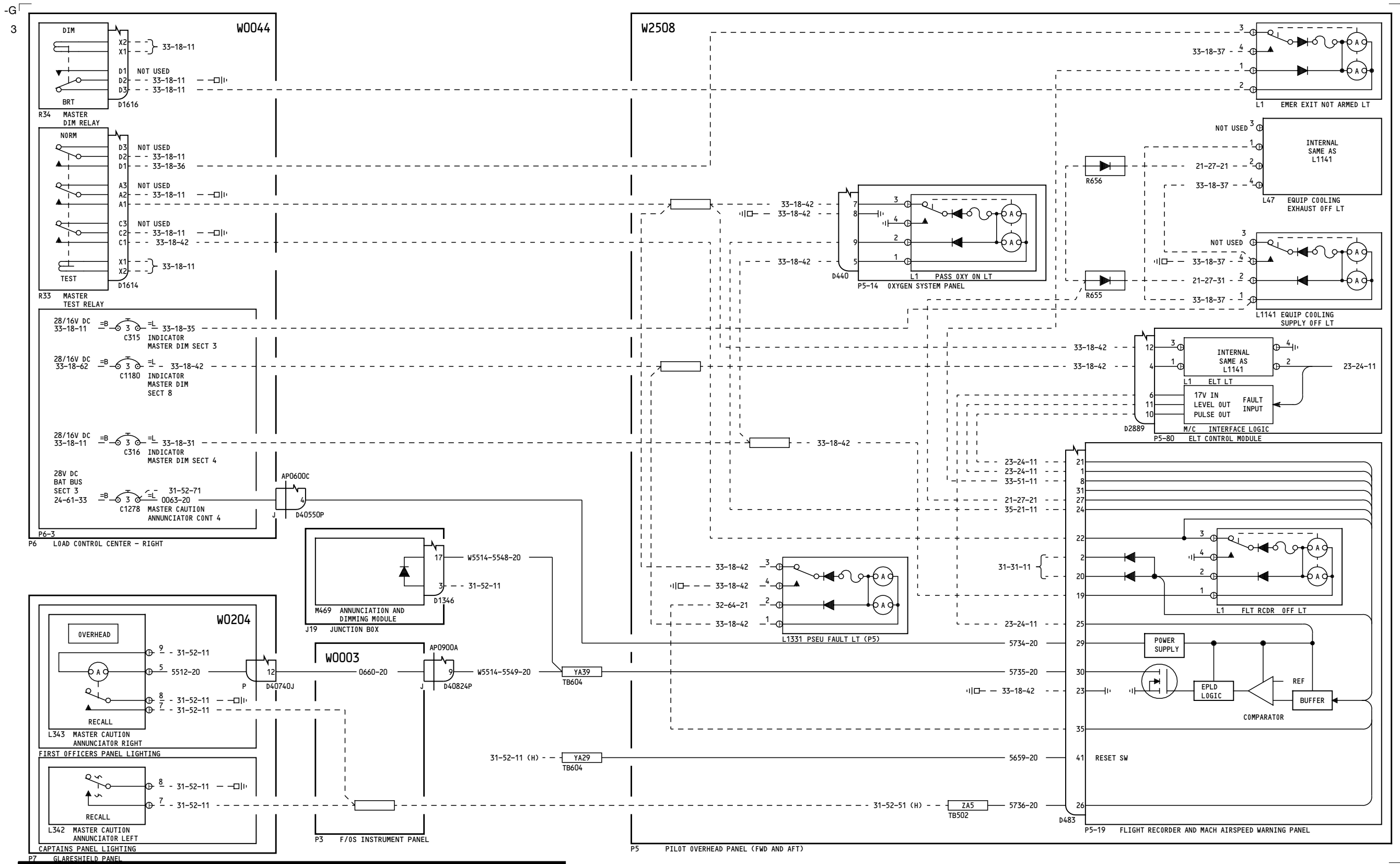

YC001-YC003

MASTER CAUTION SYSTEM - OVERHEAD CONTROL

D280A103

BOEING PROPRIETARY - Copyright © - Unpublished Work - See title page for details.

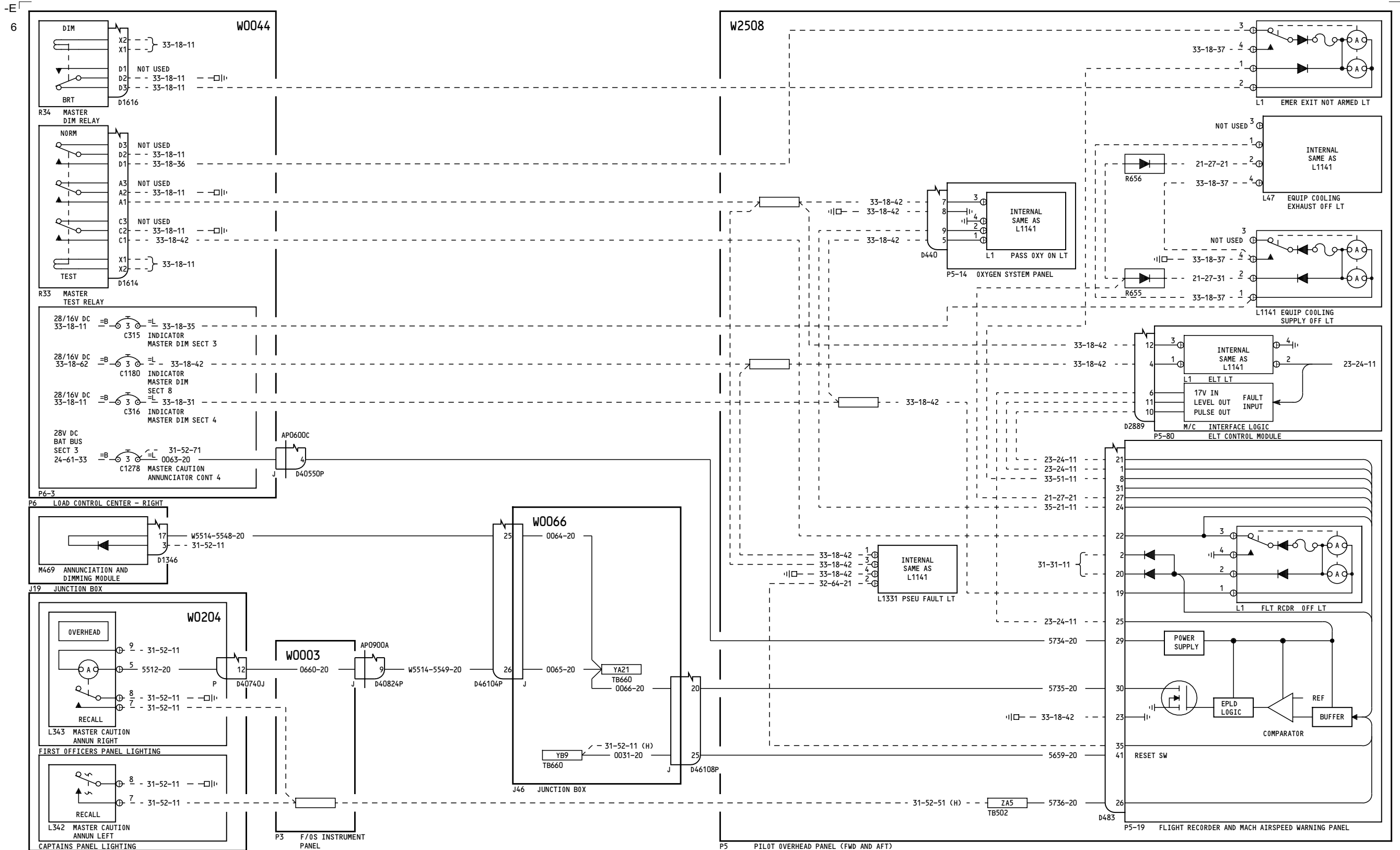

YC004-YC007

MASTER CAUTION SYSTEM - OVERHEAD CONTROL

31-52-75

D280A103

31-52-75

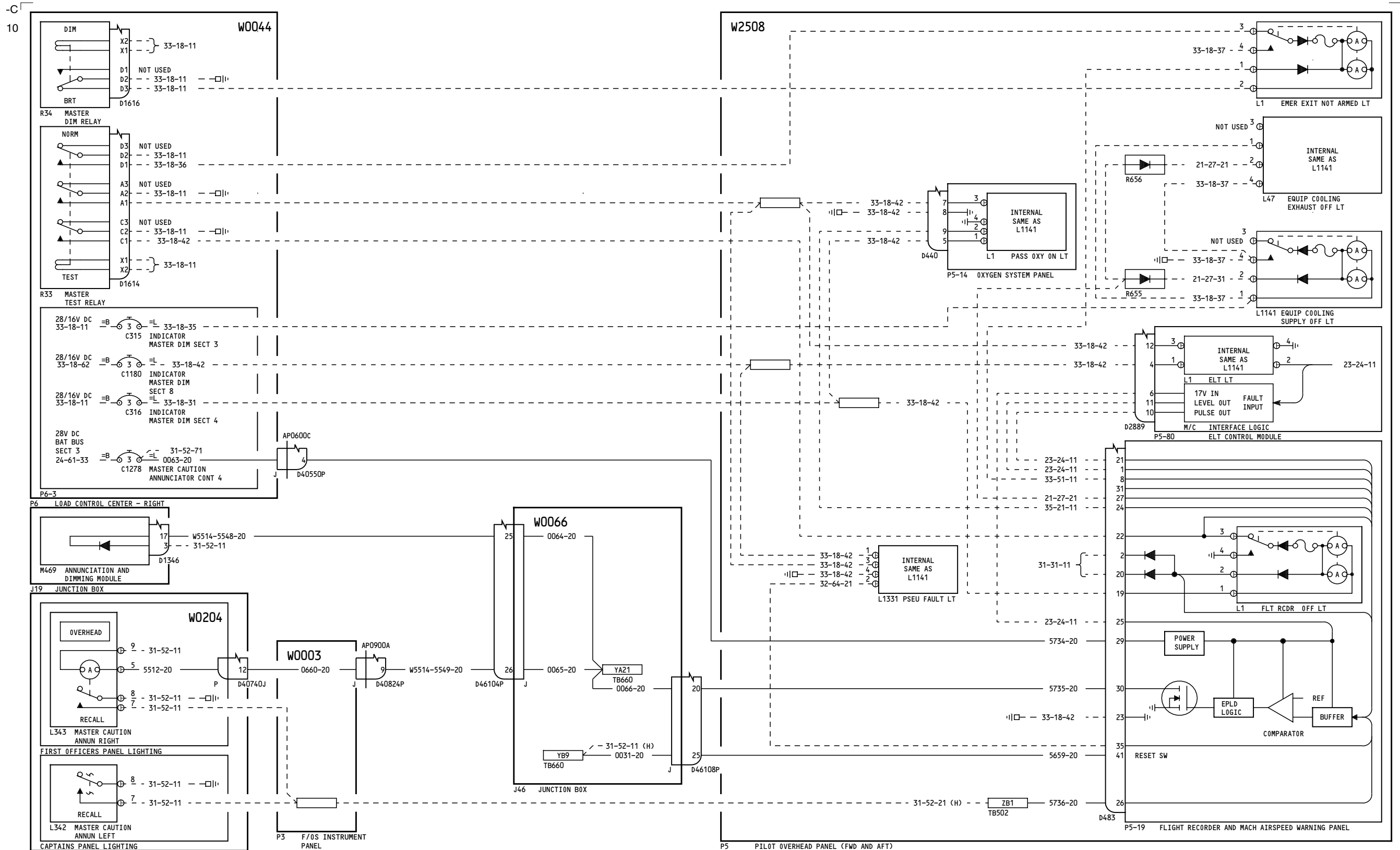

YC008-YC030

MASTER CAUTION SYSTEM - OVERHEAD CONTROL

31-52-75

Page 3

D280A103

Jul 17/2007

31-52-75

Page 3

Jul 17/2007

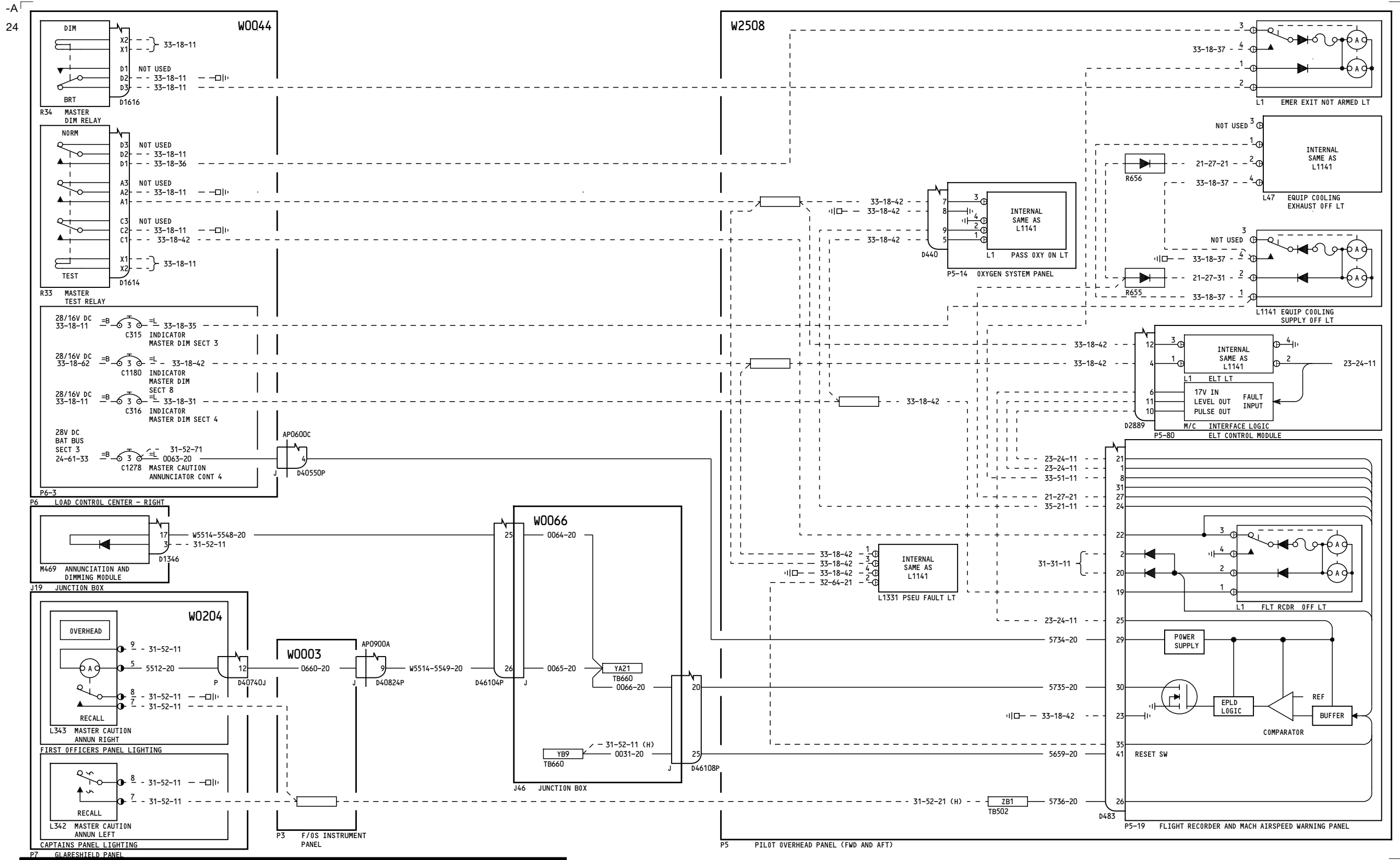

YC031-YM670

MASTER CAUTION SYSTEM - OVERHEAD CONTROL

31-52-75

Page 4

Feb 09/2009

D280A103

31-52-75

Page 4

Feb 09/2009

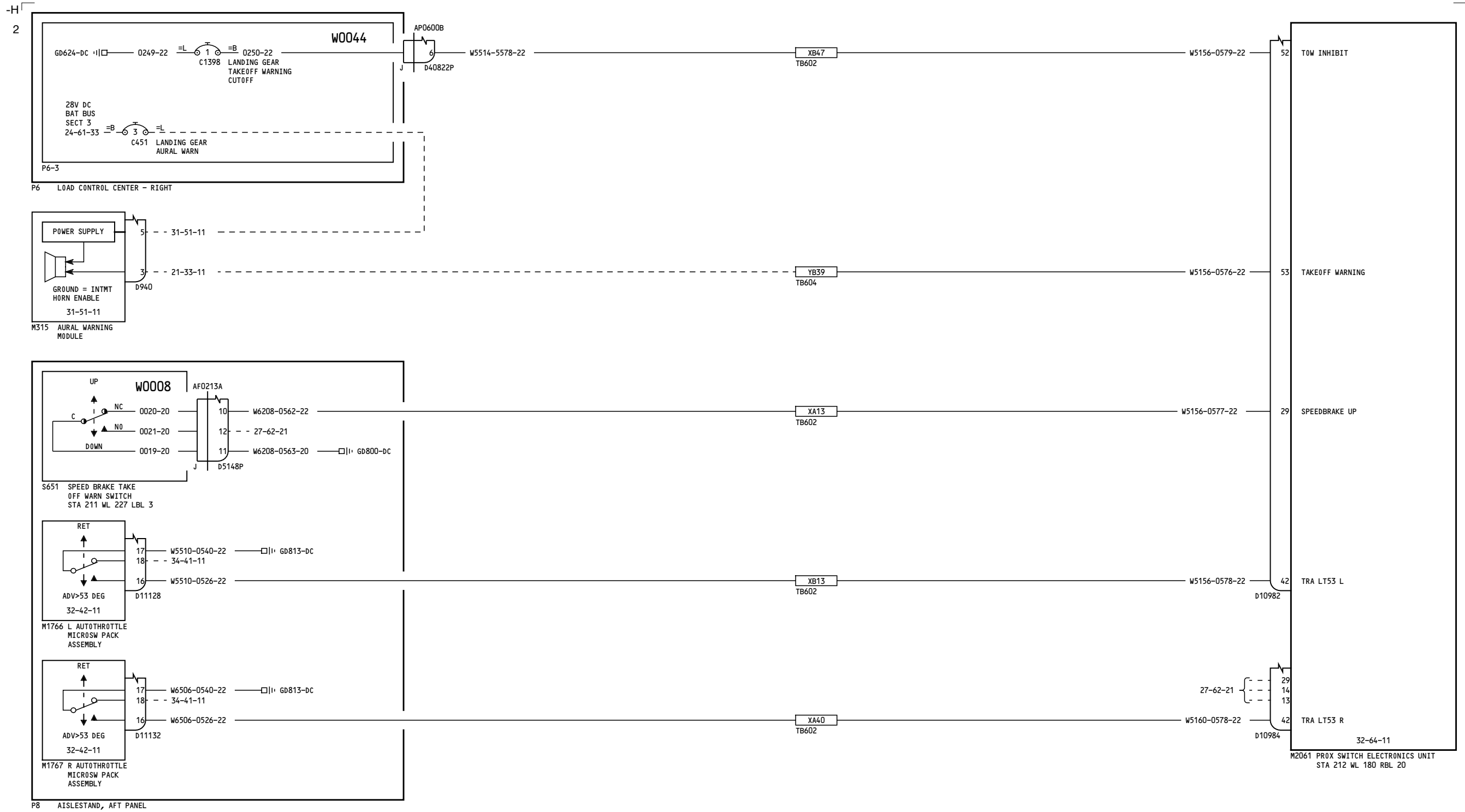

YC001-YC003

**AURAL WARNING -
TAKEOFF WARNING**

31-53-11

Page 1
Sheet 1
Mar 31/2005

D280A103

31-53-11

Page 1
Sheet 1
Mar 31/2005

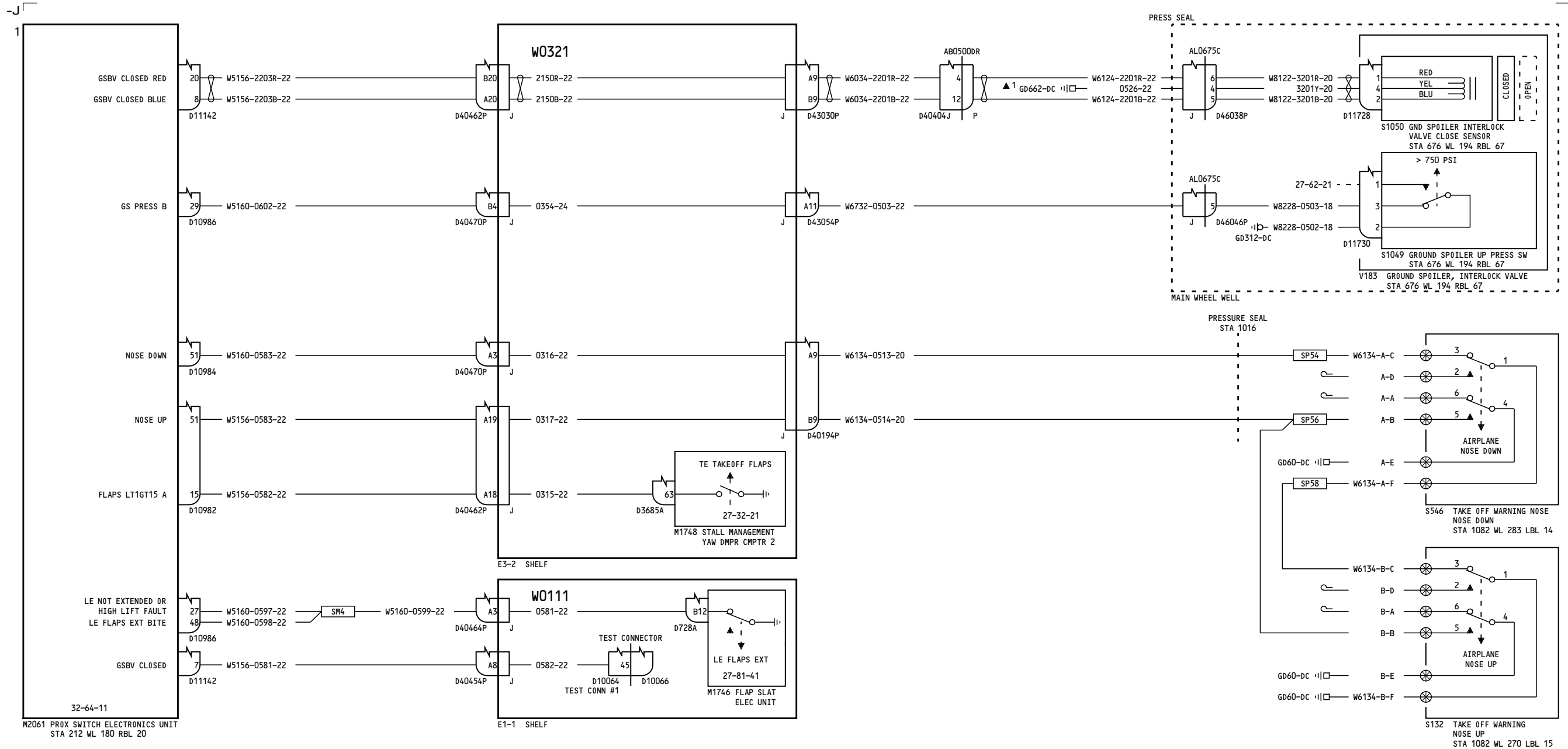

YC001-YC003

AURAL WARNING - TAKEOFF WARNING

31-53-11

Page 1
Sheet 2
May 11/2009

D280A103

31-53-11

Page 1
Sheet 2
May 11/2009

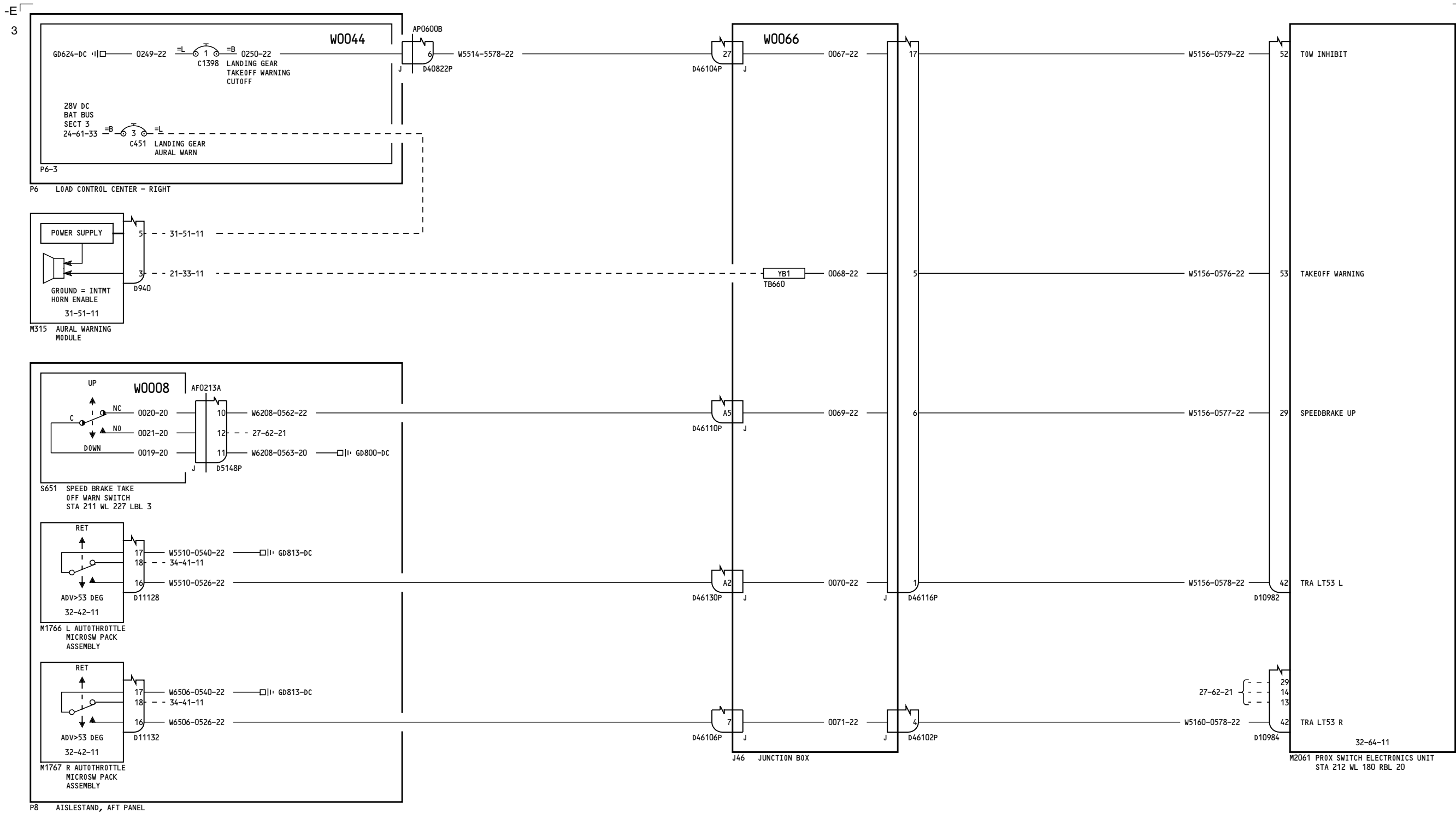

YC004-YC007

**AURAL WARNING -
TAKEOFF WARNING**

D280A103

31-53-11

Page 2
Sheet 1
Mar 31/2005

31-53-11

Page 2
Sheet 1
Mar 31/2005

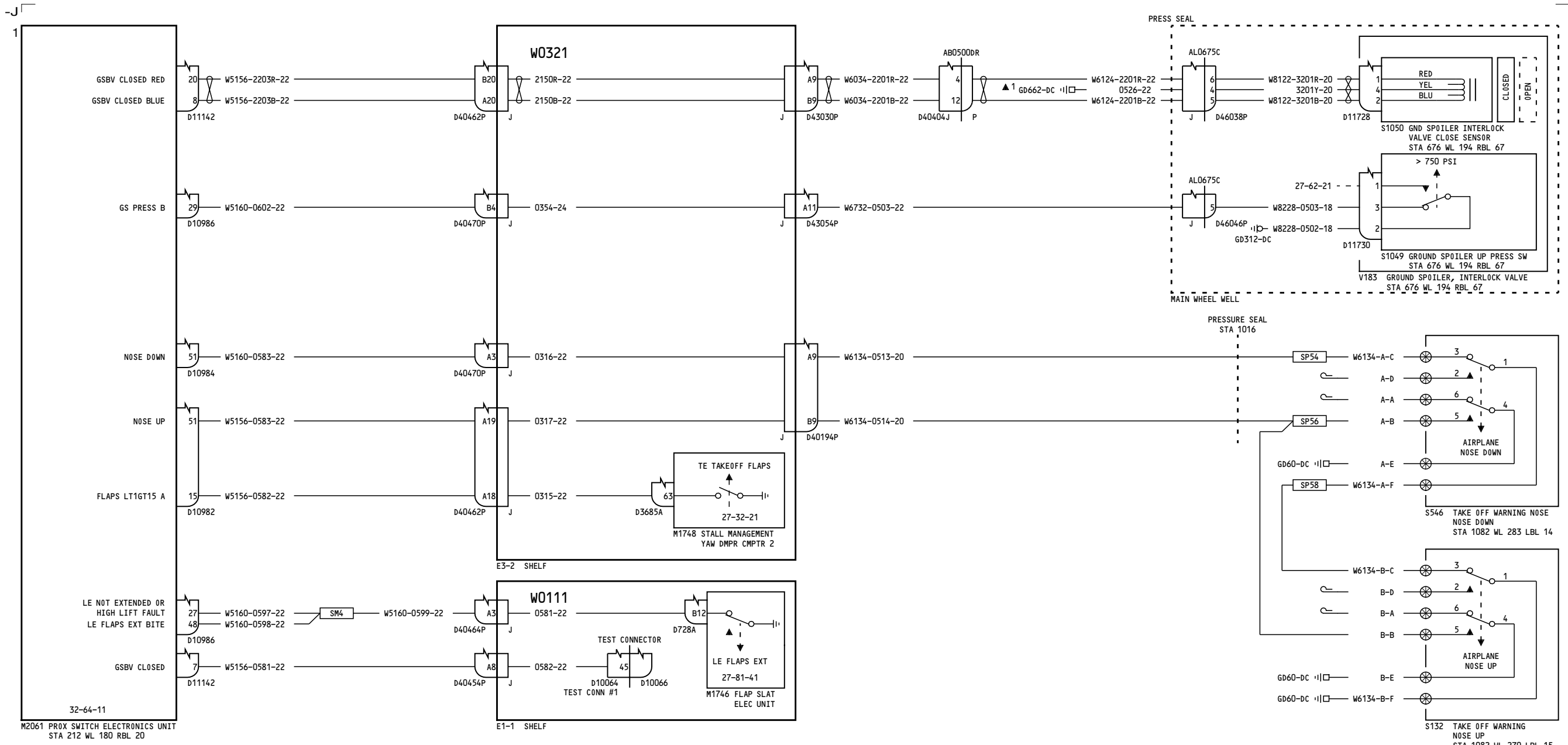

YC004-YC007

AURAL WARNING - TAKEOFF WARNING

31-53-11

Page 2
Sheet 2
May 11/2009

D280A103

31-53-11

Page 2
Sheet 2
May 11/2009

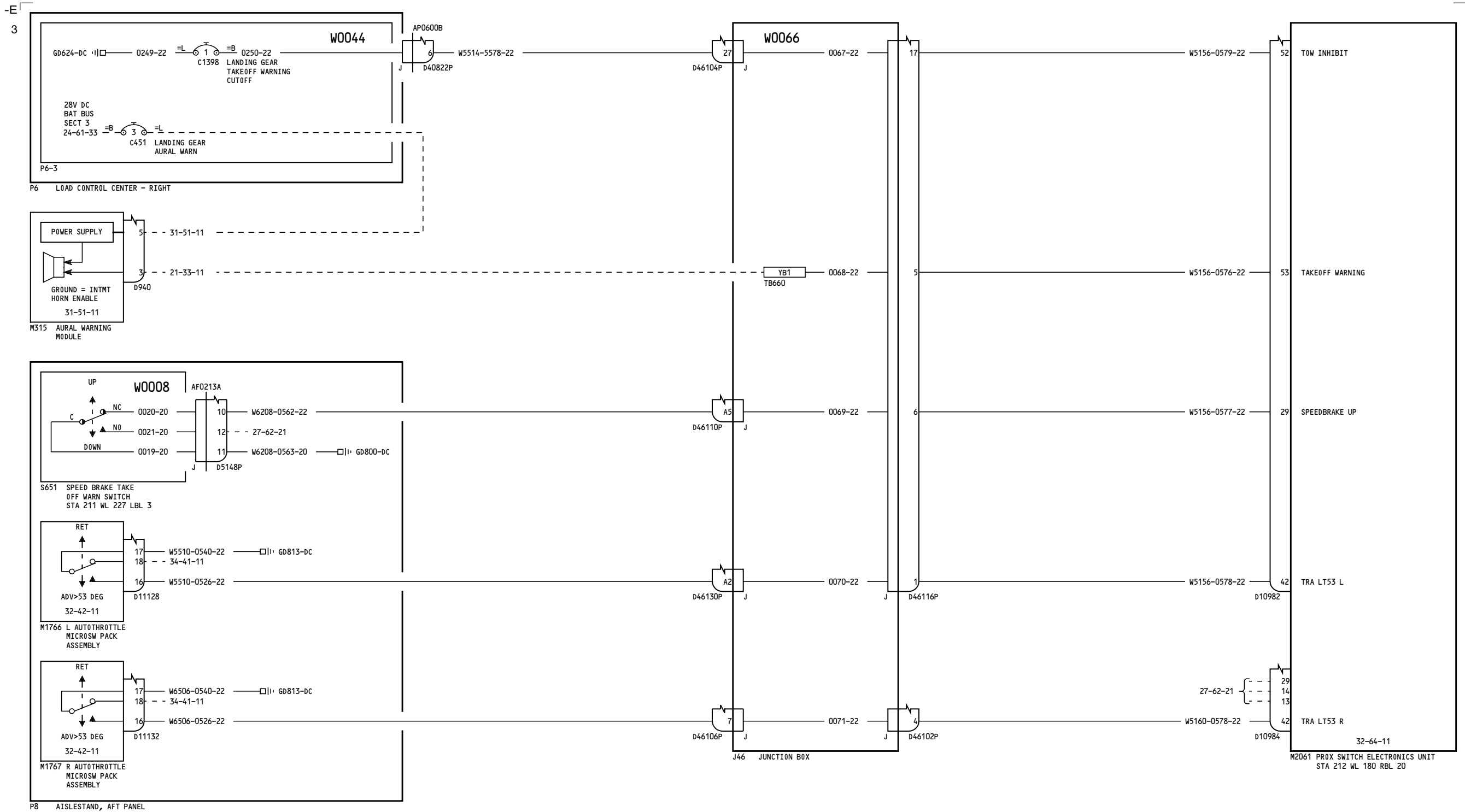

YC008-YC030

**AURAL WARNING -
TAKEOFF WARNING**

31-53-11

Page 3
Sheet 1
Jul 17/2007

D280A103

31-53-11

Page 3
Sheet 1
Jul 17/2007

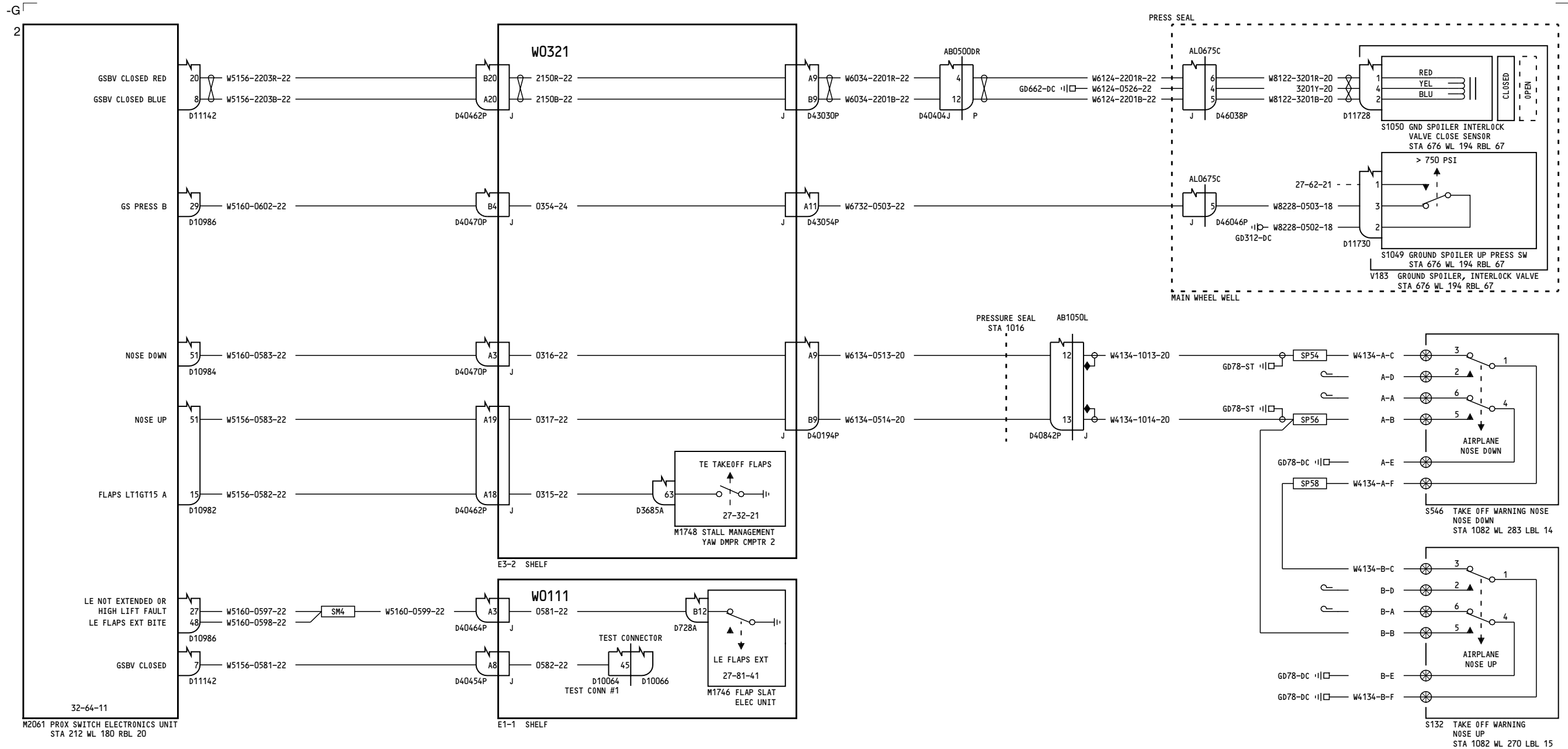

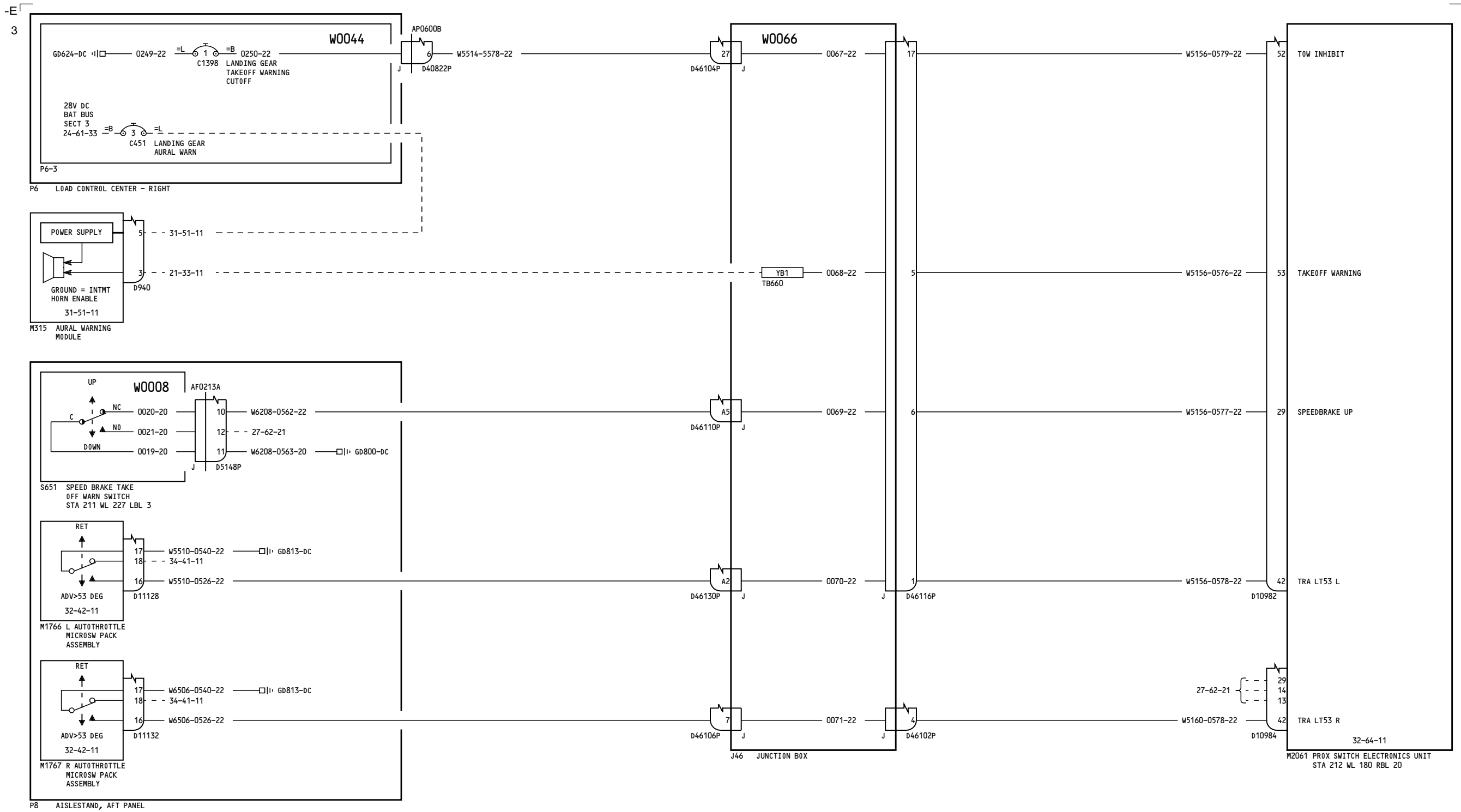

YC031-YK910, YL421-YL423

**AURAL WARNING -
TAKEOFF WARNING**

D280A103

31-53-11

Page 4
Sheet 1
May 11/2009

31-53-11

Page 4
Sheet 1
May 11/2009

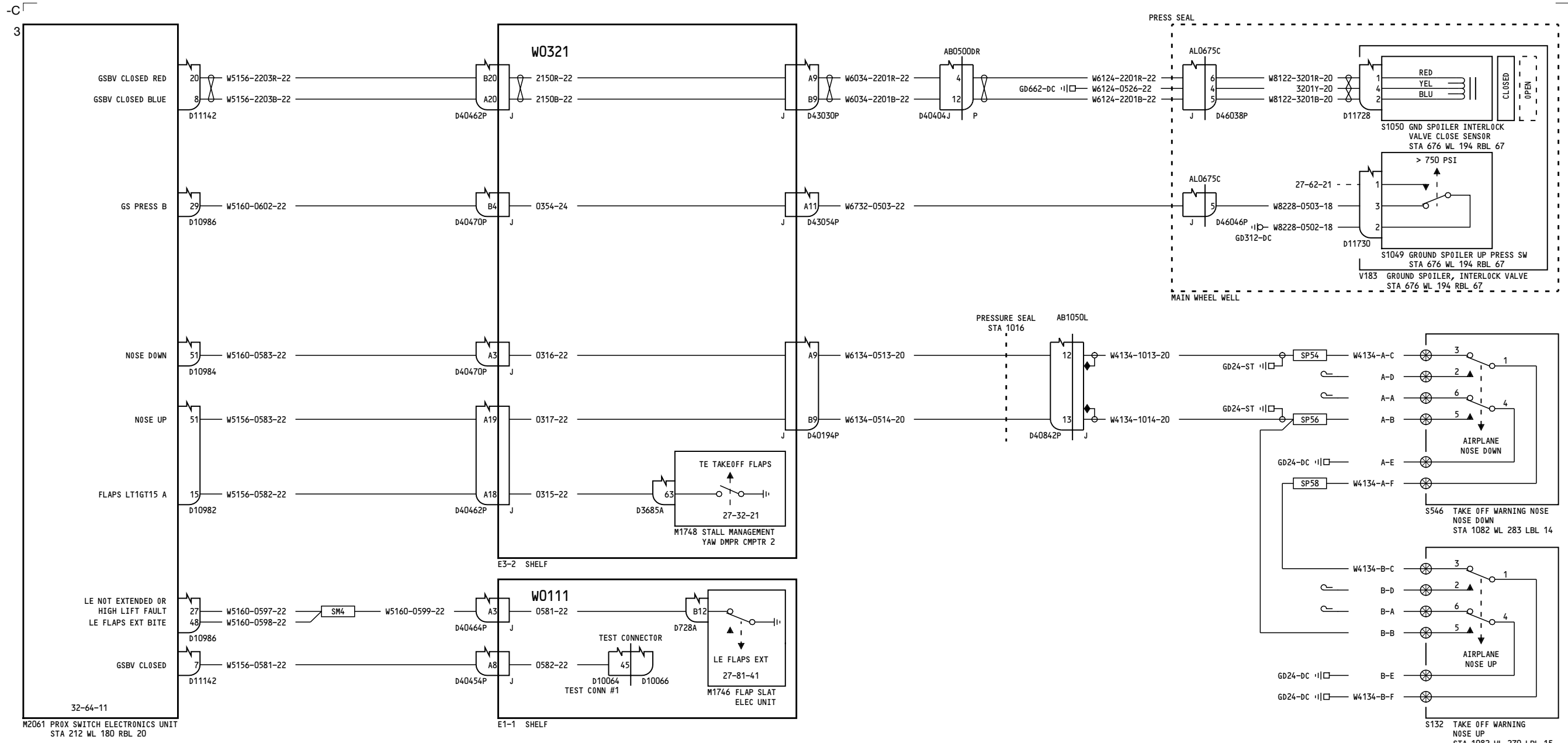

YC031-YK910, YL421-YL423

AURAL WARNING - TAKEOFF WARNING

31-53-11

Page 4
Sheet 2
May 11/2009

D280A103

31-53-11

Page 4
Sheet 2
May 11/2009

23

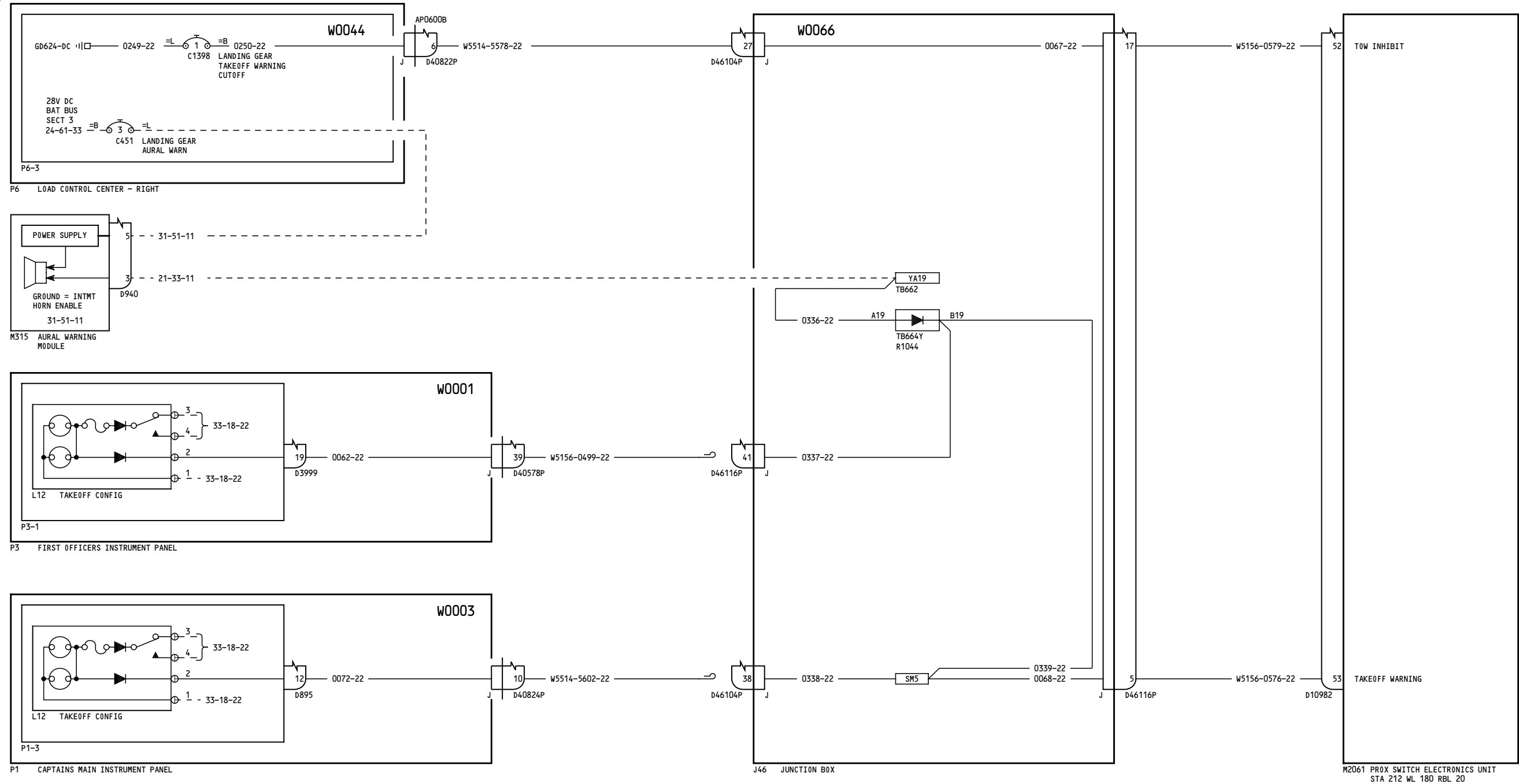

YK911

**AURAL WARNING -
TAKEOFF WARNING**

31-53-11

D280A103

31-53-11

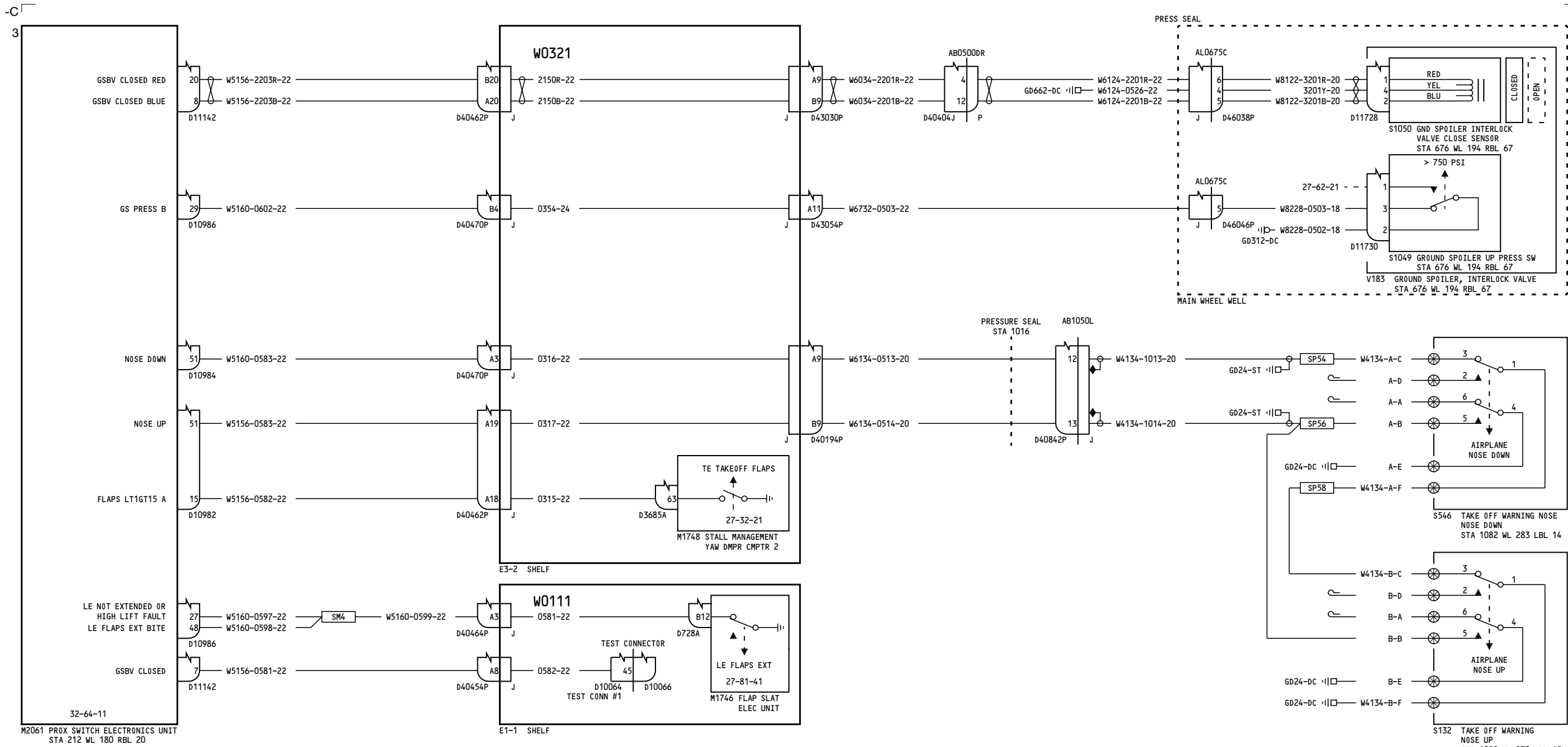

YK911

**AURAL WARNING -
TAKEOFF WARNING**

D280A103

31-53-11

Page 5
Sheet 2
May 11/2009

31-53-11

Page 5
Sheet 2
May 11/2009

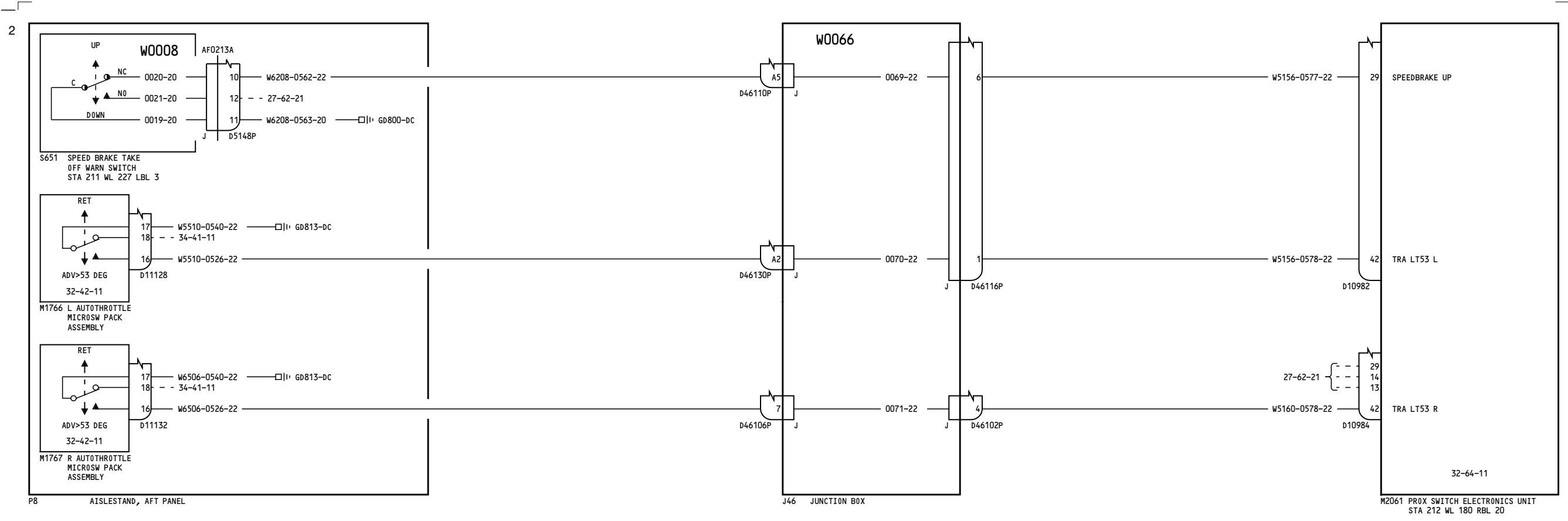

YK911

**AURAL WARNING -
TAKEOFF WARNING**

D280A103

31-53-11

Page 5
Sheet 3
May 11/2009

31-53-11

Page 5
Sheet 3
May 11/2009

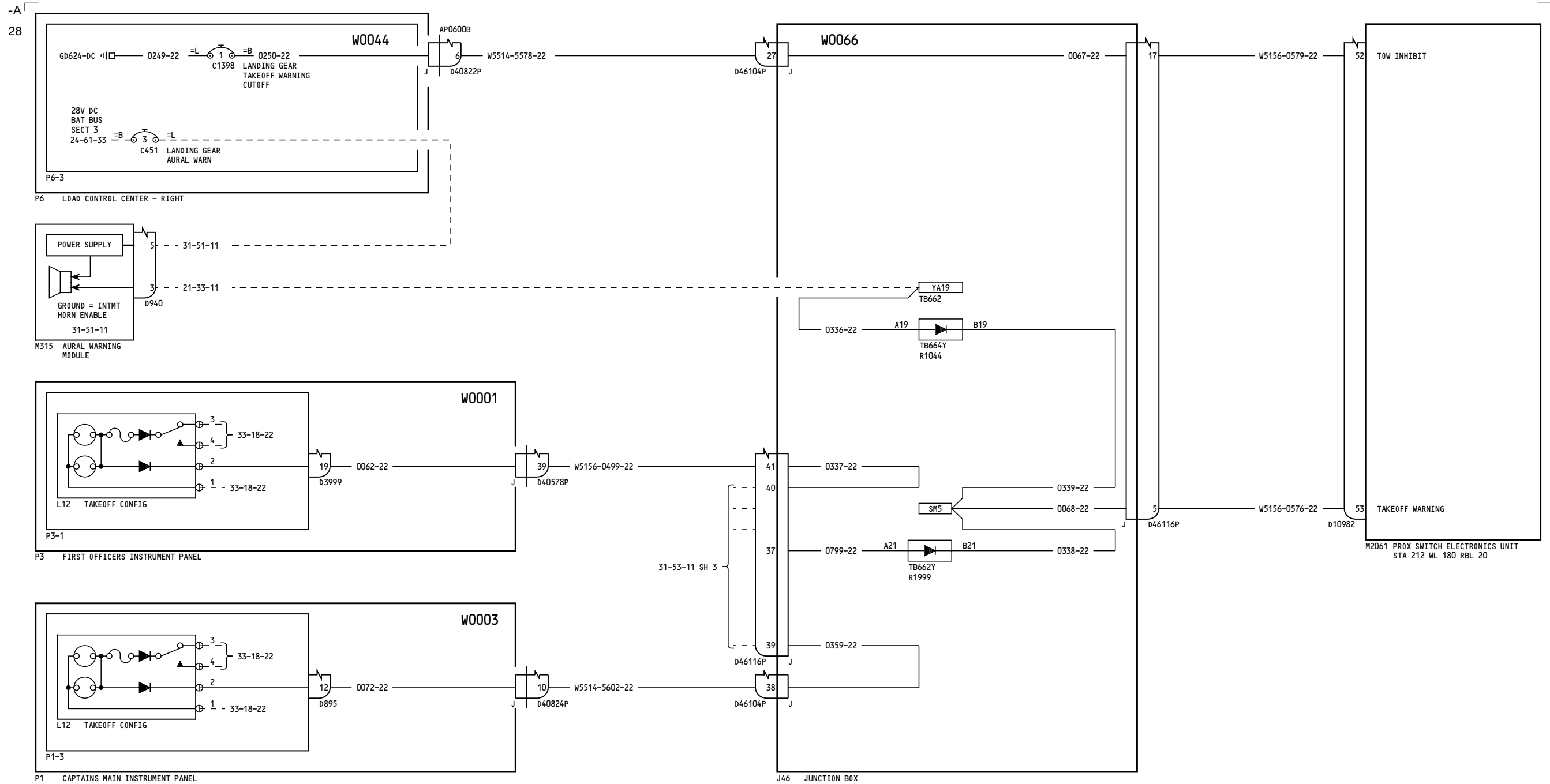

YK912, YK919, YL401, YL427-YL429

**AURAL WARNING -
TAKEOFF WARNING**

D280A103

31-53-11

Page 6
Sheet 1
Aug 10/2009

31-53-11

Page 6
Sheet 1
Aug 10/2009

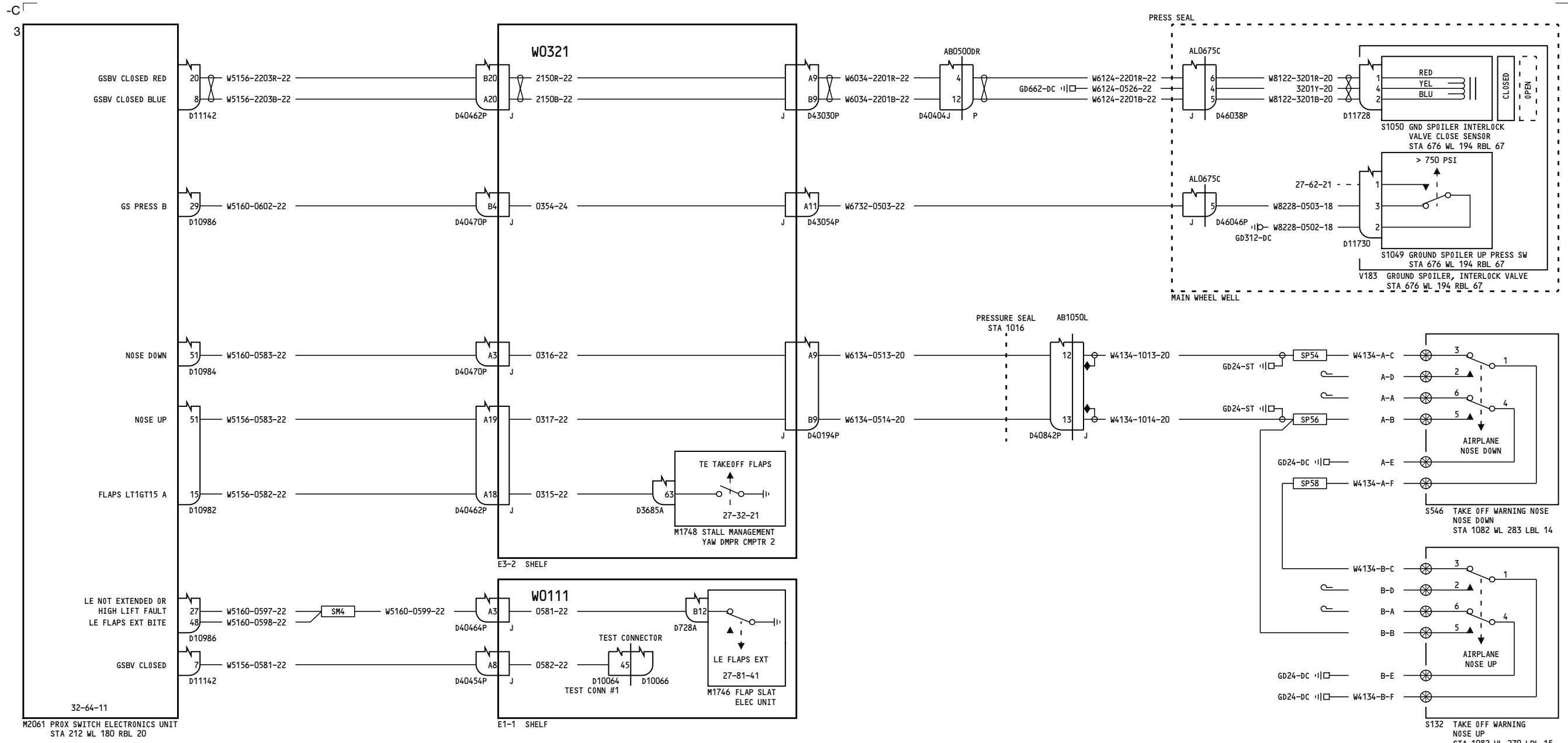

YK912, YK919, YL401, YL427-YL429

AURAL WARNING - TAKEOFF WARNING

31-53-11

Page 6
Sheet 2
Aug 10/2009

D280A103

31-53-11

Page 6
Sheet 2
Aug 10/2009

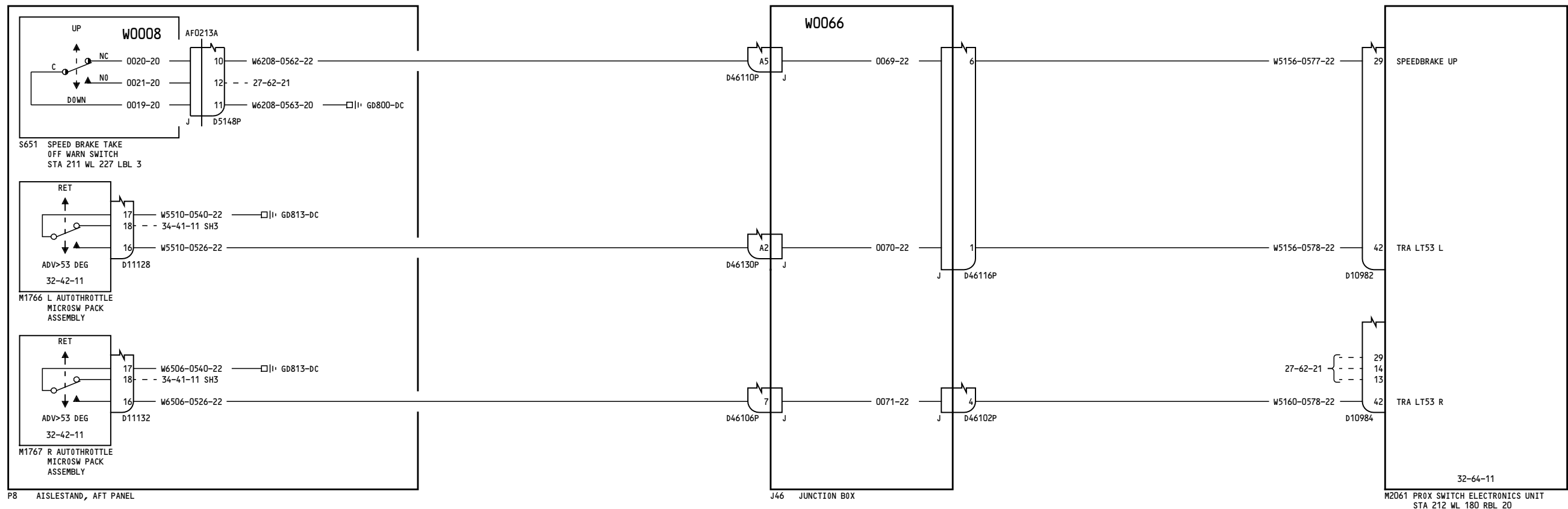
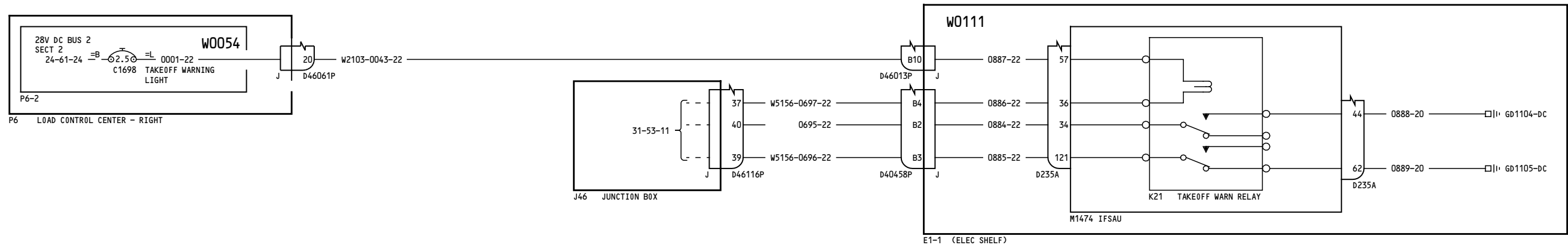

YK912, YK919, YL401, YL427-YL429

AURAL WARNING - TAKEOFF WARNING

31-53-11

Page 6
Sheet 3
Aug 10/2009

D280A103

31-53-11

Page 6
Sheet 3
Aug 10/2009

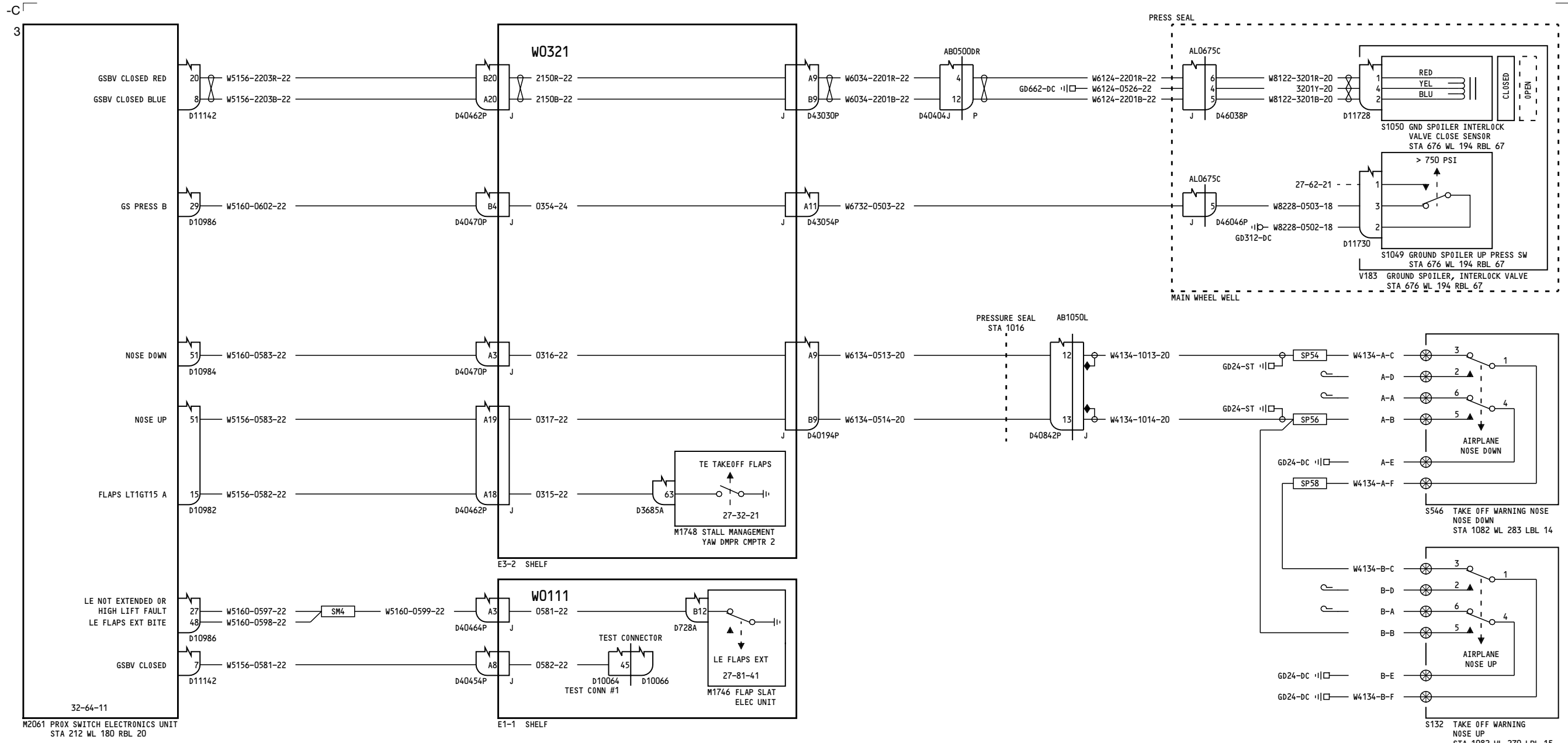

YK918, YL424-YL426

AURAL WARNING - TAKEOFF WARNING

31-53-11

Page 7
Sheet 2
May 11/2009

D280A103

31-53-11

Page 7
Sheet 2
May 11/2009

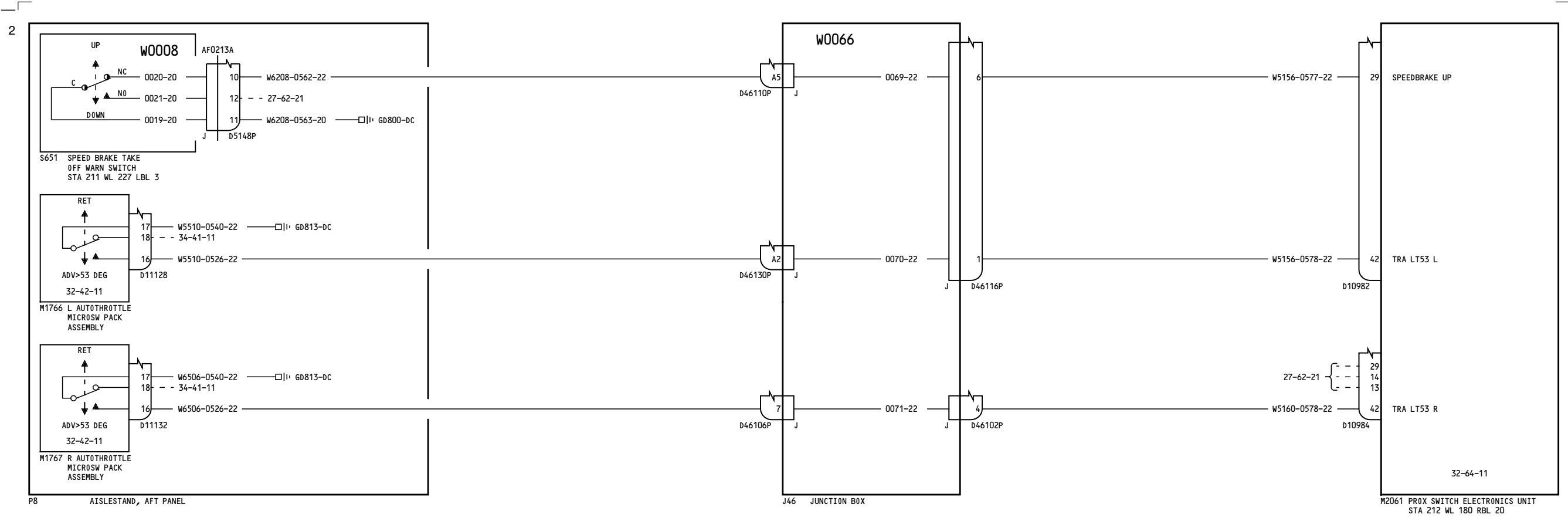

YK918, YL424-YL426

**AURAL WARNING -
TAKEOFF WARNING**

D280A103

31-53-11

Page 7
Sheet 3
May 11/2009

31-53-11

Page 7
Sheet 3
May 11/2009

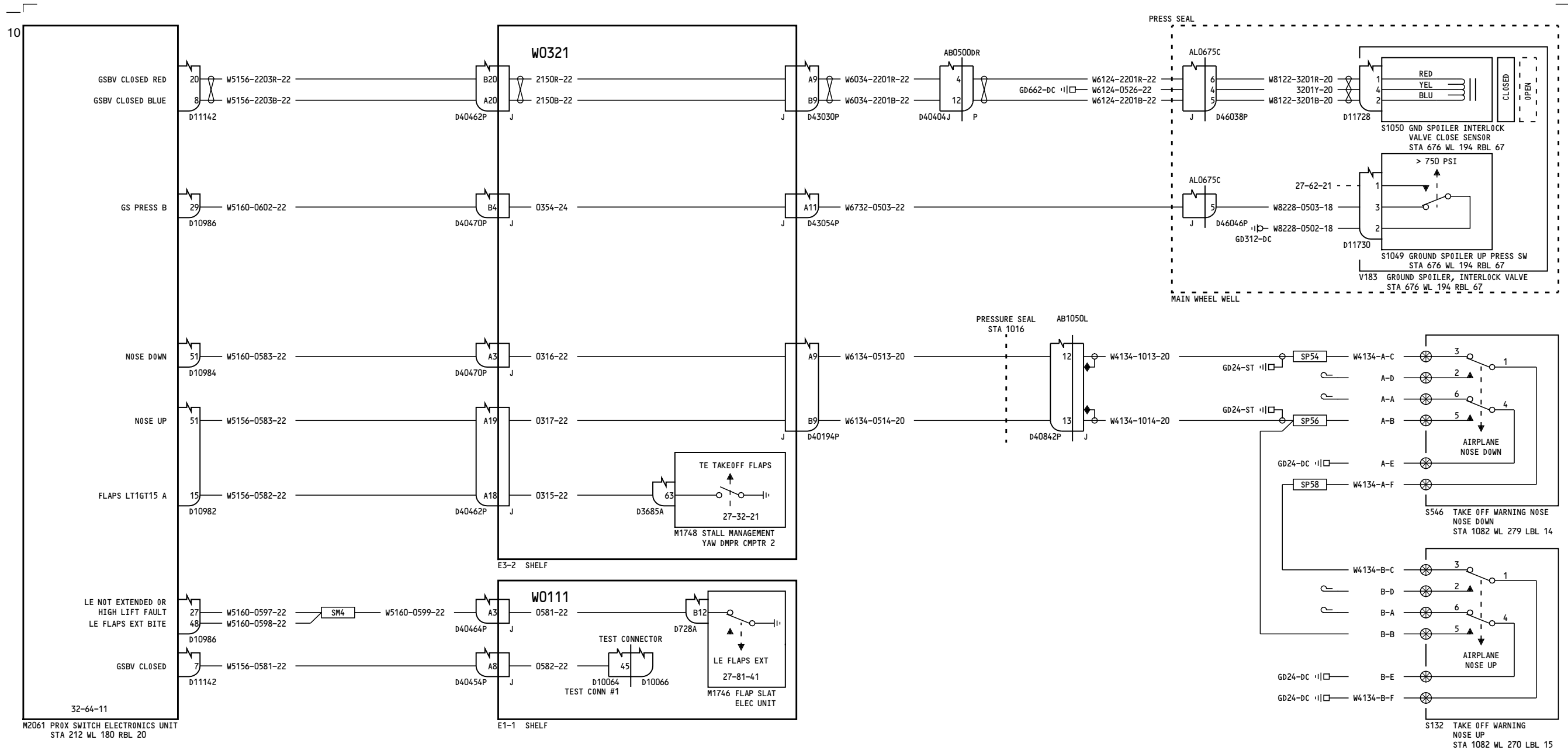

YM643

AURAL WARNING - TAKEOFF WARNING

D280A103

31-53-11

Page 8
Sheet 2
May 11/2009

31-53-11

Page 8
Sheet 2
May 11/2009

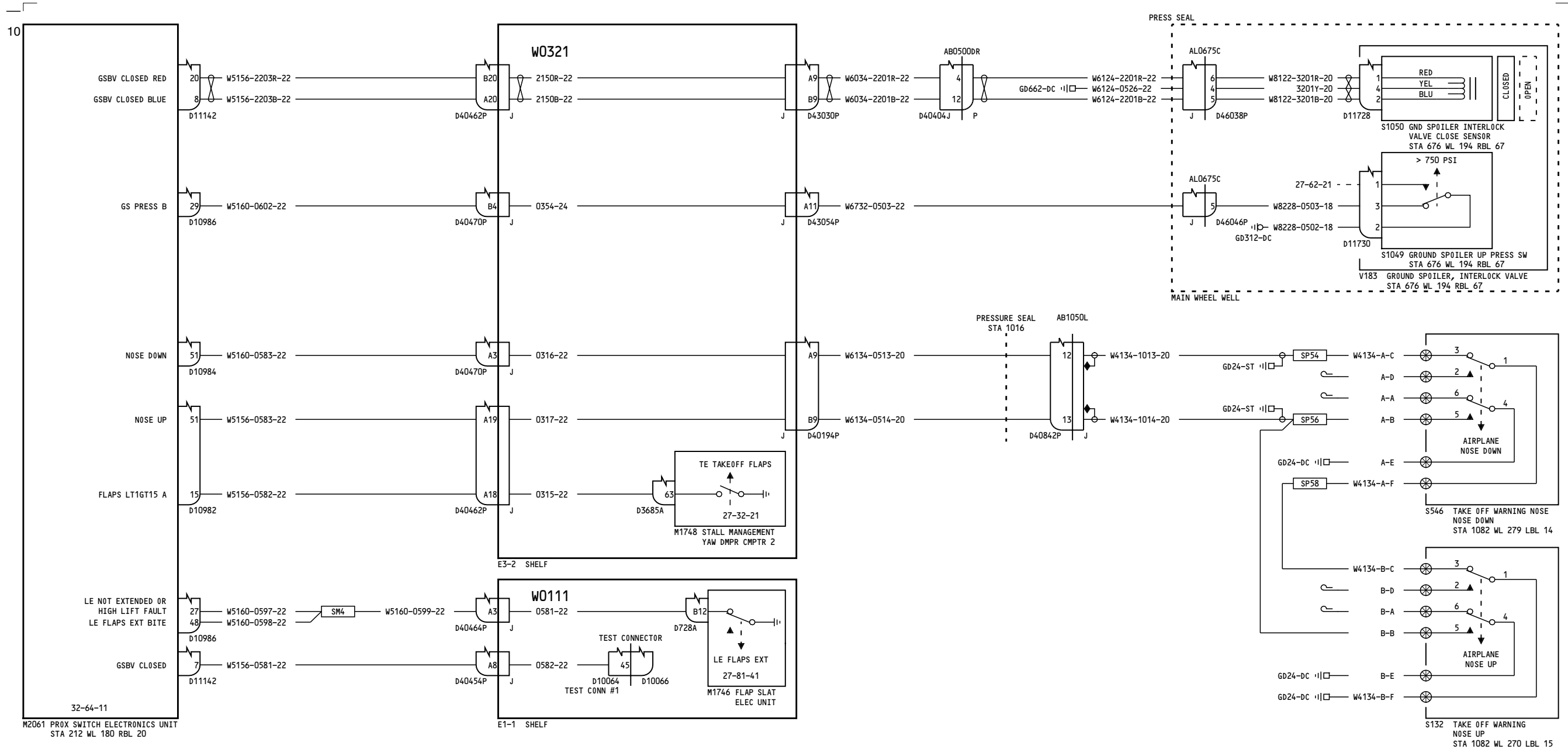

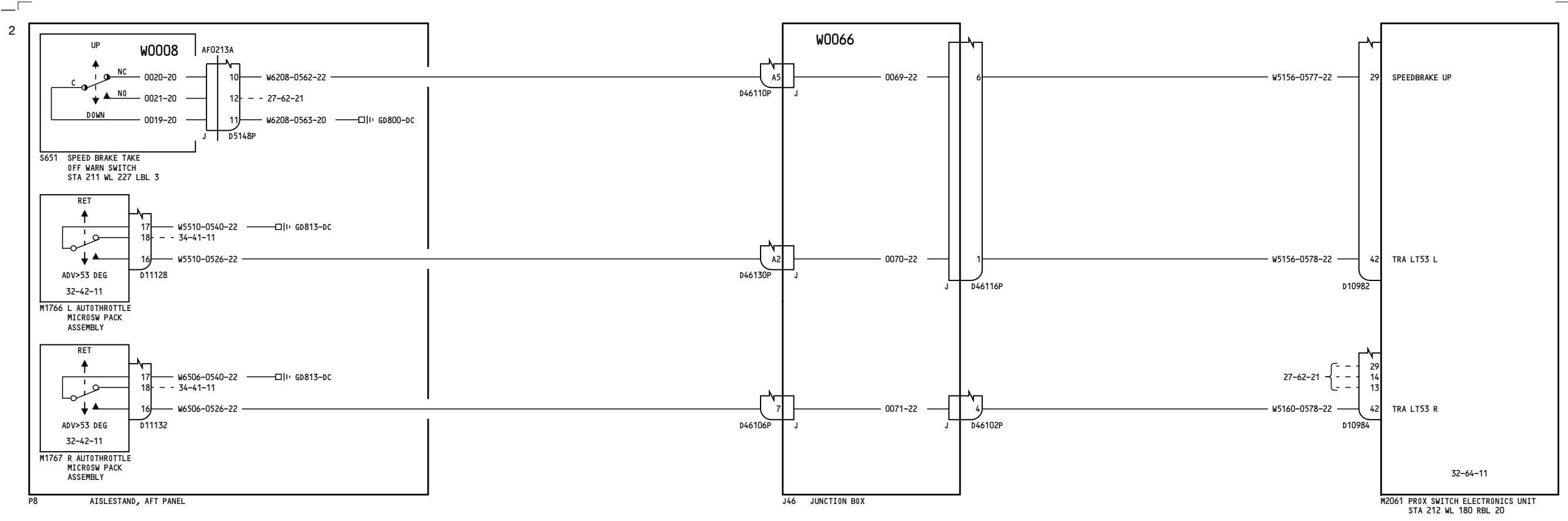

YM645-YM649

**AURAL WARNING -
TAKEOFF WARNING**

D280A103

31-53-11

Page 9
Sheet 3
May 11/2009

31-53-11

Page 9
Sheet 3
May 11/2009

23

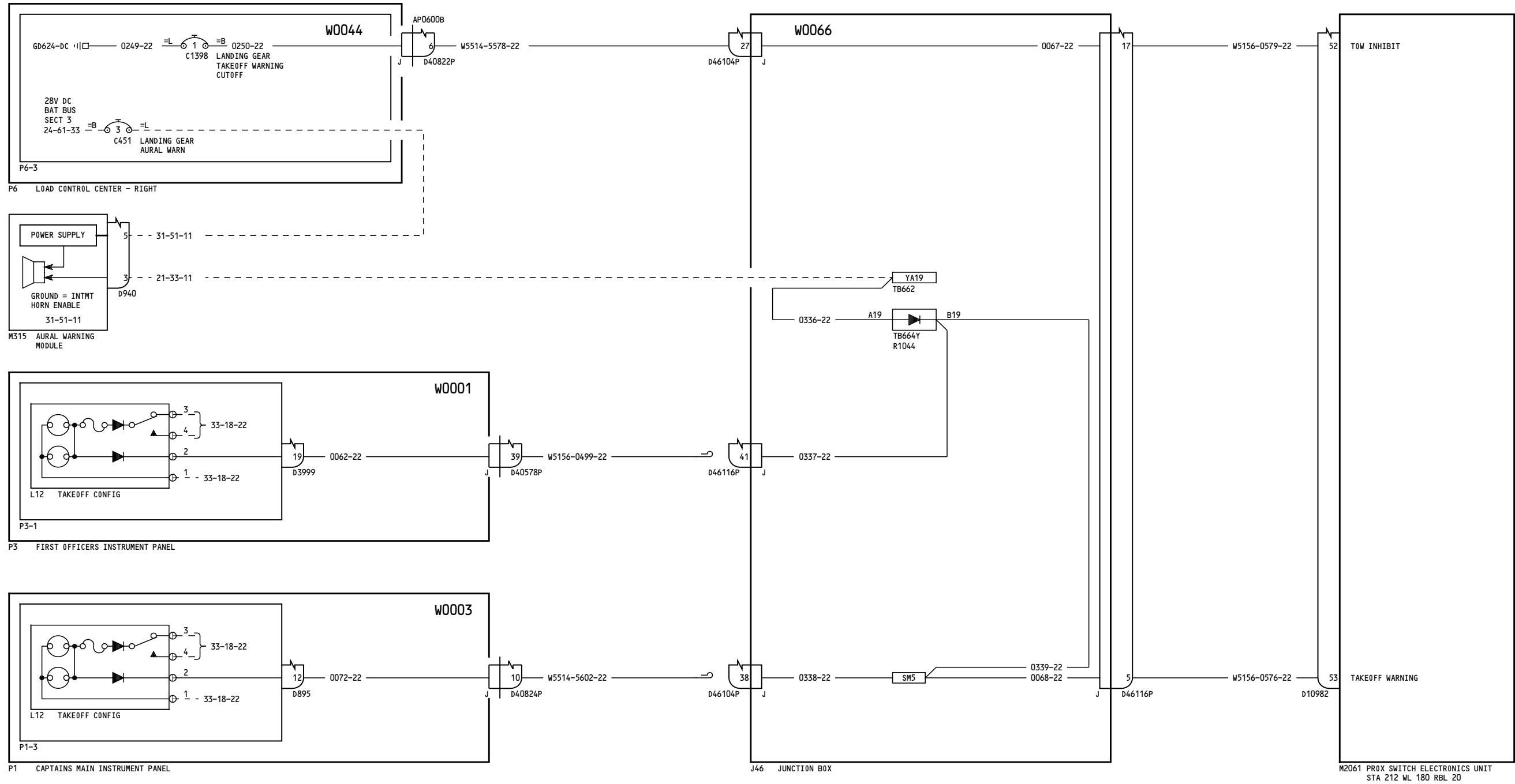

YM651

**AURAL WARNING -
TAKEOFF WARNING**

D280A103

31-53-11

Page 10
Sheet 1
May 11/2009

31-53-11

Page 10
Sheet 1
May 11/2009

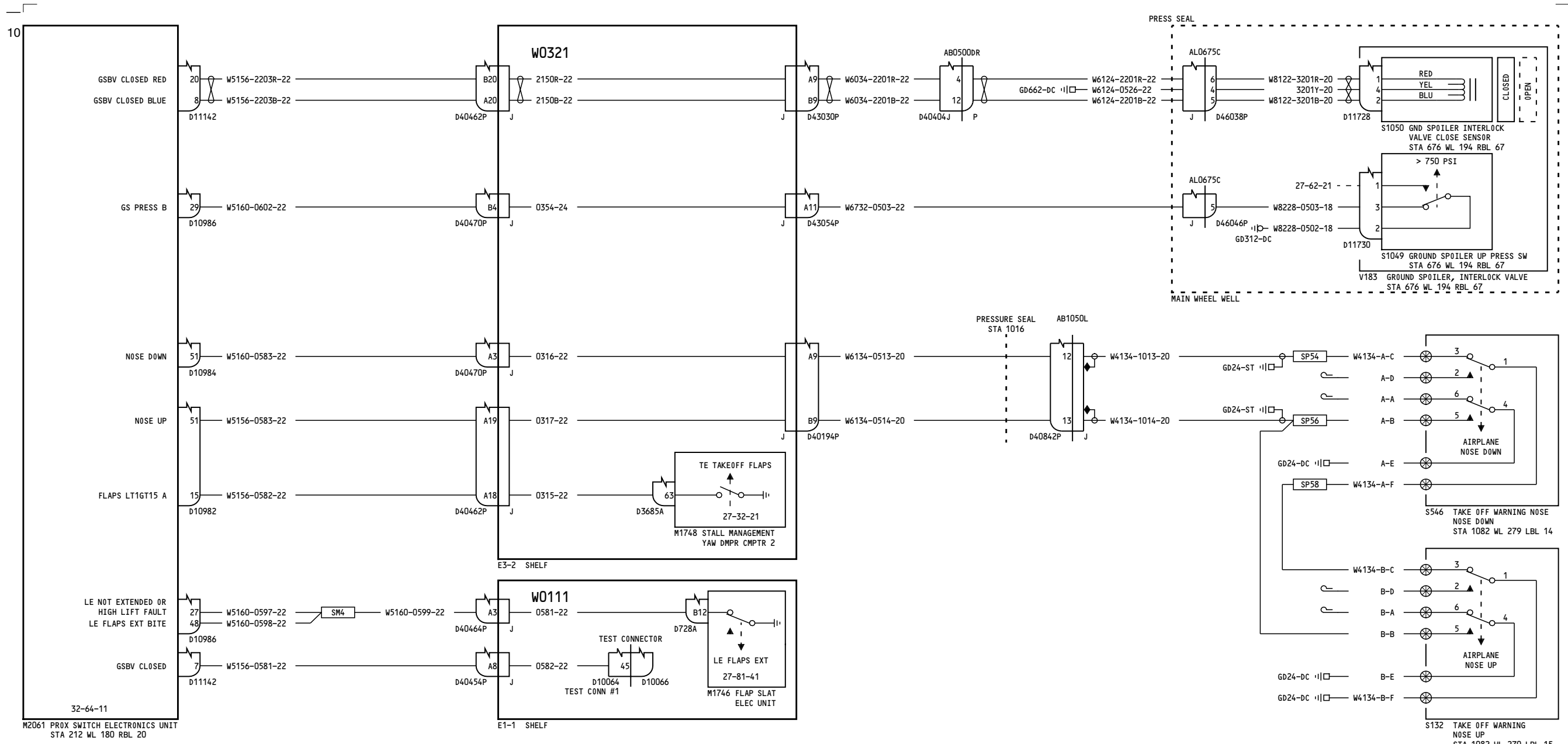

YM651

AURAL WARNING - TAKEOFF WARNING

31-53-11

Page 10
Sheet 2
May 11/2009

D280A103

31-53-11

Page 10
Sheet 2
May 11/2009

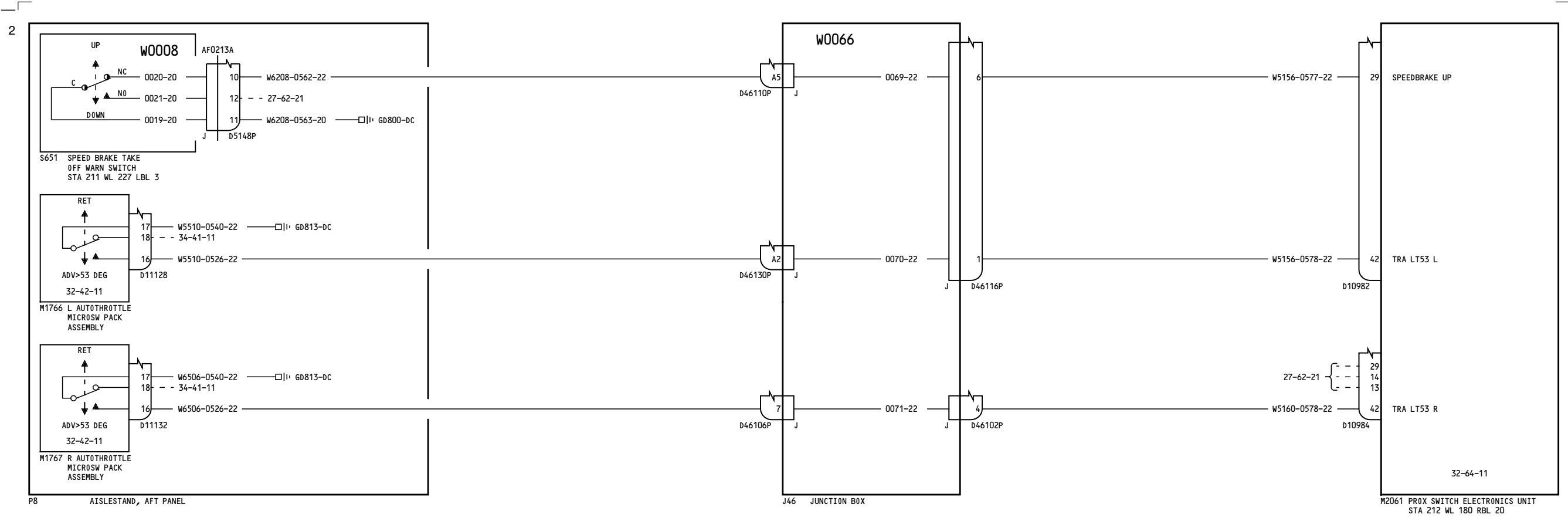

YM651	<p>AURAL WARNING - TAKEOFF WARNING</p> <p>D280A103</p>
-------	---

31-53-11

Page 10
Sheet 3
May 11/2009

31-53-11

Page 10
Sheet 3
May 11/2009

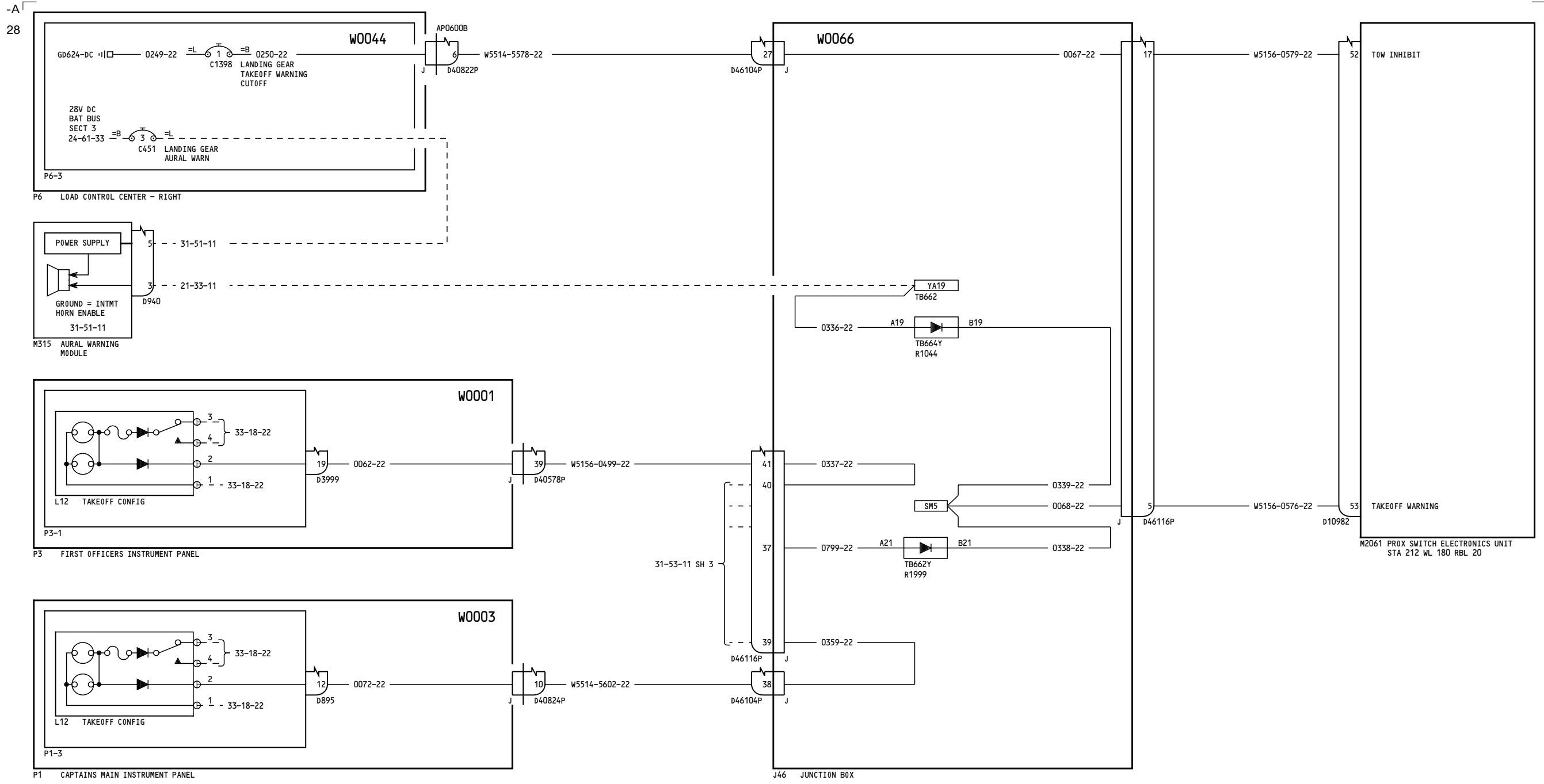

YM652

AURAL WARNING - TAKEOFF WARNING

D280A103

31-53-11

Page 11
Sheet 1
Aug 10/2009

31-53-11

Page 11
Sheet 1
Aug 10/2009

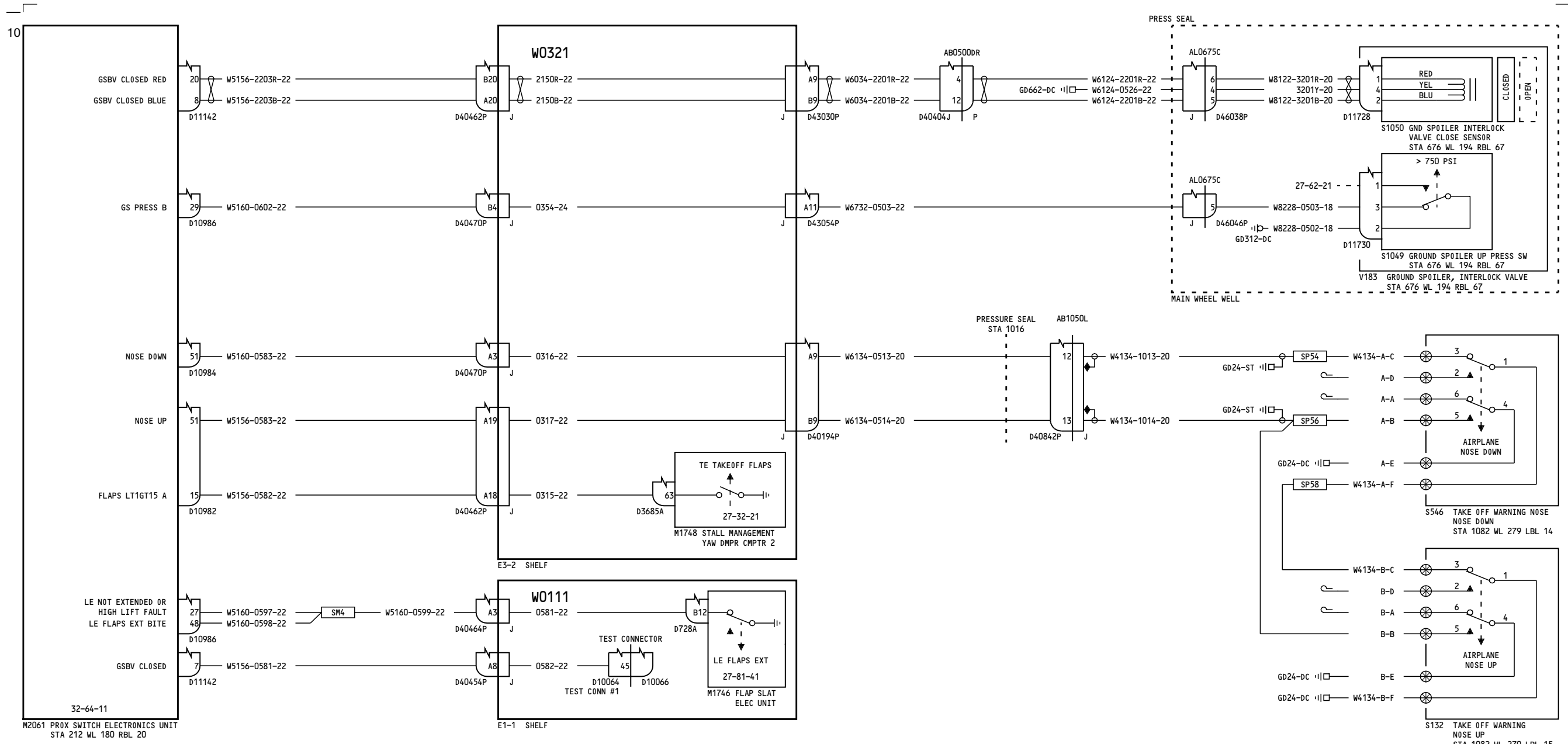

YM652

AURAL WARNING - TAKEOFF WARNING

31-53-11

Page 11
Sheet 2
Aug 10/2009

D280A103

31-53-11

Page 11
Sheet 2
Aug 10/2009

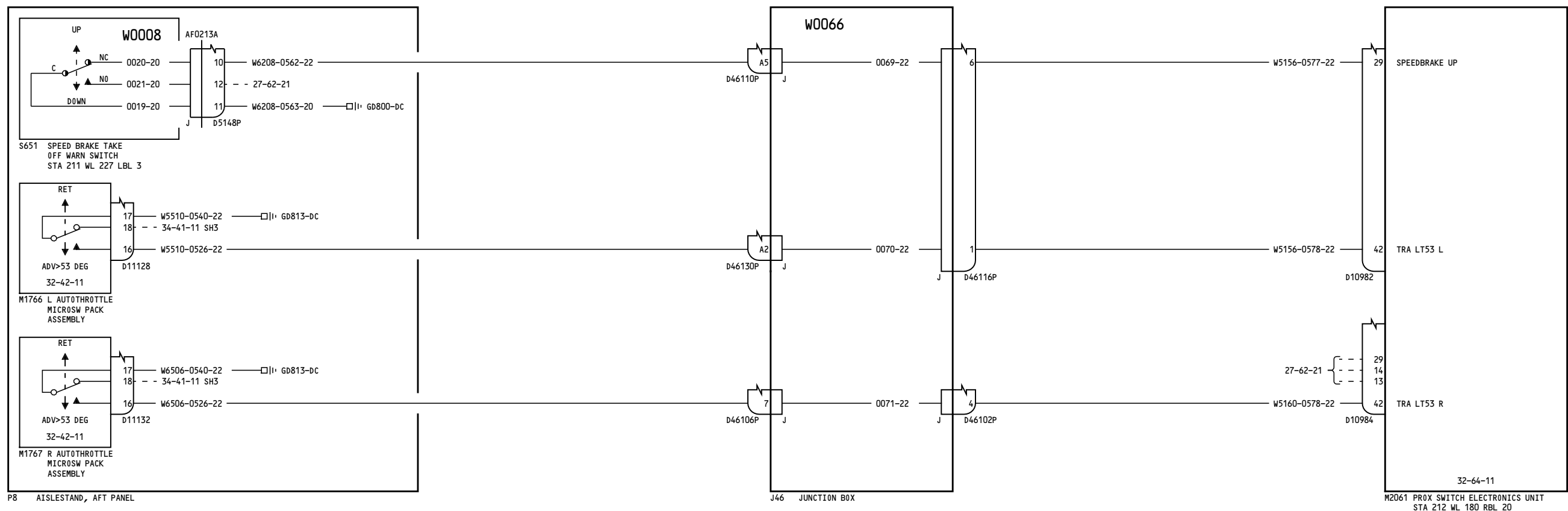
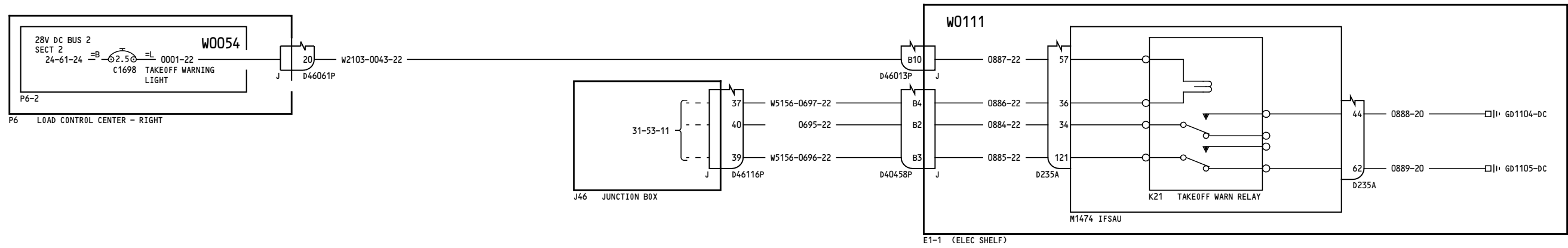

YM652

AURAL WARNING - TAKEOFF WARNING

31-53-11

Page 11
Sheet 3
Aug 10/2009

D280A103

31-53-11

Page 11
Sheet 3
Aug 10/2009

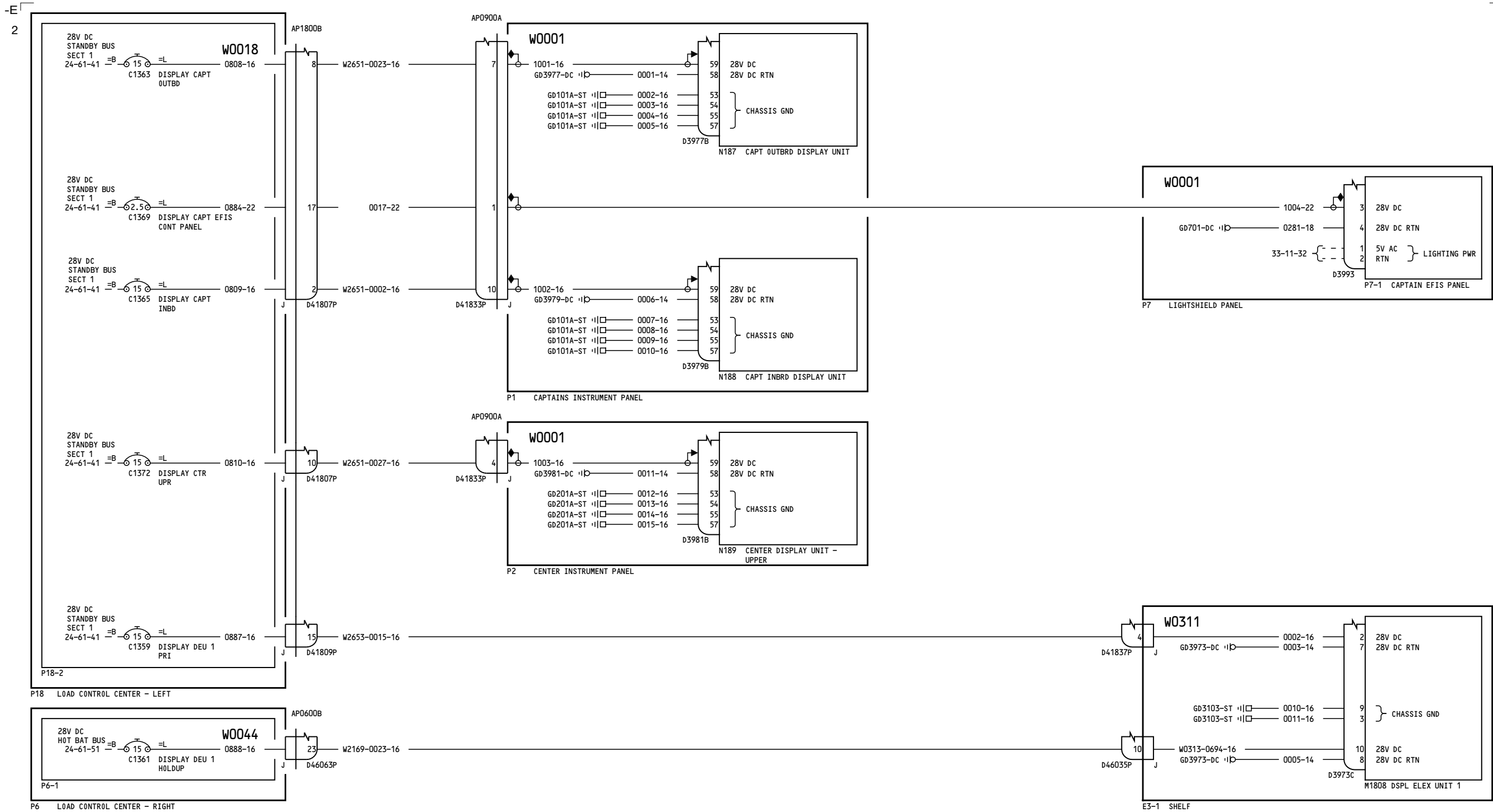

ALL

CDS - POWER DISTRIBUTION AND INSTRUMENT LIGHTING CAPTAINS

31-62-11

Page 1
Sheet 1
Feb 09/2009

D280A103

31-62-11

Page 1
Sheet 1
Feb 09/2009

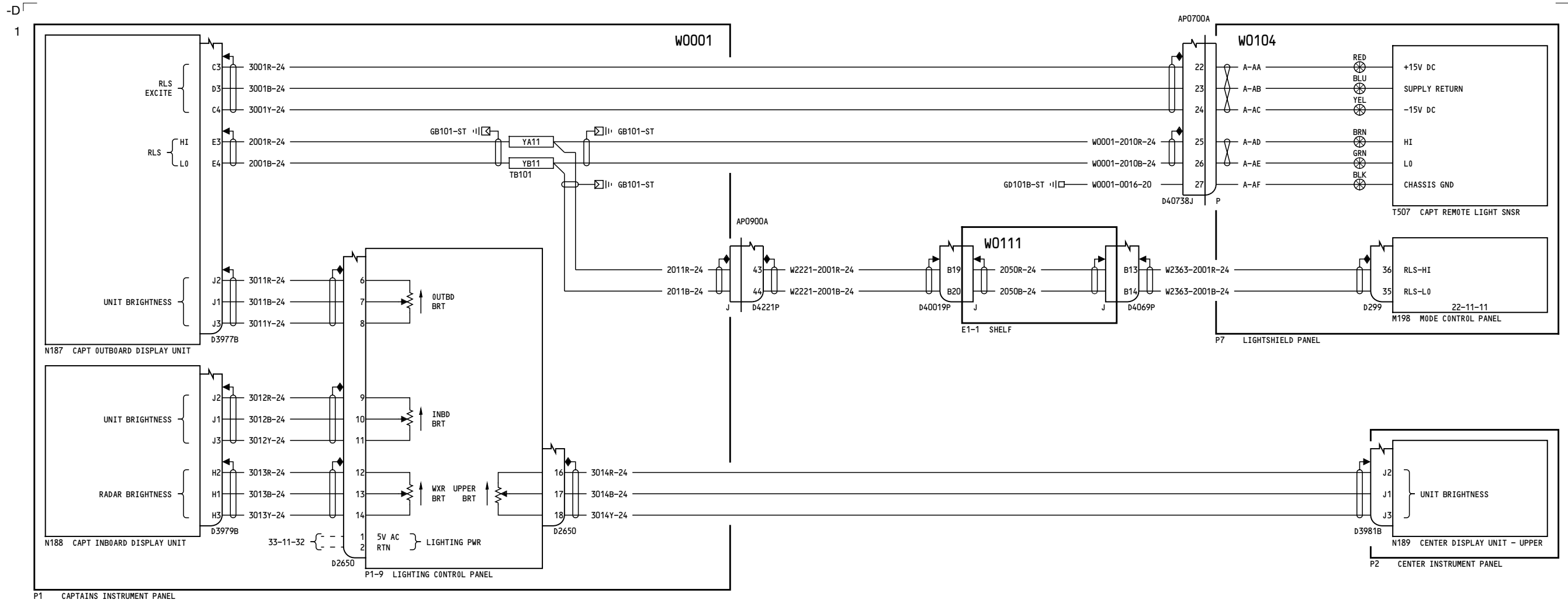

ALL

CDS - POWER DISTRIBUTION AND INSTRUMENT LIGHTING CAPTAINS

D280A103

31-62-11

Page 1
Sheet 2
Feb 09/2009

31-62-11

Page 1
Sheet 2
Feb 09/2009

-C
1

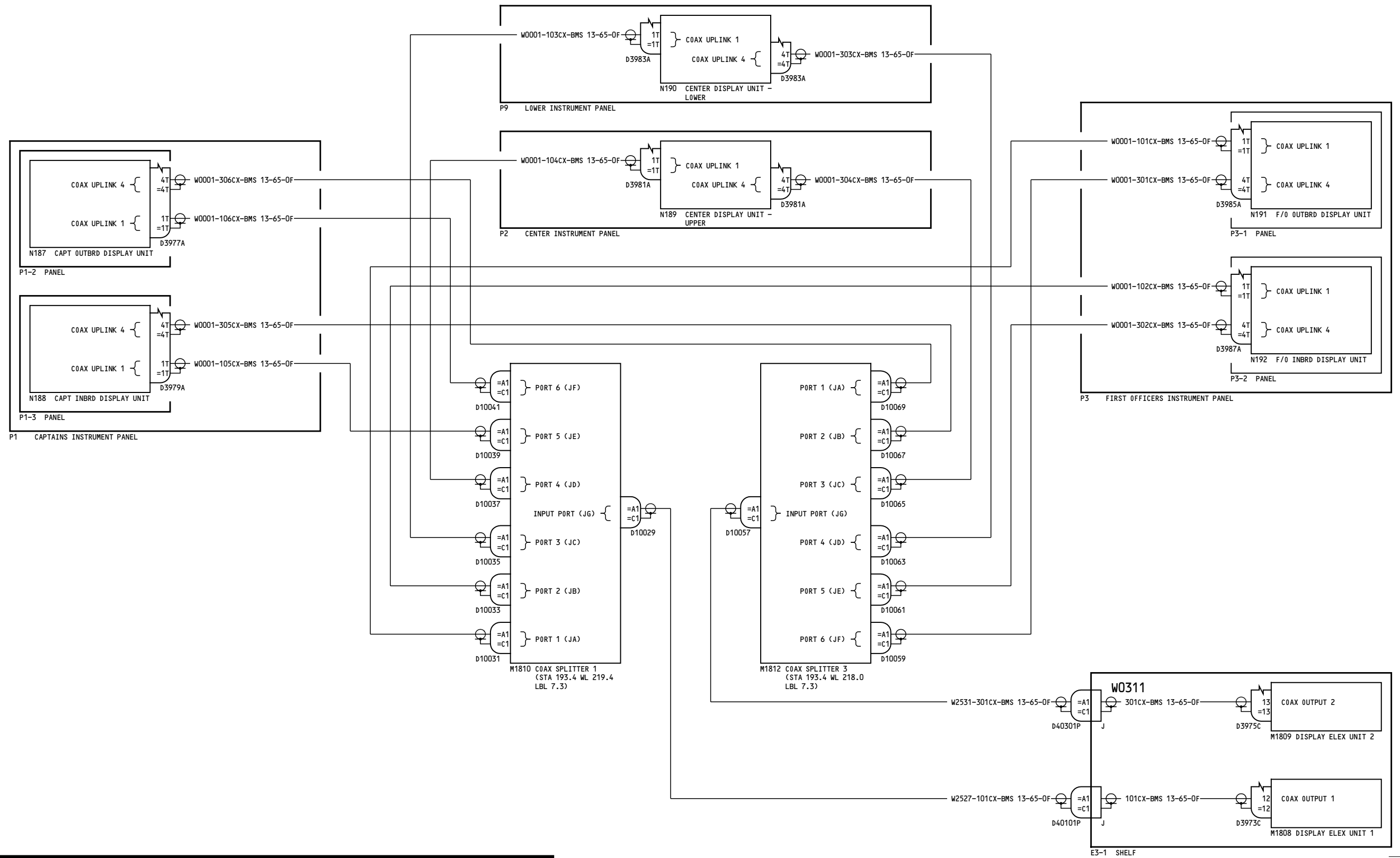

ALL

CDS - VIDEO COAX SPLITTERS 1 AND 3 DU STATUS

D280A103

31-62-12

Page 1
Sheet 1
Feb 09/2009

31-62-12

Page 1
Sheet 1
Feb 09/2009

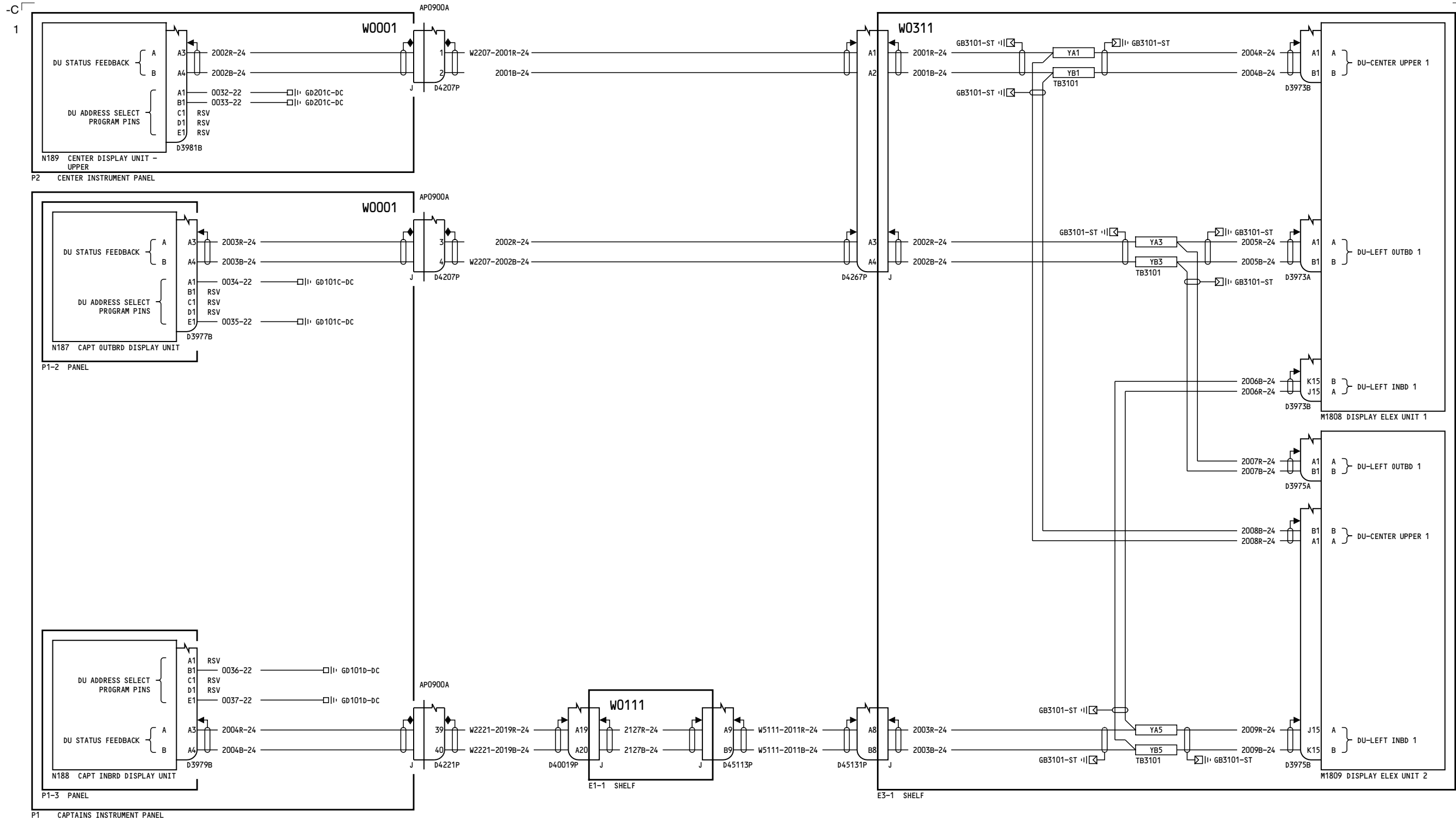

ALL

**CDS - VIDEO COAX
SPLITTERS 1 AND 3
DU STATUS**

D280A103

31-62-12

Page 1
Sheet 2
Feb 09/2009

31-62-12

Page 1
Sheet 2
Feb 09/2009

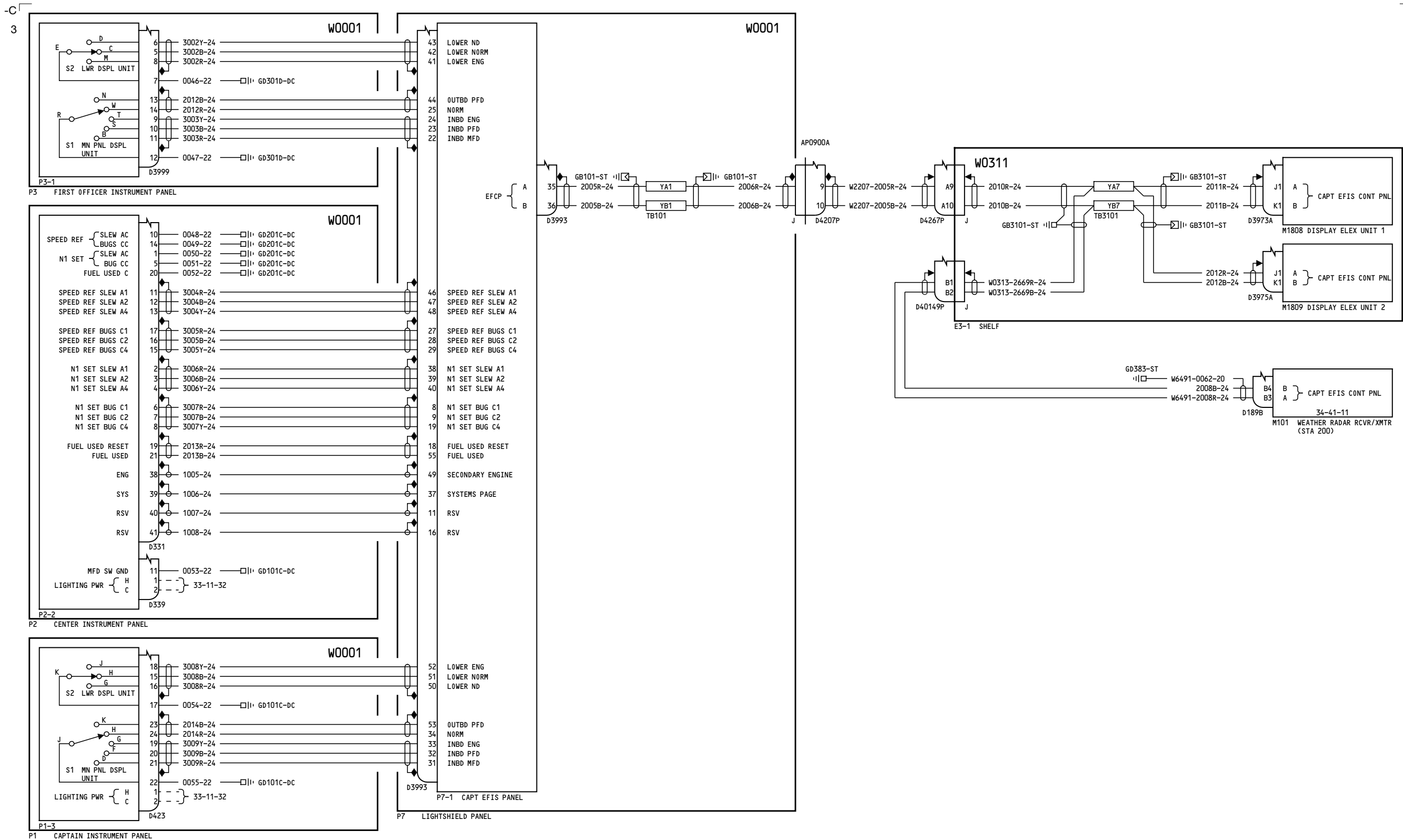

YC001-YC002, YC007

CDS - CONTROL PANEL INTERFACES - CAPTAINS

31-62-13

Page 1

D280A103

Mar 31/2005

31-62-13

Page 1

Mar 31/2005

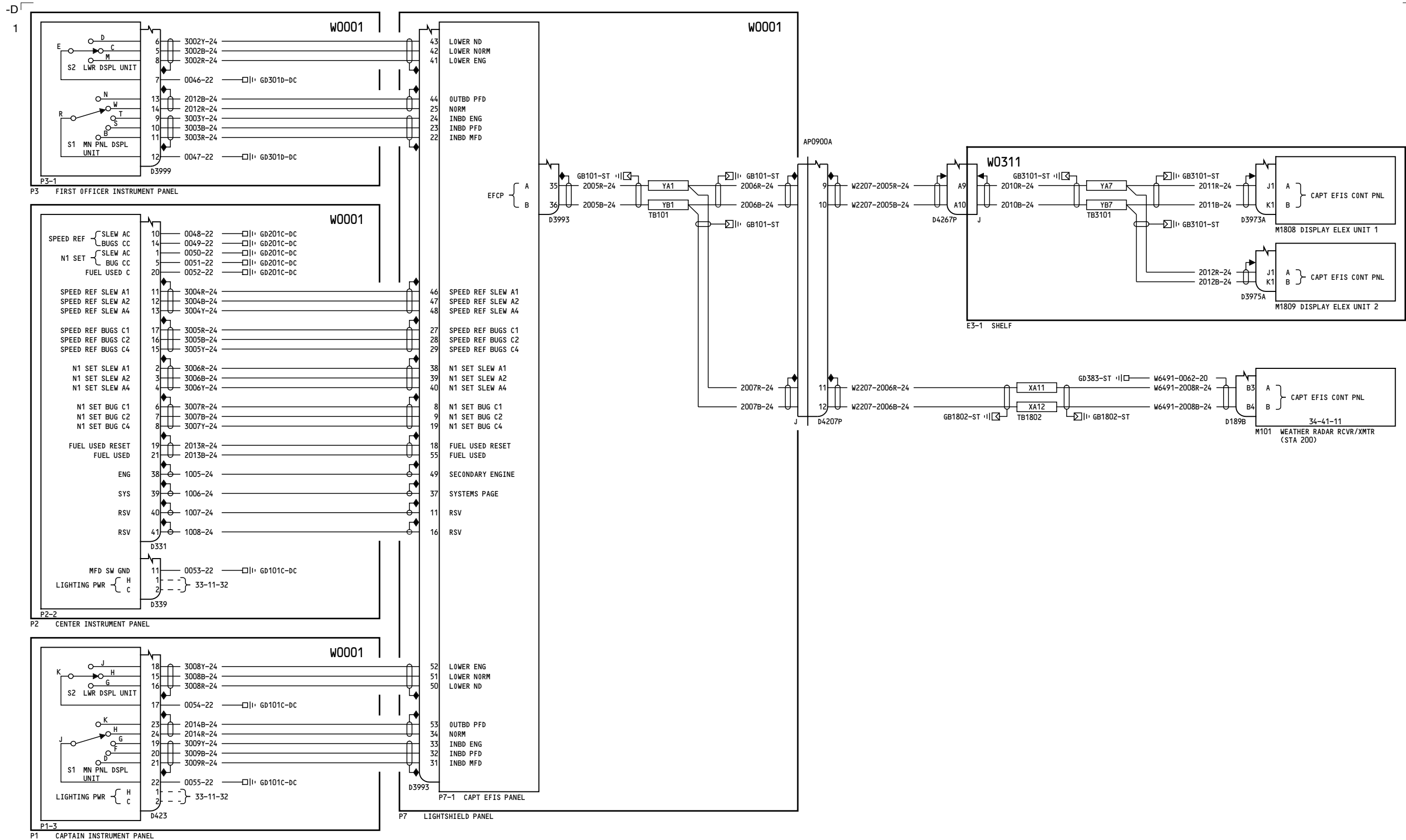

YC003

CDS - CONTROL PANEL INTERFACES - CAPTAINS

31-62-13

Page 2

D280A103

Mar 31/2005

31-62-13

Page 2

Mar 31/2005

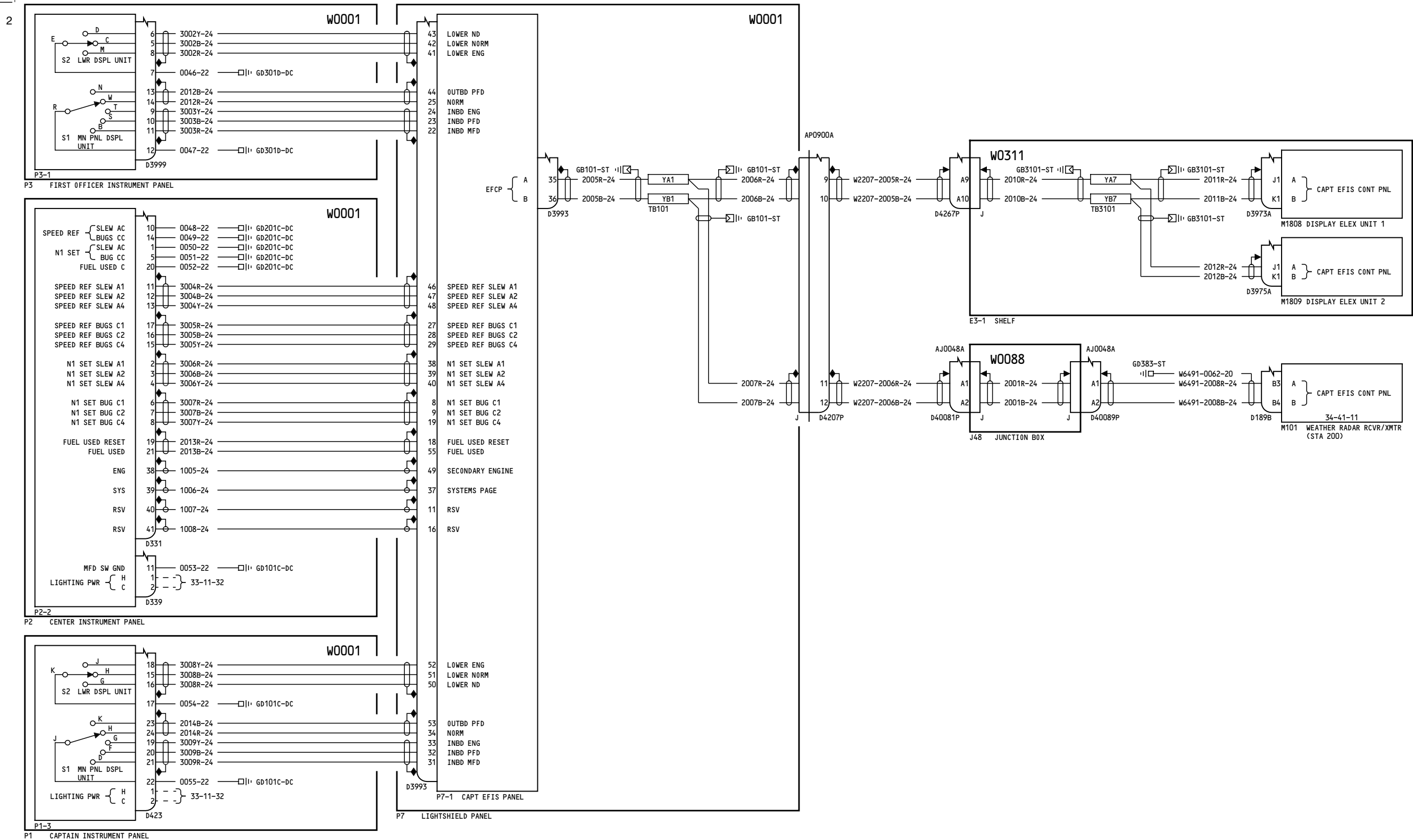

YC004-YC006

CDS - CONTROL PANEL INTERFACES - CAPTAINS

31-62-13

Page 3

D280A103

Mar 31/2005

31-62-13

Page 3

Mar 31/2005

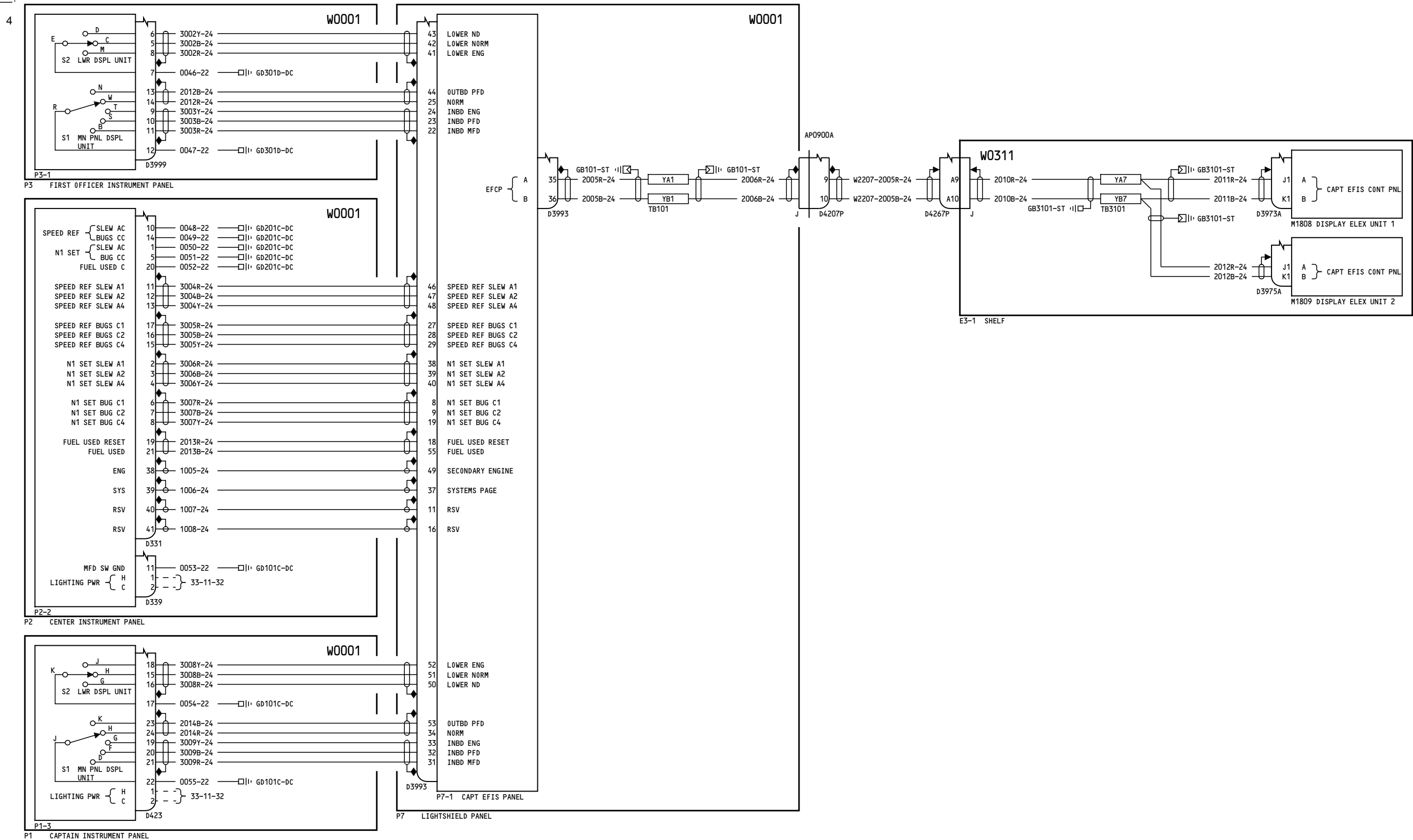

YC008-YK920, YM643-YM646

CDS - CONTROL PANEL INTERFACES - CAPTAINS

31-62-13

Page 4

D280A103

Feb 09/2009

31-62-13

Page 4

Feb 09/2009

12

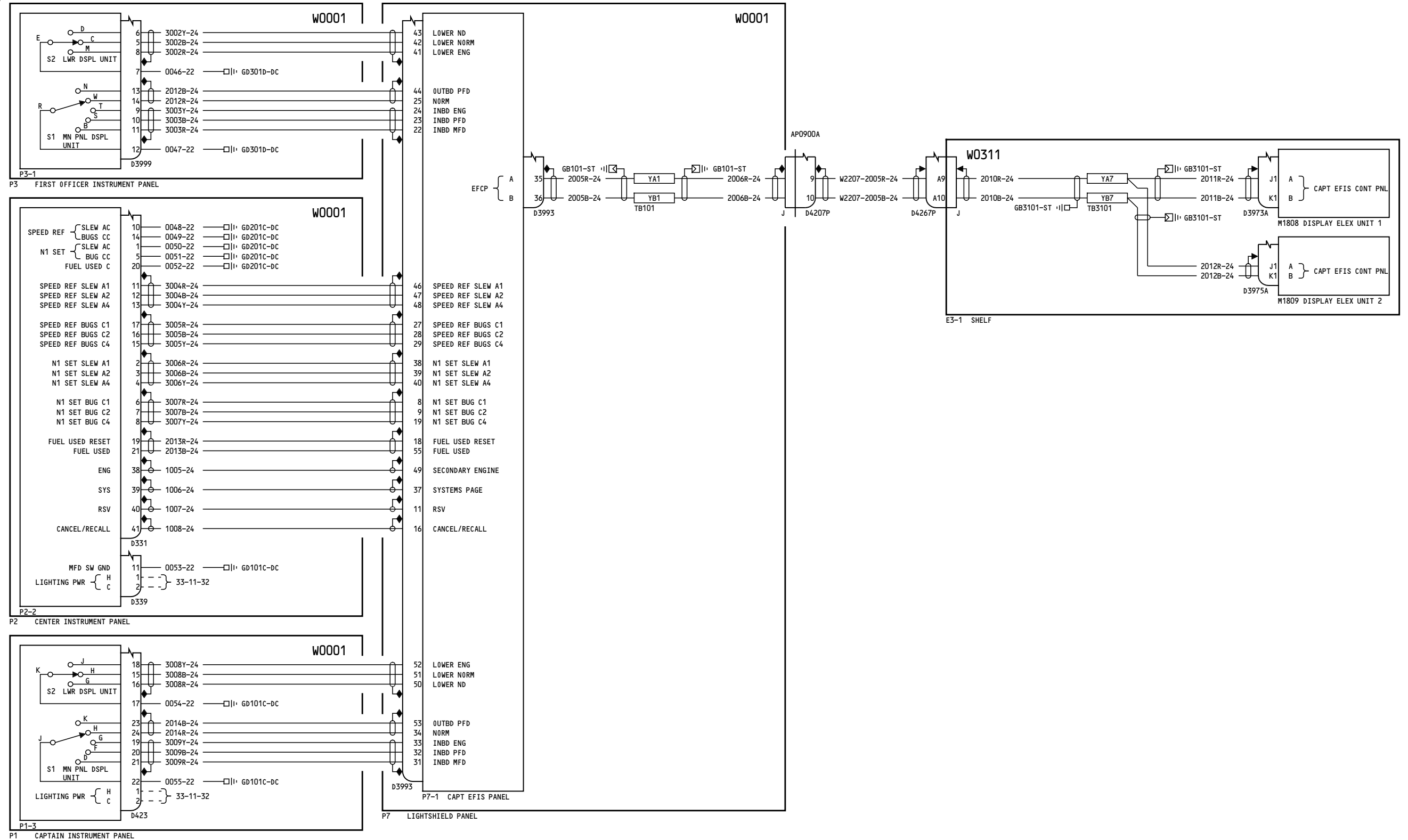

YL401-YL430, YM647-YM670

CDS - CONTROL PANEL INTERFACES - CAPTAINS

31-62-13

Page 5

D280A103

Aug 13/2008

31-62-13

Page 5

Aug 13/2008

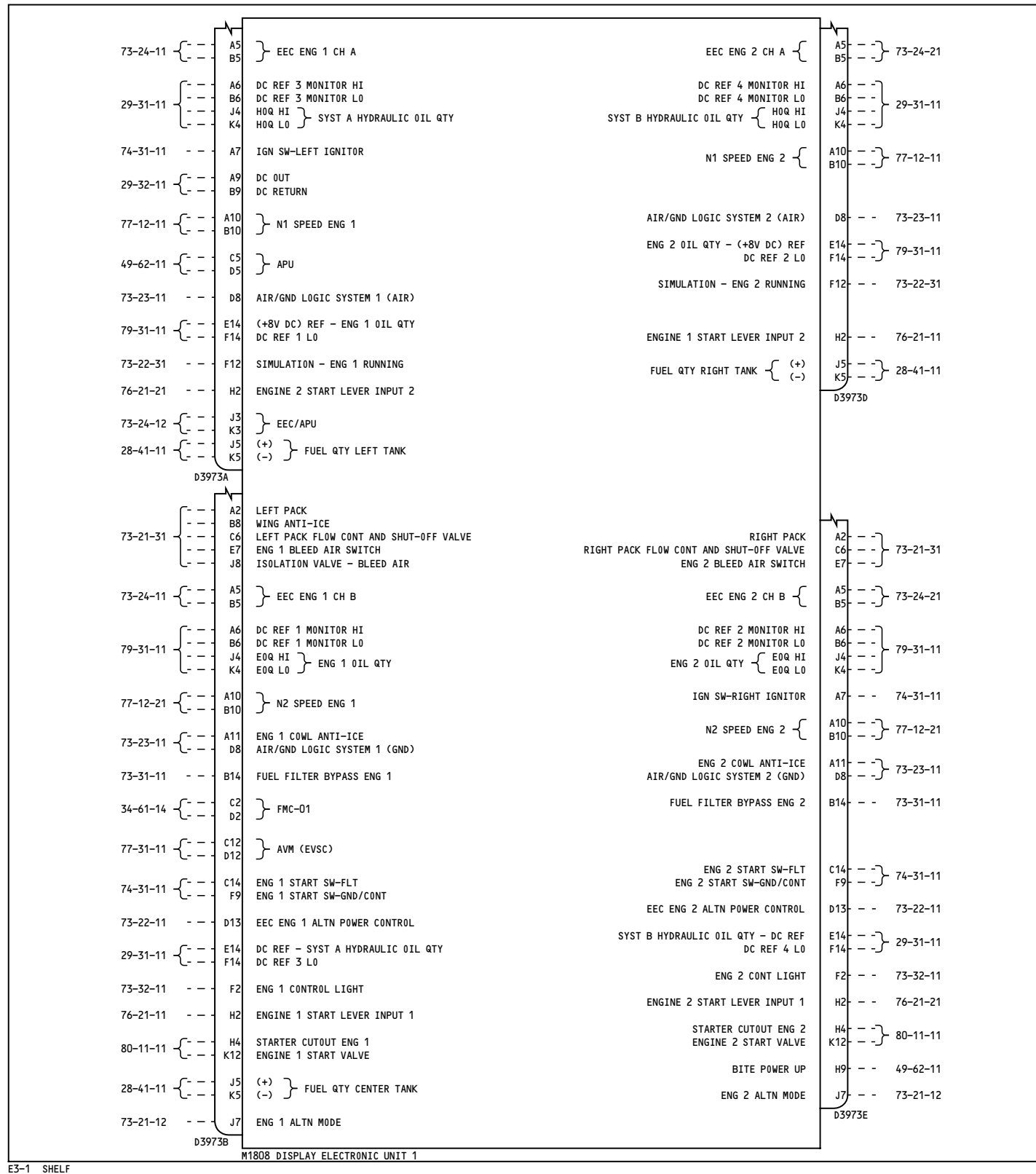

E3-1 SHELF

M1808 DISPLAY ELECTRONIC UNIT 1

YC001-YC030

**CDS - DEU 1 ENGINE
HYDRAULIC, APU AND FUEL
INTERFACES**

31-62-14

D280A103

Page 1
Sheet 1
Jul 17/2007

31-62-14

Page 1
Sheet 1
Jul 17/2007

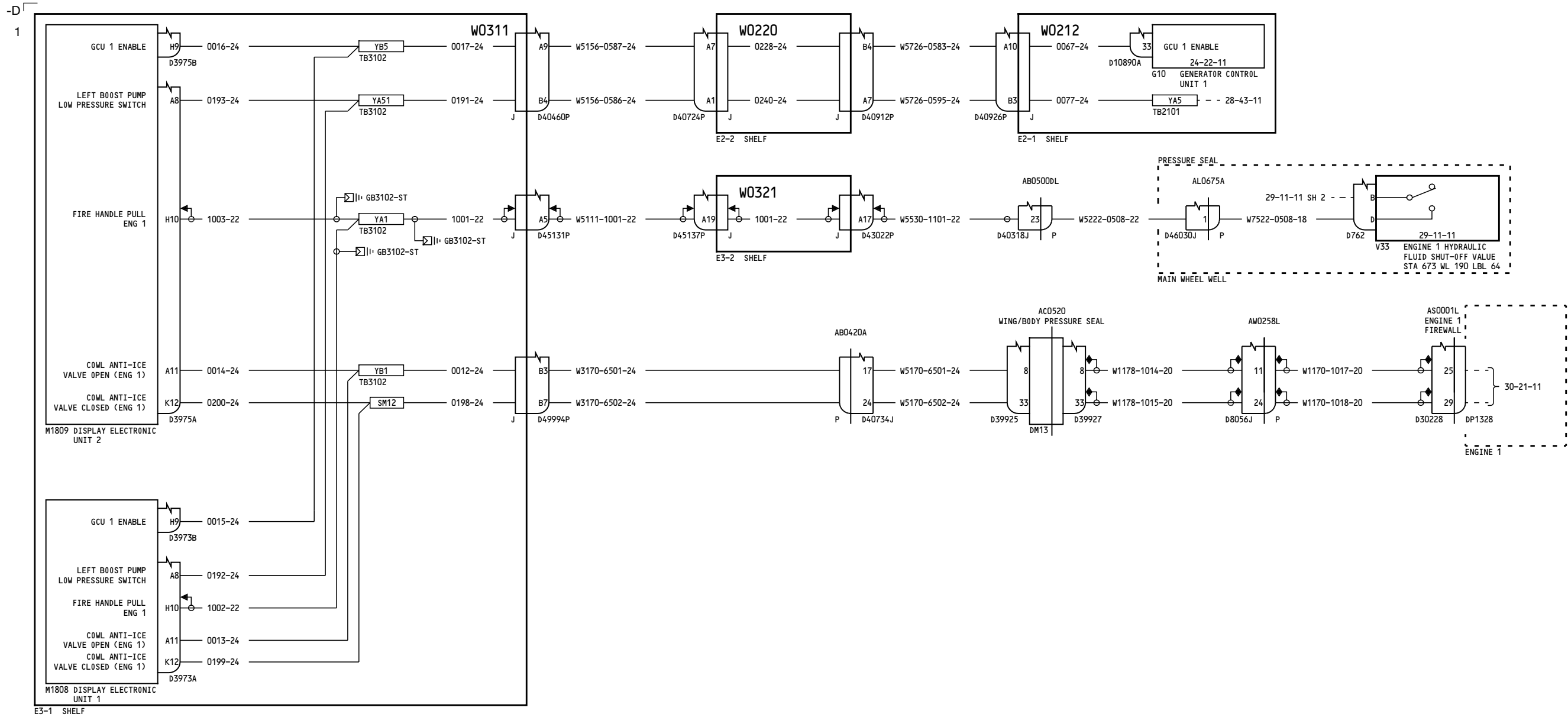

YC001-YC030

**CDS - DEU 1 ENGINE
HYDRAULIC, APU AND FUEL
INTERFACES**

D280A103

31-62-14

Page 1
Sheet 2
Jul 17/2007

31-62-14

Page 1
Sheet 2
Jul 17/2007

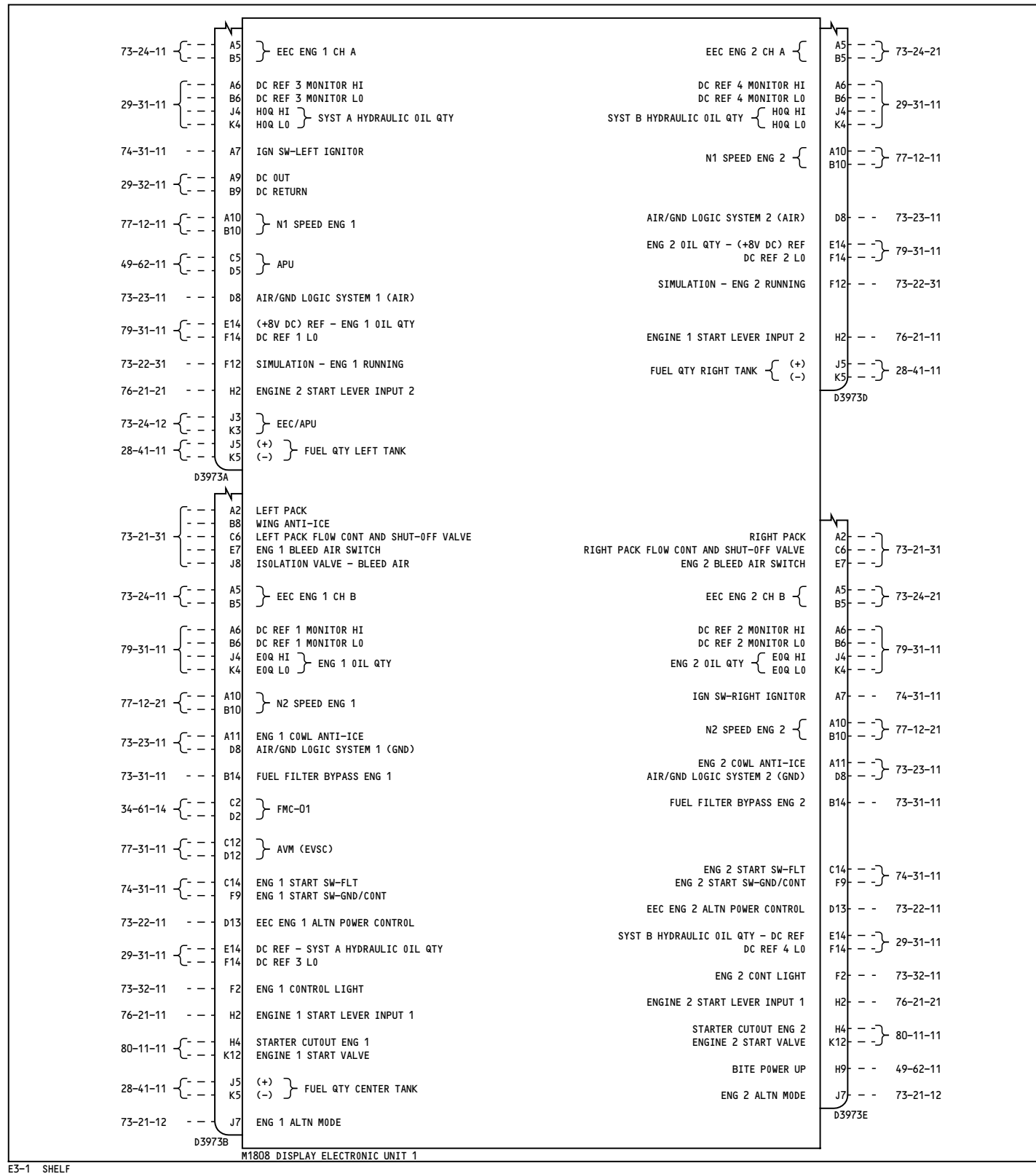

E3-1 SHELF

YC031-YM670

**CDS - DEU 1 ENGINE
HYDRAULIC, APU AND FUEL
INTERFACES**

D280A103

31-62-14

Page 2
Sheet 1
Feb 09/2009

31-62-14

Page 2
Sheet 1
Feb 09/2009

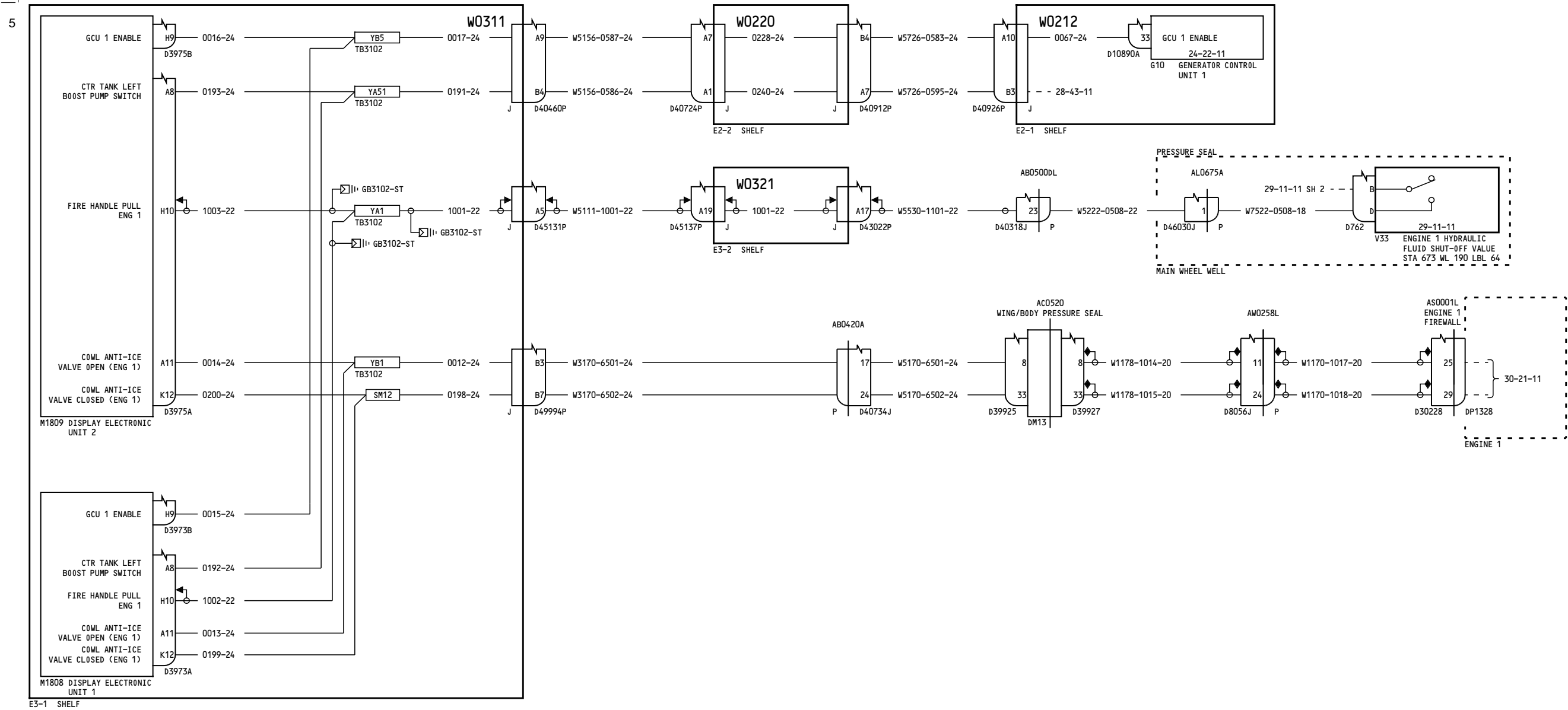

YC031-YM670

**CDS - DEU 1 ENGINE
HYDRAULIC, APU AND FUEL
INTERFACES**

D280A103

31-62-14

Page 2
Sheet 2
Feb 09/2009

31-62-14

Page 2
Sheet 2
Feb 09/2009

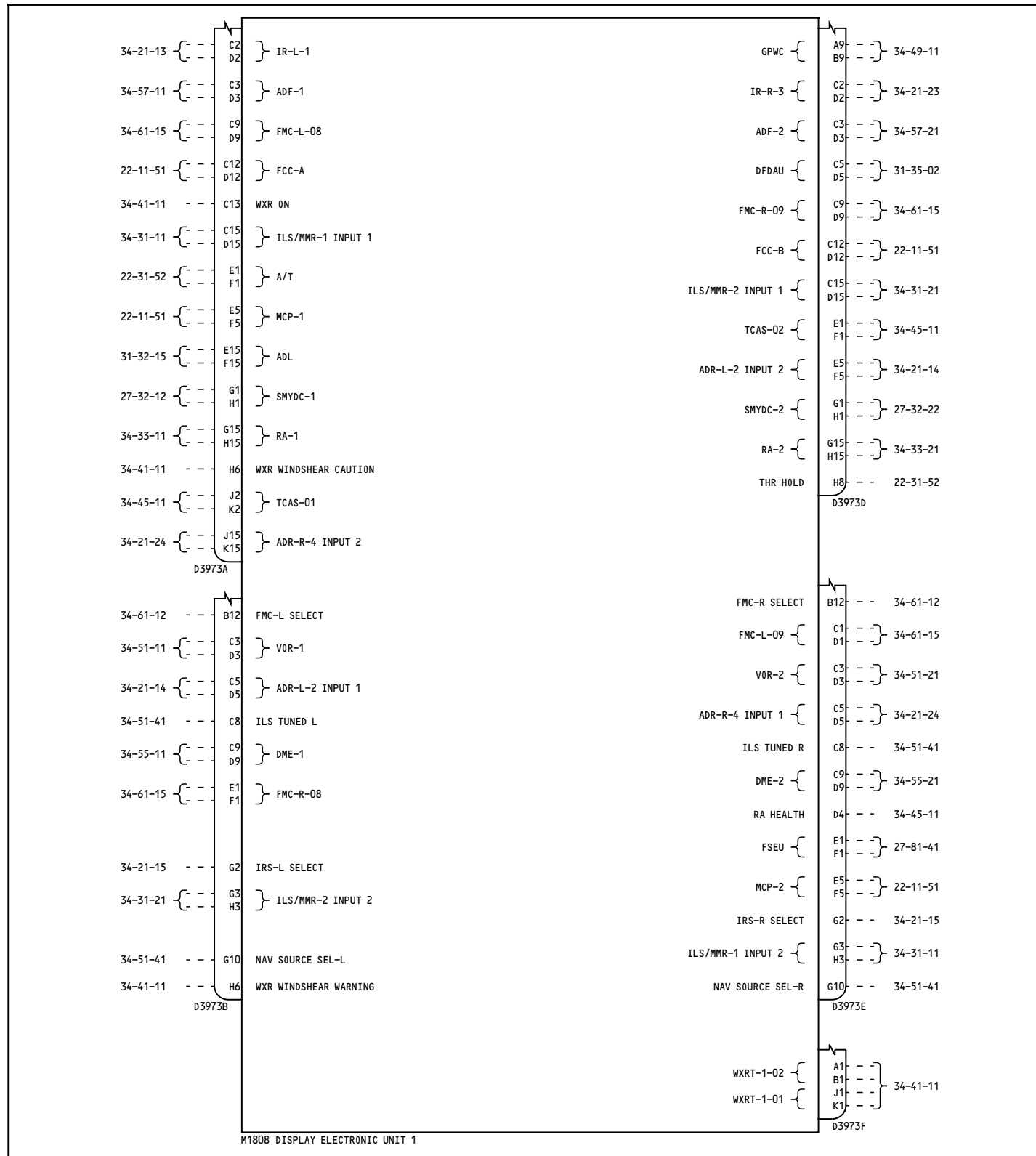

E3-1 SHELF

M1808 DISPLAY ELECTRONIC UNIT 1

YC001-YC007

CDS - DEU 1 AVIONICS INTERFACES

D280A103

31-62-15

Page 1.1A
Sheet 1
Mar 31/2005

Incorporates
31-1136

31-62-15

Page 1.1A
Sheet 1
Mar 31/2005

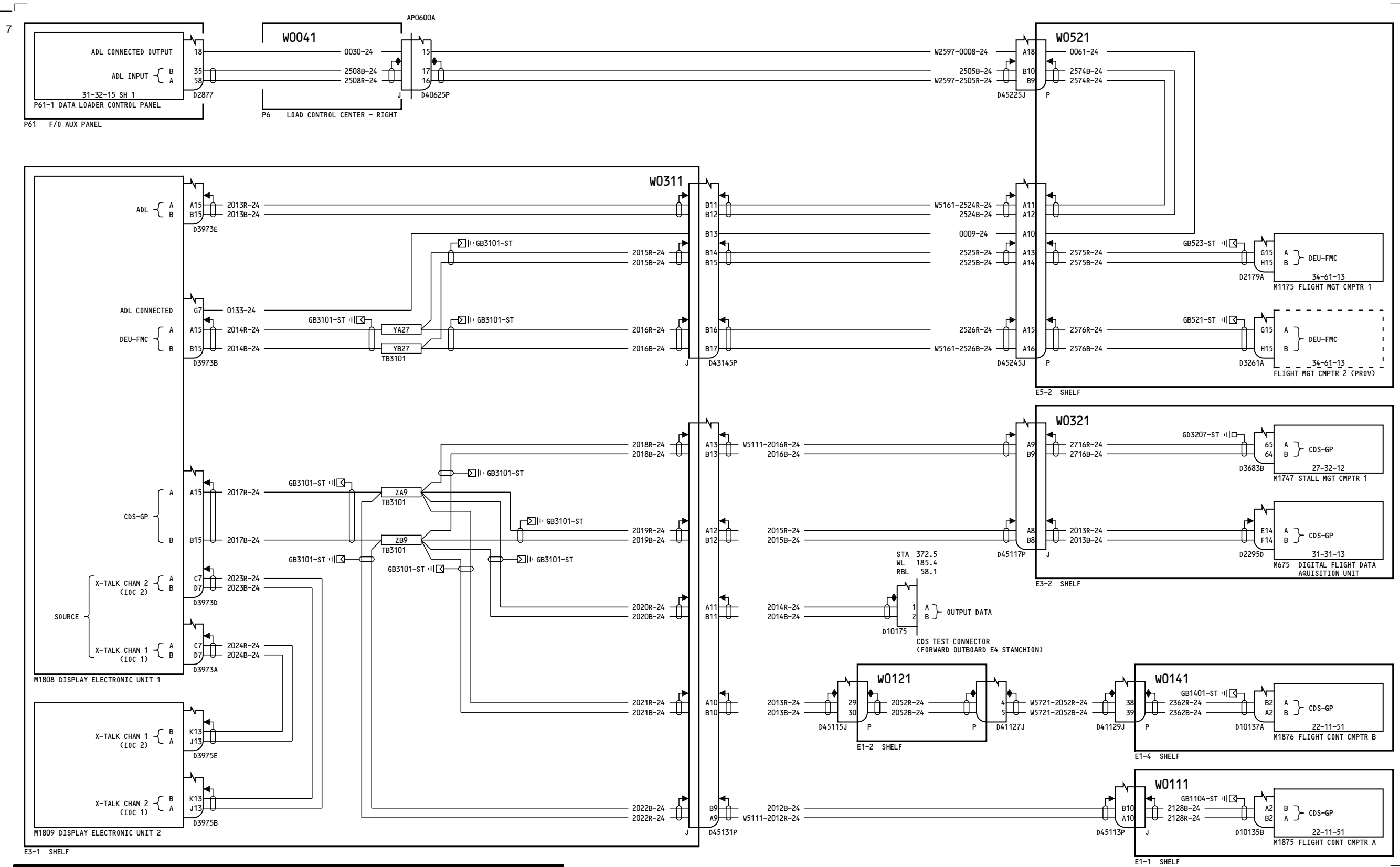

YC001-YC007

CDS - DEU 1 AVIONICS INTERFACES

D280A103

31-62-15

Page 1.1A
Sheet 2
Mar 31/2005

Incorporates
31-1136

31-62-15

Page 1.1A
Sheet 2
Mar 31/2005

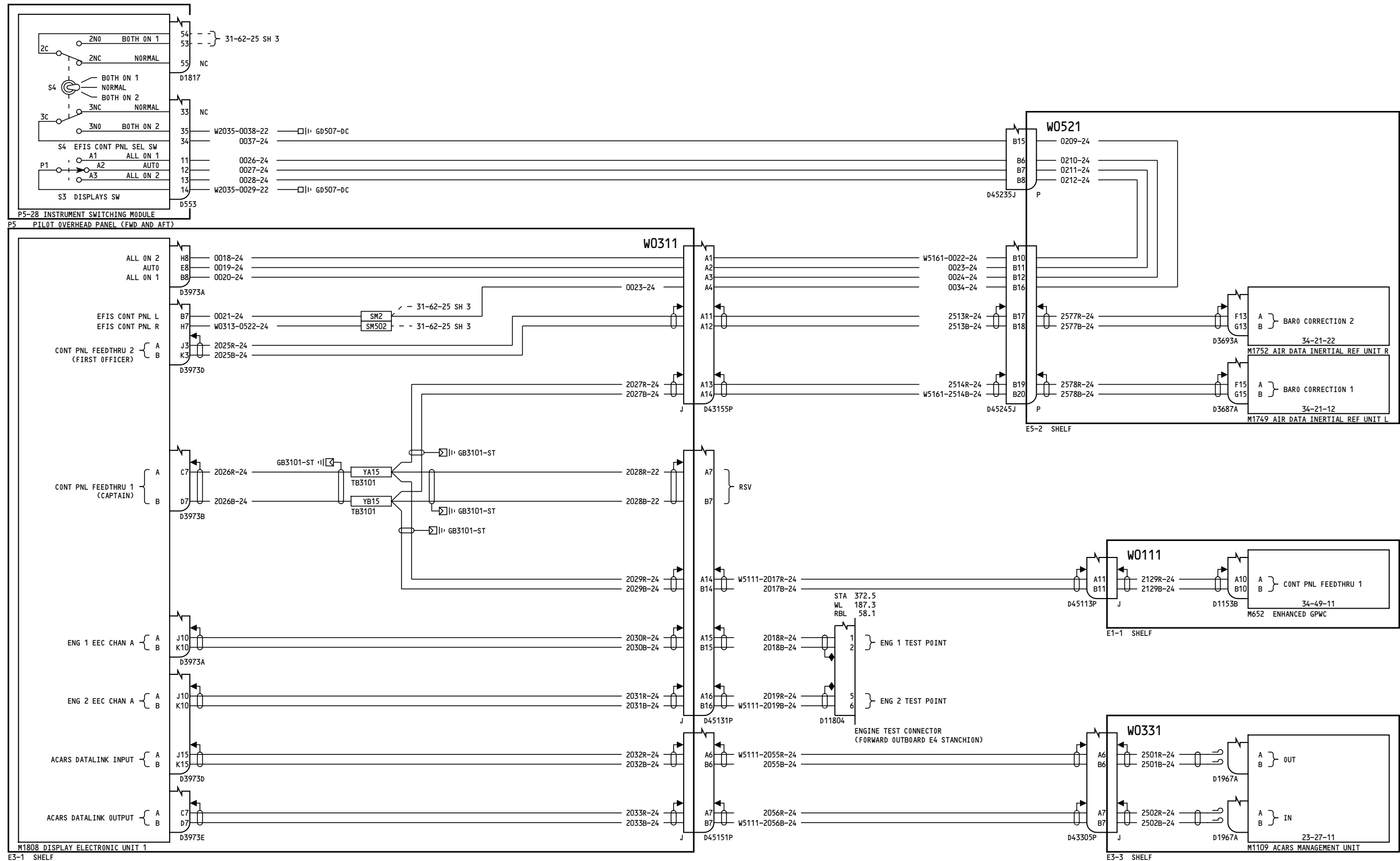

YC001-YC007

CDS - DEU 1 AVIONICS INTERFACES

31-62-15

Incorporates 737-EB34-0155 R04

31-62-15

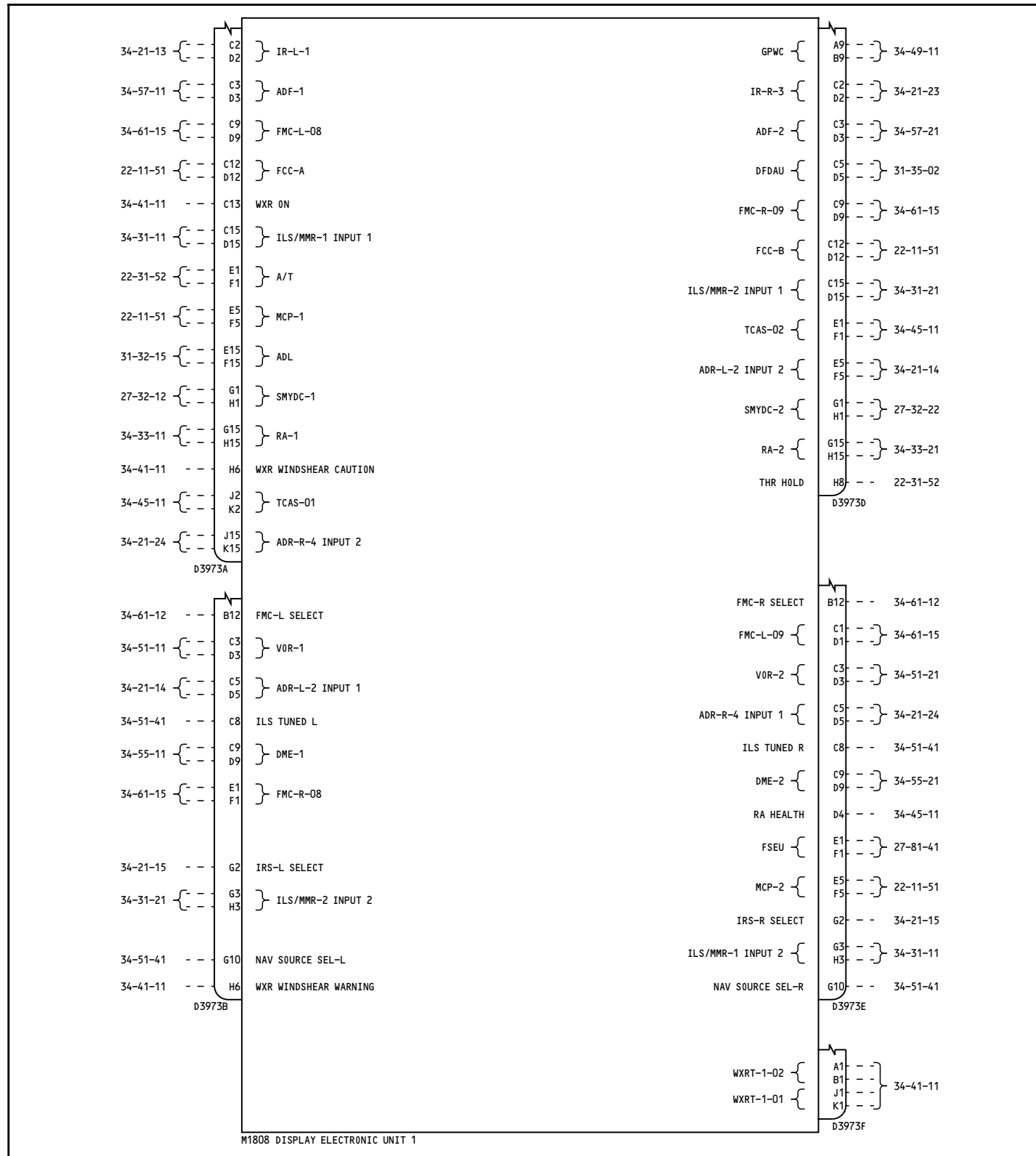

E3-1 SHELF

M1808 DISPLAY ELECTRONIC UNIT 1

YC008-YC011

CDS - DEU 1 AVIONICS INTERFACES

D280A103

31-62-15

Page 2.1
Sheet 1
Mar 31/2005

Incorporates
31-1136

31-62-15

Page 2.1
Sheet 1
Mar 31/2005

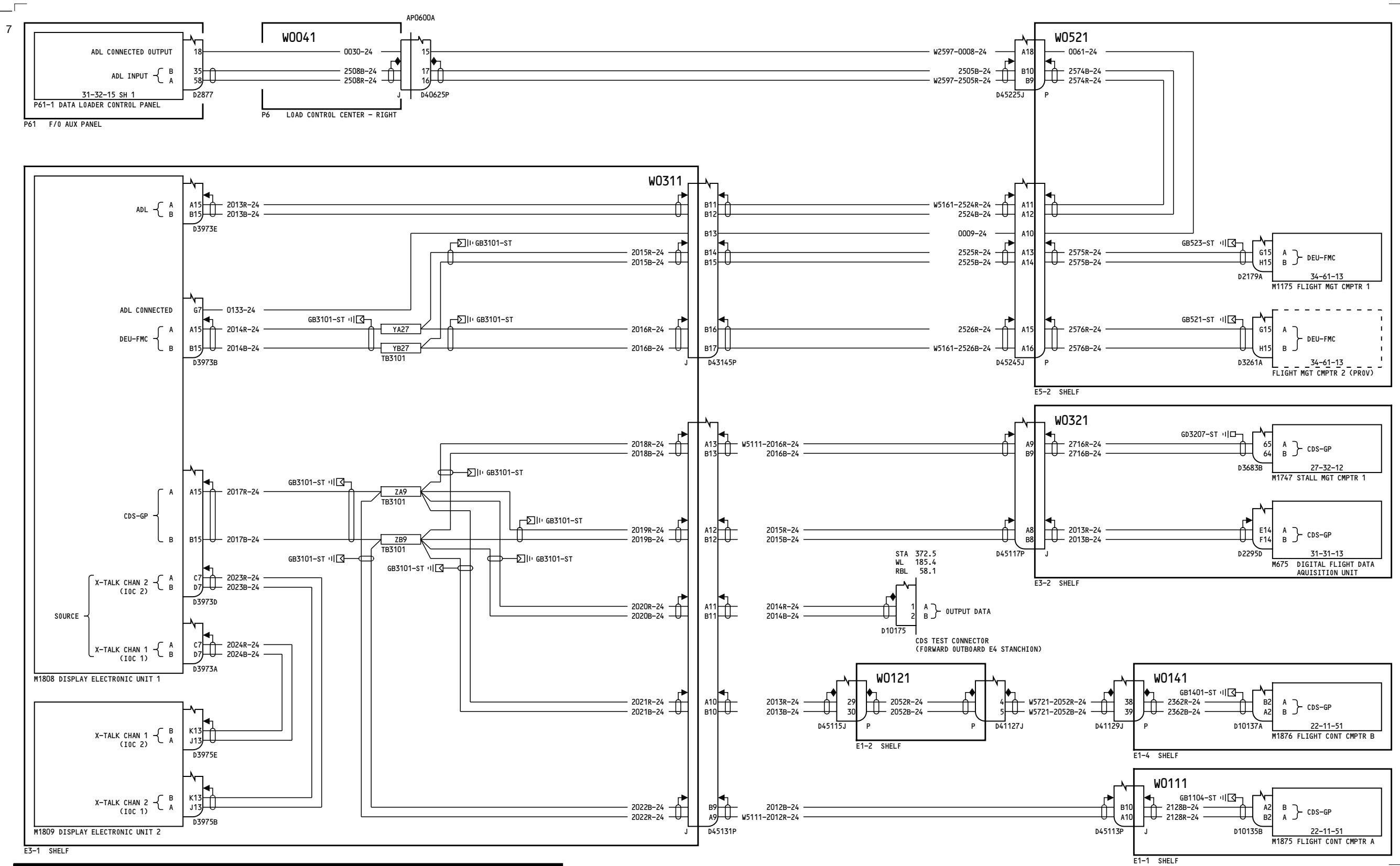

YC008-YC011

CDS - DEU 1 AVIONICS INTERFACES

31-62-15

Page 2.1
Sheet 2
Mar 31/2005

D280A103

Incorporates
31-1136

31-62-15

Page 2.1
Sheet 2
Mar 31/2005

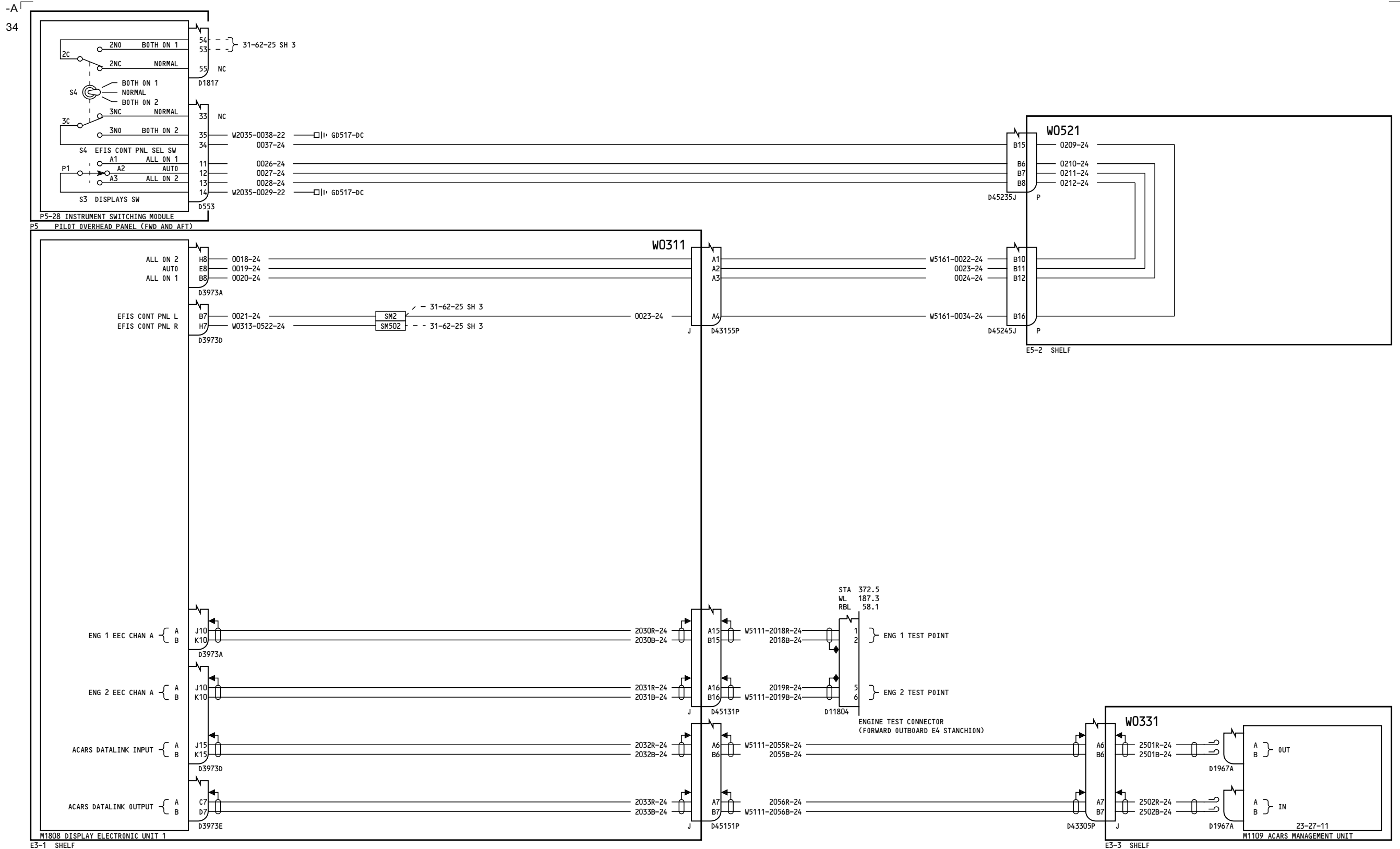

YC008-YC011

CDS - DEU 1 AVIONICS INTERFACES

31-62-15

Page 2.1
Sheet 3
Mar 31/2005

D280A103

31-62-15

Page 2.1
Sheet 3
Mar 31/2005

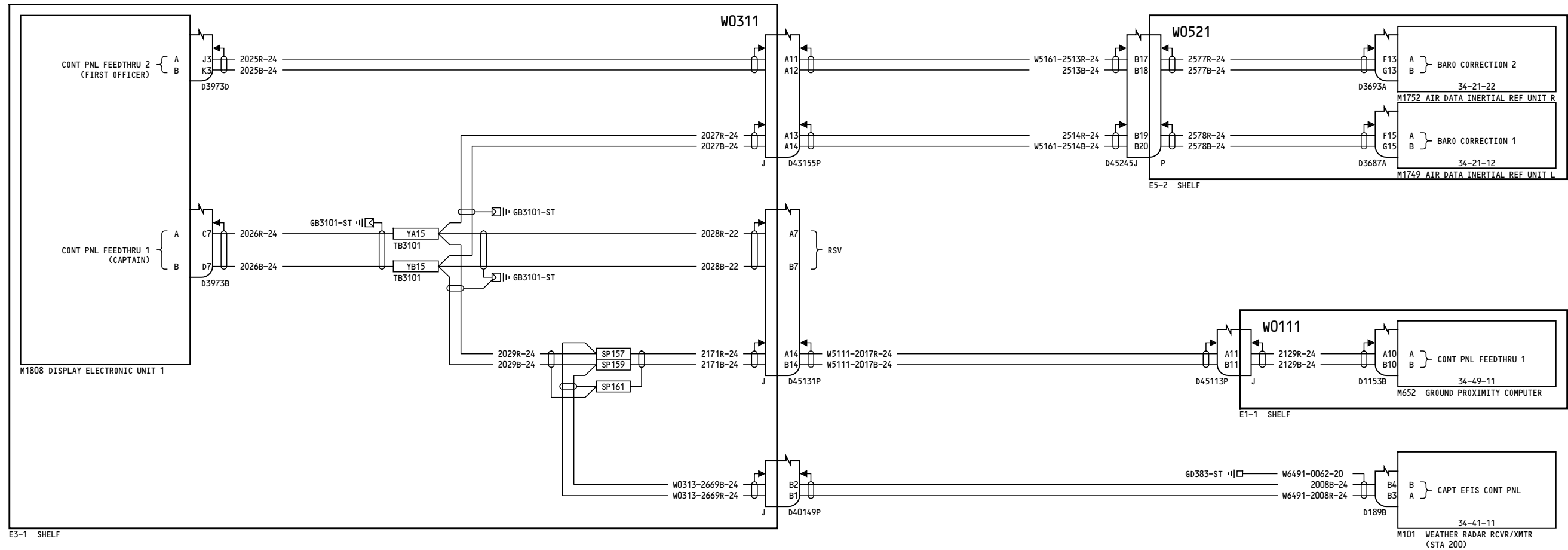

YC008-YC011

CDS - DEU 1 AVIONICS INTERFACES

D280A103

31-62-15

Page 2.1
Sheet 4
Mar 31/2005

31-62-15

Page 2.1
Sheet 4
Mar 31/2005

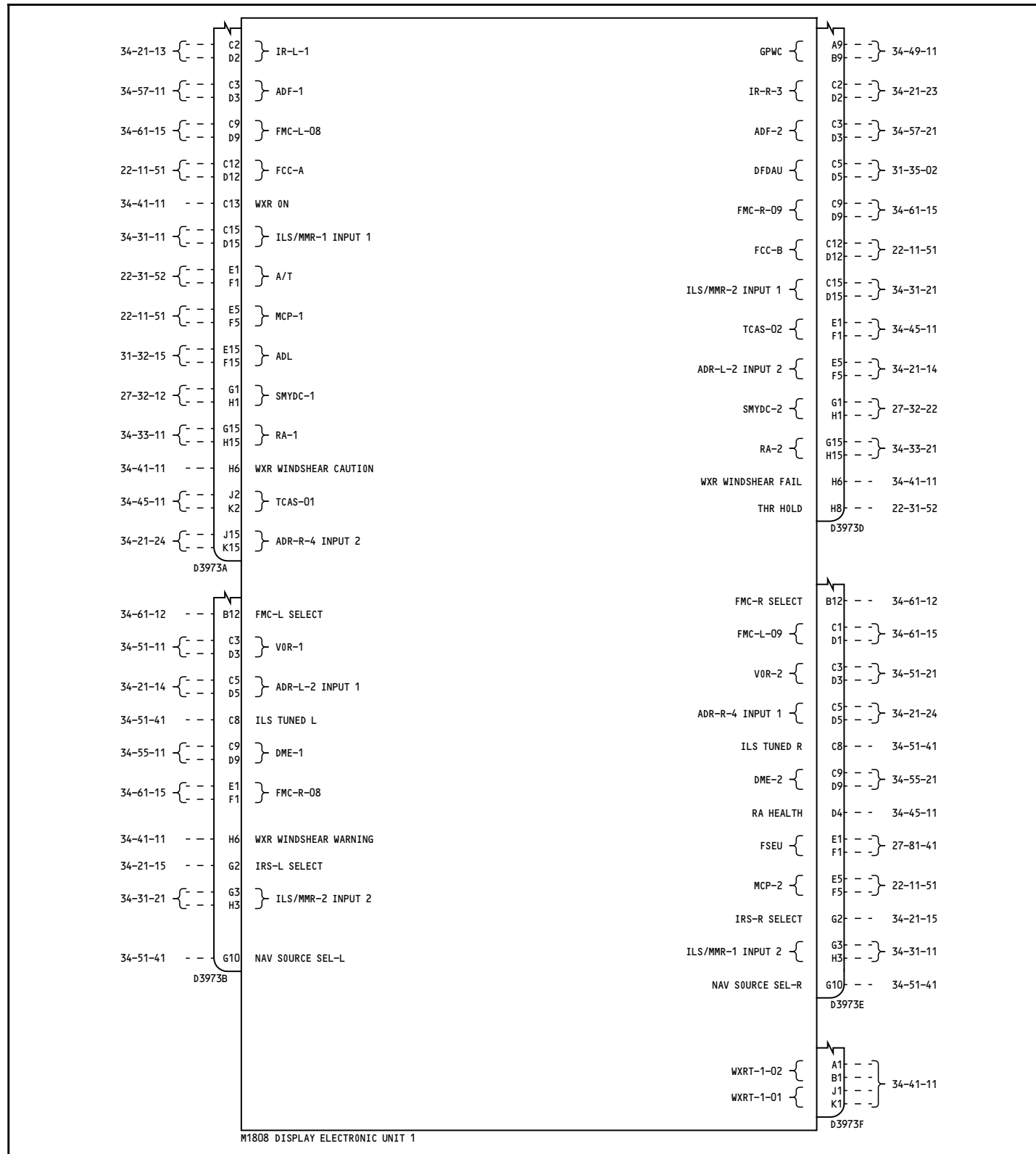

E3-1 SHELF

YC012-YC030

CDS - DEU 1 AVIONICS INTERFACES

D280A103

31-62-15

Page 3
Sheet 1
Jul 17/2007

31-62-15

Page 3
Sheet 1
Jul 17/2007

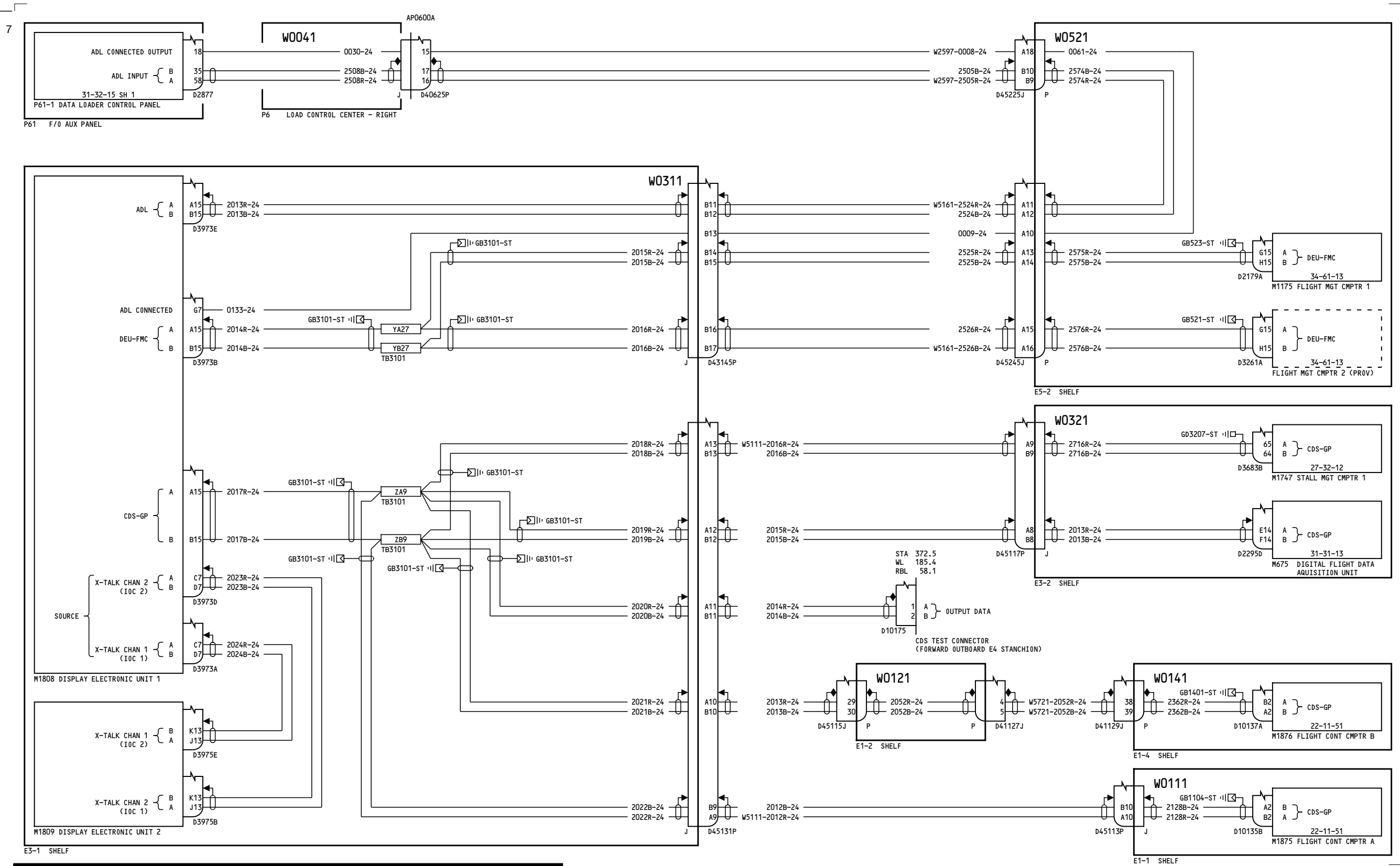

YC012-YC030

CDS - DEU 1 AVIONICS INTERFACES

31-62-15

Page 3
Sheet 2
Jul 17/2007

D280A103

31-62-15

Page 3
Sheet 2
Jul 17/2007

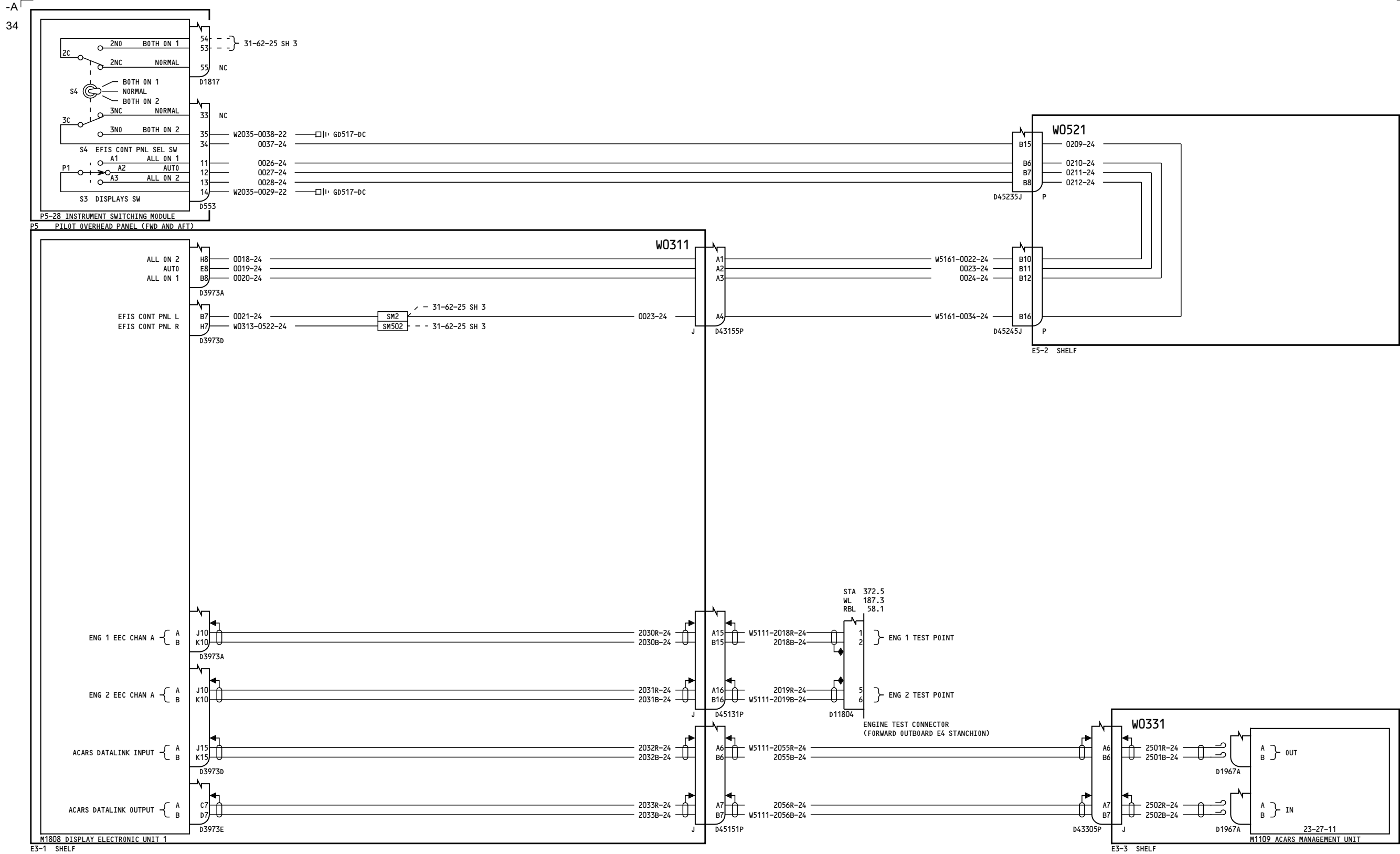

YC012-YC030

CDS - DEU 1 AVIONICS INTERFACES

31-62-15

Page 3
Sheet 3
Jul 17/2007

D280A103

31-62-15

Page 3
Sheet 3
Jul 17/2007

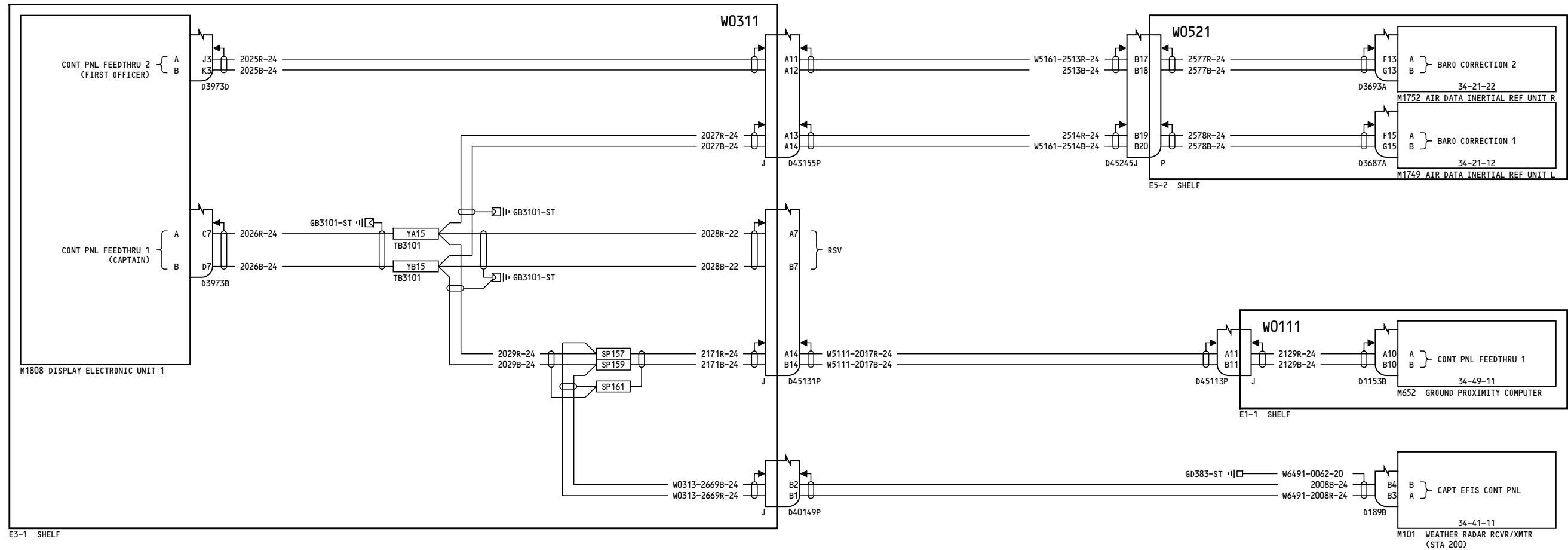

YC012-YC030

CDS - DEU 1 AVIONICS INTERFACES

31-62-15

Page 3
Sheet 4
Jul 17/2007

D280A103

31-62-15

Page 3
Sheet 4
Jul 17/2007

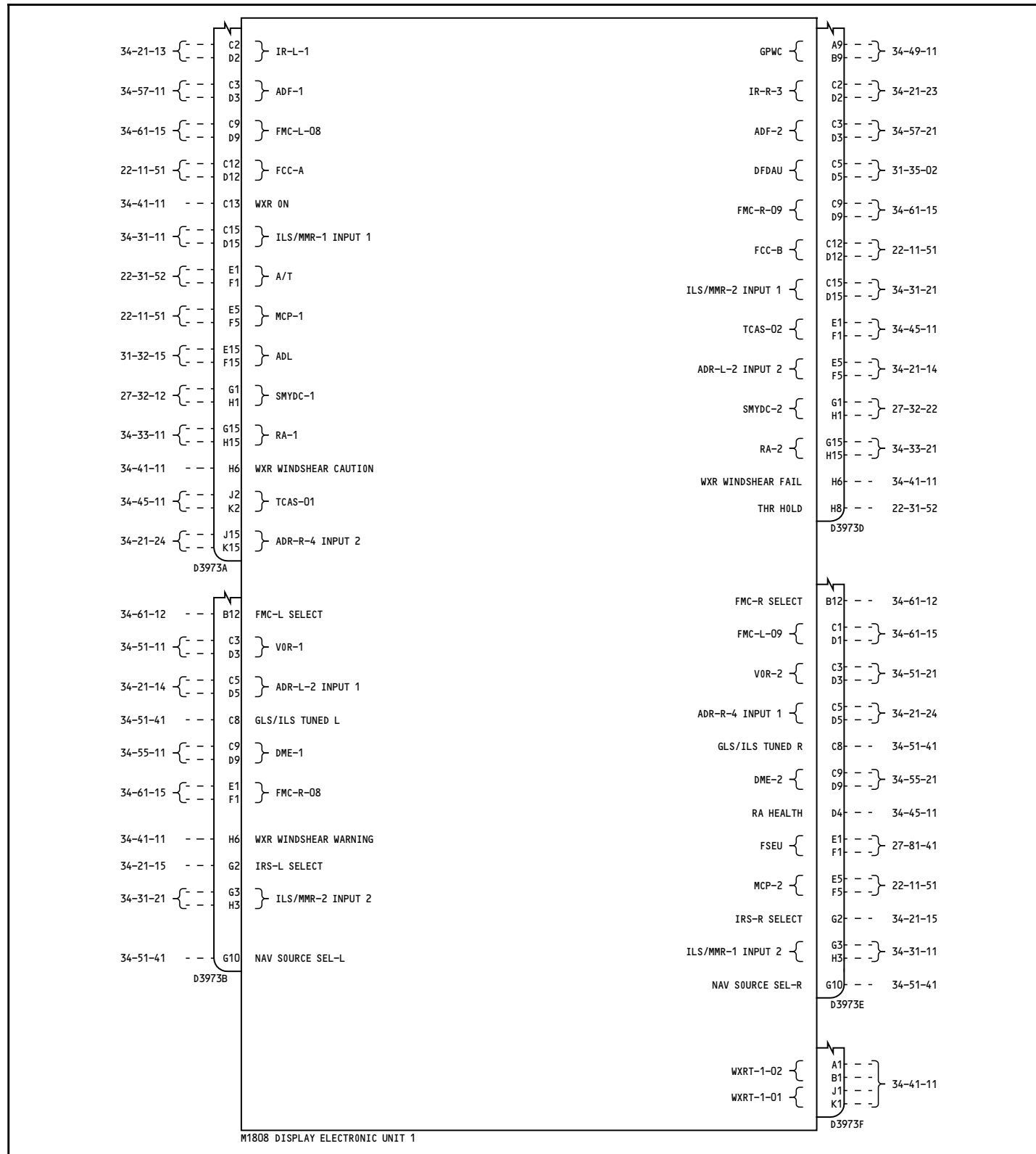

M1808 DISPLAY ELECTRONIC UNIT 1

E3-1 SHELF

YK901-YK906

CDS - DEU 1 AVIONICS INTERFACES

D280A103

31-62-15

Page 4
Sheet 1
Oct 20/2006

31-62-15

Page 4
Sheet 1
Oct 20/2006

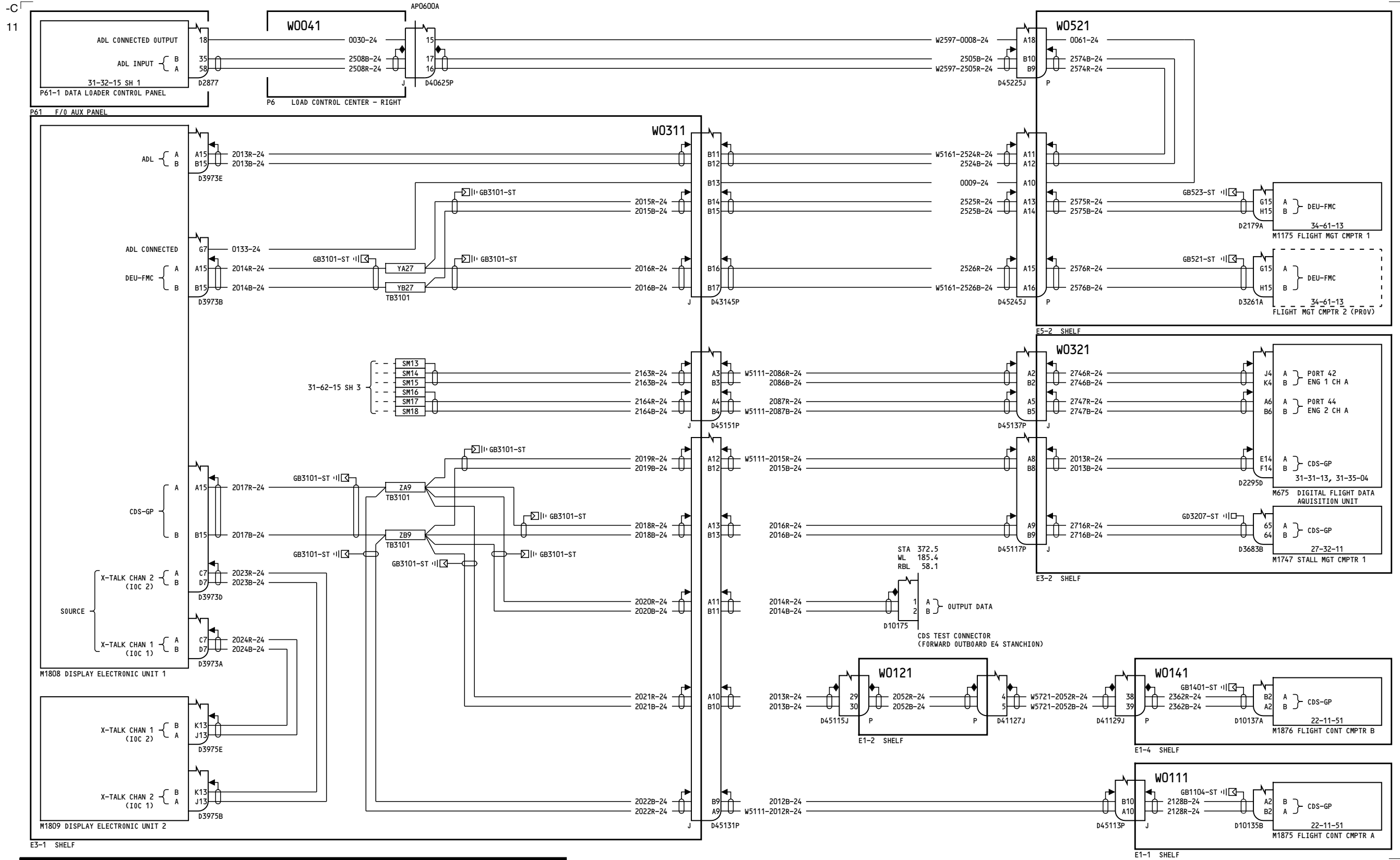

YK901-YK906

CDS - DEU 1 AVIONICS INTERFACES

31-62-15

Page 4
Sheet 2
May 13/2008

D280A103

31-62-15

Page 4
Sheet 2
May 13/2008

131

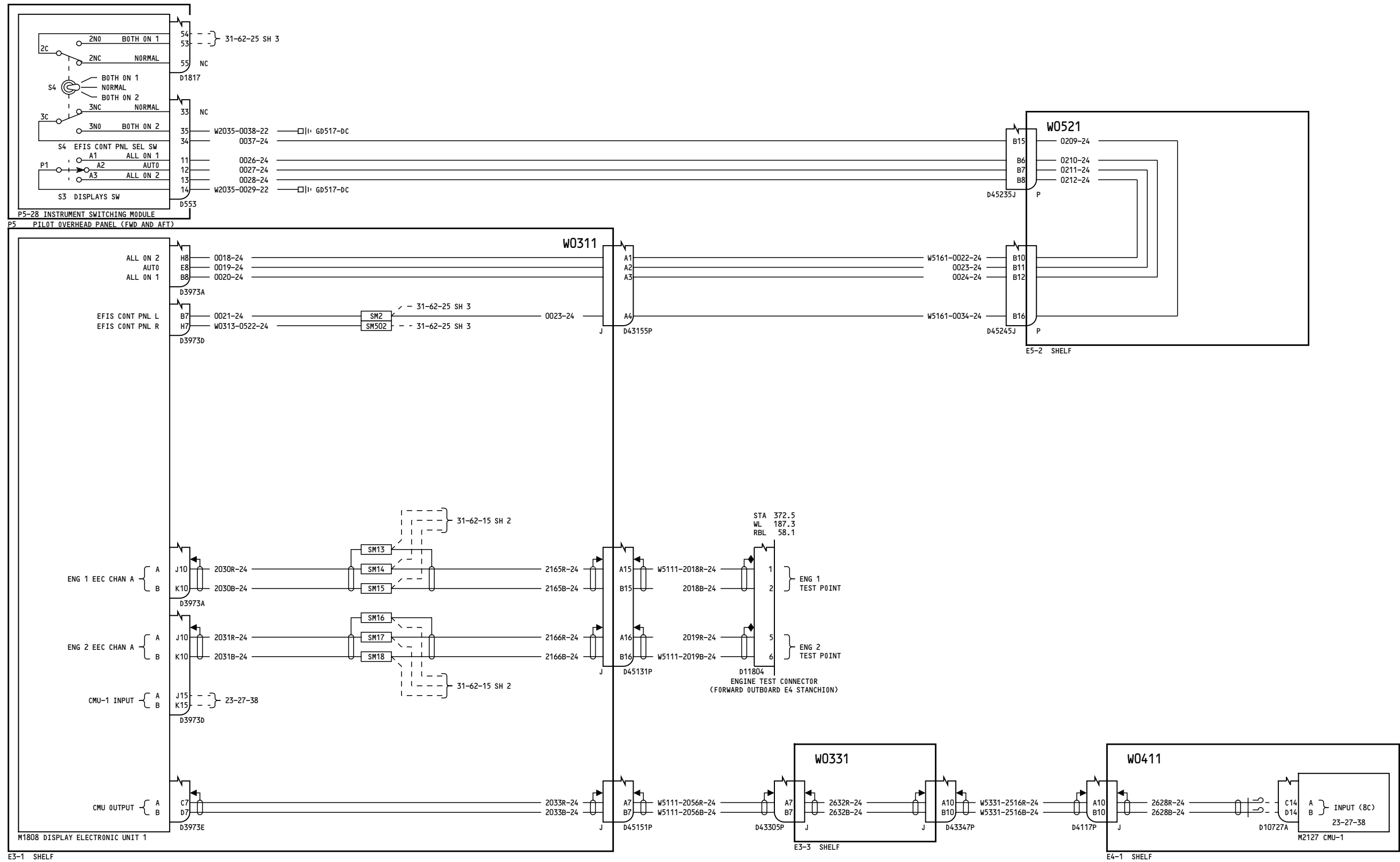

YK901-YK906

CDS - DEU 1 AVIONICS INTERFACES

D280A103

31-62-15

Page 4
Sheet 3
Oct 20/2006

31-62-15

Page 4
Sheet 3
Oct 20/2006

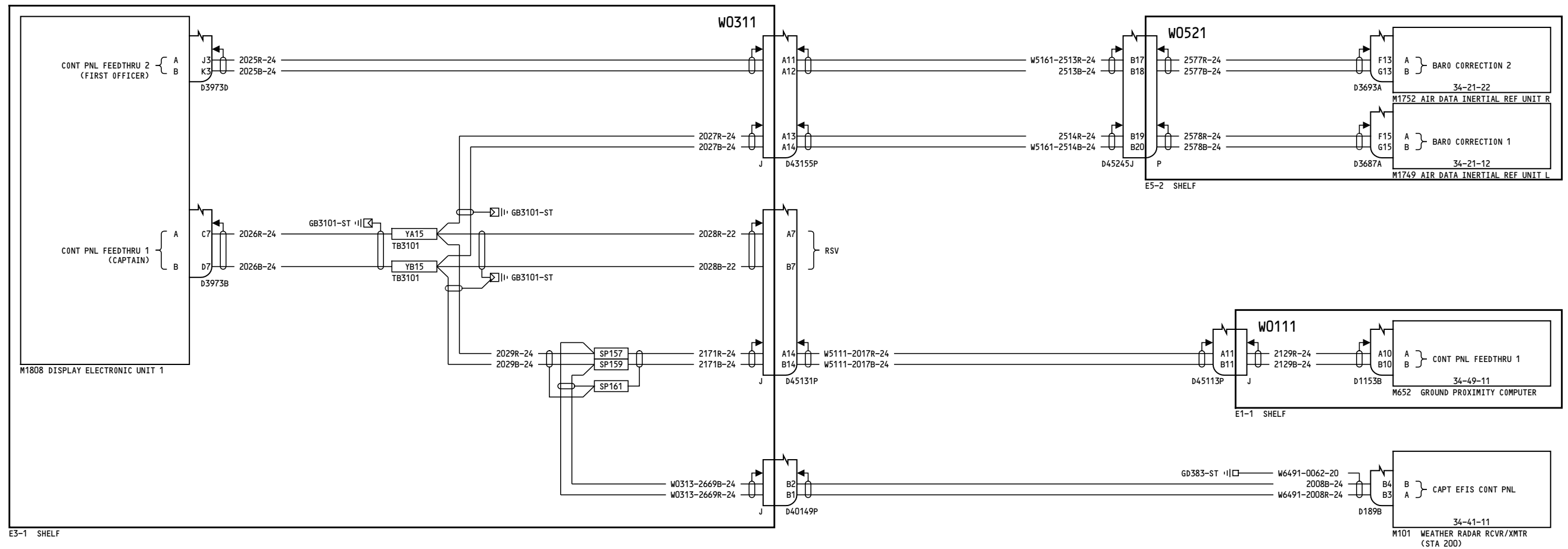

YK901-YK906

**CDS - DEU 1 AVIONICS
INTERFACES**

D280A103

31-62-15

Page 4
Sheet 4
Oct 20/2006

31-62-15

Page 4
Sheet 4
Oct 20/2006

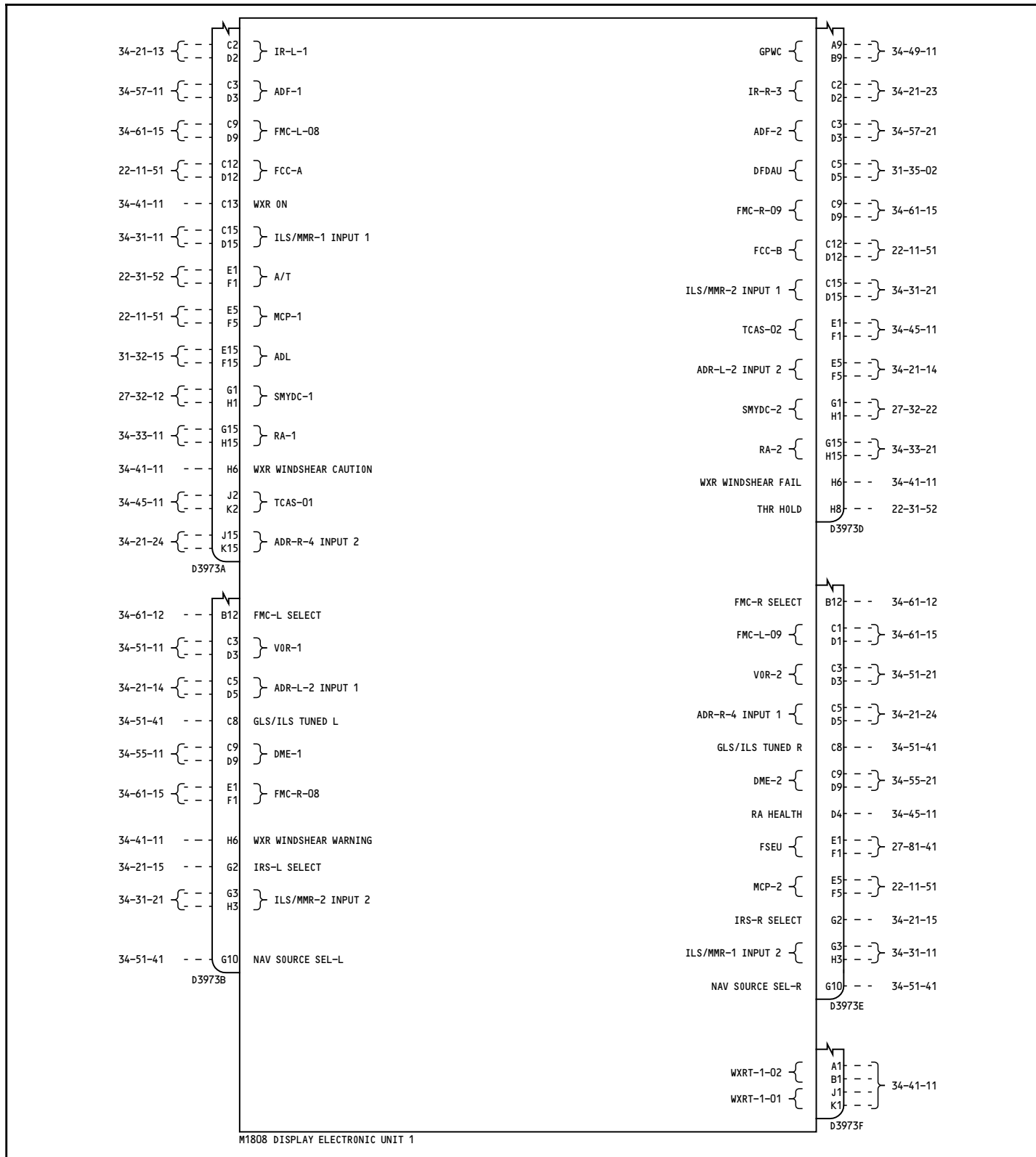

E3-1 SHELF

M1808 DISPLAY ELECTRONIC UNIT 1

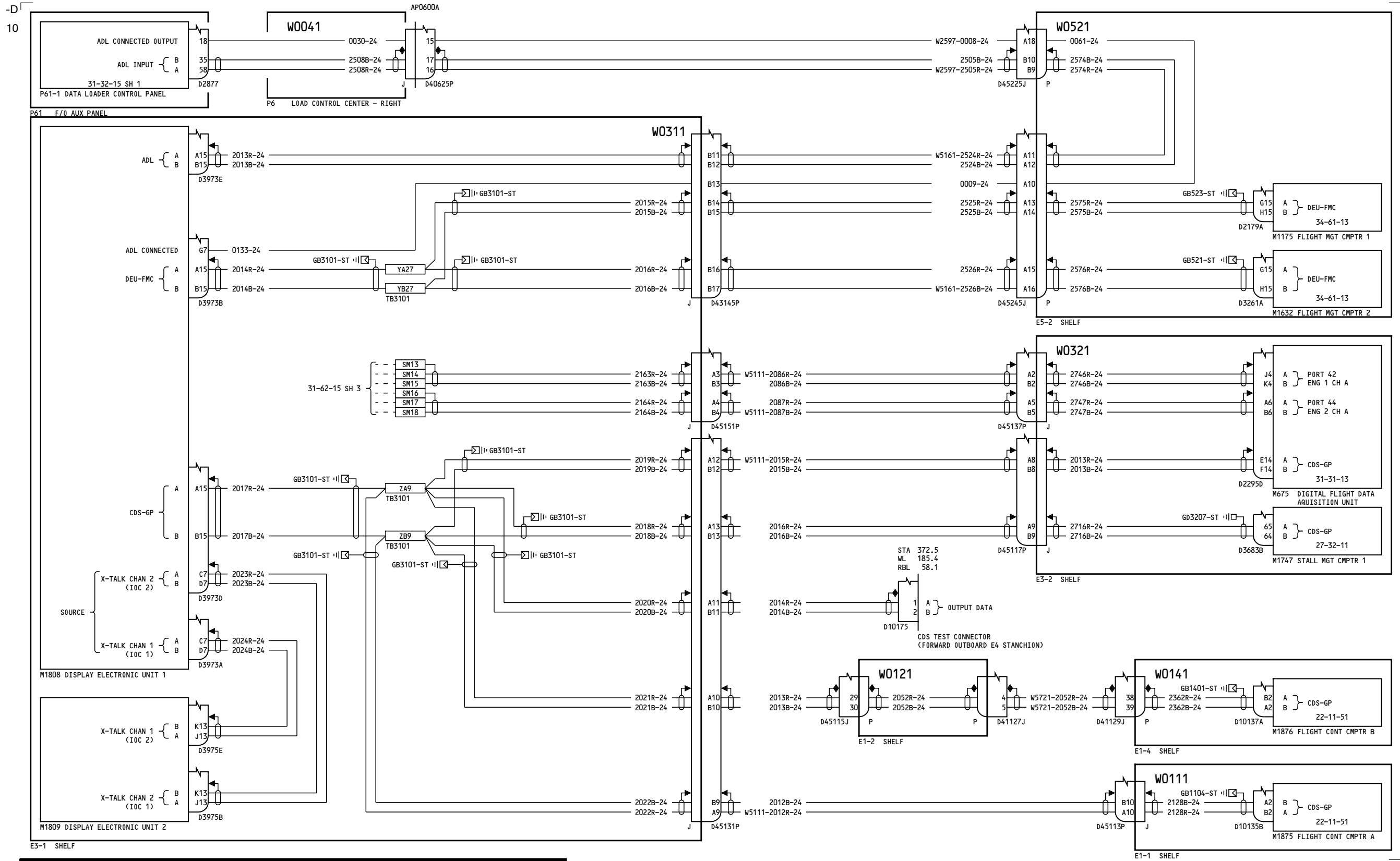

YK907-YM670

CDS - DEU 1 AVIONICS INTERFACES

31-62-15

Page 5
Sheet 2
Feb 09/2009

D280A103

31-62-15

Page 5
Sheet 2
Feb 09/2009

-A
131

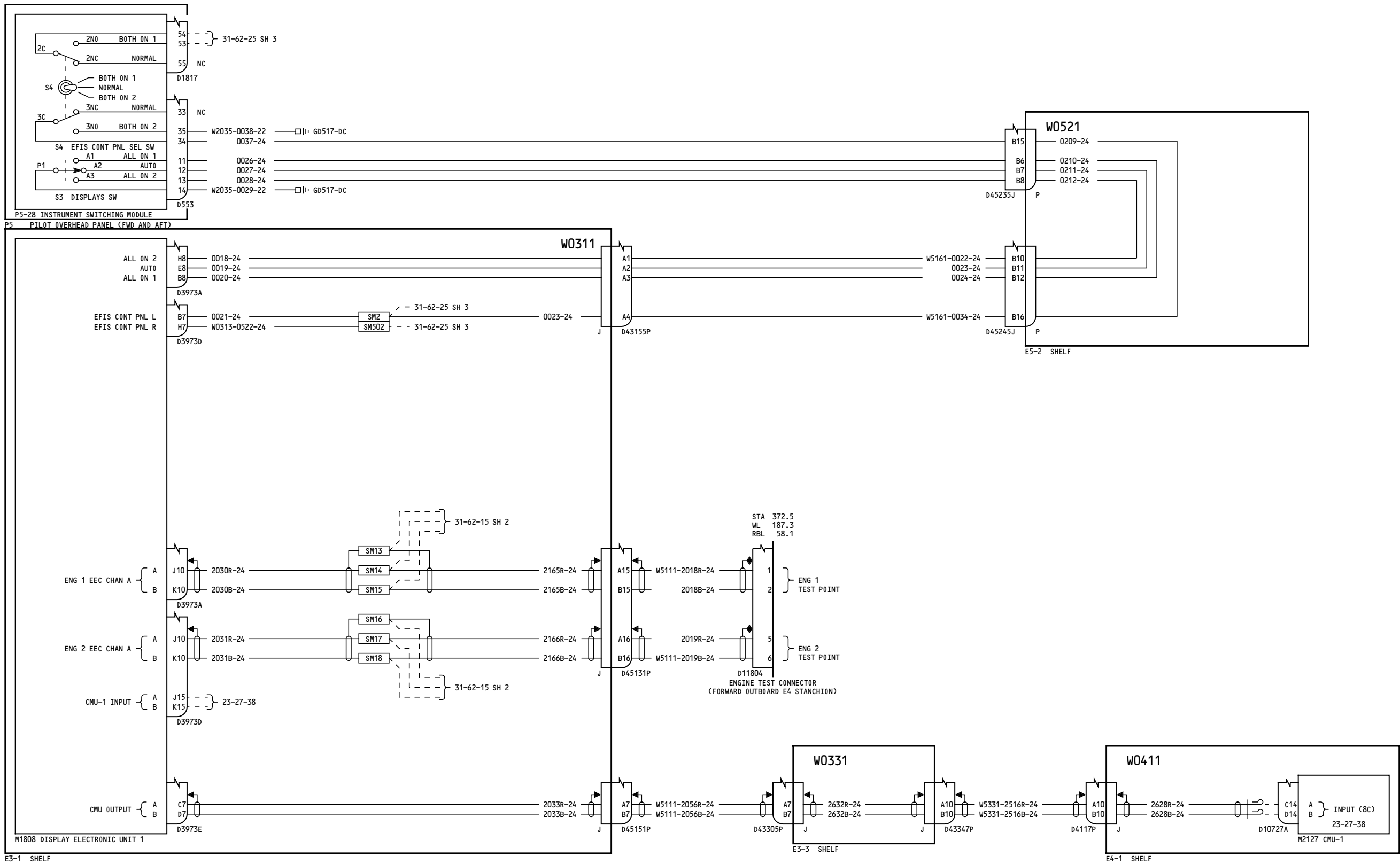

YK907-YM670

CDS - DEU 1 AVIONICS INTERFACES

D280A103

31-62-15

Page 5
Sheet 3
Feb 09/2009

31-62-15

Page 5
Sheet 3
Feb 09/2009

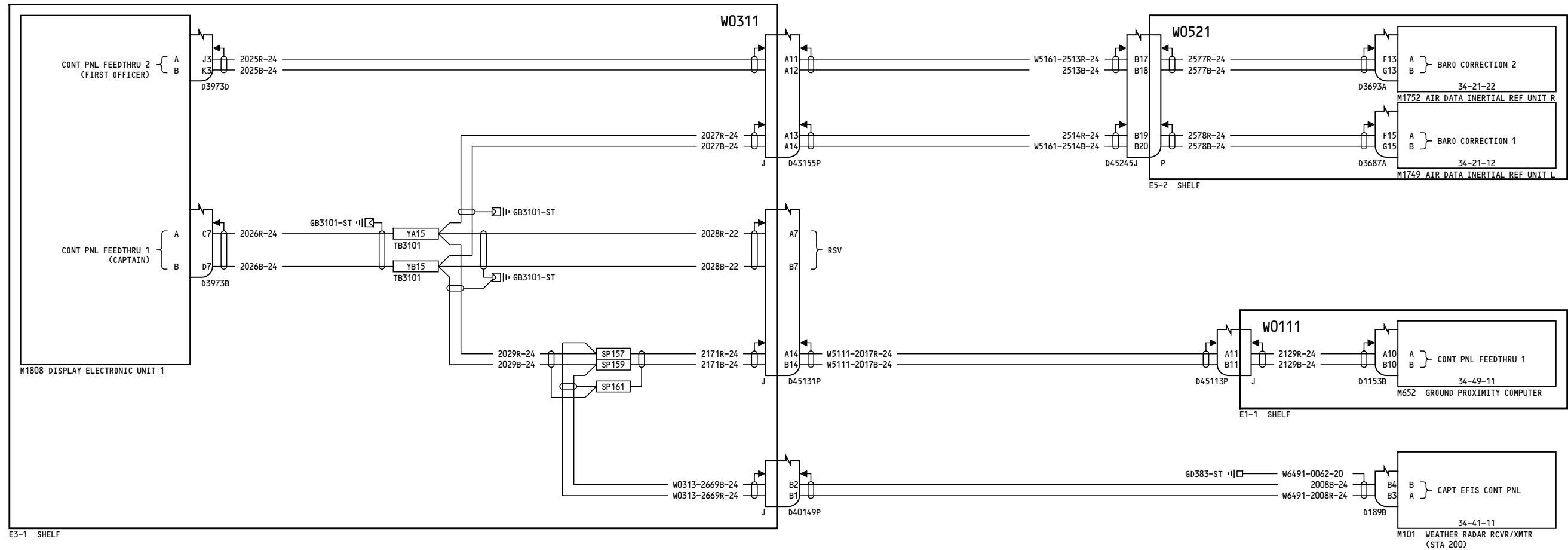

YK907-YM670

CDS - DEU 1 AVIONICS INTERFACES

D280A103

31-62-15

Page 5
Sheet 4
Feb 09/2009

31-62-15

Page 5
Sheet 4
Feb 09/2009

-B

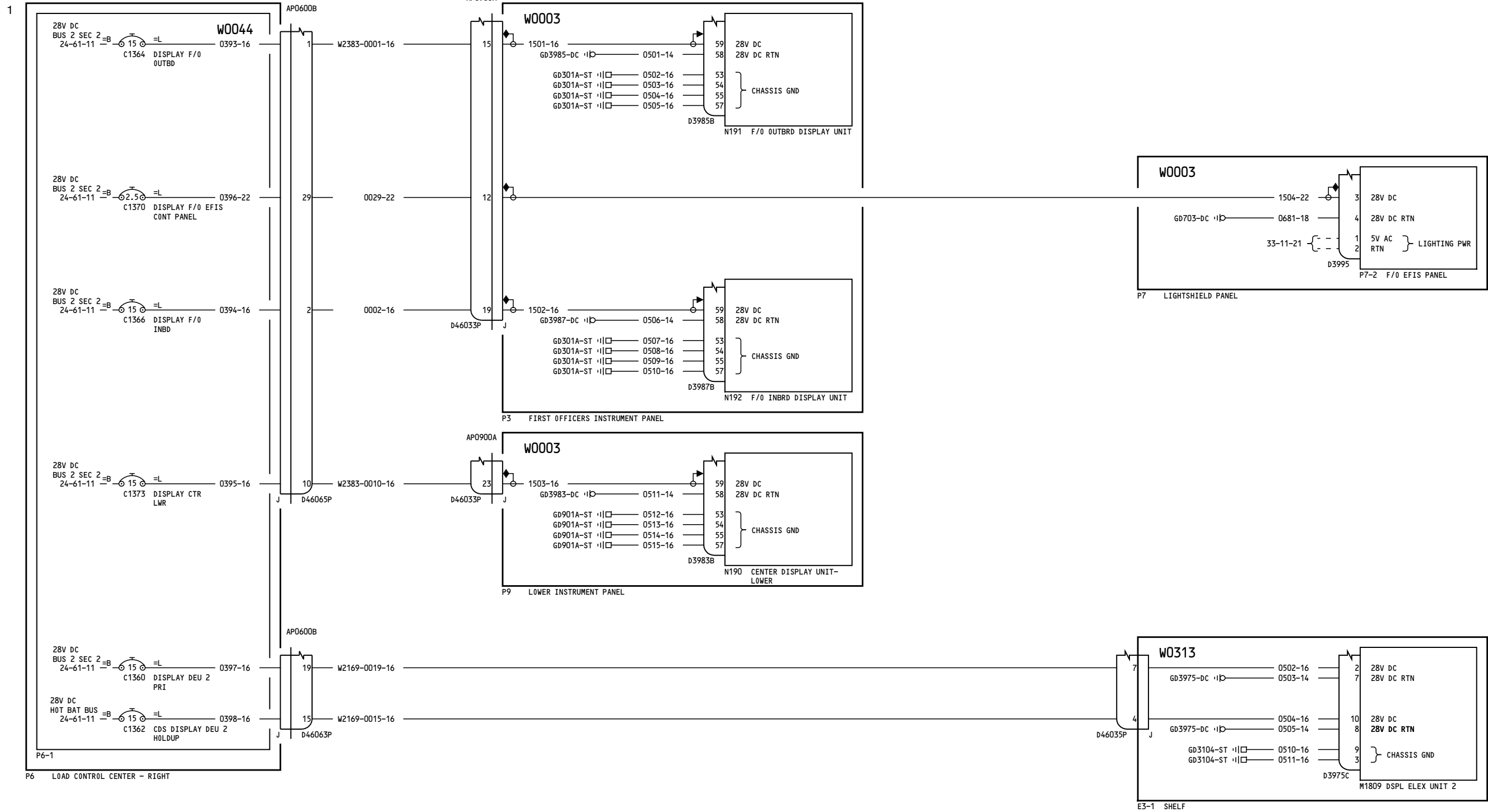

ALL

CDS - POWER DISTRIBUTION AND INSTRUMENT LIGHTING FIRST OFFICER

31-62-21

31-62-21

D280A103

Page 1
Sheet 1
Feb 09/2009

Page 1
Sheet 1
Feb 09/2009

-D

1

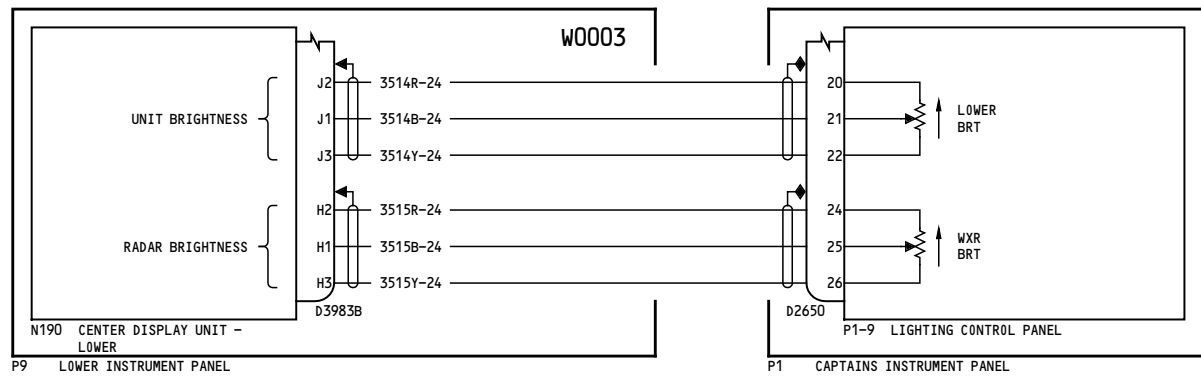
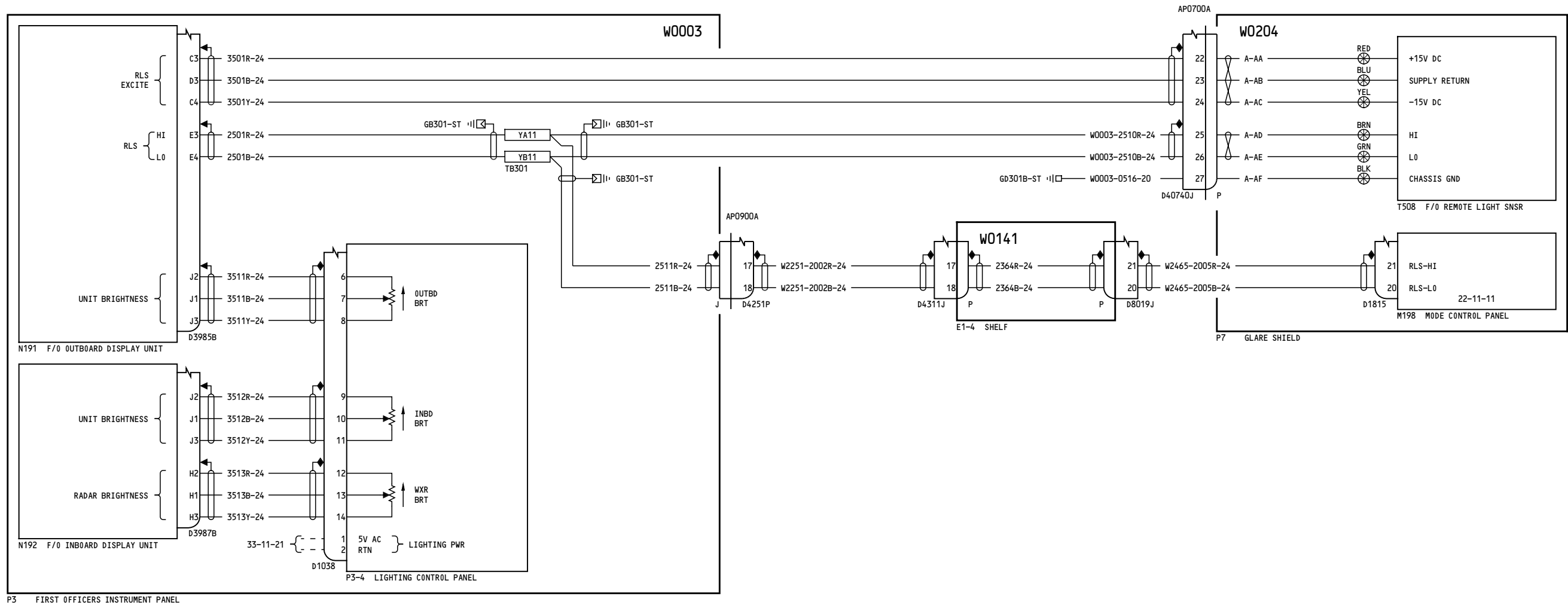

ALL

CDS - POWER DISTRIBUTION AND INSTRUMENT LIGHTING FIRST OFFICER

D280A103

31-62-21

Page 1
Sheet 2
Feb 09/2009

31-62-21

Page 1
Sheet 2
Feb 09/2009

-C
1

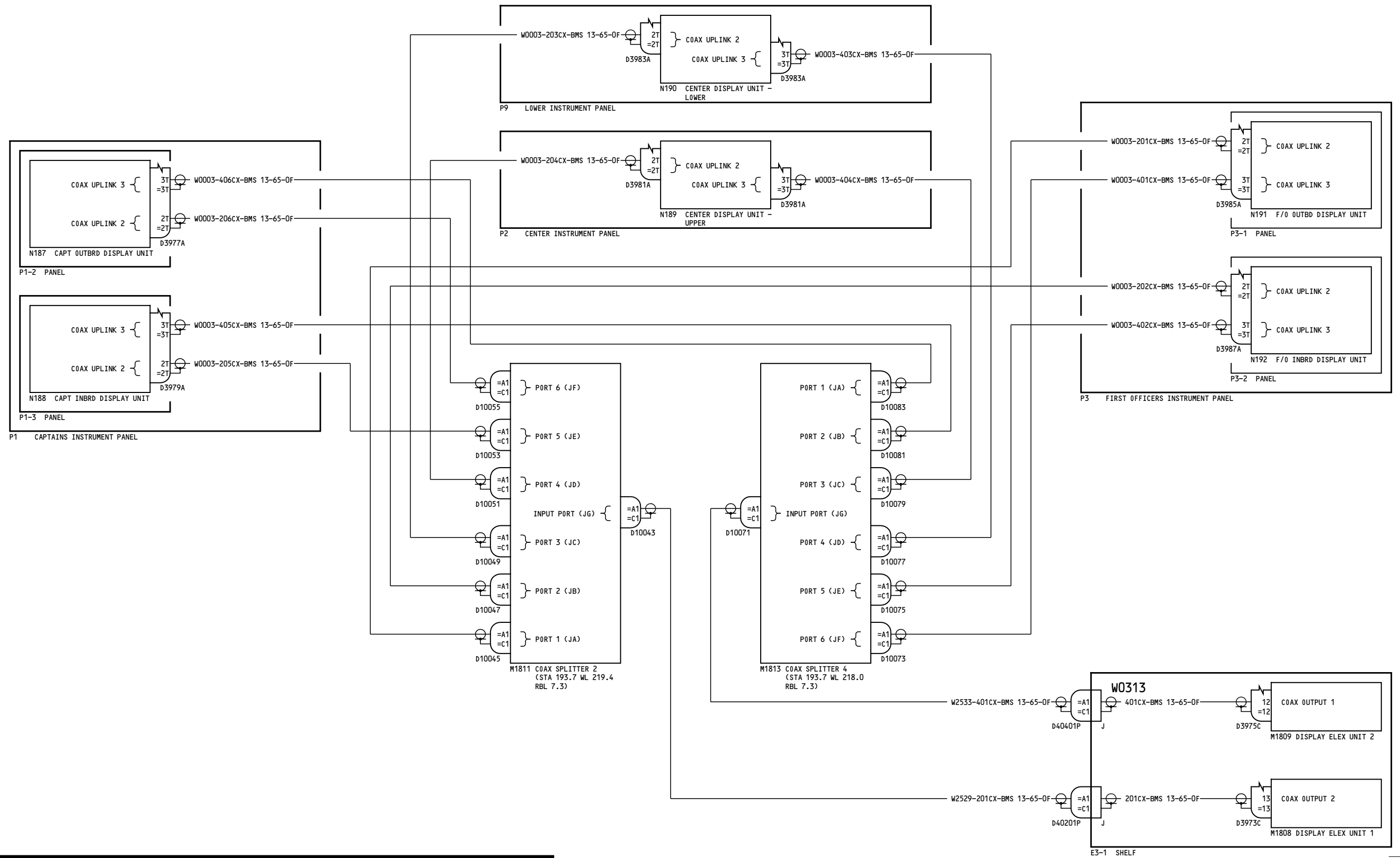

ALL

CDS - VIDEO COAX SPLITTERS 2 AND 4 DU STATUS

D280A103

31-62-22

Page 1
Sheet 1
Feb 09/2009

31-62-22

Page 1
Sheet 1
Feb 09/2009

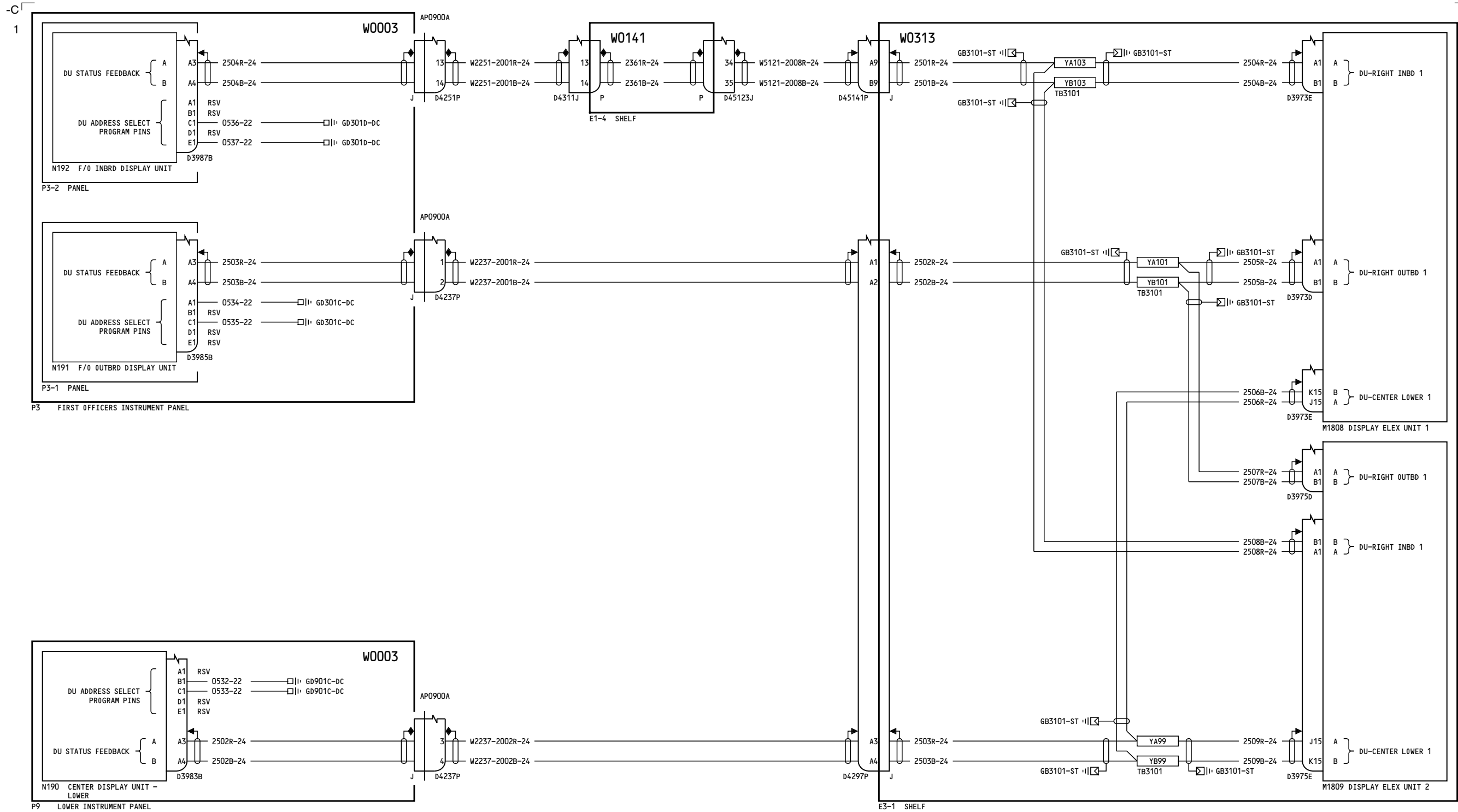

ALL

**CDS - VIDEO COAX
SPLITTERS 2 AND 4
DU STATUS**

31-62-22

Page 1
Sheet 2
Feb 09/2009

D280A103

31-62-22

Page 1
Sheet 2
Feb 09/2009

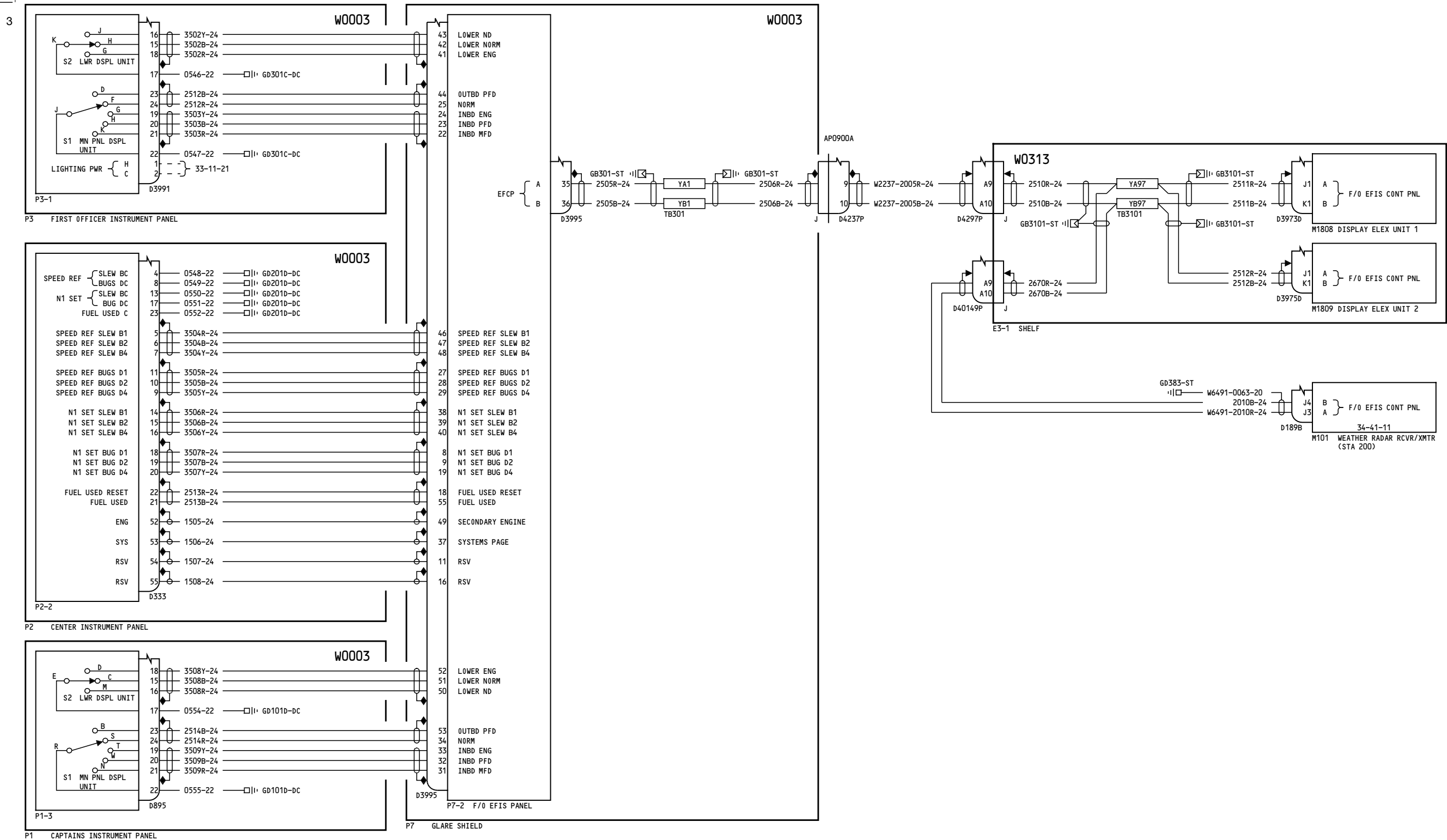

YC001-YC002, YC007

CDS - CONTROL PANEL INTERFACES - F/O

31-62-23

Page 1

D280A103

Mar 31/2005

31-62-23

Page 1

Mar 31/2005

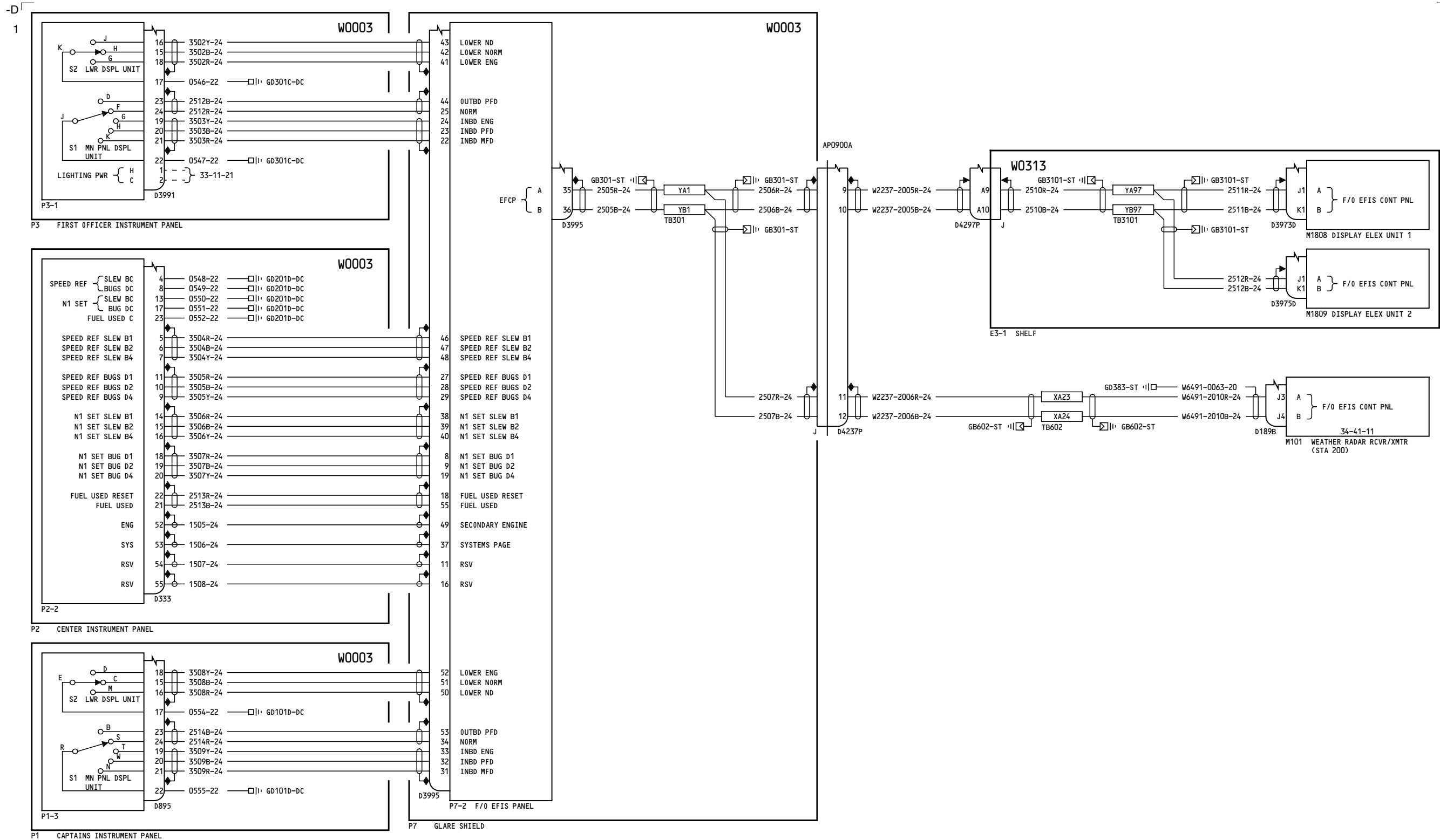

YC003

CDS - CONTROL PANEL INTERFACES - F/O

31-62-23

Page 2

D280A103

Mar 31/2005

31-62-23

Page 2

Mar 31/2005

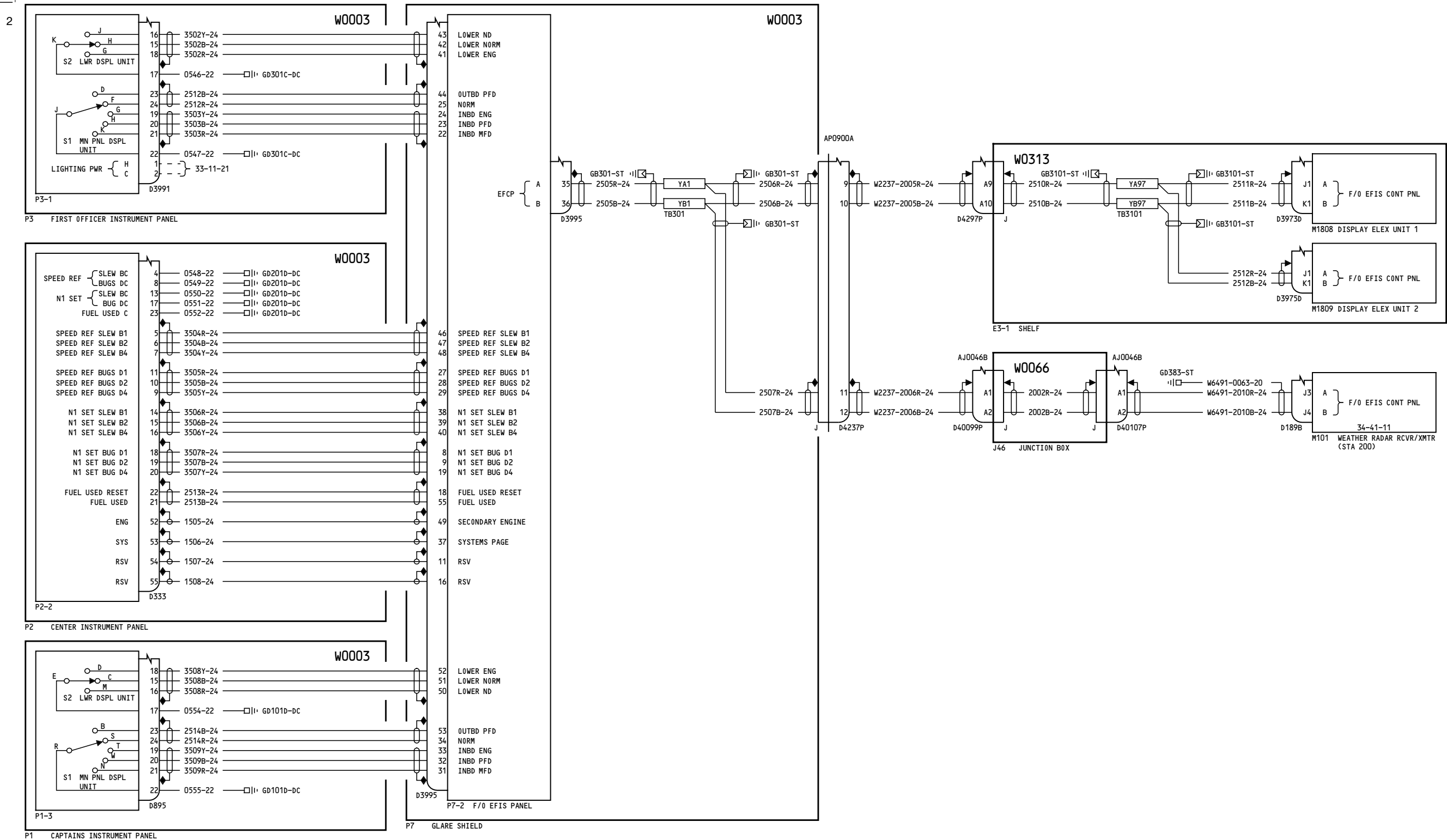

YC004-YC006

CDS - CONTROL PANEL INTERFACES - F/O

31-62-23

Page 3

D280A103

Mar 31/2005

31-62-23

Page 3

Mar 31/2005

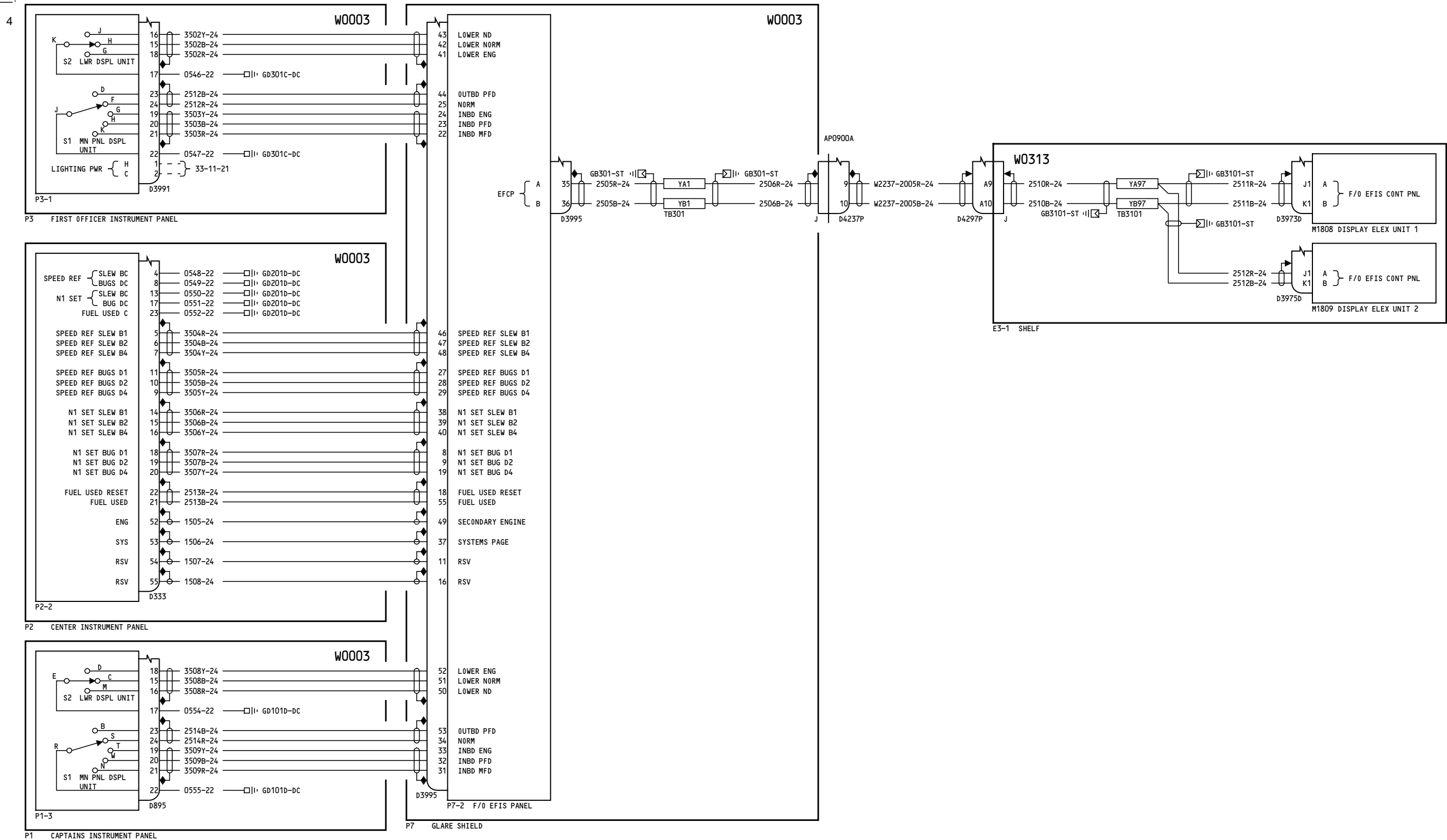

YC008-YK920, YM643-YM646

CDS - CONTROL PANEL INTERFACES - F/O

31-62-23

Page 4

D280A103

Feb 09/2009

31-62-23

Page 4

Feb 09/2009

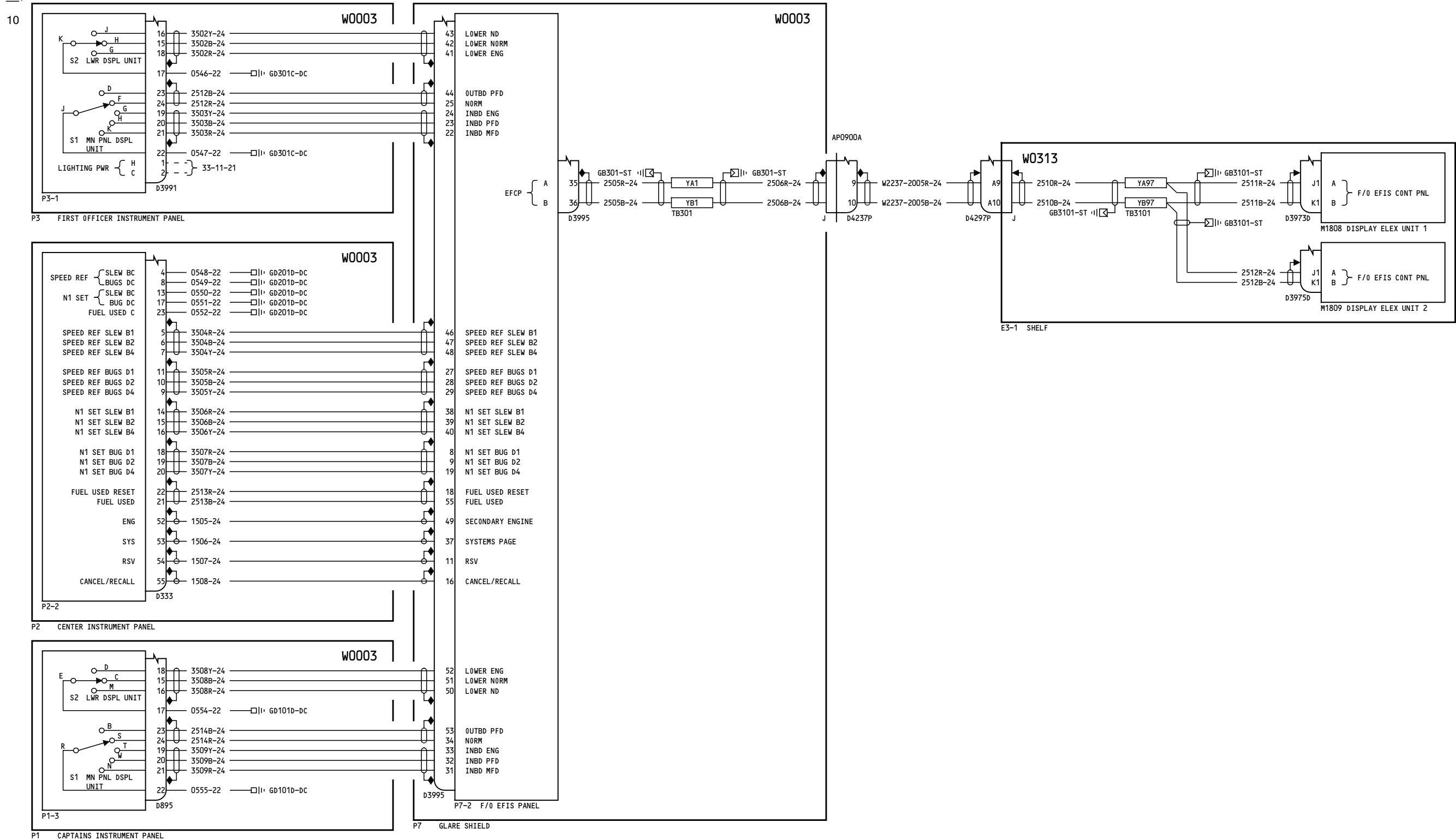

YL401-YL430, YM647-YM670

**CDS - CONTROL PANEL
INTERFACES - F/O**

31-62-23

Page 5

D280A103

Aug 13/2008

31-62-23

Page 5

Aug 13/2008

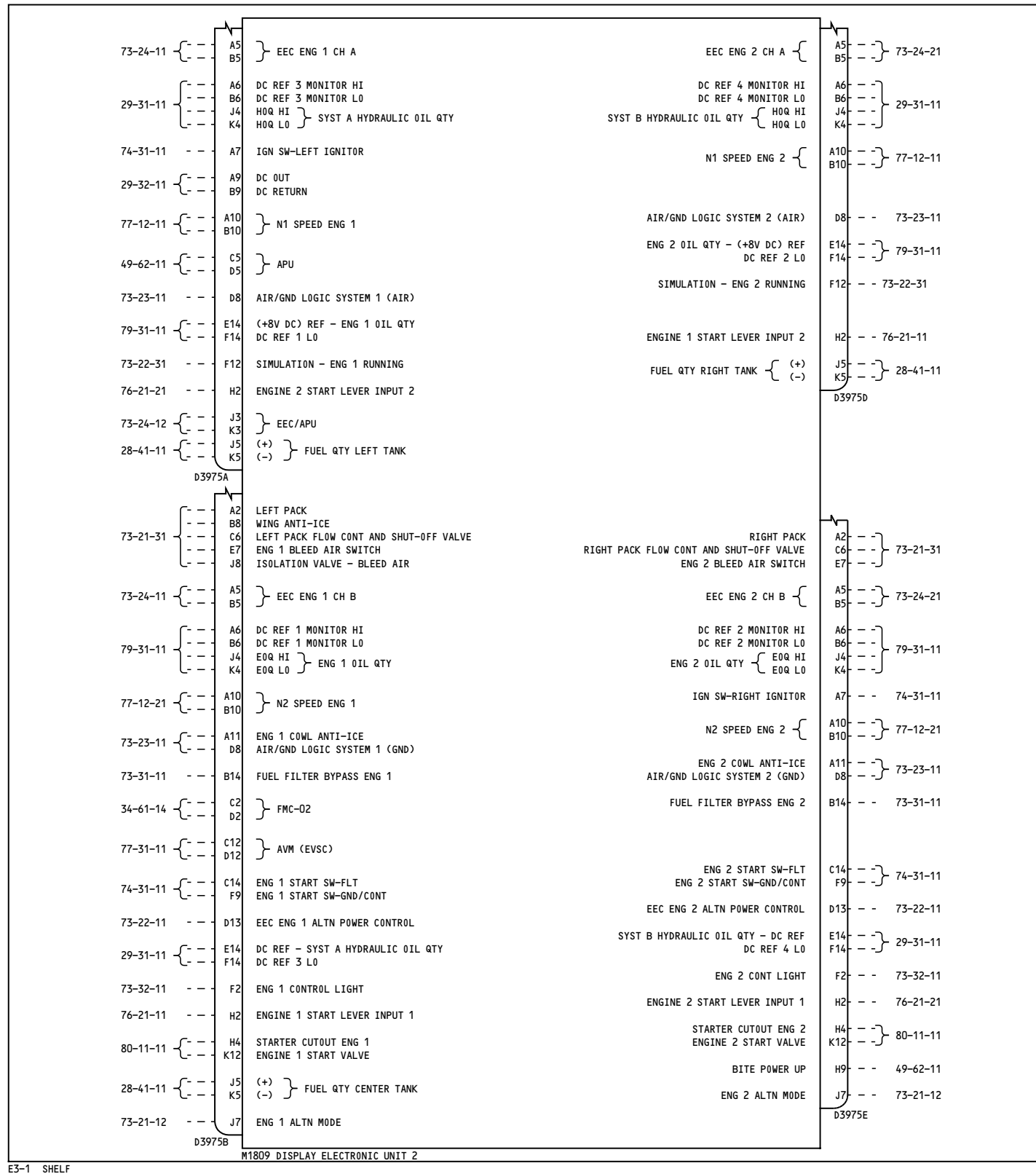

YC001-YC030

**CDS - DEU 2 ENGINE
HYDRAULIC, APU AND FUEL
INTERFACES**

D280A103

31-62-24

Page 1
Sheet 1
Jul 17/2007

31-62-24

Page 1
Sheet 1
Jul 17/2007

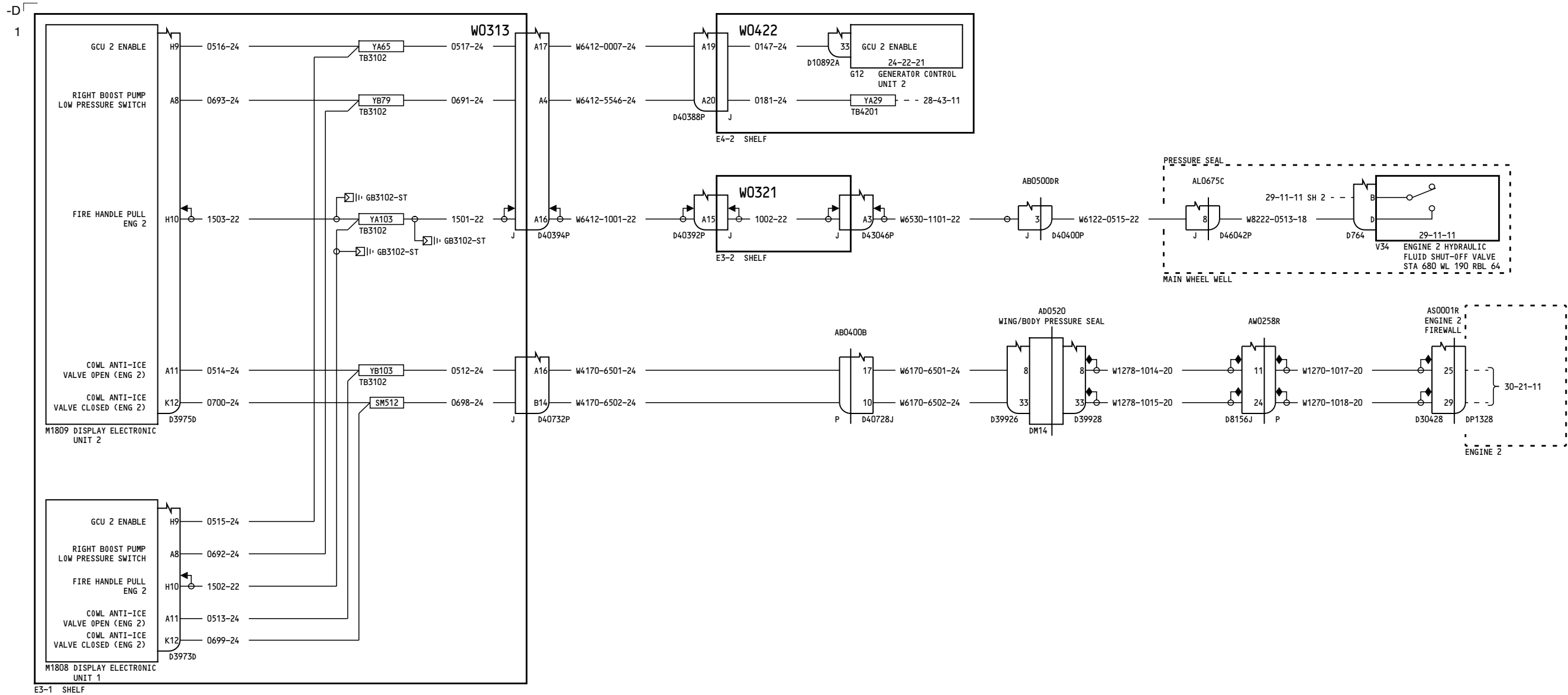

YC001-YC030

**CDS - DEU 2 ENGINE
HYDRAULIC, APU AND FUEL
INTERFACES**

D280A103

31-62-24

Page 1
Sheet 2
Jul 17/2007

31-62-24

Page 1
Sheet 2
Jul 17/2007

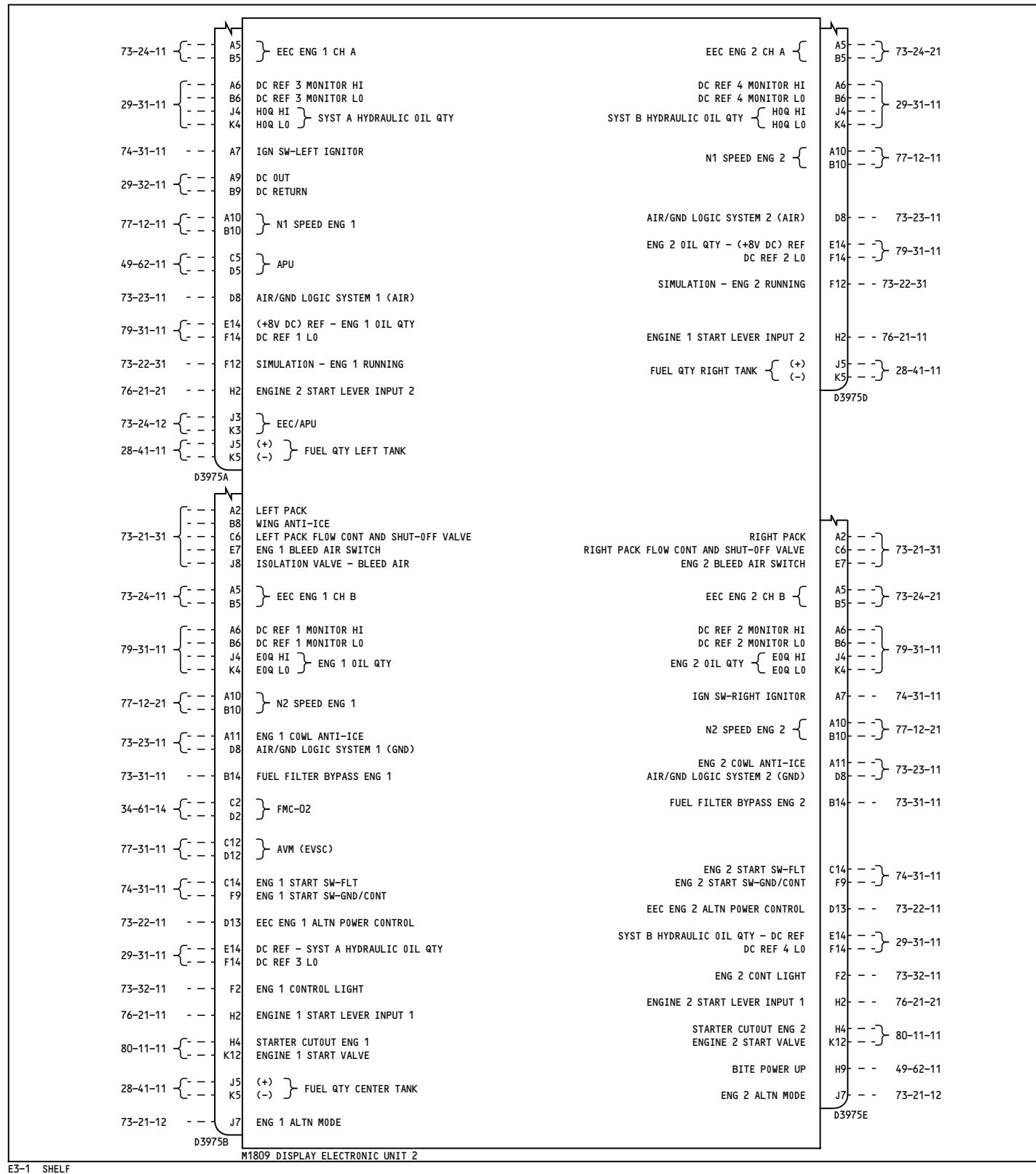

E3-1 SHELF

YC031-YM670

**CDS - DEU 2 ENGINE
HYDRAULIC, APU AND FUEL
INTERFACES**

D280A103

31-62-24

Page 2
Sheet 1
Feb 09/2009

31-62-24

Page 2
Sheet 1
Feb 09/2009

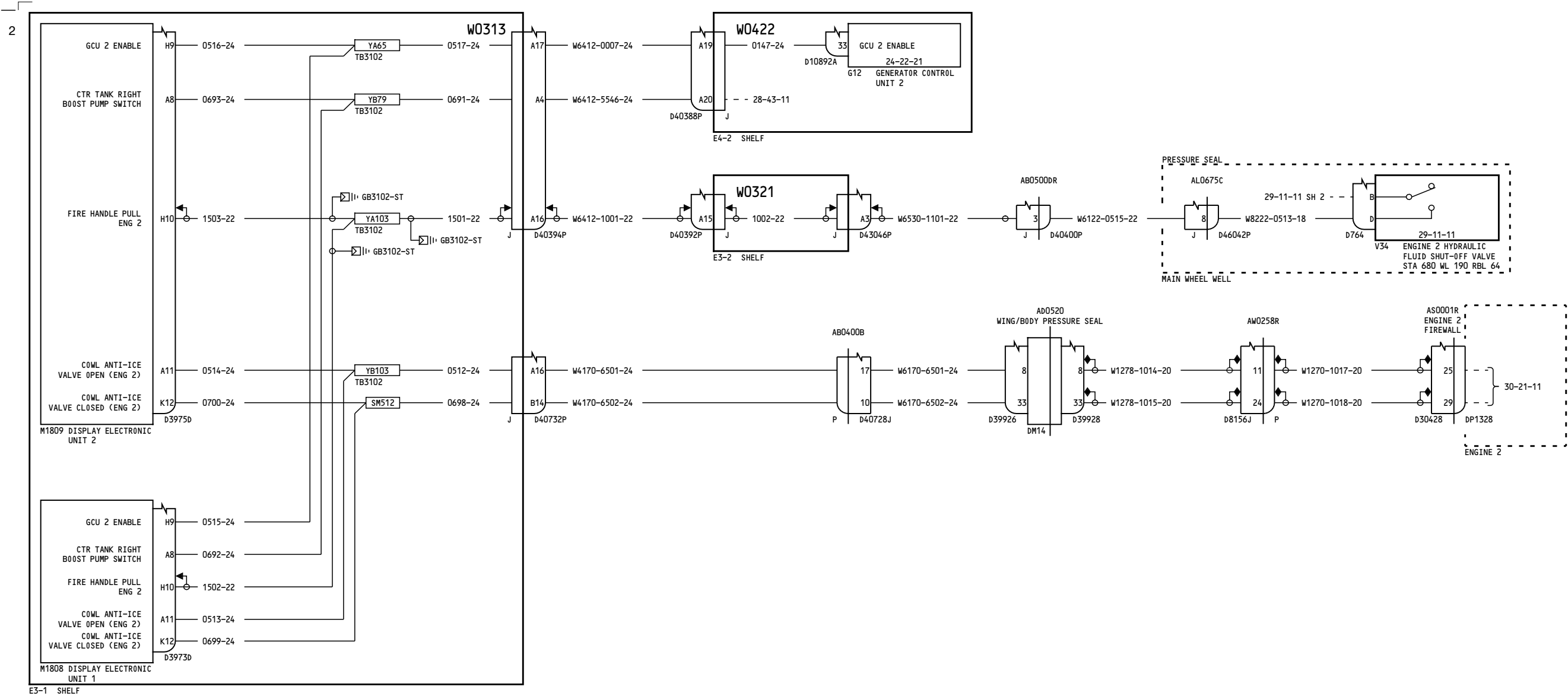

YC031-YM670

**CDS - DEU 2 ENGINE
HYDRAULIC, APU AND FUEL
INTERFACES**

D280A103

31-62-24

Page 2
Sheet 2
Feb 09/2009

31-62-24

Page 2
Sheet 2
Feb 09/2009

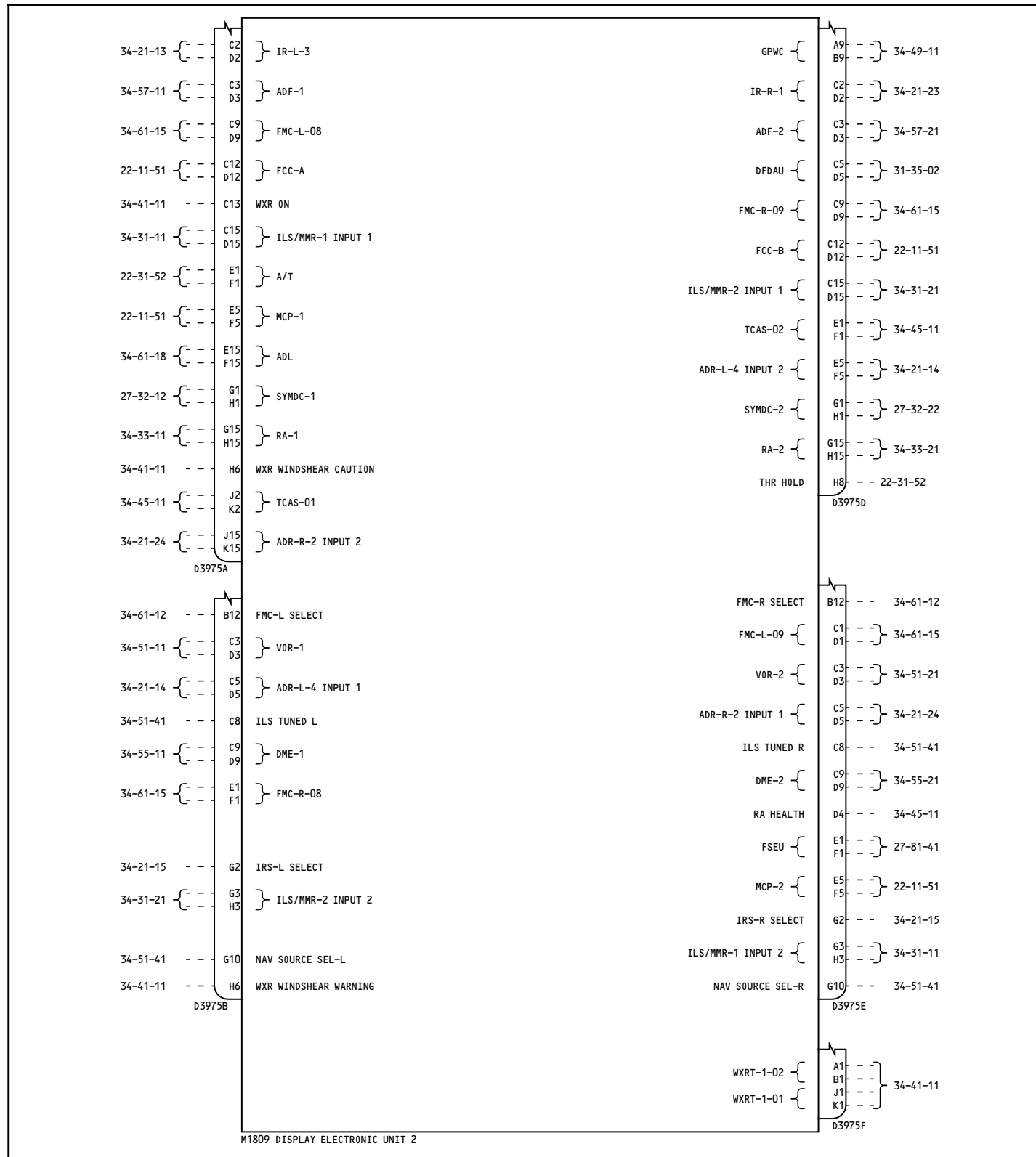

E3-1 SHELF

YC001-YC007

CDS - DEU 2 AVIONICS INTERFACES

D280A103

31-62-25

Page 1.1A
Sheet 1
Mar 31/2005

Incorporates
31-1136

31-62-25

Page 1.1A
Sheet 1
Mar 31/2005

-A
13

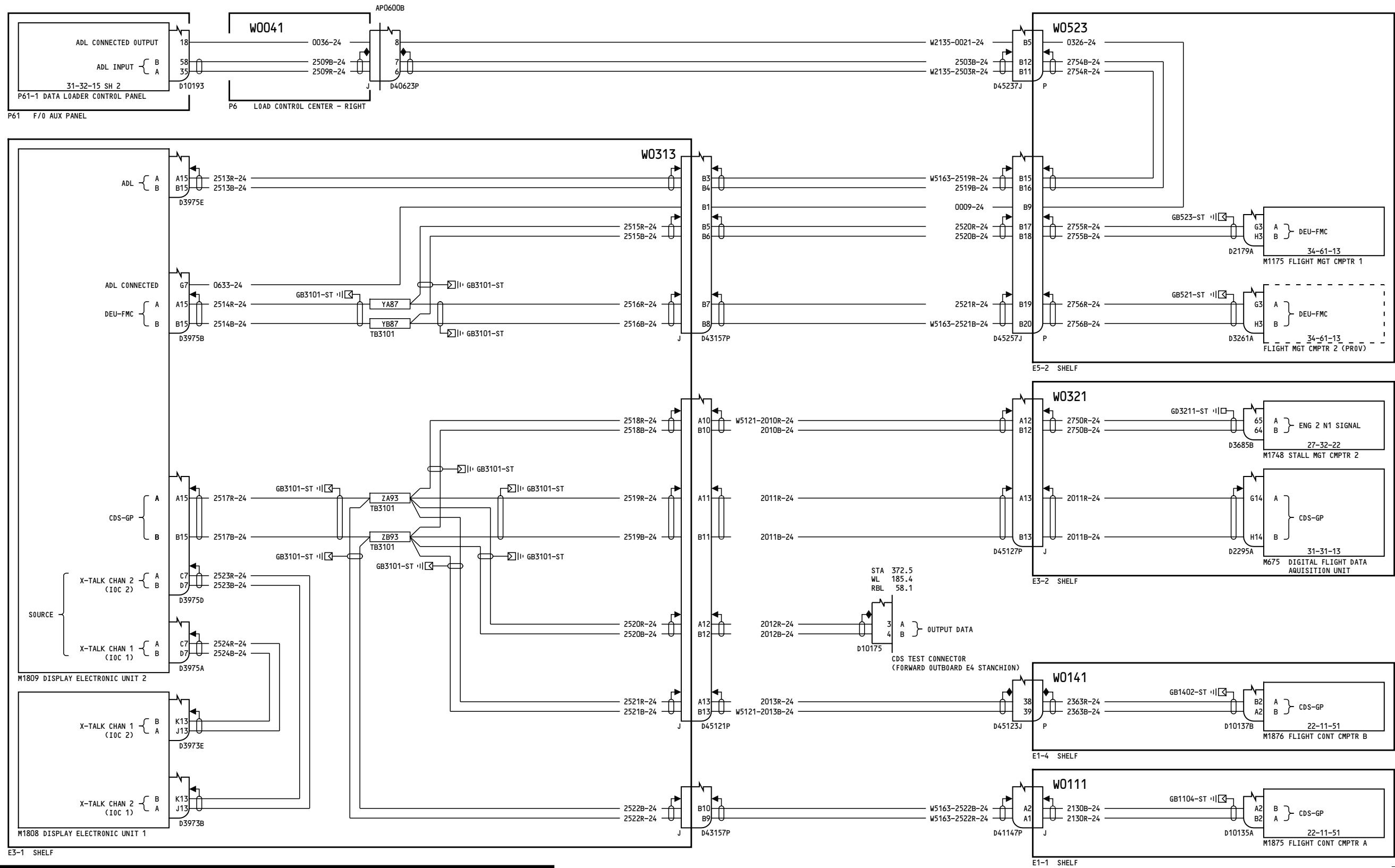

YC001-YC007

CDS - DEU 2 AVIONICS INTERFACES

31-62-25

Page 1.1A
Sheet 2
Mar 31/2005

D280A103

Incorporates
31-1136

31-62-25

Page 1.1A
Sheet 2
Mar 31/2005

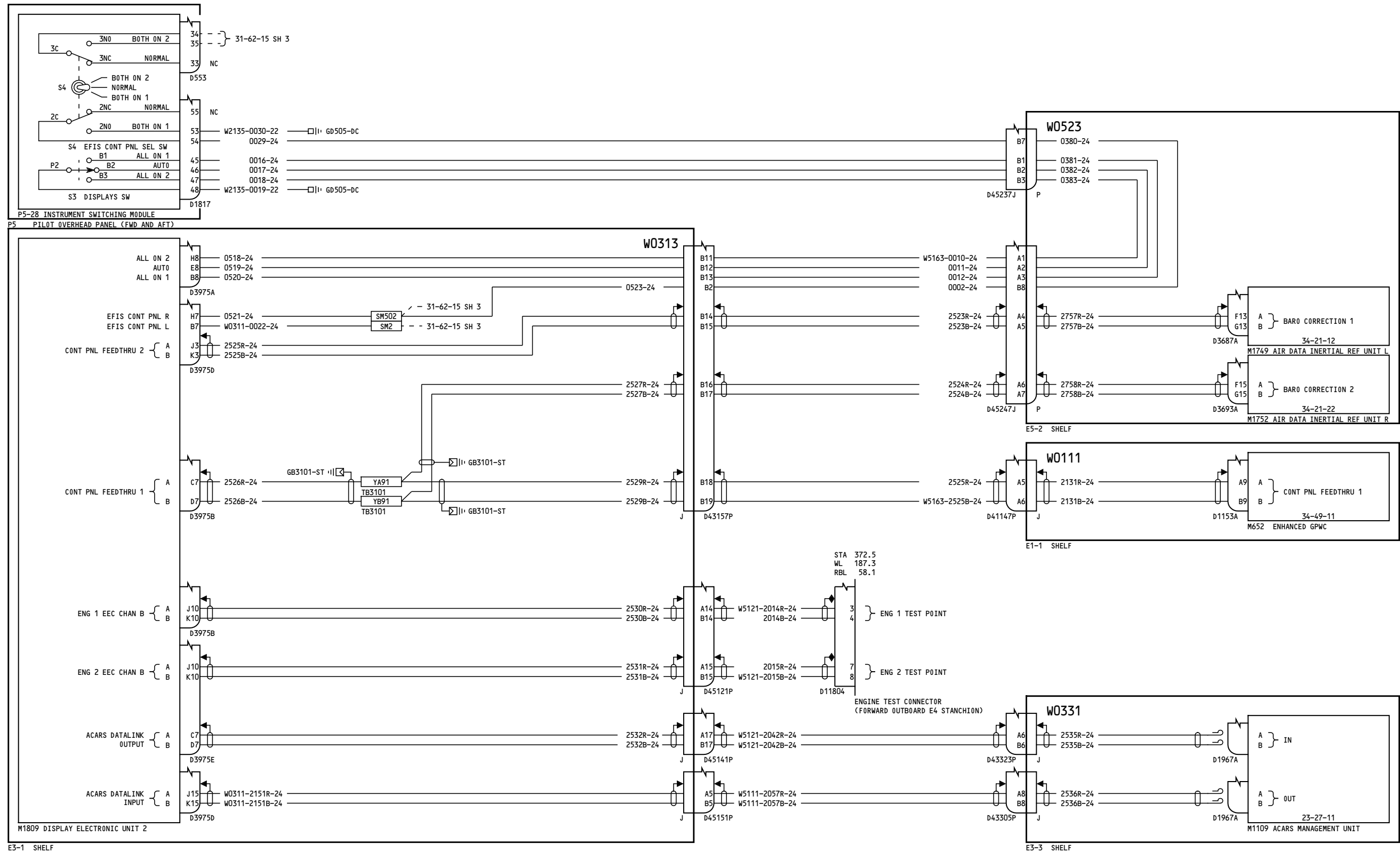

YC001-YC007

CDS - DEU 2 AVIONICS INTERFACES

31-62-25

Page 1.1A
Sheet 3
Mar 31/2005

D280A103

Incorporates
737-EB34-0155 R04

31-62-25

Page 1.1A
Sheet 3
Mar 31/2005

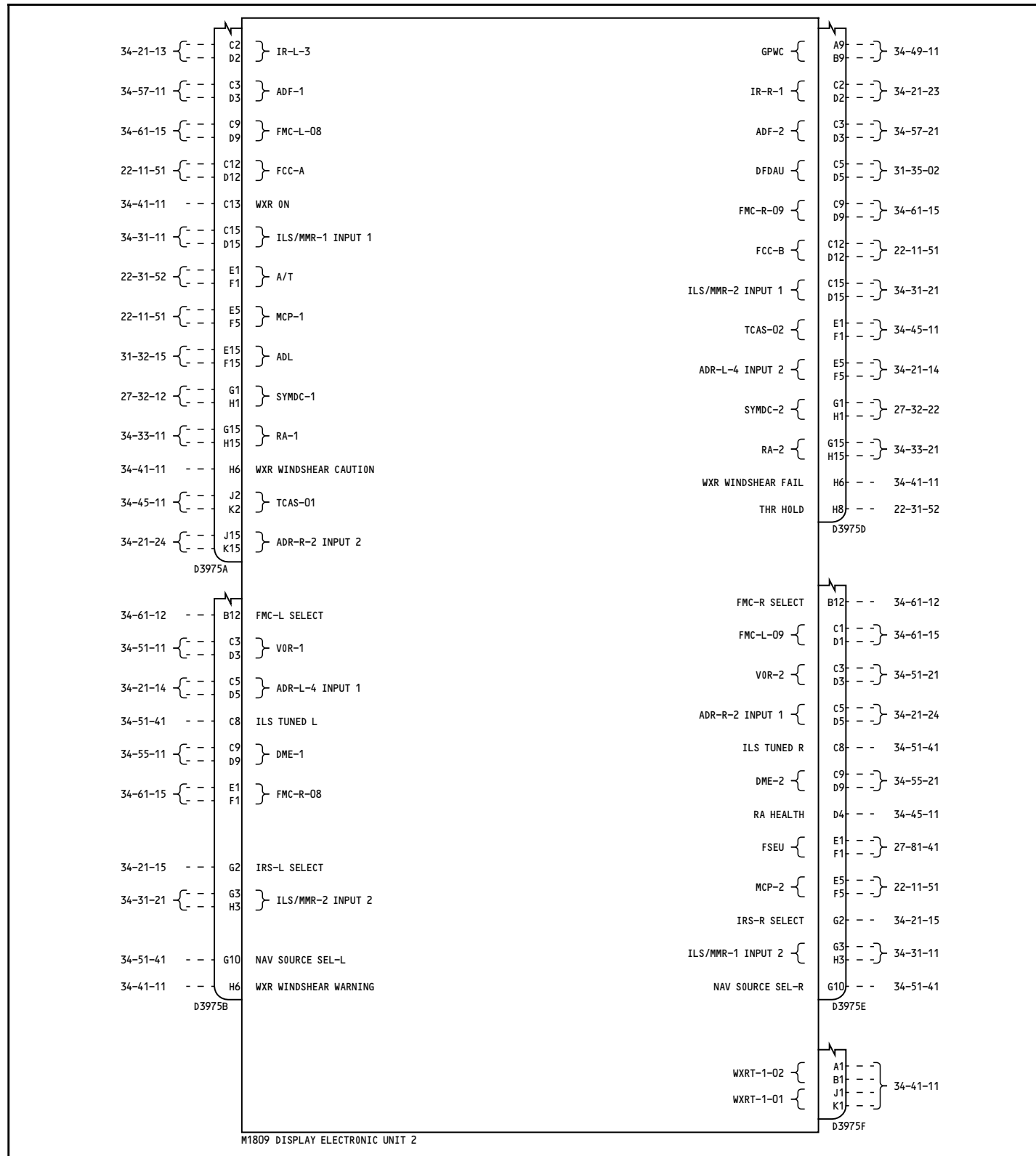

E3-1 SHELF

M1809 DISPLAY ELECTRONIC UNIT 2

YC008-YC011

CDS - DEU 2 AVIONICS INTERFACES

D280A103

31-62-25

Page 2.1
Sheet 1
Mar 31/2005

Incorporates
31-1136

31-62-25

Page 2.1
Sheet 1
Mar 31/2005

-A
13

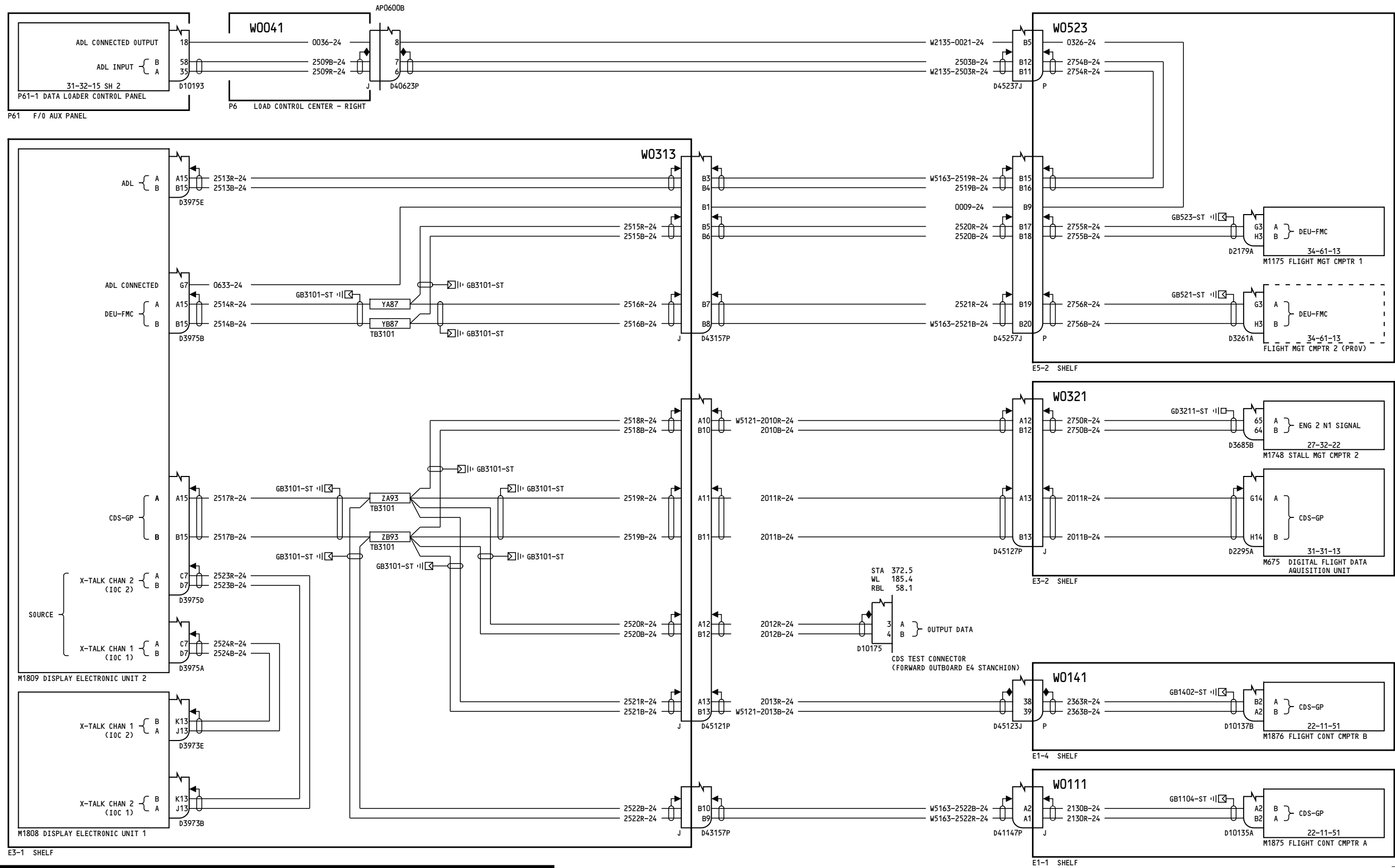

YC008-YC011

CDS - DEU 2 AVIONICS INTERFACES

31-62-25

Page 2.1
Sheet 2
Mar 31/2005

D280A103

Incorporates
31-1136

31-62-25

Page 2.1
Sheet 2
Mar 31/2005

33

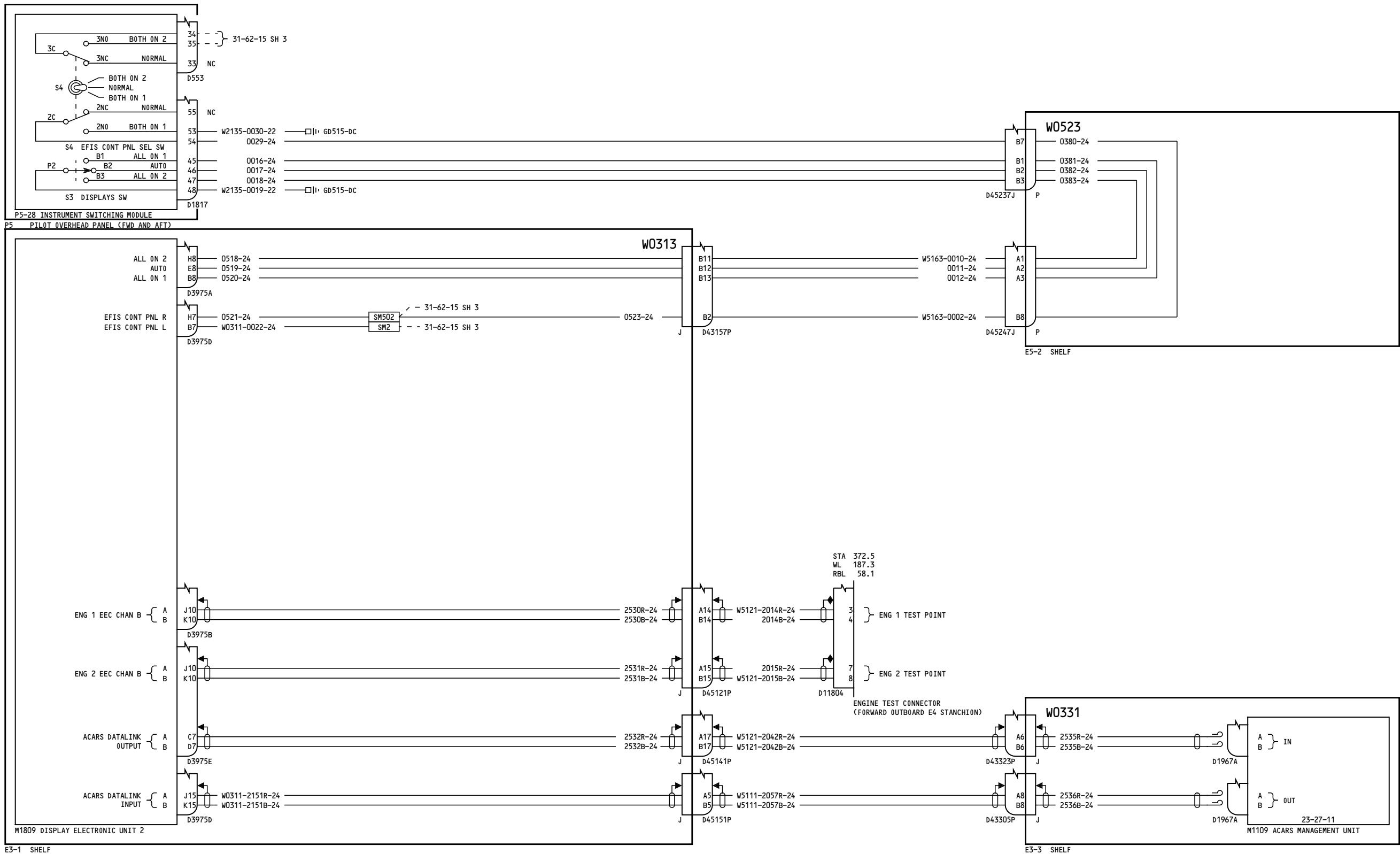

YC008-YC011

CDS - DEU 2 AVIONICS INTERFACES

31-62-25

Page 2.1
Sheet 3
Mar 31/2005

D280A103

31-62-25

Page 2.1
Sheet 3
Mar 31/2005

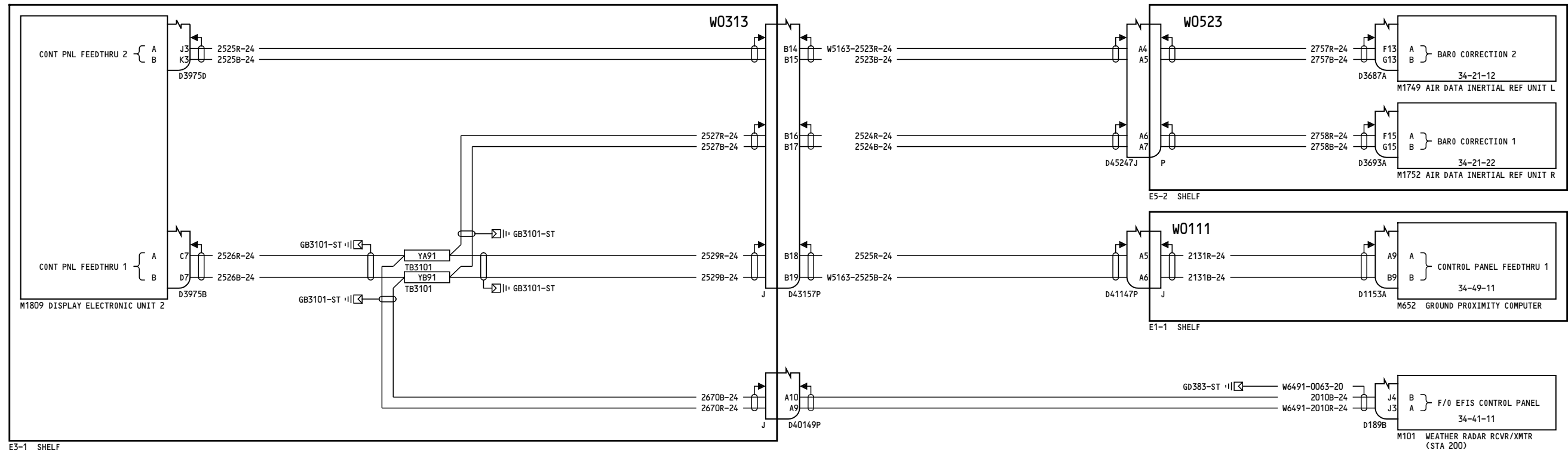

YC008-YC011

CDS - DEU 2 AVIONICS INTERFACES

D280A103

31-62-25

Page 2.1
Sheet 4
Mar 31/2005

31-62-25

Page 2.1
Sheet 4
Mar 31/2005

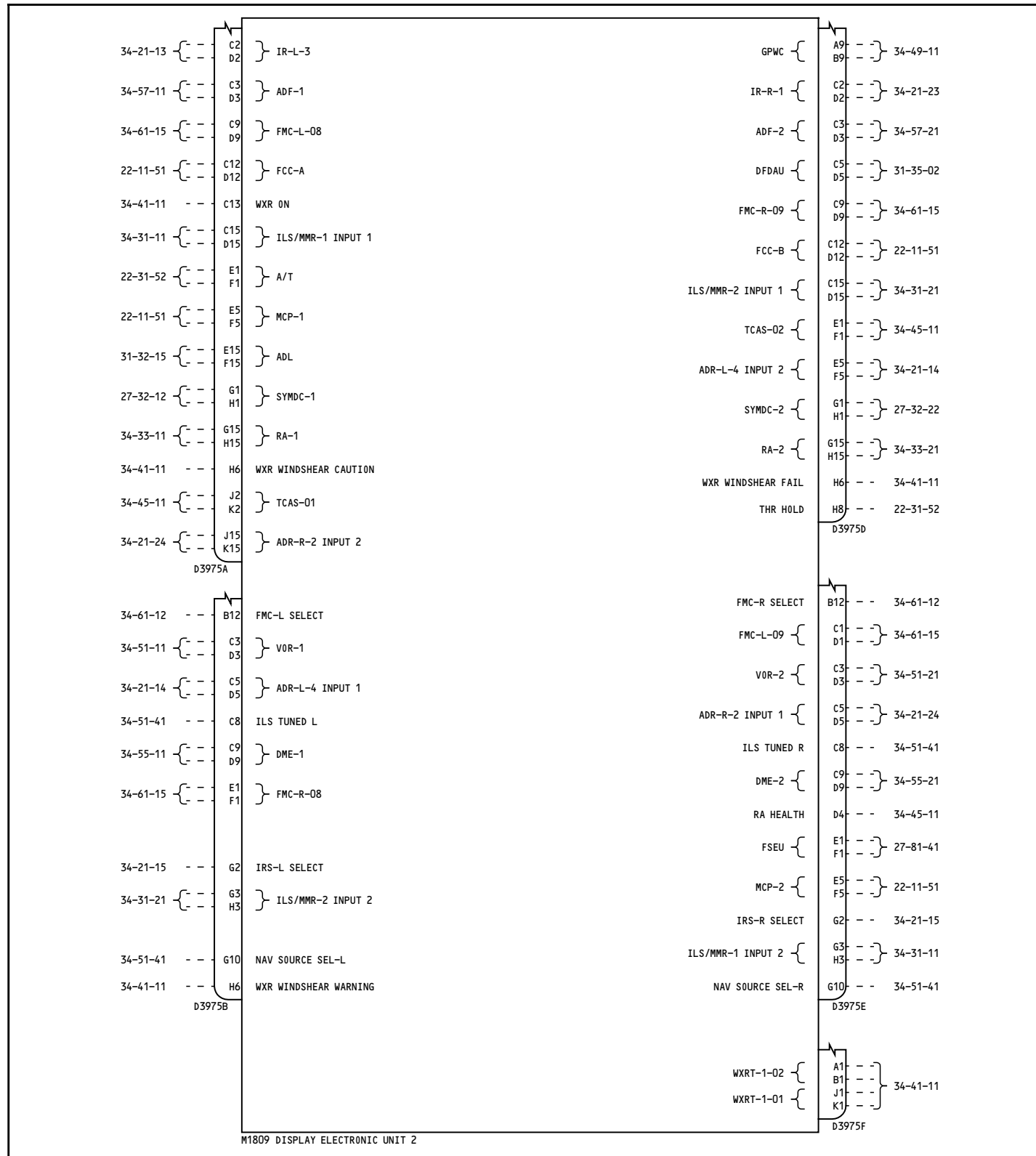

E3-1 SHELF

YC012-YC030

CDS - DEU 2 AVIONICS INTERFACES

D280A103

31-62-25

Page 3
Sheet 1
Jul 17/2007

31-62-25

Page 3
Sheet 1
Jul 17/2007

-A

13

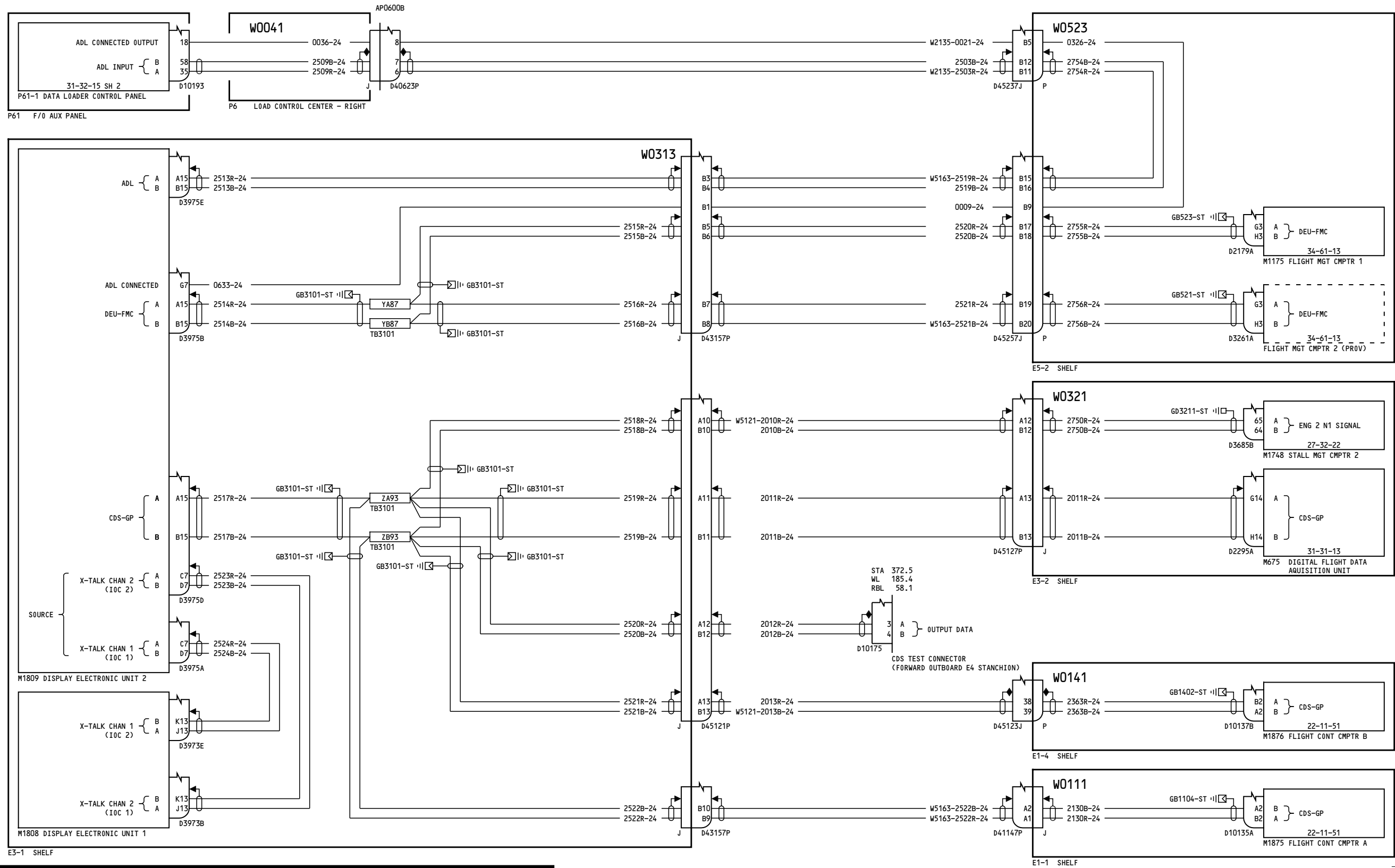

YC012-YC030

CDS - DEU 2 AVIONICS INTERFACES

31-62-25

Page 3
Sheet 2
Jul 17/2007

D280A103

31-62-25

Page 3
Sheet 2
Jul 17/2007

33

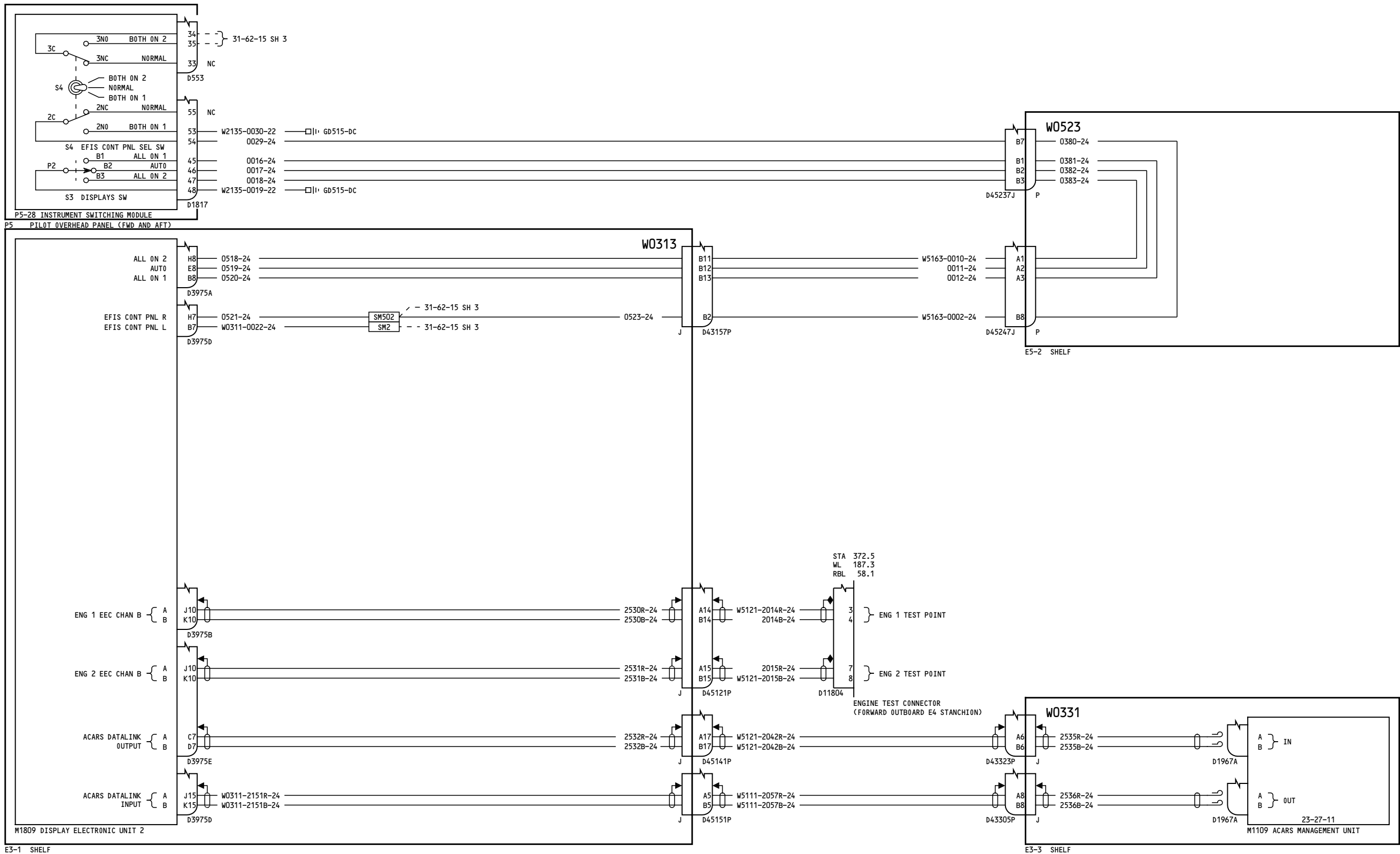

YC012-YC030

CDS - DEU 2 AVIONICS INTERFACES

31-62-25

Page 3
Sheet 3
Jul 17/2007

D280A103

31-62-25

Page 3
Sheet 3
Jul 17/2007

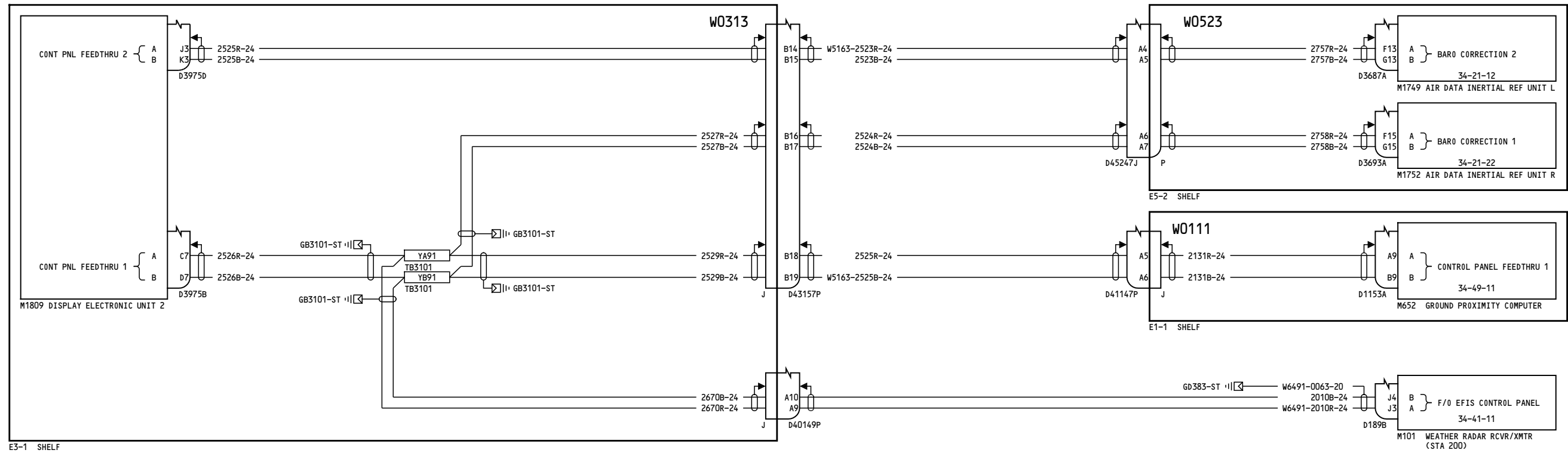

YC012-YC030

CDS - DEU 2 AVIONICS INTERFACES

D280A103

31-62-25

Page 3
Sheet 4
Jul 17/2007

31-62-25

Page 3
Sheet 4
Jul 17/2007

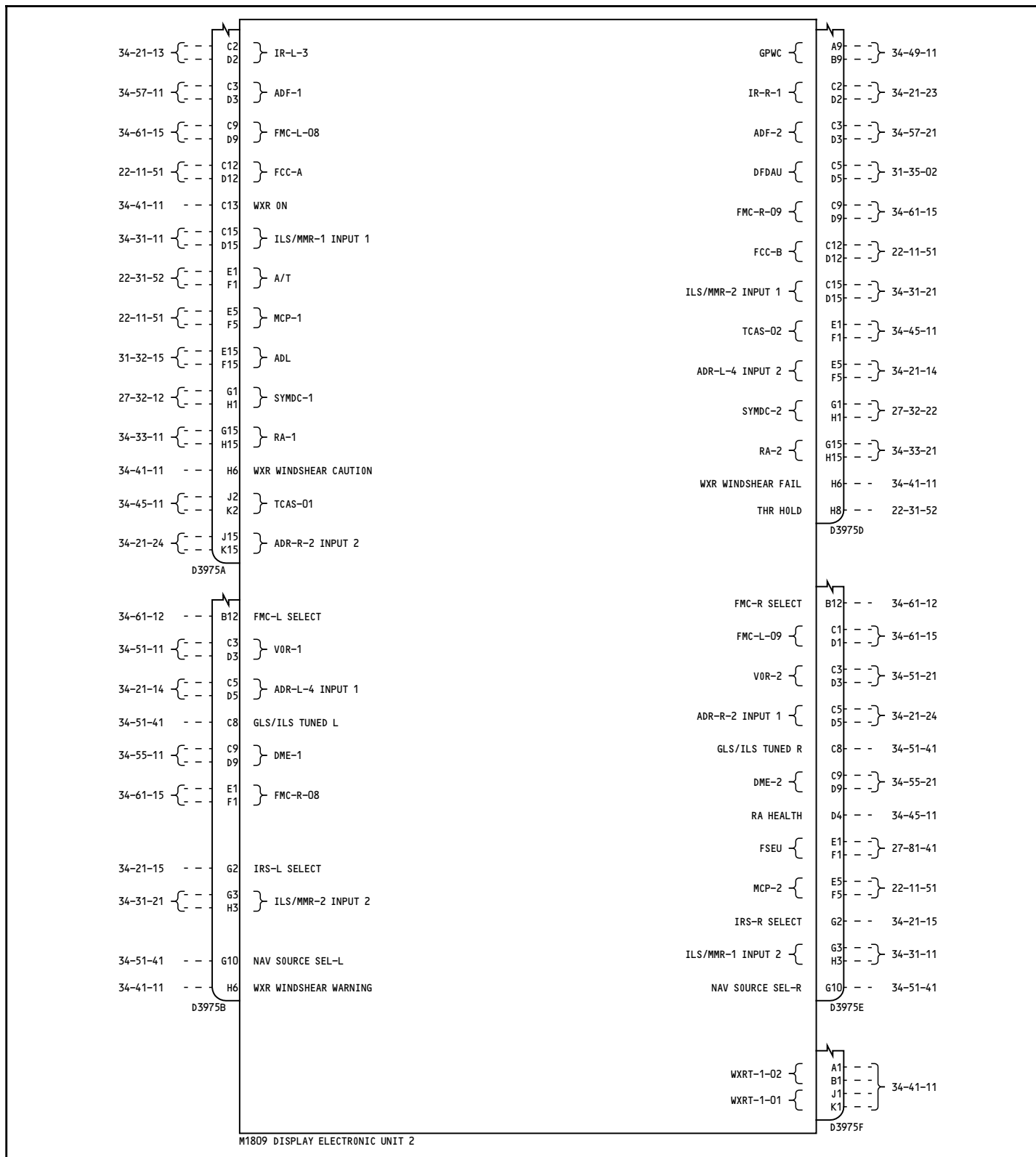

E3-1 SHELF

M1809 DISPLAY ELECTRONIC UNIT 2

YK901-YK906

CDS - DEU 2 AVIONICS INTERFACES

D280A103

31-62-25

Page 4
Sheet 1
Oct 20/2006

31-62-25

Page 4
Sheet 1
Oct 20/2006

-A
13

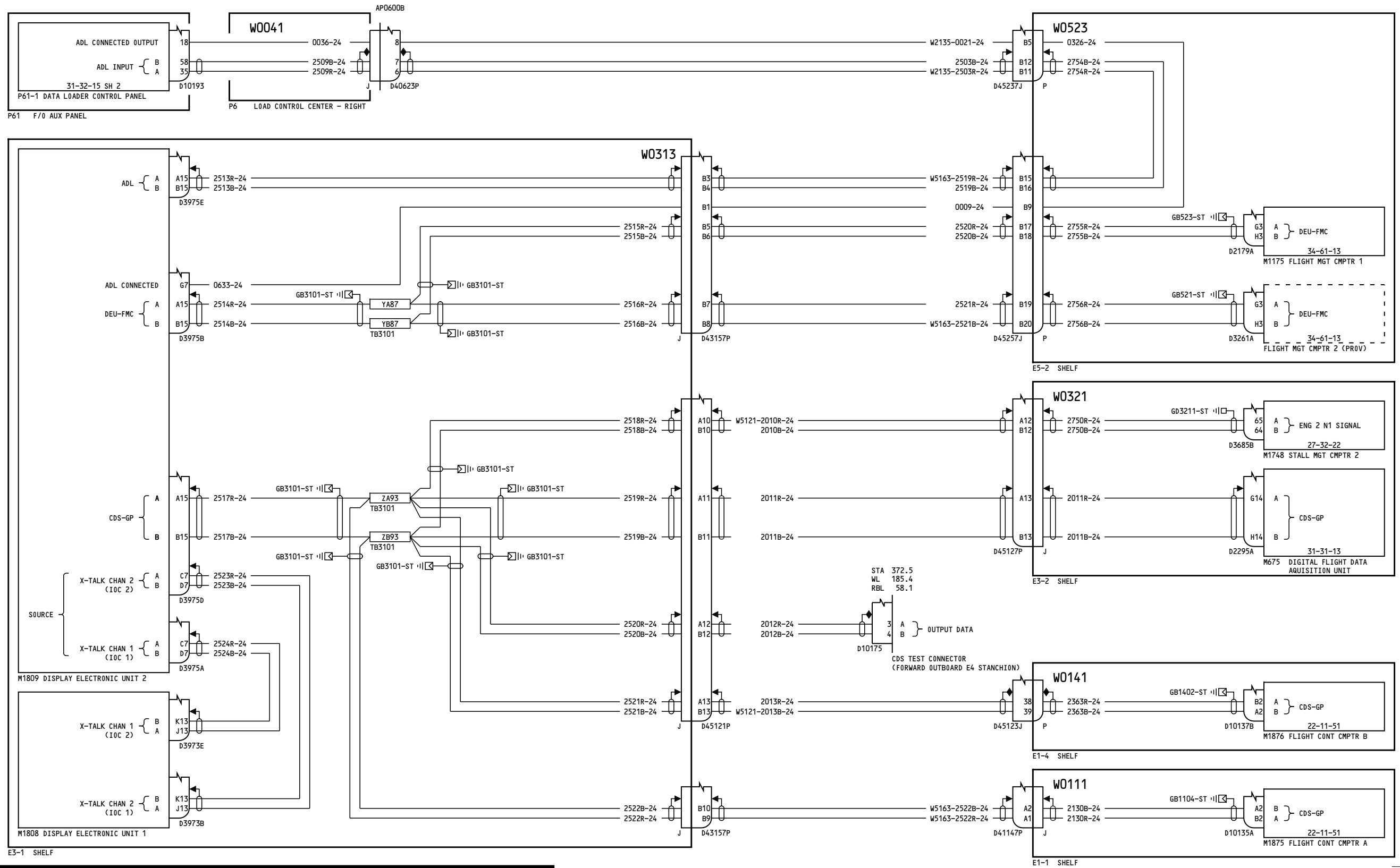

YK901-YK906

CDS - DEU 2 AVIONICS INTERFACES

31-62-25

Page 4
Sheet 2
Oct 20/2006

D280A103

31-62-25

Page 4
Sheet 2
Oct 20/2006

-C
115

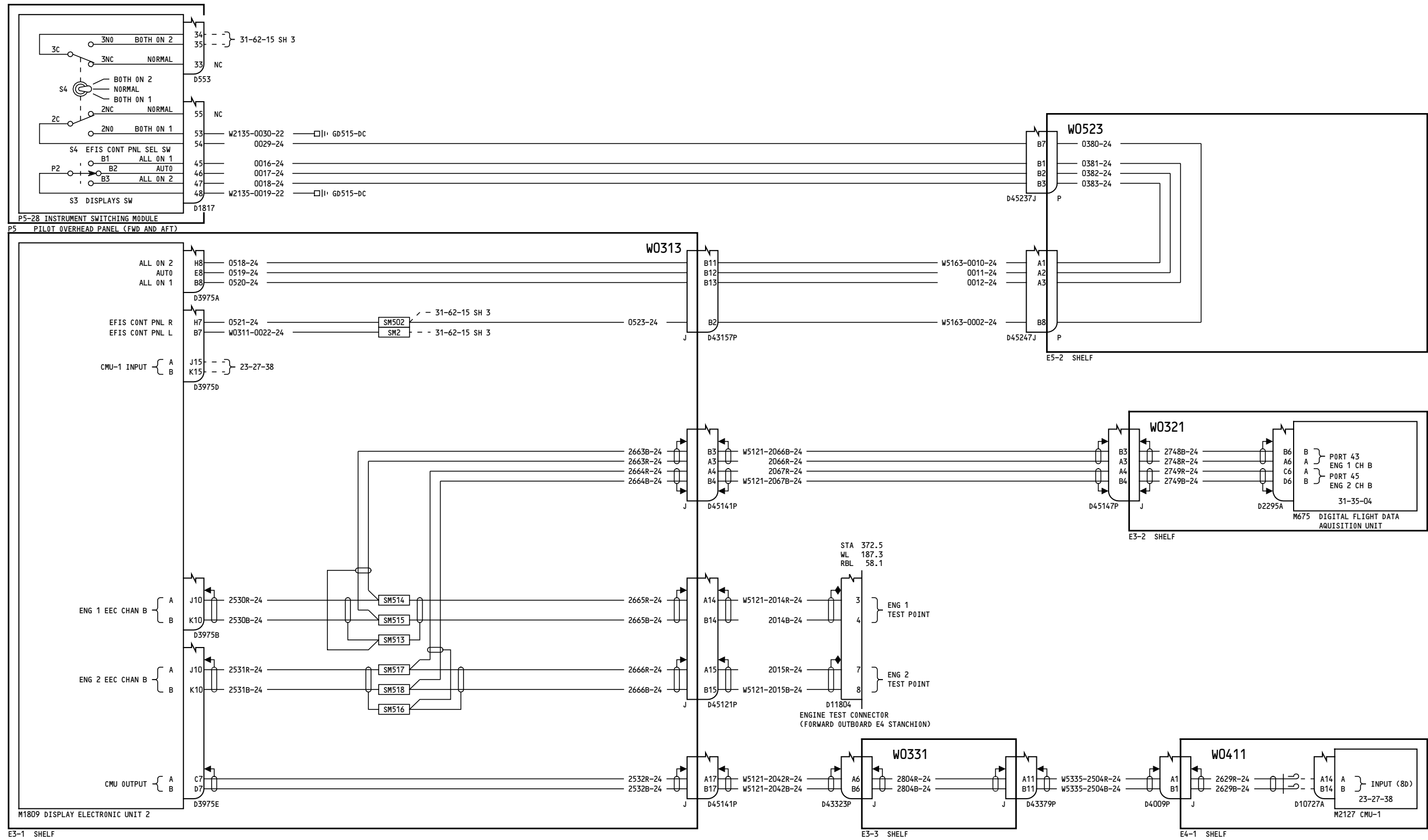

YK901-YK906

CDS - DEU 2 AVIONICS INTERFACES

31-62-25

Page 4
Sheet 3
Jan 18/2007

D280A103

31-62-25

Page 4
Sheet 3
Jan 18/2007

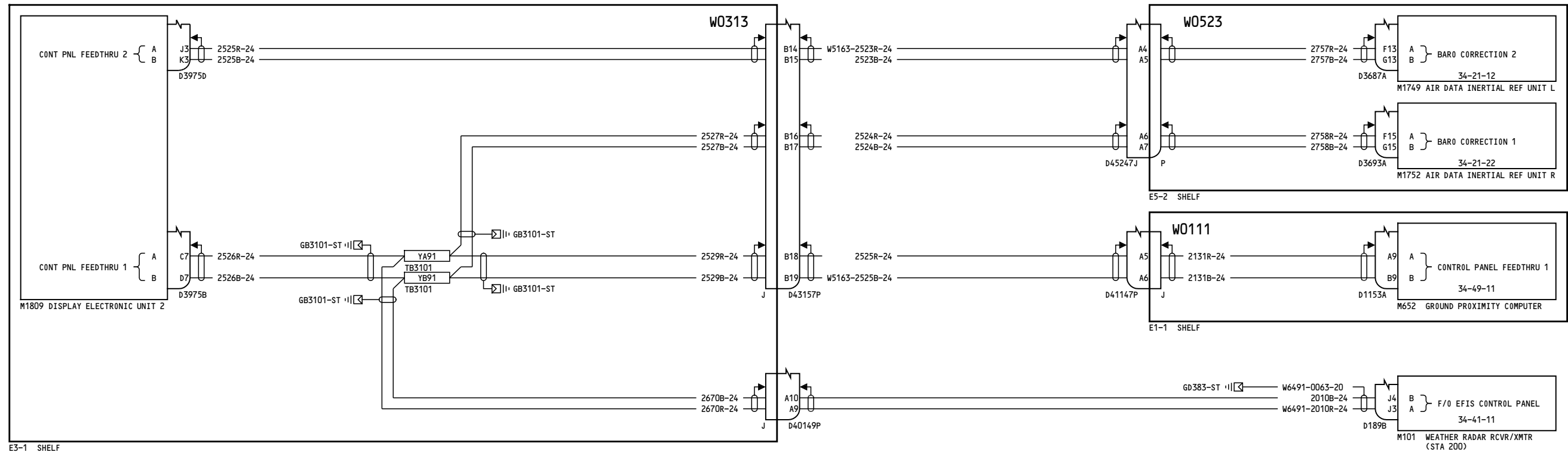

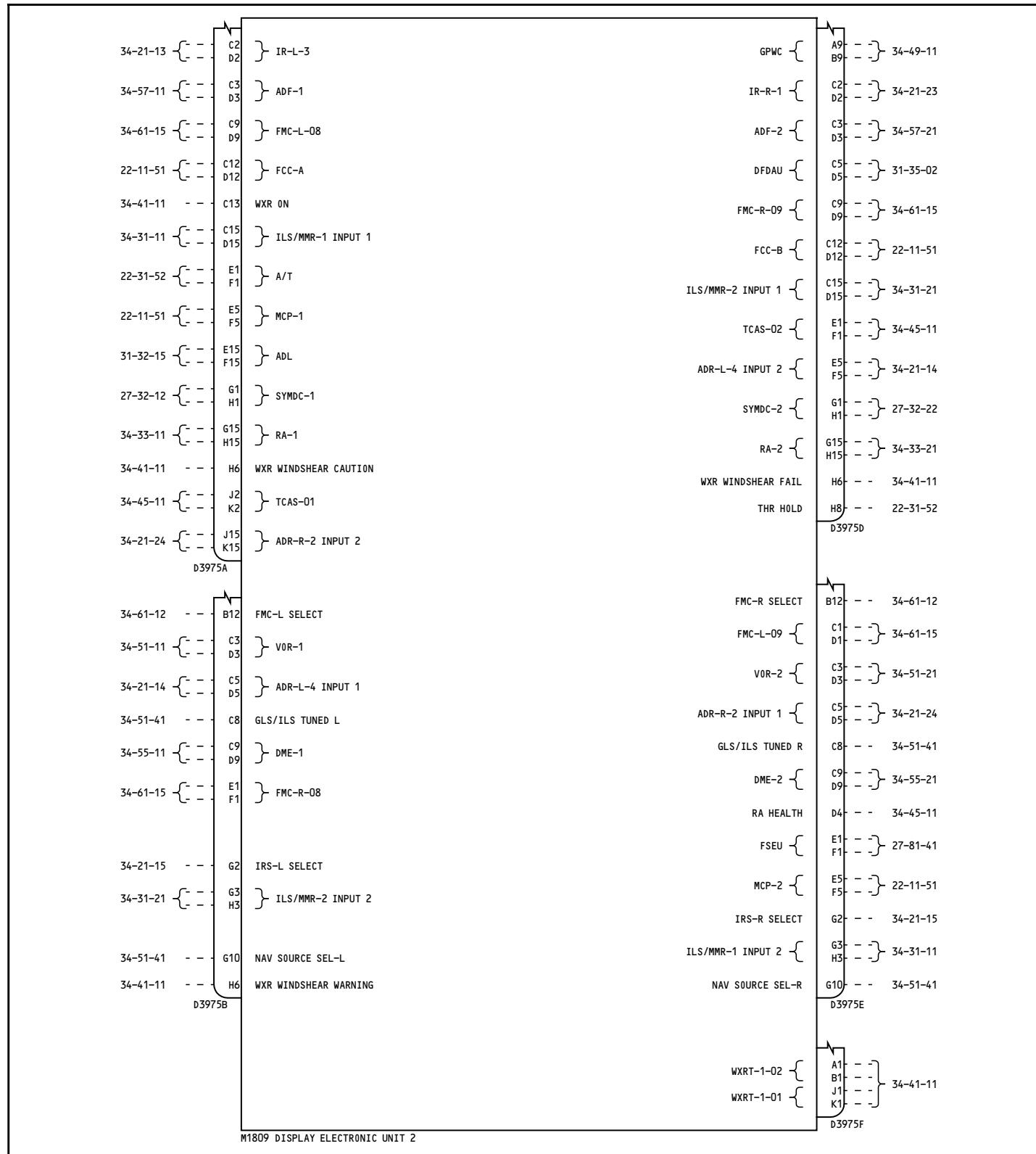

E3-1 SHELF

-A
15

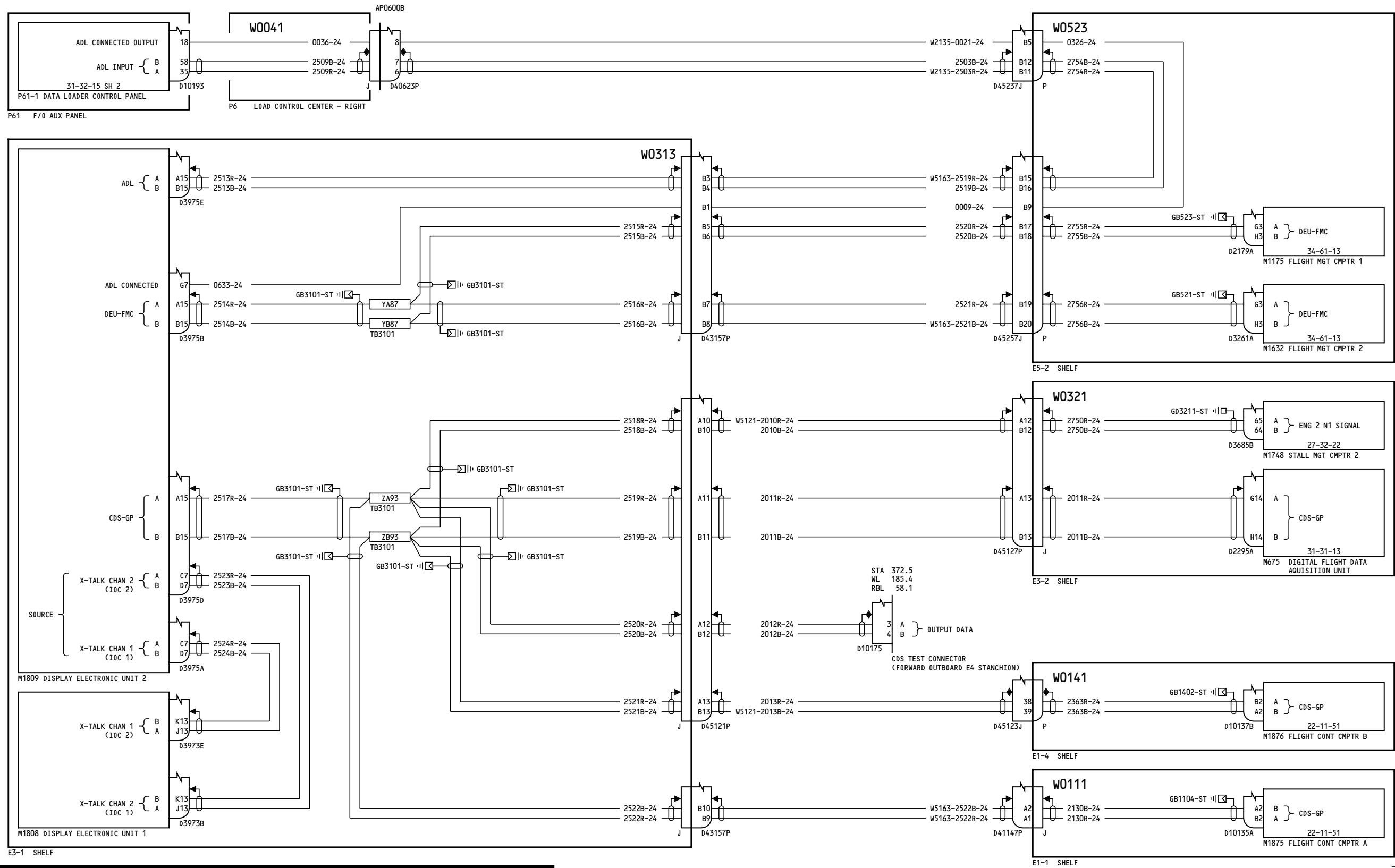

YK907-YM670

CDS - DEU 2 AVIONICS INTERFACES

31-62-25

Page 5
Sheet 2
Feb 09/2009

D280A103

31-62-25

Page 5
Sheet 2
Feb 09/2009

115

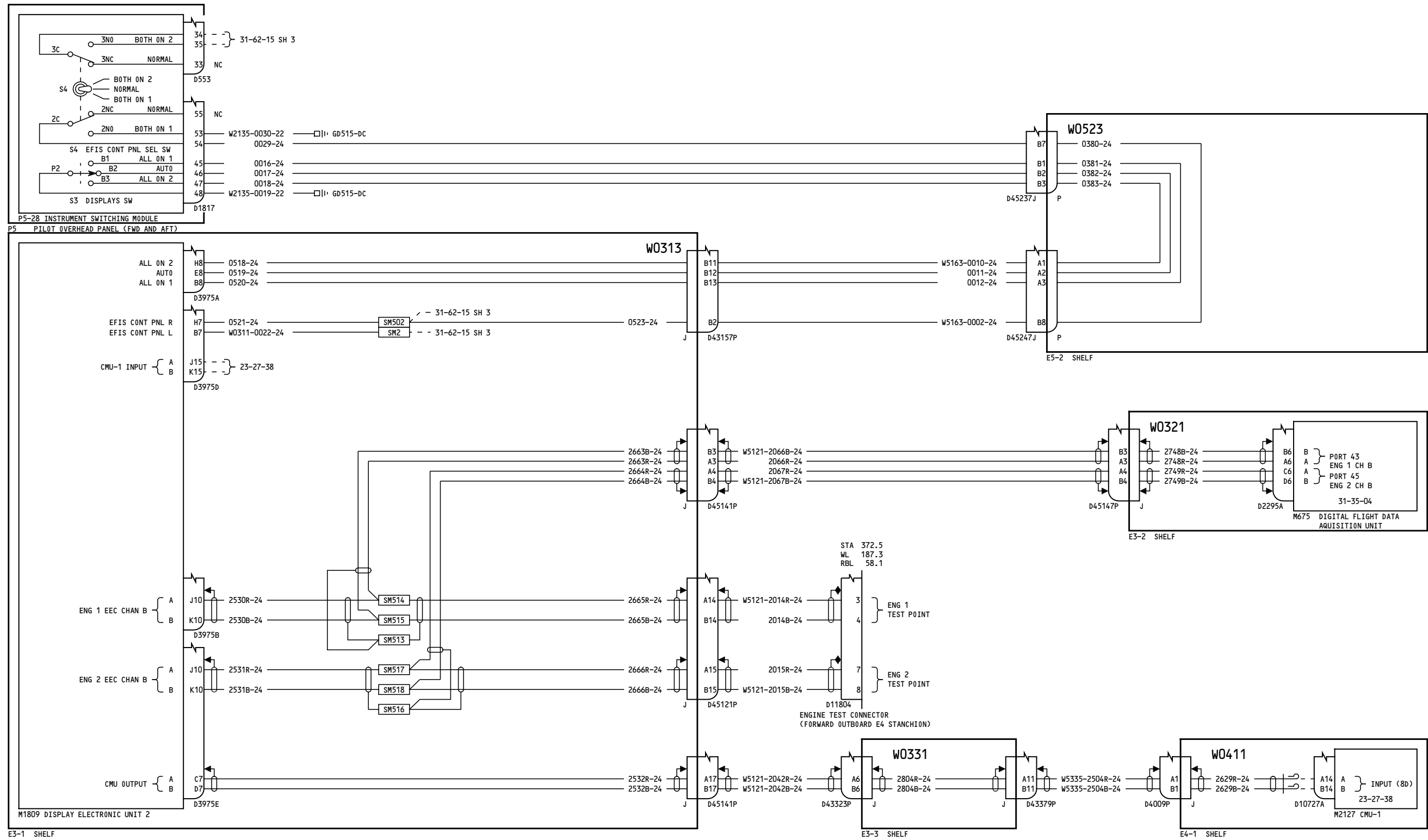

YK907-YM670

CDS - DEU 2 AVIONICS INTERFACES

31-62-25

Page 5
Sheet 3
Feb 09/2009

D280A103

31-62-25

Page 5
Sheet 3
Feb 09/2009

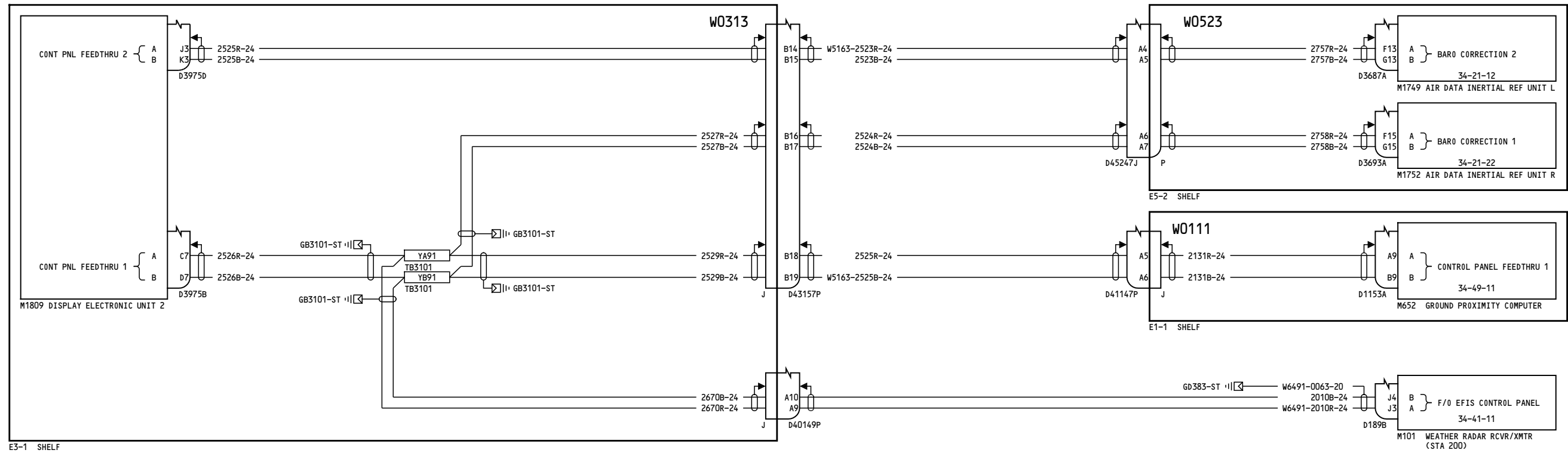

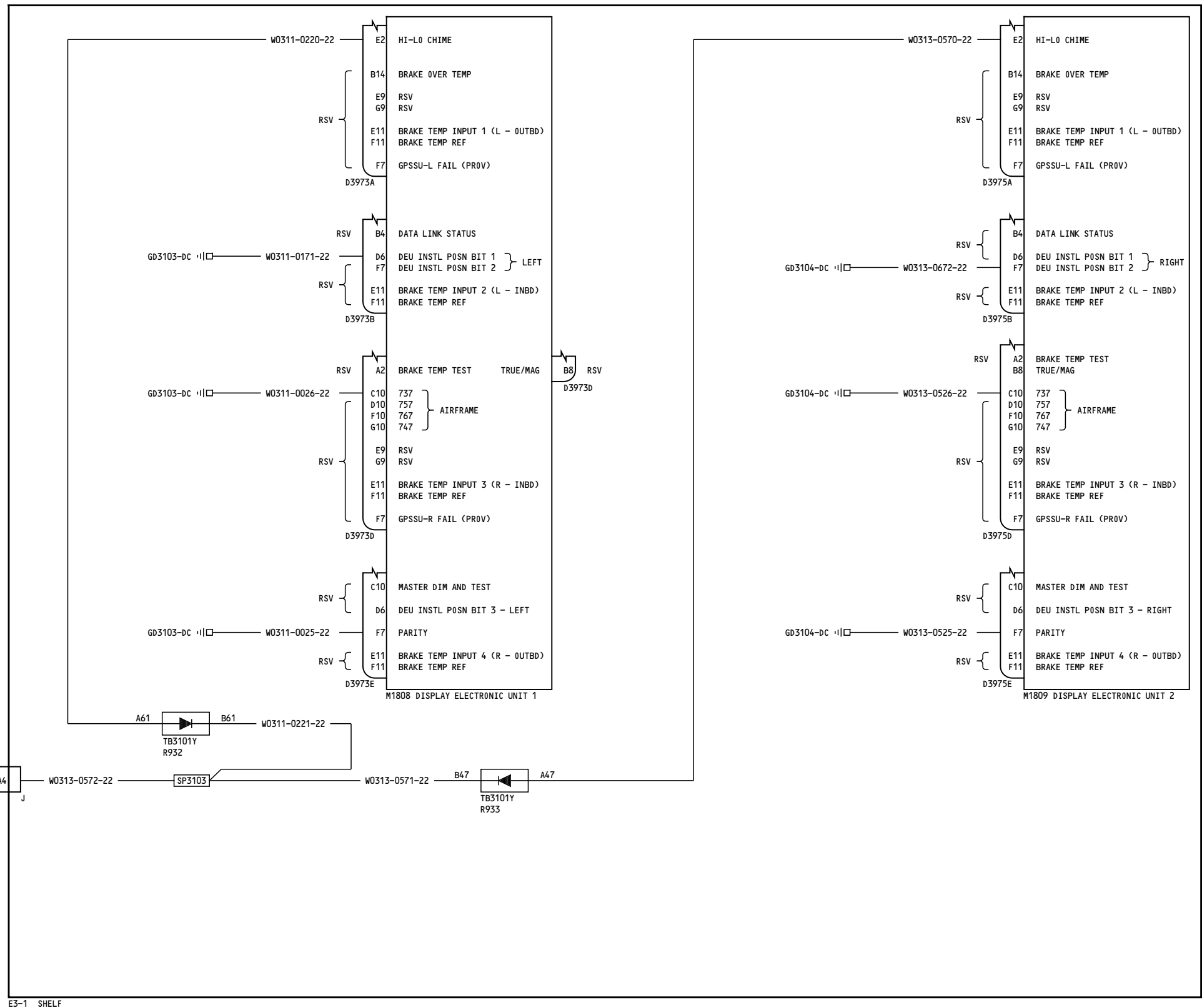
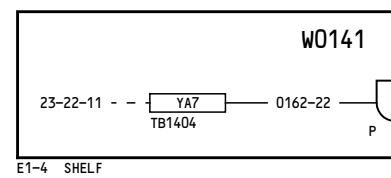

YC001-YC030

CDS - DEU SELECT AND PROGRAM PINS

31-62-41

Incorporates
▶ 31-1267

31-62-41

Page 1.1

Page 1.1

D280A103

Jul 17/2007

Jul 17/2007

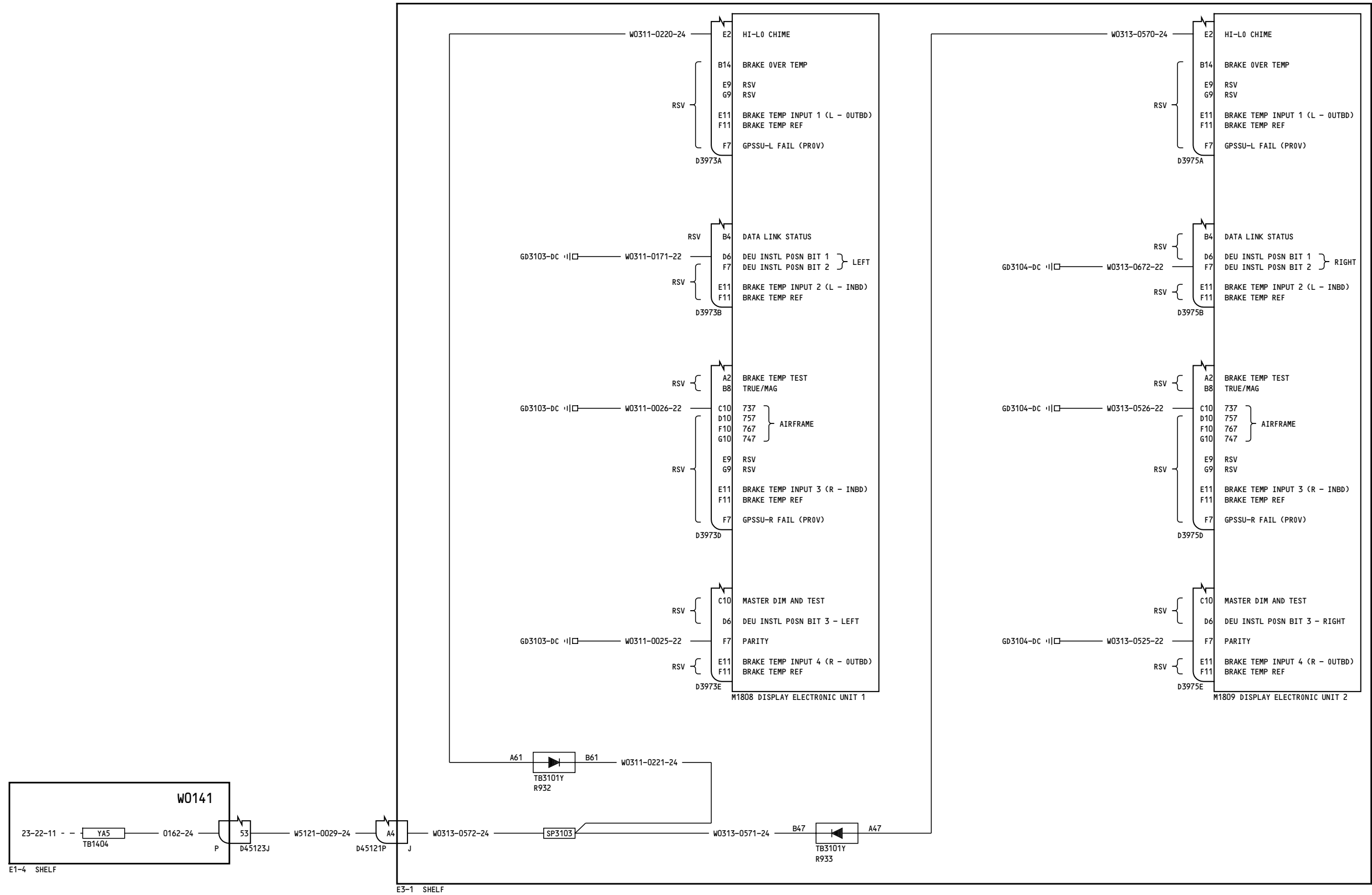

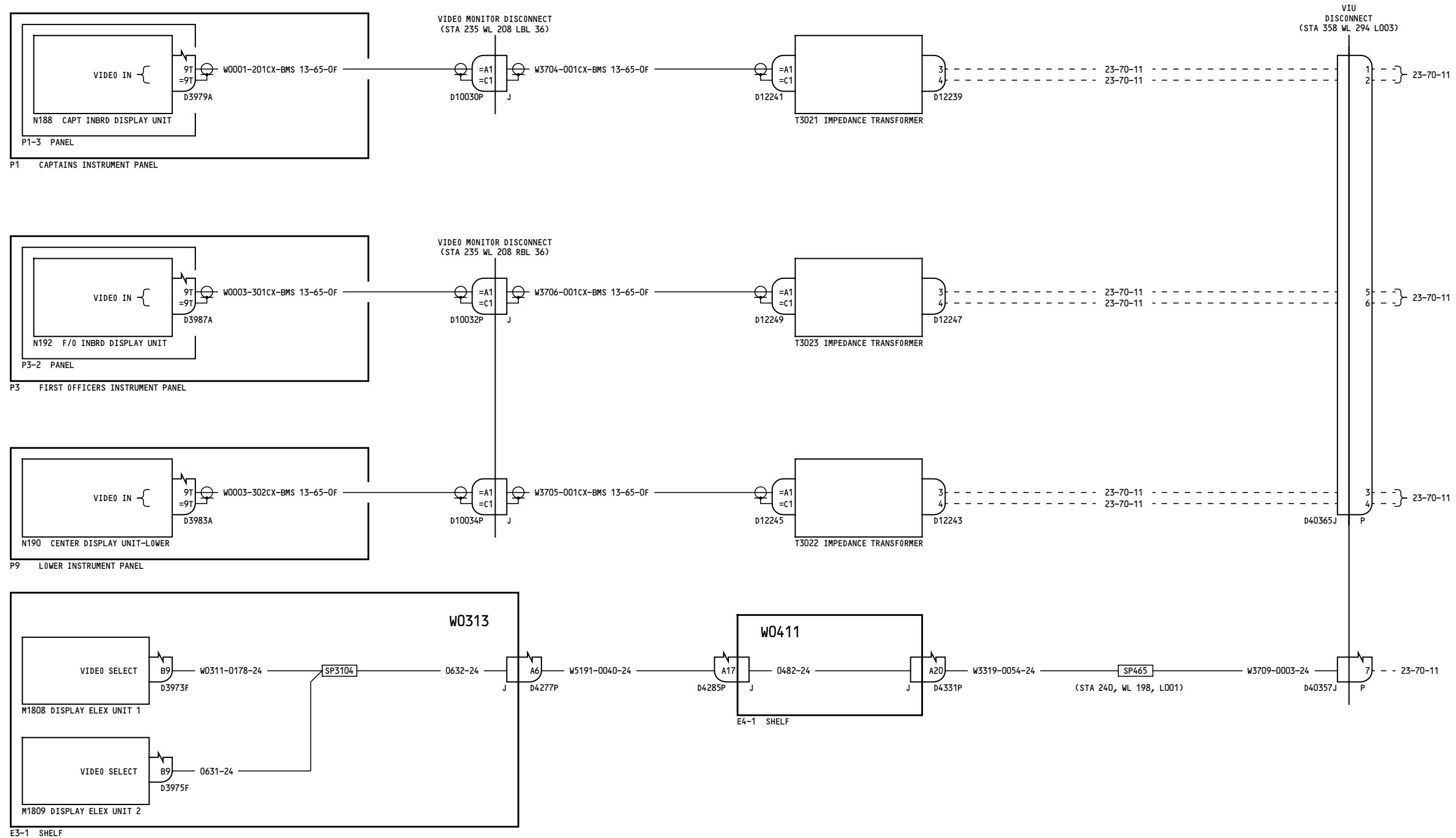

YK907-YK911, YK918, YL421-YL426, YM643-YM651

CDS - VIDEO MONITORING

31-62-42

Page 1

Feb 09/2009

D280A103

31-62-42

Page 1

Feb 09/2009

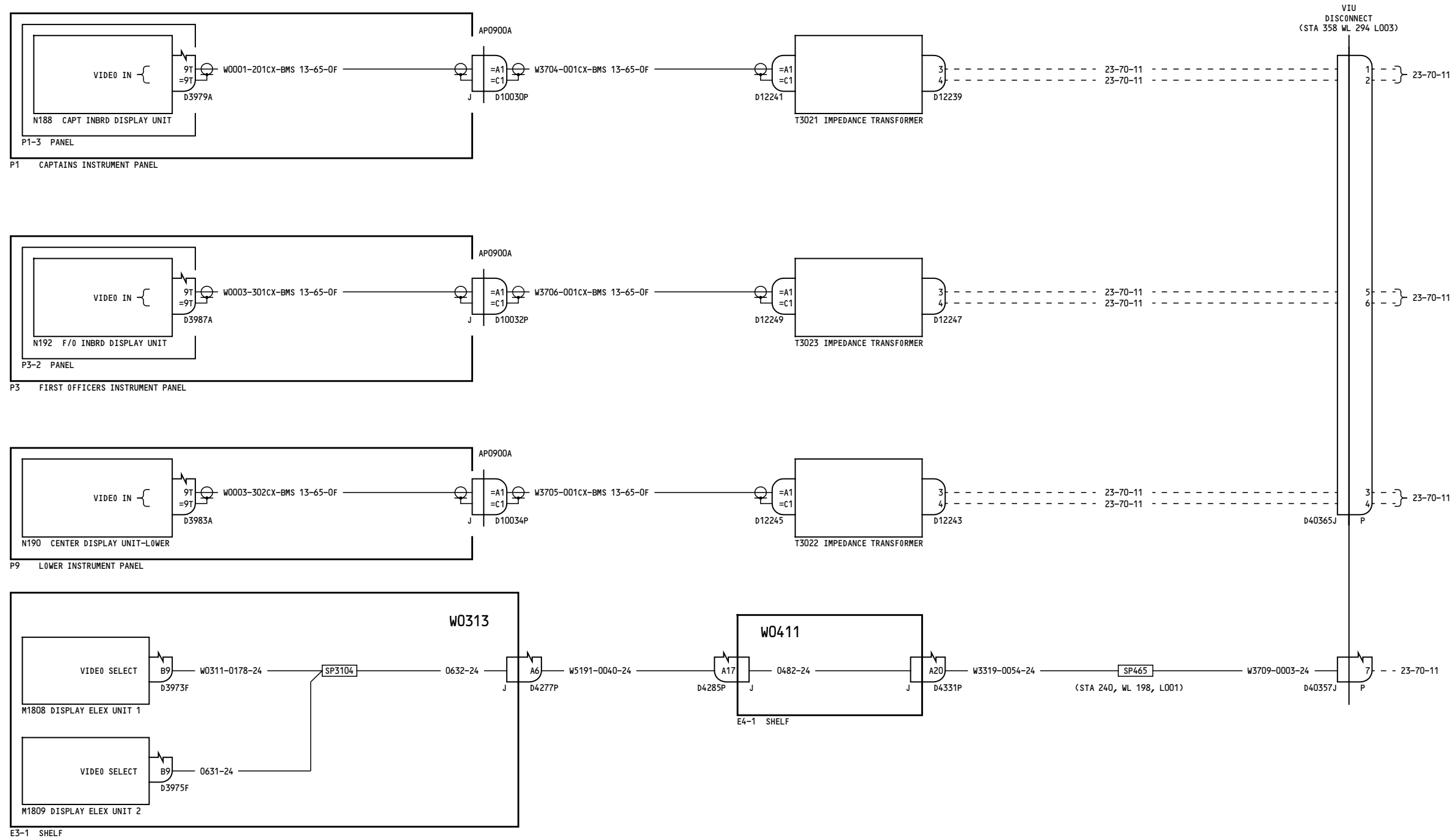

YK912-YK917, YK919-YL401, YL427-YL430, YM652-YM670

CDS - VIDEO MONITORING

31-62-42

Page 2

Feb 09/2009

D280A103

31-62-42

Page 2

Feb 09/2009