

CHAPTER

32

LANDING GEAR



737-700/800

WIRING DIAGRAM MANUAL

CHAPTER 32
LANDING GEAR

CH-SC-SU	Schem	Page	Sheet	Date	CH-SC-SU	Schem	Page	Sheet	Date
32-EFFECTIVE PAGES		1 thru 2		Aug 10/2009	32-31-12 (cont.)		6		
32-CONTENTS								3	May 11/2009
		1		Feb 09/2009			7	1	May 11/2009
		2		May 11/2009				2	May 11/2009
		3		Feb 09/2009				3	May 11/2009
R		4		Aug 10/2009			8	1	Aug 13/2008
O		5		Aug 10/2009				2	Aug 13/2008
		6		BLANK				3	Aug 13/2008
32-ALPHABETICAL INDEX							9	1	Aug 13/2008
		1		Jan 18/2007				2	Aug 13/2008
		2		BLANK			10	1	May 11/2009
32-31-11								2	May 11/2009
		1	1	Jul 17/2007				3	May 11/2009
			2	Jul 17/2007	32-35-11				
			3	Jul 17/2007			1		Feb 09/2009
		2	1	Mar 31/2005	32-41-11				
			2	Mar 31/2005			1	1	Mar 31/2005
			3	Mar 31/2005				2	Mar 31/2005
		3	1	Feb 09/2009			2	1	Jul 17/2007
			2	Feb 09/2009				2	Jul 17/2007
			3	Feb 09/2009			3	1	Feb 09/2009
		4	1	Aug 13/2008				2	Feb 09/2009
			2	Aug 13/2008	32-42-11				
			3	Feb 09/2009			1	1	Apr 18/2006
		5	1	Aug 13/2008				2	Mar 31/2005
			2	Aug 13/2008			2	1	Apr 18/2006
			3	Feb 09/2009				2	Mar 31/2005
		6	1	Nov 11/2008			3	1	Jul 17/2007
			2	Nov 11/2008				2	Jul 17/2007
			3	Feb 09/2009			4	1	Feb 09/2009
		7	1	Nov 11/2008				2	Feb 09/2009
			2	Nov 11/2008			5	1	Feb 09/2009
			3	Feb 09/2009				2	Feb 09/2009
32-31-12					32-44-11				
		1	1	Mar 31/2005			1		Mar 31/2005
			2	Apr 18/2007			2		Jul 17/2007
			3	Apr 18/2007			3		Feb 09/2009
		2	1	Jul 17/2007	32-51-11				
			2	Jul 17/2007			1		Apr 18/2007
			3	Jul 17/2007			2		Feb 09/2009
		3	1	Apr 18/2006	32-64-11				
			2	Apr 18/2007			1	1	Mar 31/2005
			3	Apr 18/2007				2	Mar 31/2005
		4	1	Oct 15/2007			1.1	1	Mar 31/2005
			2	Oct 15/2007				2	Mar 31/2005
			3	Oct 15/2007			2	1	Jul 17/2007
		5	1	May 11/2009				2	Jul 17/2007
			2	May 11/2009			3	1	Mar 31/2005
			3	May 11/2009				2	Mar 31/2005
		6	1	May 11/2009			4	1	Feb 09/2009
			2	May 11/2009				2	Feb 09/2009

A = Added, R = Revised, D = Deleted, O = Overflow

32-EFFECTIVE PAGES

Page 1
Aug 10/2009

D280A103



737-700/800

WIRING DIAGRAM MANUAL

CHAPTER 32 LANDING GEAR

CH-SC-SU	Schem	Page	Sheet	Date	CH-SC-SU	Schem	Page	Sheet	Date
32-64-12		1	1	Mar 31/2005					
			2	Mar 31/2005					
		2	1	Jul 17/2007					
			2	Jul 17/2007					
		3	1	Feb 09/2009					
			2	Feb 09/2009					
R		4	1	Aug 10/2009					
R			2	Aug 10/2009					
32-64-21									
		1		Nov 11/2008					
		2		Nov 11/2008					
		3		Feb 09/2009					
		4		May 11/2009					
		5		May 11/2009					

A = Added, R = Revised, D = Deleted, O = Overflow

32-EFFECTIVE PAGES

Page 2
Aug 10/2009

D280A103



737-700/800

WIRING DIAGRAM MANUAL

CHAPTER 32
LANDING GEAR

Title	CH-SC-SU	Schem	Page	Sheet	Date	Effectivity		
LANDING GEAR CONTROL SYSTEM								
AIR/GND SYSTEM 1 & LEVER LATCH	32-31-11		1	1	Jul 17/2007	YC001-YC028		
				2	Jul 17/2007	YC001-YC028		
				3	Jul 17/2007	YC001-YC028		
			2	1	Mar 31/2005	YC029-YC030		
				2	Mar 31/2005	YC029-YC030		
				3	Mar 31/2005	YC029-YC030		
				3	1	Feb 09/2009	YC031-YK910 YK918 YL421-YL428 YL430	
				2	2	Feb 09/2009	YC031-YK910 YK918 YL421-YL428 YL430	
				3	3	Feb 09/2009	YC031-YK910 YK918 YL421-YL428 YL430	
				4	1	Aug 13/2008	YK911-YK917 YM652-YM670	
					2	Aug 13/2008	YK911-YK917 YM652-YM670	
					3	Feb 09/2009	YK911-YK917 YM652-YM670	
					5	1	Aug 13/2008	YK919-YL401
						2	Aug 13/2008	YK919-YL401
						3	Feb 09/2009	YK919-YL401
					6	1	Nov 11/2008	YL429
						2	Nov 11/2008	YL429
						3	Feb 09/2009	YL429
					7	1	Nov 11/2008	YM643-YM651
						2	Nov 11/2008	YM643-YM651
						3	Feb 09/2009	YM643-YM651
AIR/GND SYSTEM 2 AND NOSE GEAR GROUND SENSING RELAYS	32-31-12		1	1	Mar 31/2005	YC001-YC003		
				2	Apr 18/2007	YC001-YC003		
				3	Apr 18/2007	YC001-YC003		
			2	1	Jul 17/2007	YC004-YC028		
				2	Jul 17/2007	YC004-YC028		

32-CONTENTS

Page 1
Feb 09/2009

D280A103



737-700/800

WIRING DIAGRAM MANUAL

CHAPTER 32
LANDING GEAR

Title	CH-SC-SU	Schem	Page	Sheet	Date	Effectivity		
AIR/GND SYSTEM 2 AND NOSE GEAR GROUND SENSING RELAYS (cont.)	32-31-12			3	Jul 17/2007	YC004-YC028		
			3	1	Apr 18/2006	YC029-YC030 YK901-YK905		
				2	Apr 18/2007	YC029-YC030 YK901-YK905		
				3	Apr 18/2007	YC029-YC030 YK901-YK905		
				4	1	Oct 15/2007	YC031-YC050 YK906	
			2		Oct 15/2007	YC031-YC050 YK906		
				3	Oct 15/2007	YC031-YC050 YK906		
				5	1	May 11/2009	YK907-YK910 YK918 YL421-YL429	
			2		May 11/2009	YK907-YK910 YK918 YL421-YL429		
			3		May 11/2009	YK907-YK910 YK918 YL421-YL429		
				6	1	May 11/2009	YK911-YK912	
			2		May 11/2009	YK911-YK912		
			3		May 11/2009	YK911-YK912		
				7	1	May 11/2009	YK919	
			2		May 11/2009	YK919		
			3		May 11/2009	YK919		
				8	1	Aug 13/2008	YL401	
			2		Aug 13/2008	YL401		
			3		Aug 13/2008	YL401		
				9	1	Aug 13/2008	YM643-YM651	
			2		Aug 13/2008	YM643-YM651		
			3		Aug 13/2008	YM643-YM651		
				10	1	May 11/2009	YM652	
			2		May 11/2009	YM652		
			3		May 11/2009	YM652		
		<u>ALTERNATE EXTENSION</u>						
		ALTERNATE LANDING GEAR EXTENSION SYSTEM	32-35-11		1		Feb 09/2009	ALL

32-CONTENTS

Page 2

May 11/2009

D280A103



737-700/800

WIRING DIAGRAM MANUAL

CHAPTER 32
LANDING GEAR

Title	CH-SC-SU	Schem	Page	Sheet	Date	Effectivity
<u>ANTISKID BRAKE SYSTEM</u>						
ANTISKID SYSTEM	32-41-11		1	1	Mar 31/2005	YC001-YC003
				2	Mar 31/2005	YC001-YC003
			2	1	Jul 17/2007	YC004-YK907 YL421
				2	Jul 17/2007	YC004-YK907 YL421
			3	1	Feb 09/2009	YK908-YL401 YL422-YM670
				2	Feb 09/2009	YK908-YL401 YL422-YM670
<u>AUTOBRAKE SYSTEM</u>						
AUTOBRAKE SYSTEM	32-42-11		1	1	Apr 18/2006	YC001-YC003
				2	Mar 31/2005	YC001-YC003
			2	1	Apr 18/2006	YC004-YC007
				2	Mar 31/2005	YC004-YC007
			3	1	Jul 17/2007	YC008-YC028
				2	Jul 17/2007	YC008-YC028
			4	1	Feb 09/2009	YC029-YC050 YK911-YK917 YK919-YL401 YL427-YL430 YM652-YM670
				2	Feb 09/2009	YC029-YC050 YK911-YK917 YK919-YL401 YL427-YL430 YM652-YM670
				5	Feb 09/2009	YK901-YK910 YK918 YL421-YL426 YM643-YM651
				2	Feb 09/2009	YK901-YK910 YK918 YL421-YL426 YM643-YM651
<u>PARKING BRAKE SYSTEM</u>						
PARKING BRAKE SYSTEM	32-44-11		1		Mar 31/2005	YC001-YC003
				2	Jul 17/2007	YC004-YK907 YL421
				3	Feb 09/2009	YK908-YK912 YK918-YK919 YL401 YL422-YL429 YM643-YM652

32-CONTENTS

Page 3
Feb 09/2009

D280A103



737-700/800

WIRING DIAGRAM MANUAL

CHAPTER 32
LANDING GEAR

Title	CH-SC-SU	Schem	Page	Sheet	Date	Effectivity
<u>NOSE WHEEL STEERING SYSTEM</u>						
NOSE GEAR STEERING	32-51-11		1		Apr 18/2007	YC001-YC003
			2		Feb 09/2009	YC004-YM670
<u>LANDING GEAR POSITION INDICATING AND WARNING SYSTEM</u>						
LANDING GEAR POSITION INDICATING SYSTEM 1	32-64-11		1	1	Mar 31/2005	YC001-YC018
				2	Mar 31/2005	YC001-YC018
			1.1	1	Mar 31/2005	YC001-YC018
				2	Mar 31/2005	YC001-YC018
			2	1	Jul 17/2007	YC019-YC028
				2	Jul 17/2007	YC019-YC028
			3	1	Mar 31/2005	YC029-YC050
				2	Mar 31/2005	YC029-YC050
			4	1	Feb 09/2009	YK901-YM670
				2	Feb 09/2009	YK901-YM670
LANDING GEAR POSITION INDICATING SYSTEM 2	32-64-12		1	1	Mar 31/2005	YC001-YC003
				2	Mar 31/2005	YC001-YC003
			2	1	Jul 17/2007	YC004-YC028
				2	Jul 17/2007	YC004-YC028
			3	1	Feb 09/2009	YC029-YK911 YK918 YL421-YL426 YM643-YM651
				2	Feb 09/2009	YC029-YK911 YK918 YL421-YL426 YM643-YM651
			4	1	Aug 10/2009	YK912 YK919 YL401 YL427-YL429 YM652
				2	Aug 10/2009	YK912 YK919 YL401 YL427-YL429 YM652
LANDING GEAR WARNING	32-64-21		1		Nov 11/2008	YC001-YC003
			2		Nov 11/2008	YC004-YK906 YM643-YM649
			3		Feb 09/2009	YK907-YK910 YK918 YL421-YL426
			4		May 11/2009	YK911-YK912 YK919 YL401 YL427-YL429

32-CONTENTS

Page 4
Aug 10/2009

D280A103



737-700/800

WIRING DIAGRAM MANUAL

**CHAPTER 32
LANDING GEAR**

Title	CH-SC-SU	Schem	Page	Sheet	Date	Effectivity
LANDING GEAR WARNING (cont.)	32-64-21		5		May 11/2009	YM651-YM652

32-CONTENTS

Page 5
Aug 10/2009

D280A103



737-700/800

WIRING DIAGRAM MANUAL

CHAPTER 32 LANDING GEAR

CH-SC-SU	Title
32-31-11	AIR/GND SYSTEM 1 & LEVER LATCH
32-31-12	AIR/GND SYSTEM 2 AND NOSE GEAR GROUND SENSING RELAYS
32-35-11	ALTERNATE LANDING GEAR EXTENSION SYSTEM
32-41-11	ANTISKID SYSTEM
32-42-11	AUTOBRAKE SYSTEM
32-64-11	LANDING GEAR POSITION INDICATING SYSTEM 1
32-64-12	LANDING GEAR POSITION INDICATING SYSTEM 2
32-64-21	LANDING GEAR WARNING
32-51-11	NOSE GEAR STEERING
32-44-11	PARKING BRAKE SYSTEM

32-ALPHABETICAL INDEX

D280A103

Page 1
Jan 18/2007

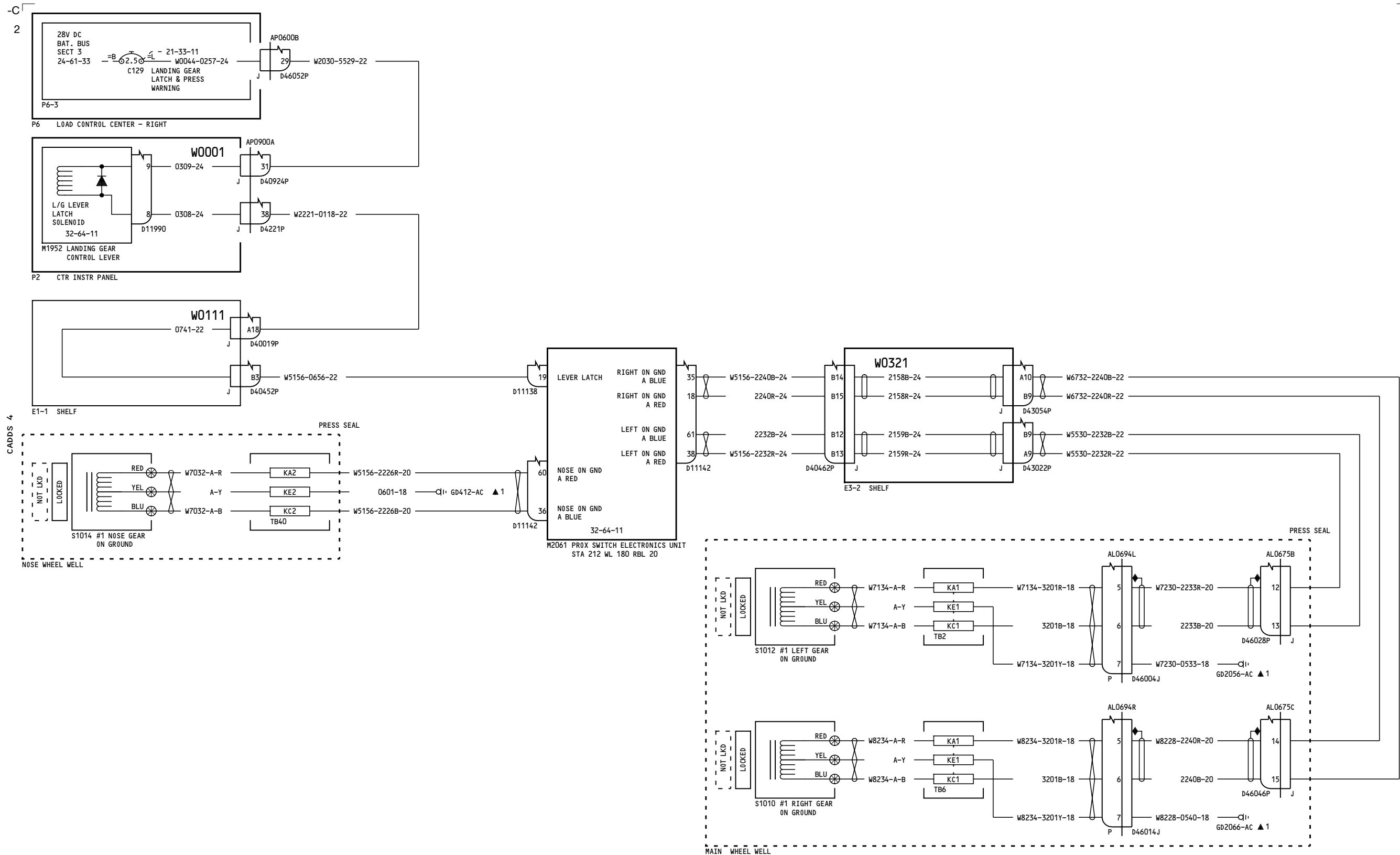

YC001-YC028

AIR/GND SYSTEM 1 & LEVER LATCH

D280A103

32-31-11

Page 1
Sheet 1
Jul 17/2007

32-31-11

Page 1
Sheet 1
Jul 17/2007

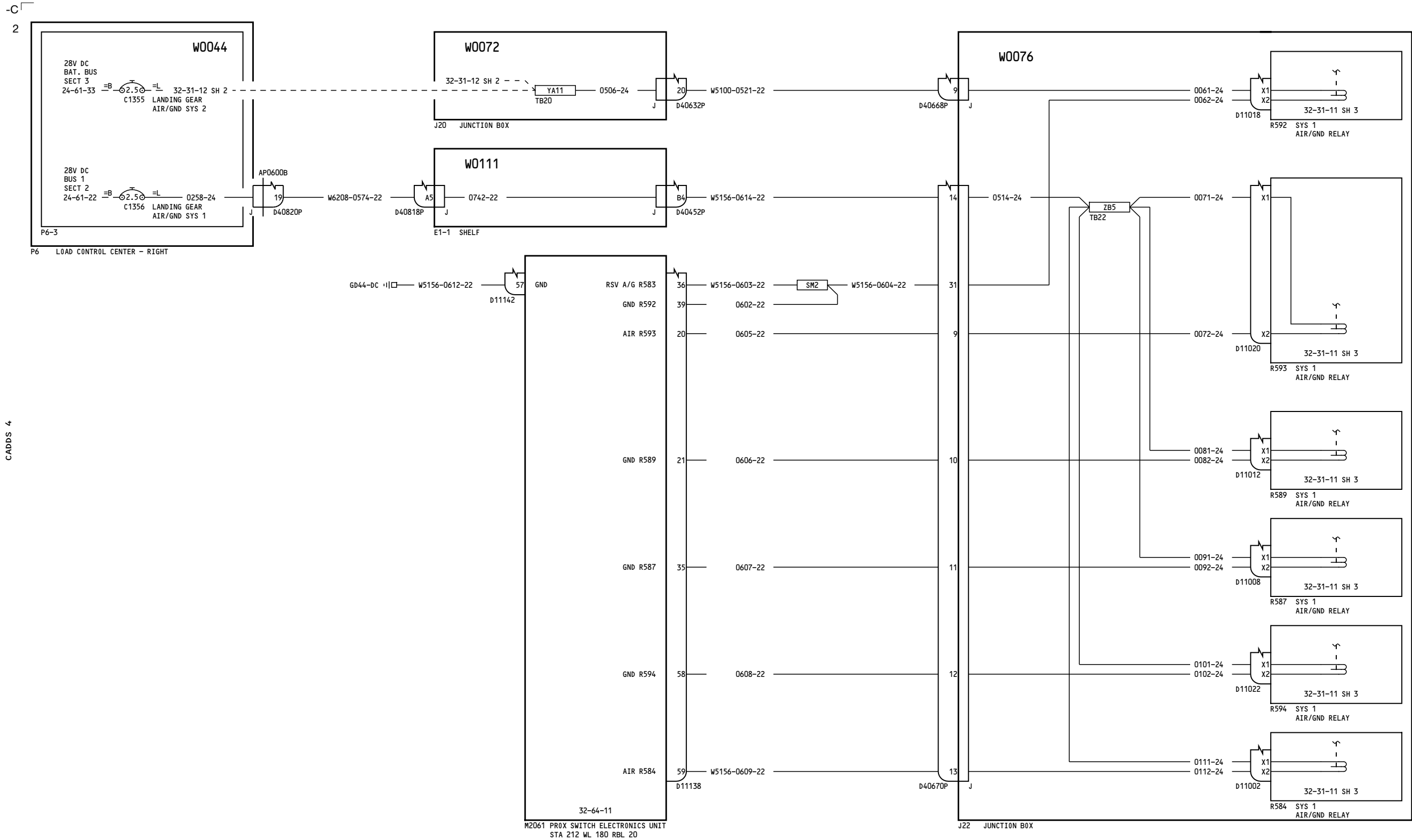

CADDS 4

YC001-YC028

AIR/GND SYSTEM 1 & LEVER LATCH

32-31-11

Page 1
Sheet 2
Jul 17/2007

D280A103

32-31-11

Page 1
Sheet 2
Jul 17/2007

-F
2

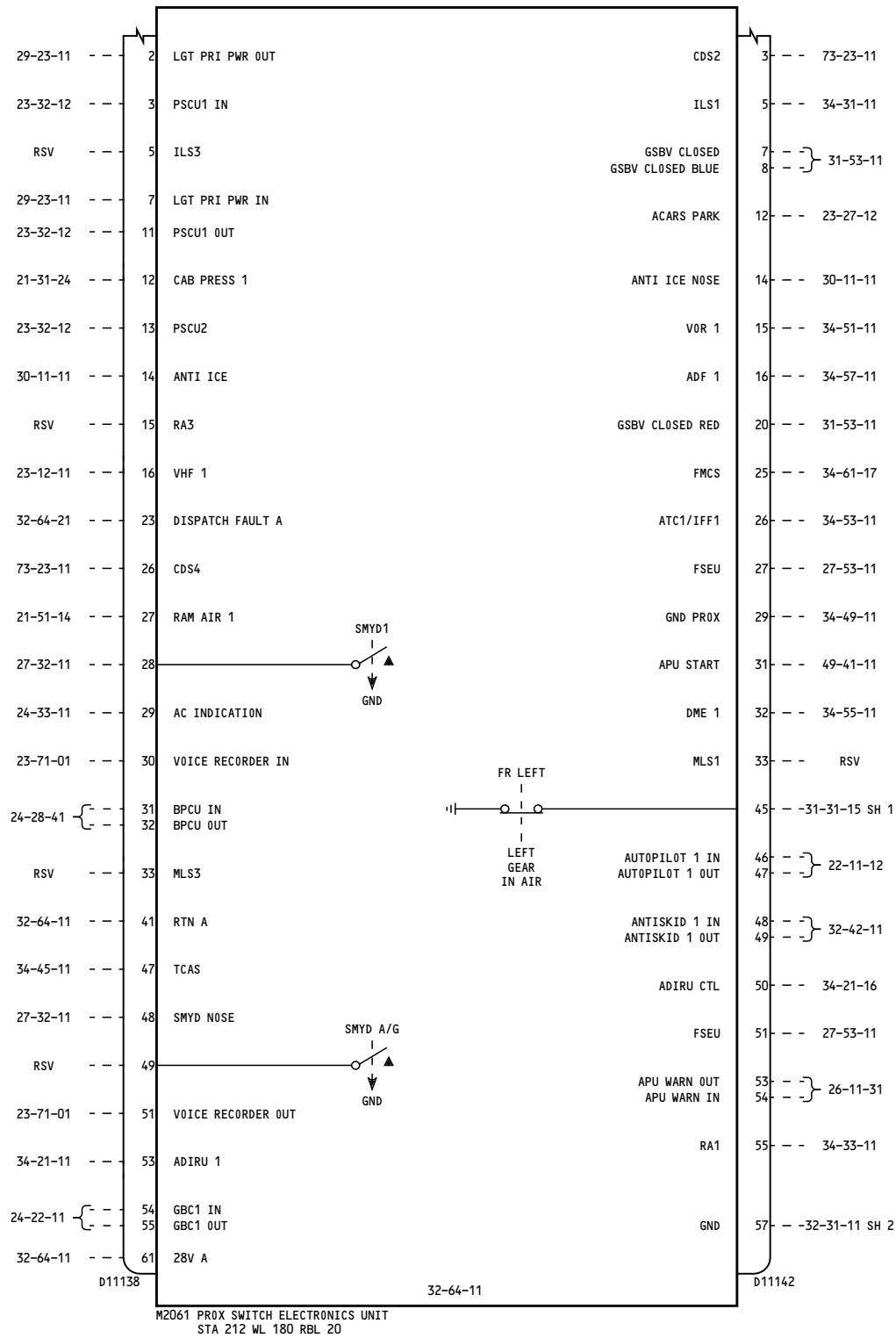

M2061 PROX SWITCH ELECTRONICS UNIT
STA 212 WL 180 RBL 20

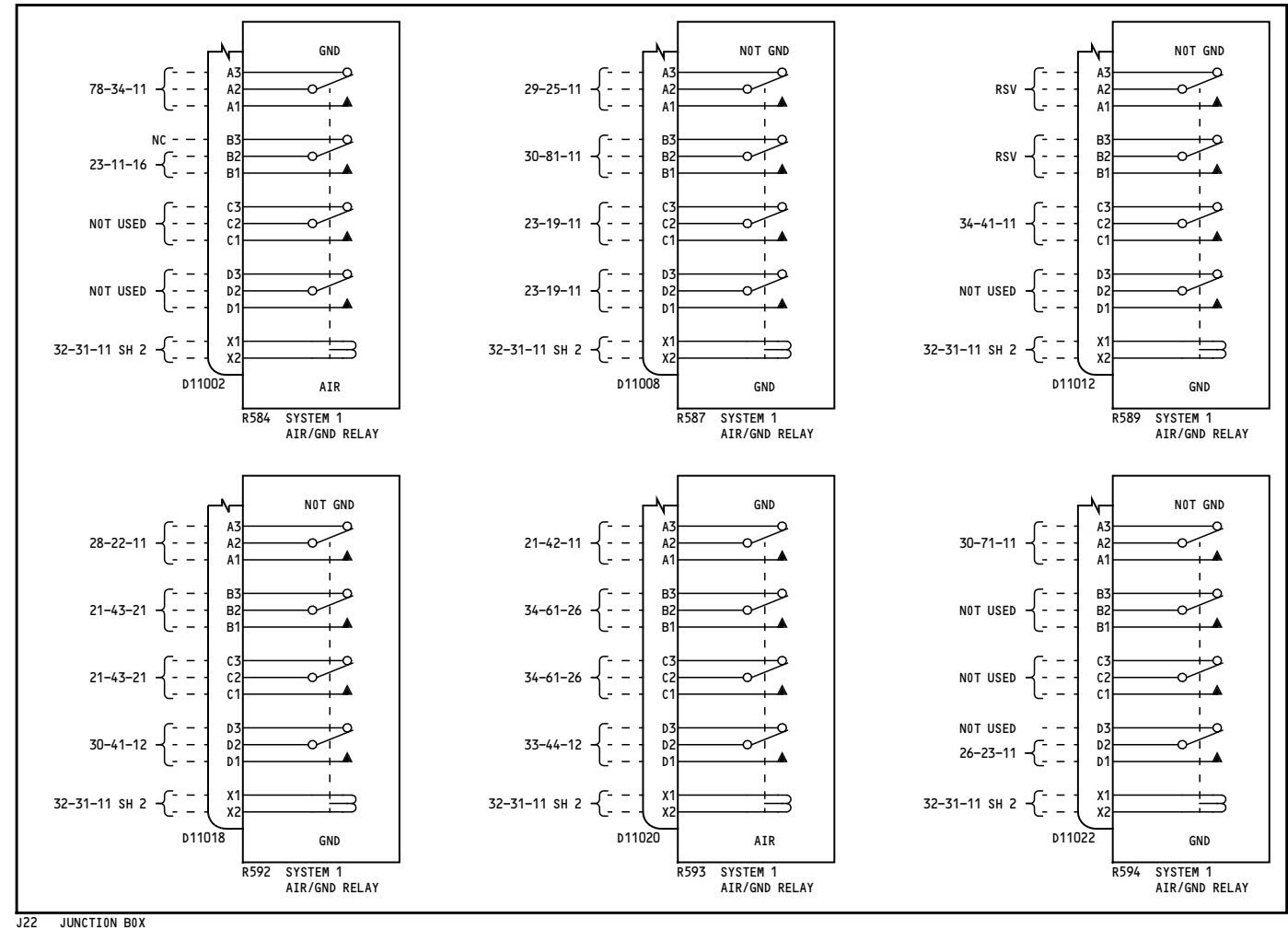

J22 JUNCTION BOX

NOTES:
THE DIAGRAM REFERENCES REPRESENT A
MAXIMUM CONFIGURATION. FOR INDIVIDUAL
AIRPLANES, SEE HOOKUP CHART.

YC001-YC028

**AIR/GND SYSTEM 1 & LEVER
LATCH**

D280A103

32-31-11

Page 1
Sheet 3
Jul 17/2007

32-31-11

Page 1
Sheet 3
Jul 17/2007

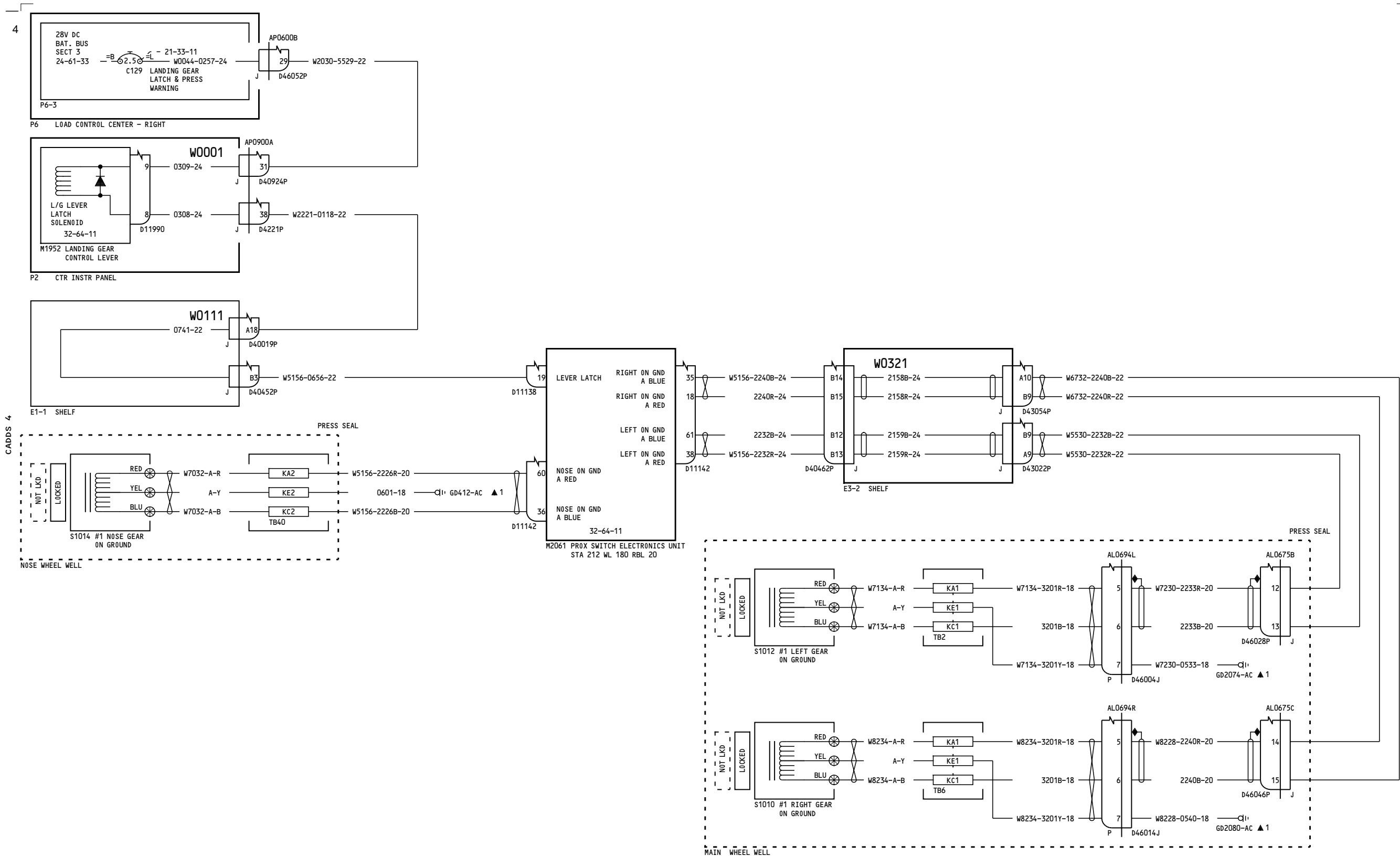

YC029-YC030

AIR/GND SYSTEM 1 & LEVER LATCH

D280A103

32-31-11

Page 2
Sheet 1
Mar 31/2005

32-31-11

Page 2
Sheet 1
Mar 31/2005

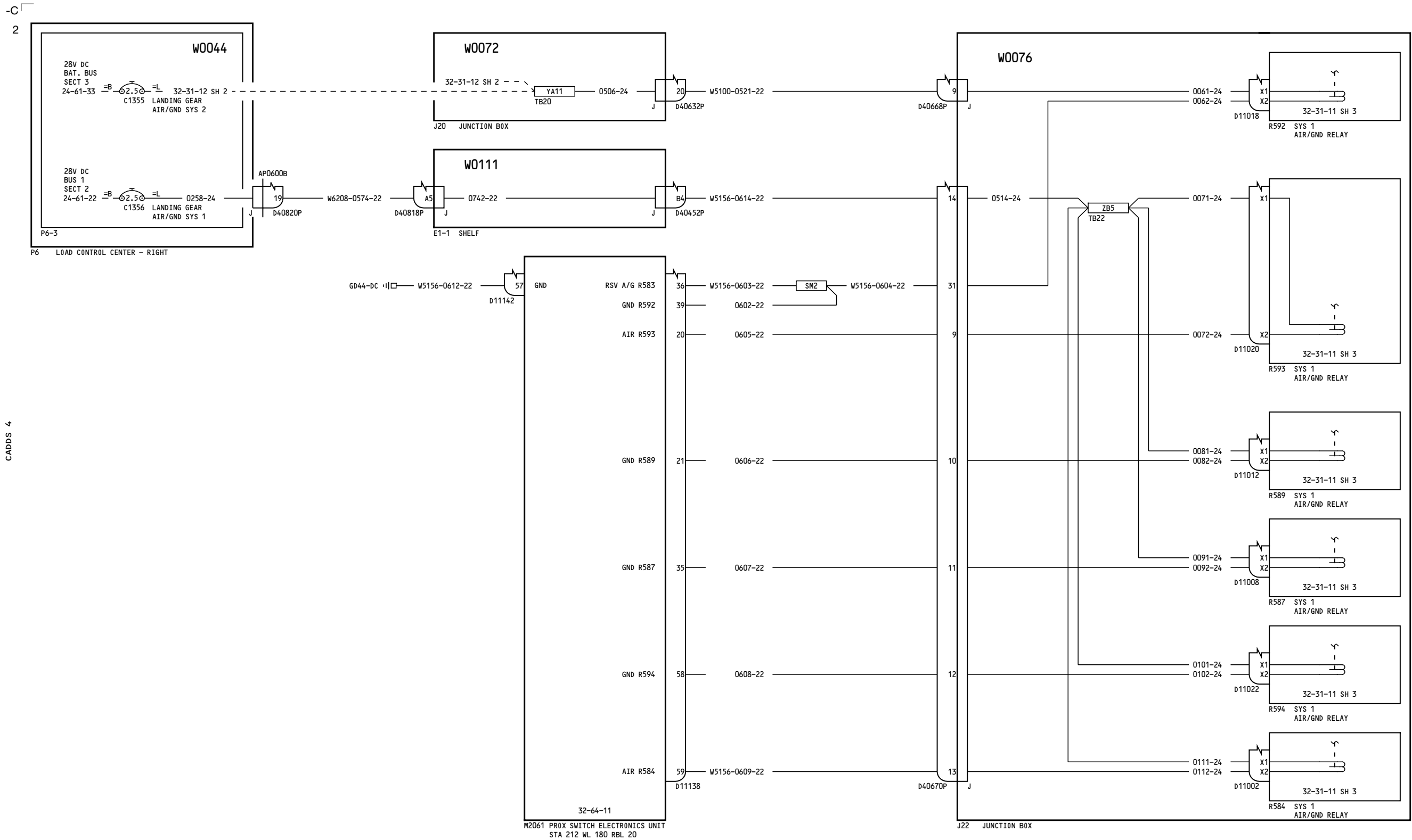

CADDs 4

YC029-YC030

AIR/GND SYSTEM 1 & LEVER LATCH

D280A103

32-31-11

Page 2
Sheet 2
Mar 31/2005

32-31-11

Page 2
Sheet 2
Mar 31/2005

-F
2

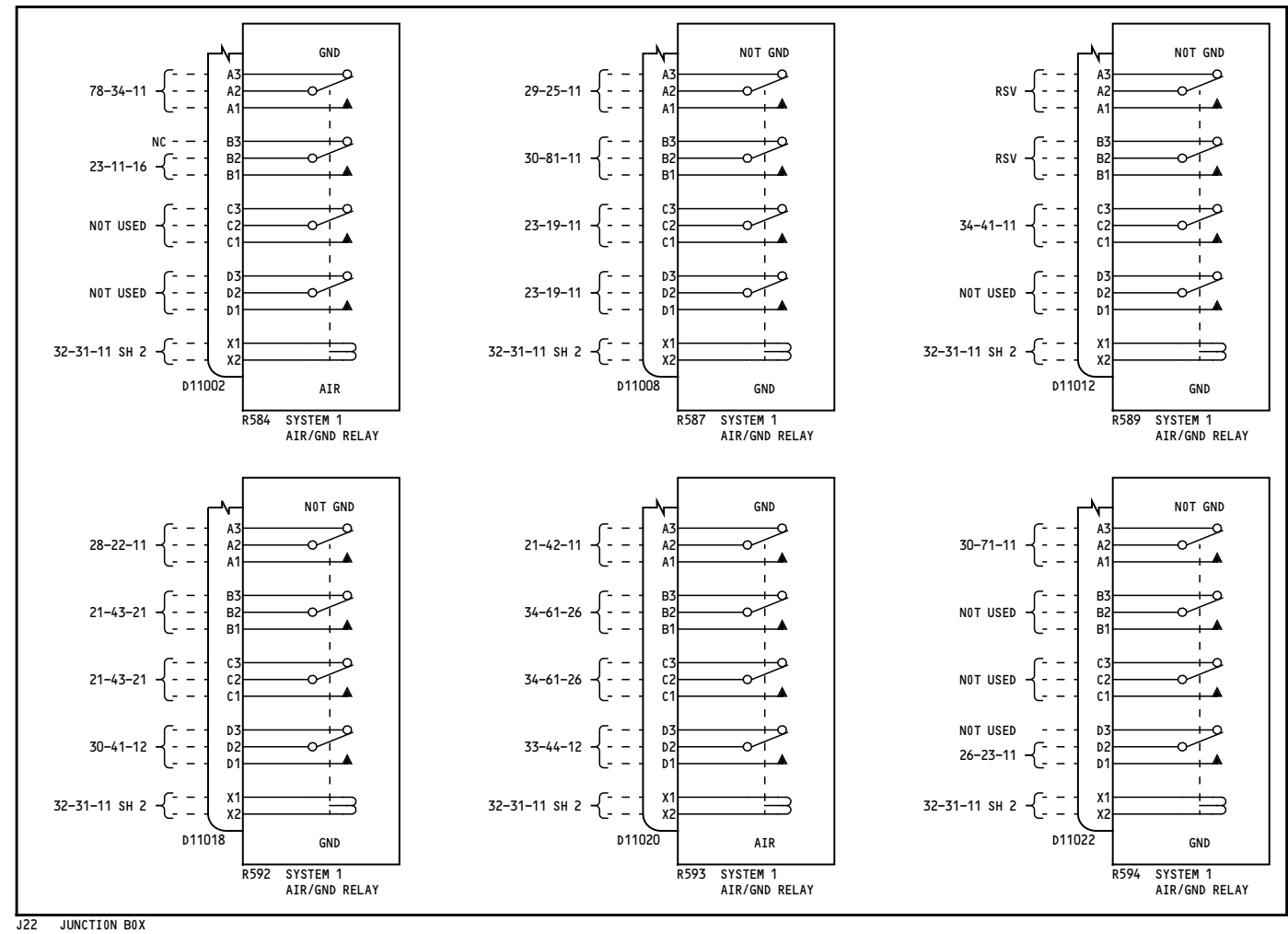
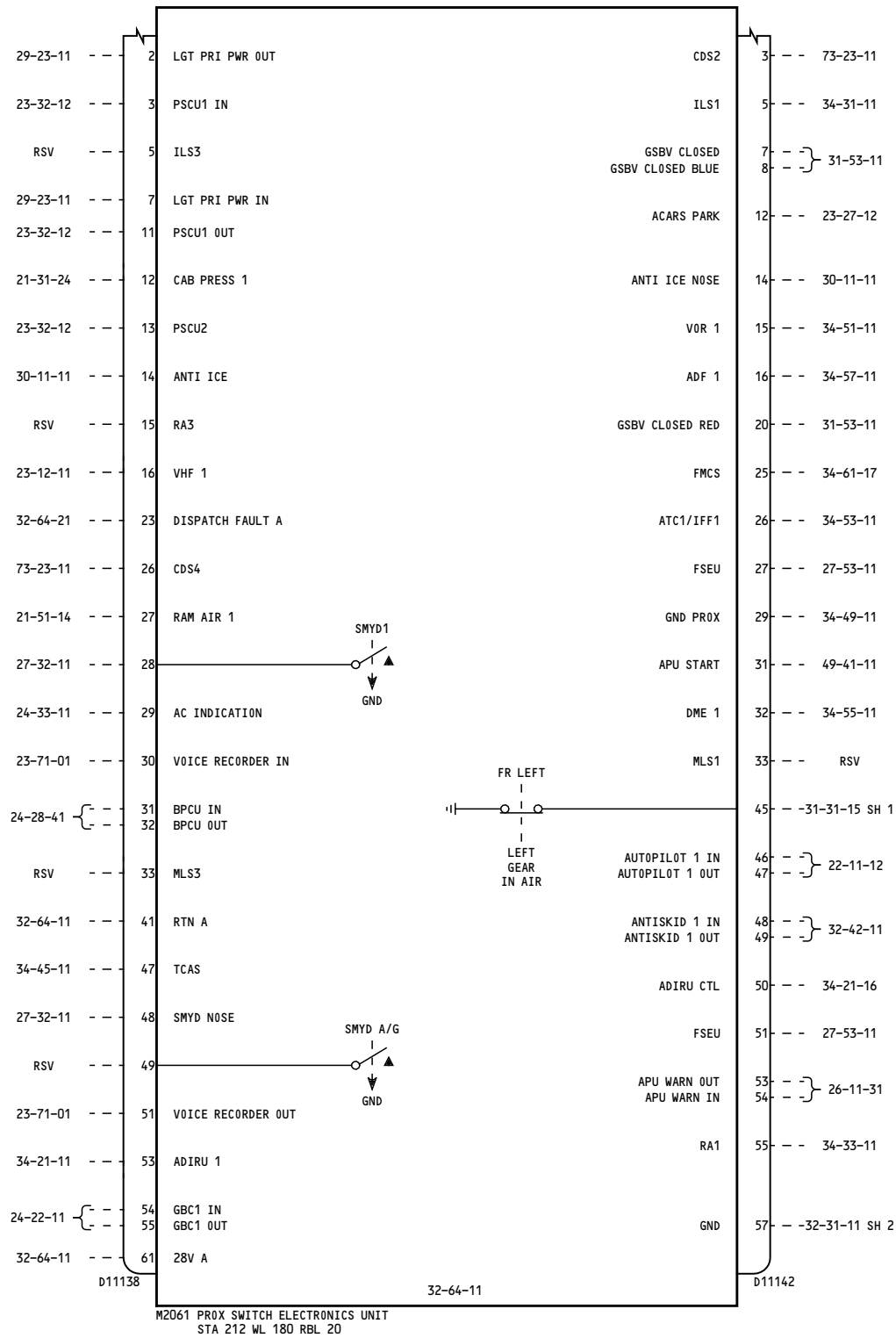

NOTES:
THE DIAGRAM REFERENCES REPRESENT A MAXIMUM CONFIGURATION. FOR INDIVIDUAL AIRPLANES, SEE HOOKUP CHART.

YC029-YC030

AIR/GND SYSTEM 1 & LEVER LATCH

D280A103

32-31-11

Page 2
Sheet 3
Mar 31/2005

32-31-11

Page 2
Sheet 3
Mar 31/2005

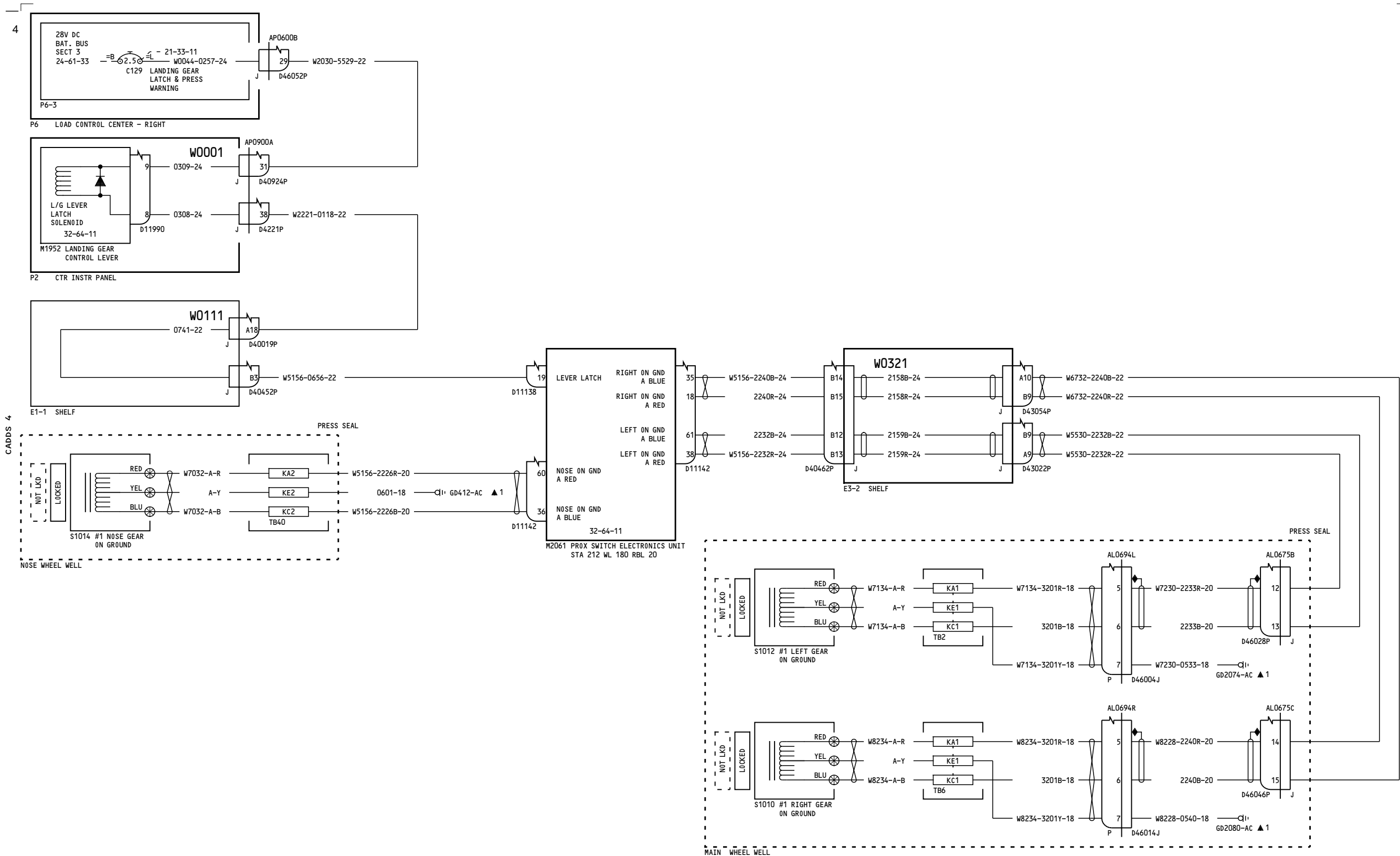

YC031-YK910, YK918, YL421-YL428, YL430

AIR/GND SYSTEM 1 & LEVER LATCH

D280A103

32-31-11

Page 3
Sheet 1
Feb 09/2009

32-31-11

Page 3
Sheet 1
Feb 09/2009

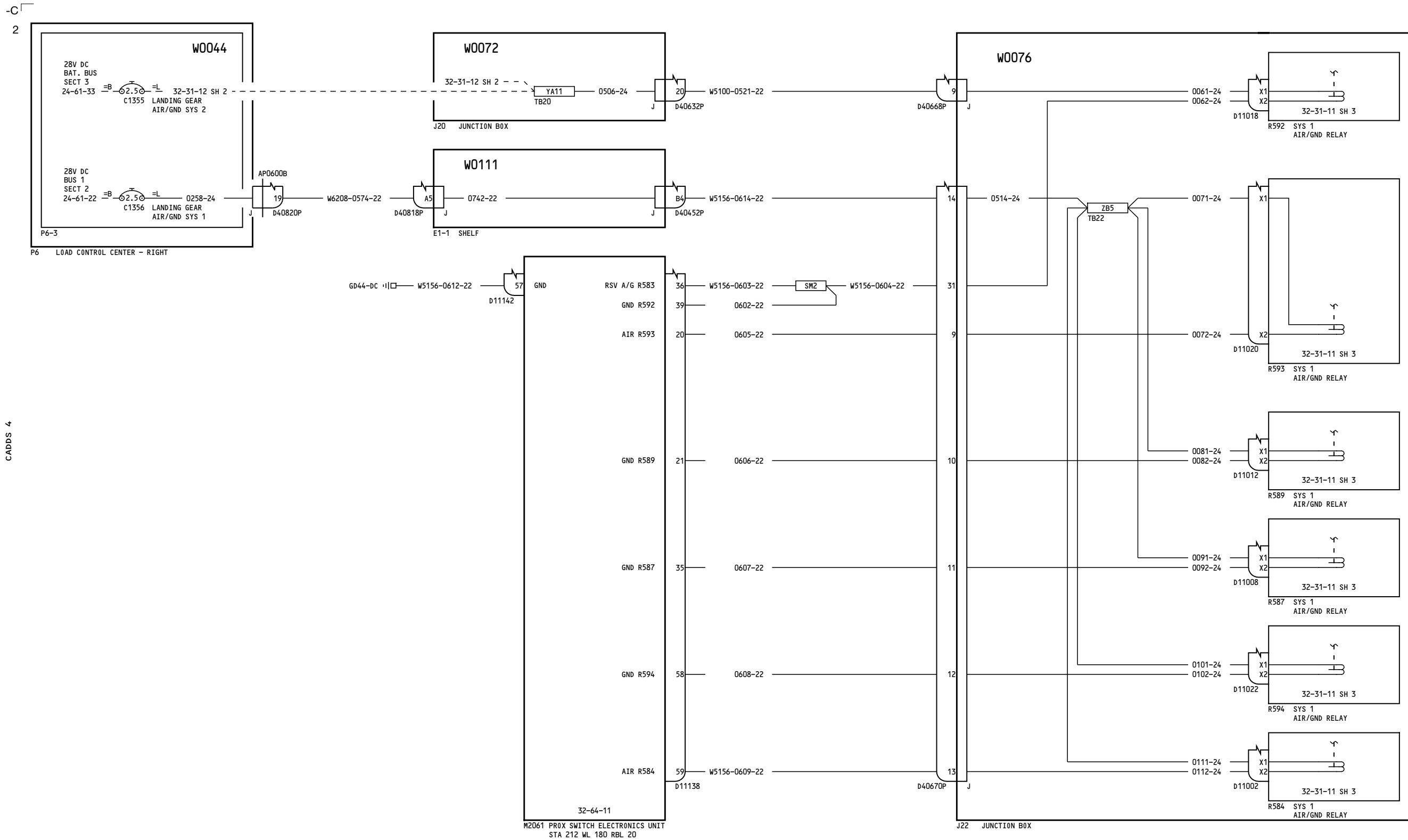

CADDS 4

YC031-YK910, YK918, YL421-YL428, YL430

AIR/GND SYSTEM 1 & LEVER LATCH

D280A103

32-31-11

Page 3
 Sheet 2
 Feb 09/2009

32-31-11

Page 3
 Sheet 2
 Feb 09/2009

-B
24

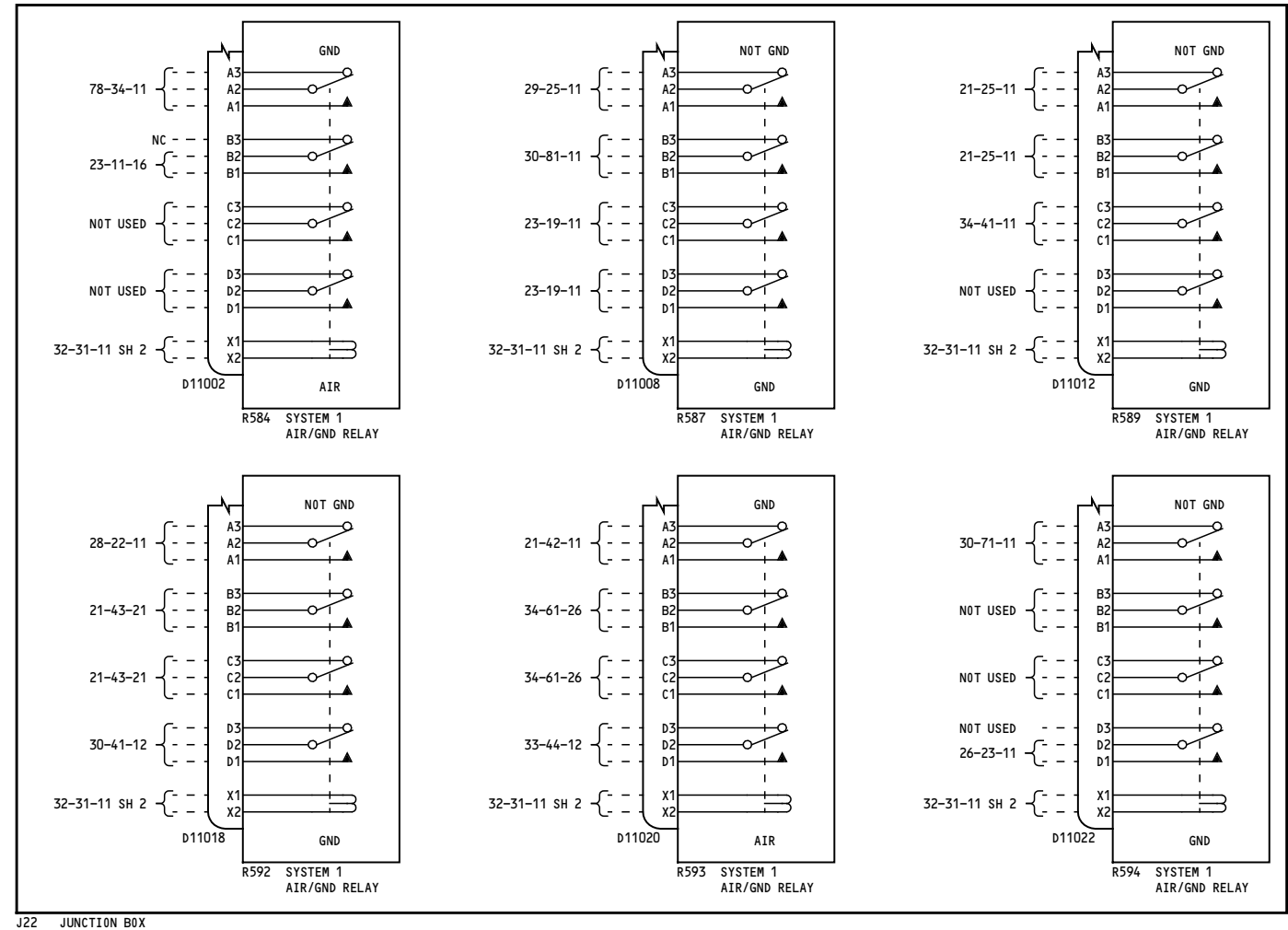
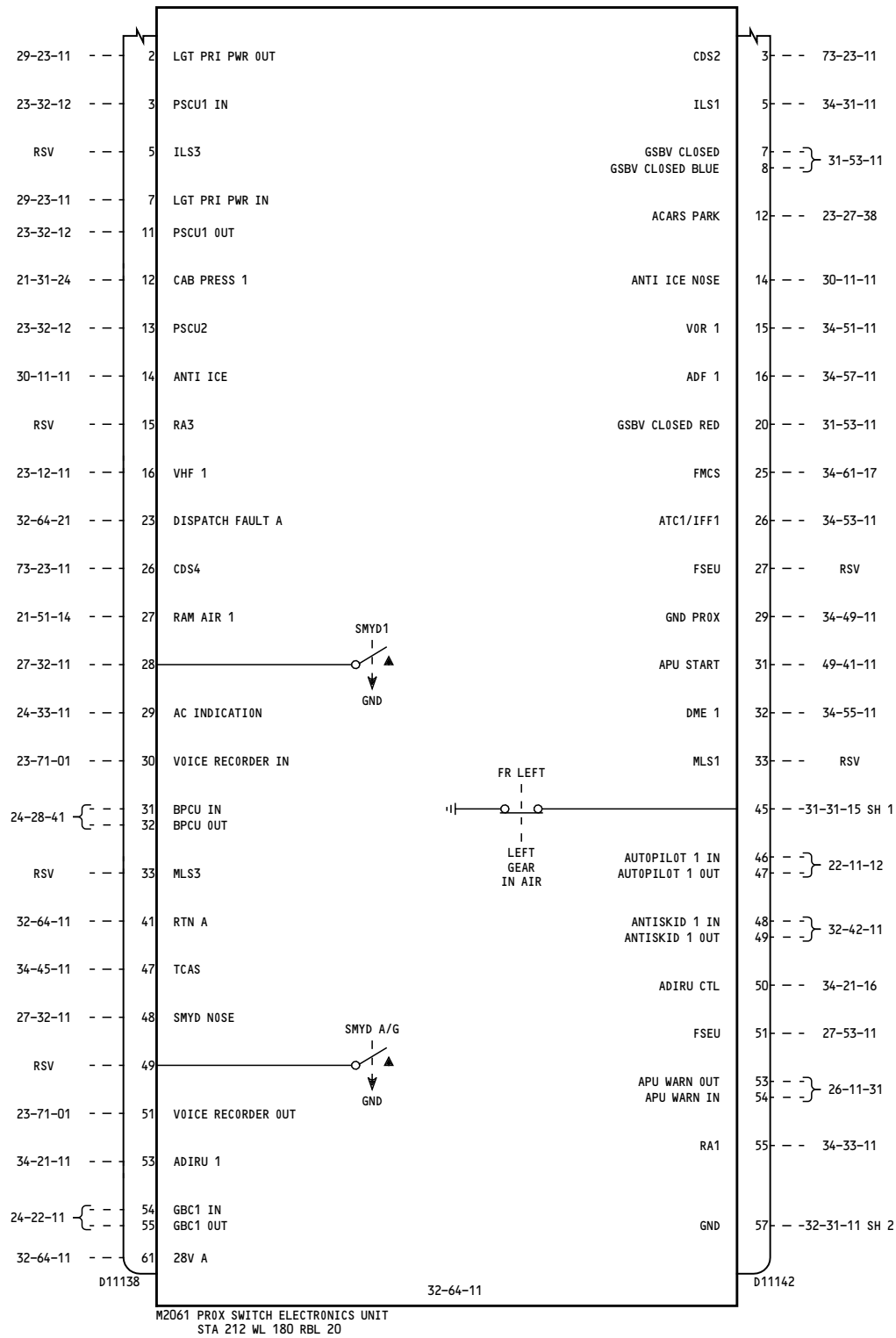

NOTES:
THE DIAGRAM REFERENCES REPRESENT A MAXIMUM CONFIGURATION. FOR INDIVIDUAL AIRPLANES, SEE HOOKUP CHART.

YC031-YK910, YK918, YL421-YL428, YL430

AIR/GND SYSTEM 1 & LEVER LATCH

D280A103

32-31-11

Page 3
Sheet 3
Feb 09/2009

32-31-11

Page 3
Sheet 3
Feb 09/2009

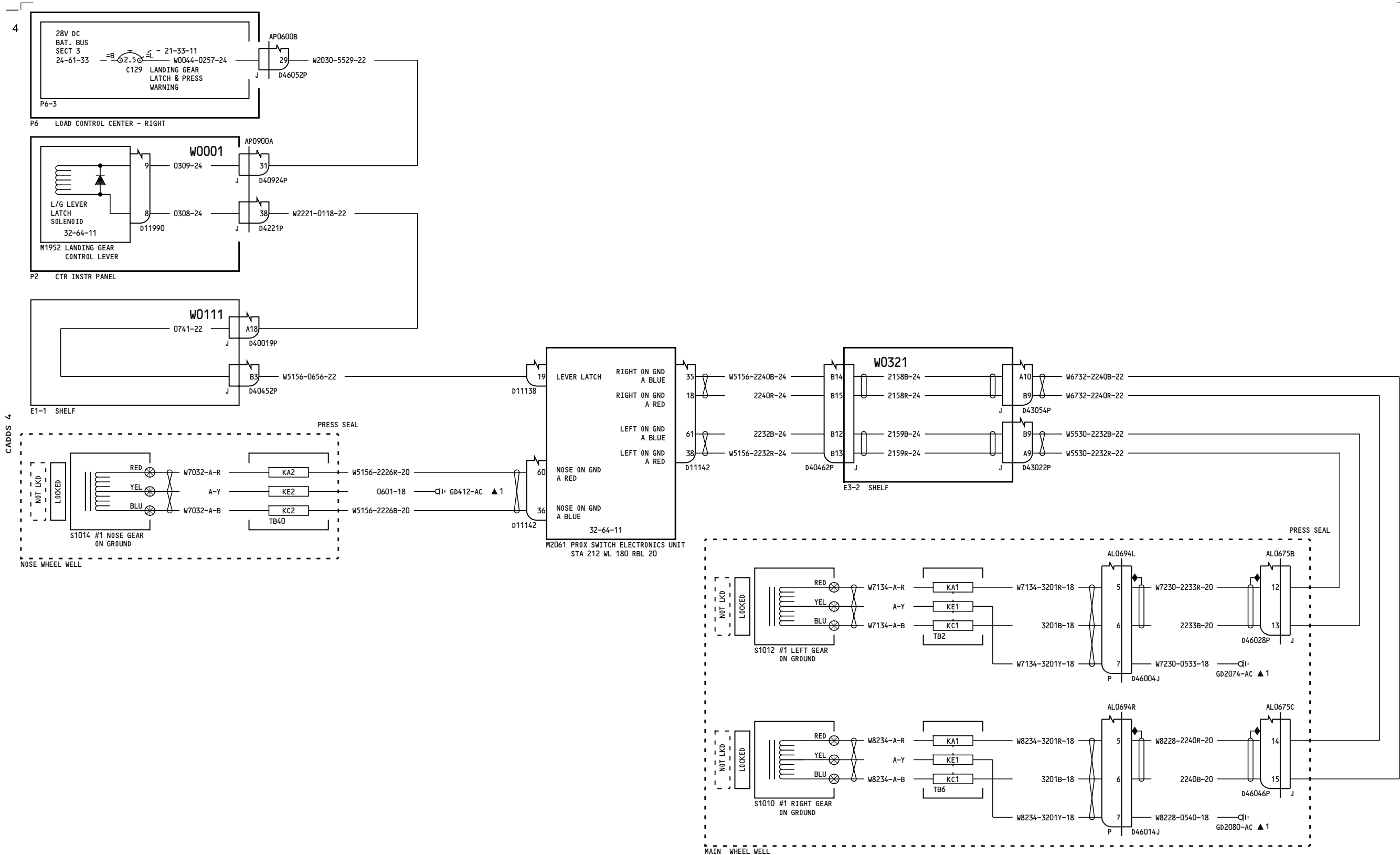

YK911-YK917, YM652-YM670

AIR/GND SYSTEM 1 & LEVER LATCH

D280A103

32-31-11

Page 4
Sheet 1
Aug 13/2008

32-31-11

Page 4
Sheet 1
Aug 13/2008

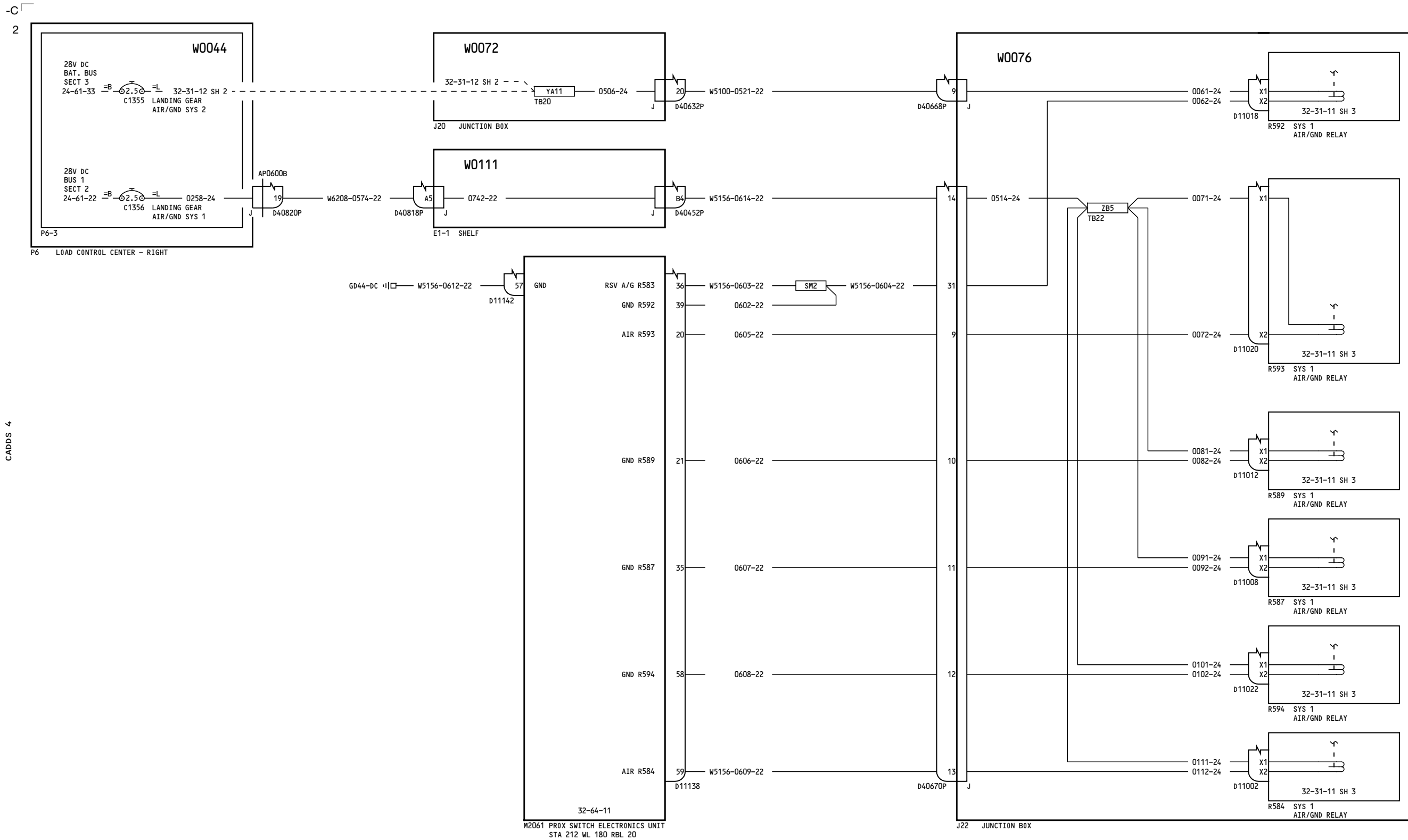

CADDS 4

YK911-YK917, YM652-YM670

AIR/GND SYSTEM 1 & LEVER LATCH

32-31-11

Page 4
Sheet 2
Aug 13/2008

D280A103

32-31-11

Page 4
Sheet 2
Aug 13/2008

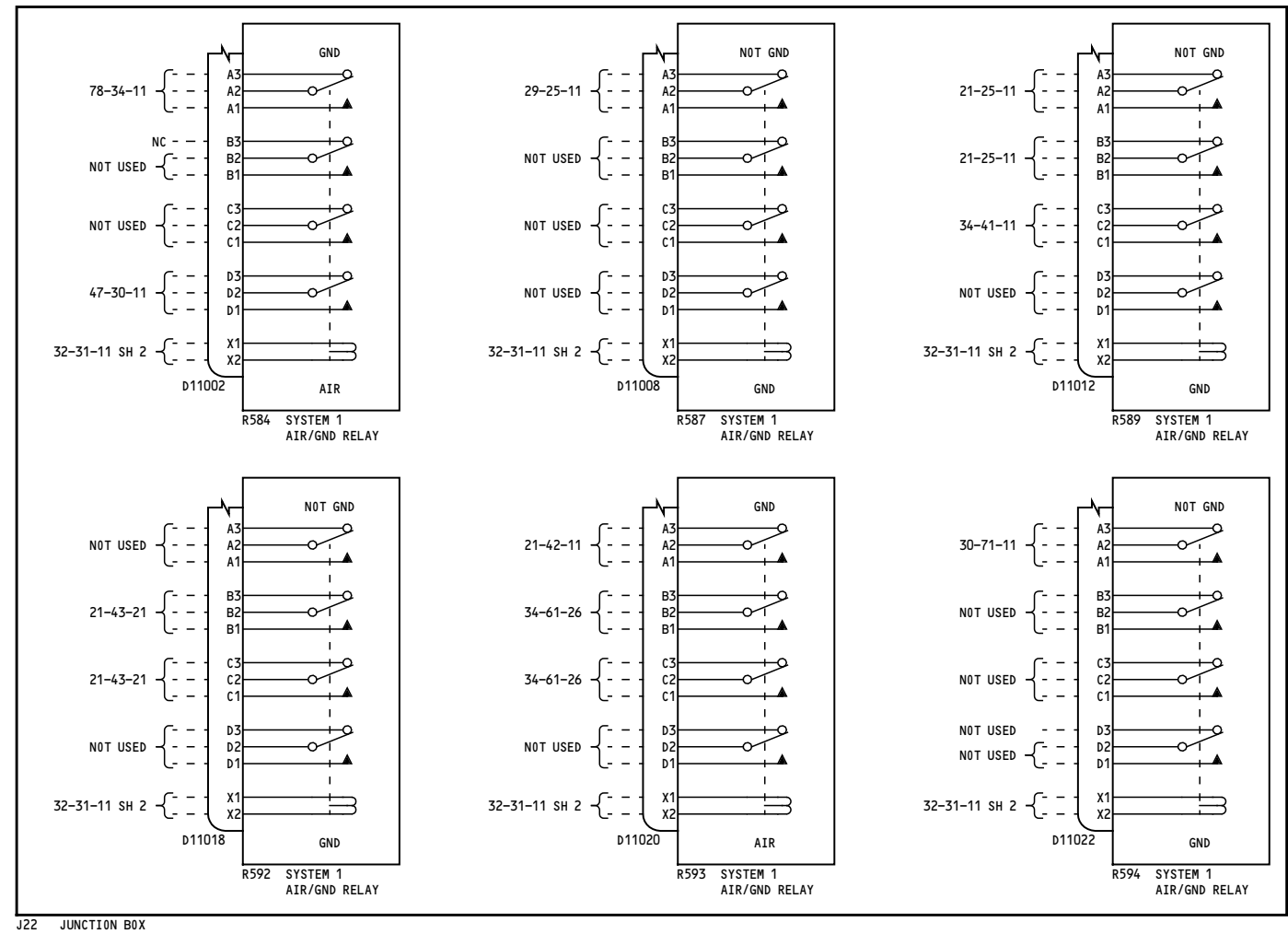
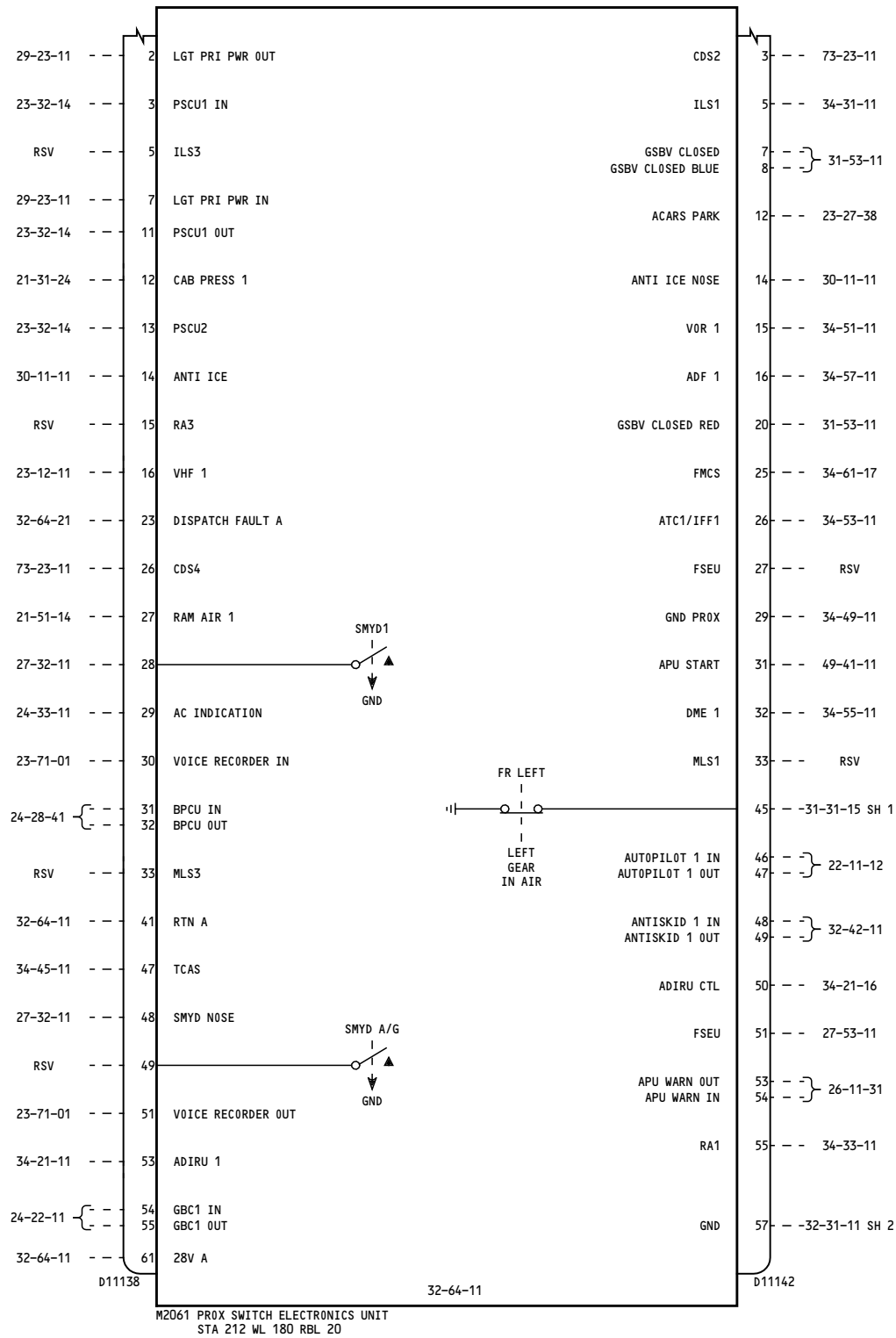

NOTES:
THE DIAGRAM REFERENCES REPRESENT A MAXIMUM CONFIGURATION. FOR INDIVIDUAL AIRPLANES, SEE HOOKUP CHART.

YK911-YK917, YM652-YM670

AIR/GND SYSTEM 1 & LEVER LATCH

D280A103

32-31-11

Page 4
Sheet 3
Feb 09/2009

32-31-11

Page 4
Sheet 3
Feb 09/2009

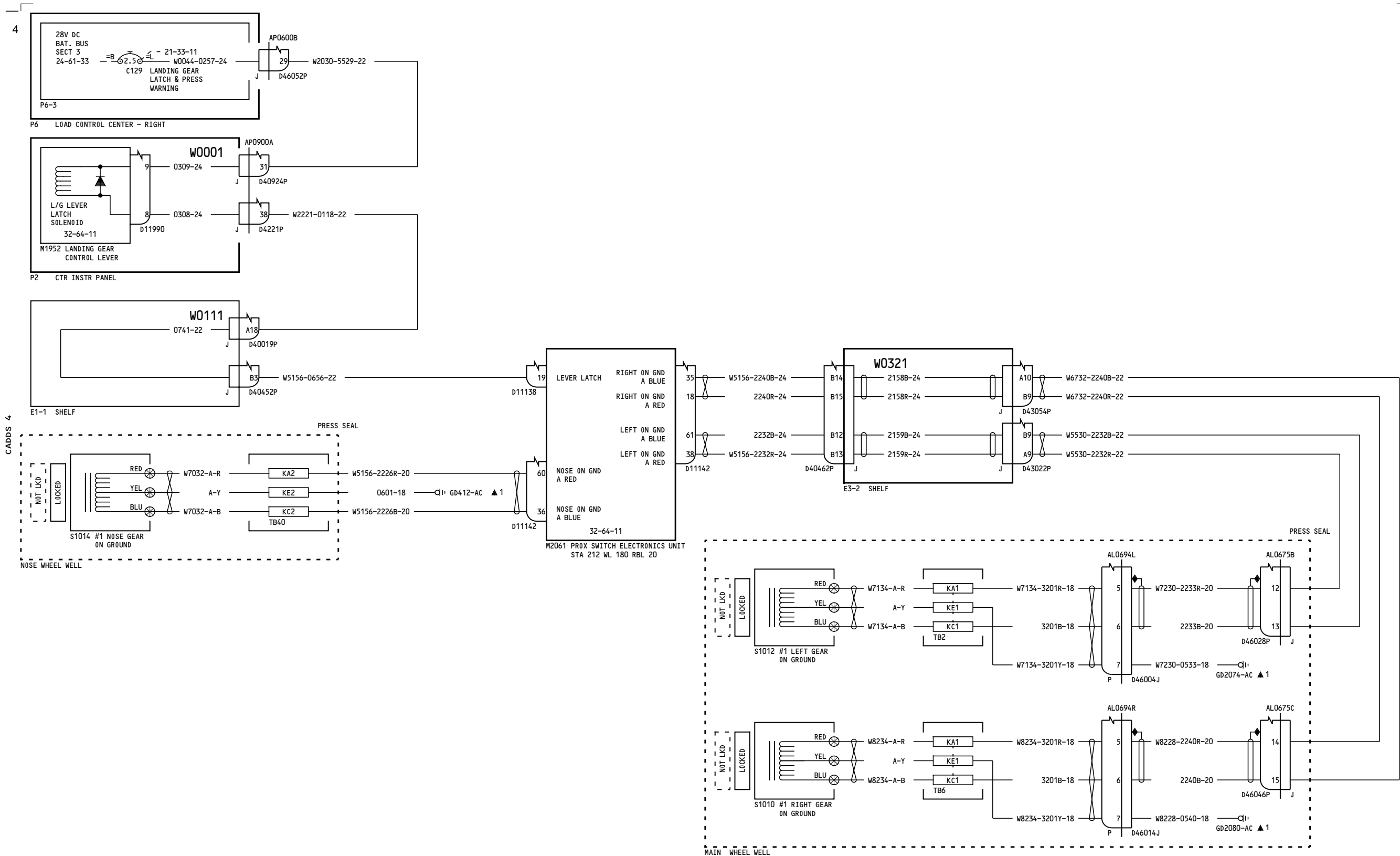

YK919-YL401

AIR/GND SYSTEM 1 & LEVER LATCH

D280A103

32-31-11

Page 5
Sheet 1
Aug 13/2008

32-31-11

Page 5
Sheet 1
Aug 13/2008

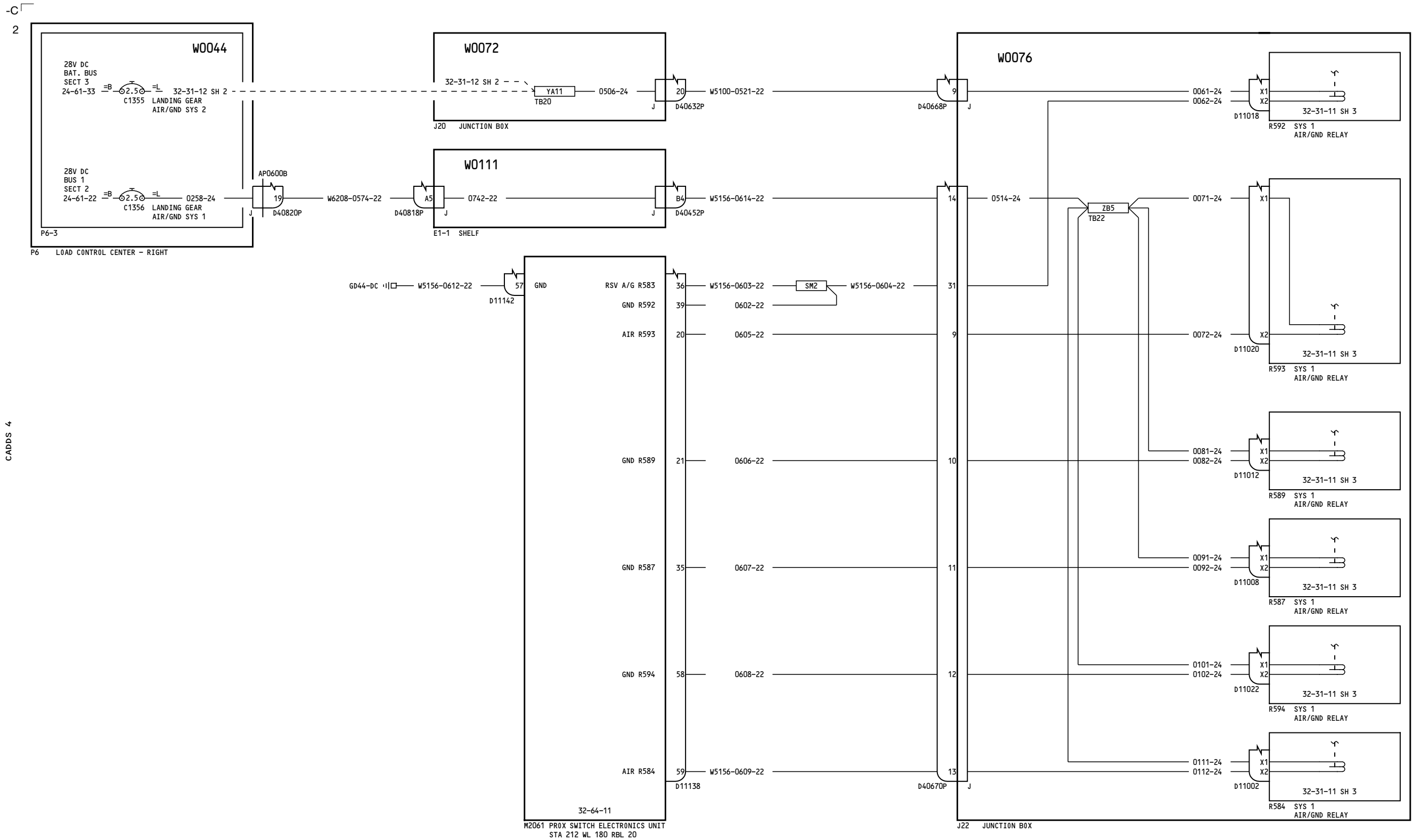

CADDS 4

YK919-YL401

AIR/GND SYSTEM 1 & LEVER LATCH

32-31-11

Page 5
Sheet 2
Aug 13/2008

D280A103

32-31-11

Page 5
Sheet 2
Aug 13/2008

-A
80

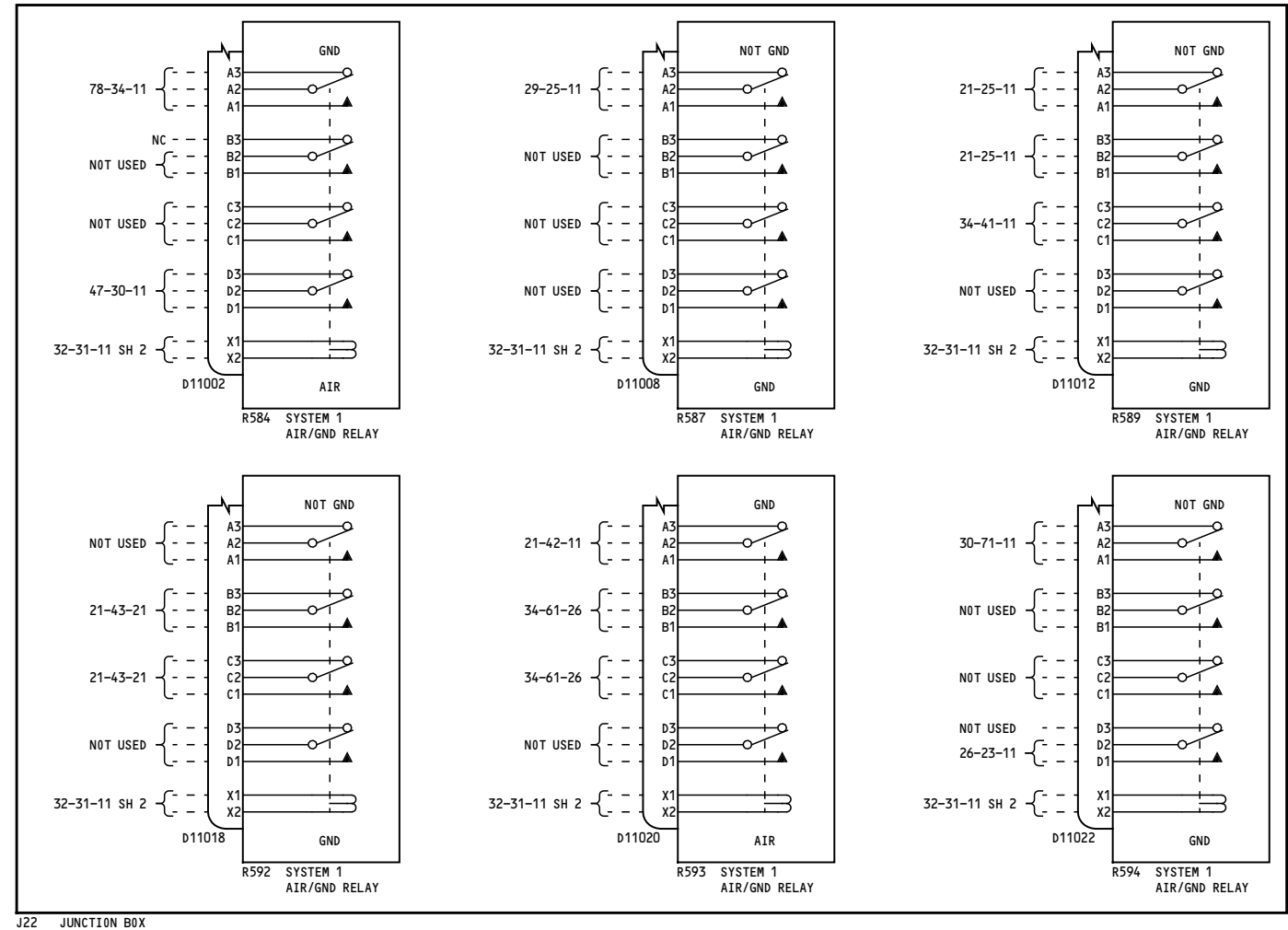
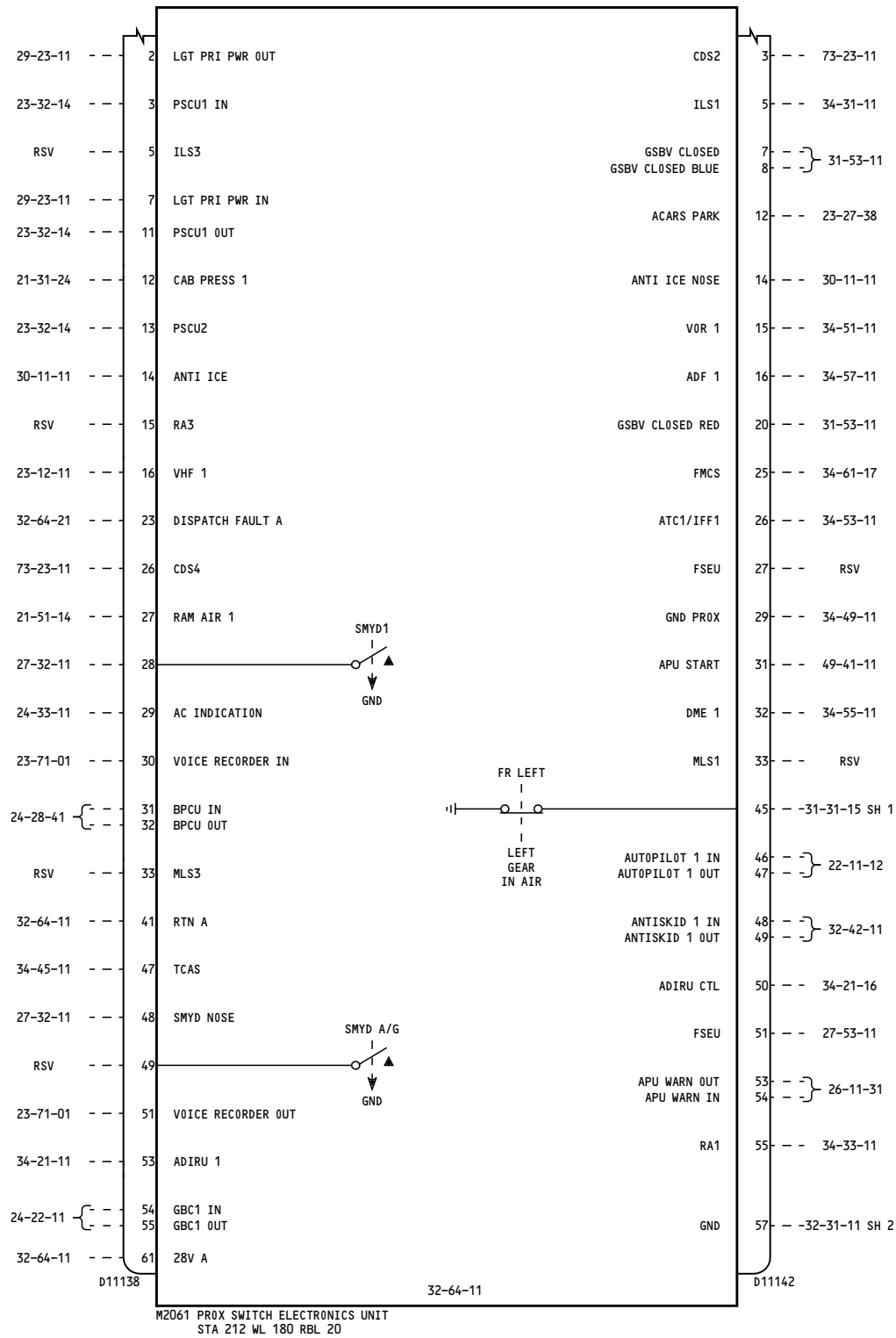

NOTES:
THE DIAGRAM REFERENCES REPRESENT A MAXIMUM CONFIGURATION. FOR INDIVIDUAL AIRPLANES, SEE HOOKUP CHART.

YK919-YL401

AIR/GND SYSTEM 1 & LEVER LATCH

D280A103

32-31-11

Page 5
Sheet 3
Feb 09/2009

32-31-11

Page 5
Sheet 3
Feb 09/2009

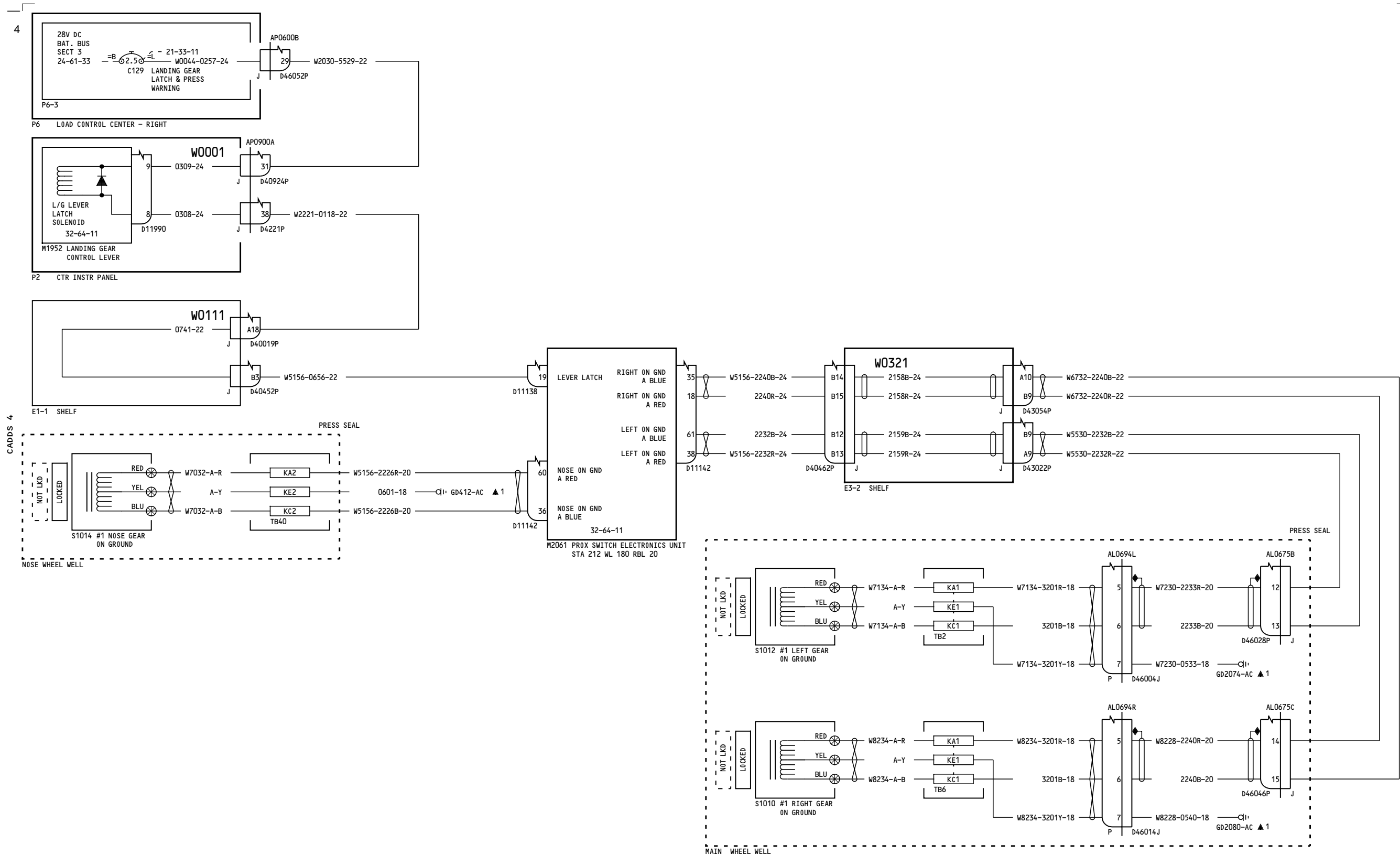

YL429

AIR/GND SYSTEM 1 & LEVER LATCH

D280A103

32-31-11

Page 6
Sheet 1
Nov 11/2008

32-31-11

Page 6
Sheet 1
Nov 11/2008

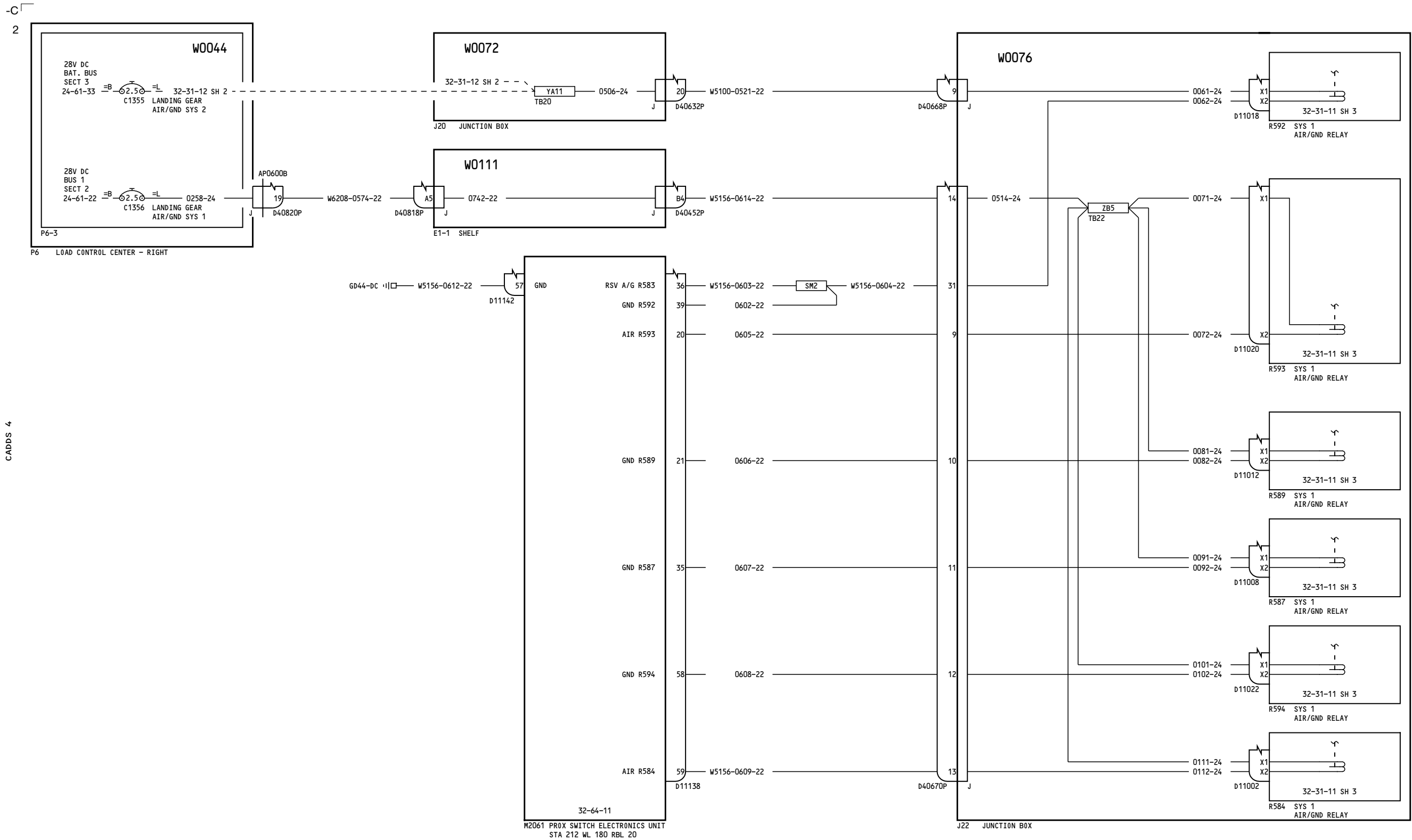

CADDS 4

YL429

AIR/GND SYSTEM 1 & LEVER LATCH

D280A103

32-31-11

Page 6
Sheet 2
Nov 11/2008

32-31-11

Page 6
Sheet 2
Nov 11/2008

-A
91

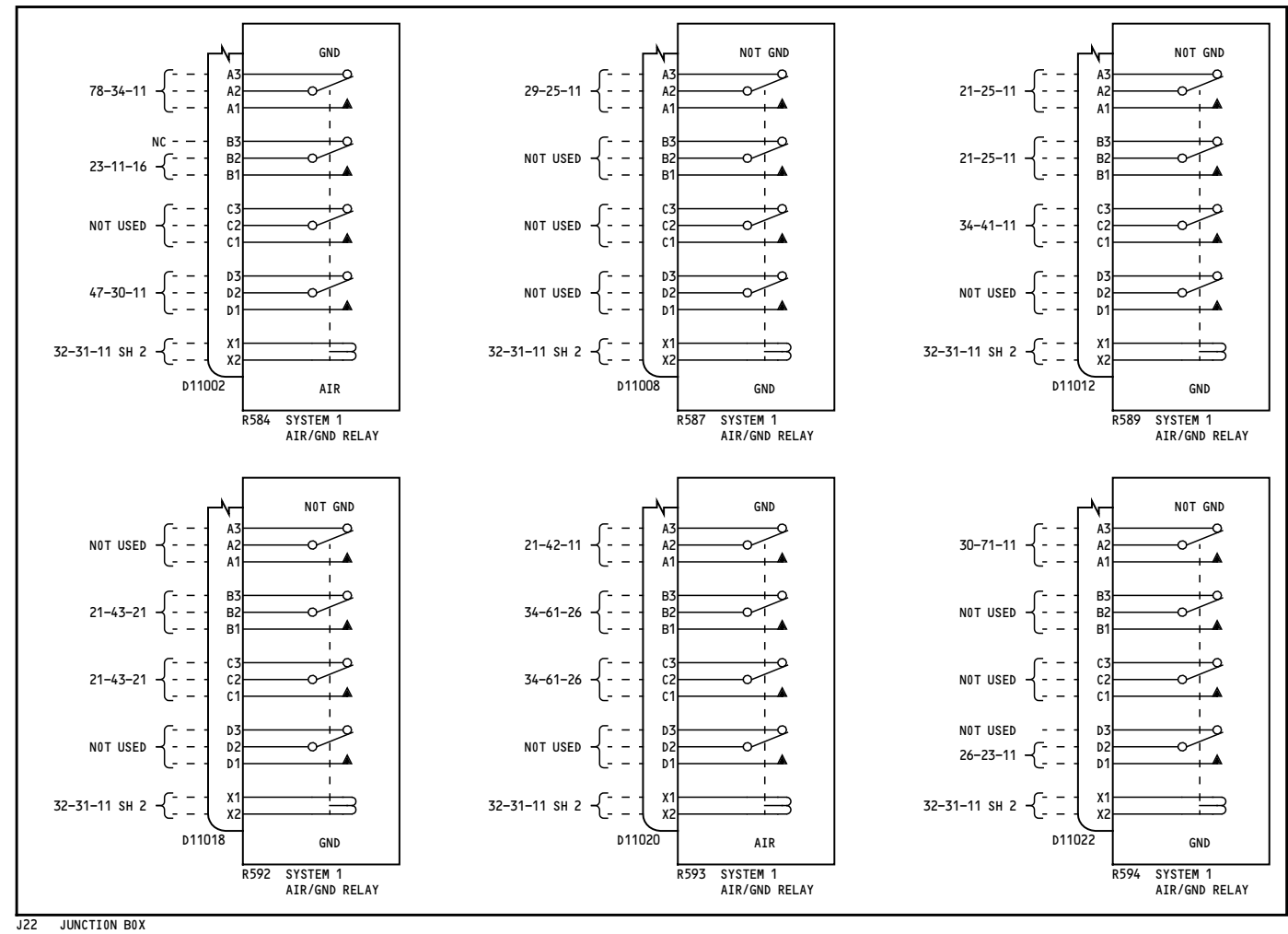
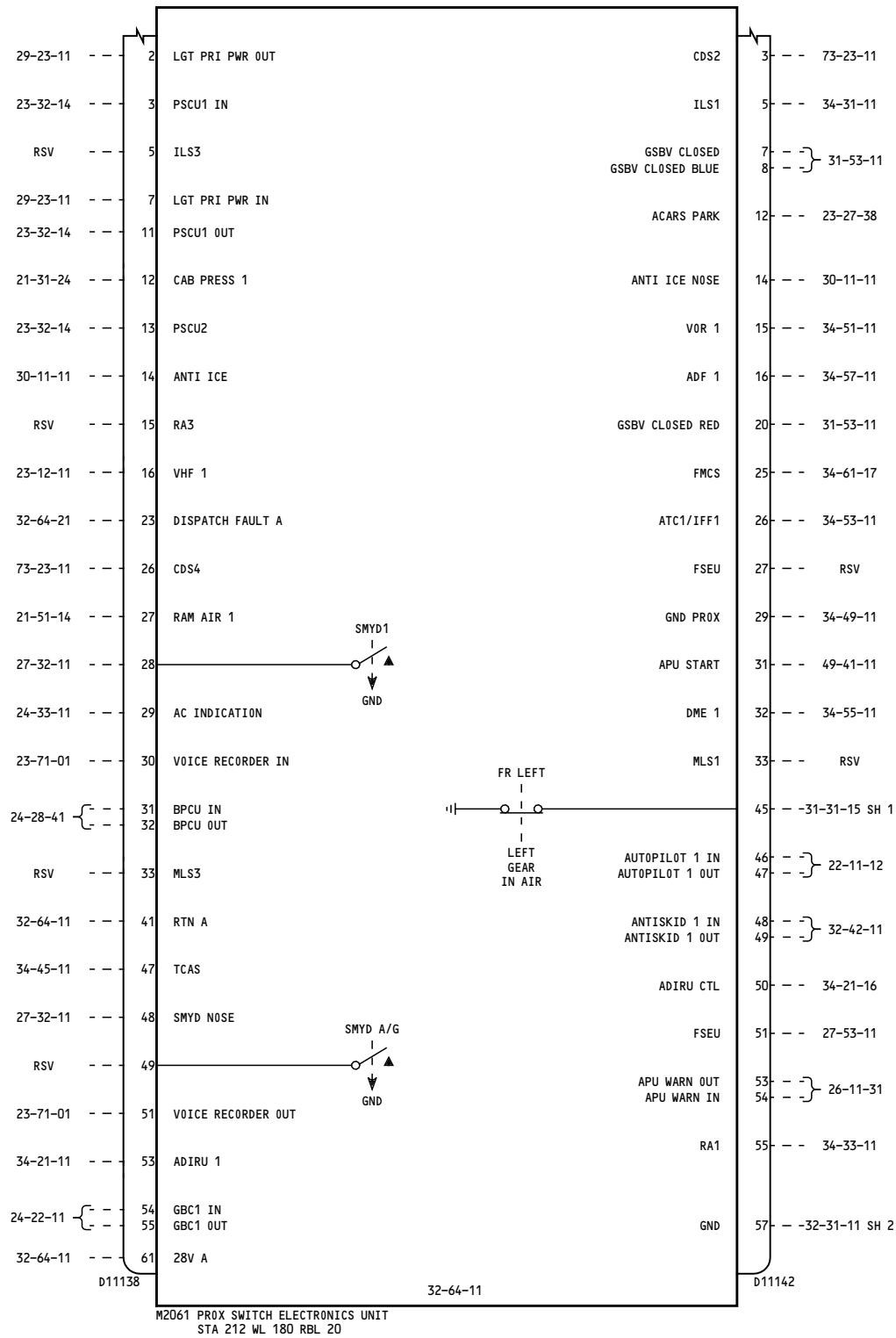

NOTES:
THE DIAGRAM REFERENCES REPRESENT A MAXIMUM CONFIGURATION. FOR INDIVIDUAL AIRPLANES, SEE HOOKUP CHART.

YL429	AIR/GND SYSTEM 1 & LEVER LATCH D280A103
-------	---

32-31-11

Page 6
Sheet 3
Feb 09/2009

32-31-11

Page 6
Sheet 3
Feb 09/2009

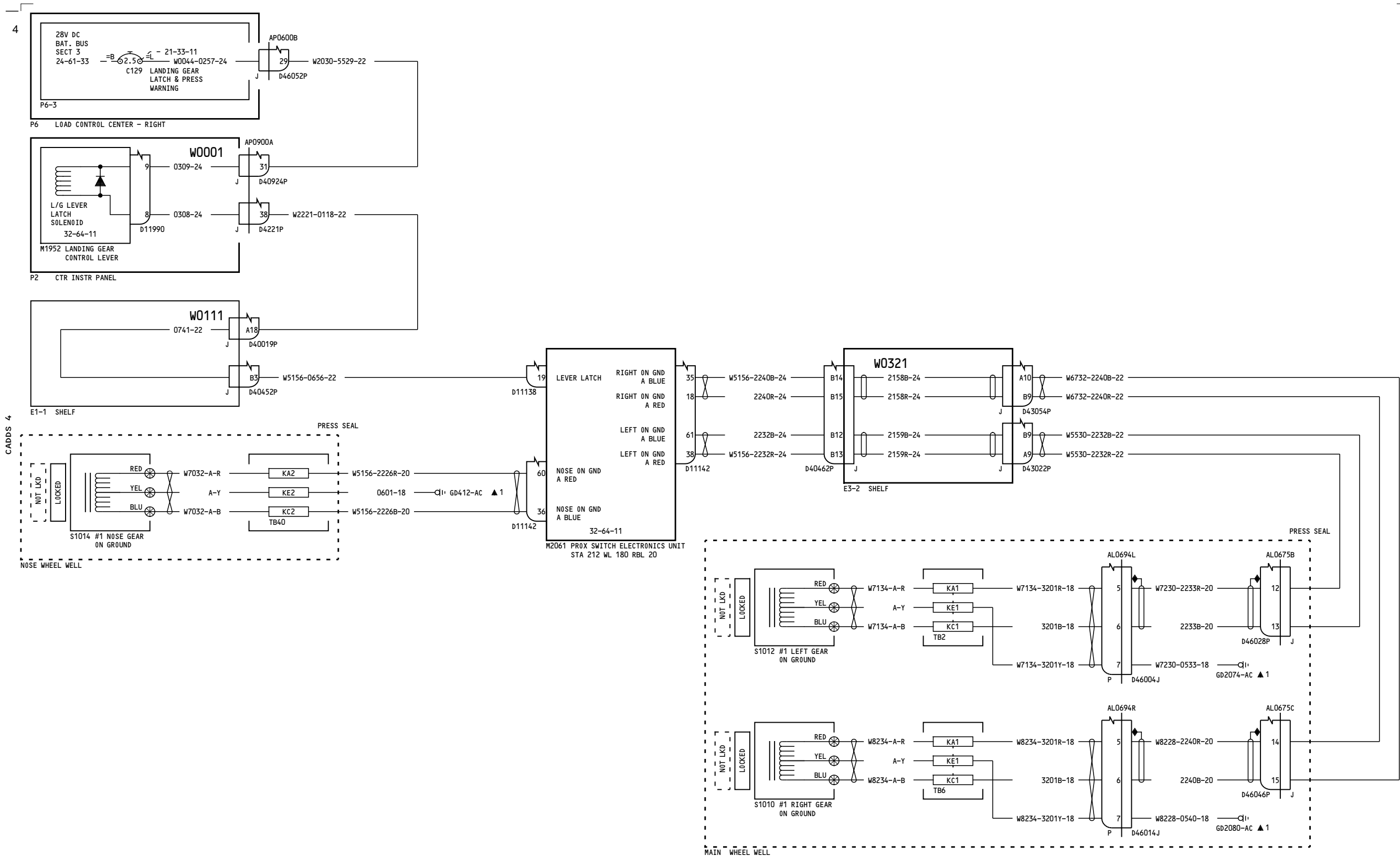

YM643-YM651

AIR/GND SYSTEM 1 & LEVER LATCH

D280A103

32-31-11

Page 7
Sheet 1
Nov 11/2008

32-31-11

Page 7
Sheet 1
Nov 11/2008

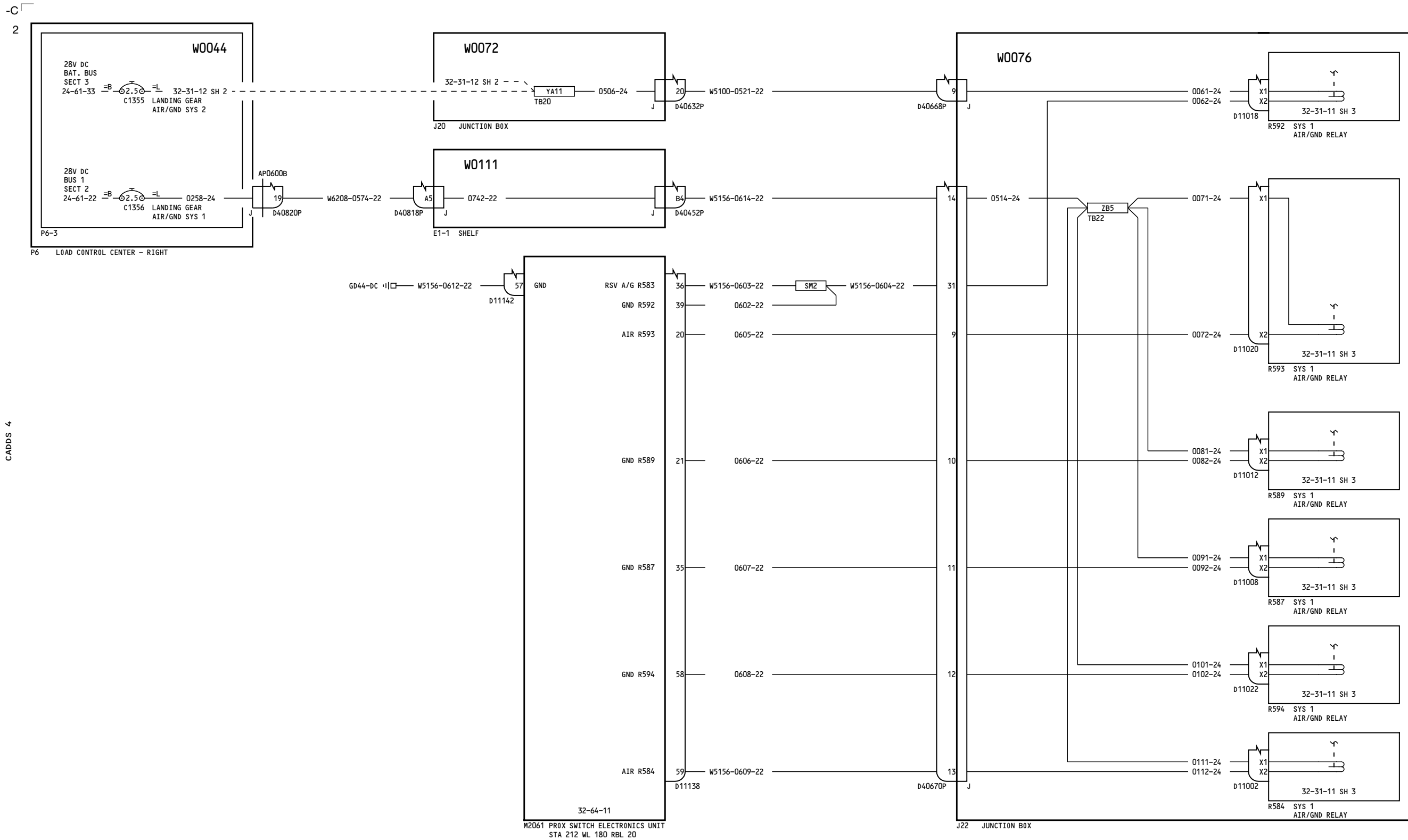

CADDS 4

YM643-YM651

AIR/GND SYSTEM 1 & LEVER LATCH

32-31-11

Page 7
Sheet 2
Nov 11/2008

D280A103

32-31-11

Page 7
Sheet 2
Nov 11/2008

-A
38

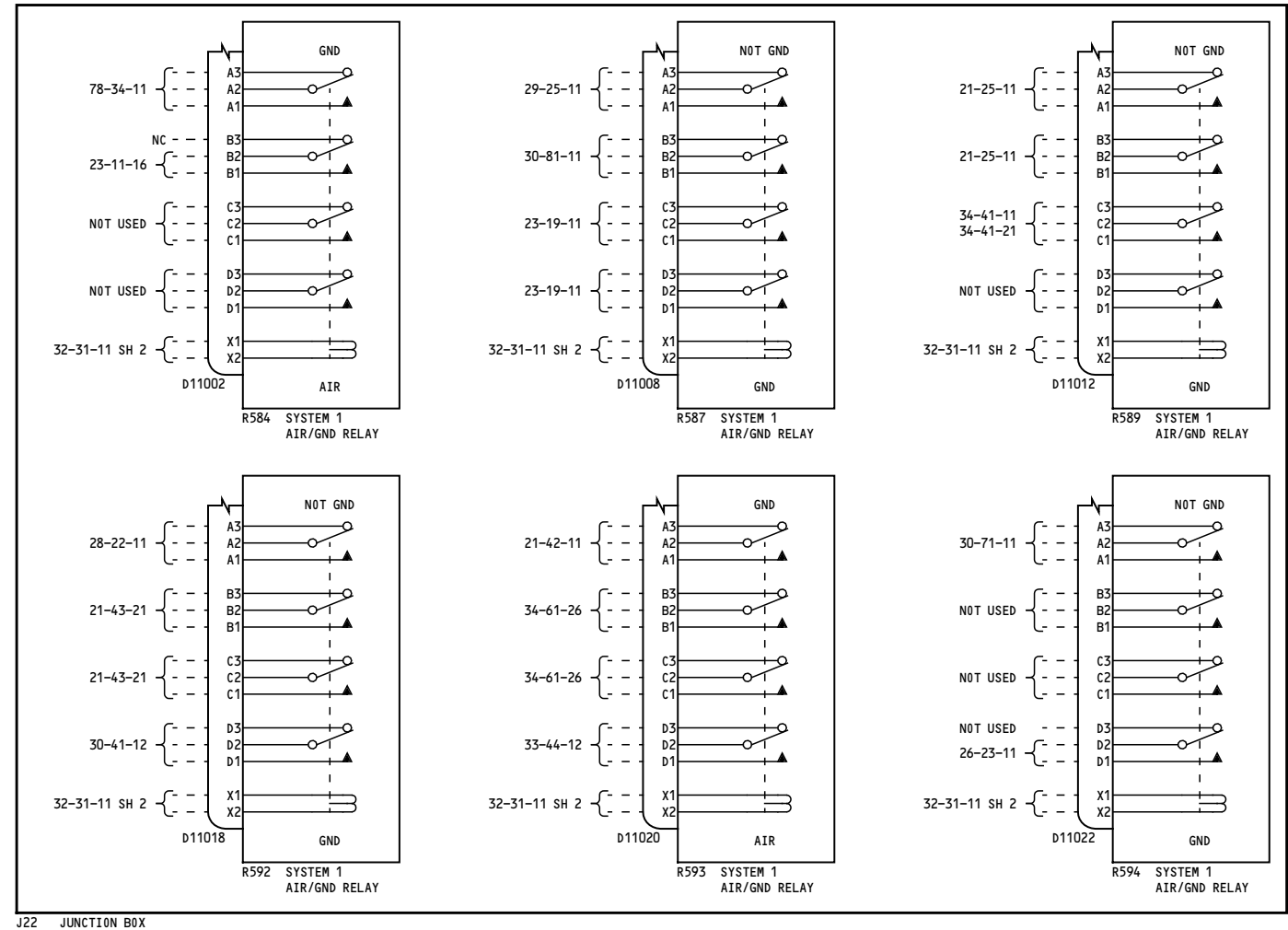
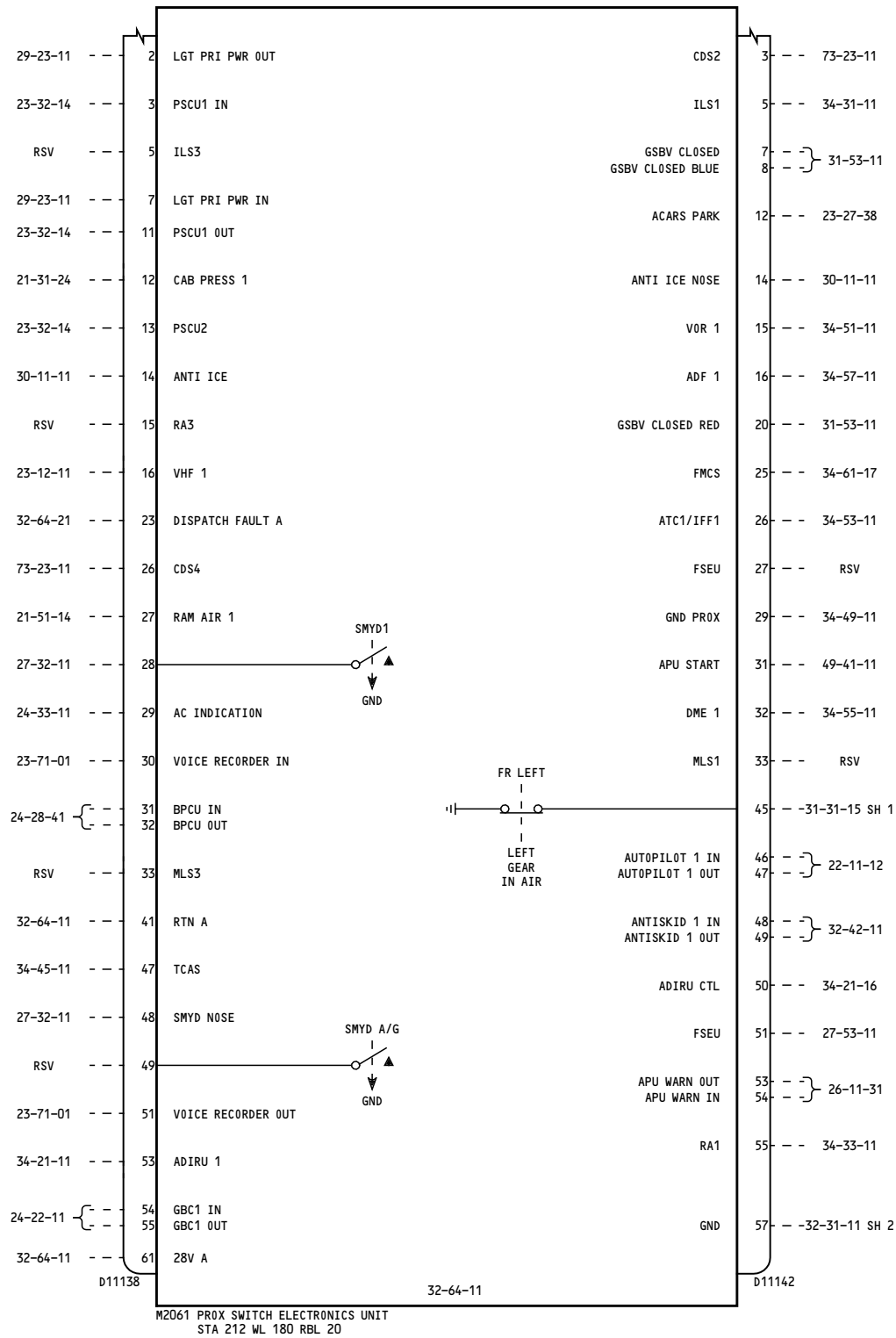

NOTES:
THE DIAGRAM REFERENCES REPRESENT A MAXIMUM CONFIGURATION. FOR INDIVIDUAL AIRPLANES, SEE HOOKUP CHART.

YM643-YM651

AIR/GND SYSTEM 1 & LEVER LATCH

D280A103

32-31-11

Page 7
Sheet 3
Feb 09/2009

32-31-11

Page 7
Sheet 3
Feb 09/2009

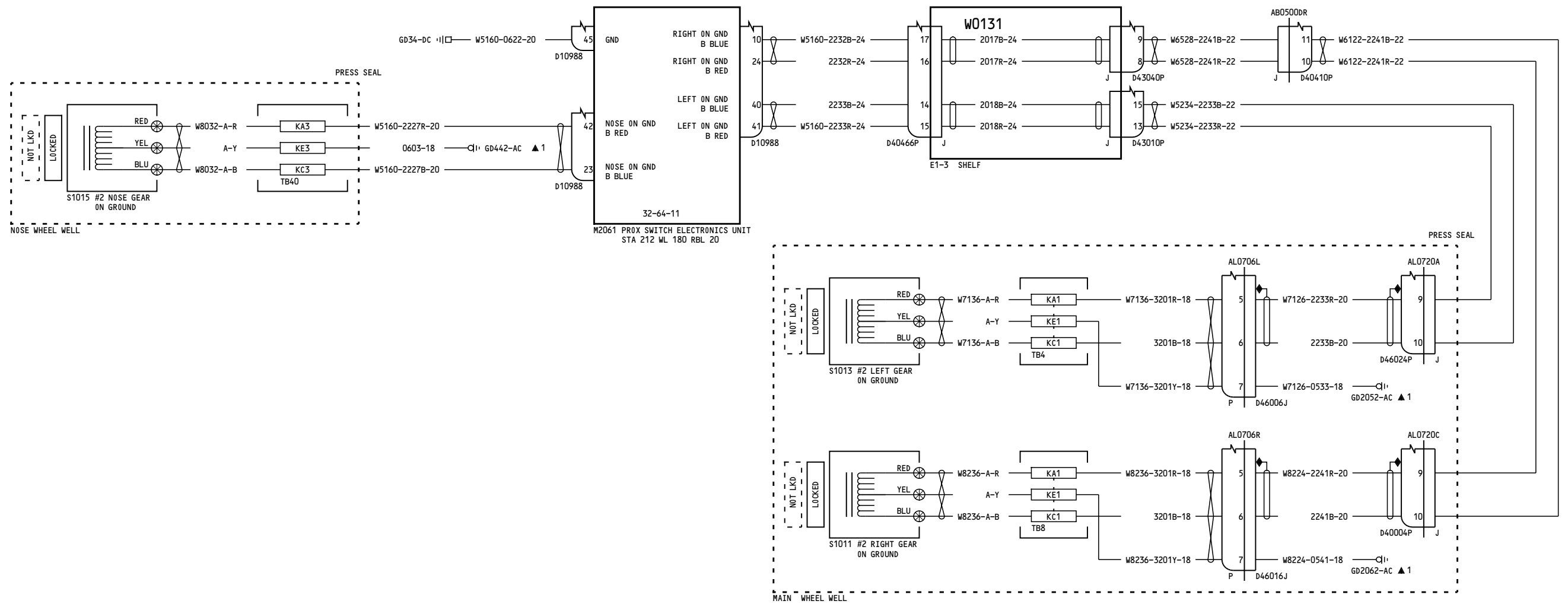

CADDS 4

YC001-YC003

**AIR/GND SYSTEM 2 AND
NOSE GEAR GROUND SENSING
RELAYS**

D280A103

32-31-12

Page 1
Sheet 1
Mar 31/2005

32-31-12

Page 1
Sheet 1
Mar 31/2005

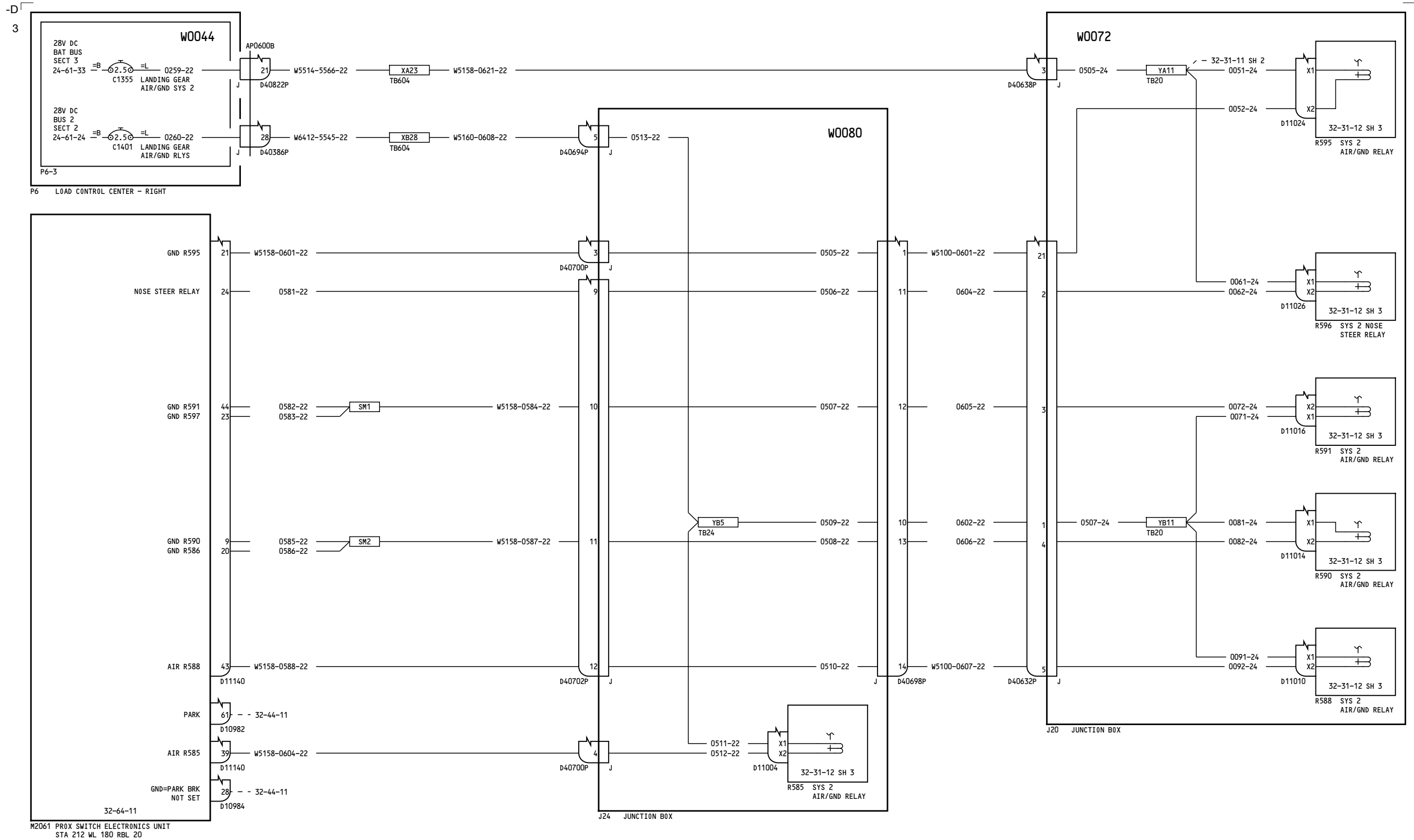

YC001-YC003

**AIR/GND SYSTEM 2 AND
NOSE GEAR GROUND SENSING
RELAYS**

D280A103

32-31-12

Page 1
Sheet 2
Apr 18/2007

32-31-12

Page 1
Sheet 2
Apr 18/2007

-R
1

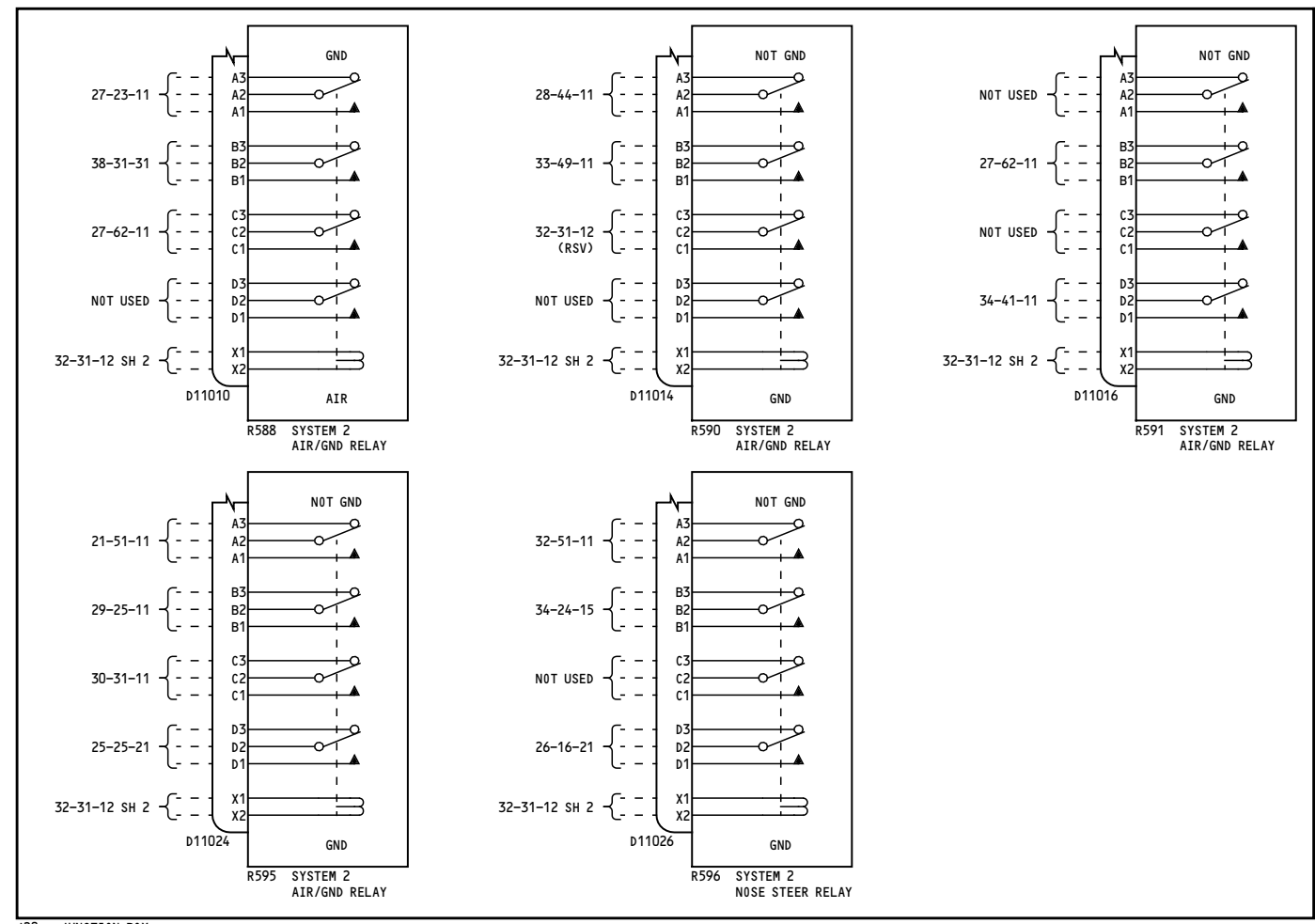
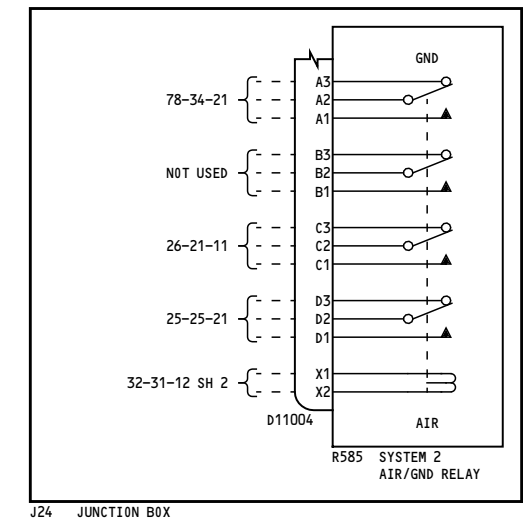
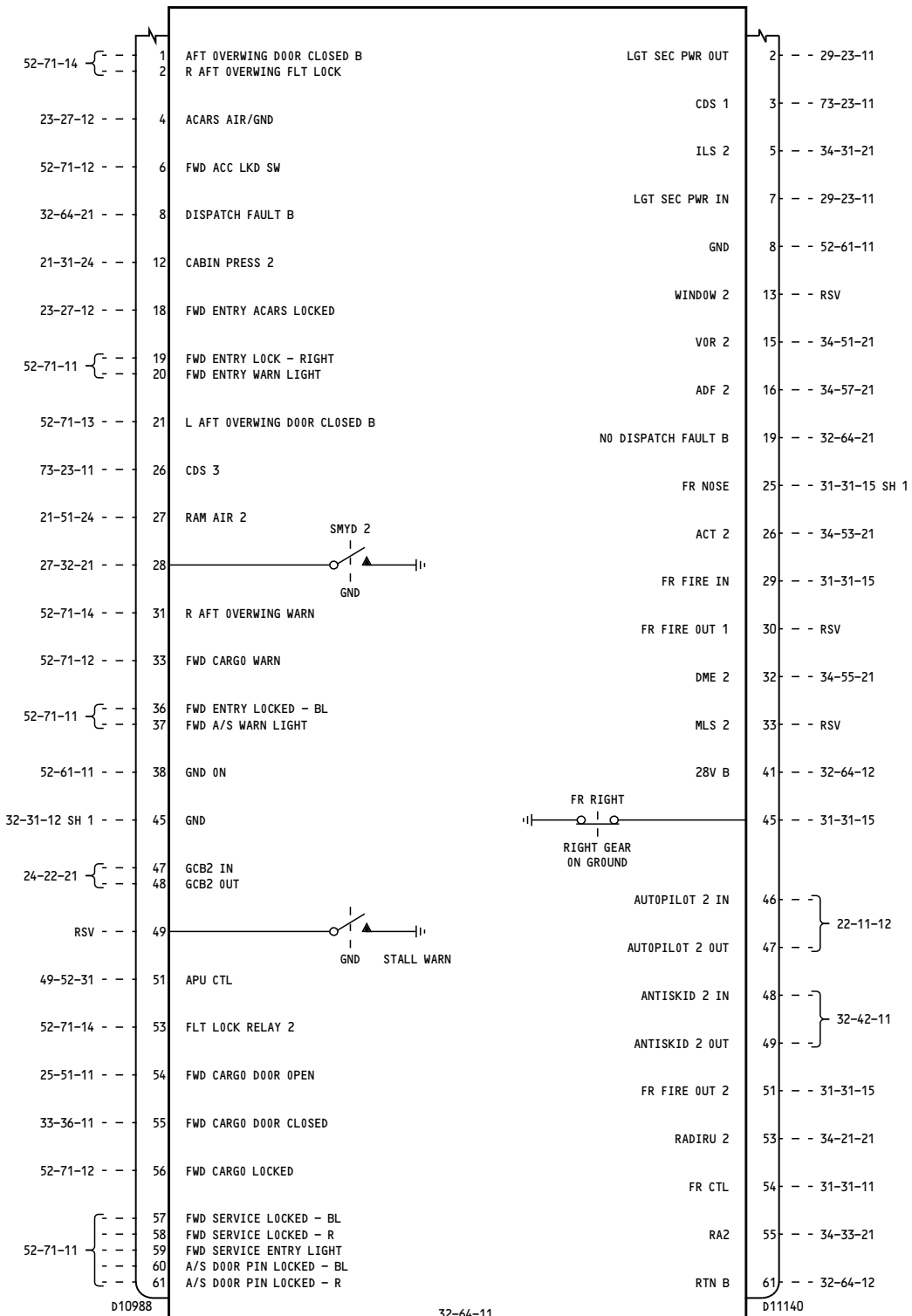

NOTES:
M2061 PROX SWITCH ELECTRONICS UNIT
STA 212 WL 180 RBL 20
THE DIAGRAM REFERENCES REPRESENT A MAXIMUM CONFIGURATION. FOR INDIVIDUAL AIRPLANES, SEE HOOKUP CHART.

YC001-YC003

AIR/GND SYSTEM 2 AND NOSE GEAR GROUND SENSING RELAYS

D280A103

32-31-12

Page 1
Sheet 3
Apr 18/2007

32-31-12

Page 1
Sheet 3
Apr 18/2007

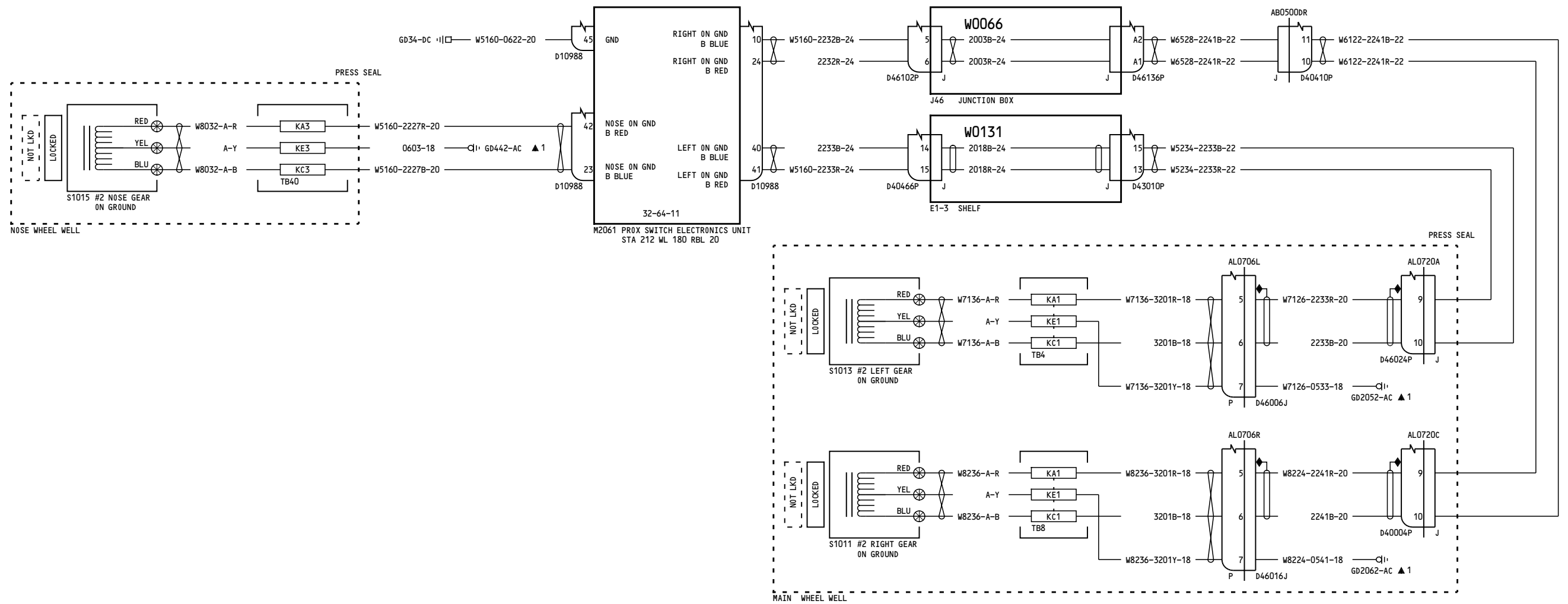

CADD5 4

YC004-YC028

**AIR/GND SYSTEM 2 AND
NOSE GEAR GROUND SENSING
RELAYS**

D280A103

32-31-12

Page 2
Sheet 1
Jul 17/2007

32-31-12

Page 2
Sheet 1
Jul 17/2007

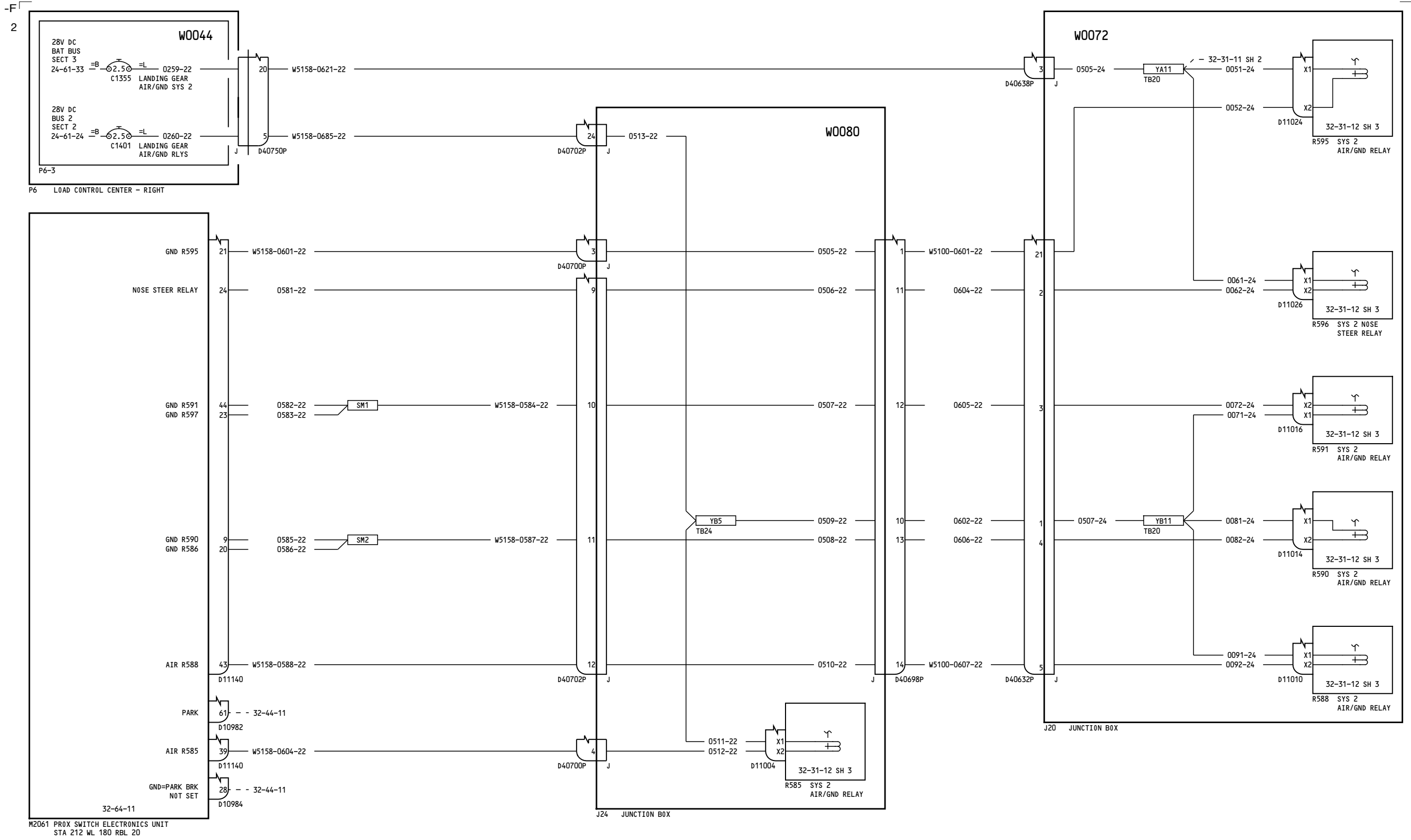

YC004-YC028

**AIR/GND SYSTEM 2 AND
NOSE GEAR GROUND SENSING
RELAYS**

D280A103

32-31-12

Page 2
Sheet 2
Jul 17/2007

32-31-12

Page 2
Sheet 2
Jul 17/2007

-R
1

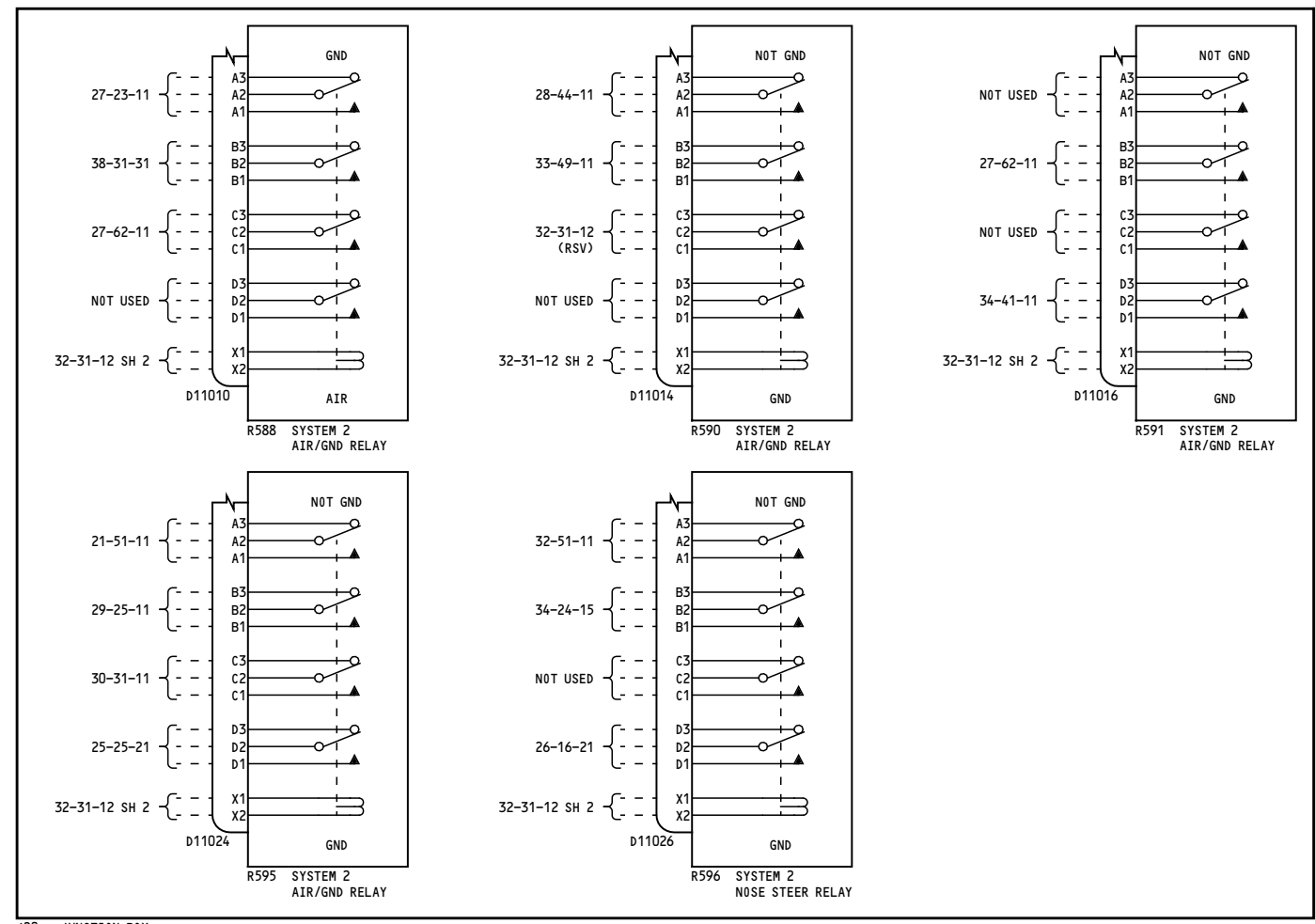
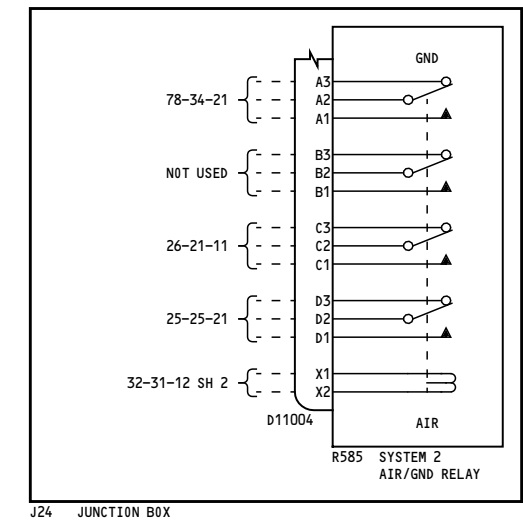
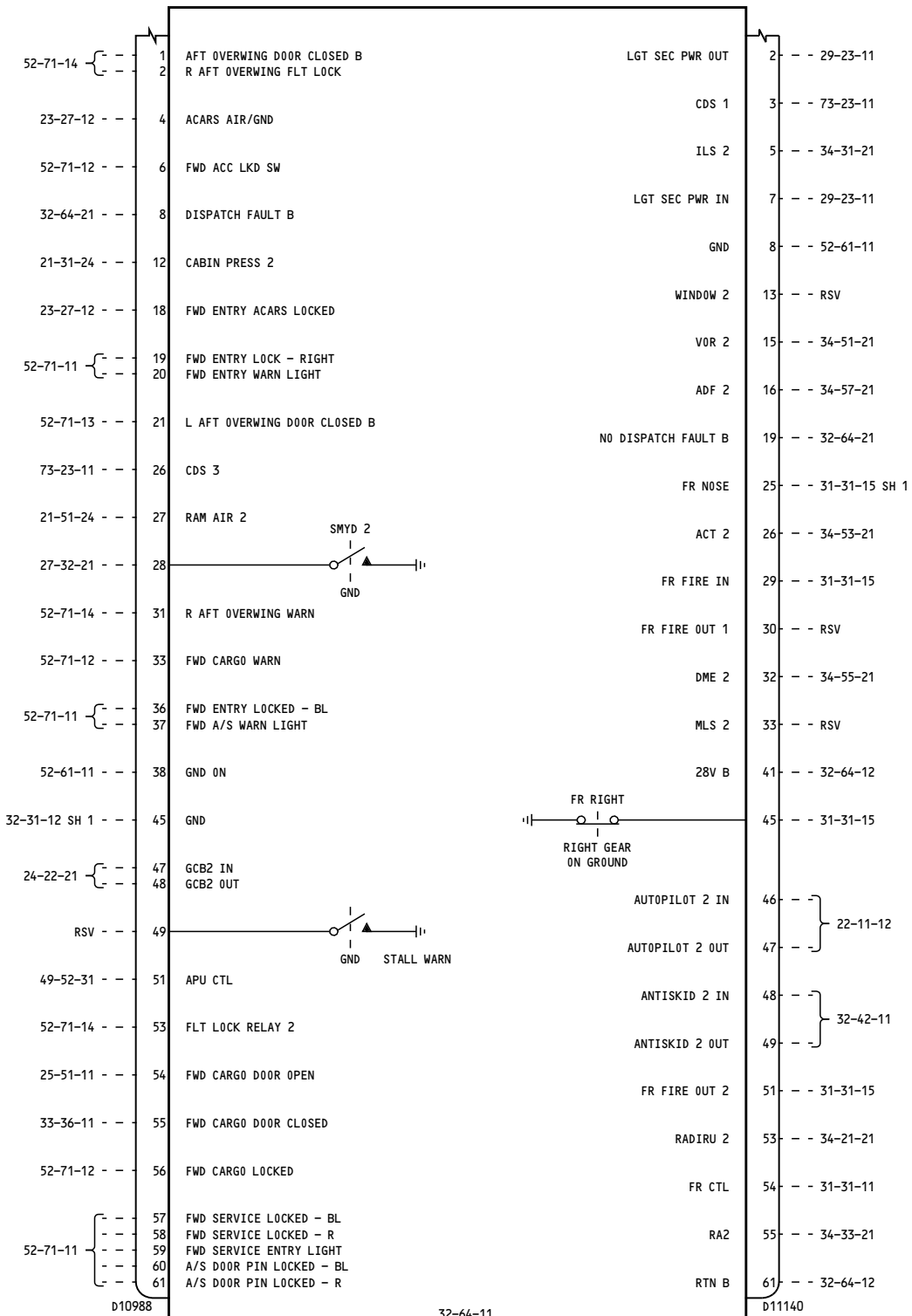

NOTES:
M2061 PROX SWITCH ELECTRONICS UNIT
STA 212 WL 180 RBL 20
THE DIAGRAM REFERENCES REPRESENT A
MAXIMUM CONFIGURATION. FOR INDIVIDUAL
AIRPLANES, SEE HOOKUP CHART.

YC004-YC028	AIR/GND SYSTEM 2 AND NOSE GEAR GROUND SENSING RELAYS
	D280A103

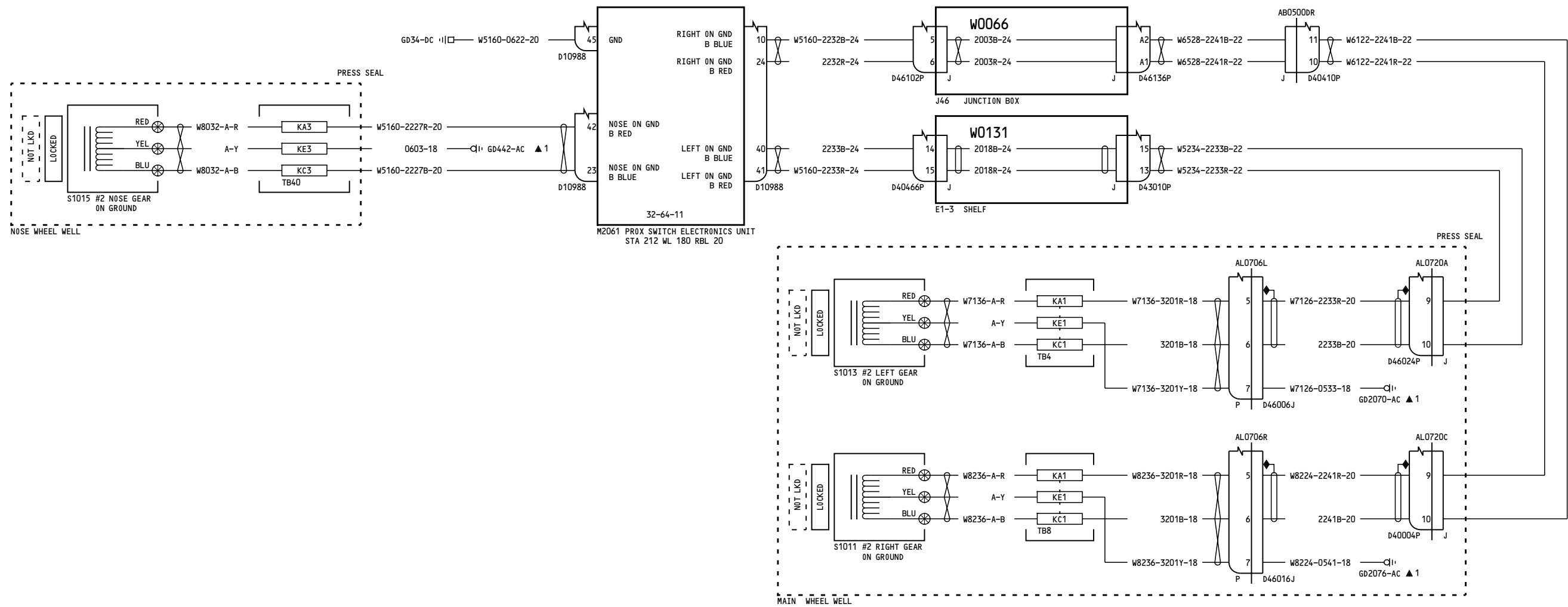

CADDS 4

YC029-YC030, YK901-YK905

AIR/GND SYSTEM 2 AND NOSE GEAR GROUND SENSING RELAYS

D280A103

32-31-12

Page 3
Sheet 1
Apr 18/2006

32-31-12

Page 3
Sheet 1
Apr 18/2006

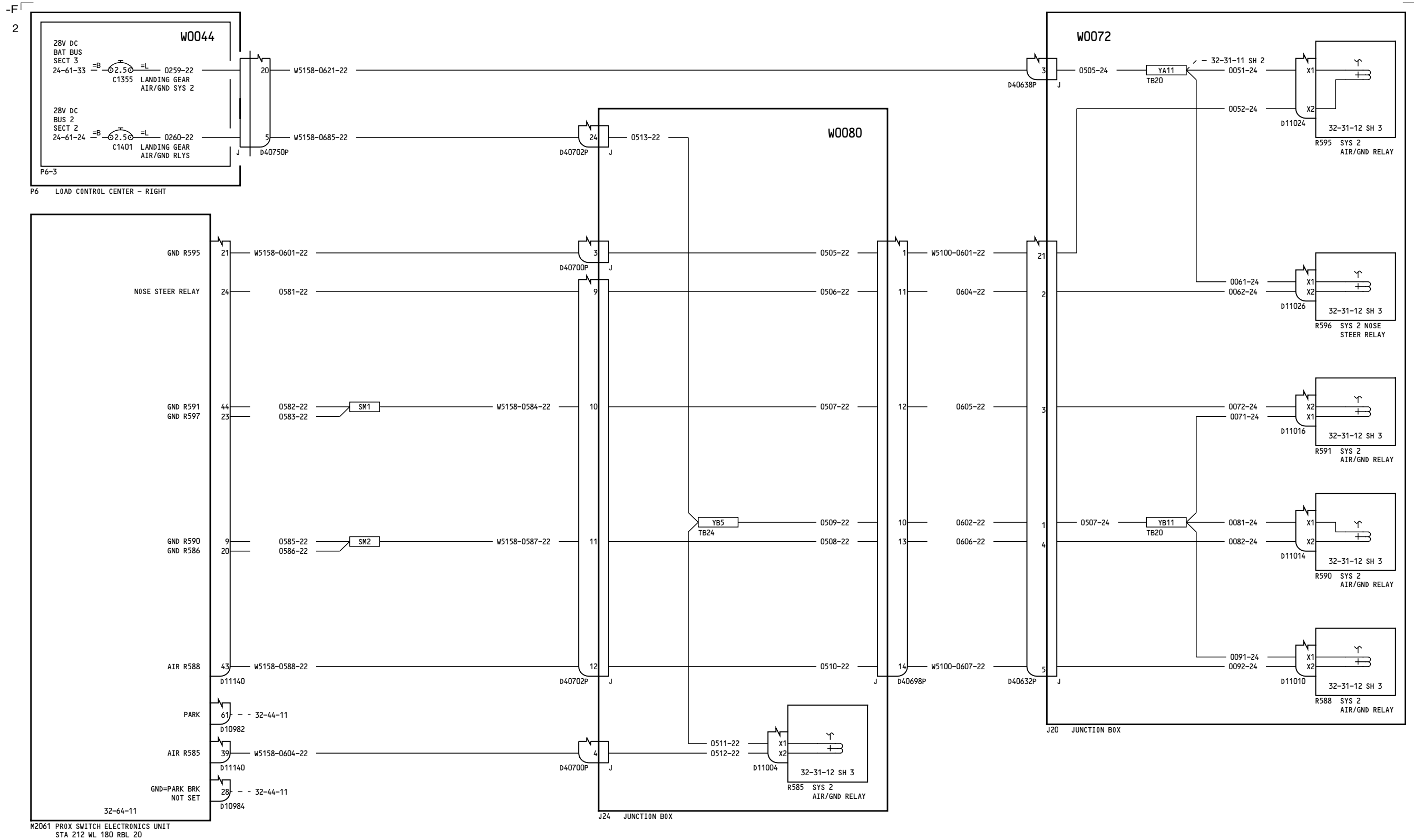

YC029-YC030, YK901-YK905

**AIR/GND SYSTEM 2 AND
NOSE GEAR GROUND SENSING
RELAYS**

D280A103

32-31-12

Page 3
Sheet 2
Apr 18/2007

32-31-12

Page 3
Sheet 2
Apr 18/2007

-R
1

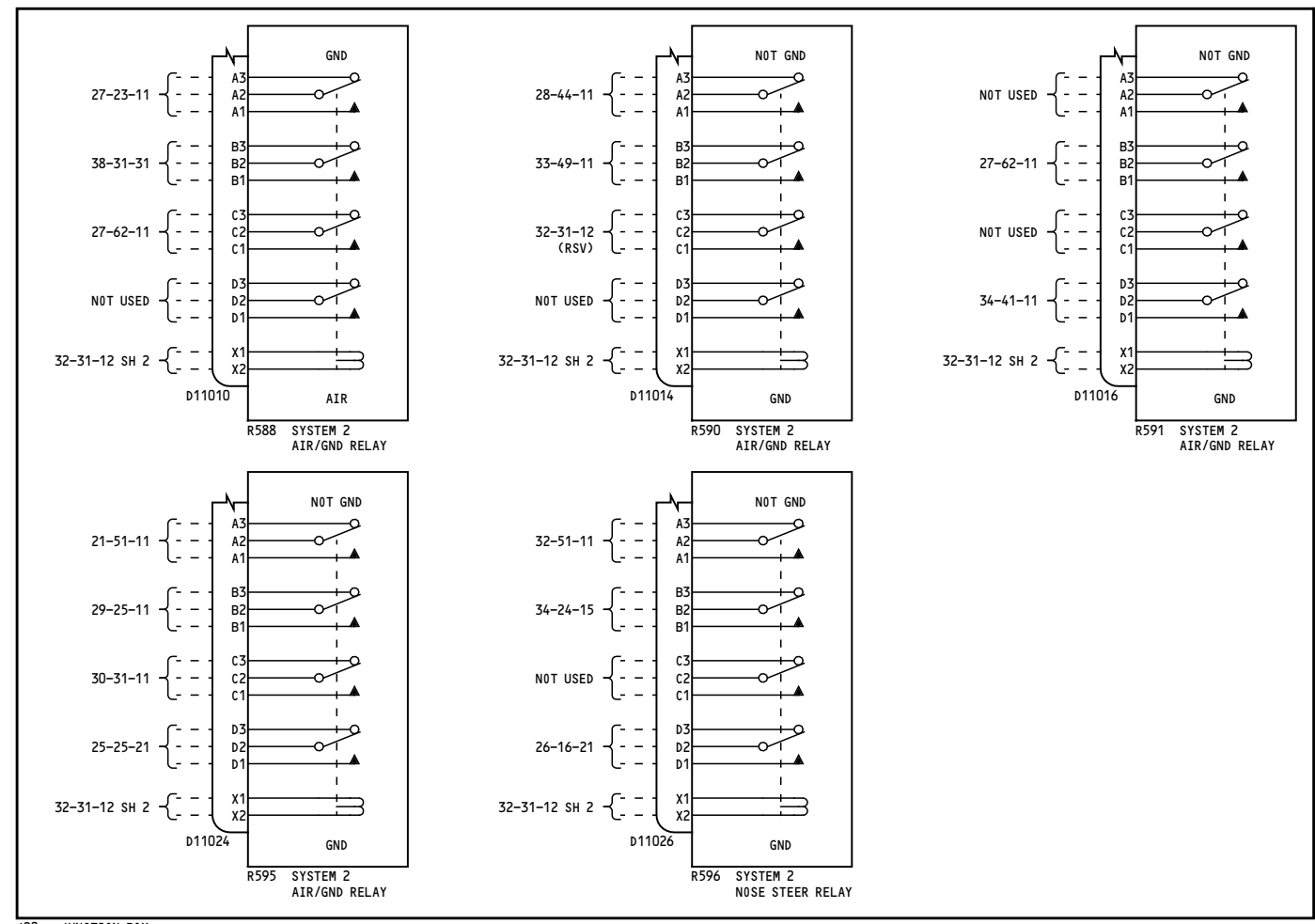
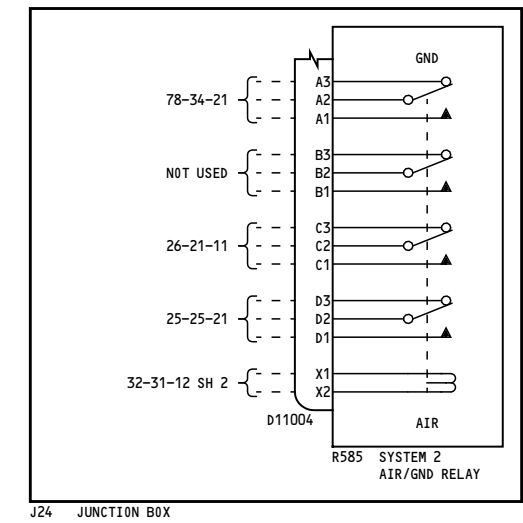
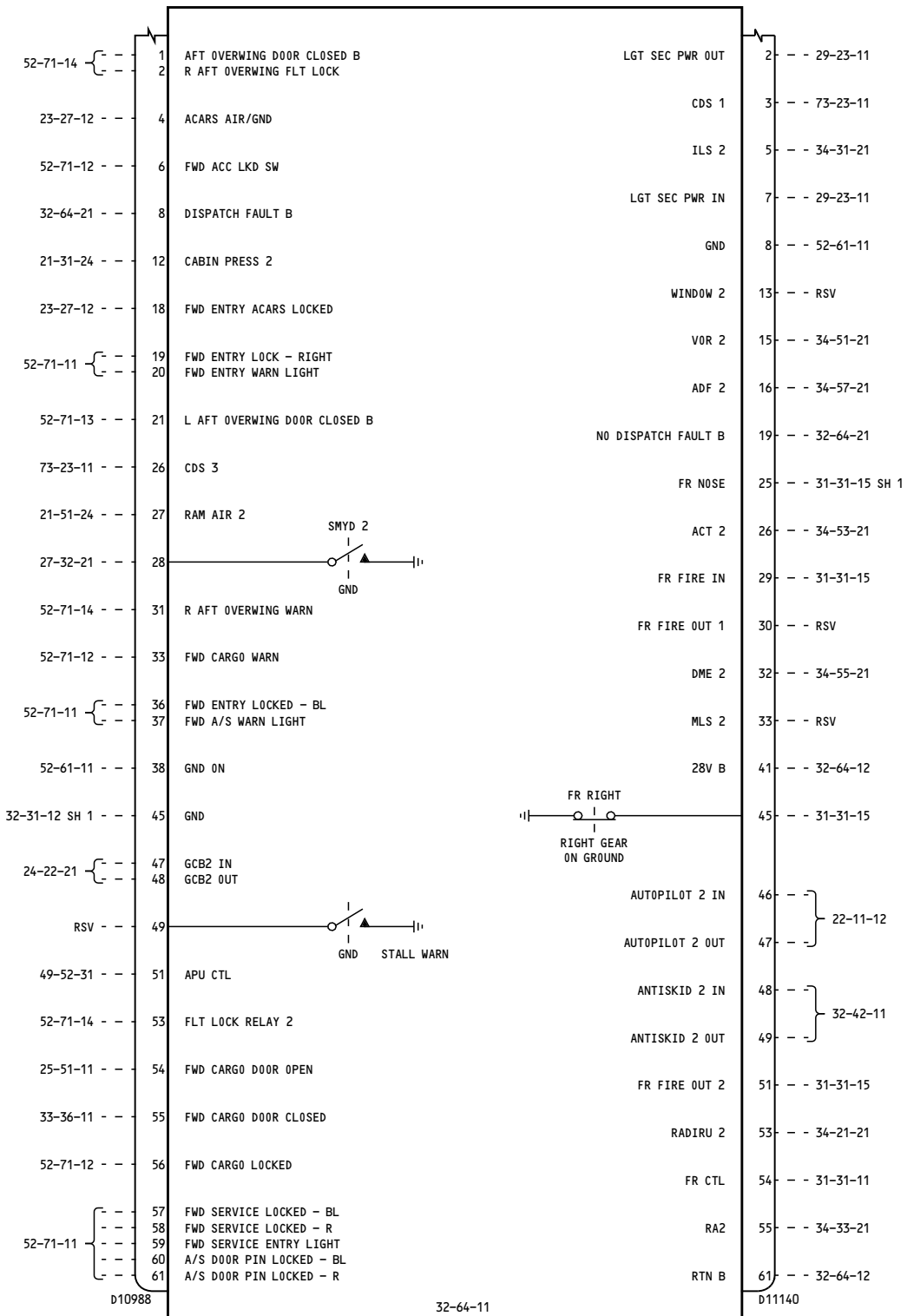

NOTES:
M2061 PROX SWITCH ELECTRONICS UNIT
STA 212 WL 180 RBL 20
THE DIAGRAM REFERENCES REPRESENT A
MAXIMUM CONFIGURATION. FOR INDIVIDUAL
AIRPLANES, SEE HOOKUP CHART.

YC029-YC030, YK901-YK905

**AIR/GND SYSTEM 2 AND
NOSE GEAR GROUND SENSING
RELAYS**

D280A103

32-31-12

Page 3
Sheet 3
Apr 18/2007

32-31-12

Page 3
Sheet 3
Apr 18/2007

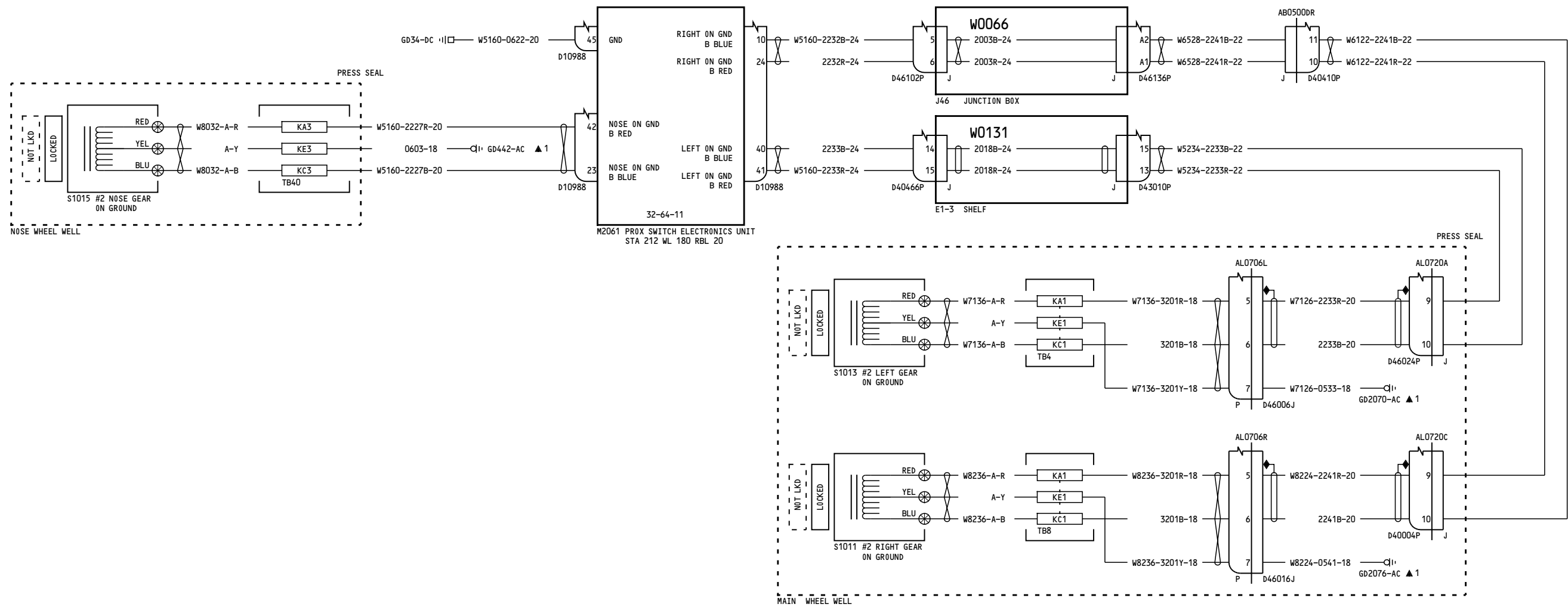

CADD5 4

YC031-YC050, YK906

**AIR/GND SYSTEM 2 AND
NOSE GEAR GROUND SENSING
RELAYS**

D280A103

32-31-12

Page 4
Sheet 1
Oct 15/2007

32-31-12

Page 4
Sheet 1
Oct 15/2007

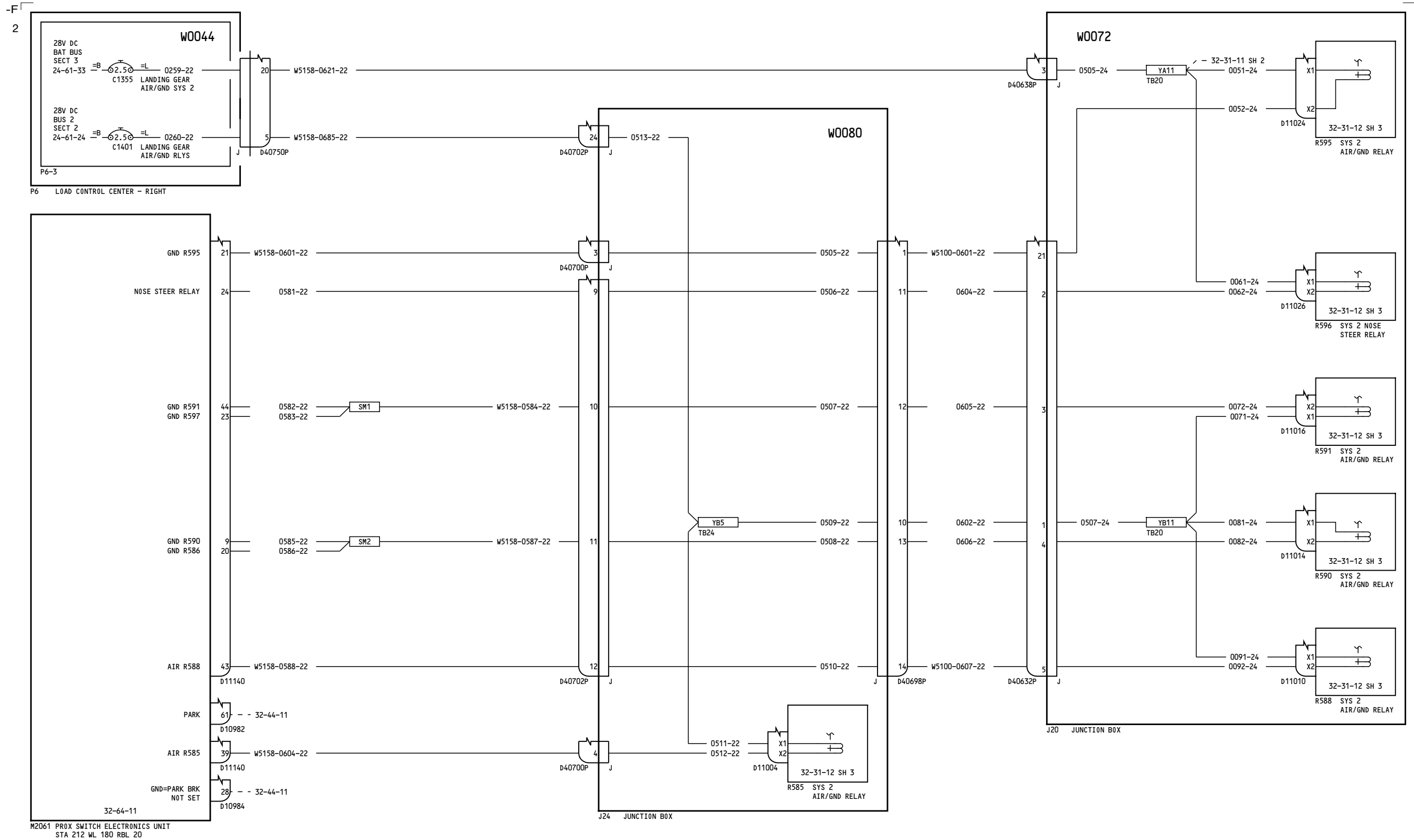

YC031-YC050, YK906

AIR/GND SYSTEM 2 AND NOSE GEAR GROUND SENSING RELAYS

D280A103

32-31-12

Page 4
Sheet 2
Oct 15/2007

32-31-12

Page 4
Sheet 2
Oct 15/2007

-B
15

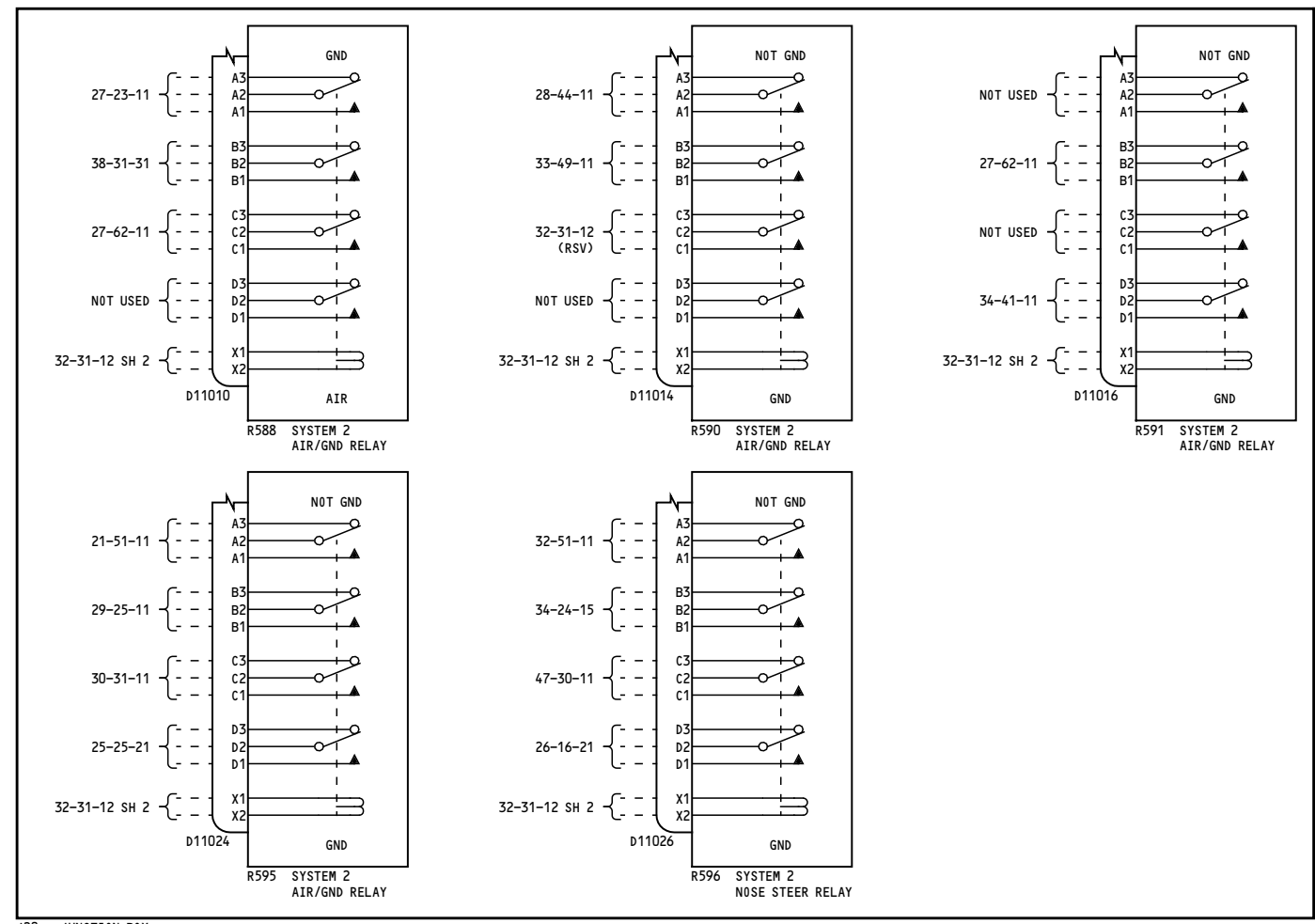
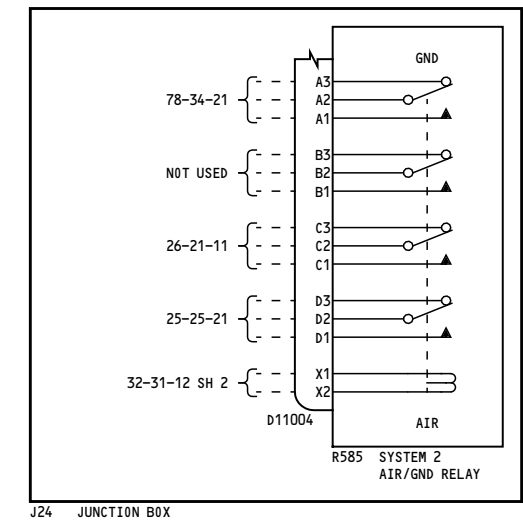
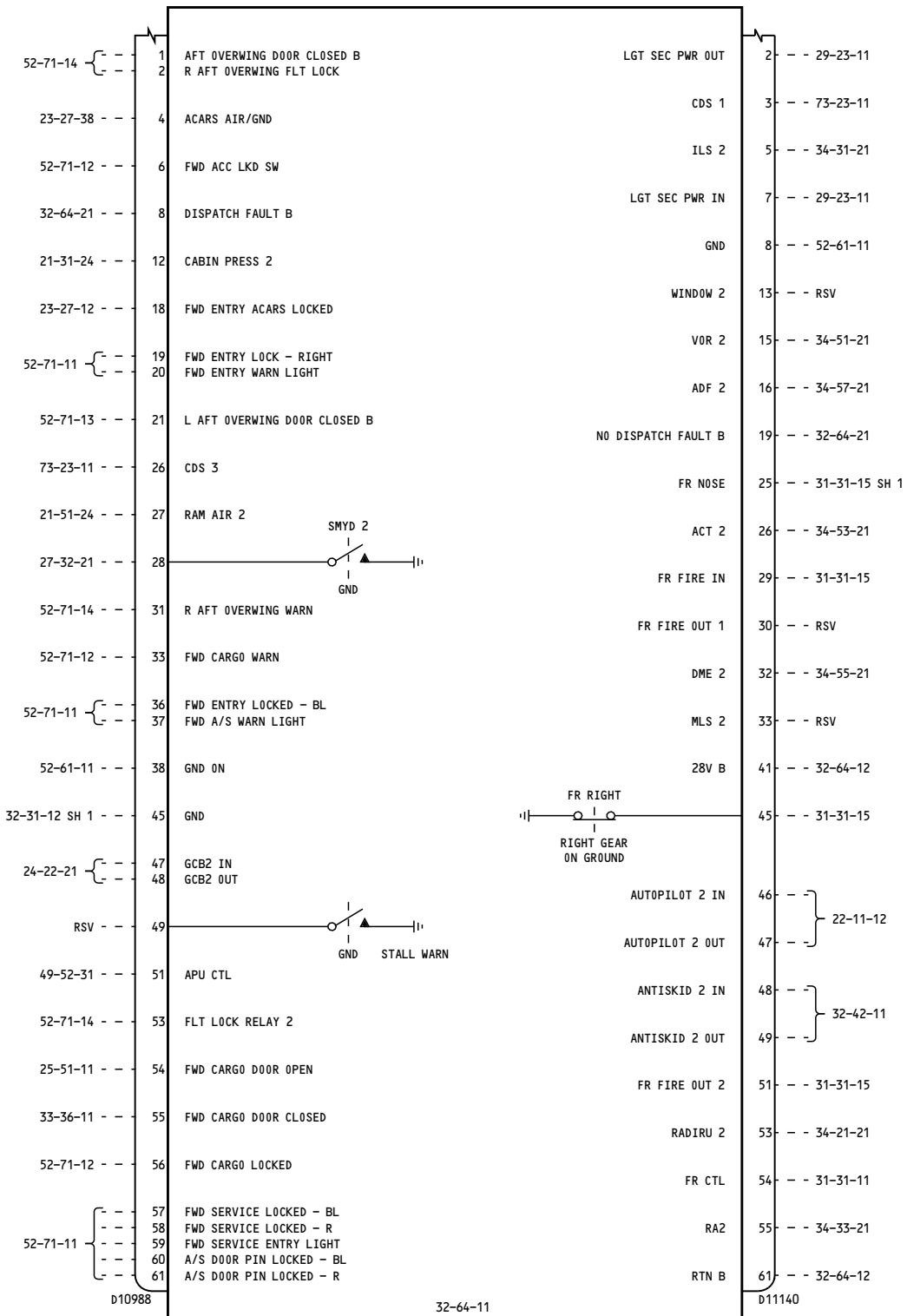

NOTES:
M2061 PROX SWITCH ELECTRONICS UNIT
STA 212 WL 180 RBL 20
THE DIAGRAM REFERENCES REPRESENT A MAXIMUM CONFIGURATION. FOR INDIVIDUAL AIRPLANES, SEE HOOKUP CHART.

YC031-YC050, YK906

AIR/GND SYSTEM 2 AND NOSE GEAR GROUND SENSING RELAYS

D280A103

32-31-12

Page 4
Sheet 3
Oct 15/2007

32-31-12

Page 4
Sheet 3
Oct 15/2007

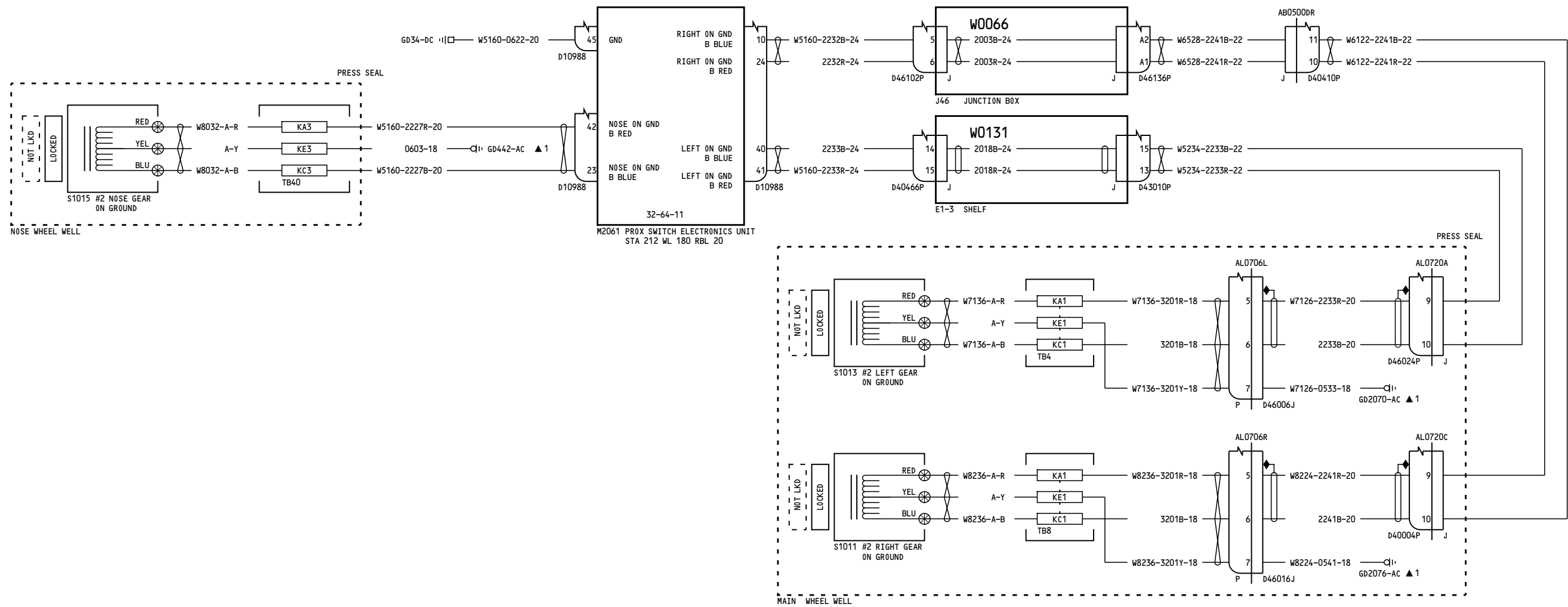

CADDs 4

YK907-YK910, YK918, YL421-YL429

**AIR/GND SYSTEM 2 AND
NOSE GEAR GROUND SENSING
RELAYS**

D280A103

32-31-12

Page 5
Sheet 1
May 11/2009

32-31-12

Page 5
Sheet 1
May 11/2009

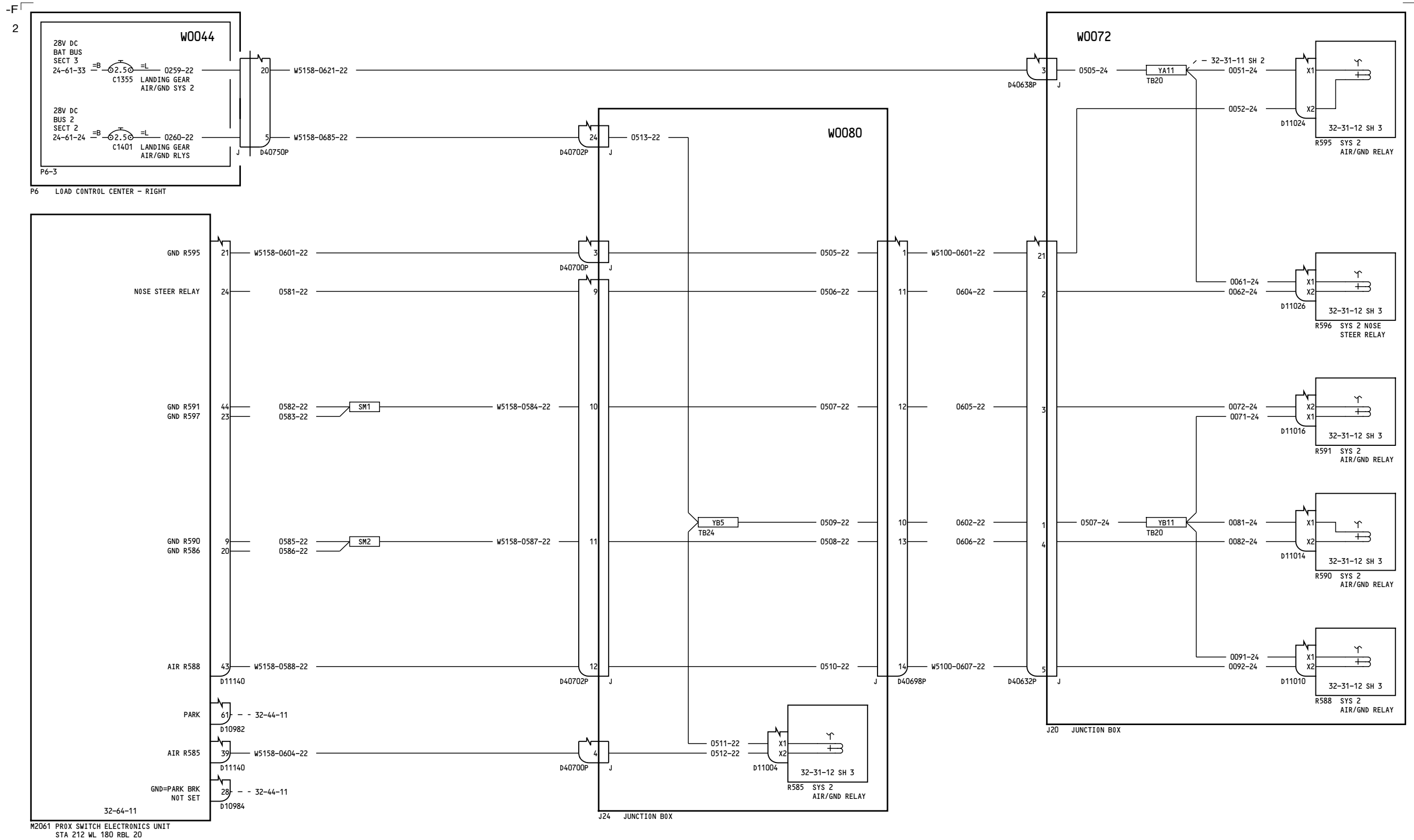

YK907-YK910, YK918, YL421-YL429

**AIR/GND SYSTEM 2 AND
NOSE GEAR GROUND SENSING
RELAYS**

D280A103

32-31-12

Page 5
Sheet 2
May 11/2009

32-31-12

Page 5
Sheet 2
May 11/2009

-A
30

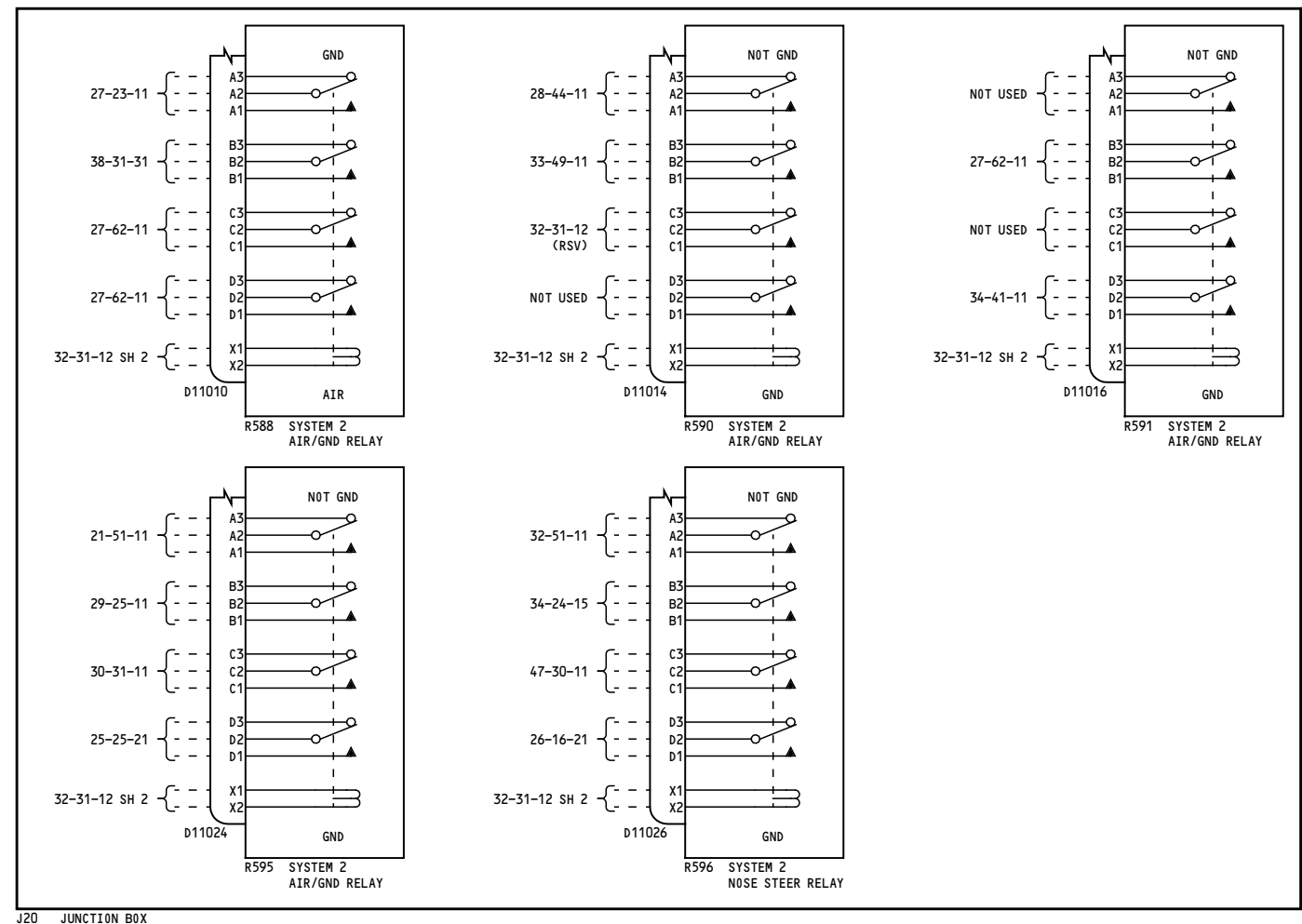
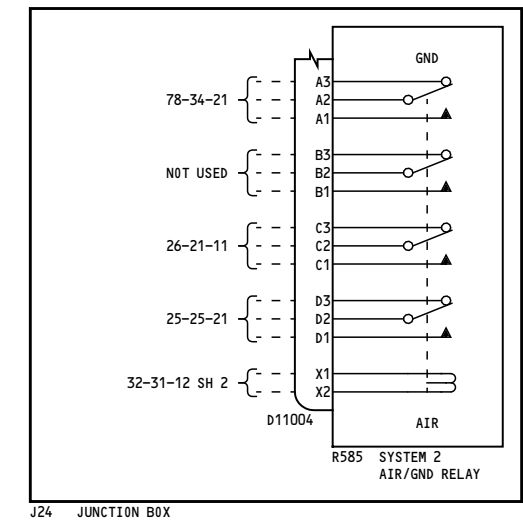
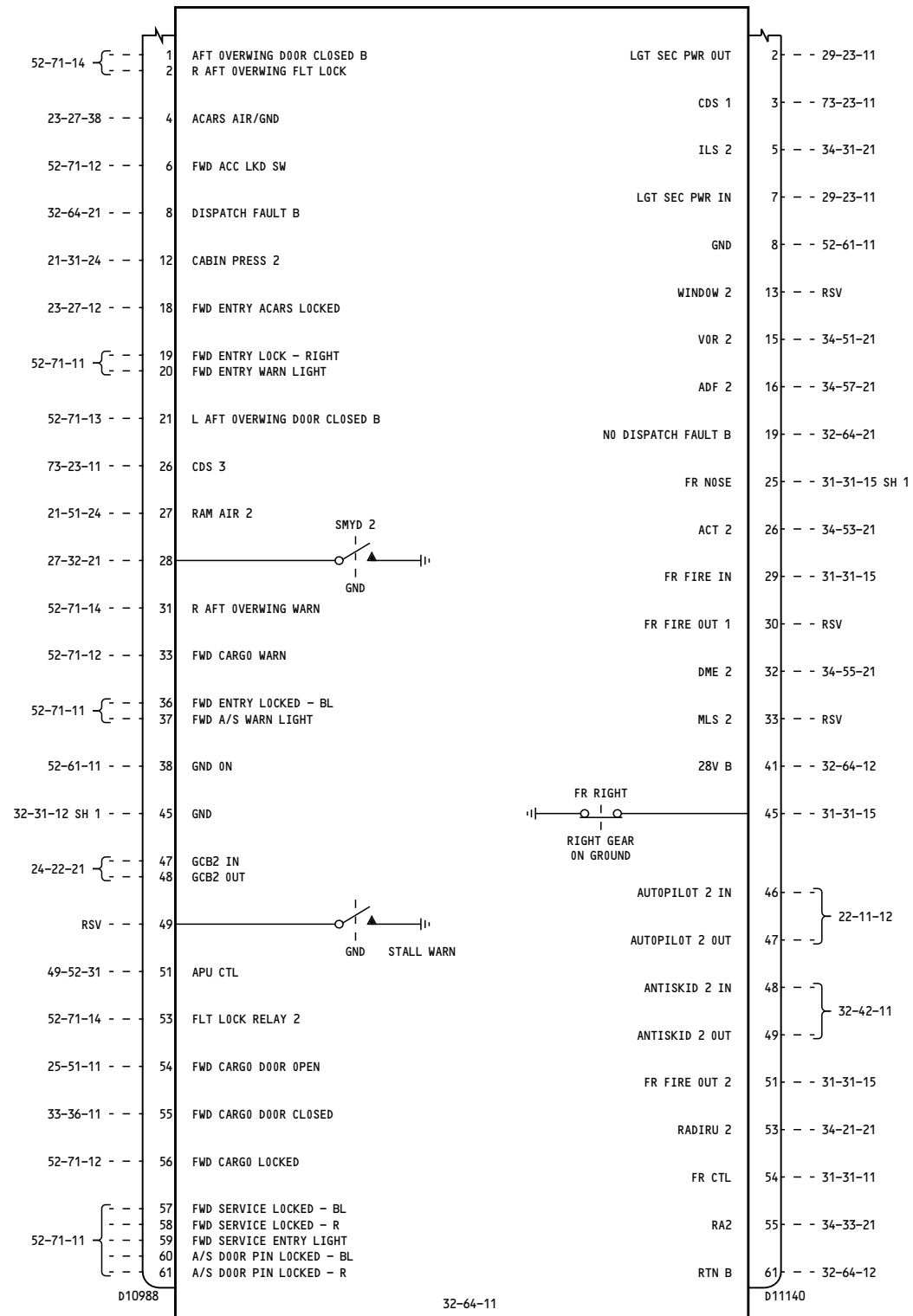

NOTES:
M2061 PROX SWITCH ELECTRONICS UNIT
STA 212 WL 180 RBL 20
THE DIAGRAM REFERENCES REPRESENT A
MAXIMUM CONFIGURATION. FOR INDIVIDUAL
AIRPLANES, SEE HOOKUP CHART.

YK907-YK910, YK918, YL421-YL429

**AIR/GND SYSTEM 2 AND
NOSE GEAR GROUND SENSING
RELAYS**

D280A103

32-31-12

Page 5
Sheet 3
May 11/2009

32-31-12

Page 5
Sheet 3
May 11/2009

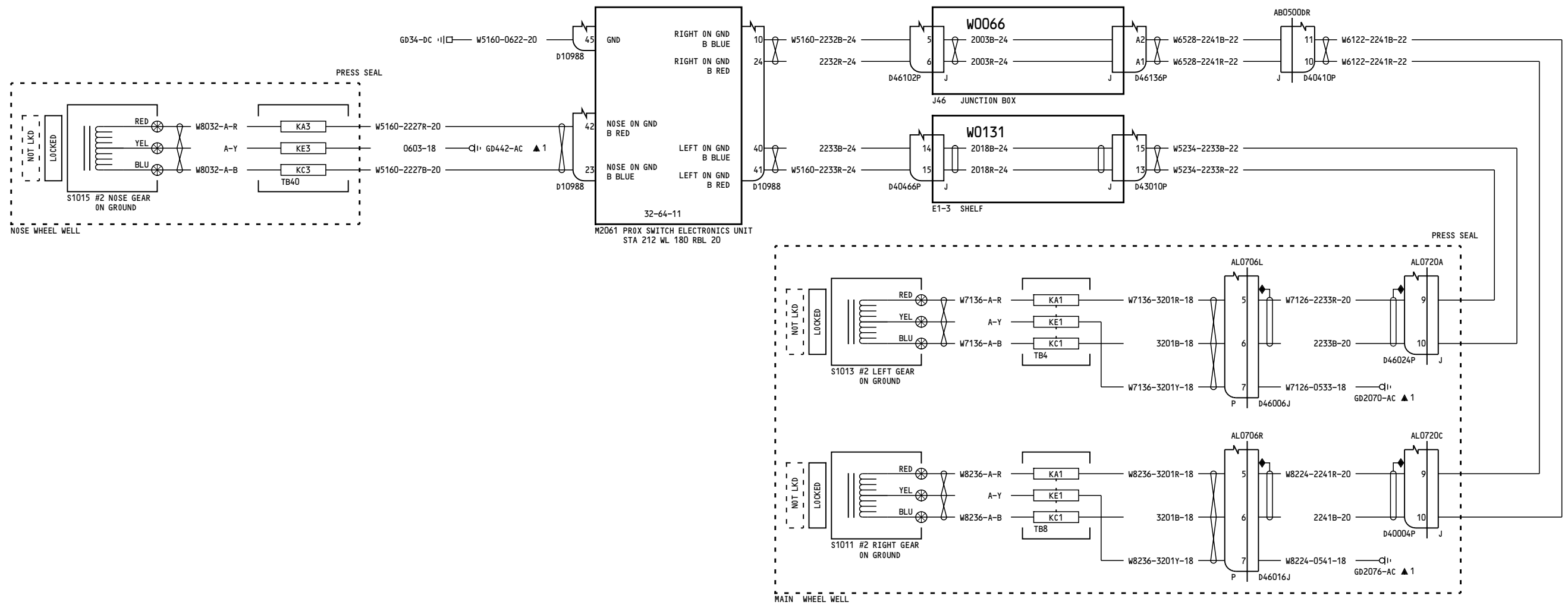

CADD 4

YK911-YK912

**AIR/GND SYSTEM 2 AND
NOSE GEAR GROUND SENSING
RELAYS**

D280A103

32-31-12

Page 6
Sheet 1
May 11/2009

32-31-12

Page 6
Sheet 1
May 11/2009

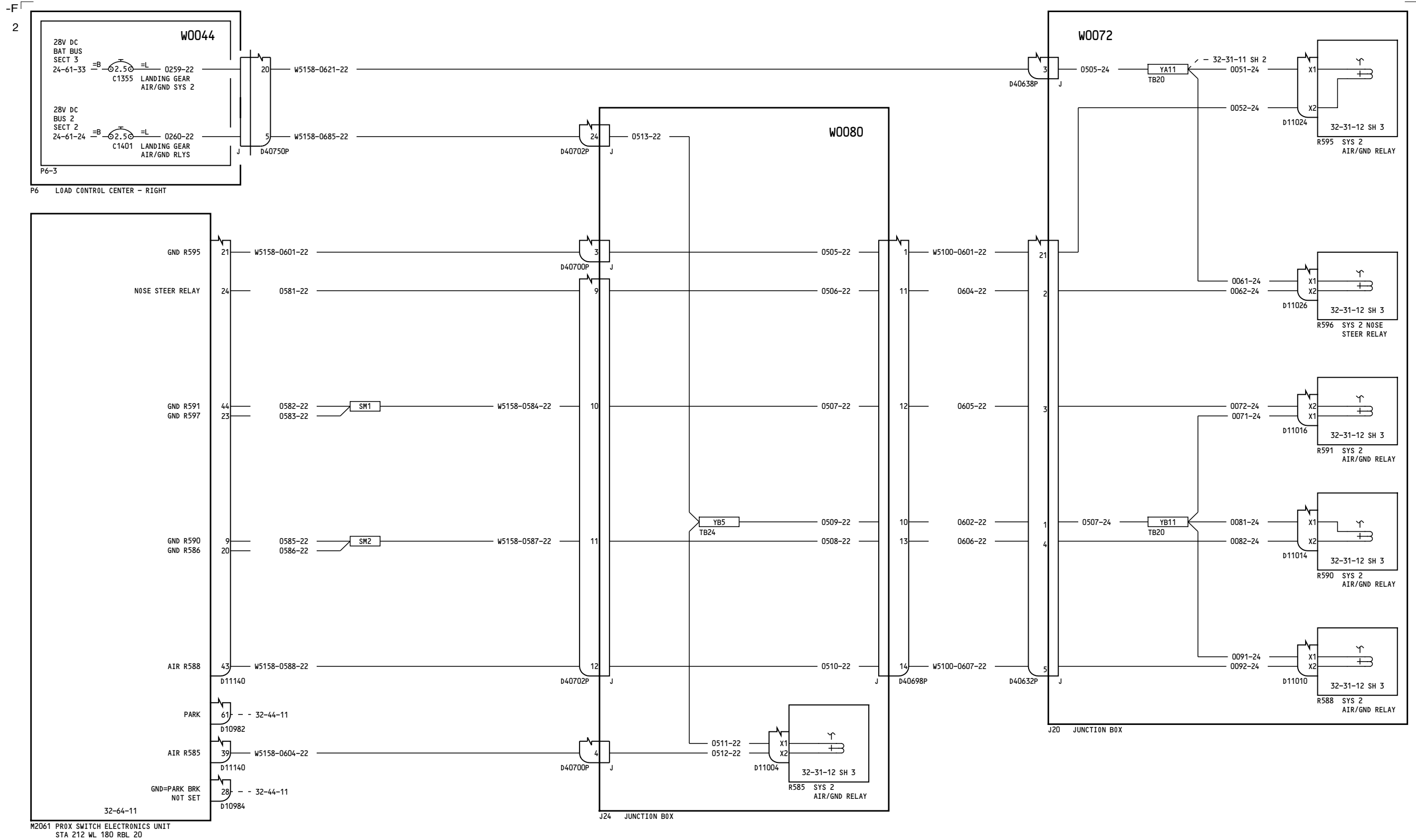

YK911-YK912

**AIR/GND SYSTEM 2 AND
NOSE GEAR GROUND SENSING
RELAYS**

D280A103

32-31-12

Page 6
Sheet 2
May 11/2009

32-31-12

Page 6
Sheet 2
May 11/2009

-B
56

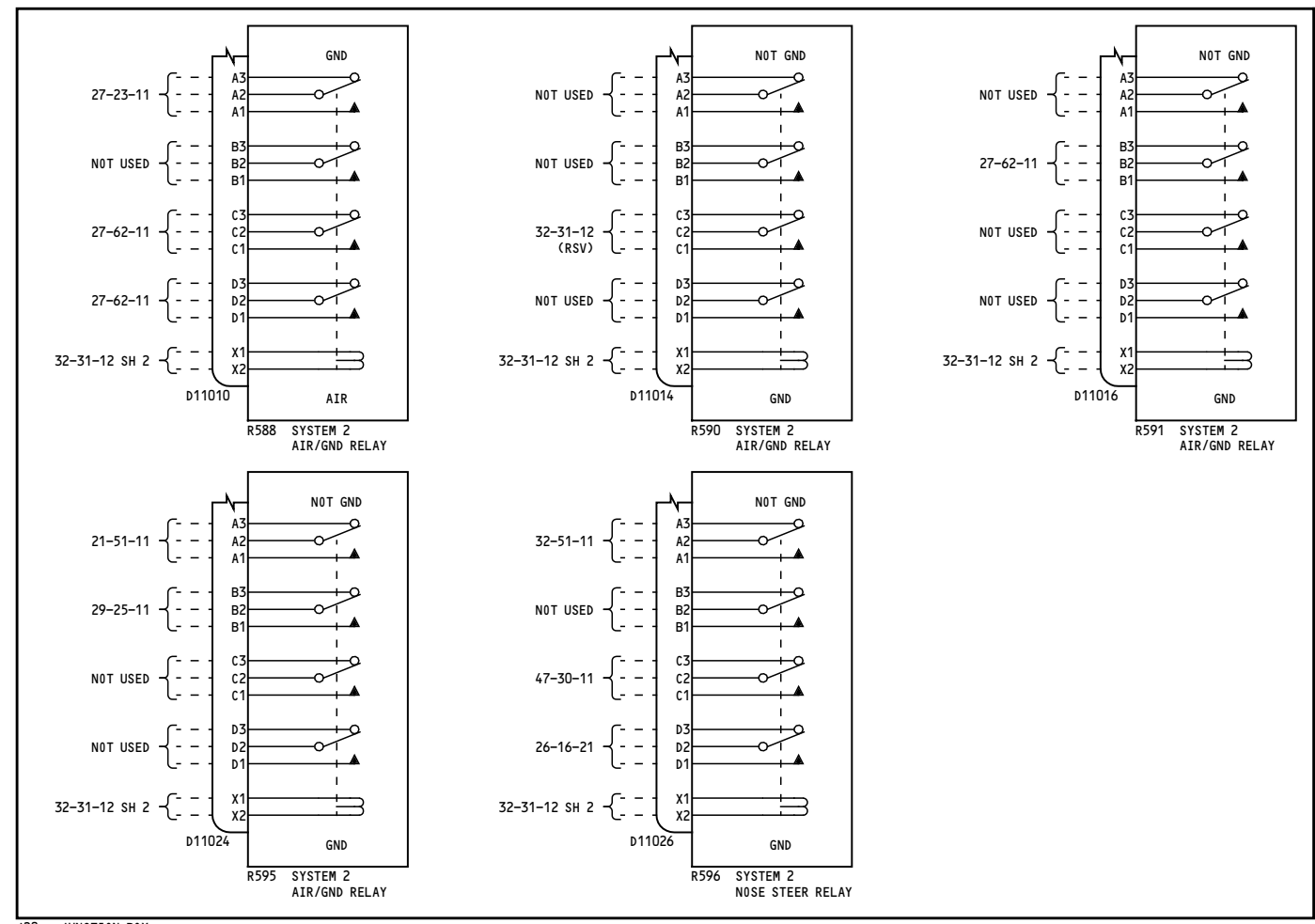
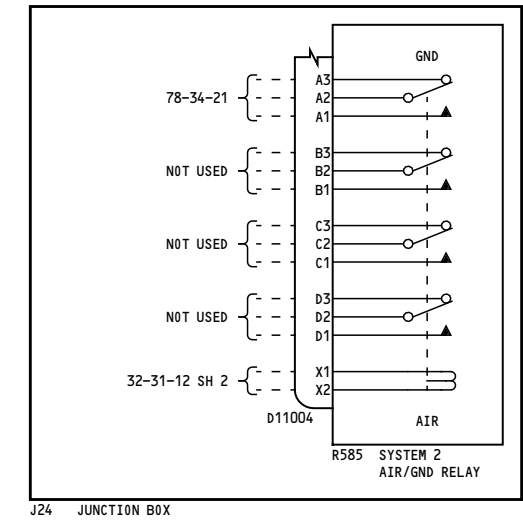
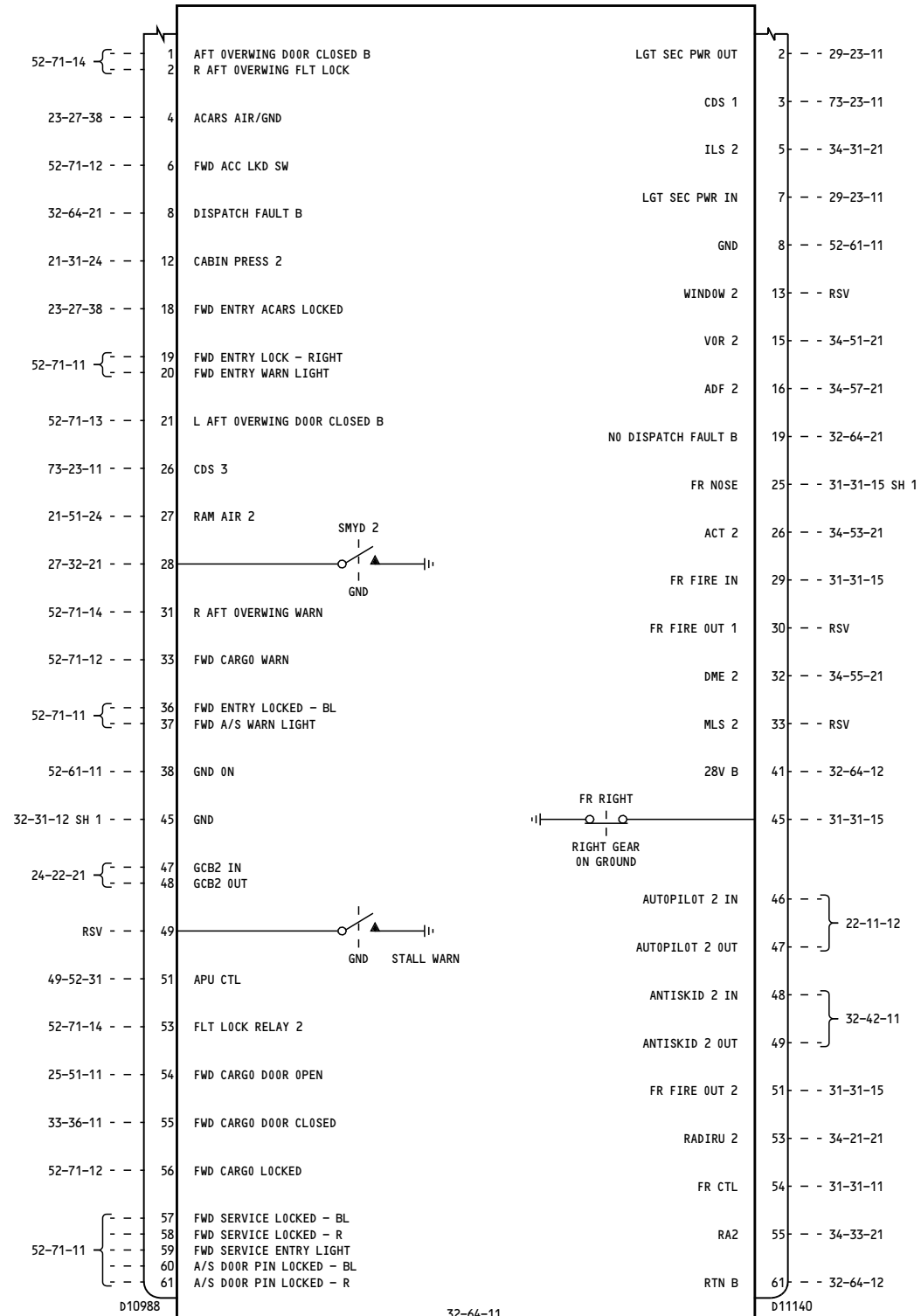

NOTES:
M2061 PROX SWITCH ELECTRONICS UNIT STA 212 WL 180 RBL 20
THE DIAGRAM REFERENCES REPRESENT A MAXIMUM CONFIGURATION. FOR INDIVIDUAL AIRPLANES, SEE HOOKUP CHART.

YK911-YK912

AIR/GND SYSTEM 2 AND NOSE GEAR GROUND SENSING RELAYS

D280A103

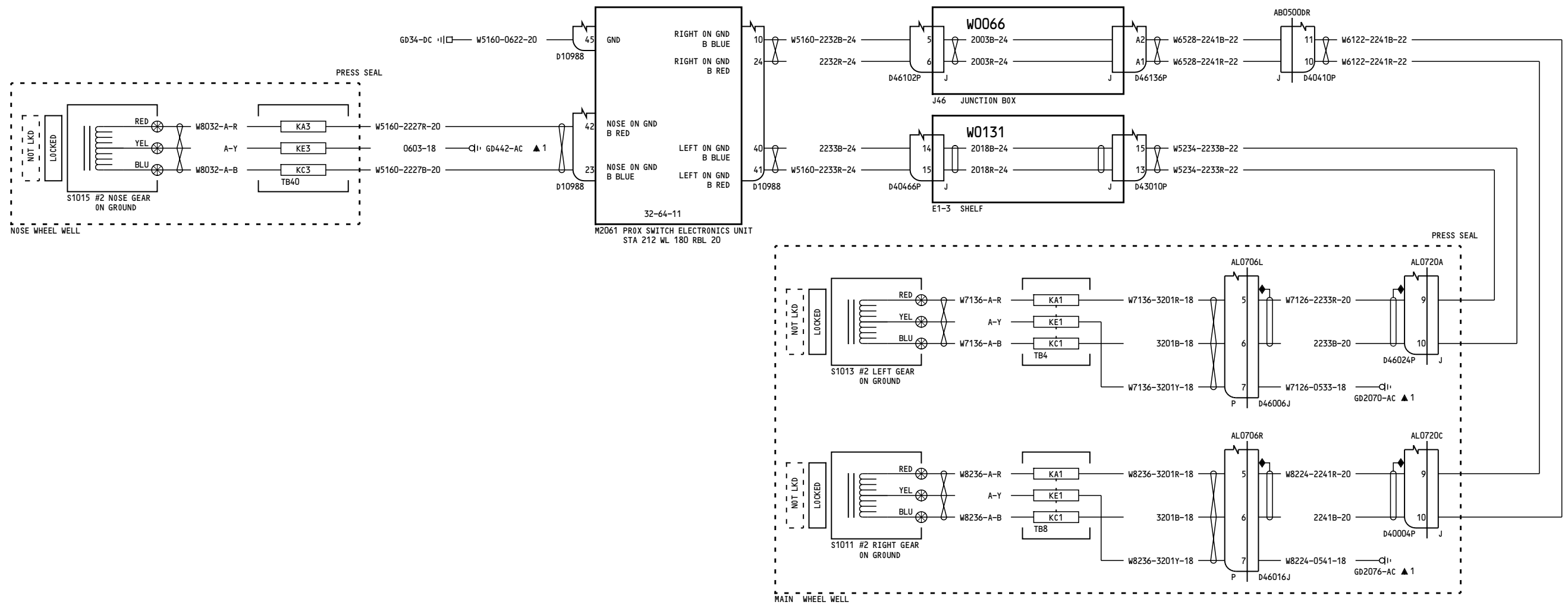

CADD 4

YK919

**AIR/GND SYSTEM 2 AND
NOSE GEAR GROUND SENSING
RELAYS**

D280A103

32-31-12

Page 7
Sheet 1
May 11/2009

32-31-12

Page 7
Sheet 1
May 11/2009

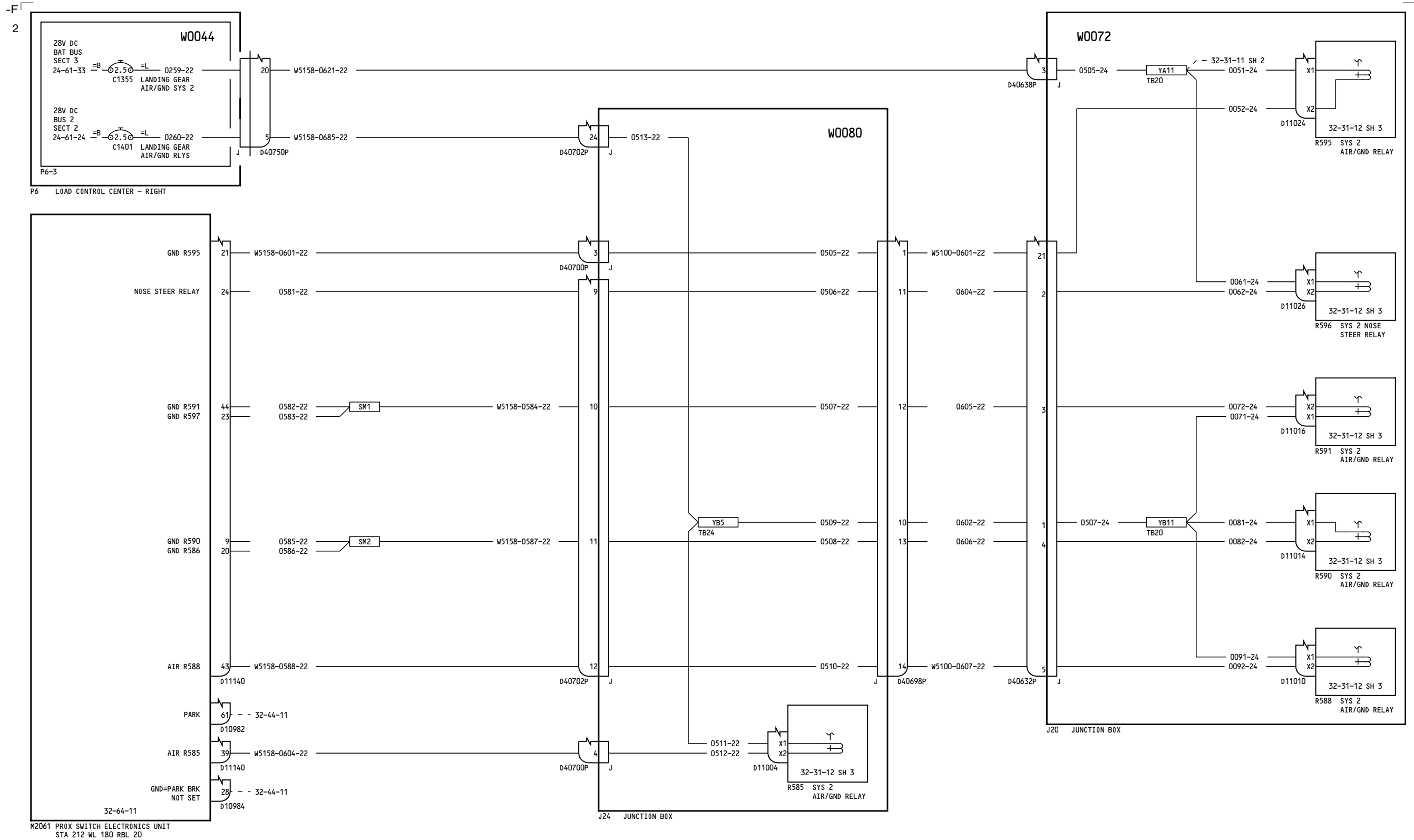

YK919

**AIR/GND SYSTEM 2 AND
NOSE GEAR GROUND SENSING
RELAYS**

D280A103

32-31-12

Page 7
Sheet 2
May 11/2009

32-31-12

Page 7
Sheet 2
May 11/2009

-A
71

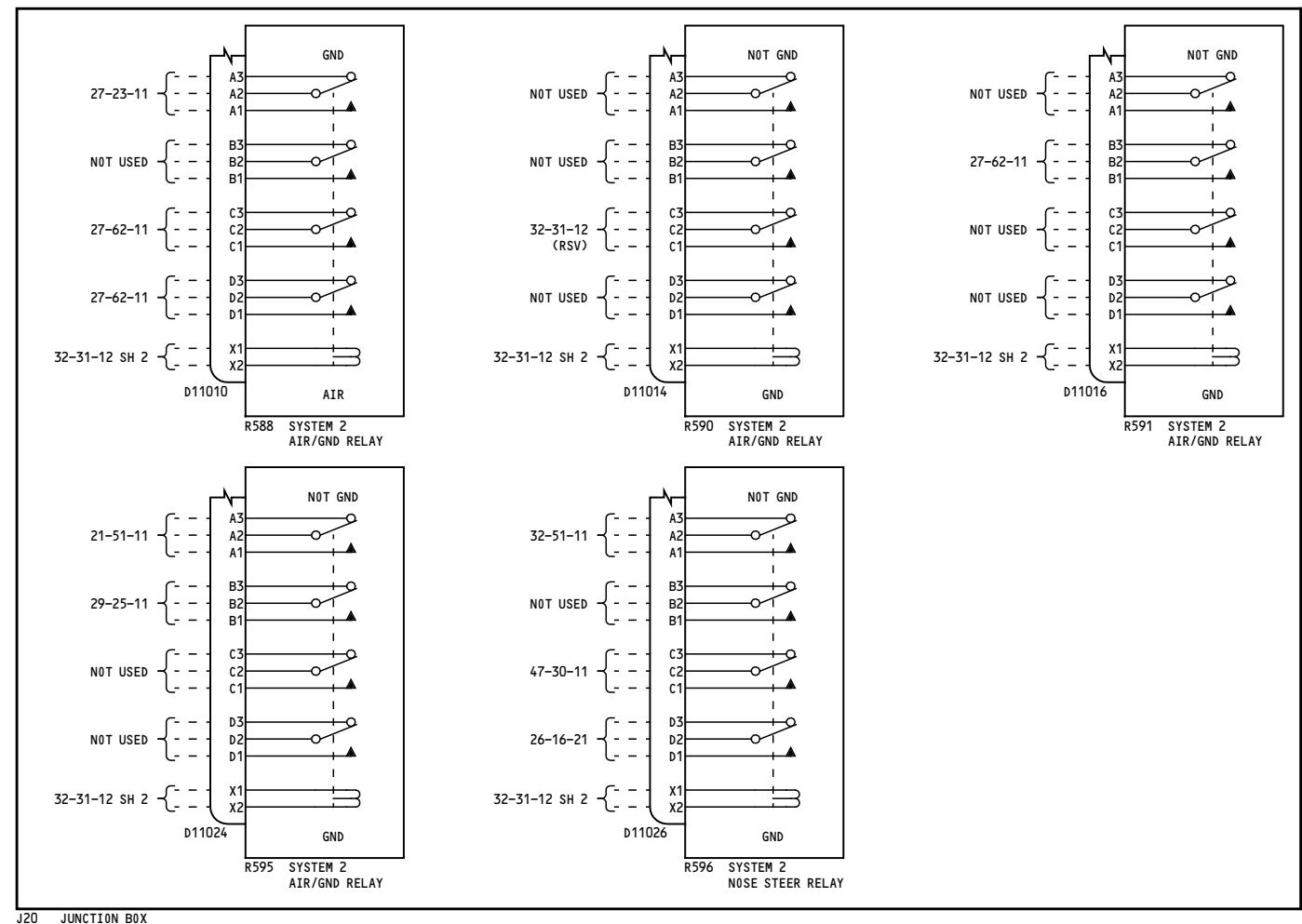
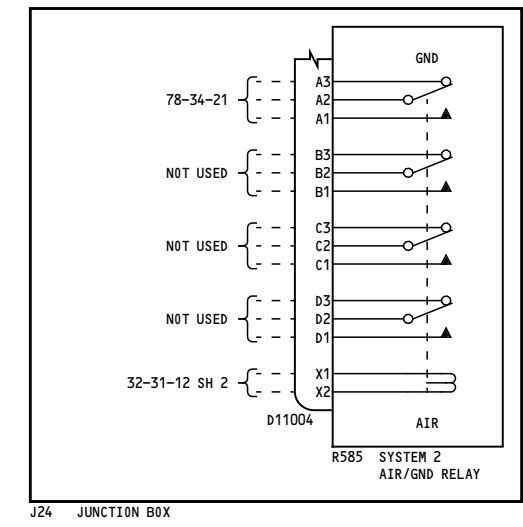
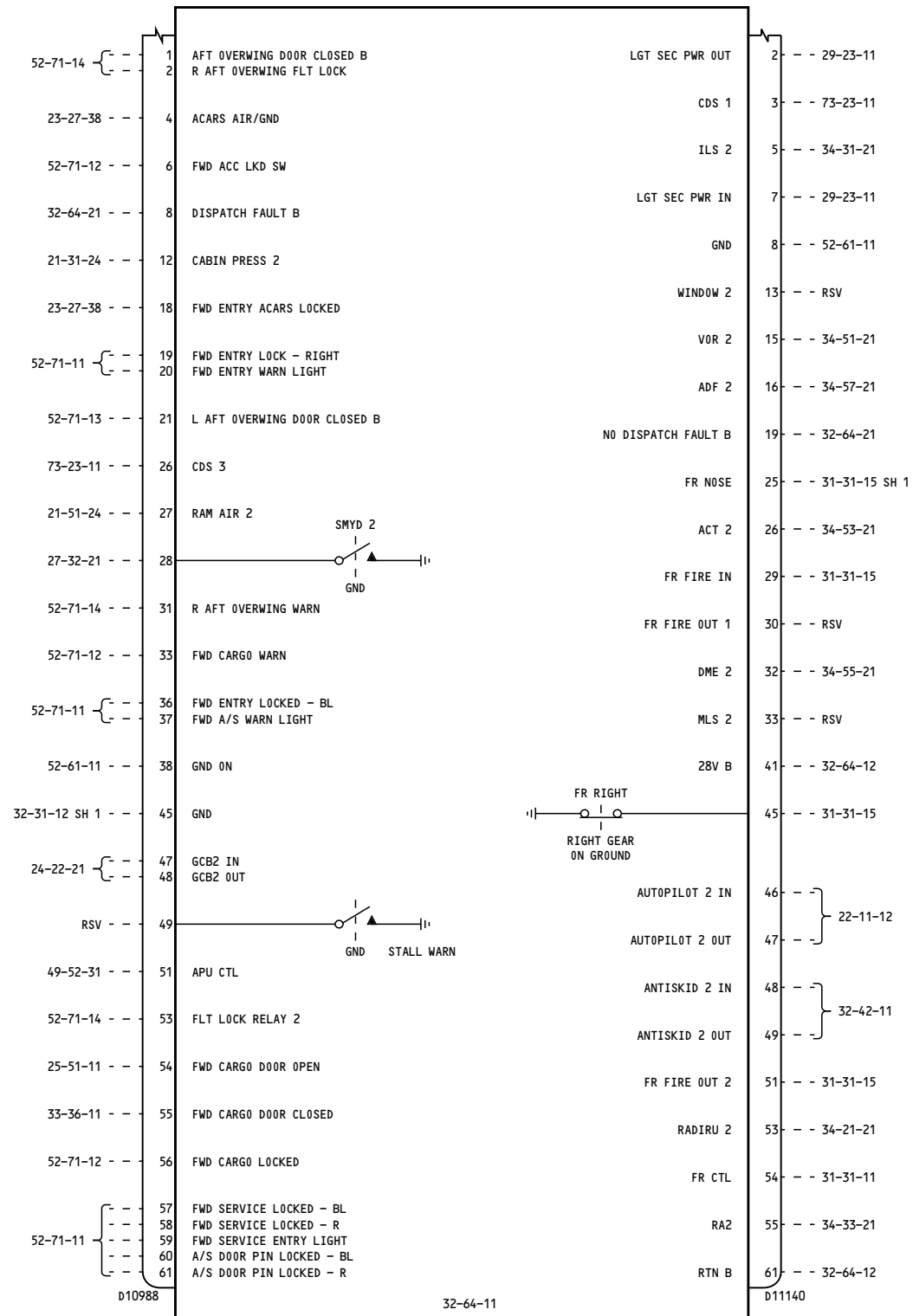

NOTES:
M2061 PROX SWITCH ELECTRONICS UNIT
STA 212 WL 180 RBL 20
THE DIAGRAM REFERENCES REPRESENT A
MAXIMUM CONFIGURATION. FOR INDIVIDUAL
AIRPLANES, SEE HOOKUP CHART.

YK919	AIR/GND SYSTEM 2 AND NOSE GEAR GROUND SENSING RELAYS
	D280A103

32-31-12

Page 7
Sheet 3
May 11/2009

32-31-12

Page 7
Sheet 3
May 11/2009

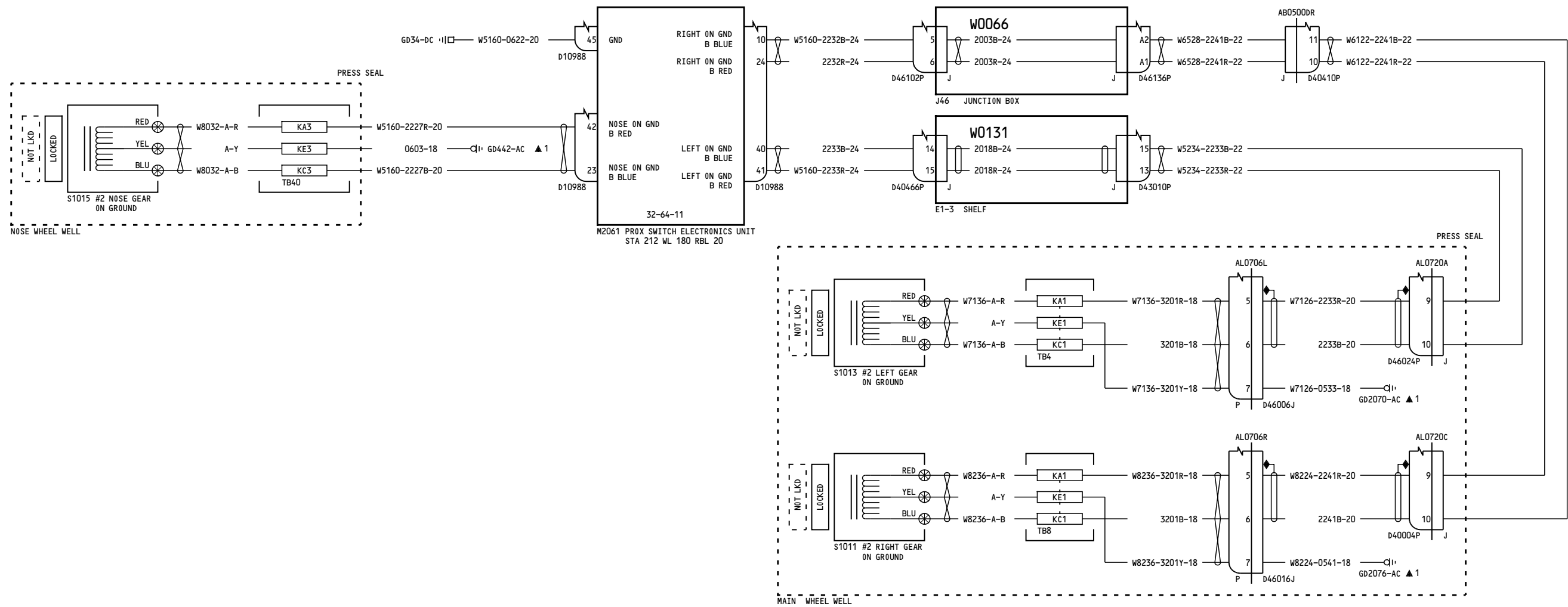

CADDs 4

YL401

**AIR/GND SYSTEM 2 AND
NOSE GEAR GROUND SENSING
RELAYS**

D280A103

32-31-12

Page 8
Sheet 1
Aug 13/2008

32-31-12

Page 8
Sheet 1
Aug 13/2008

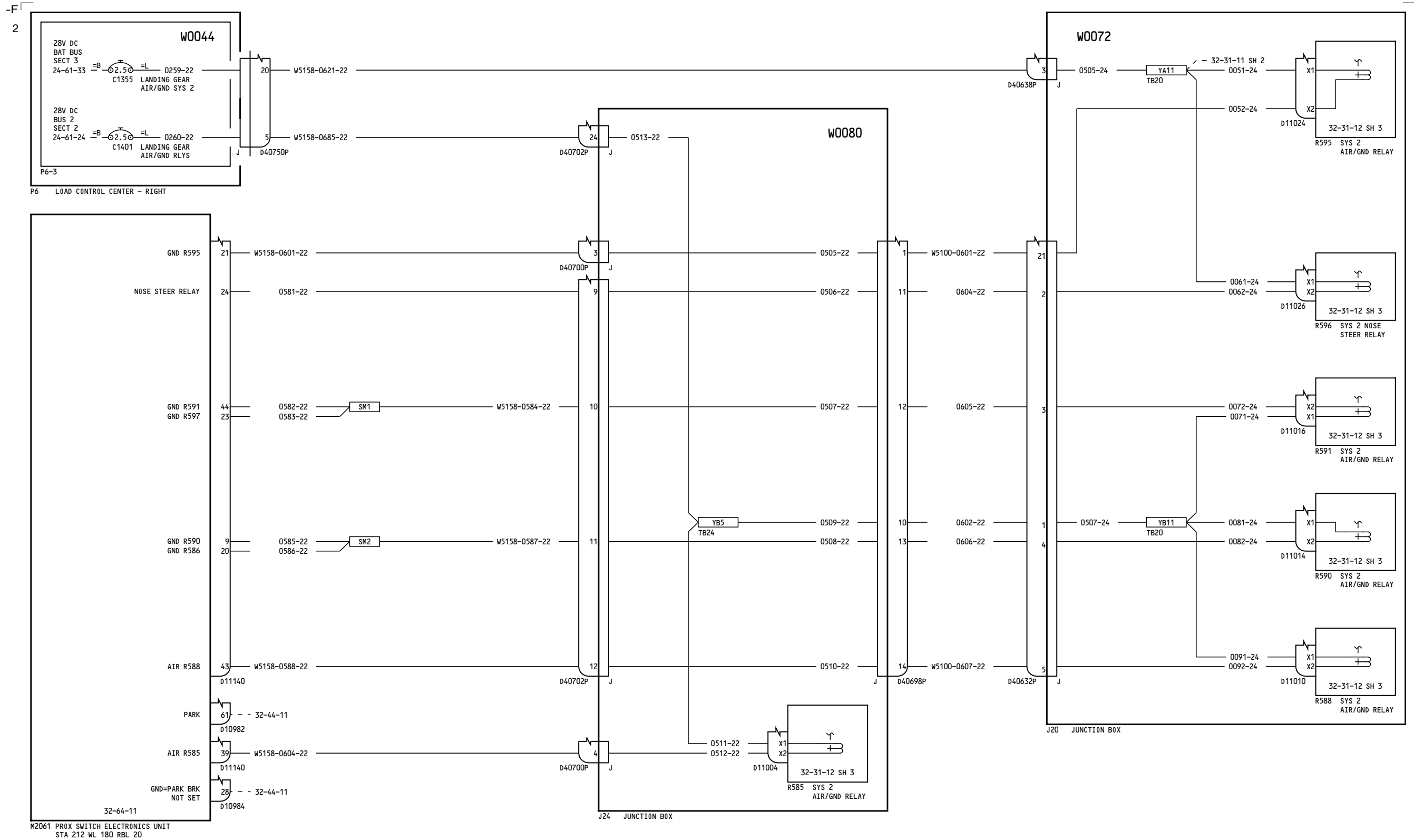

YL401

**AIR/GND SYSTEM 2 AND
NOSE GEAR GROUND SENSING
RELAYS**

D280A103

32-31-12

Page 8
Sheet 2
Aug 13/2008

32-31-12

Page 8
Sheet 2
Aug 13/2008

69

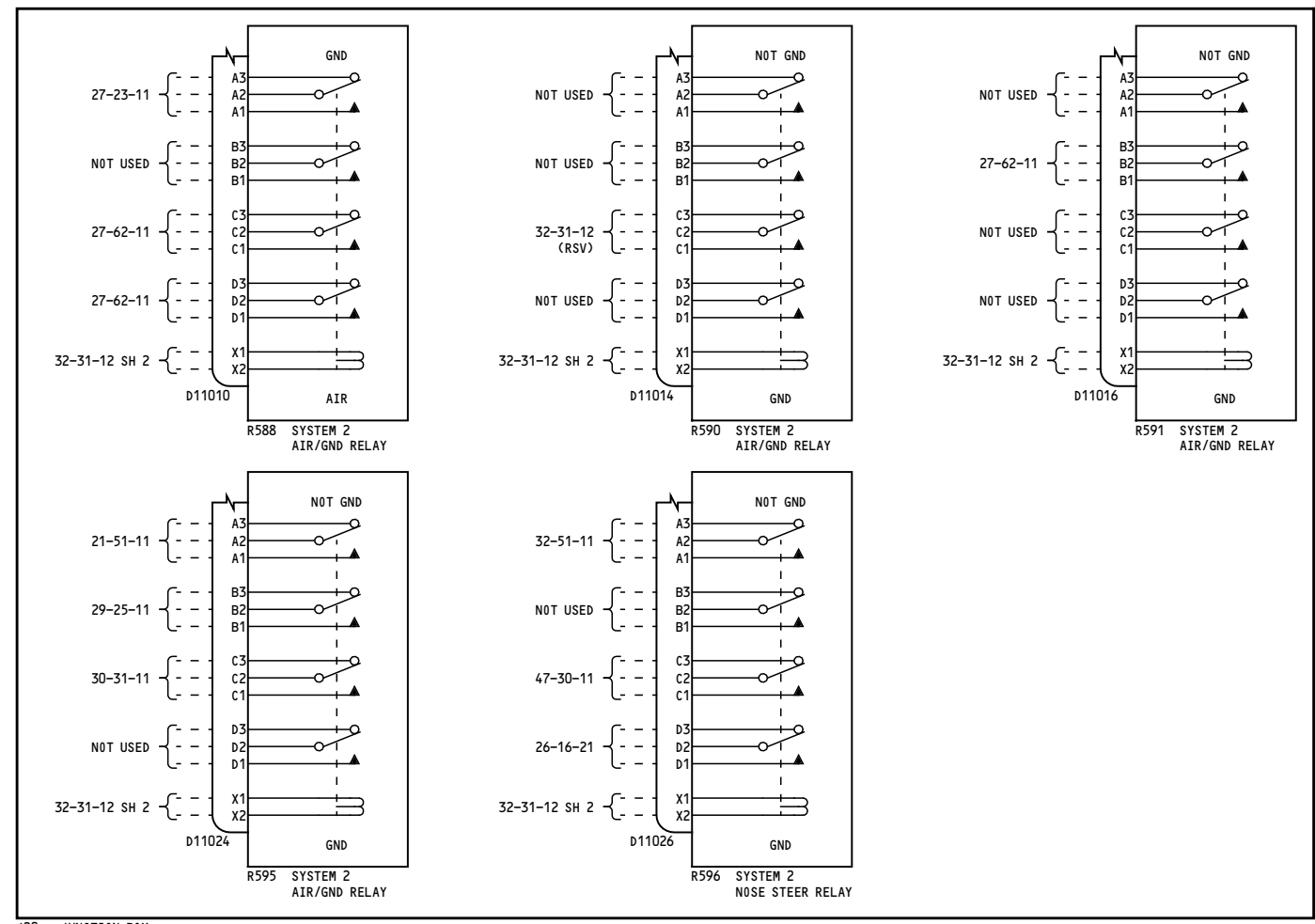
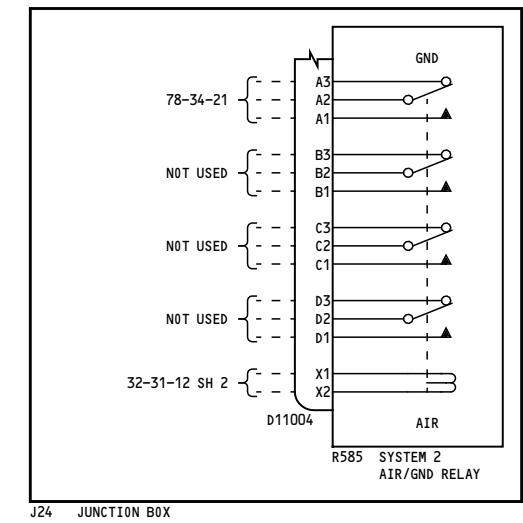
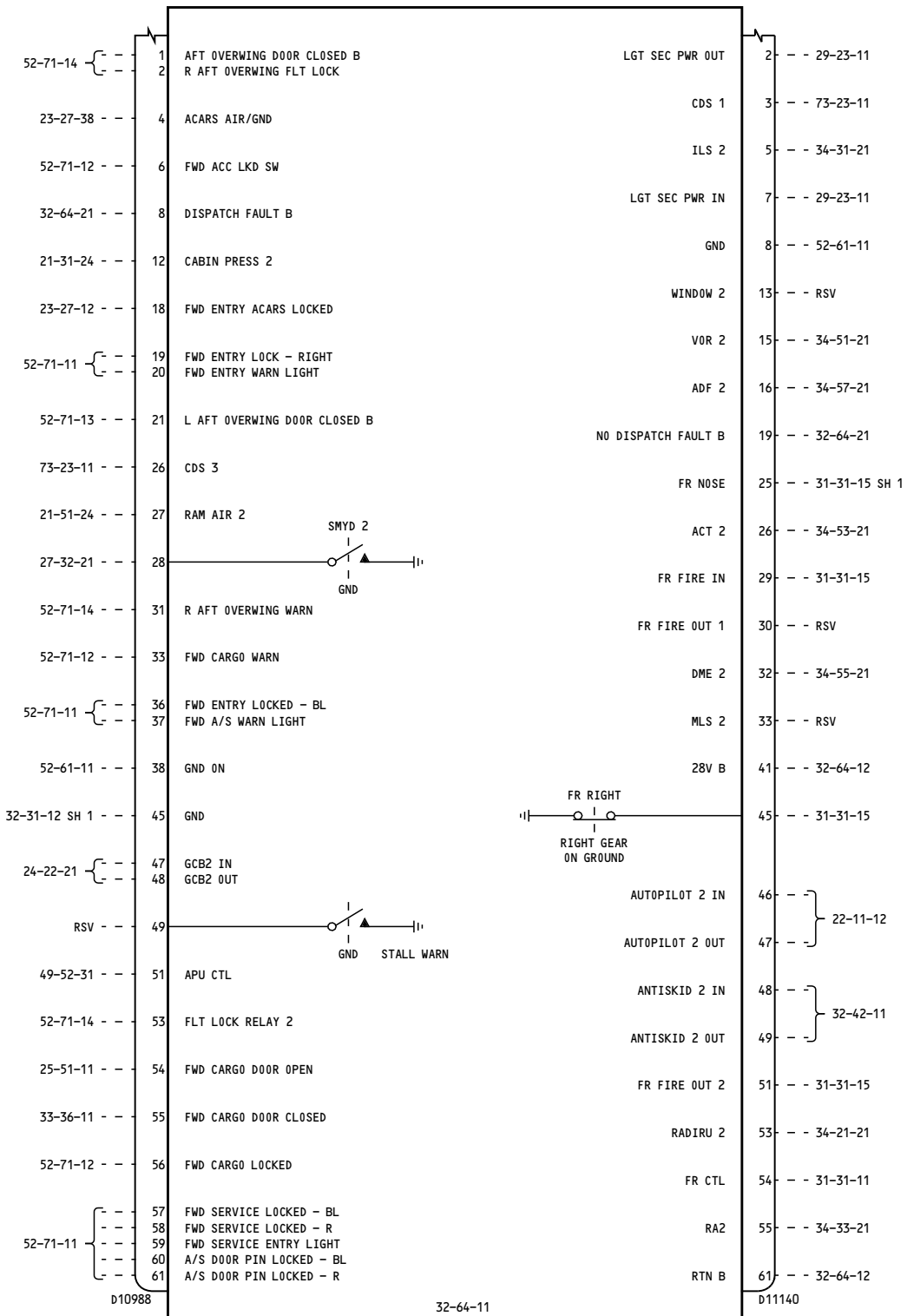

NOTES:
 M2061 PROX SWITCH ELECTRONICS UNIT STA 212 WL 180 RBL 20
 THE DIAGRAM REFERENCES REPRESENT A MAXIMUM CONFIGURATION. FOR INDIVIDUAL AIRPLANES, SEE HOOKUP CHART.

YL401	AIR/GND SYSTEM 2 AND NOSE GEAR GROUND SENSING RELAYS D280A103
-------	---

32-31-12
 Page 8
 Sheet 3
 Aug 13/2008

32-31-12
 Page 8
 Sheet 3
 Aug 13/2008

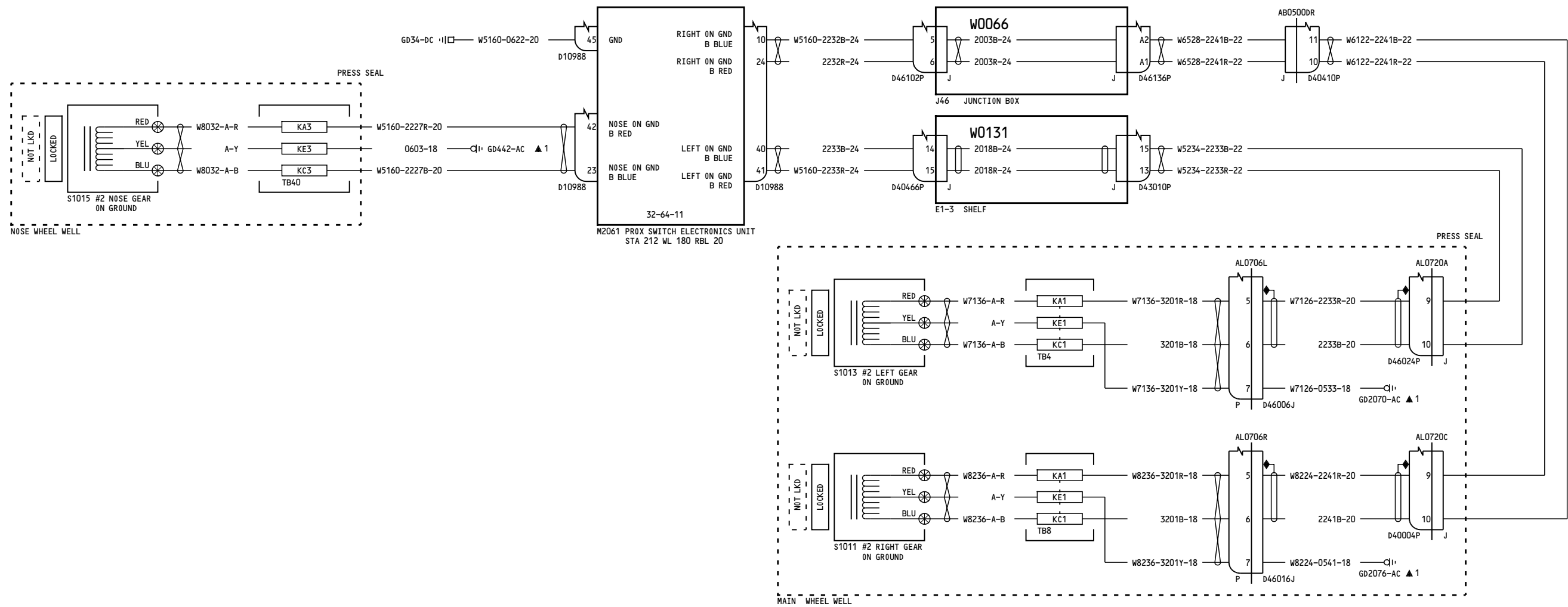

CADDs 4

YM643-YM651

**AIR/GND SYSTEM 2 AND
NOSE GEAR GROUND SENSING
RELAYS**

D280A103

32-31-12

Page 9
Sheet 1
Aug 13/2008

32-31-12

Page 9
Sheet 1
Aug 13/2008

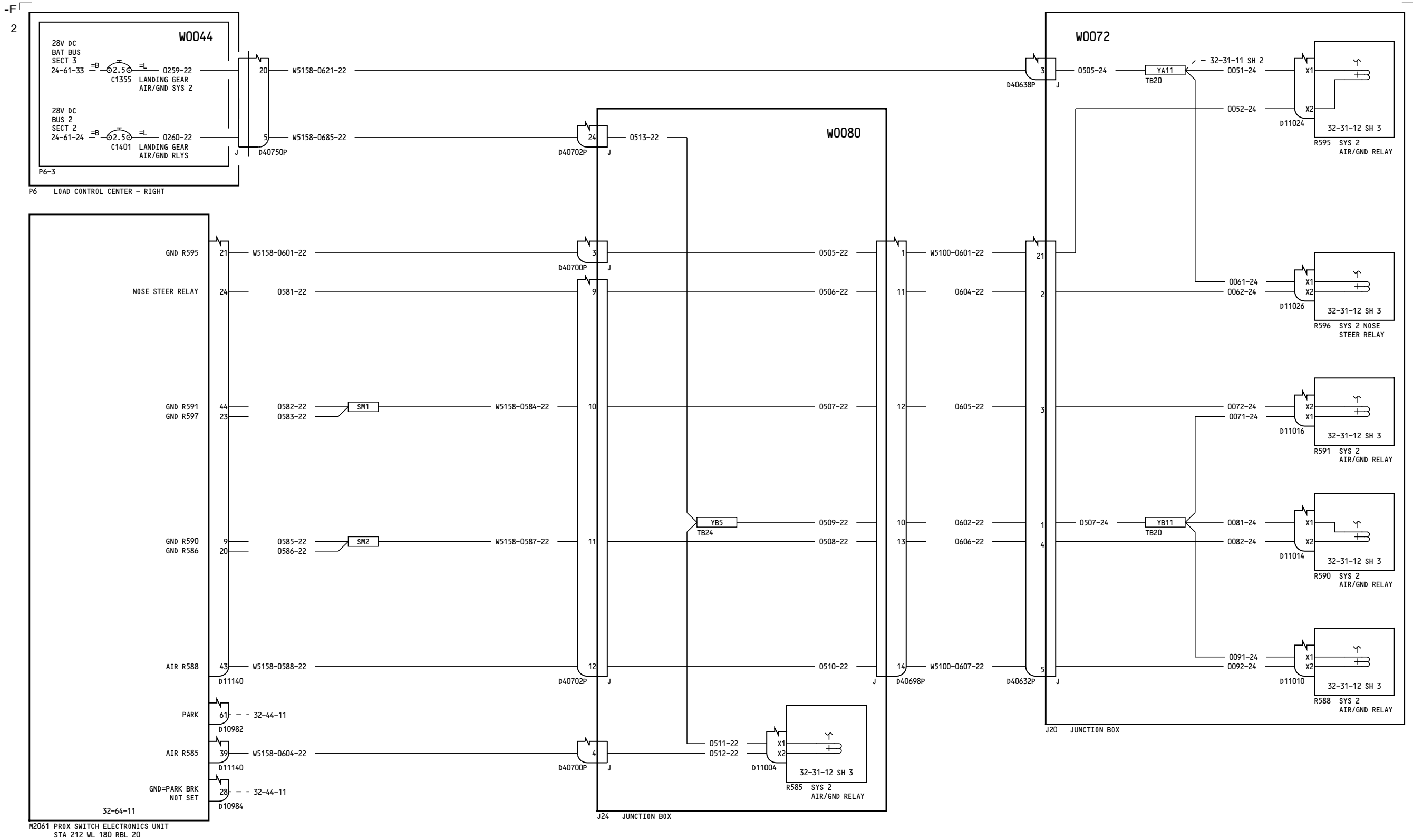

YM643-YM651

**AIR/GND SYSTEM 2 AND
NOSE GEAR GROUND SENSING
RELAYS**

D280A103

32-31-12

Page 9
Sheet 2
Aug 13/2008

32-31-12

Page 9
Sheet 2
Aug 13/2008

-A
16

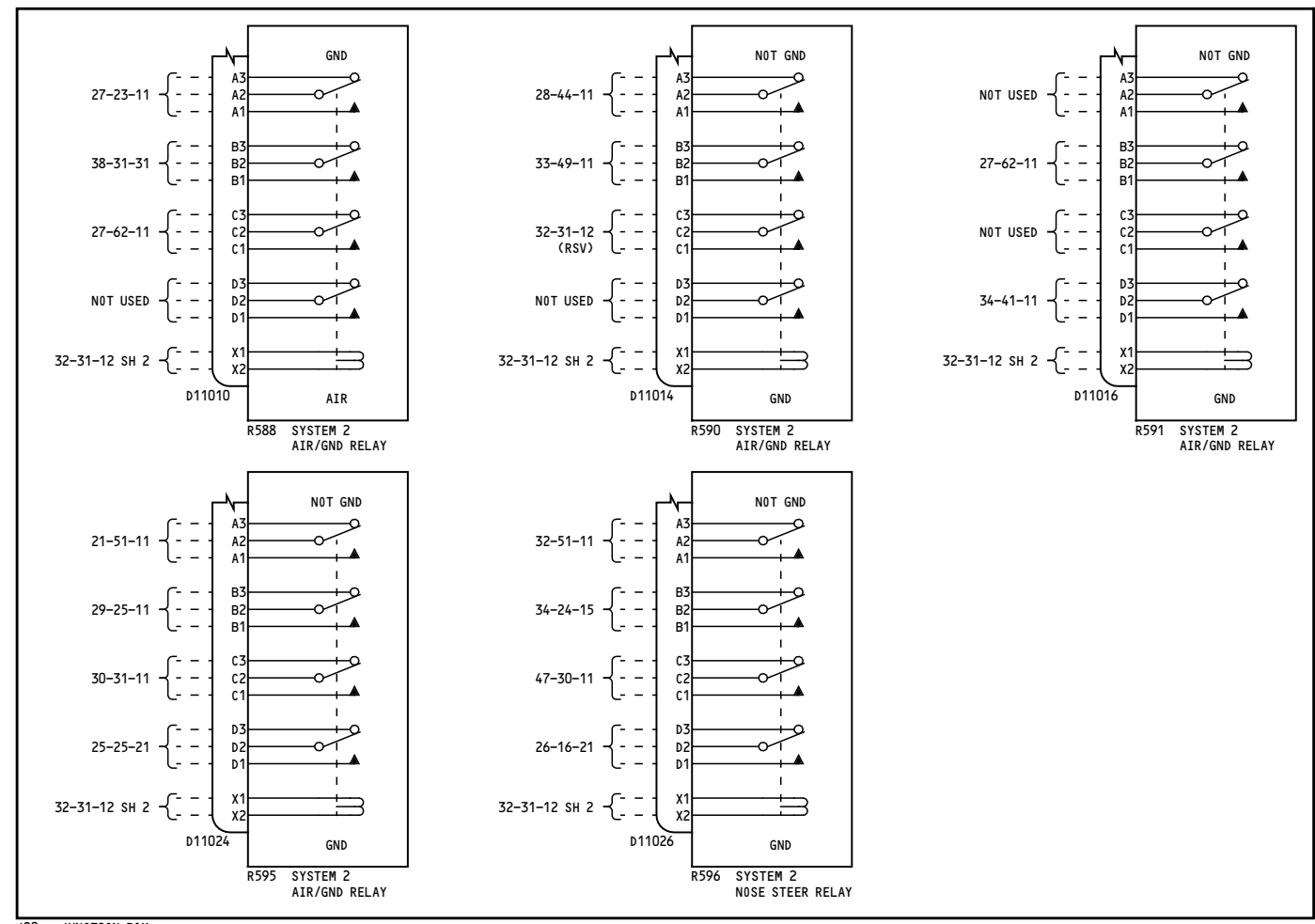
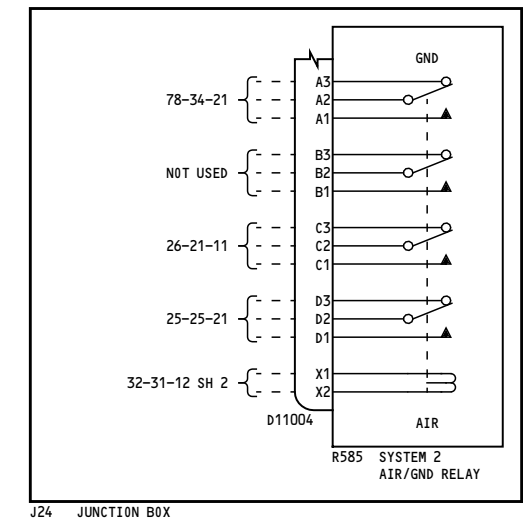
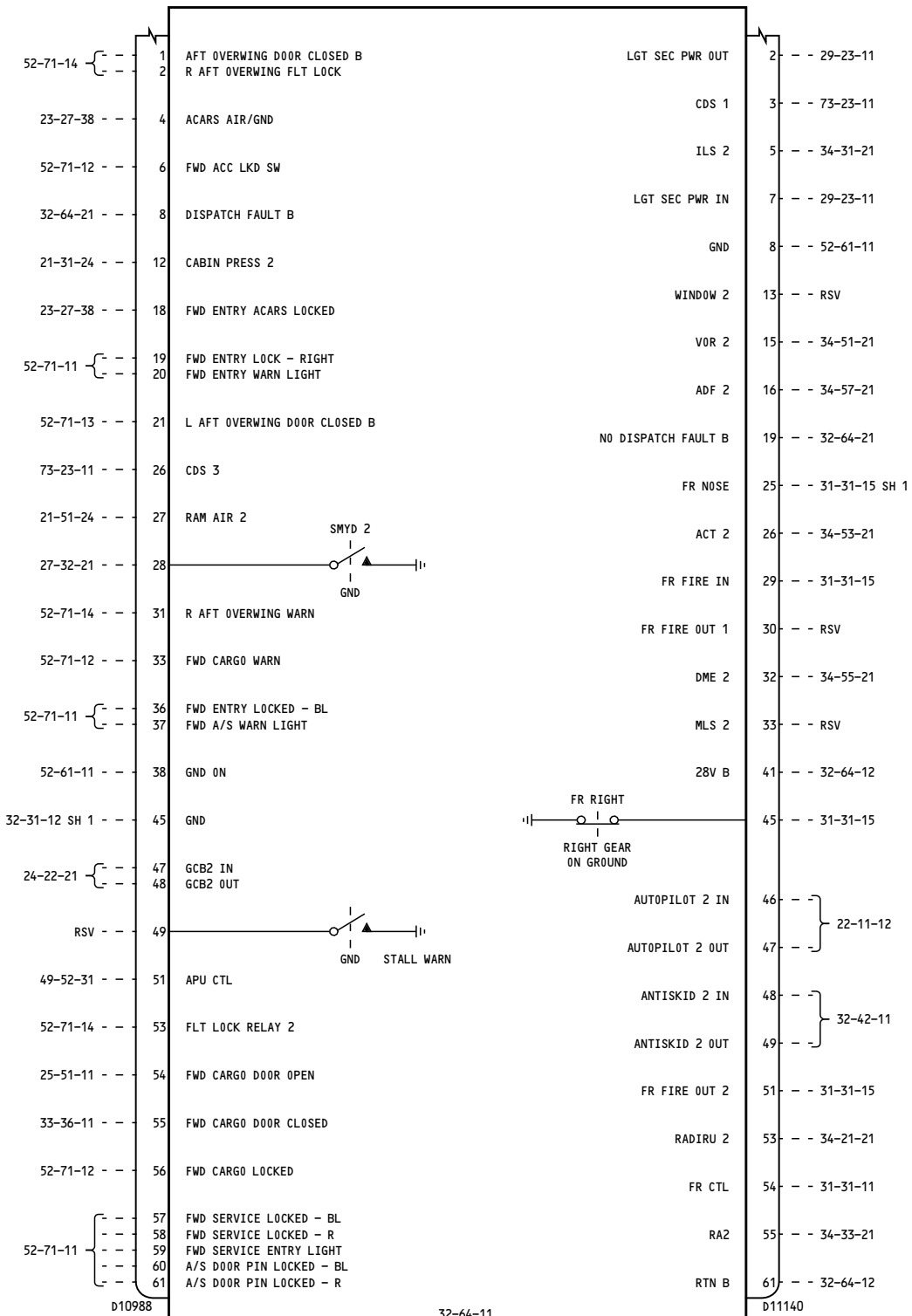

NOTES:
M2061 PROX SWITCH ELECTRONICS UNIT
STA 212 WL 180 RBL 20
THE DIAGRAM REFERENCES REPRESENT A
MAXIMUM CONFIGURATION. FOR INDIVIDUAL
AIRPLANES, SEE HOOKUP CHART.

YM643-YM651

**AIR/GND SYSTEM 2 AND
NOSE GEAR GROUND SENSING
RELAYS**

D280A103

32-31-12

Page 9
Sheet 3
Aug 13/2008

32-31-12

Page 9
Sheet 3
Aug 13/2008

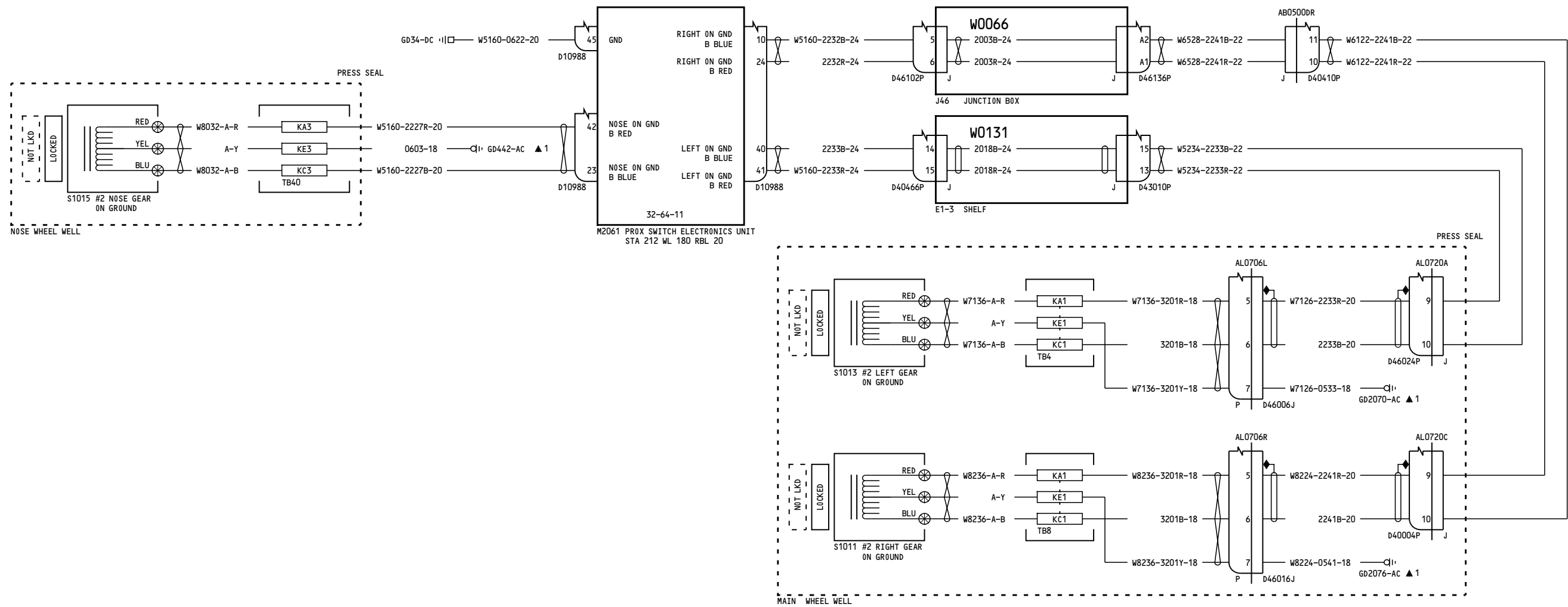

CADD 4

YM652

**AIR/GND SYSTEM 2 AND
NOSE GEAR GROUND SENSING
RELAYS**

D280A103

32-31-12

Page 10
Sheet 1
May 11/2009

32-31-12

Page 10
Sheet 1
May 11/2009

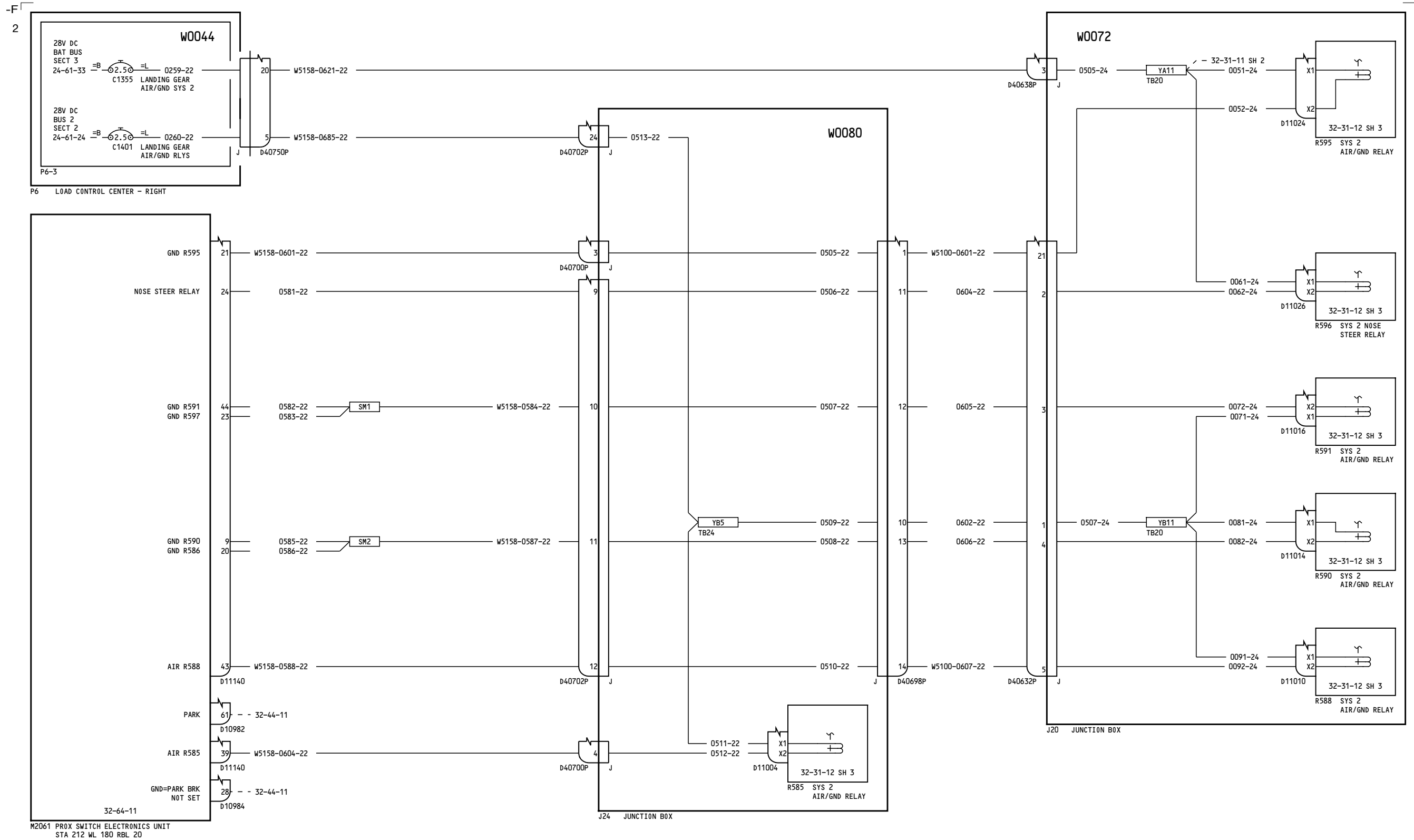

YM652

**AIR/GND SYSTEM 2 AND
NOSE GEAR GROUND SENSING
RELAYS**

D280A103

32-31-12

Page 10
Sheet 2
May 11/2009

32-31-12

Page 10
Sheet 2
May 11/2009

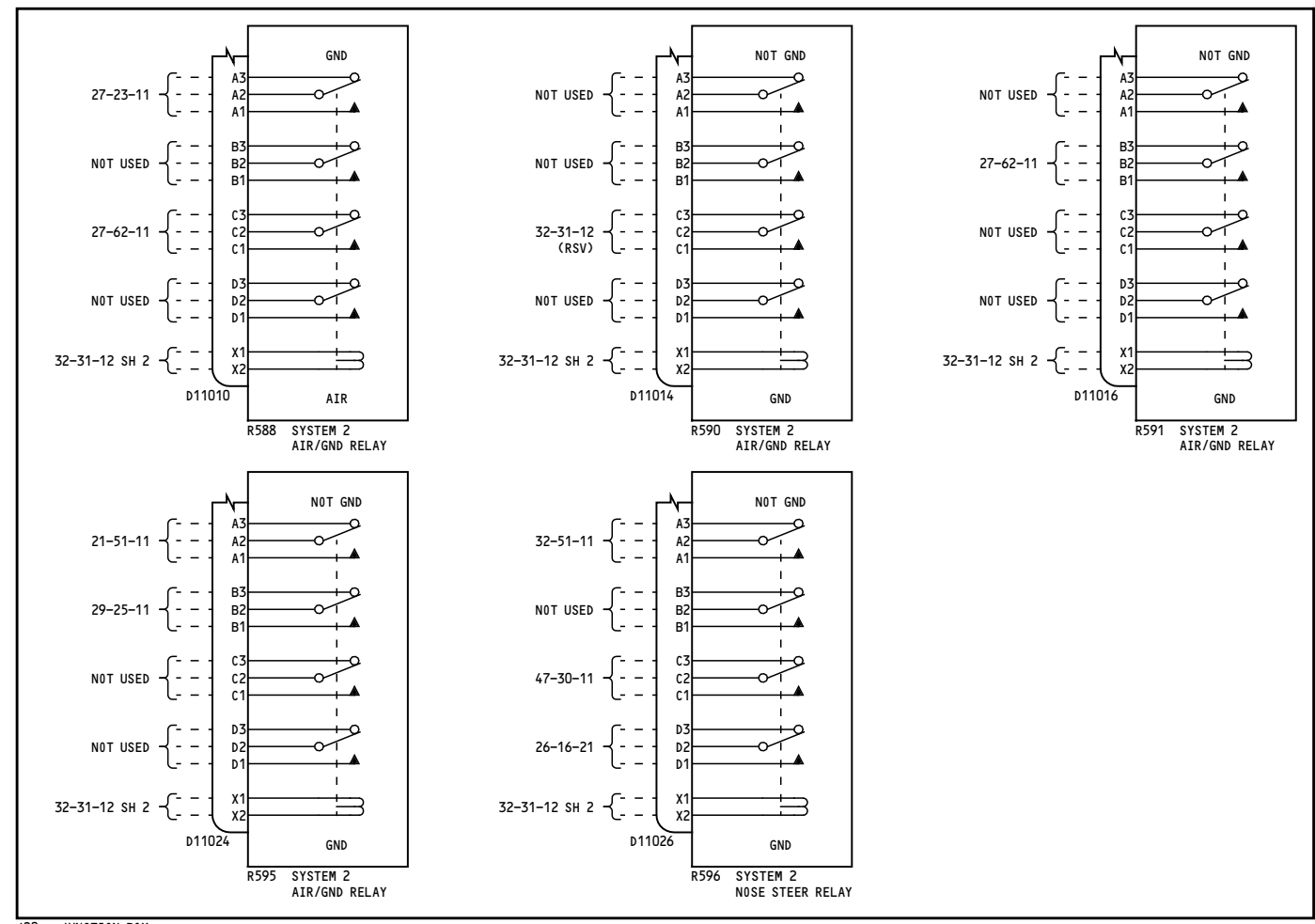
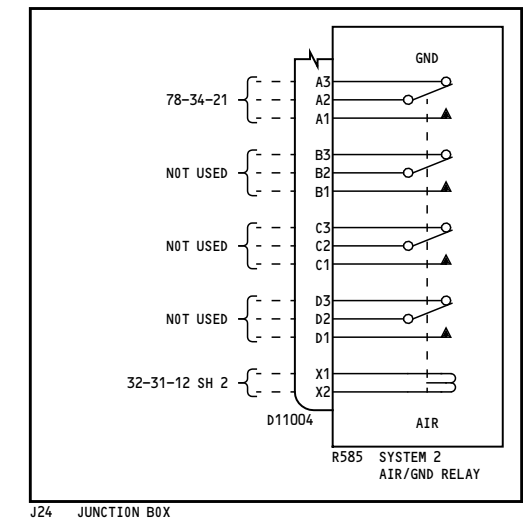
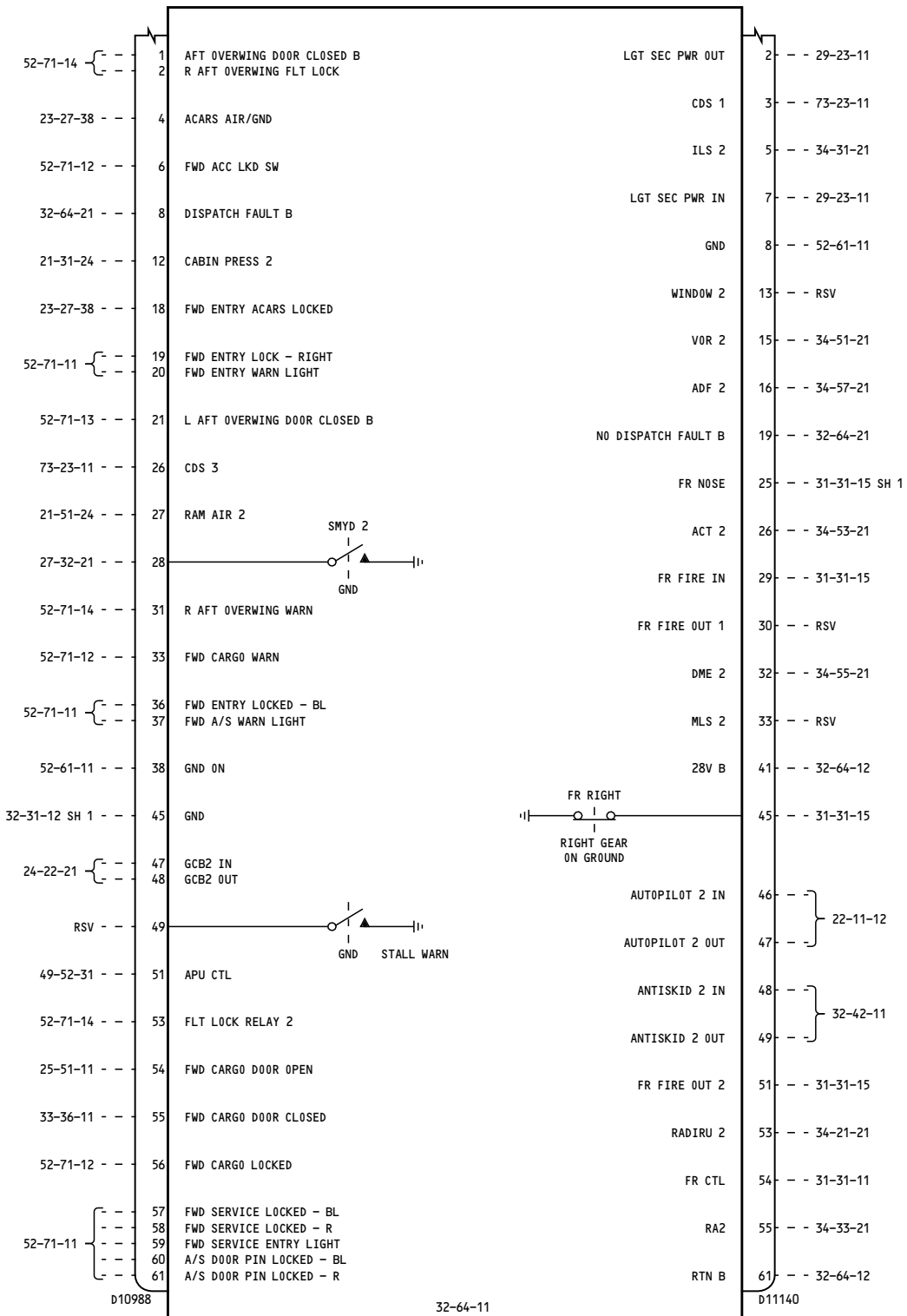

NOTES:
 M2061 PROX SWITCH ELECTRONICS UNIT
 STA 212 WL 180 RBL 20
 THE DIAGRAM REFERENCES REPRESENT A
 MAXIMUM CONFIGURATION. FOR INDIVIDUAL
 AIRPLANES, SEE HOOKUP CHART.

YM652	AIR/GND SYSTEM 2 AND NOSE GEAR GROUND SENSING RELAYS
	D280A103

32-31-12

Page 10
 Sheet 3
 May 11/2009

32-31-12

Page 10
 Sheet 3
 May 11/2009

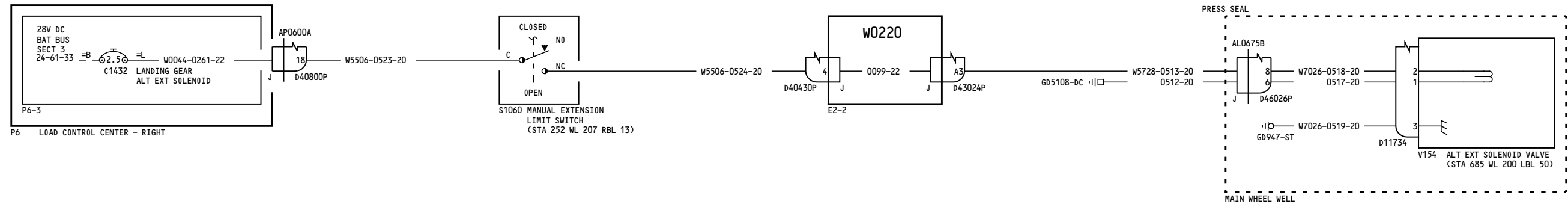

ALL	<p>ALTERNATE LANDING GEAR EXTENSION SYSTEM</p> <p>D280A103</p>
-----	---

32-35-11

Page 1

Feb 09/2009

32-35-11

Page 1

Feb 09/2009

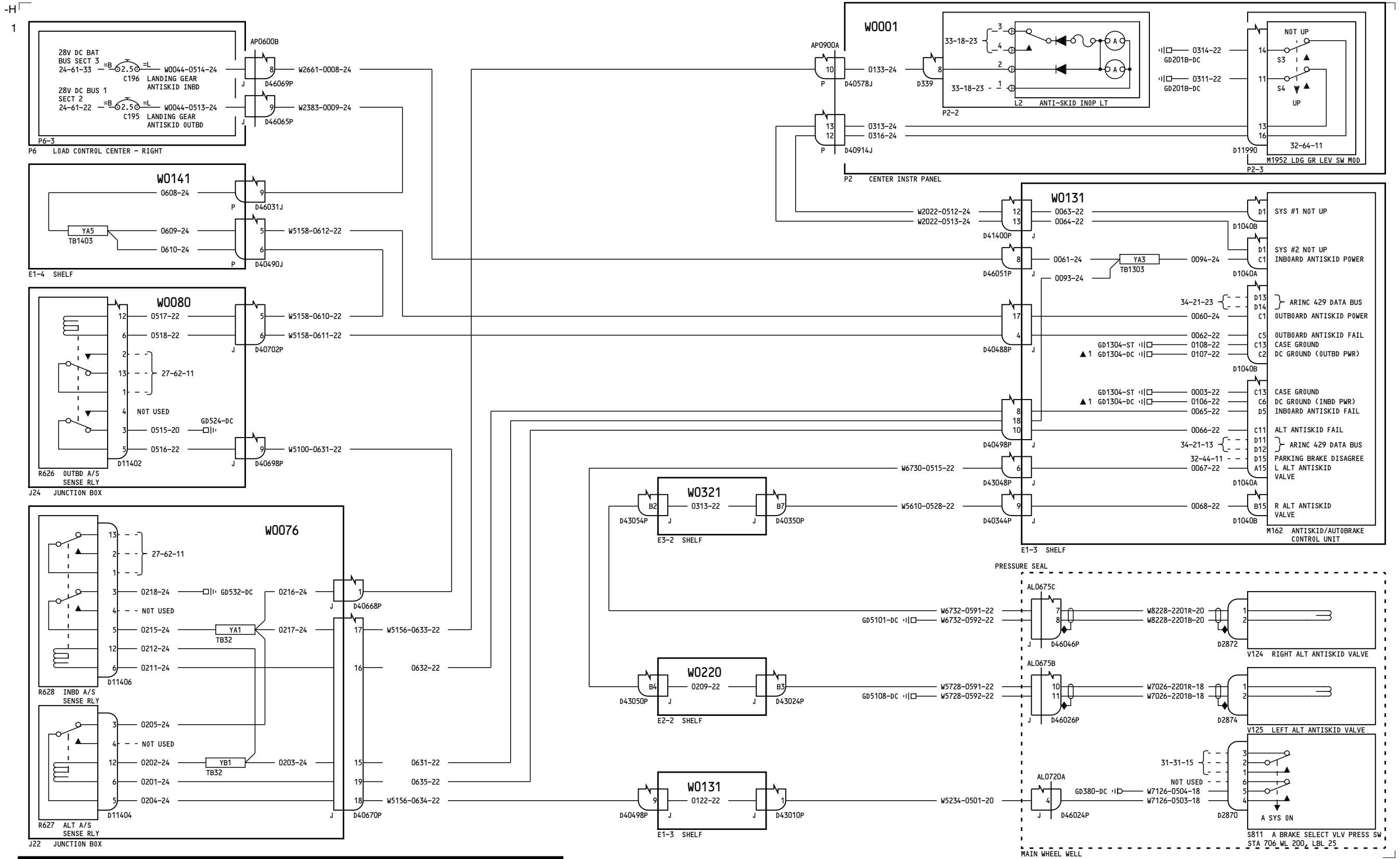

YC001-YC003

ANTISKID SYSTEM

32-41-11

Page 1
Sheet 1
Mar 31/2005

D280A103

32-41-11

Page 1
Sheet 1
Mar 31/2005

-E
2

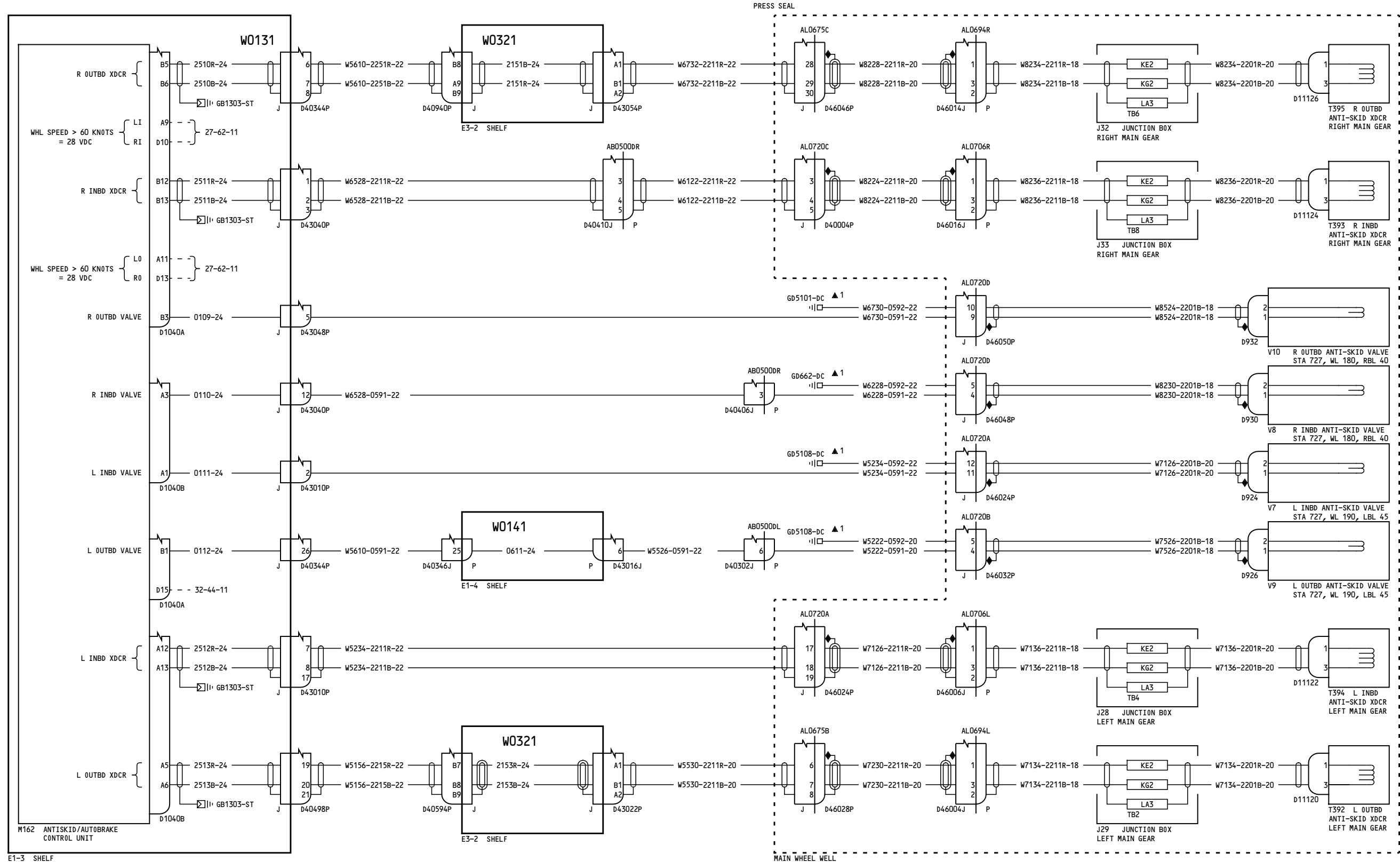

YC001-YC003

ANTISKID SYSTEM

32-41-11

Page 1
Sheet 2
Mar 31/2005

D280A103

32-41-11

Page 1
Sheet 2
Mar 31/2005

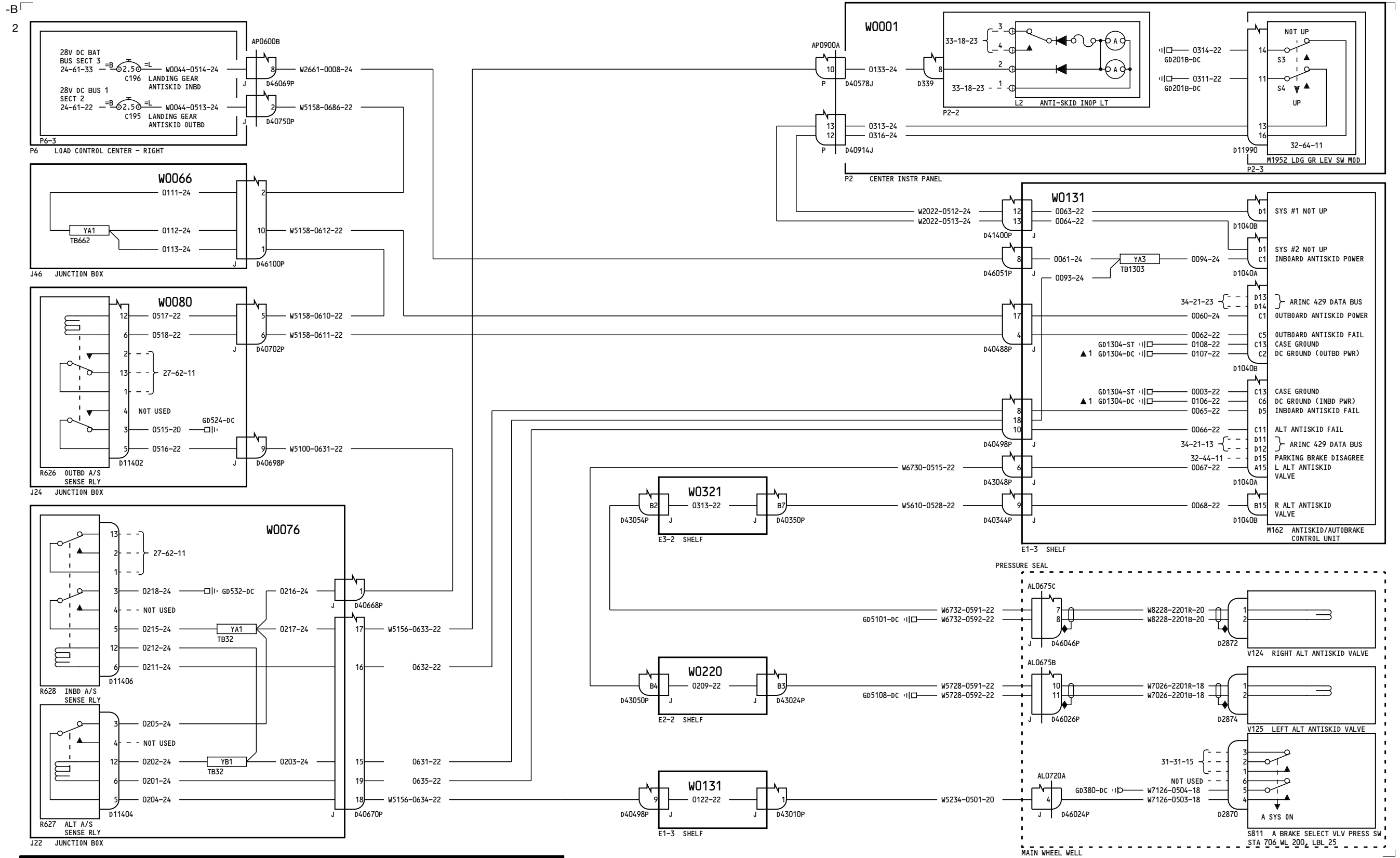

YC004-YK907, YL421

ANTISKID SYSTEM

32-41-11

Page 2
Sheet 1
Jul 17/2007

D280A103

32-41-11

Page 2
Sheet 1
Jul 17/2007

-E
2

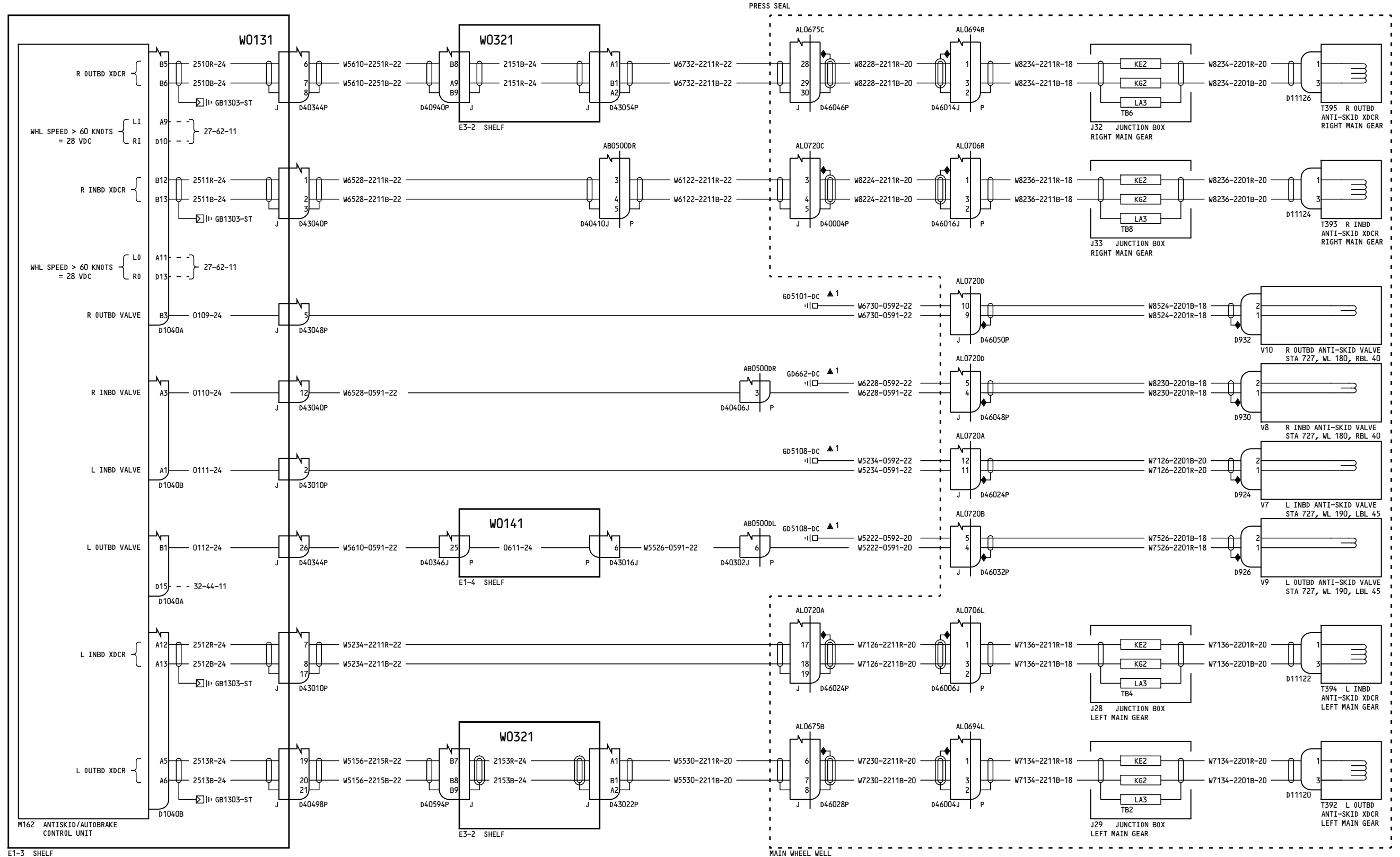

YC004-YK907, YL421

ANTISKID SYSTEM

32-41-11

Page 2
Sheet 2
Jul 17/2007

D280A103

32-41-11

Page 2
Sheet 2
Jul 17/2007

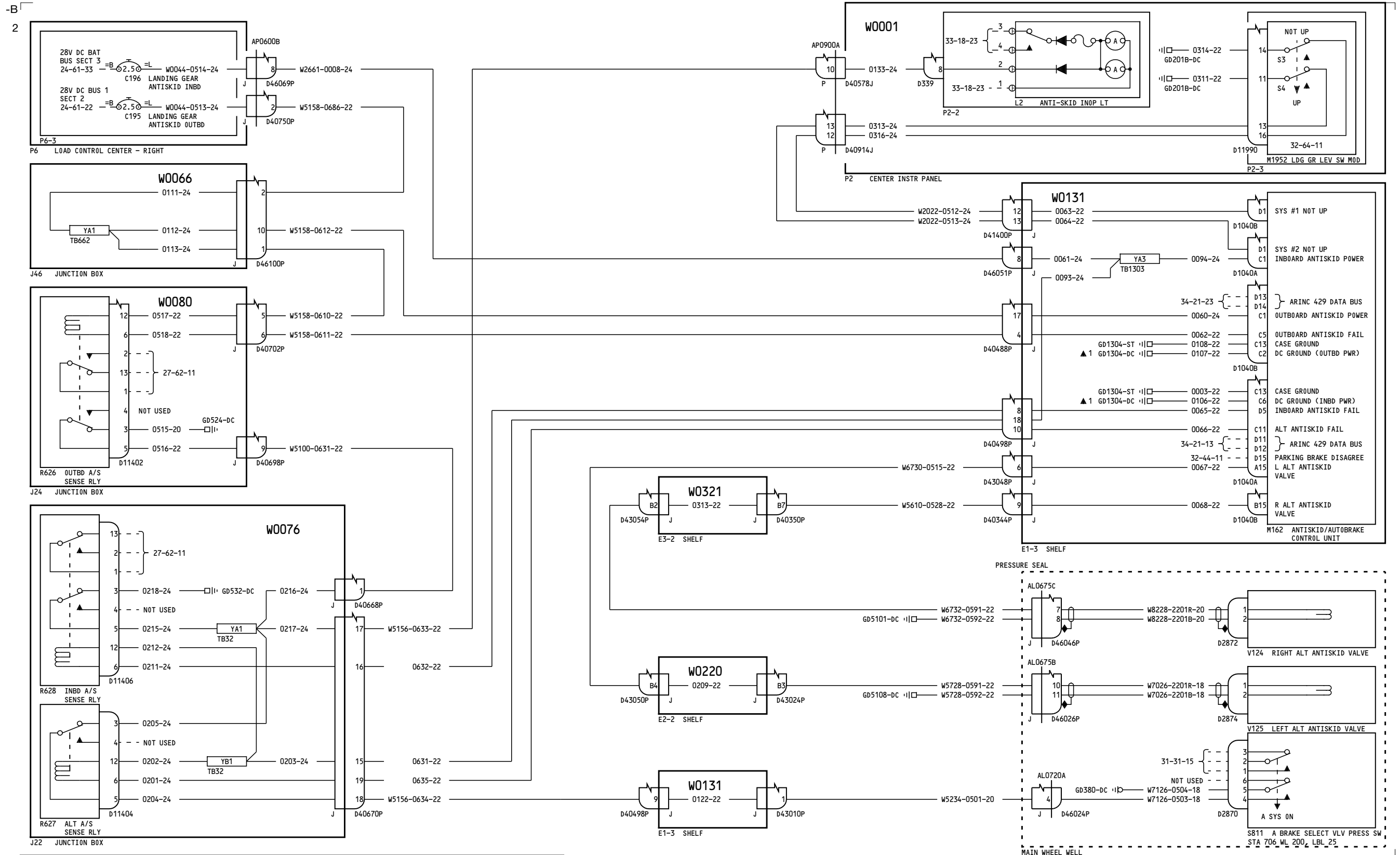

YK908-YL401, YL422-YM670

ANTISKID SYSTEM

32-41-11

D280A103

32-41-11

9

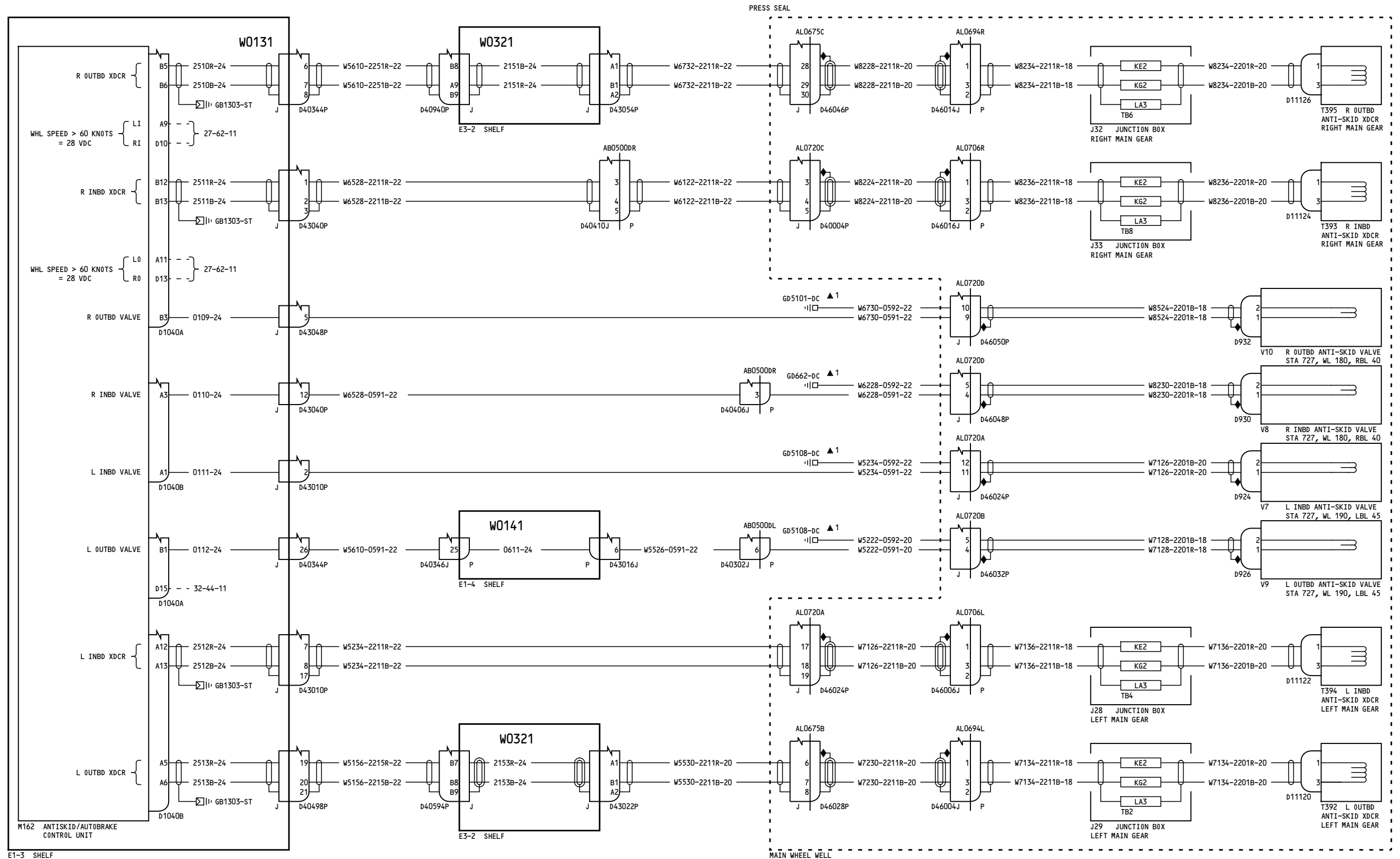

YK908-YL401, YL422-YM670

ANTISKID SYSTEM

32-41-11

Page 3
Sheet 2
Feb 09/2009

D280A103

32-41-11

Page 3
Sheet 2
Feb 09/2009

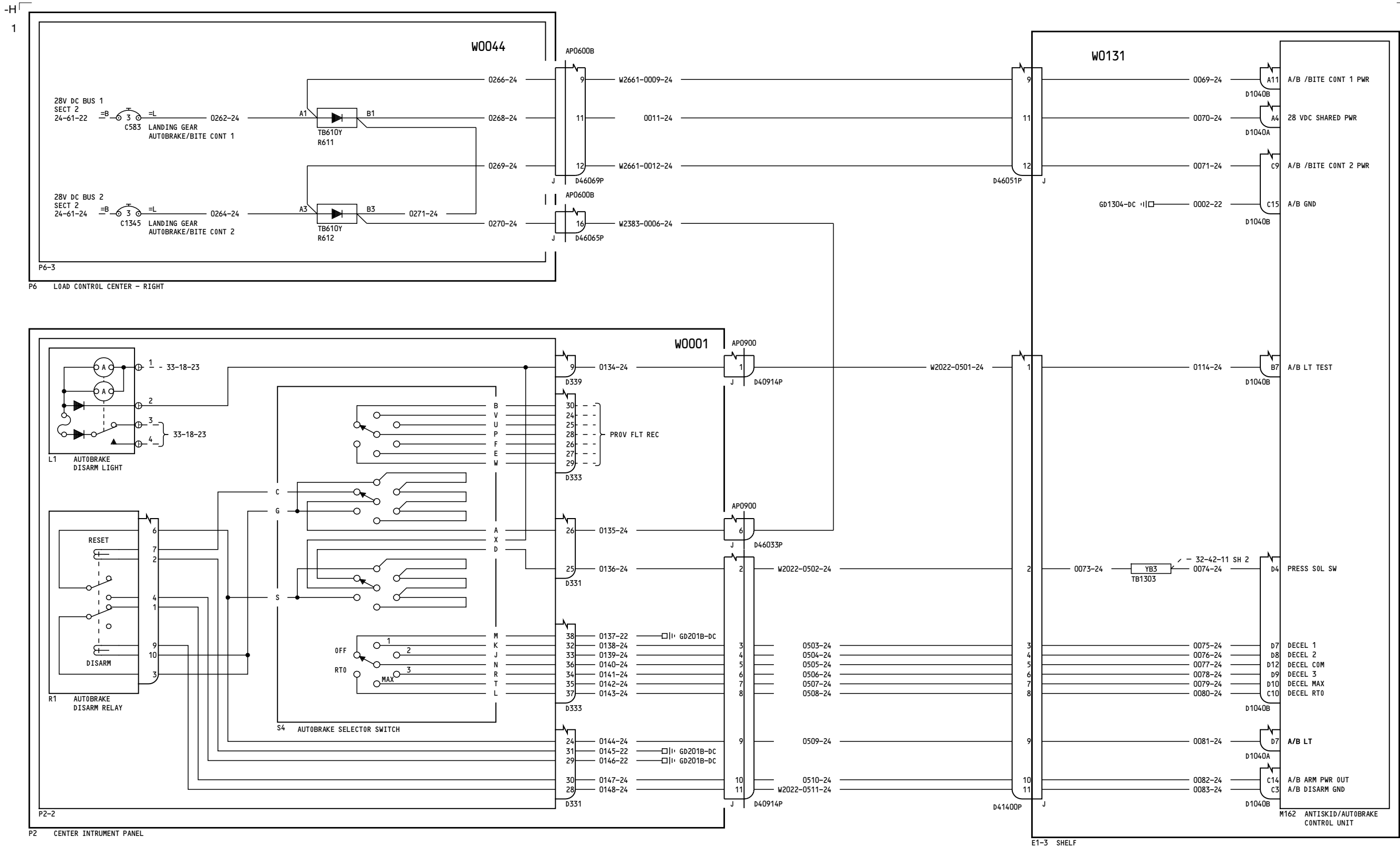

YC001-YC003

AUTOBRAKE SYSTEM

32-42-11

Page 1
Sheet 1
Apr 18/2006

D280A103

32-42-11

Page 1
Sheet 1
Apr 18/2006

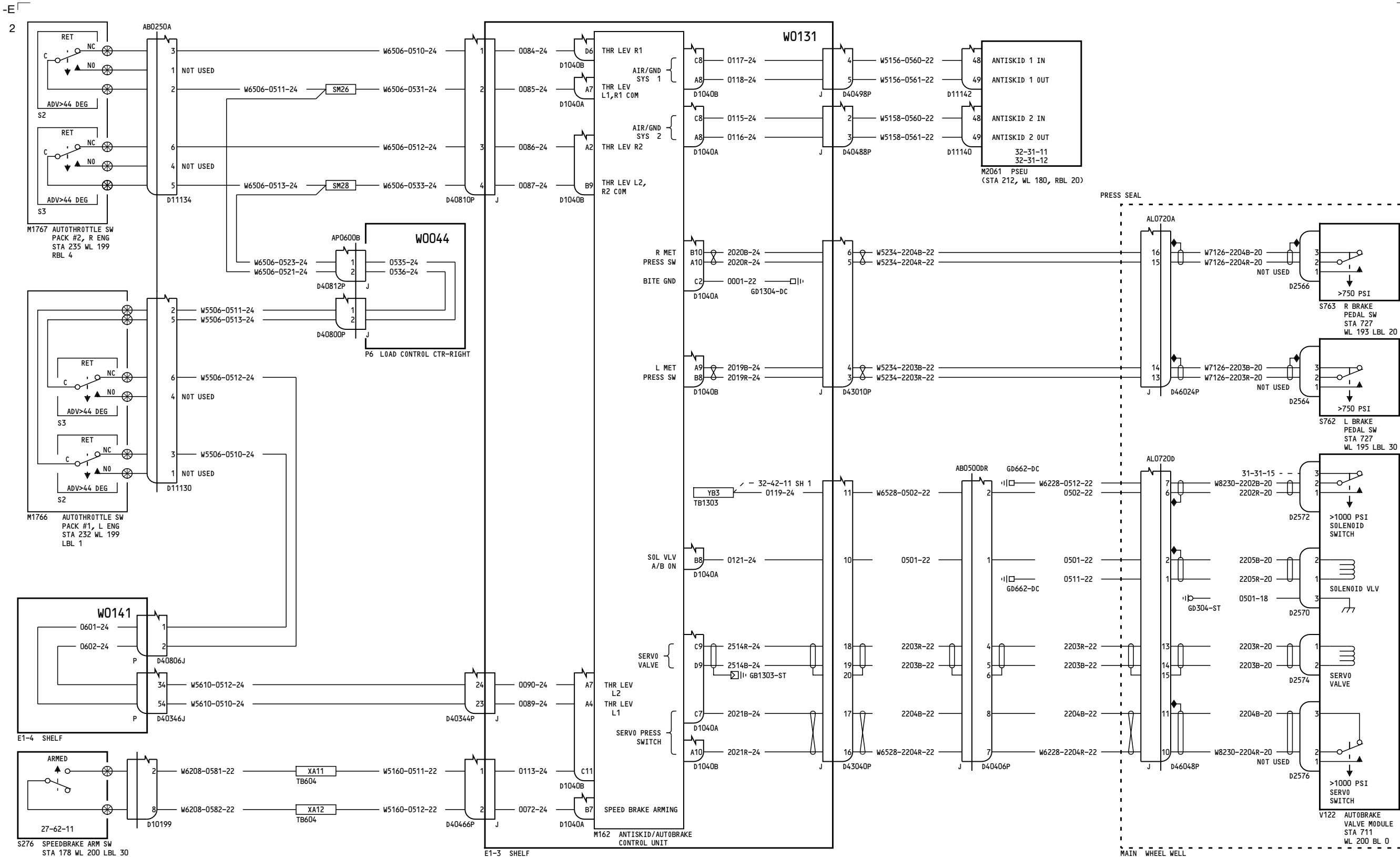

YC001-YC003

AUTOBRAKE SYSTEM

32-42-11

D280A103

32-42-11

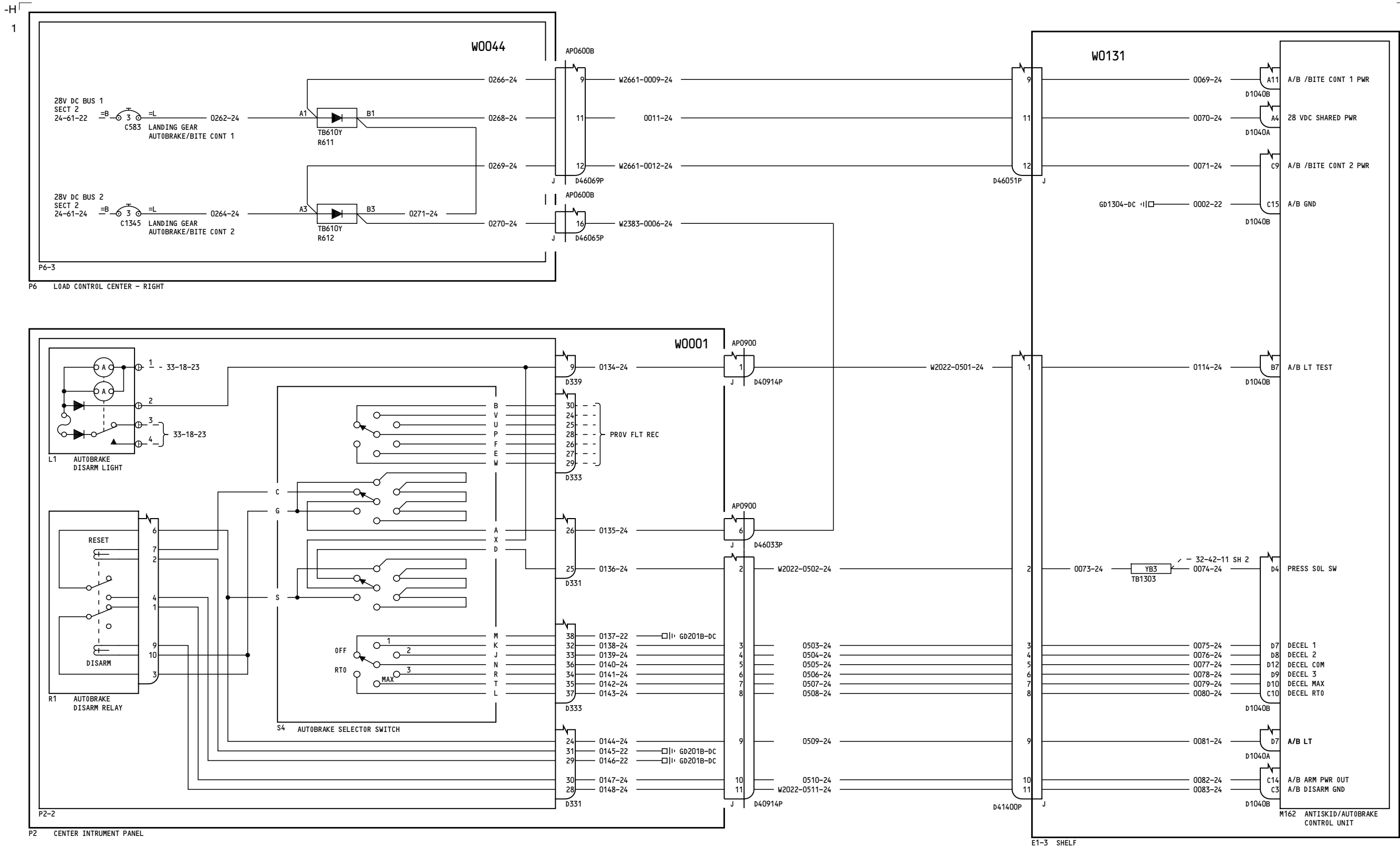

YC004-YC007

AUTOBRAKE SYSTEM

32-42-11

Page 2
Sheet 1
Apr 18/2006

D280A103

32-42-11

Page 2
Sheet 1
Apr 18/2006

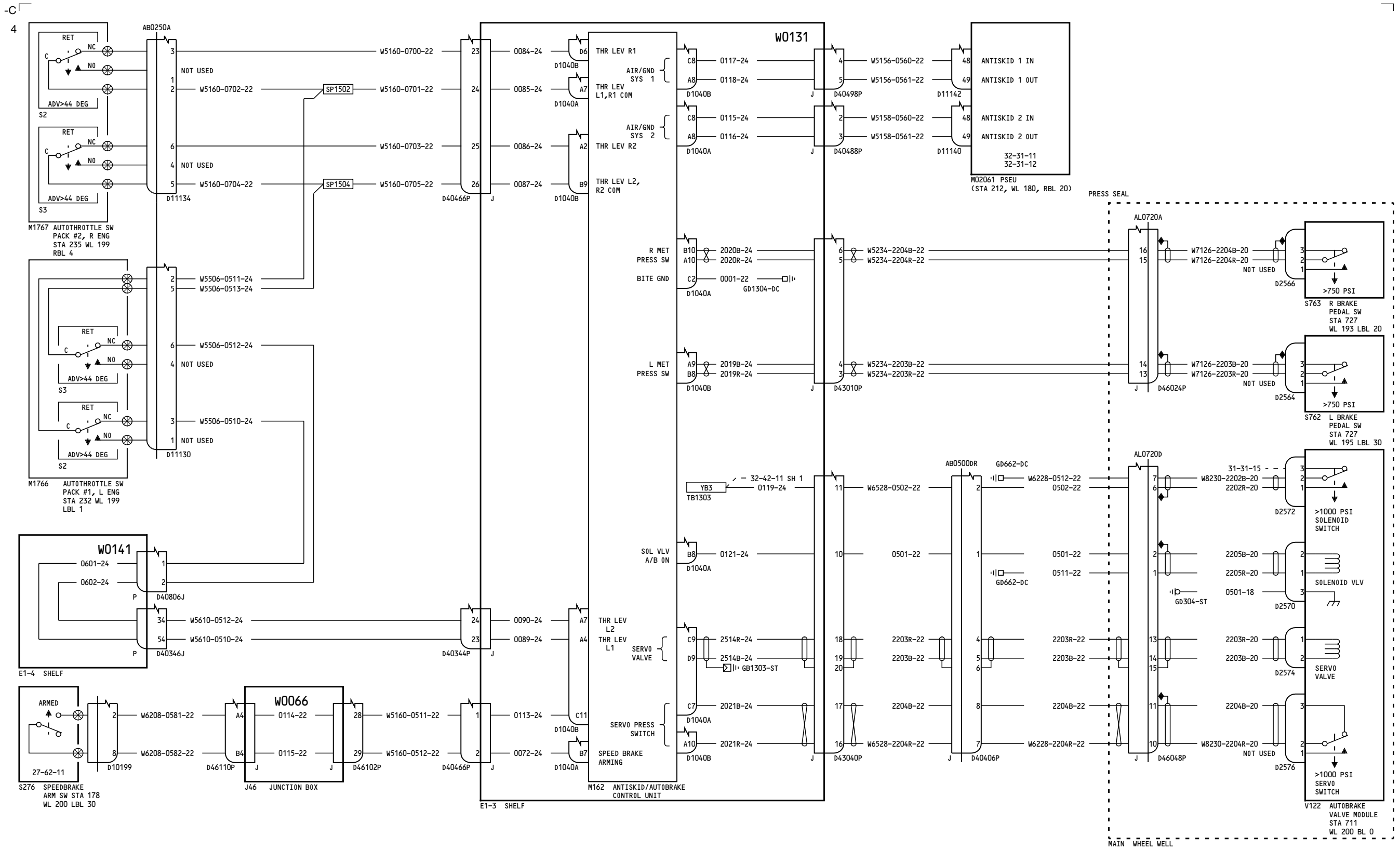

YC004-YC007

AUTOBRAKE SYSTEM

32-42-11

Page 2
Sheet 2
Mar 31/2005

D280A103

32-42-11

Page 2
Sheet 2
Mar 31/2005

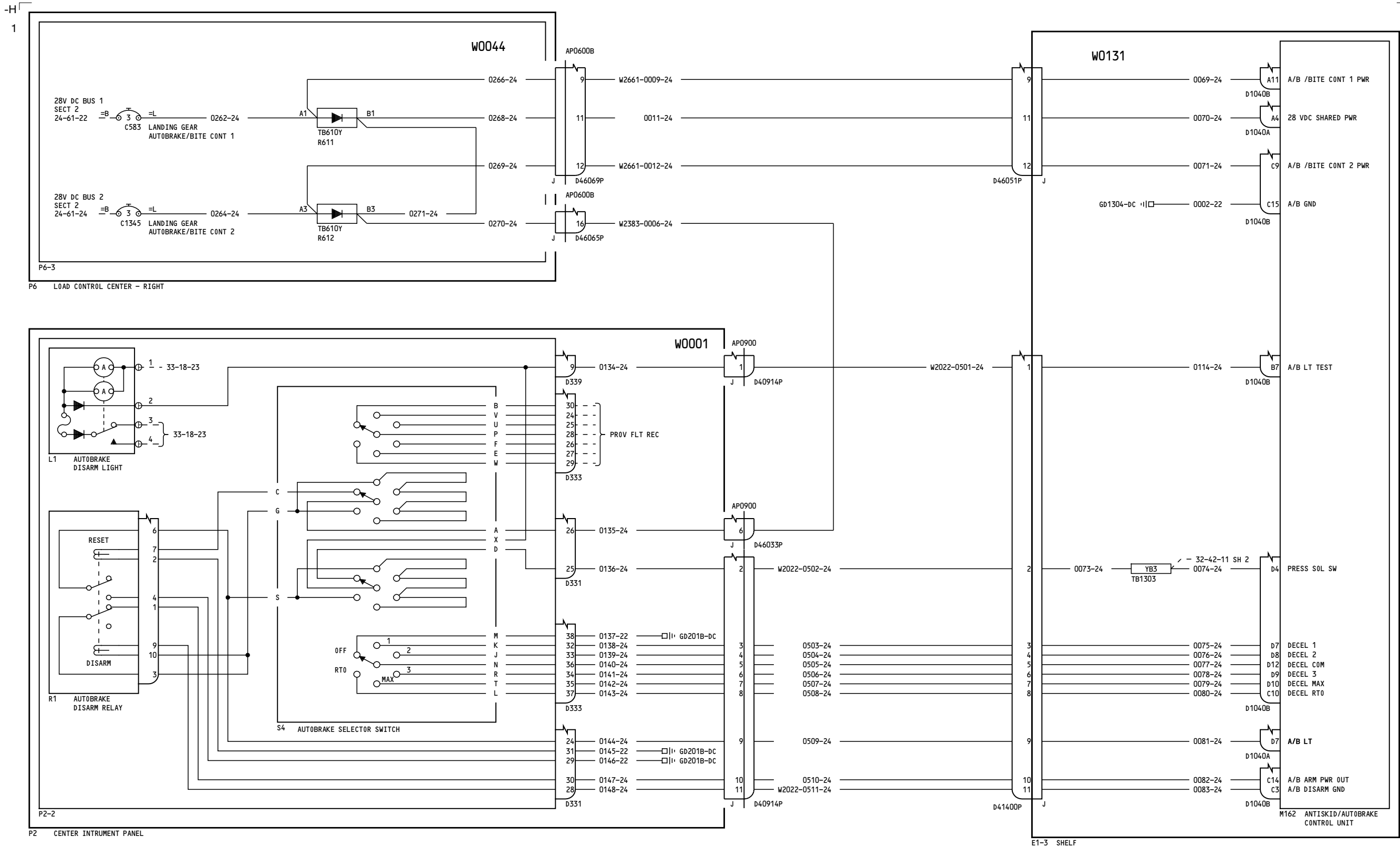

YC008-YC028

AUTOBRAKE SYSTEM

32-42-11

Page 3
Sheet 1
Jul 17/2007

D280A103

32-42-11

Page 3
Sheet 1
Jul 17/2007

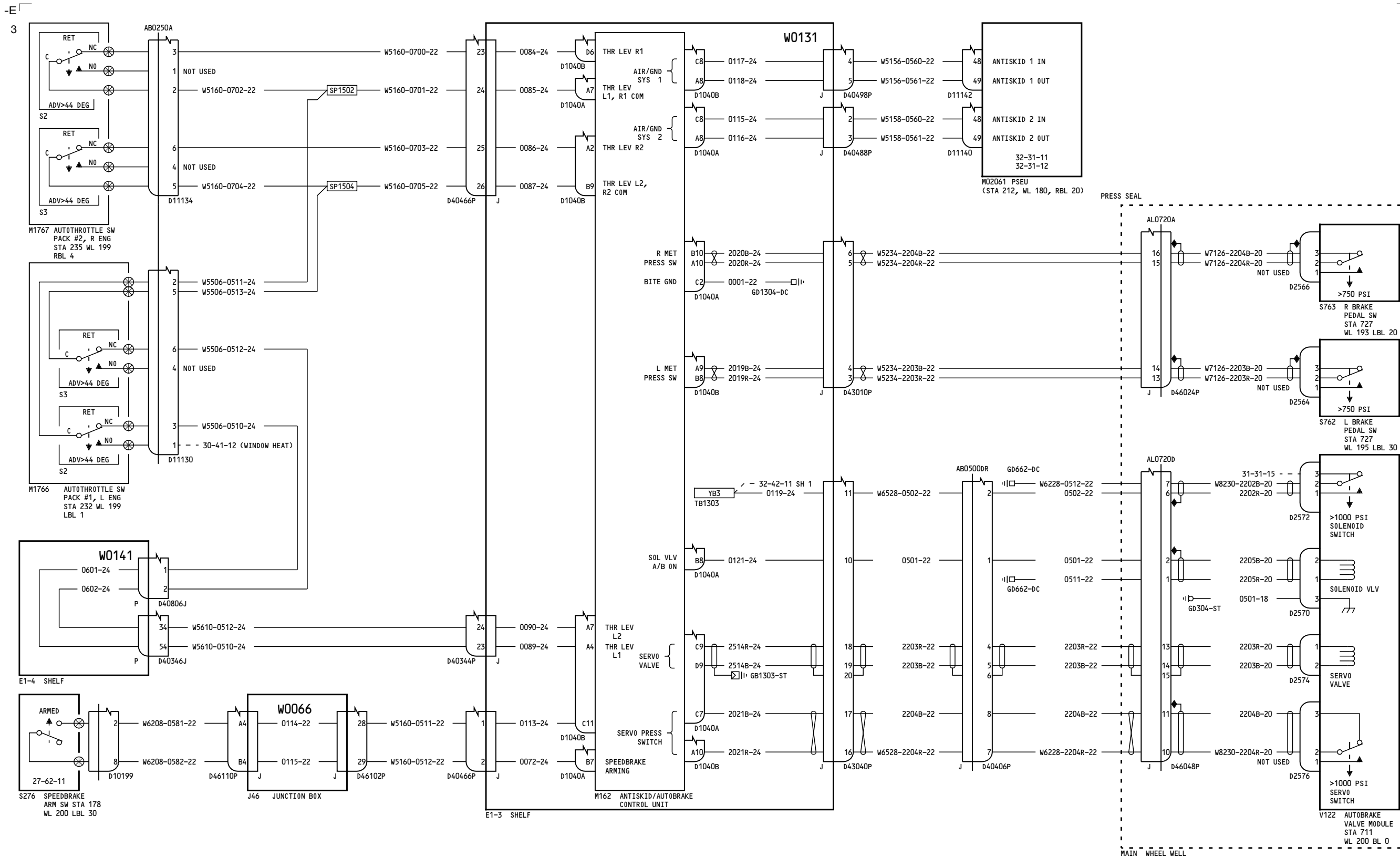

YC008-YC028

AUTOBRAKE SYSTEM

32-42-11

32-42-11

D280A103

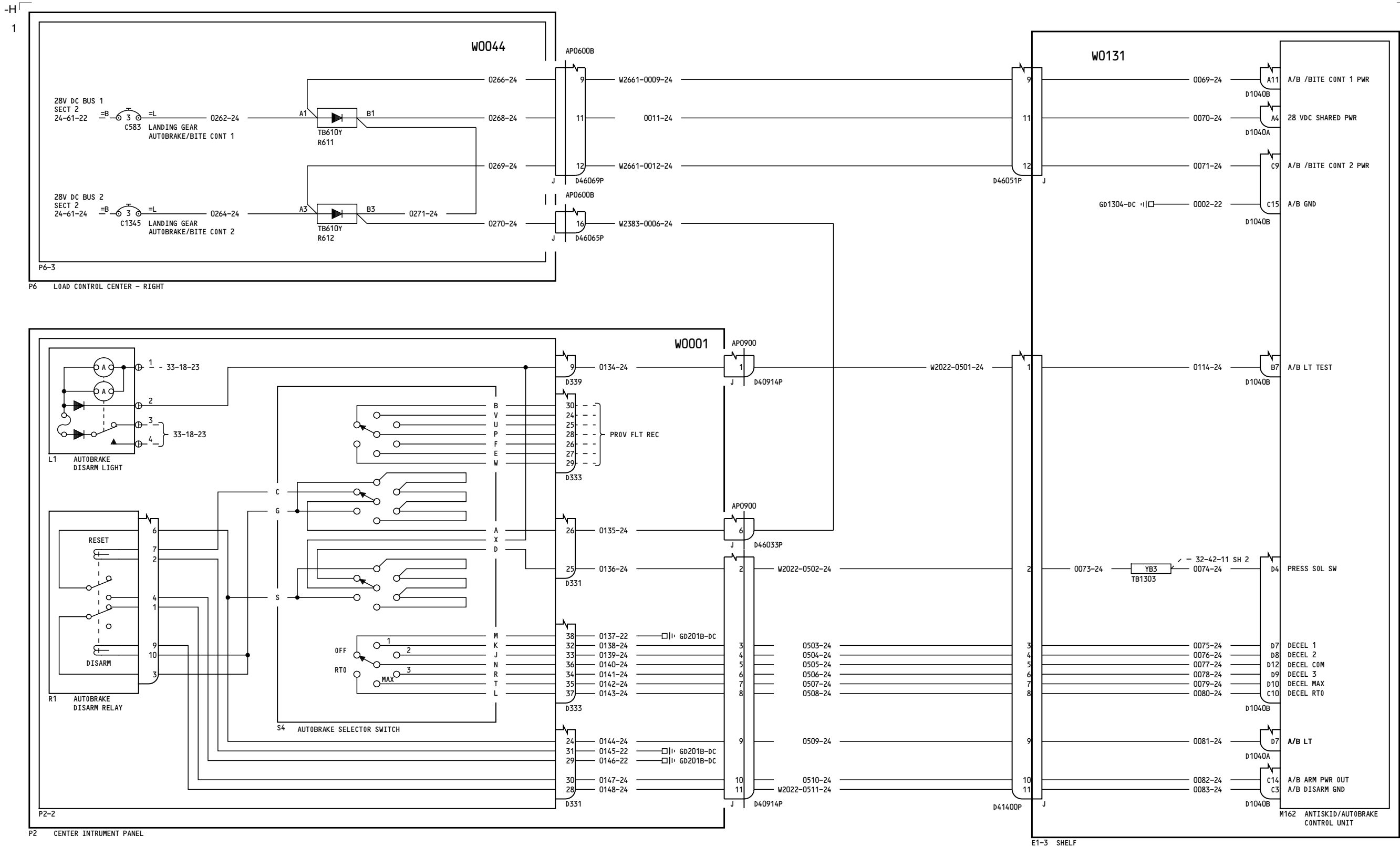

YC029-YC050, YK911-YK917, YK919-YL401, YL427-YL430, YM652-YM670

AUTOBRAKE SYSTEM

D280A103

32-42-11

Page 4
Sheet 1
Feb 09/2009

32-42-11

Page 4
Sheet 1
Feb 09/2009

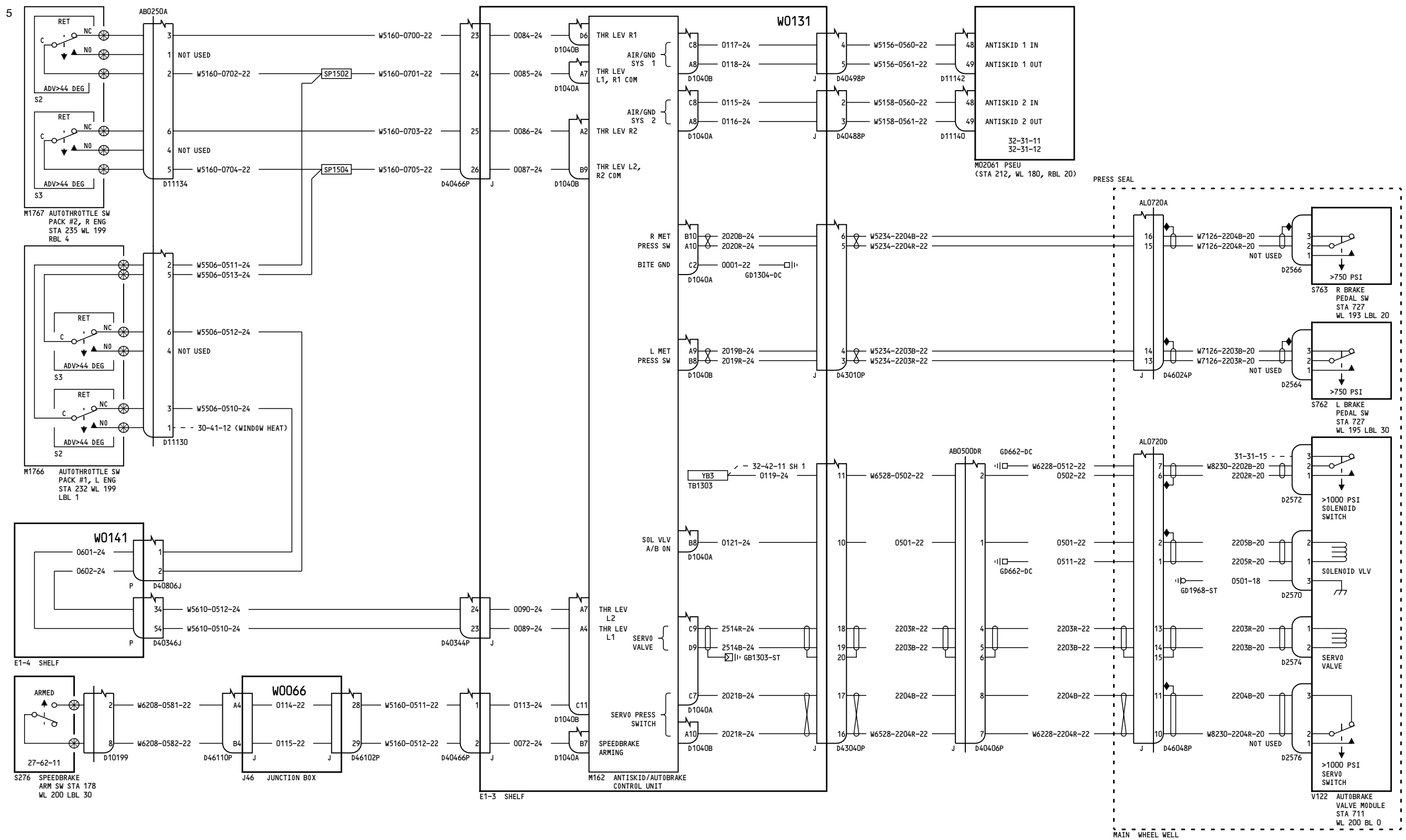

YC029-YC050, YK911-YK917, YK919-YL401, YL427-YL430, YM652-YM670

AUTOBRAKE SYSTEM

D280A103

32-42-11

Page 4
Sheet 2
Feb 09/2009

32-42-11

Page 4
Sheet 2
Feb 09/2009

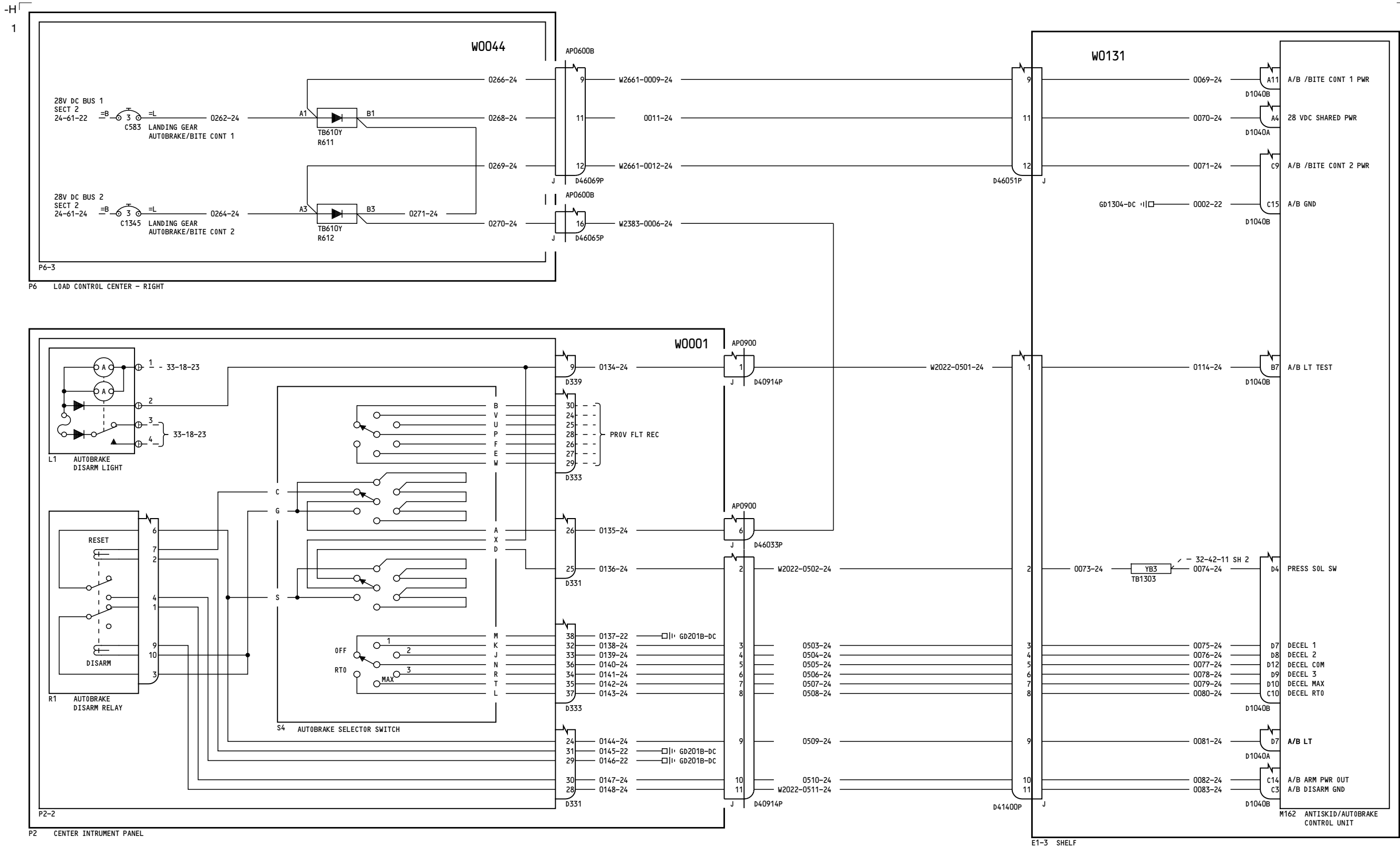

YK901-YK910, YK918, YL421-YL426, YM643-YM651

AUTOBRAKE SYSTEM

32-42-11

Page 5
Sheet 1
Feb 09/2009

D280A103

32-42-11

Page 5
Sheet 1
Feb 09/2009

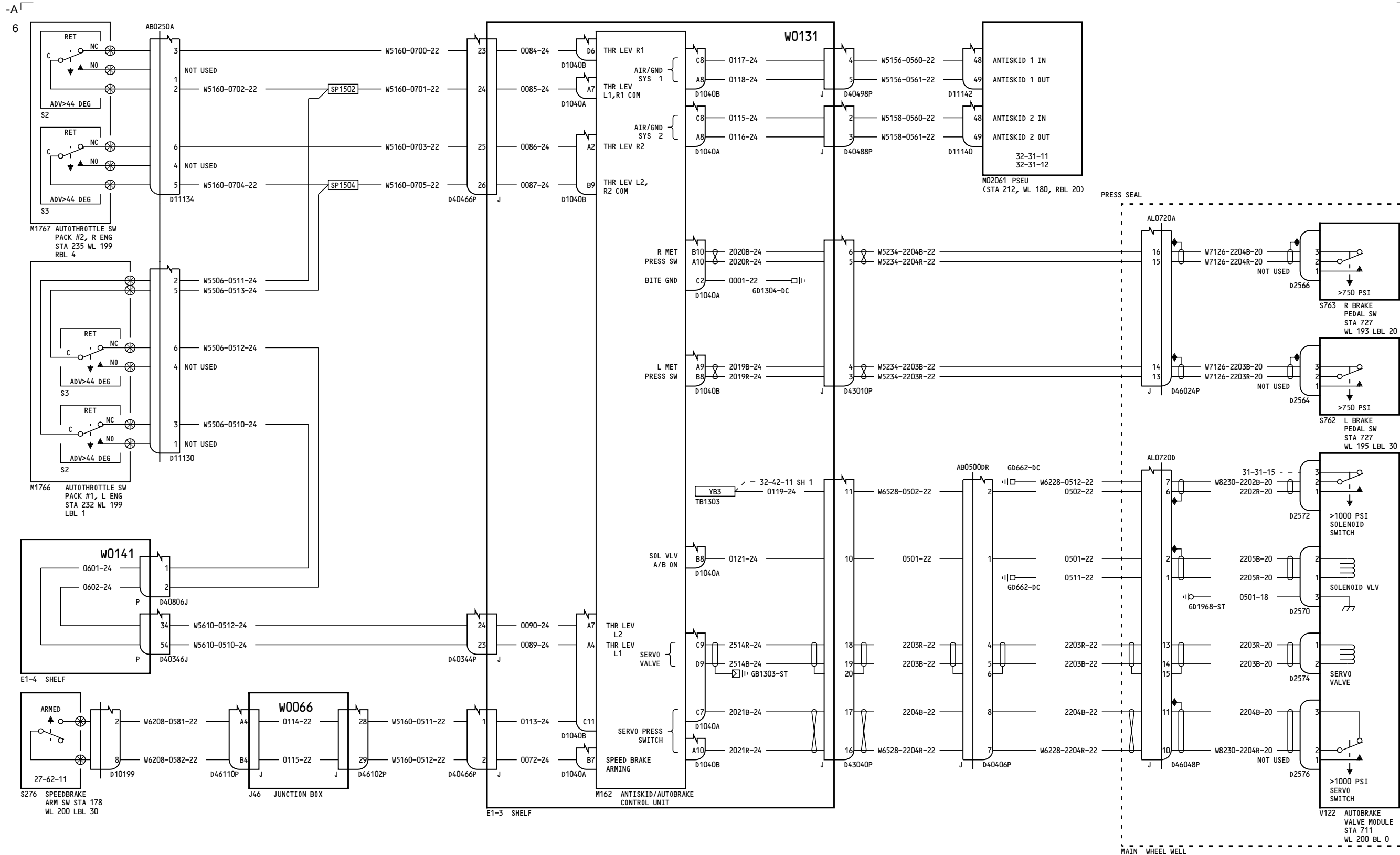

YK901-YK910, YK918, YL421-YL426, YM643-YM651

AUTOBRAKE SYSTEM

D280A103

32-42-11

Page 5
Sheet 2
Feb 09/2009

32-42-11

Page 5
Sheet 2
Feb 09/2009

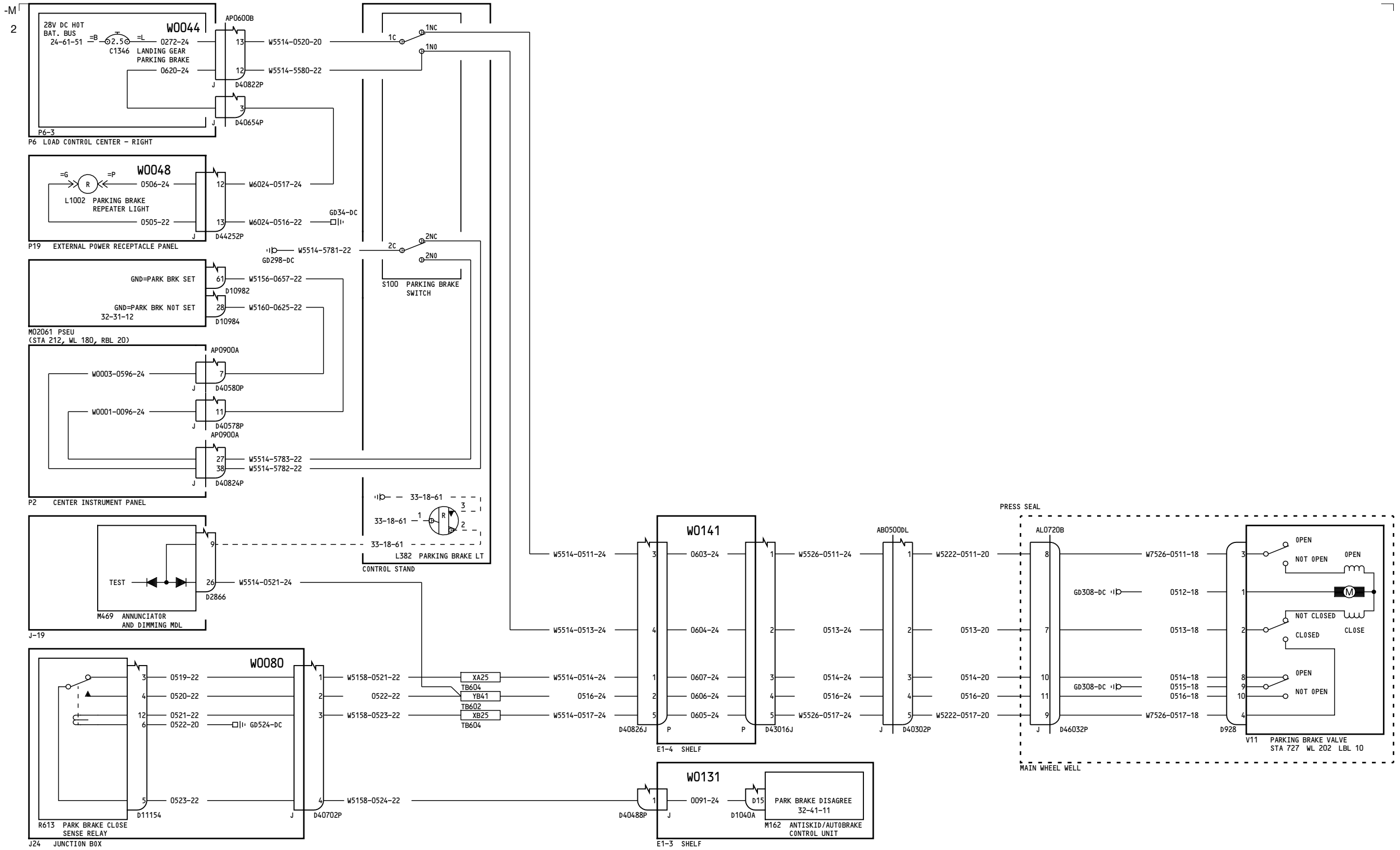

YC001-YC003

PARKING BRAKE SYSTEM

32-44-11

Page 1

Mar 31/2005

D280A103

32-44-11

Page 1

Mar 31/2005

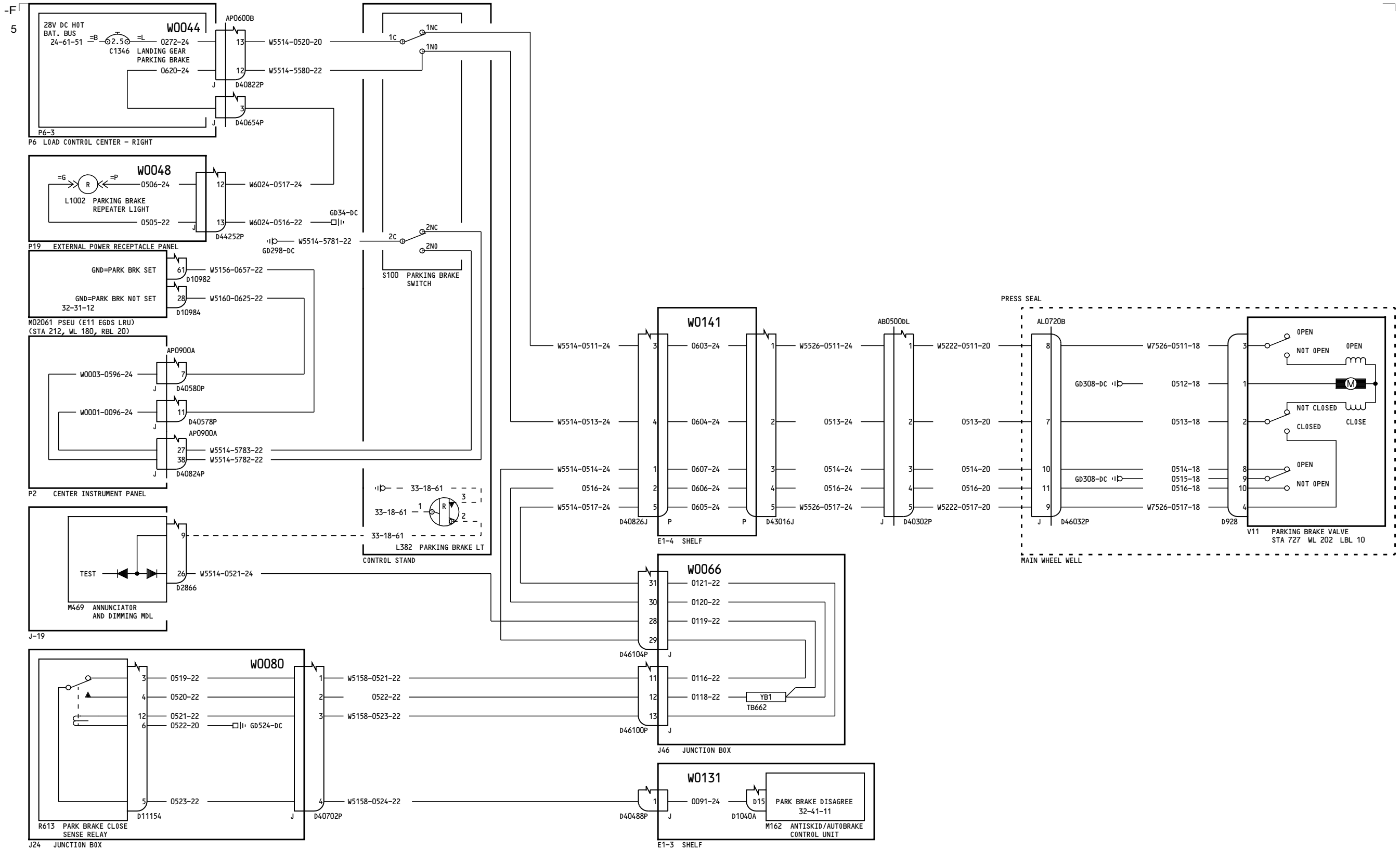

YC004-YK907, YL421

PARKING BRAKE SYSTEM

32-44-11

32-44-11

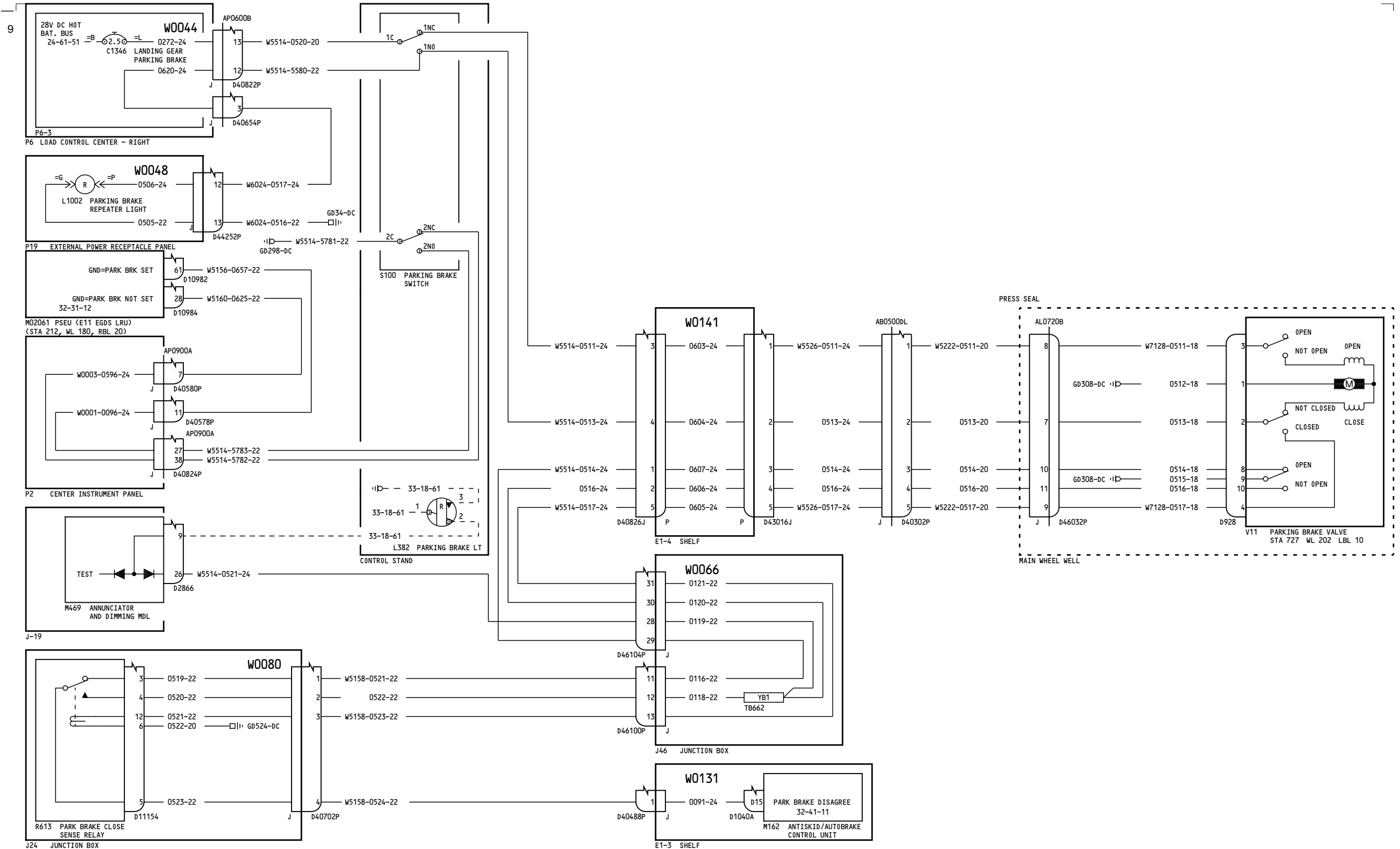

YK908-YK912, YK918-YK919, YL401, YL422-YL429, YM643-YM652

PARKING BRAKE SYSTEM

32-44-11

Page 3

Feb 09/2009

D280A103

32-44-11

Page 3

Feb 09/2009

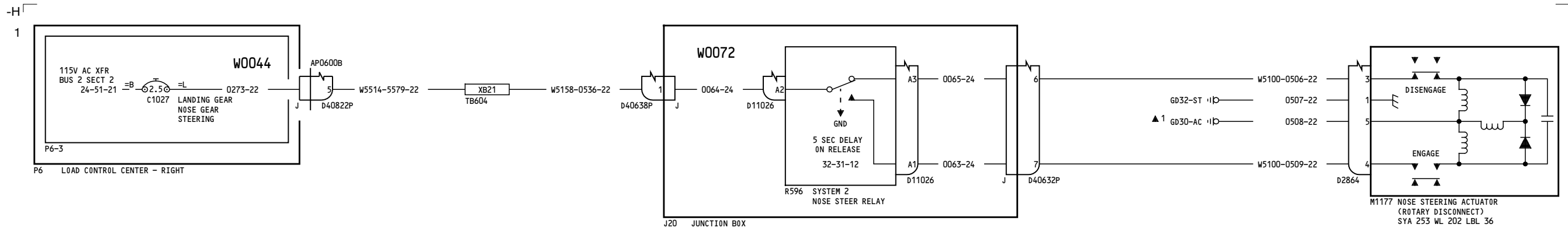

YC001-YC003

NOSE GEAR STEERING

32-51-11

Page 1

Apr 18/2007

D280A103

32-51-11

Page 1

Apr 18/2007

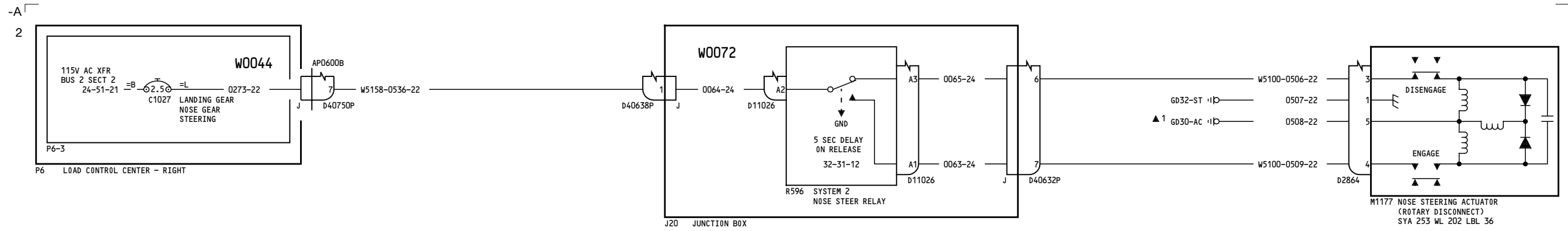

YC004-YM670

NOSE GEAR STEERING

D280A103

32-51-11

Page 2

Feb 09/2009

32-51-11

Page 2

Feb 09/2009

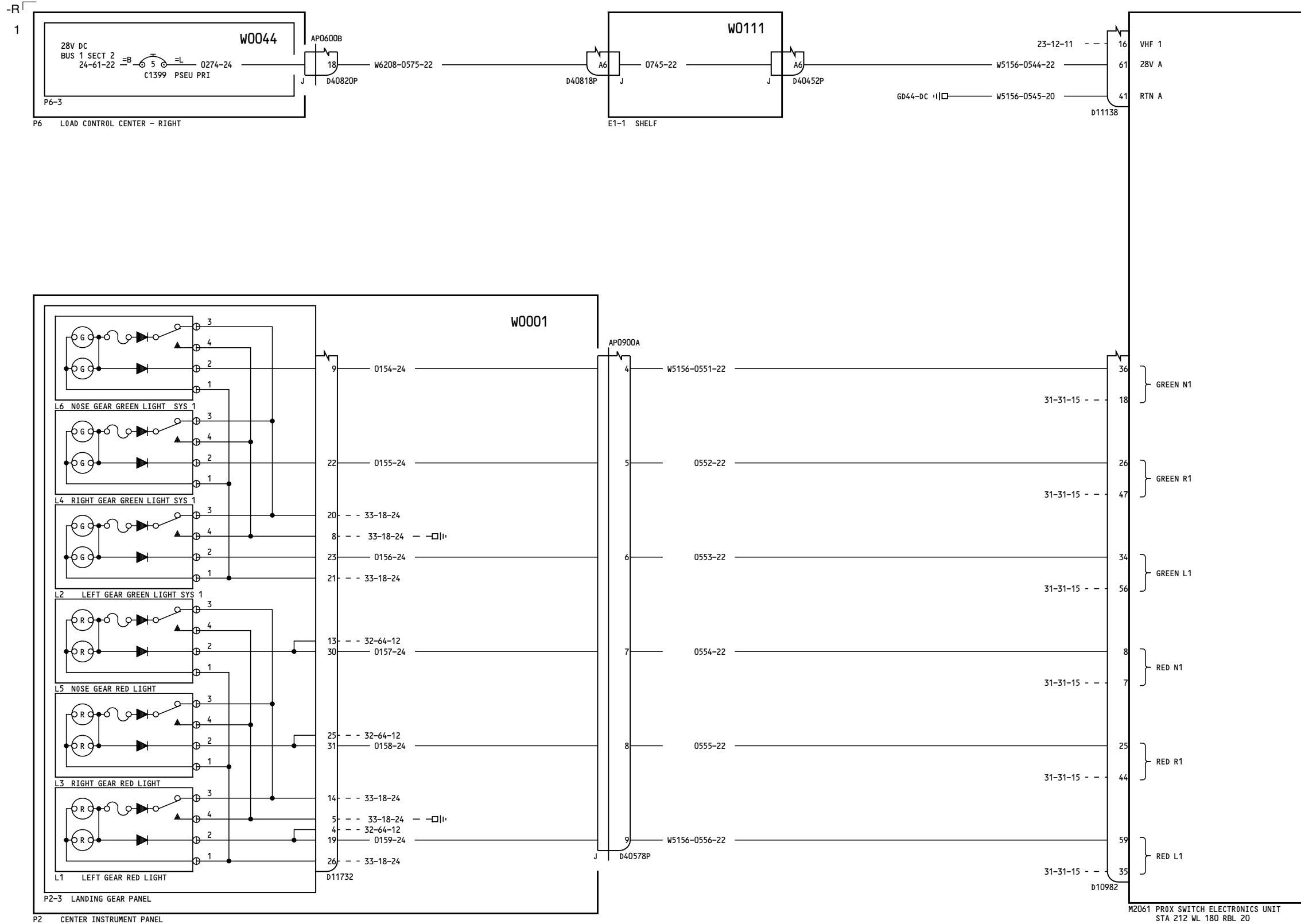

YC001-YC018

LANDING GEAR POSITION INDICATING SYSTEM 1

D280A103

32-64-11

Page 1
Sheet 1
Mar 31/2005

32-64-11

Page 1
Sheet 1
Mar 31/2005

-K

2

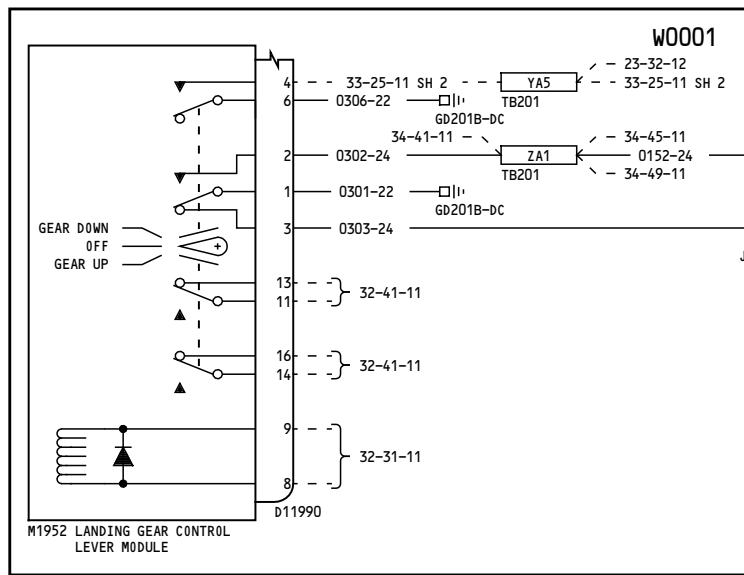

P2-3 LANDING GEAR PANEL

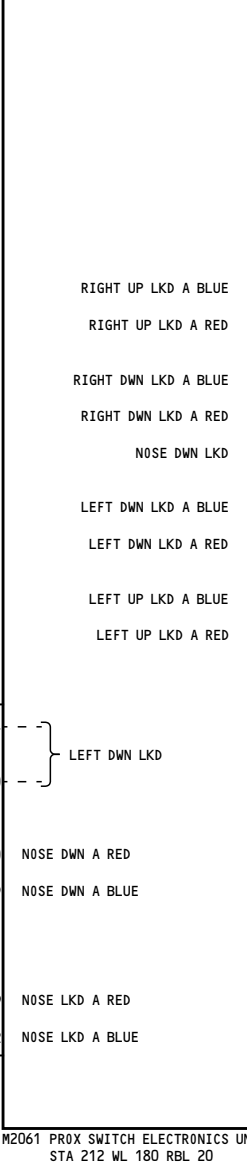
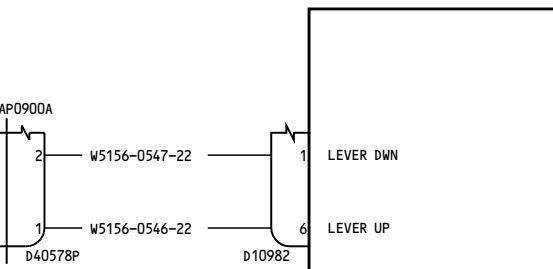

W2061 PROX SWITCH ELECTRONICS UNIT STA 212 WL 180 RBL 20

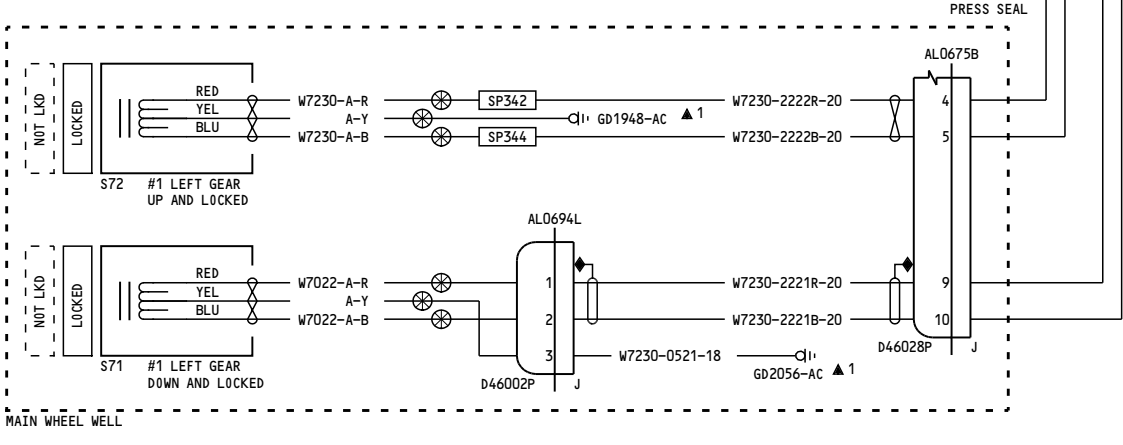
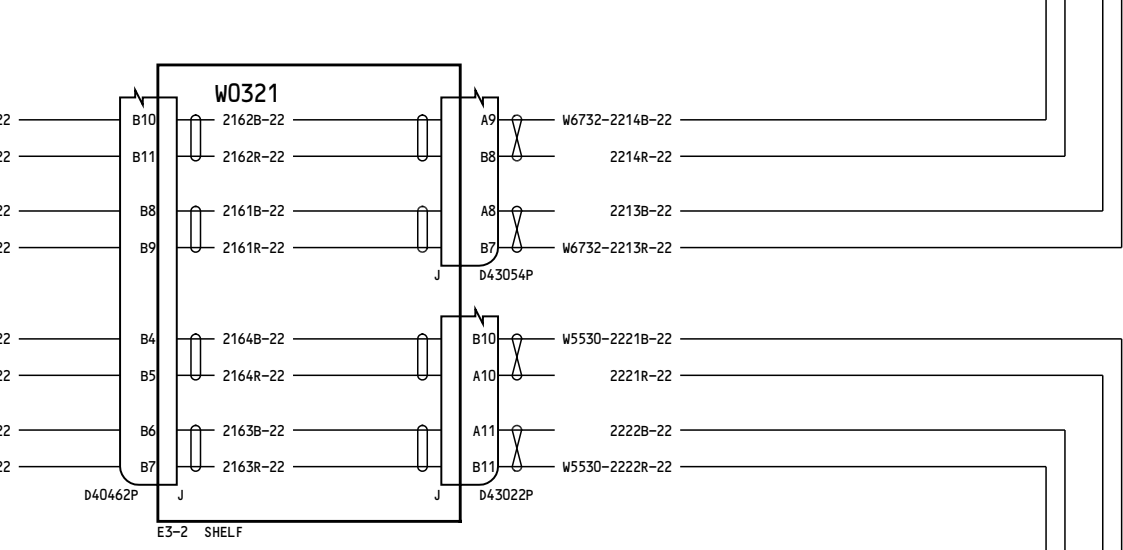
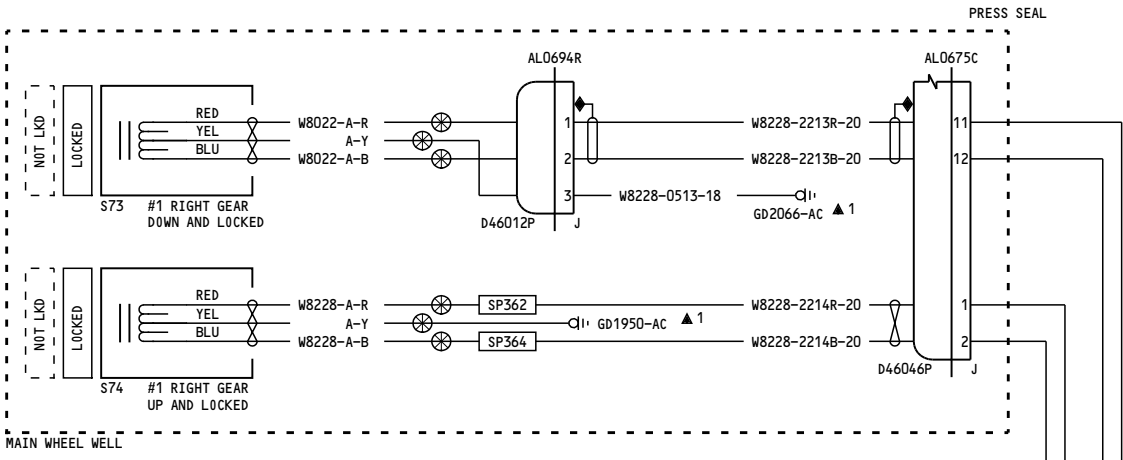
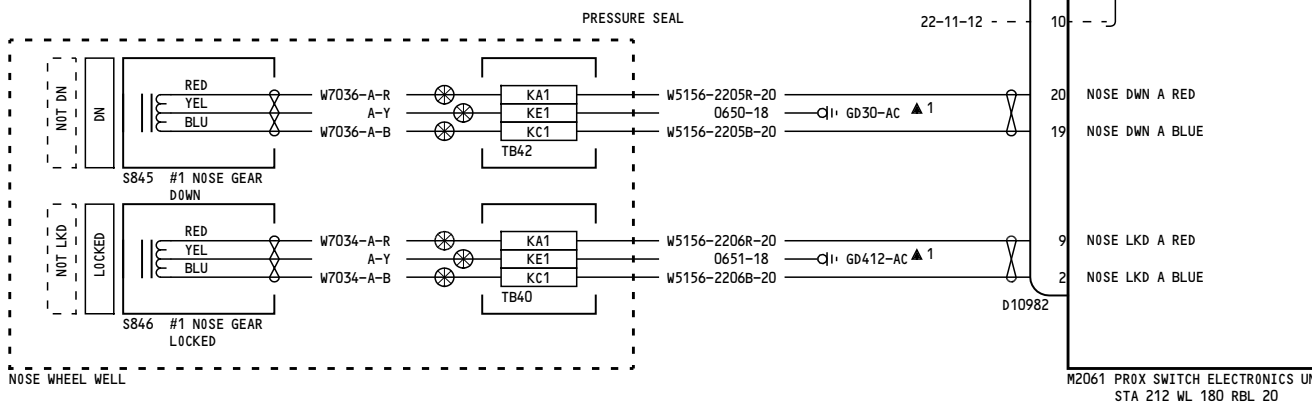

YC001-YC018

LANDING GEAR POSITION INDICATING SYSTEM 1

32-64-11

Page 1
Sheet 2
Mar 31/2005

D280A103

32-64-11

Page 1
Sheet 2
Mar 31/2005

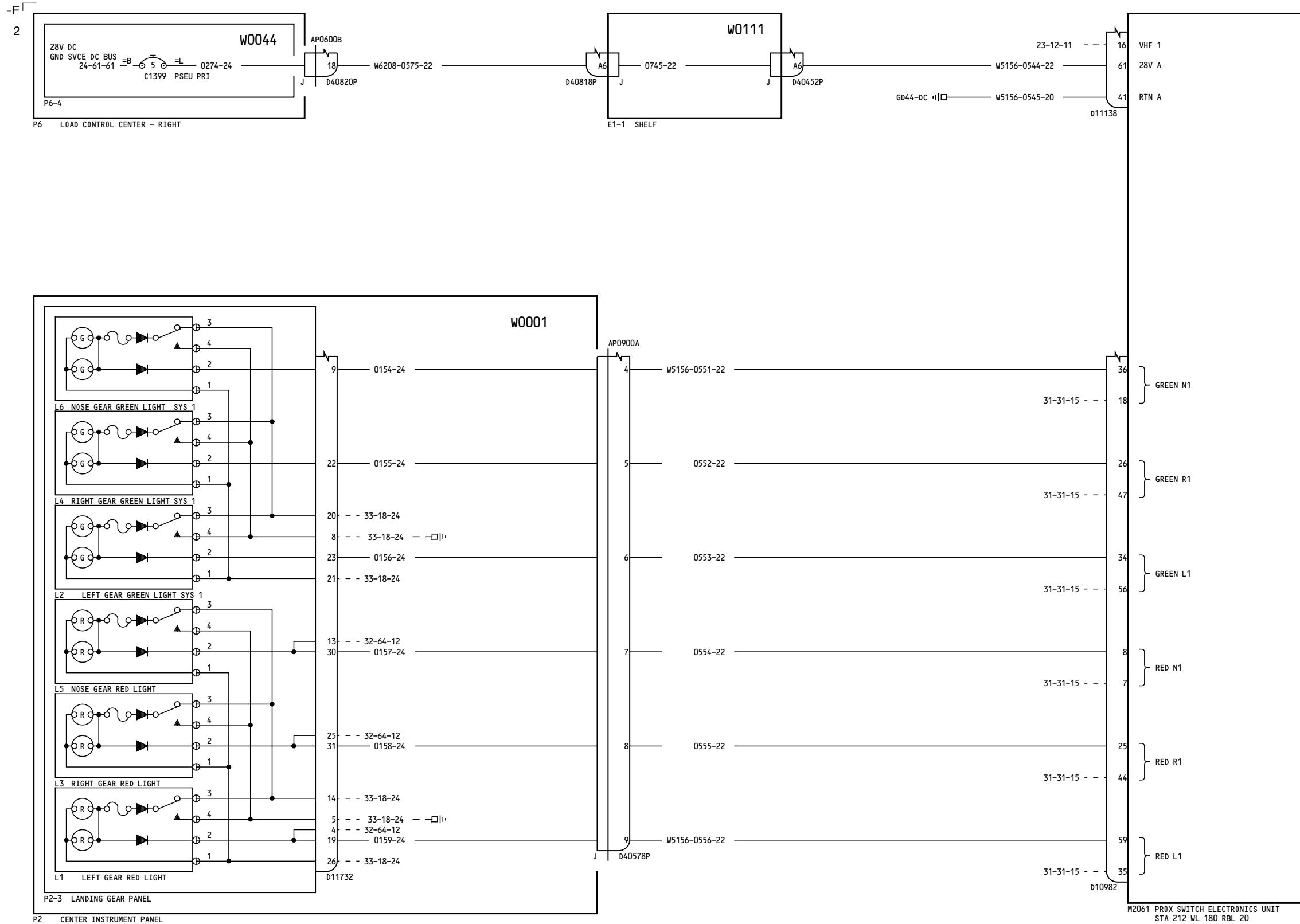

YC001-YC018

LANDING GEAR POSITION INDICATING SYSTEM 1

D280A103

32-64-11

Page 1.1
Sheet 1
Mar 31/2005

Incorporates
24-1142

32-64-11

Page 1.1
Sheet 1
Mar 31/2005

-K
2

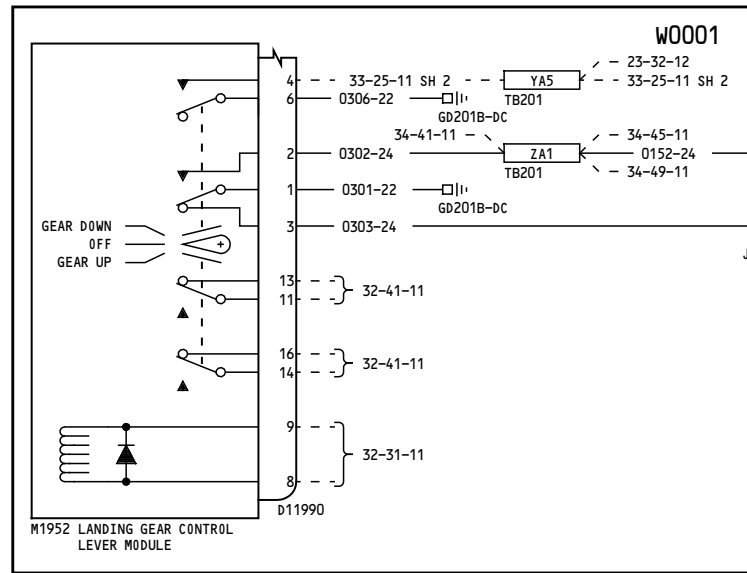

P2-3 LANDING GEAR PANEL

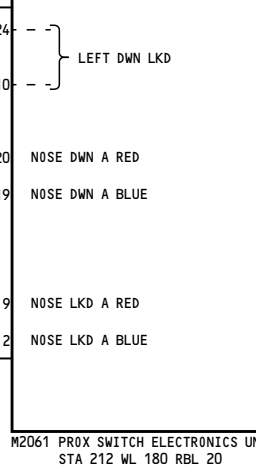
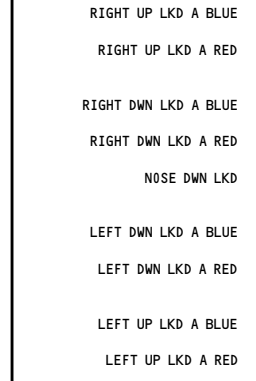
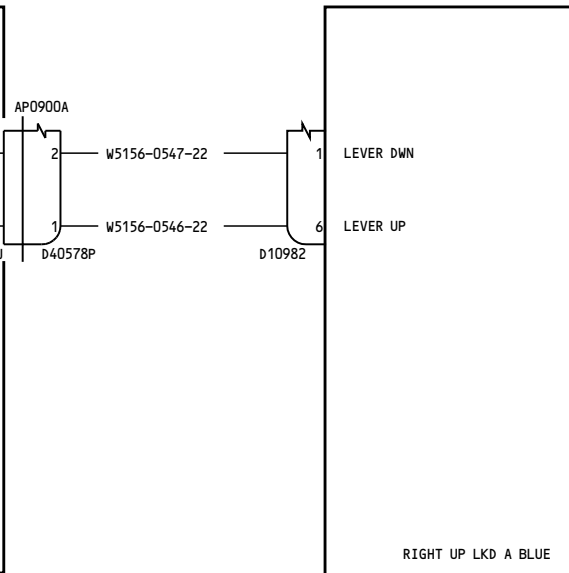

W2061 PROX SWITCH ELECTRONICS UNIT
STA 212 WL 180 RBL 20

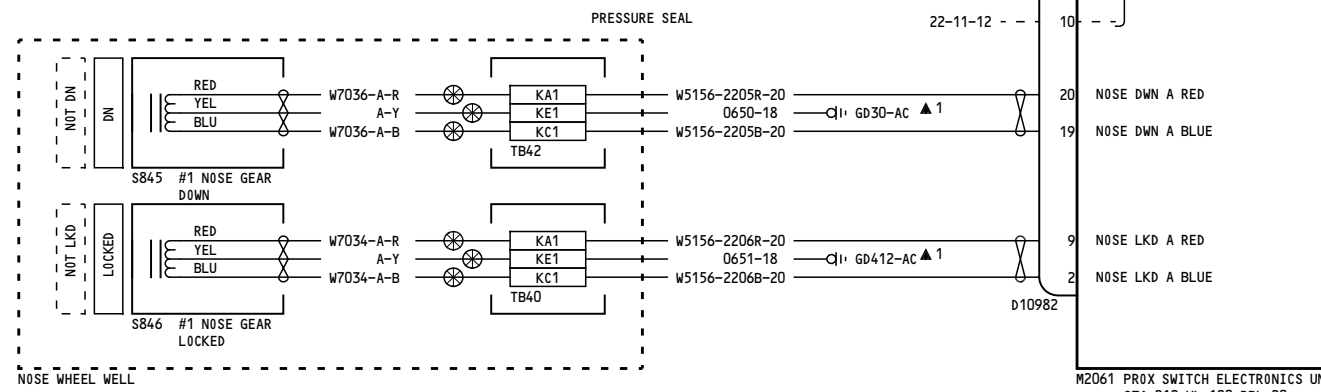
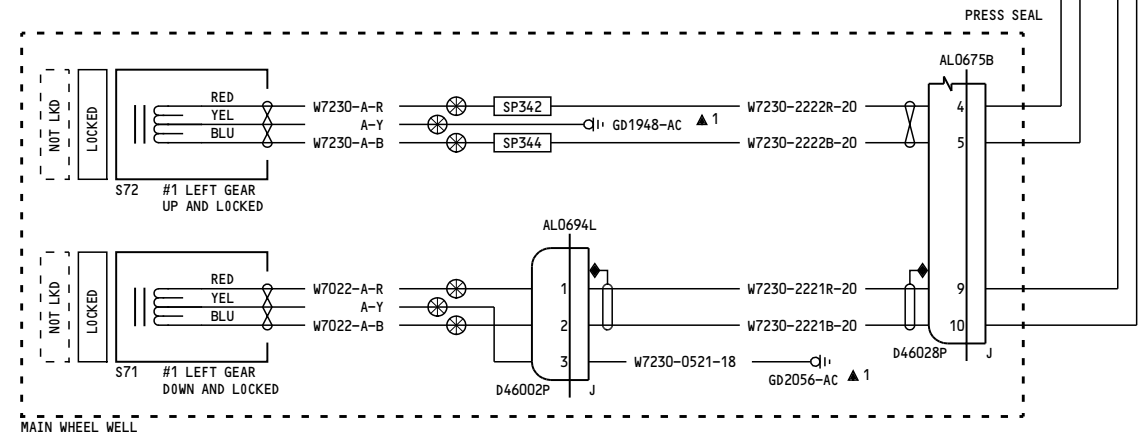
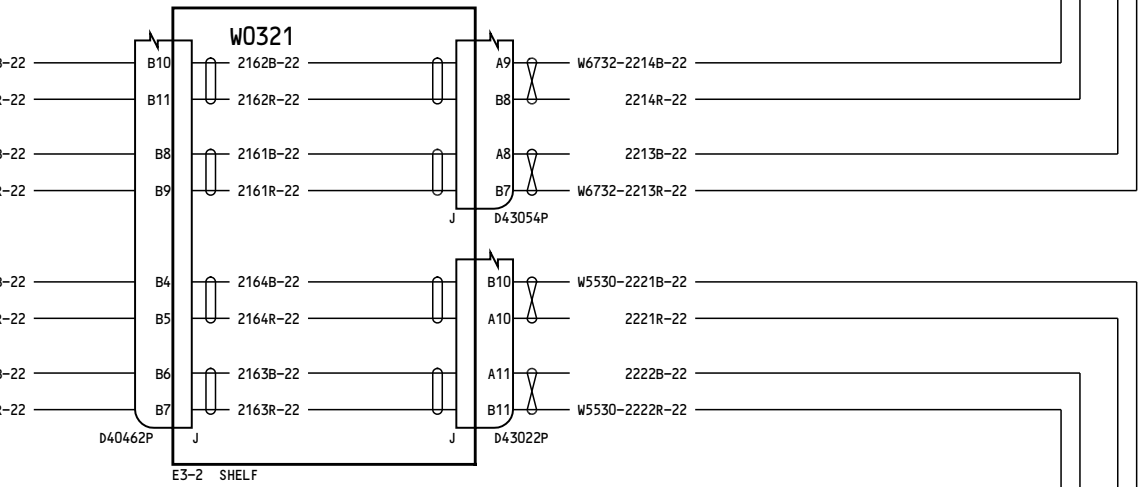
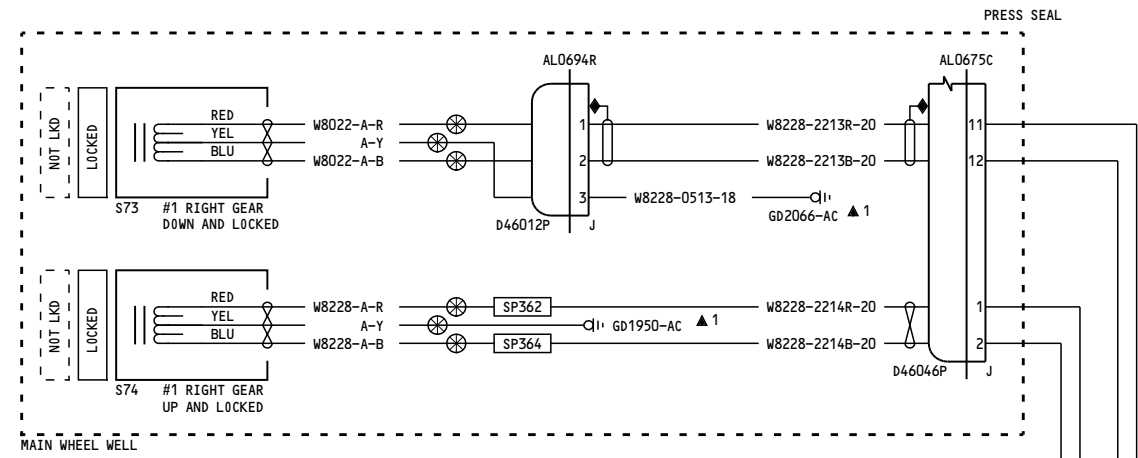

YC001-YC018

LANDING GEAR POSITION INDICATING SYSTEM 1

D280A103

32-64-11

Page 1.1
Sheet 2
Mar 31/2005

32-64-11

Page 1.1
Sheet 2
Mar 31/2005

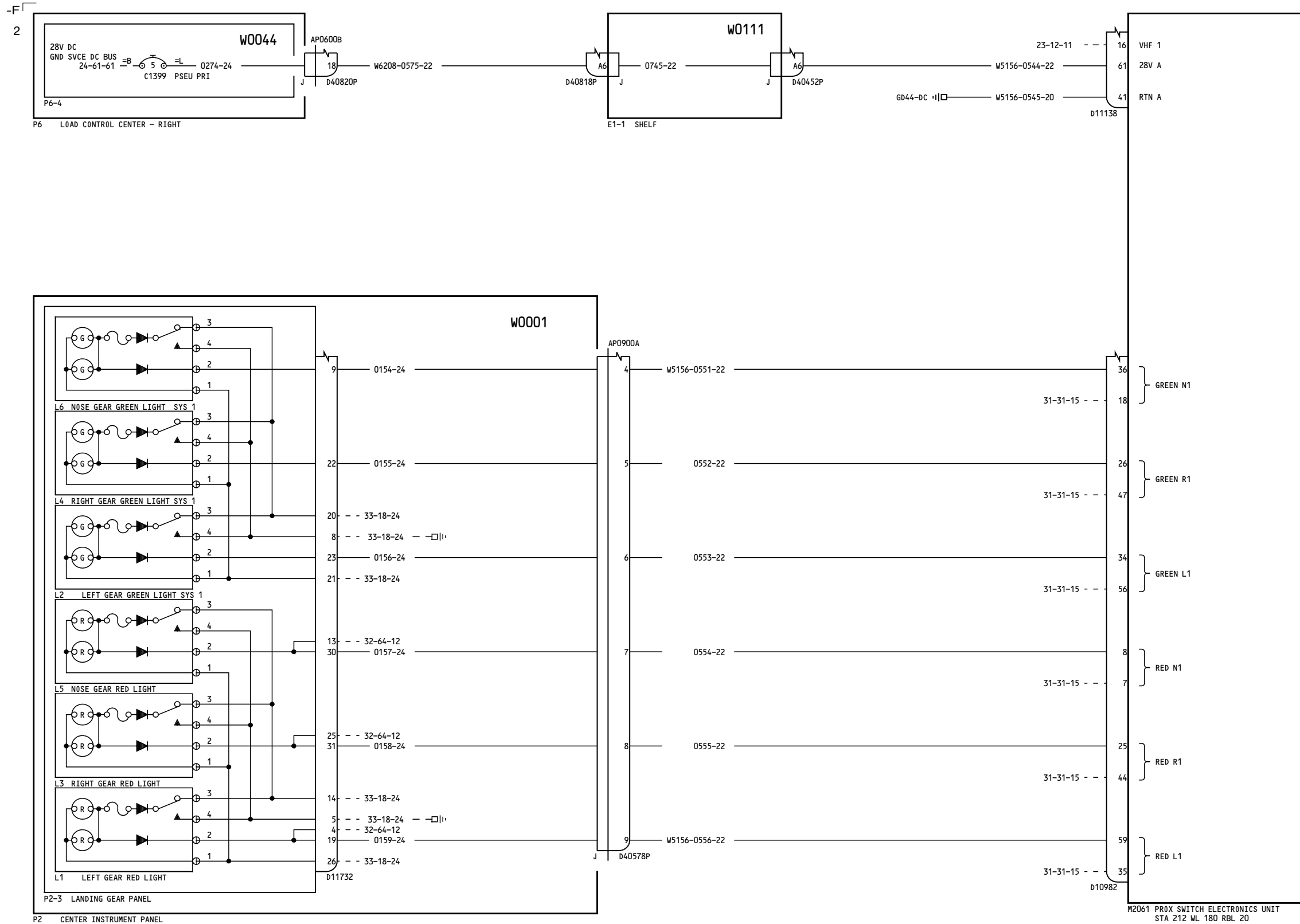

YC019-YC028

LANDING GEAR POSITION INDICATING SYSTEM 1

32-64-11

Page 2
Sheet 1
Jul 17/2007

D280A103

32-64-11

Page 2
Sheet 1
Jul 17/2007

-K
2

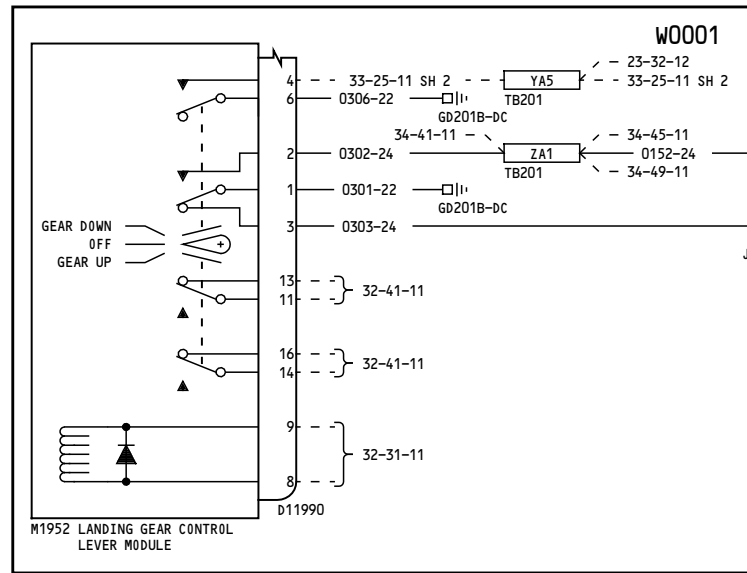

P2-3 LANDING GEAR PANEL

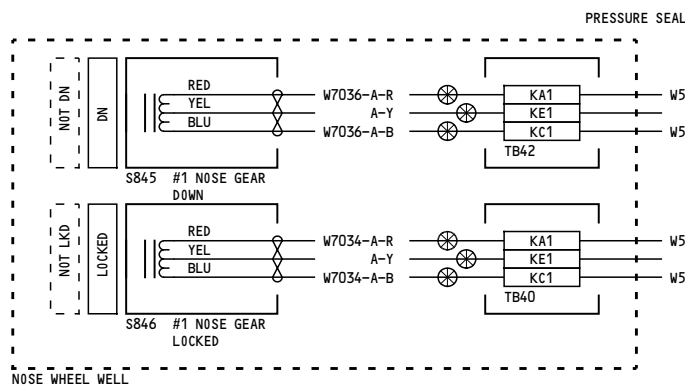
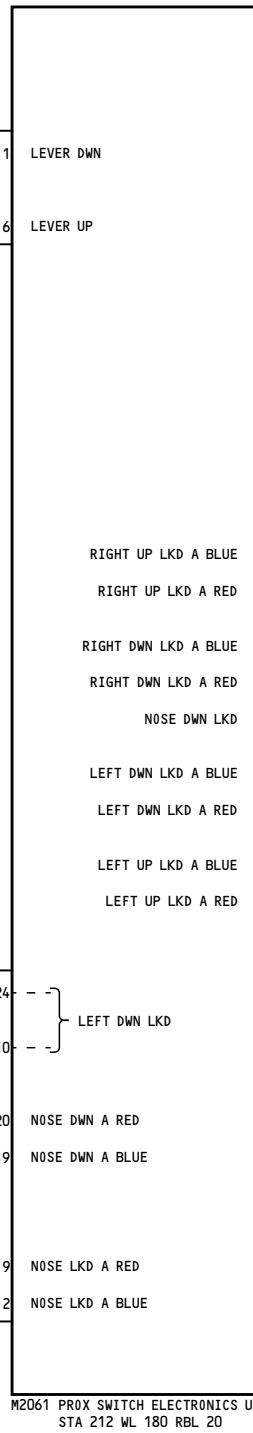

NOSE WHEEL WELL

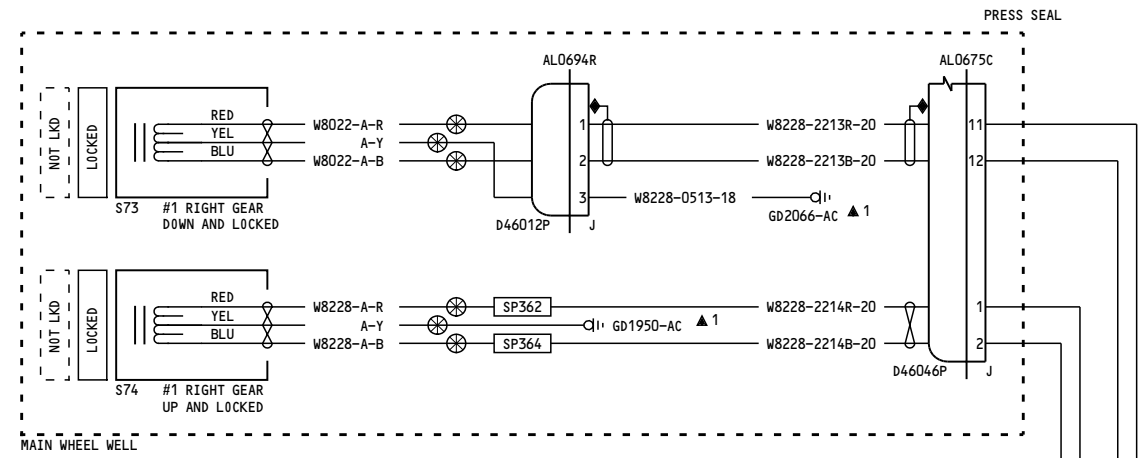

MAIN WHEEL WELL

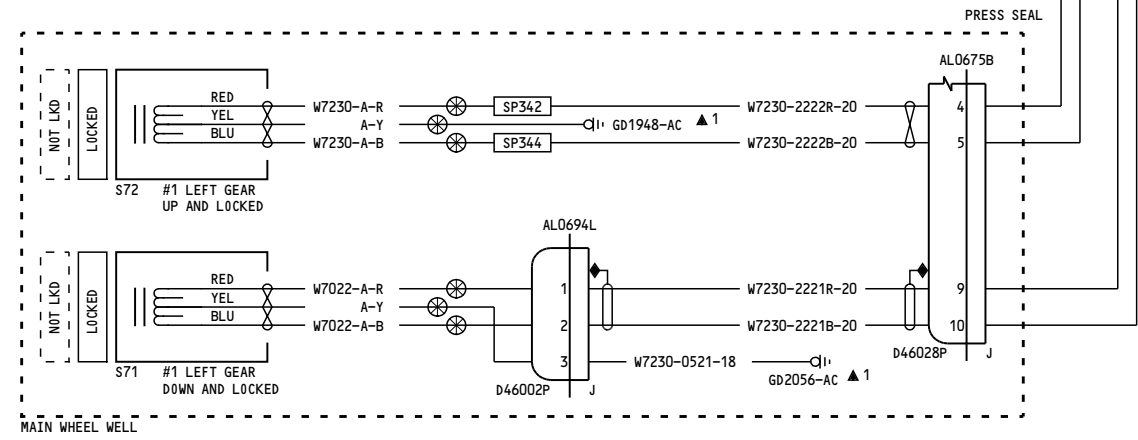
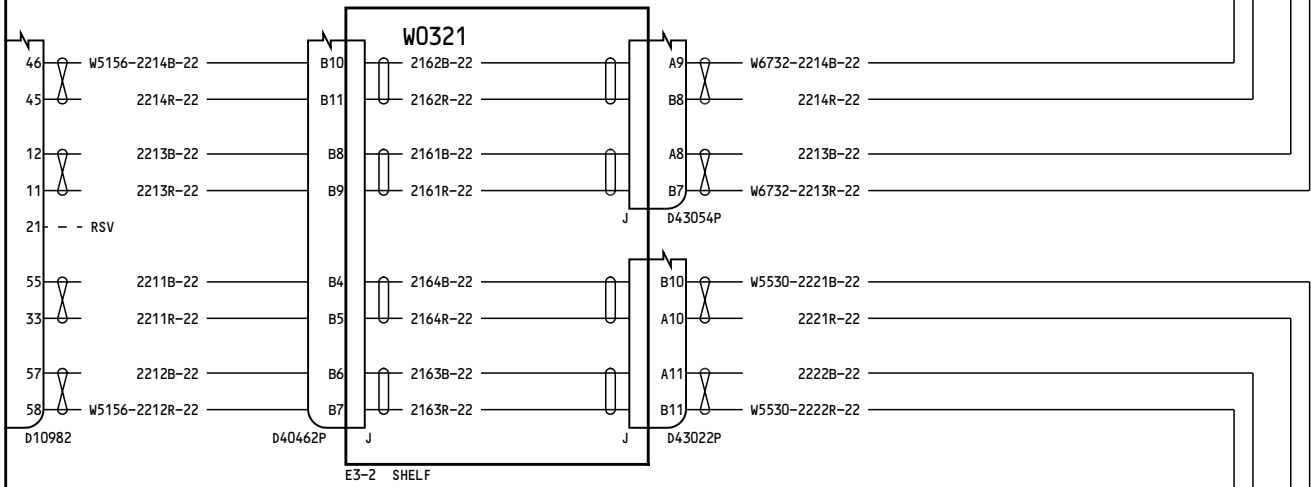

MAIN WHEEL WELL

YC019-YC028

LANDING GEAR POSITION INDICATING SYSTEM 1

32-64-11

Page 2
Sheet 2
Jul 17/2007

D280A103

32-64-11

Page 2
Sheet 2
Jul 17/2007

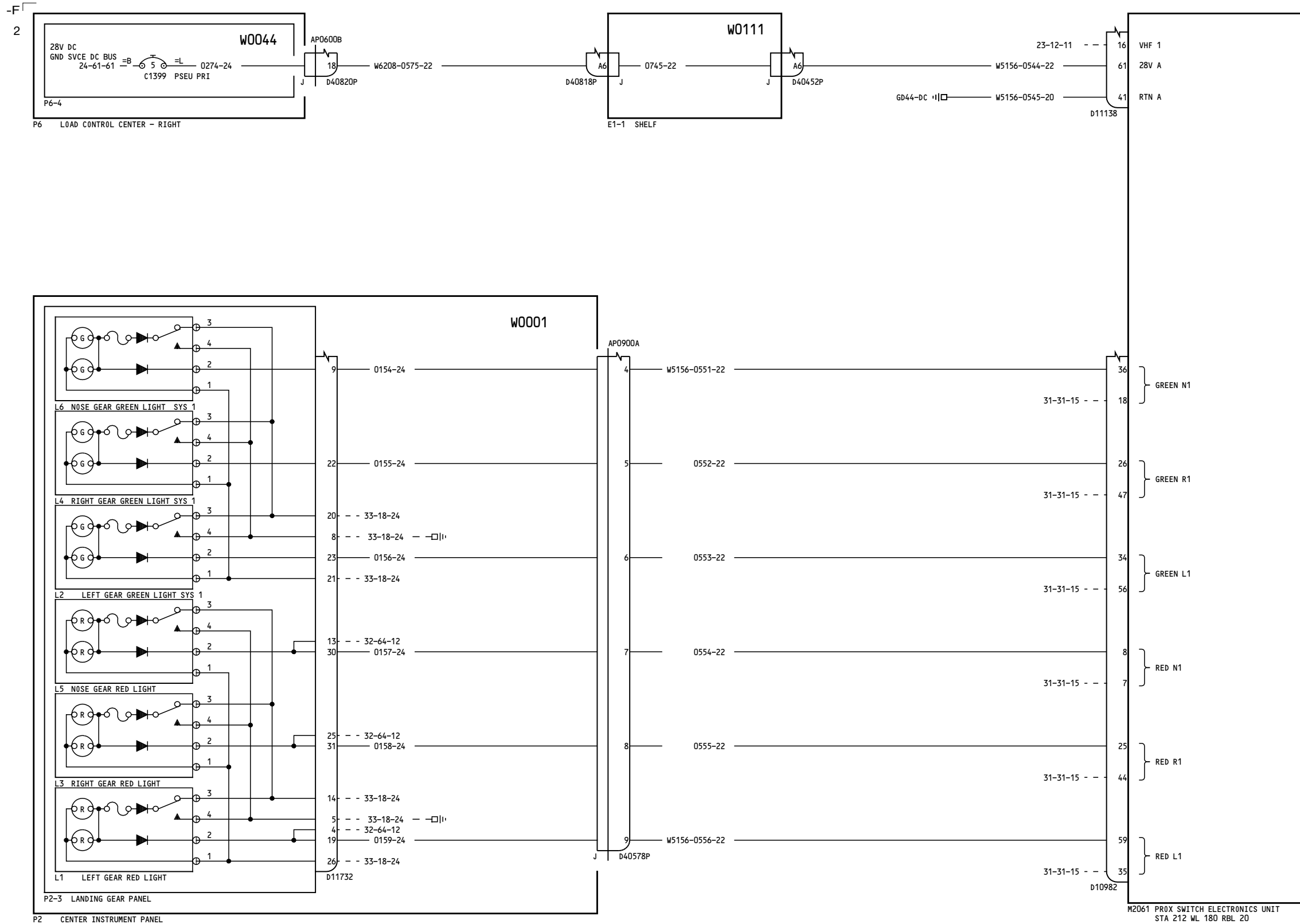

YC029-YC050

LANDING GEAR POSITION INDICATING SYSTEM 1

D280A103

32-64-11

Page 3
Sheet 1
Mar 31/2005

32-64-11

Page 3
Sheet 1
Mar 31/2005

-B

13

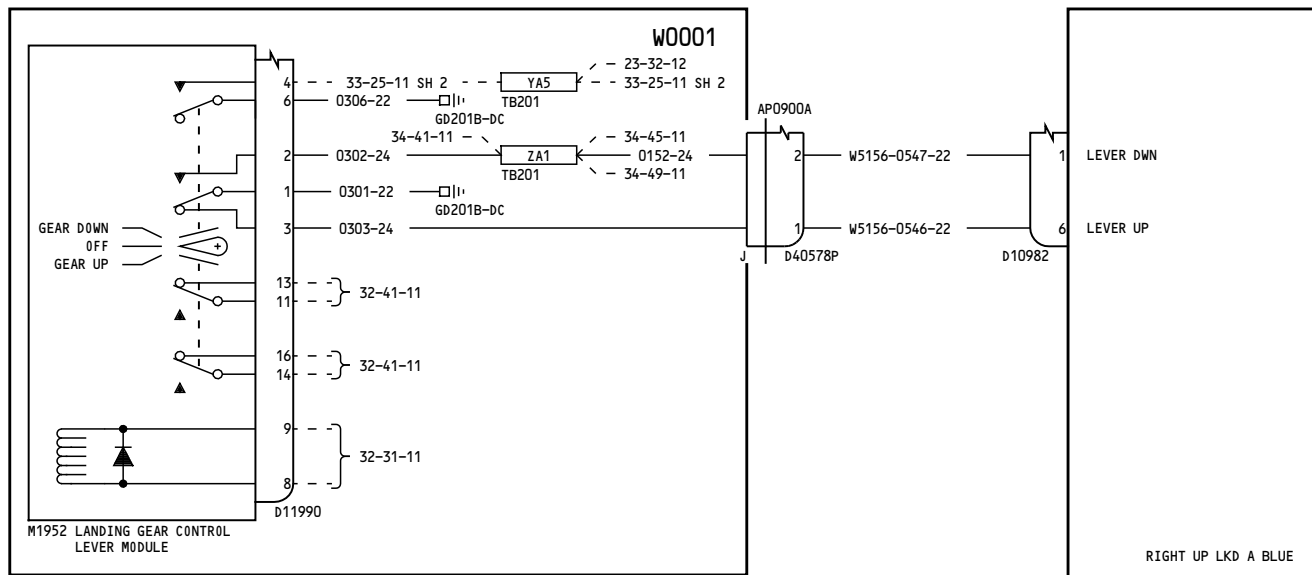

P2-3 LANDING GEAR PANEL

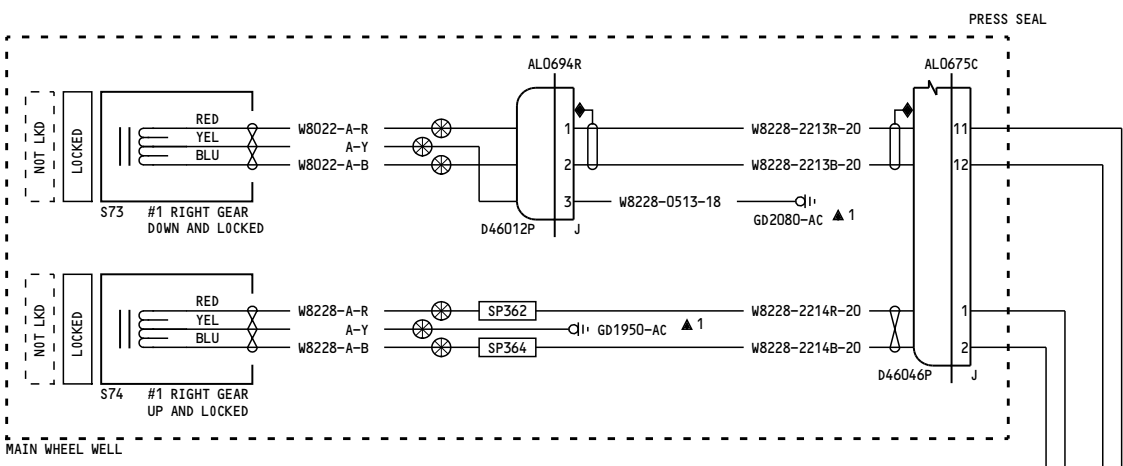

- RIGHT UP LKD A BLUE
- RIGHT UP LKD A RED
- RIGHT DWN LKD A BLUE
- RIGHT DWN LKD A RED
- NOSE DWN LKD
- LEFT DWN LKD A BLUE
- LEFT DWN LKD A RED
- LEFT UP LKD A BLUE
- LEFT UP LKD A RED

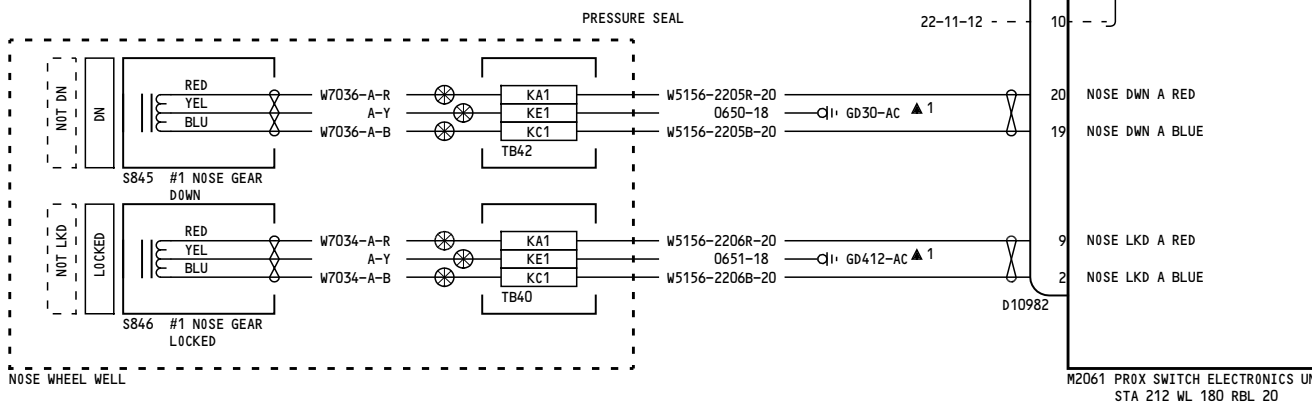
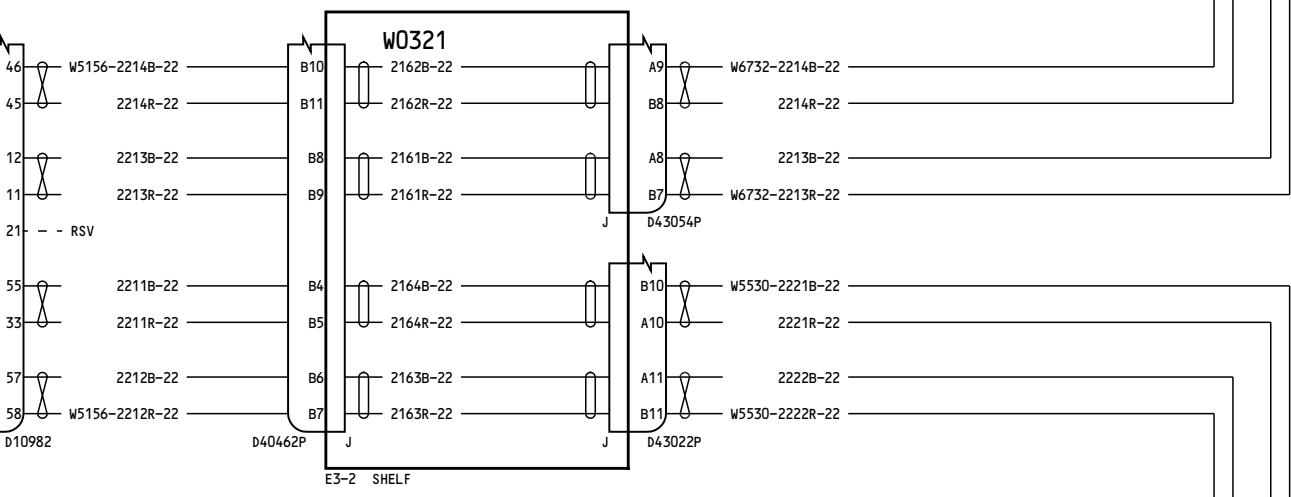

M2061 PROX SWITCH ELECTRONICS UNIT STA 212 WL 180 RBL 20

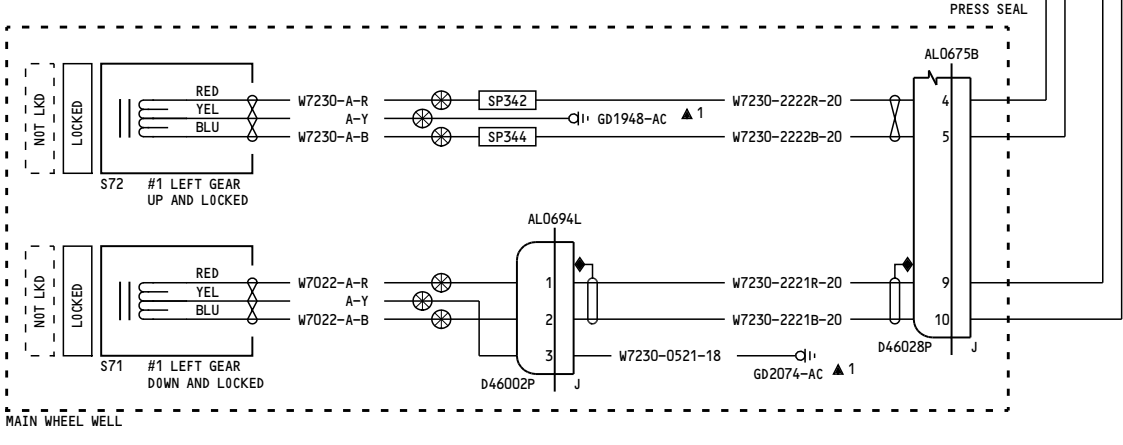

YC029-YC050

LANDING GEAR POSITION INDICATING SYSTEM 1

32-64-11

Page 3
Sheet 2
Mar 31/2005

D280A103

32-64-11

Page 3
Sheet 2
Mar 31/2005

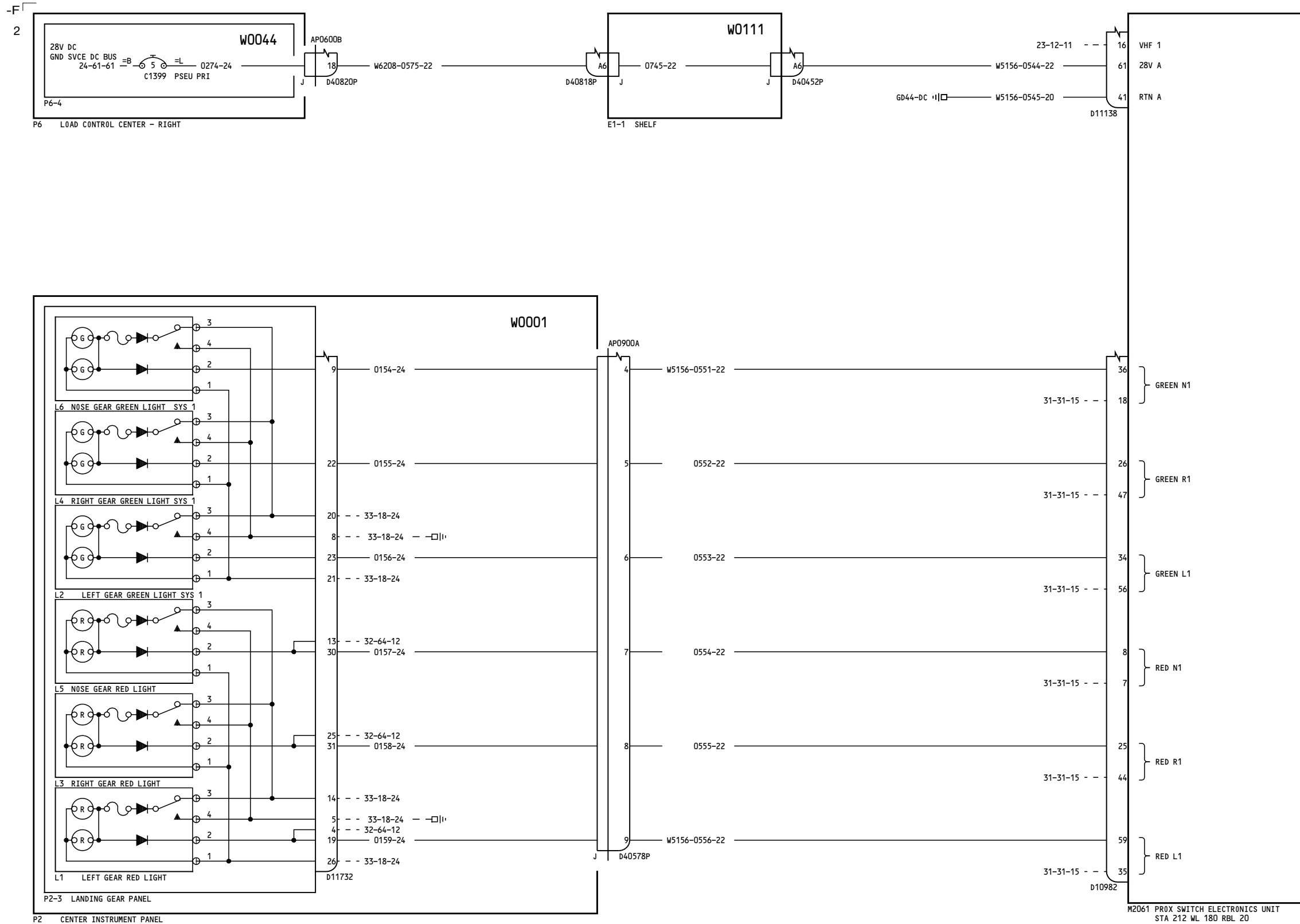

YK901-YM670

LANDING GEAR POSITION INDICATING SYSTEM 1

32-64-11

Page 4
Sheet 1
Feb 09/2009

D280A103

32-64-11

Page 4
Sheet 1
Feb 09/2009

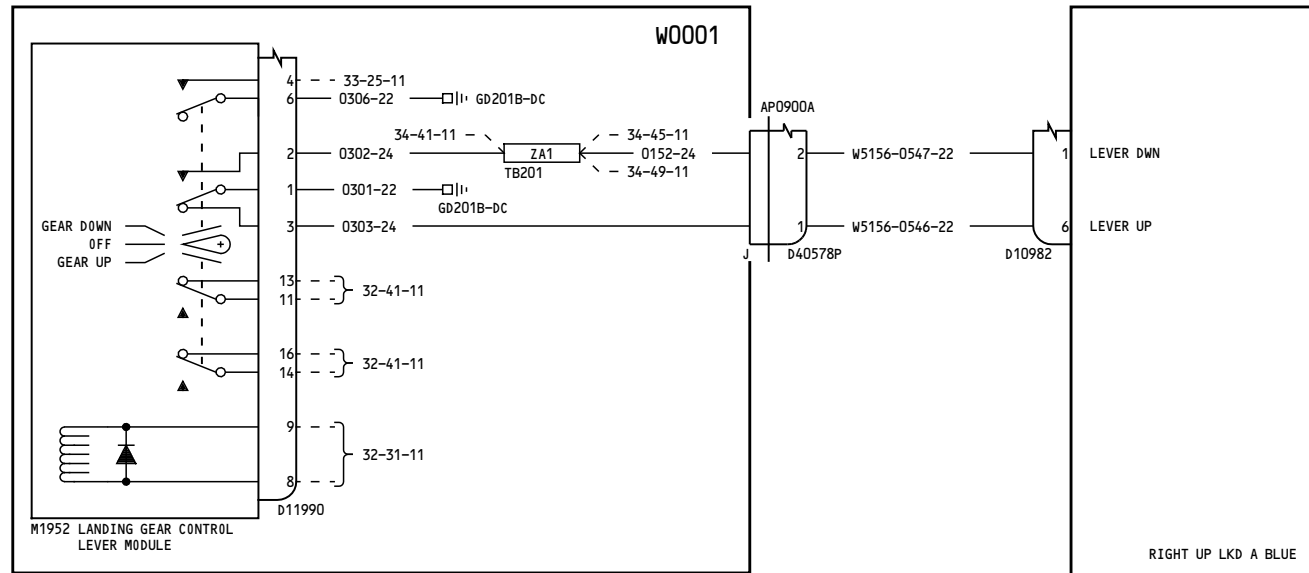

P2-3 LANDING GEAR PANEL

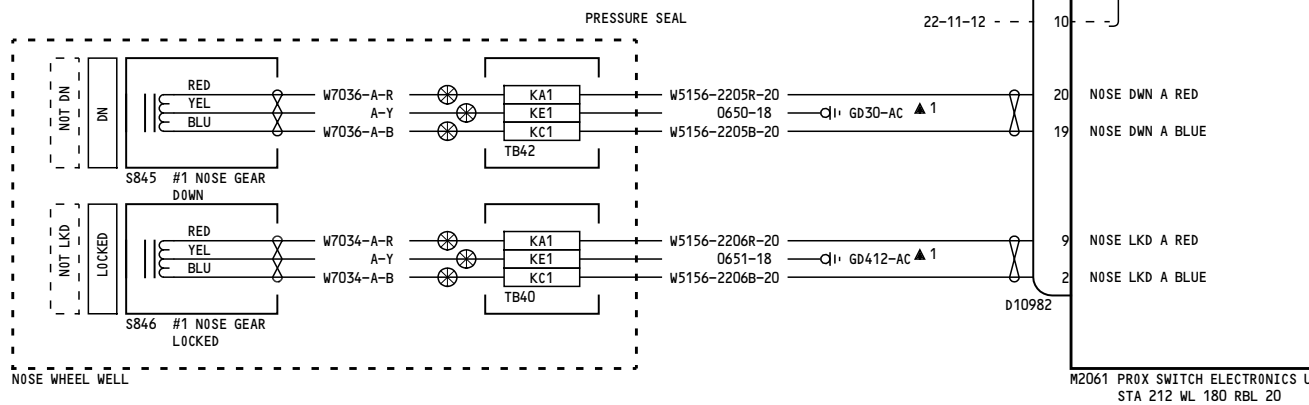
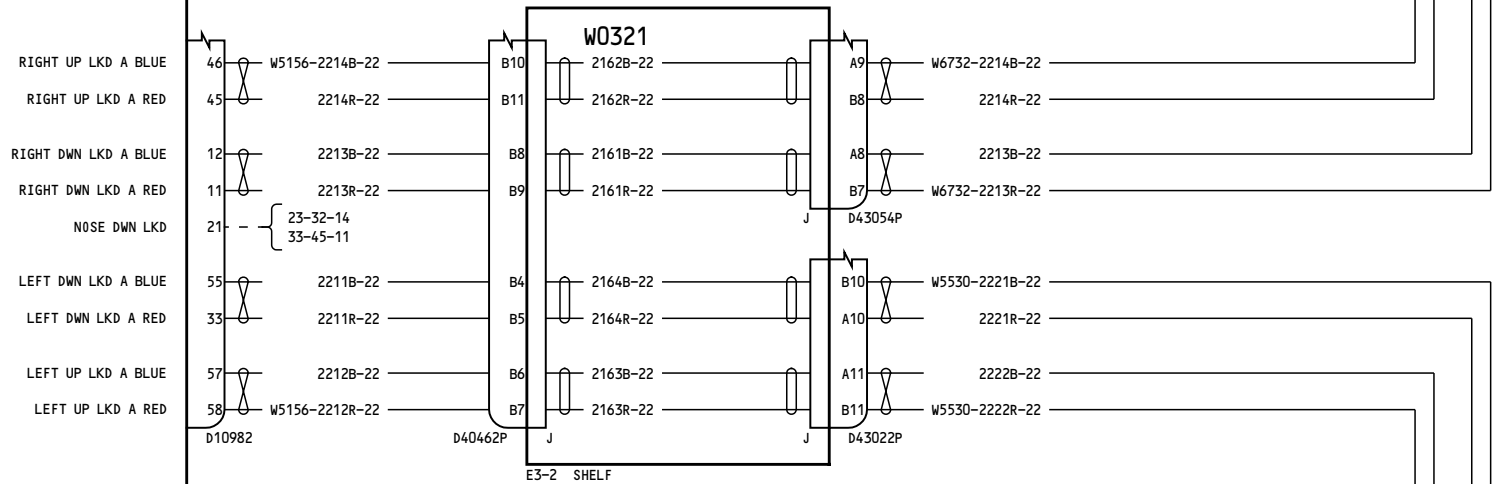
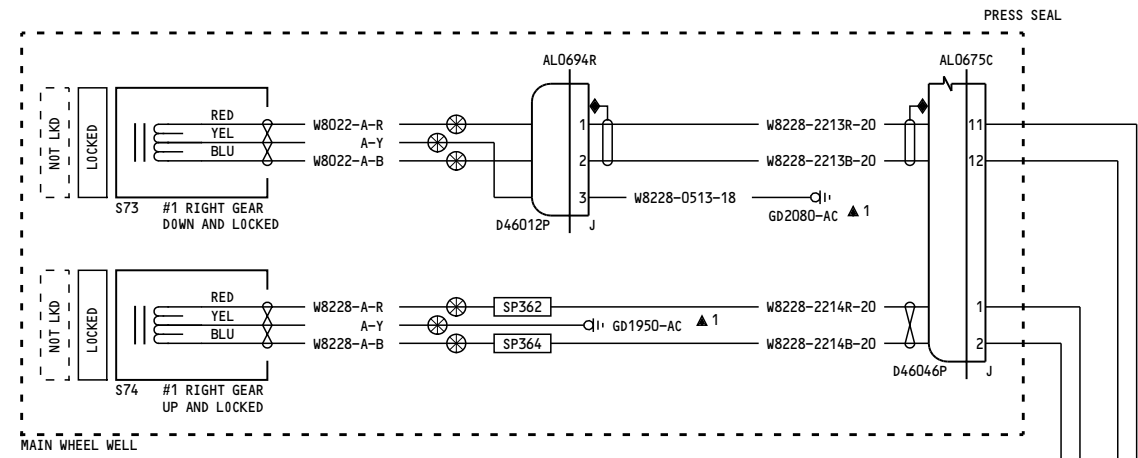

NOSE WHEEL WELL

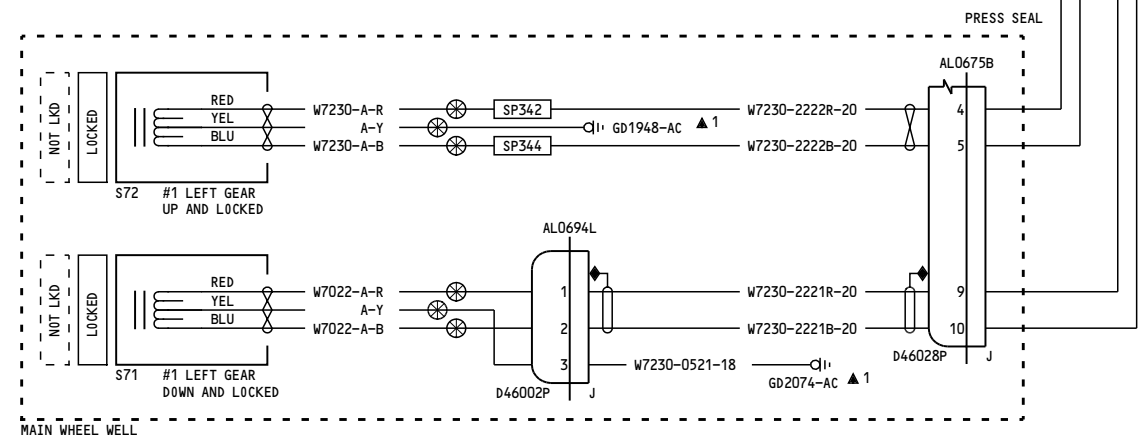

MAIN WHEEL WELL

M2061 PROX SWITCH ELECTRONICS UNIT
STA 212 WL 180 RBL 20

YK901-YM670

**LANDING GEAR POSITION
INDICATING SYSTEM 1**

32-64-11

Page 4
Sheet 2
Feb 09/2009

D280A103

32-64-11

Page 4
Sheet 2
Feb 09/2009

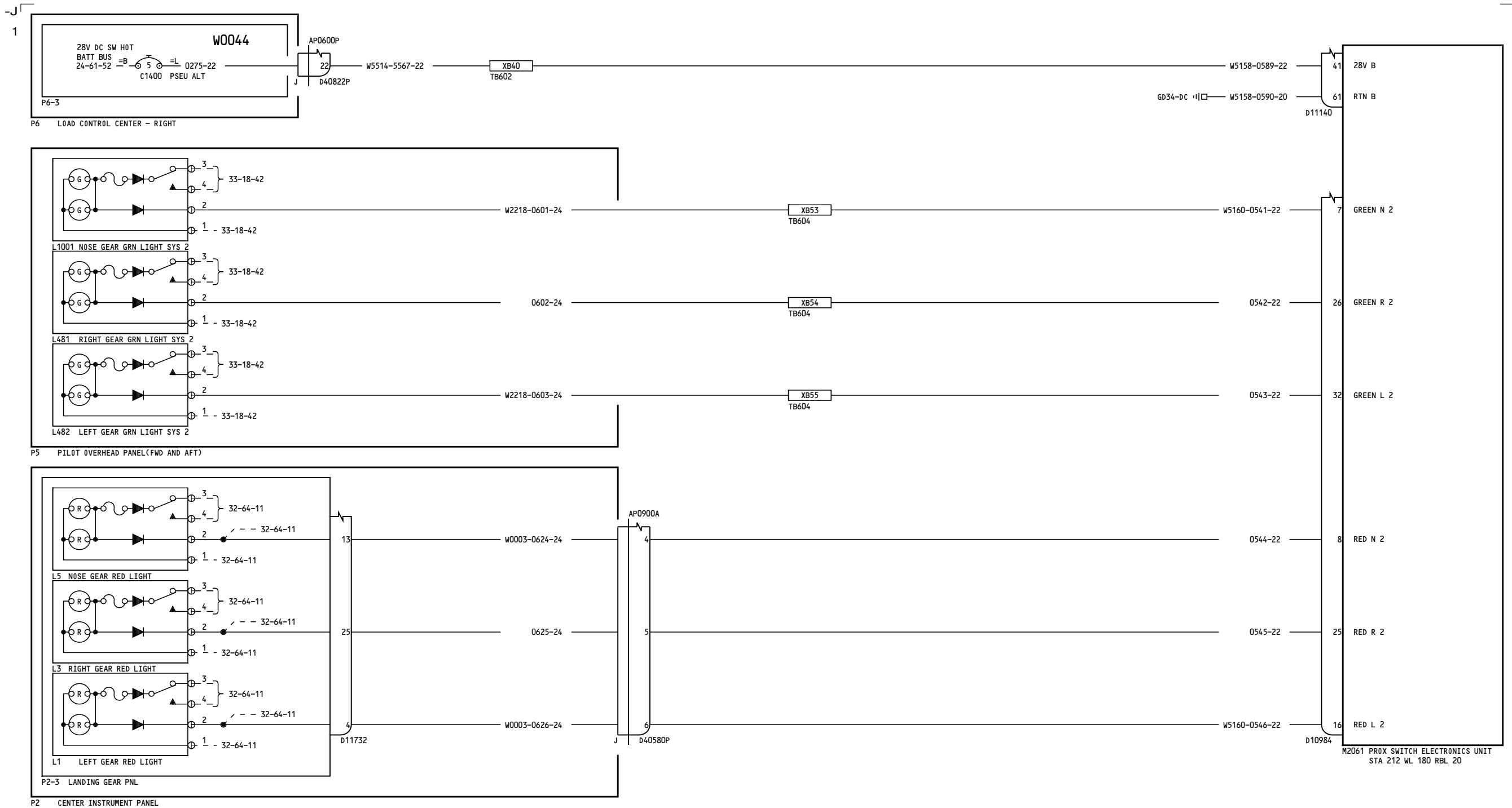

YC001-YC003

**LANDING GEAR POSITION
INDICATING SYSTEM 2**

32-64-12

Page 1
Sheet 1
Mar 31/2005

D280A103

32-64-12

Page 1
Sheet 1
Mar 31/2005

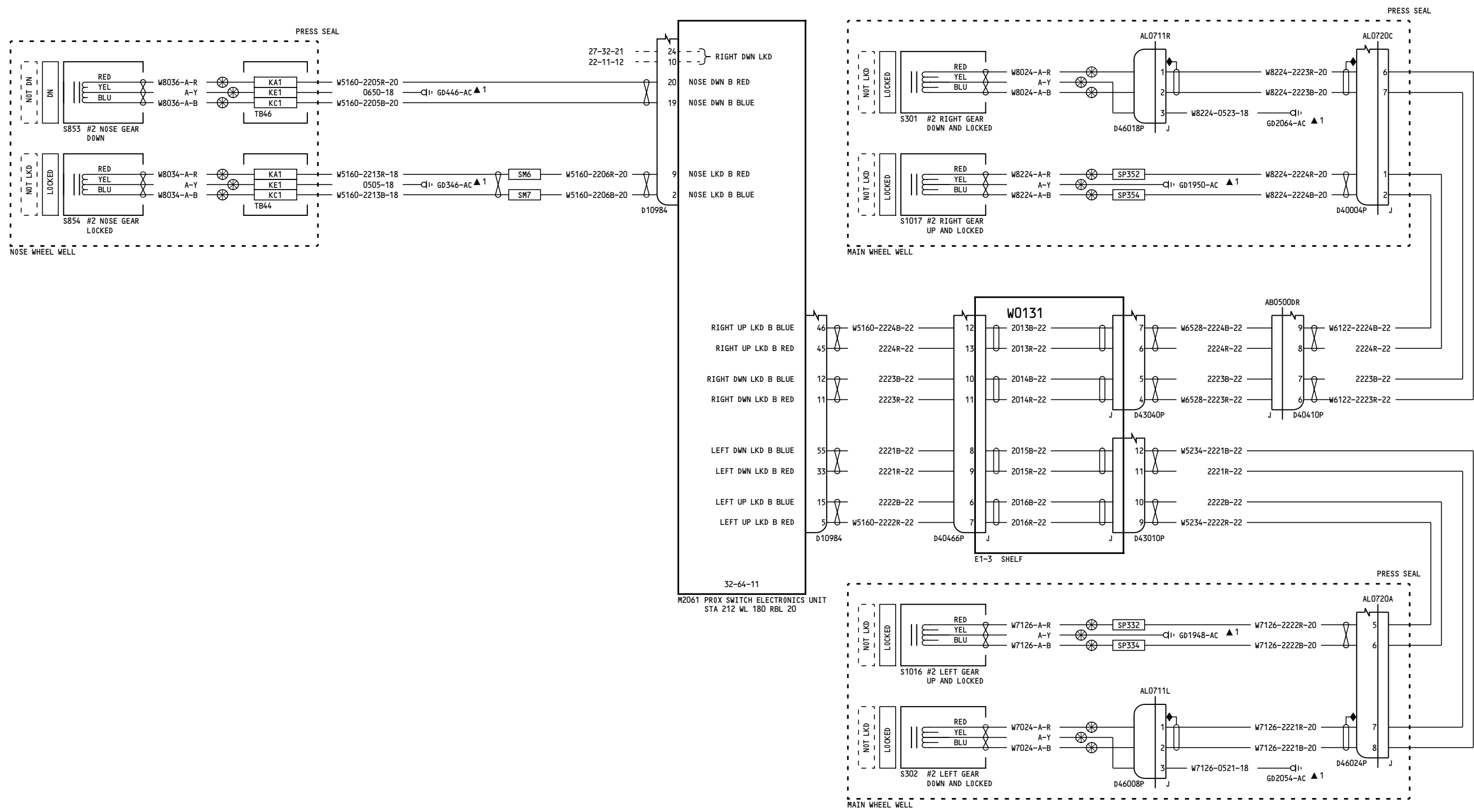

YC001-YC003

LANDING GEAR POSITION INDICATING SYSTEM 2

D280A103

32-64-12

Page 1
Sheet 2
Mar 31/2005

32-64-12

Page 1
Sheet 2
Mar 31/2005

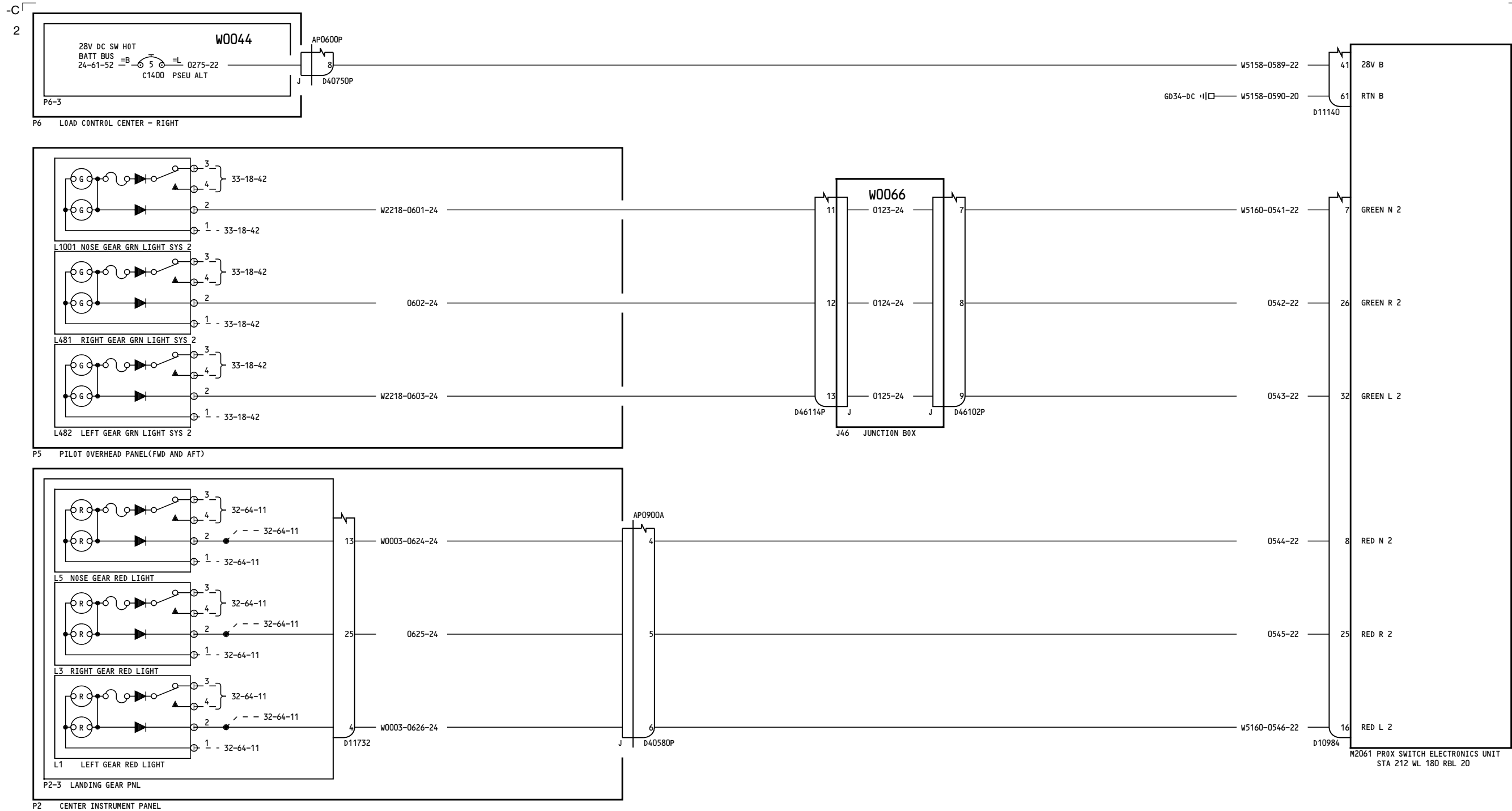

YC004-YC028

**LANDING GEAR POSITION
INDICATING SYSTEM 2**

32-64-12

Page 2
Sheet 1
Jul 17/2007

D280A103

32-64-12

Page 2
Sheet 1
Jul 17/2007

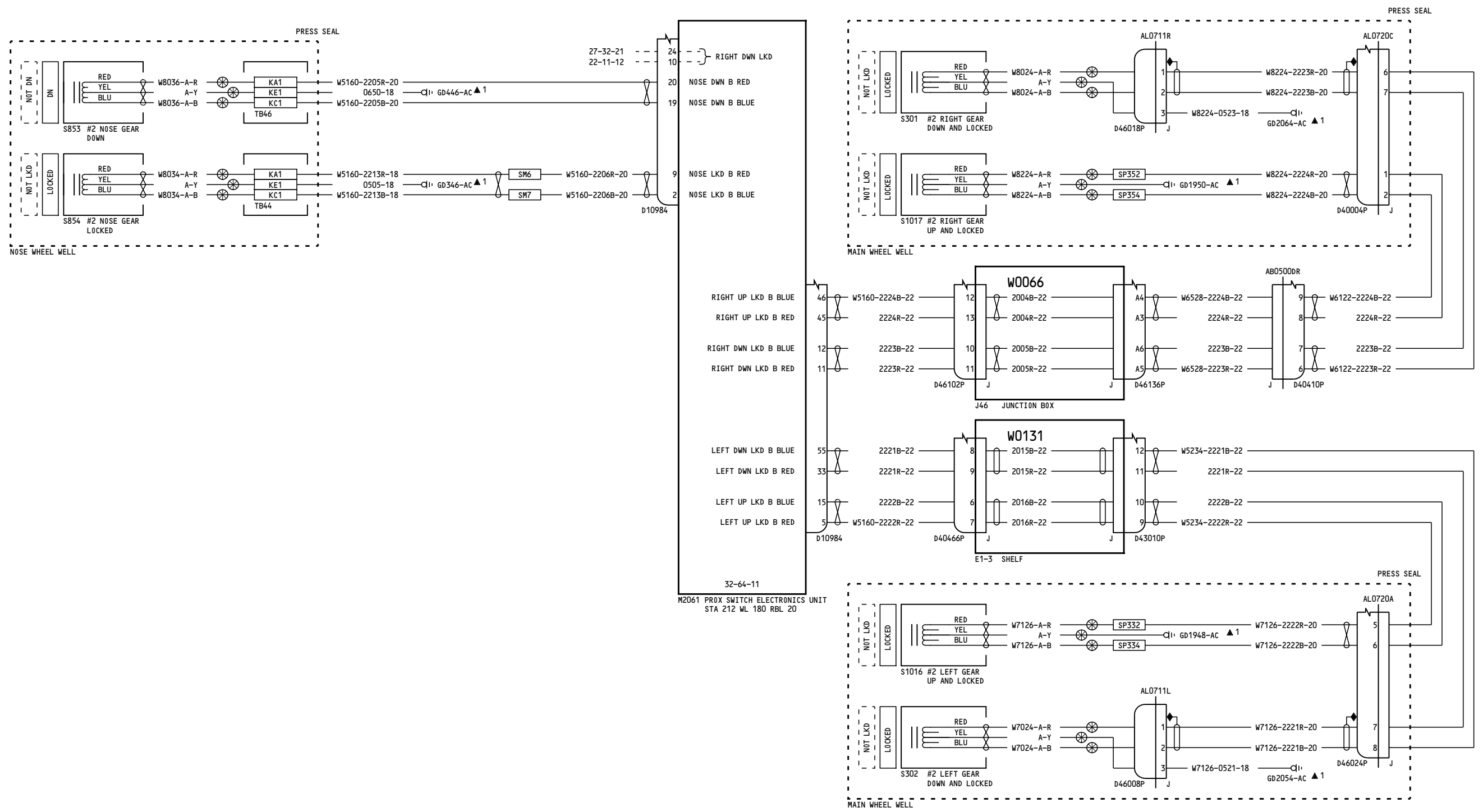

YC004-YC028

LANDING GEAR POSITION INDICATING SYSTEM 2

32-64-12

Page 2
Sheet 2
Jul 17/2007

D280A103

32-64-12

Page 2
Sheet 2
Jul 17/2007

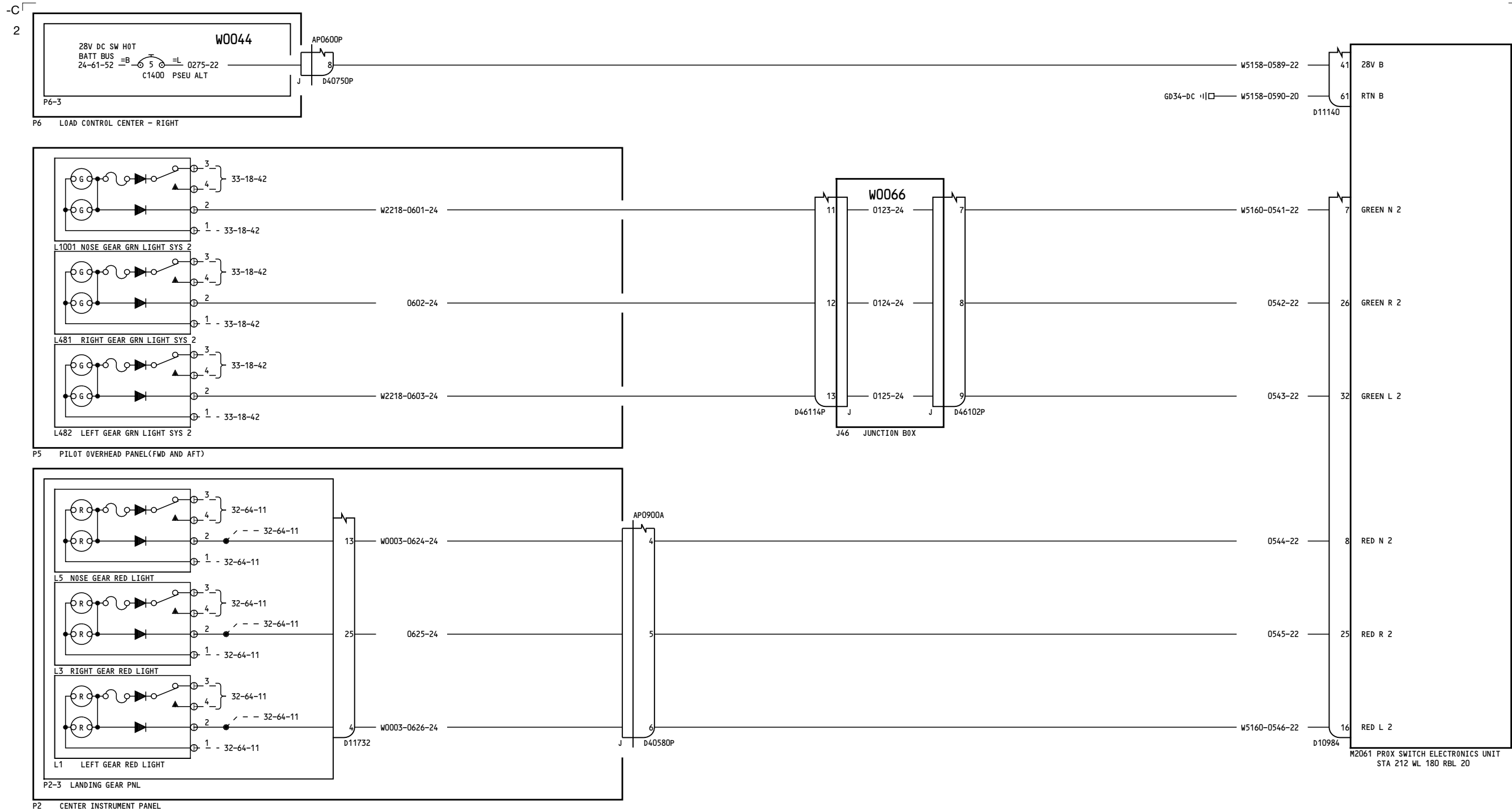

YC029-YK911, YK918, YL421-YL426, YM643-YM651

LANDING GEAR POSITION INDICATING SYSTEM 2

32-64-12

Page 3
Sheet 1
Feb 09/2009

D280A103

32-64-12

Page 3
Sheet 1
Feb 09/2009

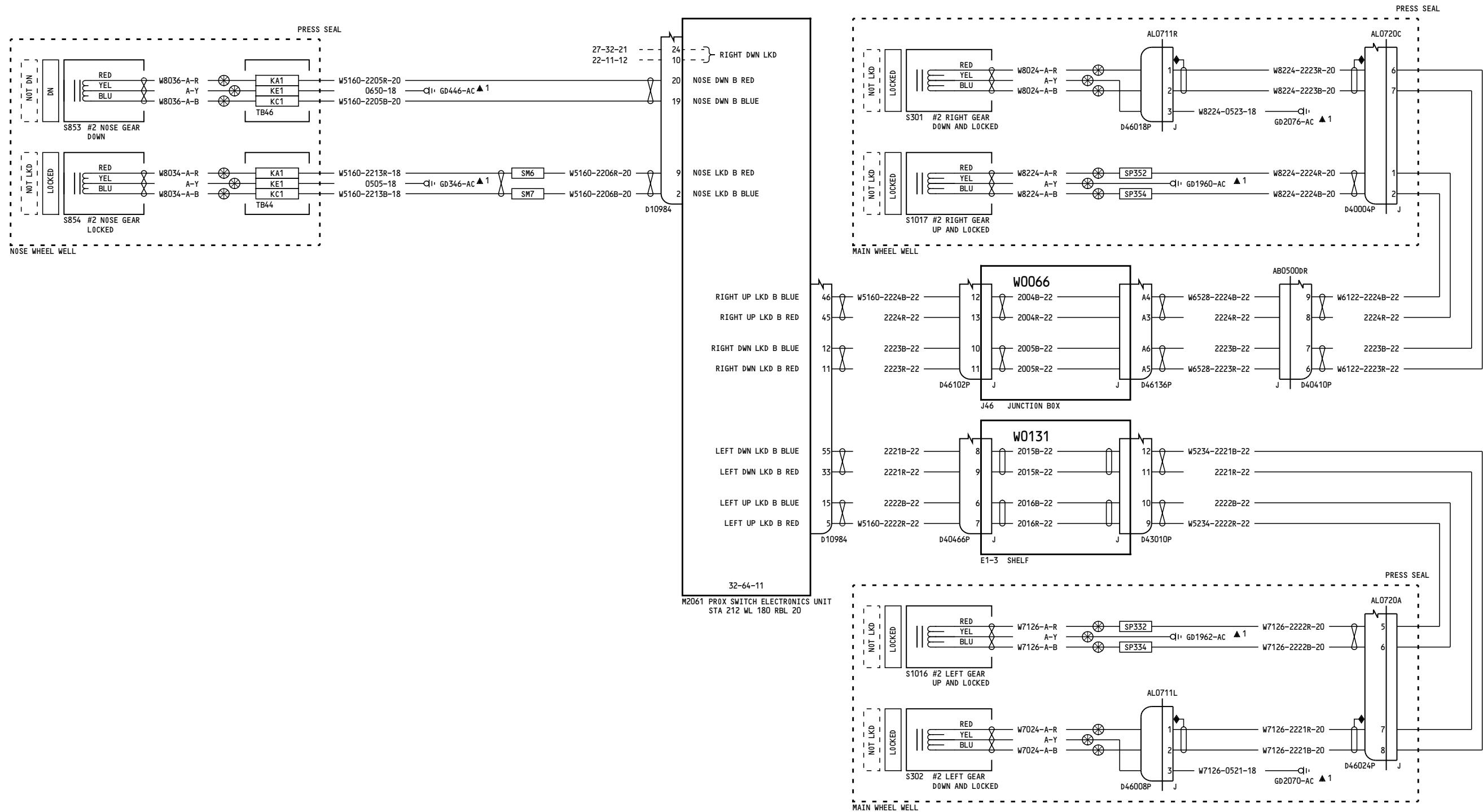

YC029-YK911, YK918, YL421-YL426, YM643-YM651

LANDING GEAR POSITION INDICATING SYSTEM 2

D280A103

32-64-12

Page 3
Sheet 2
Feb 09/2009

32-64-12

Page 3
Sheet 2
Feb 09/2009

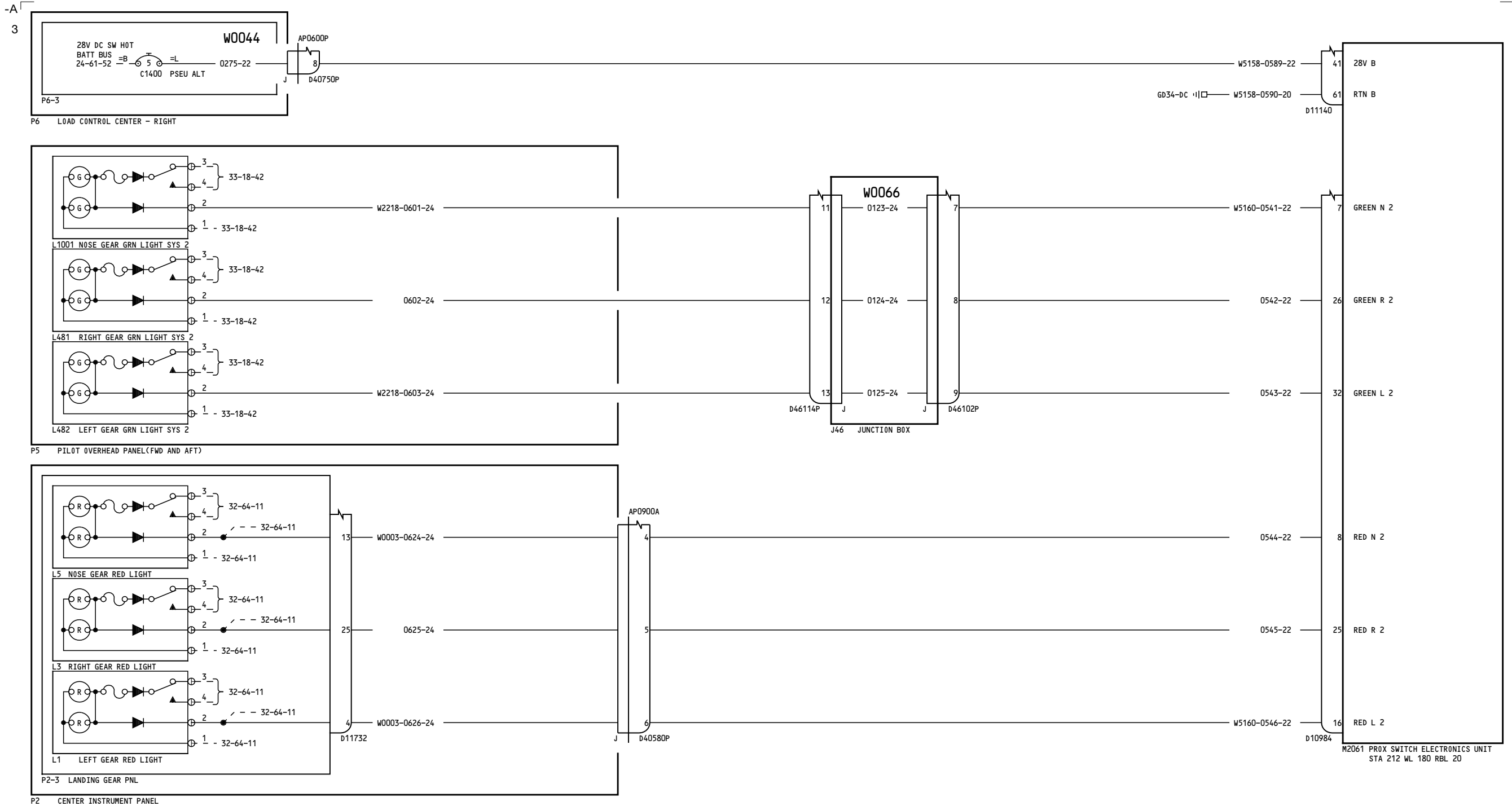

YK912, YK919, YL401, YL427-YL429, YM652

LANDING GEAR POSITION INDICATING SYSTEM 2

32-64-12

Page 4
Sheet 1
Aug 10/2009

D280A103

32-64-12

Page 4
Sheet 1
Aug 10/2009

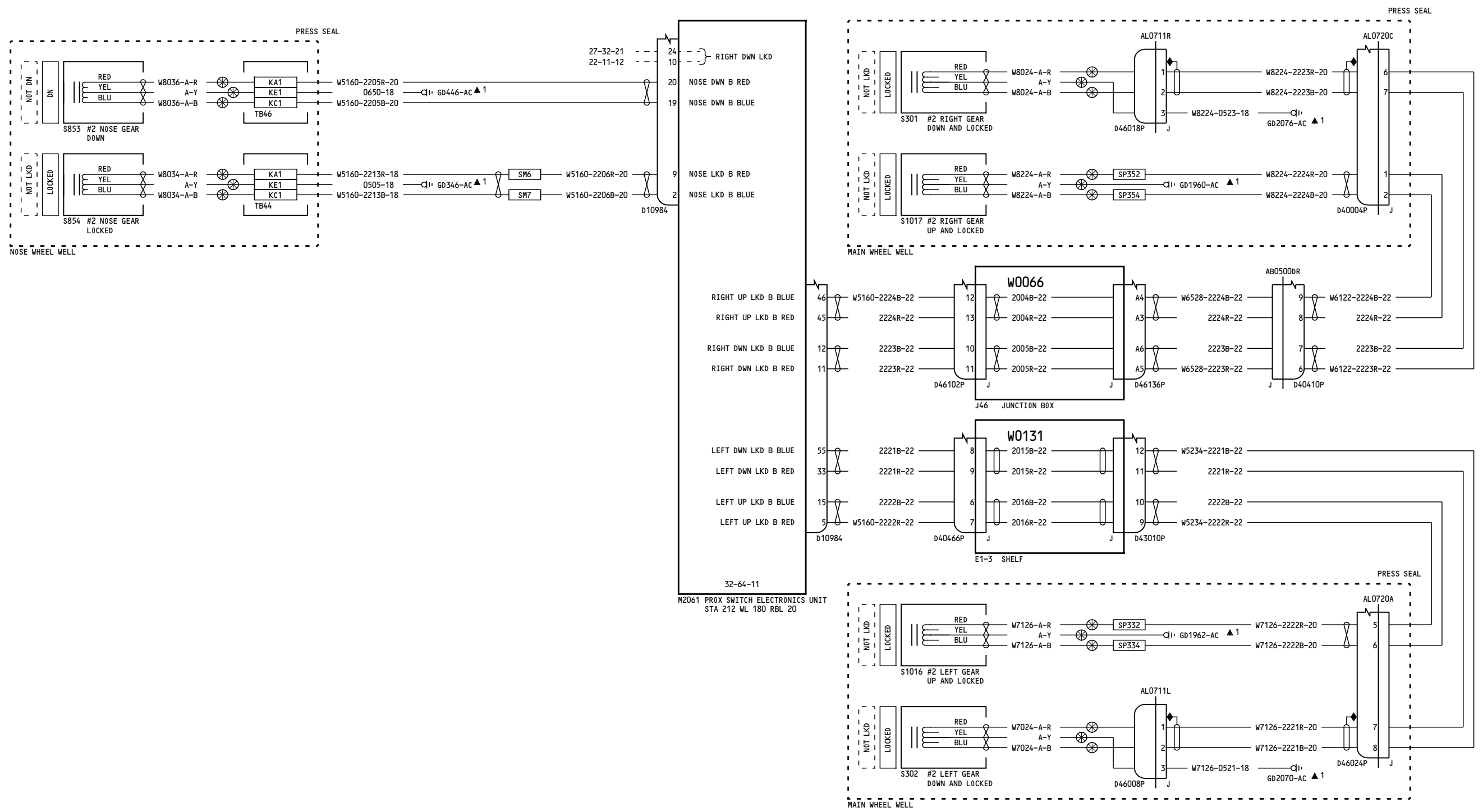

YK912, YK919, YL401, YL427-YL429, YM652

LANDING GEAR POSITION INDICATING SYSTEM 2

32-64-12

Page 4
Sheet 2
Aug 10/2009

D280A103

32-64-12

Page 4
Sheet 2
Aug 10/2009

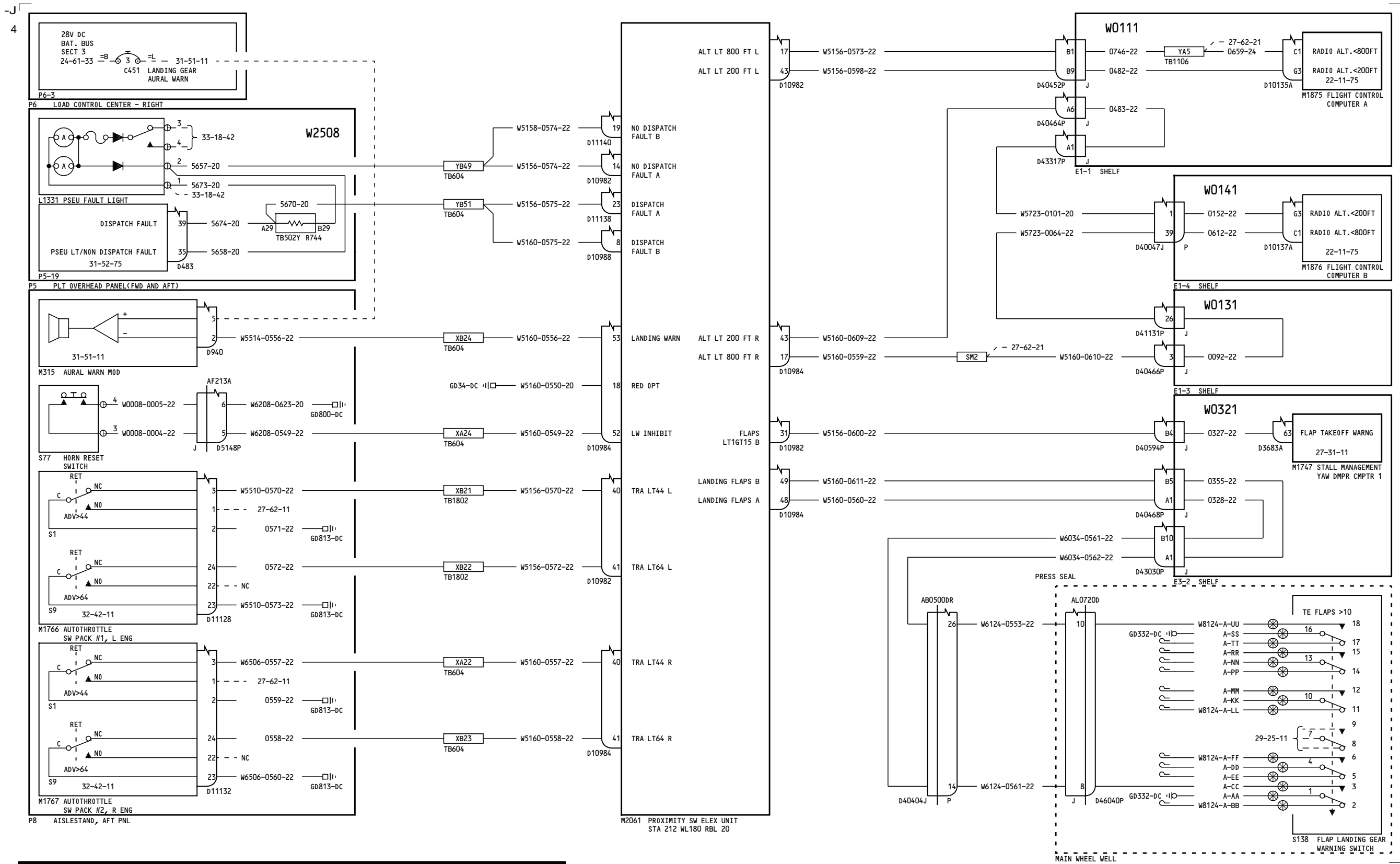

YC001-YC003

LANDING GEAR WARNING

32-64-21

Page 1

D280A103

Nov 11/2008

32-64-21

Page 1

Nov 11/2008

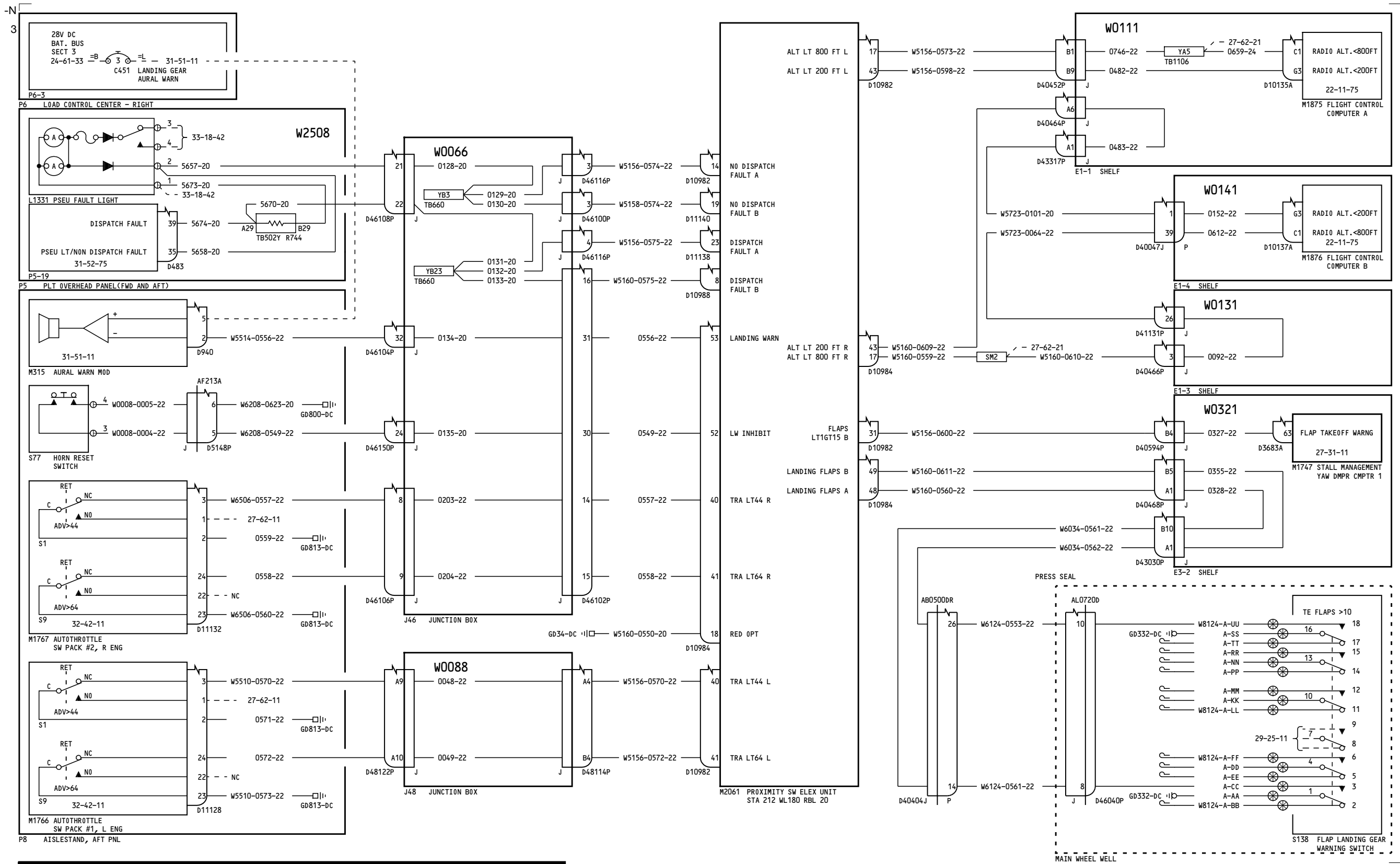

YC004-YK906, YM643-YM649

LANDING GEAR WARNING

32-64-21
Page 2
Nov 11/2008

D280A103

32-64-21
Page 2
Nov 11/2008

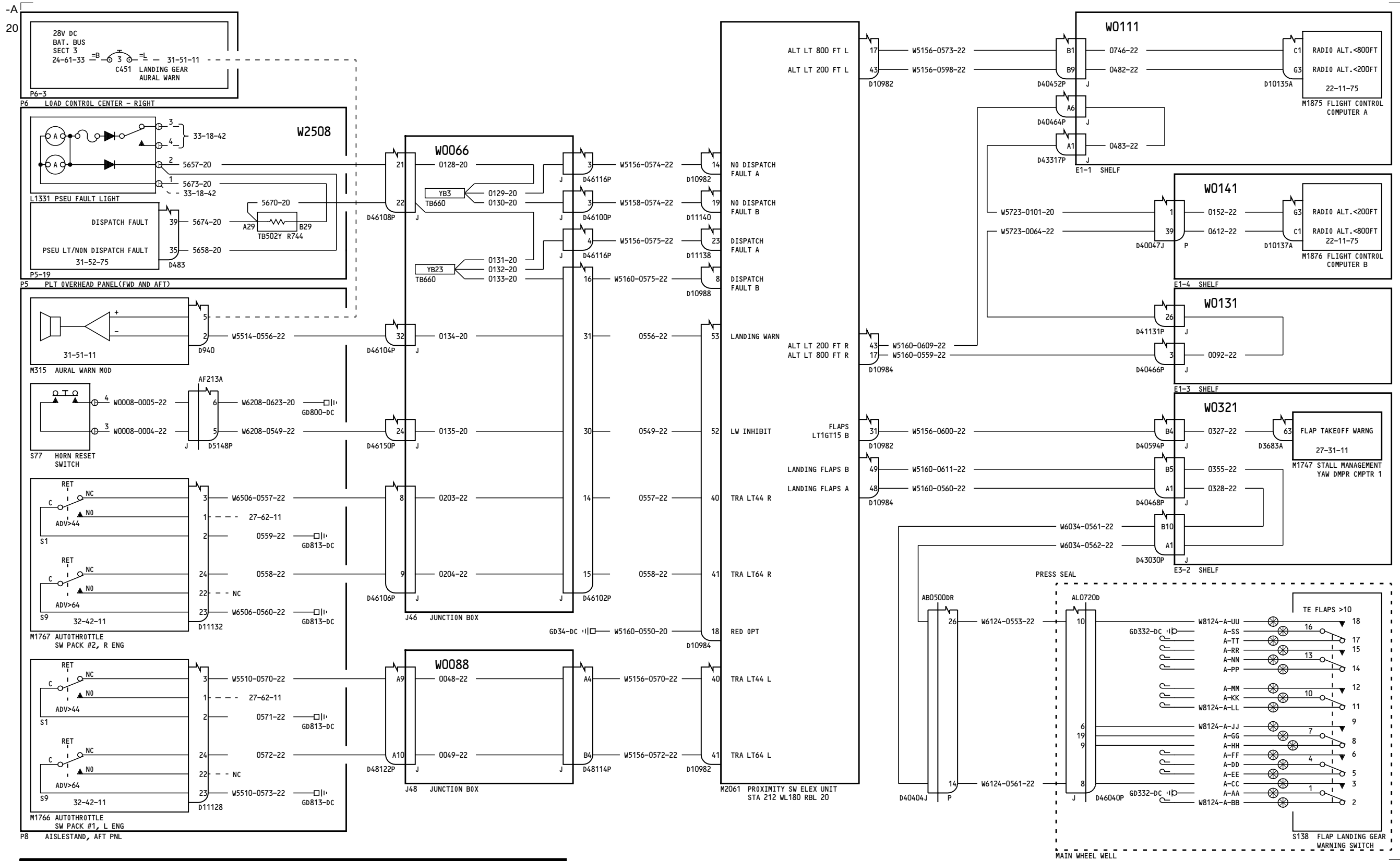

YK911-YK912, YK919, YL401, YL427-YL429

LANDING GEAR WARNING

32-64-21

Page 4

D280A103

May 11/2009

32-64-21

Page 4

May 11/2009

32-64-21

Page 4

May 11/2009

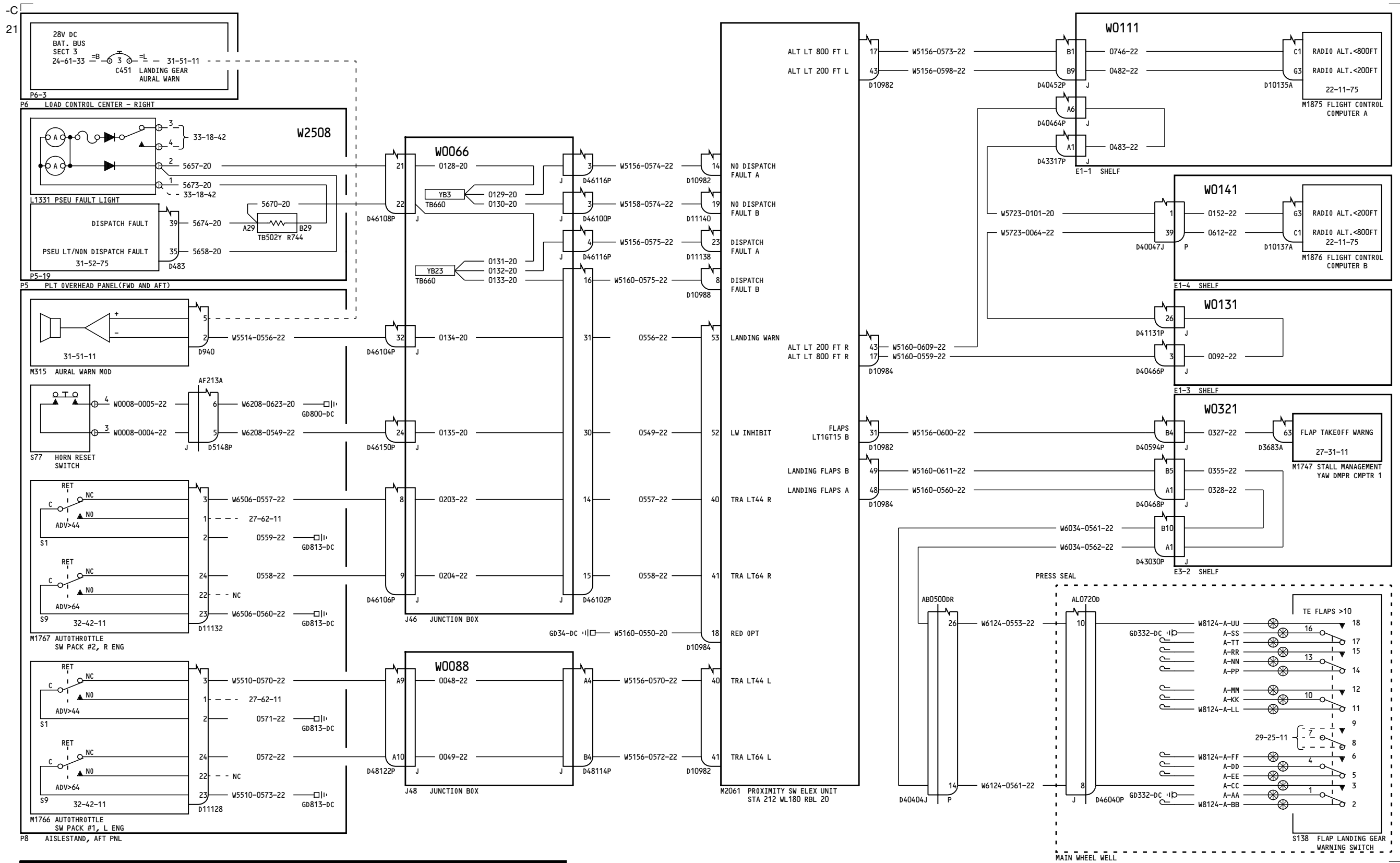

YM651-YM652

LANDING GEAR WARNING

32-64-21

Page 5

D280A103

May 11/2009

32-64-21

Page 5

May 11/2009