

**CHAPTER**

**49**

**AIRBORNE**

**AUXILIARY POWER**



737-700/800

**WIRING DIAGRAM MANUAL**

**CHAPTER 49  
AIRBORNE AUXILIARY POWER**

CH-SC-SU	Schem	Page	Sheet	Date	CH-SC-SU	Schem	Page	Sheet	Date
49-EFFECTIVE PAGES		1		Aug 10/2009	49-94-21 (cont.)		2		May 11/2009
		2		BLANK			3		May 11/2009
49-CONTENTS		1		May 11/2009					
		2		May 11/2009					
49-ALPHABETICAL INDEX		1		Jan 18/2007					
		2		BLANK					
49-41-11		1		Jul 26/2006					
		2		Jul 26/2006					
		3		Jul 26/2006					
		4		Feb 09/2009					
		5		Jan 14/2008					
49-52-31		1		Mar 31/2005					
		2		Feb 09/2009					
		3		Jan 14/2008					
49-62-11		1.1	1	Mar 31/2005					
			2	Mar 31/2005					
			3	Mar 31/2005					
		2.1	1	Mar 31/2005					
			2	Mar 31/2005					
			3	Mar 31/2005					
		3	1	Jul 17/2007					
			2	Jul 17/2007					
			3	Jul 17/2007					
		4	1	Oct 20/2005					
			2	Oct 20/2005					
			3	Oct 20/2005					
		5	1	Feb 09/2009					
			2	Feb 09/2009					
			3	Feb 09/2009					
		6	1	Jan 14/2008					
			2	Jan 14/2008					
			3	Jan 14/2008					
49-62-12		1		Jul 26/2006					
		2		May 11/2009					
		3		May 11/2009					
49-62-51		1		Mar 31/2005					
		2		Feb 09/2009					
		3		Jan 14/2008					
49-71-21		1		Mar 31/2005					
		2		Feb 09/2009					
		3		Jan 14/2008					
49-94-21		1		May 11/2009					

A = Added, R = Revised, D = Deleted, O = Overflow

**49-EFFECTIVE PAGES**

Page 1  
Aug 10/2009

D280A103



737-700/800

**WIRING DIAGRAM MANUAL**

**CHAPTER 49  
AIRBORNE AUXILIARY POWER**

Title	CH-SC-SU	Schem	Page	Sheet	Date	Effectivity
<b><u>APU IGNITION AND START SYSTEM</u></b>						
APU IGNITION AND STARTING SYSTEM	49-41-11		1		Jul 26/2006	YC001-YC004
			2		Jul 26/2006	YC005-YC007
			3		Jul 26/2006	YC008-YC019
			4		Feb 09/2009	YC020-YL430
			5		Jan 14/2008	YM643-YM670
<b><u>APU BLEED AIR SYSTEM</u></b>						
APU BLEED AIR AND SURGE CONTROL SYSTEM	49-52-31		1		Mar 31/2005	YC001-YC007
			2		Feb 09/2009	YC008-YL430
			3		Jan 14/2008	YM643-YM670
<b><u>APU CONTROL SYSTEM</u></b>						
APU CONTROL- AIRPLANE INTERFACE	49-62-11		1.1	1	Mar 31/2005	YC001-YC007
				2	Mar 31/2005	YC001-YC007
				3	Mar 31/2005	YC001-YC007
			2.1	1	Mar 31/2005	YC008-YC011
				2	Mar 31/2005	YC008-YC011
				3	Mar 31/2005	YC008-YC011
			3	1	Jul 17/2007	YC012-YC026
				2	Jul 17/2007	YC012-YC026
				3	Jul 17/2007	YC012-YC026
			4	1	Oct 20/2005	YC028-YC030
				2	Oct 20/2005	YC028-YC030
				3	Oct 20/2005	YC028-YC030
			5	1	Feb 09/2009	YC031-YL430
				2	Feb 09/2009	YC031-YL430
				3	Feb 09/2009	YC031-YL430
			6	1	Jan 14/2008	YM643-YM670
				2	Jan 14/2008	YM643-YM670
				3	Jan 14/2008	YM643-YM670
		APU CONTROL- APU INTERFACE	49-62-12		1	
	2				May 11/2009	YC008-YL430

**49-CONTENTS**

Page 1  
May 11/2009

D280A103



737-700/800

## WIRING DIAGRAM MANUAL

### CHAPTER 49 AIRBORNE AUXILIARY POWER

Title	CH-SC-SU	Schem	Page	Sheet	Date	Effectivity
APU CONTROL- APU INTERFACE (cont.)	49-62-12		3		May 11/2009	YM643-YM670
ECU PINOUT	49-62-51		1		Mar 31/2005	YC001-YC007
			2		Feb 09/2009	YC008-YL430
			3		Jan 14/2008	YM643-YM670
<b><u>EGT INDICATING SYSTEM</u></b>						
APU EGT SYSTEM	49-71-21		1		Mar 31/2005	YC001-YC007
			2		Feb 09/2009	YC008-YL430
			3		Jan 14/2008	YM643-YM670
<b><u>APU OIL INDICATING SYSTEM</u></b>						
APU OIL SYSTEM	49-94-21		1		May 11/2009	YC001-YC007
			2		May 11/2009	YC008-YL430
			3		May 11/2009	YM643-YM670

## 49-CONTENTS

Page 2  
May 11/2009

D280A103



737-700/800

**WIRING DIAGRAM MANUAL**

**CHAPTER 49  
AIRBORNE AUXILIARY POWER**

<b>CH-SC-SU</b>	<b>Title</b>
49-52-31	APU BLEED AIR AND SURGE CONTROL SYSTEM
49-62-11	APU CONTROL- AIRPLANE INTERFACE
49-62-12	APU CONTROL- APU INTERFACE
49-71-21	APU EGT SYSTEM
49-41-11	APU IGNITION AND STARTING SYSTEM
49-94-21	APU OIL SYSTEM
49-62-51	ECU PINOUT

**49-ALPHABETICAL INDEX**

D280A103

Page 1  
Jan 18/2007

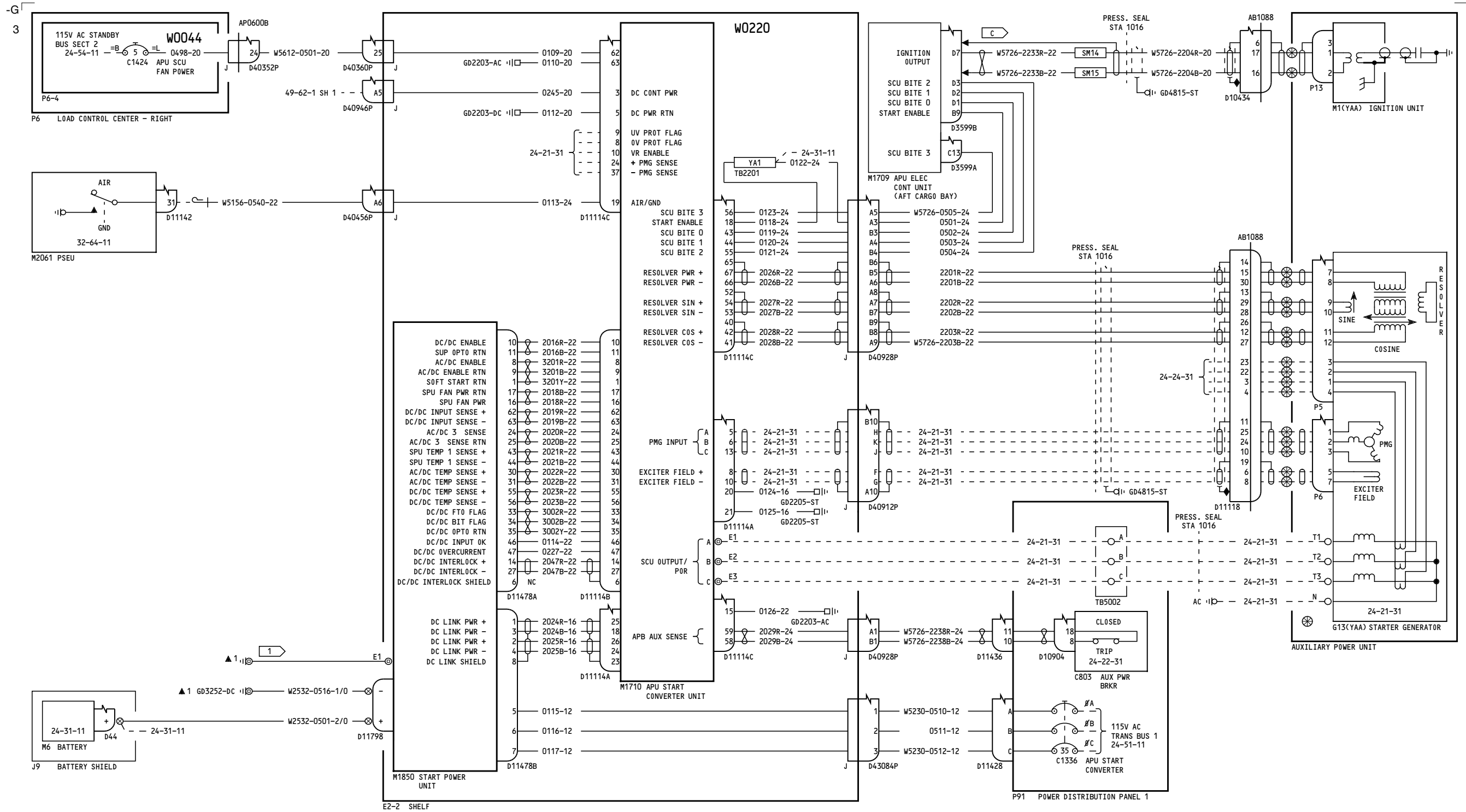

**NOTES:**  
 1 BONDING JUMPER GROUND SIZED FOR CURRENT OF 2500 AMPS INSTALLED BY EQUIPMENT INSTALLATION.

YC001-YC004	<b>APU IGNITION AND STARTING SYSTEM</b>
	D280A103

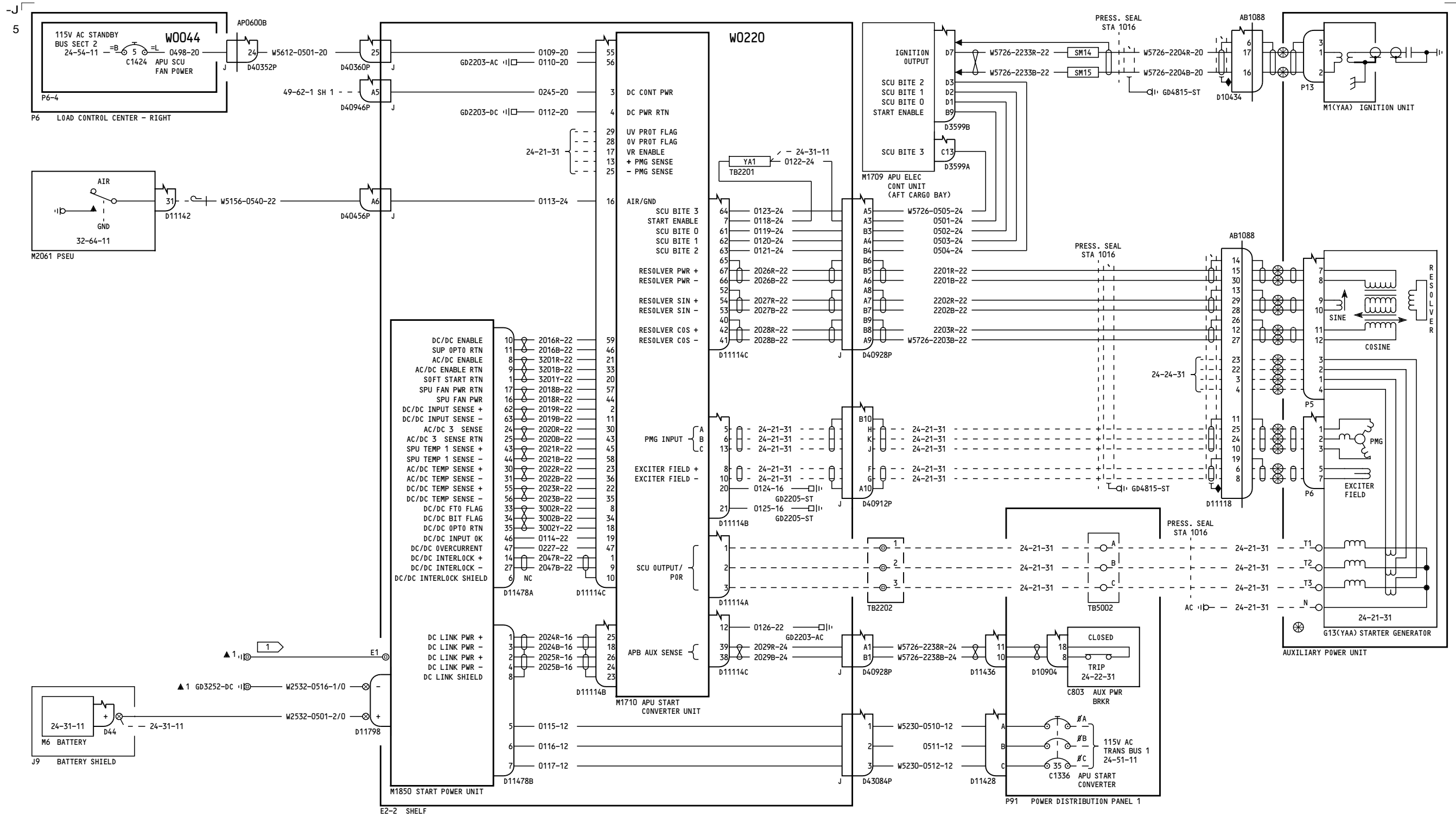

**NOTES:**  
 1 BONDING JUMPER GROUND SIZED FOR CURRENT OF 2500 AMPS INSTALLED BY EQUIPMENT INSTALLATION.

YC005-YC007	<b>APU IGNITION AND STARTING SYSTEM</b>
	<b>49-41-11</b>
	Page 2
	D280A103
	Jul 26/2006

<b>49-41-11</b>
Page 2
Jul 26/2006

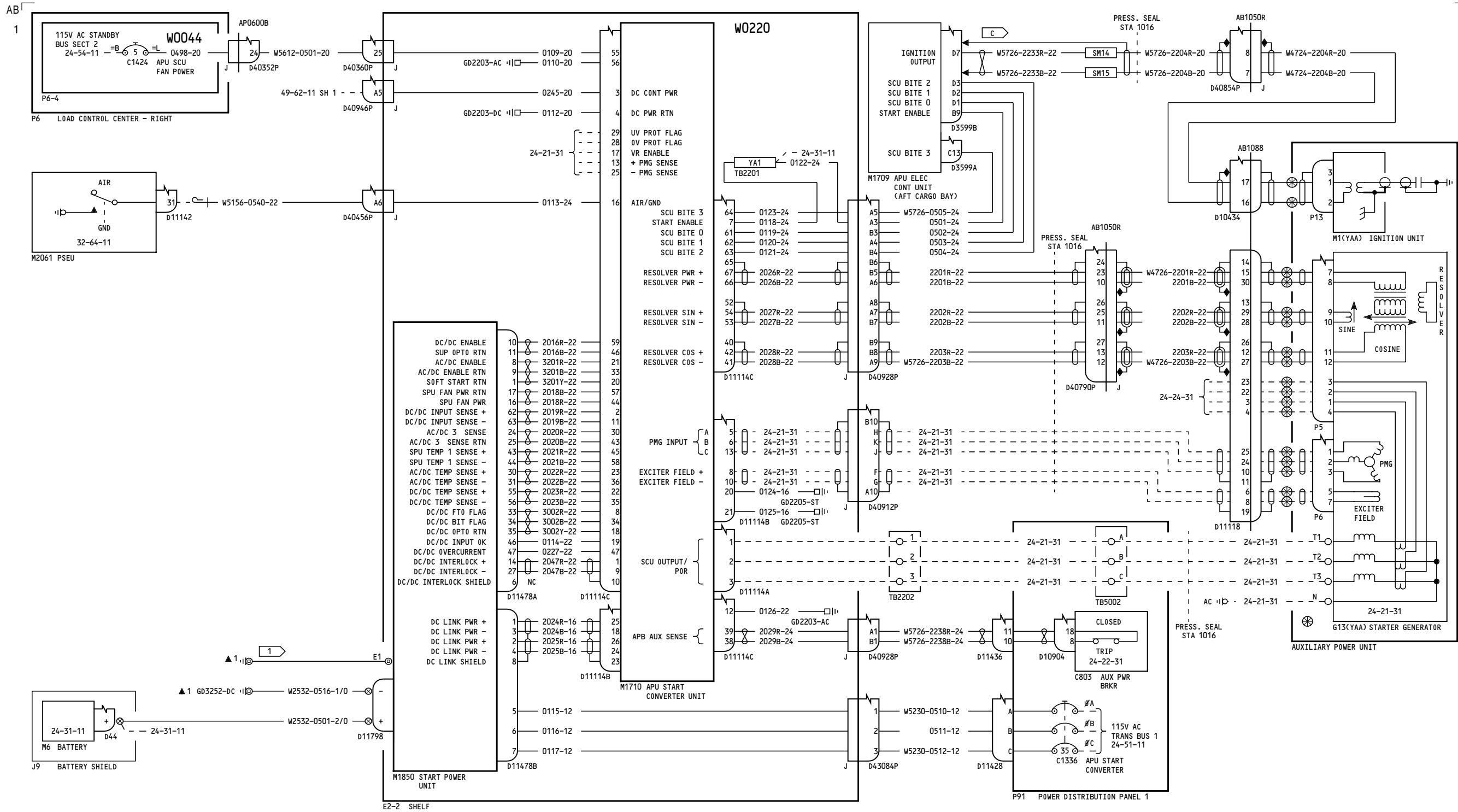

**NOTES:**  
 1 BONDING JUMPER GROUND SIZED FOR CURRENT OF 2500 AMPS INSTALLED BY EQUIPMENT INSTALLATION.

YC008-YC019

**APU IGNITION AND STARTING SYSTEM**

**49-41-11**

Page 3

D280A103

Jul 26/2006

**49-41-11**

Page 3

Jul 26/2006



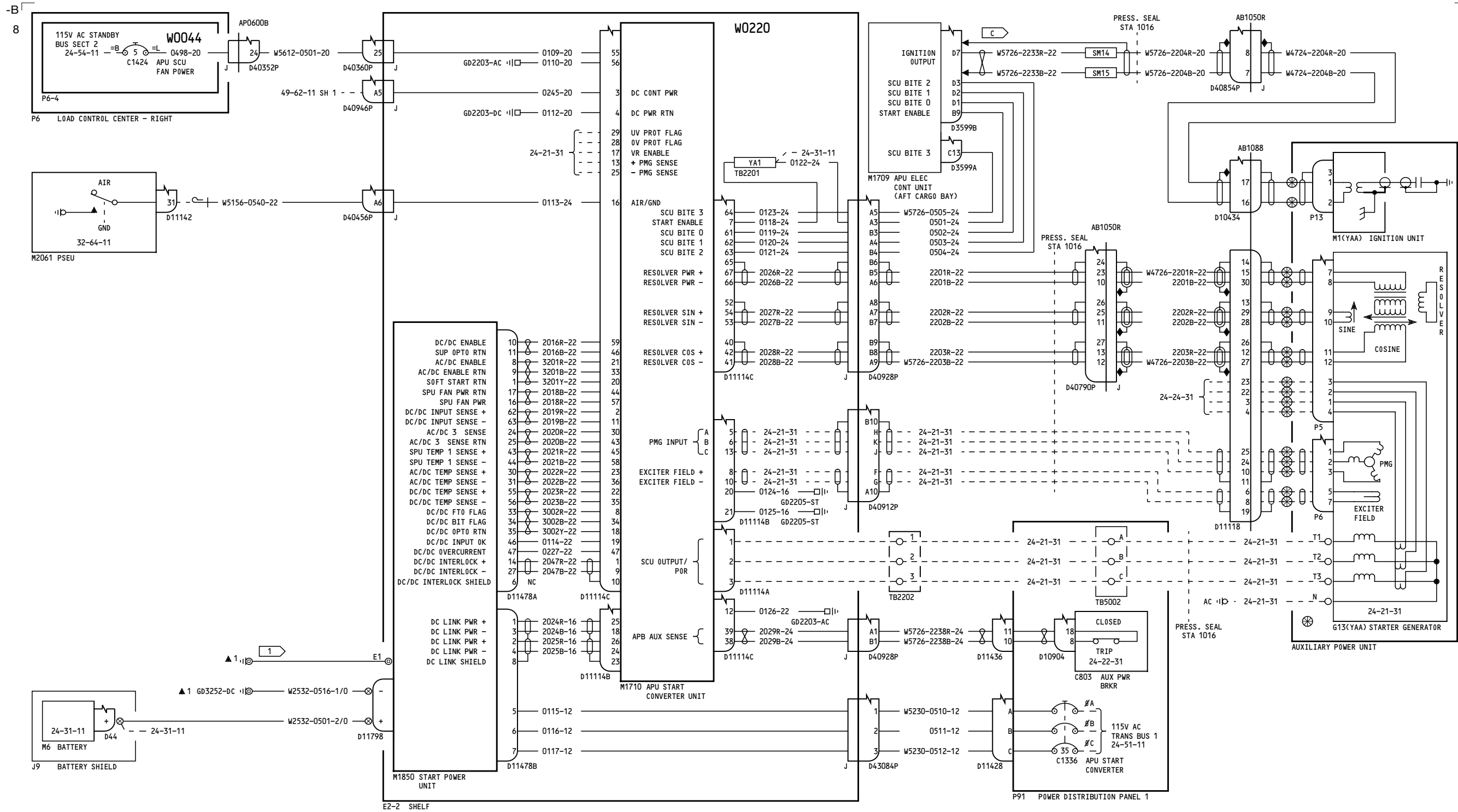

**NOTES:**  
 1 BONDING JUMPER GROUND SIZED FOR CURRENT OF 2500 AMPS INSTALLED BY EQUIPMENT INSTALLATION.

YC020-YL430

**APU IGNITION AND STARTING SYSTEM**

**49-41-11**

Page 4

D280A103

Feb 09/2009

**49-41-11**

Page 4

Feb 09/2009

BOEING PROPRIETARY - Copyright © - Unpublished Work - See title page for details.

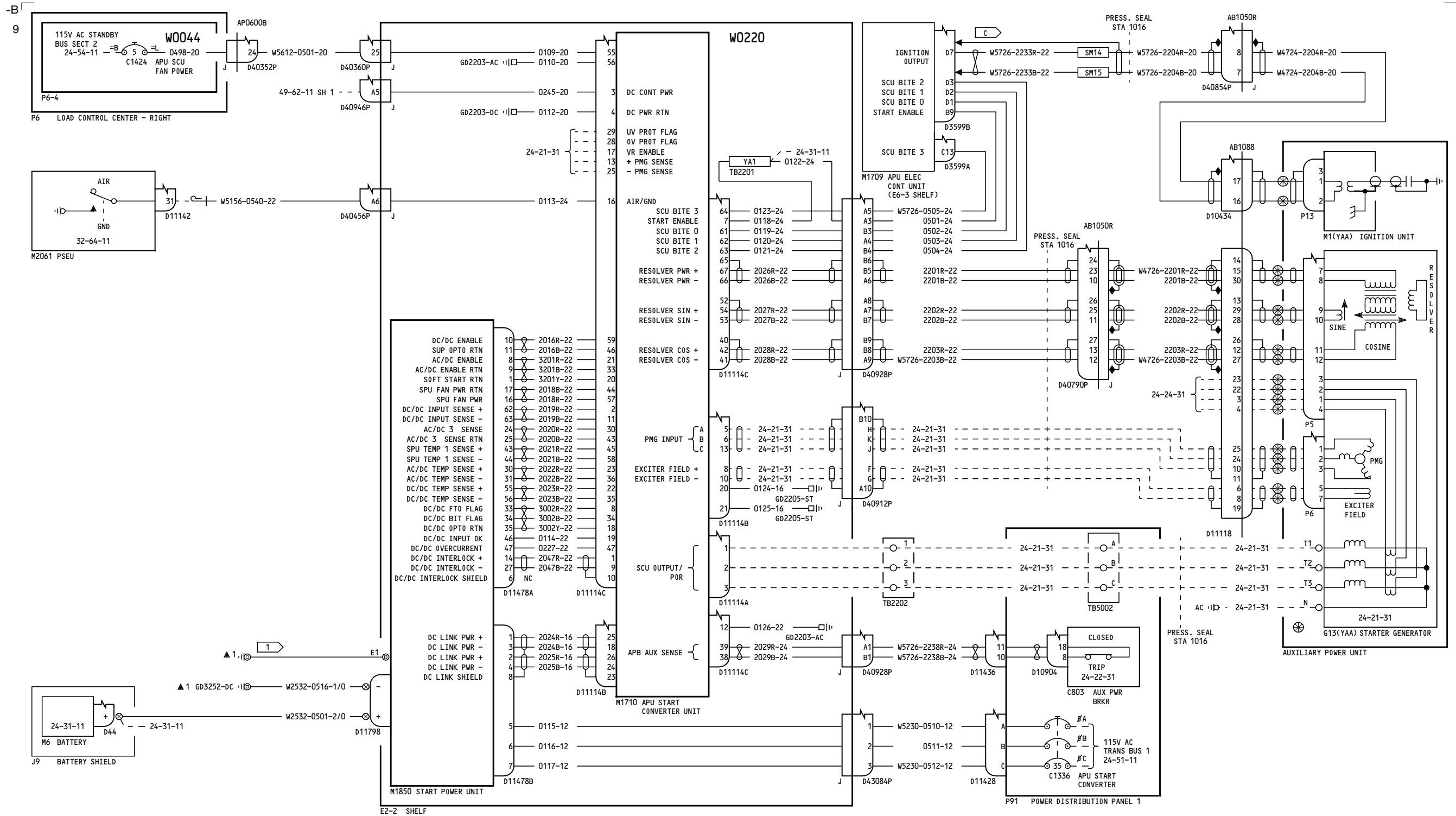

**NOTES:**

1 BONDING JUMPER GROUND SIZED FOR CURRENT OF 2500 AMPS INSTALLED BY EQUIPMENT INSTALLATION.

YM643-YM670	<b>APU IGNITION AND STARTING SYSTEM</b>
	D280A103

**49-41-11**

Page 5

Jan 14/2008

**49-41-11**

Page 5

Jan 14/2008

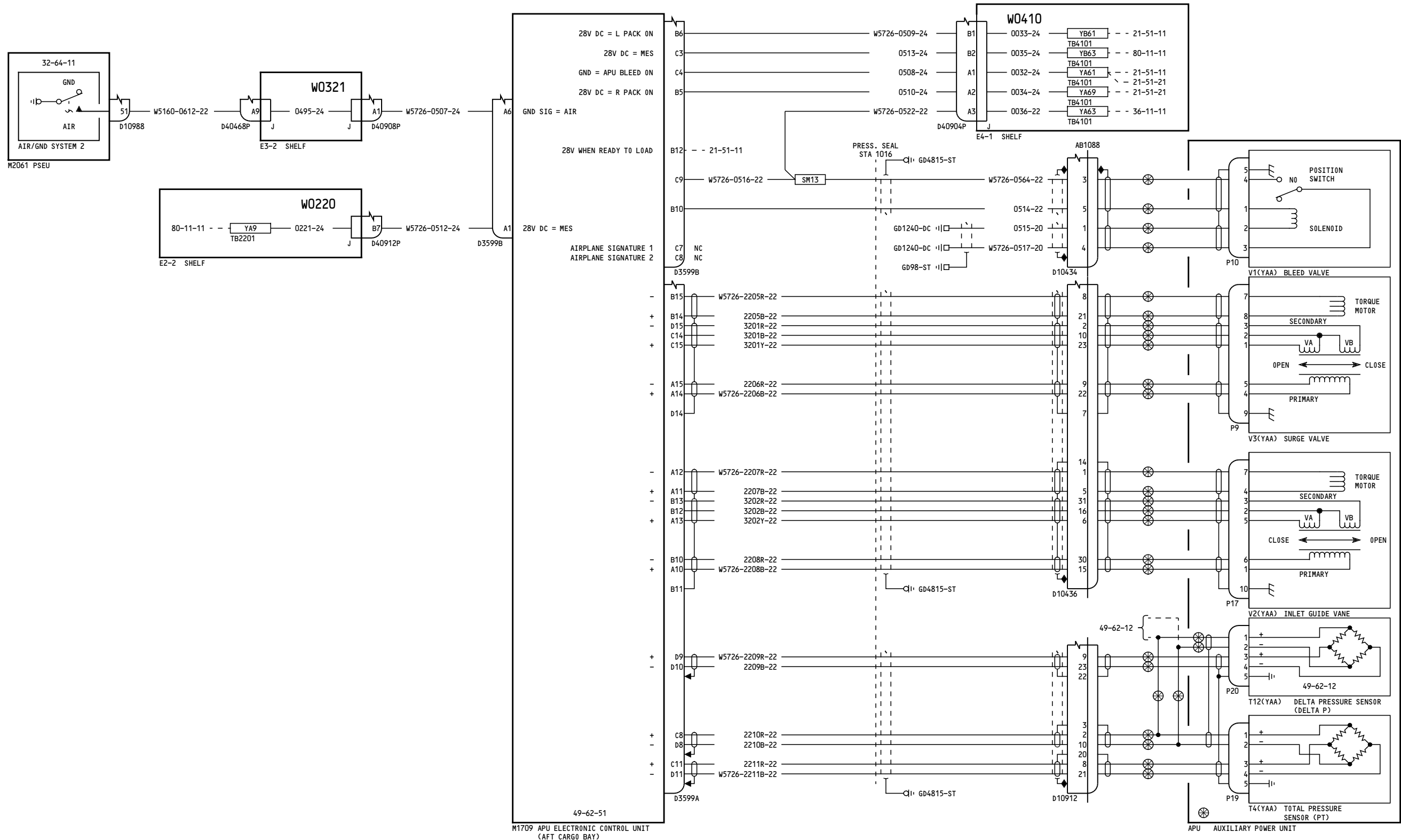

YC001-YC007

**APU BLEED AIR AND SURGE CONTROL SYSTEM**

**49-52-31**

Page 1

D280A103

Mar 31/2005

**49-52-31**

Page 1

Mar 31/2005

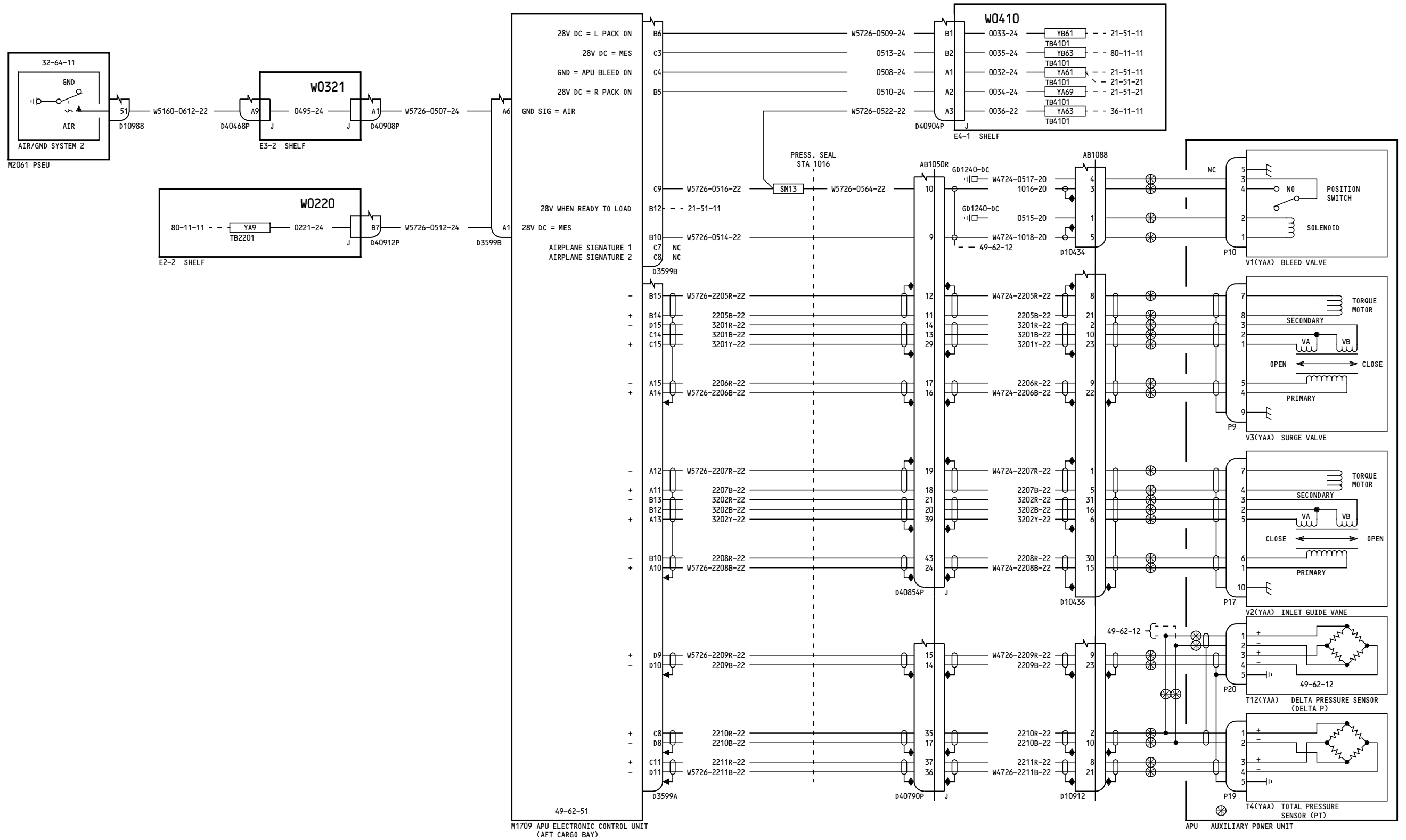

YC008-YL430

**APU BLEED AIR AND SURGE CONTROL SYSTEM**

**49-52-31**

Page 2

D280A103

Feb 09/2009

**49-52-31**

Page 2

Feb 09/2009

-G  
4

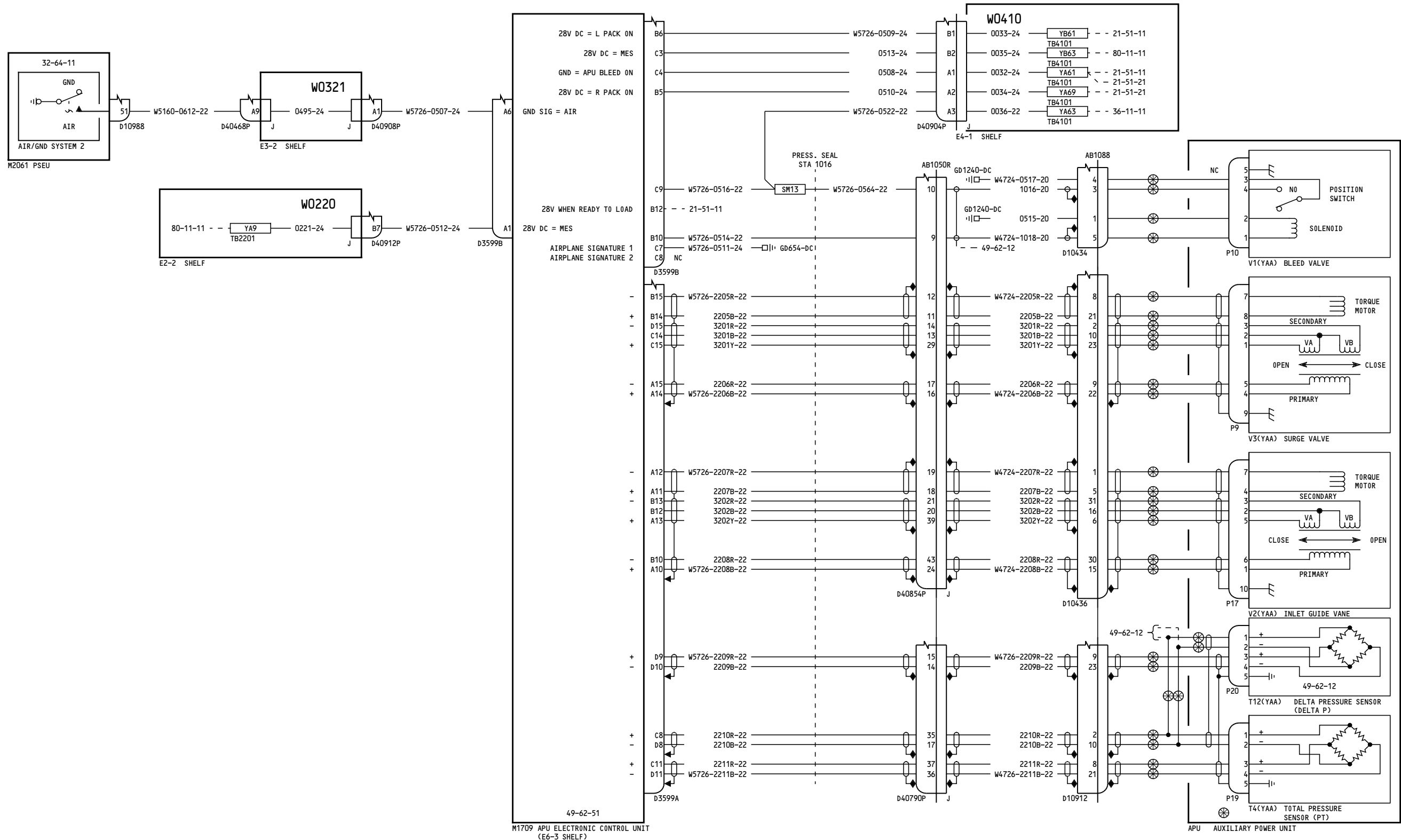

YM643-YM670

**APU BLEED AIR AND SURGE CONTROL SYSTEM**

**49-52-31**

Page 3

D280A103

Jan 14/2008

**49-52-31**

Page 3

Jan 14/2008

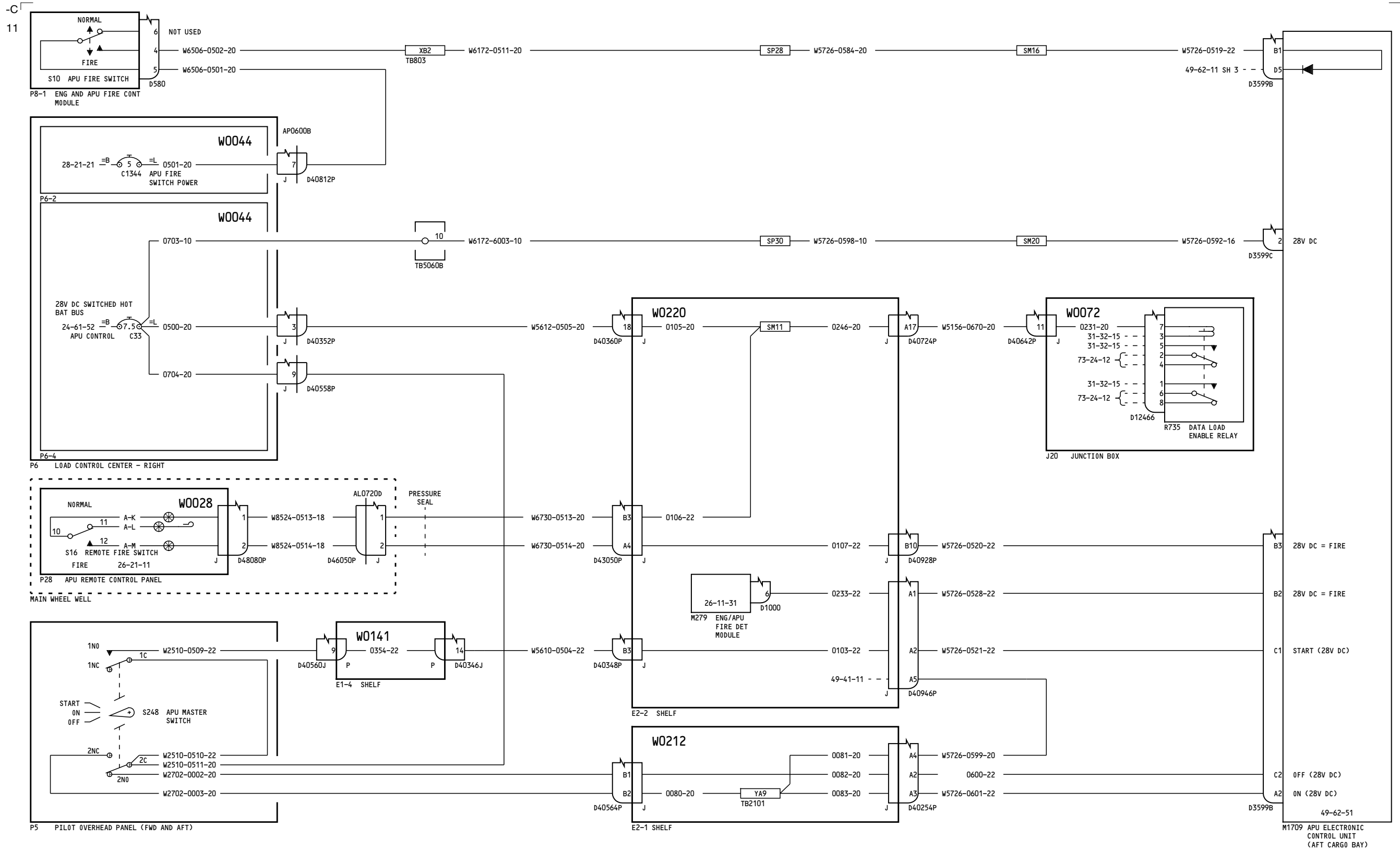

YC001-YC007

APU CONTROL-AIRPLANE INTERFACE

D280A103

49-62-11

Page 1.1  
Sheet 1  
Mar 31/2005

Incorporates  
31-1136

49-62-11

Page 1.1  
Sheet 1  
Mar 31/2005

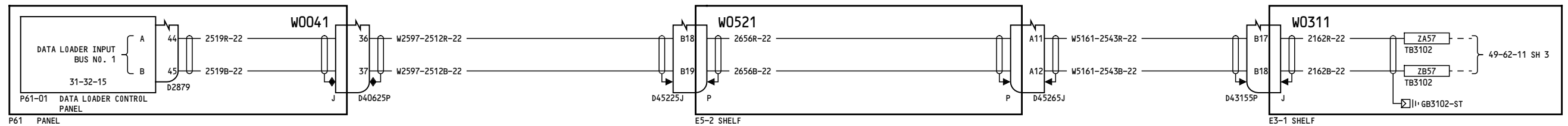
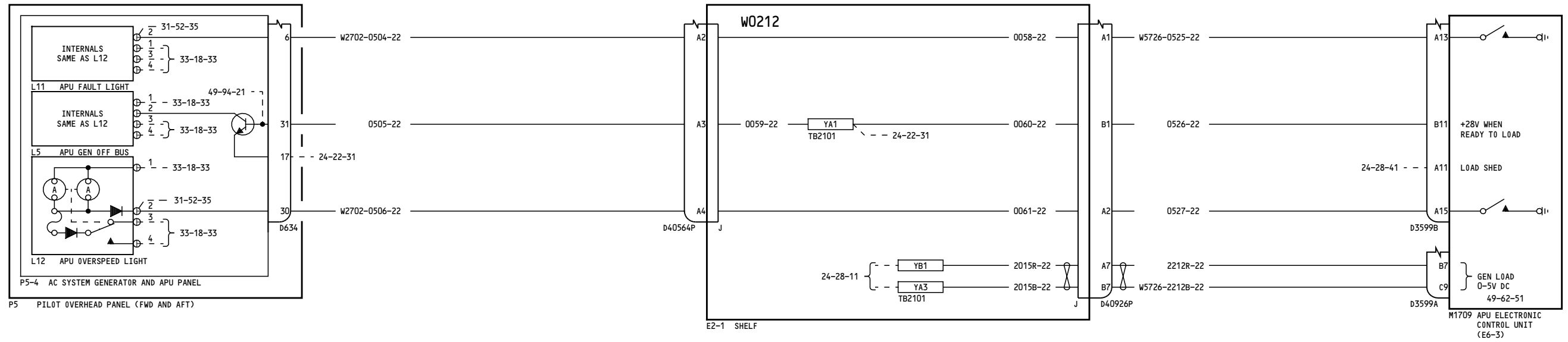

YC001-YC007

**APU CONTROL-  
AIRPLANE INTERFACE**

D280A103

**49-62-11**

Page 1.1  
Sheet 2  
Mar 31/2005

Incorporates  
31-1136

**49-62-11**

Page 1.1  
Sheet 2  
Mar 31/2005

-E

1

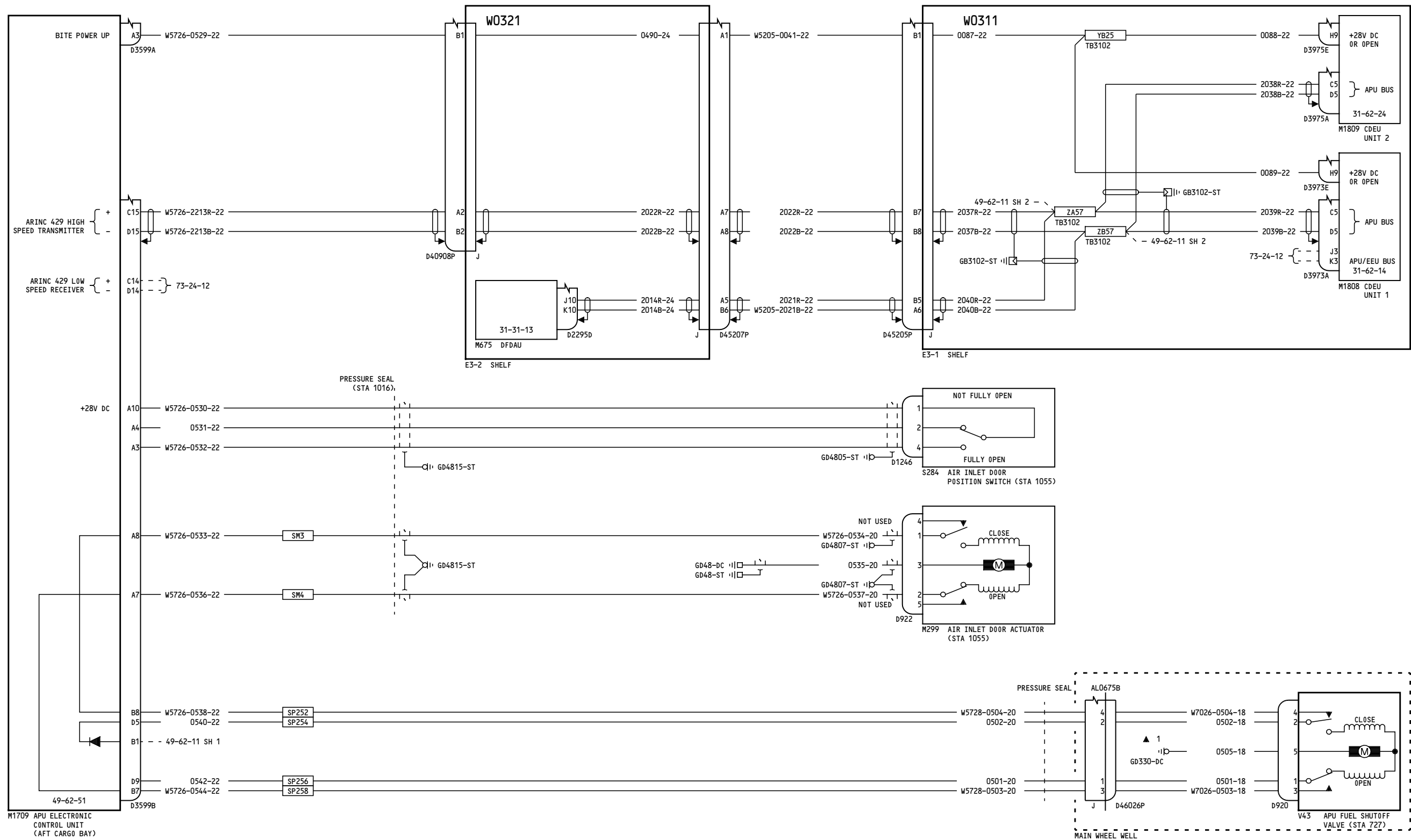

YC001-YC007

**APU CONTROL-  
AIRPLANE INTERFACE**

**49-62-11**

Page 1.1  
Sheet 3  
Mar 31/2005

D280A103

**49-62-11**

Page 1.1  
Sheet 3  
Mar 31/2005



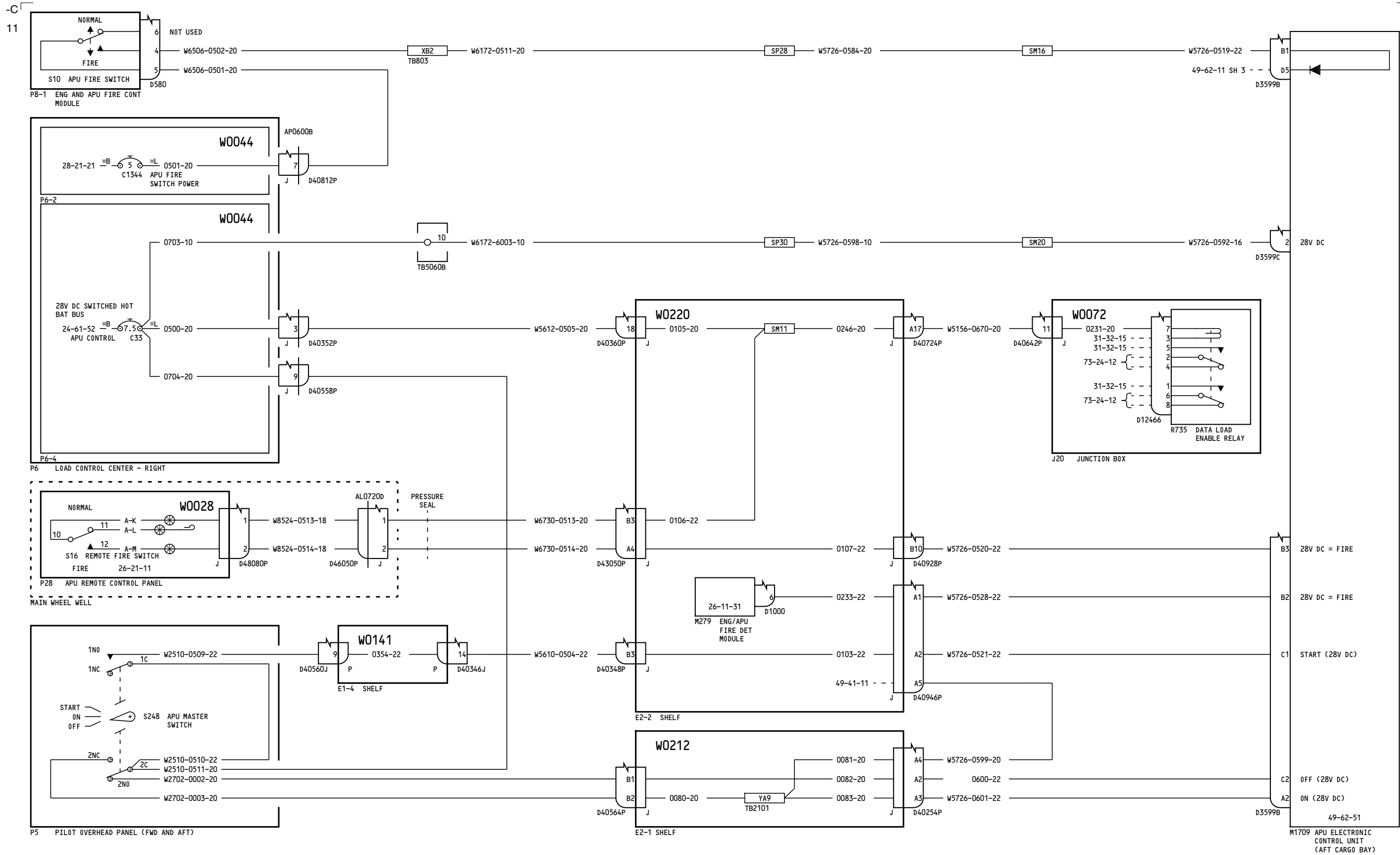

YC008-YC011

APU CONTROL-AIRPLANE INTERFACE

D280A103

49-62-11

Page 2.1  
Sheet 1  
Mar 31/2005

Incorporates  
31-1136

49-62-11

Page 2.1  
Sheet 1  
Mar 31/2005

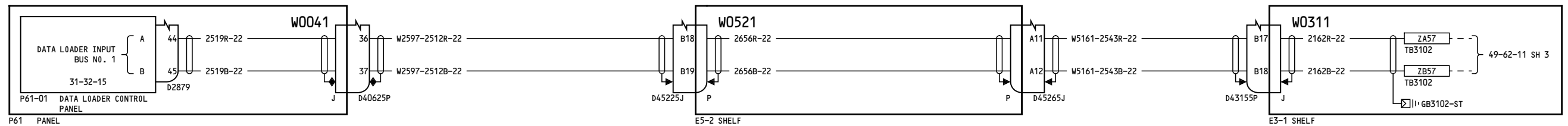
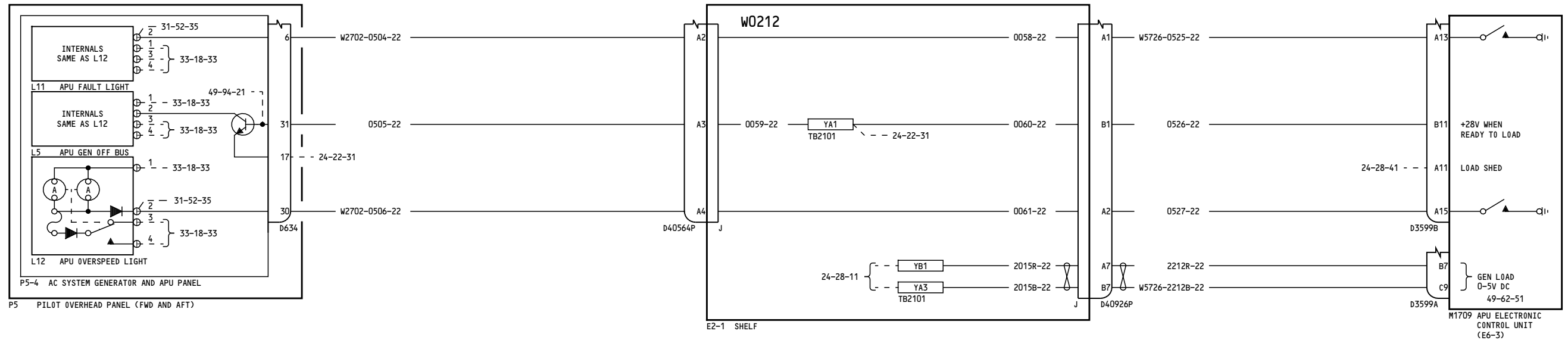

YC008-YC011

**APU CONTROL-  
AIRPLANE INTERFACE**

D280A103

**49-62-11**

Page 2.1  
Sheet 2  
Mar 31/2005

Incorporates  
▶ 31-1136

**49-62-11**

Page 2.1  
Sheet 2  
Mar 31/2005

-E  
5

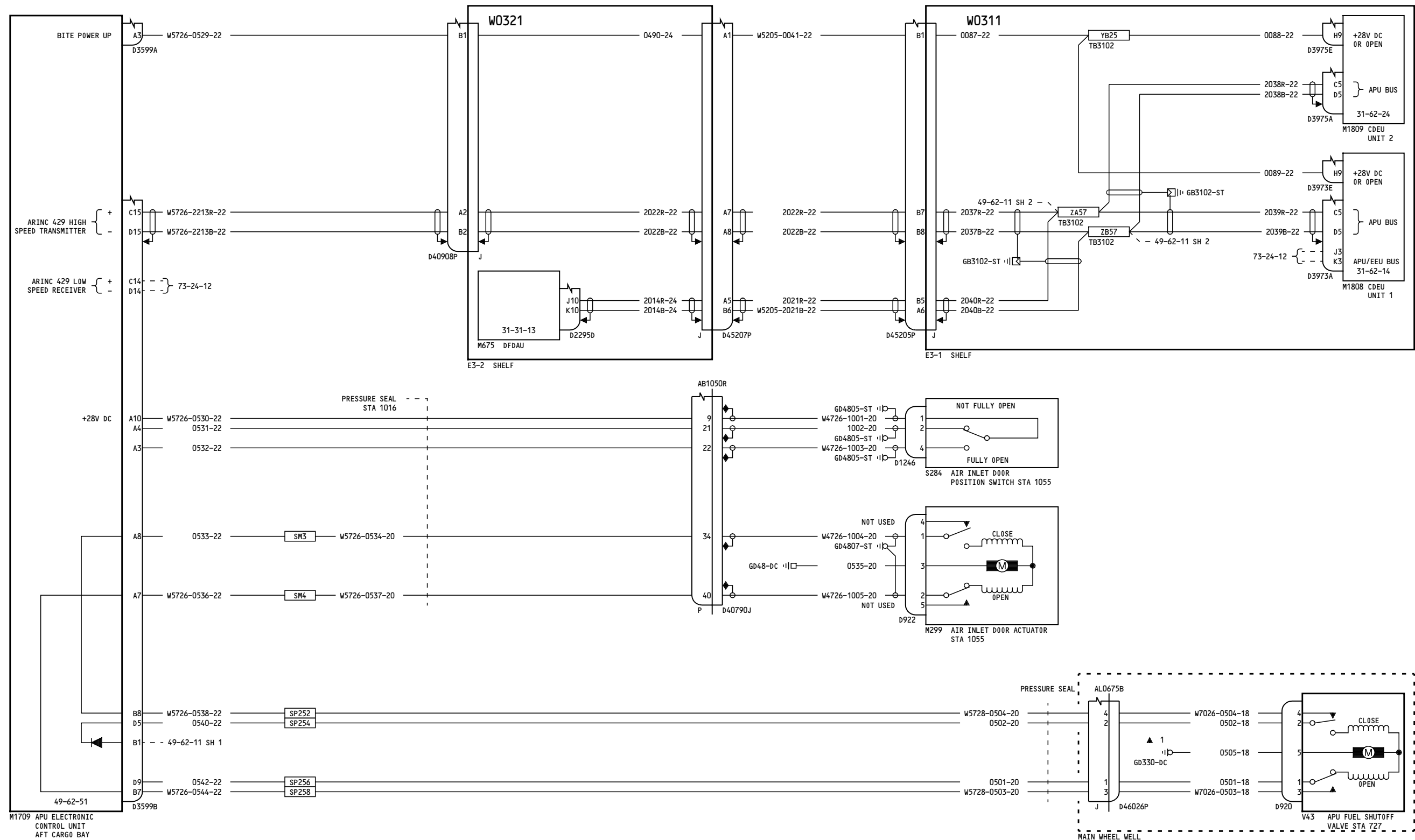

YC008-YC011

**APU CONTROL-  
AIRPLANE INTERFACE**

**49-62-11**

Page 2.1  
Sheet 3  
Mar 31/2005

D280A103

**49-62-11**

Page 2.1  
Sheet 3  
Mar 31/2005

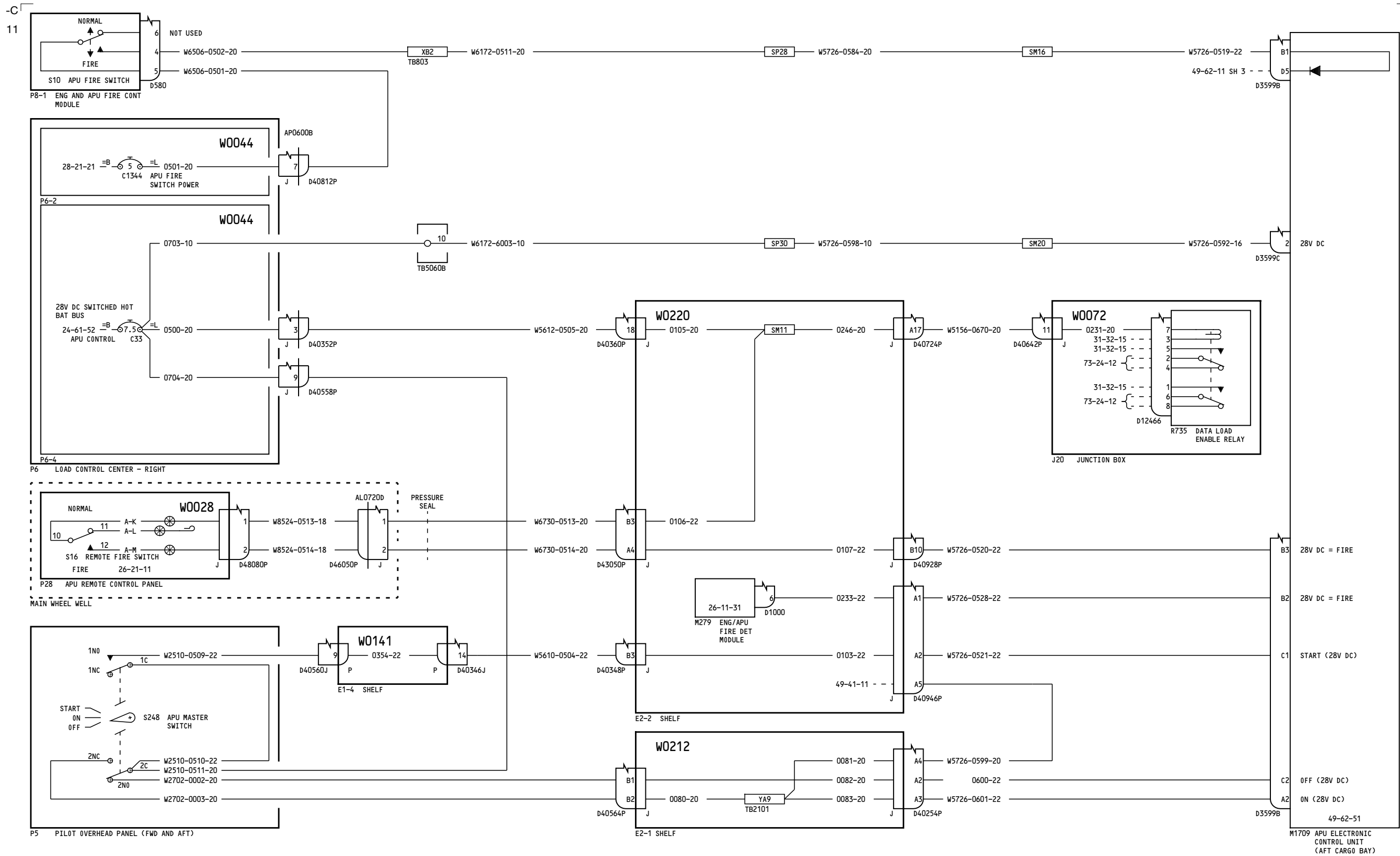

YC012-YC026

**APU CONTROL-  
AIRPLANE INTERFACE**

D280A103

**49-62-11**

Page 3  
Sheet 1  
Jul 17/2007

**49-62-11**

Page 3  
Sheet 1  
Jul 17/2007

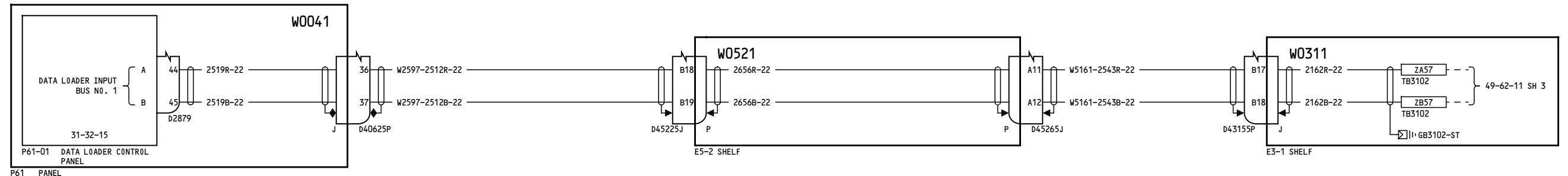
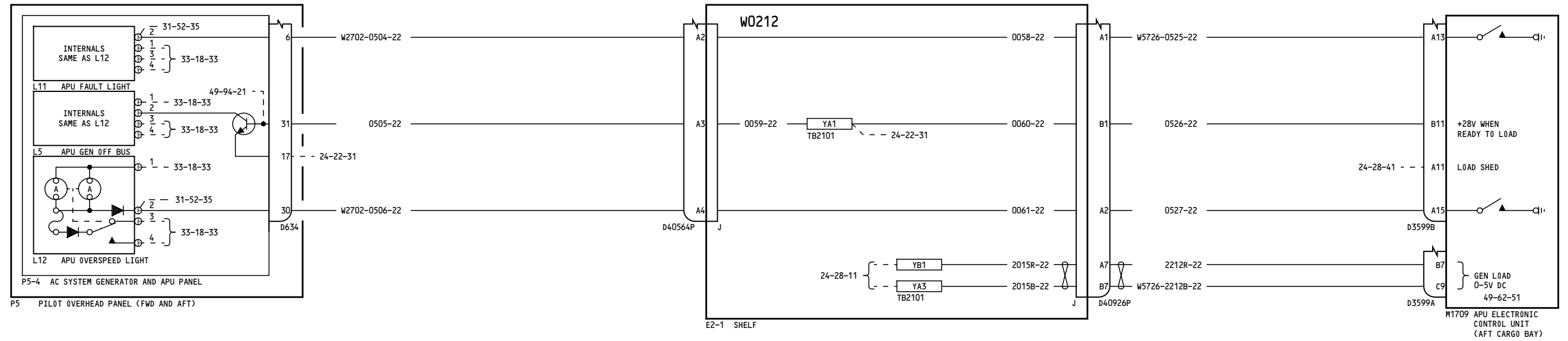

-E  
5

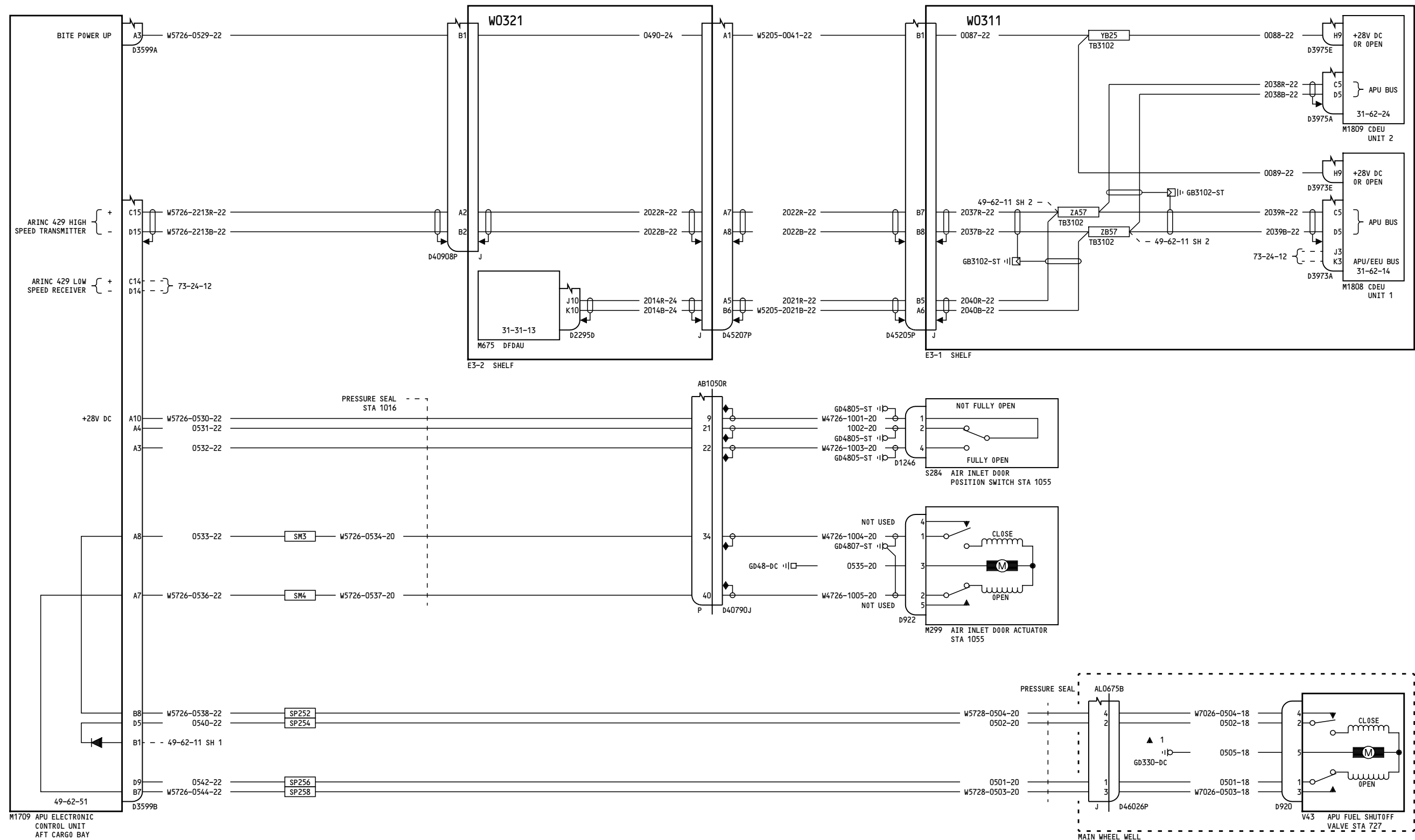

YC012-YC026

**APU CONTROL-  
AIRPLANE INTERFACE**

**49-62-11**

Page 3  
Sheet 3  
Jul 17/2007

D280A103

**49-62-11**

Page 3  
Sheet 3  
Jul 17/2007

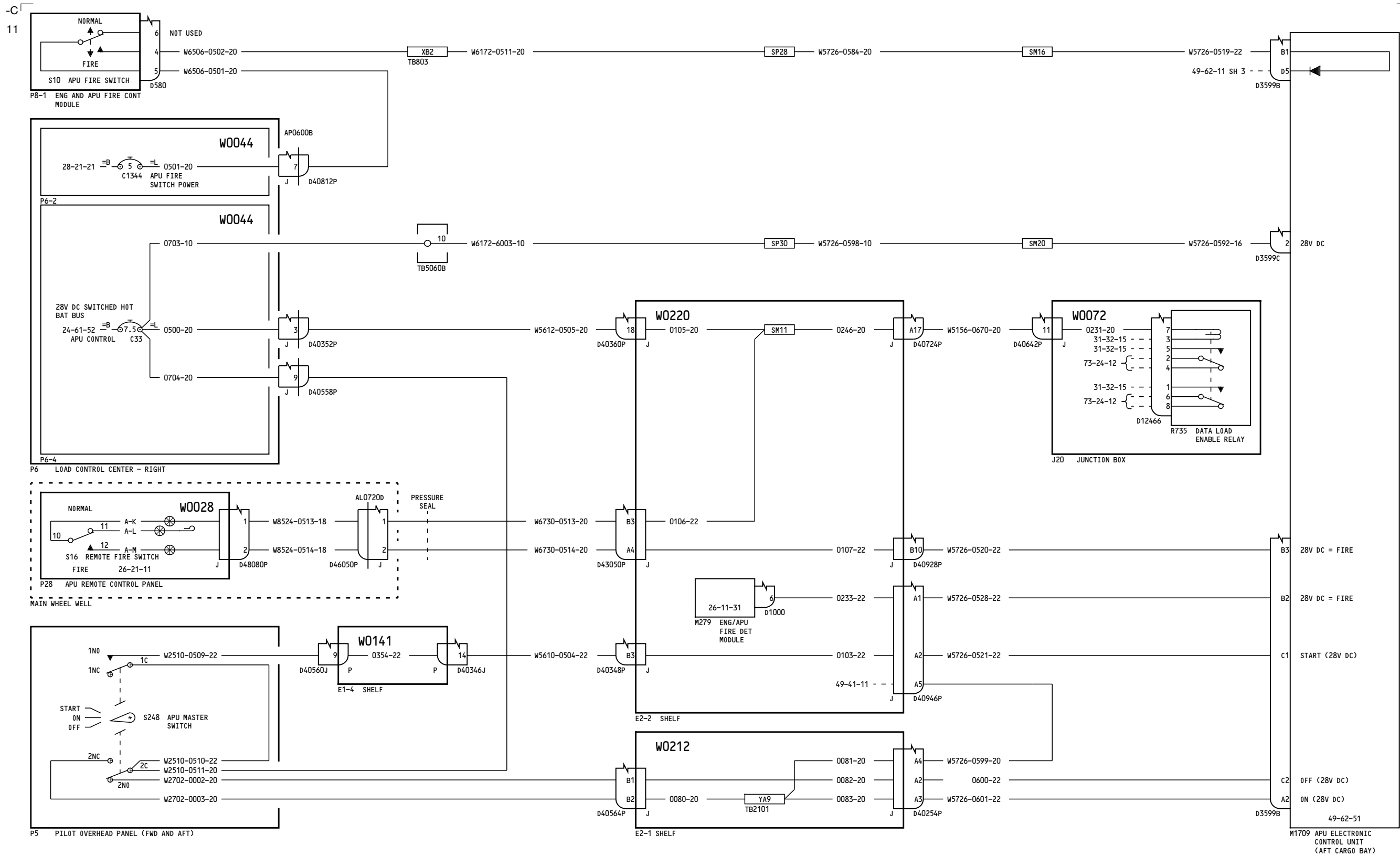

YC028-YC030

**APU CONTROL-AIRPLANE INTERFACE**

D280A103

**49-62-11**

Page 4  
Sheet 1  
Oct 20/2005

**49-62-11**

Page 4  
Sheet 1  
Oct 20/2005

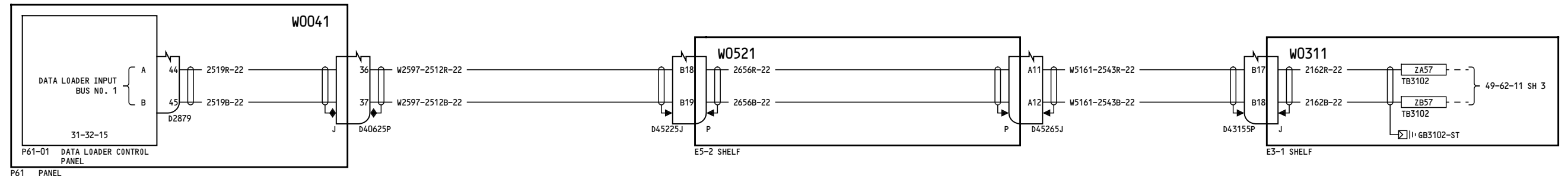
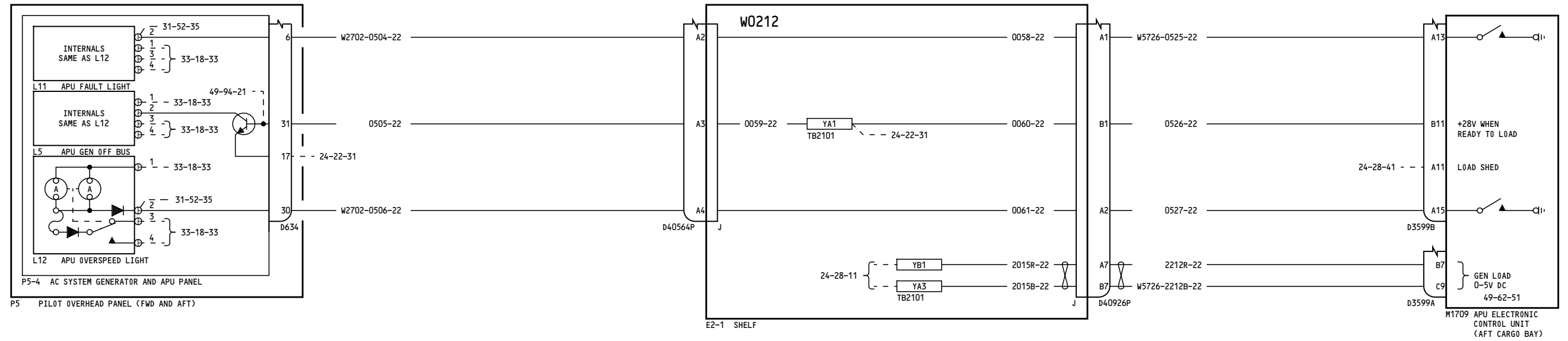



9

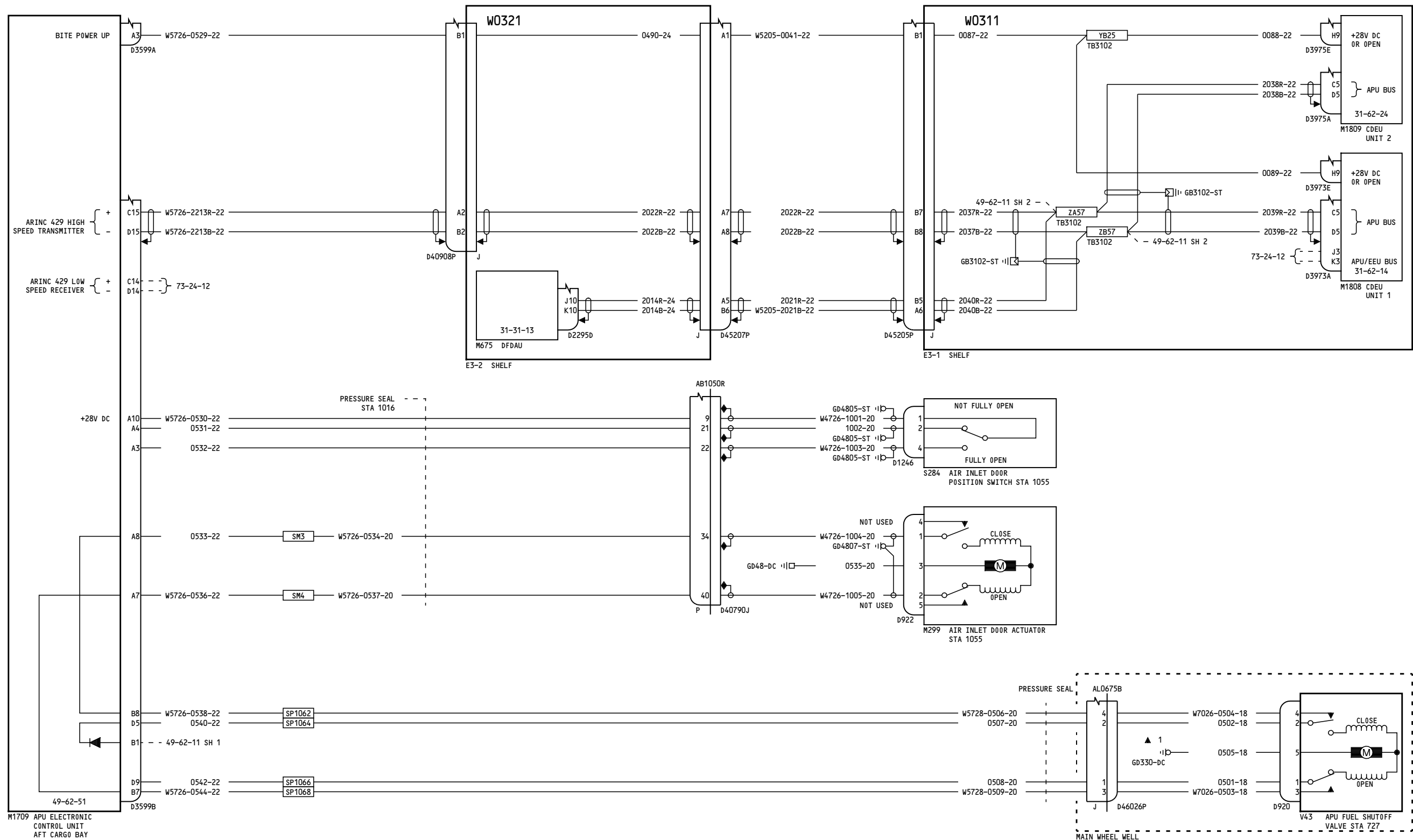

YC028-YC030

**APU CONTROL-  
AIRPLANE INTERFACE**

**49-62-11**

Page 4  
Sheet 3  
Oct 20/2005

D280A103

**49-62-11**

Page 4  
Sheet 3  
Oct 20/2005

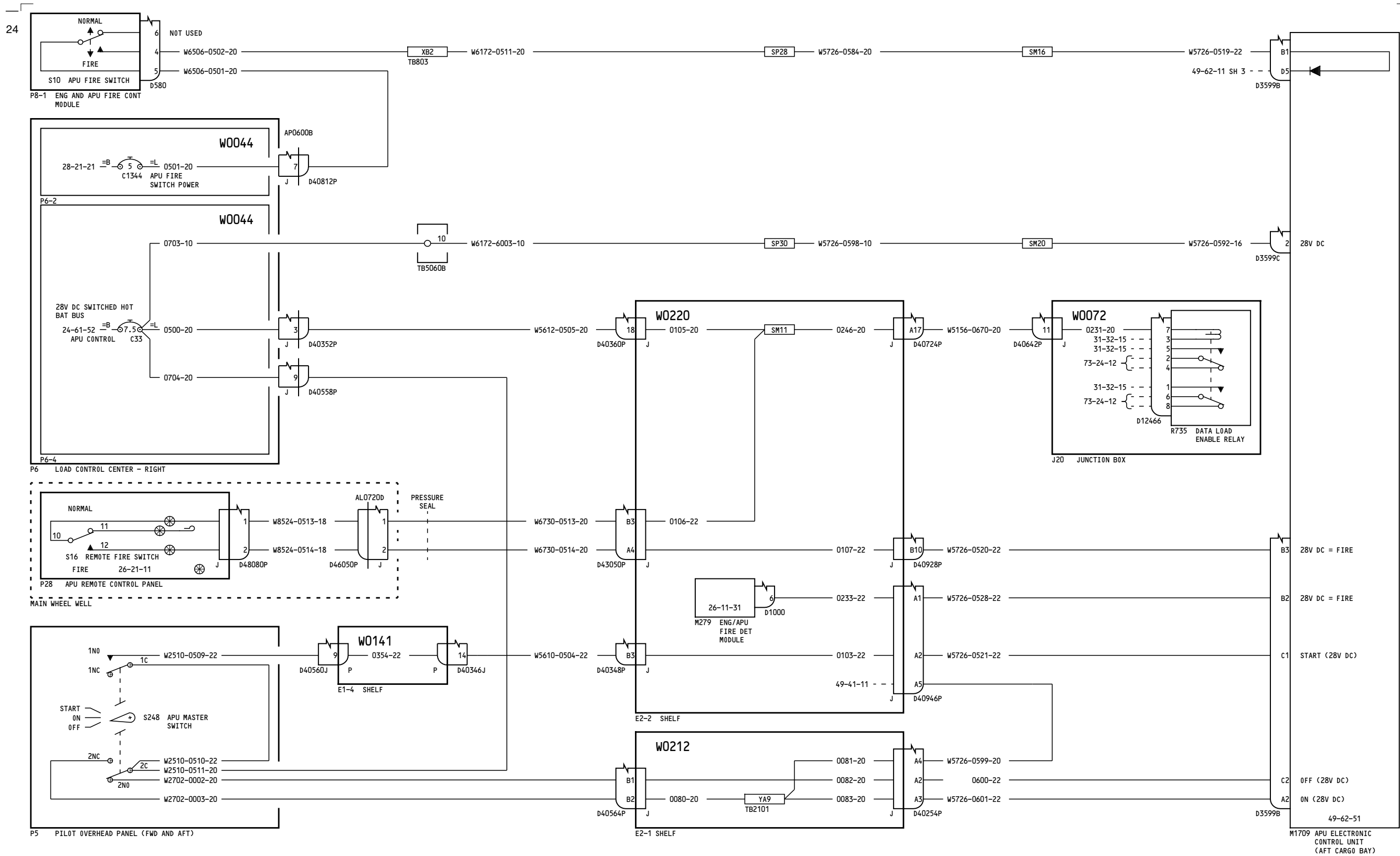

YC031-YL430

**APU CONTROL-  
AIRPLANE INTERFACE**

D280A103

**49-62-11**

Page 5  
Sheet 1  
Feb 09/2009

**49-62-11**

Page 5  
Sheet 1  
Feb 09/2009

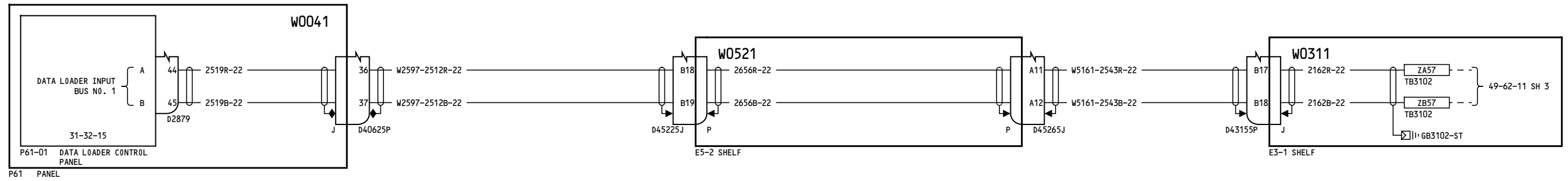
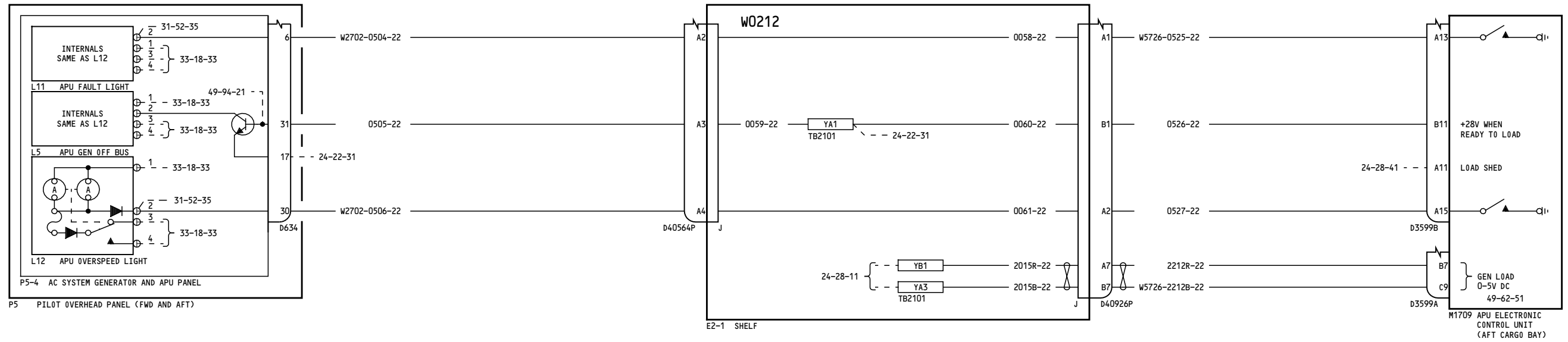

9

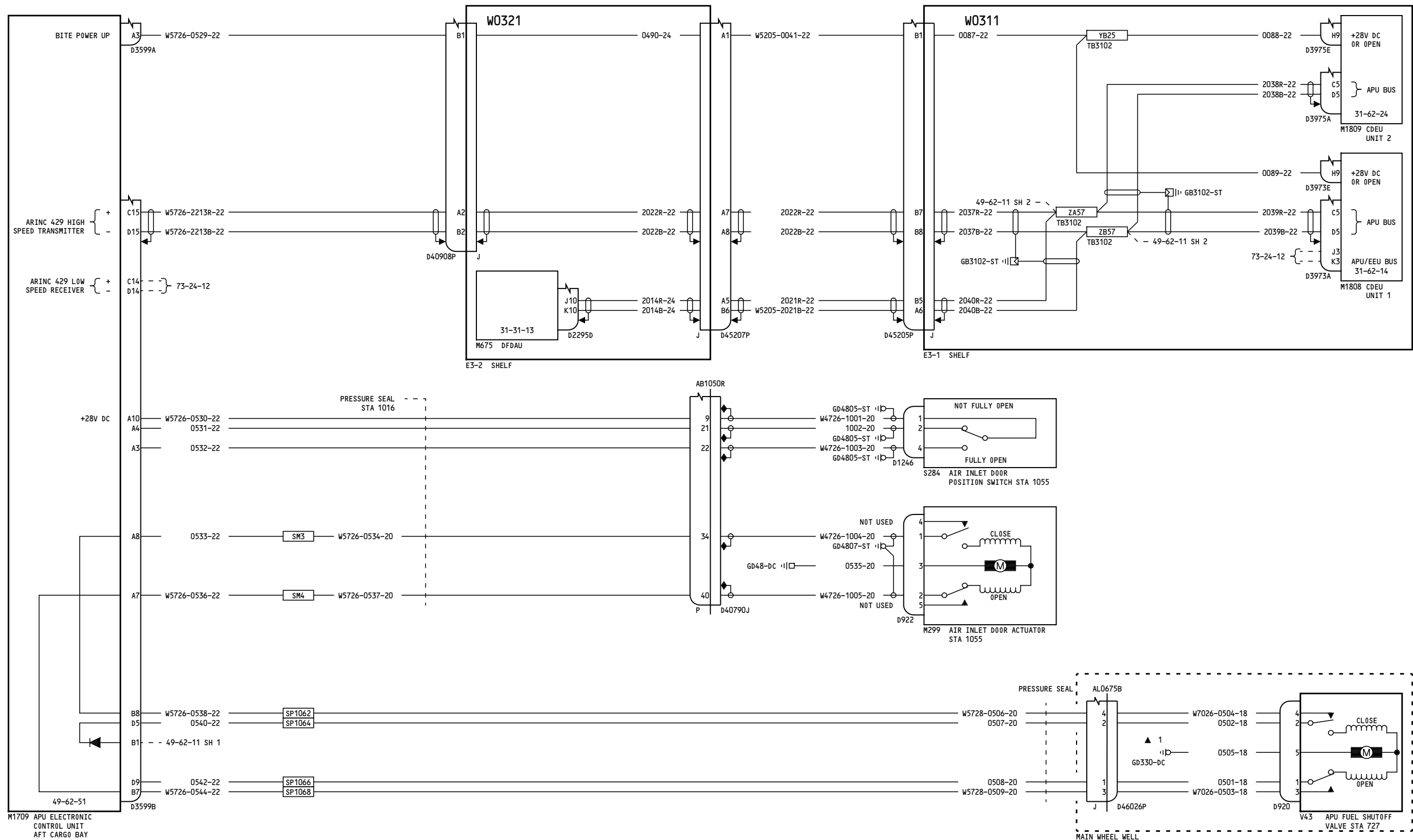

YC031-YL430

**APU CONTROL-  
AIRPLANE INTERFACE**

**49-62-11**

Page 5  
Sheet 3  
Feb 09/2009

D280A103

**49-62-11**

Page 5  
Sheet 3  
Feb 09/2009

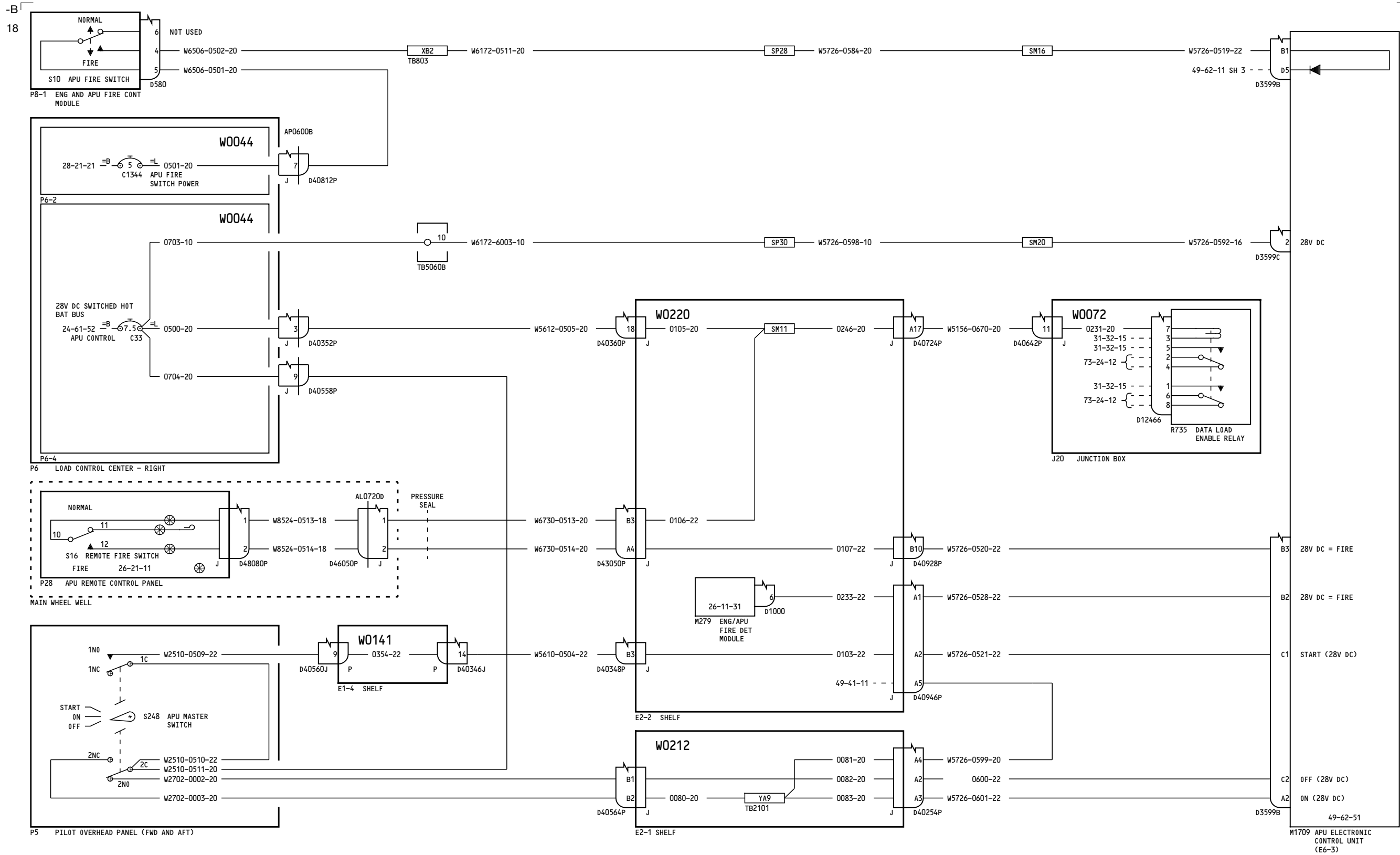

YM643-YM670

APU CONTROL-AIRPLANE INTERFACE

D280A103

49-62-11

Page 6  
Sheet 1  
Jan 14/2008

49-62-11

Page 6  
Sheet 1  
Jan 14/2008

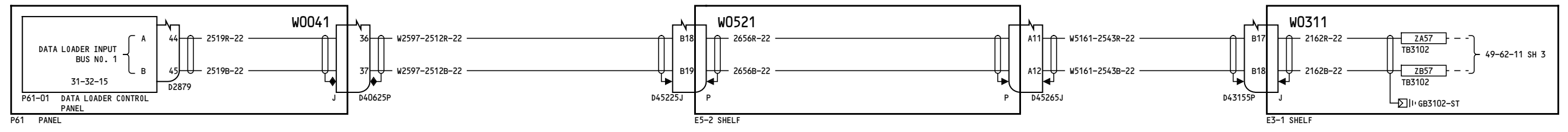
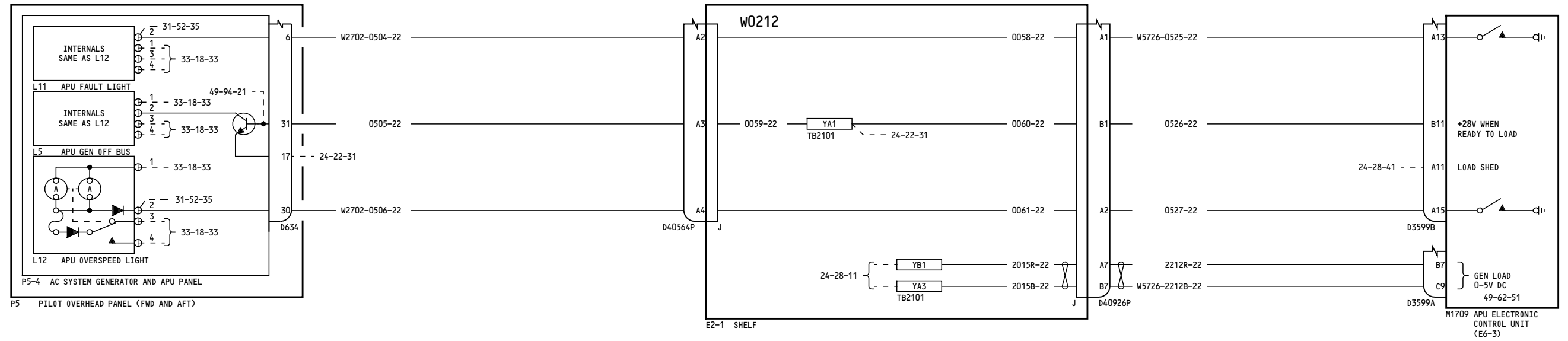

YM643-YM670

**APU CONTROL-  
AIRPLANE INTERFACE**

D280A103

**49-62-11**

Page 6  
Sheet 2  
Jan 14/2008

**49-62-11**

Page 6  
Sheet 2  
Jan 14/2008

-D  
7

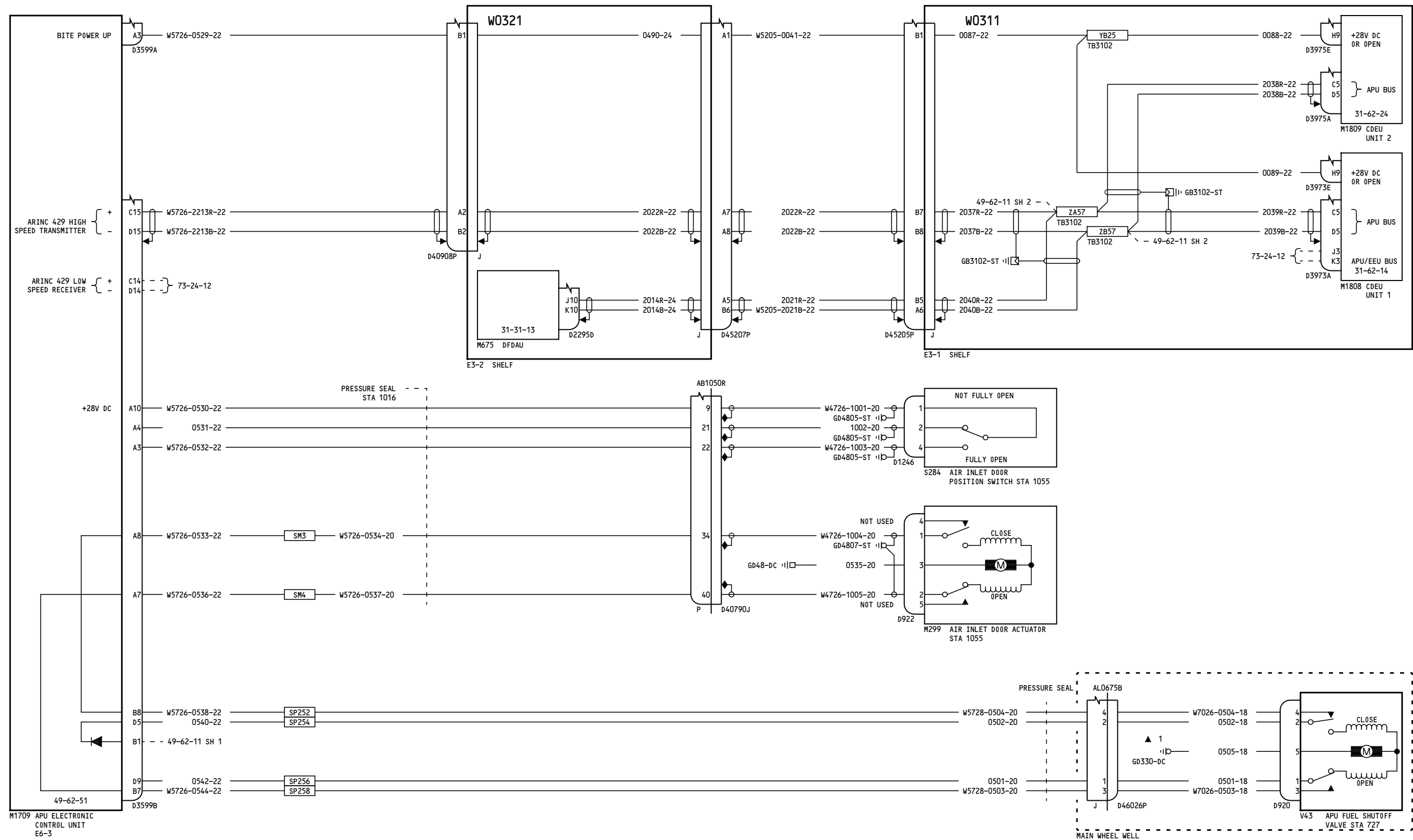

YM643-YM670

**APU CONTROL-  
AIRPLANE INTERFACE**

**49-62-11**

Page 6  
Sheet 3  
Jan 14/2008

D280A103

**49-62-11**

Page 6  
Sheet 3  
Jan 14/2008

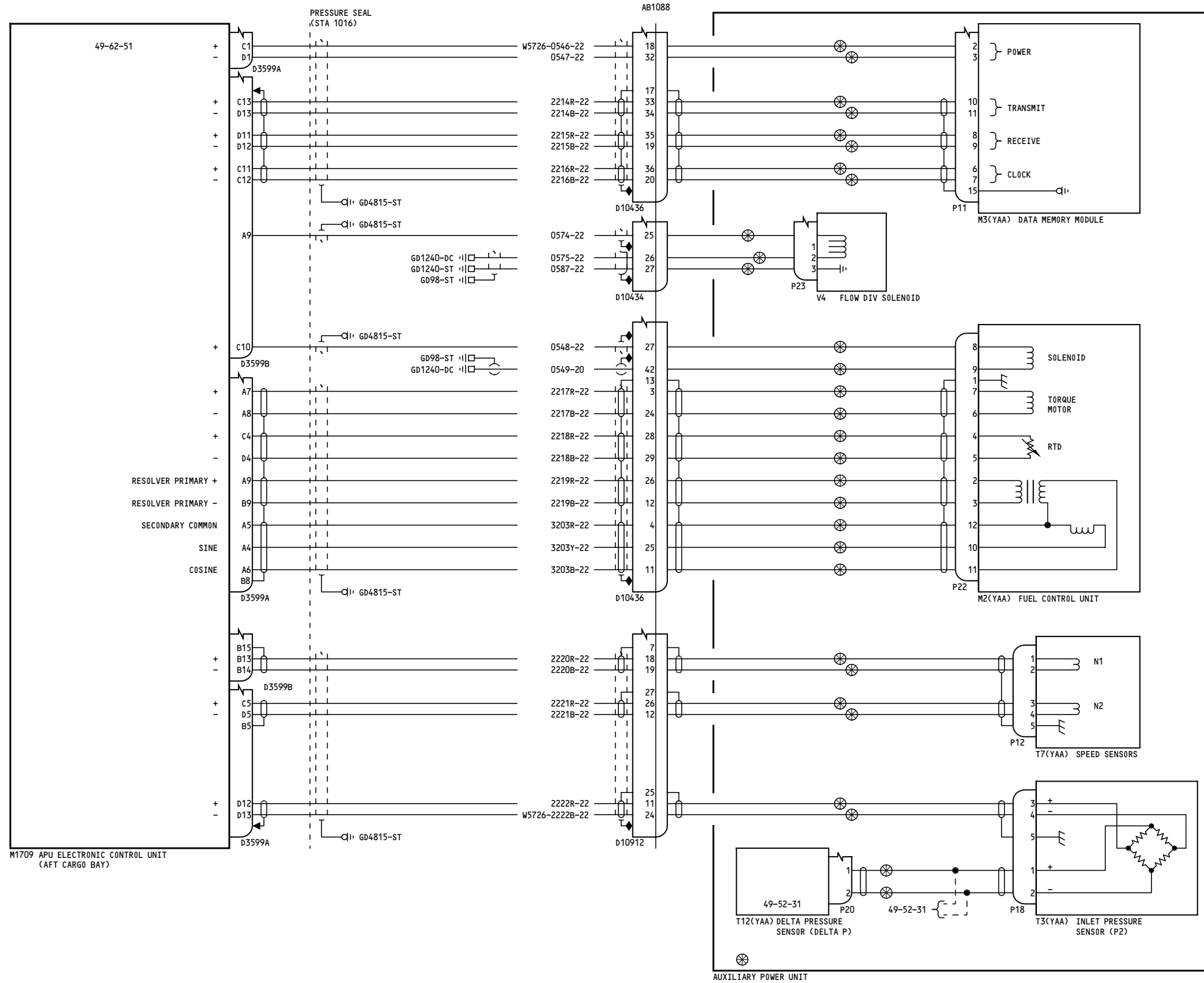

YC001-YC007

**APU CONTROL-  
APU INTERFACE**

**49-62-12**

Page 1

D280A103

Jul 26/2006

**49-62-12**

Page 1

Jul 26/2006



-D  
3

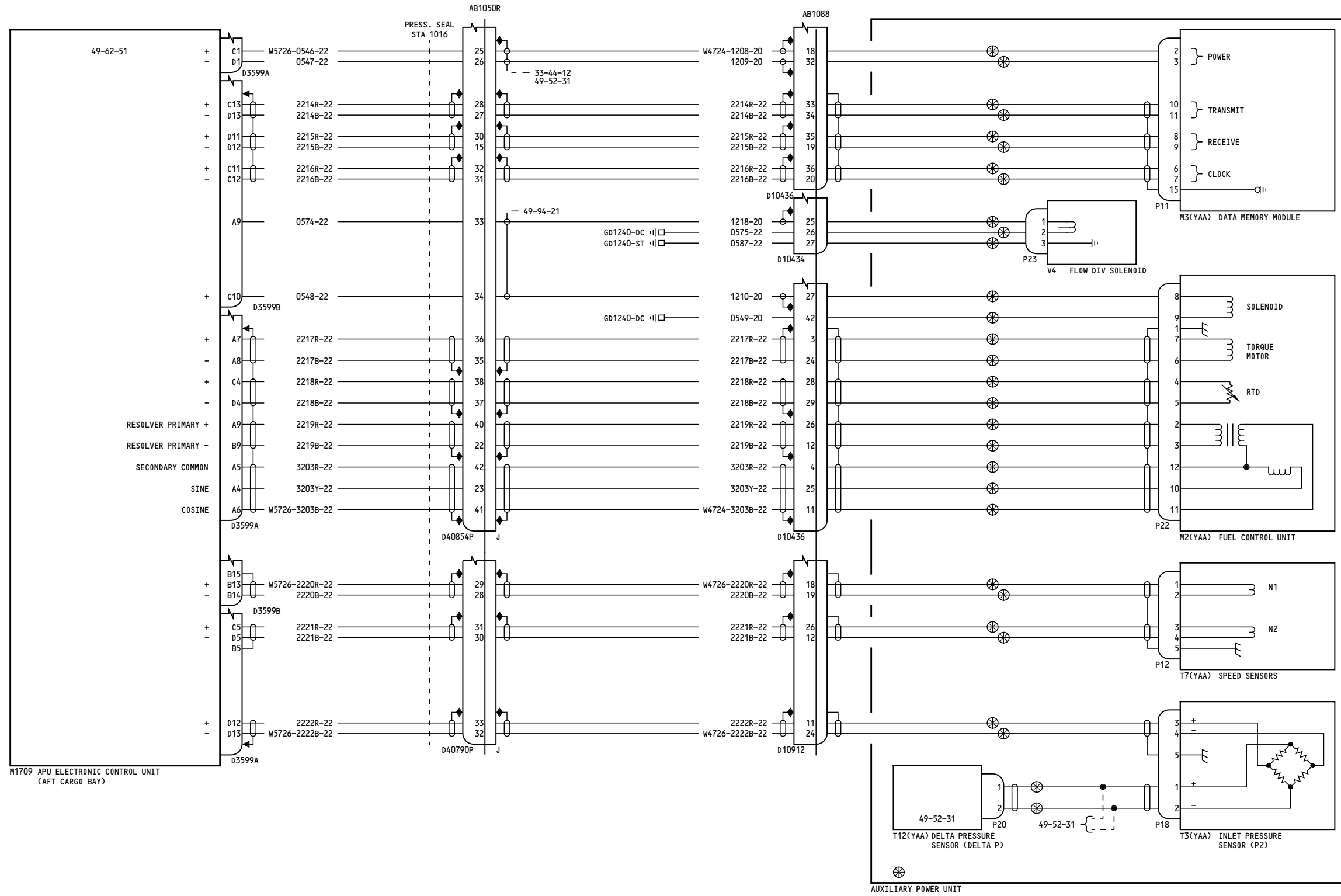

YC008-YL430

**APU CONTROL-  
APU INTERFACE**

**49-62-12**

Page 2

D280A103

May 11/2009

**49-62-12**

Page 2

May 11/2009

-D  
4

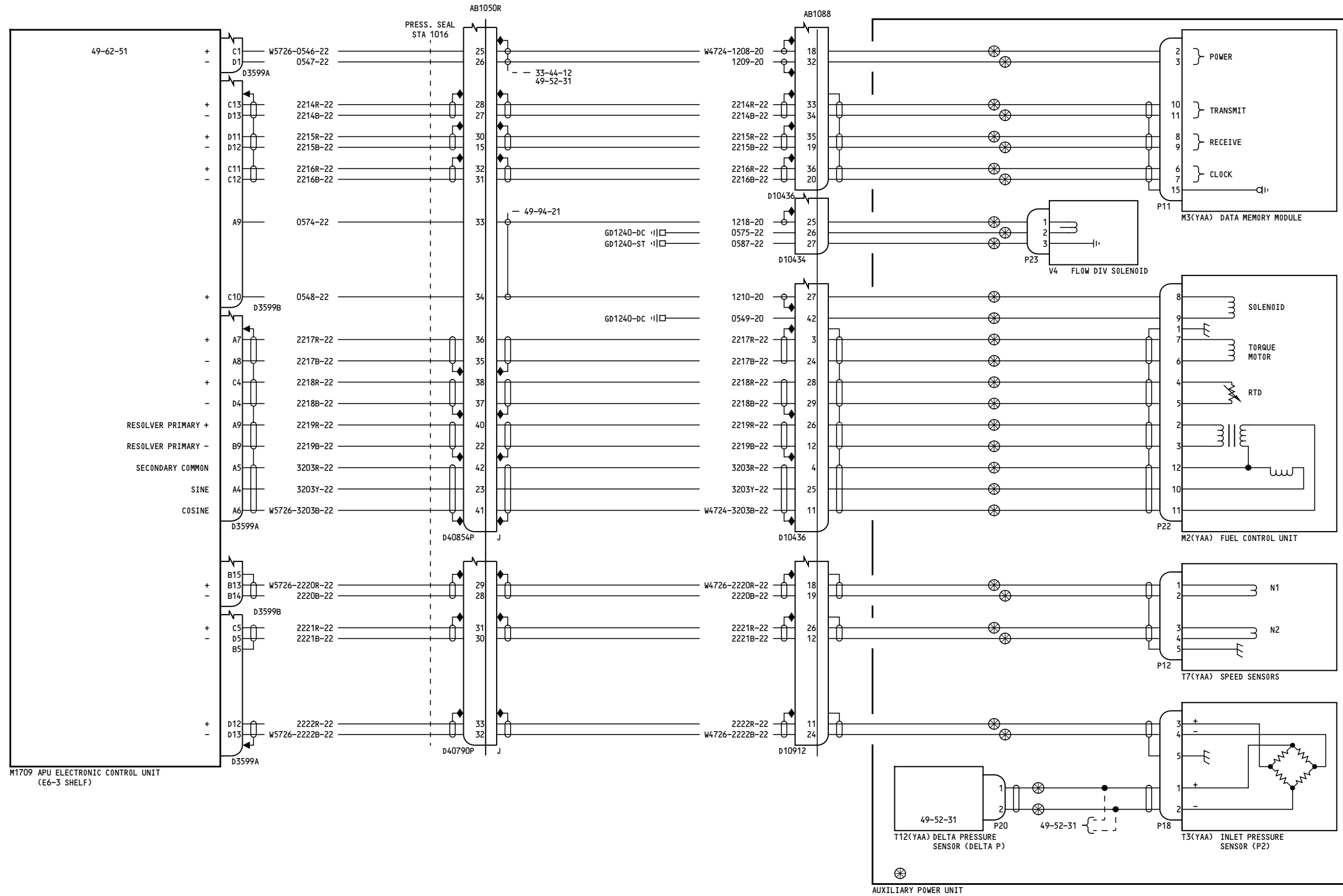

YM643-YM670

**APU CONTROL-  
APU INTERFACE**

**49-62-12**

Page 3

D280A103

May 11/2009

**49-62-12**

Page 3

May 11/2009

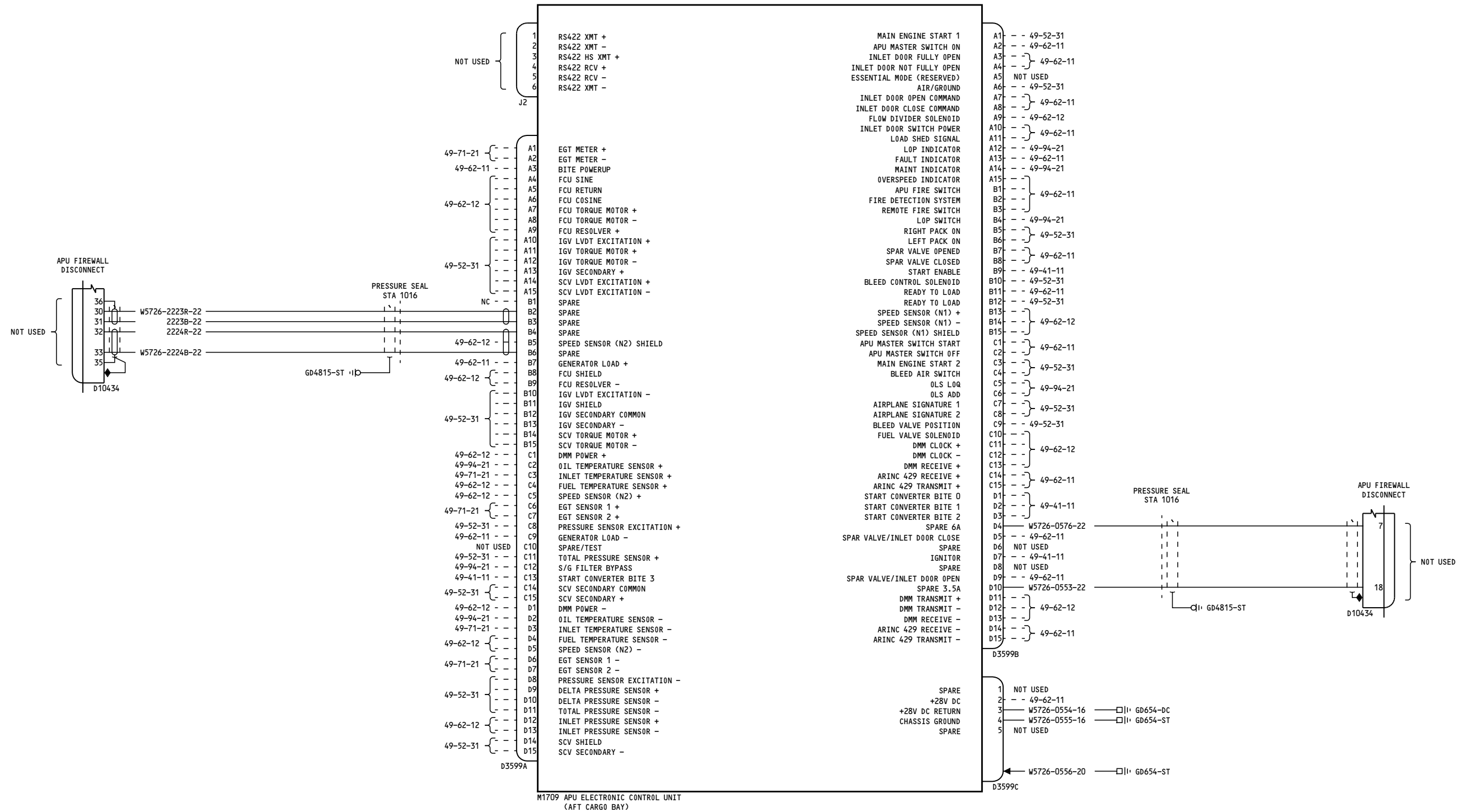

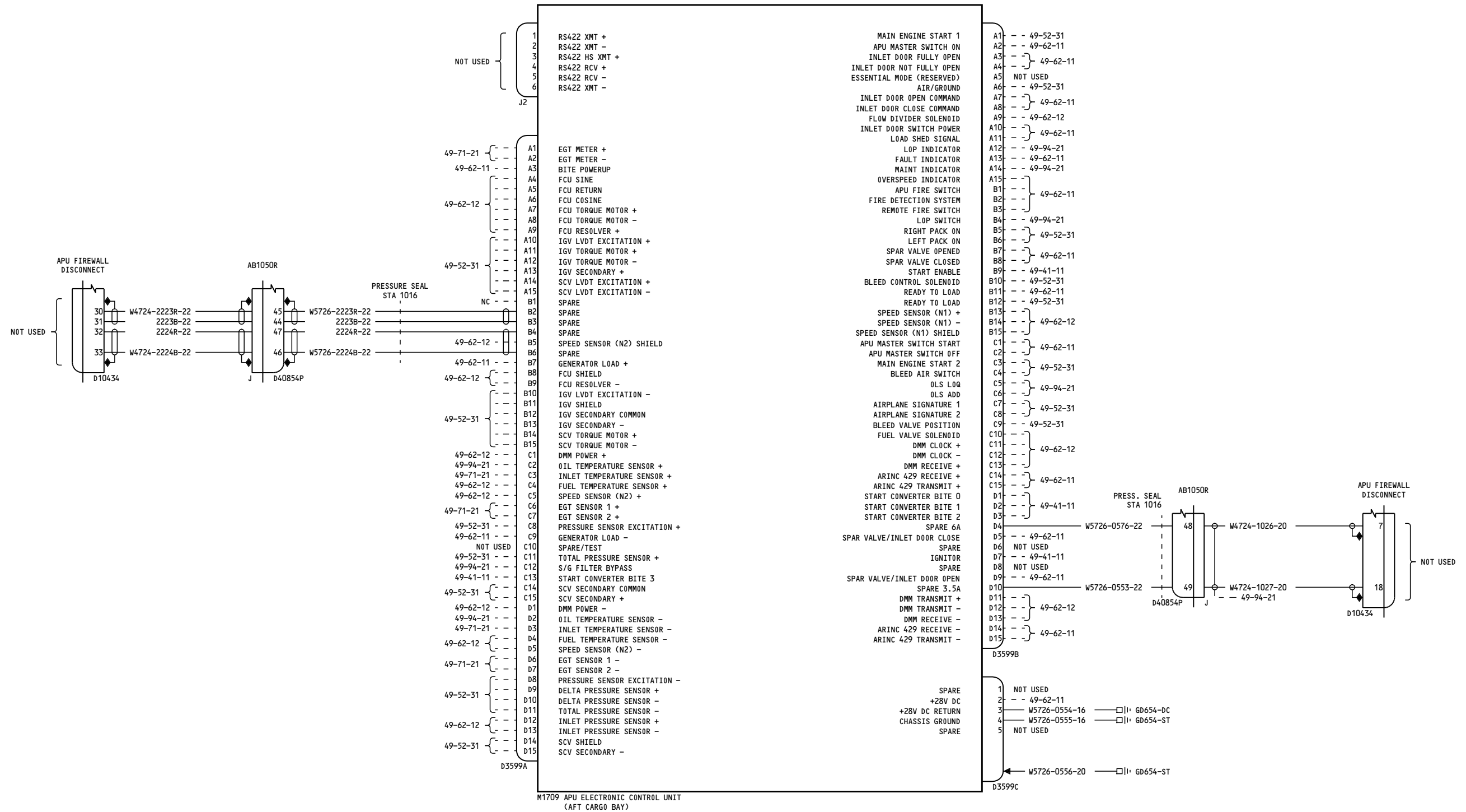

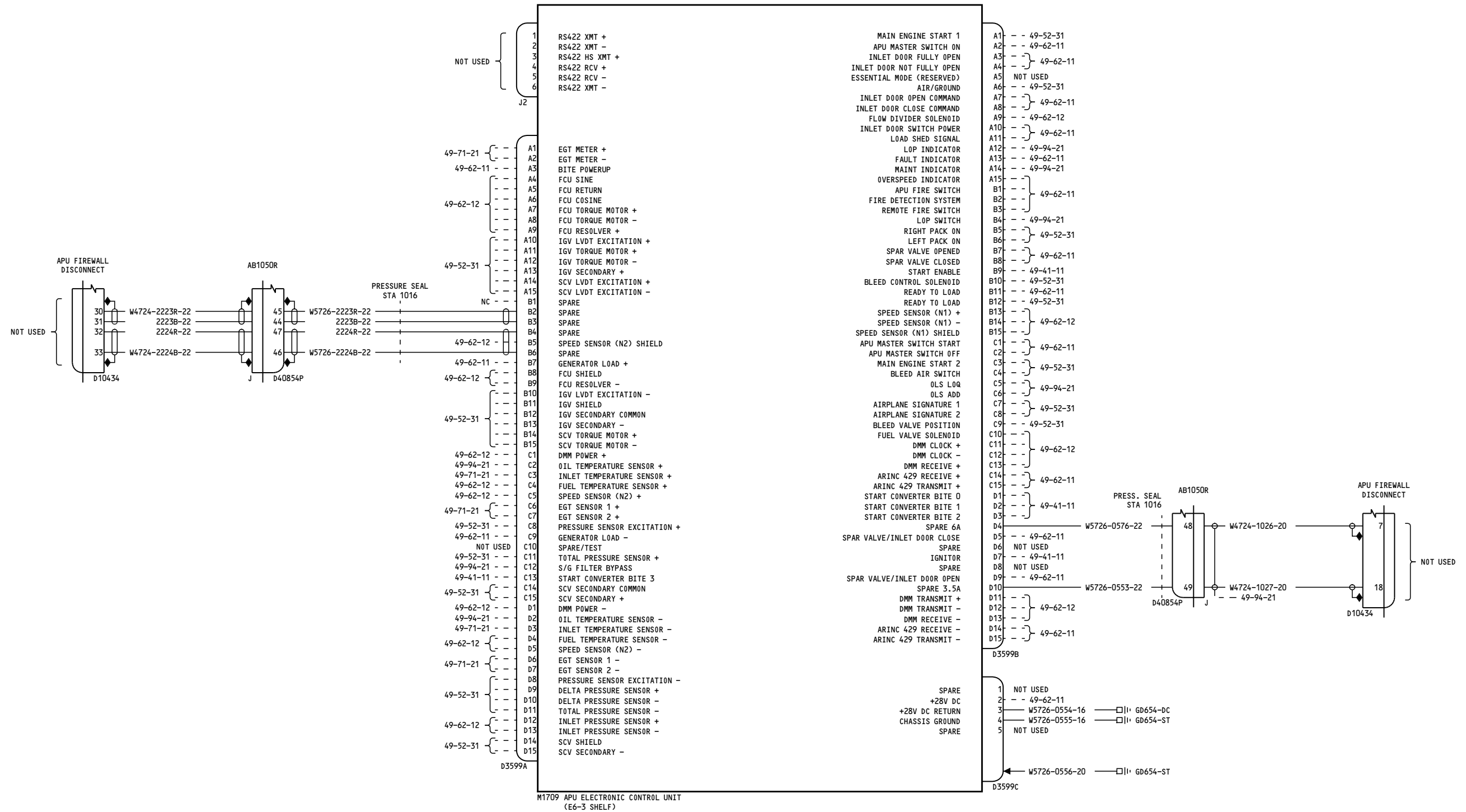

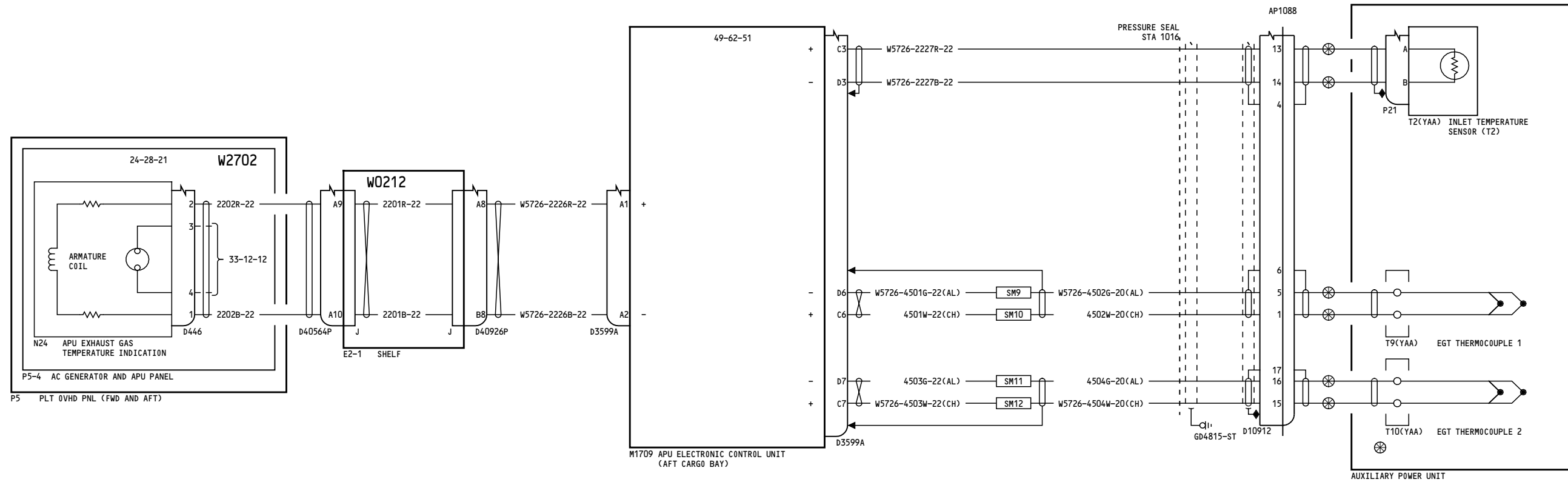

YC001-YC007

**APU EGT SYSTEM**

D280A103

**49-71-21**

Page 1

Mar 31/2005

**49-71-21**

Page 1

Mar 31/2005

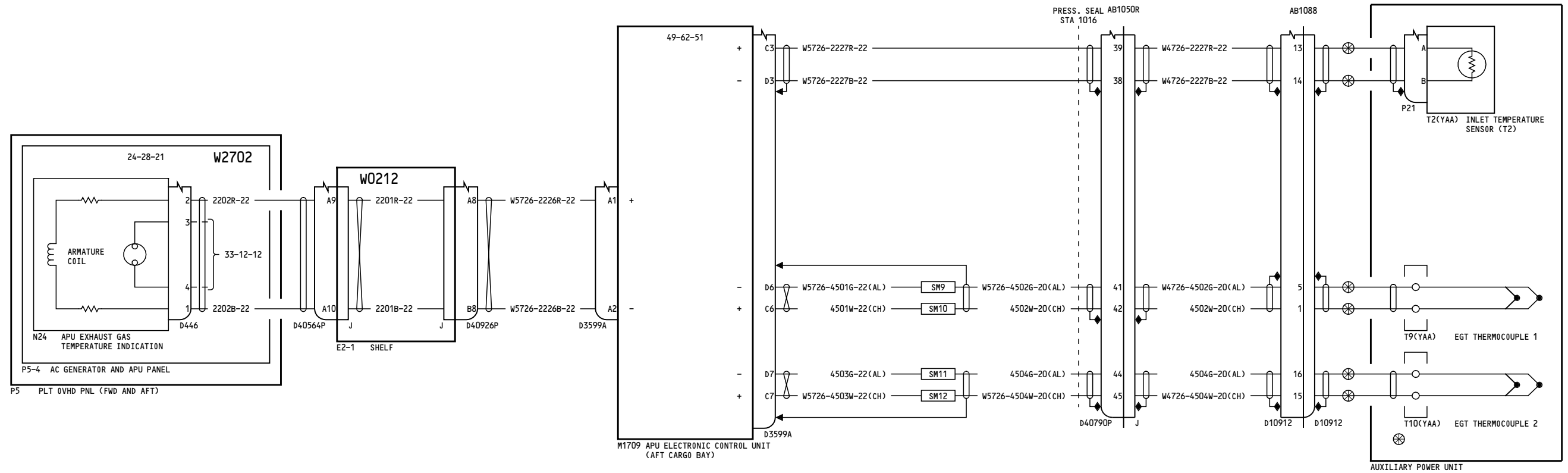

YC008-YL430

**APU EGT SYSTEM**

D280A103

**49-71-21**

Page 2

Feb 09/2009

**49-71-21**

Page 2

Feb 09/2009

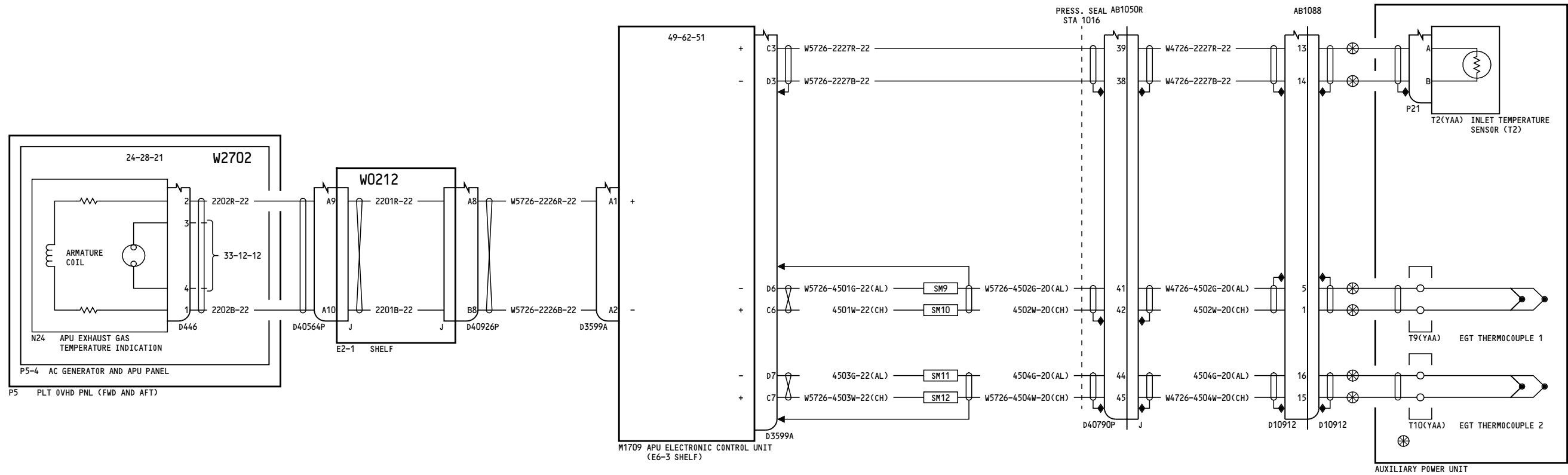

YM643-YM670

**APU EGT SYSTEM**

**49-71-21**

Page 3

Jan 14/2008

D280A103

**49-71-21**

Page 3

Jan 14/2008



-N  
1

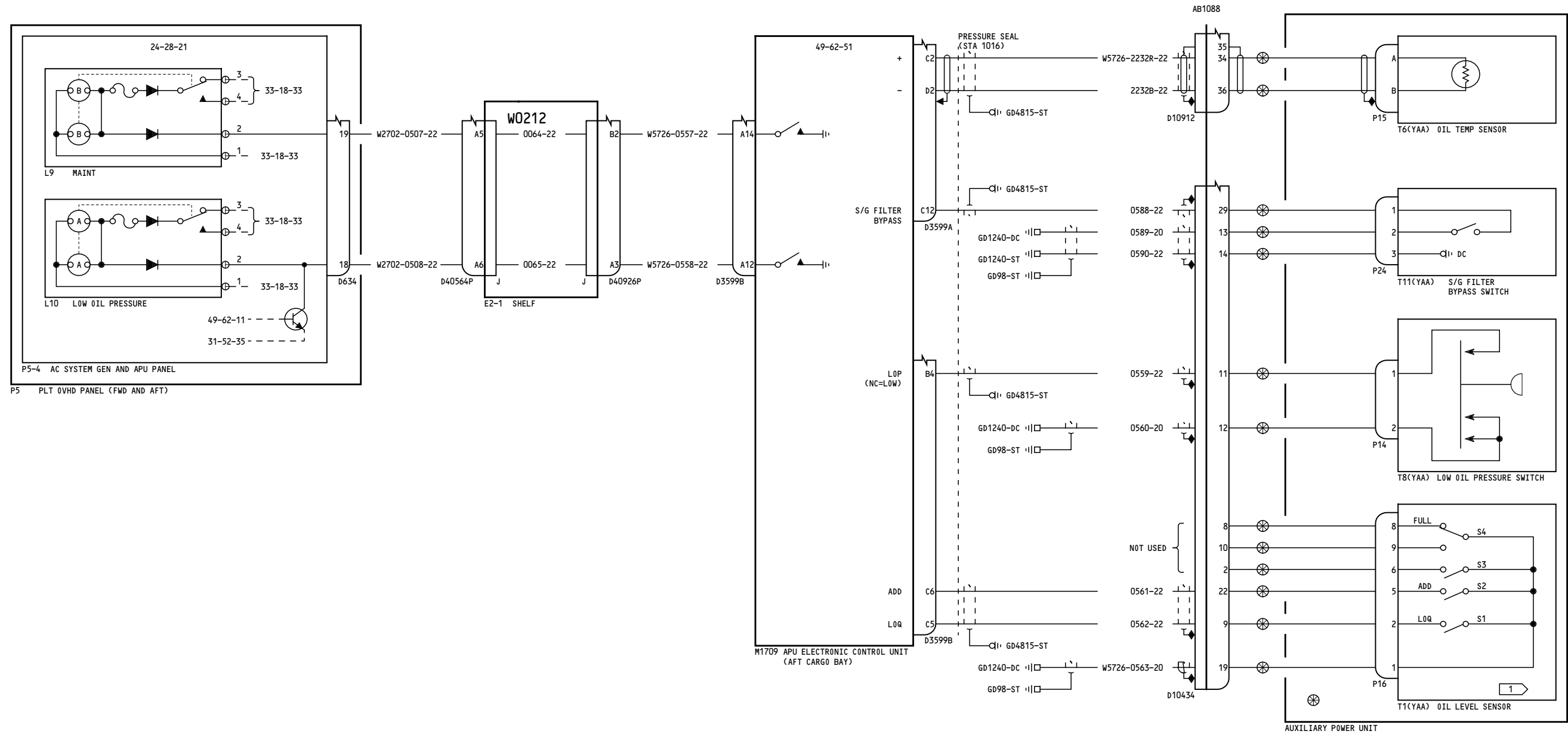

**NOTES:**

1 SHOWN IN FULL OIL POSITION WITH ENGINE OFF.

YC001-YC007

**APU OIL SYSTEM**

**49-94-21**

Page 1

May 11/2009

D280A103

**49-94-21**

Page 1

May 11/2009

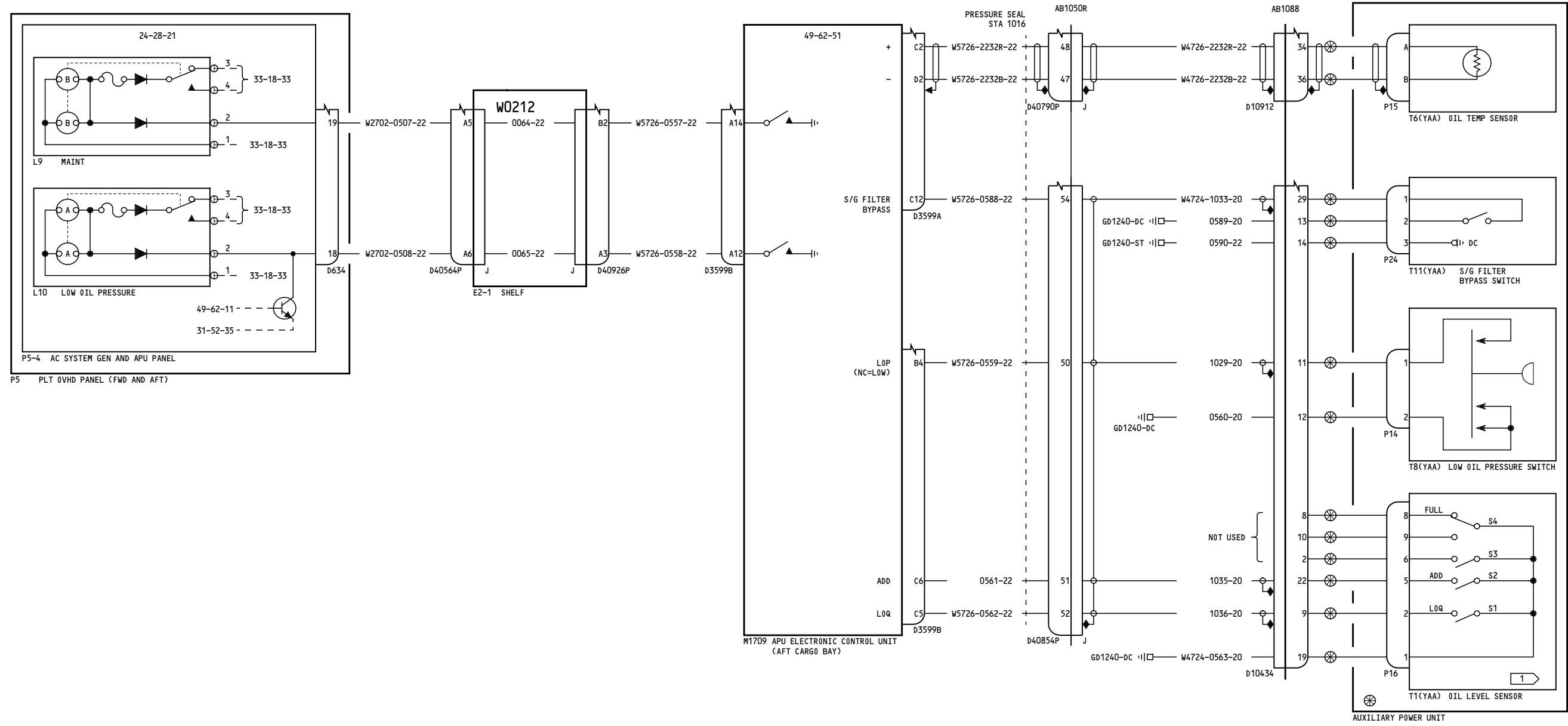

**NOTES:**

1 SHOWN IN FULL OIL POSITION WITH ENGINE OFF.

YC008-YL430

**APU OIL SYSTEM**

**49-94-21**

Page 2

May 11/2009

D280A103

**49-94-21**

Page 2

May 11/2009

-F  
4

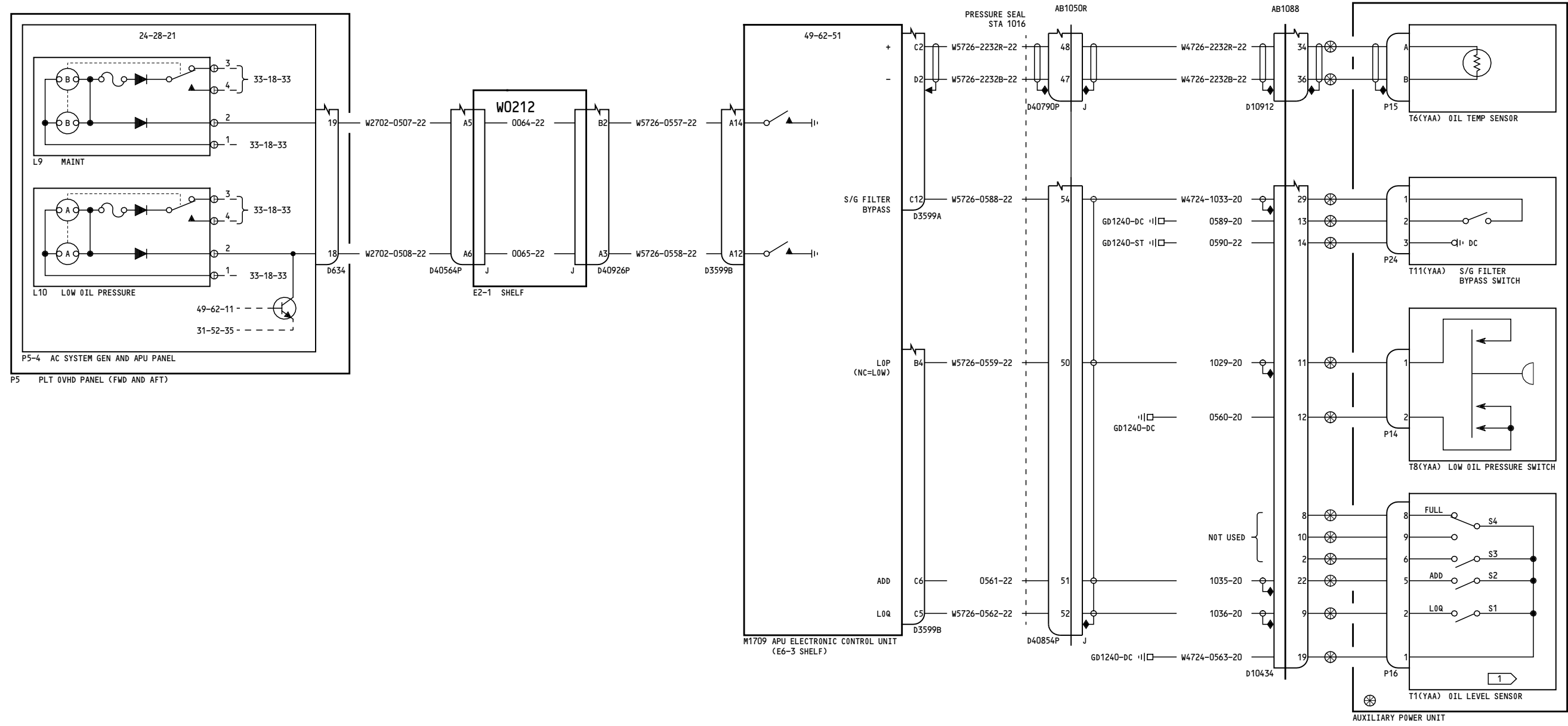

**NOTES:**

1 SHOWN IN FULL OIL POSITION WITH ENGINE OFF.

YM643-YM670  <b>APU OIL SYSTEM</b>  D280A103
--

**49-94-21**

Page 3

May 11/2009

**49-94-21**

Page 3

May 11/2009