

CHAPTER

52

DOORS



737-700/800

WIRING DIAGRAM MANUAL

CHAPTER 52
DOORS

CH-SC-SU	Schem	Page	Sheet	Date	CH-SC-SU	Schem	Page	Sheet	Date
52-EFFECTIVE PAGES									
		1		Aug 10/2009					
		2		BLANK					
52-CONTENTS									
		1		Feb 09/2009					
		2		Feb 09/2009					
52-ALPHABETICAL INDEX									
		1		Jan 18/2007					
		2		BLANK					
52-51-11		1		Jul 17/2007					
		2		Feb 09/2009					
52-71-11		1		Mar 31/2005					
		2		Jul 17/2007					
		3		Jul 26/2006					
		4		Feb 09/2009					
52-71-12		1		Mar 31/2005					
		2		Jul 17/2007					
		3		May 13/2008					
		4		Feb 09/2009					
		5		Aug 13/2008					
		6		Aug 13/2008					
		7		Aug 13/2008					
		8		Aug 13/2008					
52-71-13		1	1	Mar 31/2005					
			2	Mar 31/2005					
			3	Mar 31/2005					
		2	1	Jul 17/2007					
			2	Jul 17/2007					
			3	Jul 17/2007					
		3	1	Feb 09/2009					
			2	Feb 09/2009					
			3	Feb 09/2009					
		4	1	Jan 14/2008					
			2	Jan 14/2008					
52-71-14		1	1	Mar 31/2005					
			2	Mar 31/2005					
			3	Mar 31/2005					
		2	1	Jul 17/2007					
			2	Jul 17/2007					
			3	Jul 17/2007					
		3	1	Feb 09/2009					
			2	Feb 09/2009					
			3	Feb 09/2009					
		4	1	Jan 14/2008					
			2	Jan 14/2008					

A = Added, R = Revised, D = Deleted, O = Overflow

52-EFFECTIVE PAGES

Page 1
Aug 10/2009

D280A103



737-700/800

WIRING DIAGRAM MANUAL

CHAPTER 52
DOORS

Title	CH-SC-SU	Schem	Page	Sheet	Date	Effectivity
<u>CREW DOOR</u>						
CONTROL CABIN DOOR LOCK	52-51-11		1		Jul 17/2007	YC001-YC030
			2		Feb 09/2009	YC031-YM670
<u>DOOR WARNING SYSTEM</u>						
DOOR WARNING SYSTEM - ENTRY AND SERVICE	52-71-11		1		Mar 31/2005	YC001-YC003
			2		Jul 17/2007	YC004-YC050
			3		Jul 26/2006	YK901-YK906
			4		Feb 09/2009	YK907-YM670
DOOR WARNING SYSTEM - CARGO AND EQUIPMENT	52-71-12		1		Mar 31/2005	YC001-YC003
			2		Jul 17/2007	YC004-YC050
			3		May 13/2008	YK901-YK910 YL421-YL426
			4		Feb 09/2009	YK911 YK913-YK918
			5		Aug 13/2008	YK912 YK919-YK920
			6		Aug 13/2008	YL401 YL427-YL430
			7		Aug 13/2008	YM643-YM651
			8		Aug 13/2008	YM652-YM670
DOOR WARNING OVERWING - LEFT OVERWING	52-71-13		1	1	Mar 31/2005	YC001-YC003
			2		Mar 31/2005	YC001-YC003
			3		Mar 31/2005	YC001-YC003
			2	1	Jul 17/2007	YC004-YC050
			2		Jul 17/2007	YC004-YC050
			3		Jul 17/2007	YC004-YC050
			3	1	Feb 09/2009	YK901-YL430
			2		Feb 09/2009	YK901-YL430
			3		Feb 09/2009	YK901-YL430
			4	1	Jan 14/2008	YM643-YM670
2		Jan 14/2008	YM643-YM670			
DOOR WARNING OVERWING - RIGHT OVERWING	52-71-14		1	1	Mar 31/2005	YC001-YC003

52-CONTENTS

Page 1
Feb 09/2009

D280A103



737-700/800

WIRING DIAGRAM MANUAL

CHAPTER 52 DOORS

Title	CH-SC-SU	Schem	Page	Sheet	Date	Effectivity
DOOR WARNING OVERWING - RIGHT OVERWING (cont.)	52-71-14			2	Mar 31/2005	YC001-YC003
				3	Mar 31/2005	YC001-YC003
			2	1	Jul 17/2007	YC004-YC050
				2	Jul 17/2007	YC004-YC050
				3	Jul 17/2007	YC004-YC050
			3	1	Feb 09/2009	YK901-YL430
				2	Feb 09/2009	YK901-YL430
				3	Feb 09/2009	YK901-YL430
			4	1	Jan 14/2008	YM643-YM670
				2	Jan 14/2008	YM643-YM670

52-CONTENTS

Page 2
Feb 09/2009

D280A103



737-700/800

WIRING DIAGRAM MANUAL

CHAPTER 52 DOORS

CH-SC-SU	Title
52-51-11	CONTROL CABIN DOOR LOCK
52-71-13	DOOR WARNING OVERWING - LEFT OVERWING
52-71-14	DOOR WARNING OVERWING - RIGHT OVERWING
52-71-12	DOOR WARNING SYSTEM - CARGO AND EQUIPMENT
52-71-11	DOOR WARNING SYSTEM - ENTRY AND SERVICE

52-ALPHABETICAL INDEX

D280A103

Page 1
Jan 18/2007

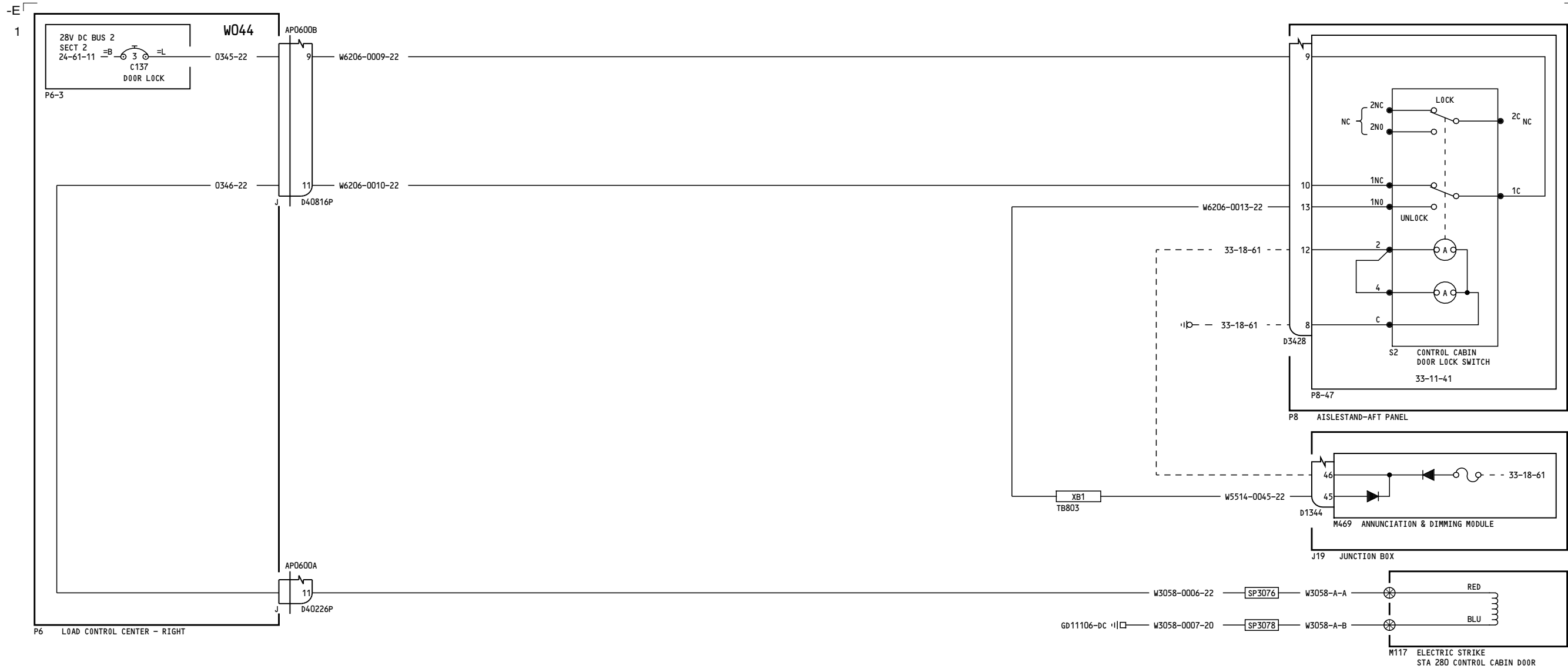

YC001-YC030

CONTROL CABIN DOOR LOCK

52-51-11

Page 1

D280A103

Jul 17/2007

52-51-11

Page 1

Jul 17/2007

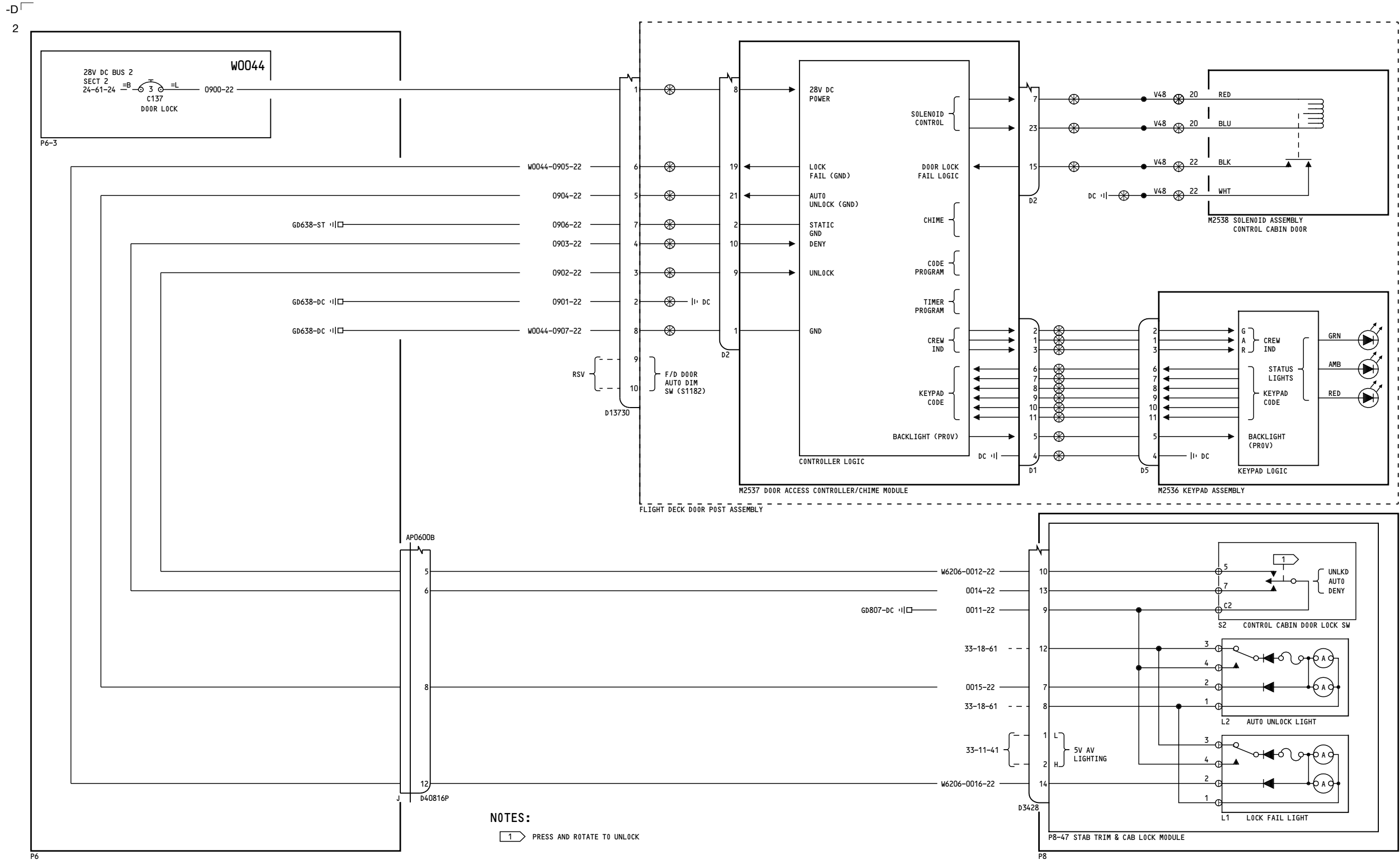

YC031-YM670

CONTROL CABIN DOOR LOCK

52-51-11

Page 2

D280A103

Feb 09/2009

52-51-11

Page 2

Feb 09/2009

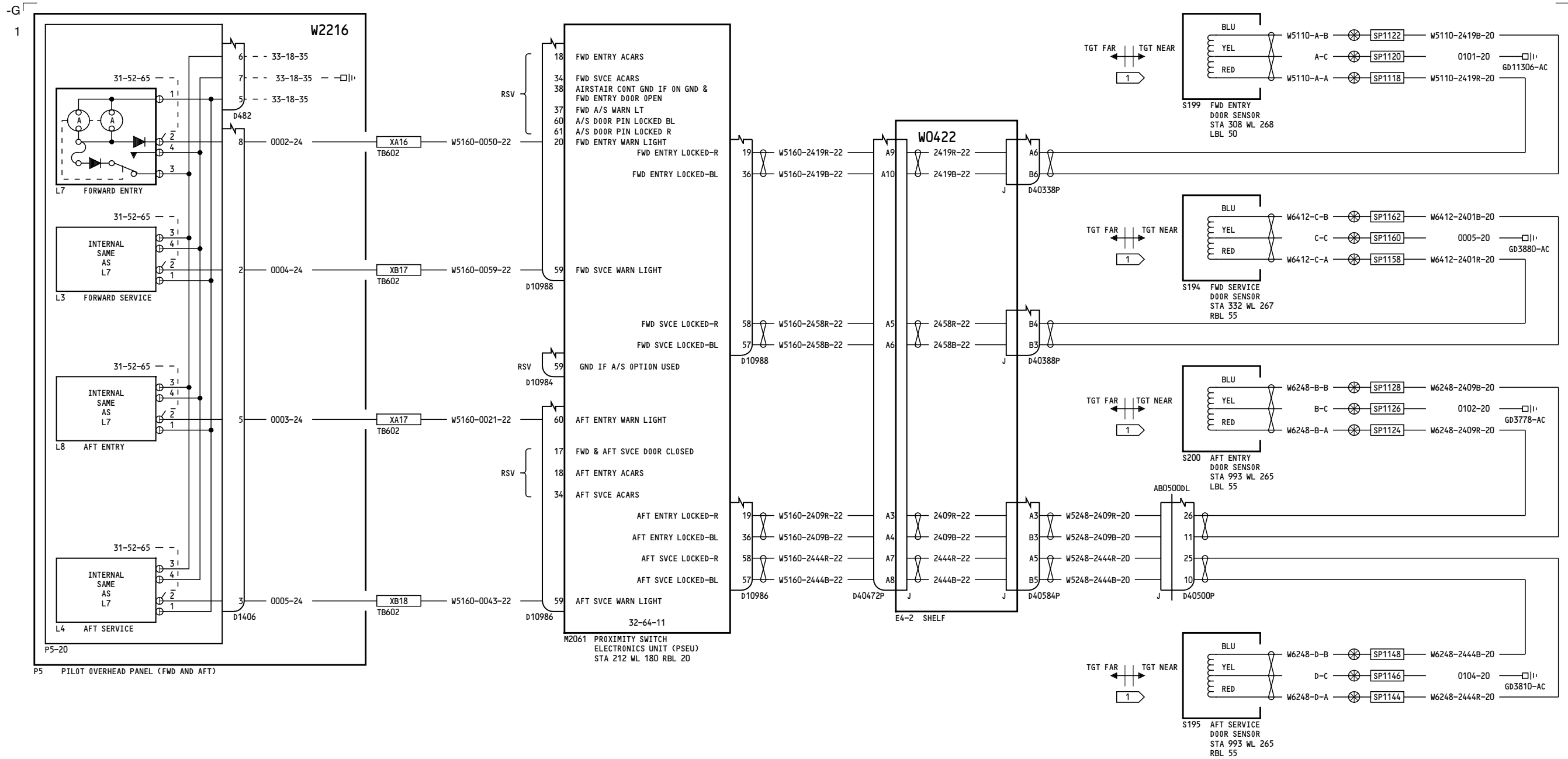

NOTES:
 1 TARGET FAR = DOOR OPEN
 TARGET NEAR = DOOR CLOSED

YC001-YC003	DOOR WARNING SYSTEM - ENTRY AND SERVICE
	D280A103

52-71-11
 Page 1
 Mar 31/2005

52-71-11
 Page 1
 Mar 31/2005

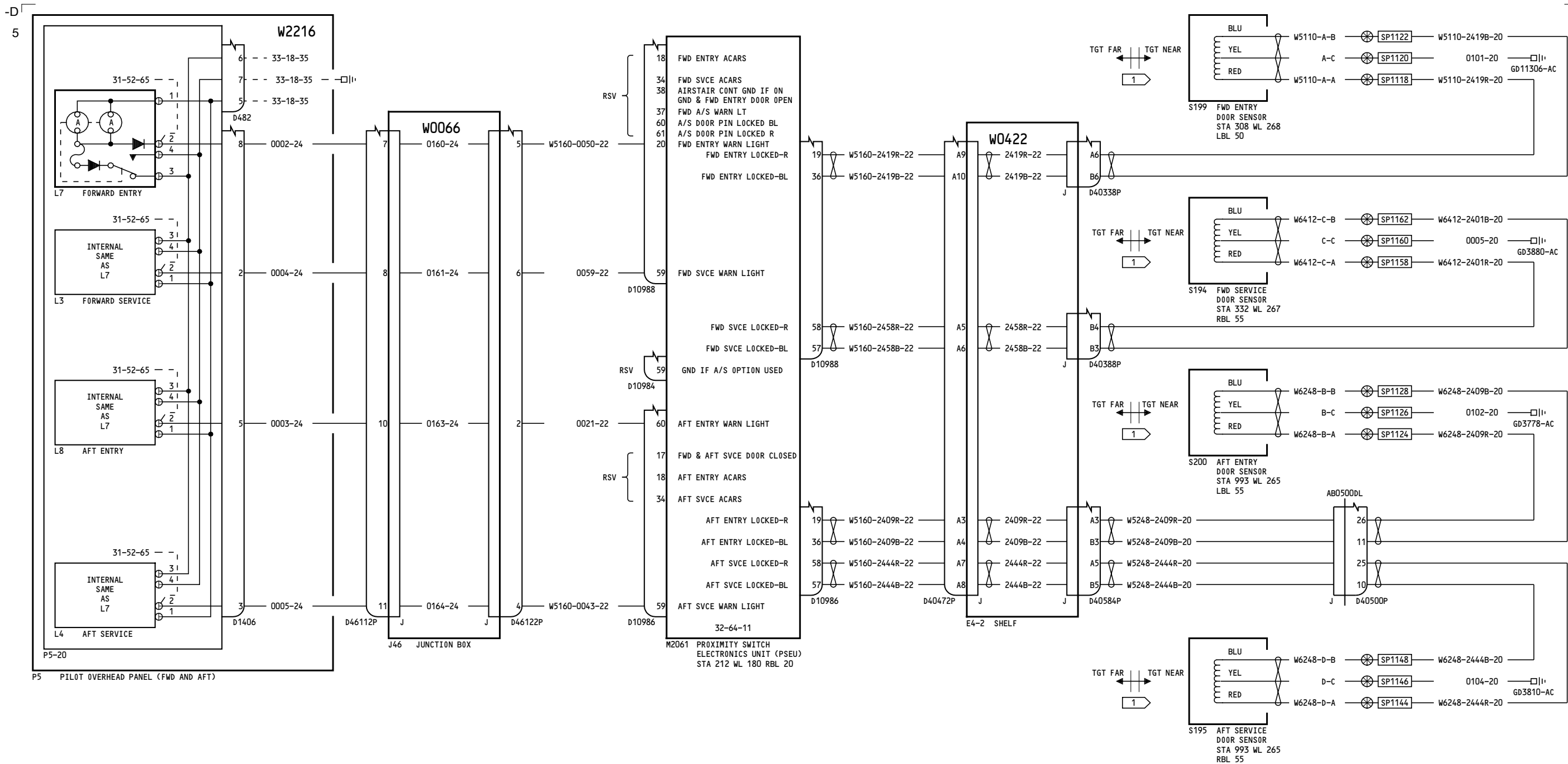

NOTES:
 1 TARGET FAR = DOOR OPEN
 TARGET NEAR = DOOR CLOSED

YC004-YC050

**DOOR WARNING SYSTEM -
 ENTRY AND SERVICE**

52-71-11

Page 2

D280A103

Jul 17/2007

52-71-11

Page 2

Jul 17/2007

26

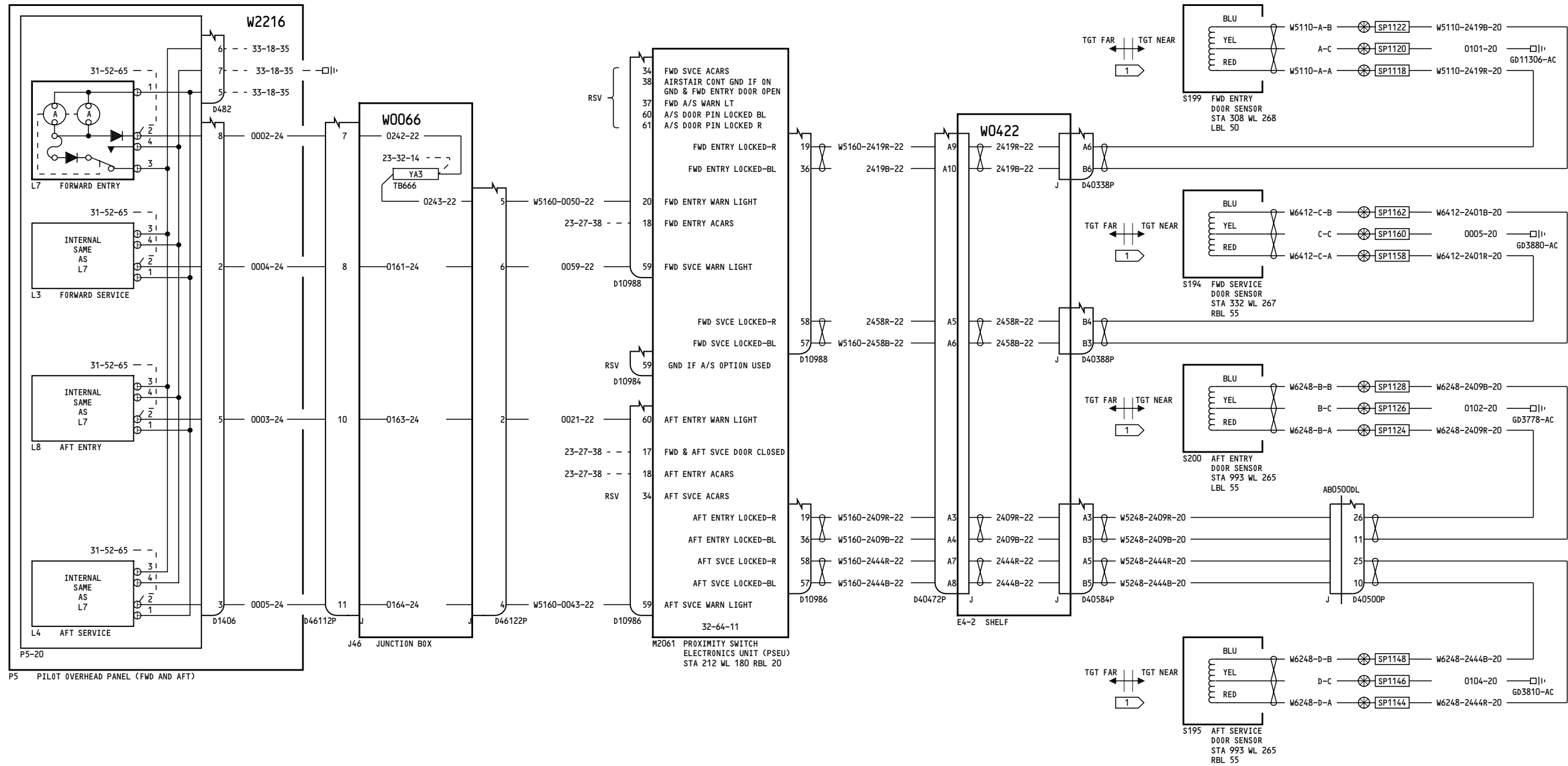

NOTES:

1 TARGET FAR = DOOR OPEN
 TARGET NEAR = DOOR CLOSED

YK901-YK906

DOOR WARNING SYSTEM - ENTRY AND SERVICE

52-71-11

Page 3

D280A103

Jul 26/2006

52-71-11

Page 3

Jul 26/2006

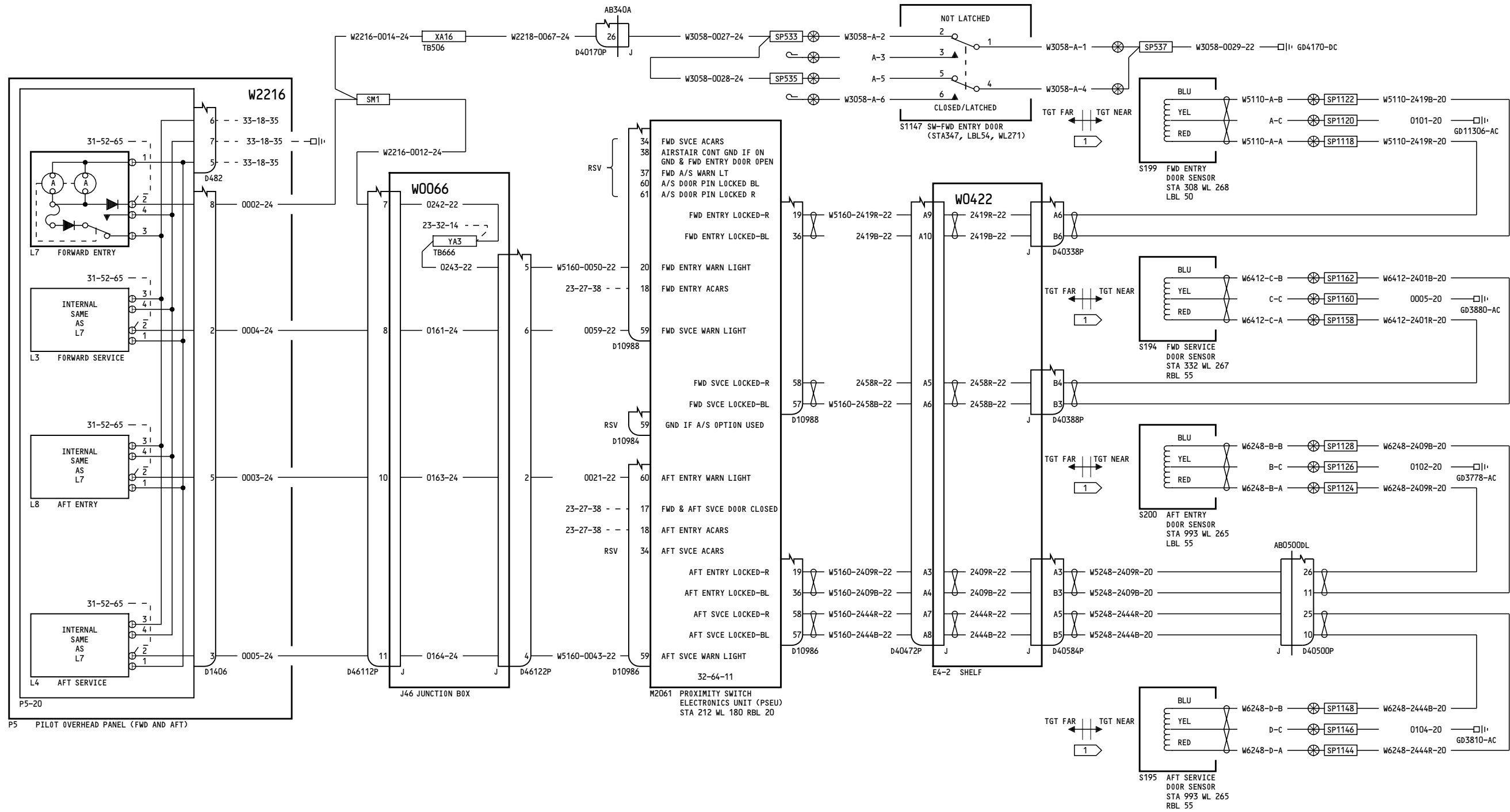

NOTES:
 1 TARGET FAR = DOOR OPEN
 TARGET NEAR = DOOR CLOSED

YK907-YM670

**DOOR WARNING SYSTEM -
ENTRY AND SERVICE**

52-71-11

Page 4

D280A103

Feb 09/2009

52-71-11

Page 4

Feb 09/2009

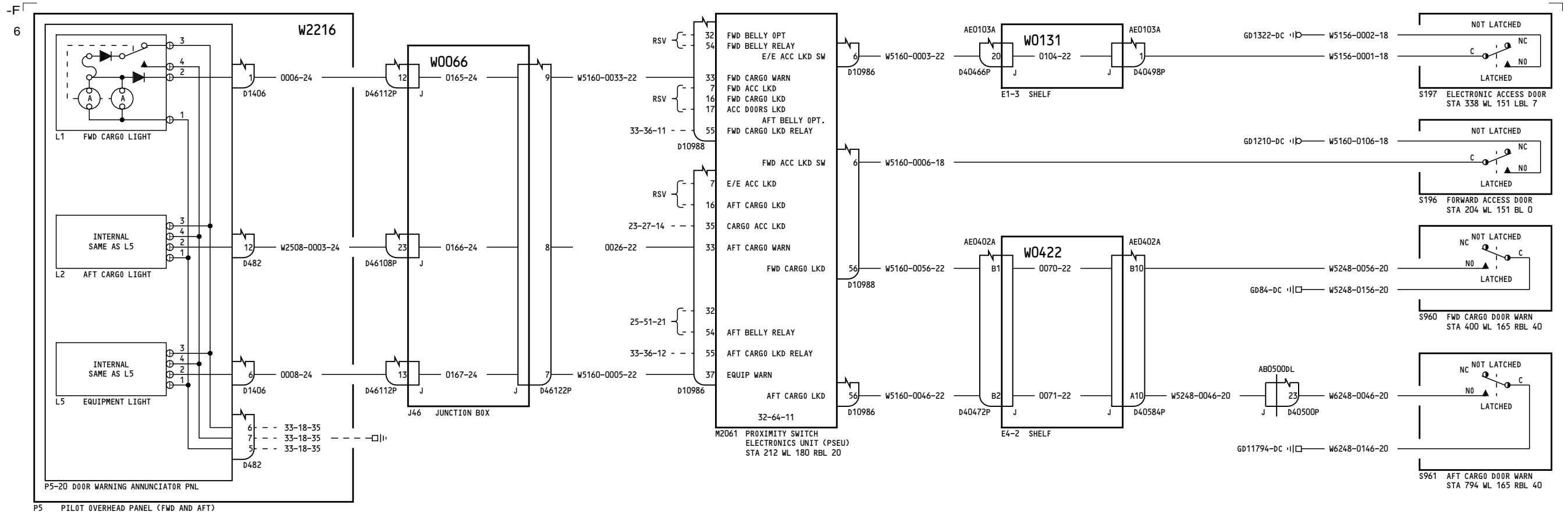

YC004-YC050

**DOOR WARNING SYSTEM -
CARGO AND EQUIPMENT**

52-71-12

Page 2

D280A103

Jul 17/2007

52-71-12

Page 2

Jul 17/2007

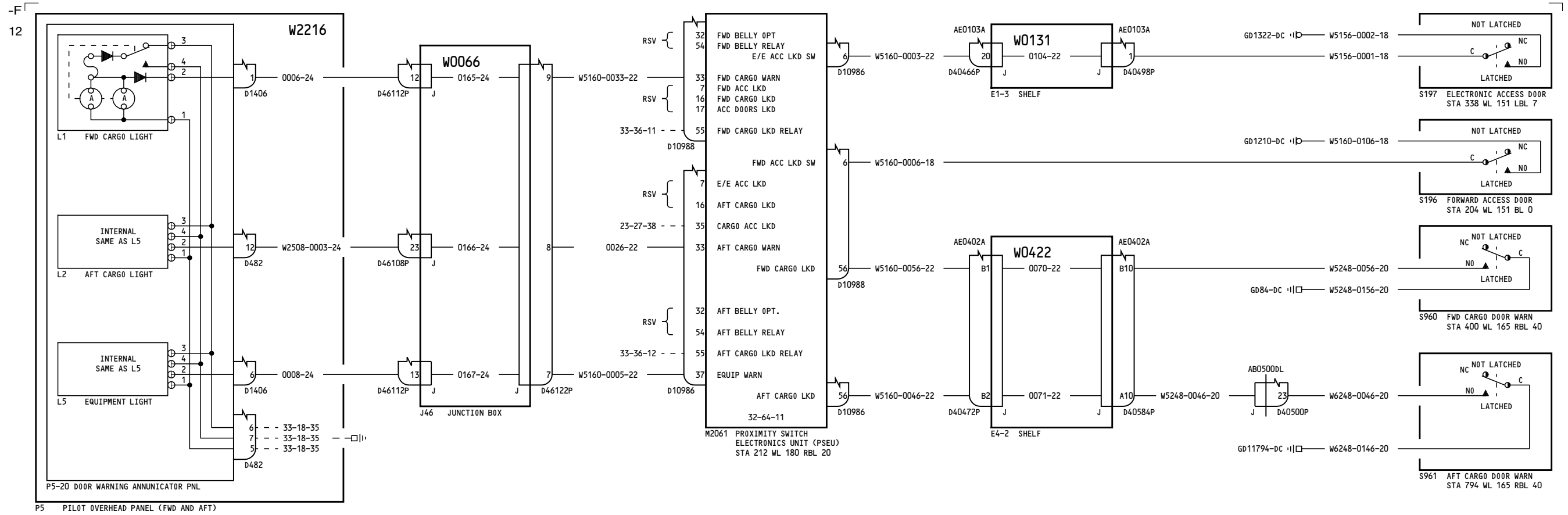

YK901-YK910, YL421-YL426

DOOR WARNING SYSTEM - CARGO AND EQUIPMENT

52-71-12

Page 3

D280A103

May 13/2008

52-71-12

Page 3

May 13/2008

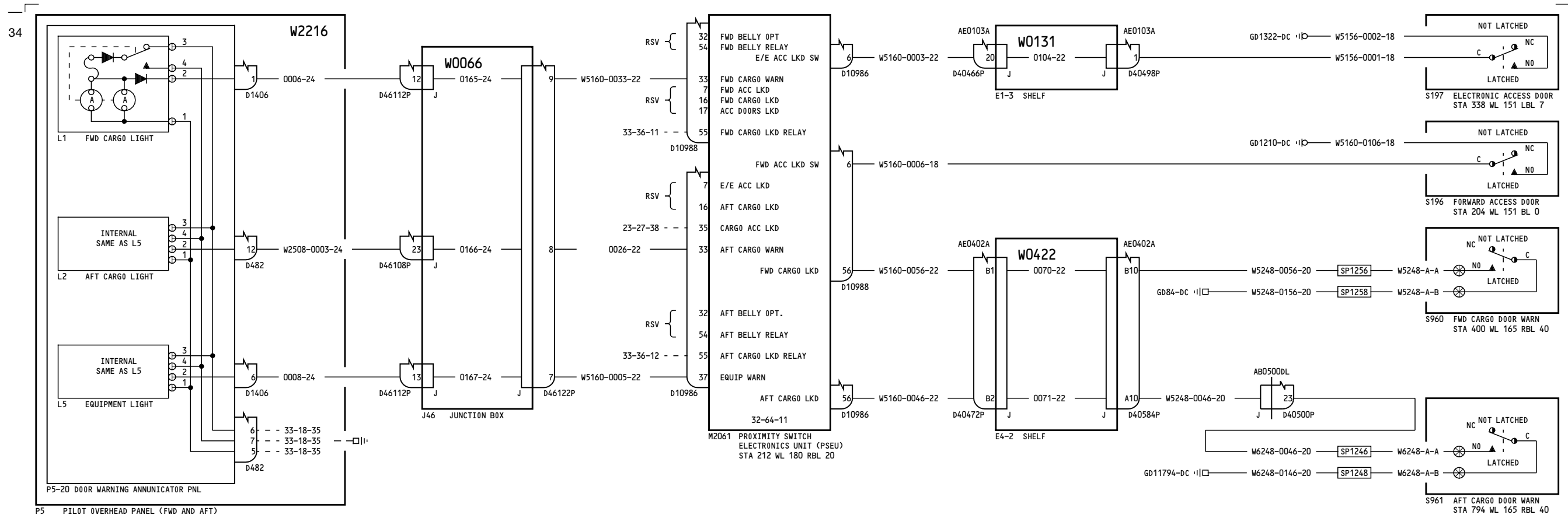

YL401, YL427-YL430

**DOOR WARNING SYSTEM -
CARGO AND EQUIPMENT**

52-71-12

Page 6

D280A103

Aug 13/2008

52-71-12

Page 6

Aug 13/2008

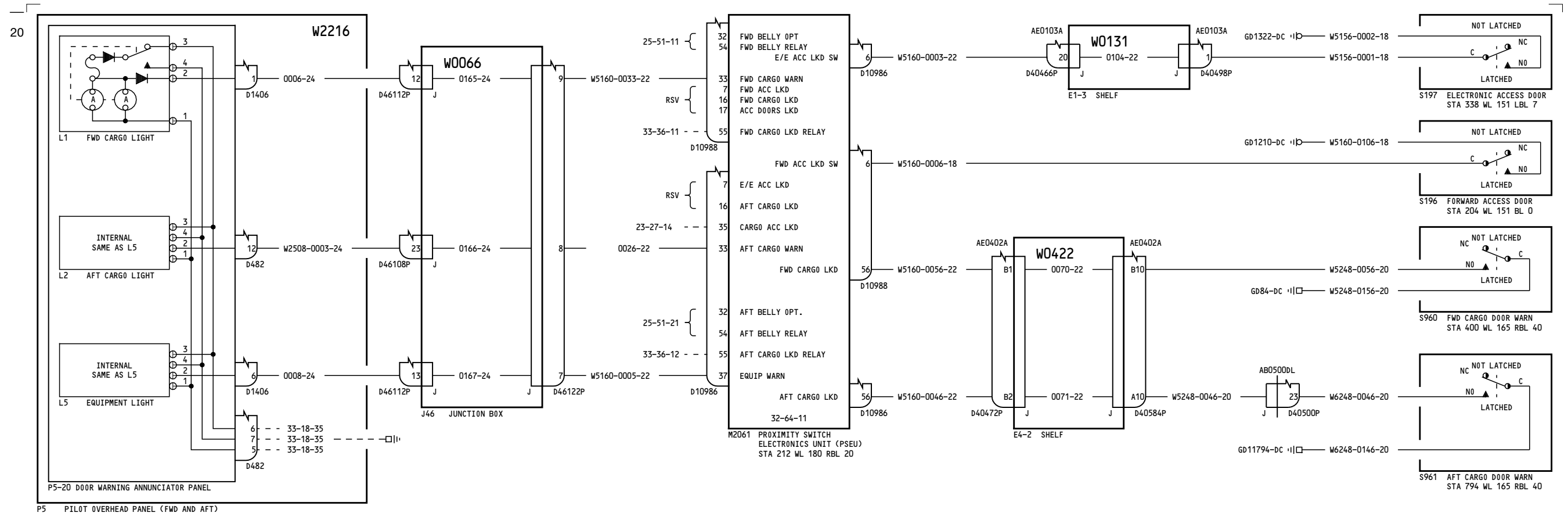

YM643-YM651

DOOR WARNING SYSTEM - CARGO AND EQUIPMENT

52-71-12

Page 7

D280A103

Aug 13/2008

52-71-12

Page 7

Aug 13/2008

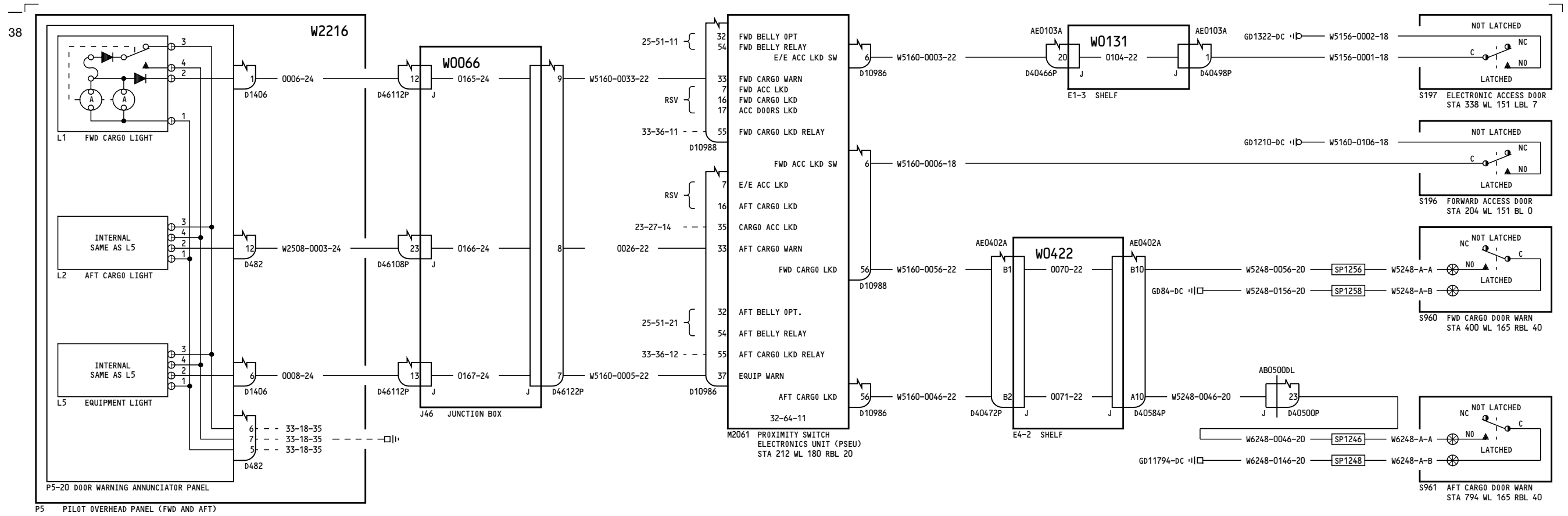

YM652-YM670

**DOOR WARNING SYSTEM -
CARGO AND EQUIPMENT**

52-71-12

Page 8

D280A103

Aug 13/2008

52-71-12

Page 8

Aug 13/2008

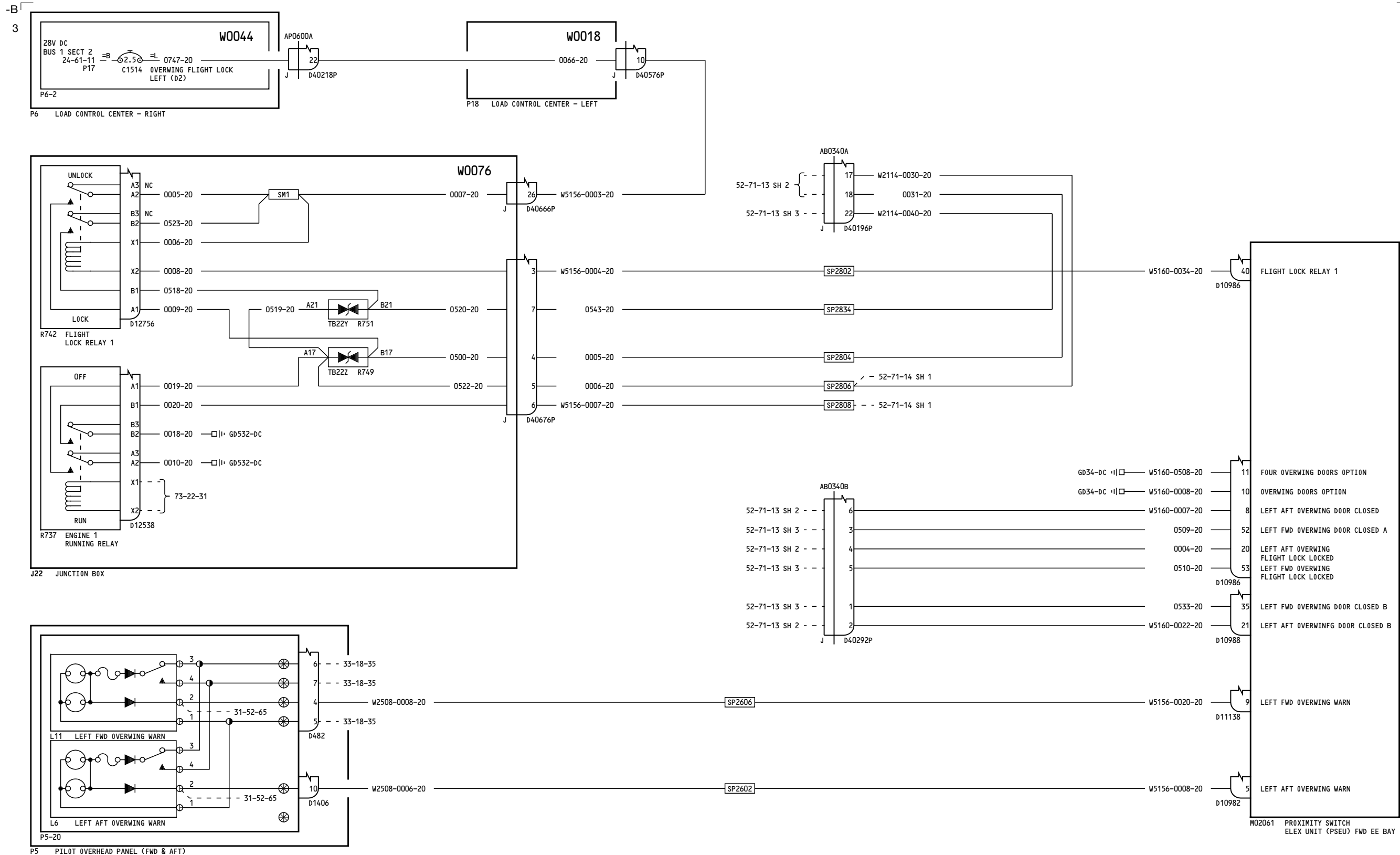

YC001-YC003

DOOR WARNING OVERWING - LEFT OVERWING

52-71-13

Page 1
Sheet 1
Mar 31/2005

D280A103

52-71-13

Page 1
Sheet 1
Mar 31/2005

-B
2

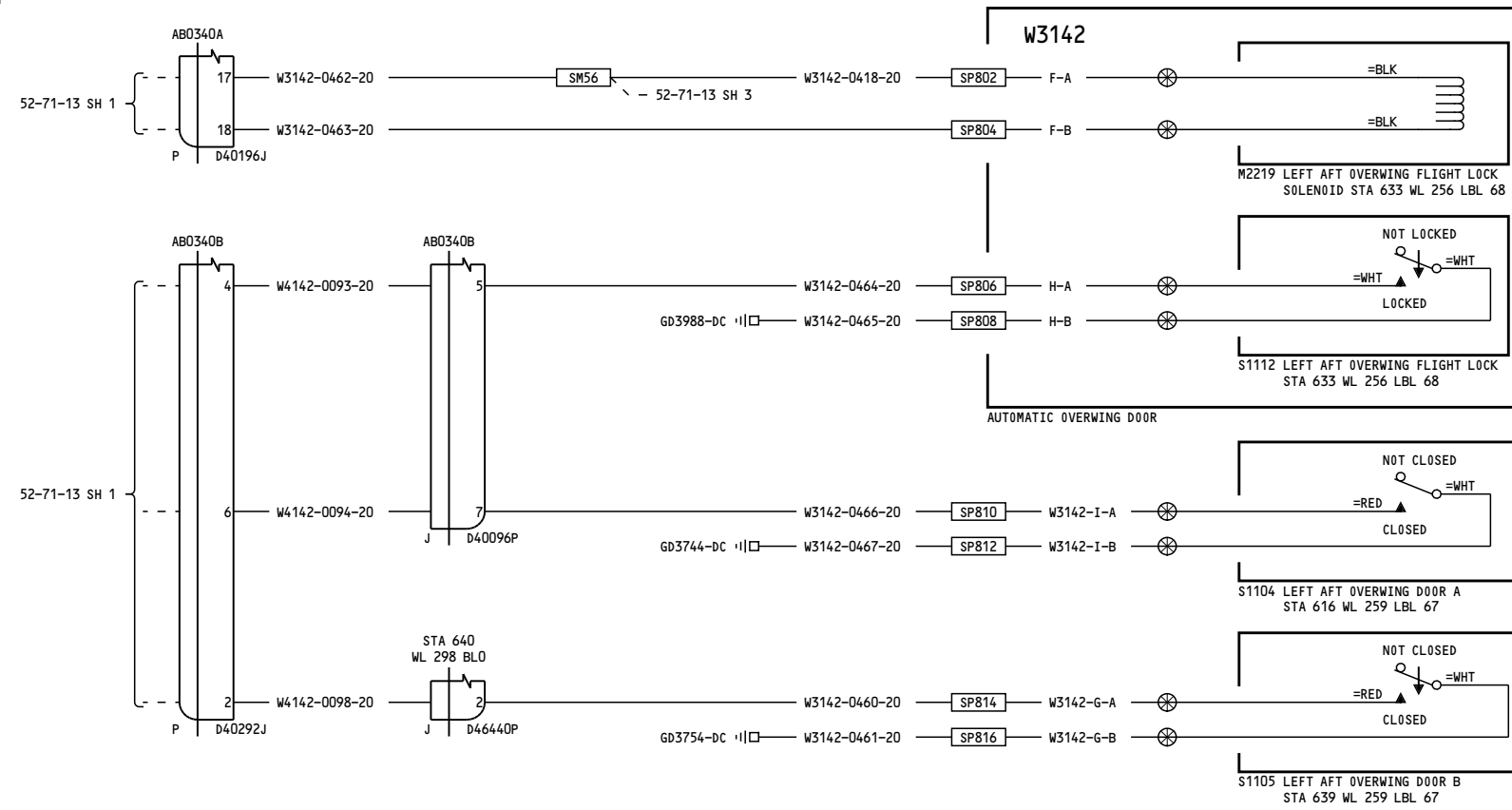

YC001-YC003

**DOOR WARNING OVERWING -
LEFT OVERWING**

D280A103

52-71-13

Page 1
Sheet 2
Mar 31/2005

52-71-13

Page 1
Sheet 2
Mar 31/2005

-B
1

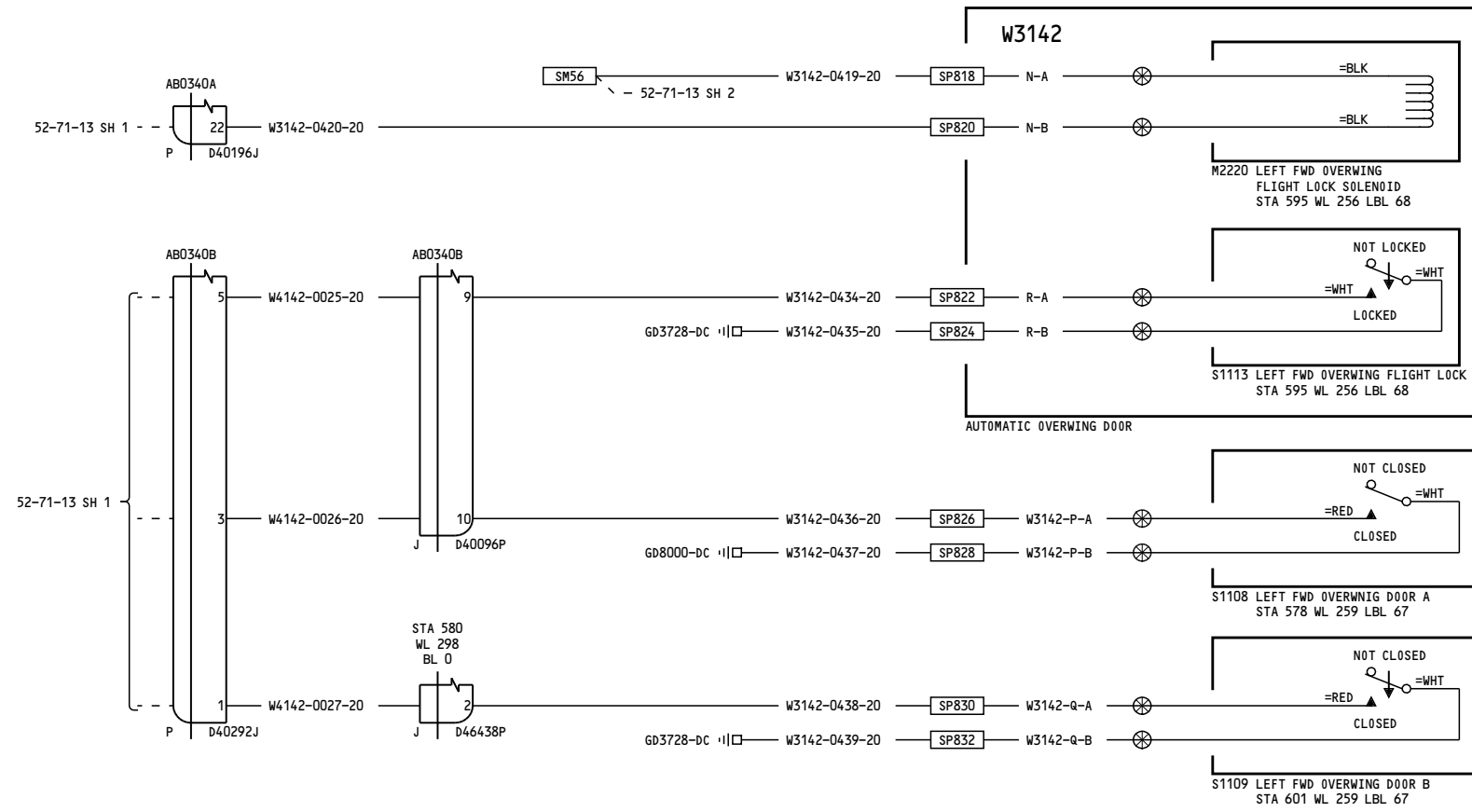

YC001-YC003

**DOOR WARNING OVERWING -
LEFT OVERWING**

D280A103

52-71-13

Page 1
Sheet 3
Mar 31/2005

52-71-13

Page 1
Sheet 3
Mar 31/2005

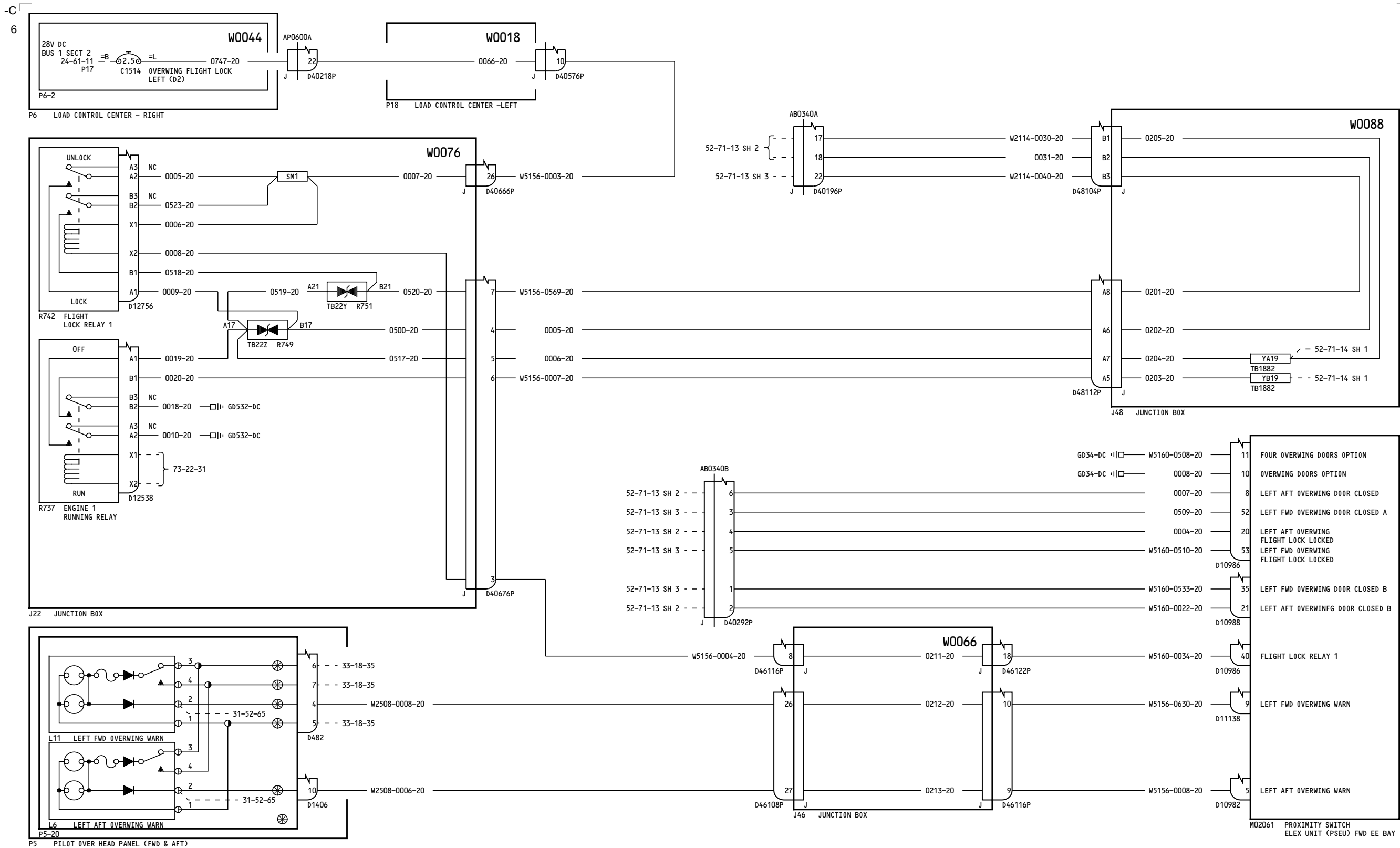

YC004-YC050

DOOR WARNING OVERWING - LEFT OVERWING

D280A103

52-71-13

Page 2
Sheet 1
Jul 17/2007

52-71-13

Page 2
Sheet 1
Jul 17/2007

-B
2

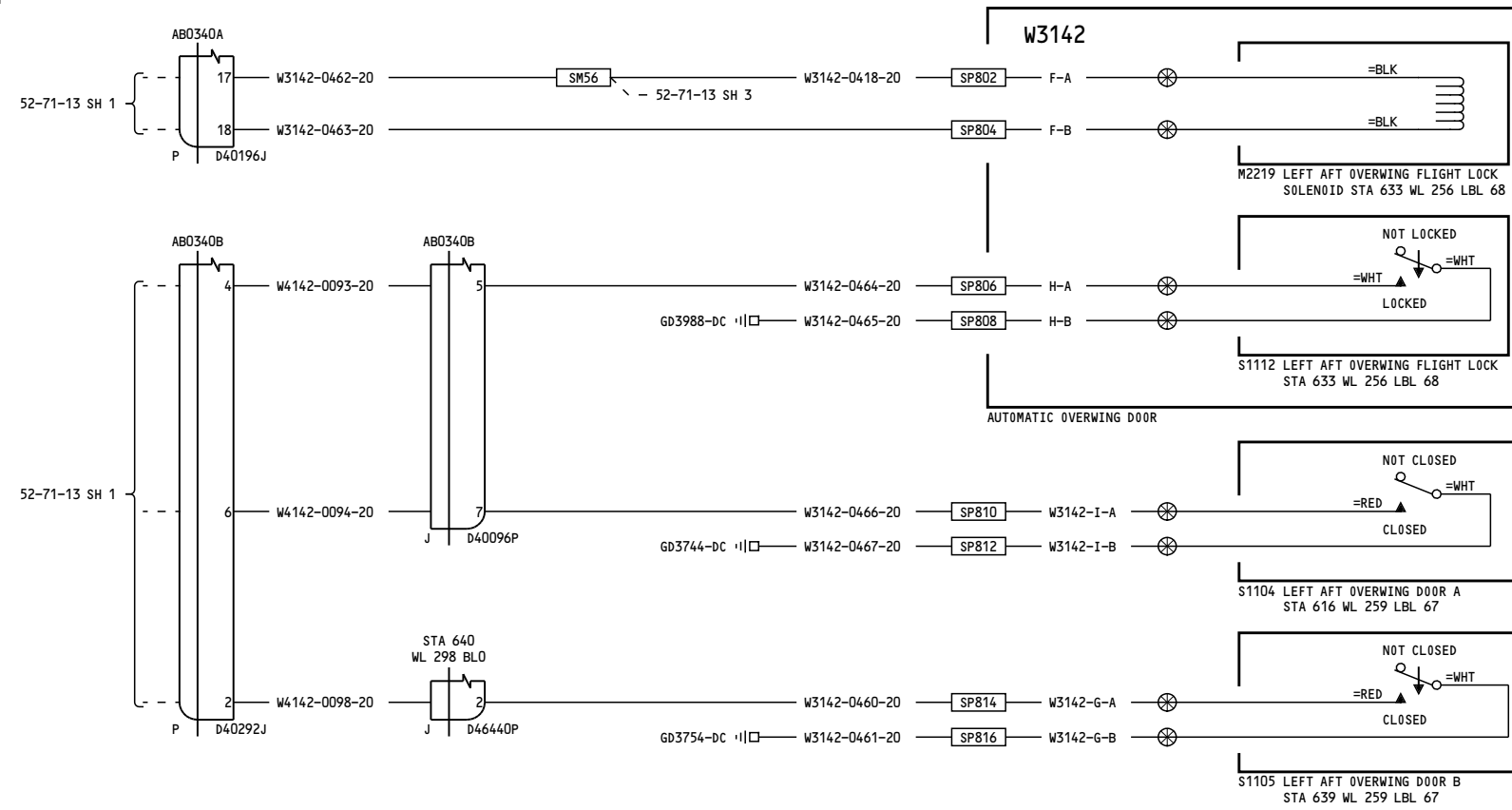

YC004-YC050

**DOOR WARNING OVERWING -
LEFT OVERWING**

D280A103

52-71-13

Page 2
Sheet 2
Jul 17/2007

52-71-13

Page 2
Sheet 2
Jul 17/2007

-B
1

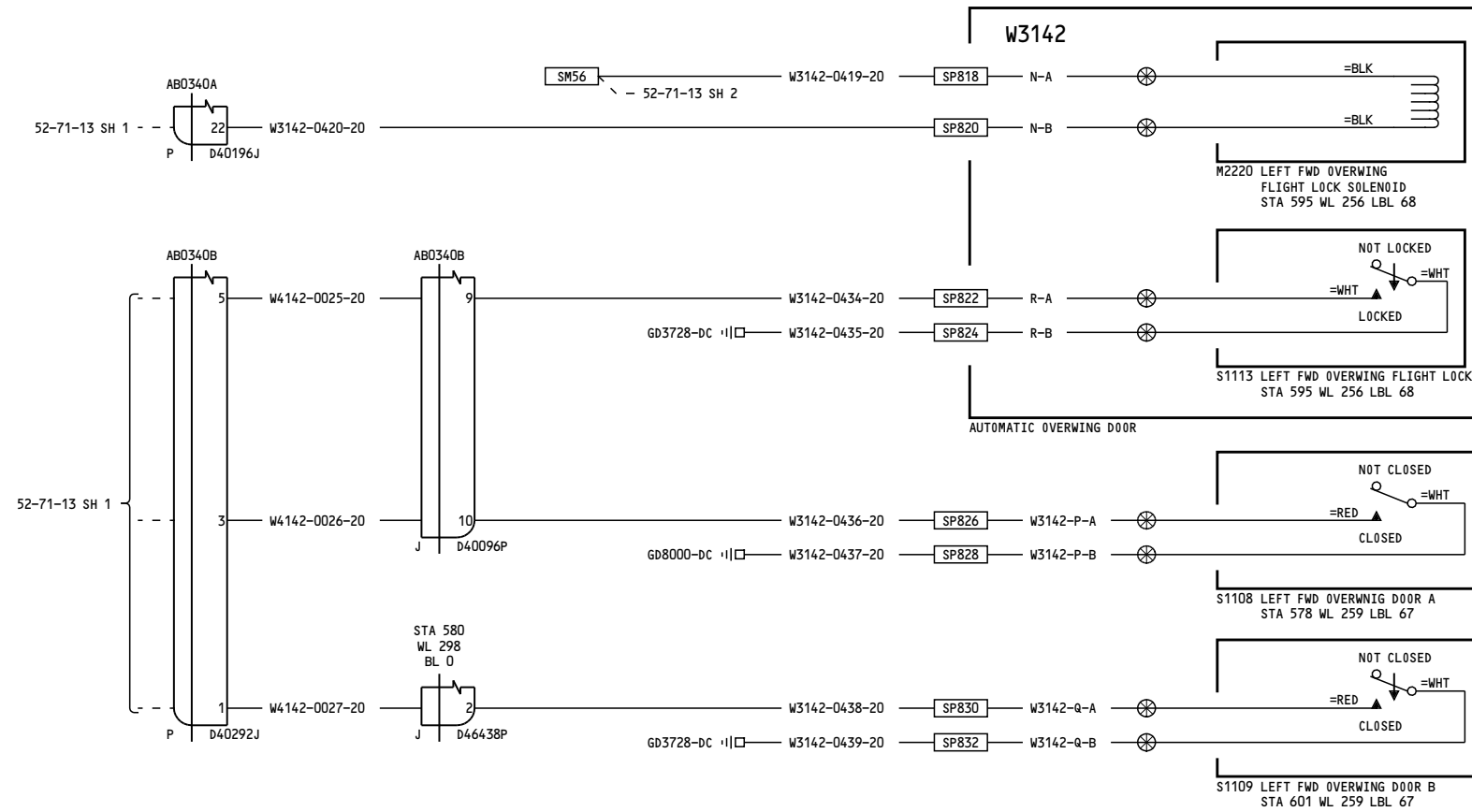

YC004-YC050

**DOOR WARNING OVERWING -
LEFT OVERWING**

D280A103

52-71-13

Page 2
Sheet 3
Jul 17/2007

52-71-13

Page 2
Sheet 3
Jul 17/2007

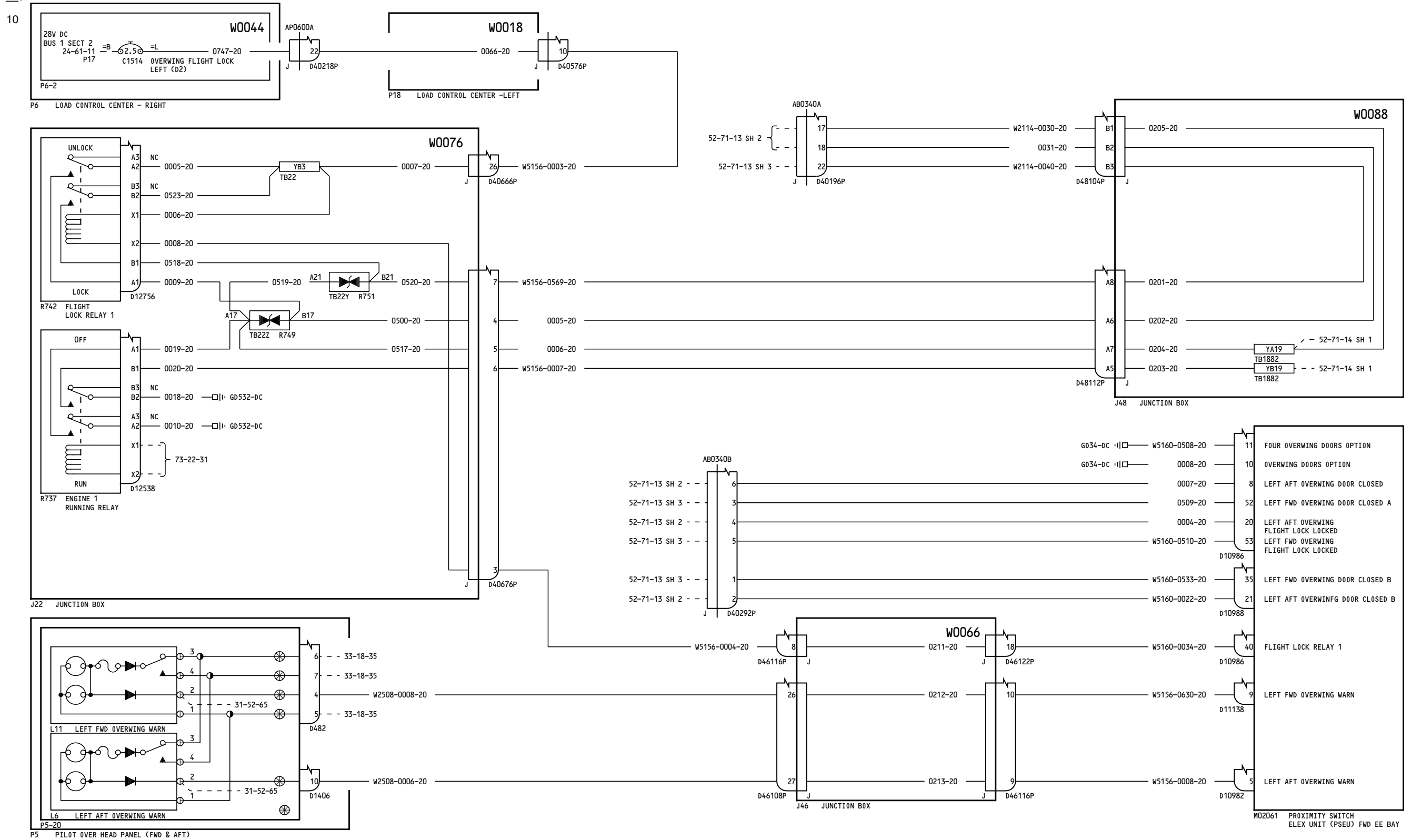

YK901-YL430

DOOR WARNING OVERWING - LEFT OVERWING

D280A103

52-71-13

Page 3
Sheet 1
Feb 09/2009

52-71-13

Page 3
Sheet 1
Feb 09/2009

-B
2

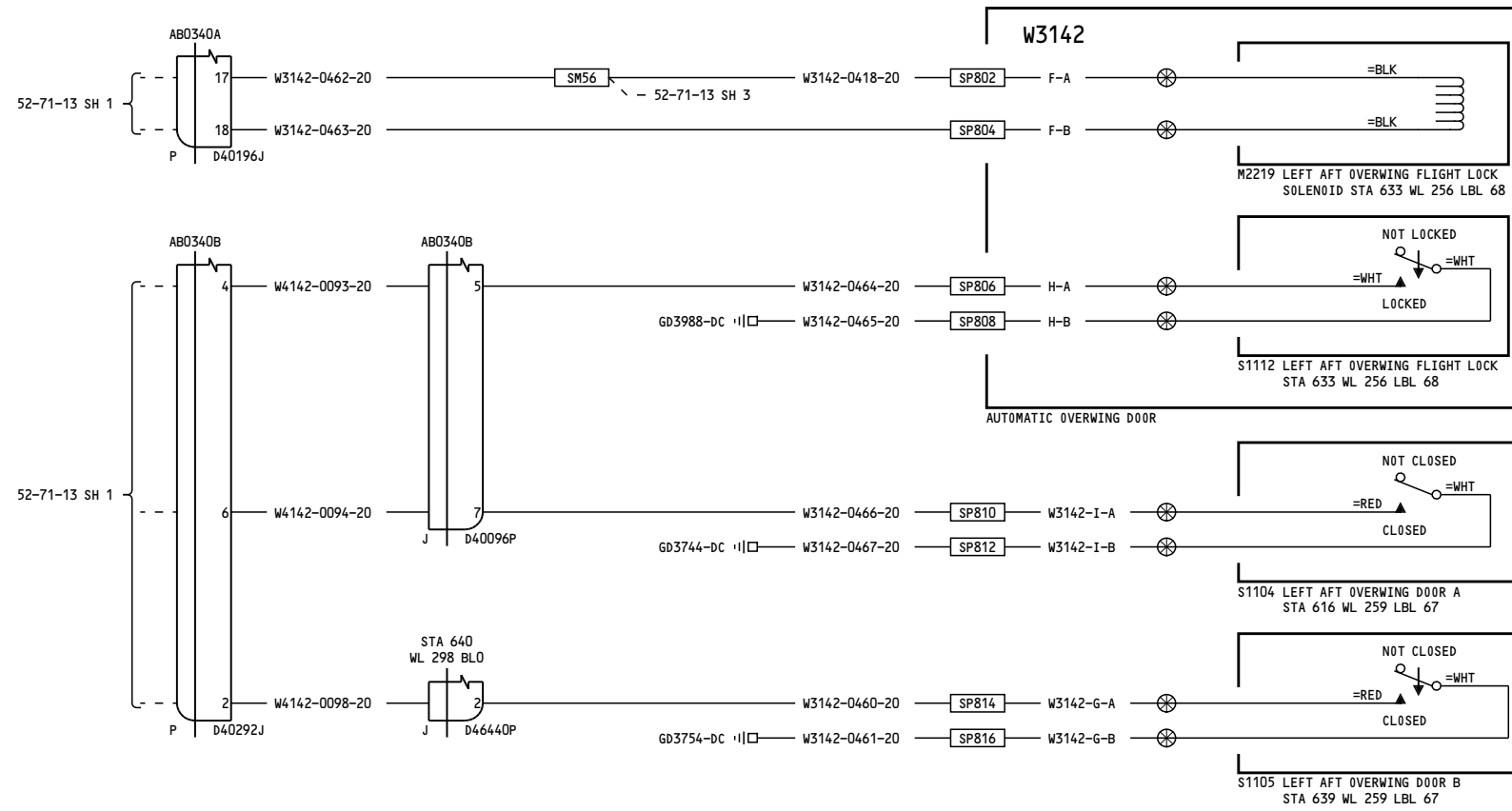

YK901-YL430

**DOOR WARNING OVERWING -
LEFT OVERWING**

D280A103

52-71-13

Page 3
Sheet 2
Feb 09/2009

52-71-13

Page 3
Sheet 2
Feb 09/2009

-B
1

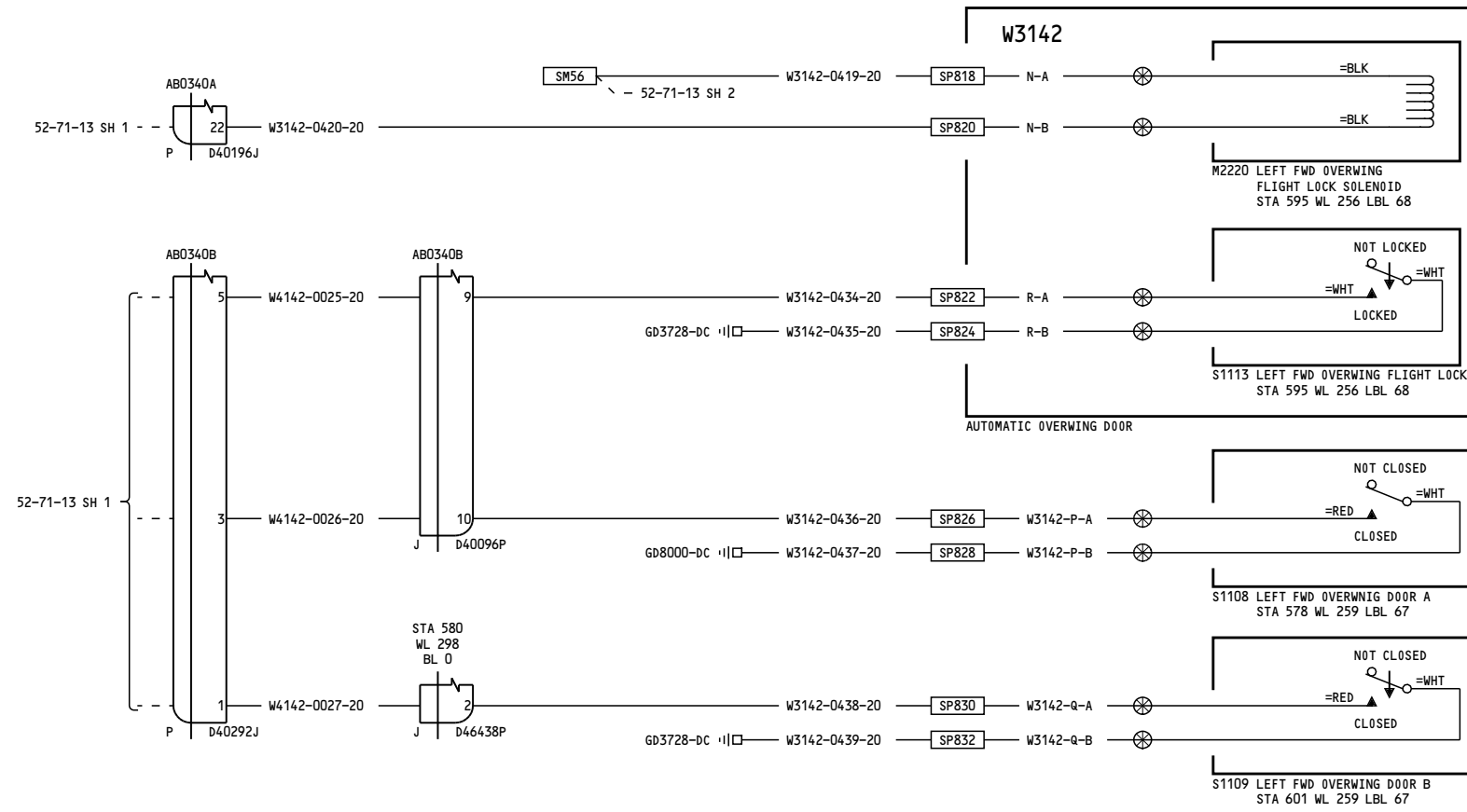

YK901-YL430

**DOOR WARNING OVERWING -
LEFT OVERWING**

D280A103

52-71-13

Page 3
Sheet 3
Feb 09/2009

52-71-13

Page 3
Sheet 3
Feb 09/2009

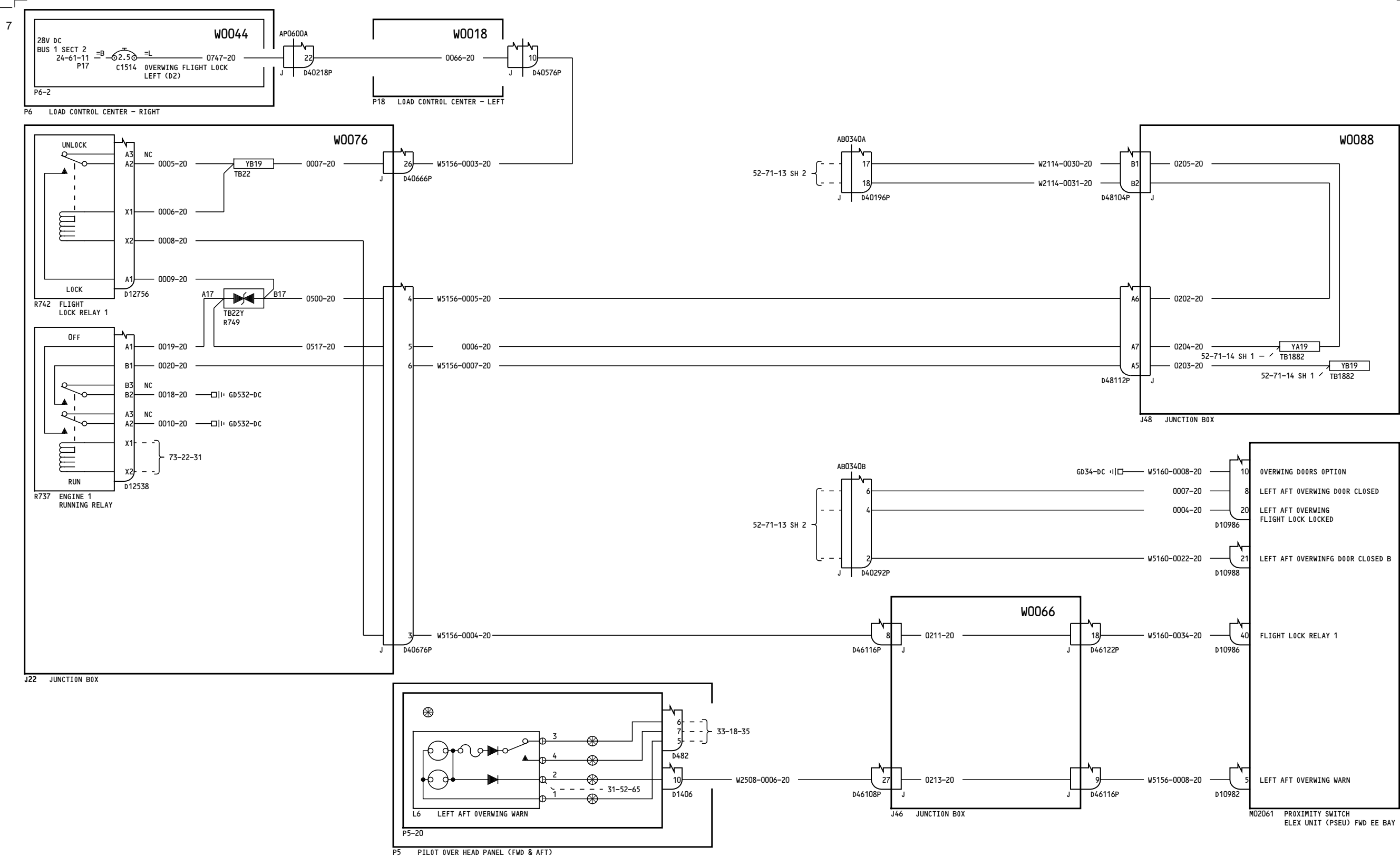

YM643-YM670

DOOR WARNING OVERWING - LEFT OVERWING

52-71-13

Page 4
Sheet 1
Jan 14/2008

D280A103

52-71-13

Page 4
Sheet 1
Jan 14/2008

-A
1

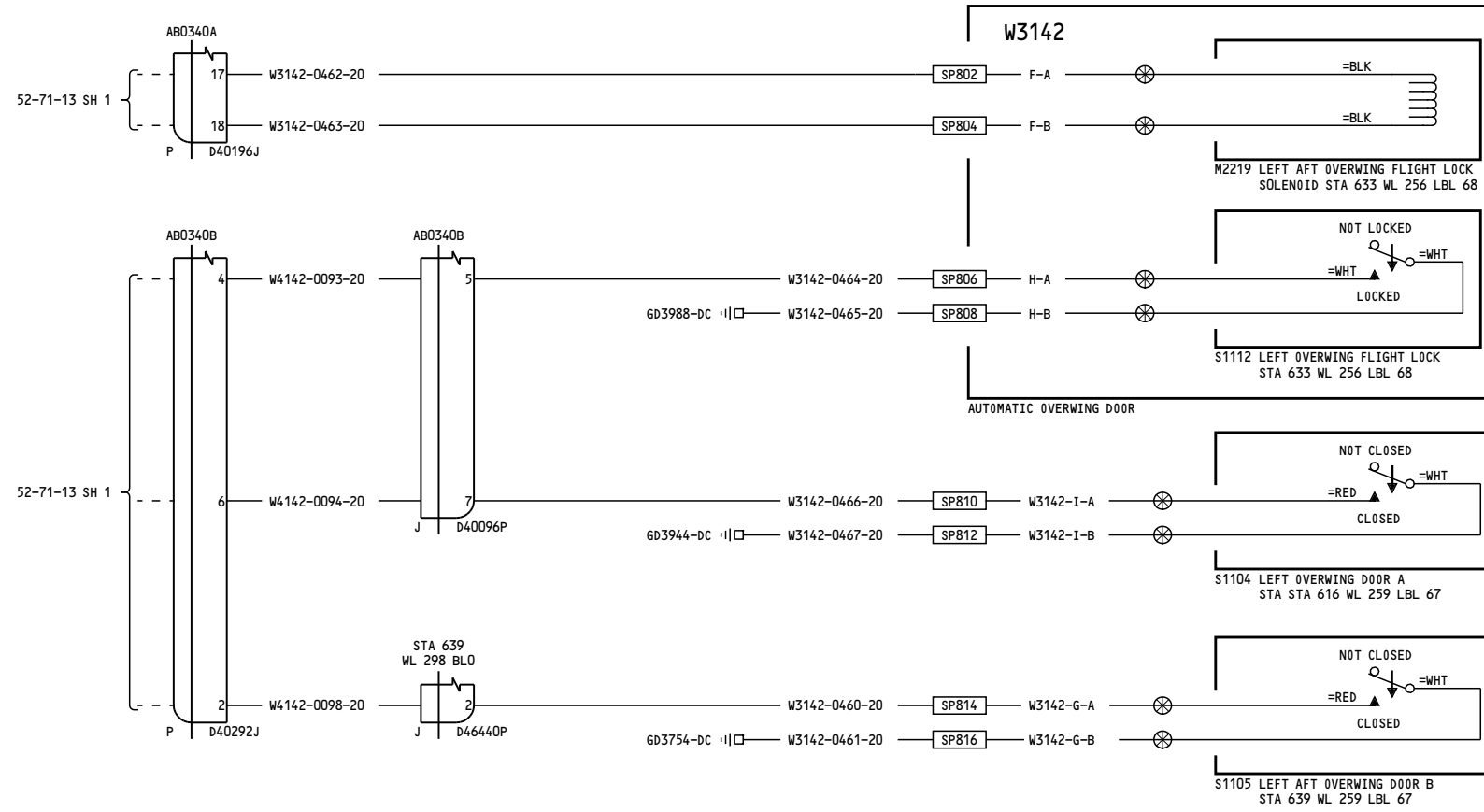

YM643-YM670

**DOOR WARNING OVERWING -
LEFT OVERWING**

D280A103

52-71-13

Page 4
Sheet 2
Jan 14/2008

52-71-13

Page 4
Sheet 2
Jan 14/2008

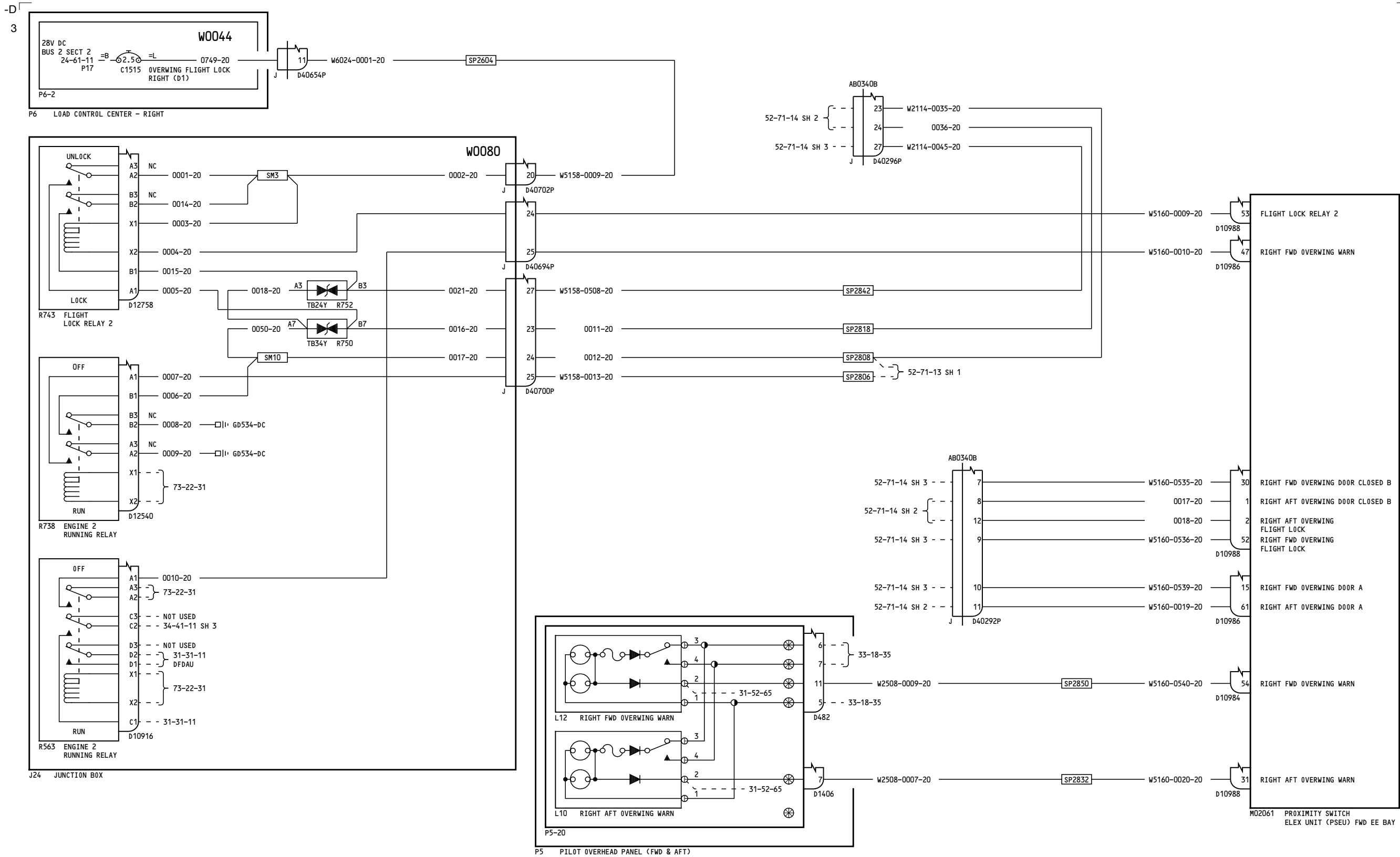

YC001-YC003

**DOOR WARNING OVERWING -
RIGHT OVERWING**

52-71-14

Page 1
Sheet 1
Mar 31/2005

D280A103

52-71-14

Page 1
Sheet 1
Mar 31/2005

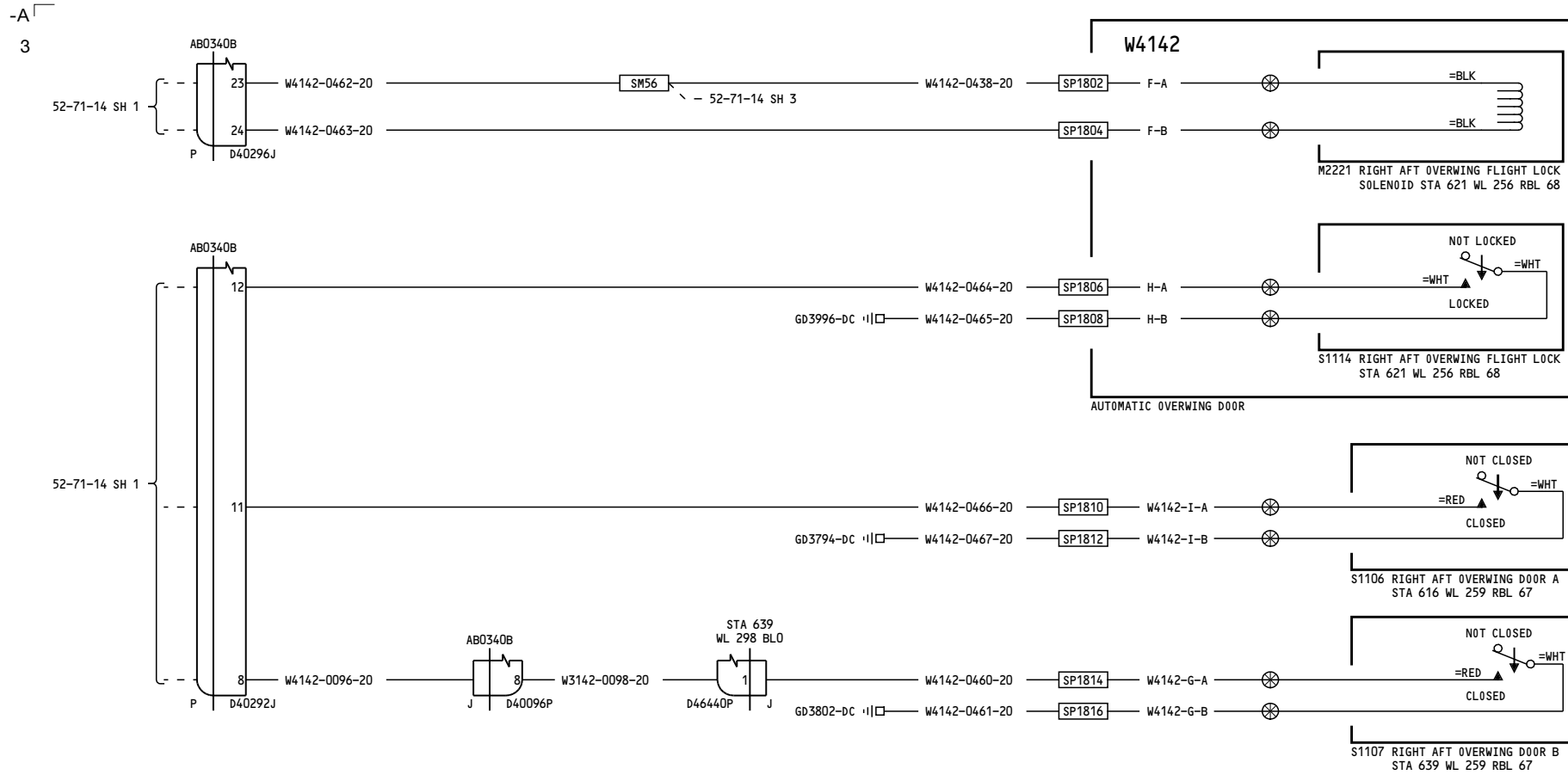

YC001-YC003

**DOOR WARNING OVERWING -
RIGHT OVERWING**

D280A103

52-71-14

Page 1
Sheet 2
Mar 31/2005

52-71-14

Page 1
Sheet 2
Mar 31/2005

-B
1

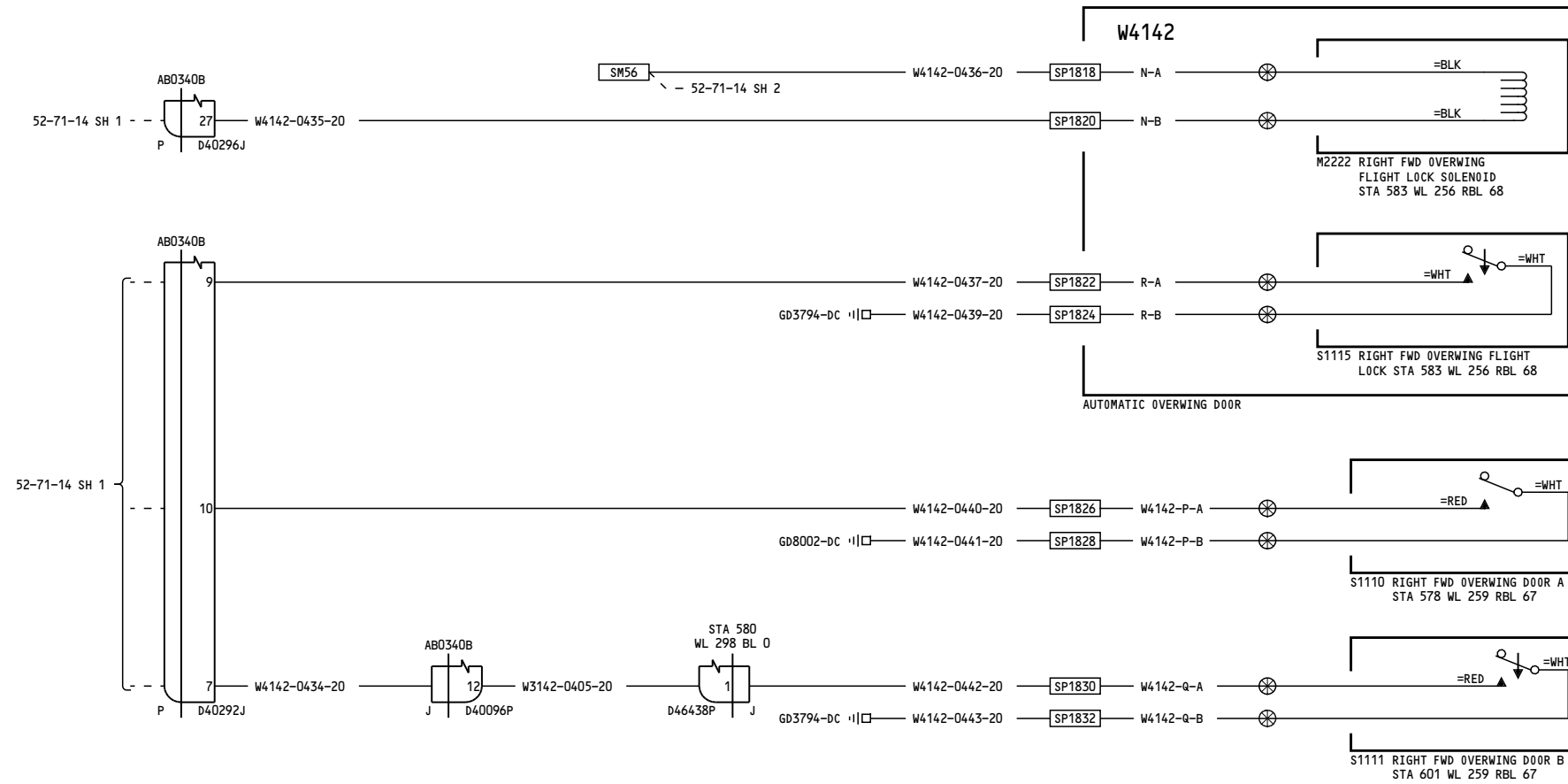

YC001-YC003

**DOOR WARNING OVERWING -
RIGHT OVERWING**

D280A103

52-71-14

Page 1
Sheet 3
Mar 31/2005

52-71-14

Page 1
Sheet 3
Mar 31/2005

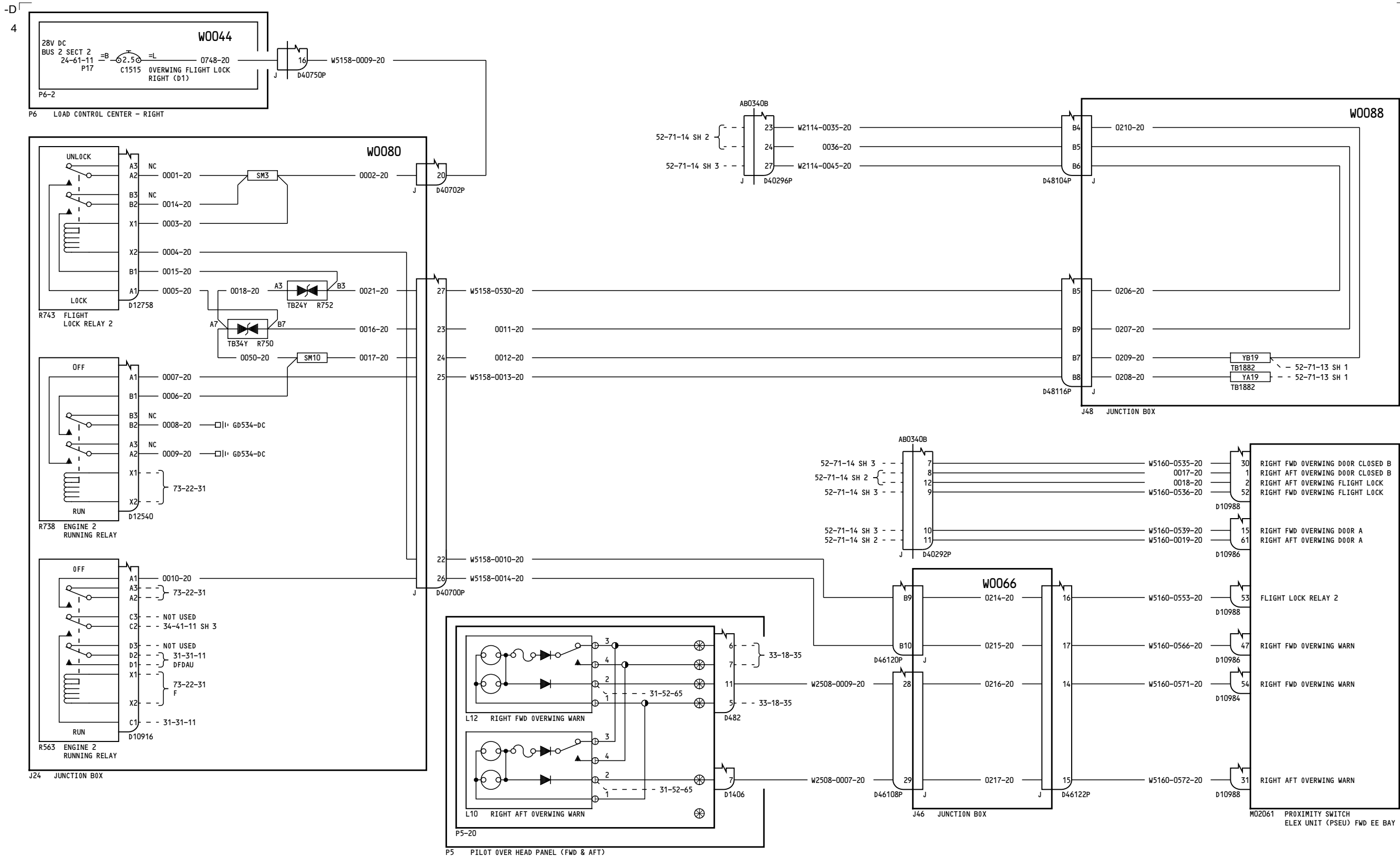

YC004-YC050

**DOOR WARNING OVERWING -
RIGHT OVERWING**

52-71-14

Page 2
Sheet 1
Jul 17/2007

D280A103

52-71-14

Page 2
Sheet 1
Jul 17/2007

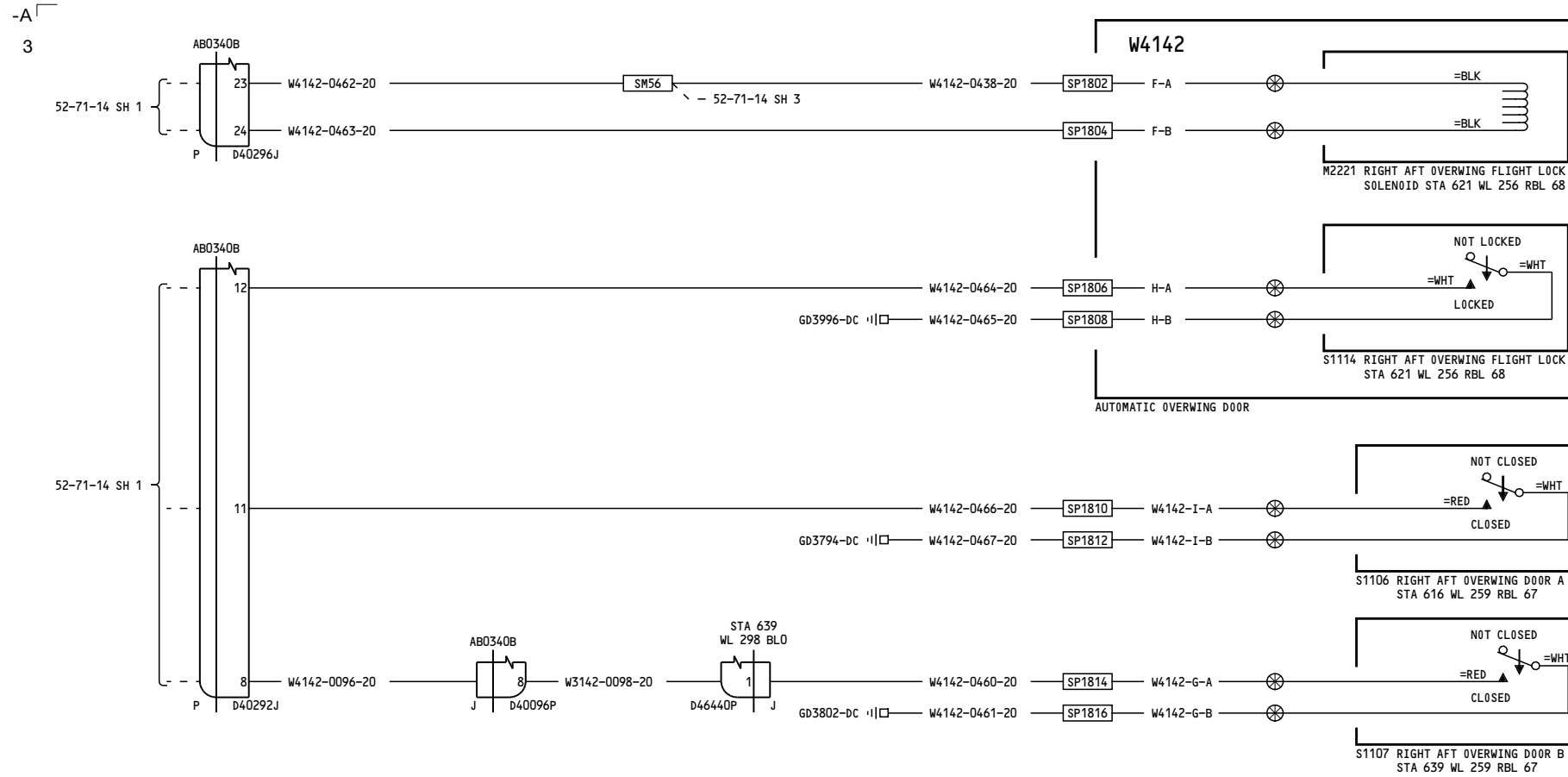

YC004-YC050

**DOOR WARNING OVERWING -
RIGHT OVERWING**

D280A103

52-71-14

Page 2
Sheet 2
Jul 17/2007

52-71-14

Page 2
Sheet 2
Jul 17/2007

-B
1

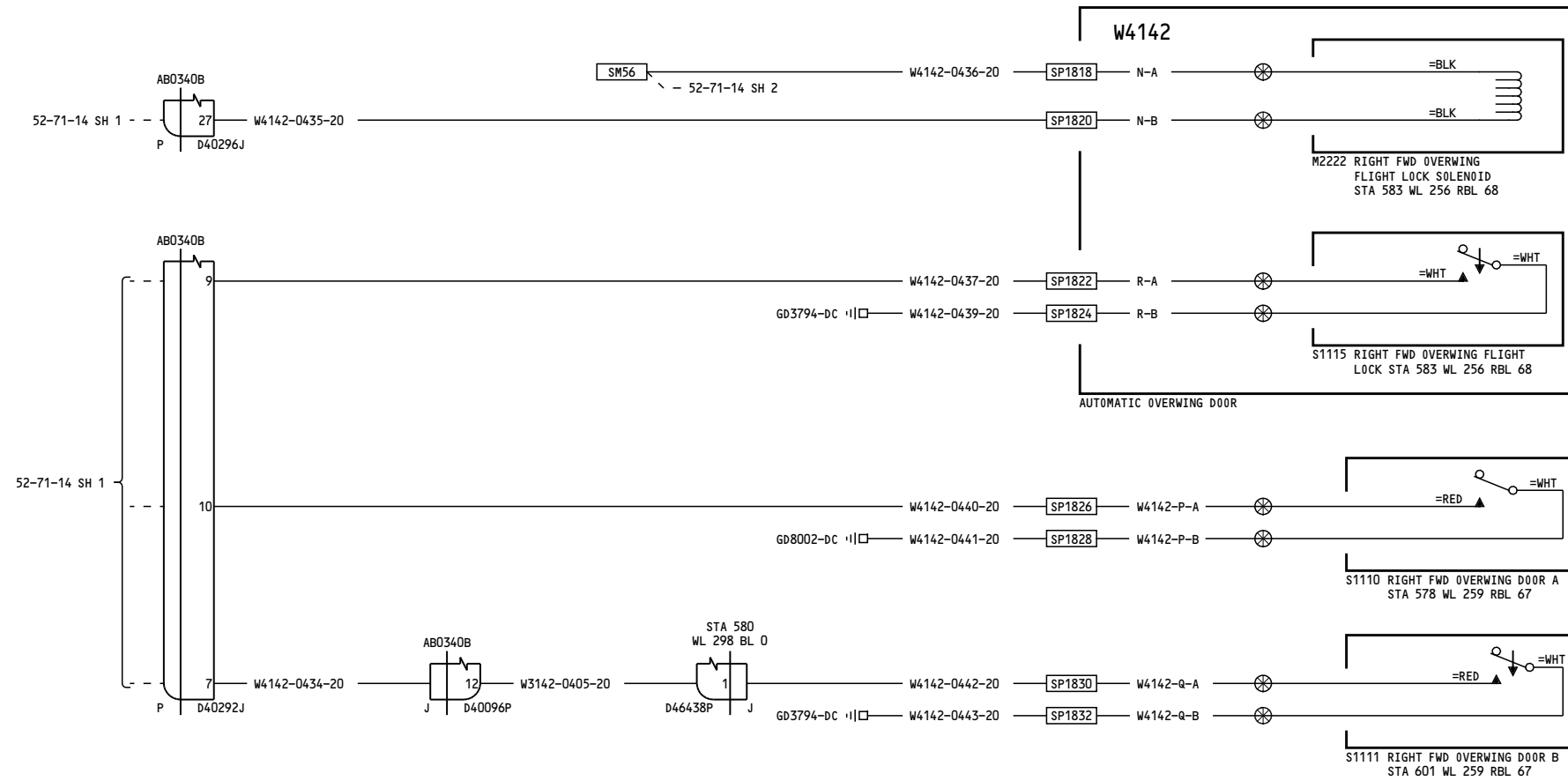

YC004-YC050

**DOOR WARNING OVERWING -
RIGHT OVERWING**

D280A103

52-71-14

Page 2
Sheet 3
Jul 17/2007

52-71-14

Page 2
Sheet 3
Jul 17/2007

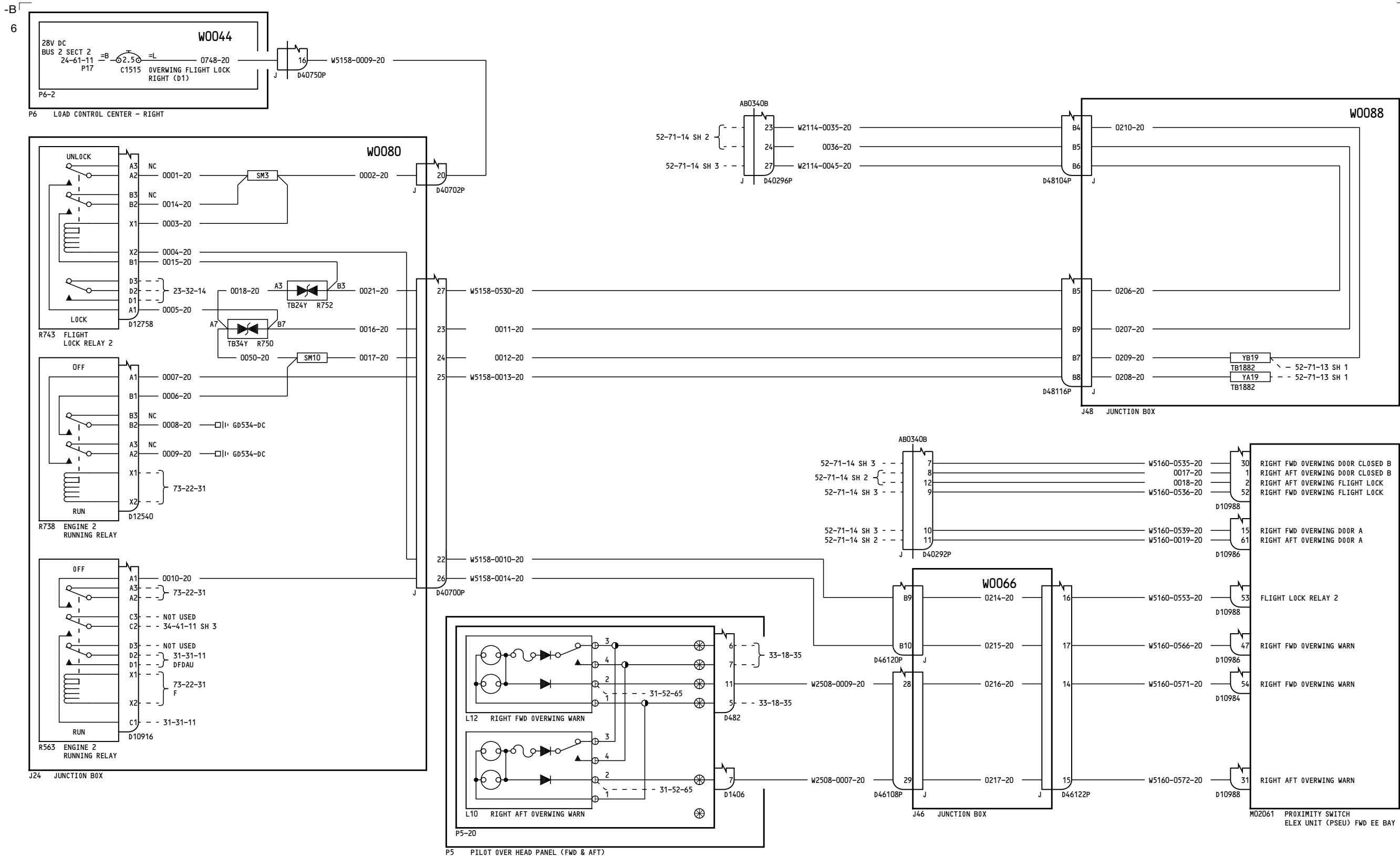

YK901-YL430

DOOR WARNING OVERWING - RIGHT OVERWING

52-71-14

Page 3
Sheet 1
Feb 09/2009

D280A103

52-71-14

Page 3
Sheet 1
Feb 09/2009

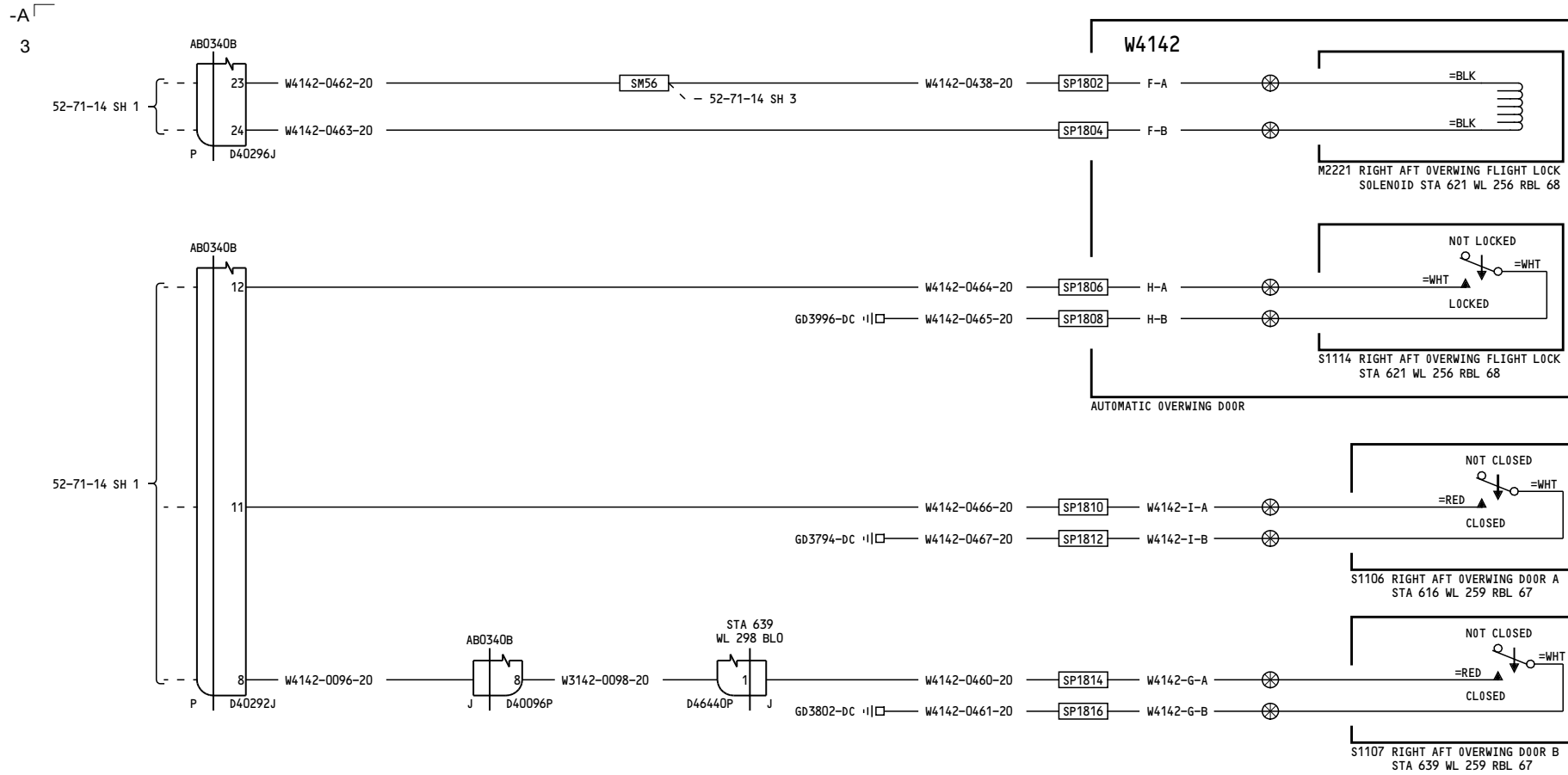

YK901-YL430

**DOOR WARNING OVERWING -
RIGHT OVERWING**

D280A103

52-71-14

Page 3
Sheet 2
Feb 09/2009

52-71-14

Page 3
Sheet 2
Feb 09/2009

-B
1

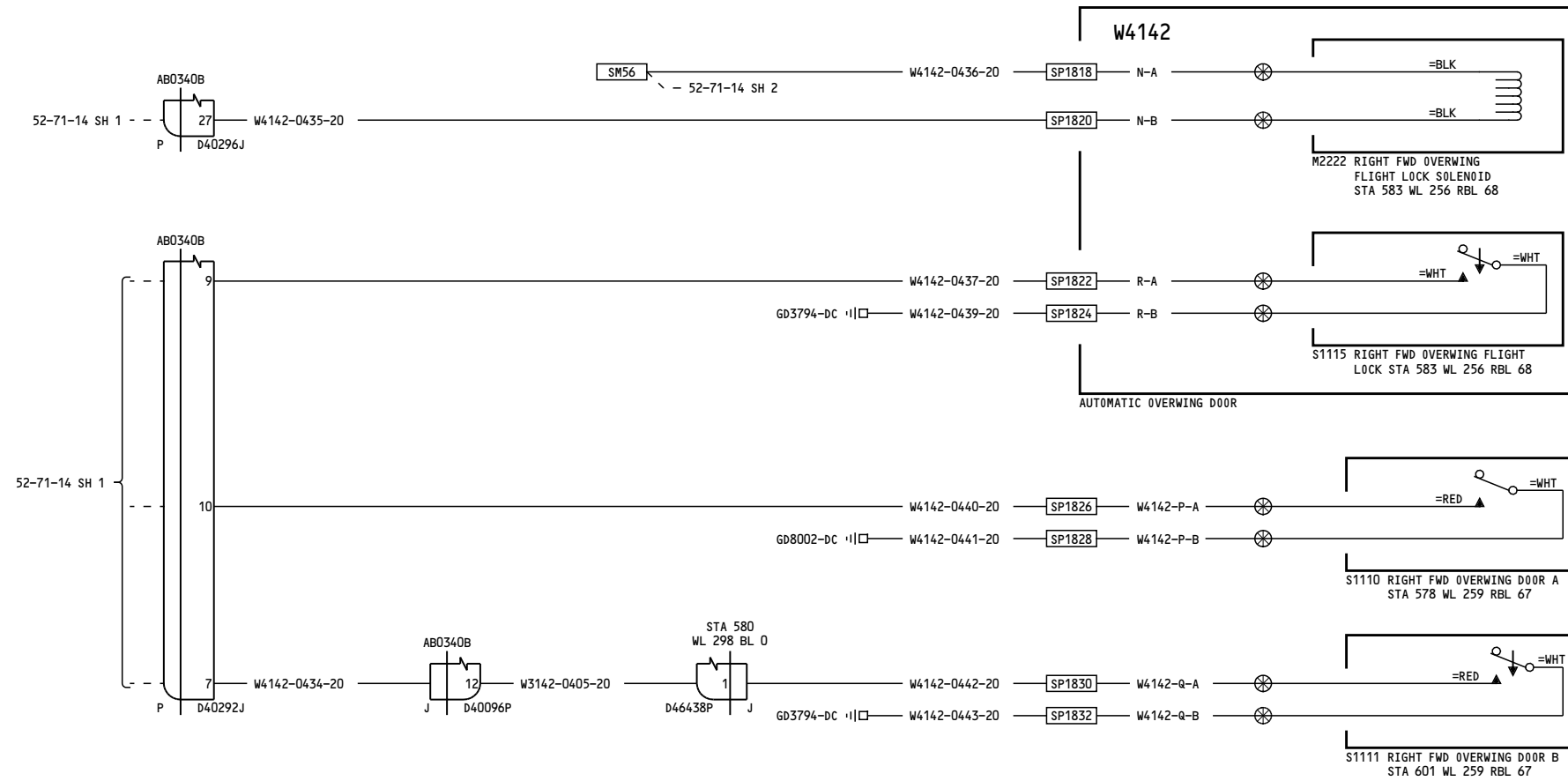

YK901-YL430

**DOOR WARNING OVERWING -
RIGHT OVERWING**

D280A103

52-71-14

Page 3
Sheet 3
Feb 09/2009

52-71-14

Page 3
Sheet 3
Feb 09/2009

8

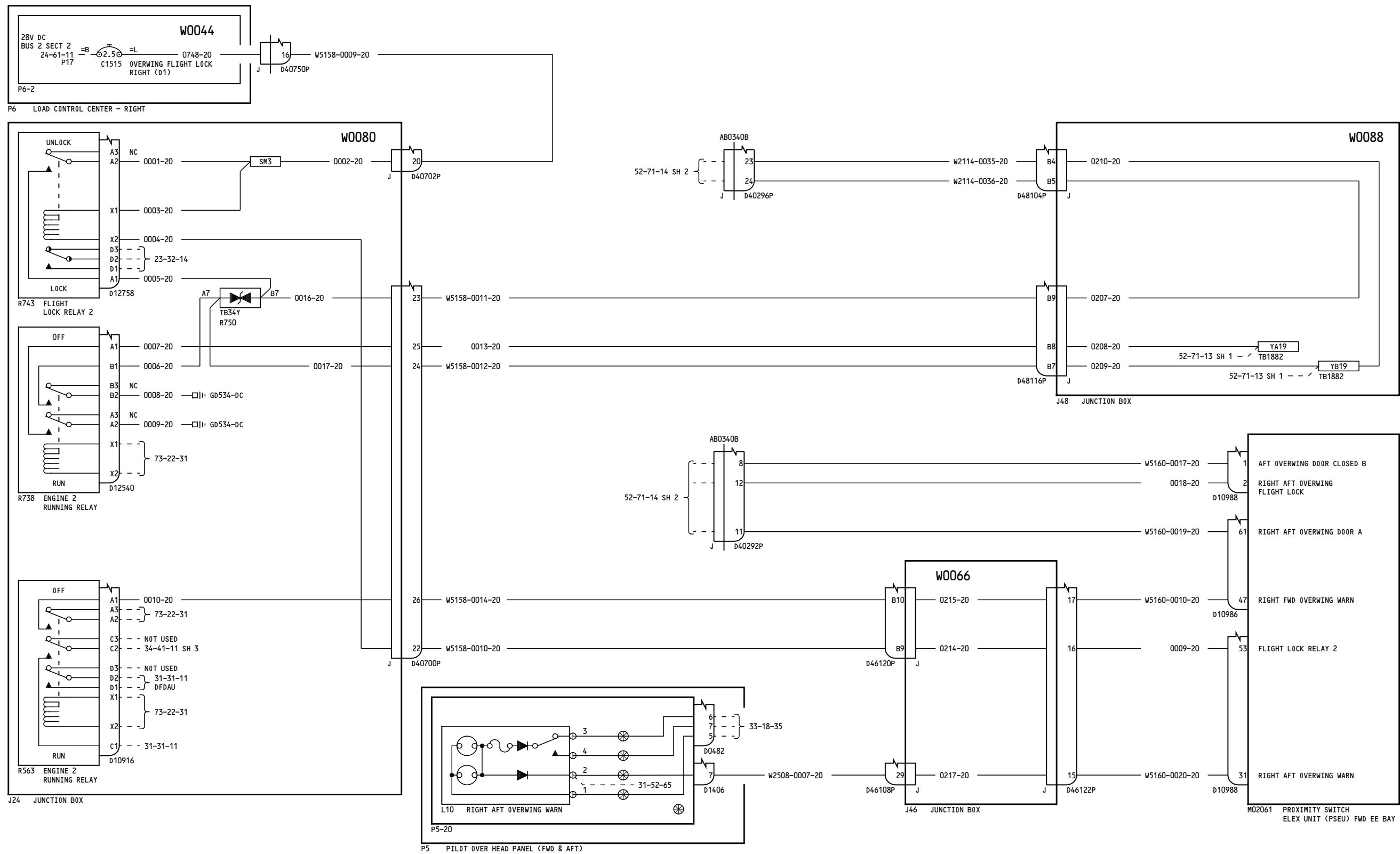

YM643-YM670

DOOR WARNING OVERWING - RIGHT OVERWING

52-71-14

Page 4
Sheet 1
Jan 14/2008

D280A103

52-71-14

Page 4
Sheet 1
Jan 14/2008

