

CHAPTER

73

**ENGINE FUEL AND
CONTROL**



737-700/800

WIRING DIAGRAM MANUAL

CHAPTER 73
ENGINE FUEL AND CONTROL

CH-SC-SU	Schem	Page	Sheet	Date	CH-SC-SU	Schem	Page	Sheet	Date
73-EFFECTIVE PAGES		1		Aug 10/2009	73-24-21		1		Mar 31/2005
		2		BLANK			2		Jul 17/2007
73-CONTENTS							3		Feb 09/2009
		1		Feb 09/2009			4		Feb 09/2009
		2		Feb 09/2009	73-25-11				
		3		Feb 09/2009			1		Oct 20/2006
		4		BLANK			2		Feb 09/2009
73-ALPHABETICAL INDEX					73-25-21				
		1		Jan 18/2007			1		Apr 18/2006
		2		BLANK			2		Feb 09/2009
73-21-11					73-31-11				
		1		Mar 31/2005			1		Feb 09/2009
		2		Mar 31/2005	73-32-11				
		3		Mar 31/2005			1		Feb 09/2009
		4		Feb 09/2009					
		5		Jan 14/2008					
73-21-12									
		1		Mar 31/2005					
		2		Mar 31/2005					
		3		Feb 09/2009					
73-21-21									
		1		Mar 31/2005					
		2		Feb 09/2009					
73-21-31									
		1		Feb 09/2009					
73-22-11									
		1		Mar 31/2005					
		2		Feb 09/2009					
73-22-31									
		1.1	1	Apr 18/2006					
			2	Oct 20/2005					
		2.1	1	Apr 18/2006					
			2	Oct 20/2005					
		3	1	Jul 17/2007					
			2	Jul 17/2007					
		4	1	Aug 13/2008					
			2	Aug 13/2008					
		5	1	Feb 09/2009					
			2	Feb 09/2009					
73-23-11									
		1		Mar 31/2005					
		2		Feb 09/2009					
73-24-11									
		1		Mar 31/2005					
		2		Jul 17/2007					
		3		Feb 09/2009					
		4		Feb 09/2009					
73-24-12									
		1		Mar 31/2005					
		2		Feb 09/2009					
		3		Jan 14/2008					

A = Added, R = Revised, D = Deleted, O = Overflow

73-EFFECTIVE PAGES

Page 1
Aug 10/2009

D280A103



737-700/800

WIRING DIAGRAM MANUAL

**CHAPTER 73
ENGINE FUEL AND CONTROL**

Title	CH-SC-SU	Schem	Page	Sheet	Date	Effectivity
<u>ENGINE CONTROL SYSTEM</u>						
ENGINE EXTERNAL RESET AND CONFIGURATION CONTROL	73-21-11		1		Mar 31/2005	YC001-YC003
			2		Mar 31/2005	YC004-YC006
			3		Mar 31/2005	YC007
			4		Feb 09/2009	YC008-YL430
			5		Jan 14/2008	YM643-YM670
ELECTRONIC ENGINE CONTROL ALTERNATE MODE	73-21-12		1		Mar 31/2005	YC001-YC003
			2		Mar 31/2005	YC004-YC007
			3		Feb 09/2009	YC008-YM670
ENGINE THRUST-LEVER-ANGLE RESOLVER	73-21-21		1		Mar 31/2005	YC001-YC007
			2		Feb 09/2009	YC008-YM670
ENGINE BLEED AIR THRUST CONTROL	73-21-31		1		Feb 09/2009	ALL
<u>ELECTRICAL POWER AND CONTROL</u>						
ELECTRONIC ENGINE CONTROL ELECTRICAL POWER	73-22-11		1		Mar 31/2005	YC001-YC003
			2		Feb 09/2009	YC004-YM670
ENGINE RUNNING CONTROL	73-22-31		1.1	1	Apr 18/2006	YC001-YC003
				2	Oct 20/2005	YC001-YC003
			2.1	1	Apr 18/2006	YC004-YC007
				2	Oct 20/2005	YC004-YC007
			3	1	Jul 17/2007	YC008-YC030 YK901-YK905
				2	Jul 17/2007	YC008-YC030 YK901-YK905
			4	1	Aug 13/2008	YC031-YC050 YK906-YK909 YL401
				2	Aug 13/2008	YC031-YC050 YK906-YK909 YL401
	5	1	Feb 09/2009	YK910-YK920 YL421-YM670		

73-CONTENTS

Page 1
Feb 09/2009

D280A103



737-700/800

WIRING DIAGRAM MANUAL

CHAPTER 73 ENGINE FUEL AND CONTROL

Title	CH-SC-SU	Schem	Page	Sheet	Date	Effectivity
ENGINE RUNNING CONTROL (cont.)	73-22-31			2	Feb 09/2009	YK910-YK920 YL421-YM670
<u>ENGINE IDLE CONTROL</u>						
ENGINE IDLE CONTROL	73-23-11		1		Mar 31/2005	YC001-YC007
			2		Feb 09/2009	YC008-YM670
<u>ENGINE DATABUS OUTPUT</u>						
ENGINE 1 DATABUS OUTPUT	73-24-11		1		Mar 31/2005	YC001-YC007
			2		Jul 17/2007	YC008-YC030
			3		Feb 09/2009	YC031-YK910 YK918 YL421-YL426 YM643-YM649
			4		Feb 09/2009	YK911-YK917 YK919-YL401 YL427-YL430 YM651-YM670
ENGINE DATABUS INPUT	73-24-12		1		Mar 31/2005	YC001-YC007
			2		Feb 09/2009	YC008-YL430
			3		Jan 14/2008	YM643-YM670
ENGINE 2 DATABUS OUTPUT	73-24-21		1		Mar 31/2005	YC001-YC007
			2		Jul 17/2007	YC008-YC030
			3		Feb 09/2009	YC031-YK910 YK918 YL421-YL426 YM643-YM649
			4		Feb 09/2009	YK911-YK917 YK919-YL401 YL427-YL430 YM651-YM670
<u>ENGINE FUEL CONTROL</u>						
ENGINE 1 FUEL CONTROL	73-25-11		1		Oct 20/2006	YC001-YC016
			2		Feb 09/2009	YC017-YM670
ENGINE 2 FUEL CONTROL	73-25-21		1		Apr 18/2006	YC001-YC016
			2		Feb 09/2009	YC017-YM670
<u>FUEL FLOW INDICATING SYSTEM</u>						
ENGINE FUEL SYSTEM INDICATION	73-31-11		1		Feb 09/2009	ALL



737-700/800

WIRING DIAGRAM MANUAL

**CHAPTER 73
ENGINE FUEL AND CONTROL**

Title	CH-SC-SU	Schem	Page	Sheet	Date	Effectivity
<u>ENGINE FAULT INDICATION</u>						
ENGINE CONTROL EEC FAULT INDICATION	73-32-11		1		Feb 09/2009	ALL



737-700/800

WIRING DIAGRAM MANUAL

CHAPTER 73 ENGINE FUEL AND CONTROL

CH-SC-SU	Title
73-21-12	ELECTRONIC ENGINE CONTROL ALTERNATE MODE
73-22-11	ELECTRONIC ENGINE CONTROL ELECTRICAL POWER
73-24-11	ENGINE 1 DATABUS OUTPUT
73-25-11	ENGINE 1 FUEL CONTROL
73-24-21	ENGINE 2 DATABUS OUTPUT
73-25-21	ENGINE 2 FUEL CONTROL
73-21-31	ENGINE BLEED AIR THRUST CONTROL
73-32-11	ENGINE CONTROL EEC FAULT INDICATION
73-24-12	ENGINE DATABUS INPUT
73-21-11	ENGINE EXTERNAL RESET AND CONFIGURATION CONTROL
73-31-11	ENGINE FUEL SYSTEM INDICATION
73-23-11	ENGINE IDLE CONTROL
73-22-31	ENGINE RUNNING CONTROL
73-21-21	ENGINE THRUST-LEVER-ANGLE RESOLVER

73-ALPHABETICAL INDEX

D280A103

Page 1
Jan 18/2007

-G
2

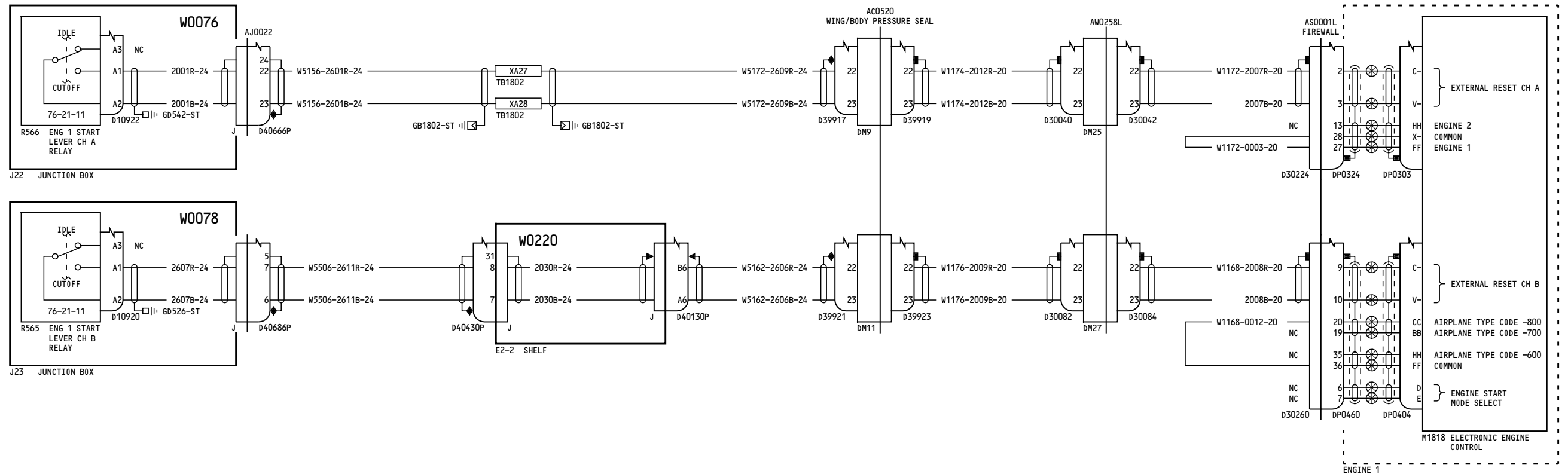
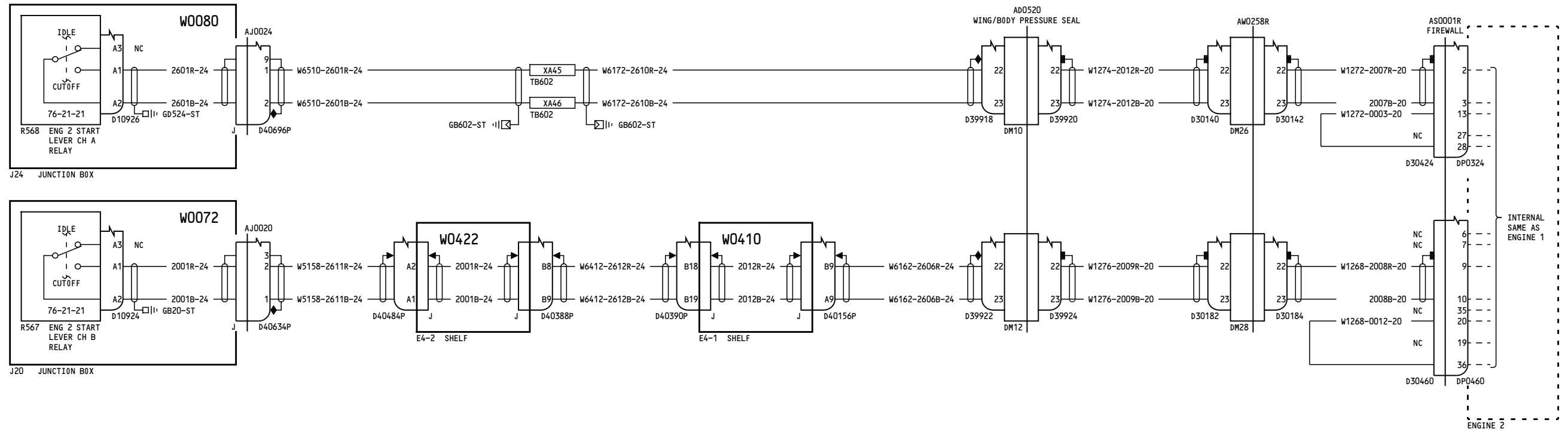

YC001-YC003

ENGINE EXTERNAL RESET AND CONFIGURATION CONTROL

73-21-11

Page 1

D280A103

Mar 31/2005

73-21-11

Page 1

Mar 31/2005

-E

5

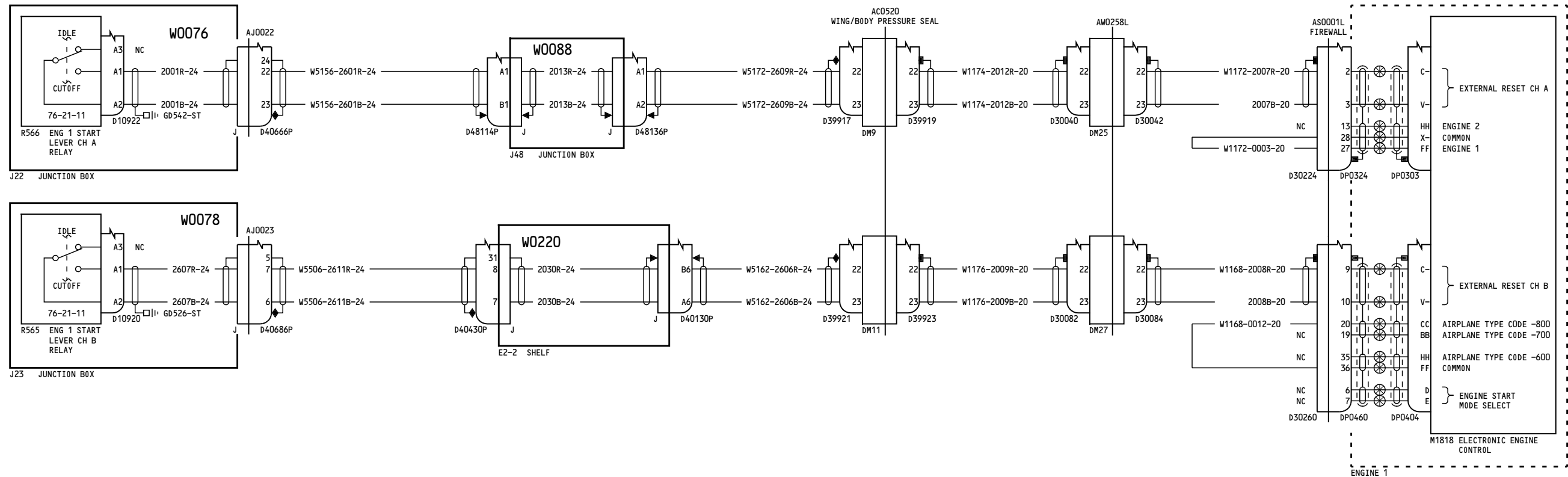
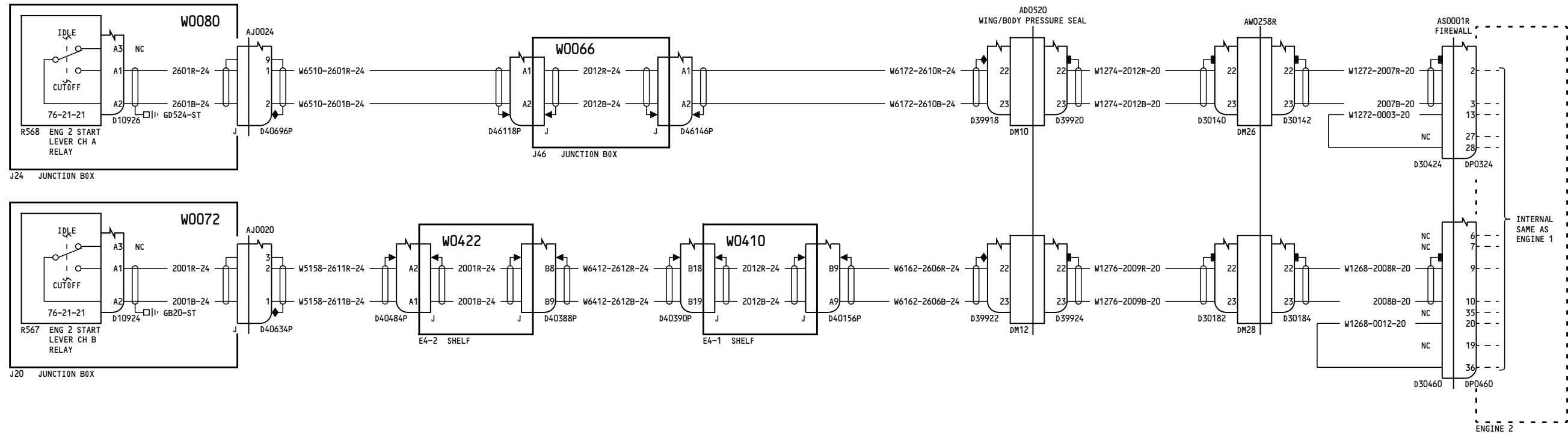

YC004-YC006

ENGINE EXTERNAL RESET AND CONFIGURATION CONTROL

73-21-11

Page 2

D280A103

Mar 31/2005

73-21-11

Page 2

Mar 31/2005

-C
9

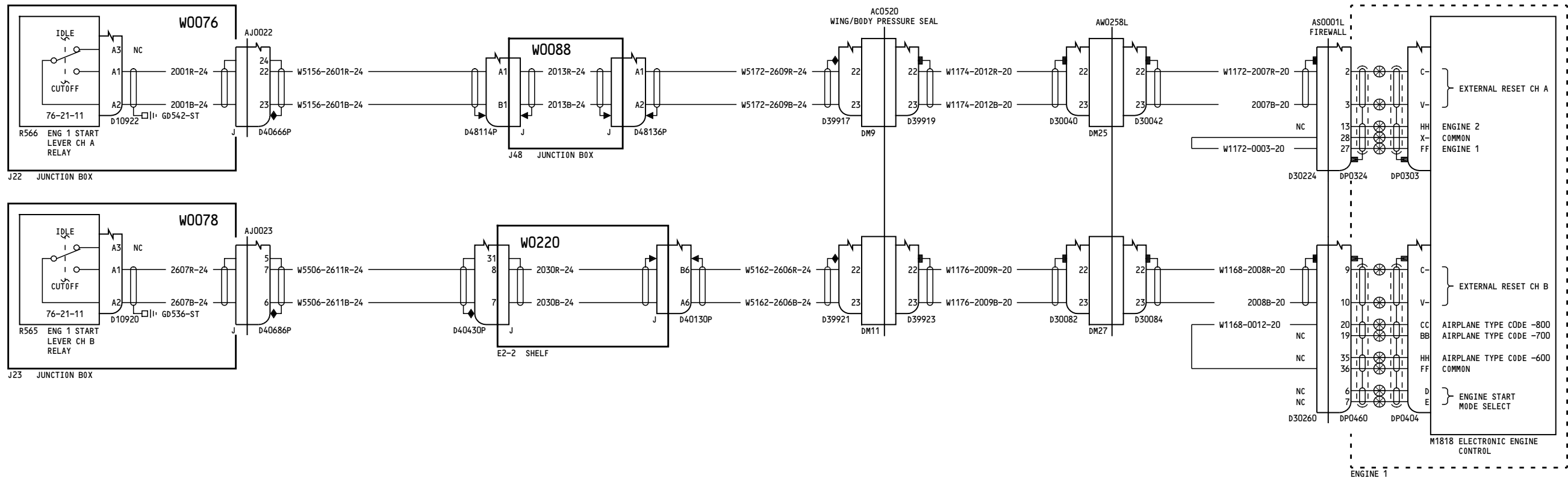
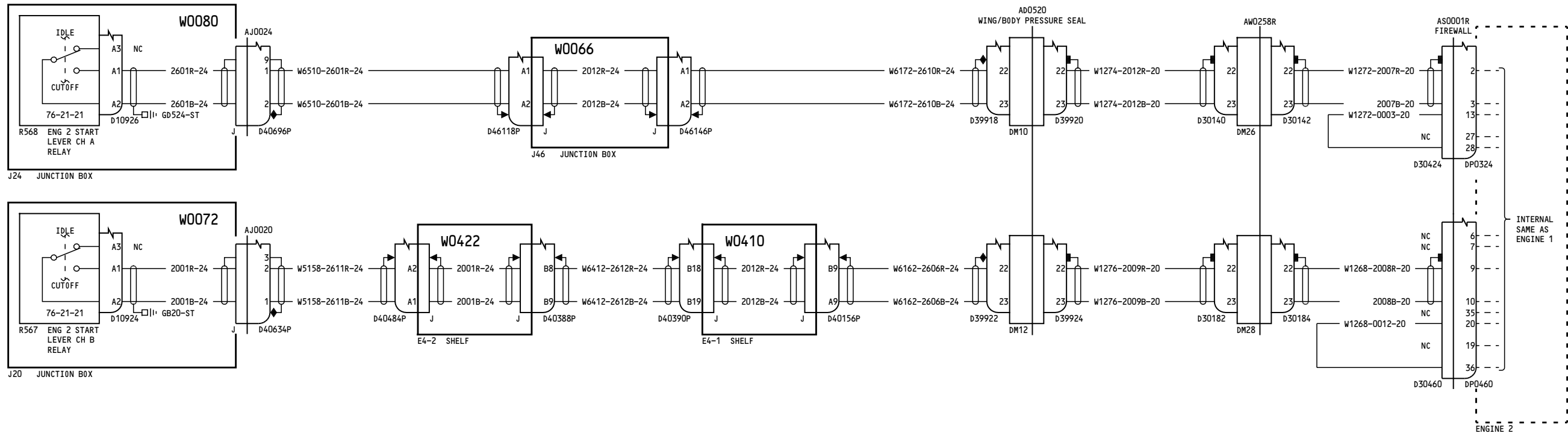

YC007

ENGINE EXTERNAL RESET AND CONFIGURATION CONTROL

73-21-11

Page 3

D280A103

Mar 31/2005

73-21-11

Page 3

Mar 31/2005

-B
26

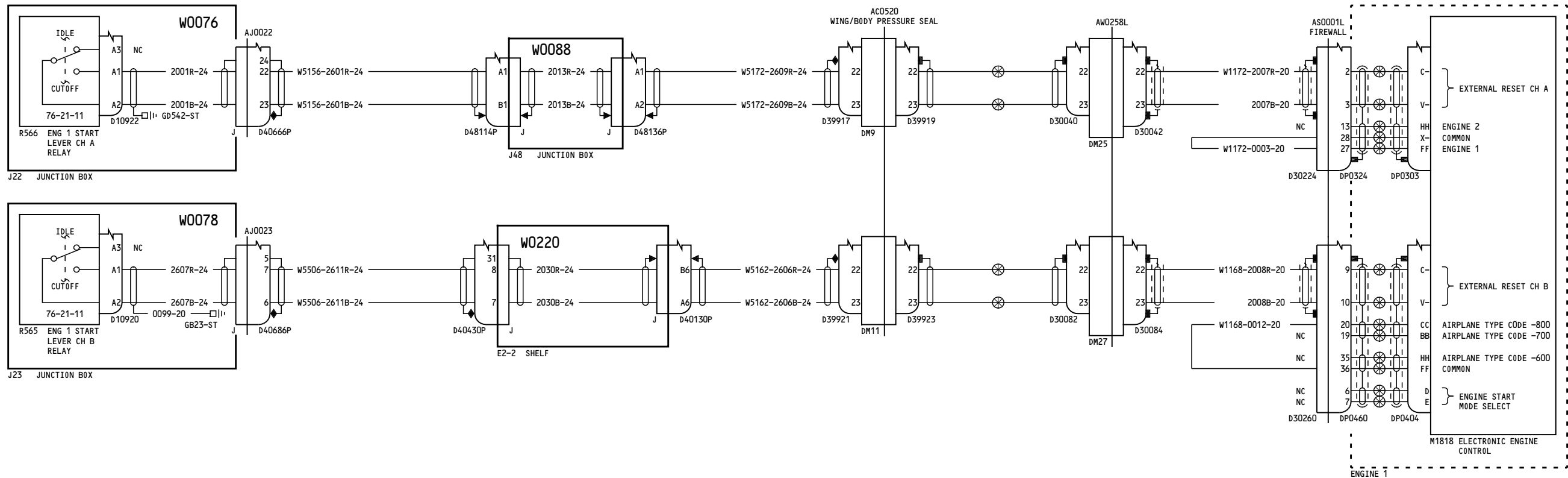
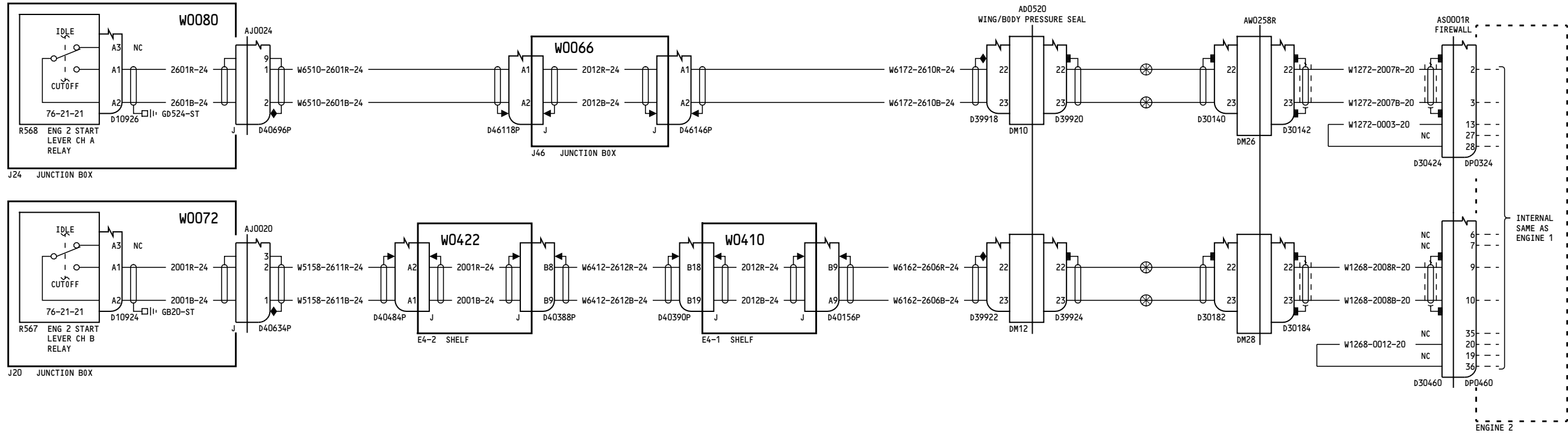

YC008-YL430

ENGINE EXTERNAL RESET AND CONFIGURATION CONTROL

73-21-11

Page 4

D280A103

Feb 09/2009

73-21-11

Page 4

Feb 09/2009

-B
25

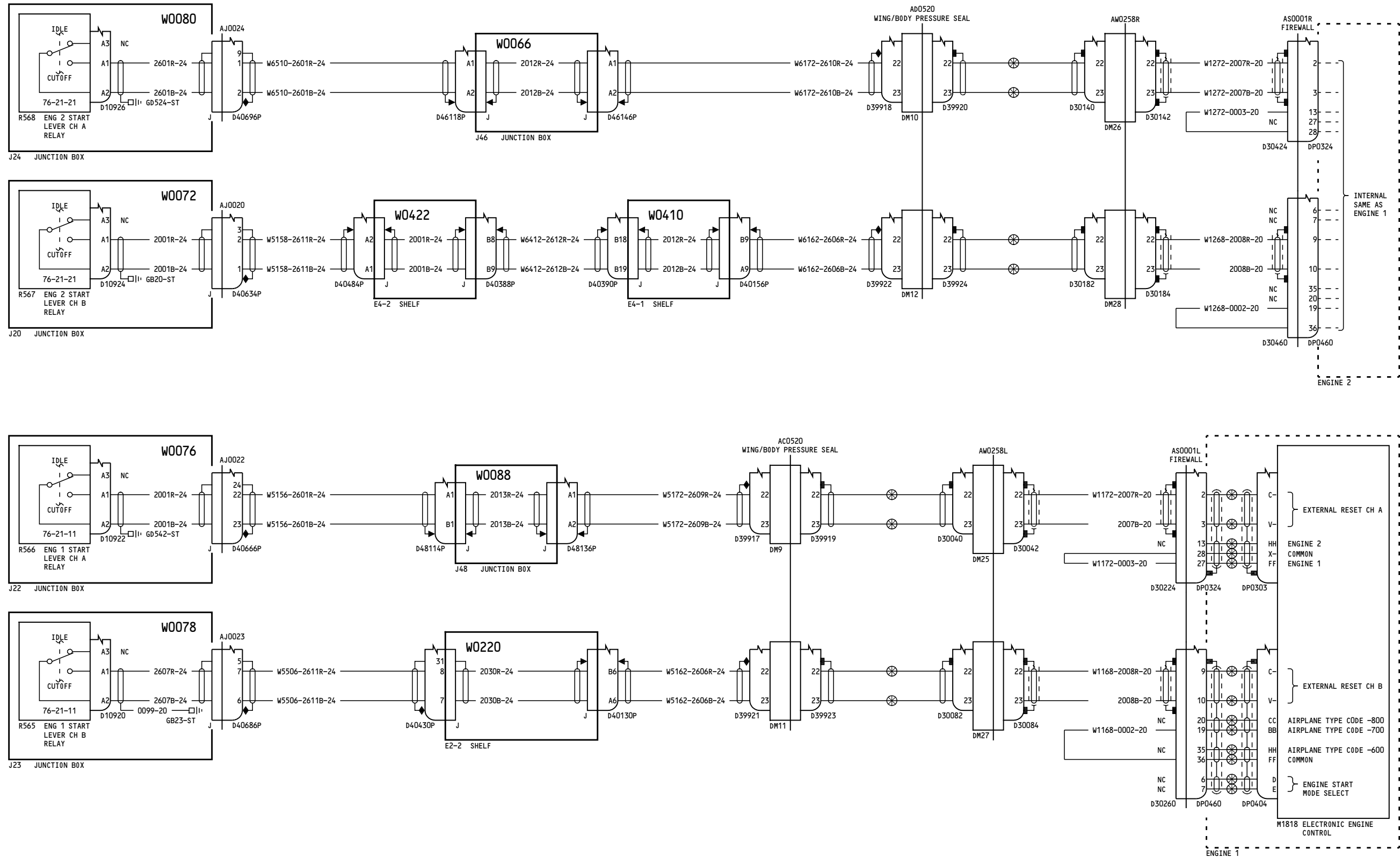

YM643-YM670

ENGINE EXTERNAL RESET AND CONFIGURATION CONTROL

73-21-11

Page 5

D280A103

Jan 14/2008

73-21-11

Page 5

Jan 14/2008

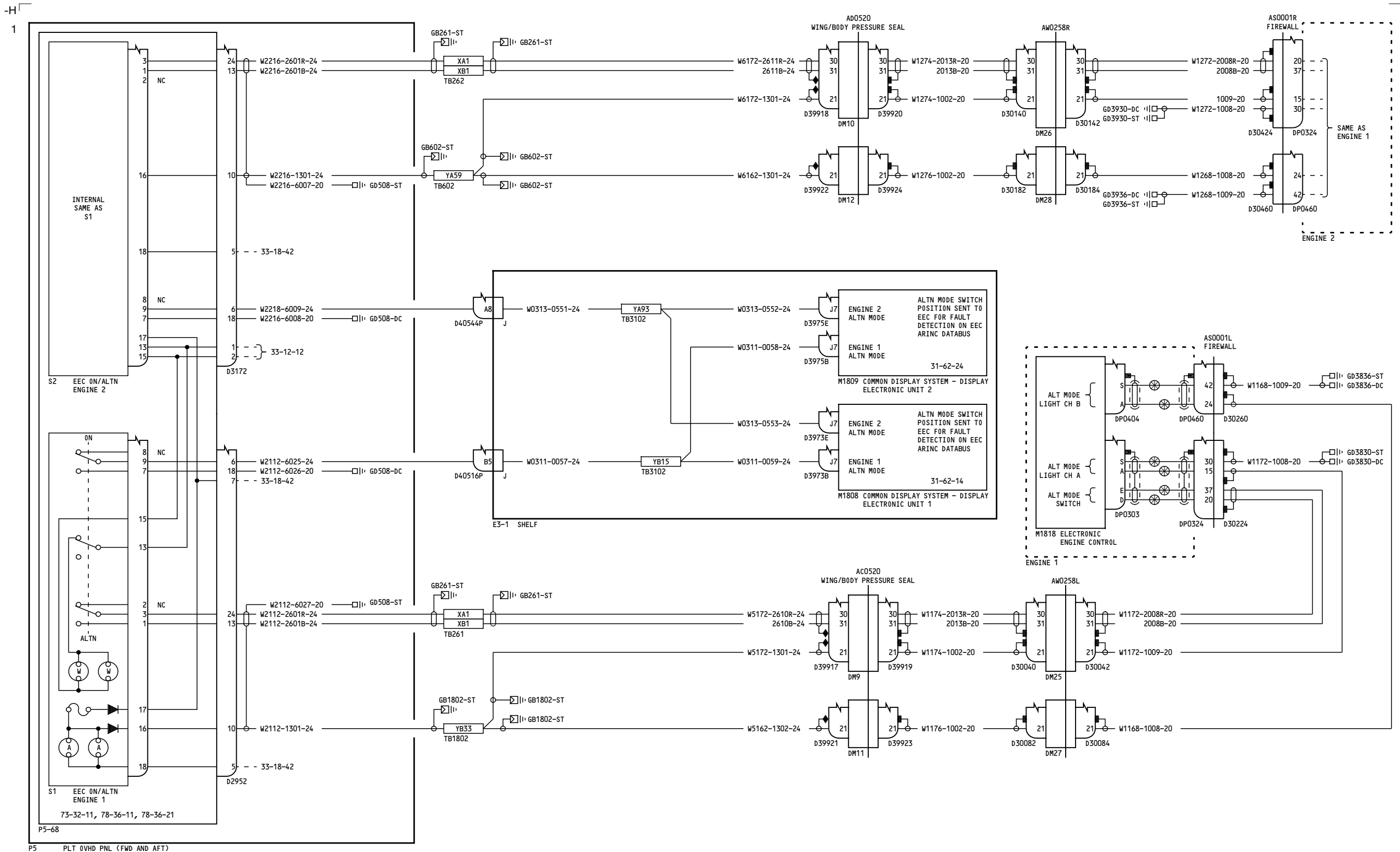

YC001-YC003

ELECTRONIC ENGINE CONTROL ALTERNATE MODE

73-21-12

Page 1

D280A103

Mar 31/2005

73-21-12

Page 1

Mar 31/2005

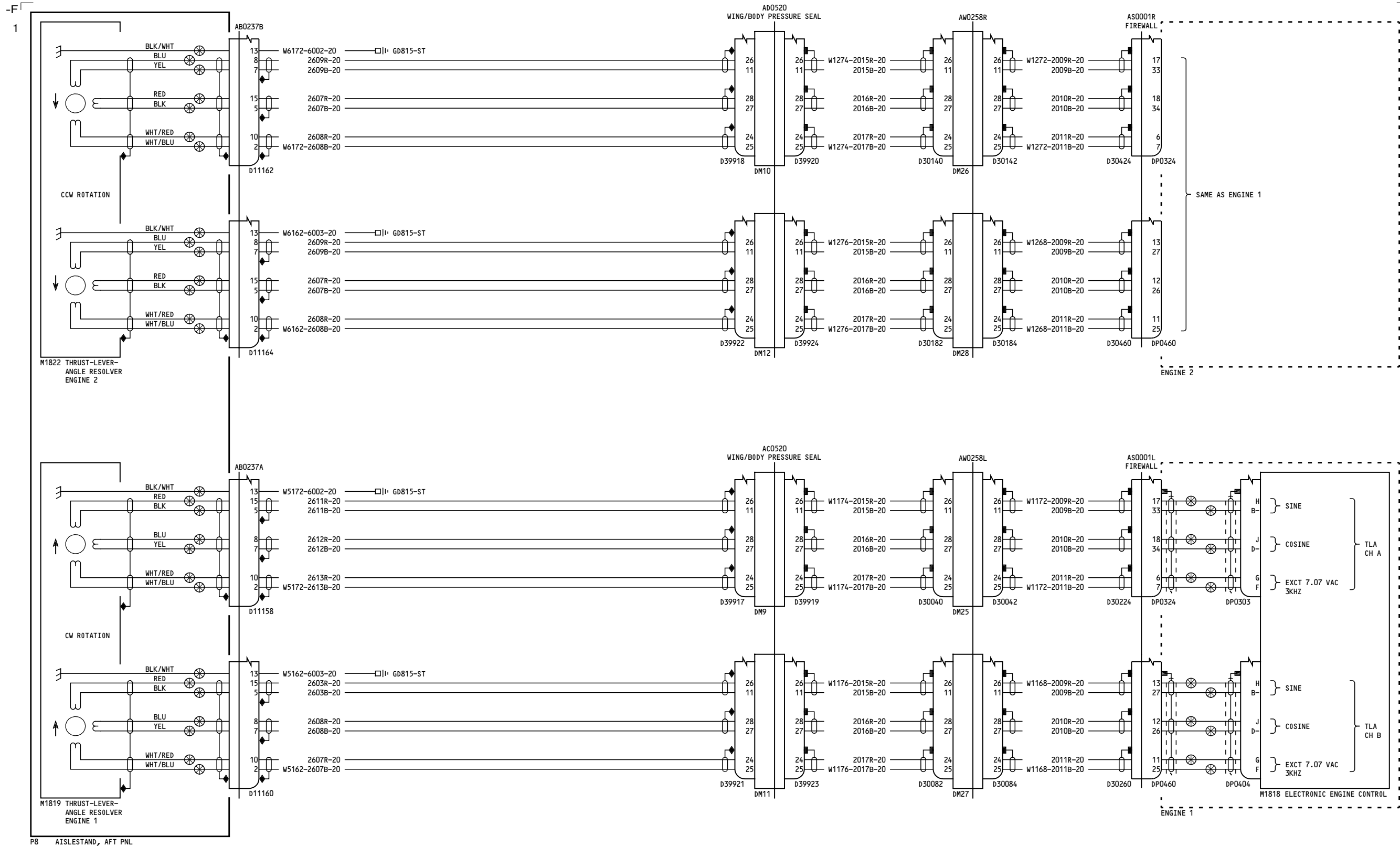

YC001-YC007

ENGINE THRUST-LEVER-ANGLE RESOLVER

73-21-21

Page 1

D280A103

Mar 31/2005

73-21-21

Page 1

Mar 31/2005

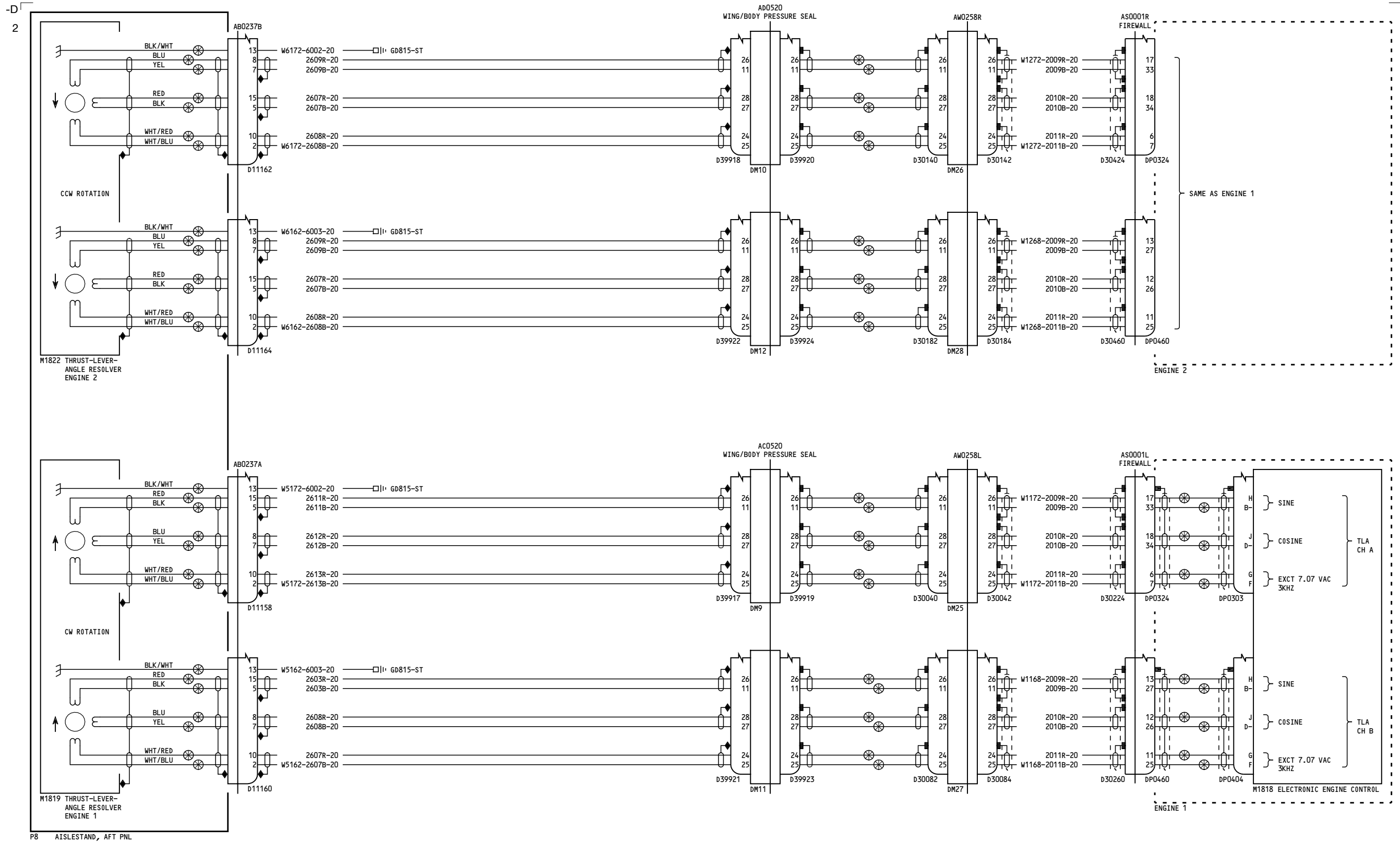

YC008-YM670

ENGINE THRUST-LEVER-ANGLE RESOLVER

73-21-21

Page 2

D280A103

Feb 09/2009

73-21-21

Page 2

Feb 09/2009

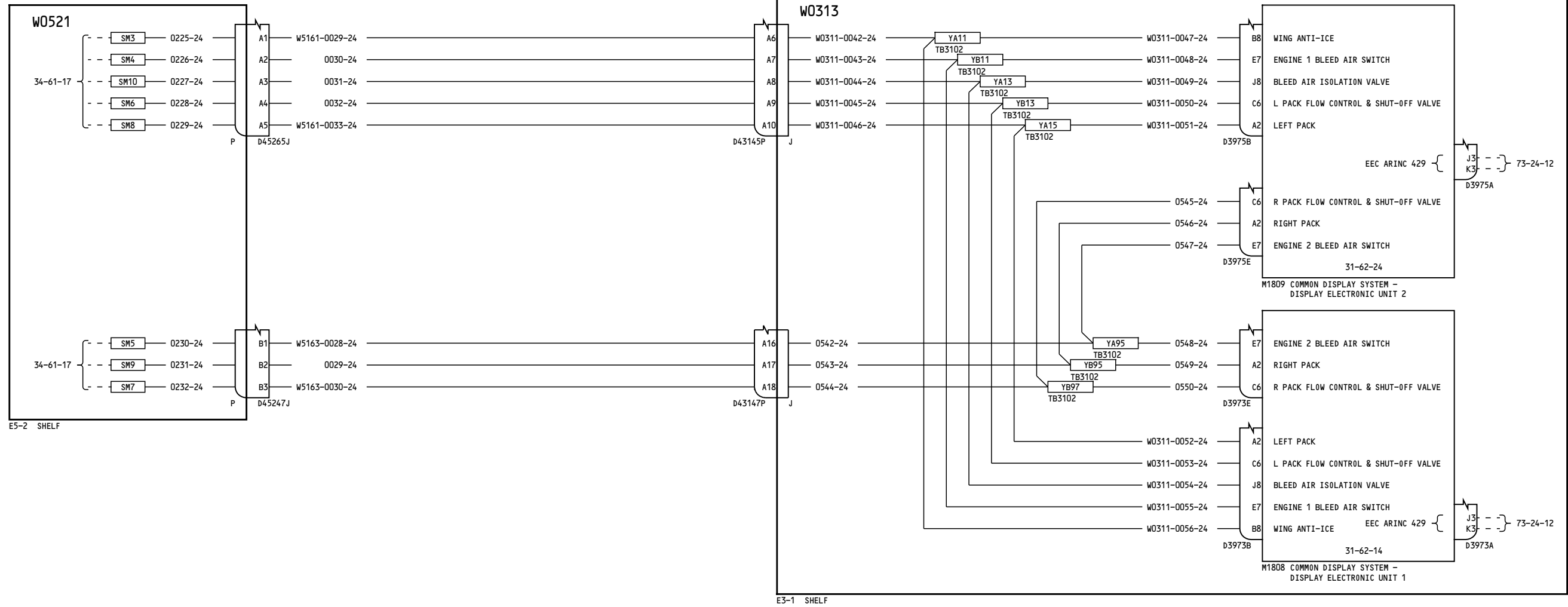

ALL	ENGINE BLEED AIR THRUST CONTROL
	D280A103

73-21-31

73-21-31

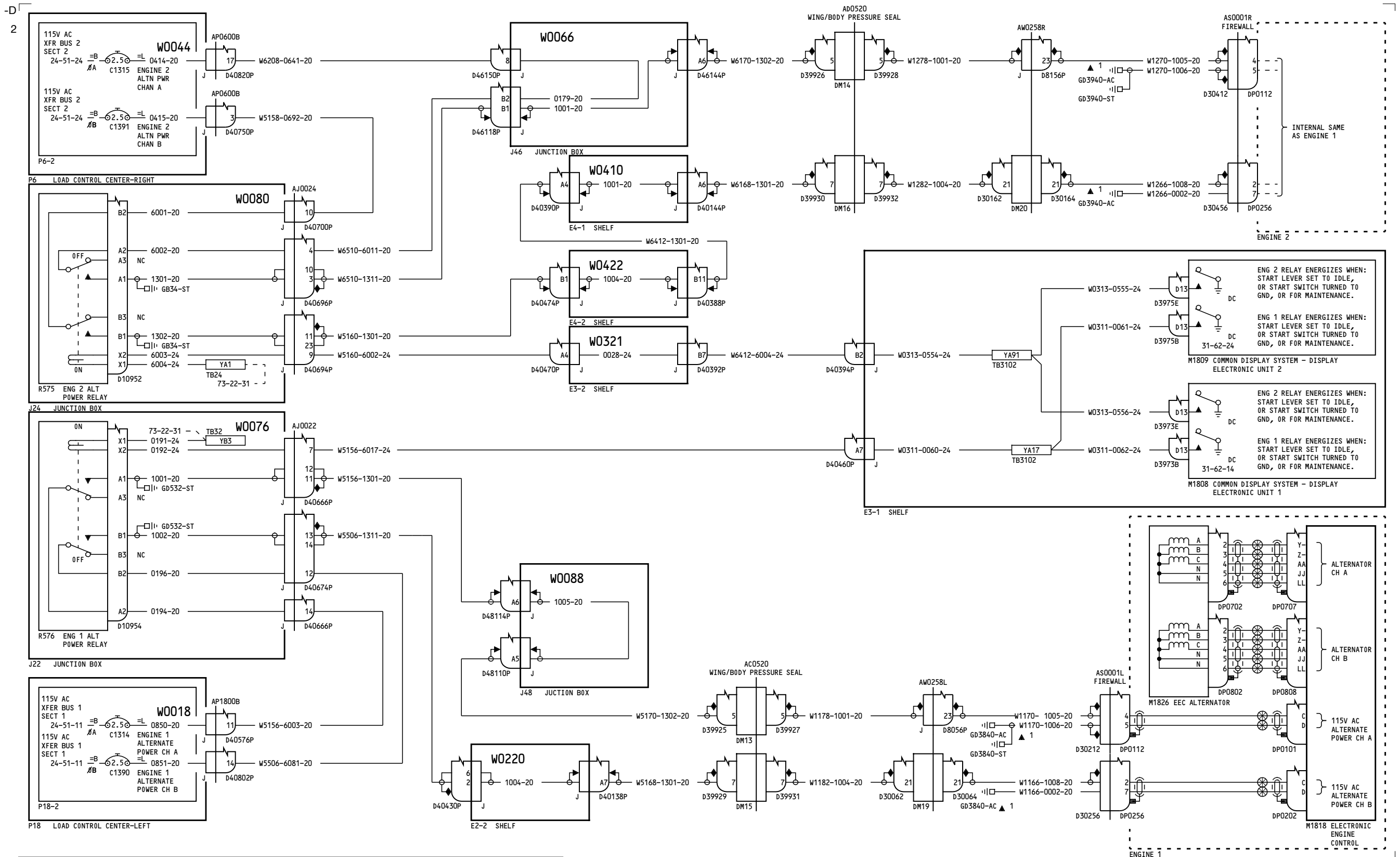

YC004-YM670

ELECTRONIC ENGINE CONTROL ELECTRICAL POWER

73-22-11

Page 2

D280A103

Feb 09/2009

73-22-11

Page 2

Feb 09/2009

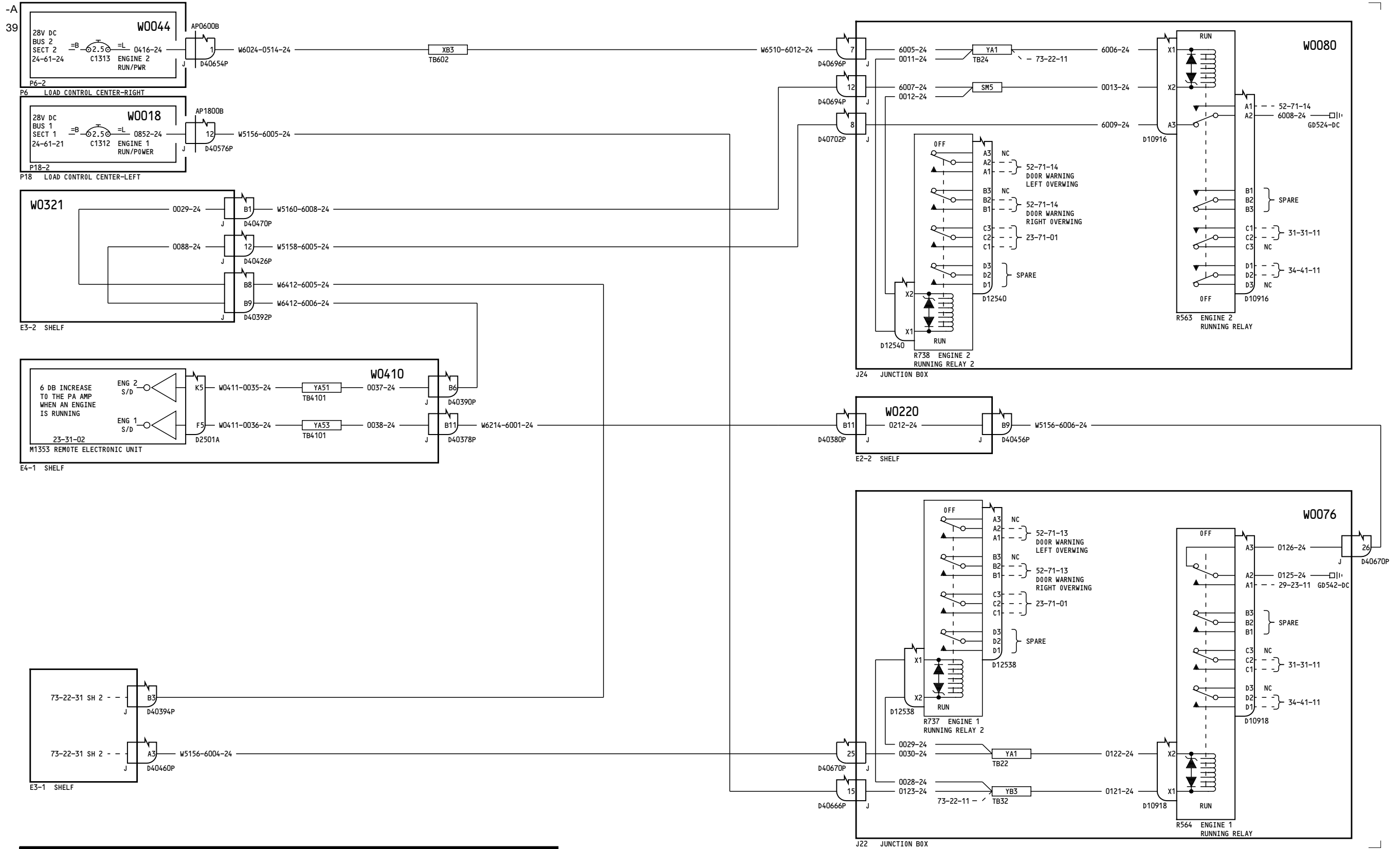

YC001-YC003

ENGINE RUNNING CONTROL

73-22-31

Page 1.1
Sheet 1
Apr 18/2006

D280A103

Incorporates
23-1107

73-22-31

Page 1.1
Sheet 1
Apr 18/2006

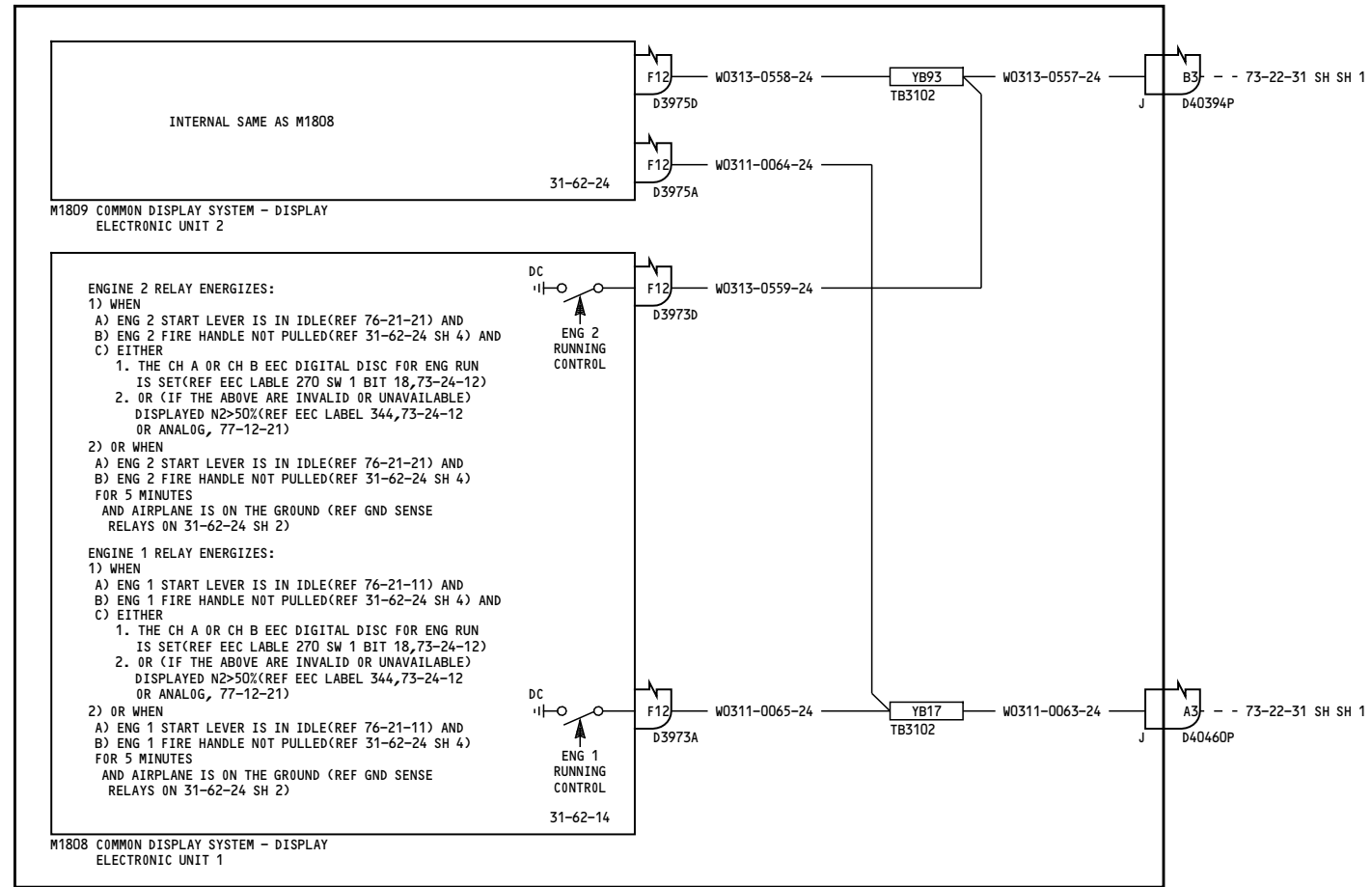

E3-1 SHELF

YC001-YC003

ENGINE RUNNING CONTROL

D280A103

73-22-31

Page 1.1
Sheet 2
Oct 20/2005

73-22-31

Page 1.1
Sheet 2
Oct 20/2005

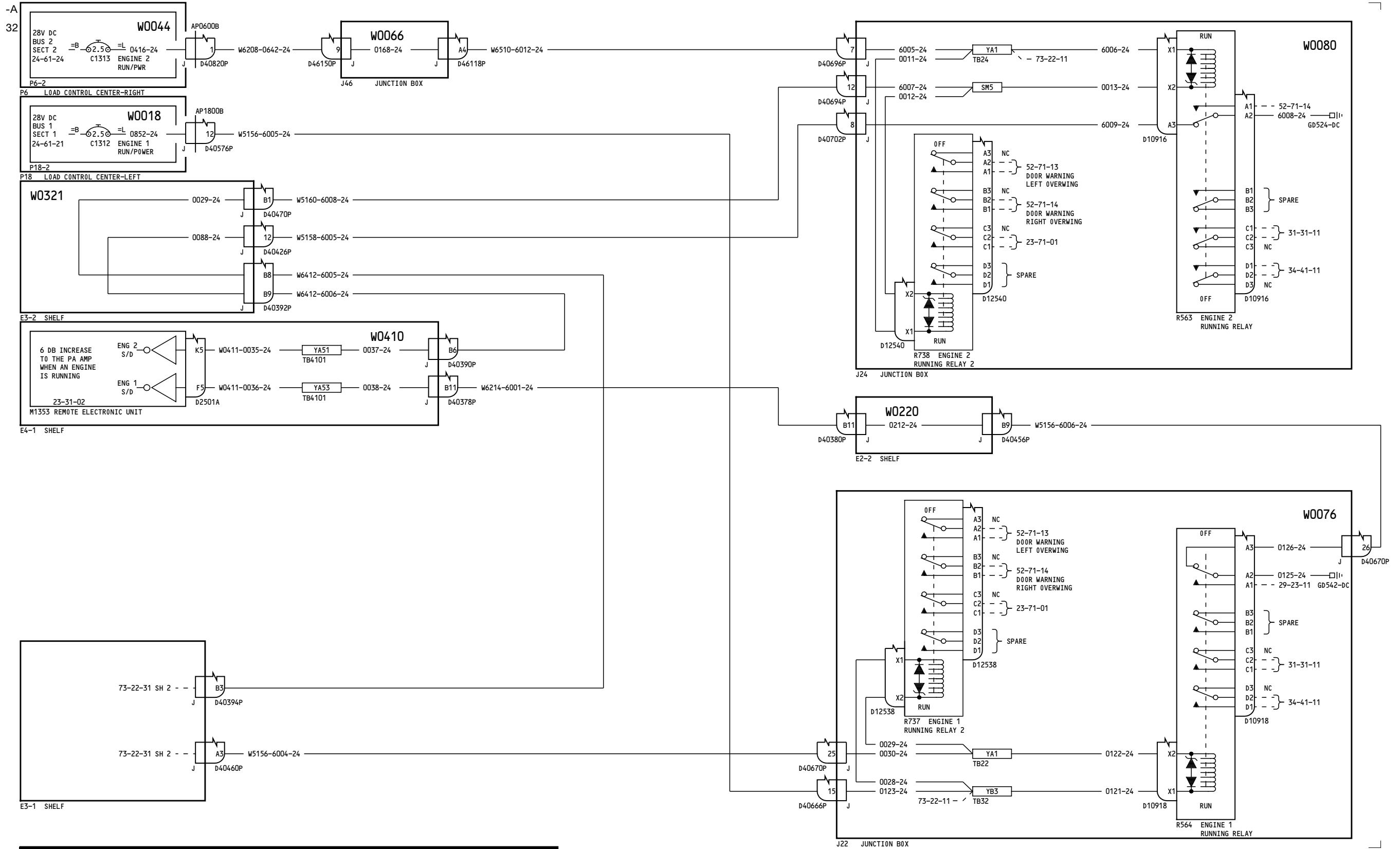

YC004-YC007

ENGINE RUNNING CONTROL

73-22-31

Page 2.1
Sheet 1
Apr 18/2006

D280A103

Incorporates
23-1107

73-22-31

Page 2.1
Sheet 1
Apr 18/2006

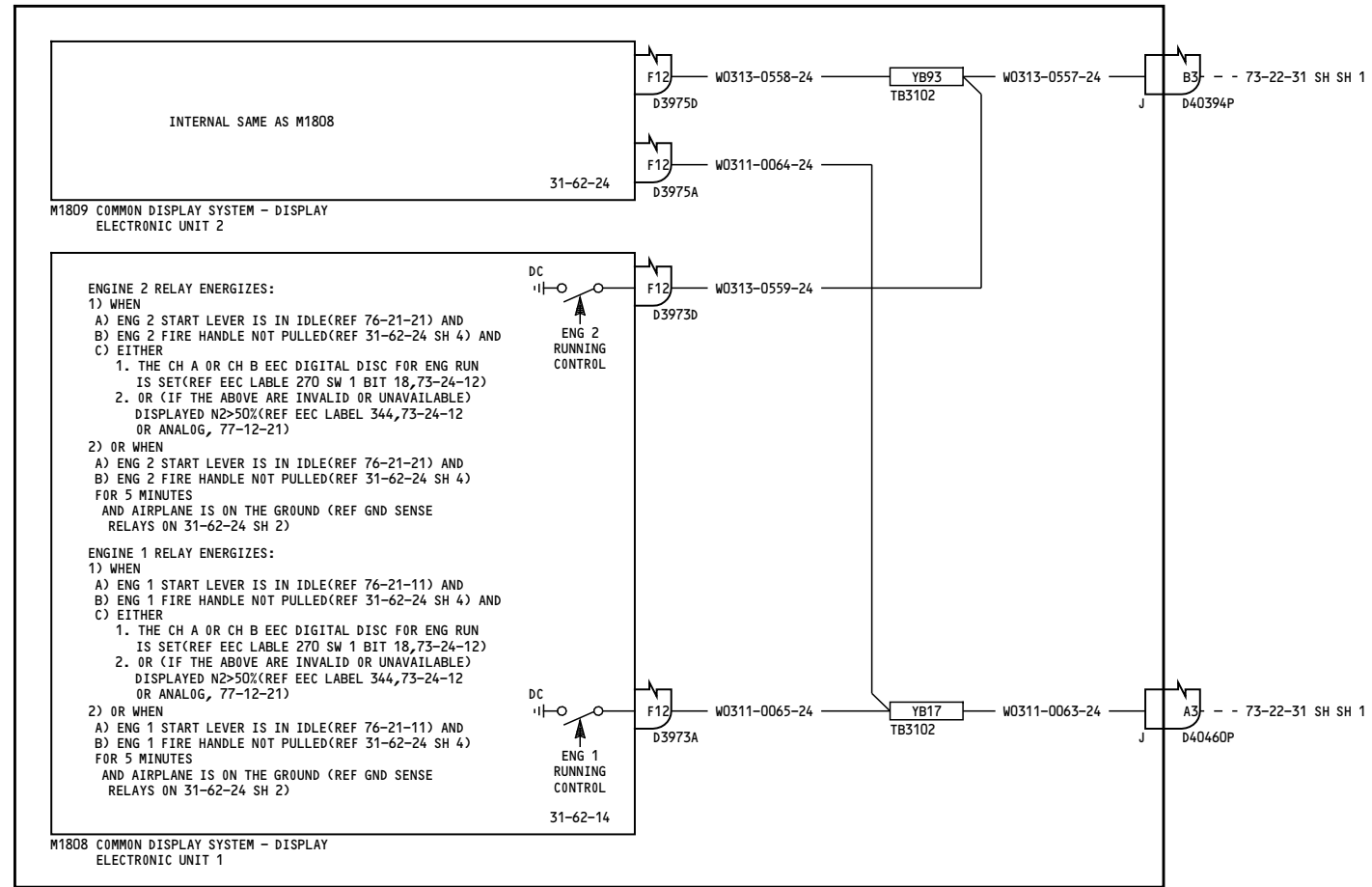

YC004-YC007

ENGINE RUNNING CONTROL

D280A103

73-22-31

Page 2.1
Sheet 2
Oct 20/2005

73-22-31

Page 2.1
Sheet 2
Oct 20/2005

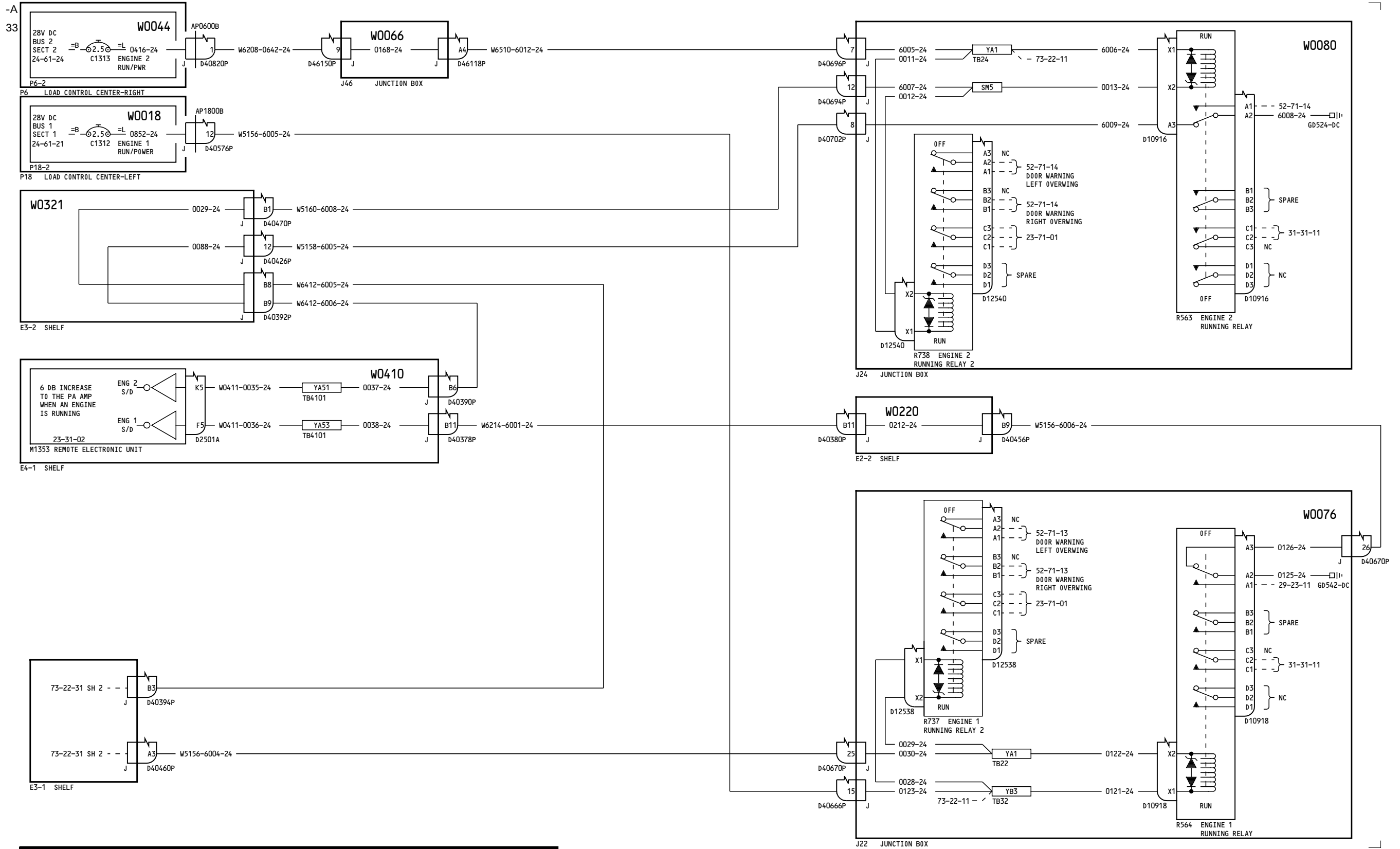

YC008-YC030, YK901-YK905

ENGINE RUNNING CONTROL

73-22-31

Page 3
Sheet 1
Jul 17/2007

D280A103

73-22-31

Page 3
Sheet 1
Jul 17/2007

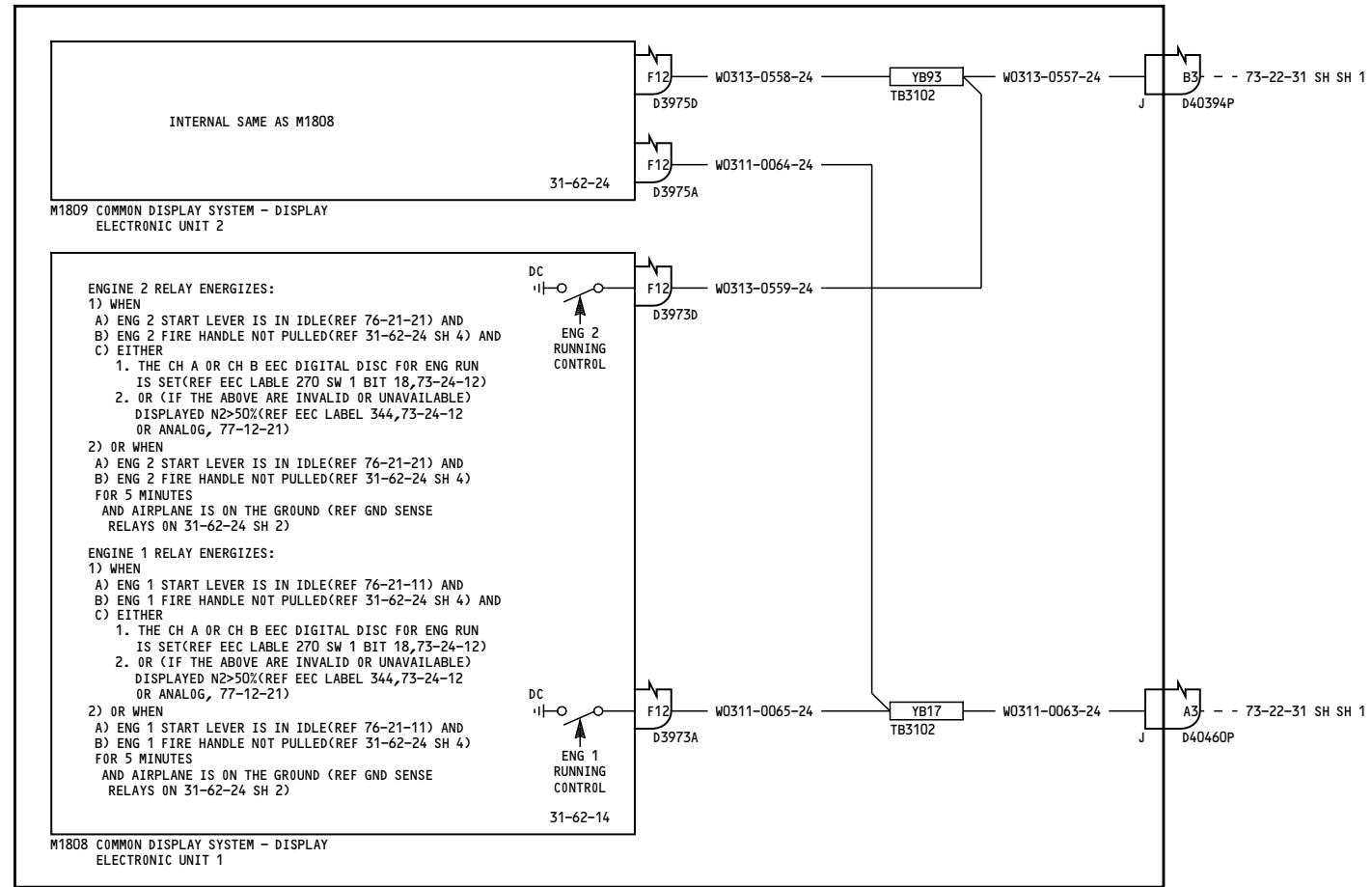

E3-1 SHELF

YC008-YC030, YK901-YK905

ENGINE RUNNING CONTROL

D280A103

73-22-31

Page 3
 Sheet 2
 Jul 17/2007

73-22-31

Page 3
 Sheet 2
 Jul 17/2007

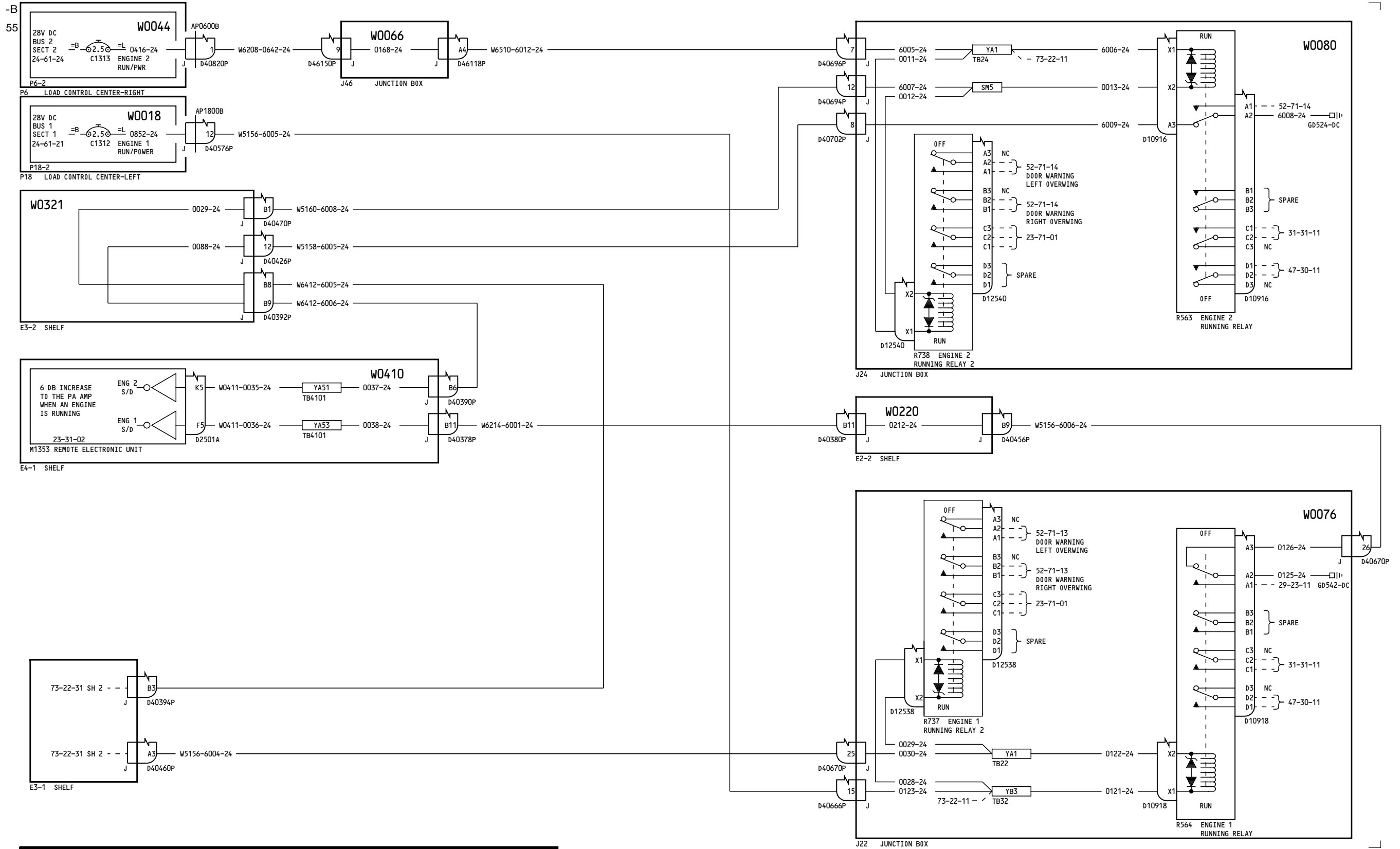

YC031-YC050, YK906-YK909, YL401

ENGINE RUNNING CONTROL

73-22-31

Page 4
Sheet 1
Aug 13/2008

D280A103

73-22-31

Page 4
Sheet 1
Aug 13/2008

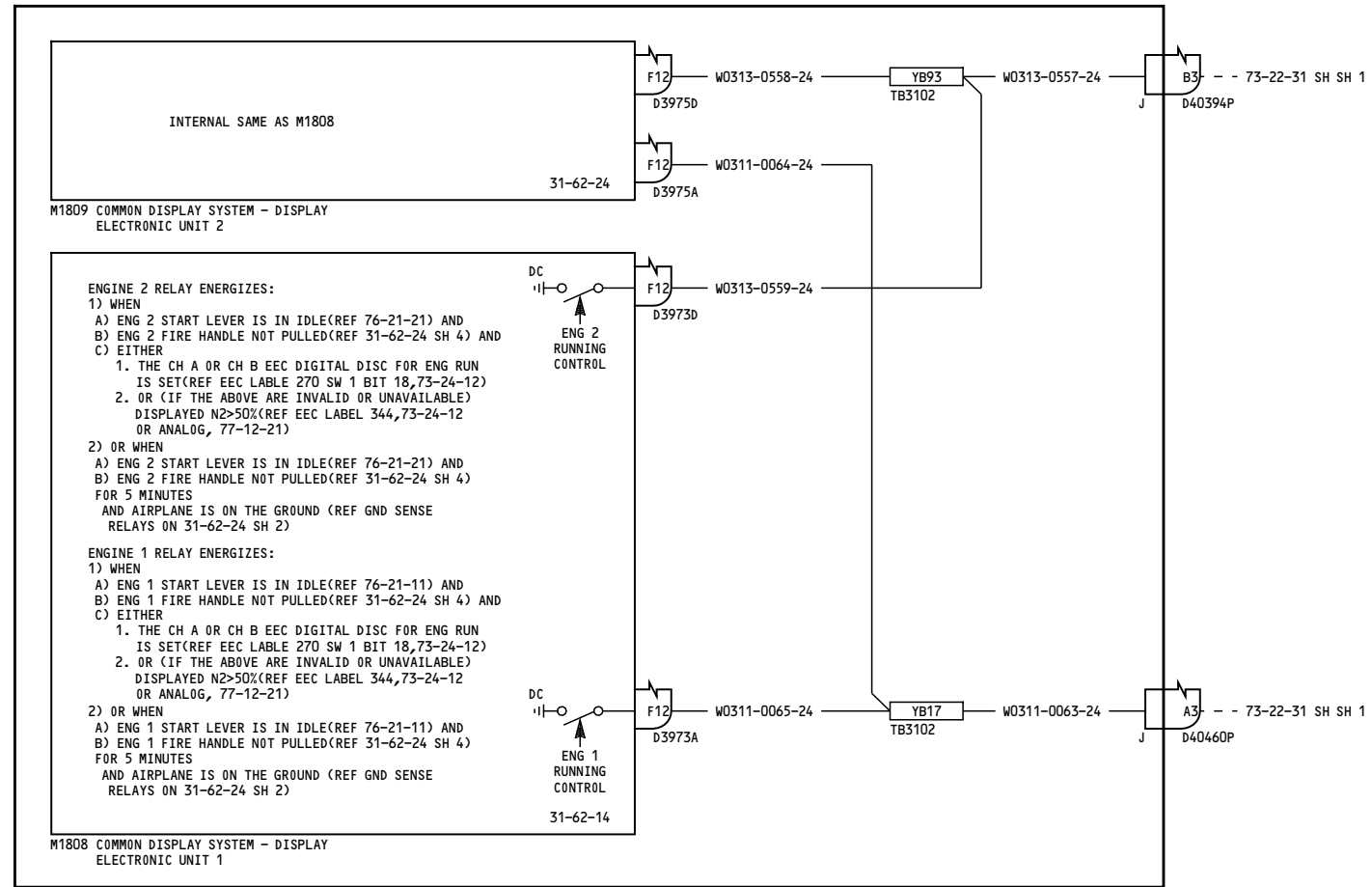

E3-1 SHELF

YC031-YC050, YK906-YK909, YL401

ENGINE RUNNING CONTROL

D280A103

73-22-31

Page 4
 Sheet 2
 Aug 13/2008

73-22-31

Page 4
 Sheet 2
 Aug 13/2008

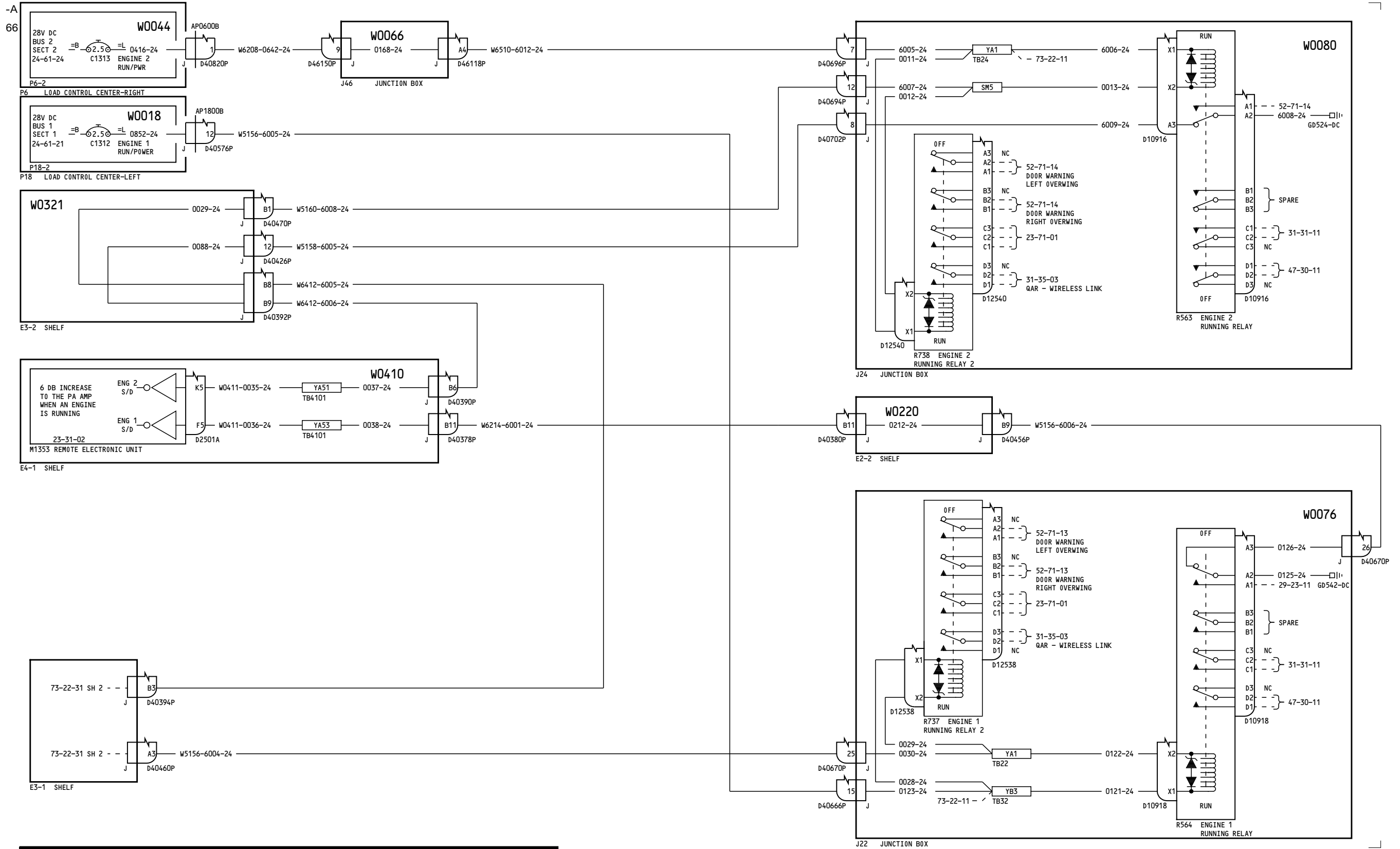

YK910-YK920, YL421-YM670

ENGINE RUNNING CONTROL

73-22-31

Page 5
Sheet 1
Feb 09/2009

D280A103

73-22-31

Page 5
Sheet 1
Feb 09/2009

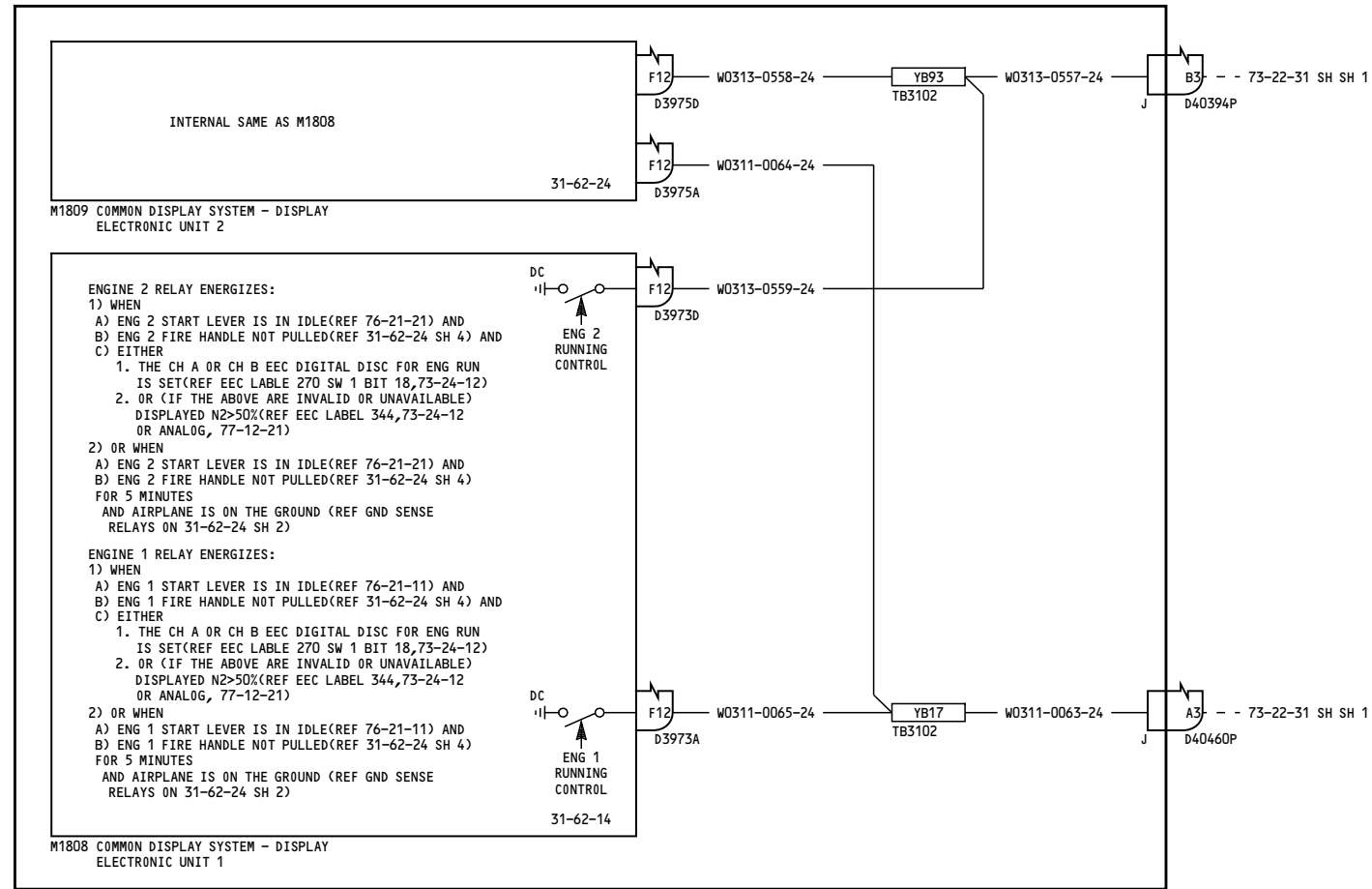

E3-1 SHELF

YK910-YK920, YL421-YM670

ENGINE RUNNING CONTROL

D280A103

73-22-31

Page 5
Sheet 2
Feb 09/2009

73-22-31

Page 5
Sheet 2
Feb 09/2009

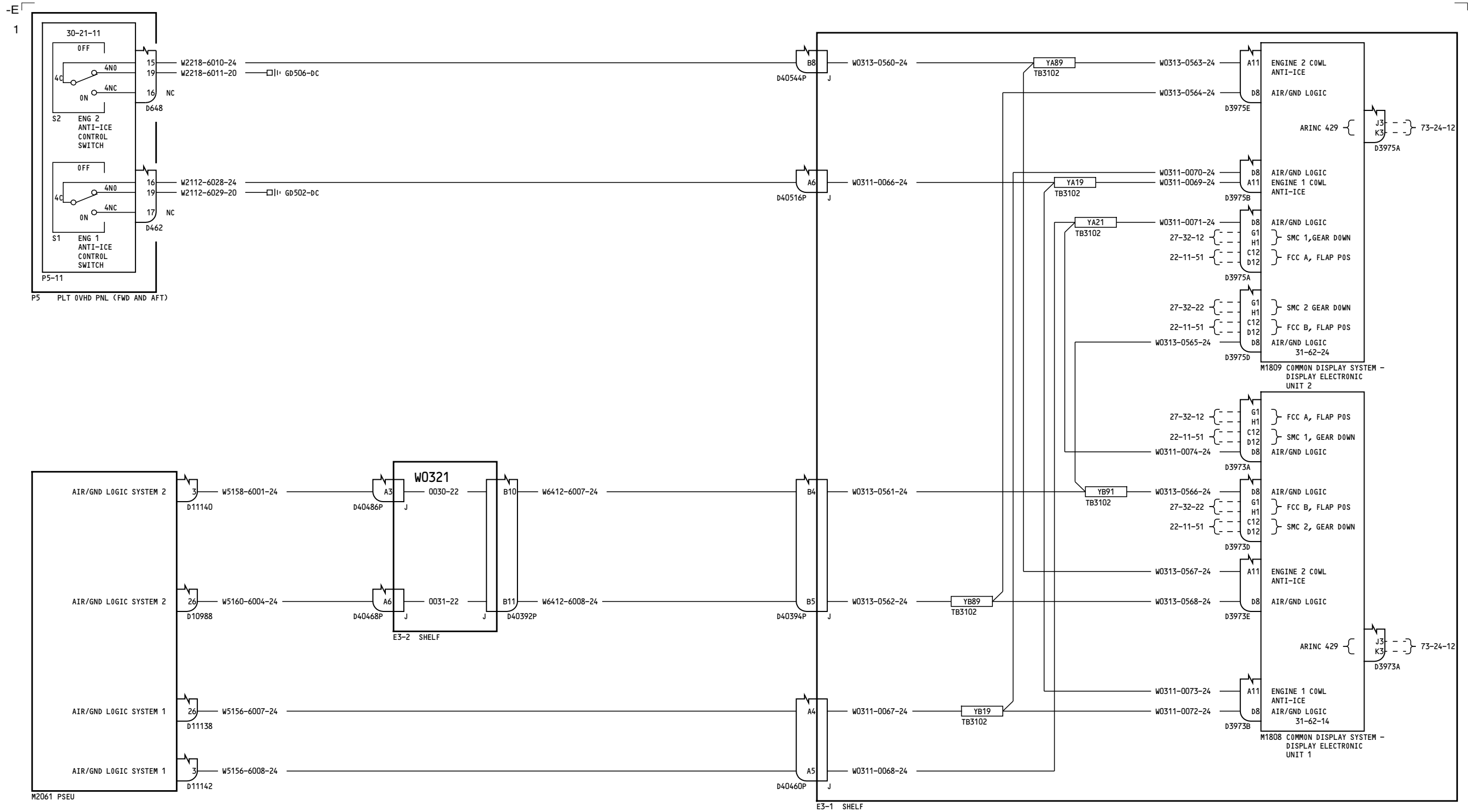

YC001-YC007

ENGINE IDLE CONTROL

73-23-11

Page 1

D280A103

Mar 31/2005

73-23-11

Page 1

Mar 31/2005

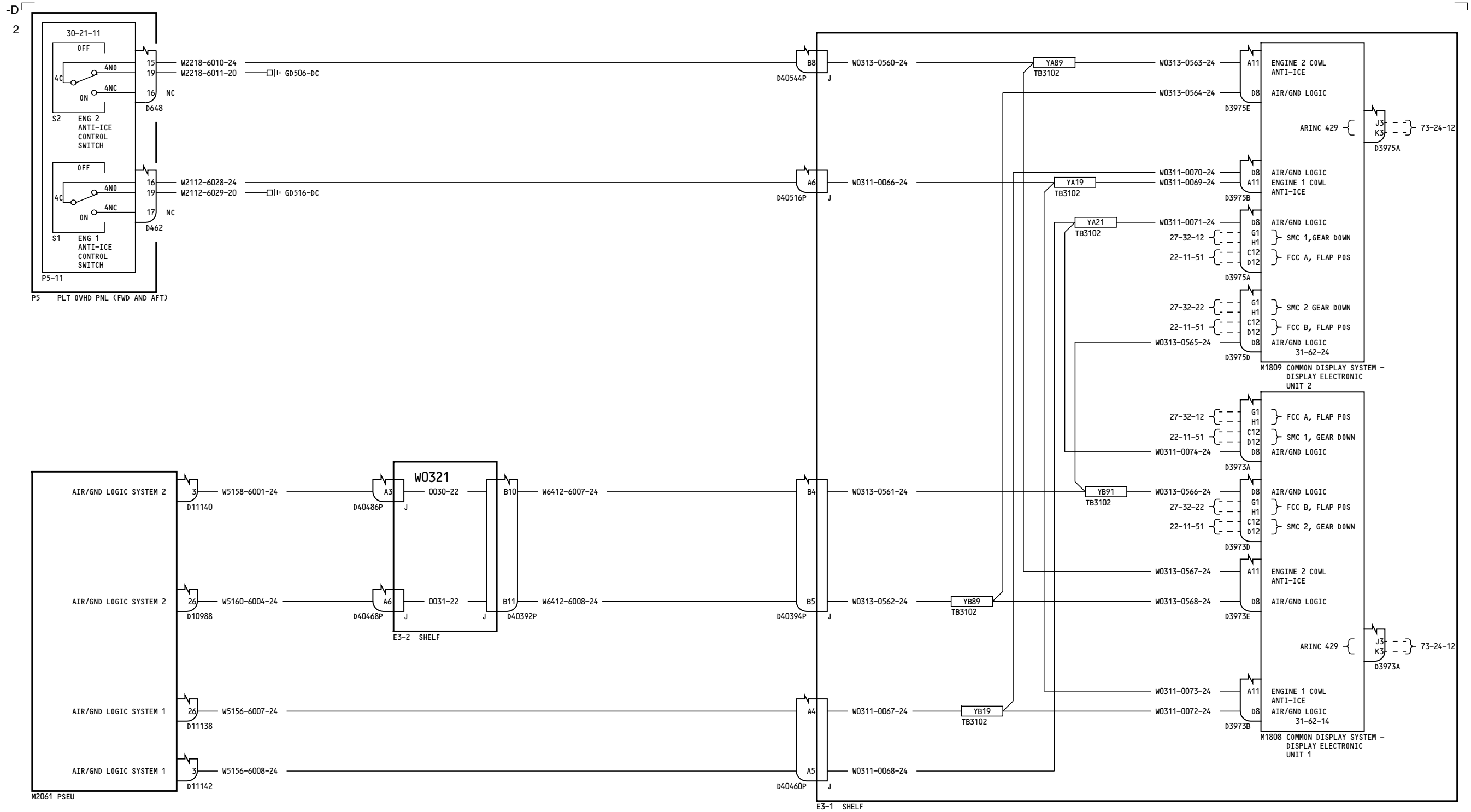

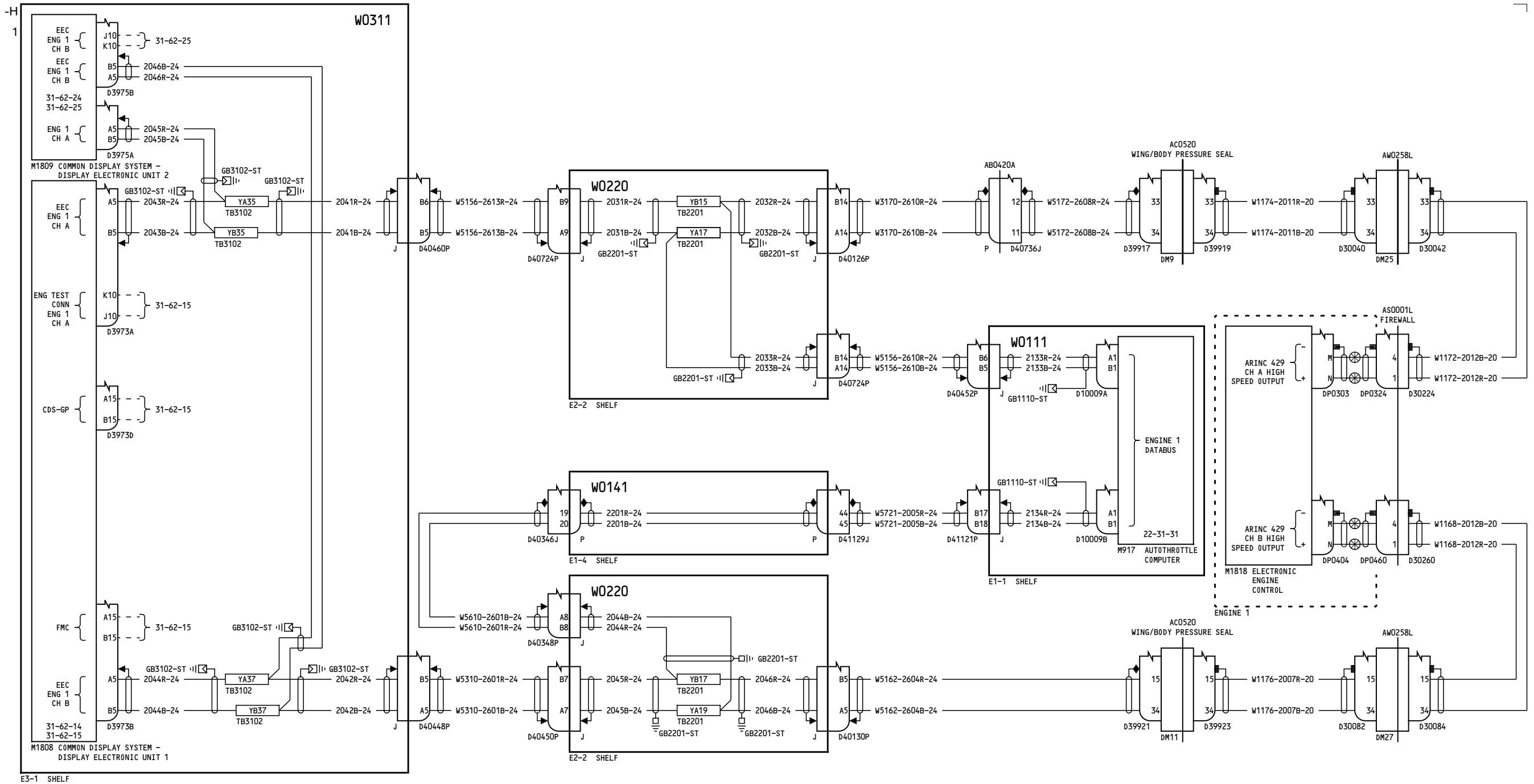

YC001-YC007

ENGINE 1 DATABUS OUTPUT

73-24-11

Page 1

D280A103

Mar 31/2005

73-24-11

Page 1

Mar 31/2005

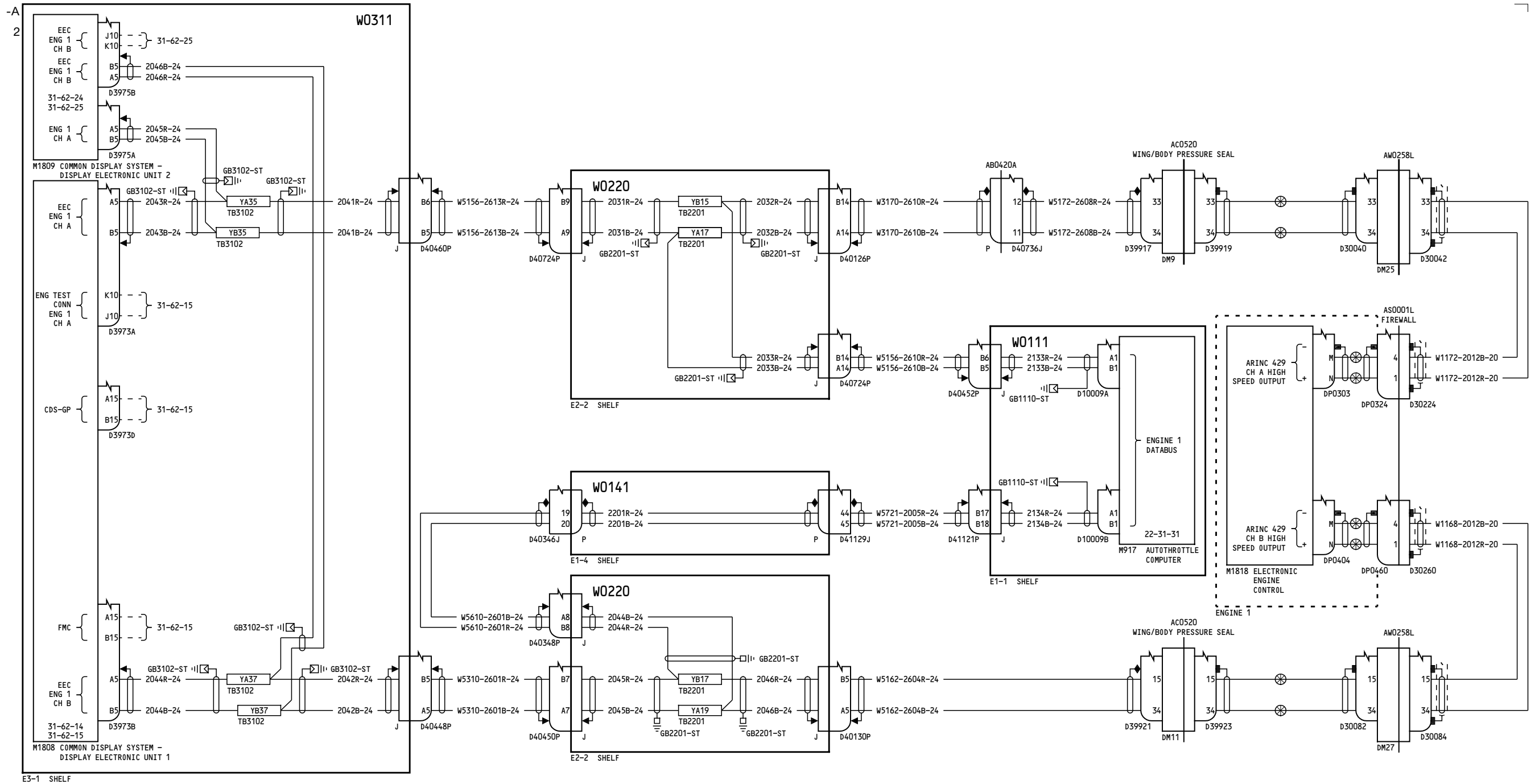

YC008-YC030

ENGINE 1 DATABUS OUTPUT

73-24-11

Page 2

D280A103

Jul 17/2007

73-24-11

Page 2

Jul 17/2007

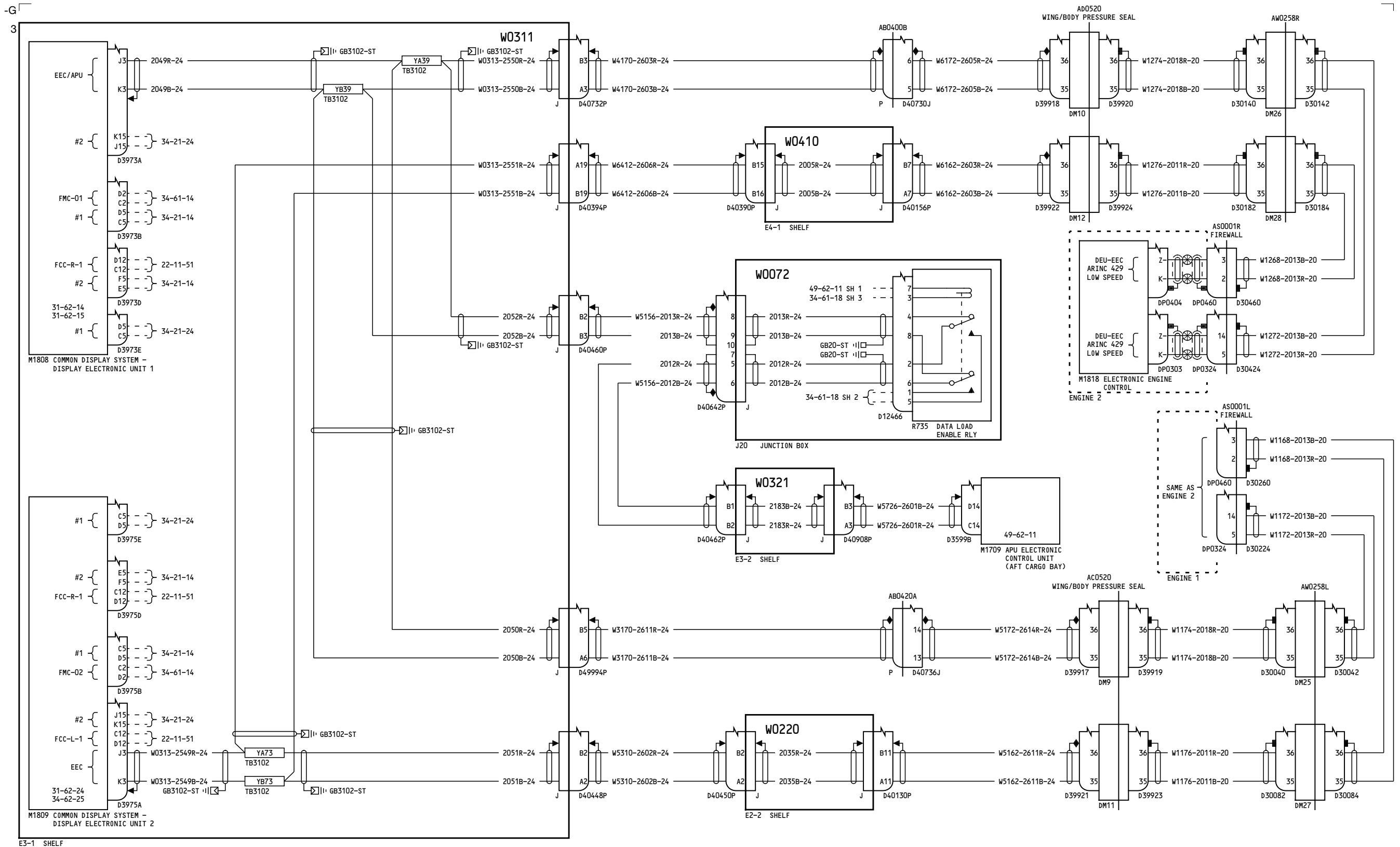

YC001-YC007

ENGINE DATABUS INPUT

73-24-12

73-24-12

Page 1

Page 1

D280A103

Mar 31/2005

Mar 31/2005

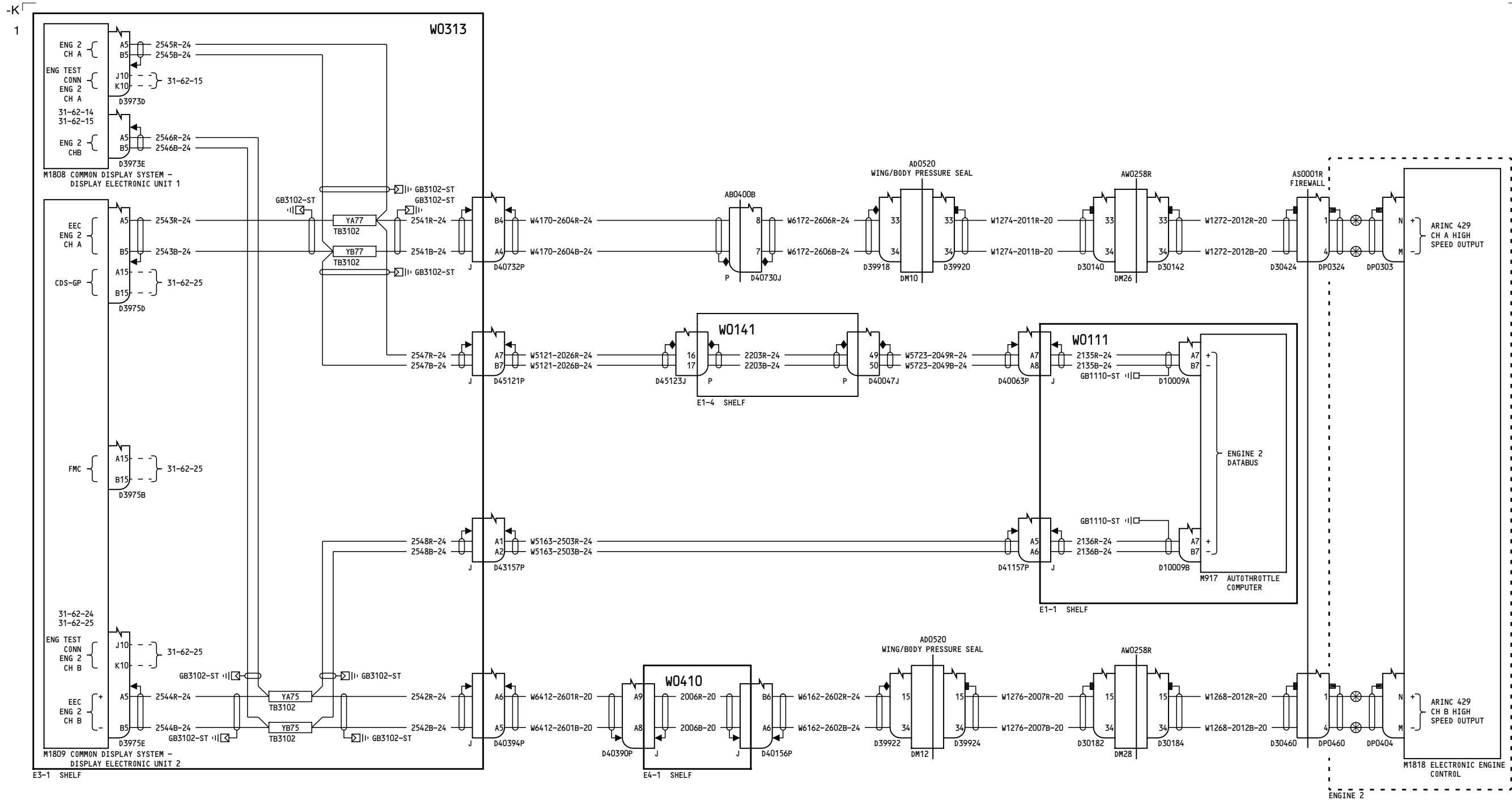

YC001-YC007

ENGINE 2 DATABUS OUTPUT

73-24-21

Page 1

D280A103

Mar 31/2005

73-24-21

Page 1

Mar 31/2005

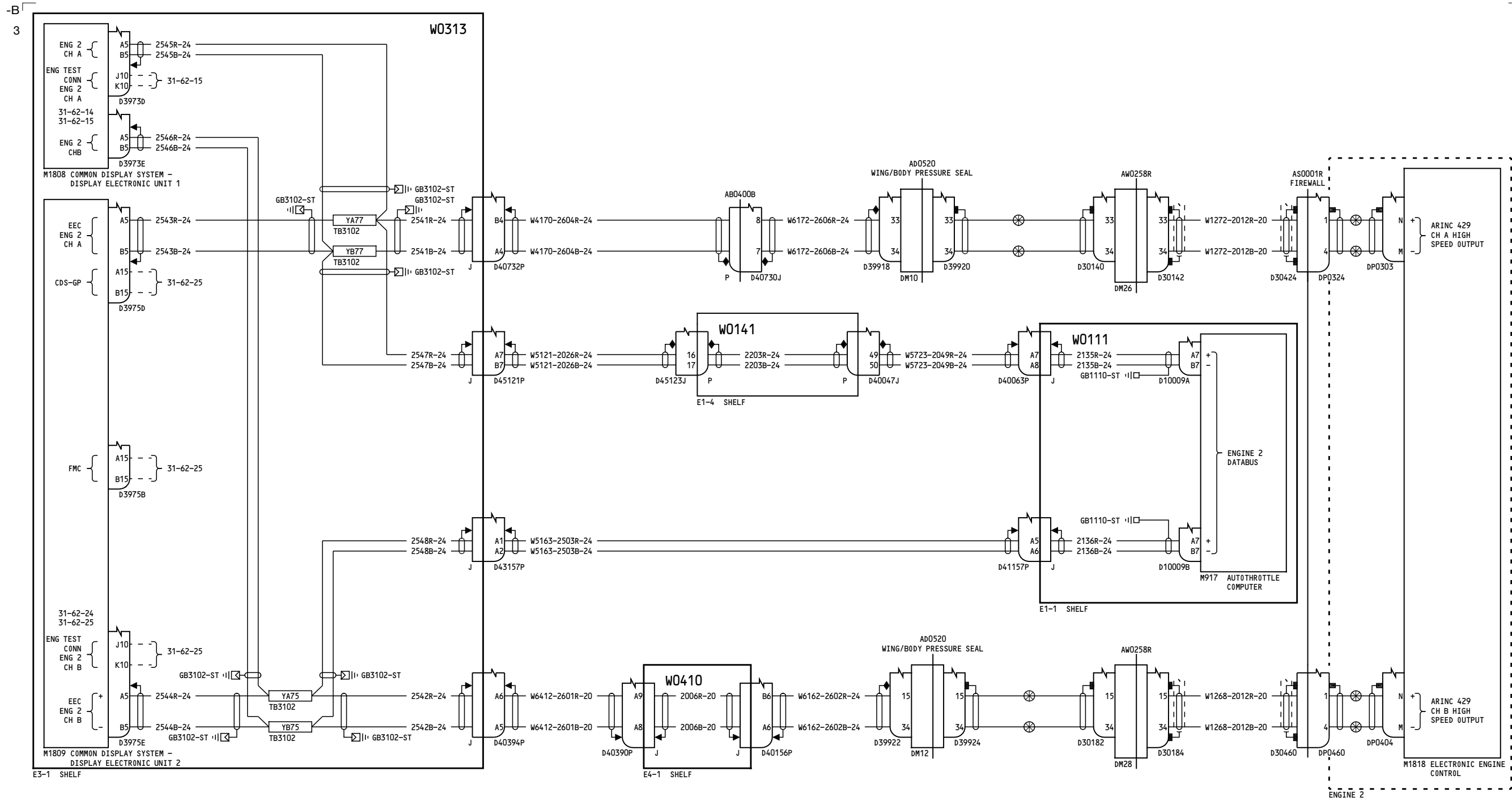

YC008-YC030

ENGINE 2 DATABUS OUTPUT

73-24-21

Page 2

D280A103

Jul 17/2007

73-24-21

Page 2

Jul 17/2007

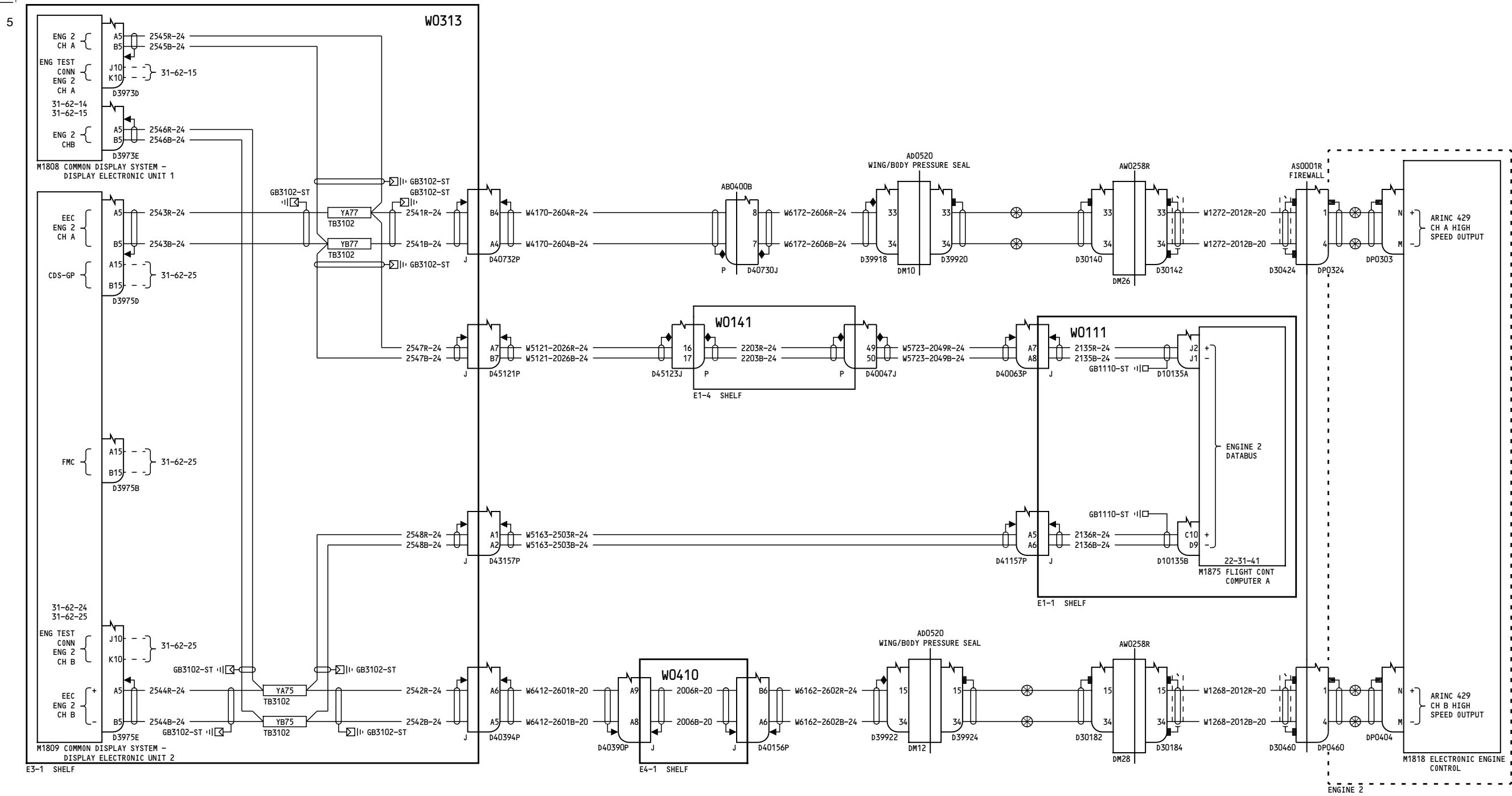

YC031-YK910, YK918, YL421-YL426, YM643-YM649

ENGINE 2 DATABUS OUTPUT

73-24-21

Page 3

D280A103

Feb 09/2009

73-24-21

Page 3

Feb 09/2009

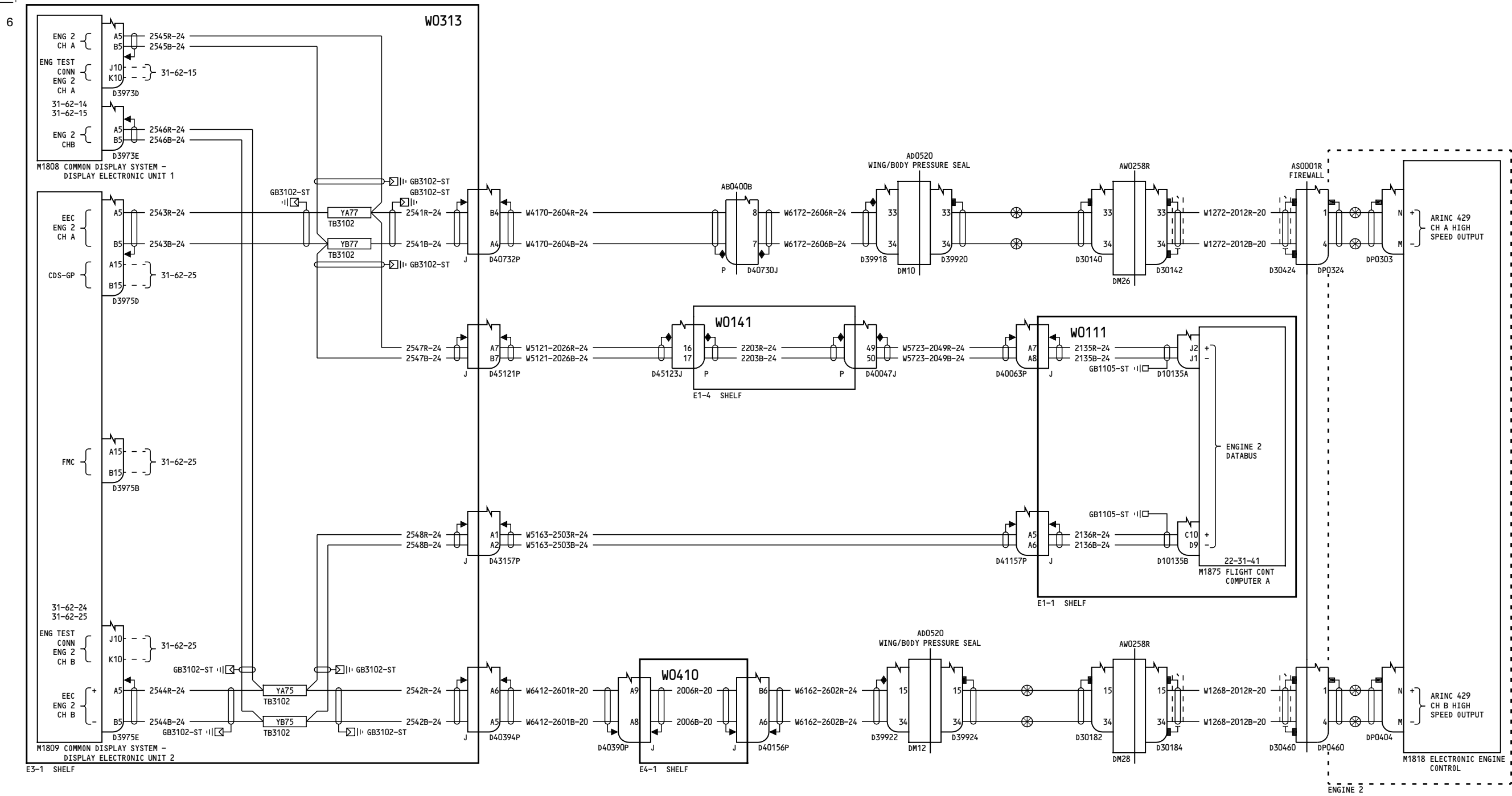

YK911-YK917, YK919-YL401, YL427-YL430, YM651-YM670

ENGINE 2 DATABUS OUTPUT

73-24-21

Page 4

D280A103

Feb 09/2009

73-24-21

Page 4

Feb 09/2009

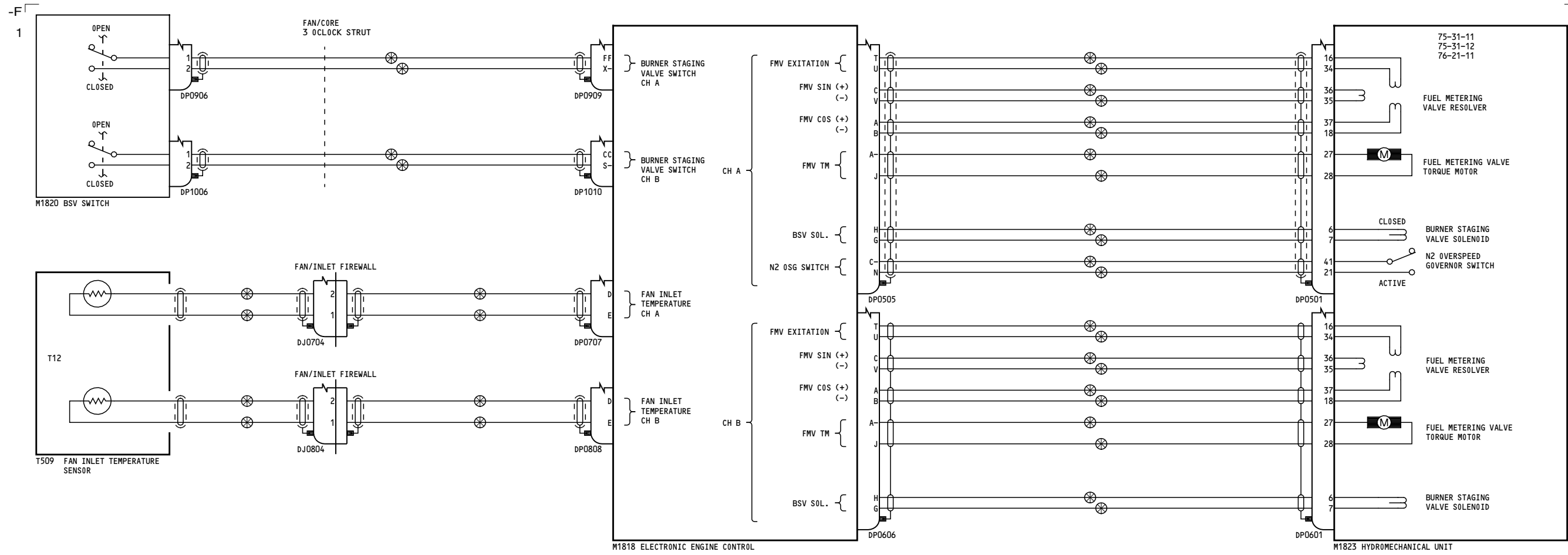

NOTES:

1 SINGLE ANNULAR COMBUSTER CONFIGURATION

YC001-YC016

ENGINE 1 FUEL CONTROL

73-25-11

Page 1

D280A103

Oct 20/2006

73-25-11

Page 1

Oct 20/2006

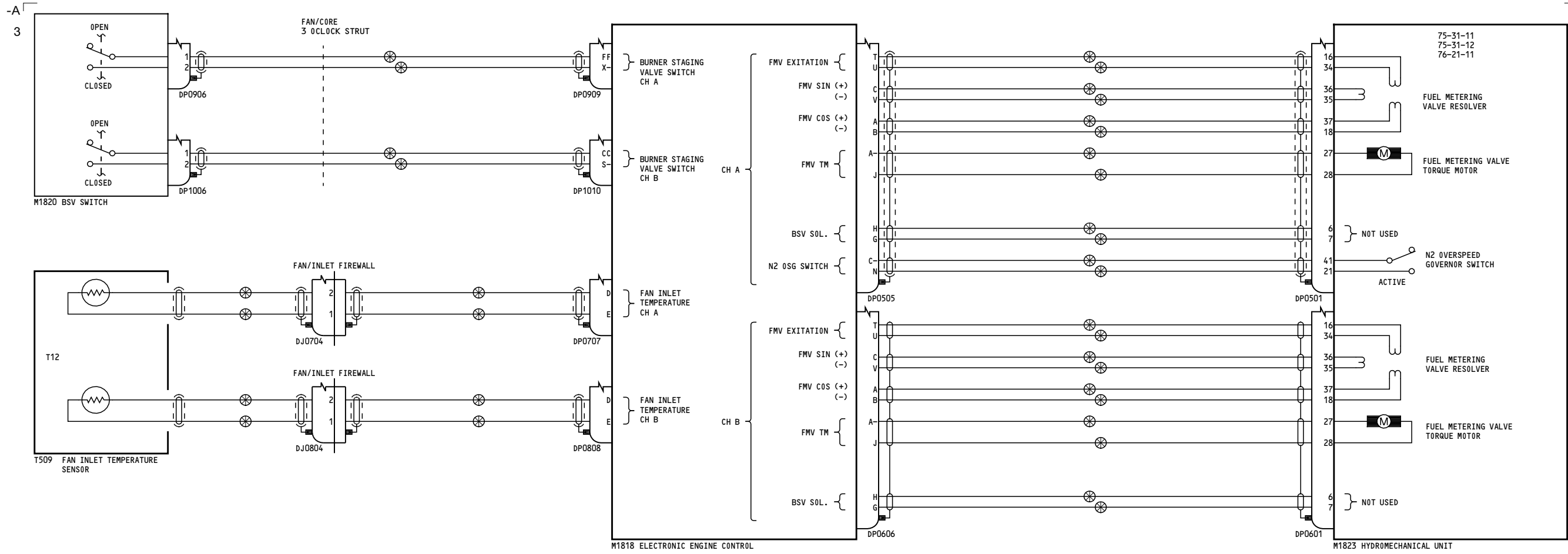

NOTES:

1 SINGLE ANNULAR COMBUSTER CONFIGURATION

YC017-YM670

ENGINE 1 FUEL CONTROL

D280A103

73-25-11

Page 2

Feb 09/2009

73-25-11

Page 2

Feb 09/2009

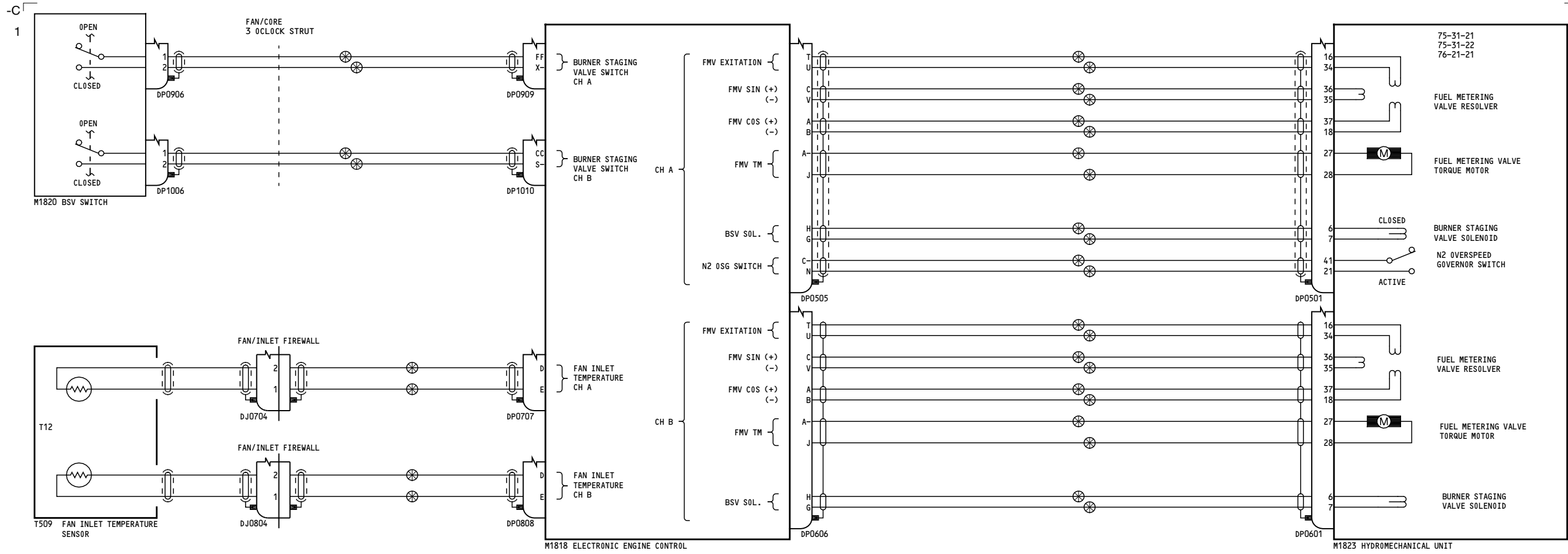

YC001-YC016

ENGINE 2 FUEL CONTROL

73-25-21

Page 1

D280A103

Apr 18/2006

73-25-21

Page 1

Apr 18/2006

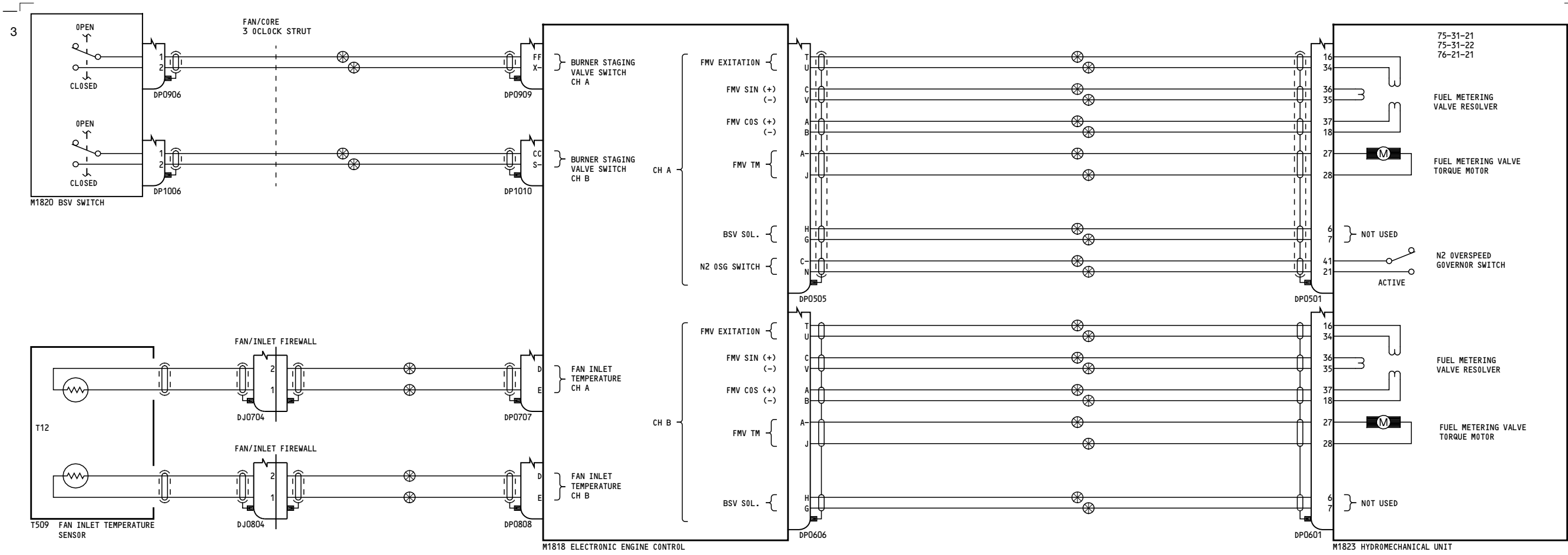

YC017-YM670

ENGINE 2 FUEL CONTROL

73-25-21

Page 2

D280A103

Feb 09/2009

73-25-21

Page 2

Feb 09/2009

-E
1

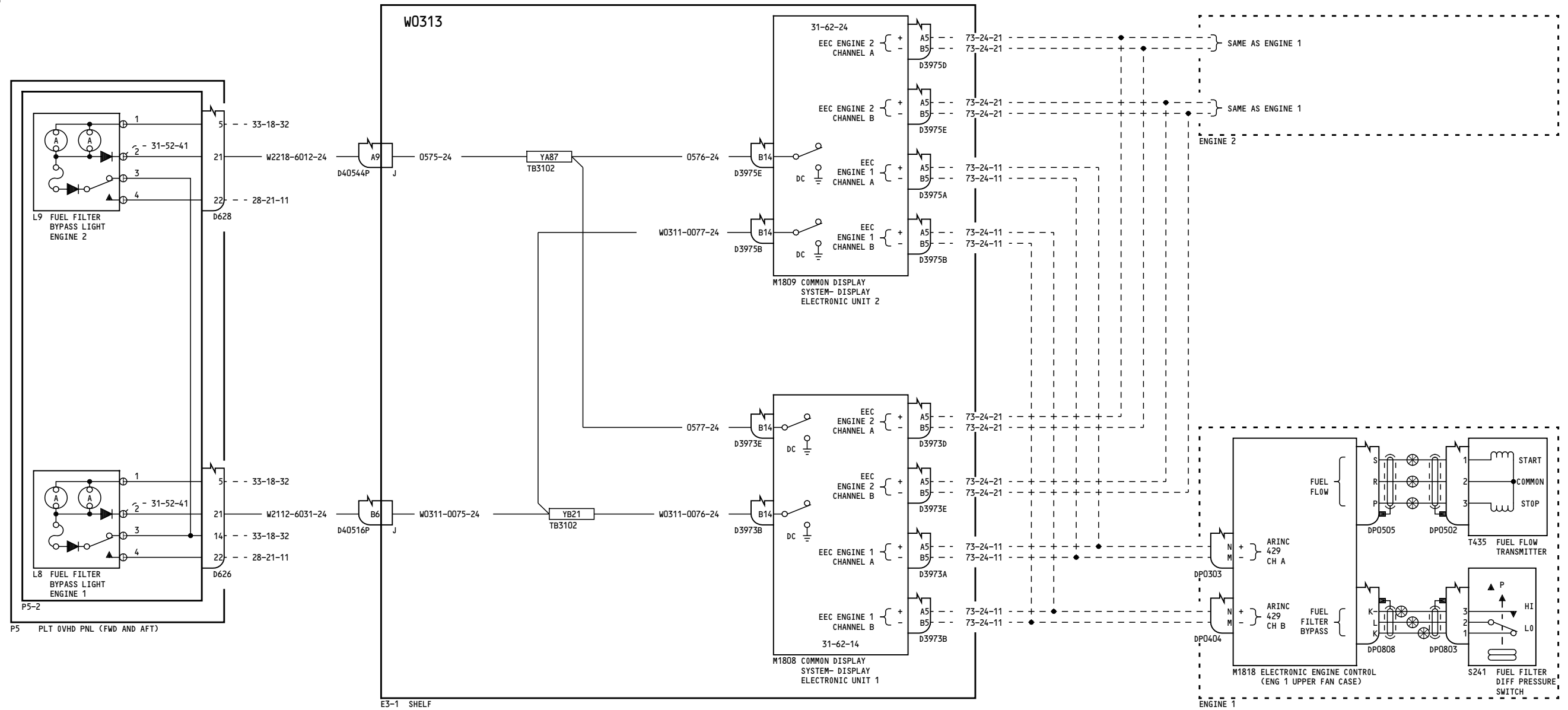

ALL

ENGINE FUEL SYSTEM INDICATION

73-31-11

Page 1

D280A103

Feb 09/2009

73-31-11

Page 1

Feb 09/2009

-D
1

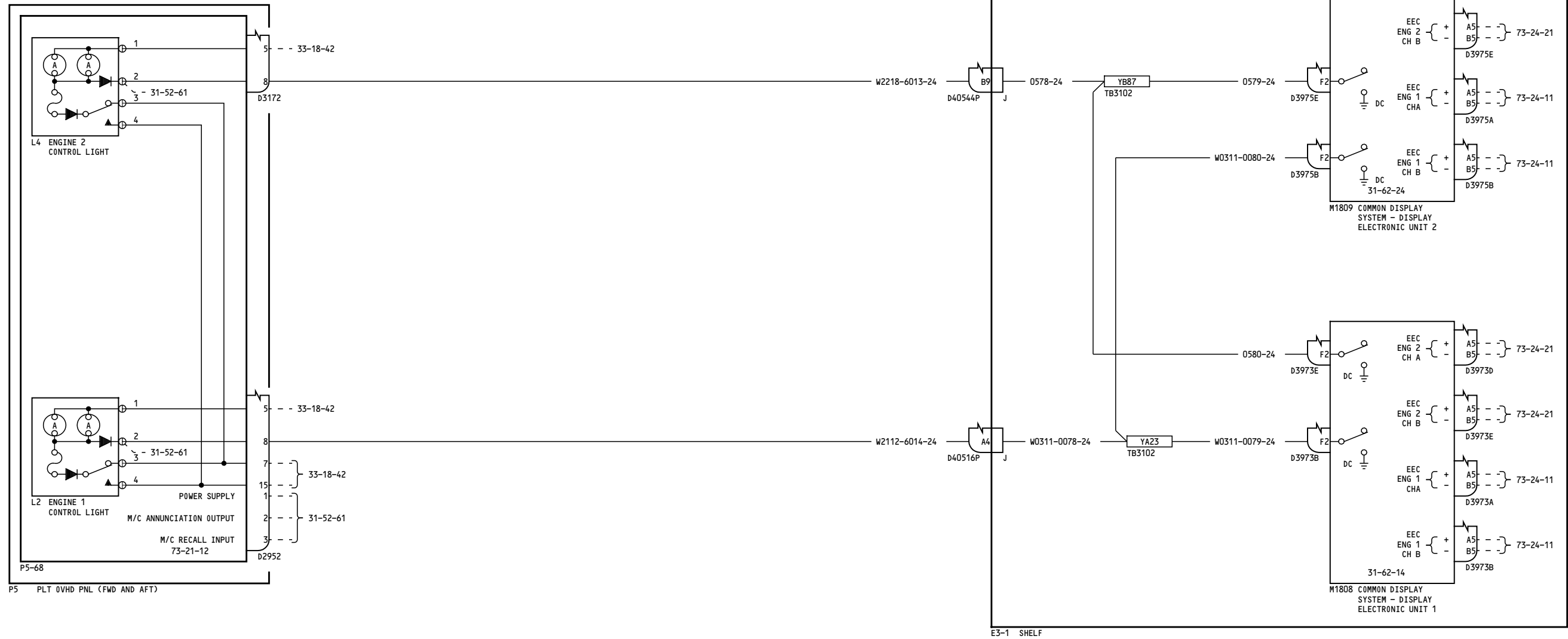

ALL	<p align="center">ENGINE CONTROL EEC FAULT INDICATION</p> <p align="center">D280A103</p>
-----	---

73-32-11
Page 1
Feb 09/2009

73-32-11
Page 1
Feb 09/2009