

CHAPTER

76

ENGINE CONTROLS



737-700/800

WIRING DIAGRAM MANUAL

CHAPTER 76
ENGINE CONTROLS

CH-SC-SU	Schem	Page	Sheet	Date	CH-SC-SU	Schem	Page	Sheet	Date
76-EFFECTIVE PAGES									
		1		Aug 10/2009					
		2		BLANK					
76-CONTENTS									
R		1		Aug 10/2009					
		2		BLANK					
76-ALPHABETICAL INDEX									
		1		Jan 18/2007					
		2		BLANK					
	76-21-11	1		Mar 31/2005					
		2		Jul 17/2007					
R		3		Aug 10/2009					
	76-21-21	1		Mar 31/2005					
		2	1	Mar 31/2005					
			2	Mar 31/2005					
		3	1	Jul 17/2007					
			2	Jul 17/2007					
R		4	1	Aug 10/2009					
R			2	Aug 10/2009					

A = Added, R = Revised, D = Deleted, O = Overflow

76-EFFECTIVE PAGES

Page 1
Aug 10/2009

D280A103



737-700/800

WIRING DIAGRAM MANUAL

CHAPTER 76 ENGINE CONTROLS

Title	CH-SC-SU	Schem	Page	Sheet	Date	Effectivity
ENGINE FIRE EMERGENCY SHUTDOWN						
ENGINE 1 FUEL CONDITION CONTROL	76-21-11		1		Mar 31/2005	YC001-YC003
			2		Jul 17/2007	YC004-YC028
			3		Aug 10/2009	YC029-YK912 YK918-YK919 YL401-YL429 YM643-YM652
ENGINE 2 FUEL CONDITION CONTROL	76-21-21		1		Mar 31/2005	YC001-YC003
			2	1	Mar 31/2005	YC004-YC007
				2	Mar 31/2005	YC004-YC007
			3	1	Jul 17/2007	YC008-YC028
				2	Jul 17/2007	YC008-YC028
			4	1	Aug 10/2009	YC029-YK912 YK918-YK919 YL401-YL429 YM643-YM652
				2	Aug 10/2009	YC029-YK912 YK918-YK919 YL401-YL429 YM643-YM652

76-CONTENTS

Page 1
Aug 10/2009

D280A103



737-700/800

WIRING DIAGRAM MANUAL

**CHAPTER 76
ENGINE CONTROLS**

CH-SC-SU	Title
76-21-11	ENGINE 1 FUEL CONDITION CONTROL
76-21-21	ENGINE 2 FUEL CONDITION CONTROL

76-ALPHABETICAL INDEX

D280A103

Page 1
Jan 18/2007

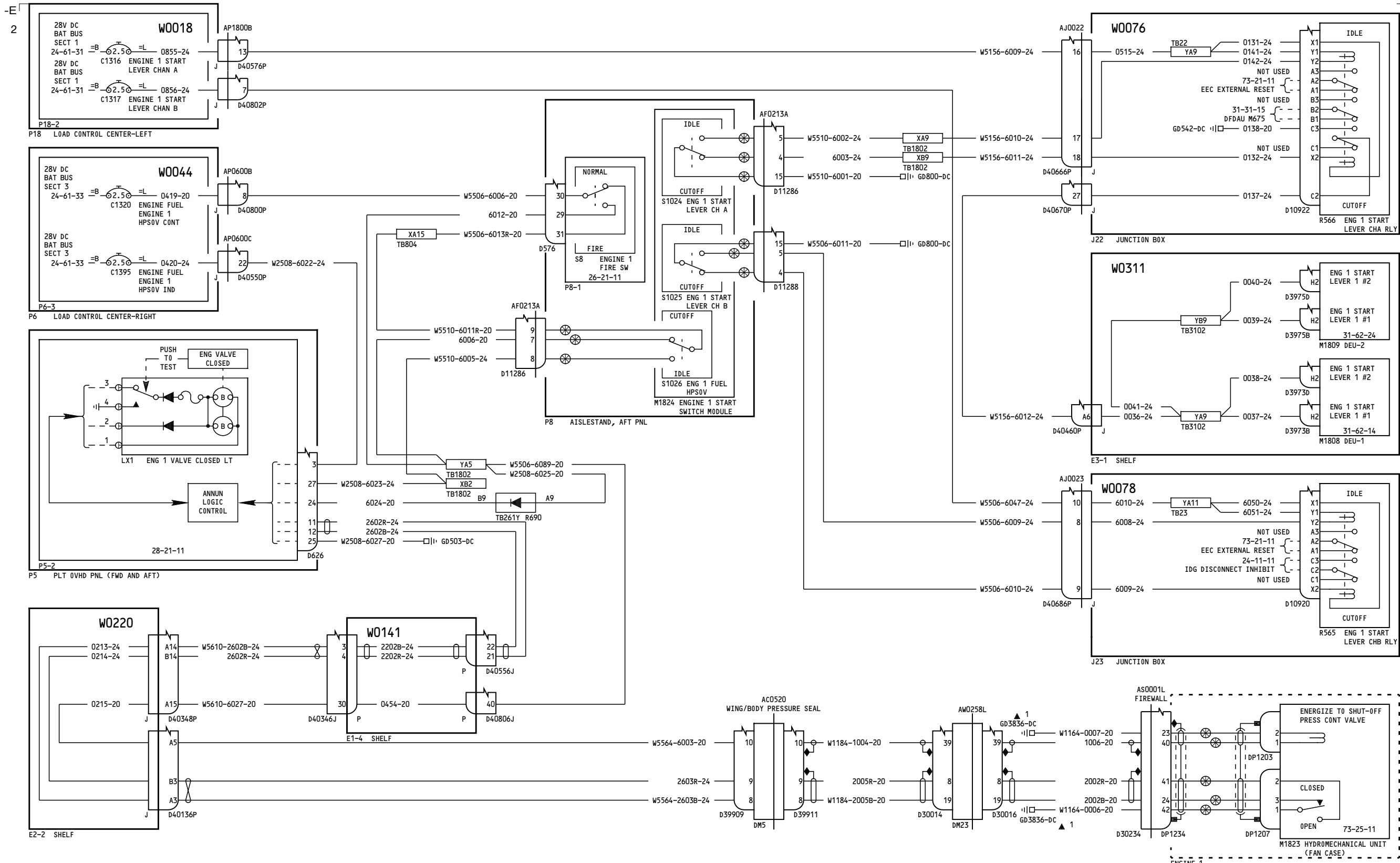

YC001-YC003

ENGINE 1 FUEL CONDITION CONTROL

76-21-11

Page 1

D280A103

Mar 31/2005

76-21-11

Page 1

Mar 31/2005

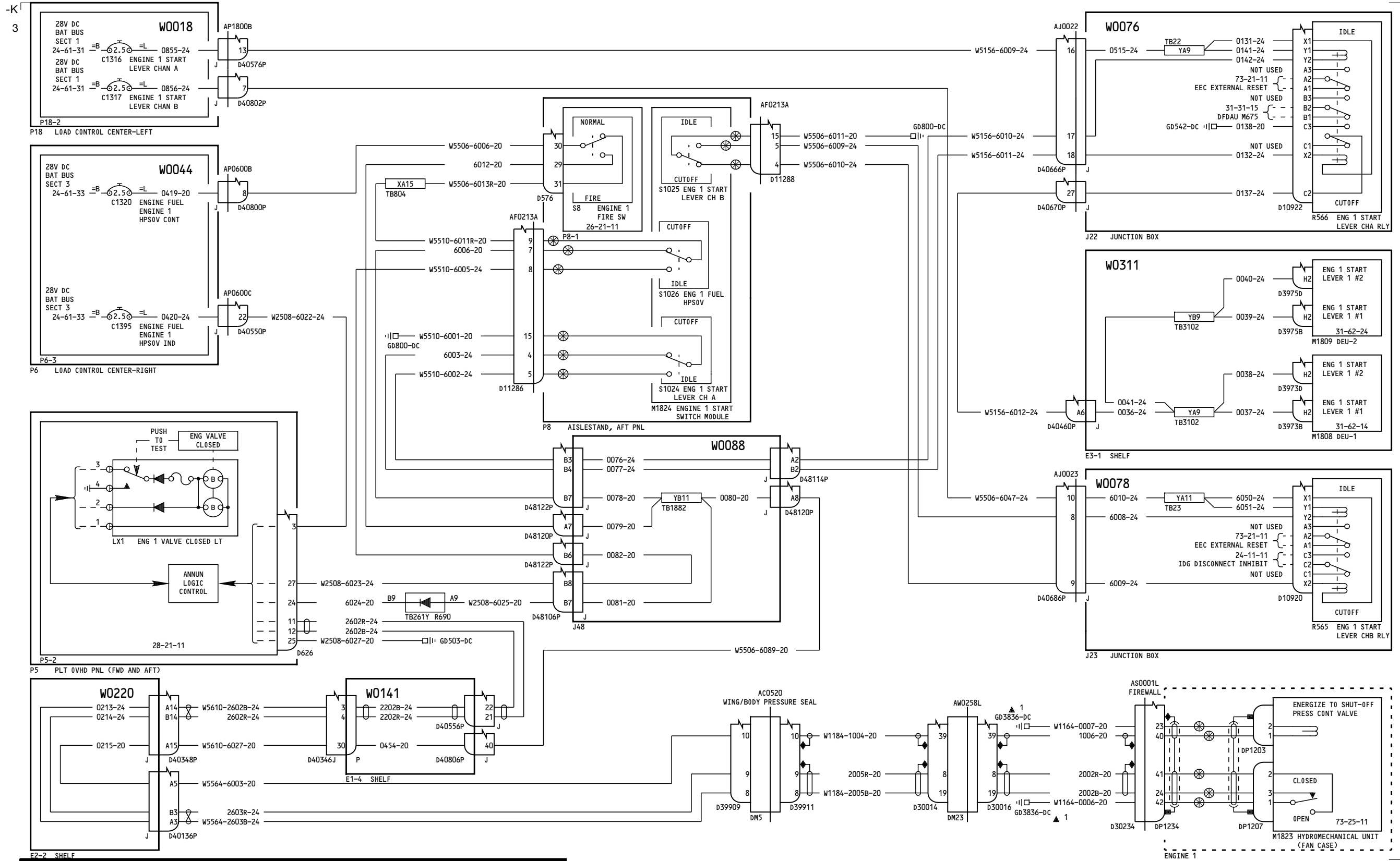

YC004-YC028

**ENGINE 1 FUEL
CONDITION CONTROL**

D280A103

76-21-11

Page 2

Jul 17/2007

76-21-11

Page 2

Jul 17/2007

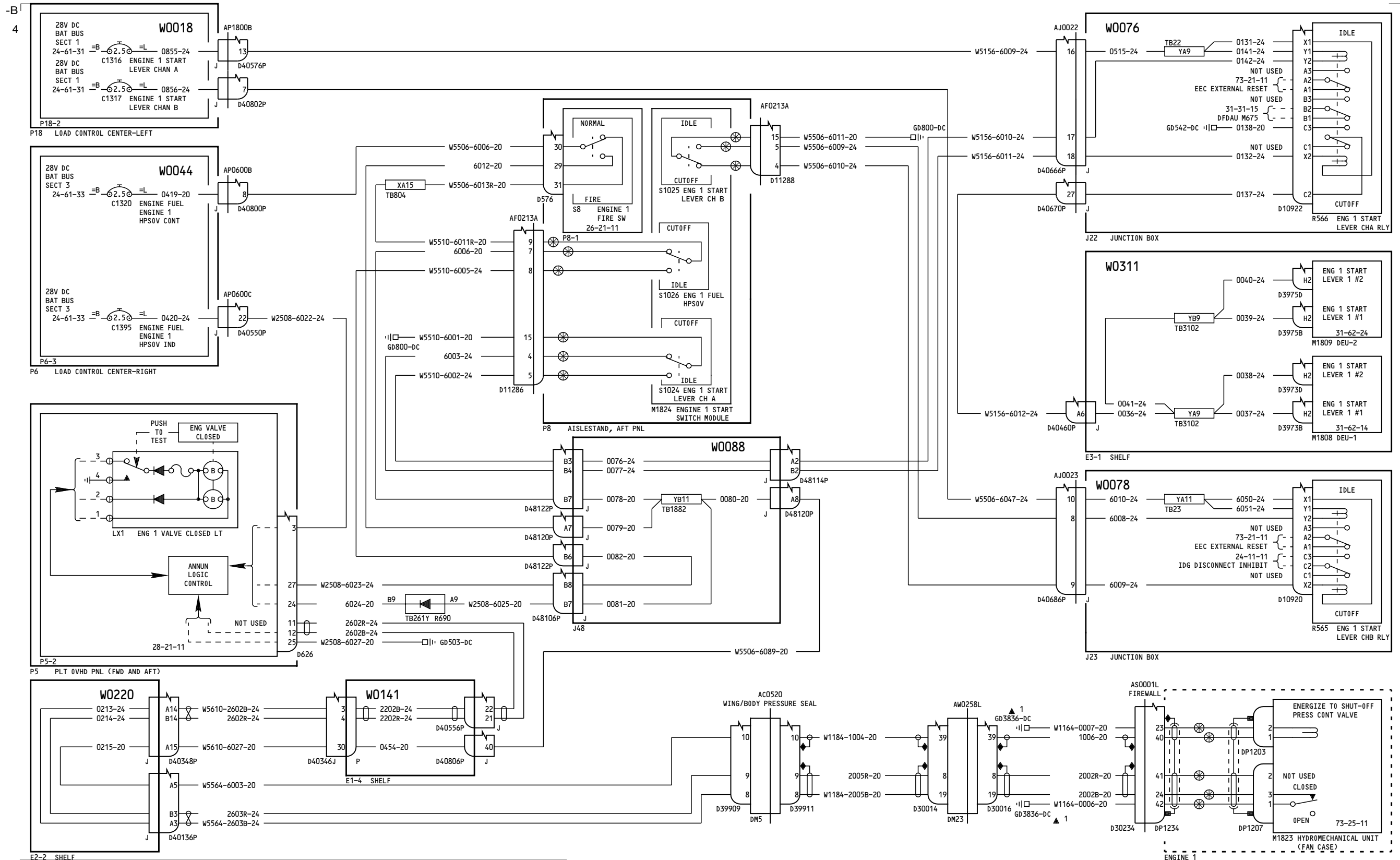

YC029-YK912, YK918-YK919, YL401-YL429, YM643-YM652

**ENGINE 1 FUEL
CONDITION CONTROL**

76-21-11

76-21-11

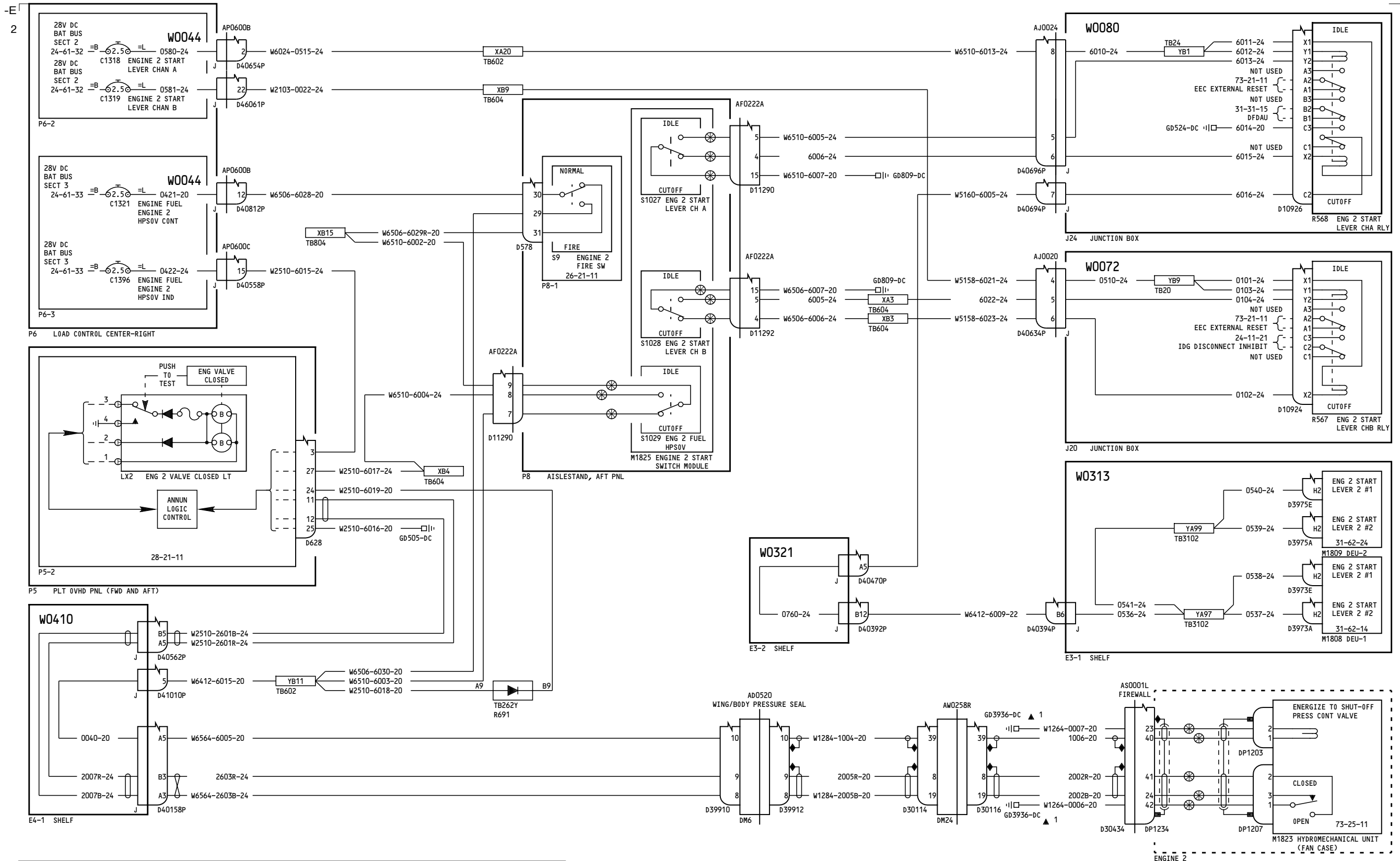

YC001-YC003

ENGINE 2 FUEL CONDITION CONTROL

76-21-21

Page 1

D280A103

Mar 31/2005

76-21-21

Page 1

Mar 31/2005

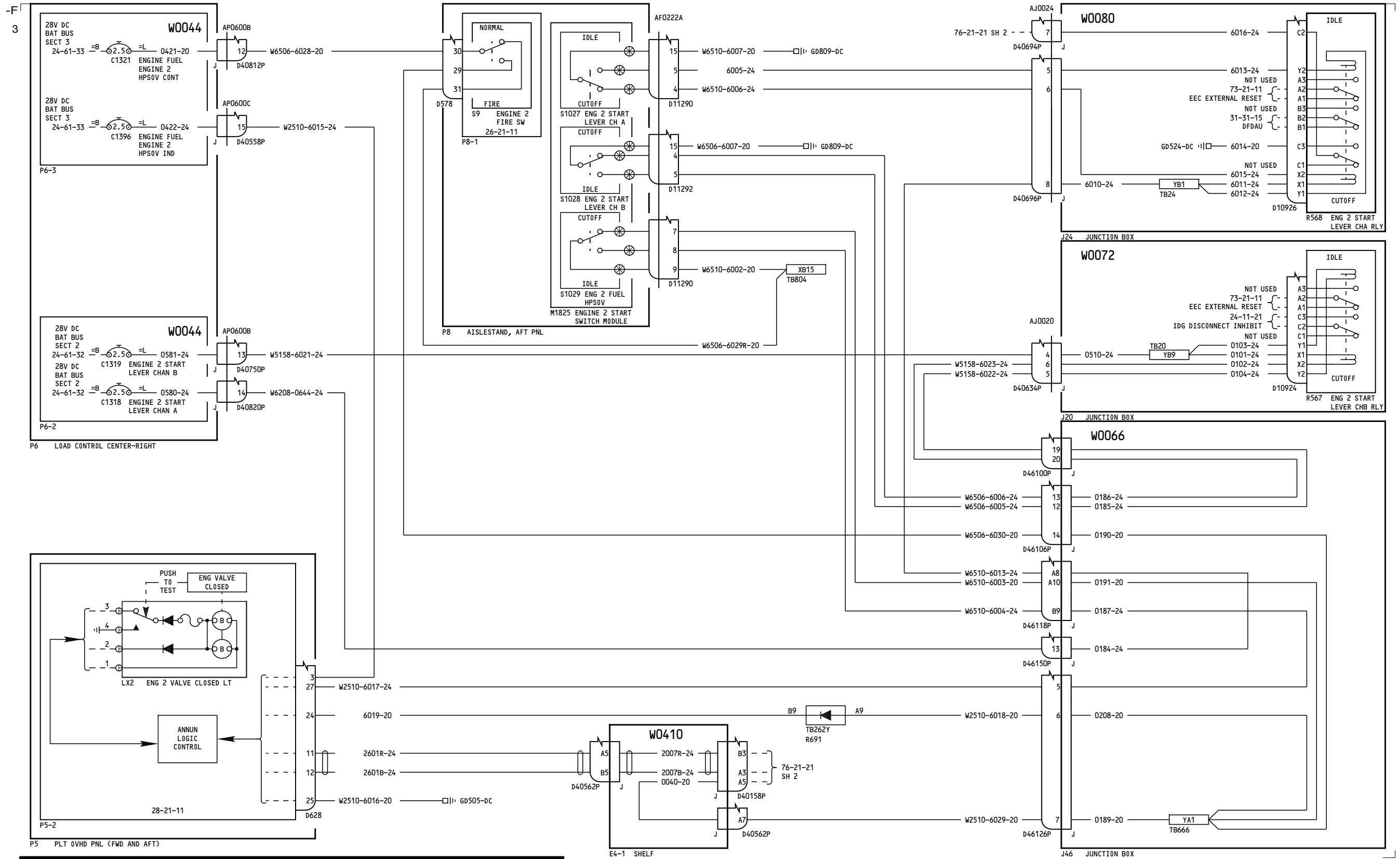

YC004-YC007

**ENGINE 2 FUEL
CONDITION CONTROL**

76-21-21

Page 2
Sheet 1
Mar 31/2005

D280A103

76-21-21

Page 2
Sheet 1
Mar 31/2005

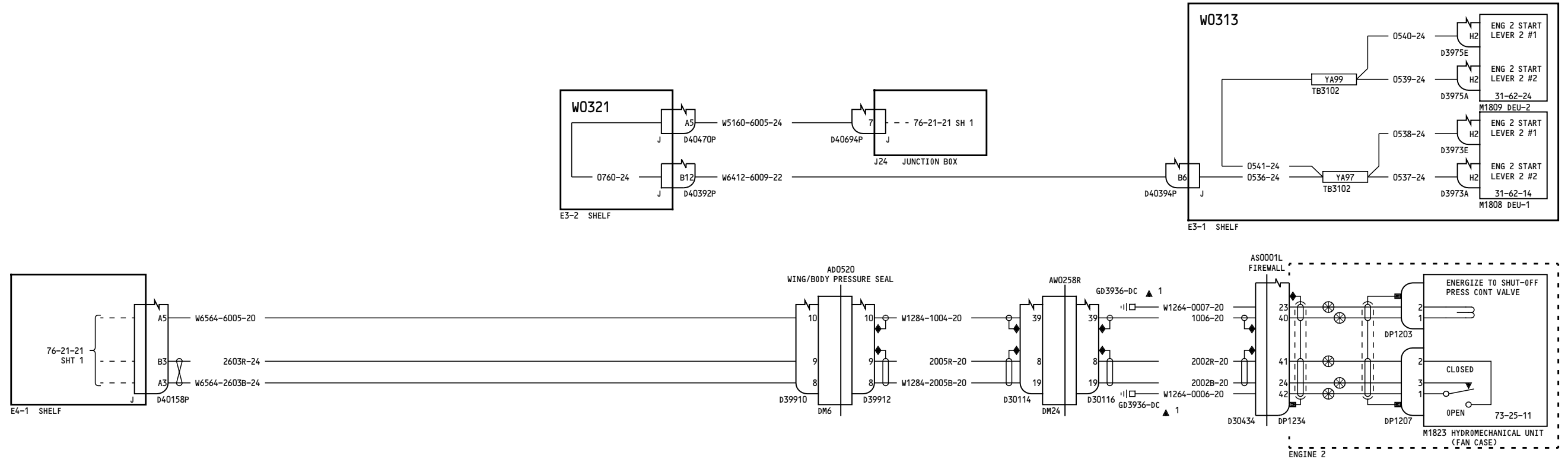

YC004-YC007

**ENGINE 2 FUEL
CONDITION CONTROL**

D280A103

76-21-21

Page 2
Sheet 2
Mar 31/2005

76-21-21

Page 2
Sheet 2
Mar 31/2005

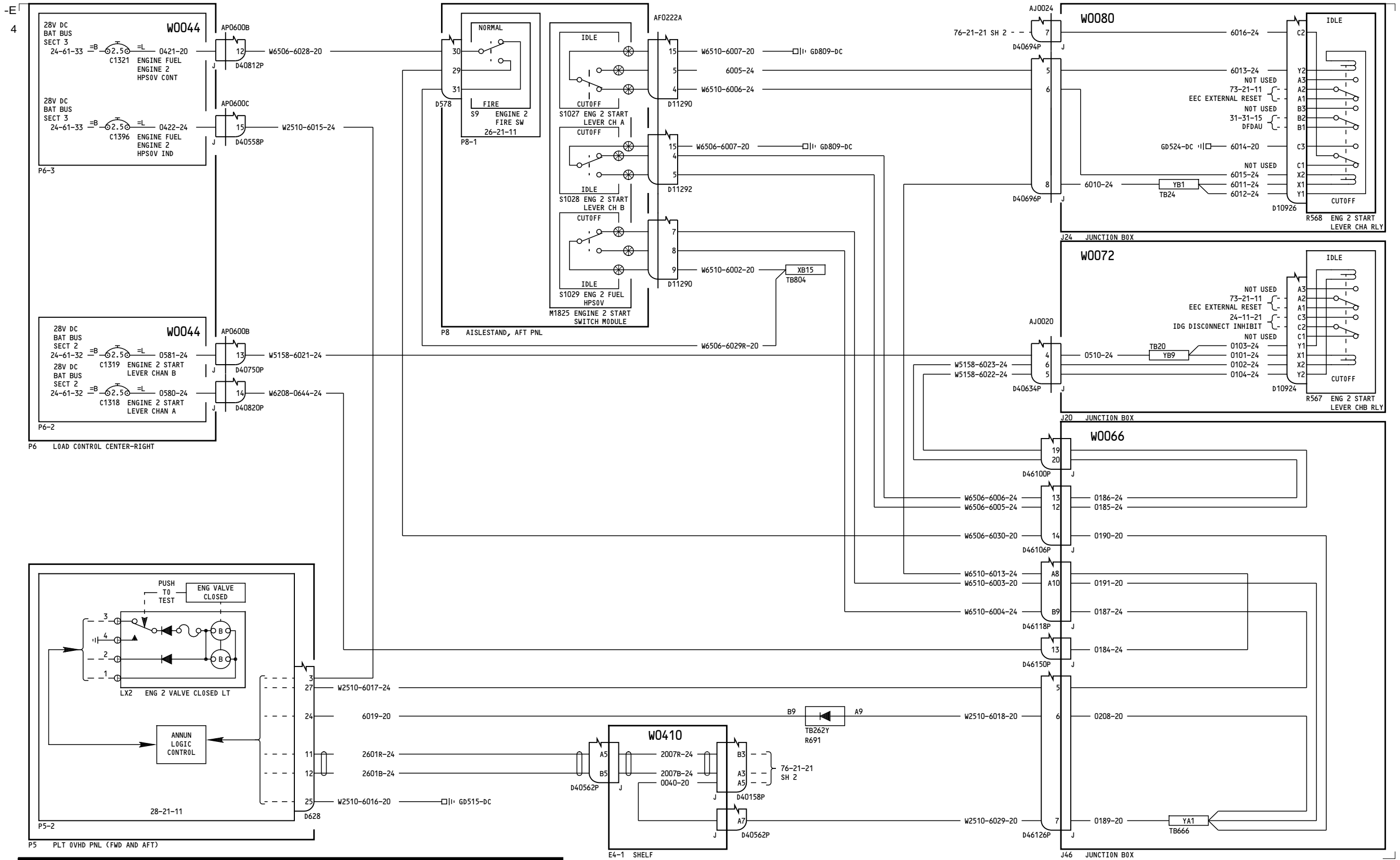

YC008-YC028

**ENGINE 2 FUEL
CONDITION CONTROL**

D280A103

76-21-21

Page 3
Sheet 1
Jul 17/2007

76-21-21

Page 3
Sheet 1
Jul 17/2007

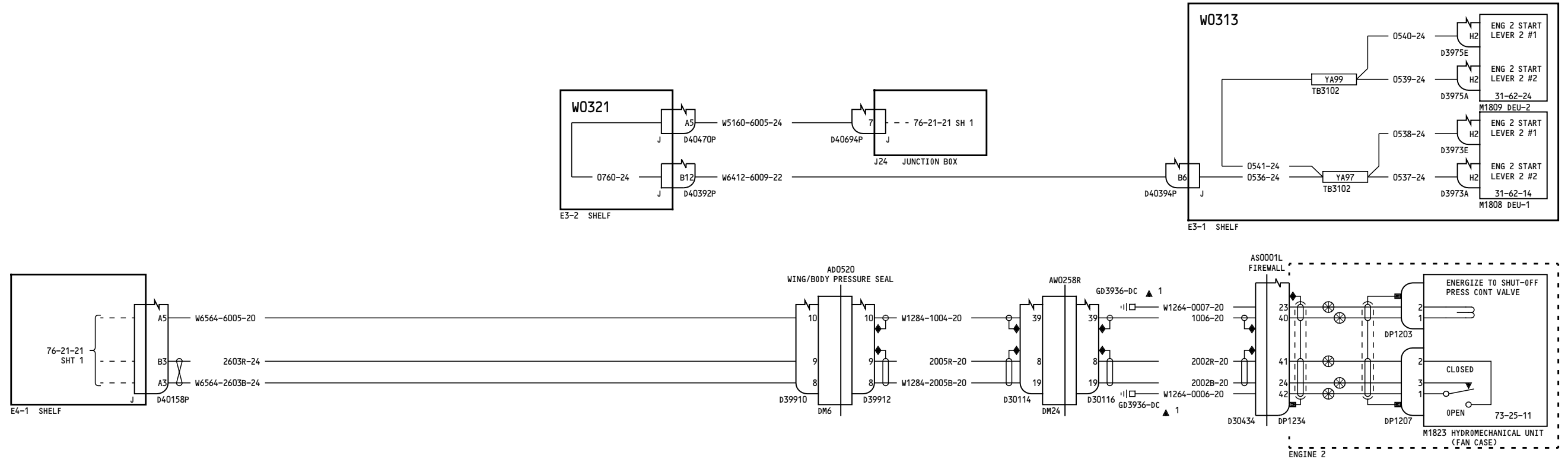

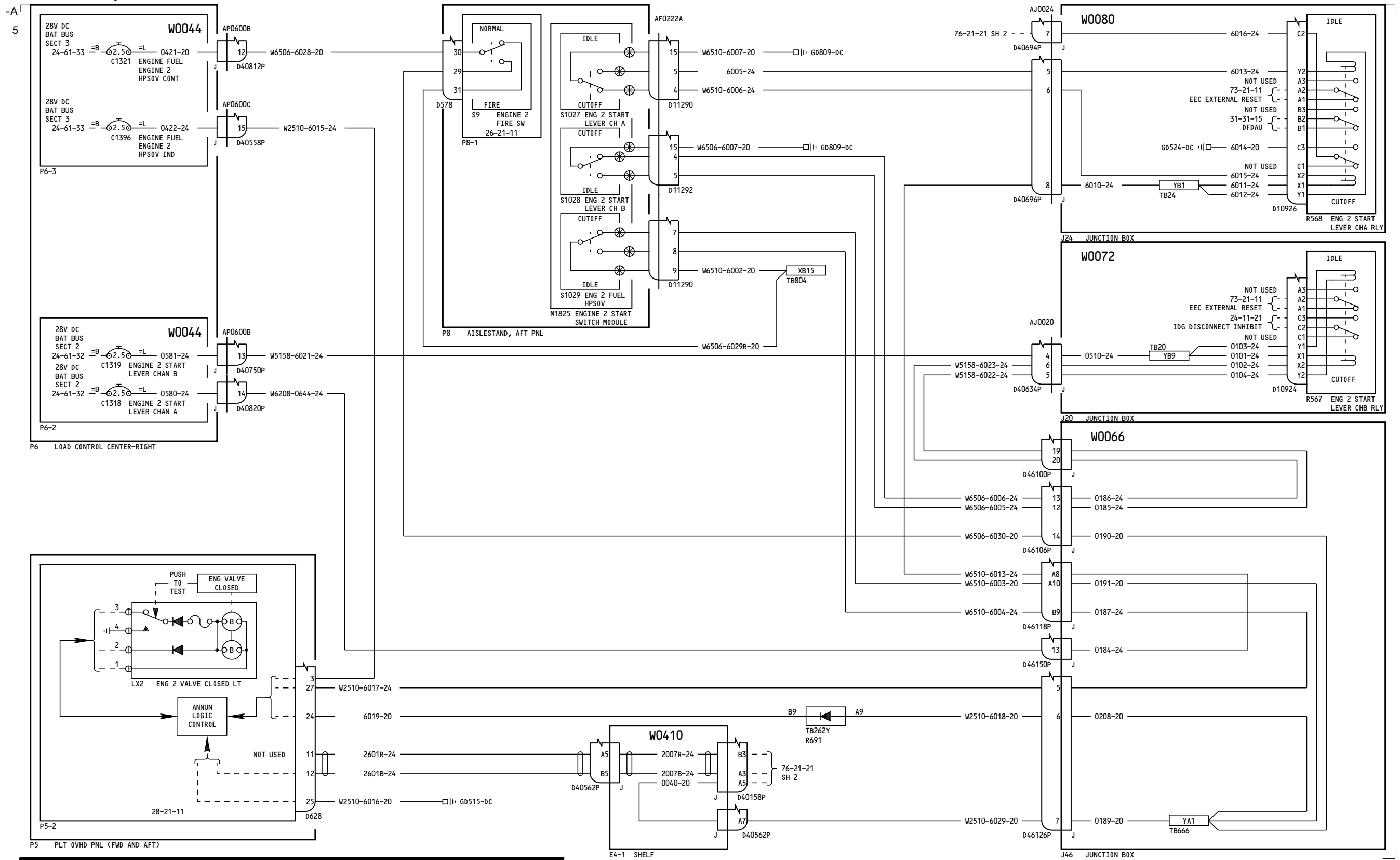

YC029-YK912, YK918-YK919, YL401-YL429, YM643-YM652

**ENGINE 2 FUEL
CONDITION CONTROL**

D280A103

76-21-21

Page 4
Sheet 1
Aug 10/2009

76-21-21

Page 4
Sheet 1
Aug 10/2009

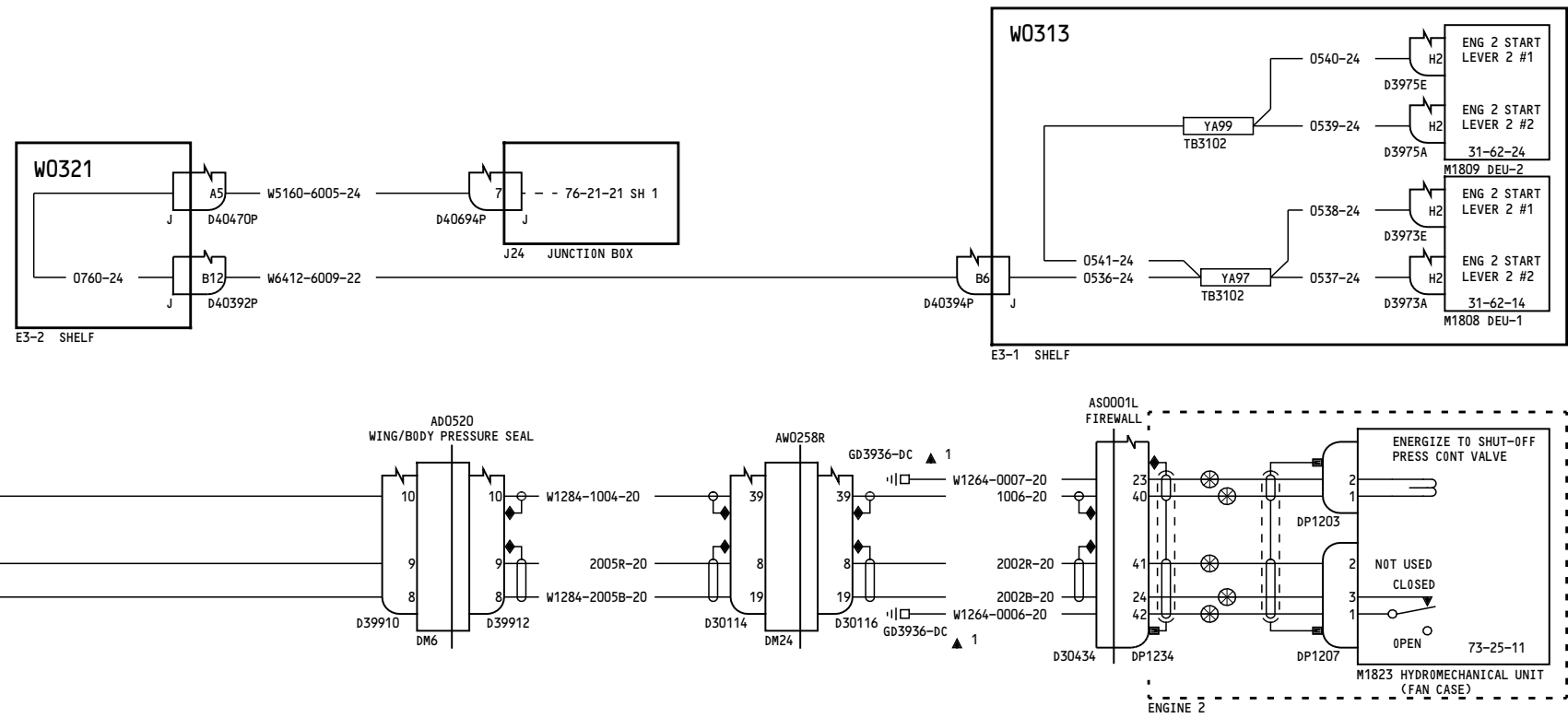

YC029-YK912, YK918-YK919, YL401-YL429, YM643-YM652

**ENGINE 2 FUEL
CONDITION CONTROL**

D280A103

76-21-21

Page 4
Sheet 2
Aug 10/2009

76-21-21

Page 4
Sheet 2
Aug 10/2009