

CHAPTER

77

ENGINE INDICATING



737-700/800

WIRING DIAGRAM MANUAL

**CHAPTER 77
ENGINE INDICATING**

CH-SC-SU	Schem	Page	Sheet	Date	CH-SC-SU	Schem	Page	Sheet	Date
77-EFFECTIVE PAGES									
		1		Aug 10/2009					
		2		BLANK					
77-CONTENTS									
		1		May 11/2009					
		2		BLANK					
77-ALPHABETICAL INDEX									
		1		Jan 18/2007					
		2		BLANK					
77-12-11									
		1		Feb 09/2009					
77-12-21									
		1		Feb 09/2009					
		1.1		May 11/2009					
		2		Feb 09/2009					
77-21-11									
		1		Feb 09/2009					
77-31-11									
		1		Mar 31/2005					
		1.1		Oct 15/2007					
		2		Mar 31/2005					
		2.1		Oct 15/2007					
		3		Jul 17/2007					
		3.1		Oct 15/2007					
		4		May 11/2009					
77-31-21									
		1		Mar 31/2005					
		1.1		Oct 15/2007					
		2		Jul 17/2007					
		2.1		Oct 15/2007					
		3		Feb 09/2009					

A = Added, R = Revised, D = Deleted, O = Overflow

77-EFFECTIVE PAGES

Page 1
Aug 10/2009

D280A103



737-700/800

WIRING DIAGRAM MANUAL

**CHAPTER 77
ENGINE INDICATING**

Title	CH-SC-SU	Schem	Page	Sheet	Date	Effectivity
<u>ENGINE TACHOMETER SYSTEM</u>						
ENGINE N1 SPEED INDICATION	77-12-11		1		Feb 09/2009	ALL
ENGINE N2 SPEED INDICATION	77-12-21		1		Feb 09/2009	YC001-YK910 YK918 YL421-YL423 YM643-YM646
			1.1		May 11/2009	YM643
			2		Feb 09/2009	YK911-YK917 YK919-YL401 YL424-YL430 YM647-YM670
<u>EXHAUST GAS TEMPERATURE (EGT) INDICATING SYSTEM</u>						
ENGINE EXHAUST GAS TEMPERATURE INDICATION	77-21-11		1		Feb 09/2009	ALL
<u>AIRBORNE VIBRATION MONITORING (AVM) SYSTEM</u>						
ENGINE 1 VIBRATION MONITORING SYSTEM	77-31-11		1		Mar 31/2005	YC001-YC007
			1.1		Oct 15/2007	YC001-YC007
			2		Mar 31/2005	YC008-YC022
			2.1		Oct 15/2007	YC008-YC022
			3		Jul 17/2007	YC023-YC030
			3.1		Oct 15/2007	YC023-YC030
			4		May 11/2009	YC031-YK912 YK918-YK919 YL401-YL429 YM643-YM652
ENGINE 2 VIBRATION MONITORING SYSTEM	77-31-21		1		Mar 31/2005	YC001-YC007
			1.1		Oct 15/2007	YC001-YC007
			2		Jul 17/2007	YC008-YC030
			2.1		Oct 15/2007	YC008-YC030
			3		Feb 09/2009	YC031-YM670

77-CONTENTS



737-700/800

WIRING DIAGRAM MANUAL

CHAPTER 77 ENGINE INDICATING

CH-SC-SU	Title
77-31-11	ENGINE 1 VIBRATION MONITORING SYSTEM
77-31-21	ENGINE 2 VIBRATION MONITORING SYSTEM
77-21-11	ENGINE EXHAUST GAS TEMPERATURE INDICATION
77-12-11	ENGINE N1 SPEED INDICATION
77-12-21	ENGINE N2 SPEED INDICATION

77-ALPHABETICAL INDEX

D280A103

Page 1
Jan 18/2007

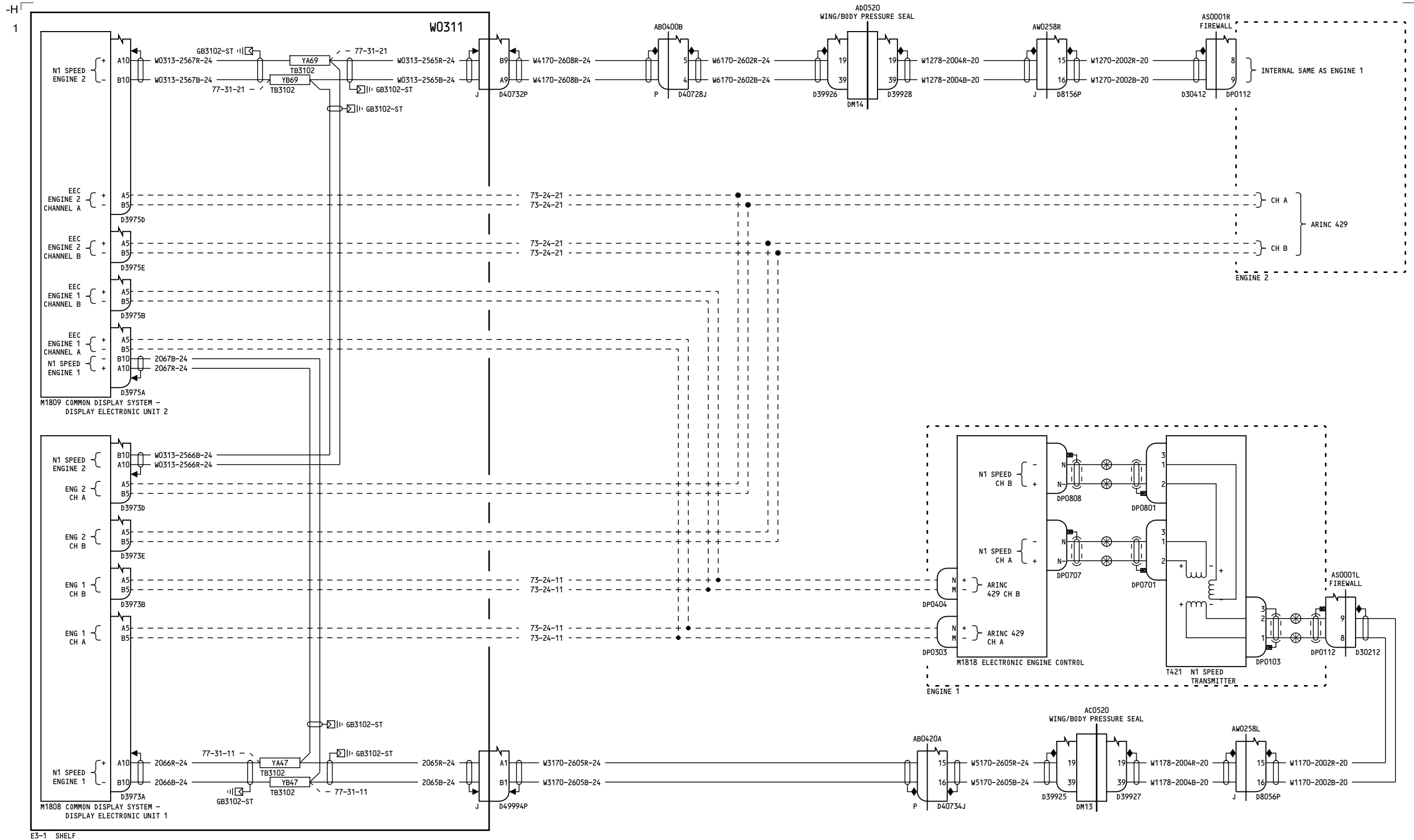

ALL

ENGINE N1 SPEED INDICATION

77-12-11

Page 1

D280A103

Feb 09/2009

77-12-11

Page 1

Feb 09/2009

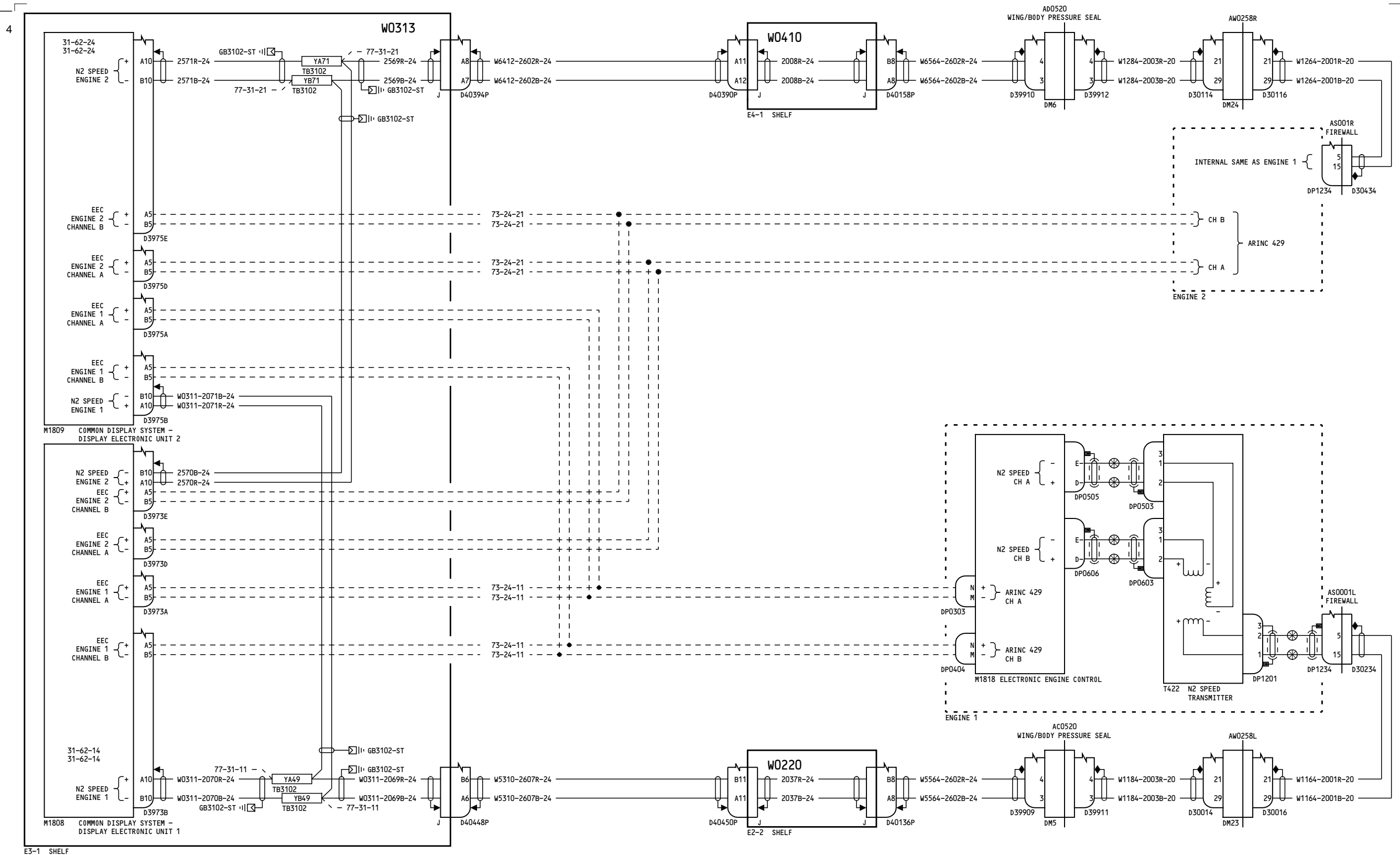

YM643

ENGINE N2 SPEED INDICATION

D280A103

77-12-21

Page 1.1

May 11/2009

Incorporates 24-1176 R01

77-12-21

Page 1.1

May 11/2009

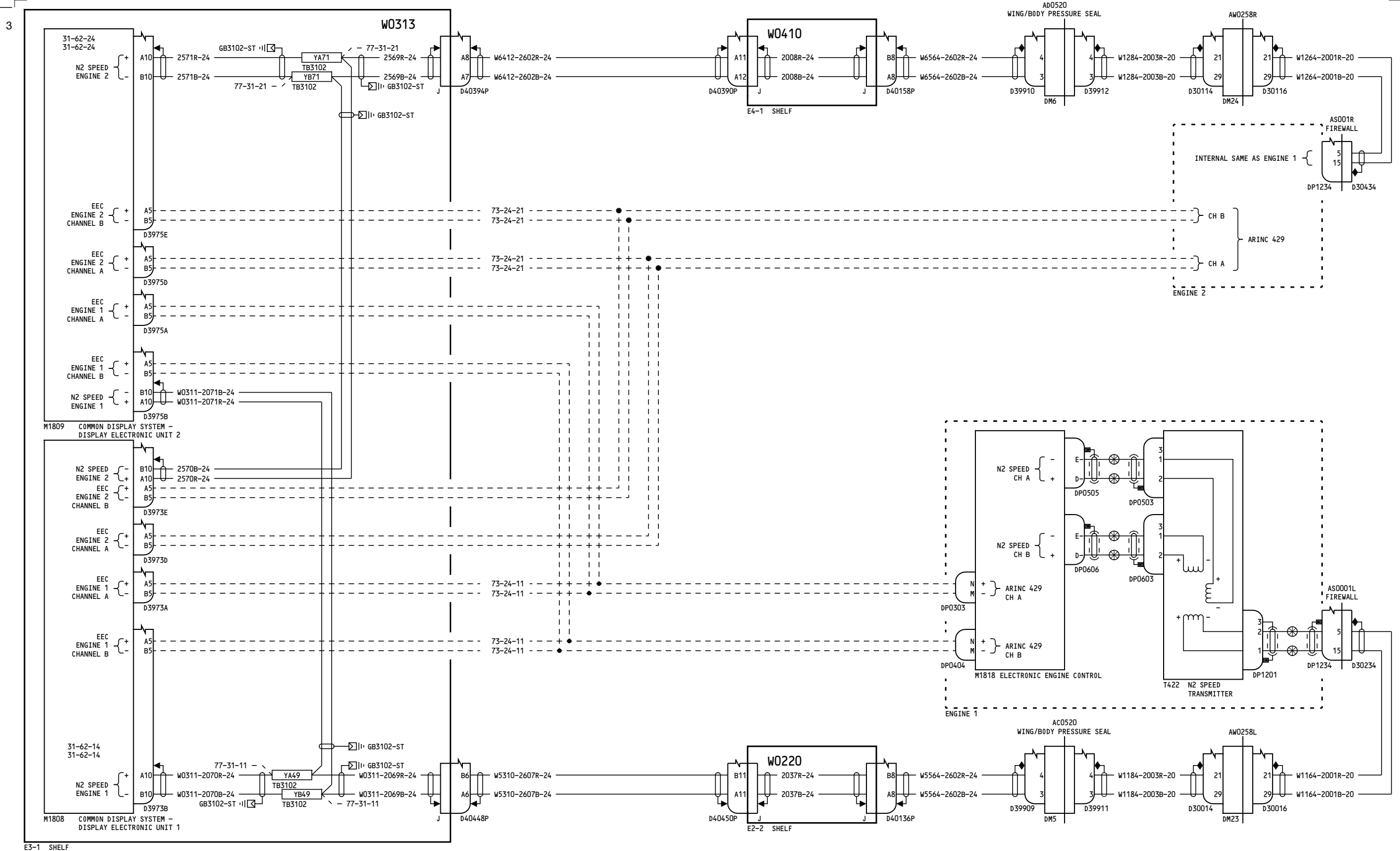

YK911-YK917, YK919-YL401, YL424-YL430, YM647-YM670

ENGINE N2 SPEED INDICATION

D280A103

77-12-21

Page 2

Feb 09/2009

77-12-21

Page 2

Feb 09/2009

-C
1

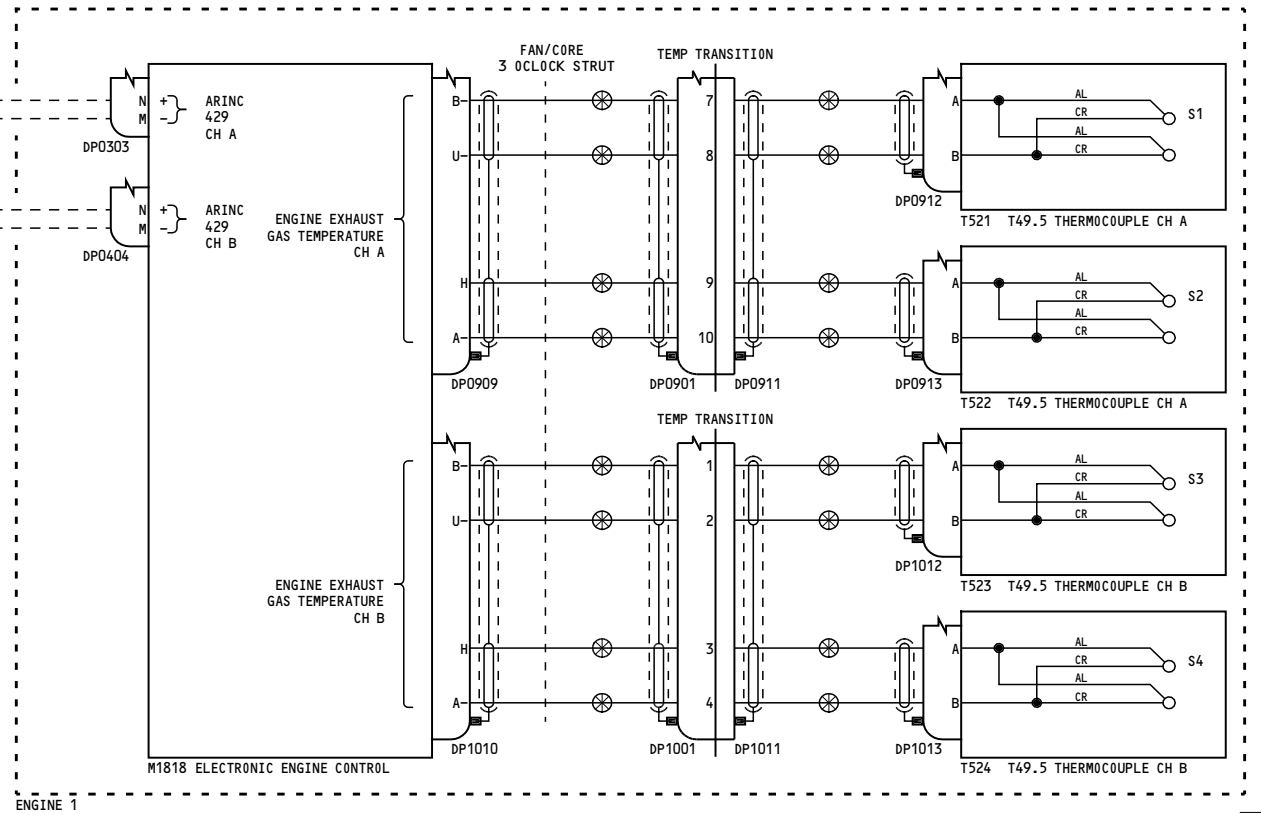
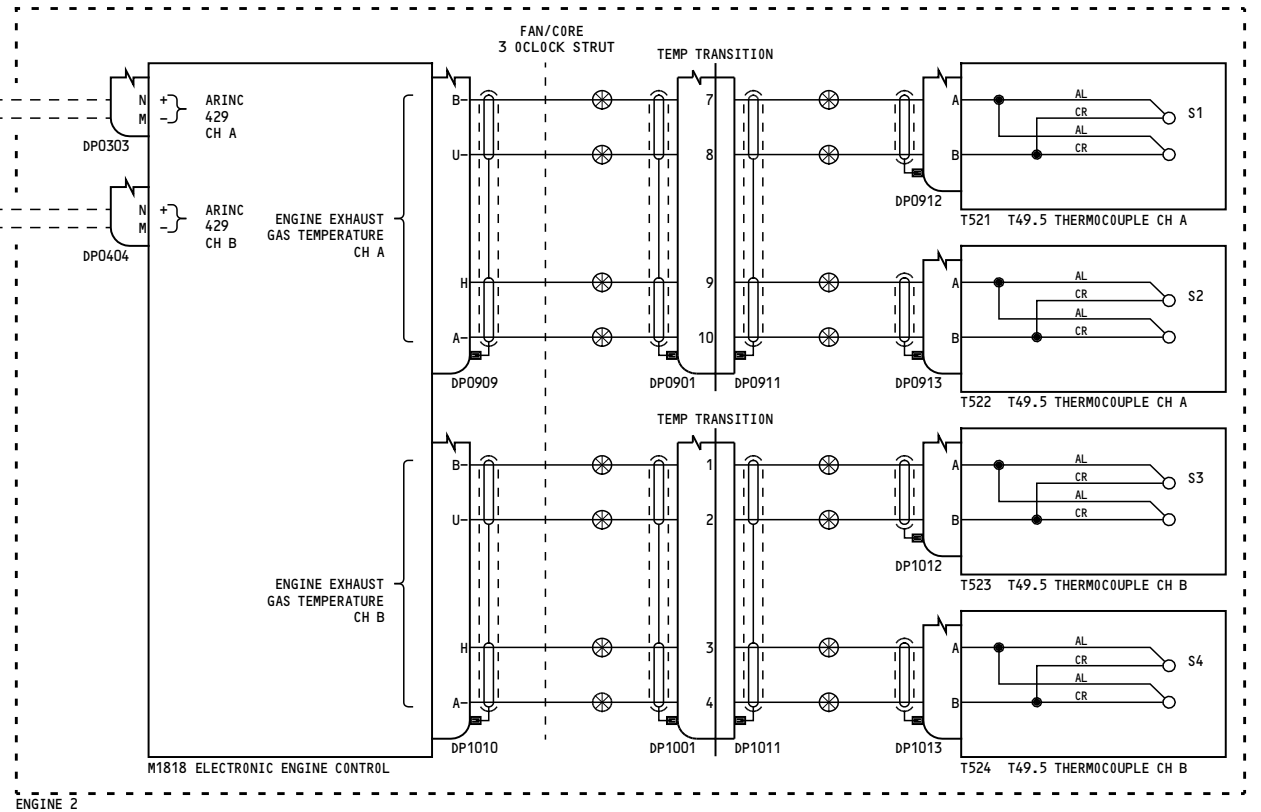
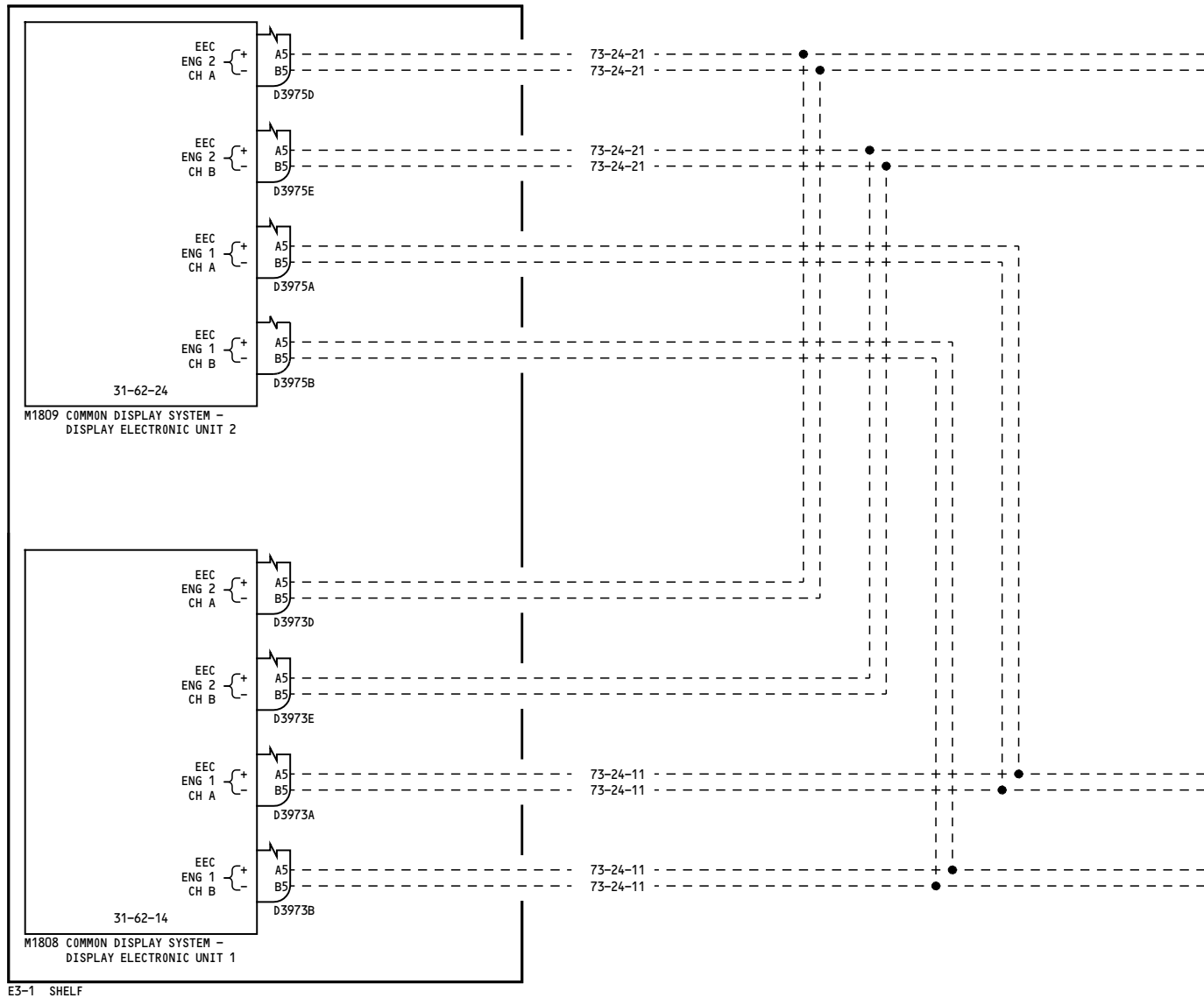

ALL

ENGINE EXHAUST GAS TEMPERATURE INDICATION

D280A103

77-21-11

Page 1

Feb 09/2009

77-21-11

Page 1

Feb 09/2009

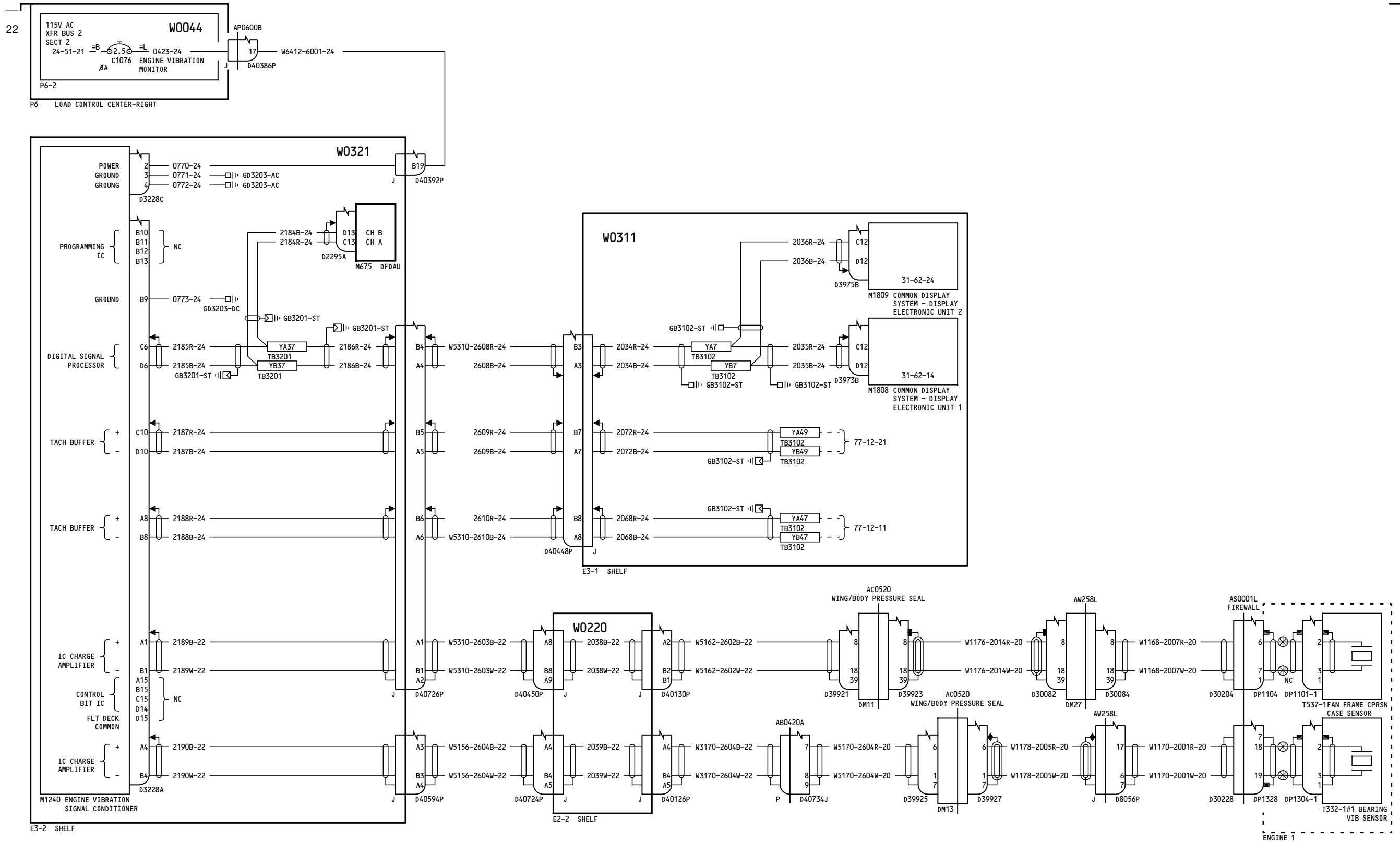

YC001-YC007

ENGINE 1 VIBRATION MONITORING SYSTEM

77-31-11

Page 1.1

D280A103

Oct 15/2007

Incorporates 28-1194 R02

77-31-11

Page 1.1

Oct 15/2007

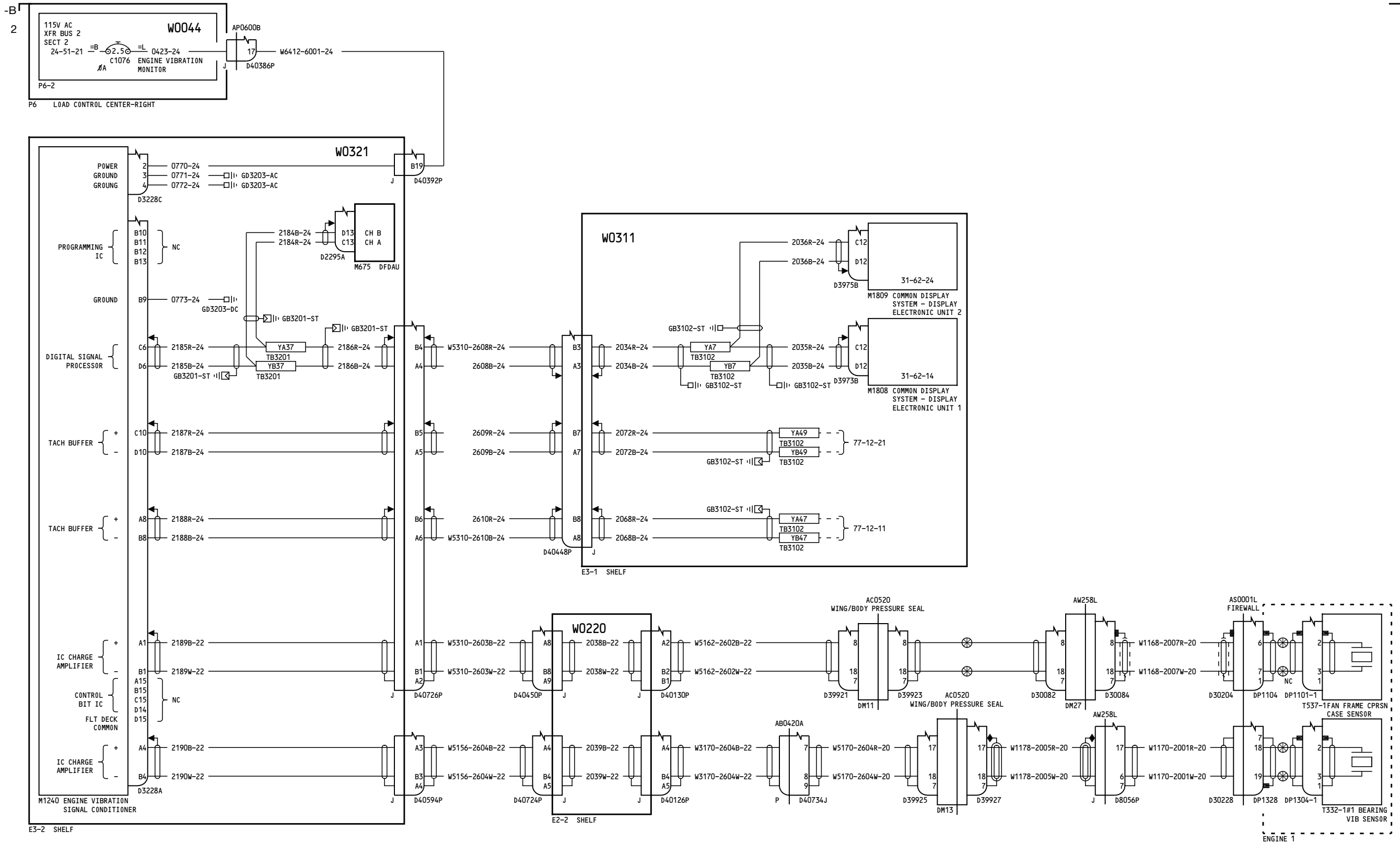

YC008-YC022

ENGINE 1 VIBRATION MONITORING SYSTEM

77-31-11

Page 2

D280A103

Mar 31/2005

77-31-11

Page 2

Mar 31/2005

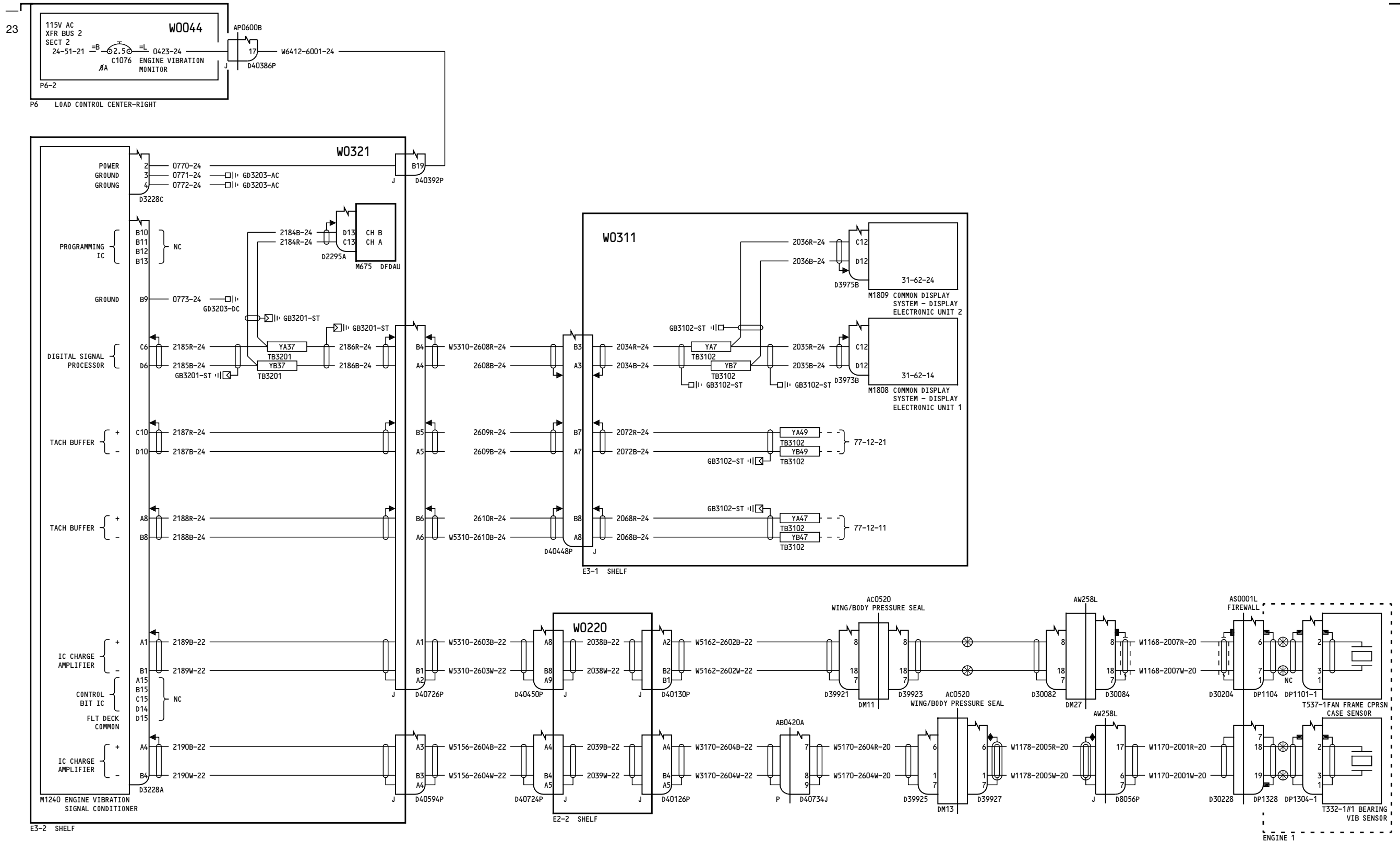

YC008-YC022

ENGINE 1 VIBRATION MONITORING SYSTEM

77-31-11

Page 2.1

D280A103

Oct 15/2007

Incorporates
28-1194 R02

77-31-11

Page 2.1

Oct 15/2007

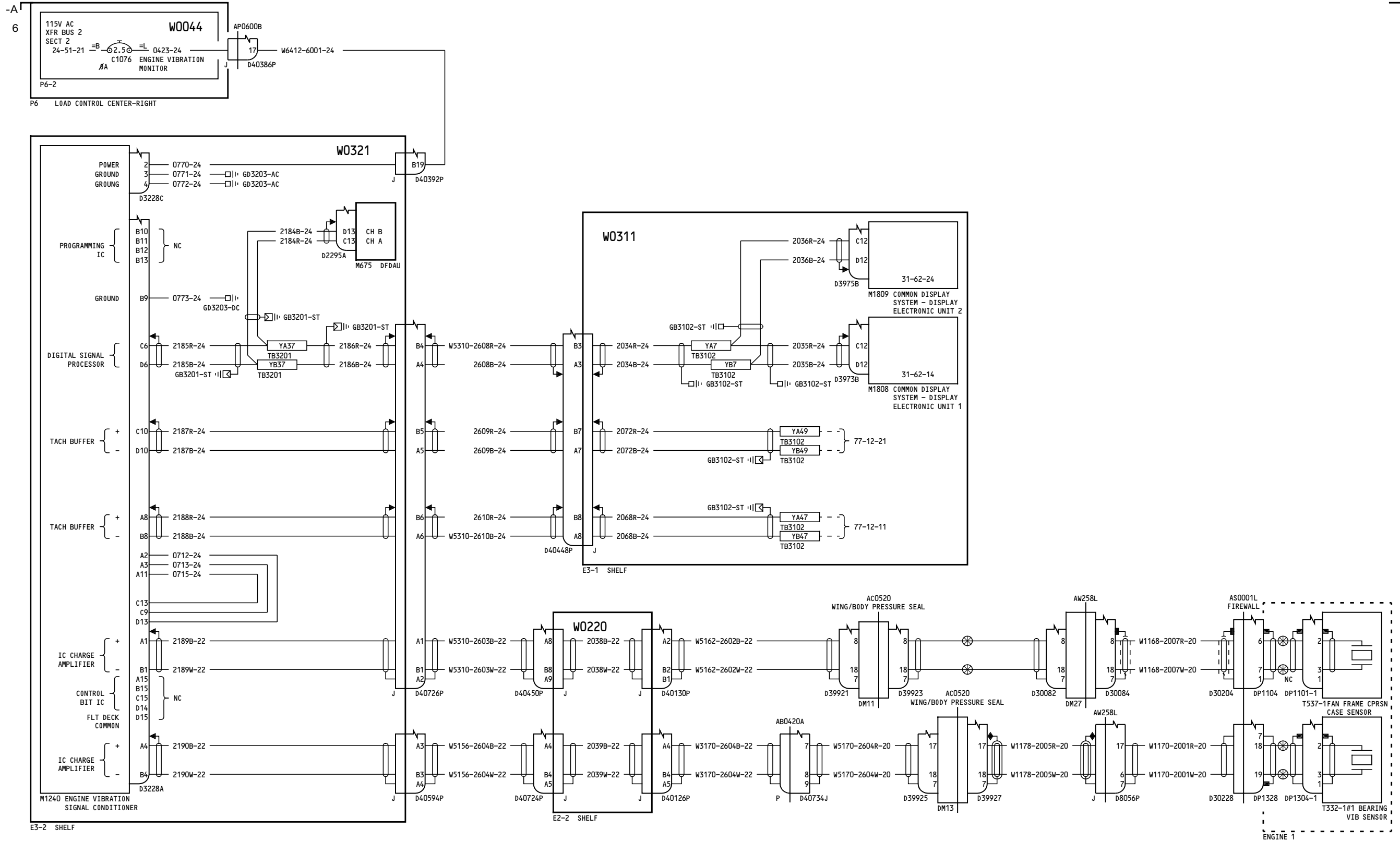

YC023-YC030

ENGINE 1 VIBRATION MONITORING SYSTEM

77-31-11

Page 3

D280A103

Jul 17/2007

77-31-11

Page 3

Jul 17/2007

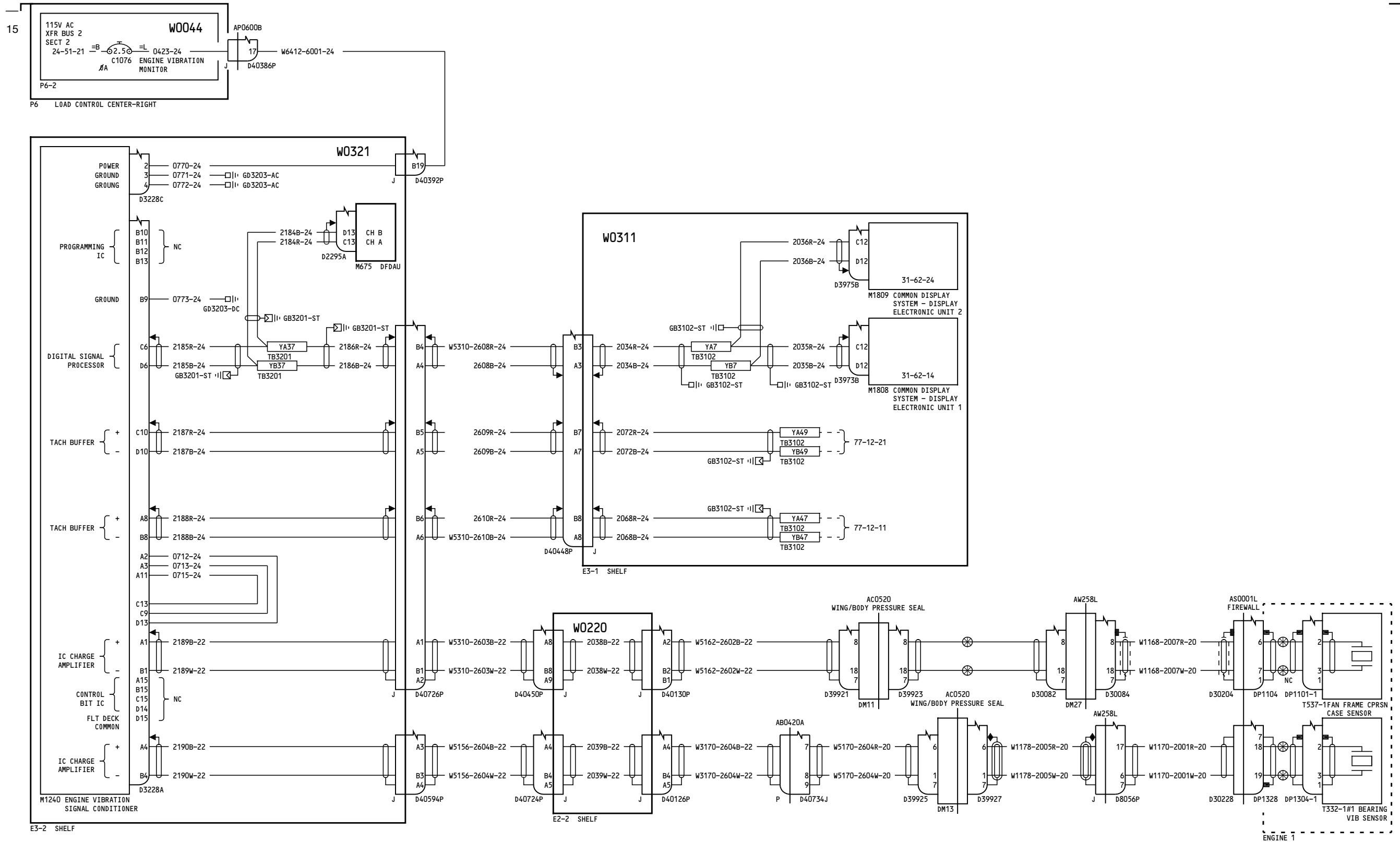

YC023-YC030

ENGINE 1 VIBRATION MONITORING SYSTEM

77-31-11

Incorporates 28-1194 R02

Page 3.1

D280A103

Oct 15/2007

77-31-11

Page 3.1

Oct 15/2007

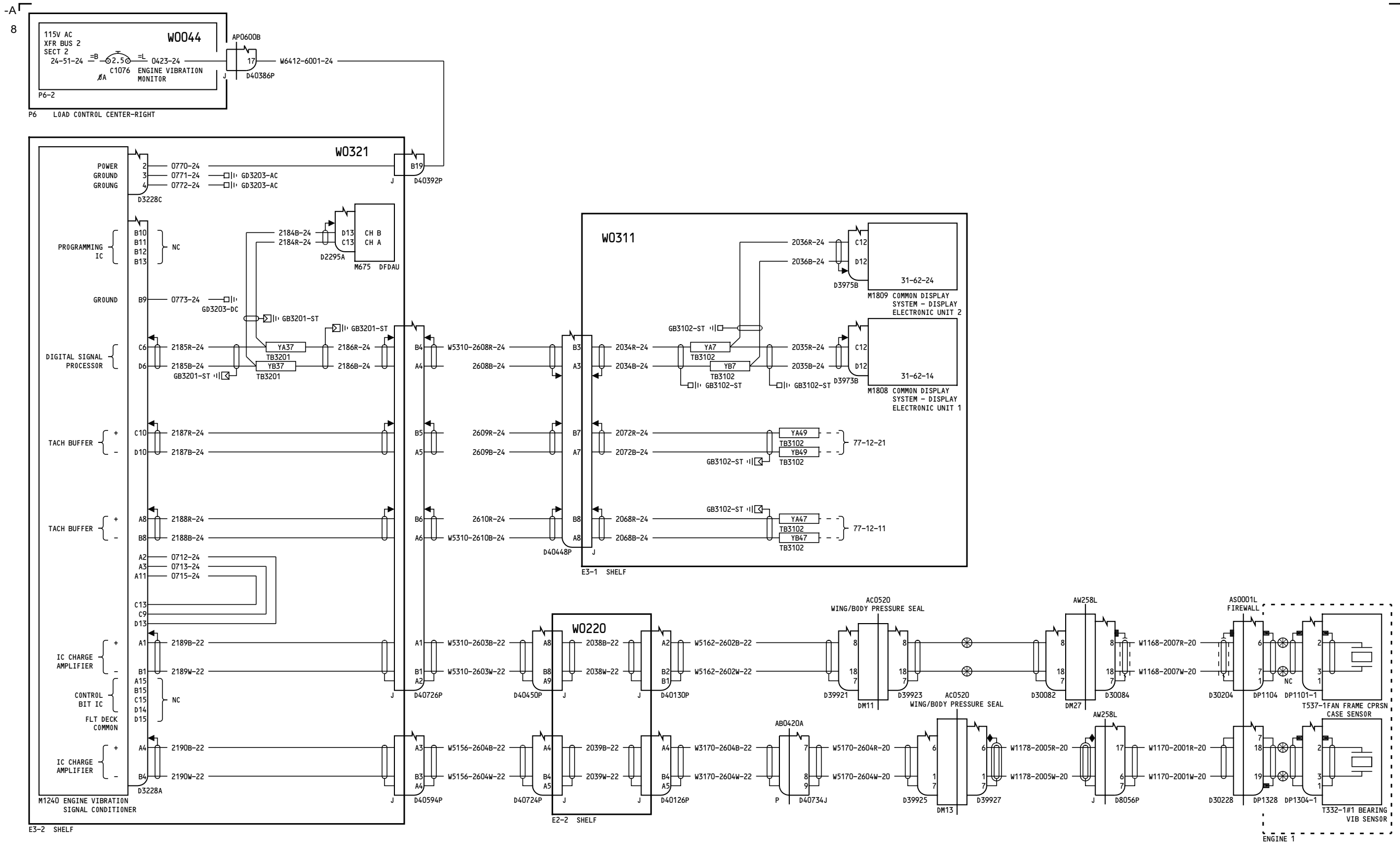

YC031-YK912, YK918-YK919, YL401-YL429, YM643-YM652

ENGINE 1 VIBRATION MONITORING SYSTEM

77-31-11

Page 4

D280A103

May 11/2009

77-31-11

Page 4

May 11/2009

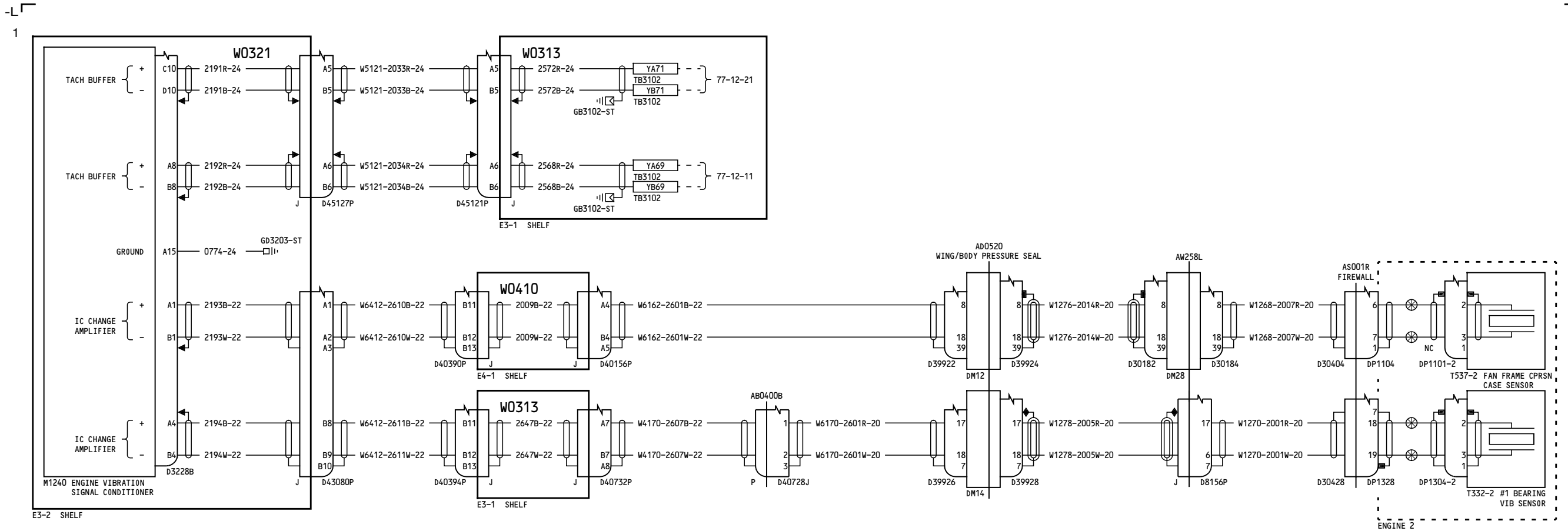

YC001-YC007

ENGINE 2 VIBRATION MONITORING SYSTEM

77-31-21

Page 1

D280A103

Mar 31/2005

77-31-21

Page 1

Mar 31/2005

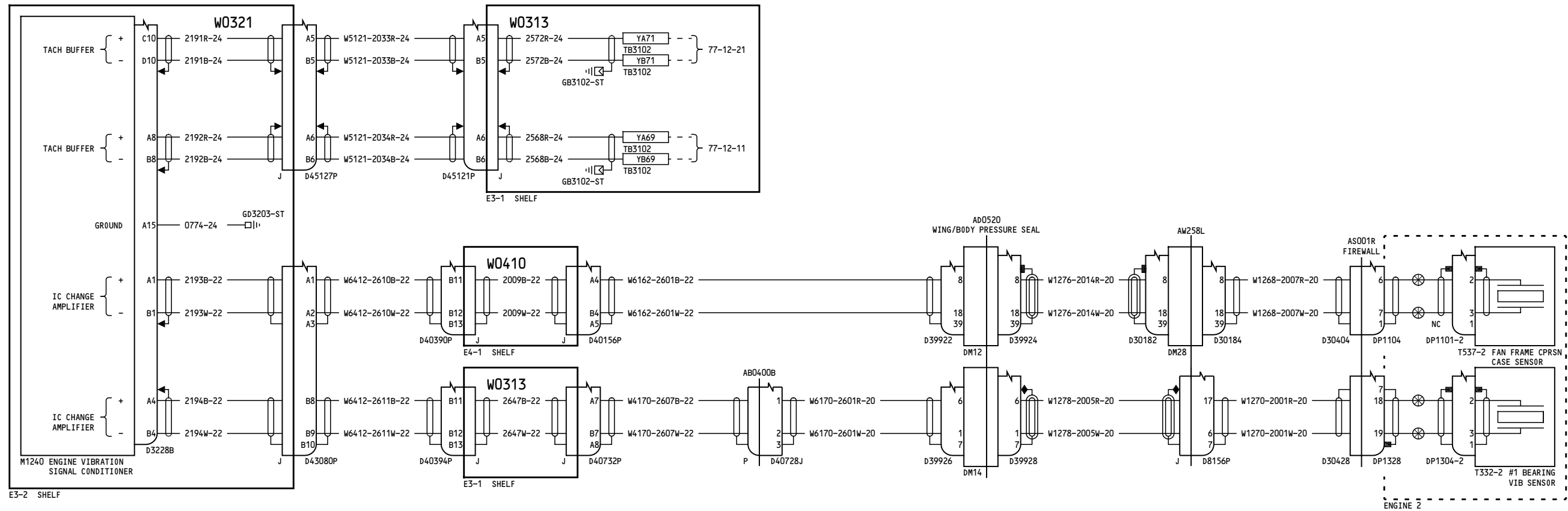

YC001-YC007

ENGINE 2 VIBRATION MONITORING SYSTEM

D280A103

77-31-21

Page 1.1

Oct 15/2007

Incorporates
 28-1194 R02

77-31-21

Page 1.1

Oct 15/2007

-B
3

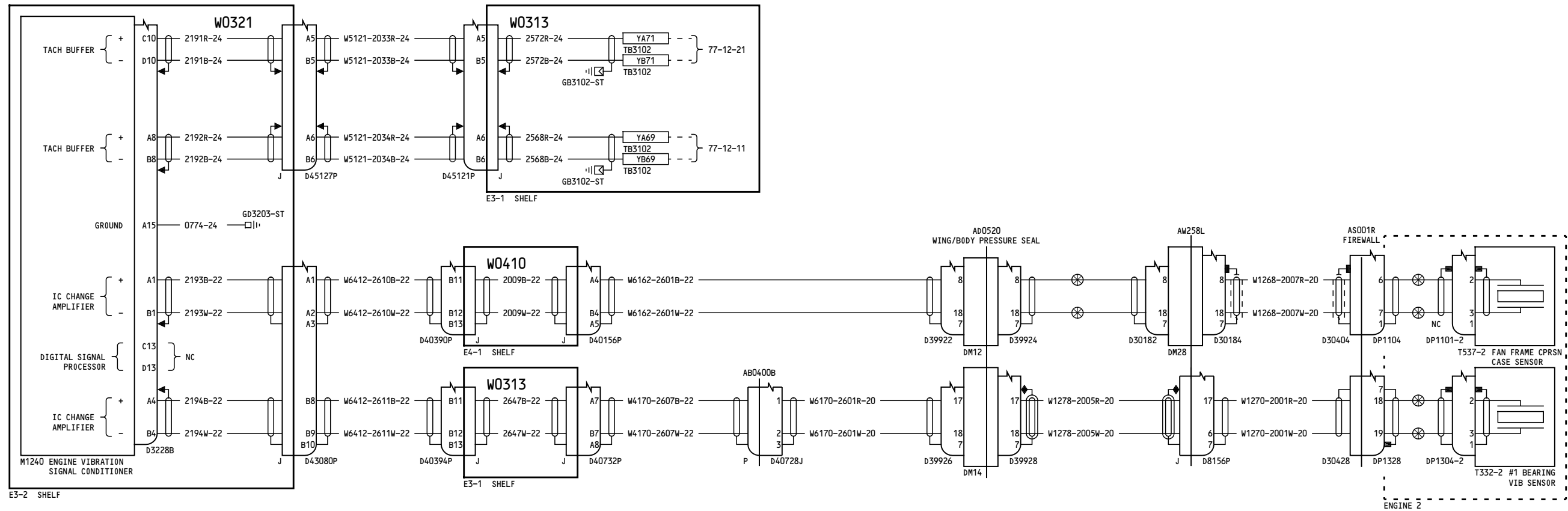

YC008-YC030

ENGINE 2 VIBRATION MONITORING SYSTEM

77-31-21

Page 2

D280A103

Jul 17/2007

77-31-21

Page 2

Jul 17/2007

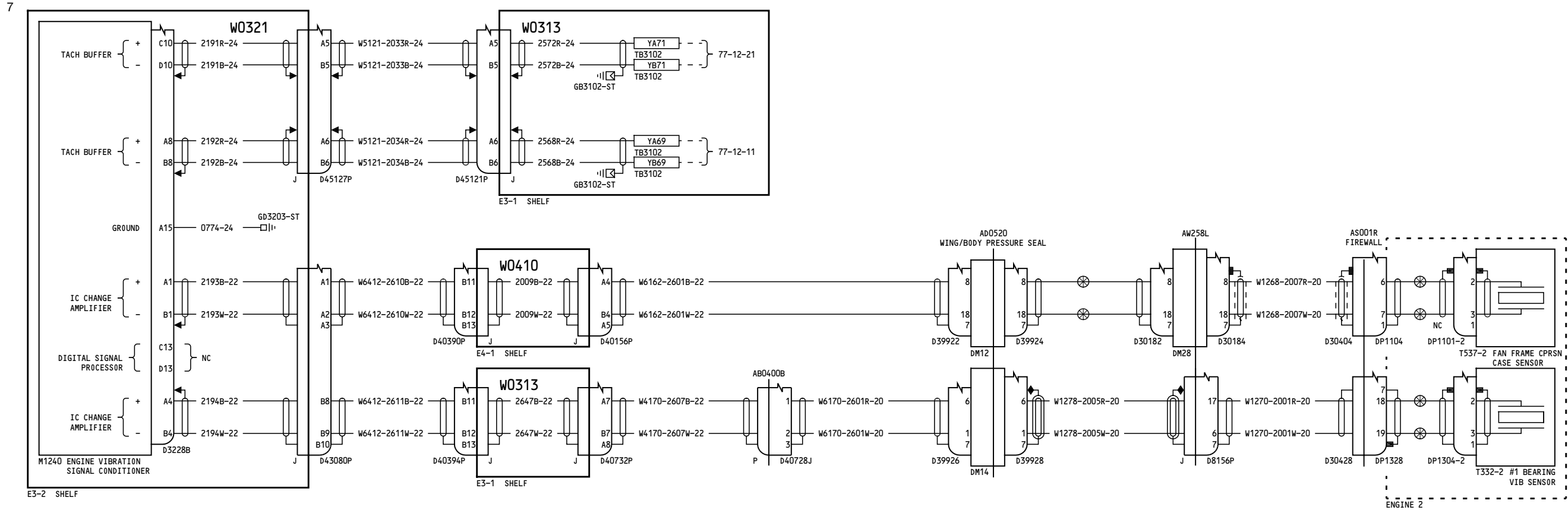

YC008-YC030

ENGINE 2 VIBRATION MONITORING SYSTEM

77-31-21

Page 2.1

D280A103

Oct 15/2007

Incorporates
28-1194 R02

77-31-21

Page 2.1

Oct 15/2007

