

CHAPTER

78

EXHAUST



737-700/800

WIRING DIAGRAM MANUAL

CHAPTER 78
EXHAUST

CH-SC-SU	Schem	Page	Sheet	Date	CH-SC-SU	Schem	Page	Sheet	Date
78-EFFECTIVE PAGES									
		1		Aug 10/2009					
		2		BLANK					
78-CONTENTS									
		1		May 11/2009					
		2		Feb 09/2009					
78-ALPHABETICAL INDEX									
		1		Jan 18/2007					
		2		BLANK					
78-32-51		1		May 11/2009					
		2		May 11/2009					
		3		May 11/2009					
		4		May 11/2009					
78-32-61		1		May 11/2009					
		2		May 11/2009					
		3		May 11/2009					
		4		May 11/2009					
		5		May 11/2009					
78-34-11		1		Feb 09/2009					
78-34-21		1		Aug 13/2008					
		2		Aug 13/2008					
		3		Feb 09/2009					
78-35-11		1		Mar 31/2005					
		2		Mar 31/2005					
		3		Feb 09/2009					
78-35-21		1		Mar 31/2005					
		2		Mar 31/2005					
		3		Feb 09/2009					
78-36-11		1		Mar 31/2005					
		2		Feb 09/2009					
78-36-21		1		Mar 31/2005					
		2		Feb 09/2009					

A = Added, R = Revised, D = Deleted, O = Overflow

78-EFFECTIVE PAGES

Page 1
Aug 10/2009

D280A103



737-700/800

WIRING DIAGRAM MANUAL

CHAPTER 78 EXHAUST

Title	CH-SC-SU	Schem	Page	Sheet	Date	Effectivity
<u>THRUST REVERSER SYSTEM</u>						
ENGINE 1 THRUST REVERSER SYNCHRONOUS SHAFT LOCKS	78-32-51		1		May 11/2009	YC001-YC003
			2		May 11/2009	YC004-YC007
			3		May 11/2009	YC008-YC050
			4		May 11/2009	YK901-YM670
ENGINE 2 THRUST REVERSER SYNCHRONOUS SHAFT LOCKS	78-32-61		1		May 11/2009	YC001-YC003
			2		May 11/2009	YC004-YC007
			3		May 11/2009	YC008-YC050
			4		May 11/2009	YK901-YL430
			5		May 11/2009	YM643-YM670
<u>THRUST REVERSER CONTROL SYSTEM</u>						
ENGINE 1 THRUST REVERSER CONTROL	78-34-11		1		Feb 09/2009	ALL
ENGINE 2 THRUST REVERSER CONTROL	78-34-21		1		Aug 13/2008	YC001-YC003
			2		Aug 13/2008	YC004-YC050
			3		Feb 09/2009	YK901-YM670
<u>ENGINE THRUST REVERSER POSITION / THRUST LEVER INTERLOCK</u>						
ENGINE 1 THRUST REVERSER POSITION / THRUST LEVER INTERLOCK	78-35-11		1		Mar 31/2005	YC001-YC003
			2		Mar 31/2005	YC004-YC007
			3		Feb 09/2009	YC008-YM670
ENGINE 2 THRUST REVERSER POSITION / THRUST LEVER INTERLOCK	78-35-21		1		Mar 31/2005	YC001-YC003
			2		Mar 31/2005	YC004-YC007
			3		Feb 09/2009	YC008-YM670
<u>THRUST REVERSER INDICATING SYSTEM</u>						
ENGINE 1 THRUST REVERSER FLIGHT DECK INDICATION	78-36-11		1		Mar 31/2005	YC001-YC007
			2		Feb 09/2009	YC008-YM670

78-CONTENTS

Page 1

May 11/2009

D280A103



737-700/800

WIRING DIAGRAM MANUAL

CHAPTER 78 EXHAUST

Title	CH-SC-SU	Schem	Page	Sheet	Date	Effectivity
ENGINE 2 THRUST REVERSER FLIGHT DECK INDICATION	78-36-21		1		Mar 31/2005	YC001-YC007
			2		Feb 09/2009	YC008-YM670

78-CONTENTS

D280A103

Page 2
Feb 09/2009



737-700/800

WIRING DIAGRAM MANUAL

CHAPTER 78 EXHAUST

CH-SC-SU	Title
78-34-11	ENGINE 1 THRUST REVERSER CONTROL
78-36-11	ENGINE 1 THRUST REVERSER FLIGHT DECK INDICATION
78-35-11	ENGINE 1 THRUST REVERSER POSITION / THRUST LEVER INTERLOCK
78-32-51	ENGINE 1 THRUST REVERSER SYNCHRONOUS SHAFT LOCKS
78-34-21	ENGINE 2 THRUST REVERSER CONTROL
78-36-21	ENGINE 2 THRUST REVERSER FLIGHT DECK INDICATION
78-35-21	ENGINE 2 THRUST REVERSER POSITION / THRUST LEVER INTERLOCK
78-32-61	ENGINE 2 THRUST REVERSER SYNCHRONOUS SHAFT LOCKS

78-ALPHABETICAL INDEX

D280A103

Page 1
Jan 18/2007

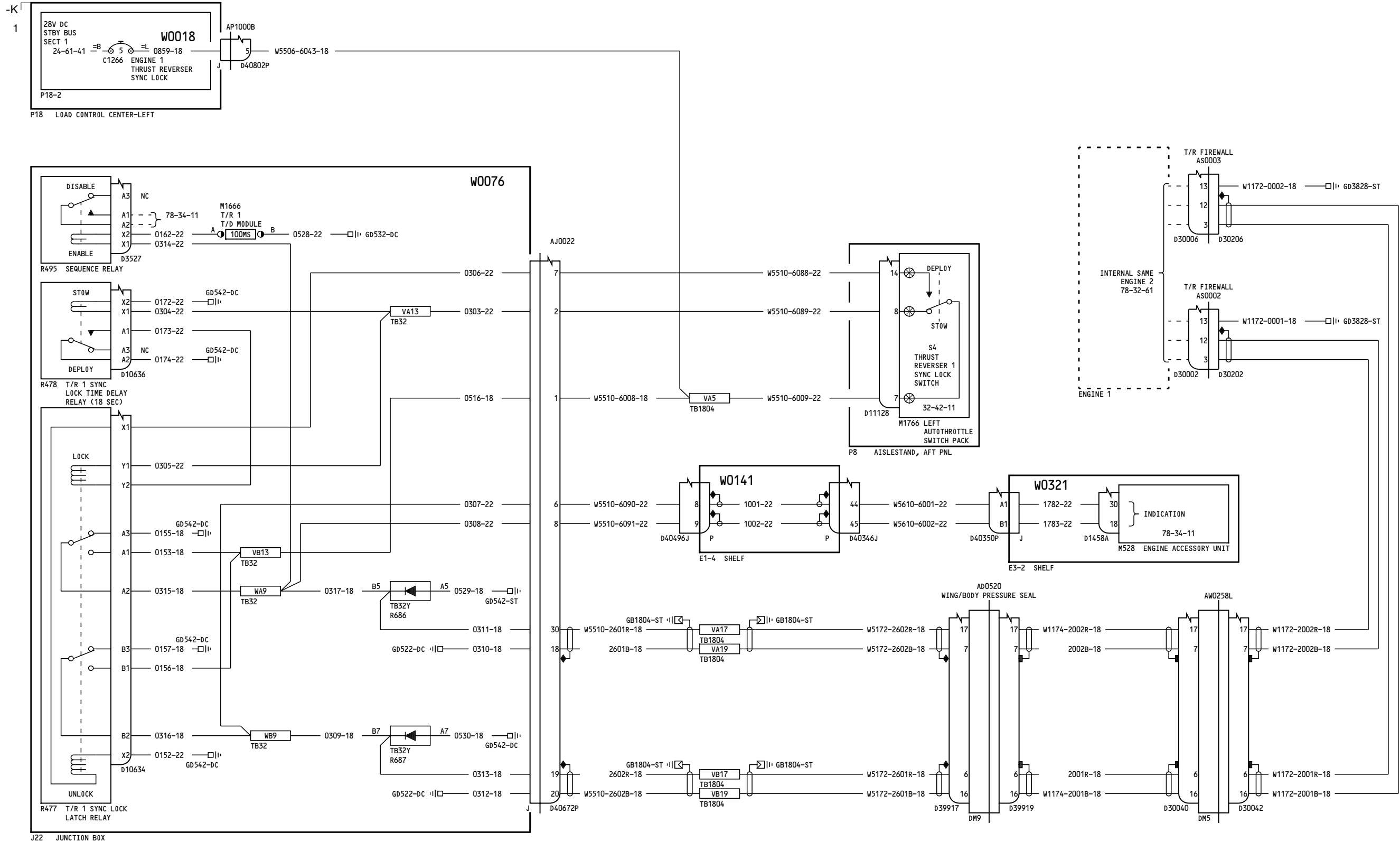

YC001-YC003

ENGINE 1 THRUST REVERSER SYNCHRONOUS SHAFT LOCKS

78-32-51

Page 1

May 11/2009

D280A103

78-32-51

Page 1

May 11/2009

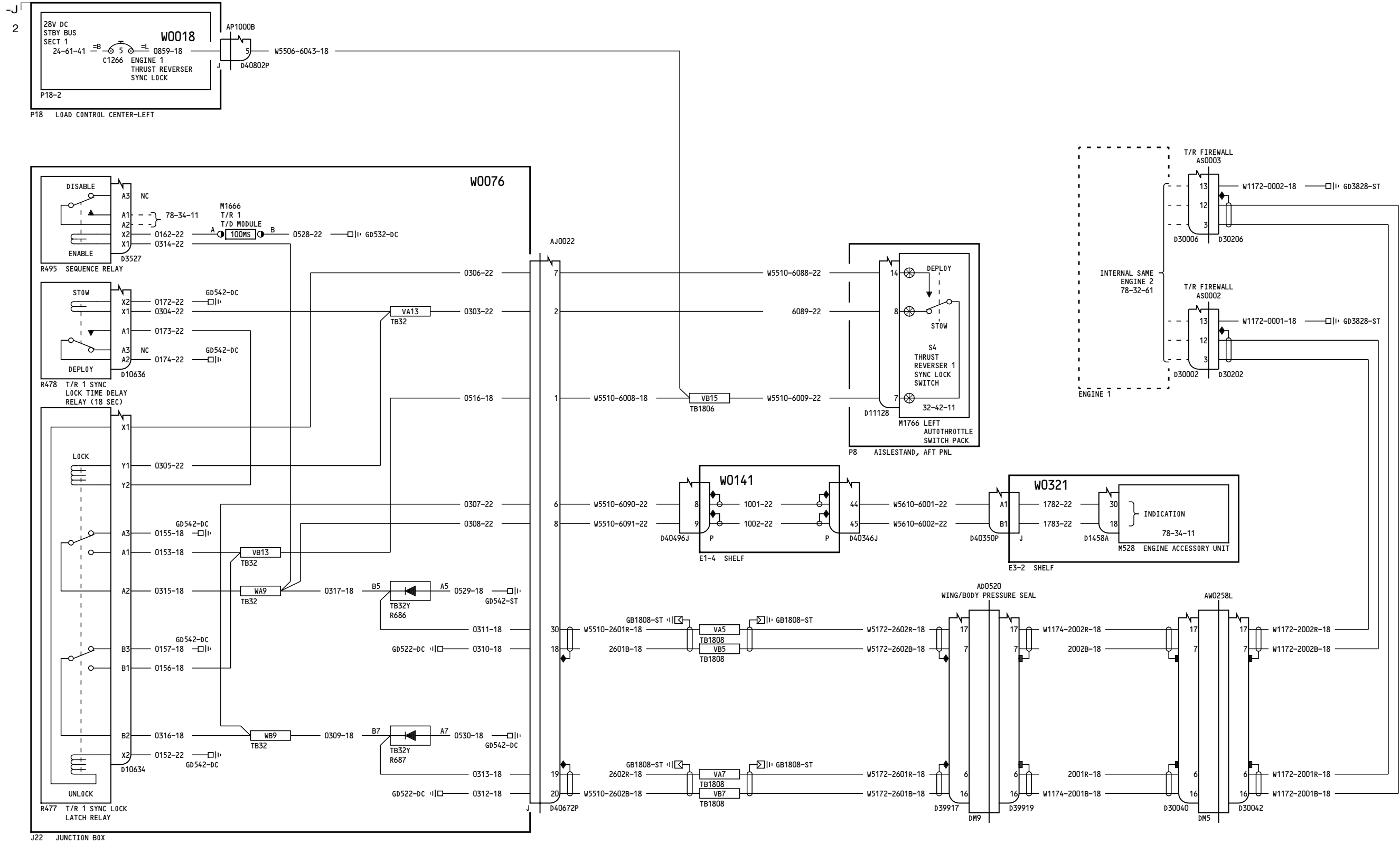

YC004-YC007

ENGINE 1 THRUST REVERSER SYNCHRONOUS SHAFT LOCKS

78-32-51

Page 2

May 11/2009

D280A103

78-32-51

Page 2

May 11/2009

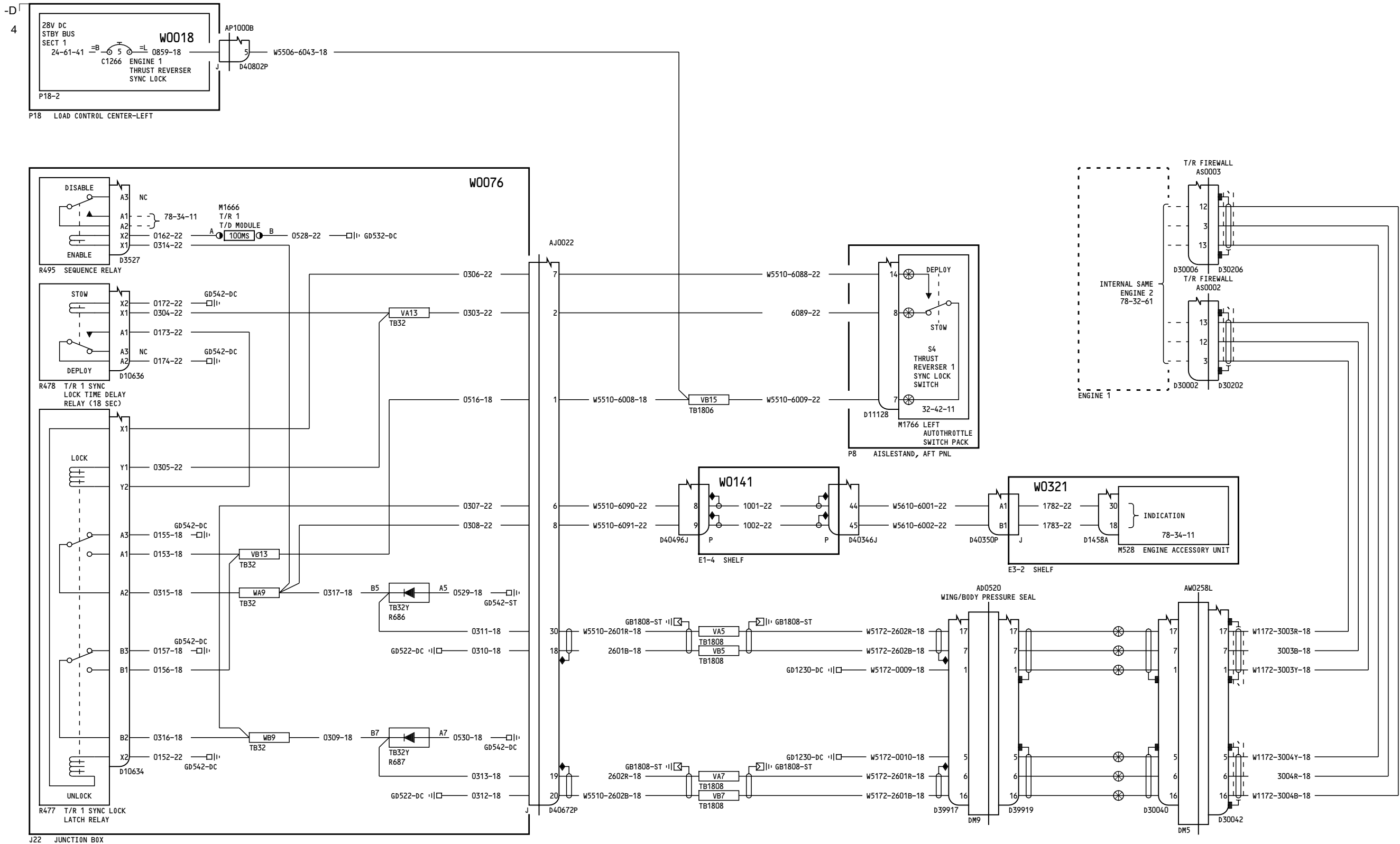

YC008-YC050

ENGINE 1 THRUST REVERSER SYNCHRONOUS SHAFT LOCKS

78-32-51

Page 3

May 11/2009

D280A103

78-32-51

Page 3

May 11/2009

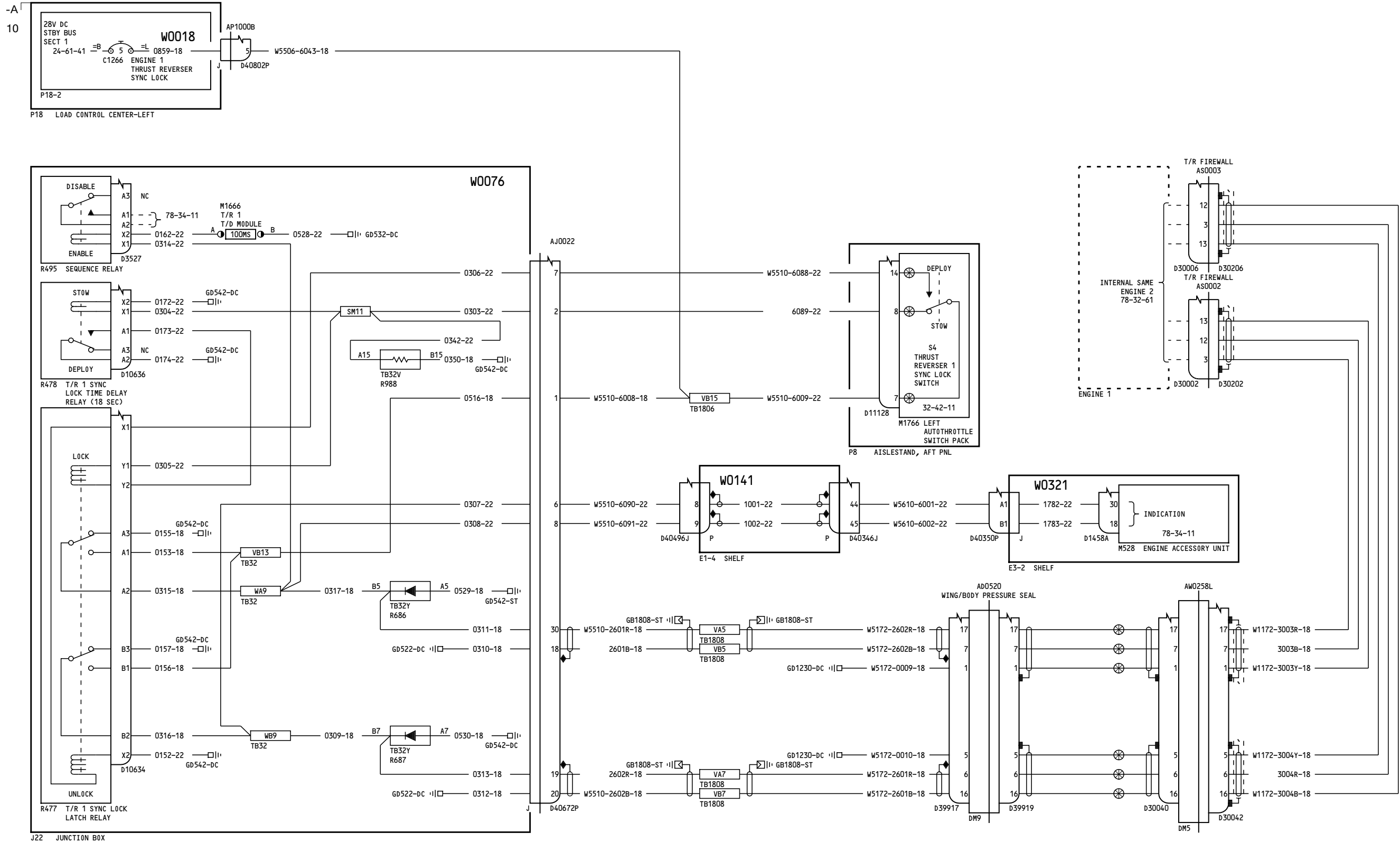

YK901-YM670

ENGINE 1 THRUST REVERSER SYNCHRONOUS SHAFT LOCKS

78-32-51

Page 4

May 11/2009

D280A103

78-32-51

Page 4

May 11/2009

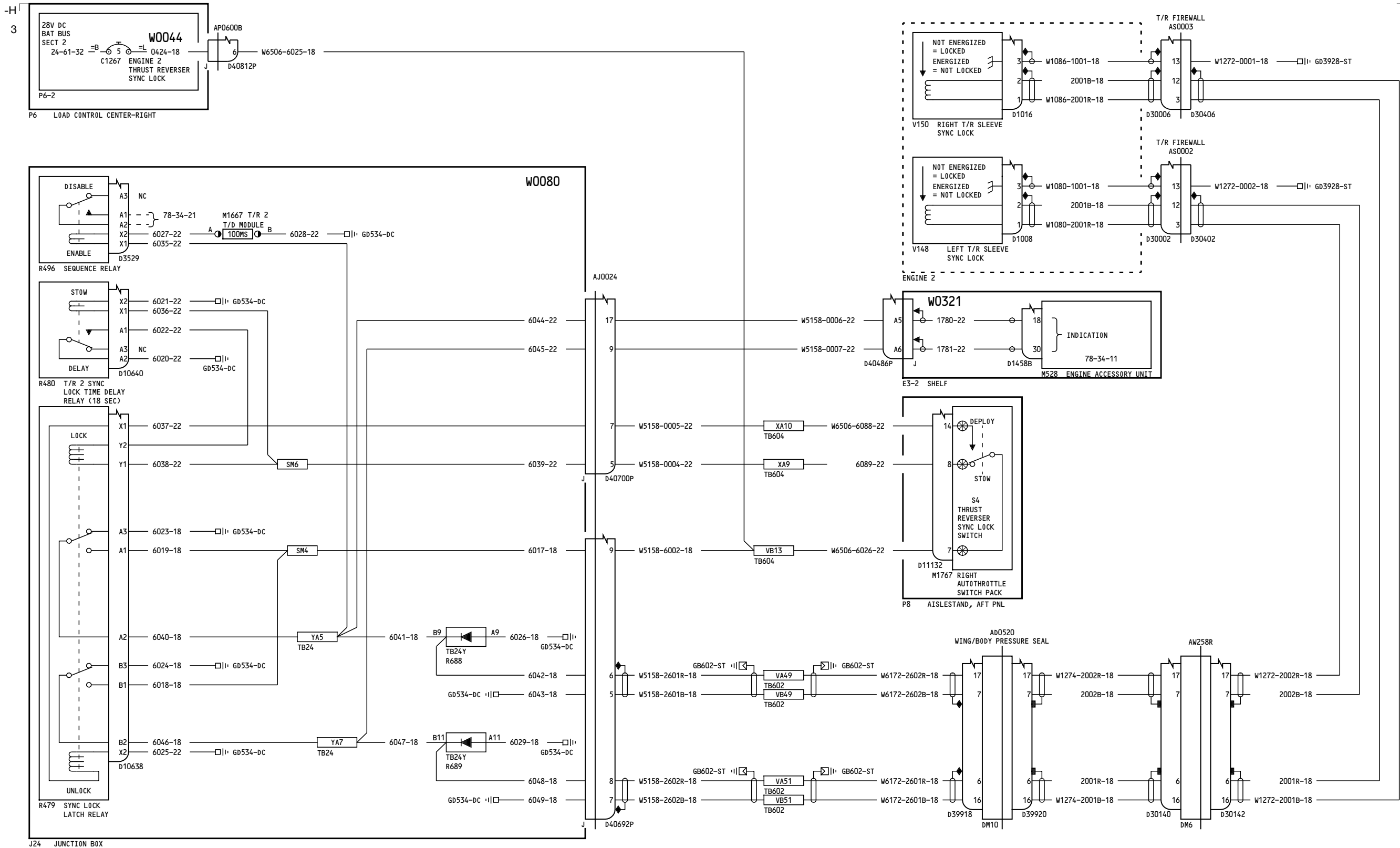

YC001-YC003

ENGINE 2 THRUST REVERSER SYNCHRONOUS SHAFT LOCKS

78-32-61

Page 1

D280A103

May 11/2009

78-32-61

Page 1

May 11/2009

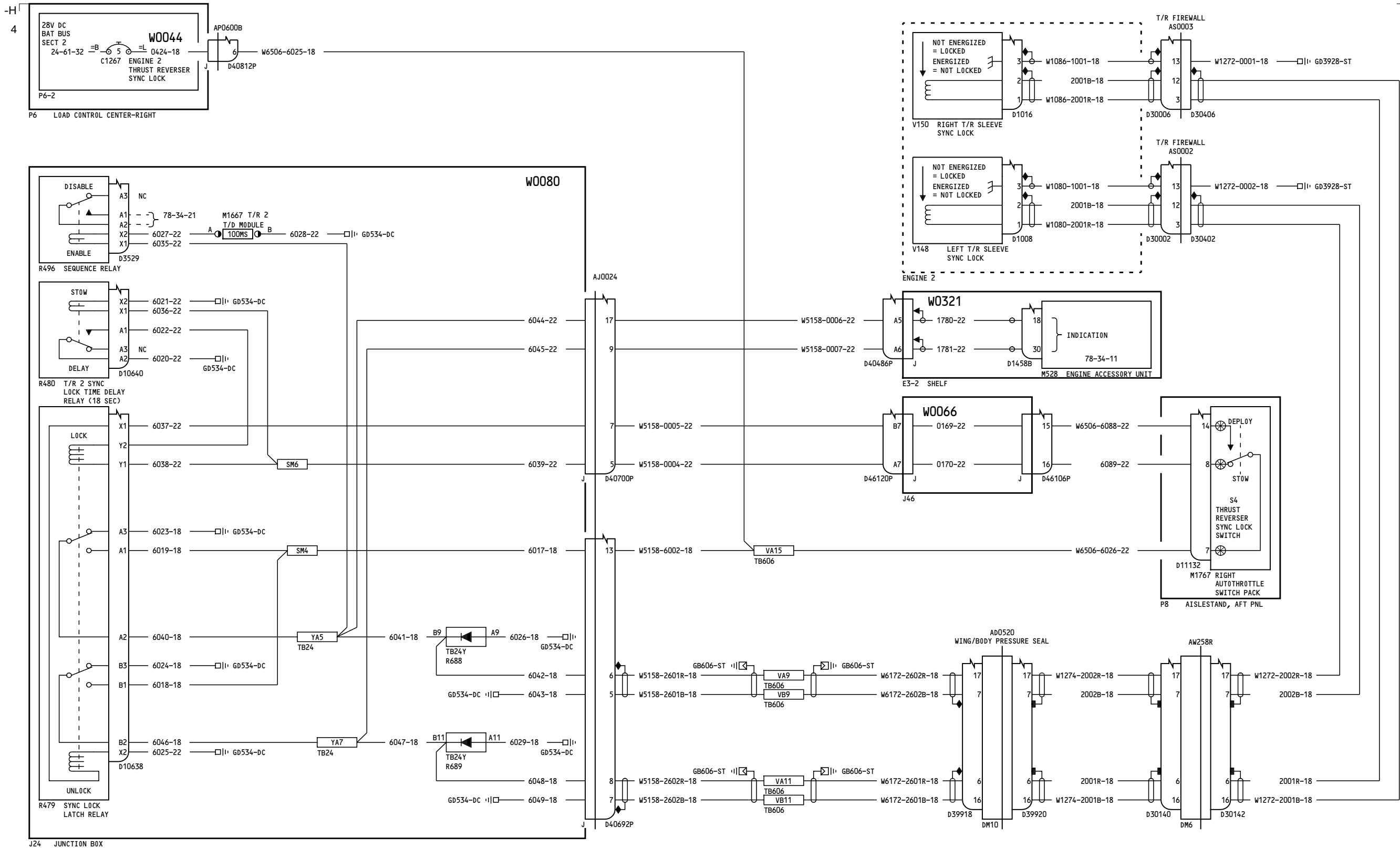

YC004-YC007

ENGINE 2 THRUST REVERSER SYNCHRONOUS SHAFT LOCKS

78-32-61

Page 2

D280A103

May 11/2009

78-32-61

Page 2

May 11/2009

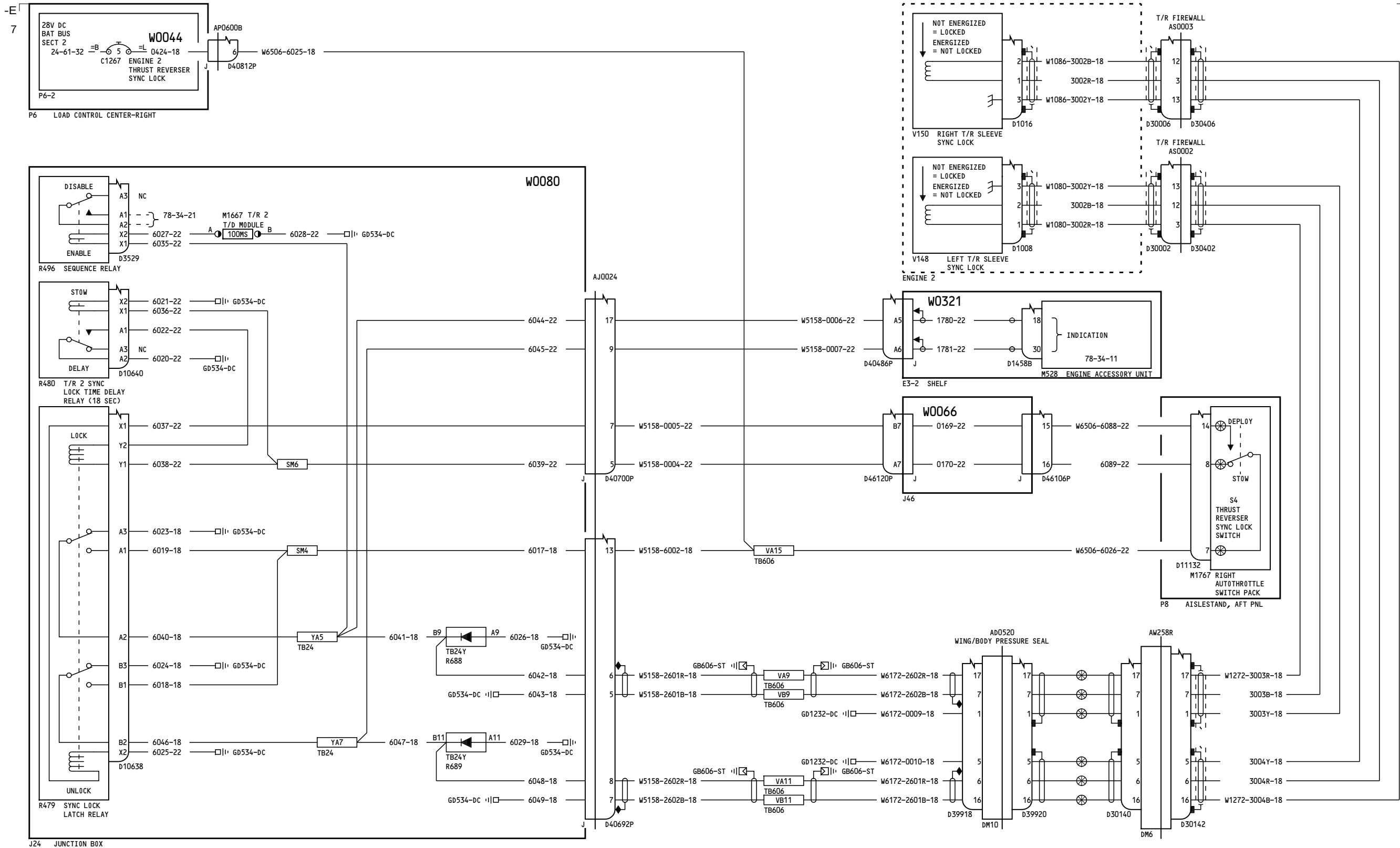

YC008-YC050

ENGINE 2 THRUST REVERSER SYNCHRONOUS SHAFT LOCKS

78-32-61

Page 3

D280A103

May 11/2009

78-32-61

Page 3

May 11/2009

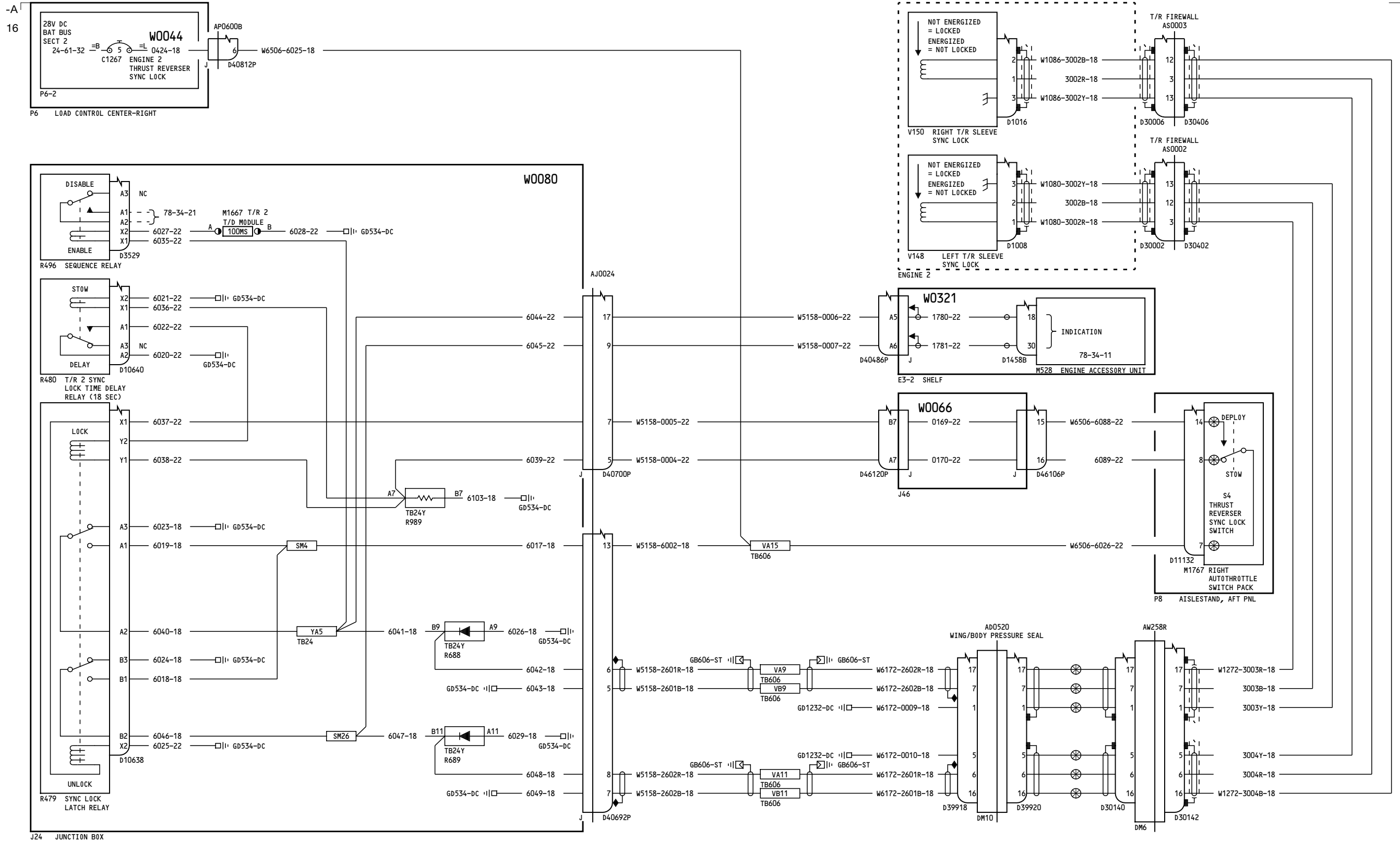

YK901-YL430

ENGINE 2 THRUST REVERSER SYNCHRONOUS SHAFT LOCKS

78-32-61

Page 4

May 11/2009

D280A103

78-32-61

Page 4

May 11/2009

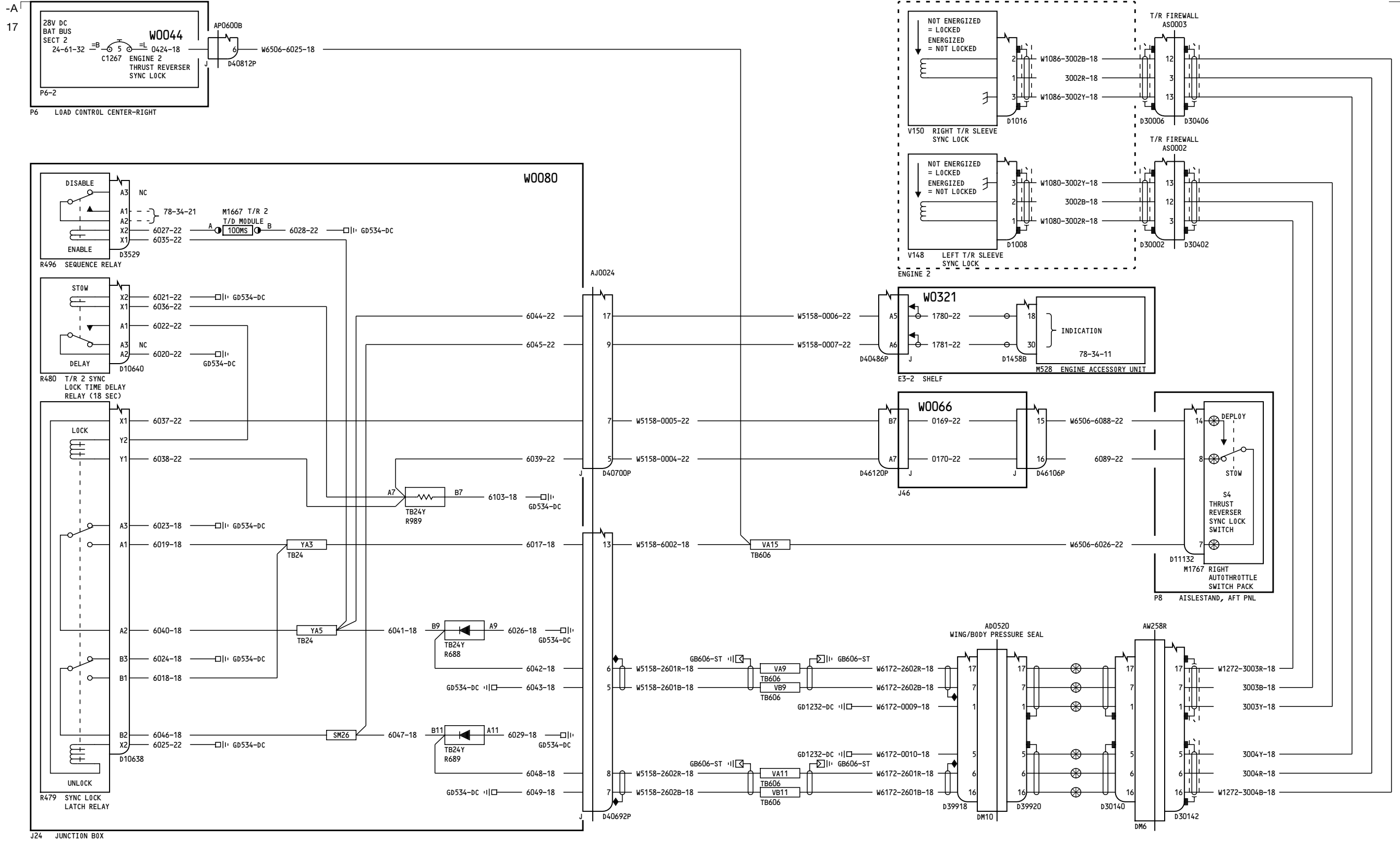

YM643-YM670

ENGINE 2 THRUST REVERSER SYNCHRONOUS SHAFT LOCKS

78-32-61

Page 5

May 11/2009

D280A103

78-32-61

Page 5

May 11/2009

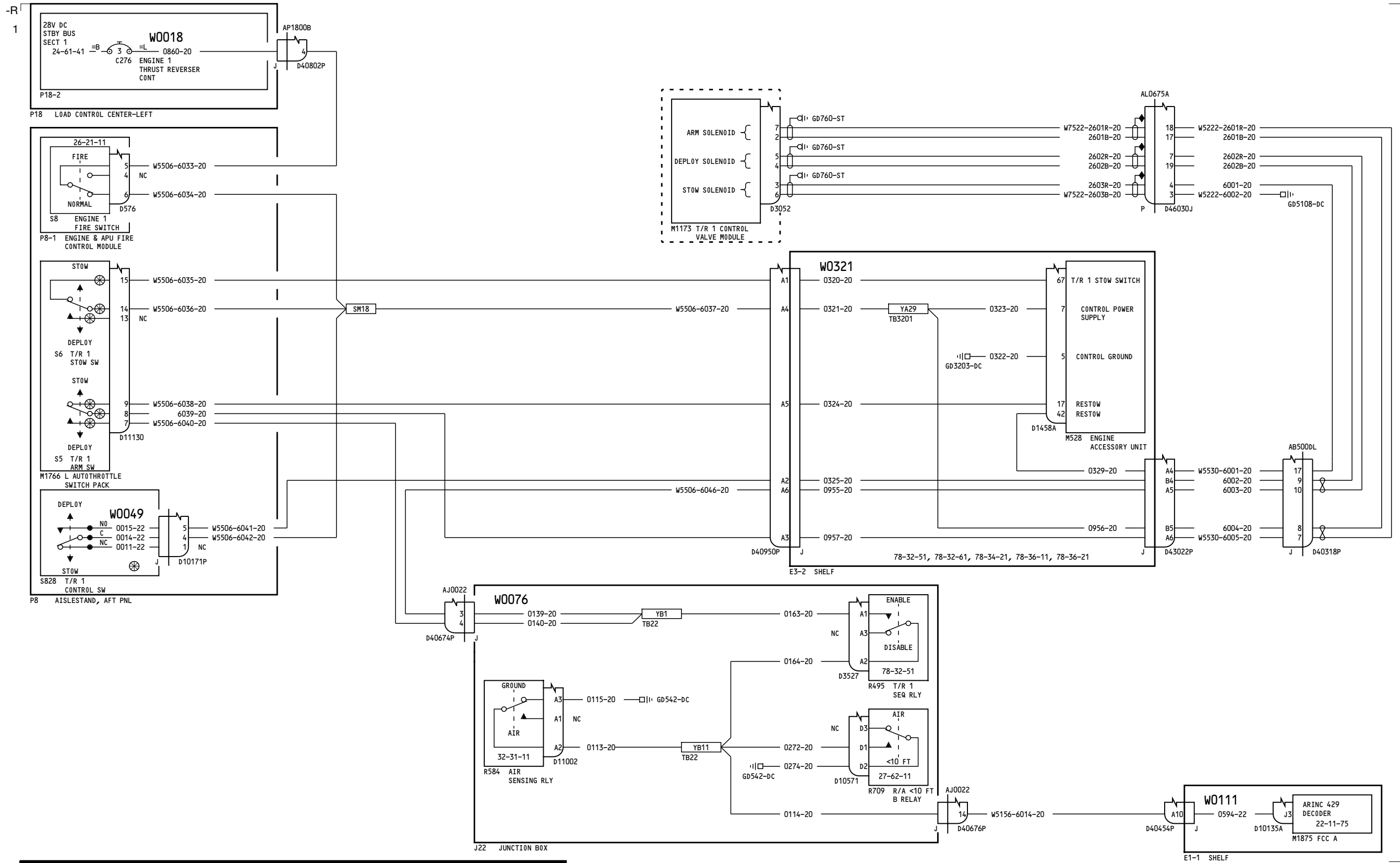

ALL

ENGINE 1 THRUST REVERSER CONTROL

D280A103

78-34-11

Page 1

Feb 09/2009

78-34-11

Page 1

Feb 09/2009

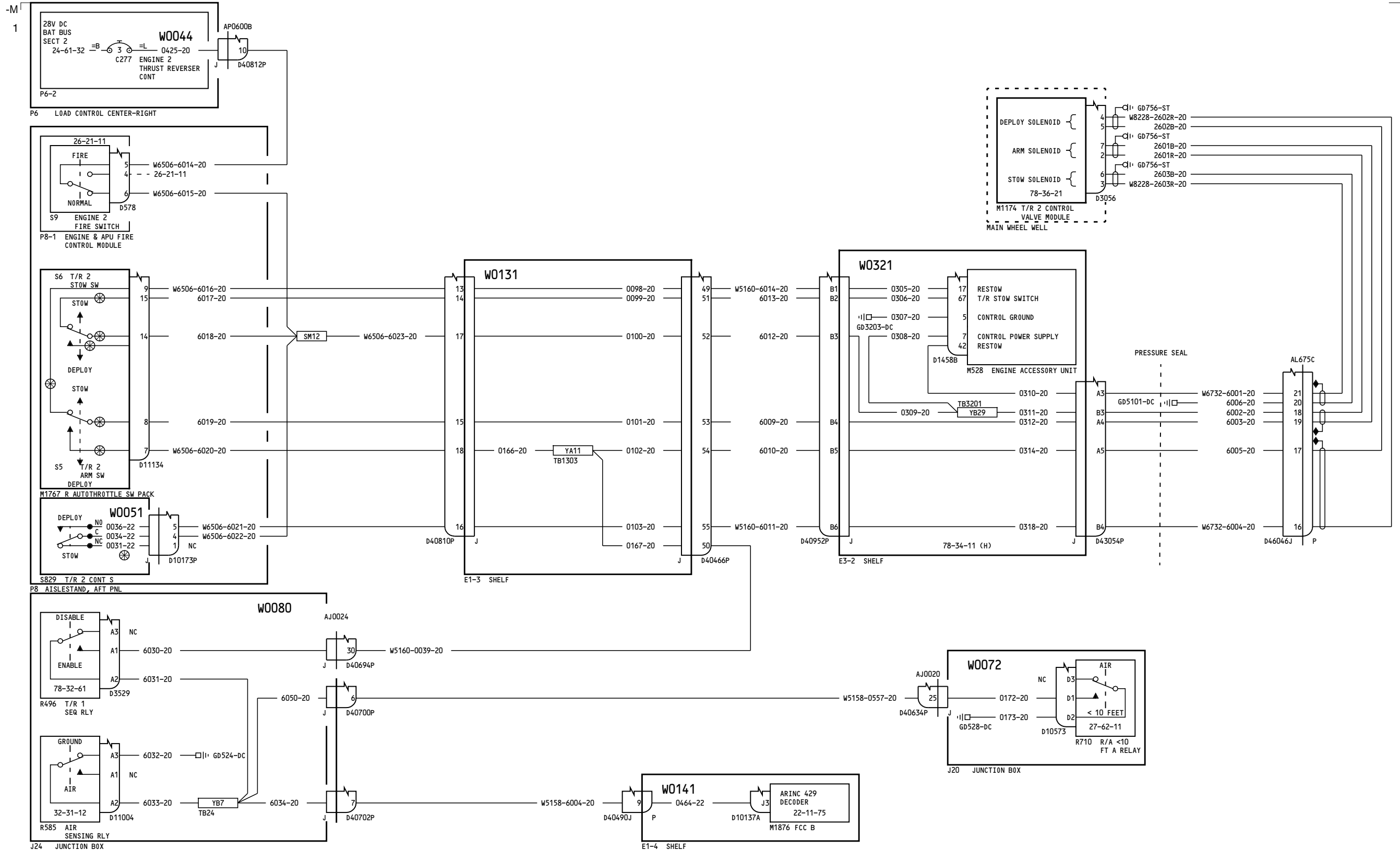

YC001-YC003

ENGINE 2 THRUST REVERSER CONTROL

78-34-21

Page 1

Aug 13/2008

D280A103

78-34-21

Page 1

Aug 13/2008

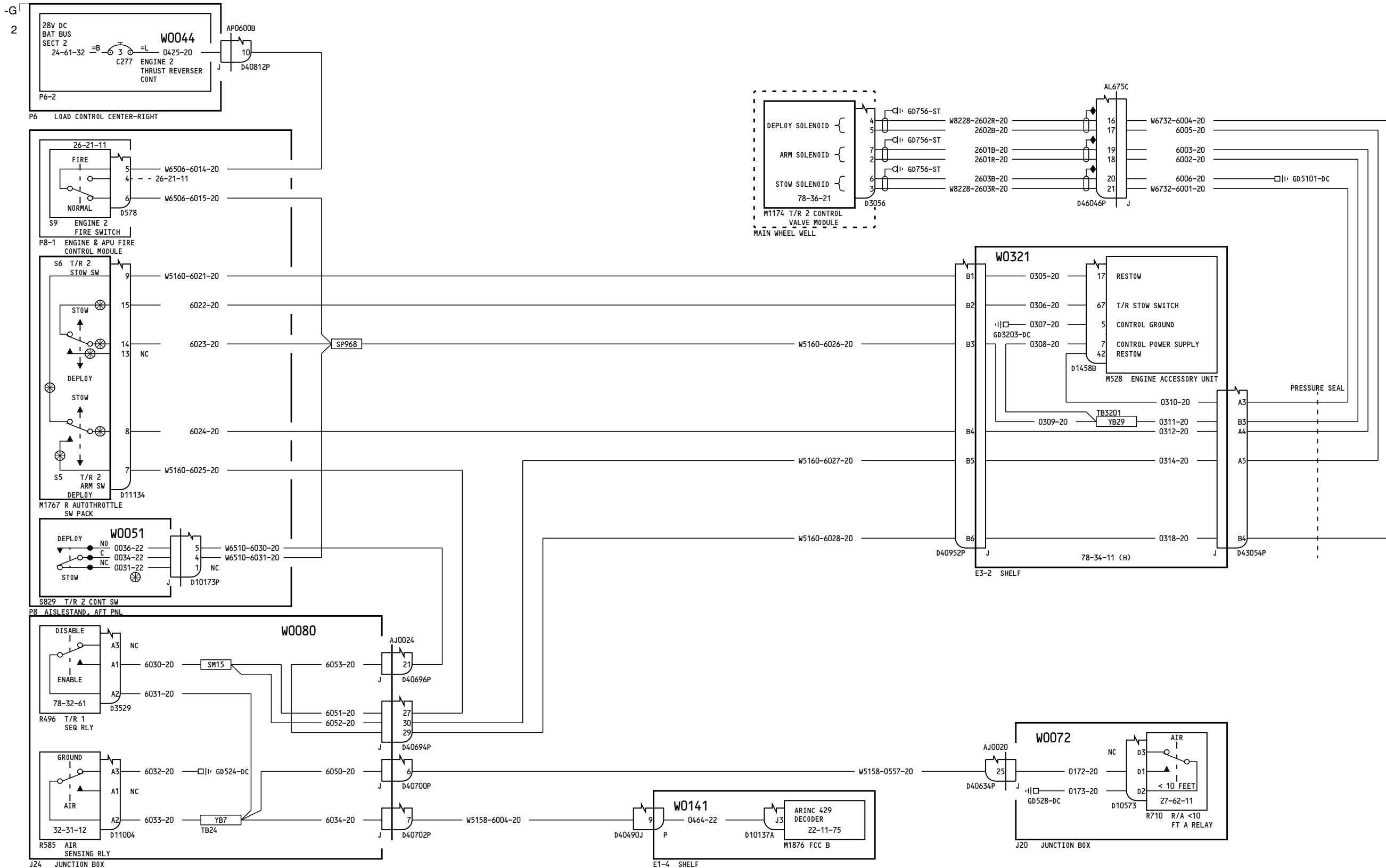

YC004-YC050

ENGINE 2 THRUST REVERSER CONTROL

78-34-21

Page 2

Aug 13/2008

D280A103

78-34-21

Page 2

Aug 13/2008

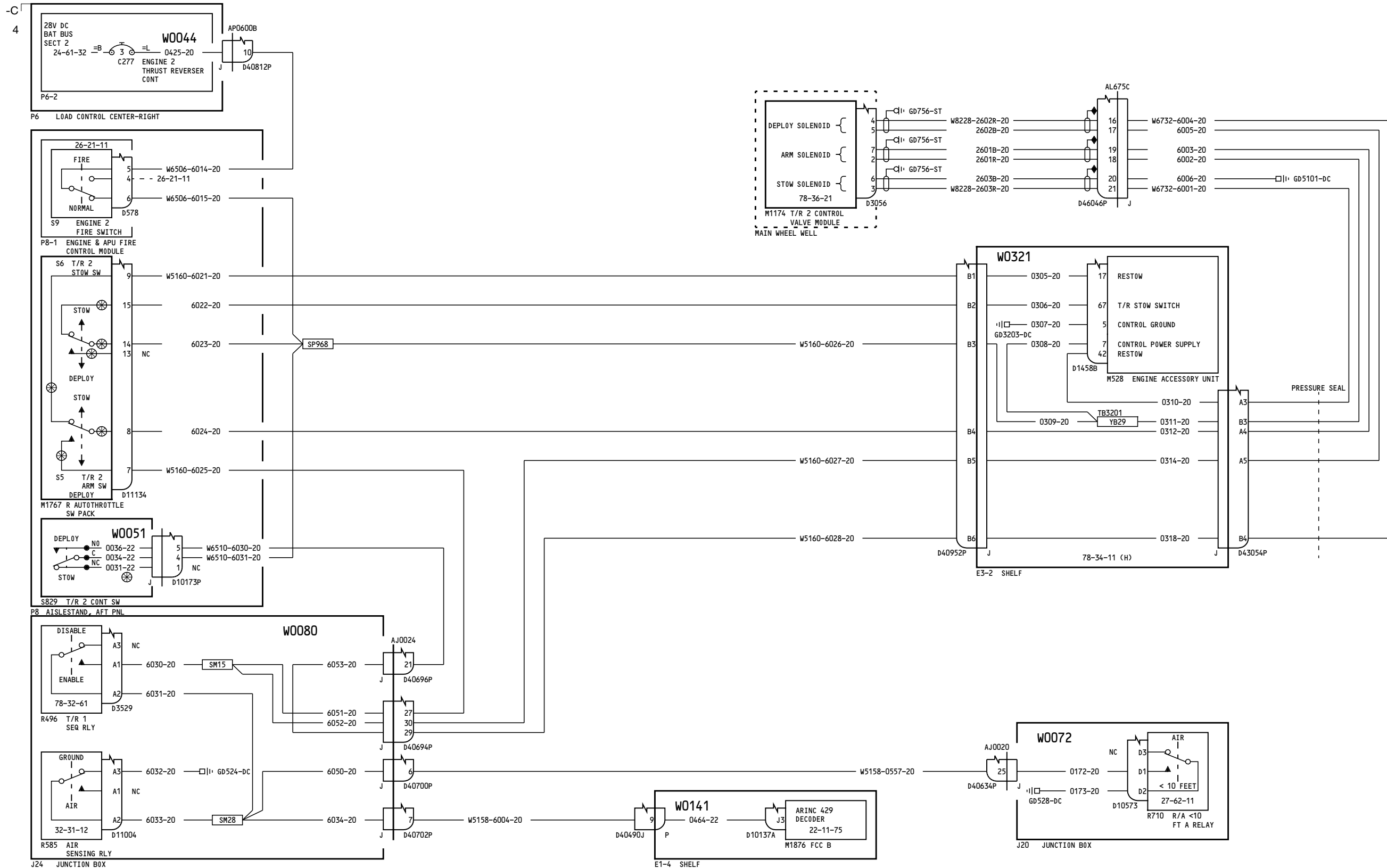

YK901-YM670

ENGINE 2 THRUST REVERSER CONTROL

78-34-21

Page 3

Feb 09/2009

D280A103

78-34-21

Page 3

Feb 09/2009

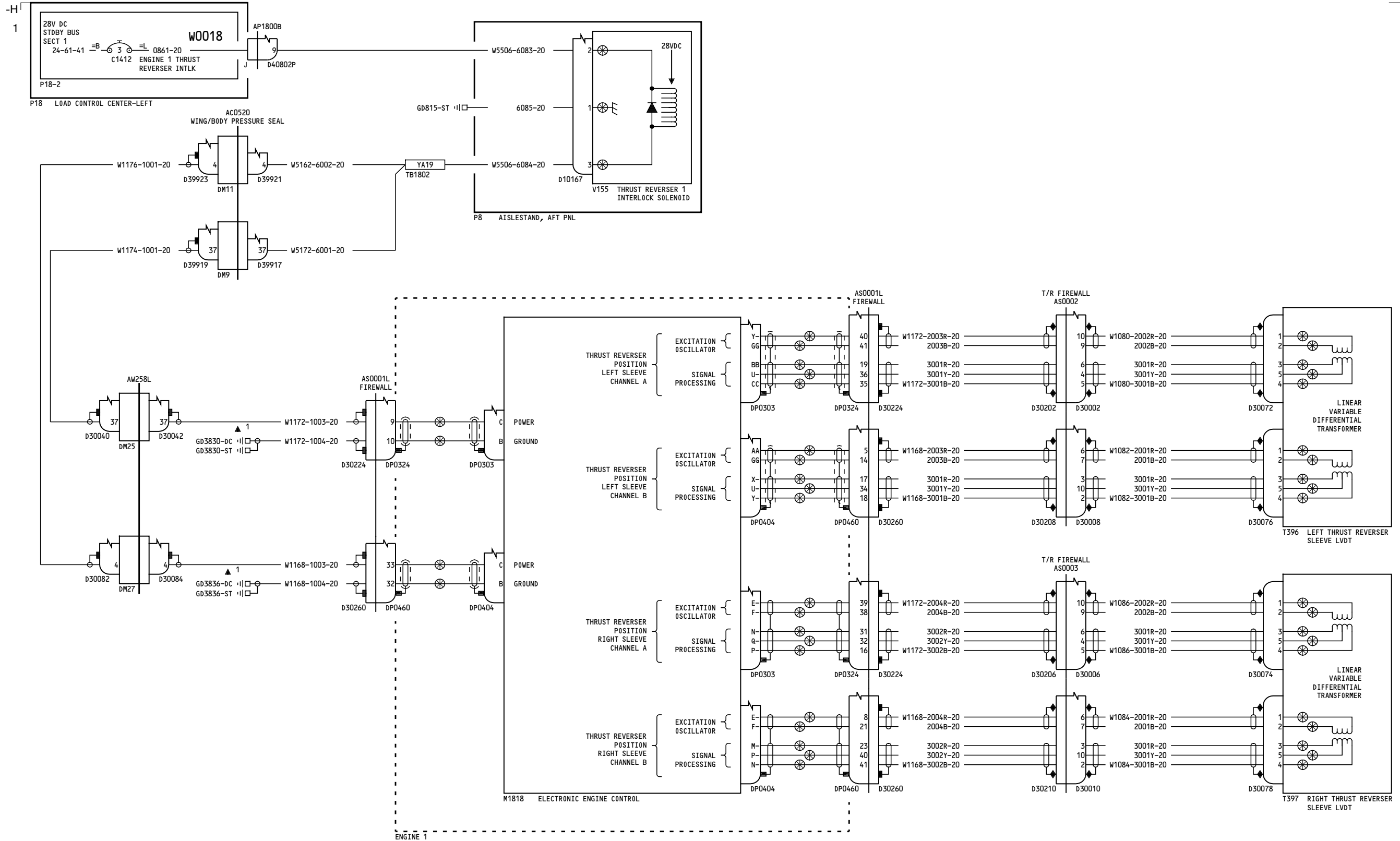

YC001-YC003

**ENGINE 1 THRUST REVERSER
POSITION / THRUST LEVER
INTERLOCK**

78-35-11

Page 1

D280A103

Mar 31/2005

78-35-11

Page 1

Mar 31/2005

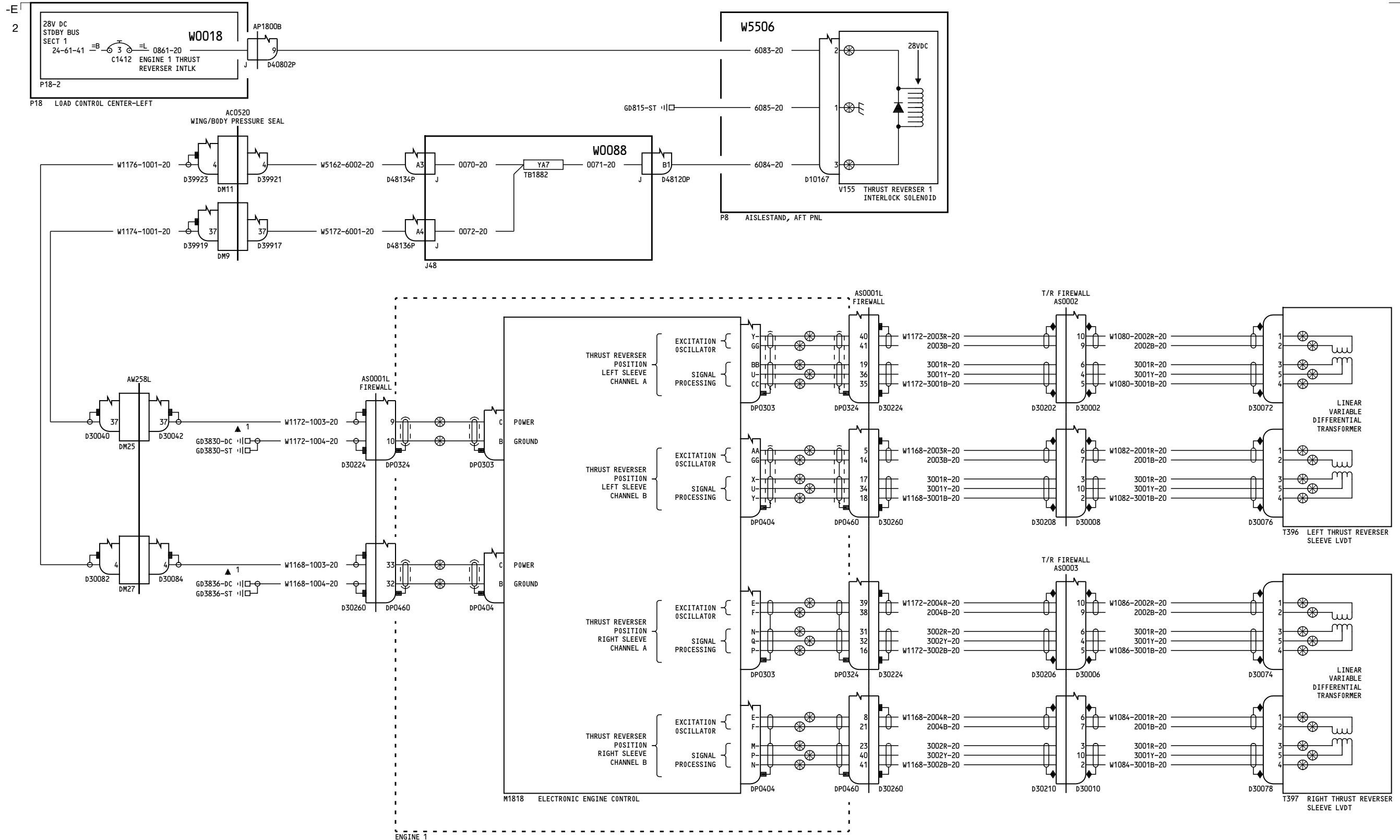

YC004-YC007

**ENGINE 1 THRUST REVERSER
POSITION / THRUST LEVER
INTERLOCK**

78-35-11

Page 2

D280A103

Mar 31/2005

78-35-11

Page 2

Mar 31/2005

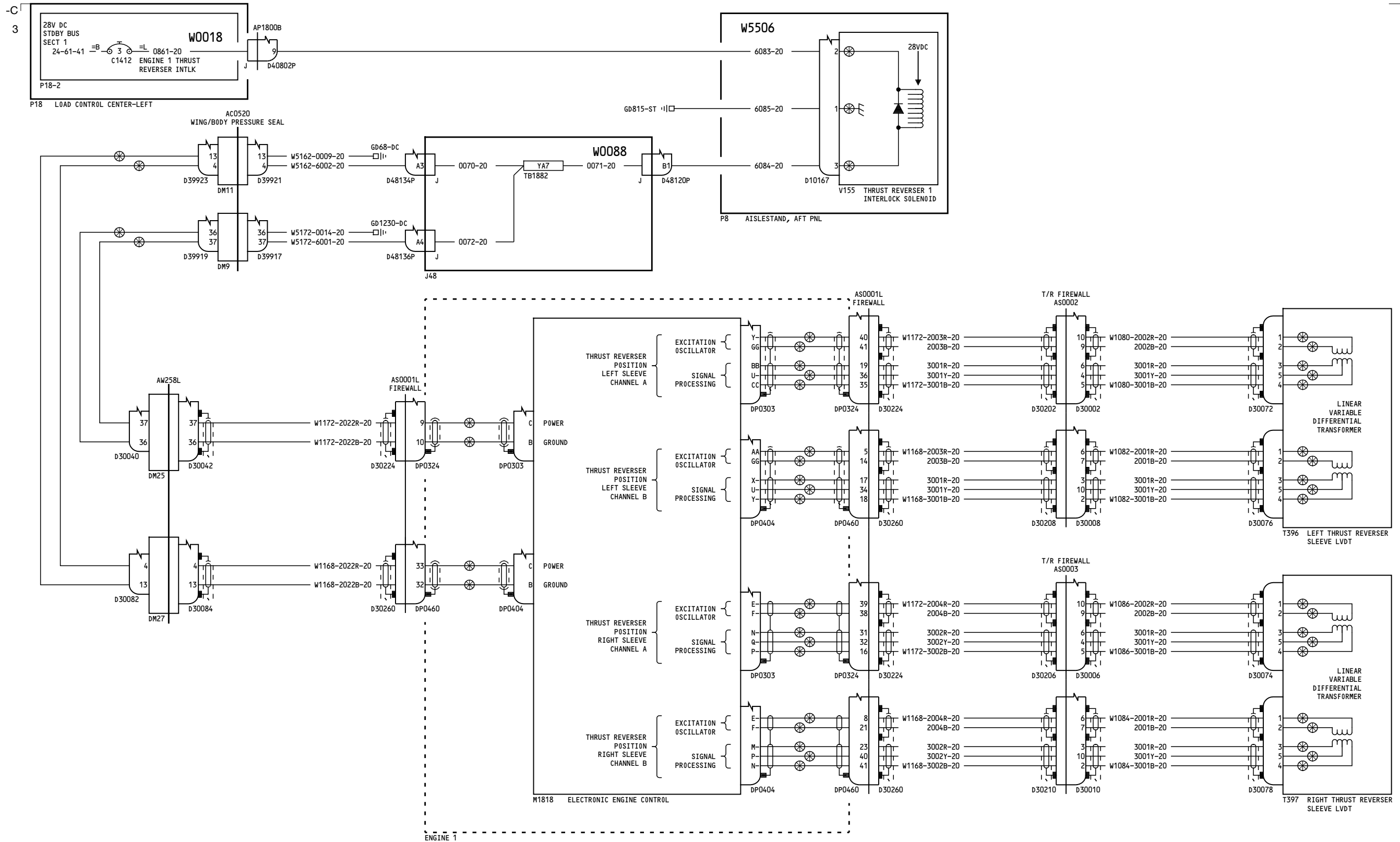

YC008-YM670

ENGINE 1 THRUST REVERSER POSITION / THRUST LEVER INTERLOCK

78-35-11

Page 3

D280A103

Feb 09/2009

78-35-11

Page 3

Feb 09/2009

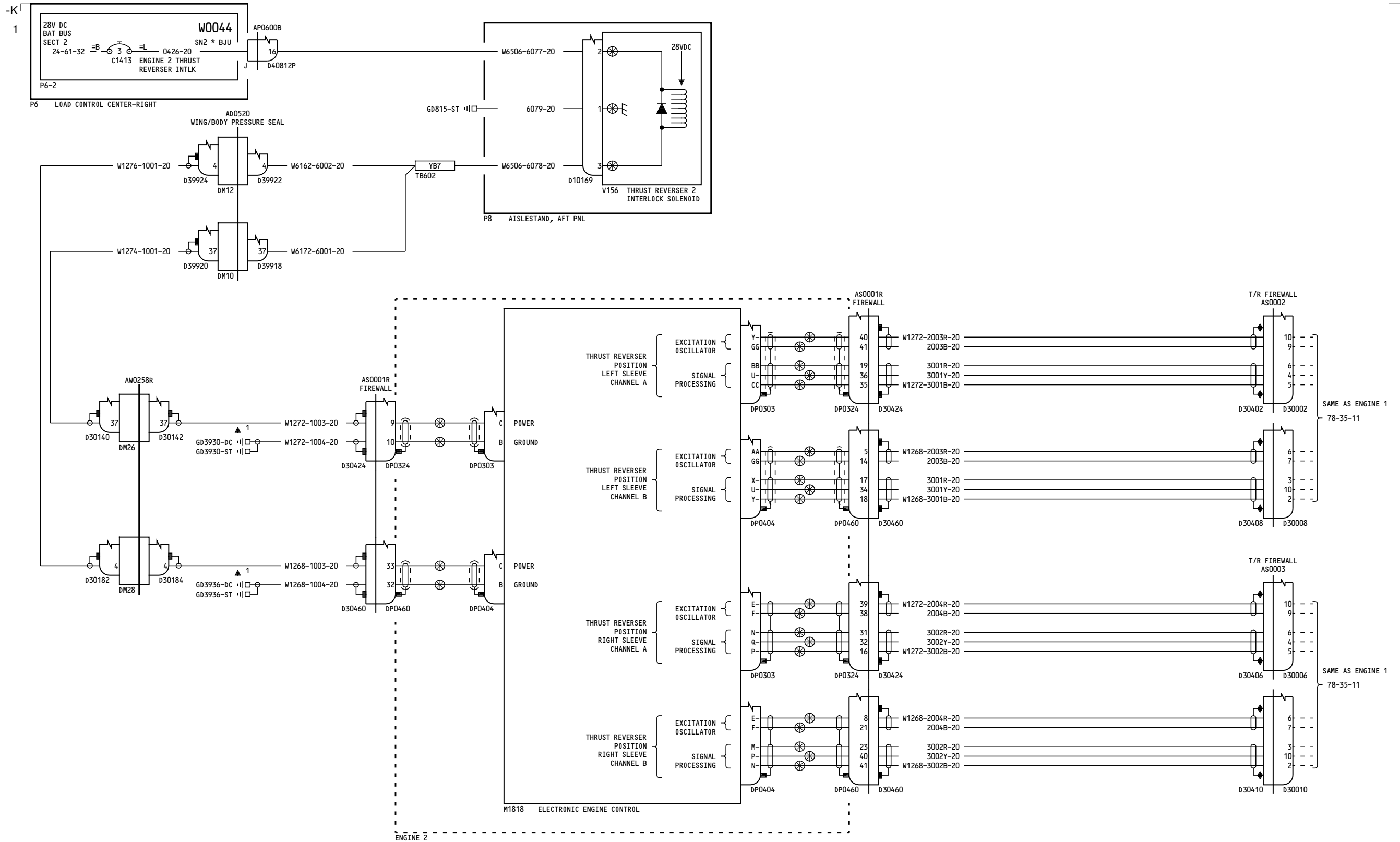

YC001-YC003

ENGINE 2 THRUST REVERSER POSITION / THRUST LEVER INTERLOCK

78-35-21

Page 1

D280A103

Mar 31/2005

78-35-21

Page 1

Mar 31/2005

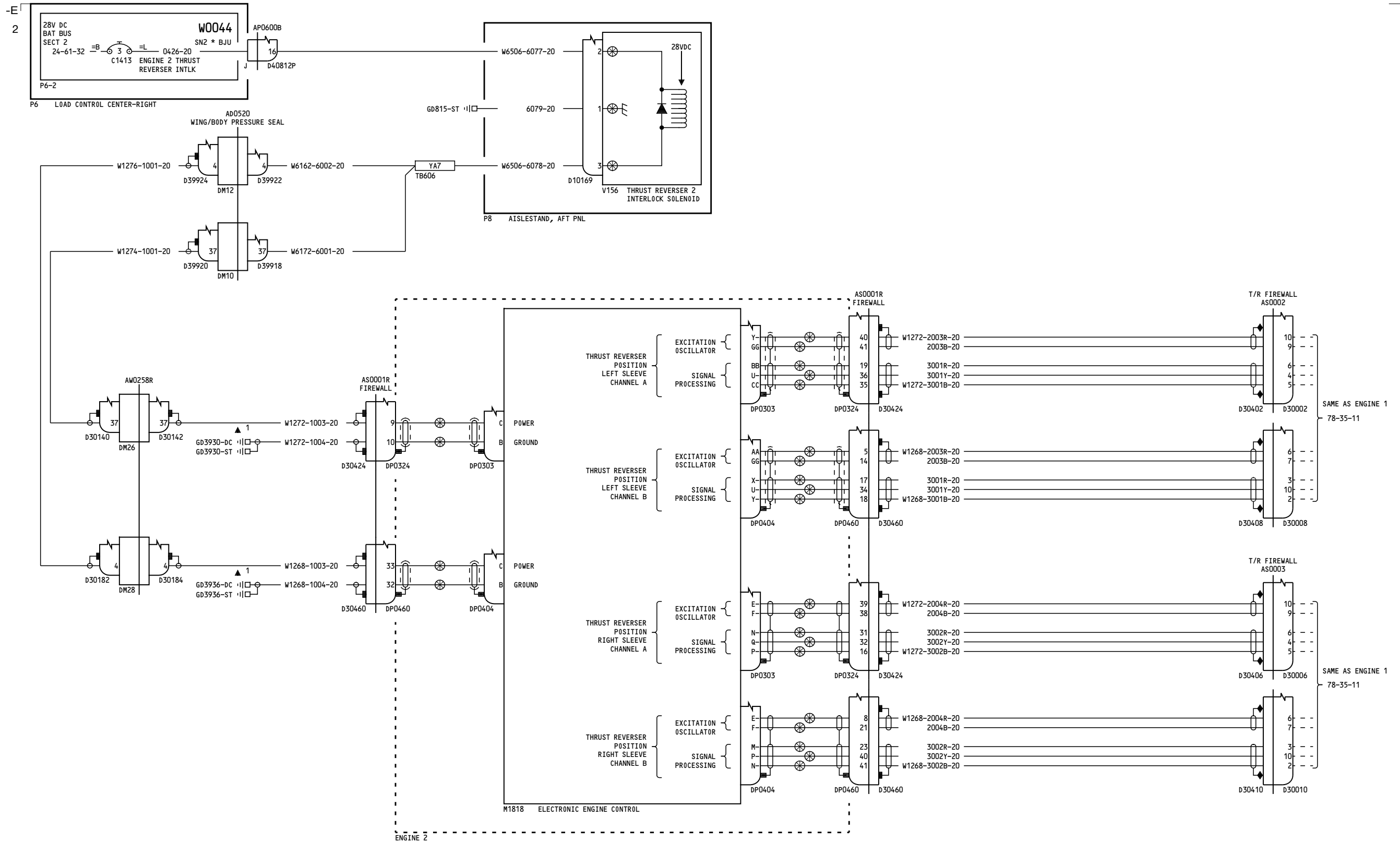

YC004-YC007

**ENGINE 2 THRUST REVERSER
POSITION / THRUST LEVER
INTERLOCK**

78-35-21

Page 2

D280A103

Mar 31/2005

78-35-21

Page 2

Mar 31/2005

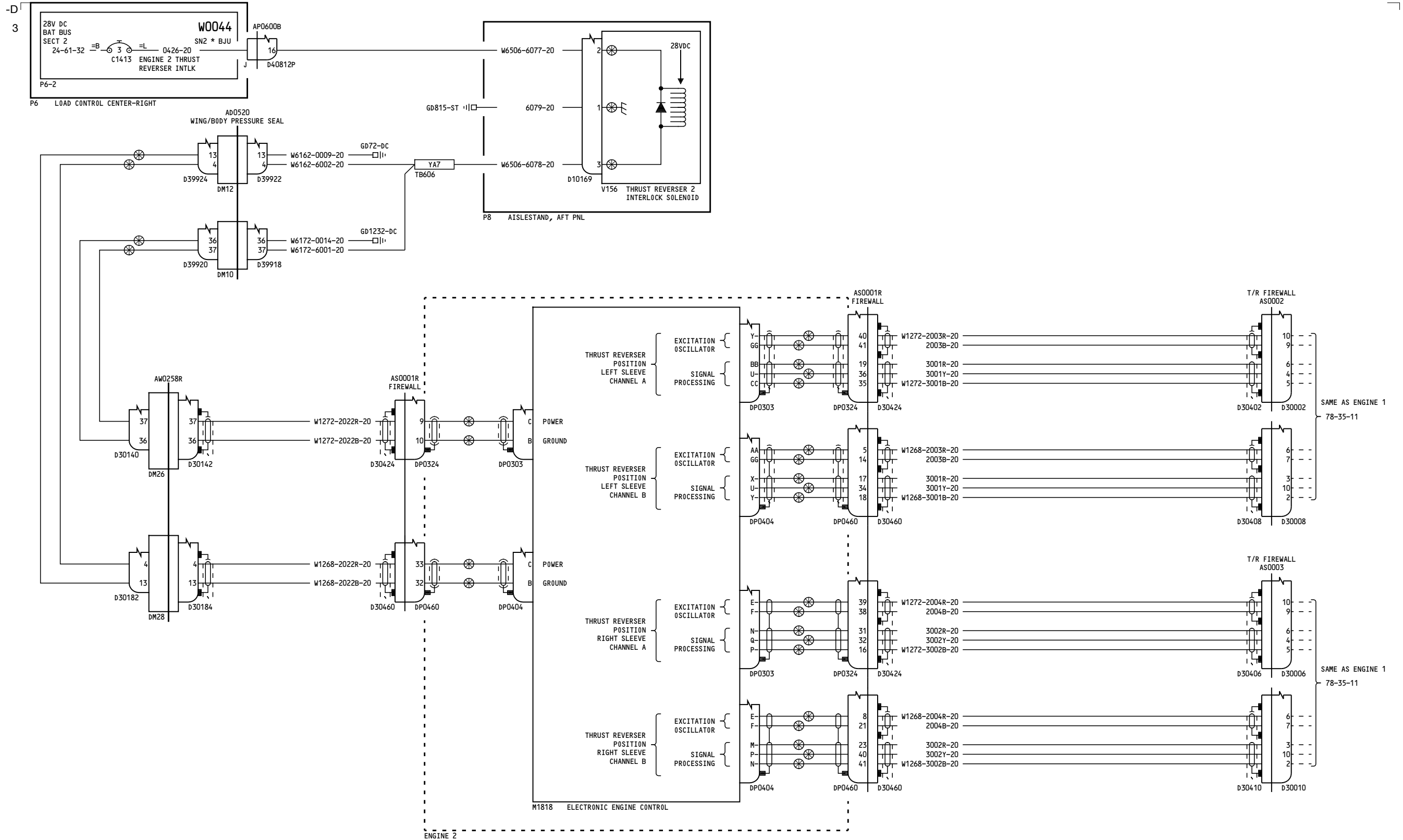

YC008-YM670

**ENGINE 2 THRUST REVERSER
POSITION / THRUST LEVER
INTERLOCK**

78-35-21

Page 3

D280A103

Feb 09/2009

78-35-21

Page 3

Feb 09/2009

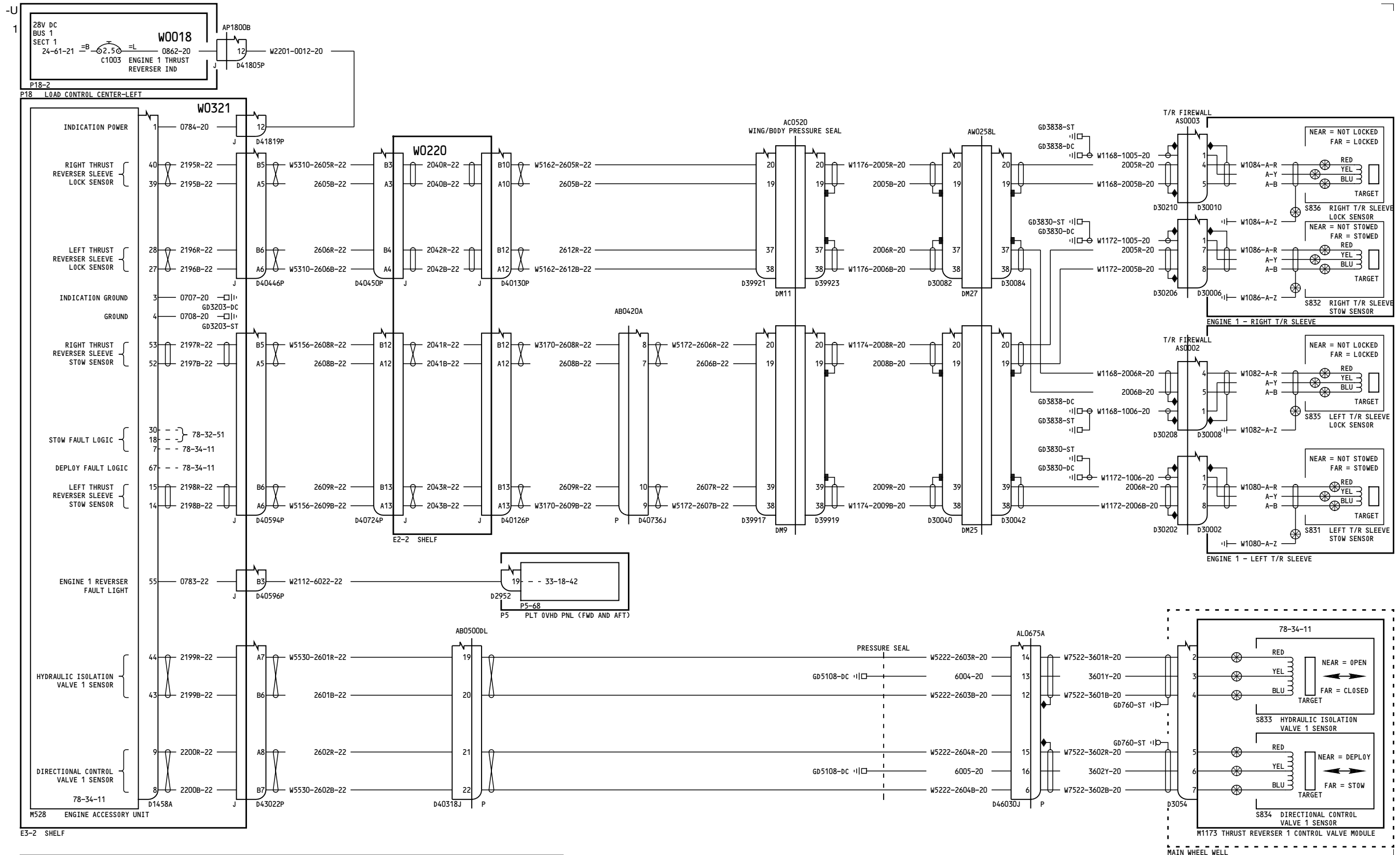

YC001-YC007

ENGINE 1 THRUST REVERSER FLIGHT DECK INDICATION

78-36-11

Page 1

D280A103

Mar 31/2005

78-36-11

Page 1

Mar 31/2005

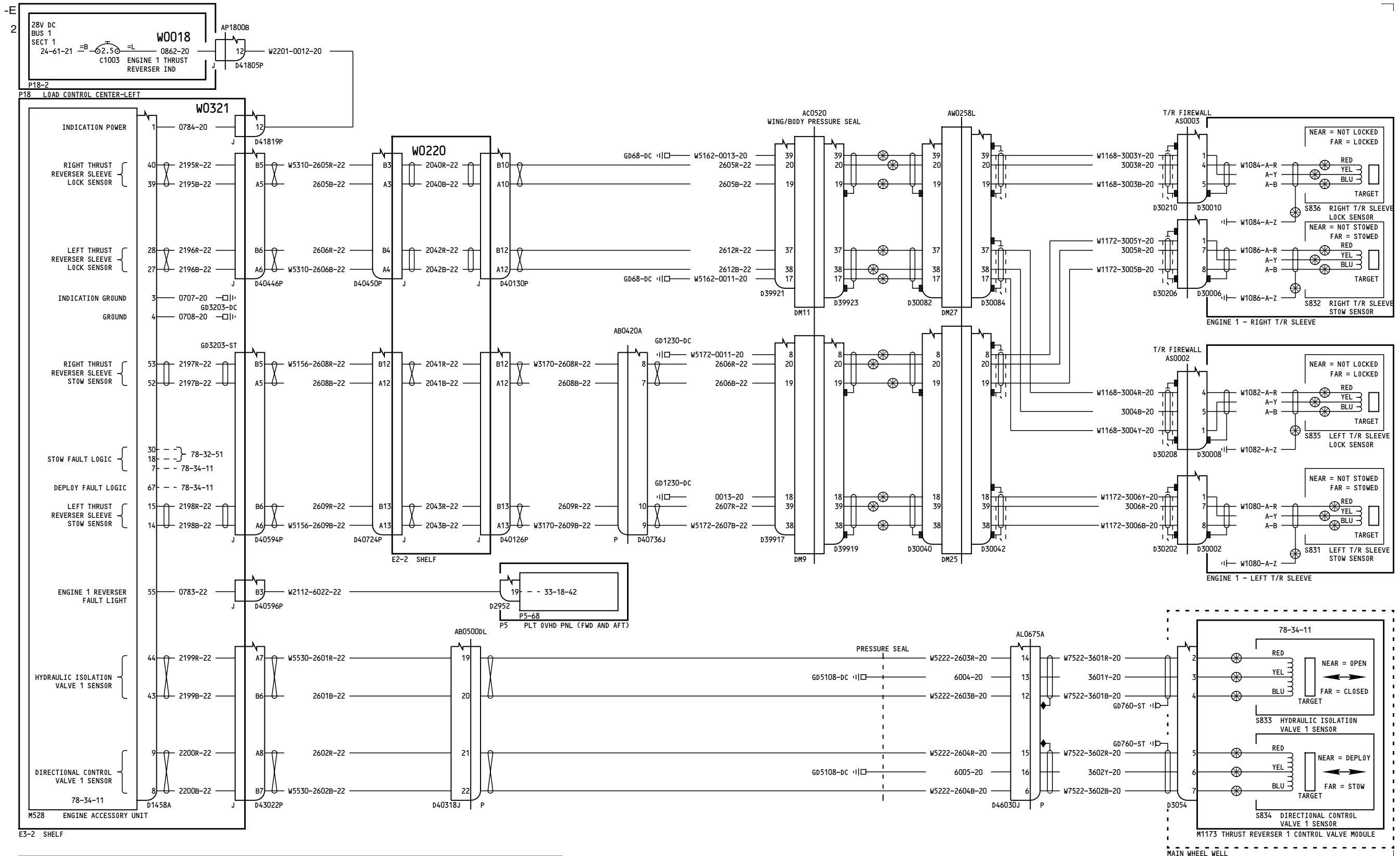

YC008-YM670

ENGINE 1 THRUST REVERSER FLIGHT DECK INDICATION

78-36-11

Page 2

D280A103

Feb 09/2009

78-36-11

Page 2

Feb 09/2009

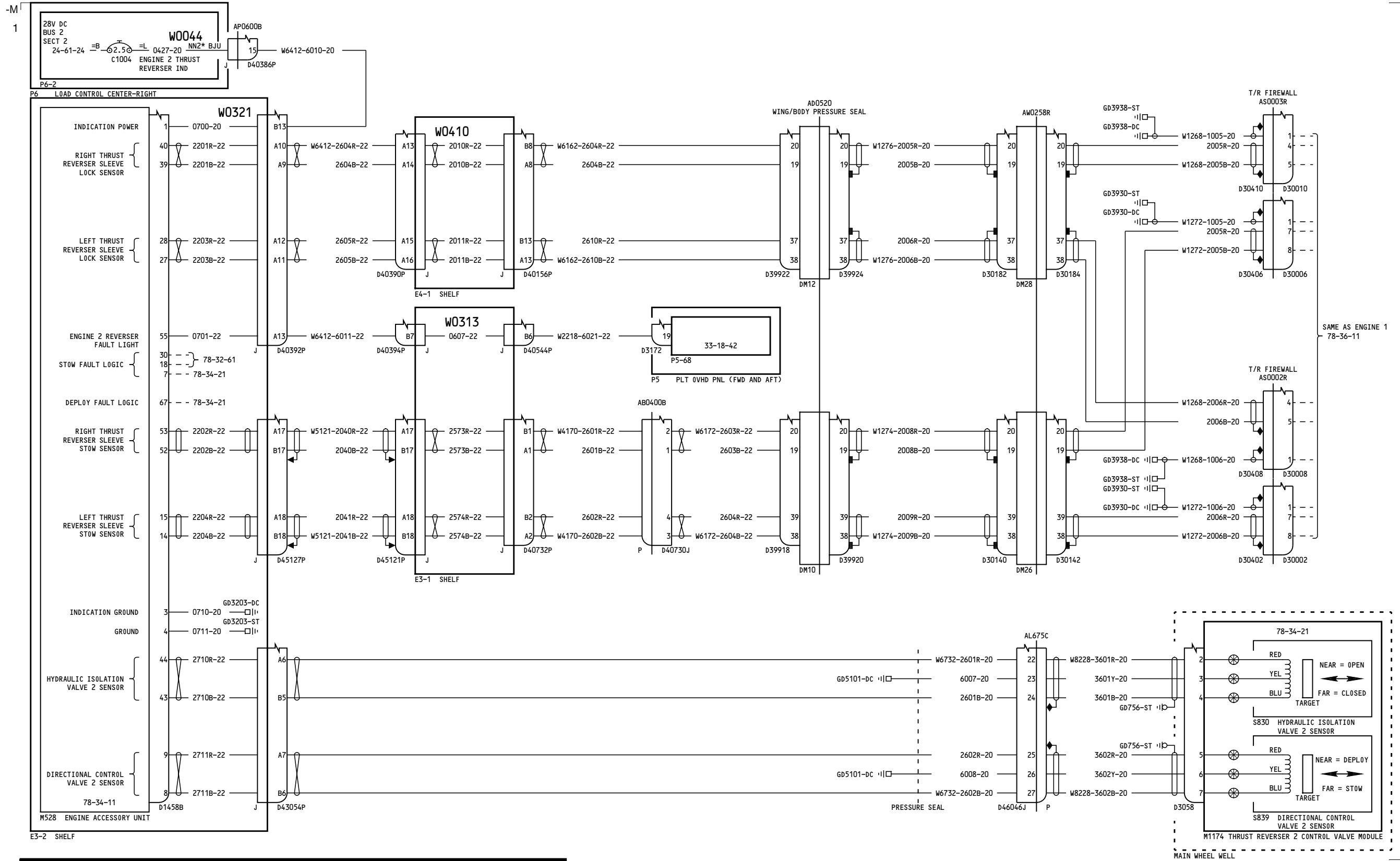

YC001-YC007

ENGINE 2 THRUST REVERSER FLIGHT DECK INDICATION

78-36-21

Page 1

D280A103

Mar 31/2005

78-36-21

Page 1

Mar 31/2005

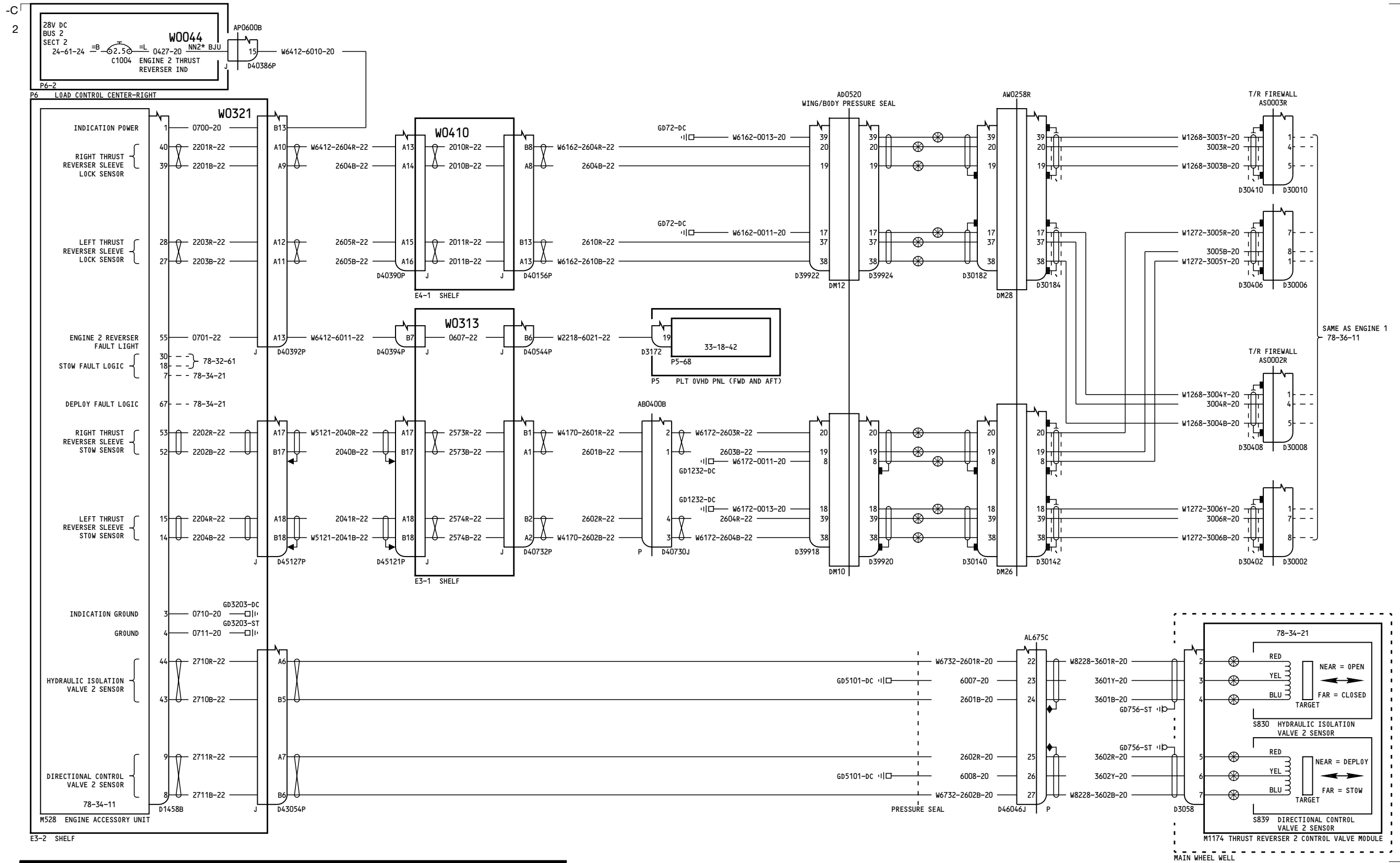

YC008-YM670

ENGINE 2 THRUST REVERSER FLIGHT DECK INDICATION

78-36-21

Page 2

D280A103

Feb 09/2009

78-36-21

Page 2

Feb 09/2009