

CHAPTER

79

OIL



737-700/800

WIRING DIAGRAM MANUAL

CHAPTER 79 OIL

CH-SC-SU	Schem	Page	Sheet	Date	CH-SC-SU	Schem	Page	Sheet	Date
79-EFFECTIVE PAGES									
		1		Aug 10/2009					
		2		BLANK					
79-CONTENTS									
		1		Feb 09/2009					
		2		BLANK					
79-ALPHABETICAL INDEX									
		1		Jan 18/2007					
		2		BLANK					
79-31-11									
		1		Feb 09/2009					
79-32-11									
		1		Feb 09/2009					
79-33-11									
		1		Feb 09/2009					
79-34-11									
		1		Feb 09/2009					

A = Added, R = Revised, D = Deleted, O = Overflow

79-EFFECTIVE PAGES

Page 1
Aug 10/2009

D280A103



737-700/800

WIRING DIAGRAM MANUAL

CHAPTER 79 OIL

Title	CH-SC-SU	Schem	Page	Sheet	Date	Effectivity
<u>OIL QUANTITY INDICATING SYSTEM</u>						
ENGINE OIL QUANTITY INDICATION	79-31-11		1		Feb 09/2009	ALL
<u>OIL PRESSURE INDICATING SYSTEM</u>						
ENGINE OIL PRESSURE INDICATION	79-32-11		1		Feb 09/2009	ALL
<u>LOW OIL PRESSURE WARNING SYSTEM</u>						
ENGINE OIL FILTER BYPASS WARNING	79-33-11		1		Feb 09/2009	ALL
<u>OIL TEMPERATURE INDICATING SYSTEM</u>						
ENGINE OIL TEMPERATURE INDICATION	79-34-11		1		Feb 09/2009	ALL

79-CONTENTS

Page 1
Feb 09/2009

D280A103



737-700/800

WIRING DIAGRAM MANUAL

CHAPTER 79 OIL

CH-SC-SU	Title
79-33-11	ENGINE OIL FILTER BYPASS WARNING
79-32-11	ENGINE OIL PRESSURE INDICATION
79-31-11	ENGINE OIL QUANTITY INDICATION
79-34-11	ENGINE OIL TEMPERATURE INDICATION

79-ALPHABETICAL INDEX

D280A103

Page 1
Jan 18/2007

-E

1

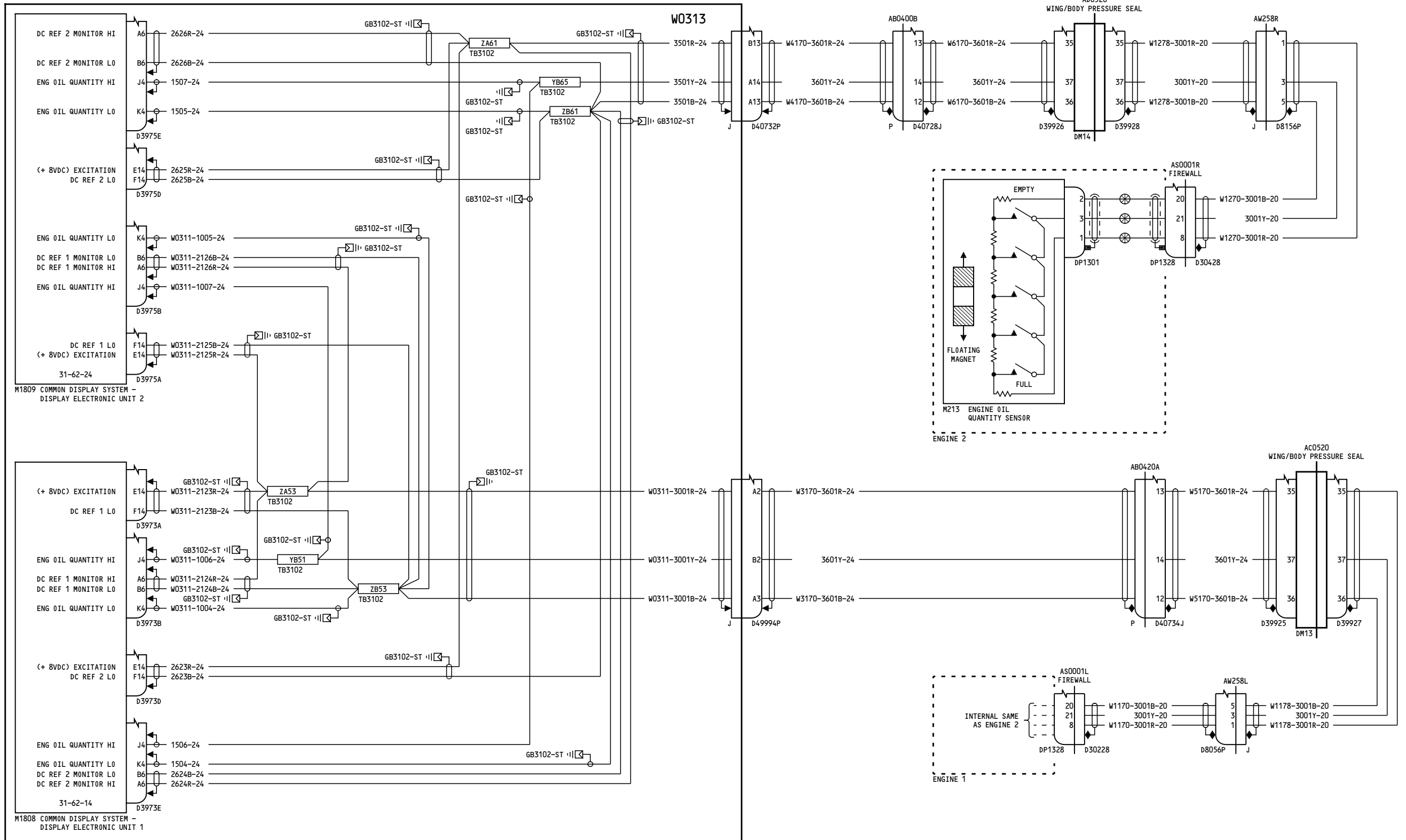

E3-1 SHELF

ALL

ENGINE OIL QUANTITY INDICATION

D280A103

79-31-11

Page 1

Feb 09/2009

79-31-11

Page 1

Feb 09/2009

-B

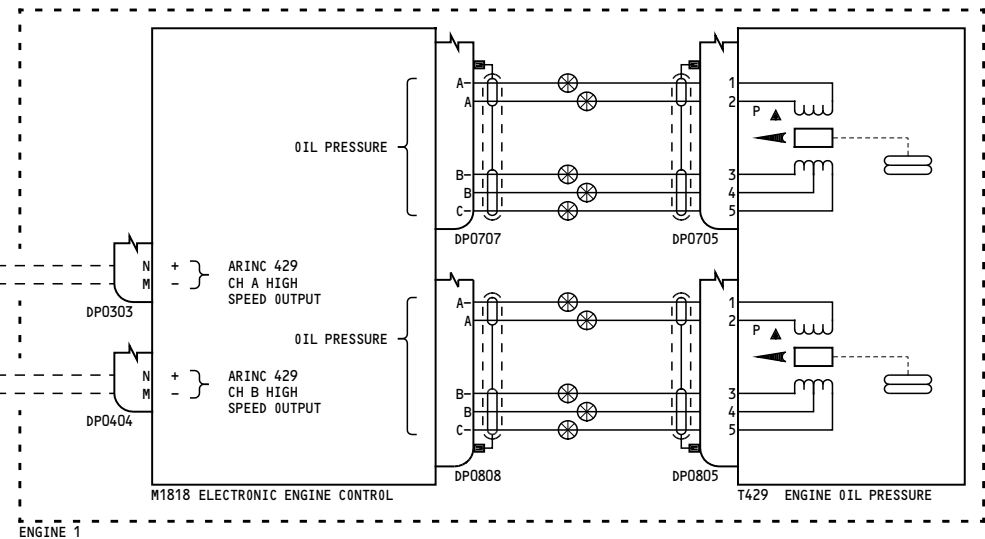
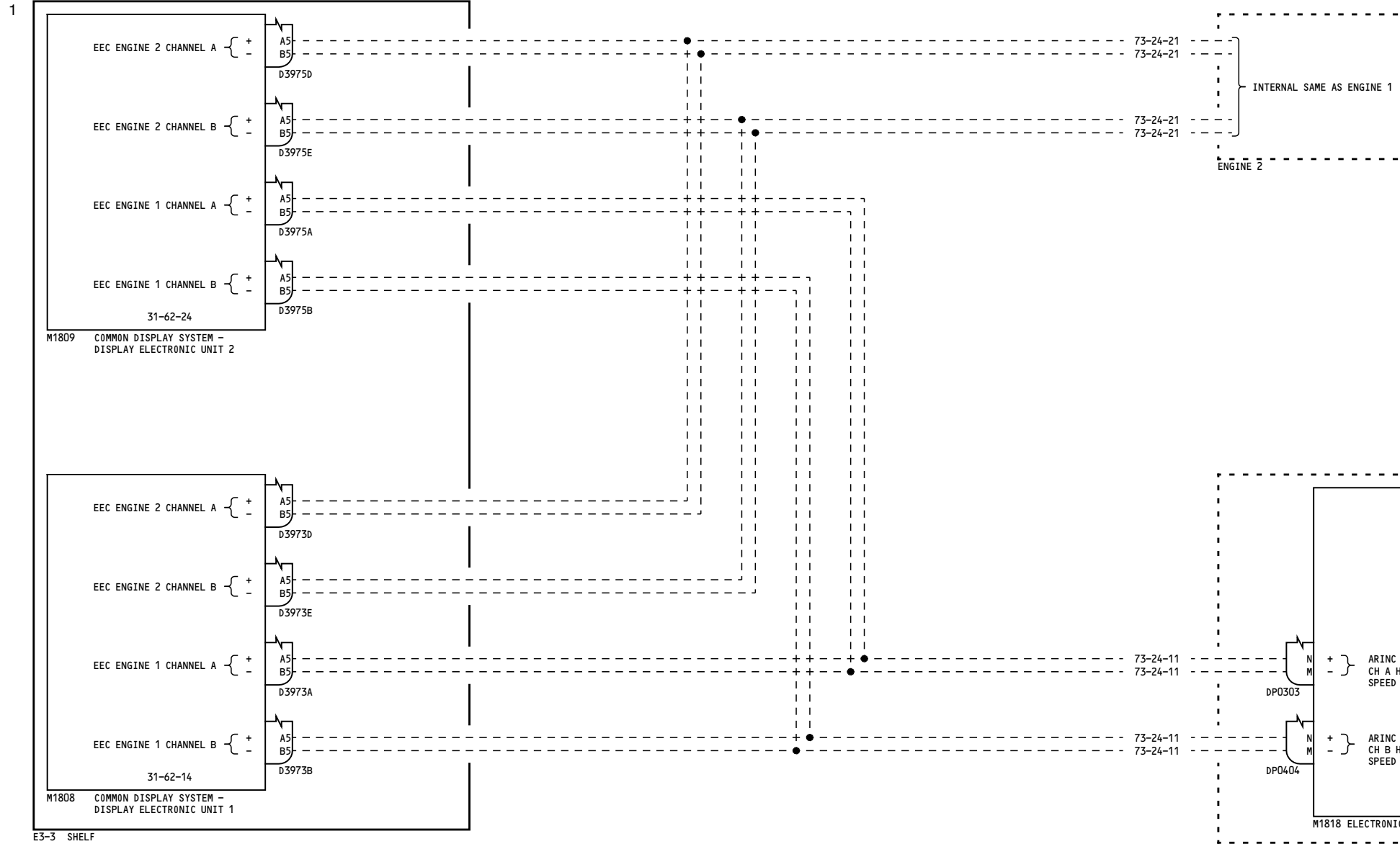

ALL	<p align="center">ENGINE OIL PRESSURE INDICATION</p> <p align="center">D280A103</p>
-----	--------------------------------------------------------------------------------------------

79-32-11

Page 1

Feb 09/2009

79-32-11

Page 1

Feb 09/2009

-C
1

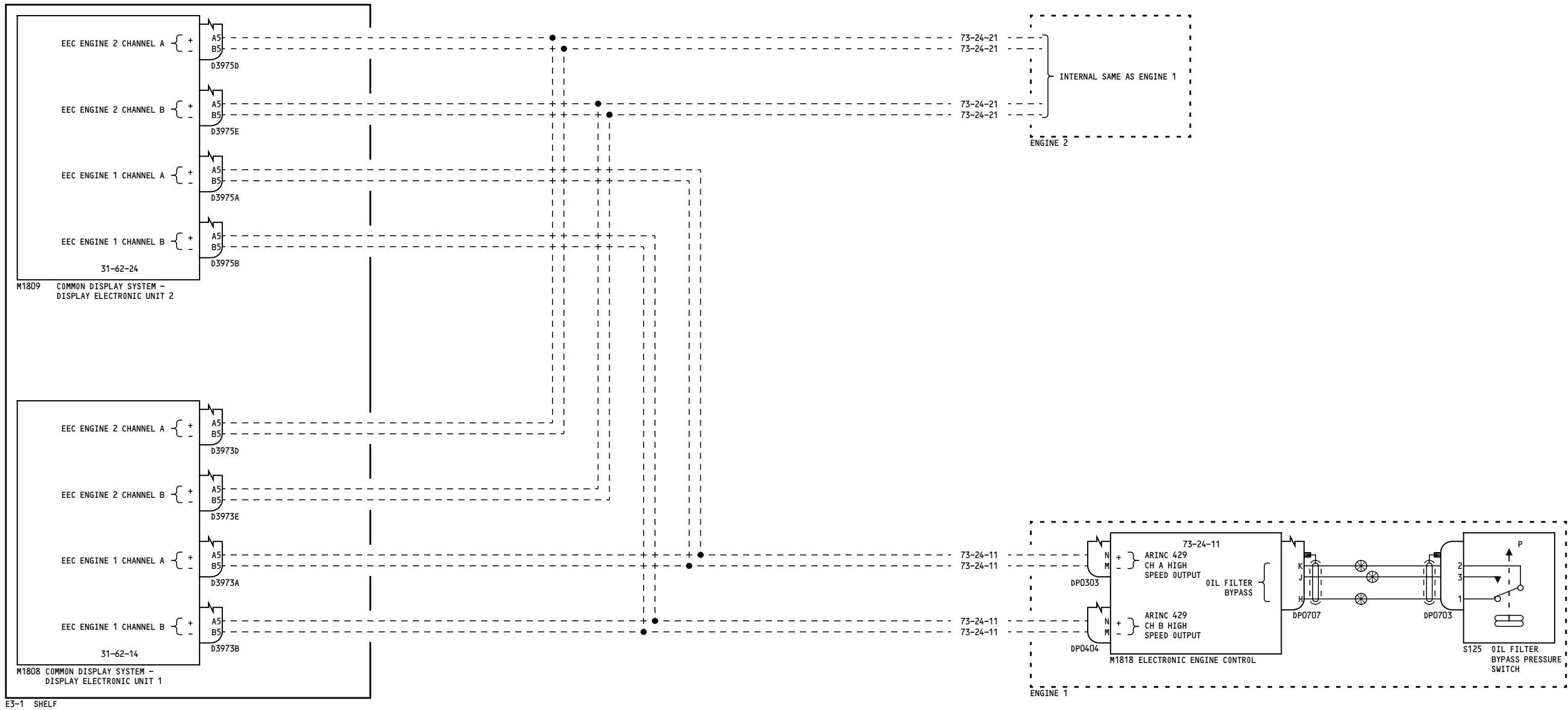

ALL

**ENGINE OIL FILTER
BYPASS WARNING**

79-33-11

Page 1

Feb 09/2009

D280A103

79-33-11

Page 1

Feb 09/2009

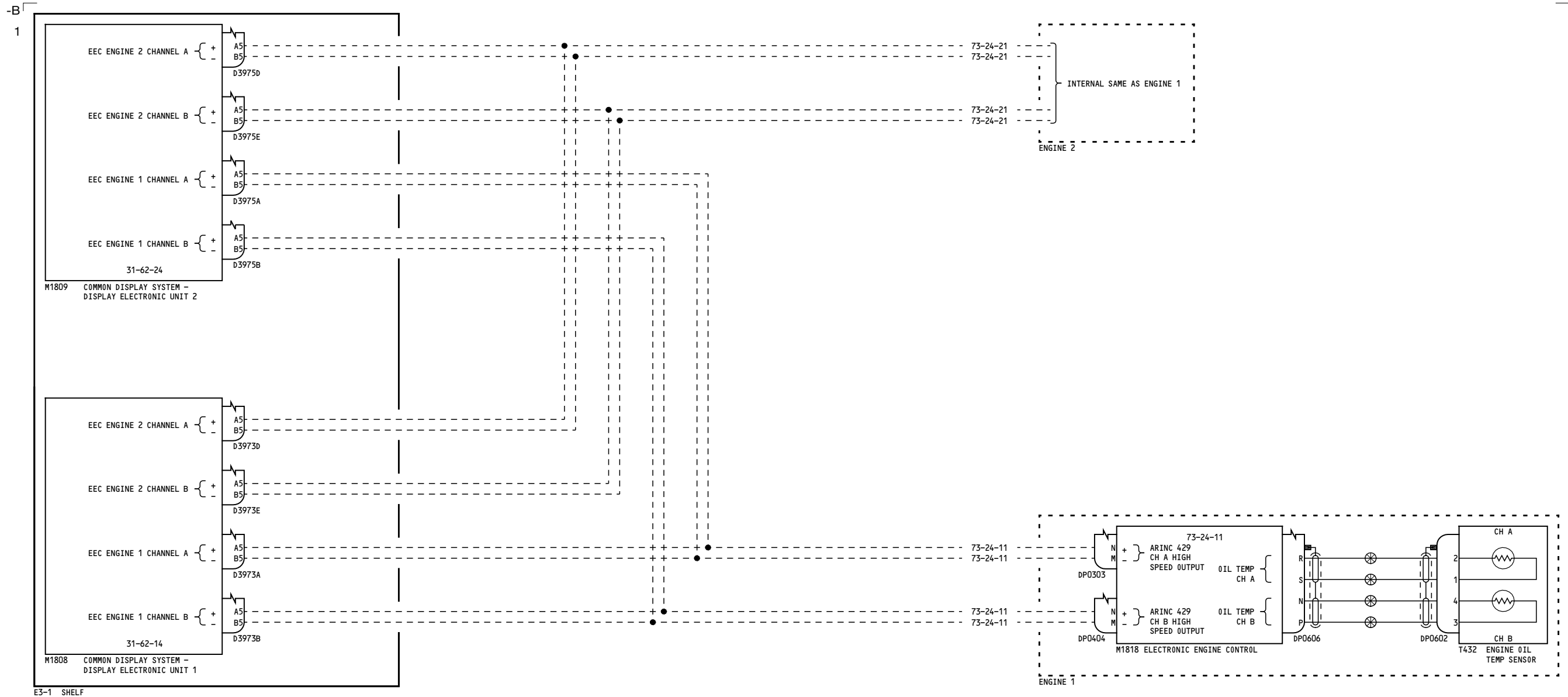

ALL

ENGINE OIL TEMPERATURE INDICATION

D280A103

79-34-11

Page 1

Feb 09/2009

79-34-11

Page 1

Feb 09/2009