



**737-600/700/800/900**

# **CFM56-7 Powerplant Buildup Manual**

## **TUI Airlines Nederland B.V.**

This document has EAR data with Export Control Classification Numbers (ECCN) of:  
9E991

Export of this technology is controlled under the United States Export Administration Regulations (EAR) (15 CFR 730-774). An export license may be required before it is used for development, production or use by foreign persons from specific countries. The controller of this data has the individual responsibility to abide by all export laws.

**BOEING PROPRIETARY, CONFIDENTIAL, AND/OR TRADE SECRET**

Copyright © 1996 The Boeing Company  
Unpublished Work - All Rights Reserved

Boeing claims copyright in each page of this document only to the extent that the page contains copyrightable subject matter. Boeing also claims copyright in this document as a compilation and/or collective work.

This document includes proprietary information owned by The Boeing Company and/or one or more third parties. Treatment of the document and the information it contains is governed by contract with Boeing. For more information, contact The Boeing Company, P.O. Box 3707, Seattle, Washington 98124.

Boeing, the Boeing signature, the Boeing symbol, 707, 717, 727, 737, 747, 757, 767, 777, 787, Dreamliner, BBJ, DC-8, DC-9, DC-10, MD-10, MD-11, MD-80, MD-88, MD-90, P-8A, Poseidon and the Boeing livery are all trademarks owned by The Boeing Company; and no trademark license is granted in connection with this document unless provided in writing by Boeing.

**DOCUMENT D633A106-HXL**

ORIGINAL ISSUE DATE: OCTOBER 5, 2007  
PUBLISHED BY BOEING COMMERCIAL AIRPLANES GROUP, SEATTLE, WASHINGTON, USA  
A DIVISION OF THE BOEING COMPANY  
PAGE DATE: Feb 05/2008



**737-600/700/800/900  
POWERPLANT BUILDUP MANUAL**

TUI Airlines Nederland B.V.  
HXL  
Revision No. 35  
Feb 05/2008

To: All holders of this Boeing Document D633A106-HXL

Attached is the current revision to the Boeing 737-600/700/800/900 CFM56-7 Powerplant Buildup Manual.

The CFM56-7 Powerplant Buildup Manual (PPBU) is furnished either as a printed manual, on microfilm, or digital products, or any combination of the three. This revision replaces all previous microfilm cartridges or digital products. All microfilm and digital products are reissued with all obsolete data deleted and all updated pages added.

For printed manuals, changes are indicated on the List of Effective Pages (LEP). The pages which are revised will be identified on the LEP by an R (Revised), A (Added), O (Overflow, i.e. changes to the document structure and/or page layout), or D (Deleted). The pages that contain customer originated data will be identified on the LEP by a C (COC). Each page in the LEP is identified by Chapter-Section-Subject number, page number and page date.

Pages replaced or made obsolete by this revision should be removed and destroyed.

ATTENTION

IF YOU RECEIVE PRINTED REVISIONS, PLEASE VERIFY THAT YOU HAVE RECEIVED AND FILED THE PREVIOUS REVISION. BOEING MUST BE NOTIFIED WITHIN 30 DAYS IF YOU HAVE NOT RECEIVED THE PREVIOUS REVISION. REQUESTS FOR REVISIONS OTHER THAN THE PREVIOUS REVISION WILL REQUIRE A COMPLETE MANUAL REPRINT SUBJECT TO REPRINT CHARGES SHOWN IN THE DATA AND SERVICES CATALOG.

**TRANSMITTAL LETTER**

Page 1  
Feb 05/2008

D633A106-HXL



**737-600/700/800/900**

## **POWERPLANT BUILDUP MANUAL**

### TEMPORARY REVISIONS

Remove any Temporary Revisions that have a date earlier than the date of this revision.

Do not remove any Temporary Revisions (TRs) that have a date later than the date of this revision. TRs with a later date will be incorporated into the next revision of the manual (unless they are superseded by a subsequent TR).

A TR status report is sent with each TR. The TR status report has a list of all TRs that were sent for this manual during the last two revision cycles. At the top of the list is the date and time that the list was created.

When you have more than one TR, the TR status report with the latest date and time gives you the most current information.

# **TRANSMITTAL LETTER**

Page 2  
Feb 05/2008

D633A106-HXL



737-600/700/800/900

## POWERPLANT BUILDUP MANUAL

<u>Location of Change</u>	<u>Description of Change</u>
<u>CHAPTER 71</u>	
71-00-02	
FIGURE 1-1	Changed the data to show current DB-REF references.
FIGURE 2-1	Changed the data to update the instructions to the PPBU manual.
FIGURE 3-1	Changed the data to show the correct part nomenclature of pin in ITEM 25 and correct paragraph format of pre instruction before item 70.
FIGURE 4-1	Changed the data clarify BACW10BP4ACU washer quantities.
FIGURE 5-1	Changed the data to show replacement part number for the BRACKET (item 330).
FIGURE 7-1	Changed the data to update the instructions to the PPBU manual.
FIGURE 10-1	Added the data to show "(REF)" to item 105 on illustration sheet 7.
FIGURE 13-1	Changed the data to update the instructions to the PPBU manual. Changed the data to update the torque requirement.
FIGURE 16-1	Changed the data to update the instructions to the PPBU manual.
FIGURE 22-1	Changed the data to show current DB-REF references. Changed the data to place item 60 under the pre-instruction for AEW&C Airplanes. Changed pre-instruction from AEW&C to AEW&C AIRPLANES.
FIGURE 25-1	Changed the data to update the instructions to the PPBU manual.
FIGURE 27-1	Changed the data to update the instructions to the PPBU manual.
FIGURE 28-1	Added the data to show latest detector installation configuration with CFM56-7B SB72-0258.
FIGURE 29-1	Changed the data to show new part number for the WIRE BUNDLE (item 5).
FIGURE 31-1	Changed the data to update the instructions to the PPBU manual.
FIGURE 32-1	Changed the data to clarify bolt installation.

## HIGHLIGHTS



**737-600/700/800/900  
POWERPLANT BUILDUP MANUAL**

Subject/Page	Date	COC	Subject/Page	Date	COC	Subject/Page	Date	COC
TITLE PAGE			INTRODUCTION (cont)			NUMERICAL INDEX (cont)		
O 1	Feb 05/2008		22	Oct 05/2007		O 30	Feb 05/2008	
2	BLANK		23	Oct 05/2007				
TRANSMITTAL LETTER			24	Oct 05/2007				
R 1	Feb 05/2008		25	Oct 05/2007				
R 2	Feb 05/2008		26	BLANK				
HIGHLIGHTS			INSTALLATION INDEX					
A 1	Feb 05/2008		1	Oct 05/2007				
A 2	BLANK		2	Oct 05/2007				
EFFECTIVE PAGES			NUMERICAL INDEX					
1	Feb 05/2008		1	Oct 05/2007				
2	BLANK		2	Oct 05/2007				
REVISION RECORD			3	Oct 05/2007				
1	Oct 05/2007		4	Oct 05/2007				
2	Oct 05/2007		5	Oct 05/2007				
RECORD OF TEMPORARY REVISIONS			6	Oct 05/2007				
1	Oct 05/2007		7	Oct 05/2007				
2	Oct 05/2007		8	Oct 05/2007				
INTRODUCTION			9	Oct 05/2007				
1	Oct 05/2007		10	Oct 05/2007				
2	Oct 05/2007		11	Oct 05/2007				
3	Oct 05/2007		12	Oct 05/2007				
4	Oct 05/2007		13	Oct 05/2007				
5	Oct 05/2007		14	Oct 05/2007				
6	Oct 05/2007		15	Oct 05/2007				
7	Oct 05/2007		16	Oct 05/2007				
8	Oct 05/2007		17	Oct 05/2007				
9	Oct 05/2007		18	Oct 05/2007				
10	Oct 05/2007		19	Oct 05/2007				
11	Oct 05/2007		20	Oct 05/2007				
12	Oct 05/2007		21	Oct 05/2007				
13	Oct 05/2007		R 22	Feb 05/2008				
14	Oct 05/2007		O 23	Feb 05/2008				
15	Oct 05/2007		O 24	Feb 05/2008				
16	Oct 05/2007		O 25	Feb 05/2008				
R 17	Feb 05/2008		O 26	Feb 05/2008				
O 18	Feb 05/2008		R 27	Feb 05/2008				
R 19	Feb 05/2008		R 28	Feb 05/2008				
20	Oct 05/2007		O 29	Feb 05/2008				
21	Oct 05/2007							

A = Added, R = Revised, O = Overflow, D = Deleted, C = Customer Originated Change

## EFFECTIVE PAGES













# 737-600/700/800/900 POWERPLANT BUILDUP MANUAL

## INTRODUCTION

### 1. General

- A. The 737-600/700/800/900 CFM56-7 series Powerplant Buildup Manual provides procedures for installing a Boeing QEC kit on a CFM56-7 series engine.
- (1) The manual is divided into four major sections: Front Matter, 71-00-02 Powerplant Buildup, 71-00-03 QEC System Tests, and 71-00-04 QEC Inspection/Check.
  - (2) Section Front Matter contains these items:
    - (a) Description of major characteristics of the powerplant
    - (b) Usage instructions for this manual
    - (c) List of special tools, fixtures, and equipment used in this manual
    - (d) List of vendor names and addresses
    - (e) List of all consumable materials used in this manual
    - (f) A summary of applicable standard practices
    - (g) An index which lists all installation tasks in the manual in alphanumerical sequence by title, and
    - (h) A numerical index which lists all part numbers contained in each installation parts list.
  - (3) Section 71-00-02 Powerplant Buildup contains these items:
    - (a) An illustrated installation index of all buildup installations in order of accomplishment.
    - (b) Parts lists and procedures to build up a basic engine into a demountable powerplant.
  - (4) Section 71-00-03 QEC System Test contains procedures that are used to test the installed components before engine installation on an airplane.
  - (5) Section 71-00-04 QEC Inspection/Check contains general inspection/check procedures for QEC components.
- B. Abbreviations and terms used in this manual are defined below as follows:

**Table 1:**

<b>ABBREVIATION</b>	<b>DEFINITION</b>
AEW&C	Airborne Early Warning and Control
AGB	Accessory Gearbox
ASSY	Assembly
BIFUR	Bifurcation
BLD	Bleed
BRKT	Bracket
BTWN	Between
CFMI	Commercial Fan Moteur International
CON	Consumable
CONFIG	Configuration
C/L	Centerline
CONT	Control or Continued
COMP	Compressor

# INTRODUCTION



737-600/700/800/900  
**POWERPLANT BUILDUP MANUAL**

(Continued)

<b>ABBREVIATION</b>	<b>DEFINITION</b>
CSK	Countersink/Countersunk
CRES	Corrosion Resistant Steel
CW	Clockwise
DAC	Double Annular Combustor
DEL	Deleted
DET	Detector, Detection
DIM	Dimension
DN	Down
DR	Drain
EEC	Electronic Engine Control
ELEC	Electrical
ENG	Engine
EXH	Exhaust
EXT	Extension
FIG	Figure
FLG	Flange
FLT	Flight
FTG	Fitting
FURN	Furnished
FWD	Forward
GE	General Electric
GRD	Ground
GSE	Ground Support Equipment
HDWR	Hardware
HMU	Hydro/Mechanical Unit
HORIZ	Horizontal
HPT	High Pressure Turbine
HYD	Hydraulic
ID	Inner Diameter
IDG	Integrated Drive Generator
INBD	Inboard
INCLD	Included
INSTL	Install
INSTLD	Installed
INSTLN	Installation

## **INTRODUCTION**



737-600/700/800/900

## POWERPLANT BUILDUP MANUAL

(Continued)

ABBREVIATION	DEFINITION
LB-FT	Pound-Feet (Torque)
LB-IN	Pound-Inches (Torque)
LH, LFT	Left
LTD	Limited
LPT	Low Pressure Turbine
LWR	Lower
MAX	Maximum
MIN	Minimum
MISC	Miscellaneous
MNFLD	Manifold
MTG	Mounting
N.M	Newton-Meters (Torque)
N1	Low Pressure Rotor
N2	High Pressure Rotor
OD	Outer Diameter
OPP	Opposite
OPT	Optional
OUTBD	Outboard
OVRHT	Overheat
PNEU	Pneumatic
PRESS	Pressure
QAD	Quick Attach Detach
QEC	Quick Engine Change (Kit)
QTY	Quantity
R/B	Replaced By
REF	Reference
REG	Regulator
REQD	Required
RH, RT	Right
SAC	Single Annular Combustor
SN	SNECMA
SUPT	Support
SWT	Switch
SYS	System
TAI	Thermal Anti-Ice

# INTRODUCTION



**737-600/700/800/900  
POWERPLANT BUILDUP MANUAL**

(Continued)

ABBREVIATION	DEFINITION
TBF	To Be Furnished
TEMP	Temperature
TGB	Transfer Gearbox
TOL	Tool
TRF	Turbine Rear Frame
UPR	Upper
VBV	Variable Bleed Valve
VSV	Variable Stator Vane
VEN	Vendor
W/B	Wire Bundle
W/	With
W/O	Without
XFMR	Transformer
XMTR	Transmitter

**Table 2:**

TERMS:	DEFINITION
Basic Engine	The assembled engine as furnished by the engine manufacturer.
Demountable Powerplant	Basic engine with QEC equipment installed.
QEC Equipment	Airframe manufacturer supplied parts installed during powerplant buildup.
Run-On Torque	Torque required to check self-locking features of nuts or nut plates.

**2. Description**

A. CFM56-7 Series Basic Engine

- (1) The CFM56-7 series engine is a dual-rotor, axial-flow, high bypass ratio turbofan. A single-stage high pressure turbine drives the 9 stage high pressure compressor. A four stage low pressure turbine drives the integrated front fan and low pressure compressor. The accessory drive system extracts energy from the high pressure, high-speed rotor to drive engine accessories and engine mounted airplane accessories.
- (2) Accessory items pertaining to engine operation such as hydro/mechanical unit, electronic engine control, fuel filter, fuel pump, oil/fuel heat exchanger, oil tank, oil filter, oil pump, starter, and other necessary equipment are supplied and installed by CFMI. Installation procedures for these items are contained in the CFMI CFM56-7 Engine Manual.
- (3) Identification of engine flanges is given in Figure 1.

B. Demountable Powerplant

- (1) The demountable powerplant consists of the CFMI CFM56-7 series basic engine and Boeing furnished QEC kit parts.

# INTRODUCTION



**737-600/700/800/900  
POWERPLANT BUILDUP MANUAL**

(2) Principal physical characteristics of the powerplant are approximately Figure 2:

**NOTE:** The weights provided below are approximate and should not be used for weight and balance purposes.

**Table 3:**

<b>ITEM</b>	<b>WEIGHT</b>	<b>LENGTH</b>	<b>DIAMETER</b>
Basic Engine	5185 lb (2357 kg)	121.7 in. (309 cm.)	66.1 in. (167.8 cm.)
Primary Nozzle Assembly	111 lb (50 kg)	45 in. (115 cm.)	38 in. (96 cm.)
Primary Plug Assembly	53 lb (24 kg)	43 in. (110 cm.)	26 in. (66 cm.)
Inlet Cowl	355 lb (161 kg)	TBD in. (TBD cm.)	89 in. (225 cm.)
Demountable Powerplant	6600 lb (3000 kg)	203 in. (516 cm.)	89 in.* (225 cm.)
* Maximum diameter.			

(3) Engines and inlet cowls are directly interchangeable between engine positions 1 and 2 on all 737-600/700/800/900 series airplanes.

**C. QEC Equipment**

(1) Accessory items installed on the engine are supplied by Boeing in the form of a QEC (Quick Engine Change) kit. Contact Boeing Customer Services-Spares for the correct kit part/dash number. Procedures for installing this equipment are given in this manual.

(2) QEC kit parts packaging

(a) The QEC kit parts are packaged in a series of tasks identified in the Special Spares Breakdown - Powerplant document issued by Boeing Customer Services - Spares. The task numbers correlate to the figure numbers of 71-00-02. As an example, parts for Figure 8-1 are contained in Task No. 8.

(b) Task No. 110 contains all standards and attaching hardware of the QEC kit with the exception of, Figure 2-1, Figure 3-1, and Figure 31-1. For these figures, the standards and attaching hardware will be packaged together with the other Figure/Item hardware. As an example, the standards and attaching hardware for Figure 2-1 are contained in Task No. 2.

(3) The installations that follow make up a QEC kit:

**Table 4:**

<b>INSTALLATION</b>	<b>DWG NUMBER</b>
ENGINE TO STRUT	310A2010
FWD ENGINE MOUNT	310A2020
AFT ENGINE MOUNT	310A2030
THRUST LINK	310A2040
MARKER	330A2010
DRAINS	332A2100

# INTRODUCTION



**737-600/700/800/900  
POWERPLANT BUILDUP MANUAL**

(Continued)

<b>INSTALLATION</b>	<b>DWG NUMBER</b>
FUEL SUPPLY HOSE	332A2100
IDG PLUMBING	332A2100
PNEU BLEED SYSTEM	332A2100
WIRE HARNESS	332A2200
INLET COWL TAI SYSTEM	332A2300
PNEU BLEED CONTROLLER	332A2300
PNEU BLEED DUCT	332A2300
START VALVE AND DUCT	332A2300
12 O'CLOCK STRUT	332A2370
HYDRAULIC PUMP	332A2400
FIRE DETECTION	332A2500
IDG	332A2600
BRACKET	332A2900
PRIMARY EXHAUST	333A2100
INLET	334A2000

# INTRODUCTION

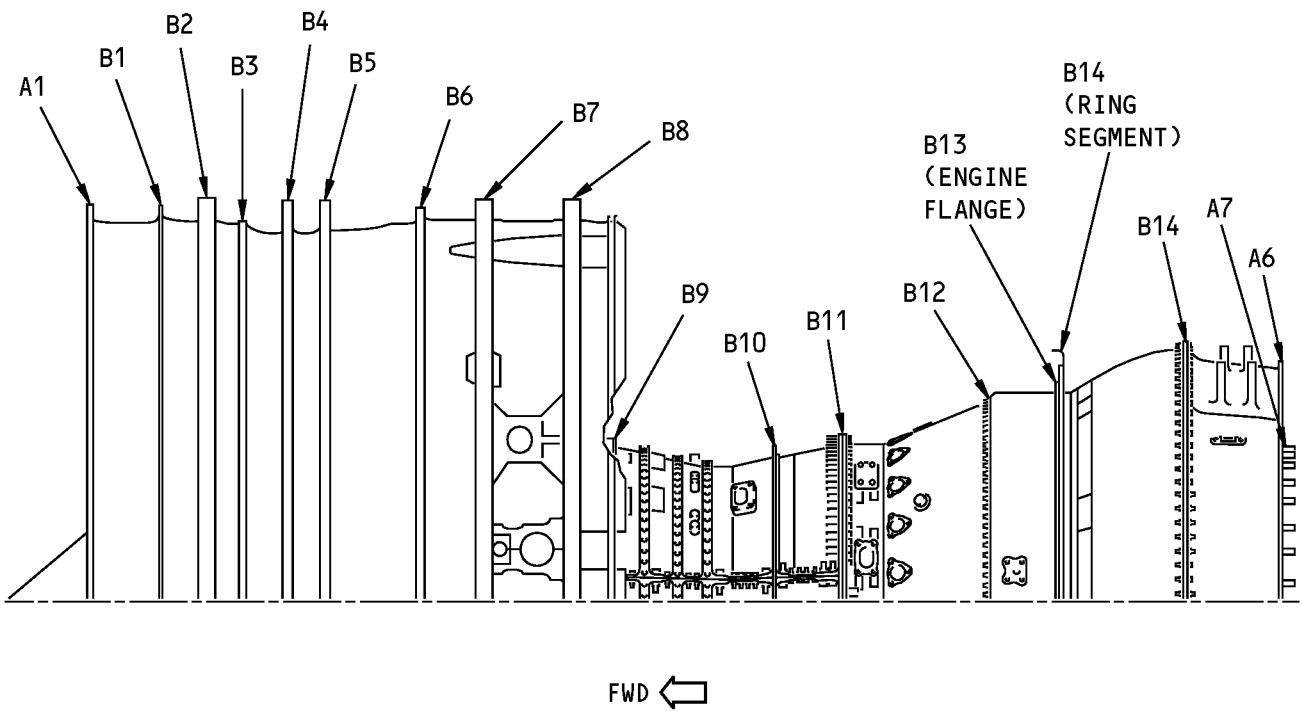

**Engine Flange Locations  
Figure 1**

# INTRODUCTION





**737-600/700/800/900  
POWERPLANT BUILDUP MANUAL**

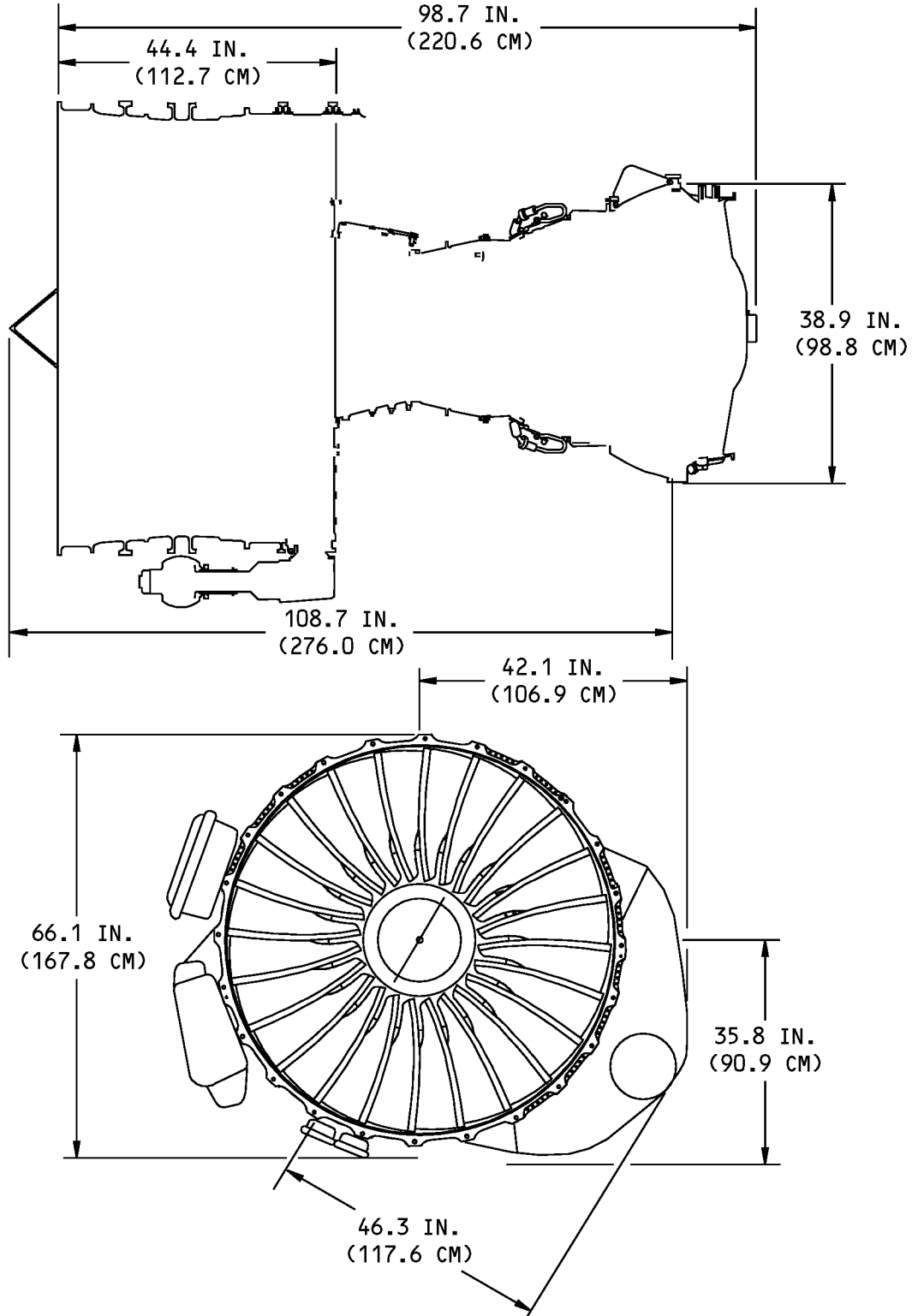

**Bare Engine Dimensions  
Figure 2**

# INTRODUCTION



737-600/700/800/900

## POWERPLANT BUILDUP MANUAL

### 3. Instructions for Using Manual

#### A. Figure and Item Numbers (71-00-02)

- (1) Figure numbers are assigned to individual segments of build up in a sequential order of accomplishment. Figures in 71-00-02, Powerplant Buildup, utilize a two-part naming nomenclature. The first part is the assigned buildup sequence number. The second part is used to control the configuration. (An exception is Figure 1-1, which is an index figure for 71-00-02.). Please note that if a particular configuration is not applicable to your fleet, it will not be included.
- (2) Item numbers are assigned to parts, wherever possible, in order of installation. The part listing with item numbers and nomenclatures appear on the text pages immediately following the applicable steps for installation of the parts. Unless specified differently, each figure is a complete task and contains its individual set of item numbers.
- (3) Item numbers for consumable materials are assigned a prefix C (e.g. C1). Each of the consumable materials has a unique item number that remains the same throughout each figure. The item number, bulk code number, nomenclature and specification for each consumable material appears on the text page immediately following the applicable steps for the use of that consumable material.
- (4) Item numbers for special tools, fixtures and equipment are assigned a prefix T (e.g. T1). Each of the tools has a unique item number that remains the same throughout each figure. The item number, tool part number and nomenclature for each tool appears on the text page immediately following the applicable steps for the use of that tool.
- (5) Item numbers preceded by a dash (-) in the FIG. ITEM or ITEM NO. column indicates the item is not illustrated.
- (6) Gaps in item numbers are used either for configuration control or for future growth, and does not indicate missing parts.
- (7) This manual uses the indenture system for listing its parts. This system shows the relationship of one part to another. For a given part, the number of indentures defines the relationship of that part to the associated installation, next higher assembly, or components of the part as follows:  
Detail parts, Assembly, or Attaching parts for assembly  
Detail parts for assembly, or Sub-assembly, or Attaching parts for sub-assembly

#### B. Locating a Part

- (1) If a part number is known and it is required to identify the location of the part, find the part number in the Numerical Index in section 71-00-00 and note the section, figure and item number of the part. Locate the item number on the text page of the applicable figure for identification of the part.
- (2) If the part number is not known, but the system or general area on the engine is known, then it may be possible to locate the applicable figure from the alphabetical listing of installations in the Installation Index, 71-00-00, or from the sequential listing in Figure 1-1.
- (3) BCREf ( ) - (Boeing Company Ref) part number is a reference number assigned to all part numbers that exceed 15 digits.
  - (a) The actual part number is included in parenthesis after the part name in the nomenclature column.
  - (b) When ordering these parts from Boeing, use either the BCREf ( ) part number or the actual part number.

#### C. Use of Assembly Procedures

# INTRODUCTION



737-600/700/800/900

## POWERPLANT BUILDUP MANUAL

- (1) Assembly procedures assume the engine is supported on pedestals, adapters, and brackets.
- (2) Each area of work as illustrated has the instructions and parts list located on the page facing the illustration. The parts required to perform a step are listed immediately following the step.
- (3) Vendor codes are listed for vendor parts in the parts list to enable identification of the vendors. A list of vendors and their codes and addresses is provided in the Vendor Codes list.
- (4) All tightening requirements are specified in the applicable steps of the buildup procedures.
- (5) Consumable materials, such as lubricants, sealants and tape as specified in buildup procedures, are listed in section 71-00-00 with their specification. In addition, if all usage location are required for a consumable, use the table in paragraph () of section 71-00-00 to determine the bulk code. Then use the Numerical Index, section 71-00-00 to find all locations where that consumable is used.

### D. Definitions of part effectivity terms

- (1) AR - Parts with AR (AS REQUIRED) in the QTY (quantity) column can be used as required.
- (2) BOE - Parts with BOE (BOEING) in the UC (usage code) column, and a dash in the QTY (quantity) column, are Boeing Specification numbers.
  - (a) The assigned vendor part number(s) is (are) assigned the same Item No. and is (are) listed immediately above the Boeing Specification number.

**NOTE:** Some Boeing Specification numbers are assigned multiple vendor part numbers.

- (3) CON - Items with CON (CONSUMABLE) in the UC (usage code) column, and AR (as required) in the QTY (quantity) column, are consumable materials that are used in that figure. Each consumable material's bulk code is listed in the PART NUMBER column and the description and specification are listed in the NOMENCLATURE column. These consumable materials are not part of the QEC kit.
- (4) DEL - Parts with DEL in the UC (usage code) column and a dash in the QTY (quantity) column should not be used or reinstalled.
- (5) OPT - Parts with OPT (OPTIONAL) in the NOMENCLATURE column, OPT in the UC (usage code) column and a dash in the QTY (quantity) column, are optional and interchangeable with the same item number listed with a quantity listed in the QTY column. Parts listed with a quantity are preferred and should be used if available.
- (6) REF - Parts with REF (REFERENCE) in the UC (usage code) column and a dash in the QTY (quantity) column have been identified and installed on an earlier or later sheet or page in the same figure or is a sub-part of an assembly and included for clarification.
- (7) REPLD BY - Parts with REPLD BY (REPLACED BY) in the NOMENCLATURE column, a LTD (LIMITED) in the UC (usage code) column and a dash in the QTY (quantity) column have been installed on engines delivered on earlier new airplanes and/or have been supplied in earlier QEC kits. These parts are no longer preferred and should not be ordered. Parts having the same item number with a quantity listed in the QTY column are improved designs or are required due to adjacent engine configuration changes and are supplied in current QEC kits.
- (8) TOL - Parts with TOL (TOOL) in the UC (usage code) column, and a dash in the QTY (quantity) column, are special tools, fixtures and equipment that may be required. These tools are not part of the QEC kit.
- (9) VEN - Parts with a vendor cage code in the NOMENCLATURE column and/or VEN (VENDOR) in the UC (usage code) column are vendor part number.

# INTRODUCTION



737-600/700/800/900

## POWERPLANT BUILDUP MANUAL

### 4. Standard Practices

- A. Before starting engine buildup, read applicable section of manual to become familiar with items to be installed and procedures to be followed.

Also, review the Standard Overhaul Practices Manual (D6-51702) for additional information on standard practices, specifically the following:

Table 5:

Title	Standard Overhaul Practices Manual Chapter
Repair of electrical terminations and electrical bonding areas	20-11-03
Bolt and Nut Installation	20-50-01
Installation of Safety Devices	20-50-02
Bearing Installation and Retention	20-50-03
Installation of Permanent Drill Passage Pin and Plug	20-50-04
Application of Aluminum Foil and Other Markers	20-50-05
Installation of O-Rings and Teflon Seals	20-50-06
Lubrication	20-50-07
Application of Dry Lubricant	20-50-08
Installation of Protective Grommets	20-50-09
Application of Stencils, Insignia, Silk Screen, Part Numbering and Identification Markings	20-50-10
Application of Aerodynamic Smoothing Sealant	20-50-11
Application of Adhesives	20-50-12
Application of Weather, Fuel Oil, Solvent and Heat Resistant Protective Coatings	20-50-13
Cleaners	20-60-01
Finishing Materials	20-60-02
Lubricants	20-60-03
Miscellaneous Materials	20-60-04

- B. Counter-Sunk (CSK) Washers

- (1) CSK washers are manufactured with a chamfer on one of the edges of the inside diameter. Position the chamfered edge of the washer against the bottom surface of the bolt head.

- C. Electrical Harness

- (1) Position electrical harness between connectors to provide equal distribution of support loading on clamps. Maintain sufficient slack at connectors to prevent stress loading the connection.
- (2) Do not wrap tape on the wire bundle under the clamp.
- (3) When connecting to electrical connectors, turn knurled coupling ring while wiggling the backshell assembly. After fully seating the coupling ring, use soft-jawed pliers or a strap wrench to tighten the coupling ring an additional 1/8 turn or until plier slippage occurs Figure 3 (Sheet 1).

# INTRODUCTION



737-600/700/800/900

## POWERPLANT BUILDUP MANUAL

(4) Install protective covers on connectors and receptacles not connected. Lockwire all threaded connectors after installation.

(5) Boeing-furnished wire bundles shall have a maximum tie spacing of 2 inches.

### D. Floating Clamps.

(1) Floating clamps are utilized to establish adequate clearance between tubing, hoses and wire bundles to dampen vibration and prevent chafing.

(2) Illustrations which show clamping for wire bundles, tubing, and hoses in most cases show floating clamp installations in approximate clamping locations.

(3) Actual clamp locations may be adjusted from those illustrated and additional clamps may be used to provide required clearances. A minimum clearance of 0.5 inch is desirable, however, 0.2 inch is permissible where 0.5 inch cannot be obtained.

### E. Lockwiring

(1) Perform all lockwiring using double twist method per Overhaul Manual 20-50-02 and standard industry practice.

(2) Use of safety cable in place of lockwire is allowed. Safety cable can only be used with bolts which have center drilled heads. Refer to the applicable installation figures for usage instructions.

### F. Lubrication

(1) Lubricate O-ring packings and fittings prior to installation unless specified otherwise.

(2) Apply grease or antiseize compound to splines as specified.

### G. Tubes and Fittings

(1) Proper alignment must be obtained between fittings and tubing to prevent preloading of lines and assure proper mating of threaded parts.

**Table 6:**

<b>FLUID TUBING MINIMUM CLEARANCE REQUIREMENTS: (UNLESS NOTED OTHERWISE)</b>	
BETWEEN ALL RIGID LINES AND ADJACENT STRUCTURE	
0.50 INCH	- AT NON-SUPPORTED LOCATIONS
0.10 INCH	- AT SUPPORTED LOCATIONS (OR THE THICKNESS OF THE SUPPORTING CLAMPS WHEN THE TUBING IS CLAMPED DIRECTLY TO THE SUPPORTING STRUCTURE)
NEAR ANY POSITION OF AN OPERATING MECHANISM	
0.50 INCH	- AT NON-SUPPORTED LOCATIONS
0.25 INCH	- AT SUPPORTED LOCATIONS WHEN IT IS EVIDENT THAT NO CHAFING OR INTERFERENCE WILL RESULT
BETWEEN TUBES THAT CROSS OR RUN PARALLEL	
0.50 INCH	- OR THE THICKNESS RESULTING FROM BACK-TO-BACK CLAMPING (ADDITIONAL BACK-TO-BACK CLAMPING MAY BE USED TO MEET MINIMUM CLEARANCE REQUIREMENTS)
BETWEEN TUBES AND CONTROL CABLES	
0.625 INCH	- BETWEEN BREAK POINTS OR FAIRLEADS AND CLAMPBLOCK

# INTRODUCTION



**737-600/700/800/900  
POWERPLANT BUILDUP MANUAL**

(Continued)

<b>FLUID TUBING MINIMUM CLEARANCE REQUIREMENTS: (UNLESS NOTED OTHERWISE)</b>
<b>NOTE:</b> Tubing installations shall be considered supported for a distance of 3 inches from a B-nut that attaches a tube to a rigid piece of equipment.

- (2) Allowable preload shall not exceed the following limits at clamp points when end fittings are attached and torqued.

**Table 7:**

Tube Size	Max. Preload
5/8" & Larger	20 lbs.
1/2"	10 lbs.
3/8"	5 lbs.
1/4"	3 lbs.

- (3) Up to three BACS18AF spacers may be used under support clamp to meet preload limitations.

**NOTE:** Ovality of tubes shall not exceed 5% after installation.

H. Tamper-proof "Inspection Verification" seal

- (1) This seal can be used as a visual check of the component after the final torque is applied. It is not required, but its application may be operator policy.
- (2) Make the seal an 1/8-inch wide strip of tamper-proof putty that extends across the junction of the mating parts and continues for 1/2-inch on each side of the mating connection.
  - (a) On tubes, locate the tamper-proof putty to minimize the possibility of the putty entering the tube when the tube is disconnected later.

# INTRODUCTION

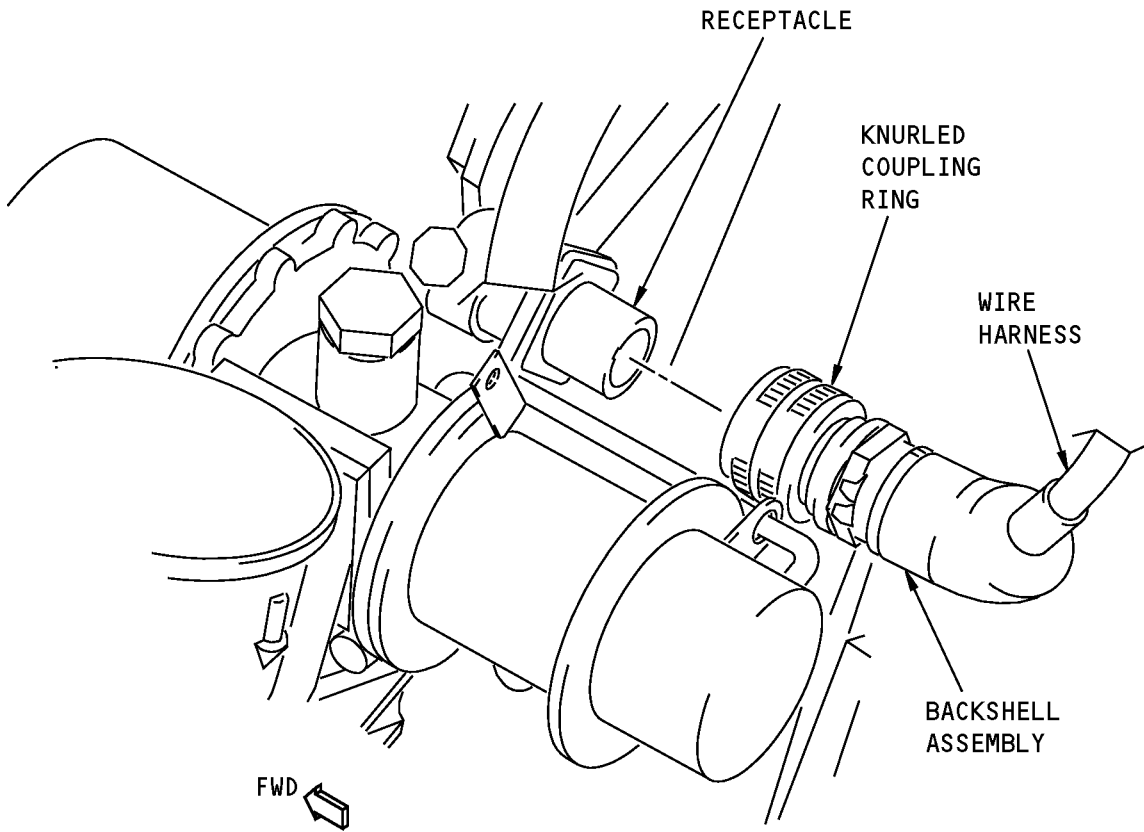

**Wire Harness Connectors  
Figure 3**

# INTRODUCTION



## 737-600/700/800/900 POWERPLANT BUILDUP MANUAL

### 5. Part Substitution

- A. Preferred parts are listed first and are applicable to the engine buildup configuration which was installed on the most recent engine configuration to be delivered.
- B. Replaced-by parts should not be used on new engines but may be required for buildup of previous engine configurations.
- C. Optional parts are listed immediately below the preferred part and may be used in place of preferred parts.
- D. Optional parts may be ordered if preferred parts are not available.
- E. Replaced by parts should not be ordered if preferred parts are not available.
- F. The following table lists obsolete part numbers for standard parts. These obsolete parts are no longer preferred and are not shown in the installation procedure.

**Table 8:**

<b>OBSOLETE PART NUMBER</b>	<b>PREFERRED PART NUMBER</b>
AS3236-06	BACB30ZF3-06
AS3236-08	BACB30ZF3-08
AS3236-10	BACB30ZF3-10
AS3236-28	BACB30ZF3-28
AS3237-05	BACB30ZF4-05
AS3237-06	BACB30ZF4-06
AS3237-07	BACB30ZF4-07
AS3237-08	BACB30ZF4-08
AS3237-09	BACB30ZF4-09
AS3237-10	BACB30ZF4-10
AS3237-11	BACB30ZF4-11
AS3237-12	BACB30ZF4-12
AS3237-14	BACB30ZF4-14
AS3237-22	BACB30ZF4-22
AS3237-23	BACB30ZF4-23
AS3237-24	BACB30ZF4-24
AS3237-29	BACB30ZF4-29
AS3237-32	BACB30ZF4-32
AS3237-34	BACB30ZF4-34
AS3510-02( )K	BACC13AT3K( )
MS21043-3	BACN10JC3C
MS21902K6	MS21902J6
MS24391J6	AS5169J06
MS35338-120	BACW10EC4M

# INTRODUCTION





**737-600/700/800/900  
POWERPLANT BUILDUP MANUAL**

(Continued)

<b>OBSOLETE PART NUMBER</b>	<b>PREFERRED PART NUMBER</b>
MS35842-12	BACC10JB034C064
NAS1611-024	NAS1611-024A
NAS1611-153	NAS1611-153A
NAS1612-12	NAS1612-12A
NAS1612-20	NAS1612-20A
NAS1612-6	NAS1612-6A
NAS1802-4-16	BACS12HN4U16
NAS1805-3	BACN11Z3CK
NAS1805-4	BACN11Z4CK
NAS1805-6L	BACN11Z6CD
NAS1805-8P	BACN11Z8C

**6. Customer Originated Material**

- A. Customer originated material, incorporated into the manual at customer request to reflect data or procedures originated by and peculiar to that specific customer, will be permanently identified by the customer's three-letter designator in the space adjacent to the revision bar. In addition, these pages are identified on the List of Effective Pages (LEP) with a special character called a hollow lozenge which is located to the right of the date field. THE BOEING COMPANY does not assume responsibility for the validity and/or the technical accuracy of material so identified. THE BOEING COMPANY will not undertake to test or evaluate in any form the validity or the technical accuracy of the customer-originated material, and the customer shall have the sole and exclusive responsibility for the validity and accuracy of material submitted for incorporation into the manual.
- B. THE BOEING COMPANY HEREBY EXPRESSLY DISCLAIMS ANY AND ALL WARRANTIES, EXPRESSED OR IMPLIED, ORAL OR WRITTEN, ARISING BY LAW, COURSE OF DEALING, OR OTHERWISE, AND WITHOUT LIMITATION ALL WARRANTIES AS TO QUALITY, OPERATION, MERCHANTABILITY, FITNESS FOR ANY INTENDED PURPOSE, AND ALL OTHER CHARACTERISTICS WHATSOEVER, OF CUSTOMER-ORIGINATED MATERIAL INCORPORATED INTO THIS MANUAL. THE FOREGOING DISCLAIMER SHALL ALSO APPLY TO ANY OTHER PORTION OF THIS MANUAL WHICH MAY BE AFFECTED OR COMPROMISED BY SUCH CUSTOMER-ORIGINATED CHANGES.

**7. Normal Revision Service**

- A. Aircraft operators who have contracted continuing revision service for this manual receive revisions 3 times per year dated February 5, June 5 and October 5. Pages which are revised will be so indicated on the list of effective pages by an symbol (R) and identified by both a date and a page code. A revised page may carry a new or the same code and may be dated prior to, the same as, or subsequent to the date of the page it replaces. On each individual page the revised area is indicated by a revision bar on the left margin. Those pages which have not been technically revised, but have been reprinted due to recomposition, are so indicated by a revision bar opposite the page number and date.

# INTRODUCTION



737-600/700/800/900

## POWERPLANT BUILDUP MANUAL

### 8. Temporary Revision Service

- A. Temporary revision service to this manual will be issued as necessary to alert the customer of configuration changes and to provide advance information prior to the next scheduled revision. Each temporary revision will be incorporated into the next available scheduled revision of the manual, except for "open dated" temporary revisions issued to cover temporary configuration changes, due to e.g., installation of test equipment. These "open dated" temporary revisions will remain active until Boeing has been advised by the customer that the final configuration has been completed.
- B. Each temporary revision will apply to one subject only and will be keyed within this manual so that the temporary revision may be filed facing or to replace the affected pages. Temporary revisions will not be revised.

If changes are required to an existing temporary revision, the temporary revision will be reissued.

### 9. Publications Change Requests

- A. Communications concerning this publication should be directed to Boeing Commercial Airplanes; Attention: Maintenance Engineering Technical Services, M/S 2J-02; P.O. Box 3707, Seattle WA 98124. To facilitate uniform handling and to provide direct routing of your questions to the proper Boeing organization, use of the Publications Change Request (PCR) Form is encouraged. Boeing makes this form available through your publications organization.

### 10. Consumable Material Lists

The tables that follow list all of the consumable materials used in this manual.

A separate table will be shown for each different material code. The data in the table is then sorted by the bulk reference number.

- The first set of tables contain all the standard consumable materials.
- The second set of tables contain all the engine consumable materials and will include the engine manufacturers reference number.

**Table 9:** Adhesives, Cements, Sealants

Reference	Description	Specification	Material	Supplier
A00027	Adhesive - Silicone Rubber, 1 Part, RTV	BAC5010, Type 60	RTV 102	71984
A00160	Sealant - Firewall, High Temperature, 2 Part, Hydraulic Fluid Resistant	BMS5-63		
A00803	Sealant - Firewall - Hydraulic Fluid Resistant	BMS5-63 Type I	Dapco 18-4	0V7G8

**Table 10:** Cleaners, Polishes

Reference	Description	Specification	Material	Supplier
B00074	Solvent - Degreasing	MIL-PRF-680 (Supersedes P-D-680)		
B00083	Solvent - Aliphatic Naphtha (For Acrylic Plastics)	TT-N-95, Type II, ASTM D-3735 Type III		
B00130	Alcohol - Isopropyl	TT-I-735		

# INTRODUCTION



**737-600/700/800/900  
POWERPLANT BUILDUP MANUAL**

Reference	Description	Specification	Material	Supplier
B00571	Coating - Clear Hydraulic Fluid Resistant Topcoat	BAC5710, Type 41		

**Table 11: Finishing Materials**

Reference	Description	Specification	Material	Supplier
C00944	Primer - Firewall - Dapco No. 1-100	BMS5-63, Type I	Dapco No. 1-100	58093

**Table 12: Lubricants (Oils, Greases, Dry Lubes)**

Reference	Description	Specification	Material	Supplier
D00006	Compound - Antiseize Pure Nickel Special - Never-Seez NSBT-8N	MIL-PRF-907F	Never-Seez NSBT-8N	5W425
D00054	Fluid - Hydraulic Assembly Lubricant - MCS 352B (Formally Monsanto MCS 352B)		MCS 352B	1CHP6
D00109	engine, synthetic base	MIL-L-7808		
D00153	Fluid - Hydraulic, Erosion Arresting, Fire Resistant	BMS3-11, Type IV (interchangeable & intermixable with Type V)		
D00173	Grease - Aircraft and Instrument, Fuel And Oxidizer Resistant	MIL-PRF-27617 (Supersedes MIL-G-27617)		
D00254	Compound - Silicone	SAE AS8660 (NATO S-736) (Supercedes MIL-S-8660)	DC-4	71984
D00504	Grease - Petrolatum	VV-P-236		
D00523	engine, MIL-L-23699	MIL-L-23699		
D00648	Lubricant - O-Ring - Syn-Tech NS-6074			
D50004	Compound - Antiseize	BMS3-28	ARMITE LF-AS 328	81205

**Table 13: Miscellaneous Materials**

Reference	Description	Specification	Material	Supplier
G00251	Abrasive - Non-Woven, Non-Metallic, Mats - Scotchbrite	A-A-58054	Scotch-Brite	28112

# INTRODUCTION



**737-600/700/800/900  
POWERPLANT BUILDUP MANUAL**

Reference	Description	Specification	Material	Supplier
G01912	Lockwire - Monel (0.032 In. Dia.)	NASM20995NC32 (QQ-N-281)		
G02061	Marker - Permanent, Felt Tip Pen		13601 or 13801	86874
G02185	Agent - Parting, Peelable, 4A-183 Green Strippable Coating (598-5002 GSC)	BAC5000, PSD 6-187	AZ 634-2	81205
G50043	Sleeve - Viton, 3/16 inch - RT1146			
G50044	Sleeve - Ben-Har Viton 44, 3/16 inch, P/N 3800300503			
G50375	Kit - Safety Cable, 321 CRES - 0.032 Inch (0.81 mm) Diameter, (Contains both Cable and Ferrule)	BACC13AT3K, AMS 5689	BAC~ C13AT3K	70958

**Table 14:** Lubricants (Oils, Greases, Dry Lubes) - CFM International

Reference	Engine Mfr Reference	Description	Specification	Material	Supplier
D00601	CP2101	Grease - Graphite, High Temperature	SAE AMS2518		

**11. Tool Lists**

Refer to the tables below for the complete applicability before you use a tool.

The tables that follow show all of the tools that are referred to in this manual.

There is a table for each type of tool. The data in each table is sorted by the GSE requirement identifier.

- The table for Standard Tools shows the standard tools.
- The table for Commercial Tools shows the tools that are commercially available.
- The table for Special Tools shows the tools that are manufactured for specific requirements.
- When there is a fourth table, it shows the airline-specific tools.

**Table 15:** Commercial Tools

Reference	Description	Part Number	Supplier	A/P Effectivity
COM-1443	Jack - Hydraulic, General Low Profile, Capacity: 2000 lbs, Lift: 10 to 44 Inches, or Equivalent Jack Capable of Lifting 300 lbs.	HW93718	28047	737-ALL
		Opt: W93718	36251	737-ALL
COM-1568	Jack - Hydraulic, General Low Profile	B67563	36251	737-ALL
		HW93718	28047	737-ALL
		Opt: W93718	36251	737-ALL

# INTRODUCTION



**737-600/700/800/900  
POWERPLANT BUILDUP MANUAL**

Reference	Description	Part Number	Supplier	A/P Effectivity
COM-2060	Dolly - Nose Cowl, Removal/ Installation, CFM56-3 and -7 Engine	AM1940-400	9M323	737-300, -400, -500, -600, -700, -700C, -700ER, -700QC, -800, -900, -900ER, -BBJ
		Opt: AM1940	9M323	737-300, -400, -500

**Table 16: Special Tools**

Reference	Description	Part Number	Supplier	A/P Effectivity
SPL-1634	Jack Adapter - VSCF and IDG	C24002-40	81205	737-600, -700, -700C, -700ER, -700QC, -800, -900, -900ER, -BBJ
		C24002-41	81205	737-600, -700, -700C, -700ER, -700QC, -800, -900, -900ER, -BBJ
		C24002-45	81205	737-600, -700, -700C, -700ER, -700QC, -800, -900, -900ER, -BBJ
SPL-2062	Sling - Inlet Cowl	B71040-39	81205	737-600, -700, -700C, -700ER, -700QC, -800, -900, -900ER, -BBJ

# INTRODUCTION



**737-600/700/800/900  
POWERPLANT BUILDUP MANUAL**

Reference	Description	Part Number	Supplier	A/P Effectivity
		Opt: B71040-38	81205	737-600, -700, -700C, -700ER, -700QC, -800, -900, -900ER, -BBJ
SPL-2107	Fixture - Lift, CFM56-7 Engine Aft Mount	C71024-1	81205	737-600, -700, -700C, -700ER, -700QC, -800, -900, -900ER, -BBJ
SPL-2165	Cowl - Inlet, Installation/Removal Frame Assembly	C71027-1	81205	737-600, -700, -700C, -700ER, -700QC, -800, -900, -900ER, -BBJ
SPL-2419	Equipment - Handling, Primary Exhaust Sleeve and Plug	C78009-33	81205	737-300, -400, -500, -600, -700, -700C, -700ER, -700QC, -800, -900, -900ER, -BBJ
SPL-2430	Hoist - Boom, Ground Based	C78026-156	81205	737-600, -700, -700C, -700ER, -700QC, -800, -900, -900ER, -BBJ

**12. Supplier List for Consumables and Tools**

The table that follows lists all of the suppliers for the consumable materials and tools used in this manual.

The table is sorted by the CAGE code.

# INTRODUCTION



737-600/700/800/900

## POWERPLANT BUILDUP MANUAL

### VENDOR CODES

Code	Name
00624	EATON AEROQUIP INC ENGINEERED SYSTEMS DIV 300 S EAST AVE JACKSON, MICHIGAN 49203-1972 FORMERLY AEROQUIP ELBEE PLANT V99879 OR WESTERN PLANT V70128; FORMERLY AEROQUIP AEROSP DIV JACKSON PLANT; FORMERLY V11328 AEROQUIP LINAIR DIV; LAWRENCE PLANT V26622
05228	PTI TECHNOLOGIES INC 501 DEL NORTE BLVD OXNARD, CALIFORNIA 93030-7983 FORMERLY PUROLATOR TECH; PTI TECH; TEXTRON FILTRATION SYS; FORMERLY IN NEWBURY PARK, CA
0V7G8	CYTEC INDUSTRIES INC 5 GARRET MOUNTAIN PLZ LITTLE FALLS, NJ 0 Telephone: 973-357-3100
11362	PARKER-HANIFFIN CORP STRATOFLEX DIV 3353 OLD CONEJO ROAD NEWBURY PARK, CALIFORNIA 91320-2162 FORMERLY SYMETRICS INC.
15284	PERKINELMER INC DBA PERKINELMER FLUID SERVICES 11642 OLD BALTIMORE PIKE BELTSVILLE, MARYLAND 20705-1294 FORMERLY V0NYS5; EGG PRESSURE SCIENCE INC
1CHP6	SOLUTIA INC. 575 MARYVILLE CENTRE DRIVE SAINT LOUIS, MO 63166-6760 Telephone: 314-674-3651
25693	WHITTAKER CORP WHITTAKER SAFETY SYSTEMS DIV 2731 SYSTRON DRIVE CONCORD, CALIFORNIA 94518-1355 FORMERLY IN BERKLEY, CALIF.; LINDBERG, JOHN E VB0124 FORMERLY SAFETY SYS DIV SYSTRON DONNER; SYSTRON-DONNER CORP

## INTRODUCTION



737-600/700/800/900

## POWERPLANT BUILDUP MANUAL

<b>Code</b>	<b>Name</b>
28047	HEIN-WERNER CORP. 1005 PERKINS AVENUE P. O. BOX 1606 WAUKESHA, WI 53187-1606 Telephone: (262) 542-6611 Facsimile: (414) 464-4298 (SALES DEPT)
28112	3M CO 3M CTR BLDG 223-06-S-04 SAINT PAUL, MN 0 Telephone: 651-733-0444
36251	MCNEIL OHIO CORP 1 LINCOLN WAY SAINT LOUIS, MISSOURI 63120
51563	ROHR INC FOOT OF H STREET PO BOX 878 CHULA VISTA, CALIFORNIA 92012
58093	D AIRCRAFT PRODUCTS CO 1191 HAWK CIR ANAHEIM ANAHEIM, CA 0 Telephone: 714-632-8444
59364	HONEYWELL INTERNATIONAL INC DBA ENGINES & SYSTEMS DIV 1300 WEST WARNER ORAD M/S 1207-2W TEMPE, ARIZONA 85285-2986 FORMERLY IN PHOENIX, ARIZONA FORMERLY GARRETT PNEUMATIC SYSTEMS DIV OF GARRETT CORP
5W425	BOSTIK INC 211 BOSTON ST MIDDLETON, MA 0 Telephone: 978-777-0100
60980	MEGGITT-OREGON INC DBA MEGGITT SILICONE PROD DIV MSP 2010 LAFAYETTE AVE P.O. BOX 887 MCMINNVILLE, OREGON 97128 FORMERLY ELASTOMERIC SILICON PRODUCTS

# INTRODUCTION





737-600/700/800/900

## POWERPLANT BUILDUP MANUAL

<b>Code</b>	<b>Name</b>
62983	EATON AEROSPACE VICKERS FLUID POWER 5353 HIGHLAND DRIVE JACKSON, MISSISSIPPI 39206-3449 FORMERLY V63977; FORMERLY VICKERS INC AEROSP
70958	BERGEN CABLE TECHNOLOGIES INC 343 KAPLAN DRIVE FAIRFIELD, NJ 07004-2510 Telephone: 973-276-9596 Facsimile: 973-276-9566
71984	DOW CORNING CORPORATION P.O. BOX 994 2200 WEST SALZBURG ROAD MIDLAND, MI 48686-0994 Telephone: 1-989-496-4400 Facsimile: 1-989-496-6731
78570	TITFLEX CORP SUB OF BUNDY CORP 603 HENDEE STREET PO BOX 90054 SPRINGFIELD, MASSACHUSETTS 01139
78943	TRIUMPH THERMAL SYSTEMS INC 200 RAILROAD STREET FOREST, OHIO 45843-9193 FORMERLY UNITED AIRCRAFT PRODUCTS FORMERLY PARKER HANNIFIN CORP. UNITED AIRCRAFT PRODUCTS DIV.
81205	BOEING CO THE 7755 EAST MARGINAL WAY PO BOX 3707 SEATTLE, WASHINGTON 98124
84971	TA MFG CO TA DIV 28065 W FRANKLIN PKY PO BOX 931 VALENCIA, CALIFORNIA 91380-9031 FORMERLY IN LA, CALIF; SUB OF CRITON CORP, GLENDALE, CALIF
86874	SANFORD CORP 2740 WASHINGTON BLVD BELLWOOD, IL 0 Telephone: 708-547-6650

# INTRODUCTION



737-600/700/800/900

## POWERPLANT BUILDUP MANUAL

<b>Code</b>	<b>Name</b>
97393	SHUR-LOK CORPORATION 2541 WHITE ROAD PO BOX 19584 IRVINE, CALIFORNIA 92713 FORMERLY SHUR LOK CORP VB0060 FORMERLY IN SANTA ANA, CALIFORNIA 92714
98441	STRATOFLEX AEROSPACE MILITARY CONNECTOR DIV 220 ROBERTS CUT-OFF FT. WORTH, TEXAS 76114 FORMERLY STRATOFLEX INC; PARKER-HANNIFIN FLUID CONN GROUP; FORMERLY PARKER-HANNIFIN FLUID PWR DIV V82271
99167	HAMILTON SUNDSTRAND CORP 4747 HARRISON AVE PO BOX 7002 ROCKFORD, ILLINOIS 61125-7002 FORMERLY SUNDSTRAND DENVER DIV V05237; V50907 & V77200
99755	FMH INVESTOR GROUP 17072 DAIMLER STREET IRVINE, CALIFORNIA 92614-4541 FORMERLY FLEXIBLE METAL HOSE MFG CO
9M323	ADVANCED GROUND SYSTEMS ENGINEERING CORP (AGSE) 10805 PAINTER AVENUE SANTA FE SPRINGS, CA 90670 Telephone: (562) 906-9300 Facsimile: (562) 906-9308 / (714) 632-9095

# INTRODUCTION



737-600/700/800/900  
POWERPLANT BUILDUP MANUAL

INSTALLATION INDEX (ALPHA/NUMERICAL ORDER)

FIGURE TITLE	LOCATION	
	SUBJECT	FIG
AFT ENGINE MOUNT INSTALLATION	71-00-02	3-1
BLEED CONTROL SYSTEM INSTALLATION - LOWER	71-00-02	15-1
BLEED CONTROL SYSTEM INSTALLATION - UPPER	71-00-02	17-1
BLEED CONTROLLER INSTALLATION	71-00-02	14-1
BLEED DUCT INSTALLATION - LOWER 5TH- AND 9TH-STAGE	71-00-02	16-1
BLEED DUCT INSTALLATION - UPPER 5TH- AND 9TH-STAGE	71-00-02	18-1
BRACKET INSTALLATION - LEFT SIDE CORE CASE	71-00-02	7-1
BRACKET INSTALLATION - LOWER LEFT FAN CASE	71-00-02	5-1
BRACKET INSTALLATION - RIGHT SIDE CORE CASE	71-00-02	8-1
BRACKET INSTALLATION - RIGHT SIDE FAN CASE	71-00-02	6-1
BRACKET INSTALLATION - UPPER LEFT FAN CASE	71-00-02	4-1
DRAINS INSTL - LEFT SIDE FAN CASE	71-00-02	9-1
DRAINS INSTL - RIGHT SIDE FAN CASE	71-00-02	10-1
FIRE/OVERHEAT DETECTOR INSTALLATION	71-00-02	28-1
FORWARD ENGINE MOUNT INSTALLATION	71-00-02	2-1
FUEL SUPPLY HOSE INSTALLATION	71-00-02	12-1
HYDRAULIC PLUMBING INSTALLATION	71-00-02	21-1
HYDRAULIC PUMP INSTALLATION - VICKERS	71-00-02	20-1
IDG AIR/OIL COOLER INSTALLATION	71-00-02	23-1
IDG PLUMBING INSTALLATION	71-00-02	24-1
INLET COWL INSTALLATION	71-00-02	33-1
INLET COWL TAI SYSTEM INSTALLATION	71-00-02	27-1
INTEGRATED DRIVE GENERATOR INSTALLATION	71-00-02	22-1
MARKERS INSTALLATION	71-00-02	30-1
PRIMARY EXHAUST INSTALLATION	71-00-02	32-1
STARTER VALVE AND DUCT INSTALLATION	71-00-02	25-1

# INSTALLATION INDEX



**737-600/700/800/900  
POWERPLANT BUILDUP MANUAL**

FIGURE TITLE	LOCATION	
	SUBJECT	FIG
THIS FIGURE NOT USED	71-00-02	11-1
THIS FIGURE NOT USED	71-00-02	19-1
THIS FIGURE NOT USED	71-00-02	26-1
THRUST LINK INSTALLATION	71-00-02	31-1
W1062 WIRE BUNDLE INSTALLATION	71-00-02	29-1
12 O'CLOCK STRUT INSTALLATION	71-00-02	13-1

# INSTALLATION INDEX



**737-600/700/800/900  
POWERPLANT BUILDUP MANUAL**

**NUMERICAL INDEX**

PART NUMBER	AIRLINE PART NUMBER	LOCATION			QTY
		SUBJECT	FIG	ITEM	
		71-00-02	3-1	T1	-
AE713733-1		71-00-02	12-1	10	1
AM1940-400		71-00-02	33-1	T2	-
AS1895-1-350		71-00-02	16-1	180	1
AS1895-1-350		71-00-02	16-1	210	1
AS1895-1-350		71-00-02	18-1	55	1
AS1895-1-350		71-00-02	18-1	110	1
AS1895-4-175		71-00-02	16-1	320	1
AS1895-4-175		71-00-02	27-1	260	1
AS1895-4-200		71-00-02	27-1	235	1
AS1895-4-200		71-00-02	27-1	305	1
AS1895-4-200		71-00-02	27-1	380	1
AS1895-4-200		71-00-02	33-1	100	-
AS1895-4-325		71-00-02	25-1	110	1
AS1895-4-350		71-00-02	16-1	260	1
AS1895-4-350		71-00-02	16-1	310	2
AS1895-4-400		71-00-02	14-1	120	1
AS1895-4-450		71-00-02	18-1	155	1
AS1895-7-175		71-00-02	16-1	315	1
AS1895-7-175		71-00-02	27-1	255	1
AS1895-7-200		71-00-02	27-1	230	1
AS1895-7-200		71-00-02	27-1	300	1
AS1895-7-200		71-00-02	27-1	375	1
AS1895-7-200		71-00-02	33-1	50	-
AS1895-7-300		71-00-02	25-1	180	1
AS1895-7-300		71-00-02	25-1	255	1
AS1895-7-300		71-00-02	25-1	300	1
AS1895-7-325		71-00-02	25-1	105	1
AS1895-7-350		71-00-02	16-1	175	1
AS1895-7-350		71-00-02	16-1	205	1
AS1895-7-350		71-00-02	16-1	255	1

**NUMERICAL INDEX**



**737-600/700/800/900  
POWERPLANT BUILDUP MANUAL**

PART NUMBER	AIRLINE PART NUMBER	LOCATION			QTY
		SUBJECT	FIG	ITEM	
AS1895-7-350		71-00-02	16-1	305	2
AS1895-7-350		71-00-02	18-1	50	1
AS1895-7-350		71-00-02	18-1	105	1
AS1895-7-400		71-00-02	14-1	115	1
AS1895-7-450		71-00-02	18-1	150	1
AS3209-216		71-00-02	22-1	55	-
AS3485-09		71-00-02	14-1	110	4
AS3485-09		71-00-02	25-1	235	1
AS3485-09		71-00-02	27-1	360	1
AS3485-10		71-00-02	4-1	20	2
AS3485-10		71-00-02	4-1	90	2
AS3485-10		71-00-02	4-1	115	2
AS3485-10		71-00-02	4-1	290	2
AS3485-10		71-00-02	4-1	380	2
AS3485-10		71-00-02	4-1	565	1
AS3485-10		71-00-02	4-1	610	2
AS3485-10		71-00-02	4-1	670	2
AS3485-10		71-00-02	4-1	720	2
AS3485-10		71-00-02	4-1	785	2
AS3485-10		71-00-02	4-1	815	2
AS3485-10		71-00-02	4-1	840	2
AS3485-10		71-00-02	5-1	20	3
AS3485-10		71-00-02	5-1	40	2
AS3485-10		71-00-02	5-1	165	2
AS3485-10		71-00-02	5-1	195	3
AS3485-10		71-00-02	5-1	215	3
AS3485-10		71-00-02	5-1	240	2
AS3485-10		71-00-02	5-1	265	2
AS3485-10		71-00-02	6-1	90	2
AS3485-10		71-00-02	6-1	140	2
AS3485-10		71-00-02	6-1	190	1
AS3485-10		71-00-02	6-1	365	1

# NUMERICAL INDEX



**737-600/700/800/900  
POWERPLANT BUILDUP MANUAL**

PART NUMBER	AIRLINE PART NUMBER	LOCATION			QTY
		SUBJECT	FIG	ITEM	
AS3485-10		71-00-02	6-1	425	2
AS3485-10		71-00-02	6-1	465	2
AS3485-10		71-00-02	7-1	185	3
AS3485-10		71-00-02	7-1	235	2
AS3485-10		71-00-02	7-1	310	2
AS3485-10		71-00-02	7-1	360	2
AS3485-10		71-00-02	8-1	35	1
AS3485-10		71-00-02	9-1	25	1
AS3485-10		71-00-02	9-1	45	1
AS3485-10		71-00-02	9-1	90	1
AS3485-10		71-00-02	9-1	120	1
AS3485-10		71-00-02	9-1	165	2
AS3485-10		71-00-02	9-1	260	2
AS3485-10		71-00-02	10-1	20	2
AS3485-10		71-00-02	10-1	45	2
AS3485-10		71-00-02	10-1	65	2
AS3485-10		71-00-02	10-1	90	1
AS3485-10		71-00-02	10-1	120	1
AS3485-10		71-00-02	10-1	145	2
AS3485-10		71-00-02	16-1	30	1
AS3485-10		71-00-02	16-1	65	1
AS3485-10		71-00-02	16-1	420	1
AS3485-10		71-00-02	16-1	470	1
AS3485-10		71-00-02	21-1	155	1
AS3485-10		71-00-02	21-1	242	1
AS3485-10		71-00-02	24-1	65	1
AS3485-10		71-00-02	24-1	165	2
AS3485-10		71-00-02	25-1	80	2
AS3485-10		71-00-02	25-1	145	2
AS3485-10		71-00-02	27-1	205	2
AS3485-10		71-00-02	27-1	270	3
AS3485-10		71-00-02	27-1	340	2

# NUMERICAL INDEX



737-600/700/800/900  
POWERPLANT BUILDUP MANUAL

PART NUMBER	AIRLINE PART NUMBER	LOCATION			QTY
		SUBJECT	FIG	ITEM	
AS3485-10		71-00-02	28-1	290	1
AS3485-10		71-00-02	29-1	35	4
AS3485-10		71-00-02	33-1	140	1
AS3485-10		71-00-02	33-1	265	1
AS3485-11		71-00-02	22-1	30	3
AS3485-11		71-00-02	22-1	110	1
AS3485-11		71-00-02	22-1	125	1
AS3485-12		71-00-02	5-1	300	1
AS3485-12		71-00-02	16-1	535	1
AS5169J06		71-00-02	18-1	35	1
A00027		71-00-02	4-1	C6	AR
A00027		71-00-02	27-1	C6	AR
A00160		71-00-02	4-1	C4	AR
A00160		71-00-02	13-1	C3	AR
A00160		71-00-02	27-1	C4	AR
A00803		71-00-02	4-1	C5	AR
A00803		71-00-02	13-1	C4	AR
A00803		71-00-02	27-1	C5	AR
BACB28AK03-027		71-00-02	4-1	885	1
BACB28AK04-030		71-00-02	16-1	55	1
BACB28AK04-030		71-00-02	16-1	410	1
BACB28AK04-030		71-00-02	16-1	460	1
BACB28AK04-030		71-00-02	25-1	70	2
BACB28AK04-030		71-00-02	25-1	135	2
BACB28AK04-030		71-00-02	27-1	195	2
BACB28AK04-030		71-00-02	27-1	330	2
BACB28AK04-042		71-00-02	16-1	20	1
BACB28AK06-040		71-00-02	16-1	525	1
BACB28AK06-055		71-00-02	16-1	525	-
BACB28BA0608060		71-00-02	5-1	290	1
BACB30LE3U18		71-00-02	4-1	875	1
BACB30LE4HU1		71-00-02	7-1	30	1

## NUMERICAL INDEX





737-600/700/800/900  
POWERPLANT BUILDUP MANUAL

PART NUMBER	AIRLINE PART NUMBER	LOCATION			QTY
		SUBJECT	FIG	ITEM	
BACB30LE4HU1		71-00-02	7-1	50	2
BACB30LE4HU2		71-00-02	7-1	31	1
BACB30LE4K10		71-00-02	5-1	180	3
BACB30LE4K4		71-00-02	13-1	215	2
BACB30LE4K6		71-00-02	5-1	135	2
BACB30LE4K6		71-00-02	13-1	210	-
BACB30LE4K6		71-00-02	13-1	210	2
BACB30LE4K8		71-00-02	13-1	215	-
BACB30LE5K14		71-00-02	22-1	100	1
BACB30LE5K8		71-00-02	22-1	20	3
BACB30LE5K8		71-00-02	22-1	115	1
BACB30LE5U6		71-00-02	4-1	955	2
BACB30LE5U6		71-00-02	6-1	230	2
BACB30LE6K14		71-00-02	5-1	280	1
BACB30LH3U4		71-00-02	14-1	105	4
BACB30LK4U1		71-00-02	32-1	15	-
BACB30NM4K5		71-00-02	4-1	630	1
BACB30NM4K5		71-00-02	5-1	230	2
BACB30NM4K6		71-00-02	5-1	30	2
BACB30NM4K6		71-00-02	21-1	145	1
BACB30NM4K7		71-00-02	4-1	655	2
BACB30NM4K7		71-00-02	5-1	10	3
BACB30NM4K7		71-00-02	5-1	205	3
BACB30NN4K11		71-00-02	13-1	250	-
BACB30NN4K16		71-00-02	13-1	110	2
BACB30NN4K18		71-00-02	13-1	105	4
BACB30NN4K6		71-00-02	13-1	100	-
BACB30NN4K6		71-00-02	13-1	250	2
BACB30NN4K7		71-00-02	13-1	100	6
BACB30PN10-19		71-00-02	2-1	100	-
BACB30PN10-19M		71-00-02	2-1	100	4
BACB30PN14-32M		71-00-02	3-1	100	4

## NUMERICAL INDEX



737-600/700/800/900  
POWERPLANT BUILDUP MANUAL

PART NUMBER	AIRLINE PART NUMBER	LOCATION			QTY
		SUBJECT	FIG	ITEM	
BACB30PN4-10		71-00-02	32-1	125	3
BACB30PN4-10		71-00-02	32-1	175	3
BACB30PN4-14		71-00-02	16-1	40	1
BACB30PN4-14		71-00-02	16-1	400	1
BACB30PN4-14		71-00-02	16-1	450	1
BACB30PN4-14		71-00-02	25-1	50	2
BACB30PN4-14		71-00-02	25-1	125	2
BACB30PN4-14		71-00-02	27-1	175	2
BACB30PN4-14		71-00-02	27-1	320	2
BACB30PN4-16		71-00-02	16-1	5	1
BACB30PN4-6		71-00-02	32-1	225	85
BACB30PN4H7		71-00-02	13-1	15	4
BACB30PN5H3		71-00-02	16-1	100	4
BACB30PN6C22		71-00-02	16-1	500	1
BACB30PN6C24		71-00-02	16-1	500	-
BACB30US4-10		71-00-02	32-1	125	-
BACB30US4-10		71-00-02	32-1	175	-
BACB30US4-6		71-00-02	32-1	225	-
BACB30US8K29		71-00-02	33-1	75	24
BACB30VF4K3		71-00-02	13-1	60	2
BACB30ZF3-06		71-00-02	25-1	225	1
BACB30ZF3-06		71-00-02	27-1	350	1
BACB30ZF3-08		71-00-02	14-1	205	3
BACB30ZF3-08		71-00-02	27-1	70	-
BACB30ZF3-08		71-00-02	27-1	70	2
BACB30ZF3-10		71-00-02	14-1	200	1
BACB30ZF3-28		71-00-02	14-1	15	3
BACB30ZF4-05		71-00-02	15-1	40	2
BACB30ZF4-05		71-00-02	15-1	135	2
BACB30ZF4-05		71-00-02	17-1	240	2
BACB30ZF4-06		71-00-02	4-1	120	2
BACB30ZF4-06		71-00-02	4-1	365	-

## NUMERICAL INDEX



737-600/700/800/900  
POWERPLANT BUILDUP MANUAL

PART NUMBER	AIRLINE PART NUMBER	LOCATION			QTY
		SUBJECT	FIG	ITEM	
BACB30ZF4-06		71-00-02	4-1	385	2
BACB30ZF4-06		71-00-02	4-1	615	2
BACB30ZF4-06		71-00-02	6-1	330	2
BACB30ZF4-06		71-00-02	7-1	105	5
BACB30ZF4-06		71-00-02	7-1	130	4
BACB30ZF4-06		71-00-02	7-1	280	2
BACB30ZF4-06		71-00-02	7-1	330	2
BACB30ZF4-06		71-00-02	8-1	130	2
BACB30ZF4-06		71-00-02	10-1	180	1
BACB30ZF4-06		71-00-02	17-1	20	2
BACB30ZF4-06		71-00-02	17-1	115	2
BACB30ZF4-06		71-00-02	21-1	130	1
BACB30ZF4-06		71-00-02	21-1	180	2
BACB30ZF4-06		71-00-02	24-1	115	3
BACB30ZF4-06		71-00-02	24-1	160	2
BACB30ZF4-06		71-00-02	24-1	215	3
BACB30ZF4-06		71-00-02	28-1	25	4
BACB30ZF4-06		71-00-02	28-1	50	2
BACB30ZF4-06		71-00-02	28-1	55	1
BACB30ZF4-06		71-00-02	28-1	150	4
BACB30ZF4-06		71-00-02	28-1	175	8
BACB30ZF4-06		71-00-02	28-1	275	2
BACB30ZF4-06		71-00-02	28-1	300	2
BACB30ZF4-06		71-00-02	28-1	302	2
BACB30ZF4-06		71-00-02	28-1	400	2
BACB30ZF4-06		71-00-02	28-1	425	1
BACB30ZF4-06		71-00-02	29-1	55	3
BACB30ZF4-07		71-00-02	5-1	335	-
BACB30ZF4-07		71-00-02	7-1	155	2
BACB30ZF4-07		71-00-02	7-1	205	3
BACB30ZF4-07		71-00-02	7-1	305	2
BACB30ZF4-07		71-00-02	7-1	355	2

# NUMERICAL INDEX



737-600/700/800/900  
POWERPLANT BUILDUP MANUAL

PART NUMBER	AIRLINE PART NUMBER	LOCATION			QTY
		SUBJECT	FIG	ITEM	
BACB30ZF4-07		71-00-02	8-1	30	1
BACB30ZF4-07		71-00-02	10-1	40	1
BACB30ZF4-07		71-00-02	10-1	60	2
BACB30ZF4-07		71-00-02	10-1	85	2
BACB30ZF4-07		71-00-02	12-1	55	4
BACB30ZF4-07		71-00-02	24-1	60	1
BACB30ZF4-07		71-00-02	24-1	170	2
BACB30ZF4-07		71-00-02	28-1	215	1
BACB30ZF4-07		71-00-02	28-1	250	4
BACB30ZF4-07		71-00-02	28-1	405	2
BACB30ZF4-07		71-00-02	29-1	60	1
BACB30ZF4-08		71-00-02	4-1	270	2
BACB30ZF4-08		71-00-02	4-1	485	1
BACB30ZF4-08		71-00-02	4-1	770	2
BACB30ZF4-08		71-00-02	5-1	350	2
BACB30ZF4-08		71-00-02	7-1	230	2
BACB30ZF4-08		71-00-02	8-1	10	1
BACB30ZF4-08		71-00-02	9-1	40	1
BACB30ZF4-08		71-00-02	9-1	85	1
BACB30ZF4-08		71-00-02	9-1	110	1
BACB30ZF4-08		71-00-02	9-1	160	3
BACB30ZF4-08		71-00-02	9-1	255	3
BACB30ZF4-08		71-00-02	10-1	15	2
BACB30ZF4-08		71-00-02	10-1	35	1
BACB30ZF4-08		71-00-02	10-1	115	1
BACB30ZF4-08		71-00-02	13-1	155	2
BACB30ZF4-08		71-00-02	14-1	280	4
BACB30ZF4-08		71-00-02	21-1	190	2
BACB30ZF4-08		71-00-02	21-1	240	5
BACB30ZF4-08		71-00-02	21-1	275	3
BACB30ZF4-08		71-00-02	21-1	315	1
BACB30ZF4-08		71-00-02	21-1	330	4

# NUMERICAL INDEX



737-600/700/800/900  
POWERPLANT BUILDUP MANUAL

PART NUMBER	AIRLINE PART NUMBER	LOCATION			QTY
		SUBJECT	FIG	ITEM	
BACB30ZF4-08		71-00-02	24-1	1	-
BACB30ZF4-08		71-00-02	24-1	161	2
BACB30ZF4-08		71-00-02	27-1	105	-
BACB30ZF4-08		71-00-02	28-1	276	1
BACB30ZF4-08		71-00-02	28-1	301	1
BACB30ZF4-08		71-00-02	29-1	30	4
BACB30ZF4-08		71-00-02	33-1	125	4
BACB30ZF4-09		71-00-02	5-1	105	2
BACB30ZF4-09		71-00-02	9-1	20	1
BACB30ZF4-10		71-00-02	4-1	370	2
BACB30ZF4-10		71-00-02	4-1	510	1
BACB30ZF4-10		71-00-02	5-1	85	2
BACB30ZF4-10		71-00-02	5-1	155	2
BACB30ZF4-10		71-00-02	5-1	255	2
BACB30ZF4-10		71-00-02	6-1	130	2
BACB30ZF4-10		71-00-02	6-1	180	1
BACB30ZF4-10		71-00-02	7-1	180	-
BACB30ZF4-10		71-00-02	10-1	135	2
BACB30ZF4-10		71-00-02	21-1	241	1
BACB30ZF4-10		71-00-02	21-1	280	1
BACB30ZF4-10		71-00-02	23-1	15	8
BACB30ZF4-10		71-00-02	27-1	10	1
BACB30ZF4-10		71-00-02	27-1	265	3
BACB30ZF4-11		71-00-02	4-1	80	2
BACB30ZF4-11		71-00-02	4-1	105	2
BACB30ZF4-12		71-00-02	4-1	10	2
BACB30ZF4-12		71-00-02	4-1	155	2
BACB30ZF4-12		71-00-02	4-1	765	1
BACB30ZF4-12		71-00-02	4-1	805	2
BACB30ZF4-12		71-00-02	4-1	830	2
BACB30ZF4-12		71-00-02	6-1	80	2
BACB30ZF4-12		71-00-02	6-1	355	1

# NUMERICAL INDEX



737-600/700/800/900  
POWERPLANT BUILDUP MANUAL

PART NUMBER	AIRLINE PART NUMBER	LOCATION			QTY
		SUBJECT	FIG	ITEM	
BACB30ZF4-12		71-00-02	6-1	455	2
BACB30ZF4-12		71-00-02	7-1	180	3
BACB30ZF4-12		71-00-02	21-1	355	2
BACB30ZF4-14		71-00-02	4-1	555	1
BACB30ZF4-14		71-00-02	4-1	760	1
BACB30ZF4-14		71-00-02	12-1	15	4
BACB30ZF4-22		71-00-02	6-1	410	1
BACB30ZF4-23		71-00-02	4-1	265	1
BACB30ZF4-23		71-00-02	4-1	605	2
BACB30ZF4-24		71-00-02	6-1	415	1
BACB30ZF4-24		71-00-02	29-1	10	2
BACB30ZF4-29		71-00-02	4-1	260	1
BACB30ZF4-32		71-00-02	21-1	50	3
BACB30ZF4-34		71-00-02	4-1	710	2
BACC10GF24CT		71-00-02	27-1	50	1
BACC10GT2-04		71-00-02	15-1	30	4
BACC10GT2-04		71-00-02	15-1	125	4
BACC10GT2-04		71-00-02	17-1	15	4
BACC10GT2-04		71-00-02	17-1	110	4
BACC10GT2-04		71-00-02	17-1	235	4
BACC10GT2-06		71-00-02	9-1	35	4
BACC10GT2-08		71-00-02	28-1	65	-
BACC10GT2-08		71-00-02	28-1	185	-
BACC10GT2-08		71-00-02	28-1	285	-
BACC10GT2-08		71-00-02	28-1	310	-
BACC10GT2-08		71-00-02	28-1	435	-
BACC10JB034C064		71-00-02	33-1	105	1
BACC14AD04J		71-00-02	25-1	200	-
BACE21BT0606JN		71-00-02	27-1	125	1
BACE21BT0606JN		71-00-02	27-1	140	1
BACE21BT0606T		71-00-02	21-1	100	1
BACJ40AC54-7		71-00-02	4-1	500	1

## NUMERICAL INDEX



737-600/700/800/900  
POWERPLANT BUILDUP MANUAL

PART NUMBER	AIRLINE PART NUMBER	LOCATION			QTY
		SUBJECT	FIG	ITEM	
BACJ40AC54-9		71-00-02	27-1	5	1
BACM10L1EBZ		71-00-02	30-1	5	1
BACM10L1EBZ		71-00-02	30-1	35	1
BACN10HR4C		71-00-02	32-1	145	3
BACN10HR4C		71-00-02	32-1	195	3
BACN10HR4C		71-00-02	32-1	240	85
BACN10HR5CS		71-00-02	22-1	30	-
BACN10HR5CS		71-00-02	22-1	110	-
BACN10HR5CS		71-00-02	22-1	125	-
BACN10HR8C		71-00-02	32-1	60	16
BACN10HR8CS		71-00-02	33-1	90	24
BACN10HY6AC		71-00-02	20-1	120	6
BACN10JC3C		71-00-02	28-1	105	-
BACN10JC3C		71-00-02	28-1	205	-
BACN10JC3C		71-00-02	28-1	355	-
BACN10JC3C		71-00-02	28-1	455	-
BACN10JC8CM		71-00-02	2-1	85	3
BACN10JC8CM		71-00-02	31-1	40	2
BACN10JC8CM		71-00-02	31-1	65	2
BACN10YR3C		71-00-02	28-1	105	-
BACN10YR3C		71-00-02	28-1	205	-
BACN10YR3C		71-00-02	28-1	355	-
BACN10YR3C		71-00-02	28-1	455	-
BACN10YR4CD		71-00-02	4-1	525	1
BACN10YR4CD		71-00-02	27-1	20	1
BACN10YR4CM		71-00-02	28-1	120	1
BACN10YR4CM		71-00-02	33-1	15	2
BACN11Z3CK		71-00-02	4-1	900	1
BACN11Z4CK		71-00-02	6-1	40	1
BACN11Z4CK		71-00-02	6-1	210	1
BACN11Z4CK		71-00-02	13-1	70	2
BACN11Z4CK		71-00-02	13-1	120	6

## NUMERICAL INDEX



737-600/700/800/900  
POWERPLANT BUILDUP MANUAL

PART NUMBER	AIRLINE PART NUMBER	LOCATION			QTY
		SUBJECT	FIG	ITEM	
BACN11Z4CK		71-00-02	13-1	270	2
BACN11Z8C		71-00-02	3-1	35	2
BACN11Z8C		71-00-02	3-1	65	2
BACP18BC03B06P		71-00-02	2-1	87	3
BACP18BC03B06P		71-00-02	3-1	40	-
BACP18BC03B06P		71-00-02	3-1	70	2
BACP18BC03B06P		71-00-02	31-1	42	2
BACP18BC03B06P		71-00-02	31-1	67	2
BACP18BC03B07P		71-00-02	2-1	87	-
BACP18BC03B07P		71-00-02	3-1	40	2
BACP18BC03B07P		71-00-02	3-1	70	-
BACP18BC03B07P		71-00-02	31-1	42	-
BACP18BC03B07P		71-00-02	31-1	67	-
BACP18BC03B08P		71-00-02	2-1	87	-
BACP18BC03B08P		71-00-02	3-1	40	-
BACP18BC03B08P		71-00-02	3-1	70	-
BACP18BC03B08P		71-00-02	31-1	42	-
BACP18BC03B08P		71-00-02	31-1	67	-
BACS12HN4U16		71-00-02	4-1	50	1
BACS18K25-39W		71-00-02	5-1	380	2
BACS18K25-45W		71-00-02	6-1	405	2
BACV10CE12		71-00-02	21-1	15	1
BACW10BN6UC		71-00-02	16-1	520	1
BACW10BP10ACU		71-00-02	2-1	105	4
BACW10BP12ACU		71-00-02	31-1	30	2
BACW10BP12ACU		71-00-02	31-1	55	2
BACW10BP14ACU		71-00-02	3-1	105	4
BACW10BP3ACU		71-00-02	4-1	880	1
BACW10BP4ACU		71-00-02	4-1	85	2
BACW10BP4ACU		71-00-02	4-1	110	2
BACW10BP4ACU		71-00-02	4-1	160	2
BACW10BP4ACU		71-00-02	4-1	560	1

## NUMERICAL INDEX





737-600/700/800/900  
POWERPLANT BUILDUP MANUAL

PART NUMBER	AIRLINE PART NUMBER	LOCATION			QTY
		SUBJECT	FIG	ITEM	
BACW10BP4ACU		71-00-02	4-1	635	1
BACW10BP4ACU		71-00-02	4-1	660	2
BACW10BP4ACU		71-00-02	4-1	780	1
BACW10BP4ACU		71-00-02	5-1	15	3
BACW10BP4ACU		71-00-02	5-1	35	2
BACW10BP4ACU		71-00-02	5-1	140	2
BACW10BP4ACU		71-00-02	5-1	185	3
BACW10BP4ACU		71-00-02	5-1	210	3
BACW10BP4ACU		71-00-02	5-1	235	2
BACW10BP4ACU		71-00-02	7-1	35	2
BACW10BP4ACU		71-00-02	7-1	60	2
BACW10BP4ACU		71-00-02	13-1	17	4
BACW10BP4ACU		71-00-02	16-1	15	1
BACW10BP4ACU		71-00-02	16-1	50	1
BACW10BP4ACU		71-00-02	16-1	405	1
BACW10BP4ACU		71-00-02	16-1	455	1
BACW10BP4ACU		71-00-02	21-1	150	1
BACW10BP4ACU		71-00-02	25-1	60	2
BACW10BP4ACU		71-00-02	25-1	130	2
BACW10BP4ACU		71-00-02	27-1	190	2
BACW10BP4ACU		71-00-02	27-1	325	2
BACW10BP4ACU		71-00-02	32-1	135	3
BACW10BP4ACU		71-00-02	32-1	185	3
BACW10BP4ACU		71-00-02	32-1	230	85
BACW10BP4APU		71-00-02	4-1	60	2
BACW10BP4CD		71-00-02	5-1	140	-
BACW10BP4CD		71-00-02	27-1	190	-
BACW10BP4PK		71-00-02	13-1	65	2
BACW10BP4PK		71-00-02	13-1	115	6
BACW10BP4PK		71-00-02	13-1	265	2
BACW10BP5ACU		71-00-02	4-1	960	2
BACW10BP5ACU		71-00-02	6-1	235	2

## NUMERICAL INDEX



737-600/700/800/900  
POWERPLANT BUILDUP MANUAL

PART NUMBER	AIRLINE PART NUMBER	LOCATION			QTY
		SUBJECT	FIG	ITEM	
BACW10BP5ACU		71-00-02	16-1	115	4
BACW10BP5ACU		71-00-02	22-1	25	3
BACW10BP5ACU		71-00-02	22-1	105	1
BACW10BP5ACU		71-00-02	22-1	120	1
BACW10BP5APU		71-00-02	22-1	106	1
BACW10BP5CD		71-00-02	22-1	25	-
BACW10BP5CD		71-00-02	22-1	105	-
BACW10BP5CD		71-00-02	22-1	120	-
BACW10BP6ACU		71-00-02	5-1	285	1
BACW10BP8ACU		71-00-02	2-1	25	10
BACW10BP8ACU		71-00-02	33-1	85	24
BACW10BP8APU		71-00-02	32-1	55	16
BACW10EC4M		71-00-02	4-1	55	1
BAC27DHY0337		71-00-02	30-1	25	1
BAC27DPP466		71-00-02	30-1	15	-
BAC27DPP470		71-00-02	30-1	15	1
B00083		71-00-02	28-1	C1	AR
B00083		71-00-02	30-1	C1	AR
B00130		71-00-02	4-1	C2	AR
B00130		71-00-02	5-1	C1	AR
B00130		71-00-02	6-1	C1	AR
B00130		71-00-02	7-1	C1	AR
B00130		71-00-02	8-1	C1	AR
B00130		71-00-02	14-1	C1	AR
B00130		71-00-02	27-1	C2	AR
B00571		71-00-02	30-1	C2	AR
B700-2		71-00-02	10-1	100	1
B71040-39		71-00-02	33-1	T1	-
C00944		71-00-02	4-1	C3	AR
C00944		71-00-02	13-1	C2	AR
C00944		71-00-02	27-1	C3	AR
C24002-41		71-00-02	22-1	T1	-

## NUMERICAL INDEX



737-600/700/800/900  
POWERPLANT BUILDUP MANUAL

PART NUMBER	AIRLINE PART NUMBER	LOCATION			QTY
		SUBJECT	FIG	ITEM	
C71024-1		71-00-02	3-1	T1	-
C71027-1		71-00-02	33-1	T3	-
C78009-33		71-00-02	32-1	T1	-
C78026-146		71-00-02	33-1	T4	-
D00006		71-00-02	2-1	C1	AR
D00006		71-00-02	3-1	C1	AR
D00006		71-00-02	7-1	C2	AR
D00006		71-00-02	9-1	C6	AR
D00006		71-00-02	10-1	C6	AR
D00006		71-00-02	13-1	C1	AR
D00006		71-00-02	14-1	C2	AR
D00006		71-00-02	15-1	C1	AR
D00006		71-00-02	16-1	C1	AR
D00006		71-00-02	17-1	C1	AR
D00006		71-00-02	18-1	C1	AR
D00006		71-00-02	22-1	C5	AR
D00006		71-00-02	23-1	C1	AR
D00006		71-00-02	24-1	C1	AR
D00006		71-00-02	25-1	C1	AR
D00006		71-00-02	27-1	C7	AR
D00006		71-00-02	28-1	C2	AR
D00006		71-00-02	29-1	C1	AR
D00006		71-00-02	31-1	C1	AR
D00006		71-00-02	32-1	C1	AR
D00054		71-00-02	20-1	C1	AR
D00054		71-00-02	21-1	C1	AR
D00109		71-00-02	22-1	C2	AR
D00153		71-00-02	20-1	C2	AR
D00173		71-00-02	21-1	C2	AR
D00254		71-00-02	22-1	C4	AR
D00276		71-00-02	20-1	C3	AR
D00504		71-00-02	9-1	C1	AR

## NUMERICAL INDEX



737-600/700/800/900  
POWERPLANT BUILDUP MANUAL

PART NUMBER	AIRLINE PART NUMBER	LOCATION			QTY
		SUBJECT	FIG	ITEM	
D00504		71-00-02	10-1	C1	AR
D00504		71-00-02	12-1	C1	AR
D00523		71-00-02	22-1	C3	AR
D00601		71-00-02	33-1	C1	AR
D00648		71-00-02	22-1	C1	AR
D50004		71-00-02	4-1	C7	AR
D50004		71-00-02	5-1	C2	AR
D50004		71-00-02	6-1	C6	AR
G00251		71-00-02	27-1	C1	AR
G01912		71-00-02	2-1	C2	AR
G01912		71-00-02	7-1	C4	AR
G01912		71-00-02	13-1	C7	AR
G01912		71-00-02	16-1	C2	AR
G01912		71-00-02	22-1	C7	AR
G01912		71-00-02	25-1	C2	AR
G01912		71-00-02	27-1	C8	AR
G02061		71-00-02	4-1	C1	AR
G02185		71-00-02	13-1	C5	AR
G50043		71-00-02	2-1	C4	AR
G50044		71-00-02	2-1	C5	-
G50375		71-00-02	2-1	C3	1
G50375		71-00-02	7-1	C3	3
G50375		71-00-02	13-1	C6	AR
G50375		71-00-02	16-1	C3	2
G50375		71-00-02	22-1	C6	1
G50375		71-00-02	25-1	C3	2
G50375		71-00-02	27-1	C9	2
J1221G06		71-00-02	9-1	15	1
J1221G06		71-00-02	9-1	30	2
J1221G06		71-00-02	9-1	80	2
J1221G06		71-00-02	9-1	105	1
J1221G06		71-00-02	9-1	155	3

## NUMERICAL INDEX



**737-600/700/800/900  
POWERPLANT BUILDUP MANUAL**

PART NUMBER	AIRLINE PART NUMBER	LOCATION			QTY
		SUBJECT	FIG	ITEM	
J1221G06		71-00-02	9-1	250	3
J1221G06		71-00-02	10-1	110	1
J1221G06		71-00-02	10-1	130	3
J1221G06		71-00-02	10-1	175	1
J1221G06		71-00-02	21-1	125	1
J1221G06		71-00-02	21-1	140	1
J1221G06		71-00-02	21-1	175	2
J1221G08		71-00-02	10-1	10	2
J1221G08		71-00-02	10-1	30	2
J1221G08		71-00-02	10-1	55	2
J1221G08		71-00-02	10-1	80	2
J1221G10		71-00-02	24-1	55	1
J1221G10		71-00-02	24-1	110	3
J1221G12		71-00-02	24-1	155	4
J1221G12		71-00-02	24-1	210	3
J1221G28		71-00-02	21-1	310	1
J1238P54		71-00-02	14-1	30	1
J1238P54		71-00-02	15-1	155	1
J522P52		71-00-02	14-1	160	2
J522P52		71-00-02	14-1	260	1
J522P52		71-00-02	16-1	155	1
J522P52		71-00-02	18-1	15	1
J522P53		71-00-02	14-1	85	2
J522P53		71-00-02	14-1	170	1
J522P53		71-00-02	14-1	270	1
J522P53		71-00-02	17-1	175	1
J522P53		71-00-02	18-1	25	1
MS21902-12T		71-00-02	20-1	10	1
MS21902-6T		71-00-02	20-1	80	1
MS21902-6T		71-00-02	21-1	30	1
MS21902J6		71-00-02	27-1	130	1
MS21914-4J		71-00-02	25-1	200	-

# NUMERICAL INDEX



737-600/700/800/900  
POWERPLANT BUILDUP MANUAL

PART NUMBER	AIRLINE PART NUMBER	LOCATION			QTY
		SUBJECT	FIG	ITEM	
MS21924-20T		71-00-02	20-1	55	1
MS21924J20		71-00-02	20-1	55	-
MS27198-24		71-00-02	12-1	5	1
MS35650-3254		71-00-02	4-1	65	1
M83248/1-216		71-00-02	22-1	55	-
NAS1057T3-050		71-00-02	14-1	10	3
NAS1057W4A-064		71-00-02	4-1	275	-
NAS1057W4A-080		71-00-02	4-1	280	-
NAS1057W4A025		71-00-02	13-1	220	-
NAS1057W4A025		71-00-02	13-1	255	-
NAS1149C0316R		71-00-02	25-1	230	1
NAS1149C0316R		71-00-02	27-1	355	1
NAS1149C0316R		71-00-02	28-1	100	2
NAS1149C0316R		71-00-02	28-1	200	2
NAS1149C0316R		71-00-02	28-1	350	2
NAS1149C0316R		71-00-02	28-1	450	2
NAS1149C0332R		71-00-02	28-1	100	-
NAS1149C0332R		71-00-02	28-1	200	-
NAS1149C0332R		71-00-02	28-1	350	-
NAS1149C0332R		71-00-02	28-1	450	-
NAS1149C0363R		71-00-02	27-1	75	-
NAS1149C0416R		71-00-02	13-1	25	AR
NAS1149C0432R		71-00-02	4-1	15	2
NAS1149C0432R		71-00-02	4-1	285	2
NAS1149C0432R		71-00-02	4-1	375	2
NAS1149C0432R		71-00-02	4-1	715	2
NAS1149C0432R		71-00-02	4-1	775	1
NAS1149C0432R		71-00-02	4-1	810	2
NAS1149C0432R		71-00-02	4-1	835	2
NAS1149C0432R		71-00-02	5-1	110	2
NAS1149C0432R		71-00-02	5-1	160	2
NAS1149C0432R		71-00-02	5-1	190	3

## NUMERICAL INDEX



737-600/700/800/900  
POWERPLANT BUILDUP MANUAL

PART NUMBER	AIRLINE PART NUMBER	LOCATION			QTY
		SUBJECT	FIG	ITEM	
NAS1149C0432R		71-00-02	5-1	260	2
NAS1149C0432R		71-00-02	6-1	35	1
NAS1149C0432R		71-00-02	6-1	85	4
NAS1149C0432R		71-00-02	6-1	135	2
NAS1149C0432R		71-00-02	6-1	185	1
NAS1149C0432R		71-00-02	6-1	205	1
NAS1149C0432R		71-00-02	6-1	360	1
NAS1149C0432R		71-00-02	6-1	420	2
NAS1149C0432R		71-00-02	6-1	460	2
NAS1149C0432R		71-00-02	8-1	15	1
NAS1149C0432R		71-00-02	10-1	140	2
NAS1149C0432R		71-00-02	13-1	20	AR
NAS1149C0432R		71-00-02	16-1	25	1
NAS1149C0432R		71-00-02	16-1	60	1
NAS1149C0432R		71-00-02	16-1	415	1
NAS1149C0432R		71-00-02	16-1	465	1
NAS1149C0432R		71-00-02	21-1	55	3
NAS1149C0432R		71-00-02	25-1	75	2
NAS1149C0432R		71-00-02	25-1	140	2
NAS1149C0432R		71-00-02	27-1	200	2
NAS1149C0432R		71-00-02	27-1	335	2
NAS1149C0432R		71-00-02	28-1	115	1
NAS1149C0432R		71-00-02	28-1	220	1
NAS1149C0463R		71-00-02	23-1	20	8
NAS1149C0632R		71-00-02	5-1	295	1
NAS1149D0416H		71-00-02	4-1	515	2
NAS1149D0416H		71-00-02	4-1	665	2
NAS1149D0416H		71-00-02	27-1	15	3
NAS1149E0332R		71-00-02	4-1	895	1
NAS1149E0432P		71-00-02	9-1	115	1
NAS1149E0432P		71-00-02	33-1	10	2
NAS1149E0432R		71-00-02	33-1	130	4

# NUMERICAL INDEX



737-600/700/800/900  
POWERPLANT BUILDUP MANUAL

PART NUMBER	AIRLINE PART NUMBER	LOCATION			QTY
		SUBJECT	FIG	ITEM	
NAS1149E0432R		71-00-02	33-1	135	1
NAS1149E0432R		71-00-02	33-1	255	1
NAS1149E0516P		71-00-02	22-1	27	2
NAS1149E0516P		71-00-02	22-1	122	1
NAS1149E0532P		71-00-02	22-1	26	4
NAS1149E0532P		71-00-02	22-1	121	1
NAS1149E0563R		71-00-02	22-1	28	3
NAS1149E0563R		71-00-02	22-1	107	1
NAS1149E0563R		71-00-02	22-1	123	1
NAS1149E0616R		71-00-02	16-1	505	4
NAS1149E0632R		71-00-02	16-1	530	1
NAS1611-024A		71-00-02	21-1	301	-
NAS1611-153A		71-00-02	20-1	100	-
NAS1612-12A		71-00-02	20-1	5	1
NAS1612-20A		71-00-02	20-1	50	1
NAS1612-6A		71-00-02	20-1	75	1
NAS1612-6A		71-00-02	21-1	10	1
NAS1612-6A		71-00-02	21-1	25	1
RC2769-1		71-00-02	4-1	890	1
RP235-00		71-00-02	33-1	200	-
SL4147CA10A		71-00-02	2-1	110	4
SL4147CA14EBSP1		71-00-02	3-1	110	4
S281A001-101		71-00-02	22-1	50	-
S281A001-501		71-00-02	22-1	75	-
S314A210-21		71-00-02	33-1	25	-
S314A210-5		71-00-02	33-1	25	-
S332A002-2		71-00-02	25-1	175	-
S332A102-1		71-00-02	14-1	100	-
S332A210-11		71-00-02	21-1	300	-
S332A210-16		71-00-02	21-1	200	-
S332A210-20		71-00-02	20-1	20	-
S332A210-21		71-00-02	21-1	225	-

## NUMERICAL INDEX





**737-600/700/800/900  
POWERPLANT BUILDUP MANUAL**

PART NUMBER	AIRLINE PART NUMBER	LOCATION			QTY
		SUBJECT	FIG	ITEM	
S332A210-23		71-00-02	21-1	75	-
S332A239-4		71-00-02	27-1	225	-
S332A240-2		71-00-02	24-1	200	-
S332A240-4		71-00-02	24-1	100	-
S332A260-1		71-00-02	23-1	5	-
S332A260-4		71-00-02	23-1	10	-
S332A280-5		71-00-02	12-1	10	-
S332T100-30		71-00-02	28-1	10	-
S332T100-38		71-00-02	28-1	20	-
S332T100-43		71-00-02	28-1	15	-
S332T100-44		71-00-02	28-1	5	-
S332W110-2		71-00-02	10-1	100	-
TAO910064-06		71-00-02	21-1	185	1
TAO910083		71-00-02	21-1	325	2
TAO910083		71-00-02	21-1	350	1
TAO910091H1		71-00-02	12-1	50	2
TA025146-15		71-00-02	29-1	25	5
TA025146-15		71-00-02	29-1	50	4
UA538551-3		71-00-02	23-1	5	1
U542648		71-00-02	23-1	10	1
VR1030-300		71-00-02	25-1	185	-
VR1030-300		71-00-02	25-1	260	-
VR1030-300		71-00-02	25-1	305	-
W93718		71-00-02	22-1	T2	-
W93718		71-00-02	32-1	T2	-
X-310A		71-00-02	30-1		-
0646C624-18		71-00-02	22-1	90	-
10-60555-7		71-00-02	21-1	5	-
10-62008-1		71-00-02	16-1	250	-
10-62008-22		71-00-02	14-1	5	-
10-62008-30		71-00-02	18-1	5	-
10-62008-32		71-00-02	16-1	150	-

# NUMERICAL INDEX



737-600/700/800/900  
POWERPLANT BUILDUP MANUAL

PART NUMBER	AIRLINE PART NUMBER	LOCATION			QTY
		SUBJECT	FIG	ITEM	
10-62008-33		71-00-02	14-1	75	-
10-62008-41		71-00-02	14-1	250	-
10-62167-3		71-00-02	20-1	15	-
107484-7		71-00-02	14-1	150	1
107492-6		71-00-02	14-1	250	1
115096-2		71-00-02	24-1	200	1
115096-4		71-00-02	24-1	100	1
11777-08		71-00-02	28-1	60	3
11777-08		71-00-02	28-1	180	8
11777-08		71-00-02	28-1	280	3
11777-08		71-00-02	28-1	305	5
11777-08		71-00-02	28-1	430	1
155006-06-16		71-00-02	21-1	200	1
155006-06-23		71-00-02	21-1	75	1
155012-12-21		71-00-02	21-1	225	1
155012-73-20		71-00-02	20-1	20	1
155016-20-11		71-00-02	21-1	300	1
16135-80		71-00-02	17-1	50	1
16135-80		71-00-02	17-1	275	1
16135-81		71-00-02	17-1	125	1
16135-83		71-00-02	17-1	75	1
16135-84		71-00-02	15-1	175	1
1794M49P01		71-00-02	15-1	35	2
1794M49P01		71-00-02	15-1	130	2
1794M49P01		71-00-02	17-1	10	2
1794M49P01		71-00-02	17-1	105	2
1794M49P01		71-00-02	17-1	230	2
21SN41-52		71-00-02	27-1	60	-
21SN41-52		71-00-02	27-1	60	1
286A1062		71-00-02	29-1	5	-
286A1062-002		71-00-02	29-1	5	1
30645-300		71-00-02	25-1	185	1

## NUMERICAL INDEX



**737-600/700/800/900  
POWERPLANT BUILDUP MANUAL**

PART NUMBER	AIRLINE PART NUMBER	LOCATION			QTY
		SUBJECT	FIG	ITEM	
30645-300		71-00-02	25-1	260	1
30645-300		71-00-02	25-1	305	1
310A2020-11		71-00-02	2-1	15	1
310A2020-6		71-00-02	2-1	20	2
310A2021-4		71-00-02	2-1	50	1
310A2029-11		71-00-02	2-1	5	8
310A2029-19		71-00-02	2-1	10	2
310A2030-17		71-00-02	3-1	5	1
310A2037-14		71-00-02	3-1	25	2
310A2037-15		71-00-02	3-1	50	1
310A2037-16		71-00-02	3-1	55	1
310A2039-1		71-00-02	3-1	30	2
310A2039-2		71-00-02	3-1	60	2
310A2040-7		71-00-02	2-1	78	2
310A2040-7		71-00-02	31-1	32	1
310A2040-7		71-00-02	31-1	57	1
310A2041-10		71-00-02	31-1	10	1
310A2041-9		71-00-02	31-1	5	1
310A2042-3		71-00-02	2-1	75	3
310A2042-3		71-00-02	31-1	25	2
310A2042-3		71-00-02	31-1	50	2
310A2043-1		71-00-02	2-1	80	3
310A2043-1		71-00-02	31-1	35	2
310A2043-1		71-00-02	31-1	60	2
314-2100-2		71-00-02	33-1	25	-
314-2100-3		71-00-02	33-1	25	1
314A2610-1		71-00-02	32-1	100	-
314A2610-62		71-00-02	32-1	100	1
314A2620-1		71-00-02	32-1	5	-
314A2620-1		71-00-02	32-1	5	1
314A2620-2		71-00-02	32-1	10	-
314A2620-5		71-00-02	32-1	20	-

# NUMERICAL INDEX



**737-600/700/800/900  
POWERPLANT BUILDUP MANUAL**

PART NUMBER	AIRLINE PART NUMBER	LOCATION			QTY
		SUBJECT	FIG	ITEM	
314T3019-3		71-00-02	33-1	5	2
315A2080-1		71-00-02	13-1	72	-
315A2080-4		71-00-02	13-1	72	1
315A2081-5		71-00-02	13-1	80	-
315A2083-1		71-00-02	13-1	75	-
3202222-1		71-00-02	16-1	250	1
320548-2		71-00-02	14-1	5	1
3214446-4		71-00-02	16-1	150	1
3214552-5		71-00-02	18-1	5	1
3215618-4		71-00-02	27-1	225	1
322U2338-2		71-00-02	25-1	55	2
3289562-5		71-00-02	14-1	75	1
3289630-2		71-00-02	25-1	175	1
332A1325-1		71-00-02	27-1	55	-
332A1325-1		71-00-02	27-1	55	1
332A2240-1		71-00-02	24-1	50	1
332A2240-10		71-00-02	24-1	5	1
332A2240-11		71-00-02	24-1	150	1
332A2310-4		71-00-02	25-1	250	1
332A2313-1		71-00-02	25-1	100	1
332A2321-10		71-00-02	16-1	200	1
332A2322-54		71-00-02	16-1	300	1
332A2323-14		71-00-02	16-1	105	1
332A2326-45		71-00-02	18-1	100	1
332A2341-2		71-00-02	27-1	185	1
332A2341-3		71-00-02	27-1	180	1
332A2341-4		71-00-02	16-1	10	1
332A2341-5		71-00-02	16-1	45	1
332A2350-1		71-00-02	27-1	145	1
332A2350-11		71-00-02	15-1	55	1
332A2350-12		71-00-02	17-1	200	1
332A2350-13		71-00-02	17-1	225	1

# NUMERICAL INDEX



737-600/700/800/900  
POWERPLANT BUILDUP MANUAL

PART NUMBER	AIRLINE PART NUMBER	LOCATION			QTY
		SUBJECT	FIG	ITEM	
332A2350-14		71-00-02	17-1	150	1
332A2350-4		71-00-02	15-1	100	1
332A2350-5		71-00-02	17-1	5	1
332A2350-7		71-00-02	17-1	100	1
332A2350-9		71-00-02	15-1	5	1
332A2371-3		71-00-02	13-1	5	1
332A2372-3		71-00-02	13-1	50	1
332A2372-4		71-00-02	13-1	55	1
332A2373-1		71-00-02	13-1	30	AR
332A2373-2		71-00-02	13-1	35	AR
332A2374-10		71-00-02	13-1	205	-
332A2374-13		71-00-02	13-1	200	1
332A2374-14		71-00-02	13-1	205	1
332A2374-9		71-00-02	13-1	200	-
332A2376-1		71-00-02	13-1	225	-
332A2376-1		71-00-02	13-1	260	-
332A2390-12		71-00-02	27-1	250	1
332A2390-3		71-00-02	27-1	100	-
332A2390-43		71-00-02	13-1	10	-
332A2390-45		71-00-02	13-1	10	1
332A2390-48		71-00-02	27-1	100	1
332A2410-1		71-00-02	21-1	110	1
332A2600-4		71-00-02	22-1	5	1
332A2600-5		71-00-02	22-1	10	1
332A2600-6		71-00-02	22-1	15	1
332A2710-1		71-00-02	9-1	10	1
332A2710-11		71-00-02	9-1	125	-
332A2710-13		71-00-02	9-1	150	1
332A2710-15		71-00-02	9-1	200	1
332A2710-25		71-00-02	10-1	105	1
332A2710-27		71-00-02	9-1	225	1
332A2710-3		71-00-02	9-1	5	1

## NUMERICAL INDEX



737-600/700/800/900  
POWERPLANT BUILDUP MANUAL

PART NUMBER	AIRLINE PART NUMBER	LOCATION			QTY
		SUBJECT	FIG	ITEM	
332A2710-30		71-00-02	9-1	100	-
332A2710-31		71-00-02	10-1	75	1
332A2710-32		71-00-02	10-1	5	1
332A2710-33		71-00-02	10-1	50	1
332A2710-36		71-00-02	9-1	75	1
332A2710-38		71-00-02	9-1	100	1
332A2910-1		71-00-02	27-1	65	-
332A2910-101		71-00-02	5-1	225	1
332A2910-104		71-00-02	5-1	375	1
332A2910-106		71-00-02	7-1	275	1
332A2910-108		71-00-02	7-1	325	1
332A2910-11		71-00-02	7-1	225	1
332A2910-111		71-00-02	7-1	150	1
332A2910-112		71-00-02	5-1	100	1
332A2910-125		71-00-02	4-1	700	1
332A2910-128		71-00-02	7-1	200	1
332A2910-130		71-00-02	4-1	400	1
332A2910-132		71-00-02	4-1	450	1
332A2910-134		71-00-02	5-1	75	1
332A2910-136		71-00-02	4-1	755	1
332A2910-138		71-00-02	4-1	625	1
332A2910-141		71-00-02	5-1	375	-
332A2910-143		71-00-02	4-1	75	1
332A2910-24		71-00-02	5-1	5	1
332A2910-26		71-00-02	6-1	325	1
332A2910-39		71-00-02	7-1	300	1
332A2910-41		71-00-02	4-1	505	1
332A2910-46		71-00-02	4-1	400	-
332A2910-48		71-00-02	4-1	450	-
332A2910-51		71-00-02	6-1	400	1
332A2910-67		71-00-02	5-1	325	-
332A2910-69		71-00-02	5-1	75	-

## NUMERICAL INDEX



737-600/700/800/900  
POWERPLANT BUILDUP MANUAL

PART NUMBER	AIRLINE PART NUMBER	LOCATION			QTY
		SUBJECT	FIG	ITEM	
332A2910-74		71-00-02	5-1	150	1
332A2910-87		71-00-02	4-1	355	-
332A2910-89		71-00-02	4-1	755	-
332A2910-91		71-00-02	4-1	625	-
332A2910-95		71-00-02	6-1	125A	-
332A2910-96		71-00-02	6-1	125B	-
332A2910-99		71-00-02	6-1	125	1
332A2911-1		71-00-02	5-1	275	1
332A2911-2		71-00-02	5-1	175	1
332A2911-5		71-00-02	5-1	200	1
332A2911-9		71-00-02	8-1	125	1
332A2920-110		71-00-02	5-1	25	-
332A2920-115		71-00-02	4-1	360	-
332A2920-117		71-00-02	4-1	255	-
332A2920-119		71-00-02	5-1	250	1
332A2920-124		71-00-02	7-1	25	-
332A2920-131		71-00-02	4-1	250	-
332A2920-132		71-00-02	6-1	175	2
332A2920-142		71-00-02	4-1	150	1
332A2920-143		71-00-02	7-1	100	-
332A2920-15		71-00-02	4-1	825	1
332A2920-157		71-00-02	4-1	250	1
332A2920-178		71-00-02	4-1	325	1
332A2920-179		71-00-02	7-1	175	1
332A2920-182		71-00-02	5-1	330	-
332A2920-185		71-00-02	7-1	125	1
332A2920-193		71-00-02	5-1	25	1
332A2920-197		71-00-02	4-1	350	1
332A2920-199		71-00-02	7-1	100	1
332A2920-201		71-00-02	7-1	25	1
332A2920-222		71-00-02	4-1	800	1
332A2920-224		71-00-02	4-1	750	1

## NUMERICAL INDEX



737-600/700/800/900  
POWERPLANT BUILDUP MANUAL

PART NUMBER	AIRLINE PART NUMBER	LOCATION			QTY
		SUBJECT	FIG	ITEM	
332A2920-225		71-00-02	7-1	55	1
332A2920-228		71-00-02	4-1	600	1
332A2920-229		71-00-02	4-1	5	1
332A2920-230		71-00-02	8-1	5	1
332A2920-232		71-00-02	4-1	100	1
332A2920-235		71-00-02	5-1	330	1
332A2920-29		71-00-02	6-1	175	-
332A2920-39		71-00-02	7-1	125	-
332A2920-48		71-00-02	6-1	450	1
332A2920-55		71-00-02	7-1	350	1
332A2920-92		71-00-02	5-1	80	1
332A2920-92		71-00-02	5-1	130	1
332A2921-1		71-00-02	8-1	25	1
332A2930-1		71-00-02	6-1	50	1
332A2930-1		71-00-02	6-1	75	1
332A2930-17		71-00-02	7-1	175	-
332A2930-26		71-00-02	6-1	405	-
332A2930-30		71-00-02	4-1	325	-
332A2930-33		71-00-02	4-1	550	-
332A2930-49		71-00-02	14-1	10	-
332A2930-54		71-00-02	5-1	330	-
332A2930-57		71-00-02	4-1	700	-
332A2930-60		71-00-02	5-1	380	-
332A2930-61		71-00-02	4-1	950	1
332A2930-62		71-00-02	6-1	225	1
332A2930-7		71-00-02	4-1	650	1
332A2930-85		71-00-02	4-1	550	1
332A2930-88		71-00-02	4-1	705	1
332A2930-89		71-00-02	4-1	602	1
332A2930-90		71-00-02	6-1	350	1
332A2931-3		71-00-02	5-1	125	1
332T3323-2		71-00-02	20-1	110	1

## NUMERICAL INDEX





**737-600/700/800/900  
POWERPLANT BUILDUP MANUAL**

PART NUMBER	AIRLINE PART NUMBER	LOCATION			QTY
		SUBJECT	FIG	ITEM	
332W1910-9		71-00-02	24-1	220	3
332W3130-18		71-00-02	21-1	245	3
332W3130-18		71-00-02	21-1	285	2
332W5101-10		71-00-02	21-1	250	3
332W5101-10		71-00-02	21-1	290	2
333A2020-5		71-00-02	32-1	130	1
333A2020-5		71-00-02	32-1	180	1
334A2010-1		71-00-02	33-1	80	24
340-087-904-0		71-00-02	24-1	2	-
370D1005-5		71-00-02	6-1	30	1
370D1005-5		71-00-02	6-1	200	1
387999		71-00-02	20-1	105	-
60B90135-80		71-00-02	17-1	50	-
60B90135-80		71-00-02	17-1	275	-
60B90135-81		71-00-02	17-1	125	-
60B90135-83		71-00-02	17-1	75	-
60B90135-84		71-00-02	15-1	175	-
649-304-004-0		71-00-02	33-1	270	-
649-341-011-0		71-00-02	33-1	260	-
683-3-20		71-00-02	30-1		-
69A94		71-00-02	33-1	250	-
731476		71-00-02	22-1	85	-
7579078		71-00-02	21-1	5	1
761574		71-00-02	22-1	50	-
761574B		71-00-02	22-1	50	1
762075		71-00-02	22-1	80	-
762246		71-00-02	22-1	75	1
801A50-0004A		71-00-02	14-1	25	1
801A50-0004A		71-00-02	15-1	150	1
801A50-0005A		71-00-02	14-1	155	2
801A50-0005A		71-00-02	14-1	255	1
801A50-0005A		71-00-02	16-1	160	1

# NUMERICAL INDEX



**737-600/700/800/900  
POWERPLANT BUILDUP MANUAL**

PART NUMBER	AIRLINE PART NUMBER	LOCATION			QTY
		SUBJECT	FIG	ITEM	
801A50-0005A		71-00-02	18-1	10	1
801A50-0006A		71-00-02	14-1	80	2
801A50-0006A		71-00-02	14-1	165	1
801A50-0006A		71-00-02	14-1	265	1
801A50-0006A		71-00-02	17-1	180	1
801A50-0006A		71-00-02	18-1	20	1
801A50-0006A		71-00-02	18-1	30	1
801A50-0006A		71-00-02	27-1	135	1
82C10020-1		71-00-02	14-1	100	1
849589		71-00-02	20-1	15	1
8757-350		71-00-02	16-1	110	1
902016-01		71-00-02	28-1	10	1
902018-01		71-00-02	28-1	20	1
902862		71-00-02	28-1	15	1
902864		71-00-02	28-1	5	1
9134M25P29		71-00-02	13-1	150	1
9352M41P03		71-00-02	9-1	35	-
9352M41P04		71-00-02	28-1	65	6
9352M41P04		71-00-02	28-1	185	16
9352M41P04		71-00-02	28-1	285	6
9352M41P04		71-00-02	28-1	310	10
9352M41P04		71-00-02	28-1	435	2
9352M41P16		71-00-02	15-1	30	-
9352M41P16		71-00-02	15-1	125	-
9352M41P16		71-00-02	17-1	15	-
9352M41P16		71-00-02	17-1	110	-
9352M41P16		71-00-02	17-1	235	-
974219		71-00-02	20-1	150	-

# NUMERICAL INDEX

**CHAPTER**

**71**

**POWERPLANT  
BUILDUP**

**737-600/700/800/900  
POWERPLANT BUILDUP MANUAL**

**CHAPTER 71**

Subject/Page	Date	COC	Subject/Page	Date	COC	Subject/Page	Date	COC
EFFECTIVE PAGES			71-00-02 P/P BUILDUP FIGURE 4-1			71-00-02 P/P BUILDUP FIGURE 4-1		
1 thru 6	Feb 05/2008		1	Oct 05/2007		(cont)		
71-CONTENTS			2	Oct 05/2007		40	Oct 05/2007	
1	Oct 05/2007		3	Oct 05/2007		41	Oct 05/2007	
2	Oct 05/2007		4	Oct 05/2007		42	Oct 05/2007	
71-00-02 SUBJECT INDEX FIGURE 1-1			5	Oct 05/2007		43	Oct 05/2007	
1	Oct 05/2007		6	Oct 05/2007		44	Oct 05/2007	
2	Oct 05/2007		7	Oct 05/2007		45	Oct 05/2007	
R 3	Feb 05/2008		8	Oct 05/2007		R 46	Feb 05/2008	
4	Oct 05/2007		9	Oct 05/2007		47	Oct 05/2007	
5	Oct 05/2007		10	Oct 05/2007		48	Oct 05/2007	
6	Oct 05/2007		11	Oct 05/2007		49	Oct 05/2007	
7	Oct 05/2007		12	Oct 05/2007		50	Oct 05/2007	
8	BLANK		13	Oct 05/2007		51	Oct 05/2007	
71-00-02 P/P BUILDUP FIGURE 2-1			14	Oct 05/2007		52	Oct 05/2007	
1	Oct 05/2007		15	Oct 05/2007		53	Oct 05/2007	
2	Oct 05/2007		16	Oct 05/2007		54	Oct 05/2007	
3	Oct 05/2007		17	Oct 05/2007		55	Oct 05/2007	
4	Oct 05/2007		18	Oct 05/2007		56	BLANK	
R 5	Feb 05/2008		19	Oct 05/2007		71-00-02 P/P BUILDUP FIGURE 5-1		
6	Oct 05/2007		20	Oct 05/2007		1	Oct 05/2007	
7	Oct 05/2007		21	Oct 05/2007		2	Oct 05/2007	
8	Oct 05/2007		22	Oct 05/2007		3	Oct 05/2007	
9	Oct 05/2007		23	Oct 05/2007		4	Oct 05/2007	
10	Oct 05/2007		24	Oct 05/2007		5	Oct 05/2007	
11	Oct 05/2007		25	Oct 05/2007		6	Oct 05/2007	
12	BLANK		26	Oct 05/2007		7	Oct 05/2007	
71-00-02 P/P BUILDUP FIGURE 3-1			27	Oct 05/2007		8	Oct 05/2007	
1	Oct 05/2007		28	Oct 05/2007		9	Oct 05/2007	
2	Oct 05/2007		29	Oct 05/2007		10	Oct 05/2007	
3	Oct 05/2007		30	Oct 05/2007		11	Oct 05/2007	
4	Oct 05/2007		31	Oct 05/2007		12	Oct 05/2007	
R 5	Feb 05/2008		32	Oct 05/2007		13	Oct 05/2007	
6	Oct 05/2007		33	Oct 05/2007		14	Oct 05/2007	
R 7	Feb 05/2008		34	Oct 05/2007		15	Oct 05/2007	
8	Oct 05/2007		35	Oct 05/2007		16	Oct 05/2007	
9	Oct 05/2007		36	Oct 05/2007		17	Oct 05/2007	
10	BLANK		37	Oct 05/2007		18	Oct 05/2007	
			38	Oct 05/2007		19	Oct 05/2007	
			39	Oct 05/2007		20	Oct 05/2007	

A = Added, R = Revised, O = Overflow, D = Deleted, C = Customer Originated Change

## 71-EFFECTIVE PAGES

**737-600/700/800/900  
POWERPLANT BUILDUP MANUAL**

**CHAPTER 71**

Subject/Page	Date	COC	Subject/Page	Date	COC	Subject/Page	Date	COC
71-00-02 P/P BUILDUP FIGURE 5-1 (cont)			71-00-02 P/P BUILDUP FIGURE 7-1			71-00-02 P/P BUILDUP FIGURE 8-1 (cont)		
21	Oct 05/2007		1	Oct 05/2007		9	Oct 05/2007	
22	Oct 05/2007		2	Oct 05/2007		10	Oct 05/2007	
23	Oct 05/2007		3	Oct 05/2007		11	Oct 05/2007	
24	Oct 05/2007		4	Oct 05/2007		12	BLANK	
R 25	Feb 05/2008		5	Oct 05/2007		71-00-02 P/P BUILDUP FIGURE 9-1		
26	Oct 05/2007		6	Oct 05/2007		1	Oct 05/2007	
27	Oct 05/2007		7	Oct 05/2007		2	Oct 05/2007	
28	Oct 05/2007		8	Oct 05/2007		3	Oct 05/2007	
29	Oct 05/2007		9	Oct 05/2007		4	Oct 05/2007	
30	BLANK		10	Oct 05/2007		5	Oct 05/2007	
71-00-02 P/P BUILDUP FIGURE 6-1			R 11	Feb 05/2008		6	Oct 05/2007	
1	Oct 05/2007		12	Oct 05/2007		7	Oct 05/2007	
2	Oct 05/2007		13	Oct 05/2007		8	Oct 05/2007	
3	Oct 05/2007		14	Oct 05/2007		9	Oct 05/2007	
4	Oct 05/2007		15	Oct 05/2007		10	Oct 05/2007	
5	Oct 05/2007		16	Oct 05/2007		11	Oct 05/2007	
6	Oct 05/2007		17	Oct 05/2007		12	Oct 05/2007	
7	Oct 05/2007		18	Oct 05/2007		13	Oct 05/2007	
8	Oct 05/2007		19	Oct 05/2007		14	Oct 05/2007	
9	Oct 05/2007		20	Oct 05/2007		15	Oct 05/2007	
10	Oct 05/2007		21	Oct 05/2007		16	Oct 05/2007	
11	Oct 05/2007		22	Oct 05/2007		17	Oct 05/2007	
12	Oct 05/2007		23	Oct 05/2007		18	BLANK	
13	Oct 05/2007		24	Oct 05/2007		71-00-02 P/P BUILDUP FIGURE 10-1		
14	Oct 05/2007		25	Oct 05/2007		1	Oct 05/2007	
15	Oct 05/2007		26	Oct 05/2007		2	Oct 05/2007	
16	Oct 05/2007		27	Oct 05/2007		3	Oct 05/2007	
17	Oct 05/2007		28	Oct 05/2007		4	Oct 05/2007	
18	Oct 05/2007		29	Oct 05/2007		5	Oct 05/2007	
19	Oct 05/2007		30	BLANK		6	Oct 05/2007	
20	Oct 05/2007		71-00-02 P/P BUILDUP FIGURE 8-1			7	Oct 05/2007	
21	Oct 05/2007		1	Oct 05/2007		8	Oct 05/2007	
22	Oct 05/2007		2	Oct 05/2007		9	Oct 05/2007	
23	Oct 05/2007		3	Oct 05/2007		10	Oct 05/2007	
24	Oct 05/2007		4	Oct 05/2007		11	Oct 05/2007	
25	Oct 05/2007		5	Oct 05/2007		12	Oct 05/2007	
26	BLANK		6	Oct 05/2007		13	Oct 05/2007	
			7	Oct 05/2007		R 14	Feb 05/2008	
			8	Oct 05/2007				

A = Added, R = Revised, O = Overflow, D = Deleted, C = Customer Originated Change

## 71-EFFECTIVE PAGES

**737-600/700/800/900  
POWERPLANT BUILDUP MANUAL**

**CHAPTER 71**

Subject/Page	Date	COC	Subject/Page	Date	COC	Subject/Page	Date	COC
71-00-02 P/P BUILDUP FIGURE 10-1 (cont)			71-00-02 P/P BUILDUP FIGURE 13-1 (cont)			71-00-02 P/P BUILDUP FIGURE 15-1 (cont)		
15	Oct 05/2007		24	Oct 05/2007		10	Oct 05/2007	
16	BLANK		25	Oct 05/2007		11	Oct 05/2007	
71-00-02 P/P BUILDUP FIGURE 11-1			26	BLANK		12	Oct 05/2007	
1	Oct 05/2007		71-00-02 P/P BUILDUP FIGURE 14-1			13	Oct 05/2007	
2	Oct 05/2007		1	Oct 05/2007		14	BLANK	
3	Oct 05/2007		2	Oct 05/2007		71-00-02 P/P BUILDUP FIGURE 16-1		
4	BLANK		3	Oct 05/2007		1	Oct 05/2007	
71-00-02 P/P BUILDUP FIGURE 12-1			4	Oct 05/2007		2	Oct 05/2007	
1	Oct 05/2007		5	Oct 05/2007		3	Oct 05/2007	
2	Oct 05/2007		6	Oct 05/2007		4	Oct 05/2007	
3	Oct 05/2007		7	Oct 05/2007		5	Oct 05/2007	
4	Oct 05/2007		8	Oct 05/2007		6	Oct 05/2007	
5	Oct 05/2007		9	Oct 05/2007		R 7	Feb 05/2008	
6	BLANK		10	Oct 05/2007		8	Oct 05/2007	
71-00-02 P/P BUILDUP FIGURE 13-1			11	Oct 05/2007		9	Oct 05/2007	
1	Oct 05/2007		12	Oct 05/2007		10	Oct 05/2007	
2	Oct 05/2007		13	Oct 05/2007		11	Oct 05/2007	
R 3	Feb 05/2008		14	Oct 05/2007		12	Oct 05/2007	
4	Oct 05/2007		15	Oct 05/2007		13	Oct 05/2007	
5	Oct 05/2007		16	Oct 05/2007		14	Oct 05/2007	
6	Oct 05/2007		17	Oct 05/2007		15	Oct 05/2007	
7	Oct 05/2007		18	Oct 05/2007		16	Oct 05/2007	
8	Oct 05/2007		19	Oct 05/2007		17	Oct 05/2007	
9	Oct 05/2007		20	Oct 05/2007		18	Oct 05/2007	
10	Oct 05/2007		21	Oct 05/2007		19	Oct 05/2007	
11	Oct 05/2007		22	Oct 05/2007		20	Oct 05/2007	
12	Oct 05/2007		23	Oct 05/2007		21	Oct 05/2007	
13	Oct 05/2007		24	BLANK		22	Oct 05/2007	
14	Oct 05/2007		71-00-02 P/P BUILDUP FIGURE 15-1			R 23	Feb 05/2008	
15	Oct 05/2007		1	Oct 05/2007		24	Oct 05/2007	
16	Oct 05/2007		2	Oct 05/2007		25	Oct 05/2007	
17	Oct 05/2007		3	Oct 05/2007		26	BLANK	
18	Oct 05/2007		4	Oct 05/2007		71-00-02 P/P BUILDUP FIGURE 17-1		
19	Oct 05/2007		5	Oct 05/2007		1	Oct 05/2007	
20	Oct 05/2007		6	Oct 05/2007		2	Oct 05/2007	
21	Oct 05/2007		7	Oct 05/2007		3	Oct 05/2007	
22	Oct 05/2007		8	Oct 05/2007		4	Oct 05/2007	
23	Oct 05/2007		9	Oct 05/2007		5	Oct 05/2007	

A = Added, R = Revised, O = Overflow, D = Deleted, C = Customer Originated Change

## 71-EFFECTIVE PAGES

**737-600/700/800/900  
POWERPLANT BUILDUP MANUAL**

**CHAPTER 71**

Subject/Page	Date	COC	Subject/Page	Date	COC	Subject/Page	Date	COC
71-00-02 P/P BUILDUP FIGURE 17-1 (cont)			71-00-02 P/P BUILDUP FIGURE 20-1 (cont)			71-00-02 P/P BUILDUP FIGURE 21-1 (cont)		
6	Oct 05/2007		3	Oct 05/2007		26	Oct 05/2007	
7	Oct 05/2007		4	Oct 05/2007		27	Oct 05/2007	
8	Oct 05/2007		5	Oct 05/2007		28	Oct 05/2007	
9	Oct 05/2007		6	Oct 05/2007		29	Oct 05/2007	
10	Oct 05/2007		7	Oct 05/2007		30	Oct 05/2007	
11	Oct 05/2007		8	Oct 05/2007		71-00-02 P/P BUILDUP FIGURE 22-1		
12	Oct 05/2007		9	Oct 05/2007		1	Oct 05/2007	
13	Oct 05/2007		10	Oct 05/2007		2	Oct 05/2007	
14	Oct 05/2007		11	Oct 05/2007		3	Oct 05/2007	
15	Oct 05/2007		12	Oct 05/2007		R 4	Feb 05/2008	
16	Oct 05/2007		13	Oct 05/2007		R 5	Feb 05/2008	
17	Oct 05/2007		14	BLANK		6	Oct 05/2007	
18	Oct 05/2007		71-00-02 P/P BUILDUP FIGURE 21-1			7	Oct 05/2007	
19	Oct 05/2007		1	Oct 05/2007		8	Oct 05/2007	
20	Oct 05/2007		2	Oct 05/2007		9	Oct 05/2007	
21	Oct 05/2007		3	Oct 05/2007		10	Oct 05/2007	
22	BLANK		4	Oct 05/2007		R 11	Feb 05/2008	
71-00-02 P/P BUILDUP FIGURE 18-1			5	Oct 05/2007		12	Oct 05/2007	
1	Oct 05/2007		6	Oct 05/2007		13	Oct 05/2007	
2	Oct 05/2007		7	Oct 05/2007		14	Oct 05/2007	
3	Oct 05/2007		8	Oct 05/2007		15	Oct 05/2007	
4	Oct 05/2007		9	Oct 05/2007		16	BLANK	
5	Oct 05/2007		10	Oct 05/2007		71-00-02 P/P BUILDUP FIGURE 23-1		
6	Oct 05/2007		11	Oct 05/2007		1	Oct 05/2007	
7	Oct 05/2007		12	Oct 05/2007		2	Oct 05/2007	
8	Oct 05/2007		13	Oct 05/2007		3	Oct 05/2007	
9	Oct 05/2007		14	Oct 05/2007		4	BLANK	
10	Oct 05/2007		15	Oct 05/2007		71-00-02 P/P BUILDUP FIGURE 24-1		
11	Oct 05/2007		16	Oct 05/2007		1	Oct 05/2007	
12	BLANK		17	Oct 05/2007		2	Oct 05/2007	
71-00-02 P/P BUILDUP FIGURE 19-1			18	Oct 05/2007		3	Oct 05/2007	
1	Oct 05/2007		19	Oct 05/2007		4	Oct 05/2007	
2	Oct 05/2007		20	Oct 05/2007		5	Oct 05/2007	
3	Oct 05/2007		21	Oct 05/2007		6	Oct 05/2007	
4	BLANK		22	Oct 05/2007		7	Oct 05/2007	
71-00-02 P/P BUILDUP FIGURE 20-1			23	Oct 05/2007		8	Oct 05/2007	
1	Oct 05/2007		24	Oct 05/2007		9	Oct 05/2007	
2	Oct 05/2007		25	Oct 05/2007		10	Oct 05/2007	

A = Added, R = Revised, O = Overflow, D = Deleted, C = Customer Originated Change

## 71-EFFECTIVE PAGES

**737-600/700/800/900  
POWERPLANT BUILDUP MANUAL**

**CHAPTER 71**

Subject/Page	Date	COC	Subject/Page	Date	COC	Subject/Page	Date	COC
71-00-02 P/P BUILDUP FIGURE 24-1 (cont)			71-00-02 P/P BUILDUP FIGURE 26-1			71-00-02 P/P BUILDUP FIGURE 28-1 (cont)		
11	Oct 05/2007		1	Oct 05/2007		10	Oct 05/2007	
12	Oct 05/2007		2	Oct 05/2007		11	Oct 05/2007	
13	Oct 05/2007		3	Oct 05/2007		12	Oct 05/2007	
14	Oct 05/2007		4	BLANK		13	Oct 05/2007	
15	Oct 05/2007		71-00-02 P/P BUILDUP FIGURE 27-1			14	Oct 05/2007	
16	Oct 05/2007		1	Oct 05/2007		15	Oct 05/2007	
17	Oct 05/2007		2	Oct 05/2007		16	Oct 05/2007	
18	Oct 05/2007		3	Oct 05/2007		17	Oct 05/2007	
19	Oct 05/2007		4	Oct 05/2007		18	Oct 05/2007	
20	Oct 05/2007		5	Oct 05/2007		19	Oct 05/2007	
21	Oct 05/2007		6	Oct 05/2007		20	Oct 05/2007	
22	Oct 05/2007		7	Oct 05/2007		21	Oct 05/2007	
23	Oct 05/2007		8	Oct 05/2007		R 22	Feb 05/2008	
24	BLANK		9	Oct 05/2007		R 23	Feb 05/2008	
71-00-02 P/P BUILDUP FIGURE 25-1			10	Oct 05/2007		R 24	Feb 05/2008	
1	Oct 05/2007		11	Oct 05/2007		O 25	Feb 05/2008	
2	Oct 05/2007		12	Oct 05/2007		R 26	Feb 05/2008	
3	Oct 05/2007		13	Oct 05/2007		O 27	Feb 05/2008	
4	Oct 05/2007		14	Oct 05/2007		R 28	Feb 05/2008	
5	Oct 05/2007		15	Oct 05/2007		O 29	Feb 05/2008	
6	Oct 05/2007		16	Oct 05/2007		R 30	Feb 05/2008	
7	Oct 05/2007		17	Oct 05/2007		R 31	Feb 05/2008	
8	Oct 05/2007		18	Oct 05/2007		R 32	Feb 05/2008	
R 9	Feb 05/2008		R 19	Feb 05/2008		A 33	Feb 05/2008	
10	Oct 05/2007		20	Oct 05/2007		A 34	Feb 05/2008	
11	Oct 05/2007		21	Oct 05/2007		A 35	Feb 05/2008	
12	Oct 05/2007		22	Oct 05/2007		A 36	BLANK	
13	Oct 05/2007		23	Oct 05/2007		71-00-02 P/P BUILDUP FIGURE 29-1		
14	Oct 05/2007		24	BLANK		1	Oct 05/2007	
15	Oct 05/2007		71-00-02 P/P BUILDUP FIGURE 28-1			2	Oct 05/2007	
16	Oct 05/2007		1	Oct 05/2007		3	Oct 05/2007	
17	Oct 05/2007		2	Oct 05/2007		4	Oct 05/2007	
18	Oct 05/2007		3	Oct 05/2007		R 5	Feb 05/2008	
19	Oct 05/2007		4	Oct 05/2007		6	Oct 05/2007	
20	Oct 05/2007		5	Oct 05/2007		7	Oct 05/2007	
21	Oct 05/2007		6	Oct 05/2007		8	Oct 05/2007	
22	BLANK		7	Oct 05/2007		9	Oct 05/2007	
			8	Oct 05/2007		10	BLANK	
			9	Oct 05/2007				

A = Added, R = Revised, O = Overflow, D = Deleted, C = Customer Originated Change

## 71-EFFECTIVE PAGES



**737-600/700/800/900  
POWERPLANT BUILDUP MANUAL**

**CHAPTER 71**

Subject/Page	Date	COC	Subject/Page	Date	COC	Subject/Page	Date	COC
71-00-02 P/P BUILDUP FIGURE 30-1			71-00-02 P/P BUILDUP FIGURE 32-1 (cont)					
1	Oct 05/2007		16	Oct 05/2007				
2	Oct 05/2007		17	Oct 05/2007				
3	Oct 05/2007		18	BLANK				
4	Oct 05/2007		71-00-02 P/P BUILDUP FIGURE 33-1					
5	Oct 05/2007		1	Oct 05/2007				
6	Oct 05/2007		2	Oct 05/2007				
7	Oct 05/2007		3	Oct 05/2007				
8	Oct 05/2007		4	Oct 05/2007				
9	Oct 05/2007		5	Oct 05/2007				
10	Oct 05/2007		6	Oct 05/2007				
11	Oct 05/2007		7	Oct 05/2007				
12	Oct 05/2007		8	Oct 05/2007				
13	Oct 05/2007		9	Oct 05/2007				
14	BLANK		10	Oct 05/2007				
71-00-02 P/P BUILDUP FIGURE 31-1			11	Oct 05/2007				
1	Oct 05/2007		12	Oct 05/2007				
2	Oct 05/2007		13	Oct 05/2007				
3	Oct 05/2007		14	Oct 05/2007				
4	Oct 05/2007		15	Oct 05/2007				
R 5	Feb 05/2008		16	Oct 05/2007				
6	Oct 05/2007		17	Oct 05/2007				
R 7	Feb 05/2008		18	Oct 05/2007				
8	BLANK		19	Oct 05/2007				
71-00-02 P/P BUILDUP FIGURE 32-1			20	Oct 05/2007				
1	Oct 05/2007		21	Oct 05/2007				
2	Oct 05/2007		22	Oct 05/2007				
3	Oct 05/2007		23	Oct 05/2007				
4	Oct 05/2007		24	BLANK				
5	Oct 05/2007		71-00-03 FIGURE 1					
6	Oct 05/2007		1	Oct 05/2007				
7	Oct 05/2007		2	Oct 05/2007				
8	Oct 05/2007		71-00-04 FIGURE 1					
9	Oct 05/2007		1	Oct 05/2007				
10	Oct 05/2007		2	Oct 05/2007				
R 11	Feb 05/2008							
12	Oct 05/2007							
R 13	Feb 05/2008							
14	Oct 05/2007							
R 15	Feb 05/2008							

A = Added, R = Revised, O = Overflow, D = Deleted, C = Customer Originated Change

## 71-EFFECTIVE PAGES

737-600/700/800/900  
**POWERPLANT BUILDUP MANUAL**

**CHAPTER 71**

**CHAPTER  
SECTION  
SUBJECT**

**SUBJECT**

**POWERPLANT BUILDUP**

71-00-02

FIGURE 1-1, CFM56-7 SERIES POWERPLANT WITH QEC INSTALLED  
FIGURE 2-1, FORWARD ENGINE MOUNT INSTALLATION  
FIGURE 3-1, AFT ENGINE MOUNT INSTALLATION  
FIGURE 4-1, BRACKET INSTALLATION - UPPER LEFT FAN CASE  
FIGURE 5-1, BRACKET INSTALLATION - LOWER LEFT FAN CASE  
FIGURE 6-1, BRACKET INSTALLATION - RIGHT SIDE FAN CASE  
FIGURE 7-1, BRACKET INSTALLATION - LEFT SIDE CORE CASE  
FIGURE 8-1, BRACKET INSTALLATION - RIGHT SIDE CORE CASE  
FIGURE 9-1, DRAINS INSTL - LEFT SIDE FAN CASE  
FIGURE 10-1, DRAINS INSTL - RIGHT SIDE FAN CASE  
FIGURE 11-1, THIS FIGURE NOT USED  
FIGURE 12-1, FUEL SUPPLY HOSE INSTALLATION  
FIGURE 13-1, 12 O'CLOCK STRUT INSTALLATION  
FIGURE 14-1, BLEED CONTROLLER INSTALLATION  
FIGURE 15-1, BLEED CONTROL SYSTEM INSTALLATION - LOWER  
FIGURE 16-1, BLEED DUCT INSTALLATION - LOWER 5TH- AND 9TH-STAGE  
FIGURE 17-1, BLEED CONTROL SYSTEM INSTALLATION - UPPER  
FIGURE 18-1, BLEED DUCT INSTALLATION - UPPER 5TH- AND 9TH-STAGE  
FIGURE 19-1, THIS FIGURE NOT USED  
FIGURE 20-1, HYDRAULIC PUMP INSTALLATION - VICKERS  
FIGURE 21-1, HYDRAULIC PLUMBING INSTALLATION  
FIGURE 22-1, INTEGRATED DRIVE GENERATOR INSTALLATION

# 71-CONTENTS

737-600/700/800/900  
**POWERPLANT BUILDUP MANUAL**

**CHAPTER 71**

**CHAPTER  
SECTION  
SUBJECT**

**SUBJECT**

FIGURE 23-1, IDG AIR/OIL COOLER INSTALLATION  
FIGURE 24-1, IDG PLUMBING INSTALLATION  
FIGURE 25-1, STARTER VALVE AND DUCT INSTALLATION  
FIGURE 26-1, THIS FIGURE NOT USED  
FIGURE 27-1, INLET COWL TAI SYSTEM INSTALLATION  
FIGURE 28-1, FIRE/OVERHEAT DETECTOR INSTALLATION  
FIGURE 29-1, W1062 WIRE BUNDLE INSTALLATION  
FIGURE 30-1, MARKERS INSTALLATION  
FIGURE 31-1, THRUST LINK INSTALLATION  
FIGURE 32-1, PRIMARY EXHAUST INSTALLATION  
FIGURE 33-1, INLET COWL INSTALLATION

**QEC SYSTEM TESTS**

71-00-03

FIGURE 1, QEC System Tests  
General  
IDG Cooling Lines Flushing Procedure

**QEC INSPECTION/CHECK**

71-00-04

FIGURE 1, QEC INSPECTION/CHECK  
General  
Inspection

# 71-CONTENTS

FIGURE 1-1

# CFM56-7 SERIES POWERPLANT WITH QEC INSTALLED

REF DWG: 300A2020

**71-00-02**

SUBJECT INDEX FIGURE 1-1

Page 1

Oct 05/2007

D633A106-HXL

737-600/700/800/900  
**POWERPLANT BUILDUP MANUAL**

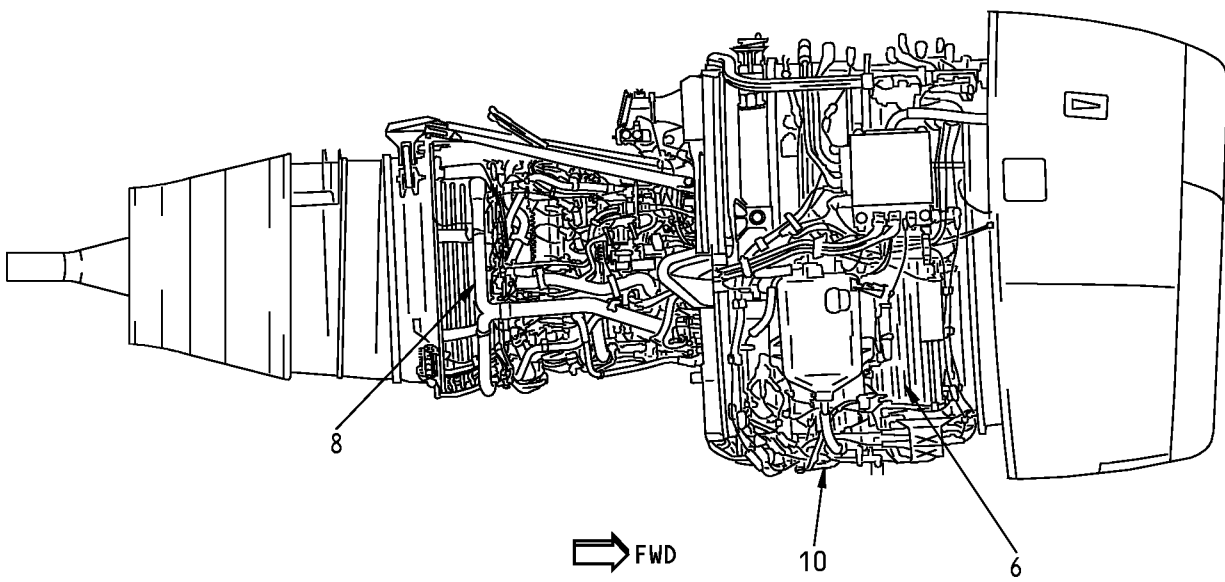
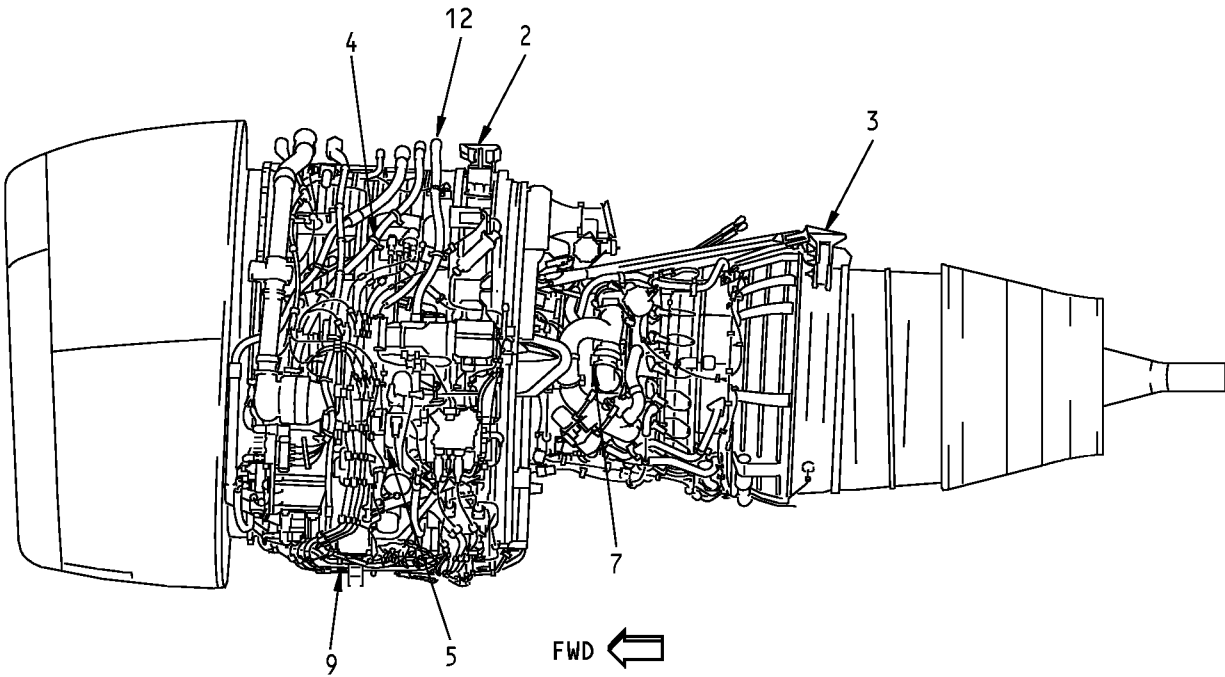

**CFM56-7 Powerplant with QEC Installed**  
**Figure 1-1 (Sheet 1)**

**71-00-02**

SUBJECT INDEX FIGURE 1-1

Page 2

Oct 05/2007

D633A106-HXL

**737-600/700/800/900  
POWERPLANT BUILDUP MANUAL**

<b>ITEM NO.</b>	<b>FIGURE TITLE</b>	<b>FIGURE</b>
<b>1-1</b>	<b>CFM56-7 POWERPLANT WITH QEC INSTALLED (FIGURE 1-1, SHEET 1)</b>	
2-1	FORWARD ENGINE MOUNT INSTALLATION	2-1
3-1	AFT ENGINE MOUNT INSTALLATION	3-1
4-1	BRACKET INSTALLATION - UPPER LEFT FAN CASE	4-1
5-1	BRACKET INSTALLATION - LOWER LEFT FAN CASE	5-1
6-1	BRACKET INSTALLATION - RIGHT SIDE FAN CASE	6-1
7-1	BRACKET INSTALLATION - LEFT SIDE CORE CASE	7-1
8-1	BRACKET INSTALLATION - RIGHT SIDE CORE CASE	8-1
9-1	DRAINS INSTL - LEFT SIDE FAN CASE	9-1
10-1	DRAINS INSTL - RIGHT SIDE FAN CASE	10-1
11-1	THIS FIGURE NOT USED	11-1
12-1	FUEL SUPPLY HOSE INSTALLATION	12-1

**71-00-02**

SUBJECT INDEX FIGURE 1-1

Page 3

Feb 05/2008

D633A106-HXL

737-600/700/800/900  
POWERPLANT BUILDUP MANUAL

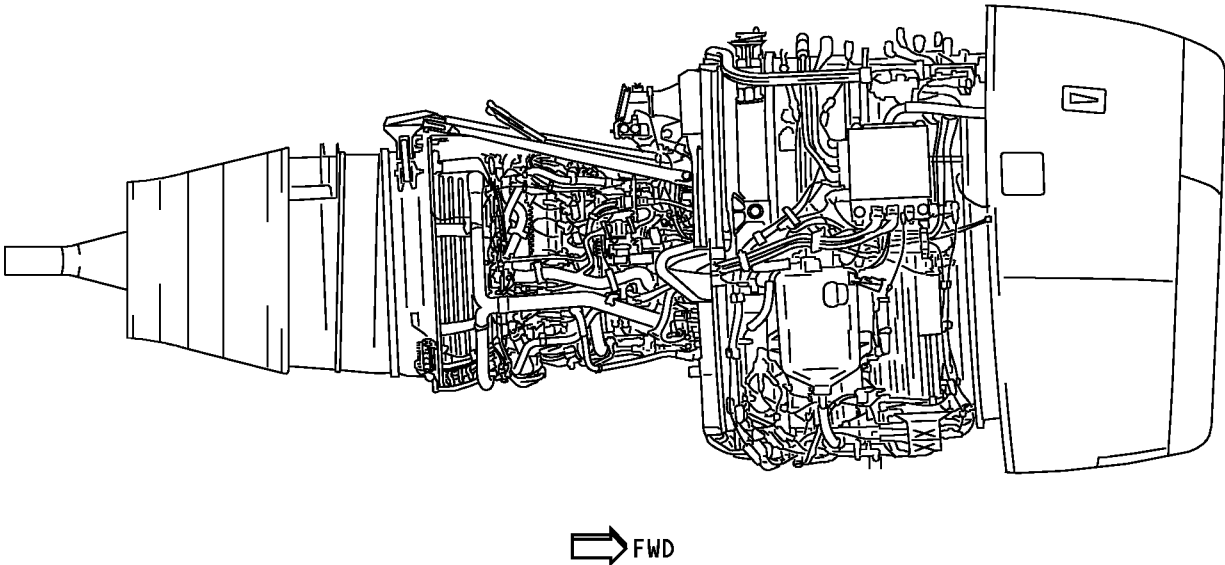
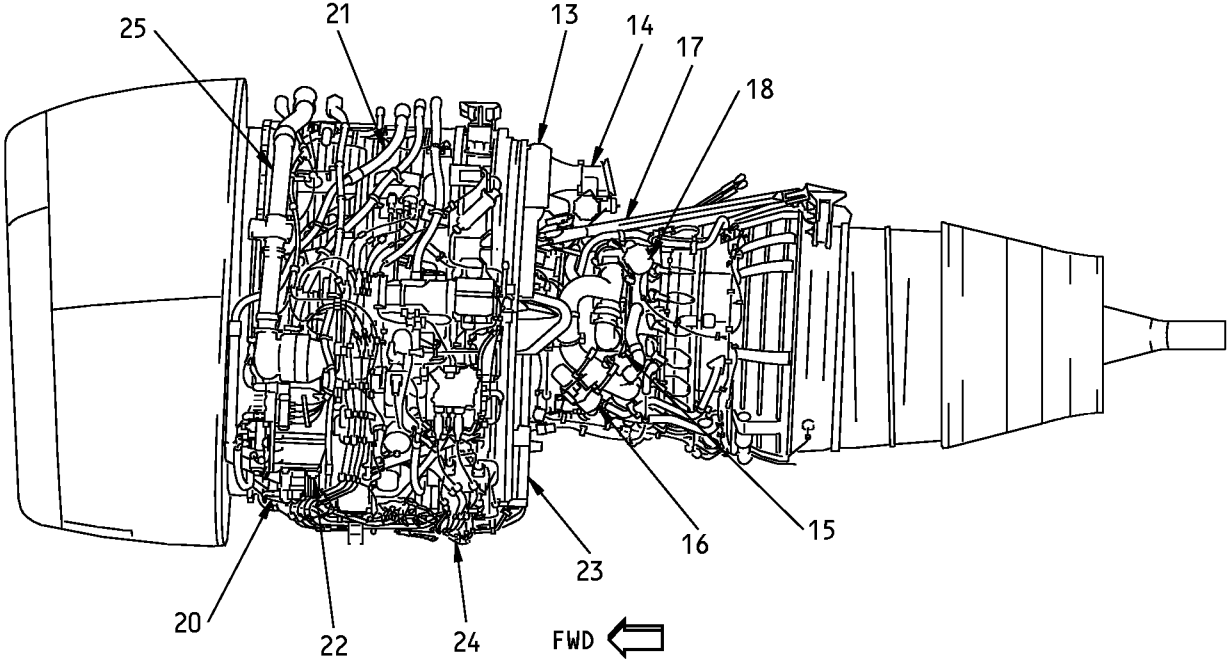

CFM56-7 Powerplant with QEC Installed  
Figure 1-1 (Sheet 2)

71-00-02

SUBJECT INDEX FIGURE 1-1  
Page 4  
Oct 05/2007

D633A106-HXL

**737-600/700/800/900  
POWERPLANT BUILDUP MANUAL**

<b>ITEM NO.</b>	<b>FIGURE TITLE</b>	<b>FIGURE</b>
<b>1-1</b>	<b>CFM56-7 POWERPLANT WITH QEC INSTALLED (FIGURE 1-1, SHEET 2)</b>	
13-1	12 O'CLOCK STRUT INSTALLATION	13-1
14-1	BLEED CONTROLLER INSTALLATION	14-1
15-1	BLEED CONTROL SYSTEM INSTALLATION - LOWER	15-1
16-1	BLEED DUCT INSTALLATION - LOWER 5TH- AND 9TH-STAGE	16-1
17-1	BLEED CONTROL SYSTEM INSTALLATION - UPPER	17-1
18-1	BLEED DUCT INSTALLATION - UPPER 5TH- AND 9TH-STAGE	18-1
19-1	THIS FIGURE NOT USED	19-1
20-1	HYDRAULIC PUMP INSTALLATION - VICKERS	20-1
21-1	HYDRAULIC PLUMBING INSTALLATION	21-1
22-1	INTEGRATED DRIVE GENERATOR INSTALLATION	22-1
23-1	IDG AIR/OIL COOLER INSTALLATION	23-1
24-1	IDG PLUMBING INSTALLATION	24-1
25-1	STARTER VALVE AND DUCT INSTALLATION	25-1
26-1	THIS FIGURE NOT USED	26-1

**71-00-02**

SUBJECT INDEX FIGURE 1-1

Page 5

Oct 05/2007

D633A106-HXL



737-600/700/800/900  
**POWERPLANT BUILDUP MANUAL**

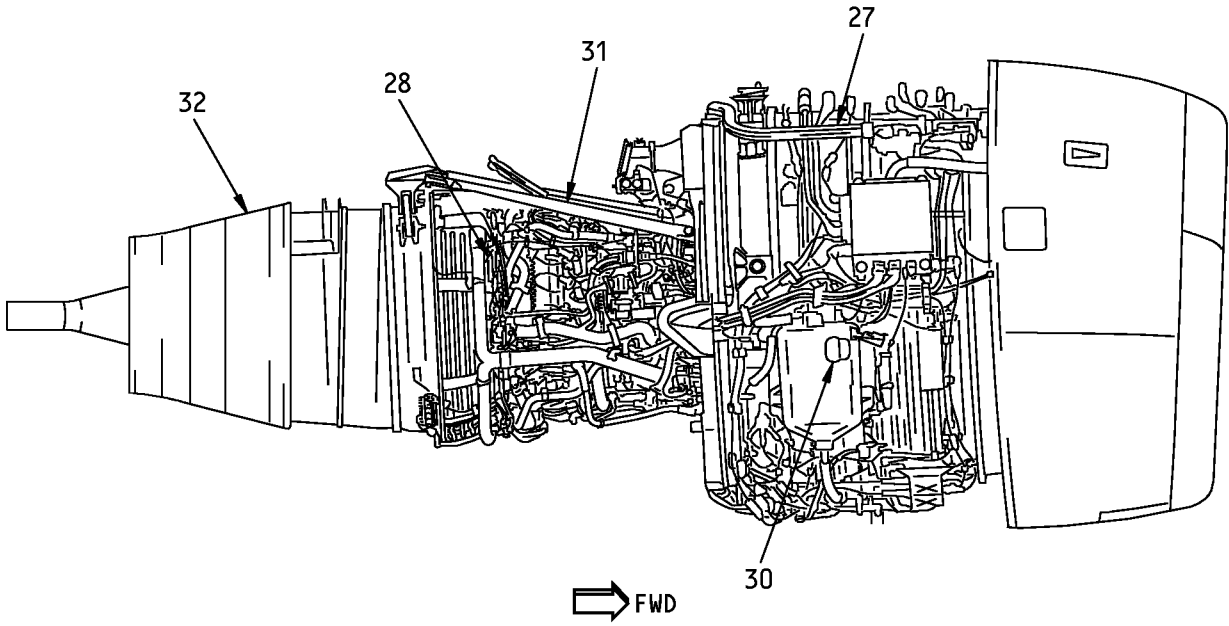
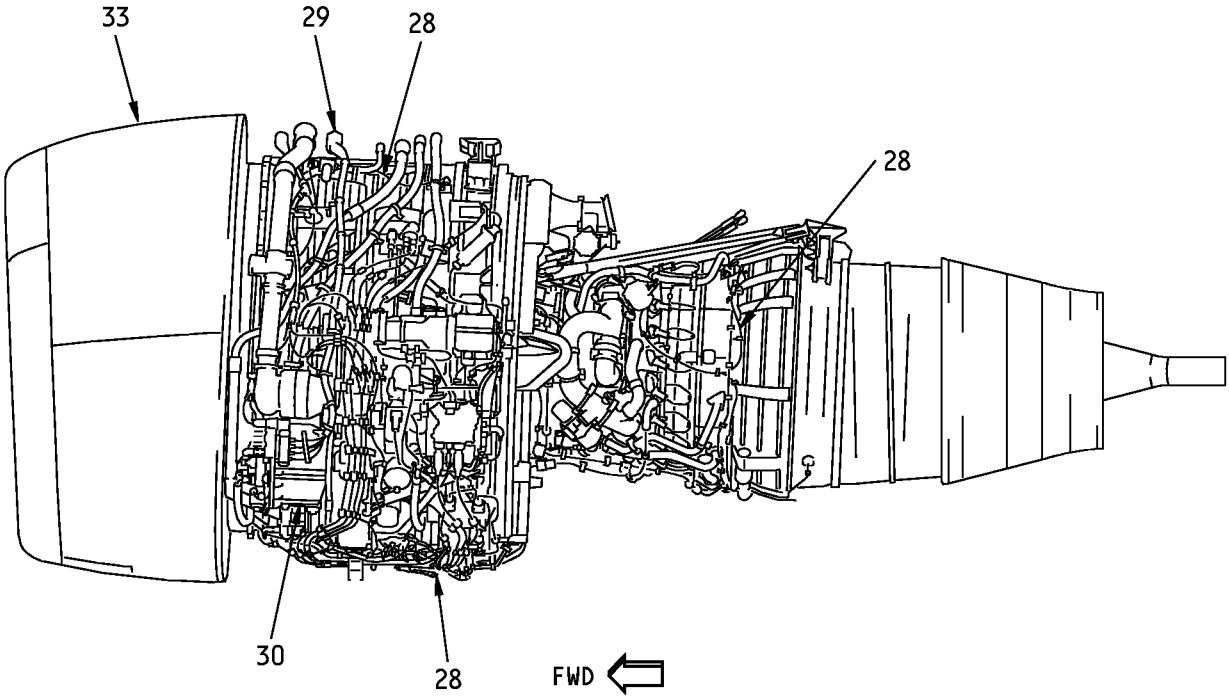

**CFM56-7 Powerplant with QEC Installed**  
**Figure 1-1 (Sheet 3)**

**71-00-02**

SUBJECT INDEX FIGURE 1-1

Page 6

Oct 05/2007

D633A106-HXL

**737-600/700/800/900  
POWERPLANT BUILDUP MANUAL**

<b>ITEM NO.</b>	<b>FIGURE TITLE</b>	<b>FIGURE</b>
1-1	<b>CFM56-7 POWERPLANT WITH QEC INSTALLED (FIGURE 1-1, SHEET 3)</b>	
27-1	INLET COWL TAI SYSTEM INSTALLATION	27-1
28-1	FIRE/OVERHEAT DETECTOR INSTALLATION	28-1
29-1	W1062 WIRE BUNDLE INSTALLATION	29-1
30-1	MARKERS INSTALLATION	30-1
31-1	THRUST LINK INSTALLATION	31-1
32-1	PRIMARY EXHAUST INSTALLATION	32-1
33-1	INLET COWL INSTALLATION	33-1

**71-00-02**

SUBJECT INDEX FIGURE 1-1

Page 7

Oct 05/2007

D633A106-HXL

**FIGURE 2-1**

# **FORWARD ENGINE MOUNT INSTALLATION**

**REF QEC TASK NO.: 2**

**REF DWG: 310A2020  
310A2010**

**71-00-02**

P/P BUILDUP FIGURE 2-1

Page 1

Oct 05/2007

D633A106-HXL

737-600/700/800/900  
**POWERPLANT BUILDUP MANUAL**

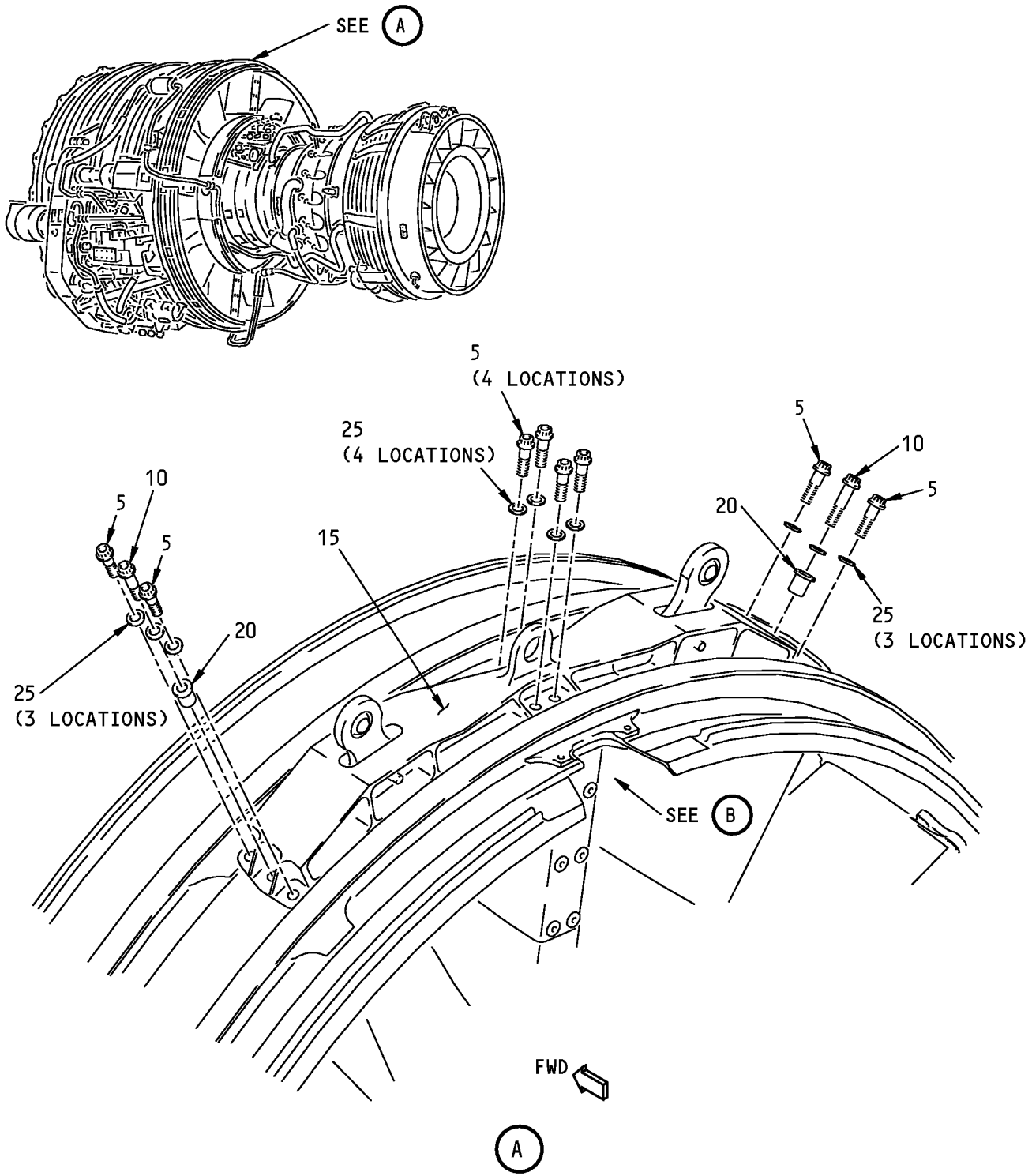

**Forward Engine Mount Installation**  
**Figure 2-1 (Sheet 1)**

**71-00-02**

P/P BUILDUP FIGURE 2-1

Page 2

Oct 05/2007

D633A106-HXL

## POWERPLANT BUILDUP MANUAL

ITEM NO.	PART NUMBER	NOMENCLATURE	UC	QTY
2-1		<p><b>FORWARD ENGINE MOUNT INSTALLATION</b> (FIGURE 2-1, SHEET 1)</p> <p><b>NOTE:</b> DUE TO LIMITED ACCESS, IT IS RECOMMENDED THAT Figure 4-1 ITEM NO. (800) BRACKET ASSY BE INSTALLED PRIOR TO FORWARD MOUNT SUB-ASSY (15) INSTALLATION.</p> <p>APPLY LIGHT COATING OF Never-Seez NSBT-8N compound, D00006 (C1) TO THREADS AND UNDERSIDE HEAD OF BOLTS (5) AND (10).</p> <p><b>NOTE:</b> DO NOT APPLY LUBRICANT IN HEAVY AMOUNTS.</p>		
5	310A2029-11	. BOLT		8
10	310A2029-19	. BOLT		2
C1	D00006	. COMPOUND, NEVER-SEEZ NSBT-8N	CON	AR
		<p><b>WARNING:</b> FWD MOUNT SUB-ASSY WEIGHS APPROXIMATELY 55 POUNDS (25 KG). MAKE SURE YOU USE A SLING OR A SUFFICIENT NUMBER OF PERSONS TO LIFT THE MOUNT ONTO ENGINE. IF YOU DO NOT, MOUNT CAN FALL AND CAUSE INJURIES TO PERSONS.</p> <p>USE SLING OR TWO PERSONS TO POSITION FWD MOUNT SUB-ASSY (15) ON ENGINE FAN FRAME BETWEEN FLANGES B7 AND B8.</p>		
15	310A2020-11	. FWD MOUNT SUB-ASSY		1
		<p>LOOSELY SECURE FWD MOUNT SUB-ASSY (15) TO ENGINE WITH LUBRICATED BOLTS (5) AND (10), BUSHINGS (20) AND WASHERS (25). MAKE SURE BOLTS (10) AND BUSHINGS (20) ARE IN OUTBOARD CENTER POSITION ONLY AND CSK SIDE OF WASHER IS AGAINST BOLT HEAD.</p>		
20	310A2020-6	. BUSHING		2
25	BACW10BP8ACU	. WASHER (CSK)		10

71-00-02

P/P BUILDUP FIGURE 2-1

Page 3

Oct 05/2007

D633A106-HXL

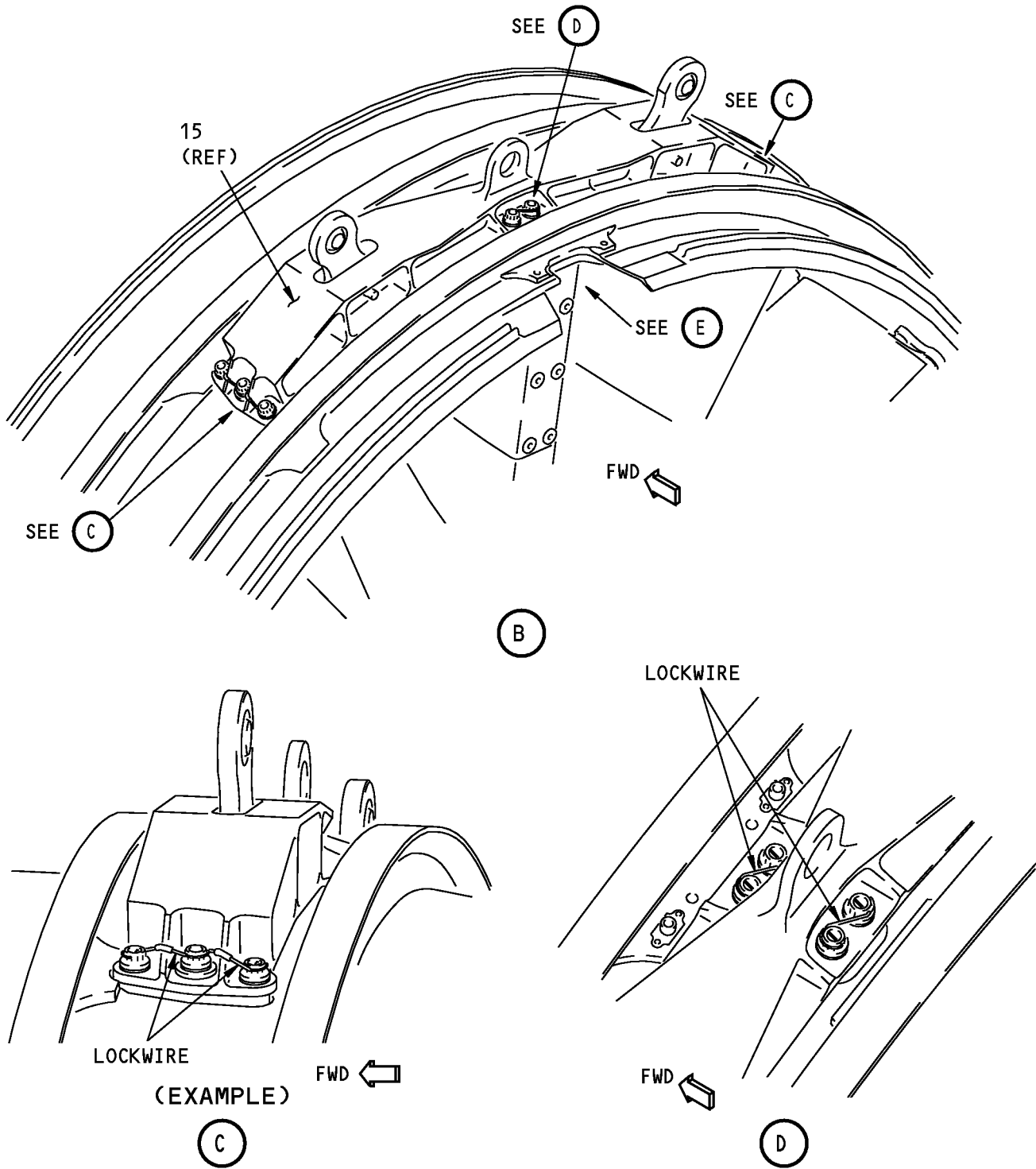

Forward Engine Mount Installation  
Figure 2-1 (Sheet 2)

**71-00-02**

P/P BUILDUP FIGURE 2-1

Page 4

Oct 05/2007

**737-600/700/800/900  
POWERPLANT BUILDUP MANUAL**

ITEM NO.	PART NUMBER	NOMENCLATURE	UC	QTY
2-1		<p><b>FORWARD ENGINE MOUNT INSTALLATION (FIGURE 2-1, SHEET 2)</b></p> <p>TIGHTEN BOLTS (5) AND (10) TO 585-715 POUND-INCHES (66-81 NEWTON METERS).</p> <p>ATTACH lockwire, G01912 (C2) OR safety cable kit, G50375 (C3) BETWEEN BOLTS (5) AT 12 O'CLOCK POSITION AND BETWEEN OUTBOARD BOLTS (5) AND (10). COVER EXPOSED LOCKWIRE OR SAFETY CABLE WITH RT1146 sleeve, G50043 (C4) OR Viton sleeve, G50044 (C5) BETWEEN FASTENER HEADS TO PREVENT CONTACT WITH LOCKWIRE AND FAN CASE FITTING.</p>		
C2	G01912	. LOCKWIRE, MS20995NC32	CON	AR
C3	G50375	. SAFETY CABLE, BACC13AT3K ( ) <sup>[1]</sup>	CON	1
C4	G50043	. SLEEVE, RT1146	CON	AR
C5	G50044	. SLEEVE, 584800113 (OPTIONAL)	OPT	-
		*[1] USE 12 OR 18 INCH LENGTH SAFETY CABLE		

**71-00-02**

P/P BUILDUP FIGURE 2-1

Page 5

Feb 05/2008

D633A106-HXL

737-600/700/800/900  
**POWERPLANT BUILDUP MANUAL**

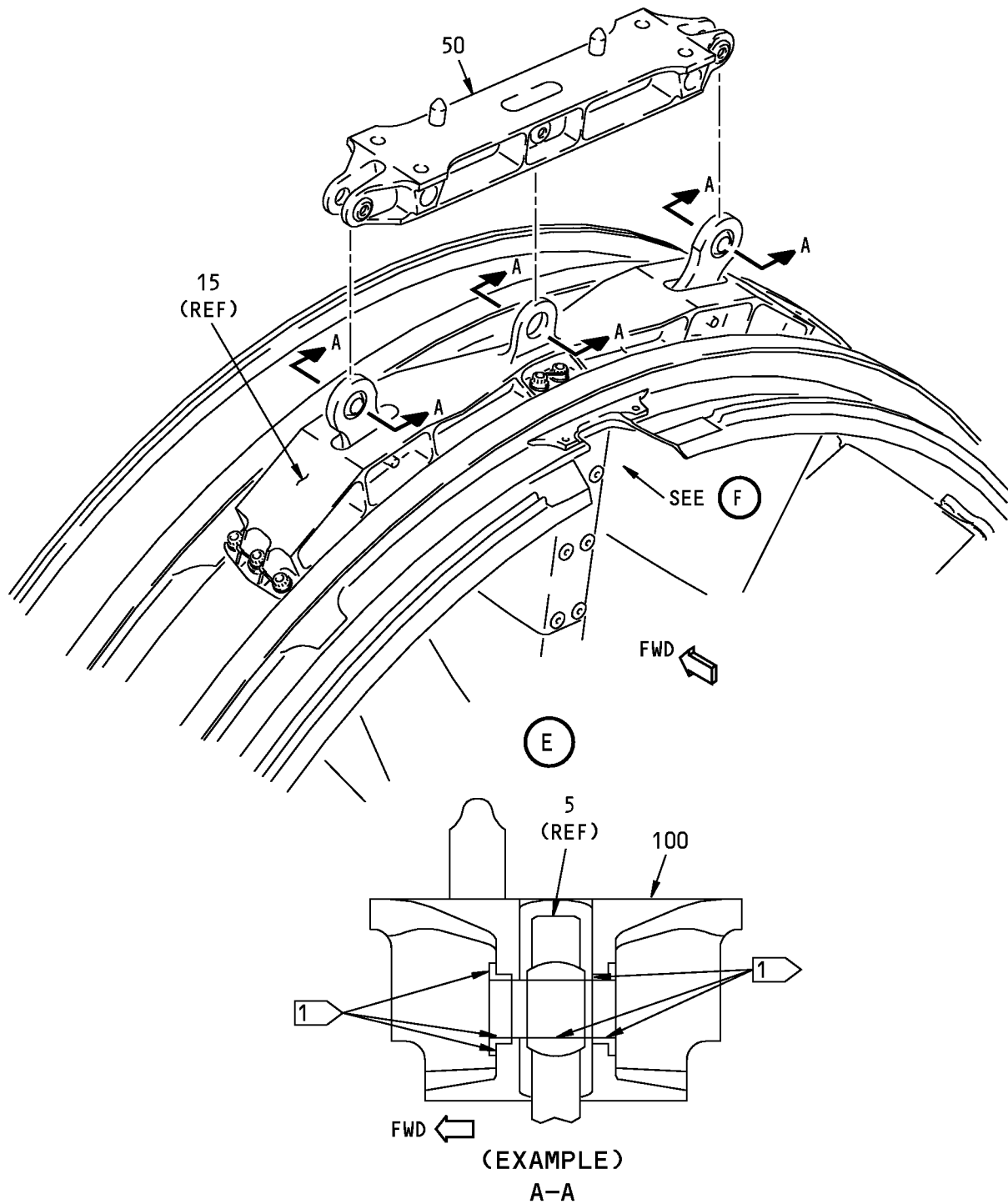

**1** APPLY ANTI-SEIZE COMPOUND AS INDICATED.

**Forward Engine Mount Installation  
Figure 2-1 (Sheet 3)**



**737-600/700/800/900  
POWERPLANT BUILDUP MANUAL**

ITEM NO.	PART NUMBER	NOMENCLATURE	UC	QTY
2-1		<p><b>FORWARD ENGINE MOUNT INSTALLATION (FIGURE 2-1, SHEET 3)</b></p> <p>POSITION HANGER FTG ASSY (50) ON FWD MOUNT SUB ASSY (15). MAKE SURE ALL HOLES ARE ALIGNED.</p> <p><b>CAUTION:</b> MAKE SURE SHEAR PINS ARE ON FWD SIDE OF HANGER FTG ASSY. IF THEY ARE NOT, DAMAGE TO AIRPLANE STRUT CAN OCCUR DURING ENGINE INSTALLATION.</p>		
50	310A2021-4	<p>. HANGER FTG ASSY</p> <p>APPLY LIGHT COATING OF Never-Seez NSBT-8N compound, D00006 (C1) TO SPHERICAL BEARING BORE AND BALL FLAT SURFACES OF HANGER FTG ASSY (50).</p> <p>APPLY LIGHT COATING OF Never-Seez NSBT-8N compound, D00006 (C1) TO BUSHING BORES AND FLANGE FACES OF FWD MOUNT SIDE LINKS.</p> <p><b>NOTE:</b> DO NOT APPLY LUBRICANT IN HEAVY AMOUNTS.</p>		1
C1	D00006	<p>. COMPOUND, NEVER-SEEZ NSBT-8N</p>	CON	AR

**71-00-02**

P/P BUILDUP FIGURE 2-1

Page 7

Oct 05/2007

D633A106-HXL

737-600/700/800/900  
**POWERPLANT BUILDUP MANUAL**

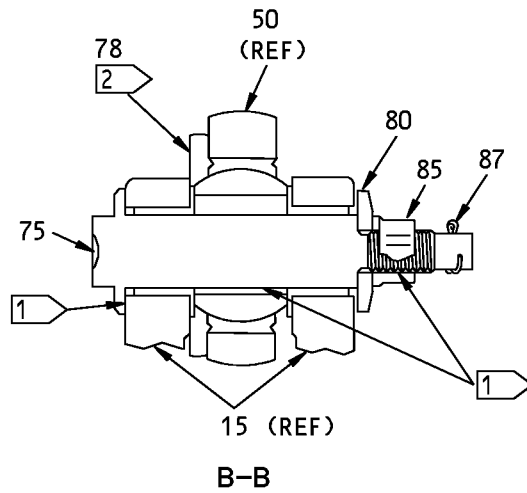
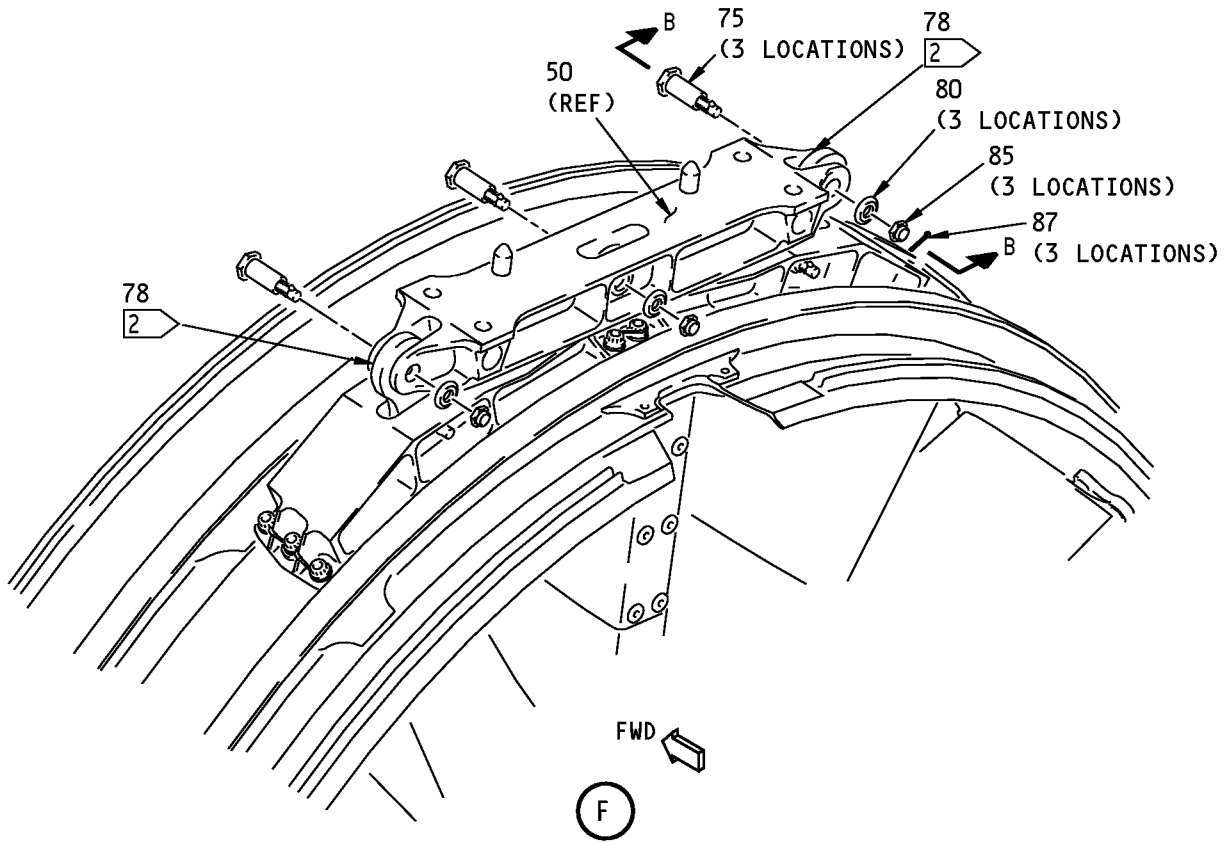

- 1 APPLY ANTI-SEIZE COMPOUND AS INDICATED.
- 2 INSTALL ON EITHER FORWARD OR AFT SIDE OF HANGER FITTING ASSEMBLY (50).

**Forward Engine Mount Installation**  
**Figure 2-1 (Sheet 4)**

**737-600/700/800/900  
POWERPLANT BUILDUP MANUAL**

ITEM NO.	PART NUMBER	NOMENCLATURE	UC	QTY
2-1		<p><b>FORWARD ENGINE MOUNT INSTALLATION (FIGURE 2-1, SHEET 4)</b></p> <p>APPLY LIGHT COATING OF Never-Seez NSBT-8N compound, D00006 (C1) TO THREADS, SHANK AND UNDERNEATH HEAD OF PINS (75).</p> <p><b>NOTE:</b> DO NOT APPLY LUBRICANT IN HEAVY AMOUNTS.</p>		
75 C1	310A2042-3 D00006	<p>. THRUST LINK PIN</p> <p>. COMPOUND, NEVER-SEEZ NSBT-8N</p> <p>INSTALL THRUST LINK PIN (75) WITH HEAD SIDE FORWARD IN THREE LOCATIONS ON HANGER FTG ASSY (50). INSTALL WASHER (78) BETWEEN EITHER FORWARD OR AFT SIDE OF HANGER FITTING ASSY (50) AND FORWARD MOUNT (15). ENSURE WASHER (78) CHAMFER FACES BEARING THEN ATTACH WITH END CAP (80) AND NUT (85).</p> <p><b>NOTE:</b> MAKE SURE FLAT SIDE OF END CAP IS AGAINST PIN SHOULDER.</p>	CON	3 AR
78	310A2040-7	. WASHER		2
80	310A2043-1	. END CAP		3
85	BACN10JC8CM	. NUT		3
		TIGHTEN NUT (85) TO 290-510 POUND-INCHES (33-58 N.M.). APPLY TORQUE TO NUT.		
		INSTALL COTTER PINS (87).		
87	BACP18BC03B06P	. COTTER PIN		3
87	BACP18BC03B07P	. COTTER PIN (OPTIONAL TO BACP18BC03B06P)	OPT	-
87	BACP18BC03B08P	. COTTER PIN (OPTIONAL TO BACP18BC03B06P)	OPT	-

**71-00-02**

P/P BUILDUP FIGURE 2-1

Page 9

Oct 05/2007

D633A106-HXL

**737-600/700/800/900  
POWERPLANT BUILDUP MANUAL**

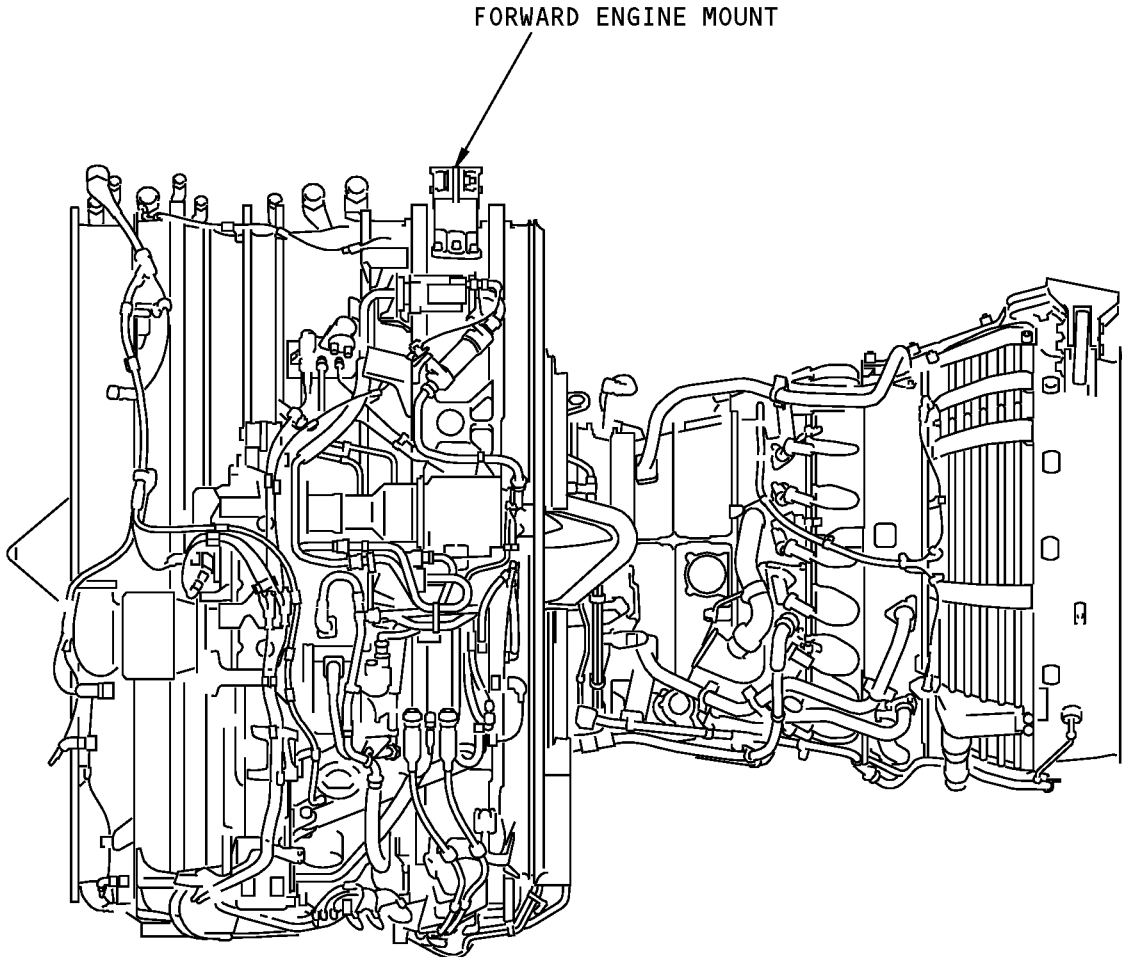

**Forward Engine Mount Installation  
Figure 2-1 (Sheet 5)**

**71-00-02**

P/P BUILDUP FIGURE 2-1  
Page 10  
Oct 05/2007

D633A106-HXL

**737-600/700/800/900  
POWERPLANT BUILDUP MANUAL**

ITEM NO.	PART NUMBER	NOMENCLATURE	UC	QTY
2-1		<p><b>FORWARD ENGINE MOUNT INSTALLATION (FIGURE 2-1, SHEET 5)</b></p> <p>PUT ITEMS (100) THRU (110) IN A BAG AND SECURE TO FWD MOUNT ASSY.</p> <p><b>NOTE:</b> ITEMS (100) THRU (110) ARE INSTALLED DURING POWERPLANT INSTALLATION ON AIRPLANE STRUT (AMM PAGEBLOCK 71-00-02/401).</p>		
100	BACB30PN10-19M	. BOLT <sup>*[1]</sup>		4
100	BACB30PN10-19	. BOLT (OPTIONAL TO BACB30PN10-19M) <sup>*[1]</sup>	OPT	-
105	BACW10BP10ACU	. WASHER <sup>*[1]</sup>		4
110	SL4147CA10A	. BARREL NUT ASSY (V97393) <sup>*[1]</sup>	VEN	4
		*[1] ITEM NOT ILLUSTRATED		

**71-00-02**

P/P BUILDUP FIGURE 2-1

Page 11

Oct 05/2007

D633A106-HXL

**FIGURE 3-1**

# **AFT ENGINE MOUNT INSTALLATION**

**REF QEC TASK NO.: 3**

**REF DWG: 310A2030  
310A2010**

**71-00-02**

P/P BUILDUP FIGURE 3-1

Page 1

Oct 05/2007

D633A106-HXL

737-600/700/800/900  
**POWERPLANT BUILDUP MANUAL**

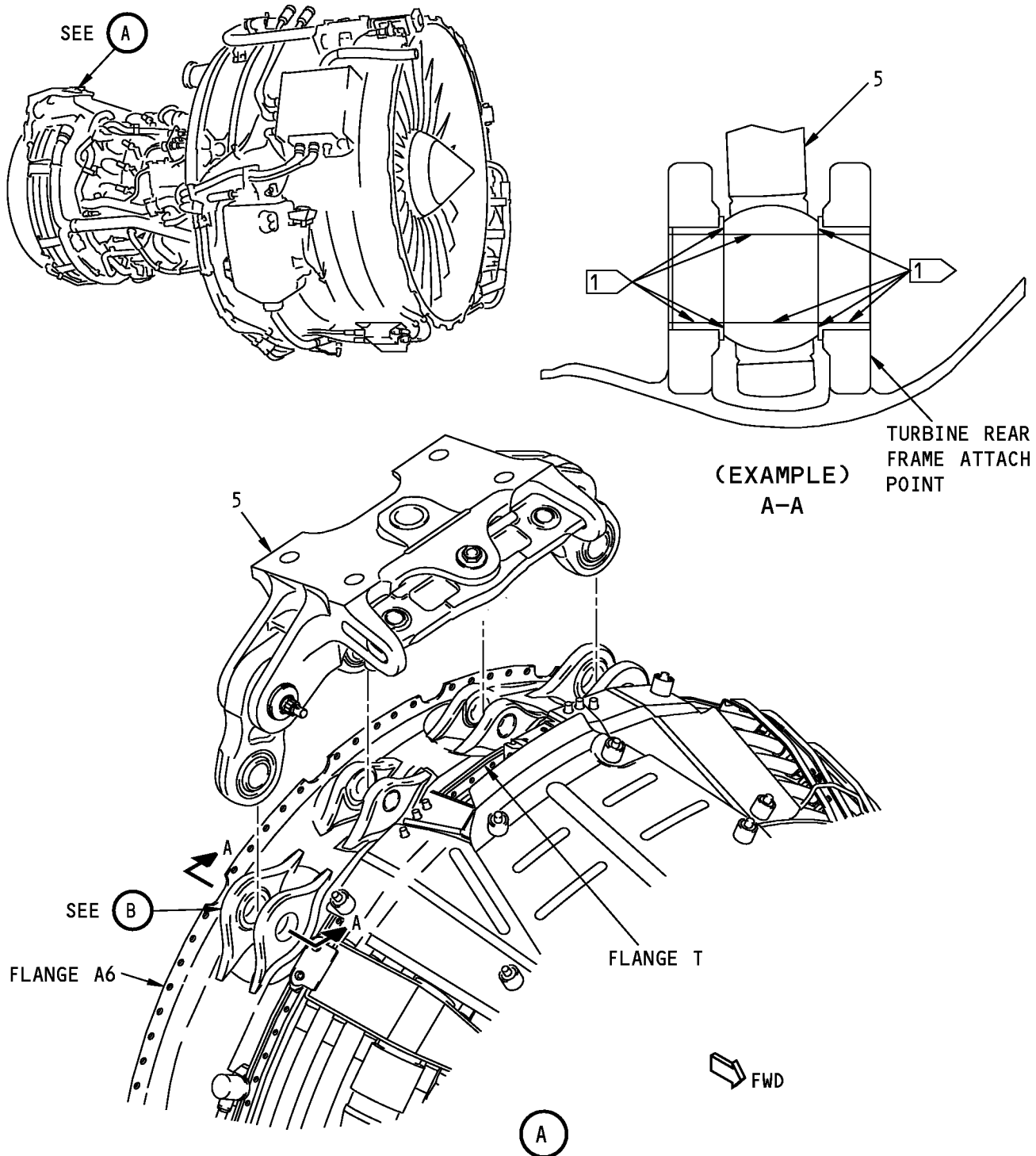

1 APPLY ANTI-SEIZE COMPOUND AS INDICATED.

**Aft Engine Mount Installation**  
**Figure 3-1 (Sheet 1)**

**71-00-02**

**737-600/700/800/900  
POWERPLANT BUILDUP MANUAL**

ITEM NO.	PART NUMBER	NOMENCLATURE	UC	QTY
3-1		<p><b>AFT ENGINE MOUNT INSTALLATION (FIGURE 3-1, SHEET 1)</b></p> <p>APPLY LIGHT COATING OF Never-Seez NSBT-8N compound, D00006 (C1) TO SPHERICAL BEARING BORE AND BALL FLAT SURFACES OF AFT ENGINE MOUNT ASSY (5).</p> <p>APPLY LIGHT COATING OF Never-Seez NSBT-8N compound, D00006 (C1) TO BUSHING BORES AND FLANGE FACES OF TURBINE REAR FRAME ATTACH POINTS.</p> <p><b>NOTE:</b> DO NOT APPLY LUBRICANT IN HEAVY AMOUNTS.</p>		
5 C1	310A2030-17 D00006	<p>. AFT ENGINE MOUNT ASSY</p> <p>. COMPOUND, NEVER-SEEZ NSBT-8N</p> <p><b>WARNING:</b> AFT ENGINE MOUNT ASSY WEIGHS APPROXIMATELY 80 POUNDS (36 KG). MAKE SURE YOU USE SLING OR SUFFICIENT NUMBER OF PERSONS TO LIFT MOUNT ONTO ENGINE. IF YOU DO NOT, MOUNT CAN FALL AND CAUSE INJURIES TO PERSONS.</p>	CON	1 AR
T1	C71024-1	<p>ATTACH fixture, SPL-2107 (T1) TO AFT ENGINE MOUNT ASSY (5) AND POSITION MOUNT ON ENGINE TURBINE REAR FRAME BETWEEN FLANGES T AND A6.</p> <p>. AFT ENGINE MOUNT SLING (V81205)</p>	TOL	-

**71-00-02**

P/P BUILDUP FIGURE 3-1

Page 3

Oct 05/2007

D633A106-HXL



737-600/700/800/900  
**POWERPLANT BUILDUP MANUAL**

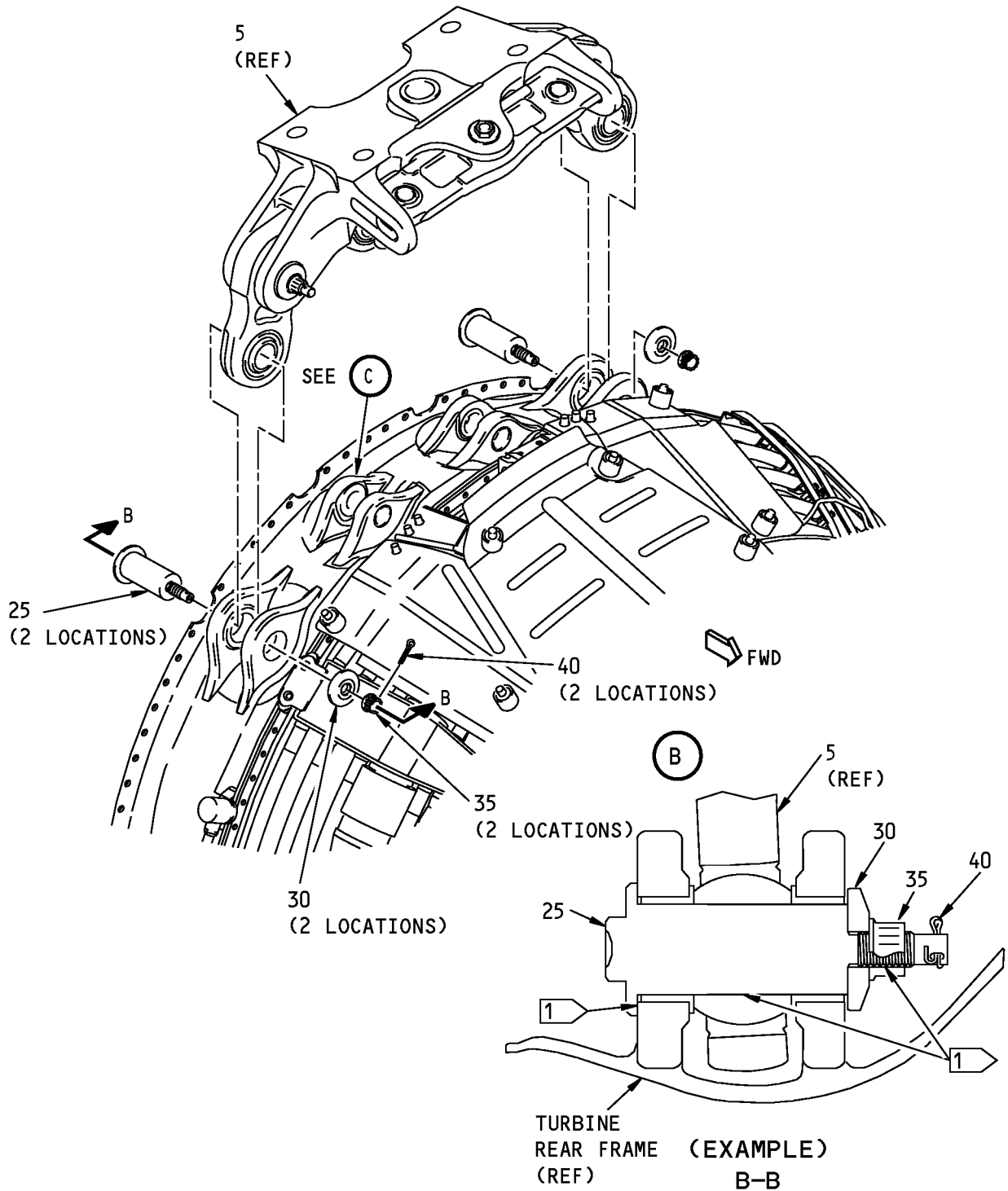

**1** → APPLY ANTI-SEIZE COMPOUND AS INDICATED.

**Aft Engine Mount Installation**  
**Figure 3-1 (Sheet 2)**

**71-00-02**

P/P BUILDUP FIGURE 3-1

Page 4

Oct 05/2007

D633A106-HXL

## POWERPLANT BUILDUP MANUAL

ITEM NO.	PART NUMBER	NOMENCLATURE	UC	QTY
3-1		<b>AFT ENGINE MOUNT INSTALLATION (FIGURE 3-1, SHEET 2)</b>  APPLY LIGHT COATING OF Never-Seez NSBT-8N compound, D00006 (C1) TO THREADS, SHANK AND UNDERNEATH HEAD OF PIN (25).  <b>NOTE:</b> DO NOT APPLY LUBRICANT IN HEAVY AMOUNTS.		
25 C1	310A2037-14 D00006	. LINK PIN USED WITH COTTER PIN . COMPOUND, NEVER-SEEZ NSBT-8N  INSTALL PIN (25) IN OUTBOARD LOCATIONS OF ENGINE MOUNT (5) AND ATTACH WITH END CAP (30) AND NUT (35).  <b>NOTE:</b> MAKE SURE FLAT SIDE OF END CAP IS AGAINST PIN SHOULDER.  MAKE SURE NO PRELOAD IS PRESENT WHEN LINK PINS ARE INSTALLED.	CON	2 AR
30	310A2039-1	. END CAP		2
35	BACN11Z8C	. NUT  TIGHTEN NUT (35) TO 440-650 POUND-INCHES (50-73 N.M.). APPLY TORQUE TO EITHER NUT OR PIN HEAD.  INSTALL COTTER PINS (40).		2
40	BACP18BC03B07P	. COTTER PIN		2
40	BACP18BC03B06P	. COTTER PIN (OPTIONAL TO BACP18BC03B07P)	OPT	-
40	BACP18BC03B08P	. COTTER PIN (OPTIONAL TO BACP18BC03B07P)	OPT	-

**71-00-02**

P/P BUILDUP FIGURE 3-1

Page 5

Feb 05/2008

D633A106-HXL

737-600/700/800/900  
**POWERPLANT BUILDUP MANUAL**

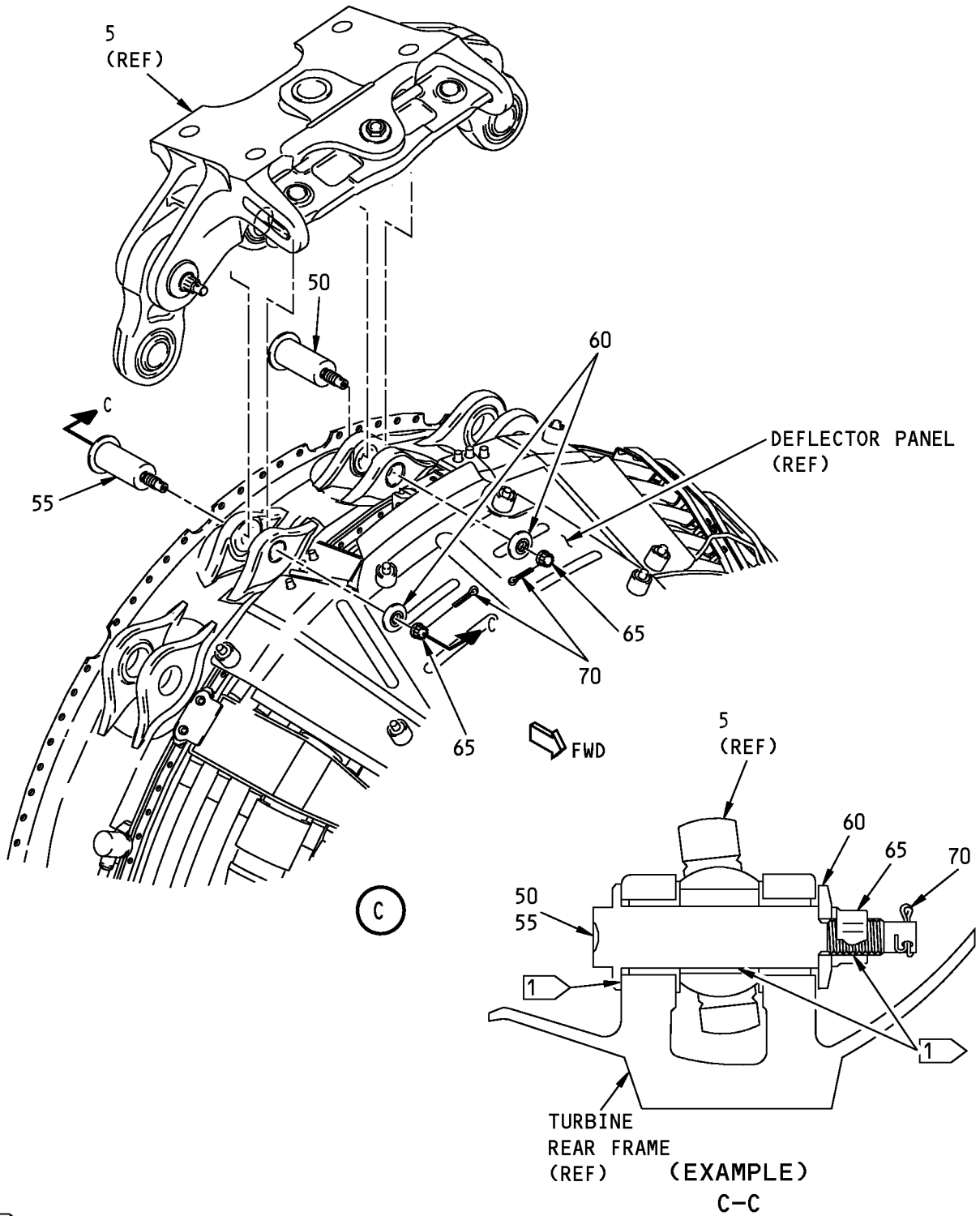

1 APPLY ANTI-SEIZE COMPOUND AS INDICATED.

**Aft Engine Mount Installation**  
**Figure 3-1 (Sheet 3)**

**71-00-02**

P/P BUILDUP FIGURE 3-1

Page 6

Oct 05/2007

**737-600/700/800/900  
POWERPLANT BUILDUP MANUAL**

ITEM NO.	PART NUMBER	NOMENCLATURE	UC	QTY
3-1		<p><b>AFT ENGINE MOUNT INSTALLATION (FIGURE 3-1, SHEET 3)</b></p> <p>APPLY LIGHT COATING OF Never-Seez NSBT-8N compound, D00006 (C1) TO THREADS, SHANK AND UNDERNEATH HEAD OF PINS (50) AND (55).</p> <p><b>NOTE:</b> DO NOT APPLY LUBRICANT IN HEAVY AMOUNTS.</p>		
50	310A2037-15	. LINK PIN USED WITH COTTER PIN		1
55	310A2037-16	. LINK PIN USED WITH COTTER PIN		1
C1	D00006	. COMPOUND, NEVER-SEEZ NSBT-8N	CON	AR
		<p>INSTALL PIN (50) IN LEFT INBOARD LOCATION OF ENGINE MOUNT (5) AND PIN (55) IN RIGHT INBOARD LOCATION. ATTACH WITH END CAPS (60) AND NUTS (65).</p> <p><b>NOTE:</b> MAKE SURE FLAT SIDE OF END CAP IS AGAINST PIN SHOULDER. MAKE SURE NO PRELOAD IS PRESENT WHEN LINK PINS ARE INSTALLED.</p>		
60	310A2039-2	. END CAP		2
65	BACN11Z8C	. NUT		2
		<p>TIGHTEN NUTS (65) TO 440-650 POUND-INCHES (50-73 N.M.). APPLY TORQUE TO EITHER NUT OR PIN HEAD.</p> <p><b>NOTE:</b> PIN (55) DIAMETER IS UNDERSIZED TO SPHERICAL BEARING BORE OF MOUNT BY DESIGN. PIN SERVES AS A FAIL-SAFE BOLT.</p> <p>INSTALL PROTECTIVE PAD BETWEEN AFT ENGINE MOUNT ASSY (5) AND DEFLECTOR PANEL.</p> <p><b>NOTE:</b> PROTECTIVE PAD WILL BE REMOVED AFTER THRUST LINKS ARE INSTALLED.</p>		
70	BACP18BC03B06P	. COTTER PIN		2
70	BACP18BC03B07P	. COTTER PIN (OPTIONAL TO BACP18BC03B06P)	OPT	-
70	BACP18BC03B08P	. COTTER PIN (OPTIONAL TO BACP18BC03B06P)	OPT	-

**71-00-02**

P/P BUILDUP FIGURE 3-1

Page 7

Feb 05/2008

D633A106-HXL

**737-600/700/800/900  
POWERPLANT BUILDUP MANUAL**

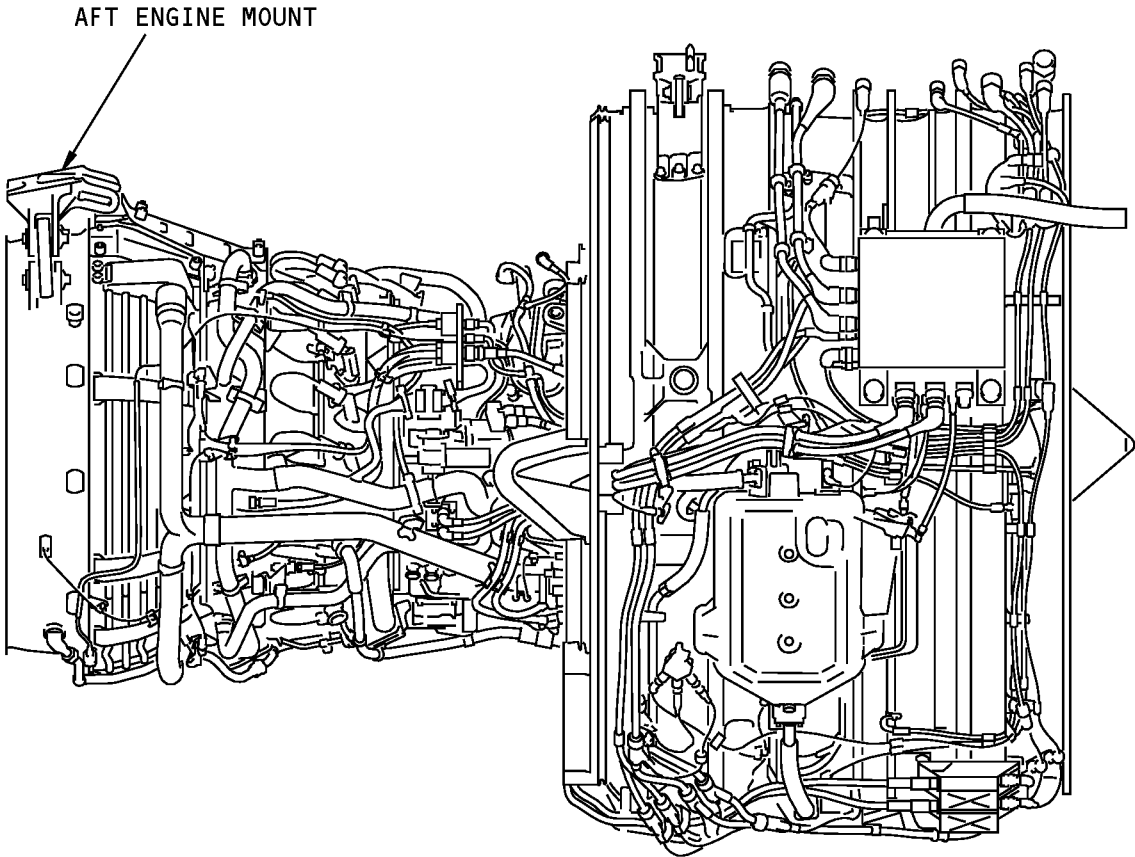

**Aft Engine Mount Installation  
Figure 3-1 (Sheet 4)**

**71-00-02**

**737-600/700/800/900  
POWERPLANT BUILDUP MANUAL**

ITEM NO.	PART NUMBER	NOMENCLATURE	UC	QTY
3-1		<b>AFT ENGINE MOUNT INSTALLATION (FIGURE 3-1, SHEET 4)</b>		
T1		REMOVE fixture, SPL-2107 (T1) FROM AFT ENGINE MOUNT. . AFT ENGINE MOUNT SLING  PUT ITEMS (100) THRU (110) IN A BAG AND SECURE TO AFT MOUNT ASSY.  <b>NOTE:</b> ITEMS (100) THRU (110) ARE INSTALLED DURING POWERPLANT INSTALLATION ON AIRPLANE STRUT (AMM PAGEBLOCK 71-00-02/401).	TOL	-
100	BACB30PN14-32M	. BOLT <sup>[1]</sup>		4
105	BACW10BP14ACU	. WASHER <sup>[1]</sup>		4
110	SL4147CA14EBSP1	. BARREL NUT ASSY (V97393) <sup>[1]</sup>	VEN	4
		*[1] ITEM NOT ILLUSTRATED		

**71-00-02**

P/P BUILDUP FIGURE 3-1

Page 9

Oct 05/2007

D633A106-HXL

**FIGURE 4-1**

**BRACKET INSTALLATION - UPPER LEFT FAN  
CASE**

**REF QEC TASK NO.: 4**

**REF DWG: 332A2900**

**NOTE:** ALL STANDARDS AND ATTACHING HARDWARE FOR THIS FIGURE WILL BE PACKAGED  
IN QEC TASK NO. 110.

**71-00-02**

P/P BUILDUP FIGURE 4-1

Page 1

Oct 05/2007

D633A106-HXL

737-600/700/800/900  
**POWERPLANT BUILDUP MANUAL**

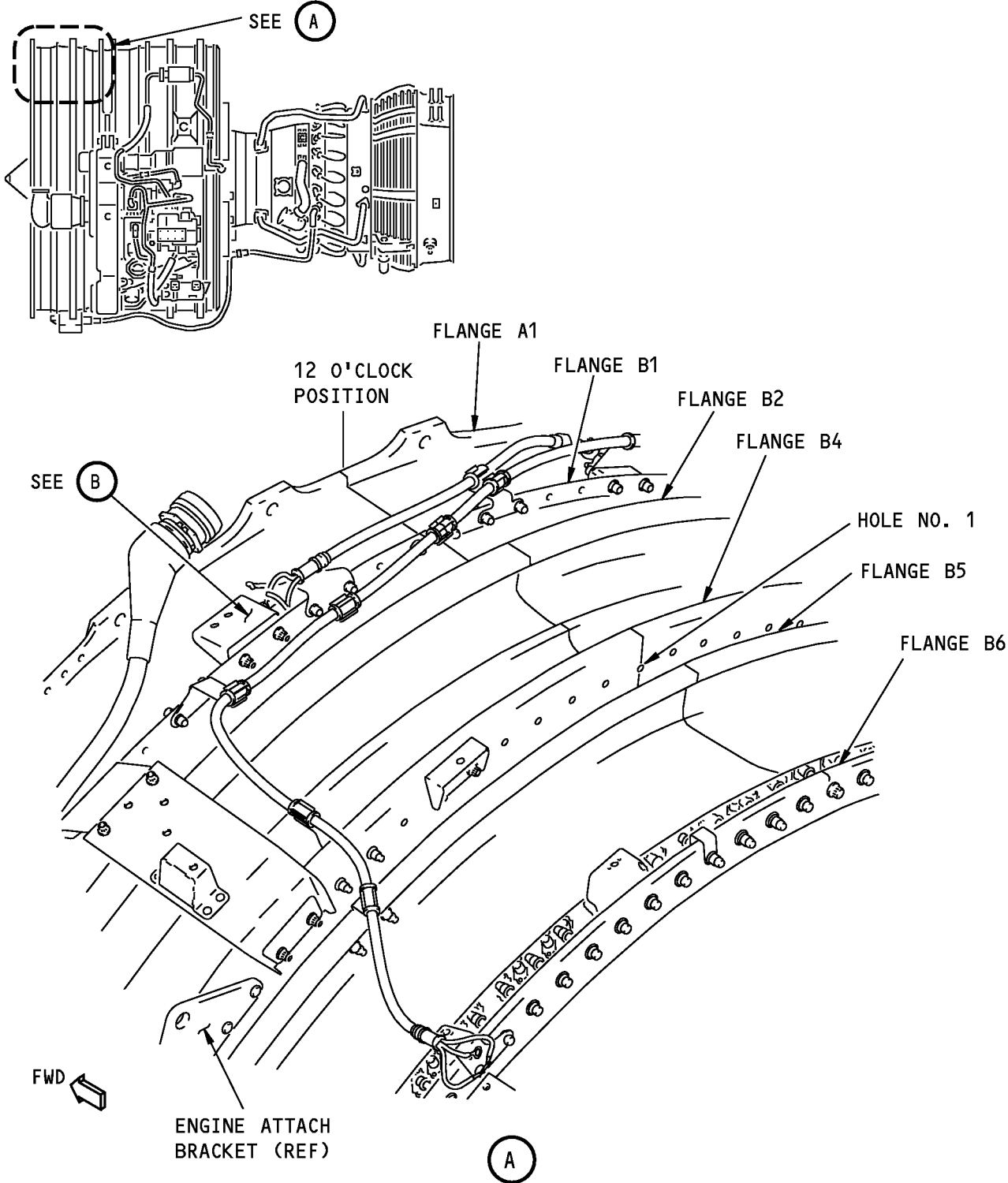

**Bracket Installation - Upper Left Side Fan Case**  
**Figure 4-1 (Sheet 1)**

**71-00-02**

P/P BUILDUP FIGURE 4-1

Page 2

Oct 05/2007

D633A106-HXL



**737-600/700/800/900  
POWERPLANT BUILDUP MANUAL**

ITEM NO.	PART NUMBER	NOMENCLATURE	BRACKET LOCATION AND ORIENTATION			QTY
			BRKT OR FLG SIDE	ANGLE FACES	UC	
4-1		<p><b>BRACKET INSTALLATION - UPPER LEFT SIDE FAN CASE (FIGURE 4-1, SHEET 1)</b></p> <p>COUNT 12 HOLES UP FROM ENGINE ATTACH BRACKET ON FLANGE B4. USE A marker, G02061 (C1) TO MARK THE LOCATION OF THIS HOLE ON ALL FAN FLANGES. THIS IS HOLE NO. 1 AND INDICATES THE 12 O'CLOCK POSITION.</p> <p><b>NOTE:</b> IN THIS FIGURE, HOLES ARE COUNTED FROM THE NO. 1 HOLE COUNTERCLOCKWISE (AFT LOOKING FWD) UNLESS OTHERWISE STATED.</p>				
C1	G02061	. MARKER, FELT TIP PEN			CON	AR

# 71-00-02

P/P BUILDUP FIGURE 4-1

Page 3

Oct 05/2007

D633A106-HXL

737-600/700/800/900  
**POWERPLANT BUILDUP MANUAL**

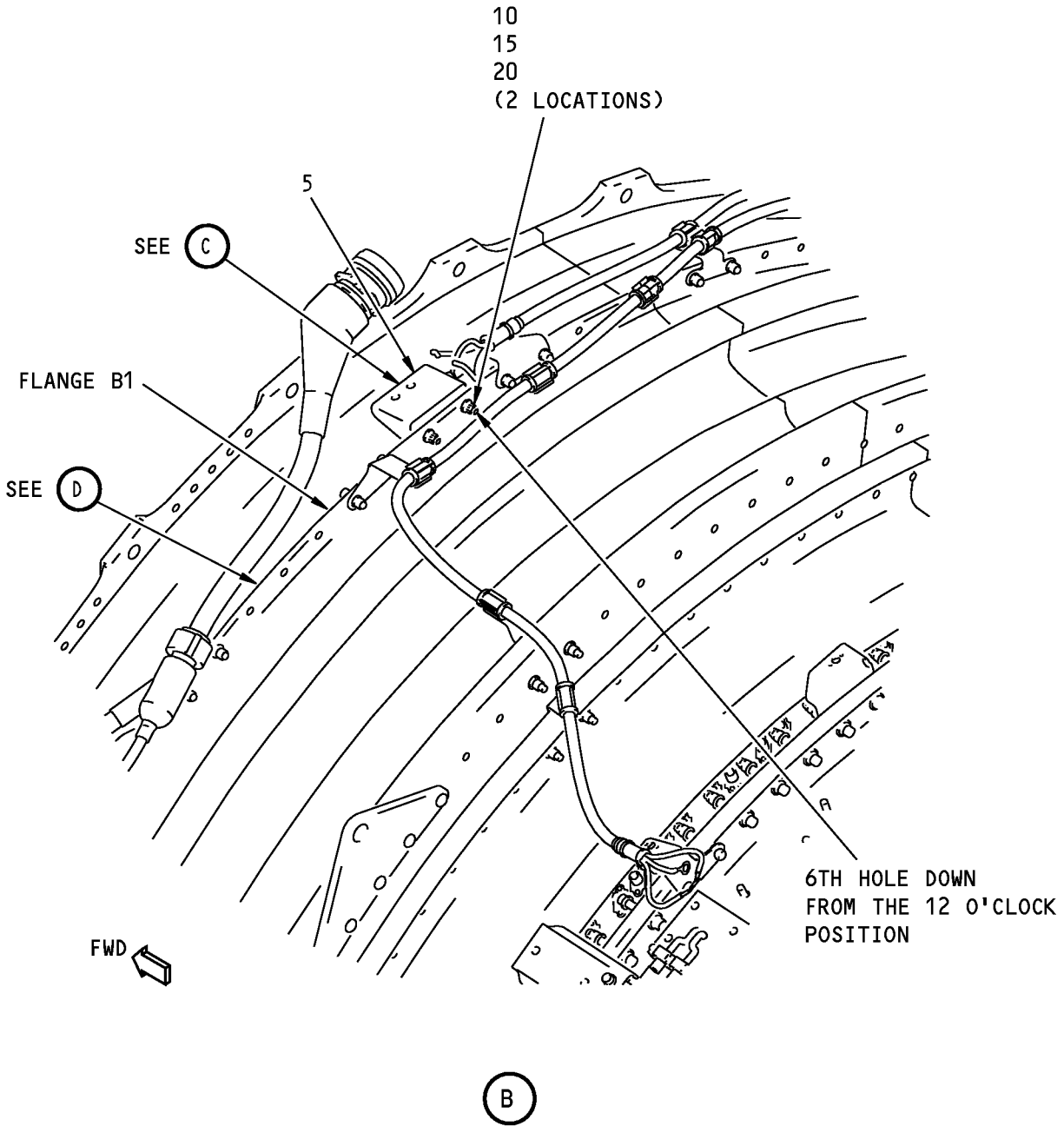

**Bracket Installation - Upper Left Side Fan Case**  
**Figure 4-1 (Sheet 2)**

**71-00-02**

**737-600/700/800/900  
POWERPLANT BUILDUP MANUAL**

ITEM NO.	PART NUMBER	NOMENCLATURE	BRACKET LOCATION AND ORIENTATION			QTY
			BRKT OR FLG SIDE	ANGLE FACES	UC	
4-1		<b>BRACKET INSTALLATION - UPPER LEFT SIDE FAN CASE (FIGURE 4-1, SHEET 2)</b>  CLEAN MATING SURFACES OF BRACKET ASSY (5) AND FLANGE B1 WITH alcohol, B00130 (C2). MAKE SURE YOU REMOVE ALL GREASE AND OTHER CONTAMINANTS.  . BRACKET ASSY . SOLVENT, TT-I-735  <b>NOTE:</b> DUE TO LIMITED ACCESS, IT IS RECOMMENDED ITEMS 50 THRU 65 BE INSTALLED PRIOR TO BRACKET (5) ATTACHMENT.  ATTACH BRACKET ASSY (5) TO 6TH AND 7TH HOLE DOWN FROM 12 O'CLOCK ON FLANGE B1. USE BOLTS (10), WASHERS (15) AND NUT (20).  . BOLT (FWD SIDE) . WASHER (UNDER NUT) . NUT  TIGHTEN BOLTS (10) TO 110-120 POUND-INCHES (12.4-13.6 NEWTON METERS).				
5	332A2920-229		FWD	FWD		1
C2	B00130				CON	AR
10	BACB30ZF4-12					2
15	NAS1149C0432R					2
20	AS3485-10					2

# 71-00-02

P/P BUILDUP FIGURE 4-1

Page 5

Oct 05/2007

D633A106-HXL

737-600/700/800/900  
POWERPLANT BUILDUP MANUAL

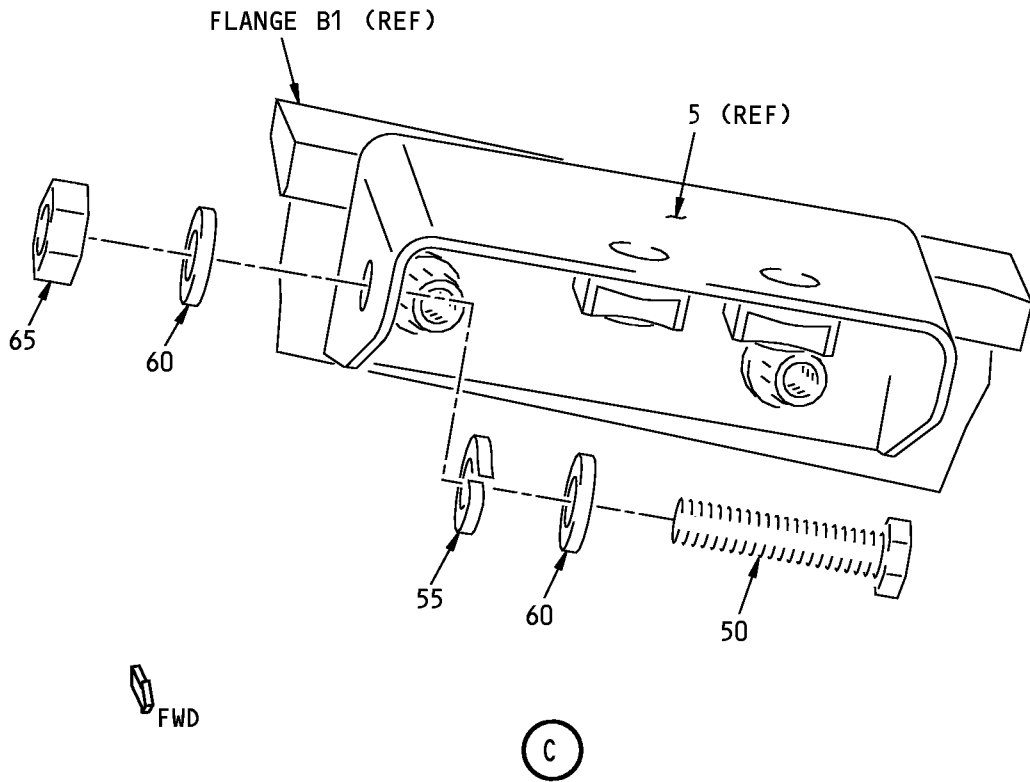

Bracket Installation - Upper Left Side Fan Case  
Figure 4-1 (Sheet 3)

**71-00-02**

P/P BUILDUP FIGURE 4-1

Page 6

Oct 05/2007

D633A106-HXL

**737-600/700/800/900  
POWERPLANT BUILDUP MANUAL**

ITEM NO.	PART NUMBER	NOMENCLATURE	BRACKET LOCATION AND ORIENTATION			QTY
			BRKT OR FLG SIDE	ANGLE FACES	UC	
4-1		<b>BRACKET INSTALLATION - UPPER LEFT SIDE FAN CASE (FIGURE 4-1, SHEET 3)</b>  CLEAN SURFACES OF TOP BOLT HOLE ON BRACKET ASSY (5) WITH alcohol, B00130 (C2). MAKE SURE YOU REMOVE ALL GREASE AND OTHER CONTAMINANTS.  . SOLVENT, TT-I-735  ON TOP HOLE OF BRACKET ASSY (5), ATTACH GROUNDING BOLT (50), LOCK WASHER (55), WASHERS (60) AND ELECTRICAL NUT (65).  . SCREW . LOCK WASHER . WASHER . ELECTRICAL NUT  TIGHTEN BOLT (50) TO 90-105 POUND-INCHES (10.2-11.9 NEWTON METERS).				
C2	B00130				CON	AR
50	BACS12HN4U16					1
55	BACW10EC4M					1
60	BACW10BP4APU					2
65	MS35650-3254					1

# 71-00-02

P/P BUILDUP FIGURE 4-1

Page 7

Oct 05/2007

D633A106-HXL

737-600/700/800/900  
**POWERPLANT BUILDUP MANUAL**

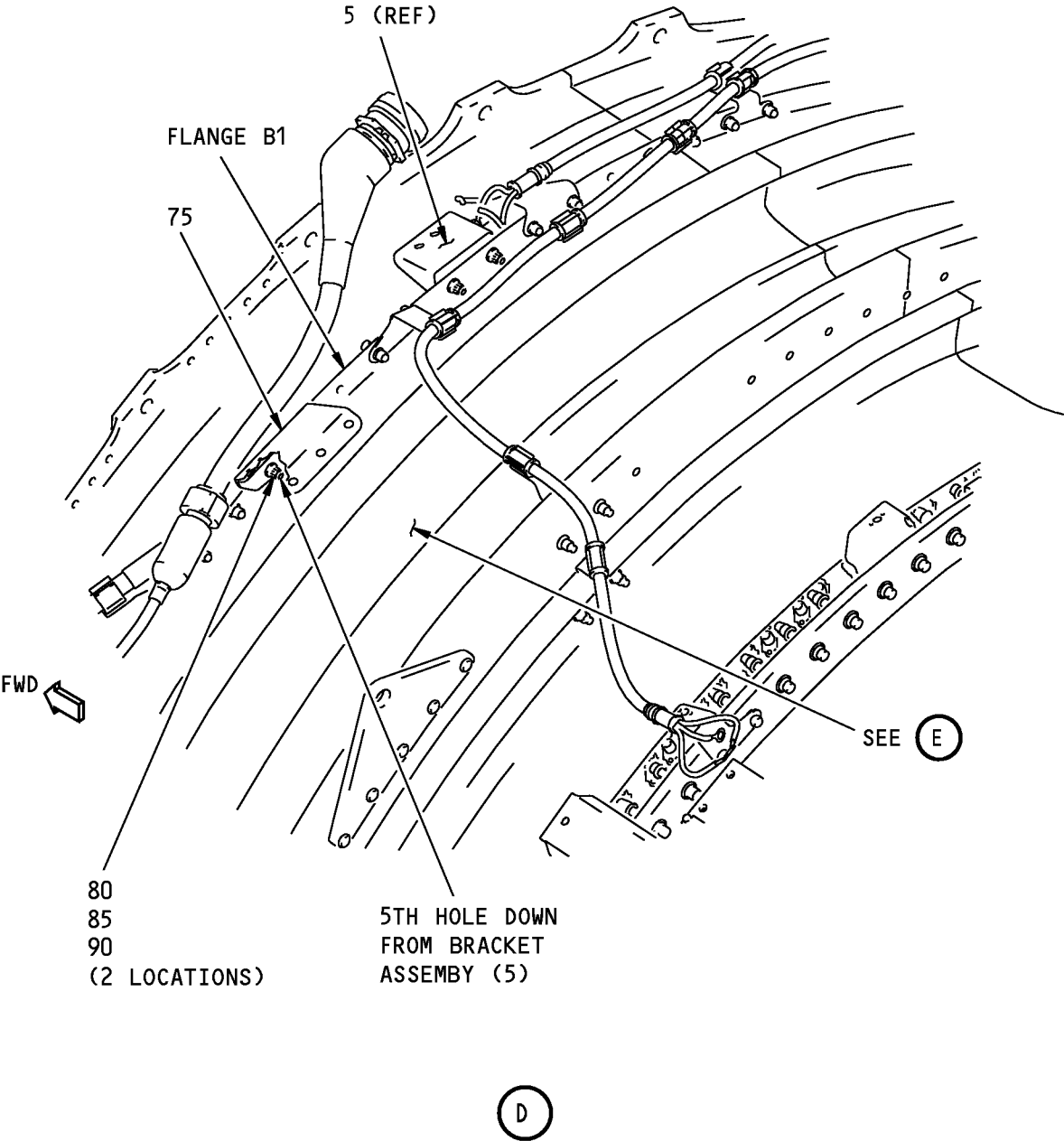

**Bracket Installation - Upper Left Side Fan Case**  
**Figure 4-1 (Sheet 4)**

**71-00-02**

D633A106-HXL

**737-600/700/800/900  
POWERPLANT BUILDUP MANUAL**

ITEM NO.	PART NUMBER	NOMENCLATURE	BRACKET LOCATION AND ORIENTATION			QTY
			BRKT OR FLG SIDE	ANGLE FACES	UC	
4-1		<b>BRACKET INSTALLATION - UPPER LEFT SIDE FAN CASE (FIGURE 4-1, SHEET 4)</b>  ATTACH BRACKET (75) TO 4TH AND 5TH HOLES DOWN FROM BRACKET ASSY (5) ON FLANGE B1. USE BOLTS (80), WASHERS (85) AND NUTS (90).  . BRACKET . BOLT (FWD SIDE) . WASHER (UNDER BOLT) . NUT  TIGHTEN BOLTS (80) TO 110-120 POUND-INCHES (12.4-13.6 NEWTON METERS).				
75	332A2910-143	. BRACKET	AFT	AFT		1
80	BACB30ZF4-11	. BOLT (FWD SIDE)				2
85	BACW10BP4ACU	. WASHER (UNDER BOLT)				2
90	AS3485-10	. NUT				2

# 71-00-02

P/P BUILDUP FIGURE 4-1

Page 9

Oct 05/2007

D633A106-HXL

737-600/700/800/900  
**POWERPLANT BUILDUP MANUAL**

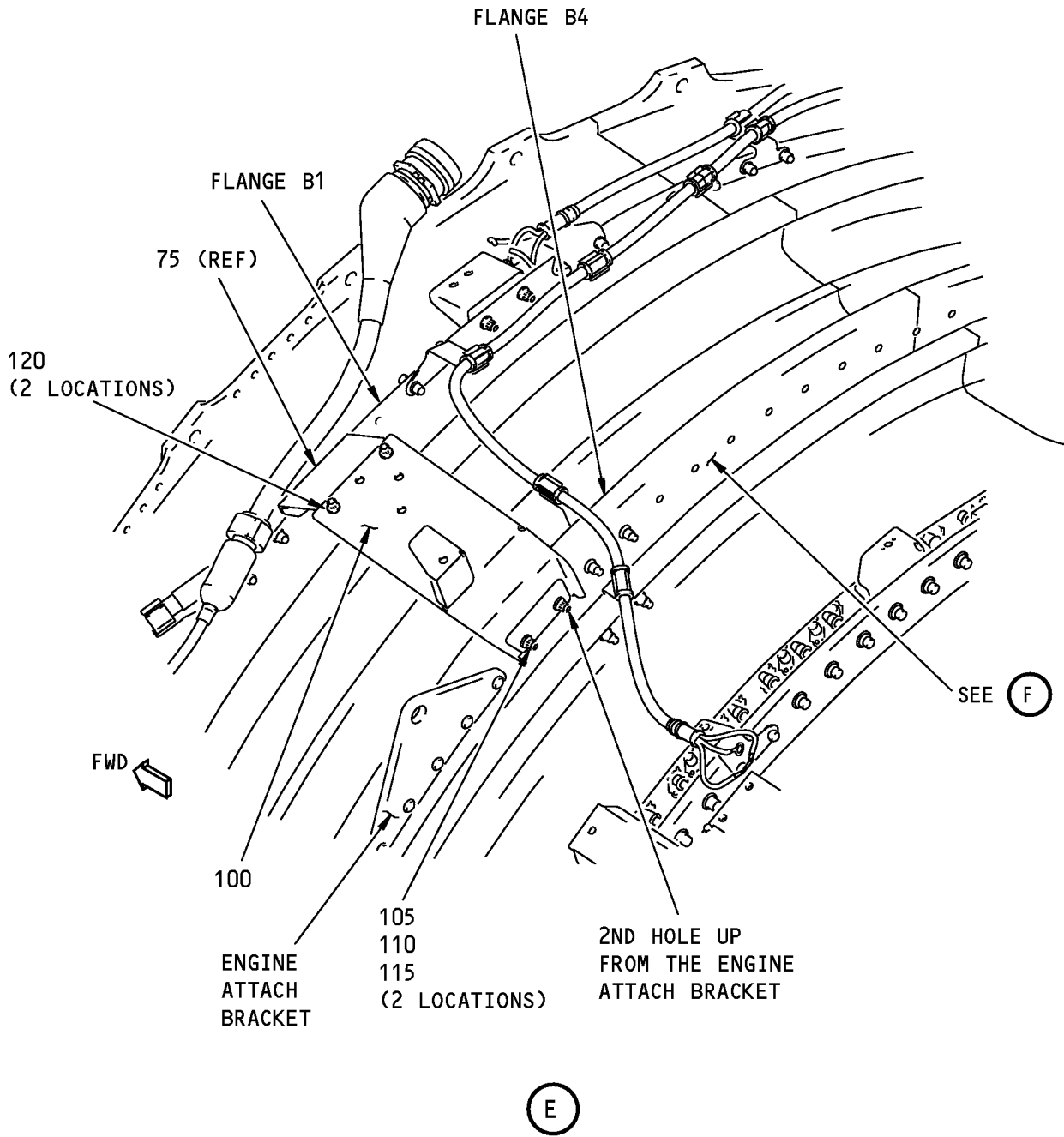

**Bracket Installation - Upper Left Side Fan Case**  
**Figure 4-1 (Sheet 5)**

**71-00-02**

P/P BUILDUP FIGURE 4-1

Page 10

Oct 05/2007

D633A106-HXL



**737-600/700/800/900  
POWERPLANT BUILDUP MANUAL**

ITEM NO.	PART NUMBER	NOMENCLATURE	BRACKET LOCATION AND ORIENTATION			QTY
			BRKT OR FLG SIDE	ANGLE FACES	UC	
4-1		<p><b>BRACKET INSTALLATION - UPPER LEFT SIDE FAN CASE (FIGURE 4-1, SHEET 5)</b></p> <p>ATTACH BRACKET ASSY (100) TO 1ST AND 2ND HOLES UP FROM ENGINE ATTACH BRACKET ON FLANGE B4 ALIGNING HOLES ON FWD END WITH BRACKET (75). USE BOLTS (105), WASHERS (110) AND NUTS (115) ON FLANGE B4 AND BOLTS (120) ON BRACKET (75).</p> <p><b>NOTE:</b> DO NOT INSTALL BOLT IN CENTER HOLE OF BRACKET ASSY (100). HOLE WILL BE USED TO ATTACH HYDRAULIC FILTER (REF )Figure 21-1.</p>				
100	332A2920-232	. BRKT ASSY	AFT	FWD		1
105	BACB30ZF4-11	. BOLT (FWD SIDE)				2
110	BACW10BP4ACU	. WASHER (UNDER BOLT)				2
115	AS3485-10	. NUT				2
120	BACB30ZF4-06	. BOLT				2
		TIGHTEN BOLTS (105) AND (120) TO 110-120 POUND-INCHES (12.4-13.6 NEWTON METERS).				

# 71-00-02

P/P BUILDUP FIGURE 4-1

Page 11

Oct 05/2007

D633A106-HXL

737-600/700/800/900  
**POWERPLANT BUILDUP MANUAL**

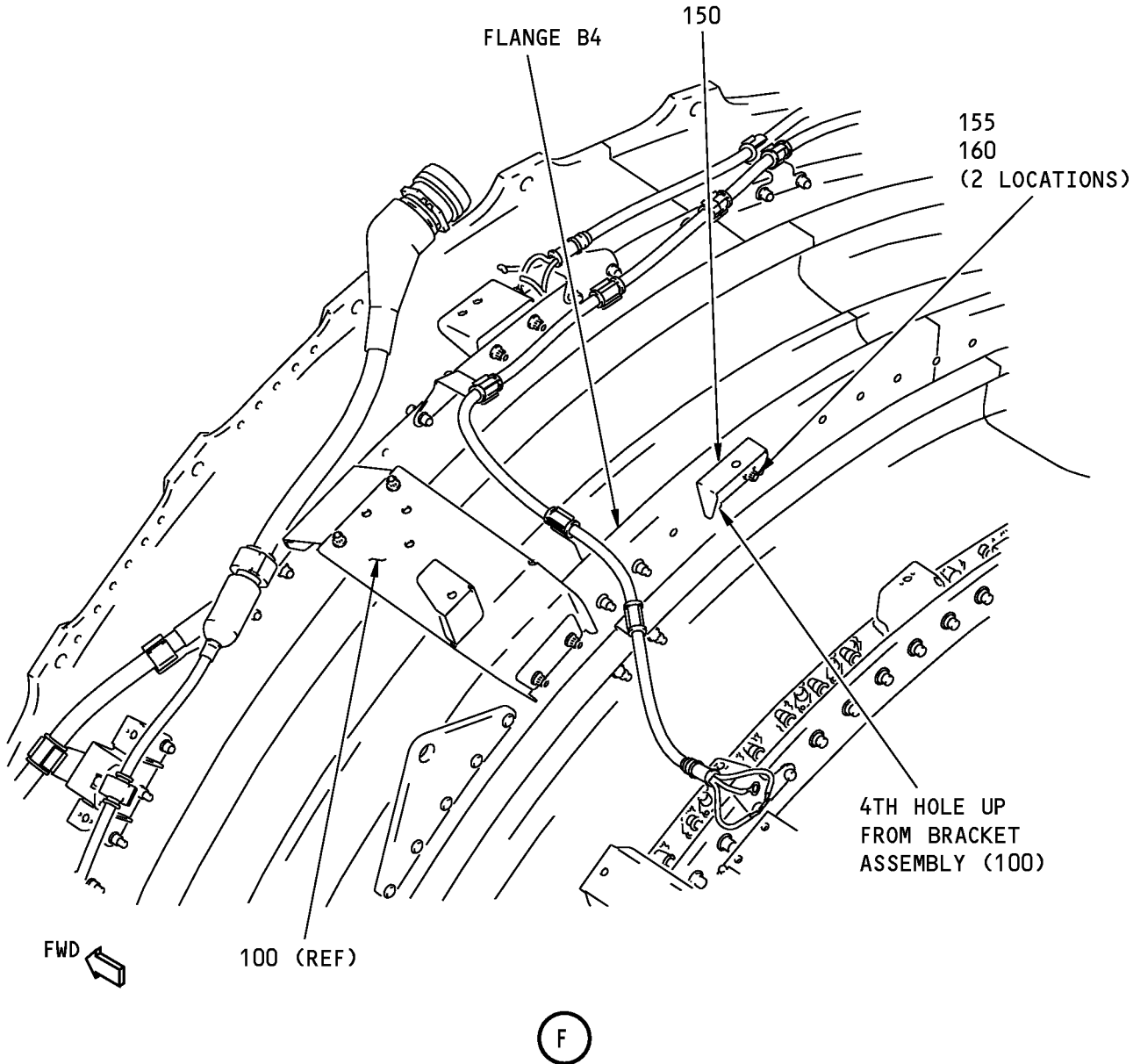

**Bracket Installation - Upper Left Side Fan Case**  
**Figure 4-1 (Sheet 6)**

**71-00-02**

P/P BUILDUP FIGURE 4-1  
Page 12  
Oct 05/2007

D633A106-HXL

**737-600/700/800/900  
POWERPLANT BUILDUP MANUAL**

ITEM NO.	PART NUMBER	NOMENCLATURE	BRACKET LOCATION AND ORIENTATION			QTY
			BRKT OR FLG SIDE	ANGLE FACES	UC	
4-1		<b>BRACKET INSTALLATION - UPPER LEFT SIDE FAN CASE (FIGURE 4-1, SHEET 6)</b>  ATTACH BRACKET ASSY (150) TO 4TH AND 5TH HOLES UP FROM BRACKET ASSY (100) ON FLANGE B4. USE BOLTS (155) AND WASHERS (160).  . BRACKET ASSY . BOLT (FWD SIDE) . WASHER (UNDER BOLT)  TIGHTEN BOLTS (155) TO 110-120 POUND-INCHES (12.4-13.6 NEWTON METERS).				
150	332A2920-142	. BRACKET ASSY	AFT	AFT		1
155	BACB30ZF4-12	. BOLT (FWD SIDE)				2
160	BACW10BP4ACU	. WASHER (UNDER BOLT)				2

# 71-00-02

P/P BUILDUP FIGURE 4-1

Page 13

Oct 05/2007

D633A106-HXL

**737-600/700/800/900  
POWERPLANT BUILDUP MANUAL**

**THIS SHEET NOT USED**

**Bracket Installation - Upper Left Side Fan Case  
Figure 4-1 (Sheet 7)**

**71-00-02**

P/P BUILDUP FIGURE 4-1

Page 14

Oct 05/2007

D633A106-HXL

737-600/700/800/900  
POWERPLANT BUILDUP MANUAL

ITEM NO.	PART NUMBER	NOMENCLATURE	UC	QTY
4-1		BRACKET INSTALLATION - UPPER LEFT SIDE FAN CASE (FIGURE 4-1, SHEET 7)  THIS SHEET NOT USED		

**71-00-02**

P/P BUILDUP FIGURE 4-1

Page 15

Oct 05/2007

D633A106-HXL

**737-600/700/800/900  
POWERPLANT BUILDUP MANUAL**

**THIS SHEET NOT USED**

**Bracket Installation - Upper Left Side Fan Case  
Figure 4-1 (Sheet 8)**

**71-00-02**

P/P BUILDUP FIGURE 4-1

Page 16

Oct 05/2007

D633A106-HXL

737-600/700/800/900  
POWERPLANT BUILDUP MANUAL

ITEM NO.	PART NUMBER	NOMENCLATURE	UC	QTY
4-1		BRACKET INSTALLATION - UPPER LEFT SIDE FAN CASE (FIGURE 4-1, SHEET 8)  THIS SHEET NOT USED		

**71-00-02**

P/P BUILDUP FIGURE 4-1

Page 17

Oct 05/2007

D633A106-HXL

737-600/700/800/900  
**POWERPLANT BUILDUP MANUAL**

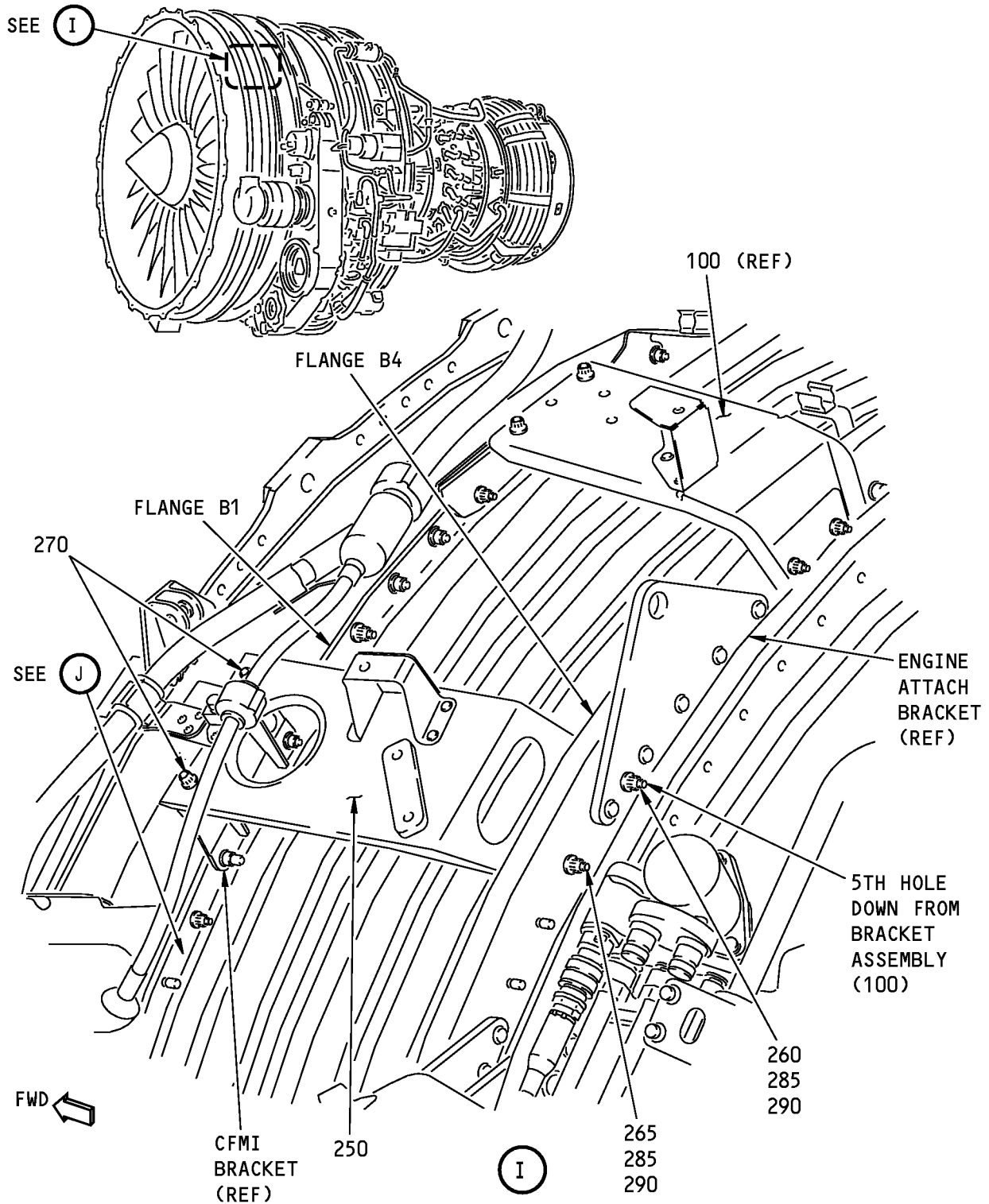

**Bracket Installation - Upper Left Side Fan Case**  
**Figure 4-1 (Sheet 9)**

**71-00-02**

P/P BUILDUP FIGURE 4-1

Page 18

Oct 05/2007

D633A106-HXL



**737-600/700/800/900  
POWERPLANT BUILDUP MANUAL**

ITEM NO.	PART NUMBER	NOMENCLATURE	BRACKET LOCATION AND ORIENTATION			QTY
			BRKT OR FLG SIDE	ANGLE FACES	UC	
4-1		<p><b>BRACKET INSTALLATION - UPPER LEFT SIDE FAN CASE (FIGURE 4-1, SHEET 9)</b></p> <p>ATTACH BRACKET ASSY (250) OR (255) TO 5TH AND 7TH HOLES DOWN FROM BRACKET ASSY (100) ON FLANGE B4, ALIGNING FWD HOLES WITH CFMI BRACKET ON FLANGE B1. USE BOLTS (260) AND (265), WASHERS (285) AND NUTS (290) ON FLANGE B4 AND BOLTS (270) ON CFMI BRACKET ON FLANGE B1.</p> <p>IF BRACKET ASSY (255) IS USED, INSTALL SPACER (275) ON UPR HOLE AND SPACER (280) ON LWR HOLE.</p>				
250	332A2920-157	. BRACKET ASSY	FWD	FWD		1
250	332A2920-131	. BRACKET ASSY (OPTIONAL)	FWD	FWD	OPT	-
255	332A2920-117	. BRACKET ASSY (OPTIONAL) <sup>*[1]*[2]</sup>	FWD	FWD	OPT	-
260	BACB30ZF4-29	. BOLT (FWD SIDE) (UPPER HOLE)				1
265	BACB30ZF4-23	. BOLT (FWD SIDE) (LOWER HOLE)				1
270	BACB30ZF4-08	. BOLT				2
275	NAS1057W4A-064	. SPACER (UPR HOLE) (1 REQD) <sup>*[1]*[2]</sup>			OPT	-
280	NAS1057W4A-080	. SPACER (LWR HOLE) (1 REQD) <sup>*[1]*[2]</sup>			OPT	-
285	NAS1149C0432R	. WASHER (UNDER NUT)				2
290	AS3485-10	. NUT				2
		<p>TIGHTEN BOLTS (260), (265) AND (270) TO 110-120 POUND-INCHES (12.4-13.6 NEWTON METERS).</p> <p>*[1] BRACKET ASSY (255) WITH SPACERS (275) AND (280) IS OPTIONAL TO BRACKET ASSY (250)</p> <p>*[2] ITEM NOT ILLUSTRATED</p>				

# 71-00-02

P/P BUILDUP FIGURE 4-1

Page 19

Oct 05/2007

D633A106-HXL

737-600/700/800/900  
**POWERPLANT BUILDUP MANUAL**

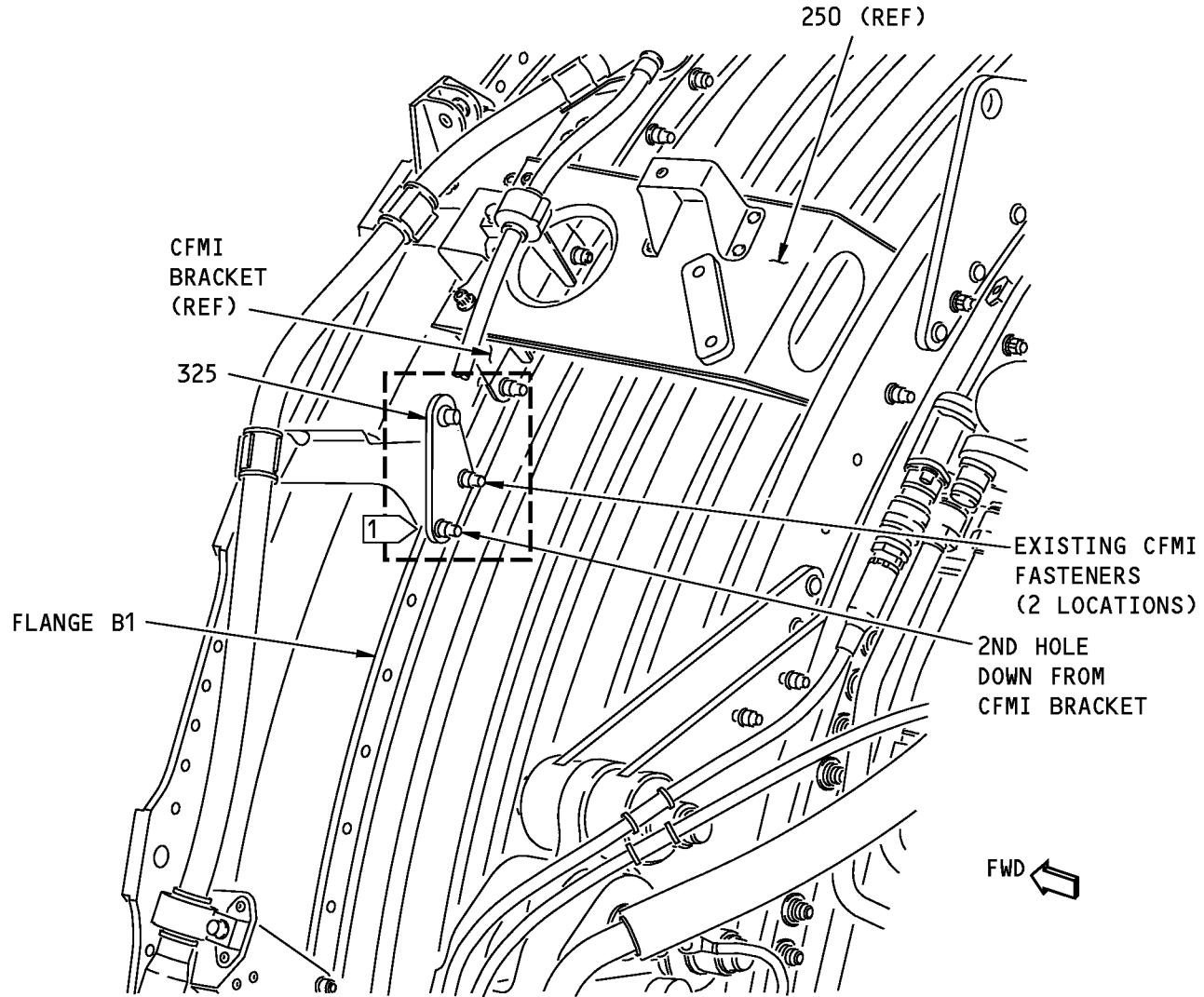
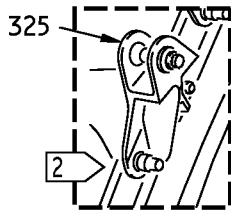

- 1 PREFERRED BRACKET ASSEMBLY
- 2 OPTIONAL BRACKET ASSEMBLY

J

**Bracket Installation - Upper Left Side Fan Case**  
**Figure 4-1 (Sheet 10)**

**71-00-02**

P/P BUILDUP FIGURE 4-1

Page 20

Oct 05/2007

D633A106-HXL

**737-600/700/800/900  
POWERPLANT BUILDUP MANUAL**

ITEM NO.	PART NUMBER	NOMENCLATURE	BRACKET LOCATION AND ORIENTATION			QTY
			BRKT OR FLG SIDE	ANGLE FACES	UC	
4-1		<b>BRACKET INSTALLATION - UPPER LEFT SIDE FAN CASE (FIGURE 4-1, SHEET 10)</b>  REMOVE EXISTING CFMI FASTENERS FROM 1ST AND 2ND HOLES DOWN FROM CFMI BRACKET ON FLANGE B1.  ATTACH BRACKET ASSY (325) USING EXISTING CFMI FASTENERS.				
325	332A2920-178	. BRACKET ASSY	AFT			1
325	332A2930-30	. BRKT ASSY (OPTIONAL TO 332A2920-178)	AFT		OPT	-
		TIGHTEN EXISTING CFMI FASTENERS TO 110-120 POUND-INCHES (12.4-13.6 NEWTON METERS).				

# 71-00-02

P/P BUILDUP FIGURE 4-1

Page 21

Oct 05/2007

D633A106-HXL

737-600/700/800/900  
**POWERPLANT BUILDUP MANUAL**

SEE (K)

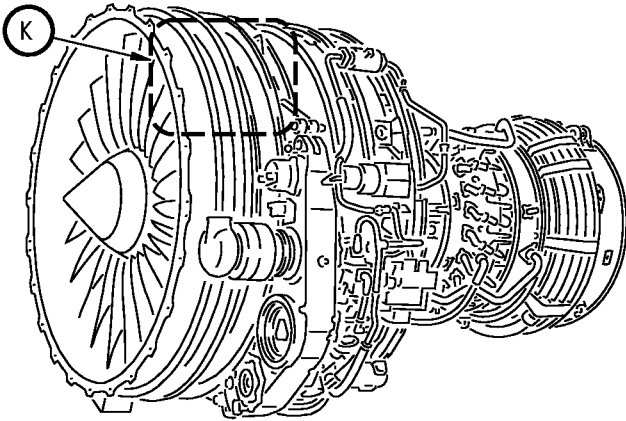

365 (2 LOCATIONS) 360 385 (2 LOCATIONS)

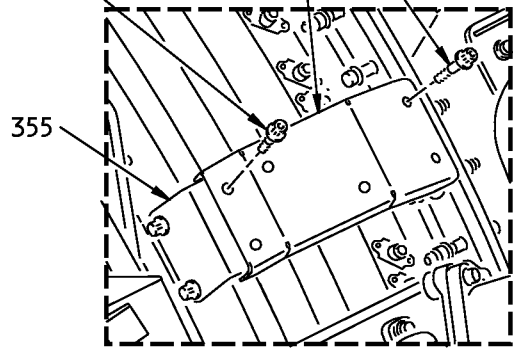

**OPTIONAL CONFIGURATION**

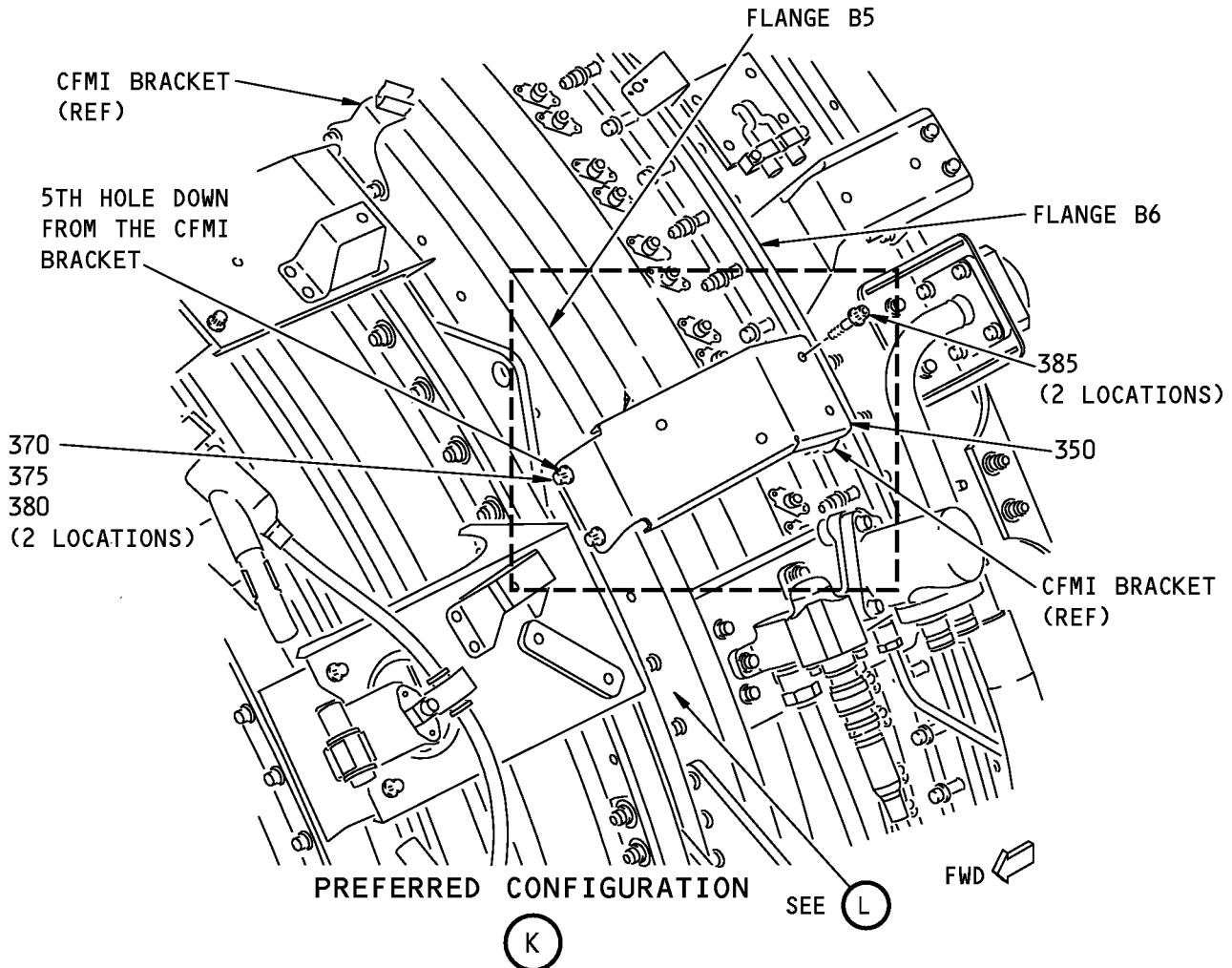

**PREFERRED CONFIGURATION**

SEE (L)

(K)

**Bracket Installation - Upper Left Side Fan Case  
Figure 4-1 (Sheet 11)**

**71-00-02**

P/P BUILDUP FIGURE 4-1

Page 22

Oct 05/2007

**737-600/700/800/900  
POWERPLANT BUILDUP MANUAL**

ITEM NO.	PART NUMBER	NOMENCLATURE	BRACKET LOCATION AND ORIENTATION			QTY
			BRKT OR FLG SIDE	ANGLE FACES	UC	
4-1		<p><b>BRACKET INSTALLATION - UPPER LEFT SIDE FAN CASE (FIGURE 4-1, SHEET 11)</b></p> <p>PREFERRED CONFIGURATION;</p> <p>ATTACH BRACKET ASSY (350) TO 5TH AND 6TH HOLES DOWN FROM CFMI BRACKET ON FLANGE B5 USING BOLTS (370), WASHERS (375) AND NUTS (380) AND TO CFMI BRACKET ON FLANGE B6 USING BOLTS (385).</p> <p>OPTIONAL CONFIGURATION;</p> <p>ATTACH BRACKET (355) TO BRACKET ASSY (360) USING BOLTS (365). TIGHTEN BOLTS TO 110-120 POUND-INCHES (12.4-13.6 NEWTON METERS).</p> <p>ATTACH BRACKET (355) TO 5TH AND 6TH HOLES DOWN FROM CFMI BRACKET ON FLANGE B5 USING BOLTS (370), WASHERS (375) AND NUTS (380).</p> <p>ATTACH BRACKET (360) TO CFMI BRACKET ON FLANGE B6 USING BOLTS (385).</p>				
350	332A2920-197	. BRACKET ASSY	FWD	AFT		1
355	332A2910-87	. BRACKET (1 REQD)	FWD	AFT	OPT	-
360	332A2920-115	. BRACKET ASSY (1 REQD)			OPT	-
365	BACB30ZF4-06	. BOLT (2 REQD)			OPT	-
370	BACB30ZF4-10	. BOLT (FWD SIDE)				2
375	NAS1149C0432R	. WASHER (UNDER NUT)				2
380	AS3485-10	. NUT				2
385	BACB30ZF4-06	. BOLT				2
		TIGHTEN BOLTS (370, 385) TO 110-120 POUND-INCHES (12.4-13.6 NEWTON METERS).				

# 71-00-02

P/P BUILDUP FIGURE 4-1

Page 23

Oct 05/2007

D633A106-HXL

737-600/700/800/900  
**POWERPLANT BUILDUP MANUAL**

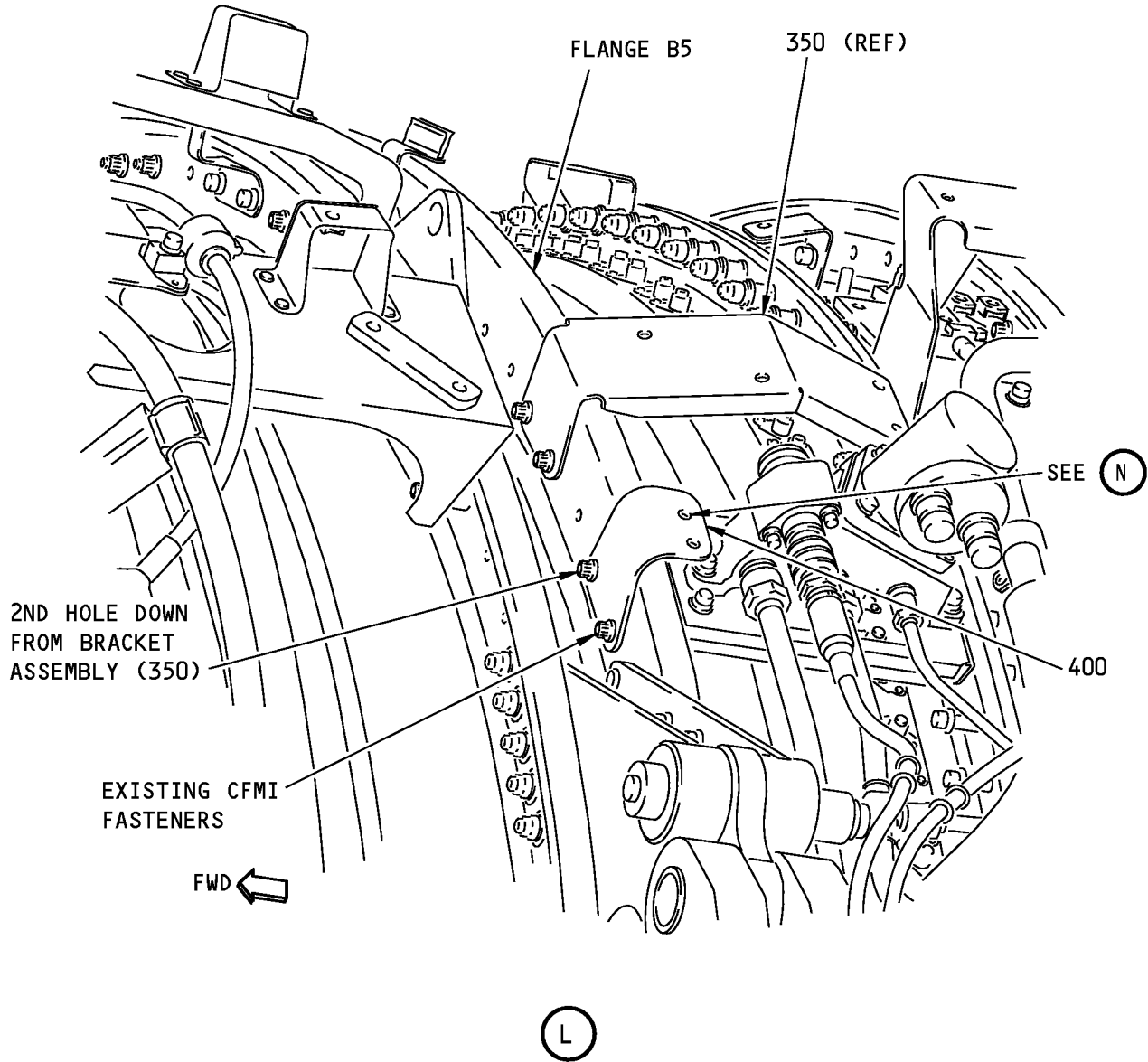

**Bracket Installation - Upper Left Side Fan Case**  
**Figure 4-1 (Sheet 12)**

**71-00-02**

P/P BUILDUP FIGURE 4-1

Page 24

Oct 05/2007

D633A106-HXL

**737-600/700/800/900  
POWERPLANT BUILDUP MANUAL**

ITEM NO.	PART NUMBER	NOMENCLATURE	BRACKET LOCATION AND ORIENTATION			QTY
			BRKT OR FLG SIDE	ANGLE FACES	UC	
4-1		<p><b>BRACKET INSTALLATION - UPPER LEFT SIDE FAN CASE (FIGURE 4-1, SHEET 12)</b></p> <p>REMOVE EXISTING CFMI FASTENERS FROM 2ND AND 3RD HOLES DOWN FROM BRACKET (350) (OR BRACKET (355).</p> <p>IF OPTIONAL CONFIGURATION IS USED) ON FLANGE B5; DISCARD THE RED CFMI SPACERS. ATTACH BRACKET ASSY (400) USING EXISTING CFMI FASTENERS.</p>				
400	332A2910-130	. BRACKET ASSY	FWD	AFT		1
400	332A2910-46	. BRACKET ASSY (OPTIONAL TO 332A2910-130)	FWD	AFT	OPT	-
		TIGHTEN EXISTING CFMI FASTENERS TO 110-120 POUND-INCHES (12.4-13.6 NEWTON METERS).				

# 71-00-02

P/P BUILDUP FIGURE 4-1

Page 25

Oct 05/2007

D633A106-HXL

**737-600/700/800/900  
POWERPLANT BUILDUP MANUAL**

**THIS SHEET NOT USED**

**Bracket Installation - Upper Left Side Fan Case  
Figure 4-1 (Sheet 13)**

**71-00-02**

P/P BUILDUP FIGURE 4-1

Page 26

Oct 05/2007

D633A106-HXL



**737-600/700/800/900  
POWERPLANT BUILDUP MANUAL**

ITEM NO.	PART NUMBER	NOMENCLATURE	UC	QTY
4-1		BRACKET INSTALLATION - UPPER LEFT SIDE FAN CASE (FIGURE 4-1, SHEET 13)  THIS SHEET NOT USED		

**71-00-02**

P/P BUILDUP FIGURE 4-1

Page 27

Oct 05/2007

D633A106-HXL

737-600/700/800/900  
**POWERPLANT BUILDUP MANUAL**

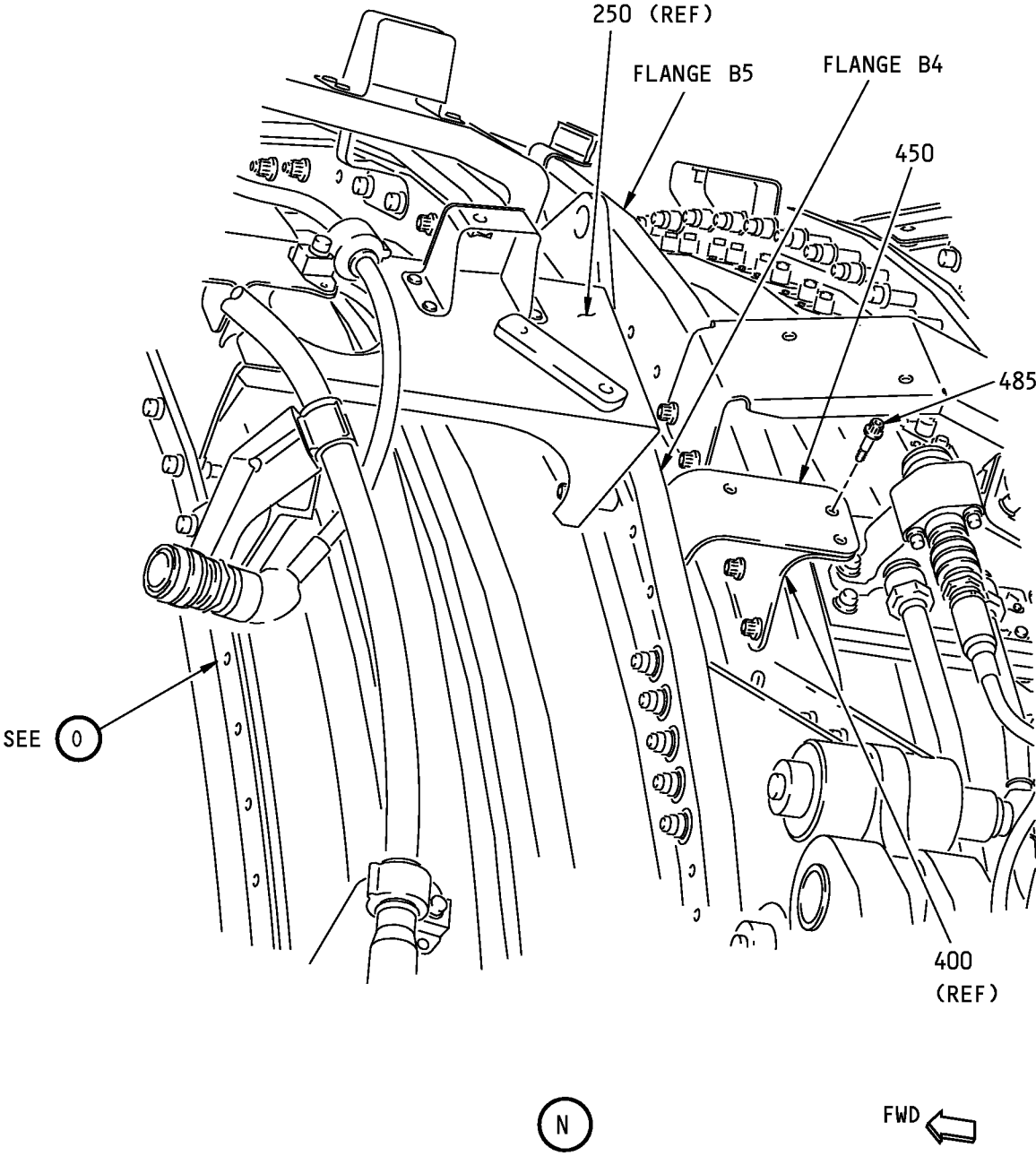

**Bracket Installation - Upper Left Side Fan Case**  
**Figure 4-1 (Sheet 14)**

**71-00-02**

P/P BUILDUP FIGURE 4-1  
Page 28  
Oct 05/2007

D633A106-HXL

**737-600/700/800/900  
POWERPLANT BUILDUP MANUAL**

ITEM NO.	PART NUMBER	NOMENCLATURE	BRACKET LOCATION AND ORIENTATION			QTY
			BRKT OR FLG SIDE	ANGLE FACES	UC	
4-1		<b>BRACKET INSTALLATION - UPPER LEFT SIDE FAN CASE (FIGURE 4-1, SHEET 14)</b>  ATTACH BRACKET ASSY (450) TO BRACKET ASSY (400) WITH BOLT (485) AT UPPER LOCATION ONLY. TIGHTEN BOLT TO 110-120 POUND-INCHES (12.4-13.6 NEWTON METERS)  <b>NOTE:</b> LOWER HOLE WILL BE USED TO ATTACH HYD PRESSURE HOSE (REF Figure 21-1).  BRACKET (450) FASTENERS TO FLANGE B4 ARE INSTALLED LATER.				
450	332A2910-132	. BRACKET ASSY	AFT	AFT		1
450	332A2910-48	. BRACKET ASSY (OPTIONAL TO 332A2910-132)	AFT	AFT	OPT	-
485	BACB30ZF4-08	. BOLT				1

# 71-00-02

P/P BUILDUP FIGURE 4-1

Page 29

Oct 05/2007

D633A106-HXL

737-600/700/800/900  
**POWERPLANT BUILDUP MANUAL**

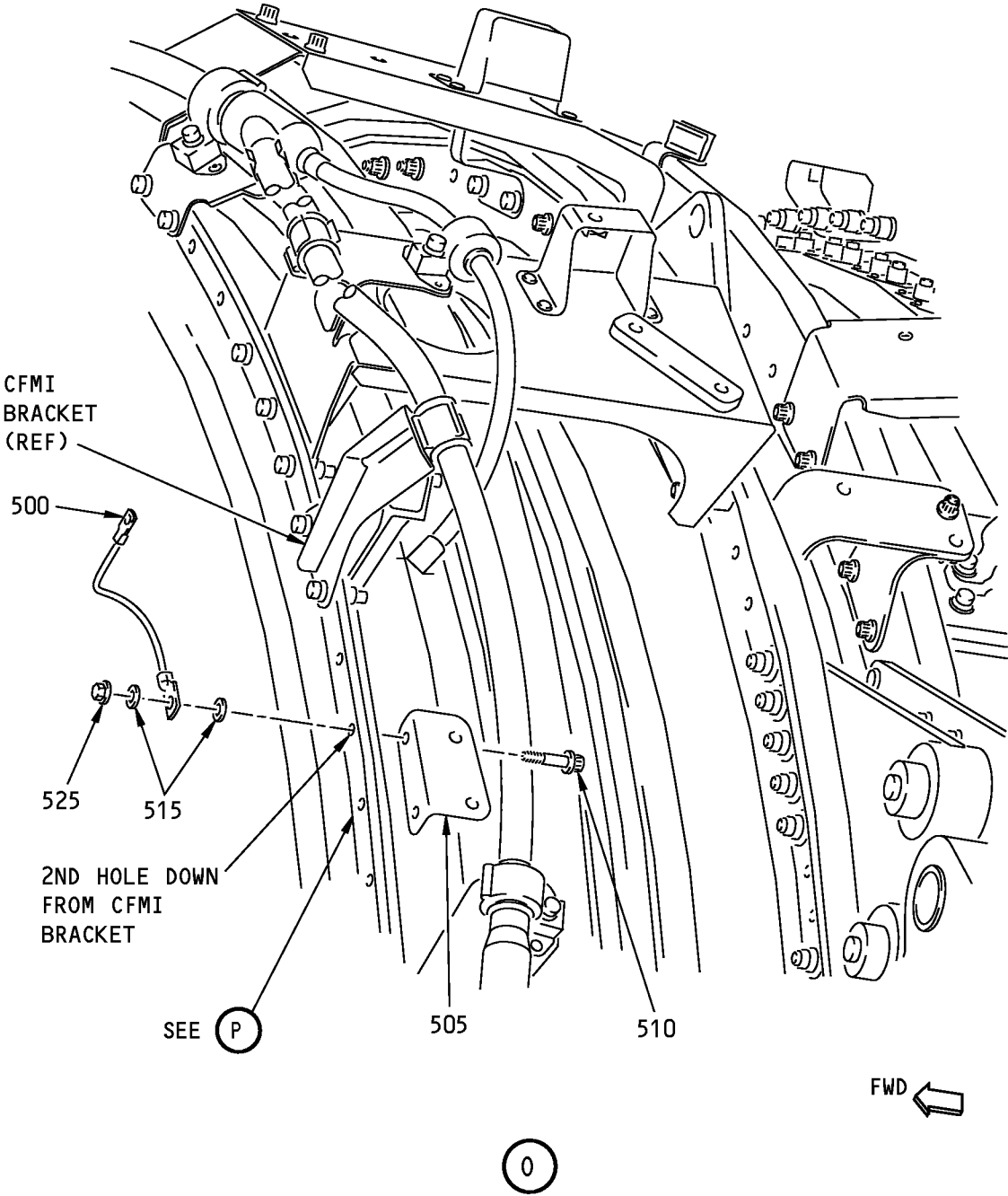

**Bracket Installation - Upper Left Side Fan Case**  
**Figure 4-1 (Sheet 15)**

**71-00-02**

P/P BUILDUP FIGURE 4-1  
Page 30  
Oct 05/2007

D633A106-HXL

**737-600/700/800/900  
POWERPLANT BUILDUP MANUAL**

ITEM NO.	PART NUMBER	NOMENCLATURE	BRACKET LOCATION AND ORIENTATION			QTY
			BRKT OR FLG SIDE	ANGLE FACES	UC	
4-1		<p><b>BRACKET INSTALLATION - UPPER LEFT SIDE FAN CASE (FIGURE 4-1, SHEET 15)</b></p> <p>CLEAN MATING SURFACES OF BONDING JUMPER (500) AND 2ND HOLE DOWN FROM CFMI BRKT ON FLANGE B1 WITH alcohol, B00130 (C2). MAKE SURE YOU REMOVE ALL GREASE AND OTHER CONTAMINANTS.</p>				
500 C2	BACJ40AC54-7 B00130	<p>. BONDING JUMPER</p> <p>. SOLVENT, TT-I-735</p> <p>POSITION BRACKET ASSY (505) ON 2ND AND 3RD HOLE DOWN FROM CFMI BRKT. AT UPPER HOLE, LOOSELY ATTACH BONDING JUMPER (500) WITH BOLT (510), WASHERS (515) AND NUT (525) (LOWER BOLT WILL BE ATTACHED LATER).</p> <p><b>NOTE:</b> 3RD HOLE DOWN IS SHARED WITH BRACKET ASSY (550).</p> <p><b>NOTE:</b> UPPER END OF BONDING JUMPER (500) IS ATTACHED IN Figure 4-1 (Sheet 25).</p>			CON	1 AR
505 510 515 525	332A2910-41 BACB30ZF4-10 NAS1149D0416H BACN10YR4CD	<p>. BRACKET ASSY</p> <p>. BOLT (AFT SIDE) (UPPER HOLE)</p> <p>. WASHER</p> <p>. NUT</p>	AFT	AFT		1 1 2 1

# 71-00-02

P/P BUILDUP FIGURE 4-1

Page 31

Oct 05/2007

D633A106-HXL

737-600/700/800/900  
**POWERPLANT BUILDUP MANUAL**

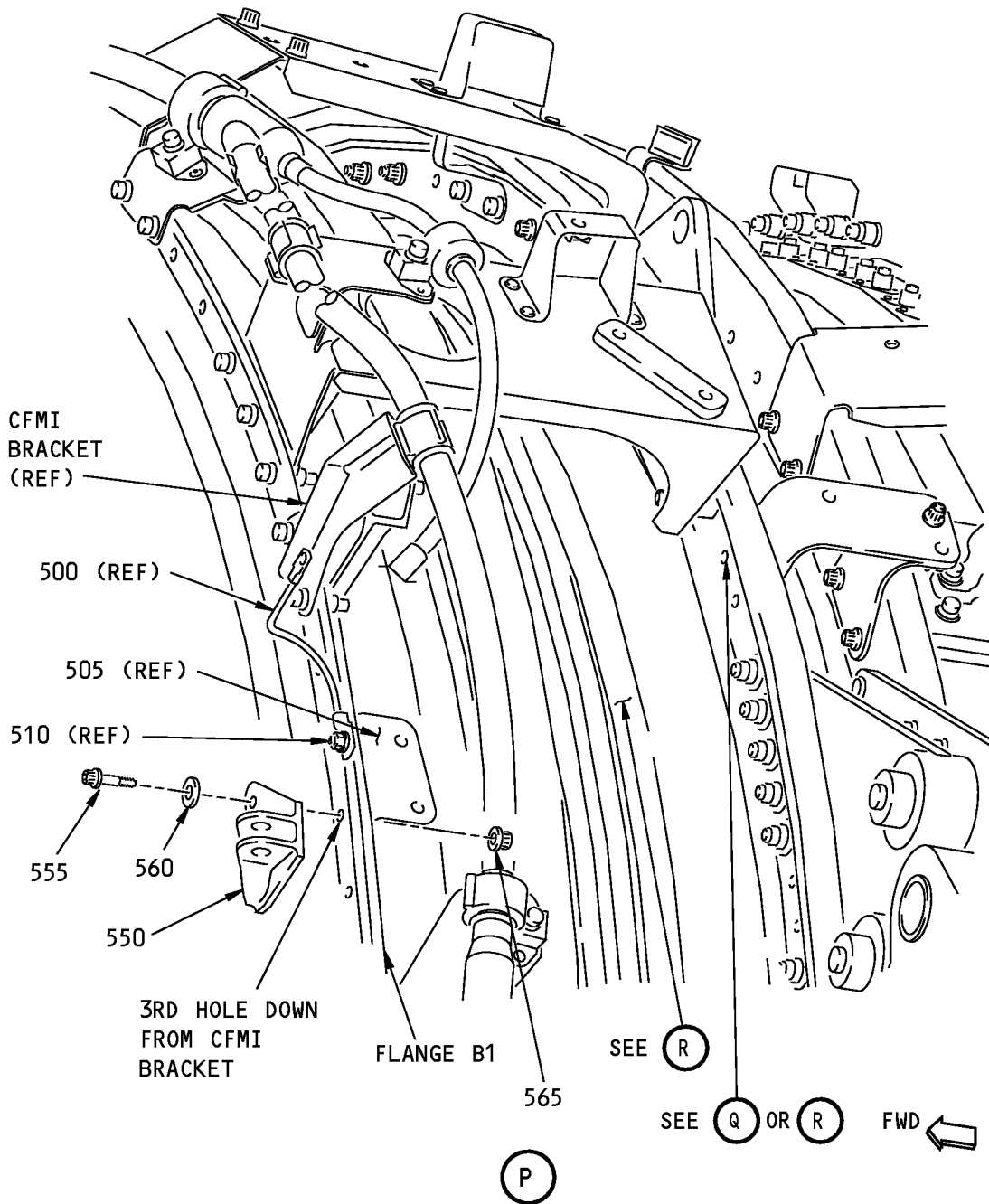

**Bracket Installation - Upper Left Side Fan Case**  
**Figure 4-1 (Sheet 16)**

**71-00-02**

P/P BUILDUP FIGURE 4-1

Page 32

Oct 05/2007

D633A106-HXL

## POWERPLANT BUILDUP MANUAL

ITEM NO.	PART NUMBER	NOMENCLATURE	BRACKET LOCATION AND ORIENTATION			QTY
			BRKT OR FLG SIDE	ANGLE FACES	UC	
4-1		<b>BRACKET INSTALLATION - UPPER LEFT SIDE FAN CASE (FIGURE 4-1, SHEET 16)</b>  LOOSELY ATTACH BRACKET ASSY (550) TO 3RD HOLE DOWN FROM CFMI BRKT. USE BOLT (555), WASHER (560) AND NUT (565) AT UPPER LOCATION ONLY (LOWER HOLE WILL BE ATTACHED LATER).  <b>NOTE:</b> 3RD HOLE DOWN IS SHARED WITH BRACKET ASSY (505).				
550	332A2930-85	. BRACKET ASSY	FWD			1
550	332A2930-33	. BRKT ASSY (OPTIONAL TO 332A2930-85)	FWD		OPT	-
555	BACB30ZF4-14	. BOLT (FWD SIDE)				1
560	BACW10BP4ACU	. WASHER (CSK) (UNDER BOLT HEAD)				1
565	AS3485-10	. NUT				1
		WHILE ALIGNING LOWER HOLE ON BRACKET ASSY (550), TIGHTEN BOLTS (510) AND (555) TO 110-120 POUND-INCHES (12.4-13.6 NEWTON METERS).  APPLY FILLET SEAL OF sealant, A00160 (C4) OR sealant, A00803 (C5) OR adhesive, A00027 (C6) AROUND JUMPER (500) AND BOLT (510). IF sealant, A00160 (C4) IS USED, APPLY Dapco No. 1-100 primer, C00944 (C3) BEFORE SEALANT APPLICATION.				
C3	C00944	. PRIMER, DAPCO NO. 1-100			CON	AR
C4	A00160	. SEALANT, BMS 5-63 TYPE I			CON	AR
C5	A00803	. SEALANT, BMS 5-63 TYPE II			CON	AR
C6	A00027	. SEALANT, BAC5010 TYPE 60			CON	AR

71-00-02

P/P BUILDUP FIGURE 4-1

Page 33

Oct 05/2007

D633A106-HXL

**737-600/700/800/900  
POWERPLANT BUILDUP MANUAL**

**THIS SHEET NOT USED**

**Bracket Installation - Upper Left Side Fan Case  
Figure 4-1 (Sheet 17)**

**71-00-02**

P/P BUILDUP FIGURE 4-1

Page 34

Oct 05/2007

D633A106-HXL



737-600/700/800/900  
POWERPLANT BUILDUP MANUAL

ITEM NO.	PART NUMBER	NOMENCLATURE	UC	QTY
4-1		BRACKET INSTALLATION - UPPER LEFT SIDE FAN CASE (FIGURE 4-1, SHEET 17)  THIS SHEET NOT USED		

**71-00-02**

P/P BUILDUP FIGURE 4-1

Page 35

Oct 05/2007

D633A106-HXL

**737-600/700/800/900  
POWERPLANT BUILDUP MANUAL**

**THIS SHEET NOT USED**

**Bracket Installation - Upper Left Side Fan Case  
Figure 4-1 (Sheet 18)**

**71-00-02**

P/P BUILDUP FIGURE 4-1

Page 36

Oct 05/2007

D633A106-HXL

## POWERPLANT BUILDUP MANUAL

ITEM NO.	PART NUMBER	NOMENCLATURE	UC	QTY
4-1		BRACKET INSTALLATION - UPPER LEFT SIDE FAN CASE (FIGURE 4-1, SHEET 18)  THIS SHEET NOT USED		

**71-00-02**

P/P BUILDUP FIGURE 4-1

Page 37

Oct 05/2007

D633A106-HXL

737-600/700/800/900  
**POWERPLANT BUILDUP MANUAL**

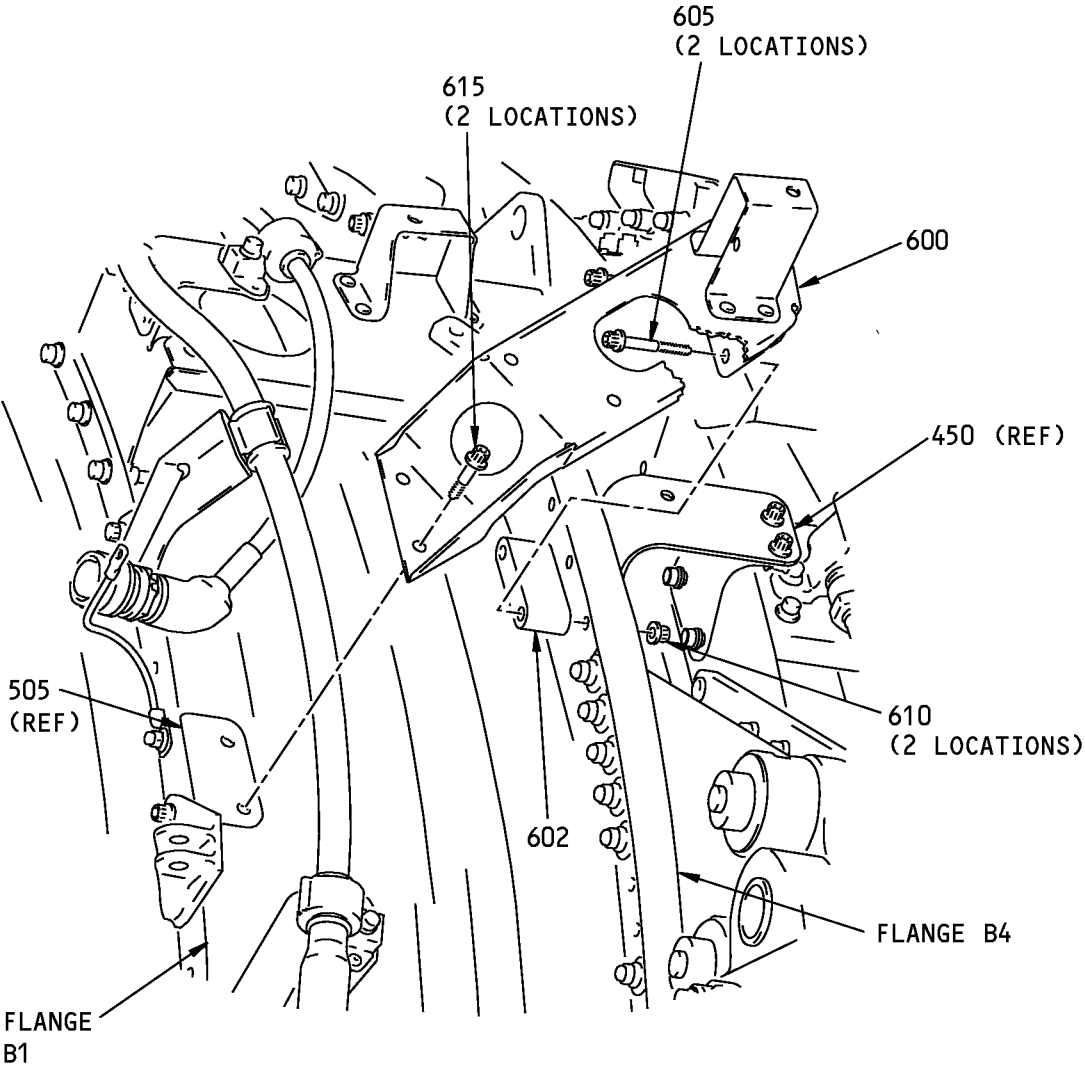

(R)

**Bracket Installation - Upper Left Side Fan Case**  
**Figure 4-1 (Sheet 19)**

**71-00-02**

P/P BUILDUP FIGURE 4-1  
Page 38  
Oct 05/2007

D633A106-HXL

**737-600/700/800/900  
POWERPLANT BUILDUP MANUAL**

ITEM NO.	PART NUMBER	NOMENCLATURE	BRACKET LOCATION AND ORIENTATION			QTY
			BRKT OR FLG SIDE	ANGLE FACES	UC	
4-1		<b>BRACKET INSTALLATION - UPPER LEFT SIDE FAN CASE (FIGURE 4-1, SHEET 19)</b>  ATTACH BRACKET ASSY (600), BRACKET DETAIL (602), AND BRACKET ASSY (450) TO FLANGE B4 USING BOLTS (605) AND NUTS (610).				
600	332A2920-228	. BRACKET ASSY	FWD			1
602	332A2930-89	. BRACKET DETAIL				1
605	BACB30ZF4-23	. BOLT (FWD SIDE)				2
610	AS3485-10	. NUT				2
		ATTACH BRACKET ASSY (600) TO BRACKET (505) USING BOLTS (615).				
615	BACB30ZF4-06	. BOLT  TIGHTEN BOLTS (605) AND BOLTS (615) TO 110-120 POUND-INCHES (12.4-13.6 NEWTON METERS).				2

# 71-00-02

P/P BUILDUP FIGURE 4-1

Page 39

Oct 05/2007

D633A106-HXL

737-600/700/800/900  
**POWERPLANT BUILDUP MANUAL**

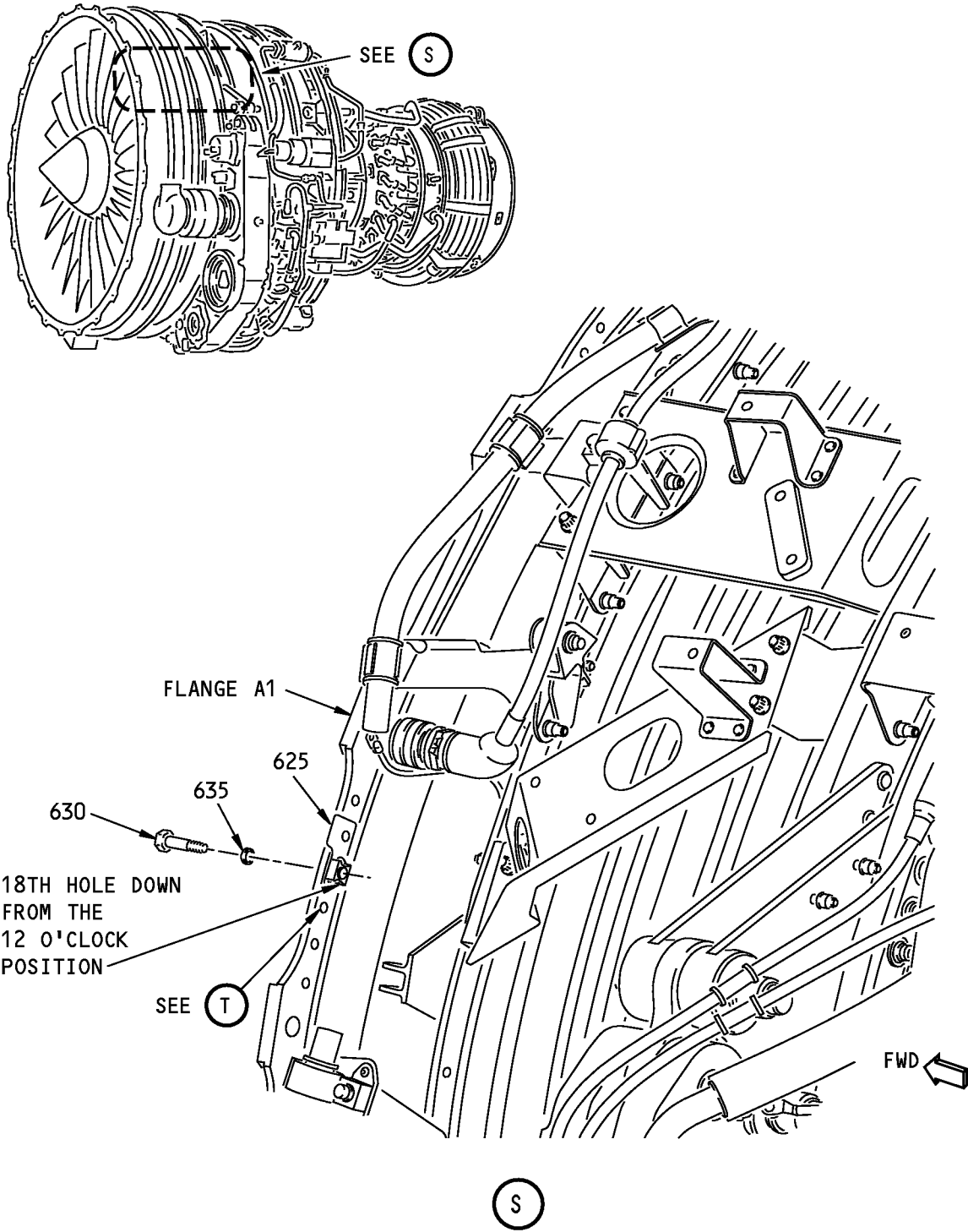

**Bracket Installation - Upper Left Side Fan Case**  
**Figure 4-1 (Sheet 20)**

**71-00-02**

P/P BUILDUP FIGURE 4-1  
Page 40  
Oct 05/2007

D633A106-HXL

**737-600/700/800/900  
POWERPLANT BUILDUP MANUAL**

ITEM NO.	PART NUMBER	NOMENCLATURE	BRACKET LOCATION AND ORIENTATION			QTY
			BRKT OR FLG SIDE	ANGLE FACES	UC	
4-1		<b>BRACKET INSTALLATION - UPPER LEFT SIDE FAN CASE (FIGURE 4-1, SHEET 20)</b> ATTACH BRACKET ASSY (625) TO 18TH HOLE DOWN ON FLANGE A1. USE BOLT (630) AND WASHER (635).				
625	332A2910-138	. BRACKET ASSY	AFT			1
625	332A2910-91	. BRACKET ASSY (OPTIONAL TO 332A2910-138)	AFT		OPT	-
630	BACB30NM4K5	. BOLT (FWD SIDE)				1
635	BACW10BP4ACU	. WASHER (CSK) (UNDER BOLT HEAD)				1
		TIGHTEN BOLT (630) TO 90-110 POUND-INCHES (10.2-12.4 NEWTON METERS).				

# 71-00-02

P/P BUILDUP FIGURE 4-1

Page 41

Oct 05/2007

D633A106-HXL

737-600/700/800/900  
**POWERPLANT BUILDUP MANUAL**

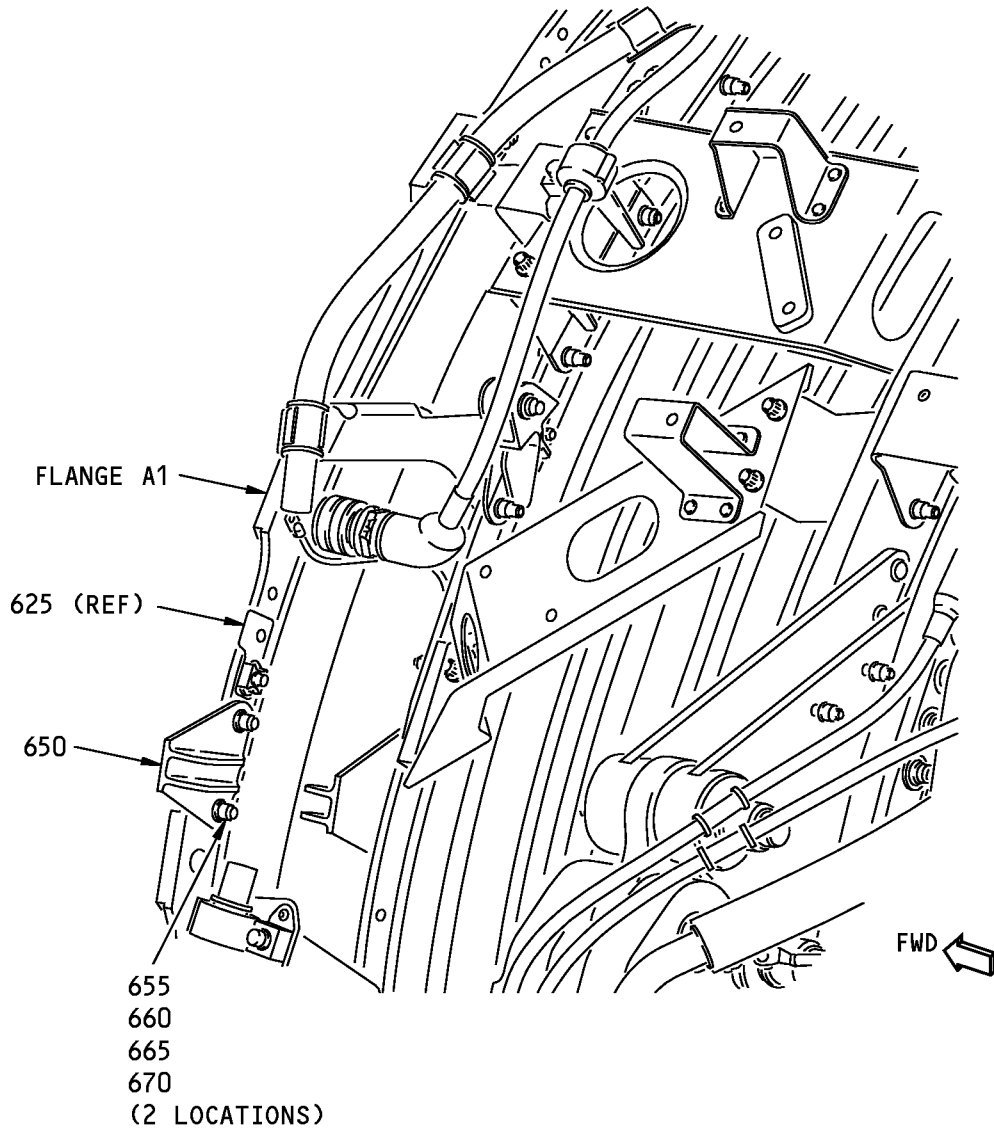

T

**Bracket Installation - Upper Left Side Fan Case**  
**Figure 4-1 (Sheet 21)**

**71-00-02**  
P/P BUILDUP FIGURE 4-1  
Page 42  
Oct 05/2007

D633A106-HXL



**737-600/700/800/900  
POWERPLANT BUILDUP MANUAL**

ITEM NO.	PART NUMBER	NOMENCLATURE	BRACKET LOCATION AND ORIENTATION			QTY
			BRKT OR FLG SIDE	ANGLE FACES	UC	
4-1		<b>BRACKET INSTALLATION - UPPER LEFT SIDE FAN CASE (FIGURE 4-1, SHEET 21)</b>  ATTACH BRACKET ASSY (650) TO 1ST AND 3RD HOLES DOWN FROM BRACKET ASSY (625) ON FLANGE A1. USE BOLTS (655), WASHER (660) AND (665), AND NUTS (670).				
650	332A2930-7	. BRACKET ASSY	AFT			1
655	BACB30NM4K7	. BOLT (FWD SIDE)				2
660	BACW10BP4ACU	. WASHER (CSK) (UNDER BOLT)				2
665	NAS1149D0416H	. WASHER (UNDER NUT)				2
670	AS3485-10	. NUT				2
		TIGHTEN BOLTS (655) TO 50-80 POUND-INCHES (5.6-9.0 NEWTON METERS).				

# 71-00-02

P/P BUILDUP FIGURE 4-1

Page 43

Oct 05/2007

D633A106-HXL

737-600/700/800/900  
**POWERPLANT BUILDUP MANUAL**

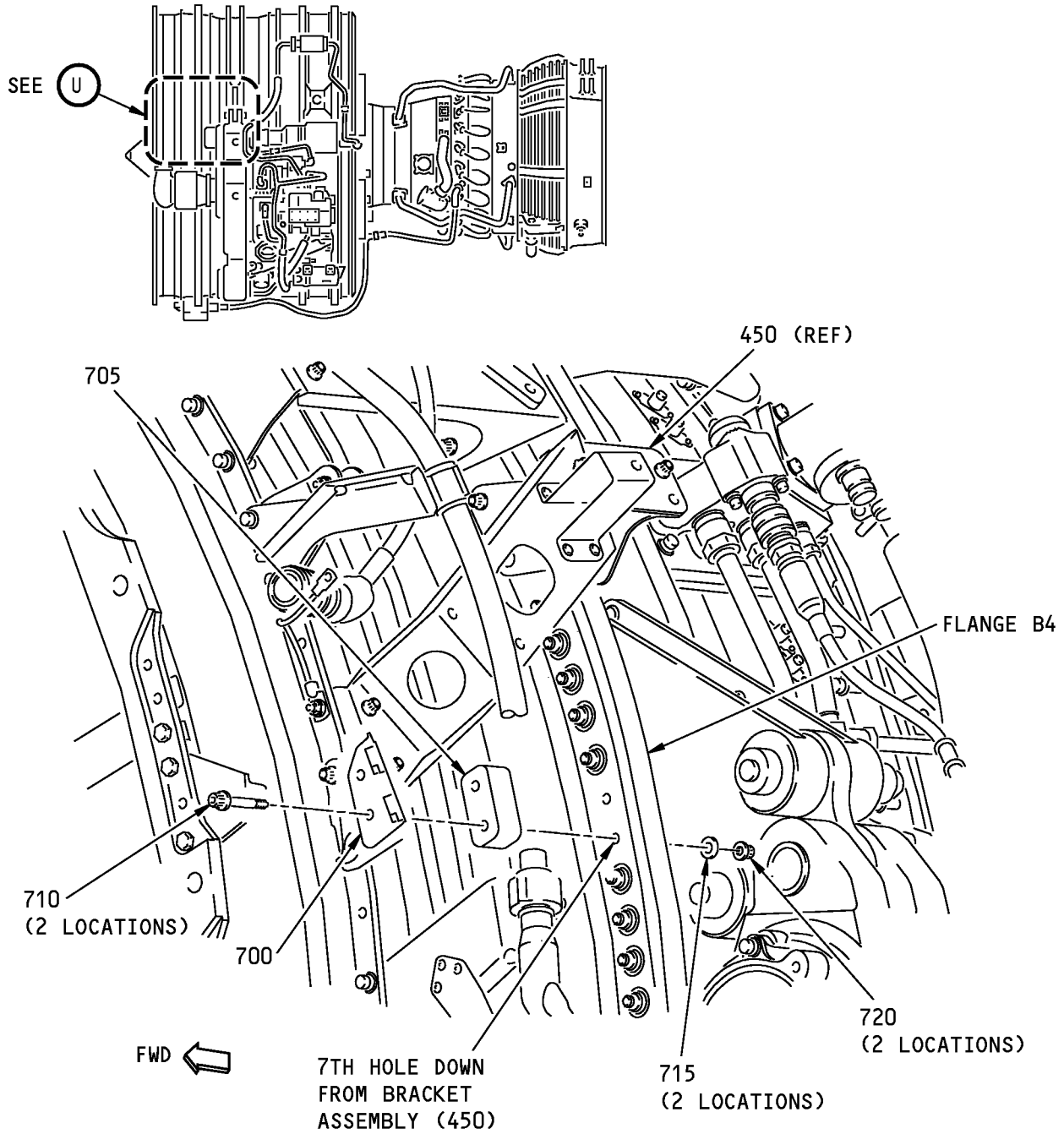

**Bracket Installation - Upper Left Side Fan Case**  
**Figure 4-1 (Sheet 22)**

**71-00-02**

P/P BUILDUP FIGURE 4-1

Page 44

Oct 05/2007

D633A106-HXL

**737-600/700/800/900  
POWERPLANT BUILDUP MANUAL**

ITEM NO.	PART NUMBER	NOMENCLATURE	BRACKET LOCATION AND ORIENTATION			QTY
			BRKT OR FLG SIDE	ANGLE FACES	UC	
4-1		<b>BRACKET INSTALLATION - UPPER LEFT SIDE FAN CASE (FIGURE 4-1, SHEET 22)</b>  ATTACH BRACKET ASSYS (700) AND (705) TO 6TH AND 7TH HOLES DOWN FROM BRACKET ASSY (450) ON FLANGE B4. USE BOLTS (710), WASHERS (715) AND NUTS (720).				
700	332A2910-125	. BRACKET ASSY	FWD	FWD		1
700	332A2930-57	. BRACKET ASSY (OPTIONAL TO 332A2930-125)	FWD	FWD	OPT	-
705	332A2930-88	. BRACKET	FWD			1
710	BACB30ZF4-34	. BOLT (FWD SIDE)				2
715	NAS1149C0432R	. WASHER (UNDER NUT)				2
720	AS3485-10	. NUT				2
		TIGHTEN BOLTS (710) TO 110-120 POUND-INCHES (12.4-13.6 NEWTON METERS).				

# 71-00-02

P/P BUILDUP FIGURE 4-1

Page 45

Oct 05/2007

D633A106-HXL

737-600/700/800/900  
**POWERPLANT BUILDUP MANUAL**

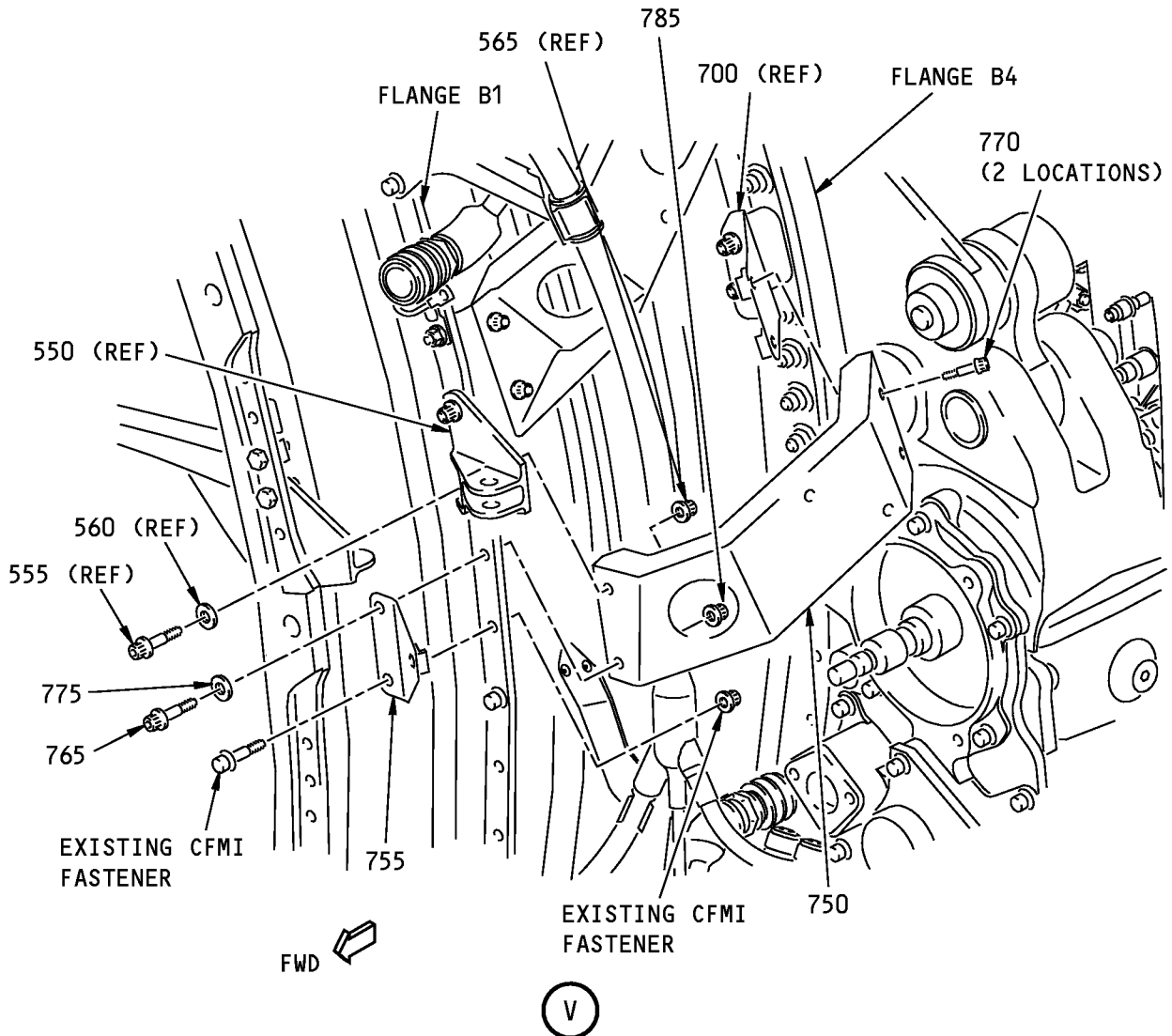
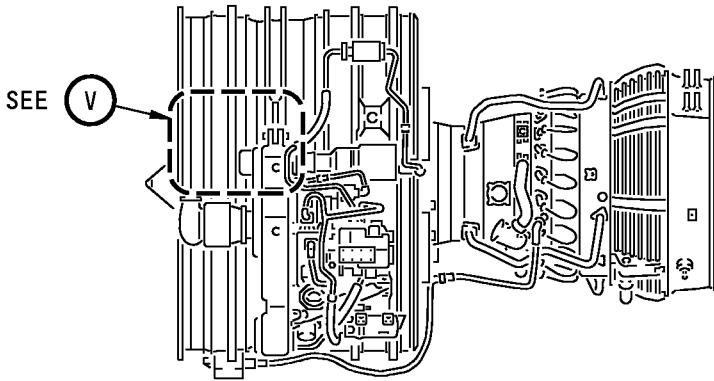

F40640 S00041153680\_V2

**Bracket Installation - Upper Left Side Fan Case**  
**Figure 4-1 (Sheet 23)**

**71-00-02**

P/P BUILDUP FIGURE 4-1

Page 46

Feb 05/2008

D633A106-HXL

**737-600/700/800/900  
POWERPLANT BUILDUP MANUAL**

ITEM NO.	PART NUMBER	NOMENCLATURE	BRACKET LOCATION AND ORIENTATION			QTY
			BRKT OR FLG SIDE	ANGLE FACES	UC	
4-1		<b>BRACKET INSTALLATION - UPPER LEFT SIDE FAN CASE (FIGURE 4-1, SHEET 23)</b>  ATTACH BRACKET ASSY (750) TO BRACKET ASSY (700) ON FLANGE B4 AND BRACKET ASSYS (550) AND (755) ON FLANGE B1. USE BOLTS (760), (765) AND (770), WASHERS (775) AND (780), NUT (785) AND EXISTING CFMI FASTENER.  . BRACKET ASSY . BRACKET ASSY . BRACKET ASSY (OPTIONAL TO 332A2910-136) . BOLT (FWD SIDE) (UPPER HOLE) . BOLT (FWD SIDE) (LOWER HOLE) . BOLT . WASHER (UNDER BOLT (765)) . WASHER (CSK) (UNDER BOLT (760)) . NUT  TIGHTEN BOLTS (760), (765) AND (770) AND EXISTING CFMI FASTENER TO 110-120 POUND-INCHES (12.4-13.6 NEWTON METERS).				
750	332A2920-224	. BRACKET ASSY	AFT	AFT		1
755	332A2910-136	. BRACKET ASSY	FWD			1
755	332A2910-89	. BRACKET ASSY (OPTIONAL TO 332A2910-136)	FWD		OPT	-
760	BACB30ZF4-14	. BOLT (FWD SIDE) (UPPER HOLE)				1
765	BACB30ZF4-12	. BOLT (FWD SIDE) (LOWER HOLE)				1
770	BACB30ZF4-08	. BOLT				2
775	NAS1149C0432R	. WASHER (UNDER BOLT (765))				1
780	BACW10BP4ACU	. WASHER (CSK) (UNDER BOLT (760))				1
785	AS3485-10	. NUT				2

# 71-00-02

P/P BUILDUP FIGURE 4-1

Page 47

Oct 05/2007

D633A106-HXL

737-600/700/800/900  
**POWERPLANT BUILDUP MANUAL**

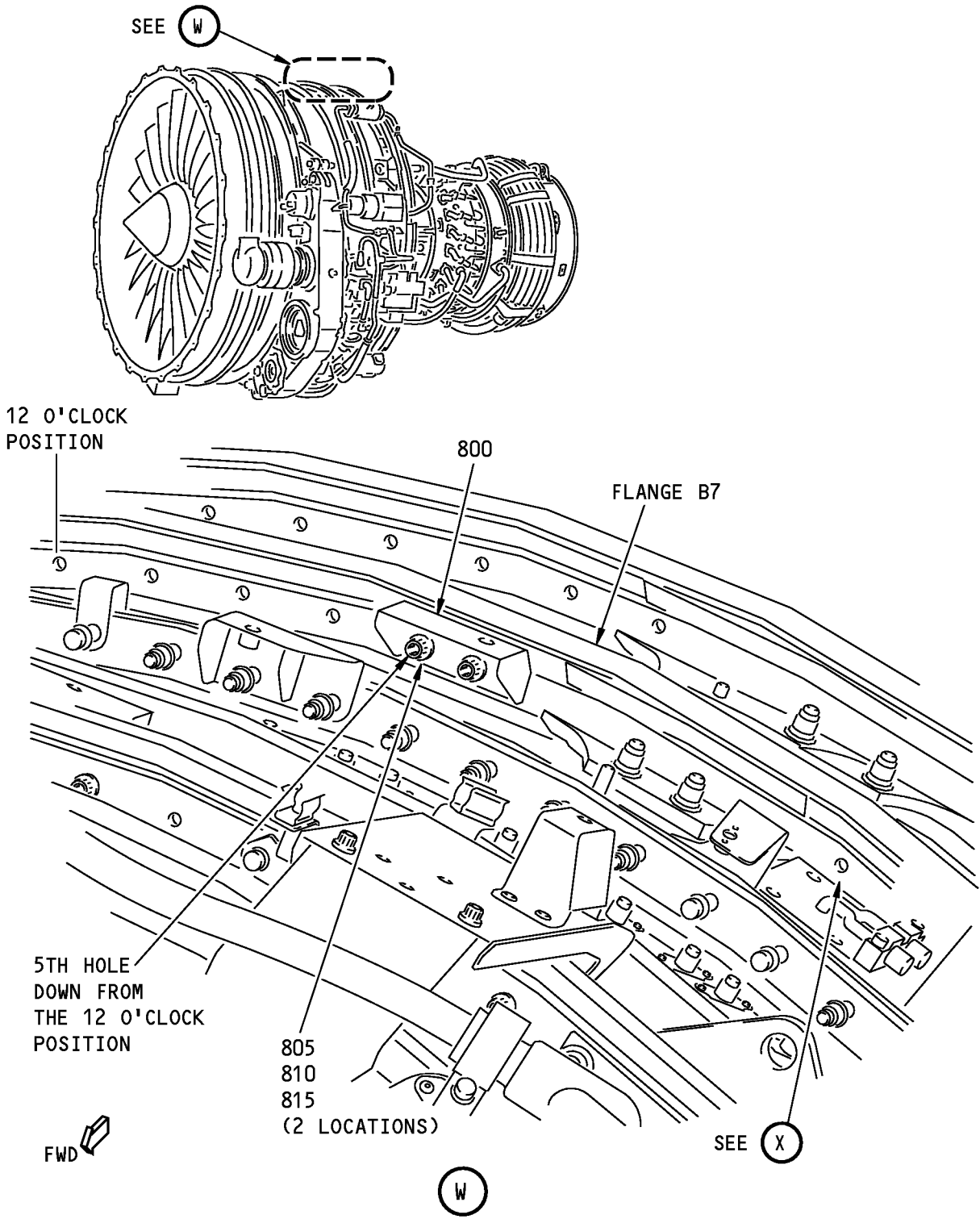

**Bracket Installation - Upper Left Side Fan Case**  
**Figure 4-1 (Sheet 24)**

**71-00-02**

P/P BUILDUP FIGURE 4-1

Page 48

Oct 05/2007

D633A106-HXL

**737-600/700/800/900  
POWERPLANT BUILDUP MANUAL**

ITEM NO.	PART NUMBER	NOMENCLATURE	BRACKET LOCATION AND ORIENTATION			QTY
			BRKT OR FLG SIDE	ANGLE FACES	UC	
4-1		<b>BRACKET INSTALLATION - UPPER LEFT SIDE FAN CASE (FIGURE 4-1, SHEET 24)</b>  ATTACH BRACKET ASSY (800) TO 5TH AND 6TH HOLES DOWN FROM 12 O'CLOCK ON FLANGE B7. USE BOLTS (805), WASHERS (810), AND NUTS (815).  . BRACKET ASSY . BOLT (FWD SIDE) . WASHER (UNDER NUT) . NUT  TIGHTEN BOLTS (805) TO 110-120 POUND-INCHES (12.4-13.6 NEWTON METERS).  <b>NOTE:</b> BRACKET (800) MAY BE INSTALLED IN Figure 2-1 FORWARD ENGINE MOUNT INSTALLATION.				
800	332A2920-222	. BRACKET ASSY	FWD	FWD		1
805	BACB30ZF4-12	. BOLT (FWD SIDE)				2
810	NAS1149C0432R	. WASHER (UNDER NUT)				2
815	AS3485-10	. NUT				2

# 71-00-02

P/P BUILDUP FIGURE 4-1

Page 49

Oct 05/2007

D633A106-HXL

737-600/700/800/900  
**POWERPLANT BUILDUP MANUAL**

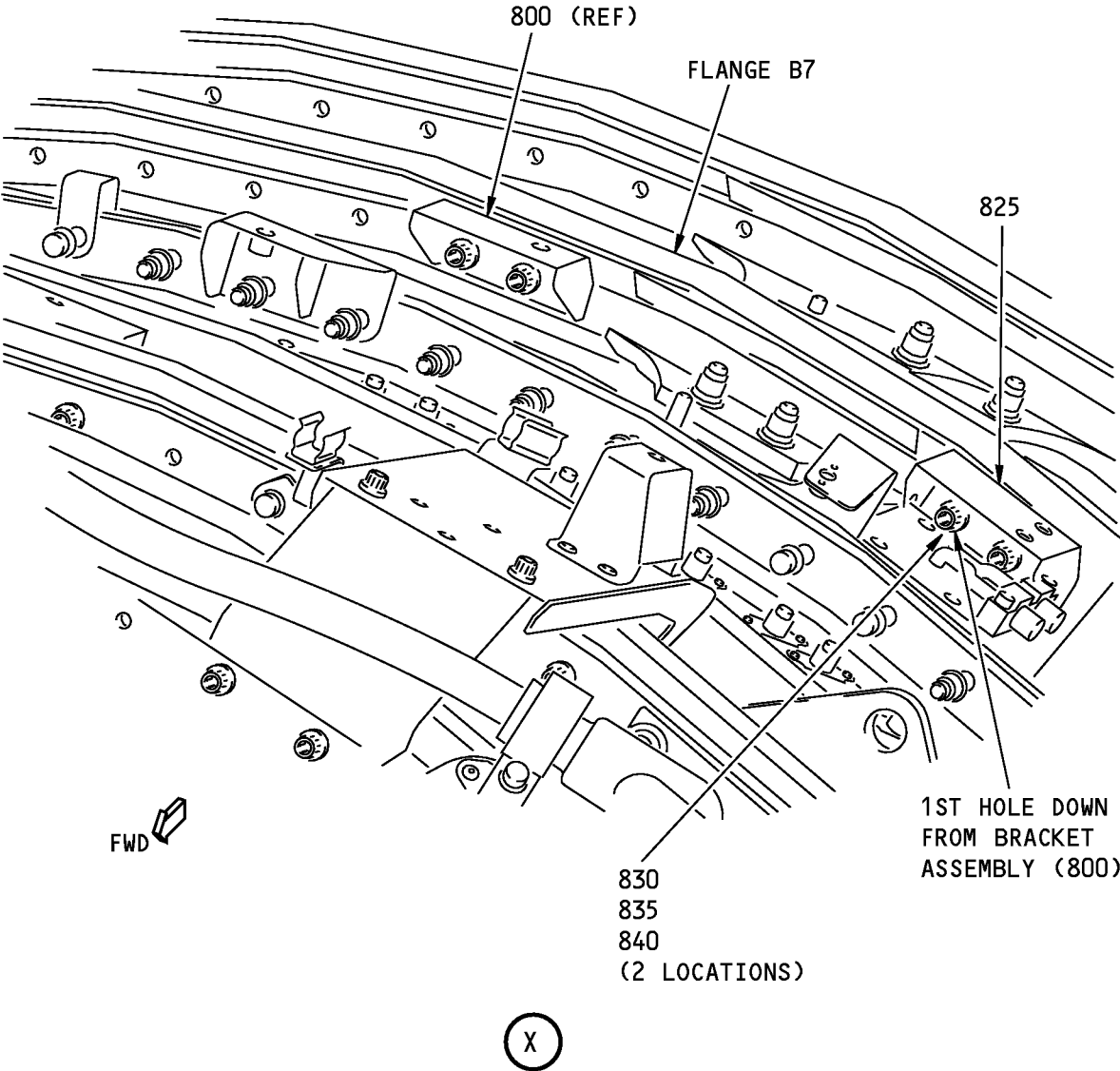

**Bracket Installation - Upper Left Side Fan Case**  
**Figure 4-1 (Sheet 25)**

**71-00-02**

P/P BUILDUP FIGURE 4-1  
Page 50  
Oct 05/2007

D633A106-HXL



**737-600/700/800/900  
POWERPLANT BUILDUP MANUAL**

ITEM NO.	PART NUMBER	NOMENCLATURE	BRACKET LOCATION AND ORIENTATION			QTY
			BRKT OR FLG SIDE	ANGLE FACES	UC	
4-1		<b>BRACKET INSTALLATION - UPPER LEFT SIDE FAN CASE (FIGURE 4-1, SHEET 25)</b>  CLEAN MATING SURFACES OF BRACKET ASSY (825) AND FLANGE B7 WITH alcohol, B00130 (C2). MAKE SURE YOU REMOVE ALL GREASE AND OTHER CONTAMINANTS.				
825 C2	332A2920-15 B00130	. BRACKET ASSY . SOLVENT, TT-I-735  ATTACH BRACKET ASSY (825) TO 1ST AND 2ND HOLES DOWN FROM BRACKET ASSY (800) ON FLANGE B7. USE BOLTS (830), WASHERS (835), AND NUTS (840).	FWD	FWD	CON	1 AR
830	BACB30ZF4-12	. BOLT (FWD SIDE)				2
835	NAS1149C0432R	. WASHER (UNDER NUT)				2
840	AS3485-10	. NUT  TIGHTEN BOLTS (830) TO 110-120 POUND-INCHES (12.4-13.6 NEWTON METERS).				2

# 71-00-02

P/P BUILDUP FIGURE 4-1

Page 51

Oct 05/2007

D633A106-HXL

737-600/700/800/900  
**POWERPLANT BUILDUP MANUAL**

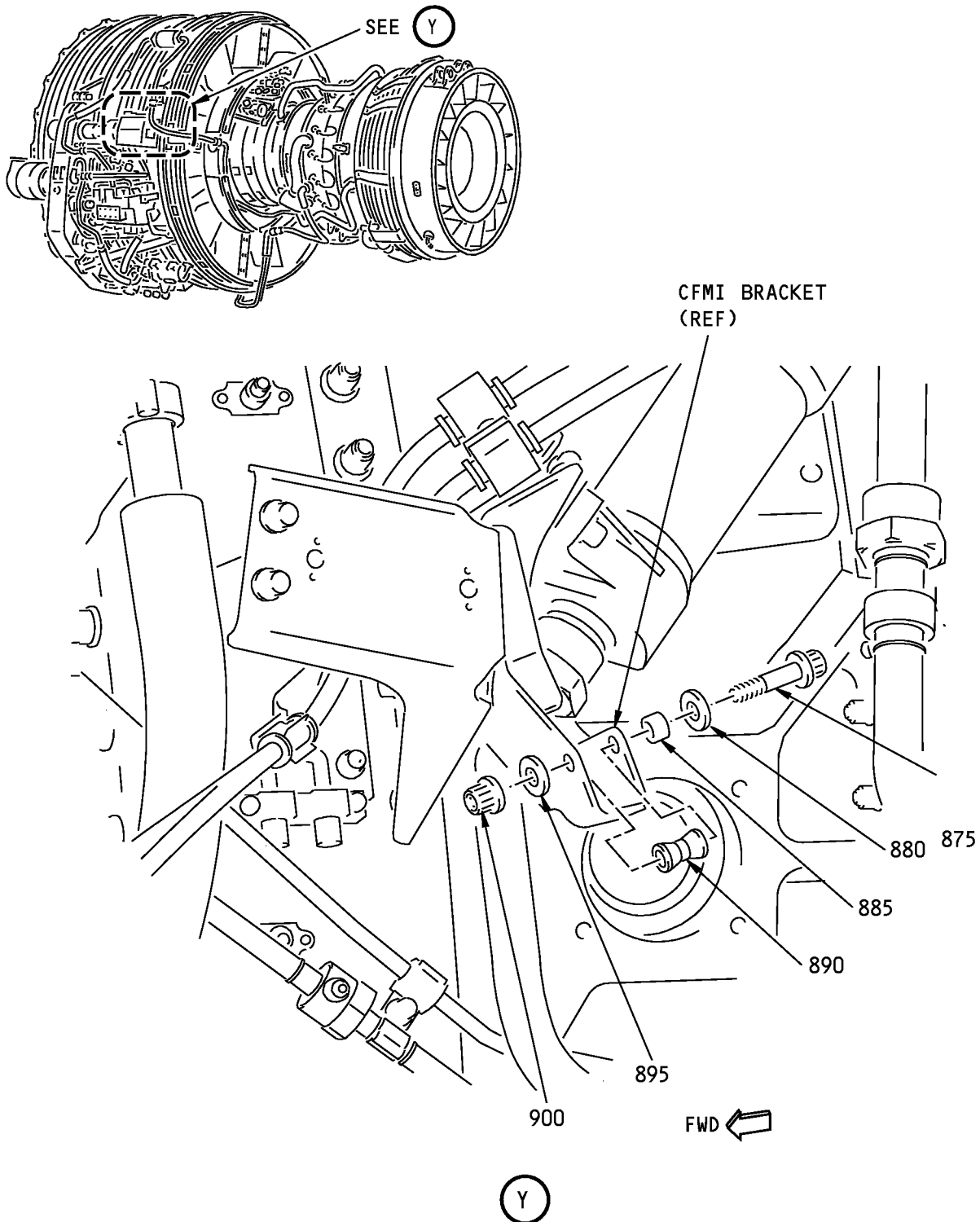

**Bracket Installation - Upper Left Side Fan Case**  
**Figure 4-1 (Sheet 26)**

**71-00-02**

P/P BUILDUP FIGURE 4-1

Page 52

Oct 05/2007

D633A106-HXL

**737-600/700/800/900  
POWERPLANT BUILDUP MANUAL**

ITEM NO.	PART NUMBER	NOMENCLATURE	BRACKET LOCATION AND ORIENTATION			QTY
			BRKT OR FLG SIDE	ANGLE FACES	UC	
4-1		<b>BRACKET INSTALLATION - UPPER LEFT SIDE FAN CASE (FIGURE 4-1, SHEET 26)</b>  INSTALL SPOOL (890) USING BOLT (875), WASHERS (880) AND (895), BUSHING (885) AND NUT (900).				
875	BACB30LE3U18	. BOLT (AFT SIDE)				1
880	BACW10BP3ACU	. WASHER (CSK) (UNDER BOLT HEAD)				1
885	BACB28AK03-027	. BUSHING				1
890	RC2769-1	. SPOOL				1
895	NAS1149E0332R	. WASHER (UNDER NUT)				1
900	BACN11Z3CK	. NUT (FWD SIDE)				1
		TIGHTEN BOLT (875) TO 30-35 POUND-INCHES (3.4-4.0 NEWTON METERS).				

# 71-00-02

P/P BUILDUP FIGURE 4-1

Page 53

Oct 05/2007

D633A106-HXL

737-600/700/800/900  
**POWERPLANT BUILDUP MANUAL**

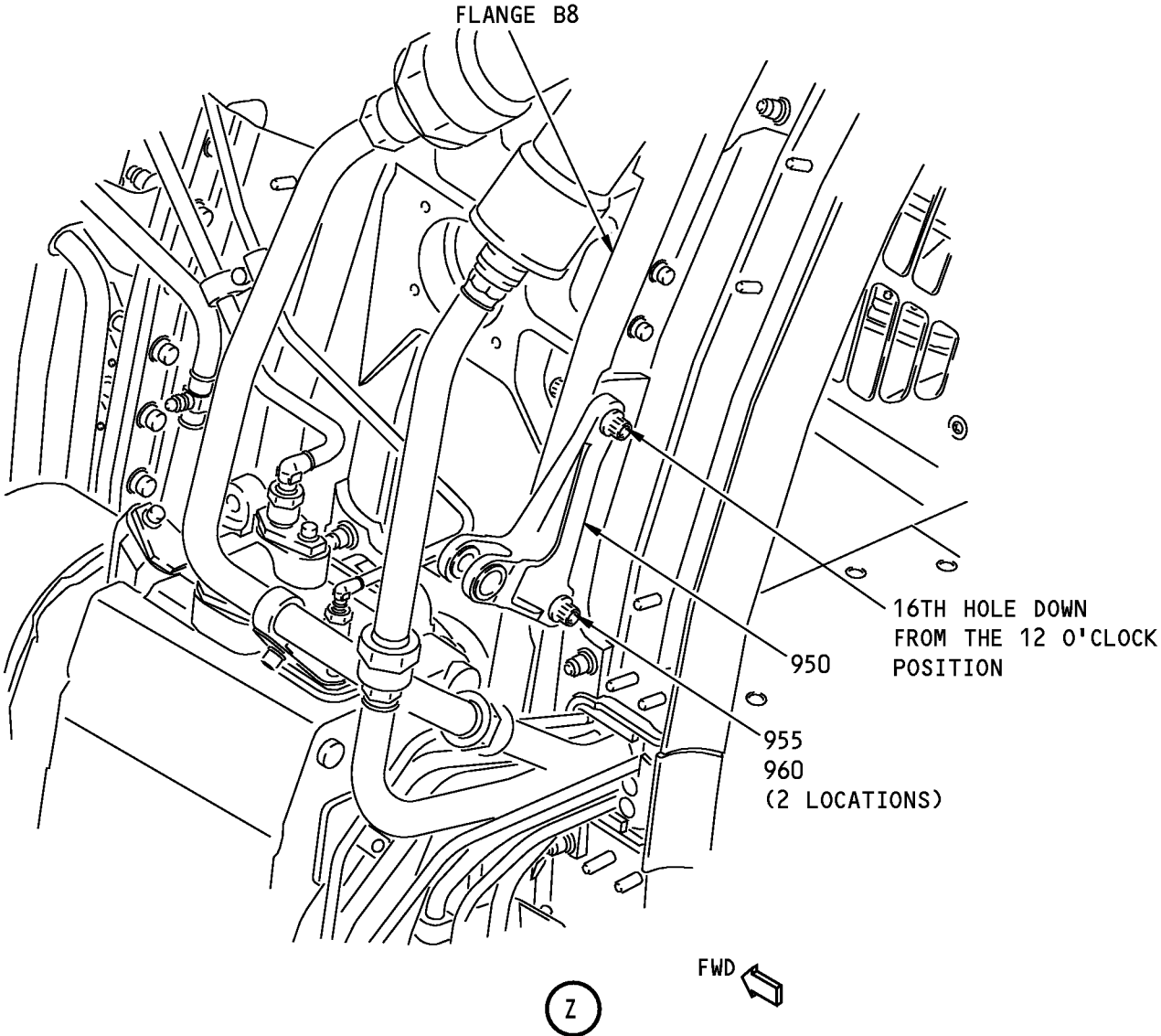
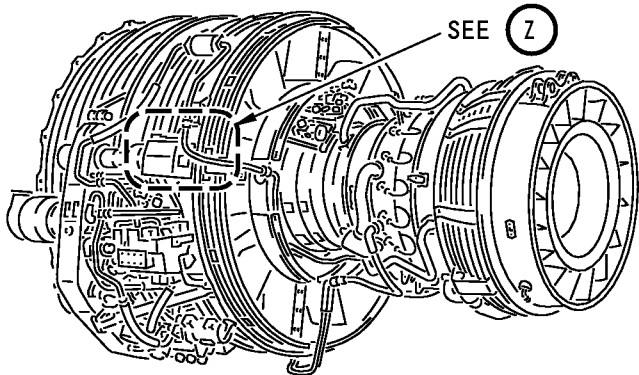

**Bracket Installation - Upper Left Side Fan Case**  
**Figure 4-1 (Sheet 27)**

**71-00-02**

P/P BUILDUP FIGURE 4-1  
Page 54  
Oct 05/2007

**737-600/700/800/900  
POWERPLANT BUILDUP MANUAL**

ITEM NO.	PART NUMBER	NOMENCLATURE	BRACKET LOCATION AND ORIENTATION			QTY
			BRKT OR FLG SIDE	ANGLE FACES	UC	
4-1		<b>BRACKET INSTALLATION - UPPER LEFT SIDE FAN CASE (FIGURE 4-1, SHEET 27)</b>  APPLY A THIN COATING OF ANTI-SEIZE compound, D50004 (C7) TO BOLTS (955).  ATTACH BRACKET ASSY (950) TO 16TH AND 17TH HOLE DOWN FROM 12 O'CLOCK ON FLANGE B8. USE BOLTS (955) AND WASHERS (960).				
950	332A2930-61	. BRACKET ASSY	AFT			1
955	BACB30LE5U6	. BOLT (AFT SIDE)				2
960	BACW10BP5ACU	. WASHER (CSK) (UNDER BOLT HEAD)				2
C7	D50004	. COMPOUND, ANTI-SEIZE, BMS-3-28			CON	AR
		TIGHTEN BOLTS (955) TO 123-136 POUND-INCHES (13.9-15.4 NEWTON METERS).				

# 71-00-02

P/P BUILDUP FIGURE 4-1

Page 55

Oct 05/2007

D633A106-HXL

**FIGURE 5-1**

**BRACKET INSTALLATION - LOWER LEFT FAN  
CASE**

**REF QEC TASK NO.: 5**

**REF DWG: 332A2900**

**NOTE:** ALL STANDARDS AND ATTACHING HARDWARE FOR THIS FIGURE WILL BE PACKAGED  
IN QEC TASK NO. 110.

**71-00-02**

P/P BUILDUP FIGURE 5-1

Page 1

Oct 05/2007

D633A106-HXL

737-600/700/800/900  
**POWERPLANT BUILDUP MANUAL**

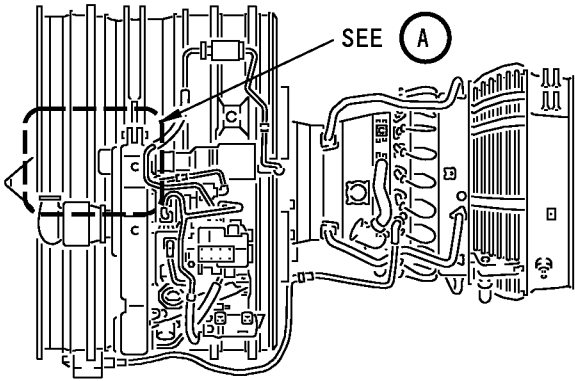

4TH HOLE DOWN  
FROM BRACKET  
ASSEMBLY  
(REF FIG. 4-1,  
ITEM 650)

BRACKET ASSEMBLY  
(REF FIG. 4-1, ITEM 650)

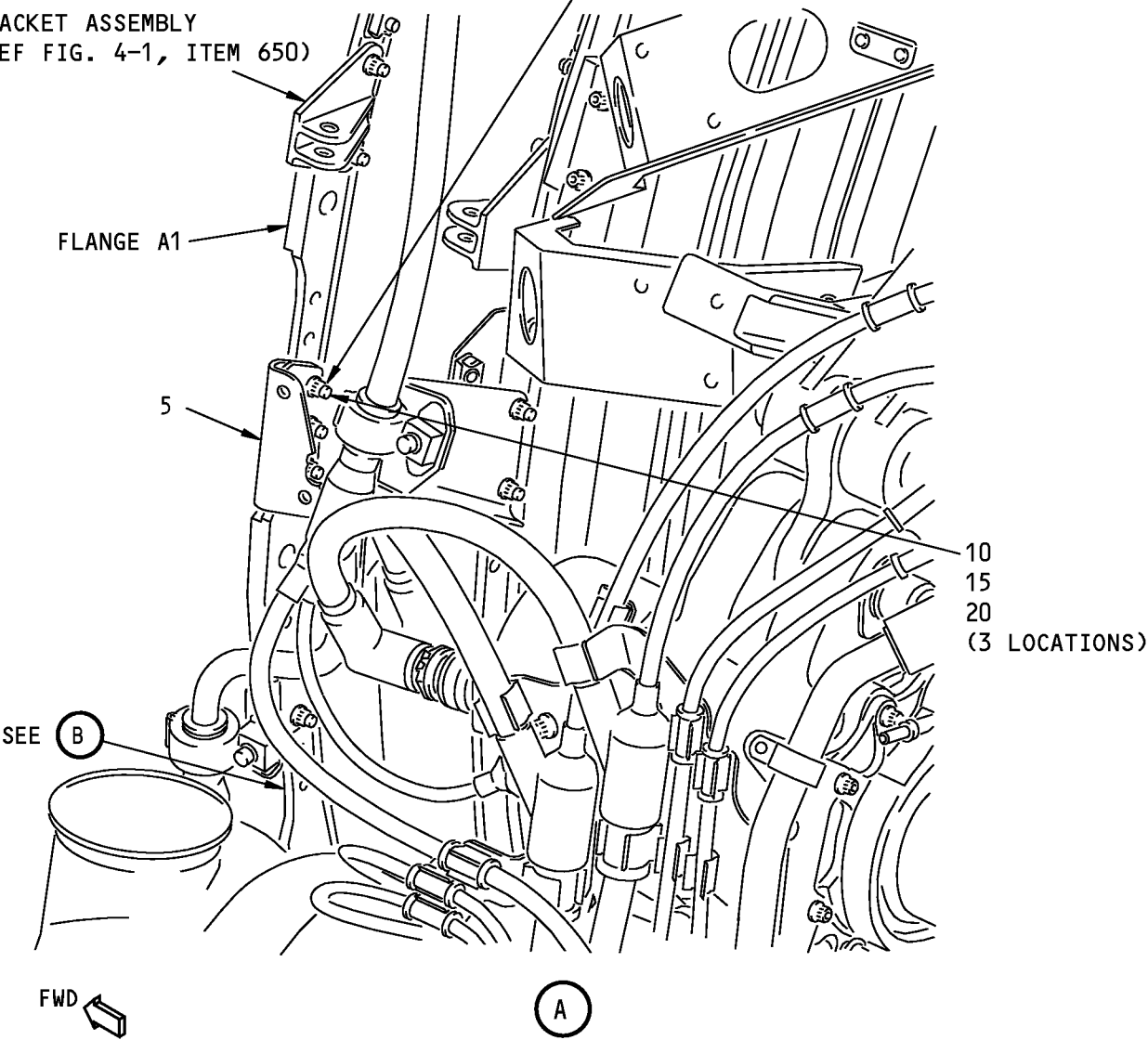

**Bracket Installation - Lower Left Side Fan Case**  
**Figure 5-1 (Sheet 1)**

**71-00-02**

P/P BUILDUP FIGURE 5-1  
Page 2  
Oct 05/2007

D633A106-HXL

**737-600/700/800/900  
POWERPLANT BUILDUP MANUAL**

ITEM NO.	PART NUMBER	NOMENCLATURE	BRACKET LOCATION AND ORIENTATION			QTY
			BRKT OR FLG SIDE	ANGLE FACES	UC	
5-1		<b>BRACKET INSTALLATION - LOWER LEFT SIDE FAN CASE (FIGURE 5-1, SHEET 1)</b>  ATTACH BRACKET ASSY (5) TO 4TH, 5TH AND 6TH HOLE DOWN FROM BRACKET ASSY(Figure 4-1 ITEM (650) ON FLANGE A1.  USE BOLTS (10), WASHERS (15) AND NUTS (20).				
5	332A2910-24	. BRACKET ASSY	AFT	AFT		1
10	BACB30NM4K7	. BOLT (FWD SIDE)				3
15	BACW10BP4ACU	. WASHER (CSK) (UNDER BOLT HEAD)				3
20	AS3485-10	. NUT				3
		TIGHTEN BOLTS (10) TO 50-80 POUND-INCHES (5.6-9.0 NEWTON METERS).				

# 71-00-02

P/P BUILDUP FIGURE 5-1

Page 3

Oct 05/2007

D633A106-HXL



737-600/700/800/900  
**POWERPLANT BUILDUP MANUAL**

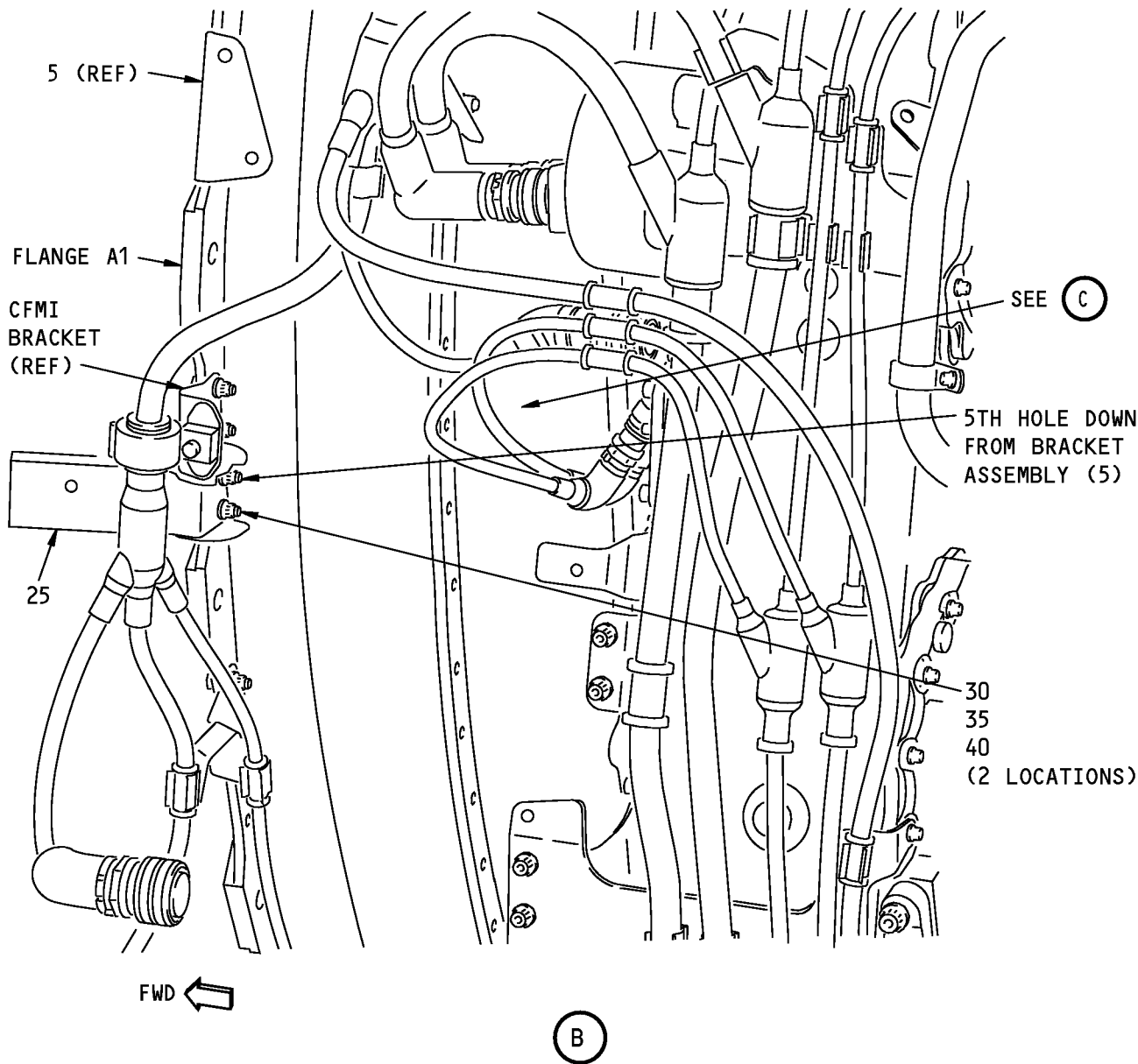

**NOTE:** STARTER NOT SHOWN FOR CLARITY.

**Bracket Installation - Lower Left Side Fan Case  
Figure 5-1 (Sheet 2)**

**71-00-02**  
P/P BUILDUP FIGURE 5-1  
Page 4  
Oct 05/2007

D633A106-HXL

**737-600/700/800/900  
POWERPLANT BUILDUP MANUAL**

ITEM NO.	PART NUMBER	NOMENCLATURE	BRACKET LOCATION AND ORIENTATION			QTY
			BRKT OR FLG SIDE	ANGLE FACES	UC	
5-1		<b>BRACKET INSTALLATION - LOWER LEFT SIDE FAN CASE (FIGURE 5-1, SHEET 2)</b>  ATTACH BRACKET ASSY (25) TO 5TH AND 6TH HOLE DOWN FROM BRACKET ASSY (5) ON FLANGE A1.  USE BOLTS (30), WASHERS (35) AND NUTS (40).				
25	332A2920-193	. BRACKET ASSY	AFT	FWD		1
25	332A2920-110	. BRACKET ASSY (OPTIONAL TO 332A2920-193)	AFT	FWD	OPT	-
30	BACB30NM4K6	. BOLT (FWD SIDE)				2
35	BACW10BP4ACU	. WASHER (CSK) (UNDER BOLT HEAD)				2
40	AS3485-10	. NUT				2
		TIGHTEN BOLTS (30) TO 50-80 POUND-INCHES (5.6-9.0 NEWTON METERS).				

# 71-00-02

P/P BUILDUP FIGURE 5-1

Page 5

Oct 05/2007

D633A106-HXL

737-600/700/800/900  
**POWERPLANT BUILDUP MANUAL**

6TH HOLE DOWN FROM  
BRACKET ASSEMBLY  
(REF FIG. 4-1, ITEM 550)

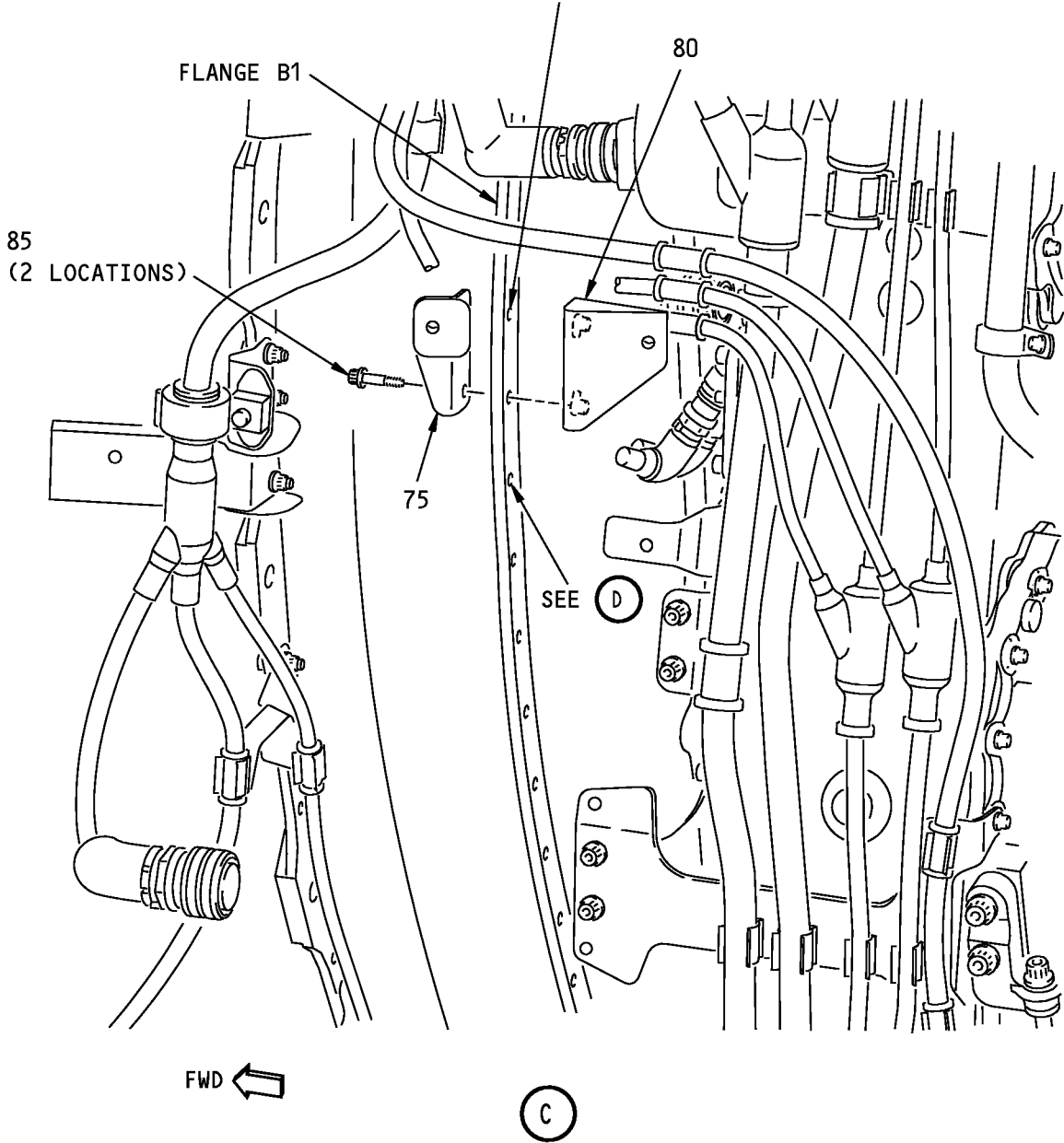

**NOTE:** STARTER NOT SHOWN FOR CLARITY.

**Bracket Installation - Lower Left Side Fan Case  
Figure 5-1 (Sheet 3)**

**71-00-02**

P/P BUILDUP FIGURE 5-1

Page 6

Oct 05/2007

D633A106-HXL

**737-600/700/800/900  
POWERPLANT BUILDUP MANUAL**

ITEM NO.	PART NUMBER	NOMENCLATURE	BRACKET LOCATION AND ORIENTATION			QTY
			BRKT OR FLG SIDE	ANGLE FACES	UC	
5-1		<b>BRACKET INSTALLATION - LOWER LEFT SIDE FAN CASE (FIGURE 5-1, SHEET 3)</b>  ATTACH BRACKET ASSYS (75) AND (80) ON 6TH AND 7TH HOLE DOWN FROM BRACKET ASSY (Figure 4-1 ITEM (550) ON FLANGE B1.  USE BOLTS (85).				
75	332A2910-134	. BRACKET ASSY	FWD	FWD		1
75	332A2910-69	. BRACKET ASSY (OPTIONAL TO 332A2910-134)	FWD	FWD	OPT	-
80	332A2920-92	. BRACKET ASSY	AFT	AFT		1
85	BACB30ZF4-10	. BOLT (FWD SIDE)				2
		TIGHTEN BOLTS (85) TO 110-120 POUND-INCHES (12.4-13.6 NEWTON METERS).				

# 71-00-02

P/P BUILDUP FIGURE 5-1

Page 7

Oct 05/2007

D633A106-HXL

737-600/700/800/900  
**POWERPLANT BUILDUP MANUAL**

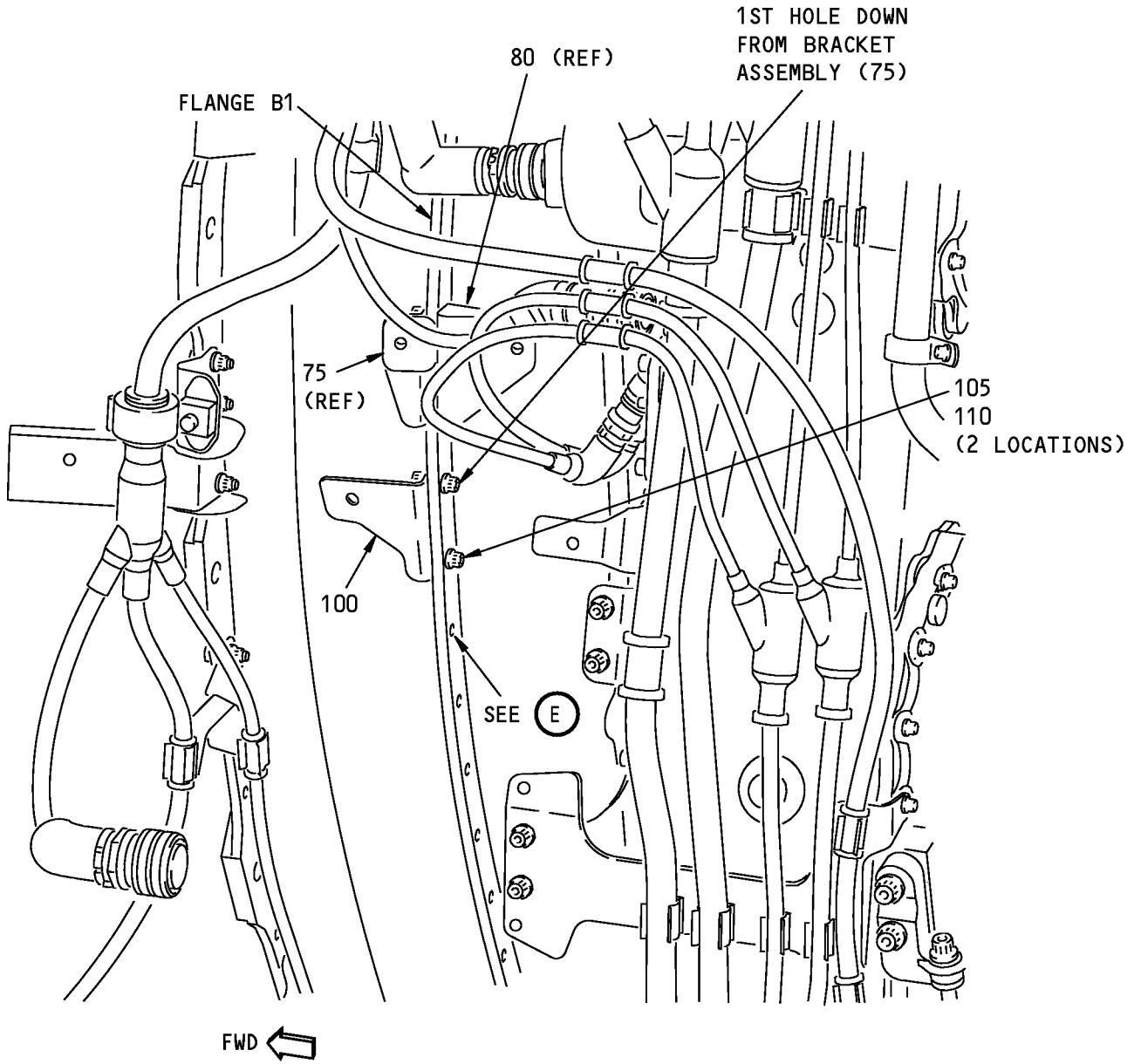

D

**NOTE:** STARTER NOT SHOWN FOR CLARITY.

**Bracket Installation - Lower Left Side Fan Case  
Figure 5-1 (Sheet 4)**

**71-00-02**

P/P BUILDUP FIGURE 5-1

Page 8

Oct 05/2007

D633A106-HXL

**737-600/700/800/900  
POWERPLANT BUILDUP MANUAL**

ITEM NO.	PART NUMBER	NOMENCLATURE	BRACKET LOCATION AND ORIENTATION			QTY
			BRKT OR FLG SIDE	ANGLE FACES	UC	
5-1		<b>BRACKET INSTALLATION - LOWER LEFT SIDE FAN CASE (FIGURE 5-1, SHEET 4)</b>  ATTACH BRACKET ASSY (100) ON 1ST AND 2ND HOLE DOWN FROM BRACKET ASSY (75) ON FLANGE B1.  USE BOLTS (105) AND WASHERS (110).				
100	332A2910-112	. BRKT ASSY	FWD	FWD		1
105	BACB30ZF4-09	. BOLT (AFT SIDE)				2
110	NAS1149C0432R	. WASHER (UNDER BOLT)				2
		TIGHTEN BOLTS (105) TO 110-120 POUND-INCHES (12.4-13.6 NEWTON METERS).				

# 71-00-02

P/P BUILDUP FIGURE 5-1

Page 9

Oct 05/2007

D633A106-HXL

737-600/700/800/900  
**POWERPLANT BUILDUP MANUAL**

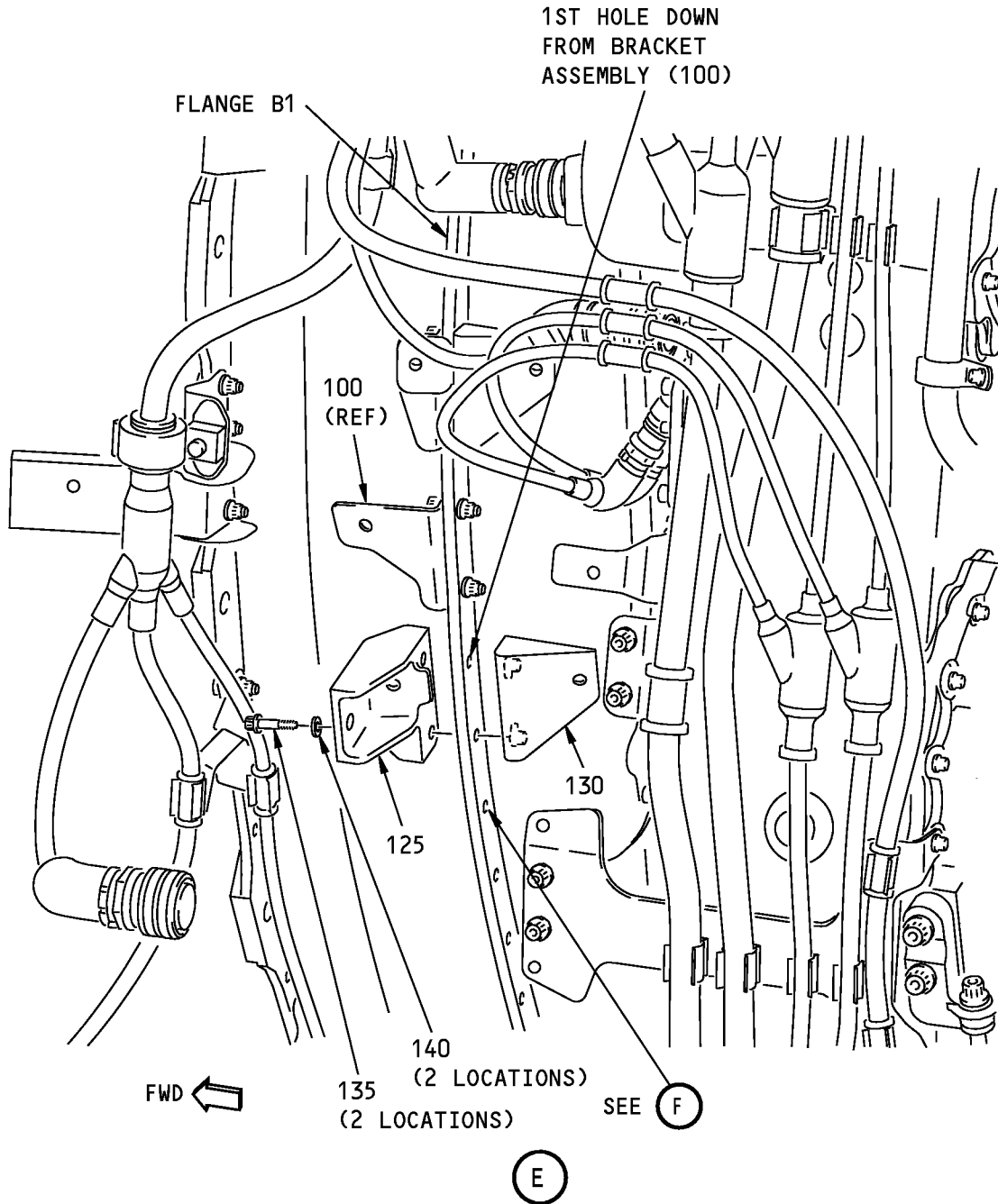

**NOTE:** STARTER NOT SHOWN FOR CLARITY.

**Bracket Installation - Lower Left Side Fan Case  
Figure 5-1 (Sheet 5)**

**71-00-02**

P/P BUILDUP FIGURE 5-1

Page 10

Oct 05/2007

D633A106-HXL

**737-600/700/800/900  
POWERPLANT BUILDUP MANUAL**

ITEM NO.	PART NUMBER	NOMENCLATURE	BRACKET LOCATION AND ORIENTATION			QTY
			BRKT OR FLG SIDE	ANGLE FACES	UC	
5-1		<p><b>BRACKET INSTALLATION - LOWER LEFT SIDE FAN CASE (FIGURE 5-1, SHEET 5)</b></p> <p><b>NOTE:</b> DUE TO LIMITED ACCESS, IT IS RECOMMENDED THAT Figure 22-1 ITEM NO. (15) LANYARD ASSY BE LOOSELY ATTACHED TO BRACKET (125) PRIOR TO BRACKET INSTALLATION.</p> <p>ATTACH BRACKET (125) AND BRACKET ASSY (130) ON 1ST AND 2ND HOLES DOWN FROM BRACKET ASSY (100) ON FLANGE B1.</p> <p>USE BOLTS (135) AND WASHERS (140).</p>				
125	332A2931-3	. BRACKET	FWD	FWD		1
130	332A2920-92	. BRACKET ASSY	AFT	AFT		1
135	BACB30LE4K6	. BOLT (FWD SIDE)				2
140	BACW10BP4ACU	. WASHER (CSK) (UNDER BOLT HEAD)				2
140	BACW10BP4CD	. WASHER (CSK) (OPTIONAL TO BACW10BP4ACU)			OPT	-
		TIGHTEN BOLTS (135) TO 90-110 POUND-INCHES (10.2-12.4 NEWTON METERS).				

**71-00-02**

P/P BUILDUP FIGURE 5-1

Page 11

Oct 05/2007

D633A106-HXL



737-600/700/800/900  
**POWERPLANT BUILDUP MANUAL**

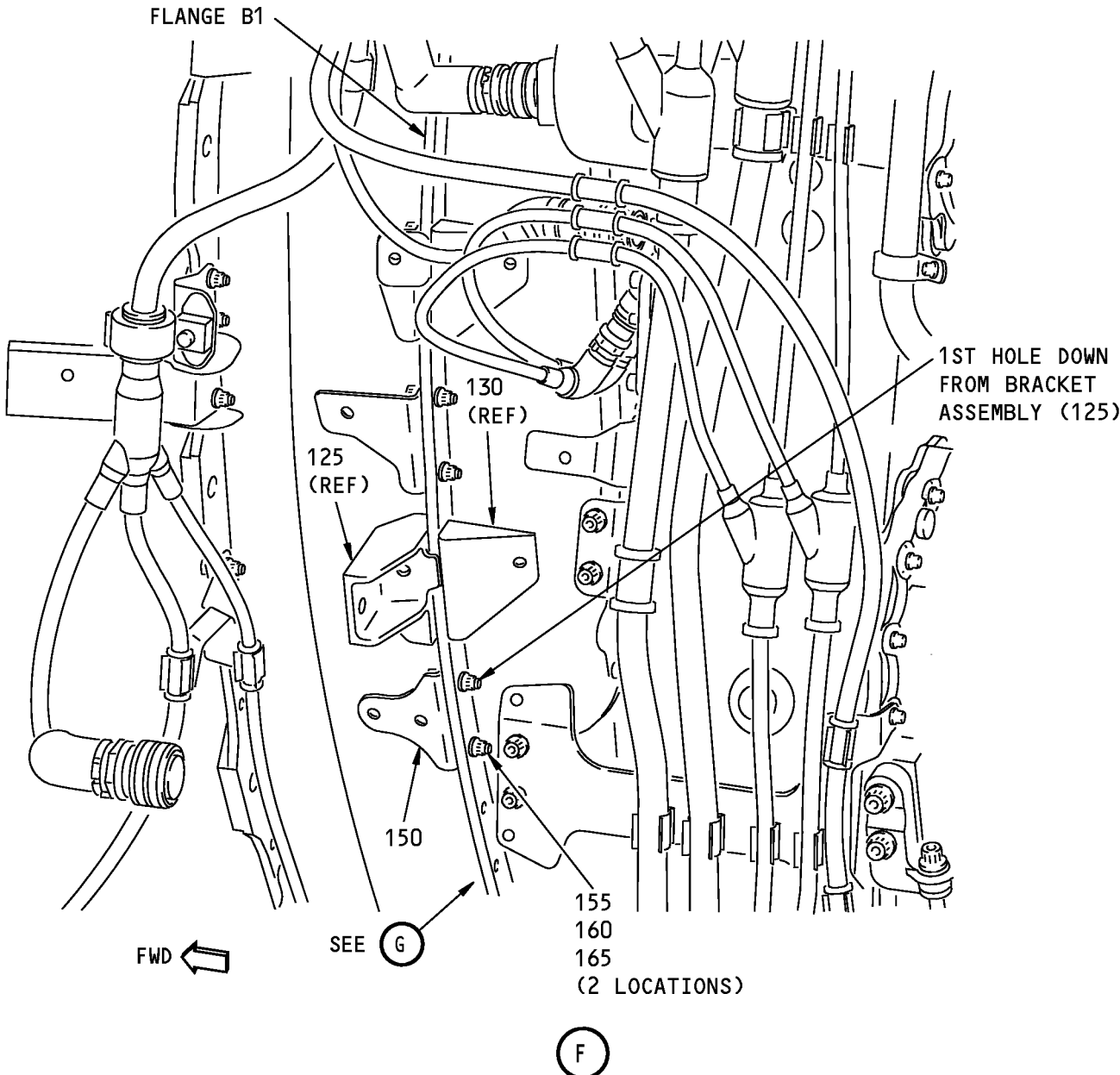

NOTE: STARTER NOT SHOWN FOR CLARITY.

**Bracket Installation - Lower Left Side Fan Case**  
**Figure 5-1 (Sheet 6)**

**71-00-02**

P/P BUILDUP FIGURE 5-1  
Page 12  
Oct 05/2007

**737-600/700/800/900  
POWERPLANT BUILDUP MANUAL**

ITEM NO.	PART NUMBER	NOMENCLATURE	BRACKET LOCATION AND ORIENTATION			QTY
			BRKT OR FLG SIDE	ANGLE FACES	UC	
5-1		<b>BRACKET INSTALLATION - LOWER LEFT SIDE FAN CASE (FIGURE 5-1, SHEET 6)</b>  ATTACH BRACKET ASSY (150) ON 1ST AND 2ND HOLE DOWN FROM BRACKET ASSY (125) ON FLANGE B1.  USE BOLTS (155), WASHERS (160) AND NUTS (165).				
150	332A2910-74	. BRACKET ASSY	FWD	FWD		1
155	BACB30ZF4-10	. BOLT (FWD SIDE)				2
160	NAS1149C0432R	. WASHER (UNDER NUT)				2
165	AS3485-10	. NUT				2
		TIGHTEN BOLTS (155) TO 110-120 POUND-INCHES (12.4-13.6 NEWTON METERS).				

# 71-00-02

P/P BUILDUP FIGURE 5-1

Page 13

Oct 05/2007

D633A106-HXL

737-600/700/800/900  
**POWERPLANT BUILDUP MANUAL**

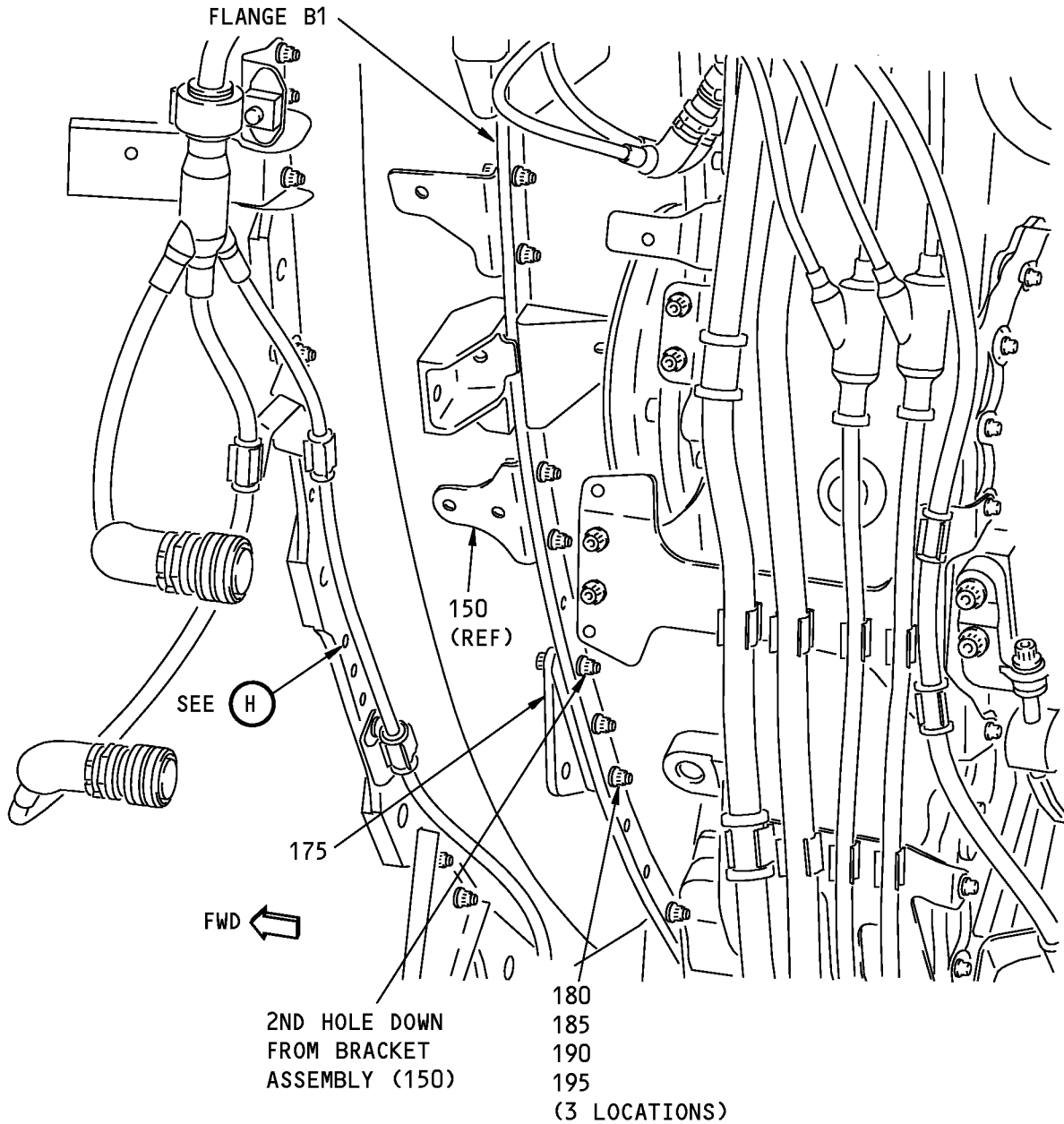

**NOTE:** STARTER NOT SHOWN FOR CLARITY.

G

**Bracket Installation - Lower Left Side Fan Case  
Figure 5-1 (Sheet 7)**

**71-00-02**

P/P BUILDUP FIGURE 5-1

Page 14

Oct 05/2007

D633A106-HXL

**737-600/700/800/900  
POWERPLANT BUILDUP MANUAL**

ITEM NO.	PART NUMBER	NOMENCLATURE	BRACKET LOCATION AND ORIENTATION			QTY
			BRKT OR FLG SIDE	ANGLE FACES	UC	
5-1		<p><b>BRACKET INSTALLATION - LOWER LEFT SIDE FAN CASE (FIGURE 5-1, SHEET 7)</b></p> <p><b>NOTE:</b> DUE TO LIMITED ACCESS, IT IS RECOMMENDED THAT Figure 22-1 ITEM NO. (5) LANYARD ASSY BE LOOSELY ATTACHED TO BRACKET ASSY (175) PRIOR TO BRACKET ASSY INSTALLATION.</p> <p>ATTACH BRACKET ASSY (175) TO 2ND, 3RD AND 4TH HOLES DOWN FROM BRACKET ASSY (150) ON FLANGE B1.</p> <p>USE BOLTS (180), WASHERS (185) AND (190) AND NUTS (195).</p>				
175	332A2911-2	. BRACKET ASSY	FWD			1
180	BACB30LE4K10	. BOLT (FWD SIDE)				3
185	BACW10BP4ACU	. WASHER (CSK) (UNDER BOLT HEAD)				3
190	NAS1149C0432R	. WASHER (UNDER NUT)				3
195	AS3485-10	. NUT				3
		TIGHTEN BOLTS (180) TO 72-88 POUND-INCHES (8.1-9.9 NEWTON METERS).				

# 71-00-02

P/P BUILDUP FIGURE 5-1

Page 15

Oct 05/2007

D633A106-HXL

737-600/700/800/900  
**POWERPLANT BUILDUP MANUAL**

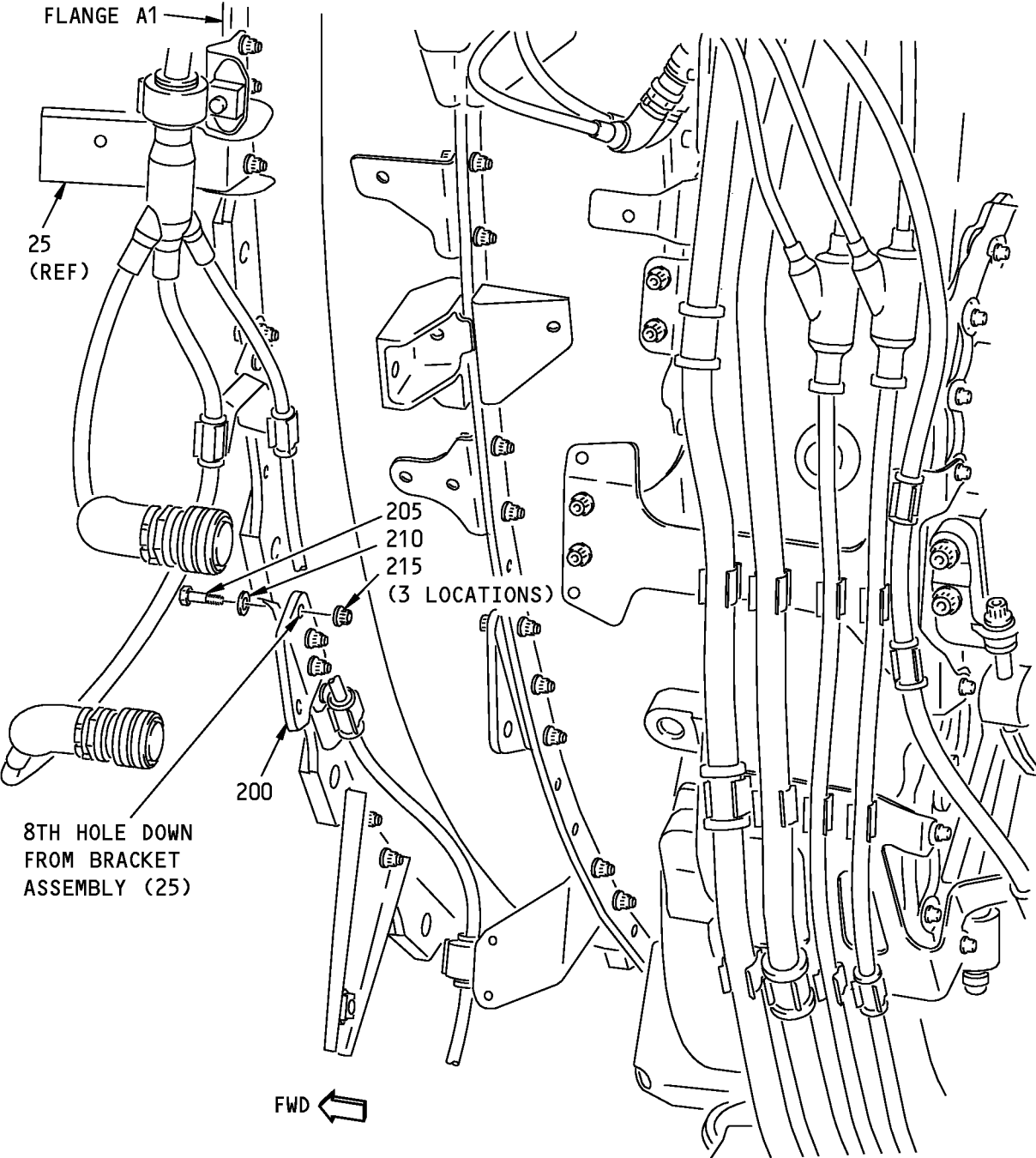

**NOTE:** STARTER NOT SHOWN FOR CLARITY.

**Bracket Installation - Lower Left Side Fan Case  
Figure 5-1 (Sheet 8)**

**71-00-02**

P/P BUILDUP FIGURE 5-1  
Page 16  
Oct 05/2007

D633A106-HXL

**737-600/700/800/900  
POWERPLANT BUILDUP MANUAL**

ITEM NO.	PART NUMBER	NOMENCLATURE	BRACKET LOCATION AND ORIENTATION			QTY
			BRKT OR FLG SIDE	ANGLE FACES	UC	
5-1		<p><b>BRACKET INSTALLATION - LOWER LEFT SIDE FAN CASE (FIGURE 5-1, SHEET 8)</b></p> <p><b>NOTE:</b> DUE TO LIMITED ACCESS, IT IS RECOMMENDED THAT Figure 22-1 ITEM NO. (10) LANYARD ASSY BE LOOSELY ATTACHED TO BRACKET (200) PRIOR TO BRACKET INSTALLATION.</p> <p>ATTACH BRACKET DETAIL (200) TO 8TH, 9TH AND 10TH HOLES DOWN FROM BRACKET ASSY (25) ON FLANGE A1.</p> <p>USE BOLTS (205), WASHERS (210) AND NUTS (215).</p>				
200	332A2911-5	. BRACKET DETAIL	AFT	AFT		1
205	BACB30NM4K7	. BOLT (FWD SIDE)				3
210	BACW10BP4ACU	. WASHER (CSK) (UNDER BOLT HEAD)				3
215	AS3485-10	. NUT				3
		TIGHTEN BOLTS (205) TO 50-80 POUND-INCHES (5.6-9.0 NEWTON METERS).				

# 71-00-02

P/P BUILDUP FIGURE 5-1

Page 17

Oct 05/2007

D633A106-HXL

737-600/700/800/900  
**POWERPLANT BUILDUP MANUAL**

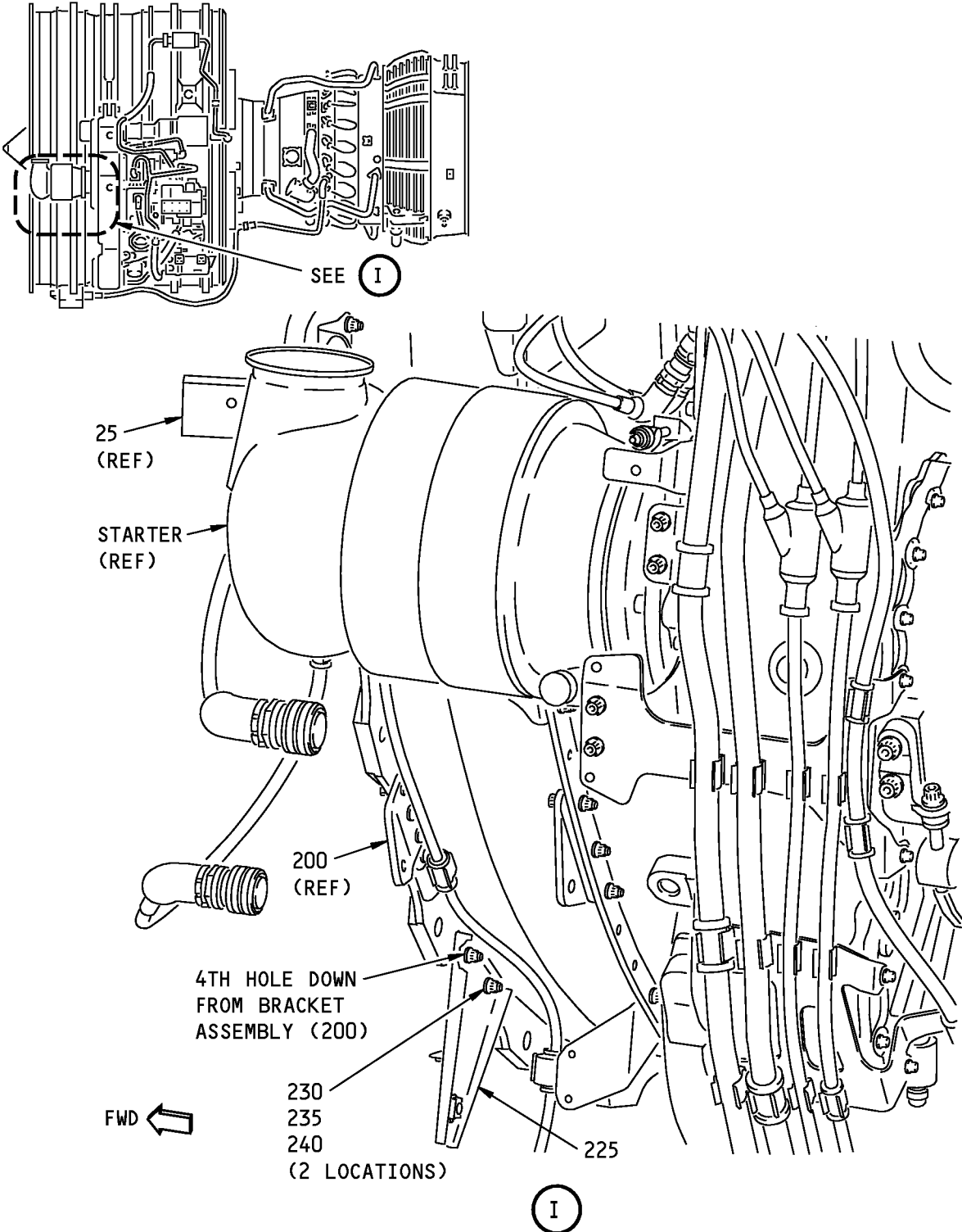

**Bracket Installation - Lower Left Side Fan Case**  
**Figure 5-1 (Sheet 9)**

**71-00-02**

P/P BUILDUP FIGURE 5-1  
Page 18  
Oct 05/2007

D633A106-HXL

**737-600/700/800/900  
POWERPLANT BUILDUP MANUAL**

ITEM NO.	PART NUMBER	NOMENCLATURE	BRACKET LOCATION AND ORIENTATION			QTY
			BRKT OR FLG SIDE	ANGLE FACES	UC	
5-1		<b>BRACKET INSTALLATION - LOWER LEFT SIDE FAN CASE (FIGURE 5-1, SHEET 9)</b>  ATTACH BRACKET ASSY (225) TO 4TH AND 6TH HOLES DOWN FROM BRACKET DETAIL (200) ON FLANGE A1.  USE BOLTS (230), WASHERS (235) AND NUTS (240).				
225	332A2910-101	. BRACKET ASSY	AFT	AFT		1
230	BACB30NM4K5	. BOLT (FWD SIDE)				2
235	BACW10BP4ACU	. WASHER (CSK) (UNDER BOLT HEAD)				2
240	AS3485-10	. NUT				2
		TIGHTEN BOLTS (230) TO 50-80 POUND-INCHES (5.6-9.0 NEWTON METERS).				

# 71-00-02

P/P BUILDUP FIGURE 5-1

Page 19

Oct 05/2007

D633A106-HXL



737-600/700/800/900  
**POWERPLANT BUILDUP MANUAL**

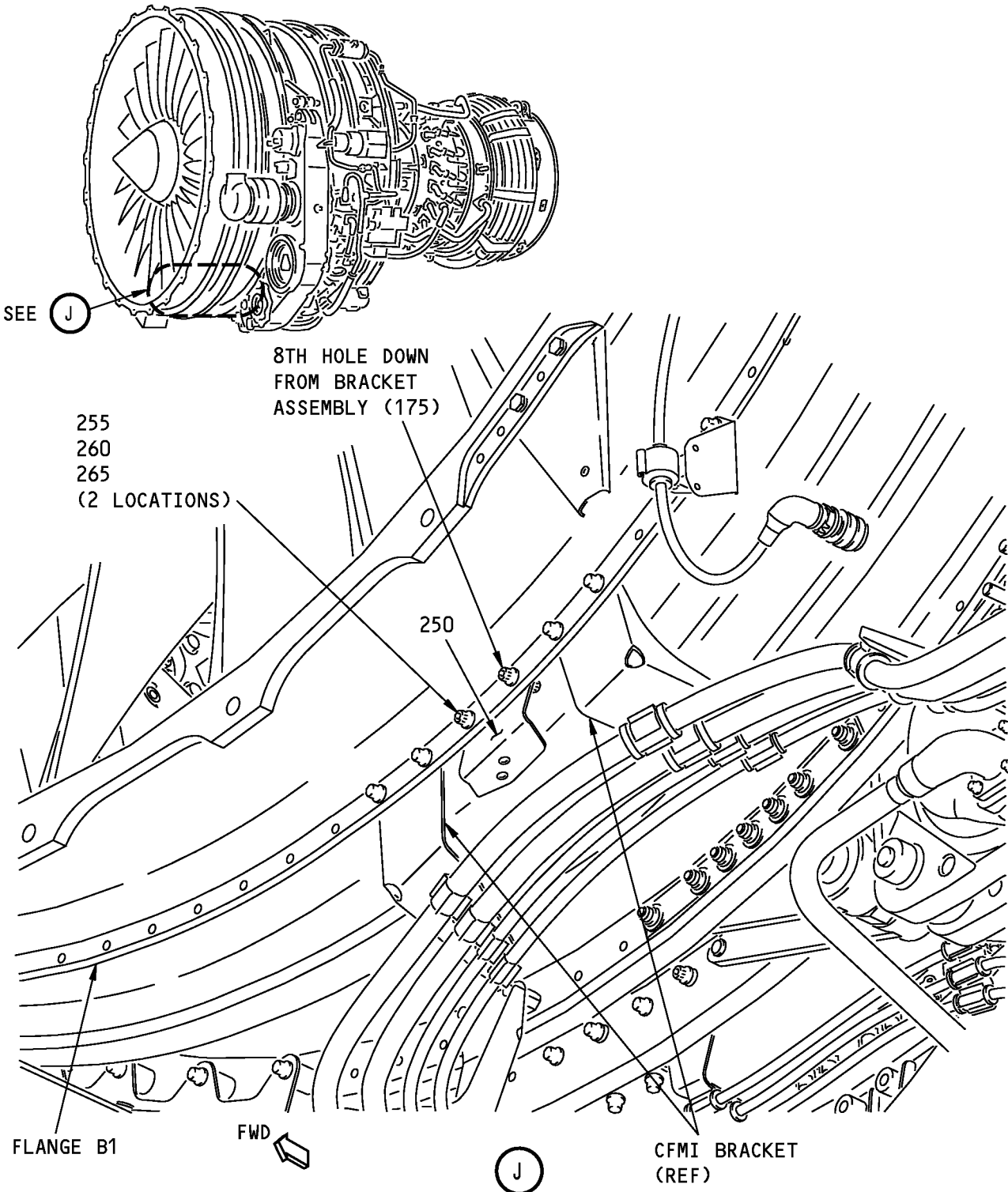

**Bracket Installation - Lower Left Side Fan Case**  
**Figure 5-1 (Sheet 10)**

**71-00-02**

P/P BUILDUP FIGURE 5-1  
Page 20  
Oct 05/2007

D633A106-HXL

**737-600/700/800/900  
POWERPLANT BUILDUP MANUAL**

ITEM NO.	PART NUMBER	NOMENCLATURE	BRACKET LOCATION AND ORIENTATION			QTY
			BRKT OR FLG SIDE	ANGLE FACES	UC	
5-1		<b>BRACKET INSTALLATION - LOWER LEFT SIDE FAN CASE (FIGURE 5-1, SHEET 10)</b>  ATTACH BRACKET (250) TO 8TH AND 9TH HOLES DOWN FROM BRACKET ASSY (175) ON FLANGE B1 (BETWEEN TWO CFMI BRACKETS).  USE BOLTS (255), WASHERS (260), AND NUTS (265).				
250	332A2920-119	. BRACKET ASSY	AFT	AFT		1
255	BACB30ZF4-10	. BOLT (FWD SIDE)				2
260	NAS1149C0432R	. WASHER (UNDER BOLT HEAD)				2
265	AS3485-10	. NUT				2
		TIGHTEN BOLTS (255) TO 110-120 POUND-INCHES (12.4-13.6 NEWTON METERS).				

# 71-00-02

P/P BUILDUP FIGURE 5-1

Page 21

Oct 05/2007

D633A106-HXL

737-600/700/800/900  
**POWERPLANT BUILDUP MANUAL**

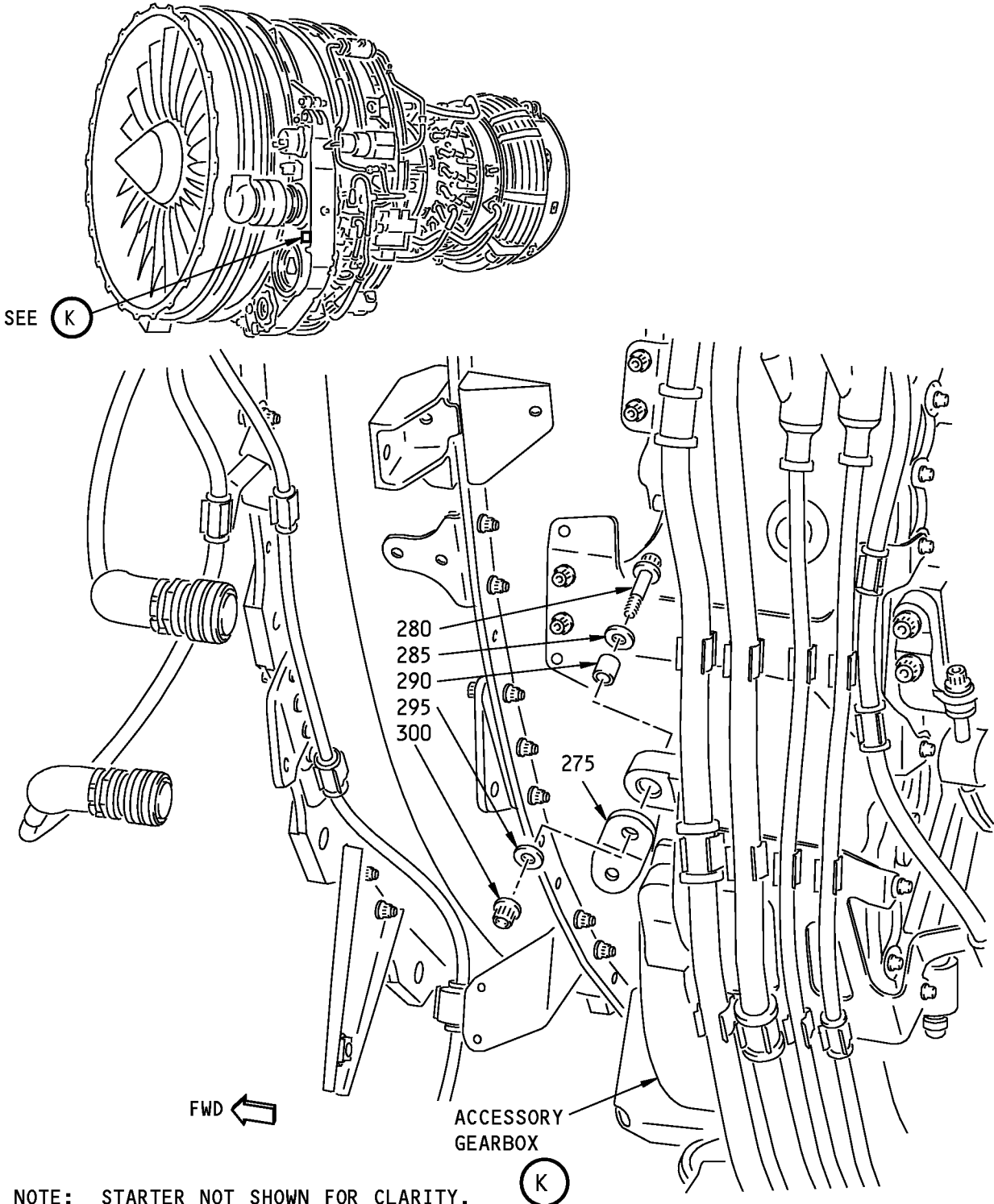

**NOTE:** STARTER NOT SHOWN FOR CLARITY.

**Bracket Installation - Lower Left Side Fan Case**  
**Figure 5-1 (Sheet 11)**

**71-00-02**

P/P BUILDUP FIGURE 5-1  
Page 22  
Oct 05/2007

D633A106-HXL

**737-600/700/800/900  
POWERPLANT BUILDUP MANUAL**

ITEM NO.	PART NUMBER	NOMENCLATURE	BRACKET LOCATION AND ORIENTATION			QTY
			BRKT OR FLG SIDE	ANGLE FACES	UC	
5-1		<b>BRACKET INSTALLATION - LOWER LEFT SIDE FAN CASE (FIGURE 5-1, SHEET 11)</b>  ATTACH BRACKET DETAIL (275) TO ACCESSORY GEARBOX NEAR IDG PAD. USE BOLT (280), WASHER (285), BUSHING (290) AND NUT (295).				
275	332A2911-1	. BRACKET DETAIL				1
280	BACB30LE6K14	. BOLT				1
285	BACW10BP6ACU	. WASHER (CSK) (UNDER BOLT HEAD)				1
290	BACB28BA0608060	. BUSHING				1
295	NAS1149C0632R	. WASHER (UNDER NUT)				1
300	AS3485-12	. NUT				1
		TIGHTEN BOLT (280) TO 160-240 POUND-INCHES (18.0-27.2 NEWTON METERS).				

# 71-00-02

P/P BUILDUP FIGURE 5-1

Page 23

Oct 05/2007

D633A106-HXL

737-600/700/800/900  
**POWERPLANT BUILDUP MANUAL**

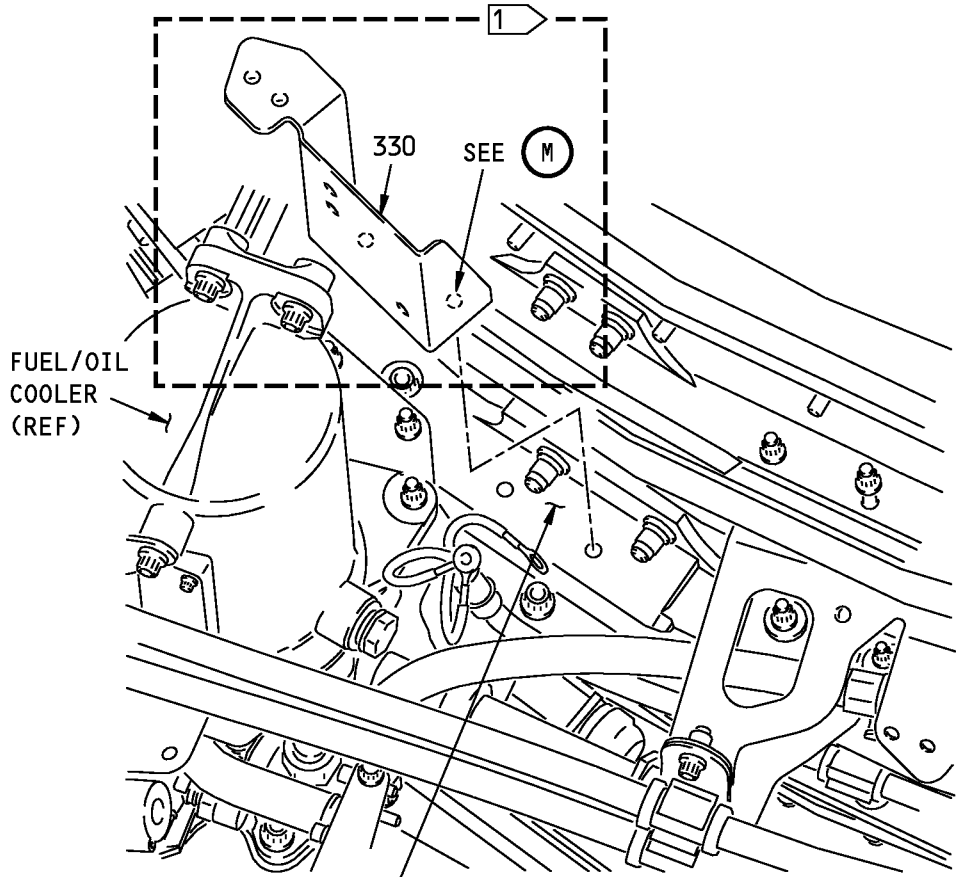
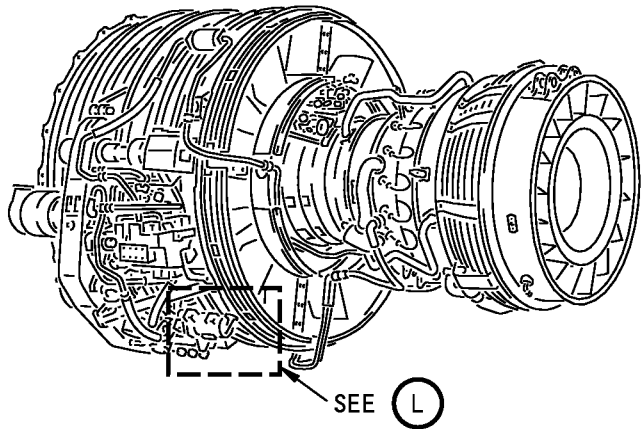
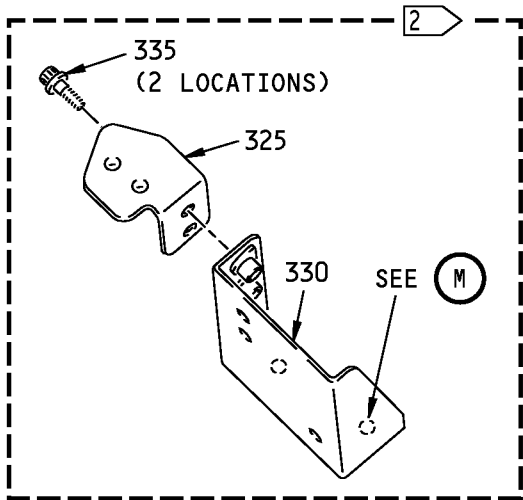

- 1 PREFERRED BRACKET
- 2 OPTIONAL BRACKET

**Bracket Installation - Lower Left Side Fan Case**  
**Figure 5-1 (Sheet 12)**

**71-00-02**

P/P BUILDUP FIGURE 5-1

Page 24

Oct 05/2007

D633A106-HXL

**737-600/700/800/900  
POWERPLANT BUILDUP MANUAL**

ITEM NO.	PART NUMBER	NOMENCLATURE	BRACKET LOCATION AND ORIENTATION			QTY
			BRKT OR FLG SIDE	ANGLE FACES	UC	
5-1		<b>BRACKET INSTALLATION - LOWER LEFT SIDE FAN CASE (FIGURE 5-1, SHEET 12)</b>  PREFERRED BRACKET CONFIGURATION; ATTACH BRACKET ASSY (330) TO FLANGE ON SHEET 13.  . BRACKET ASSY (1 PIECE BRACKET)  . BRACKET ASSY (REPLACED BY 332A2920-235) (1 PIECE BRACKET)  OPTIONAL BRACKET CONFIGURATION; ATTACH BRACKET ASSY (325) TO BRACKET ASSY (330) USING BOLTS (335).  . BRACKET ASSY (OPT) . BRACKET ASSY (OPT) . BOLT (2 REQD) (OPT)  TIGHTEN BOLTS (335) TO 110-120 POUND-INCHES (12.4-13.6 NEWTON METERS).				
330	332A2920-235	. BRACKET ASSY (1 PIECE BRACKET)	AFT	AFT		1
330	332A2920-182	. BRACKET ASSY (REPLACED BY 332A2920-235) (1 PIECE BRACKET)	AFT	AFT	LTD	-
325	332A2910-67	. BRACKET ASSY (OPT)	OTBD	OUTBD	OPT	-
330	332A2930-54	. BRACKET ASSY (OPT)	AFT	AFT	OPT	-
335	BACB30ZF4-07	. BOLT (2 REQD) (OPT)			OPT	-

# 71-00-02

P/P BUILDUP FIGURE 5-1

Page 25

Feb 05/2008

D633A106-HXL

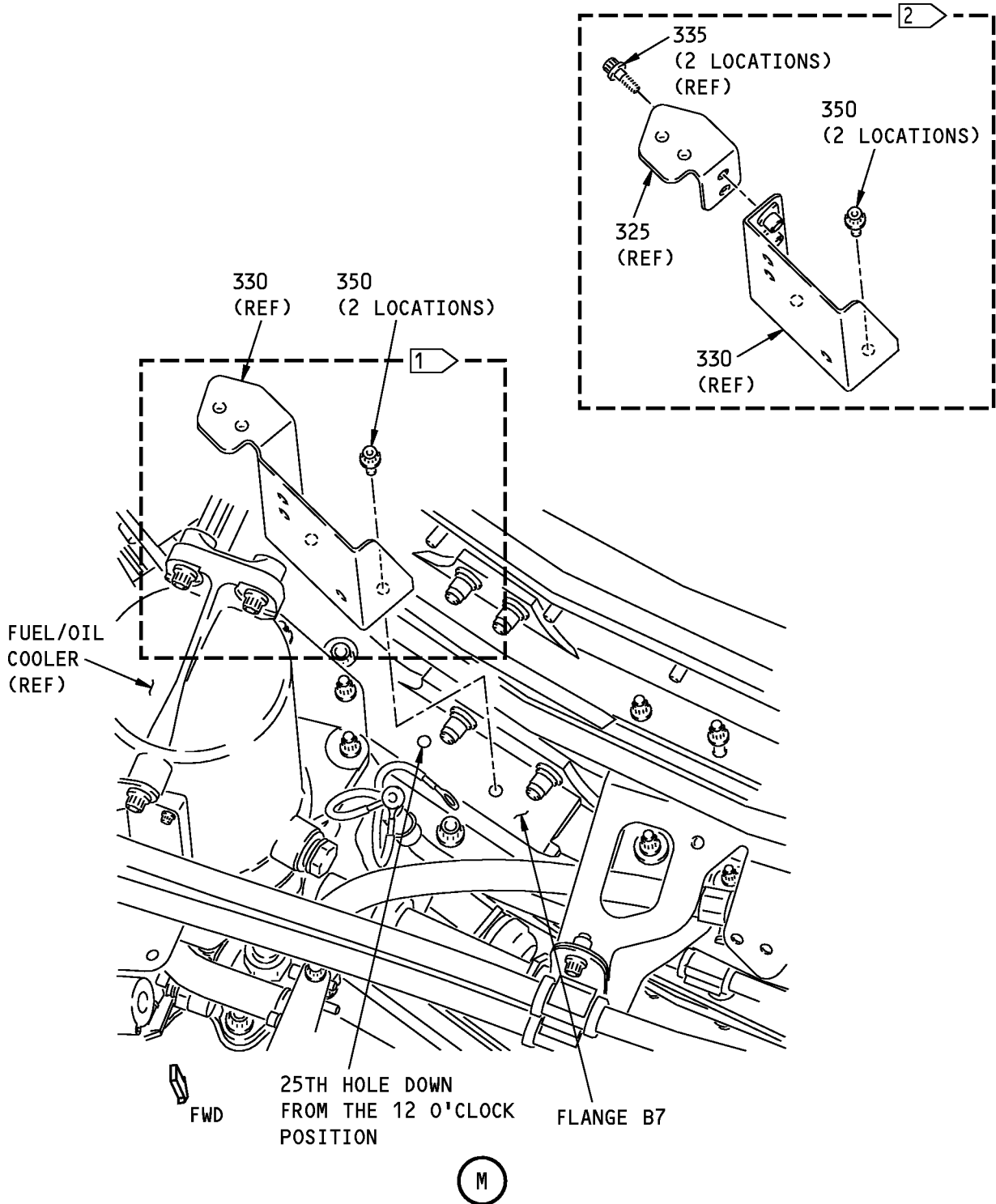

**Bracket Installation - Lower Left Side Fan Case**  
**Figure 5-1 (Sheet 13)**

**71-00-02**

P/P BUILDUP FIGURE 5-1

Page 26

Oct 05/2007

D633A106-HXL

**737-600/700/800/900  
POWERPLANT BUILDUP MANUAL**

ITEM NO.	PART NUMBER	NOMENCLATURE	BRACKET LOCATION AND ORIENTATION			QTY
			BRKT OR FLG SIDE	ANGLE FACES	UC	
5-1		<b>BRACKET INSTALLATION - LOWER LEFT SIDE FAN CASE (FIGURE 5-1, SHEET 13)</b>  CLEAN MATING SURFACES OF BRACKET (330) AND 25TH AND 26TH HOLES DOWN FROM 12 O'CLOCK ON FLANGE B7 WITH alcohol, B00130 (C1). MAKE SURE YOU REMOVE ALL GREASE AND OTHER CONTAMINANTS.				
C1	B00130	. SOLVENT, TT-I-735			CON	AR
350	BACB30ZF4-08	ATTACH BRACKET ASSY (330) TO FLANGE B7 WITH BOLTS (350).  . BOLT  TIGHTEN BOLTS (350) TO 110-120 POUND-INCHES (12.4-13.6 NEWTON METERS).				2

# 71-00-02

P/P BUILDUP FIGURE 5-1

Page 27

Oct 05/2007

D633A106-HXL



737-600/700/800/900  
**POWERPLANT BUILDUP MANUAL**

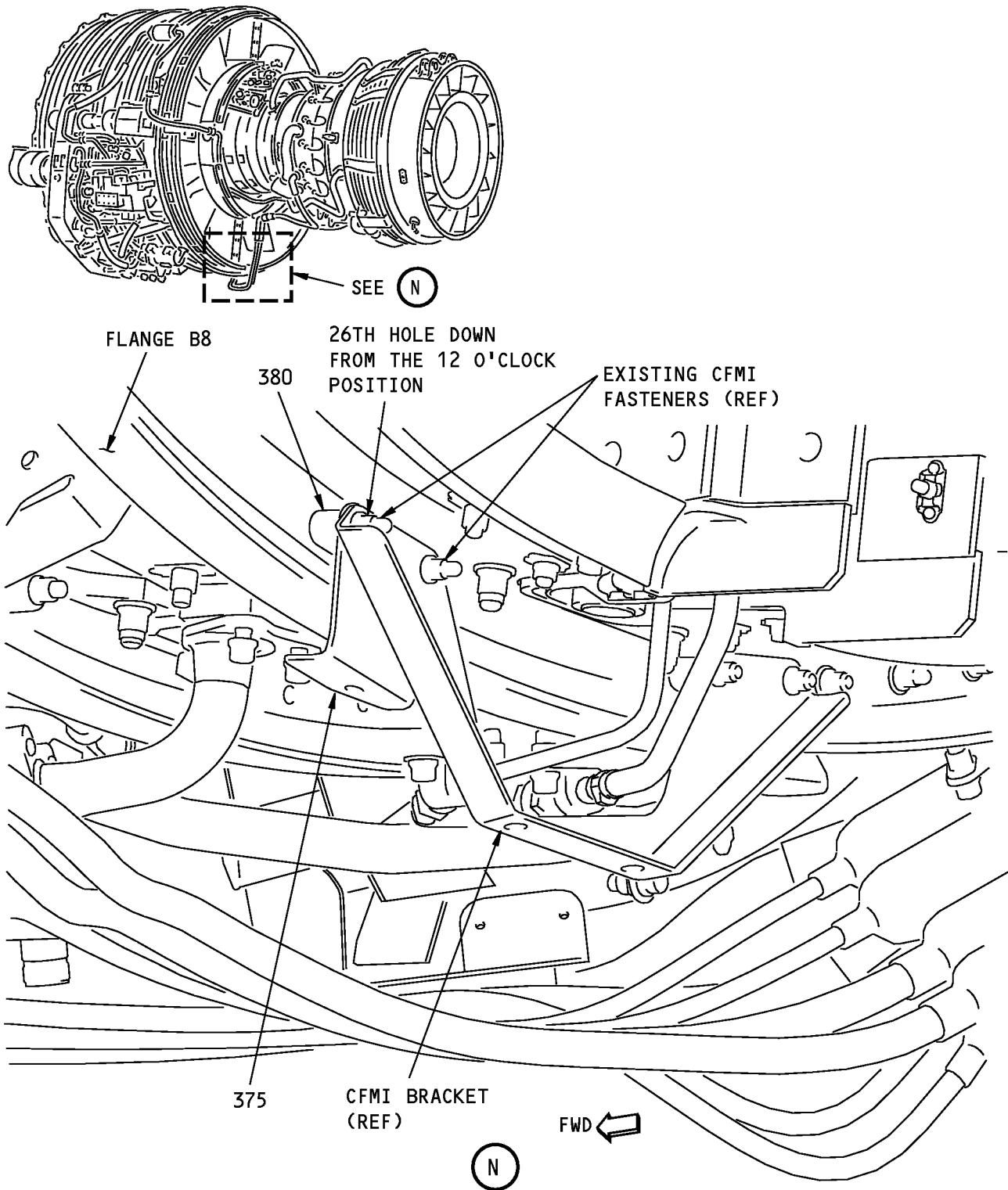

**Bracket Installation - Lower Left Side Fan Case**  
**Figure 5-1 (Sheet 14)**

**71-00-02**

P/P BUILDUP FIGURE 5-1  
Page 28  
Oct 05/2007

D633A106-HXL

**737-600/700/800/900  
POWERPLANT BUILDUP MANUAL**

ITEM NO.	PART NUMBER	NOMENCLATURE	BRACKET LOCATION AND ORIENTATION			QTY
			BRKT OR FLG SIDE	ANGLE FACES	UC	
5-1		<p><b>BRACKET INSTALLATION - LOWER LEFT SIDE FAN CASE (FIGURE 5-1, SHEET 14)</b></p> <p>REMOVE EXISTING CFMI FASTENERS AND SPACER FROM 26TH AND 27TH HOLES DOWN FROM 12 O'CLOCK ON FLANGE B8.</p> <p>APPLY THIN COATING OF ANTI-SEIZE compound, D50004 (C2) TO EXISTING CFMI FASTENERS.</p> <p>ATTACH BRACKET ASSY (375) AND SPACERS (380) OR BRACKET DETAIL (380) BETWEEN CFMI BRACKET AND FLANGE B8 USING EXISTING FASTENERS.</p>				
375	332A2910-104	. BRACKET ASSY	AFT	FWD		1
375	332A2910-141	. BRACKET ASSY (OPTIONAL TO 332A2910-104)	AFT	FWD	OPT	-
380	BACS18K25-39W	. SPACER <sup>[1]</sup>	AFT			2
380	332A2930-60	. BRACKET DETAIL (1 REQD) <sup>[1]</sup>	AFT		OPT	-
C2	D50004	. COMPOUND, ANTI-SEIZE BMS-3-28			CON	AR
		<p>TIGHTEN EXISTING CFMI FASTENERS TO 98-110 POUND-INCHES (11.1-12.4 NEWTON METERS).</p> <p>*[1] QTY (1) 332A2930-60 BRACKET DETAIL OPTIONAL TO QTY (2) BACS18K25-39W SPACER.</p>				

# 71-00-02

P/P BUILDUP FIGURE 5-1

Page 29

Oct 05/2007

D633A106-HXL

**FIGURE 6-1**

**BRACKET INSTALLATION - RIGHT SIDE FAN  
CASE**

**REF QEC TASK NO.: 6**

**REF DWG: 332A2900**

**NOTE:** ALL STANDARDS AND ATTACHING HARDWARE FOR THIS FIGURE WILL BE PACKAGED  
IN QEC TASK NO. 110.

**71-00-02**

P/P BUILDUP FIGURE 6-1

Page 1

Oct 05/2007

D633A106-HXL

**737-600/700/800/900  
POWERPLANT BUILDUP MANUAL**

**THIS SHEET NOT USED**

**Bracket Installation - Right Side Fan Case  
Figure 6-1 (Sheet 1)**

**71-00-02**

P/P BUILDUP FIGURE 6-1

Page 2

Oct 05/2007

D633A106-HXL

737-600/700/800/900  
POWERPLANT BUILDUP MANUAL

ITEM NO.	PART NUMBER	NOMENCLATURE	UC	QTY
6-1		BRACKET INSTALLATION - RIGHT SIDE FAN CASE (FIGURE 6-1, SHEET 1)  THIS SHEET NOT USED		

**71-00-02**

P/P BUILDUP FIGURE 6-1

Page 3

Oct 05/2007

D633A106-HXL

737-600/700/800/900  
**POWERPLANT BUILDUP MANUAL**

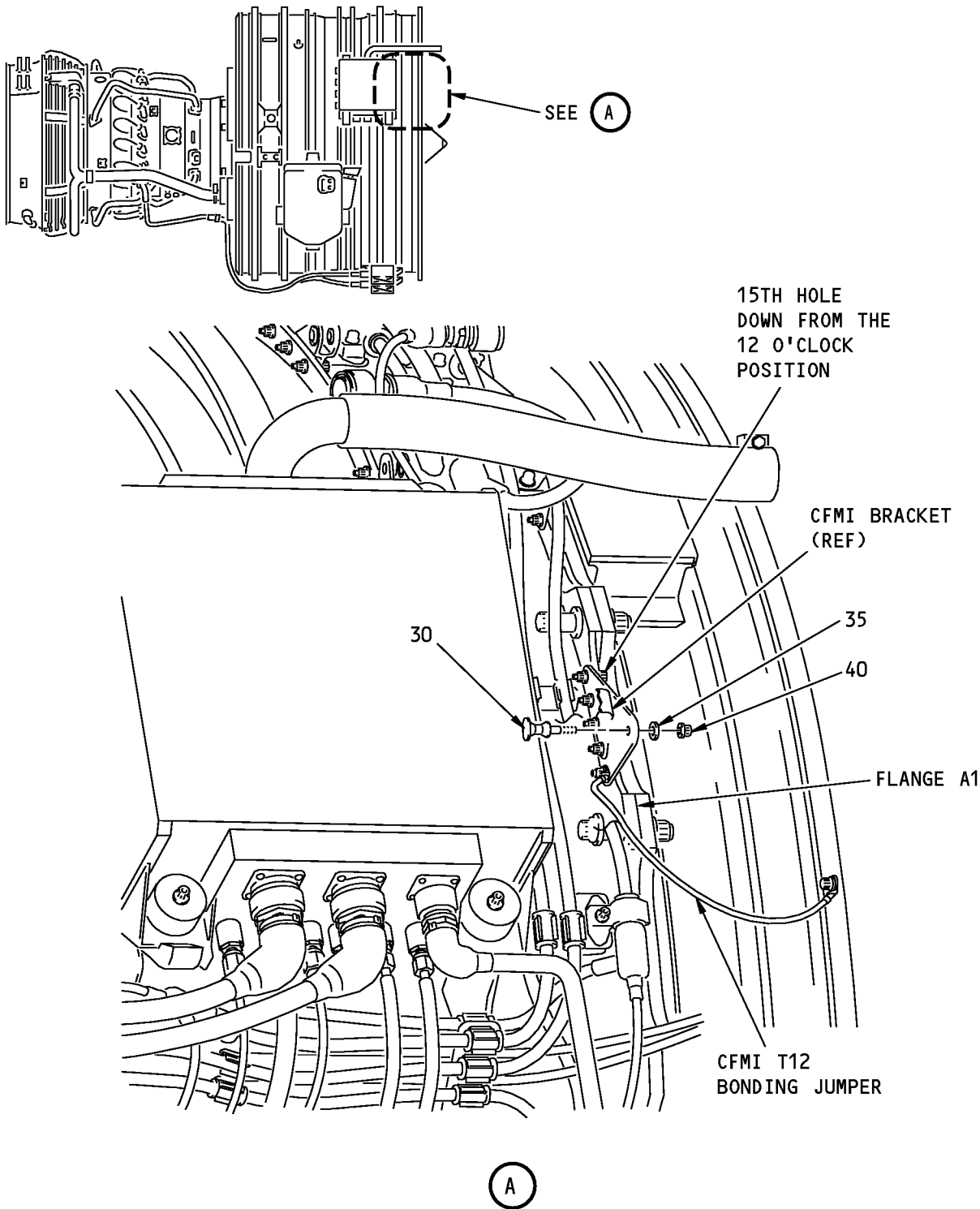

**Bracket Installation - Right Side Fan Case**  
**Figure 6-1 (Sheet 2)**

**71-00-02**

**737-600/700/800/900  
POWERPLANT BUILDUP MANUAL**

ITEM NO.	PART NUMBER	NOMENCLATURE	BRACKET LOCATION AND ORIENTATION			QTY
			BRKT OR FLG SIDE	ANGLE FACES	UC	
6-1		<b>BRACKET INSTALLATION - RIGHT SIDE FAN CASE (FIGURE 6-1, SHEET 2)</b>  ATTACH RECEIVER (30) TO HOLE ON CFMI BRACKET LOCATED ON 15TH THRU 19TH HOLES DOWN FROM 12 O'CLOCK POSITION ON FLANGE A1. USE WASHER (35) AND NUT (40).				
30	370D1005-5	. RECEIVER	AFT			1
35	NAS1149C0432R	. WASHER (UNDER NUT)				1
40	BACN11Z4CK	. NUT				1
		TIGHTEN NUT (40) TO 65-100 POUND-INCHES (7.3-11.3 NEWTON METERS).				

# 71-00-02

P/P BUILDUP FIGURE 6-1

Page 5

Oct 05/2007

D633A106-HXL

737-600/700/800/900  
**POWERPLANT BUILDUP MANUAL**

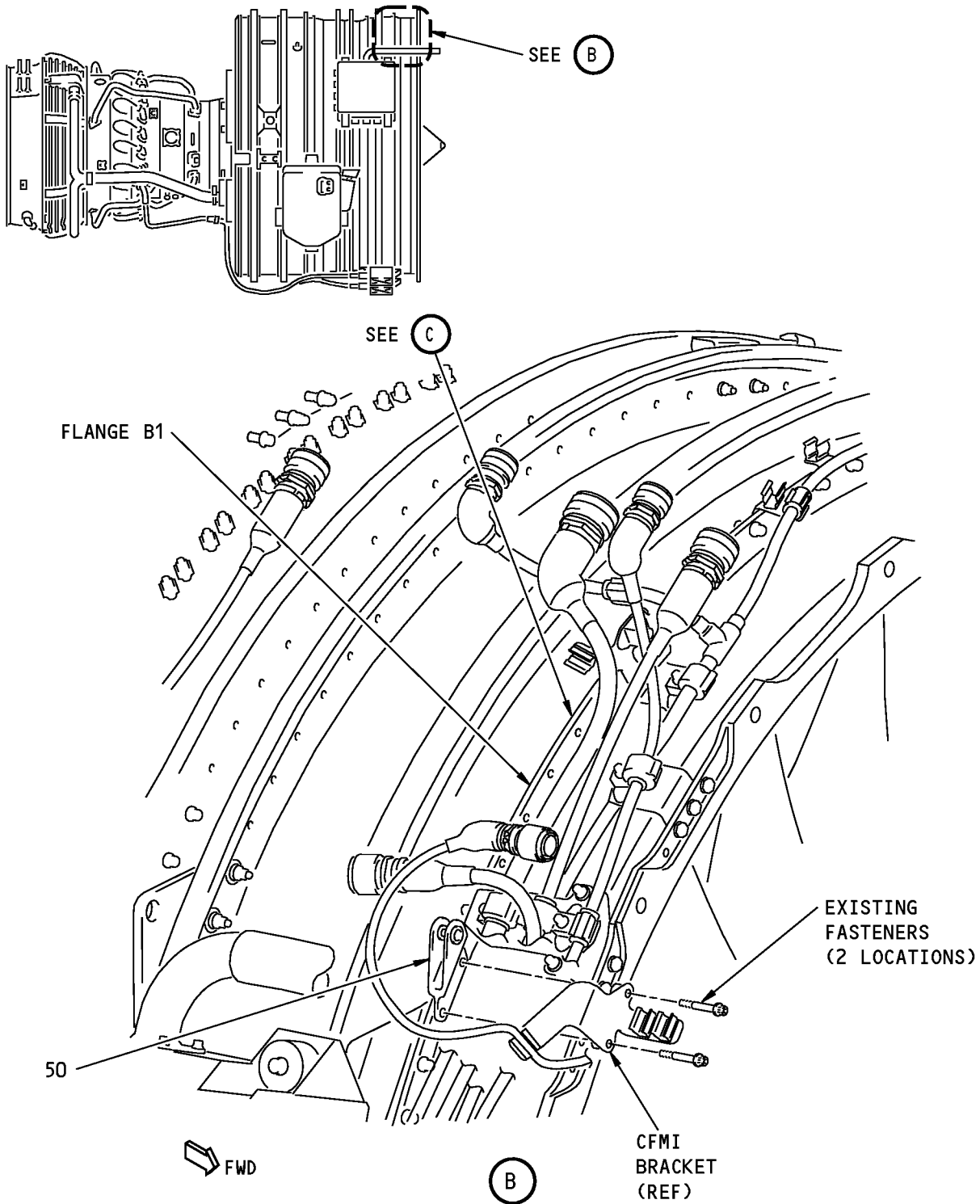

**Bracket Installation - Right Side Fan Case**  
**Figure 6-1 (Sheet 3)**

**71-00-02**

P/P BUILDUP FIGURE 6-1

Page 6

Oct 05/2007



**737-600/700/800/900  
POWERPLANT BUILDUP MANUAL**

ITEM NO.	PART NUMBER	NOMENCLATURE	BRACKET LOCATION AND ORIENTATION			QTY
			BRKT OR FLG SIDE	ANGLE FACES	UC	
6-1		<b>BRACKET INSTALLATION - RIGHT SIDE FAN CASE (FIGURE 6-1, SHEET 3)</b>  REMOVE EXISTING CFMI FASTENERS AND CFMI BRACKET FROM FLANGE B1. INSTALL BRACKET ASSY (50) BETWEEN FLANGE B1 AND CFMI BRACKET. REINSTALL CFMI BRACKET USING EXISTING CFMI FASTENERS.				
50	332A2930-1	. BRACKET ASSY  TIGHTEN EXISTING CFMI FASTENERS TO 110-120 POUND-INCHES (12.4-13.6 NEWTON METERS).	FWD			1

# 71-00-02

P/P BUILDUP FIGURE 6-1

Page 7

Oct 05/2007

D633A106-HXL

737-600/700/800/900  
**POWERPLANT BUILDUP MANUAL**

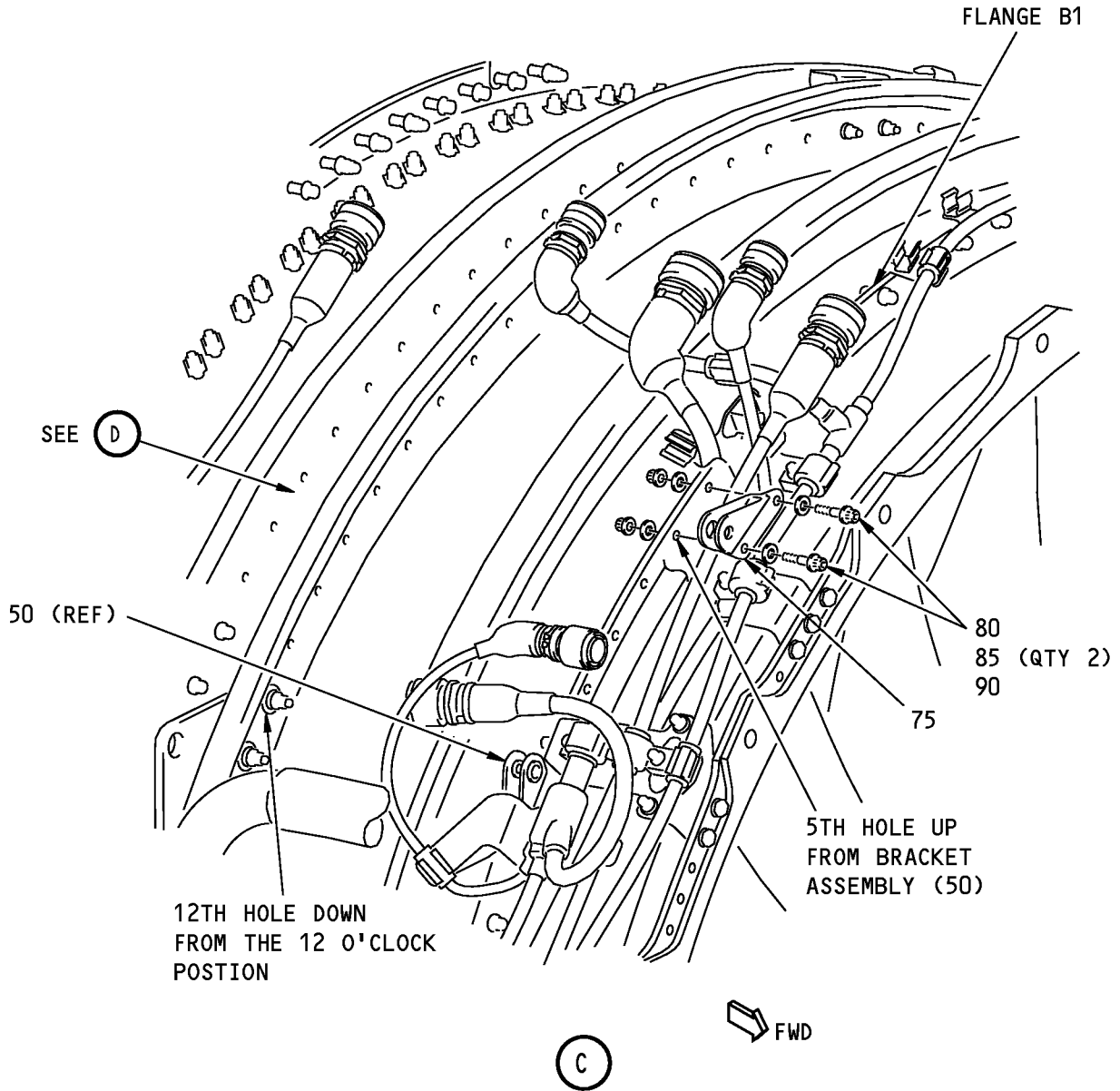

**Bracket Installation - Right Side Fan Case**  
**Figure 6-1 (Sheet 4)**

**71-00-02**

P/P BUILDUP FIGURE 6-1

Page 8

Oct 05/2007

D633A106-HXL

**737-600/700/800/900  
POWERPLANT BUILDUP MANUAL**

ITEM NO.	PART NUMBER	NOMENCLATURE	BRACKET LOCATION AND ORIENTATION			QTY
			BRKT OR FLG SIDE	ANGLE FACES	UC	
6-1		<b>BRACKET INSTALLATION - RIGHT SIDE FAN CASE (FIGURE 6-1, SHEET 4)</b>  ATTACH BRACKET ASSY (75) TO 5TH AND 6TH HOLES UP FROM BRACKET ASSY (50) ON FLANGE B1. USE BOLTS (80), WASHERS (85) AND NUTS (90).				
75	332A2930-1	. BRACKET ASSY	FWD			1
80	BACB30ZF4-12	. BOLT (FWD SIDE)				2
85	NAS1149C0432R	. WASHER				4
90	AS3485-10	. NUT				2
		TIGHTEN BOLTS (80) TO 110-120 POUND-INCHES (12.4-13.6 NEWTON METERS).				

# 71-00-02

P/P BUILDUP FIGURE 6-1

Page 9

Oct 05/2007

D633A106-HXL

737-600/700/800/900  
**POWERPLANT BUILDUP MANUAL**

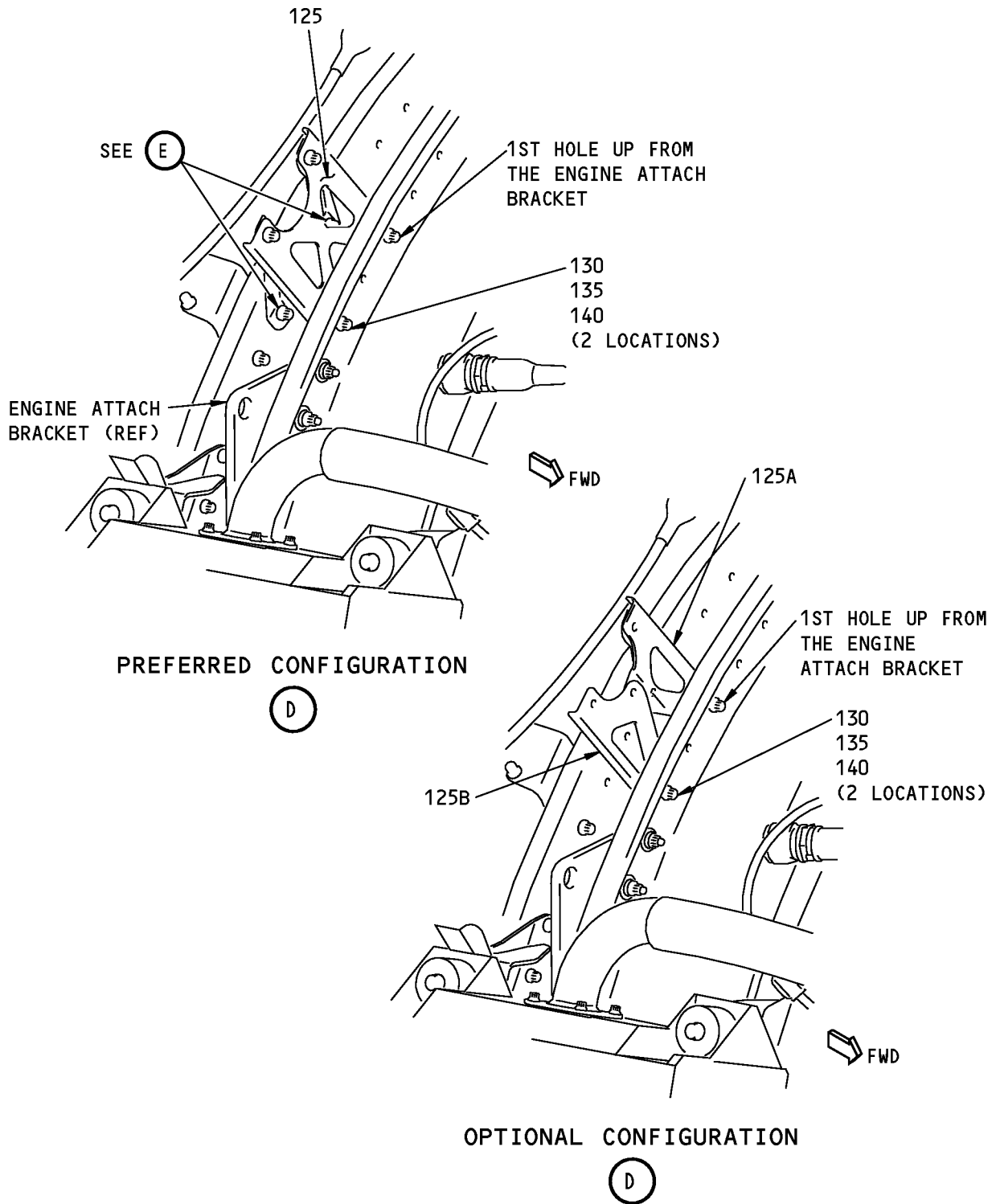

**Bracket Installation - Right Side Fan Case**  
**Figure 6-1 (Sheet 5)**

**71-00-02**

P/P BUILDUP FIGURE 6-1

Page 10

Oct 05/2007

D633A106-HXL

**737-600/700/800/900  
POWERPLANT BUILDUP MANUAL**

ITEM NO.	PART NUMBER	NOMENCLATURE	BRACKET LOCATION AND ORIENTATION			QTY
			BRKT OR FLG SIDE	ANGLE FACES	UC	
6-1		<p><b>BRACKET INSTALLATION - RIGHT SIDE FAN CASE (FIGURE 6-1, SHEET 5)</b></p> <p>PREFERRED CONFIGURATION;</p> <p>ATTACH BRACKET ASSY (125) TO 1ST AND 3RD HOLES UP FROM ENGINE ATTACH BRACKET ON FLANGE B4. USE BOLTS (130), WASHERS (135) AND NUTS (140).</p> <p>OPTIONAL CONFIGURATION;</p> <p>ATTACH BRACKET (125B) TO 1ST HOLE UP FROM ENGINE ATTACH BRACKET AND ATTACH BRACKET (125A) TO 3RD HOLE UP. USE BOLTS (130), WASHERS (135) AND NUTS (140).</p> <p><b>NOTE:</b> DO NOT INSTALL A FASTENER BETWEEN BRACKETS (125A) AND (125B) AT THIS TIME.</p>				
125	332A2910-99	. BRACKET	AFT			1
125A	332A2910-95	. BRACKET (OPTIONAL) <sup>*[1]</sup>	AFT		OPT	-
125B	332A2910-96	. BRACKET (OPTIONAL) <sup>*[1]</sup>	AFT		OPT	-
130	BACB30ZF4-10	. BOLT (FWD SIDE)				2
135	NAS1149C0432R	. WASHER (UNDER BOLT HEAD)				2
140	AS3485-10	. NUT				2
		<p>TIGHTEN BOLTS (130) TO 110-120 POUND-INCHES (12.4-13.6 NEWTON METERS).</p> <p>*[1] BRACKETS (125A) AND (125B) TOGETHER ARE OPTIONAL TO BRACKET (125).</p>				

# 71-00-02

P/P BUILDUP FIGURE 6-1

Page 11

Oct 05/2007

D633A106-HXL

737-600/700/800/900  
**POWERPLANT BUILDUP MANUAL**

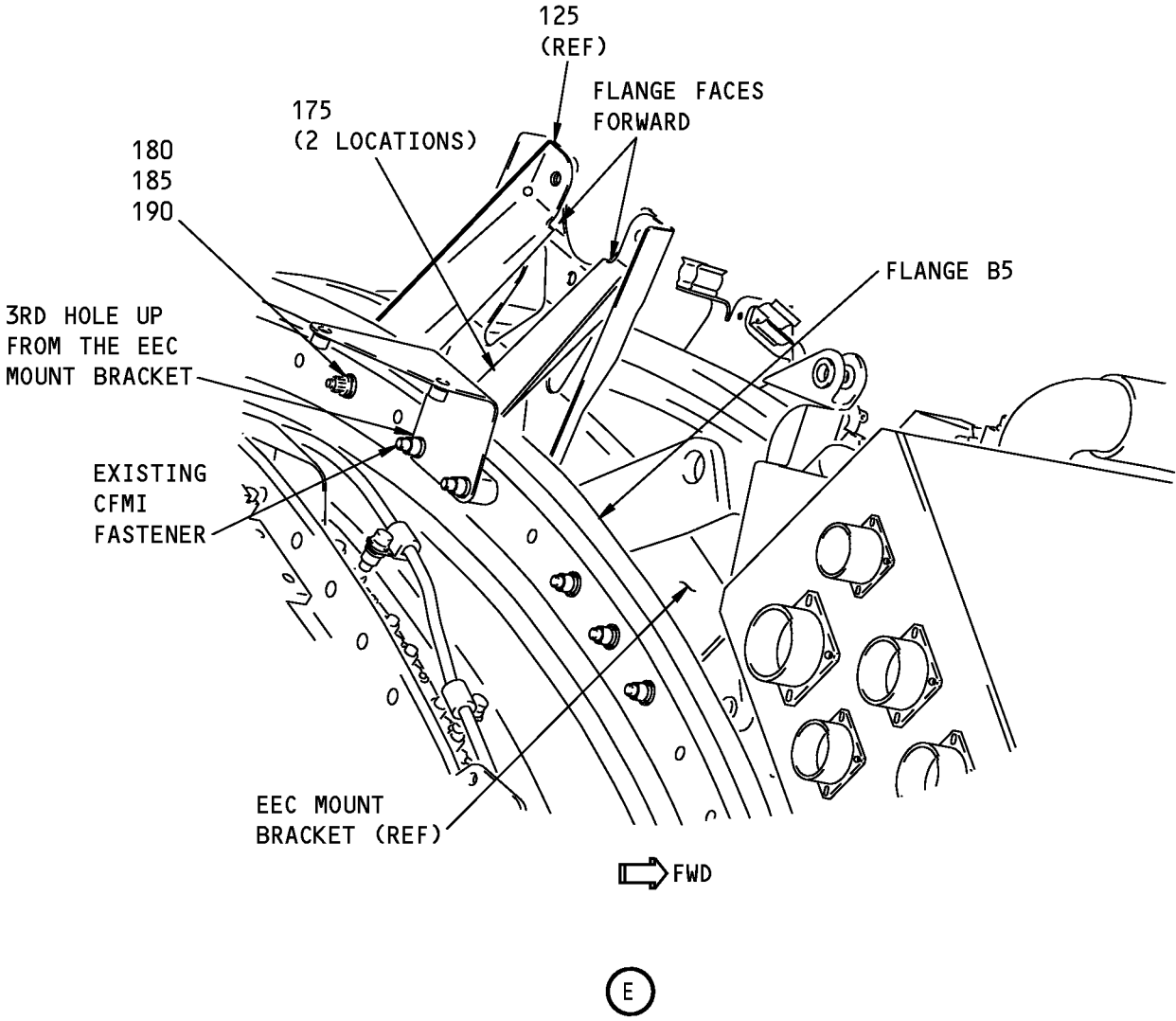

**Bracket Installation - Right Side Fan Case**  
**Figure 6-1 (Sheet 6)**

**71-00-02**

P/P BUILDUP FIGURE 6-1  
Page 12  
Oct 05/2007

D633A106-HXL

**737-600/700/800/900  
POWERPLANT BUILDUP MANUAL**

ITEM NO.	PART NUMBER	NOMENCLATURE	BRACKET LOCATION AND ORIENTATION			QTY
			BRKT OR FLG SIDE	ANGLE FACES	UC	
6-1		<p><b>BRACKET INSTALLATION - RIGHT SIDE FAN CASE (FIGURE 6-1, SHEET 6)</b></p> <p>REMOVE EXISTING CFMI FASTENER FROM 3RD HOLE UP FROM EEC MOUNT BRACKET ON FLANGE B5.</p> <p>ATTACH BRACKET ASSYS (175) TO 3RD AND 5TH HOLES UP FROM EEC MOUNT BRACKET ON FLANGE B5. USE EXISTING CFMI FASTENER AT LOWER HOLE AND BOLT (180), WASHER (185) AND NUT (190) AT UPPER HOLE.</p> <p><b>NOTE:</b> BRACKETS (125) AND (175) WILL BE CONNECTED TO INLET COWL TAI DUCT (REF Figure 27-1).</p>				
175	332A2920-132	. BRACKET ASSY	FWD	FWD		2
175	332A2920-29	. BRACKET ASSY (OPTIONAL)	FWD	FWD	OPT	-
180	BACB30ZF4-10	. BOLT (FWD SIDE)				1
185	NAS1149C0432R	. WASHER (UNDER NUT)				1
190	AS3485-10	. NUT				1
		TIGHTEN BOLT (180) AND EXISTING CFMI FASTENER TO 110-120 POUND-INCHES (12.4-13.6 NEWTON METERS).				

# 71-00-02

P/P BUILDUP FIGURE 6-1

Page 13

Oct 05/2007

D633A106-HXL

737-600/700/800/900  
**POWERPLANT BUILDUP MANUAL**

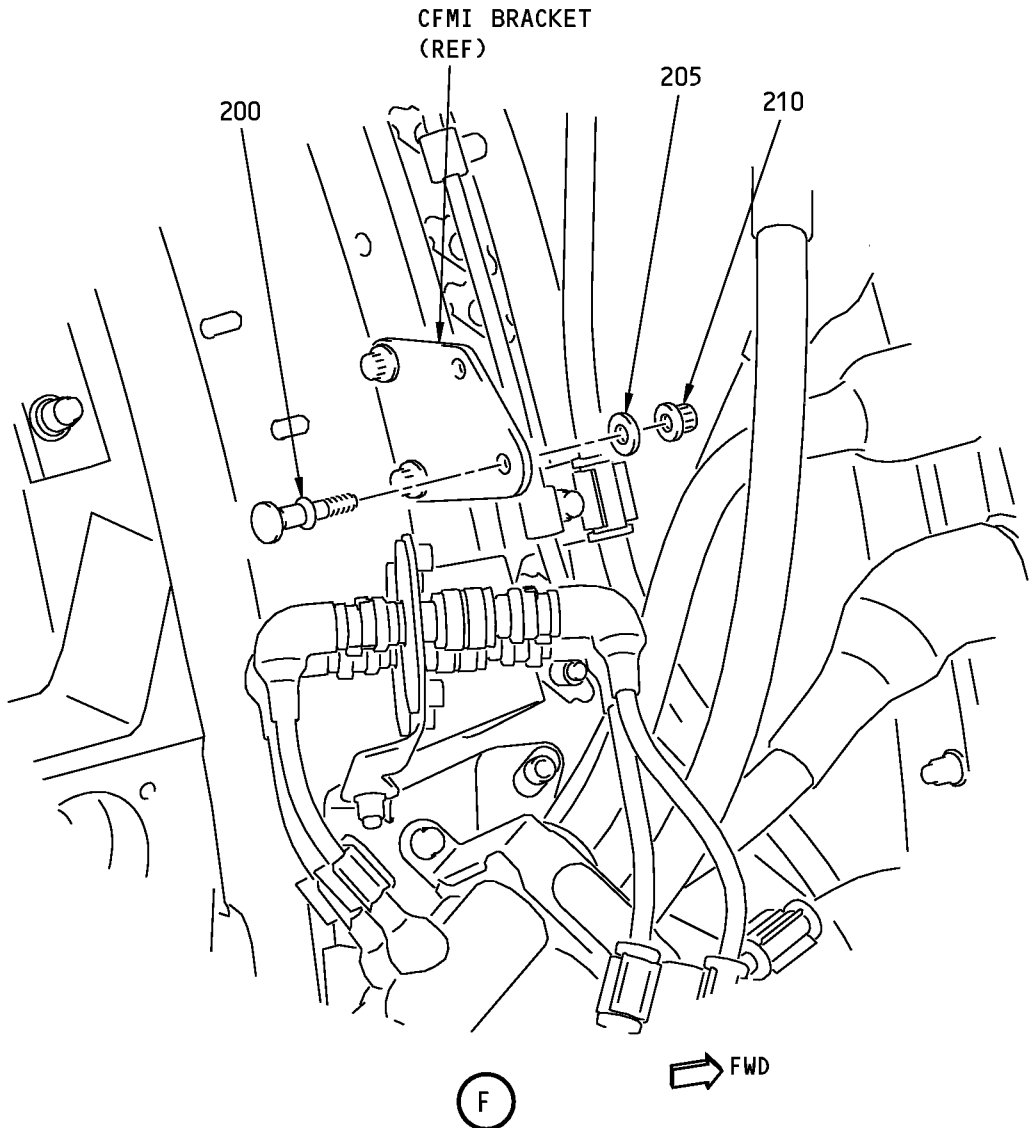
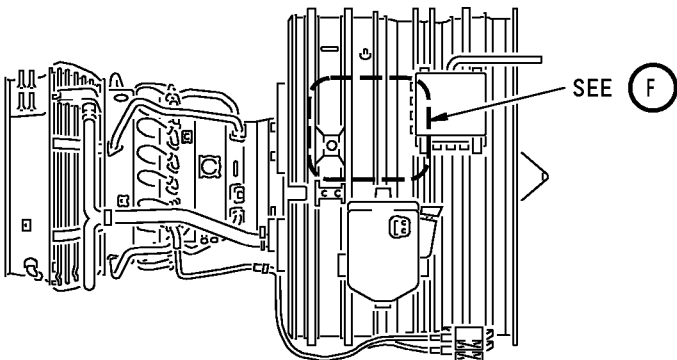

**Bracket Installation - Right Side Fan Case**  
**Figure 6-1 (Sheet 7)**

**71-00-02**

P/P BUILDUP FIGURE 6-1  
Page 14  
Oct 05/2007

D633A106-HXL



**737-600/700/800/900  
POWERPLANT BUILDUP MANUAL**

ITEM NO.	PART NUMBER	NOMENCLATURE	BRACKET LOCATION AND ORIENTATION			QTY
			BRKT OR FLG SIDE	ANGLE FACES	UC	
6-1		<b>BRACKET INSTALLATION - RIGHT SIDE FAN CASE (FIGURE 6-1, SHEET 7)</b>  ATTACH RECEIVER (200) TO HOLE ON CFMI BRACKET ON 21ST AND 22ND HOLES DOWN FROM 12 O'CLOCK POSITION ON FLANGE B6. USE WASHER (205) AND NUT (210).				
200	370D1005-5	. RECEIVER	AFT			1
205	NAS1149C0432R	. WASHER (UNDER NUT)				1
210	BACN11Z4CK	. NUT				1
		TIGHTEN NUT (210) TO 65-100 POUND-INCHES (7.3-11.3 NEWTON METERS).				

# 71-00-02

P/P BUILDUP FIGURE 6-1

Page 15

Oct 05/2007

D633A106-HXL

737-600/700/800/900  
**POWERPLANT BUILDUP MANUAL**

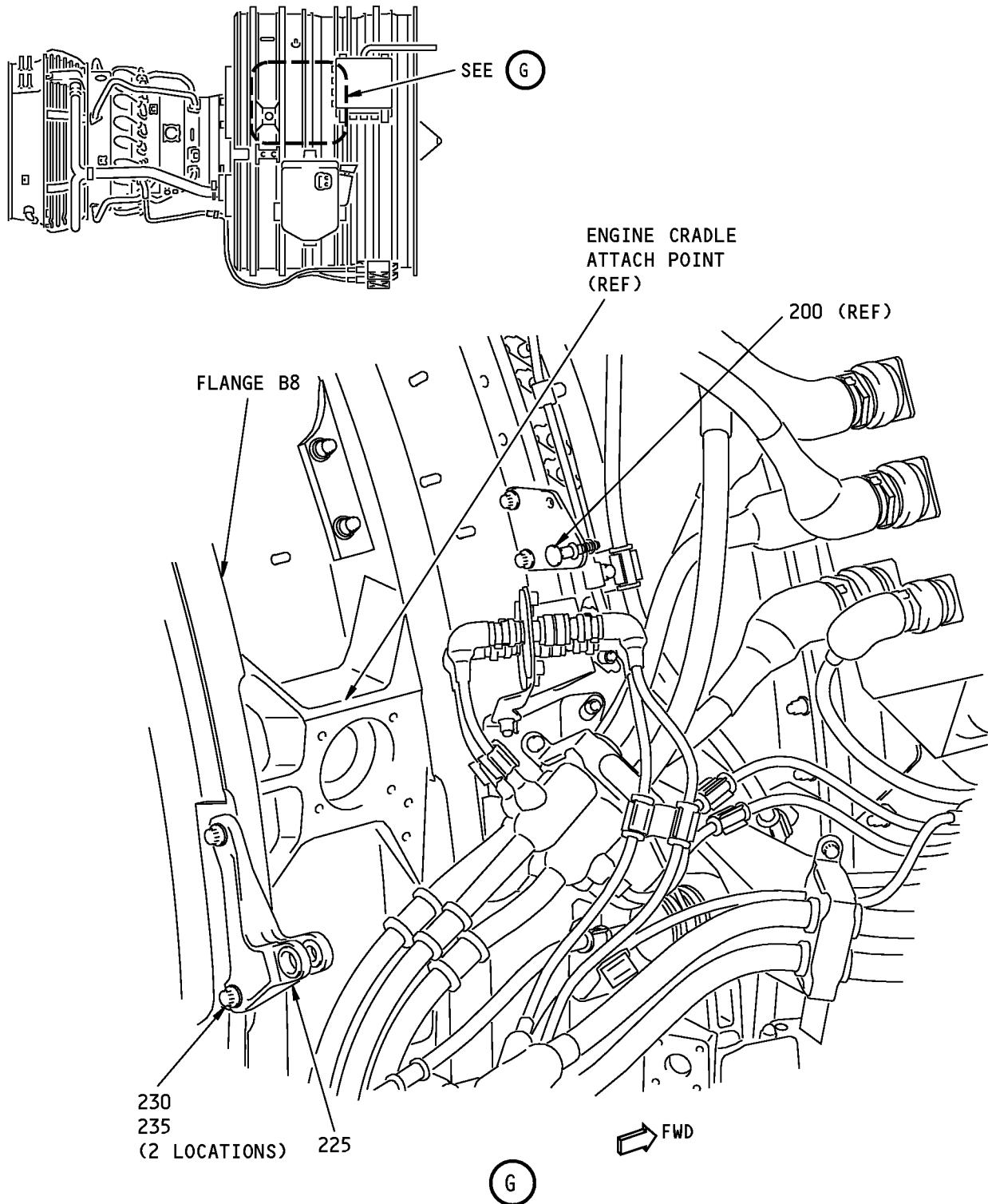

**Bracket Installation - Right Side Fan Case**  
**Figure 6-1 (Sheet 8)**

**71-00-02**

P/P BUILDUP FIGURE 6-1

Page 16

Oct 05/2007

D633A106-HXL

**737-600/700/800/900  
POWERPLANT BUILDUP MANUAL**

ITEM NO.	PART NUMBER	NOMENCLATURE	BRACKET LOCATION AND ORIENTATION			QTY
			BRKT OR FLG SIDE	ANGLE FACES	UC	
6-1		<b>BRACKET INSTALLATION - RIGHT SIDE FAN CASE (FIGURE 6-1, SHEET 8)</b>  APPLY A THIN COATING OF ANTI-SEIZE compound, D50004 (C6) TO BOLTS (230).  ATTACH BRACKET ASSY (225) TO FLANGE B8 JUST ABOVE 3 O'CLOCK POSITION AND AFT OF ENGINE CRADLE ATTACH POINT. USE BOLTS (230) AND WASHERS (235).				
225	332A2930-62	. BRACKET ASSY	AFT			1
230	BACB30LE5U6	. BOLT (AFT SIDE)				2
235	BACW10BP5ACU	. WASHER (UNDER BOLT HEAD)				2
C6	D50004	. COMPOUND, ANTI-SEIZE, BMS-3-28			CON	AR
		TIGHTEN BOLTS (230) TO 123-136 POUND-INCHES (13.89-15.36 NEWTON METERS).				

# 71-00-02

P/P BUILDUP FIGURE 6-1

Page 17

Oct 05/2007

D633A106-HXL

737-600/700/800/900  
**POWERPLANT BUILDUP MANUAL**

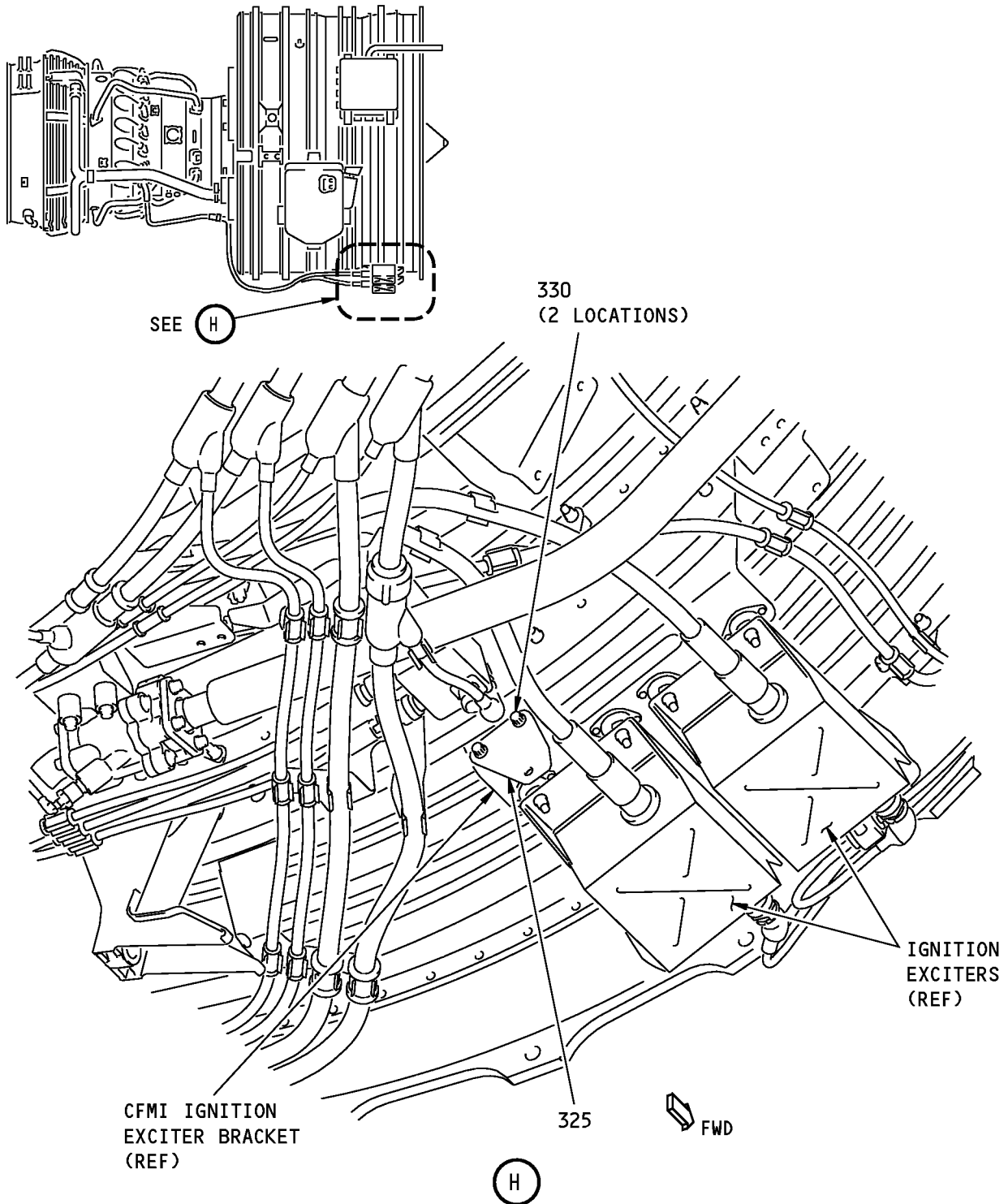

**Bracket Installation - Right Side Fan Case**  
**Figure 6-1 (Sheet 9)**

**71-00-02**

P/P BUILDUP FIGURE 6-1

Page 18

Oct 05/2007

D633A106-HXL

## POWERPLANT BUILDUP MANUAL

ITEM NO.	PART NUMBER	NOMENCLATURE	BRACKET LOCATION AND ORIENTATION			QTY
			BRKT OR FLG SIDE	ANGLE FACES	UC	
6-1		<b>BRACKET INSTALLATION - RIGHT SIDE FAN CASE (FIGURE 6-1, SHEET 9)</b>  ATTACH BRACKET (325) TO LOWER AFT SIDE OF CFMI IGNITION EXCITER BRACKET ON FLANGE B4. USE BOLTS (330).				
325	332A2910-26	. BRACKET				1
330	BACB30ZF4-06	. BOLT  TIGHTEN BOLTS (330) TO 110-120 POUND-INCHES (12.4-13.6 NEWTON METERS).				2

**71-00-02**

P/P BUILDUP FIGURE 6-1

Page 19

Oct 05/2007

D633A106-HXL

737-600/700/800/900  
**POWERPLANT BUILDUP MANUAL**

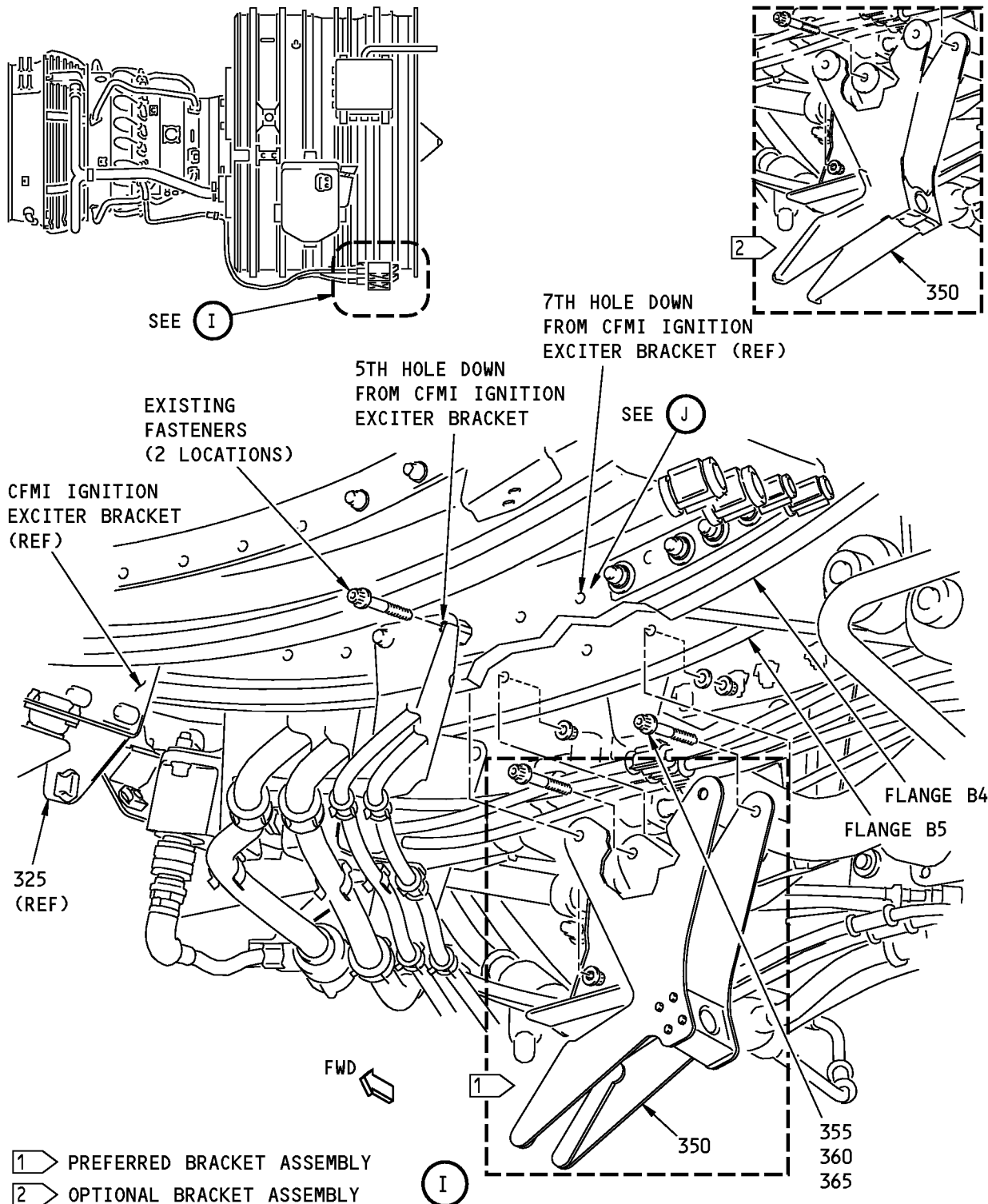

**Bracket Installation - Right Side Fan Case**  
**Figure 6-1 (Sheet 10)**

**71-00-02**

P/P BUILDUP FIGURE 6-1

Page 20

Oct 05/2007

**737-600/700/800/900  
POWERPLANT BUILDUP MANUAL**

ITEM NO.	PART NUMBER	NOMENCLATURE	BRACKET LOCATION AND ORIENTATION			QTY
			BRKT OR FLG SIDE	ANGLE FACES	UC	
6-1		<p><b>BRACKET INSTALLATION - RIGHT SIDE FAN CASE (FIGURE 6-1, SHEET 10)</b></p> <p>REMOVE EXISTING CFMI FASTENERS FROM 5TH AND 7TH HOLES DOWN ON FLANGE B4 FROM CFMI IGNITION EXCITER BRACKET AND 7TH HOLE DOWN ON FLANGE B5.</p> <p>POSITION BRACKET ASSY (350) BETWEEN FLANGES B4 AND B5 AND ATTACH WITH EXISTING CFMI FASTENERS AT 5TH HOLES DOWN ON FLANGES B4 AND B5 AND BOLT (355), WASHER (360) AND NUT (365) AT 7TH HOLE DOWN ON FLANGE B5.</p> <p><b>NOTE:</b> DO NOT INSTALL A FASTENER AT THE 7TH HOLE DOWN ON FLANGE B4 AT THIS TIME.</p>				
350	332A2930-90	. BRKT ASSY		*[1]		1
355	BACB30ZF4-12	. BOLT (FWD SIDE)				1
360	NAS1149C0432R	. WASHER (UNDER NUT)				1
365	AS3485-10	. NUT				1
		<p>TIGHTEN BOLT (355) TO 80-90 POUNDS-INCHES (9.0-10.1 NEWTON METERS) AND EXISTING CFM BOLTS TO 100-112 POUND-INCHES (11.3-12.6 NEWTON METERS).</p> <p>*[1] FORKS OF BRACKET ASSY (350) FACE RIGHT SIDE OF ENGINE (SIDE WITH THE OIL TANK).</p>				

# 71-00-02

P/P BUILDUP FIGURE 6-1

Page 21

Oct 05/2007

D633A106-HXL

737-600/700/800/900  
**POWERPLANT BUILDUP MANUAL**

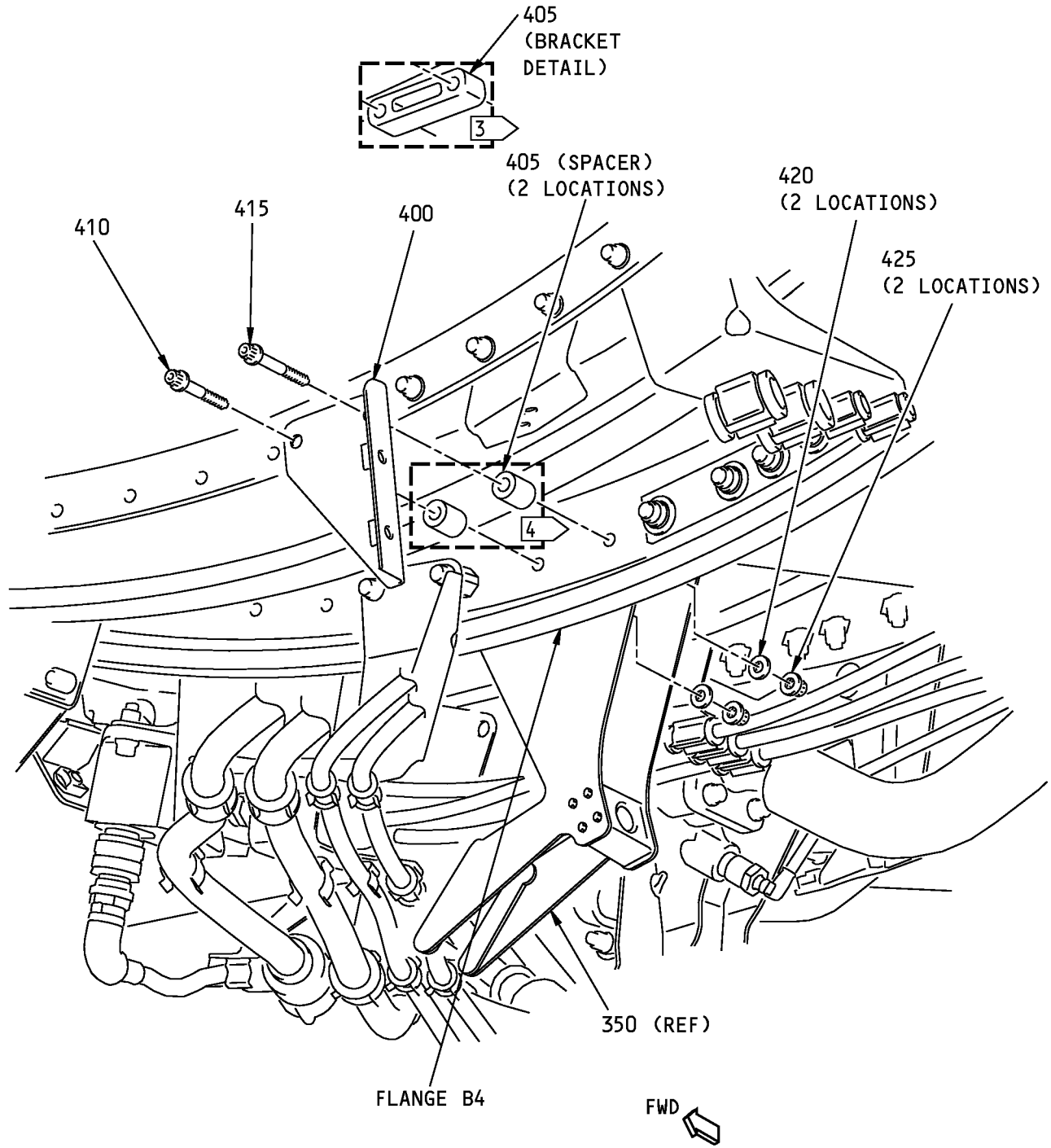

- [3] OPTIONAL CONFIGURATION
- [4] PREFERRED CONFIGURATION

J

**Bracket Installation - Right Side Fan Case**  
**Figure 6-1 (Sheet 11)**

**71-00-02**  
P/P BUILDUP FIGURE 6-1  
Page 22  
Oct 05/2007



**737-600/700/800/900  
POWERPLANT BUILDUP MANUAL**

ITEM NO.	PART NUMBER	NOMENCLATURE	BRACKET LOCATION AND ORIENTATION			QTY
			BRKT OR FLG SIDE	ANGLE FACES	UC	
6-1		<b>BRACKET INSTALLATION - RIGHT SIDE FAN CASE (FIGURE 6-1, SHEET 11)</b>  AT REMAINING BOLT LOCATION ON BRACKET ASSY (350), ATTACH BRACKET ASSY (400) AND SPACERS (405) OR BRACKET DETAIL (405) TO FLANGE B4. USE BOLTS (410) AND (415), WASHERS (420) AND NUTS (425).				
400	332A2910-51	. BRACKET ASSY	FWD	FWD		1
405	BACS18K25-45W	. SPACER (PREFERRED CONFIGURATION)				2
405	332A2930-26	. BRACKET DETAIL (OPT CONFIGURATION)			OPT	-
410	BACB30ZF4-22	. BOLT (FWD SIDE)				1
415	BACB30ZF4-24	. BOLT (FWD SIDE)				1
420	NAS1149C0432R	. WASHER (UNDER NUT)				2
425	AS3485-10	. NUT				2
		TIGHTEN BOLTS (410) AND (415) TO 110-120 POUND-INCHES (12.4-13.6 NEWTON METERS).				

# 71-00-02

P/P BUILDUP FIGURE 6-1

Page 23

Oct 05/2007

D633A106-HXL

737-600/700/800/900  
**POWERPLANT BUILDUP MANUAL**

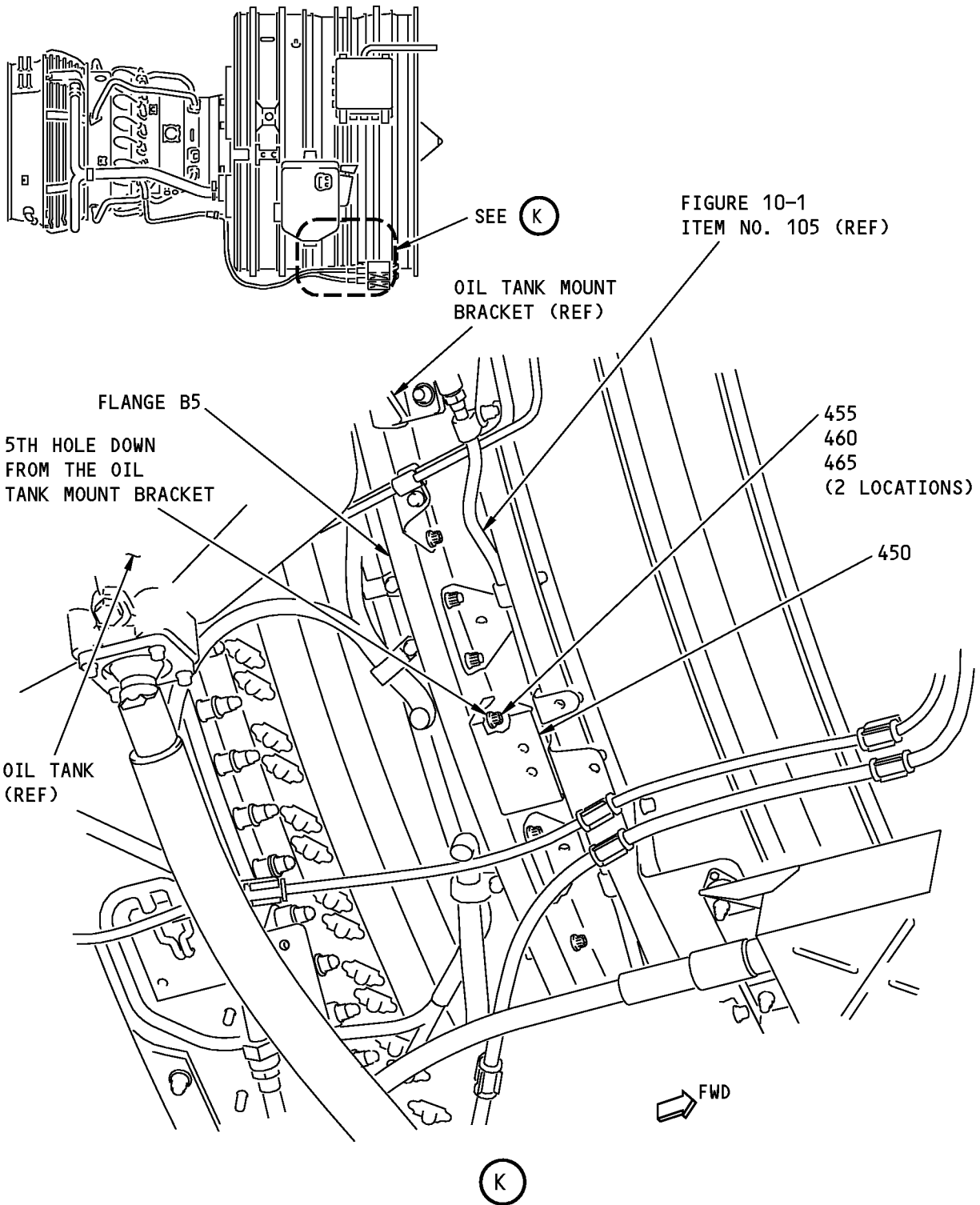

**Bracket Installation - Right Side Fan Case**  
Figure 6-1 (Sheet 12)

**71-00-02**

P/P BUILDUP FIGURE 6-1

Page 24

Oct 05/2007

D633A106-HXL

**737-600/700/800/900  
POWERPLANT BUILDUP MANUAL**

ITEM NO.	PART NUMBER	NOMENCLATURE	BRACKET LOCATION AND ORIENTATION			QTY
			BRKT OR FLG SIDE	ANGLE FACES	UC	
6-1		<p><b>BRACKET INSTALLATION - RIGHT SIDE FAN CASE</b> <b>(FIGURE 6-1, SHEET 12)</b></p> <p><b>NOTE:</b> DUE TO LIMITED ACCESS, IT IS RECOMMENDED THAT Figure 10-1 ITEM NO. (100) HOSE ASSY AND (105) TUBE ASSY BE INSTALLED PRIOR TO INSTALLATION OF BRACKET ASSY (450).</p> <p>CLEAN MATING SURFACES OF BRACKET ASSY (450) AND FLANGE B5 WITH alcohol, B00130 (C1). MAKE SURE YOU REMOVE ALL GREASE AND OTHER CONTAMINANTS.</p>				
450 C1	332A2920-48 B00130	<p>. BRACKET ASSY . SOLVENT, TT-I-735</p> <p>ATTACH BRACKET ASSY (450) TO 5TH AND 6TH HOLES DOWN FROM OIL TANK MOUNT BRACKET ON FLANGE B5. USE BOLTS (455), WASHERS (460) AND NUTS (465).</p>	FWD		CON	1 AR
455	BACB30ZF4-12	. BOLT (FWD SIDE)				2
460	NAS1149C0432R	. WASHER (UNDER NUT)				2
465	AS3485-10	. NUT				2
		TIGHTEN BOLTS (455) TO 110-120 POUND-INCHES (12.4-13.6 NEWTON METERS).				

# 71-00-02

P/P BUILDUP FIGURE 6-1

Page 25

Oct 05/2007

D633A106-HXL

**FIGURE 7-1**

**BRACKET INSTALLATION - LEFT SIDE CORE  
CASE**

**REF QEC TASK NO.: 7**

**REF DWG: 332A2900**

**NOTE:** ALL STANDARDS AND ATTACHING HARDWARE FOR THIS FIGURE WILL BE PACKAGED  
IN QEC TASK NO. 110.

**71-00-02**

P/P BUILDUP FIGURE 7-1

Page 1

Oct 05/2007

D633A106-HXL

**737-600/700/800/900  
POWERPLANT BUILDUP MANUAL**

**THIS SHEET NOT USED**

**Bracket Installation - Left Side Core Case  
Figure 7-1 (Sheet 1)**

**71-00-02**

P/P BUILDUP FIGURE 7-1

Page 2

Oct 05/2007

D633A106-HXL

737-600/700/800/900  
POWERPLANT BUILDUP MANUAL

ITEM NO.	PART NUMBER	NOMENCLATURE	UC	QTY
7-1		BRACKET INSTALLATION - LEFT SIDE CORE CASE (FIGURE 7-1, SHEET 1)  THIS SHEET NOT USED		

**71-00-02**

P/P BUILDUP FIGURE 7-1

Page 3

Oct 05/2007

D633A106-HXL

737-600/700/800/900  
**POWERPLANT BUILDUP MANUAL**

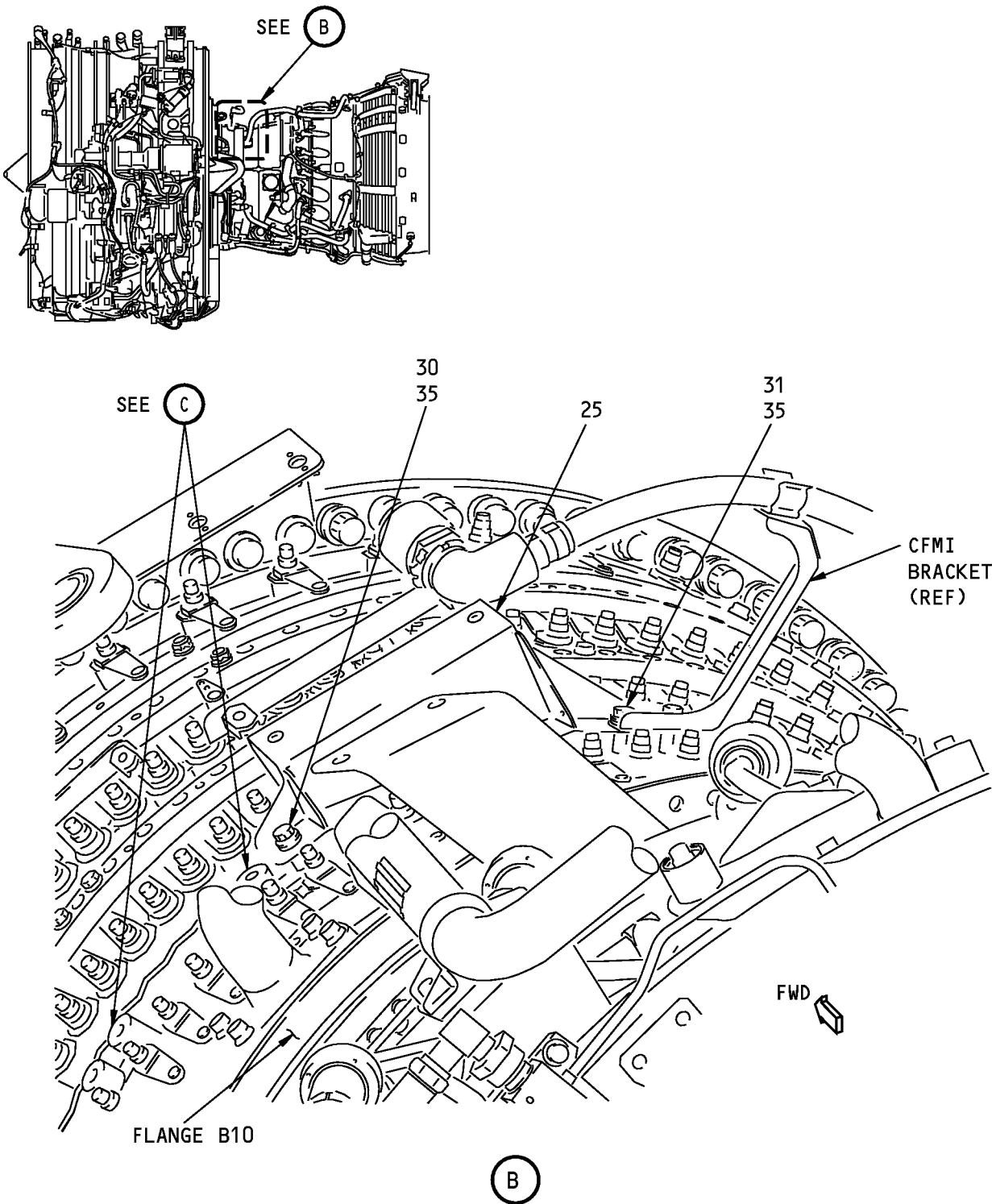

**Bracket Installation - Left Side Core Case**  
**Figure 7-1 (Sheet 2)**

**71-00-02**

**737-600/700/800/900  
POWERPLANT BUILDUP MANUAL**

ITEM NO.	PART NUMBER	NOMENCLATURE	BRACKET LOCATION AND ORIENTATION			QTY
			BRKT OR FLG SIDE	ANGLE FACES	UC	
7-1		<b>BRACKET INSTALLATION - LEFT SIDE CORE CASE (FIGURE 7-1, SHEET 2)</b>  <b>NOTE:</b> IN THIS PROCEDURE, DO NOT TIGHTEN BOLTS UNTIL INSTRUCTED.  CLEAN MATING SURFACES OF BRACKET ASSY (25) AND ENGINE BOSSES FWD OF FLANGE B10 WITH alcohol, B00130 (C1). MAKE SURE YOU REMOVE ALL GREASE AND OTHER CONTAMINANTS.				
25	332A2920-201	. BRACKET ASSY				1
25	332A2920-124	. BRKT ASSY (OPTIONAL TO 332A2920-201)			OPT	-
C1	B00130	. SOLVENT, TT-I-735			CON	AR
		APPLY LIGHT COATING OF Never-Seez NSBT-8N compound, D00006 (C2) TO BOLT (30) AND BOLT (31) THREADS.				
30	BACB30LE4HU1	. BOLT				1
31	BACB30LE4HU2	. BOLT				1
C2	D00006	. COMPOUND, NEVER-SEEZ NSBT-8N			CON	AR
		LOOSELY ATTACH BRACKET ASSY (25) TO ENGINE BOSSES WITH LUBRICATED BOLTS (30, 31) AND WASHERS (35). POSITION UPPER FLANGE OF BRACKET UNDER CFMI BRACKET (IF INSTALLED)				
35	BACW10BP4ACU	. WASHER (CSK)				2

# 71-00-02

P/P BUILDUP FIGURE 7-1

Page 5

Oct 05/2007

D633A106-HXL



737-600/700/800/900  
**POWERPLANT BUILDUP MANUAL**

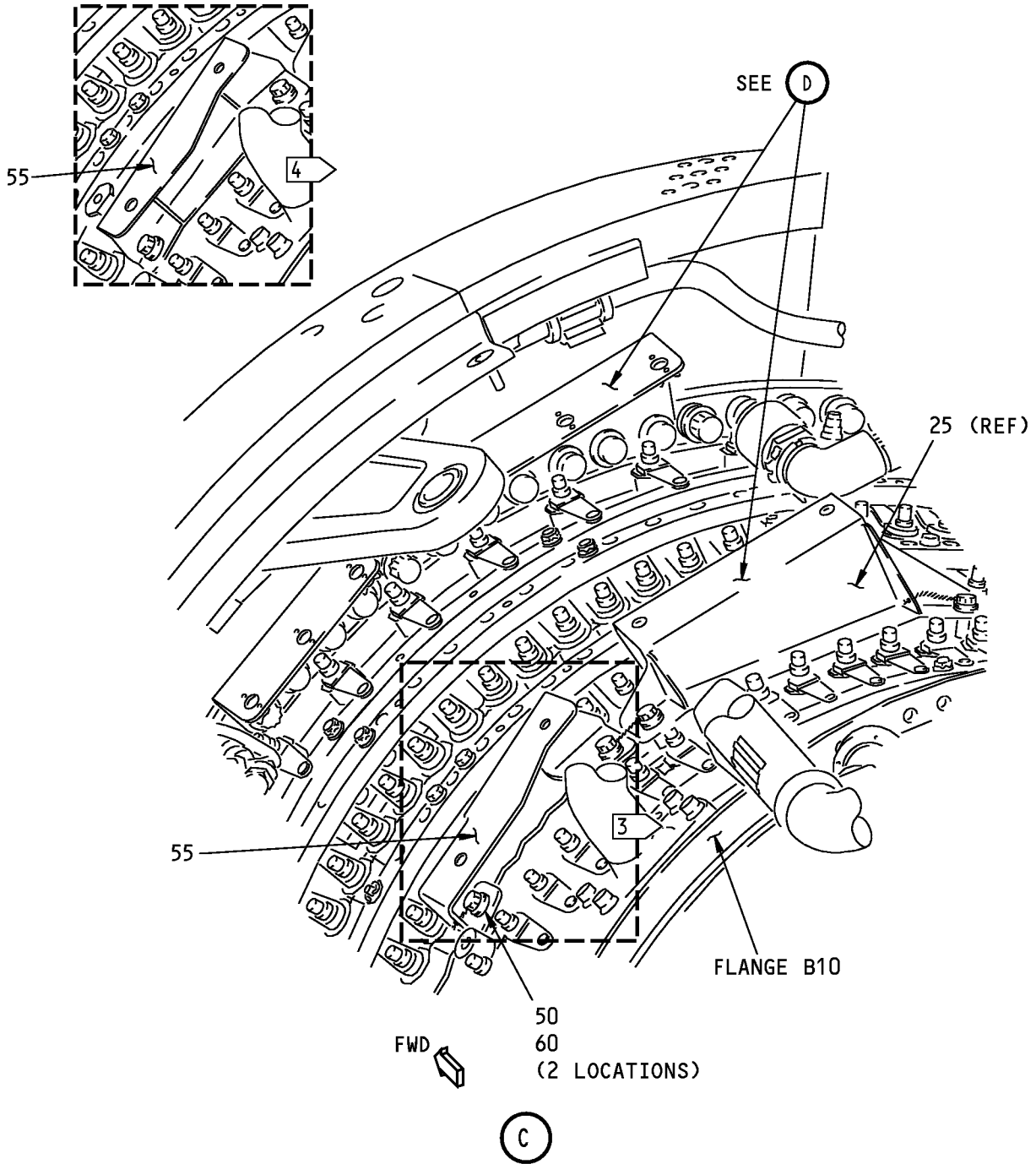

**3** PREFERRED CONFIGURATION

**4** OPTIONAL CONFIGURATION

**Bracket Installation - Left Side Core Case**  
**Figure 7-1 (Sheet 3)**

**71-00-02**

P/P BUILDUP FIGURE 7-1

Page 6

Oct 05/2007

D633A106-HXL

**737-600/700/800/900  
POWERPLANT BUILDUP MANUAL**

ITEM NO.	PART NUMBER	NOMENCLATURE	BRACKET LOCATION AND ORIENTATION			QTY
			BRKT OR FLG SIDE	ANGLE FACES	UC	
7-1		<b>BRACKET INSTALLATION - LEFT SIDE CORE CASE (FIGURE 7-1, SHEET 3)</b>  APPLY LIGHT COATING OF Never-Seez NSBT-8N compound, D00006 (C2) TO BOLT (50) THREADS.				
50	BACB30LE4HU1	. BOLT				2
C2	D00006	. COMPOUND, NEVER-SEEZ NSBT-8N  LOOSELY ATTACH BRACKET ASSY (55) TO ENGINE BOSSES FWD OF FLANGE B10 AT APPROXIMATELY 10 O'CLOCK POSITION WITH LUBRICATED BOLTS (50) AND WASHERS (60).				AR
55	332A2920-225	. BRACKET ASSY				1
60	BACW10BP4ACU	. WASHER (CSK)				2

# 71-00-02

P/P BUILDUP FIGURE 7-1

Page 7

Oct 05/2007

D633A106-HXL

737-600/700/800/900  
**POWERPLANT BUILDUP MANUAL**

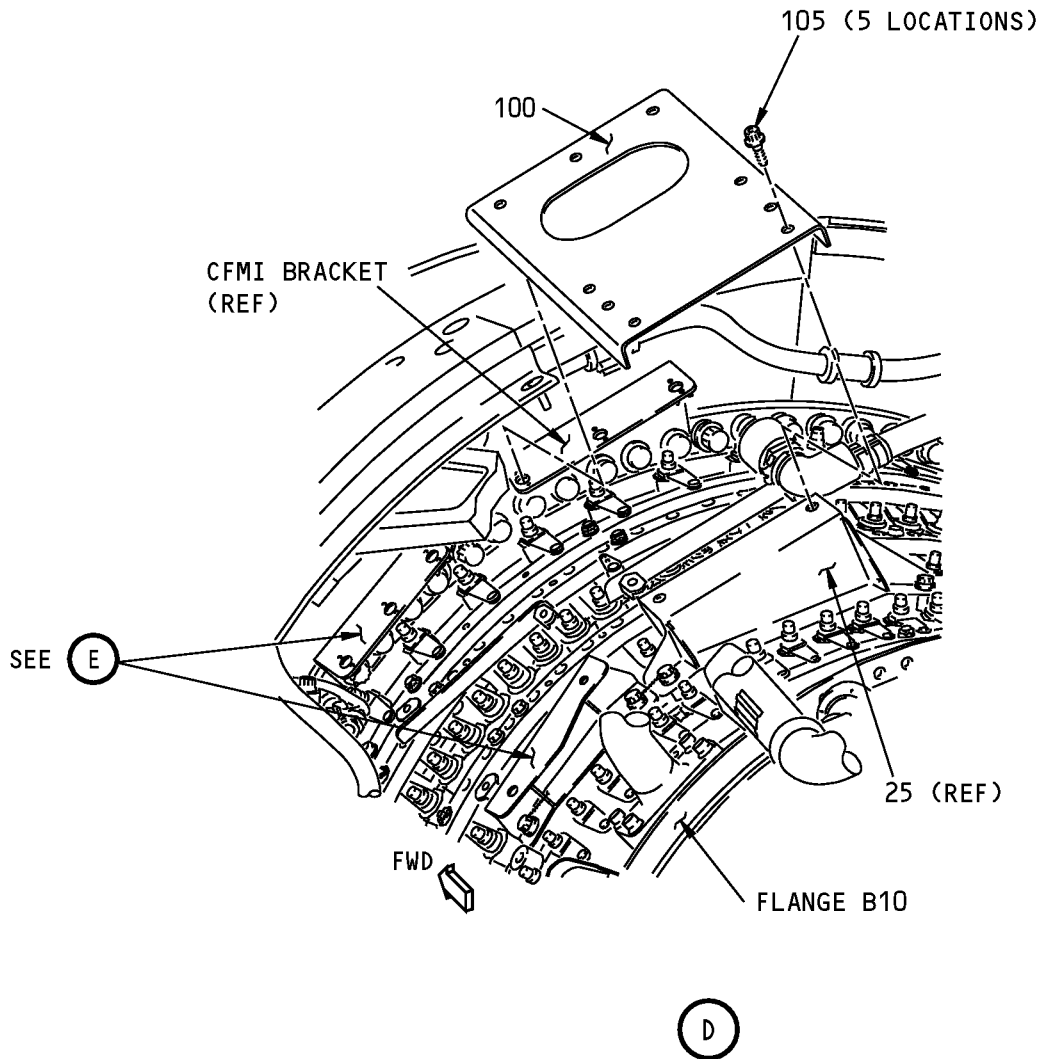

**Bracket Installation - Left Side Core Case**  
**Figure 7-1 (Sheet 4)**

**737-600/700/800/900  
POWERPLANT BUILDUP MANUAL**

ITEM NO.	PART NUMBER	NOMENCLATURE	BRACKET LOCATION AND ORIENTATION			QTY
			BRKT OR FLG SIDE	ANGLE FACES	UC	
7-1		<b>BRACKET INSTALLATION - LEFT SIDE CORE CASE (FIGURE 7-1, SHEET 4)</b>  CLEAN MATING SURFACES OF CFMI BRACKET, BRACKET ASSY (100) AND BRACKET ASSY (25) WITH alcohol, B00130 (C1).				
100	332A2920-199	. BRACKET ASSY				1
100	332A2920-143	. BRKT ASSY (OPTIONAL TO 332A2920-199)			OPT	-
C1	B00130	. SOLVENT, TT-I-735			CON	AR
		ATTACH BRACKET ASSY (100) TO BRACKET BRACKET ASSY (25) AND CFMI BRACKET USING BOLTS (105).				
105	BACB30ZF4-06	. BOLT  TIGHTEN BOLTS (105) TO 70-80 POUND-INCHES (7.9-9.0 NEWTON METERS).				5

# 71-00-02

P/P BUILDUP FIGURE 7-1

Page 9

Oct 05/2007

D633A106-HXL

737-600/700/800/900  
**POWERPLANT BUILDUP MANUAL**

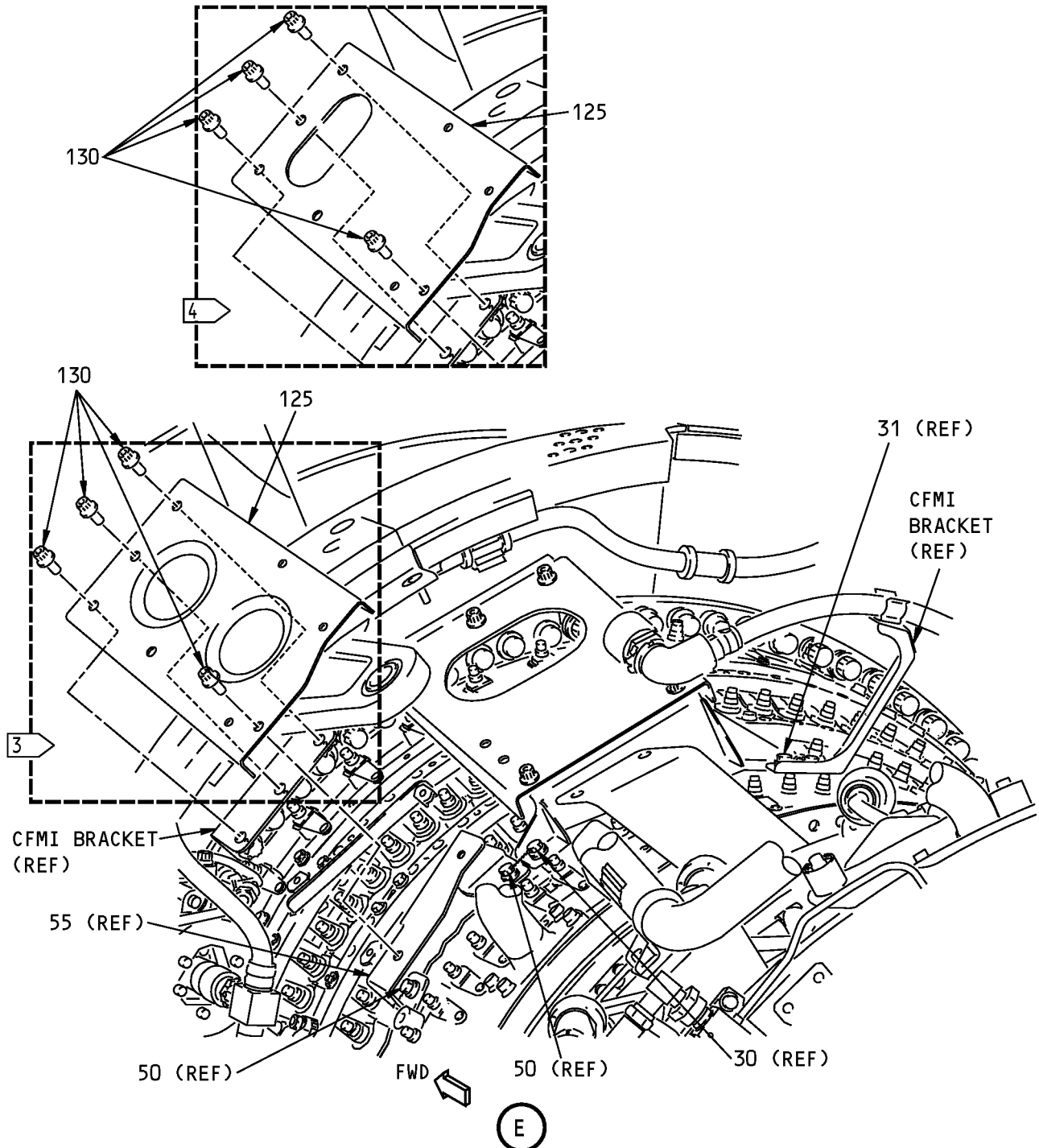

- 3 PREFERRED CONFIGURATION
- 4 OPTIONAL CONFIGURATION

**Bracket Installation - Left Side Core Case**  
**Figure 7-1 (Sheet 5)**

**71-00-02**  
P/P BUILDUP FIGURE 7-1  
Page 10  
Oct 05/2007

**737-600/700/800/900  
POWERPLANT BUILDUP MANUAL**

ITEM NO.	PART NUMBER	NOMENCLATURE	BRACKET LOCATION AND ORIENTATION			QTY
			BRKT OR FLG SIDE	ANGLE FACES	UC	
7-1		<b>BRACKET INSTALLATION - LEFT SIDE CORE CASE (FIGURE 7-1, SHEET 5)</b>  ATTACH BRACKET ASSY (125) TO BRACKET ASSY (55) AND CFMI BRACKET USING BOLTS (130).  . BRACKET ASSY . BRKT ASSY (OPTIONAL TO 332A2920-185) . BOLT  TIGHTEN BOLTS (130) TO 110-120 POUND-INCHES (12.4-13.6 NEWTON METERS).  TIGHTEN BOLT (30), BOLT (31) AND BOLTS (50) TO 90-110 POUND-INCHES (10.2-12.4 NEWTON METERS). SECURE BOLTS USING safety cable kit, G50375 (C3) OR lockwire, G01912 (C4) AS SHOWN.  <b>NOTE:</b> IF OPT BRACKET ASSY (55) IS INSTALLED, SECURE LOWER BOLT (50) TO STIFFENER ABOVE BOLT.				
125	332A2920-185	. BRACKET ASSY			OPT	1
125	332A2920-39	. BRKT ASSY (OPTIONAL TO 332A2920-185)				-
130	BACB30ZF4-06	. BOLT				4
C3	G50375	. SAFETY CABLE, BACC13AT3K18			CON	3
C4	G01912	. LOCKWIRE, MS20995NC32			CON	AR

# 71-00-02

P/P BUILDUP FIGURE 7-1

Page 11

Feb 05/2008

D633A106-HXL

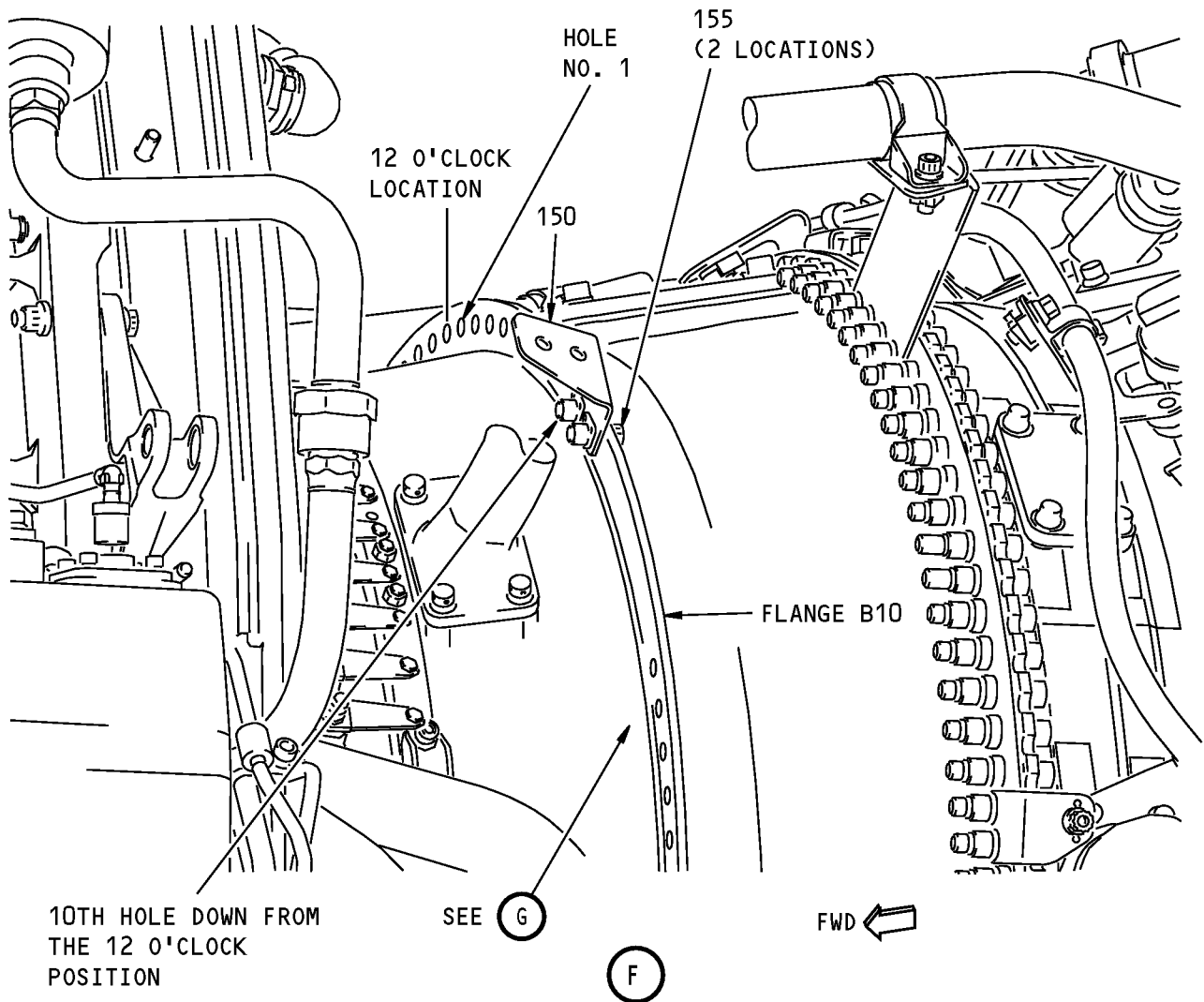
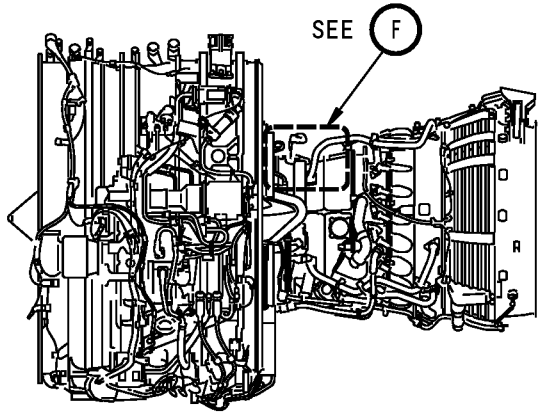

**Bracket Installation - Left Side Core Case  
Figure 7-1 (Sheet 6)**

**71-00-02**

P/P BUILDUP FIGURE 7-1

Page 12

Oct 05/2007

D633A106-HXL

**737-600/700/800/900  
POWERPLANT BUILDUP MANUAL**

ITEM NO.	PART NUMBER	NOMENCLATURE	BRACKET LOCATION AND ORIENTATION			QTY
			BRKT OR FLG SIDE	ANGLE FACES	UC	
7-1		<b>BRACKET INSTALLATION - LEFT SIDE CORE CASE (FIGURE 7-1, SHEET 6)</b>  ATTACH BRACKET ASSY (150) TO LEFT BOTTOM 2 HOLES ON TOP HOLE SEGMENT (10TH AND 11TH HOLE DOWN FROM 12 O'CLOCK) ON FLANGE B10. USE BOLTS (155).				
150	332A2910-111	. BRACKET ASSY	FWD	FWD		1
155	BACB30ZF4-07	. BOLT  TIGHTEN BOLTS (155) TO 110-120 POUND-INCHES (12.4-13.6 NEWTON METERS).				2

# 71-00-02

P/P BUILDUP FIGURE 7-1

Page 13

Oct 05/2007

D633A106-HXL



737-600/700/800/900  
**POWERPLANT BUILDUP MANUAL**

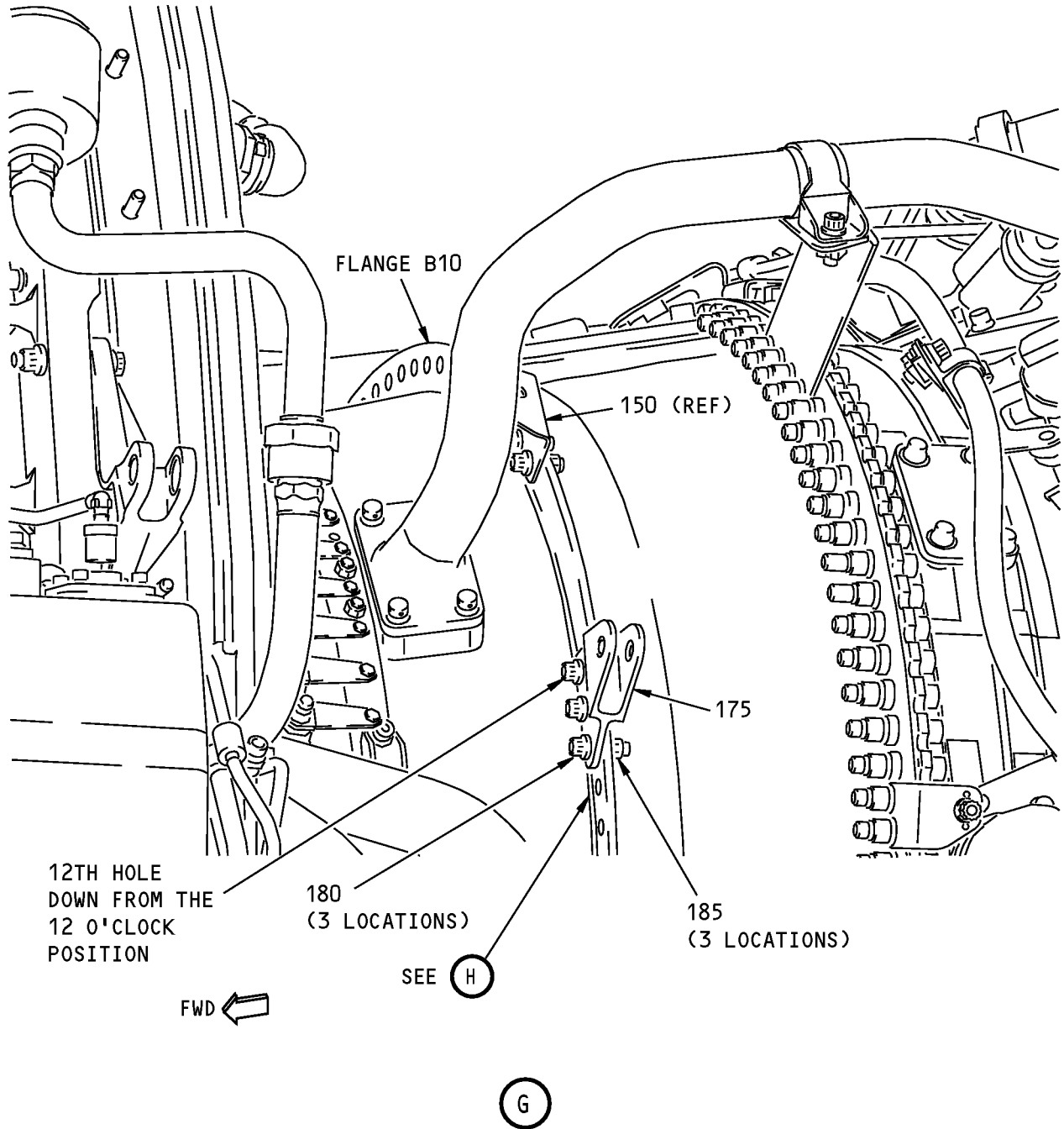

**Bracket Installation - Left Side Core Case**  
**Figure 7-1 (Sheet 7)**

**71-00-02**

P/P BUILDUP FIGURE 7-1

Page 14

Oct 05/2007

D633A106-HXL

**737-600/700/800/900  
POWERPLANT BUILDUP MANUAL**

ITEM NO.	PART NUMBER	NOMENCLATURE	BRACKET LOCATION AND ORIENTATION			QTY
			BRKT OR FLG SIDE	ANGLE FACES	UC	
7-1		<p><b>BRACKET INSTALLATION - LEFT SIDE CORE CASE (FIGURE 7-1, SHEET 7)</b></p> <p>ATTACH BRACKET ASSY (175) TO FIRST THREE HOLES IN CENTER BOLT HOLE SEGMENT (12TH, 13TH AND 14TH HOLE DOWN FROM 12 O'CLOCK) ON FLANGE B10. USE BOLTS (180) AND NUTS (185).</p>				
175	332A2920-179	. BRACKET ASSY	FWD			1
175	332A2930-17	. BRACKET ASSY <sup>[1]</sup>	FWD		OPT	-
180	BACB30ZF4-12	. BOLT (FWD SIDE)				3
180	BACB30ZF4-10	. BOLT (FWD SIDE) <sup>[1]</sup>			OPT	-
185	AS3485-10	. NUT				3
		<p>TIGHTEN BOLTS (180) TO 110-120 POUND-INCHES (12.4-13.6 NEWTON METERS).</p> <p>*[1] 332A2930-17 BRACKET ASSY (175) TOGETHER WITH BACB30ZF4-10 BOLTS (180) OPTIONAL TO 332A2920-179 BRACKET ASSY (175) TOGETHER WITH BACB30ZF4-12 BOLTS (180).</p>				

**71-00-02**

P/P BUILDUP FIGURE 7-1

Page 15

Oct 05/2007

D633A106-HXL

**POWERPLANT BUILDUP MANUAL**

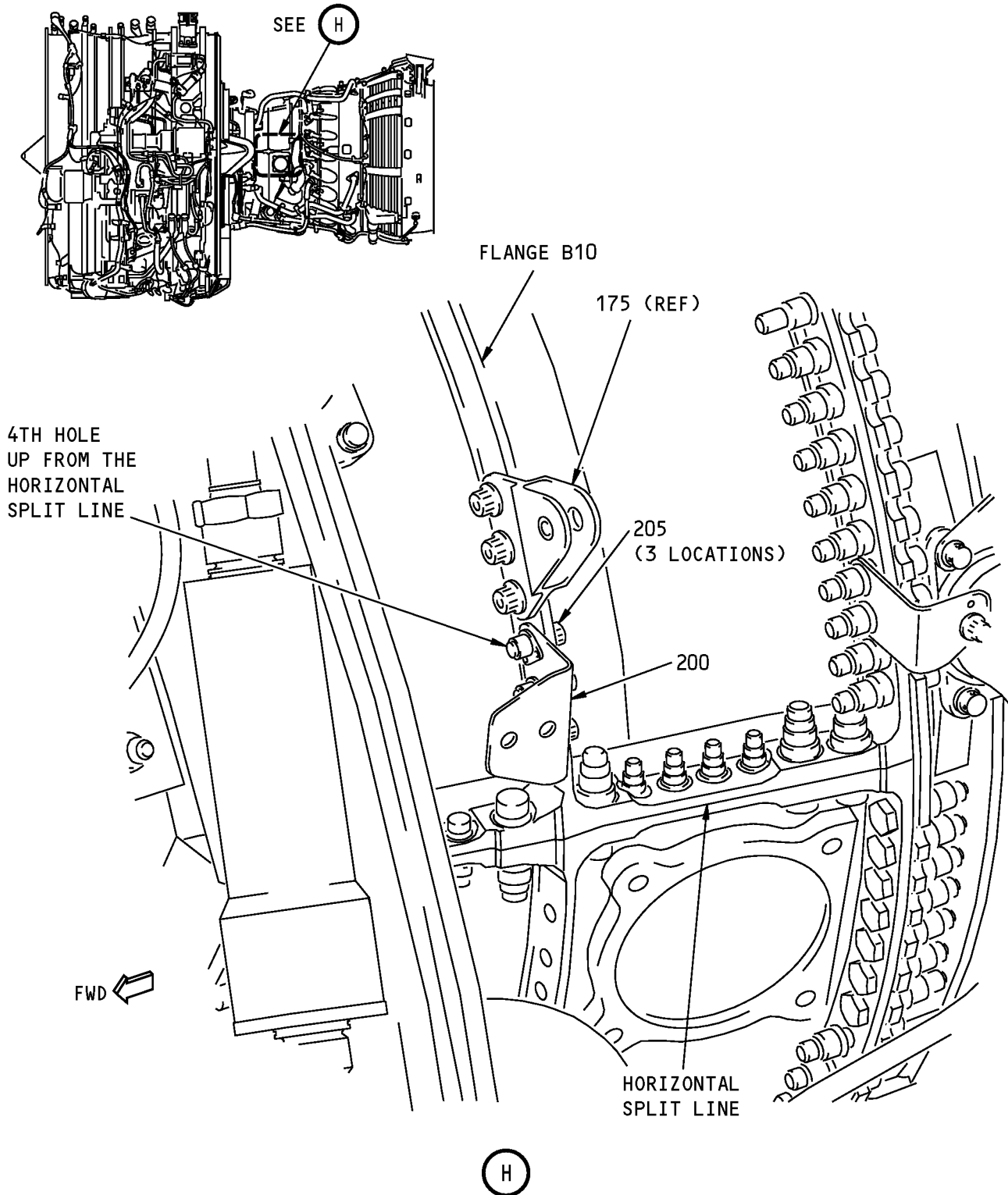

**Bracket Installation - Left Side Core Case  
Figure 7-1 (Sheet 8)**

**71-00-02**

P/P BUILDUP FIGURE 7-1

Page 16

Oct 05/2007

D633A106-HXL

**737-600/700/800/900  
POWERPLANT BUILDUP MANUAL**

ITEM NO.	PART NUMBER	NOMENCLATURE	BRACKET LOCATION AND ORIENTATION			QTY
			BRKT OR FLG SIDE	ANGLE FACES	UC	
7-1		<b>BRACKET INSTALLATION - LEFT SIDE CORE CASE (FIGURE 7-1, SHEET 8)</b>  ATTACH BRACKET ASSY (200) TO 2ND, 3RD AND 4TH HOLES UP FROM HORIZONTAL SPLIT LINE ON FLANGE B10. USE BOLTS (205).				
200	332A2910-128	. BRACKET ASSY	FWD	FWD		1
205	BACB30ZF4-07	. BOLT  TIGHTEN BOLTS (205) TO 110-120 POUND-INCHES (12.4-13.6 NEWTON METERS).				3

# 71-00-02

P/P BUILDUP FIGURE 7-1

Page 17

Oct 05/2007

D633A106-HXL

737-600/700/800/900  
**POWERPLANT BUILDUP MANUAL**

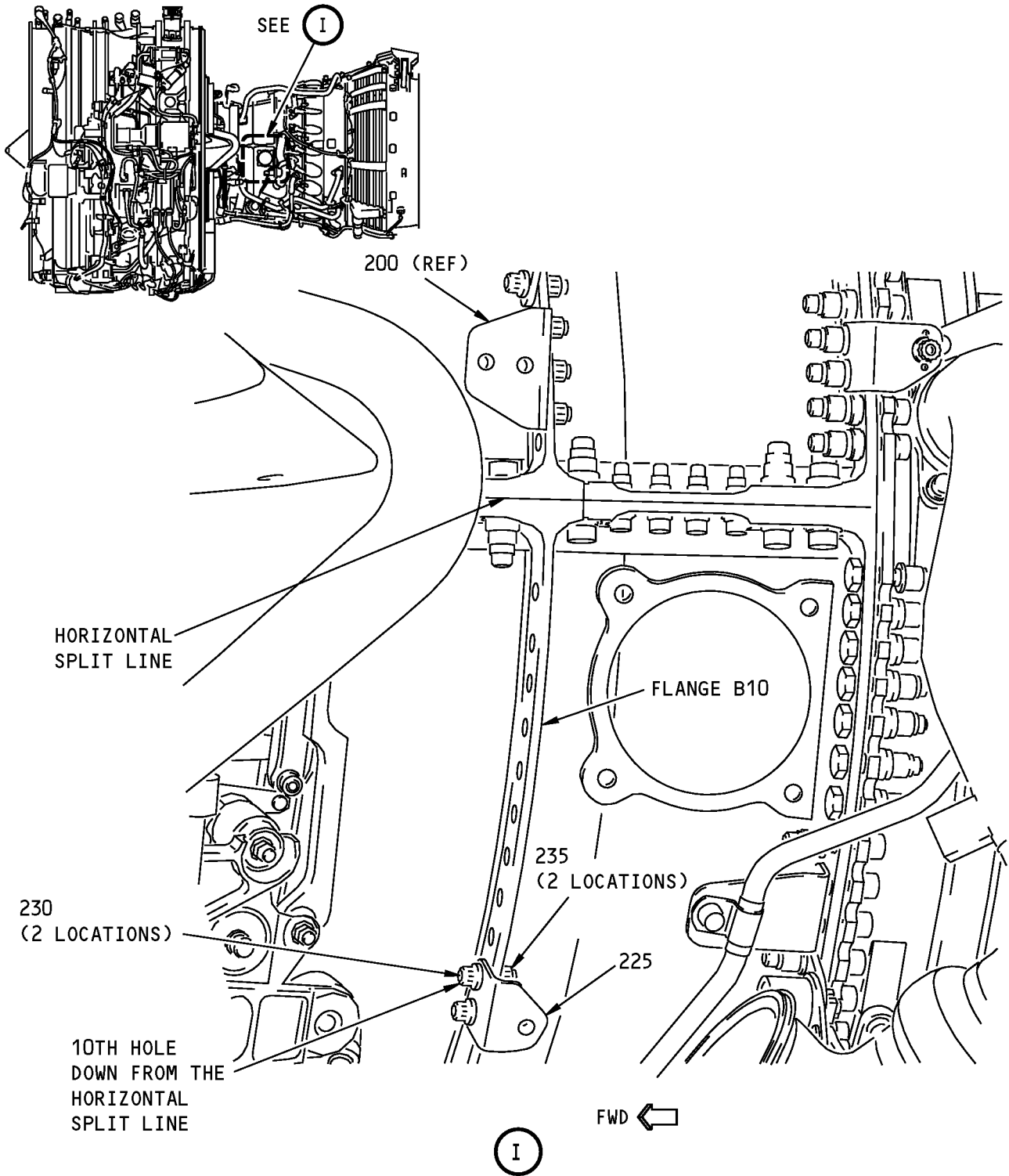

**Bracket Installation - Left Side Core Case**  
**Figure 7-1 (Sheet 9)**

**71-00-02**

P/P BUILDUP FIGURE 7-1

Page 18

Oct 05/2007

D633A106-HXL

**737-600/700/800/900  
POWERPLANT BUILDUP MANUAL**

ITEM NO.	PART NUMBER	NOMENCLATURE	BRACKET LOCATION AND ORIENTATION			QTY
			BRKT OR FLG SIDE	ANGLE FACES	UC	
7-1		<b>BRACKET INSTALLATION - LEFT SIDE CORE CASE (FIGURE 7-1, SHEET 9)</b>  ATTACH BRACKET ASSY (225) TO 10TH AND 11TH HOLE DOWN FROM HORIZONTAL SPLIT LINE ON FLANGE B10. USE BOLTS (230) AND NUTS (235).				
225	332A2910-11	. BRACKET ASSY	FWD	AFT		1
230	BACB30ZF4-08	. BOLT (FWD SIDE)				2
235	AS3485-10	. NUT				2
		TIGHTEN BOLTS (230) TO 110-120 POUND-INCHES (12.4-13.6 NEWTON METERS).				

# 71-00-02

P/P BUILDUP FIGURE 7-1

Page 19

Oct 05/2007

D633A106-HXL

**737-600/700/800/900  
POWERPLANT BUILDUP MANUAL**

**THIS SHEET NOT USED**

**Bracket Installation - Left Side Core Case  
Figure 7-1 (Sheet 10)**

**71-00-02**

P/P BUILDUP FIGURE 7-1

Page 20

Oct 05/2007

D633A106-HXL

737-600/700/800/900  
POWERPLANT BUILDUP MANUAL

ITEM NO.	PART NUMBER	NOMENCLATURE	UC	QTY
7-1		BRACKET INSTALLATION - LEFT SIDE CORE CASE (FIGURE 7-1, SHEET 10)  THIS SHEET NOT USED		

**71-00-02**

P/P BUILDUP FIGURE 7-1

Page 21

Oct 05/2007

D633A106-HXL



**737-600/700/800/900  
POWERPLANT BUILDUP MANUAL**

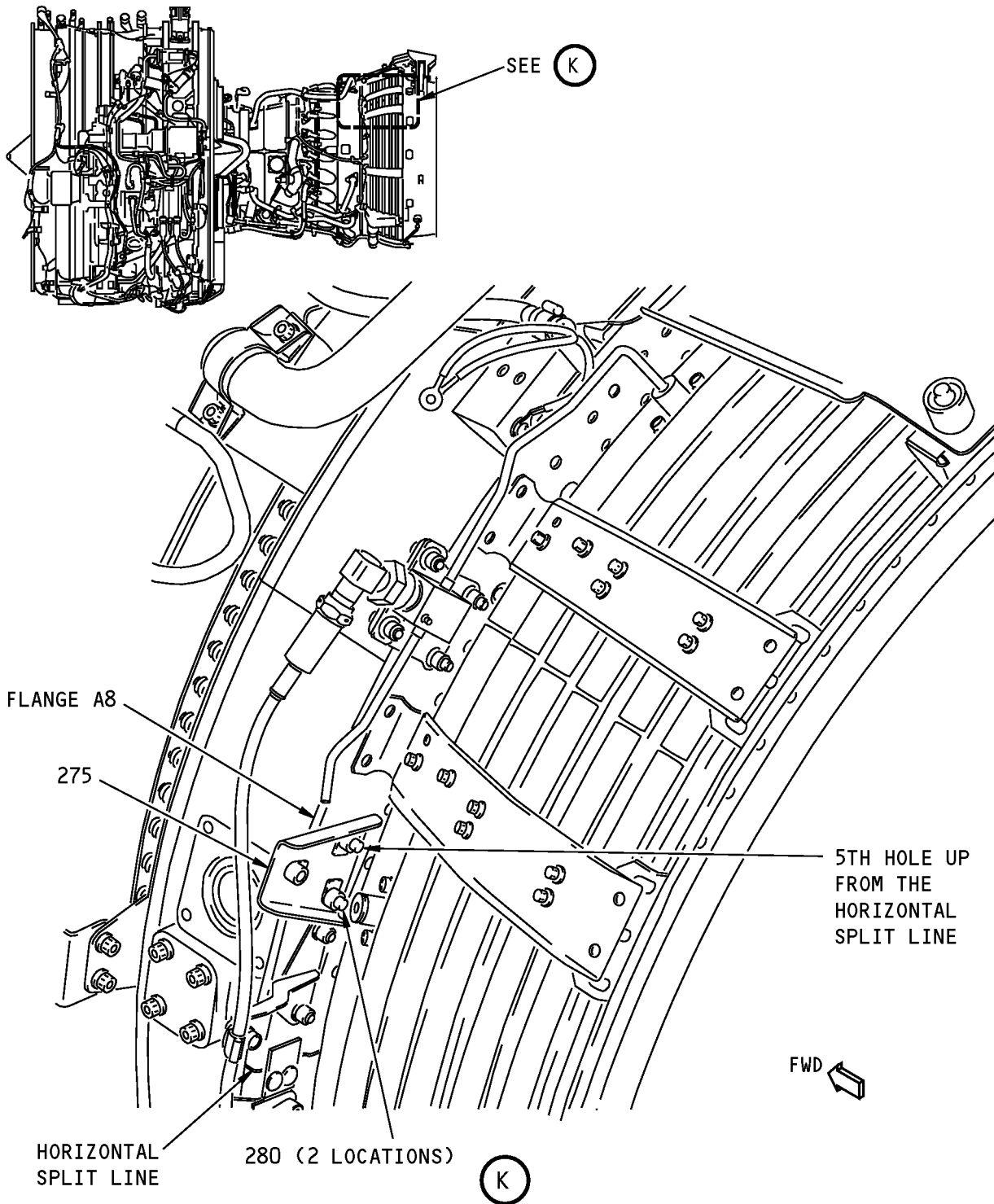

**Bracket Installation - Left Side Core Case  
Figure 7-1 (Sheet 11)**

**71-00-02**  
P/P BUILDUP FIGURE 7-1  
Page 22  
Oct 05/2007

D633A106-HXL

## POWERPLANT BUILDUP MANUAL

ITEM NO.	PART NUMBER	NOMENCLATURE	BRACKET LOCATION AND ORIENTATION			QTY
			BRKT OR FLG SIDE	ANGLE FACES	UC	
7-1		<b>BRACKET INSTALLATION - LEFT SIDE CORE CASE</b> <b>(FIGURE 7-1, SHEET 11)</b> ATTACH BRACKET ASSY (275) TO 4TH AND 5TH HOLES UP FROM HORIZONTAL SPLIT LINE ON FLG A8 USING BOLTS (280).				
275	332A2910-106	. BRACKET ASSY	AFT			1
280	BACB30ZF4-06	. BOLT (FWD SIDE)  TIGHTEN BOLTS (280) TO 110-120 POUND-INCHES (12.4-13.6 NEWTON METERS).				2

**71-00-02**

P/P BUILDUP FIGURE 7-1

Page 23

Oct 05/2007

D633A106-HXL

737-600/700/800/900  
**POWERPLANT BUILDUP MANUAL**

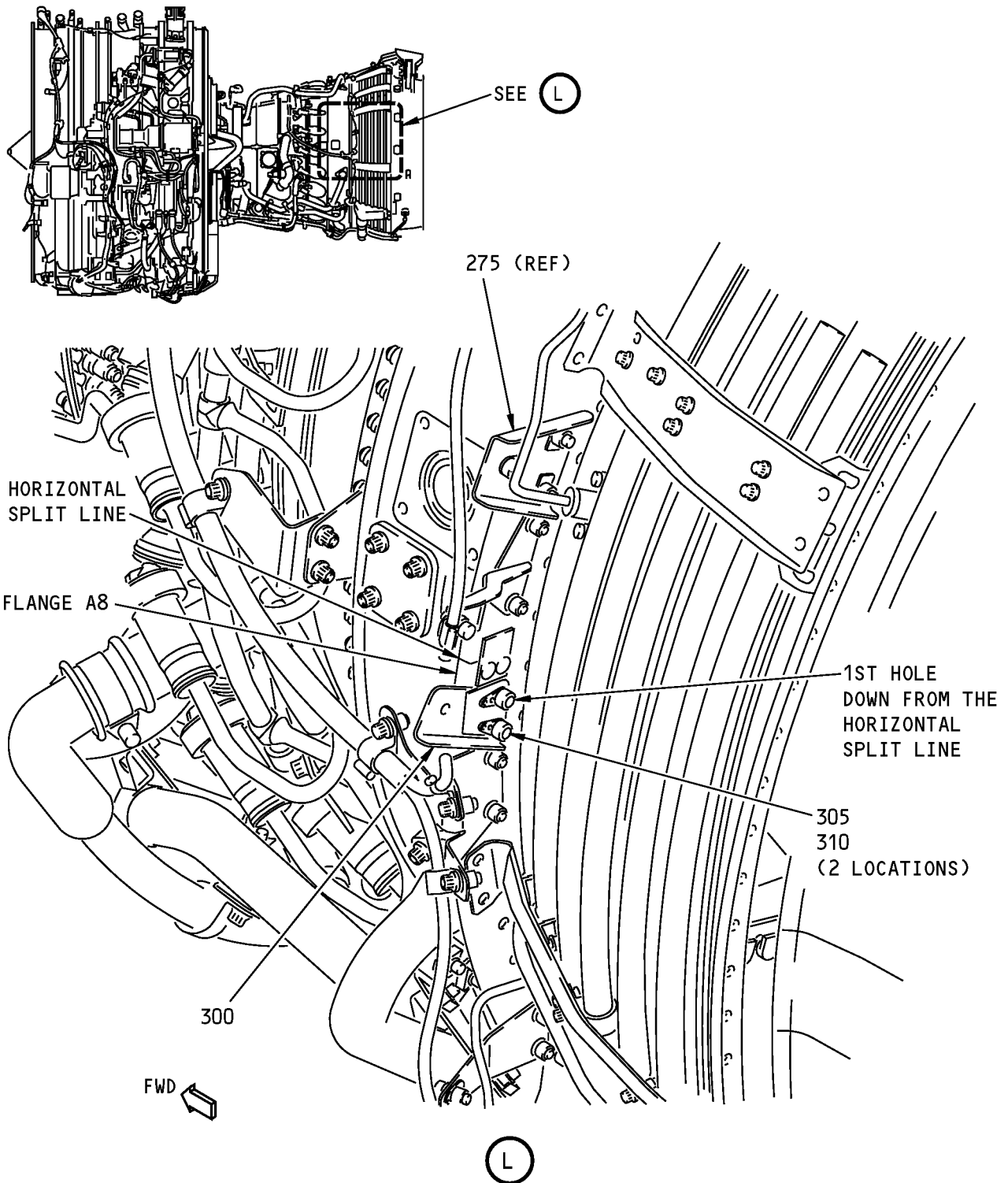

**Bracket Installation - Left Side Core Case**  
**Figure 7-1 (Sheet 12)**

**71-00-02**

P/P BUILDUP FIGURE 7-1

Page 24

Oct 05/2007

D633A106-HXL

**737-600/700/800/900  
POWERPLANT BUILDUP MANUAL**

ITEM NO.	PART NUMBER	NOMENCLATURE	BRACKET LOCATION AND ORIENTATION			QTY
			BRKT OR FLG SIDE	ANGLE FACES	UC	
7-1		<b>BRACKET INSTALLATION - LEFT SIDE CORE CASE (FIGURE 7-1, SHEET 12)</b>  ATTACH BRACKET ASSY (300) TO 1ST AND 2ND HOLES DOWN FROM HORIZONTAL SPLIT LINE ON FLANGE A8 USING BOLTS (305) AND NUTS (310).				
300	332A2910-39	. BRACKET ASSY	AFT			1
305	BACB30ZF4-07	. BOLT (FWD SIDE)				2
310	AS3485-10	. NUT				2
		TIGHTEN BOLTS (305) TO 110-120 POUND-INCHES (12.4-13.6 NEWTON METERS).				

# 71-00-02

P/P BUILDUP FIGURE 7-1

Page 25

Oct 05/2007

D633A106-HXL

737-600/700/800/900  
**POWERPLANT BUILDUP MANUAL**

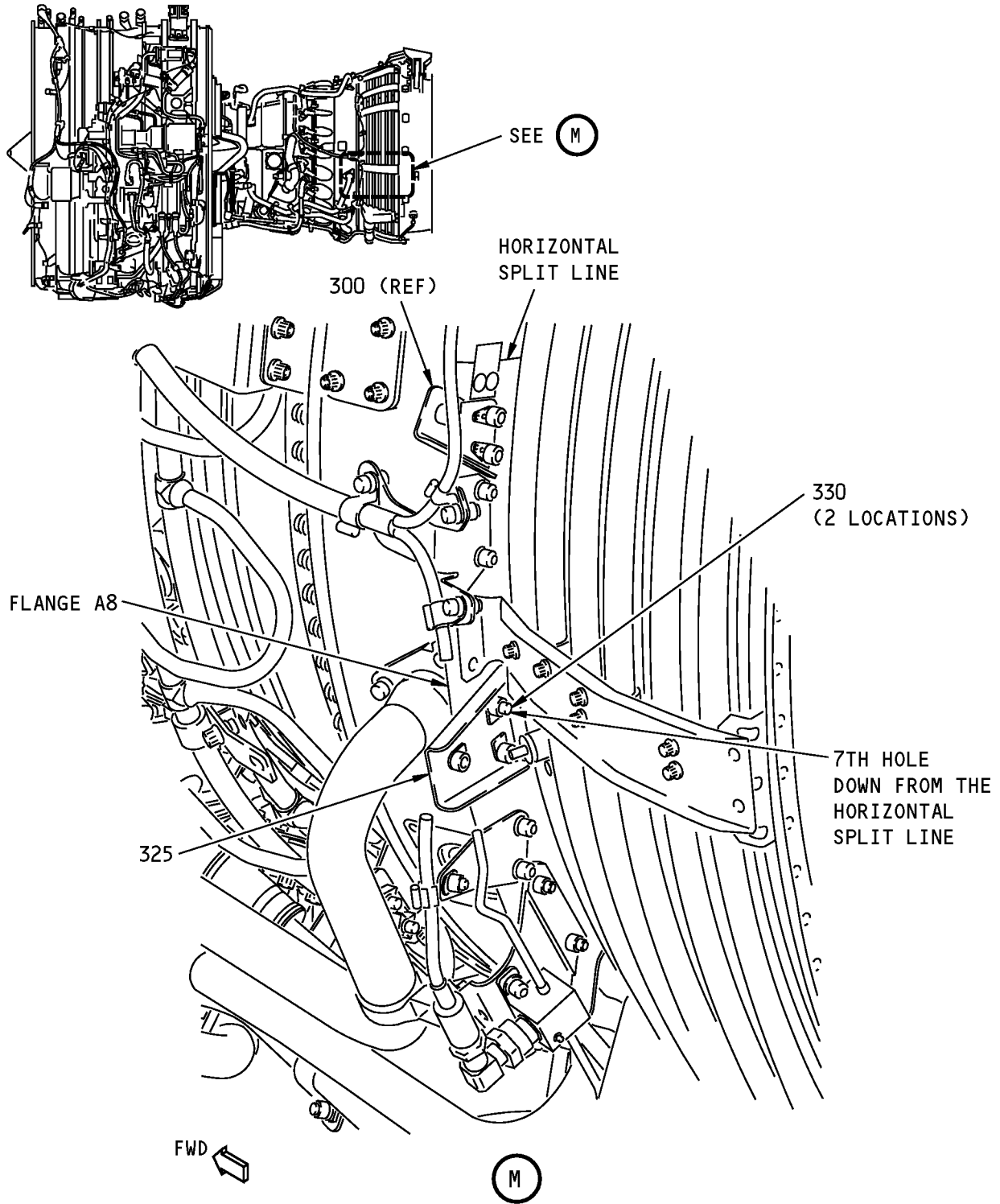

**Bracket Installation - Left Side Core Case**  
**Figure 7-1 (Sheet 13)**

**71-00-02**

P/P BUILDUP FIGURE 7-1

Page 26

Oct 05/2007

D633A106-HXL

**737-600/700/800/900  
POWERPLANT BUILDUP MANUAL**

ITEM NO.	PART NUMBER	NOMENCLATURE	BRACKET LOCATION AND ORIENTATION			QTY
			BRKT OR FLG SIDE	ANGLE FACES	UC	
7-1		<b>BRACKET INSTALLATION - LEFT SIDE CORE CASE (FIGURE 7-1, SHEET 13)</b>  ATTACH BRACKET ASSY (325) TO 7TH AND 8TH HOLES DOWN FROM HORIZONTAL SPLIT LINE ON FLANGE A8 USING BOLTS (330).				
325	332A2910-108	. BRACKET ASSY	AFT			1
330	BACB30ZF4-06	. BOLT (FWD SIDE)  TIGHTEN BOLTS (330) TO 110-120 POUND-INCHES (12.4-13.6 NEWTON METERS).				2

# 71-00-02

P/P BUILDUP FIGURE 7-1

Page 27

Oct 05/2007

D633A106-HXL

737-600/700/800/900  
**POWERPLANT BUILDUP MANUAL**

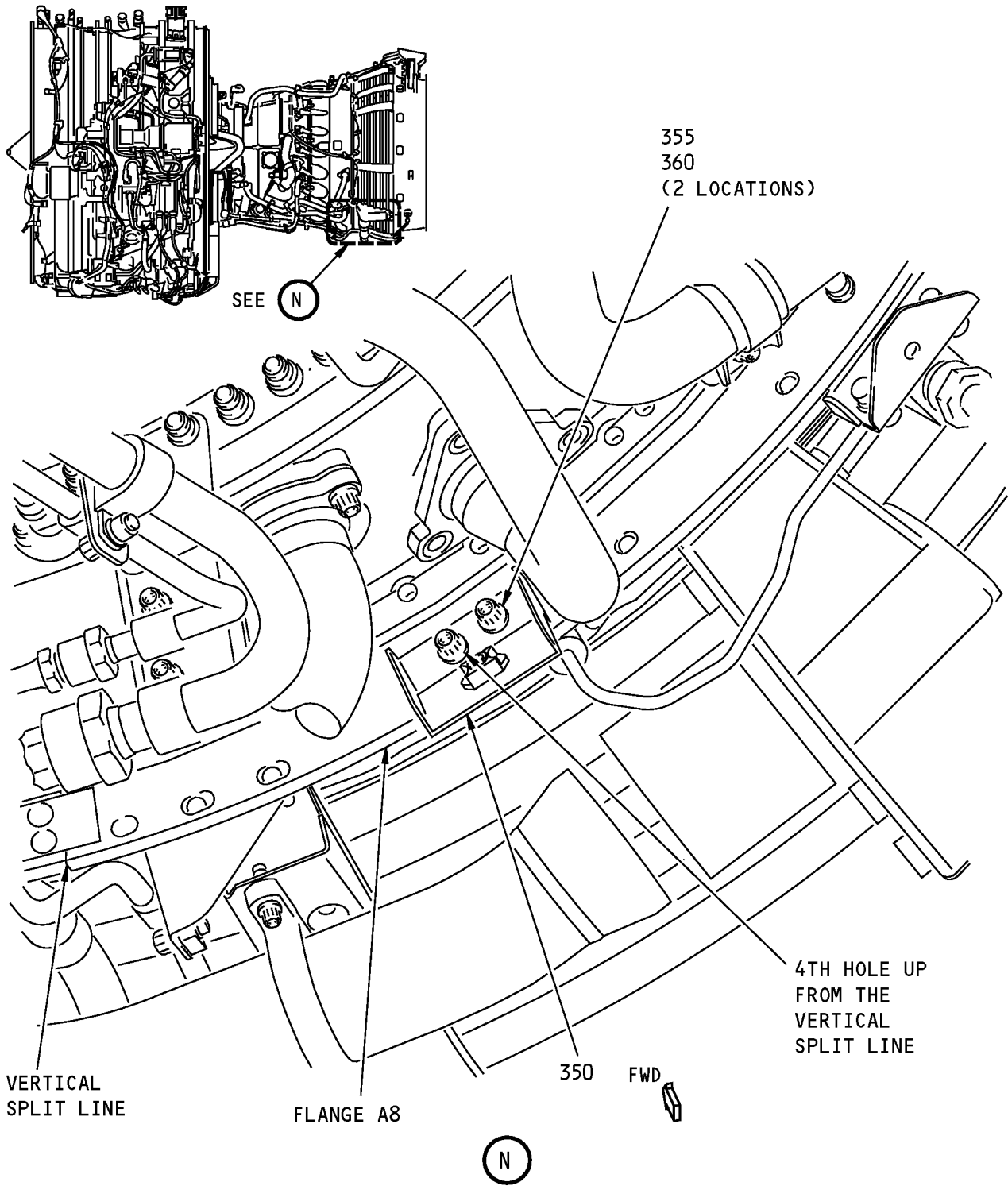

**Bracket Installation - Left Side Core Case**  
**Figure 7-1 (Sheet 14)**

**71-00-02**

P/P BUILDUP FIGURE 7-1  
Page 28  
Oct 05/2007

D633A106-HXL

**737-600/700/800/900  
POWERPLANT BUILDUP MANUAL**

ITEM NO.	PART NUMBER	NOMENCLATURE	BRACKET LOCATION AND ORIENTATION			QTY
			BRKT OR FLG SIDE	ANGLE FACES	UC	
7-1		<b>BRACKET INSTALLATION - LEFT SIDE CORE CASE (FIGURE 7-1, SHEET 14)</b>  ATTACH BRACKET ASSY (350) TO 4TH AND 5TH HOLES UP FROM VERTICAL SPLIT LINE AT 6 O'CLOCK POSITION ON FLANGE A8. USE BOLTS (355) AND NUTS (360).				
350	332A2920-55	. BRACKET ASSY	FWD			1
355	BACB30ZF4-07	. BOLT (FWD SIDE)				2
360	AS3485-10	. NUT				2
		TIGHTEN BOLTS (355) TO 110-120 POUND-INCHES (12.4-13.6 NEWTON METERS).				

# 71-00-02

P/P BUILDUP FIGURE 7-1

Page 29

Oct 05/2007

D633A106-HXL



**FIGURE 8-1**

**BRACKET INSTALLATION - RIGHT SIDE CORE  
CASE**

**REF QEC TASK NO.: 8**

**REF DWG: 332A2900**

**NOTE:** ALL STANDARDS AND ATTACHING HARDWARE FOR THIS FIGURE WILL BE PACKAGED  
IN QEC TASK NO. 110.

**71-00-02**

P/P BUILDUP FIGURE 8-1

Page 1

Oct 05/2007

D633A106-HXL

737-600/700/800/900  
**POWERPLANT BUILDUP MANUAL**

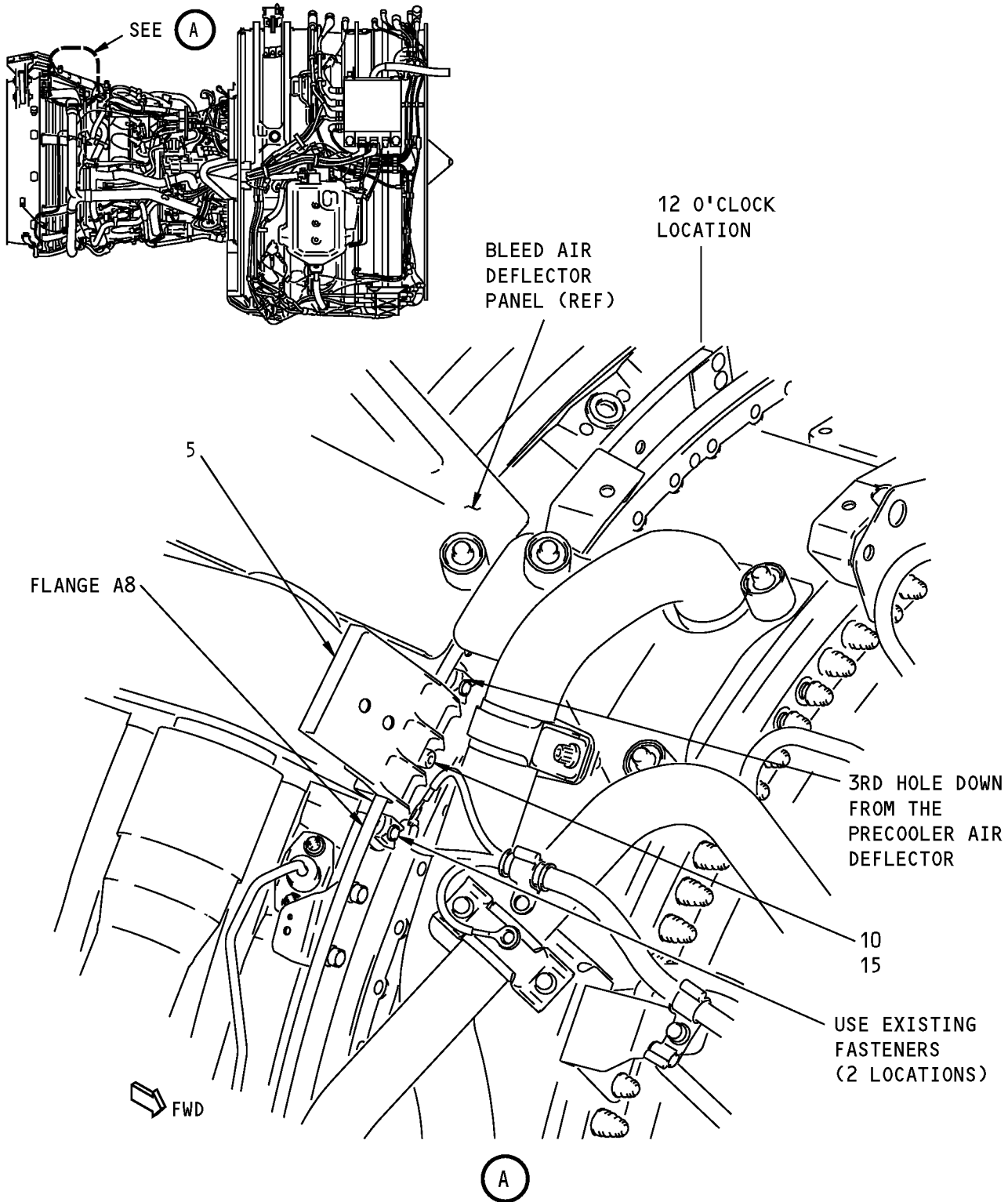

**Bracket Installation - Right Side Core Case**  
**Figure 8-1 (Sheet 1)**

**71-00-02**

P/P BUILDUP FIGURE 8-1

Page 2

Oct 05/2007

D633A106-HXL

**737-600/700/800/900  
POWERPLANT BUILDUP MANUAL**

ITEM NO.	PART NUMBER	NOMENCLATURE	BRACKET LOCATION AND ORIENTATION			QTY
			BRKT OR FLG SIDE	ANGLE FACES	UC	
8-1		<b>BRACKET INSTALLATION - RIGHT SIDE CORE CASE (FIGURE 8-1, SHEET 1)</b>  REMOVE EXISTING CFMI FASTENERS FROM 3RD, 4TH AND 5TH HOLES DOWN FROM PRECOOLER AIR DEFLECTOR ON FLANGE A8. CLEAN MATING SURFACES OF BRACKET ASSY (5) AND ENGINE FLANGE WITH alcohol, B00130 (C1). MAKE SURE YOU REMOVE ALL GREASE AND OTHER CONTAMINANTS.				
5 C1	332A2920-230 B00130	. BRACKET ASSY . SOLVENT, TT-I-735  ATTACH BRACKET ASSY (5) TO ENGINE FLANGE A8. USE EXISTING CFMI FASTENERS ON OUTBOARD HOLES AND BOLT (10), WASHER (15) AND EXISTING CFMI NUT AT CENTER LOCATION.	FWD		CON	1 AR
10 15	BACB30ZF4-08 NAS1149C0432R	. BOLT (FWD SIDE) . WASHER (UNDER BOLT HEAD)  TIGHTEN BOLT (10) AND EXISTING CFMI BOLTS TO 110-120 POUND-INCHES (12.4-13.6 NEWTON METERS).				1 1

# 71-00-02

P/P BUILDUP FIGURE 8-1

Page 3

Oct 05/2007

D633A106-HXL

737-600/700/800/900  
**POWERPLANT BUILDUP MANUAL**

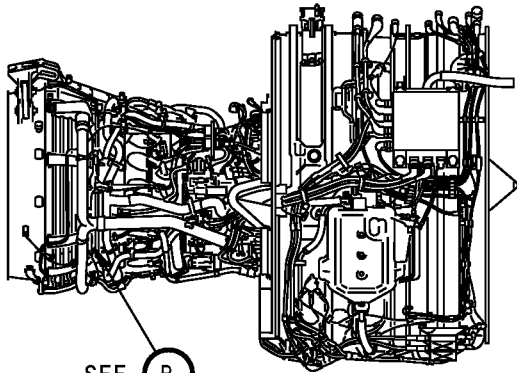

SEE **B**

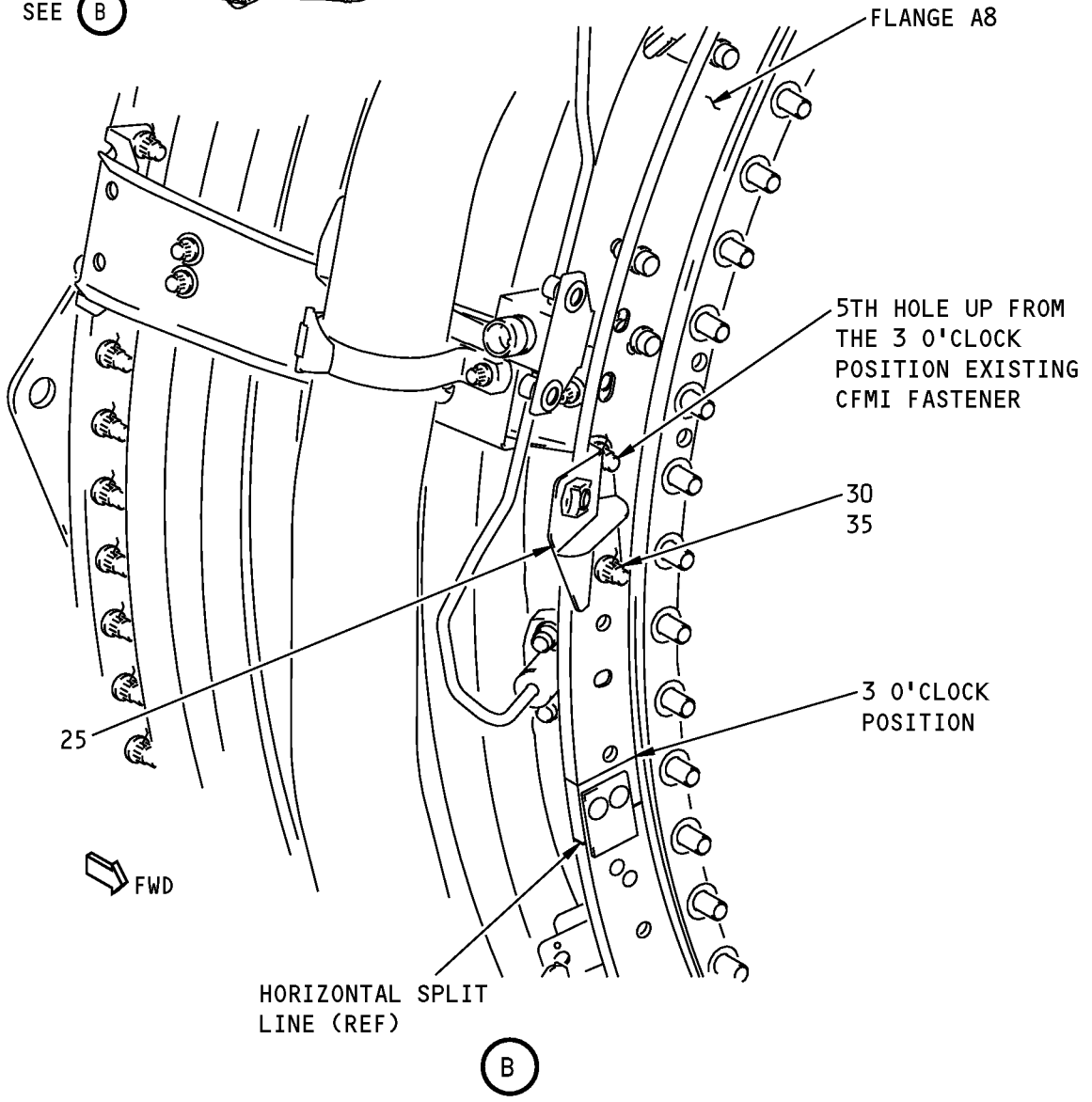

**Bracket Installation - Right Side Core Case**  
**Figure 8-1 (Sheet 2)**

**71-00-02**

## POWERPLANT BUILDUP MANUAL

ITEM NO.	PART NUMBER	NOMENCLATURE	BRACKET LOCATION AND ORIENTATION			QTY
			BRKT OR FLG SIDE	ANGLE FACES	UC	
8-1		<b>BRACKET INSTALLATION - RIGHT SIDE CORE CASE</b> <b>(FIGURE 8-1, SHEET 2)</b>  REMOVE EXISTING CFMI FASTENER FROM 5TH HOLE UP FROM 3 O'CLOCK POSITION ON FLANGE A8.  ATTACH BRACKET ASSY (25) TO 5TH HOLE UP FROM 3 O'CLOCK POSITION ON FLANGE A8 USING EXISTING CFMI FASTENER AND 4TH HOLE UP USING BOLT (30) AND NUT (35).  . BRACKET ASSY . BOLT . NUT  TIGHTEN BOLTS (30) TO 110-120 POUND-INCHES (12.4-13.6 NEWTON METERS).				
25	332A2921-1	. BRACKET ASSY	FWD			1
30	BACB30ZF4-07	. BOLT				1
35	AS3485-10	. NUT				1

**71-00-02**

P/P BUILDUP FIGURE 8-1

Page 5

Oct 05/2007

D633A106-HXL

**737-600/700/800/900  
POWERPLANT BUILDUP MANUAL**

**THIS SHEET NOT USED**

**Bracket Installation - Right Side Core Case  
Figure 8-1 (Sheet 3)**

**71-00-02**

P/P BUILDUP FIGURE 8-1

Page 6

Oct 05/2007

D633A106-HXL

737-600/700/800/900  
POWERPLANT BUILDUP MANUAL

ITEM NO.	PART NUMBER	NOMENCLATURE	UC	QTY
8-1		BRACKET INSTALLATION - RIGHT SIDE CORE CASE (FIGURE 8-1, SHEET 3)  THIS SHEET NOT USED		

**71-00-02**

P/P BUILDUP FIGURE 8-1

Page 7

Oct 05/2007

D633A106-HXL

**737-600/700/800/900  
POWERPLANT BUILDUP MANUAL**

**THIS SHEET NOT USED**

**Bracket Installation - Right Side Core Case  
Figure 8-1 (Sheet 4)**

**71-00-02**

P/P BUILDUP FIGURE 8-1

Page 8

Oct 05/2007

D633A106-HXL



737-600/700/800/900  
POWERPLANT BUILDUP MANUAL

ITEM NO.	PART NUMBER	NOMENCLATURE	UC	QTY
8-1		BRACKET INSTALLATION - RIGHT SIDE CORE CASE (FIGURE 8-1, SHEET 4)  THIS SHEET NOT USED		

**71-00-02**

P/P BUILDUP FIGURE 8-1  
Page 9  
Oct 05/2007

D633A106-HXL

737-600/700/800/900  
**POWERPLANT BUILDUP MANUAL**

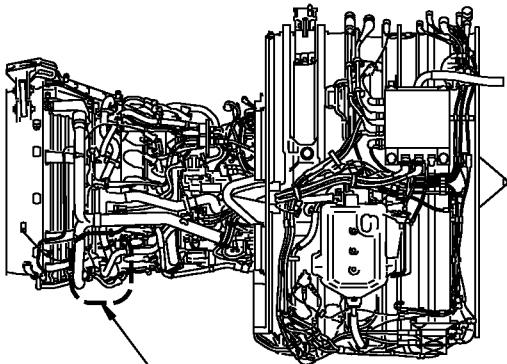

SEE **E**

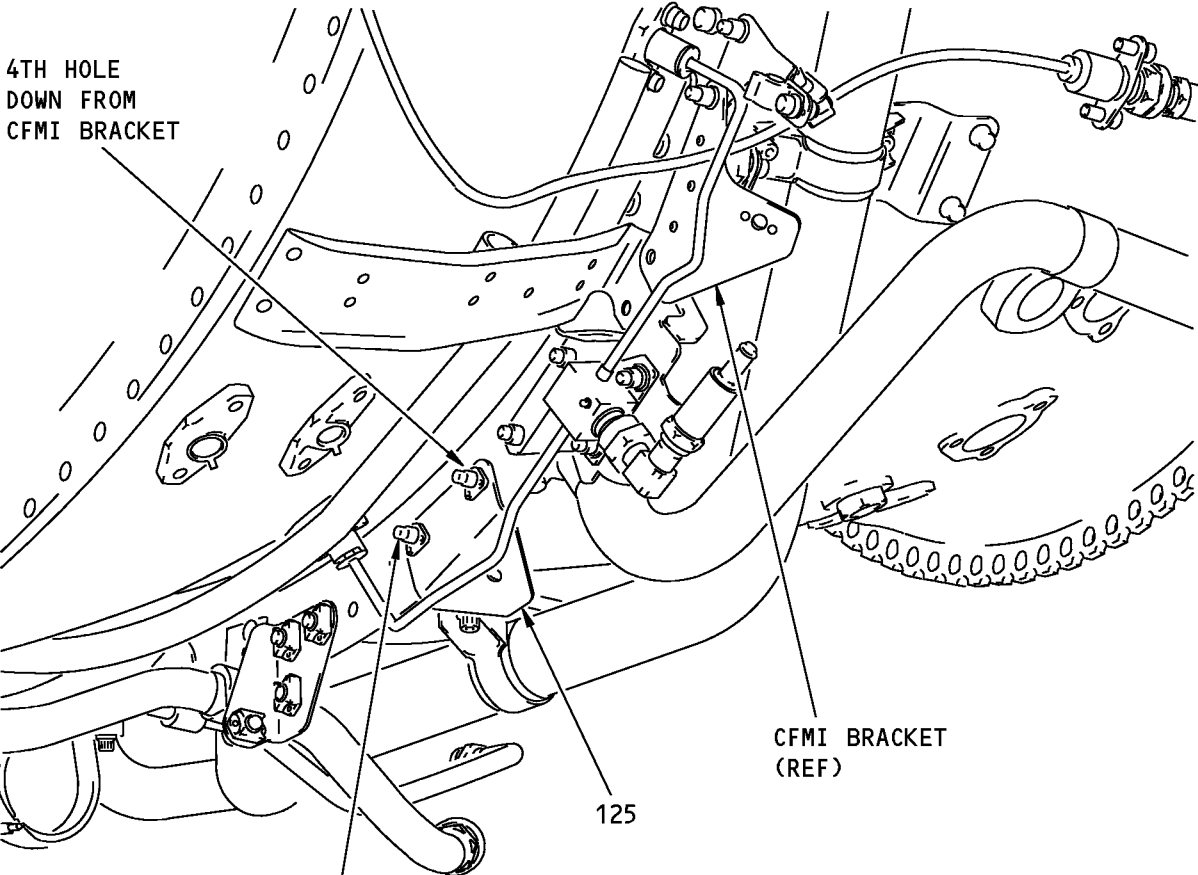

4TH HOLE  
DOWN FROM  
CFMI BRACKET

CFMI BRACKET  
(REF)

125

130  
(2 LOCATIONS)

FWD

**E**

**Bracket Installation - Right Side Core Case**  
**Figure 8-1 (Sheet 5)**

**71-00-02**

## POWERPLANT BUILDUP MANUAL

ITEM NO.	PART NUMBER	NOMENCLATURE	BRACKET LOCATION AND ORIENTATION			QTY
			BRKT OR FLG SIDE	ANGLE FACES	UC	
8-1		<b>BRACKET INSTALLATION - RIGHT SIDE CORE CASE</b> <b>(FIGURE 8-1, SHEET 5)</b> ATTACH BRACKET ASSY (125) TO 4TH AND 5TH HOLES DOWN FROM CFMI BRACKET (REF) ON FLANGE A8. USE BOLTS (130). . BRACKET ASSY . BOLT TIGHTEN BOLTS (130) TO 110-120 POUND-INCHES (12.4-13.6 NEWTON METERS).				
125	332A2911-9		AFT	FWD		1
130	BACB30ZF4-06					2

**71-00-02**

P/P BUILDUP FIGURE 8-1

Page 11

Oct 05/2007

D633A106-HXL

**FIGURE 9-1**

**DRAINS INSTL - LEFT SIDE FAN CASE**

**REF QEC TASK NO.: 9**

**REF DWG: 332A2100**

**NOTE:** ALL STANDARDS AND ATTACHING HARDWARE FOR THIS FIGURE WILL BE PACKAGED IN QEC TASK NO. 110.

**71-00-02**

P/P BUILDUP FIGURE 9-1

Page 1

Oct 05/2007

D633A106-HXL

737-600/700/800/900  
**POWERPLANT BUILDUP MANUAL**

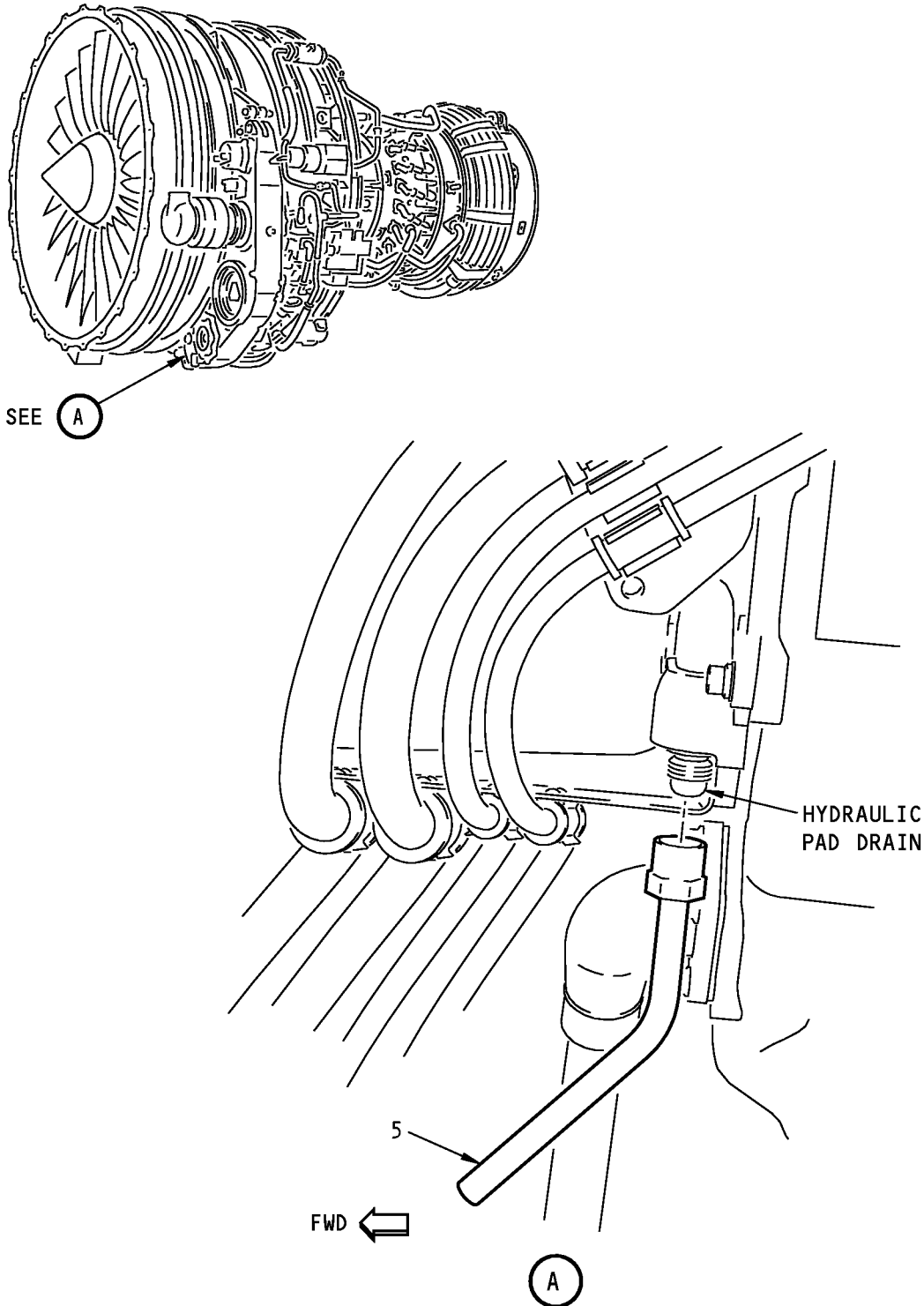

**Drains Installation - Left Side Fan Case**  
**Figure 9-1 (Sheet 1)**

**71-00-02**

**737-600/700/800/900  
POWERPLANT BUILDUP MANUAL**

ITEM NO.	PART NUMBER	NOMENCLATURE	UC	QTY
9-1		<p><b>DRAINS INSTALLATION - LEFT SIDE FAN CASE (FIGURE 9-1, SHEET 1)</b></p> <p><b>NOTE:</b> IN THIS PROCEDURE, DO NOT TIGHTEN SCREWS AND TUBE OR HOSE NUTS TO THE INDICATED TORQUE UNTIL INSTRUCTED. WHEN TIGHTENING TUBE AND HOSE NUTS, USE TWO WRENCHES; ONE TO HOLD THE SPANNER FLATS ON THE NIPPLE AND ONE TO TIGHTEN THE NUT.</p> <p>APPLY grease, D00504 (C1) UNDER HEAD OF BOLTS ATTACHING LOOP CLAMPS TO PREVENT DISTORTION OF CLAMP DURING TORQUING. APPLY LIGHT COATING OF Never-Seez NSBT-8N compound, D00006 (C6) TO THREADS AND UNDERSIDE HEAD OF BOLTS.</p> <p>REMOVE PROTECTIVE CAP FROM NIPPLE ON HYDRAULIC PAD DRAIN. LUBRICATE THREADS OF NIPPLE WITH grease, D00504 (C1).</p>		
C1	D00504	. LUBRICANT, VV-P-236	CON	AR
C6	D00006	. COMPOUND, NEVER-SEEZ NSBT-8N	CON	AR
5	332A2710-3	<p>LOOSELY ATTACH TUBE ASSY (5) TO NIPPLE.</p> <p>. TUBE ASSY</p>		1

**71-00-02**

P/P BUILDUP FIGURE 9-1

Page 3

Oct 05/2007

D633A106-HXL

737-600/700/800/900  
**POWERPLANT BUILDUP MANUAL**

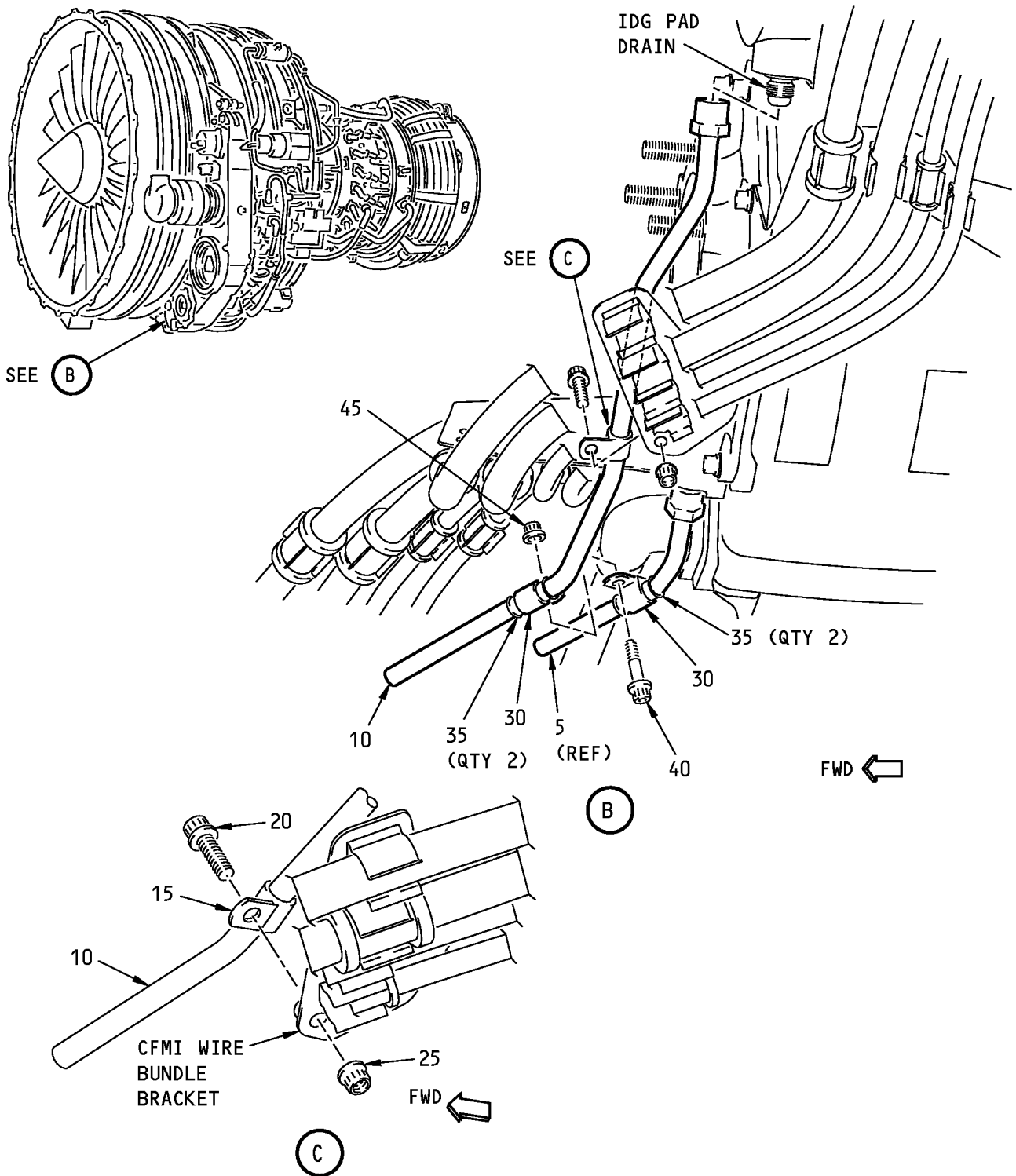

**Drains Installation - Left Side Fan Case**  
**Figure 9-1 (Sheet 2)**

**71-00-02**

P/P BUILDUP FIGURE 9-1

Page 4

Oct 05/2007

D633A106-HXL

**737-600/700/800/900  
POWERPLANT BUILDUP MANUAL**

ITEM NO.	PART NUMBER	NOMENCLATURE	UC	QTY
9-1		<b>DRAINS INSTALLATION - LEFT SIDE FAN CASE (FIGURE 9-1, SHEET 2)</b>		
		REMOVE PROTECTIVE CAP FROM NIPPLE ON IDG PAD DRAIN AND LUBRICATE THREADS OF NIPPLE WITH grease, D00504 (C1). APPLY LIGHT COATING OF Never-Seez NSBT-8N compound, D00006 (C6) TO THREADS AND UNDERSIDE HEAD OF BOLTS.		
C1	D00504	. LUBRICANT, VV-P-236	CON	AR
C6	D00006	. COMPOUND, NEVER-SEEZ NSBT-8N	CON	AR
		ROUTE TUBE ASSY (10) INBOARD OF CFMI WIRE BUNDLE BRACKET AND LOOSELY ATTACH TO NIPPLE.		
10	332A2710-1	. TUBE ASSY		1
		APPLY LIGHT COATING OF Never-Seez NSBT-8N compound, D00006 (C6) TO THREADS AND UNDERSIDE HEAD OF BOLT. LOOSELY ATTACH TUBE ASSY (10) TO CFMI WIRE BUNDLE BRACKET WITH CLAMP (15), BOLT (20) AND NUT (25).		
15	J1221G06	. CLAMP		1
20	BACB30ZF4-09	. BOLT		1
25	AS3485-10	. NUT		1
C6	D00006	. COMPOUND, NEVER-SEEZ NSBT-8N	CON	AR
		APPLY LIGHT COATING OF Never-Seez NSBT-8N compound, D00006 (C6) TO THREADS AND UNDERSIDE HEAD OF BOLT. LOOSELY INSTALL FLOATING CLAMPS (30) BETWEEN TUBE ASSY (5) AND (10) AT APPROXIMATE LOCATION SHOWN. USE CLAMPSHELLS (35), BOLT (40) AND NUT (45).		
30	J1221G06	. CLAMP		2
35	BACC10GT2-06	. CLAMPSHELL		4
35	9352M41P03	. CLAMPSHELL (OPTIONAL)	OPT	-
40	BACB30ZF4-08	. BOLT		1
45	AS3485-10	. NUT		1
C6	D00006	. COMPOUND, NEVER-SEEZ NSBT-8N	CON	AR
		ADJUST TUBE ASSY (5) AND (10) TO BEST POSITION. MAKE SURE PRELOAD AT ALL CLAMP POINTS IS NOT MORE THAN 10 POUNDS (44.5 NEWTONS).		
		TIGHTEN TUBE ASSY (5) AND (10) TO 257-284 POUND-INCHES (29.0-32.0 NEWTON METERS). BACK OFF NUT TO RELAX TORQUE, THEN RETIGHTEN.		
		TIGHTEN BOLTS (20) AND (40) TO 110-120 POUND-INCHES (12.4-13.6 NEWTON METERS).		

# 71-00-02

P/P BUILDUP FIGURE 9-1

Page 5

Oct 05/2007

D633A106-HXL



737-600/700/800/900  
**POWERPLANT BUILDUP MANUAL**

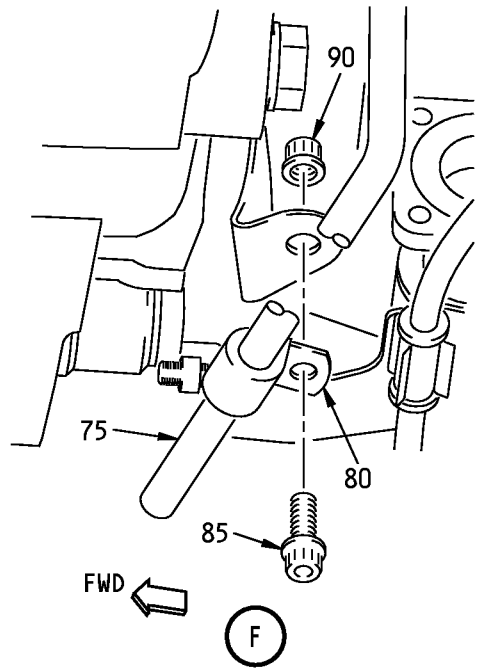
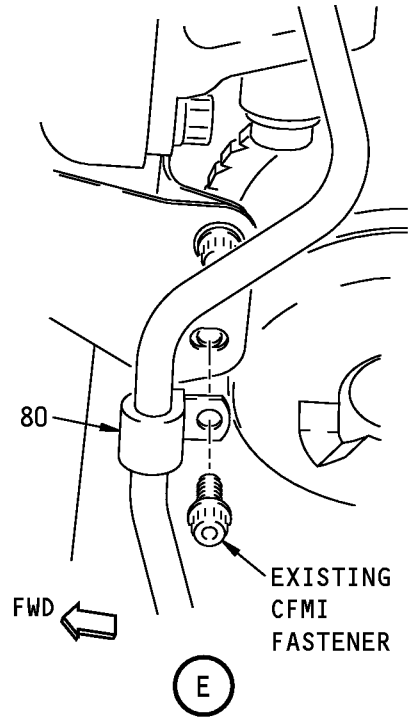
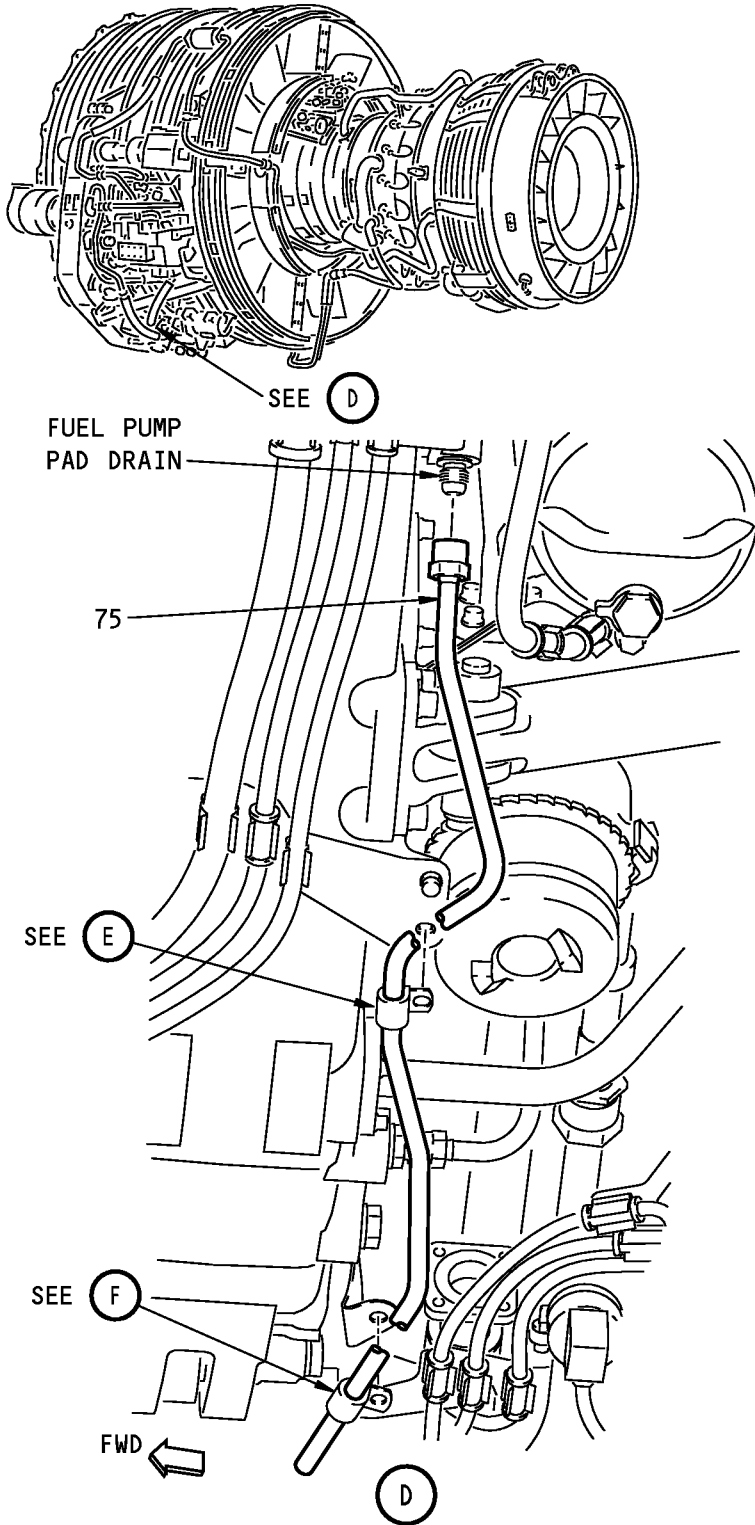

**Drains Installation - Left Side Fan Case**  
**Figure 9-1 (Sheet 3)**

**71-00-02**

P/P BUILDUP FIGURE 9-1

Page 6

Oct 05/2007

**737-600/700/800/900  
POWERPLANT BUILDUP MANUAL**

ITEM NO.	PART NUMBER	NOMENCLATURE	UC	QTY
9-1		<b>DRAINS INSTALLATION - LEFT SIDE FAN CASE (FIGURE 9-1, SHEET 3)</b>		
C1	D00504	REMOVE PROTECTIVE CAP FROM NIPPLE ON FUEL PUMP PAD DRAIN AND LUBRICATE THREADS OF NIPPLE WITH grease, D00504 (C1). . LUBRICANT, VV-P-236	CON	AR
75	332A2710-36	LOOSELY ATTACH TUBE ASSY (75) TO NIPPLE. . TUBE ASSY		1
80	J1221G06	APPLY LIGHT COATING OF Never-Seez NSBT-8N compound, D00006 (C6) TO THREADS AND UNDERSIDE HEAD OF BOLT. AT 2 LOCATIONS, LOOSELY ATTACH TUBE ASSY (75) TO ENGINE BRACKETS ON AFT SIDE OF AGB. USE CLAMP (80) AND EXISTING CFMI FASTENERS AT UPPER LOCATION AND CLAMP (80), BOLT (85) AND NUT (90) AT LOWER LOCATION. . CLAMP		2
85	BACB30ZF4-08	. BOLT		1
90	AS3485-10	. NUT		1
C6	D00006	. COMPOUND, NEVER-SEEZ NSBT-8N  ADJUST TUBE ASSY (75) TO BEST POSITION. MAKE SURE PRELOAD AT ALL CLAMP POINTS IS NOT MORE THAN 10 POUNDS (44.5 NEWTONS).  TIGHTEN TUBE ASSY (75) TO 257-284 POUND-INCHES (29.0-32.0 NEWTON METERS). BACK OFF NUT TO RELAX TORQUE, THEN RETIGHTEN.  TIGHTEN BOLT (85) AND EXISTING CFMI FASTENER TO 110-120 POUND-INCHES (12.4-13.6 NEWTON METERS).	CON	AR

**71-00-02**

P/P BUILDUP FIGURE 9-1

Page 7

Oct 05/2007

D633A106-HXL

737-600/700/800/900  
**POWERPLANT BUILDUP MANUAL**

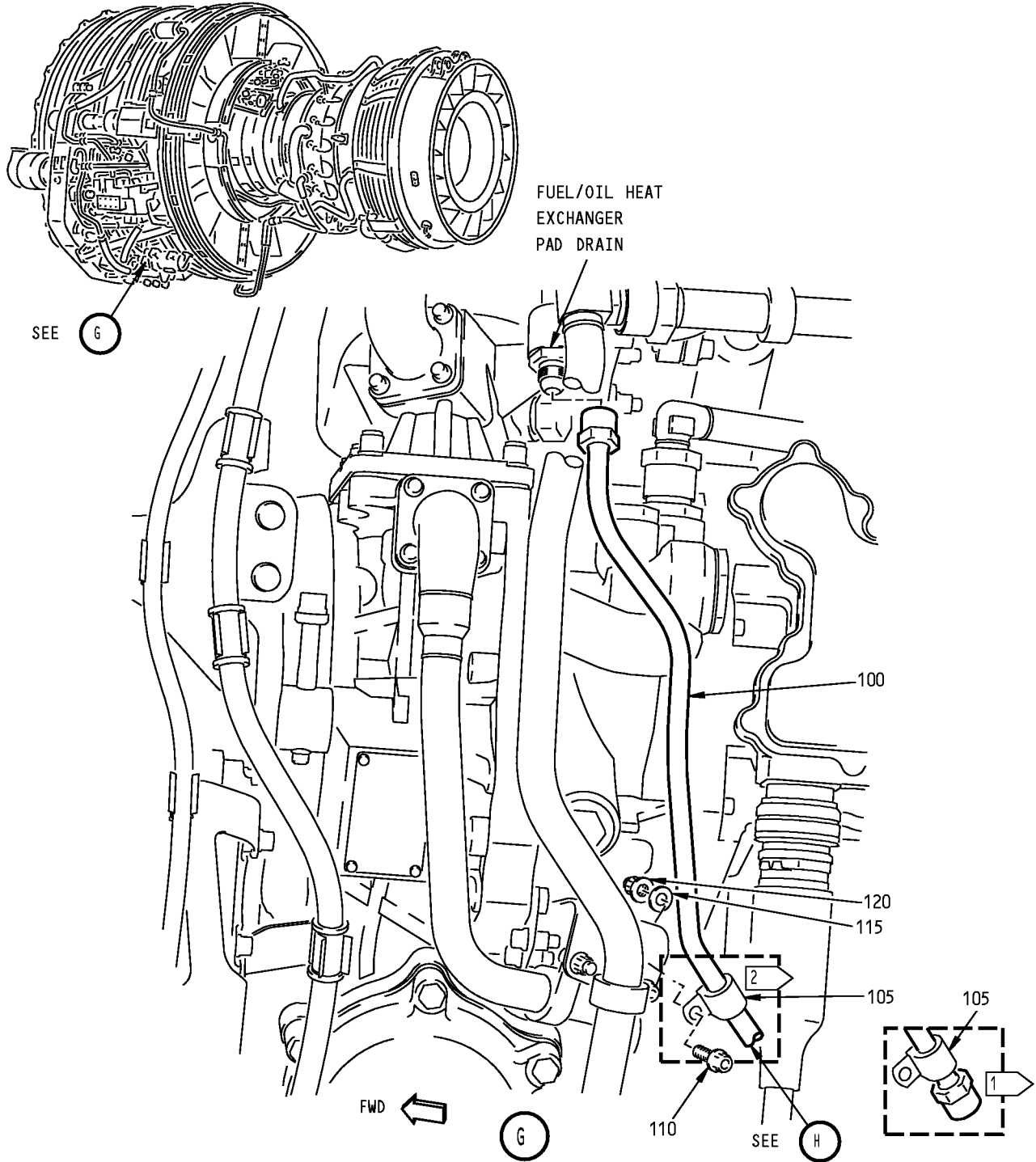

- 1 ENGINES WITH 332A2710-30 TUBE ASSEMBLY (100) (OPTIONAL)
- 2 ENGINES WITH 332A2710-38 TUBE ASSEMBLY (100) (PREFERRED)

**Drains Installation - Left Side Fan Case**  
**Figure 9-1 (Sheet 4)**

**71-00-02**

P/P BUILDUP FIGURE 9-1

Page 8

Oct 05/2007

D633A106-HXL

**737-600/700/800/900  
POWERPLANT BUILDUP MANUAL**

ITEM NO.	PART NUMBER	NOMENCLATURE	UC	QTY
9-1		<b>DRAINS INSTALLATION - LEFT SIDE FAN CASE (FIGURE 9-1, SHEET 4)</b>		
		<b>NOTE:</b> DUE TO LIMITED ACCESS, IT IS RECOMMENDED Figure 23-1 IDG AIR/OIL COOLER INSTALLATION AND Figure 24-1 IDG PLUMBING INSTALLATION BE INSTALLED AT THIS TIME.		
C1	D00504	REMOVE PROTECTIVE CAP FROM NIPPLE ON FUEL/OIL HEAT EXCHANGER PAD DRAIN AND LUBRICATE THREADS OF NIPPLE WITH grease, D00504 (C1). . LUBRICANT, VV-P-236	CON	AR
		PREFERRED CONFIGURATION; ENGINES WITH 332A2710-38 TUBE ASSY (100); ROUTE TUBE ASSY (100) UNDER CFMI WIRE BUNDLE (REF SHEET 5) AND LOOSELY ATTACH TUBE ASSY (100) TO NIPPLE.		
		OPTIONAL CONFIGURATION; ENGINES WITH 332A2710-30 TUBE ASSY (100); LOOSELY ATTACH TUBE ASSY (100) TO NIPPLE.		
100	332A2710-38	. TUBE ASSY <sup>[1]</sup>		1
100	332A2710-30	. TUBE ASSY <sup>[1]</sup>	OPT	-
		APPLY LIGHT COATING OF Never-Seez NSBT-8N compound, D00006(C6) TO THREADS AND UNDERSIDE HEAD OF BOLT. LOOSELY ATTACH TUBE ASSY (100) TO ENGINE BRACKET JUST ABOVE FUEL FILTER. USE CLAMP (105), BOLT (110), WASHER (115) AND NUT (120).		
105	J1221G06	. CLAMP		1
110	BACB30ZF4-08	. BOLT		1
115	NAS1149E0432P	. WASHER		1
120	AS3485-10	. NUT		1
C6	D00006	. COMPOUND, NEVER-SEEZ NSBT-8N	CON	AR
		ADJUST TUBE ASSY (100) TO BEST POSITION. MAKE SURE PRELOAD AT ALL CLAMP POINTS IS NOT MORE THAN 10 POUNDS (44.5 NEWTONS).		
		TIGHTEN TUBE ASSY (100) TO HAND TIGHT.		
		*[1] 332A2710-30 TUBE ASSY (100) TOGETHER WITH 332A2710-11 TUBE ASSY (125) OPTIONAL TO 332A2710-38 TUBE ASSY (100). ENGINES WITH 332A2710-38 TUBE ASSY (100) DO NOT REQUIRE TUBE (125).		

**71-00-02**

P/P BUILDUP FIGURE 9-1

Page 9

Oct 05/2007

D633A106-HXL

**737-600/700/800/900  
POWERPLANT BUILDUP MANUAL**

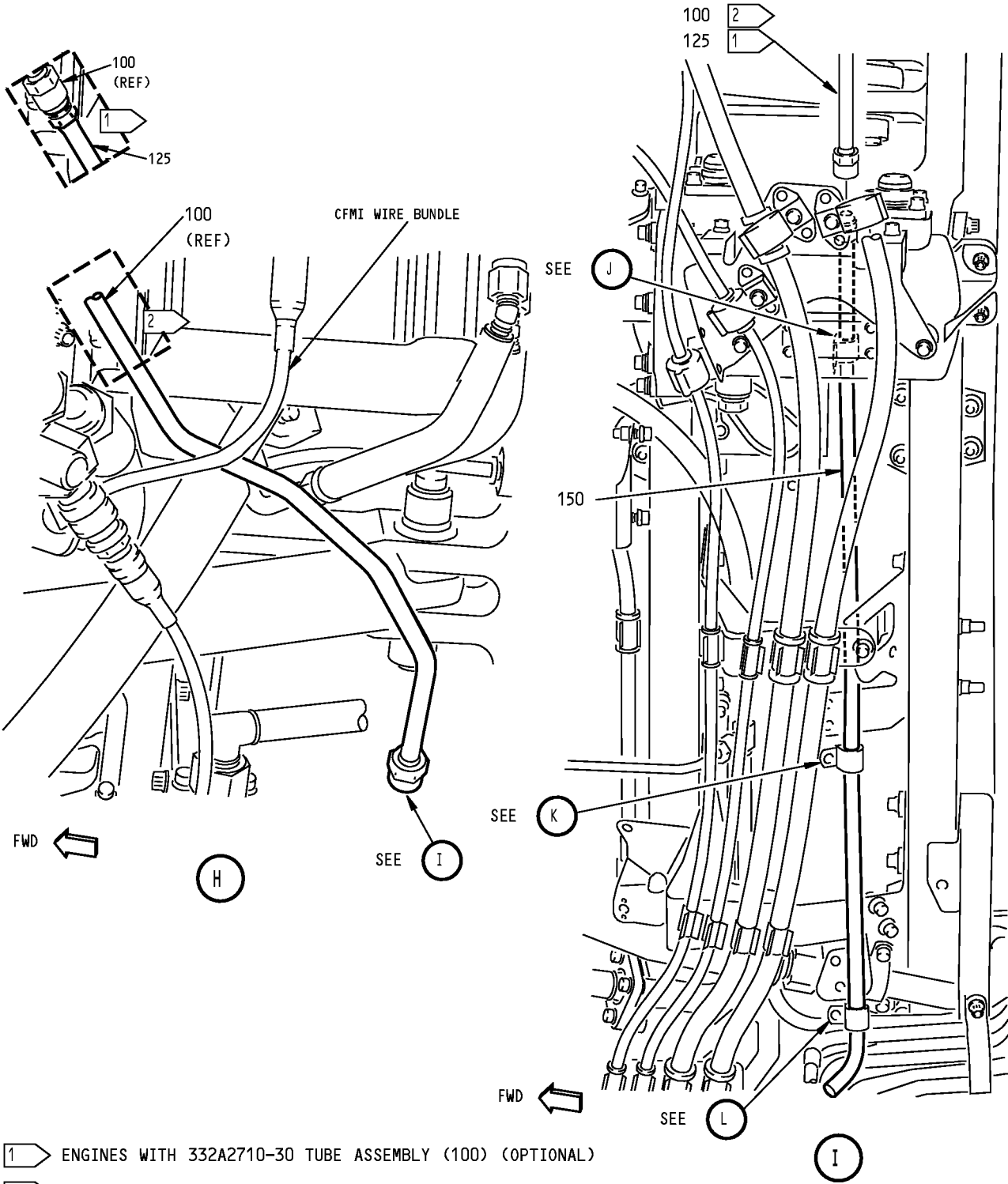

**Drains Installation - Left Side Fan Case  
Figure 9-1 (Sheet 5)**

**71-00-02**

**737-600/700/800/900  
POWERPLANT BUILDUP MANUAL**

ITEM NO.	PART NUMBER	NOMENCLATURE	UC	QTY
9-1		<b>DRAINS INSTALLATION - LEFT SIDE FAN CASE (FIGURE 9-1, SHEET 5)</b>		
125 C1	332A2710-11 D00504	<p>ENGINES WITH 332A2710-30 TUBE ASSY (100); LUBRICATE THREADS OF TUBE ASSY (125) WITH grease, D00504 (C1). ROUTE TUBE ASSY (125) UNDER CFMI WIRE BUNDLE AND LOOSELY ATTACH TO 332A2710-30 TUBE ASSY (100).</p> <p>. TUBE ASSY*<sup>[1]</sup> . LUBRICANT, VV-P-236</p>	OPT CON	- AR
150 C1	332A2710-13 D00504	<p>LUBRICATE THREADS OF TUBE ASSY (150) WITH grease, D00504 (C1). ROUTE TUBE ASSY (150) BEHIND FUEL/OIL COOLER AND UNDER CFMI WIRE BUNDLE BRACKETS AND LOOSELY ATTACH TO 332A2710-38 TUBE ASSY (100) OR TUBE ASSY (125).</p> <p>. TUBE ASSY . LUBRICANT, VV-P-236</p>	CON	1 AR
		<p>*[1] 332A2710-30 TUBE ASSY (100) TOGETHER WITH 332A2710-11 TUBE ASSY (125) OPTIONAL TO 332A2710-38 TUBE ASSY (100). ENGINES WITH 332A2710-38 TUBE ASSY (100) DO NOT REQUIRE TUBE (125).</p>		

**71-00-02**

P/P BUILDUP FIGURE 9-1

Page 11

Oct 05/2007

D633A106-HXL

737-600/700/800/900  
**POWERPLANT BUILDUP MANUAL**

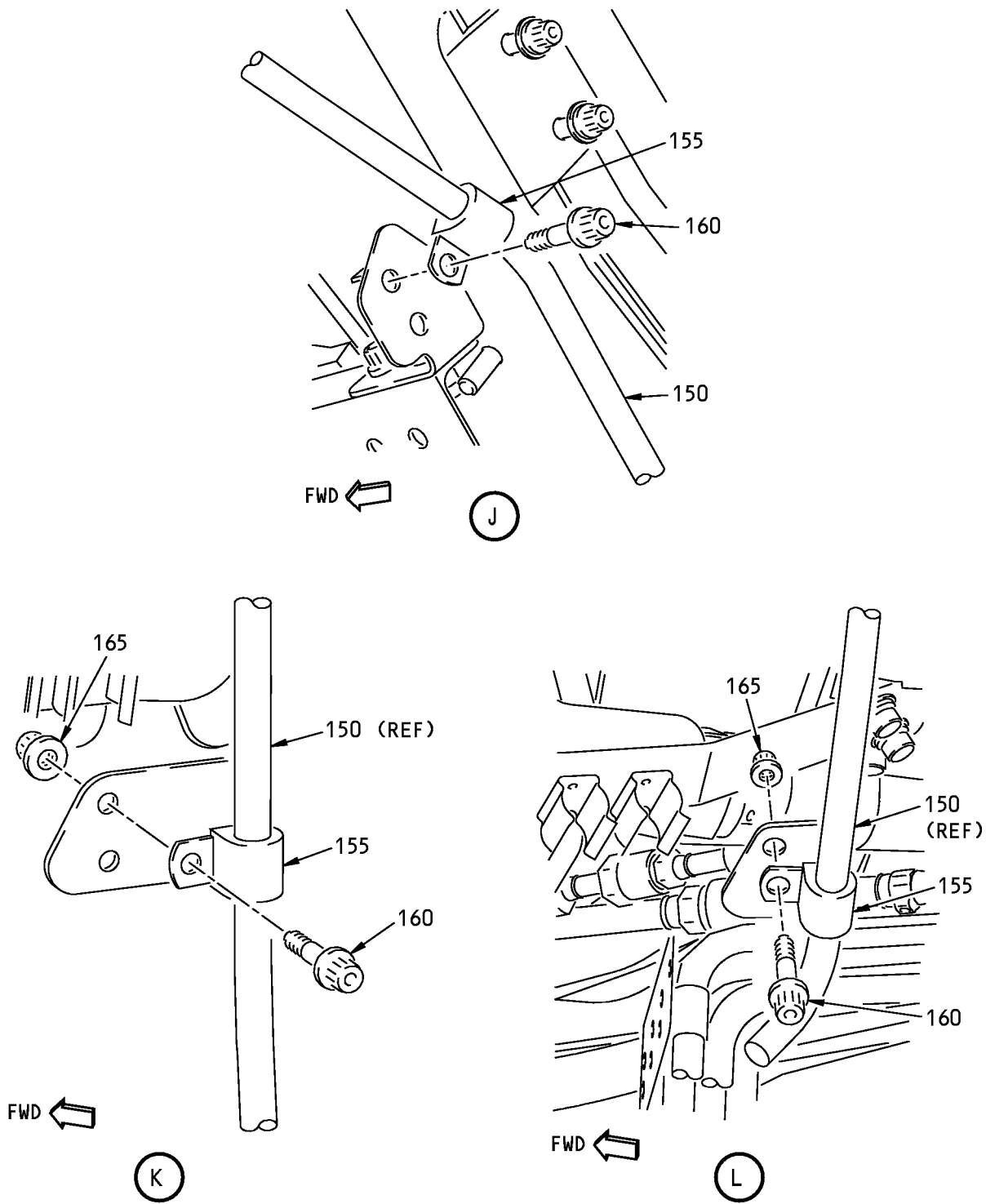

**Drains Installation - Left Side Fan Case**  
**Figure 9-1 (Sheet 6)**

**71-00-02**

P/P BUILDUP FIGURE 9-1

Page 12

Oct 05/2007

D633A106-HXL

**737-600/700/800/900  
POWERPLANT BUILDUP MANUAL**

ITEM NO.	PART NUMBER	NOMENCLATURE	UC	QTY
9-1		<p><b>DRAINS INSTALLATION - LEFT SIDE FAN CASE (FIGURE 9-1, SHEET 6)</b></p> <p>APPLY LIGHT COATING OF Never-Seez NSBT-8N compound, D00006(C6) TO THREADS AND UNDERSIDE HEAD OF BOLTS. AT 3 LOCATIONS, ATTACH TUBE (150) TO ENGINE BRACKETS. USE CLAMP (155) AND BOLT (160) AT UPR LOCATION AND CLAMPS (155), BOLTS (160) AND NUTS (165) AT LWR LOCATIONS.</p> <p>. CLAMP</p> <p>. BOLT</p> <p>. NUT</p> <p>. COMPOUND, NEVER-SEEZ NSBT-8N</p> <p>ADJUST TUBE ASSY (100), (125) (IF USED) AND (150) TO BEST POSITION. MAKE SURE PRELOAD AT ALL CLAMP POINTS IS NOT MORE THAN 10 POUNDS (44.5 NEWTONS).</p> <p>TIGHTEN TUBE ASSY (100), (125) (IF USED) AND (150) TO 257-284 POUND-INCHES (29.0-32.0 NEWTON METERS). BACK OFF NUT TO RELAX TORQUE, THEN RETIGHTEN.</p> <p>TIGHTEN BOLTS (110) AND (160) TO 110-120 POUND-INCHES (12.4-13.6 NEWTON METERS).</p>	CON	<p>3</p> <p>3</p> <p>2</p> <p>AR</p>
155	J1221G06			
160	BACB30ZF4-08			
165	AS3485-10			
C6	D00006			

**71-00-02**

P/P BUILDUP FIGURE 9-1

Page 13

Oct 05/2007

D633A106-HXL



737-600/700/800/900  
**POWERPLANT BUILDUP MANUAL**

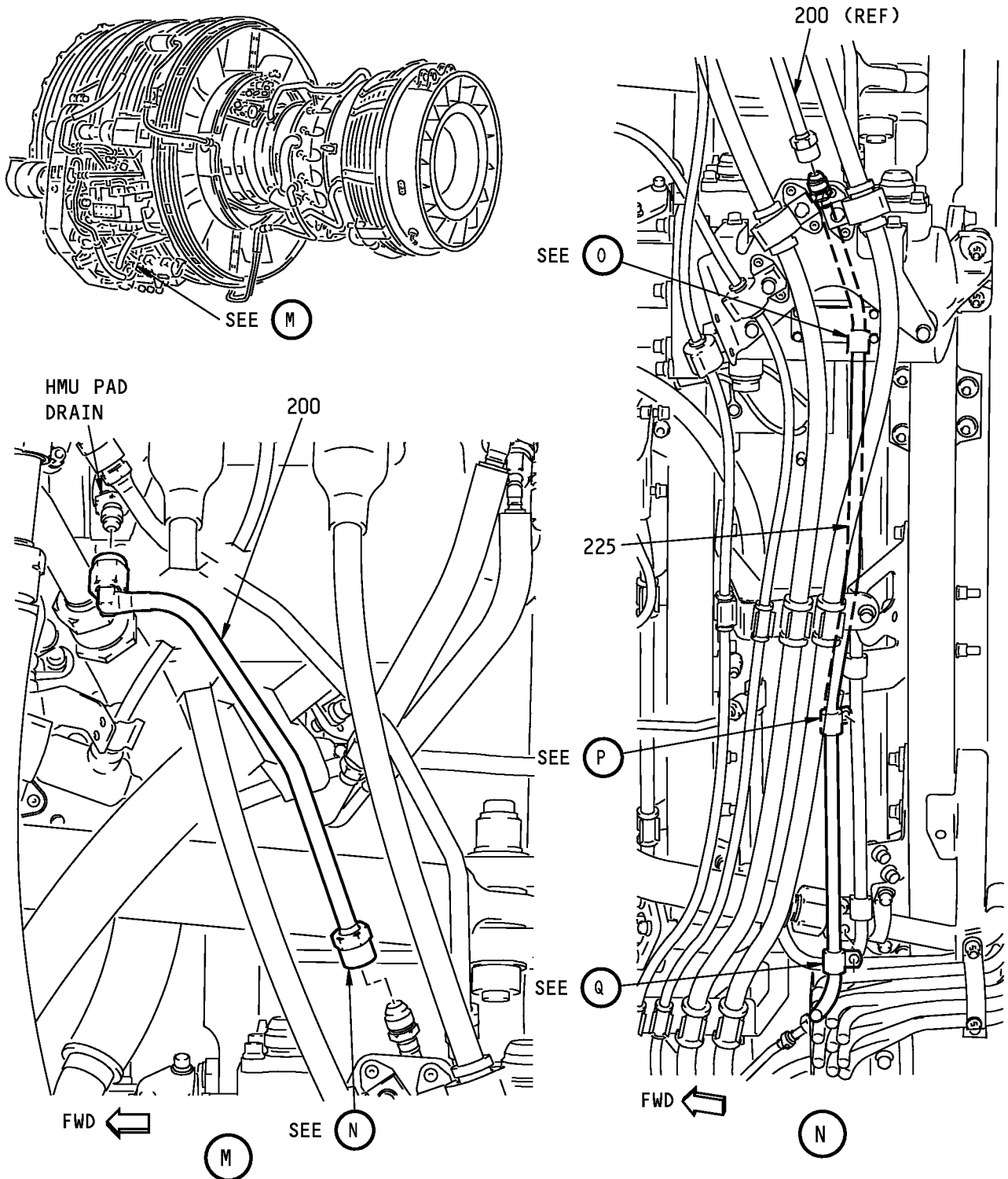

**Drains Installation - Left Side Fan Case**  
**Figure 9-1 (Sheet 7)**

**71-00-02**

P/P BUILDUP FIGURE 9-1

Page 14

Oct 05/2007

D633A106-HXL

**737-600/700/800/900  
POWERPLANT BUILDUP MANUAL**

ITEM NO.	PART NUMBER	NOMENCLATURE	UC	QTY
9-1		<b>DRAINS INSTALLATION - LEFT SIDE FAN CASE (FIGURE 9-1, SHEET 7)</b>		
C1	D00504	REMOVE PROTECTIVE CAP FROM NIPPLE ON HMU PAD DRAIN AND LUBRICATE THREADS OF NIPPLE WITH grease, D00504 (C1). . LUBRICANT, VV-P-236	CON	AR
200	332A2710-15	LOOSELY ATTACH TUBE ASSY (200) TO NIPPLE. . TUBE ASSY		1
C1	D00504	LUBRICATE THREADS OF TUBE ASSY (225) WITH grease, D00504 (C1). . LUBRICANT, VV-P-236	CON	AR
225	332A2710-27	ROUTE TUBE ASSY (225) BEHIND FUEL/OIL COOLER AND UNDER CFMI WIRE BUNDLE BRACKETS AND LOOSELY ATTACH TO TUBE ASSY (200). . TUBE ASSY		1

**71-00-02**

P/P BUILDUP FIGURE 9-1

Page 15

Oct 05/2007

D633A106-HXL

737-600/700/800/900  
POWERPLANT BUILDUP MANUAL

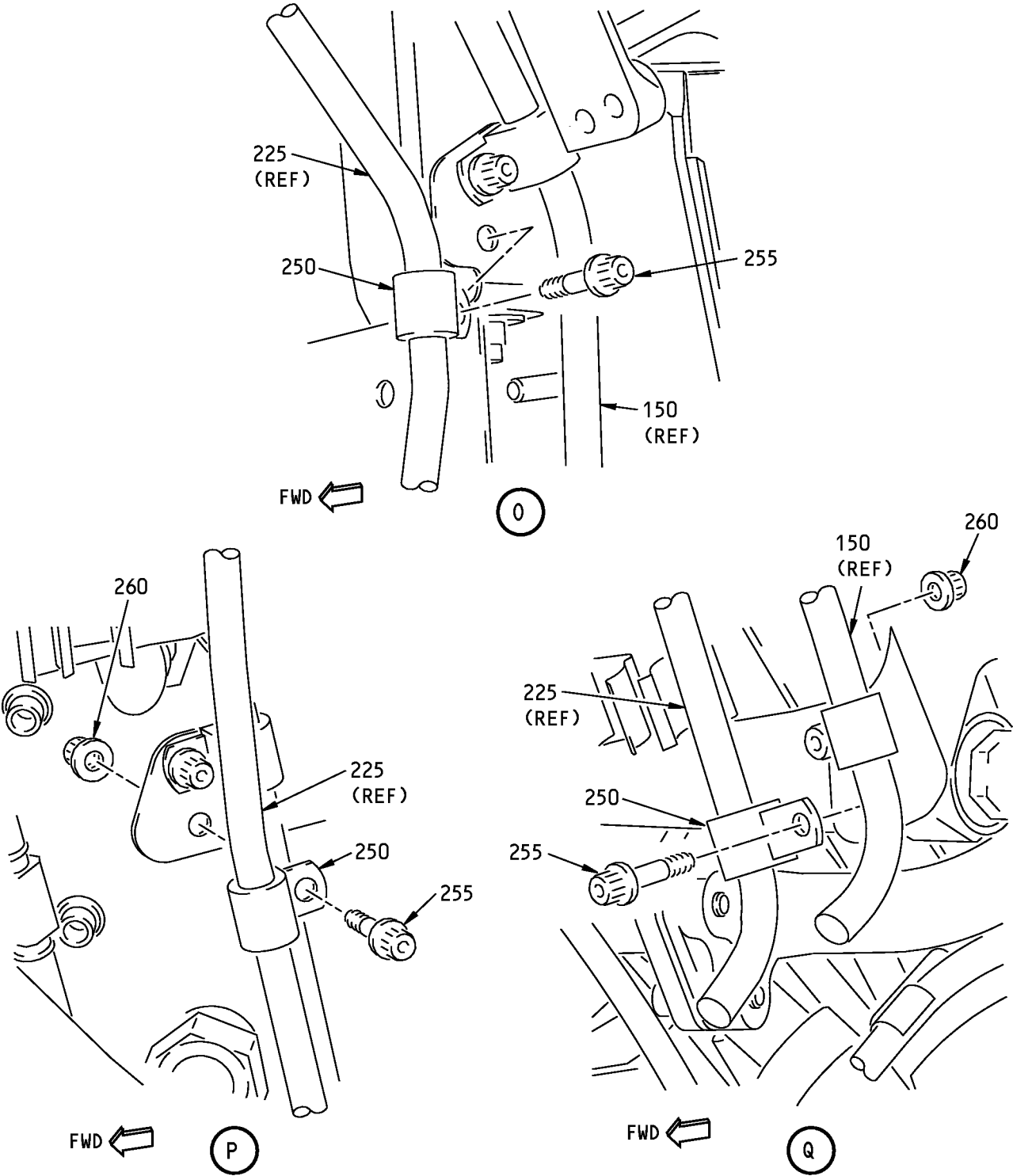

Drains Installation - Left Side Fan Case  
Figure 9-1 (Sheet 8)

**71-00-02**

P/P BUILDUP FIGURE 9-1  
Page 16  
Oct 05/2007

D633A106-HXL

**737-600/700/800/900  
POWERPLANT BUILDUP MANUAL**

ITEM NO.	PART NUMBER	NOMENCLATURE	UC	QTY
9-1		<p><b>DRAINS INSTALLATION - LEFT SIDE FAN CASE (FIGURE 9-1, SHEET 8)</b></p> <p>APPLY LIGHT COATING OF Never-Seez NSBT-8N compound, D00006(C6) TO THREADS AND UNDERSIDE HEAD OF BOLTS. AT 3 LOCATIONS, ATTACH TUBE ASSY (225) TO ENGINE BRACKETS. USE CLAMP (250) AND BOLT (255) AT UPR LOCATION AND CLAMPS (250), BOLTS (255) AND NUTS (260) AT LWR LOCATIONS.</p> <p>. CLAMP</p> <p>. BOLT</p> <p>. NUT</p> <p>. COMPOUND, NEVER-SEEZ NSBT-8N</p> <p>ADJUST TUBES ASSY (200) AND (225) TO BEST POSITION. MAKE SURE PRELOAD AT ALL CLAMP POINTS IS NOT MORE THAN 10 POUNDS (44.5 NEWTONS).</p> <p>TIGHTEN TUBE ASSY (200) AND (225) TO 257-284 POUND-INCHES (53.7-59.3 NEWTON METERS). BACK OFF NUT TO RELAX TORQUE, THEN RETIGHTEN.</p> <p>TIGHTEN BOLTS (255) TO 110-120 POUND-INCHES (12.4-13.6 NEWTON METERS).</p>		
250	J1221G06			3
255	BACB30ZF4-08			3
260	AS3485-10			2
C6	D00006		CON	AR

**71-00-02**

P/P BUILDUP FIGURE 9-1

Page 17

Oct 05/2007

D633A106-HXL

**FIGURE 10-1**

**DRAINS INSTL - RIGHT SIDE FAN CASE**

**REF QEC TASK NO.: 10**

**REF DWG: 332A2100**

**NOTE:** ALL STANDARDS AND ATTACHING HARDWARE FOR THIS FIGURE WILL BE PACKAGED IN QEC TASK NO. 110.

**71-00-02**

P/P BUILDUP FIGURE 10-1

Page 1

Oct 05/2007

D633A106-HXL

737-600/700/800/900  
**POWERPLANT BUILDUP MANUAL**

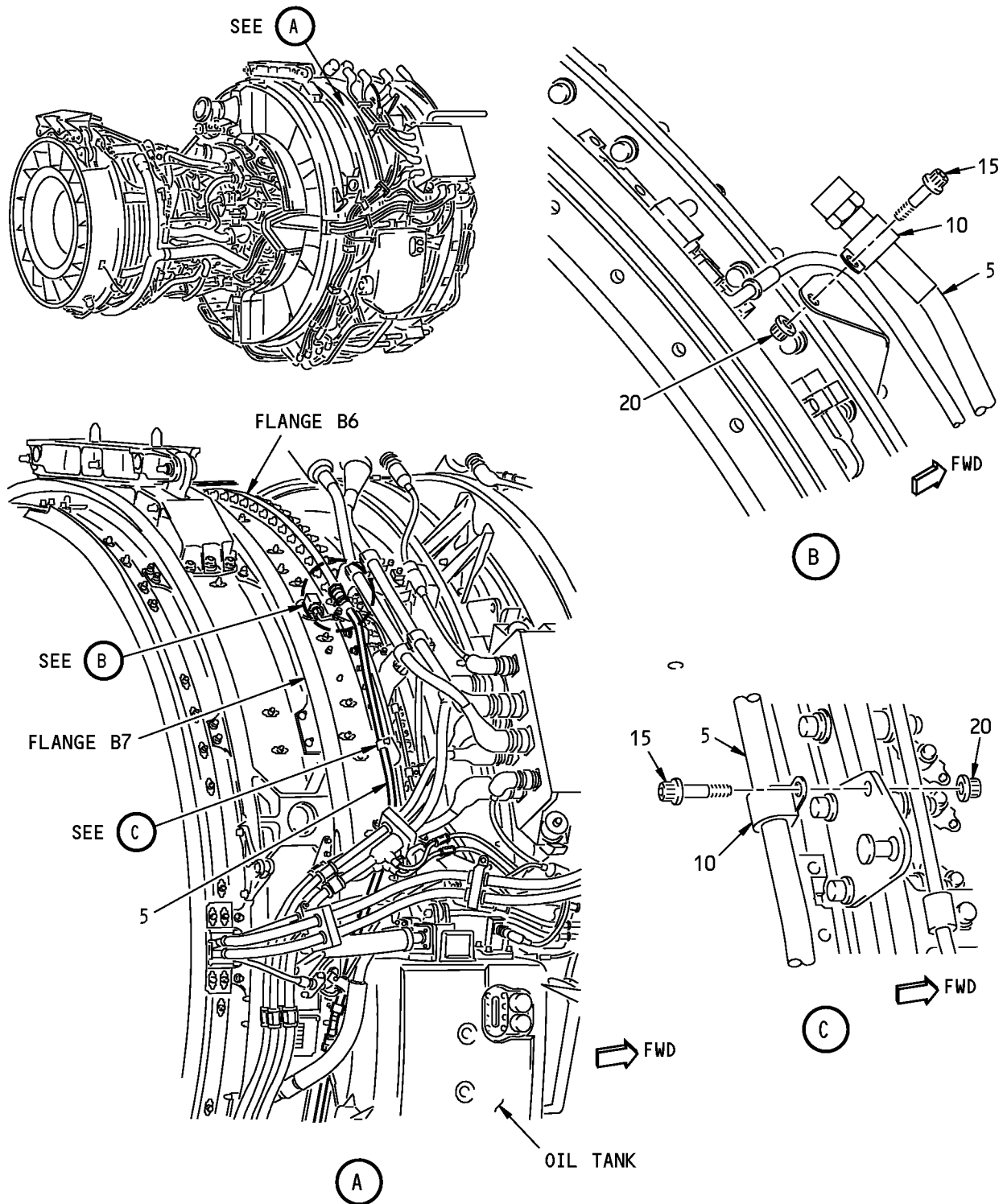

**Drains Installation - Right Side Fan Case**  
**Figure 10-1 (Sheet 1)**

**71-00-02**

P/P BUILDUP FIGURE 10-1

Page 2

Oct 05/2007

**737-600/700/800/900  
POWERPLANT BUILDUP MANUAL**

ITEM NO.	PART NUMBER	NOMENCLATURE	UC	QTY
10-1		<p><b>DRAINS INSTALLATION - RIGHT SIDE FAN CASE (FIGURE 10-1, SHEET 1)</b></p> <p><b>NOTE:</b> IN THIS PROCEDURE, DO NOT TIGHTEN SCREWS AND TUBE OR HOSE NUTS TO THE INDICATED TORQUE UNTIL INSTRUCTED. WHEN TIGHTENING TUBE AND HOSE NUTS, USE TWO WRENCHES; ONE TO HOLD THE SPANNER FLATS ON THE NIPPLE AND ONE TO TIGHTEN THE NUT.</p> <p>APPLY grease, D00504 (C1) UNDER HEAD OF BOLTS ATTACHING LOOP CLAMPS TO PREVENT DISTORTION OF CLAMP DURING TORQUING. APPLY LIGHT COATING OF Never-Seez NSBT-8N compound, D00006 (C6) TO THREADS AND UNDERSIDE HEAD OF BOLTS.</p>		
C1	D00504	. LUBRICANT, VV-P-236	CON	AR
C6	D00006	. COMPOUND, NEVER-SEEZ NSBT-8N	CON	AR
		POSITION TUBE ASSY (5) ON ENGINE FAN CASE AT 1 AND 3 O'CLOCK POSITIONS BETWEEN FLANGES B6 AND B7.		
		LOOSELY ATTACH TUBE ASSY (5) AT TOP TWO LOCATIONS TO ENGINE BRACKETS WITH CLAMPS (10), BOLTS (15) AND NUTS (20). MAKE SURE UPPER CLAMP (10) IS INSTALLED BETWEEN MARKS ON TUBE ASSY (5).		
5	332A2710-32	. TUBE ASSY		1
10	J1221G08	. CLAMP		2
15	BACB30ZF4-08	. BOLT		2
20	AS3485-10	. NUT		2
		ADJUST TUBE ASSY (5) TO BEST POSITION. MAKE SURE PRELOAD ON ALL CLAMP POINTS IS NOT MORE THAN 10 POUNDS (44.5 NEWTONS).		
		TIGHTEN BOLTS (15) TO 110-120 POUND-INCHES (12.4-13.6 NEWTON METERS).		
		INSTALL PROTECTIVE CAP ON UPPER END OF TUBE ASSY (5).		

# 71-00-02

P/P BUILDUP FIGURE 10-1

Page 3

Oct 05/2007

D633A106-HXL

737-600/700/800/900  
**POWERPLANT BUILDUP MANUAL**

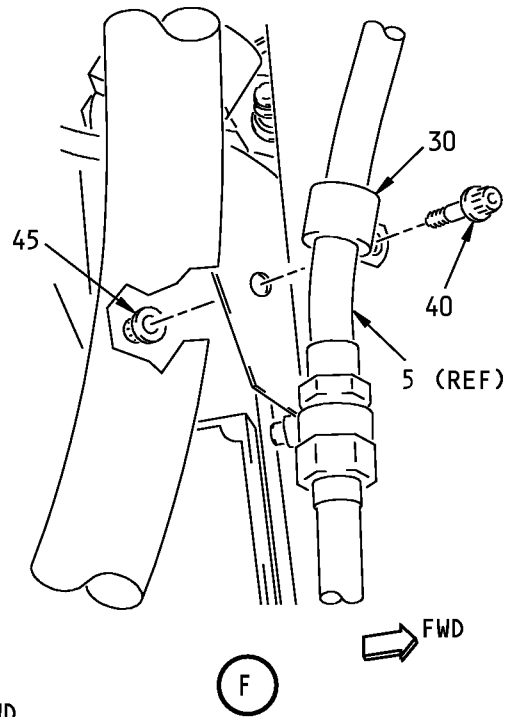
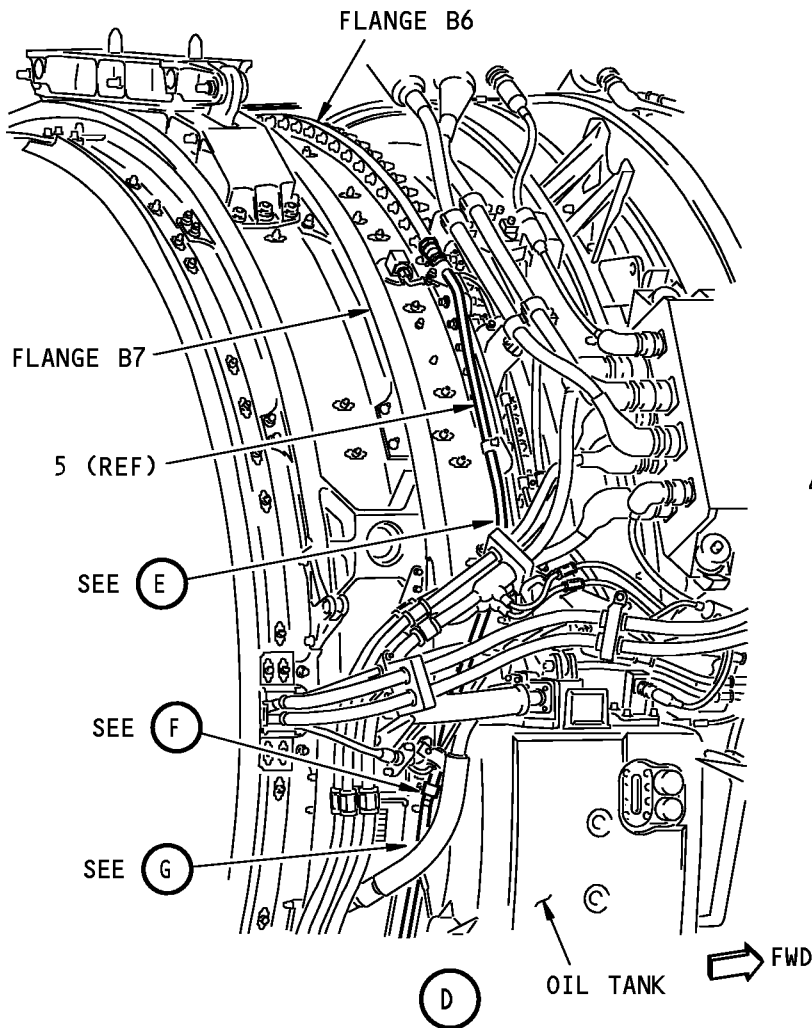
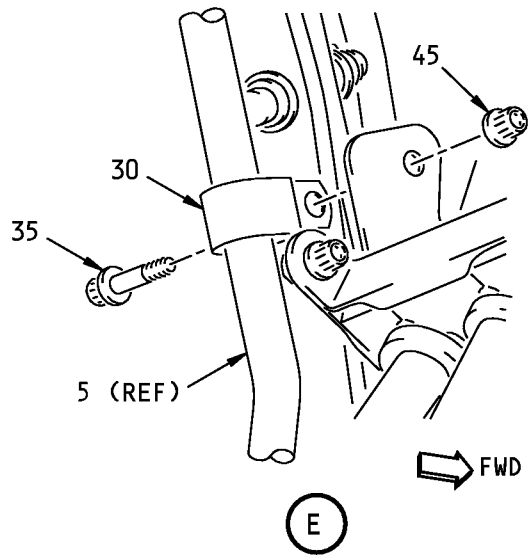
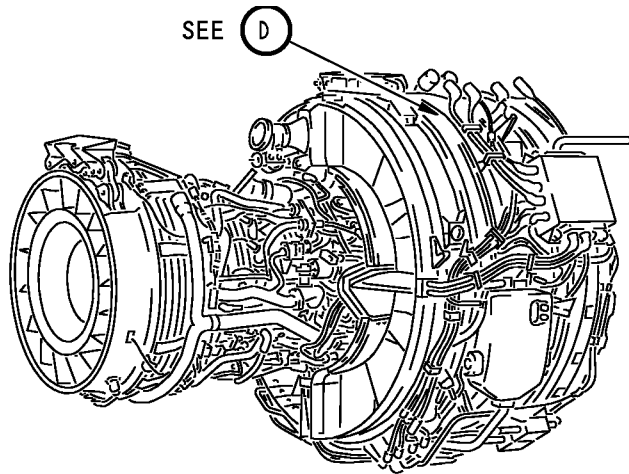

**Drains Installation - Right Side Fan Case**  
Figure 10-1 (Sheet 2)

**71-00-02**

P/P BUILDUP FIGURE 10-1

Page 4

Oct 05/2007

D633A106-HXL



**737-600/700/800/900  
POWERPLANT BUILDUP MANUAL**

ITEM NO.	PART NUMBER	NOMENCLATURE	UC	QTY
10-1		<p><b>DRAINS INSTALLATION - RIGHT SIDE FAN CASE (FIGURE 10-1, SHEET 2)</b></p> <p>APPLY LIGHT COATING OF Never-Seez NSBT-8N compound, D00006 (C6) TO THREADS AND UNDERSIDE HEAD OF BOLTS. LOOSELY ATTACH TUBE ASSY (5) WITH CLAMP (30), BOLT (35) AND NUT (45) AT UPPER LOCATION AND CLAMP (30), BOLT (40) AND NUT (45) AT LOWER LOCATION.</p> <p>. CLAMP</p> <p>. BOLT</p> <p>. BOLT</p> <p>. NUT</p> <p>. COMPOUND, NEVER-SEEZ NSBT-8N</p> <p>TIGHTEN BOLT (35) AND (40) TO 110-120 POUND-INCHES (12.4-13.6 NEWTON METERS).</p>	CON	<p>2</p> <p>1</p> <p>1</p> <p>2</p> <p>AR</p>
30	J1221G08			
35	BACB30ZF4-08			
40	BACB30ZF4-07			
45	AS3485-10			
C6	D00006			

# 71-00-02

P/P BUILDUP FIGURE 10-1

Page 5

Oct 05/2007

D633A106-HXL

737-600/700/800/900  
**POWERPLANT BUILDUP MANUAL**

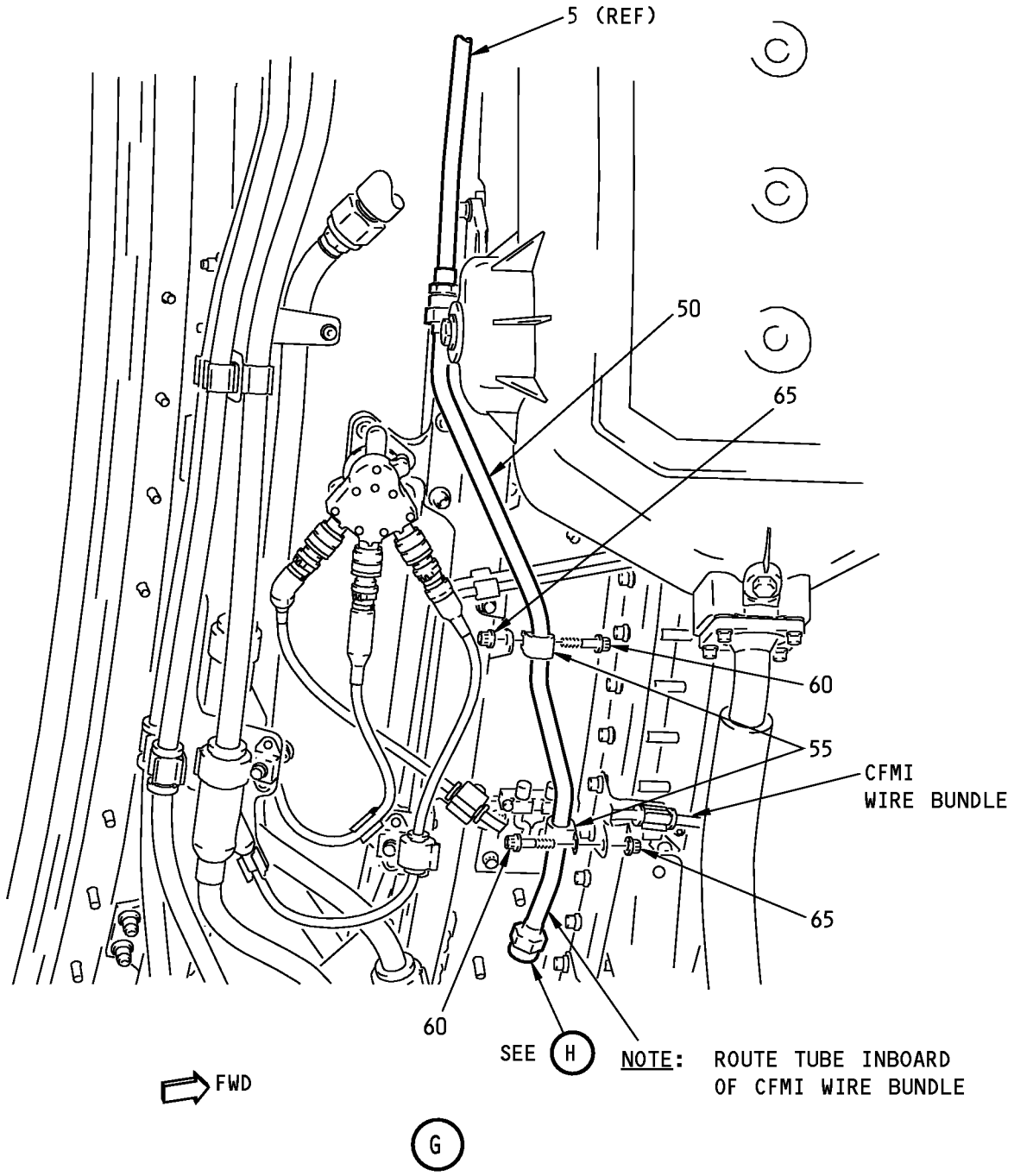

**Drains Installation - Right Side Fan Case**  
**Figure 10-1 (Sheet 3)**

**71-00-02**

P/P BUILDUP FIGURE 10-1

Page 6

Oct 05/2007

D633A106-HXL

**737-600/700/800/900  
POWERPLANT BUILDUP MANUAL**

ITEM NO.	PART NUMBER	NOMENCLATURE	UC	QTY
10-1		<p><b>DRAINS INSTALLATION - RIGHT SIDE FAN CASE (FIGURE 10-1, SHEET 3)</b></p> <p>LUBRICATE THREADS OF TUBE ASSY (5) WITH grease, D00504(C1). ALIGN TUBE ASSY (50) ON ENGINE FAN CASE AND LOOSELY CONNECT TO TUBE ASSY (5).</p> <p><b>NOTE:</b> ROUTE TUBE ASSY (50) INBOARD OF CFMI WIRE BUNDLE.</p>		
50	332A2710-33	. TUBE ASSY		1
C1	D00504	. LUBRICANT, VV-P-236	CON	AR
		APPLY LIGHT COATING OF Never-Seez NSBT-8N compound, D00006 (C6) TO THREADS AND UNDERSIDE HEAD OF BOLTS. LOOSELY SECURE TUBE ASSY (50) TO ENGINE BRACKETS AT 2 LOCATIONS WITH CLAMPS (55), BOLTS (60) AND NUTS (65).		
55	J1221G08	. CLAMP		2
60	BACB30ZF4-07	. BOLT		2
65	AS3485-10	. NUT		2
C6	D00006	. COMPOUND, NEVER-SEEZ NSBT-8N	CON	AR
		TIGHTEN TUBE ASSY (50) TO 475-525 POUND-INCHES (53.7-59.3 NEWTON METERS). BACK OFF NUT TO RELAX TORQUE, THEN RETIGHTEN.		
		ADJUST TUBE ASSY (50) TO BEST POSITION. MAKE SURE PRELOAD AT CLAMP POINTS IS NOT MORE THAN 10 POUNDS (44.5 NEWTONS).		
		TIGHTEN BOLTS (60) TO 110-120 POUND-INCHES (12.4-13.6 NEWTON METERS).		

# 71-00-02

P/P BUILDUP FIGURE 10-1

Page 7

Oct 05/2007

D633A106-HXL

737-600/700/800/900  
POWERPLANT BUILDUP MANUAL

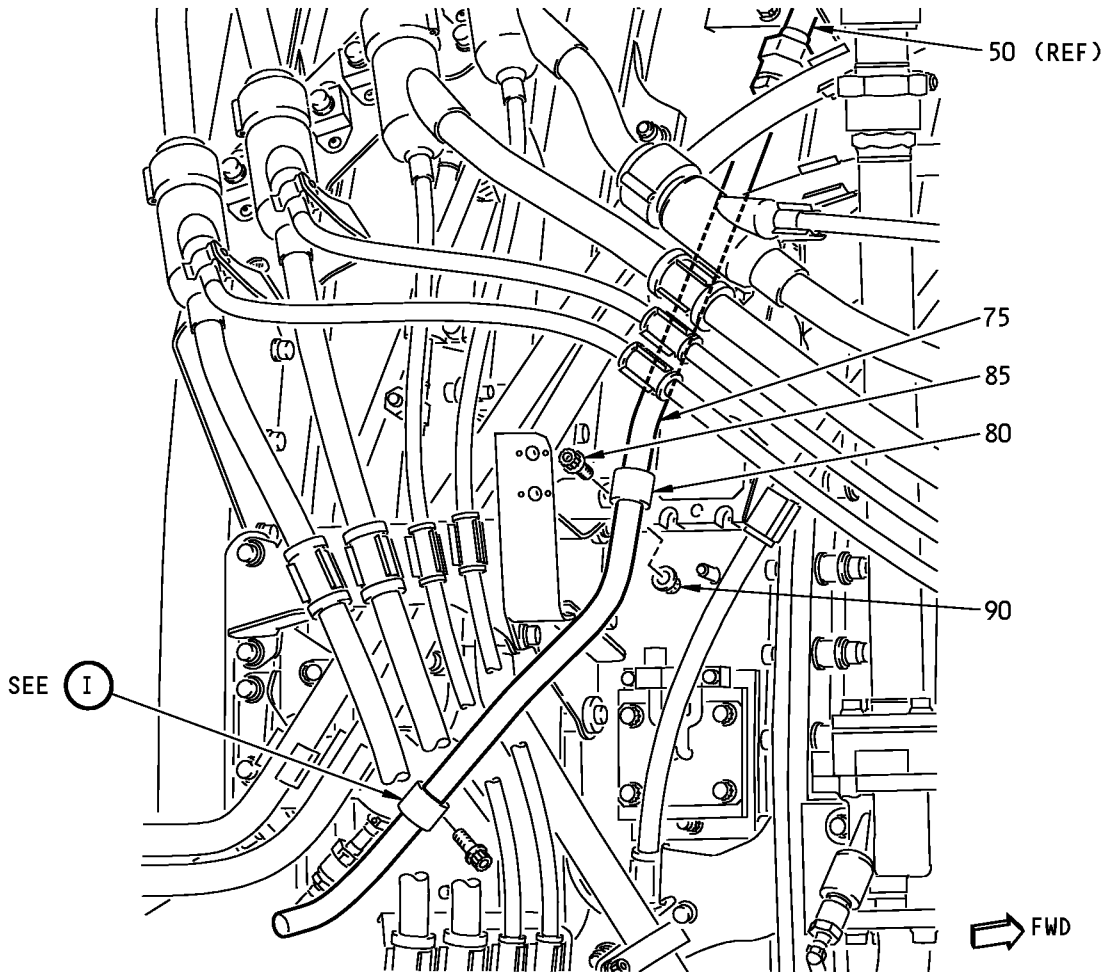

(H)

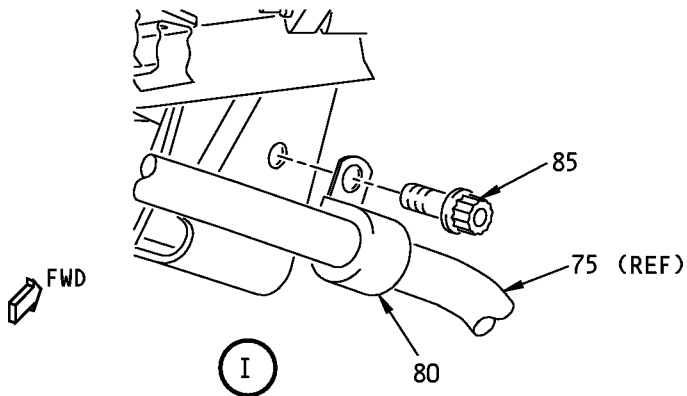

Drains Installation - Right Side Fan Case  
Figure 10-1 (Sheet 4)

**71-00-02**

P/P BUILDUP FIGURE 10-1

Page 8

Oct 05/2007

D633A106-HXL

**737-600/700/800/900  
POWERPLANT BUILDUP MANUAL**

ITEM NO.	PART NUMBER	NOMENCLATURE	UC	QTY
10-1		<b>DRAINS INSTALLATION - RIGHT SIDE FAN CASE (FIGURE 10-1, SHEET 4)</b>		
		LUBRICATE THREADS OF TUBE ASSY (50) WITH grease, D00504 (C1). APPLY LIGHT COATING OFNever-Seez NSBT-8N compound, D00006 (C6) TO THREADS AND UNDERSIDE HEAD OF BOLTS. POSITION TUBE ASSY (75) UNDER CFMI WIRE BUNDLES AND BRACKETS AND LOOSELY CONNECT TO TUBE ASSY (50).		
75	332A2710-31	. TUBE ASSY		1
C1	D00504	. LUBRICANT, VV-P-236	CON	AR
C6	D00006	. COMPOUND, NEVER-SEEZ NSBT-8N	CON	AR
		APPLY LIGHT COATING OFNever-Seez NSBT-8N compound, D00006 (C6) TO THREADS AND UNDERSIDE HEAD OF BOLTS. LOOSELY ATTACH TUBE ASSY (75) AT TWO LOCATIONS TO ENGINE BRACKETS WITH CLAMPS (80), BOLTS (85) AND NUT (90).		
80	J1221G08	. CLAMP		2
85	BACB30ZF4-07	. BOLT		2
90	AS3485-10	. NUT		1
C6	D00006	. COMPOUND, NEVER-SEEZ NSBT-8N	CON	AR
		TIGHTEN TUBE ASSY (75) TO 475-525 POUND-INCHES (53.7-59.3 NEWTON METERS). BACK OFF NUT TO RELAX TORQUE, THEN RETIGHTEN.		
		ADJUST TUBE ASSY (75) TO BEST POSITION. MAKE SURE PRELOAD AT ALL CLAMP POINTS IS NOT MORE THAN 10 POUNDS (44.5 NEWTONS).		
		TIGHTEN BOLTS (85) TO 110-120 POUND-INCHES (12.4-13.6 NEWTON METERS).		

**71-00-02**

P/P BUILDUP FIGURE 10-1

Page 9

Oct 05/2007

D633A106-HXL

737-600/700/800/900  
**POWERPLANT BUILDUP MANUAL**

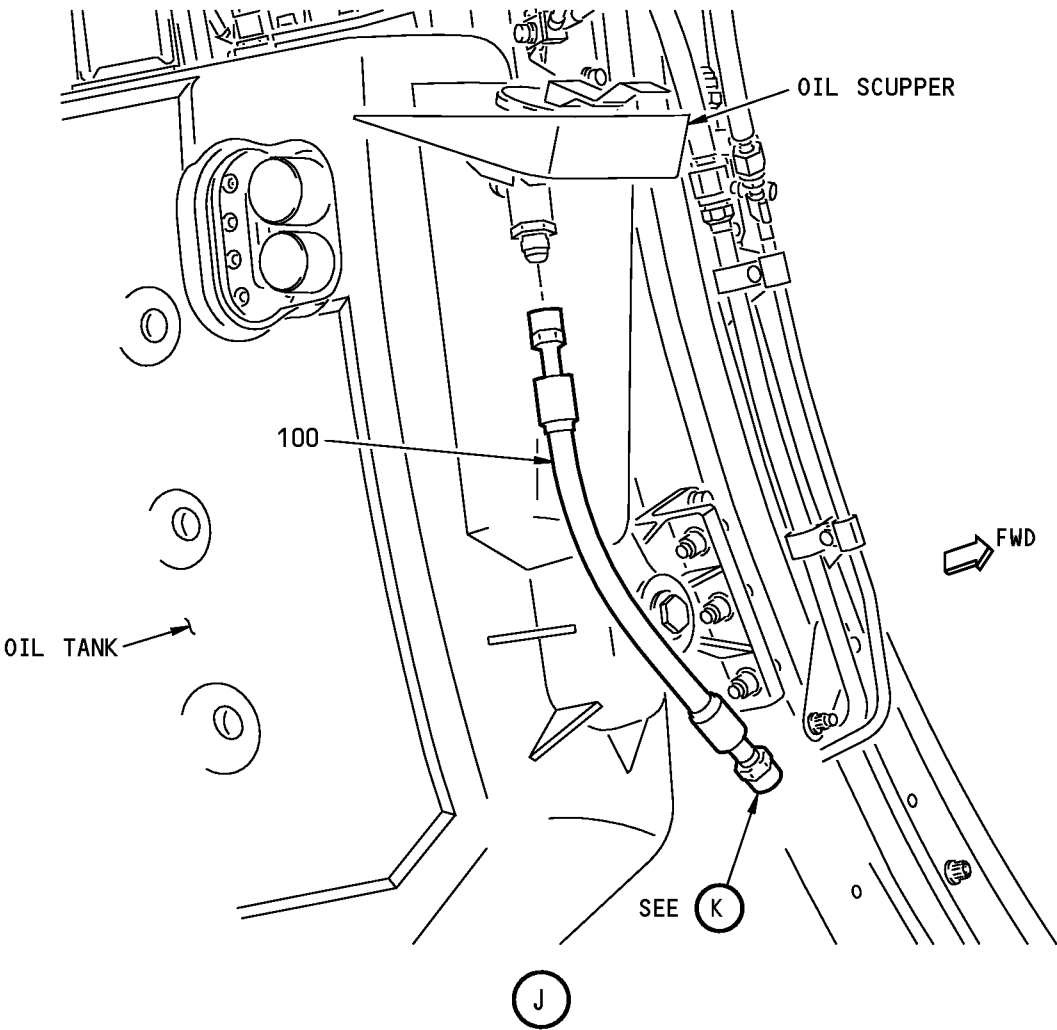
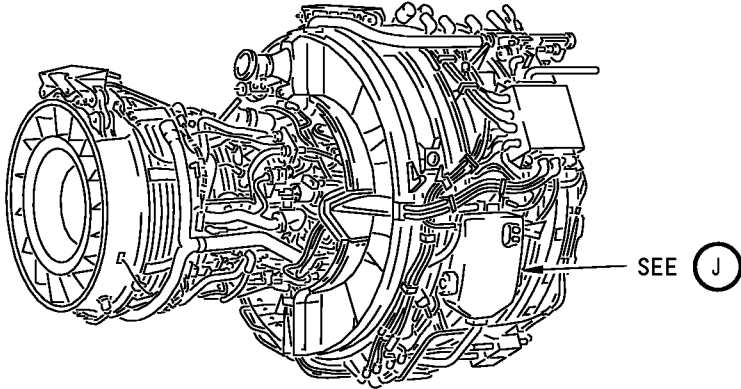

**Drains Installation - Right Side Fan Case**  
**Figure 10-1 (Sheet 5)**

**71-00-02**

**737-600/700/800/900  
POWERPLANT BUILDUP MANUAL**

ITEM NO.	PART NUMBER	NOMENCLATURE	UC	QTY
10-1		<b>DRAINS INSTALLATION - RIGHT SIDE FAN CASE (FIGURE 10-1, SHEET 5)</b>		
C1	D00504	REMOVE PROTECTIVE CAP FROM OIL SCUPPER DRAIN NIPPLE. LUBRICATE THREADS OF NIPPLE WITH grease, D00504 (C1). . LUBRICANT, VV-P-236	CON	AR
100	B700-2	ATTACH HOSE ASSY (100) TO NIPPLE AND TIGHTEN TO 257-284 POUND-INCHES (29.0-32.0 NEWTON METERS). BACK OFF NUT TO RELAX TORQUE, THEN RETIGHTEN. . HOSE ASSY (V98441)	VEN	1
100	S332W110-2	. BOEING SPEC FOR B700-2	BOE	-

**71-00-02**

P/P BUILDUP FIGURE 10-1

Page 11

Oct 05/2007

D633A106-HXL

**POWERPLANT BUILDUP MANUAL**

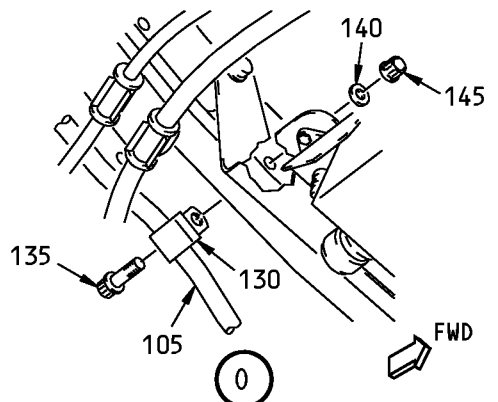
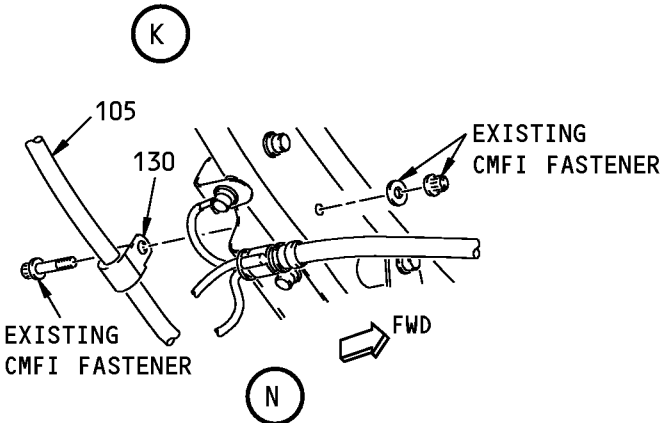
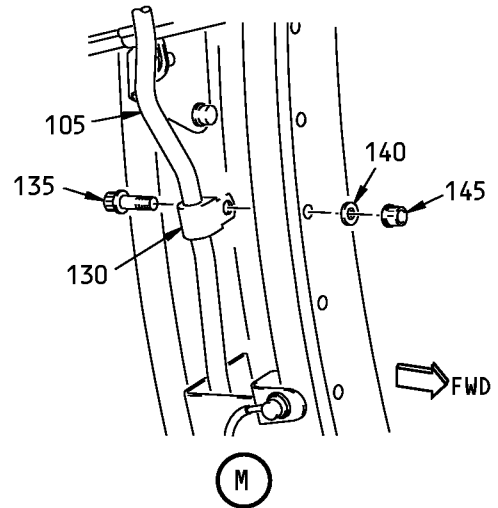
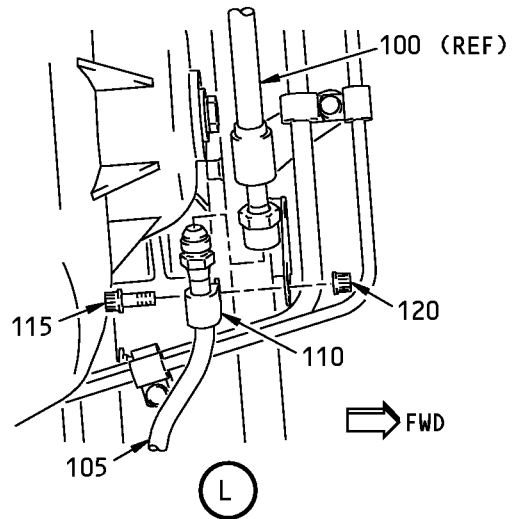
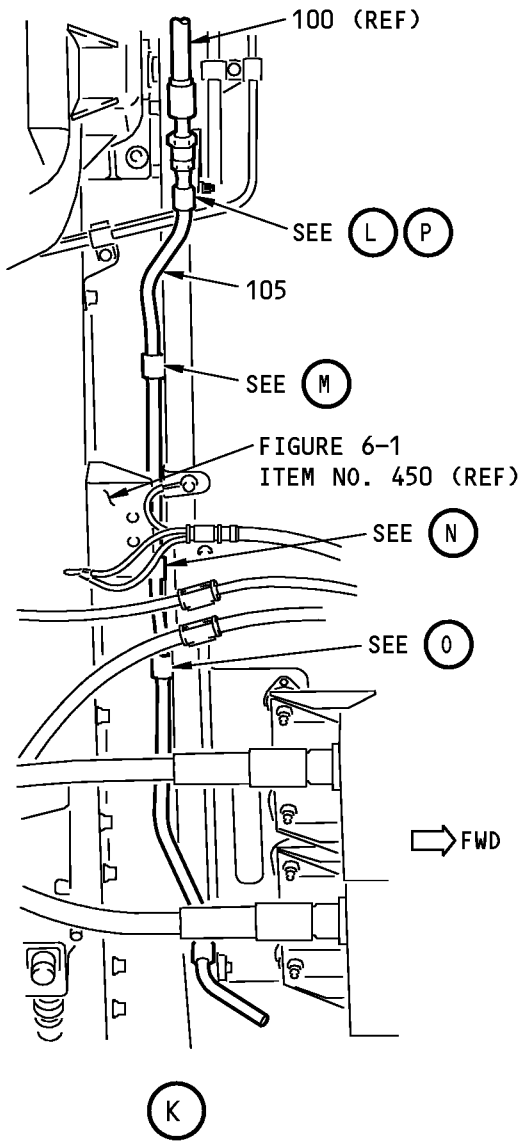

**Drains Installation - Right Side Fan Case  
Figure 10-1 (Sheet 6)**

**71-00-02**

P/P BUILDUP FIGURE 10-1

Page 12

Oct 05/2007

D633A106-HXL



**737-600/700/800/900  
POWERPLANT BUILDUP MANUAL**

ITEM NO.	PART NUMBER	NOMENCLATURE	UC	QTY
<b>10-1</b>		<b>DRAINS INSTALLATION - RIGHT SIDE FAN CASE (FIGURE 10-1, SHEET 6)</b>		
		LUBRICATE THREADS ON TUBE ASSY (105) WITH grease, D00504 (C1) AND POSITION TUBE ASSY (105) ON ENGINE FAN CASE AND LOOSELY CONNECT TO HOSE ASSY (100).		
105	332A2710-25	. TUBE ASSY		1
C1	D00504	. LUBRICANT, VV-P-236	CON	AR
		APPLY LIGHT COATING OFNever-Seez NSBT-8N compound, D00006 (C6) TO THREADS AND UNDERSIDE HEAD OF BOLTS. JUST BELOW TUBE UNION, LOOSELY ATTACH TUBE (105) TO ENGINE BRACKETS WITH CLAMP (110), BOLT (115) AND NUT (120).		
110	J1221G06	. CLAMP		1
115	BACB30ZF4-08	. BOLT		1
120	AS3485-10	. NUT		1
C6	D00006	. COMPOUND, NEVER-SEEZ NSBT-8N	CON	AR
		APPLY LIGHT COATING OFNever-Seez NSBT-8N compound, D00006 (C6) TO THREADS AND UNDERSIDE HEAD OF BOLTS. AT FIRST AND THIRD THREE LOCATIONS, LOOSELY ATTACH TUBE ASSY (105) TO ENGINE BRACKETS. USE CLAMPS (130), BOLTS (135), WASHERS (140) AND NUTS (145). AT REMAINING LOCATION USE EXISTING CFMI FASTENER.		
130	J1221G06	. CLAMP		3
135	BACB30ZF4-10	. BOLT		2
140	NAS1149C0432R	. WASHER (AGAINST ENGINE CASE)		2
145	AS3485-10	. NUT		2
C6	D00006	. COMPOUND, NEVER-SEEZ NSBT-8N	CON	AR
		TIGHTEN TUBE ASSY (105) TO 257-284 POUND-INCHES (29.0-32.0 NEWTON METERS). BACK OFF NUT TO RELAX TORQUE, THEN RETIGHTEN.		

# 71-00-02

P/P BUILDUP FIGURE 10-1

Page 13

Oct 05/2007

D633A106-HXL

737-600/700/800/900  
**POWERPLANT BUILDUP MANUAL**

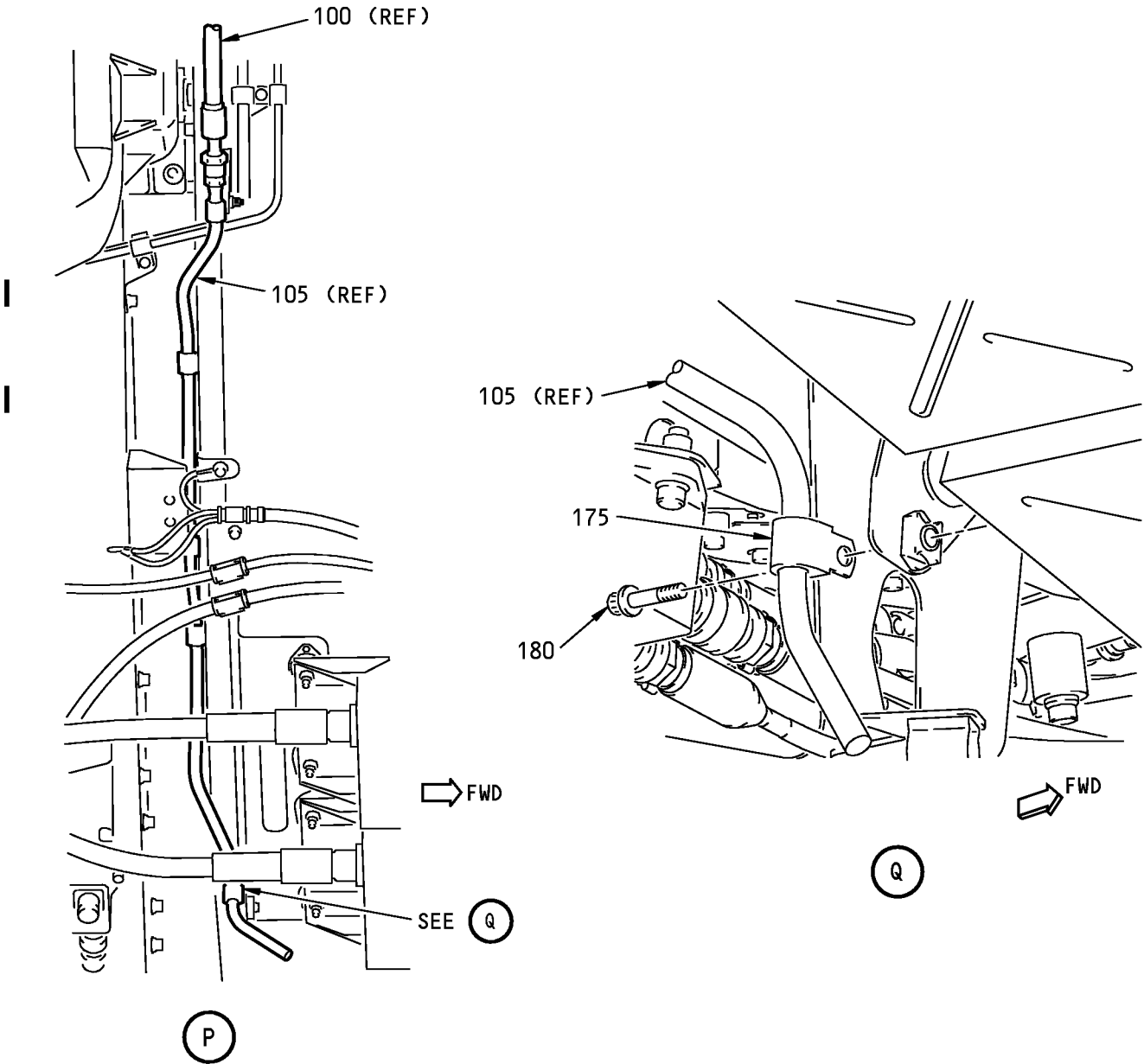

G75061 S00041153786\_V2

**Drains Installation - Right Side Fan Case**  
**Figure 10-1 (Sheet 7)**

**71-00-02**

P/P BUILDUP FIGURE 10-1  
Page 14  
Feb 05/2008

D633A106-HXL

**737-600/700/800/900  
POWERPLANT BUILDUP MANUAL**

ITEM NO.	PART NUMBER	NOMENCLATURE	UC	QTY
10-1		<p><b>DRAINS INSTALLATION - RIGHT SIDE FAN CASE (FIGURE 10-1, SHEET 7)</b></p> <p>APPLY LIGHT COATING OF Never-Seez NSBT-8N compound, D00006 (C6) TO THREADS AND UNDERSIDE HEAD OF BOLTS. AT BOTTOM LOCATION, LOOSELY ATTACH TUBE ASSY (105) TO ENGINE BRACKET WITH CLAMP (175) AND BOLT (180).</p> <p>. CLAMP</p> <p>. BOLT</p> <p>. COMPOUND, NEVER-SEEZ NSBT-8N</p> <p>ADJUST TUBE ASSY (105) TO BEST POSITION. MAKE SURE PRELOAD AT ALL CLAMP POINTS IS NOT MORE THAN 10 POUNDS (44.5 NEWTONS).</p> <p>TIGHTEN BOLTS (115), (135), (180) AND EXISTING CFMI FASTENER TO 110-120 POUND-INCHES (12.4-13.6 NEWTON METERS).</p>	CON	1 1 AR
175	J1221G06			1
180	BACB30ZF4-06			1
C6	D00006			AR

**71-00-02**

P/P BUILDUP FIGURE 10-1

Page 15

Oct 05/2007

D633A106-HXL

FIGURE 11-1

**THIS FIGURE NOT USED**

**71-00-02**

P/P BUILDUP FIGURE 11-1

Page 1

Oct 05/2007

D633A106-HXL

**737-600/700/800/900  
POWERPLANT BUILDUP MANUAL**

**THIS SHEET NOT USED**

**THIS SHEET NOT USED  
Figure 11-1 (Sheet 1)**

**71-00-02**

P/P BUILDUP FIGURE 11-1

Page 2

Oct 05/2007

D633A106-HXL

737-600/700/800/900  
POWERPLANT BUILDUP MANUAL

ITEM NO.	PART NUMBER	NOMENCLATURE	UC	QTY
11-1		THIS SHEET NOT USED (FIGURE 11-1, SHEET 1) THIS SHEET NOT USED		

**71-00-02**

P/P BUILDUP FIGURE 11-1

Page 3

Oct 05/2007

D633A106-HXL

**FIGURE 12-1**

# **FUEL SUPPLY HOSE INSTALLATION**

**REF QEC TASK NO.: 12**

**REF DWG: 332A2100**

**NOTE:** ALL STANDARDS AND ATTACHING HARDWARE FOR THIS FIGURE WILL BE PACKAGED IN QEC TASK NO. 110.

**71-00-02**

P/P BUILDUP FIGURE 12-1

Page 1

Oct 05/2007

D633A106-HXL

737-600/700/800/900  
**POWERPLANT BUILDUP MANUAL**

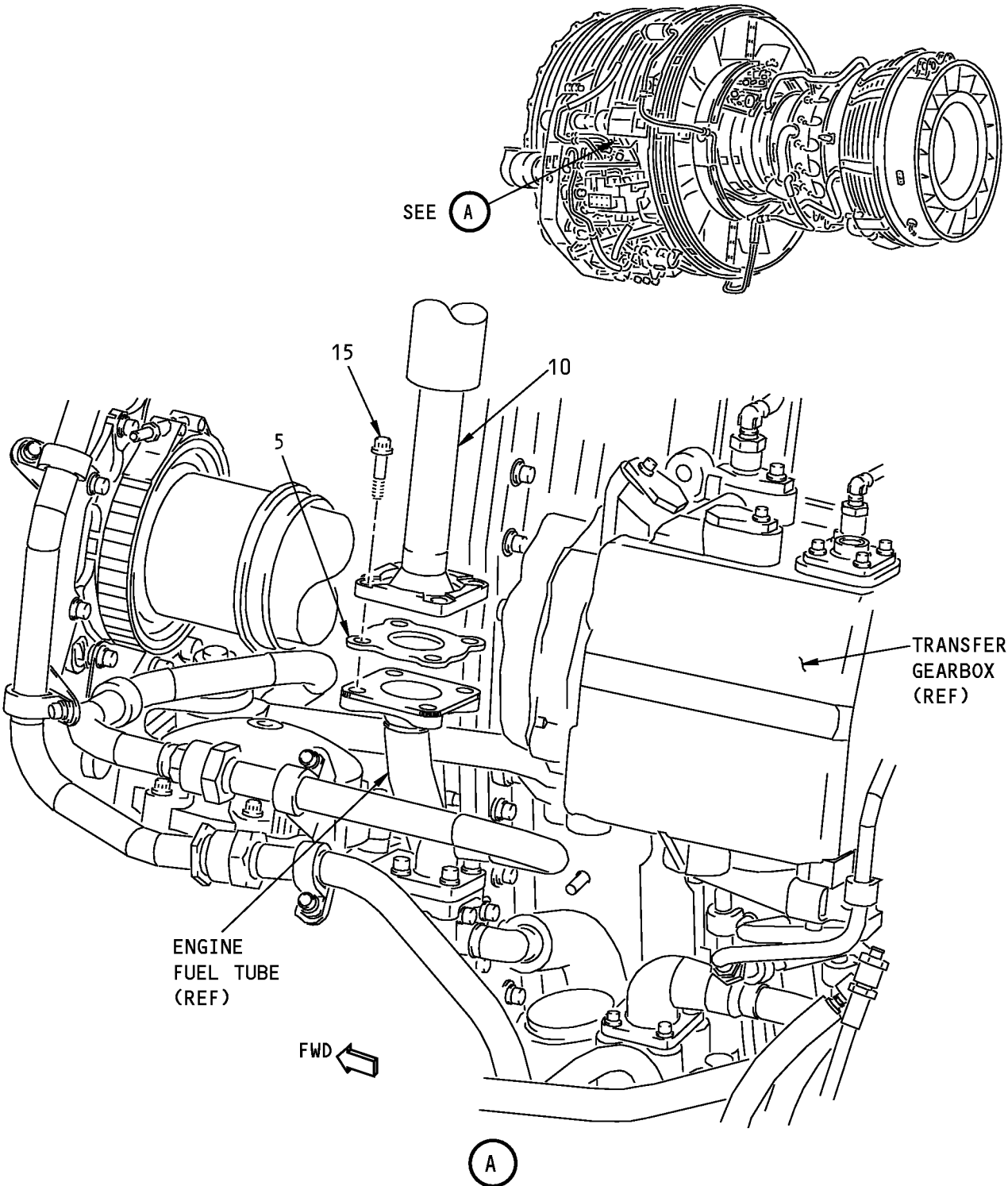

**Fuel Supply Hose Installation**  
**Figure 12-1 (Sheet 1)**

**71-00-02**

P/P BUILDUP FIGURE 12-1

Page 2

Oct 05/2007

D633A106-HXL



**737-600/700/800/900  
POWERPLANT BUILDUP MANUAL**

ITEM NO.	PART NUMBER	NOMENCLATURE	UC	QTY
12-1		<b>FUEL SUPPLY HOSE INSTALLATION (FIGURE 12-1, SHEET 1)</b>		
		VISUALLY EXAMINE ALL GASKETS AND FITTINGS FOR DAMAGE. REJECT PARTS WITH DAMAGE TO THREADS, SEAL AREAS ON FITTINGS, AND O-RINGS.		
		LUBRICATE GASKET (5) WITH grease, D00504 (C1). POSITION GASKET (5) ON ENGINE FUEL TUBE.		
5	MS27198-24	. GASKET		1
C1	D00504	. LUBRICANT, VV-P-236	CON	AR
		POSITION FUEL SUPPLY HOSE ASSY (10) ON ENGINE FUEL TUBE AND GASKET (5). ATTACH HOSE ASSY (10) TO ENGINE FUEL TUBE WITH BOLTS (15).		
10	AE713733-1	. HOSE ASSY, FUEL SUPPLY (V00624)	VEN	1
10	S332A280-5	. BOEING SPEC FOR AE713733-1	BOE	-
15	BACB30ZF4-14	. BOLT		4
		TIGHTEN BOLTS (15) TO 55-60 POUND-INCHES (6.2-6.8 NEWTON METERS)		

**71-00-02**

P/P BUILDUP FIGURE 12-1

Page 3

Oct 05/2007

D633A106-HXL

737-600/700/800/900  
**POWERPLANT BUILDUP MANUAL**

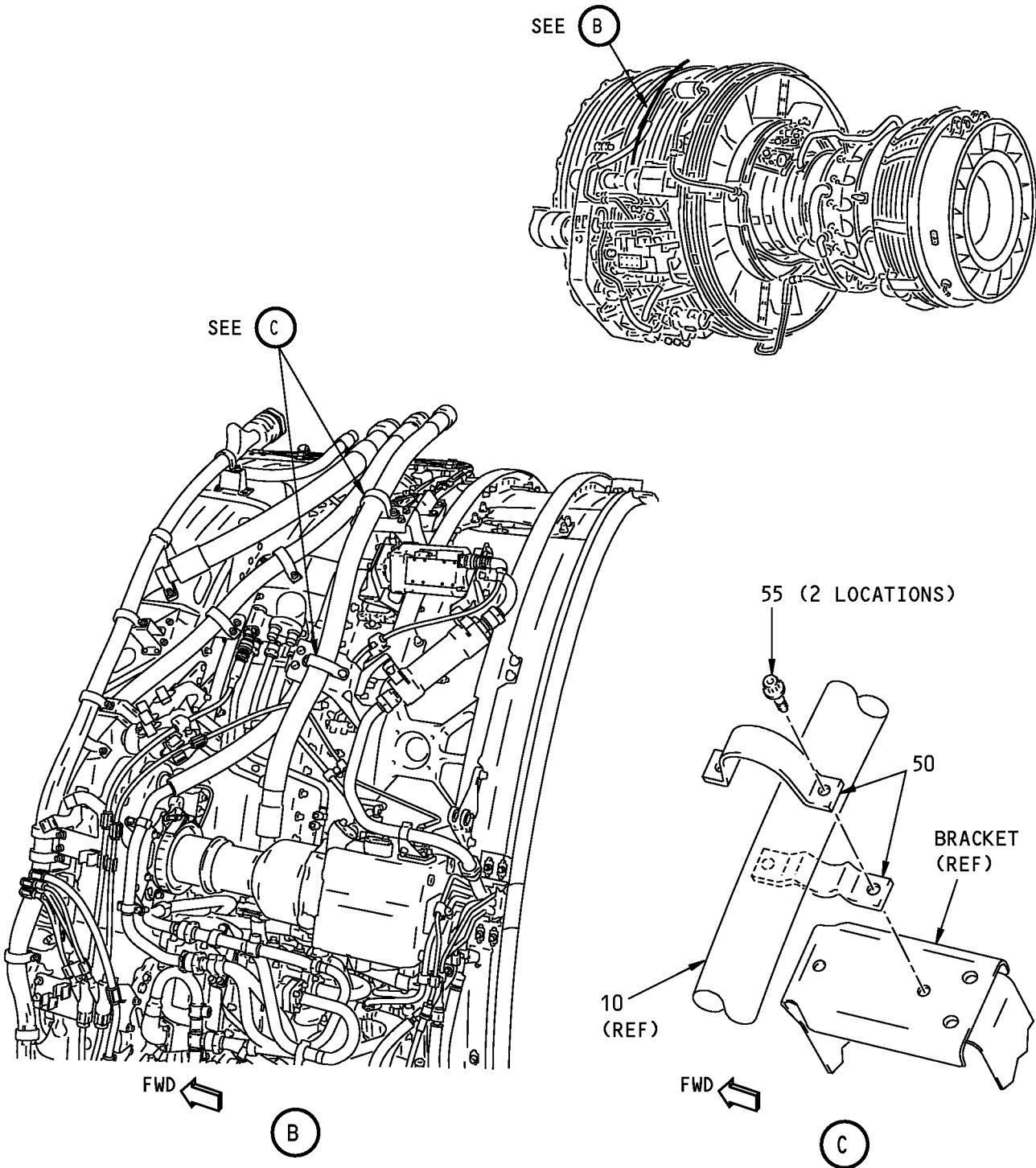

**Fuel Supply Hose Installation**  
Figure 12-1 (Sheet 2)

**71-00-02**

P/P BUILDUP FIGURE 12-1

Page 4

Oct 05/2007

D633A106-HXL

**737-600/700/800/900  
POWERPLANT BUILDUP MANUAL**

ITEM NO.	PART NUMBER	NOMENCLATURE	UC	QTY
12-1		<p><b>FUEL SUPPLY HOSE INSTALLATION (FIGURE 12-1, SHEET 2)</b></p> <p>AT TWO LOCATIONS, LOOSELY INSTALL HOSE ASSY (10) ON LEFT FAN CASE WITH CLAMP (50) AND BOLTS (55).</p> <p>. CLAMP (V84971)</p> <p>. BOLT</p> <p>ADJUST HOSE ASSY (10) TO BEST POSITION AND TIGHTEN BOLTS (55) TO 110-120 POUND-INCHES (12.4-13.6 NEWTON METERS).</p>	VEN	2 4
50	TAO910091H1			
55	BACB30ZF4-07			

**71-00-02**

P/P BUILDUP FIGURE 12-1

Page 5

Oct 05/2007

D633A106-HXL

**FIGURE 13-1**

# **12 O’CLOCK STRUT INSTALLATION**

**REF QEC TASK NO.: 13**

**REF DWG: 332A2300  
332A2370**

**NOTE:** ALL STANDARDS AND ATTACHING HARDWARE FOR THIS FIGURE WILL BE PACKAGED IN QEC TASK NO. 110.

**71-00-02**

P/P BUILDUP FIGURE 13-1

Page 1

Oct 05/2007

D633A106-HXL

737-600/700/800/900  
POWERPLANT BUILDUP MANUAL

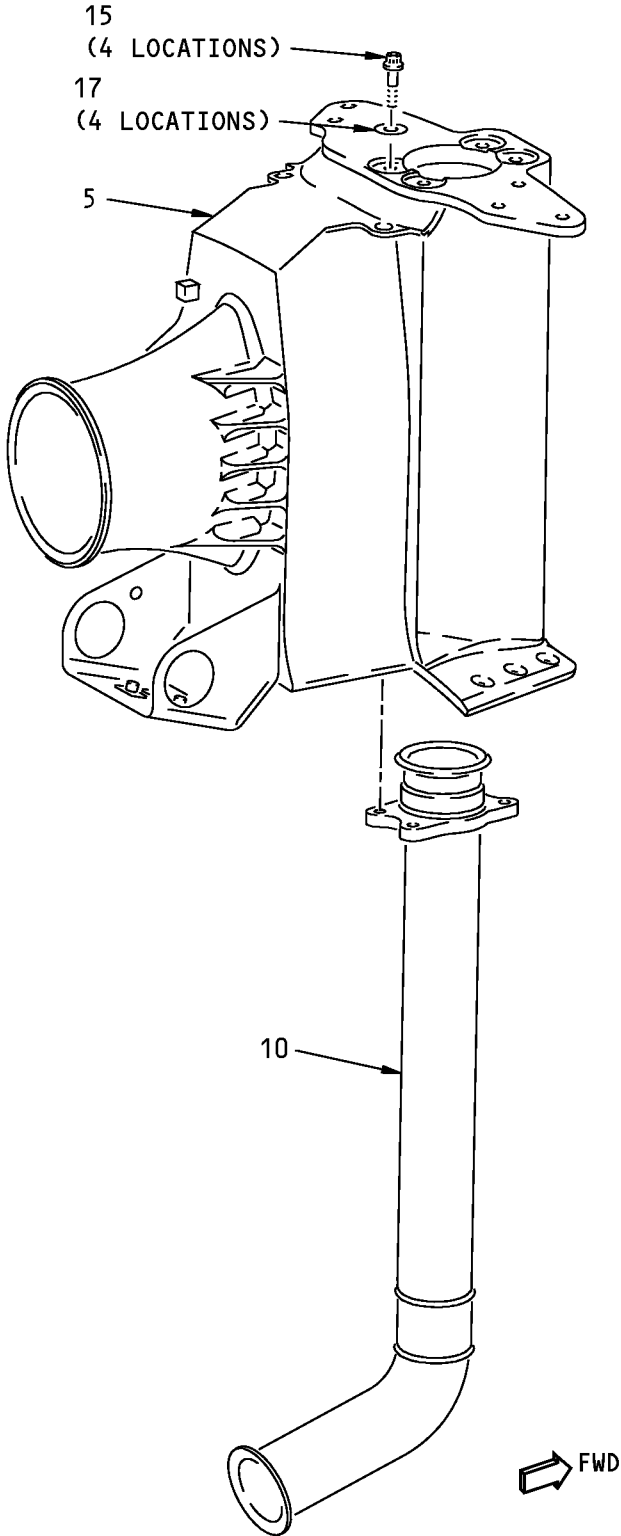

12 O'Clock Strut Installation  
Figure 13-1 (Sheet 1)

**71-00-02**

**737-600/700/800/900  
POWERPLANT BUILDUP MANUAL**

ITEM NO.	PART NUMBER	NOMENCLATURE	UC	QTY
13-1		<p><b>12 O'CLOCK STRUT INSTALLATION (FIGURE 13-1, SHEET 1)</b></p> <p>IN THIS PROCEDURE, DO NOT TIGHTEN BOLTS UNLESS INSTRUCTED OR INSTALL PARTS IN A DIFFERENT SEQUENCE.</p> <p>PREASSEMBLY OF 12 O'CLOCK STRUT</p> <p><b>CAUTION:</b> BE CAREFUL NOT TO GOUGE THE INNER WALL OF THE 12 O'CLOCK STRUT WHEN THE CTAI DUCT ASSY IS INSTALLED.</p> <p>APPLY Never-Seez NSBT-8N compound, D00006 (C1) TO THREADS AND SHANK OF BOLTS (15).</p> <p>INSTALL DUCT ASSY (10) INTO 12 O'CLOCK STRUT (5) FROM BOTTOM.</p> <p>SECURE WITH BOLTS (15), WASHERS (17), AND safety cable kit, G50375 (C6) OR lockwire, G01912 (C7).</p>		
5	332A2371-3	. 12 O'CLOCK STRUT ASSY		1
10	332A2390-45	. DUCT ASSY-CTAI		1
10	332A2390-43	. DUCT ASSY-CTAI (OPTIONAL TO 332A2390-45)	OPT	-
15	BACB30PN4H7	. BOLT		4
17	BACW10BP4ACU	. WASHER		4
C1	D00006	. COMPOUND, NEVER-SEEZ NSBT-8N	CON	AR
C6	G50375	. SAFETY CABLE, BACC13AT3K18	CON	AR
C7	G01912	. LOCKWIRE, MS20995NC32	CON	AR
		TIGHTEN BOLTS (15) TO 73-77 POUND-INCHES (8.25-8.7 NEWTON METERS).		

# 71-00-02

P/P BUILDUP FIGURE 13-1

Page 3

Feb 05/2008

D633A106-HXL

737-600/700/800/900  
**POWERPLANT BUILDUP MANUAL**

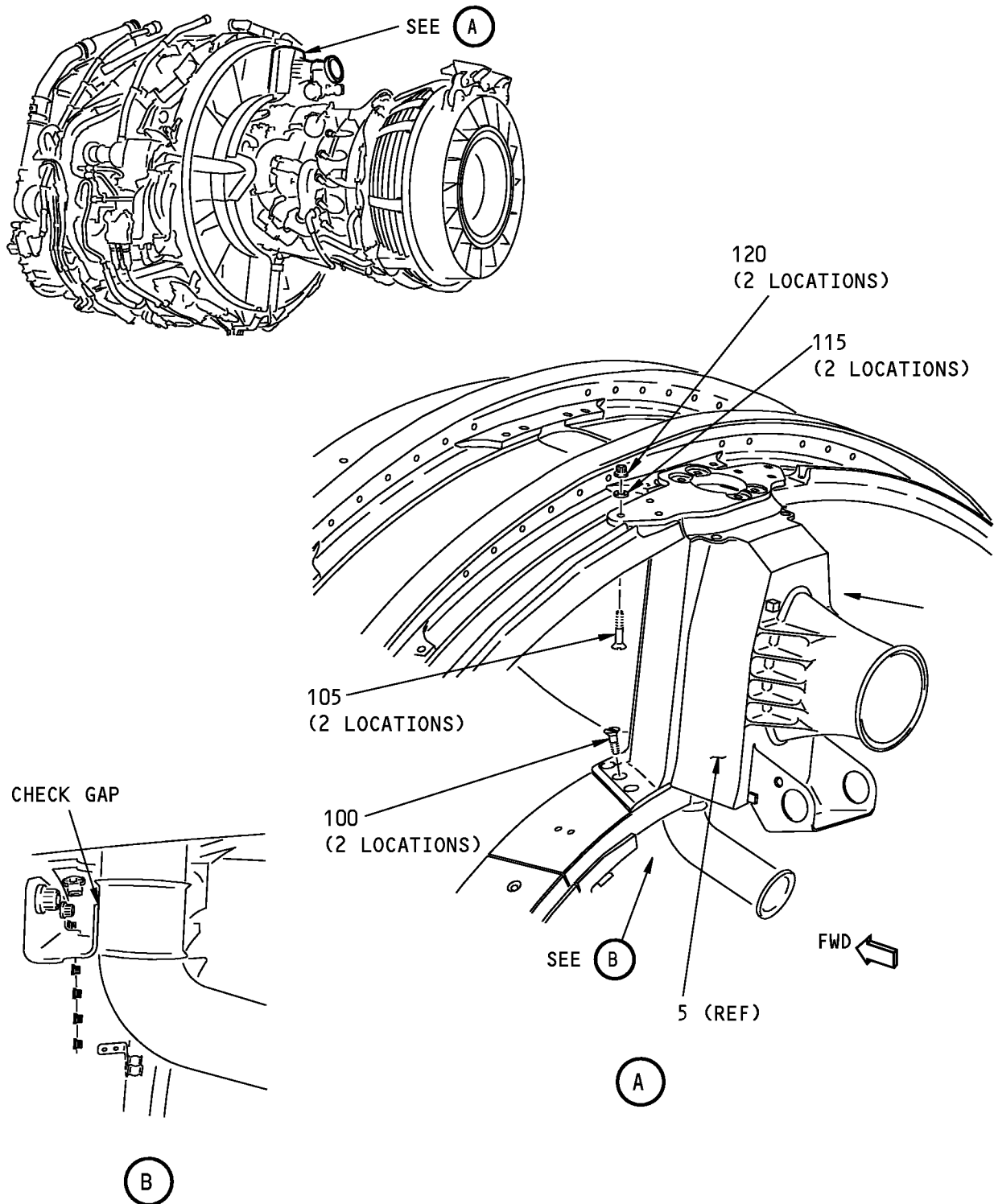

**12 O'Clock Strut Installation**  
**Figure 13-1 (Sheet 2)**

**71-00-02**

P/P BUILDUP FIGURE 13-1

Page 4

Oct 05/2007

D633A106-HXL

**737-600/700/800/900  
POWERPLANT BUILDUP MANUAL**

ITEM NO.	PART NUMBER	NOMENCLATURE	UC	QTY
13-1		<p><b>12 O'CLOCK STRUT INSTALLATION (FIGURE 13-1, SHEET 2)</b></p> <p>TEMPORARILY SECURE 12 O'CLOCK STRUT ASSY (5) TO FAN CASE.</p> <p>ATTACH LOWER FLANGES OF STRUT ASSY TO EXTENSION RING OF ENGINE USING BOLTS (100) IN CENTER HOLE OF FLANGES.</p> <p>ATTACH UPPER FLANGES OF STRUT ASSY TO OUTER FAN CASE USING BOLTS (105), WASHERS (115) AND NUTS (120) IN OUTER HOLE OF FLANGES.</p> <p>CHECK DUCT ASSY (10) POSITION.</p> <p>DUCT MUST BE FLUSH TO FAN FRAME MOUNTING SURFACE WITHOUT PRELOADING DUCT.</p> <p>TO ADJUST DUCT POSITION AFT;</p> <p>REMOVE 12 O'CLOCK STRUT ASSY (5) FROM ENGINE. REMOVE DUCT ASSY (10) FROM 12 O'CLOCK STRUT.</p> <p>INSTALL WASHERS (20) OR WASHERS (25) BETWEEN FWD FLANGE HOLES OF DUCT ASSY AND 12 O'CLOCK STRUT. WASHERS MUST BE INSTALLED IN MATCHED FORWARD, AFT, LEFT OR RIGHT PAIRS ONLY. DIAGONAL PAIRS NOT ACCEPTABLE.</p> <p>TO ADJUST DUCT POSITION FWD;</p> <p>REMOVE 12 O'CLOCK STRUT ASSY (5) FROM ENGINE. REMOVE DUCT ASSY (10) FROM 12 O'CLOCK STRUT.</p> <p>INSTALL WASHERS (20) OR WASHERS (25) BETWEEN AFT FLANGE HOLES OF DUCT ASSY AND 12 O'CLOCK STRUT. WASHERS MUST BE INSTALLED IN MATCHED FORWARD, AFT, LEFT OR RIGHT PAIRS ONLY. DIAGONAL PAIRS NOT ACCEPTABLE.</p>		
20	NAS1149C0432R	. WASHER (THICK) <sup>*[1]</sup>		AR
25	NAS1149C0416R	. WASHER (THIN) <sup>*[1]</sup>		AR
		<p>TEMPORARILY RE-SECURE 12 O'CLOCK STRUT. RECHECK DUCT POSITION. REPEAT THE ABOVE PROCEDURE UNTIL DUCT IS ALIGNED.</p> <p>*[1] ITEM NOT ILLUSTRATED</p>		

**71-00-02**

P/P BUILDUP FIGURE 13-1

Page 5

Oct 05/2007

D633A106-HXL



737-600/700/800/900  
**POWERPLANT BUILDUP MANUAL**

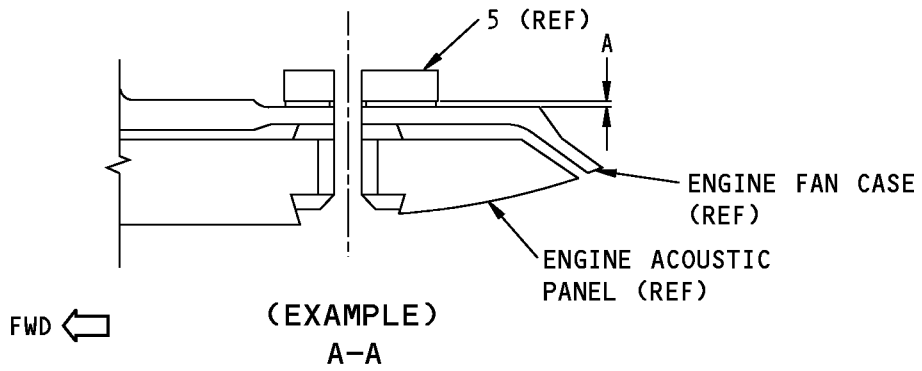
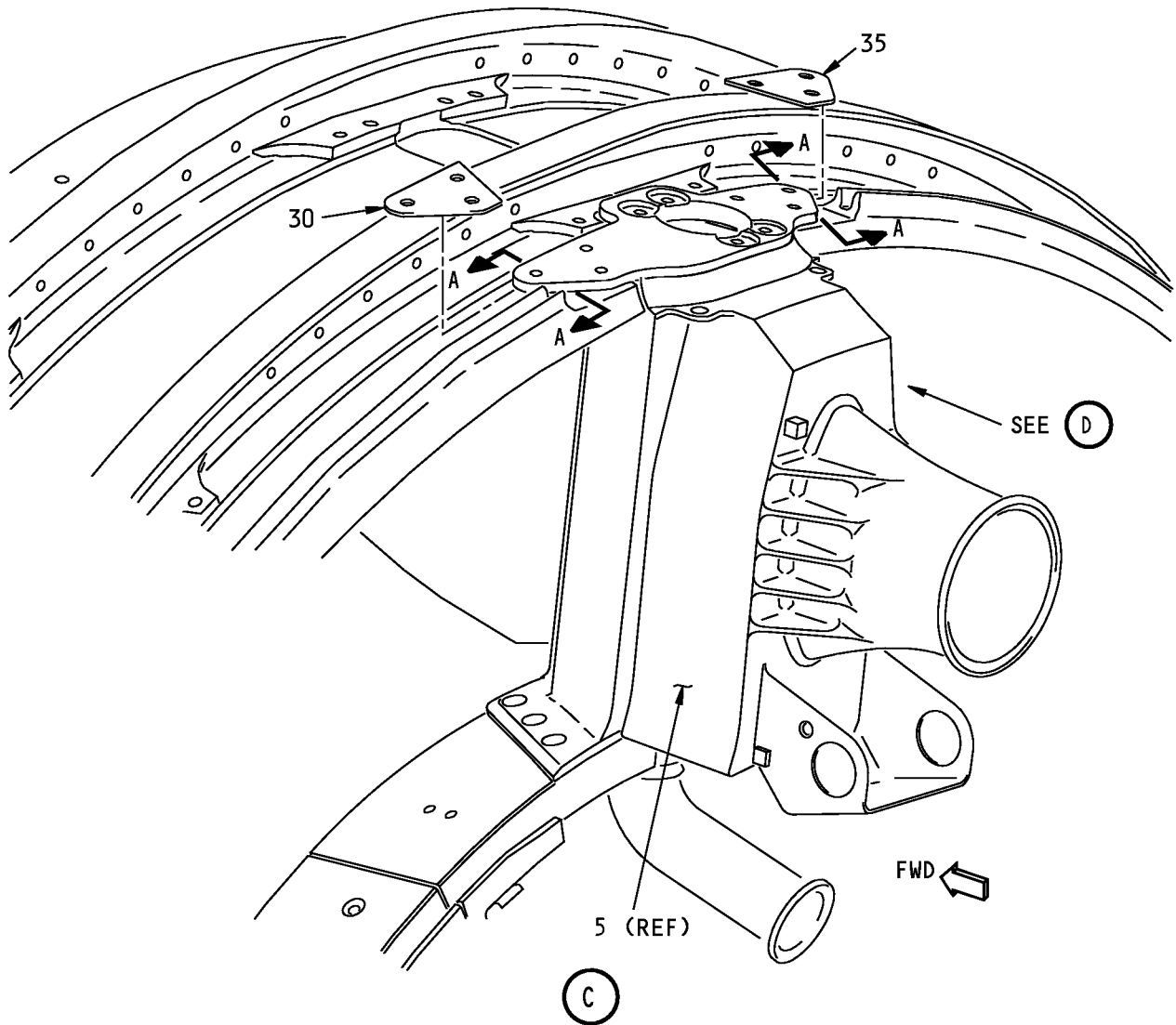

**12 O'Clock Strut Installation**  
**Figure 13-1 (Sheet 3)**

**71-00-02**

P/P BUILDUP FIGURE 13-1

Page 6

Oct 05/2007

D633A106-HXL

**737-600/700/800/900  
POWERPLANT BUILDUP MANUAL**

ITEM NO.	PART NUMBER	NOMENCLATURE	UC	QTY
13-1		<p><b>12 O'CLOCK STRUT INSTALLATION (FIGURE 13-1, SHEET 3)</b></p> <p>MEASURE GAP "A" BETWEEN OUTER FAN CASE AND 12 O'CLOCK STRUT ON BOTH SIDES. PEEL SHIMS (30) AND (35) UNTIL DESIRED THICKNESS IS ACHIEVED.</p> <p><b>NOTE:</b> IF GAP EXCEEDS 0.063 INCH (1.6 MM), USE TWO SHIMS. GAPS OF 0.070 INCH (1.78 MM) OR MORE ARE NOT PERMITTED.</p>		
30	332A2373-1	. SHIM, LH (MAX OF 2)		AR
35	332A2373-2	. SHIM, RH (MAX OF 2)		AR
		<p>REMOVE 12 O'CLOCK STRUT (5) FROM ENGINE. KEEP SHIMS AND FASTENERS FOR LATER INSTALLATION.</p>		

**71-00-02**

P/P BUILDUP FIGURE 13-1

Page 7

Oct 05/2007

D633A106-HXL

737-600/700/800/900  
POWERPLANT BUILDUP MANUAL

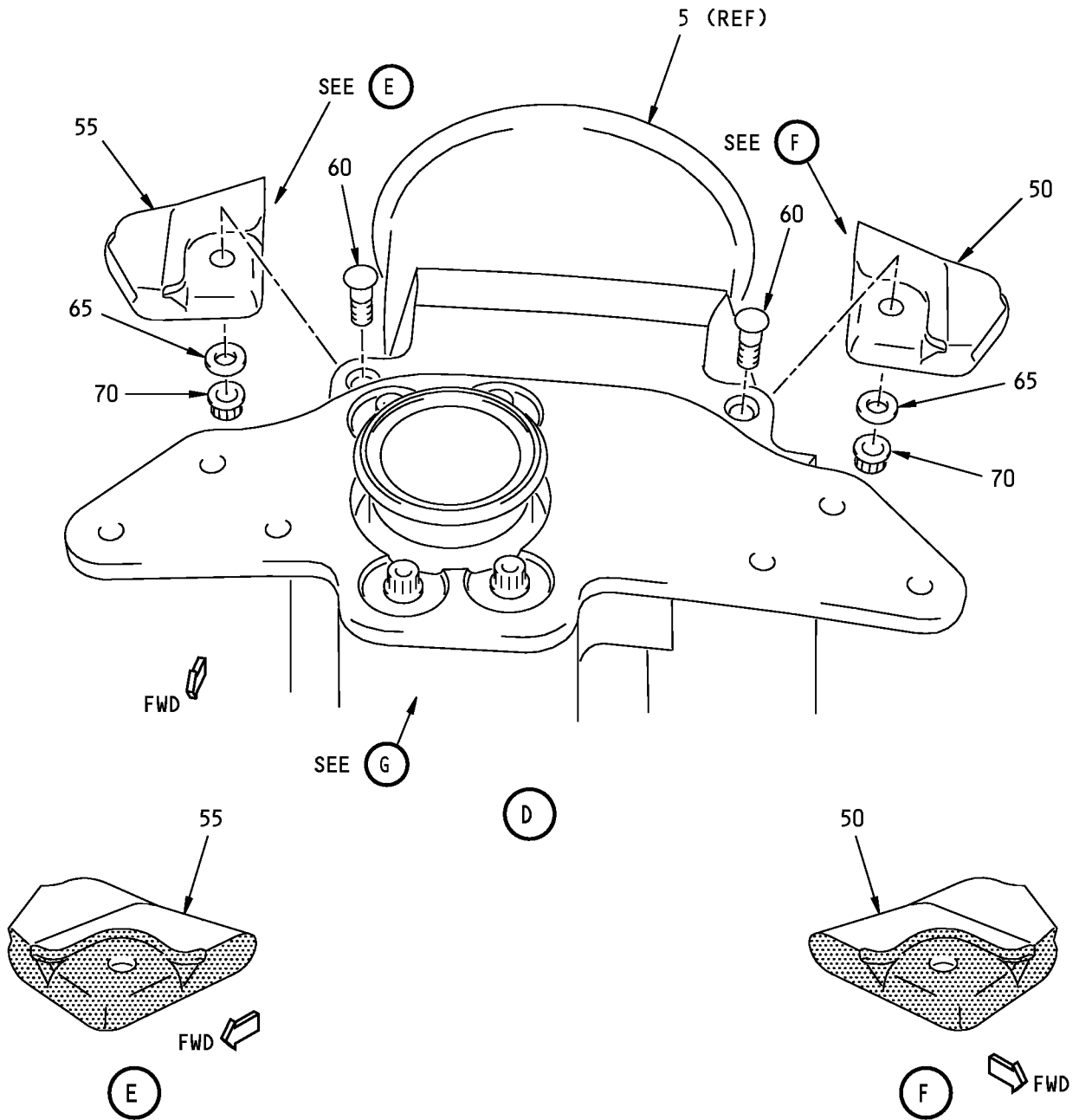

 AREAS OF SEALANT APPLICATION.

12 O'Clock Strut Installation  
Figure 13-1 (Sheet 4)

**71-00-02**

P/P BUILDUP FIGURE 13-1

Page 8

Oct 05/2007

D633A106-HXL

**737-600/700/800/900  
POWERPLANT BUILDUP MANUAL**

ITEM NO.	PART NUMBER	NOMENCLATURE	UC	QTY
13-1		<p><b>12 O'CLOCK STRUT INSTALLATION (FIGURE 13-1, SHEET 4)</b></p> <p><b>CAUTION:</b> MAKE SURE ALL SEALANTS ARE APPLIED CORRECTLY. 12 O'CLOCK STRUT IS PART OF FIRE SHIELD BETWEEN ENGINE AND STRUT. INCORRECT APPLICATION OF SEALANTS MAY WEAKEN FIRE PROTECTION.</p> <p>IF sealant, A00160 (C3) IS USED, BRUSH APPLY Dapco No. 1-100 primer, C00944 (C2) TO FAYING SURFACES ON SEALS (50) AND (55) AND 12 O'CLOCK STRUT (5).</p>		
50	332A2372-3	. SEAL, LH		1
55	332A2372-4	. SEAL, RH		1
C2	C00944	. PRIMER, DAPCO NO. 1-100	CON	AR
		APPLY sealant, A00160 (C3) OR sealant, A00803 (C4) TO FAYING SURFACES SHOWN ON SEALS (50) AND (55). ATTACH SEALS TO 12 O'CLOCK STRUT (5) WITH BOLTS (60), WASHERS (65) AND NUTS (70).		
60	BACB30VF4K3	. BOLT		2
65	BACW10BP4PK	. WASHER (UNDER NUT)		2
70	BACN11Z4CK	. NUT		2
C3	A00160	. SEALANT, BMS5-63 TYPE I	CON	AR
C4	A00803	. SEALANT, BMS5-63 TYPE II	CON	AR
		TIGHTEN BOLTS (60) TO 10 POUND-INCHES (1.1 NEWTON METERS).		
		<b>NOTE:</b> TO FACILITATE INSTALLATION, Figure 14-1 ITEMS 5 THRU 30 MAY BE ATTACHED TO 12 O'CLOCK STRUT (5) AT THIS TIME.		

# 71-00-02

P/P BUILDUP FIGURE 13-1

Page 9

Oct 05/2007

D633A106-HXL

737-600/700/800/900  
**POWERPLANT BUILDUP MANUAL**

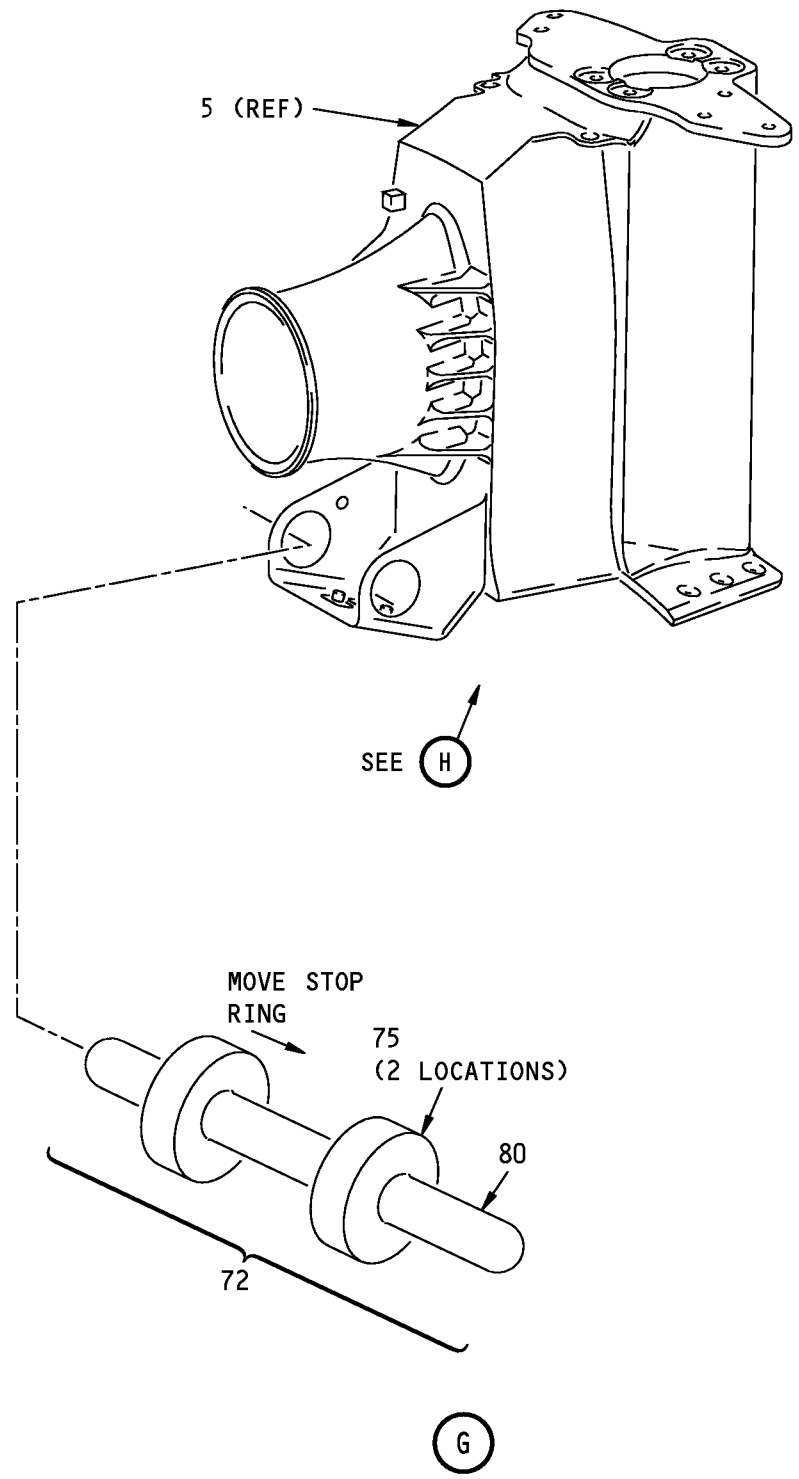

**12 O'Clock Strut Installation**  
**Figure 13-1 (Sheet 5)**

**71-00-02**

## POWERPLANT BUILDUP MANUAL

ITEM NO.	PART NUMBER	NOMENCLATURE	UC	QTY
13-1		<b>12 O'CLOCK STRUT INSTALLATION (FIGURE 13-1, SHEET 5)</b>  MOVE LH RUBBER STOP RING (75) TOWARDS CENTER OF ROD (80). POSITION ROD ASSY (72) IN 12 O'CLOCK STRUT (5) BRACKET.  RE-POSITION LH STOP RING (75) IN ROD (80) CHANNEL.		
72	315A2080-4	. ROD ASSY		1
72	315A2080-1	. ROD ASSY (OPTIONAL TO 315A2080-4)	OPT	-
75	315A2083-1	. . STOP RING (QTY 2)	REF	-
80	315A2081-5	. . ROD (QTY 1)	REF	-

**71-00-02**

P/P BUILDUP FIGURE 13-1

Page 11

Oct 05/2007

D633A106-HXL

737-600/700/800/900  
**POWERPLANT BUILDUP MANUAL**

APPLY SEALANT APPROXIMATELY  
0.5 INCH (1.3 cm) THICK BY  
1.0 INCH (2.5 cm) WIDE IN  
THIS AREA.

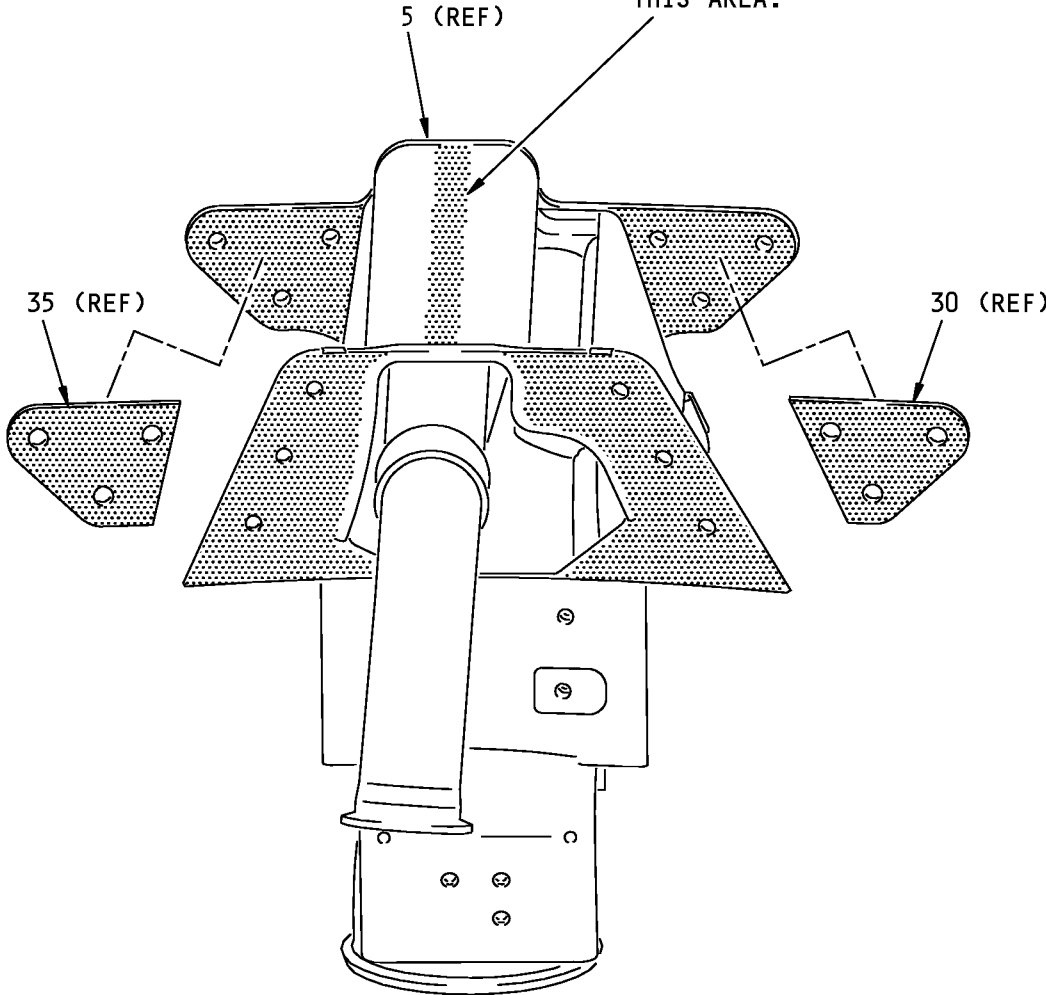

H



AREAS OF SEALANT APPLICATION.

**12 O'Clock Strut Installation**  
**Figure 13-1 (Sheet 6)**

**71-00-02**

P/P BUILDUP FIGURE 13-1

Page 12

Oct 05/2007

D633A106-HXL

## POWERPLANT BUILDUP MANUAL

ITEM NO.	PART NUMBER	NOMENCLATURE	UC	QTY
13-1		<p><b>12 O'CLOCK STRUT INSTALLATION (FIGURE 13-1, SHEET 6)</b></p> <p>IF sealant, A00160 (C3) IS USED, APPLY Dapco No. 1-100 primer, C00944 (C2) TO FAYING SURFACES OF 12 O'CLOCK STRUT ASSY (5) AND INNER AND OUTER ENGINE FAN CASE AND TO BOTH SIDES OF SHIMS (30) AND (35). PERMIT PRIMER TO DRY.</p> <p><b>NOTE:</b> Dapco No. 1-100 primer, C00944 (C2) DRIES IN APPROXIMATELY 1 HOUR AND CHANGES FROM A GREEN COLOR TO A PINK COLOR.</p>		
C2	C00944	<p>. PRIMER, DAPCO NO. 1-100</p> <p>APPLY sealant, A00160 (C3) OR sealant, A00803 (C4) TO FAYING SURFACES OF 12 O'CLOCK STRUT ASSY (5) WITH INNER AND OUTER FAN CASE, TO FORWARD LOCATION OF 12 O'CLOCK STRUT AND TO BOTTOM OF SHIMS (30) AND (35) AS SHOWN.</p> <p><b>NOTE:</b> WHEN APPLYING SEALANT, ENSURE LAYER IS UNIFORM AND COVERS ENTIRE FAYING SURFACE TO A DEPTH OF 0.005-0.010 INCH. AN ADDITIONAL SMALL BEAD OF SEALANT NEAR EDGE OF FAYING SURFACE IS PERMITTED TO ENSURE PROPER SQUEEZE-OUT OF SEALANT.</p> <p>ATTACH SHIMS (30) AND (35) TO OUTER ENGINE FAN CASE FAYING SURFACES, ALIGNING HOLES IN SHIMS WITH HOLES IN ENGINE FAN CASE. APPLY sealant, A00160 (C3) TO TOP FAYING SURFACE OF SHIMS (30) AND (35).</p> <p><b>NOTE:</b> SEALANT MUST BE APPLIED ON BOTH SIDES OF SHIMS.</p>	CON	AR
C3	A00160	. SEALANT, BMS5-63 TYPE I	CON	AR
C4	A00803	. SEALANT, BMS5-63 TYPE II	CON	AR

71-00-02

P/P BUILDUP FIGURE 13-1

Page 13

Oct 05/2007

D633A106-HXL



737-600/700/800/900  
**POWERPLANT BUILDUP MANUAL**

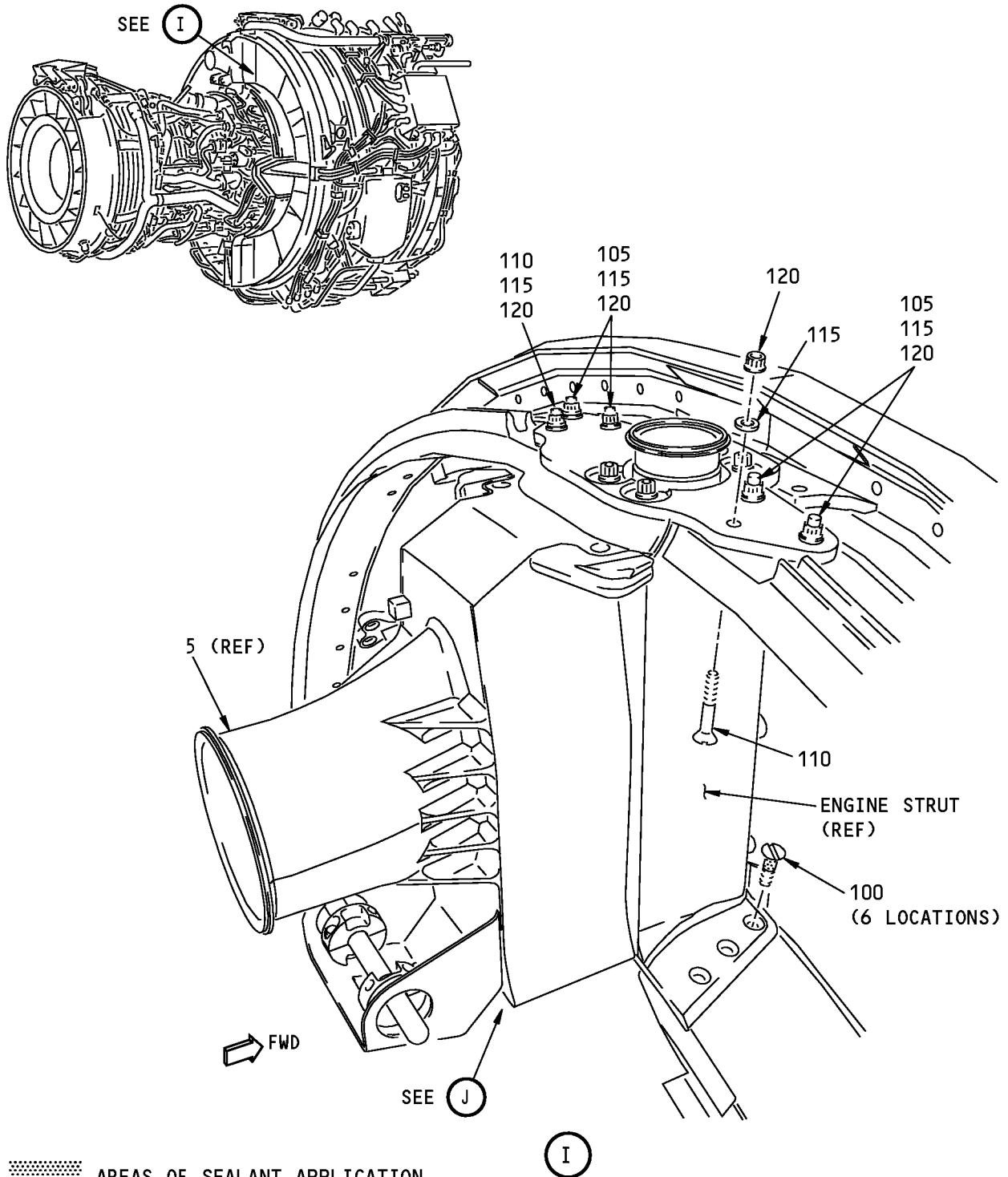

▨ AREAS OF SEALANT APPLICATION.

**12 O'Clock Strut Installation**  
**Figure 13-1 (Sheet 7)**

**71-00-02**

P/P BUILDUP FIGURE 13-1

Page 14

Oct 05/2007

D633A106-HXL

**737-600/700/800/900  
POWERPLANT BUILDUP MANUAL**

ITEM NO.	PART NUMBER	NOMENCLATURE	UC	QTY
13-1		<p><b>12 O'CLOCK STRUT INSTALLATION (FIGURE 13-1, SHEET 7)</b></p> <p>APPLY Guardsman 598-5002 coating, G02185 (C5) TO SURFACES ON ENGINE OPPOSITE WHERE PRIMER (C2) WAS APPLIED (INNER AND OUTER ENGINE FAN CASE INTERFACES AND DOWN THE CENTER AREA OF ENGINE STRUT INTERFACE WITH 12 O'CLOCK STRUT (5)).</p> <p><b>NOTE:</b> APPLY AGENT TO A WIDE ENOUGH AREA TO ALLOW FOR SEALANT SQUEEZE-OUT.</p>		
C5	G02185	. AGENT-PARTING, 598-5002	CON	AR
		LUBRICATE SHANKS OF BOLTS (105) AND (110) WITH sealant, A00160 (C3) OR sealant, A00803 (C4).		
		APPLY Never-Seez NSBT-8N compound, D00006 (C1) TO THREADS AND SHANK OF BOLTS (100).		
100	BACB30NN4K7	. BOLT		6
100	BACB30NN4K6	. BOLT <sup>[1]</sup>	OPT	-
105	BACB30NN4K18	. BOLT		4
110	BACB30NN4K16	. BOLT		2
C1	D00006	. COMPOUND, NEVER-SEEZ NSBT-8N	CON	AR
C3	A00160	. SEALANT, BMS5-63 TYPE I	CON	AR
C4	A00803	. SEALANT, BMS5-63 TYPE II	CON	AR
		POSITION 12 O'CLOCK STRUT ASSY (5) ON ENGINE FAN CASE. ATTACH 12 O'CLOCK STRUT ASSY (5) TO INNER FAN CASE WITH LUBRICATED BOLTS (100).		
		ATTACH 12 O'CLOCK STRUT ASSY TO OUTER FAN CASE WITH LUBRICATED BOLTS (105) AND (110), WASHERS (115) AND NUTS (120).		
		<b>NOTE:</b> IF GAP REMAINS AFTER TIGHTENING BOLT (105, 110), USE OF AN ADDITIONAL WASHER (115) IS PERMITTED.		
115	BACW10BP4PK	. WASHER		6
120	BACN11Z4CK	. NUT		6
		MAKE SURE BOLTS (100) FULLY ENGAGE NUTPLATES. CHECK BOLT PROTRUSION. MINIMUM BOLT PROTRUSION IS WHEN BOLT IS FLUSH WITH THE END OF THE NUTPLATE.		
		TIGHTEN BOLTS (100) TO 68-82 POUND-INCHES (7.7-9.3 NEWTON METERS).		
		TIGHTEN BOLTS (105) AND (110) TO 72-88 POUND-INCHES (8.1-9.9 NEWTON METERS).		
		*[1] USE IF BACB30NN4K7 CANNOT BE FULLY TIGHTENED		

# 71-00-02

P/P BUILDUP FIGURE 13-1

Page 15

Oct 05/2007

D633A106-HXL

737-600/700/800/900  
**POWERPLANT BUILDUP MANUAL**

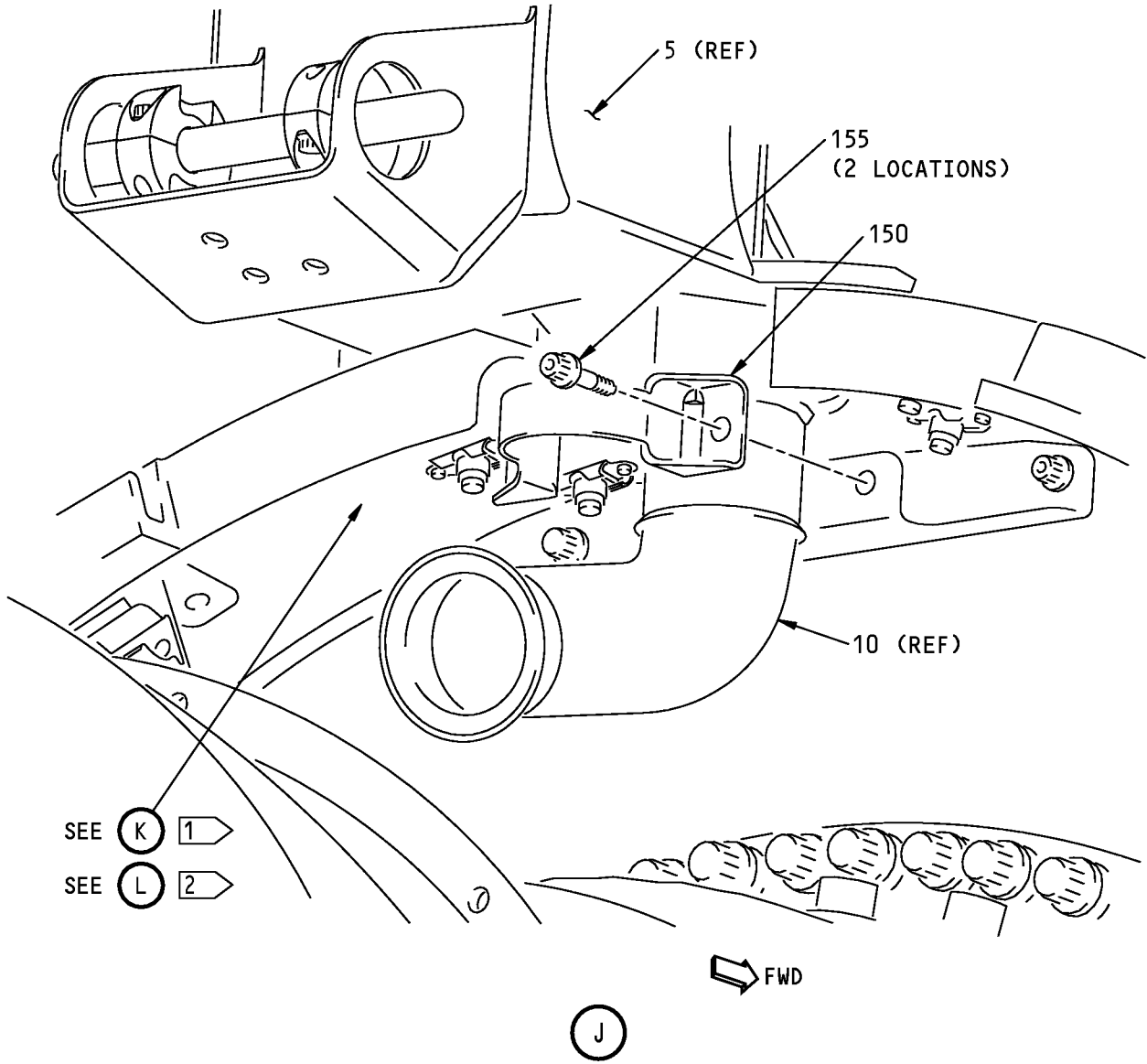

- 1 ➤ PREFERRED CONFIGURATION
- 2 ➤ OPTIONAL CONFIGURATION

**12 O'Clock Strut Installation**  
**Figure 13-1 (Sheet 8)**

**71-00-02**

**737-600/700/800/900  
POWERPLANT BUILDUP MANUAL**

ITEM NO.	PART NUMBER	NOMENCLATURE	UC	QTY
13-1		<p><b>12 O'CLOCK STRUT INSTALLATION (FIGURE 13-1, SHEET 8)</b></p> <p>SECURE CTAI DUCT (10) TO ENGINE FAN FRAME WITH RETAINING STRAP (150) AND BOLTS (155).</p> <p>. RETAINING STRAP</p> <p>. BOLT</p> <p>TIGHTEN BOLTS (155) TO 60-70 POUND-INCHES (6.77-7.9 NEWTON METERS).</p>		1 2
150	9134M25P29			1
155	BACB30ZF4-08			2

# 71-00-02

P/P BUILDUP FIGURE 13-1

Page 17

Oct 05/2007

D633A106-HXL

737-600/700/800/900  
POWERPLANT BUILDUP MANUAL

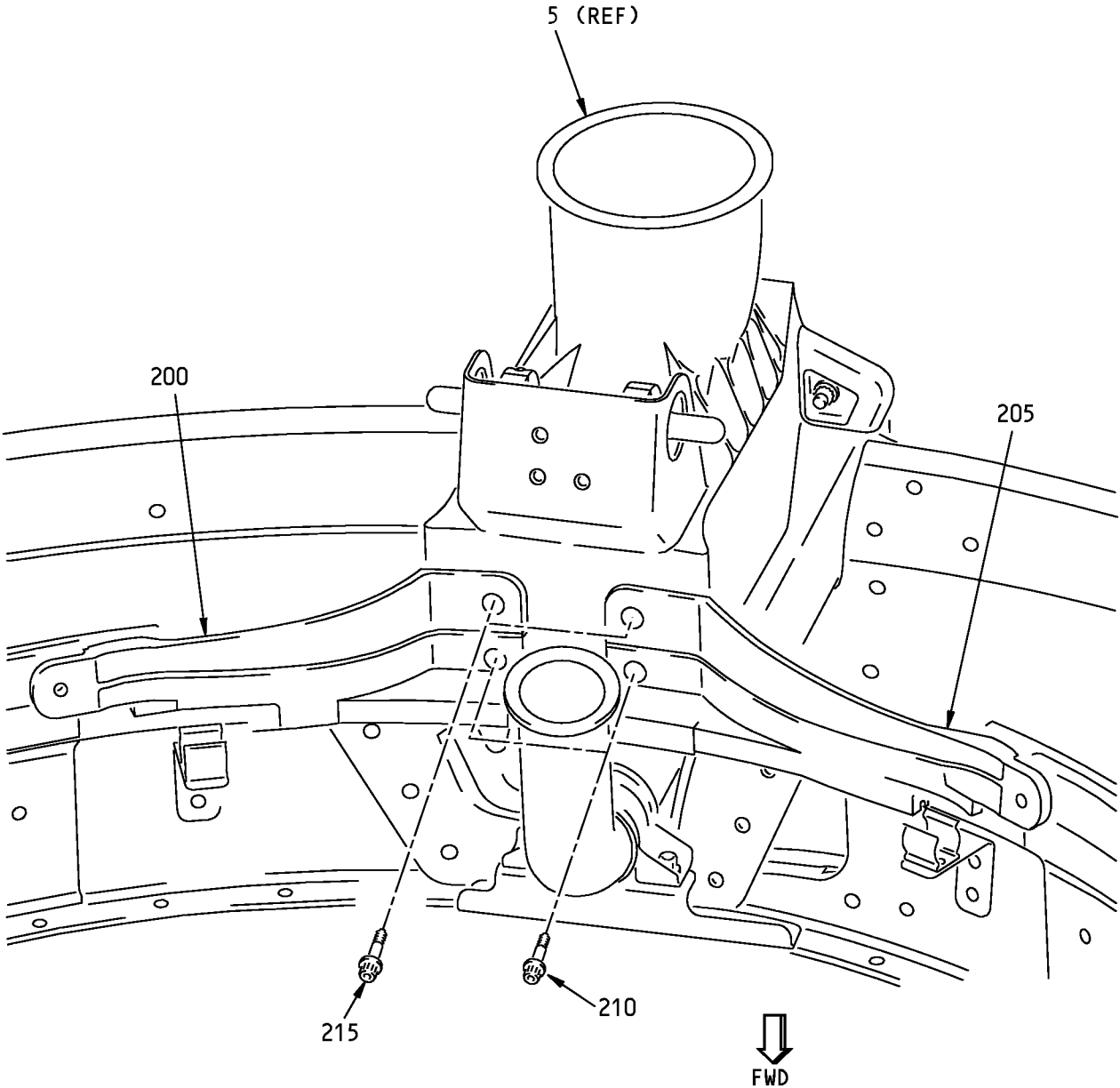

PREFERRED CONFIGURATION

(K)

12 O'Clock Strut Installation  
Figure 13-1 (Sheet 9)

**71-00-02**

**737-600/700/800/900  
POWERPLANT BUILDUP MANUAL**

ITEM NO.	PART NUMBER	NOMENCLATURE	UC	QTY
13-1		<p><b>12 O'CLOCK STRUT INSTALLATION (FIGURE 13-1, SHEET 9)</b></p> <p>PREFERRED CONFIGURATION</p> <p>APPLY Never-Seez NSBT-8N compound, D00006 Never-Seez NSBT-8N compound, D00006(C1) TO THREADS AND SHANK OF BOLTS (210) AND (215).</p> <p>LOOSELY ATTACH TRANSITION FITTINGS (200) AND (205) TO BOTTOM OF 12 O'CLOCK STRUT ASSY (5). USE BOLT (210) AT FWD LOCATIONS AND BOLT (215) AT AFT LOCATIONS.</p>		
200	332A2374-13	. TRANSITION FITTING ASSY, LH		1
205	332A2374-14	. TRANSITION FITTING ASSY, RH		1
210	BACB30LE4K6	. BOLT (FWD LOCATIONS)		2
215	BACB30LE4K4	. BOLT (AFT LOCATIONS)		2
C1	D00006	. COMPOUND, NEVER-SEEZ NSBT-8N	CON	AR
		<p>TIGHTEN BOLTS (210) AND (215) TO 68-82 POUND-INCHES (7.7-9.3 NEWTON METERS).</p> <p><b>NOTE:</b> BOLTS (210) AND (215) WILL BE TIGHTENED AFTER OUTBOARD FASTENERS ARE INSTALLED.</p>		

**71-00-02**

P/P BUILDUP FIGURE 13-1

Page 19

Oct 05/2007

D633A106-HXL

**737-600/700/800/900  
POWERPLANT BUILDUP MANUAL**

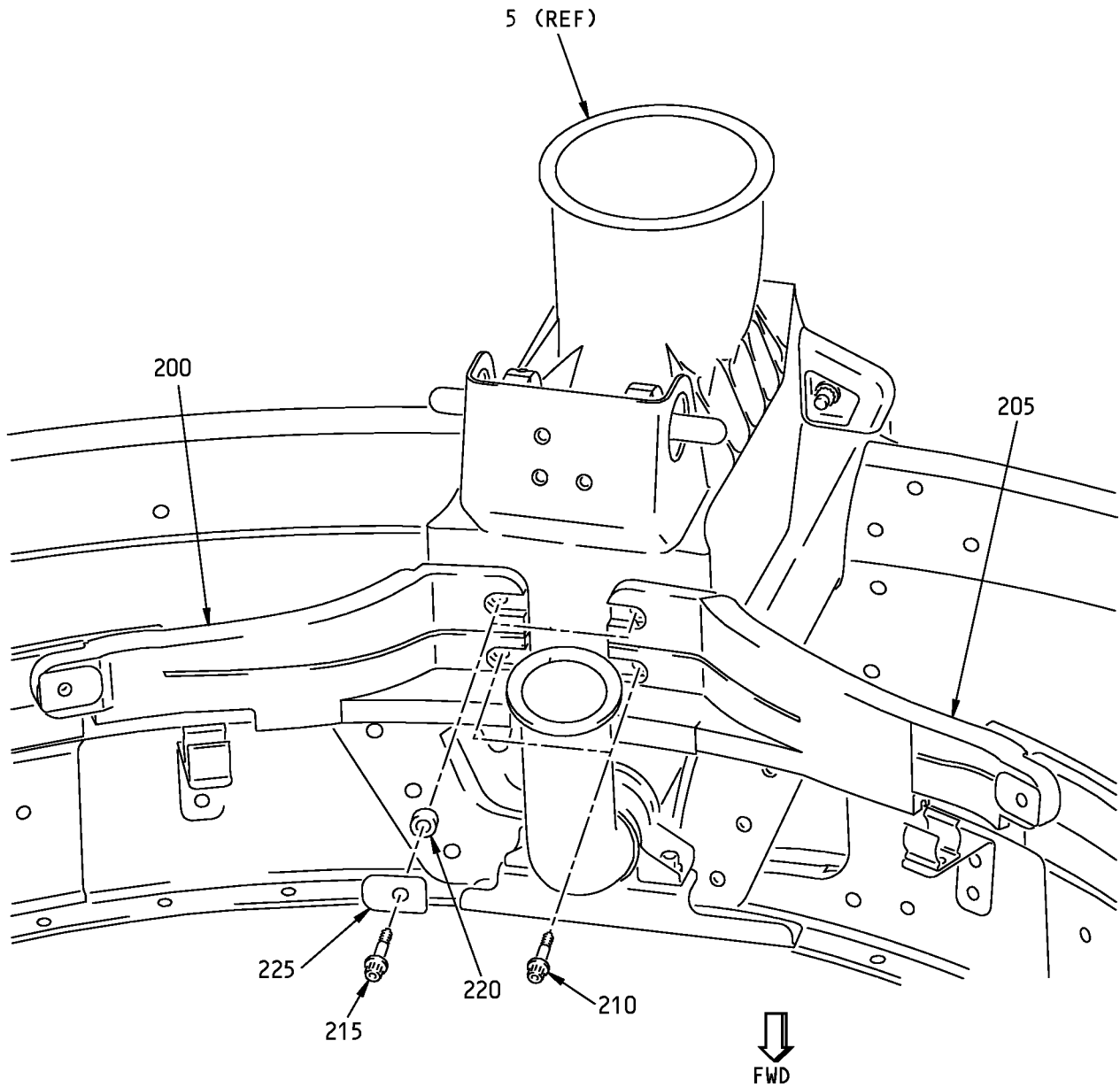

**OPTIONAL CONFIGURATION**

(L)

**12 O'Clock Strut Installation  
Figure 13-1 (Sheet 10)**

**71-00-02**

P/P BUILDUP FIGURE 13-1

Page 20

Oct 05/2007

D633A106-HXL

**737-600/700/800/900  
POWERPLANT BUILDUP MANUAL**

ITEM NO.	PART NUMBER	NOMENCLATURE	UC	QTY
13-1		<p><b>12 O'CLOCK STRUT INSTALLATION (FIGURE 13-1, SHEET 10)</b></p> <p>OPTIONAL CONFIGURATION</p> <p>LOOSELY ATTACH TRANSITION FITTINGS (200) AND (205) TO BOTTOM OF 12 O'CLOCK STRUT ASSY (5).</p> <p>USE BOLT (210) AT FWD LOCATIONS AND BOLT (215), SPACER (220) AND CLIP (225) AT AFT LOCATIONS.</p> <p>. TRANSITION FITTING ASSY, LH (1 REQD)</p> <p>. TRANSITION FITTING ASSY, RH (1 REQD)</p> <p>. BOLT (FWD LOCATIONS) (2 REQD)</p> <p>. BOLT (AFT LOCATIONS) (2 REQD)</p> <p>. SPACER (AFT LOCATIONS) (2 REQD)</p> <p>. CLIP (AFT LOCATIONS) (2 REQD)</p> <p><b>NOTE:</b> BOLTS (210) AND (215) WILL BE TIGHTENED AFTER OUTBOARD FASTENERS ARE INSTALLED.</p>		
200	332A2374-9	. TRANSITION FITTING ASSY, LH (1 REQD)	OPT	-
205	332A2374-10	. TRANSITION FITTING ASSY, RH (1 REQD)	OPT	-
210	BACB30LE4K6	. BOLT (FWD LOCATIONS) (2 REQD)	OPT	-
215	BACB30LE4K8	. BOLT (AFT LOCATIONS) (2 REQD)	OPT	-
220	NAS1057W4A025	. SPACER (AFT LOCATIONS) (2 REQD)	OPT	-
225	332A2376-1	. CLIP (AFT LOCATIONS) (2 REQD)	OPT	-

**71-00-02**

P/P BUILDUP FIGURE 13-1

Page 21

Oct 05/2007

D633A106-HXL



737-600/700/800/900  
**POWERPLANT BUILDUP MANUAL**

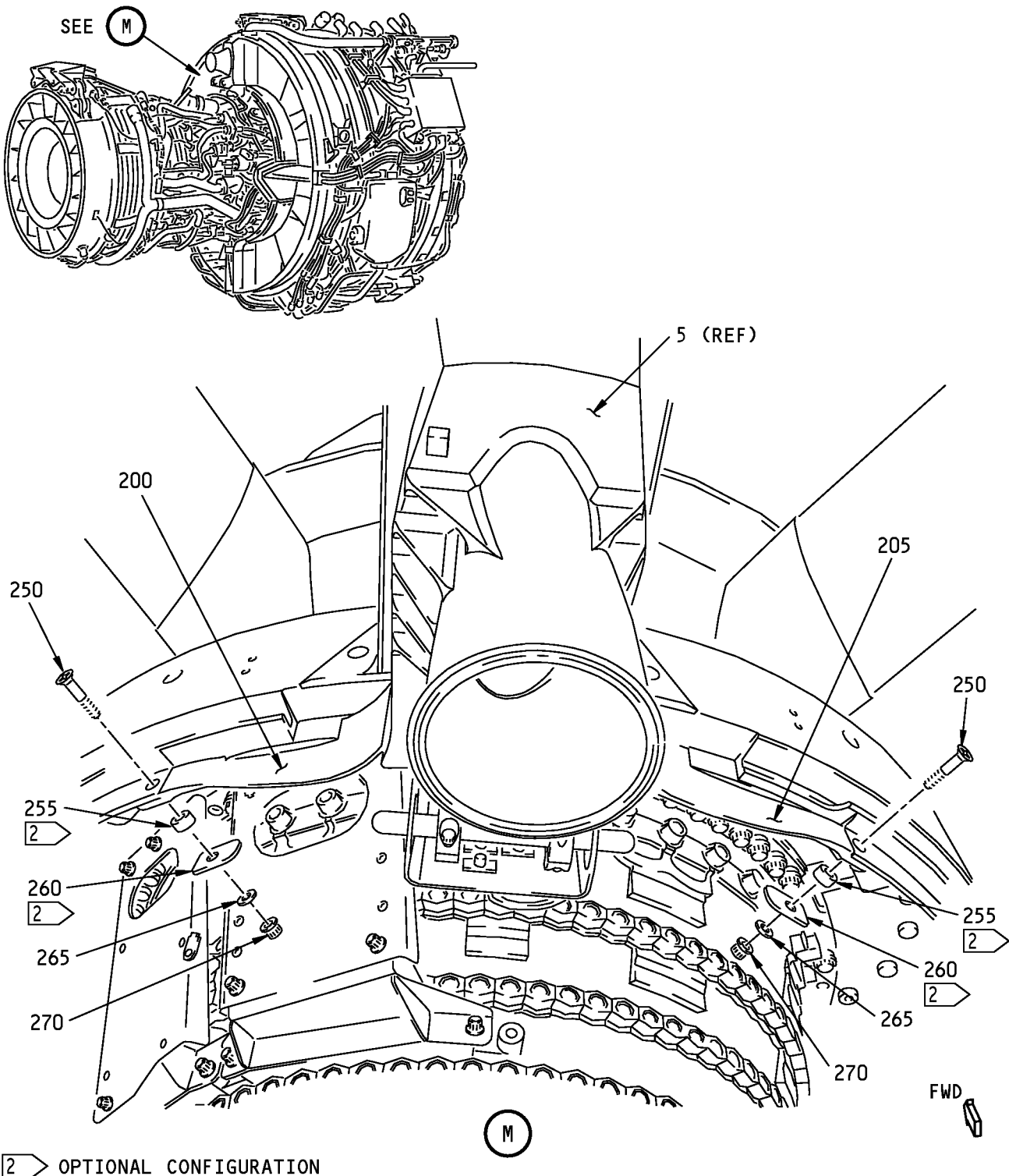

**12 O'Clock Strut Installation**  
**Figure 13-1 (Sheet 11)**

**71-00-02**

P/P BUILDUP FIGURE 13-1  
Page 22  
Oct 05/2007

D633A106-HXL

**737-600/700/800/900  
POWERPLANT BUILDUP MANUAL**

ITEM NO.	PART NUMBER	NOMENCLATURE	UC	QTY
13-1		<p><b>12 O'CLOCK STRUT INSTALLATION (FIGURE 13-1, SHEET 11)</b></p> <p>SECURE LEFT AND RIGHT TRANSITION FITTINGS (200) AND (205) TO ENGINE EXTENSION RING WITH BOLTS (250), WASHERS (265) AND NUTS (270).</p> <p>USE SPACERS (255) AND CLIPS (260) IF OPTIONAL CONFIGURATION IS INSTALLED.</p>		
250	BACB30NN4K6	. BOLT <sup>[2]</sup>		2
250	BACB30NN4K11	. BOLT (2 REQD) <sup>[1]</sup>	OPT	-
255	NAS1057W4A025	. SPACER (2 REQD) <sup>[1]</sup>	OPT	-
260	332A2376-1	. CLIP (2 REQD) <sup>[1]</sup>	OPT	-
265	BACW10BP4PK	. WASHER		2
270	BACN11Z4CK	. NUT		2
		TIGHTEN BOLTS (210) AND (215) TO 90-110 POUND-INCHES (10.2-12.4 NEWTON METERS).		
		TIGHTEN BOLTS (250) TO 65-100 POUND-INCHES (7.3-11.3 NEWTON METERS).		
		*[1] USED WITH OPTIONAL CONFIGURATION 332A2374-9 (LH) AND 332A2374-10 (RH) FITTING ASSEMBLIES (REF VIEW L).		
		*[2] USED WITH PREFERRED CONFIGURATION 332A2374-13 (LH) AND 332A2374-14 (RH) FITTING ASSEMBLIES (REF VIEW K).		

**71-00-02**

P/P BUILDUP FIGURE 13-1

Page 23

Oct 05/2007

D633A106-HXL

737-600/700/800/900  
**POWERPLANT BUILDUP MANUAL**

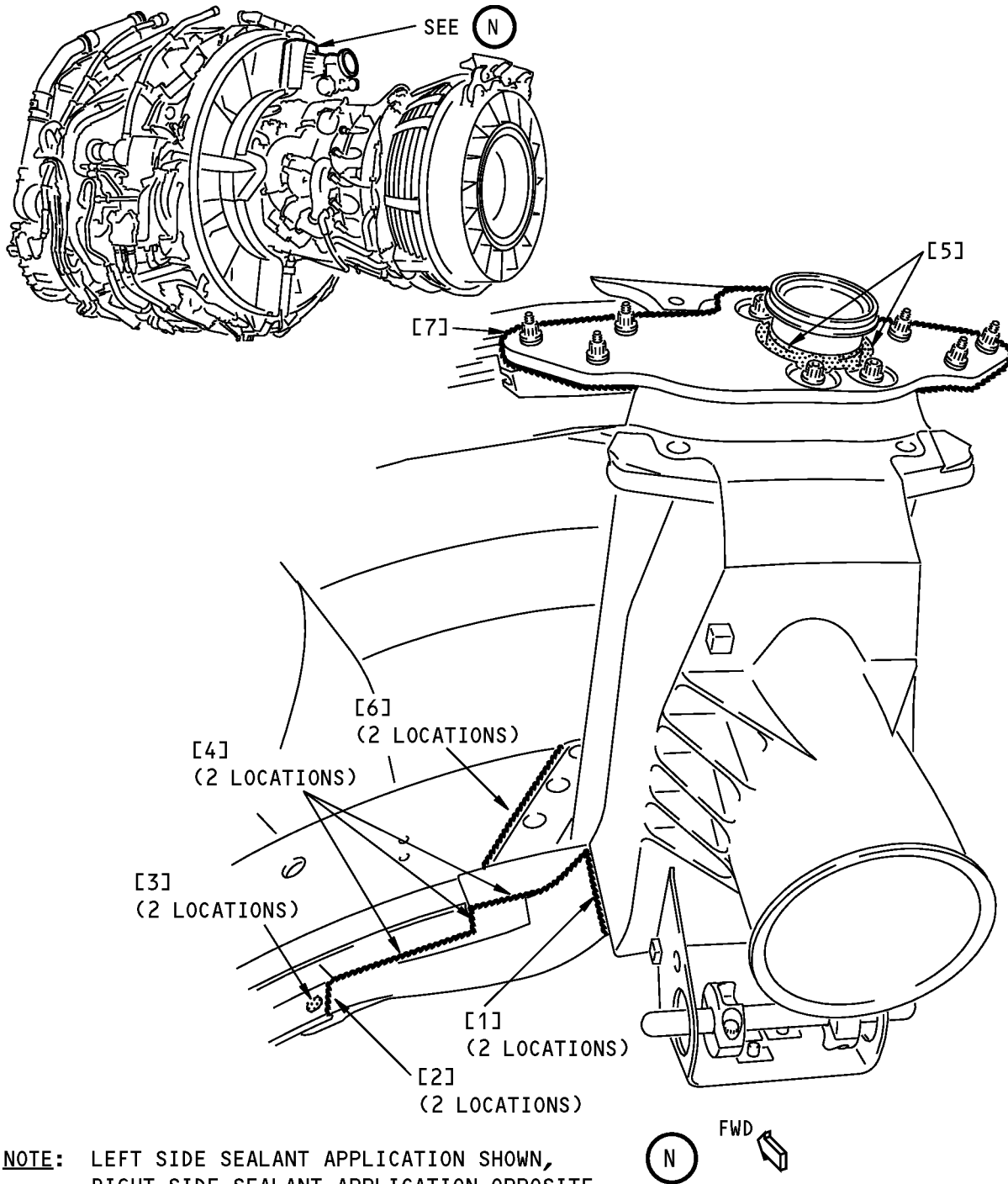

**NOTE:** LEFT SIDE SEALANT APPLICATION SHOWN,  
RIGHT SIDE SEALANT APPLICATION OPPOSITE.

 AND , AREAS OF SEALANT APPLICATION.

**12 O'Clock Strut Installation**  
**Figure 13-1 (Sheet 12)**

**71-00-02**

P/P BUILDUP FIGURE 13-1

Page 24

Oct 05/2007

D633A106-HXL

**737-600/700/800/900  
POWERPLANT BUILDUP MANUAL**

ITEM NO.	PART NUMBER	NOMENCLATURE	UC	QTY
13-1		<p><b>12 O'CLOCK STRUT INSTALLATION (FIGURE 13-1, SHEET 12)</b></p> <p>APPLY FILLET SEAL AROUND PARTS OF 12 O'CLOCK STRUT ASSY (5) IDENTIFIED BELOW USING sealant, A00160 (C3) OR sealant, A00803 (C4).</p> <p>MAKE SURE ALL AREAS IDENTIFIED BELOW ARE FLUSH AND/OR SMOOTH WITH SURROUNDING SURFACES.</p> <p>IF sealant, A00160 (C3) IS USED, MAKE SURE ALL FILLET SURFACES HAVE BEEN PRIMED USING Dapco No. 1-100 primer, C00944 (C2) BEFORE SEALANT APPLICATION.</p> <ol style="list-style-type: none"> <li>1. TRANSITION FITTINGS AND 12 O'CLOCK STRUT.</li> <li>2. TRANSITION FITTINGS AND ENGINE EXTENSION RING.</li> <li>3. BOLT (200) CAVITY AND ENGINE EXTENSION RING.</li> <li>4. FWD EDGE OF TRANSITION FITTINGS AND ENGINE EXTENSION RING.</li> <li>5. 12 O'CLOCK STRUT AND CTAI DUCT.</li> <li>6. 12 O'CLOCK STRUT LOWER FLANGE AND ENGINE EXTENSION RING.</li> <li>7. 12 O'CLOCK STRUT AND ENGINE OUTER FAN CASE.</li> </ol>		
C2	C00944	. PRIMER, DAPCO NO. 1-100	CON	AR
C3	A00160	. SEALANT, BMS5-63 TYPE I	CON	AR
C4	A00803	. SEALANT, BMS5-63 TYPE II	CON	AR

**71-00-02**

P/P BUILDUP FIGURE 13-1

Page 25

Oct 05/2007

D633A106-HXL

**FIGURE 14-1**

# **BLEED CONTROLLER INSTALLATION**

**REF QEC TASK NO.: 14**

**REF DWG: 332A2300  
332A2100**

**NOTE:** ALL STANDARDS AND ATTACHING HARDWARE FOR THIS FIGURE WILL BE PACKAGED IN QEC TASK NO. 110.

**71-00-02**

P/P BUILDUP FIGURE 14-1

Page 1

Oct 05/2007

D633A106-HXL

737-600/700/800/900  
**POWERPLANT BUILDUP MANUAL**

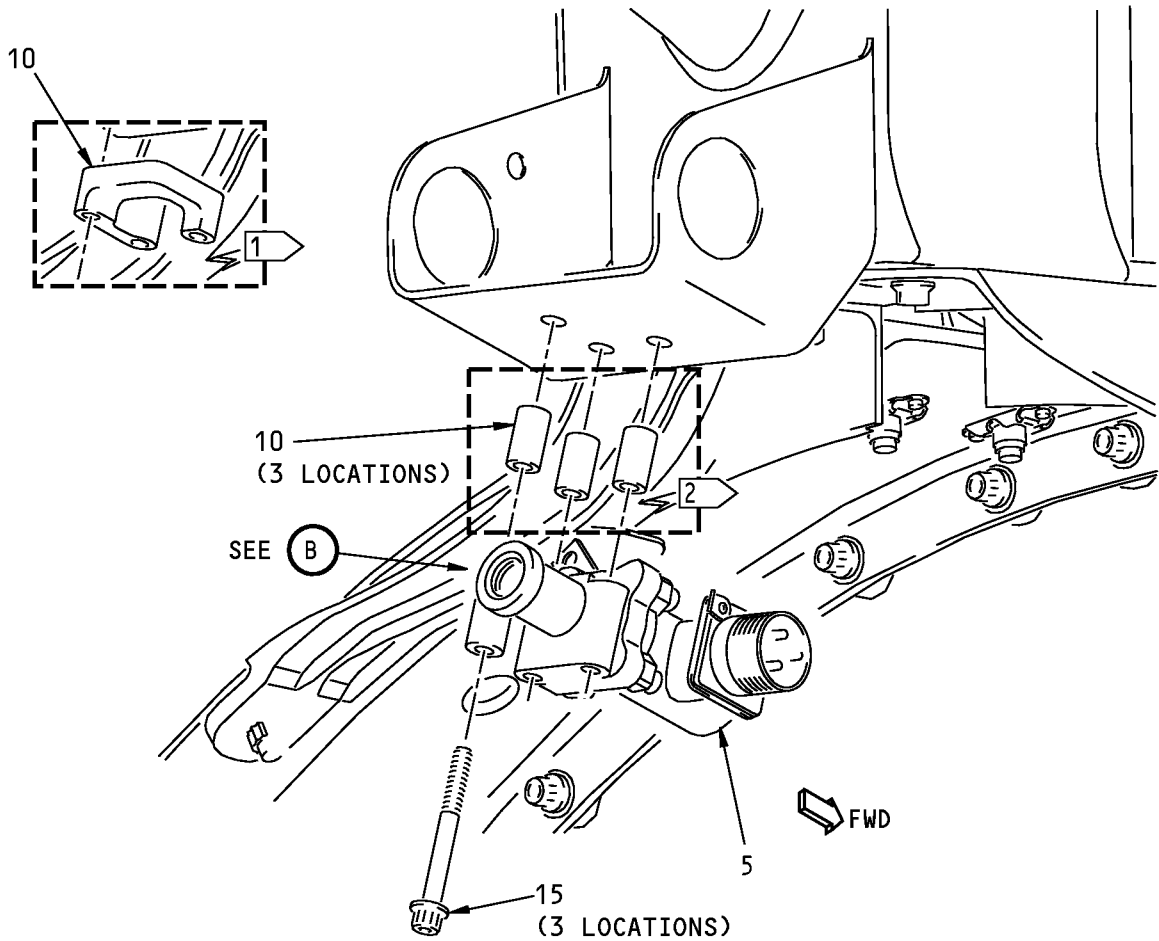
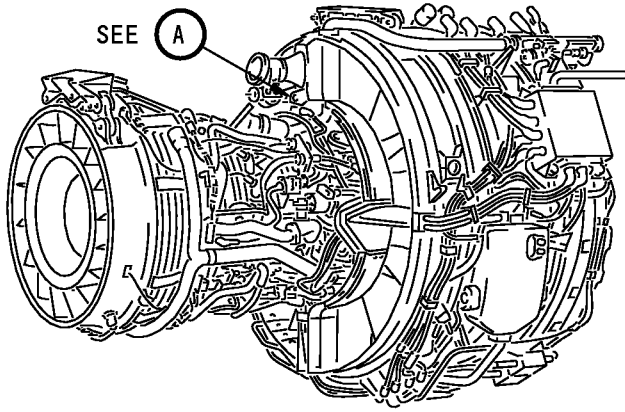

- 1 OPTIONAL CONFIGURATION
- 2 PREFERRED CONFIGURATION



**Bleed Controller Installation**  
**Figure 14-1 (Sheet 1)**

**71-00-02**

P/P BUILDUP FIGURE 14-1

Page 2

Oct 05/2007

D633A106-HXL

**737-600/700/800/900  
POWERPLANT BUILDUP MANUAL**

ITEM NO.	PART NUMBER	NOMENCLATURE	UC	QTY
14-1		<p><b>BLEED CONTROLLER INSTALLATION (FIGURE 14-1, SHEET 1)</b></p> <p>ROTATE BONDING TAB ON VALVE (5) TO GIVE A MINIMUM OF 0.25 INCH (6.4 MM) OF CLEARANCE WITH STRUCTURE.</p> <p>CLEAN MATING SURFACES OF VALVE (5), SPACERS (10) OR SPACER BLOCK (10) AND ENGINE BRACKET WITH alcohol, B00130 (C1).</p> <p>MAKE SURE YOU REMOVE ALL GREASE AND OTHER CONTAMINANTS.</p>		
5	320548-2	. VALVE, GROUND WING TAI TEMP SOLENOID (V59364)	VEN	1
5	10-62008-22	. BOEING SPEC FOR 320548-2	BOE	-
10	NAS1057T3-050	. SPACER		3
10	332A2930-49	. SPACER BLOCK (1 REQD)	OPT	-
C1	B00130	. SOLVENT, TT-I-735	CON	AR
		<p>INSTALL VALVE (5) ON BOTTOM BRACKET ON 12 O'CLOCK STRUT SUCH THAT ELECTRICAL CONNECTOR IS ON RIGHT SIDE.</p> <p>INSTALL WITH SPACERS (10) OR SPACER BLOCK (10) AND BOLTS (15).</p>		
15	BACB30ZF3-28	. BOLT		3
		<p>TIGHTEN BOLTS (15) TO 50-56 POUND-INCHES (5.6-6.3 NEWTON METERS).</p>		

**71-00-02**

P/P BUILDUP FIGURE 14-1

Page 3

Oct 05/2007

D633A106-HXL

**737-600/700/800/900  
POWERPLANT BUILDUP MANUAL**

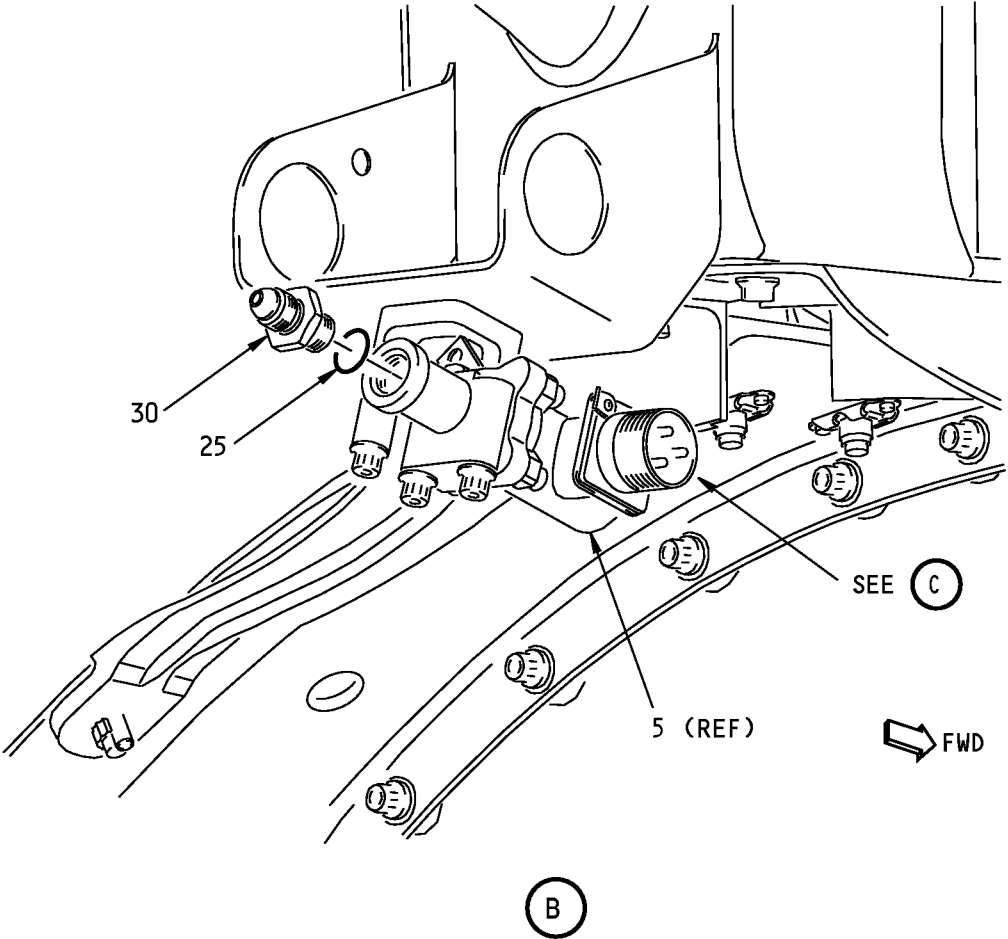

**Bleed Controller Installation  
Figure 14-1 (Sheet 2)**

**71-00-02**

P/P BUILDUP FIGURE 14-1

Page 4

Oct 05/2007

D633A106-HXL





**737-600/700/800/900  
POWERPLANT BUILDUP MANUAL**

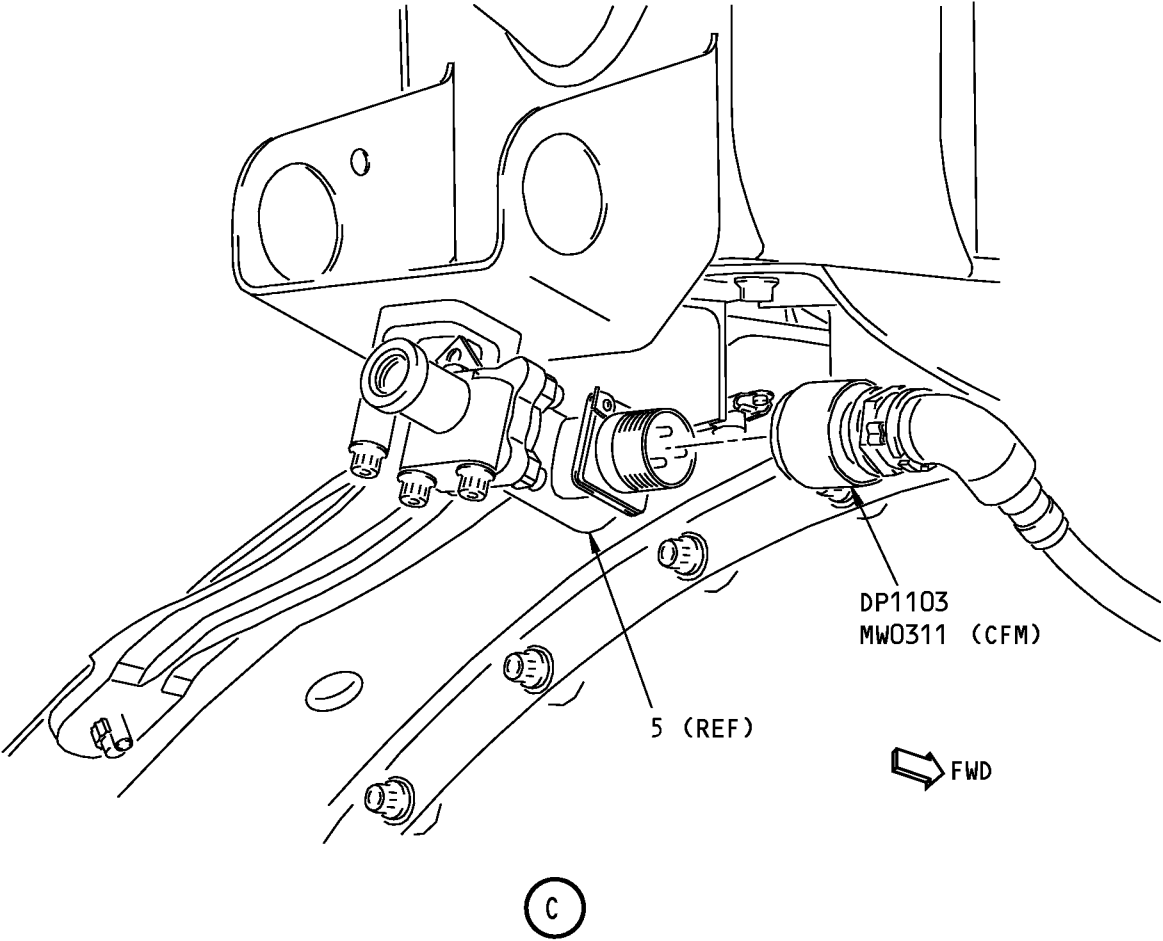

**Bleed Controller Installation  
Figure 14-1 (Sheet 3)**

**71-00-02**

**737-600/700/800/900  
POWERPLANT BUILDUP MANUAL**

ITEM NO.	PART NUMBER	NOMENCLATURE	UC	QTY
14-1		<p><b>BLEED CONTROLLER INSTALLATION (FIGURE 14-1, SHEET 3)</b></p> <p><b>CAUTION:</b> DO NOT OVERTIGHTEN THE PLUG COUPLING RING. DO NOT USE WATER PUMP PLIERS, PIPE WRENCHES OR VISE GRIPS TO TIGHTEN THE COUPLING RING OR DAMAGE TO THE ELECTRICAL CONNECTOR CAN OCCUR.</p> <p>CONNECT MW0311 ELECTRICAL CONNECTOR, DP1103, TO RECEPTACLE ON GROUND WING TAI TEMP SOLENOID VALVE (5).</p> <p>TURN KNURLED COUPLING RING WHILE WIGGLING THE BACKSHELL ASSEMBLY.</p> <p>AFTER FULLY SEATING THE COUPLING RING, USE SOFT-JAWED PLIERS OR A STRAP WRENCH TO TIGHTEN THE COUPLING RING AN ADDITIONAL 1/8-TURN OR UNTIL PLIER SLIPPAGE OCCURS.</p>		

**71-00-02**

P/P BUILDUP FIGURE 14-1

Page 7

Oct 05/2007

D633A106-HXL

737-600/700/800/900  
**POWERPLANT BUILDUP MANUAL**

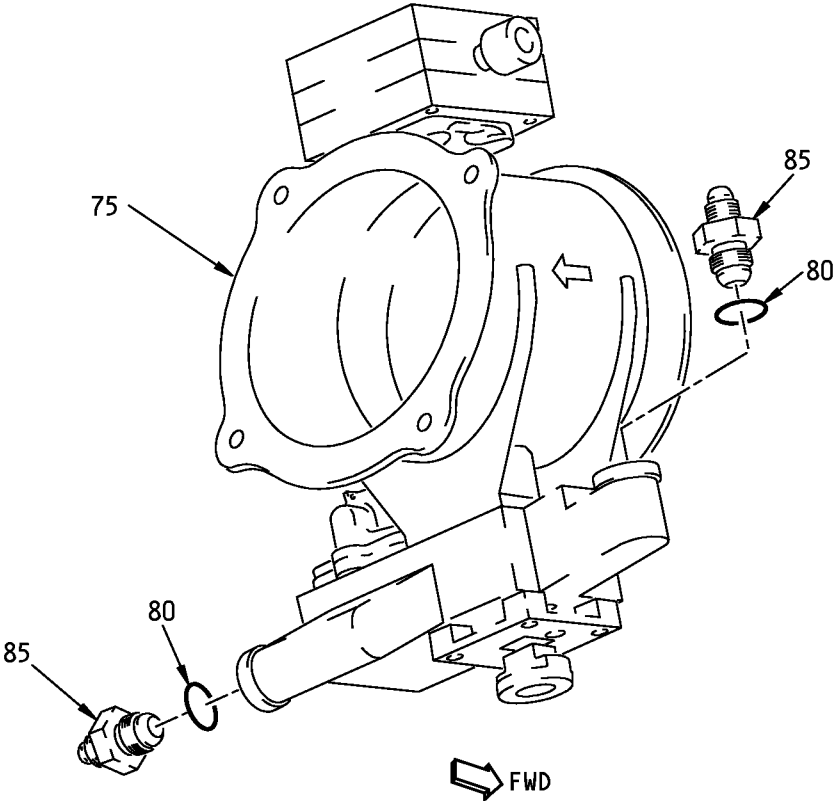

**Bleed Controller Installation**  
**Figure 14-1 (Sheet 4)**

**71-00-02**

P/P BUILDUP FIGURE 14-1

Page 8

Oct 05/2007

D633A106-HXL

**737-600/700/800/900  
POWERPLANT BUILDUP MANUAL**

ITEM NO.	PART NUMBER	NOMENCLATURE	UC	QTY
14-1		<p><b>BLEED CONTROLLER INSTALLATION (FIGURE 14-1, SHEET 4)</b></p> <p>INSTALL ONE O-RING (80) ON EACH REDUCER (85).</p> <p>LUBRICATE THREADS OF REDUCERS WITH Never-Seez NSBT-8N compound, D00006 (C2) AND INSTALL ON PRECOOLER CONTROL VALVE (75).</p>		
75	3289562-5	. PRECOOLER CONTROL VALVE (V59364)	VEN	1
75	10-62008-33	. BOEING SPEC FOR 3289562-5	BOE	-
80	801A50-0006A	. O-RING (V15284)	VEN	2
85	J522P53	. REDUCER		2
C2	D00006	. COMPOUND, NEVER-SEEZ NSBT-8N	CON	AR
		TIGHTEN REDUCERS (85) TO 258-284 POUND-INCHES (29-32 NEWTON METERS).		
		INSTALL PROTECTIVE CAPS ON ENDS OF UNION (30) AND REDUCER (85).		

# 71-00-02

P/P BUILDUP FIGURE 14-1

Page 9

Oct 05/2007

D633A106-HXL

737-600/700/800/900  
**POWERPLANT BUILDUP MANUAL**

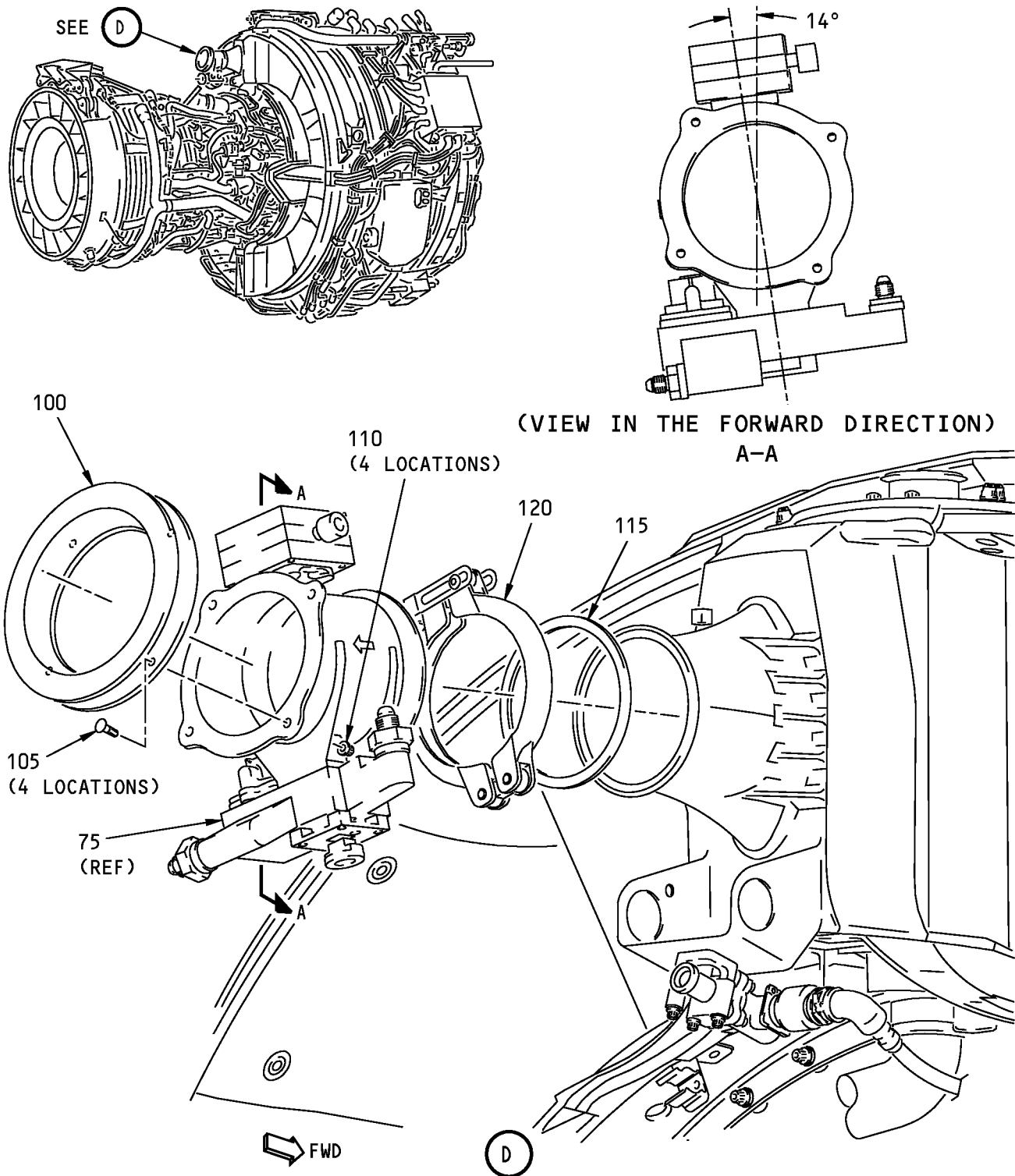

**Bleed Controller Installation**  
**Figure 14-1 (Sheet 5)**

**71-00-02**

P/P BUILDUP FIGURE 14-1

Page 10

Oct 05/2007

D633A106-HXL

**737-600/700/800/900  
POWERPLANT BUILDUP MANUAL**

ITEM NO.	PART NUMBER	NOMENCLATURE	UC	QTY
14-1		<p><b>BLEED CONTROLLER INSTALLATION (FIGURE 14-1, SHEET 5)</b></p> <p>INSTALL SEAL (100) ON PRECOOLER CONTROL VALVE (75) WITH BOLTS (105) AND NUTS (110).</p>		
100	82C10020-1	. SEAL (V60980)	VEN	1
100	S332A102-1	. BOEING SPEC FOR 82C10020-1	BOE	-
105	BACB30LH3U4	. BOLT		4
110	AS3485-09	. NUT		4
		<p>TIGHTEN BOLTS (105) UNTIL 1 1/2 TO 2 THREADS EXTEND OUT FROM NUTS (110).</p> <p><b>NOTE:</b> REQUIRED TORQUE RANGE 14-22 POUND-INCHES (1.6-2.5 NEWTON METERS).</p> <p>INSTALL A PROTECTIVE COVER OVER THE SEAL OPENING.</p> <p>POSITION SEAL (115) AND VALVE (75) ON 12 O'CLOCK STRUT FLANGE WITH VALVE ORIENTED AS SHOWN.</p> <p>LOOSELY CONNECT WITH COUPLING (120).</p> <p>MAKE SURE COUPLING IS POSITIONED AS SHOWN. LOOSELY TIGHTEN COUPLING BOLT.</p> <p><b>NOTE:</b> COUPLING ORIENTATION ALLOWS ADEQUATE TOOL ACCESS TO COUPLING NUT WHEN VALVE IS REPLACED WITH T/R INSTALLED.</p> <p><b>NOTE:</b> DO NOT TIGHTEN COUPLING AT THIS TIME. FINAL ORIENTATION OF VALVE WILL OCCUR DURING UPPER BLEED CONTROL INSTALLATION (REF Figure 17-1 ).</p>		
115	AS1895-7-400	. SEAL		1
120	AS1895-4-400	. COUPLING		1

**71-00-02**

P/P BUILDUP FIGURE 14-1

Page 11

Oct 05/2007

D633A106-HXL

737-600/700/800/900  
**POWERPLANT BUILDUP MANUAL**

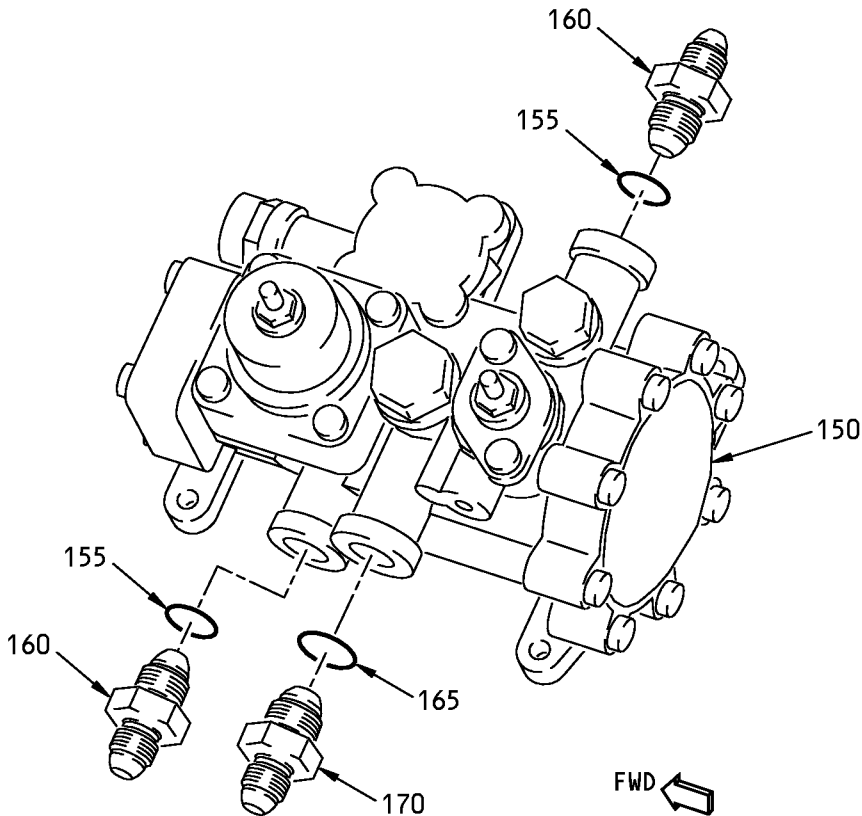

**Bleed Controller Installation**  
**Figure 14-1 (Sheet 6)**

**71-00-02**



**737-600/700/800/900  
POWERPLANT BUILDUP MANUAL**

ITEM NO.	PART NUMBER	NOMENCLATURE	UC	QTY
14-1		<p><b>BLEED CONTROLLER INSTALLATION (FIGURE 14-1, SHEET 6)</b></p> <p>INSTALL ONE O-RING (155) ON EACH REDUCER (160) AND INSTALL O-RING (165) ON REDUCER (170).</p> <p>LUBRICATE THREADS OF REDUCERS WITH Never-Seez NSBT-8N compound, D00006 (C2) AND INSTALL ON HIGH STAGE REGULATOR (150) AS SHOWN.</p>		
150	107484-7	. HIGH STAGE REGULATOR (V59364)	VEN	1
155	801A50-0005A	. O-RING (V15284)	VEN	2
160	J522P52	. REDUCER		2
165	801A50-0006A	. O-RING (V15284)	VEN	1
170	J522P53	. REDUCER		1
C2	D00006	. COMPOUND, NEVER-SEEZ NSBT-8N	CON	AR
		TIGHTEN REDUCERS (160) TO 180-200 POUND-INCHES (20-22 NEWTON METERS) AND TIGHTEN REDUCER (170) TO 258-284 POUND-INCHES (29-32 NEWTON METERS).		

**71-00-02**

P/P BUILDUP FIGURE 14-1

Page 13

Oct 05/2007

D633A106-HXL

737-600/700/800/900  
**POWERPLANT BUILDUP MANUAL**

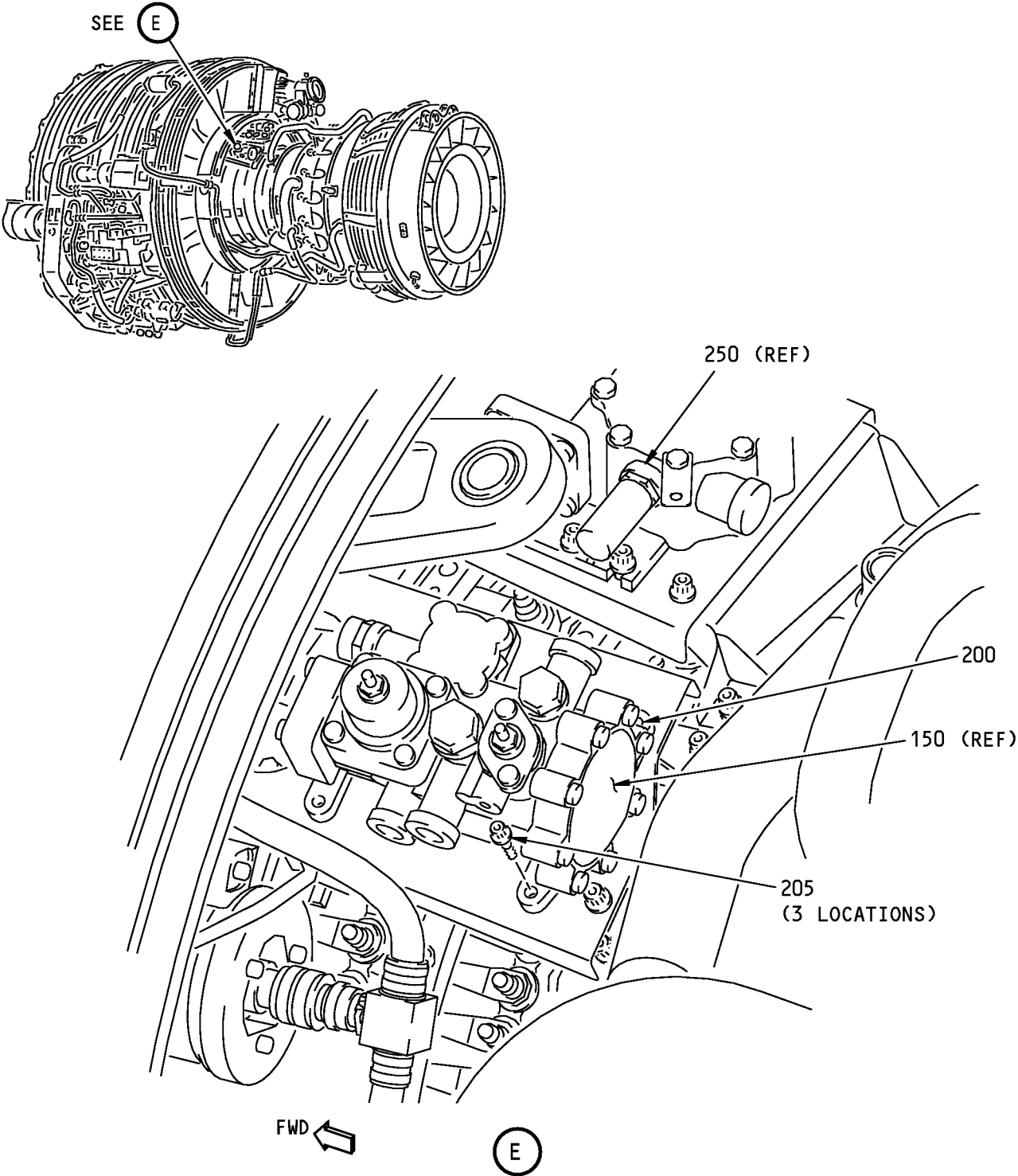

**Bleed Controller Installation**  
**Figure 14-1 (Sheet 7)**

**71-00-02**

**737-600/700/800/900  
POWERPLANT BUILDUP MANUAL**

ITEM NO.	PART NUMBER	NOMENCLATURE	UC	QTY
14-1		<b>BLEED CONTROLLER INSTALLATION (FIGURE 14-1, SHEET 7)</b>  ATTACH HIGH STAGE REGULATOR (150) TO ENGINE CORE BRACKET.  USE BOLT (200) AT UPPER AFT LOCATION AND BOLTS (205) AT REMAINING LOCATIONS.		
200	BACB30ZF3-10	. BOLT		1
205	BACB30ZF3-08	. BOLT		3
		TIGHTEN BOLTS (200) AND (205) TO 34-36 POUND-INCHES (3.8-4.1 NEWTON METERS).		

# 71-00-02

P/P BUILDUP FIGURE 14-1

Page 15

Oct 05/2007

D633A106-HXL

737-600/700/800/900  
POWERPLANT BUILDUP MANUAL

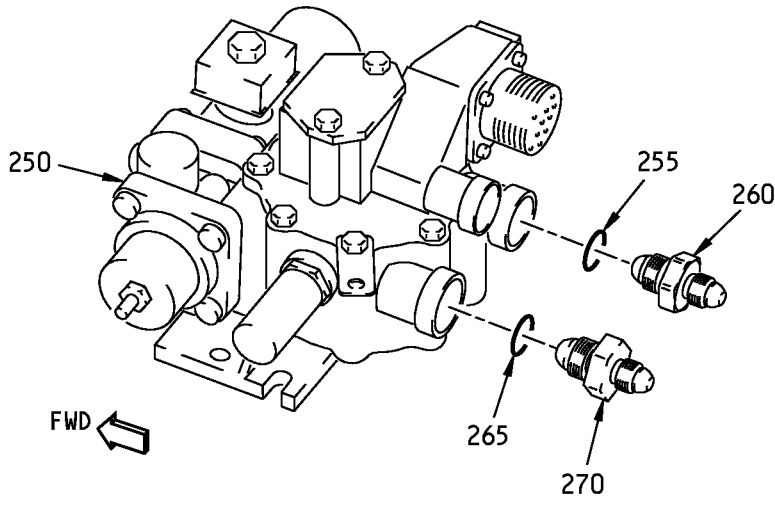

Bleed Controller Installation  
Figure 14-1 (Sheet 8)

**71-00-02**

**737-600/700/800/900  
POWERPLANT BUILDUP MANUAL**

ITEM NO.	PART NUMBER	NOMENCLATURE	UC	QTY
14-1		<p><b>BLEED CONTROLLER INSTALLATION (FIGURE 14-1, SHEET 8)</b></p> <p>INSTALL O-RING (255) ON REDUCER (260) AND INSTALL O-RING (265) ON REDUCER (270).</p> <p>APPLY Never-Seez NSBT-8N compound, D00006 (C2) TO THREADS OF REDUCERS.</p> <p>INSTALL REDUCER (260) IN TOP PORT OF REGULATOR AND INSTALL REDUCER (270) IN BOTTOM PORT OF REGULATOR (250).</p>		
250	107492-6	. BLEED AIR REGULATOR (V59364)	VEN	1
250	10-62008-41	. BOEING SPEC FOR 107492-6	BOE	-
255	801A50-0005A	. O-RING (V15284)	VEN	1
260	J522P52	. REDUCER		1
265	801A50-0006A	. O-RING (V15284)	VEN	1
270	J522P53	. REDUCER		1
C2	D00006	. COMPOUND, NEVER-SEEZ NSBT-8N	CON	AR
		<p>TIGHTEN REDUCER (260) TO 180-200 POUND-INCHES (20-22 NEWTON METERS). TIGHTEN REDUCER (270) TO 258-284 POUND-INCHES (29-32 NEWTON METERS).</p> <p>INSTALL PROTECTIVE CAPS ON ENDS OF REDUCERS (260) AND (270).</p>		

**71-00-02**

P/P BUILDUP FIGURE 14-1

Page 17

Oct 05/2007

D633A106-HXL

**737-600/700/800/900  
POWERPLANT BUILDUP MANUAL**

**THIS SHEET NOT USED**

**Bleed Controller Installation  
Figure 14-1 (Sheet 9)**

**71-00-02**

P/P BUILDUP FIGURE 14-1

Page 18

Oct 05/2007

D633A106-HXL

737-600/700/800/900  
POWERPLANT BUILDUP MANUAL

ITEM NO.	PART NUMBER	NOMENCLATURE	UC	QTY
14-1		BLEED CONTROLLER INSTALLATION (FIGURE 14-1, SHEET 9)  THIS SHEET NOT USED		

**71-00-02**

P/P BUILDUP FIGURE 14-1  
Page 19  
Oct 05/2007

D633A106-HXL

737-600/700/800/900  
**POWERPLANT BUILDUP MANUAL**

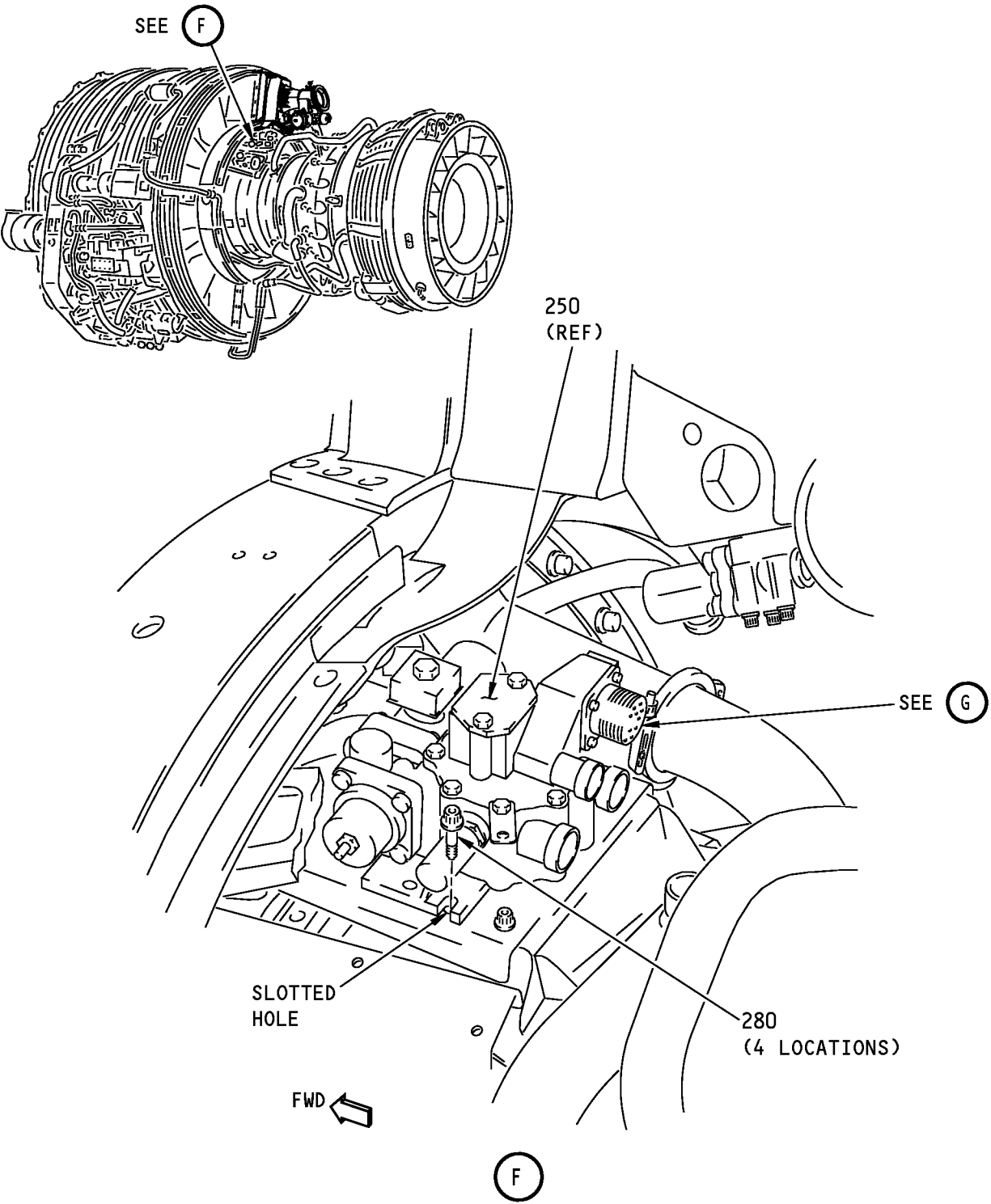

**Bleed Controller Installation**  
**Figure 14-1 (Sheet 10)**

**71-00-02**

P/P BUILDUP FIGURE 14-1  
Page 20  
Oct 05/2007

D633A106-HXL



**737-600/700/800/900  
POWERPLANT BUILDUP MANUAL**

ITEM NO.	PART NUMBER	NOMENCLATURE	UC	QTY
14-1		<b>BLEED CONTROLLER INSTALLATION (FIGURE 14-1, SHEET 10)</b>  INSTALL ONE BOLT (280) IN AFT OUTBOARD HOLE OF UPPER CORE BRACKET.  PUT SLOTTED HOLE OF BLEED AIR REGULATOR OVER BOLT AND INSTALL REMAINING BOLTS (280).		
280	BACB30ZF4-08	. BOLT  TIGHTEN BOLTS (280) TO 78-82 POUND-INCHES (8.8-9.3 NEWTON METERS).		4

**71-00-02**

P/P BUILDUP FIGURE 14-1

Page 21

Oct 05/2007

D633A106-HXL

737-600/700/800/900  
**POWERPLANT BUILDUP MANUAL**

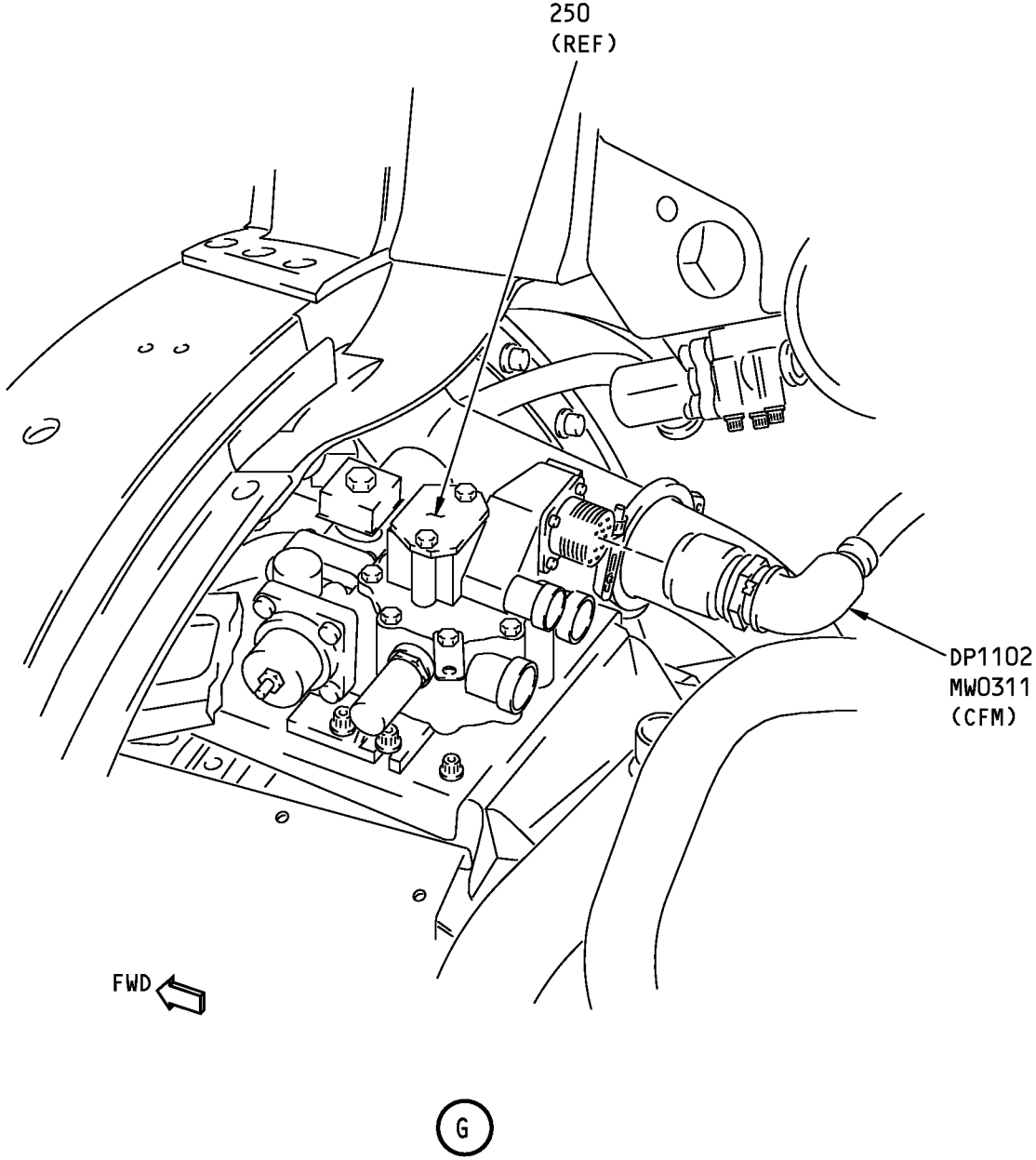

**Bleed Controller Installation**  
**Figure 14-1 (Sheet 11)**

**71-00-02**

P/P BUILDUP FIGURE 14-1  
Page 22  
Oct 05/2007

D633A106-HXL

**737-600/700/800/900  
POWERPLANT BUILDUP MANUAL**

ITEM NO.	PART NUMBER	NOMENCLATURE	UC	QTY
14-1		<p><b>BLEED CONTROLLER INSTALLATION (FIGURE 14-1, SHEET 11)</b></p> <p><b>CAUTION:</b> DO NOT OVERTIGHTEN THE PLUG COUPLING RING. DO NOT USE WATER PUMP PLIERS, PIPE WRENCHES OR VISE GRIPS TO TIGHTEN THE COUPLING RING OR DAMAGE TO THE ELECTRICAL CONNECTOR CAN OCCUR.</p> <p>CONNECT MW0311 ELECTRICAL CONNECTOR, DP1102, TO RECEPTACLE ON BLEED AIR REGULATOR.</p> <p>TURN KNURLED COUPLING RING WHILE WIGGLING THE BACKSHELL ASSEMBLY.</p> <p>AFTER FULLY SEATING THE COUPLING RING, USE SOFT-JAWED PLIERS OR A STRAP WRENCH TO TIGHTEN THE COUPLING RING AN ADDITIONAL 1/8-TURN OR UNTIL PLIER SLIPPAGE OCCURS.</p>		

**71-00-02**

P/P BUILDUP FIGURE 14-1

Page 23

Oct 05/2007

D633A106-HXL

FIGURE 15-1

# BLEED CONTROL SYSTEM INSTALLATION - LOWER

REF QEC TASK NO.: 15

REF DWG: 332A2100

**NOTE:** ALL STANDARDS AND ATTACHING HARDWARE FOR THIS FIGURE WILL BE PACKAGED IN QEC TASK NO. 110.

**71-00-02**

P/P BUILDUP FIGURE 15-1

Page 1

Oct 05/2007

D633A106-HXL

737-600/700/800/900  
**POWERPLANT BUILDUP MANUAL**

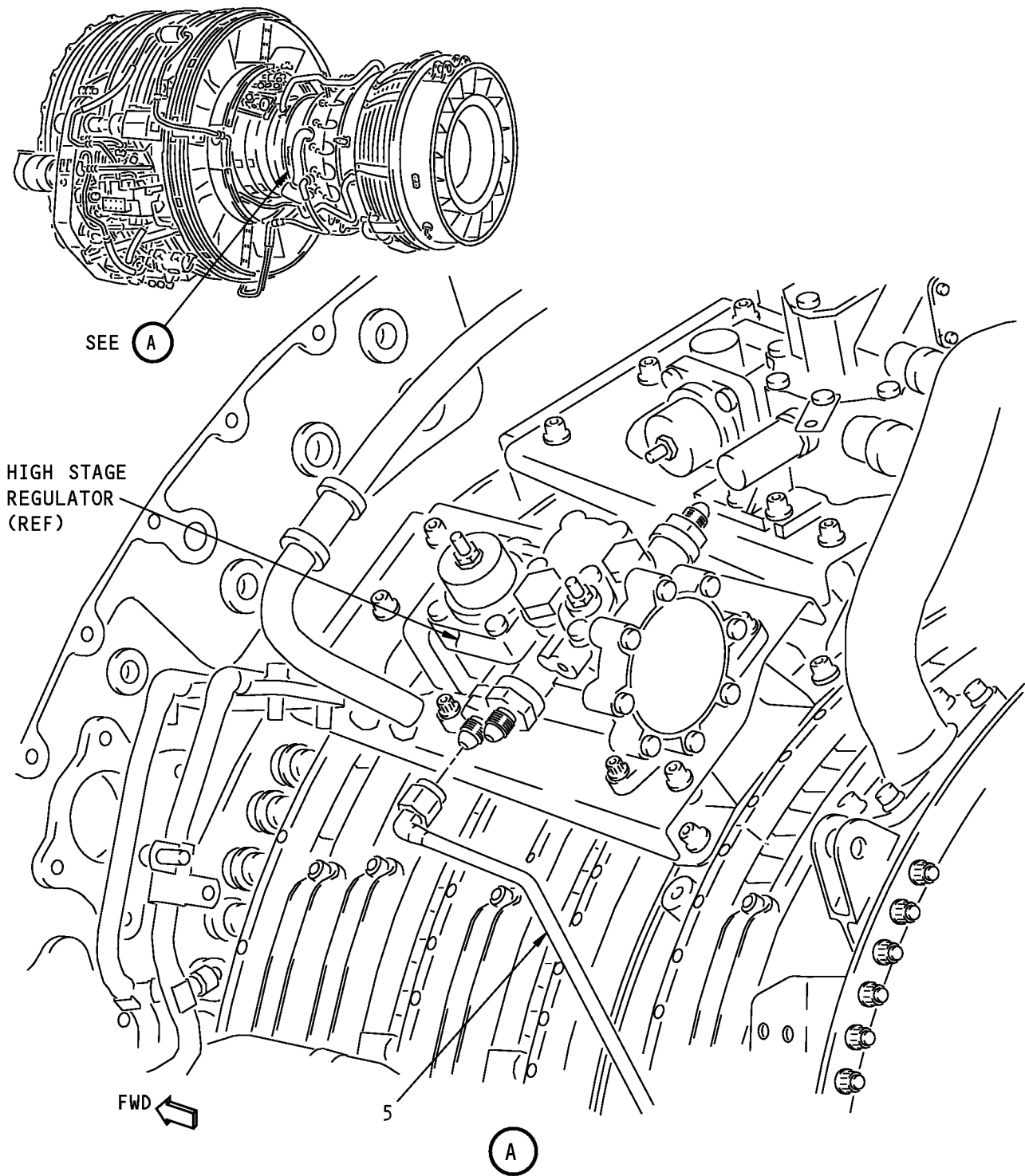

**Lower Bleed Control System Installation**  
**Figure 15-1 (Sheet 1)**

**71-00-02**

P/P BUILDUP FIGURE 15-1

Page 2

Oct 05/2007

D633A106-HXL

**737-600/700/800/900  
POWERPLANT BUILDUP MANUAL**

ITEM NO.	PART NUMBER	NOMENCLATURE	UC	QTY
5	332A2350-9	<p><b>LOWER BLEED CONTROL SYSTEM INSTALLATION (FIGURE 15-1, SHEET 1)</b></p> <p><b>NOTE:</b> IN THIS PROCEDURE, DO NOT TIGHTEN SCREWS AND TUBE OR HOSE NUTS TO THE INDICATED TORQUE UNTIL INSTRUCTED.</p> <p>WHEN TIGHTENING TUBE AND HOSE NUTS, USE TWO WRENCHES; ONE TO HOLD THE SPANNER FLATS ON THE NIPPLE AND ONE TO TIGHTEN THE NUT.</p> <p>ALL TUBE NUTS HAVE A DRY-FILM LUBRICANT AND DO NOT NEED ADDITIONAL LUBRICATION.</p> <p>LOOSELY ATTACH TUBE (5) TO UNION ON FWD PORT OF HIGH STAGE REGULATOR.</p> <p>. TUBE ASSY</p>		1

**71-00-02**

P/P BUILDUP FIGURE 15-1

Page 3

Oct 05/2007

D633A106-HXL

737-600/700/800/900  
**POWERPLANT BUILDUP MANUAL**

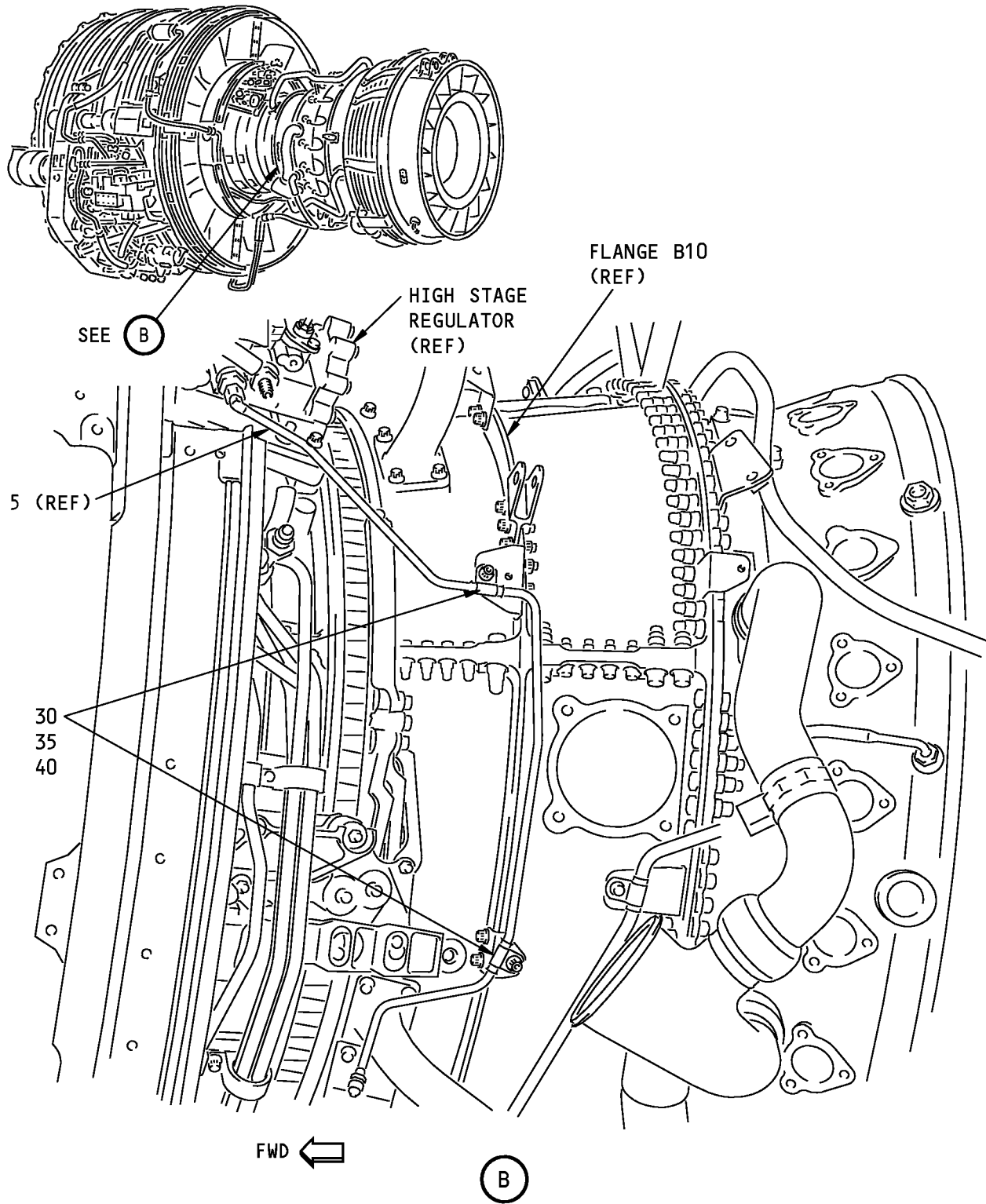

**Lower Bleed Control System Installation**  
**Figure 15-1 (Sheet 2)**

**71-00-02**

P/P BUILDUP FIGURE 15-1

Page 4

Oct 05/2007

D633A106-HXL

**737-600/700/800/900  
POWERPLANT BUILDUP MANUAL**

ITEM NO.	PART NUMBER	NOMENCLATURE	UC	QTY
15-1		<p><b>LOWER BLEED CONTROL SYSTEM INSTALLATION (FIGURE 15-1, SHEET 2)</b></p> <p>LOOSELY ATTACH TUBE (5) TO ENGINE BRACKETS AT 8 AND 9 O'CLOCK POSITIONS ON FLANGE B10 WITH CLAMPSHELLS (30), CLAMPS (35) AND BOLTS (40).</p> <p><b>NOTE:</b> USE FWD HOLE ON BRACKET LOCATED AT 9 O'CLOCK POSITION.</p>		
30	BACC10GT2-04	. CLAMPSHELL		4
30	9352M41P16	. CLAMPSHELL (OPTIONAL)	OPT	-
35	1794M49P01	. CLAMP		2
40	BACB30ZF4-05	. BOLT		2
		<p>MAKE SURE NO PRELOAD FORCE ON TUBE, OR REGULATOR IS PRESENT.</p> <p>IF PRELOAD IS PRESENT, ADJUST TUBE (5) AND CLAMPS (35) TO BEST POSITION.</p> <p>TIGHTEN BOLTS (40) TO 110-120 POUND-INCHES (12.4-13.6 NEWTON METERS).</p> <p>TIGHTEN TUBE ASSY (5) TO 133-147 POUND-INCHES (15.0-16.6 NEWTON METER).</p> <p>BACK OFF NUT TO RELAX TORQUE, THEN RETIGHTEN.</p>		

**71-00-02**

P/P BUILDUP FIGURE 15-1

Page 5

Oct 05/2007

D633A106-HXL



737-600/700/800/900  
**POWERPLANT BUILDUP MANUAL**

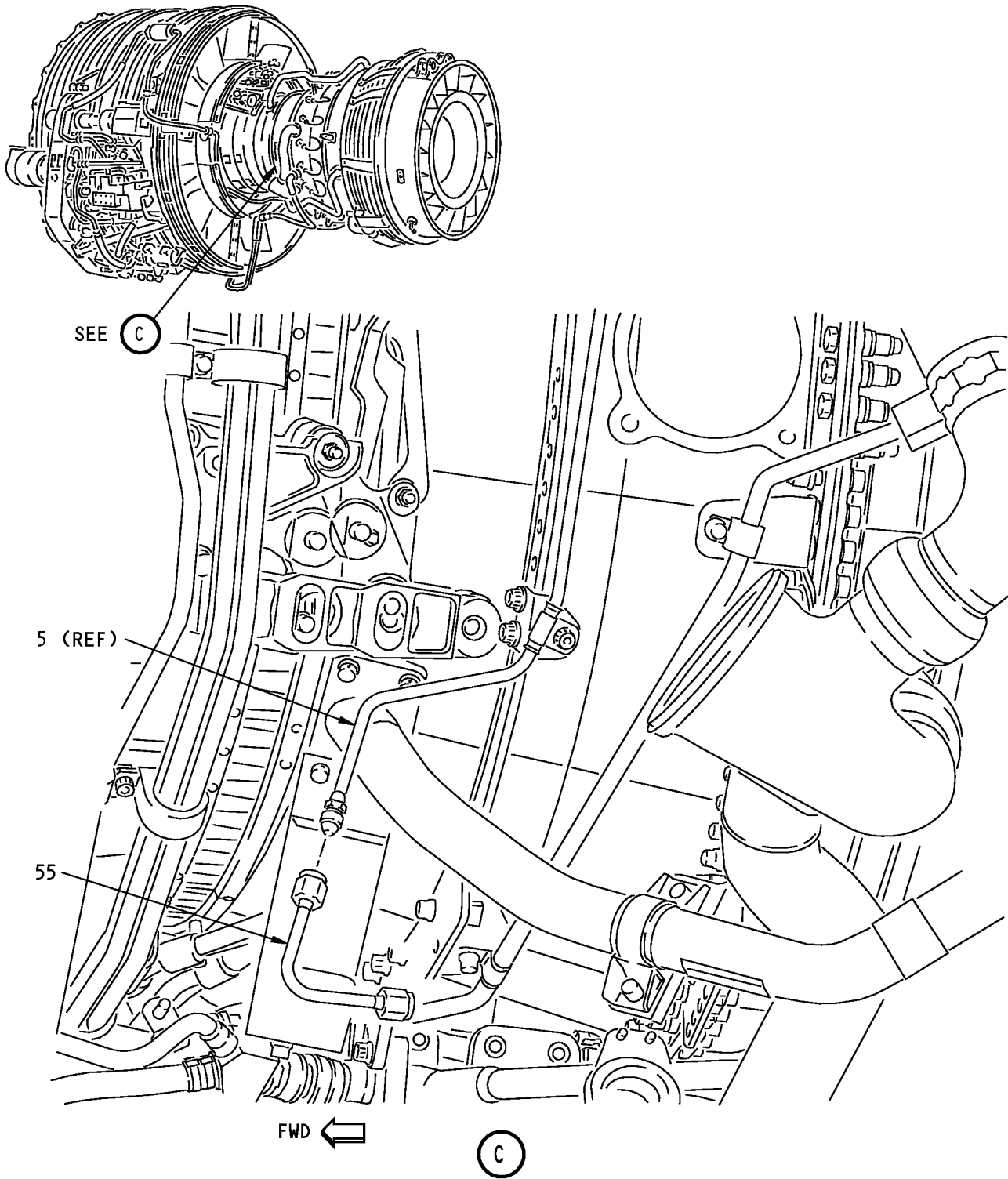

**Lower Bleed Control System Installation**  
**Figure 15-1 (Sheet 3)**

**71-00-02**

P/P BUILDUP FIGURE 15-1

Page 6

Oct 05/2007

D633A106-HXL

**737-600/700/800/900  
POWERPLANT BUILDUP MANUAL**

ITEM NO.	PART NUMBER	NOMENCLATURE	UC	QTY
15-1		<p><b>LOWER BLEED CONTROL SYSTEM INSTALLATION (FIGURE 15-1, SHEET 3)</b></p> <p>LOOSELY INSTALL TUBE (55) TO TUBE (5).</p> <p><b>NOTE:</b> DO NOT TIGHTEN TUBE (55) AT THIS TIME. TUBE WILL BE TIGHTENED DURING THE HIGH STAGE VALVE INSTALLATION (REF Figure 16-1 ).</p>		
55	332A2350-11	<p>. TUBE ASSY</p> <p>MAKE SURE PROTECTIVE CAP IS INSTALLED ON END OF TUBE (55).</p>		1

**71-00-02**

P/P BUILDUP FIGURE 15-1

Page 7

Oct 05/2007

D633A106-HXL

737-600/700/800/900  
**POWERPLANT BUILDUP MANUAL**

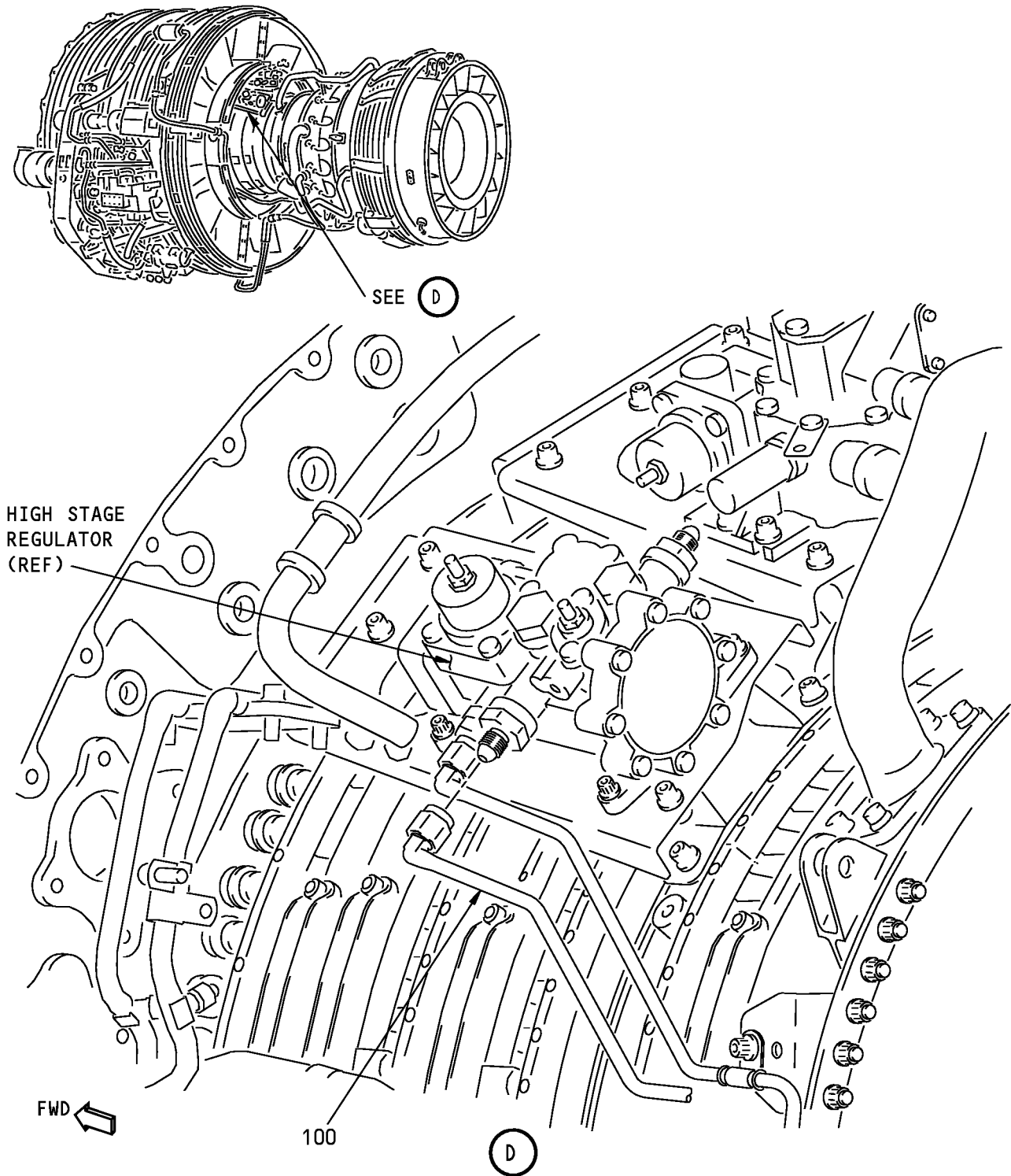

**Lower Bleed Control System Installation**  
**Figure 15-1 (Sheet 4)**

**71-00-02**

P/P BUILDUP FIGURE 15-1

Page 8

Oct 05/2007

D633A106-HXL



737-600/700/800/900  
**POWERPLANT BUILDUP MANUAL**

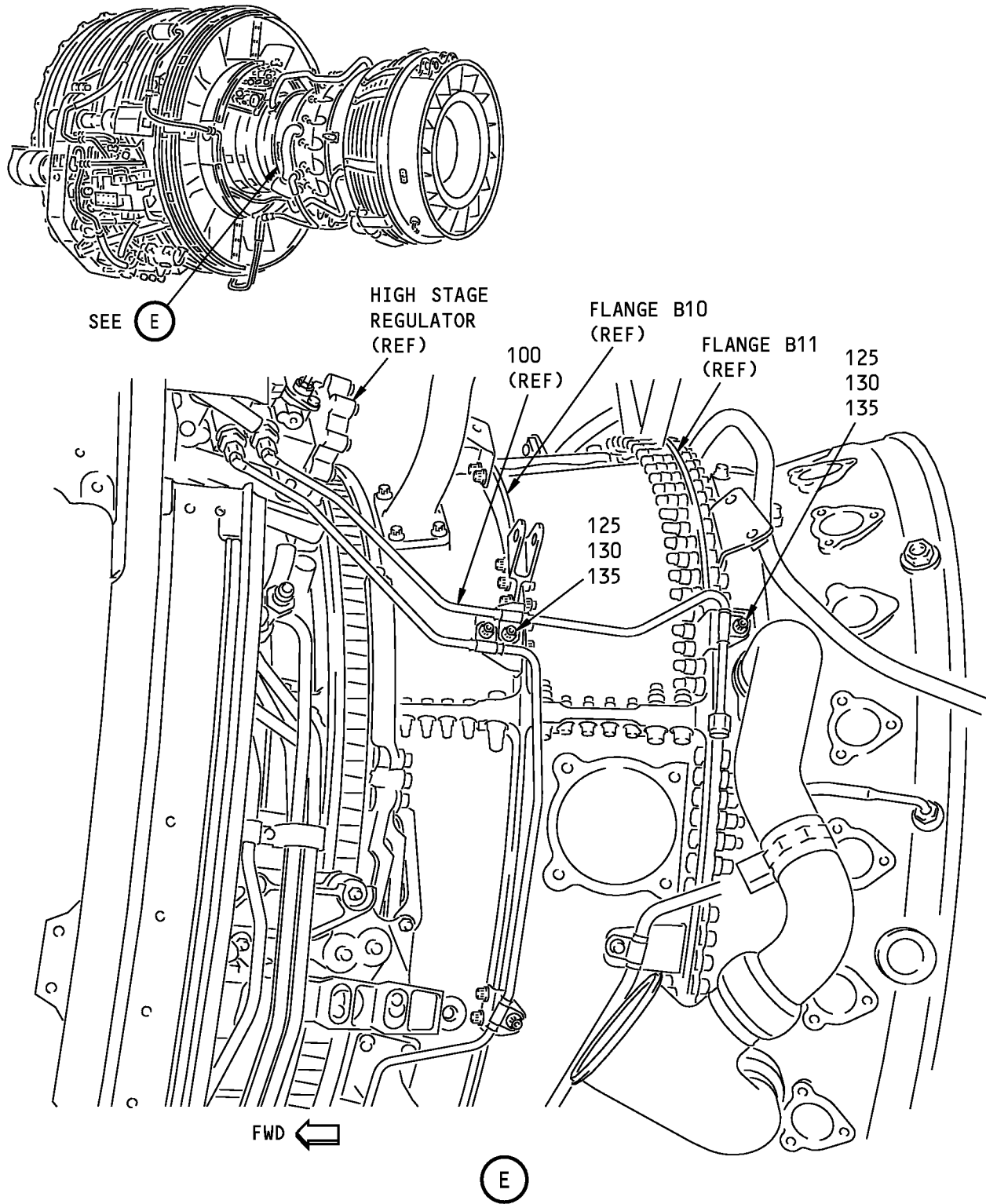

**Lower Bleed Control System Installation**  
**Figure 15-1 (Sheet 5)**

**71-00-02**

P/P BUILDUP FIGURE 15-1

Page 10

Oct 05/2007

D633A106-HXL

**737-600/700/800/900  
POWERPLANT BUILDUP MANUAL**

ITEM NO.	PART NUMBER	NOMENCLATURE	UC	QTY
15-1		<b>LOWER BLEED CONTROL SYSTEM INSTALLATION (FIGURE 15-1, SHEET 5)</b>  LOOSELY ATTACH TUBE (100) TO ENGINE BRACKETS JUST ABOVE 9 O'CLOCK POSITION ON FLANGE B10 AND FLANGE B11 WITH CLAMPSHELLS (125), CLAMPS (130) AND BOLTS (135).		
125	BACC10GT2-04	. CLAMPSHELL		4
125	9352M41P16	. CLAMPSHELL (OPTIONAL)	OPT	-
130	1794M49P01	. CLAMP		2
135	BACB30ZF4-05	. BOLT		2

# 71-00-02

P/P BUILDUP FIGURE 15-1

Page 11

Oct 05/2007

D633A106-HXL

737-600/700/800/900  
**POWERPLANT BUILDUP MANUAL**

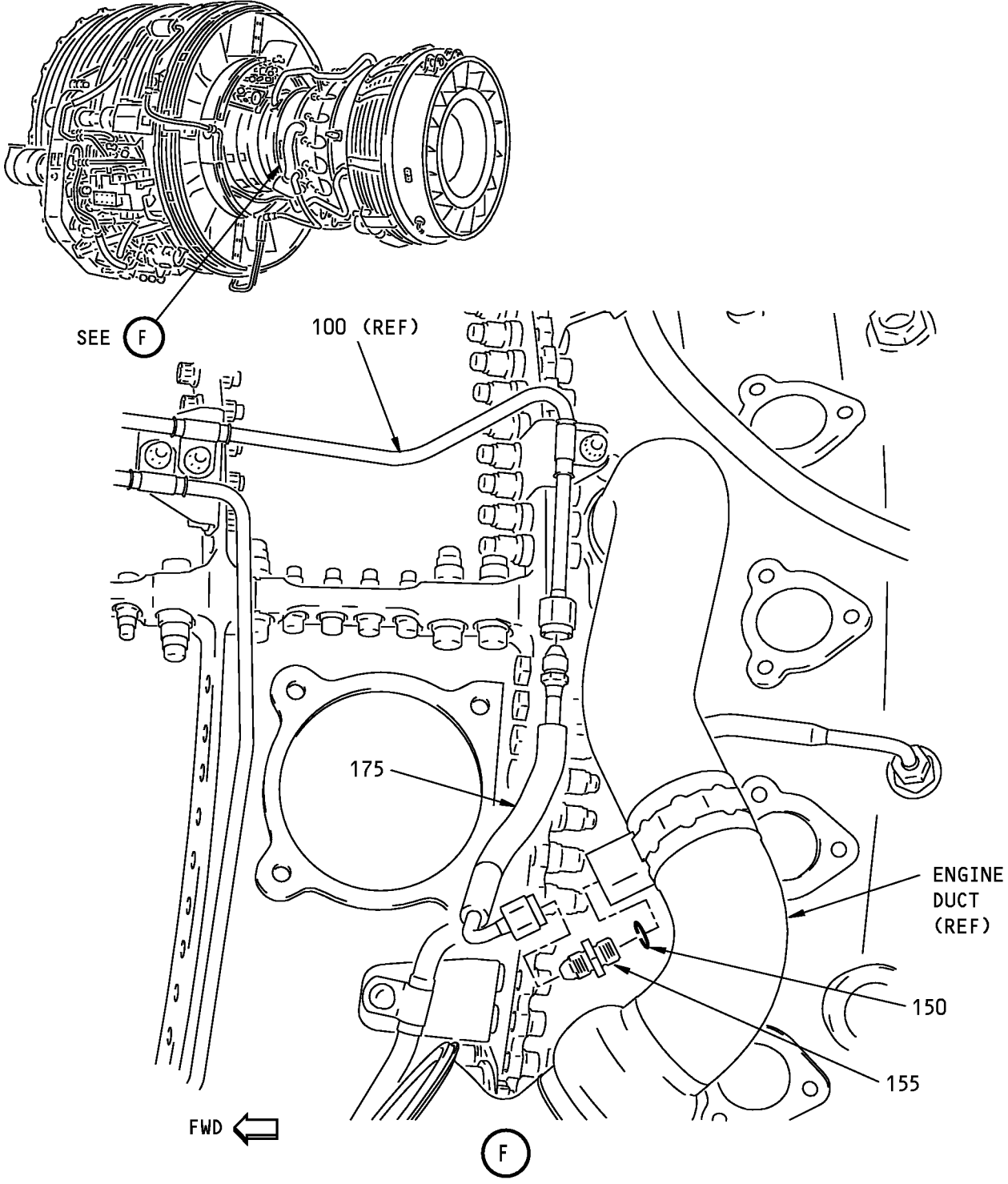

**Lower Bleed Control System Installation**  
**Figure 15-1 (Sheet 6)**

**71-00-02**

**737-600/700/800/900  
POWERPLANT BUILDUP MANUAL**

ITEM NO.	PART NUMBER	NOMENCLATURE	UC	QTY
15-1		<p><b>LOWER BLEED CONTROL SYSTEM INSTALLATION (FIGURE 15-1, SHEET 6)</b></p> <p>INSTALL O-RING (150) ON UNION (155).</p> <p>LUBRICATE THREADS OF UNION (155) WITH Never-Seez NSBT-8N compound, D00006 (C1) AND INSTALL UNION (155) ON ENGINE DUCT.</p>		
150	801A50-0004A	. O-RING (V15284)	VEN	1
155	J1238P54	. UNION		1
C1	D00006	. COMPOUND, NEVER-SEEZ NSBT-8N	CON	AR
		TIGHTEN UNION (155) TO 130-150 POUND-INCHES (14.7-16.9 NEWTON METERS)		
		LOOSELY INSTALL HOSE ASSY (175) BETWEEN TUBE (100) AND UNION (155).		
175	16135-84	. HOSE ASSY (V99755)	VEN	1
175	60B90135-84	. BOEING SPEC FOR 16135-84	BOE	-
		MAKE SURE NO PRELOAD FORCE ON TUBE, HOSE, REGULATOR OR ENGINE DUCT IS PRESENT.		
		IF PRELOAD IS PRESENT, ADJUST TUBE (100) AND CLAMPS (130) TO BEST POSITION.		
		TIGHTEN TUBE ASSY (100) AND HOSE ASSY (175) TO 133-147 POUND-INCHES (15.0-16.6 NEWTON METER), BACK OFF NUT TO RELAX TORQUE, THEN RETIGHTEN.		
		TIGHTEN BOLTS (135) TO 110-120 POUND-INCHES (12.4-13.6 NEWTON METERS).		

# 71-00-02

P/P BUILDUP FIGURE 15-1

Page 13

Oct 05/2007

D633A106-HXL



**FIGURE 16-1**

**BLEED DUCT INSTALLATION - LOWER 5TH-  
AND 9TH-STAGE**

**REF QEC TASK NO.: 16**

**REF DWG: 332A2100  
332A2300**

**NOTE:** ALL STANDARDS AND ATTACHING HARDWARE FOR THIS FIGURE WILL BE PACKAGED  
IN QEC TASK NO. 110.

**71-00-02**

P/P BUILDUP FIGURE 16-1

Page 1

Oct 05/2007

D633A106-HXL

737-600/700/800/900  
**POWERPLANT BUILDUP MANUAL**

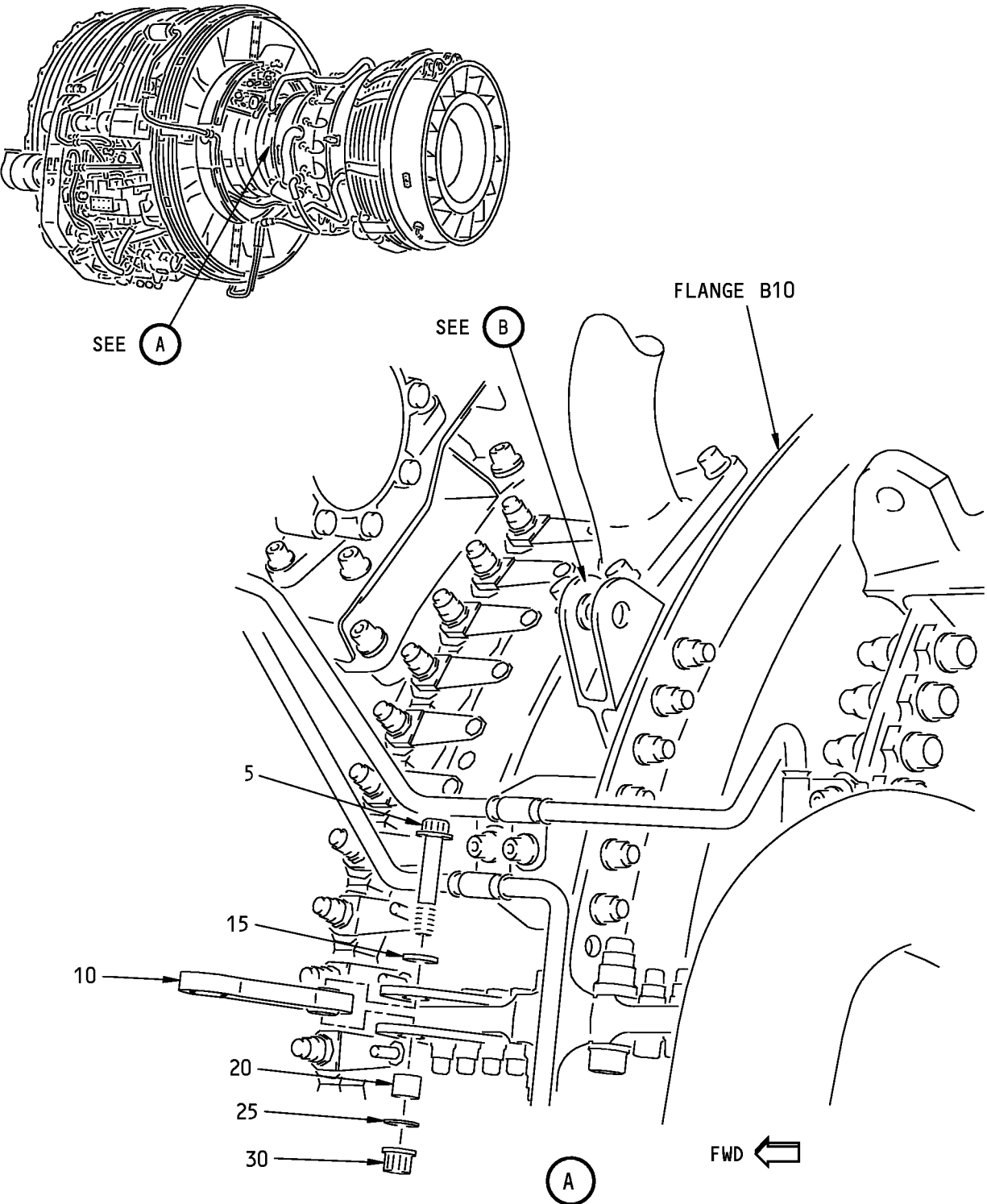

**Lower 5th- and 9th-Stage Bleed Duct Installation**  
**Figure 16-1 (Sheet 1)**

**71-00-02**

P/P BUILDUP FIGURE 16-1

Page 2

Oct 05/2007

D633A106-HXL

**737-600/700/800/900  
POWERPLANT BUILDUP MANUAL**

ITEM NO.	PART NUMBER	NOMENCLATURE	UC	QTY
16-1		<p><b>LOWER 5TH- AND 9TH-STAGE BLEED DUCT INSTALLATION (FIGURE 16-1, SHEET 1)</b></p> <p><b>NOTE:</b> IN THIS PROCEDURE, DO NOT TIGHTEN SCREWS AND TUBE OR HOSE NUTS TO THE INDICATED TORQUE UNTIL INSTRUCTED.</p> <p>WHEN TIGHTENING TUBE AND HOSE NUTS, USE TWO WRENCHES; ONE TO HOLD THE SPANNER FLATS ON THE NIPPLE AND ONE TO TIGHTEN THE NUT.</p> <p>APPLY Never-Seez NSBT-8N compound, D00006 (C1) TO THREADS AND SHANK OF BOLT (5).</p>		
5	BACB30PN4-16	. BOLT		1
C1	D00006	. COMPOUND, NEVER-SEEZ NSBT-8N	CON	AR
		<p>LOOSEN CFMI BRACKETS FWD OF FLANGE B10 AT 9 O'CLOCK POSITION ON ENGINE CORE.</p> <p>ATTACH LINK (10) BETWEEN CFMI BRACKETS USING LUBRICATED BOLT (5), WASHERS (15) AND (25), BUSHING (20) AND NUT (30).</p>		
10	332A2341-4	. LINK ASSY		1
15	BACW10BP4ACU	. WASHER (CSK) (UNDER BOLTHEAD)		1
20	BACB28AK04-042	. BUSHING		1
25	NAS1149C0432R	. WASHER (UNDER NUT)		1
30	AS3485-10	. NUT		1
		TIGHTEN BOLT (5) TO 50-75 POUND-INCHES (5.6-8.5 NEWTON METERS).		

# 71-00-02

P/P BUILDUP FIGURE 16-1

Page 3

Oct 05/2007

D633A106-HXL

737-600/700/800/900  
**POWERPLANT BUILDUP MANUAL**

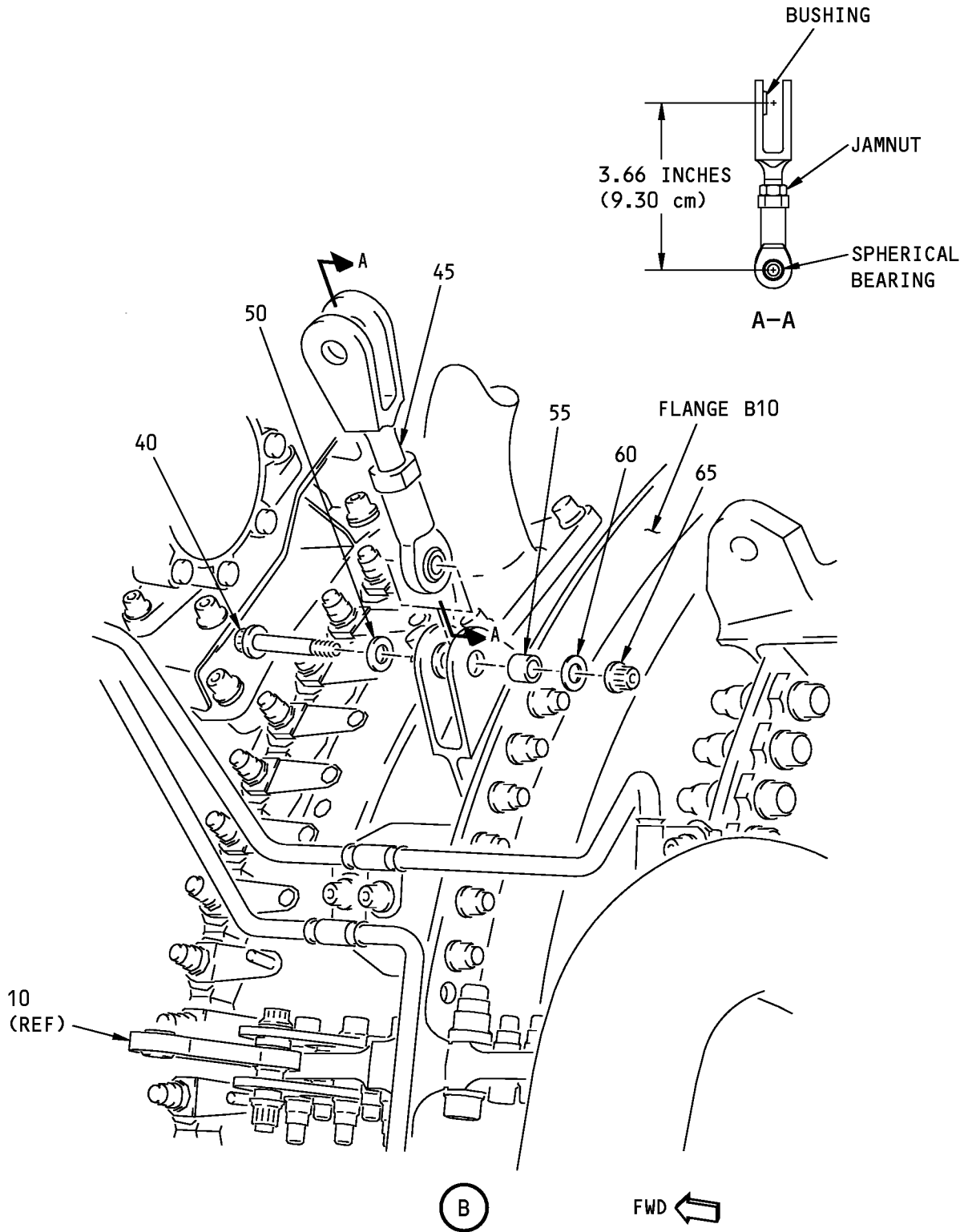

**Lower 5th- and 9th-Stage Bleed Duct Installation**  
**Figure 16-1 (Sheet 2)**

**71-00-02**

P/P BUILDUP FIGURE 16-1

Page 4

Oct 05/2007

D633A106-HXL

**737-600/700/800/900  
POWERPLANT BUILDUP MANUAL**

ITEM NO.	PART NUMBER	NOMENCLATURE	UC	QTY
16-1		<b>LOWER 5TH- AND 9TH-STAGE BLEED DUCT INSTALLATION (FIGURE 16-1, SHEET 2)</b>		
40	BACB30PN4-14	APPLY Never-Seez NSBT-8N compound, D00006 (C1) TO THREADS AND SHANK OF BOLT (40).		
C1	D00006	. BOLT . COMPOUND, NEVER-SEEZ NSBT-8N	CON	1 AR
		LOOSEN JAMNUT OF LINK ASSY (45) TO FREE ROD END.		
		ADJUST LINK ASSY TO 3.66 INCHES (9.30 CM) FROM CENTERLINE OF BUSHING TO CENTERLINE OF SPHERICAL BEARING.		
		RETIGHTEN JAMNUT.		
		LOOSEN CLEVIS BRACKET ON FLANGE B10 AT 10 O'CLOCK POSITION ON ENGINE CORE.		
		ATTACH LINK ASSY (45) TO CLEVIS BRACKET USING LUBRICATED BOLT (40), WASHERS (50) AND (60), BUSHING (55) AND NUT (65).		
45	332A2341-5	. LINK ASSY		1
50	BACW10BP4ACU	. WASHER (CSK) (UNDER BOLTHEAD)		1
55	BACB28AK04-030	. BUSHING		1
60	NAS1149C0432R	. WASHER (UNDER NUT)		1
65	AS3485-10	. NUT		1
		TIGHTEN BOLT (40) TO 50-75 POUND-INCHES (5.6-8.5 NEWTON METERS).		

**71-00-02**

P/P BUILDUP FIGURE 16-1

Page 5

Oct 05/2007

D633A106-HXL

737-600/700/800/900  
**POWERPLANT BUILDUP MANUAL**

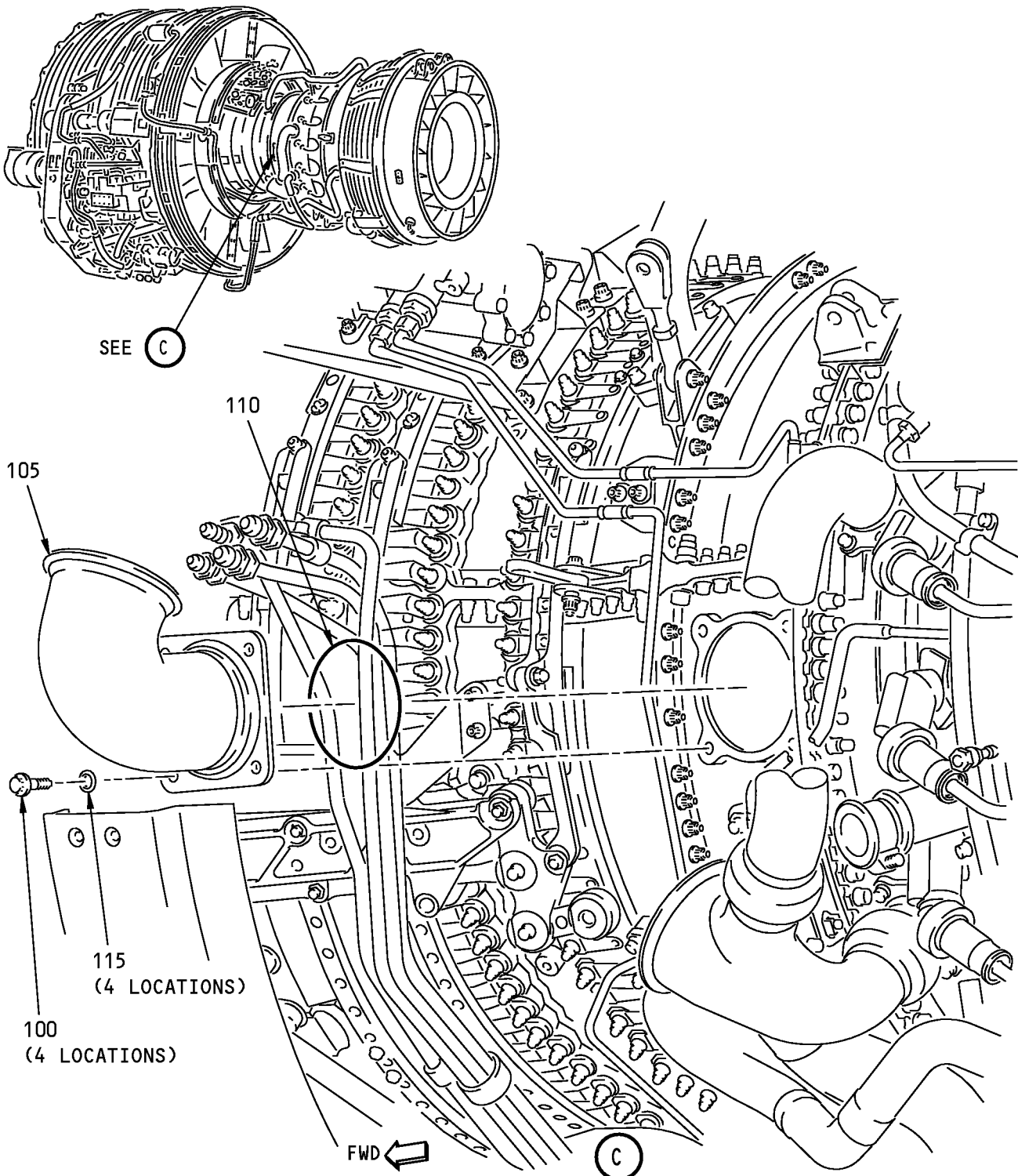

**Lower 5th- and 9th-Stage Bleed Duct Installation**  
**Figure 16-1 (Sheet 3)**

**71-00-02**

P/P BUILDUP FIGURE 16-1

Page 6

Oct 05/2007

D633A106-HXL

**737-600/700/800/900  
POWERPLANT BUILDUP MANUAL**

ITEM NO.	PART NUMBER	NOMENCLATURE	UC	QTY
16-1		<b>LOWER 5TH- AND 9TH-STAGE BLEED DUCT INSTALLATION (FIGURE 16-1, SHEET 3)</b>		
100 C1	BACB30PN5H3 D00006	APPLY Never-Seez NSBT-8N compound, D00006 (C1) TO THREADS AND SHANK OF BOLTS (100). . BOLT . COMPOUND, NEVER SEEZ NSBT-8N	CON	4 AR
105	332A2323-14	REMOVE PROTECTIVE COVER FROM ENGINE PORT. POSITION DUCT ASSY (105) AND SEAL (110) ON ENGINE PORT AND ATTACH USING BOLTS (100) AND WASHERS (115) (WITH COUNTERSINK TOWARD BOLTHEADS). . DUCT ASSY		1
110	8757-350	. SEAL		1
115	BACW10BP5ACU	. WASHERS (CSK)		4
C2 C3	G01912 G50375	TIGHTEN BOLTS (100) TO 115-125 POUND-INCHES (13.0-14.2 NEWTON METERS). INSTALL lockwire, G01912 (C2) OR safety cable kit, G50375 (C3) TO FWD AND AFT PAIR OF BOLTS (100). . LOCKWIRE, MS20995NC32 . SAFETY CABLE, BACC13AT3K18	CON CON	AR 2

# 71-00-02

P/P BUILDUP FIGURE 16-1

Page 7

Feb 05/2008

D633A106-HXL

737-600/700/800/900  
POWERPLANT BUILDUP MANUAL

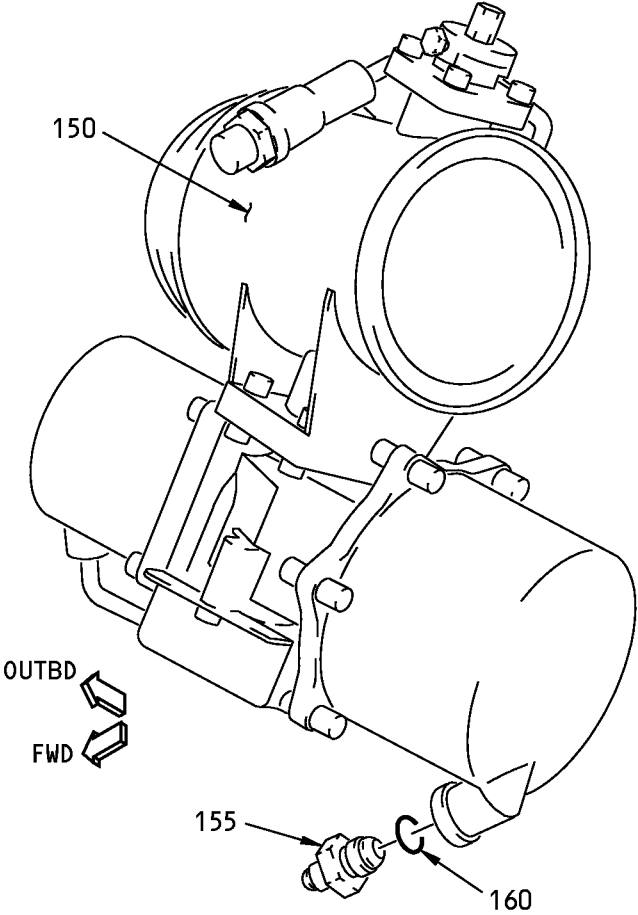

Lower 5th- and 9th-Stage Bleed Duct Installation  
Figure 16-1 (Sheet 4)

**71-00-02**

P/P BUILDUP FIGURE 16-1

Page 8

Oct 05/2007

D633A106-HXL



**737-600/700/800/900  
POWERPLANT BUILDUP MANUAL**

ITEM NO.	PART NUMBER	NOMENCLATURE	UC	QTY
16-1		<p><b>LOWER 5TH- AND 9TH-STAGE BLEED DUCT INSTALLATION (FIGURE 16-1, SHEET 4)</b></p> <p>LUBRICATE THREADS OF REDUCER (155) WITH Never-Seez NSBT-8N compound, D00006 (C1).</p> <p>INSTALL O-RING (160) ON REDUCER (155) AND INSTALL ON HIGH STAGE VALVE (150).</p>		
150	3214446-4	. HIGH STAGE VALVE (V59364)	VEN	1
150	10-62008-32	. BOEING SPEC FOR 3214446-4	BOE	-
155	J522P52	. REDUCER		1
160	801A50-0005A	. O-RING (V15284)	VEN	1
C1	D00006	. COMPOUND, NEVER SEEZ NSBT-8N	CON	AR
		TIGHTEN REDUCER (155) TO 180-200 POUND-INCHES (20.3-22.6 NEWTON METERS).		

# 71-00-02

P/P BUILDUP FIGURE 16-1

Page 9

Oct 05/2007

D633A106-HXL

737-600/700/800/900  
**POWERPLANT BUILDUP MANUAL**

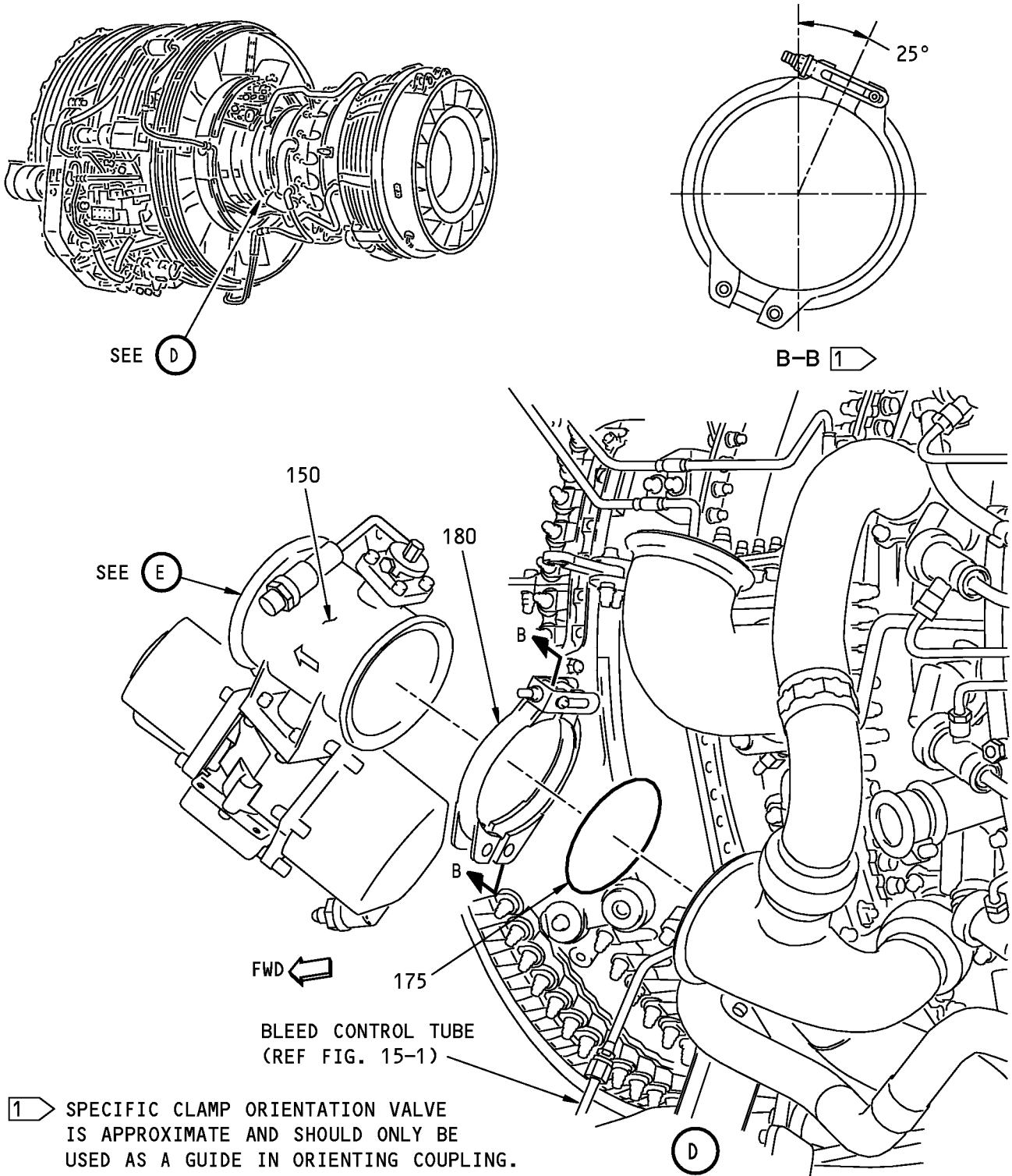

1 SPECIFIC CLAMP ORIENTATION VALVE IS APPROXIMATE AND SHOULD ONLY BE USED AS A GUIDE IN ORIENTING COUPLING.

**Lower 5th- and 9th-Stage Bleed Duct Installation**  
**Figure 16-1 (Sheet 5)**

**71-00-02**

P/P BUILDUP FIGURE 16-1

Page 10

Oct 05/2007

**737-600/700/800/900  
POWERPLANT BUILDUP MANUAL**

ITEM NO.	PART NUMBER	NOMENCLATURE	UC	QTY
16-1		<p><b>LOWER 5TH- AND 9TH-STAGE BLEED DUCT INSTALLATION (FIGURE 16-1, SHEET 5)</b></p> <p><b>NOTE:</b> ALL DUCT COUPLINGS HAVE A DRY-FILM LUBRICANT AND SHOULD NOT BE LUBRICATED FURTHER.</p> <p>VISUALLY EXAMINE ALL SEAL AND FLANGE SEALING SURFACES BEFORE INSTALLATION TO ENSURE NO SCRATCHES, CUTS, PITS, OR FORIEGN MATERIAL IS PRESENT.</p> <p>LOOSELY ATTACH HIGH STAGE VALVE (150) TO CFMI DUCT AT 8 O'CLOCK LOCATION ON ENGINE CORE.</p> <p>USE SEAL (175) AND COUPLING (180).</p> <p>. SEAL</p> <p>. COUPLING</p> <p>LOOSELY INSTALL BLEED CONTROL TUBE (REF Figure 15-1) TO UNION AND ORIENT HIGH STAGE VALVE TO BEST POSITION.</p> <p><b>NOTE:</b> FINAL ORIENTATION OF HIGH STAGE VALVE IS DETERMINED BY BLEED CONTROL TUBE.</p> <p>ORIENT COUPLING (180) WITH COUPLING BOLT ON TOP AND COUPLING NUT FACING OUTBOARD.</p> <p>COUPLING LINK MUST BE CENTERED ALONG THE TAB LOCATED AT THE BOTTOM OF THE 9TH STAGE BLEED DUCT.</p> <p>TIGHTEN COUPLING (180) TO TORQUE SPECIFIED ON PART.</p> <p>LIGHTLY TAP OUTER SURFACE OF COUPLING WITH NON-METALLIC MALLET.</p> <p>RETIGHTEN COUPLING TO TORQUE GIVEN ON PART.</p> <p>TIGHTEN BLEED CONTROL TUBE TO AT BOTH ENDS TO 133-147 POUND-INCHES (15.0-16.6 NEWTON METERS). BACK OFF NUT TO RELAX TORQUE, THEN RETIGHTEN.</p>		1 1
175	AS1895-7-350			1
180	AS1895-1-350			1

**71-00-02**

P/P BUILDUP FIGURE 16-1

Page 11

Oct 05/2007

D633A106-HXL

737-600/700/800/900  
**POWERPLANT BUILDUP MANUAL**

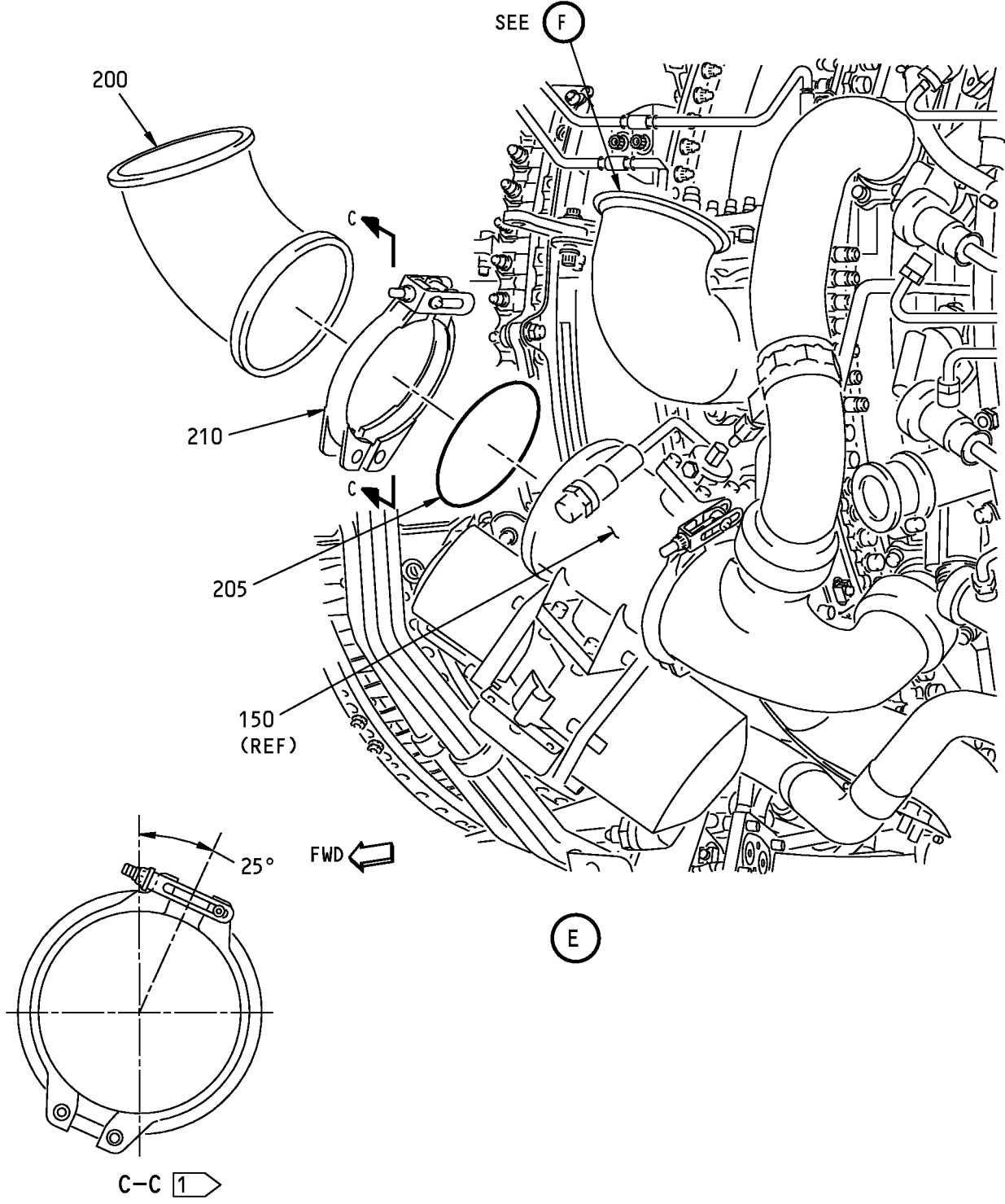

**Lower 5th- and 9th-Stage Bleed Duct Installation**  
**Figure 16-1 (Sheet 6)**

**71-00-02**

P/P BUILDUP FIGURE 16-1  
Page 12  
Oct 05/2007

D633A106-HXL

**737-600/700/800/900  
POWERPLANT BUILDUP MANUAL**

ITEM NO.	PART NUMBER	NOMENCLATURE	UC	QTY
16-1		<p><b>LOWER 5TH- AND 9TH-STAGE BLEED DUCT INSTALLATION (FIGURE 16-1, SHEET 6)</b></p> <p>LOOSELY ATTACH DUCT ASSY (200) TO HIGH STAGE VALVE (150) WITH SEAL (205) AND COUPLING (210).</p> <p>. DUCT ASSY</p> <p>. SEAL</p> <p>. COUPLING<sup>*[2]</sup></p> <p>ORIENT COUPLING (210) WITH COUPLING BOLT ON TOP AND COUPLING NUT FACING OUTBOARD.</p> <p>*[2] ORIENT COUPLING TO MAXIMIZE CLEARANCE.</p>		<p>1</p> <p>1</p> <p>1</p>
200	332A2321-10			
205	AS1895-7-350			
210	AS1895-1-350			

**71-00-02**

P/P BUILDUP FIGURE 16-1

Page 13

Oct 05/2007

D633A106-HXL

737-600/700/800/900  
**POWERPLANT BUILDUP MANUAL**

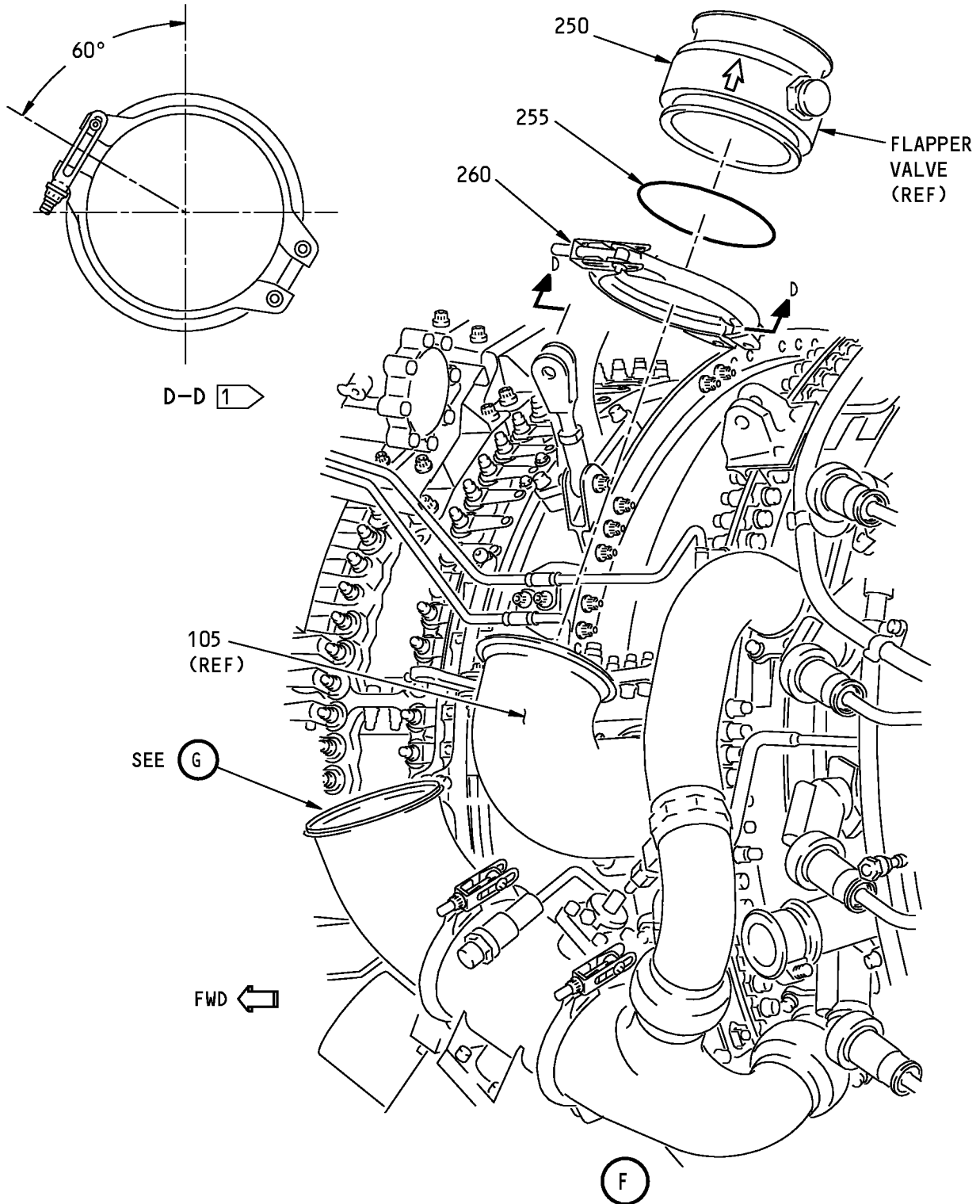

**Lower 5th- and 9th-Stage Bleed Duct Installation**  
**Figure 16-1 (Sheet 7)**

**71-00-02**

P/P BUILDUP FIGURE 16-1

Page 14

Oct 05/2007

D633A106-HXL

**737-600/700/800/900  
POWERPLANT BUILDUP MANUAL**

ITEM NO.	PART NUMBER	NOMENCLATURE	UC	QTY
16-1		<p><b>LOWER 5TH- AND 9TH-STAGE BLEED DUCT INSTALLATION (FIGURE 16-1, SHEET 7)</b></p> <p>LOOSELY ATTACH CHECK VALVE (250) TO DUCT (105) AT 9 O'CLOCK LOCATION ON ENGINE CORE.</p> <p>USE SEAL (255) AND COUPLING (260).</p> <p>ORIENT CHECK VALVE SO FLOW ARROW POINTS UP AND FLAPPER VALVE SHAFT IS APPROXIMATELY PARALLEL TO 5TH-STAGE PORT +/-0.25 INCH TO MAXIMIZE CLEARANCE WITH THRUST REVERSER.</p> <p><b>NOTE:</b> DO NOT TIGHTEN COUPLING AT THIS TIME.</p>		
250	3202222-1	. CHECK VALVE (V59364)	VEN	1
250	10-62008-1	. BOEING SPEC FOR 3202222-1	BOE	-
255	AS1895-7-350	. SEAL		1
260	AS1895-4-350	. COUPLING		1

**71-00-02**

P/P BUILDUP FIGURE 16-1

Page 15

Oct 05/2007

D633A106-HXL

737-600/700/800/900  
**POWERPLANT BUILDUP MANUAL**

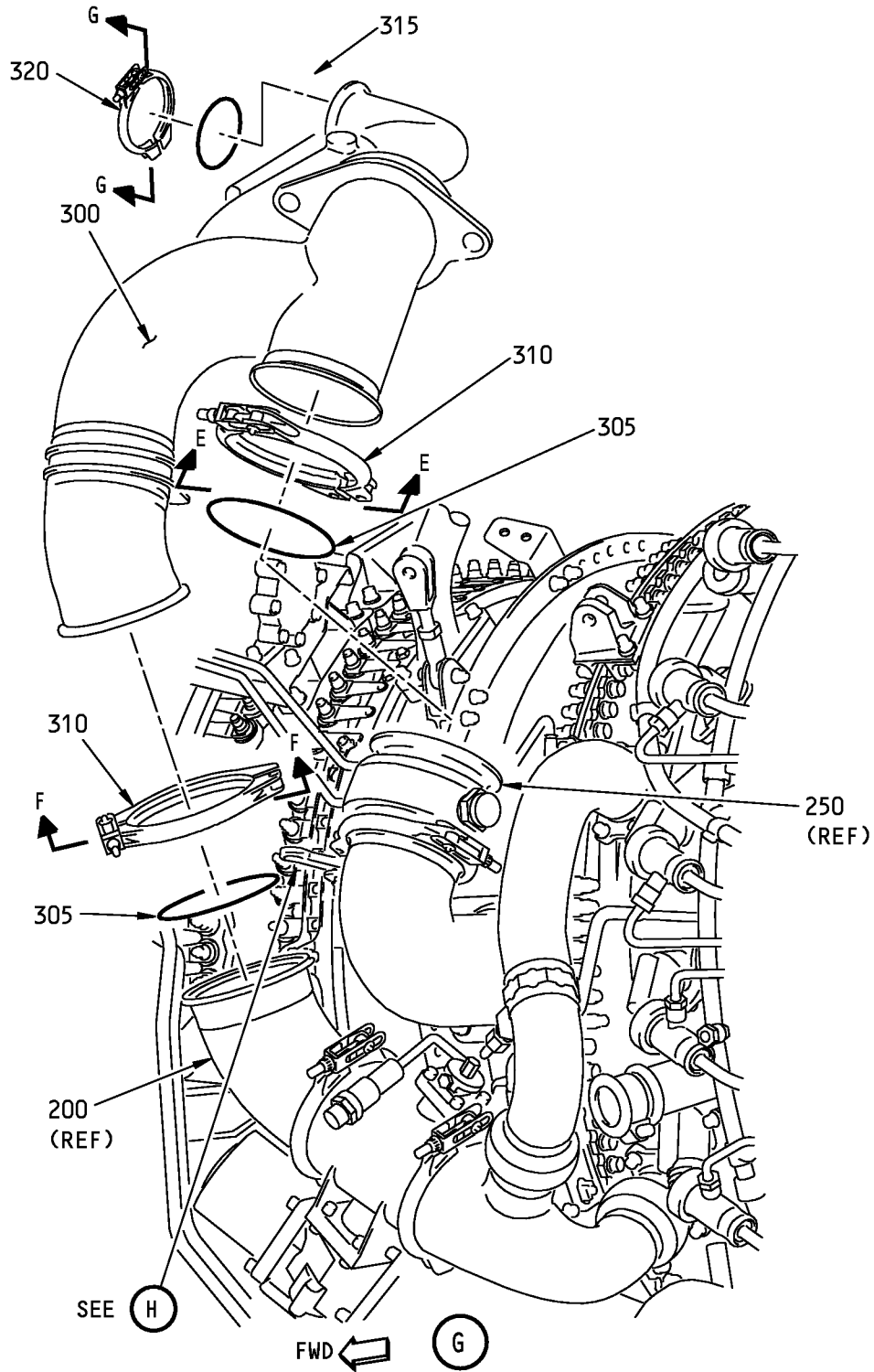

**Lower 5th- and 9th-Stage Bleed Duct Installation**  
**Figure 16-1 (Sheet 8)**

**71-00-02**

P/P BUILDUP FIGURE 16-1

Page 16

Oct 05/2007

D633A106-HXL



**737-600/700/800/900  
POWERPLANT BUILDUP MANUAL**

ITEM NO.	PART NUMBER	NOMENCLATURE	UC	QTY
16-1		<p><b>LOWER 5TH- AND 9TH-STAGE BLEED DUCT INSTALLATION (FIGURE 16-1, SHEET 8)</b></p> <p>POSITION DUCT ASSY (300) AND SEALS (305) ON DUCT ASSY (200) AND CHECK VALVE (250).</p> <p>LOOSELY CONNECT DUCT ASSY (300) WITH COUPLINGS (310).</p> <p><b>NOTE:</b> DO NOT TIGHTEN COUPLINGS AT THIS TIME.</p>		
300	332A2322-54	. DUCT ASSY, INTERSECTION MANIFOLD		1
305	AS1895-7-350	. SEAL		2
310	AS1895-4-350	. COUPLING <sup>*[2]</sup>		2
		<p>*[2] ORIENT COUPLING TO MAXIMIZE CLEARANCE.</p> <p>LOOSELY CONNECT CTAI FLANGE OF DUCT (300) TO CTAI BIFUR DUCT AT 12 O'CLOCK POSITION (REF Figure 13-1) WITH SEAL (315) AND COUPLING (320).</p> <p><b>NOTE:</b> DO NOT TIGHTEN COUPLING AT THIS TIME.</p>		
315	AS1895-7-175	. SEAL		1
320	AS1895-4-175	. COUPLING <sup>*[2]</sup>		1
		<p>MAKE SURE PROTECTIVE CAP IS INSTALLED ON TOP OF DUCT (300).</p> <p>*[2] ORIENT COUPLING TO MAXIMIZE CLEARANCE.</p>		

**71-00-02**

P/P BUILDUP FIGURE 16-1

Page 17

Oct 05/2007

D633A106-HXL

737-600/700/800/900  
**POWERPLANT BUILDUP MANUAL**

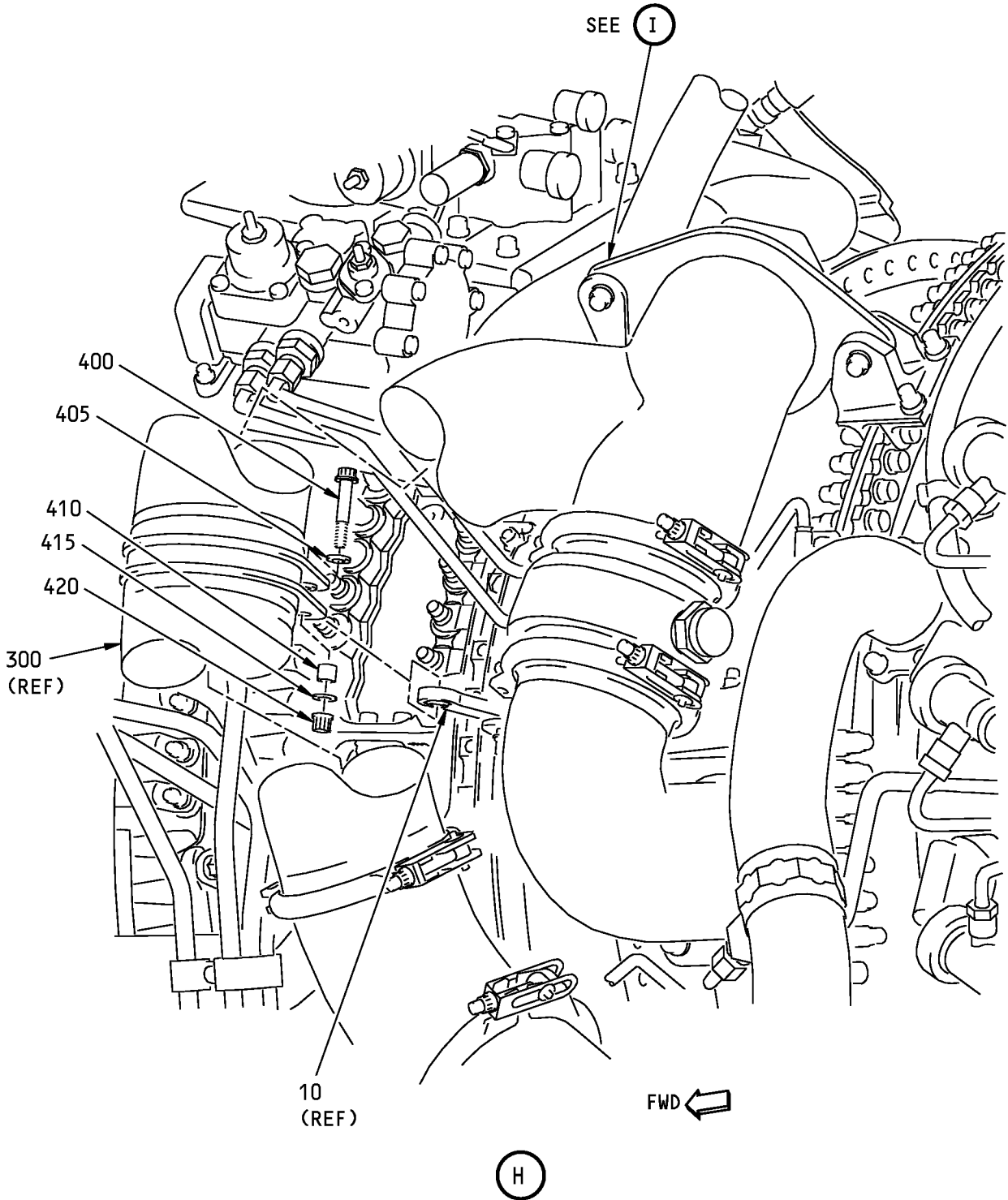

**Lower 5th- and 9th-Stage Bleed Duct Installation**  
**Figure 16-1 (Sheet 9)**

**71-00-02**

**737-600/700/800/900  
POWERPLANT BUILDUP MANUAL**

ITEM NO.	PART NUMBER	NOMENCLATURE	UC	QTY
16-1		<b>LOWER 5TH- AND 9TH-STAGE BLEED DUCT INSTALLATION (FIGURE 16-1, SHEET 9)</b>		
400	BACB30PN4-14	APPLY Never-Seez NSBT-8N compound, D00006 (C1) TO THREADS AND SHANK OF BOLT (400).		
C1	D00006	. BOLT . COMPOUND, NEVER-SEEZ NSBT-8N	CON	1 AR
		LOOSELY ATTACH DUCT (300) TO LINK ASSY (10) WITH LUBRICATED BOLT (400), WASHERS (405) AND (415), BUSHING (410) AND NUT (420).		
		<b>NOTE:</b> DO NOT TIGHTEN BOLT AT THIS TIME.		
405	BACW10BP4ACU	. WASHER (CSK) (UNDER BOLTHEAD)		1
410	BACB28AK04-030	. BUSHING		1
415	NAS1149C0432R	. WASHER (UNDER NUT)		1
420	AS3485-10	. NUT		1

# 71-00-02

P/P BUILDUP FIGURE 16-1

Page 19

Oct 05/2007

D633A106-HXL

737-600/700/800/900  
**POWERPLANT BUILDUP MANUAL**

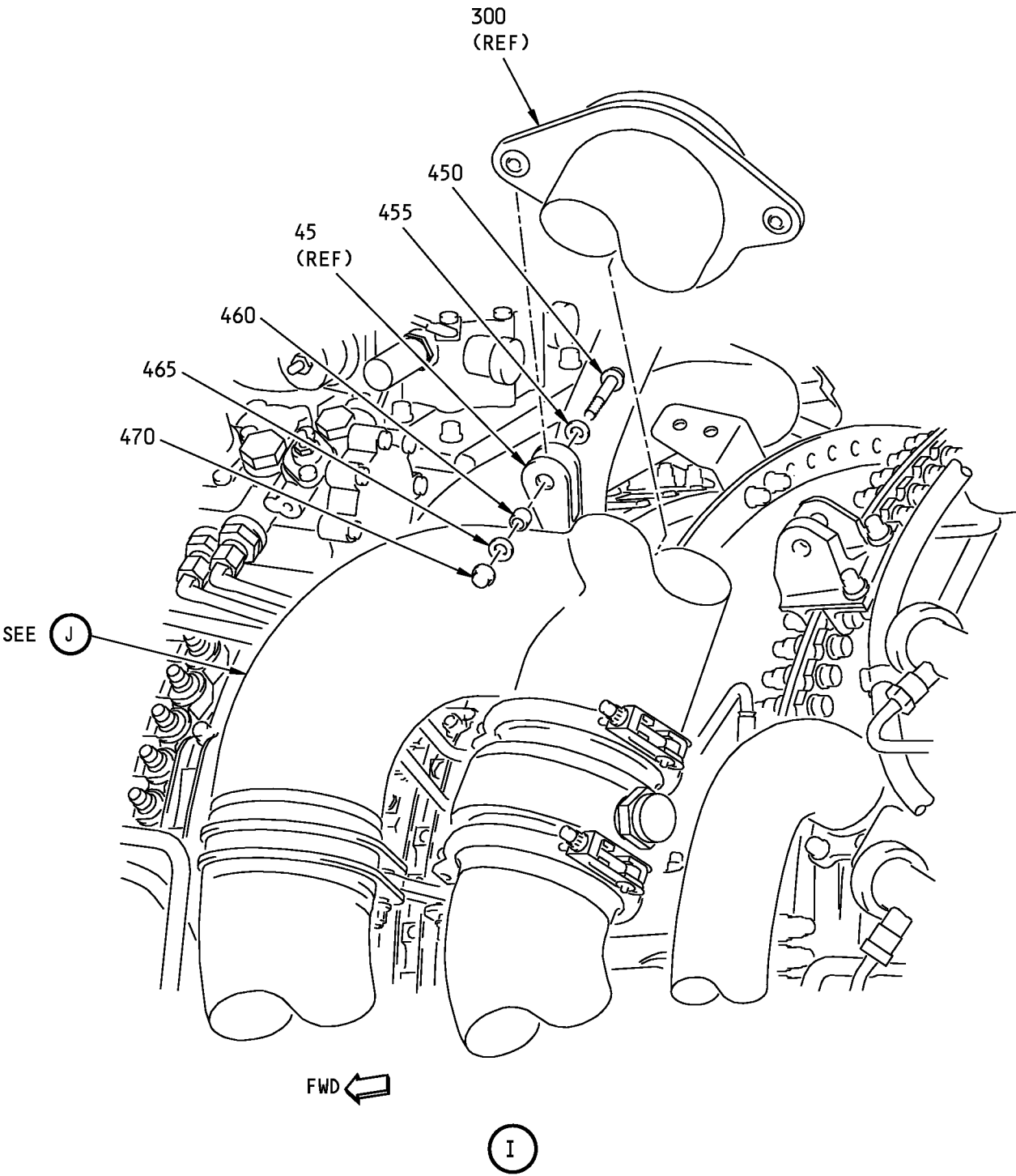

**Lower 5th- and 9th-Stage Bleed Duct Installation**  
**Figure 16-1 (Sheet 10)**

**71-00-02**

P/P BUILDUP FIGURE 16-1  
Page 20  
Oct 05/2007

D633A106-HXL

**737-600/700/800/900  
POWERPLANT BUILDUP MANUAL**

ITEM NO.	PART NUMBER	NOMENCLATURE	UC	QTY
16-1		<b>LOWER 5TH- AND 9TH-STAGE BLEED DUCT INSTALLATION (FIGURE 16-1, SHEET 10)</b>		
450	BACB30PN4-14	APPLY Never-Seez NSBT-8N compound, D00006 (C1) TO THREADS AND SHANK OF BOLT (450).		
C1	D00006	. BOLT . COMPOUND, NEVER-SEEZ NSBT-8N	CON	1 AR
455	BACW10BP4ACU	LOOSELY ATTACH LINK (45) TO ATTACH FLANGE OF DUCT ASSY (300) WITH LUBRICATED BOLT (450), WASHERS (455) AND (465), BUSHING (460) AND NUT (470).		
460	BACB28AK04-030	. WASHER (CSK) (UNDER BOLTHEAD)		1
465	NAS1149C0432R	. BUSHING		1
470	AS3485-10	. WASHER (UNDER NUT)		1
		. NUT		1

# 71-00-02

P/P BUILDUP FIGURE 16-1

Page 21

Oct 05/2007

D633A106-HXL

737-600/700/800/900  
POWERPLANT BUILDUP MANUAL

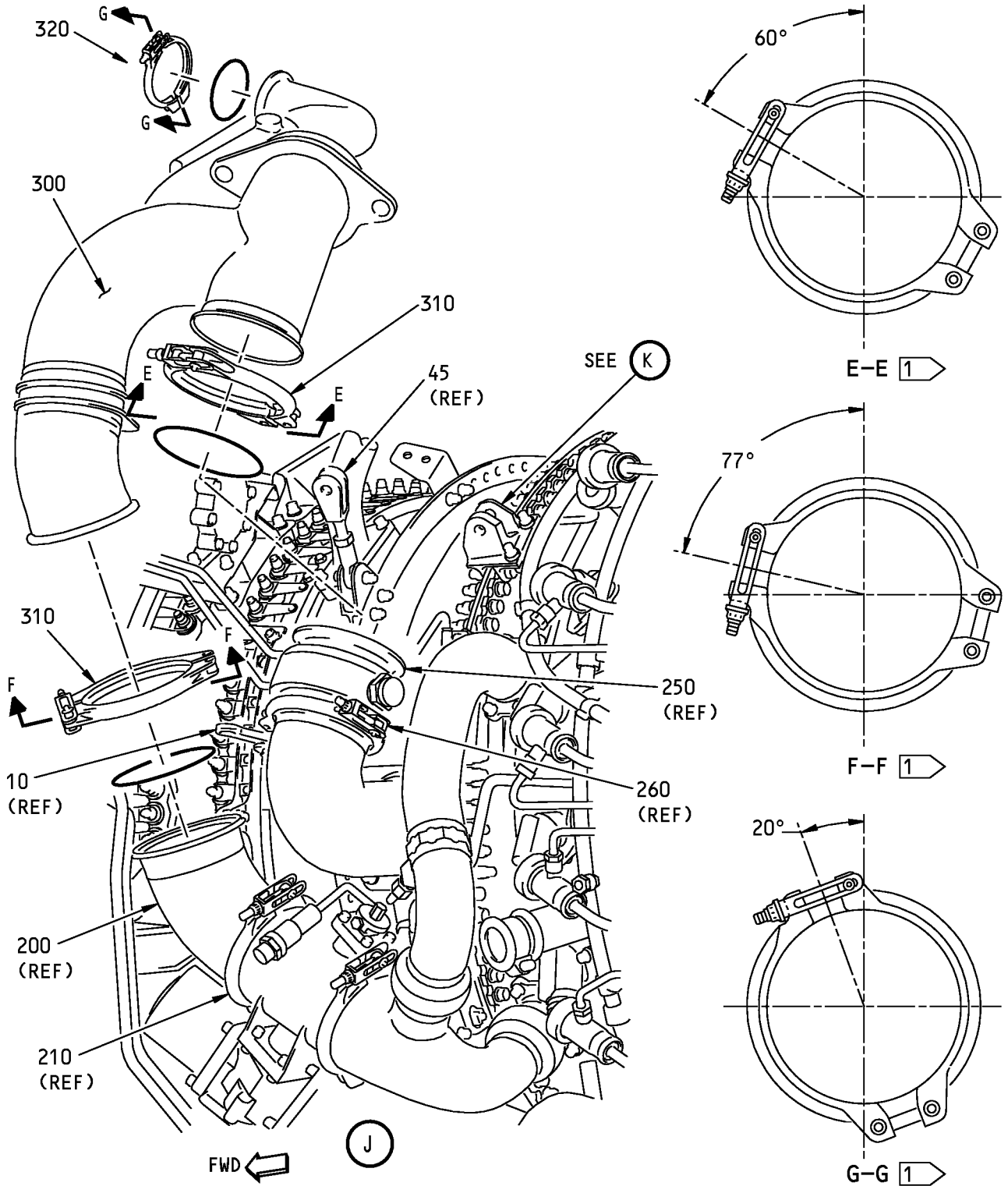

Lower 5th- and 9th-Stage Bleed Duct Installation  
Figure 16-1 (Sheet 11)

71-00-02

P/P BUILDUP FIGURE 16-1

Page 22

Oct 05/2007

D633A106-HXL

## POWERPLANT BUILDUP MANUAL

ITEM NO.	PART NUMBER	NOMENCLATURE	UC	QTY
16-1		<p><b>LOWER 5TH- AND 9TH-STAGE BLEED DUCT INSTALLATION (FIGURE 16-1, SHEET 11)</b></p> <p>ORIENT COUPLINGS (310) AND (320) AS SHOWN.</p> <p>ADJUST DUCT ASSYS (200) AND (300) TO MAKE SURE NO PRELOAD EXISTS ON DUCTS, CHECK VALVE (250) AND LINKS (10) AND (45).</p> <p>TIGHTEN COUPLINGS (210), (260), (310) AND (320) TO TORQUE GIVEN ON PART.</p> <p>LIGHTLY TAP OUTER SURFACE WITH NON-METALLIC Mallet.</p> <p>RETIGHTEN COUPLINGS TO TORQUE GIVEN ON PART.</p> <p>TIGHTEN CFMI BRACKETS SUPPORTING LINK (10) AND CLEVIS BRACKET SUPPORTING LINK (45) TO ENGINE FLANGES. TIGHTEN BOLTS TO 110-120 POUND-INCHES (12.4-13.6 NEWTON METERS).</p> <p>TIGHTEN BOLTS (400) AND (450) TO 50-75 POUND-INCHES (5.6-8.5 NEWTON METERS).</p> <p><b>NOTE:</b> MAKE SURE LINKS DO NOT APPLY A PRELOAD TO ADJACENT DUCT OR SUPPORT HARDWARE.</p> <p>IF NECESSARY, ADJUST LINK (10) BY REPOSITIONING CFMI BRACKETS.</p> <p>LOOSEN CFMI FASTENERS, REPOSITION BRACKETS AND RETIGHTEN FASTENERS TO 110-120 POUND-INCHES (12.5-13.5 NEWTON METERS).</p> <p>IF NECESSARY, ADJUST LINK (45) BY LOOSENING JAMNUT ON LINK TO FREE ROD END.</p> <p>ADJUST AS NECESSARY AND RETIGHTEN JAMNUT.</p> <p>APPLY lockwire, G01912 (C2) OR safety cable kit, G50375 (C3) BETWEEN JAMNUT AND FEMALE SIDE OF LINK (45).</p>		
C2	G01912	. LOCKWIRE, MS20995NC32	CON	AR
C3	G50375	. SAFETY CABLE, BACC13AT3K18	CON	2

71-00-02

P/P BUILDUP FIGURE 16-1

Page 23

Feb 05/2008

D633A106-HXL

737-600/700/800/900  
**POWERPLANT BUILDUP MANUAL**

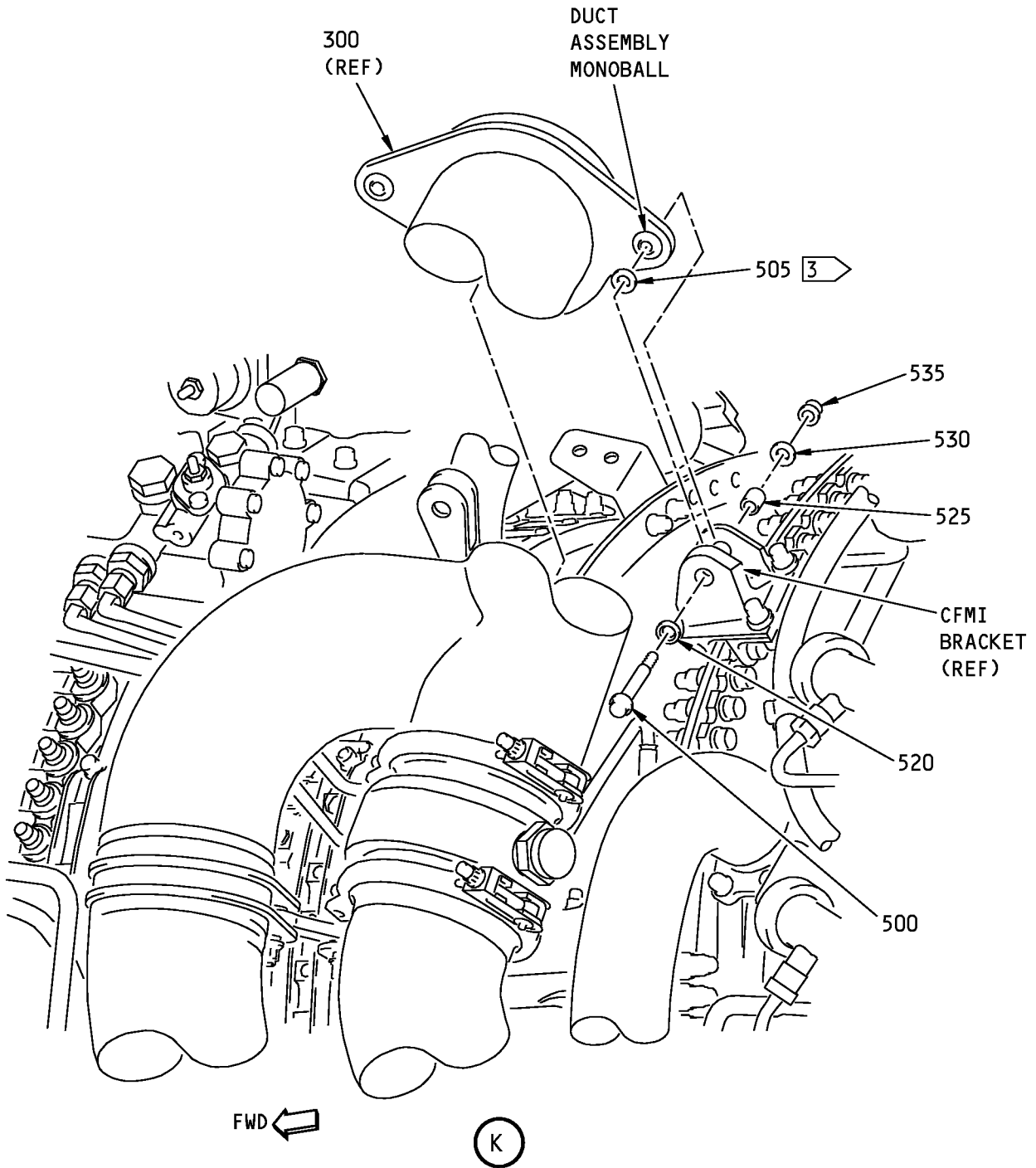

3 INSTALL UP TO 4 WASHERS AS NECESSARY BETWEEN LOWER SIDE OF DUCT ASSEMBLY MONOBALL AND CFMI BRACKET.

**Lower 5th- and 9th-Stage Bleed Duct Installation**  
**Figure 16-1 (Sheet 12)**

**71-00-02**

P/P BUILDUP FIGURE 16-1

Page 24

Oct 05/2007



**737-600/700/800/900  
POWERPLANT BUILDUP MANUAL**

ITEM NO.	PART NUMBER	NOMENCLATURE	UC	QTY
16-1		<b>LOWER 5TH- AND 9TH-STAGE BLEED DUCT INSTALLATION (FIGURE 16-1, SHEET 12)</b>		
		APPLY Never-Seez NSBT-8N compound, D00006 (C1) TO THREADS AND SHANK OF BOLT (500).		
500	BACB30PN6C22	. BOLT <sup>[4]</sup>		1
500	BACB30PN6C24	. BOLT (OPTIONAL TO BACB30PN6C22) <sup>[4]</sup>	OPT	-
C1	D00006	. COMPOUND, NEVER-SEEZ NSBT-8N	CON	AR
		INSTALL UP TO 4 WASHERS (505) TO ELIMINATE GAP BETWEEN LOWER SIDE OF DUCT ASSY MONOBALL AND CFMI BRACKET.		
		IF GAP BETWEEN CFMI BRACKET AND DUCT ASSY MONOBALL IS MORE THAN 0.12 INCHES (3.0 MM), REPOSITION CFMI BRACKET TO REDUCE GAP.		
		RETIGHTEN BRACKET FASTENERS TO 210-230 POUND-INCHES (23.7-26.0 NEWTON METERS).		
505	NAS1149E0616R	. WASHER		4
		SECURE WASHERS (505) TO DUCT FLANGE AND BRACKET CLEVIS WITH BOLT (500), WASHERS (520) AND (530), BUSHING (525), AND NUT (535).		
		MAKE SURE DUCT INSTALLATION DOES NOT APPLY A PRELOAD OF MORE THAN 50 POUNDS ON ADJACENT STRUCTURE.		
520	BACW10BN6UC	. WASHER (CSK) (UNDER BOLTHEAD)		1
525	BACB28AK06-040	. BUSHING <sup>[4]</sup>		1
525	BACB28AK06-055	. BUSHING <sup>[4]</sup>	OPT	-
530	NAS1149E0632R	. WASHER (UNDER NUT)		1
535	AS3485-12	. NUT		1
		TIGHTEN BOLT (500) TO 150-250 POUND-INCHES (17.0-28.2 NEWTON METERS).		
		*[4] BACB30PN6C24 BOLT (500) TOGETHER WITH BACB28AK06-055 BUSHING (525) OPTIONAL TO BACB30PN6C22 BOLT (500) TOGETHER WITH BACB28AK06-040 BUSHING (525).		

**71-00-02**

P/P BUILDUP FIGURE 16-1

Page 25

Oct 05/2007

D633A106-HXL

FIGURE 17-1

# BLEED CONTROL SYSTEM INSTALLATION - UPPER

REF QEC TASK NO.: 17

REF DWG: 332A2100

**NOTE:** ALL STANDARDS AND ATTACHING HARDWARE FOR THIS FIGURE WILL BE PACKAGED IN QEC TASK NO. 110.

**71-00-02**

P/P BUILDUP FIGURE 17-1

Page 1

Oct 05/2007

D633A106-HXL

737-600/700/800/900  
**POWERPLANT BUILDUP MANUAL**

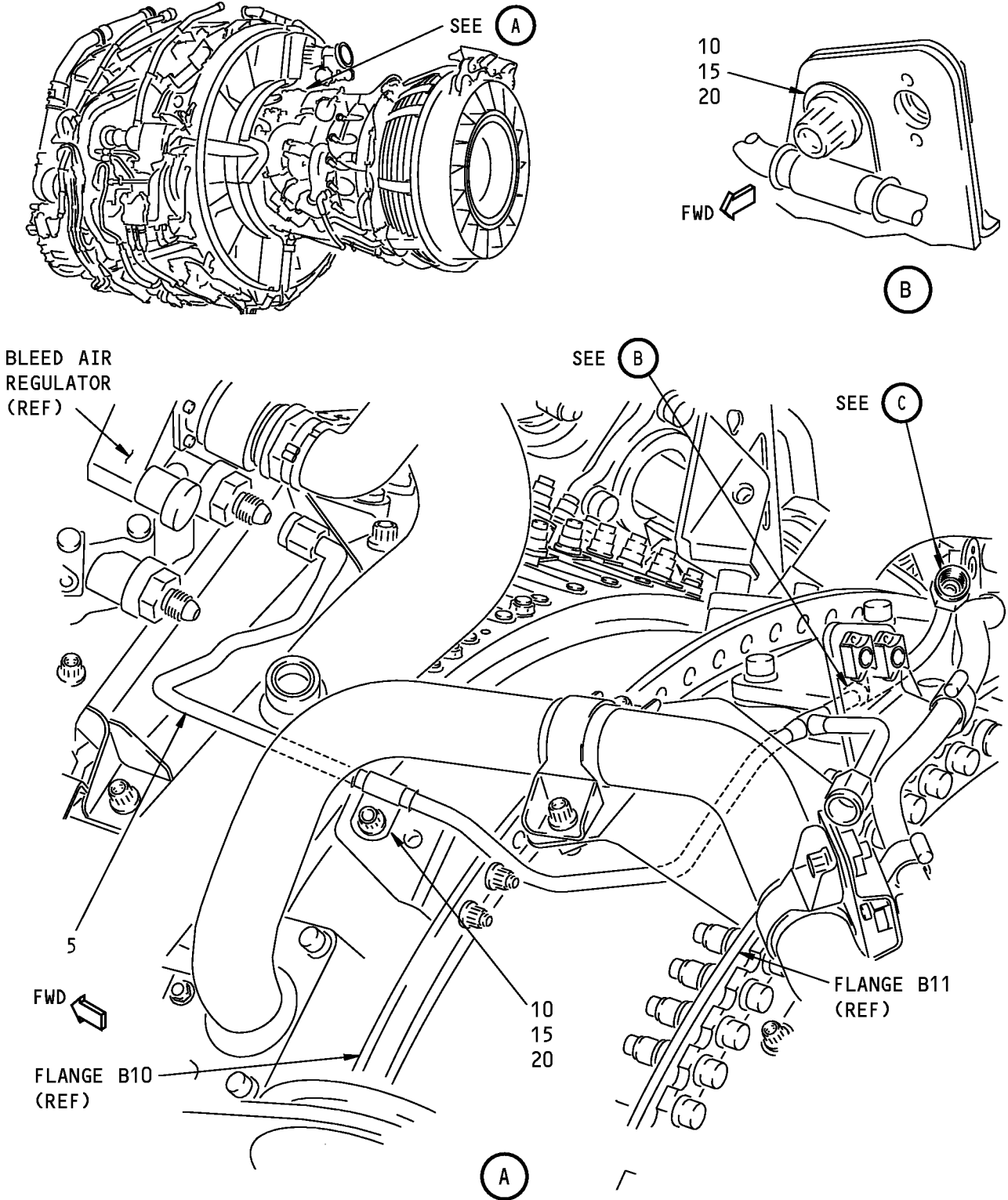

**Upper Bleed Control System Installation**  
**Figure 17-1 (Sheet 1)**

**71-00-02**

P/P BUILDUP FIGURE 17-1

Page 2

Oct 05/2007

D633A106-HXL

## POWERPLANT BUILDUP MANUAL

ITEM NO.	PART NUMBER	NOMENCLATURE	UC	QTY
17-1		<p><b>UPPER BLEED CONTROL SYSTEM INSTALLATION (FIGURE 17-1, SHEET 1)</b></p> <p><b>NOTE:</b> IN THIS PROCEDURE, DO NOT TIGHTEN SCREWS AND TUBE OR HOSE NUTS TO THE INDICATED TORQUE UNTIL INSTRUCTED.</p> <p>WHEN TIGHTENING TUBE AND HOSE NUTS, USE TWO WRENCHES; ONE TO HOLD THE SPANNER FLATS ON THE NIPPLE AND ONE TO TIGHTEN THE NUT.</p> <p>ALL TUBE NUTS HAVE A DRY-FILM LUBRICANT AND DO NOT NEED ADDITIONAL LUBRICATION.</p> <p>POSITION TUBE ASSY (5) ON ENGINE CORE, ALIGNING FOWARD END WITH UPPER UNION ON BLEED AIR REGULATOR.</p> <p>LOOSELY ATTACH TUBE ASSY (5) TO ENGINE CORE BRACKETS ON FLANGES B10 AND B11. USE CLAMPS (10), CLAMPSHELLS (15) AND BOLTS (20).</p> <p>. TUBE ASSY</p> <p>. CLAMP</p> <p>. CLAMPSHELL</p> <p>. CLAMPSHELL (OPTIONAL)</p> <p>. BOLT</p> <p>ADJUST TUBE ASSY (5) TO BEST POSITION, ENSURING NO PRELOAD EXISTS ON TUBE. TIGHTEN TUBE NUT AT BLEED AIR REGULATOR TO 133-147 POUND-INCHES (15.0-16.6 NEWTON METERS). BACK OFF TUBE NUT TO RELAX TORQUE, THEN RETIGHTEN.</p> <p>TIGHTEN BOLTS (20) TO 110-120 POUND-INCHES (12.4-13.6 NEWTON METERS).</p>		
5	332A2350-5	. TUBE ASSY		1
10	1794M49P01	. CLAMP		2
15	BACC10GT2-04	. CLAMPSHELL		4
15	9352M41P16	. CLAMPSHELL (OPTIONAL)	OPT	-
20	BACB30ZF4-06	. BOLT		2

**71-00-02**

P/P BUILDUP FIGURE 17-1

Page 3

Oct 05/2007

D633A106-HXL

737-600/700/800/900  
**POWERPLANT BUILDUP MANUAL**

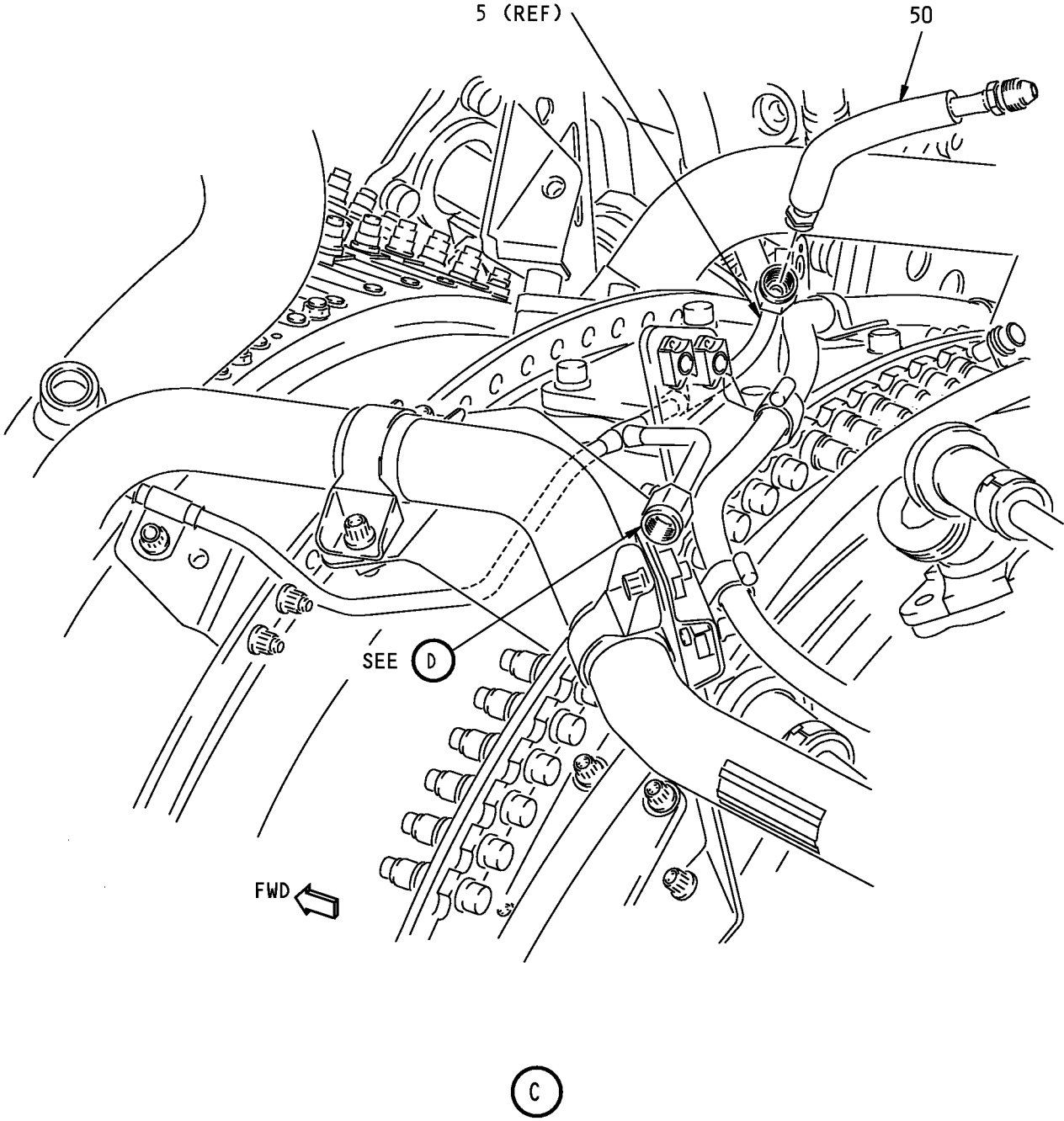

**Upper Bleed Control System Installation**  
**Figure 17-1 (Sheet 2)**

**71-00-02**

P/P BUILDUP FIGURE 17-1

Page 4

Oct 05/2007

D633A106-HXL

**737-600/700/800/900  
POWERPLANT BUILDUP MANUAL**

ITEM NO.	PART NUMBER	NOMENCLATURE	UC	QTY
17-1		<p><b>UPPER BLEED CONTROL SYSTEM INSTALLATION (FIGURE 17-1, SHEET 2)</b></p> <p>INSTALL HOSE ASSY (50) ON END OF TUBE ASSY (5).</p> <p>. HOSE ASSY (V99755)</p> <p>. BOEING SPEC FOR 16135-80</p> <p>TIGHTEN TUBE NUT ON HOSE ASSY (50) TO 133-147 POUND-INCHES (15.0-16.6 NEWTON METERS). BACK OFF TUBE NUT TO RELAX TORQUE, THEN RETIGHTEN.</p> <p>MAKE SURE PROTECTIVE CAP IS INSTALLED ON END OF HOSE ASSY (50).</p>	VEN BOE	1 -

# 71-00-02

P/P BUILDUP FIGURE 17-1

Page 5

Oct 05/2007

D633A106-HXL

737-600/700/800/900  
**POWERPLANT BUILDUP MANUAL**

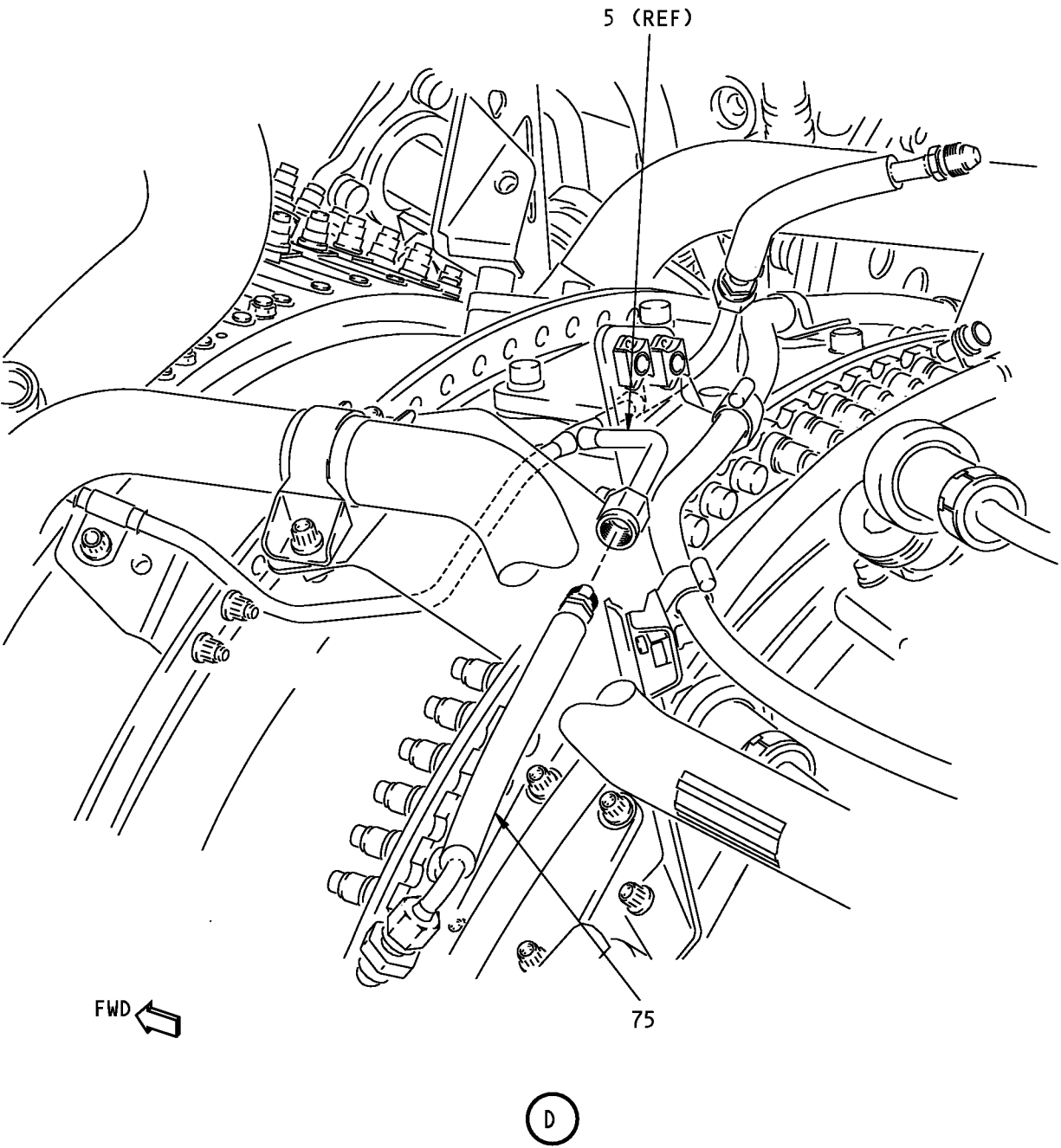

**Upper Bleed Control System Installation**  
**Figure 17-1 (Sheet 3)**

**71-00-02**

P/P BUILDUP FIGURE 17-1

Page 6

Oct 05/2007

D633A106-HXL

**737-600/700/800/900  
POWERPLANT BUILDUP MANUAL**

ITEM NO.	PART NUMBER	NOMENCLATURE	UC	QTY
17-1		<p><b>UPPER BLEED CONTROL SYSTEM INSTALLATION (FIGURE 17-1, SHEET 3)</b></p> <p>LOOSELY INSTALL HOSE ASSY (75) TO TUBE ASSY (5).</p> <p><b>NOTE:</b> DO NOT TIGHTEN HOSE ASSY (75) AT THIS TIME. HOSE WILL BE TIGHTENED DURING THE PRSOV INSTALLATION (REF Figure 18-1 ).</p>		
75	16135-83	. HOSE ASSY (V99755)	VEN	1
75	60B90135-83	. BOEING SPEC FOR 16135-83	BOE	-
		<p>MAKE SURE PROTECTIVE CAP IS INSTALLED ON END OF HOSE ASSY (75).</p>		

**71-00-02**

P/P BUILDUP FIGURE 17-1

Page 7

Oct 05/2007

D633A106-HXL



737-600/700/800/900  
**POWERPLANT BUILDUP MANUAL**

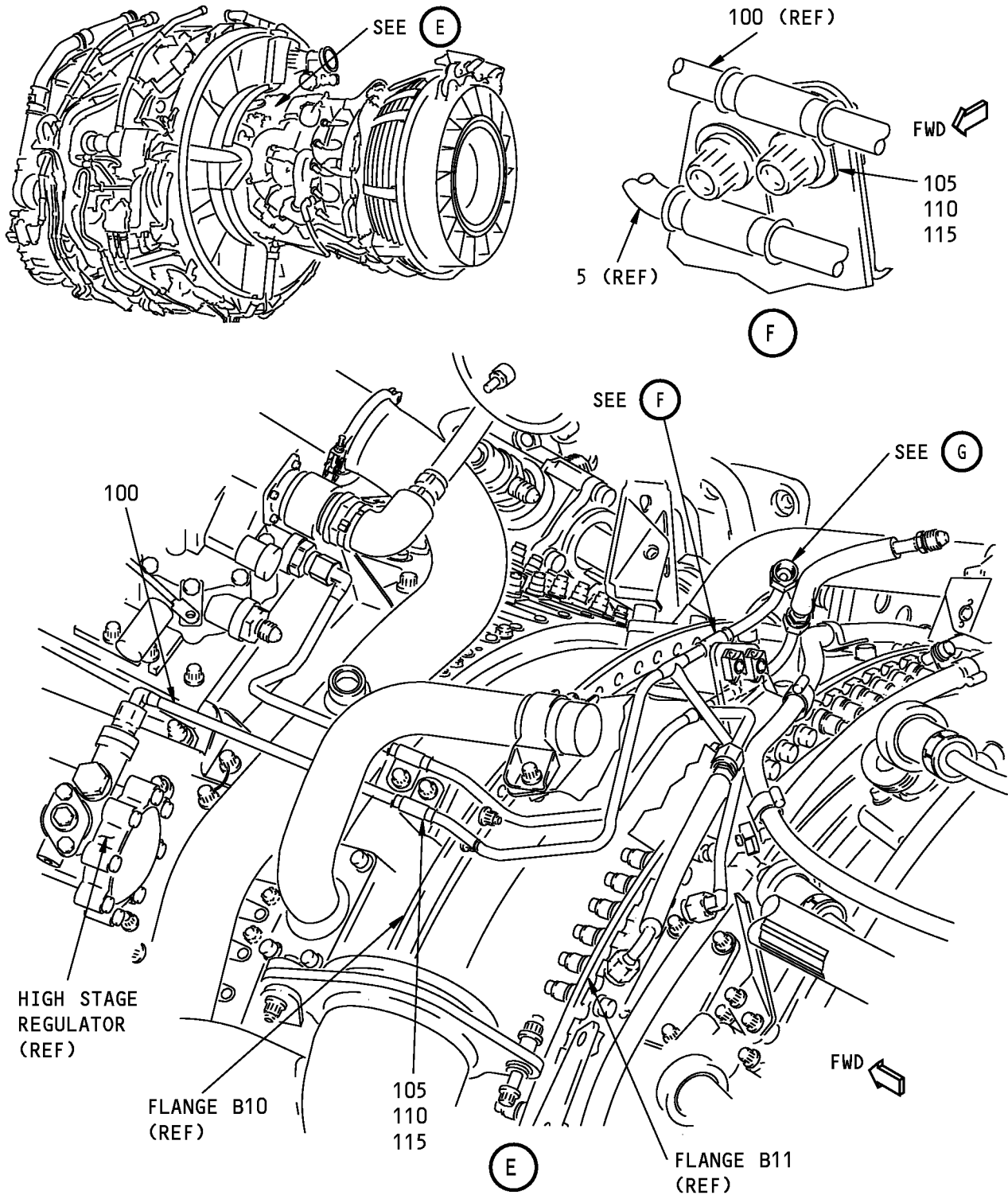

**Upper Bleed Control System Installation**  
**Figure 17-1 (Sheet 4)**

**71-00-02**

P/P BUILDUP FIGURE 17-1

Page 8

Oct 05/2007

D633A106-HXL

**737-600/700/800/900  
POWERPLANT BUILDUP MANUAL**

ITEM NO.	PART NUMBER	NOMENCLATURE	UC	QTY
17-1		<p><b>UPPER BLEED CONTROL SYSTEM INSTALLATION (FIGURE 17-1, SHEET 4)</b></p> <p>POSITION TUBE ASSY (100) ON ENGINE CORE, ALIGNING FOWARD END WITH TOP UNION ON HIGH STAGE REGULATOR.</p> <p>LOOSELY ATTACH TUBE ASSY (100) TO ENGINE CORE BRACKETS ON FLANGES B10 AND B11. USE CLAMPS (105), CLAMPSHELLS (110) AND BOLTS (115).</p> <p>ADJUST TUBE ASSY (100) TO BEST POSITION, ENSURING NO PRELOAD EXISTS ON TUBE. TIGHTEN TUBE NUT AT HIGH STAGE REGULATOR TO 133-147 POUND-INCHES (15.0-16.6 NEWTON METERS). BACK OFF TUBE NUT TO RELAX TORQUE, THEN RETIGHTEN.</p> <p>TIGHTEN BOLTS (115) TO 110-120 POUND-INCHES (12.4-13.6 NEWTON METERS).</p>		
100	332A2350-7	. TUBE ASSY		1
105	1794M49P01	. CLAMP		2
110	BACC10GT2-04	. CLAMPSHELL		4
110	9352M41P16	. CLAMPSHELL (OPTIONAL)	OPT	-
115	BACB30ZF4-06	. BOLT		2

**71-00-02**

P/P BUILDUP FIGURE 17-1

Page 9

Oct 05/2007

D633A106-HXL

737-600/700/800/900  
POWERPLANT BUILDUP MANUAL

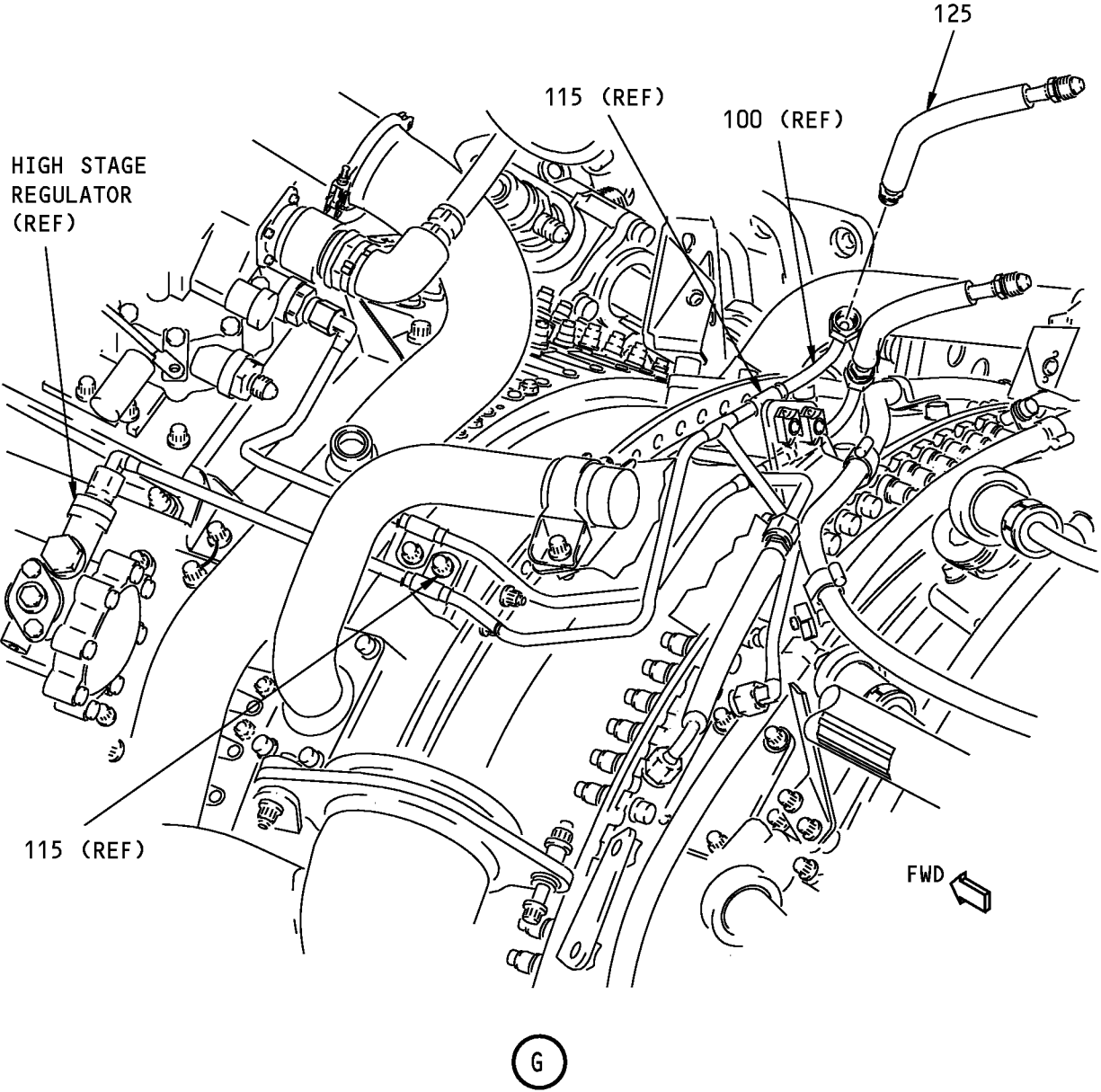

Upper Bleed Control System Installation  
Figure 17-1 (Sheet 5)

**71-00-02**

P/P BUILDUP FIGURE 17-1  
Page 10  
Oct 05/2007

D633A106-HXL

**737-600/700/800/900  
POWERPLANT BUILDUP MANUAL**

ITEM NO.	PART NUMBER	NOMENCLATURE	UC	QTY
17-1		<p><b>UPPER BLEED CONTROL SYSTEM INSTALLATION (FIGURE 17-1, SHEET 5)</b></p> <p>INSTALL HOSE ASSY (125) ON END OF TUBE ASSY (100).</p> <p>. HOSE ASSY (V99755)</p> <p>. BOEING SPEC FOR 16135-81</p> <p>TIGHTEN TUBE NUT ON HOSE ASSY TO 133-147 POUND-INCHES (15.0-16.6 NEWTON METERS). BACK OFF TUBE NUT TO RELAX TORQUE, THEN RETIGHTEN.</p> <p>MAKE SURE PROTECTIVE CAP IS INSTALLED ON END OF HOSE ASSY (125).</p>	VEN BOE	1 -

# 71-00-02

P/P BUILDUP FIGURE 17-1

Page 11

Oct 05/2007

D633A106-HXL

737-600/700/800/900  
**POWERPLANT BUILDUP MANUAL**

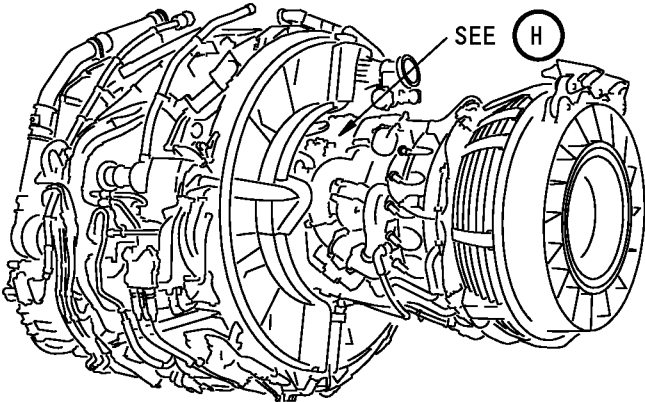

PRECOOLER  
CONTROL VALVE  
(REF)

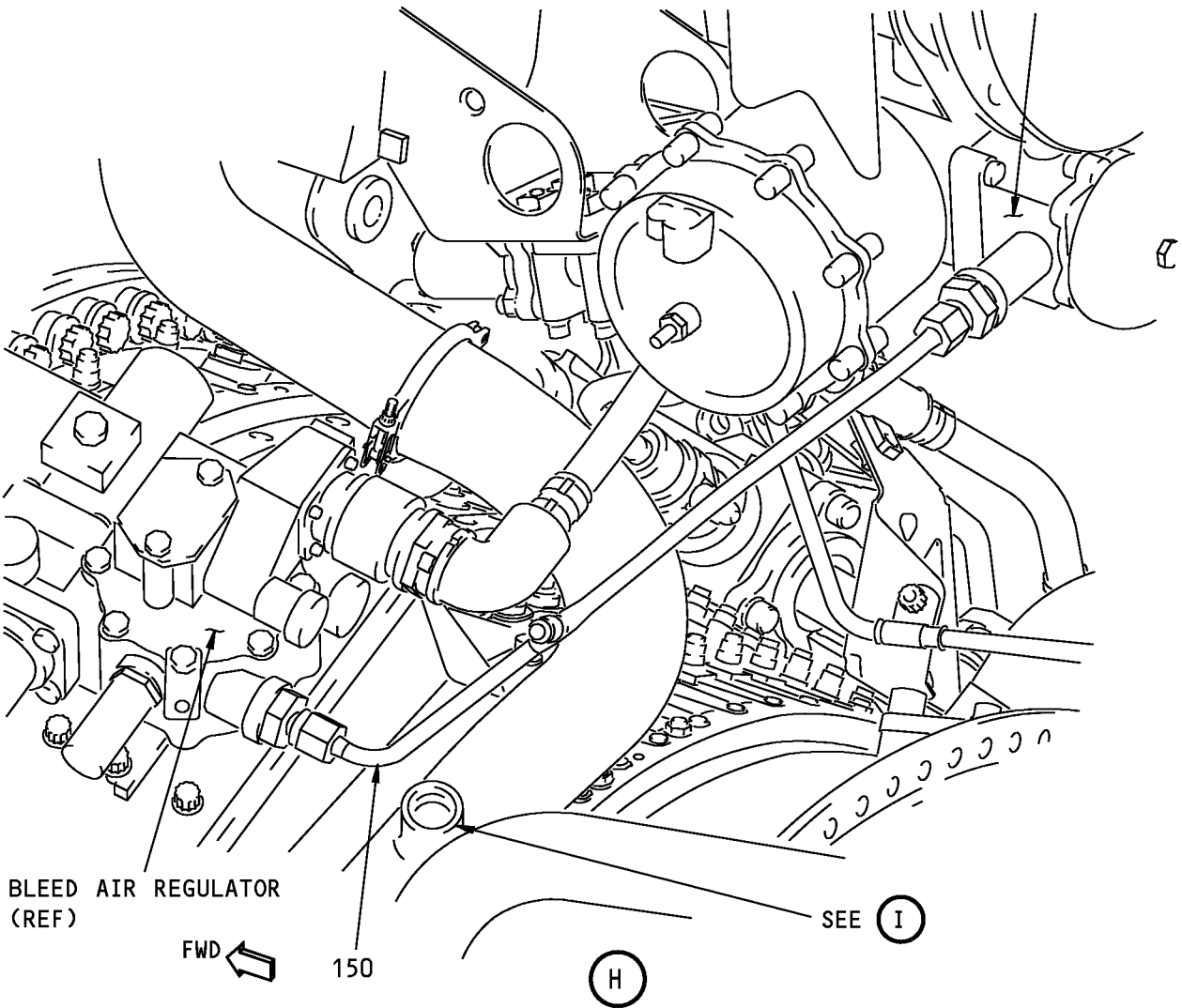

BLEED AIR REGULATOR  
(REF)

FWD

150

SEE I

H

**Upper Bleed Control System Installation**  
Figure 17-1 (Sheet 6)

**71-00-02**

P/P BUILDUP FIGURE 17-1

Page 12

Oct 05/2007

D633A106-HXL

**737-600/700/800/900  
POWERPLANT BUILDUP MANUAL**

ITEM NO.	PART NUMBER	NOMENCLATURE	UC	QTY
17-1		<p><b>UPPER BLEED CONTROL SYSTEM INSTALLATION (FIGURE 17-1, SHEET 6)</b></p> <p>LOOSELY INSTALL TUBE ASSY (150) BETWEEN UNIONS ON BLEED AIR REGULATOR AND PRECOOLER CONTROL VALVE.</p> <p><b>NOTE:</b> DO NOT TIGHTEN TUBE ASSY (150) AT THIS TIME.</p>		
150	332A2350-14	. TUBE ASSY		1

**71-00-02**

P/P BUILDUP FIGURE 17-1

Page 13

Oct 05/2007

D633A106-HXL

737-600/700/800/900  
POWERPLANT BUILDUP MANUAL

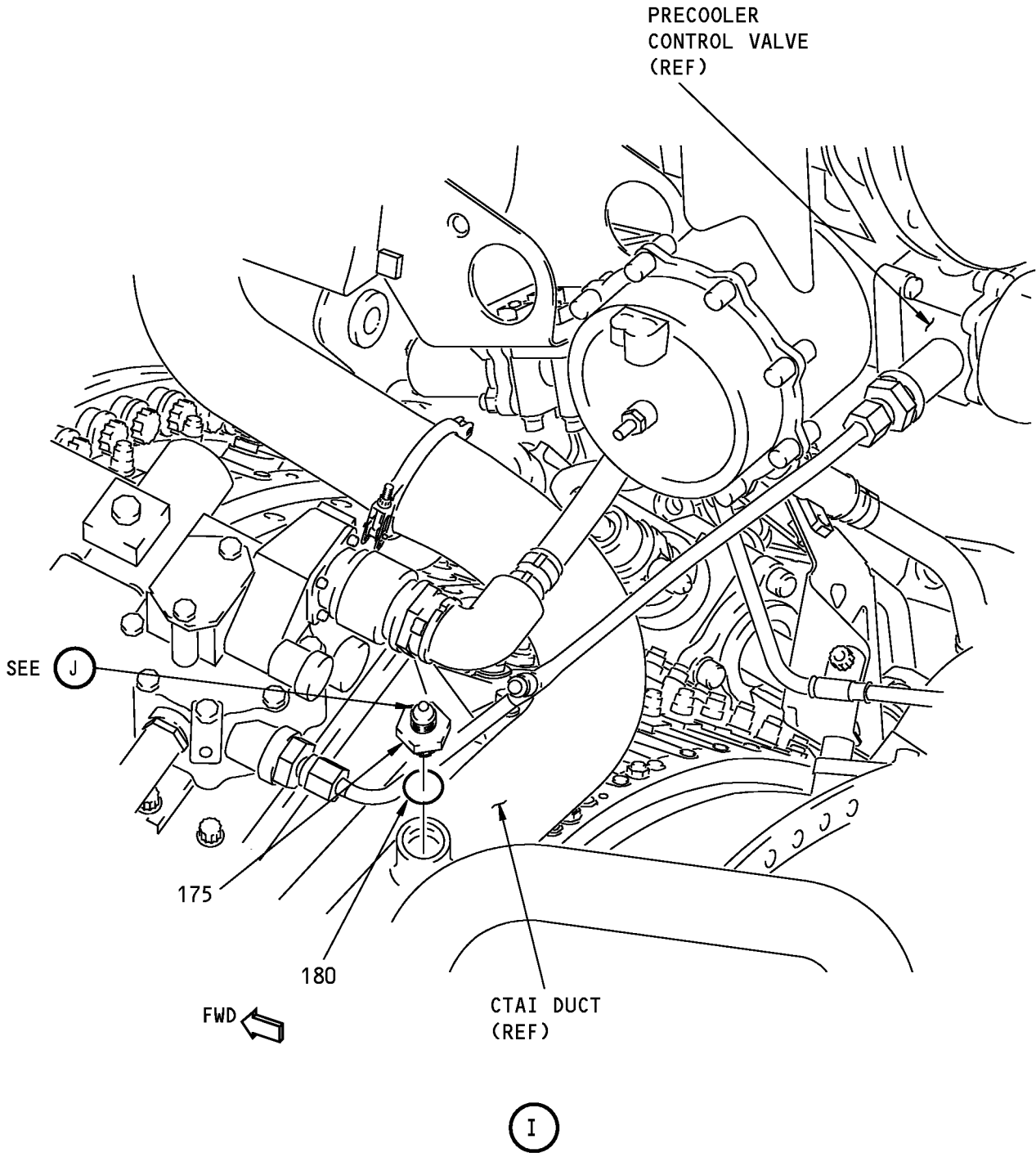

Upper Bleed Control System Installation  
Figure 17-1 (Sheet 7)

**71-00-02**

P/P BUILDUP FIGURE 17-1

Page 14

Oct 05/2007

D633A106-HXL

**737-600/700/800/900  
POWERPLANT BUILDUP MANUAL**

ITEM NO.	PART NUMBER	NOMENCLATURE	UC	QTY
17-1		<p><b>UPPER BLEED CONTROL SYSTEM INSTALLATION (FIGURE 17-1, SHEET 7)</b></p> <p>INSTALL O-RING (180) ON REDUCER (175). LUBRICATE THREADS ON O-RING SIDE OF REDUCER (175) WITH Never-Seez NSBT-8N compound, D00006 (C1) AND INSTALL ON CTAI DUCT.</p> <p>. REDUCER</p> <p>. O-RING (V15284)</p> <p>. COMPOUND, NEVER-SEEZ NSBT-8N</p> <p>TIGHTEN REDUCER (175) TO 258-284 POUND-INCHES (29-32 NEWTON METERS).</p>	VEN CON	1 1 AR

# 71-00-02

P/P BUILDUP FIGURE 17-1

Page 15

Oct 05/2007

D633A106-HXL



737-600/700/800/900  
**POWERPLANT BUILDUP MANUAL**

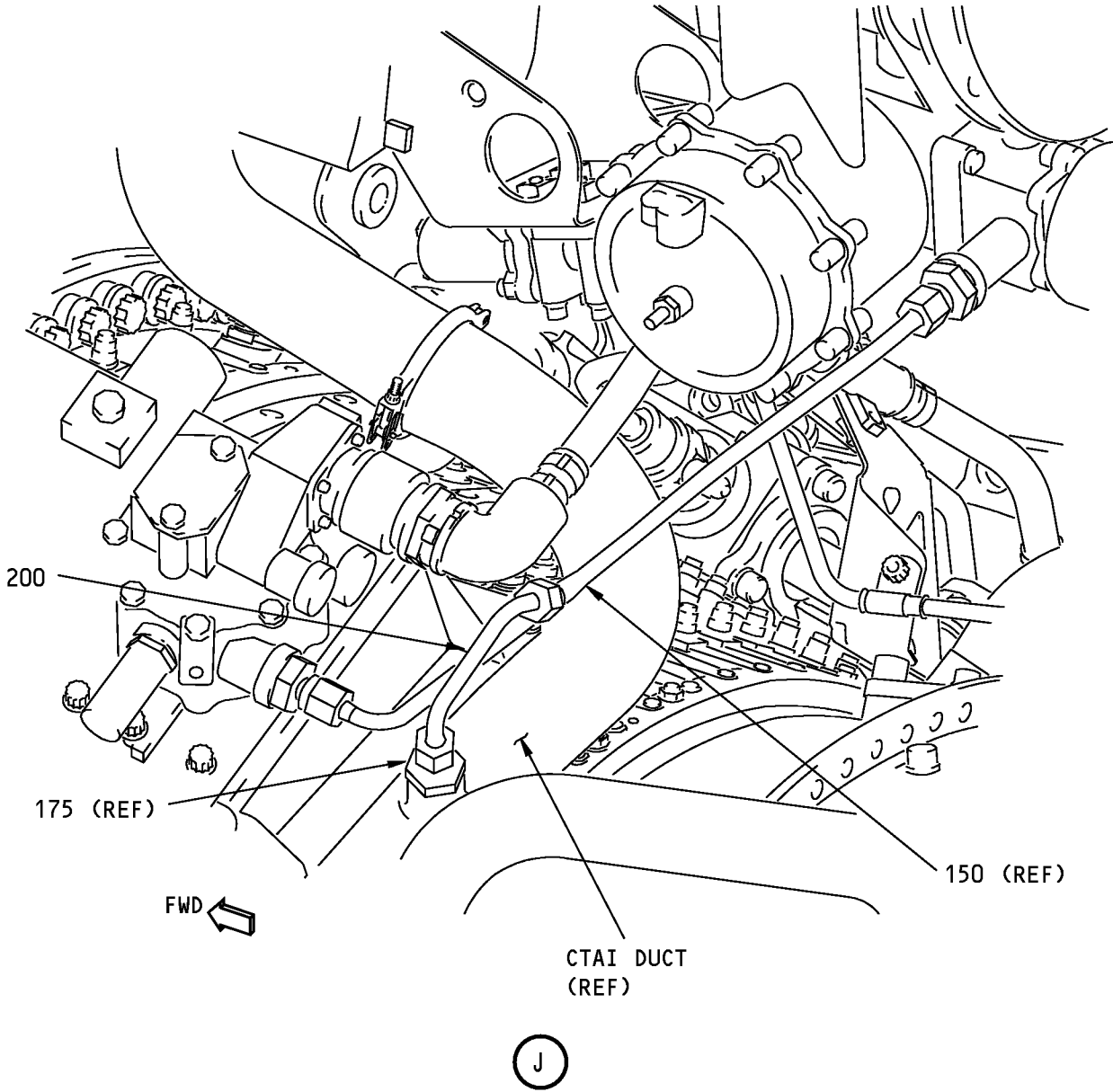

**Upper Bleed Control System Installation  
Figure 17-1 (Sheet 8)**

**71-00-02**

P/P BUILDUP FIGURE 17-1  
Page 16  
Oct 05/2007

D633A106-HXL



737-600/700/800/900  
**POWERPLANT BUILDUP MANUAL**

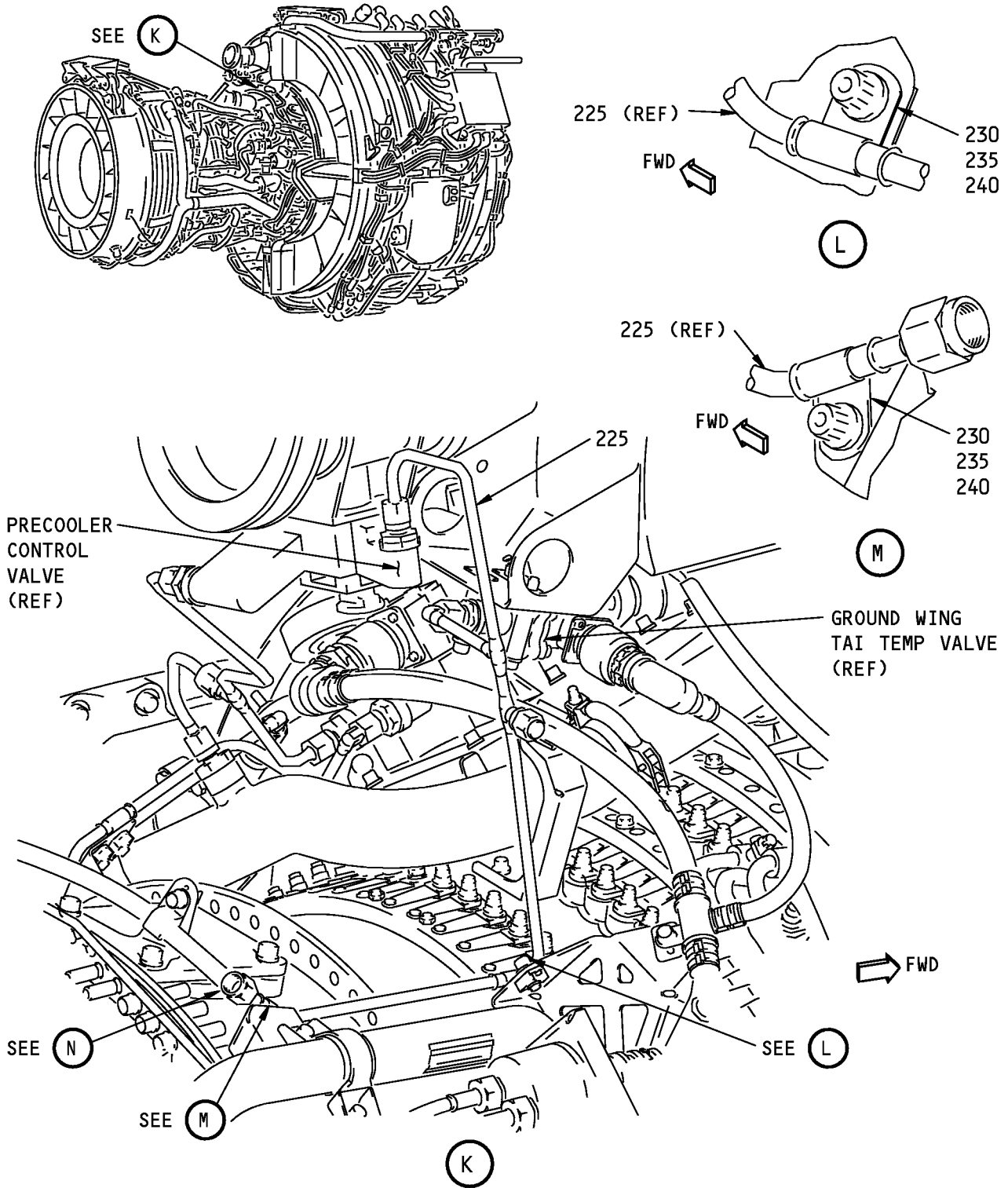

**Upper Bleed Control System Installation**  
**Figure 17-1 (Sheet 9)**

**71-00-02**

P/P BUILDUP FIGURE 17-1

Page 18

Oct 05/2007

D633A106-HXL

**737-600/700/800/900  
POWERPLANT BUILDUP MANUAL**

ITEM NO.	PART NUMBER	NOMENCLATURE	UC	QTY
17-1		<p><b>UPPER BLEED CONTROL SYSTEM INSTALLATION (FIGURE 17-1, SHEET 9)</b></p> <p>LOOSELY INSTALL TUBE ASSY (225) ON ENGINE CORE, ALIGNING FOWARD END WITH UNION ON RIGHT SIDE OF PRECOOLER CONTROL VALVE AND UNION ON GROUND WING TAI TEMP VALVE.</p> <p>LOOSELY ATTACH TUBE ASSY (225) TO ENGINE CORE BRACKETS AT 1 O'CLOCK POSITION. USE CLAMPS (230), CLAMPSHELLS (235) AND BOLTS (240).</p> <p>ADJUST TUBE ASSY (225) TO BEST POSITION, ENSURING NO PRELOAD EXISTS. TIGHTEN TUBE ASSY (225) TO 133-147 POUND-INCHES (15.0-16.6 NEWTON METER). BACK OFF TUBE NUT TO RELAX TORQUE, THEN RETIGHTEN.</p> <p>TIGHTEN PRECOOLER CONTROL VALVE COUPLING (REF Figure 14-1 ITEM NO. 120) TO TORQUE GIVEN ON PART. LIGHTLY TAP OUTER SURFACE WITH NON-METALLIC Mallet. RETIGHTEN COUPLING TO TORQUE GIVEN ON PART.</p> <p>TIGHTEN BOLTS (240) TO 110-120 POUND-INCHES (12.4-13.6 NEWTON METERS).</p>		
225	332A2350-13	. TUBE ASSY		1
230	1794M49P01	. CLAMP		2
235	BACC10GT2-04	. CLAMPSHELL		4
235	9352M41P16	. CLAMPSHELL (OPTIONAL)	OPT	-
240	BACB30ZF4-05	. BOLT		2

**71-00-02**

P/P BUILDUP FIGURE 17-1

Page 19

Oct 05/2007

D633A106-HXL

737-600/700/800/900  
**POWERPLANT BUILDUP MANUAL**

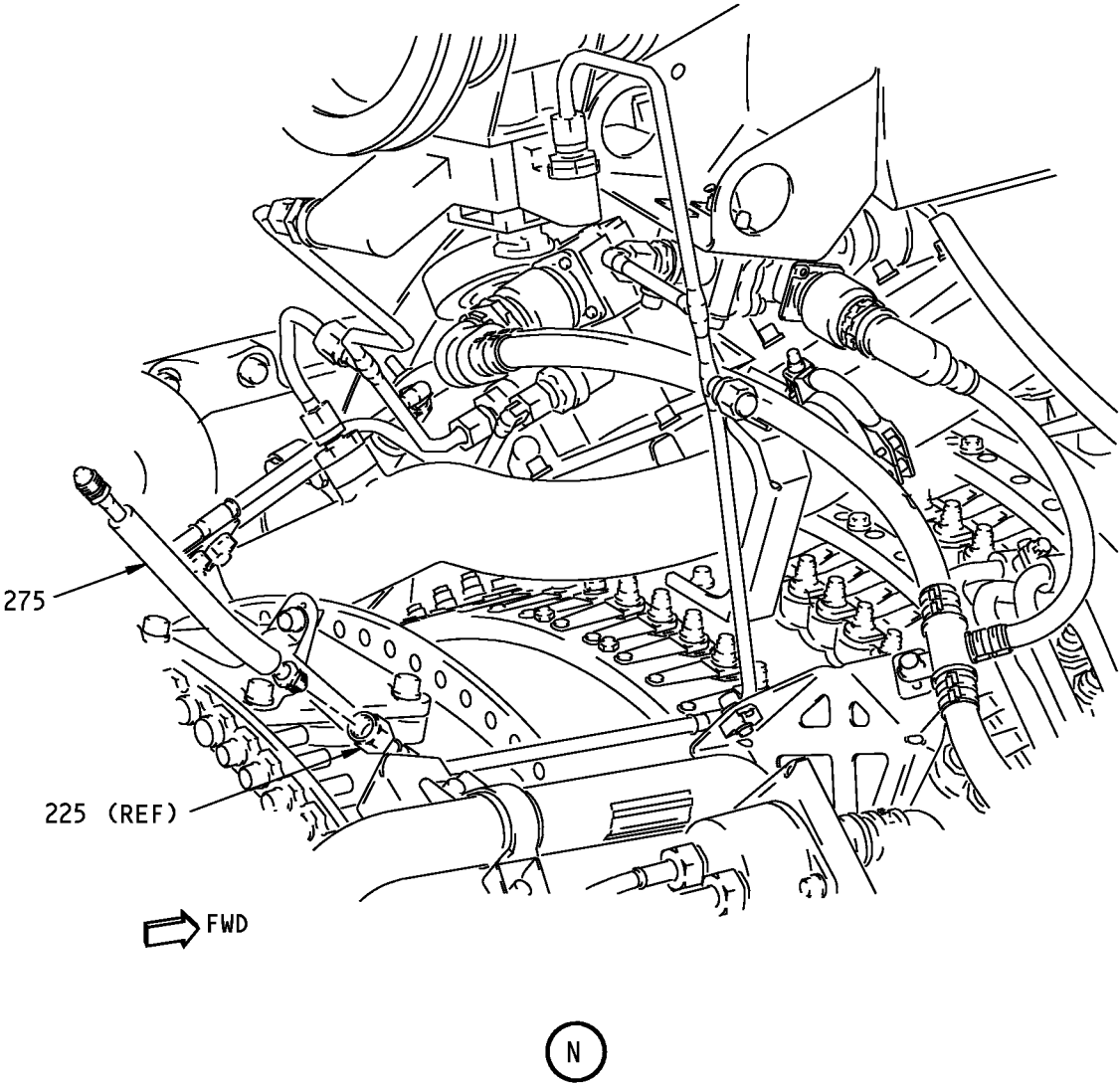

**Upper Bleed Control System Installation**  
**Figure 17-1 (Sheet 10)**

**71-00-02**

P/P BUILDUP FIGURE 17-1  
Page 20  
Oct 05/2007

D633A106-HXL

**737-600/700/800/900  
POWERPLANT BUILDUP MANUAL**

ITEM NO.	PART NUMBER	NOMENCLATURE	UC	QTY
17-1		<p><b>UPPER BLEED CONTROL SYSTEM INSTALLATION (FIGURE 17-1, SHEET 10)</b></p> <p>INSTALL HOSE ASSY (275) ON END OF TUBE ASSY (225).</p> <p>. HOSE ASSY (V99755)</p> <p>. BOEING SPEC FOR 16135-80</p> <p>TIGHTEN TUBE NUT ON HOSE ASSY (275) TO 133-147 POUND-INCHES (15.0-16.6 NEWTON METERS). BACK OFF TUBE NUT TO RELAX TORQUE, THEN RETIGHTEN.</p> <p>MAKE SURE PROTECTIVE CAP IS INSTALLED ON END OF HOSE ASSY (275).</p>	VEN BOE	1 -

**71-00-02**

P/P BUILDUP FIGURE 17-1

Page 21

Oct 05/2007

D633A106-HXL

**FIGURE 18-1**

**BLEED DUCT INSTALLATION - UPPER 5TH-  
AND 9TH-STAGE**

**REF QEC TASK NO.: 18**

**REF DWG: 332A2100  
332A2300**

**NOTE:** ALL STANDARDS AND ATTACHING HARDWARE FOR THIS FIGURE WILL BE PACKAGED  
IN QEC TASK NO. 110.

**71-00-02**

P/P BUILDUP FIGURE 18-1

Page 1

Oct 05/2007

D633A106-HXL

737-600/700/800/900  
**POWERPLANT BUILDUP MANUAL**

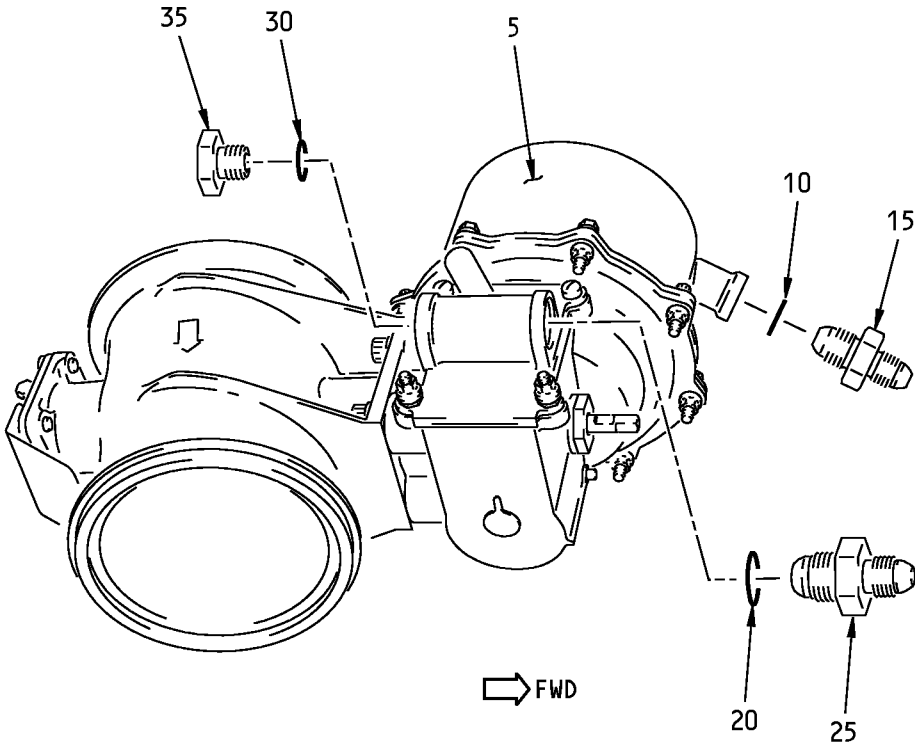

**Upper 5th- and 9th-Stage Bleed Duct Installation**  
**Figure 18-1 (Sheet 1)**

**71-00-02**

P/P BUILDUP FIGURE 18-1

Page 2

Oct 05/2007

D633A106-HXL



**737-600/700/800/900  
POWERPLANT BUILDUP MANUAL**

ITEM NO.	PART NUMBER	NOMENCLATURE	UC	QTY
18-1		<p><b>UPPER 5TH- AND 9TH-STAGE BLEED DUCT INSTALLATION (FIGURE 18-1, SHEET 1)</b></p> <p>INSTALL O-RING (10) ON REDUCER (15), O-RING (20) ON REDUCER (25) AND O-RING (30) ON PLUG (35).</p> <p>LUBRICATE THREADS OF REDUCERS (15) AND (25) AND PLUG (35) WITH Never-Seez NSBT-8N compound, D00006 (C1).</p> <p>INSTALL REDUCER (15) ON AFT PORT OF PRSOV (5).</p> <p>INSTALL REDUCER (25) ON OUTBOARD PORT OF VALVE BODY AND PLUG (35) IN INBOARD PORT OF VALVE BODY.</p>		
5	3214552-5	. PRESS REG AND SHUTOFF VALVE (PRSOV) (V59364)	VEN	1
5	10-62008-30	. BOEING SPEC FOR 3214552-5	BOE	-
10	801A50-0005A	. O-RING (V15284)	VEN	1
15	J522P52	. REDUCER		1
20	801A50-0006A	. O-RING (V15284)	VEN	1
25	J522P53	. REDUCER		1
30	801A50-0006A	. O-RING (V15284)	VEN	1
35	AS5169J06	. PLUG		1
C1	D00006	. COMPOUND, NEVER-SEEZ NSBT-8N	CON	AR
		TIGHTEN REDUCER (15) TO 180-200 POUND-INCHES (20-23 NEWTON METERS).		
		TIGHTEN REDUCER (25) AND PLUG (35) TO 257-284 POUND-INCHES (29-32 NEWTON METERS).		

# 71-00-02

P/P BUILDUP FIGURE 18-1

Page 3

Oct 05/2007

D633A106-HXL

737-600/700/800/900  
**POWERPLANT BUILDUP MANUAL**

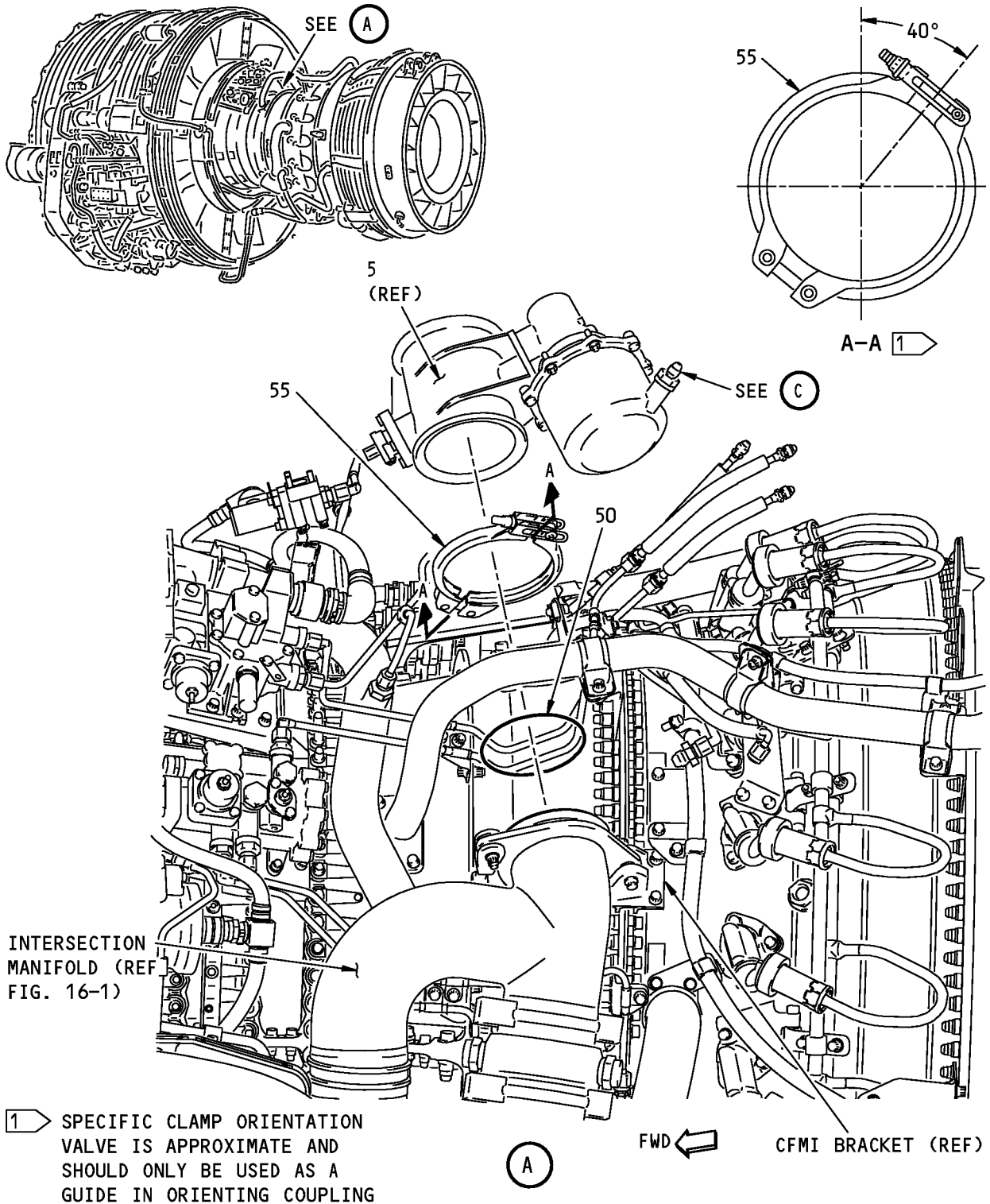

**Upper 5th- and 9th-Stage Bleed Duct Installation**  
**Figure 18-1 (Sheet 2)**

**71-00-02**

P/P BUILDUP FIGURE 18-1

Page 4

Oct 05/2007

D633A106-HXL

**737-600/700/800/900  
POWERPLANT BUILDUP MANUAL**

ITEM NO.	PART NUMBER	NOMENCLATURE	UC	QTY
18-1		<p><b>UPPER 5TH- AND 9TH-STAGE BLEED DUCT INSTALLATION (FIGURE 18-1, SHEET 2)</b></p> <p><b>NOTE:</b> ALL DUCT COUPLINGS HAVE A DRY-FILM LUBRICANT. DO NOT APPLY ANY ADDITIONAL LUBRICANT. VISUALLY EXAMINE ALL SEAL AND FLANGE SEALING SURFACES BEFORE INSTALLATION TO ENSURE NO SCRATCHES, CUTS, PITS, OR FOREIGN MATERIAL IS PRESENT.</p> <p>LOOSELY ATTACH PRSOV (5) TO TOP PORT OF INTERSECTION MANIFOLD WITH SEAL (50) AND COUPLING (55).</p> <p>ORIENT COUPLING (55) AS SHOWN.</p> <p><b>NOTE:</b> FINAL ORIENTATION OF PRSOV IS DETERMINED BY BLEED CONTROL LINES.</p>		
50	AS1895-7-350	. SEAL		1
55	AS1895-1-350	. COUPLING		1
		<p><b>NOTE:</b> CFMI BRACKET (REF) MAY BE LOOSENED TO ALLOW COUPLING (55) TO BE INSTALLED OVER VALVE (5). RETIGHTEN CFMI FASTENERS TO 209-231 POUNDS-INCHES (23.6-26.1 NEWTON METERS).</p>		

**71-00-02**

P/P BUILDUP FIGURE 18-1

Page 5

Oct 05/2007

D633A106-HXL

737-600/700/800/900  
**POWERPLANT BUILDUP MANUAL**

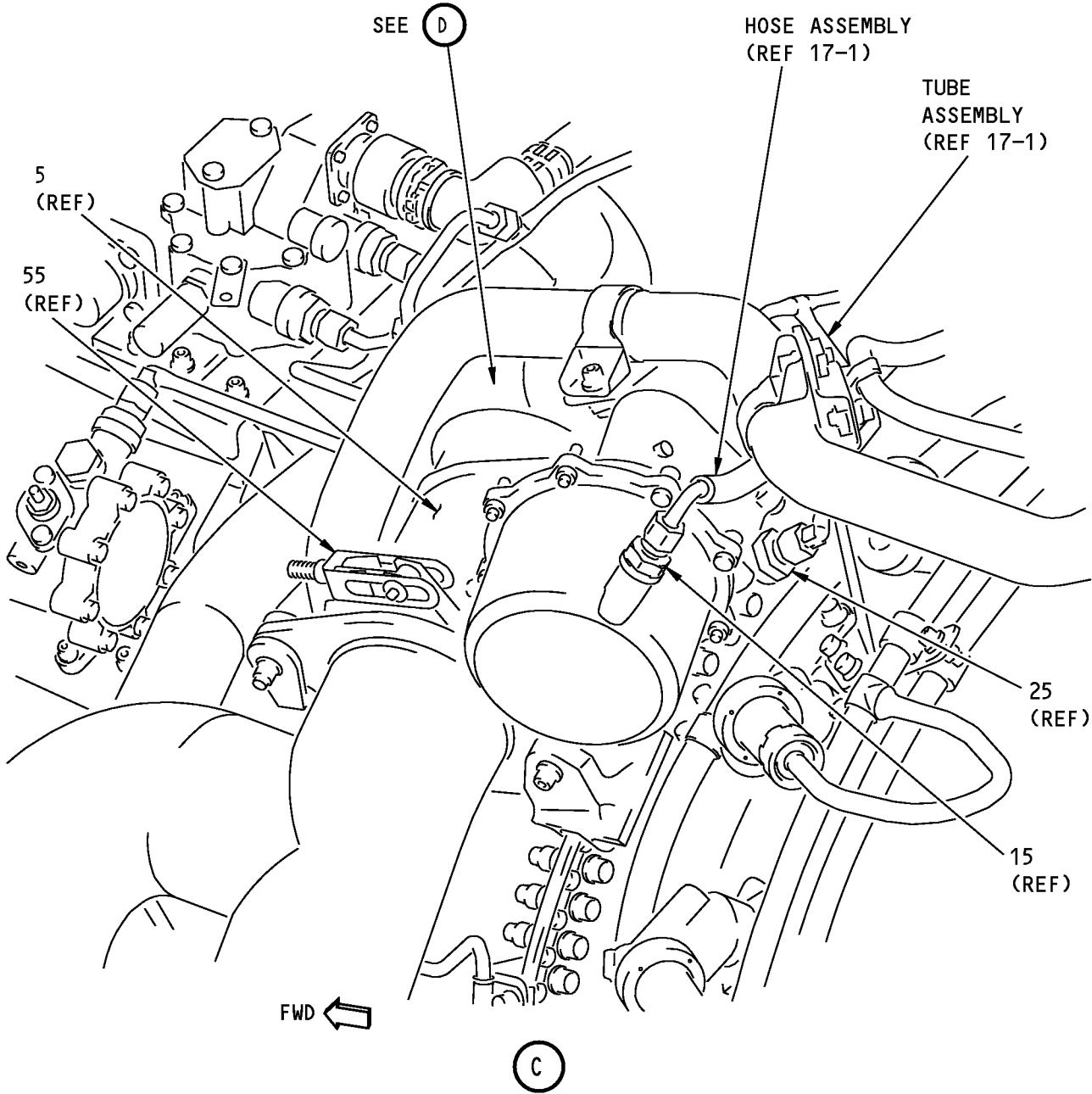

**Upper 5th- and 9th-Stage Bleed Duct Installation**  
Figure 18-1 (Sheet 3)

**71-00-02**

**737-600/700/800/900  
POWERPLANT BUILDUP MANUAL**

ITEM NO.	PART NUMBER	NOMENCLATURE	UC	QTY
18-1		<p><b>UPPER 5TH- AND 9TH-STAGE BLEED DUCT INSTALLATION (FIGURE 18-1, SHEET 3)</b></p> <p><b>CAUTION:</b> MAKE SURE NO PRELOAD EXISTS BETWEEN PRSOV AND BLEED CONTROL LINES.</p> <p>ATTACH TUBE ASSY Figure 17-1 TO REDUCER (25) AND ATTACH HOSE ASSY Figure 17-1 TO REDUCER (15).</p> <p>USE TUBE AND HOSE ASSYS TO ORIENT PRSOV (5).</p> <p>TIGHTEN COUPLING (55) TO TORQUE SPECIFIED ON PART. LIGHTLY TAP SURFACE OF COUPLING WITH NON-METALLIC Mallet.</p> <p>RETIGHTEN COUPLING TO TORQUE SPECIFIED ON PART.</p>		

**71-00-02**

P/P BUILDUP FIGURE 18-1

Page 7

Oct 05/2007

D633A106-HXL

737-600/700/800/900  
**POWERPLANT BUILDUP MANUAL**

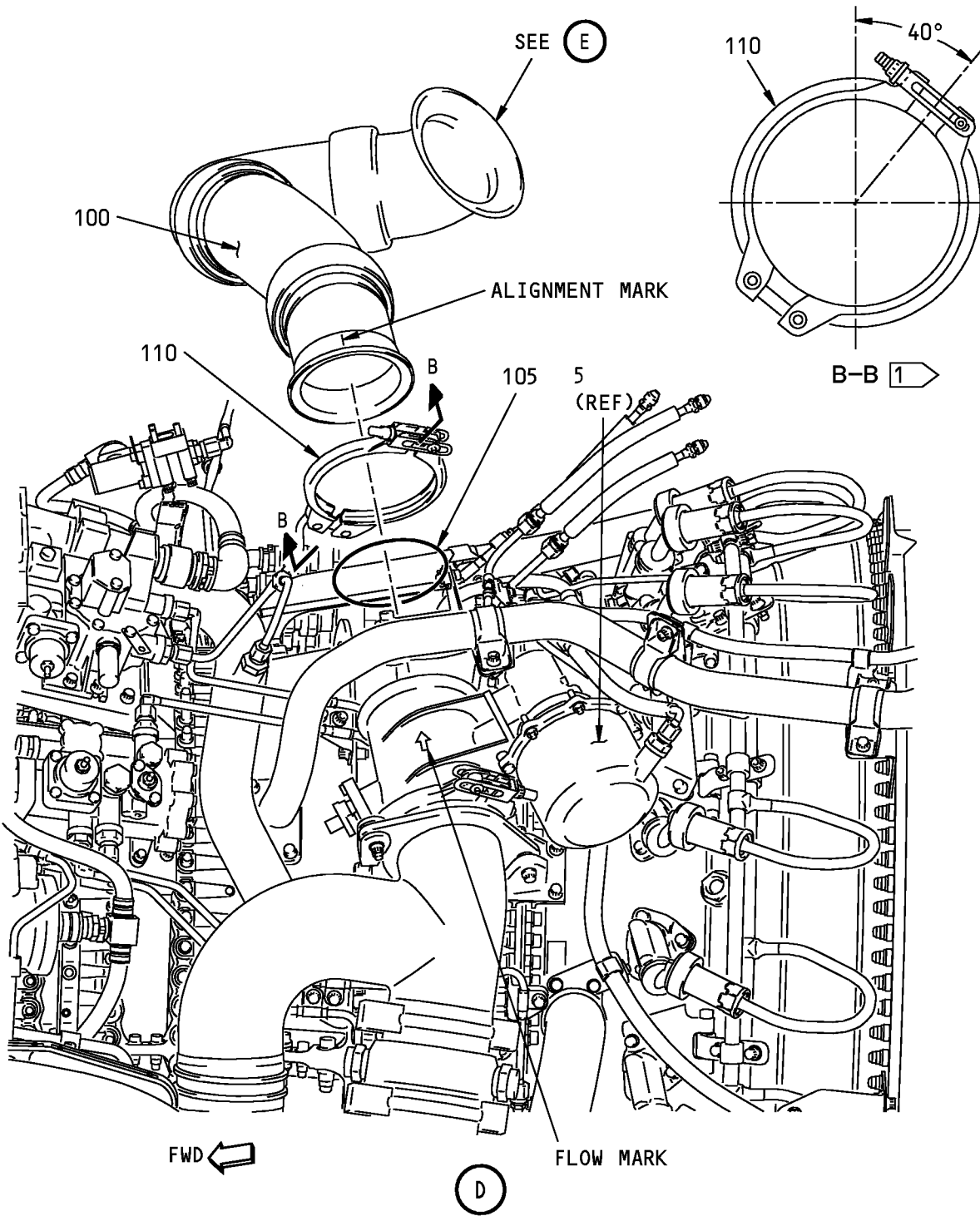

**Upper 5th- and 9th-Stage Bleed Duct Installation**  
**Figure 18-1 (Sheet 4)**

**71-00-02**

P/P BUILDUP FIGURE 18-1

Page 8

Oct 05/2007

D633A106-HXL

**737-600/700/800/900  
POWERPLANT BUILDUP MANUAL**

ITEM NO.	PART NUMBER	NOMENCLATURE	UC	QTY
18-1		<p><b>UPPER 5TH- AND 9TH-STAGE BLEED DUCT INSTALLATION (FIGURE 18-1, SHEET 4)</b></p> <p>LOOSELY ATTACH DUCT ASSY (100) TO TOP OF PRSOV (5) WITH SEAL (105) AND COUPLING (110).</p> <p>MAKE SURE ALIGNMENT MARK ON DUCT ASSY (100) ALIGNS WITH FLOW ARROW ON PRSOV (5).</p> <p>ORIENT COUPLING (110) AS SHOWN.</p> <p><b>NOTE:</b> IT WILL BE NECESSARY TO ADJUST THE DUCT ASSY FOR PROPER ALIGNMENT WITH THE PRECOOLER DURING ENGINE INSTALLATION.</p>		
100	332A2326-45	. DUCT ASSY		1
105	AS1895-7-350	. SEAL		1
110	AS1895-1-350	. COUPLING		1
		<p>TIGHTEN COUPLING (110) TO TORQUE SPECIFIED ON PART.</p> <p>LIGHTLY TAP SURFACE OF COUPLING WITH NON-METALLIC MALLET.</p> <p>RETIGHTEN COUPLING TO TORQUE SPECIFIED ON PART.</p>		

**71-00-02**

P/P BUILDUP FIGURE 18-1

Page 9

Oct 05/2007

D633A106-HXL

737-600/700/800/900  
**POWERPLANT BUILDUP MANUAL**

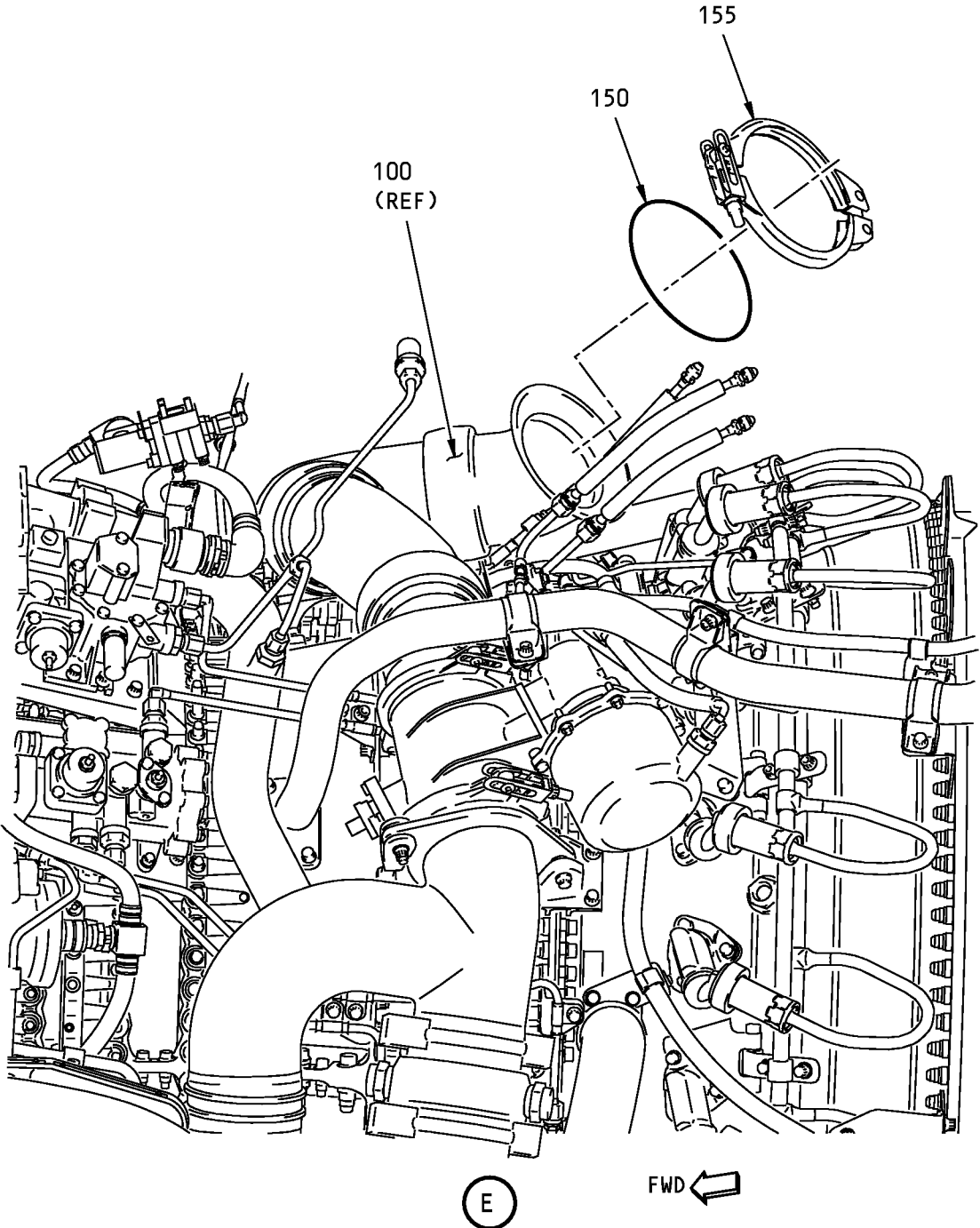

**Upper 5th- and 9th-Stage Bleed Duct Installation**  
**Figure 18-1 (Sheet 5)**

**71-00-02**

P/P BUILDUP FIGURE 18-1  
Page 10  
Oct 05/2007

D633A106-HXL



## POWERPLANT BUILDUP MANUAL

ITEM NO.	PART NUMBER	NOMENCLATURE	UC	QTY
18-1		<p><b>UPPER 5TH- AND 9TH-STAGE BLEED DUCT INSTALLATION (FIGURE 18-1, SHEET 5)</b></p> <p>PUT ITEMS (150) AND (155) IN A BAG AND SECURE TO DUCT ASSY (100).</p> <p><b>NOTE:</b> ITEMS (150) AND (155) ARE INSTALLED DURING POWERPLANT INSTALLATION ON AIRPLANE STRUT (AMM PAGEBLOCK 71-00-02/401).</p>		
150	AS1895-7-450	. SEAL		1
155	AS1895-4-450	. COUPLING		1

**71-00-02**

P/P BUILDUP FIGURE 18-1

Page 11

Oct 05/2007

D633A106-HXL

**FIGURE 19-1**

**THIS FIGURE NOT USED**

**71-00-02**

P/P BUILDUP FIGURE 19-1

Page 1

Oct 05/2007

D633A106-HXL

**737-600/700/800/900  
POWERPLANT BUILDUP MANUAL**

**THIS SHEET NOT USED**

**THIS FIGURE NOT USED  
Figure 19-1 (Sheet 1)**

**71-00-02**

P/P BUILDUP FIGURE 19-1

Page 2

Oct 05/2007

D633A106-HXL

737-600/700/800/900  
POWERPLANT BUILDUP MANUAL

ITEM NO.	PART NUMBER	NOMENCLATURE	UC	QTY
19-1		THIS FIGURE NOT USED (FIGURE 19-1, SHEET 1)  THIS SHEET NOT USED		

**71-00-02**

P/P BUILDUP FIGURE 19-1

Page 3

Oct 05/2007

D633A106-HXL

**FIGURE 20-1**

# **HYDRAULIC PUMP INSTALLATION - VICKERS**

**REF QEC TASK NO.: 20**

**REF DWG: 332A2400**

**NOTE:** ALL STANDARDS AND ATTACHING HARDWARE FOR THIS FIGURE WILL BE PACKAGED IN QEC TASK NO. 110.

**71-00-02**

P/P BUILDUP FIGURE 20-1

Page 1

Oct 05/2007

D633A106-HXL

737-600/700/800/900  
**POWERPLANT BUILDUP MANUAL**

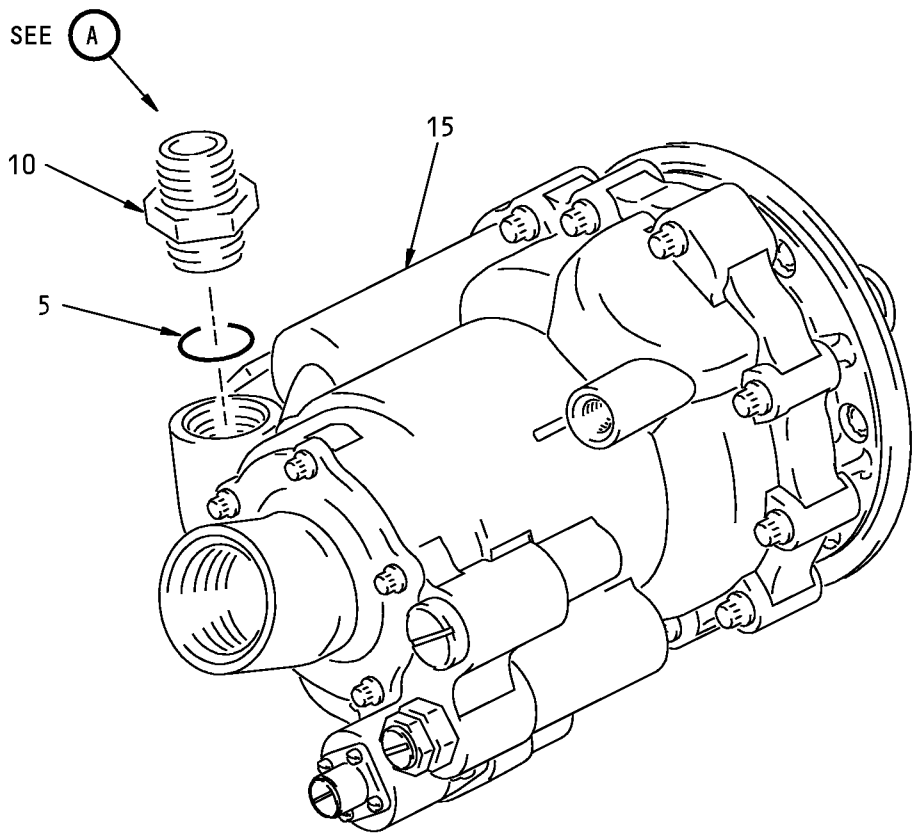

VICKERS HYDRAULIC PUMP

Hydraulic Pump Installation - Vickers  
Figure 20-1 (Sheet 1)

**71-00-02**

P/P BUILDUP FIGURE 20-1

Page 2

Oct 05/2007

D633A106-HXL

**737-600/700/800/900  
POWERPLANT BUILDUP MANUAL**

ITEM NO.	PART NUMBER	NOMENCLATURE	UC	QTY
20-1		<p><b>HYDRAULIC PUMP INSTALLATION - VICKERS (FIGURE 20-1, SHEET 1)</b></p> <p><b>WARNING:</b> FIRE-RESISTANT HYDRAULIC FLUIDS CONFORMING TO BMS 3-11 (SKYDROL) MAY CAUSE SKIN IRRITATION. AVOID PROLONGED OR REPEATED CONTACT WITH SKIN. IN CASE OF EYE CONTACT, FLUSH EYES WITH WATER AND GET MEDICAL AID. IN CASE OF INGESTION, GET MEDICAL AID.</p> <p>LUBRICATE PACKING (5) AND THREADS OF UNION (10) WITH MCS 352B fluid, D00054 (C1).</p> <p>INSTALL PACKING (5) ON UNION (10) AND INSTALL UNION (10) TO PRESSURE PORT OF HYDRAULIC PUMP (15). TIGHTEN UNION (10) TO 428-473 POUND-INCHES (48.3-53.4 NEWTON METERS).</p>		
5	NAS1612-12A	. PACKING		1
10	MS21902-12T	. UNION		1
15	849589	. VICKERS HYDRAULIC PUMP (V62983)	VEN	1
15	10-62167-3	. BOEING SPEC FOR 849589	BOE	-
C1	D00054	. HYDRAULIC ASSEMBLY LUBRICANT, MCS 352B	CON	AR

**71-00-02**

P/P BUILDUP FIGURE 20-1

Page 3

Oct 05/2007

D633A106-HXL

737-600/700/800/900  
**POWERPLANT BUILDUP MANUAL**

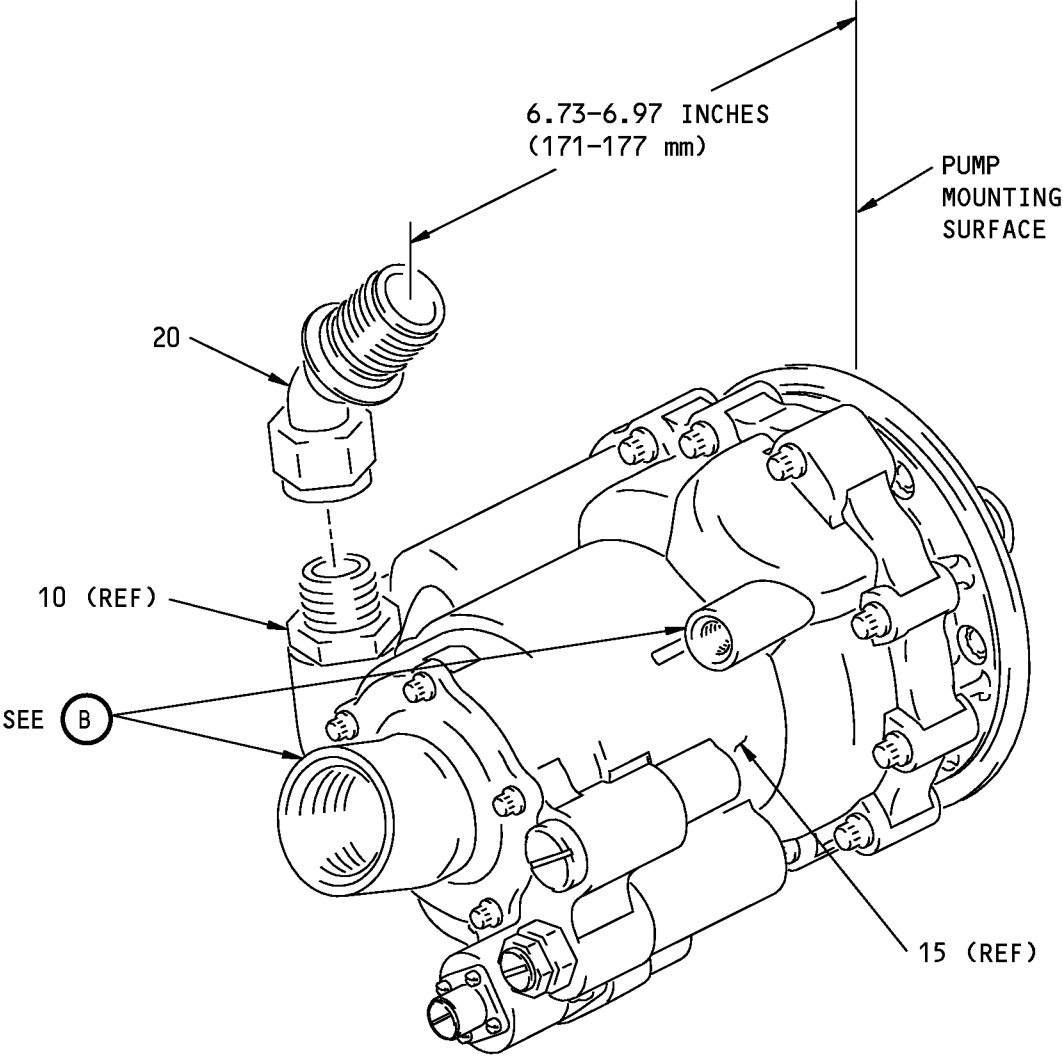

**VICKERS HYDRAULIC PUMP**

**Hydraulic Pump Installation - Vickers  
Figure 20-1 (Sheet 2)**

**71-00-02**

P/P BUILDUP FIGURE 20-1

Page 4

Oct 05/2007

D633A106-HXL



**737-600/700/800/900  
POWERPLANT BUILDUP MANUAL**

ITEM NO.	PART NUMBER	NOMENCLATURE	UC	QTY
20-1		<p><b>HYDRAULIC PUMP INSTALLATION - VICKERS (FIGURE 20-1, SHEET 2)</b></p> <p>LUBRICATE THREADS OF QUICK-RELEASE FITTING (20) WITH MCS 352B fluid, D00054 (C1) OR fluid, D00153 (C2).</p> <p>. FITTING, QUICK RELEASE (V11362)</p> <p>. BOEING SPEC FOR 155012-73-20</p> <p>. HYDRAULIC ASSEMBLY LUBRICANT, MCS 352B</p> <p>. HYDRAULIC FLUID, BMS3-11 TYPE IV</p> <p>LOOSELY ATTACH FITTING (20) TO UNION (10) AND ORIENT FITTING (20) UNTIL CENTER OF FITTING IS 6.73-6.97 (171-177 NM) FROM PUMP MOUNTING FACE.</p> <p>TIGHTEN FITTING (20) TO 855-945 POUND-INCHES (96.6-106.8 NEWTON METERS). BACK OFF FITTING TO RELAX TORQUE, THEN RETIGHTEN.</p> <p>RECHECK DISTANCE BETWEEN FITTING (20) AND PUMP MOUNTING FLANGE. IF OUTSIDE LIMIT, LOOSEN AND READJUST.</p>		
20	155012-73-20	. FITTING, QUICK RELEASE (V11362)	VEN	1
20	S332A210-20	. BOEING SPEC FOR 155012-73-20	BOE	-
C1	D00054	. HYDRAULIC ASSEMBLY LUBRICANT, MCS 352B	CON	AR
C2	D00153	. HYDRAULIC FLUID, BMS3-11 TYPE IV	CON	AR

**71-00-02**

P/P BUILDUP FIGURE 20-1

Page 5

Oct 05/2007

D633A106-HXL

737-600/700/800/900  
**POWERPLANT BUILDUP MANUAL**

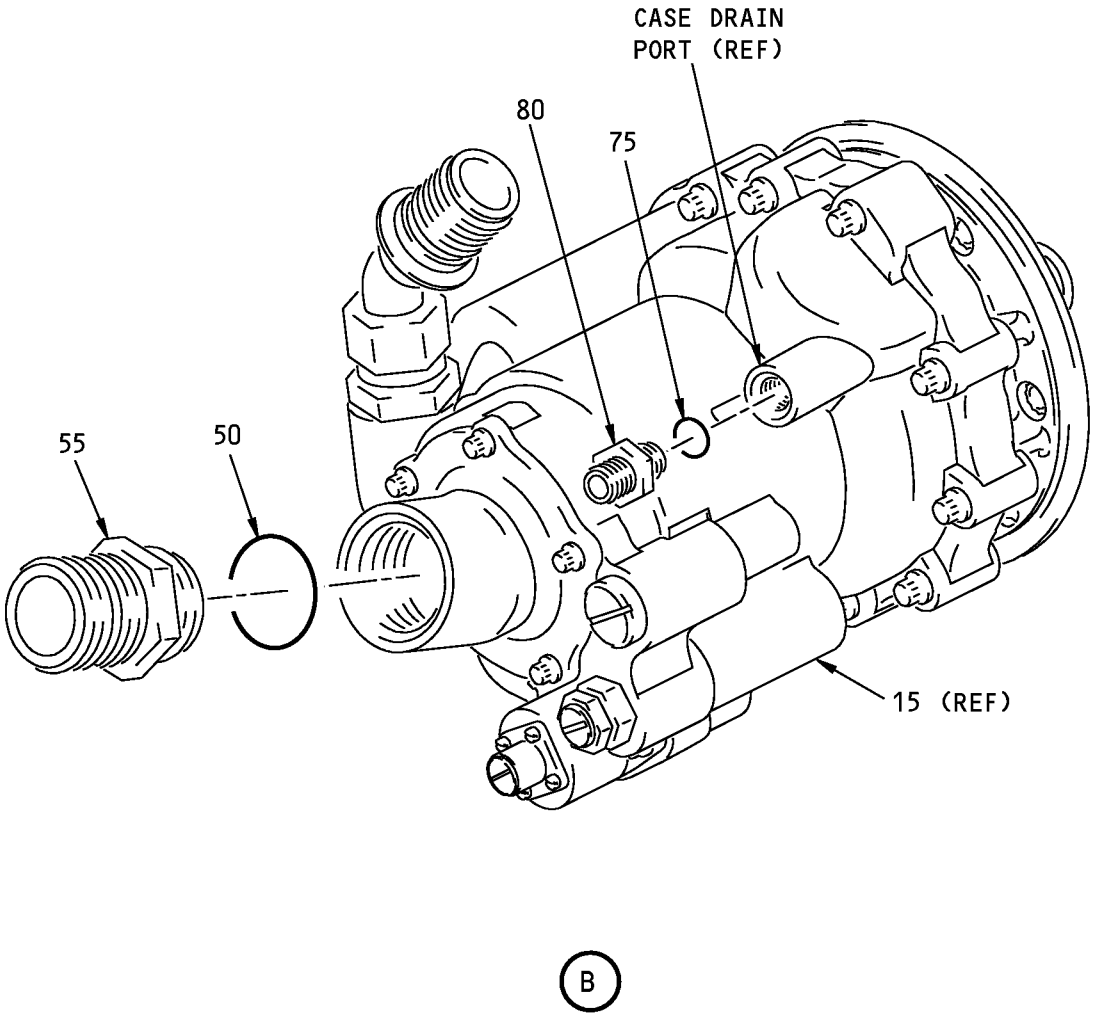

**Hydraulic Pump Installation - Vickers**  
**Figure 20-1 (Sheet 3)**

**71-00-02**

P/P BUILDUP FIGURE 20-1

Page 6

Oct 05/2007

D633A106-HXL

**737-600/700/800/900  
POWERPLANT BUILDUP MANUAL**

ITEM NO.	PART NUMBER	NOMENCLATURE	UC	QTY
20-1		<p><b>HYDRAULIC PUMP INSTALLATION - VICKERS (FIGURE 20-1, SHEET 3)</b></p> <p>LUBRICATE PACKING (50) AND THREADS OF UNION (55) WITH MCS 352B fluid, D00054 (C1).</p> <p>INSTALL PACKING (50) ON UNION (55) AND INSTALL UNION (55) TO HYDRAULIC SUPPLY PORT OF HYDRAULIC PUMP (15). TIGHTEN UNION (55) TO 855-945 POUND-INCHES (96.6-106.8 NEWTON METERS).</p> <p><b>NOTE:</b> MAKE SURE SINGLE THREADED END OF FITTING IS INSTALLED IN PUMP END.</p>		
50	NAS1612-20A	. PACKING		1
55	MS21924-20T	. UNION		1
55	MS21924J20	. UNION (OPTIONAL TO MS21924-20T)	OPT	-
C1	D00054	. HYDRAULIC ASSEMBLY LUBRICANT, MCS 352B	CON	AR
		<p>LUBRICATE PACKING (75) AND THREADS OF UNION (80) WITH MCS 352B fluid, D00054 (C1).</p> <p>INSTALL PACKING (75) ON UNION (80) AND INSTALL UNION (80) TO CASE DRAIN PORT OF HYDRAULIC PUMP (15). TIGHTEN UNION (80) TO 162-179 POUND-INCHES (18.3-20.2 NEWTON METERS).</p>		
75	NAS1612-6A	. PACKING		1
80	MS21902-6T	. UNION		1
C1	D00054	. HYDRAULIC ASSEMBLY LUBRICANT, MCS 352B	CON	AR

**71-00-02**

P/P BUILDUP FIGURE 20-1

Page 7

Oct 05/2007

D633A106-HXL

737-600/700/800/900  
**POWERPLANT BUILDUP MANUAL**

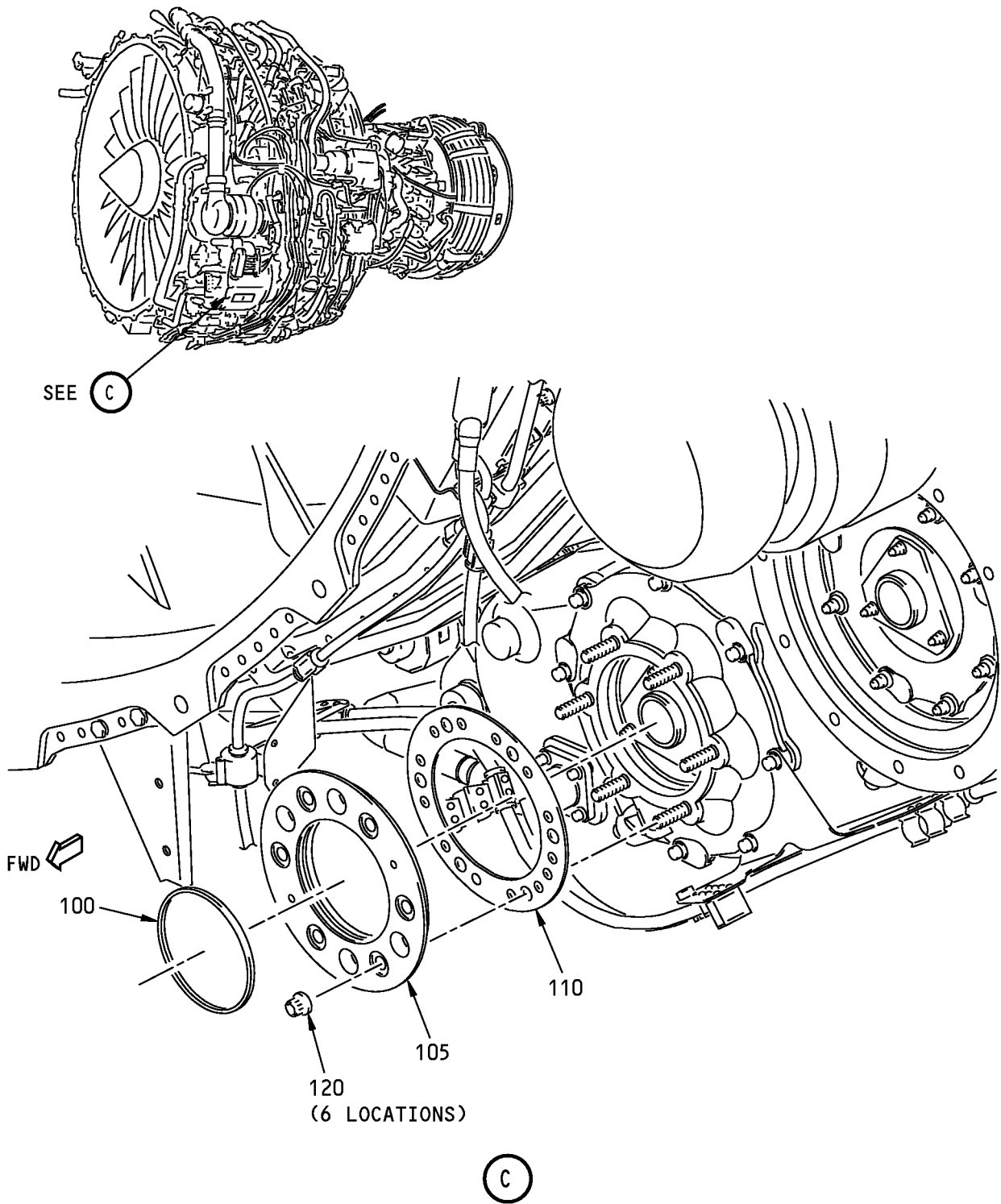

**Hydraulic Pump Installation - Vickers**  
**Figure 20-1 (Sheet 4)**

**71-00-02**

P/P BUILDUP FIGURE 20-1

Page 8

Oct 05/2007

D633A106-HXL

**737-600/700/800/900  
POWERPLANT BUILDUP MANUAL**

ITEM NO.	PART NUMBER	NOMENCLATURE	UC	QTY
20-1		<b>HYDRAULIC PUMP INSTALLATION - VICKERS (FIGURE 20-1, SHEET 4)</b>		
		REMOVE PROTECTIVE CAP, WASHERS AND NUTS FROM AGB HYDRAULIC PAD AND DISCARD.		
		LUBRICATE PUMP PACKING WITH MCS 352B fluid, D00054 (C1) AND INSTALL ON INNER SURFACE OF ADAPTER PLATE.		
100	NAS1611-153A	. . PUMP PACKING (PART OF 849589 (15)) (VENDOR PART NUMBER 972703) (V62983)	REF	-
105	387999	. . ADAPTER PLATE (PART OF 849589 (15))	REF	-
C1	D00054	. HYDRAULIC ASSEMBLY LUBRICANT, MCS 352B	CON	AR
		APPLY A THIN COATING OF GREASE (C3) TO MATING SURFACES OF ADAPTER PLATE (105) AND ACCESSORY GEARBOX.		
C3	D00276	. SILICONE GREASE, MIL-S-8660	CON	AR
		ATTACH ADAPTER PLATE (105) AND GASKET (110) TO ENGINE GEARBOX WITH NUTS (120).		
		CROSS-TIGHTEN NUTS (120) TO 260-320 POUND-INCHES (29.4-36.1 NEWTON METERS).		
		<b>NOTE:</b> MAKE SURE INDEXING PINS ON ADAPTER PLATE ARE AT 2 AND 8 O'CLOCK POSITIONS (VIEW LOOKING AFT) AFTER INSTALLATION.		
110	332T3323-2	. GASKET		1
120	BACN10HY6AC	. NUT		6

**71-00-02**

P/P BUILDUP FIGURE 20-1

Page 9

Oct 05/2007

D633A106-HXL

737-600/700/800/900  
**POWERPLANT BUILDUP MANUAL**

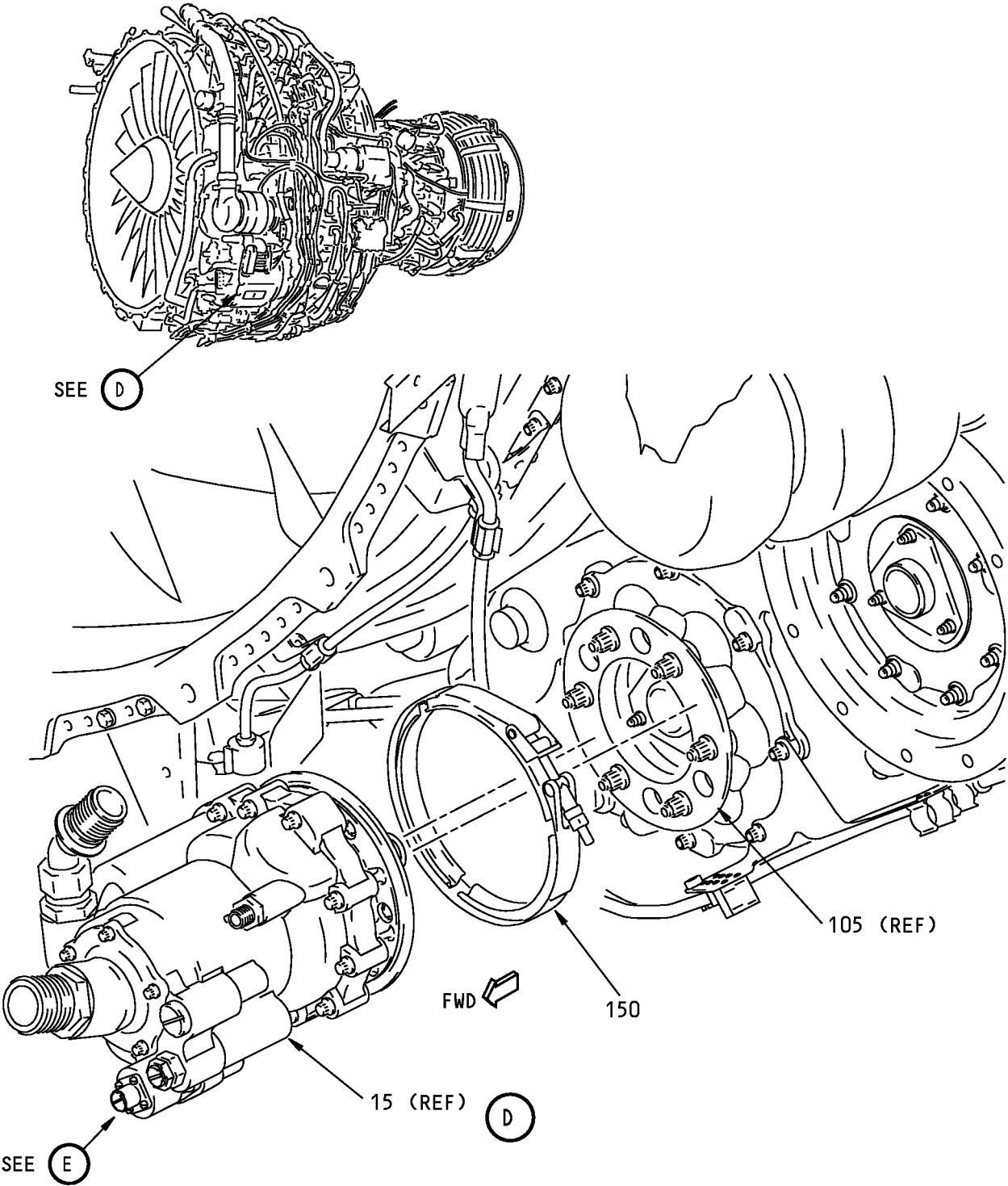

**Hydraulic Pump Installation - Vickers  
Figure 20-1 (Sheet 5)**

**71-00-02**

**737-600/700/800/900  
POWERPLANT BUILDUP MANUAL**

ITEM NO.	PART NUMBER	NOMENCLATURE	UC	QTY
20-1		<p><b>HYDRAULIC PUMP INSTALLATION - VICKERS (FIGURE 20-1, SHEET 5)</b></p> <p>INSTALL CLAMP RING (150) ON ADAPTER PLATE FLANGES.</p> <p>POSITION HYDRAULIC PUMP (15) ON ADAPTER PLATE (105) AND SECURE WITH CLAMP RING.</p> <p>POSITION CLAMP RING (150) WITH BOLT CLOCKED AT 2 O'CLOCK POSITION (LOOKING AFT) TO CLEAR ENGINE DRAIN PORT.</p> <p>TIGHTEN CLAMP RING (150) NUT TO 45-55 POUND-INCHES (5.1-6.2 NEWTON METERS).</p>		
150	974219	. . CLAMP RING (PART OF 849589 (15))	REF	-

**71-00-02**

P/P BUILDUP FIGURE 20-1

Page 11

Oct 05/2007

D633A106-HXL

737-600/700/800/900  
**POWERPLANT BUILDUP MANUAL**

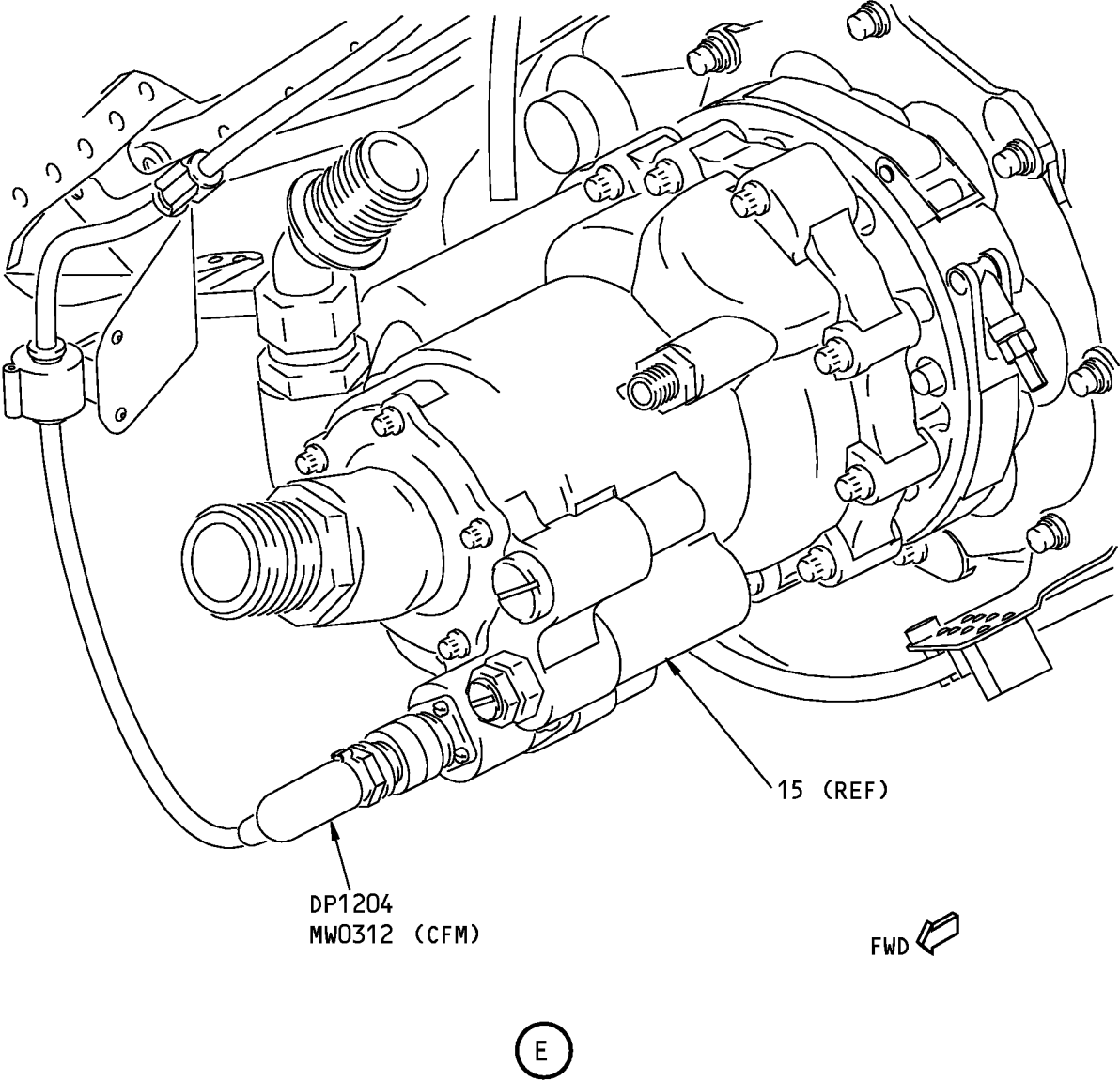

**Hydraulic Pump Installation - Vickers**  
**Figure 20-1 (Sheet 6)**

**71-00-02**



**737-600/700/800/900  
POWERPLANT BUILDUP MANUAL**

ITEM NO.	PART NUMBER	NOMENCLATURE	UC	QTY
20-1		<p><b>HYDRAULIC PUMP INSTALLATION - VICKERS (FIGURE 20-1, SHEET 6)</b></p> <p><b>CAUTION:</b> DO NOT OVERTIGHTEN THE PLUG COUPLING RING. DO NOT USE PLIERS, PIPE WRENCHES OR VISE GRIPS TO TIGHTEN THE COUPLING RING OR DAMAGE TO THE ELECTRICAL CONNECTOR CAN OCCUR.</p> <p>CONNECT MW0312 ELECTRICAL CONNECTOR, DP1204, TO PUMP CONNECTOR RECEPTACLE. TURN KNURLED COUPLING RING WHILE WIGGLING THE BACKSHELL ASSEMBLY.</p> <p>AFTER FULLY SEATING THE COUPLING RING, TIGHTEN THE COUPLING RING TO FINGER TIGHT. DO NOT TWIST BACKSHELL WHILE TIGHTENING THE COUPLING RING.</p> <p><b>NOTE:</b> AFTER TIGHTENING, MINOR ROTATION OF THE MATED BACKSHELL IS ACCEPTABLE, AND THE CONNECTOR MAY APPEAR LOOSE.</p>		

**71-00-02**

P/P BUILDUP FIGURE 20-1

Page 13

Oct 05/2007

D633A106-HXL

**FIGURE 21-1**

# **HYDRAULIC PLUMBING INSTALLATION**

**REF QEC TASK NO.: 21**

**REF DWG: 332A2400**

**NOTE:** ALL STANDARDS AND ATTACHING HARDWARE FOR THIS FIGURE WILL BE PACKAGED IN QEC TASK NO. 110.

**71-00-02**

P/P BUILDUP FIGURE 21-1

Page 1

Oct 05/2007

D633A106-HXL

737-600/700/800/900  
POWERPLANT BUILDUP MANUAL

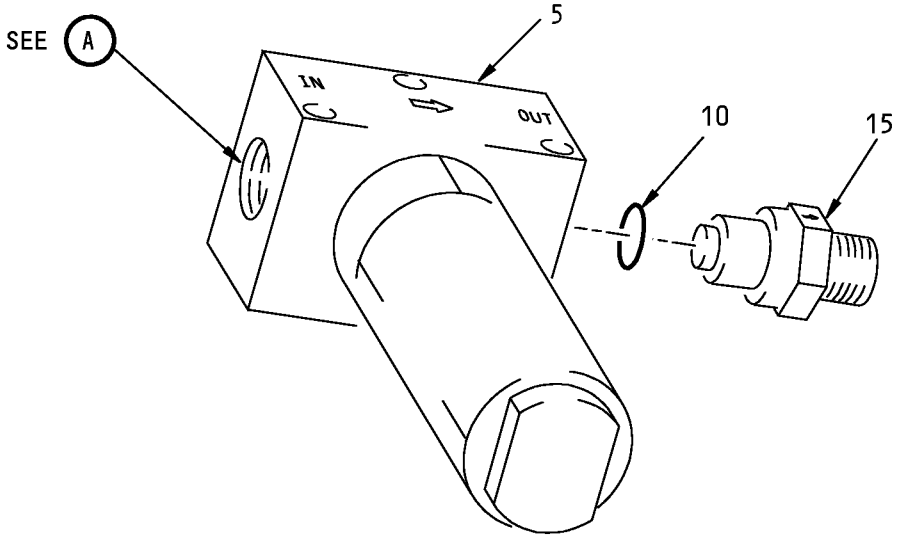

HYDRAULIC FILTER

Hydraulic Plumbing Installation  
Figure 21-1 (Sheet 1)

**71-00-02**

P/P BUILDUP FIGURE 21-1

Page 2

Oct 05/2007

D633A106-HXL

**737-600/700/800/900  
POWERPLANT BUILDUP MANUAL**

ITEM NO.	PART NUMBER	NOMENCLATURE	UC	QTY
21-1		<p><b>HYDRAULIC PLUMBING INSTALLATION (FIGURE 21-1, SHEET 1)</b></p> <p><b>WARNING:</b> FIRE-RESISTANT HYDRAULIC FLUIDS CONFORMING TO BMS 3-11 (SKYDROL) MAY CAUSE SKIN IRRITATION. AVOID PROLONGED OR REPEATED CONTACT WITH SKIN. IN CASE OF EYE CONTACT, FLUSH EYES WITH WATER AND GET MEDICAL AID. IN CASE OF INGESTION, GET MEDICAL AID.</p> <p>LUBRICATE PACKING (10) AND THREADS OF CHECK VALVE (15) WITH MCS 352B fluid, D00054 (C1).</p> <p>INSTALL PACKING (10) ON CHECK VALVE (15).</p> <p>INSTALL CHECK VALVE (15) TO "OUT" PORT OF HYDRAULIC FILTER (5).</p> <p><b>NOTE:</b> MAKE SURE FLOW ARROW ON CHECK VALVE POINTS AFT.</p>		
5	7579078	. HYDRAULIC FILTER (V05228)	VEN	1
5	10-60555-7	. BOEING SPEC FOR 7579078	BOE	-
10	NAS1612-6A	. PACKING		1
15	BACV10CE12	. CHECK VALVE, MINIATURE		1
C1	D00054	. HYDRAULIC ASSEMBLY LUBRICANT, MCS 352B	CON	AR
		TIGHTEN CHECK VALVE (15) TO 162-178 POUND-INCHES (18.3-20.1 NEWTON METERS).		

**71-00-02**

P/P BUILDUP FIGURE 21-1

Page 3

Oct 05/2007

D633A106-HXL

737-600/700/800/900  
**POWERPLANT BUILDUP MANUAL**

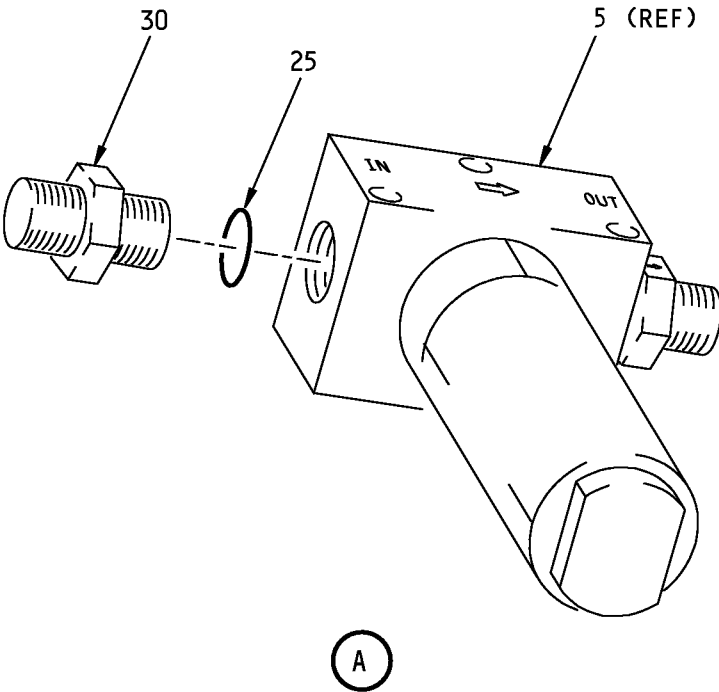

**Hydraulic Plumbing Installation**  
**Figure 21-1 (Sheet 2)**

**71-00-02**

P/P BUILDUP FIGURE 21-1

Page 4

Oct 05/2007

D633A106-HXL

**737-600/700/800/900  
POWERPLANT BUILDUP MANUAL**

ITEM NO.	PART NUMBER	NOMENCLATURE	UC	QTY
21-1		<p><b>HYDRAULIC PLUMBING INSTALLATION (FIGURE 21-1, SHEET 2)</b></p> <p>LUBRICATE PACKING (25) AND THREADS OF UNION (30) WITH MCS 352B fluid, D00054 (C1).</p> <p>INSTALL PACKING (25) ON UNION (30) AND INSTALL ON "IN" PORT OF HYDRAULIC FILTER (5).</p> <p>. PACKING</p> <p>. UNION</p> <p>. HYDRAULIC ASSEMBLY LUBRICANT, MCS 352B</p> <p>TIGHTEN UNION (30) TO 162-178 POUND-INCHES (18.3-20.1 NEWTON METERS).</p>	CON	1 1 AR
25	NAS1612-6A			1
30	MS21902-6T			1
C1	D00054			AR

# 71-00-02

P/P BUILDUP FIGURE 21-1

Page 5

Oct 05/2007

D633A106-HXL

737-600/700/800/900  
**POWERPLANT BUILDUP MANUAL**

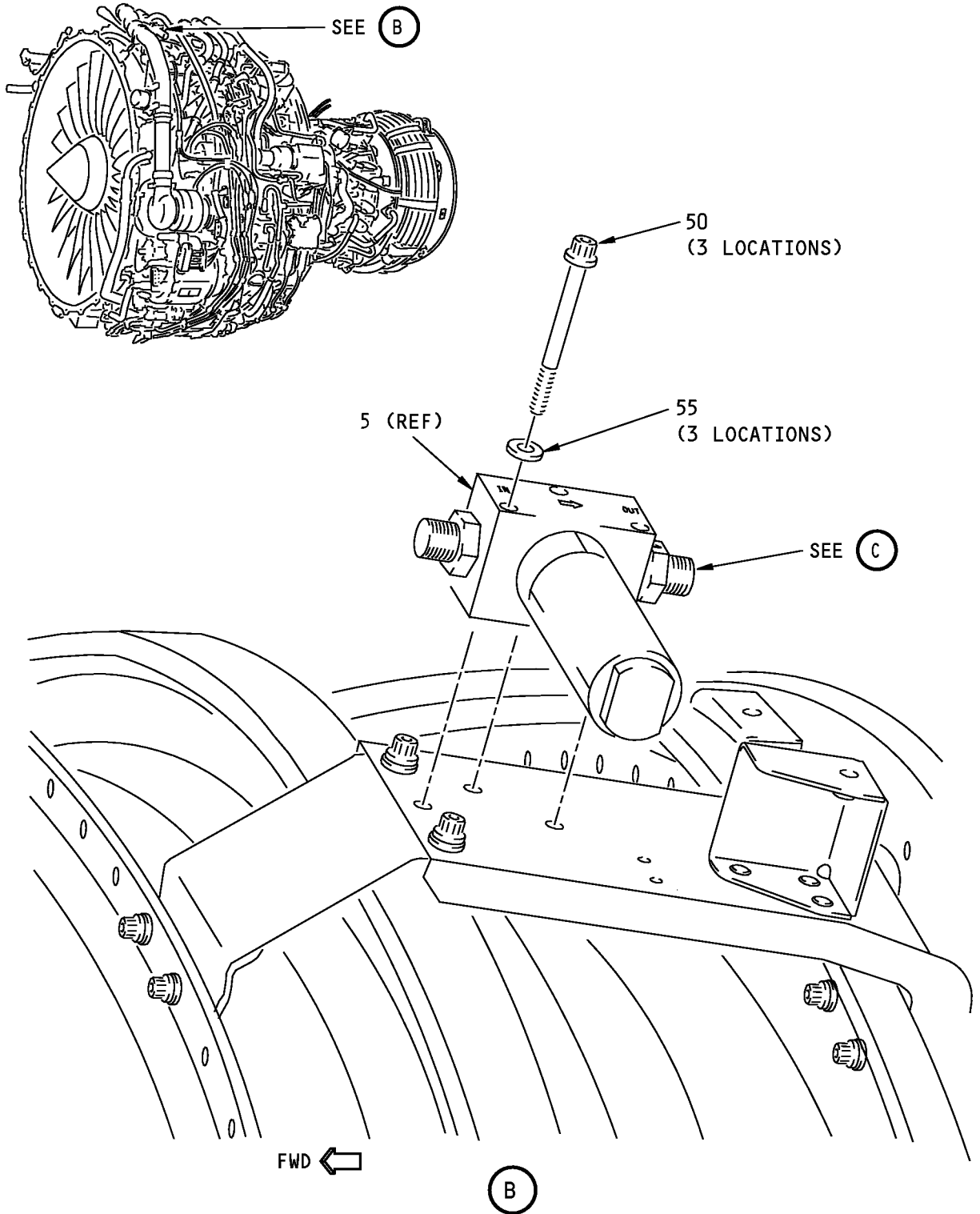

**Hydraulic Plumbing Installation**  
**Figure 21-1 (Sheet 3)**

**71-00-02**

P/P BUILDUP FIGURE 21-1

Page 6

Oct 05/2007

D633A106-HXL

**737-600/700/800/900  
POWERPLANT BUILDUP MANUAL**

ITEM NO.	PART NUMBER	NOMENCLATURE	UC	QTY
21-1		<p><b>HYDRAULIC PLUMBING INSTALLATION (FIGURE 21-1, SHEET 3)</b></p> <p>ATTACH HYDRAULIC FILTER (5) TO ENGINE BRACKET AT 11 O'CLOCK POSITION WITH BOLTS (50) AND WASHERS (55).</p> <p><b>NOTE:</b> MAKE SURE FLOW ARROW ON FILTER ASSY POINTS AFT (IN DIRECTION OF FLOW).</p>		
50	BACB30ZF4-32	. BOLT		3
55	NAS1149C0432R	. WASHER		3
		<p>TIGHTEN THE BOLTS (50) TO 110-120 POUND-INCHES (12.4-13.6 NEWTON METERS).</p>		

**71-00-02**

P/P BUILDUP FIGURE 21-1

Page 7

Oct 05/2007

D633A106-HXL



737-600/700/800/900  
**POWERPLANT BUILDUP MANUAL**

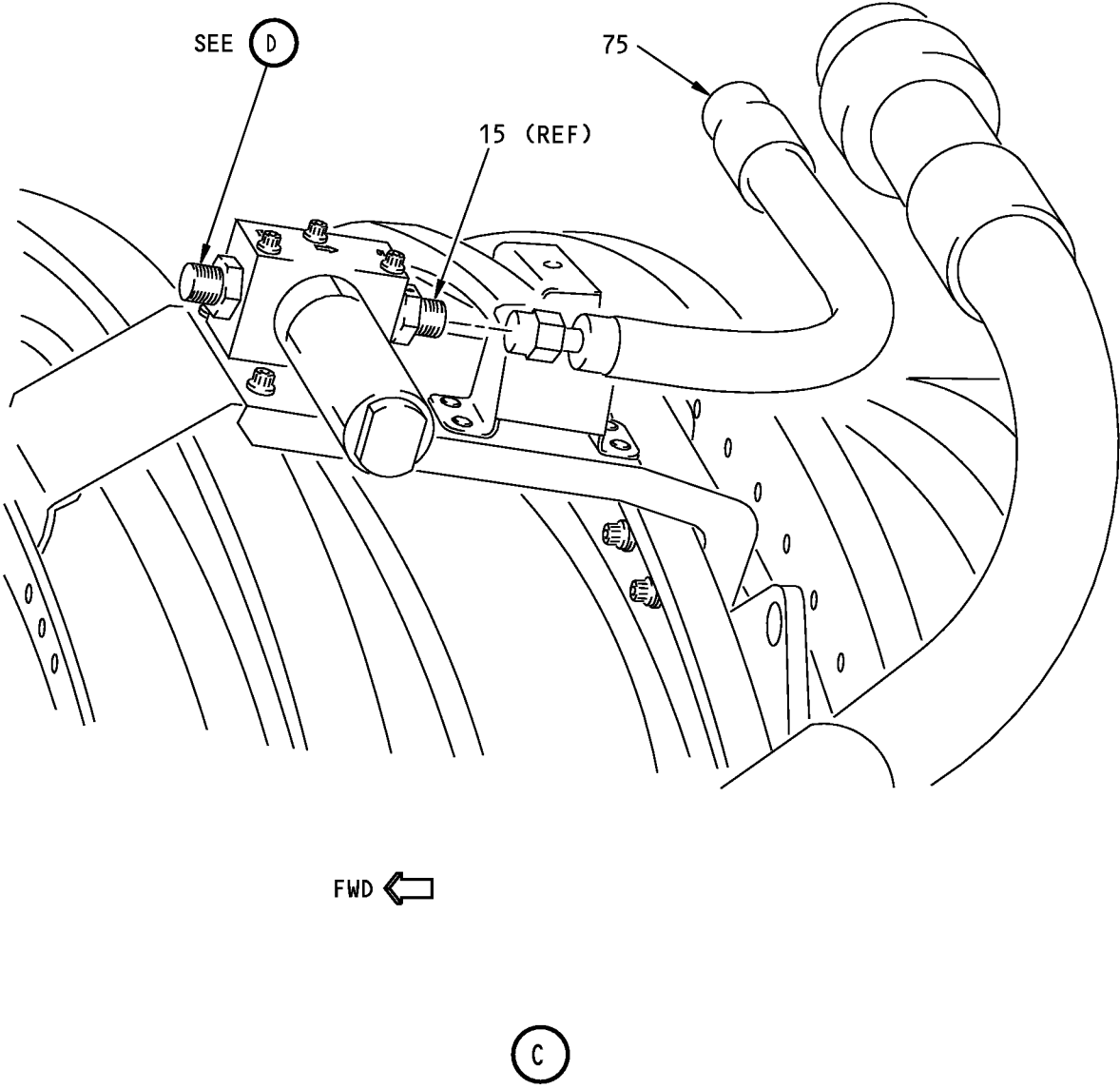

**Hydraulic Plumbing Installation**  
**Figure 21-1 (Sheet 4)**

**71-00-02**

P/P BUILDUP FIGURE 21-1

Page 8

Oct 05/2007

D633A106-HXL

**737-600/700/800/900  
POWERPLANT BUILDUP MANUAL**

ITEM NO.	PART NUMBER	NOMENCLATURE	UC	QTY
21-1		<p><b>HYDRAULIC PLUMBING INSTALLATION (FIGURE 21-1, SHEET 4)</b></p> <p>LUBRICATE THREADS OF CHECK VALVE (15) WITH MCS 352B fluid, D00054 (C1).</p> <p>SECURE HYDRAULIC CASE DRAIN HOSE ASSY (75) TO CHECK VALVE (15).</p> <p><b>NOTE:</b> MAKE SURE NO PRELOAD IS PRESENT ON HOSE ASSY.</p>		
75	155006-06-23	. HOSE ASSY, HYDRAULIC CASE DRAIN (V11362)	VEN	1
75	S332A210-23	. BOEING SPEC FOR 155006-06-23	BOE	-
C1	D00054	. HYDRAULIC ASSEMBLY LUBRICANT, MCS 352B	CON	AR
		<p>TIGHTEN HOSE ASSY (75) TO 257-283 POUND-INCHES (29.0-32.0 NEWTON METERS).</p> <p>BACK OFF TUBE NUT TO RELAX TORQUE, THEN RETIGHTEN.</p> <p>MAKE SURE PROTECTIVE CAP IS INSTALLED ON OPEN END OF HOSE ASSY (75).</p>		

**71-00-02**

P/P BUILDUP FIGURE 21-1

Page 9

Oct 05/2007

D633A106-HXL

737-600/700/800/900  
POWERPLANT BUILDUP MANUAL

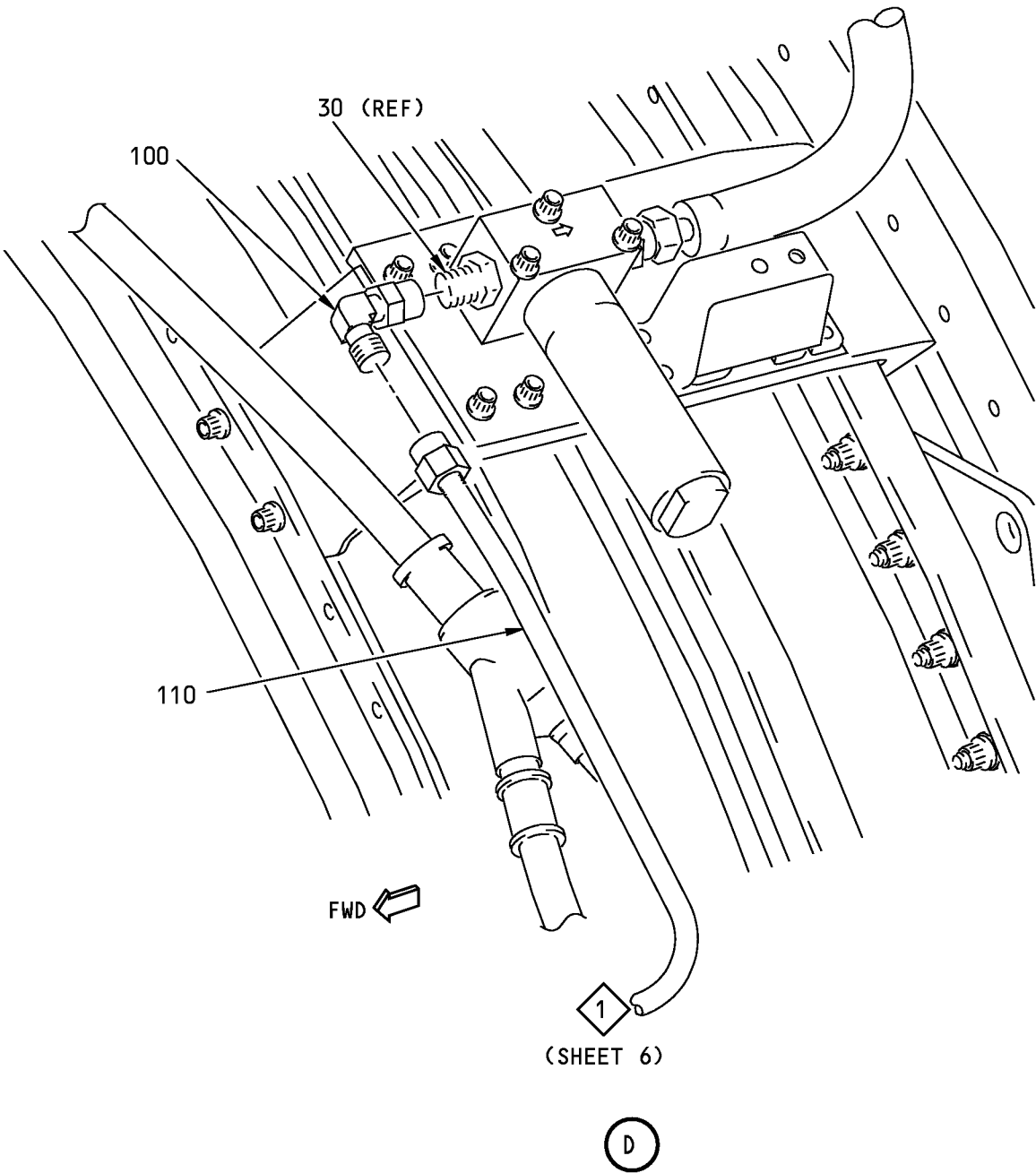

Hydraulic Plumbing Installation  
Figure 21-1 (Sheet 5)

**71-00-02**

P/P BUILDUP FIGURE 21-1  
Page 10  
Oct 05/2007

D633A106-HXL

**737-600/700/800/900  
POWERPLANT BUILDUP MANUAL**

ITEM NO.	PART NUMBER	NOMENCLATURE	UC	QTY
21-1		<p><b>HYDRAULIC PLUMBING INSTALLATION (FIGURE 21-1, SHEET 5)</b></p> <p>LOOSELY CONNECT ELBOW (100) TO UNION (30).</p> <p><b>NOTE:</b> ELBOW HAS A FILM OF DRY FILM LUBRICANT AND DOES NOT REQUIRE LUBRICATION.</p>		
100	BACE21BT0606T	<p>. TUBE ASSY</p> <p>POSITION TUBE ASSY (110) ON ENGINE FAN CASE, ALIGNING TOP END OF TUBE ASSY WITH ELBOW (100) AND LOWER END WITH CLAMP LOCATIONS.</p> <p>LOOSELY INSTALL TUBE ASSY (110) TO ELBOW (100).</p> <p><b>NOTE:</b> DO NOT TIGHTEN TUBE ASSY AND ELBOW AT THIS TIME.</p>		1
110	332A2410-1	<p>. TUBE ASSY</p>		1

**71-00-02**

P/P BUILDUP FIGURE 21-1

Page 11

Oct 05/2007

D633A106-HXL

737-600/700/800/900  
**POWERPLANT BUILDUP MANUAL**

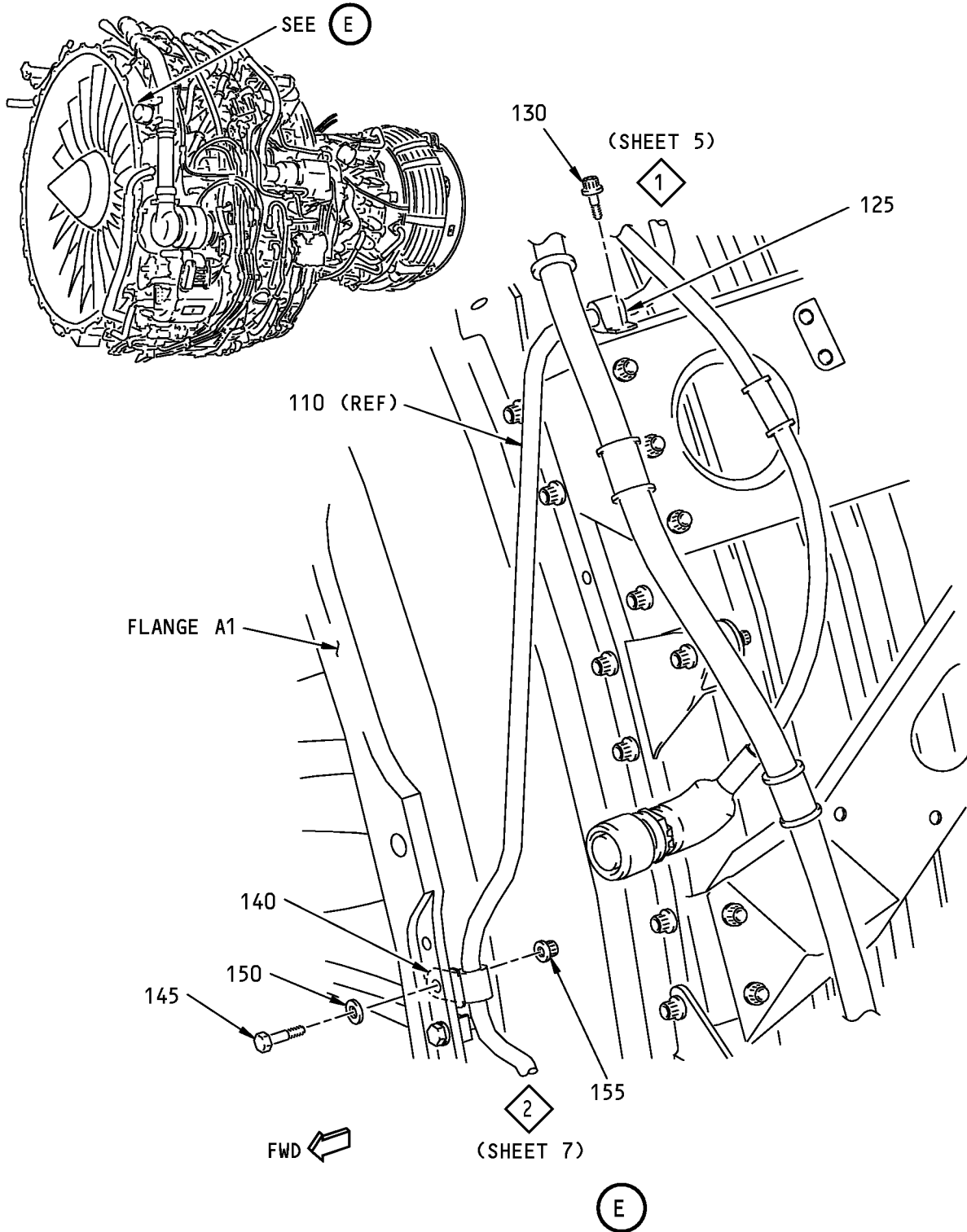

**Hydraulic Plumbing Installation**  
**Figure 21-1 (Sheet 6)**

**71-00-02**

P/P BUILDUP FIGURE 21-1

Page 12

Oct 05/2007

D633A106-HXL

**737-600/700/800/900  
POWERPLANT BUILDUP MANUAL**

ITEM NO.	PART NUMBER	NOMENCLATURE	UC	QTY
21-1		<b>HYDRAULIC PLUMBING INSTALLATION (FIGURE 21-1, SHEET 6)</b>		
125	J1221G06	ATTACH TUBE ASSY (110) TO TOP SIDE OF ENGINE BRACKET AT 10:30 O'CLOCK POSITION WITH CLAMP (125) AND BOLT (130). . CLAMP		1
130	BACB30ZF4-06	. BOLT		1
		LOOSELY ATTACH TUBE ASSY (110) TO BRACKET ON FLANGE A1. USE CLAMP (140), BOLT (145), WASHER (150) AND NUT (155).		
140	J1221G06	. CLAMP		1
145	BACB30NM4K6	. BOLT		1
150	BACW10BP4ACU	. WASHER (CSK) (UNDER BOLT HEAD)		1
155	AS3485-10	. NUT		1
		ADJUST TUBE ASSY (110) AND ELBOW (100) TO BEST POSITION. MAKE SURE NO PRELOAD FORCE EXISTS ON TUBE ASSY (110). TIGHTEN ELBOW (100) ON UNION (30) TO 257-283 POUND-INCHES (29.0-32.0 NEWTON METERS). BACK OFF UNION TO RELAX TORQUE, THEN RETIGHTEN. TIGHTEN TUBE ASSY (110) AT ELBOW (100) TO 257-283 POUND-INCHES (29.0-32.0 NEWTON METERS). BACK OFF TUBE NUT TO RELAX TORQUE, THEN RETIGHTEN. TIGHTEN BOLT (130) TO 110-120 POUND-INCHES (12.4-13.6 NEWTON METERS) AND TIGHTEN BOLT (145) TO 50-80 POUND-INCHES (5.6-9.0 NEWTON METERS).		

**71-00-02**

P/P BUILDUP FIGURE 21-1

Page 13

Oct 05/2007

D633A106-HXL

737-600/700/800/900  
**POWERPLANT BUILDUP MANUAL**

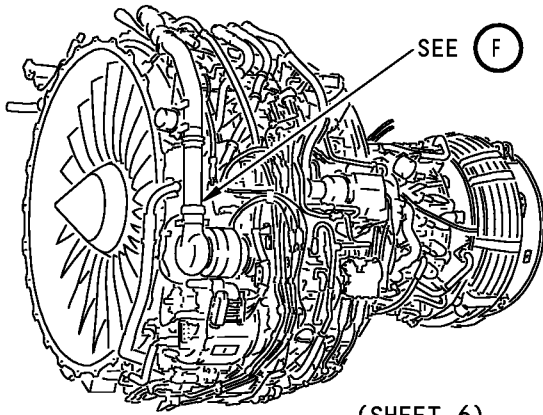

(SHEET 6)

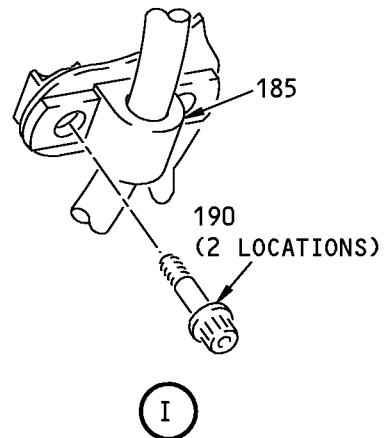
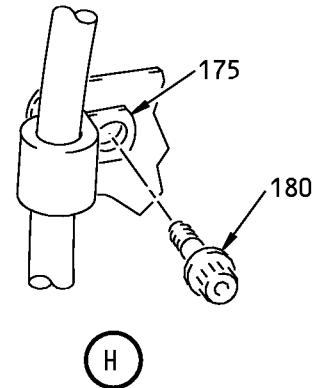
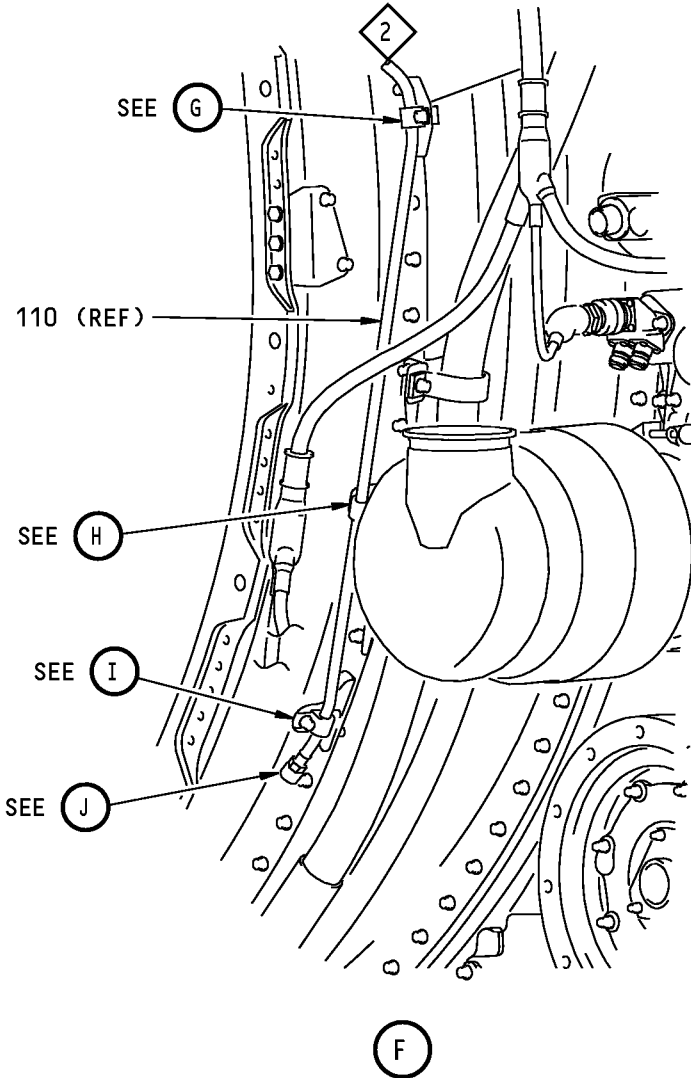
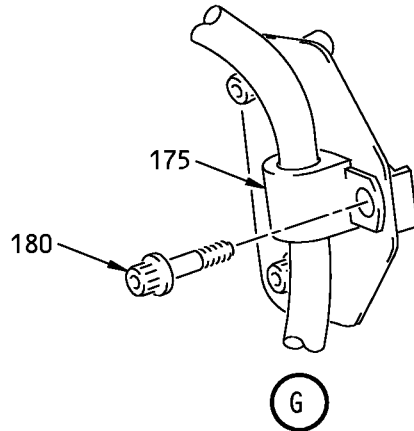

**Hydraulic Plumbing Installation**  
**Figure 21-1 (Sheet 7)**

**71-00-02**

P/P BUILDUP FIGURE 21-1

Page 14

Oct 05/2007

D633A106-HXL

**737-600/700/800/900  
POWERPLANT BUILDUP MANUAL**

ITEM NO.	PART NUMBER	NOMENCLATURE	UC	QTY
21-1		<b>HYDRAULIC PLUMBING INSTALLATION (FIGURE 21-1, SHEET 7)</b>		
175	J1221G06	ATTACH TUBE ASSY (110) TO ENGINE BRACKETS AT 9 AND 8 O'CLOCK POSITIONS USING CLAMPS (175) AND BOLTS (180). . CLAMP		2
180	BACB30ZF4-06	. BOLT		2
		TIGHTEN BOLTS (180) TO 110-120 POUND-INCHES (12.4-13.6 NEWTON METERS).		
185	TAO910064-06	ATTACH TUBE ASSY (110) TO ENGINE BRACKET AT 7:30 O'CLOCK POSITION WITH CLAMP (185) AND BOLTS (190). . CLAMP (V84971)	VEN	1
190	BACB30ZF4-08	. BOLT		2
		TIGHTEN BOLTS (190) TO 110-120 POUND-INCHES (12.4-13.6 NEWTON METERS).		

# 71-00-02

P/P BUILDUP FIGURE 21-1

Page 15

Oct 05/2007

D633A106-HXL



737-600/700/800/900  
**POWERPLANT BUILDUP MANUAL**

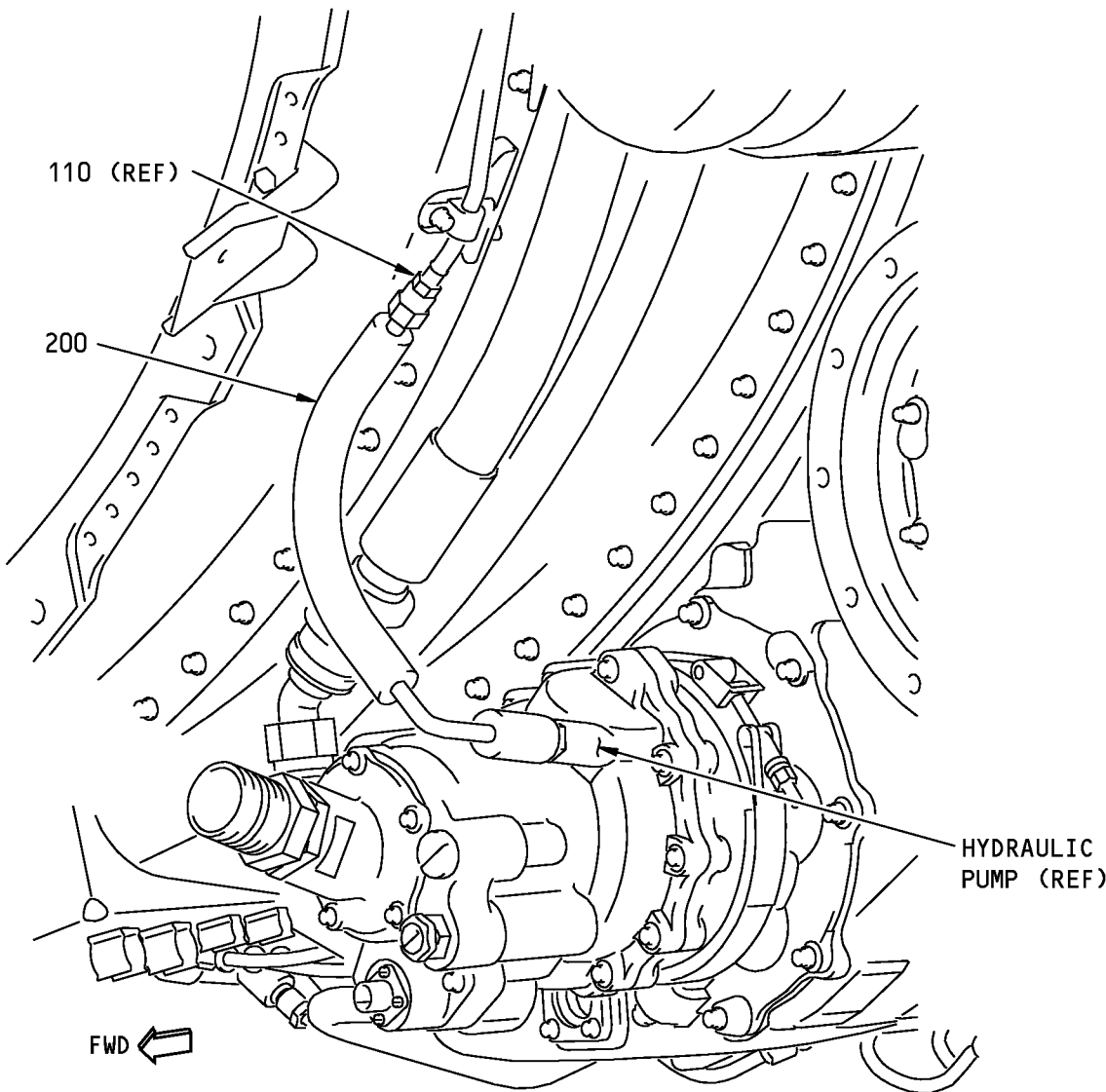

J

**Hydraulic Plumbing Installation**  
**Figure 21-1 (Sheet 8)**

**71-00-02**

P/P BUILDUP FIGURE 21-1  
Page 16  
Oct 05/2007

D633A106-HXL

737-600/700/800/900  
**POWERPLANT BUILDUP MANUAL**

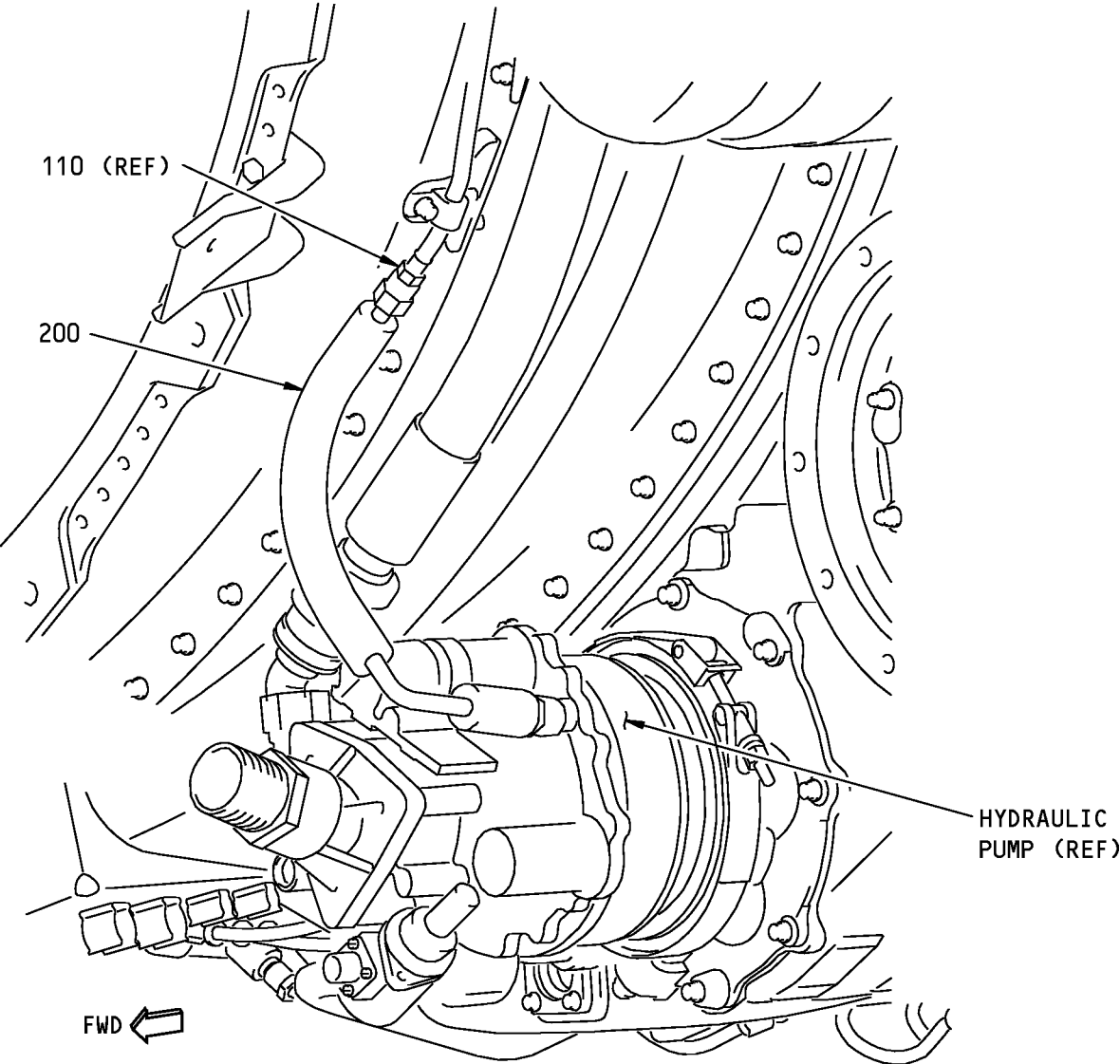

J

**Hydraulic Plumbing Installation**  
**Figure 21-1 (Sheet 9)**

**71-00-02**

P/P BUILDUP FIGURE 21-1  
Page 17  
Oct 05/2007

D633A106-HXL

**737-600/700/800/900  
POWERPLANT BUILDUP MANUAL**

ITEM NO.	PART NUMBER	NOMENCLATURE	UC	QTY
21-1		<p><b>HYDRAULIC PLUMBING INSTALLATION (FIGURE 21-1, SHEET 9)</b></p> <p>LOOSELY CONNECT HYDRAULIC CASE DRAIN HOSE ASSY (200) TO TUBE ASSY (110) AND CASE DRAIN PORT OF HYDRAULIC PUMP.</p> <p>. HOSE ASSY, HYDRAULIC CASE DRAIN (V11362)</p> <p>. BOEING SPEC FOR 155006-06-16</p> <p><b>CAUTION:</b> USE 2 WRENCHES TO TIGHTEN THE HOSE ASSY; ONE TO HOLD THE HOSE ASSY AND ONE TO HOLD THE UNION. DAMAGE TO EQUIPMENT CAN OCCUR.</p> <p>TIGHTEN HOSE ASSY (200) AT UNION ON HYDRAULIC PUMP AND AT TUBE ASSY (110) TO 257-283 POUND-INCHES (29.0-32.0 NEWTON METERS).</p> <p>BACK OFF TUBE NUT TO RELAX TORQUE, THEN RETIGHTEN. MAKE SURE HOSE DOES NOT TWIST OR KINK WHEN TIGHTENING.</p> <p>MAKE SURE NO PRELOAD FORCE IS PRESENT ON HOSE ASSY (200) AND TUBE ASSY (110).</p> <p>MAKE SURE THERE IS MINIMUM OF 0.5 INCH (12.7 MILLIMETERS) CLEARANCE WITH ADJACENT HARDWARE.</p> <p>IF NECESSARY, LOOSEN CLAMPS AND ADJUST AS REQUIRED. TIGHTEN ALL BOLTS.</p>	VEN BOE	1 -

**71-00-02**

P/P BUILDUP FIGURE 21-1

Page 18

Oct 05/2007

D633A106-HXL

737-600/700/800/900  
**POWERPLANT BUILDUP MANUAL**

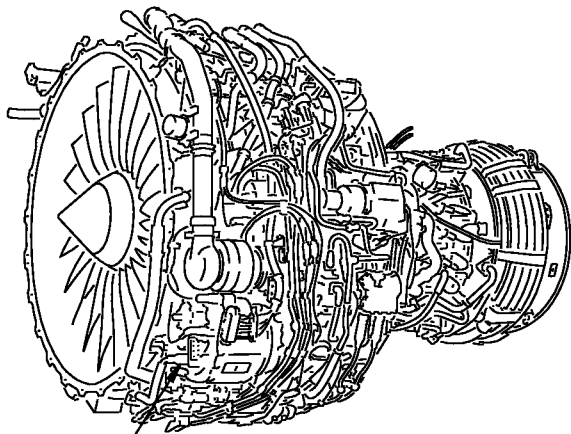

SEE (K)

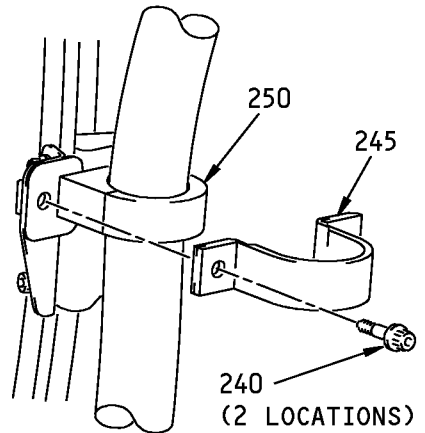

240  
(2 LOCATIONS)

(SHEET 10)

3

(EXAMPLE)

FWD

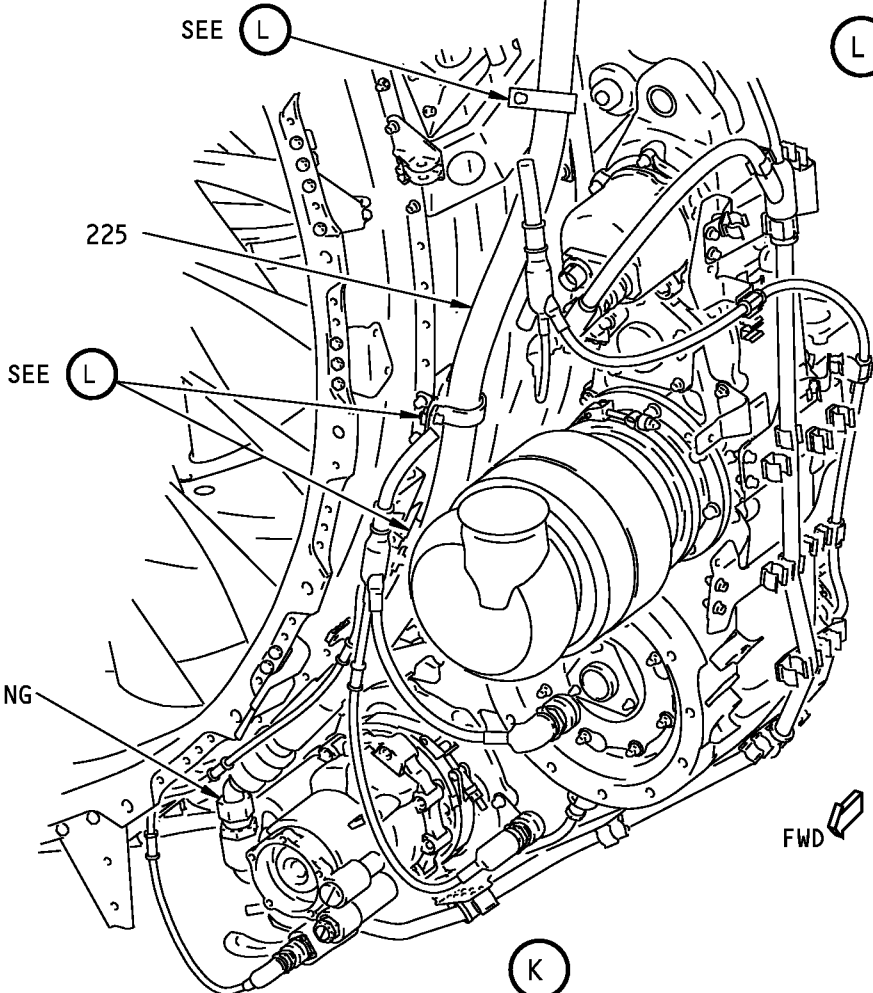

SEE (L)

225

SEE (L)

FITTING  
(REF)

FWD

(K)

**Hydraulic Plumbing Installation**  
**Figure 21-1 (Sheet 10)**

**71-00-02**

P/P BUILDUP FIGURE 21-1

Page 19

Oct 05/2007

D633A106-HXL

737-600/700/800/900  
**POWERPLANT BUILDUP MANUAL**

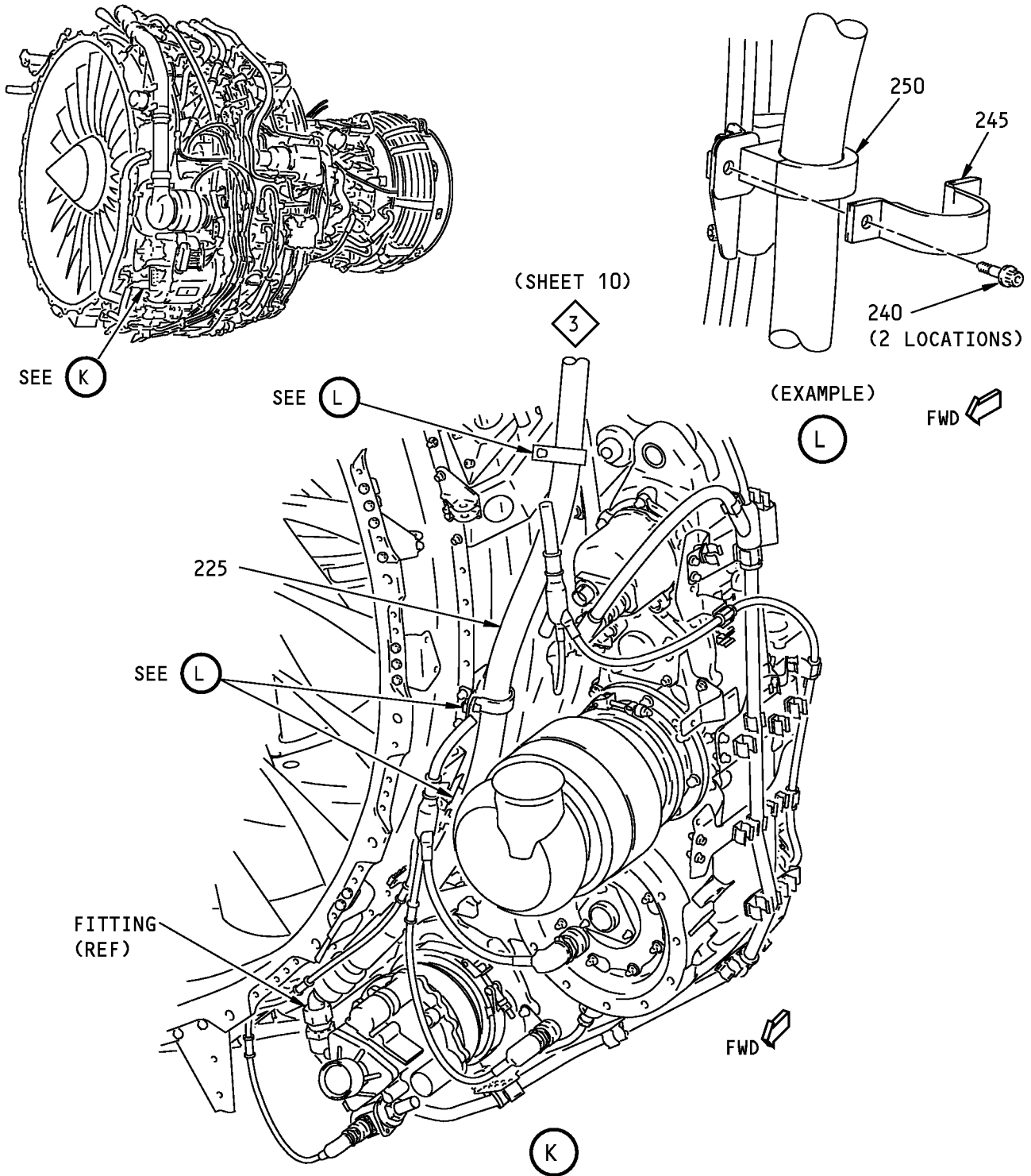

**Hydraulic Plumbing Installation**  
**Figure 21-1 (Sheet 11)**

**71-00-02**

P/P BUILDUP FIGURE 21-1

Page 20

Oct 05/2007

D633A106-HXL

**737-600/700/800/900  
POWERPLANT BUILDUP MANUAL**

ITEM NO.	PART NUMBER	NOMENCLATURE	UC	QTY
21-1		<p><b>HYDRAULIC PLUMBING INSTALLATION (FIGURE 21-1, SHEET 11)</b></p> <p>CONNECT HYDRAULIC PRESSURE HOSE ASSY (225) TO FITTING ON HYDRAULIC PUMP.</p> <p>TIGHTEN HOSE ASSY (225) UNTIL FITTING LOCKS.</p> <p><b>NOTE:</b> ENDS OF HOSE ASSY ARE IDENTICAL. THEREFORE, HOSE ASSY IS END-TO-END INTERCHANGEABLE.</p>		
225	155012-12-21	. HOSE ASSY, HYDRAULIC PRESSURE (V11362)	VEN	1
225	S332A210-21	. BOEING SPEC FOR 155012-12-21	BOE	-
		OPTIONAL STEP;		
		COAT ID OF CLAMP BLOCK (250) WITH grease, D00173 (C2) TO FACILITATE POSITIONING OF BLOCK UPON INSTALLATION.		
		AT THREE LOCATIONS ON ENGINE FAN CASE, LOOSELY ATTACH HOSE ASSY (225) TO ENGINE BRACKETS.		
		USE BOLTS (240), CLAMP BLOCK STRAPS (245) AND CLAMP BLOCKS (250).		
		USE BOLT (241) AND NUT (242) AT FWD HOLE OF LOWER BRACKET IF BRACKET DOES NOT HAVE NUTPLATE.		
240	BACB30ZF4-08	. BOLT		5
241	BACB30ZF4-10	. BOLT (NOT ILLUSTRATED)		1
242	AS3485-10	. NUT (NOT ILLUSTRATED)		1
245	332W3130-18	. CLAMP BLOCK STRAP		3
250	332W5101-10	. CLAMP BLOCK		3
C2	D00173	. GREASE, MIL-PRF-27617 TYPE III	CON	AR
		ADJUST HOSE ASSY (225) TO BEST POSITION AND TIGHTEN BOLTS (240) AND BOLT (241) TO 97-103 POUND-INCHES (11.0-11.6 NEWTON METERS). TIGHTEN NUT (242) TO 82-88 POUND-INCHES (9.26-9.94 NEWTON METERS).		

**71-00-02**

P/P BUILDUP FIGURE 21-1

Page 21

Oct 05/2007

D633A106-HXL

737-600/700/800/900  
**POWERPLANT BUILDUP MANUAL**

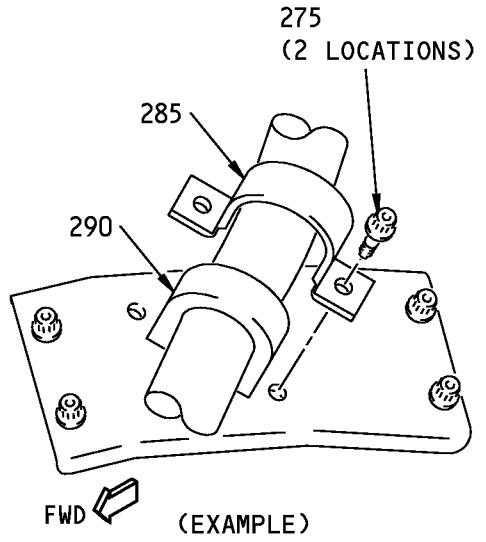
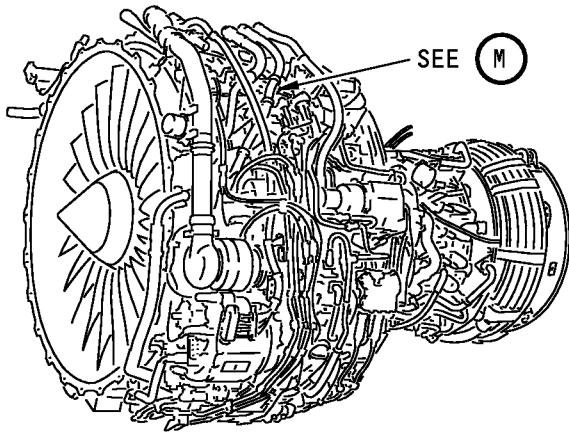

N

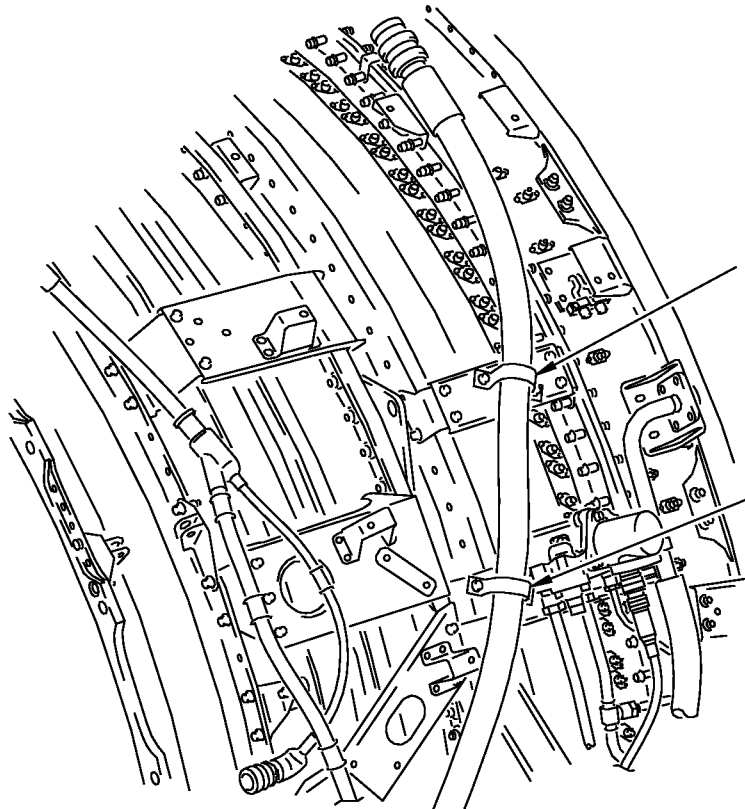

FWD

3

(SHEET 9)

M

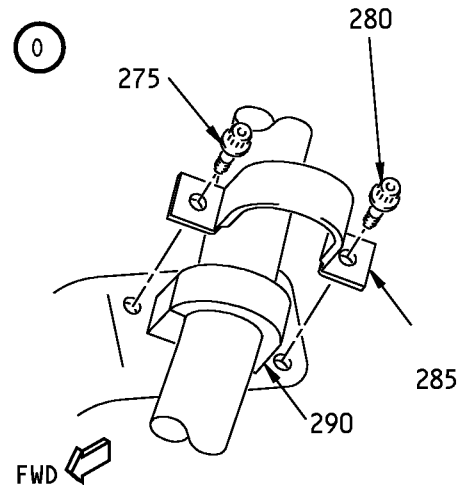

O

**Hydraulic Plumbing Installation**  
**Figure 21-1 (Sheet 12)**

**71-00-02**

P/P BUILDUP FIGURE 21-1

Page 22

Oct 05/2007

**737-600/700/800/900  
POWERPLANT BUILDUP MANUAL**

ITEM NO.	PART NUMBER	NOMENCLATURE	UC	QTY
21-1		<p><b>HYDRAULIC PLUMBING INSTALLATION (FIGURE 21-1, SHEET 12)</b></p> <p>OPTIONAL STEP; COAT ID OF CLAMP BLOCK (290) WITH grease, D00173 (C2) TO FACILITATE POSITIONING OF BLOCK UPON INSTALLATION.</p> <p>AT TWO LOCATIONS ON ENGINE FAN CASE, LOOSELY ATTACH HOSE ASSY (225) TO ENGINE BRACKETS.</p> <p>USE BOLTS (275) AND (280), CLAMP BLOCK STRAP (285) AND CLAMP BLOCK (290) AT LOWER LOCATION AND BOLTS (275), CLAMP BLOCK STRAP (285) AND CLAMP BLOCK (290) AT UPPER HOLE.</p>		
275	BACB30ZF4-08	. BOLT		3
280	BACB30ZF4-10	. BOLT		1
285	332W3130-18	. CLAMP BLOCK STRAP		2
290	332W5101-10	. CLAMP BLOCK		2
C2	D00173	. GREASE, MIL-PRF-27617 TYPE III	CON	AR
		<p>ADJUST HOSE ASSY (225) TO BEST POSITION AND TIGHTEN BOLTS (275) AND (280) TO 110-120 POUND-INCHES (12.4-13.6 NEWTON METERS).</p> <p>MAKE SURE PROTECTIVE CAP IS INSTALLED ON OPEN END OF HOSE ASSY (225).</p>		

**71-00-02**

P/P BUILDUP FIGURE 21-1

Page 23

Oct 05/2007

D633A106-HXL



737-600/700/800/900  
**POWERPLANT BUILDUP MANUAL**

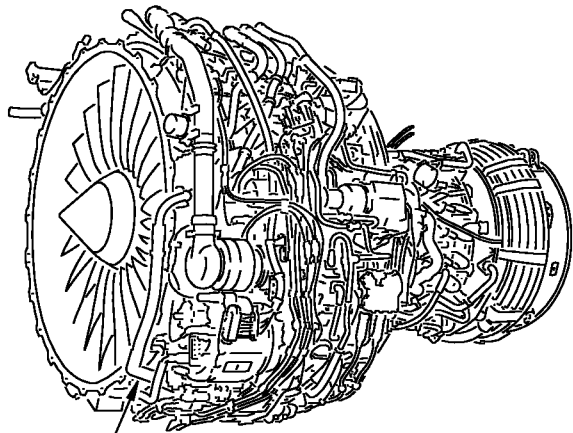

SEE (P)

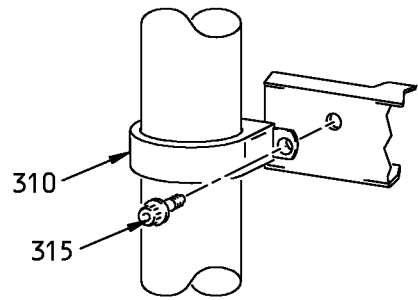

(Q)

(SHEET 12)

4

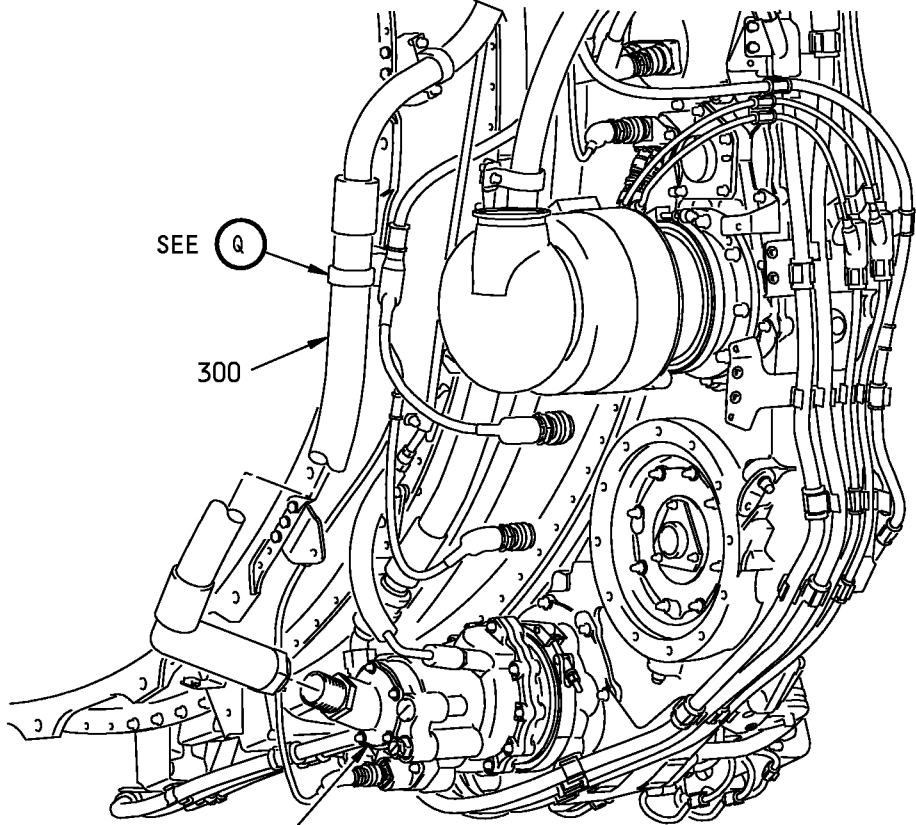

SEE (Q)

300

HYDRAULIC PUMP

FWD ←

(P)

**Hydraulic Plumbing Installation**  
**Figure 21-1 (Sheet 13)**

**71-00-02**

P/P BUILDUP FIGURE 21-1

Page 24

Oct 05/2007

D633A106-HXL

737-600/700/800/900  
**POWERPLANT BUILDUP MANUAL**

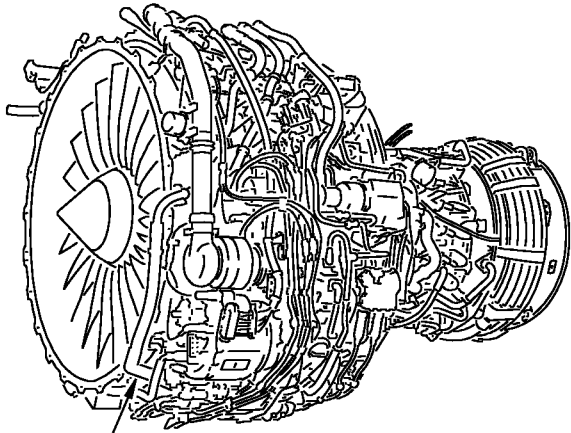

SEE (P)

(SHEET 12)

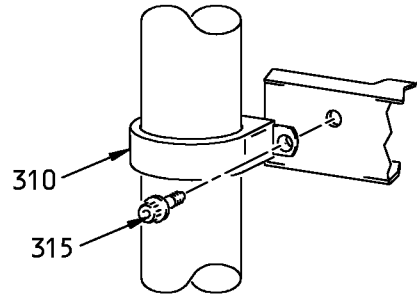

(Q)

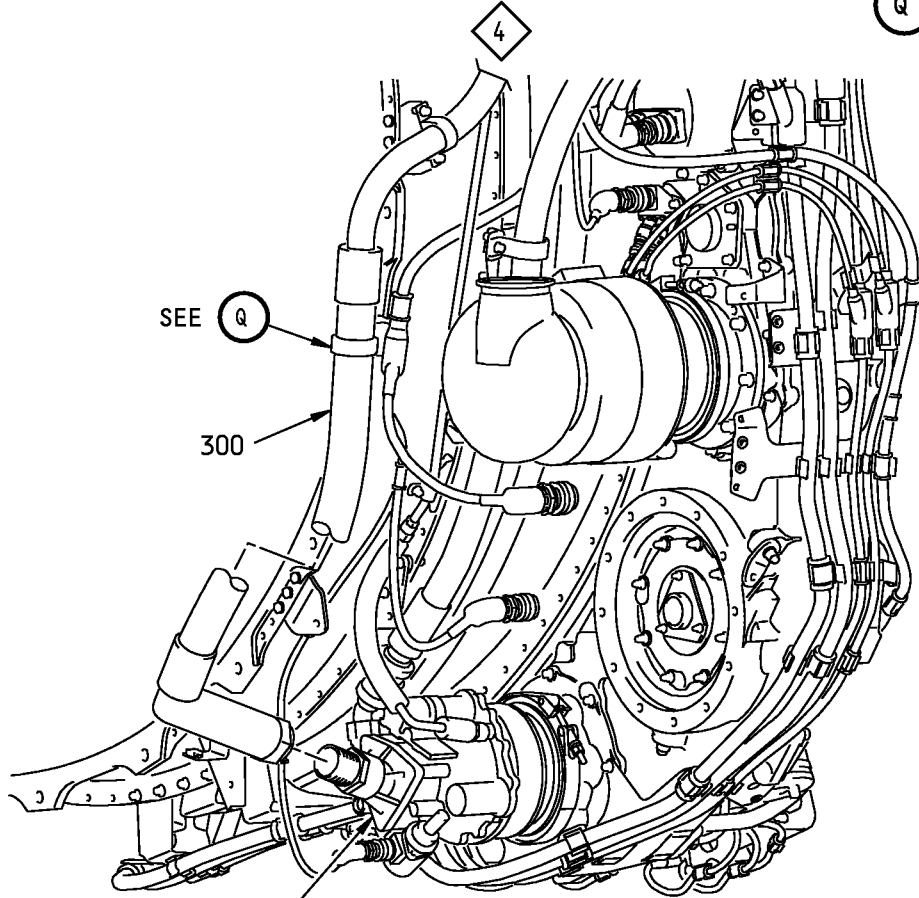

(P)

**Hydraulic Plumbing Installation**  
**Figure 21-1 (Sheet 14)**

**71-00-02**

P/P BUILDUP FIGURE 21-1

Page 25

Oct 05/2007

D633A106-HXL

**737-600/700/800/900  
POWERPLANT BUILDUP MANUAL**

ITEM NO.	PART NUMBER	NOMENCLATURE	UC	QTY
21-1		<p><b>HYDRAULIC PLUMBING INSTALLATION (FIGURE 21-1, SHEET 14)</b></p> <p><b>CAUTION:</b> USE 2 WRENCHES TO TIGHTEN THE HOSE ASSY; ONE TO HOLD THE HOSE ASSY AND ONE TO HOLD THE UNION. DAMAGE TO EQUIPMENT CAN OCCUR.</p> <p>MAKE SURE INTERNAL O-RING (301) IS INSTALLED ON HOSE ASSY (300) COUPLING.</p> <p>IF O-RING IS MISSING, INSTALL NEW O-RING (301).</p> <p><b>NOTE:</b> O-RING (301) NOT INCLUDED IN QEC KIT.</p> <p>CONNECT HOSE ASSY (300) TO SUPPLY PORT OF HYDRAULIC PUMP.</p> <p>TIGHTEN HOSE ASSY (300) TO 1520-1680 POUND-INCHES (127-140 POUND-FEET) (172-190 NEWTON METERS).</p> <p><b>NOTE:</b> MAKE SURE HOSE ASSY DOES NOT KINK OR TWIST DURING TIGHTENING.</p>		
300	155016-20-11	. HOSE ASSY, HYDRAULIC SUPPLY (V11362)	VEN	1
300	S332A210-11	. BOEING SPEC FOR 155016-20-11	BOE	-
301	NAS1611-024A	. . O-RING (1 REQD) <sup>[1]</sup>	REF	-
		<p>LOOSELY ATTACH HOSE ASSY (300) TO ENGINE BRACKET FORWARD OF FLANGE A1 WITH CLAMP (310) AND BOLT (315).</p> <p><b>NOTE:</b> DO NOT TIGHTEN BOLT (315) AT THIS TIME.</p>		
310	J1221G28	. CLAMP		1
315	BACB30ZF4-08	. BOLT		1
		*[1] ITEM NOT ILLUSTRATED		

**71-00-02**

P/P BUILDUP FIGURE 21-1

Page 26

Oct 05/2007

D633A106-HXL

737-600/700/800/900  
**POWERPLANT BUILDUP MANUAL**

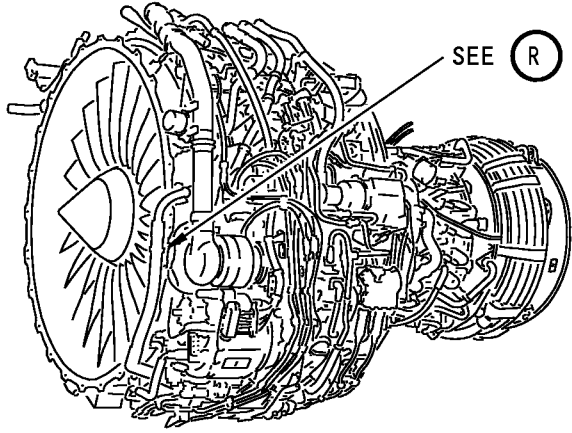

SEE R

(SHEET 13)

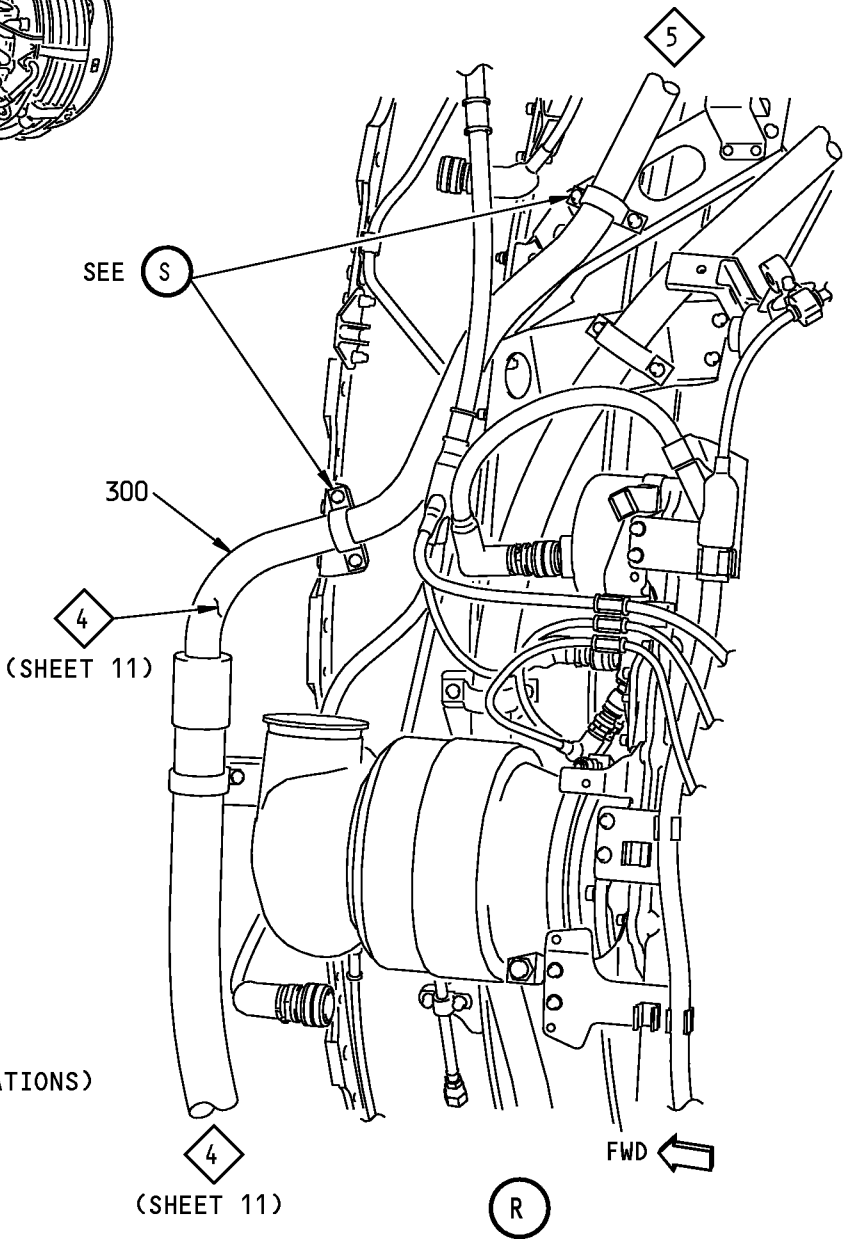

SEE S

300

4

(SHEET 11)

FWD ←

4  
(SHEET 11)

R

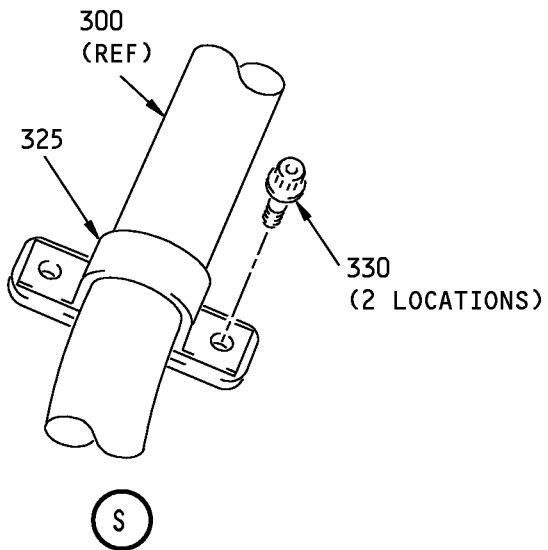

300  
(REF)

325

330  
(2 LOCATIONS)

S

**Hydraulic Plumbing Installation**  
**Figure 21-1 (Sheet 15)**

**71-00-02**

P/P BUILDUP FIGURE 21-1

Page 27

Oct 05/2007

**737-600/700/800/900  
POWERPLANT BUILDUP MANUAL**

ITEM NO.	PART NUMBER	NOMENCLATURE	UC	QTY
21-1		<p><b>HYDRAULIC PLUMBING INSTALLATION (FIGURE 21-1, SHEET 15)</b></p> <p>CONNECT HOSE ASSY (300) TO ENGINE BRACKETS AT 10:00 AND 9:00 O'CLOCK POSITIONS WITH CLAMPS (325) AND BOLTS (330).</p> <p><b>NOTE:</b> DO NOT TIGHTEN BOLTS (330) AT THIS TIME.</p>		
325	TAO910083	. CLAMP (V84971)	VEN	2
330	BACB30ZF4-08	. BOLT		4

**71-00-02**

P/P BUILDUP FIGURE 21-1

Page 28

Oct 05/2007

D633A106-HXL

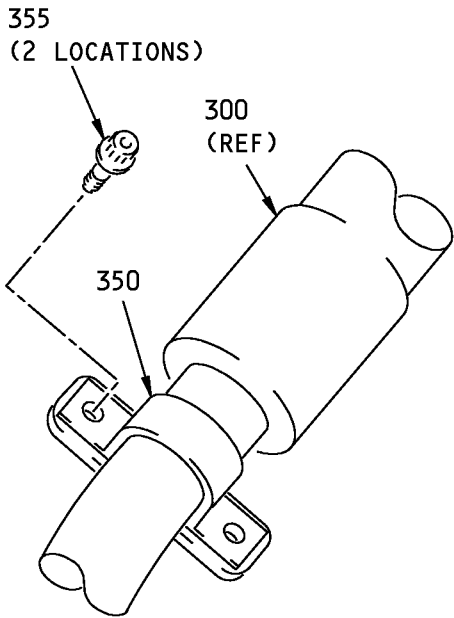
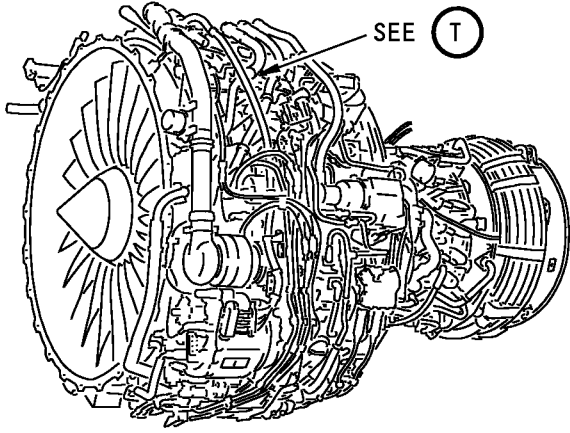

U

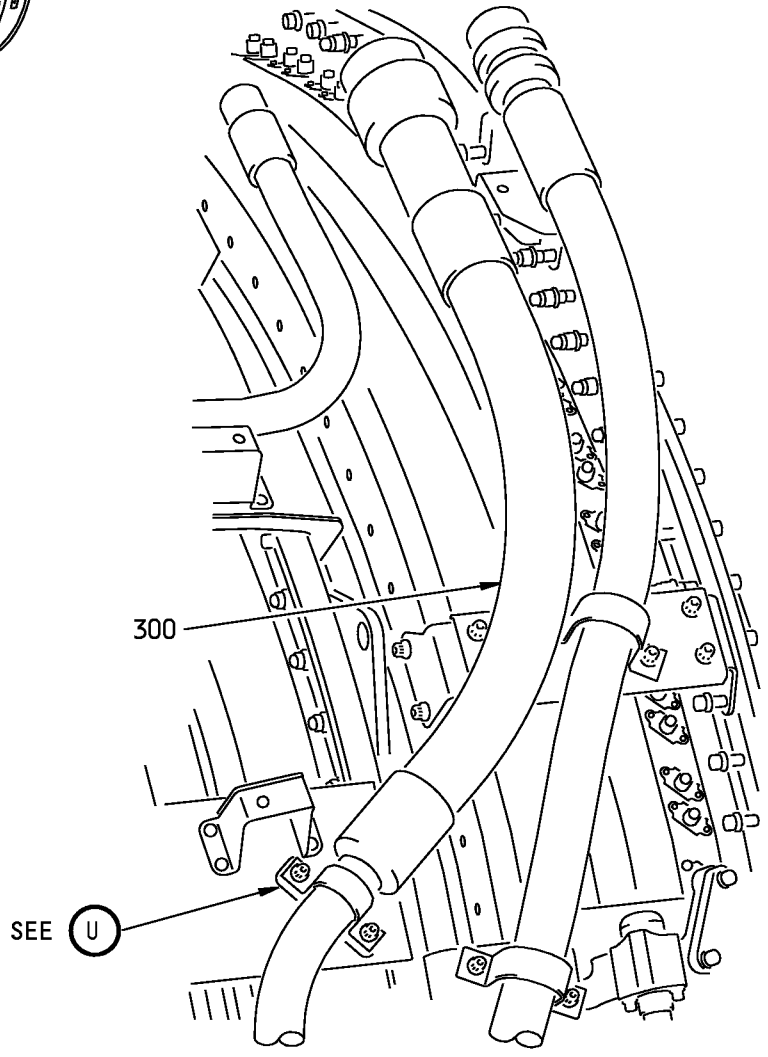

(SHEET 12)

T

**Hydraulic Plumbing Installation**  
**Figure 21-1 (Sheet 16)**

**71-00-02**

P/P BUILDUP FIGURE 21-1

Page 29

Oct 05/2007

**737-600/700/800/900  
POWERPLANT BUILDUP MANUAL**

ITEM NO.	PART NUMBER	NOMENCLATURE	UC	QTY
21-1		<p><b>HYDRAULIC PLUMBING INSTALLATION (FIGURE 21-1, SHEET 16)</b></p> <p>LOOSELY ATTACH HOSE ASSY (300) TO BRACKET AT 10:30 O'CLOCK POSITION WITH CLAMP (350) AND BOLTS (355).</p> <p>. CLAMP (V84971)</p> <p>. BOLT</p> <p>ADJUST HOSE ASSY (300) TO BEST POSITION.</p> <p>MAKE SURE THERE IS MINIMUM OF 0.5 INCH (12.7 MILLIMETERS) CLEARANCE WITH ADJACENT HARDWARE.</p> <p>TIGHTEN BOLTS (315), (330) AND (355) TO 110-120 POUND-INCHES (12.4-13.6 NEWTON METERS).</p> <p>MAKE SURE PROTECTIVE CAP IS INSTALLED ON OPEN END OF HOSE ASSY (300).</p>	VEN	1 2

**71-00-02**

P/P BUILDUP FIGURE 21-1

Page 30

Oct 05/2007

D633A106-HXL

**FIGURE 22-1**

**INTEGRATED DRIVE GENERATOR  
INSTALLATION**

**REF QEC TASK NO.: 22**

**REF DWG: 332A2600**

**NOTE:** ALL STANDARDS AND ATTACHING HARDWARE FOR THIS FIGURE WILL BE PACKAGED  
IN QEC TASK NO. 110.

**71-00-02**

P/P BUILDUP FIGURE 22-1

Page 1

Oct 05/2007

D633A106-HXL



737-600/700/800/900  
**POWERPLANT BUILDUP MANUAL**

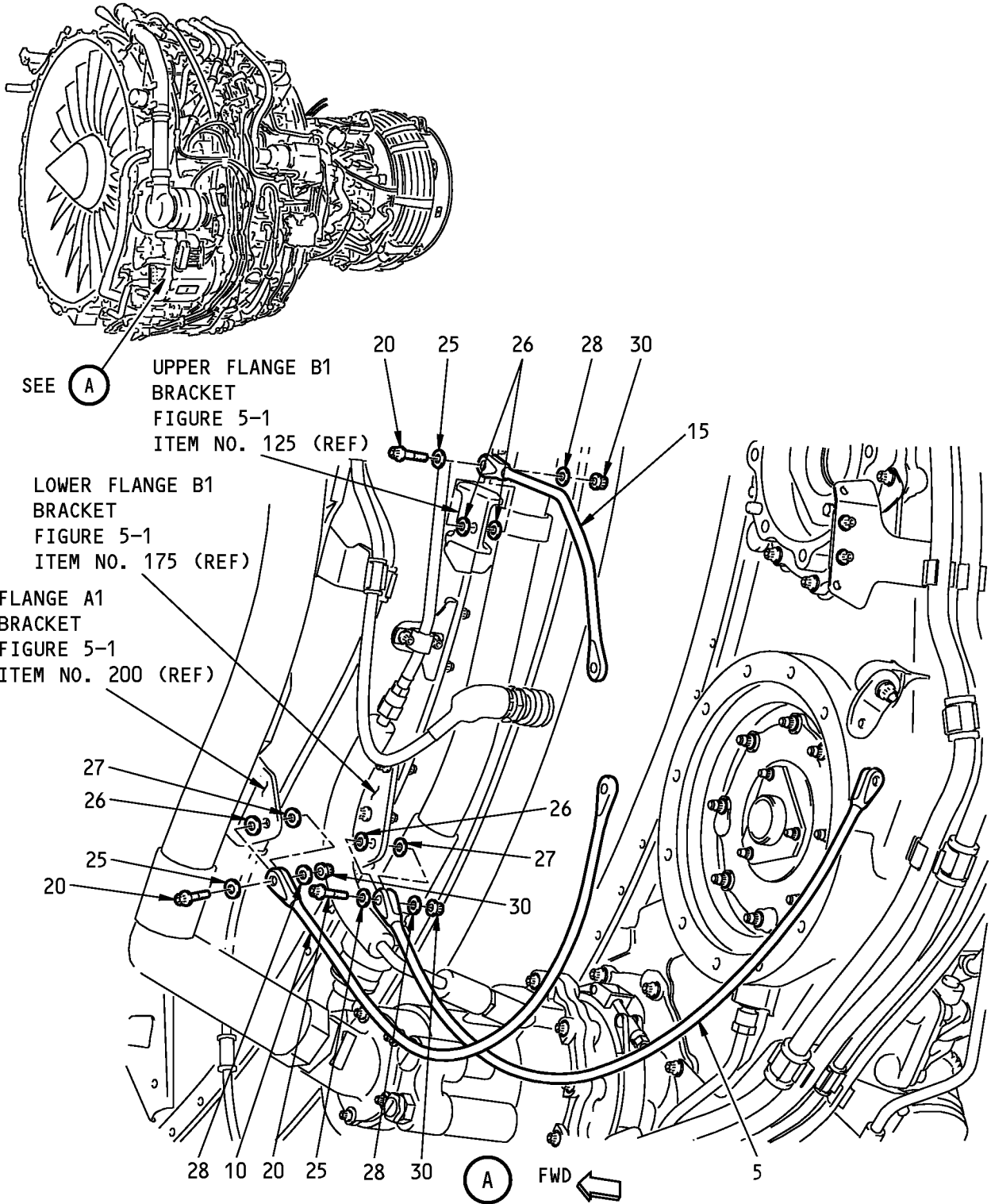

**Integrated Drive Generator Installation  
Figure 22-1 (Sheet 1)**

**71-00-02**

P/P BUILDUP FIGURE 22-1

Page 2

Oct 05/2007

D633A106-HXL

**737-600/700/800/900  
POWERPLANT BUILDUP MANUAL**

ITEM NO.	PART NUMBER	NOMENCLATURE	UC	QTY
22-1		<p><b>INTEGRATED DRIVE GENERATOR INSTALLATION (FIGURE 22-1, SHEET 1)</b></p> <p>LOOSELY ATTACH LANYARD ASSY (5) TO LOWER FLANGE B1 BRACKET Figure 5-1 ITEM NO. 175) USING BOLT (20), WASHERS (25 THRU 27) AND NUT (30).</p> <p>LOOSELY ATTACH LANYARD ASSY (10) TO FLANGE A1 BRACKET Figure 5-1 ITEM NO. 200) USING BOLT (20), WASHERS (25 THRU 27) AND NUT (30).</p> <p>LOOSELY ATTACH LANYARD ASSY (15) TO UPPER FLANGE B1 BRACKET (REF Figure 5-1 ITEM NO. 125) USING BOLT (20), WASHERS (25 THRU 28) AND NUT (30).</p>		
5	332A2600-4	. LANYARD ASSY		1
10	332A2600-5	. LANYARD ASSY		1
15	332A2600-6	. LANYARD ASSY		1
20	BACB30LE5K8	. BOLT		3
25	BACW10BP5ACU	. WASHER (CSK) (UNDER BOLT HEAD)		3
25	BACW10BP5CD	. WASHER (CSK) (OPTIONAL TO BACW10BP5ACU)	OPT	-
26	NAS1149E0532P	. WASHER (BETWEEN LANYARD CLEVIS AND ENGINE BRKT) (BOLT SIDE)		4
27	NAS1149E0516P	. WASHER (BETWEEN LANYARD CLEVIS AND ENGINE BRKT) (NUT SIDE)		2
28	NAS1149E0563R	. WASHER (UNDER NUT)		3
30	AS3485-11	. NUT		3
30	BACN10HR5CS	. NUT (OPTIONAL TO AS3485-11)	OPT	-
		POSITION LANYARD ASSYS (5), (10) AND (15) AS SHOWN AND TIGHTEN BOLTS (20) TO 100-150 POUND-INCHES (11.3-17.0 NEWTON METERS).		

**71-00-02**

P/P BUILDUP FIGURE 22-1

Page 3

Oct 05/2007

D633A106-HXL

737-600/700/800/900  
**POWERPLANT BUILDUP MANUAL**

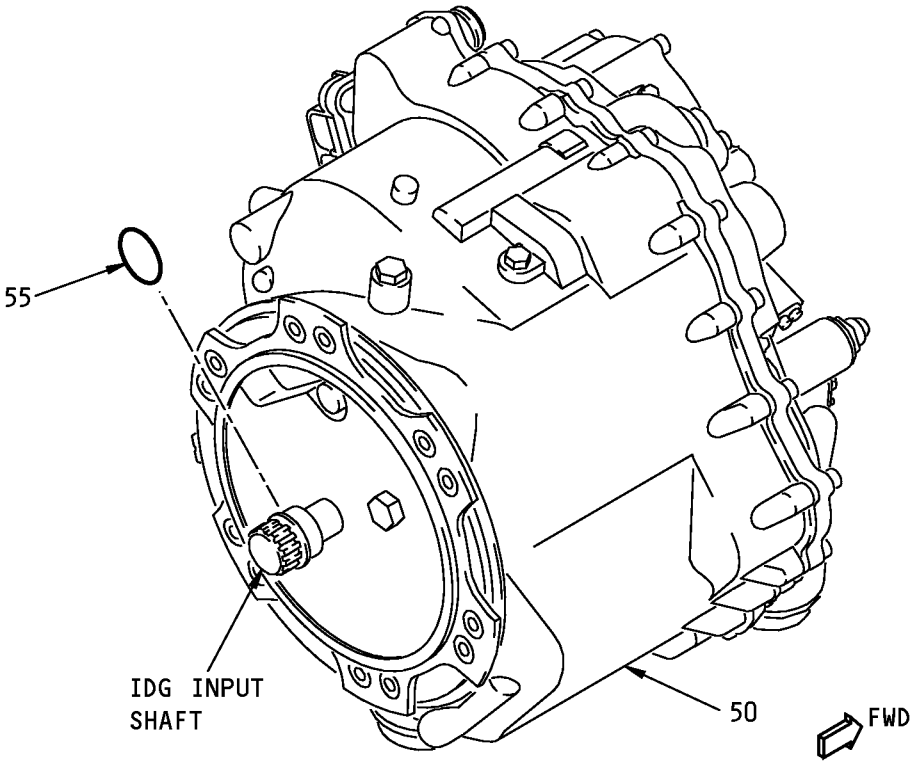

**INTEGRATED DRIVE GENERATOR**

F14927 S00041153897\_V2

**Integrated Drive Generator Installation  
Figure 22-1 (Sheet 2)**

**71-00-02**

P/P BUILDUP FIGURE 22-1

Page 4

Feb 05/2008

D633A106-HXL

**737-600/700/800/900  
POWERPLANT BUILDUP MANUAL**

ITEM NO.	PART NUMBER	NOMENCLATURE	UC	QTY
22-1		<b>INTEGRATED DRIVE GENERATOR INSTALLATION (FIGURE 22-1, SHEET 2)</b>		
		REMOVE BOLT FROM 12 O'CLOCK POSITION ON IDG (50) AND INSTALL LIFTING BOLT OR EQUIVALENT.		
50	761574B	. IDG (V99167)	VEN	1
50	761574	. IDG (V99167) (OPTIONAL TO 761574B)	OPT	-
50	S281A001-101	. BOEING SPEC FOR 761574 OR 761574B	BOE	-
		LUBRICATE O-RING (55) WITH Syn-Tech NS-6074 lubricant, D00648 (C1) OR oil, D00109 (C2) OR oil, D00523 (C3) AND INSTALL ON INPUT SHAFT OF IDG (50).		
55	AS3209-216	. . O-RING (SUPPLIED WITH IDG)	REF	-
55	M83248/1-216	. . O-RING (SUPPLIED WITH IDG) (OPTIONAL TO AS3209-216)	OPT	-
C1	D00648	. LUBRICANT, SYN-TECH NS-6074 (SUPPLIED WITH IDG)	CON	AR
C2	D00109	. OIL, AIRCRAFT TURBINE ENGINE, SYNTHETIC BASE, MIL-L-7808 (OPTIONAL)	CON	AR
C3	D00523	. OIL, AIRCRAFT TURBINE ENGINE, SYNTHETIC BASE, MIL-L-23699 (OPTIONAL)	CON	AR

**71-00-02**

P/P BUILDUP FIGURE 22-1

Page 5

Feb 05/2008

D633A106-HXL

737-600/700/800/900  
**POWERPLANT BUILDUP MANUAL**

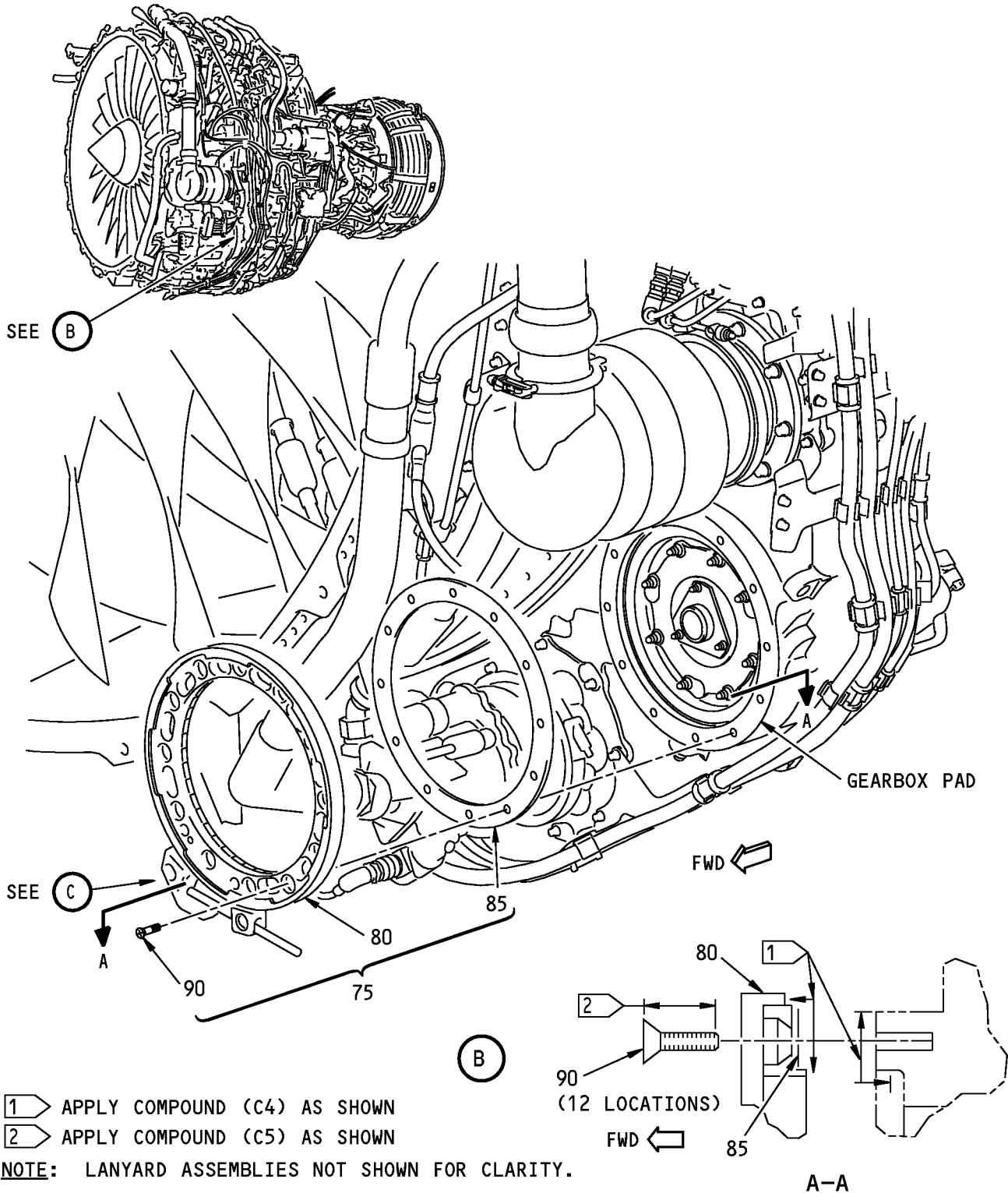

- 1 APPLY COMPOUND (C4) AS SHOWN
- 2 APPLY COMPOUND (C5) AS SHOWN

**NOTE:** LANYARD ASSEMBLIES NOT SHOWN FOR CLARITY.

**Integrated Drive Generator Installation**  
**Figure 22-1 (Sheet 3)**

**71-00-02**

P/P BUILDUP FIGURE 22-1

Page 6

Oct 05/2007

**737-600/700/800/900  
POWERPLANT BUILDUP MANUAL**

ITEM NO.	PART NUMBER	NOMENCLATURE	UC	QTY
22-1		<p><b>INTEGRATED DRIVE GENERATOR INSTALLATION (FIGURE 22-1, SHEET 3)</b></p> <p><b>CAUTION:</b> KEEP GREASE OUT OF DOWEL PIN AND BOLT HOLES. GREASE IN HOLES CAN CAUSE DAMAGE TO GEARBOX DUE TO PRESSURE BUILD-UP WHEN SCREWS ARE INSTALLED. USE CARE TO KEEP FOREIGN MATERIAL OUT OF IDG.</p> <p>APPLY A THIN COATING OF silicone compound, D00254 (C4) TO QAD RING FLANGE (80) AND GEARBOX PAD.</p> <p>APPLY A THIN COATING OF Never-Seez NSBT-8N compound, D00006 (C5) TO THE CONICAL SURFACE OF HEAD AND THREADS OF SCREWS (90).</p> <p>. SILICONE GREASE, DOW CORNING NO. 4</p> <p>. COMPOUND, NEVER-SEEZ NSBT-8N</p> <p>ENSURE GASKET (85) IS IN POSITION ON AFT SIDE OF QAD RING (80).</p> <p>POSITION QAD RING (80) ON GEARBOX ALIGNING -TOP- MARKING ON QAD RING WITH -TOP- MARKING ON GEARBOX.</p> <p>INSTALL WITH SCREWS (90) AND TIGHTEN TO 275-300 POUND-INCHES (31.1-33.9 NEWTON METERS).</p> <p>. QAD ADAPTER KIT (V99167)</p> <p>. BOEING SPEC FOR 762246</p> <p>. . QAD RING (1 SUPPLIED WITH QAD KIT (75))</p> <p>. . GASKET (1 SUPPLIED WITH QAD KIT (75))</p> <p>. . SCREW (12 SUPPLIED WITH QAD KIT (75))</p>		
C4	D00254	. SILICONE GREASE, DOW CORNING NO. 4	CON	AR
C5	D00006	. COMPOUND, NEVER-SEEZ NSBT-8N	CON	AR
75	762246	. QAD ADAPTER KIT (V99167)	VEN	1
75	S281A001-501	. BOEING SPEC FOR 762246	BOE	-
80	762075	. . QAD RING (1 SUPPLIED WITH QAD KIT (75))	REF	-
85	731476	. . GASKET (1 SUPPLIED WITH QAD KIT (75))	REF	-
90	0646C624-18	. . SCREW (12 SUPPLIED WITH QAD KIT (75))	REF	-

**71-00-02**

P/P BUILDUP FIGURE 22-1

Page 7

Oct 05/2007

D633A106-HXL

737-600/700/800/900  
**POWERPLANT BUILDUP MANUAL**

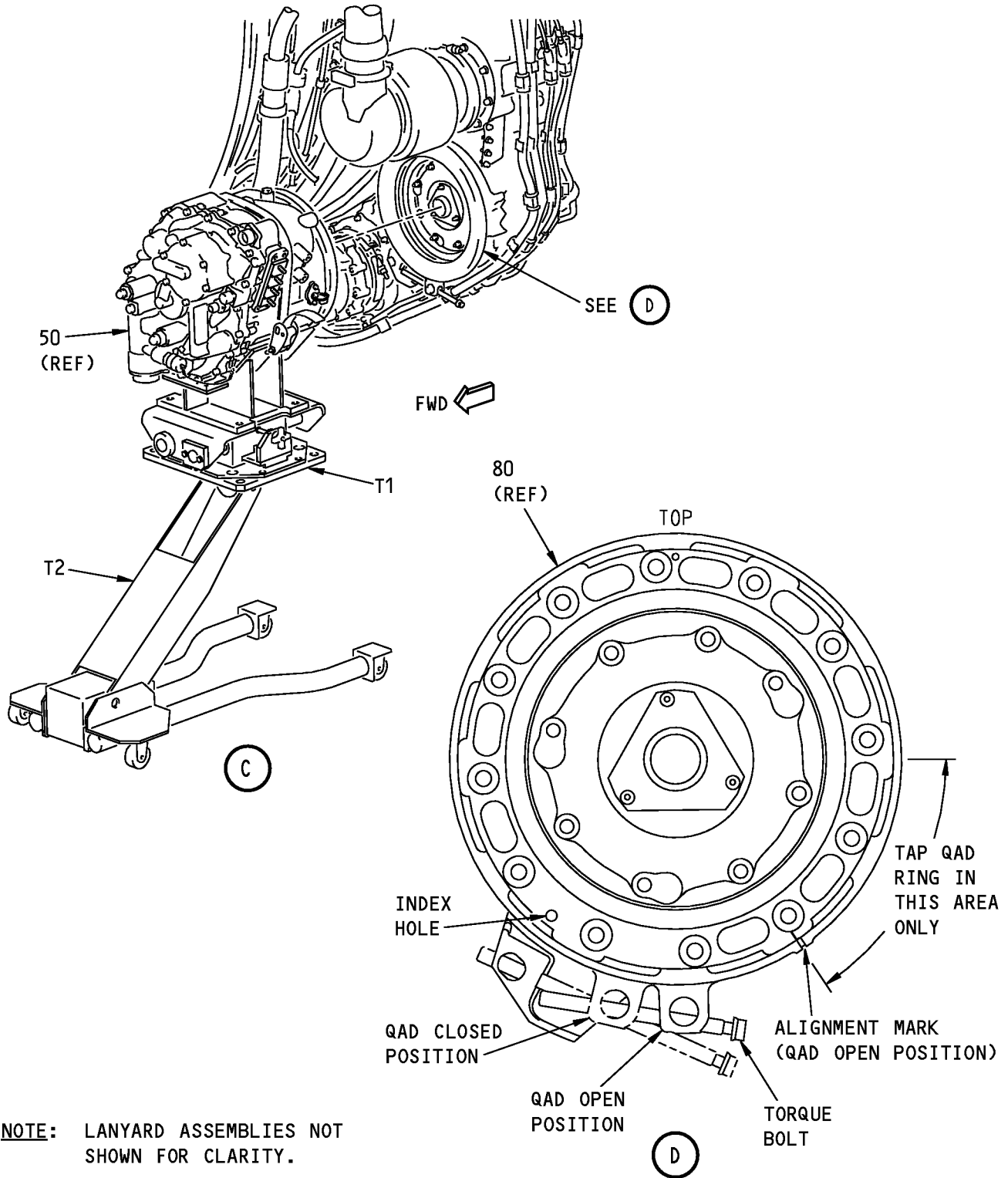

**NOTE:** LANYARD ASSEMBLIES NOT SHOWN FOR CLARITY.

**Integrated Drive Generator Installation  
Figure 22-1 (Sheet 4)**

**71-00-02**

P/P BUILDUP FIGURE 22-1

Page 8

Oct 05/2007

D633A106-HXL

**737-600/700/800/900  
POWERPLANT BUILDUP MANUAL**

ITEM NO.	PART NUMBER	NOMENCLATURE	UC	QTY
22-1		<p><b>INTEGRATED DRIVE GENERATOR INSTALLATION (FIGURE 22-1, SHEET 4)</b></p> <p><b>CAUTION:</b> DO NOT USE IDG DRIVE SHAFT FOR A HANDLE DURING INSTALLATION. USE PILOT FLANGE AREA FOR A HAND HOLD. SIDE LOADS ON DRIVE SHAFT CAN DAMAGE IDG CARBON SEALS.</p> <p>MAKE SURE adapter, SPL-1634 (T1) IS INSTALLED ON low profile hydraulic jack, COM-1443 (T2).</p> <p>SECURE IDG (50) TO JACK ADAPTER WITH STRAP.</p> <p>. JACK ADAPTER, IDG</p> <p>. JACK, TRANSMISSION (V36251) (OR EQUIVALENT)</p> <p>REMOVE LIFTING BOLT AND REINSTALL SUPPLIED FASTENER.</p> <p>TIGHTEN FASTENER TO 100-120 POUND-INCHES (11.3-13.6 NEWTON METERS).</p> <p><b>CAUTION:</b> DO NOT ALLOW IDG TO HANG ON DRIVE SHAFT DURING INSTALLATION. FAILURE TO PROPERLY SUPPORT IDG MAY RESULT IN DAMAGE TO DRIVE SHAFT AND CARBON SEALS.</p> <p>POSITION IDG (50) AT GEARBOX PAD.</p> <p>ADJUST TORQUE BOLT ON QAD UNTIL OUTER RING OF QAD ROTATES TO THE OPEN POSITION.</p> <p>ALIGN INDEX MARKS ON QAD RING (80) AND IDG (50).</p> <p>MAKE SURE LUGS ON IDG FLANGE CAN ENTER THE QAD RING OPENINGS.</p> <p>ENGAGE DRIVE SHAFT SPLINE FIRST, THEN INDEX PIN.</p> <p>MAKE SURE INDEX PIN ON IDG ENGAGES INDEX HOLE ON QAD.</p> <p>SUPPORT AFT END OF IDG FOR 360-DEGREE CONTACT BETWEEN MATING SURFACES OF QAD RING AND IDG.</p> <p>ADJUST TORQUE BOLT UNTIL QAD RING ROTATES TO THE LOCKED POSITION.</p>	TOL TOL	- -
T1	C24002-41			
T2	W93718			

**71-00-02**

P/P BUILDUP FIGURE 22-1

Page 9

Oct 05/2007

D633A106-HXL



737-600/700/800/900  
**POWERPLANT BUILDUP MANUAL**

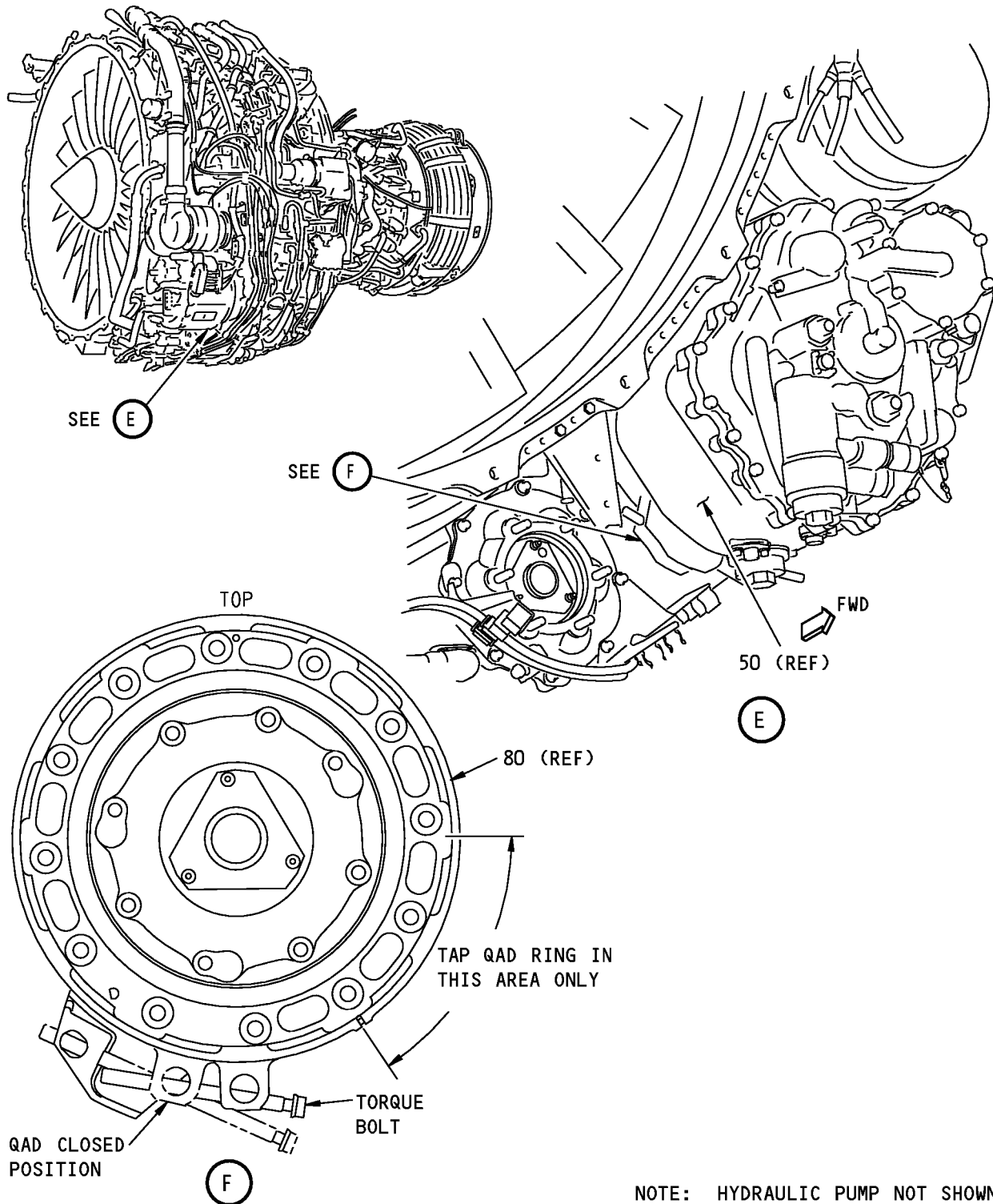

NOTE: HYDRAULIC PUMP NOT SHOWN

**Integrated Drive Generator Installation**  
**Figure 22-1 (Sheet 5)**

**71-00-02**

P/P BUILDUP FIGURE 22-1

Page 10

Oct 05/2007

D633A106-HXL

**737-600/700/800/900  
POWERPLANT BUILDUP MANUAL**

ITEM NO.	PART NUMBER	NOMENCLATURE	UC	QTY
22-1		<p><b>INTEGRATED DRIVE GENERATOR INSTALLATION (FIGURE 22-1, SHEET 5)</b></p> <p><b>CAUTION:</b> OBSERVE ACTION ON QAD RING DURING TIGHTENING TO PREVENT BINDING OR SNAGGING.</p> <p>TIGHTEN TORQUE BOLT SO THE QAD RING LUGS FULLY ENGAGE THE IDG FLANGE LUGS.</p> <p>TIGHTEN TORQUE BOLT TO 240-264 POUND-INCHES (27.1-29.8 NEWTON METERS).</p> <p>TAP QAD RING IN AREA SHOWN WITH SOFT MALLET OR BRASS DRIFT TO CENTER THE QAD RING AND PREVENT FALSE TORQUE READINGS.</p> <p>CHECK TORQUE VALUE ON TORQUE BOLT.</p> <p>IF THE TORQUE IS LESS THAN 180 POUND-INCHES (20.4 NEWTON METERS), TORQUE BOLT TO 240-264 POUND-INCHES (27.1-29.8 NEWTON METERS) AND REPEAT TAP-TORQUE PROCEDURE UNTIL THE TORQUE ON THE TORQUE BOLT DOES NOT DROP BELOW 180 POUND-INCHES (20.4 NEWTON METERS) AFTER TAPPING ON THE QAD RING.</p> <p>TIGHTEN TORQUE BOLT TO 240-264 POUND-INCHES (27.1-29.8 NEWTON METERS).</p> <p>IF THE FIRST TORQUE IS ABOVE 180 POUND-INCHES (20.4 NEWTON METERS), REPEAT TAPPING ON QAD RING AND CHECK TORQUE AGAIN.</p> <p>IF SECOND TORQUE REMAINS ABOVE 180 POUND-INCHES (20.4 NEWTON METERS), LOOSEN TORQUE BOLT.</p> <p>RETIGHTEN TORQUE BOLT TO 240-264 POUND-INCHES (27.1-29.8 NEWTON METERS).</p> <p>INSTALL safety cable kit, G50375 (C6) OR lockwire, G01912 (C7) ON TORQUE BOLT.</p> <p>. SAFETY CABLE, BACC13AT3K18</p> <p>. LOCKWIRE, MS20995NC32 (OPT)</p> <p>REMOVE IDG JACK EQUIPMENT (T1 THRU T2) FROM IDG (50).</p>		
C6	G50375		CON	1
C7	G01912		CON	AR

**71-00-02**

P/P BUILDUP FIGURE 22-1

Page 11

Feb 05/2008

D633A106-HXL

737-600/700/800/900  
**POWERPLANT BUILDUP MANUAL**

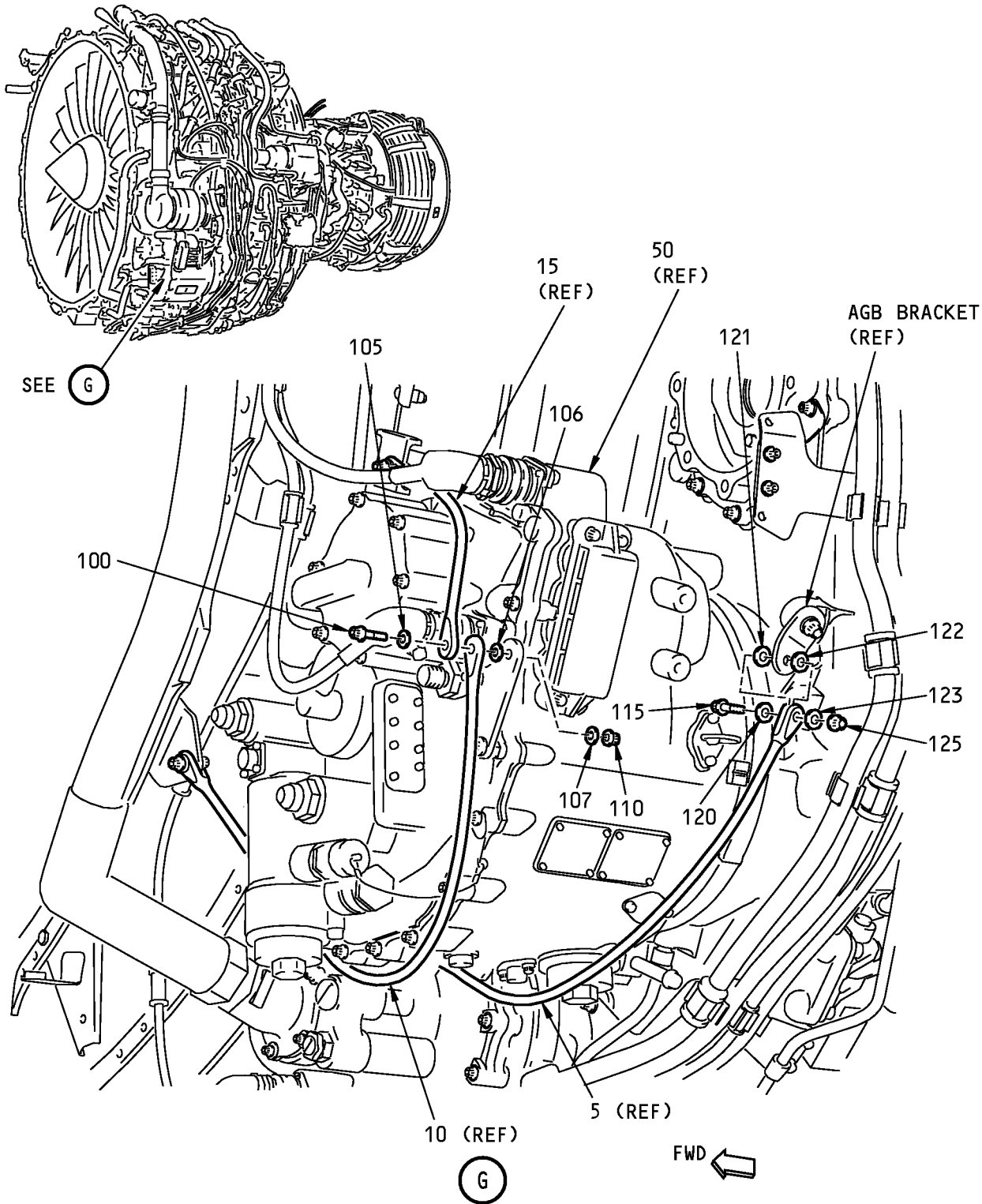

**Integrated Drive Generator Installation**  
**Figure 22-1 (Sheet 6)**

**71-00-02**

**737-600/700/800/900  
POWERPLANT BUILDUP MANUAL**

ITEM NO.	PART NUMBER	NOMENCLATURE	UC	QTY
22-1		<b>INTEGRATED DRIVE GENERATOR INSTALLATION (FIGURE 22-1, SHEET 6)</b>		
		ROUTE LANYARD ASSY (10) UNDER IDG (50) AND ROUTE LANYARD ASSY (15) OVER TOP OF IDG (50).		
		LOOSELY ATTACH LANYARD ASSYS (10) AND (15) TO IDG BRACKET USING BOLT (100), WASHERS (105, 106) AND NUT (110).		
100	BACB30LE5K14	. BOLT		1
105	BACW10BP5ACU	. WASHER (CSK) (UNDER BOLT HEAD)		1
105	BACW10BP5CD	. WASHER (CSK) (OPTIONAL TO BACW10BP5ACU)	OPT	-
106	BACW10BP5APU	. WASHER (PLAIN) (BTWN (10) AND IDG BRACKET)		1
107	NAS1149E0563R	. WASHER (UNDER NUT)		1
110	AS3485-11	. NUT		1
110	BACN10HR5CS	. NUT (OPTIONAL TO AS3485-11)	OPT	-
		ROUTE LANYARD (5) UNDER IDG (50) AND LOOSELY ATTACH TO AGB BRACKET USING BOLT (115), WASHERS (120 THRU 123) AND NUT (125).		
115	BACB30LE5K8	. BOLT		1
120	BACW10BP5ACU	. WASHER (CSK) (UNDER BOLT HEAD)		1
120	BACW10BP5CD	. WASHER (CSK) (OPTIONAL TO BACW10BP5ACU)	OPT	-
121	NAS1149E0532P	. WASHER (BETWEEN LANYARD CLEVIS AND AGB BRACKET) (BOLT SIDE)		1
122	NAS1149E0516P	. WASHER (BETWEEN LANYARD CLEVIS AND ENGINE BRKT) (NUT SIDE)		1
123	NAS1149E0563R	. WASHER (UNDER NUT)		1
125	AS3485-11	. NUT		1
125	BACN10HR5CS	. NUT (OPTIONAL TO AS3485-11)	OPT	-
		ORIENT LANYARD ASSYS (5), (10) AND (15) TO ACHIEVE MAXIMUM CLEARANCE WITH THE SURROUNDING EQUIPMENT.		
		TIGHTEN BOLTS (20) TO 100-150 POUND-INCHES (11.3-17.0 NEWTON METERS).		
		TIGHTEN BOLTS (100) AND (115) TO 100-150 POUND-INCHES (11.3-17.0 NEWTON METERS).		

**71-00-02**

P/P BUILDUP FIGURE 22-1

Page 13

Oct 05/2007

D633A106-HXL

737-600/700/800/900  
**POWERPLANT BUILDUP MANUAL**

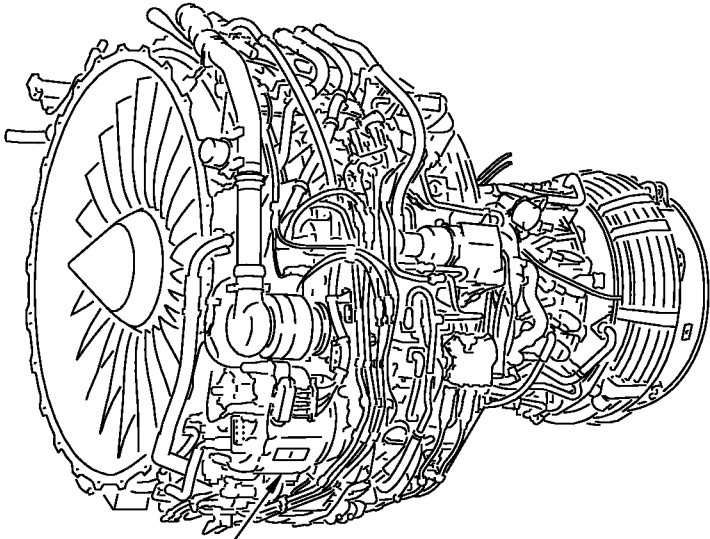

SEE (H)

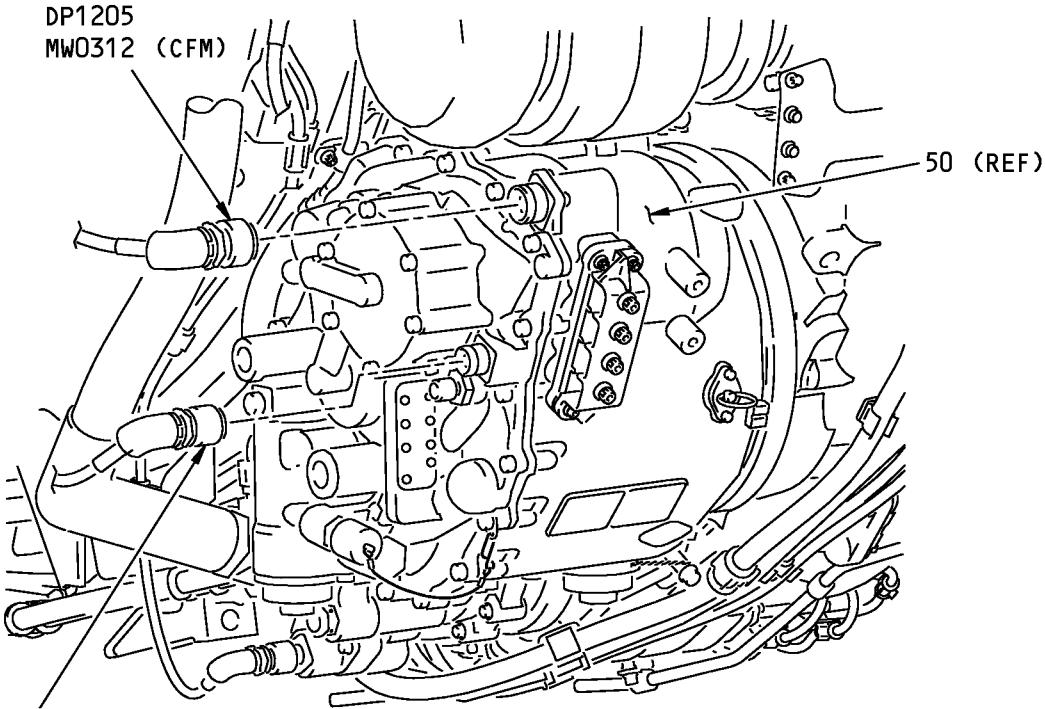

DP1206  
MW0312 (CFM)

FWD ←

(H)

**Integrated Drive Generator Installation**  
**Figure 22-1 (Sheet 7)**

**71-00-02**

P/P BUILDUP FIGURE 22-1

Page 14

Oct 05/2007

D633A106-HXL

**737-600/700/800/900  
POWERPLANT BUILDUP MANUAL**

ITEM NO.	PART NUMBER	NOMENCLATURE	UC	QTY
22-1		<p><b>INTEGRATED DRIVE GENERATOR INSTALLATION (FIGURE 22-1, SHEET 7)</b></p> <p><b>CAUTION:</b> DO NOT OVERTIGHTEN THE PLUG COUPLING RING. DO NOT USE WATER PUMP PLIERS, PIPE WRENCHES OR VISE GRIPS TO TIGHTEN THE COUPLING RING OR DAMAGE TO THE ELECTRICAL CONNECTOR CAN OCCUR.</p> <p>CONNECT MW0312 ELECTRICAL CONNECTOR, DP1205, TO TOP RECEPTACLE AND MW0312 ELECTRICAL CONNECTOR, DP1206, TO LOWER RECEPTACLE.</p> <p>TURN KNURLED COUPLING RING WHILE WIGGLING THE BACKSHELL ASSEMBLY.</p> <p>AFTER FULLY SEATING THE COUPLING RING, USE SOFT-JAWED PLIERS OR A STRAP WRENCH TO TIGHTEN THE COUPLING RING AN ADDITIONAL 1/8 TURN OR UNTIL PLIER SLIPPAGE OCCURS.</p>		

**71-00-02**

P/P BUILDUP FIGURE 22-1

Page 15

Oct 05/2007

D633A106-HXL

**FIGURE 23-1**

# **IDG AIR/OIL COOLER INSTALLATION**

**REF QEC TASK NO.: 23**

**REF DWG: 332A2600**

**NOTE:** ALL STANDARDS AND ATTACHING HARDWARE FOR THIS FIGURE WILL BE PACKAGED IN QEC TASK NO. 110.

**71-00-02**

P/P BUILDUP FIGURE 23-1

Page 1

Oct 05/2007

D633A106-HXL

737-600/700/800/900  
**POWERPLANT BUILDUP MANUAL**

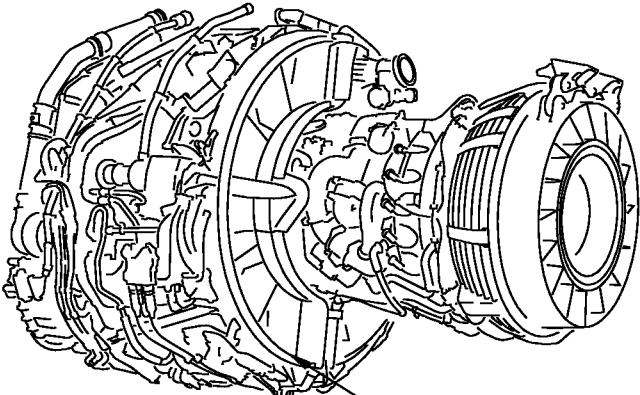

SEE (A)

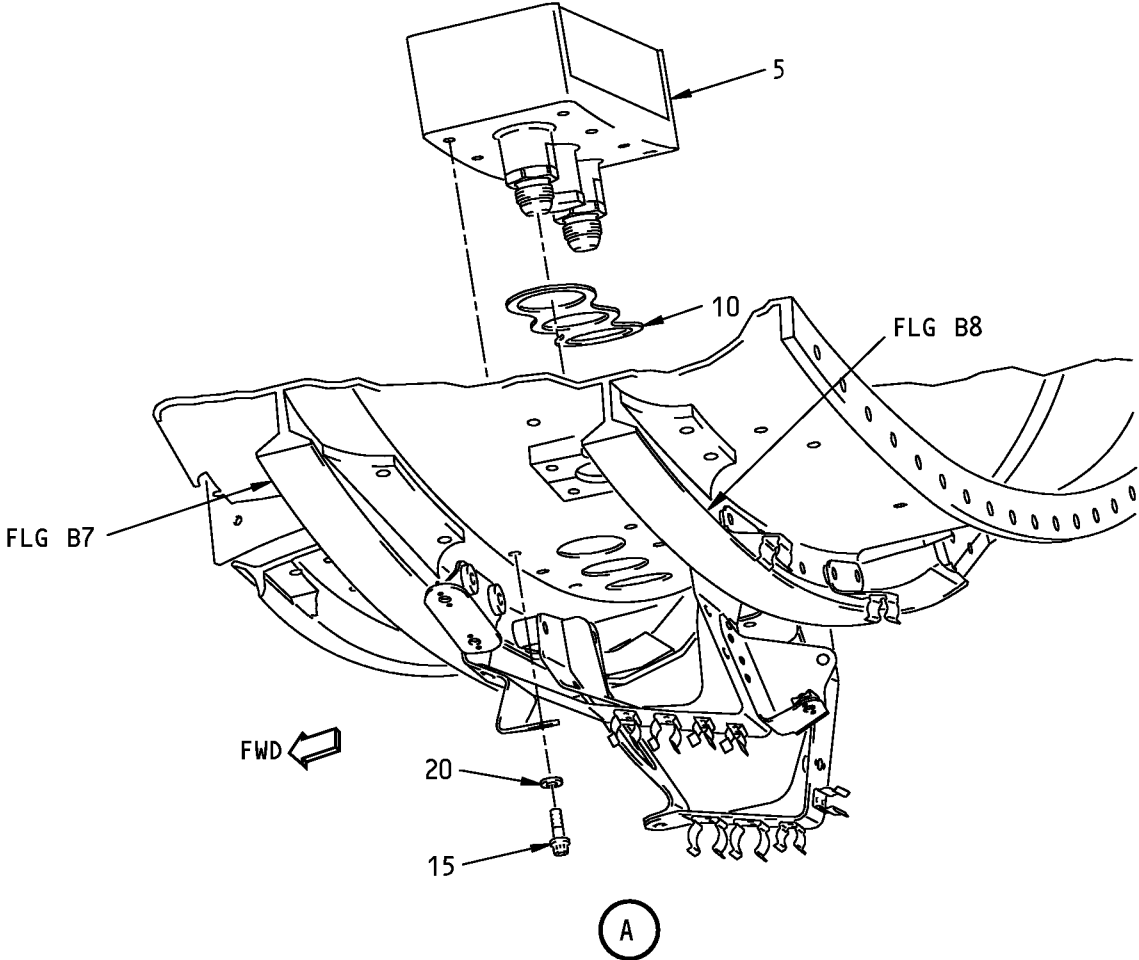

**NOTE:** CFMI WIRE HARNESSES NOT SHOWN FOR CLARITY.

**IDG Air/Oil Cooler Installation  
Figure 23-1 (Sheet 1)**

**71-00-02**



**737-600/700/800/900  
POWERPLANT BUILDUP MANUAL**

ITEM NO.	PART NUMBER	NOMENCLATURE	UC	QTY
23-1		<b>IDG AIR/OIL COOLER INSTALLATION (FIGURE 23-1, SHEET 1)</b>		
		REMOVE PROTECTIVE PLATE AND BOLTS, WASHERS AND NUTS FROM IDG COOLER PORT ON FAN CASE.		
		INSTALL GASKET (10) ON IDG AIR/OIL COOLER (5).		
5	UA538551-3	. IDG AIR/OIL COOLER (V78943)	VEN	1
5	S332A260-1	. BOEING SPEC FOR UA538551-3	BOE	-
10	U542648	. GASKET (V78943)	VEN	1
10	S332A260-4	. BOEING SPEC FOR U542648	BOE	-
		APPLY Never-Seez NSBT-8N compound, D00006 (C1) TO IDG AIR/OIL COOLER (5) THREADED INSERTS (8 LOCATIONS).		
		POSITION IDG AIR/OIL COOLER (5) ON FAN CASE AT APPROXIMATELY THE 6:30 O'CLOCK POSITION BETWEEN FLGS B7 AND B8.		
		ATTACH IDG AIR/OIL COOLER TO FAN CASE WITH BOLTS (15) AND WASHERS (20) INSTALLED THROUGH FAN CASE EXTERIOR.		
15	BACB30ZF4-10	. BOLT		8
20	NAS1149C0463R	. WASHER		8
C1	D00006	. COMPOUND, NEVER SEEZ NSBT-8N	CON	AR
		TIGHTEN BOLTS (15) TO 70-80 POUND-INCHES (7.9-9.0 NEWTON METERS).		
		MAKE SURE PROTECTIVE CAPS ARE INSTALLED ON IDG AIR/OIL COOLER PORTS.		

# 71-00-02

P/P BUILDUP FIGURE 23-1

Page 3

Oct 05/2007

D633A106-HXL

**FIGURE 24-1**

# **IDG PLUMBING INSTALLATION**

**REF QEC TASK NO.: 24**

**REF DWG: 332A2100**

**NOTE:** ALL STANDARDS AND ATTACHING HARDWARE FOR THIS FIGURE WILL BE PACKAGED IN QEC TASK NO. 110.

**71-00-02**

P/P BUILDUP FIGURE 24-1

Page 1

Oct 05/2007

D633A106-HXL

737-600/700/800/900  
**POWERPLANT BUILDUP MANUAL**

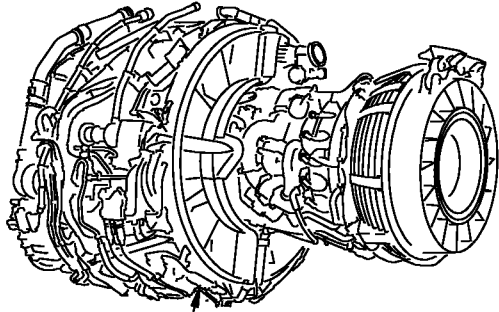

SEE (A)

SEE (B)

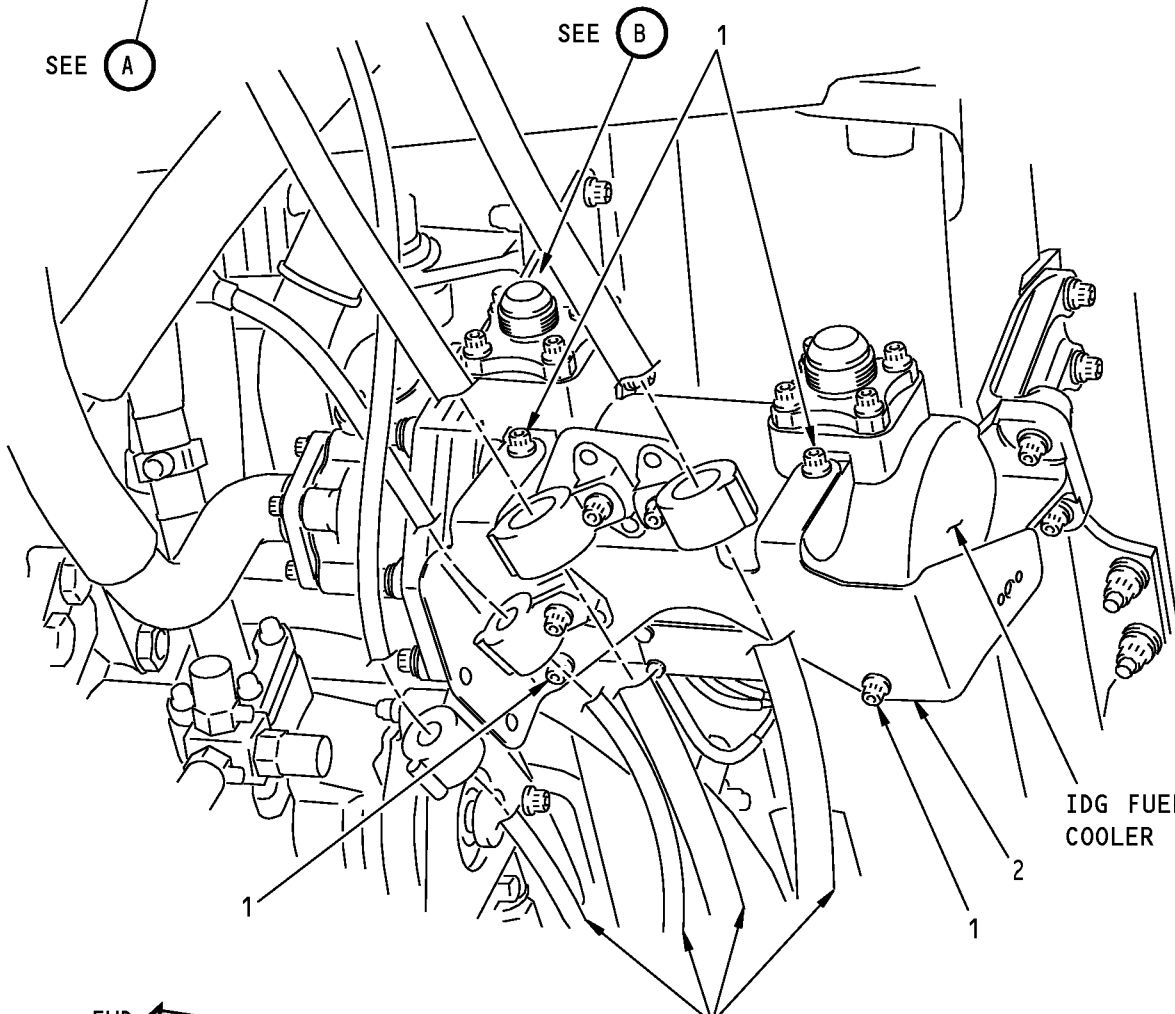

IDG FUEL/OIL COOLER

FWD ←

CFMI WIRE BUNDLES

CFMI SHIP LOOSE HARDWARE

(A)

**IDG Plumbing Installation**  
Figure 24-1 (Sheet 1)

**71-00-02**

P/P BUILDUP FIGURE 24-1

Page 2

Oct 05/2007

D633A106-HXL

**737-600/700/800/900  
POWERPLANT BUILDUP MANUAL**

ITEM NO.	PART NUMBER	NOMENCLATURE	UC	QTY
24-1		<p><b>IDG PLUMBING INSTALLATION (FIGURE 24-1, SHEET 1)</b></p> <p>IN THIS PROCEDURE, DO NOT TIGHTEN SCREWS AND TUBES OR ELBOW NUTS UNLESS INSTRUCTED OR INSTALL PARTS IN A DIFFERENT SEQUENCE.</p> <p><b>CAUTION:</b> IN THIS PROCEDURE WHEN TIGHTENING TUBE OR ELBOW NUTS, USE TWO WRENCHES; ONE TO HOLD THE SPANNER FLATS ON THE NIPPLE AND ONE TO TIGHTEN THE NUT.</p> <p>CFMI SHIP LOOSE HARDWARE (INSTALLED BY CFMI ON SOME ENGINES)</p> <p>APPLY Never-Seez NSBT-8N compound, D00006 (C1) TO THREADS OF BOLTS (1)</p>		
1	BACB30ZF4-08	. BOLT (4 REQD) <sup>*[1]</sup>	REF	-
C1	D00006	. COMPOUND, NEVER SEEZ NSBT-8N	CON	AR
2	340-087-904-0	<p>ATTACH BRACKET ASSY (2) TO IDG FUEL/OIL COOLER WITH LUBRICATED BOLTS (1).</p> <p>. BRACKET ASSY (1 REQD)<sup>*[1]</sup></p> <p>TIGHTEN BOLTS (1) TO 100-110 POUND-INCHES (11.3-12.4 NEWTON METERS).</p> <p><b>NOTE:</b> TO ALLOW BETTER ACCESS, DO NOT SECURE CFMI WIRE BUNDLES IN HINGE CLAMPS OF BRACKET ASSY AT THIS TIME. WIRE BUNDLES WILL BE SECURED AT THE END OF THE PROCEDURE.</p> <p><sup>*[1]</sup> PART NUMBERS ARE SHOWN FOR REFERENCE ONLY AND ARE SUBJECT TO CHANGE. REFER TO CFMI ILLUSTRATED PARTS CATALOG (IPC) 72-00-00-23 FOR LATEST PART NUMBER INFORMATION.</p>	REF	-

**71-00-02**

P/P BUILDUP FIGURE 24-1

Page 3

Oct 05/2007

D633A106-HXL

737-600/700/800/900  
**POWERPLANT BUILDUP MANUAL**

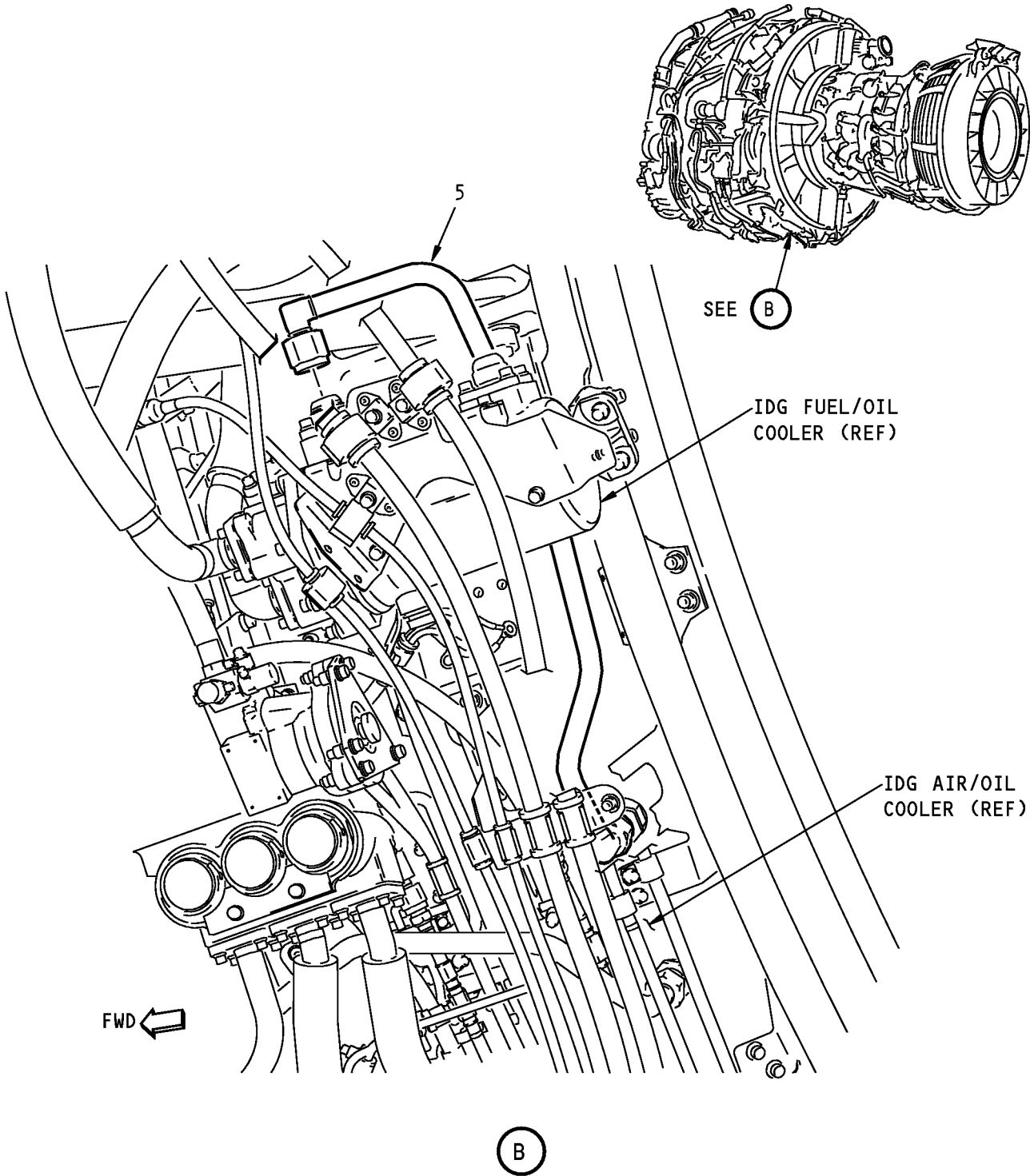

**IDG Plumbing Installation**  
Figure 24-1 (Sheet 2)

**71-00-02**

P/P BUILDUP FIGURE 24-1

Page 4

Oct 05/2007

D633A106-HXL



**737-600/700/800/900  
POWERPLANT BUILDUP MANUAL**

**THIS SHEET NOT USED**

**IDG Plumbing Installation  
Figure 24-1 (Sheet 3)**

**71-00-02**

P/P BUILDUP FIGURE 24-1

Page 6

Oct 05/2007

D633A106-HXL

737-600/700/800/900  
POWERPLANT BUILDUP MANUAL

ITEM NO.	PART NUMBER	NOMENCLATURE	UC	QTY
24-1		IDG PLUMBING INSTALLATION (FIGURE 24-1, SHEET 3)  THIS SHEET NOT USED		

**71-00-02**

P/P BUILDUP FIGURE 24-1

Page 7

Oct 05/2007

D633A106-HXL



**737-600/700/800/900  
POWERPLANT BUILDUP MANUAL**

**THIS SHEET NOT USED**

**IDG Plumbing Installation  
Figure 24-1 (Sheet 4)**

**71-00-02**

P/P BUILDUP FIGURE 24-1

Page 8

Oct 05/2007

D633A106-HXL

737-600/700/800/900  
POWERPLANT BUILDUP MANUAL

ITEM NO.	PART NUMBER	NOMENCLATURE	UC	QTY
24-1		IDG PLUMBING INSTALLATION (FIGURE 24-1, SHEET 4)  THIS SHEET NOT USED		

**71-00-02**

P/P BUILDUP FIGURE 24-1

Page 9

Oct 05/2007

D633A106-HXL



## POWERPLANT BUILDUP MANUAL

ITEM NO.	PART NUMBER	NOMENCLATURE	UC	QTY
24-1		<b>IDG PLUMBING INSTALLATION (FIGURE 24-1, SHEET 5)</b>  REMOVE PROTECTIVE COVER FROM LOWER NIPPLE ON IDG AIR/OIL COOLER.  POSITION TUBE ASSY (50) UNDER OIL SCAVENGE TUBES AND CFMI WIRE BUNDLES AND LOOSELY CONNECT TUBE NUT TO NIPPLE ON IDG AIR/OIL COOLER.		
50	332A2240-1	. TUBE ASSY		1
55	J1221G10	. CLAMP		1
60	BACB30ZF4-07	. BOLT		1
65	AS3485-10	. NUT		1
		TIGHTEN BOLT (60) TO 110-120 POUND-INCHES (12.4-13.6 NEWTON METERS).		

**71-00-02**

P/P BUILDUP FIGURE 24-1

Page 11

Oct 05/2007

D633A106-HXL

737-600/700/800/900  
**POWERPLANT BUILDUP MANUAL**

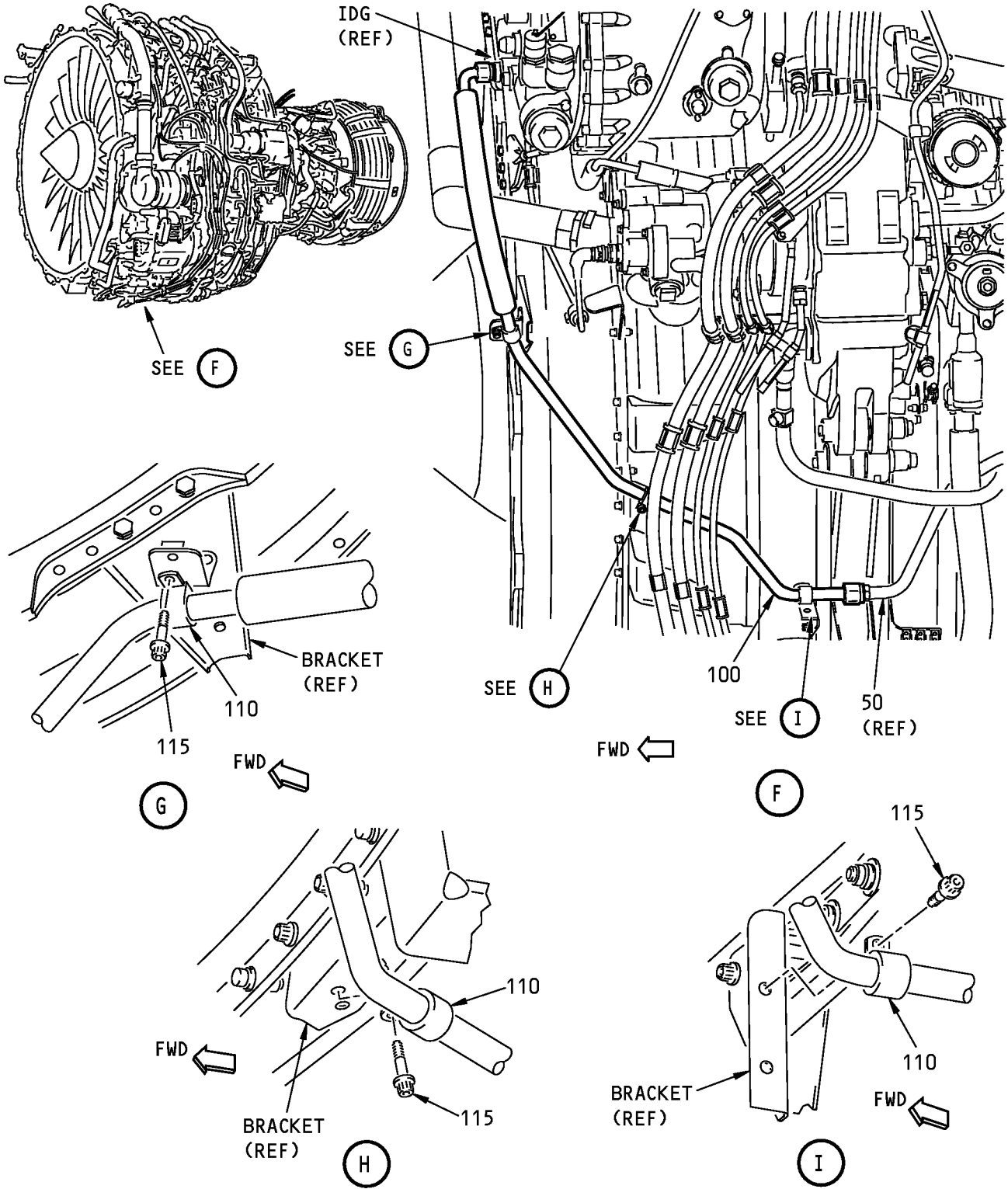

**IDG Plumbing Installation**  
Figure 24-1 (Sheet 6)

**71-00-02**

P/P BUILDUP FIGURE 24-1

Page 12

Oct 05/2007

D633A106-HXL

**737-600/700/800/900  
POWERPLANT BUILDUP MANUAL**

ITEM NO.	PART NUMBER	NOMENCLATURE	UC	QTY
24-1		<b>IDG PLUMBING INSTALLATION (FIGURE 24-1, SHEET 6)</b>		
		LOOSELY ATTACH HOSE/TUBE ASSY (100) TO TUBE ASSY (50) AND TO OIL-OUT NIPPLE (INBOARD LOCATION) ON IDG. HAND TIGHTEN TUBE NUTS ONLY.		
100	115096-4	. IDG HOSE/TUBE ASSY (V78570)	VEN	1
100	S332A240-4	. BOEING SPEC FOR 115096-4	BOE	-
		AT THREE LOCATIONS, LOOSELY ATTACH HOSE/TUBE ASSY (100) TO ENGINE BRACKETS WITH CLAMPS (110) AND BOLTS (115).		
110	J1221G10	. CLAMP		3
115	BACB30ZF4-06	. BOLT		3

# 71-00-02

P/P BUILDUP FIGURE 24-1

Page 13

Oct 05/2007

D633A106-HXL

737-600/700/800/900  
**POWERPLANT BUILDUP MANUAL**

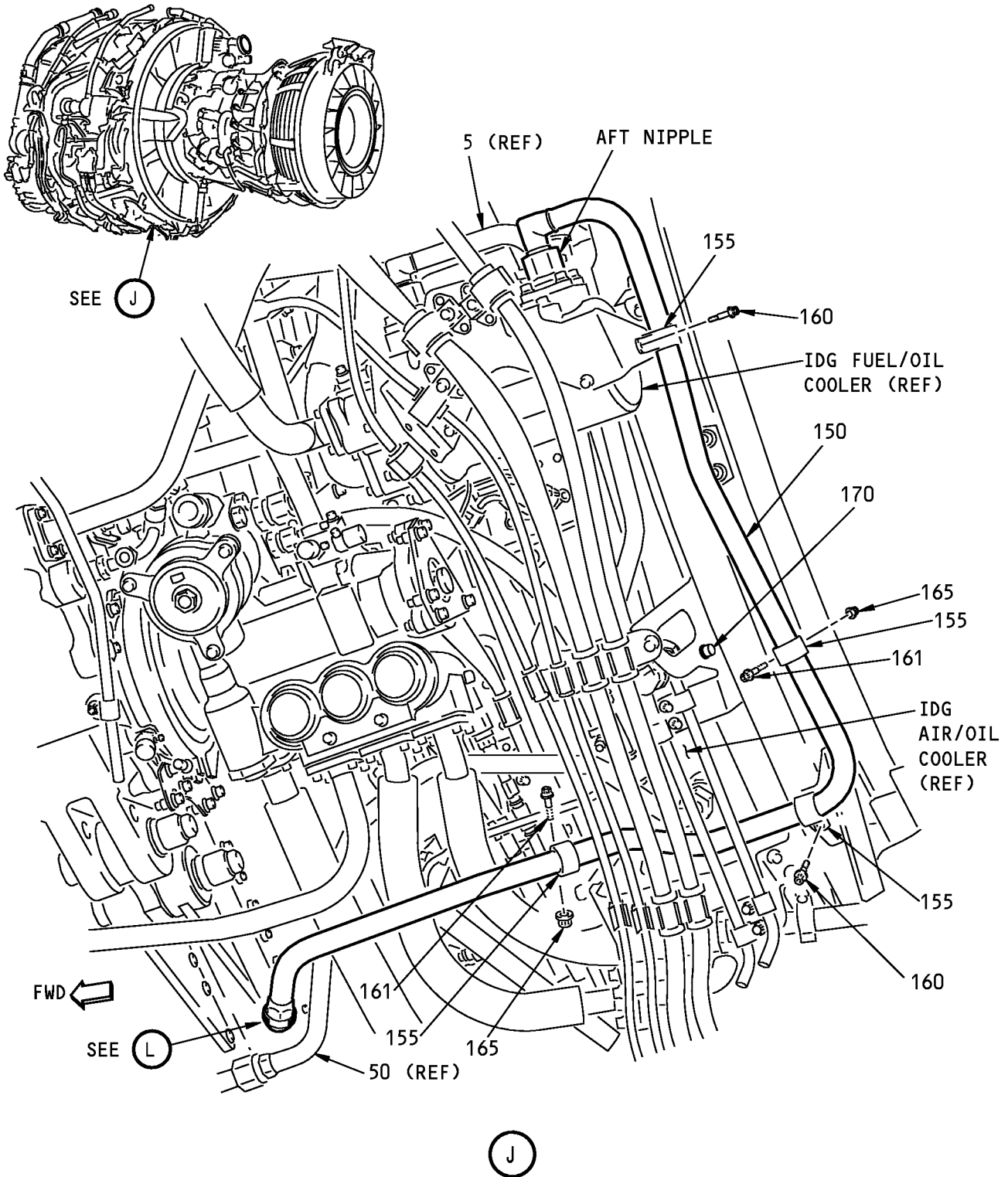

**IDG Plumbing Installation**  
**Figure 24-1 (Sheet 7)**

**71-00-02**

P/P BUILDUP FIGURE 24-1

Page 14

Oct 05/2007

D633A106-HXL

## POWERPLANT BUILDUP MANUAL

ITEM NO.	PART NUMBER	NOMENCLATURE	UC	QTY
24-1		<b>IDG PLUMBING INSTALLATION (FIGURE 24-1, SHEET 7)</b>		
		REMOVE PROTECTIVE COVER FROM AFT NIPPLE OF FUEL/OIL COOLER.		
		LOOSELY ATTACH TUBE ASSY (150) TO AFT NIPPLE ON IDG FUEL/OIL COOLER. HAND TIGHTEN TUBE NUT.		
150	332A2240-11	. TUBE ASSY		1
		AT FOUR LOCATIONS, LOOSELY ATTACH TUBE ASSY (150) TO ENGINE BRACKETS USING CLAMPS (155), BOLTS (160) (161) AND NUTS (165).		
155	J1221G12	. CLAMP		4
160	BACB30ZF4-06	. BOLT		2
161	BACB30ZF4-08	. BOLT		2
165	AS3485-10	. NUT		2
170	BACB30ZF4-07	. BOLT		2

**71-00-02**

P/P BUILDUP FIGURE 24-1

Page 15

Oct 05/2007

D633A106-HXL



**737-600/700/800/900  
POWERPLANT BUILDUP MANUAL**

**THIS SHEET NOT USED**

**IDG Plumbing Installation  
Figure 24-1 (Sheet 8)**

**71-00-02**

P/P BUILDUP FIGURE 24-1

Page 16

Oct 05/2007

D633A106-HXL

**737-600/700/800/900  
POWERPLANT BUILDUP MANUAL**

ITEM NO.	PART NUMBER	NOMENCLATURE	UC	QTY
24-1		IDG PLUMBING INSTALLATION (FIGURE 24-1, SHEET 8)  THIS SHEET NOT USED		

**71-00-02**

P/P BUILDUP FIGURE 24-1

Page 17

Oct 05/2007

D633A106-HXL

737-600/700/800/900  
**POWERPLANT BUILDUP MANUAL**

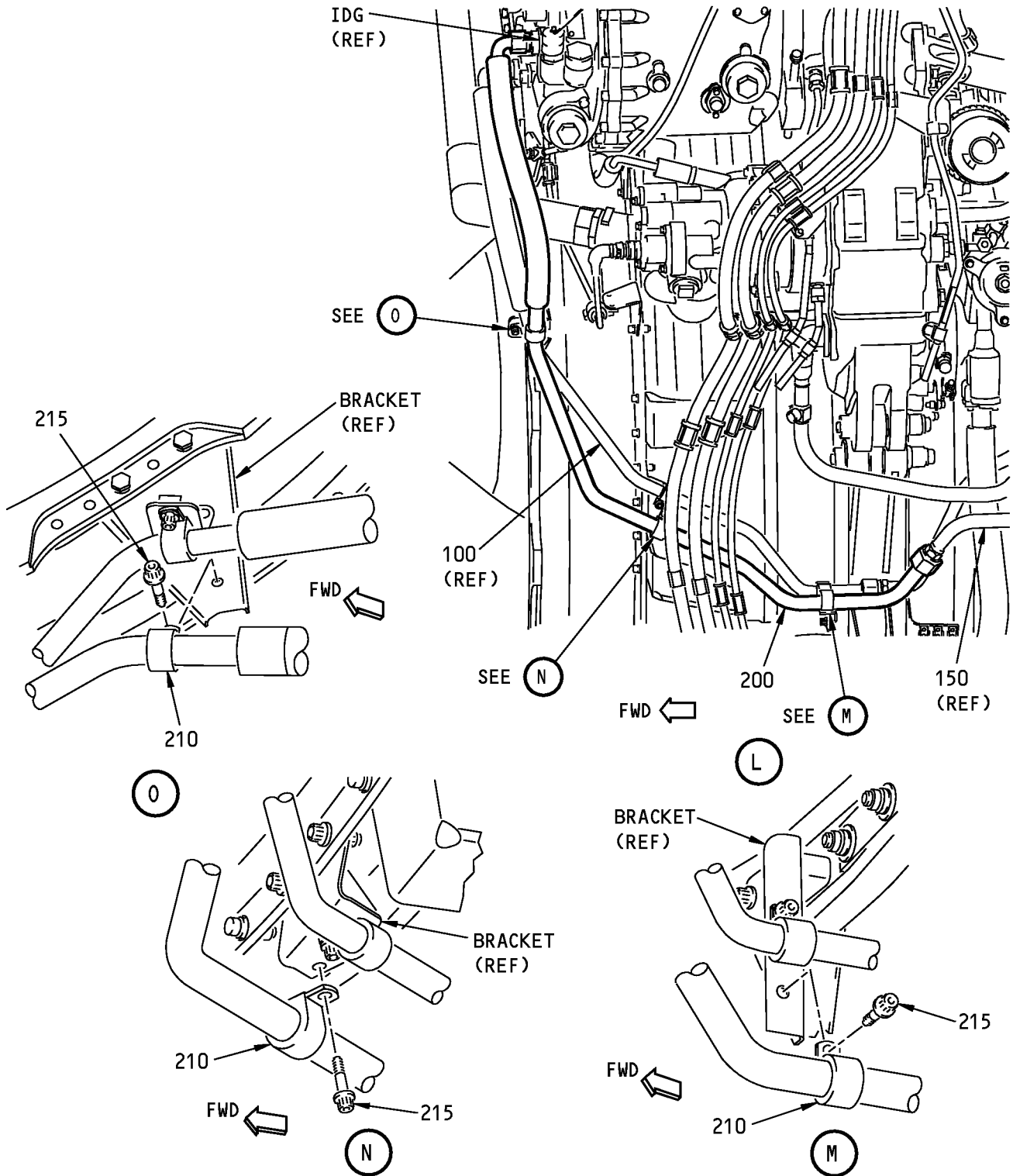

**IDG Plumbing Installation**  
Figure 24-1 (Sheet 9)

**71-00-02**

P/P BUILDUP FIGURE 24-1

Page 18

Oct 05/2007

**737-600/700/800/900  
POWERPLANT BUILDUP MANUAL**

ITEM NO.	PART NUMBER	NOMENCLATURE	UC	QTY
24-1		<b>IDG PLUMBING INSTALLATION (FIGURE 24-1, SHEET 9)</b>		
200	115096-2	LOOSELY ATTACH HOSE/TUBE ASSEMBLY (200) TO TUBE ASSY (150) AND TO OIL-IN NIPPLE (OUTBOARD LOCATION) ON IDG. HAND TIGHTEN TUBE NUTS ONLY.	VEN	1
200	S332A240-2	. IDG HOSE/TUBE ASSY (V78570) . BOEING SPEC FOR 115096-2	BOE	-
210	J1221G12	AT THREE LOCATIONS, LOOSELY ATTACH HOSE/TUBE ASSY (200) TO ENGINE BRACKETS WITH CLAMPS (210) AND BOLTS (215).		3
215	BACB30ZF4-06	. CLAMP . BOLT		3

# 71-00-02

P/P BUILDUP FIGURE 24-1

Page 19

Oct 05/2007

D633A106-HXL

737-600/700/800/900  
**POWERPLANT BUILDUP MANUAL**

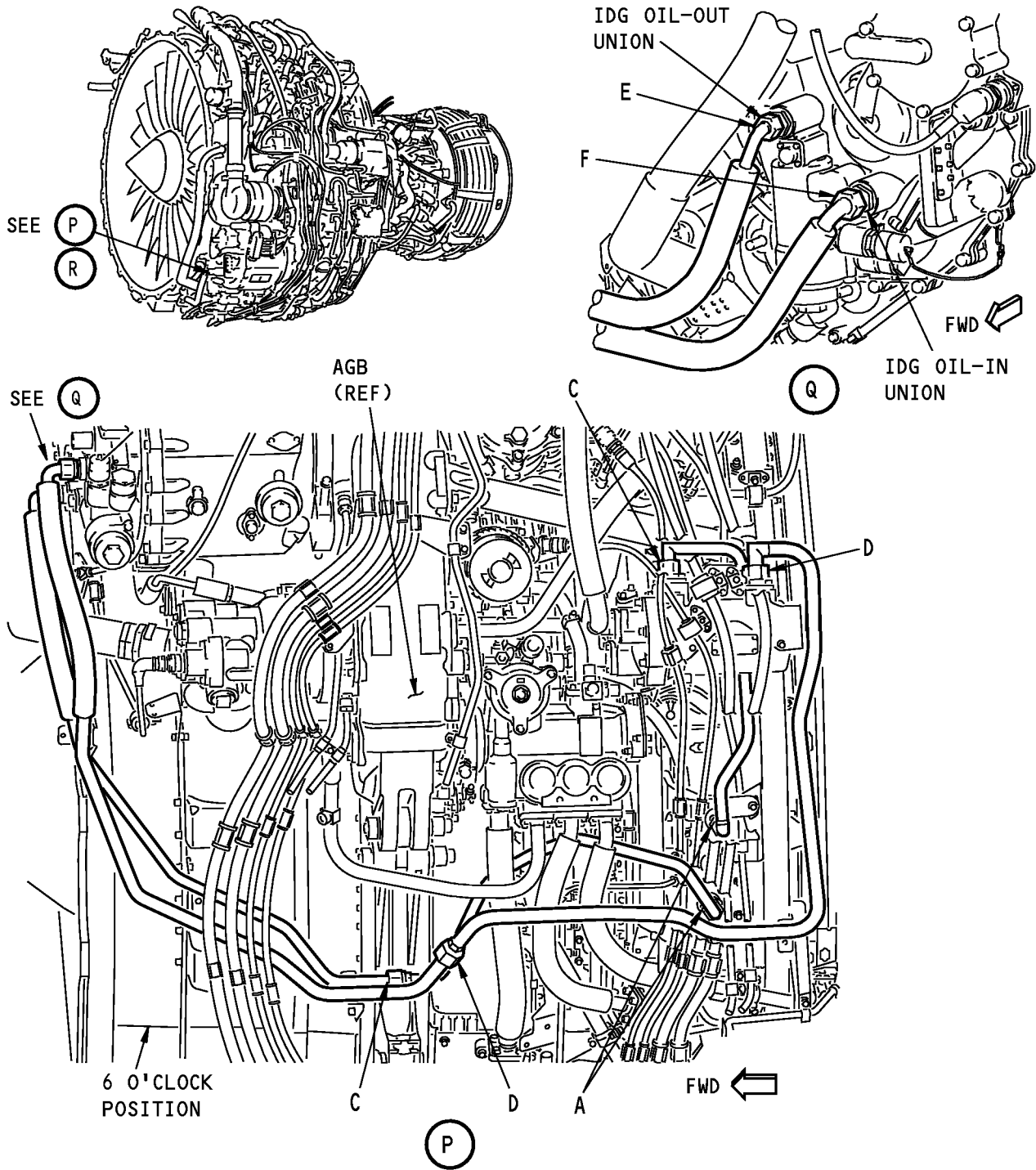

**IDG Plumbing Installation  
Figure 24-1 (Sheet 10)**

**71-00-02**

P/P BUILDUP FIGURE 24-1

Page 20

Oct 05/2007

D633A106-HXL

**737-600/700/800/900  
POWERPLANT BUILDUP MANUAL**

ITEM NO.	PART NUMBER	NOMENCLATURE	UC	QTY
24-1		<p><b>IDG PLUMBING INSTALLATION (FIGURE 24-1, SHEET 10)</b></p> <p>ADJUST ALL TUBES TO BEST POSITION TO MAKE SURE NO PRELOAD FORCE ON TUBES OR VALVE ARE PRESENT.</p> <p>TIGHTEN ALL CONNECTIONS AS FOLLOWS. USE THE LOCATION SHOWN ON THE VIEWS TO TELL YOU WHAT TORQUE VALUE TO APPLY.</p> <p>LOCATION A: TIGHTEN TUBE NUT TO 342-378 POUND-INCHES (38.6-42.7 NEWTON METERS). BACK OFF NUT TO RELAX TORQUE, THEN RETIGHTEN.</p> <p>LOCATION C: TIGHTEN TUBE NUT TO 665-735 POUND-INCHES (75.1-83.0 NEWTON METERS). BACK OFF NUT TO RELAX TORQUE, THEN RETIGHTEN.</p> <p>LOCATION D: TIGHTEN TUBE NUT TO 855-945 POUND-INCHES 96.6-106.8 NEWTON METERS). BACK OFF NUT TO RELAX TORQUE, THEN RETIGHTEN.</p> <p>LOCATION E: TIGHTEN TUBE NUT TO 475-525 POUND-INCHES 53.7-59.3 NEWTON METERS). USE BACKUP WRENCH ON IDG UNION TO PREVENT TORQUE TRANSFER. BACK OFF NUT TO RELAX TORQUE, THEN RETIGHTEN.</p> <p>LOCATION F: TIGHTEN TUBE NUT TO 665-735 POUND-INCHES 75.1-83.0 NEWTON METERS). USE BACKUP WRENCH ON IDG UNION TO PREVENT TORQUE TRANSFER. BACK OFF NUT TO RELAX TORQUE, THEN RETIGHTEN.</p>		

**71-00-02**

P/P BUILDUP FIGURE 24-1

Page 21

Oct 05/2007

D633A106-HXL

737-600/700/800/900  
**POWERPLANT BUILDUP MANUAL**

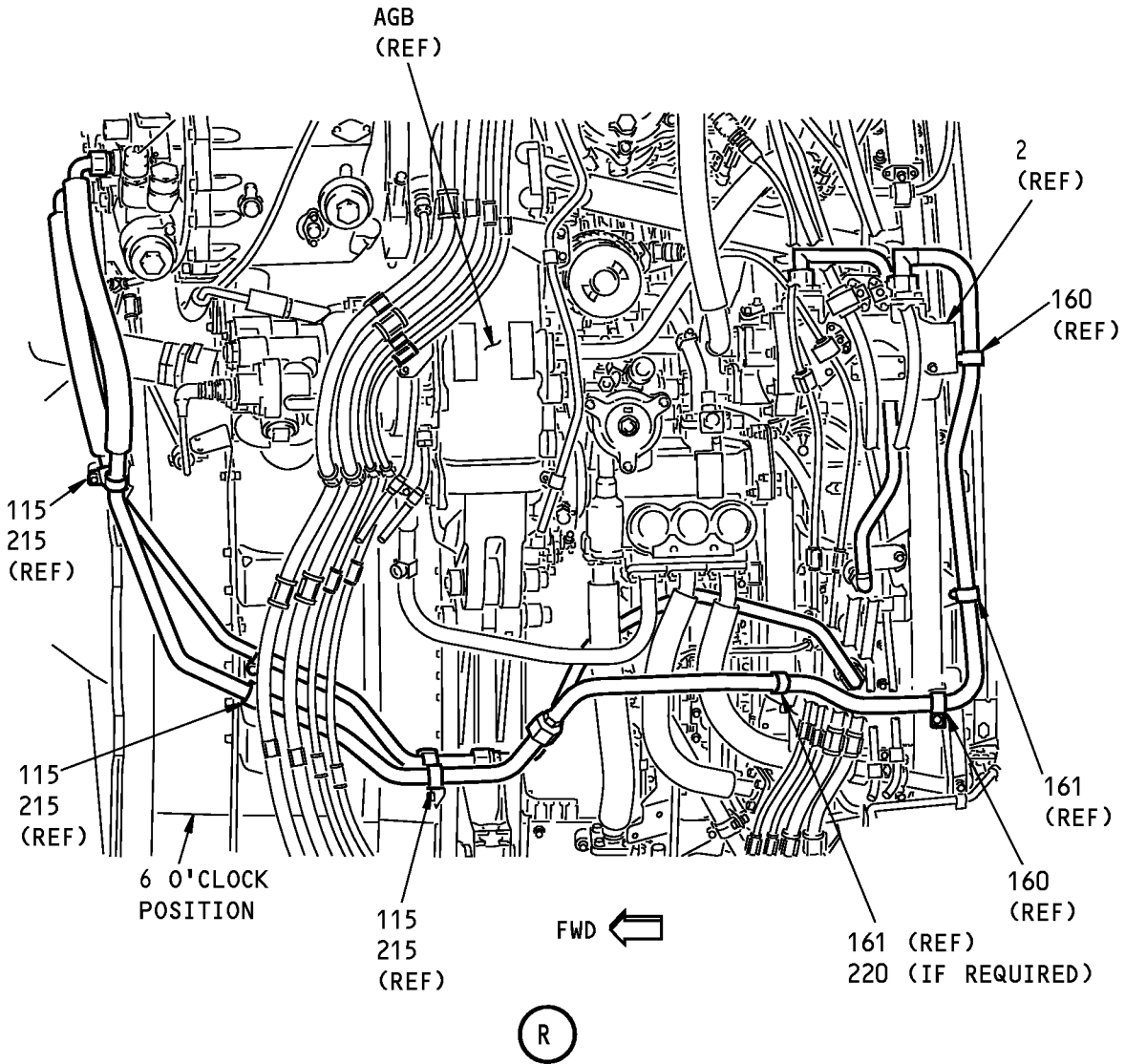

**IDG Plumbing Installation**  
**Figure 24-1 (Sheet 11)**

**71-00-02**

P/P BUILDUP FIGURE 24-1

Page 22

Oct 05/2007

D633A106-HXL





**FIGURE 25-1**

# **STARTER VALVE AND DUCT INSTALLATION**

**REF QEC TASK NO.: 25**

**REF DWG: 332A2300**

**NOTE:** ALL STANDARDS AND ATTACHING HARDWARE FOR THIS FIGURE WILL BE PACKAGED IN QEC TASK NO. 110.

**71-00-02**

P/P BUILDUP FIGURE 25-1

Page 1

Oct 05/2007

D633A106-HXL

**737-600/700/800/900  
POWERPLANT BUILDUP MANUAL**

**THIS SHEET NOT USED**

**Starter Valve and Duct Installation  
Figure 25-1 (Sheet 1)**

**71-00-02**

P/P BUILDUP FIGURE 25-1

Page 2

Oct 05/2007

D633A106-HXL

**737-600/700/800/900  
POWERPLANT BUILDUP MANUAL**

ITEM NO.	PART NUMBER	NOMENCLATURE	UC	QTY
25-1		<b>STARTER VALVE AND DUCT INSTALLATION (FIGURE 25-1, SHEET 1)</b> THIS SHEET NOT USED		

**71-00-02**

P/P BUILDUP FIGURE 25-1

Page 3

Oct 05/2007

D633A106-HXL

737-600/700/800/900  
**POWERPLANT BUILDUP MANUAL**

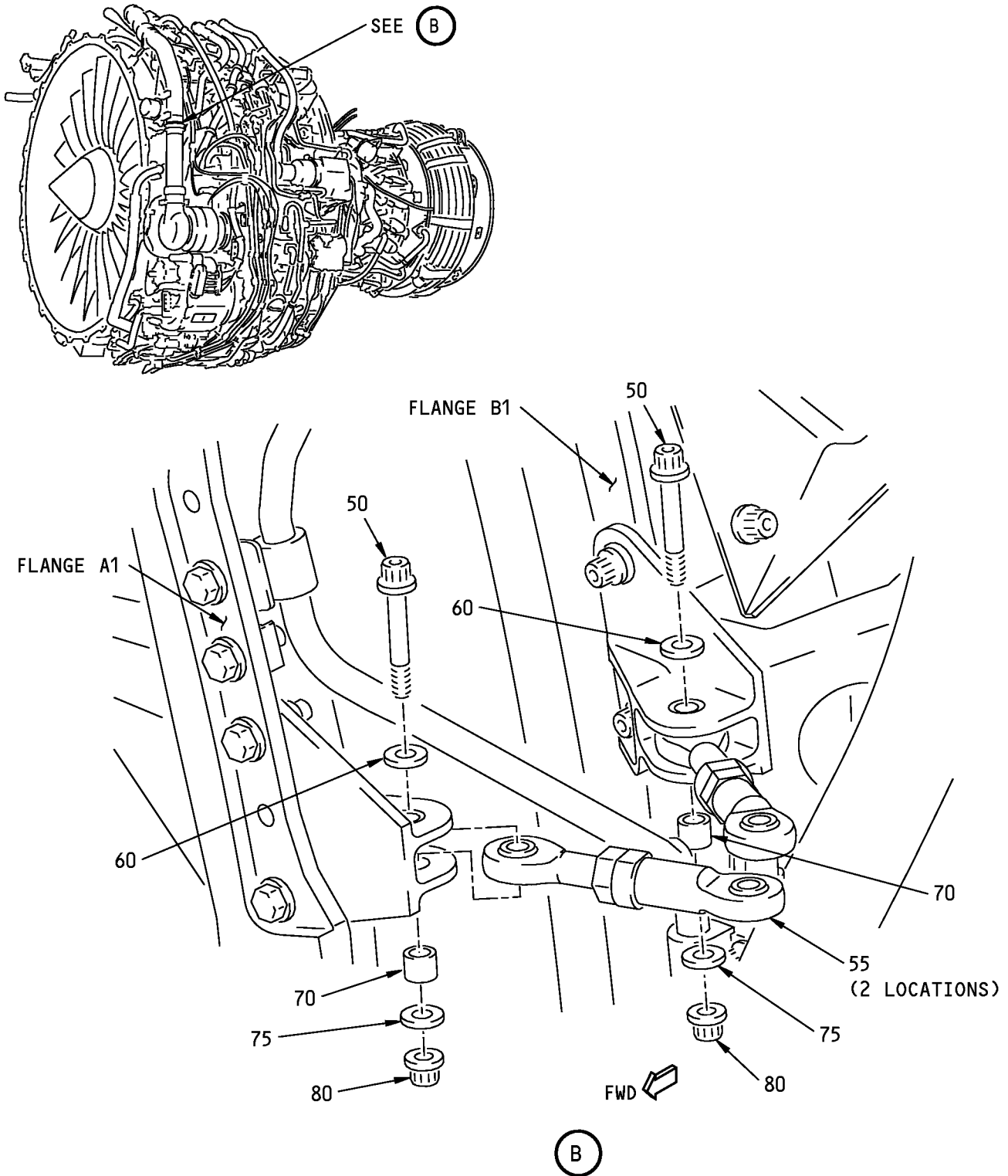

**Starter Valve and Duct Installation**  
**Figure 25-1 (Sheet 2)**

**71-00-02**

P/P BUILDUP FIGURE 25-1

Page 4

Oct 05/2007

D633A106-HXL

**737-600/700/800/900  
POWERPLANT BUILDUP MANUAL**

ITEM NO.	PART NUMBER	NOMENCLATURE	UC	QTY
25-1		<b>STARTER VALVE AND DUCT INSTALLATION (FIGURE 25-1, SHEET 2)</b>		
		LUBRICATE THREADS AND SHANK OF BOLTS (50) WITH Never-Seez NSBT-8N compound, D00006 (C1).		
50	BACB30PN4-14	. BOLT		2
C1	D00006	. COMPOUND, NEVER-SEEZ NSBT-8N	CON	AR
		LOOSEN JAMNUTS OF LINK ASSEMBLIES (55) TO FREE ROD ENDS. ADJUST LINKS TO 3.00 INCHES (7.62 CM) MEASURED FROM THE CENTERLINE OF SPHERICAL BEARINGS. RETIGHTEN JAMNUTS.		
		ATTACH LINK ASSEMBLIES (55) TO ENGINE BRACKETS AT 10:30 O'CLOCK POSITIONS ON FLGS A1 AND B1 WITH LUBRICATED BOLTS (50), WASHERS (60) AND (75), BUSHINGS (70) AND NUTS (80).		
55	322U2338-2	. LINK ASSY		2
60	BACW10BP4ACU	. WASHER (CSK) (UNDER BOLTHEAD)		2
70	BACB28AK04-030	. BUSHING		2
75	NAS1149C0432R	. WASHER (UNDER NUT)		2
80	AS3485-10	. NUT		2
		<b>CAUTION:</b> BEFORE TIGHTENING NUT, MAKE SURE BUSHING IS FULLY ENGAGED.		
		TIGHTEN BOLTS (50) TO 50-75 POUND-INCHES (5.6-8.5 NEWTON METERS).		

# 71-00-02

P/P BUILDUP FIGURE 25-1

Page 5

Oct 05/2007

D633A106-HXL

737-600/700/800/900  
**POWERPLANT BUILDUP MANUAL**

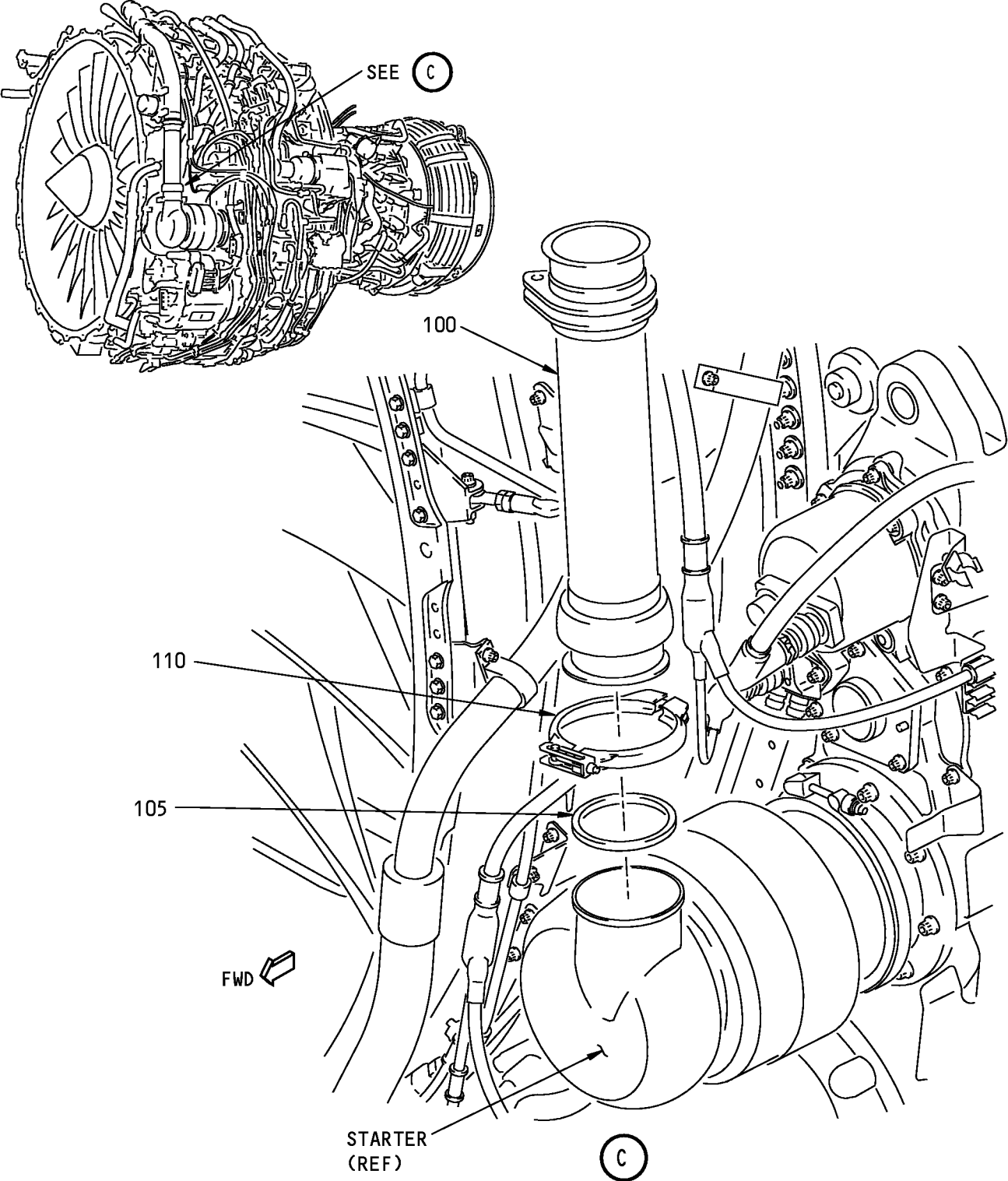

**Starter Valve and Duct Installation**  
**Figure 25-1 (Sheet 3)**

**71-00-02**

P/P BUILDUP FIGURE 25-1

Page 6

Oct 05/2007

D633A106-HXL

**737-600/700/800/900  
POWERPLANT BUILDUP MANUAL**

ITEM NO.	PART NUMBER	NOMENCLATURE	UC	QTY
25-1		<p><b>STARTER VALVE AND DUCT INSTALLATION (FIGURE 25-1, SHEET 3)</b></p> <p>INSTALL SEAL (105) IN BOTTOM END OF DUCT ASSY (100). POSITION DUCT (100) ON TOP PORT OF STARTER ALIGNING KEY-SLOT IN DUCT WITH KEY ON STARTER AND LOOSELY SECURE WITH COUPLING (110).</p> <p><b>NOTE:</b> DO NOT TIGHTEN COUPLING AT THIS TIME.</p> <p><b>NOTE:</b> EARLIER STARTERS MAY NOT HAVE KEY.</p>		
100	332A2313-1	. DUCT ASSY		1
105	AS1895-7-325	. SEAL		1
110	AS1895-4-325	. COUPLING		1

**71-00-02**

P/P BUILDUP FIGURE 25-1

Page 7

Oct 05/2007

D633A106-HXL

737-600/700/800/900  
**POWERPLANT BUILDUP MANUAL**

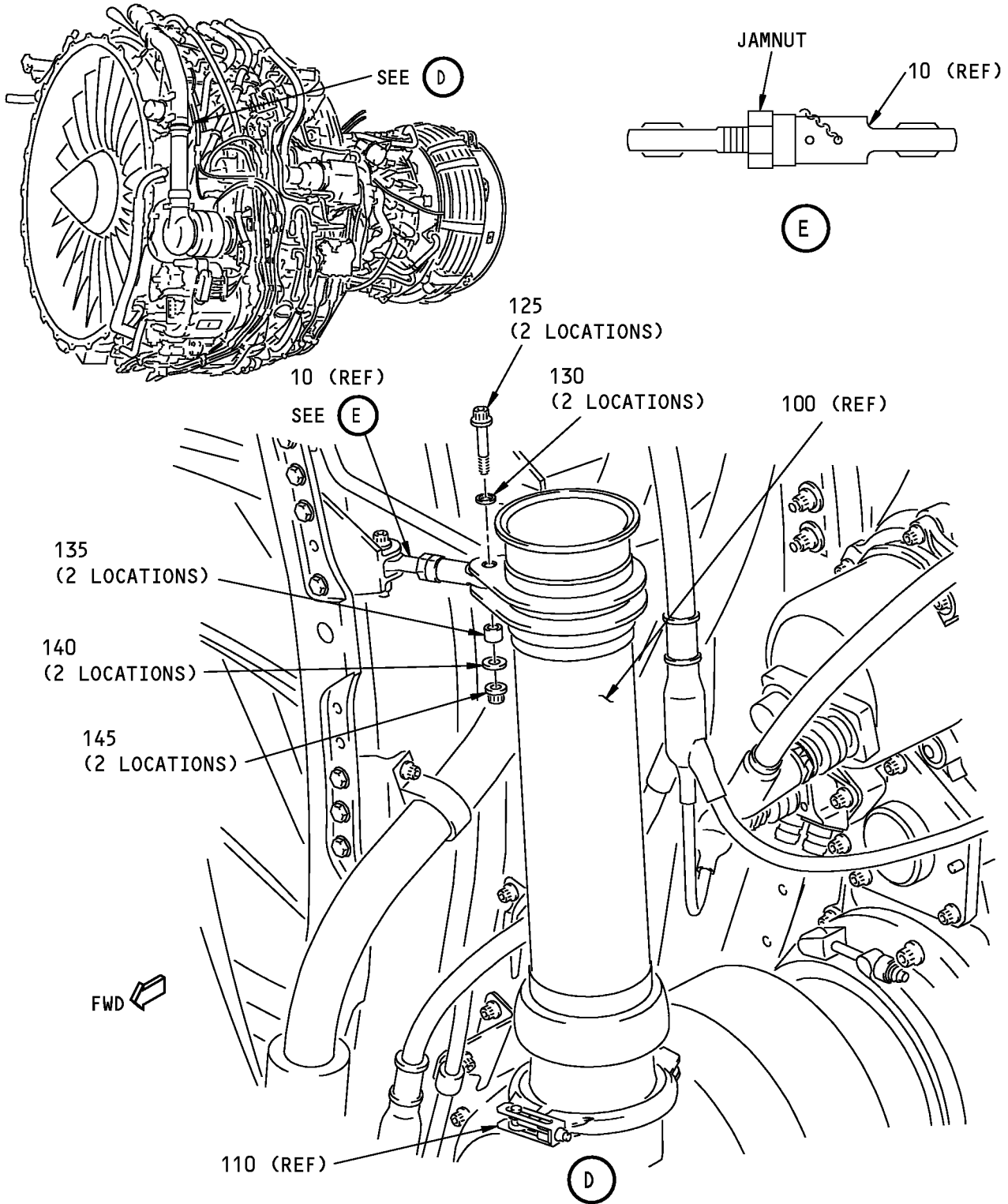

**Starter Valve and Duct Installation**  
**Figure 25-1 (Sheet 4)**

**71-00-02**

P/P BUILDUP FIGURE 25-1

Page 8

Oct 05/2007

D633A106-HXL



**737-600/700/800/900**  
**POWERPLANT BUILDUP MANUAL**

ITEM NO.	PART NUMBER	NOMENCLATURE	UC	QTY
25-1		<b>STARTER VALVE AND DUCT INSTALLATION (FIGURE 25-1, SHEET 4)</b>		
		LUBRICATE THREADS AND SHANK OF BOLTS (125) WITH Never-Seez NSBT-8N compound, D00006 (C1).		
125	BACB30PN4-14	. BOLT		2
C1	D00006	. COMPOUND, NEVER-SEEZ NSBT-8N	CON	AR
		SECURE LINKS (10) TO DUCT ASSY (100) WITH BOLTS (125), WASHERS (130) AND (140), BUSHINGS (135) AND NUTS (145).		
		<b>NOTE:</b> MAKE SURE LINK(S) DO NOT APPLY PRELOAD TO ADJACENT DUCT OR SUPPORT HARDWARE. IF NECESSARY, ADJUST LINK(S) BY LOOSENING JAMNUT ON EACH LINK TO FREE ROD END. ADJUST AS NECESSARY AND RETIGHTEN JAMNUT.		
130	BACW10BP4ACU	. WASHER (CSK) (UNDER BOLTHEAD)		2
135	BACB28AK04-030	. BUSHING		2
140	NAS1149C0432R	. WASHER (UNDER NUT)		2
145	AS3485-10	. NUT		2
		<b>CAUTION:</b> BEFORE TIGHTENING NUT, MAKE SURE BUSHING IS FULLY ENGAGED.		
		TIGHTEN BOLTS (125) TO 50-75 POUND-INCHES (5.6-8.5 NEWTON METERS).		
		APPLY lockwire, G01912 (C2) OR safety cable kit, G50375 (C3) BETWEEN JAMNUT AND FEMALE SIDE OF LINKS (10).		
C2	G01912	. LOCKWIRE, MS20995NC32	CON	AR
C3	G50375	. SAFETY CABLE, BACC13AT3K18	CON	2
		ORIENT HEAD OF COUPLING (110) UNTIL LATCH FACES FORWARD. TIGHTEN COUPLING (110) TO TORQUE SPECIFIED ON PART. LIGHTLY TAP OUTER SURFACE OF COUPLING (110) WITH NON-METALLIC Mallet. RETIGHTEN COUPLING (110) TO TORQUE GIVEN ON PART.		

# 71-00-02

P/P BUILDUP FIGURE 25-1

Page 9

Feb 05/2008

D633A106-HXL

737-600/700/800/900  
**POWERPLANT BUILDUP MANUAL**

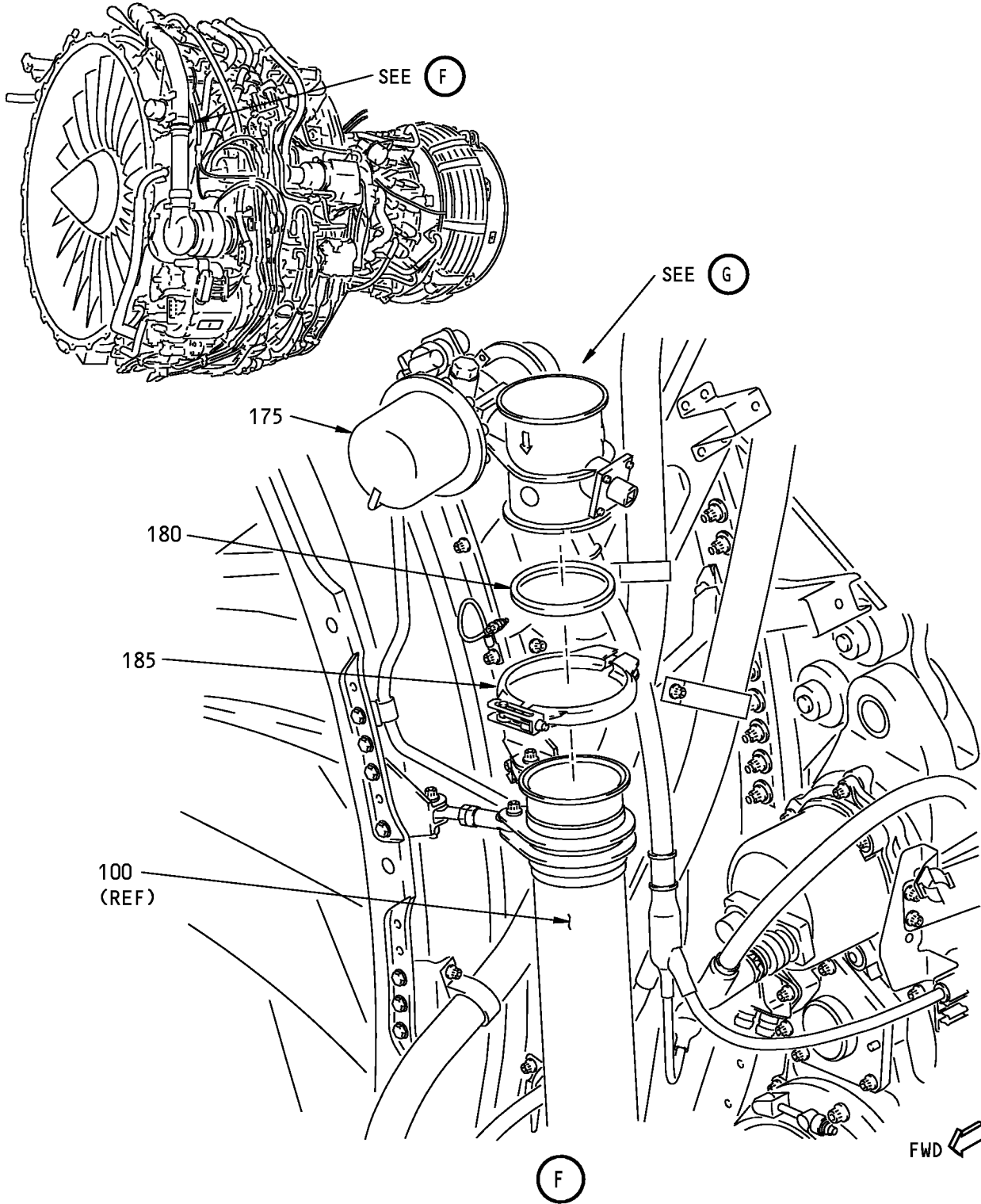

**Starter Valve and Duct Installation**  
**Figure 25-1 (Sheet 5)**

**71-00-02**

P/P BUILDUP FIGURE 25-1  
Page 10  
Oct 05/2007

D633A106-HXL

**737-600/700/800/900  
POWERPLANT BUILDUP MANUAL**

ITEM NO.	PART NUMBER	NOMENCLATURE	UC	QTY
25-1		<p><b>STARTER VALVE AND DUCT INSTALLATION (FIGURE 25-1, SHEET 5)</b></p> <p>ATTACH SEAL (180) ON BOTTOM PORT OF START VALVE (175) AND INSTALL VALVE ON DUCT ASSY (100). MAKE SURE KEY-SLOT IN VALVE FLANGE MATES WITH KEY ON DUCT FLANGE.</p> <p><b>CAUTION:</b> DO NOT TORQUE COUPLING TO MORE THAN THAT SPECIFIED ON THE PART. OVERTORQUING OF THE COUPLING CAN CAUSE DAMAGE TO START VALVE.</p> <p>SECURE START VALVE (175) TO DUCT ASSY (100) WITH COUPLING (185). TIGHTEN COUPLING (185) TO TORQUE SPECIFIED ON PART. LIGHTLY TAP OUTER SURFACE OF COUPLING (185) WITH NON-METALLIC MALLET. RETIGHTEN COUPLING (185) TO TORQUE GIVEN ON PART.</p>		
175	3289630-2	. START VALVE (V59364)	VEN	1
175	S332A002-2	. BOEING SPEC FOR 3289630-2	BOE	-
180	AS1895-7-300	. SEAL		1
185	30645-300	. COUPLING		1
185	VR1030-300	. COUPLING (OPTIONAL TO 30645-300)	OPT	-

**71-00-02**

P/P BUILDUP FIGURE 25-1

Page 11

Oct 05/2007

D633A106-HXL

737-600/700/800/900  
**POWERPLANT BUILDUP MANUAL**

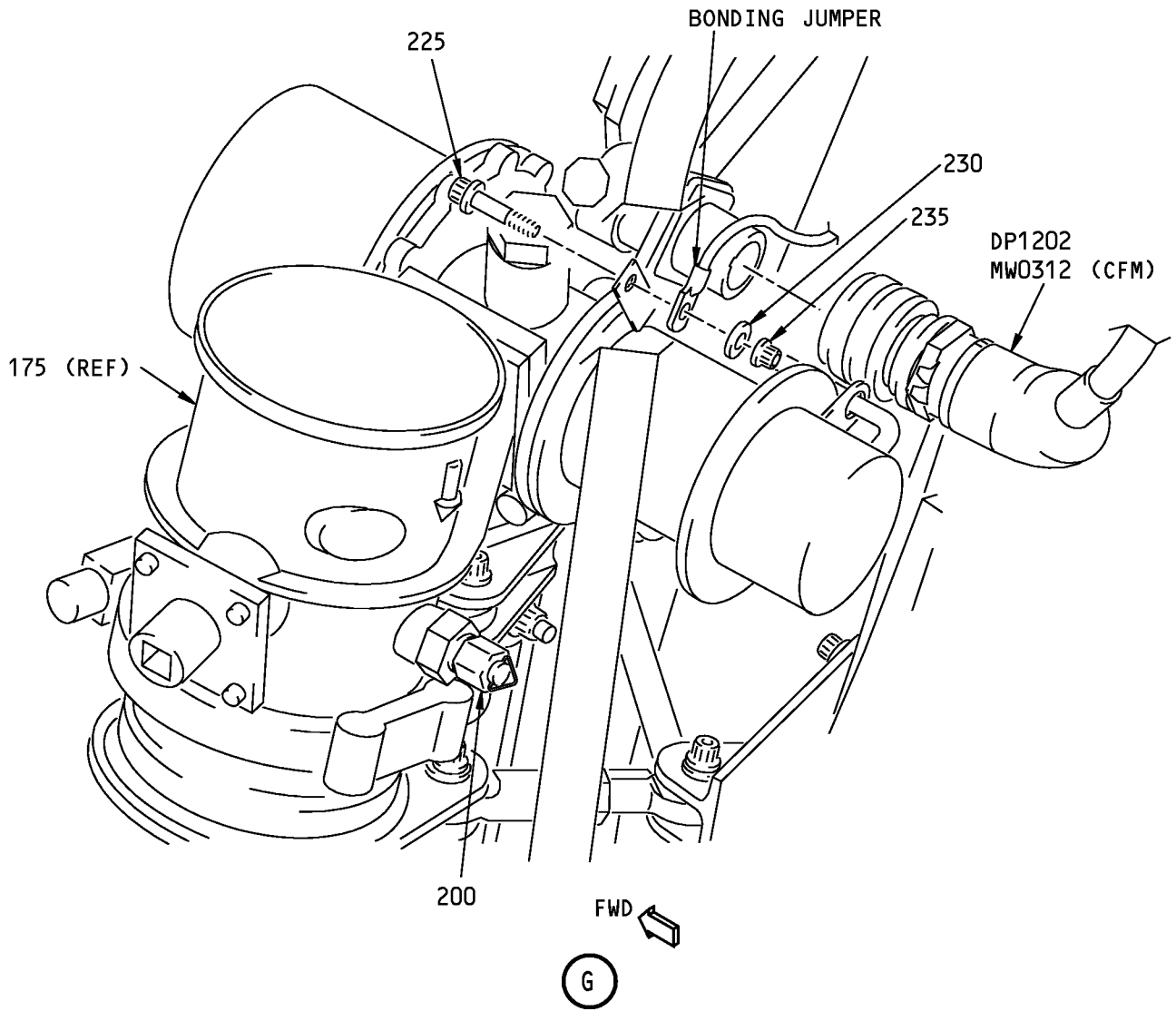

**Starter Valve and Duct Installation**  
**Figure 25-1 (Sheet 6)**

**71-00-02**

P/P BUILDUP FIGURE 25-1

Page 12

Oct 05/2007

D633A106-HXL

**737-600/700/800/900  
POWERPLANT BUILDUP MANUAL**

ITEM NO.	PART NUMBER	NOMENCLATURE	UC	QTY
25-1		<b>STARTER VALVE AND DUCT INSTALLATION (FIGURE 25-1, SHEET 6)</b>		
		MAKE SURE PRESSURE CAP IS INSTALLED ON DOWNSTREAM SENSE CONNECTION OF START VALVE. IF CAP IS MISSING, INSTALL ITEM (200).		
200	MS21914-4J	. PRESSURE CAP (1 REQD)	REF	-
200	BACC14AD04J	. PRESSURE CAP (OPTIONAL TO MS21914-4J)	OPT	-
		ATTACH BONDING JUMPER FROM FLG B1 TO START VALVE (175) WITH ITEMS (225) THRU (235).		
225	BACB30ZF3-06	. BOLT		1
230	NAS1149C0316R	. WASHER (UNDER NUT)		1
235	AS3485-09	. NUT		1
		TIGHTEN BOLT (225) TO 50-56 POUNDS-INCHES (5.6-6.3 NEWTON METERS).		
		CHECK RESISTANCE BETWEEN START VALVE HOUSING AND ENGINE BRACKET. MAX RESISTANCE IS 0.008 OHMS.		
		<b>CAUTION:</b> DO NOT OVERTIGHTEN THE PLUG COUPLING RING. DO NOT USE WATER PUMP PLIERS, PIPE WRENCHES OR VISE GRIPS TO TIGHTEN THE COUPLING RING OR DAMAGE TO THE ELECTRICAL CONNECTOR CAN OCCUR.		
		CONNECT MW0312 ELECTRICAL CONNECTOR, DP1202, TO START VALVE. TURN KNURLED COUPLING RING WHILE WIGGLING BACKSHELL ASSEMBLY. AFTER FULLY SEATING COUPLING RING, USE SOFT-JAWED PLIERS OR STRAP WRENCH TO TIGHTEN COUPLING RING AN ADDITIONAL 1/8 TURN OR UNTIL PLIER SLIPPAGE OCCURS.		

# 71-00-02

P/P BUILDUP FIGURE 25-1

Page 13

Oct 05/2007

D633A106-HXL

737-600/700/800/900  
**POWERPLANT BUILDUP MANUAL**

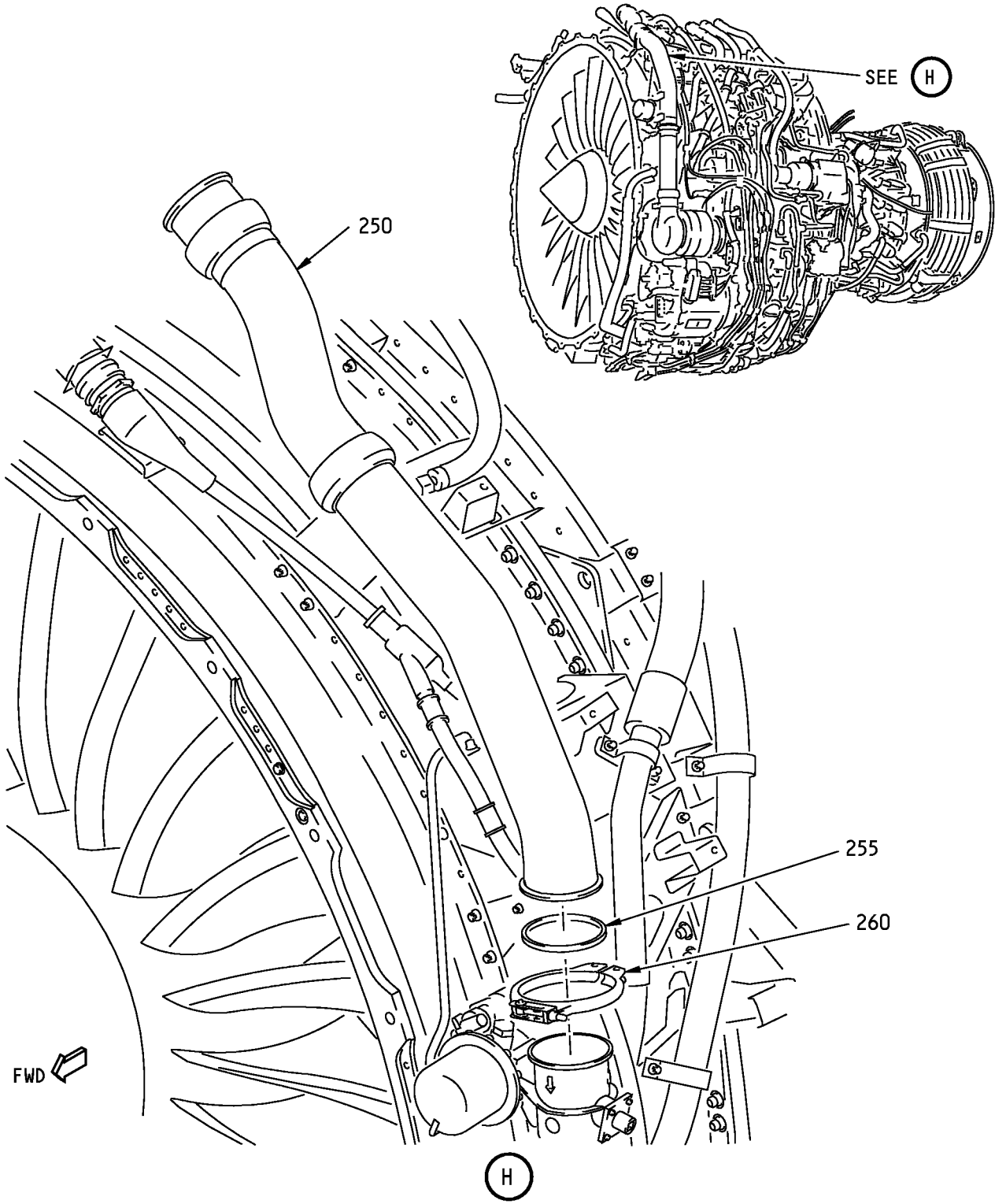

**Starter Valve and Duct Installation**  
**Figure 25-1 (Sheet 7)**

**71-00-02**

P/P BUILDUP FIGURE 25-1  
Page 14  
Oct 05/2007

D633A106-HXL

**737-600/700/800/900  
POWERPLANT BUILDUP MANUAL**

ITEM NO.	PART NUMBER	NOMENCLATURE	UC	QTY
25-1		<b>STARTER VALVE AND DUCT INSTALLATION (FIGURE 25-1, SHEET 7)</b>  INSTALL SEAL (255) IN BOTTOM END OF DUCT ASSY (250). POSITION DUCT (250) ON TOP PORT OF START VALVE AND LOOSELY SECURE WITH COUPLING (260).  <b>NOTE:</b> DO NOT TIGHTEN COUPLING AT THIS TIME.		
250	332A2310-4	. DUCT ASSY		1
255	AS1895-7-300	. SEAL		1
260	30645-300	. COUPLING		1
260	VR1030-300	. COUPLING (OPTIONAL TO 30645-300)	OPT	-

# 71-00-02

P/P BUILDUP FIGURE 25-1

Page 15

Oct 05/2007

D633A106-HXL

**737-600/700/800/900  
POWERPLANT BUILDUP MANUAL**

**THIS SHEET NOT USED**

**Starter Valve and Duct Installation  
Figure 25-1 (Sheet 8)**

**71-00-02**

P/P BUILDUP FIGURE 25-1

Page 16

Oct 05/2007

D633A106-HXL



**737-600/700/800/900  
POWERPLANT BUILDUP MANUAL**

ITEM NO.	PART NUMBER	NOMENCLATURE	UC	QTY
25-1		<b>STARTER VALVE AND DUCT INSTALLATION (FIGURE 25-1, SHEET 8)</b>  THIS SHEET NOT USED		

**71-00-02**

P/P BUILDUP FIGURE 25-1

Page 17

Oct 05/2007

D633A106-HXL

737-600/700/800/900  
**POWERPLANT BUILDUP MANUAL**

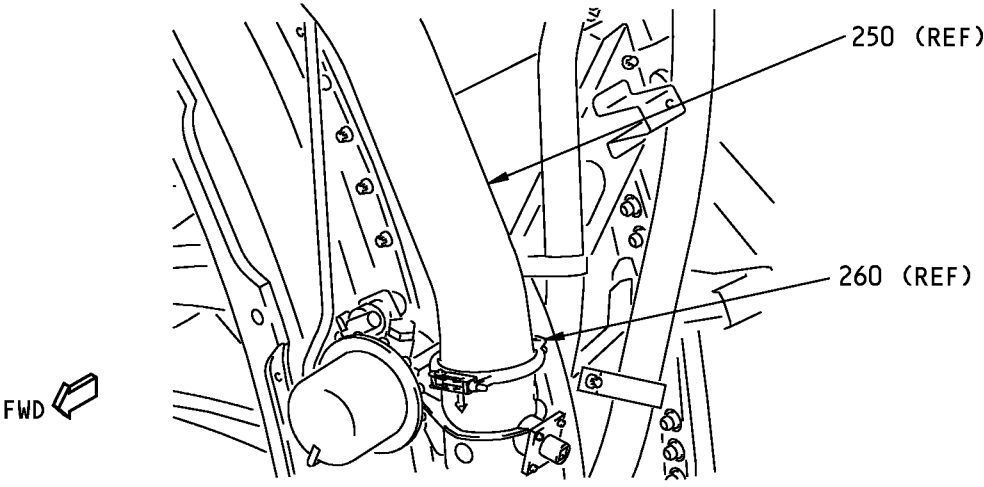
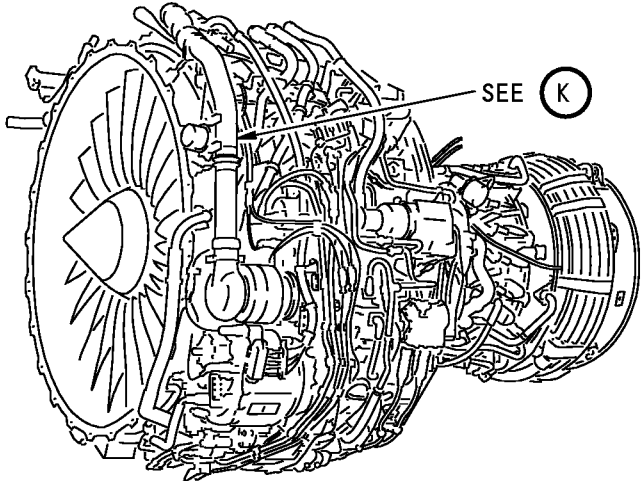

(K)

**Starter Valve and Duct Installation**  
**Figure 25-1 (Sheet 9)**

**71-00-02**

**737-600/700/800/900  
POWERPLANT BUILDUP MANUAL**

ITEM NO.	PART NUMBER	NOMENCLATURE	UC	QTY
25-1		<p><b>STARTER VALVE AND DUCT INSTALLATION (FIGURE 25-1, SHEET 9)</b></p> <p><b>CAUTION:</b> DO NOT TORQUE COUPLING TO MORE THAN THAT SPECIFIED ON THE PART. OVERTORQUING OF THE COUPLING CAN CAUSE DAMAGE TO START VALVE.</p> <p>ORIENT HEAD OF COUPLING (260) UNTIL LATCH FACES FORWARD. TIGHTEN COUPLING (260) TO TORQUE SPECIFIED ON PART. LIGHTLY TAP OUTER SURFACE OF COUPLING (260) WITH NON-METALLIC MALLET. RETIGHTEN COUPLING (260) TO TORQUE GIVEN ON PART.</p>		

**71-00-02**

P/P BUILDUP FIGURE 25-1

Page 19

Oct 05/2007

D633A106-HXL

737-600/700/800/900  
POWERPLANT BUILDUP MANUAL

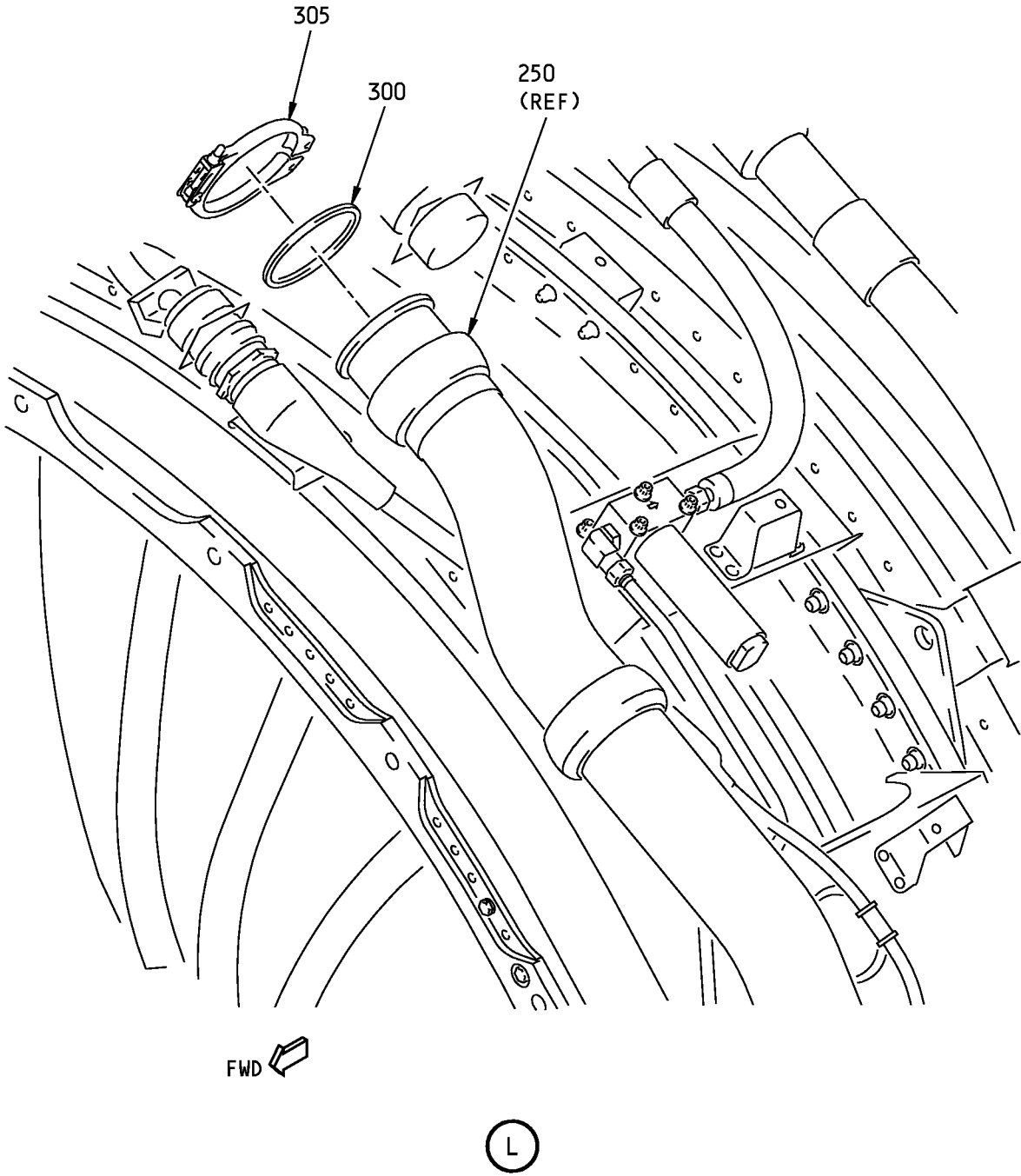

Starter Valve and Duct Installation  
Figure 25-1 (Sheet 10)

**71-00-02**

P/P BUILDUP FIGURE 25-1  
Page 20  
Oct 05/2007

D633A106-HXL

**737-600/700/800/900  
POWERPLANT BUILDUP MANUAL**

ITEM NO.	PART NUMBER	NOMENCLATURE	UC	QTY
25-1		<b>STARTER VALVE AND DUCT INSTALLATION (FIGURE 25-1, SHEET 10)</b>  PUT ITEMS (300) AND (305) IN A BAG AND SECURE TO DUCT ASSY (250).		
300	AS1895-7-300	. SEAL		1
305	30645-300	. COUPLING		1
305	VR1030-300	. COUPLING (OPTIONAL TO 30645-300)	OPT	-

# 71-00-02

P/P BUILDUP FIGURE 25-1

Page 21

Oct 05/2007

D633A106-HXL

FIGURE 26-1

**THIS FIGURE NOT USED**

**71-00-02**

P/P BUILDUP FIGURE 26-1

Page 1

Oct 05/2007

D633A106-HXL

**737-600/700/800/900  
POWERPLANT BUILDUP MANUAL**

**THIS SHEET NOT USED**

**THIS SHEET NOT USED  
Figure 26-1 (Sheet 1)**

**71-00-02**

P/P BUILDUP FIGURE 26-1

Page 2

Oct 05/2007

D633A106-HXL

737-600/700/800/900  
POWERPLANT BUILDUP MANUAL

ITEM NO.	PART NUMBER	NOMENCLATURE	UC	QTY
26-1		THIS SHEET NOT USED (FIGURE 26-1, SHEET 1)  THIS SHEET NOT USED		

**71-00-02**

P/P BUILDUP FIGURE 26-1

Page 3

Oct 05/2007

D633A106-HXL



**FIGURE 27-1**

# **INLET COWL TAI SYSTEM INSTALLATION**

**REF QEC TASK NO.: 27**

**REF DWG: 332A2300**

**NOTE:** ALL STANDARDS AND ATTACHING HARDWARE FOR THIS FIGURE WILL BE PACKAGED IN QEC TASK NO. 110.

**71-00-02**

P/P BUILDUP FIGURE 27-1

Page 1

Oct 05/2007

D633A106-HXL

737-600/700/800/900  
POWERPLANT BUILDUP MANUAL

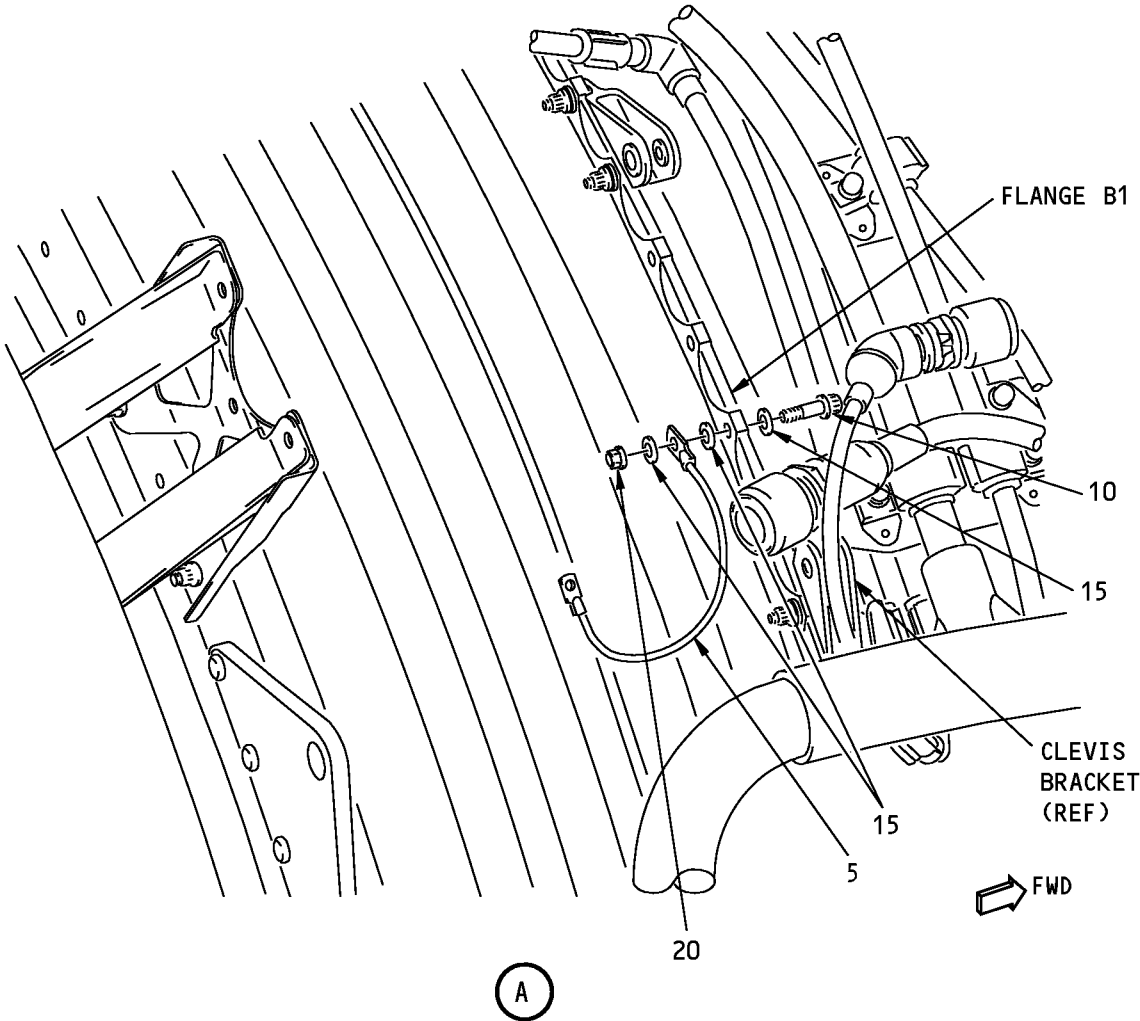
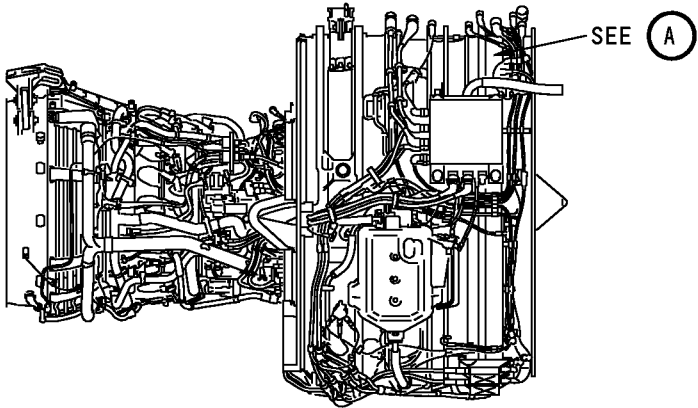

Inlet Cowling TAI System Installation  
Figure 27-1 (Sheet 1)

**71-00-02**

P/P BUILDUP FIGURE 27-1

Page 2

Oct 05/2007

D633A106-HXL

**737-600/700/800/900  
POWERPLANT BUILDUP MANUAL**

ITEM NO.	PART NUMBER	NOMENCLATURE	UC	QTY
27-1		<p><b>INLET COWL TAI SYSTEM INSTALLATION (FIGURE 27-1, SHEET 1)</b></p> <p>LOCATE 2ND HOLE UP FROM LOWER CLEVIS BRACKET ON FLANGE B1. USE Scotchbrite abrasive, G00251 (C1) TO REMOVE ANODIZED COATING AROUND HOLE. CONTINUE UNTIL BRIGHT ALUMINUM BONDING SURFACE IS VISIBLE. AFTER COATING HAS BEEN REMOVED, CLEAN SURFACE OF FLANGE AND MATING SURFACE OF BONDING JUMPER (5) WITH alcohol, B00130 (C2).</p> <p><b>NOTE:</b> REMOVE ONLY A MINIMUM AMOUNT OF ALUMINUM.</p>		
5	BACJ40AC54-9	. BONDING JUMPER		1
C1	G00251	. ABRASIVE, MIL-A-9962	CON	AR
C2	B00130	. SOLVENT, TT-I-735	CON	AR
		<p>SECURE BONDING JUMPER (5) TO HOLE. USE BOLT (10), WASHERS (15) AND NUT (20).</p> <p><b>NOTE:</b> INSTALL A WASHER UNDER THE BOLT HEAD, UNDER THE BONDING JUMPER AND UNDER THE NUT.</p>		
10	BACB30ZF4-10	. BOLT (BOLT HEAD FWD)		1
15	NAS1149D0416H	. WASHER		3
20	BACN10YR4CD	. NUT (AFT SIDE)		1
		<p>TIGHTEN BOLT (10) TO 110-120 POUND-INCHES (12.4-13.6 NEWTON METERS).</p> <p>APPLY A FILLET SEAL OF sealant, A00160 (C4) OR sealant, A00803 (C5) OR adhesive, A00027 (C6) AROUND BONDING JUMPER (5) AND BOLT (10). IF sealant, A00160 (C4) IS USED, APPLY Dapco No. 1-100 primer, C00944 (C3) BEFORE SEALANT APPLICATION.</p>		
C3	C00944	. PRIMER, DAPCO NO. 1-100	CON	AR
C4	A00160	. SEALANT, BMS 5-63 TYPE I	CON	AR
C5	A00803	. SEALANT, BMS 5-63 TYPE II	CON	AR
C6	A00027	. SEALANT, BAC5010 TYPE 60	CON	AR

**71-00-02**

P/P BUILDUP FIGURE 27-1

Page 3

Oct 05/2007

D633A106-HXL

737-600/700/800/900  
POWERPLANT BUILDUP MANUAL

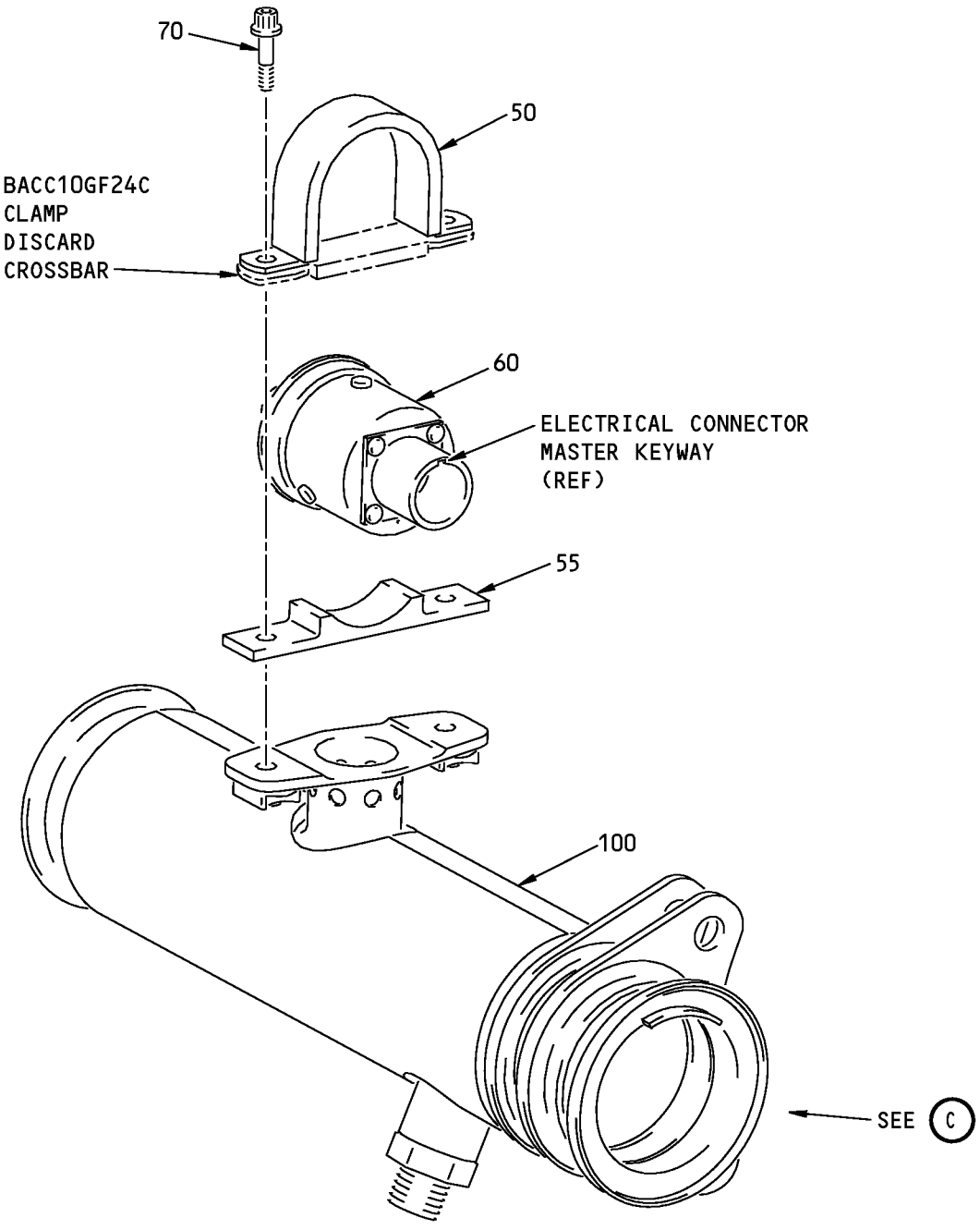

PREFERRED CONFIGURATION

(B)

Inlet Cowling TAI System Installation  
Figure 27-1 (Sheet 2)

**71-00-02**

P/P BUILDUP FIGURE 27-1

Page 4

Oct 05/2007

D633A106-HXL

**737-600/700/800/900  
POWERPLANT BUILDUP MANUAL**

ITEM NO.	PART NUMBER	NOMENCLATURE	UC	QTY
27-1		<b>INLET COWL TAI SYSTEM INSTALLATION (FIGURE 27-1, SHEET 2)</b>  PREFERRED CONFIGURATION  REMOVE CROSSBAR FROM ATTACHMENT FOOT OF CLAMP (50) AND DISCARD. IF CROSSBAR IS ATTACHED BY A RIVET, REMOVE RIVET BY SQUEEZING RIVET RING WITH PLIERS.		
50	BACC10GF24CT	. CLAMP  ATTACH PRESSURE SWITCH (60) TO DUCT ASSY (100) USING CLAMP (50), BRACKET SADDLE (55) AND BOLTS (70). IF RIVET WAS REMOVED FROM OPT CLAMP (50), INSTALL WASHERS (75) UNDER BOLTS (70).  <b>NOTE:</b> INSTALL PRESSURE SWITCH SUCH THAT ELECTRICAL CONNECTOR MASTER KEYWAY IS FARTHEST FROM DUCT.		1
55	332A1325-1	. BRACKET SADDLE		1
60	21SN41-52	. PRESSURE SWITCH		1
70	BACB30ZF3-08	. BOLT		2
75	NAS1149C0363R	. WASHER (2 REQD) <sup>[1]</sup>	OPT	-
100	332A2390-48	. DUCT ASSY  TIGHTEN BOLTS (70) TO 28-32 POUND-INCHES (3.16-3.62 NEWTON METERS).  *[1] ITEM NOT ILLUSTRATED		1

**71-00-02**

P/P BUILDUP FIGURE 27-1

Page 5

Oct 05/2007

D633A106-HXL

737-600/700/800/900  
POWERPLANT BUILDUP MANUAL

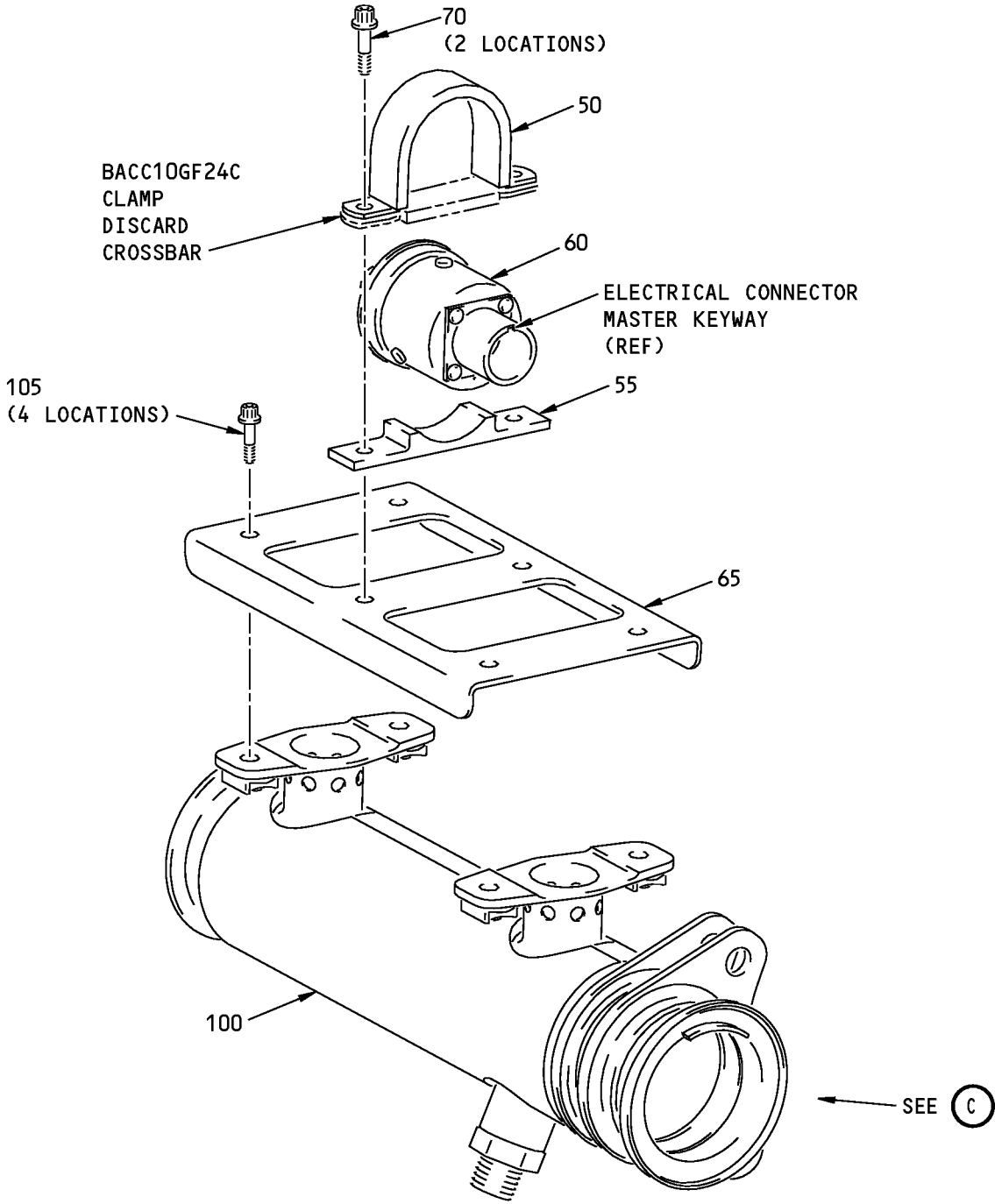

OPTIONAL CONFIGURATION  
B

Inlet Cowl TAI System Installation  
Figure 27-1 (Sheet 3)

71-00-02

P/P BUILDUP FIGURE 27-1

Page 6

Oct 05/2007

D633A106-HXL

**737-600/700/800/900  
POWERPLANT BUILDUP MANUAL**

ITEM NO.	PART NUMBER	NOMENCLATURE	UC	QTY
27-1		<b>INLET COWL TAI SYSTEM INSTALLATION (FIGURE 27-1, SHEET 3)</b>		
		OPTIONAL CONFIGURATION		
50	BACC10GF24CT	REMOVE CROSSBAR FROM ATTACHMENT FOOT OF CLAMP (50) AND DISCARD. IF CROSSBAR IS ATTACHED BY A RIVET, REMOVE RIVET BY SQUEEZING RIVET RING WITH PLIERS. . CLAMP		1
		POSITION BRACKET SADDLE (55) AND PRESSURE SWITCH (60) ON BRACKET (65) AND SECURE WITH CLAMP (50) AND BOLTS (70). IF RIVET WAS REMOVED FROM OPT CLAMP (50), INSTALL WASHERS (75) UNDER BOLTS (70).		
		<b>NOTE:</b> INSTALL PRESSURE SWITCH SUCH THAT ELECTRICAL CONNECTOR MASTER KEYWAY IS FARTHEST FROM BRACKET.		
55	332A1325-1	. BRACKET SADDLE (QTY 1)	OPT	-
60	21SN41-52	. PRESSURE SWITCH (QTY 1)	OPT	-
65	332A2910-1	. BRACKET (QTY 1)	OPT	-
70	BACB30ZF3-08	. BOLT (QTY 2)	OPT	-
75	NAS1149C0363R	. WASHER (QTY 2) <sup>[1]</sup>	OPT	-
		TIGHTEN BOLTS (70) TO 28-32 POUND-INCHES (3.16-3.62 NEWTON METERS).		
		ATTACH BRACKET AND ATTACHING PARTS TO DUCT (100) WITH BOLTS (105).		
100	332A2390-3	. DUCT ASSY (QTY 1)	OPT	-
105	BACB30ZF4-08	. BOLT (QTY 4)	OPT	-
		TIGHTEN BOLTS (105) TO 110-120 POUND-INCHES (12.4-13.6 NEWTON METERS).		
		*[1] ITEM NOT ILLUSTRATED		

**71-00-02**

P/P BUILDUP FIGURE 27-1

Page 7

Oct 05/2007

D633A106-HXL

737-600/700/800/900  
**POWERPLANT BUILDUP MANUAL**

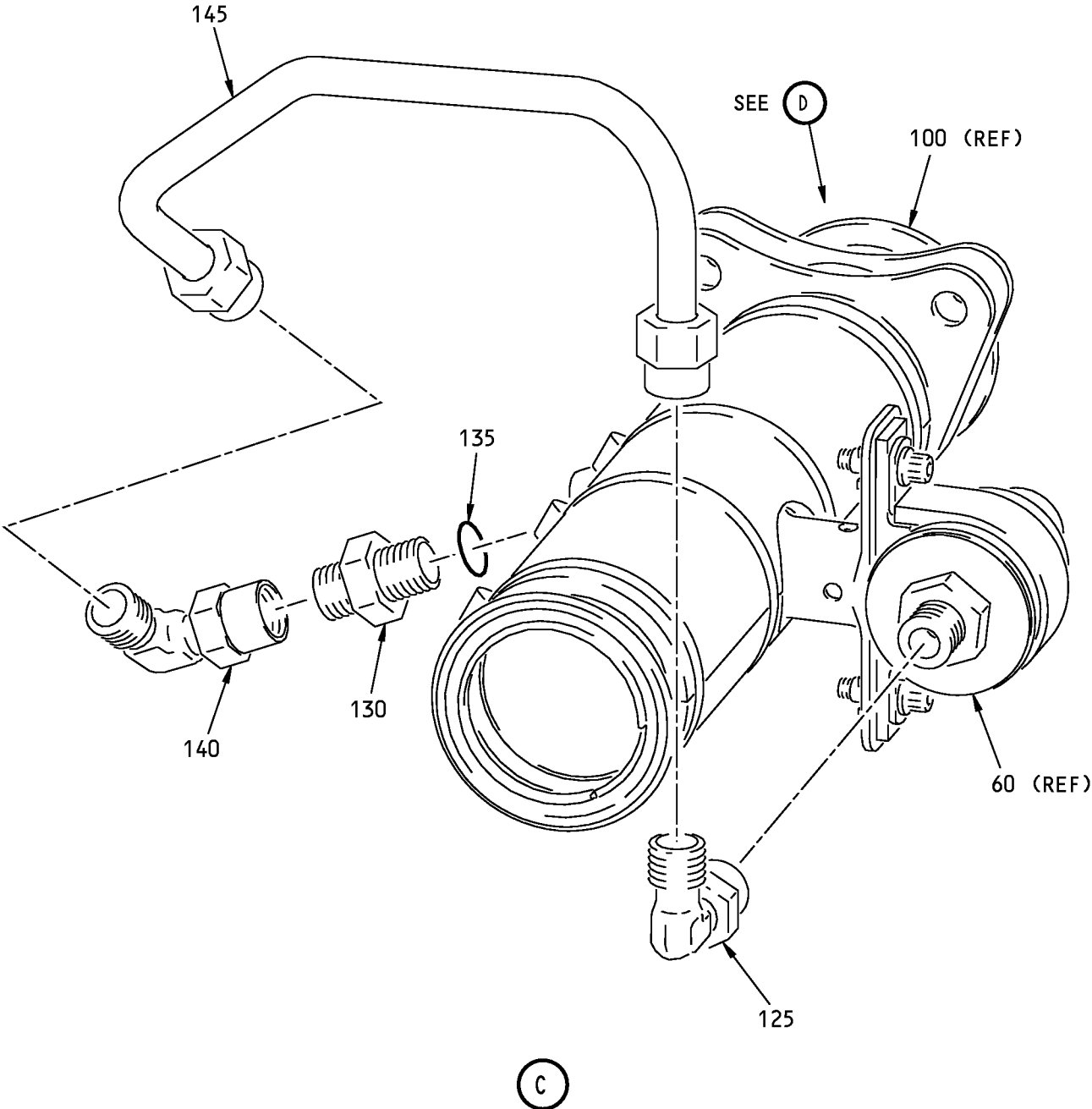

**Inlet Cowl TAI System Installation  
Figure 27-1 (Sheet 4)**

**71-00-02**

P/P BUILDUP FIGURE 27-1

Page 8

Oct 05/2007

D633A106-HXL



**737-600/700/800/900  
POWERPLANT BUILDUP MANUAL**

ITEM NO.	PART NUMBER	NOMENCLATURE	UC	QTY
27-1		<b>INLET COWL TAI SYSTEM INSTALLATION (FIGURE 27-1, SHEET 4)</b>		
125	BACE21BT0606JN	INSTALL ELBOW (125) FINGER-TIGHT ON PRESSURE SWITCH (60). . ELBOW		1
130	MS21902J6	INSTALL O-RING (135) ON UNION (130) AND INSTALL UNION (130) ON DUCT (100). INSTALL ELBOW (140) ON UNION (130) FINGER-TIGHT. . UNION		1
135	801A50-0006A	. O-RING (V15284)	VEN	1
140	BACE21BT0606JN	. ELBOW		1
145	332A2350-1	CONNECT TUBE (145) BETWEEN ELBOWS (125) AND (140). . TUBE ASSY		1
		TIGHTEN UNION (130), ELBOWS (125) AND (140) AND TUBE (145) TO 257-283 POUND-INCHES (29-32 NEWTON METERS).		

**71-00-02**

P/P BUILDUP FIGURE 27-1

Page 9

Oct 05/2007

D633A106-HXL

POWERPLANT BUILDUP MANUAL

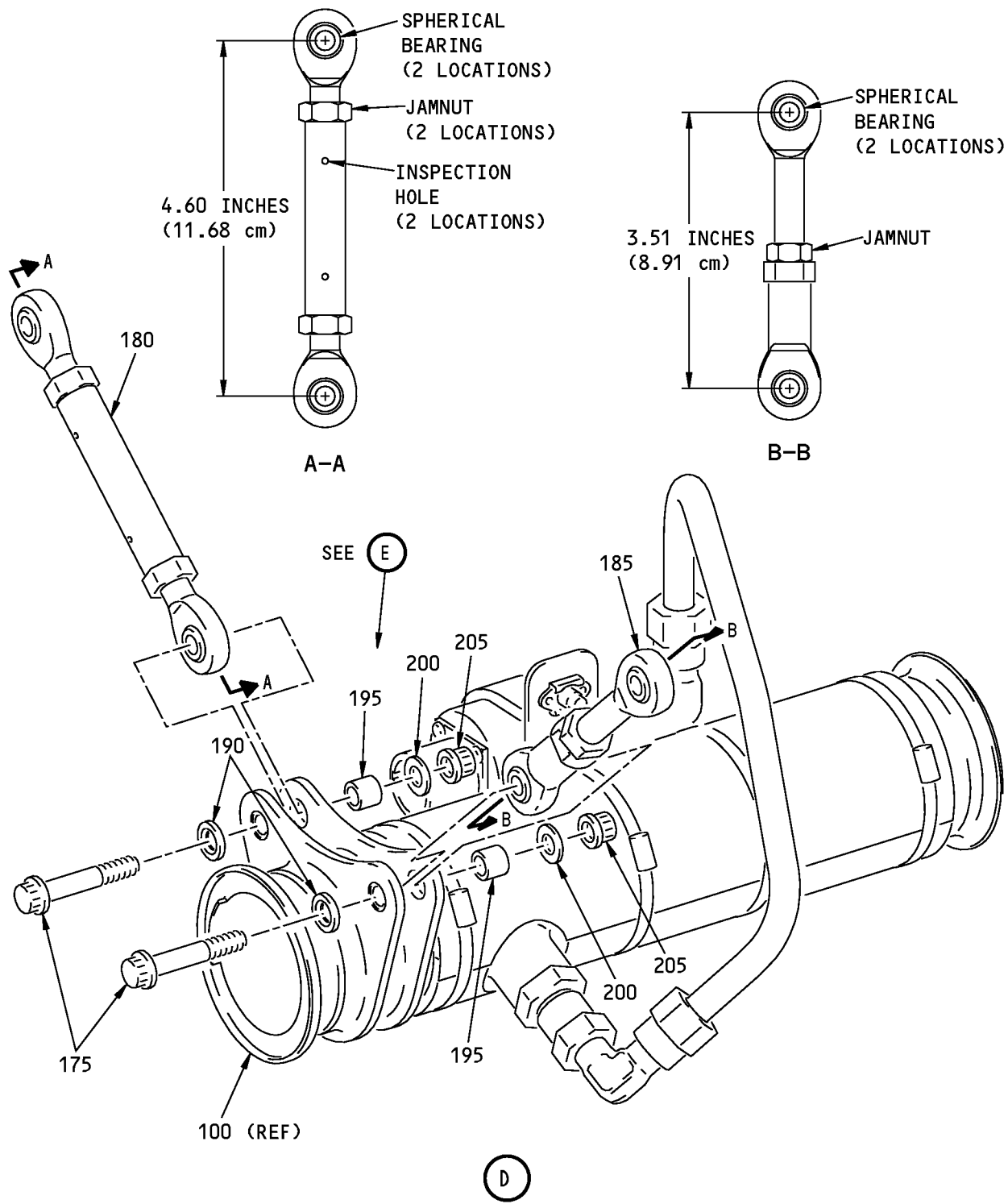

Inlet Cowl TAI System Installation  
Figure 27-1 (Sheet 5)

71-00-02

P/P BUILDUP FIGURE 27-1

Page 10

Oct 05/2007

D633A106-HXL

**737-600/700/800/900  
POWERPLANT BUILDUP MANUAL**

ITEM NO.	PART NUMBER	NOMENCLATURE	UC	QTY
27-1		<b>INLET COWL TAI SYSTEM INSTALLATION (FIGURE 27-1, SHEET 5)</b>		
C7	D00006	APPLY Never-Seez NSBT-8N compound, D00006 (C7) TO THREADS AND SHANK OF BOLTS (175).	CON	AR
175	BACB30PN4-14	. COMPOUND, NEVER-SEEZ NSBT-8N . BOLT		2
		LOOSEN JAMNUT OF LINK ASSY (180) TO FREE ROD END. ADJUST LINK ASSY TO 4.60 INCHES (11.68 CM) FROM CENTERLINE OF SPHERICAL BEARINGS. RETIGHTEN JAMNUT.		
		<b>NOTE:</b> MAKE SURE THEADS ARE VISIBLE THROUGH BOTH INSPECTION HOLES.		
		LOOSEN JAMNUT OF LINK ASSY (185) TO FREE ROD END. ADJUST LINK TO 3.51 INCHES (8.91 CM) FROM CENTERLINE OF SPHERICAL BEARINGS. RETIGHTEN JAMNUT.		
		ATTACH LINK ASSEMBLY (180) TO BOTTOM ATTACH POINT OF DUCT (100) (BOTTOM OF DUCT HAS TWO BOSSES) AND ATTACH LINK ASSEMBLY (185) TO TOP ATTACH POINT OF DUCT. USE ITEMS (175) AND (190) THRU (205).		
		<b>NOTE:</b> MAKE SURE BOLT HEAD FACES FORWARD.		
180	332A2341-3	. LINK ASSY		1
185	332A2341-2	. LINK ASSY		1
190	BACW10BP4ACU	. WASHER (CSK) (UNDER BOLT)		2
190	BACW10BP4CD	. WASHER (OPTIONAL TO BACW10BP4ACU)	OPT	-
195	BACB28AK04-030	. BUSHING		2
200	NAS1149C0432R	. WASHER (UNDER NUT)		2
205	AS3485-10	. NUT		2
		TIGHTEN BOLTS (175) TO 50-80 POUND-INCHES (5.6-9.0 NEWTON METERS).		

# 71-00-02

P/P BUILDUP FIGURE 27-1

Page 11

Oct 05/2007

D633A106-HXL

737-600/700/800/900  
**POWERPLANT BUILDUP MANUAL**

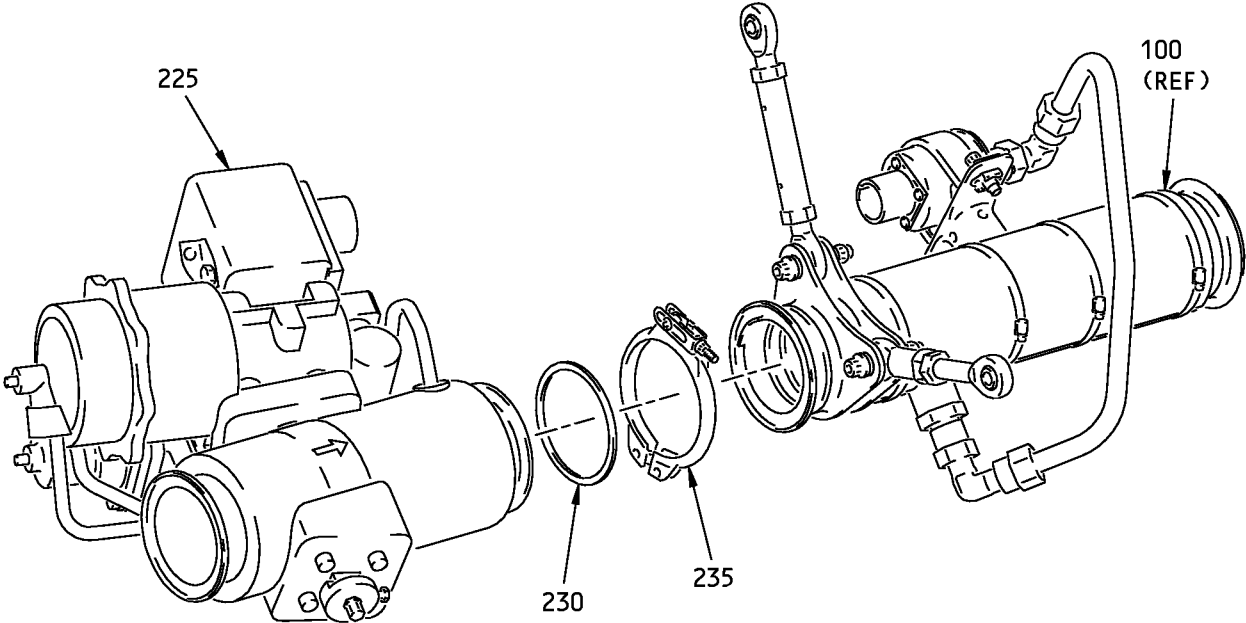

E

**Inlet Cowl TAI System Installation**  
**Figure 27-1 (Sheet 6)**

**71-00-02**

P/P BUILDUP FIGURE 27-1

Page 12

Oct 05/2007

D633A106-HXL

**737-600/700/800/900  
POWERPLANT BUILDUP MANUAL**

ITEM NO.	PART NUMBER	NOMENCLATURE	UC	QTY
27-1		<p><b>INLET COWL TAI SYSTEM INSTALLATION (FIGURE 27-1, SHEET 6)</b></p> <p>INSTALL SEAL (230) IN AFT FLANGE OF DUCT ASSY (100). ATTACH VALVE ASSEMBLY (225) TO DUCT ASSY (100) WITH COUPLING (235) FINGER TIGHT.</p> <p><b>NOTE:</b> MAKE SURE TO ALIGN THE CLOCKING FEATURE BETWEEN THE VALVE AND THE DUCT.</p> <p>ORIENT COUPLING TO MAXIMIZE CLEARANCE WITH ADJACENT EQUIPMENT.</p>		
225	3215618-4	. VALVE ASSEMBLY (V59364)	VEN	1
225	S332A239-4	. BOEING SPEC FOR 3215618-4	BOE	-
230	AS1895-7-200	. SEAL		1
235	AS1895-4-200	. COUPLING		1
		<p>TIGHTEN COUPLING (235) TO TORQUE SPECIFIED ON PART. LIGHTLY TAP OUTER SURFACE OF COUPLING WITH A NON-METALLIC MALLET. RETIGHTEN COUPLING TO TORQUE SPECIFIED ON PART.</p>		

**71-00-02**

P/P BUILDUP FIGURE 27-1

Page 13

Oct 05/2007

D633A106-HXL

737-600/700/800/900  
**POWERPLANT BUILDUP MANUAL**

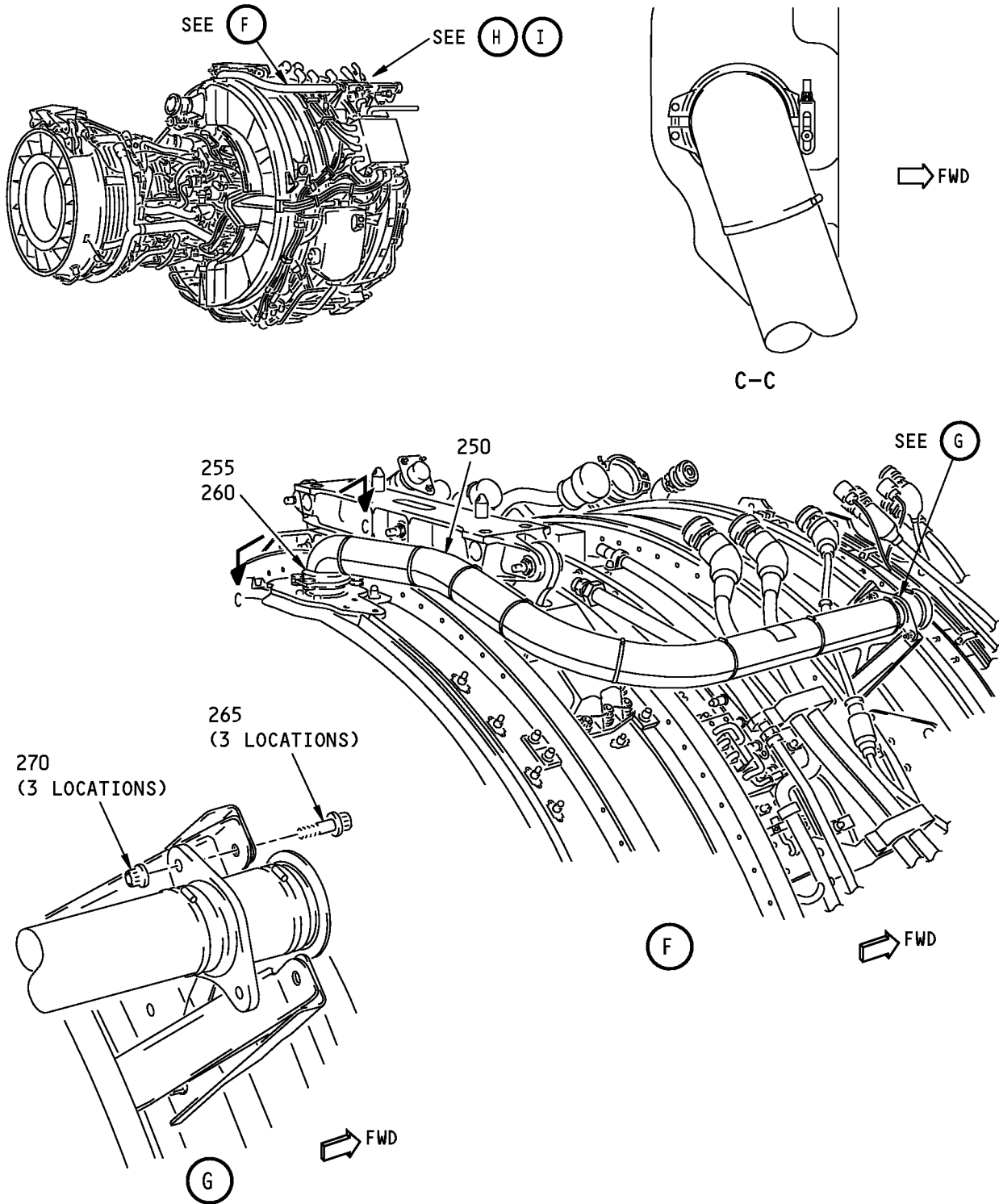

**Inlet Cowl TAI System Installation**  
**Figure 27-1 (Sheet 7)**

**71-00-02**

P/P BUILDUP FIGURE 27-1

Page 14

Oct 05/2007

D633A106-HXL

**737-600/700/800/900  
POWERPLANT BUILDUP MANUAL**

ITEM NO.	PART NUMBER	NOMENCLATURE	UC	QTY
27-1		<p><b>INLET COWL TAI SYSTEM INSTALLATION (FIGURE 27-1, SHEET 7)</b></p> <p><b>CAUTION:</b> COUPLING MUST BE INSTALLED WITH NUT FACING FORWARD ON LEFT SIDE OF ENGINE. DAMAGE TO EQUIPMENT CAN OCCUR.</p> <p>POSITION DUCT ASSY (250) ON ENGINE FAN CASE. SECURE AFT END OF DUCT TO EXISTING TAI BIFUR UPR DUCT FLANGE WITH SEAL (255) AND COUPLING (260). SECURE FWD END OF DUCT TO ENGINE FAN CASE BRACKETS WITH BOLTS (265) AND NUTS (270).</p> <p><b>NOTE:</b> MAKE SURE COUPLING NUT IS ON LEFT SIDE (EITHER FORWARD OR AFT OF DUCT).</p> <p>. DUCT ASSY</p> <p>. SEAL</p> <p>. COUPLING</p> <p>. BOLT</p> <p>. NUT</p> <p>TIGHTEN COUPLING (260) TO TORQUE SPECIFIED ON PART. LIGHTLY TAP OUTER SURFACE OF COUPLING WITH A NON-METALLIC MALLET. RETIGHTEN COUPLING TO TORQUE SPECIFIED ON PART.</p> <p>TIGHTEN BOLTS (265) TO 110-120 POUND-INCHES (12.4-13.6 NEWTON METERS).</p>		<p>1</p> <p>1</p> <p>1</p> <p>3</p> <p>3</p>
250	332A2390-12	. DUCT ASSY		1
255	AS1895-7-175	. SEAL		1
260	AS1895-4-175	. COUPLING		1
265	BACB30ZF4-10	. BOLT		3
270	AS3485-10	. NUT		3

**71-00-02**

P/P BUILDUP FIGURE 27-1

Page 15

Oct 05/2007

D633A106-HXL

737-600/700/800/900  
**POWERPLANT BUILDUP MANUAL**

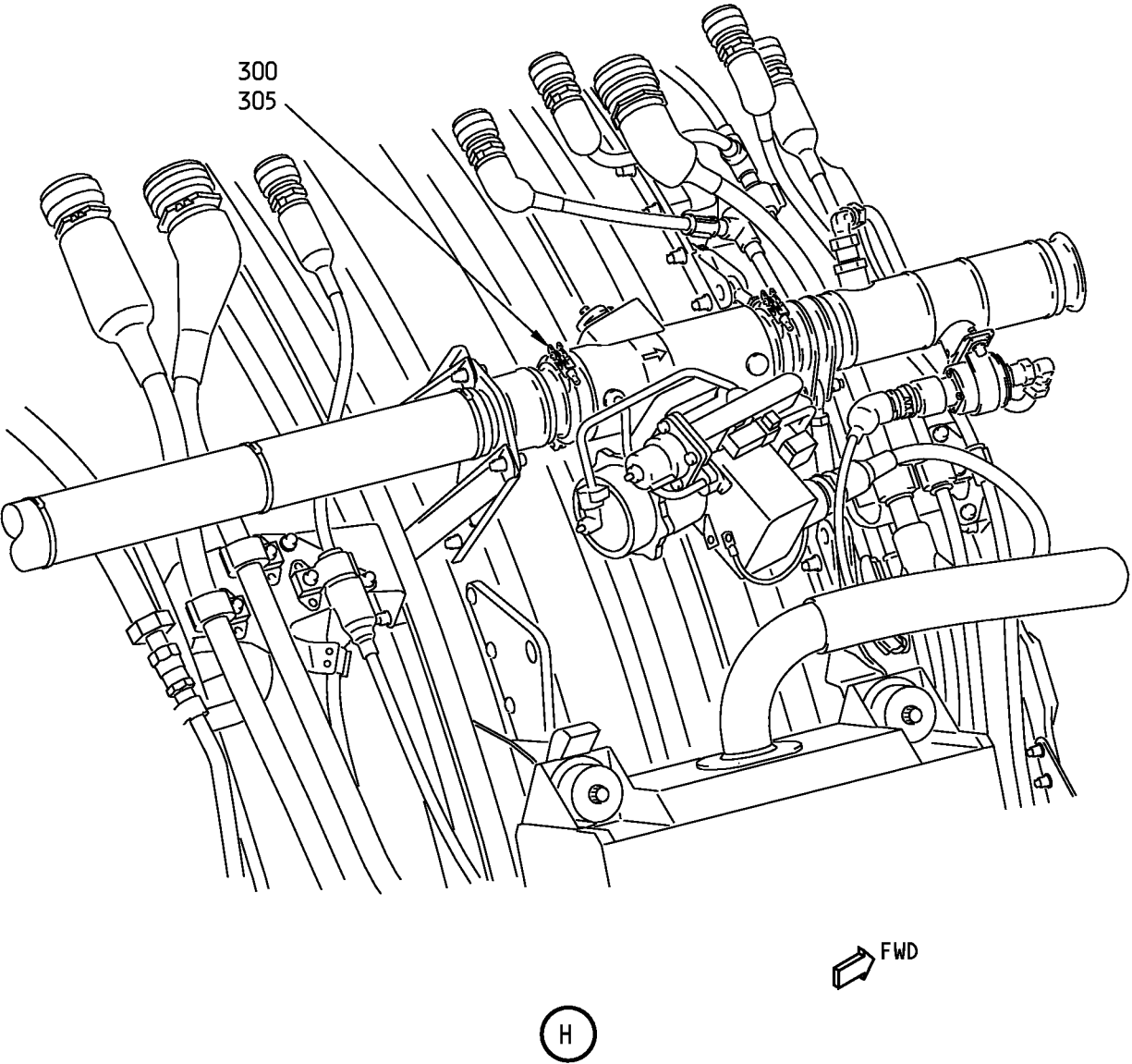

**Inlet Cowl TAI System Installation**  
**Figure 27-1 (Sheet 8)**

**71-00-02**

P/P BUILDUP FIGURE 27-1

Page 16

Oct 05/2007

D633A106-HXL



**737-600/700/800/900  
POWERPLANT BUILDUP MANUAL**

ITEM NO.	PART NUMBER	NOMENCLATURE	UC	QTY
27-1		<p><b>INLET COWL TAI SYSTEM INSTALLATION (FIGURE 27-1, SHEET 8)</b></p> <p>INSTALL SEAL (300) ON AFT FLANGE OF VALVE (225). POSITION VALVE (225)/DUCT ASSY (100) TO ENGINE FAN CASE AND LOOSELY SECURE TO AFT DUCT (250) WITH COUPLING (305).</p> <p>. SEAL</p> <p>. COUPLING</p> <p>ORIENT COUPLING (305) TO MAXIMIZE CLEARANCE WITH ADJACENT EQUIPMENT. TIGHTEN COUPLING (305) TO TORQUE SPECIFIED ON PART. LIGHTLY TAP OUTER SURFACE OF COUPLING WITH NON-METALLIC MALLET. RETIGHTEN COUPLING TO TORQUE SPECIFIED ON PART.</p>		<p>1</p> <p>1</p>
300	AS1895-7-200			
305	AS1895-4-200			

**71-00-02**

P/P BUILDUP FIGURE 27-1

Page 17

Oct 05/2007

D633A106-HXL

737-600/700/800/900  
**POWERPLANT BUILDUP MANUAL**

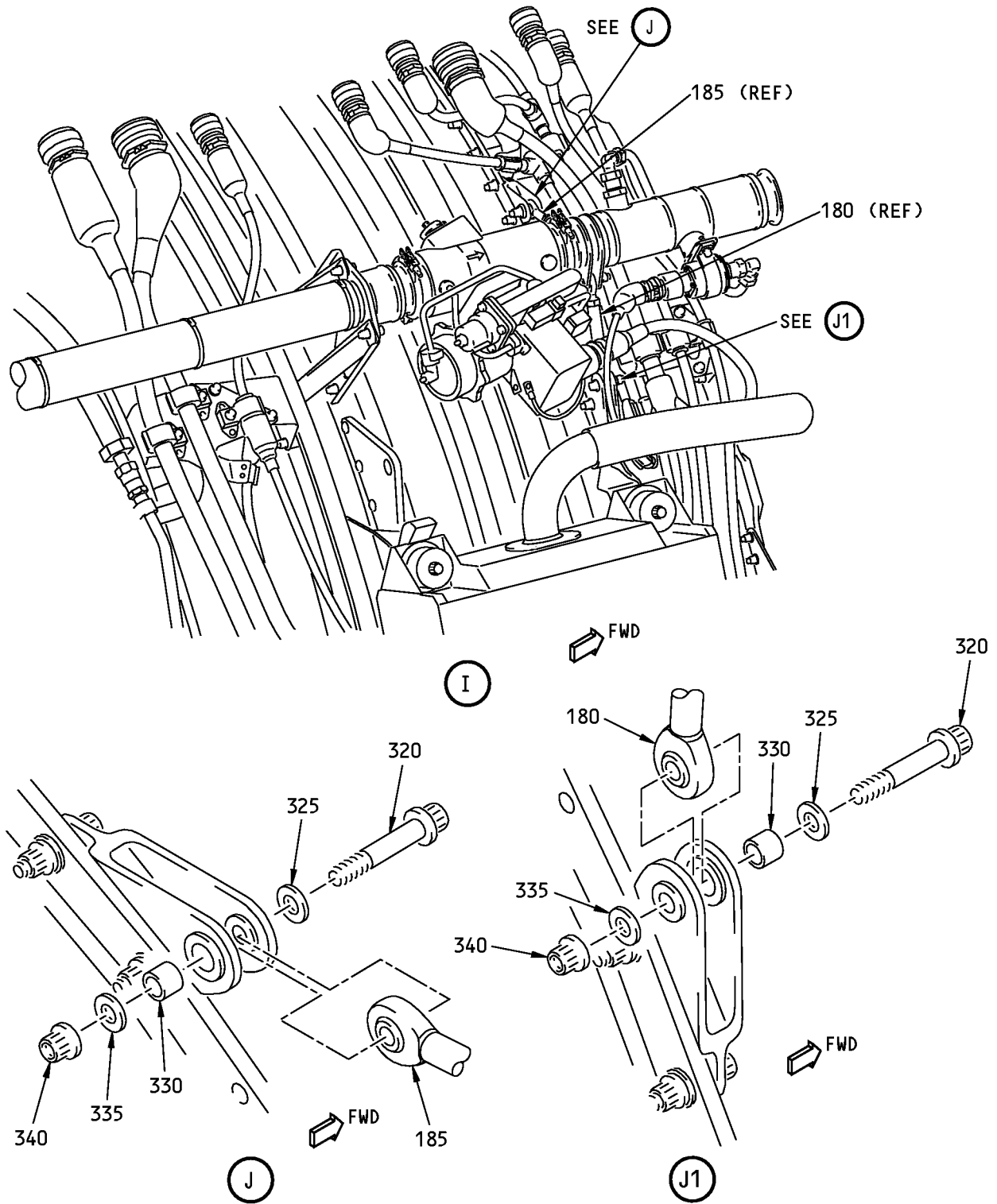

**Inlet Cowl TAI System Installation**  
**Figure 27-1 (Sheet 9)**

**71-00-02**

P/P BUILDUP FIGURE 27-1

Page 18

Oct 05/2007

D633A106-HXL

**737-600/700/800/900  
POWERPLANT BUILDUP MANUAL**

ITEM NO.	PART NUMBER	NOMENCLATURE	UC	QTY
27-1		<b>INLET COWL TAI SYSTEM INSTALLATION (FIGURE 27-1, SHEET 9)</b>		
C7 320	D00006 BACB30PN4-14	APPLY Never-Seez NSBT-8N compound, D00006 (C7) TO THREADS AND SHANK OF BOLTS (320). . COMPOUND, NEVER-SEEZ NSBT-8N . BOLT	CON	AR 2
		SECURE LINKS (180) AND (185) TO ENGINE FAN CASE BRACKETS WITH ITEMS (320) THRU (340).		
		<b>NOTE:</b> MAKE SURE NO PRELOAD FORCE EXISTS BETWEEN THE VALVE, DUCT AND ENGINE BRACKET. IF A PRELOAD FORCE EXISTS, FIRST MAKE SURE ALL COMPONENTS ARE INSTALLED CORRECTLY. THEN ADJUST LINKS (180) AND (185) LENGTHS (Ref Figure 27-1 (Sheet 5)PPBU-FIGURE).		
325	BACW10BP4ACU	. WASHER (CSK) (UNDER BOLT)		2
330	BACB28AK04-030	. BUSHING		2
335	NAS1149C0432R	. WASHER (UNDER NUT)		2
340	AS3485-10	. NUT		2
		TIGHTEN BOLTS (320) TO 50-80 POUND-INCHES (5.6-9.0 NEWTON METERS).		
		APPLY lockwire, G01912 (C8) OR safety cable kit, G50375 (C9) BETWEEN JAMNUT AND FEMALE SIDE OF LINK (180) AND LINK (185).		
C8	G01912	. LOCKWIRE, MS20995NC32	CON	AR
C9	G50375	. SAFETY CABLE, BACC13AT3K18	CON	2

# 71-00-02

P/P BUILDUP FIGURE 27-1

Page 19

Feb 05/2008

D633A106-HXL

737-600/700/800/900  
**POWERPLANT BUILDUP MANUAL**

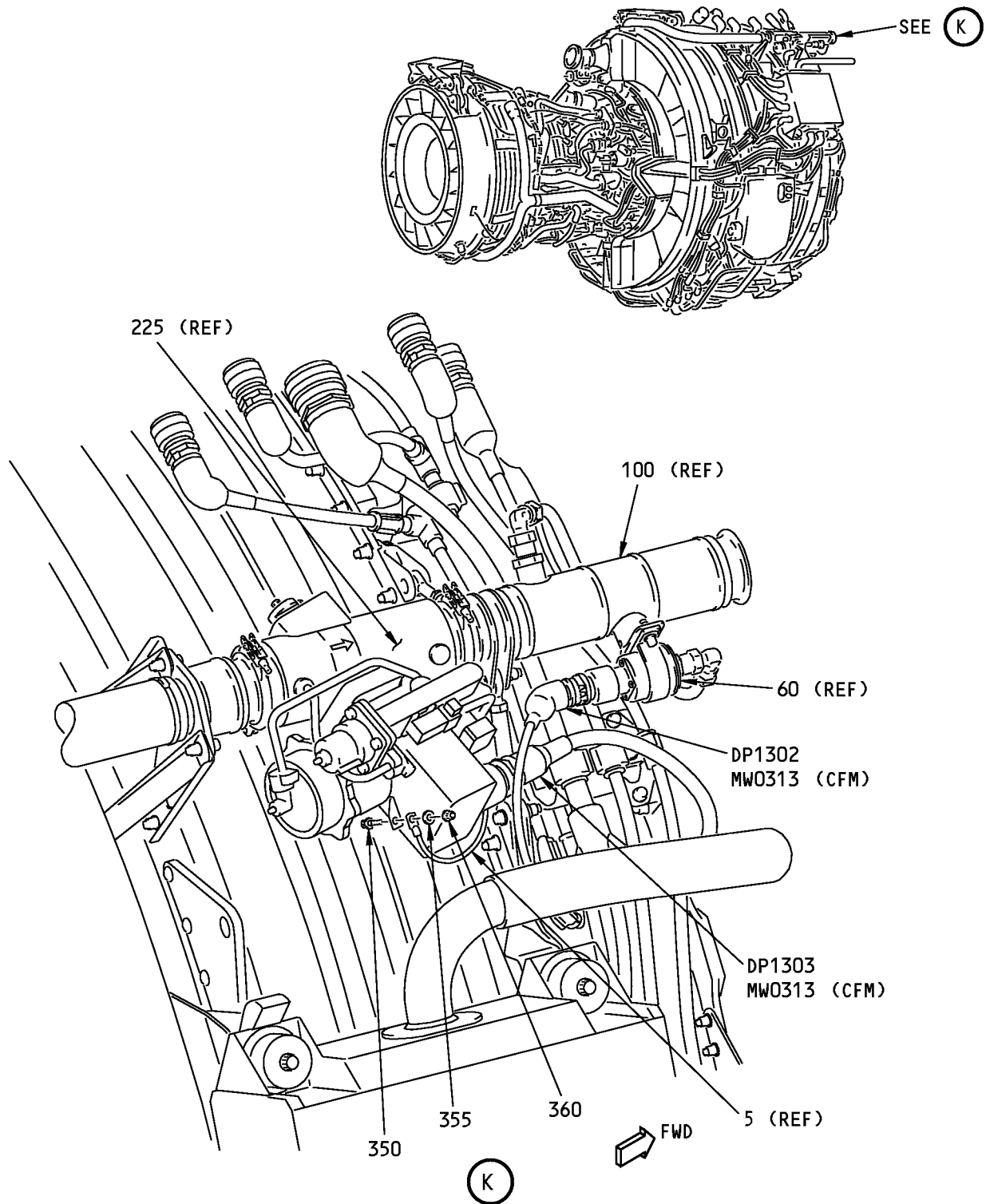

**Inlet Cowling TAI System Installation**  
**Figure 27-1 (Sheet 10)**

**71-00-02**

P/P BUILDUP FIGURE 27-1

Page 20

Oct 05/2007

D633A106-HXL

**737-600/700/800/900  
POWERPLANT BUILDUP MANUAL**

ITEM NO.	PART NUMBER	NOMENCLATURE	UC	QTY
27-1		<b>INLET COWL TAI SYSTEM INSTALLATION (FIGURE 27-1, SHEET 10)</b>		
C2	B00130	CLEAN BONDING JUMPER TAB ON VALVE (225) WITH alcohol, B00130 (C2). . SOLVENT, TT-I-735	CON	AR
350	BACB30ZF3-06	SECURE BONDING JUMPER (5) TO TAB ON VALVE (225). USE BOLT (350), WASHER (355) AND NUT (360). . BOLT (BOLT HEAD DOWN)		1
355	NAS1149C0316R	. WASHER (UNDER NUT)		1
360	AS3485-09	. NUT		1
		TIGHTEN BOLT (350) TO 50-56 POUND-INCHES (5.6-6.3 NEWTON METERS).		
		MEASURE RESISTANCE BETWEEN VALVE HOUSING AND ENGINE BRACKET. MAXIMUM PERMITTED RESISTANCE IS 0.008 OHMS.		
		<b>CAUTION:</b> DO NOT OVERTIGHTEN THE PLUG COUPLING RING. DO NOT USE WATER PUMP PLIERS, PIPE WRENCHES OR VISE GRIPS TO TIGHTEN THE COUPLING RING OR DAMAGE TO THE ELECTRICAL CONNECTOR CAN OCCUR.		
		CONNECT MW0313 ELECTRICAL CONNECTOR, DP1302, TO PRESSURE SWITCH AND MW0313 ELECTRICAL CONNECTOR, DP1303, TO VALVE. TURN KNURLED COUPLING RING WHILE WIGGLING THE BACKSHELL ASSEMBLY. AFTER FULLY SEATING THE COUPLING RING, USE SOFT-JAWED PLIERS OR A STRAP WRENCH TO TIGHTEN THE COUPLING RING AN ADDITIONAL 1/8 TURN OR UNTIL PLIER SLIPPAGE OCCURS.		

# 71-00-02

P/P BUILDUP FIGURE 27-1

Page 21

Oct 05/2007

D633A106-HXL

737-600/700/800/900  
**POWERPLANT BUILDUP MANUAL**

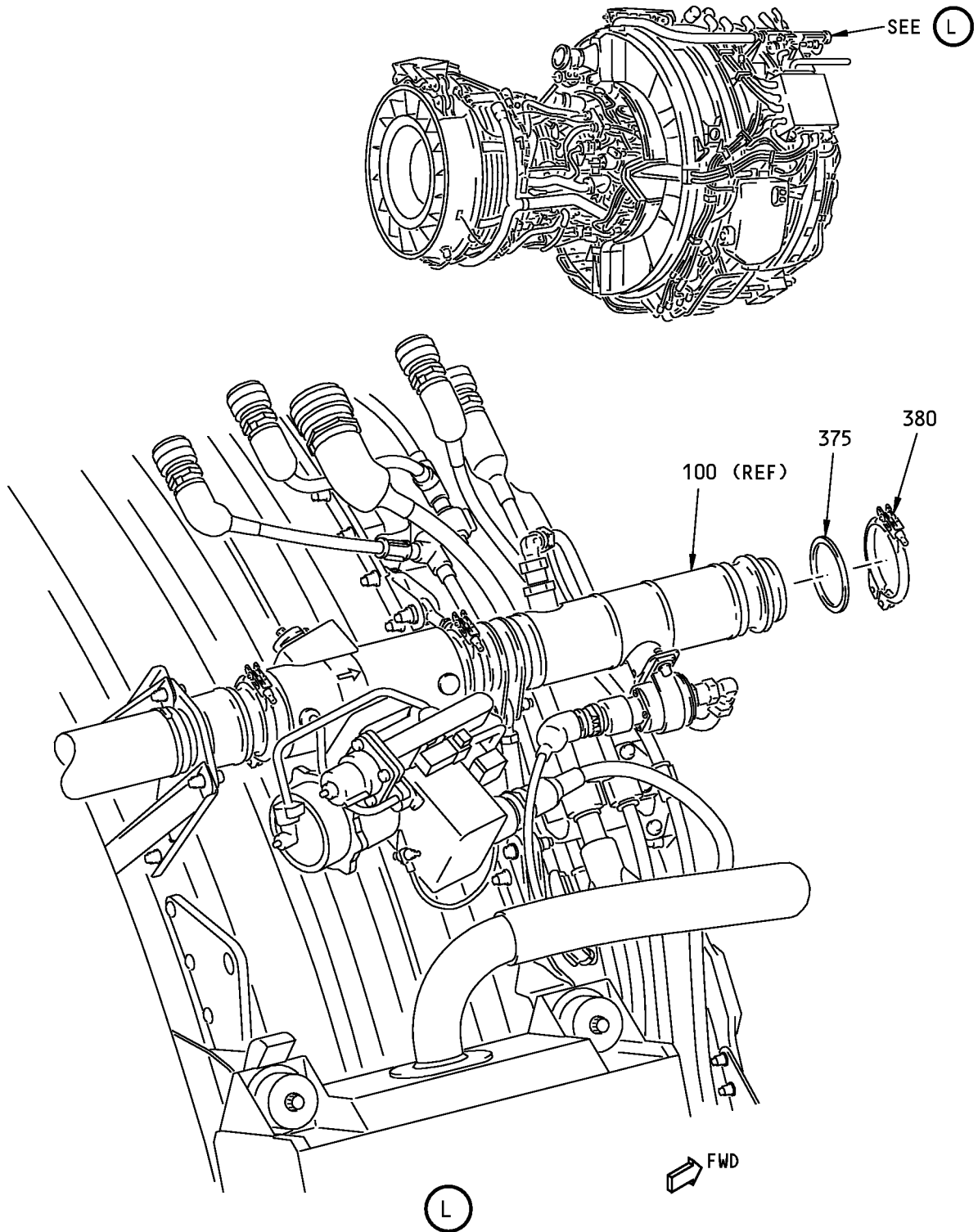

**Inlet Cowling TAI System Installation**  
**Figure 27-1 (Sheet 11)**

**71-00-02**

P/P BUILDUP FIGURE 27-1

Page 22

Oct 05/2007

D633A106-HXL

**737-600/700/800/900  
POWERPLANT BUILDUP MANUAL**

ITEM NO.	PART NUMBER	NOMENCLATURE	UC	QTY
27-1		<b>INLET COWL TAI SYSTEM INSTALLATION (FIGURE 27-1, SHEET 11)</b>  PUT ITEMS (375 AND 380) IN A BAG AND SECURE TO DUCT ASSY (100).  <b>NOTE:</b> ITEMS (375) AND (380) WILL BE INSTALLED DURING INLET COWL INSTALLATION (Figure 33-1).		
375	AS1895-7-200	. SEAL		1
380	AS1895-4-200	. COUPLING		1

**71-00-02**

P/P BUILDUP FIGURE 27-1

Page 23

Oct 05/2007

D633A106-HXL

**FIGURE 28-1**

# **FIRE/OVERHEAT DETECTOR INSTALLATION**

**REF QEC TASK NO.: 28**

**REF DWG: 332A2500**

**NOTE:** ALL STANDARDS AND ATTACHING HARDWARE FOR THIS FIGURE WILL BE PACKAGED IN QEC TASK NO. 110.

**71-00-02**

P/P BUILDUP FIGURE 28-1

Page 1

Oct 05/2007

D633A106-HXL



737-600/700/800/900  
**POWERPLANT BUILDUP MANUAL**

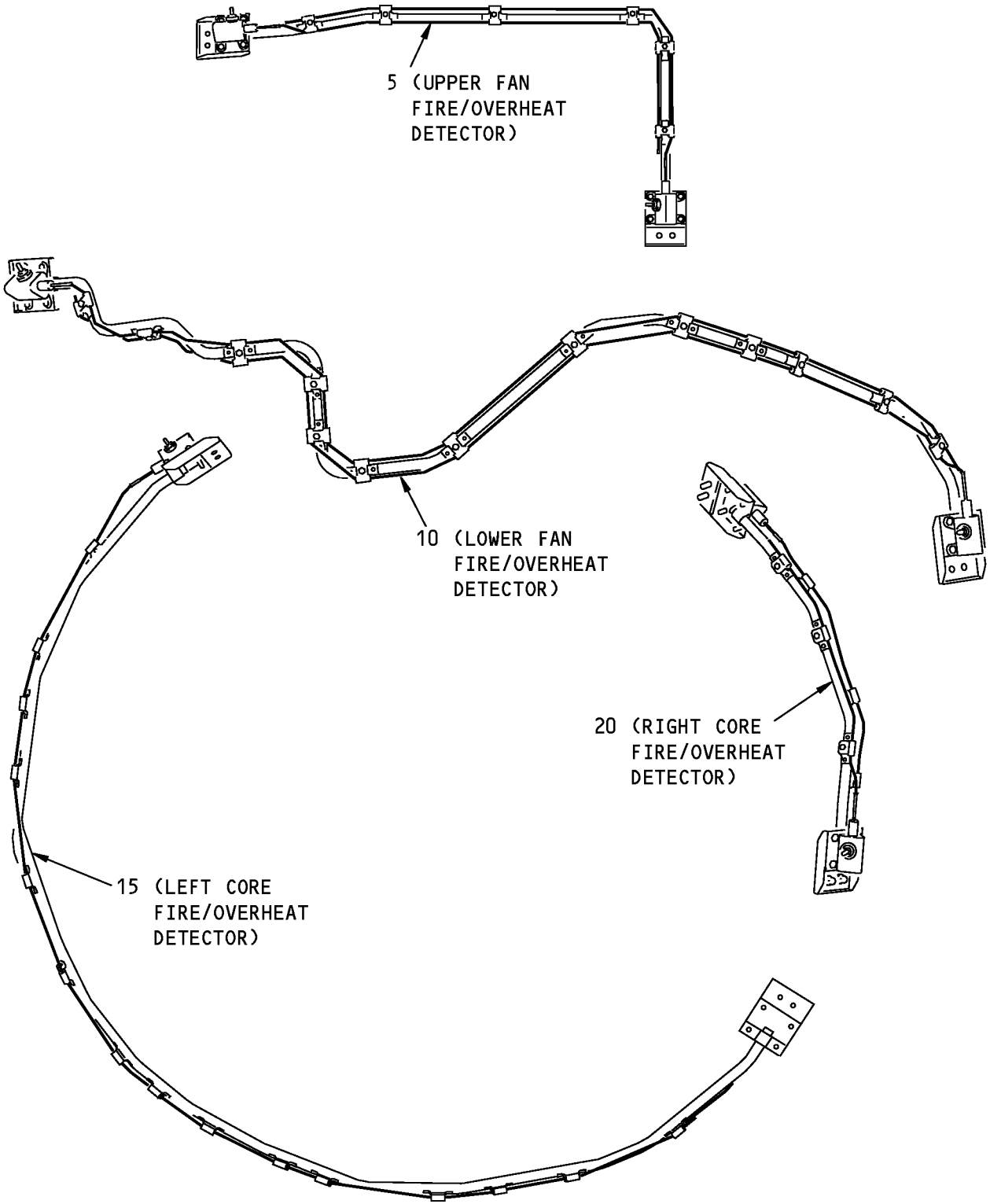

**Fire/Overheat Detector Installation**  
**Figure 28-1 (Sheet 1)**

**71-00-02**

P/P BUILDUP FIGURE 28-1

Page 2

Oct 05/2007

D633A106-HXL

**737-600/700/800/900  
POWERPLANT BUILDUP MANUAL**

ITEM NO.	PART NUMBER	NOMENCLATURE	UC	QTY
28-1		<b>FIRE/OVERHEAT DETECTOR INSTALLATION (FIGURE 28-1, SHEET 1)</b>  BENCH TEST RESISTANCE OF DETECTORS (5), (10), (15) AND (20) FROM THE DETECTOR STUD TO THE MOUNTING BRACKET.  MAKE SURE RESISTANCE IS BETWEEN THE FOLLOWING RANGES:  DETECTOR (5) BETWEEN 5624 - 6218 (OHMS) DETECTOR (10) BETWEEN 3734 - 4128 (OHMS) DETECTOR (15) BETWEEN 2860 - 3162 (OHMS) DETECTOR (20) BETWEEN 2347 - 2595 (OHMS)		
5	902864	. FIRE DETECTOR, UPPER FAN (V25693)	VEN	1
5	S332T100-44	. BOEING SPEC FOR 902864	BOE	-
10	902016-01	. FIRE DETECTOR, LOWER FAN (V25693)	VEN	1
10	S332T100-30	. BOEING SPEC FOR 902016-01	BOE	-
15	902862	. FIRE DETECTOR, LEFT CORE (V25693)	VEN	1
15	S332T100-43	. BOEING SPEC FOR 902862	BOE	-
20	902018-01	. FIRE DETECTOR, RIGHT CORE (V25693)	VEN	1
20	S332T100-38	. BOEING SPEC FOR 902018-01	BOE	-
		IF DETECTOR DOES NOT TEST WITHIN SPECIFIED RANGE, REPLACE DETECTOR.		

**71-00-02**

P/P BUILDUP FIGURE 28-1

Page 3

Oct 05/2007

D633A106-HXL

737-600/700/800/900  
**POWERPLANT BUILDUP MANUAL**

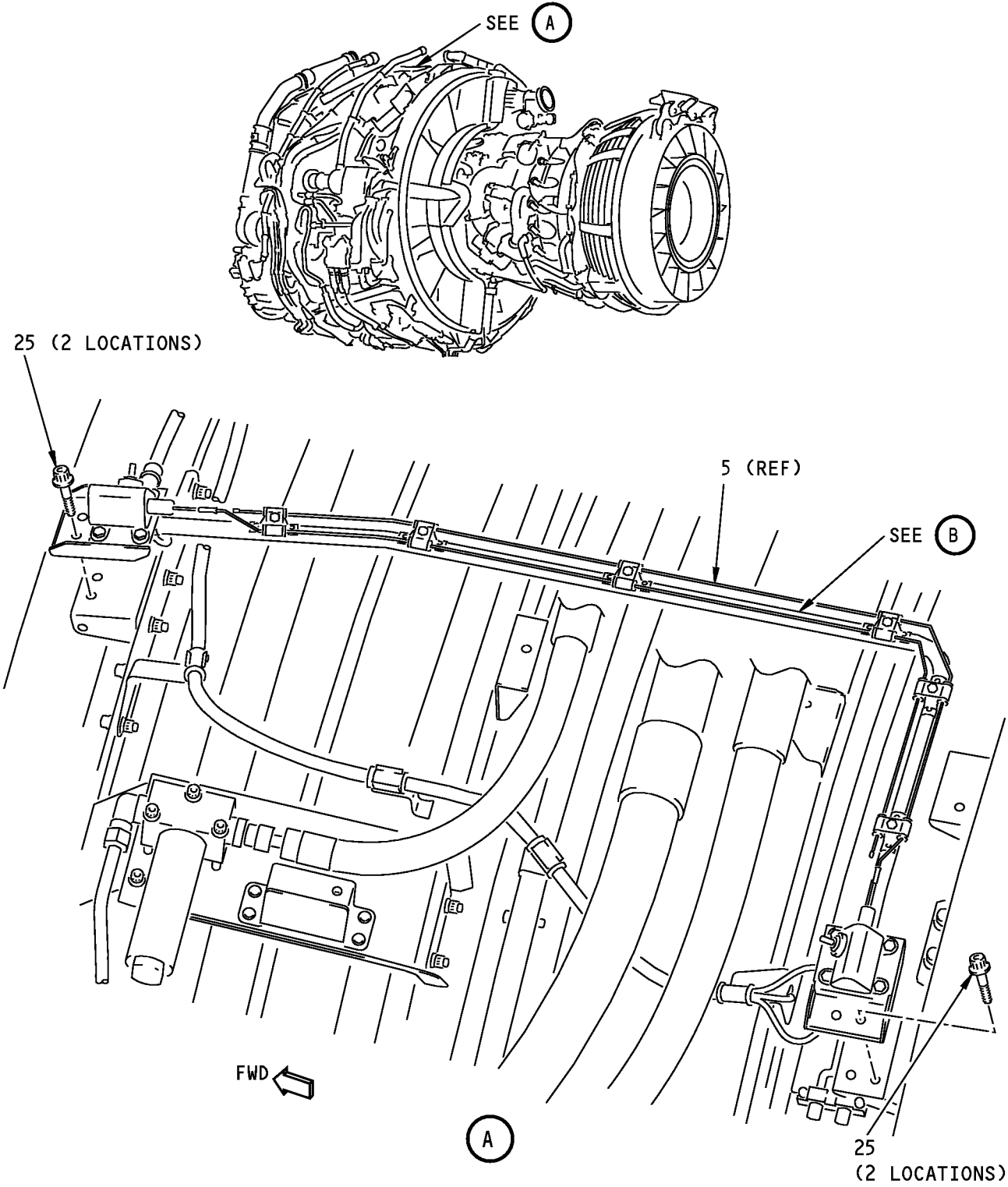

**Fire/Overheat Detector Installation**  
**Figure 28-1 (Sheet 2)**

**71-00-02**

P/P BUILDUP FIGURE 28-1

Page 4

Oct 05/2007

D633A106-HXL

**737-600/700/800/900  
POWERPLANT BUILDUP MANUAL**

ITEM NO.	PART NUMBER	NOMENCLATURE	UC	QTY
28-1		<p><b>FIRE/OVERHEAT DETECTOR INSTALLATION (FIGURE 28-1, SHEET 2)</b></p> <p>USE solvent, B00083 (C1) TO CLEAN FAY SURFACES OF BOTH ELECTRICAL DETECTOR BRACKETS ON FIRE DETECTOR (5) AND FAY SURFACES OF ENGINE BRACKETS AT 11:00 AND 11:30 O'CLOCK POSITIONS ON TOP OF FAN CASE.</p> <p>. SOLVENT, TT-N-95</p> <p>POSITION FIRE DETECTOR (5) ON ENGINE BRACKETS ON TOP OF ENGINE FAN CASE. MAKE SURE SUPPORT TUBE ALIGNS NEXT TO HOLES IN BRACKETS.</p> <p>LOOSELY ATTACH DETECTOR BRACKETS TO ENGINE BRACKETS WITH BOLTS (25).</p> <p>. BOLT</p>	CON	AR
C1	B00083			
25	BACB30ZF4-06			4

# 71-00-02

P/P BUILDUP FIGURE 28-1

Page 5

Oct 05/2007

D633A106-HXL

737-600/700/800/900  
**POWERPLANT BUILDUP MANUAL**

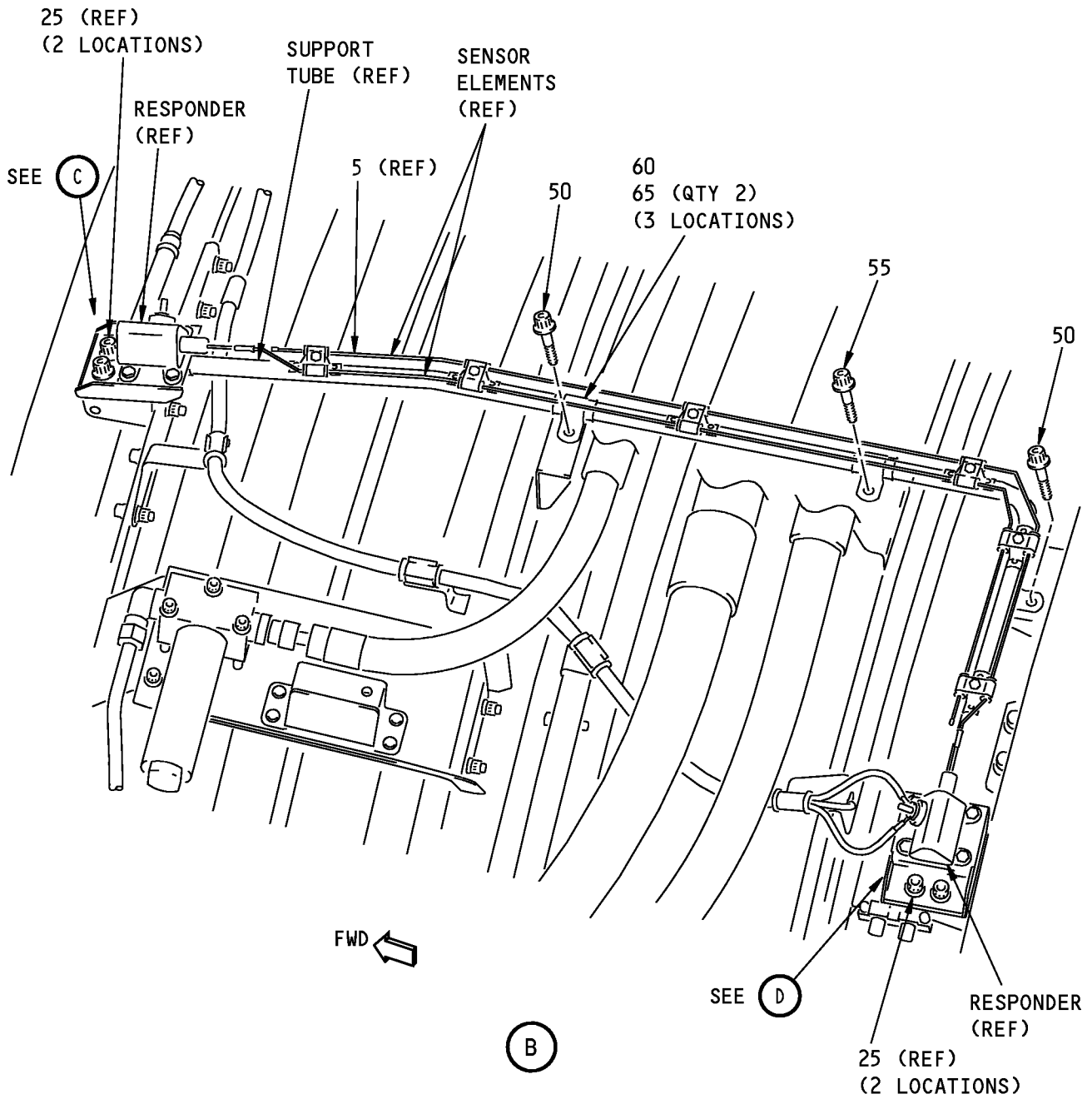

**Fire/Overheat Detector Installation**  
**Figure 28-1 (Sheet 3)**

**71-00-02**

P/P BUILDUP FIGURE 28-1

Page 6

Oct 05/2007

D633A106-HXL

**737-600/700/800/900  
POWERPLANT BUILDUP MANUAL**

ITEM NO.	PART NUMBER	NOMENCLATURE	UC	QTY
28-1		<b>FIRE/OVERHEAT DETECTOR INSTALLATION (FIGURE 28-1, SHEET 3)</b>		
		APPLY Never-Seez NSBT-8N compound, D00006 (C2) UNDER HEAD OF BOLTS (50 AND 55) TO PREVENT DISTORTION AND TWISTING OF CLAMP DURING TORQUING.		
50	BACB30ZF4-06	. BOLT		2
55	BACB30ZF4-06	. BOLT		1
C2	D00006	. COMPOUND, NEVER SEEZ NSBT-8N	CON	AR
		LOOSELY ATTACH SUPPORT TUBE OF DETECTOR (5) TO ENGINE BRACKETS WITH LOOP CLAMPS (60), CLAMPSHELLS (65) AND BOLTS (50).		
60	11777-08	. LOOP CLAMP		3
65	9352M41P04	. CLAMPSHELL		6
65	BACC10GT2-08	. CLAMPSHELL (OPTIONAL TO 9352M41P04)	OPT	-
		MAKE SURE PRELOAD BETWEEN DETECTOR ASSY AND ATTACH POINTS IS NOT MORE THAN 10 POUNDS (44.5 NEWTONS). TIGHTEN BOLTS (25), THEN BOLTS (50) TO 110-120 POUND-INCHES (12.4-13.6 NEWTON METERS). TIGHTEN BOLTS (55) TO 73-77 POUND-INCHES (8.25-8.70 NEWTON METERS).		
		CHECK THAT RESISTANCE BETWEEN RESPONDER AND ENGINE CASE IS 0.010 OHMS MAXIMUM.		
		CHECK THAT GAP BETWEEN SENSOR ELEMENTS AND SUPPORT TUBE IS NOT LESS THAN 0.12 INCH (3.0 MM).		
		AFTER TIGHTENING, MINIMUM CLEARANCE OF 0.15 INCH (3.8 MM) BETWEEN FIRE DETECTOR AND FAN COWL SUPPORT BEAM INSULATION BLANKET IS PERMITTED.		

**71-00-02**

P/P BUILDUP FIGURE 28-1

Page 7

Oct 05/2007

D633A106-HXL

737-600/700/800/900  
**POWERPLANT BUILDUP MANUAL**

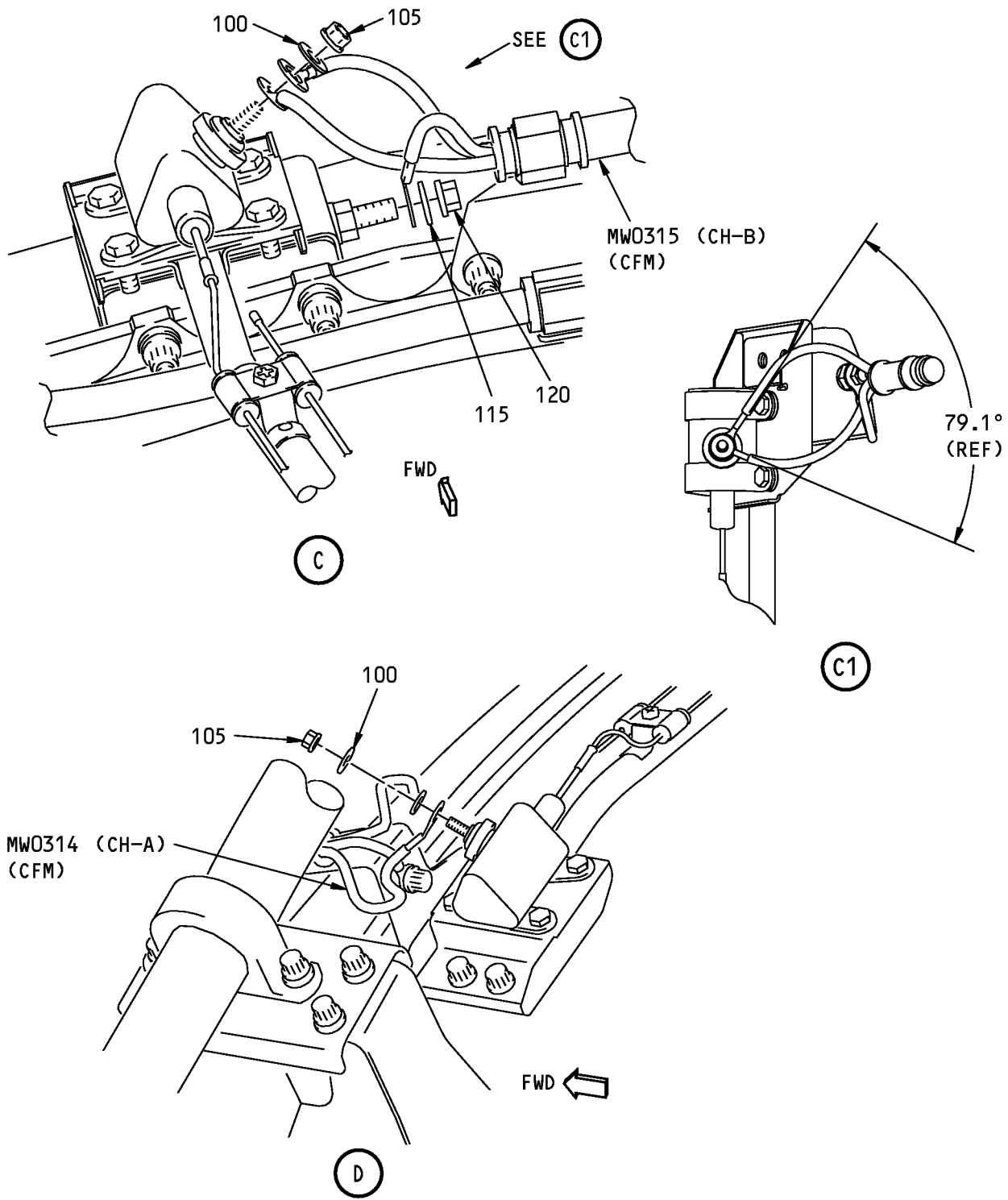

**Fire/Overheat Detector Installation**  
**Figure 28-1 (Sheet 4)**

**71-00-02**

P/P BUILDUP FIGURE 28-1

Page 8

Oct 05/2007

D633A106-HXL

**737-600/700/800/900  
POWERPLANT BUILDUP MANUAL**

ITEM NO.	PART NUMBER	NOMENCLATURE	UC	QTY
28-1		<b>FIRE/OVERHEAT DETECTOR INSTALLATION (FIGURE 28-1, SHEET 4)</b>  ATTACH W/B MW0315 (CFM) TO UPPER RESPONDER AND ATTACH W/B MW0314 (CFM) TO LOWER RESPONDER. PUT BOTH W/B LEADS ON EACH RESPONDER STUD AND SECURE WITH WASHER (100) AND NUT (105). POSITION W/B MW0315 (CFM) LEADS APPROXIMATELY AS SHOWN AND TIE WRAP WIRES AS REQUIRED TO MAINTAIN THIS POSITION. TIGHTEN NUT TO 25-35 POUND-INCHES (2.8-4.0 NEWTON METERS). MINIMUM STUD THREAD PROTRUSION MUST BE FLUSH WITH TOP OF NUT.		
100	NAS1149C0316R	. WASHER		2
100	NAS1149C0332R	. WASHER (OPTIONAL TO NAS1149C0316R) (2 REQD)	OPT	-
105	BACN10JC3C	. NUT (SUPPLIED WITH F/O DETECTOR)	REF	-
105	BACN10YR3C	. NUT (OPTIONAL TO BACN10JC3C) (2 REQD)	OPT	-
		ATTACH W/B MW0315 (CFM) GROUNDING WIRE TO UPPER RESPONDER BRACKET. SECURE WITH WASHER (115) AND NUT (120) AND TIGHTEN TO 90-105 POUND-INCHES (10.2-11.9 NEWTON METERS).		
115	NAS1149C0432R	. WASHER		1
120	BACN10YR4CM	. NUT		1

**71-00-02**

P/P BUILDUP FIGURE 28-1

Page 9

Oct 05/2007

D633A106-HXL



737-600/700/800/900  
**POWERPLANT BUILDUP MANUAL**

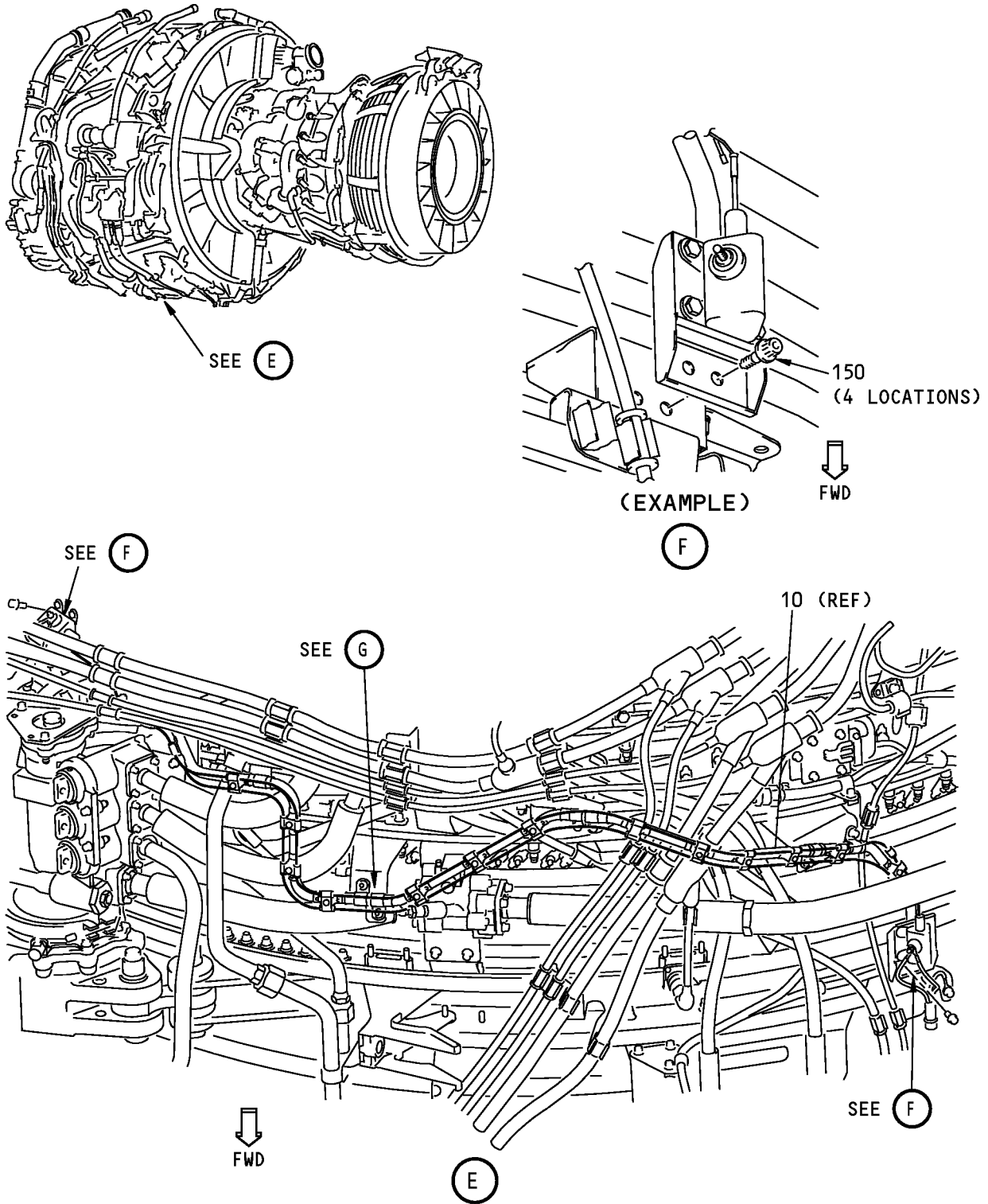

**Fire/Overheat Detector Installation**  
**Figure 28-1 (Sheet 5)**

**71-00-02**

P/P BUILDUP FIGURE 28-1

Page 10

Oct 05/2007

D633A106-HXL

**737-600/700/800/900  
POWERPLANT BUILDUP MANUAL**

ITEM NO.	PART NUMBER	NOMENCLATURE	UC	QTY
28-1		<b>FIRE/OVERHEAT DETECTOR INSTALLATION (FIGURE 28-1, SHEET 5)</b>		
C1	B00083	USE solvent, B00083 (C1) TO CLEAN FAY SURFACES OF BOTH ELECTRICAL DETECTOR BRACKETS ON FIRE DETECTOR (10) AND FAY SURFACES OF ENGINE BRACKETS AT 3:00 THRU 7:00 O'CLOCK POSITIONS ON FAN CASE. . SOLVENT, TT-N-95	CON	AR
150	BACB30ZF4-06	POSITION FIRE DETECTOR (10) ON ENGINE BRACKETS ON ENGINE FAN CASE. MAKE SURE SUPPORT TUBE ALIGNS NEXT TO HOLES IN BRACKETS. LOOSELY ATTACH DETECTOR BRACKETS TO ENGINE BRACKETS WITH BOLTS (150). . BOLT		4

**71-00-02**

P/P BUILDUP FIGURE 28-1

Page 11

Oct 05/2007

D633A106-HXL

737-600/700/800/900  
**POWERPLANT BUILDUP MANUAL**

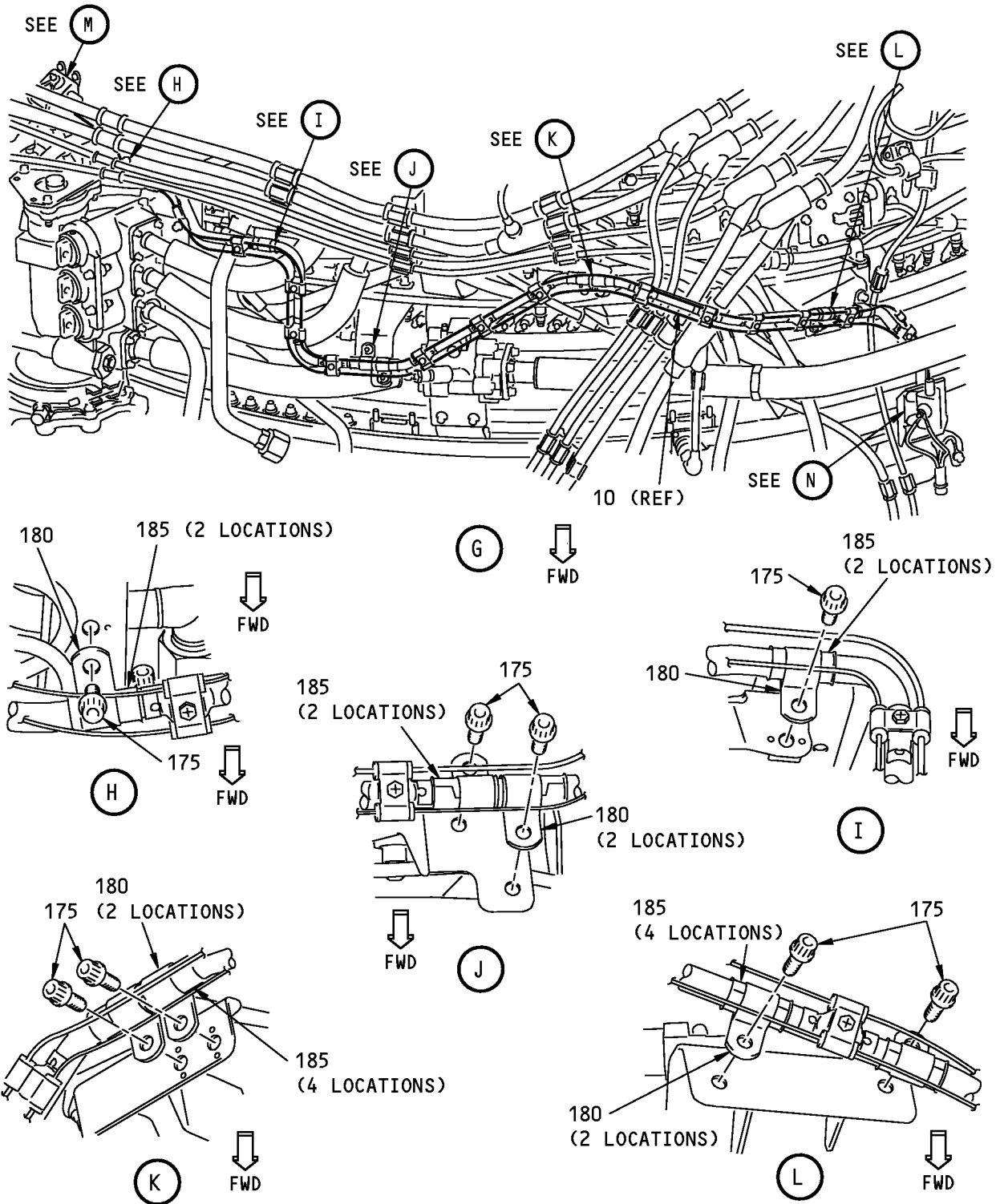

**Fire/Overheat Detector Installation**  
**Figure 28-1 (Sheet 6)**

**71-00-02**

P/P BUILDUP FIGURE 28-1

Page 12

Oct 05/2007

D633A106-HXL

**737-600/700/800/900  
POWERPLANT BUILDUP MANUAL**

ITEM NO.	PART NUMBER	NOMENCLATURE	UC	QTY
28-1		<b>FIRE/OVERHEAT DETECTOR INSTALLATION (FIGURE 28-1, SHEET 6)</b>		
		APPLY Never-Seez NSBT-8N compound, D00006 (C2) UNDER HEAD OF BOLTS (175) TO PREVENT DISTORTION AND TWISTING OF CLAMP DURING TORQUING.		
175	BACB30ZF4-06	. BOLT		8
C2	D00006	. COMPOUND, NEVER SEEZ NSBT-8N	CON	AR
		LOOSELY ATTACH SUPPORT TUBE OF DETECTOR (10) TO ENGINE BRACKETS AT 8 LOCATIONS WITH LOOP CLAMPS (180), CLAMPSHELLS (185) AND BOLTS (175).		
		<b>NOTE:</b> IN LOCATIONS WITH 2 ADJACENT CLAMPS, CLAMPSHELL-TO-CLAMPSHELL CLEARANCE IS LESS THAN 0.005 INCH (0.13 MM). IN THESE LOCATIONS, THE CLAMP MAY RIDE THE RADIUS OF THE CLAMPSHELL.		
180	11777-08	. LOOP CLAMP		8
185	9352M41P04	. CLAMPSHELL		16
185	BACC10GT2-08	. CLAMPSHELL (OPTIONAL TO 9352M41P04)	OPT	-
		MAKE SURE PRELOAD BETWEEN DETECTOR ASSY AND ATTACH POINTS IS NOT MORE THAN 10 POUNDS (44.5 NEWTONS). TIGHTEN BOLTS (150) TO 110-120 POUND-INCHES (12.4-13.6 NEWTON METERS). TIGHTEN BOLTS (175) TO 73-77 POUND-INCHES (8.25-8.70 NEWTON METERS).		
		CHECK THAT RESISTANCE BETWEEN RESPONDER AND ENGINE CASE IS 0.010 OHMS MAXIMUM.		
		CHECK THAT GAP BETWEEN SENSOR ELEMENTS AND SUPPORT TUBE IS NOT LESS THAN 0.12 INCH (3.0 MM).		

# 71-00-02

P/P BUILDUP FIGURE 28-1

Page 13

Oct 05/2007

D633A106-HXL

737-600/700/800/900  
**POWERPLANT BUILDUP MANUAL**

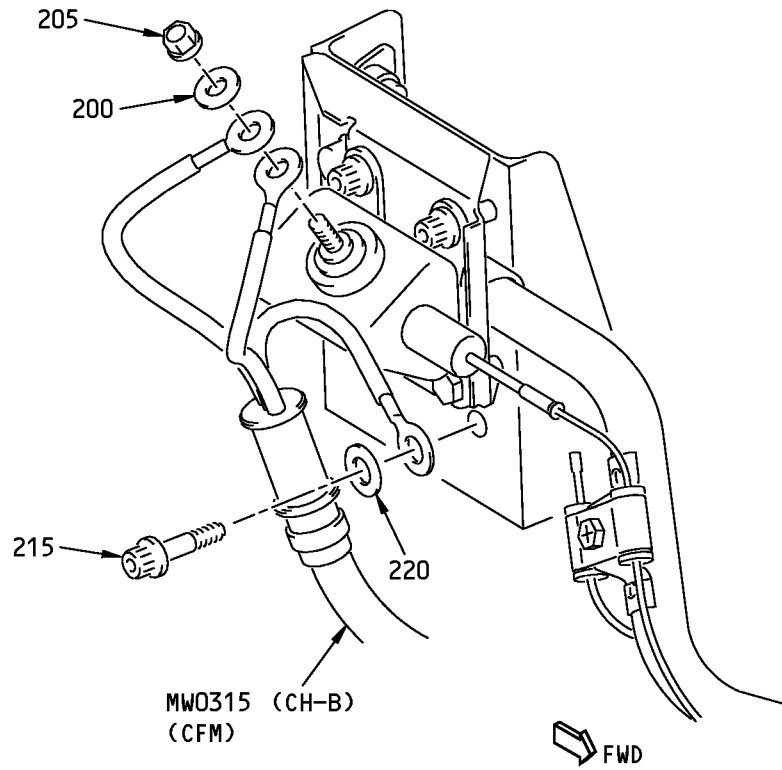

M

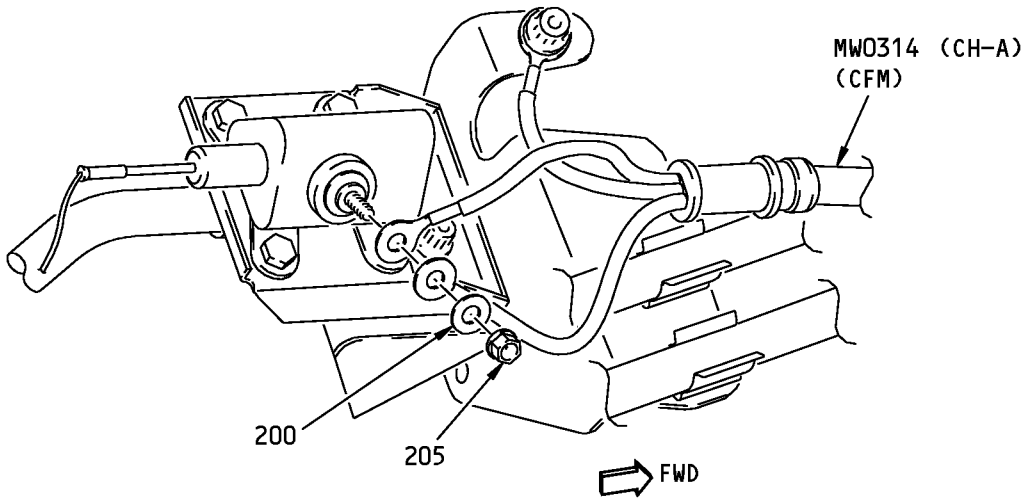

N

**Fire/Overheat Detector Installation**  
**Figure 28-1 (Sheet 7)**

**71-00-02**

P/P BUILDUP FIGURE 28-1

Page 14

Oct 05/2007

D633A106-HXL

**737-600/700/800/900  
POWERPLANT BUILDUP MANUAL**

ITEM NO.	PART NUMBER	NOMENCLATURE	UC	QTY
28-1		<b>FIRE/OVERHEAT DETECTOR INSTALLATION (FIGURE 28-1, SHEET 7)</b>		
		ATTACH W/B MW0315 (CFM) TO LEFT RESPONDER AND ATTACH W/B MW0314 (CFM) TO RIGHT RESPONDER. PUT BOTH W/B LEADS ON EACH RESPONDER STUD AND SECURE WITH WASHER (200) AND NUT (205). TIGHTEN NUT TO 25-35 POUND-INCHES (2.8-4.0 NEWTON METERS). MINIMUM STUD THREAD PROTRUSION MUST BE FLUSH WITH TOP ON NUT.		
200	NAS1149C0316R	. WASHER		2
200	NAS1149C0332R	. WASHER (OPTIONAL TO NAS1149C0316R) (2 REQD)	OPT	-
205	BACN10JC3C	. NUT (SUPPLIED WITH F/O DETECTOR)	REF	-
205	BACN10YR3C	. NUT (OPTIONAL TO BACN10JC3C) (2 REQD)	OPT	-
		ATTACH W/B MW0315 (CFM) GROUNDING WIRE TO LEFT RESPONDER BRACKET. SECURE WITH BOLT (215) AND WASHER (220) AND TIGHTEN TO 110-120 POUND-INCHES (12.4-13.6 NEWTON METERS).		
215	BACB30ZF4-07	. BOLT		1
220	NAS1149C0432R	. WASHER		1

**71-00-02**

P/P BUILDUP FIGURE 28-1

Page 15

Oct 05/2007

D633A106-HXL

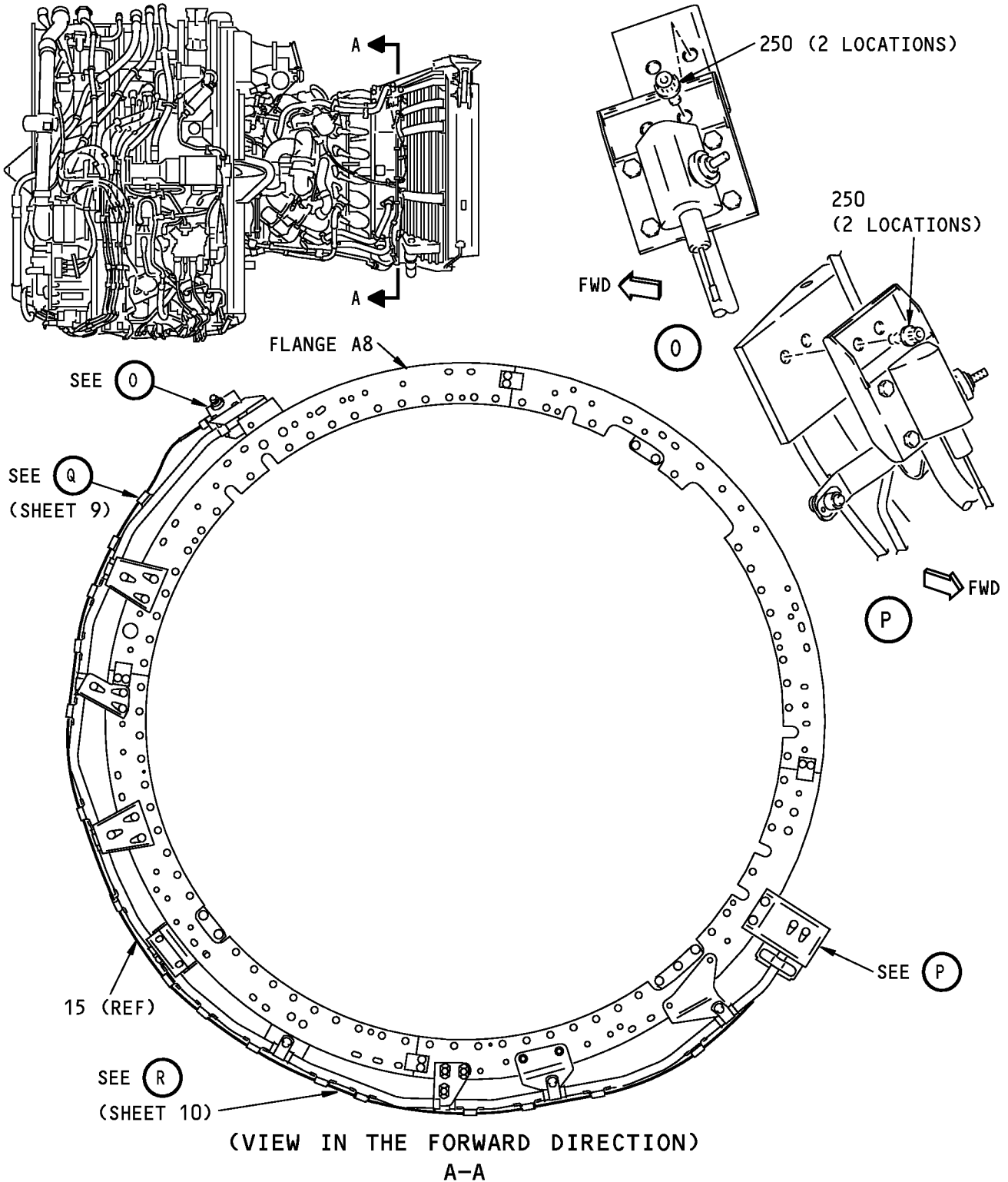

**Fire/Overheat Detector Installation**  
**Figure 28-1 (Sheet 8)**

**71-00-02**

P/P BUILDUP FIGURE 28-1

Page 16

Oct 05/2007

**737-600/700/800/900  
POWERPLANT BUILDUP MANUAL**

ITEM NO.	PART NUMBER	NOMENCLATURE	UC	QTY
28-1		<p><b>FIRE/OVERHEAT DETECTOR INSTALLATION (FIGURE 28-1, SHEET 8)</b></p> <p>USE solvent, B00083 (C1) TO CLEAN FAY SURFACES OF BOTH ELECTRICAL DETECTOR BRACKETS ON FIRE DETECTOR (15) AND FAY SURFACES OF ENGINE BRACKETS AT 10:30 AND 4:00 O'CLOCK POSITIONS ON ENGINE CORE FLANGE A8.</p> <p>. SOLVENT, TT-N-95</p> <p>POSITION FIRE DETECTOR (15) ON ENGINE BRACKETS. MAKE SURE SUPPORT TUBE ALIGNS NEXT TO HOLES IN BRACKETS.</p> <p>LOOSELY ATTACH DETECTOR BRACKETS TO ENGINE BRACKETS WITH BOLTS (250).</p> <p>. BOLT</p>		
C1	B00083		CON	AR
250	BACB30ZF4-07			4

**71-00-02**

P/P BUILDUP FIGURE 28-1

Page 17

Oct 05/2007

D633A106-HXL



737-600/700/800/900  
**POWERPLANT BUILDUP MANUAL**

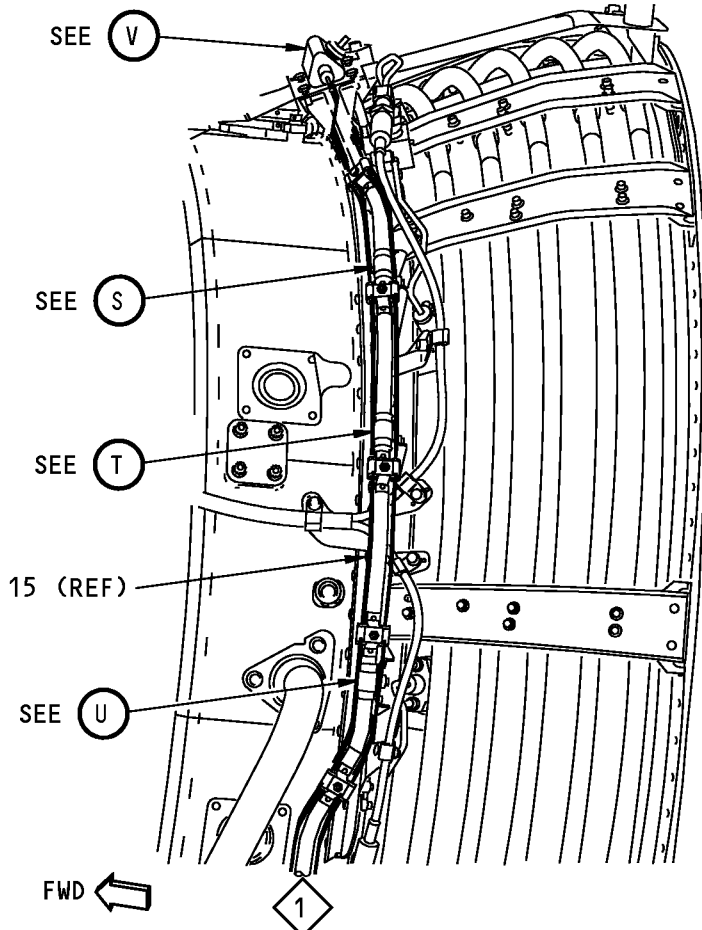

(SHEET 10)

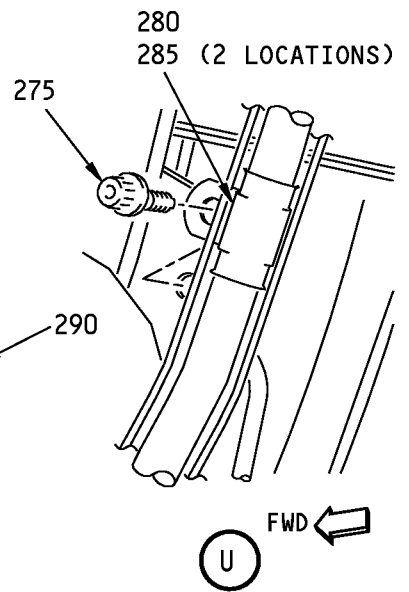
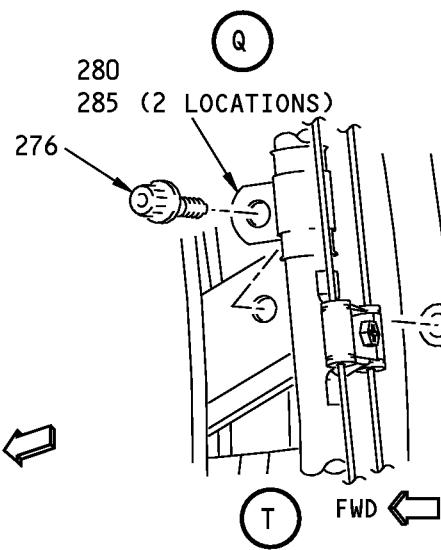
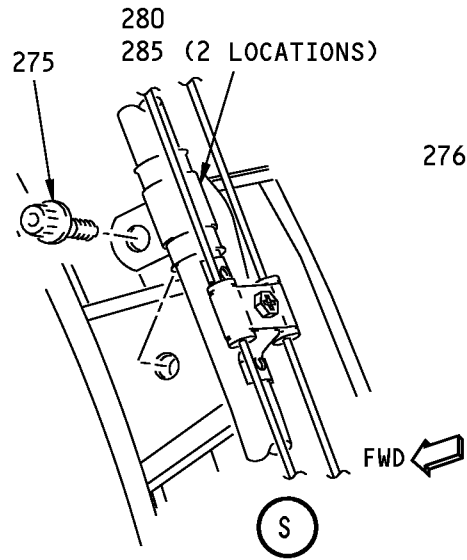

**Fire/Overheat Detector Installation**  
**Figure 28-1 (Sheet 9)**

**71-00-02**

P/P BUILDUP FIGURE 28-1

Page 18

Oct 05/2007

D633A106-HXL

**737-600/700/800/900  
POWERPLANT BUILDUP MANUAL**

ITEM NO.	PART NUMBER	NOMENCLATURE	UC	QTY
28-1		<b>FIRE/OVERHEAT DETECTOR INSTALLATION (FIGURE 28-1, SHEET 9)</b>		
		APPLY Never-Seez NSBT-8N compound, D00006 (C2) UNDER HEAD OF BOLTS (275) AND BOLT (276) TO PREVENT DISTORTION AND TWISTING OF CLAMP DURING TORQUING.		
275	BACB30ZF4-06	. BOLT		2
276	BACB30ZF4-08	. BOLT		1
C2	D00006	. COMPOUND, NEVER SEEZ NSBT-8N	CON	AR
		LOOSELY ATTACH SUPPORT TUBE OF DETECTOR (15) TO ENGINE BRACKETS AT 3 LOCATIONS WITH LOOP CLAMPS (280), CLAMPSHELLS (285), BOLTS (275) (2 LOCATIONS), BOLT (276) (1 LOCATION) AND NUT (290).		
280	11777-08	. LOOP CLAMP		3
285	9352M41P04	. CLAMPSHELL		6
285	BACC10GT2-08	. CLAMPSHELL (OPTIONAL TO 9352M41P04)	OPT	-
290	AS3485-10	. NUT		1

**71-00-02**

P/P BUILDUP FIGURE 28-1

Page 19

Oct 05/2007

D633A106-HXL

737-600/700/800/900  
**POWERPLANT BUILDUP MANUAL**

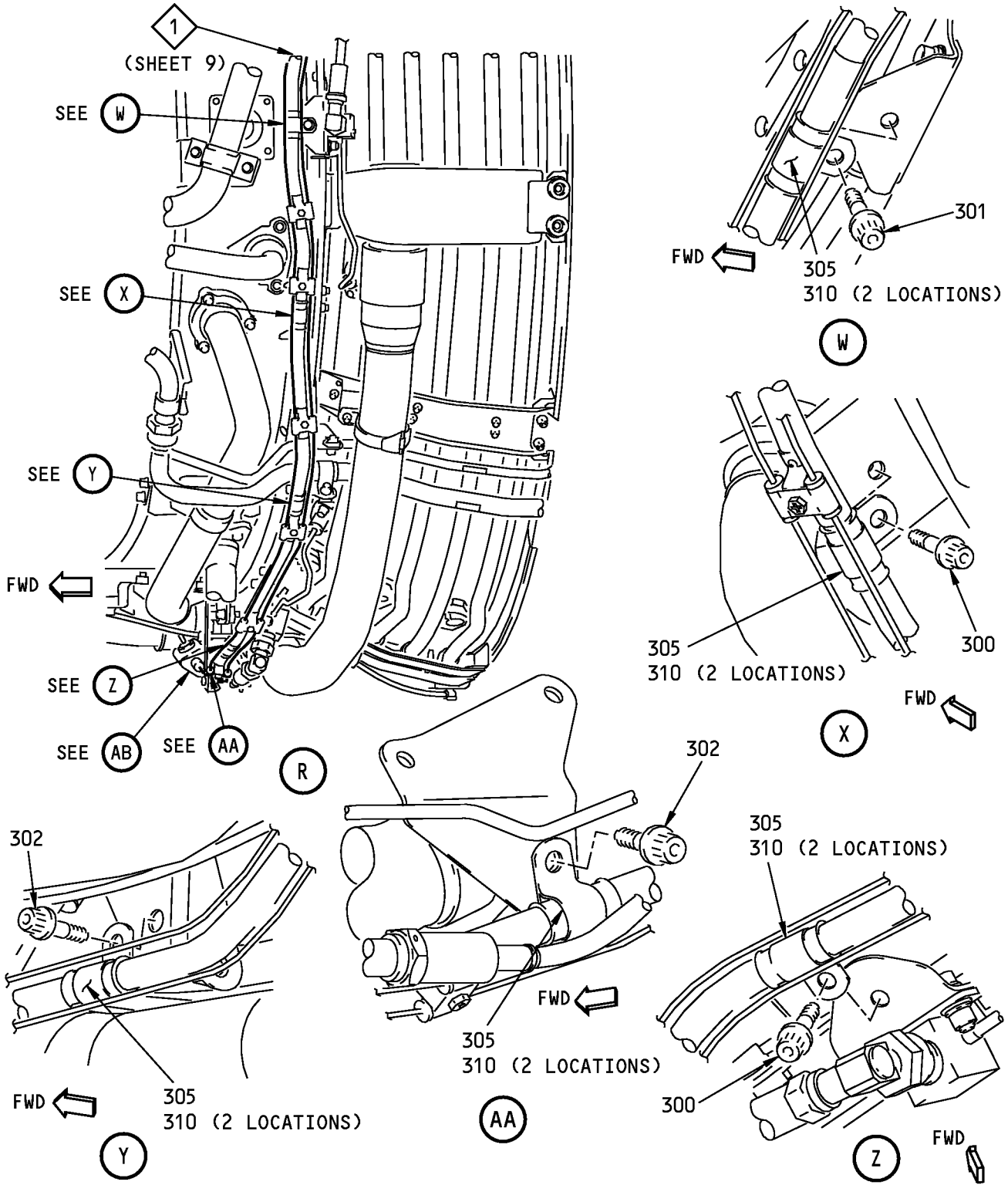

**Fire/Overheat Detector Installation**  
**Figure 28-1 (Sheet 10)**

**71-00-02**

P/P BUILDUP FIGURE 28-1

Page 20

Oct 05/2007

D633A106-HXL

**737-600/700/800/900  
POWERPLANT BUILDUP MANUAL**

ITEM NO.	PART NUMBER	NOMENCLATURE	UC	QTY
28-1		<b>FIRE/OVERHEAT DETECTOR INSTALLATION (FIGURE 28-1, SHEET 10)</b>		
		APPLY Never-Seez NSBT-8N compound, D00006 (C2) UNDER HEAD OF BOLTS (300, 301 AND 302) TO PREVENT DISTORTION AND TWISTING OF CLAMP DURING TORQUING.		
300	BACB30ZF4-06	. BOLT		2
301	BACB30ZF4-08	. BOLT		1
302	BACB30ZF4-06	. BOLT		2
C2	D00006	. COMPOUND, NEVER SEEZ NSBT-8N	CON	AR
		LOOSELY ATTACH SUPPORT TUBE OF DETECTOR (15) TO ENGINE BRACKETS AT 5 LOCATIONS WITH LOOP CLAMPS (305), CLAMPSHELLS (310), BOLTS (300, 301 AND 302).		
305	11777-08	. LOOP CLAMP		5
310	9352M41P04	. CLAMPSHELL		10
310	BACC10GT2-08	. CLAMPSHELL (OPTIONAL TO 9352M41P04)	OPT	-
		MAKE SURE PRELOAD BETWEEN DETECTOR ASSY AND ATTACH POINTS IS NOT MORE THAN 10 POUNDS (44.5 NEWTONS). TIGHTEN BOLTS (250), THEN BOLTS (301 AND 302) TO 73-77 POUND-INCHES (8.25-8.70 NEWTON METERS). TIGHTEN BOLTS (275 AND 300) TO 110-120 POUND-INCHES (12.4-13.6 NEWTON METERS).		
		CHECK THAT RESISTANCE BETWEEN RESPONDER AND ENGINE CASE IS 0.010 OHMS MAXIMUM.		
		CHECK THAT GAP BETWEEN SENSOR ELEMENTS AND SUPPORT TUBE IS NOT LESS THAN 0.12 INCH (3.0 MM).		

**71-00-02**

P/P BUILDUP FIGURE 28-1

Page 21

Oct 05/2007

D633A106-HXL

737-600/700/800/900  
**POWERPLANT BUILDUP MANUAL**

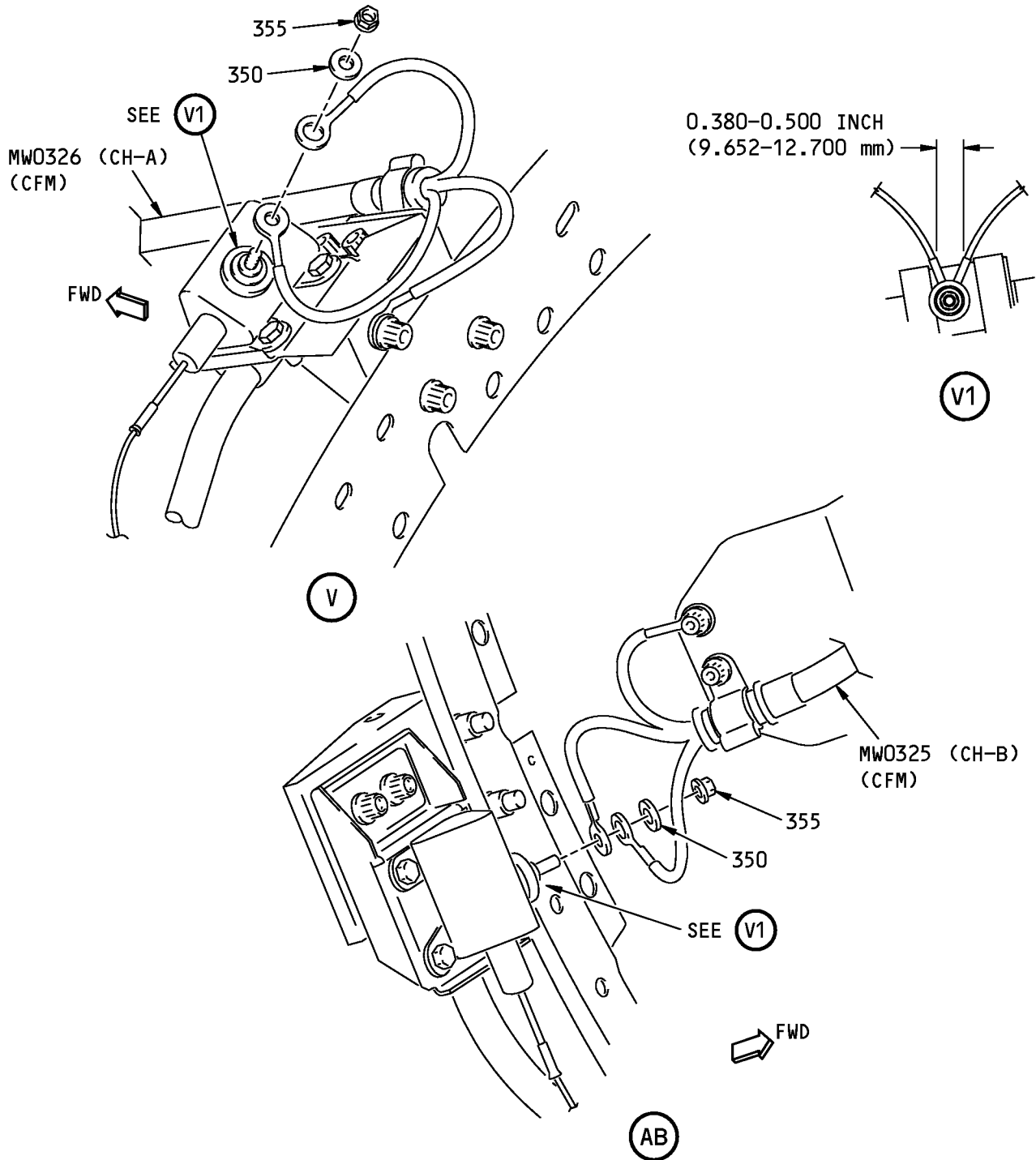

ENGINES WITH MW0325 & MW0326 HARNESSES WITH GROUND LUG AND WIRE (PRE-SB CFM56-7B-72-0258)

K06122 S00041153976\_V3

**Fire/Overheat Detector Installation**  
**Figure 28-1 (Sheet 11)**

**71-00-02**

P/P BUILDUP FIGURE 28-1

Page 22

Feb 05/2008

D633A106-HXL

**737-600/700/800/900  
POWERPLANT BUILDUP MANUAL**

ITEM NO.	PART NUMBER	NOMENCLATURE	UC	QTY
28-1		<p><b>FIRE/OVERHEAT DETECTOR INSTALLATION (FIGURE 28-1, SHEET 11)</b></p> <p>ENGINES WITH MW0325 AND MW0326 HARNESSSES WITH GROUND LUG AND WIRE (PRE SB):</p> <p><b>CAUTION:</b> DO NOT BEND THE WIRE LUG. INCORRECT INSTALLATION CAN CAUSE WIRE LUG DAMAGE AND DETECTOR LOOP FAULTS.</p> <p>ATTACH W/B MW0325 (CFM) TO UPPER RESPONDER AND ATTACH W/B MW0325 (CFM) TO LOWER RESPONDER. PUT BOTH W/B LEADS ON EACH RESPONDER STUD AND SECURE WITH WASHER (350) AND NUT (355). TIGHTEN NUT TO 25-35 POUND-INCHES (2.8-4.0 NEWTON METERS). MINIMUM STUD THREAD PROTRUSION MUST BE FLUSH WITH TOP OF NUT.</p>		
350	NAS1149C0316R	. WASHER		2
350	NAS1149C0332R	. WASHER (OPTIONAL TO NAS1149C0316R) (2 REQD)	OPT	-
355	BACN10JC3C	. NUT (SUPPLIED WITH F/O DETECTOR)	REF	-
355	BACN10YR3C	. NUT (OPTIONAL TO BACN10JC3C) (2 REQD)	OPT	-

**71-00-02**

P/P BUILDUP FIGURE 28-1

Page 23

Feb 05/2008

D633A106-HXL

737-600/700/800/900  
**POWERPLANT BUILDUP MANUAL**

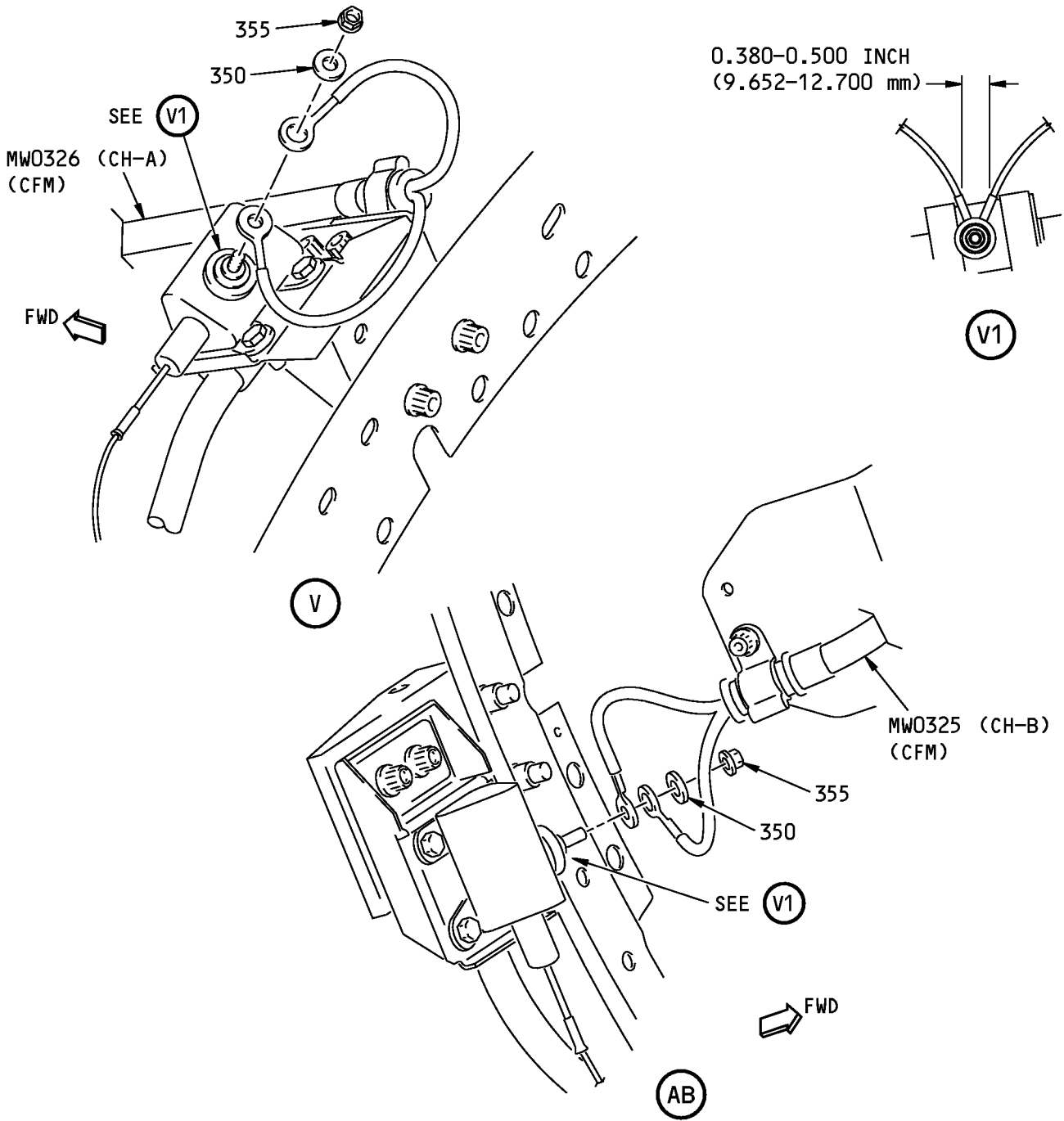

ENGINES WITH MW0325 & MW0326 HARNESSES WITHOUT GROUND LUG  
AND WIRE (POST-SB CFM56-7B-72-0258)

1477399 S0000268836\_V1

**Fire/Overheat Detector Installation**  
**Figure 28-1 (Sheet 12)**

**71-00-02**

P/P BUILDUP FIGURE 28-1

Page 24

Feb 05/2008

D633A106-HXL

**737-600/700/800/900  
POWERPLANT BUILDUP MANUAL**

ITEM NO.	PART NUMBER	NOMENCLATURE	UC	QTY
28-1		<p><b>FIRE/OVERHEAT DETECTOR INSTALLATION (FIGURE 28-1, SHEET 12)</b></p> <p>ENGINES WITH MW0325 AND MW0326 HARNESSSES WITHOUT <u>GROUND LUG AND WIRE (POST SB):</u></p> <p><b>CAUTION:</b> DO NOT BEND THE WIRE LUG. INCORRECT INSTALLATION CAN CAUSE WIRE LUG DAMAGE AND DETECTOR LOOP FAULTS.</p> <p>ATTACH W/B MW0325 (CFM) TO UPPER RESPONDER AND ATTACH W/B MW0325 (CFM) TO LOWER RESPONDER. PUT BOTH W/B LEADS ON EACH RESPONDER STUD AND SECURE WITH WASHER (350) AND NUT (355). TIGHTEN NUT TO 25-35 POUND-INCHES (2.8-4.0 NEWTON METERS). MINIMUM STUD THREAD PROTRUSION MUST BE FLUSH WITH TOP OF NUT.</p>		
350	NAS1149C0316R	. WASHER		2
350	NAS1149C0332R	. WASHER (OPTIONAL TO NAS1149C0316R) (2 REQD)	OPT	-
355	BACN10JC3C	. NUT (SUPPLIED WITH F/O DETECTOR)	REF	-
355	BACN10YR3C	. NUT (OPTIONAL TO BACN10JC3C) (2 REQD)	OPT	-

**71-00-02**

P/P BUILDUP FIGURE 28-1

Page 25

Feb 05/2008

D633A106-HXL



737-600/700/800/900  
**POWERPLANT BUILDUP MANUAL**

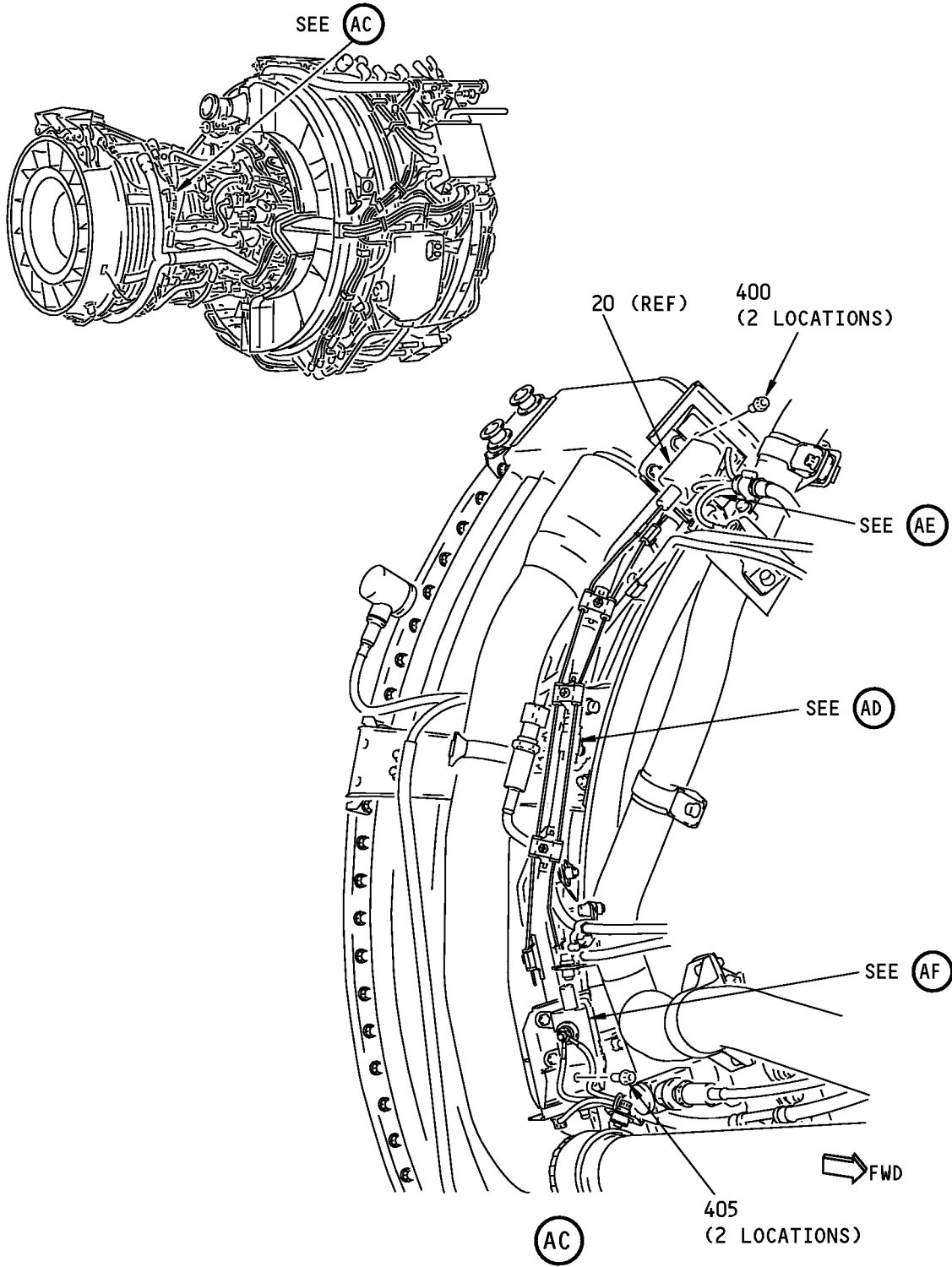

**Fire/Overheat Detector Installation**  
**Figure 28-1 (Sheet 13)**

**71-00-02**

**737-600/700/800/900  
POWERPLANT BUILDUP MANUAL**

ITEM NO.	PART NUMBER	NOMENCLATURE	UC	QTY
28-1		<b>FIRE/OVERHEAT DETECTOR INSTALLATION (FIGURE 28-1, SHEET 13)</b>		
C1	B00083	USE solvent, B00083 (C1) TO CLEAN FAY SURFACES OF BOTH ELECTRICAL DETECTOR BRACKETS ON FIRE DETECTOR (20) AND FAY SURFACES OF ENGINE BRACKETS AT 1:00 AND 3:00 O'CLOCK POSITIONS ON ENGINE CORE FLANGE A8. . SOLVENT, TT-N-95	CON	AR
400	BACB30ZF4-06	POSITION FIRE DETECTOR (20) ON ENGINE BRACKETS. MAKE SURE SUPPORT TUBE ALIGNS NEXT TO HOLES IN BRACKETS. LOOSELY ATTACH DETECTOR BRACKET TO UPPER ENGINE BRACKET WITH BOLTS (400) AND LOWER ENGINE BRACKET WITH BOLTS (405). . BOLT		2
405	BACB30ZF4-07	. BOLT		2

**71-00-02**

P/P BUILDUP FIGURE 28-1

Page 27

Feb 05/2008

D633A106-HXL

737-600/700/800/900  
**POWERPLANT BUILDUP MANUAL**

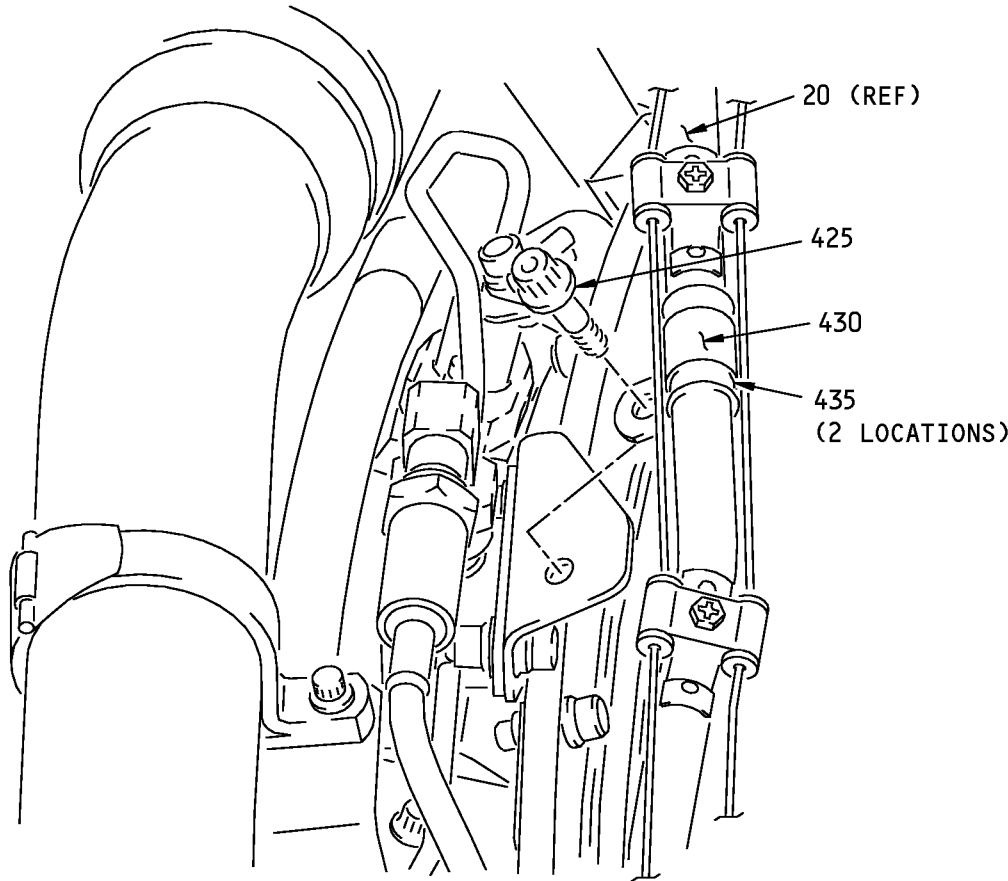

FWD ←

AD

**Fire/Overheat Detector Installation**  
**Figure 28-1 (Sheet 14)**

**71-00-02**

P/P BUILDUP FIGURE 28-1  
Page 28  
Feb 05/2008

D633A106-HXL

**737-600/700/800/900  
POWERPLANT BUILDUP MANUAL**

ITEM NO.	PART NUMBER	NOMENCLATURE	UC	QTY
28-1		<b>FIRE/OVERHEAT DETECTOR INSTALLATION (FIGURE 28-1, SHEET 14)</b>		
425	BACB30ZF4-06	. BOLT		1
C2	D00006	. COMPOUND, NEVER SEEZ NSBT-8N	CON	AR
		LOOSELY ATTACH SUPPORT TUBE OF DETECTOR (20) TO ENGINE BRACKET WITH LOOP CLAMP (430), CLAMPSHELLS (435) AND BOLT (425).		
430	11777-08	. LOOP CLAMP		1
435	9352M41P04	. CLAMPSHELL		2
435	BACC10GT2-08	. CLAMPSHELL (OPTIONAL TO 9352M41P04)	OPT	-
		MAKE SURE PRELOAD BETWEEN DETECTOR ASSY AND ATTACH POINTS IS NOT MORE THAN 10 POUNDS (44.5 NEWTONS). TIGHTEN BOLTS (400), THEN BOLT (425) TO 110-120 POUND-INCHES (12.4-13.6 NEWTON METERS).		
		CHECK THAT RESISTANCE BETWEEN RESPONDER AND ENGINE CASE IS 0.010 OHMS MAXIMUM.		
		CHECK THAT GAP BETWEEN SENSOR ELEMENTS AND SUPPORT TUBE IS NOT LESS THAN 0.12 INCH (3.0 MM).		

# 71-00-02

P/P BUILDUP FIGURE 28-1

Page 29

Feb 05/2008

D633A106-HXL

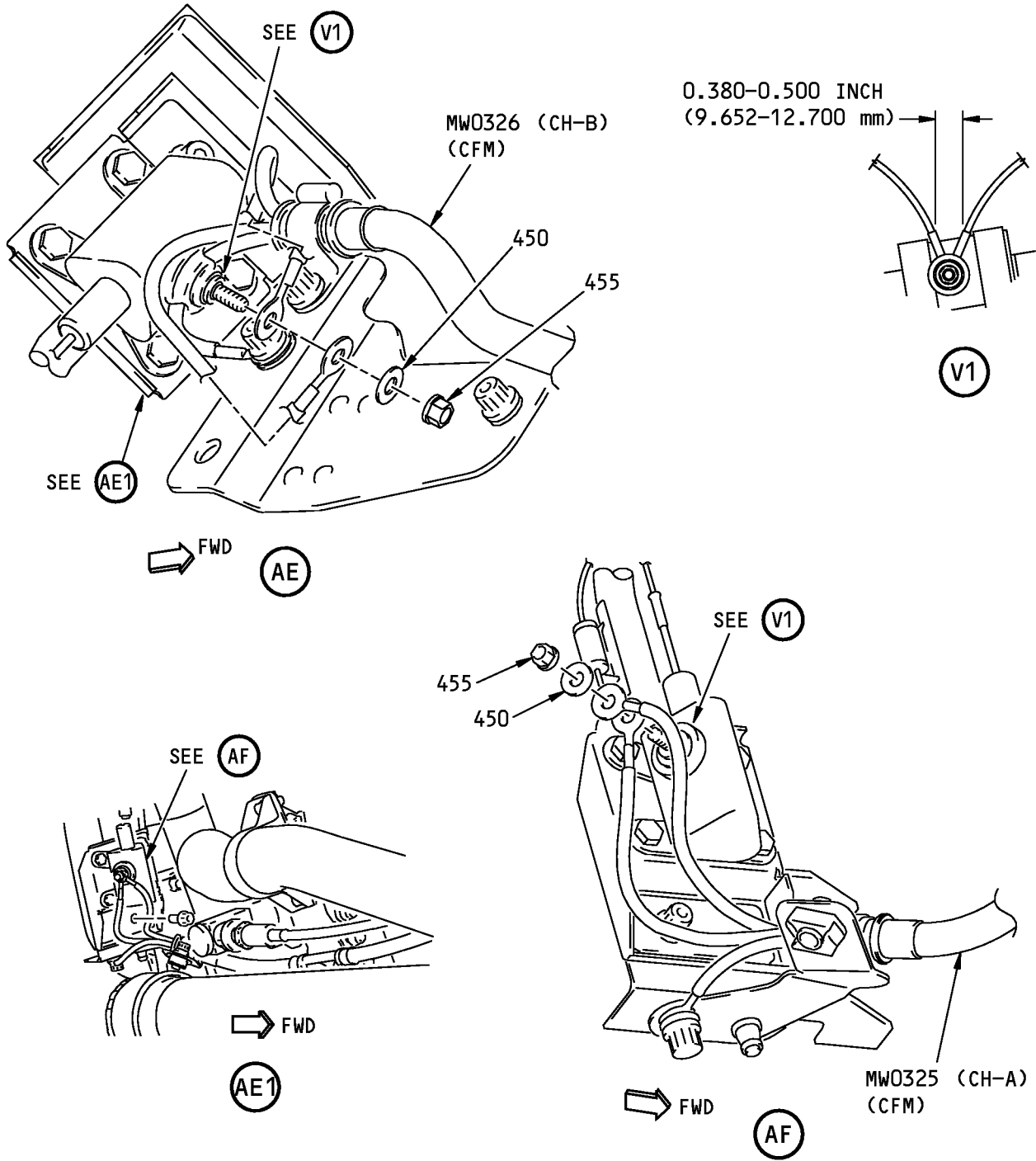

ENGINES WITH MW0325 & MW0326 HARNESSES WITH GROUND LUG AND WIRE (PRE-SB CFM56-7B-72-0258)

K56869 S00041153980\_V3

Fire/Overheat Detector Installation  
Figure 28-1 (Sheet 15)

**71-00-02**

P/P BUILDUP FIGURE 28-1

Page 30

Feb 05/2008

D633A106-HXL

**737-600/700/800/900  
POWERPLANT BUILDUP MANUAL**

ITEM NO.	PART NUMBER	NOMENCLATURE	UC	QTY
28-1		<p><b>FIRE/OVERHEAT DETECTOR INSTALLATION (FIGURE 28-1, SHEET 15)</b></p> <p>ENGINES WITH MW0325 AND MW0326 HARNESSSES WITH GROUND LUG AND WIRE (PRE SB):</p> <p><b>CAUTION:</b> DO NOT BEND THE WIRE LUG. INCORRECT INSTALLATION CAN CAUSE WIRE LUG DAMAGE AND DETECTOR LOOP FAULTS.</p> <p>ATTACH W/B MW0326 (CFM) TO UPPER RESPONDER AND ATTACH W/B MW0325 (CFM) TO LOWER RESPONDER. PUT BOTH W/B LEADS ON EACH RESPONDER STUD AND SECURE WITH WASHER (450) AND NUT (455). TIGHTEN NUT TO 25-35 POUND-INCHES (2.8-4.0 NEWTON METERS). MINIMUM STUD THREAD PROTRUSION MUST BE FLUSH WITH TOP ON NUT.</p>		
450	NAS1149C0316R	. WASHER		2
450	NAS1149C0332R	. WASHER (OPTIONAL TO NAS1149C0316R) (2 REQD)	OPT	-
455	BACN10JC3C	. NUT (SUPPLIED WITH F/O DETECTOR)	REF	-
455	BACN10YR3C	. NUT (OPTIONAL TO BACN10JC3C) (2 REQD)	OPT	-

**71-00-02**

P/P BUILDUP FIGURE 28-1

Page 31

Feb 05/2008

D633A106-HXL

737-600/700/800/900  
POWERPLANT BUILDUP MANUAL

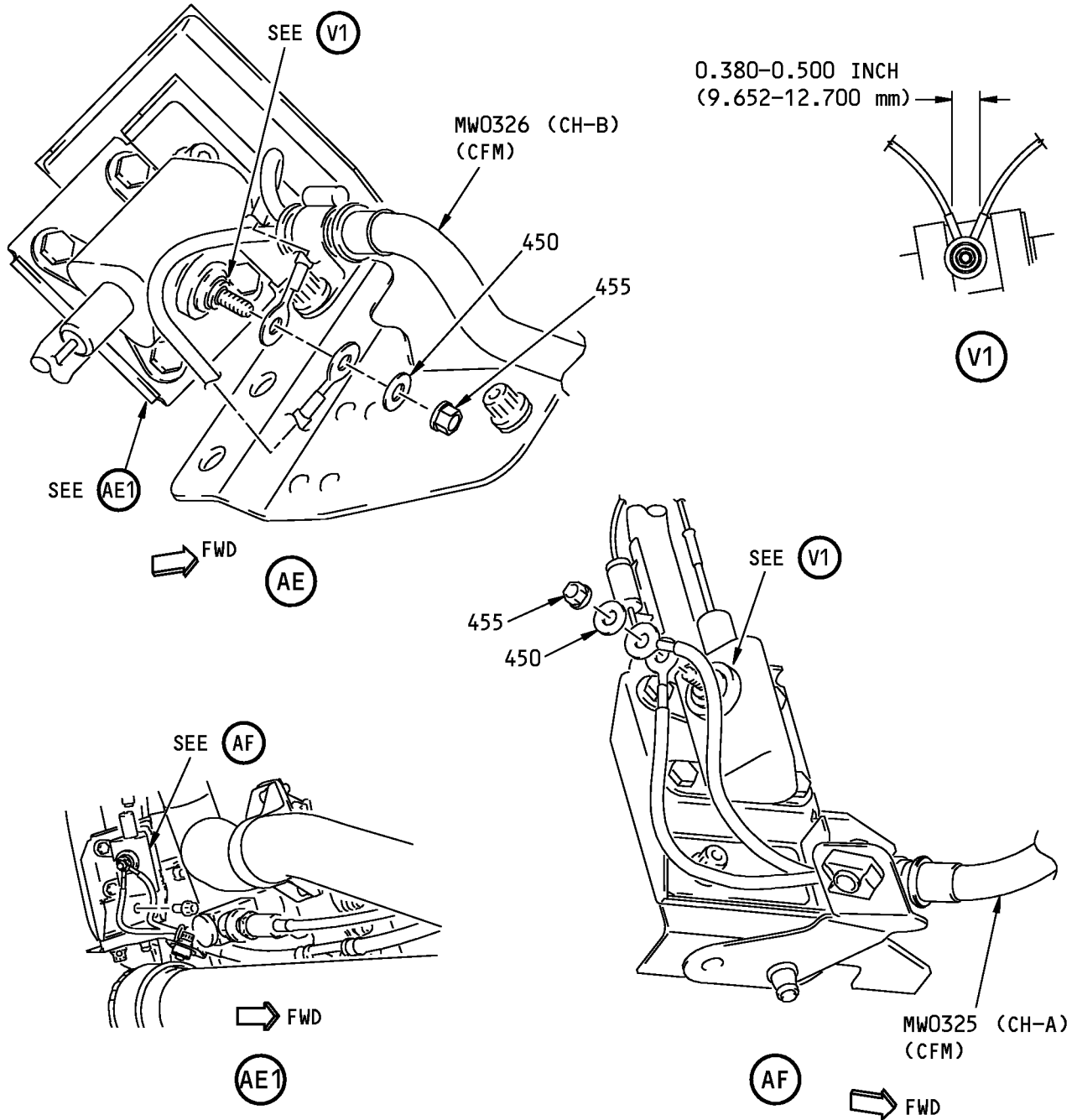

ENGINES WITH MW0325 & MW0326 HARNESSES WITHOUT GROUND LUG AND WIRE (POST-SB CFM56-7B-72-0258)

1477479 S0000269031\_V1

Fire/Overheat Detector Installation  
Figure 28-1 (Sheet 16)

**71-00-02**

P/P BUILDUP FIGURE 28-1

Page 32

Feb 05/2008

D633A106-HXL

**737-600/700/800/900  
POWERPLANT BUILDUP MANUAL**

ITEM NO.	PART NUMBER	NOMENCLATURE	UC	QTY
28-1		<p><b>FIRE/OVERHEAT DETECTOR INSTALLATION (FIGURE 28-1, SHEET 16)</b></p> <p>ENGINES WITH MW0325 AND MW0326 HARNESSSES WITHOUT <u>GROUND LUG AND WIRE (POST SB):</u></p> <p><b>CAUTION:</b> DO NOT BEND THE WIRE LUG. INCORRECT INSTALLATION CAN CAUSE WIRE LUG DAMAGE AND DETECTOR LOOP FAULTS.</p> <p>ATTACH W/B MW0326 (CFM) TO UPPER RESPONDER AND ATTACH W/B MW0325 (CFM) TO LOWER RESPONDER. PUT BOTH W/B LEADS ON EACH RESPONDER STUD AND SECURE WITH WASHER (450) AND NUT (455). TIGHTEN NUT TO 25-35 POUND-INCHES (2.8-4.0 NEWTON METERS). MINIMUM STUD THREAD PROTRUSION MUST BE FLUSH WITH TOP ON NUT.</p>		
450	NAS1149C0316R	. WASHER		2
450	NAS1149C0332R	. WASHER (OPTIONAL TO NAS1149C0316R) (2 REQD)	OPT	-
455	BACN10JC3C	. NUT (SUPPLIED WITH F/O DETECTOR)	REF	-
455	BACN10YR3C	. NUT (OPTIONAL TO BACN10JC3C) (2 REQD)	OPT	-

**71-00-02**

P/P BUILDUP FIGURE 28-1

Page 33

Feb 05/2008

D633A106-HXL



737-600/700/800/900  
**POWERPLANT BUILDUP MANUAL**

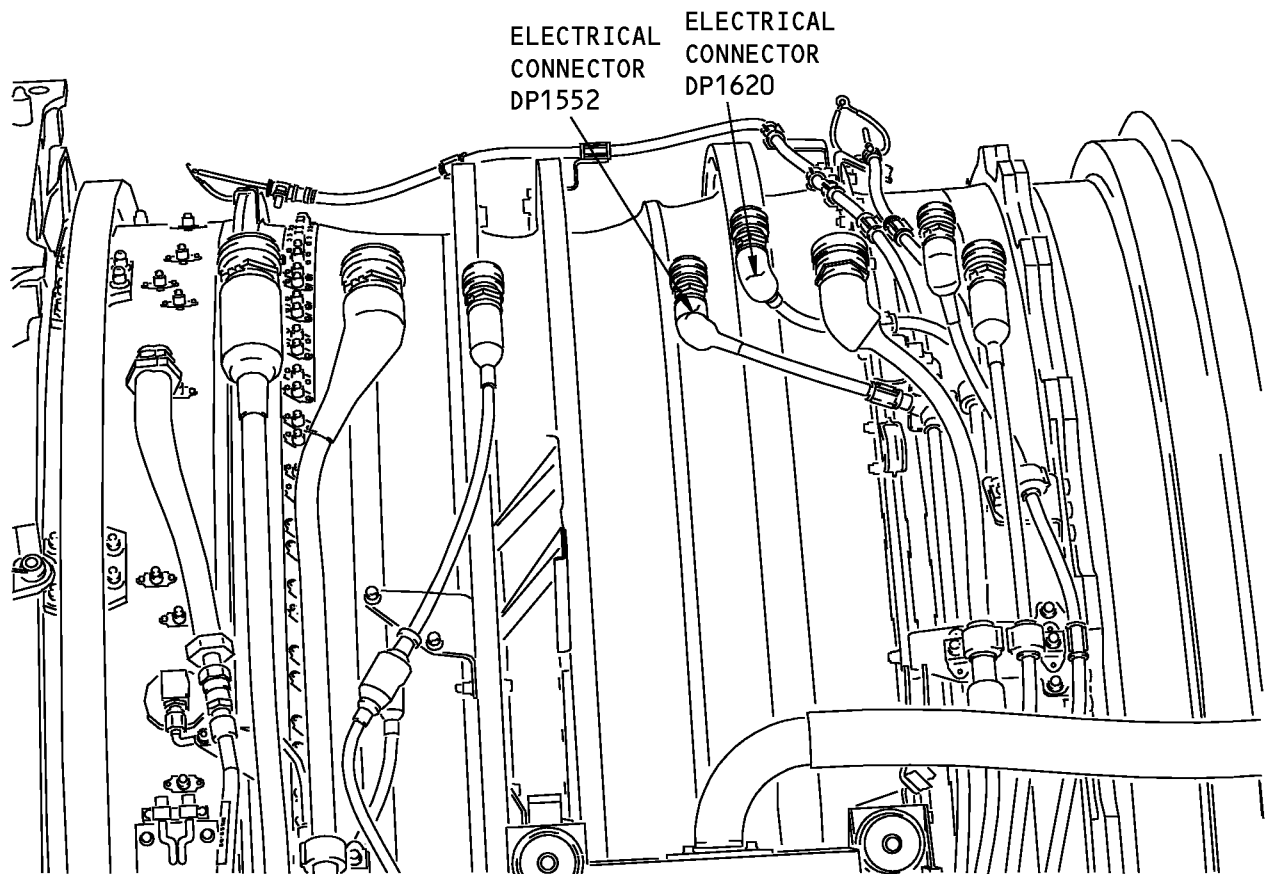
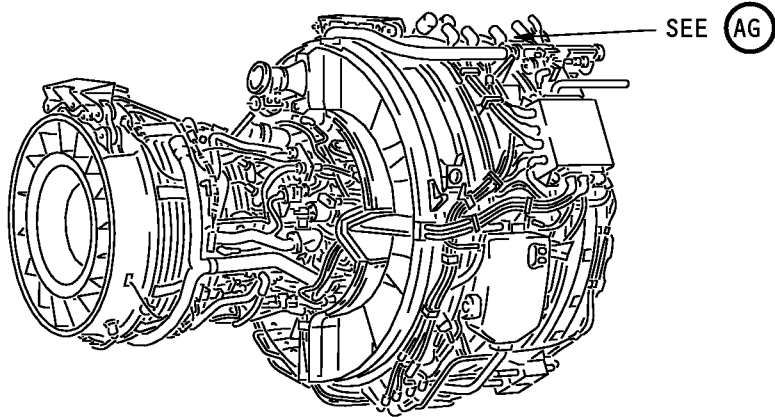

AG

➔ FWD

**NOTE:** SOME COMPONENTS NOT SHOWN FOR CLARITY.

**Fire/Overheat Detector Installation**  
**Figure 28-1 (Sheet 17)**

**71-00-02**

P/P BUILDUP FIGURE 28-1

Page 34

Feb 05/2008

D633A106-HXL

**737-600/700/800/900  
POWERPLANT BUILDUP MANUAL**

ITEM NO.	PART NUMBER	NOMENCLATURE	UC	QTY
28-1		<p><b>FIRE/OVERHEAT DETECTOR INSTALLATION (FIGURE 28-1, SHEET 17)</b></p> <p>DO A RESISTANCE TEST OF LOOP A OF THE FIRE/OVERHEAT DETECTORS AS FOLLOWS:</p> <ol style="list-style-type: none"> <li>1. ON THE TOP OF THE RIGHT FAN CASE, LOCATE THE CONNECTORS DP1552 (CFM).</li> <li>2. CHECK THE RESISTANCE BETWEEN PIN 1 ON CONNECTOR DP1552 AND GROUND.</li> <li>3. MAKE SURE THE RESISTANCE IS BETWEEN 822-902 OHMS.</li> </ol> <p>DO A RESISTANCE TEST OF LOOP B OF THE FIRE/OVERHEAT DETECTORS AS FOLLOWS:</p> <ol style="list-style-type: none"> <li>1. ON THE TOP OF THE RIGHT FAN CASE, LOCATE THE CONNECTORS DP1620 (CFM).</li> <li>2. CHECK THE RESISTANCE BETWEEN PIN 3 ON CONNECTOR DP1620 AND GROUND.</li> <li>3. MAKE SURE THE RESISTANCE IS BETWEEN 822-902 OHMS.</li> </ol>		

**71-00-02**

P/P BUILDUP FIGURE 28-1

Page 35

Feb 05/2008

D633A106-HXL

**FIGURE 29-1**

# **W1062 WIRE BUNDLE INSTALLATION**

**REF QEC TASK NO.: 29**

**REF DWG: 332A2200**

**NOTE:** ALL STANDARDS AND ATTACHING HARDWARE FOR THIS FIGURE WILL BE PACKAGED IN QEC TASK NO. 110.

**71-00-02**

P/P BUILDUP FIGURE 29-1

Page 1

Oct 05/2007

D633A106-HXL

737-600/700/800/900  
**POWERPLANT BUILDUP MANUAL**

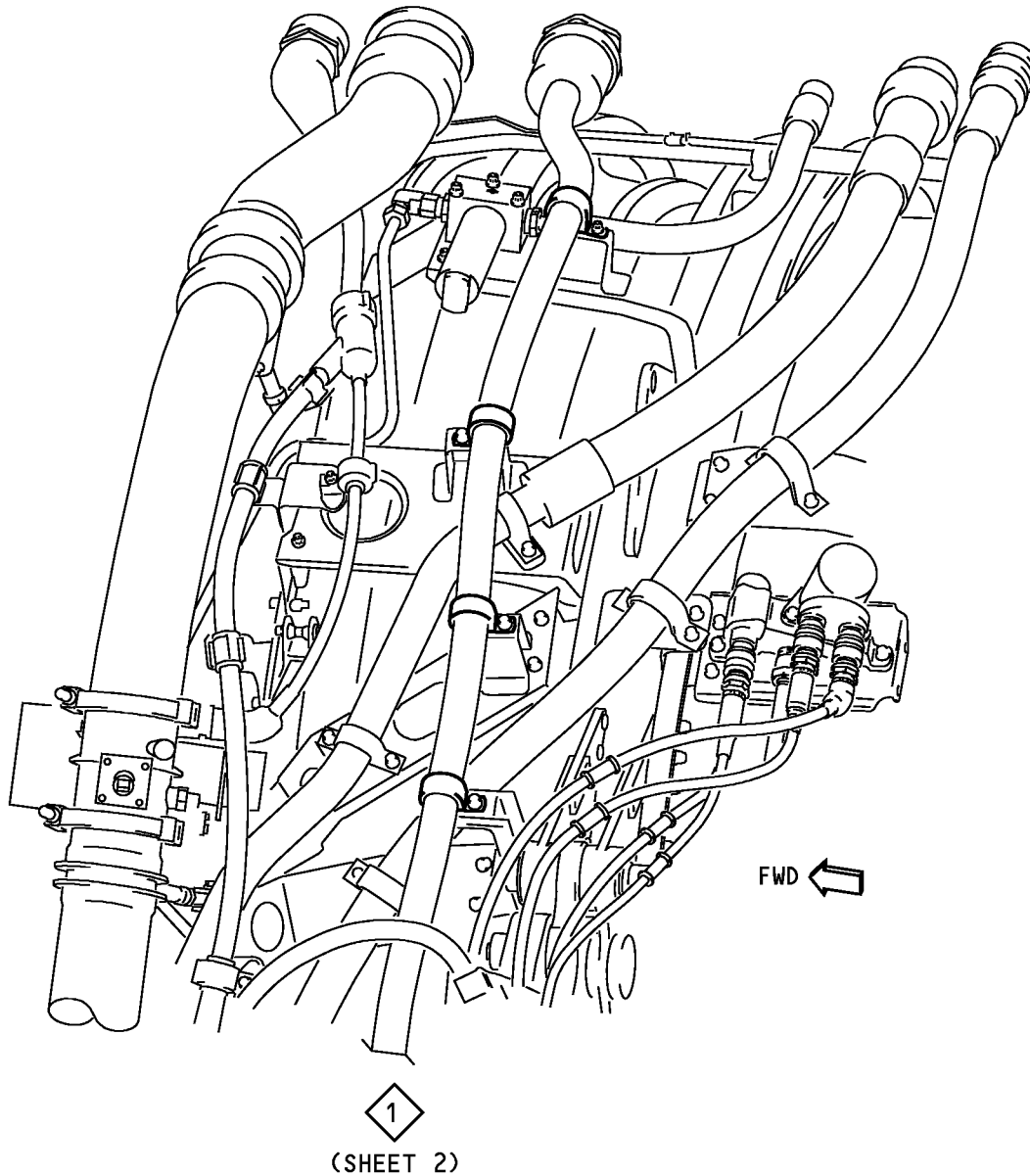

**EXAMPLE OF WIRE BUNDLE INSTALLATION**

◇ DIAMOND WITH NUMBER INDICATES A CONTINUATION TO A DIAMOND WITH THE SAME NUMBER IN ANOTHER SHEET OR ILLUSTRATION.

**W1062 Wire Bundle Installation  
Figure 29-1 (Sheet 1)**

**71-00-02**

P/P BUILDUP FIGURE 29-1

Page 2

Oct 05/2007

D633A106-HXL

**737-600/700/800/900  
POWERPLANT BUILDUP MANUAL**

ITEM NO.	PART NUMBER	NOMENCLATURE	UC	QTY
29-1		<p><b>W1062 WIRE BUNDLE INSTALLATION (FIGURE 29-1, SHEET 1)</b></p> <p><b>NOTE:</b> THIS SHEET IS PROVIDED FOR INFORMATION PURPOSES ONLY.</p> <p>REVIEW ELECTRICAL HARNESS STANDARD PRACTICES (INTRODUCTION) BEFORE BEGINNING PROCEDURE.</p> <p>SYMBOLS TO AID IN THE USE OF THESE ILLUSTRATIONS ARE SHOWN ON THE PRECEDING PAGE.</p>		

**71-00-02**

P/P BUILDUP FIGURE 29-1

Page 3

Oct 05/2007

D633A106-HXL

737-600/700/800/900  
**POWERPLANT BUILDUP MANUAL**

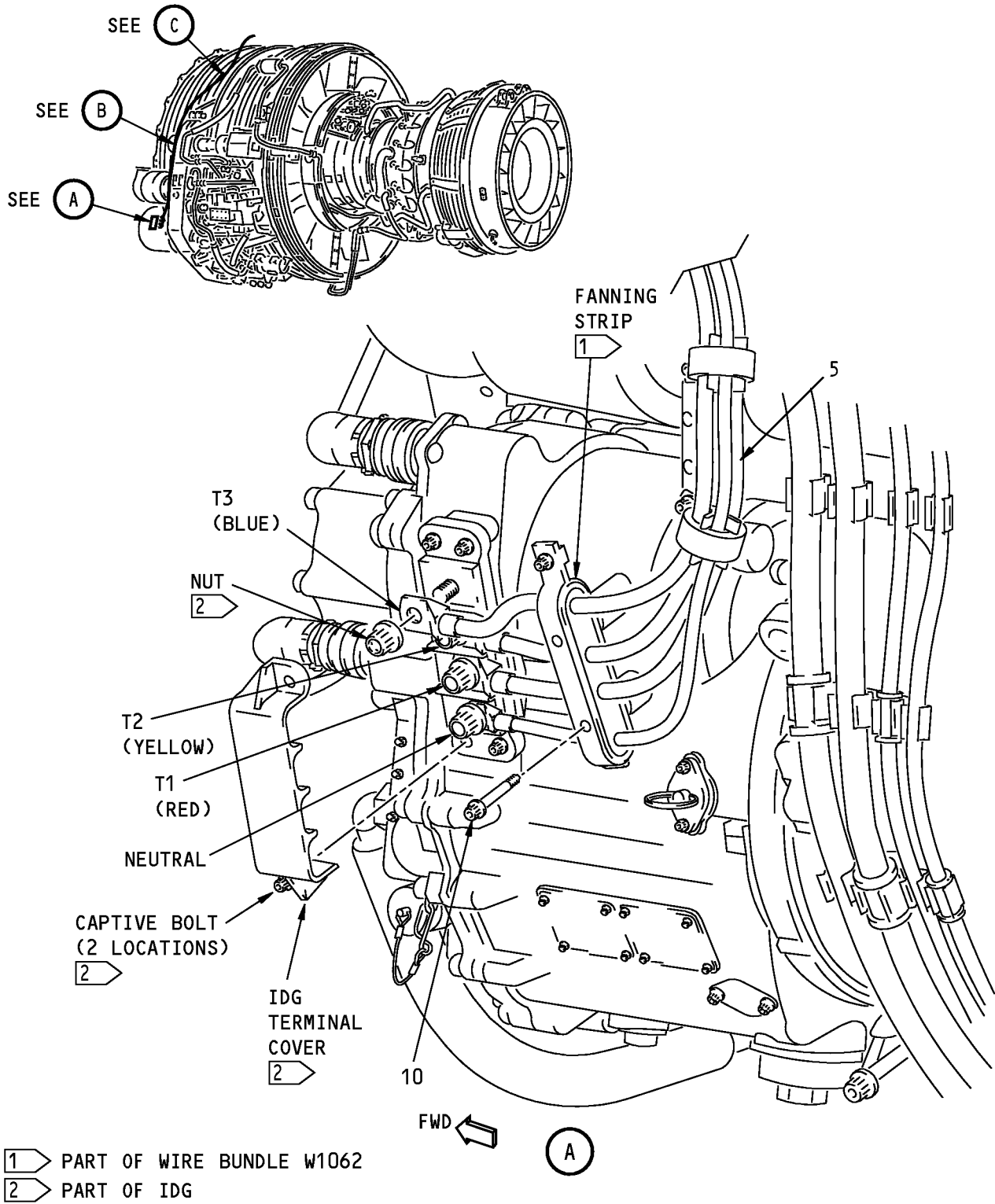

- 1 PART OF WIRE BUNDLE W1062
- 2 PART OF IDG

**W1062 Wire Bundle Installation**  
**Figure 29-1 (Sheet 2)**

**71-00-02**

P/P BUILDUP FIGURE 29-1

Page 4

Oct 05/2007

D633A106-HXL

**737-600/700/800/900  
POWERPLANT BUILDUP MANUAL**

ITEM NO.	PART NUMBER	NOMENCLATURE	UC	QTY
29-1		<b>W1062 WIRE BUNDLE INSTALLATION (FIGURE 29-1, SHEET 2)</b>		
5	286A1062-002	POSITION WIRE BUNDLE (5) ON LEFT SIDE OF FAN CASE WITH TERMINAL ENDS NEAR IDG STUDS. . WIRE BUNDLE ASSEMBLY (W1062)		1
5	286A1062	. WIRE BUNDLE ASSEMBLY (REPLACED BY 286A1062-002) (W1062)	LTD	-
		REMOVE AND RETAIN IDG TERMINAL COVER AND CAPTIVE VENDOR BOLTS.  INSTALL W/B W1062 (5) WIRE LUGS TO IDG TERMINAL BLOCK USING VENDOR NUTS. HOLD LEADS TO PREVENT ROTATION AND TIGHTEN VENDOR NUTS TO 144-168 POUND-INCHES (16.3-19.0 NEWTON METERS).  INSTALL IDG TERMINAL COVER USING CAPTIVE VENDOR BOLTS. TIGHTEN BOLTS TO 20-22 POUND-INCHES (2.3-2.5 NEWTON METERS).  APPLY Never-Seez NSBT-8N compound, D00006 (C1) TO THREADS OF BOLTS (10). POSITION WIRE BUNDLE FANNING STRIP ON IDG AND SECURE WITH LUBRICATED BOLTS (10). TIGHTEN BOLTS (10) TO 50- 75 POUND-INCHES (5.6-8.5) NEWTON METERS).		
10	BACB30ZF4-24	. BOLT		2
C1	D00006	. COMPOUND, NEVER SEEZ NSBT-8N	CON	AR

**71-00-02**

P/P BUILDUP FIGURE 29-1

Page 5

Feb 05/2008

D633A106-HXL

737-600/700/800/900  
**POWERPLANT BUILDUP MANUAL**

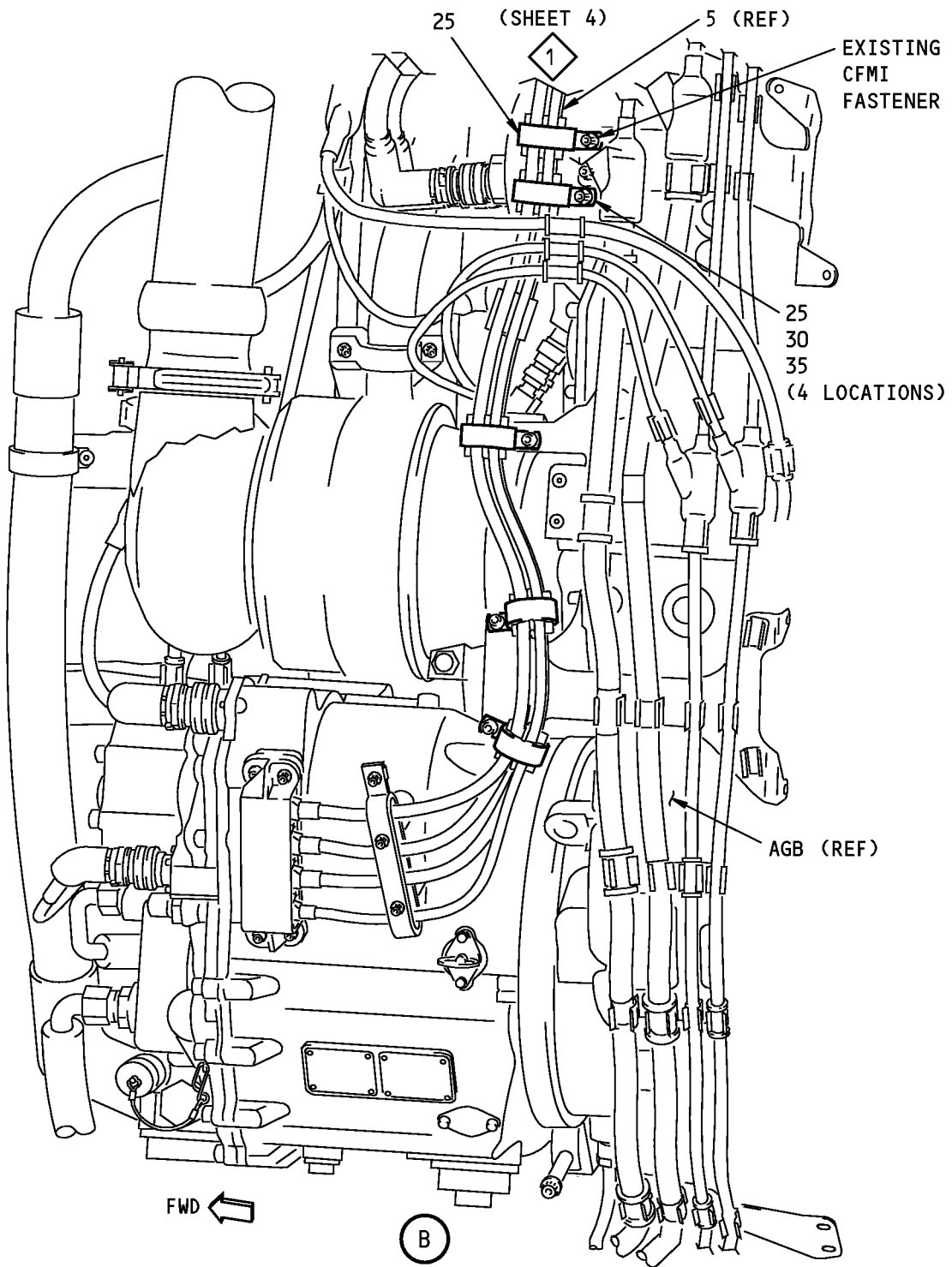

**W1062 Wire Bundle Installation**  
**Figure 29-1 (Sheet 3)**

**71-00-02**

P/P BUILDUP FIGURE 29-1

Page 6

Oct 05/2007

D633A106-HXL



**737-600/700/800/900  
POWERPLANT BUILDUP MANUAL**

ITEM NO.	PART NUMBER	NOMENCLATURE	UC	QTY
29-1		<b>W1062 WIRE BUNDLE INSTALLATION (FIGURE 29-1, SHEET 3)</b>  AT FIVE LOCATIONS, CENTER CLAMPS (25) ON WIRE BUNDLE SPACERS AND LOOSELY ATTACH TO AGB BRACKETS USING BOLTS (30), NUTS (35) AND EXISTING CFMI FASTENER.  <b>NOTE:</b> DO NOT TIGHTEN BOLTS AT THIS TIME.		
25	TA025146-15	. CLAMP (V84971)	VEN	5
30	BACB30ZF4-08	. BOLT		4
35	AS3485-10	. NUT		4

# 71-00-02

P/P BUILDUP FIGURE 29-1

Page 7

Oct 05/2007

D633A106-HXL

737-600/700/800/900  
**POWERPLANT BUILDUP MANUAL**

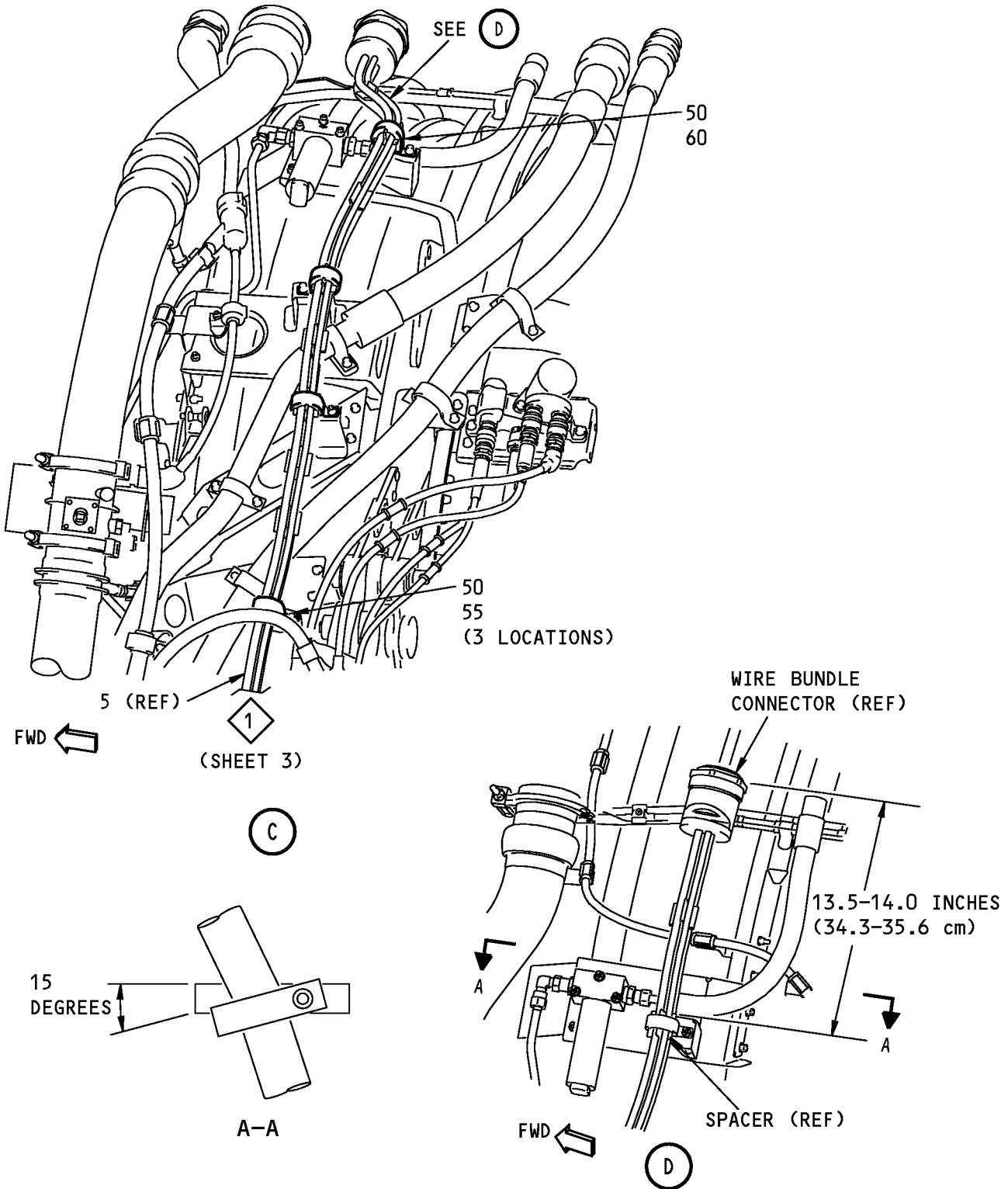

**W1062 Wire Bundle Installation**  
**Figure 29-1 (Sheet 4)**

**71-00-02**

P/P BUILDUP FIGURE 29-1

Page 8

Oct 05/2007

D633A106-HXL

**737-600/700/800/900  
POWERPLANT BUILDUP MANUAL**

ITEM NO.	PART NUMBER	NOMENCLATURE	UC	QTY
29-1		<p><b>W1062 WIRE BUNDLE INSTALLATION (FIGURE 29-1, SHEET 4)</b></p> <p>AT FOUR LOCATIONS, CENTER CLAMPS (50) ON WIRE BUNDLE SPACERS AND LOOSELY ATTACH TO BRACKETS ON LEFT FAN CASE USING BOLTS (55 AND 60).</p> <p><b>NOTE:</b> DO NOT TIGHTEN BOLTS AT THIS TIME.</p>		
50	TA025146-15	. CLAMP (V84971)	VEN	4
55	BACB30ZF4-06	. BOLT		3
60	BACB30ZF4-07	. BOLT		1
		<p>MAKE SURE WIRE BUNDLE (5) SPACER IS CENTERED IN UPPER CLAMP (50) AND MAKE SURE TOP CLAMP IS ORIENTED AS SHOWN. TIGHTEN BOLTS (55 AND 60). MEASURE DISTANCE BETWEEN TOP OF WIRE BUNDLE CONNECTOR AND SPACER WITH WIRE BUNDLE STRAIGHT. MEASUREMENT MUST BE 13.5-14.0 INCHES (34.3-35.6 CENTIMETERS). REPOSITION SPACER AS NECESSARY.</p> <p>ADJUST WIRE BUNDLE TO BEST POSITION AND TIGHTEN BOLTS (30, 55 AND 60) AND EXISTING CFMI FASTENER TO 110-120 POUND-INCHES (12.4-13.6 NEWTON METERS).</p>		

**71-00-02**

P/P BUILDUP FIGURE 29-1

Page 9

Oct 05/2007

D633A106-HXL

**FIGURE 30-1**

# **MARKERS INSTALLATION**

**REF QEC TASK NO.: 30**

**REF DWG: 330A2010  
330A2011**

**NOTE:** ALL STANDARDS AND ATTACHING HARDWARE FOR THIS FIGURE WILL BE PACKAGED IN QEC TASK NO. 110.

**71-00-02**

P/P BUILDUP FIGURE 30-1

Page 1

Oct 05/2007

D633A106-HXL

737-600/700/800/900  
**POWERPLANT BUILDUP MANUAL**

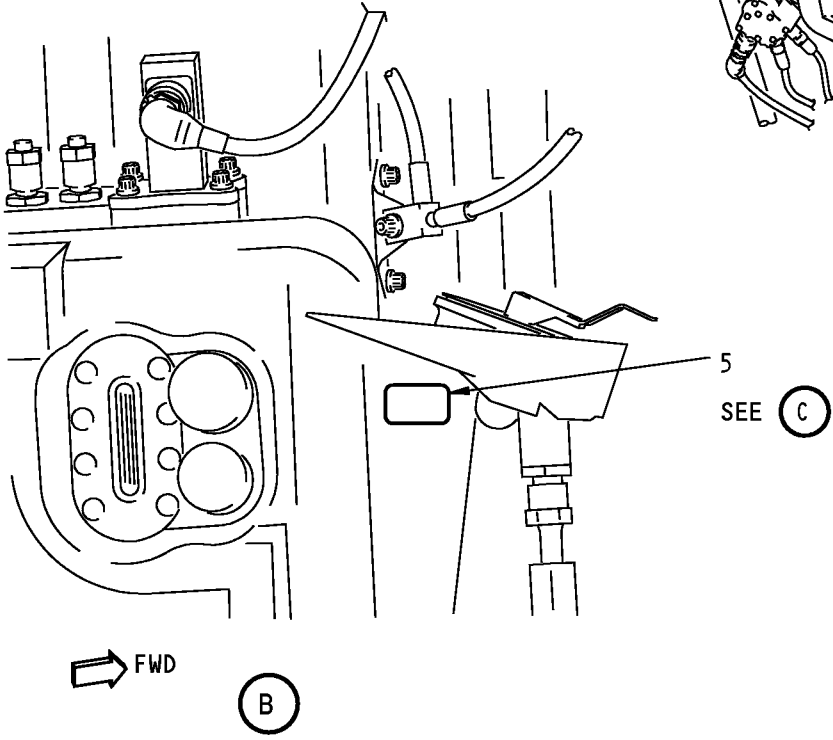
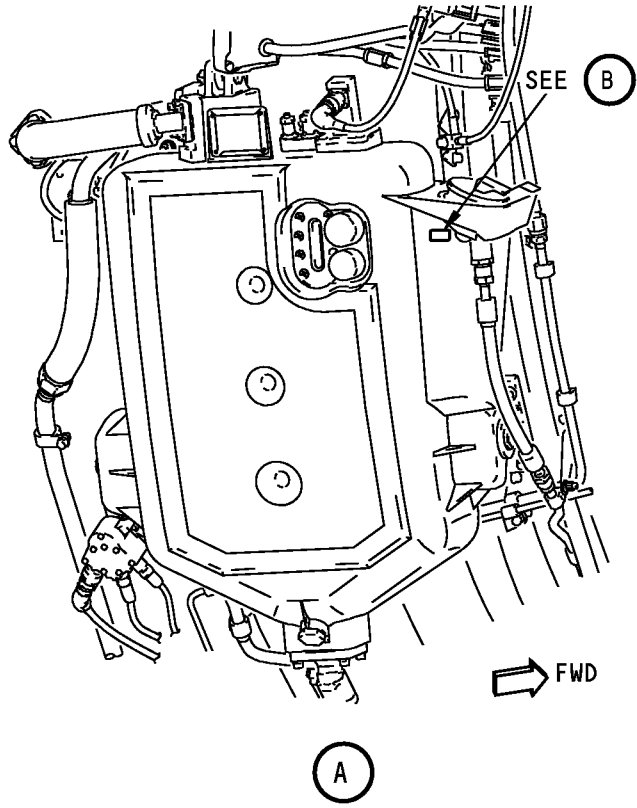
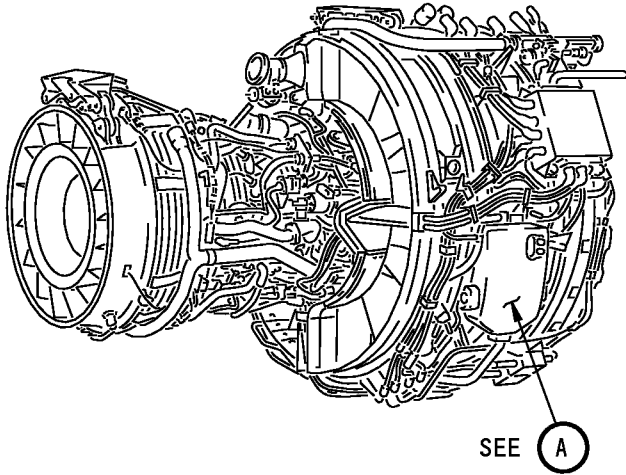

**MOBIL  
OIL  
JET II**

C

**Markers Installation  
Figure 30-1 (Sheet 1)**

**71-00-02**

P/P BUILDUP FIGURE 30-1

Page 2

Oct 05/2007

**737-600/700/800/900  
POWERPLANT BUILDUP MANUAL**

ITEM NO.	PART NUMBER	NOMENCLATURE	UC	QTY
30-1		<p><b>MARKERS INSTALLATION (FIGURE 30-1, SHEET 1)</b></p> <p><b>CAUTION:</b> APPROPRIATE OIL USAGE MARKERS MUST BE INSTALLED TO IDENTIFY THE BRAND USED BY OPERATOR. MIXING OF OIL BRANDS MAY CAUSE DAMAGE TO ENGINE AND ACCESSORIES AND VOID WARRANTIES.</p> <p>CLEAN DESIGNATED SURFACE WITH solvent, B00083 (C1) AND WIPE DRY PRIOR TO MARKER INSTALLATION.</p>		
C1	B00083	. SOLVENT, TT-N-95	CON	AR
5	BACM10L1EBZ	INSTALL MARKER (5) ON OIL TANK SCUPPER DRAIN. . ALUMINUM FOIL MARKER		1

**71-00-02**

P/P BUILDUP FIGURE 30-1

Page 3

Oct 05/2007

D633A106-HXL

737-600/700/800/900  
POWERPLANT BUILDUP MANUAL

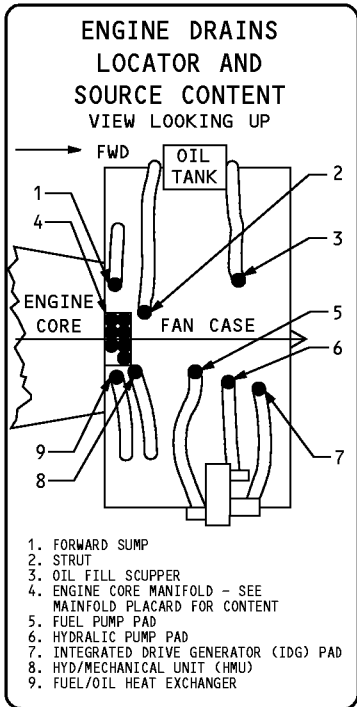
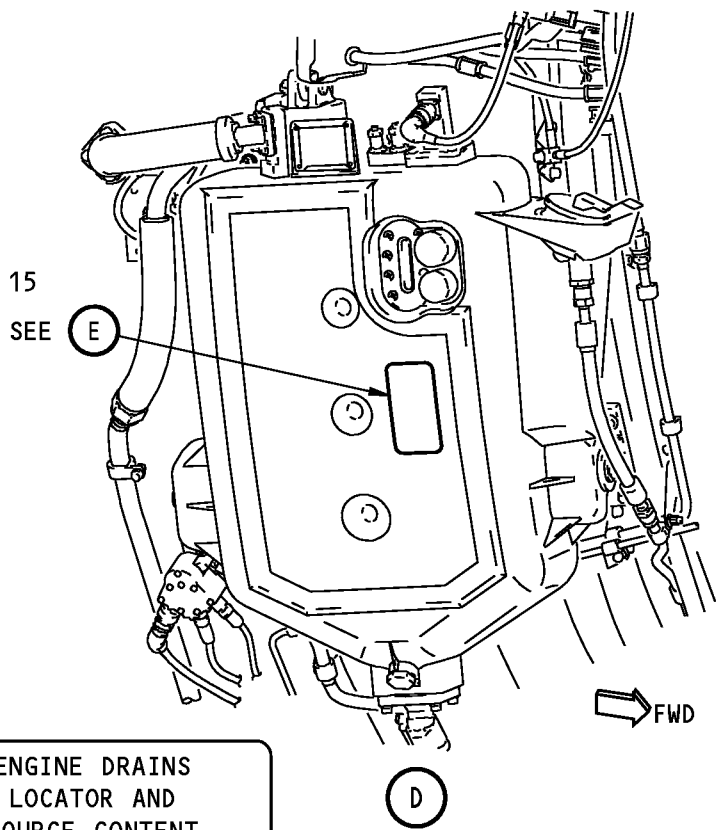
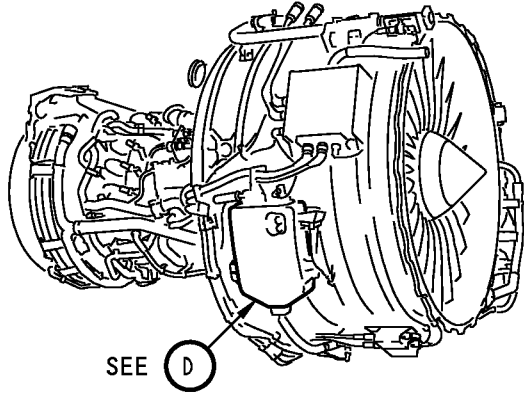

E

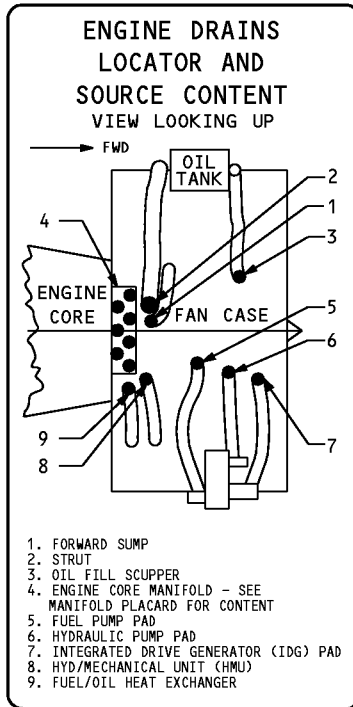

E

**Markers Installation  
Figure 30-1 (Sheet 2)**

**71-00-02**

P/P BUILDUP FIGURE 30-1

Page 4

Oct 05/2007

D633A106-HXL

**737-600/700/800/900  
POWERPLANT BUILDUP MANUAL**

ITEM NO.	PART NUMBER	NOMENCLATURE	UC	QTY
30-1		<b>MARKERS INSTALLATION (FIGURE 30-1, SHEET 2)</b>		
C1	B00083	CLEAN DESIGNATED SURFACE WITH solvent, B00083 (C1) AND WIPE DRY PRIOR TO MARKER INSTALLATION. . SOLVENT, TT-N-95 INSTALL MARKER (15) ON OIL TANK BELOW OIL LEVEL SIGHT GLASS.	CON	AR
15	BAC27DPP470	. ALUMINUM FOIL MARKER, DRAIN LOCATOR		1
15	BAC27DPP466	. ALUMINUM FOIL MARKER, DRAIN LOCATOR (OPTIONAL)	OPT	-

# 71-00-02

P/P BUILDUP FIGURE 30-1

Page 5

Oct 05/2007

D633A106-HXL



737-600/700/800/900  
**POWERPLANT BUILDUP MANUAL**

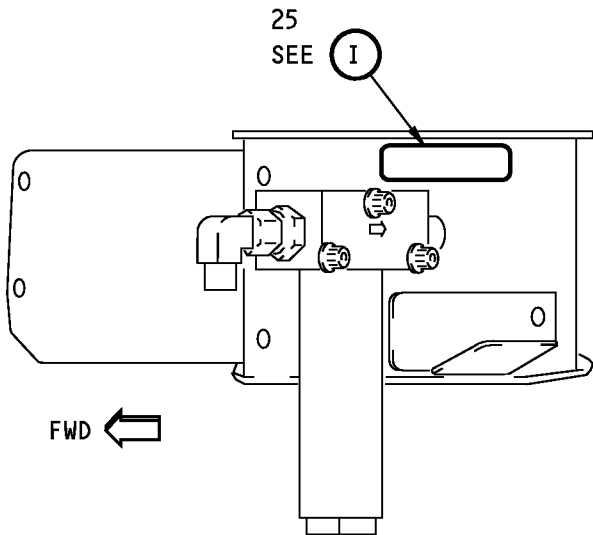
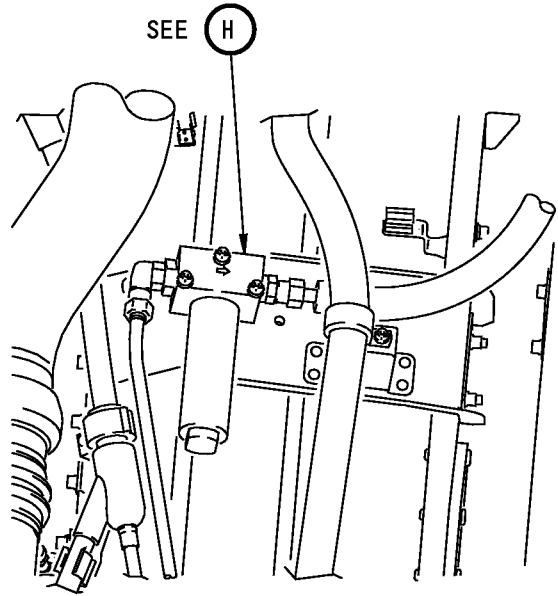
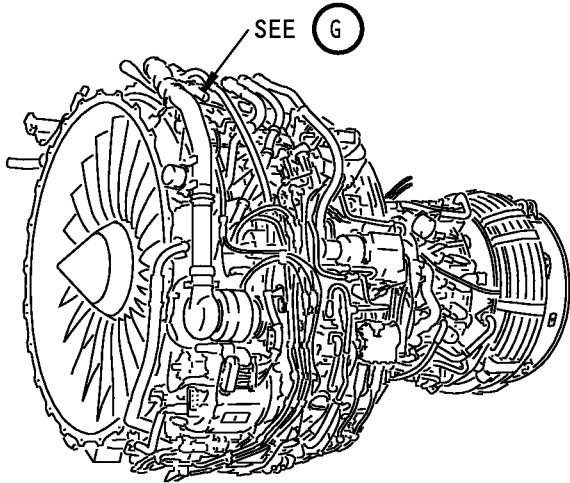

FWD ←

G

H

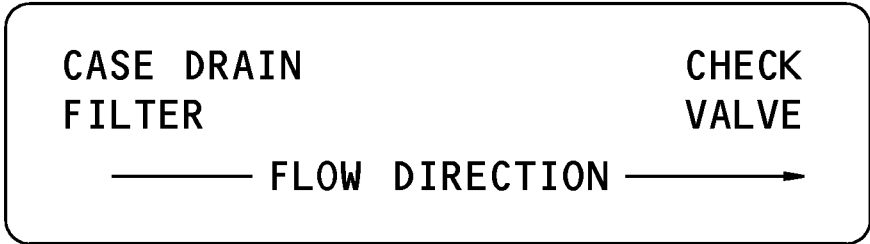

I

**Markers Installation**  
**Figure 30-1 (Sheet 3)**

**71-00-02**

P/P BUILDUP FIGURE 30-1

Page 6

Oct 05/2007

**737-600/700/800/900  
POWERPLANT BUILDUP MANUAL**

ITEM NO.	PART NUMBER	NOMENCLATURE	UC	QTY
30-1		<b>MARKERS INSTALLATION (FIGURE 30-1, SHEET 3)</b>  CLEAN DESIGNATED SURFACE WITH solvent, B00083 (C1) AND WIPE DRY PRIOR TO MARKER INSTALLATION.		
C1	B00083	. SOLVENT, TT-N-95	CON	AR
25	BAC27DHY0337	INSTALL MARKER (25) ON BRACKET ABOVE HYDRAULIC CASE DRAIN FILTER.  . ALUMINUM FOIL MARKER, CASE DRAIN FILTER		1

# 71-00-02

P/P BUILDUP FIGURE 30-1

Page 7

Oct 05/2007

D633A106-HXL

737-600/700/800/900  
**POWERPLANT BUILDUP MANUAL**

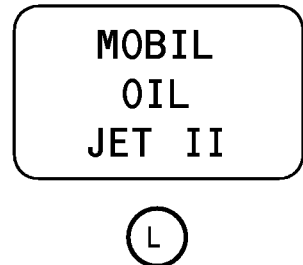
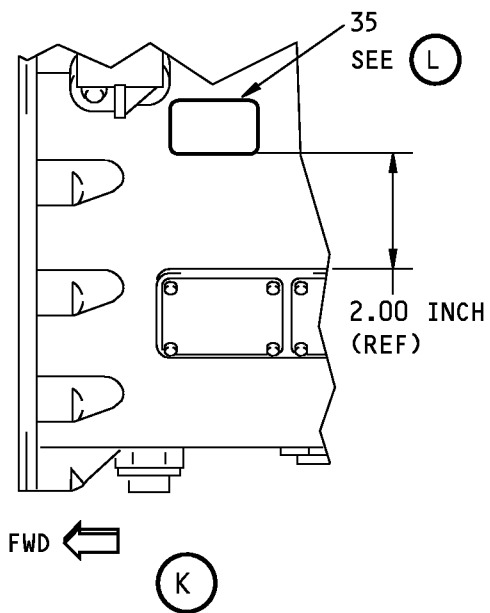
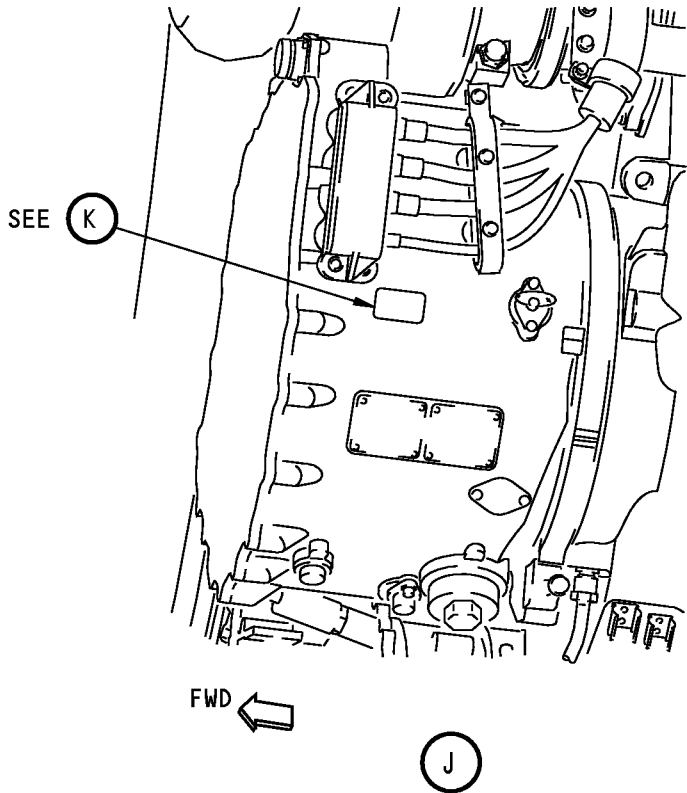
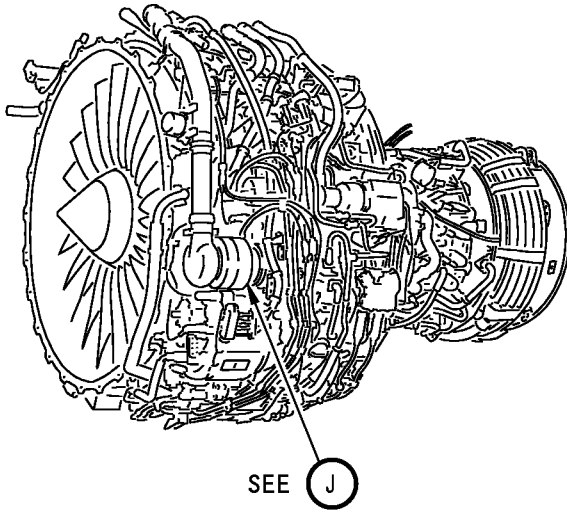

**Markers Installation**  
**Figure 30-1 (Sheet 4)**

**737-600/700/800/900  
POWERPLANT BUILDUP MANUAL**

ITEM NO.	PART NUMBER	NOMENCLATURE	UC	QTY
30-1		<p><b>MARKERS INSTALLATION (FIGURE 30-1, SHEET 4)</b></p> <p><b>CAUTION:</b> APPROPRIATE OIL USAGE MARKERS MUST BE INSTALLED TO IDENTIFY THE BRAND USED BY OPERATOR. MIXING OF OIL BRANDS MAY CAUSE DAMAGE TO ENGINE AND ACCESSORIES AND VOID WARRANTIES.</p> <p>CLEAN DESIGNATED SURFACE WITH solvent, B00083 (C1) AND WIPE DRY PRIOR TO MARKER INSTALLATION.</p>		
C1	B00083	. SOLVENT, TT-N-95	CON	AR
35	BACM10L1EBZ	INSTALL MARKER (35) ON IDG. . ALUMINUM FOIL MARKER		1

**71-00-02**

P/P BUILDUP FIGURE 30-1

Page 9

Oct 05/2007

D633A106-HXL

**737-600/700/800/900  
POWERPLANT BUILDUP MANUAL**

**THIS SHEET NOT USED**

**Markers Installation  
Figure 30-1 (Sheet 5)**

**71-00-02**

P/P BUILDUP FIGURE 30-1

Page 10

Oct 05/2007

D633A106-HXL

737-600/700/800/900  
POWERPLANT BUILDUP MANUAL

ITEM NO.	PART NUMBER	NOMENCLATURE	UC	QTY
30-1		MARKERS INSTALLATION (FIGURE 30-1, SHEET 5)  THIS SHEET NOT USED		

**71-00-02**

P/P BUILDUP FIGURE 30-1

Page 11

Oct 05/2007

D633A106-HXL

**737-600/700/800/900  
POWERPLANT BUILDUP MANUAL**

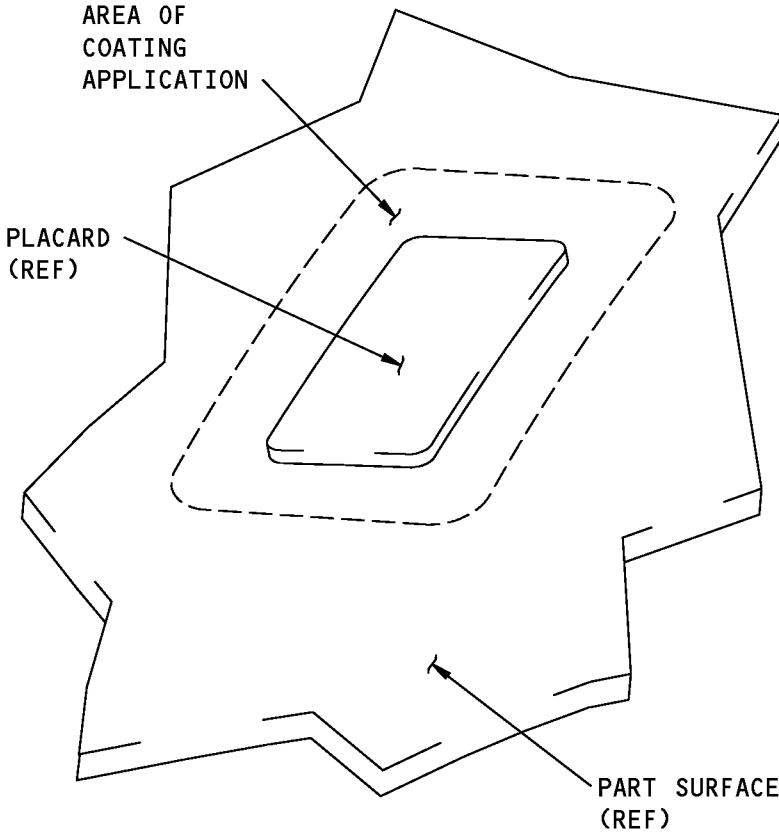

**Markers Installation  
Figure 30-1 (Sheet 6)**

**71-00-02**

**737-600/700/800/900  
POWERPLANT BUILDUP MANUAL**

ITEM NO.	PART NUMBER	NOMENCLATURE	UC	QTY
30-1		<b>MARKERS INSTALLATION (FIGURE 30-1, SHEET 6)</b>		
C1	B00083	CLEAN MARKERS (5), (15), (25) AND (35) AND ADJACENT SURFACE WITH solvent, B00083 (C1). . SOLVENT, TT-N-95  MIX THE COATING AS FOLLOWS: 1. MIX 2 PARTS BASE 683-3-20 WITH 1 PART CATALYST X-310A. <b>NOTE:</b> POT LIFE IS 30 MINUTES AT 70°F.  2. APPLY coating, B00571 (C2) TO EDGE OF MARKERS WITH BRUSH TO A DEPTH OF 0.001-0.002 INCHES (0.025-0.051 MM).  3. LET THE COATING AIR DRY FOR 30 MINUTES. <b>NOTE:</b> MINIMUM CURE BEFORE OUTDOOR EXPOSURE IS 30 MINUTES. FULL CURE IS 14 DAYS.	CON	AR
C2	B00571	. COATING, HYDRAULIC FLUID RESISTANT, BAC5710, TYPE 41, 683-3-2 BASE X310 A CATALYST	CON	AR
	683-3-20	. . BASE (PART OF B00571)	REF	-
	X-310A	. . CATALYST (PART OF B00571)	REF	-

**71-00-02**

P/P BUILDUP FIGURE 30-1

Page 13

Oct 05/2007

D633A106-HXL



**FIGURE 31-1**

# **THRUST LINK INSTALLATION**

**REF QEC TASK NO.: 31**

**REF DWG: 310A2040  
301A2092**

**NOTE:** ALL STANDARDS AND ATTACHING HARDWARE FOR THIS FIGURE WILL BE PACKAGED IN QEC TASK NO. 110.

**71-00-02**

P/P BUILDUP FIGURE 31-1

Page 1

Oct 05/2007

D633A106-HXL

737-600/700/800/900  
**POWERPLANT BUILDUP MANUAL**

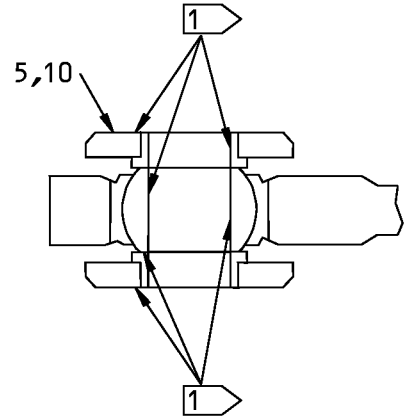
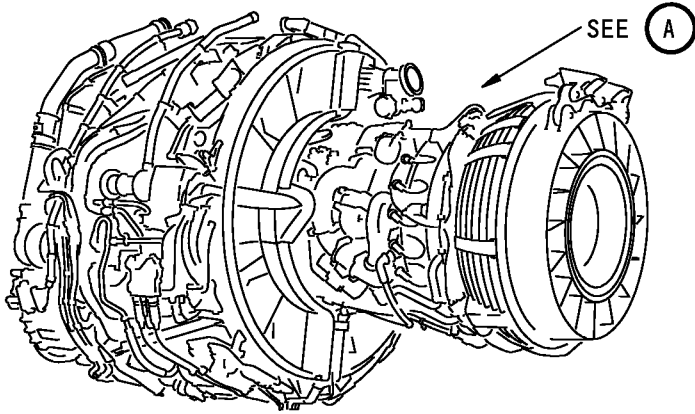

(EXAMPLE)  
A-A

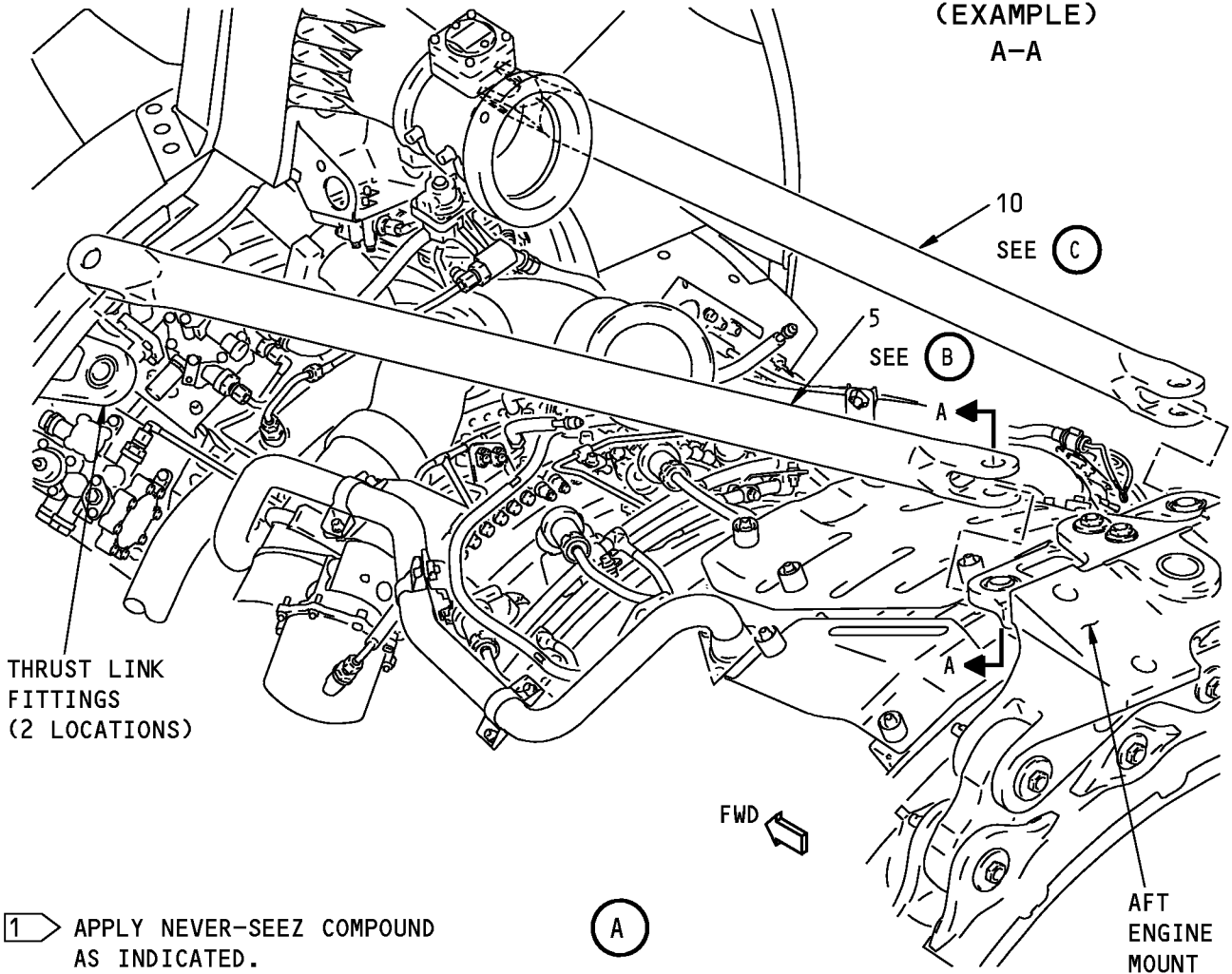

1 APPLY NEVER-SEEZ COMPOUND AS INDICATED.

A

**Thrust Link Installation**  
**Figure 31-1 (Sheet 1)**

**71-00-02**

P/P BUILDUP FIGURE 31-1

Page 2

Oct 05/2007

**737-600/700/800/900  
POWERPLANT BUILDUP MANUAL**

ITEM NO.	PART NUMBER	NOMENCLATURE	UC	QTY
31-1		<p><b>THRUST LINK INSTALLATION (FIGURE 31-1, SHEET 1)</b></p> <p>APPLY Never-Seez NSBT-8N compound, D00006 (C1) TO SPHERICAL BEARING BORES AND BALL FLAT SURFACES OF THRUST LINK FITTINGS ON ENGINE FAN FRAME AND AFT ENGINE MOUNT ATTACH POINTS.</p> <p>APPLY Never-Seez NSBT-8N compound, D00006 (C1) TO BUSHING BORES AND FLANGE FACES AT EACH END OF TWO THRUST LINKS (5) AND (10).</p> <p>. THRUST LINK ASSY, LEFT</p> <p>. THRUST LINK ASSY, RIGHT</p> <p>. COMPOUND, NEVER-SEEZ NSBT-8N</p> <p>*[1] REQUIRED WITH AFT MOUNT 310A2030-4 Figure 3-1</p>	CON	1 1 AR
5	310A2041-9			1
10	310A2041-10			1
C1	D00006			AR

**71-00-02**

P/P BUILDUP FIGURE 31-1

Page 3

Oct 05/2007

D633A106-HXL

737-600/700/800/900  
**POWERPLANT BUILDUP MANUAL**

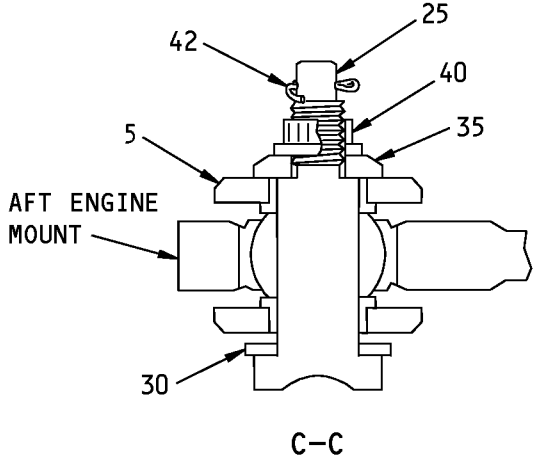
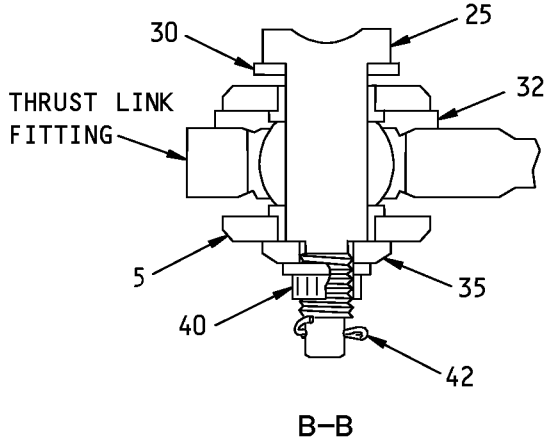
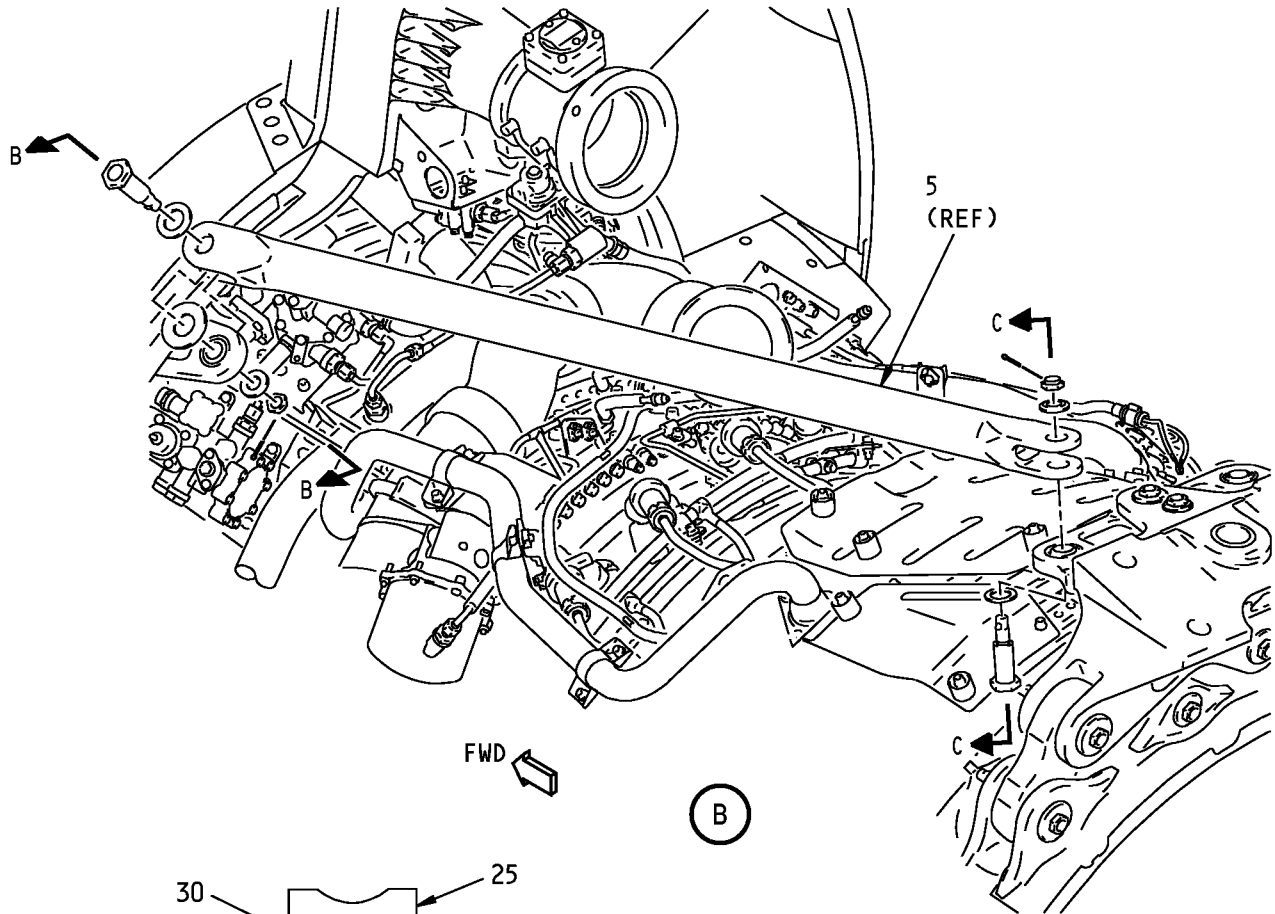

**Thrust Link Installation**  
**Figure 31-1 (Sheet 2)**

**71-00-02**

P/P BUILDUP FIGURE 31-1

Page 4

Oct 05/2007

D633A106-HXL

**737-600/700/800/900  
POWERPLANT BUILDUP MANUAL**

ITEM NO.	PART NUMBER	NOMENCLATURE	UC	QTY
31-1		<b>THRUST LINK INSTALLATION (FIGURE 31-1, SHEET 2)</b>		
		APPLY Never-Seez NSBT-8N compound, D00006 (C1) TO THREADS, SHANK AND UNDERNEATH HEAD OF PINS (25).		
25	310A2042-3	. THRUST LINK PIN		2
C1	D00006	. COMPOUND, NEVER-SEEZ NSBT-8N	CON	AR
		INSTALL LEFT THRUST LINK ASSY (5) BETWEEN FAN CASE FITTING AND AFT ENGINE MOUNT ATTACH FITTINGS. USE LUBRICATED THRUST LINK PINS (25), WASHERS (30), WASHER (32), END CAPS (35) AND NUTS (40).		
30	BACW10BP12ACU	. WASHER (CSK)		2
32	310A2040-7	. WASHER (CSK TOWARDS SPHERICAL BEARING)		1
35	310A2043-1	. END CAP (FLAT SIDE TOWARDS PIN SHOULDER)		2
40	BACN10JC8CM	. NUT		2
		TIGHTEN NUTS (40) TO 290-510 POUND-INCHES (32.8-57.6 NEWTON METERS). APPLY TORQUE TO EITHER NUT OR PIN HEAD.		
		INSTALL COTTER PINS (42).		
42	BACP18BC03B06P	. COTTER PIN		2
42	BACP18BC03B07P	. COTTER PIN (OPTIONAL TO BACP18BC03B06P)	OPT	-
42	BACP18BC03B08P	. COTTER PIN (OPTIONAL TO BACP18BC03B06P)	OPT	-

**71-00-02**

P/P BUILDUP FIGURE 31-1

Page 5

Feb 05/2008

D633A106-HXL

737-600/700/800/900  
**POWERPLANT BUILDUP MANUAL**

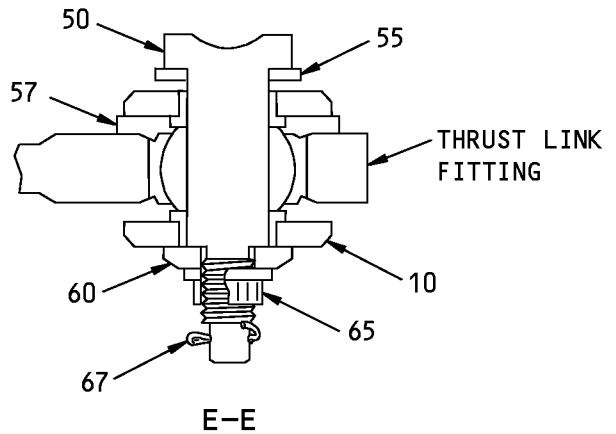
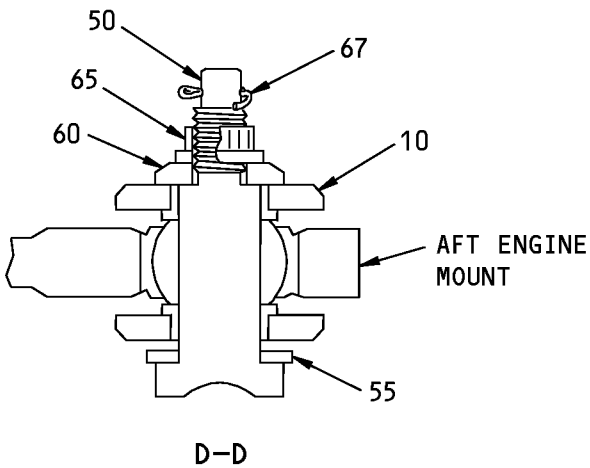
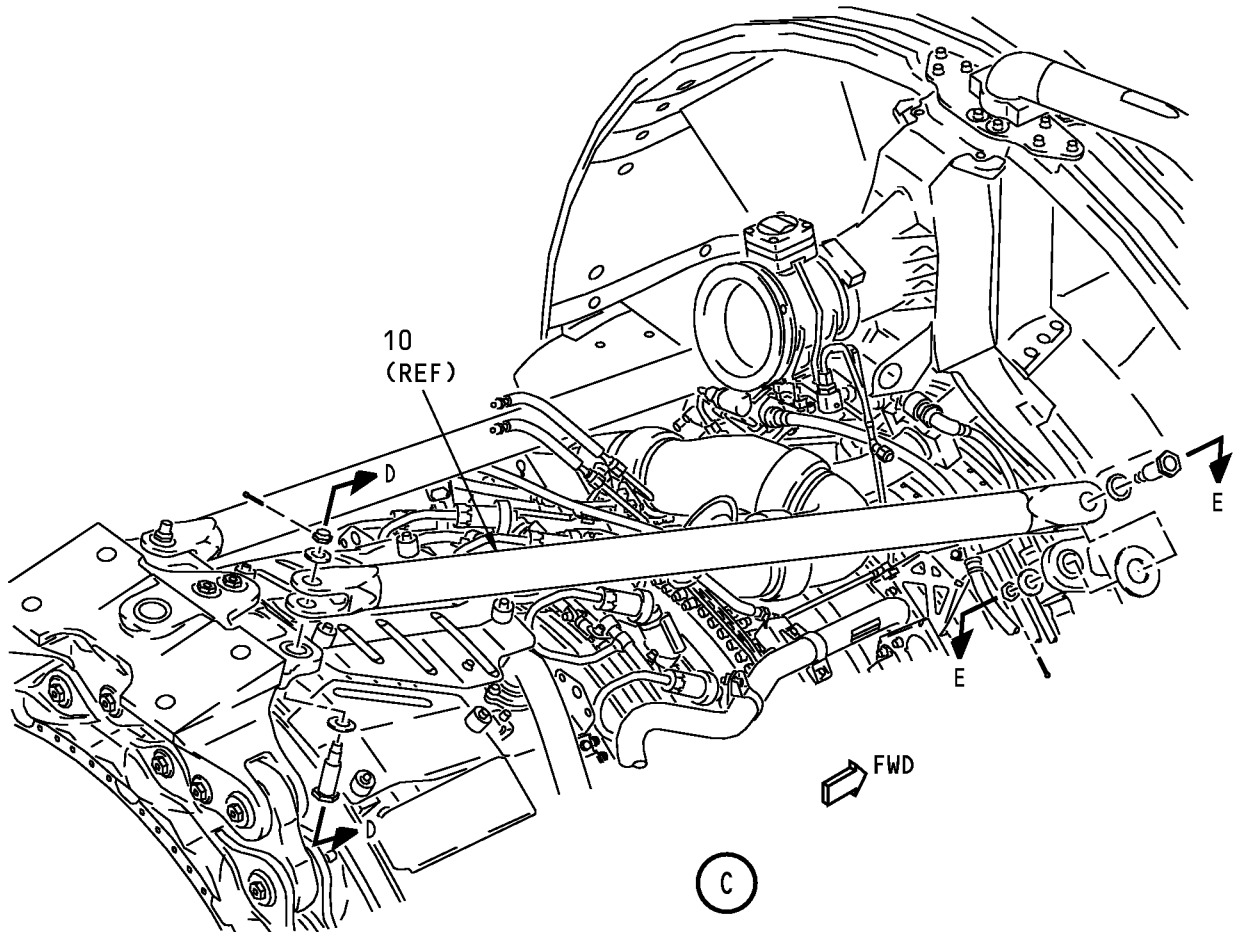

**Thrust Link Installation**  
**Figure 31-1 (Sheet 3)**

**71-00-02**

P/P BUILDUP FIGURE 31-1

Page 6

Oct 05/2007

D633A106-HXL

**737-600/700/800/900  
POWERPLANT BUILDUP MANUAL**

ITEM NO.	PART NUMBER	NOMENCLATURE	UC	QTY
31-1		<b>THRUST LINK INSTALLATION (FIGURE 31-1, SHEET 3)</b>		
		APPLY Never-Seez NSBT-8N compound, D00006 (C1) TO THREADS, SHANK AND UNDERNEATH HEAD OF PINS (50).		
50	310A2042-3	. THRUST LINK PIN		2
C1	D00006	. COMPOUND, NEVER-SEEZ NSBT-8N	CON	AR
		INSTALL RIGHT THRUST LINK ASSY (10) BETWEEN FAN CASE FITTING AND AFT ENGINE MOUNT ATTACH FITTINGS. USE LUBRICATED PINS (50), WASHERS (55), WASHER (57), END CAPS (60) AND NUTS (65).		
55	BACW10BP12ACU	. WASHER (CSK)		2
57	310A2040-7	. WASHER (CSK TOWARDS SPHERICAL BEARING)		1
60	310A2043-1	. END CAP (FLAT SIDE TOWARDS PIN SHOULDER)		2
65	BACN10JC8CM	. NUT		2
		TIGHTEN NUTS (65) TO 290-510 POUND-INCHES (32.8-57.6 NEWTON METERS). APPLY TORQUE TO EITHER NUT OR PIN HEAD.		
		INSTALL COTTER PINS (67).		
67	BACP18BC03B06P	. COTTER PIN		2
67	BACP18BC03B07P	. COTTER PIN (OPTIONAL TO BACP18BC03B06P)	OPT	-
67	BACP18BC03B08P	. COTTER PIN (OPTIONAL TO BACP18BC03B06P)	OPT	-
		REMOVE PROTECTIVE PAD FROM AFT ENGINE MOUNT (INSTALLED IN Figure 3-1).		

**71-00-02**

P/P BUILDUP FIGURE 31-1

Page 7

Feb 05/2008

D633A106-HXL

**FIGURE 32-1**

# **PRIMARY EXHAUST INSTALLATION**

**REF QEC TASK NO.: 32**

**REF DWG: 333A2100**

**NOTE:** ALL STANDARDS AND ATTACHING HARDWARE FOR THIS FIGURE WILL BE PACKAGED IN QEC TASK NO. 110.

**71-00-02**

P/P BUILDUP FIGURE 32-1

Page 1

Oct 05/2007

D633A106-HXL



737-600/700/800/900  
**POWERPLANT BUILDUP MANUAL**

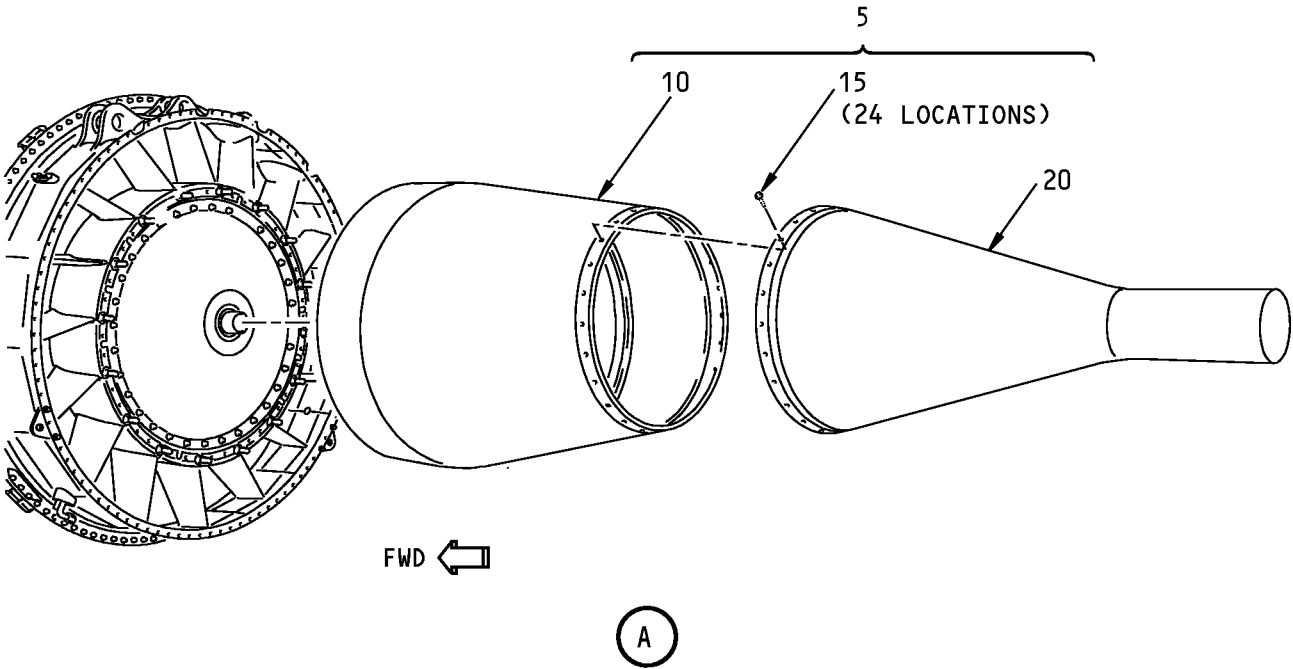
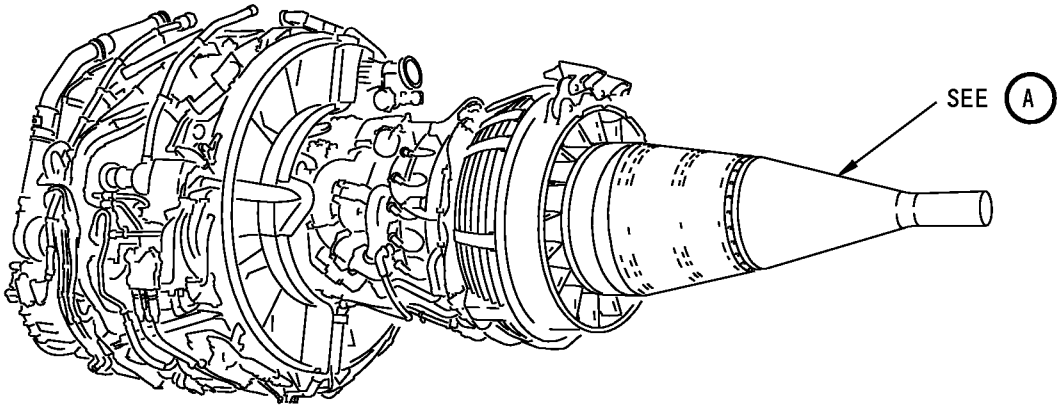

**Primary Exhaust Installation**  
**Figure 32-1 (Sheet 1)**

**71-00-02**

P/P BUILDUP FIGURE 32-1

Page 2

Oct 05/2007

D633A106-HXL

**737-600/700/800/900  
POWERPLANT BUILDUP MANUAL**

ITEM NO.	PART NUMBER	NOMENCLATURE	UC	QTY
32-1		<b>PRIMARY EXHAUST INSTALLATION (FIGURE 32-1, SHEET 1)</b>		
		REMOVE BOLTS (15) THAT ATTACH FWD (10) AND AFT (20) PLUG ASSEMBLIES. SEPARATE THE FWD AND AFT PLUG ASSEMBLIES. KEEP BOLTS (15) FOR LATER INSTALLATION.		
5	314A2620-1	. PRIMARY PLUG ASSEMBLY		1
10	314A2620-2	. . FWD PLUG ASSEMBLY (PART OF 314A2620-1)	REF	-
15	BACB30LK4U1	. . BOLT (PART OF 314A2620-1)	REF	-
20	314A2620-5	. . AFT PLUG ASSEMBLY (PART OF 314A2620-1)	REF	-

**71-00-02**

P/P BUILDUP FIGURE 32-1

Page 3

Oct 05/2007

D633A106-HXL

737-600/700/800/900  
**POWERPLANT BUILDUP MANUAL**

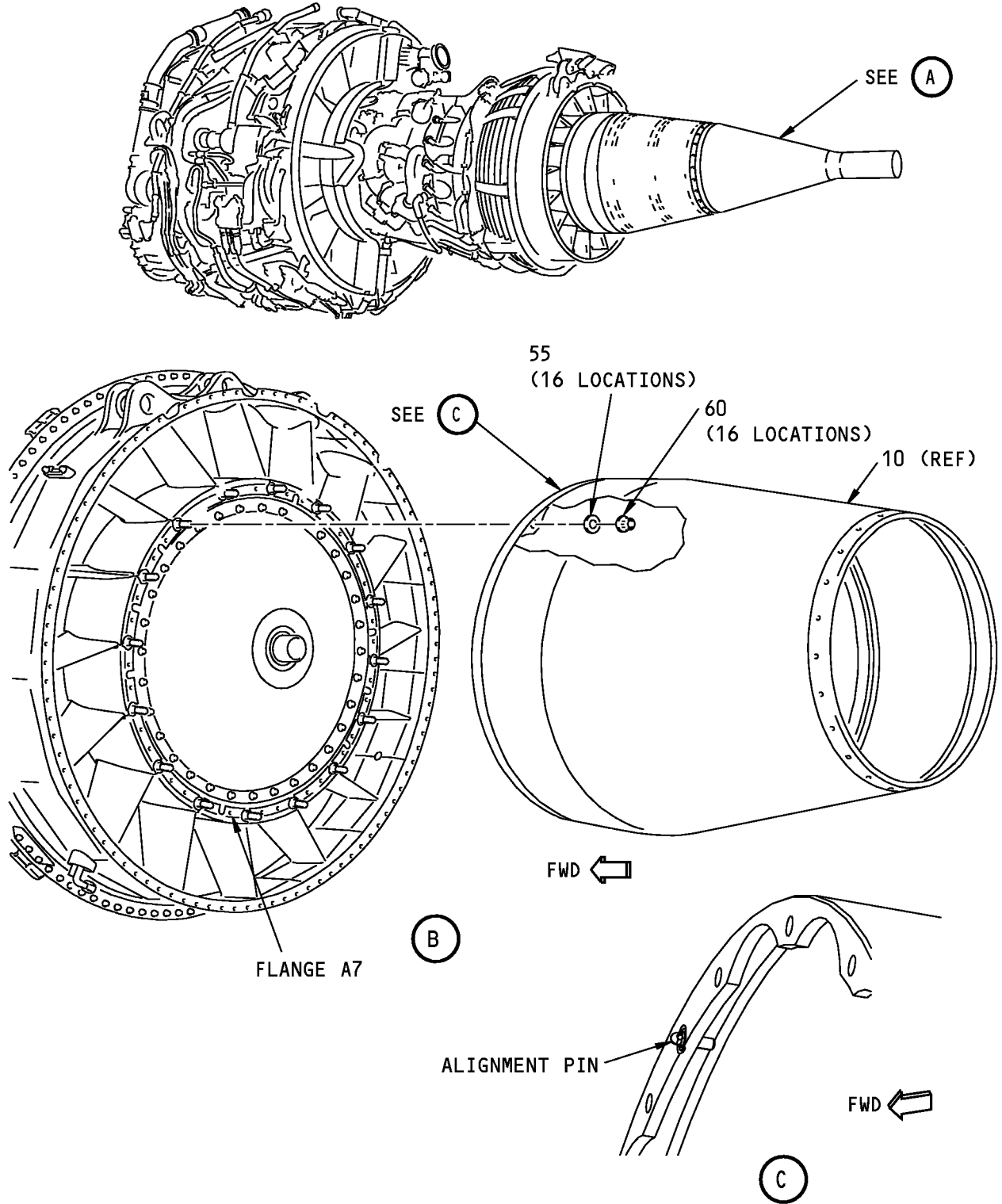

**Primary Exhaust Installation**  
**Figure 32-1 (Sheet 2)**

**71-00-02**

P/P BUILDUP FIGURE 32-1

Page 4

Oct 05/2007

D633A106-HXL

**737-600/700/800/900  
POWERPLANT BUILDUP MANUAL**

ITEM NO.	PART NUMBER	NOMENCLATURE	UC	QTY
32-1		<b>PRIMARY EXHAUST INSTALLATION (FIGURE 32-1, SHEET 2)</b>		
C1	D00006	APPLY Never-Seez NSBT-8N compound, D00006 (C1) TO THREADS OF STUDS ON ENGINE FLANGE A7. . COMPOUND, NEVER-SEEZ NSBT-8N	CON	AR
55	BACW10BP8APU	<b>WARNING:</b> FORWARD PLUG ASSY WEIGHS APPROXIMATELY 40 POUNDS (18 KG). USE CAUTION TO PREVENT INJURIES TO PERSONS OR DAMAGE TO EQUIPMENT.  POSITION FWD PLUG ASSY (10) ON FLANGE A7. MAKE SURE ALIGNMENT PIN IS ALIGNED WITH HOLE IN FWD PLUG ASSY FLANGE. LOOSELY ATTACH FWD PLUG ASSY (10) TO FLANGE A7 WITH WASHERS (55) AND NUTS (60). . WASHER		16
60	BACN10HR8C	. NUT  SNUG FIT NUTS (60) IN THE FOLLOWING SEQUENCE: 3:00 O'CLOCK, 9:00 O'CLOCK, 6:00 O'CLOCK AND 12:00 O'CLOCK POSITIONS. SNUG FIT REMAINING NUTS. TIGHTEN NUTS AT 3:00, 9:00, 6:00 AND 12:00 O'CLOCK POSITIONS TO THE FINAL TORQUE VALUE NOTED BELOW. SEQUENTIALLY TIGHTEN THE REMAINING NUTS. CHECK TORQUE AT FIRST NUT TORQUED. IF NUT IS NOT WITHIN THE SPECIFIED RANGE, RE-TORQUE AND SEQUENTIALLY CHECK REMAINING NUTS. RE-TORQUE IF REQUIRED.  FINAL TORQUE VALUE: 500-650 POUND-INCHES (56.5-73.4 NEWTON METERS)		16

**71-00-02**

P/P BUILDUP FIGURE 32-1

Page 5

Oct 05/2007

D633A106-HXL

737-600/700/800/900  
**POWERPLANT BUILDUP MANUAL**

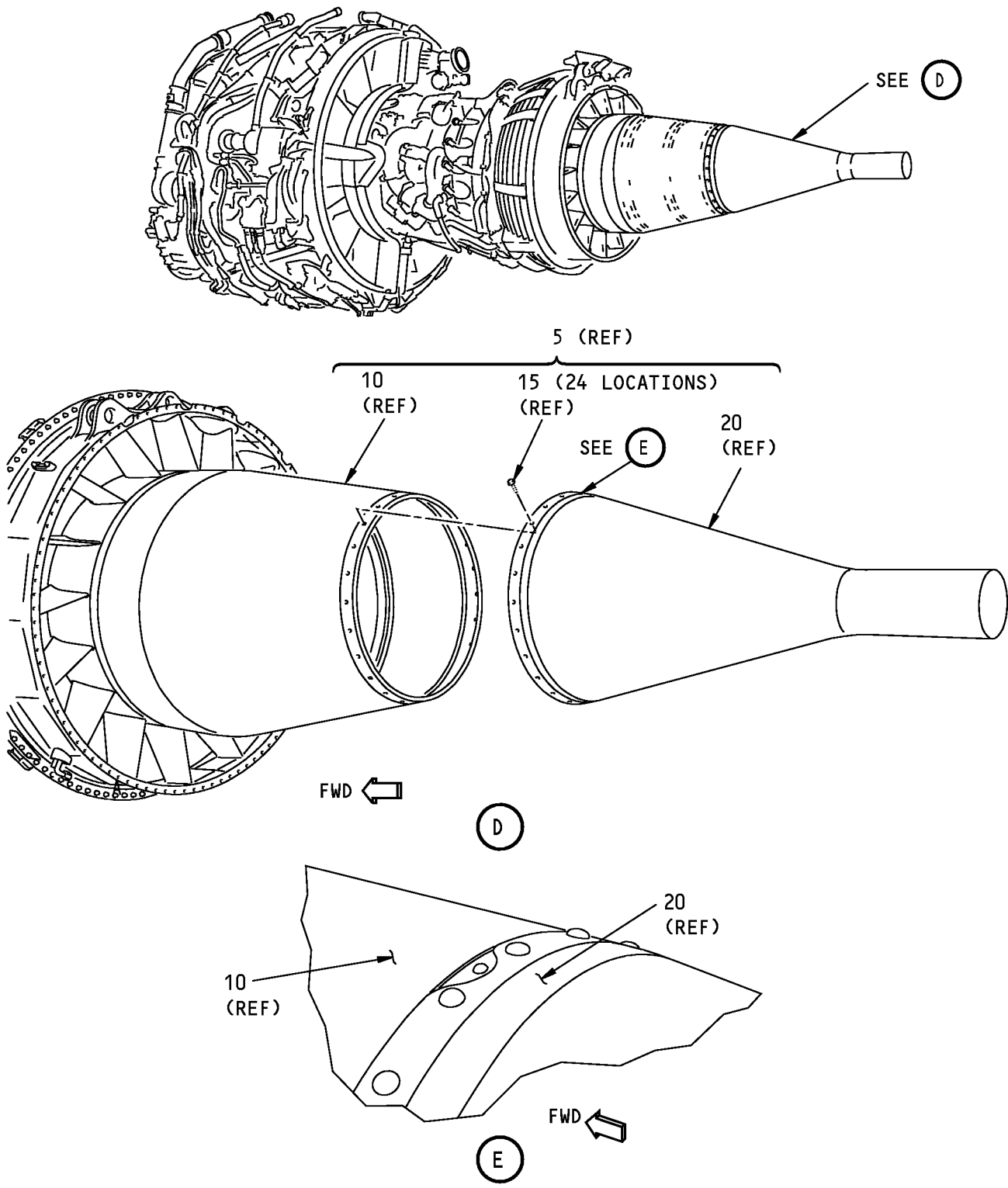

**Primary Exhaust Installation**  
**Figure 32-1 (Sheet 3)**

**71-00-02**

P/P BUILDUP FIGURE 32-1

Page 6

Oct 05/2007

D633A106-HXL

**737-600/700/800/900  
POWERPLANT BUILDUP MANUAL**

ITEM NO.	PART NUMBER	NOMENCLATURE	UC	QTY
32-1		<b>PRIMARY EXHAUST INSTALLATION (FIGURE 32-1, SHEET 3)</b>		
		APPLY Never-Seez NSBT-8N compound, D00006 (C1) TO THREADS OF BOLTS (15).		
15	BACB30LK4U1	. . BOLT (PART OF 314A2620-1)	REF	-
C1	D00006	. COMPOUND, NEVER-SEEZ NSBT-8N	CON	AR
		<b>WARNING:</b> AFT PLUG WEIGHS APPROXIMATELY 14 POUNDS (6.4 KG). USE CAUTION TO PREVENT INJURIES TO PERSONS OR DAMAGE TO EQUIPMENT.		
		POSITION AFT PLUG (20) ON FWD PLUG ASSY (10). AT 12 O'CLOCK POSITION ALIGN CUTOUT IN AFT PLUG WITH INDEXING RIVET OF FWD PLUG ASSY. AT 24 LOCATIONS, ATTACH WITH LUBRICATED BOLTS (15).		
5	314A2620-1	. PRIMARY PLUG ASSEMBLY	REF	-
10	314A2620-2	. . FWD PLUG ASSEMBLY (PART OF 314A2620-1)	REF	-
20	314A2620-5	. . AFT PLUG (PART OF 314A2620-1)	REF	-
		CROSS-TIGHTEN BOLTS (15) TO 68-82 POUND-INCHES (7.7-9.3 NEWTON METERS).		

**71-00-02**

P/P BUILDUP FIGURE 32-1

Page 7

Oct 05/2007

D633A106-HXL

737-600/700/800/900  
**POWERPLANT BUILDUP MANUAL**

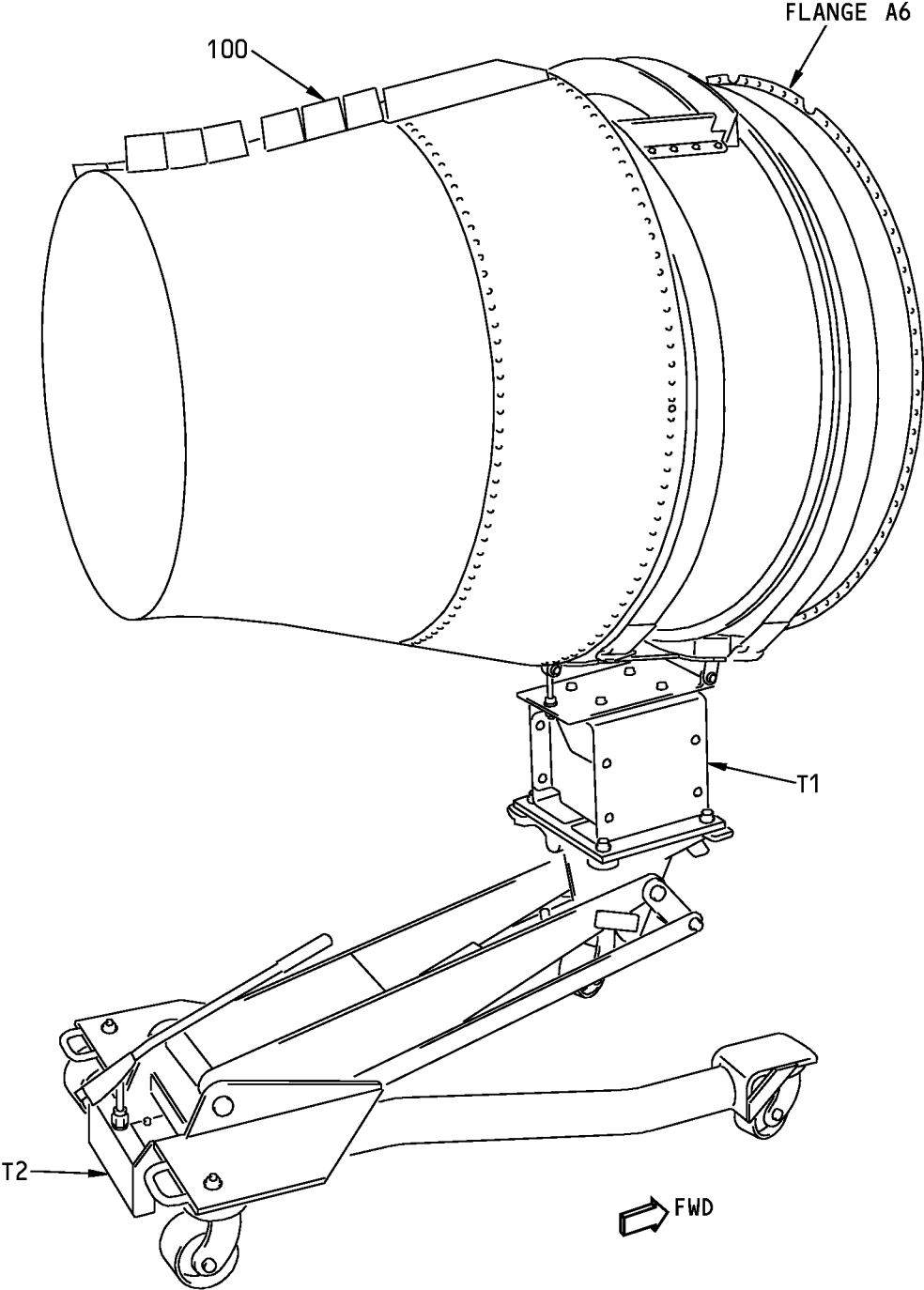

**Primary Exhaust Installation**  
**Figure 32-1 (Sheet 4)**

**71-00-02**

P/P BUILDUP FIGURE 32-1

Page 8

Oct 05/2007

D633A106-HXL

**737-600/700/800/900  
POWERPLANT BUILDUP MANUAL**

ITEM NO.	PART NUMBER	NOMENCLATURE	UC	QTY
32-1		<p><b>PRIMARY EXHAUST INSTALLATION (FIGURE 32-1, SHEET 4)</b></p> <p><b>WARNING:</b> PRIMARY NOZZLE ASSY WEIGHS APPROXIMATELY 108 POUNDS (49 KG). USE CAUTION TO PREVENT INJURIES TO PERSONS OR DAMAGE TO EQUIPMENT.</p> <p>ATTACH PRIMARY NOZZLE ASSY (100) TO equipment, SPL-2419 (T1) AND PLACE ONTO low profile hydraulic jack, COM-1568 (T2).</p> <p>. PRIMARY NOZZLE ASSY</p> <p>. PRIMARY NOZZLE ASSY (OPTIONAL TO 314A2610-62)<sup>[1]</sup></p> <p>. REM/INSTL EQPT - PRIMARY SLEEVE AND PLUG</p> <p>. JACK, TRANSMISSION (V36251) (OR EQUIVALENT)</p> <p>POSITION PRIMARY NOZZLE ASSY (100)/equipment, SPL-2419 (T1) BEHIND ENGINE. RAISE PRIMARY NOZZLE WITH low profile hydraulic jack, COM-1568(T2) UNTIL CENTERLINE IS ALIGNED WITH ENGINE CENTERLINE.</p> <p>MOVE PRIMARY NOZZLE ASSY (100) FORWARD UNTIL NOZZLE IS APPROXIMATELY 2 INCHES (5 MM) AFT OF ENGINE FLANGE A6. MAKE SURE ALIGNMENT PIN ON ENGINE FLANGE IS ALIGNED WITH HOLE IN AFT FLANGE OF NOZZLE. IF NECESSARY, MOVE NOZZLE REARWARD AND READJUST POSITION OF NOZZLE ON TOOL. MOVE NOZZLE FORWARD UNTIL ALIGNMENT PIN ENGAGES HOLE IN PRIMARY NOZZLE ASSY.</p> <p>[1] REFER TO 737-SL-78-060 FOR DETAILED INFORMATION.</p>		
100	314A2610-62	. PRIMARY NOZZLE ASSY		1
100	314A2610-1	. PRIMARY NOZZLE ASSY (OPTIONAL TO 314A2610-62) <sup>[1]</sup>	OPT	-
T1	C78009-33	. REM/INSTL EQPT - PRIMARY SLEEVE AND PLUG	TOL	-
T2	W93718	. JACK, TRANSMISSION (V36251) (OR EQUIVALENT)	TOL	-

**71-00-02**

P/P BUILDUP FIGURE 32-1

Page 9

Oct 05/2007

D633A106-HXL



737-600/700/800/900  
**POWERPLANT BUILDUP MANUAL**

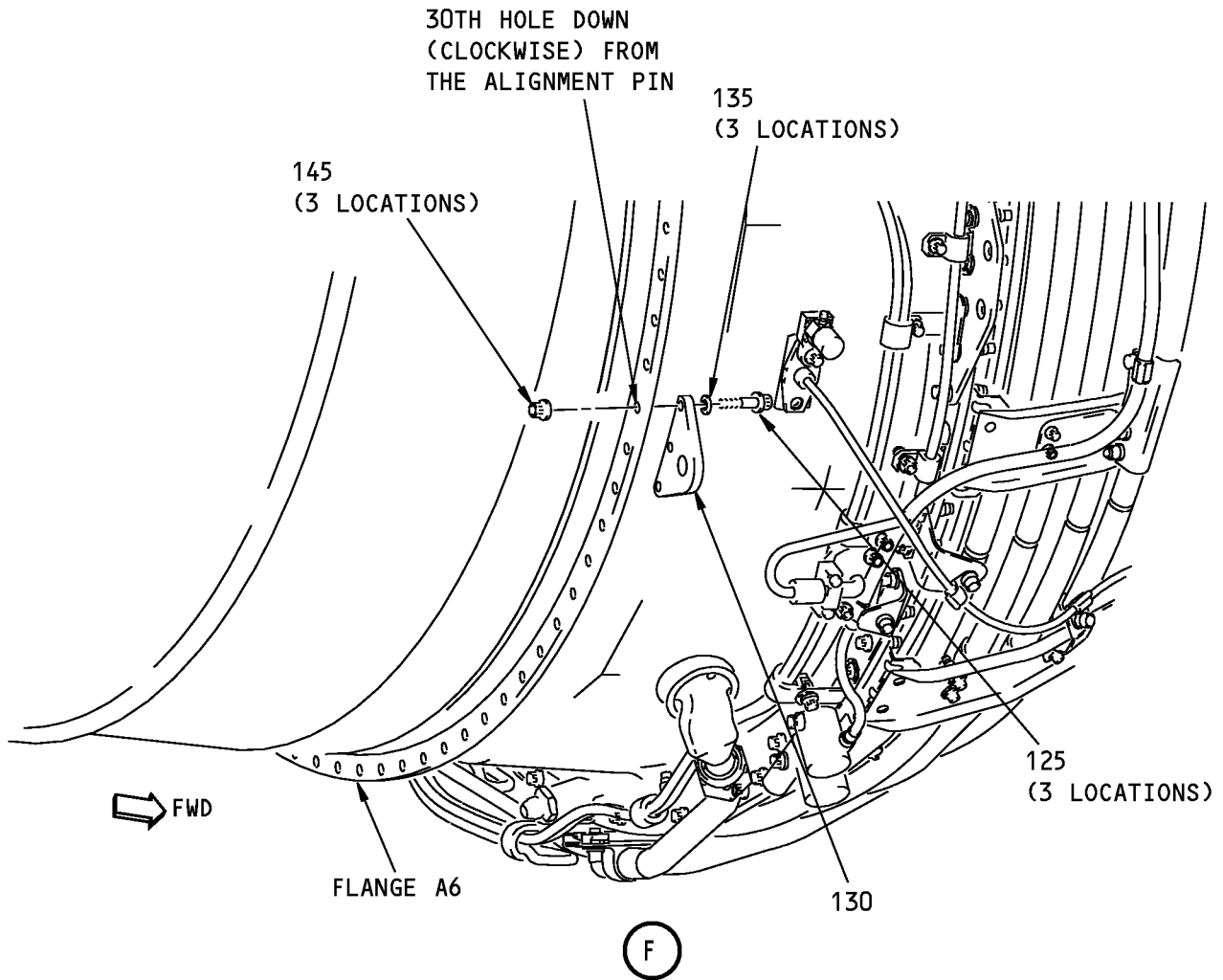
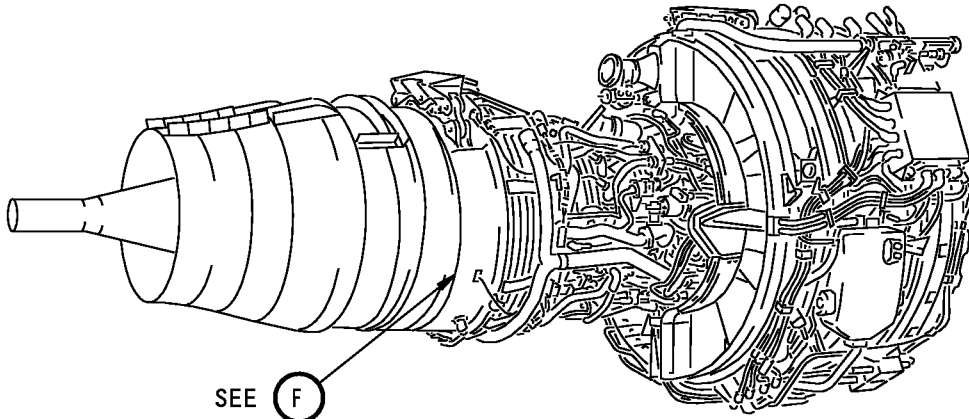

**Primary Exhaust Installation**  
**Figure 32-1 (Sheet 5)**

**71-00-02**

P/P BUILDUP FIGURE 32-1

Page 10

Oct 05/2007

D633A106-HXL

**737-600/700/800/900  
POWERPLANT BUILDUP MANUAL**

ITEM NO.	PART NUMBER	NOMENCLATURE	UC	QTY
32-1		<p><b>PRIMARY EXHAUST INSTALLATION (FIGURE 32-1, SHEET 5)</b></p> <p>AT 30TH, 31ST, AND 32ND HOLES DOWN (CLOCKWISE) FROM ALIGNMENT PIN, LOOSELY ATTACH GSE BRACKET (130) ON FWD SIDE OF FLANGE A6 WITH BOLTS (125), WASHERS (135) AND NUTS (145).</p> <p><b>NOTE:</b> IF BOLTS (125) HAVE BEEN PREVIOUSLY INSTALLED: APPLY Never-Seez NSBT-8N compound, D00006 (C1) TO THREADS OF BOLTS (125) OR REPLACE NUTS (145).</p>		
125	BACB30PN4-10	. BOLT		3
125	BACB30US4-10	. BOLT (OPTIONAL TO BACB30PN4-10)	OPT	-
130	333A2020-5	. GSE BRACKET		1
135	BACW10BP4ACU	. WASHER (CSK) (UNDER BOLT HEAD)		3
145	BACN10HR4C	. NUT		3
C1	D00006	. COMPOUND, NEVER-SEEZ NSBT-8N	CON	AR
		<p><b>NOTE:</b> DO NOT TIGHTEN NUTS (145) OR BOLTS (125) AT THIS TIME.</p>		

**71-00-02**

P/P BUILDUP FIGURE 32-1

Page 11

Feb 05/2008

D633A106-HXL

737-600/700/800/900  
**POWERPLANT BUILDUP MANUAL**

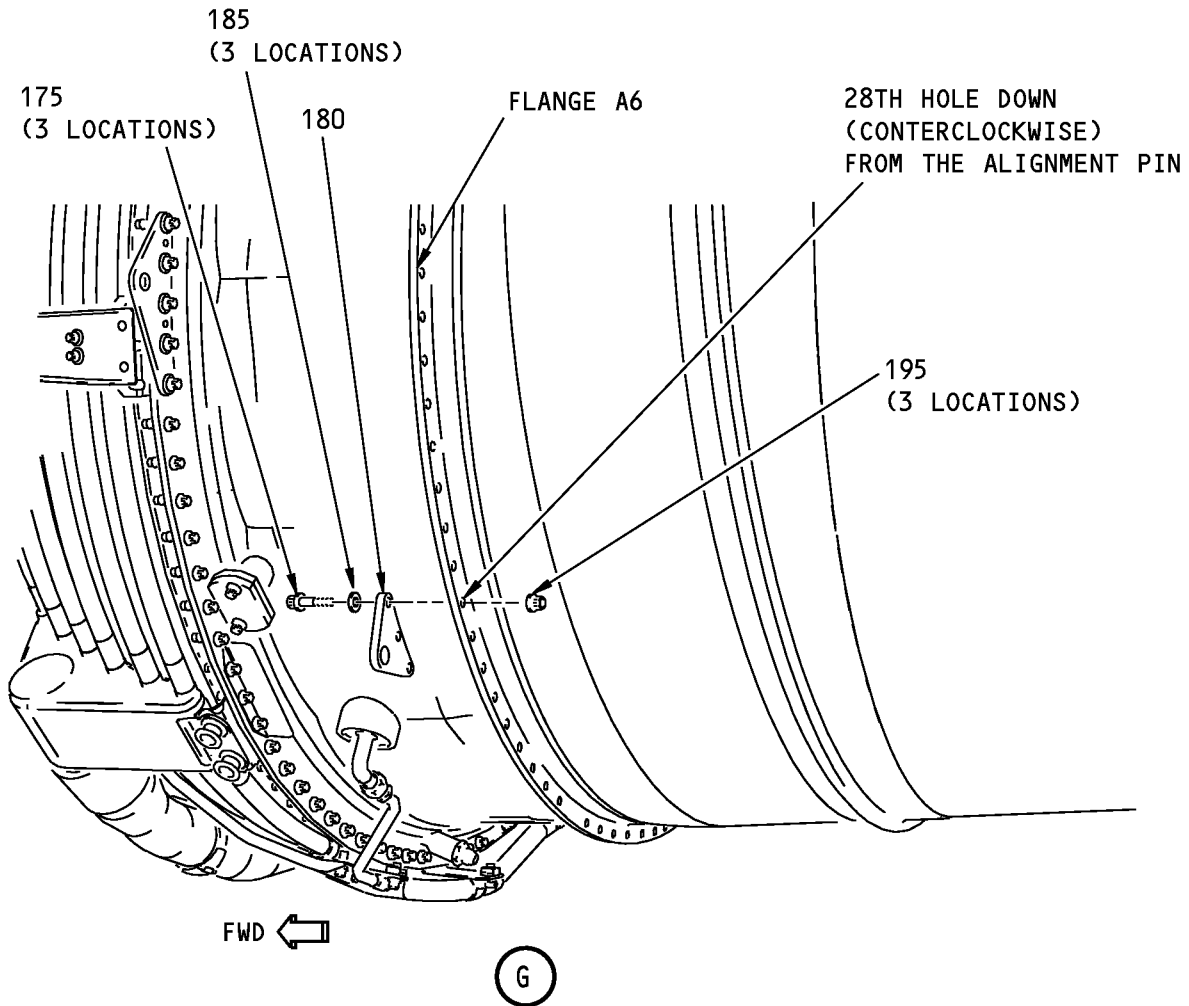
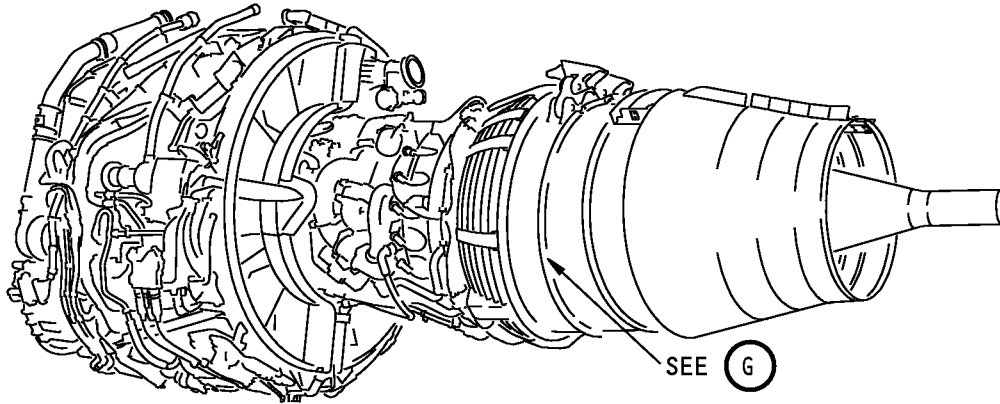

**Primary Exhaust Installation**  
Figure 32-1 (Sheet 6)

**71-00-02**

P/P BUILDUP FIGURE 32-1

Page 12

Oct 05/2007

D633A106-HXL

**737-600/700/800/900  
POWERPLANT BUILDUP MANUAL**

ITEM NO.	PART NUMBER	NOMENCLATURE	UC	QTY
32-1		<p><b>PRIMARY EXHAUST INSTALLATION (FIGURE 32-1, SHEET 6)</b></p> <p>AT 28TH, 29TH, AND 30TH HOLES DOWN (COUNTERCLOCKWISE) FROM ALIGNMENT PIN, LOOSELY ATTACH GSE BRACKET (180) ON FWD SIDE OF FLANGE A6 WITH BOLTS (175), WASHERS (185) AND NUTS (195).</p> <p><b>NOTE:</b> IF BOLTS (175) HAVE BEEN PREVIOUSLY INSTALLED: APPLY Never-Seez NSBT-8N compound, D00006 (C1) TO THREADS OF BOLTS (175) OR REPLACE NUTS (195).</p>		
175	BACB30PN4-10	. BOLT		3
175	BACB30US4-10	. BOLT (OPTIONAL TO BACB30PN4-10)	OPT	-
180	333A2020-5	. GSE BRACKET		1
185	BACW10BP4ACU	. WASHER (CSK) (UNDER BOLT HEAD)		3
195	BACN10HR4C	. NUT		3
C1	D00006	. COMPOUND, NEVER-SEEZ NSBT-8N	CON	AR
		<p><b>NOTE:</b> DO NOT TIGHTEN NUTS (195) OR BOLTS (175) AT THIS TIME.</p>		

**71-00-02**

P/P BUILDUP FIGURE 32-1

Page 13

Feb 05/2008

D633A106-HXL

737-600/700/800/900  
**POWERPLANT BUILDUP MANUAL**

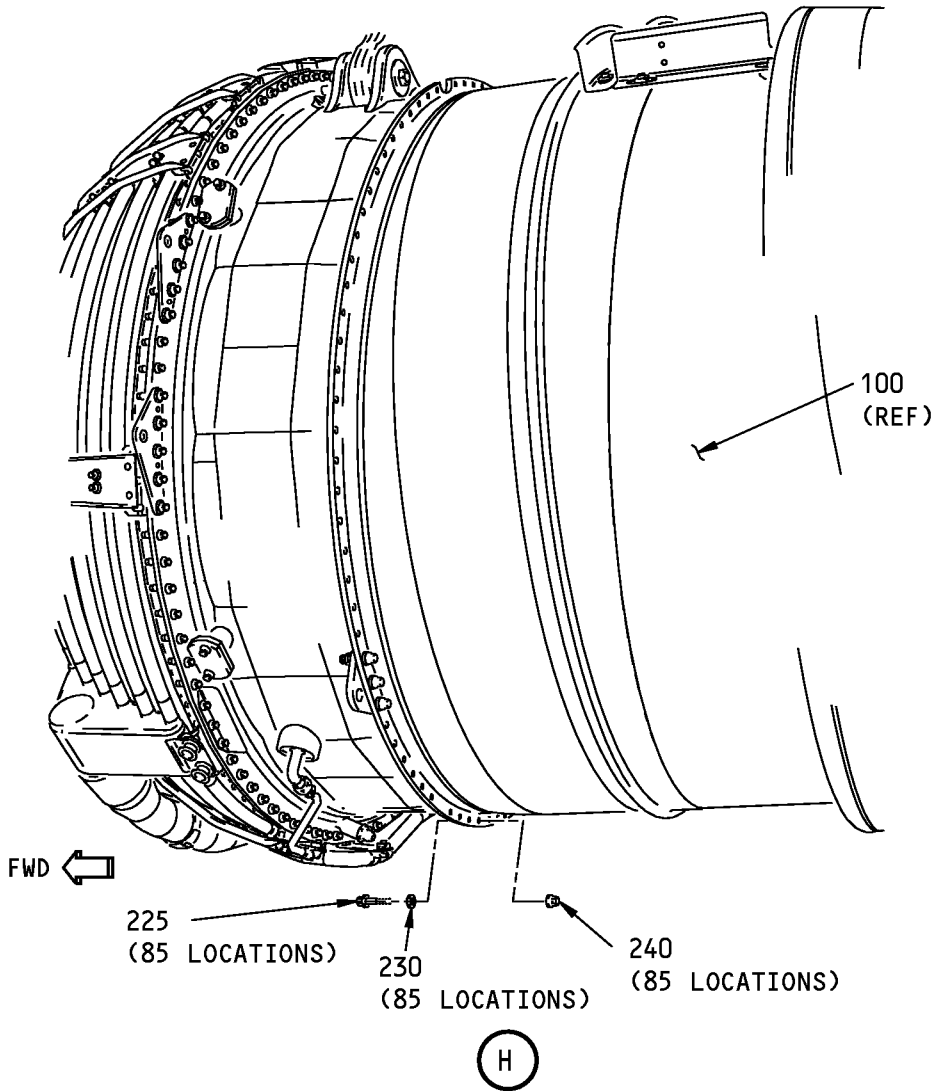
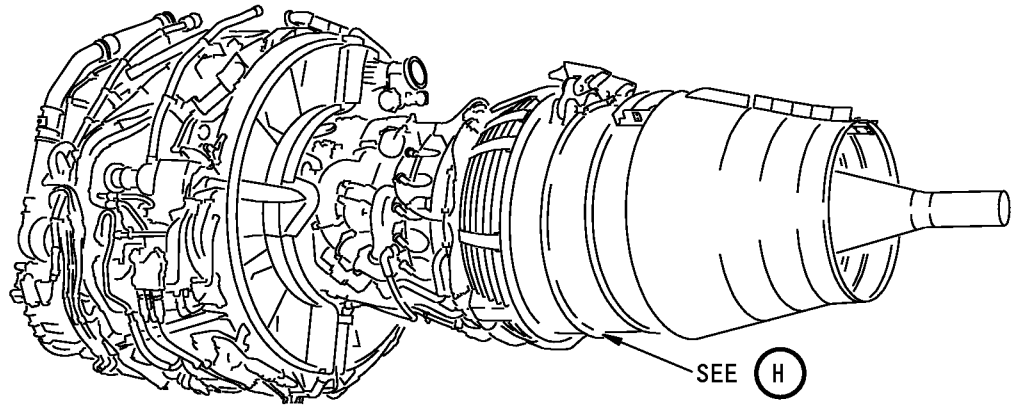

**Primary Exhaust Installation**  
Figure 32-1 (Sheet 7)

**71-00-02**

P/P BUILDUP FIGURE 32-1

Page 14

Oct 05/2007

D633A106-HXL

**737-600/700/800/900  
POWERPLANT BUILDUP MANUAL**

ITEM NO.	PART NUMBER	NOMENCLATURE	UC	QTY
32-1		<p><b>PRIMARY EXHAUST INSTALLATION (FIGURE 32-1, SHEET 7)</b></p> <p>AT REMAINING 85 LOCATIONS ON PRIMARY NOZZLE ASSY FLANGE, LOOSELY INSTALL BOLTS (225), WASHERS (230) AND NUTS (240).</p> <p><b>NOTE:</b> IF BOLTS (225) HAVE BEEN PREVIOUSLY INSTALLED: LUBRICATE BOLTS (225) WITH Never-Seez NSBT-8N compound, D00006 (C1) OR REPLACE NUTS (240).</p>		
225	BACB30PN4-6	. BOLT		85
225	BACB30US4-6	. BOLT (OPTIONAL TO BACB30PN4-6)	OPT	-
230	BACW10BP4ACU	. WASHER (CSK) (UNDER BOLT HEAD)		85
240	BACN10HR4C	. NUT		85
C1	D00006	. COMPOUND, NEVER-SEEZ NSBT-8N	CON	AR
		<p>SNUG FIT NUTS (240, 145 AND 195) OR BOLTS (225, 125 AND 175) IN THE FOLLOWING SEQUENCE: 3:00 O'CLOCK, 9:00 O'CLOCK, 6:00 O'CLOCK AND 12:00 O'CLOCK POSITIONS. SNUG FIT REMAINING NUTS OR BOLTS. TIGHTEN NUTS OR BOLTS AT 3:00, 9:00, 6:00 THEN 12:00 O'CLOCK POSITIONS TO THE FINAL TORQUE VALUE NOTED ON NEXT PAGE. SEQUENTIALLY TIGHTEN THE REMAINING NUTS OR BOLTS. CHECK TORQUE AT FIRST NUT OR BOLT TORQUED. IF NUT OR BOLT IS NOT WITHIN THE SPECIFIED RANGE, RE-TORQUE AND SEQUENTIALLY CHECK REMAINING NUTS OR BOLTS. RE-TORQUE IF REQUIRED.</p>		

**71-00-02**

P/P BUILDUP FIGURE 32-1

Page 15

Feb 05/2008

D633A106-HXL

737-600/700/800/900  
**POWERPLANT BUILDUP MANUAL**

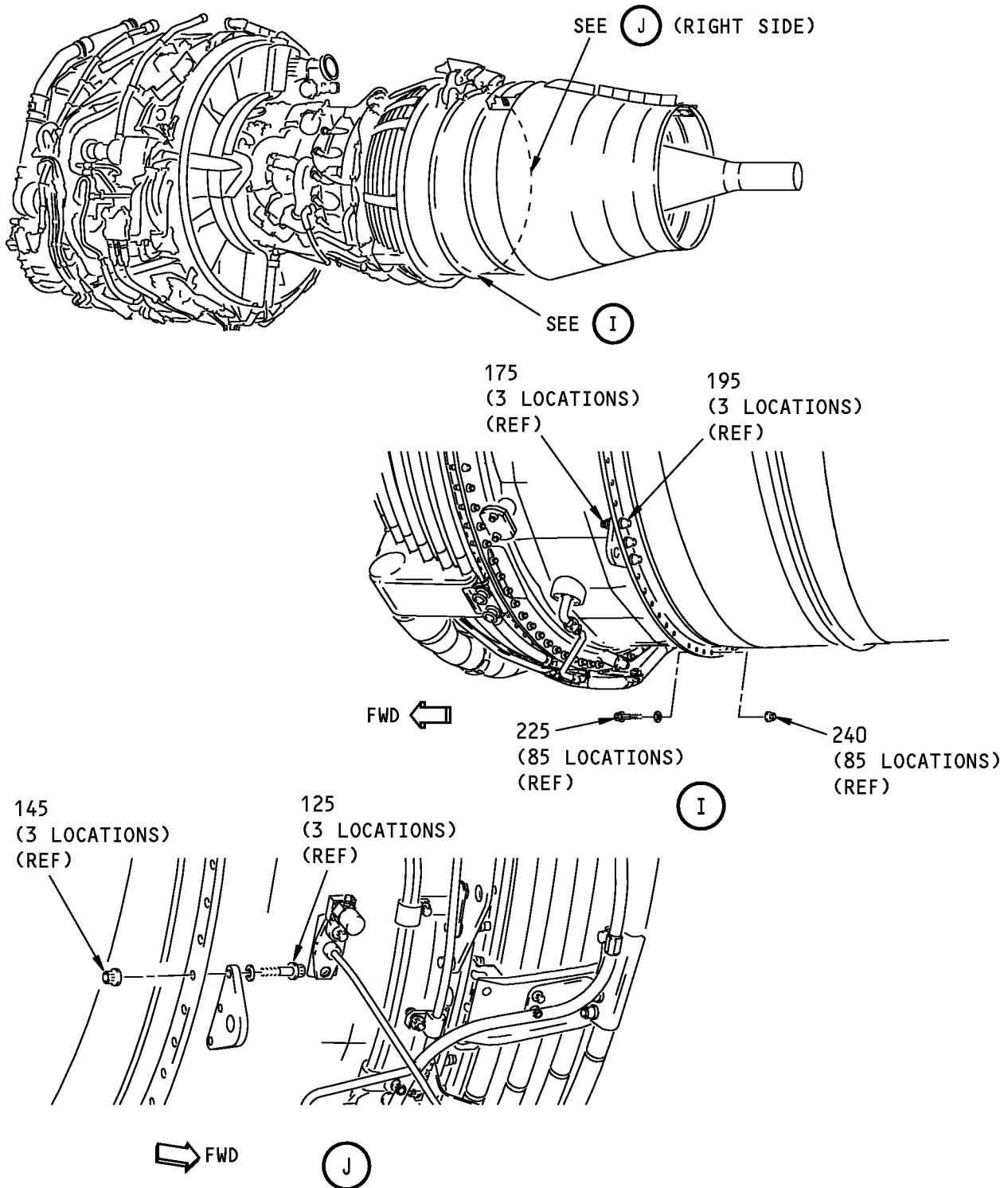

**Primary Exhaust Installation**  
**Figure 32-1 (Sheet 8)**

**71-00-02**

P/P BUILDUP FIGURE 32-1

Page 16

Oct 05/2007

D633A106-HXL

**737-600/700/800/900  
POWERPLANT BUILDUP MANUAL**

ITEM NO.	PART NUMBER	NOMENCLATURE	UC	QTY
32-1		<p><b>PRIMARY EXHAUST INSTALLATION (FIGURE 32-1, SHEET 8)</b></p> <p><u>DRY NUTS/BOLTS:</u></p> <p>FINAL TORQUE VALUE FOR BACB30PN BOLT:</p> <p>NUT (240, 145 AND 195) 65-100 POUND-INCHES (7.3-11.3 NEWTON METERS)</p> <p>BOLT (225, 125 AND 175) 90-110 POUND-INCHES (10.2-12.1 NEWTON METERS)</p> <p>FINAL TORQUE VALUE FOR OPT BACB30US BOLT:</p> <p>NUT (240, 145 AND 195) 90-125 POUND-INCHES (10.2-14.1 NEWTON METERS)</p> <p>BOLT (225, 125 AND 175) 113-138 POUND-INCHES (12.8-15.6 NEWTON METERS)</p> <p><u>LUBRICATED NUTS/BOLTS:</u></p> <p>FINAL TORQUE VALUE FOR BACB30PN BOLT:</p> <p>NUT (240, 145 AND 195) 50-75 POUND-INCHES (5.65-8.47 NEWTON METERS)</p> <p>BOLT (225, 125 AND 175) 67.5-82.5 POUND-INCHES (7.63-9.32 NEWTON METERS)</p> <p>FINAL TORQUE VALUE FOR OPT BACB30US BOLT:</p> <p>NUT (240, 145 AND 195) 70-80 POUND-INCHES (7.91-9.04 NEWTON METERS)</p> <p>BOLT (225, 125 AND 175) 72-88 POUND-INCHES (8.13-9.94 NEWTON METERS)</p>		

**71-00-02**

P/P BUILDUP FIGURE 32-1

Page 17

Oct 05/2007

D633A106-HXL



**FIGURE 33-1**

# **INLET COWL INSTALLATION**

**REF QEC TASK NO.: TBD**

**REF DWG: 334A2000  
301A2094**

**NOTE:** ALL STANDARDS AND ATTACHING HARDWARE FOR THIS FIGURE WILL BE PACKAGED IN QEC TASK NO. 110.

**71-00-02**

P/P BUILDUP FIGURE 33-1

Page 1

Oct 05/2007

D633A106-HXL

737-600/700/800/900  
POWERPLANT BUILDUP MANUAL

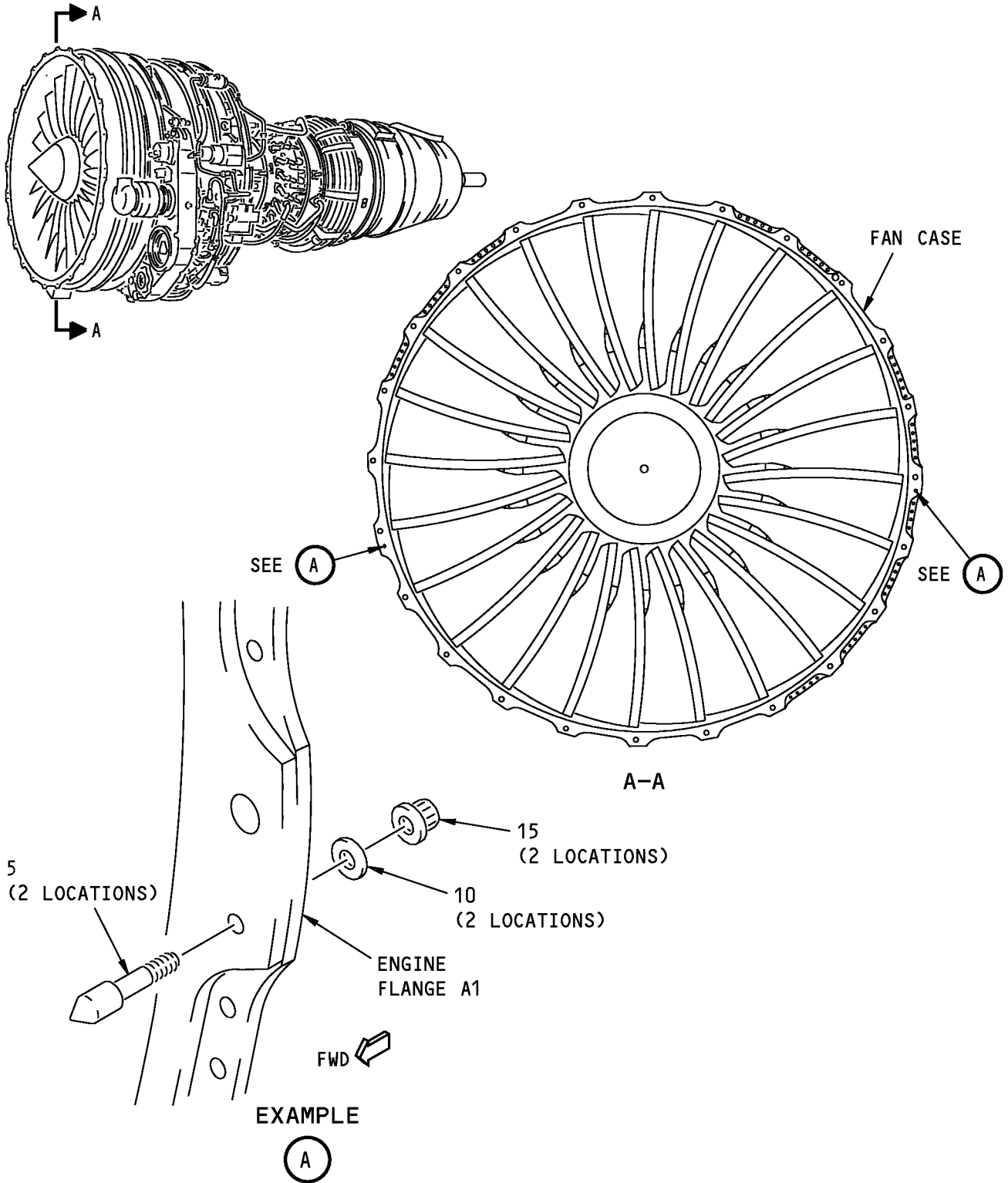

Inlet Cowl Installation  
Figure 33-1 (Sheet 1)

**71-00-02**

P/P BUILDUP FIGURE 33-1

Page 2

Oct 05/2007

D633A106-HXL

**737-600/700/800/900  
POWERPLANT BUILDUP MANUAL**

ITEM NO.	PART NUMBER	NOMENCLATURE	UC	QTY
33-1		<p><b>INLET COWL INSTALLATION (FIGURE 33-1, SHEET 1)</b></p> <p><b>NOTE:</b> INLET COWL IS INTERCHANGEABLE BETWEEN AIRPLANE ENGINE POSITIONS. NO. 1 (LEFT) ENGINE INLET IS THE SAME AS THE NO. 2 (RIGHT) ENGINE INLET.</p> <p>INSTALL SHEAR PINS (5) ON ENGINE FLANGE A1 IN HOLES JUST BELOW 3 AND 9 O'CLOCK POSITIONS WITH PINS FACING FWD. USE WASHERS (10) AND NUTS (15).</p>		
5	314T3019-3	. SHEAR PIN		2
10	NAS1149E0432P	. WASHER		2
15	BACN10YR4CM	. NUT		2
		TIGHTEN NUTS (15) TO 50-80 POUND-INCHES (5.7-9.0 NEWTON METERS).		

**71-00-02**

P/P BUILDUP FIGURE 33-1

Page 3

Oct 05/2007

D633A106-HXL

737-600/700/800/900  
**POWERPLANT BUILDUP MANUAL**

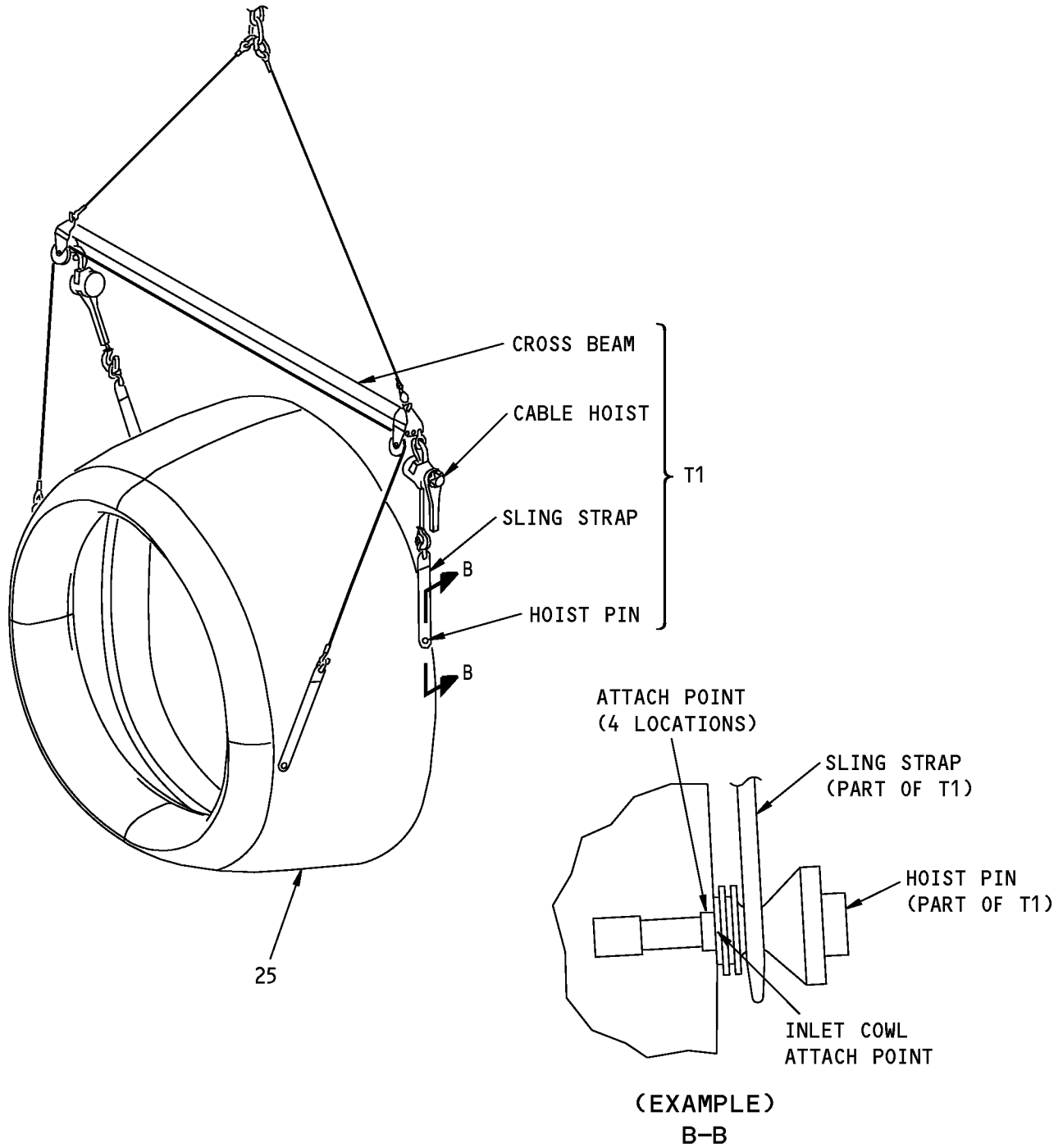

**INLET COWL INSTALLATION WITH INLET COWL SLING**

**Inlet Cowl Installation  
Figure 33-1 (Sheet 2)**

**71-00-02**

P/P BUILDUP FIGURE 33-1

Page 4

Oct 05/2007

D633A106-HXL

**737-600/700/800/900  
POWERPLANT BUILDUP MANUAL**

ITEM NO.	PART NUMBER	NOMENCLATURE	UC	QTY
33-1		<p><b>INLET COWL INSTALLATION (FIGURE 33-1, SHEET 2)</b></p> <p>INLET COWL INSTALLATION WITH INLET COWL SLING (PREFERRED METHOD)</p> <p>AT FOUR LOCATIONS, ATTACH inlet cowl sling, SPL-2062 (T1) TO INLET COWL (25) USING HOIST PINS AND SLING STRAPS.</p>		
25	314-2100-3	. INLET ASSY (V51563)	VEN	1
25	S314A210-21	. BOEING SPEC FOR 314-2100-3	BOE	-
25	314-2100-2	. INLET ASSY (V51563) (OPTIONAL TO 314-2100-3)	OPT	-
25	S314A210-5	. BOEING SPEC FOR 314-2100-2	BOE	-
T1	B71040-39	. INLET COWL SLING	TOL	-
		<p>LIFT INLET COWL OFF GROUND PALLET AND USE BOTH LEVER HOISTS TO ROTATE INLET COWL (25) UNTIL INLET ATTACHMENT FLANGE IS VERTICAL.</p> <p><b>NOTE:</b> TO TURN INLET COWL, DECREASE LENGTH OF LEVER HOIST CHAIN.</p> <p>REMOVE PROTECTIVE COVERS FROM CTAI DUCT AND EEC COOLING HOSE ON BOTH ENGINE AND INLET COWL (25).</p>		

**71-00-02**

P/P BUILDUP FIGURE 33-1

Page 5

Oct 05/2007

D633A106-HXL

737-600/700/800/900  
**POWERPLANT BUILDUP MANUAL**

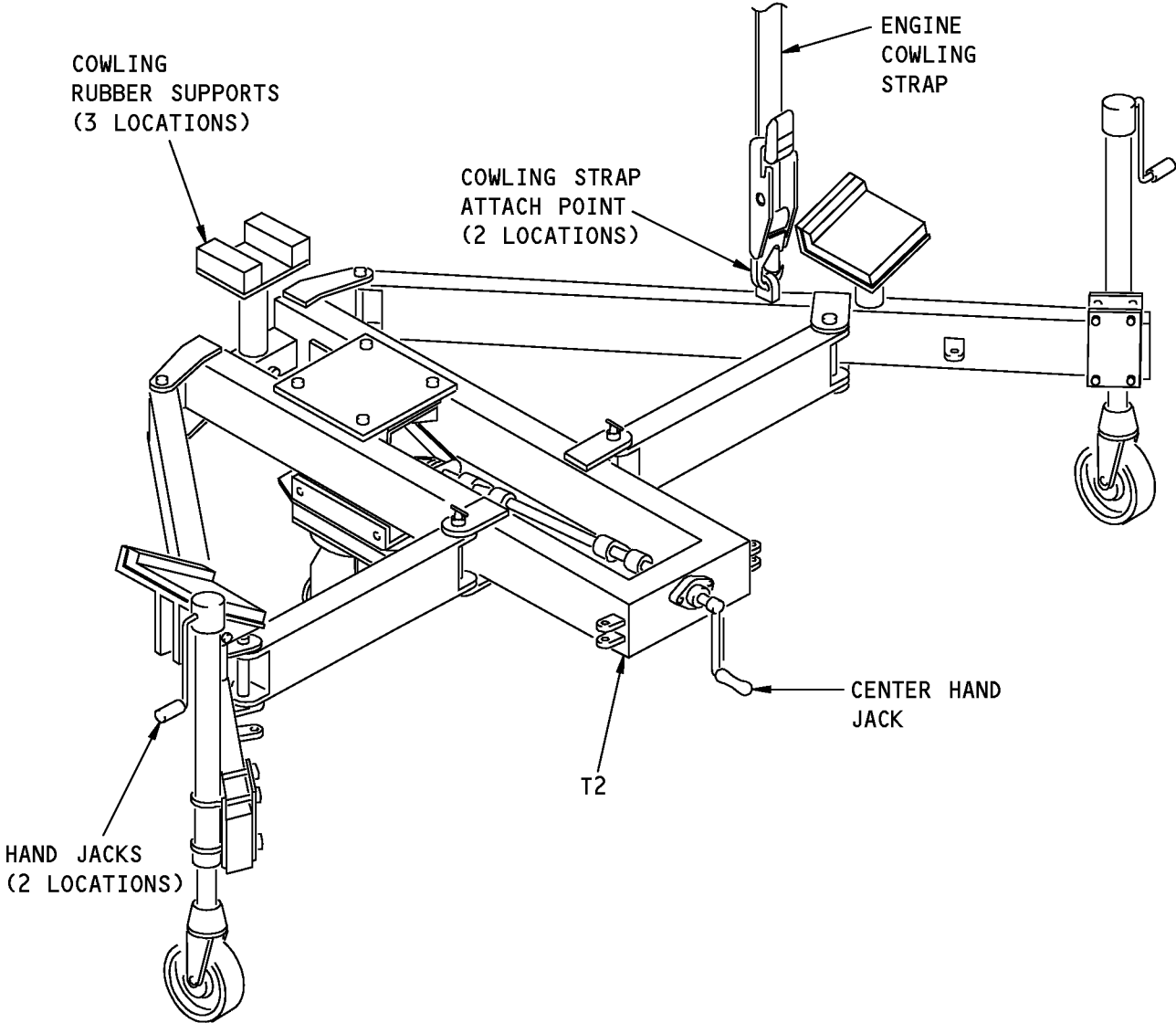

INLET COWL INSTALLATION INLET COWL DOLLY

**Inlet Cowl Installation**  
**Figure 33-1 (Sheet 3)**

**71-00-02**

P/P BUILDUP FIGURE 33-1

Page 6

Oct 05/2007

D633A106-HXL

**737-600/700/800/900  
POWERPLANT BUILDUP MANUAL**

ITEM NO.	PART NUMBER	NOMENCLATURE	UC	QTY
33-1		<p><b>INLET COWL INSTALLATION (FIGURE 33-1, SHEET 3)</b></p> <p>INLET COWL INSTALLATION WITH INLET COWL DOLLY (OPTIONAL METHOD)</p> <p><b>CAUTION:</b> APPLY ONLY THE FORCE NECESSARY TO THE ENGINE COWLING STRAP TO HOLD THE INLET COWL TO THE DOLLY. MORE FORCE CAN CAUSE DAMAGE TO THE INLET COWL.</p> <p>dolly, COM-2060 (T2) CAN BE USED TO TRANSFER AN INLET COWL FROM AN ON-WING ENGINE OR FOR A INLET COWL STORED ON THE DOLLY.</p> <p><b>NOTE:</b> THE INLET COWL DOLLY IS NOT DESIGNED TO LIFT THE INLET COWL DIRECTLY FROM A GROUND PALLET.</p>		
T2	AM1940-400	<p>. INLET COWL DOLLY (V9M323)</p> <p>REMOVE PROTECTIVE COVERS FROM CTAI DUCT AND EEC COOLING HOSE ON BOTH ENGINE AND INLET COWL (25).</p>	TOL	-

**71-00-02**

P/P BUILDUP FIGURE 33-1

Page 7

Oct 05/2007

D633A106-HXL

737-600/700/800/900  
**POWERPLANT BUILDUP MANUAL**

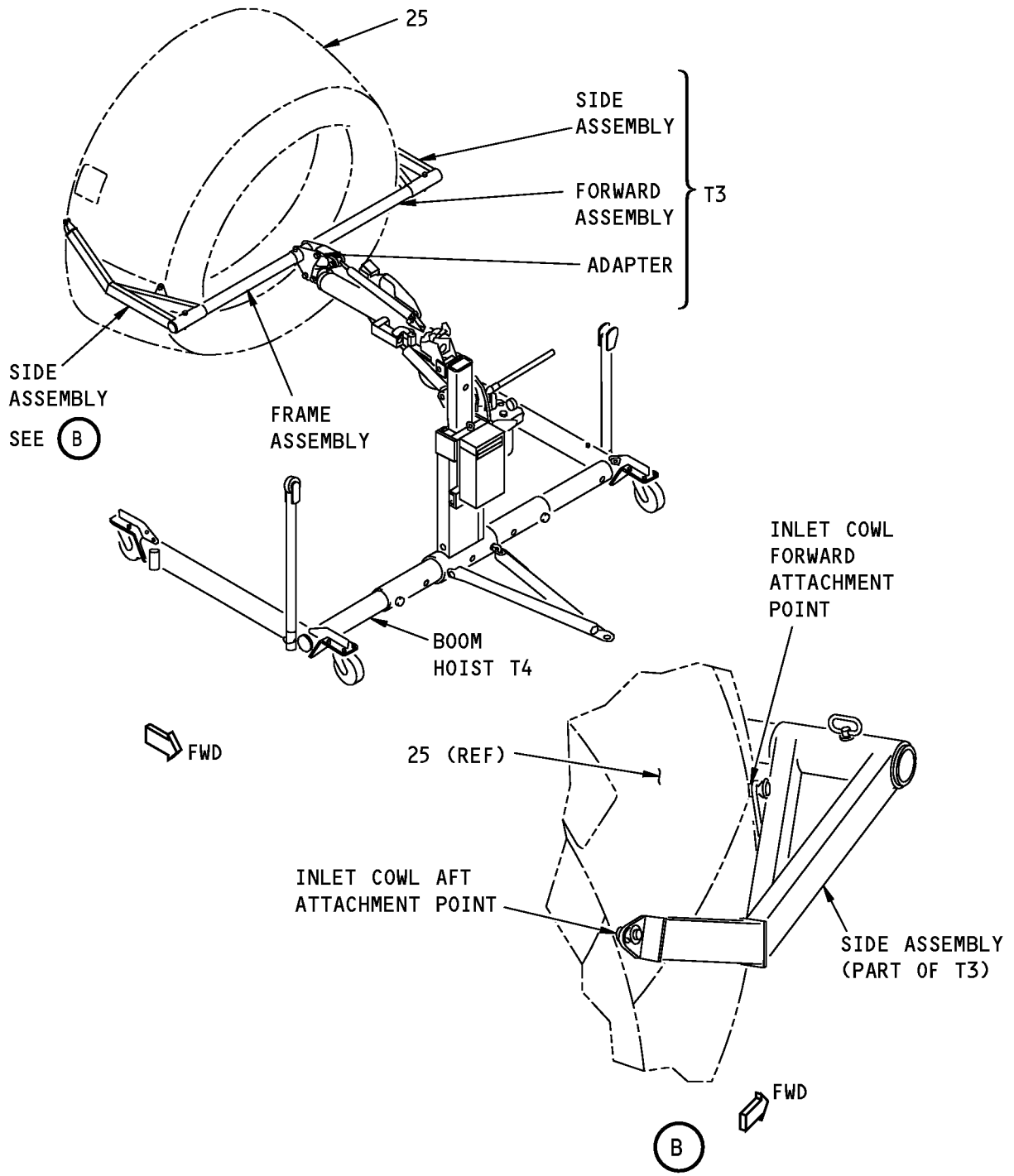

**INLET COWL INSTALLATION WITH BOOM HOIST**

**Inlet Cowl Installation  
Figure 33-1 (Sheet 4)**

**71-00-02**

P/P BUILDUP FIGURE 33-1

Page 8

Oct 05/2007

D633A106-HXL



**737-600/700/800/900  
POWERPLANT BUILDUP MANUAL**

ITEM NO.	PART NUMBER	NOMENCLATURE	UC	QTY
33-1		<p><b>INLET COWL INSTALLATION (FIGURE 33-1, SHEET 4)</b></p> <p>INLET COWL INSTALLATION WITH BOOM HOIST (OPTIONAL METHOD)</p> <p>AT FOUR LOCATIONS, ATTACH cowl, SPL-2165 (T3) TO INLET COWL (25).</p>		
T3	C71027-1	. INLET COWL FRAME EQPT	TOL	-
T4	C78026-146	<p>USING boom hoist, SPL-2430 (T4), LIFT INLET COWL OFF GROUND PALLET AND ROTATE INLET COWL (25) UNTIL INLET ATTACHMENT FLANGE IS VERTICAL.</p> <p>. BOOM HOIST</p> <p>REMOVE PROTECTIVE COVERS FROM CTAI DUCT AND EEC COOLING HOSE ON BOTH ENGINE AND INLET COWL (25).</p>	TOL	-

# 71-00-02

P/P BUILDUP FIGURE 33-1

Page 9

Oct 05/2007

D633A106-HXL

737-600/700/800/900  
**POWERPLANT BUILDUP MANUAL**

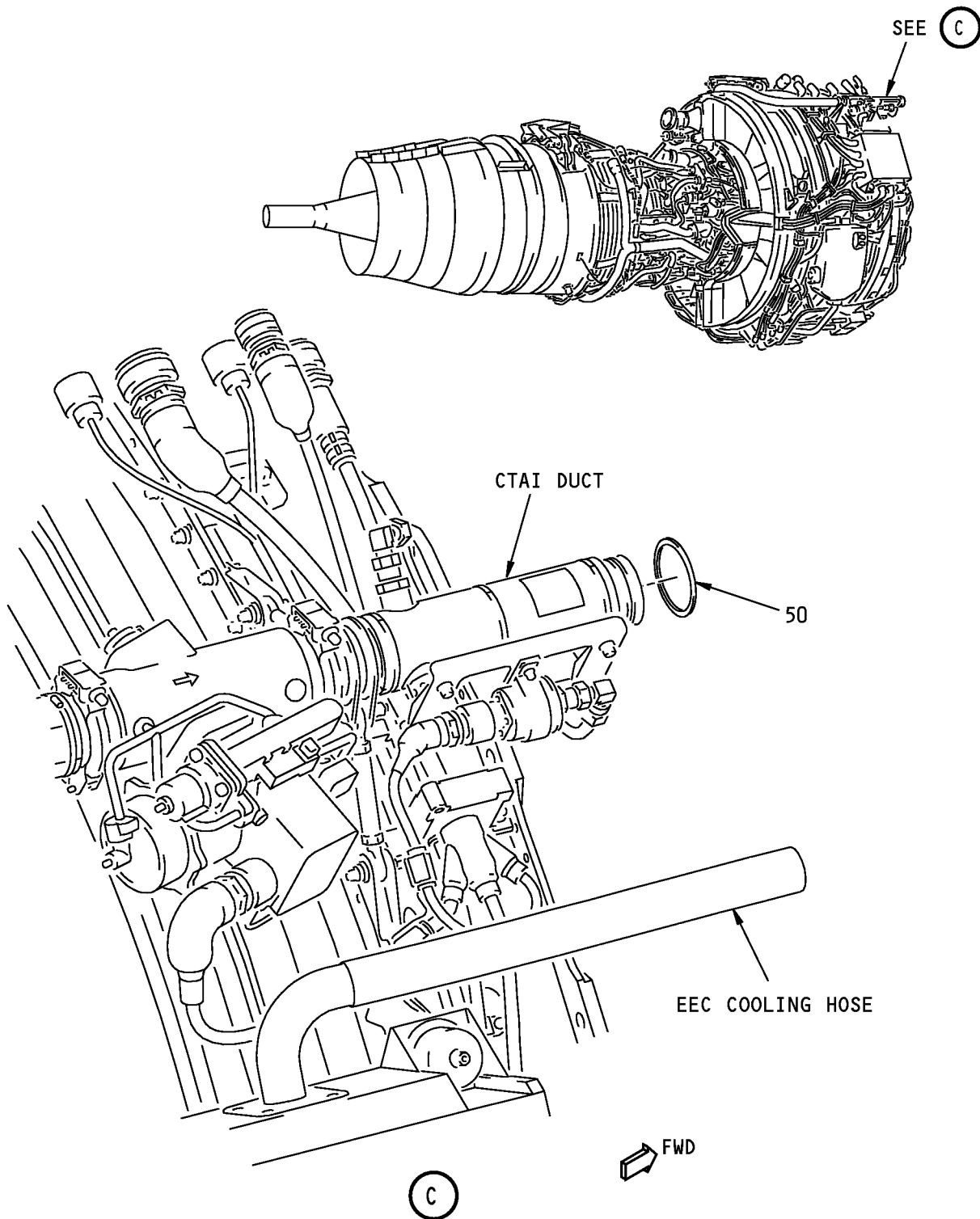

**Inlet Cowl Installation**  
**Figure 33-1 (Sheet 5)**

**71-00-02**

P/P BUILDUP FIGURE 33-1  
Page 10  
Oct 05/2007

D633A106-HXL



**POWERPLANT BUILDUP MANUAL**

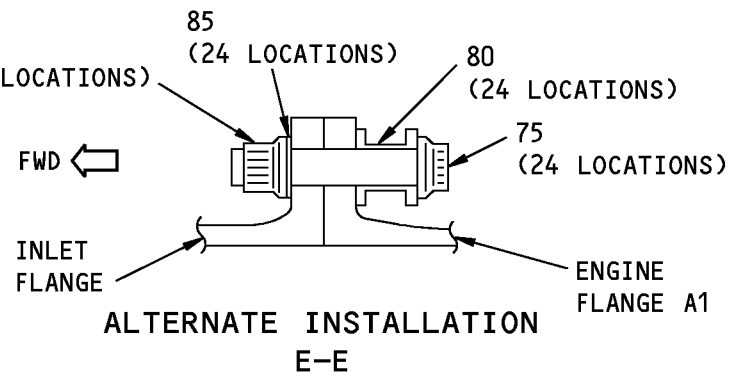
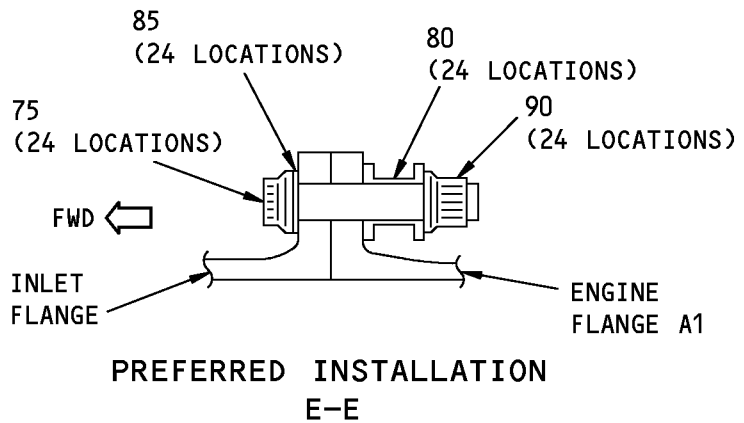
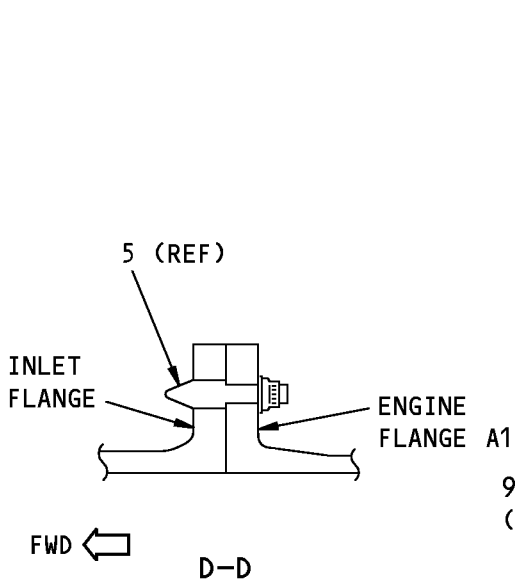
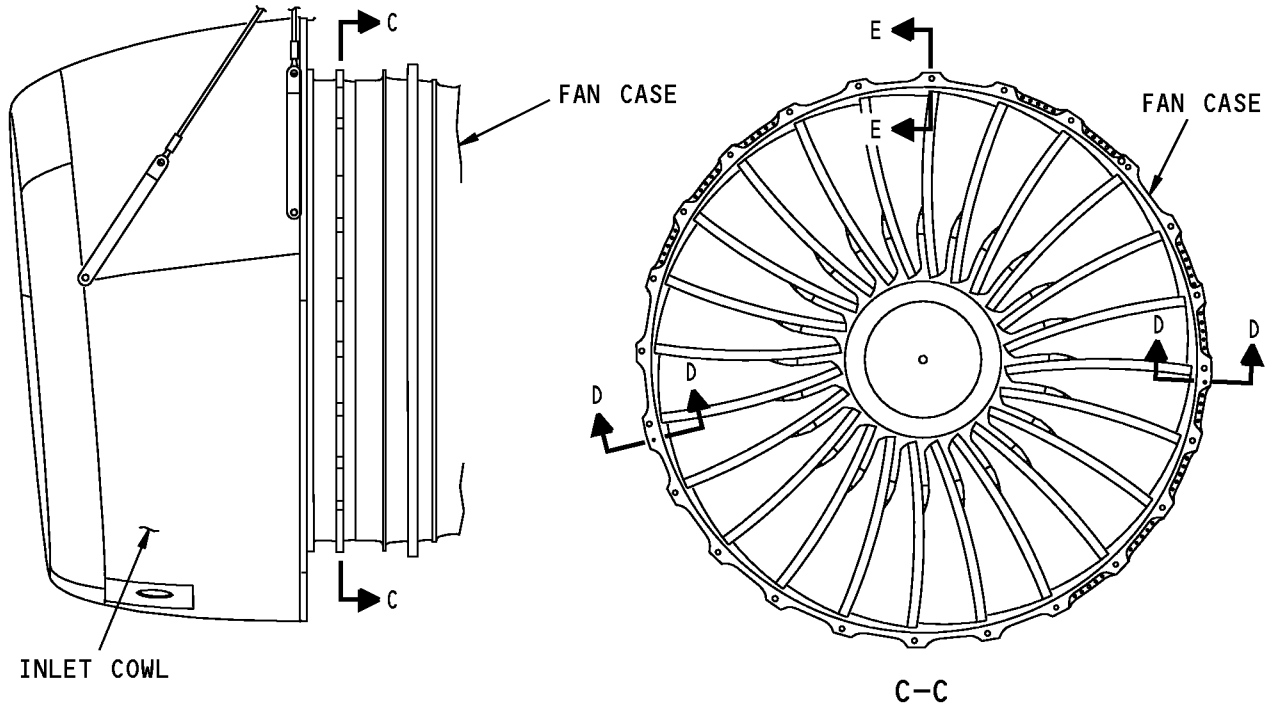

**Inlet Cowl Installation  
Figure 33-1 (Sheet 6)**

**71-00-02**

P/P BUILDUP FIGURE 33-1

Page 12

Oct 05/2007

D633A106-HXL

**737-600/700/800/900  
POWERPLANT BUILDUP MANUAL**

ITEM NO.	PART NUMBER	NOMENCLATURE	UC	QTY
33-1		<p><b>INLET COWL INSTALLATION (FIGURE 33-1, SHEET 6)</b></p> <p>POSITION INLET COWL (25) ON ENGINE ENSURING SHEAR PIN HOLES IN INLET ALIGN WITH SHEAR PINS ON ENGINE FLANGE A1.</p> <p><b>NOTE:</b> MAKE SURE CTAI DUCT AND EEC COOLING HOSE ARE ALIGNED AND SEATED CORRECTLY.</p> <p>LOOSELY ATTACH INLET COWL (25) TO ENGINE FLANGE A1 WITH BOLTS (75), SPACERS (80), WASHERS (85) AND NUTS (90).</p> <p><b>NOTE:</b> THE PREFERRED INSTALLATION HAS THE BOLT HEADS FACING FORWARD. AS AN ALTERNATE INSTALLATION, THE BOLT HEADS CAN FACE AFT. HOWEVER, IN BOTH CASES, THE WASHERS MUST BE ON THE FORWARD SIDE OF THE FLANGE AND THE SPACER MUST BE ON THE AFT SIDE OF THE FLANGE.</p>		
75	BACB30US8K29	. BOLT		24
80	334A2010-1	. SPACER (AFT SIDE OF FLANGE)		24
85	BACW10BP8ACU	. WASHER (FWD SIDE OF FLANGE)		24
90	BACN10HR8CS	. NUT		24
		<p>SNUG FIT BOLTS (75) OR NUTS (90) IN THE FOLLOWING SEQUENCE: 3 O'CLOCK, 9 O'CLOCK, 6 O'CLOCK AND 12 O'CLOCK POSITIONS. SNUG FIT REMAINING BOLTS OR NUTS. TIGHTEN BOLTS OR NUTS AT 3, 9, 6 AND 12 O'CLOCK POSITIONS TO THE FINAL TORQUE VALUE NOTED BELOW. SEQUENTIALLY TIGHTEN THE REMAINING BOLTS OR NUTS. CHECK TORQUE AT FIRST BOLT OR NUT TORQUED. IF BOLT OR NUT IS NOT WITHIN THE SPECIFIED RANGE, RE-TORQUE AND SEQUENTIALLY CHECK REMAINING FASTENERS. RE-TORQUE IF REQUIRED.</p> <p>FINAL TORQUE VALUE: BOLTS (75) 585-715 POUND INCHES (66.1-80.8 NEWTON METERS); NUTS (90) 500-650 POUND INCHES (56.5-73.4 NEWTON METERS).</p> <p>REMOVE inlet cowl sling, SPL-2062 (T1) OR dolly, COM-2060 (T2) OR cowl, SPL-2165 (T3) AND boom hoist, SPL-2430 (T4) EQUIPMENT.</p>		

**71-00-02**

P/P BUILDUP FIGURE 33-1

Page 13

Oct 05/2007

D633A106-HXL

737-600/700/800/900  
**POWERPLANT BUILDUP MANUAL**

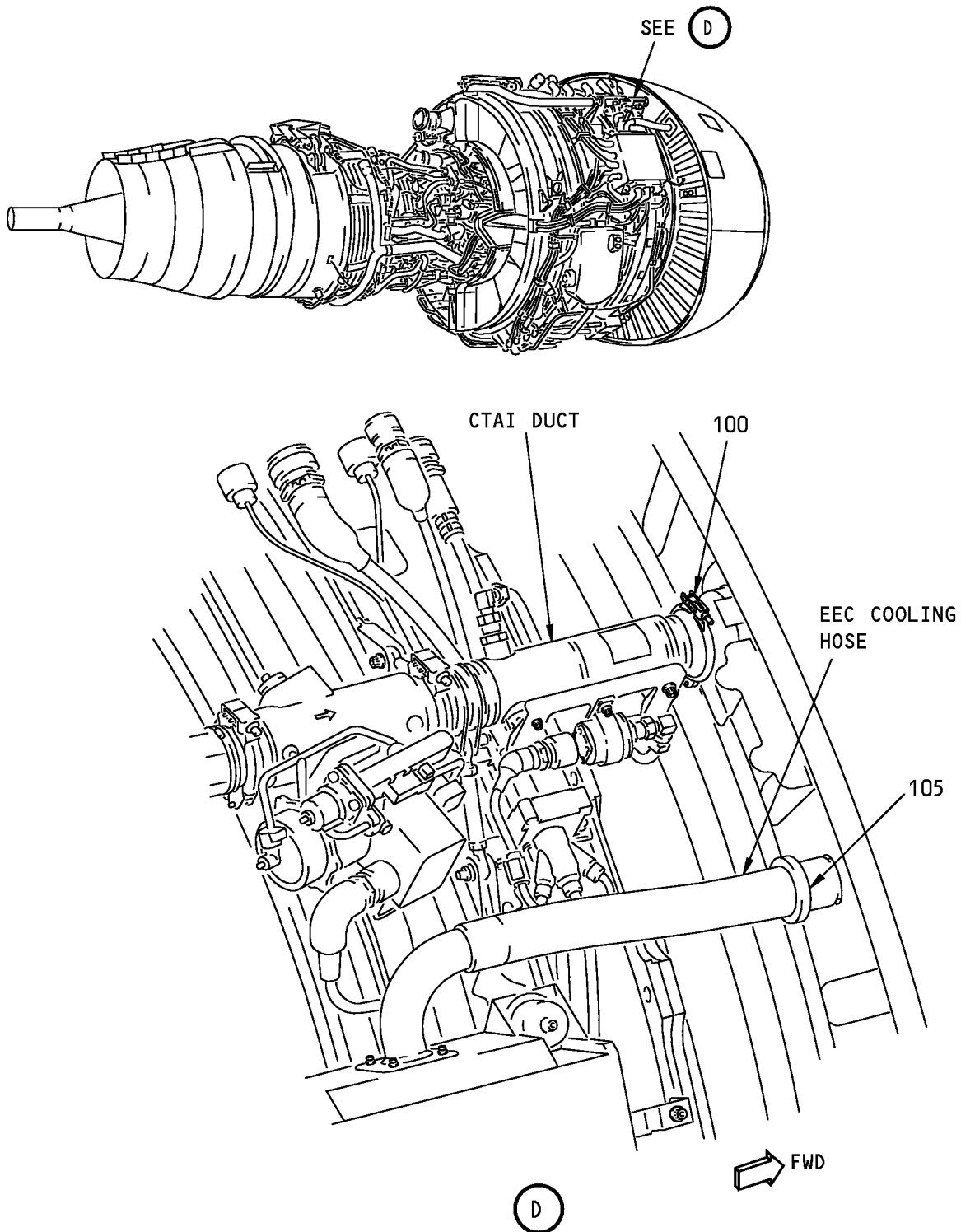

**Inlet Cowl Installation**  
**Figure 33-1 (Sheet 7)**

**71-00-02**

P/P BUILDUP FIGURE 33-1

Page 14

Oct 05/2007

D633A106-HXL

**737-600/700/800/900  
POWERPLANT BUILDUP MANUAL**

ITEM NO.	PART NUMBER	NOMENCLATURE	UC	QTY
33-1		<b>INLET COWL INSTALLATION (FIGURE 33-1, SHEET 7)</b>		
100	AS1895-4-200	REMOVE ITEM (100) FROM BAG ATTACHED TO FORWARD CTAI DUCT. . COUPLING (PART OF CTAI DUCT INSTL - Figure 27-1 )  POSITION COUPLING (100) ON CTAI DUCT, ENSURING NO PRELOAD EXISTS ON CTAI DUCT ON ENGINE OR INLET COWL. IF PRELOAD EXISTS, REMOVE COUPLING (100) AND ADJUST THE CTAI DUCT FLANGE AS FOLLOWS. LOOSEN BOLTS ON INLET COWL BULKHEAD TO FREE AFT INLET SEAL HOUSING. RE-ATTACH UPSTREAM DUCT WITH COUPLING (100). TAP ON ALUMINUM OR NON-METALLIC SPACER HELD AGAINST UPSTREAM CTAI FLANGE. FOR AFT ADJUSTMENT, APPLY A CONSTANT AFT FORCE TO SAME AFT FLANGE AND AT THE SAME TIME TAP ON PERIPHERY WITH A NON-METALLIC Mallet.  TIGHTEN COUPLING (100) TO TORQUE SPECIFIED ON PART. LIGHTLY TAP OUTER SURFACE OF COUPLING WITH NON-METALLIC Mallet. RETIGHTEN COUPLING TO TORQUE GIVEN ON PART.	REF	-
105	BACC10JB034C064	ATTACH EEC COOLING HOSE ON ENGINE TO HOSE FLANGE ON INLET COWL WITH HOSE CLAMP (105). . HOSE CLAMP  TIGHTEN HOSE CLAMP (105) TO 26-30 POUND-INCHES (2.9-3.4 NEWTON METERS).		1

# 71-00-02

P/P BUILDUP FIGURE 33-1

Page 15

Oct 05/2007

D633A106-HXL

737-600/700/800/900  
**POWERPLANT BUILDUP MANUAL**

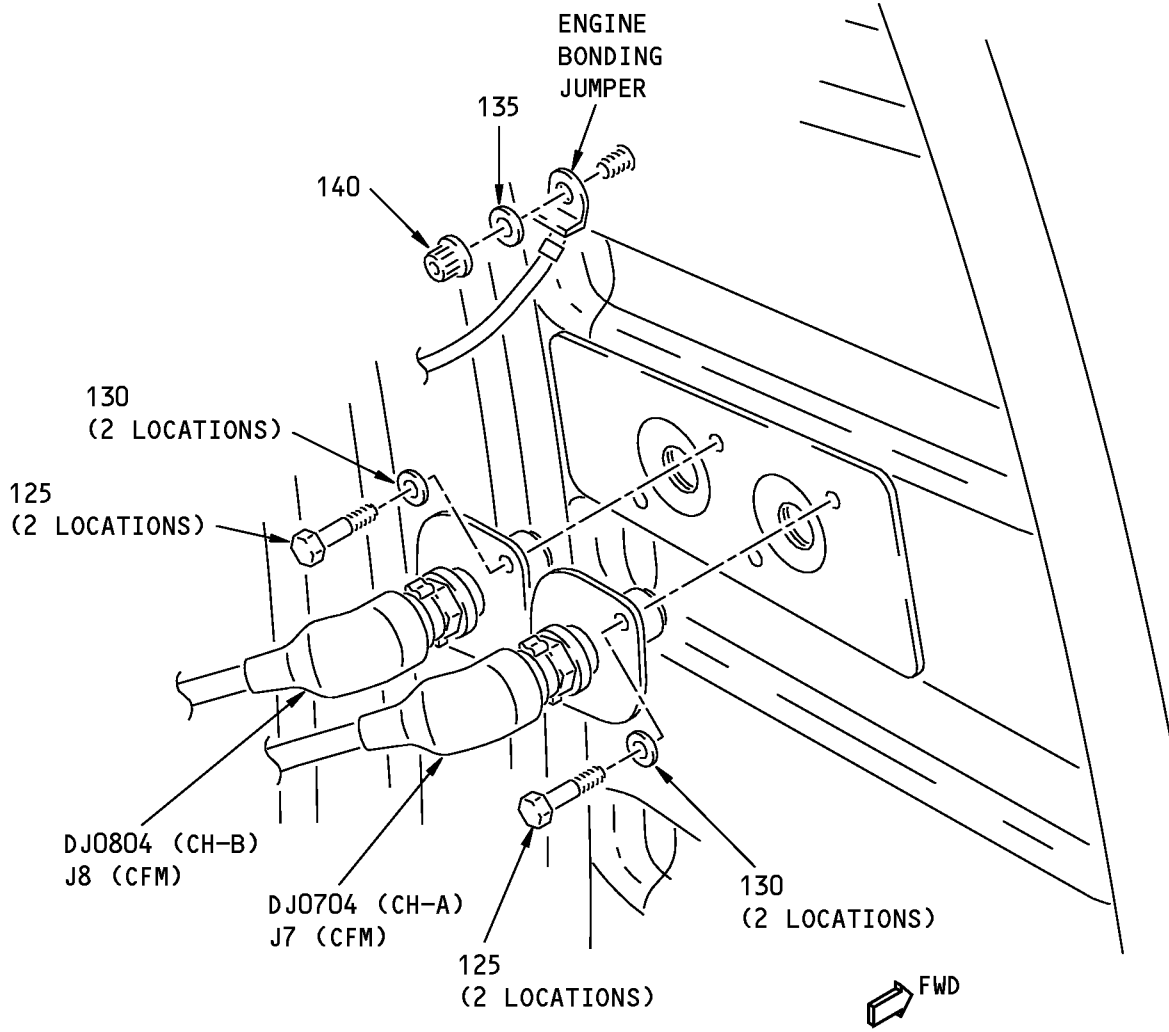
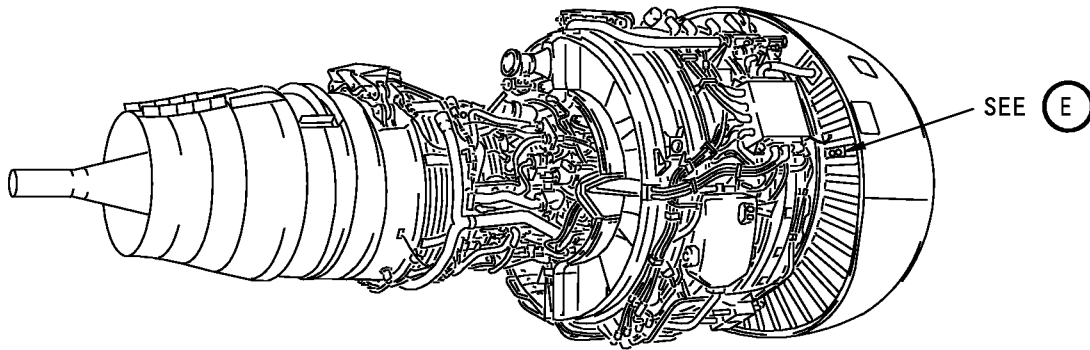

(E)

**Inlet Cowl Installation**  
**Figure 33-1 (Sheet 8)**

**71-00-02**

P/P BUILDUP FIGURE 33-1

Page 16

Oct 05/2007

D633A106-HXL



**737-600/700/800/900  
POWERPLANT BUILDUP MANUAL**

ITEM NO.	PART NUMBER	NOMENCLATURE	UC	QTY
33-1		<p><b>INLET COWL INSTALLATION (FIGURE 33-1, SHEET 8)</b></p> <p>DISCONNECT T12 SENSOR FROM ENGINE FAN CASE.</p> <p>CONNECT J8 ELECTRICAL HARNESS, DJ0804 (CH-B), TO INBOARD HOLE LOCATION AND CONNECT J7 ELECTRICAL HARNESS, DJ0704 (CH-A), TO OUTBOARD HOLE LOCATION ON INLET COWL AFT BULKHEAD. SECURE BOTH ELECTRICAL HARNESSES WITH BOLTS (125) AND WASHERS (130).</p>		
125	BACB30ZF4-08	. BOLT		4
130	NAS1149E0432R	. WASHER		4
		TIGHTEN BOLTS (125) TO 55-70 POUND-INCHES (6.3-7.9 NEWTON METERS).		
		ATTACH ENGINE BONDING JUMPER TO TERMINAL LUG AND SECURE WITH WASHER (135) AND NUT (140).		
135	NAS1149E0432R	. WASHER		1
140	AS3485-10	. NUT		1
		TIGHTEN NUT (140) TO 65-70 POUND-INCHES (7.3-7.9 NEWTON METERS).		

**71-00-02**

P/P BUILDUP FIGURE 33-1

Page 17

Oct 05/2007

D633A106-HXL

737-600/700/800/900  
POWERPLANT BUILDUP MANUAL

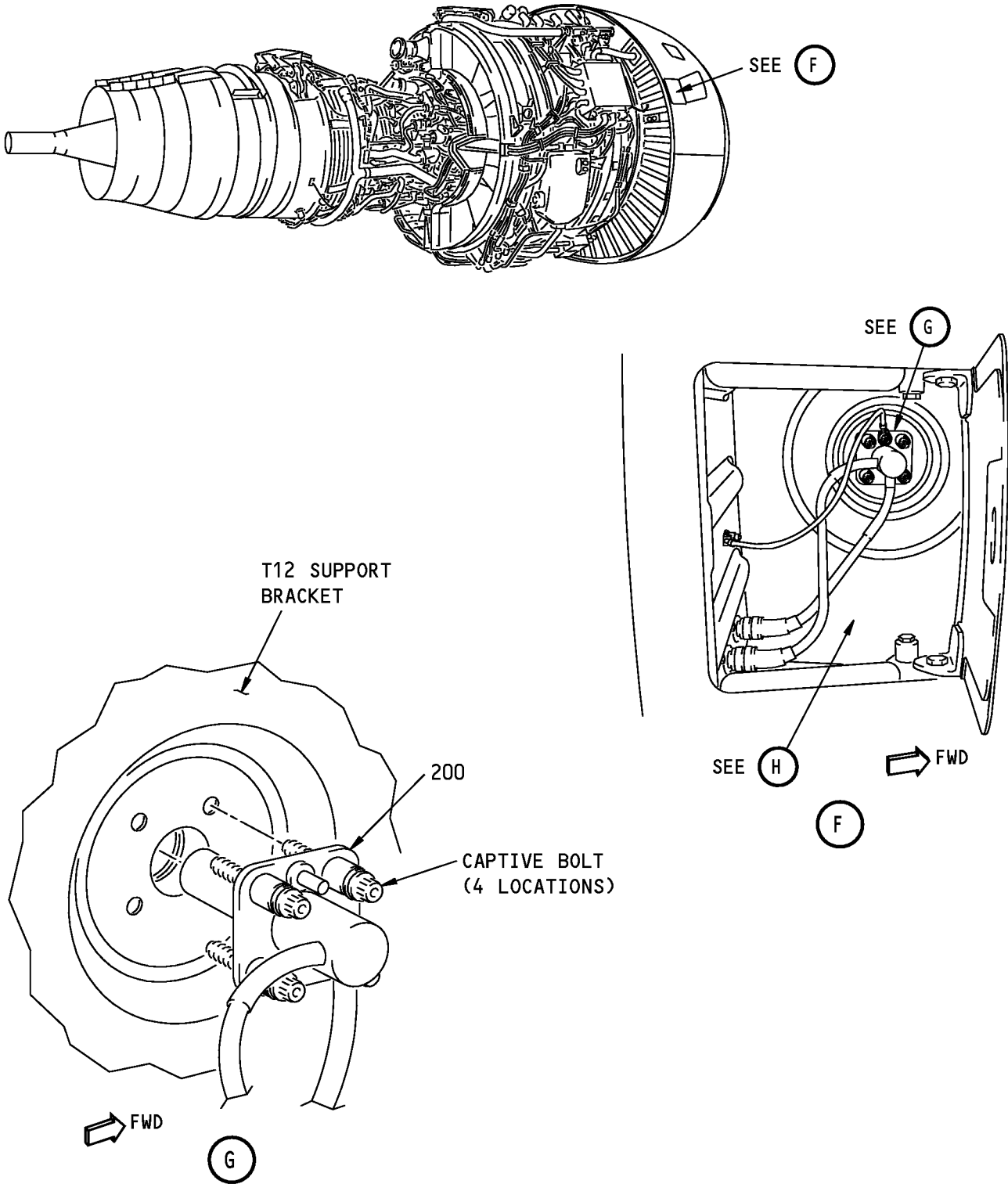

Inlet Cowl Installation  
Figure 33-1 (Sheet 9)

**71-00-02**

P/P BUILDUP FIGURE 33-1

Page 18

Oct 05/2007

D633A106-HXL



737-600/700/800/900  
**POWERPLANT BUILDUP MANUAL**

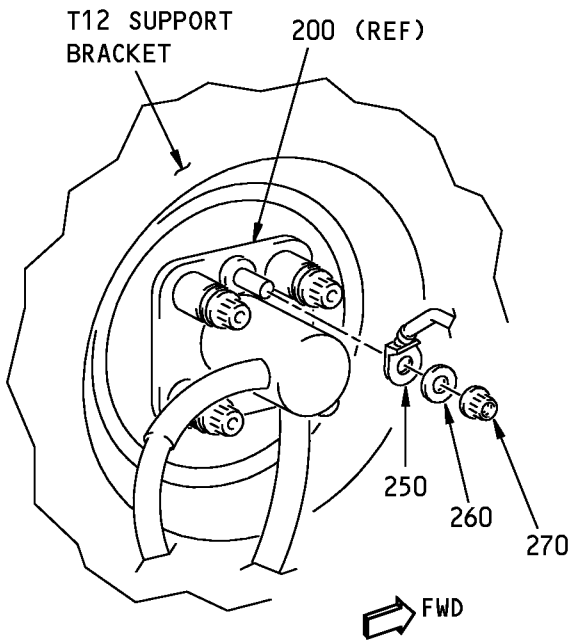

(ONLY REQUIRED IF BONDING JUMPER NOT PREVIOUSLY INSTALLED)

I

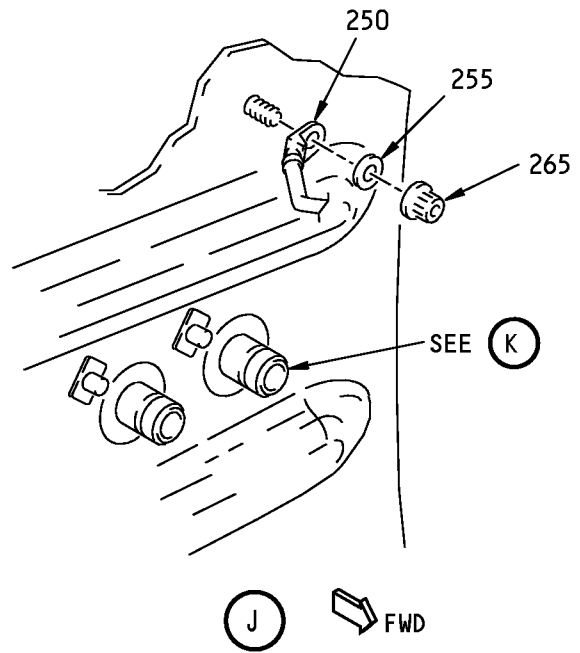
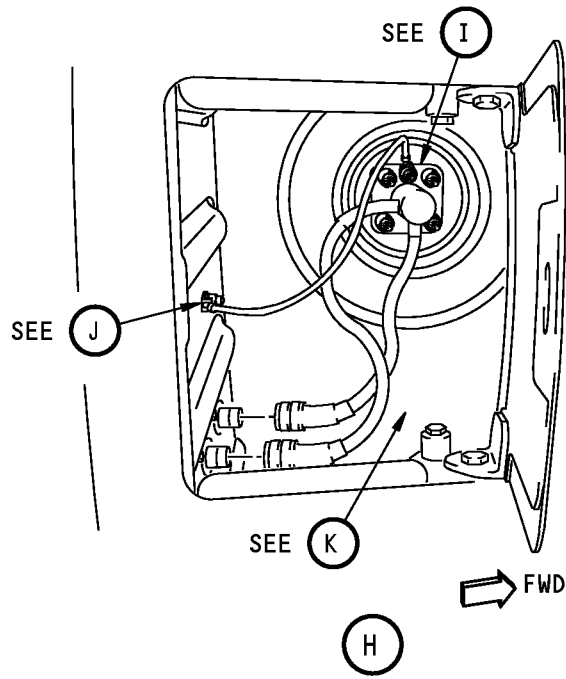

**Inlet Cowl Installation**  
**Figure 33-1 (Sheet 10)**

**71-00-02**

P/P BUILDUP FIGURE 33-1

Page 20

Oct 05/2007

**737-600/700/800/900  
POWERPLANT BUILDUP MANUAL**

ITEM NO.	PART NUMBER	NOMENCLATURE	UC	QTY
33-1		<b>INLET COWL INSTALLATION (FIGURE 33-1, SHEET 10)</b>  ATTACH BONDING JUMPER TO TERMINAL STUDS AND SECURE WITH WASHER (255) AND NUT (265).  IF BONDING JUMPER IS NOT INSTALLED ON T12 SENSOR, ATTACH BONDING JUMPER TO TERMINAL LUG AND SECURE WITH WASHER (260) AND NUT (270).		
250	69A94	. BONDING JUMPER (SUPPLIED WITH ENGINE)	REF	-
255	NAS1149E0432R	. WASHER		1
260	649-341-011-0	. WASHER (SUPPLIED WITH ENGINE) (1 REQD)	REF	-
265	AS3485-10	. NUT		1
270	649-304-004-0	. NUT (SUPPLIED WITH ENGINE) (1 REQD)	REF	-
		TIGHTEN NUT (265) TO 65-70 POUND-INCHES (7.3-7.9 NEWTON METERS) AND, IF NECESSARY, TIGHTEN NUT (270) TO 95-110 POUND-INCHES (11-12.5 NEWTON METERS).		

**71-00-02**

P/P BUILDUP FIGURE 33-1

Page 21

Oct 05/2007

D633A106-HXL

737-600/700/800/900  
**POWERPLANT BUILDUP MANUAL**

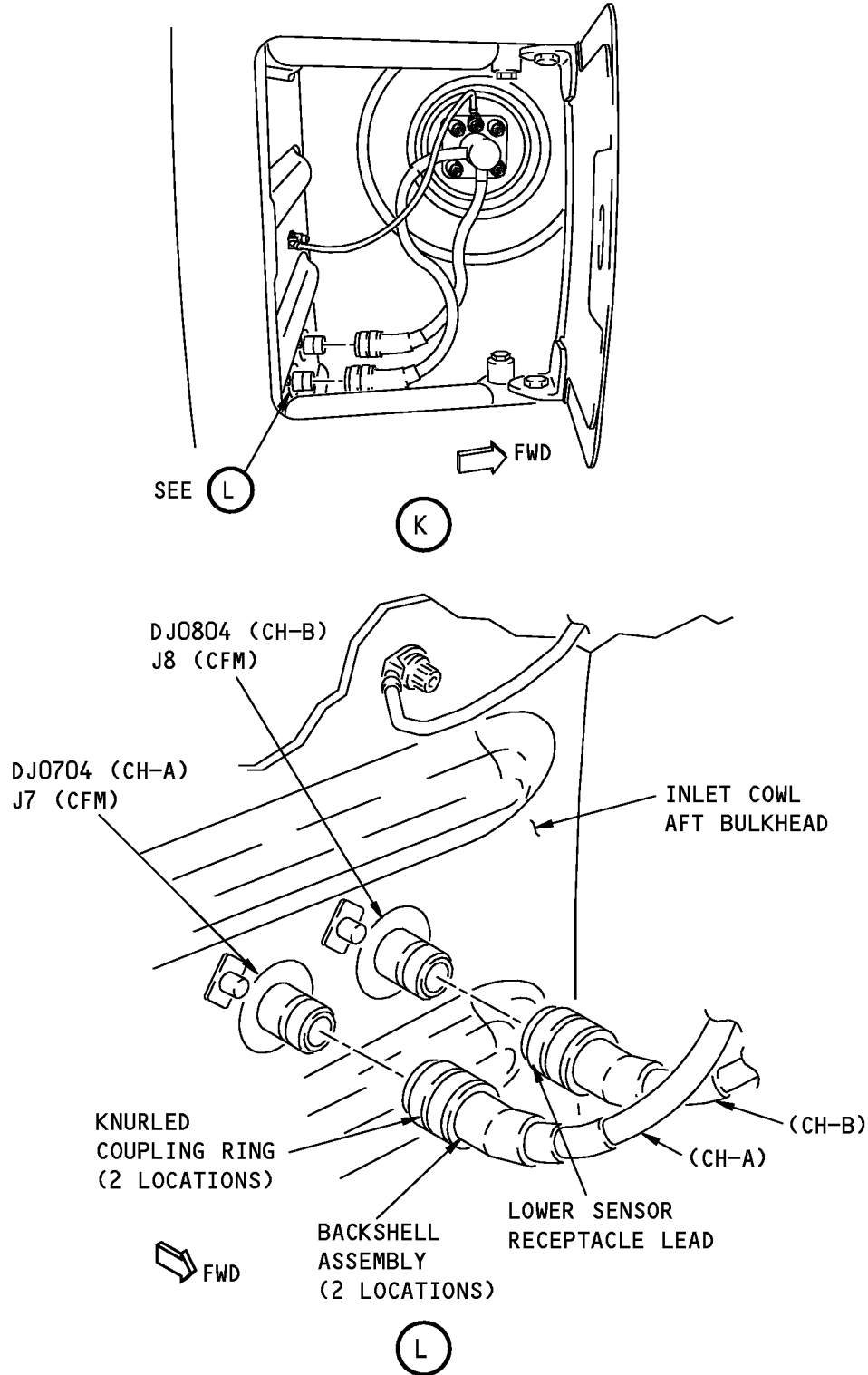

**Inlet Cowl Installation**  
**Figure 33-1 (Sheet 11)**

**71-00-02**

P/P BUILDUP FIGURE 33-1

Page 22

Oct 05/2007

D633A106-HXL

**737-600/700/800/900  
POWERPLANT BUILDUP MANUAL**

ITEM NO.	PART NUMBER	NOMENCLATURE	UC	QTY
33-1		<p><b>INLET COWL INSTALLATION (FIGURE 33-1, SHEET 11)</b></p> <p><b>CAUTION:</b> DO NOT OVERTIGHTEN THE PLUG COUPLING RING. DO NOT USE WATER PUMP PLIERS, PIPE WRENCHES OR VISE GRIPS TO TIGHTEN THE COUPLING RING OR DAMAGE TO THE ELECTRICAL CONNECTOR CAN OCCUR.</p> <p>CONNECT J8 ELECTRICAL CONNECTOR, DJ0804 (CH-B), TO INBOARD RECEPTABLE AND J7 ELECTRICAL CONNECTOR, DJ0704 (CH-A) TO OUTBOARD RECEPTACLE. TURN KNURLED COUPLING RING WHILE WIGGLING THE BACKSHELL ASSEMBLY. AFTER FULLY SEATING THE COUPLING RING, USE SOFT-JAWED PLIERS OR A STRAP WRENCH TO TIGHTEN THE COUPLING RING AN ADDITIONAL 1/8 TURN OR UNTIL PLIER SLIPPAGE OCCURS.</p> <p>CHECK THAT RESISTANCE ON ENGINE JUMPER AT INLET COWL AFT BULKHEAD AND T12 BONDING JUMPER AT INLET COWL FORWARD BULKHEAD IS NOT MORE THAN 0.001 OHMS.</p> <p>CHECK THAT RESISTANCE BETWEEN T12 BONDING JUMPER AT T12 SENSOR IS NOT MORE THAN 0.0025 OHMS.</p> <p>CLOSE T12 ACCESS DOOR ON INLET COWL.</p>		

**71-00-02**

P/P BUILDUP FIGURE 33-1

Page 23

Oct 05/2007

D633A106-HXL

**737-600/700/800/900  
POWERPLANT BUILDUP MANUAL****QEC System Tests****1. General**

- A. QEC system tests provided in this section are optional and duplicate tests normally performed after engine installation on an airplane.

**2. IDG Cooling Lines Flushing Procedure****A. General**

**CAUTION:** DO NOT FLUSH THE IDG WHEN YOU DO THIS PROCEDURE. MAKE SURE THE OIL-IN AND OIL-OUT HOSES ARE DISCONNECTED FROM THE IDG. IF THIS STEP IS NOT OBEYED, DAMAGE TO THE IDG CAN OCCUR.

- (1) This flushing procedure is done on the external IDG cooling lines only. The oil-in and oil-out lines must be disconnected from the IDG before you start this procedure.

**B. Equipment**

- (1) Flushing cart, capable of 14 GPM flow capacity and a maximum pressure of 250 psi, or;  
Flushing cart, Boeing Flush Cart F/D 1206-00.29 or equivalent.
- (2) 5-gallon container to collect cleansing oil or solvent.
- (3) Patch filter, 40 micron

**C. Consumable Materials**

- (1) solvent, B00074 (Optional Type 1)
- (2) Nitrogen, minimum of 3.5 lbs (a pressure drop of 500-1000 psig) from a 230 cubic foot nitrogen tank (atmospheric 2200 psig).

**D. Procedure**

- (1) Disconnect the oil-in and oil-out hoses from the IDG.
- (2) Connect the patch filter to the IDG oil-out hose.
- (3) Connect the flushing cart to the oil-in hose and the patch filter.

**NOTE:** Flushing direction should be in the direction of normal oil flow.

- (4) Start the flushing procedure with a new patch filter and with the patch filter in the BY-PASS position.
- (5) Permit the system to flush for a minimum of 10 minutes.
- (6) After 10 minutes, visually examine all tube fittings to make sure no leakage has occurred.
- (7) Continue to flush the external oil system for an additional 5 minutes.
- (8) Turn the patch filter selector valve to either "PATCH FILTER A" or "PATCH FILTER B" position and continue to flush the IDG external oil system for an additional 1 minute.
- (9) Turn the patch filter selector valve to the other patch filter and check the used patch filter as follows:
- (a) Examine the patch filter for signs of visible metallic particles
- 1) All metallic particles are not permitted.
- (b) Light discoloration of the patch filter is permitted.

**71-00-03**

QEC SYSTEM TESTS FIGURE 1

Page 1

Oct 05/2007

D633A106-HXL



**737-600/700/800/900  
POWERPLANT BUILDUP MANUAL**

- (10) If the patch filter is acceptable, continue on to the next step. If the patch filter is not acceptable, replace the filter and do the above steps again.

**NOTE:** Before you do the above steps again, make sure you clean the flush sample port to remove all previous contamination.

- (11) Take a 200 ml solvent sample downstream of the oil system and do a check for contamination using the criteria given in the Sundstrand Bulletin 627, or use one of the inspections methods given below:

(a) Particle Count Method

- 1) Analyze the sample you took and use the particle limits given below for different sizes to determine if the contamination is within permitted levels:

- a) 5 to 15 microns in size - 1,024,000 particles are permitted
- b) 15-25 microns in size - 182,400 particles are permitted
- c) 25-50 microns in size - 32,400 particles are permitted
- d) 50-100 microns in size - 5,760 particles are permitted
- e) More than 100 microns in size - 1,024 particles are permitted.

2) Particle Weight Method

- a) The total weight of the particles in the oil sample can not be more than 2.0 mg for each 100 ml.

- (12) If the contamination is more than the limits, do the flushing procedure again. If it is not, then do the next step.
- (13) Use nitrogen gas to purge the flushing cart hoses and to dry the IDG oil cooling circuit.
- (14) Disconnect the flushing cart from the oil-in hose and the patch filter.
- (15) Disconnect the patch filter from the oil-out hose.
- (16) Connect the oil-in and oil-out hoses to the IDG.
- (a) Use the torques given in Figure 24-1.

**71-00-03**

QEC SYSTEM TESTS FIGURE 1

Page 2

Oct 05/2007

D633A106-HXL

**737-600/700/800/900  
POWERPLANT BUILDUP MANUAL****QEC INSPECTION/CHECK****1. General**

- A. The following procedure provides general inspection limits you can use when you install new or used QEC components on the engine. This procedure should not be used by itself to determine the serviceability of a part. Rather, this procedure should be used together with your airline's existing standard practices to determine serviceability.
- B. This section is optional but may be operator policy.
- C. This inspection is applicable to Boeing QEC parts only. For parts owned by the engine manufacturer, refer to the applicable procedures in the Airplane Maintenance Manual (AMM) or Engine Shop Manual (ESM).

**2. Inspection****A. Procedure**

(1) Use the guidelines below when you must make an inspection of the parts in the QEC kit:

(a) Bolts/screws, washers, spacers, couplings, clamps, clampshells:

1) Damage is not permitted.

(b) Nuts:

1) Damage is not permitted.

2) For self-locking nuts, do a check of the self locking feature. Refer to AMM PAGEBLOCK 70-20-01/201.

(c) O-rings:

1) O-rings should not be used again.

(d) Brackets:

1) Cracks:

a) Not permitted.

2) Scratches, nicks, pits, scoring:

a) Permitted up to 5% of the original thickness. Blend smoothly to 63Ra finish.

3) Deformation:

a) Not permitted.

(e) Pneumatic ducts:

1) Refer to CMM 36-10-03 for inspection and repair information.

(f) Hoses:

1) Hoses that include fire shielding (hydraulic hoses):

a) Visually examine the hose for damage. If damage is found, refer to AMM PAGEBLOCK 20-10-52/801 for inspection and repair information.

b) Damage to the fire protection shielding is not permitted.

2) Hoses that do not include fire shielding (IDG oil cooling hoses and pneumatic hoses):

a) Visually examine the hose for damage. If damage is found, refer to AMM PAGEBLOCK 20-10-52/401 for inspection and repair information.

(g) Tubes:

**71-00-04**

QEC INSPECTION/CHECK FIGURE 1

Page 1

Oct 05/2007

**POWERPLANT BUILDUP MANUAL**

- 1) Refer to AMM PAGEBLOCK 20-10-51/801 for inspection and repair information.
- (h) Line Replaceable Units (LRU)(IDG, hydraulic pump, bleed air regulator, fire detectors, etc.):
  - 1) Refer to the applicable CMM for inspection and repair information.
- (i) Structural parts (forward and aft engine mounts, thrust links):
  - 1) Refer to the applicable CMM for inspection and repair information.
- (j) Wire Harnesses:
  - 1) For vendor wire harnesses (such as those owned by the engine manufacturer), refer to the applicable vendor CMM for inspection and repair information.
  - 2) For Boeing harnesses, refer to the Standard Wiring Practices Manual for inspection and repair information.
- (k) Aluminum foil markers:
  - 1) Refer to AMM PAGEBLOCK 20-10-21/401 for inspection and replacement information.

**71-00-04**

QEC INSPECTION/CHECK FIGURE 1

Page 2

Oct 05/2007

D633A106-HXL