

**BOEING**   
**COMMERCIAL JET**  
**OVERHAUL MANUAL**

TO: ALL HOLDERS OF OXYGEN DROP SERVICE UNIT ASSEMBLY OVERHAUL MANUAL, 25-21-10

REVISION NO. 4, DATED JUL 5/81

HIGHLIGHTS

DESCRIPTION OF CHANGE	TOPICS AFFECTED												
	D & O	D/Assy	Cleaning	Insp/Chk	Repair	Assy	F/C	Test	T/Shooting	S/Tools	Storage	IPL	L/Overhaul
Added new top assembly 65C10585-30					X							X	

# OXYGEN DROP SERVICE UNIT ASSEMBLY

## 25-21-10

I BOEING P/N 65C10585-1, -17, -28, -29, -30

AIRLINE P/N

THE FOLLOWING DIRECTIVES APPLY TO THIS SUBJECT:

BOEING SERVICE BULLETIN	BOEING TEMPORARY REVISION	OTHER DIRECTIVES	DATE DIRECTIVE INCORPORATED INTO TEXT
		PRR 32631	Jan 5/77

**BOEING**   
**COMMERCIAL JET**  
**OVERHAUL MANUAL**

LIST OF EFFECTIVE PAGES					
* Indicates pages revised, added or deleted in latest revision					
F Indicates foldout pages - print one side only					
PAGE	DATE	PAGE	DATE	PAGE	DATE
25-21-10					
* T-1	Jul 5/81				
T-2	BLANK				
* LEP-1	Jul 5/81				
LEP-2	BLANK				
T/C-1	Jan 5/77				
T/C-2	BLANK				
* 1	Jul 5/81				
2	BLANK				
* 3	Jul 5/81				
* 4	Jul 5/81				
* 5	Jul 5/81				
* 6	Jul 5/81				
* 7	Jul 5/81				
8	Jan 5/78				
9	Jan 5/78				
10	Jan 5/78				
11	Jan 5/77				
12	BLANK				

**BOEING**   
**COMMERCIAL JET**  
**OVERHAUL MANUAL**

TABLE OF CONTENTS

<u>Paragraph Title</u>	<u>Page</u>
Description and Operation . . . . .	*
Disassembly . . . . .	*
Cleaning. . . . .	*
Inspection/Check. . . . .	*
Repair. . . . .	1
Assembly. . . . .	*
Fits and Clearances (not applicable)	
Testing . . . . .	*
Trouble Shooting. . . . .	*
Storage Instructions. . . . .	*
Special Tools, Fixtures, and Equipment (not applicable)	
Illustrated Parts List. . . . .	3

\* This manual contains only repair information and illustrated parts list. All other approved procedures for this unit are in 25-20-00, Passenger Service Unit Overhaul Procedures.

**BOEING**   
**COMMERCIAL JET**  
**OVERHAUL MANUAL**

OXYGEN DROP SERVICE UNIT ASSEMBLY

1. REPAIR

A. Materials

- (1) Adhesive -- Type 70 (Ref 20-50-12)
- (2) Primer
  - (a) BMS 10-11, type 1 (Ref 20-60-02)
  - (b) Hysol AC5365, Hysol Div., The Dexter Corp., 211 Franklin St., Olean, New York 14760

B. Refinish

CAUTION: DO NOT USE HI-SPEED LACQUER TO REFINISH POLYCARBONATE PLASTIC PARTS. IT WILL CAUSE INSTANT DETERIORATION THAT MAY NOT BE VISUALLY DETECTABLE.

NOTE: Refer to 20-30-02 for stripping of protective finishes, and to 20-41-02 for explanation of F and SRF finish codes.

- (1) Latch bracket (15, Fig. 1), hinge bracket (20), brackets (110, 134C, 135, 140, 147), support fitting (132); angle (205, Fig. 2), bracket (315) -- Alodize (colored film) or chromic acid anodize followed by one coat BMS 10-11, type 1 primer (SRF-2.30) all over. Material: Alum alloy.
- (2) Spring clip (133B, Fig. 1) -- Passivate (F-8.07) all over. Material: 17-7PH CRES, 180-200 ksi.

C. Replacement

- (1) Replace brackets (110, 145, 150, Fig. 1; 290, Fig. 2), coverplate (165), and angle (205) as follows:

CAUTION: DO NOT PRIME POLYCARBONATE SURFACES, AS PRIMER DAMAGES SUCH SURFACES.

- (a) Apply a thin continuous coat of Hysol AC5365 primer on all aluminum surfaces to be bonded. Allow primer to cure from 30 minutes to 1 hour or until dry to touch.
- (b) Bond per 20-50-12 with type 70 adhesive.

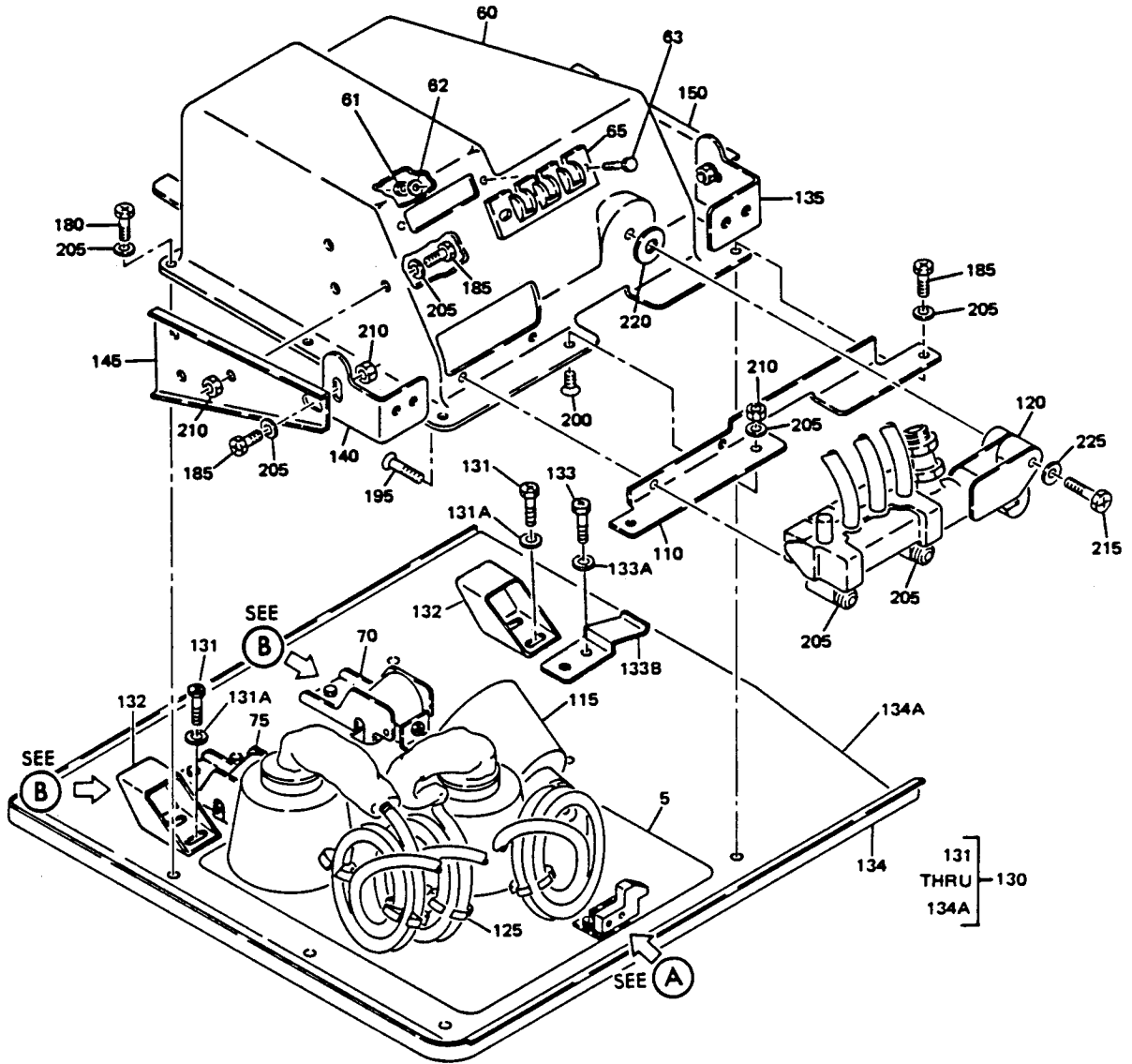

65C10585-1, -17, -28, -29

Oxygen Drop Service Unit Assembly  
Figure 1 (Sheet 1)

**BOEING**   
**COMMERCIAL JET**  
**OVERHAUL MANUAL**

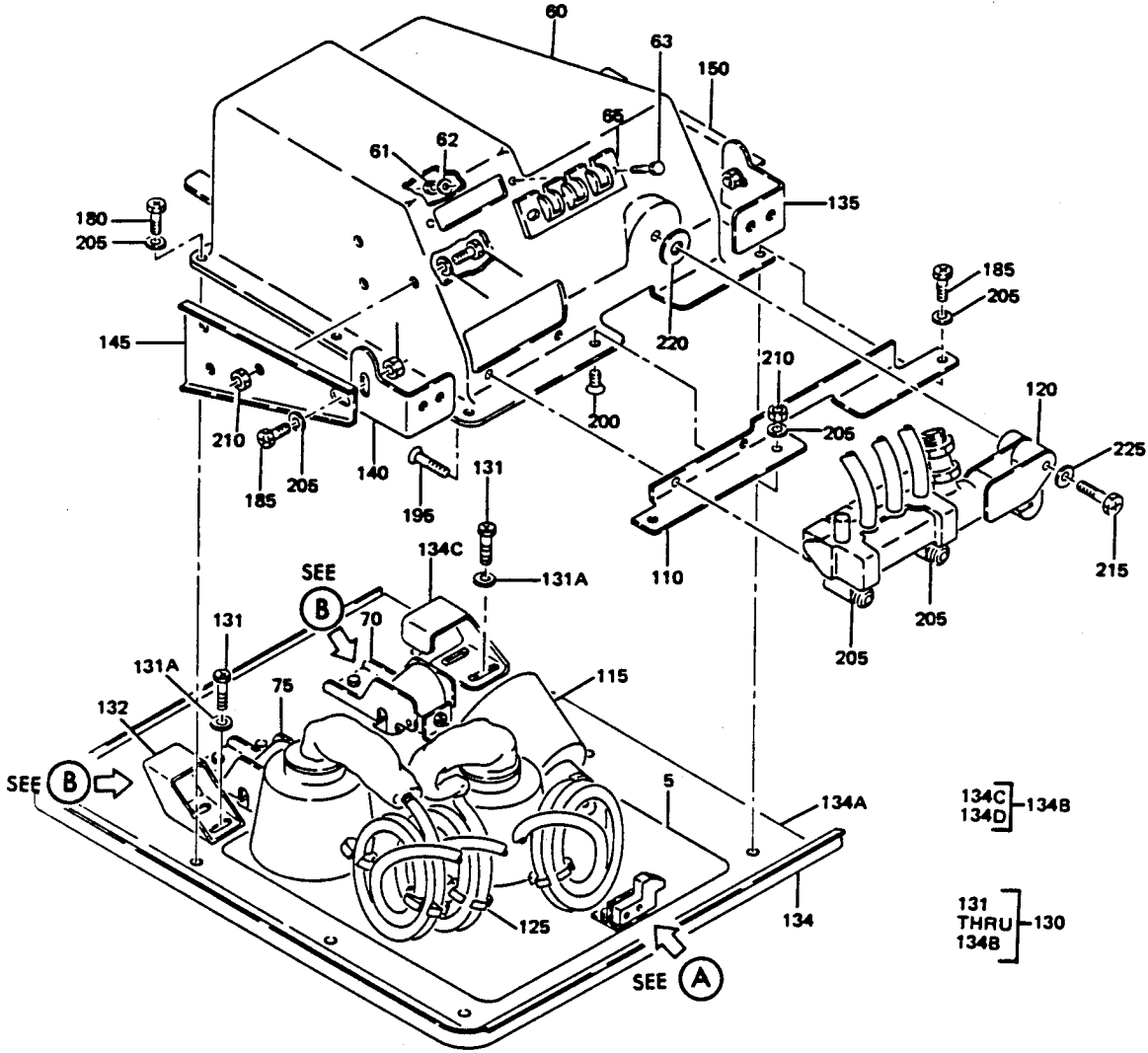

65C10585-30

Oxygen Drop Service Unit Assembly  
Figure 1 (Sheet 2)

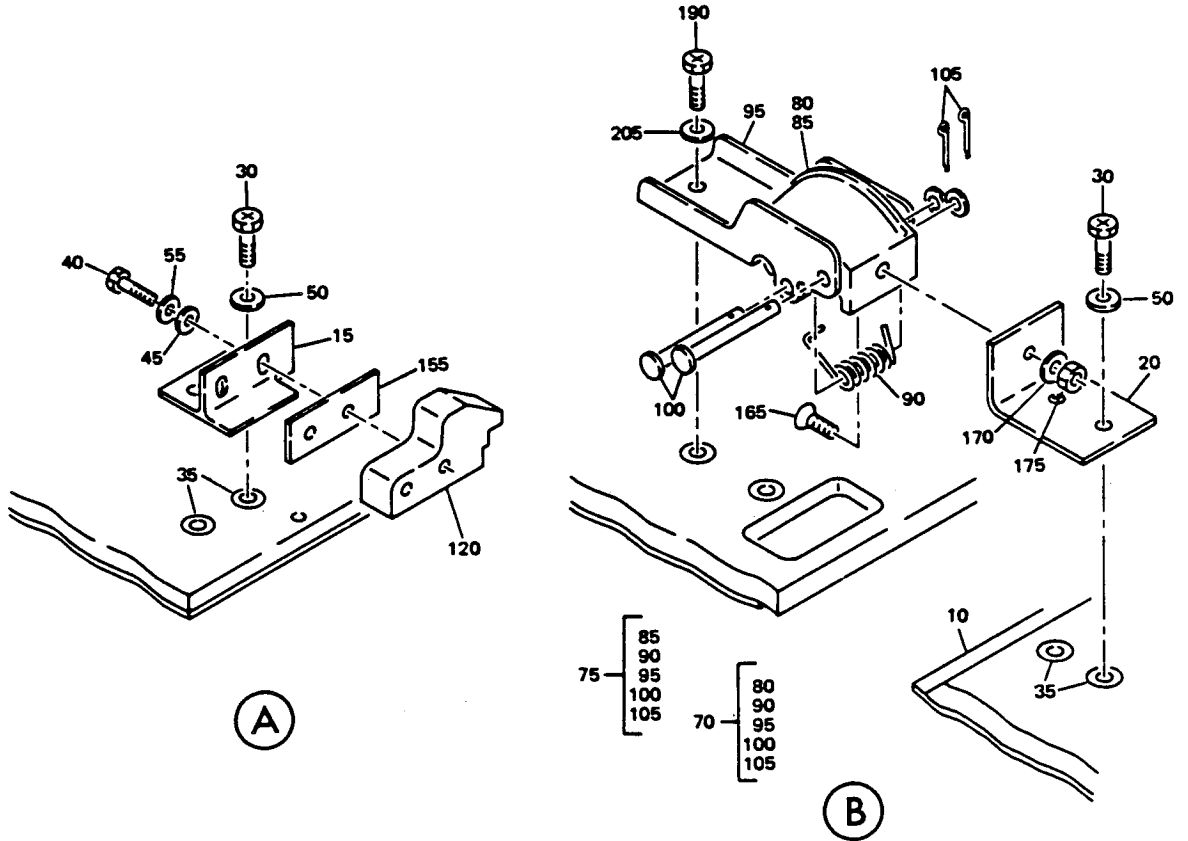



**BOEING**  
**COMMERCIAL JET**  
**OVERHAUL MANUAL**

65C10585  
DASH NUMBERS LIMITED

FIG. & ITEM NO.	PART NO.	AIRLINE PART NUMBER	N O M E N C L A T U R E							USE CODE	QTY PER ASSY
			1	2	3	4	5	6	7		
1-											
1	65C10585-1									A	RF
1	65C10585-28									B	RF
1	65C10585-29									C	RF
1	65C10585-30									D	RF
5	65C10585-10										1
10	65C10585-12										1
15	65C10585-14										1
20	65C10585-15										2
25	65C10585-16										
30	BACS12CB08-4										6
35	SL607-08-4C										6
40	BACS12CB04-6										2
45	MS35335-29										2
50	AN960PD8L										6
55	AN960PD4L										2
60	65C10585-26										1
61	BACN10JC06										2
62	AN960PD6L										2
63	BACS12CB06-6										2
65	65C10585-3										1
70	65C10585-6										1
75	65C10585-7										1
80	65C10585-4										1
85	65C10585-5										1
90	69-61458-1										1
95	69-67526-3										1
100	MS20392-1C39										2
105	MS24665-99										2
110	65C10585-8										1
115	298-701-27									AB	3
115	10-60137-70									CD	3
120	115013-01										1
120	802078-00										1
125	63-10155										6
130	65-86654-215									A	1
130	65-86654-259									BC	1
130	65-86654-285									D	1
131	BACS12CB3-4										4
131A	AN960PD10L										4

**BOEING**   
**COMMERCIAL JET**  
**OVERHAUL MANUAL**

FIG. & ITEM NO.	PART NO.	AIRLINE PART NUMBER	N O M E N C L A T U R E							USE CODE	QTY PER ASSY
			1	2	3	4	5	6	7		
1-											
132	69-66645-1									ABC	2
132	69-66645-1									D	1
133	BACS12CB3-3									BC	2
133A	AN960PD10L									BC	2
133B	65-88638-1									BC	1
133C-	SL607-3-4S									A	17
133C-	SL607-3-4S									BC	18
133C-	SL607-3-4S									D	16
134	65C10380-7									ABC	1
134	65C10380-14									D	1
134A	65-86654-216									ABC	1
134A	65-86654-286									D	1
134B	69-67526-10									D	1
134C	69-67526-11									D	1
134D-	BACF3T01B5-5									D	1
134E-	BACF3F005M 016NN									D	1
135	69-66644-3										1
140	69-66644-4										1
145	69-67526-1										1
150	69-67526-2										1
155	BACS4OR05C13F										1
165	NAS514P832-5										2
170	AN960PD8L										2
175	BACN10JC08										2
180	BACS12CB3-5										5
185	BACS12CB3-6										10
190	BACS12CB3-4										4
195	NAS514P1032- 24										2
200	NAS514P1032-4										2
205	AN960PD10L										30
210	BACN10JC3										9
215	BACS12CB3-24										1
220	BACW10P135A										1
225	MS35335-32										1

-ITEM NOT ILLUSTRATED

**BOEING**   
**COMMERCIAL JET**  
**OVERHAUL MANUAL**

65C10585

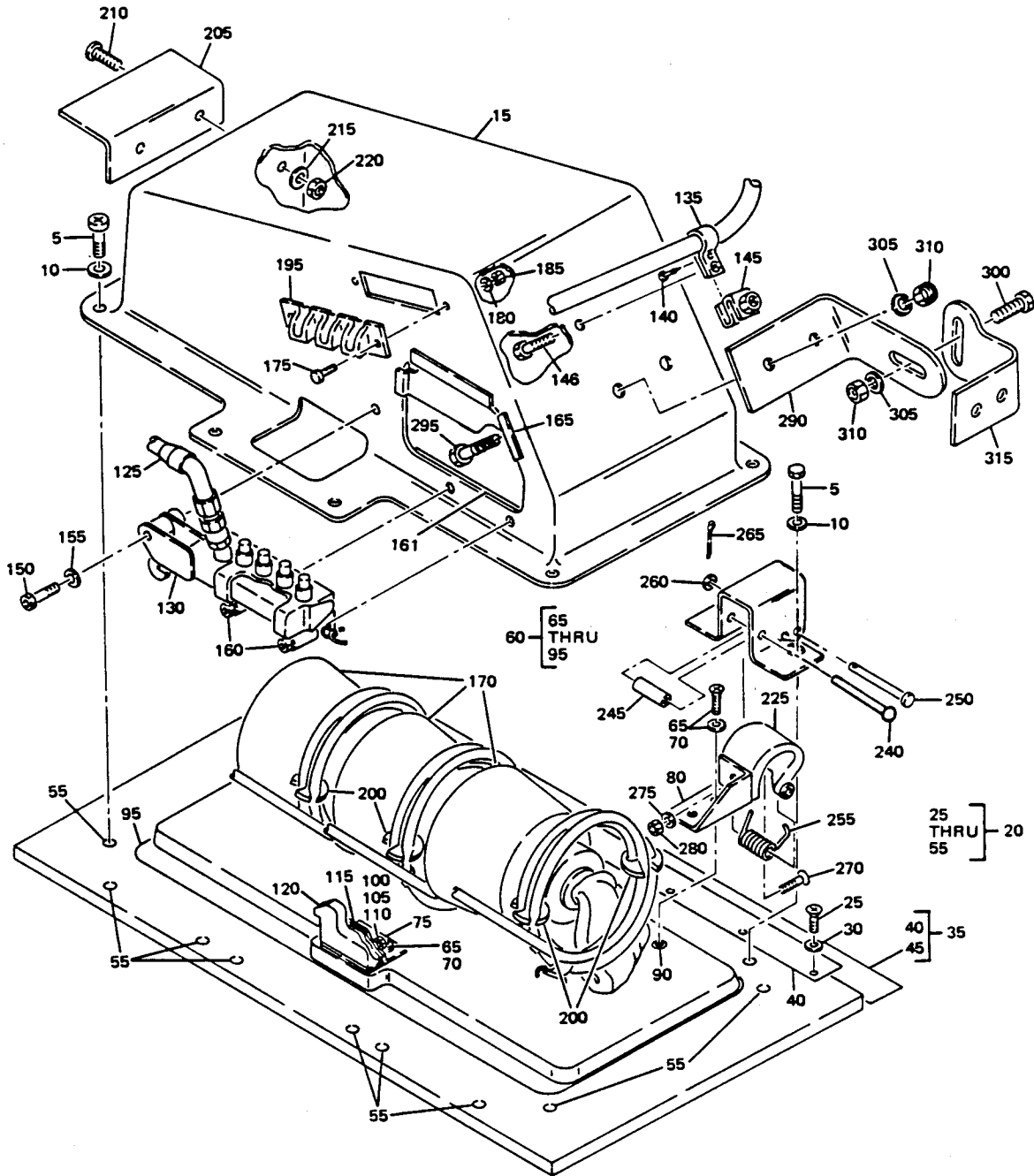

Oxygen Drop Service Unit Assembly  
 Figure 2

**BOEING**   
**COMMERCIAL JET**  
**OVERHAUL MANUAL**

FIG. & ITEM NO.	PART NO.	AIRLINE PART NUMBER	N O M E N C L A T U R E							USE CODE	QTY PER ASSY
			1	2	3	4	5	6	7		
2											
1	65C10585-17										RF
5	BACSL2CB3-5										11
10	AN960PD10L										11
15	65C10585-22										1
20	65-86654-237										1
25	MS51861-22										7
30	AN960PD6										7
35	65-88173-45										1
40	65-88173-46										1
45	65-88173-47										1
50	65-86654-238										1
55	SL607-3-4S										15
60	65C10585-18										1
65	BACSL2CB08-4										6
70	AN960PD8L										6
75	65C10585-21										1
80	69-67526-5										1
81	69-67526-4										1
90	SL607-08-4C										6
95	*[1]										1
100	BACSL2CB04-6										2
105	MS35335-29										2
110	AN960PD4L										2
115	BACS4OR05C13F										AR
120	65C10585-25										1
125	ZH833-39										1
130	115013-05										1
130	10-60513-16										1
135	BACC10DK7										1
140	BACP20BA1										1
145	BACN10FX83										1
146	BACSL2CB08-10										1
150	BACSL2CB3-18										1
155	MS38355-32										1
160	NAS514P1032-12										2
161	69-67526-9										1
165	69-67526-8										1
170	289-701-27										3

**BOEING**   
**COMMERCIAL JET**  
**OVERHAUL MANUAL**

65C10585

FIG. & ITEM NO.	PART NO.	AIRLINE PART NUMBER	N O M E N C L A T U R E							USE CODE	QTY PER ASSY
			1	2	3	4	5	6	7		
2											
175	BACS12CB06-6										2
180	AN96OPD6L										2
185	BACN10JC06										2
190	65C10585-9										1
195	65C10585-23										1
200	63-10155										6
205	65C10585-24										1
210	BACS12CB3-7										2
215	AN96OPD10-L										2
220	BACN105C3										2
225	65-79165-54										1
225	65-79165-53										1
235	69-67526-6										2
240	BACR15BB3D										2
245	NAS42DD3-70										2
250	MS20392-1C39										2
255	69-61458-1										2
260	AN96OPD4										2
265	MS24665-99										2
270	NAS514P632-6										2
275	AN96OPD6L										2
280	BACN10JC06										2
290	69-67526-7										1
295	BACS12CB3-7										2
300	BACS12CB3-6										1
305	AN96OPD10L										4
310	BACN10JC3										3
315	69-66644-3										1

\*[1] NO BOEING P/N ASSIGNED

**BOEING**   
**COMMERCIAL JET**  
**OVERHAUL MANUAL**

VENDORS

V02217	PURITAN-BENNET AERO SYSTEMS DIV., 111 PENN ST., EL SEGUNDO, CALIFORNIA 90245
V16827	PURITAN EQUIPMENT INC., 10800 PFLUMM RD., LENEXA, KANAS 66210
V53655	SCOTT AVIATION DIV. OF A-T-O INC., 225 ERIE ST., LANCASTER, NEW YORK 14086
V92114	SIERRA ENGINEERING CO. DIVISION OF CAPTECH INC., 123 E. MONTECITO AVE., SIERRA MADRE, CALIFORNIA 91024
V97393	SHUR-LOK CORP., 1300 NORMANDY PL., SANTA ANA, CALIFORNIA 92711