

CHAPTER

54

**NACELLES AND
PYLONS**



**757-200
STRUCTURAL REPAIR MANUAL**

**CHAPTER 54
NACELLES AND PYLONS**

Subject/Page	Date	Subject/Page	Date	Subject/Page	Date
EFFECTIVE PAGES		54-10-01 IDENTIFICATION 2		54-10-01 REPAIR 4 (cont)	
1 thru 8	Jan 20/2009	1	Jan 20/2005	204	BLANK
54-CONTENTS		2	Jan 20/2005	54-10-01 REPAIR 5	
1	Jan 20/2005	3	Jan 20/2005	201	May 20/2005
2	May 20/2005	4	BLANK	202	May 20/2005
3	Jan 20/2005	54-10-01 ALLOWABLE DAMAGE 1		54-10-01 REPAIR 6	
4	May 20/2008	101	May 20/2005	201	May 20/2005
5	Jan 20/2005	102	May 20/2005	202	BLANK
6	Jan 20/2006	54-10-01 ALLOWABLE DAMAGE 2		54-10-01 REPAIR 7	
7	Jan 20/2005	101	May 20/2005	201	May 20/2005
8	May 20/2008	102	Sep 20/2005	202	May 20/2005
54-00-01 REPAIR GENERAL		103	May 20/2005	203	May 20/2005
201	Sep 20/2005	104	BLANK	204	May 20/2005
202	May 20/2005	54-10-01 ALLOWABLE DAMAGE 3		54-10-01 REPAIR 8	
54-01-01 REPAIR 1		101	Jan 20/2005	201	May 20/2005
201	Jan 20/2005	102	Jan 20/2005	202	May 20/2005
202	Jan 20/2005	103	Jan 20/2005	203	May 20/2005
203	Jan 20/2005	104	Jan 20/2005	204	BLANK
204	Jan 20/2005	54-10-01 REPAIR GENERAL		54-10-01 REPAIR 9	
205	Jan 20/2005	201	Jan 20/2005	201	May 20/2005
206	Jan 20/2005	202	Jan 20/2005	202	May 20/2005
207	Jan 20/2005	203	Jan 20/2005	203	May 20/2005
208	Jan 20/2005	204	Jan 20/2005	204	May 20/2005
209	Jan 20/2005	54-10-01 REPAIR 1		54-10-01 REPAIR 10	
210	Jan 20/2005	201	Sep 20/2005	201	May 20/2005
211	Jan 20/2005	202	Sep 20/2005	202	May 20/2005
212	Jan 20/2005	203	Sep 20/2005	54-10-01 REPAIR 11	
213	Jan 20/2005	204	BLANK	201	May 20/2005
214	Jan 20/2005	54-10-01 REPAIR 2		202	May 20/2005
215	Jan 20/2005	201	May 20/2005	54-10-01 REPAIR 12	
216	Jan 20/2005	202	BLANK	201	May 20/2005
54-10-01 IDENTIFICATION 1		54-10-01 REPAIR 3		202	May 20/2005
1	Sep 20/2005	201	May 20/2005	54-10-02 IDENTIFICATION 1	
2	May 20/2005	202	May 20/2005	1	Jan 20/2005
3	Sep 20/2005	203	May 20/2005	2	Jan 20/2005
4	May 20/2005	204	May 20/2005	3	Jan 20/2005
5	May 20/2005	54-10-01 REPAIR 4		4	Jan 20/2005
6	BLANK	201	May 20/2005	54-10-02 IDENTIFICATION 2	
		202	May 20/2005	1	May 20/2005
		203	May 20/2005	2	May 20/2005

A = Added, R = Revised, O = Overflow, D = Deleted

54-EFFECTIVE PAGES



**757-200
STRUCTURAL REPAIR MANUAL**

**CHAPTER 54
NACELLES AND PYLONS**

Subject/Page	Date	Subject/Page	Date	Subject/Page	Date
54-10-02 IDENTIFICATION 2 (cont)		54-11-01 IDENTIFICATION 1 (cont)		54-20-01 IDENTIFICATION 1	
3	May 20/2005	3	Jan 20/2005	1	Jan 20/2007
4	May 20/2005	4	Jan 20/2005	2	May 20/2005
54-10-02 ALLOWABLE DAMAGE 1		54-11-01 ALLOWABLE DAMAGE 1		3	May 20/2005
101	Jan 20/2007	101	Jan 20/2007	4	May 20/2005
102	Jan 20/2005	102	Jan 20/2005	54-20-01 IDENTIFICATION 2	
103	Jan 20/2005	103	Jan 20/2005	1	May 20/2005
104	Jan 20/2005	104	Jan 20/2005	2	May 20/2005
105	Jan 20/2005	105	Jan 20/2005	3	May 20/2005
106	BLANK	106	Jan 20/2005	4	May 20/2005
54-10-02 ALLOWABLE DAMAGE 2		54-11-01 REPAIR GENERAL		5	May 20/2005
101	May 20/2005	201	Jan 20/2005	6	May 20/2005
102	May 20/2005	202	BLANK	7	May 20/2005
103	May 20/2005	54-11-01 REPAIR 1		8	May 20/2005
104	May 20/2005	201	Jan 20/2005	54-20-01 IDENTIFICATION 3	
105	May 20/2005	202	Jan 20/2005	1	Jan 20/2005
106	BLANK	54-11-01 REPAIR 2		2	Jan 20/2005
54-10-02 REPAIR 1		201	Jan 20/2005	3	Jan 20/2005
201	May 20/2005	202	Jan 20/2005	4	Jan 20/2005
202	BLANK	203	Jan 20/2005	5	Jan 20/2005
54-10-02 REPAIR 2		204	Jan 20/2005	6	Jan 20/2005
201	May 20/2005	54-11-01 REPAIR 3		7	Jan 20/2005
202	BLANK	201	Jan 20/2005	8	Jan 20/2005
54-10-15 IDENTIFICATION 1		202	Jan 20/2005	9	Jan 20/2005
1	May 20/2005	203	Jan 20/2005	10	Jan 20/2005
2	May 20/2005	204	BLANK	54-20-01 ALLOWABLE DAMAGE 1	
54-10-15 IDENTIFICATION 2		54-11-02 IDENTIFICATION 1		101	Jan 20/2007
1	Jan 20/2005	1	May 20/2005	102	Jan 20/2005
2	Jan 20/2005	2	May 20/2005	103	Jan 20/2005
54-10-15 ALLOWABLE DAMAGE 1		3	May 20/2005	104	BLANK
101	Jan 20/2007	4	May 20/2005	54-20-01 REPAIR 1	
102	Jan 20/2005	54-11-02 ALLOWABLE DAMAGE 1		201	Jan 20/2005
103	Jan 20/2005	101	Jan 20/2007	202	Jan 20/2005
104	BLANK	102	May 20/2005	203	Jan 20/2005
54-10-15 REPAIR GENERAL		103	May 20/2005	204	BLANK
201	Jan 20/2005	104	BLANK	54-20-01 REPAIR 2	
202	BLANK	54-11-02 REPAIR 1		201	May 20/2005
54-11-01 IDENTIFICATION 1		201	May 20/2005	202	May 20/2005
1	Jan 20/2005	202	May 20/2005	54-20-01 REPAIR 3	
2	Jan 20/2005			201	May 20/2005

A = Added, R = Revised, O = Overflow, D = Deleted

54-EFFECTIVE PAGES



**757-200
STRUCTURAL REPAIR MANUAL**

**CHAPTER 54
NACELLES AND PYLONS**

Subject/Page	Date	Subject/Page	Date	Subject/Page	Date
54-20-01 REPAIR 3 (cont)		54-30-01 IDENTIFICATION 1 (cont)		54-30-01 ALLOWABLE DAMAGE 2 (cont)	
202	May 20/2005	3	May 20/2005	104	May 20/2005
54-20-01 REPAIR 4		4	May 20/2005	54-30-01 ALLOWABLE DAMAGE 3	
201	May 20/2005	5	May 20/2005	101	May 20/2005
202	May 20/2005	6	BLANK	102	May 20/2005
203	May 20/2005	54-30-01 IDENTIFICATION 2		54-30-01 ALLOWABLE DAMAGE 4	
204	May 20/2005	1	Jan 20/2005	101	May 20/2005
205	May 20/2005	2	Jan 20/2005	102	May 20/2005
206	BLANK	3	Jan 20/2005	103	May 20/2005
54-20-01 REPAIR 5		4	Jan 20/2005	104	May 20/2005
201	May 20/2005	54-30-01 IDENTIFICATION 3		54-30-01 ALLOWABLE DAMAGE 5	
202	May 20/2005	1	May 20/2005	101	May 20/2005
54-20-01 REPAIR 6		2	May 20/2005	102	May 20/2005
201	May 20/2005	3	May 20/2005	103	May 20/2005
202	May 20/2005	4	May 20/2005	104	May 20/2005
203	May 20/2005	5	May 20/2005	105	May 20/2005
204	BLANK	6	BLANK	106	BLANK
54-21-01 IDENTIFICATION 1		54-30-01 IDENTIFICATION 4		54-30-01 REPAIR 1	
1	Jan 20/2005	1	May 20/2005	201	Jan 20/2005
2	Jan 20/2005	2	May 20/2005	202	BLANK
54-21-01 ALLOWABLE DAMAGE 1		3	May 20/2005	54-30-01 REPAIR 2	
101	Jan 20/2007	4	May 20/2005	201	May 20/2005
102	Jan 20/2005	5	May 20/2005	202	May 20/2005
54-21-01 REPAIR 1		6	May 20/2005	54-30-01 REPAIR 3	
201	Jan 20/2005	7	May 20/2005	201	May 20/2005
202	Jan 20/2005	8	May 20/2005	202	May 20/2005
203	Jan 20/2005	54-30-01 IDENTIFICATION 5		203	May 20/2005
204	BLANK	1	May 20/2005	204	BLANK
54-21-02 IDENTIFICATION 1		2	May 20/2005	54-30-02 IDENTIFICATION 1	
1	Jan 20/2005	3	May 20/2005	1	Jan 20/2005
2	BLANK	4	May 20/2005	2	Jan 20/2005
54-21-02 ALLOWABLE DAMAGE 1		5	May 20/2005	3	Jan 20/2005
101	Jan 20/2005	6	BLANK	4	BLANK
102	Jan 20/2005	54-30-01 ALLOWABLE DAMAGE 1		54-30-02 IDENTIFICATION 2	
54-21-02 REPAIR GENERAL		101	Jan 20/2005	1	May 20/2005
201	Jan 20/2005	102	Jan 20/2005	2	May 20/2005
202	BLANK	54-30-01 ALLOWABLE DAMAGE 2		3	May 20/2005
54-30-01 IDENTIFICATION 1		101	May 20/2005	4	May 20/2005
1	May 20/2005	102	May 20/2005	5	May 20/2005
2	May 20/2005	103	May 20/2005		

A = Added, R = Revised, O = Overflow, D = Deleted

54-EFFECTIVE PAGES



**757-200
STRUCTURAL REPAIR MANUAL**

**CHAPTER 54
NACELLES AND PYLONS**

Subject/Page	Date	Subject/Page	Date	Subject/Page	Date
54-30-02 IDENTIFICATION 2 (cont)		54-30-70 REPAIR 2 (cont)		54-31-01 REPAIR 4	
6	BLANK	204	May 20/2008	201	Jan 20/2005
54-30-02 ALLOWABLE DAMAGE 1		205	May 20/2008	202	Jan 20/2005
101	May 20/2005	206	May 20/2008	203	Jan 20/2005
102	May 20/2005	207	May 20/2008	204	BLANK
103	May 20/2005	208	BLANK	54-31-01 REPAIR 5	
104	May 20/2005	54-31-01 IDENTIFICATION 1		201	Jan 20/2005
105	May 20/2005	1	Jan 20/2005	202	Jan 20/2005
106	BLANK	2	Jan 20/2005	203	Jan 20/2005
54-30-02 ALLOWABLE DAMAGE 2		3	Jan 20/2005	204	Jan 20/2005
101	Jan 20/2005	4	Jan 20/2005	54-31-01 REPAIR 6	
102	Jan 20/2005	5	Jan 20/2005	201	Jan 20/2005
103	Jan 20/2005	6	Jan 20/2005	202	Jan 20/2005
104	Jan 20/2005	7	Jan 20/2005	203	Jan 20/2005
105	Jan 20/2005	8	Jan 20/2005	204	Jan 20/2005
106	BLANK	54-31-01 ALLOWABLE DAMAGE 1		205	Jan 20/2005
54-30-02 REPAIR 1		101	Jan 20/2007	206	BLANK
201	Jan 20/2005	102	Jan 20/2005	54-31-01 REPAIR 7	
202	BLANK	103	Jan 20/2005	201	Jan 20/2005
54-30-02 REPAIR 2		104	Jan 20/2005	202	Jan 20/2005
201	May 20/2005	105	Jan 20/2005	54-31-02 IDENTIFICATION 1	
202	BLANK	106	Jan 20/2005	1	Jan 20/2005
54-30-70 IDENTIFICATION 1		107	Jan 20/2005	2	Jan 20/2005
1	Jan 20/2005	108	BLANK	3	Jan 20/2005
2	Jan 20/2005	54-31-01 REPAIR 1		4	BLANK
54-30-70 IDENTIFICATION 2		201	Jan 20/2005	54-31-02 ALLOWABLE DAMAGE 1	
1	May 20/2005	202	Jan 20/2005	101	Jan 20/2005
2	BLANK	203	Jan 20/2005	102	Jan 20/2005
54-30-70 ALLOWABLE DAMAGE 1		204	Jan 20/2005	103	Jan 20/2005
101	May 20/2008	205	Jan 20/2005	104	Jan 20/2005
102	May 20/2008	206	BLANK	105	Jan 20/2005
103	May 20/2008	54-31-01 REPAIR 2		106	BLANK
104	BLANK	201	Jan 20/2005	54-40-01 IDENTIFICATION 1	
54-30-70 REPAIR 1		202	Jan 20/2005	1	Jan 20/2005
201	May 20/2008	203	Jan 20/2005	2	BLANK
202	May 20/2008	204	BLANK	54-40-01 ALLOWABLE DAMAGE GENERAL	
54-30-70 REPAIR 2		54-31-01 REPAIR 3		101	May 20/2008
201	May 20/2008	201	Jan 20/2005	102	Jan 20/2005
202	May 20/2008	202	Jan 20/2005	103	Jan 20/2005
203	May 20/2008				

A = Added, R = Revised, O = Overflow, D = Deleted

54-EFFECTIVE PAGES



**757-200
STRUCTURAL REPAIR MANUAL**

**CHAPTER 54
NACELLES AND PYLONS**

Subject/Page	Date	Subject/Page	Date	Subject/Page	Date
54-40-01 ALLOWABLE DAMAGE GENERAL (cont)		54-41-01 REPAIR 2		54-50-01 REPAIR GENERAL	
104	Jan 20/2005	201	Jan 20/2005	201	Jan 20/2005
105	Jan 20/2005	202	Jan 20/2005	202	BLANK
106	Jan 20/2005	54-41-02 IDENTIFICATION 1		54-50-01 REPAIR 1	
54-40-01 REPAIR 1		1	Jan 20/2005	201	Jan 20/2005
201	Jan 20/2005	2	BLANK	202	BLANK
202	BLANK	54-41-02 ALLOWABLE DAMAGE 1		54-50-01 REPAIR 2	
54-40-01 REPAIR 2		101	Jan 20/2005	201	Jan 20/2005
201	May 20/2008	102	Jan 20/2005	202	BLANK
202	BLANK	103	Jan 20/2005	54-50-02 IDENTIFICATION 1	
54-40-01 REPAIR 3		104	Jan 20/2005	1	Jan 20/2005
201	May 20/2005	54-41-30 IDENTIFICATION 1		2	Jan 20/2005
202	May 20/2005	1	Jan 20/2005	3	Jan 20/2005
54-40-01 REPAIR 4		2	Jan 20/2005	4	Jan 20/2005
201	May 20/2005	3	Jan 20/2005	54-50-02 ALLOWABLE DAMAGE 1	
202	BLANK	4	BLANK	101	Jan 20/2007
54-40-01 REPAIR 5		54-41-30 ALLOWABLE DAMAGE 1		102	Jan 20/2005
201	May 20/2005	101	Jan 20/2005	103	Jan 20/2005
202	May 20/2005	102	Jan 20/2005	104	Jan 20/2005
203	May 20/2005	103	Jan 20/2005	105	Jan 20/2005
204	BLANK	104	Jan 20/2005	106	Jan 20/2005
54-40-02 IDENTIFICATION 1		54-41-30 REPAIR GENERAL		54-50-70 IDENTIFICATION 1	
1	Jan 20/2005	201	Jan 20/2005	1	Jan 20/2005
2	Jan 20/2005	202	BLANK	2	Jan 20/2005
54-41-01 IDENTIFICATION 1		54-50-01 IDENTIFICATION 1		3	Jan 20/2005
1	Jan 20/2005	1	Jan 20/2005	4	Jan 20/2005
2	BLANK	2	Jan 20/2005	5	Jan 20/2005
54-41-01 ALLOWABLE DAMAGE 1		3	Jan 20/2005	6	Jan 20/2005
101	Jan 20/2005	4	BLANK	7	Jan 20/2005
102	Jan 20/2005	54-50-01 IDENTIFICATION 2		8	Jan 20/2005
103	Jan 20/2005	1	Jan 20/2005	9	Jan 20/2005
104	BLANK	2	Jan 20/2005	10	Jan 20/2005
54-41-01 REPAIR GENERAL		3	Jan 20/2005	54-50-70 IDENTIFICATION 2	
201	Jan 20/2005	4	BLANK	1	May 20/2006
202	BLANK	54-50-01 ALLOWABLE DAMAGE 1		2	Jan 20/2005
54-41-01 REPAIR 1		101	Jan 20/2005	3	Jan 20/2005
201	Jan 20/2005	102	Jan 20/2005	4	Jan 20/2005
202	Jan 20/2005	103	Jan 20/2005	5	Jan 20/2005
		104	Jan 20/2005	6	Jan 20/2005
				7	Jan 20/2005

A = Added, R = Revised, O = Overflow, D = Deleted

54-EFFECTIVE PAGES



**757-200
STRUCTURAL REPAIR MANUAL**

**CHAPTER 54
NACELLES AND PYLONS**

Subject/Page	Date	Subject/Page	Date	Subject/Page	Date
54-50-70 IDENTIFICATION 2 (cont)		54-50-71 REPAIR GENERAL		54-50-90 REPAIR 4	
8	Jan 20/2005	201	Jan 20/2005	201	Jan 20/2005
9	May 20/2006	202	BLANK	202	Jan 20/2005
10	Jan 20/2005	54-50-71 REPAIR 1		203	Jan 20/2005
54-50-70 ALLOWABLE DAMAGE 1		201	Jan 20/2006	204	Jan 20/2005
101	Jan 20/2007	202	Jan 20/2006	205	Jan 20/2005
102	Jan 20/2005	203	Jan 20/2006	206	Jan 20/2005
103	Jan 20/2005	204	BLANK	207	Jan 20/2005
104	Jan 20/2005	54-50-90 IDENTIFICATION 1		208	Jan 20/2005
105	Jan 20/2005	1	Jan 20/2005	209	Jan 20/2005
106	Jan 20/2005	2	Jan 20/2005	210	Jan 20/2005
54-50-70 ALLOWABLE DAMAGE 2		54-50-90 IDENTIFICATION 2		54-50-90 REPAIR 5	
101	Jan 20/2005	1	Jan 20/2005	201	Jan 20/2005
102	Jan 20/2005	2	BLANK	202	Jan 20/2005
103	Jan 20/2005	54-50-90 ALLOWABLE DAMAGE 1		203	Jan 20/2005
104	Jan 20/2005	101	Jan 20/2005	204	Jan 20/2005
105	Jan 20/2005	102	Jan 20/2005	205	Jan 20/2005
106	Jan 20/2005	103	Jan 20/2005	206	Jan 20/2005
54-50-70 REPAIR GENERAL		104	Jan 20/2005	207	Jan 20/2005
201	Jan 20/2005	105	Jan 20/2005	208	Jan 20/2005
202	BLANK	106	BLANK	54-50-90 REPAIR 6	
54-50-70 REPAIR 1		54-50-90 REPAIR GENERAL		201	May 20/2006
201	Jan 20/2005	201	Jan 20/2005	202	May 20/2006
202	Jan 20/2005	202	BLANK	203	Jan 20/2005
203	Jan 20/2005	54-50-90 REPAIR 1		204	Jan 20/2005
204	BLANK	201	Jan 20/2005	54-51-01 IDENTIFICATION 1	
54-50-71 IDENTIFICATION 1		202	BLANK	1	Jan 20/2005
1	Jan 20/2005	54-50-90 REPAIR 2		2	Jan 20/2005
2	Jan 20/2005	201	Jan 20/2005	3	Jan 20/2005
3	Jan 20/2005	202	BLANK	4	BLANK
4	Jan 20/2005	54-50-90 REPAIR 3		54-51-01 ALLOWABLE DAMAGE 1	
5	Jan 20/2005	201	Jan 20/2005	101	Jan 20/2005
6	Jan 20/2005	202	Jan 20/2005	102	Jan 20/2005
54-50-71 ALLOWABLE DAMAGE 1		203	Jan 20/2005	103	Jan 20/2005
101	Jan 20/2007	204	Jan 20/2005	104	Jan 20/2005
102	Jan 20/2005	205	Jan 20/2005	105	Jan 20/2005
103	Jan 20/2005	206	Jan 20/2005	106	Jan 20/2005
104	Jan 20/2005	207	Jan 20/2005	107	Jan 20/2005
105	Jan 20/2005	208	Jan 20/2005	108	BLANK
106	BLANK				

A = Added, R = Revised, O = Overflow, D = Deleted

54-EFFECTIVE PAGES



**757-200
STRUCTURAL REPAIR MANUAL**

**CHAPTER 54
NACELLES AND PYLONS**

Subject/Page	Date	Subject/Page	Date	Subject/Page	Date
54-51-01 REPAIR 1		54-51-70 ALLOWABLE DAMAGE 1 (cont)		54-51-90 ALLOWABLE DAMAGE 1	
201	Jan 20/2005	103	Jan 20/2005	101	May 20/2006
202	Jan 20/2005	104	Jan 20/2005	102	Jan 20/2005
54-51-01 REPAIR 2		105	Jan 20/2005	103	Jan 20/2005
201	Jan 20/2005	106	BLANK	104	Jan 20/2005
202	Jan 20/2005	54-51-70 REPAIR 1		105	Jan 20/2005
203	Jan 20/2005	201	Jan 20/2005	106	BLANK
204	BLANK	202	Jan 20/2005	54-51-90 ALLOWABLE DAMAGE 2	
54-51-02 IDENTIFICATION 1		203	Jan 20/2005	101	Jan 20/2005
1	Jan 20/2005	204	Jan 20/2005	102	Jan 20/2005
2	Jan 20/2005	54-51-71 IDENTIFICATION 1		103	Jan 20/2005
3	Jan 20/2005	1	Jan 20/2005	104	BLANK
4	BLANK	2	Jan 20/2005	54-51-90 REPAIR GENERAL	
54-51-02 ALLOWABLE DAMAGE 1		3	Jan 20/2005	201	Jan 20/2005
101	Jan 20/2005	4	Jan 20/2005	202	BLANK
102	Jan 20/2005	5	Jan 20/2005	54-51-90 REPAIR 1	
103	Jan 20/2005	6	BLANK	201	Jan 20/2005
104	Jan 20/2005	54-51-71 ALLOWABLE DAMAGE 1		202	BLANK
105	Jan 20/2005	101	Jan 20/2005	54-51-90 REPAIR 2	
106	BLANK	102	Jan 20/2005	201	Jan 20/2005
54-51-02 REPAIR 1		103	Jan 20/2005	202	BLANK
201	Jan 20/2005	104	Jan 20/2005	54-51-90 REPAIR 3	
202	Jan 20/2005	105	Jan 20/2005	201	Jan 20/2005
203	Jan 20/2005	106	Jan 20/2005	202	Jan 20/2005
204	Jan 20/2005	54-51-71 REPAIR GENERAL		203	Jan 20/2005
54-51-02 REPAIR 2		201	Jan 20/2005	204	Jan 20/2005
201	Jan 20/2005	202	BLANK	205	Jan 20/2005
202	Jan 20/2005	54-51-71 REPAIR 1		206	Jan 20/2005
54-51-70 IDENTIFICATION 1		201	Jan 20/2005	207	Jan 20/2005
1	Jan 20/2005	202	Jan 20/2005	208	Jan 20/2005
2	Jan 20/2005	203	Jan 20/2005	54-51-90 REPAIR 4	
3	Jan 20/2005	204	Jan 20/2005	201	Jan 20/2005
4	Jan 20/2005	54-51-90 IDENTIFICATION 1		202	Jan 20/2005
5	Jan 20/2005	1	Jan 20/2005	203	Jan 20/2005
6	Jan 20/2005	2	Jan 20/2005	204	Jan 20/2005
7	Jan 20/2005	54-51-90 IDENTIFICATION 2		205	Jan 20/2005
8	Jan 20/2005	1	Jan 20/2005	206	Jan 20/2005
54-51-70 ALLOWABLE DAMAGE 1		2	BLANK	207	Jan 20/2005
101	Jan 20/2007			208	Jan 20/2005
102	Jan 20/2005			209	Jan 20/2005

A = Added, R = Revised, O = Overflow, D = Deleted

54-EFFECTIVE PAGES



**757-200
STRUCTURAL REPAIR MANUAL**

**CHAPTER 54
NACELLES AND PYLONS**

Subject/Page	Date	Subject/Page	Date	Subject/Page	Date
54-51-90 REPAIR 4 (cont)					
210	Jan 20/2005				
54-51-90 REPAIR 5					
201	Jan 20/2005				
202	Jan 20/2005				
203	Jan 20/2005				
204	Jan 20/2005				
205	Jan 20/2005				
206	Jan 20/2005				
207	Jan 20/2005				
208	Jan 20/2005				
54-71-91 IDENTIFICATION 1					
1	May 20/2008				
2	May 20/2008				
54-71-91 ALLOWABLE DAMAGE 1					
101	May 20/2008				
102	May 20/2008				
103	May 20/2008				
104	BLANK				

A = Added, R = Revised, O = Overflow, D = Deleted

54-EFFECTIVE PAGES

Page 8
Jan 20/2009

D634N201



757-200
STRUCTURAL REPAIR MANUAL

CHAPTER 54
NACELLES AND PYLONS

<u>SUBJECT</u>	<u>CHAPTER SECTION SUBJECT</u>
<u>NACELLES/PYLONS - RB211-535 ENGINE</u>	54-00-01
REPAIR GENERAL - Acoustic Panel Area Loss Limits - RB211-535 Engine	
<u>NACELLES/PYLONS - PW2000 ENGINE</u>	54-01-01
REPAIR 1 - Typical Repairs for Perforated Aluminum Acoustic Panels - PW2000 Engine	
<u>INLET COWL SKIN - RB211-535 ENGINE</u>	54-10-01
IDENTIFICATION 1 - Inlet Cowl Skin - RB211-535E4 Engine	
IDENTIFICATION 2 - Inlet Cowl Skin - RB211-535C Engine	
ALLOWABLE DAMAGE 1 - Inlet Cowl Outer Barrel - RB211-535E4 Engine	
ALLOWABLE DAMAGE 2 - Inlet Cowl Skin - RB211-535E4 Engine	
ALLOWABLE DAMAGE 3 - Plates and Skins, Nose Cowl - RB211-535C Engine	
REPAIR GENERAL - Inlet Cowl Repairs - RB211-535 Engine	
REPAIR 1 - Inlet Cowl Lip - Repair by Patching - RB211-535 Engine	
REPAIR 2 - Inlet Cowl - Inner Barrel Acoustic Panel - Repair of Dyna Rohr Leading Edge Delamination - RB211-535E4 Engine	
REPAIR 3 - Inlet Cowl - Inner Barrel - Repair for Partial Penetration of Perforated Skin - RB211-535E4 Engine	
REPAIR 4 - Inlet Cowl - Acoustic Lining - Repair of Perforated Skin - RB211-535E4 Engine	
REPAIR 5 - Inlet Cowl - Acoustic Barrel - Repair for Wire Mesh - RB211-535E4 Engine	
REPAIR 6 - Inlet Cowl Outer Skin - Repair to Damage that Does Not Break Fibers - RB211-535E4 Engine	
REPAIR 7 - Inlet Cowl Outer Skin - Repair to Damage Not Extending Through Laminate - RB211-535E4 Engine	
REPAIR 8 - Inlet Cowl Outer Skin - Repair to Damage Extending Through Laminate - RB211-535E4 Engine	
REPAIR 9 - Intake Acoustic Liner - Repair for Disbonded Honeycomb Core - RB211-535E4 and RB211-535E4B Engine	
REPAIR 10 - Inlet Cowl - Repair to Local Damage of Acoustic Linings - RB211-535C Engine	

54-CONTENTS



757-200
STRUCTURAL REPAIR MANUAL

CHAPTER 54
NACELLES AND PYLONS

CHAPTER
SECTION
SUBJECT

SUBJECT

REPAIR 11 - Inlet Cowl Outer Skin - Permanent Patch Adjacent to Stiffener - RB211-535C Engine

REPAIR 12 - Inlet Cowl Outer Skin - External Patch Adjacent to Stiffener - RB211-535C Engine

INLET COWL STRUCTURE - RB211-535 ENGINE

54-10-02

IDENTIFICATION 1 - Inlet Cowl Structure - RB211-535E4 Engine

IDENTIFICATION 2 - Inlet Cowl Structure - RB211-535C Engine

ALLOWABLE DAMAGE 1 - Inlet Cowl Structure - RB211-535E4 Engine

ALLOWABLE DAMAGE 2 - Inlet Cowl Structure - RB211-535C Engine

REPAIR 1 - Inlet Cowl Structure - RB211-535E4 Engine

REPAIR 2 - Inlet Cowl Structure - RB211-535C Engine

INLET COWL DOOR SURROUND STRUCTURE

54-10-15

IDENTIFICATION 1 - Inlet Cowl Door and Access Panel Surround Structure - RB211-535E4 Engine

IDENTIFICATION 2 - Inlet Cowl Door Surround Structure - RB211-535C Engine

ALLOWABLE DAMAGE 1 - Door Surround Structure, Nose Cowl - RB211-535C Engine

REPAIR GENERAL - Inlet Cowl Door Surround Structure - RB211-535 Engine

INLET COWL SKIN - PW2000 ENGINE

54-11-01

IDENTIFICATION 1 - Inlet Cowl Skin - PW2000 Engine

ALLOWABLE DAMAGE 1 - Inlet Cowl Skin - PW2000 Engine

REPAIR GENERAL - Inlet Cowl Skin Repair Index - PW2000 Engine

REPAIR 1 - Inlet Cowl - Leading Edge Skin - PW2000 Engine

REPAIR 2 - Inlet Cowl - Leading Edge Skin - PW2000 Engine

REPAIR 3 - Inlet Cowl - Outer Panel - PW2000 Engine

INLET COWL STRUCTURE - PW2000 ENGINE

54-11-02

IDENTIFICATION 1 - Inlet Cowl Structure - PW2000 Engine

ALLOWABLE DAMAGE 1 - Inlet Cowl Structure - PW2000 Engine

REPAIR 1 - Inlet Cowl Structure - Attach Ring Repair - PW2000 Engine

54-CONTENTS



757-200
STRUCTURAL REPAIR MANUAL

CHAPTER 54
NACELLES AND PYLONS

SUBJECT

CHAPTER
SECTION
SUBJECT

FAN COWL - RB211-535 ENGINE

54-20-01

- IDENTIFICATION 1 - Fan Cowl Skin Panel - RB211-535E4 Engine
- IDENTIFICATION 2 - R.H Fan Cowl Skin Panel - RB211-535C Engine
- IDENTIFICATION 3 - L.H. Fan Cowl Skin Panel - RB211-535C Engine
- ALLOWABLE DAMAGE 1 - Fan Cowl Skin - RB211-535 Engine
- REPAIR 1 - Left and Right Fan Cowl Panels - Edge Erosion Damage - RB211-535 Engine
- REPAIR 2 - Fan Cowl Skin Panel - RB211-535 Engine
- REPAIR 3 - Fan Cowl - Repair of Skin Adjacent to Latches - RB211-535 Engine
- REPAIR 4 - Fan Cowl - Repair to Corners - Erosion and Impact Corners Damage - RB211-535 Engine
- REPAIR 5 - Fan Cowl - Delamination Corners Damage - RB211-535 Engine
- REPAIR 6 - Fan Cowl - Access Panel - RB211-535 Engine

FAN COWL SKIN - PW2000 ENGINE

54-21-01

- IDENTIFICATION 1 - Fan Cowl Skin - PW2000 Engine
- ALLOWABLE DAMAGE 1 - Fan Cowl Skin - PW2000 Engine
- REPAIR 1 - Fan Cowl Skin - PW2000 Engine

FAN COWL SKIN - PW2000 ENGINE

54-21-02

- IDENTIFICATION 1 - Fan Cowl Structure - PW2000 Engine
- ALLOWABLE DAMAGE 1 - Fan Cowl Structure - PW2000 Engine
- REPAIR GENERAL - Fan Cowl Structure - PW2000 Engine

FAN DUCT AND THRUST REVERSER SKIN - RB211-535 ENGINE

54-30-01

- IDENTIFICATION 1 - Reverser Cowl Hinge Access Door - RB211-535E4 Engine
- IDENTIFICATION 2 - Reverser Cowl Skin Panel - RB211-535E4 Engine
- IDENTIFICATION 3 - Reverser Cowl Latch Access Doors - RB211-535E4 Engine
- IDENTIFICATION 4 - Reverser Cowl Skin Panel - RB211-535C Engine
- IDENTIFICATION 5 - Reverser Cowl Latch Access Doors - RB211-535C Engine
- ALLOWABLE DAMAGE 1 - Reverser Cowl Skin - RB211-535 Engine
- ALLOWABLE DAMAGE 2 - Fan Duct Nozzle - RB211-535 Engine

54-CONTENTS



757-200
STRUCTURAL REPAIR MANUAL

CHAPTER 54
NACELLES AND PYLONS

CHAPTER
SECTION
SUBJECT

SUBJECT

ALLOWABLE DAMAGE 3-Reverser Cowl Hinge Access Doors - RB211-535 Engine
ALLOWABLE DAMAGE 4-Reverser Cowl Latch Access Doors - RB211-535E4 Engine
ALLOWABLE DAMAGE 5-Reverser Cowl Latch Access Doors - RB211-535C Engine
REPAIR 1-Reverser Cowl Skin - RB211-535 Engine
REPAIR 2-Reverser Cowl Hinge Door - RB211-535 Engine
REPAIR 3-Reverser Cowl Latch Access Door - RB211-535C Engine

FAN DUCT AND THRUST REVERSER STRUCTURE - RB211-535 ENGINE

54-30-02

IDENTIFICATION 1-Reverser Cowl Ribs and Stringers - RB211-535E4 Engine
IDENTIFICATION 2-Reverser Cowl Ribs and Stringers - RB211-535C Engine
ALLOWABLE DAMAGE 1-Reverser Cowl Ribs and Stringers - RB211-535E4 Engine
ALLOWABLE DAMAGE 2-Reverser Cowl Ribs and Stringers - RB211-535C Engine
REPAIR 1-Reverser Cowl Ribs and Stringers - RB211-535E4 Engine
REPAIR 2-Reverser Cowl Ribs and Stringers - RB211-535C Engine

TORQUE RING

54-30-70

IDENTIFICATION 1-Torque Ring Outer Fairing - RB211-535E4 Engine
IDENTIFICATION 2-Torque Ring Outer Fairing - RB211-535C Engine
ALLOWABLE DAMAGE 1-Torque Ring Outer Fairing - All RB211-535 Engines
REPAIR 1-Typical Torque Ring Outer Fairing - All RB211-535 Engines
REPAIR 2-Torque Ring Outer Fairing - Patch Repair - All RB211-535 Engines

FAN DUCT AND THRUST REVERSER SKIN - PW2000 ENGINE

54-31-01

IDENTIFICATION 1-Fan Duct Cowl and Thrust Reverser Skin - PW2000 Engine
ALLOWABLE DAMAGE 1-Fan Duct Cowl and Thrust Reverser Skin - PW2000 Engine
REPAIR 1-Fan Duct Cowl and Thrust Reverser Skin - PW2000 Engine
REPAIR 2-Fan Duct Inner Wall Bonded Skin - PW2000 Engine
REPAIR 3-Fan Duct Cowl Inner Wall Fireshield Delamination - PW2000 Engine
REPAIR 4-Fan Duct Cowl Inner Wall Fireshield - Repair Using Ablative Coating - PW2000 Engine
REPAIR 5-Thrust Reverser Inner Wall Aft Cowl External - PW2000 Engine

54-CONTENTS



757-200
STRUCTURAL REPAIR MANUAL

CHAPTER 54
NACELLES AND PYLONS

<u>SUBJECT</u>	<u>CHAPTER SECTION SUBJECT</u>
REPAIR 6 - Engine Thrust Reverser Hinge Beam Access Fairing - PW2000 Engine	
REPAIR 7 - Fan Duct Cowl and Thrust Reverser Forward Hinge Fitting Rib - PW2000 Engine	
<u>FAN DUCT AND THRUST REVERSER STRUCTURE - PW2000 ENGINE</u>	54-31-02
IDENTIFICATION 1 - Fan Duct Cowl and Thrust Reverser Structure - PW2000 Engine	
ALLOWABLE DAMAGE 1 - Fan Duct Cowl and Thrust Reverser Structure PW2000 Engine	
<u>CORE COWL SKIN - RB211-535 ENGINE</u>	54-40-01
IDENTIFICATION 1 - Common Nozzle Assembly Skin - RB211-535E4 Engine	
ALLOWABLE DAMAGE GENERAL - Common Nozzle Assembly Skin - RB211-535E4 Engine	
REPAIR 1 - Common Nozzle Assembly Crack - RB211-535E4 Engine	
REPAIR 2 - Common Nozzle Assembly Scratch - RB211-535E4 Engine	
REPAIR 3 - Common Nozzle Assembly Dent - RB211-535E4 Engine	
REPAIR 4 - Common Nozzle Assembly Nick or Puncture - RB211-535E4 Engine	
REPAIR 5 - Common Nozzle Assembly through Skin and Delamination - RB211-535E4 Engine	
<u>CORE COWL STRUCTURE - RB211-535 ENGINE</u>	54-40-02
IDENTIFICATION 1 - Common Nozzle Assembly Structure - RB211-535E4 Engine	
<u>CORE COWL SKIN - PW2000 ENGINE</u>	54-41-01
IDENTIFICATION 1 - Core Cowl Skin - PW2000 Engine	
ALLOWABLE DAMAGE 1 - Core Cowl Skin - PW2000 Engine	
REPAIR GENERAL - Core Cowl Skin - PW2000 Engine	
REPAIR 1 - Core Cowl Skin - Flush Repair Between Frames - PW2000 Engine	
REPAIR 2 - Fireshield Delamination - PW2000 Engine	
<u>CORE COWL STRUCTURE - PW2000 ENGINE</u>	54-41-02
IDENTIFICATION 1 - Core Cowl Structure - PW2000 Engine	
ALLOWABLE DAMAGE 1 - Core Cowl Structure - PW2000 Engine	

54-CONTENTS



757-200
STRUCTURAL REPAIR MANUAL

CHAPTER 54
NACELLES AND PYLONS

<u>SUBJECT</u>	<u>CHAPTER SECTION SUBJECT</u>
<u>PRIMARY EXHAUST - PW2000 ENGINE</u>	54-41-30
IDENTIFICATION 1 - Primary Exhaust - PW2000 Engine	
ALLOWABLE DAMAGE 1 - Primary Exhaust - PW2000 Engine	
REPAIR GENERAL - Primary Exhaust - PW2000 Engine	
<u>STRUT SKIN - RB211-535 ENGINE</u>	54-50-01
IDENTIFICATION 1 - Strut Skin - RB211-535E4 Engine	
IDENTIFICATION 2 - Strut Skin - RB211-535C Engine	
ALLOWABLE DAMAGE 1 - Strut Skin - RB211-535 Engine	
REPAIR GENERAL - Strut Skin - RB211-535 Engine - Service Bulletin List	
REPAIR 1 - Strut Skin - RB211-535E4 Engine	
REPAIR 2 - Strut Skin - RB211-535C Engine	
<u>STRUT STRUCTURE - RB211-535 ENGINE</u>	54-50-02
IDENTIFICATION 1 - Strut Structure - RB211-535 Engine	
ALLOWABLE DAMAGE 1 - Strut Structure - RB211-535 Engine	
<u>STRUT FAIRING SKIN - RB211-535 ENGINE</u>	54-50-70
IDENTIFICATION 1 - Strut Fairing Skin - RB211-535E4 Engine	
IDENTIFICATION 2 - Strut Fairing Skin - RB211-535C Engines	
ALLOWABLE DAMAGE 1 - Strut Fairing Skin - RB211-535E4 Engine	
ALLOWABLE DAMAGE 2 - Strut Fairing Skin - RB211-535C Engine	
REPAIR GENERAL - Strut Fairing Skin - RB211-535 Engine - Service Bulletin List	
REPAIR 1 - Strut Fairing Skin - RB211-535 Engine	
<u>STRUT FAIRING STRUCTURE - RB211-535 ENGINE</u>	54-50-71
IDENTIFICATION 1 - Strut Fairing Structure - RB211-535 Engine	
ALLOWABLE DAMAGE 1 - Strut Fairing Structure - RB211-535 Engine	
REPAIR GENERAL - Strut Fairing Structure - RB211-535 Engine - Service Bulletin List	
REPAIR 1 - Strut Fairing Structure - RB211-535 Engine	

54-CONTENTS



757-200
STRUCTURAL REPAIR MANUAL

CHAPTER 54
NACELLES AND PYLONS

CHAPTER
SECTION
SUBJECT

SUBJECT

ATTACHMENT FITTINGS - STRUT - RB211-535 ENGINE

54-50-90

IDENTIFICATION 1 - Strut Fitting - RB211-535 Engine

IDENTIFICATION 2 - Attachment Linkage - RB211-535 Engine

ALLOWABLE DAMAGE 1 - Links and Fittings - RB211-535 Engine

REPAIR GENERAL - Strut Attachment Fittings and Linkage - RB211-535 Engine -
Service Bulletin List

REPAIR 1 - Strut Fitting - RB211-535 Engine

REPAIR 2 - Attachment Linkage - RB211-535 Engine

REPAIR 3 - Forward Upper Spar Fitting, Lug Hole Repair with Interference Fit Bushing
Procedure - RB211-535 Engine

REPAIR 4 - Midspar Fitting, Lug Hole Repair with Interference Fit Bushing Procedure -
RB211-535 Engine

REPAIR 5 - Lower Spar Fitting, Lug Hole Repair with Interference Fit Bushing
Procedure - RB211-535 Engine

REPAIR 6 - Pylon Shim Migration Inspection and Replacement - RB211-535 Engine

STRUT SKIN - PW2000 ENGINE

54-51-01

IDENTIFICATION 1 - Strut Skin - PW2000 Engine

ALLOWABLE DAMAGE 1 - Strut Skin - PW2000 Engine

REPAIR 1 - Strut Top Skin Repair - PW2000 Engine

REPAIR 2 - Strut Side Skin Small Hole or Crack - PW2000 Engine

STRUT STRUCTURE - PW2000 ENGINE

54-51-02

IDENTIFICATION 1 - Strut Structure - PW2000 Engine

ALLOWABLE DAMAGE 1 - Strut Structure - PW2000 Engine

REPAIR 1 - Fan Cowl Support Beam Web Repair - PW2000 Engine

REPAIR 2 - Aft Engine Mount Alignment Pin Hole - PW2000 Engine

STRUT FAIRING SKIN - PW2000 ENGINE

54-51-70

IDENTIFICATION 1 - Strut Fairing Skin - PW2000 Engine

ALLOWABLE DAMAGE 1 - Strut Fairing Skin - PW2000 Engine

REPAIR 1 - Strut Fairing Skin - PW2000 Engine

54-CONTENTS

Page 7
Jan 20/2005

D634N201



757-200
STRUCTURAL REPAIR MANUAL

CHAPTER 54
NACELLES AND PYLONS

CHAPTER
SECTION
SUBJECT

SUBJECT

STRUT FAIRING STRUCTURE - PW2000 ENGINE

54-51-71

IDENTIFICATION 1 - Strut Fairing Support Structure - PW2000 Engine

ALLOWABLE DAMAGE 1 - Strut Fairing Support Structure - PW2000 Engine

REPAIR GENERAL - Strut Fairing Structure - PW2000 Engine - Service Bulletin List

REPAIR 1 - Strut Fairing Support Structure - PW2000 Engine

ATTACHMENT FITTINGS - STRUT - PW2000 ENGINE

54-51-90

IDENTIFICATION 1 - Strut Fitting - PW2000 Engine

IDENTIFICATION 2 - Attachment Linkage - PW2000 Engine

ALLOWABLE DAMAGE 1 - Strut Fittings - PW2000 Engine

ALLOWABLE DAMAGE 2 - Attachment Linkage - PW2000 Engine

REPAIR GENERAL - Strut Attachment Fittings - PW2000 Engine - Service Bulletin List

REPAIR 1 - Strut Fitting - PW2000 Engine

REPAIR 2 - Attachment Linkage - PW2000 Engine

REPAIR 3 - Forward Upper Spar Fitting, Lug Hole Repair with Interference Fit Bushing Procedure - PW2000 Engine

REPAIR 4 - Midspar Fitting, Lug Hole Repair with Interference Fit Bushing Procedure - PW2000 Engine

REPAIR 5 - Lower Spar Fitting, Lug Hole Repair with Interference Fit Bushing Procedure - PW2000 Engine

FORWARD ENGINE MOUNT

54-71-91

IDENTIFICATION 1 - Forward Engine Mount Beam

ALLOWABLE DAMAGE 1 - Forward Engine Mount Beam - PW2000 Engine

54-CONTENTS

757-200
STRUCTURAL REPAIR MANUAL

REPAIR GENERAL - ACOUSTIC PANEL AREA LOSS LIMITS - RB211-535 ENGINE

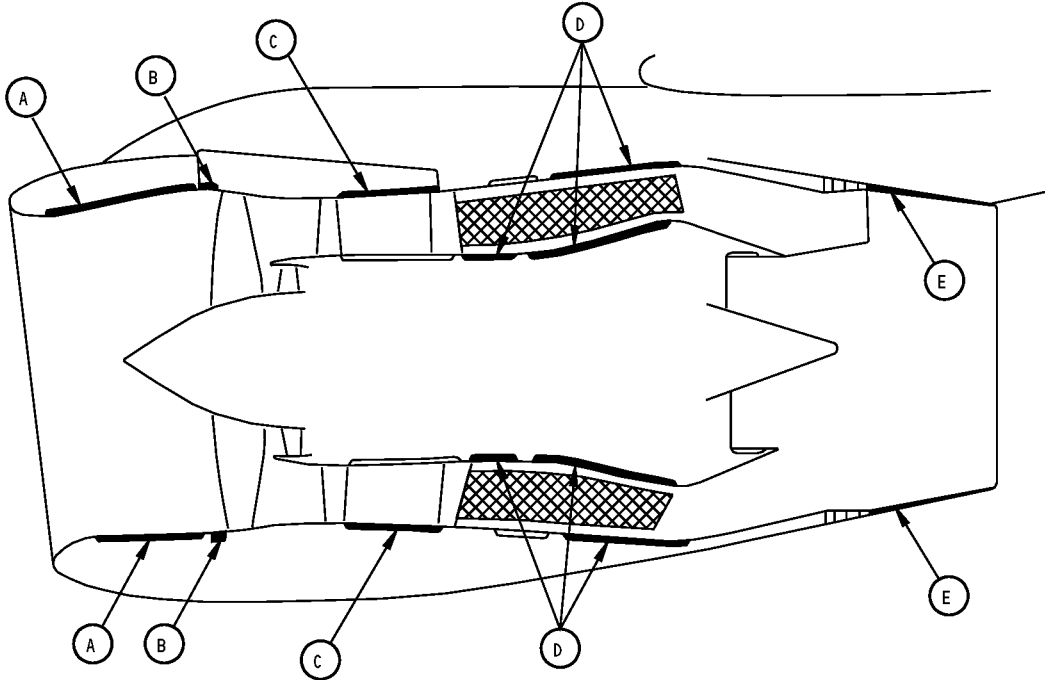

REPAIR AREA	DESCRIPTION	MAX ALLOWABLE LOSS OF PERFORATED SKIN AREA FROM ACCUMULATED REPAIRS
(A)	INLET	216 SQUARE INCHES (1394 SQUARE cm)
(B)	FRONT FAN CASE	
(C)	REAR FAN CASE	403 SQUARE INCHES (2600 SQUARE cm)
(D)	BYPASS DUCT	173 SQUARE INCHES (1116 SQUARE cm)
(E)	MIXING CHAMBER	144 SQUARE INCHES (929 SQUARE cm)

TABLE I

Acoustic Panel Area Loss Limits - RB211-535E4 Engine
Figure 201

D634N201

54-00-01

REPAIR GENERAL
Page 201
Sep 20/2005

757-200
STRUCTURAL REPAIR MANUAL

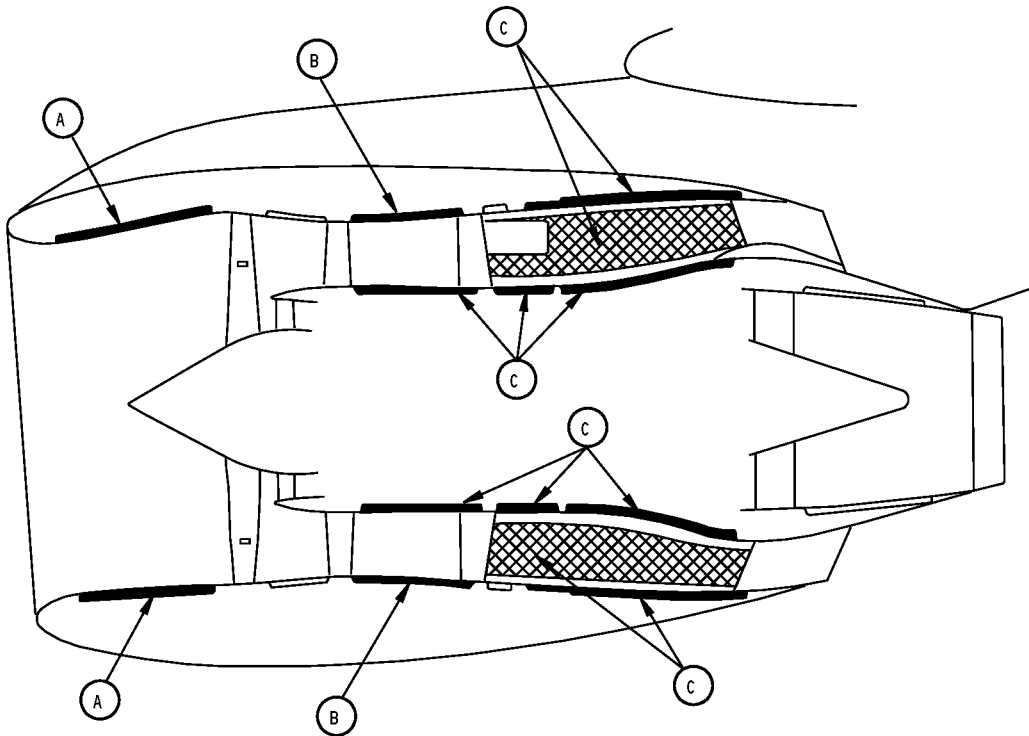

REPAIR AREA	DESCRIPTION	MAX ALLOWABLE LOSS OF PERFORATED SKIN AREA FROM ACCUMULATED REPAIRS
(A)	INLET	216 SQUARE INCHES (1394 SQUARE cm)
(B)	REAR FAN CASE	403 SQUARE INCHES (2600 SQUARE cm)
(C)	BYPASS DUCT	202 SQUARE INCHES (1303 SQUARE cm)

TABLE I

Acoustic Panel Area Loss Limits - RB211-535C Engine
Figure 202

STRUCTURAL REPAIR MANUAL

REPAIR 1 - TYPICAL REPAIRS FOR PERFORATED ALUMINUM ACOUSTIC PANELS - PW2000 ENGINE

REPAIR INSTRUCTIONS

1. Refer to Detail I to select applicable repair details and repair instructions.

NOTE: EACH ENGINE INSTALLATION IS COMPRISED OF INTERCHANGEABLE COMPONENTS. IT IS NECESSARY THAT RECORDS BE ACCURATELY LOGGED AND MAINTAINED. THE REPAIR DATA FROM THESE RECORDS SHOULD BE USED TO CALCULATE THE ACOUSTIC PANEL BLOCKAGE SHOWN IN DETAIL I. THE TOTAL ACOUSTIC PANEL BLOCKAGE FOR THE ENGINE INSTALLATION MUST BE RECALCULATED WHEN COMPONENTS ARE CHANGED.

NOTES

- WHEN YOU USE THIS REPAIR REFER TO:
 - AMM 51-21 FOR INTERIOR AND EXTERIOR FINISHES
 - SRM 51-10-01 FOR AERODYNAMIC SMOOTHNESS REQUIREMENTS. WHERE THE DAMAGE IS MORE THAN THE LIMITS SHOWN IN SRM 51-10-01, CONSIDERATION SHOULD BE GIVEN TO THE LOSS OF PERFORMANCE INVOLVED
 - SRM 51-10-02 FOR INSPECTION AND REMOVAL OF DAMAGE
 - SRM 51-20-01 FOR PROTECTIVE TREATMENT OF METAL
 - SRM 51-30-03 FOR SOURCE OF REPAIR MATERIALS
 - SRM 51-40 FOR FASTENER CODE, REMOVAL, INSTALLATION, HOLE SIZES AND EDGE MARGINS
 - SRM 51-40-03 FOR FASTENER SUBSTITUTION
 - SRM 51-40-08 FOR COUNTERSINKING AND USE OF COUNTERSINK REPAIR WASHERS
 - SRM 51-70-09 FOR STRUCTURAL BONDING.

- A** THE TOTAL COMBINED PERFORATED ACOUSTIC PANEL BLOCKAGE AREA FROM REPAIRS MUST NOT BE MORE THAN THE LIMITS IN DETAIL I.
- B** MATERIAL SHALL BE HEATED AT A MAXIMUM RATE OF 5 TO 7°F FOR EACH MINUTE, THEN HELD AT THE CURE TEMPERATURE FOR THE INDICATED TIME.
- C** MIX PER MANUFACTURERS INSTRUCTIONS. VISCOSITY CAN BE INCREASED BY ADDING MILLED GLASS FIBERS UP TO 20% MAXIMUM BY WEIGHT.
- D** MIX RATIO 32 TO 34 PARTS HARDENER (PART B) TO 100 PARTS RESIN (PART A) BY WEIGHT.
- E** MIX RATIO 100 PARTS HARDENER (PART B) TO 140 PARTS RESIN (PART A) BY WEIGHT.
- F** TWO PART - ROOM TEMP CURE, POURABLE WITH ONE YEAR OF STORAGE TIME AT 40°-80°F.

- G** ONE PART FROZEN - HEAT CURE, TROWELABLE PUTTY WITH 3 MONTHS OF STORAGE TIME AT 0°F OR BELOW. OPTIONAL TO TYPE 3 AND 7 IN AREAS WHERE HIGH VISCOSITY IS NEEDED TO PREVENT POTTING COMPOUND FROM FLOWING OUT OF THE HOLE.
- H** TWO PART - ROOM TEMP CURE, TROWELABLE SLUMPING PASTE WITH ONE YEAR OF STORAGE TIME AT 40°-80°F.
- I** OPTIONAL TO BMS 5-109 TYPE 2, CLASS 2 IN REPAIRS WHERE LONGER WORK TIME IS REQUIRED.
- J** FASTENERS MUST BE INSTALLED WHILE ADHESIVE IS STILL WORKABLE.
- K** REPAIRS FOR THE FAN CASE ACOUSTIC PANELS (SOUND ABSORBING LINERS) ARE PROVIDED IN AMM 72-33-03 AND AMM 72-33-05.
- L** REPAIRS TO THE TURBINE EXHAUST SLEEVE ARE PROVIDED IN THE CMM 78-11-01.
- M** REINFORCED AREAS ARE THOSE AREAS WITH DOUBLERS AND/OR HIGH DENSITY CORE.
- N** FOR OPTIMUM PROPERTIES, CURE 7 DAYS AT 65°F (19°C) OR 5 HOURS AT 125°F (52°C).

FASTENER SYMBOLS

- + REFERENCE FASTENER LOCATION
- △ INITIAL FASTENER LOCATION
- ◆ REPAIR FASTENER LOCATION

**Typical Repairs for Perforated Aluminum Acoustic Panels - PW2000 Engine
Figure 201 (Sheet 1 of 16)**



**757-200
STRUCTURAL REPAIR MANUAL**

WARNING: THESE CHEMICALS CONTAIN TOXIC INGREDIENTS. PROVIDE ADEQUATE VENTILATION AND PROTECT THE SKIN AND EYES FROM CONTACT WITH UNCURED RESINS OR CURING AGENT. WEAR RUBBER GLOVES OVER COTTON GLOVES FOR PROTECTION OF HANDS. IF SKIN IS EXPOSED TO DIRECT CONTACT WITH UNCURED RESINS OR CURING AGENT, WASH WITH WARM WATER OR SOAP. AVOID THE USE OF SOLVENTS FOR CLEANING THE SKIN.

CAUTION: TO PREVENT CONTAMINATION OF THE RESIN, DO NOT USE WAXED CONTAINERS FOR MIXING.

NOTE: ADD HARDENER TO RESIN AND MIX THOROUGHLY.

ADHESIVE AND POTTING COMPOUND CURE TABLE				
ADHESIVE OR POTTING COMPOUND	COMPONENTS	PARTS BY WEIGHT	GEL TIME	CURING TIME B
BMS 5-28 TYPE 7 CLASS 1 CLASS 2 POTTING F	CG1305 FR 7162 A/B EPOCAST 89537 A/B	C	60 MINUTES	2 HRS AT 125°F N
BMS 5-28 TYPE 14 CLASS 2 POTTING G	EPOCAST 1614 EPOCAST 840	C	8 HOURS	90 MINUTES AT 260±10°F
BMS 5-109 TYPE 2, CLASS 2 ADHESIVE	EA 9394 EA 934NA EA 9394S	D	30 MINUTES J	1 HOUR AT 200 ±10°F 9 HOURS AT 160 ±10°F 25 HOURS AT 120 ±10°F 7 DAYS AT 77 ±10°F
I	BR 95/AB	D	60 MINUTES J	70 MINUTES AT 200 ±10°F (93 ±5C) 120 HOURS AT 77 ±10°F (25 ±5C)

TABLE I

**Typical Repairs for Perforated Aluminum Acoustic Panels - PW2000 Engine
Figure 201 (Sheet 2 of 16)**

**757-200
STRUCTURAL REPAIR MANUAL**

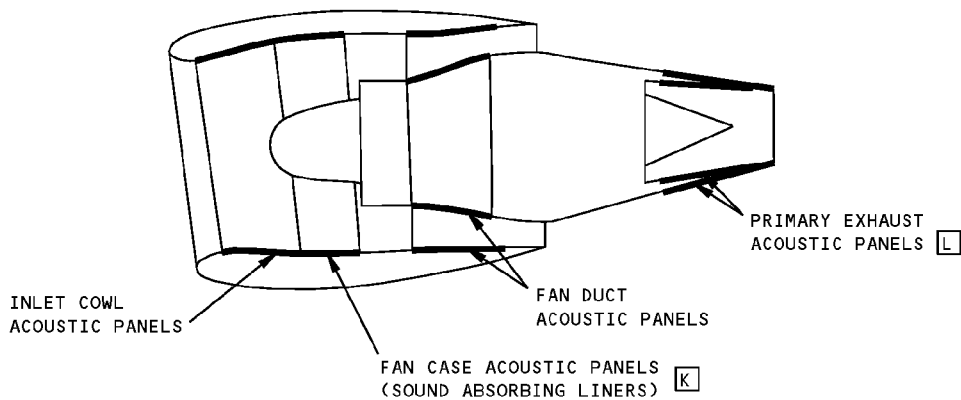

REPAIR TO ACOUSTIC PANELS CAN BE MADE AFTER VERIFICATION HAS BEEN MADE THAT THE REPAIR WILL NOT REDUCE THE NOISE SUPPRESSION CAPABILITIES OF THE NACELLE BEYOND ESTABLISHED LIMITS. THIS CAN BE VERIFIED WHEN THE FOLLOWING EQUATION HAS BEEN SATISFIED.

$$\frac{A}{504} + \frac{B}{792} + \frac{C}{648} + \frac{D}{1944} < 1.0$$

WHERE: A = ACOUSTIC PANEL BLOCKAGE IN THE INLET COWL (IN²)
 B = ACOUSTIC PANEL BLOCKAGE IN THE FAN CASE (IN²) [K]
 C = ACOUSTIC PANEL BLOCKAGE IN THE FAN DUCT (IN²)
 D = ACOUSTIC PANEL BLOCKAGE IN PRIMARY EXHAUST (IN²) [L]

EXAMPLE: AN OPERATOR PLANS TO REPAIR AN INLET COWL. THE SIZE OF THE REPAIR HAS BEEN CALCULATED TO BE 135 IN². ONE REPAIR ALREADY EXISTS IN THE FAN DUCT AND MEASURES 90 IN². TO VERIFY THAT THE NACELLE WILL PERFORM WITHIN THE LIMITS ESTABLISHED FOR NOISE, THE EQUATION IS SET UP AS FOLLOWS:

$$\frac{135}{504} + 0 + \frac{90}{648} + 0 < 1.0$$

WHERE: A = 135 IN² AND C = 90 IN²; B AND D = 0
 $\frac{135}{504} + 0 < 1.0$
 $\frac{90}{648} < 1.0$

BECAUSE 0.407 IS LESS THAN 1.0, ACCOMPLISHMENT OF THIS REPAIR WILL NOT CAUSE THE NACELLE TO EXCEED THE NOISE LIMITS.

REPAIR DETAILS FOR PERFORATED ALUMINUM ACOUSTIC PANELS IN THE INLET AND FAN DUCT COWL:

- SEE DETAIL II FOR REPAIR OF LIMITED DAMAGE BY POTTING
- SEE DETAIL III FOR REPAIR OF LARGE CRACKS OR DAMAGE NEAR PANEL EDGE
- SEE DETAIL IV FOR REPAIR OF LARGE DAMAGE AREAS IN PANEL

REFER TO AMM 71-00-04 FOR REPAIRS TO FAN CASE AND PRIMARY EXHAUST

DETAIL I

**Typical Repairs for Perforated Aluminum Acoustic Panels - PW2000 Engine
Figure 201 (Sheet 3 of 16)**

STRUCTURAL REPAIR MANUAL

APPLICABILITY

THIS REPAIR IS FOR DAMAGE THAT IS NOT MORE THAN 3 INCHES (75 mm) IN DIAMETER. REFER TO DETAIL III FOR DAMAGE ADJACENT TO PANEL EDGE AND DETAIL IV FOR LARGE DAMAGE.

REPAIR INSTRUCTIONS FOR DETAIL II

1. Cut out the damaged skin, leaving the core intact. Undercut the core and septum at perimeter of cutout as shown to allow for injection of resin into one further row of cells around cutout.

NOTE: REMOVAL OF DAMAGED CORE IS NOT REQUIRED WHEN USING A POTTED RESIN REPAIR, HOWEVER THE DAMAGED CORE MUST EITHER BE CLEANED OR CUT OUT.

3. Inject potting compound, BMS 5-28, type 7, into the boundary cells and core as shown. Fill to the level of the skin allowing for adhesive shrinkage during the cure cycle. The full cure cycle is shown in Table I, but the potting compound is sufficiently cured after 2 hours at 80°F or 1 hour at 125°F for the panel to be returned to service.

NOTE: GEL TIME IS 20 MINUTES.

4. When potting compound has cured sufficiently, sand down the surplus resin flush with the surrounding skin.

2. Clean out all particles from exposed core.

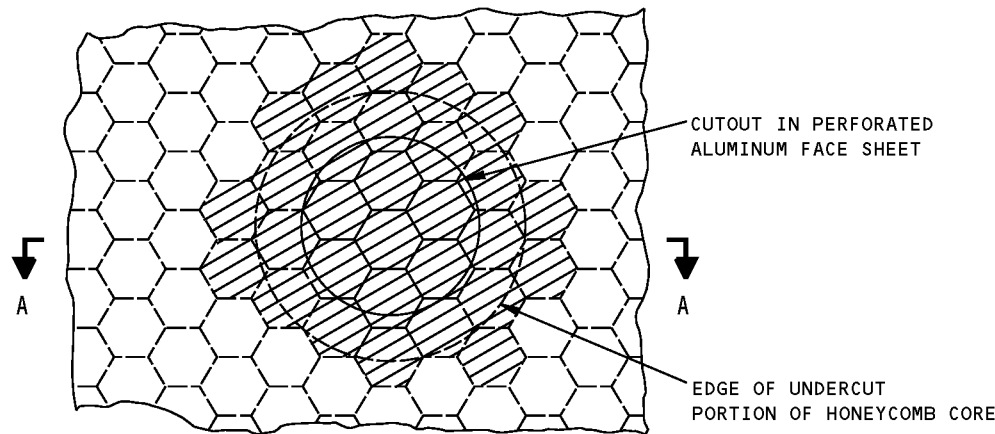

PORTION OF CORE FILLED WITH POTTING COMPOUND

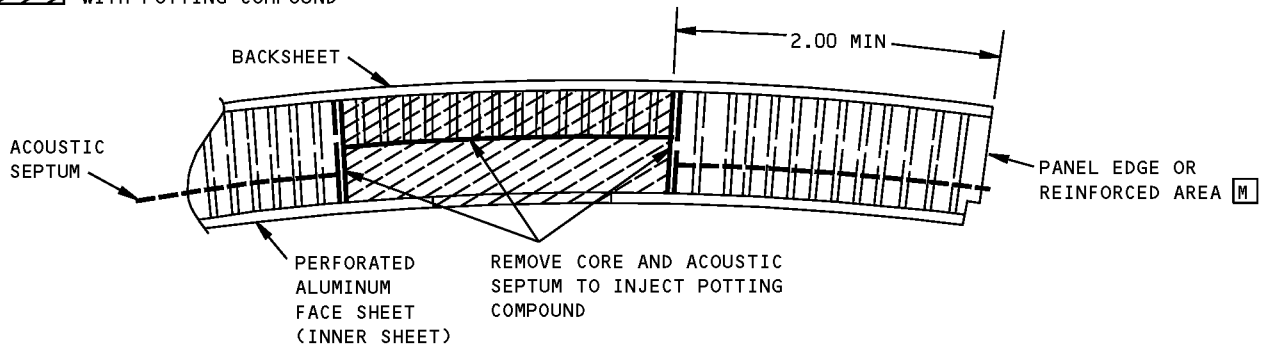

SECTION A-A

**REPAIR OF LIMITED DAMAGE BY POTTING
DETAIL II**

**Typical Repairs for Perforated Aluminum Acoustic Panels - PW2000 Engine
Figure 201 (Sheet 4 of 16)**

STRUCTURAL REPAIR MANUAL

APPLICABILITY
THIS REPAIR IS FOR CRACKS WITHIN 2 INCHES (50 mm) OF PANEL EDGE AND/OR CORE DAMAGE THAT IS NOT MORE THAN 3 INCHES (75 mm) IN DIAMETER. REFER TO DETAILS II AND IV FOR REPAIRS OUTSIDE OF THIS AREA.

REPAIR MATERIAL			
PART		QTY	MATERIAL
1	REPAIR PLATE	1	0.080 INCH 2024-T3
2	REPAIR WASHER	AS REQ'D	IN ACCORDANCE WITH SRM 51-40-08

TABLE I

REPAIR INSTRUCTIONS FOR DETAIL III

1. Drill a 0.25-inch (6.4 mm) diameter hole at each end of the crack.

NOTE: If core is also damaged and needs to be repaired, refer to Detail II for potted resin repair.

2. Drill out sufficient edge fasteners to permit installation of the repair plate 1.
3. Locate repair plate on panel and drill holes to match existing edge fastener holes.
4. Drill additional repair fasteners holes in the repair plate 1 as shown.
5. Solvent clean the faying surfaces of the original panel and repair plate 1 as detailed in SRM 51-70-10.
6. Apply Alodine to all bare surfaces and raw edges of existing and repair parts per SRM 51-20-01.
7. Prime faying surfaces of initial panel and repair doubler with Courtaulds Aerospace 515X346 corrosion inhibiting adhesive primer.
8. Inject potting compound BMS 5-28, Type 7 thru perforations and bolt holes on solid face, to ensure potting compound is on both sides of septum, in area of fastener holes before installation.
9. Apply adhesive, BMS 5-109, Type II, Class 2 to the panel and part 1. Install fasteners and allow to cure as shown in Table I and SRM 51-70-10.

**Typical Repairs for Perforated Aluminum Acoustic Panels - PW2000 Engine
Figure 201 (Sheet 5 of 16)**

**757-200
STRUCTURAL REPAIR MANUAL**

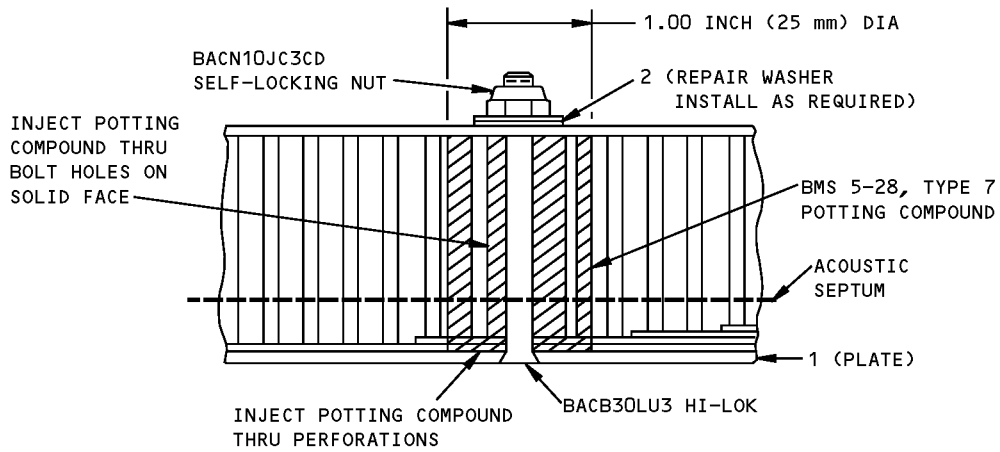
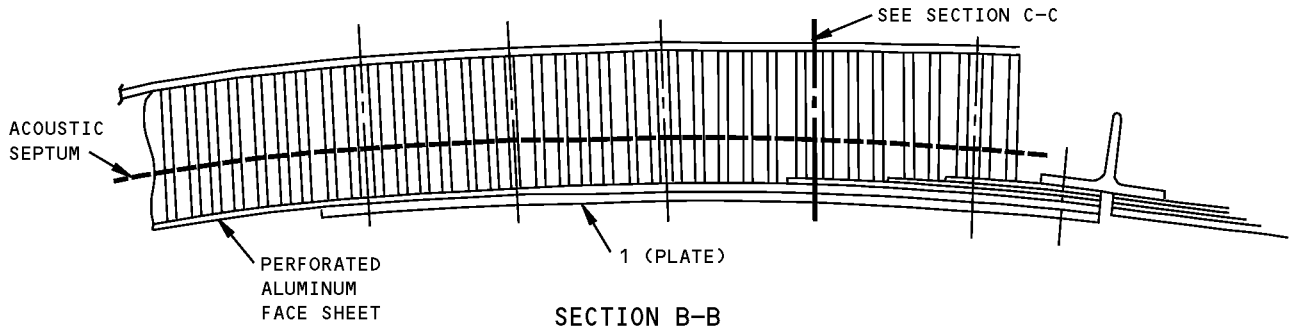
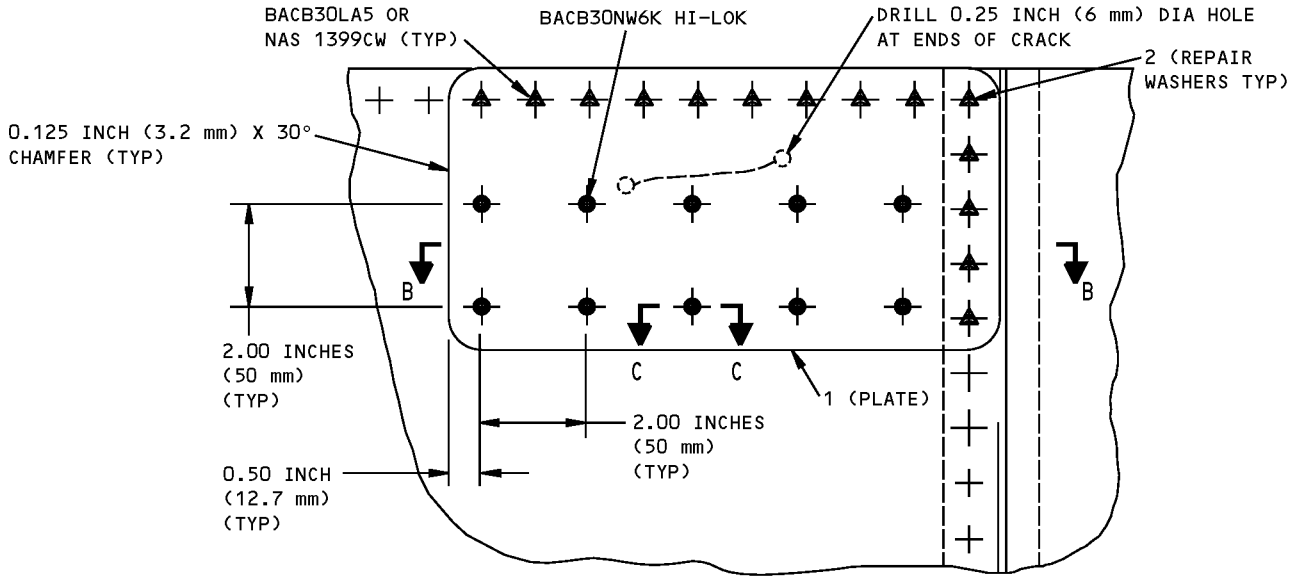

**REPAIR FASTENER INSTALLATION
SECTION C-C**

**REPAIR OF LARGE CRACKS OR DAMAGE NEAR PANEL EDGE
DETAIL III**

**Typical Repairs for Perforated Aluminum Acoustic Panels - PW2000 Engine
Figure 201 (Sheet 6 of 16)**

STRUCTURAL REPAIR MANUAL

APPLICABILITY
THIS REPAIR IS FOR DAMAGE THAT IS MORE THAN 3 INCHES (75 mm) BUT NOT GREATER THAN 6 INCHES (150 mm) IN DIAMETER. REFER TO DETAIL II FOR SMALLER DAMAGE AND DETAIL III FOR DAMAGE ADJACENT TO PANEL EDGE.

REPAIR MATERIAL			
PART		QTY	MATERIAL
1	REPAIR PLATE	1	0.080 INCH PLATE 2024-T3
2	REPAIR CORE	1	SAME SIZE AND DENSITY AS ORIGINAL

TABLE I

REPAIR INSTRUCTIONS FOR DETAIL IV

1. Cut away damaged portion of panel leaving non-perforated skin intact.
2. Make repair part.
3. Break sharp edges of original and repair part 0.015 to 0.030 inch (0.38 to 0.76 mm).
4. Remove all nicks, scratches, burrs and sharp corners from original and repair part.
5. Install repair core with BMS 5-28, Type 7 potting compound.
6. Locate repair plate on panel and drill fastener holes.
7. Solvent clean the faying surfaces of the panel and plate as detailed in SRM 51-70-00.
8. Apply Alodine to all bare surfaces and raw edges of existing and repair parts per SRM 51-20-01.
9. Prime faying surfaces of initial panel and repair doubler with Courtaulds Aerospace 515X346 corrosion inhibiting adhesive primer.
10. Inject BMS 5-28, Type 7 potting compound thru perforations and bolt holes on solid face, to ensure potting compound is on both sides of septum, in area of fastener holes before installation.
11. Apply adhesive BMS 5-109, Type II, Class 2 to panel and plate 1. Install fasteners and allow to cure per Table I.

**Typical Repairs for Perforated Aluminum Acoustic Panels - PW2000 Engine
Figure 201 (Sheet 7 of 16)**

**757-200
STRUCTURAL REPAIR MANUAL**

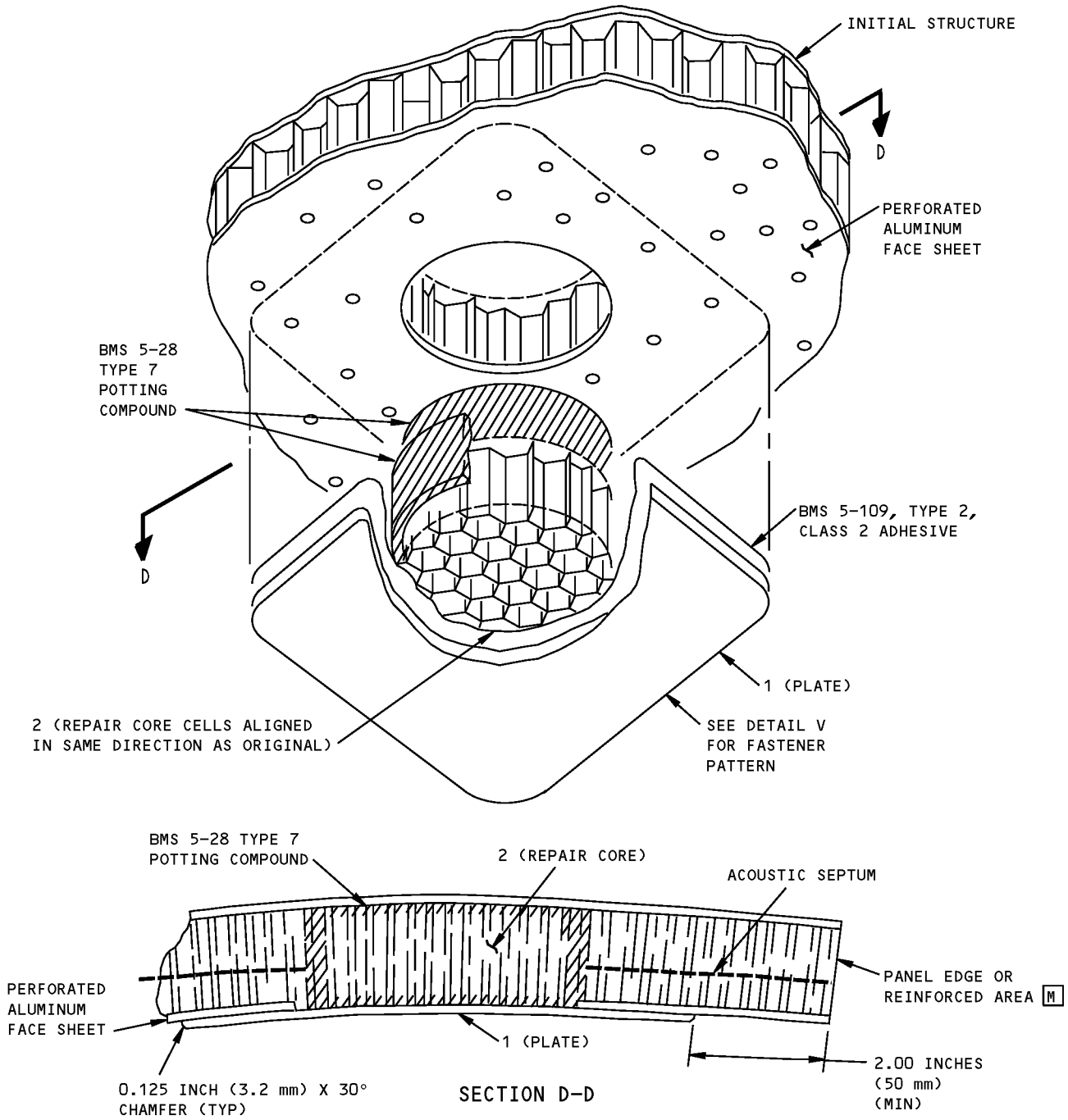

**REPAIR OF LARGE DAMAGE AREA IN PANEL
DETAIL IV**

**Typical Repairs for Perforated Aluminum Acoustic Panels - PW2000 Engine
Figure 201 (Sheet 8 of 16)**

**757-200
STRUCTURAL REPAIR MANUAL**

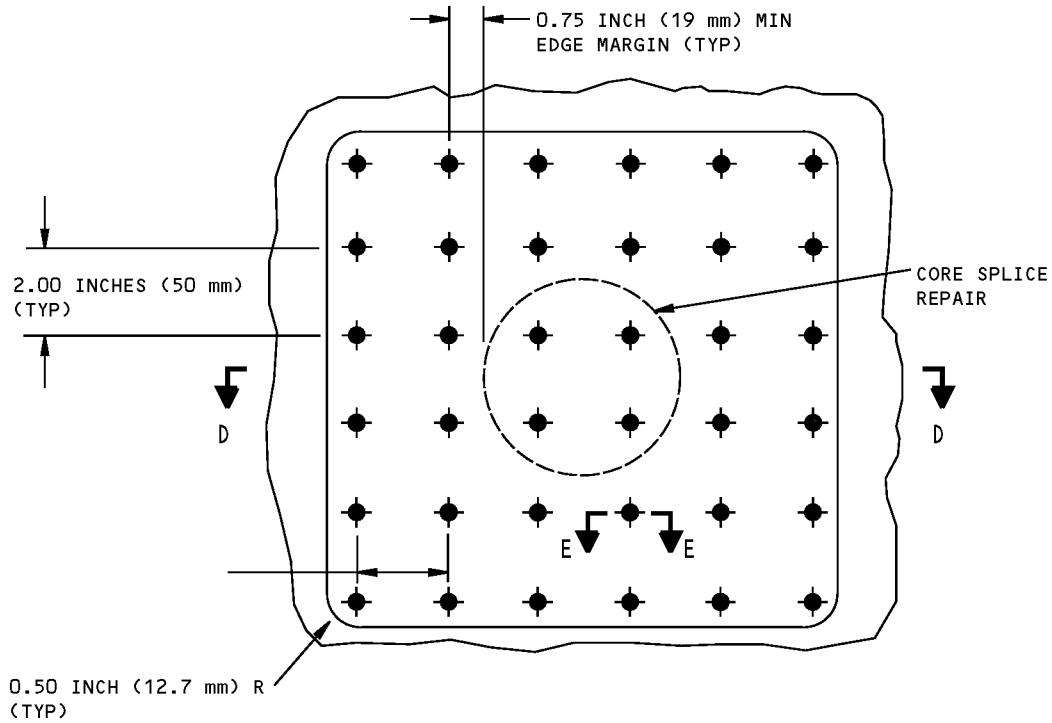

**TYPICAL FASTENER PATTERN
DETAIL V**

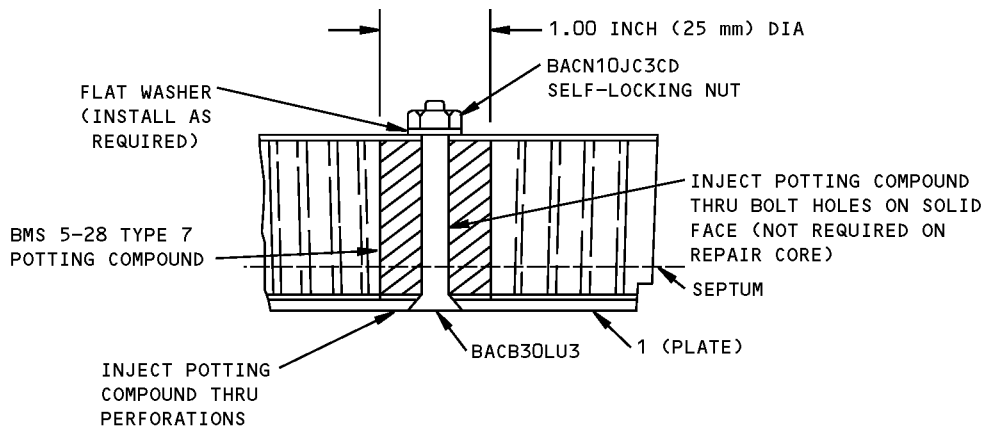

**TYPICAL BOLT INSTALLATION
SECTION E-E**

**Typical Repairs for Perforated Aluminum Acoustic Panels - PW2000 Engine
Figure 201 (Sheet 9 of 16)**

STRUCTURAL REPAIR MANUAL

APPLICABILITY
<p>THIS REPAIR IS LIMITED TO INLET COWL ACOUSTIC PANEL ONLY. THIS REPAIR IS FOR BACKSHEET. DISBOND LIMITED TO AN AREA OF 100 SQUARE INCHES (645 SQUARE cm) FOR EACH PANEL. MAXIMUM DISBOND SHALL NOT BE MORE THAN 30 INCHES (760 mm) IN THE CIRCUMFERENTIAL DIRECTION AND 10 INCHES (250 mm) IN THE FORE AND AFT DIRECTION. A CIRCUMFERENTIAL SEPARATION OF A MINIMUM OF 12 INCHES (300 mm) IS REQUIRED BETWEEN ADJACENT DISBONDS GREATER THAN 20 INCHES (500 mm) IN LENGTH. NO DISBOND ALONG PANEL EDGE IS PERMITTED. IN NO CASE SHALL THE NOISE SUPPRESSION CAPABILITIES OF THE ACOUSTICAL PANELS BE COMPROMISED. REFER TO DETAIL I FOR REPAIR LIMITS.</p>

NOTES

- WHEN YOU USE THIS REPAIR, REFER TO:
 - AMM 70-42-12 FOR LOCAL SURFACE PROTECTION
 - SRM 51-20-01 FOR PROTECTIVE TREATMENT OF METAL
 - SRM 51-20-05 FOR THE SEALING OF REPAIRS
 - SRM 51-30-03 FOR NONMETALLIC MATERIAL SOURCES
 - SRM 51-40 FOR FASTENER CODE, REMOVAL, INSTALLATION, HOLE SIZES, AND EDGE MARGINS.

REPAIR INSTRUCTIONS FOR DETAIL VI

1. Drill 0.161 inch (4.09 mm) diameter pilot holes through the disbanded area of acoustic panel as required. Be careful not to penetrate through the panel facesheet.
2. Increase the diameter of honeycomb core by flycutting through the fastener hole to a diameter of 1.0 inch (25 mm) with tool ST-1227A-2.
3. Inject BMS 5-28, Type 7 potting compound into fastener holes. When the potting compound has cured sufficiently (See Table I), redrill the fastener holes to a diameter of 0.161 inch (4.09 mm) at initial pilot locations.
4. Countersink the fastener holes in the face sheet of the acoustic panel. See Detail VI.
5. Secure the disbanded area using a BACB30LU3 bolt, a BACN10JC3 nut, and a AN96OPD10 washer.
6. Clean the outer surface of the reworked area and apply protective treatment as given in SRM 51-20-01.
7. Apply one coat of BMS 10-11, Type I over the entire reworked area of the backsheets.
8. Cap nuts and washers with BMS 5-26 sealant.

SYMBOLS

- ✦ REPAIR FASTENER LOCATION.
INSTALL BACB30LU3 BOLT WITH BACN10JC3 NUT AND AN96OPD10 WASHER.

**Typical Repairs for Perforated Aluminum Acoustic Panels - PW2000 Engine
Figure 201 (Sheet 10 of 16)**

**757-200
STRUCTURAL REPAIR MANUAL**

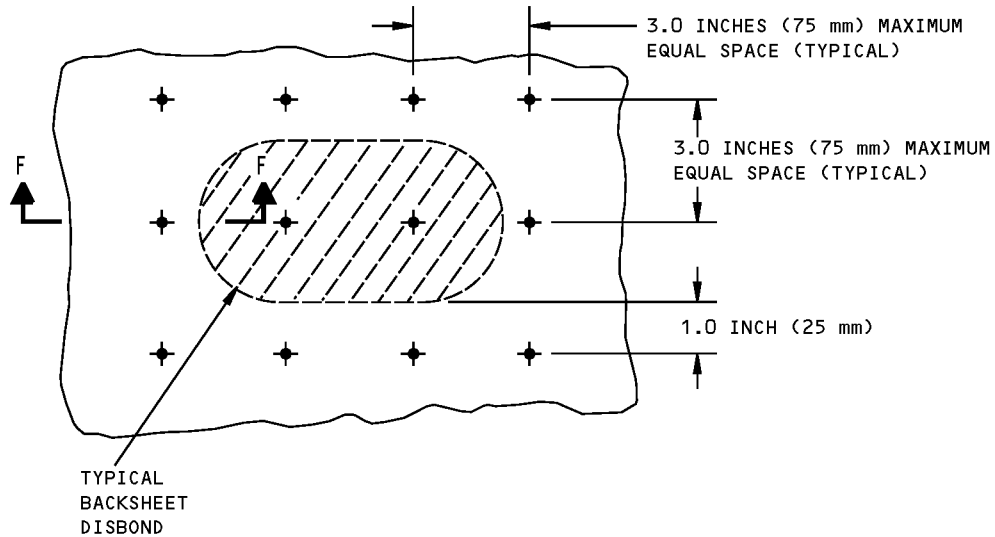

PANEL SHOWN WITH OUTER SKIN PANEL LOWER HALF REMOVED
DETAIL VI

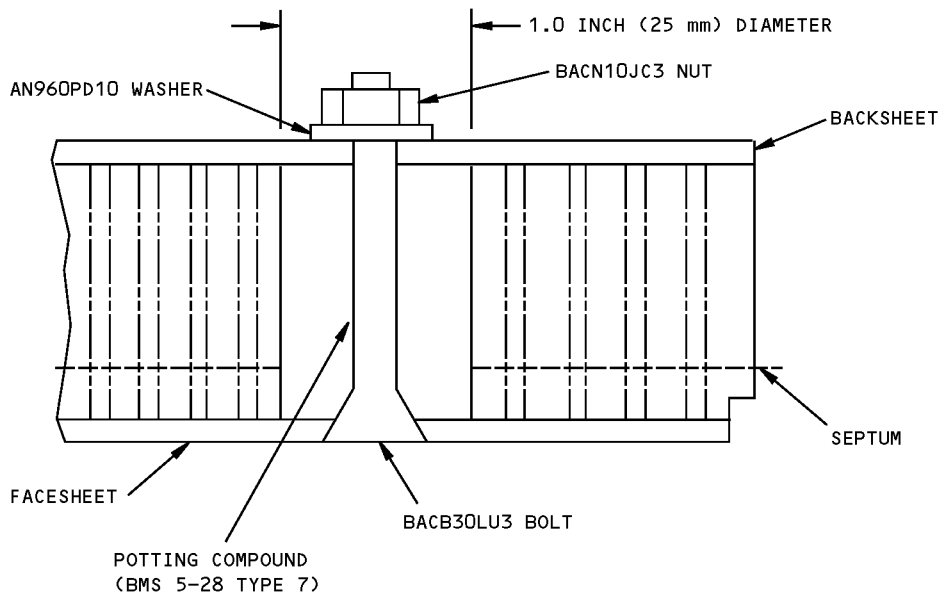

SECTION F-F

Typical Repairs for Perforated Aluminum Acoustic Panels - PW2000 Engine
Figure 201 (Sheet 11 of 16)

STRUCTURAL REPAIR MANUAL

APPLICABILITY
<p>THIS REPAIR IS FOR BACKSHEET DISBOND LIMITED TO AN AREA OF 200 SQUARE INCHES (1290 square cm) FOR EACH PANEL. MAXIMUM DISBOND SHALL NOT BE MORE THAN 30 INCHES (760 mm) IN LENGTH IN THE CIRCUMFERENTIAL DIRECTION OR 10 INCHES (250 mm) IN LENGTH IN THE FORE AN AFT DIRECTION. FOR ADJACENT DISTANCES WITH LENGTH GREATER THAN 20 INCHES (500 mm) A MINIMUM SEPARATION OF 12 INCHES (300 mm) IS REQUIRED. IN NO CASE SHALL THE SUPPRESSION CAPABILITIES OF THE ACOUSTIC PANELS BE COMPROMISED. REFER TO DETAIL I FOR REPAIR LIMITS.</p>

REPAIR INSTRUCTIONS FOR DETAIL VII

1. Cut out the delaminated or damaged backsheet using a router template.

NOTE: Inspect the backsheet for cracks by dye penetrant inspection or other comparable method. If no cracks are present the original backsheet may be used in the repair.
2. Make the repair doubler and if necessary a backsheet replacement.
3. Remove all nicks, scratches, burrs and sharp edges from original and repair parts.
4. Prefit the repair backsheet and doubler without adhesive. Apply a vacuum bag over the backsheet side (non perforated side) and check that a minimum vacuum value of 20 inches of mercury (67.7 KPa) is obtained. After check remove vacuum bag.
5. Remove any moisture from the honeycomb core with oil free compressed air and an air dryer (Do not heat over 300°F - 149°C). clean the honeycomb edge, backsheet, backsheet repair plate and doubler with MEK solvent as detailed in SRM 51-70-09.
6. Clean and finish the faying surfaces of the repair parts and backsheet using the HF/Alodine method as shown in SRM 51-70-09.
7. Apply Courtaulds Aerospace 515X346 CIAP (Corrosion Inhibiting Adhesive Primer) primer. Refer to SRM 51-70-09.
8. Apply BMS 5-109, Type II, Class 2 adhesive between repair doubler and repair backsheet faying surfaces. See Table I for cure instructions.
9. After repair backsheet and picture frame doubler have cured, apply BMS 5-109, Type II adhesive between repair backsheet/doubler and honeycomb panel. While adhesive is curing install BACB30LU3 bolt with BACN10JC3 nut and AN960PD10 washer as shown in Detail VII. See Table I for cure instructions.

10. Clean outer surface of reworked area and apply protective treatment per SRM 51-20-01.
11. Apply one coat of BMS 10-11, Type I primer over entire reworked area.
12. Cap seal repair fasteners with BMS 5-26 sealant.
13. Fillet seal edges of repair parts with BMS 5-26 sealant.

NOTES

- WHEN YOU USE THIS REPAIR REFER TO:
 - AMM 51-21 FOR INTERIOR AND EXTERIOR FINISHES
 - SRM 51-10-01 FOR AERODYNAMIC SMOOTHNESS REQUIREMENTS
 - REFER TO SRM 51-10-02 FOR INSPECTION AND REMOVAL OF DAMAGE
 - SRM 51-20-01 FOR PROTECTIVE TREATMENT OF METAL
 - SRM 51-20-05 FOR REPAIR SEALING
 - SRM 51-40 FOR FASTENER CODE, REMOVAL, INSTALLATION, HOLE SIZES AND EDGE MARGINS
 - SRM 51-40-03 FOR FASTENER SUBSTITUTION.

FASTENER SYMBOLS

⊕ REPAIR FASTENER LOCATION. INSTALL BACB30LU3 BOLT AND BACN10JC3 NUT AND AN960PD10 WASHER.

REPAIR MATERIAL			
PART		QTY	MATERIAL
1	REPAIR BACK-SHEET	1	SAME GAGE AS INITIAL MATERIAL 2024-T62
2	REPAIR DOUBLER	1	0.025 INCH CLAD 2024-T62 (2024-T3 OPTIONAL)

TABLE I

**Typical Repairs for Perforated Aluminum Acoustic Panels - PW2000 Engine
Figure 201 (Sheet 12 of 16)**

STRUCTURAL REPAIR MANUAL

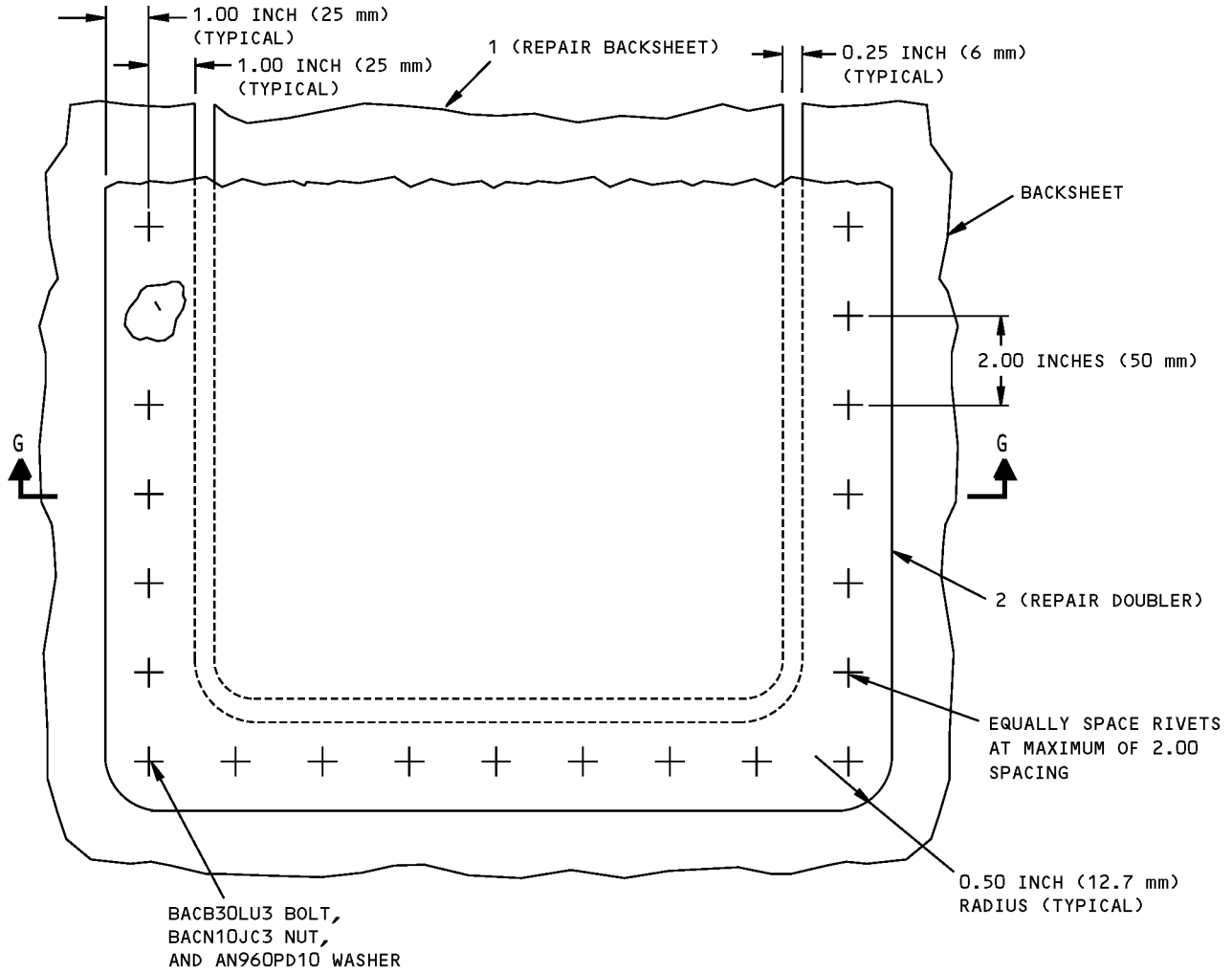

DETAIL VII

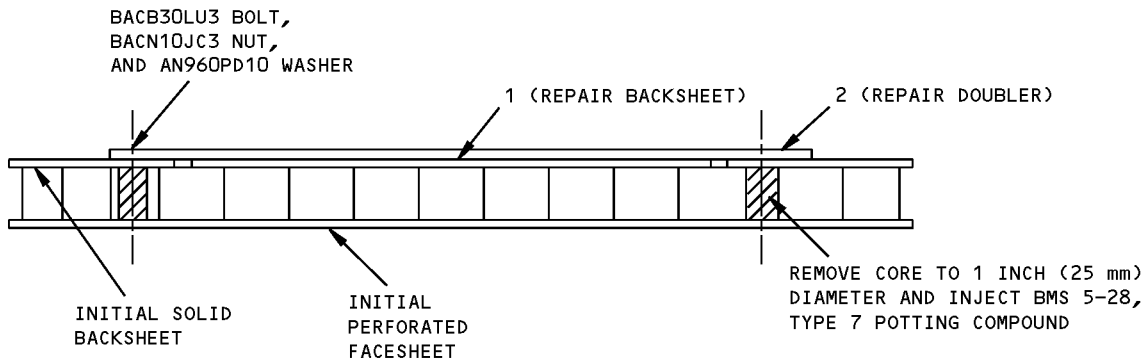

SECTION G-G

Typical Repairs for Perforated Aluminum Acoustic Panels - PW2000 Engine
Figure 201 (Sheet 13 of 16)

STRUCTURAL REPAIR MANUAL

APPLICABILITY
<p>THIS REPAIR IS LIMITED TO THE ACOUSTIC PANEL OF THE INLET COWL. THE BACKSHEET OF THE ACOUSTIC PANEL MUST NOT BE DISBONDED FOR MORE THAN 200 SQUARE INCHES (1290 SQUARE cm) FOR EACH PANEL. THIS REPAIR IS TO BE USED ON BACKSHEET DISBOND WITH ACCOMPANYING HONEYCOMB CORE DAMAGE NO GREATER THAN 30 INCHES (760 mm) IN LENGTH IN THE CIRCUMFERENTIAL DIRECTION OR 10 INCHES (250 mm) IN LENGTH IN THE FORE AND AFT DIRECTION. FOR ADJACENT DISBONDS WITH A LENGTH GREATER THAN 20 INCHES (500 mm), A MINIMUM SEPARATION LESS THAN 12 INCHES (300 mm) IS REQUIRED. IN NO CASE SHALL THE NOISE SUPPRESSION CAPABILITIES OF THE ACOUSTICAL PANELS BE COMPROMISED. REFER TO DETAIL I FOR REPAIR LIMITS.</p>

REPAIR INSTRUCTIONS FOR DETAIL VIII

1. Cut out the delaminated or damaged backsheet using a router template.
 - NOTE:** Inspect the backsheet for cracks by dye penetrant inspection or other comparable method. If no cracks are present the initial backsheet may be used in the repair.
2. Remove damaged honeycomb core.
3. Make the repair doubler and if necessary a backsheet replacement.
4. Remove all nicks, scratches, burrs and sharp edges from initial and repair parts.
5. If repair is made at lowest point of panel make drain hole doubler.
6. Make replacement core to fit in removed core opening.
7. Prefit the repair backsheet and doubler without adhesive. Apply a vacuum bag over the backsheet side (non perforated side) and check that a minimum vacuum value of 20 inches of mercury (67.7 KPa) is obtained. After check remove vacuum bag.
8. Remove any moisture from the honeycomb core with oil free compressed air and an air dryer (Do not heat over 300°F - 149°C). Clean the honeycomb edge and backsheet with MEK solvent. Apply a protective alodine coating to the repair parts and the cut edges of the initial parts using the HF/Alodine method as shown in SRM 51-70-09.
9. Prepare the bond side of the perforated face sheet by wiping with MEK solvent and then drying with a cheese cloth. Lightly sand surface to remove remaining core and adhesive fillet. (Complete removal of core material is not necessary).
10. Apply masking tape to airflow side of perforated face sheet to prevent flow of adhesive through facesheet holes.
11. Clean core surfaces with MEK and dry with cheese cloth. Place core on clean release film, with the surface to be bonded to the backsheet up, and apply BMS 5-109, Type II, Class 2 adhesive to that surface using a soft rubber roller to obtain even coverage. Within the potlife of the adhesive apply nylon peel ply Burlington Industries style 52006 or equivalent. Apply BMS 5-28 Type 7 to the edges of the core plug and the adjacent original core. Apply BMS 5-109 adhesive to the core side of the perforated sheet. Insert core plug (with peel ply showing). Remove any excess or apply additional BMS 5-28 Type 7 to fill gaps between repair core plug and original panel core.
12. Position a sheet of mylar over exposed core, then install a vacuum bag or apply 10 pounds per square inch weight while supporting the panel.
13. While maintaining pressure on repair core, remove masking tape from facesheet and remove any BMS 5-109 that flows through facesheet perforation. Use compressed air to blow any remaining BMS 5-109 out of perforated holes. Cure per Table I.
14. Remove vacuum bag or weight. Place the picture frame doubler in place and with pencil mark around outer edge of doubler. To protect panel from adhesive apply tape around outside of pencil line.
15. Clean and finish the faying surfaces of the initial backface repair backsheet and repair doubler using the HF/alodine method per SRM 51-70-09.
16. Apply Courtaulds Aerospace 515X346 CIAP (Corrosion Inhibiting Adhesive Primer) primer. Refer to SRM 51-70-09.
17. Apply BMS 5-109, Type II, Class 2 adhesive between repair doubler and repair backsheet faying surfaces. See Fig. 201, Sheet 2 for cure instructions.
18. After bond has cured remove mylar peel ply from honeycomb core and apply with a soft rubber roller BMS 5-109, Type II, Class 2 to exposed core. Apply BMS 5-109 adhesive on faying surface of pictureframe doubler and initial backsheet. While adhesive is curing, position repair doubler/backsheet in place and install BACB30LU3 bolt, BACN10JC3 nut and AN960PD10 washer as shown in Detail VIII. See Table I for cure instructions.

**Typical Repairs for Perforated Aluminum Acoustic Panels - PW2000 Engine
Figure 201 (Sheet 14 of 16)**



757-200

STRUCTURAL REPAIR MANUAL

REPAIR INSTRUCTIONS FOR DETAIL VIII
(CONT)

- 19. Clean outer surface of reworked area and apply protective treatment as shown in SRM 51-20-01.
- 20. Apply one coat of BMS 10-11, Type I primer over entire repair area.
- 21. Cap fasteners with BMS 5-26 sealant.
- 22. Fillet seal edges of repair parts.

NOTES

- WHEN YOU USE THIS REPAIR REFER TO:
 - AMM 51-21-01 FOR INTERIOR AND EXTERIOR FINISHES
 - SRM 51-10-01 FOR AERODYNAMIC SMOOTHNESS REQUIREMENTS
 - REFER TO SRM 51-10-02 FOR INSPECTION AND REMOVAL OF DAMAGE
 - SRM 51-20-01 FOR PROTECTIVE TREATMENT OF METAL
 - SRM 51-20-05 FOR REPAIR SEALING
 - SRM 51-40 FOR FASTENER CODE, REMOVAL, INSTALLATION, HOLE SIZES AND EDGE MARGINS.

FASTENERS SYMBOLS

- + REPAIR FASTENER LOCATION
INSTALL BACB30LU3 BOLT, BACN10JC3 NUT AND AN96OPD10 WASHER

REPAIR MATERIAL			
PART		QTY	MATERIAL
1	REPAIR BACK-SHEET	1	SAME GAGE AS INITIAL MATERIAL 2024-T62
2	REPAIR DOUBLER	1	0.025 INCH CLAD 2024-T62
3	REPAIR CORE	AS REQ'D	FLEX CORE PER BMS 4-6, TYPE 4.1-25, CLASS I
4	DRAINHOLE DOUBLER	1	0.025 INCH CLAD 2024-T62

TABLE I

Typical Repairs for Perforated Aluminum Acoustic Panels - PW2000 Engine
Figure 201 (Sheet 15 of 16)

**757-200
STRUCTURAL REPAIR MANUAL**

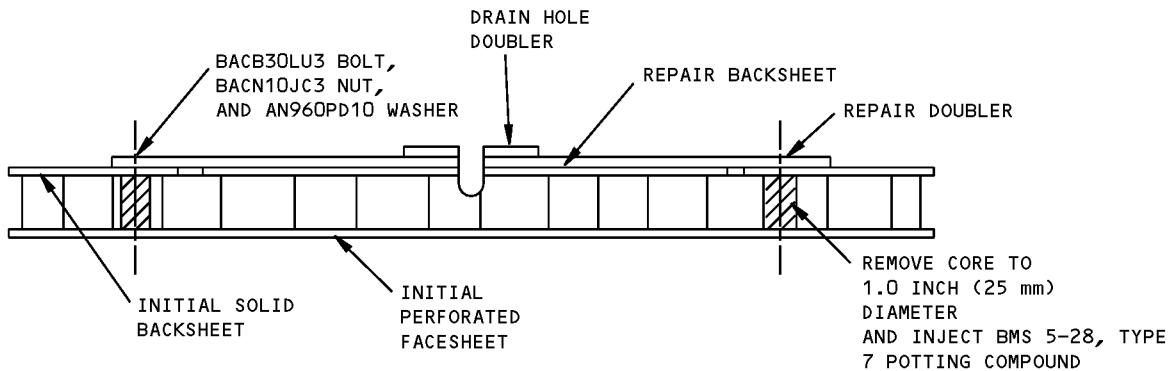
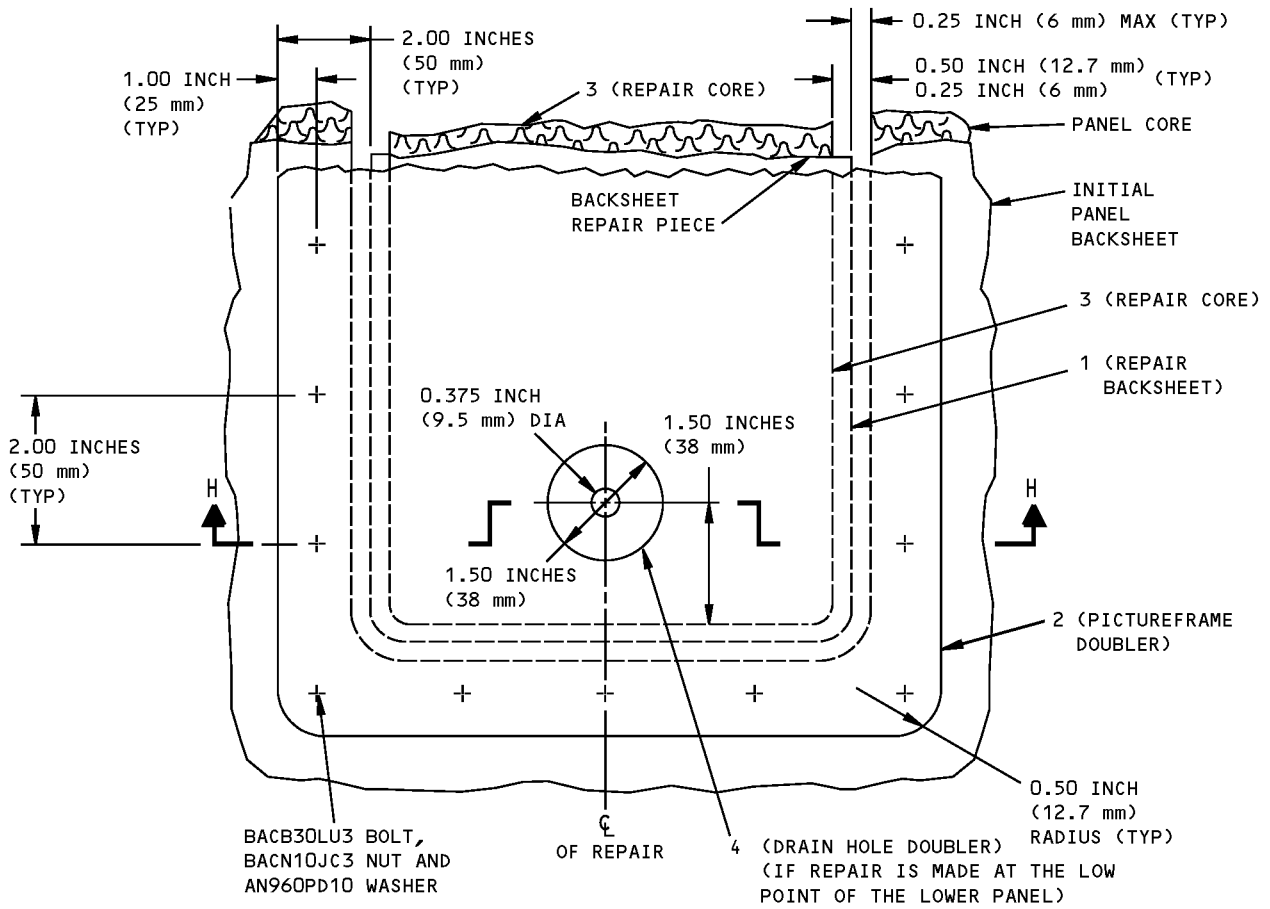

SECTION H-H

DETAIL VIII

**Typical Repairs for Perforated Aluminum Acoustic Panels - PW2000 Engine
Figure 201 (Sheet 16 of 16)**

757-200
STRUCTURAL REPAIR MANUAL

IDENTIFICATION 1 - INLET COWL SKIN - RB211-535E4 ENGINE

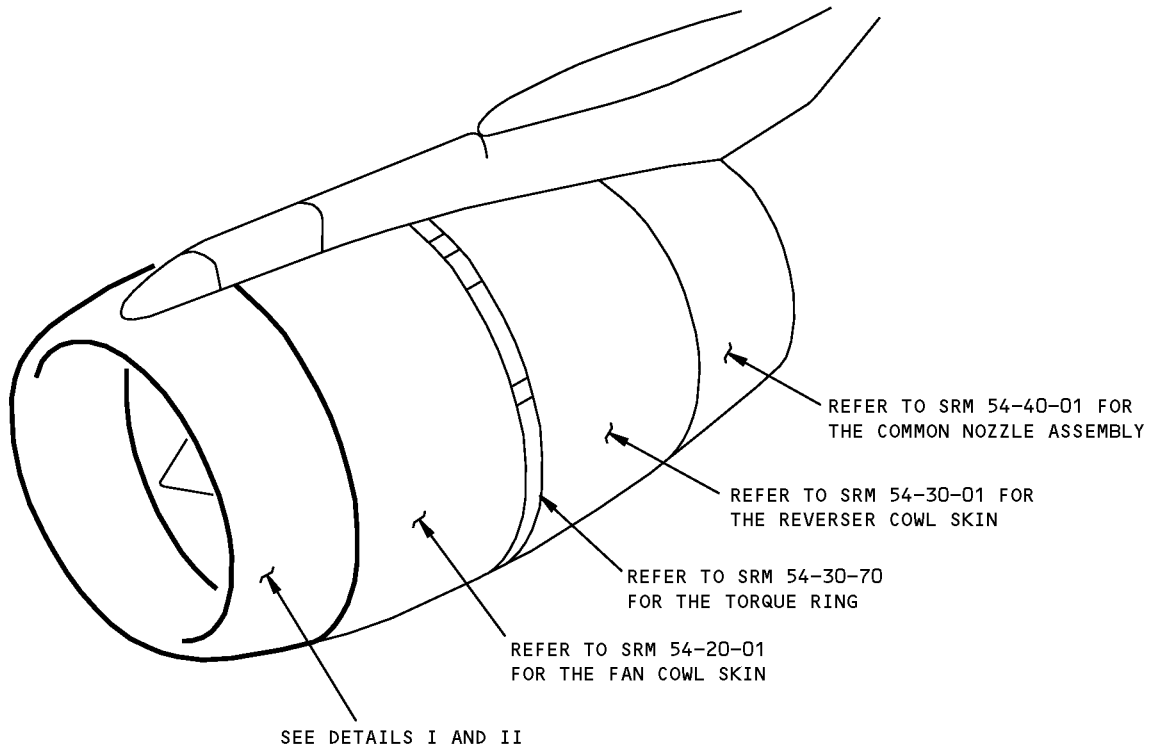

NOTES

- | | |
|---|---|
| <p>A PLY ORIENTATION CONVENTION DEGREES INDICATED IS PARALLEL TO FABRIC WARP DIRECTION.</p> <p>B GRAPHITE PREPREG SPEC SMS 30, TYPE III, CLASS 2, STYLE 3K-135-8H.</p> <p>C GRAPHITE PREPREG SPEC SMS 30, TYPE III, CLASS 1, GRADE 145.</p> <p>D GRAPHITE PREPREG SPEC SMS 30, TYPE IV, CLASS 2, STYLE 3K-70-PW.</p> <p>E BUTT FIT - NO OVERLAP.</p> <p>F NO SPLICE IS PERMITTED.</p> <p>G DELETED BY ROLLS-ROYCE SB 71-9634.</p> <p>H STAINLESS STEEL WIRE MESH.</p> <p>J DELETED BY ROLLS-ROYCE SB 71-9634 AND SB 71-7854.</p> <p>K HONEYCOMB CORE, 5052 ALUMINUM AS GIVEN IN MIL-C-7438G, 1/8-INCH CELL, DENSITY 22 LB/FT.</p> | <p>L HONEYCOMB CORE, COMPOSITE, CORE DENSITY 1.5 LB/FT AS GIVEN BY ROLLS-ROYCE SB71-9634.</p> <p>M HONEYCOMB CORE, COMPOSITE, CORE DENSITY 3.0 LB/FT AS GIVEN BY ROLLS-ROYCE SB71-9909 AND SB71-9958.</p> <p>N INTAKE MODIFICATION STANDARD IDENTIFICATION</p> <ul style="list-style-type: none"> - PRE-ROLLS-ROYCE SB71-9634, P/N LJ3XXXX, S/N 4XXX. - POST ROLLS-ROYCE SB71-9634, P/N LJ5XXXX, S/N 9XXX. |
|---|---|

Inlet Cowl Skin Identification - RB211-535E4 Engine
Figure 1 (Sheet 1 of 5)

757-200
STRUCTURAL REPAIR MANUAL

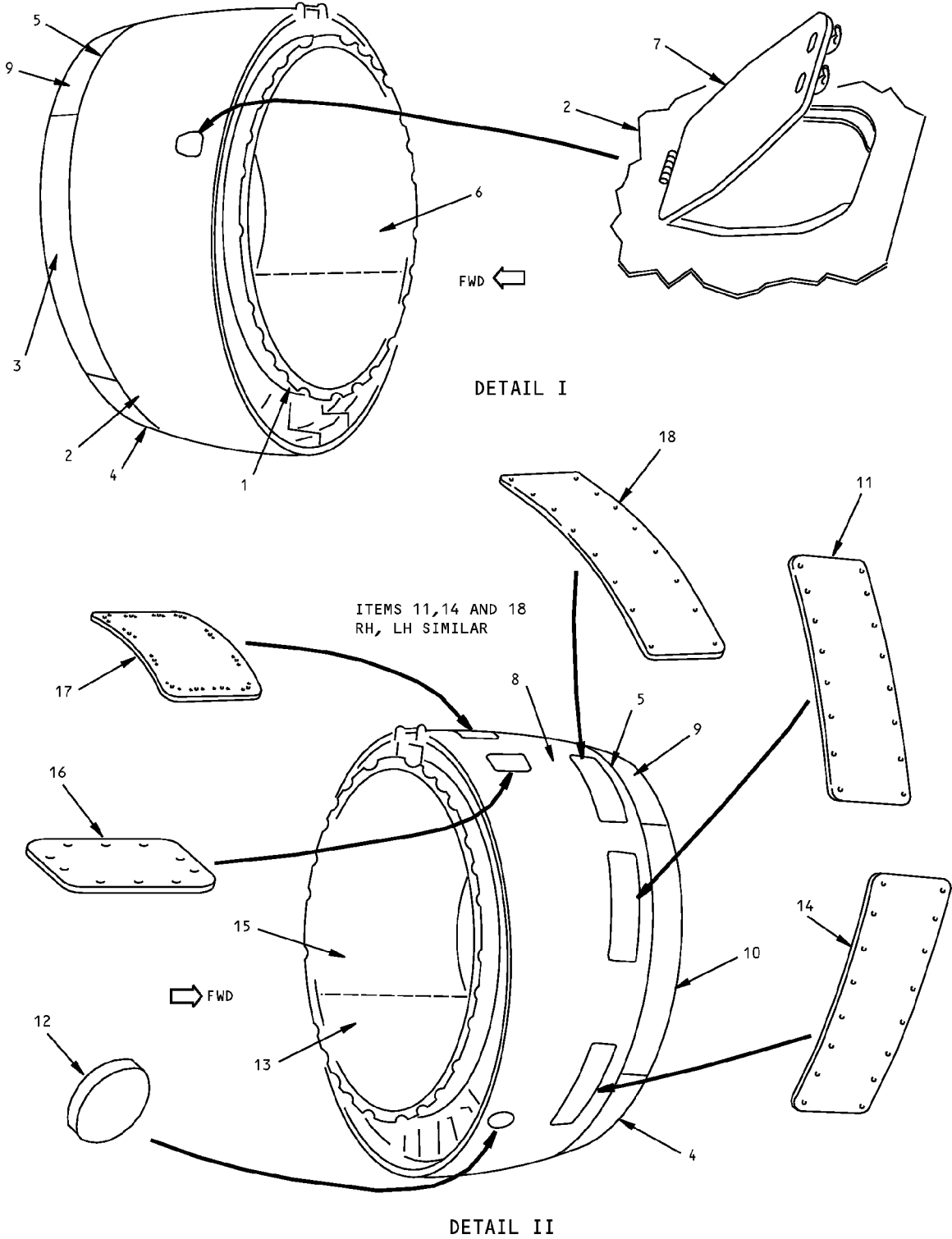

**Inlet Cowl Skin Identification - RB211-535E4 Engine
Figure 1 (Sheet 2 of 5)**

757-200
STRUCTURAL REPAIR MANUAL

ITEM	DESCRIPTION	GAGE	MATERIAL	EFFECTIVITY
1	CLOSING SKIN	0.028	L165	
2	OUTER SKIN LEFT SIDE SEGMENT		GRAPHITE PREPREG SPEC SMS 30, TYPE III, CLASS 2, STYLE 3K-135-8H GRAPHITE PREPREG SPEC SMS 30, TYPE III, CLASS 1, GRADE 145 GRAPHITE PREPREG SPEC SMS 30, TYPE IV, CLASS 2, STYLE 3K-70-PW	
3	LIP SKIN	0.092	2219-T62	
4	LIP SKIN	0.092	2219-T62	
5	EDGE STRIP		GLASS FABRIC PREPREG SPEC SMS 34	
6	UPPER RIGHT SIDE INNER SKIN N PRE-ROLL-ROYCE SB71-9634 POST ROLLS-ROYCE SB71-9634	0.056	DYNAROHR H K N COMPOSITE H L M N	
7	BLOW-OUT DOOR G		GRAPHITE PREPREG SPEC SMS 30, TYPE IV, CLASS 2, 3K-70-PW	
8	OUTER SKIN RIGHT SIDE SEGMENT		GRAPHITE PREPREG SPEC SMS 30, TYPE III, CLASS 2, STYLE 3K-135-8H GRAPHITE PREPREG SPEC SMS 30, TYPE III, CLASS 1, GRADE 145 GRAPHITE PREPREG SPEC SMS 30, TYPE IV, CLASS 2, STYLE 3K-70-PW	
9	LIP SKIN	0.092	2219-T62	
10	LIP SKIN	0.092	2219-T62	
11	PANEL ACCESS (LEFT SIDE SIMILAR)		GRAPHITE PREPREG SPEC SMS 30, TYPE IV, CLASS 2, 3K-70-PW	
12	ACCESS DOOR J		GRAPHITE PREPREG SPEC SMS 30, TYPE IV, CLASS 2, 3K-70-PW	
13	LOWER CENTER INNER SKIN N PRE-ROLL-ROYCE SB71-9634 POST ROLLS-ROYCE SB71-9634	0.056	DYNAROHR H K N COMPOSITE H L M N	
14	PANEL ACCESS (LEFT SIDE SIMILAR)		GRAPHITE PREPREG SPEC SMS 30, TYPE IV, CLASS 2, 3K-70-PW	
15	UPPER LEFT SIDE INNER SKIN N PRE-ROLL-ROYCE SB71-9634 POST ROLLS-ROYCE SB71-9634	0.056	DYNAROHR H K N COMPOSITE H L M N	
16	ACCESS PANEL		GRAPHITE PREPREG SPEC SMS 30, TYPE IV, CLASS 2, 3K-70-PW	
17	ACCESS PANEL		GRAPHITE PREPREG SPEC SMS 30, TYPE IV, CLASS 2, 3K-70-PW	
18	PANEL ACCESS (LEFT SIDE SIMILAR)		GRAPHITE PREPREG SPEC SMS 30, TYPE IV, CLASS 2, 3K-70-PW	

LIST OF MATERIALS FOR DETAILS I AND II

Inlet Cowl Skin Identification - RB211-535E4 Engine
Figure 1 (Sheet 3 of 5)

IDENTIFICATION 1
Page 3
Sep 20/2005

54-10-01

D634N201

757-200
STRUCTURAL REPAIR MANUAL

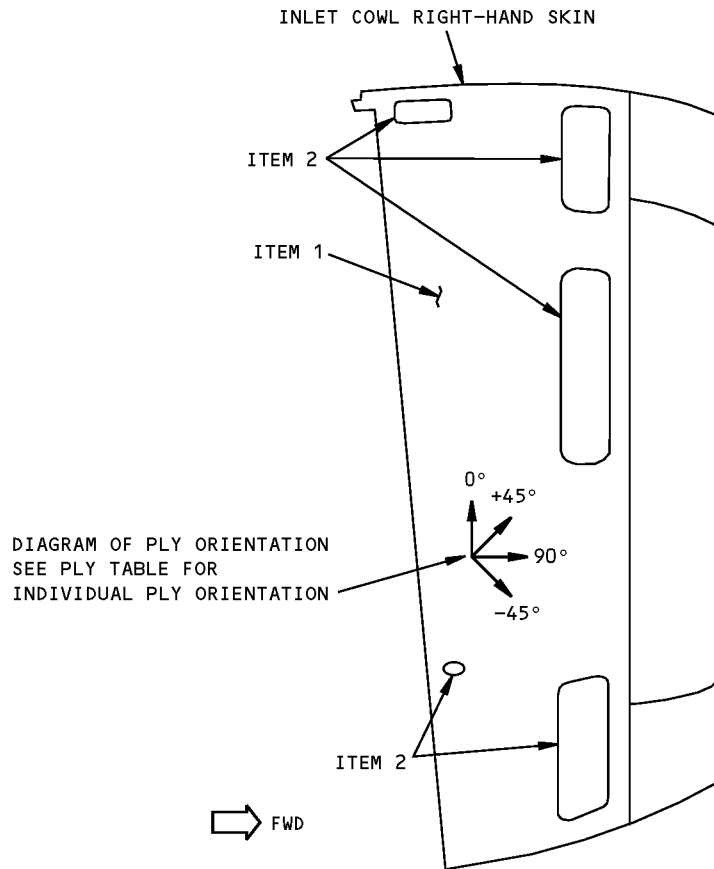
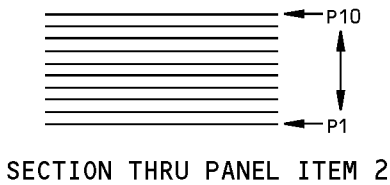
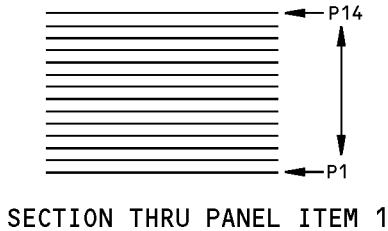

PLY ORIENTATION DIAGRAM FOR
RIGHT-HAND INLET COWL SKIN

DETAIL V

ITEM NO.	PLY NO.	MATERIAL	PLY ORIENTATION	NOTE REFER SHEET 1
1	P1,P5 AND P14	B	±45°	A E
	P2 TO P4 AND P6 TO P8	C	0°	A E
	P9,P10 AND P13	D	±45°	A E
	P11 AND P12	D	0° OR 90°	A E
2	P1,P2,P5 AND P8 TO P10	D	±45°	A F
	P3,P4,P6 AND P7	D	0° OR 90°	A F

PLY TABLE FOR DETAIL V

68449

Inlet Cowl Skin Identification - RB211-535E4 Engine
Figure 1 (Sheet 4 of 5)

STRUCTURAL REPAIR MANUAL

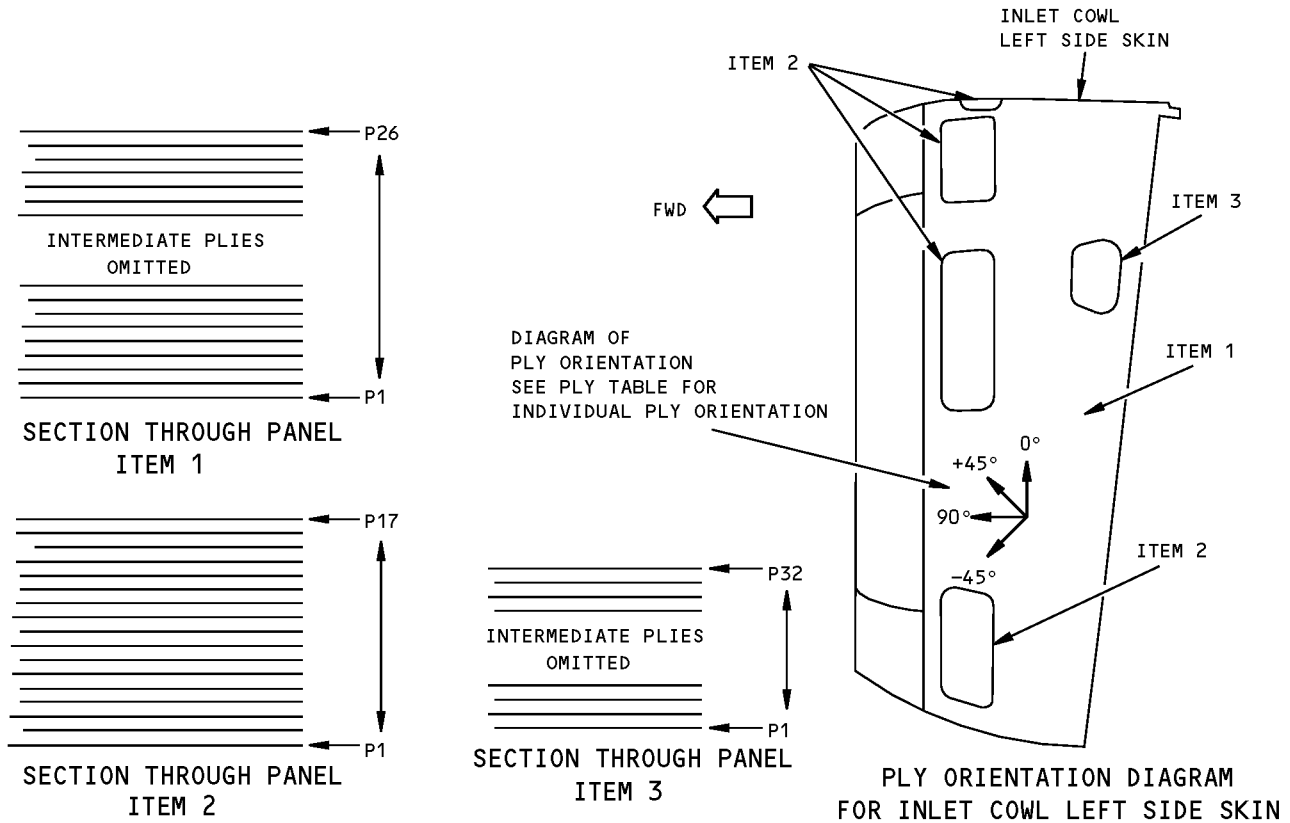

DETAIL VI

ITEM NO.	PLY NO.	MATERIAL	PLY ORIENTATION	NOTE REFER SHEET 1
1	P1,P5,P14 AND P26	B	±45°	A E
	P2 TO P4 AND P6 TO P8 P11 TO P13 AND P15 TO P17	C	0°	A E
	P9 AND P10	C	±45°	A E
	P18,P21,P22 AND P25	D	±45°	A E
	P19,P20, P23 AND P24	D	0° OR 90°	A E
2	P1,P2,P5 AND P8 TO P17	D	±45°	A F
	P3,P4,P6 AND P7	D	0° OR 90°	A F
3 G	P1,P5 AND P6,P10,P17 AND P18,P25 AND P26 P31 AND P32	D	±45°	A F
	P2 TO P4,P7 TO P9,P11 TO P16 P19 TO P24,P27 TO P30	D	0° OR 90°	A F

PLY TABLE FOR DETAIL VI

68450

Inlet Cowl Skin Identification - RB211-535E4 Engine
Figure 1 (Sheet 5 of 5)

IDENTIFICATION 1
Page 5
May 20/2005

54-10-01

D634N201

757-200
STRUCTURAL REPAIR MANUAL

IDENTIFICATION 2 - INLET COWL SKIN - RB211-535C ENGINE

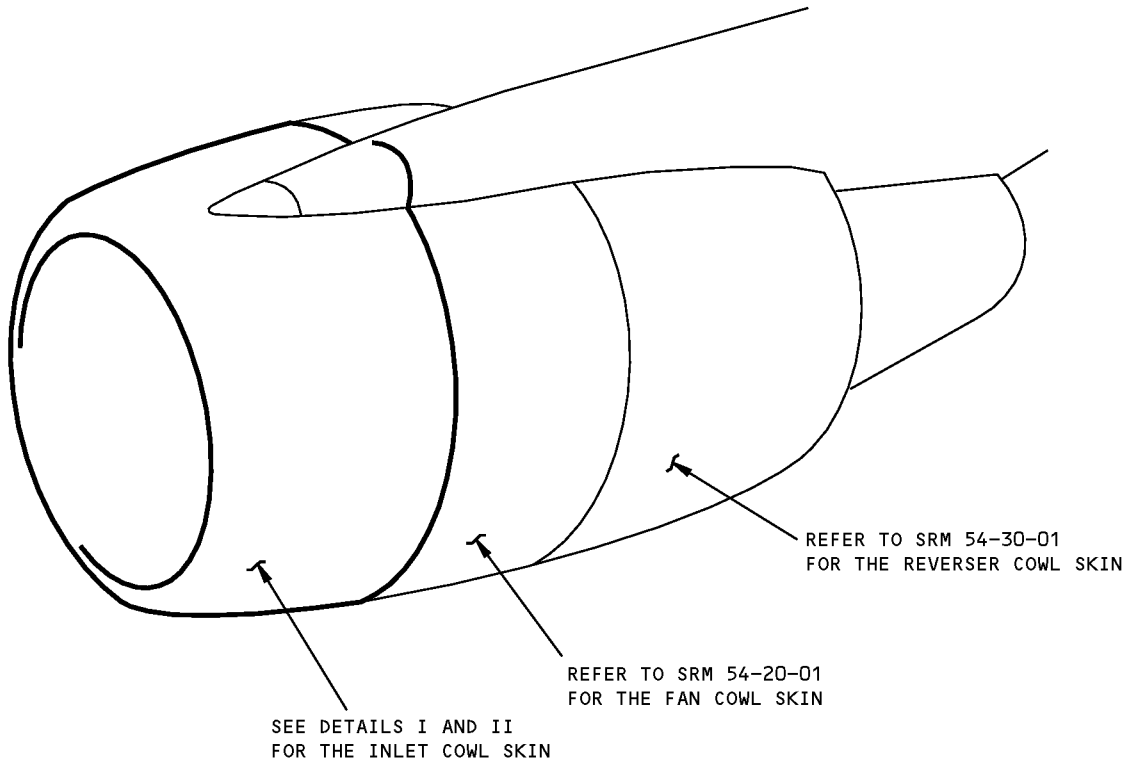

Inlet Cowl Skin Identification - RB211-535C Engine
Figure 1 (Sheet 1 of 3)

757-200
STRUCTURAL REPAIR MANUAL

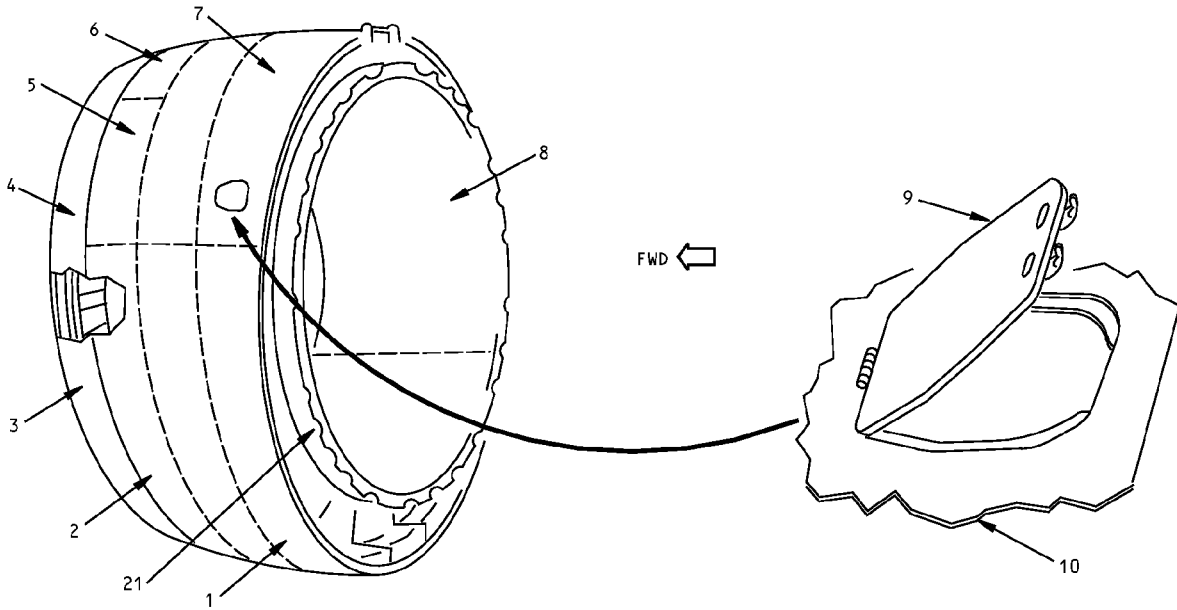

DETAIL I

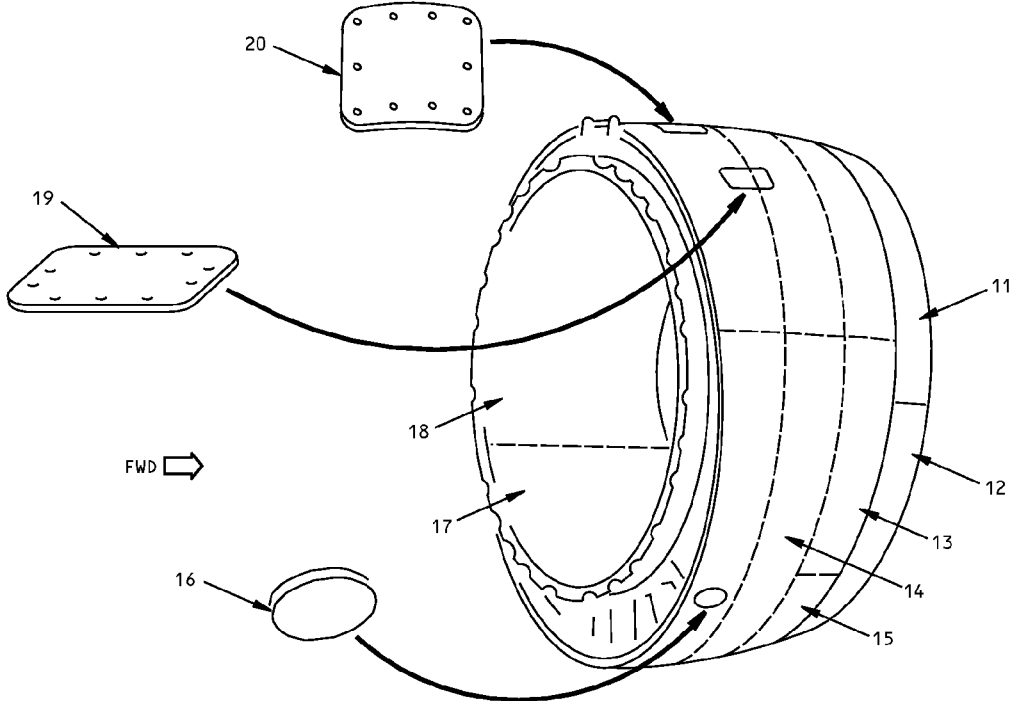

DETAIL II

LIST OF
MATERIAL

Inlet Cowl Skin Identification - RB211-535C Engine
Figure 1 (Sheet 2 of 3)

757-200
STRUCTURAL REPAIR MANUAL

ITEM	DESCRIPTION	GAGE	MATERIAL	EFFECTIVITY
1	LOWER LH REAR SKIN	0.064	L165	
2	LOWER LH FORWARD SKIN	0.064	L165	
3	LIP SKIN	0.092	2219-T62	
4	LIP SKIN	0.092	2219-T62	
5	UPPER LH FORWARD SKIN	0.064	L165	
6	UPPER FORWARD SKIN	0.064	L165	
7	UPPER REAR SKIN	0.064	L165	
8	UPPER RH INNER SKIN	0.056	L165	
9	BLOW-OUT DOOR	0.080	L164	
10	BLOW-OUT DOOR PANEL	0.128	L165	
11	LIP SKIN	0.092	2219-T62	
12	LIP SKIN	0.092	2219-T62	
13	LOWER RH FORWARD SKIN	0.064	L165	
14	LOWER RH REAR SKIN	0.064	L165	
15	LOWER RH FORWARD SKIN	0.064	L165	
16	ACCESS DOOR	0.064	L164	
17	LOWER CENTER INNER SKIN	0.056	L165	
18	UPPER LH INNER SKIN	0.056	L165	
19	ACCESS PANEL	0.128	L165	
20	ACCESS PANEL	0.128	L165	
21	CLOSING SKIN	0.028	L165	

LIST OF MATERIALS FOR DETAILS I AND II

Inlet Cowl Skin Identification - RB211-535C Engine
Figure 1 (Sheet 3 of 3)

D634N201

54-10-01

IDENTIFICATION 2
Page 3
Jan 20/2005

757-200
STRUCTURAL REPAIR MANUAL

ALLOWABLE DAMAGE 1 - INLET COWL OUTER BARREL - RB211-535E4 ENGINE

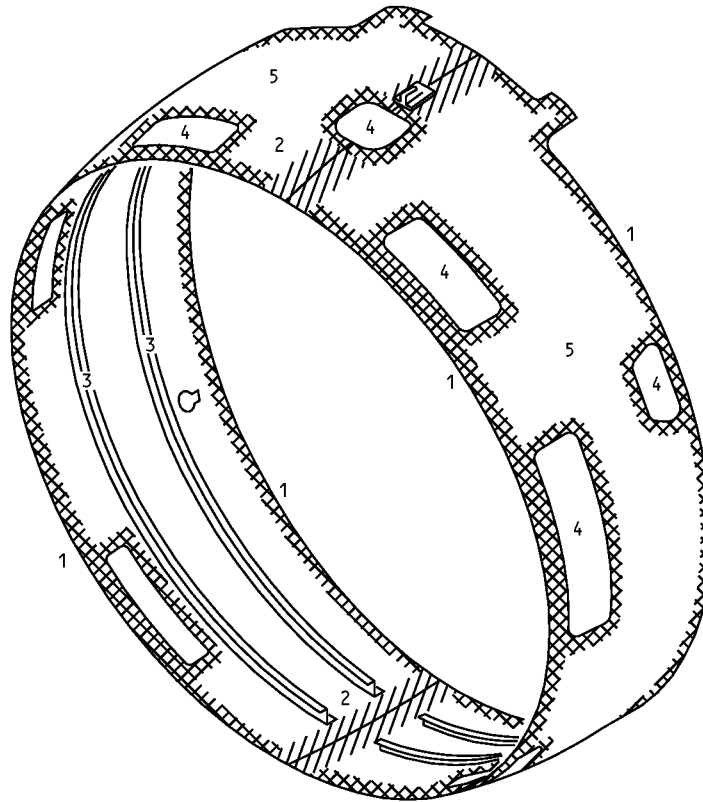

- 1. FORWARD AND AFT BARREL LANDS
- 2. UPPER AND LOWER BARREL JOINT
- 3. CIRCUMFERENTIAL STIFFENING FRAME
- 4. ACCESS PANELS
- 5. BASIC SKIN IN OTHER AREAS

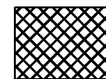

2.0 WIDTH

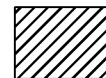

9.0 WIDTH

A6899A

Inlet Cowl Outer Barrel Allowable Damage - RB211-535E4 Engine
Figure 101 (Sheet 1 of 2)

D634N201

ALLOWABLE DAMAGE 1
Page 101
54-10-01
May 20/2005

STRUCTURAL REPAIR MANUAL

LOCATION	SCRATCH/GOUGE/NICK	HOLES	CRACKS	DELAMINATION
ZONE 1 ZONE 2	MAX DEPTH 0.015 INCH (0.38 mm). MAX WIDTH 0.10 INCH (2.54 mm). MAX LENGTH 10.0 INCHES (250 mm). MIN 10.0 INCHES (250 mm) FROM OTHER DAMAGE. A B	NOT PERMITTED	NOT PERMITTED	NOT PERMITTED
ZONE 3	MAX DEPTH 0.015 INCH (0.38 mm). MAX WIDTH 0.10 INCH (2.54 mm). MAX LENGTH 10.0 INCHES (250 mm). MIN 10.0 INCHES (250 mm) FROM OTHER DAMAGE. A B	NOT PERMITTED	NOT PERMITTED	MAX LENGTH 3.0 INCHES (75 mm) ANY DIRECTION. MIN 10.0 INCHES (250 mm) FROM ANY OTHER DAMAGE. MAX 5 AREAS OF DELAMINATION IN EACH HALF. F
ZONE 4	MAX DEPTH 0.015 INCH (0.38 mm). MAX WIDTH 0.10 INCH (2.54 mm). MAX LENGTH 10.0 INCHES (250 mm). MIN 10.0 INCHES (250 mm) FROM OTHER DAMAGE. A B	MAX 1.0 INCH (25 mm) DIA. MIN 10.0 INCHES (250 mm) FROM OTHER DAMAGE. MAX 1 HOLE. A E	MAX 3.0 INCHES (75 mm) LENGTH. MIN 10.0 INCHES (250 mm) FROM OTHER DAMAGE. MAX 1 CRACK A C	MAX LENGTH 3.0 INCHES (75 mm) ANY DIRECTION. MIN 10.0 INCHES (250 mm) FROM ANY OTHER DAMAGE. MAX 1 DELAMINATION. F
ZONE 5	MAX DEPTH 0.015 INCH (0.38 mm). MAX WIDTH 0.10 INCH (2.54 mm). MAX LENGTH 10.0 INCHES (250 mm). MIN 10.0 INCHES (250 mm) FROM OTHER DAMAGE. A B	MAX 3.0 INCHES (75 mm) DIA. MIN 10.0 INCHES (250 mm) FROM OTHER DAMAGE. MAX 5 HOLES EACH HALF. A D	MAX 3.0 INCHES (75 mm) LENGTH. MIN 10.0 INCHES (250 mm) FROM OTHER DAMAGE. MAX 5 CRACKS IN EACH HALF. A C	MAX LENGTH 3.0 INCHES (75 mm) ANY DIRECTION. MIN 10.0 INCHES (250 mm) FROM ANY OTHER DAMAGE. MAX 5 DELAMINATIONS IN EACH HALF. F

NOTES

- ABRASIONS – SURFACE RESIN DAMAGE ONLY IN ALL ZONES **A** **B**
- ANY DAMAGE THAT PENETRATES THE OUTER SKIN, AND IS WITHIN THE ACCEPTABLE LIMITS, MUST BE PROTECTED FROM WATER INGRESS BY THE APPLICATION OF SCOTCH 425 TAPE.

- A**
1. REMOVE MATERIAL PROTRUDING OUTSIDE AERODYNAMIC SURFACE.
 2. APPLY 600 MPH SPEED TAPE TO PREVENT WATER INGRESS.
 3. RECORD LOCATION OF DAMAGE.

- B**
1. INSPECT AT EACH "A" CHECK AND REPLACE TAPE OR APPLY COSMETIC REPAIR PROCEDURE. REFER TO SRM 54-10-01, REPAIR 6.

- C**
1. INSPECT AT EACH "A" CHECK AND REPLACE TAPE.
 2. APPLY STRUCTURAL REPAIR PROCEDURES AT OR BEFORE NEXT "C" CHECK.

- D**
1. REPAIR AT FIRST "A" CHECK.

- E**
1. REPAIR AT OR BEFORE NEXT "C" CHECK.

- F**
1. RECORD LOCATION OF DAMAGE
 2. INSPECT AT "A" CHECK
 3. REPAIR DAMAGE AT OR BEFORE NEXT "C" CHECK.

**Inlet Cowl Outer Barrel Allowable Damage - RB211-535E4 Engine
Figure 101 (Sheet 2 of 2)**

757-200
STRUCTURAL REPAIR MANUAL

ALLOWABLE DAMAGE 2 - INLET COWL SKIN - RB211-535E4 ENGINE

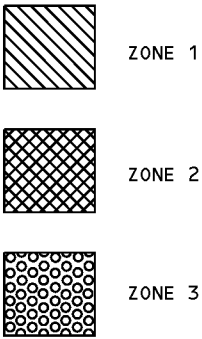
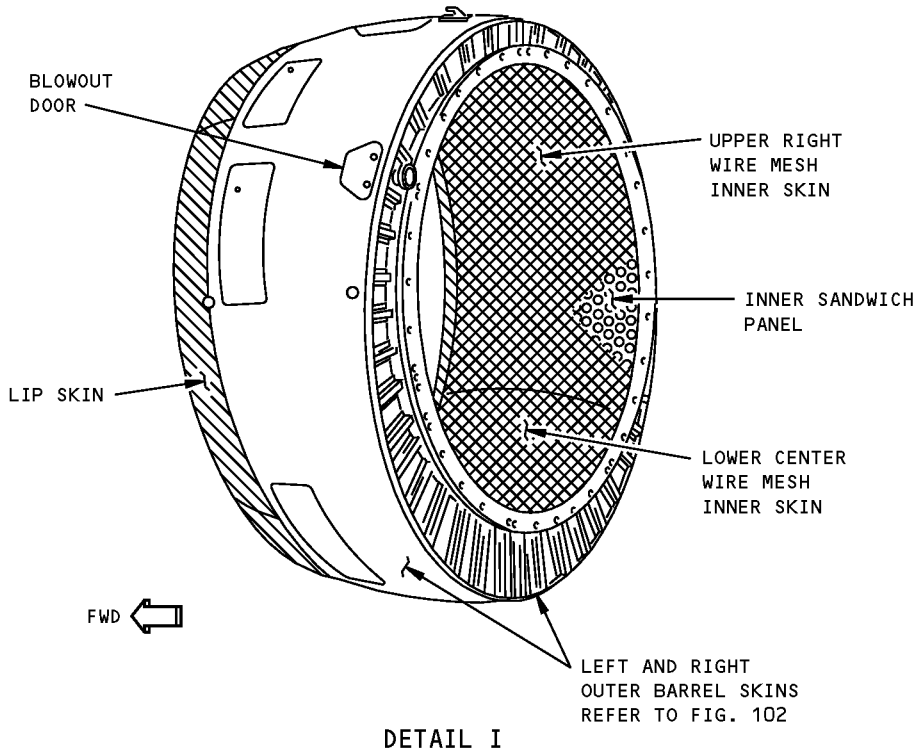

A8983

Inlet Cowl Skin Allowable Damage - RB211-535E4 Engine
Figure 101 (Sheet 1 of 3)

D634N201

ALLOWABLE DAMAGE 2
Page 101
54-10-01 May 20/2005

STRUCTURAL REPAIR MANUAL

LOCATION		HOLES	CRACKS	NICKS/GOUGES CORROSION	DELAMINATION DISBOND	DENTS OR DISTORTION
INLET COWL ZONES	LIP SKIN	NOT PERMITTED	NOT PERMITTED	[A]	NOT APPLICABLE	SEE DETAIL III [B]
	WIRE MESH [C]	[D]	NOT APPLICABLE	[E]	[D] [F]	
	INNER SANDWICH PANEL	NOT PERMITTED	NOT PERMITTED	[A]	NOT PERMITTED	

NOTES

- REFINISH REWORKED AREAS AS GIVEN IN SRM 51-21-01.

- [A] NICKS, GOUGES, AND CORROSION ARE PERMITTED IF ALL THESE CONDITIONS ARE OBEYED SEE (DETAIL II):
- THE DAMAGE IS BLENDED OUT
 - THE DEPTH OF THE DAMAGE ("X" DIMENSION) IS LESS THAN 25% OF THE THICKNESS ("T" DIMENSION)
 - THE BLENDED OUT AREA AGREES WITH THE CONTOUR SHOWN IN DETAIL II AND IS LESS THAN 2 INCHES (50 mm) IN LENGTH.
- [B] DENTS AND DISTORTIONS ARE PERMITTED IF ALL THESE CONDITIONS ARE OBEYED (SEE DETAIL III):
- THE DEPTH OF THE DENT ("X" DIMENSION) IS EQUAL OR LESS THAN 0.150 INCH (3.8 mm)
 - THE RADIUS ("Z" DIMENSION) IS EQUAL OR LARGER THAN 5 TIMES THE THICKNESS ("M" DIMENSION)
 - THE MAXIMUM DIAMETER ("W" DIMENSION) IS LESS THAN 4 INCHES (100 mm)
 - THERE IS A MINIMUM SEPARATION OF 4 INCHES BETWEEN TWO ADJACENT AREAS OF DAMAGE
- [C] DAMAGE TO THE WIRE MESH WILL REDUCE THE ACOUSTIC EFFECTIVENESS OF THE INLET. REFER TO SRM 54-00-01 FOR ACOUSTIC TREATMENT LOSS LIMITS.
- [D] DISBOND OR LOSS OF MESH MUST NOT STRUCTURALLY DEGRADE THE INLET COWL. IF DAMAGE AREA IS MORE THAN 1.4 SQUARE FEET (1300 SQUARE cm), THE INLET COWL MUST BE REMOVED/REPAIRED WITHIN 90 DAYS.
- [E] NICKS/GOUGES THAT DO NOT BREAK AND RELEASE WIRE STRANDS ARE ACCEPTABLE.
- [F] DEBONDED MESH IS PERMITTED IF:
- THE TOTAL DEBONDED AREA IS LESS THAN 1.4 SQUARE FEET (1300 SQUARE cm)
 - NO EDGES ARE DEBONDED
 - THE DEBONDED MESH IS INSPECTED EVERY 25 FLIGHT HOURS

Inlet Cowl Skin Allowable Damage - RB211-535E4 Engine
Figure 101 (Sheet 2 of 3)

757-200
STRUCTURAL REPAIR MANUAL

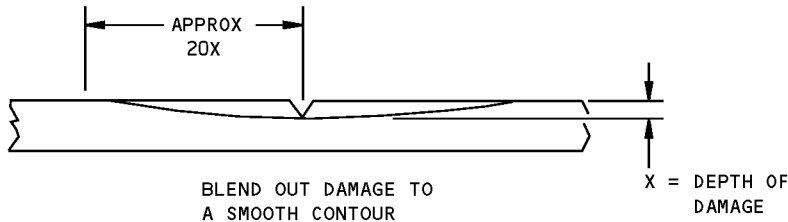
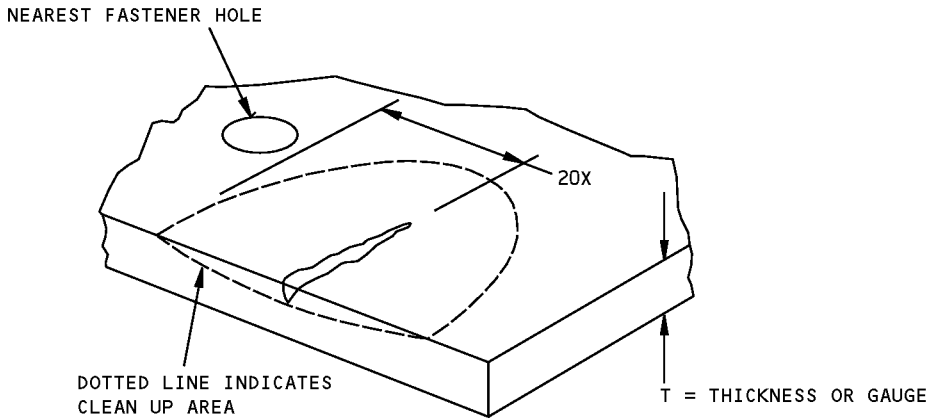

DETAIL II

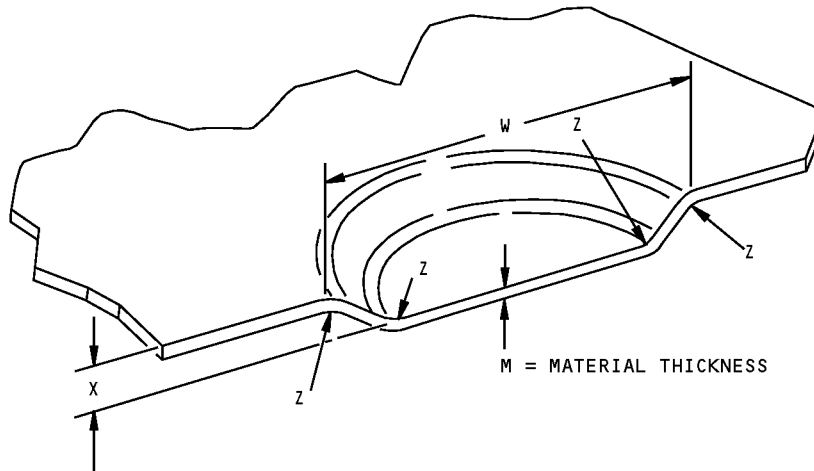

DETAIL III

Inlet Cowl Skin Allowable Damage - RB211-535E4 Engine
Figure 101 (Sheet 3 of 3)

**757-200
STRUCTURAL REPAIR MANUAL**

ALLOWABLE DAMAGE 3 - PLATES AND SKINS, NOSE COWL - RB211-535C ENGINE

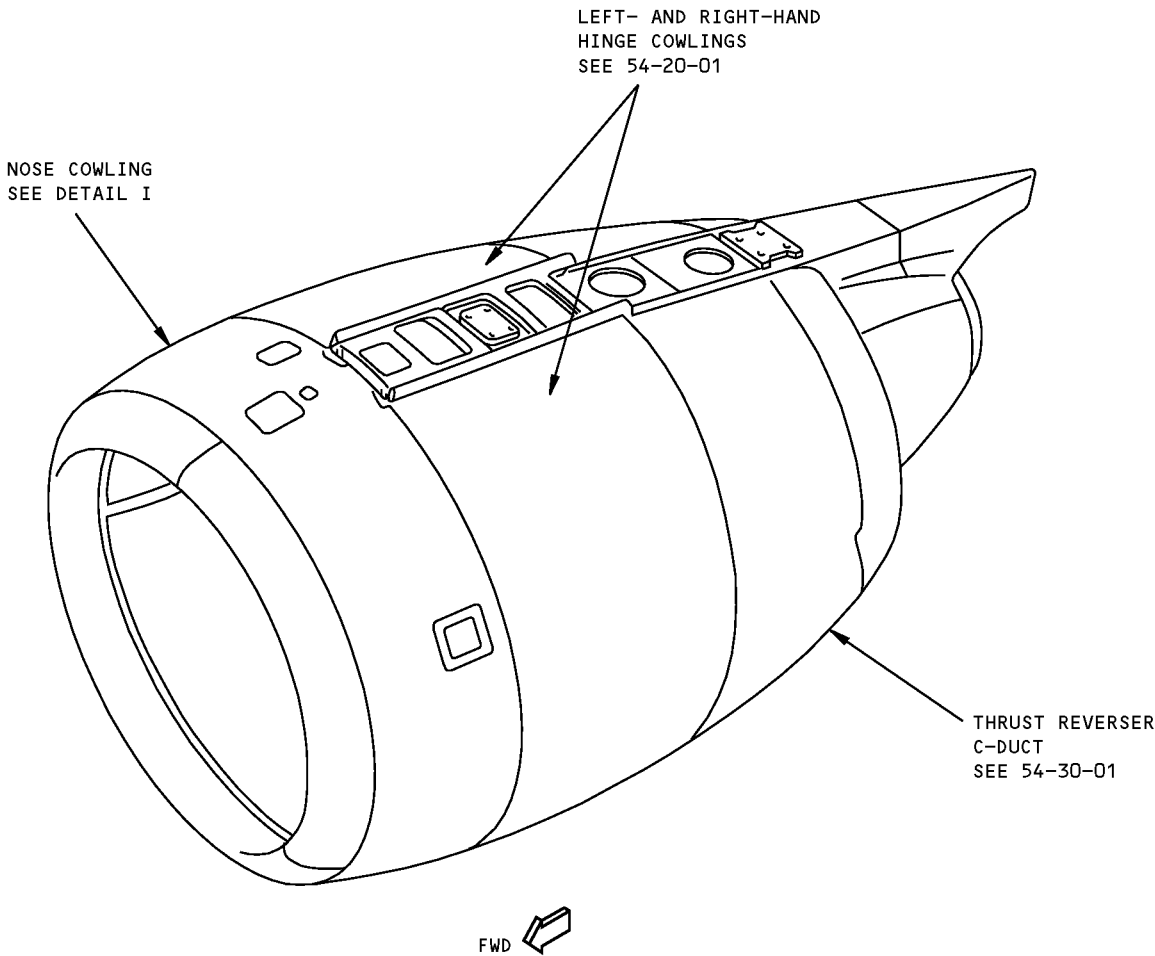

**Plates and Skins, Nose Cowl Allowable Damage - RB211-535C Engine
Figure 101 (Sheet 1 of 4)**

757-200
STRUCTURAL REPAIR MANUAL

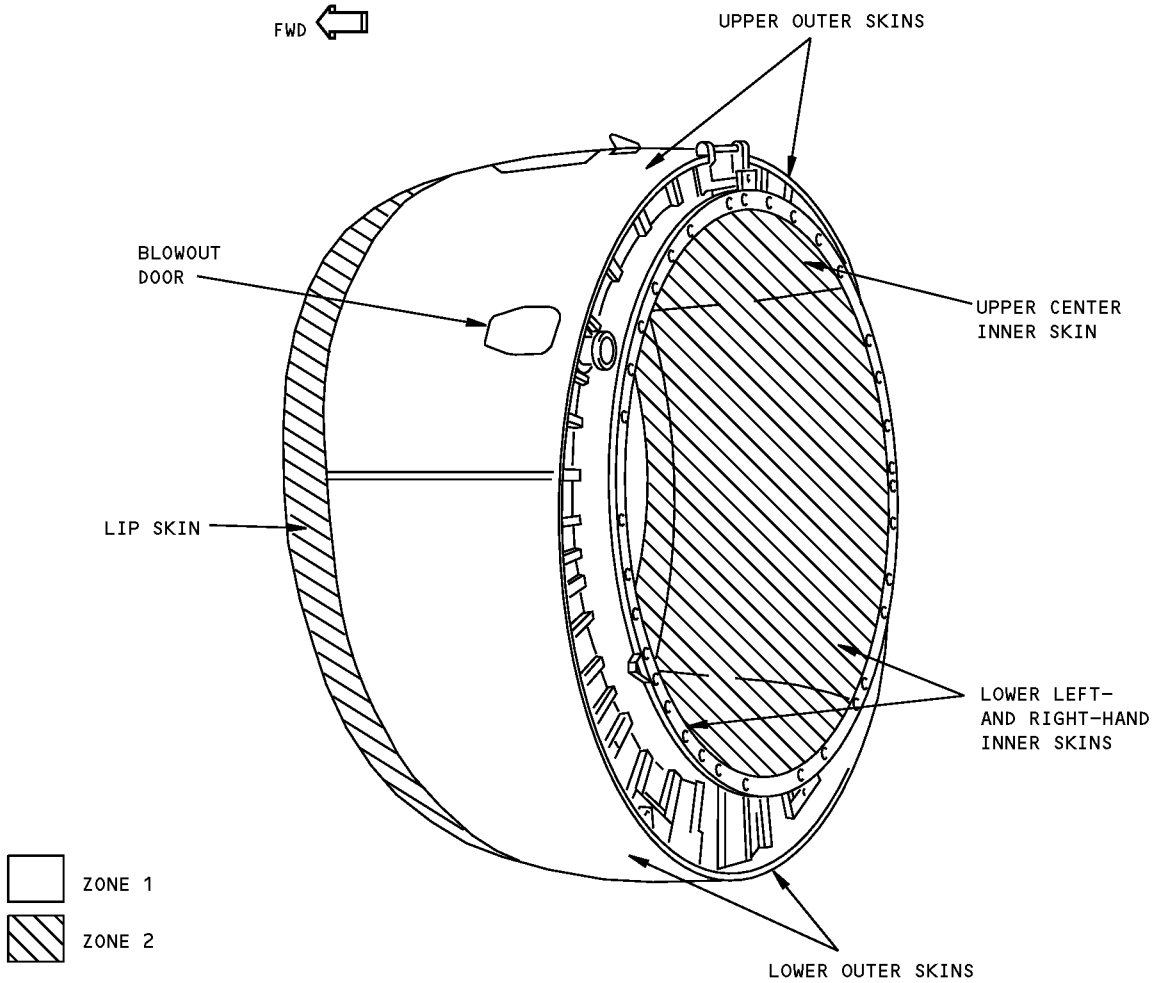

DETAIL I

LOCATION		CRACKS	NICKS, GOUGES AND CORROSION	DENTS	HOLES
NOSE COWLING	ZONE 1 SKINS	A	SEE DETAIL II	SEE DETAIL III	NOT ALLOWED
	ZONE 2 SKINS	B		C	

Plates and Skins, Nose Cowl Allowable Damage - RB211-535C Engine
Figure 101 (Sheet 2 of 4)

**757-200
STRUCTURAL REPAIR MANUAL**

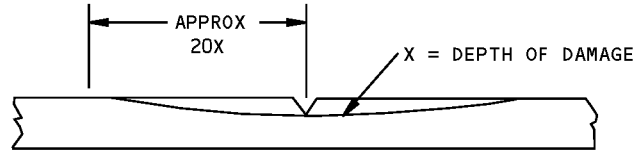
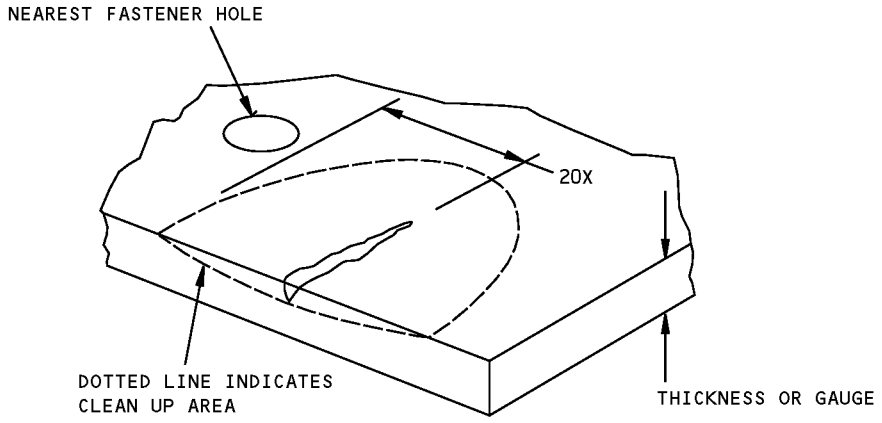

BLEND OUT DAMAGE TO A SMOOTH CONTOUR

DETAIL II

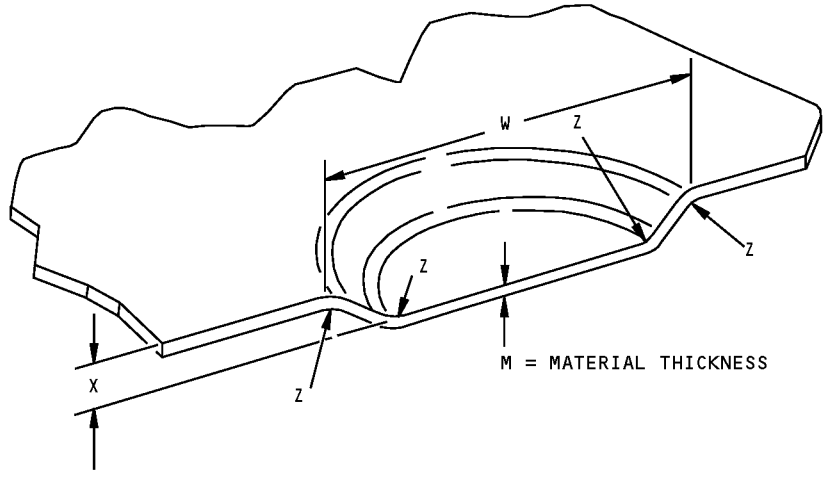

DETAIL III

**Plates and Skins, Nose Cowl Allowable Damage - RB211-535C Engine
Figure 101 (Sheet 3 of 4)**

**757-200
STRUCTURAL REPAIR MANUAL****NOTES**

- REFINISH REWORKED AREAS PER 51-21-01.
- A** CRACKS TO A MAXIMUM OF 1.00 ARE ACCEPTABLE. CLEAN OUT CRACKS TO A SMOOTH ROUND HOLE WITH A 1.0 MAX DIAMETER AND APPLY FIBER-GLASS OVERLAY PATCH. CRACKS WITHIN 3.00 OF A SKIN EDGE OR WITHIN 4.00 OF ANOTHER PATCH OR CRACK ARE NOT ACCEPTABLE.
- B** CRACKS ARE NOT ACCEPTABLE.
- C** DAMAGE IS ALLOWABLE UP TO 25% OF MATERIAL THICKNESS IN DEPTH AND 2.00 IN LENGTH. REMOVE DAMAGE.
- D** DENTS AND DISTORTION ARE ALLOWED PROVIDING "X" (DETAIL III) DOES NOT EXCEED 0.150 AND RADIUS AT "Z" IS NOT LESS THAN FIVE TIMES "M." DAMAGE "W" MUST NOT EXCEED 4.00 DIAMETER WITH A MINIMUM OF 4.00 SEPARATING EACH DAMAGED AREA.

**Plates and Skins, Nose Cowl Allowable Damage - RB211-535C Engine
Figure 101 (Sheet 4 of 4)**

757-200
STRUCTURAL REPAIR MANUAL

REPAIR GENERAL - INLET COWL REPAIRS - RB211-535 ENGINE

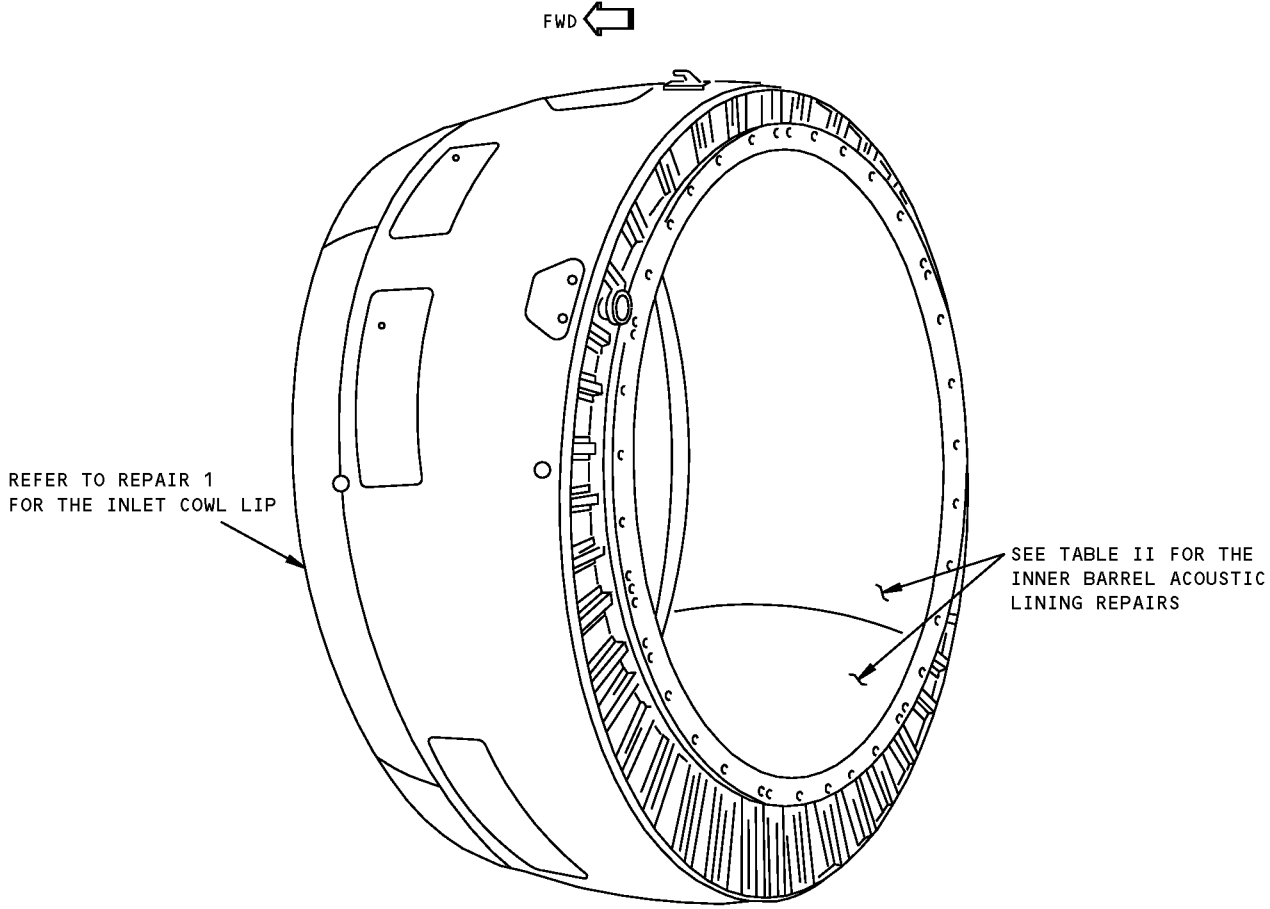

RB211-535E4 INLET COWL
DETAIL II

A8983

Inlet Cowl Skin Repairs - RB211-535E4 Engine
Figure 201

D634N201

REPAIR GENERAL
Page 201
54-10-01
Jan 20/2005



757-200

STRUCTURAL REPAIR MANUAL

REPAIR GENERAL

Page 202

Jan 20/2005

54-10-01

D634N201

757-200
STRUCTURAL REPAIR MANUAL

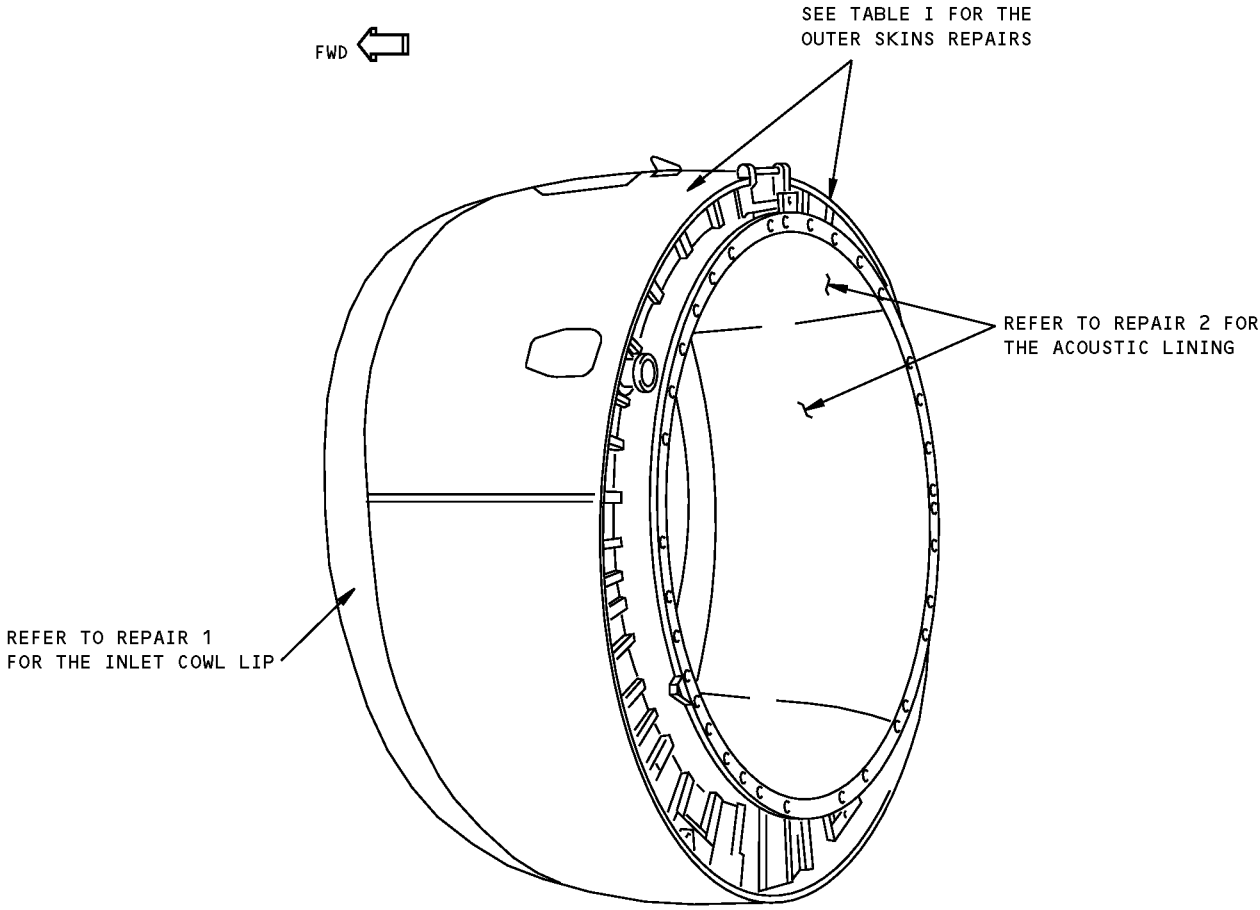

RB211-535C INLET COWL
DETAIL I

Inlet Cowl Skin Repairs - RB211-535C Engine
Figure 202

757-200
STRUCTURAL REPAIR MANUAL

REPAIR DESCRIPTION	REPAIR
RB211-535C ENGINE INLET OUTER SKIN REPAIR - PERMANENT PATCH ADJACENT TO STIFFENER	11
RB211-535C ENGINE INLET OUTER SKIN REPAIR - EXTERNAL PATCH ADJACENT TO STIFFENER	12

RB211-535C OUTER SKIN REPAIRS
TABLE I

REPAIR DESCRIPTION	REPAIR
RB211-535E4 ENGINE INLET COWL - INNER BARREL ACOUSTIC PANEL - REPAIR OF DYNA ROHR LEADING EDGE DELAMINATION	2
INLET COWL - INNER BARREL - REPAIR FOR PARTIAL PENETRATION OF PERFORATED SKIN - RB211-535E4 ENGINES	3
INLET COWL - ACOUSTIC LINING - REPAIR OF PERFORATED SKIN - RB211-535E4 ENGINES	4
INLET COWL - ACOUSTIC BARREL - REPAIR FOR WIRE MESH - RB211-535E4 ENGINES	5

RB211-535E4 INNER BARREL ACOUSTIC
LINING REPAIRS
TABLE II

Inlet Cowl Skin Repairs - RB211-535 Engine
Figure 203

STRUCTURAL REPAIR MANUAL

REPAIR 1 - INLET COWL LIP - REPAIR BY PATCHING - RB211-535 ENGINE

REPAIR INSTRUCTIONS

1. Mark and cut out damaged area. Use hand tools.
2. Manufacture doubler plate, part 1.
NOTE: Detail I shows a doubler plate for use when the nose lip skin has been cut back to the circumferential butt strap. If it has not been necessary to cut back that far, the doubler plate can be extended to complete the attachment of the patch. See Detail II.
3. Manufacture patch, part 2, from correct spareable nose lip skin.
4. Drill, countersink and deburr nose cowl patch and doubler plate.
5. Apply alodine (refer to SRM 51-20-01) or alochrom (refer to SRM 51-21-01) coating.
6. Apply one coat of BMS 10-11, Type I primer to each surface (refer to AMM 51-21-10).
7. Rivet doubler plate to nose cowl. Use solid rivets MS20426DD6 or equivalent. Refer to SRM 51-41-01.
8. Rivet patch to doubler plate. Use Cherrylock "Bulbed" countersunk rivets CR2238 series. Refer to SRM 51-41-01.

NOTES

- WHEN YOU USE THIS REPAIR REFER TO:
 - AMM 51-21-00 FOR INTERIOR AND EXTERIOR FINISHES
 - AMM 70-42-12 FOR LOCAL SURFACE PROTECTION
 - SRM 51-21-01 FOR PROTECTIVE TREATMENT OF METAL REPAIR PARTS
 - SRM 51-21-05 FOR REPAIR SEALING INSTRUCTIONS
 - SRM 51-31-03 FOR NON-METALLIC MATERIAL SOURCES
 - SRM 51-41-01 FOR FASTENER TYPES.
- DIMENSIONS ARE IN INCHES. IN ALL CASES, DISTANCE FROM EDGE OF MATERIAL TO CENTERLINE OF FIRST ROW OF RIVETS HOLES TO BE 0.312. DISTANCE BETWEEN CENTERLINE OF ROWS OF RIVET HOLES TO BE 0.469.

A SPAREABLE PART NUMBER:

LJ34524

B SPAREABLE PART NUMBERS - RB211-535C:

UPPER LEFT - LJ33541
 UPPER RIGHT - LJ33542
 LOWER LEFT - LJ33543
 LOWER RIGHT - LJ33544

C SPAREABLE PART NUMBERS - RB211-535E4 AND RB211-535E4-B:

UPPER - LJ35280
 RIGHT SIDE - LJ35282
 LEFT SIDE - LJ35281
 LOWER - LJ35283

REPAIR MATERIAL			
	PART	QTY	MATERIAL
1	DOUBLER PLATE (SPAREABLE)	1	0.080 AMS4094 A 2219-T81
2	PATCH (SPAREABLE)	1	0.092 AMS4094 B C 2219-T81

TABLE I

Inlet Cowl Lip - Repair by Patching - RB211-535 Engine
Figure 201 (Sheet 1 of 3)

STRUCTURAL REPAIR MANUAL

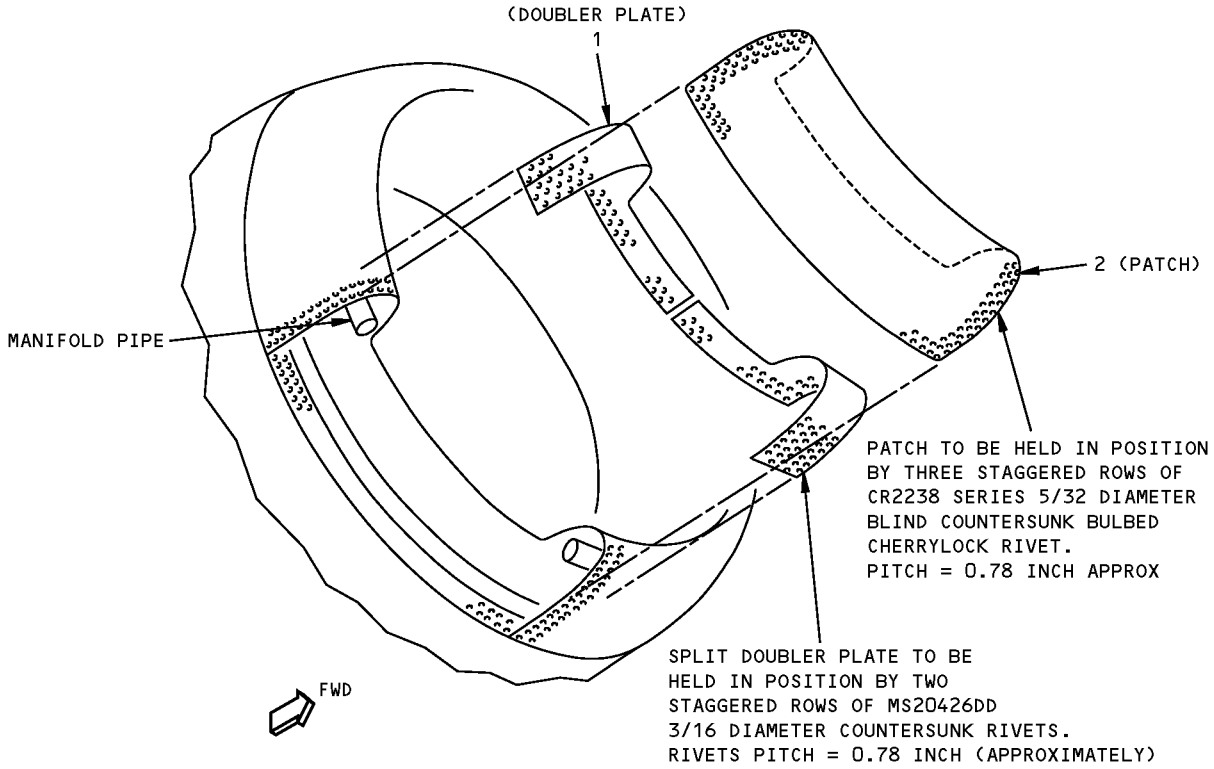

(SEE DETAILS I AND II)
VIEW ON INLET COWLING ASSEMBLY

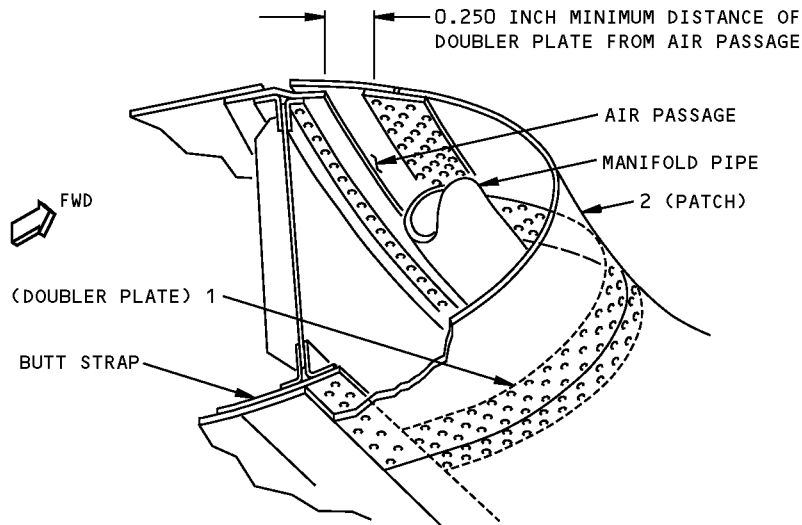

REPAIR ENCOMPASSING BUTT STRAP
DETAIL I

**Inlet Cowl Lip - Repair by Patching - RB211-535 Engine
Figure 201 (Sheet 2 of 3)**

757-200
STRUCTURAL REPAIR MANUAL

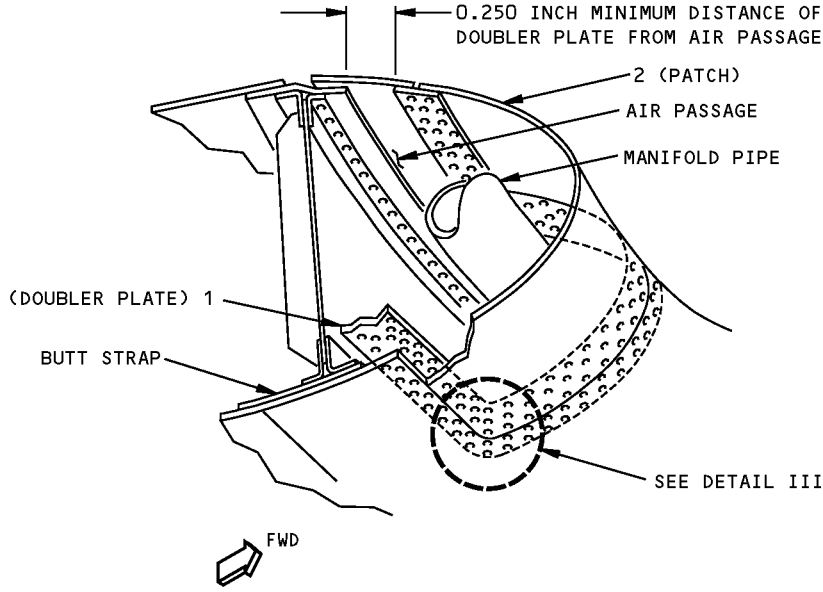

REPAIR USING EXTENDED DOUBLER PLATE
DETAIL II

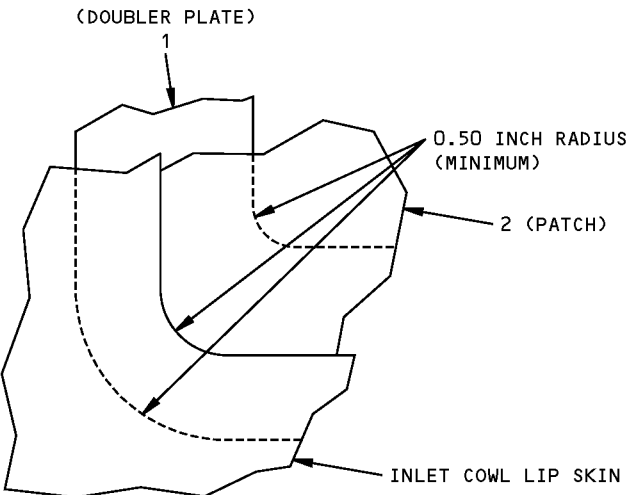

NOTE: MINIMUM CORNER RADIUS TO BE 0.50 INCHES

DETAIL III

Inlet Cowl Lip - Repair by Patching - RB211-535 Engine
Figure 201 (Sheet 3 of 3)

**757-200
STRUCTURAL REPAIR MANUAL****REPAIR 2 - INLET COWL - INNER BARREL ACOUSTIC PANEL - REPAIR OF DYNA ROHR LEADING EDGE
DELAMINATION - RB211-535E4 ENGINE****APPLICABILITY**

THIS REPAIR IS FOR DELAMINATION LIMITED TO 2.5 INCHES FROM INLET COWL LEADING EDGE.

REPAIR INSTRUCTIONS

WARNING: WEAR PROTECTIVE GLOVES AND CLOTHING WHEN WORKING WITH SOLVENTS AND ADHESIVES. VENTILATE WORK AREA TO PREVENT HAZARDOUS AND EXPLOSIVE VAPORS FROM COLLECTING. KEEP AWAY FROM SPARKS OR OTHER IGNITION SOURCES.

1. Using clean cotton cloth and methyl ethyl ketone (MEK), clean area and faying surfaces. Wipe area dry before solvent evaporates.
2. Use teflon tape to mask an area 0.25 inch beyond edge of delamination. Mask off anti-icing air outlet.
3. Trim away all loose wire. Use fingernail scissors or equivalent.
4. Mix adhesive filler EA934NA in accordance with manufacturer's instructions.
5. Apply adhesive filler to cavity and gaps in inner skin and edge of wire mesh. Fill flush with surrounding area.
6. Remove the masking tape and feather edges of adhesive filler using clean cotton cloth and MEK.
7. Cure adhesive filler for 1 hour at 180 to 200°F (82 to 93°C).
8. Visually inspect repair.
9. Using a permanent marker pen, write FRS 6152 next to assembly number.

**Inlet Cowl - Inner Barrel Acoustic Panel - Repair of Dyna Rohr Leading Edge Delamination - RB211-535E4
Engine
Figure 201**

D634N201

54-10-01REPAIR 2
Page 201
May 20/2005

STRUCTURAL REPAIR MANUAL

**REPAIR 3 - INLET COWL - INNER BARREL - REPAIR FOR PARTIAL PENETRATION OF PERFORATED SKIN -
RB211-535E4 ENGINE**

APPLICABILITY
THIS REPAIR IS FOR PARTIAL PENETRATION OF INNER BARREL PERFORATED SKIN.

REPAIR INSTRUCTIONS

1. Using a hole saw cut out core damage to smallest diameter possible to remove all damage.
2. Using finger nail scissors cut away and remove the wire mesh 0.875 inch larger than cut out core.
3. Mask around damaged area 1.125 inches larger than cut out using 0.50 inch Teflon tape.

WARNING: PROTECTIVE GLOVES SHOULD BE WORN WHEN USING DEGREASERS. USE ONLY IN WELL VENTILATED AREAS. VERY FLAMMABLE, KEEP AWAY FROM IGNITION SOURCES.

4. Clean repair area using methylethylketone and clean cotton cloth. Wipe dry before solvent evaporates.
5. Prepare adhesive EA934NA.

WARNING: USE EPOXY COMPOUNDS ONLY IN WELL VENTILATED AREAS. TAKE PRECAUTIONS TO PREVENT MATERIAL COMING INTO CONTACT WITH THE SKIN.

6. Apply adhesive over the wire mesh between the teflon tape and wire mesh edge.

NOTE: Do not apply adhesive more than 0.015 inch thick over wire mesh surface.

7. Cure adhesive for 1 hour at 60°C (140°F).
8. Remove Teflon tape.
9. Prepare plug patch using repair panel.
10. Mask cutting area on the wire mesh of the repair panel using Teflon tape.

NOTE: The plug patch should be larger than the repair hole to give a landing of 0.75 inch.

WARNING: PROTECTIVE GLOVES SHOULD BE WORN WHEN USING DEGREASERS. USE ONLY IN WELL VENTILATED AREAS. VERY FLAMMABLE, KEEP AWAY FROM IGNITION SOURCES.

11. Clean panel surface using methylethylketone and clean cotton cloth. Wipe dry before solvent evaporates.

12. Prepare adhesive EA934NA.

WARNING: USE EPOXY COMPOUNDS ONLY IN WELL VENTILATED AREAS. TAKE PRECAUTIONS TO PREVENT MATERIAL FROM COMING INTO CONTACT WITH THE SKIN.

13. Apply adhesive over the wire mesh between the tapes to totally encapsulate the wire strands to prevent breakaway during cutting operation.

NOTE: Do not apply adhesive thicker than 0.015 inches over wire mesh surface.

14. Cure adhesive for 1 hour at 60°C (140°F).
15. Cut the plug repair patch 0.75 inch larger than hole to give a landing of 0.75 inch.
16. Trim the plug repair patch core to fit hole precisely and fit into the hole.
17. Drill and de-burr rivet attachment holes in repair patch and inner barrel skin. Minimum 3D fastener spacing.

CAUTION: PROTECT SURROUNDING AREA FROM DUST AND DEBRIS CONTAMINATION.

18. Abrade faying surfaces of plug repair patch and the inner barrel structure using abrasive paper (180 grit).

**Inlet Cowl - Inner Barrel - Repair for Partial Penetration of Perforated Skin - RB211-535E4 Engine
Figure 201 (Sheet 1 of 4)**

STRUCTURAL REPAIR MANUAL

REPAIR INSTRUCTIONS (CONT)

WARNING: PROTECTIVE GLOVES SHOULD BE WORN WHEN USING DEGREASERS. USE ONLY IN WELL VENTILATED AREAS. VERY FLAMMABLE, KEEP AWAY FROM IGNITION SOURCES.

19. Clean faying surfaces using clean cotton cloth and methylethylketone. Wipe dry before solvent evaporates.
20. Protect exposed areas of metal using Aloetom 1200. Apply by brush to rivet holes, cut edges and areas of exposed metal.

WARNING: USE EPOXY COMPOUNDS ONLY IN WELL VENTILATED AREAS. TAKE PRECAUTIONS TO PREVENT MATERIAL FROM COMING INTO CONTACT WITH THE SKIN.

21. Apply adhesive EA934NA to faying surfaces and open cells of the honeycomb core.
22. Install the plug patch aligning holes and clamp to the inner barrel structure.
23. Install blind rivets NAS1738E5-2 with EA934NA adhesive.
24. Apply adhesive around edges of patch to fill gaps to fair with surrounding area to form a smooth profile.

WARNING: PROTECTIVE GLOVES SHOULD BE WORN WHEN USING DEGREASERS. USE ONLY IN WELL VENTILATED AREA. VERY FLAMMABLE KEEP AWAY FROM IGNITION SOURCES.

25. Clean surface using clean cotton cloth soaked with MEK. Wipe excess adhesive from repair area. Do not remove adhesive in fillet.
26. Cure adhesive for 1 hour at 60°C (140°F).

WARNING: SANDING OR CUTTING OF COMPOSITE MATERIALS PRODUCES DUST AND FLYING PARTICLES WHICH ARE POTENTIAL HEALTH HAZARDS. WEAR PROTECTIVE CLOTHING, GLOVES, DUST MASKS, AND SAFETY GLASSES. AVOID BREATHING OF DUST OR PROLONGED CONTACT OF DUST ON THE SKIN.

CAUTION: PROTECT SURROUNDING AREA FROM DUST CONTAMINATION.

27. Smooth the adhesive at the edges of the plug repair patch using abrasive paper (grit 180) to obtain a smooth surface between plug patch and original face skin.

WARNING: PROTECTIVE GLOVES SHOULD BE WORN WHEN USING DEGREASERS. USE ONLY IN WELL VENTILATED AREAS. VERY FLAMMABLE, KEEP AWAY FROM IGNITION SOURCES.

28. Remove sanding dust from surface using clean cotton cloth soaked in MEK. Wipe dry before solvent evaporates.

29. Visually inspect area of repair.

NOTES

- THE TOTAL REPAIR AREA OF ACCOUSTIC LINING IS LIMITED. REFER TO SRM 54-00-01.
- THE MAXIMUM DAMAGE SIZE FOR THIS REPAIR IS 10.0 INCHES LINEAR DIMENSION.
- THE MINIMUM SPACING PERMITTED BETWEEN TWO REPAIRS MEASURED EDGE TO EDGE IS 10.0 INCHES.
- NO REPAIR CAN BE LESS THAN 2.5 INCHES FROM THE EDGE CLOSURE.

REPAIR MATERIAL			
	PART	QTY	MATERIAL
1	PLUG PATCH (SPARABLE) LJ76219	1	ALUMINIUM ACOUSTIC PANEL (DYNAROHR)

**Inlet Cowl - Inner Barrel - Repair for Partial Penetration of Perforated Skin - RB211-535E4 Engine
Figure 201 (Sheet 2 of 4)**

757-200
STRUCTURAL REPAIR MANUAL

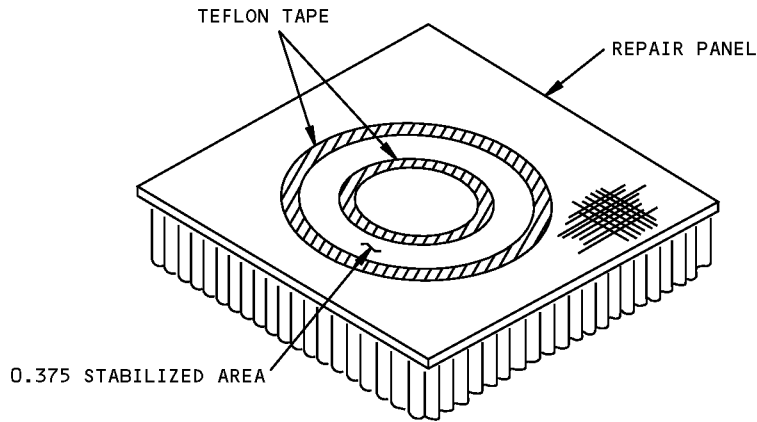

USING CUTTING DISC,
CUT THROUGH FACE SKIN
USING CENTER OF STABILIZED
AREA AS A GUIDE

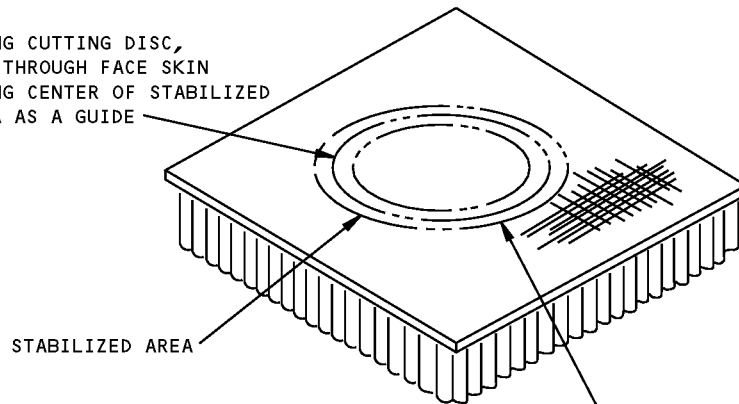

AFTER CUTTING WIRE MESH AND
FACE SKIN USE A KNIFE AND
CUT THROUGH CORE

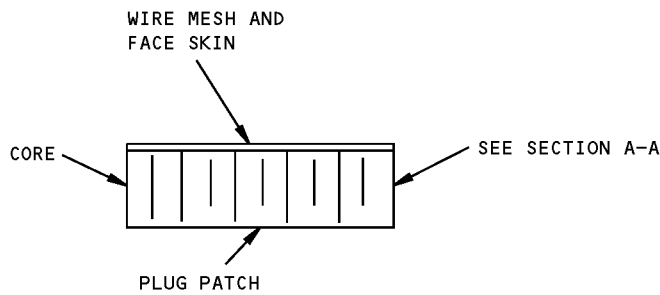

A7627

Inlet Cowl - Inner Barrel - Repair for Partial Penetration of Perforated Skin - RB211-535E4 Engine
Figure 201 (Sheet 3 of 4)

**757-200
STRUCTURAL REPAIR MANUAL**

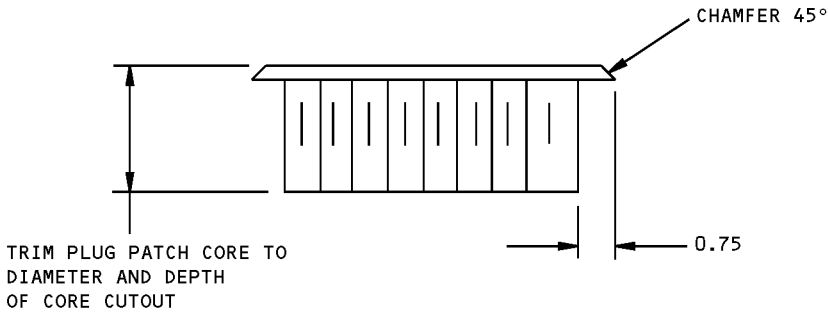
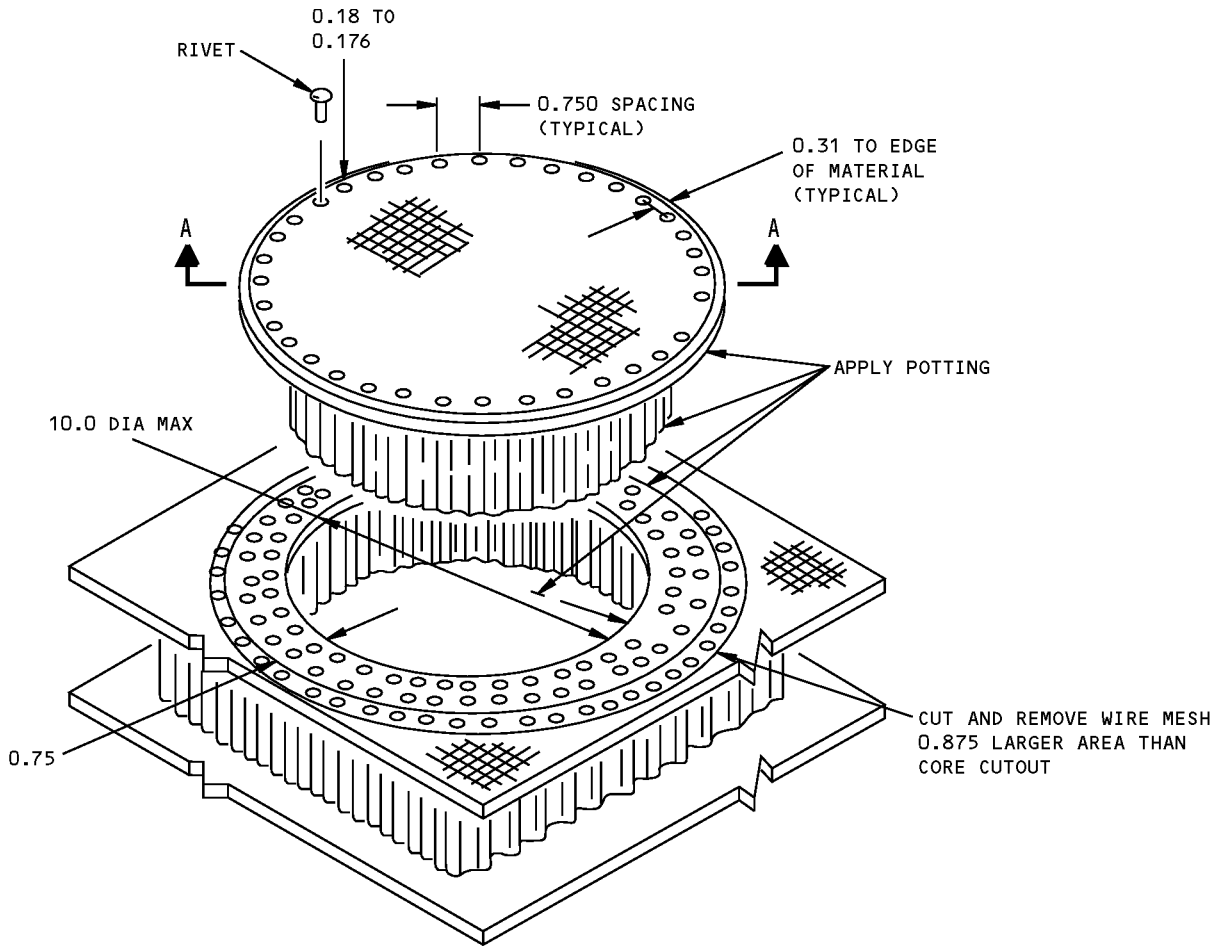

SECTION A-A

A7628

**Inlet Cowl - Inner Barrel - Repair for Partial Penetration of Perforated Skin - RB211-535E4 Engine
Figure 201 (Sheet 4 of 4)**

STRUCTURAL REPAIR MANUAL

REPAIR 4 - INLET COWL - ACOUSTIC LINING - REPAIR OF PERFORATED SKIN - RB211-535E4 ENGINE

APPLICABILITY
THIS REPAIR IS FOR THE INLET COWL ACOUSTIC LINING PERFORATED SKIN.

REPAIR INSTRUCTIONS

- WARNING:** PROTECTIVE GLOVES SHOULD BE WORN WHEN USING DEGREASERS. USE ONLY IN WELL VENTILATED AREAS. VERY FLAMMABLE KEEP AWAY FROM IGNITION SOURCES.

Clean repair area using clean cotton cloth soaked in Methylethylketone. Wipe dry with clean cotton cloth before solvent evaporates.

- WARNING:** USE EPOXY COMPOUNDS ONLY IN WELL VENTILATED AREAS. TAKE PRECAUTIONS TO PREVENT MATERIAL FROM COMING INTO CONTACT WITH THE SKIN.

Prepare stabilized area by using teflon tape to define a band 0.375 inch wide with the internal line 1.175 inches from damage.

- Apply adhesive fillet EA934NA over the wire mesh within the 0.375 masked band area, ensuring total encapsulation for cutting operation.

NOTE: Do not apply adhesive filler thicker than 0.015 inch.

- Cure adhesive filler for 1 hour at 60°C (140°F) using explosion proof heat lamps.
- Remove the Telfon tape.
- Fabricate doubler from 2024-O aluminium sheet 0.03 inch thick 1.0 inches larger than damaged area.
- Trim wire mesh to leave 0.125 inch clear margin around doubler.
- Position doubler and drill rivet holes.
- Remove doubler, deburr rivet holes and apply alodine to the doubler faces, edges and rivet holes.

- WARNING:** PROTECTIVE GLOVES SHOULD BE WORN WHEN USING DEGREASERS. USE ONLY IN WELL VENTILATED AREAS. VERY FLAMMABLE, KEEP AWAY FROM IGNITION SOURCES.

Clean repair area using clean cotton cloth soaked in MEK. Wipe dry with clean cotton cloth before solvent evaporates.

- Protect exposed area of metal using Alocrom 1200. Apply by brush to rivet holes cut edges and areas of exposed metal.
- WARNING:** USE EPOXY COMPOUNDS ONLY IN WELL VENTILATED AREAS. TAKE PRECAUTIONS TO PREVENT MATERIAL FROM COMING INTO CONTACT WITH THE SKIN.

Apply adhesive filler EA934NA over faying surface of panel and doubler.

- Fit doubler aligning rivet holes and wet install blind rivets NAS1738E5-2.
- Seal edges of doubler using adhesive filler EA934NA. Fill gaps flush with surrounding area.
- Cure adhesive filler for 1 hour at 60°C (140°F).

- WARNING:** SANDING OR CUTTING OF COMPOSITE MATERIALS PRODUCES DUST AND FLYING PARTICLES WHICH ARE POTENTIAL HEALTH HAZARDS. WEAR PROTECTIVE CLOTHING, GLOVES, DUST MASKS AND SAFETY GLASSES. AVOID BREATHING OF DUST OR PROLONGED CONTACT OF DUST ON THE SKIN.

CAUTION: PROTECT SURROUNDING AREA FROM DUST CONTAMINATION.

Abrade the repair area using abrasive paper (GRIT 180) to obtain a smooth aerodynamic surface.

**Inlet Cowl - Acoustic Lining - Repair of Perforated Skin - RB211-535E4 Engine
Figure 201 (Sheet 1 of 3)**

**757-200
STRUCTURAL REPAIR MANUAL****REPAIR INSTRUCTIONS (CONT)**

17. **WARNING:** PROTECTIVE GLOVES SHOULD BE WORN WHEN USING DEGREASERS. USE ONLY IN WELL VENTILATED AREAS. VERY FLAMMABLE, KEEP AWAY FROM IGNITION SOURCES.

Remove sanding dust from surface using clean cotton cloth soaked in methylethylketone. Wipe surface dry before solvent evaporates using a clean cotton cloth.

18. Visually inspect repair area.

NOTES:

- THE MAXIMUM DAMAGE SIZE FOR THIS REPAIR IS 8.0 INCHES LINEAR DIMENSION.
- THE MINIMUM SPACING ALLOWED BETWEEN REPAIRS, MEASURED EDGE TO EDGE, IS 5.0 INCHES.
- NO MORE THAN 3 REPAIRS ARE ALLOWED AND NO REPAIR MAY BE LESS THAN 2.0 INCHES FROM AN EDGE.
- THE TOTAL AREA OF ACOUSTIC LINING REPAIR IS LIMITED. REFER TO 54-00-01.

**Inlet Cowl - Acoustic Lining - Repair of Perforated Skin - RB211-535E4 Engine
Figure 201 (Sheet 2 of 3)**

757-200
STRUCTURAL REPAIR MANUAL

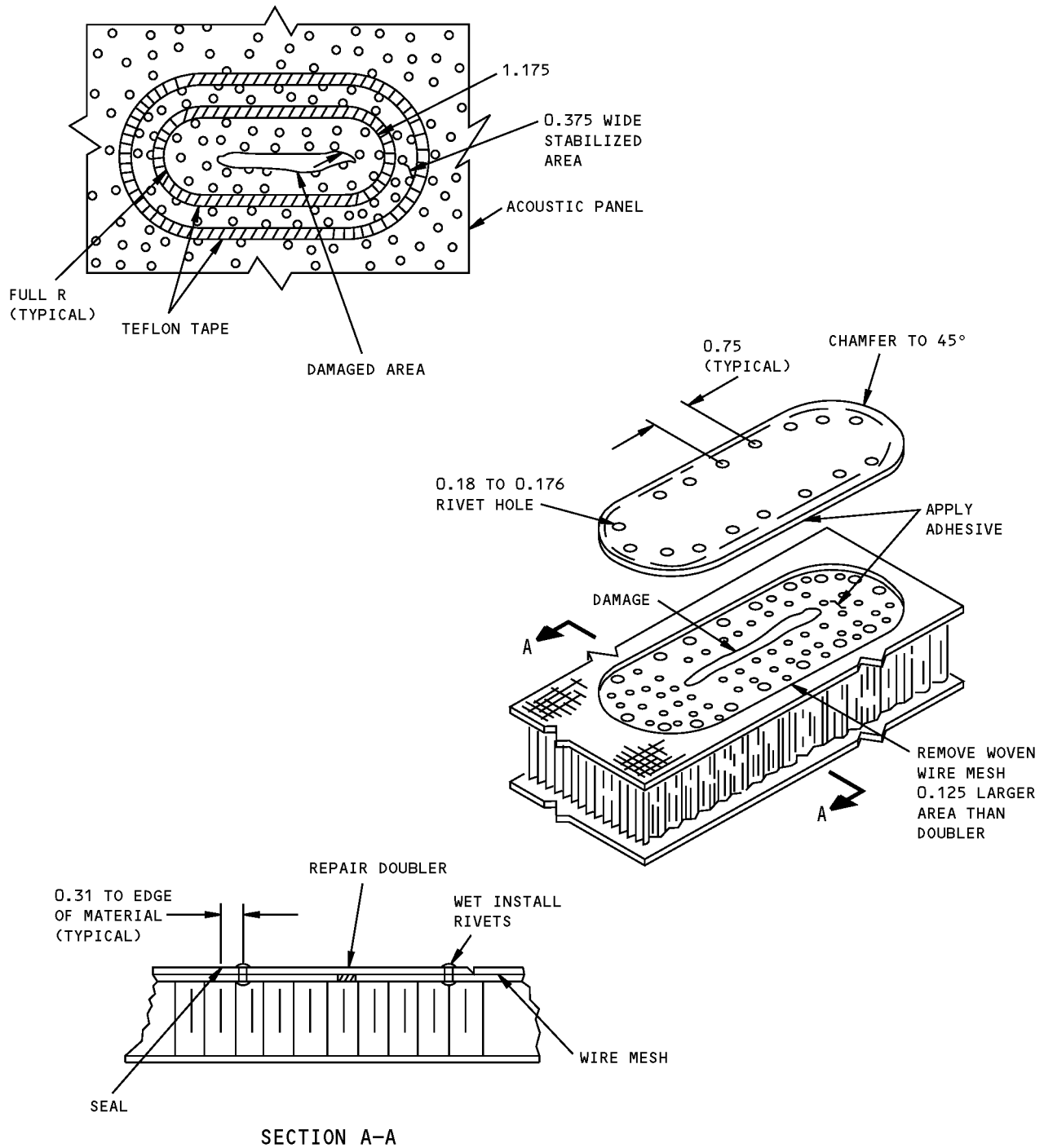

A7626B

Inlet Cowl - Acoustic Lining - Repair of Perforated Skin - RB211-535E4 Engine
Figure 201 (Sheet 3 of 3)

STRUCTURAL REPAIR MANUAL

REPAIR 5 - INLET COWL - ACOUSTIC BARREL - REPAIR FOR WIRE MESH - RB211-535E4 ENGINE

APPLICABILITY
THIS REPAIR IS FOR INNER BARREL ACOUSTIC LINING WIRE MESH.

REPAIR INSTRUCTIONS

- Trim all loose wire from damaged mesh using finger nail scissors.
- Repair area less than 1.0 inches dia, mask around damage using Teflon tape leaving 0.25 inch of exposed mesh. Areas greater than 1.0 inches dia, mask around damage using Teflon tape leaving 0.25 inch of exposed mesh, and mask within area leaving 0.25 inch between edge of mesh and Teflon tape.
- WARNING:** PROTECTIVE GLOVES SHOULD BE WORN WHEN USING DEGREASERS. USE ONLY IN WELL VENTILATED AREAS. VERY FLAMMABLE, KEEP AWAY FROM IGNITION SOURCES.

Clean repair area and faying surfaces using a clean cotton cloth soaked in methylethylketone. Wipe dry with clean cotton cloth before solvent evaporates.

- WARNING:** USE SEALANT IN WELL VENTILATED AREAS. TAKE PRECAUTIONS TO PREVENT MATERIAL FROM COMING INTO SKIN CONTACT.

Mix adhesive filler EA934NA per manufacturers instructions and fill gaps flush with surrounding area.

- WARNING:** PROTECTIVE GLOVES SHOULD BE WORN WHEN USING DEGREASERS. USE ONLY IN WELL VENTILATED AREAS. VERY FLAMMABLE, KEEP AWAY FROM IGNITION SOURCES.

Clean repair area using clean cotton cloth soaked in methylethylketone. Wipe dry using clean cotton cloth before solvent evaporates. Wipe away excess adhesive prior to curing to obtain smooth surface.

- Cure adhesive filler EA934NA for 1 hour at 60°C (140°F).
- Remove Teflon tape.
- WARNING:** SANDING OR CUTTING OF COMPOSITE MATERIALS PRODUCES DUST AND FLYING PARTICLES WHICH ARE POTENTIAL HEALTH HAZARDS WEAR PROTECTIVE CLOTHING, GLOVES, DUST MASKS AND SAFETY GLASSES. AVOID BREATHING OF DUST OR PROLONGED CONTACT OF DUST ON THE SKIN.

CAUTION: PROTECT SURROUNDING AREA FROM DUST CONTAMINATION AND ENSURE THE UNDERLYING STRUCTURE IS NOT DAMAGED.

Sand adhesive filler using aluminium oxide abrasive paper (180 grit) to obtain aerodynamic smoothness.

- Visually inspect repair area.

NOTES

- THE TOTAL AREA OF ACOUSTIC LINING REPAIR IS LIMITED, REFER TO 54-00-01.
- THE LOSS OF ACOUSTIC LINING AREA FOR THIS REPAIR IS THE TOTAL AREA COVERED BY OR ENCLOSED WITHIN ADHESIVE.

**Inlet Cowl - Acoustic Barrel - Repair for Wire Mesh - RB211-535E4 Engine
Figure 201 (Sheet 1 of 2)**

**757-200
STRUCTURAL REPAIR MANUAL**

THE LOSS OF ACOUSTIC LINING AREA FOR THIS REPAIR IS THE TOTAL AREA COVERED BY OR ENCLOSED WITHIN THE ADHESIVE. REFER TO 54-00-01 FOR SIZE LIMITS

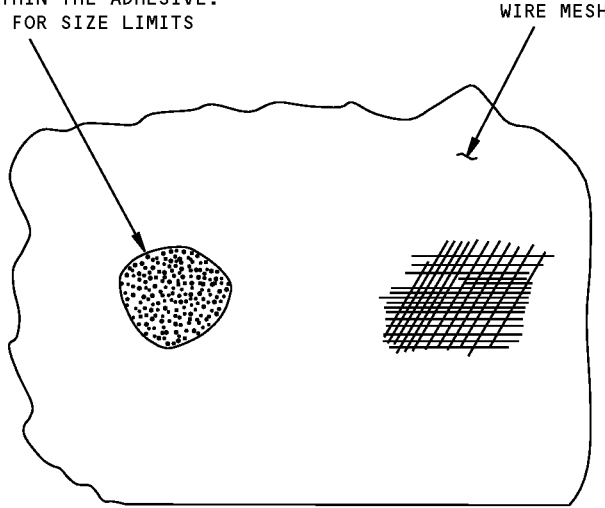

DETAIL I

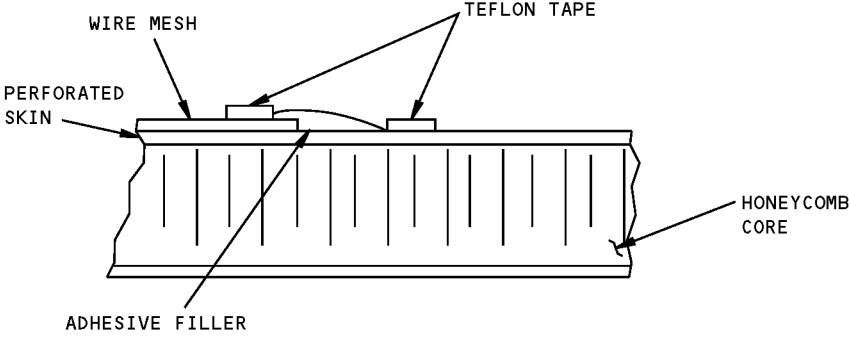

DETAIL II

A7625

**Inlet Cowl - Acoustic Barrel - Repair for Wire Mesh - RB211-535E4 Engine
Figure 201 (Sheet 2 of 2)**

757-200
STRUCTURAL REPAIR MANUAL

REPAIR 6 - INLET COWL OUTER SKIN - REPAIR TO DAMAGE THAT DOES NOT BREAK FIBERS - RB211-535E4 ENGINE

REPAIR INSTRUCTIONS

1. Thoroughly degrease the damaged area. Refer to 51-31-03.
2. Dry the damaged area by heating it for 1 hour minimum at 150-170°F (66-78°C). The rate of temperature change should not be above 5°F (3°C) per minute.
3. Mark out the damaged area using masking tape.
4. Remove the surface finish in the masked area. Use 150 grade at finer silicon carbide abrasive.
5. Fill the damaged area with EA9390 adhesive/filler and mix it per the manufacturer's instructions. Ensure there is no depression.
6. Place a non-porous release film over the total repair area and extend it at least 1.0 inch beyond the damage. Use tape to hold it in place.
7. Cure the adhesive by stabilizing it at room temperature for 120 minutes followed by curing at 200°F (94°C) for 220 minutes. If accelerated curing is required, cure at 300°F (150°C) for 130 minutes.
8. Remove all the equipment from repair area. Abrade the repair resin to restore smooth aerodynamic surface.
9. Clean the area using MEK solvent and clean cotton cloth. Wipe dry before the solvent evaporates.
10. Refinish the surface to original. Refer to 71-11-01 of the Maintenance Manual.

NOTES

- ALL DIMENSIONS ARE IN INCHES.
- DO NOT BREAK FIBERS FROM THE SURFACE PLY.
- DO NOT USE PAINT STRIPPER AS IT WILL DAMAGE THE RESIN.
- REFER TO THE FOLLOWING WHEN USING THIS REPAIR:
 - 71-11-01 OF THE MAINTENANCE MANUAL FOR RESTORING FINISH.

Inlet Cowl Outer Skin - Repair to Damage that Does Not Break Fibers - RB211-535E4 Engine
Figure 201

STRUCTURAL REPAIR MANUAL

**REPAIR 7 - INLET COWL OUTER SKIN - REPAIR TO DAMAGE NOT EXTENDING THROUGH LAMINATE -
RB211-535E4 ENGINE**

REPAIR INSTRUCTIONS

1. Mark out the damaged area.
2. Thoroughly degrease the damaged area. Refer to 51-31-03.
3. Dry the damaged area by heating it for 1 hour minimum at 150-170°F (66-78°C) maximum. The rate of temperature rise should not be above 5°F (3°C) per minute.
4. Cut out the damaged area to a regular shape with rounded corners. Ensure that the damaged area plus an extra 0.5 inch is removed.
5. Taper abrade the edge of the cut-out allowing 0.5 inch taper for each damaged ply all around damaged area.
6. Determine the number of external repair plies required. One repair ply is required for each damaged ply plus one extra. Refer to Detail I. Additionally, cut a glass sanding ply with a 0.5 inch overlap all around.
7. Outline the repair area using teflon masking tape as indicated on Detail I. Calculate the area to be masked using the method specified in par. 6 above.
8. Abrade the masked area (including the taper abraded area) using 150 grit or finer silicon carbide abrasive.
9. Unmask the repair area and thoroughly clean the surface using MEK solvent and lint free cotton cloth.
10. Cut one ply of adhesive film, Narmco 1515-3M, Grade 03, 0.0625 inch larger than the masked area.
11. Position the adhesive ply over the repair area.
12. Cut filler plies from Cycom 985-GF-3135-H8 prepreg. Cut each ply 0.5 inch larger all around than the ply it replaces and with the same ply orientation as the original.
13. Place the filler plies over the abraded area starting with the smallest plies first. Use the same orientation as the original. Each ply to overlap the ply beneath it by 0.5 inch. Refer to Detail I.
14. Cut the external repair plies from Cycom 985-GF-3135-H8 prepreg. Cut the first repair ply 1.0 inch larger all around than the cut-out and with the same orientation as the bottom damaged ply. Cut the subsequent repair plies 0.75 inch larger all around than the ply below it and with 0/90° orientation. For these subsequent repair plies, one repair ply is required for each damaged ply. Refer to Detail I.
15. Cut a sanding ply from Narmco 588-120 Volan A prepreg. Make it 0.5 inch larger all around than the previous ply and with 0/90° orientation.
16. Place the external plies onto the filler plies smallest first. Refer to Detail I. Place the sanding ply over the external plies.
17. Refer to Detail II and place thermocouples just outside the edge of the sanding ply and on all sides of the repair.
18. Place perforated release film over the repair area so that it extends a minimum of 0.5 inch beyond the glass sanding ply.
19. Place dry peel ply over the perforated release film ensuring that it makes contact with the surface breather. Refer to par. 24 of this repair.
20. Place a non-perforated release film over the lay-up so that it lays 0.5 inch short of the dry peel ply all around.

**Inlet Cowl Outer Skin - Repair to Damage Not Extending Through Laminate - RB211-535E4 Engine
Figure 201 (Sheet 1 of 4)**

**757-200
STRUCTURAL REPAIR MANUAL****REPAIR INSTRUCTIONS (CONT)**

21. Place a silicon rubber blanket over the release film so that it extends over the edges of the repair area, but not over the non-perforated release film.
22. Place two plies of surface breather over the silicon rubber blanket, ensuring that it contacts the dry peel ply.
23. Place a heating blanket over the breather film so that the heating blanket extends a minimum of 2.0 inches beyond the edge of the glass sanding ply.
24. Place a vacuum point on the edge of the breather.
25. Vacuum bag the repair area. Refer to Detail III.
26. Apply a minimum vacuum of 22 inches of mercury inside the bag.
27. Check for leaks and reseal if necessary.
28. Energize the heater blanket and raise the temperature to 350°F (177°C) at a maximum rate of 5°F (3°C) per minute. Monitor for 120 to 180 minutes.
29. Allow the repair to cool at a maximum rate of 5°F (3°C) per minute until repair cools to 120°F (50°C) then release vacuum and remove all equipment.
30. Abrade the glass sanding ply to chamfer edges of repair to a smooth contour. Exercise extreme care to avoid damaging adjoining carbon ply.
31. Inspect for voids using instrumental NDI. If faulty repair is indicated, clean out repair and re-apply.
32. If repair is satisfactory, restore the surface finish.

NOTES

- ALL DIMENSIONS ARE IN INCHES.
- DO NOT USE PAINT STRIPPER AS IT WILL DAMAGE THE RESIN.
- REFER TO THE FOLLOWING WHEN USING THIS REPAIR:
 - 71-11-01 OF THE 757 MAINTENANCE MANUAL FOR RESTORATION OF SURFACE FINISH.

**Inlet Cowl Outer Skin - Repair to Damage Not Extending Through Laminate - RB211-535E4 Engine
Figure 201 (Sheet 2 of 4)**

757-200
STRUCTURAL REPAIR MANUAL

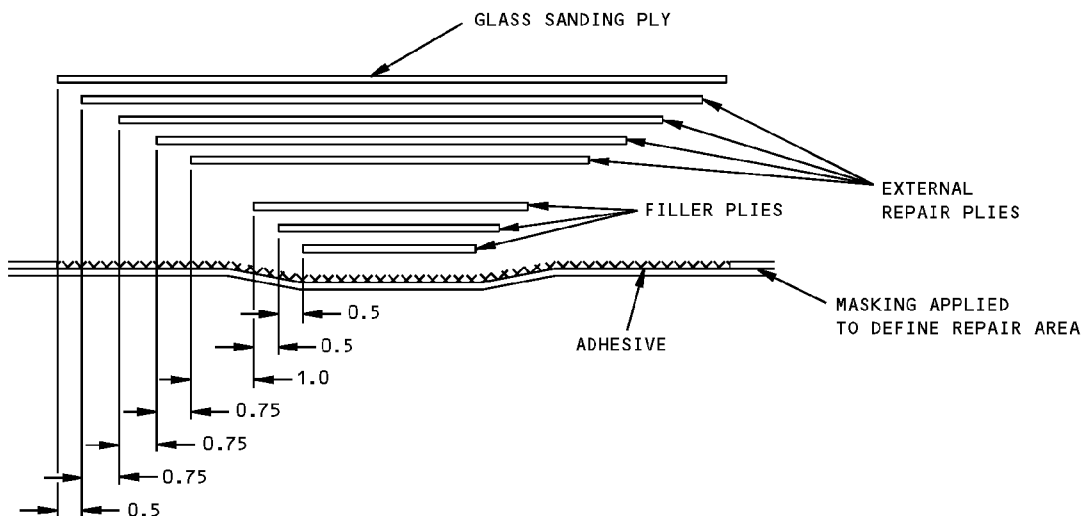

VIEW SHOWING PARENT LAMINATE
WITH THREE DAMAGED PLYS
DETAIL I

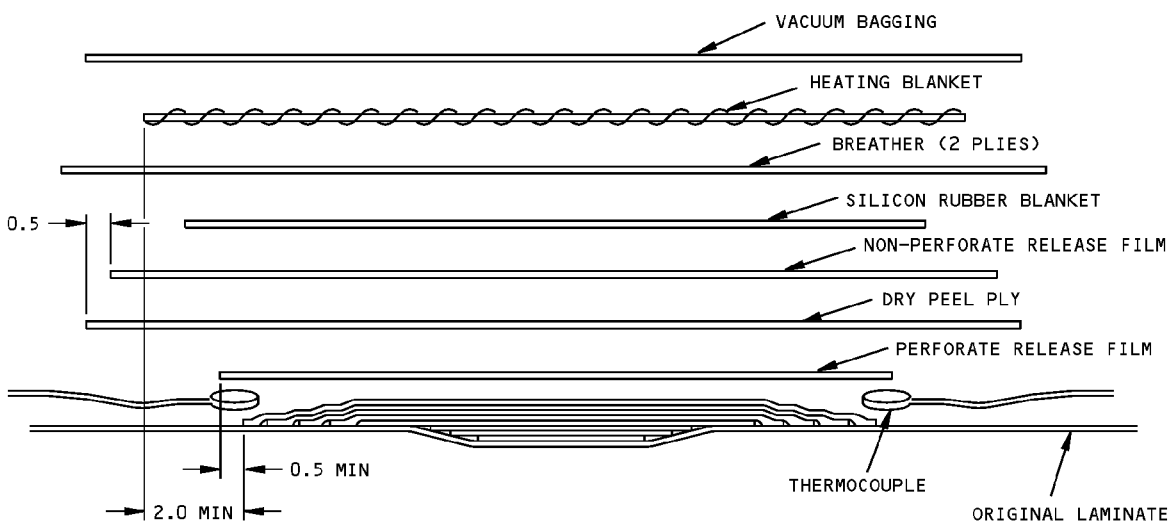

HEATER BLANKET AND VACUUM BAGGING
SET UP SEQUENCE
DETAIL II

A9709

Inlet Cowl Outer Skin - Repair to Damage Not Extending Through Laminate - RB211-535E4 Engine
Figure 201 (Sheet 3 of 4)

757-200
STRUCTURAL REPAIR MANUAL

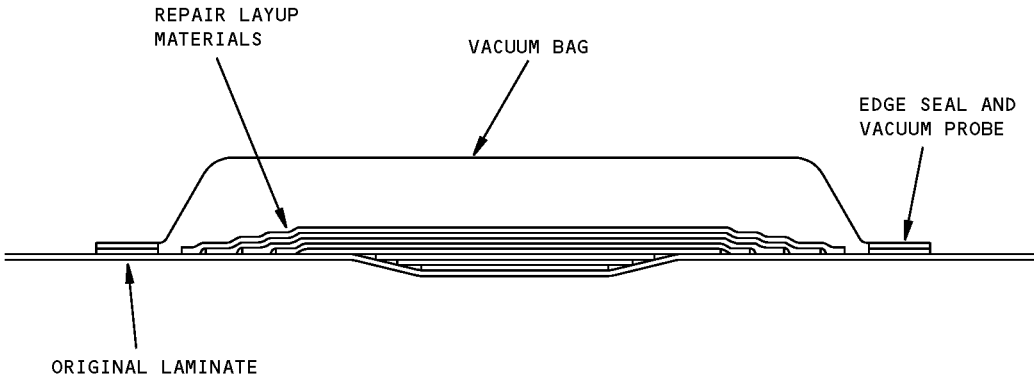

DETAIL III

A9710

Inlet Cowl Outer Skin - Repair to Damage Not Extending Through Laminate - RB211-535E4 Engine
Figure 201 (Sheet 4 of 4)

D634N201

54-10-01

REPAIR 7
Page 204
May 20/2005

STRUCTURAL REPAIR MANUAL

REPAIR 8 - INLET COWL OUTER SKIN - REPAIR TO DAMAGE EXTENDING THROUGH LAMINATE - RB211-535E4 ENGINE

REPAIR INSTRUCTIONS

1. Mark out the damaged area.
2. Thoroughly degrease the damaged area. Refer to 51-31-03.
3. Dry the damaged area by heating it for 1 hour minimum at 150-170°F (66-78°C) maximum. The rate of temperature rise should not be above 5°F (3°C) per minute.
4. Cut out the damaged area to a regular shape with rounded corners. Ensure that the damaged area plus an extra 0.5 inch is removed.
5. Taper abrade the edge of the cut-out allowing 0.5 inch taper for each damaged ply all around area.
6. Determine the number of external repair plies required. One repair ply is required for each damaged ply plus one extra. Refer to Detail I. Additionally cut a glass sanding ply extending 0.5 inch beyond the largest external repair ply.
7. Outline the repair area using Teflon masking tape as indicated in Detail I. Calculate the area to be masked using the method stated in par. 6 above.
8. Abrade the masked area (including the taper abraded area) using 150 grade or finer silicon carbide abrasive.
9. Abrade the reverse face of the laminate by working through the cut-out. Lightly abrade the under surface for 1.0 inch around the cut-out.
10. Remove any debris and clean the interior and exterior skin surfaces using MEK solvent on a clean lint free cotton cloth. Wipe dry before solvent evaporates.
11. Prepare a fiberglass back-up plate using steps 12 through 16.
12. Determine the size and shape of the back-up plate that will pass through the cut-out and give an overlap of 1.0 inch all around the cut-out when fitted.
13. Cut three off 0/90° plies of Narmco 588-120 Volan A glass prepreg 0.5 inch larger all around than that required.
14. Lay-up the fiberglass with the warp direction of the center ply at right angles to the two outer plies. Include a layer of Fiberite MXM 7701/52006 peel ply on one surface.
15. Cure the back-up plate at 350°F (177°C) at 22 inches mercury vacuum for 2 hours.
16. When cured, trim the plate to 1.0 inch larger than the cut-out.
17. Drill two pairs of holes 0.07 inch diameter 0.375 inch apart, near the centerline.
18. Mix Epocast 35A resin with 927 hardener in the ratio 100:25 by weight.
19. Remove the peel ply from the backing plate and pass the short loop of the locking wire through each pair of holes.
20. Apply the resin to the faying surface of back-up plate from which the peel ply has been removed.
21. Pass the back-up plate through cut-out.
22. Bridge the cut-out using a metal rod in conjunction with the locking wire to pull the backing plate into contact with the parent laminate. Tighten up the wires to ensure that even pressure is maintained and avoiding distortion. Refer to Detail II.
23. Cure the assembly at 170-180°F (77-82°C) for 150 minutes.

**Inlet Cowl Outer Skin - Repair to Damage Extending Through Laminate - RB211-535E4 Engine
Figure 201 (Sheet 1 of 3)**

**757-200
STRUCTURAL REPAIR MANUAL****REPAIR INSTRUCTIONS (CONT)**

24. Remove the locking wire and the rod.
25. Replace the cut-out skin as shown in Repair 7, steps 9 through 32.

NOTES

- THE BACKING PLATE IS NOT REMOVED ON COMPLETION OF REPAIR IT FORMS AN INTEGRAL PART OF THE REPAIRED STRUCTURE.
- DO NOT USE PAINT STRIPPER AS IT WILL DAMAGE THE RESIN.

**Inlet Cowl Outer Skin - Repair to Damage Extending Through Laminate - RB211-535E4 Engine
Figure 201 (Sheet 2 of 3)**

757-200 STRUCTURAL REPAIR MANUAL

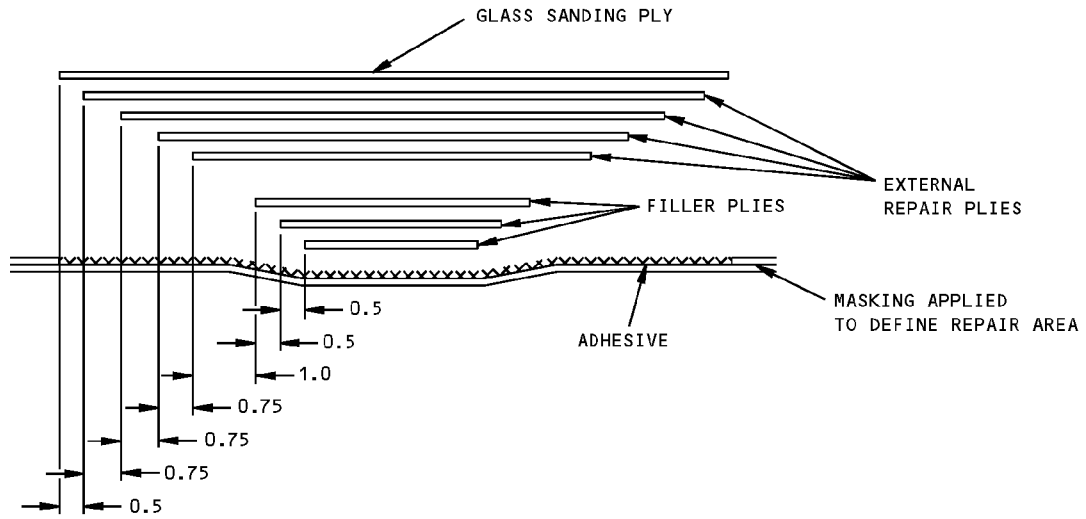

VIEW SHOWING PARENT LAMINATE
WITH THREE DAMAGED PLYS
DETAIL I

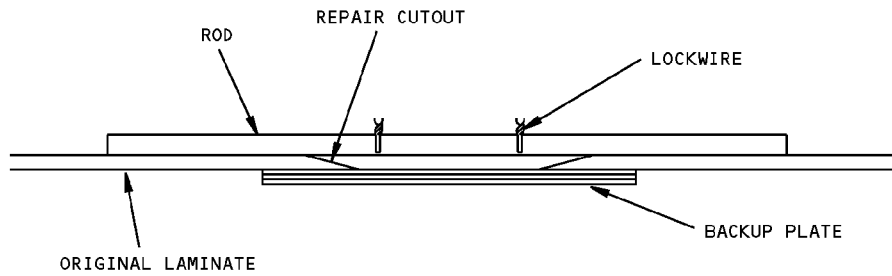

DETAIL II

A9710

Inlet Cowl Outer Skin - Repair to Damage Extending Through Laminate - RB211-535E4 Engine Figure 201 (Sheet 3 of 3)

STRUCTURAL REPAIR MANUAL

REPAIR 9 - INTAKE ACOUSTIC LINER - REPAIR FOR DISBONDED HONEYCOMB CORE - RB211-535E4 AND RB211-535E4B ENGINE

APPLICABILITY
THIS REPAIR IS APPLICABLE IF THE REPAIR AREA IS NO MORE THAN 216 SQUARE INCHES PER INLET AND FRONT FAN CASE. SEE A AND B

REPAIR INSTRUCTIONS

1. Get access to the area of the disbonded core. Remove the cowl if necessary. Refer to AMM 71-11-01.

NOTE: THE EA934NA FILLER THAT WILL BE USED TO FILL THE DISBONDED AREA IS A HIGH VISCOSITY FLUID. IF THE DAMAGED AREA IS IN A POSITION WHERE THE FILLER IS LIKELY TO RUN OUT OF THE FILLER HOLES, REMOVE THE COWL AND POSITION THE DAMAGE SO THAT THE FILLER WILL NOT RUN OUT.

WARNING: WEAR PROTECTIVE GLOVES WHEN USING DEGREASERS. WORK IN WELL VENTILATED AREAS. KEEP AWAY FROM IGNITION SOURCES.

2. Clean the repair area with a clean lint-free cloth moistened with solvent. Refer to SOPM 20-30-03. Wipe dry with a clean cotton cloth before solvent evaporates.
3. Mix the EA934NA filler as specified in the manufacturer's instructions.
4. Apply the EA934NA filler to the wire mesh. Use a spatula to make sure the filler goes into the wire mesh as far as possible without causing more damage to the liner. Use care to avoid damaging the wire mesh.
5. Cure the filler for one hour at 140°F (60°C). The heat must be controlled to make sure the temperature does not exceed 140°F (60°C). **C**
6. Mark the hole pattern with a 1.73 to 1.77 inch (44 to 45 mm) staggered pitch. Make the disbonded area the center of the marked hole pattern. See Detail I.
7. Protect the area around the repair with masking tape. The edge of the tape will be near the boundary of the injected filler. See Detail I.

CAUTION: USE A DRILL STOP TO AVOID DAMAGE TO THE BACKING SKIN OF THE HONEYCOMB PANEL.
8. Make the 0.19 inch (4.83 mm) diameter holes for filler injection through the wire mesh and facing skin. Use the drill stop to limit the penetration to the facing skin. See Detail I.
9. If not already available, make the repair tool to cut the core. See Detail III.
10. Cut the debonded core at the holes marked . See Details I and II. Do not use power tools to turn the cutter.



11. Make sure you remove the core debris to ensure good adhesion of the adhesive filler. Use suction to remove the core debris.

CAUTION: DO NOT INJECT EA934NA IN AMOUNTS LARGER THAN 5.29 OUNCES (150 GRAMS). THE EA934NA FILLER CURES EXOTHERMICALLY. AMOUNTS LARGER THAN 5.29 OUNCES (150 GRAMS) CAN PRODUCE HIGH HEAT AND DAMAGE THE PANEL.

12. Inject filler through the holes marked . Use speed tape to prevent the filler to leak out of the holes if necessary. Do not inject the filler in amounts larger than 5.29 ounces (150 grams).

13. Cure the EA934NA filler at 194°F to 203°F (90°C to 95°C) for a minimum of one hour. **C**

CAUTION: DO NOT CUT INTO THE CURED FILLER. THE CUTTING TOOL WILL NOT CUT THROUGH CURED FILLER. MORE DAMAGE TO THE PANEL COULD OCCUR.

14. Cut the debonded core at the holes marked . See Details I and II. Do not use power tools to turn the cutter.
15. Make sure you remove the core debris to ensure good adhesion of the adhesive filler. Use suction to remove the core debris.
16. Mix the EA934NA filler as specified in the manufacturer's instructions.
17. Inject EA934NA filler through the holes marked . Use speed tape to prevent the filler to leak out of the holes if necessary. Do not inject the filler in amounts larger than 5.29 ounces (150 grams).
18. Cure the EA934NA filler at 194°F to 203°F (90°C to 95°C) for a minimum of one hour. **C** **D**
19. Remove the masking tape and the speed tape as necessary.

WARNING: SANDING OF FILLER MATERIAL PRODUCES DUST AND FLYING PARTICLES WHICH ARE POTENTIAL HEALTH HAZARDS. WEAR PROTECTIVE CLOTHING, GLOVES, DUST MASKS AND SAFETY GLASSES. AVOID BREATHING OF DUST OR PROLONGED CONTACT OF THE DUST WITH THE SKIN.

CAUTION: PROTECT SURROUNDING AREA FROM DUST CONTAMINATION. DUST CAN BECOME EMBEDDED INTO THE WIRE MESH.

Intake Acoustic Liner - Repair for Disbonded Honeycomb Core - RB211-535E4 and RB211- 535E4B Engine Figure 201 (Sheet 1 of 4)

**757-200
STRUCTURAL REPAIR MANUAL****REPAIR INSTRUCTIONS (CONT)**

20. Sand the adhesive filler to make the area smooth and to remove any excess filler. Do not sand into the wire mesh. Use 180 grit aluminum oxide abrasive paper.
21. Vacuum the repair area and around the repair area.
22. Make sure all the disbanded core has been repaired. Do a tap test to make sure that no more disbanded core exists. As an alternative, use acoustic NDT inspection. If disbanded core is detected, repeat these instructions until disbanded core is repaired.
23. Install the cowl if you removed it to make the repair. Refer to AMM 71-11-01.

NOTES

- WHEN YOU USE THIS REPAIR, REFER TO:
 - AMM 71-11-01 FOR COWL REMOVAL/INSTALLATION
 - SOPM 20-30-03 FOR CLEANING PROCEDURES
 - SRM 51-10-02 FOR INSPECTION AND REMOVAL OF DAMAGE.
- A** THE TOTAL REPAIR AREA IS THE SUM OF ALL THE INLET AREAS REPAIRED IN ONE INLET AND FRONT FAN CASE. THE SUM INCLUDES PREVIOUS AND NEW REPAIRS.
- B** IF YOU MAKE THE TOTAL REPAIR AREA MORE THAN 216 SQUARE INCHES (1393 SQUARE cm) BUT LESS THAN 500 SQUARE INCHES (3225 SQUARE cm) INCLUDING PREVIOUS REPAIRS, YOU MUST REPLACE REPAIRED PANELS WITHIN 90 DAYS IN SERVICE. REPLACE PANELS AS REQUIRED SO THAT THE TOTAL REPAIR AREA IS NO MORE THAN 216 SQUARE INCHES (1393 SQUARE cm).
- C** A TYPICAL INITIATION TEMPERATURE OF 104°F (40°C), WITH AN OUTSIDE TEMPERATURE OF 62.6°F (17°C) WILL RESULT INTO A CURE TEMPERATURE OF 194°F (90°C). HIGHER TEMPERATURES CAN BE REACHED DEPENDING ON THE AMOUNT OF THE FILLER USED.
- D** DETAIL I SHOWS A TYPICAL AREA OF REPAIR. YOU CAN INCREASE THIS AREA RADIALY WITHIN THE LIMITS **A** **B**.
- E** DO AN INSPECTION OF THE REPAIR AREA AT EVERY 600 FLIGHT CYCLES UNTIL THE NEXT 3,000 FLIGHT CYCLES. IF DAMAGE IS FOUND OR THE DISBONDED AREA HAD INCREASED, ASK BOEING FOR SPECIFIC INSTRUCTIONS. IF THERE IS NO DAMAGE AND THE DISBOND HAD NOT INCREASED, THE INSPECTIONS CAN BE RETURNED TO THE NORMAL INSPECTION SCHEDULE.

**Intake Acoustic Liner - Repair for Disbonded Honeycomb Core - RB211-535E4 and RB211- 535E4B Engine
Figure 201 (Sheet 2 of 4)**

757-200
STRUCTURAL REPAIR MANUAL

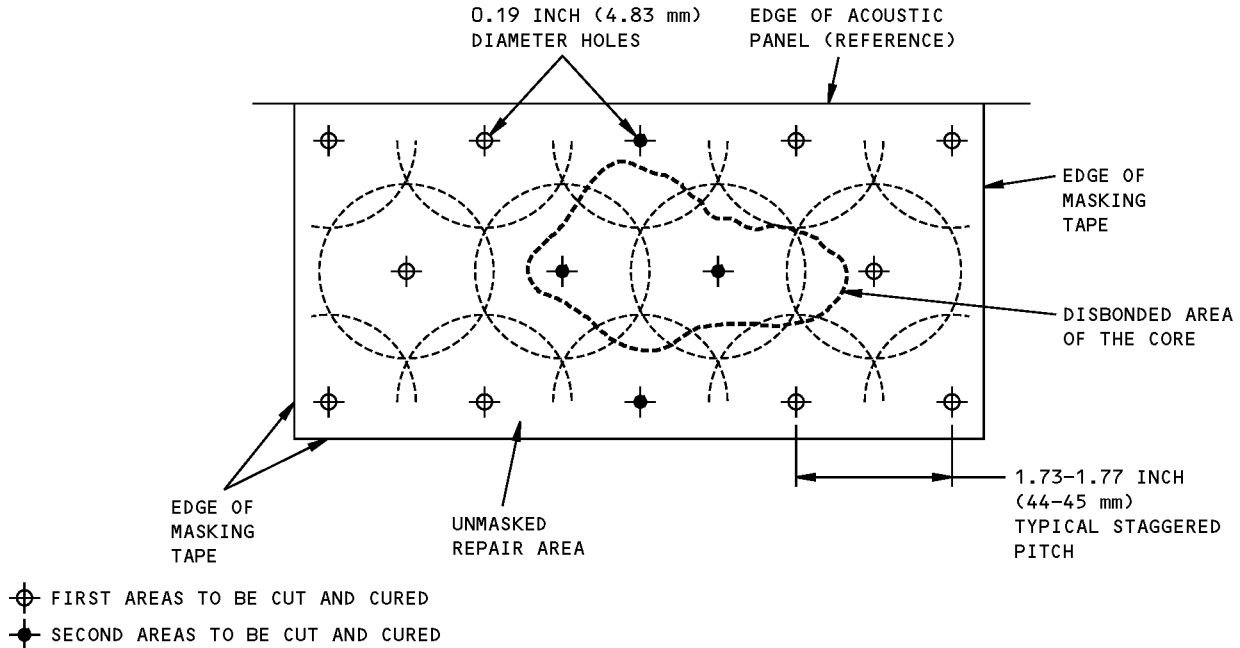

VIEW ON NOSE COWL SHOWING TYPICAL REPAIR AREA TO BE FILLED
DETAIL I D

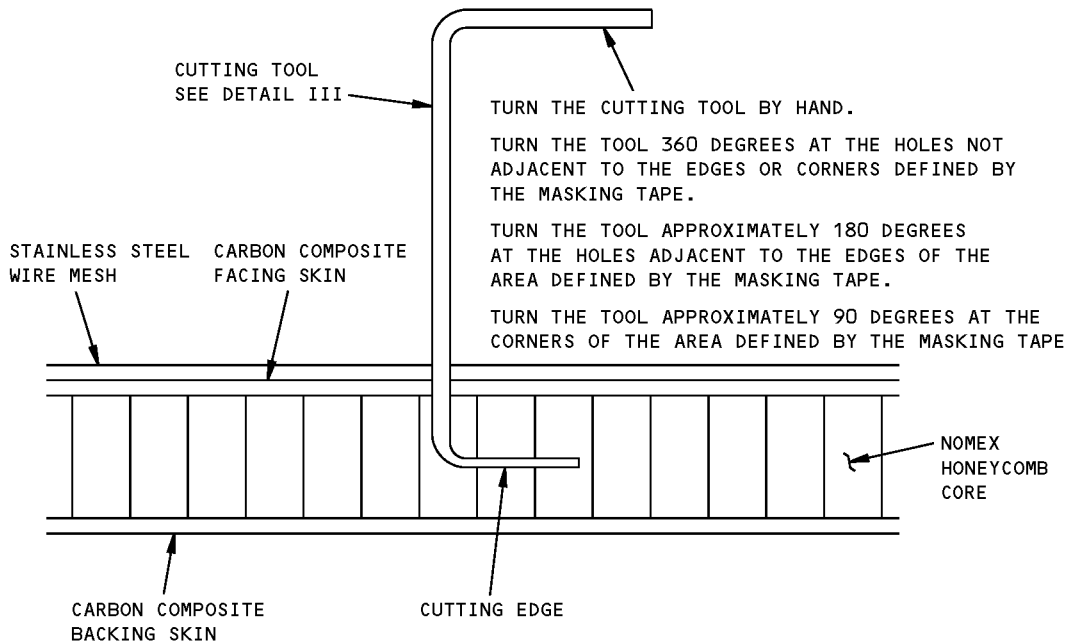

DETAIL II

Intake Acoustic Liner - Repair for Disbonded Honeycomb Core - RB211-535E4 and RB211- 535E4B Engine
Figure 201 (Sheet 3 of 4)

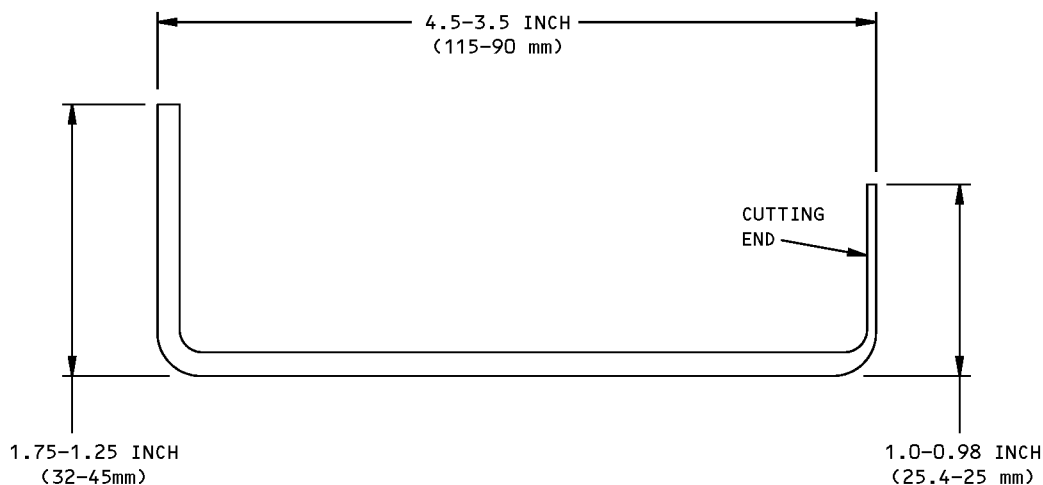
**757-200
STRUCTURAL REPAIR MANUAL**

NOTE: MAKE CUTTING TOOL FROM 0.063 INCH (1.59 mm) DIAMETER STEEL ROD BENT AT BOTH ENDS. FLATTEN AND SHARPEN CUTTING EDGE AS SHOWN.

DETAIL III

**Intake Acoustic Liner - Repair for Disbonded Honeycomb Core - RB211-535E4 and RB211- 535E4B Engine
Figure 201 (Sheet 4 of 4)**

STRUCTURAL REPAIR MANUAL

REPAIR 10 - INLET COWL - REPAIR TO LOCAL DAMAGE OF ACOUSTIC LININGS - RB211-535C ENGINE

REPAIR INSTRUCTIONS

1. Dress damaged area to remove loose debris. Use hand tools.
2. Remove any sharp splits in perforate by radiusing affected area to prevent propagation of cracks. Use hand tools.
3. Lightly planish as necessary to ensure edges of damage are underflush.
4. Thoroughly degrease repair area. Use inhibited trichloroethane. Refer to 51-31-03.
5. Dry area immediately using oil-free dry air supply.
6. Mix EC3524 B/A resin filler. Measure one hundred (100) parts EC3524B (blue) to ninety-four (94) parts of EC3524A (white) by weight. Mix materials by kneading until uniform blue color, free of streaks is obtained. Refer to 51-31-03.
7. Spread material on a clean surface to a depth of 0.5 in.

NOTE: This allows exothermic heat dissipation and provides maximum working life of one (1) hour at room temperature 72°F (22°C).
8. Slightly overfill damaged area with resin filler. Use suitable hand applicators.
9. Partially cure until resin filler starts to stiffen.
10. Remove majority of excess filler material in a planing/burnishing action. Use a heated pallet knife or trowel which must be cleaned prior to reheating.
11. Cure the filler material for 24 hours at 72°F (22°C) or half an hour at 200°F (93°C).
12. Blend filler material to contour. Use Garnet paper 60-80 grade. Refer to 51-31-03.
13. Paint repaired area. Use an aluminum filled, room curing epoxy paint. Refer to 51-21-01.
14. Visually inspect.

NOTES

- ALL DIMENSIONS ARE IN INCHES.
- DAMAGE MUST NOT BE LESS THAN 6.0 FROM ANY PANEL EDGE.
- DAMAGE IS LIMITED TO ONE AREA OF 1.50 DIA PER PANEL OR TWO AREAS OF 1.0 DIA PER PANEL PROVIDING THEY ARE A MINIMUM OF 12.0 APART.
- DAMAGE NECESSITATING REPLACEMENT - DAMAGE IN EXCESS OF THE CONDITIONS SPECIFIED ABOVE REQUIRES REPLACEMENT.
- REFER TO 51-31-03 FOR NON-METALLIC MATERIAL SOURCES.

**Inlet Cowl - Repair to Local Damage of Acoustic Linings - RB211-535C Engine
Figure 201 (Sheet 1 of 2)**

757-200
STRUCTURAL REPAIR MANUAL

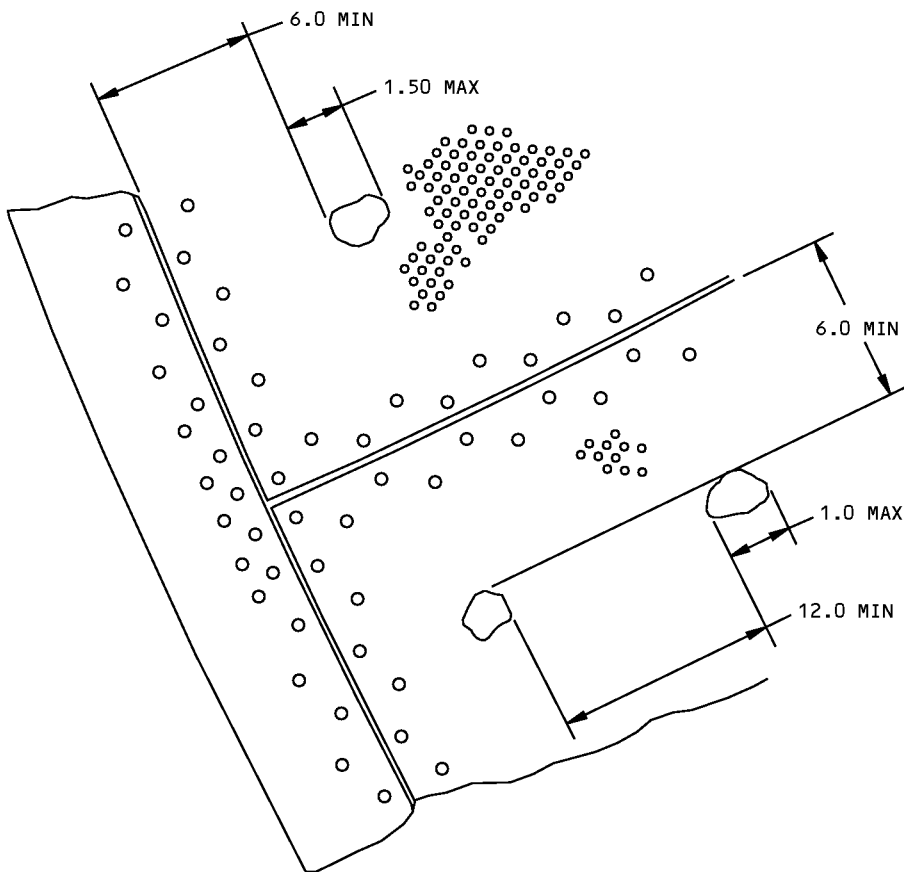

VIEW ON COWLING ASSEMBLY, SHOWING ACOUSTIC LINING



SECTION THROUGH REPAIR

Inlet Cowl - Repair to Local Damage of Acoustic Linings - RB211-535C Engine
Figure 201 (Sheet 2 of 2)

STRUCTURAL REPAIR MANUAL

**REPAIR 11 - INLET COWL OUTER SKIN - PERMANENT PATCH ADJACENT TO STIFFENER - RB211-535C
ENGINE**



REPAIR INSTRUCTIONS

1. Mark and cut out damaged area to rectangular shape, taking care not to damage stiffener member. Apply Skydrol resistant faying surface finish (refer to AMM 51-24-01) to raw edges of skin. Use hand tools.
2. Make patch, part 1.
3. Make landing plates, part 2.
4. Make packer plates, part 3.
NOTE: Only required when repairing chemically etched skin.
5. Drill the existing skin, patch, packer plates, and landing plates.
6. Countersink the patch and existing skin. Deburr all parts.
7. Apply alodine (refer to SRM 51-20-01) or alochrom (refer to SRM 51-21-01) coating.
8. Apply one coat of BMS 10-11, type I primer to each surface (refer to SRM 51-21-00)
9. Apply faying surface seal to stiffener member, underside of landing plates and patch. Use Hylomar PL32M. Refer to SRM 51-31-03.
10. Fit the landing plates and patch.
NOTE: Place the packer plate between landing plates and the panel skin if a chemically etched skin is being repaired.
11. Rivet parts in position. Use 1/8-inch 100° countersunk SP71 or NASM20426A-D in aluminum alloy or if inaccessible from both sides use 1/8-inch 100° countersunk Bulbed Cherrylock CR2238 series in repair rivet locations and 5/32 inch in existing locations. Refer to SRM 51-41-01.
12. Apply Skydrol resistant finish to the repaired area.

NOTES

- REFER TO THE FOLLOWING WHEN USING THE REPAIR:
 - AMM 70-42-12 FOR LOCAL SURFACE PROTECTION
 - SRM 51-21-01 FOR PROTECTIVE TREATMENT OF METAL REPAIR PARTS
 - SRM 51-21-05 FOR REPAIR SEALING INSTRUCTIONS
 - SRM 51-24-01 FOR HYDRAULIC FLUID RESISTANT FINISH
 - SRM 51-31-03 FOR NON-METALLIC MATERIAL SOURCES
- DIMENSIONS ARE IN INCHES.
- CARE MUST BE TAKEN NOT TO DAMAGE THE FRAME MEMBER.
- PATCH AND LANDING PLATE TO BE OF SAME THICKNESS AND SPEC AS EXISTING SKIN. USE 1/8 DIAMETER 100° COUNTERSUNK RIVETS SP71, NASM20426A-D OR EQUIVALENT IN ALUMINUM ALLOY; OR IF INACCESSIBLE AVDEL EQUIVALENTS.

FASTENER SYMBOLS

-  EXISTING RIVET
 REPAIR RIVET

REPAIR MATERIAL			
PART		QTY	MATERIAL
1	PATCH	1	0.064 L165
2	LANDING PLATES	2	0.064 L165
3	PACKER PLATES	2 LOWER SKINS ONLY	0.024 L165

**Inlet Cowl Outer Skin Repair - Permanent Patch Adjacent to Stiffener - RB211-535C Engine
Figure 201 (Sheet 1 of 2)**

757-200
STRUCTURAL REPAIR MANUAL

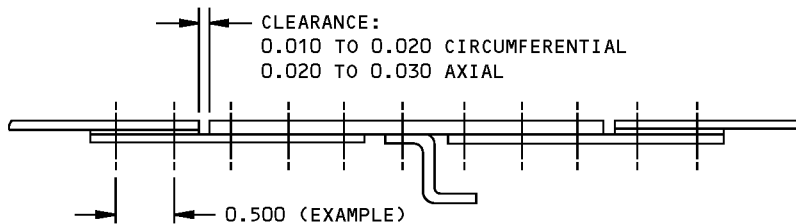
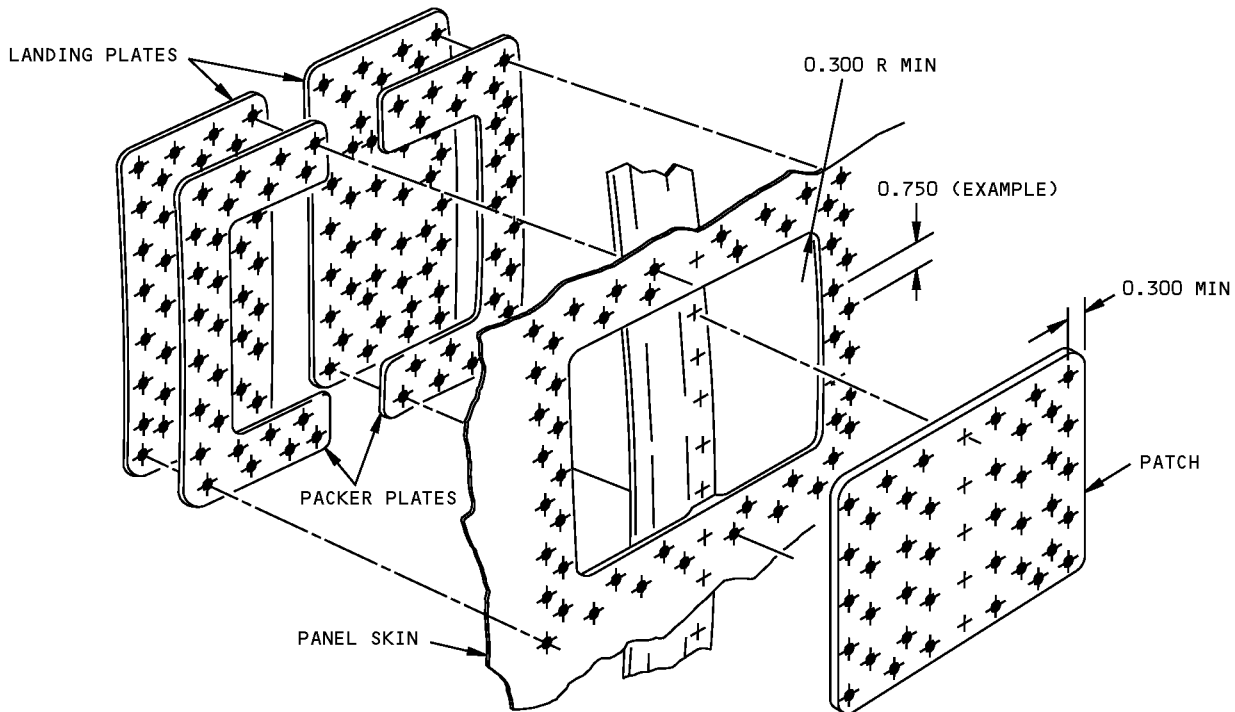

SECTION THROUGH INLET COWLING ASSEMBLY SHOWING EXAMPLE REPAIR

A3605

**Inlet Cowl Outer Skin Repair - Permanent Patch Adjacent to Stiffener - RB211-535C Engine
Figure 201 (Sheet 2 of 2)**

STRUCTURAL REPAIR MANUAL

REPAIR 12 - INLET COWL OUTER SKIN - EXTERNAL PATCH ADJACENT TO STIFFENER - RB211-535C ENGINE

REPAIR INSTRUCTIONS

1. Mark and cut out damage area to a rectangular shape taking care not to damage the stiffener member. Use hand tools.
2. Produce patch, part 1.
3. Produce filler, part 2.
4. Drill existing skin, patch and filler.
5. Countersink patch and deburr all parts.
6. Apply alodine (refer to SRM 51-20-01) or alochrom (refer to SRM 51-21-01) coating.
7. Apply one coat of BMS 10-11, type I primer to each surface. Refer to AMM 51-21.
8. Apply fay surface seal to stiffener member filler and underside of patch. Use Hylomar SQ32M. Refer to SRM 51-21-05.
9. Fit filler and patch and rivet in position. Use 1/8 inch 100° countersunk, SP71 or NASM20426AD4, in aluminum alloy or if inaccessible from both sides, use 1/8 inch 100° Bulbed Cherrylock CR2238 series in repair rivet locations and 5/32 inch in existing locations. Refer to SRM 51-41-01.

NOTES

- REFER TO THE FOLLOWING WHEN USING THE REPAIR:
 - AMM 70-42-12 FOR LOCAL SURFACE PROTECTION
 - SRM 51-21-01 FOR PROTECTIVE TREATMENT OF METAL REPAIR PARTS
 - SRM 51-21-05 FOR REPAIR SEALING INSTRUCTIONS
 - SRM 51-31-03 FOR NON-METALLIC MATERIAL SOURCES
- DIMENSIONS ARE IN INCHES.

FASTENER SYMBOLS

+ EXISTING RIVET

⊕ REPAIR RIVET

REPAIR MATERIAL			
PART		QTY	MATERIAL
1	PATCH	1	0.040 L165
2	FILLER	1	0.064 L165

**Inlet Cowl Outer Skin Repair - External Patch Adjacent to Stiffener - RB211-535C Engine
Figure 201 (Sheet 1 of 2)**

757-200
STRUCTURAL REPAIR MANUAL

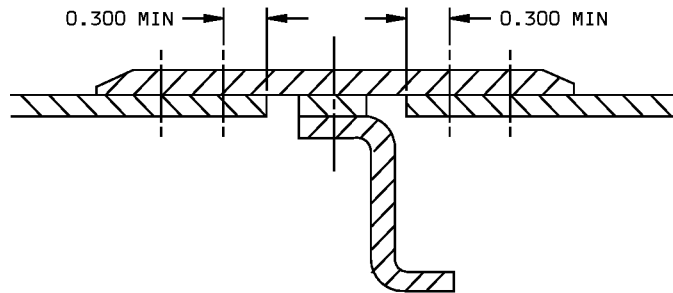
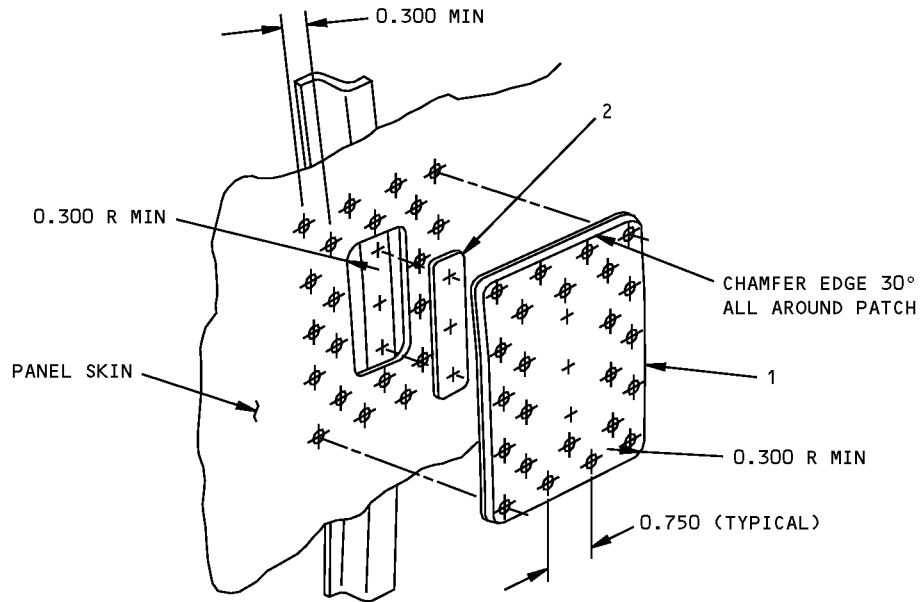

SECTION THROUGH INLET COWLING ASSEMBLY SHOWING TYPICAL REPAIR

Inlet Cowl Outer Skin Repair - External Patch Adjacent to Stiffener - RB211-535C Engine
Figure 201 (Sheet 2 of 2)

757-200
STRUCTURAL REPAIR MANUAL

IDENTIFICATION 1 - INLET COWL STRUCTURE - RB211-535E4 ENGINE

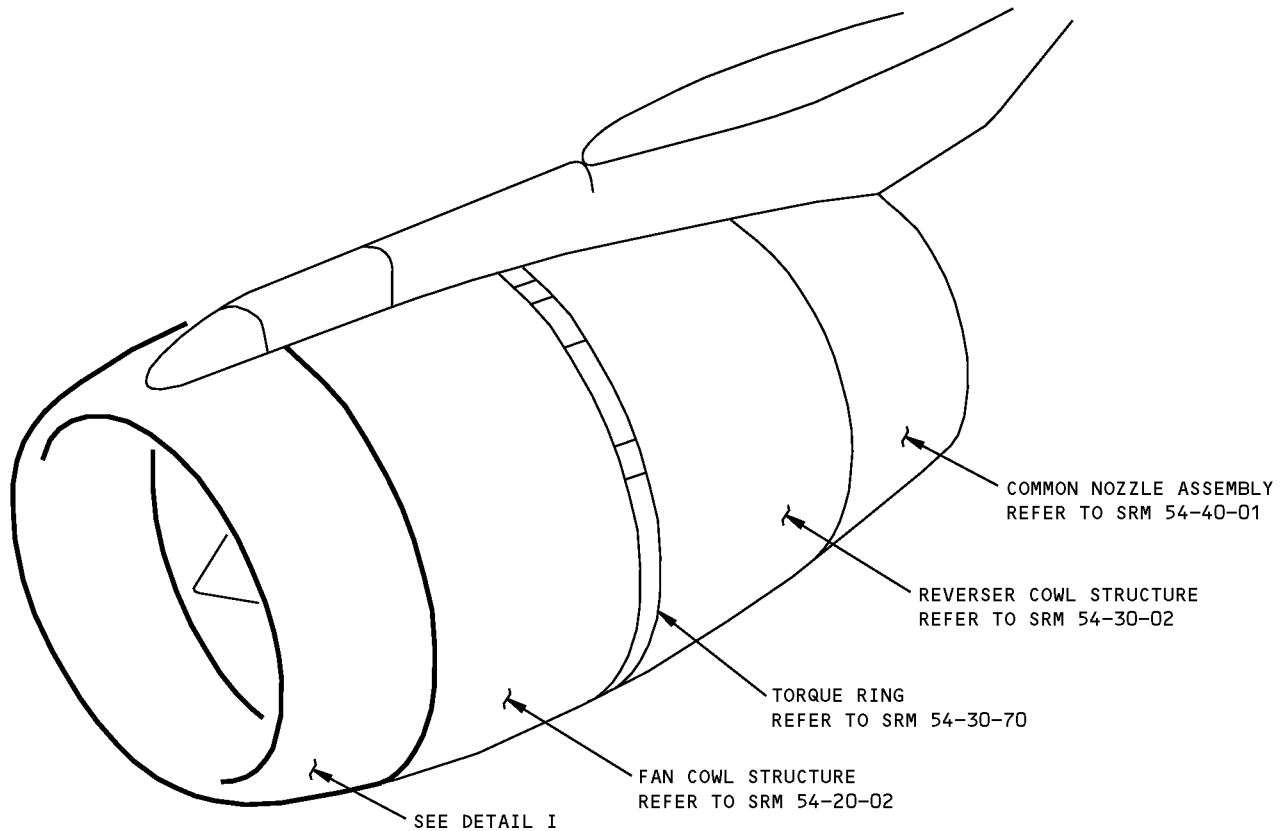

NOTES

- A** PLY ORIENTATION CONVENTION DEGREES INDICATED IS PARALLEL TO THE FABRIC WARP DIRECTION.
- B** GRAPHITE PREPREG BMS 8-212 TYPE IV CLASS 2 STYLE 3K-70-PW.
- C** GRAPHITE PREPREG BMS 8-212 TYPE III CLASS 1 GRADE 145.
- D** NO SPLICE ALLOWED.
- E** BUTT FIT (NO OVERLAP).

Inlet Cowl Structure Identification - RB211-535E4 Engine
Figure 1 (Sheet 1 of 4)

757-200
STRUCTURAL REPAIR MANUAL

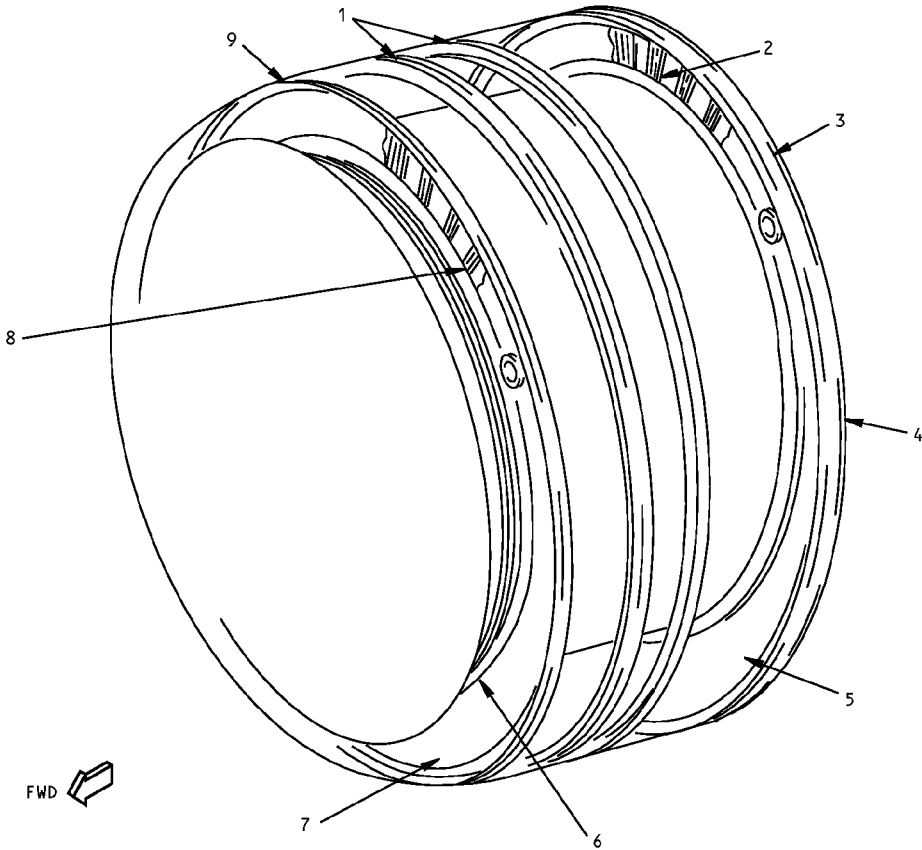

DETAIL I



Inlet Cowl Structure Identification - RB211-535E4 Engine
Figure 1 (Sheet 2 of 4)

IDENTIFICATION 1
Page 2
Jan 20/2005

54-10-02

D634N201

757-200
STRUCTURAL REPAIR MANUAL

ITEM	DESCRIPTION	GAGE	MATERIAL	EFFECTIVITY
1	SKIN STIFFENERS	0.048	GRAPHITE EPOXY LAMINATE (SEE DETAIL II)	
2	REAR DIAPHRAGM STIFFENERS	0.048	L165	
3	UPPER REINFORCING ANGLE	0.048	S.527	
4	REINFORCING ANGLE	0.048	L165	
5	REAR DIAPHRAGM	0.064	TA6	
6	REINFORCING ANGLE FRONT INNER	0.048	TA6	
	REAR INNER	0.036	TA6	
7	FRONT DIAPHRAGM	0.028	TA6	
8	FRONT DIAPHRAGM STIFFENERS	0.040	TA6	
9	REINFORCING ANGLE FRONT AND REAR OUTER	0.040	DTD5070	

LIST OF MATERIALS FOR DETAIL I

Inlet Cowl Structure Identification - RB211-535E4 Engine
Figure 1 (Sheet 3 of 4)

D634N201

54-10-02

IDENTIFICATION 1
Page 3
Jan 20/2005

**757-200
STRUCTURAL REPAIR MANUAL**

PPS 56-80 IS 20-90

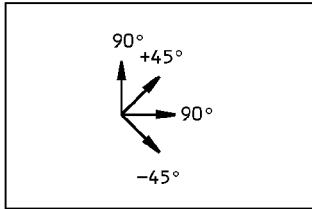

PPS 61-75 IS 20-90

ITEM 1
REAR STIFFENER
SKIN SUPPORT
(L/H AND R/H)

ITEM 1
FRONT STIFFENER
SKIN SUPPORT
(L/H AND R/H)

VIEW ON INLET COWL
RIGHT HAND SIDE

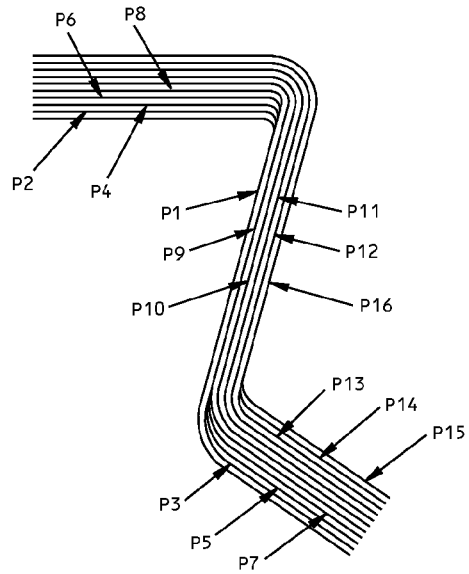

SECTION THROUGH CARBON
FIBRE LAYERS

ITEM NO.	PLY NO.	MATERIAL	PLY ORIENTATION [A]	NOTE
1	P1 [E]	[B]	±45°	[A] [E]
	P2 TO P8 [D]	[C]	0°	[A] [D]
	P9 TO P12 [E]	[B]	±45°	[A] [E]
	P13 TO P15 [D]	[C]	0°	[A] [D]
	P16 [E]	[B]	±45°	[A] [E]

PLY TABLE

PLY ORIENTATION DIAGRAM FOR RB211-535E4
DETAIL II

68474

Inlet Cowl Structure Identification - RB211-535E4 Engine
Figure 1 (Sheet 4 of 4)

IDENTIFICATION 1
Page 4
Jan 20/2005

54-10-02

D634N201

757-200
STRUCTURAL REPAIR MANUAL

IDENTIFICATION 2 - INLET COWL STRUCTURE - RB211-535C ENGINE

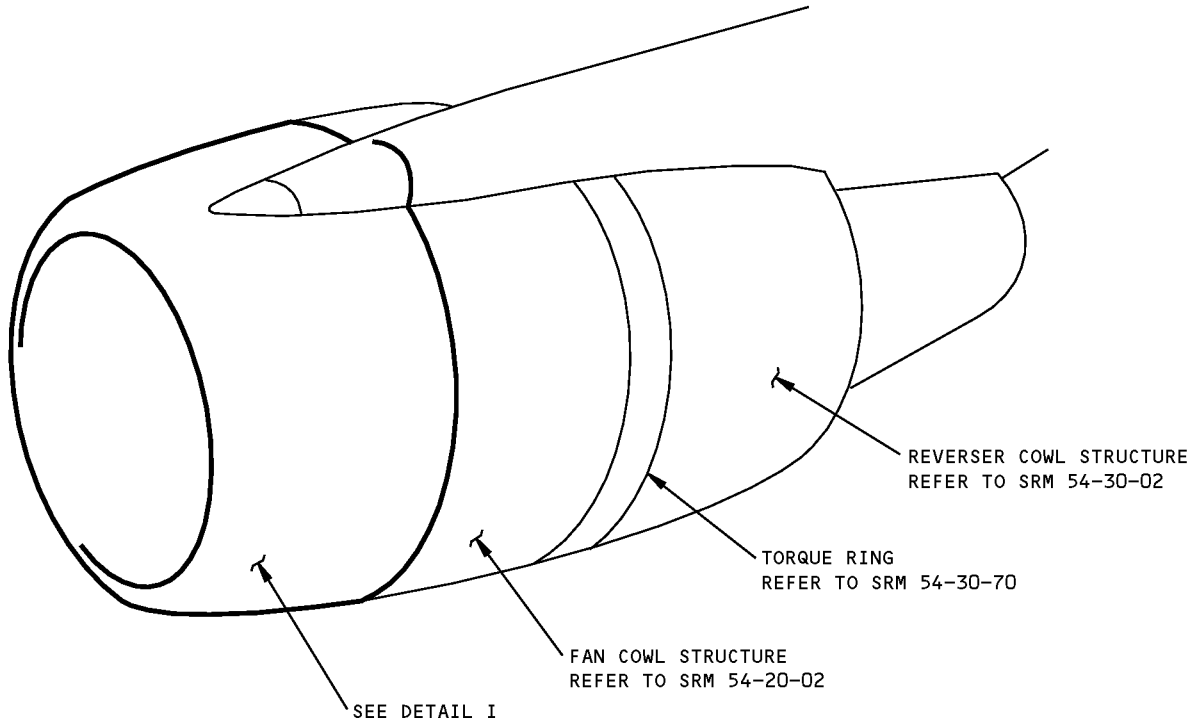

NOTES

- A** PLY ORIENTATION CONVENTION DEGREES INDICATED IS PARALLEL TO THE FABRIC WARP DIRECTION.
- B** GRAPHITE PREPREG BMS 8-212 TYPE IV CLASS 2 STYLE 3K-70-PW.
- C** GRAPHITE PREPREG BMS 8-212 TYPE III CLASS 1 GRADE 145.
- D** NO SPLICE ALLOWED.
- E** BUTT FIT (NO OVERLAP).

Inlet Cowl Structure Identification - RB211-535C Engine
Figure 1 (Sheet 1 of 4)

757-200
STRUCTURAL REPAIR MANUAL

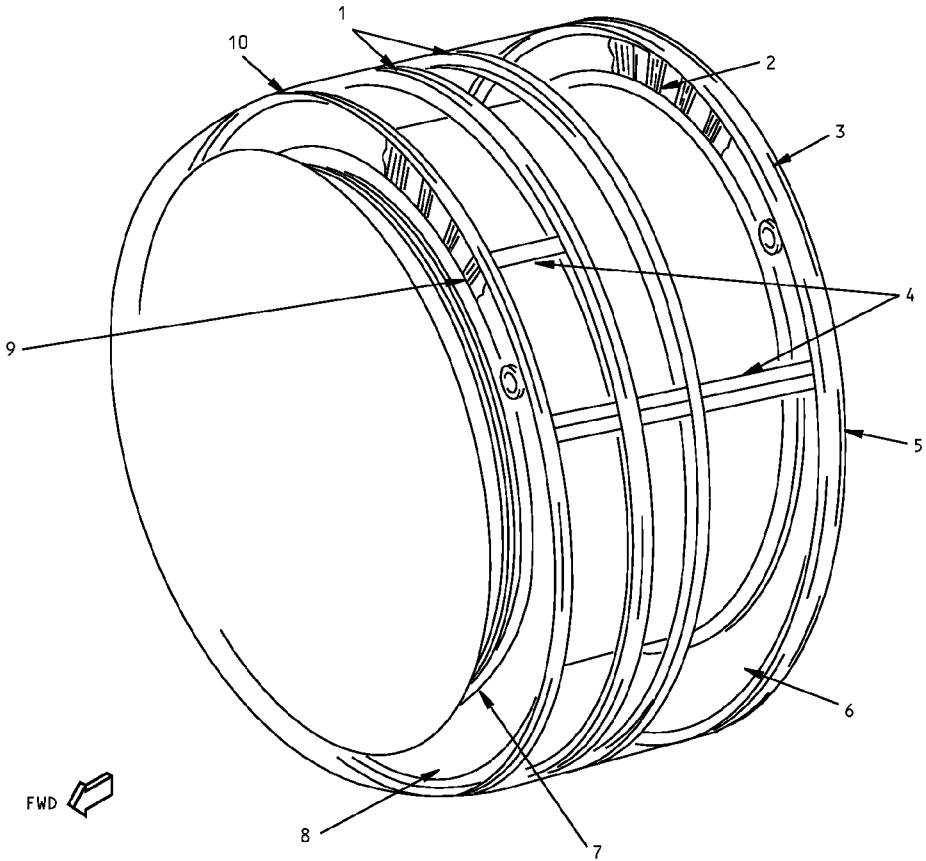

DETAIL I

LIST OF
MATERIAL

Inlet Cowl Structure Identification - RB211-535C Engine
Figure 1 (Sheet 2 of 4)

IDENTIFICATION 2
Page 2
May 20/2005

54-10-02

D634N201

757-200
STRUCTURAL REPAIR MANUAL

ITEM	DESCRIPTION	GAGE	MATERIAL	EFFECTIVITY
1	SKIN STIFFENERS	0.048	L164 (SEE DETAIL II)	
2	REAR DIAPHRAGM STIFFENERS	0.048	L165	
3	UPPER REINFORCING ANGLE	0.048	S.527	
4	BUTT STRAPS	0.048	L165	
5	REINFORCING ANGLE	0.048	L165	
6	REAR DIAPHRAGM	0.064	TA6	
7	REINFORCING ANGLE FRONT INNER REAR INNER	0.048 0.036	TA6 TA6	
8	FRONT DIAPHRAGM	0.028	TA6	
9	FRONT DIAPHRAGM STIFFENERS	0.040	TA6	
10	REINFORCING ANGLE FRONT AND REAR OUTER	0.040	DTD5070	

LIST OF MATERIALS FOR DETAIL I

Inlet Cowl Structure Identification - RB211-535C Engine
Figure 1 (Sheet 3 of 4)

D634N201

54-10-02

IDENTIFICATION 2
Page 3
May 20/2005

**757-200
STRUCTURAL REPAIR MANUAL**

PPS 56-80 IS 20-90

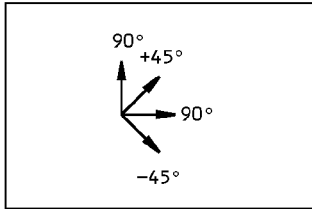

PPS 61-75 IS 20-90

ITEM 1
REAR STIFFENER
SKIN SUPPORT
(L/H AND R/H)

ITEM 1
FRONT STIFFENER
SKIN SUPPORT
(L/H AND R/H)

VIEW ON INLET COWL
RIGHT HAND SIDE

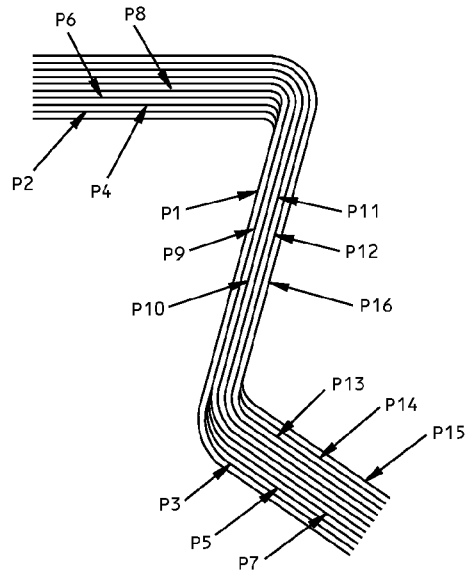

SECTION THROUGH CARBON
FIBRE LAYERS

ITEM NO.	PLY NO.	MATERIAL	PLY ORIENTATION [A]	NOTE
1	P1 [E]	[B]	±45°	[A] [E]
	P2 TO P8 [D]	[C]	0°	[A] [D]
	P9 TO P12 [E]	[B]	±45°	[A] [E]
	P13 TO P15 [D]	[C]	0°	[A] [D]
	P16 [E]	[B]	±45°	[A] [E]

PLY TABLE

PLY ORIENTATION DIAGRAM FOR RB211-535C
DETAIL II

68474

**Inlet Cowl Structure Identification - RB211-535C Engine
Figure 1 (Sheet 4 of 4)**

IDENTIFICATION 2
Page 4
May 20/2005

54-10-02

D634N201

757-200
STRUCTURAL REPAIR MANUAL

ALLOWABLE DAMAGE 1 - INLET COWL STRUCTURE - RB211-535E4 ENGINE

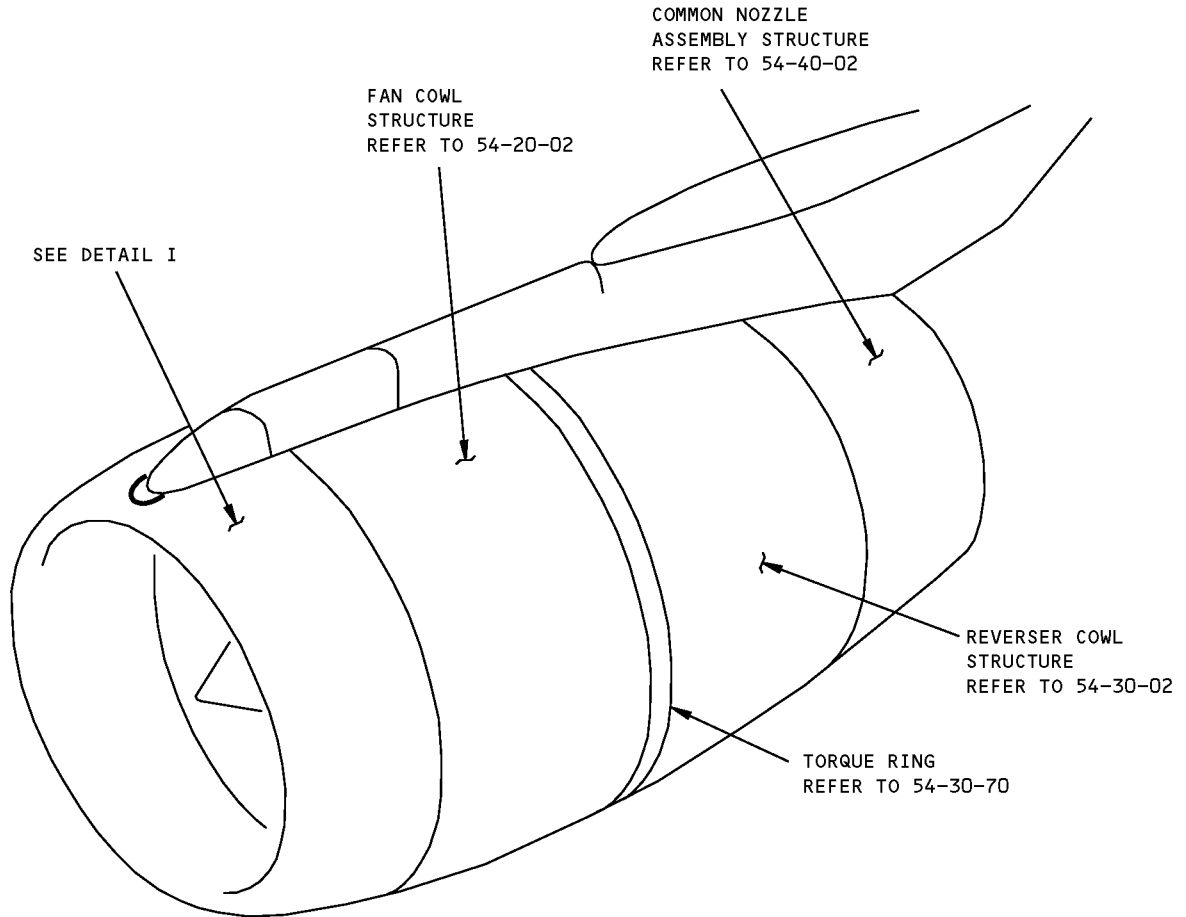

Allowable Damage - Inlet Cowl Structure - RB211-535E4 Engine
Figure 101 (Sheet 1 of 5)

757-200
STRUCTURAL REPAIR MANUAL

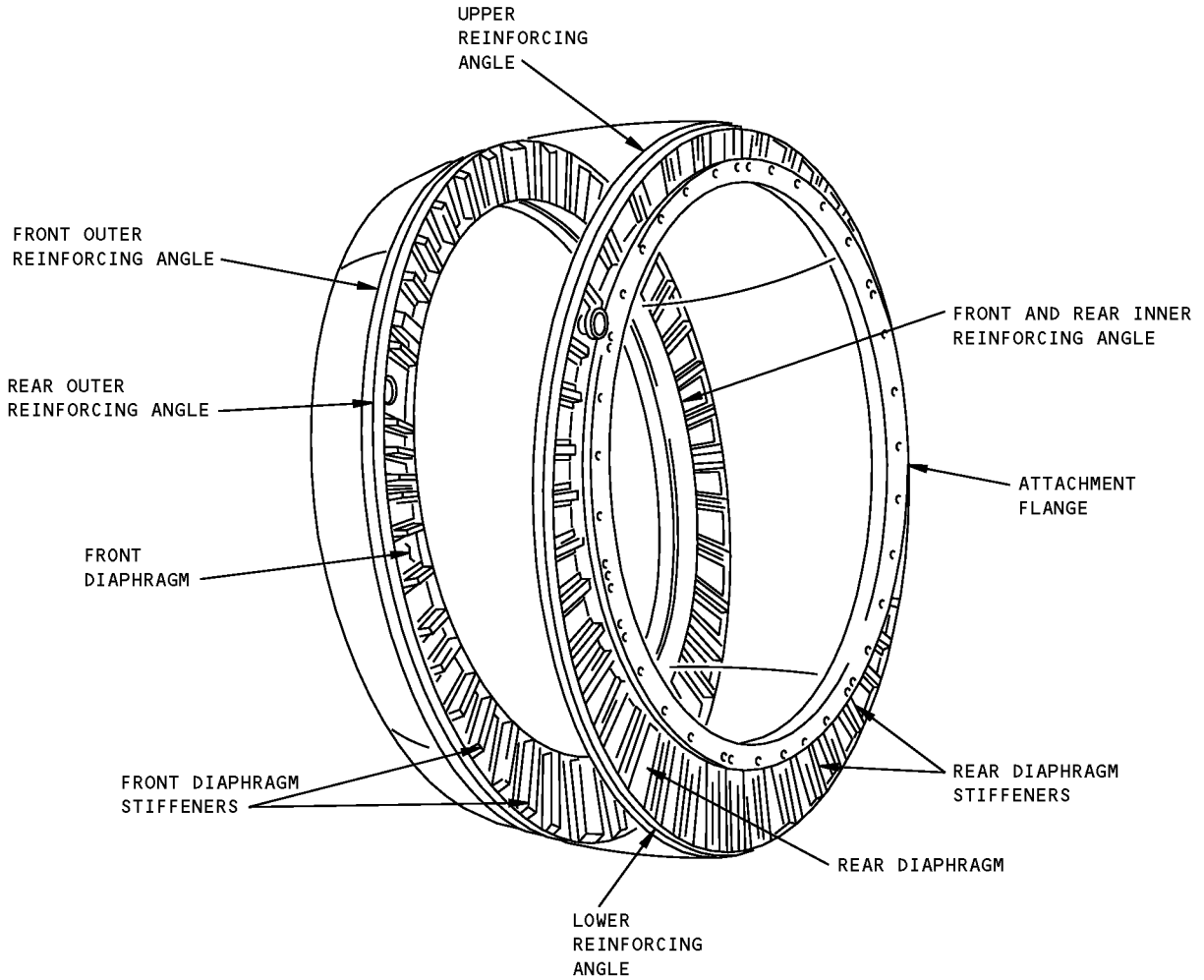

LOCATION		CRACKS	NICKS, GOUGES AND CORROSION	DENTS	HOLES
NOSE COWL	DIAPHRAGMS	NOT ALLOWED	SEE DETAIL II A	SEE DETAIL III B	NOT ALLOWED
	FRONT DIAPHRAGM STIFFENERS			SEE DETAILS IV AND V C	
	REAR DIAPHRAGM STIFFENERS			SEE DETAIL VI D	
	ATTACHMENT FLANGE			NOT ALLOWED	

Allowable Damage - Inlet Cowl Structure - RB211-535E4 Engine
Figure 101 (Sheet 2 of 5)

757-200
STRUCTURAL REPAIR MANUAL

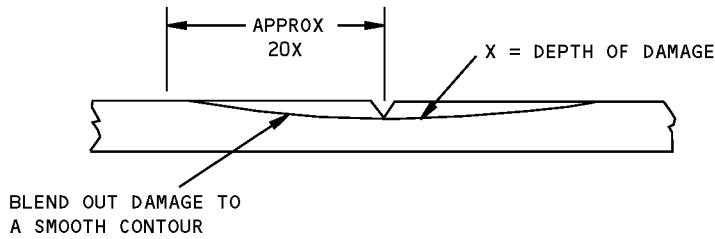
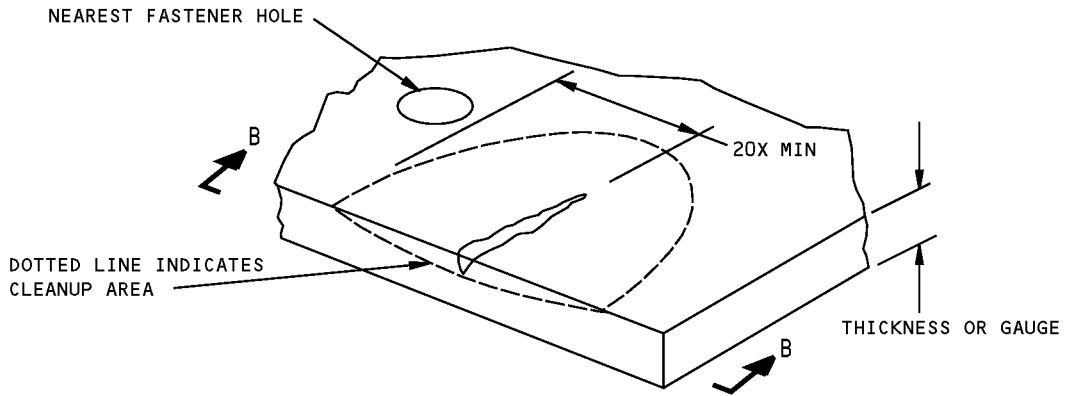

SECTION B-B

DETAIL II

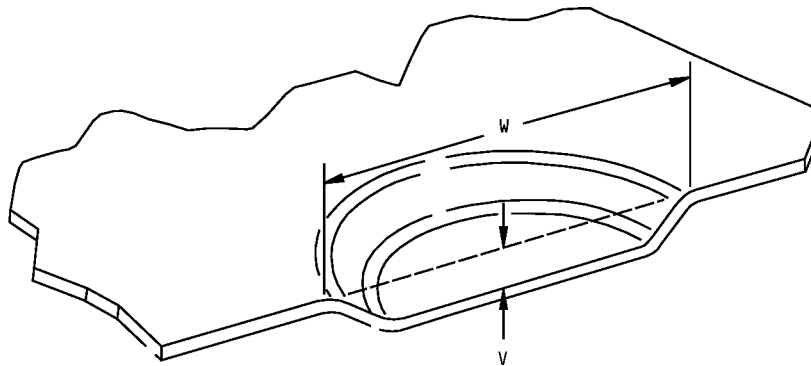

DETAIL III

Allowable Damage - Inlet Cowl Structure - RB211-535E4 Engine
Figure 101 (Sheet 3 of 5)

757-200
STRUCTURAL REPAIR MANUAL

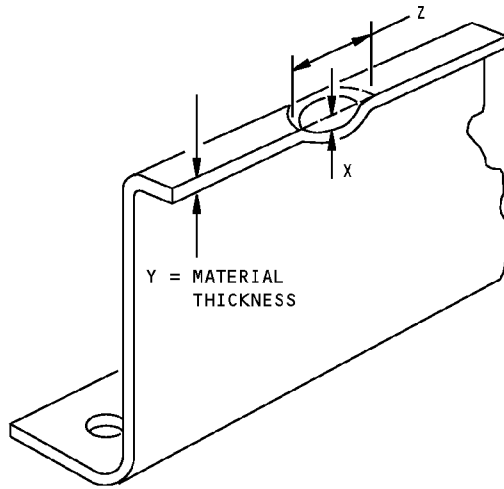

DETAIL IV

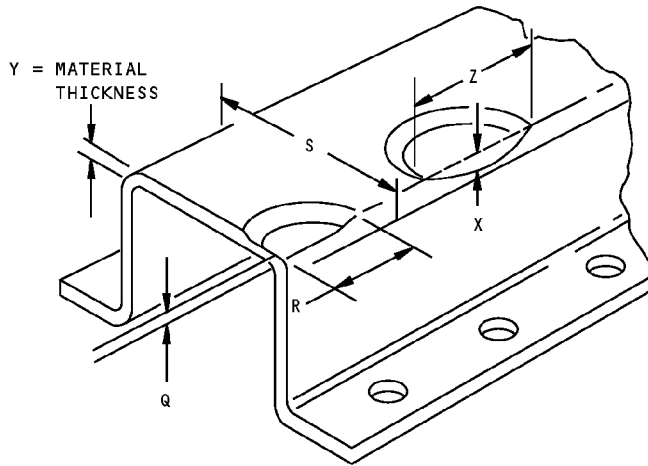

DETAIL V

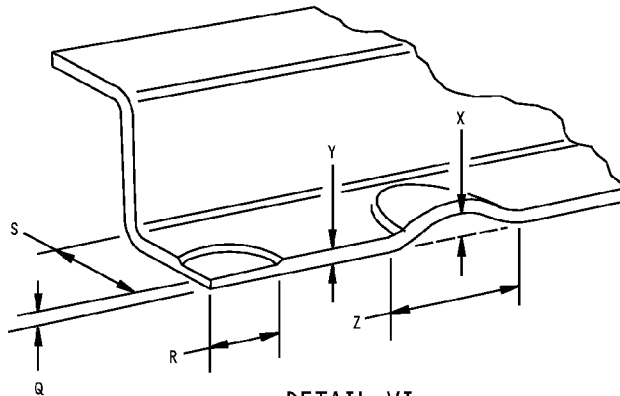

DETAIL VI

Allowable Damage - Inlet Cowl Structure - RB211-535E4 Engine
Figure 101 (Sheet 4 of 5)

**757-200
STRUCTURAL REPAIR MANUAL****NOTES**

- REFINISH REWORKED AREAS AS SHOWN IN SRM 51-21-01.
- A** DAMAGE IS PERMITTED UP TO 4% OF MATERIAL THICKNESS AND 2.00 INCHES (50 mm) LONG. REMOVE DAMAGE AS SHOWN IN DETAIL II.
- B** SMOOTH DENTS ARE PERMITTED, OTHER THAN IN FRONT DIAPHRAGM, PROVIDING "V" (DETAIL III) DOES NOT EXCEED 0.10 INCH (2.5 mm), AREA OF DAMAGE "W" DOES NOT EXCEED 2.00 INCHES (50 mm) DIAMETER AND THERE IS A MINIMUM OF 4.00 INCHES (100 mm) SEPARATING EACH DAMAGED AREA. NO DENTS ARE PERMITTED IN FRONT DIAPHRAGM.
- C** DISTORTION IS PERMITTED PROVIDING "X" (DETAILS IV AND V) DOES NOT EXCEED TWO TIMES "Y" AND DAMAGE "Z" DOES NOT EXCEED 1.50 INCHES (38 mm). THINNING IS PERMITTED (DETAIL V) PROVIDING "Q" IS NOT LESS THAN HALF (1/2) "Y" AND AREA OF THINNING "R" DOES NOT EXCEED ONE EIGHTH (1/8) OF "S" WIDE BY 1.50 INCHES (38 mm).
- D** DISTORTION IS PERMITTED PROVIDING "X" (DETAIL VI) DOES NOT EXCEED TWO TIMES "Y" AND DAMAGE "Z" DOES NOT EXCEED 1.50 INCHES (38 mm). THINNING IS PERMITTED (DETAIL VI) PROVIDING "Q" IS NOT LESS THAN HALF (1/2) "Y" AND AREA OF THINNING "R" DOES NOT EXCEED ONE EIGHTH (1/8) OF "S" BY 1.50 INCHES (38 mm).

**Allowable Damage - Inlet Cowl Structure - RB211-535E4 Engine
Figure 101 (Sheet 5 of 5)**

757-200
STRUCTURAL REPAIR MANUAL

ALLOWABLE DAMAGE 2 - INLET COWL STRUCTURE - RB211-535C ENGINE

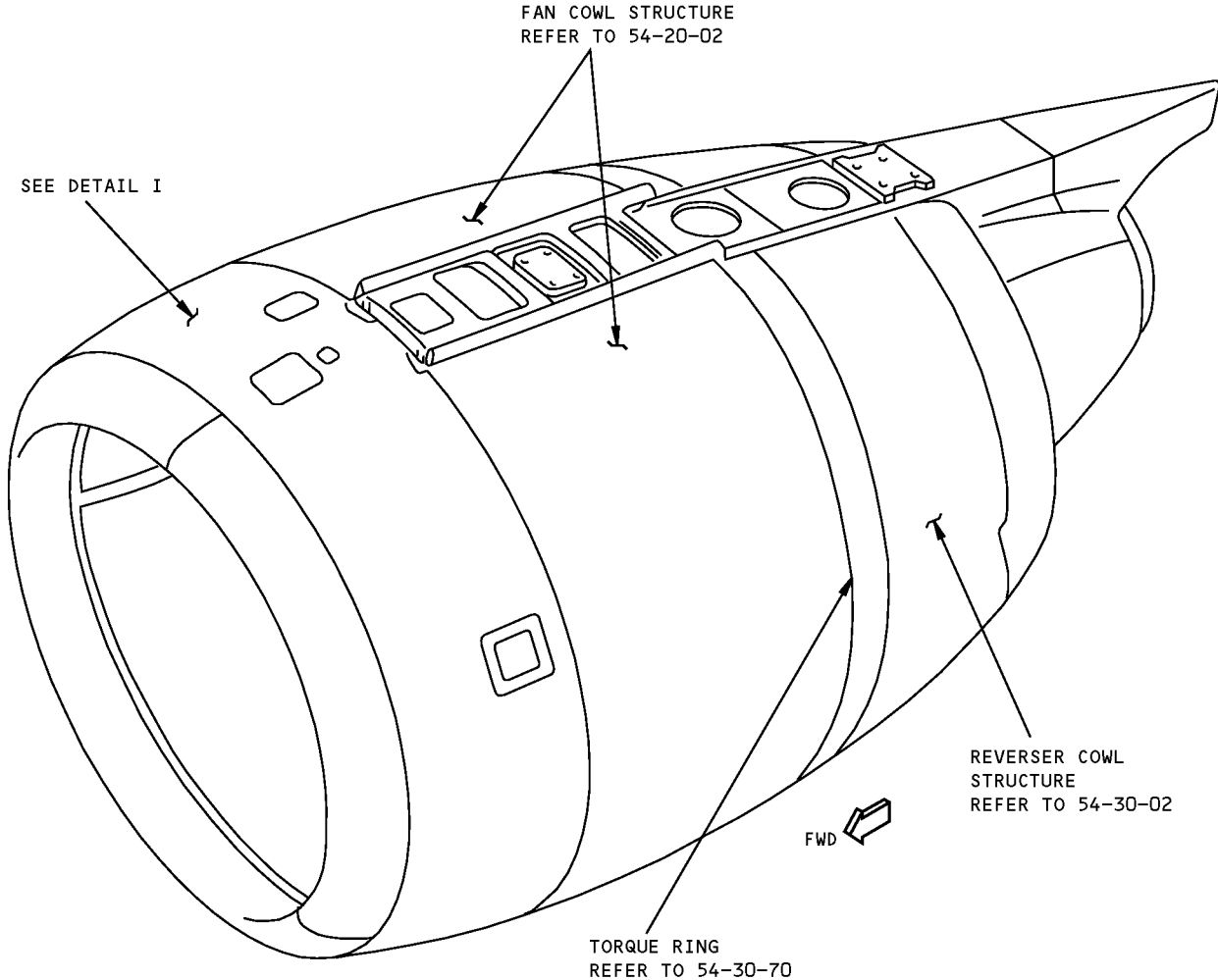

Allowable Damage - Inlet Cowl Structure - RB211-535C Engine
Figure 101 (Sheet 1 of 5)

757-200
STRUCTURAL REPAIR MANUAL

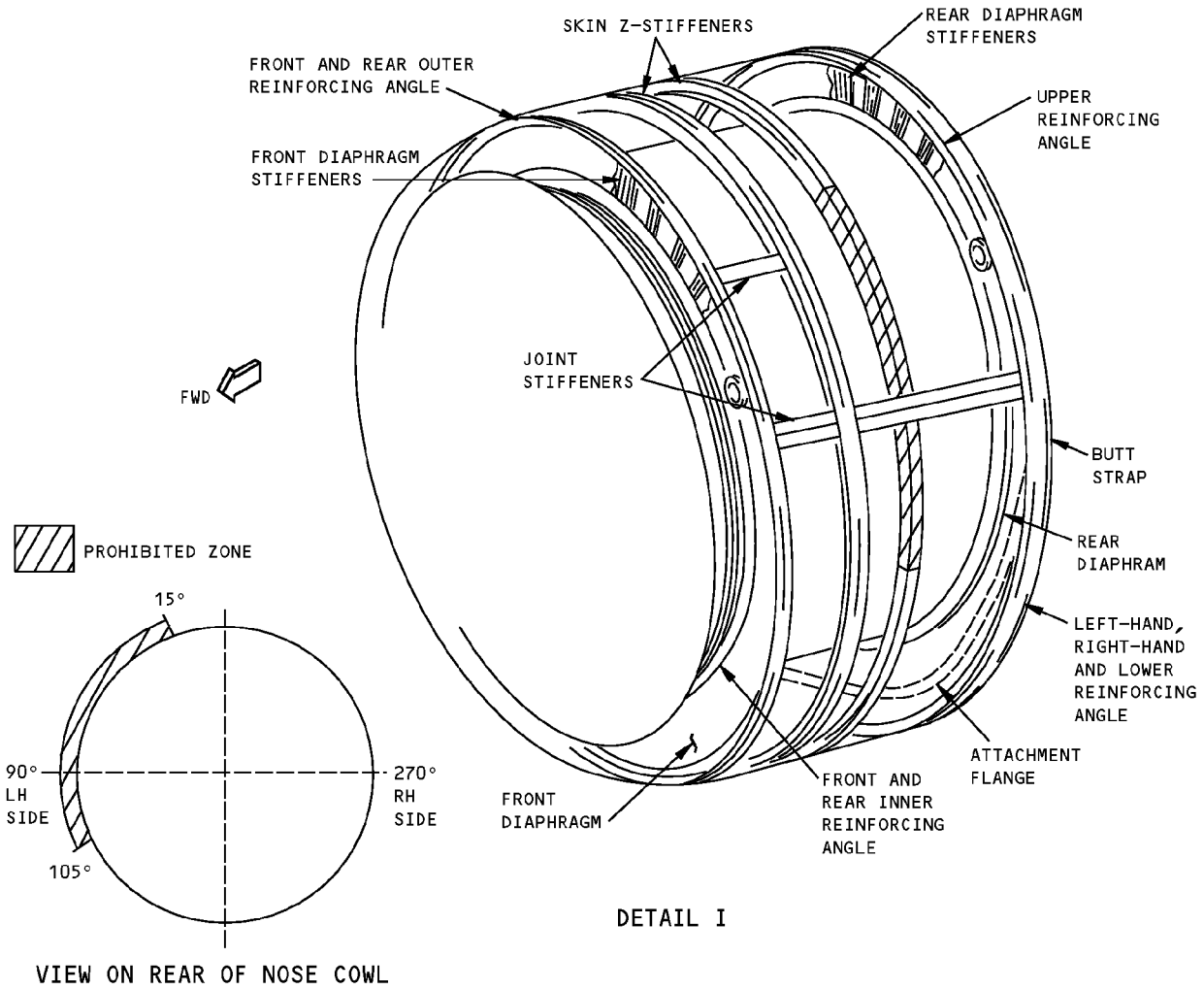

DETAIL I

VIEW ON REAR OF NOSE COWL

LOCATION		CRACKS	NICKS, GOUGES AND CORROSION	DENTS	HOLES
NOSE COWL	DIAPHRAGMS	NOT ALLOWED	SEE DETAIL II A	SEE DETAIL III B	NOT ALLOWED
	FRONT DIAPHRAGM STIFFENERS			SEE DETAILS IV AND V C	
	REAR DIAPHRAGM STIFFENERS			SEE DETAIL VI D	
	SKIN Z-STIFFENERS			NOT ALLOWED	
	JOINT STIFFENERS				
	BUTT STRAPS				
	ATTACHMENT FLANGE				

Allowable Damage - Inlet Cowl Structure - RB211-535C Engine
Figure 101 (Sheet 2 of 5)

757-200
STRUCTURAL REPAIR MANUAL

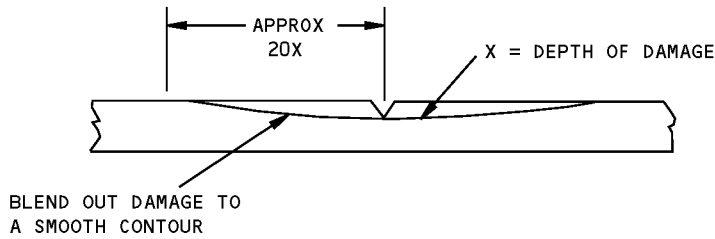
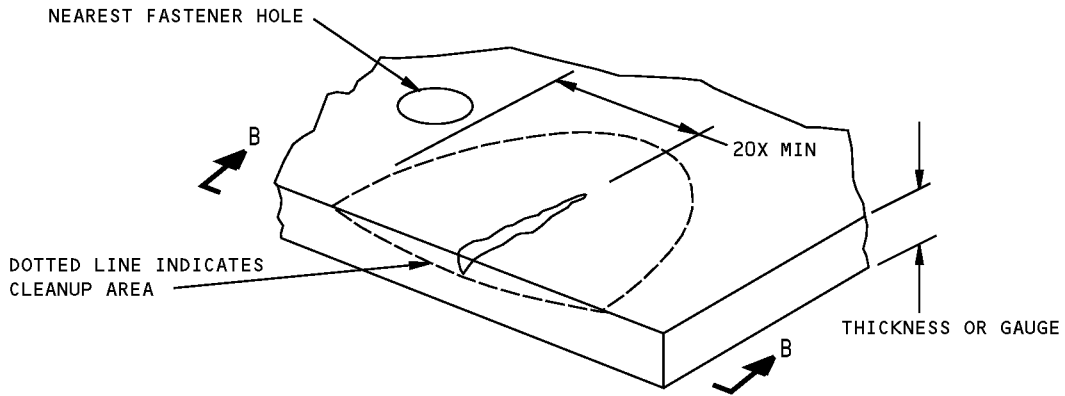

SECTION B-B

DETAIL II

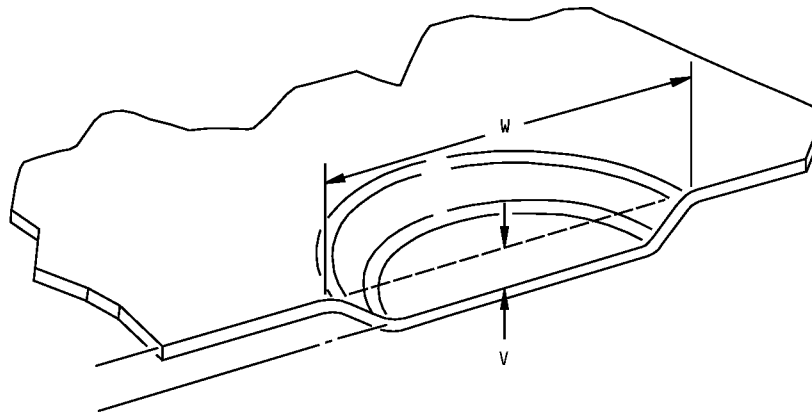

DETAIL III

Allowable Damage - Inlet Cowl Structure - RB211-535C Engine
Figure 101 (Sheet 3 of 5)

757-200
STRUCTURAL REPAIR MANUAL

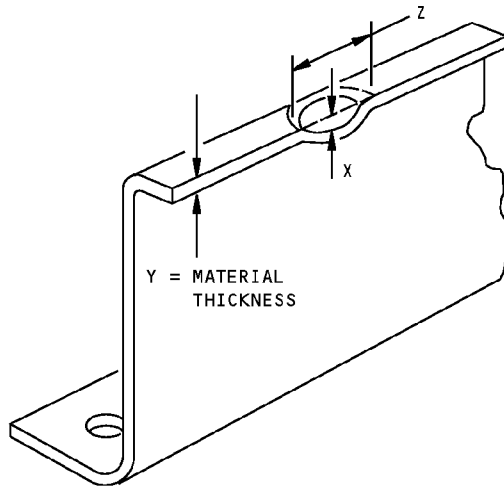

DETAIL IV

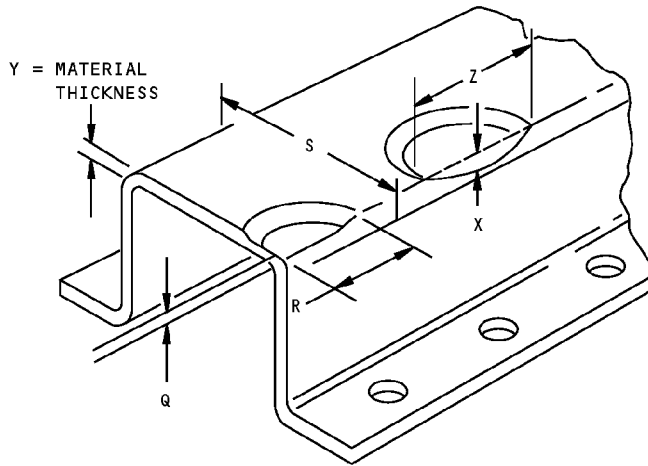

DETAIL V

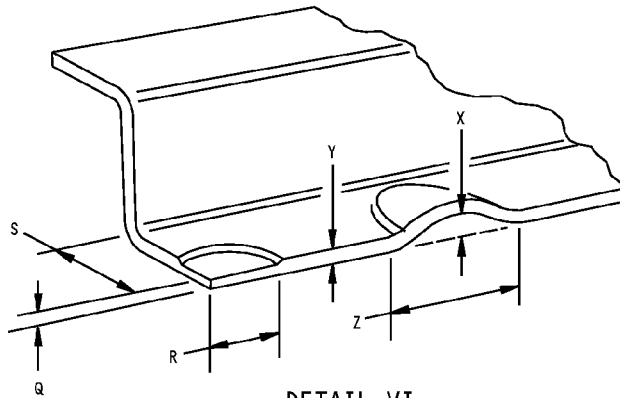

DETAIL VI

Allowable Damage - Inlet Cowl Structure - RB211-535C Engine
Figure 101 (Sheet 4 of 5)

**757-200
STRUCTURAL REPAIR MANUAL****NOTES**

- REFINISH REWORKED AREAS AS SHOWN IN SRM 51-21-01.
- A** DAMAGE IS PERMITTED UP TO 4% OF MATERIAL THICKNESS AND 2.00 INCHES (50 mm) LONG. REMOVE DAMAGE AS SHOWN IN DETAIL II.
- B** SMOOTH DENTS ARE PERMITTED, OTHER THAN IN FRONT DIAPHRAGM, PROVIDING "V" (DETAIL III) DOES NOT EXCEED 0.10 INCH (2.5 mm), AREA OF DAMAGE "W" DOES NOT EXCEED 2.00 INCHES (50 mm) DIAMETER AND THERE IS A MINIMUM OF 4.00 INCHES (100 mm) SEPARATING EACH DAMAGED AREA. NO DENTS ARE PERMITTED IN FRONT DIAPHRAGM.
- C** DISTORTION IS PERMITTED PROVIDING "X" (DETAILS IV AND V) DOES NOT EXCEED TWO TIMES "Y" AND DAMAGE "Z" DOES NOT EXCEED 1.50 INCHES (38 mm). THINNING IS PERMITTED (DETAIL V) PROVIDING "Q" IS NOT LESS THAN HALF (1/2) "Y" AND AREA OF THINNING "R" DOES NOT EXCEED ONE EIGHTH (1/8) OF "S" WIDE BY 1.50 INCHES (38 mm).
- D** DISTORTION IS PERMITTED PROVIDING "X" (DETAIL VI) DOES NOT EXCEED TWO TIMES "Y" AND DAMAGE "Z" DOES NOT EXCEED 1.50 INCHES (38 mm). THINNING IS PERMITTED (DETAIL VI) PROVIDING "Q" IS NOT LESS THAN HALF (1/2) "Y" AND AREA OF THINNING "R" DOES NOT EXCEED ONE EIGHTH (1/8) OF "S" BY 1.50 INCHES (38 mm). NO DAMAGE IS PERMITTED IN PROHIBITED ZONE.

**Allowable Damage - Inlet Cowl Structure - RB211-535C Engine
Figure 101 (Sheet 5 of 5)**

757-200
STRUCTURAL REPAIR MANUAL

REPAIR 1 - INLET COWL STRUCTURE - RB211-535E4 ENGINE

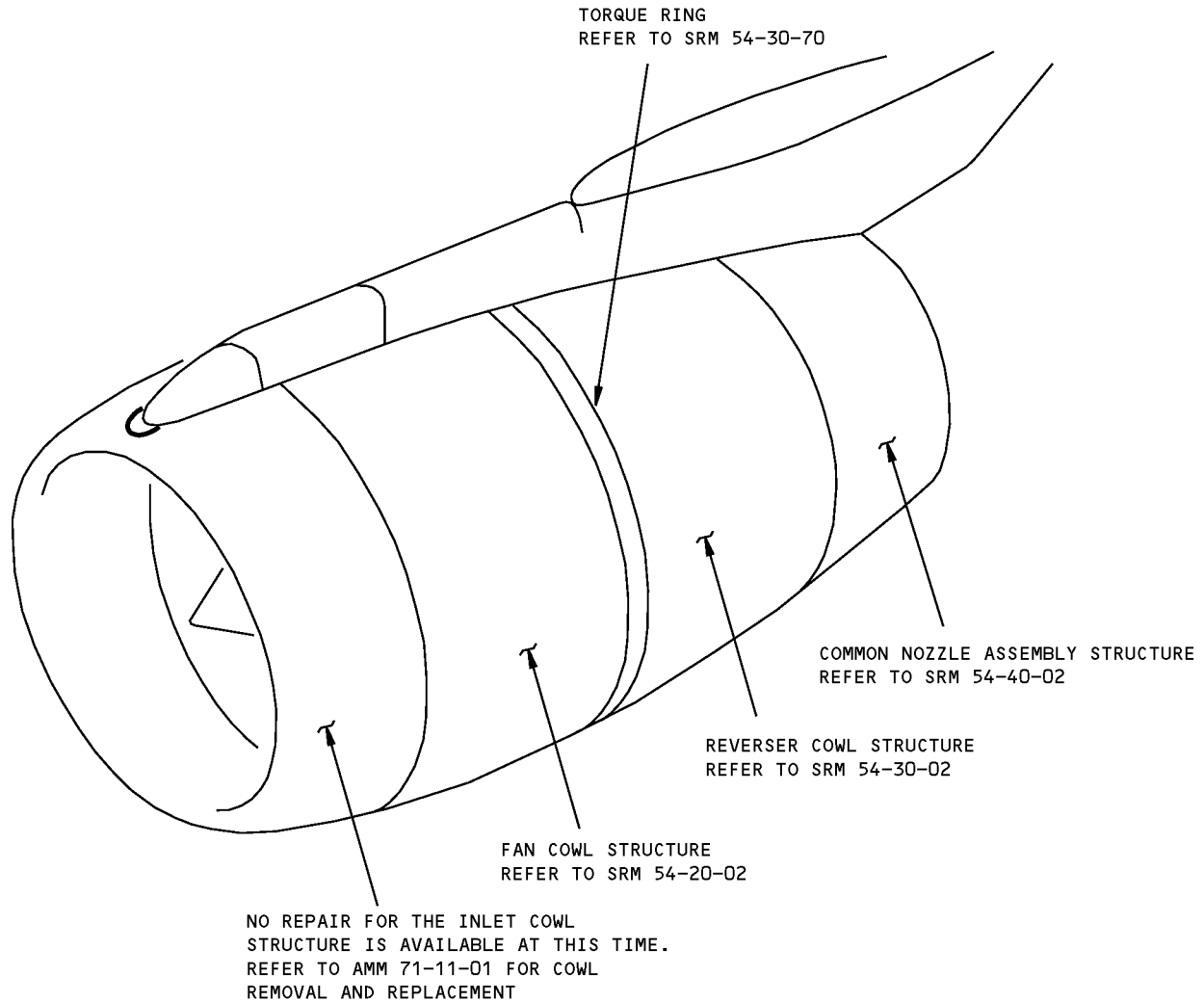

Inlet Cowl Structure Repair - RB211-535E4 Engine
Figure 201

757-200
STRUCTURAL REPAIR MANUAL

REPAIR 2 - INLET COWL STRUCTURE - RB211-535C ENGINE

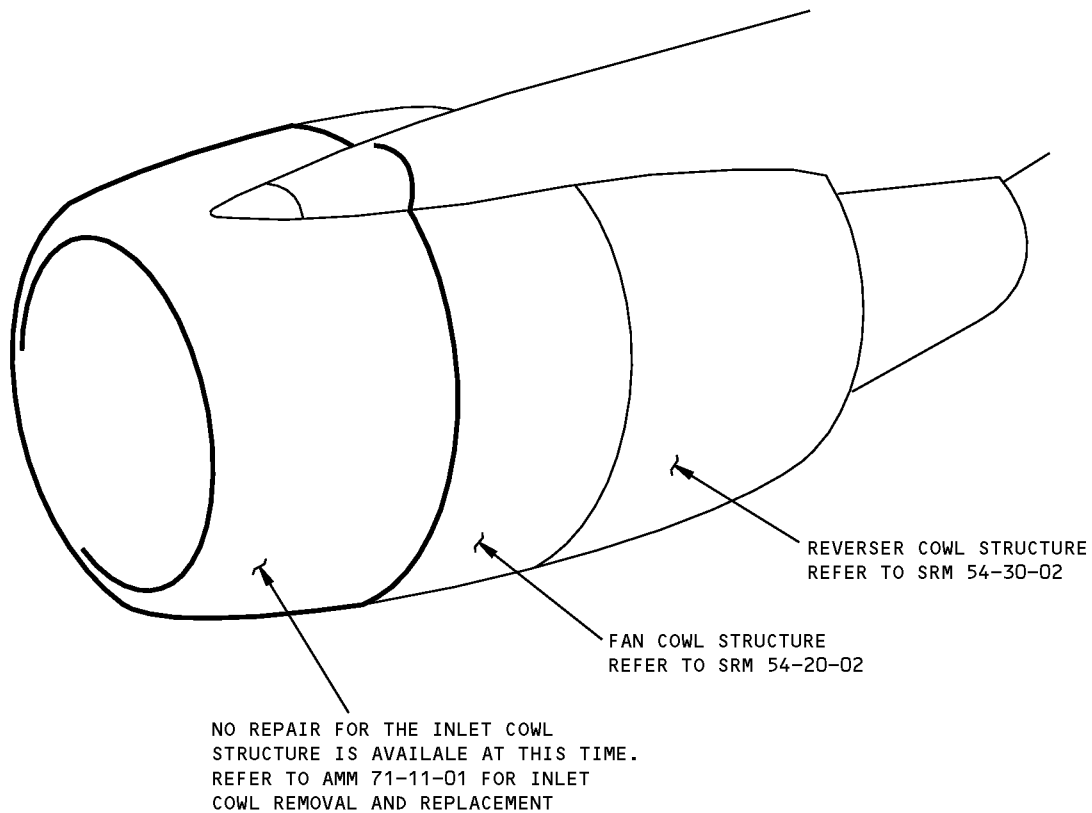

Inlet Cowl Structure - RB211-535C Engine
Figure 201

**757-200
STRUCTURAL REPAIR MANUAL**

**IDENTIFICATION 1 - INLET COWL DOOR AND ACCESS PANEL SURROUND STRUCTURE - RB211-535E4
ENGINE**

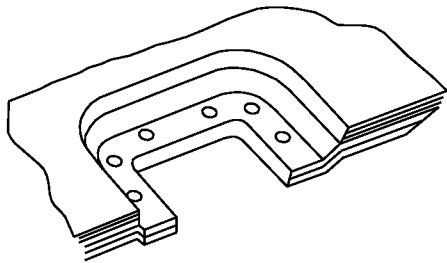
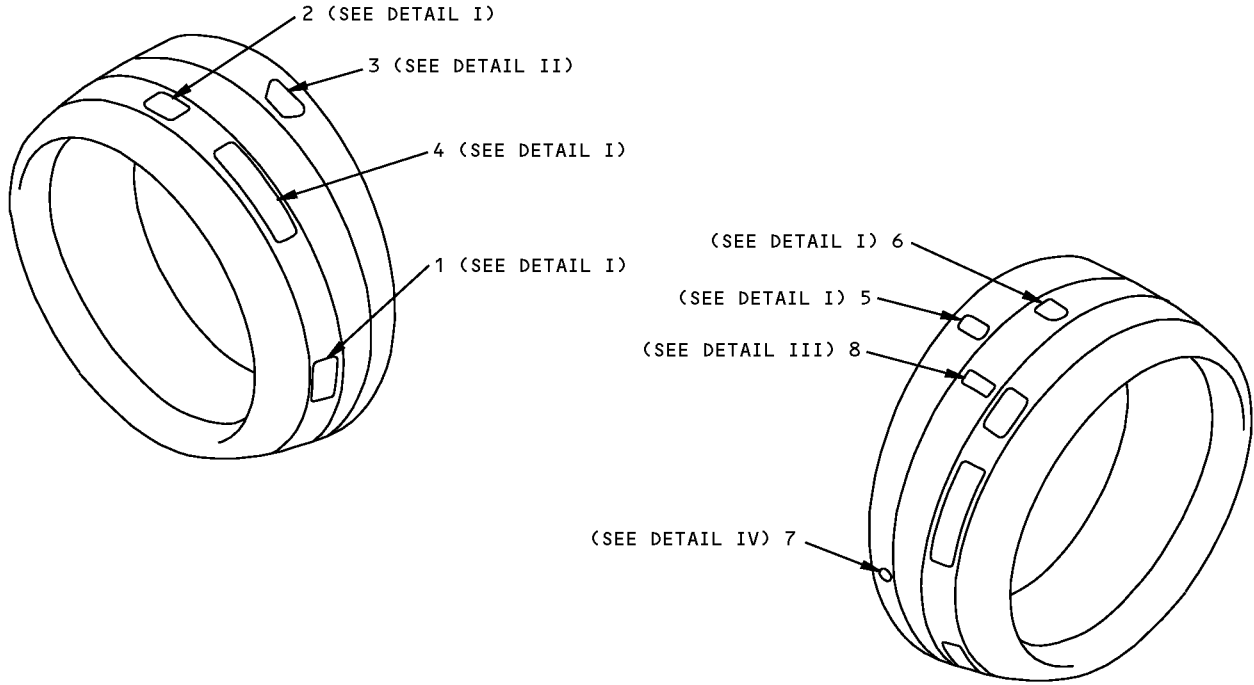

TYPICAL ACCESS PANEL SURROUND
STRUCTURE FOR ITEMS 1, 2, 4, 5, AND 6 **A**

DETAIL I

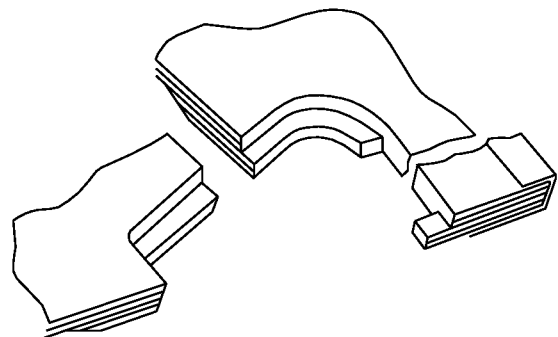

BLOWOUT DOOR SURROUND STRUCTURE
(RAD 65°) **A** **C**

DETAIL II

**Inlet Cowl Door and Access Panel Surround Structure Identification - RB211-535E4 Engine
Figure 1 (Sheet 1 of 2)**

757-200
STRUCTURAL REPAIR MANUAL

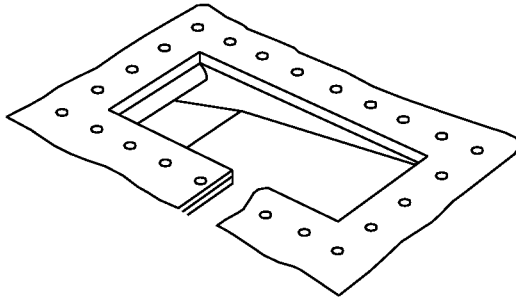
INLET DUCT SURROUND STRUCTURE A

DETAIL III

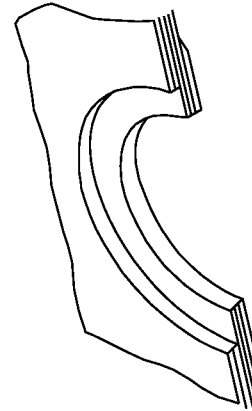
INTERCOM ACCESS PANEL
SURROUND STRUCTURE A D

DETAIL IV

NOTES

- A FOR LIST OF MATERIALS AND PLY ORIENTATION REFER TO SRM 54-10-01, IDENTIFICATION 1
- B LEFT SIDE SHOWN, RIGHT SIDE SIMILAR
- C DELETED BY ROLLS-ROYCE SB 71-9634
- D DELETED BY ROLLS-ROYCE SB 71-7854 AND SB 71-9634

ITEM	DESCRIPTION A
1	PANEL ACCESS SURROUND (FWD) RAD 130° TO 160° B
2	PANEL ACCESS SURROUND (FWD) RAD 20° TO 45° B
3	BLOWOUT DOOR SURROUND RAD 65°
4	PANEL ACCESS SURROUND (FWD) RAD 60° TO 90° B
5	PANEL ACCESS SURROUND REAR
6	PANEL ACCESS RAD 0°
7	INTERCOM ACCESS PANEL RAD 235°
8	INLET DUCT SURROUND RAD 330°

Inlet Cowl Door and Access Panel Surround Structure Identification - RB211-535E4 Engine
Figure 1 (Sheet 2 of 2)

757-200
STRUCTURAL REPAIR MANUAL

IDENTIFICATION 2 - INLET COWL DOOR SURROUND STRUCTURE - RB211-535C ENGINE

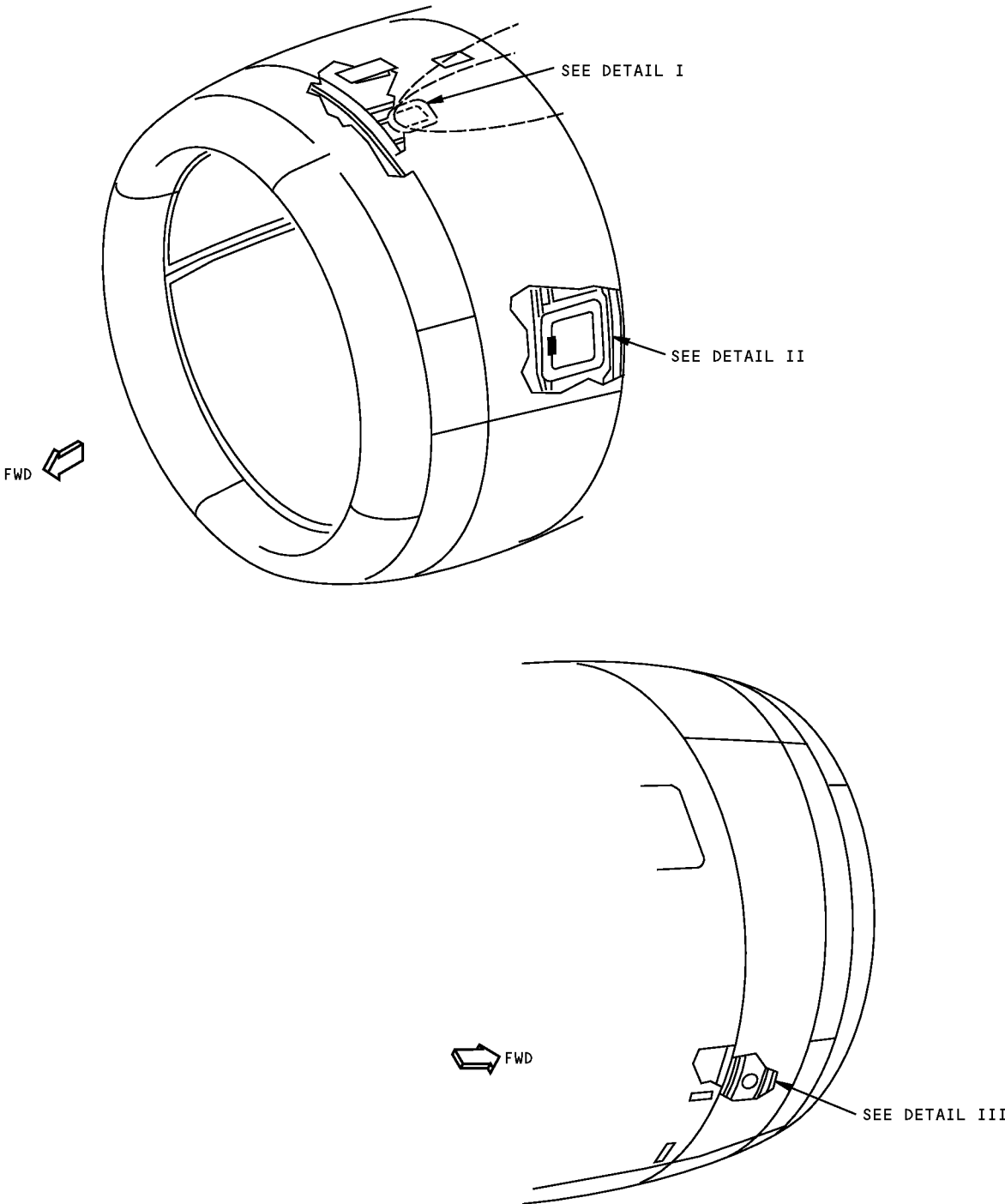

Inlet Cowl Door Surround Structure Identification - RB211-535C Engine
Figure 1 (Sheet 1 of 2)

757-200
STRUCTURAL REPAIR MANUAL

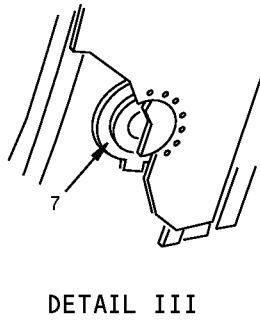
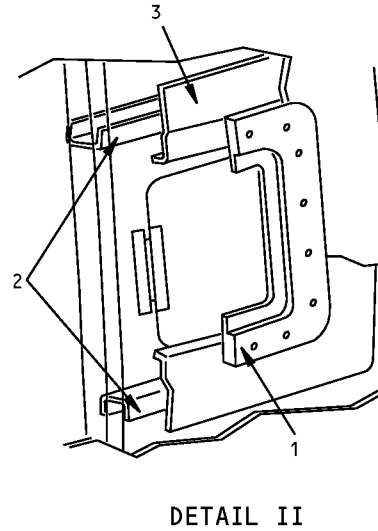
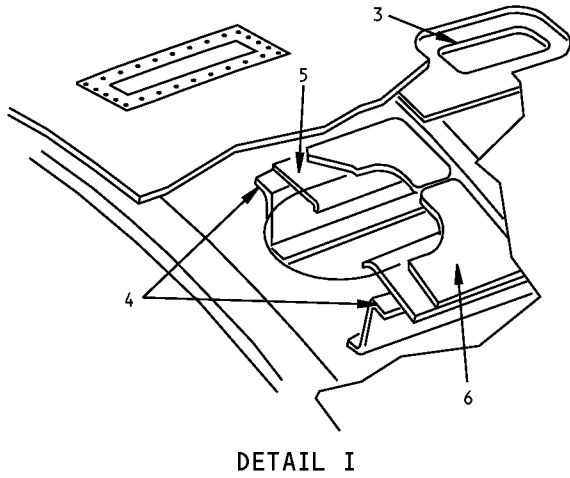

ITEM	DESCRIPTION	GAGE	MATERIAL	EFFECTIVITY
1	BEARING PLATE	0.022	S527	
2	CHANNEL	0.048	L164	
3	COAMING PLATE	0.048	L164	
4	"Z" STIFFENER	0.048	L164	
5	DOUBLE COAMING	0.048	L164	
6	PACKING PIECE	0.048	L164	
7	LAND PLATE	0.048	L164	

LIST OF MATERIALS

Inlet Cowl Door Surround Structure Identification - RB211-535C Engine
Figure 1 (Sheet 2 of 2)

757-200
STRUCTURAL REPAIR MANUAL

ALLOWABLE DAMAGE 1 - DOOR SURROUND STRUCTURE, NOSE COWL - RB211-535C ENGINE

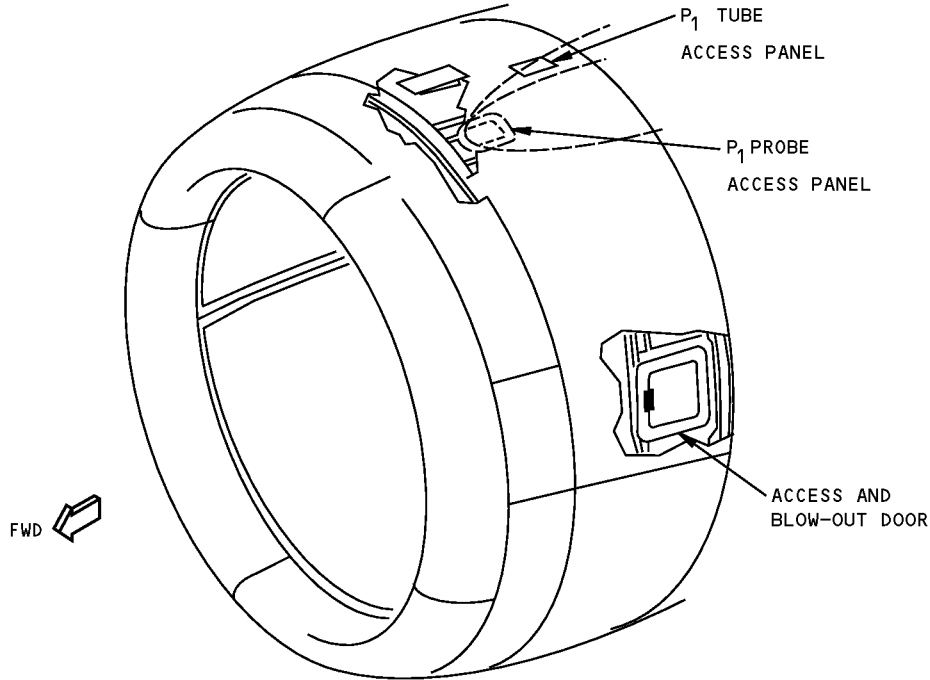

		CRACKS	NICKS, GOUGES AND CORROSION	DENTS	HOLES
NOSE COWLING	BEARING PLATE	NOT ALLOWED	SEE DETAIL I [A]	SEE DETAIL II [B]	NOT ALLOWED
	CHANNEL				
	COAMING PLATE				
	'Z' STIFFENER				
	DOUBLE COAMING				
	PACKING PIECE				
	LAND PLATE				

Allowable Damage - Door Surround Structure, Nose Cowl - RB211-535C Engine
Figure 101 (Sheet 1 of 3)

757-200
STRUCTURAL REPAIR MANUAL

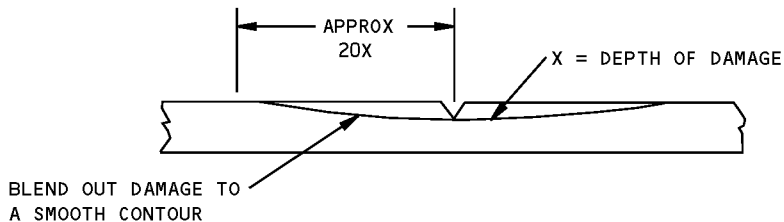
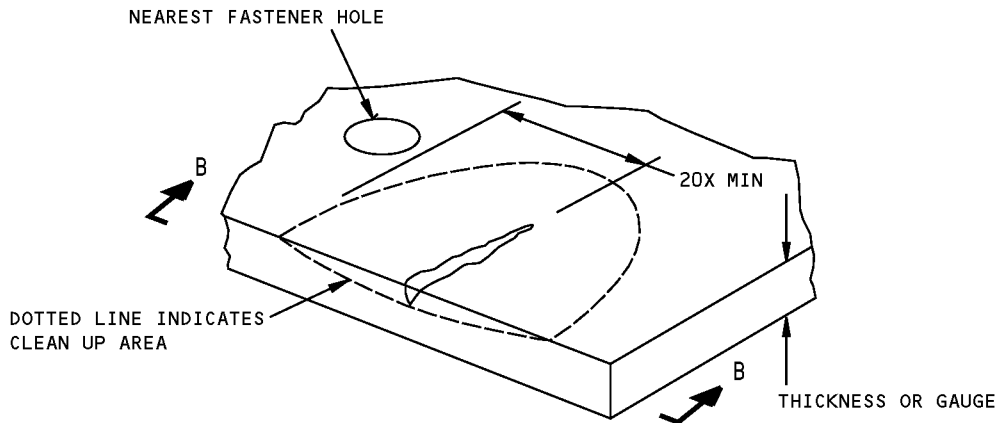

SECTION B-B

DETAIL I

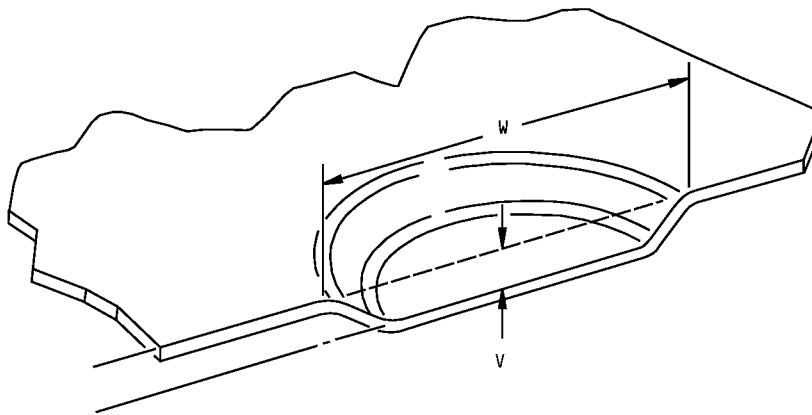

DETAIL II

Allowable Damage - Door Surround Structure, Nose Cowl - RB211-535C Engine
Figure 101 (Sheet 2 of 3)

757-200
STRUCTURAL REPAIR MANUAL**NOTES**

- REFINISH REWORKED AREAS AS SHOWN IN SRM 51-21-01
- A** DAMAGE IS PERMITTED UP TO 4% OF MATERIAL THICKNESS AND 2.00 INCHES (50 mm) LONG. REMOVE DAMAGE AS SHOWN IN DETAIL I
- B** SMOOTH DENTS ARE PERMITTED PROVIDING "V" (DETAIL II) DOES NOT EXCEED 0.10 INCH (2.5 mm), AREA OF DAMAGE "W" DOES NOT EXCEED 2.00 INCHES (50 mm) DIAMETER, AND THERE IS A MINIMUM OF 4.00 INCHES (100 mm) SEPARATING EACH DAMAGED AREA

Allowable Damage - Door Surround Structure, Nose Cowl - RB211-535C Engine
Figure 101 (Sheet 3 of 3)

757-200
STRUCTURAL REPAIR MANUAL

REPAIR GENERAL - INLET COWL DOOR SURROUND STRUCTURE - RB211-535 ENGINE

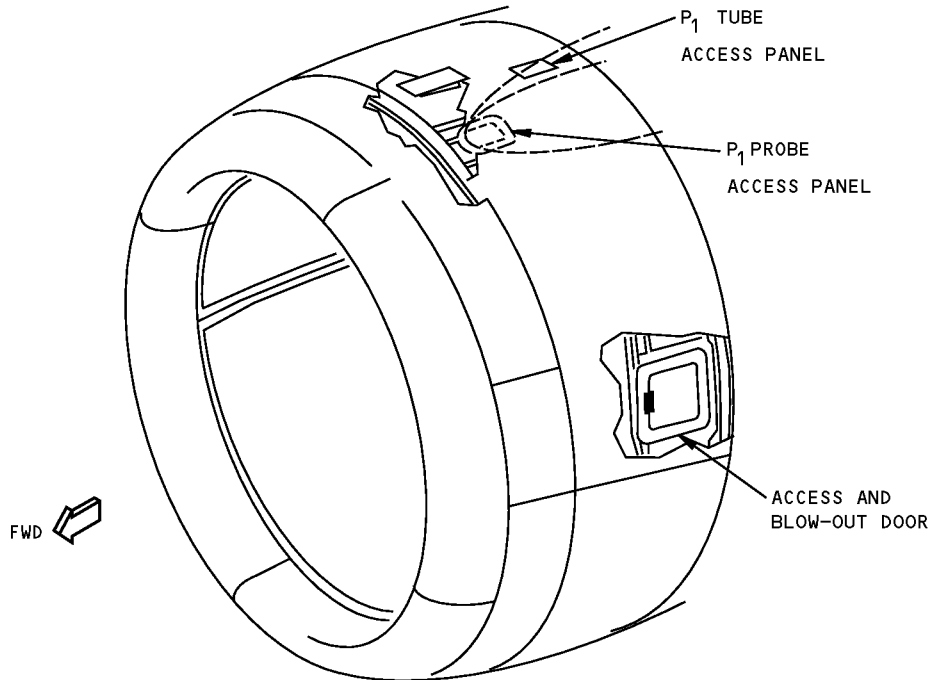

NOTES

- REPAIRS TO THIS AREA ARE IMPRACTICABLE
DAMAGE TO BE REPAIRED BY REPLACEMENT

Inlet Cowl Door Surround Structure Repair - RB211-535 Engine
Figure 201

D634N201

54-10-15

REPAIR GENERAL
Page 201
Jan 20/2005

757-200
STRUCTURAL REPAIR MANUAL

IDENTIFICATION 1 - INLET COWL SKIN - PW2000 ENGINE

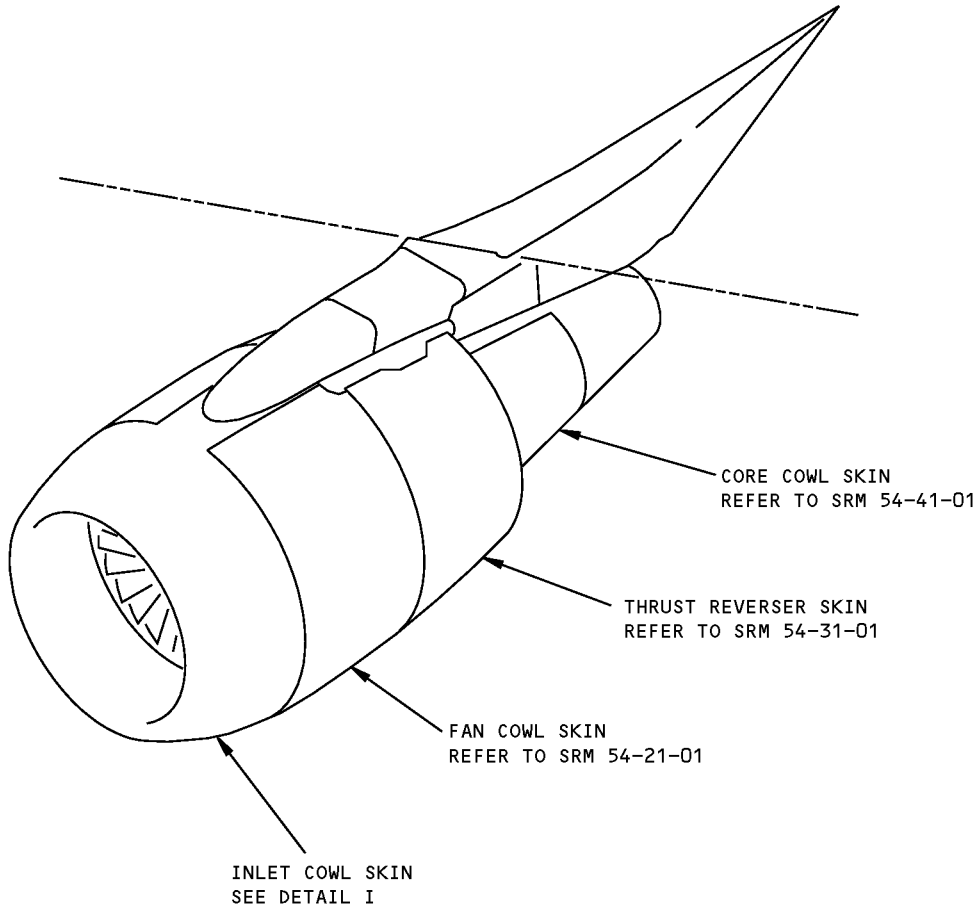

Inlet Cowl Skin Identification - PW2000 Engine
Figure 1 (Sheet 1 of 4)

**757-200
STRUCTURAL REPAIR MANUAL**

REF DWG
314N3010

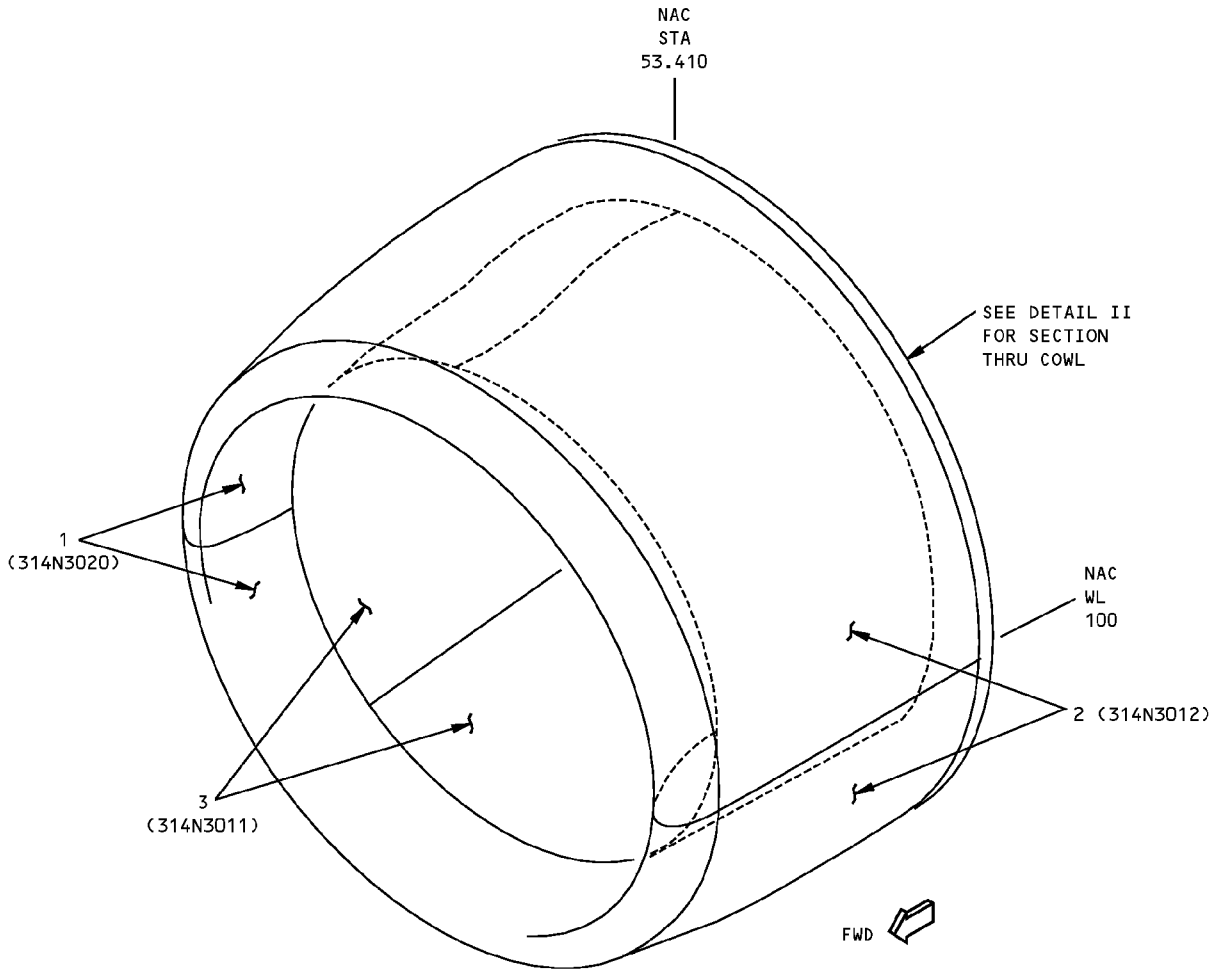

DETAIL I



**Inlet Cowl Skin Identification - PW2000 Engine
Figure 1 (Sheet 2 of 4)**

IDENTIFICATION 1
Page 2
Jan 20/2005

54-11-01

D634N201

**757-200
STRUCTURAL REPAIR MANUAL**

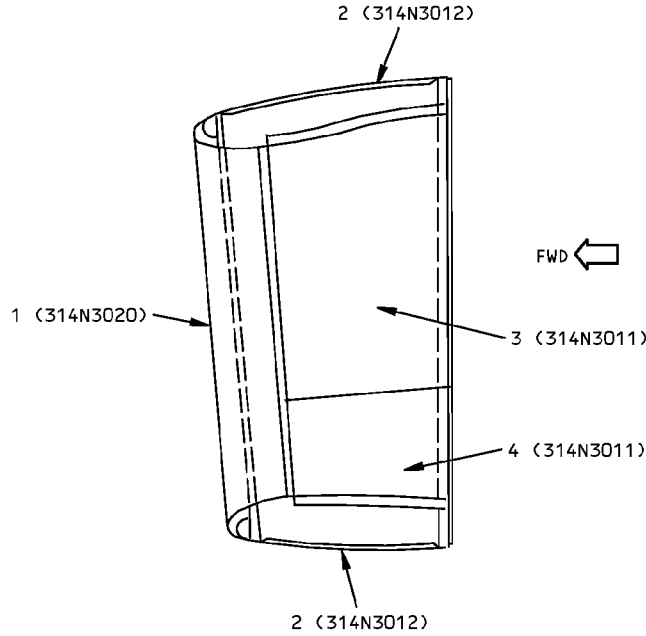

SECTION THRU COWL
DETAIL II

ITEM	DESCRIPTION	GAGE	MATERIAL	EFFECTIVITY
1	L/E SKIN	0.125	2219-T62 CHEM MILLED	
2	OUTER PANEL SKIN CORE	0.60	GRAPHITE/EPOXY HONEYCOMB SANDWICH SEE DETAIL III NONMETALLIC HONEYCOMB PER BMS 8-124, CLASS IV, TYPE I, GRADE 4.0	
3	INNER ACOUSTIC PANEL (LEFT AND RIGHT) BACKSHEET CORE INNER SKIN	0.071 1.443 0.025	2024-T62 CHEM MILLED FLEX CORE PER BMS 4-6, TYPE 4.1-25, CLASS I PERFORATED CLAD 2024-T62 SHEET PER BMS 7-209, TYPE 1B-25, GRADE 1A, CLASS 39-96	
4	INNER ACOUSTIC PANEL (LOWER) BACKSHEET CORE INNER SKIN	0.071 1.443 0.032	2024-T62 CHEM MILLED FLEX CORE PER BMS 4-6, TYPE 4.1-25, CLASS 1 PERFORATED CLAD 2024-T62 PER BMS 7-209, TYPE 1B-32, GRADE 1A, CLASS 39-96	

LIST OF MATERIALS FOR DETAILS I AND II

**Inlet Cowl Skin Identification - PW2000 Engine
Figure 1 (Sheet 3 of 4)**

**757-200
STRUCTURAL REPAIR MANUAL**

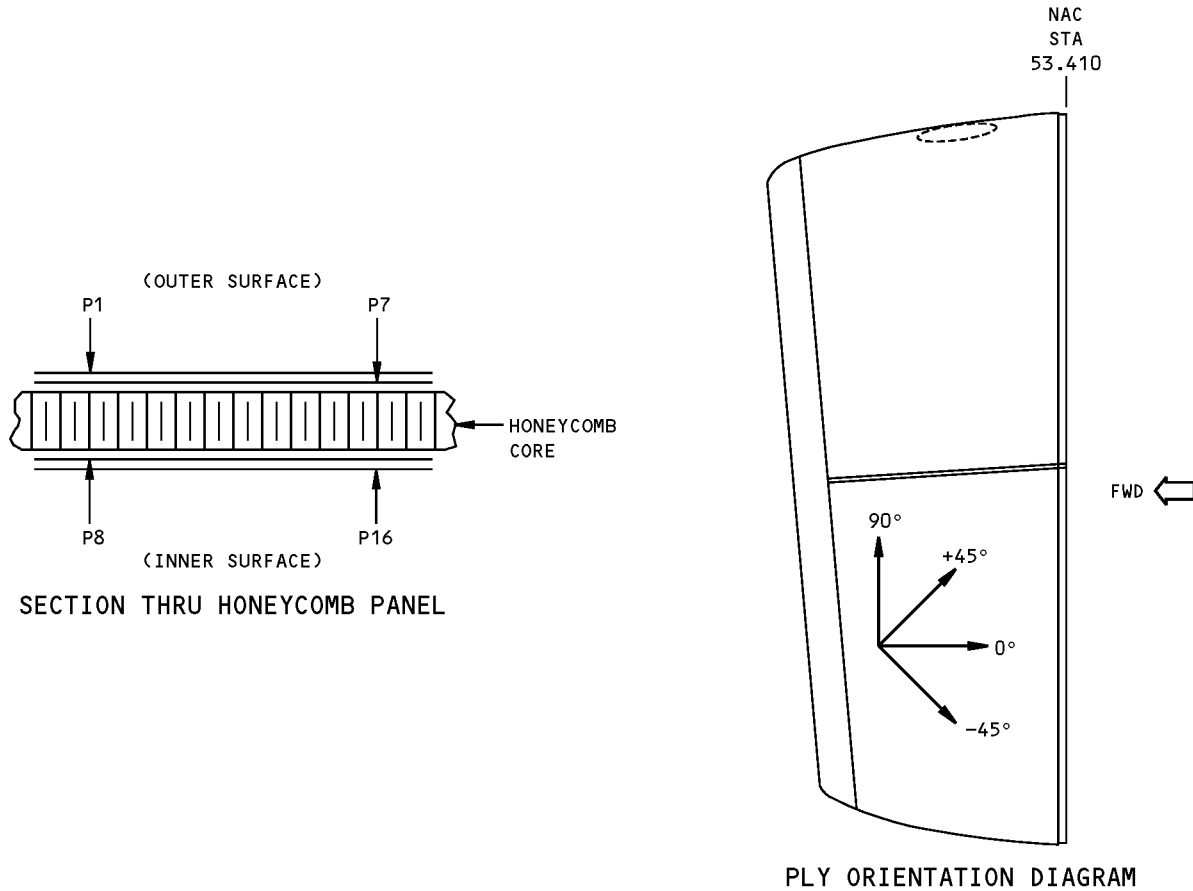

ITEM NO.	PLY NO.	MATERIAL	PLY ORIENTATION ^[A]
2	P1,P16	[C]	0°
	P7,P8	[D]	± 45°

PLY TABLE ^[B]
DETAIL III

NOTES

- ^[A] PLY ORIENTATION CONVENTION, DEGREES INDICATED, IS PARALLEL TO THE FABRIC WARP DIRECTION
- ^[B] MATERIAL AND PLY ORIENTATION SHOWN FOR FIELD AREAS ONLY. SEE BOEING DRAWINGS FOR EDGE BANDS AND AREAS WITH DOUBLERS
- ^[C] GRAPHITE/EPOXY FABRIC PER BMS 8-212, TYPE III, CLASS 2, STYLE 3K-135-8H, 350°F (177°C) CURE
- ^[D] ARAMID/EPOXY FABRIC PER BMS 8-218, STYLE 120, 350°F (177°C) CURE

**Inlet Cowl Skin Identification - PW2000 Engine
Figure 1 (Sheet 4 of 4)**

**757-200
STRUCTURAL REPAIR MANUAL**

ALLOWABLE DAMAGE 1 - INLET COWL SKIN - PW2000 ENGINE

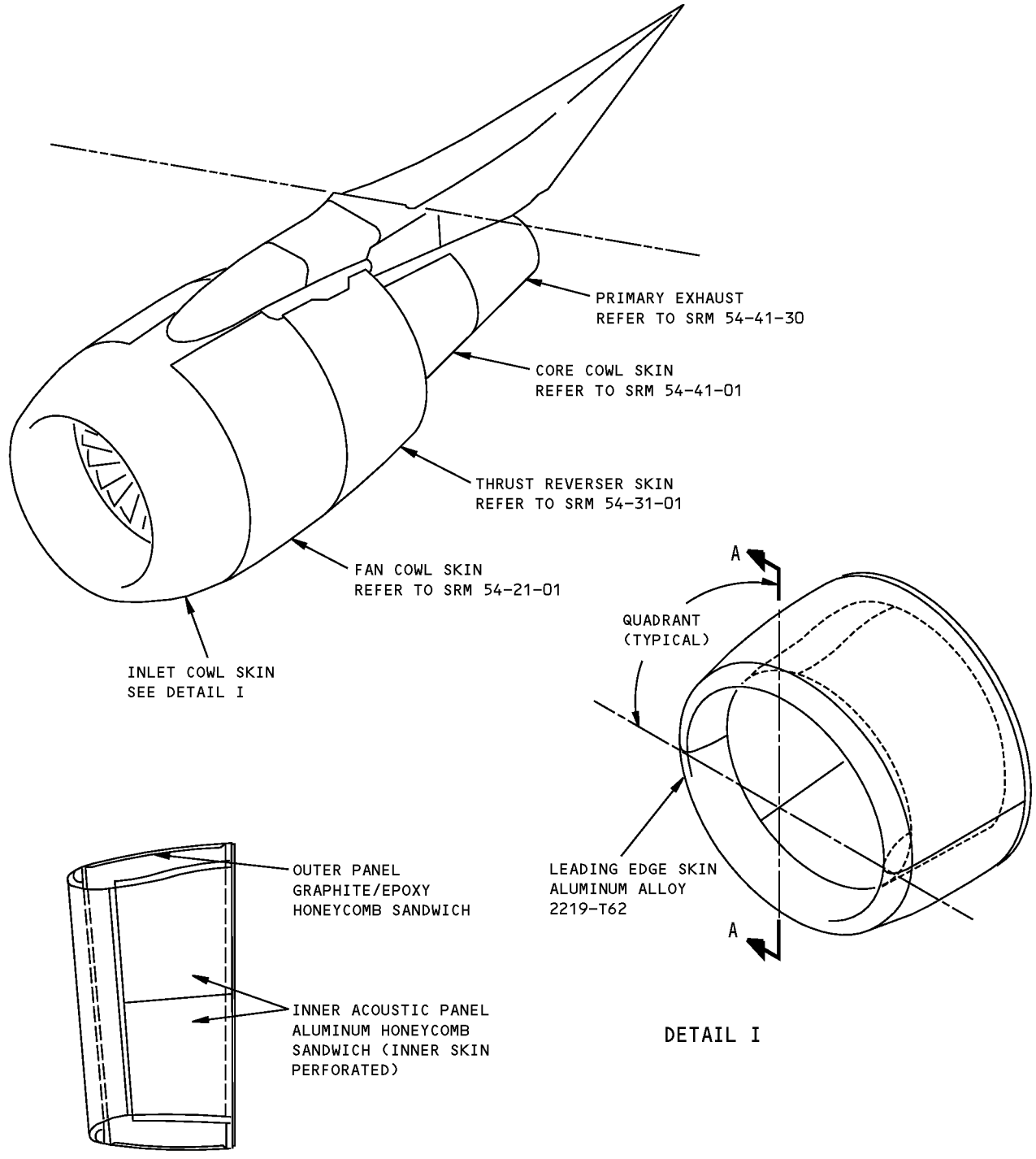

**Inlet Cowl Skin Allowable Damage - PW2000 Engine
Figure 101 (Sheet 1 of 6)**

STRUCTURAL REPAIR MANUAL

DESCRIPTION	CRACKS	NICKS, GOUGES, CORROSION, AND SCRATCHES	DENTS	HOLES AND PUNCTURES	PANEL DELAMINATION
LEADING EDGE SKIN	A	B	J	C	--
OUTER PANEL	F	G	H	I	E
INNER PANEL—PERFORATED FACESHEET, SOLID BACK-FACE	A	B	J	NOT PERMITTED	K

NOTES

- THESE ALLOWABLE DAMAGE LIMITS ARE FAA APPROVED CONTINGENT ON ACCOMPLISHMENT OF THE INSPECTIONS AT THE INTERVALS CONTAINED HEREIN
- REFINISH REWORKED AREAS AS SHOWN IN AMM 51-21
- REFER TO SRM 51-10-01 FOR AERODYNAMIC SMOOTHNESS REQUIREMENTS. WHERE DAMAGE EXCEEDS THE LIMITS SHOWN IN SRM 51-10-01 CONSIDERATION SHOULD BE GIVEN TO THE LOSS OF PERFORMANCE INVOLVED
- REFER TO SRM 51-10-02 FOR INSPECTION AND REMOVAL OF DAMAGE
- TYPICAL DAMAGE TO A PANEL EDGE BAND MAY CONSIST OF EDGE CRUSHING, CRACKS OR DELAMINATION. DAMAGE AROUND HOLES MAY CONSIST OF OVALIZATION, FASTENER PULL-THROUGH OR CRACKS OUT OF HOLE. DAMAGE MAY REDUCE THE EFFECTIVE CROSS SECTIONAL AREA OF AN EDGE BAND. A MAX OF 0.10 INCH (2.5 mm) DELAMINATION FROM EDGE IS PERMITTED. IF FIBERS ARE DAMAGED, TREAT AS A CRACK.

- A** CRACKS ARE NOT PERMITTED EXCEPT FOR EDGE CRACKS, WHICH MUST BE REMOVED AS SHOWN IN DETAILS II AND VI.
- B** REMOVE DAMAGE AS SHOWN IN DETAILS II, III, AND V.
- C** CLEAN PUNCTURES UP TO 0.25 INCH (6.3 mm) DIAMETER MAXIMUM. HOLES ALLOWED UP TO 0.25 INCH (6.3 mm) DIAMETER, NOT CLOSER THAN 4D TO ANY ADJACENT HOLE. HOLE IS TO BE FILLED WITH A NAS 1399D BLIND RIVET FOR HOLE UP TO 0.16 INCH (4.0 mm) DIAMETER AND NAS 1398D BLIND RIVET FOR HOLE 0.19 TO 0.25 INCH (4.8 TO 6.3 mm) DIAMETER, INSTALLED WET WITH BAC5710, TYPE 51 (DESOTO HI-TEMP) PRIMER. OTHER HOLES TO BE REPAIRED

D REMOVE MOISTURE FROM DAMAGE AREA. USE OF VACUUM AND HEAT (MAX OF 125°F (52°C)) TO REMOVE MOISTURE FROM HONEYCOMB CELLS IS RECOMMENDED. PROTECT DAMAGE FROM ENTRANCE OF WATER, SUNLIGHT OR OTHER FOREIGN MATTER BY SEALING WITH ALUMINUM FOIL TAPE (SPEED TAPE). RECORD THE LOCATION AND INSPECT EACH AIRPLANE "A" CHECK. REPLACE THE ALUMINUM FOIL TAPE IF ANY PEELING OR DETERIORATION IS EVIDENT. REPAIR NO LATER THAN NEXT AIRPLANE "C" CHECK.

E 4.00 INCHES (100 mm) MAXIMUM DIAMETER IS PERMITTED IN HONEYCOMB AREA. A MAXIMUM OF 0.10 INCH (2.5 mm) DELAMINATION FROM EDGE IS PERMITTED. REPAIR DELAMINATION IN HONEYCOMB AREA AS SHOWN IN SRM 51-70 NO LATER THAN THE NEXT "C" CHECK. **D**

F CRACKS IN FASTENER HOLES ALONG LONGITUDINAL SPLICE PERMITTED AS SHOWN IN DETAIL VII **D**. FOR DAMAGE OTHER THAN LONGITUDINAL SPLICE: CLEAN UP EDGE CRACKS AS SHOWN IN DETAILS II AND VI. NOT MORE THAN ONE FASTENER HOLE IN SIX MAY BE CRACKED OR DAMAGED. DAMAGE IS NOT MORE THAN 2 PERCENT OF EDGE BAND LENGTH. 0.50 INCH (12.7 mm) MAXIMUM DIMENSION IN EDGE BAND AND 2.00 INCHES (50 mm) MAXIMUM DIMENSION (D) IN HONEYCOMB AREA IS PERMITTED FOR EACH SQUARE FOOT (930 SQUARE cm) OF AREA AND A MINIMUM OF 3D (EDGE TO EDGE) FROM ANY OTHER DAMAGE, FASTENER HOLE OR PANEL EDGE. **D**

G IF FIBERS ARE DAMAGED, TREAT AS A CRACK. IF FIBERS ARE NOT DAMAGED PROTECT AS SHOWN IN NOTE **D**

Inlet Cowl Skin Allowable Damage - PW2000 Engine
Figure 101 (Sheet 2 of 6)

STRUCTURAL REPAIR MANUAL

NOTES (CONT)

- H** DENTS GENERALLY RESULT IN FIBER DAMAGE OR DELAMINATION. HOWEVER, PROVIDED THAT THERE IS NO FIBER DAMAGE OR DELAMINATION, DENTS UP TO 2.0 INCHES (50 mm) DIAMETER MAXIMUM ARE PERMITTED. ONE DENT FOR EACH SQUARE FOOT (930 SQUARE cm) OF AREA PERMITTED WHICH MUST BE A MINIMUM OF 6 INCHES (150 mm) FROM ANY OTHER DAMAGE, FASTENER HOLE, OR PANEL EDGE. IF FIBER DAMAGE OR DELAMINATION IS PRESENT, REFER TO APPLICABLE DAMAGE DATA IN TABLE
- I** 1.0 INCH (25 mm) MAXIMUM DIAMETER IN HONEYCOMB AREA ONLY AND MINIMUM OF 4D FROM NEAREST HOLE, MATERIAL EDGE OR OTHER DAMAGE (EDGE TO EDGE). DO NOT CLEAN UP DAMAGE EXCEPT TO REMOVE RESIN BURRS EXTENDING INTO SURFACE CONTOUR. **D**

- J** MAXIMUM OF TWO DENTS ARE PERMITTED FOR EACH QUADRANT (SEE DETAIL I), WITH NO LESS THAN 15.0 INCHES (380 mm) BETWEEN DENTS. SEE DETAIL IV
- K** SEE DETAIL VIII FOR DELAMINATION (DISBONDING) OF PERFORATED FACESHEET. SEE DETAIL IX FOR SOLID BACKFACE. DAMAGE NOT EXCEEDING THESE LIMITS ARE ALLOWED, PROVIDING THAT PANELS ARE INSPECTED EVERY 300 FLIGHT HOURS UNTIL PANEL IS REPAIRED OR REPLACED

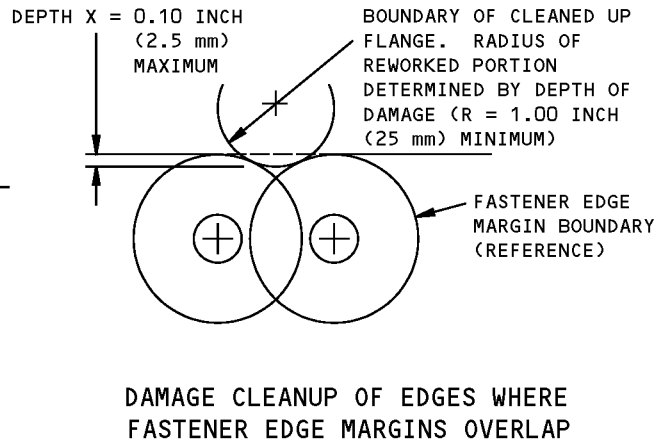
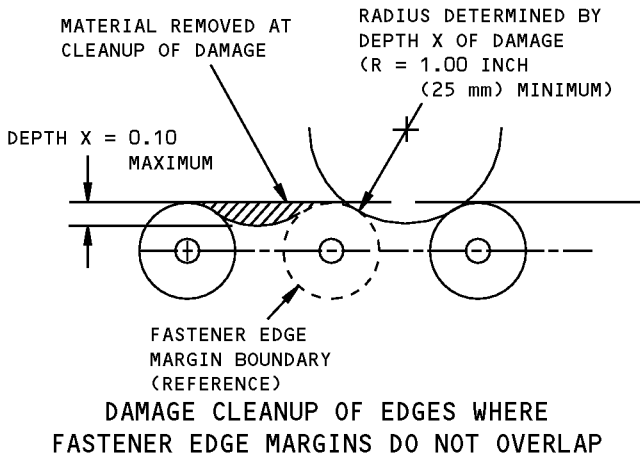

DETAIL II

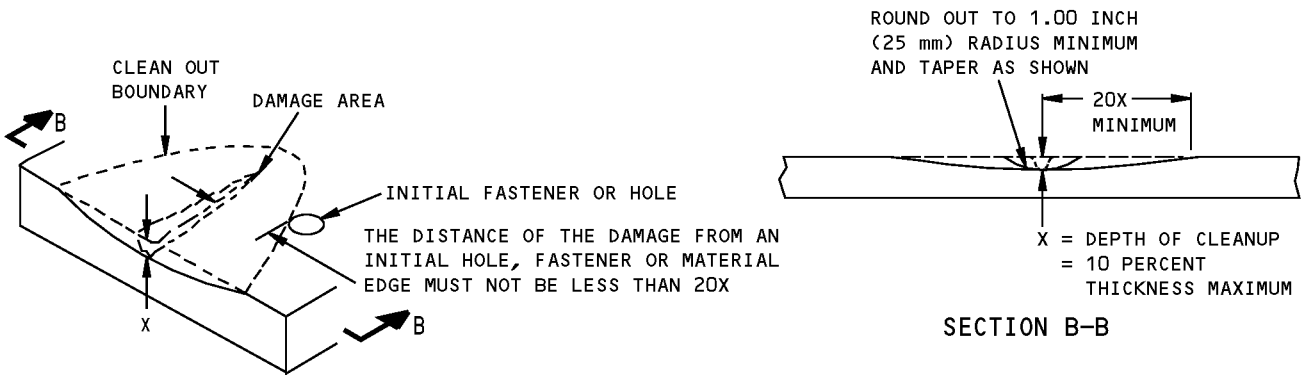

DETAIL III

Inlet Cowl Skin Allowable Damage - PW2000 Engine
Figure 101 (Sheet 3 of 6)

STRUCTURAL REPAIR MANUAL

CAUTION: DO NOT FILL DENTS

$\frac{A}{Y}$ MUST NOT BE LESS THAN 30

FOR LEADING EDGE SKIN:
 $Y = 0.125$ MAX
 MAJOR AXIS = 4.0 MAX

FOR INNER PANEL, PERFORATED
 INNER SKIN:
 $Y = 0.050$ MAX
 MAJOR AXIS = 3.0 MAX

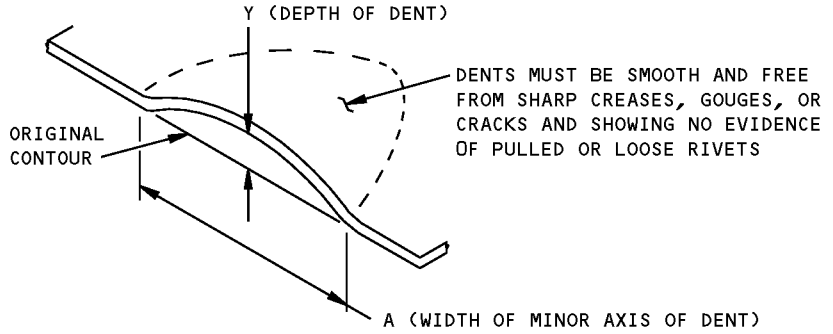

**ALLOWABLE DAMAGE FOR DENT
 DETAIL IV**

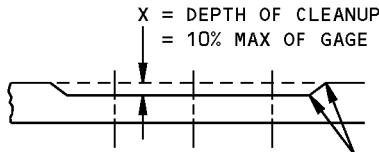
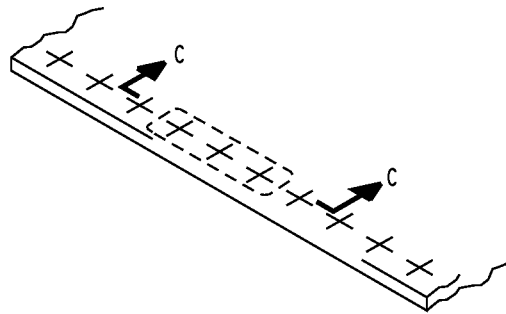

SMOOTH BLEND-OUT RADIUS 0.50 INCH MINIMUM.
 CORROSION CLEANUP AROUND ANY THREE FASTENERS
 IN TEN IS PERMITTED TO MAX DEPTH

SECTION C-C

**CORROSION CLEANUP
 DETAIL V**

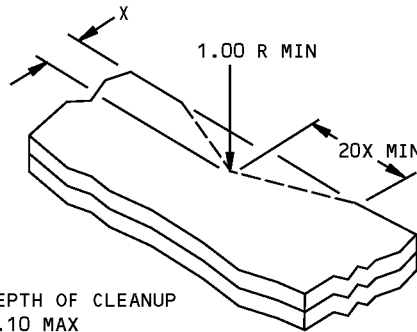

DETAIL VI

**Inlet Cowl Skin Allowable Damage - PW2000 Engine
 Figure 101 (Sheet 4 of 6)**

**757-200
STRUCTURAL REPAIR MANUAL**

L = EXISTING FASTENER SPACING

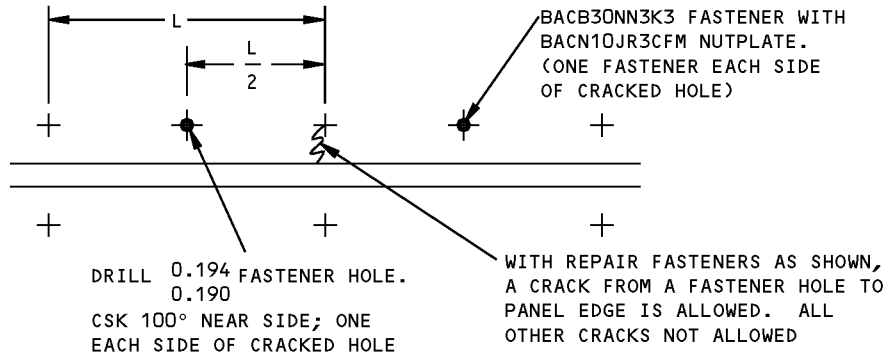

**ALLOWABLE CRACKS ALONG A LONGITUDINAL SPLICE
DETAIL VII**

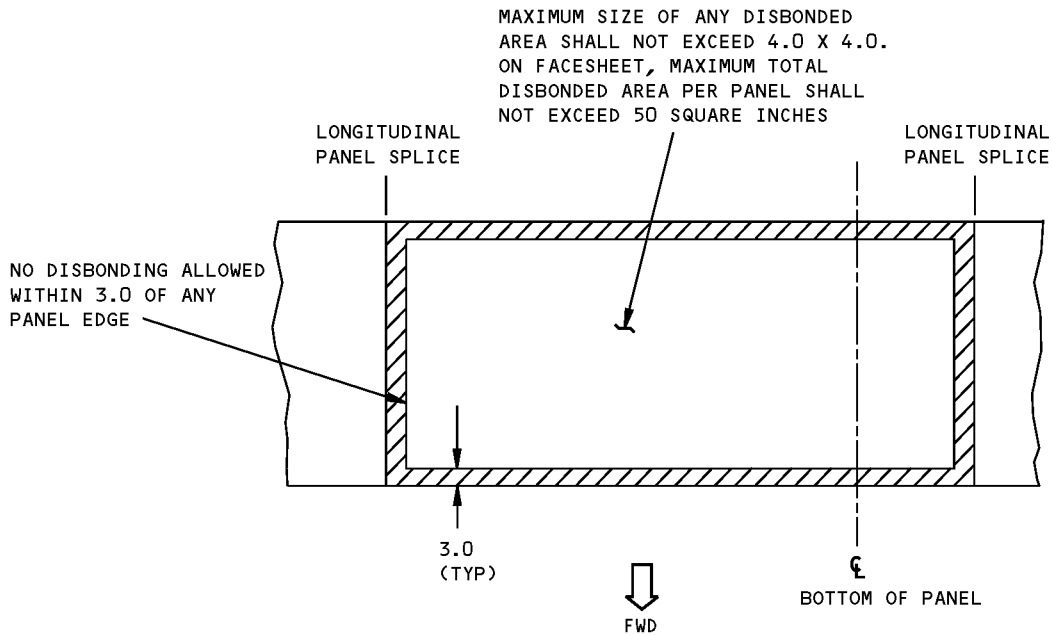

**ALLOWABLE DISBOND LIMITS FOR INNER
ACOUSTIC PANEL, PERFORATED FACESHEET
DETAIL VIII**

**Inlet Cowl Skin Allowable Damage - PW2000 Engine
Figure 101 (Sheet 5 of 6)**

**757-200
STRUCTURAL REPAIR MANUAL**

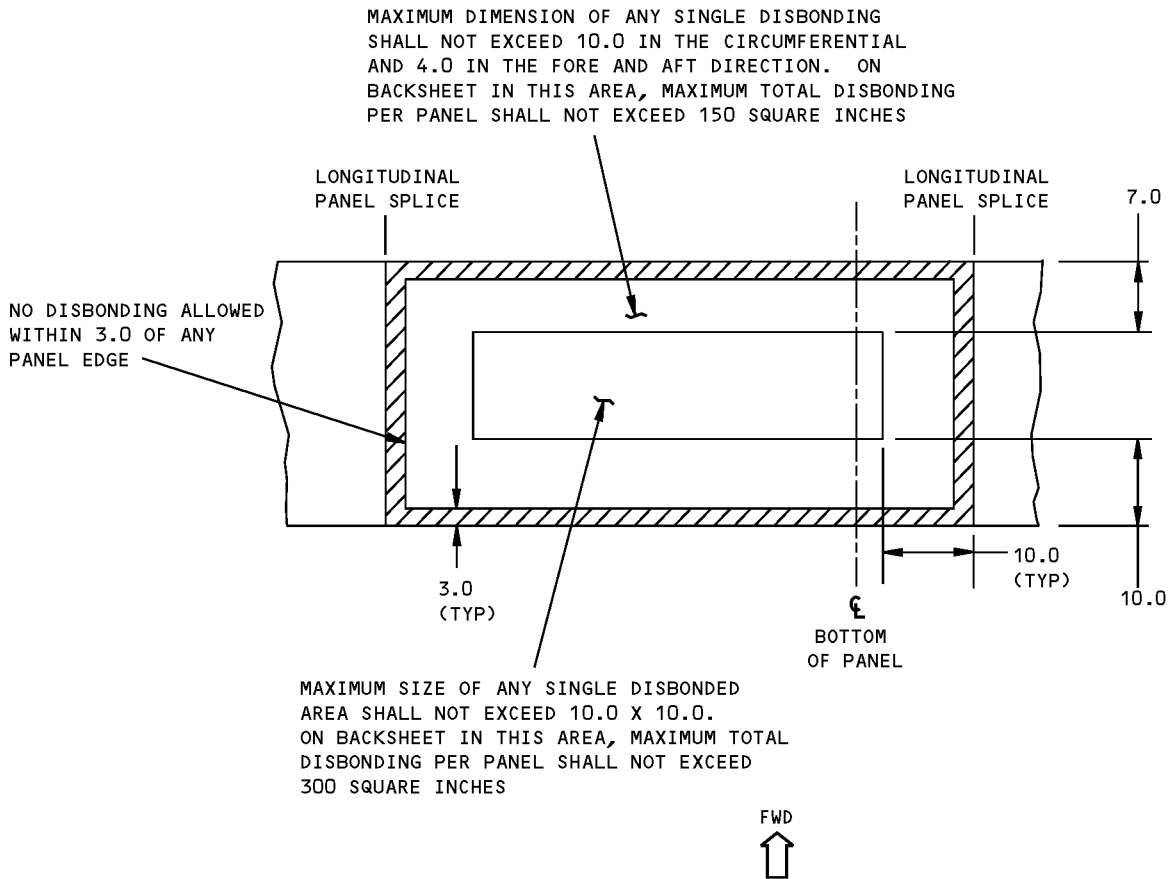

ALLOWABLE DISBOND LIMITS FOR SOLID BACKFACE
(SHOWN WITH OUTER PANEL REMOVED)
DETAIL IX

**Inlet Cowl Skin Allowable Damage - PW2000 Engine
Figure 101 (Sheet 6 of 6)**

**757-200
STRUCTURAL REPAIR MANUAL**

REPAIR GENERAL - INLET COWL SKIN REPAIR INDEX - PW2000 ENGINE

REFERENCE DRAWING
314N3010

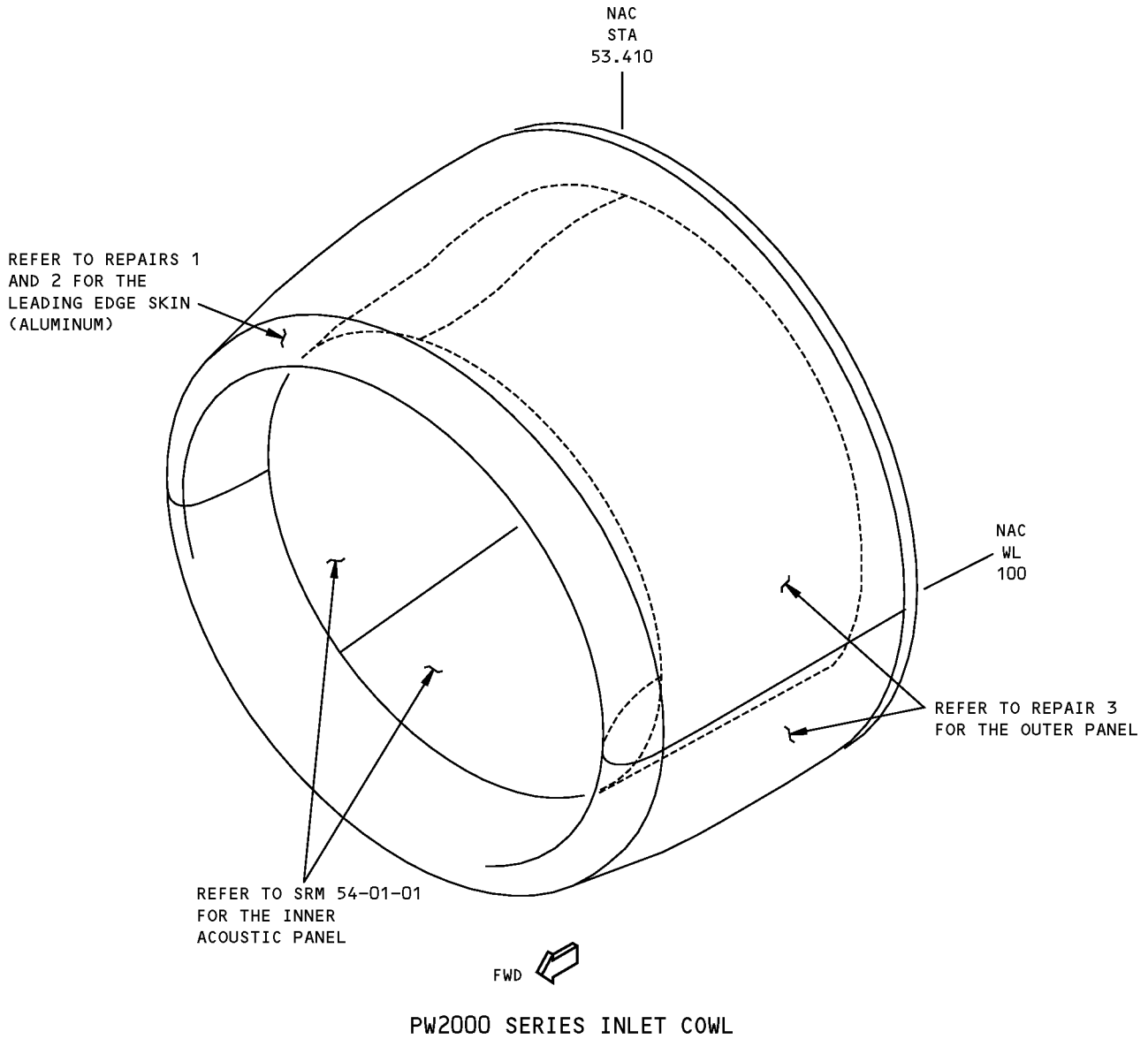

**Inlet Cowl Skin Repair Index - PW2000 Series Engine
Figure 201**

D634N201

54-11-01

REPAIR GENERAL
Page 201
Jan 20/2005



757-200
STRUCTURAL REPAIR MANUAL

REPAIR 1 - INLET COWL - LEADING EDGE SKIN - PW2000 ENGINE

REPAIR INSTRUCTIONS

1. Cut out the damaged skin to a rectangular shape. The cut can not be closer than 3.80 inches to the outer row of fasteners nor 2.10 inches to the inner row of fasteners.
2. Make the repair parts. Form doublers to required contour. The repair skin may be cut from scrap or spare nose cowl.
3. Break all sharp edges of original and repair parts 0.015 to 0.030 inches.
4. Locate, drill and countersink fastener holes.
5. Remove all nicks, scratches, burrs, and corners from original and repair parts.
6. Alodize and apply one coat of Desoto Hi-Temp primer to repair parts and raw edges of skin.
7. Rivet doublers to existing skin using BACR15CE5D rivets.
8. Rivet skin to doublers using blind rivets NAS1399CW5. Install wet with Desoto Hi-Temp primer.
9. Fill gaps with aerodynamic smoother.
10. Restore the finish.

NOTES

- WHEN YOU USE THIS REPAIR REFER TO:
 - AMM 51-20 FOR INTERIOR AND EXTERIOR FINISHES
 - SRM 51-10-01 FOR AERODYNAMIC SMOOTHNESS REQUIREMENTS, WHERE THE REPAIR EXCEEDS THE LIMITS SHOWN IN 51-10-01 CONSIDERATION SHOULD BE GIVEN TO THE LOSS OF PERFORMANCE INVOLVED
 - SRM 51-20-01 FOR PROTECTIVE TREATMENT OF METAL REPAIR PARTS
 - SRM 51-20-05 FOR SEALING OF REPAIRS
 - SRM 51-40 FOR FASTENER CODE, REMOVAL, INSTALLATION, HOLE SIZES AND EDGE MARGINS
 - SRM 51-40-03 FOR FASTENER SUBSTITUTION.

FASTENER SYMBOLS

✦ REPAIR FASTENER LOCATION

Inlet Cowl - Leading Edge Skin Repair - PW2000 Engine
Figure 201 (Sheet 1 of 2)

D634N201

54-11-01

REPAIR 1
Page 201
Jan 20/2005

**757-200
STRUCTURAL REPAIR MANUAL**

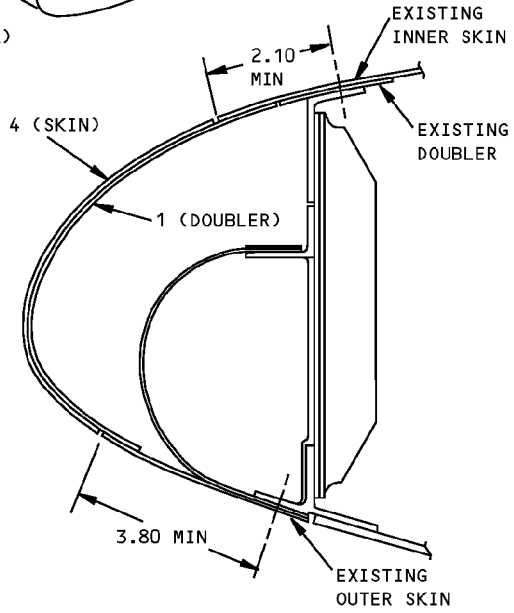
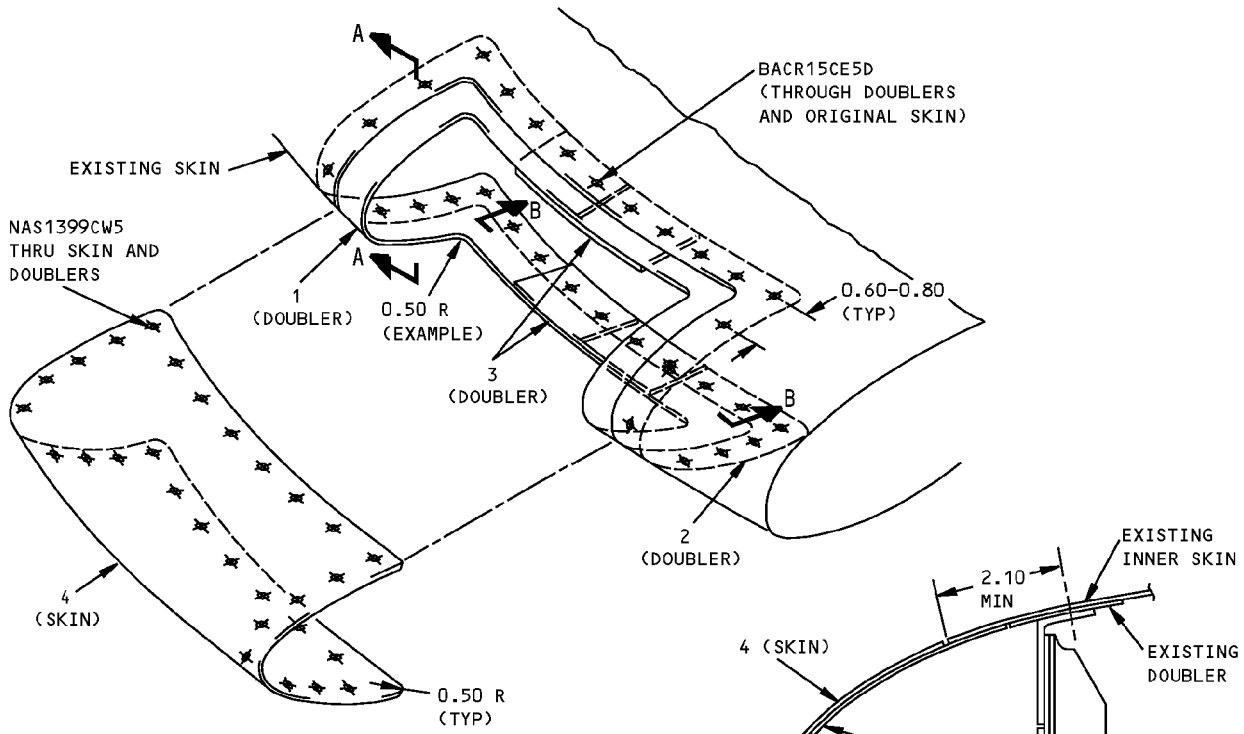

SECTION A-A

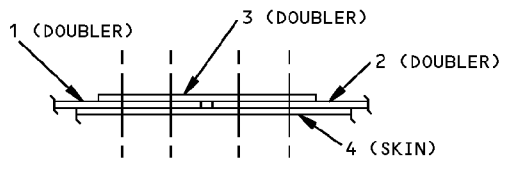

SECTION B-B

REPAIR MATERIAL			
PART	QTY	MATERIAL	
1	DOUBLER	1	0.080 2219-T62 OPTIONAL: 0.080 CLAD 2024-T3
2	DOUBLER	1	0.080 2219-T62 OPTIONAL: 0.080 CLAD 2024-T3
3	DOUBLER	2	0.080 CLAD 2024-T3
4	SKIN	1	SAME GAGE AS ORIGINAL MATERIAL AT DAMAGE CUTOUT 2219-T62 OPTIONAL: CLAD 2024-T3

**Inlet Cowl - Leading Edge Skin Repair - PW2000 Engine
Figure 201 (Sheet 2 of 2)**

STRUCTURAL REPAIR MANUAL

REPAIR 2 - INLET COWL - LEADING EDGE SKIN - PW2000 ENGINE

REPAIR INSTRUCTIONS

1. Drill out the fasteners as necessary in the area of the damage.

CAUTION: DO NOT DAMAGE THE STRUCTURE BELOW THE SKIN WHEN YOU REMOVE THE DAMAGED PART OF THE SKIN.

2. Carefully cut out the damaged skin. Make the shape of the cutout rectangular. Use sheet metal guards at the corners of the cutout to prevent damage to the structure below the skin.

3. Make the repair parts. See Detail I thru IV and Table I.

NOTE: The repair skin splice can be made from a spare nose cowl that has been damaged.

4. Assemble the repair parts and drill and countersink fastener holes.

5. Disassemble the repair parts.

6. Remove the nicks, scratches, gouges, burrs and sharp edges from the repair parts and the initial parts.

7. Apply a chemical conversion coating to the repair parts and to the bare surfaces of the initial parts. Refer to SRM 51-20-01.

8. Apply one layer of BAC5710, Type 51 high temperature primer (DeSoto Hi-Temp) to the repair parts and to the bare surfaces of the initial parts.

9. Install the repair parts.

10. Install the fasteners wet with BAC5710, Type 51 high temperature primer.

11. Remove unwanted primer from the outer surface of the skin and repair skin with MEK, MIBK, Trichloroethylene, or acetone.

12. Apply BMS 5-63 sealant to the gaps between the Part 1 skin and the initial skin. Refer to SRM 51-20-05.

13. Apply a finish to the repair. Refer to AMM 51-21.

NOTES

- **CAUTION:** MAKE SURE THERE ARE NO LOOSE FASTENERS IN THE LIPSKIN. FASTER INGESTION MAY CAUSE ENGINE DAMAGE. INSPECT FOR AND REPLACE LOOSE FASTENERS AT EVERY "A" CHECK.
- ALL DIMENSIONS ARE IN INCHES UNLESS GIVEN DIFFERENTLY.
- WHEN YOU USE THIS REPAIR REFER TO:
 - AMM 51-21 FOR INTERIOR AND EXTERIOR FINISHES
 - SRM 51-10-01 FOR AERODYNAMIC SMOOTHNESS REQUIREMENTS

- SRM 51-10-02 FOR INSPECTION AND REMOVAL OF DAMAGE
- SRM 51-20-01 FOR PROTECTIVE TREATMENT OF METAL
- SRM 51-20-05 FOR REPAIR SEALING
- SRM 51-30 FOR THE SOURCES OF REPAIR MATERIALS
- SRM 51-40 FOR FASTENER CODE, REMOVAL, INSTALLATION, HOLE SIZES AND EDGE MARGINS
- SRM 51-40-03 FOR FASTENER SUBSTITUTION
- SRM 51-40-08 FOR COUNTERSINKING.

- A** PUT A CHAMFER ON THE END TO FIT.
- B** AN OPTION TO THE NAS1399CW5() BLIND RIVETS IS TO INSTALL BACN10JP3()CD NUTPLATES WITH BACR15CE3D()C RIVETS ON TO ITEM 3 DOUBLERS AND TO USE BACB30VF3K() 100 DEGREE REDUCED HEAD BOLTS. (SEE DETAIL IV ON PAGE 5). IF THIS OPTION IS USED THE "A" CHECK INSPECTIONS IN THE CAUTION NOTE ARE NOT REQUIRED. ONLY NORMAL LIPSKIN INSPECTION IS REQUIRED.

FASTENER SYMBOLS

- + INITIAL FASTENER LOCATION. INSTALL A BACB30NW6K()X BOLT AND BACC30M COLLAR.
- ⊕ INITIAL FASTENER OR REPAIR FASTENER LOCATIONS. INSTALL NAS1399CW6 RIVETS.
- ✦ REPAIR FASTENER LOCATION. INSTALL A BACR15CE5D() RIVET.
- ⊙ REPAIR FASTENER LOCATION. INSTALL NAS1399CW5() BLIND RIVET. **B**

REPAIR MATERIAL			
	PART	QTY	MATERIAL
1	SKIN SPLICE	1	SAME GAGE AS THE GAGE OF THE INITIAL SKIN (IF THE INITIAL SKIN IS CHEM-MILLED, USE THE GAGE OF THE THICKER PAD) CLAD 2219-T62 OPTIONAL: CLAD 2024-T3
2	DOUBLER	2	0.100 CLAD 2219-T62 OPTIONAL: 0.100 CLAD 2024-T3
3	DOUBLER	2	0.100 CLAD 2219-T62 OPTIONAL: 0.100 CLAD 2024-T3
4	TAPERED FILLER	2	CLAD 2024-T4

TABLE I

**Inlet Cowl - Leading Edge Skin Repair - PW2000 Engine
Figure 201 (Sheet 1 of 4)**

**757-200
STRUCTURAL REPAIR MANUAL**

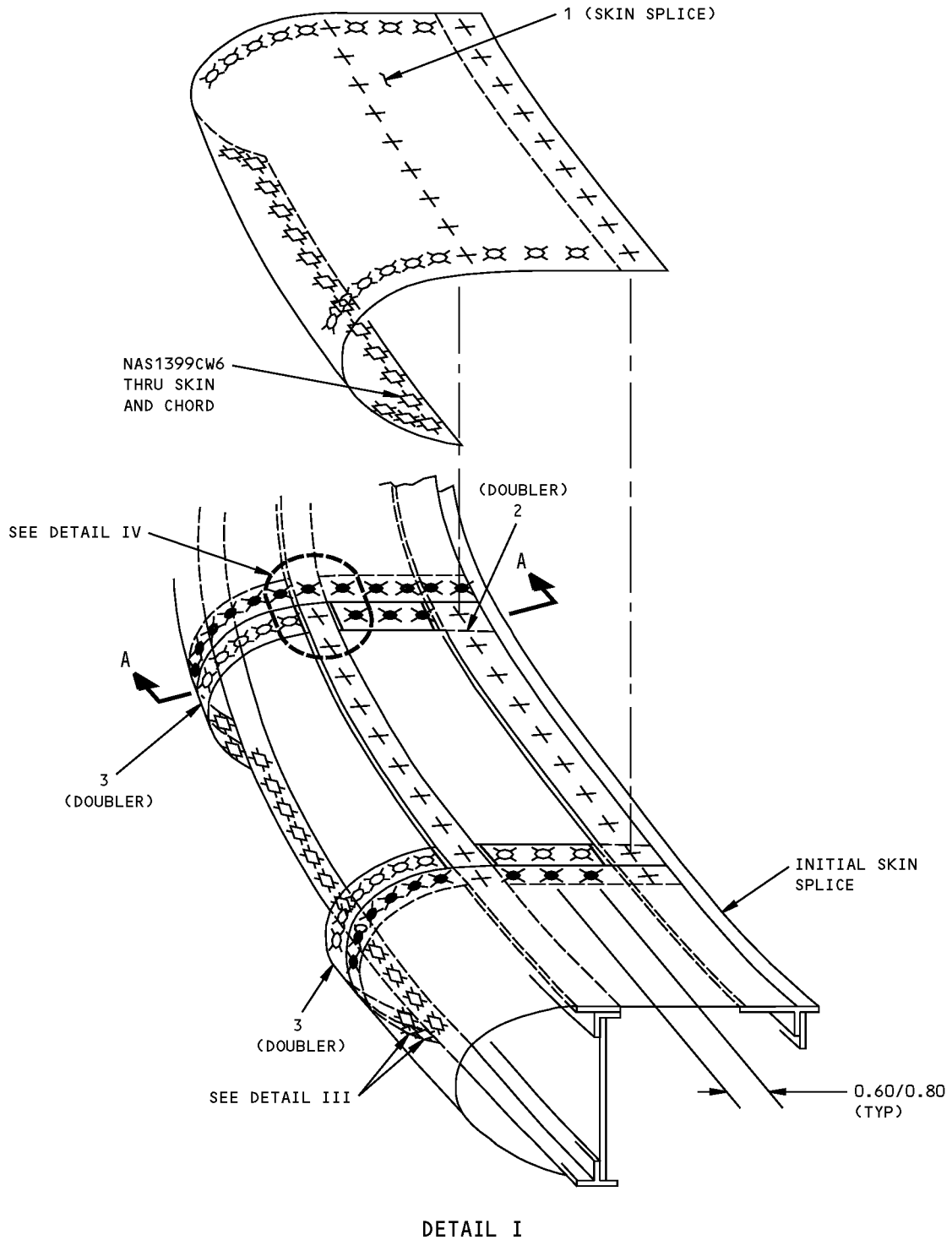

**Inlet Cowl - Leading Edge Skin Repair - PW2000 Engine
Figure 201 (Sheet 2 of 4)**

**757-200
STRUCTURAL REPAIR MANUAL**

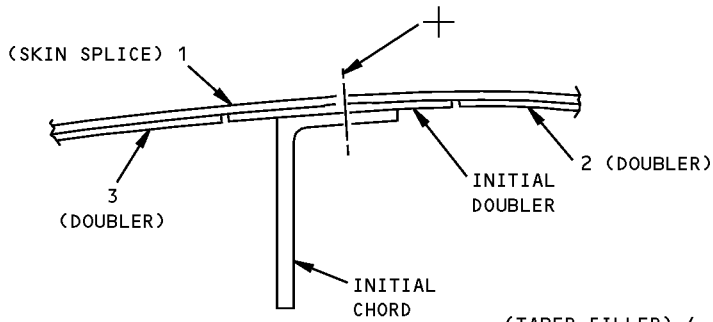
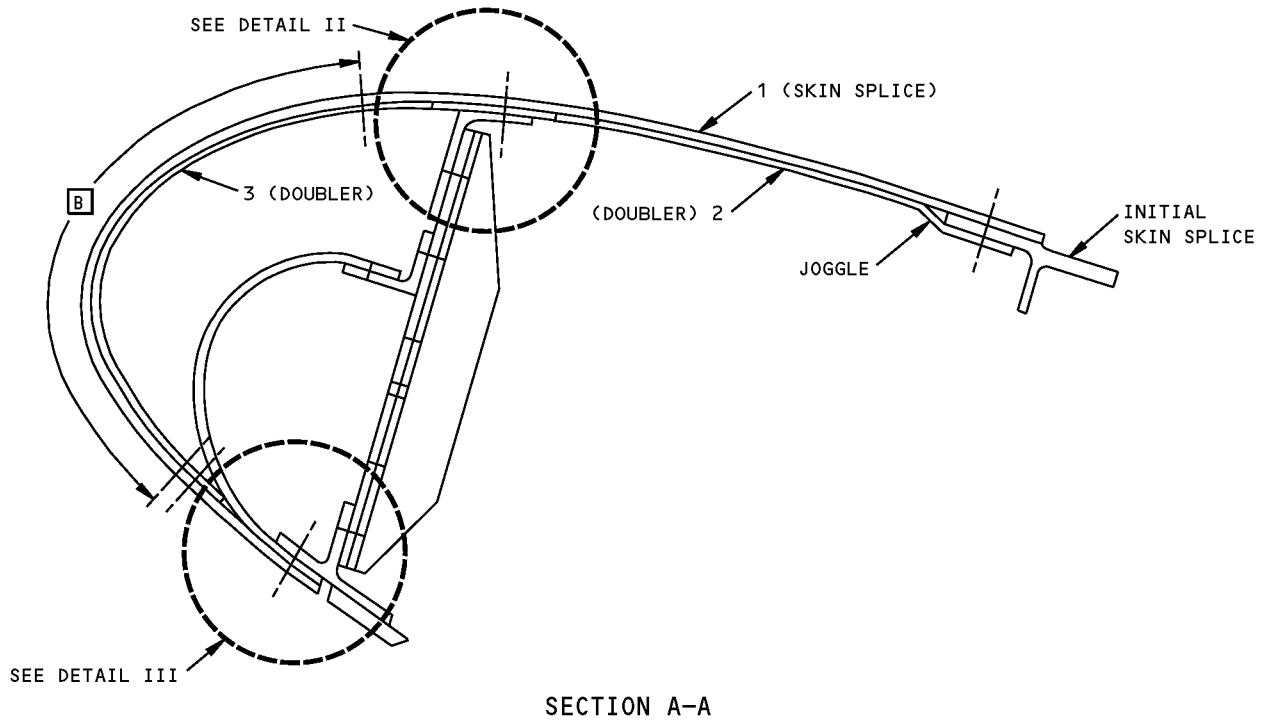

DETAIL II

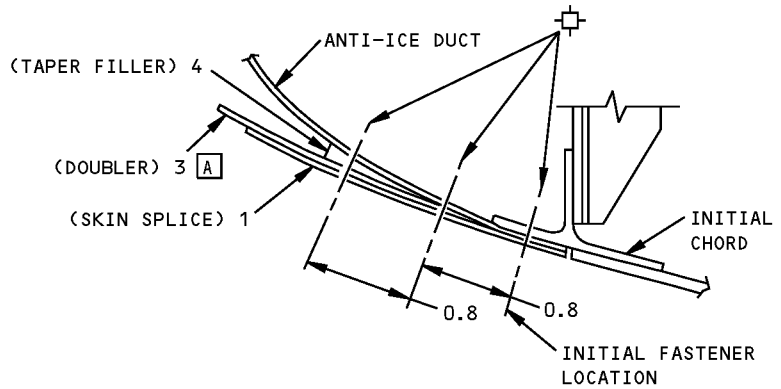

DETAIL III

**Inlet Cowl - Leading Edge Skin Repair - PW2000 Engine
Figure 201 (Sheet 3 of 4)**

**757-200
STRUCTURAL REPAIR MANUAL**

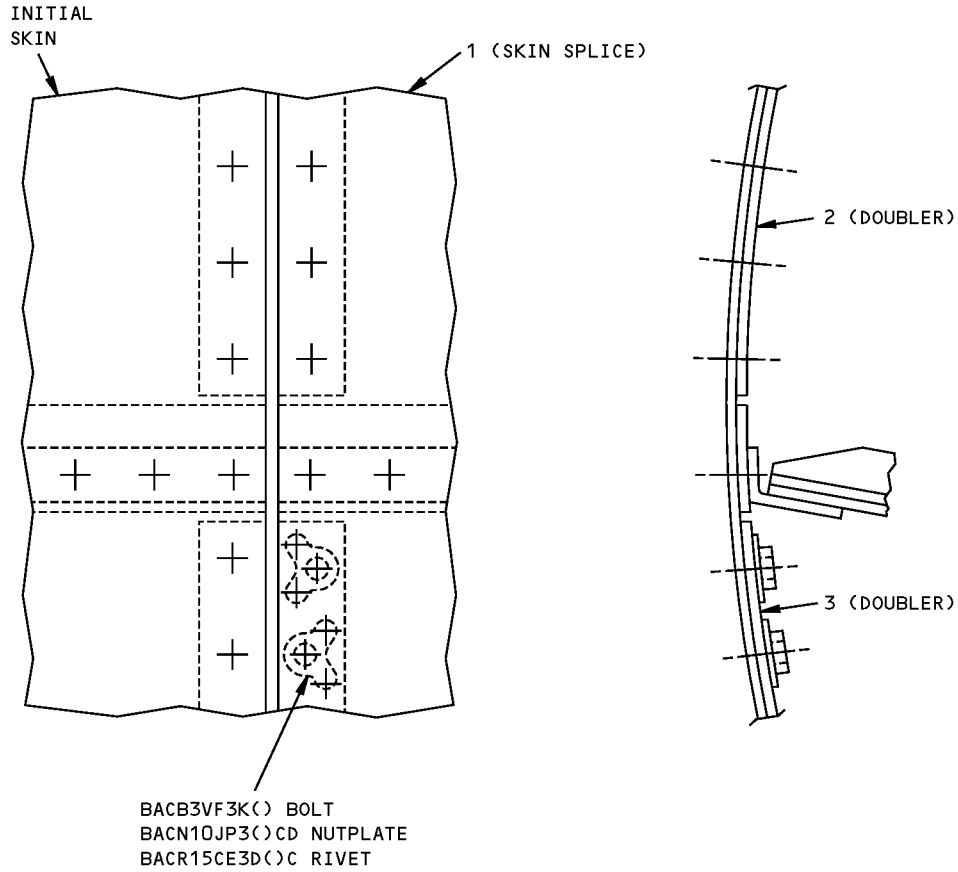

**DETAIL IV
OPTIONAL FASTENER INSTALLATION**

**Inlet Cowl - Leading Edge Skin Repair - PW2000 Engine
Figure 201 (Sheet 4 of 4)**



757-200

STRUCTURAL REPAIR MANUAL

REPAIR 3 - INLET COWL - OUTER PANEL - PW2000 ENGINE

NOTES

- REFINISH REWORKED AREAS AS SHOWN IN AMM 51-20
 - REFER TO SRM 51-10-01 FOR AERODYNAMIC SMOOTHNESS REQUIREMENTS. WHERE THE DAMAGE IS MORE THAN THE LIMITS SHOWN IN SRM 51-10-01, CONSIDERATION SHOULD BE GIVEN TO THE LOSS OF PERFORMANCE INVOLVED
- A** LIMITED TO REPAIR OF DAMAGE TO ONE FACE-SHEET SKIN AND HONEYCOMB CORE. ONE REPAIR FOR EACH SQUARE FOOT (930 SQUARE cm) OF AREA AND MINIMUM OF 6.0 INCHES (150 mm) (EDGE TO EDGE) FROM ANY OTHER DAMAGE, FASTENER HOLE, OR EDGE OF PANEL
- B** INSPECT INTERIM REPAIR USING INSTRUMENTED NDI METHODS OR "TAP" TEST EVERY AIRPLANE "2A" CHECK. FOR "TAP" TEST, USE A SOLID METAL DISK AND TAP THE REPAIR AREA LIGHTLY BUT FIRMLY. VOID AREAS WILL PRODUCE A DULL SOUND AS OPPOSED TO A SHARP RING ON A SOLID BONDED AREA. PERMANENT REPAIR IS REQUIRED IF ANY DETERIORATION IS EVIDENT. REFER TO SRM 51-70-03, PAR. 4.I. AND THE NONDESTRUCTIVE TEST MANUAL **D**
- C** ONE REPAIR FOR EACH SQUARE FOOT (930 SQUARE cm) OF AREA AND A MINIMUM OF 6.0 INCHES (150 mm) (EDGE TO EDGE) FROM ANY OTHER DAMAGE, FASTENER HOLE, OR EDGE OR PANEL
- D** THIS REPAIR HAS FAA APPROVAL CONTINGENT ON ACCOMPLISHMENT OF THE INSPECTIONS CONTAINED HEREIN
- E** FOR PERMANENT WET LAYUP REPAIRS USE A 1.0 INCH (25 mm) OVERLAP FOR EACH REPAIR PLY AND CURE AT 230°F (110°C). ALTERNATIVELY, FOR OUTER SKIN REPAIRS ONLY, USE A 0.50 INCH (12.7 mm) OVERLAP FOR EACH REPAIR PLY AND CURE AT 200°F (93°C).

Inlet Cowl - Outer Panel Repair - PW2000 Engine
Figure 201 (Sheet 1 of 3)

D634N201

54-11-01

REPAIR 3
Page 201
Jan 20/2005

STRUCTURAL REPAIR MANUAL

DAMAGE	INTERIM REPAIRS [B]	PERMANENT REPAIRS	
	WET LAYUP 150°F (66°C) CURE (SRM 51-70-03)	WET LAYUP 200°F (93°C) CURE (SRM 51-70-17) [E]	350°F (177°C) CURE (SRM 51-70-04)
CRACKS	UP TO 3.0 INCHES (75 mm) LONG, REPAIR WITH PATCH AS GIVEN IN SRM 51-70-03, PARAGRAPH 5.N. [A]	CLEAN UP DAMAGE AND REPAIR AS A HOLE.	CLEAN UP DAMAGE AND REPAIR AS A HOLE.
HOLES AND PUNCTURES	3.0 INCHES (75 mm) MAXIMUM DIAMETER NOT TO EXCEED 30 PERCENT OF SMALLEST DIMENSION ACROSS HONEYCOMB PANEL AT THE DAMAGE LOCATION. FILL WITH BMS 5-28, TYPE 7 POTTING COMPOUND AND PATCH AS GIVEN IN SRM 51-70-03, PARAGRAPH 5.N. [A]	12.0 INCHES (300 mm) MAXIMUM DIA NOT TO EXCEED 50 PERCENT OF SMALLEST DIMENSION ACROSS HONEYCOMB PANEL AT THE DAMAGE LOCATION. USE TWO EXTRA PLYS FOR EACH FACESHEET REPAIRED. [C]	NO SIZE LIMIT
DELAMINATION	CUT OUT AND REPAIR AS A HOLE.		
EDGE EROSION	_____	FOR DAMAGE NOT LARGER THAN 35% OF EDGE BAND THICKNESS, REPAIR AS GIVEN IN SRM 51-70-03, PARAGRAPH 5.O. FOR LARGER DAMAGE, REPAIR AS GIVEN IN: SRM 51-70-17, PARAGRAPH 4.G.	SRM 51-70-04, PARAGRAPH 5.G.
NICKS AND GOUGES	IF THERE IS NO FIBER DAMAGE OR DELAMINATION, FILL NICKS OR GOUGES AS GIVEN IN SRM 51-70-03. IF YOU FIND FIBER DAMAGE OR DELAMINATION, THEN REPAIR AS A HOLE.		
DENTS	DENTS RESULT IN FIBER DAMAGE AND DELAMINATION. USE REPAIR DATA FOR HOLES AND PUNCTURES TO DETERMINE DENT REPAIR.		

REPAIR DATA FOR 350°F (177°C) CURE GRAPHITE/EPOXY HONEYCOMB PANELS
TABLE I

Inlet Cowl - Outer Panel Repair - PW2000 Engine
Figure 201 (Sheet 2 of 3)

**757-200
STRUCTURAL REPAIR MANUAL**

DAMAGE	INTERIM REPAIRS B	PERMANENT REPAIRS	
	WET LAYUP 150°F (66°C) CURE (SRM 51-70-03)	WET LAYUP 200°F (93°C)/230°F (110°C) CURE (SRM 51-70-17) E	350°F (177°C) CURE (SRM 51-70-04)
HOLES	REPAIR THE DAMAGE TO THE FASTENER HOLES AS GIVEN IN SRM 51-70-03, FIG. 10. FOR THE LIMITS THAT FOLLOW, REPAIR OTHER DAMAGE AS GIVEN IN SRM 51-70-03, FIG. 9: A MAXIMUM OF 15% OF THE AREA OF THE CROSS SECTION THROUGH THE EDGE BAND - A MAXIMUM OF 10% OF THE LENGTH OF THE EDGE BAND FOR EACH SIDE THAT IS DAMAGED.	REPAIR THE DAMAGE TO THE FASTENER HOLES AS GIVEN IN SRM 51-70-17, FIG. 16. REPAIR ALL OTHER DAMAGE AS GIVEN IN SRM 51-70-17, FIG. 15.	REPAIR THE DAMAGE TO THE FASTENER HOLES AS GIVEN IN SRM 51-70-04, FIG. 10. REPAIR ALL OTHER DAMAGE AS GIVEN IN SRM 51-70-04, FIG. 9.
CRACKS	USE THE SAME LIMITS AND REPAIRS AS FOR HOLES.	USE THE SAME REPAIRS AS FOR HOLES.	
DELAMINATION	IF THE DELAMINATION FROM THE PANEL EDGE IS NOT LESS THAN 2D FROM ANY FASTENER HOLE, REPAIR AS GIVEN IN SRM 51-70-03, FIG. 12. FOR ANY OTHER DELAMINATION, USE THE SAME LIMITS AND REPAIRS AS FOR HOLES.	USE THE SAME REPAIRS AS FOR HOLES.	
NICKS AND GOUGES	IF THERE IS FIBER DAMAGE, USE THE SAME REPAIRS AS FOR HOLES. IF THERE IS DELAMINATION, USE THE SAME LIMITS AND REPAIRS AS FOR DELAMINATION.	IF THERE IS NO FIBER DAMAGE OR DELAMINATION, FILL THE NICKS OR GOUGES AS GIVEN IN SRM 51-70-03. IF THERE IS FIBER DAMAGE OR DELAMINATION, USE THE SAME REPAIRS AS FOR HOLES.	
DENTS	IF THERE IS FIBER DAMAGE, USE THE SAME LIMITS AND REPAIRS AS FOR HOLES. IF THERE IS DELAMINATION, USE THE SAME LIMITS AND REPAIRS AS FOR DELAMINATION.	IF THERE IS NO FIBER DAMAGE OR DELAMINATION, REPAIR AS GIVEN IN SRM 51-70-03, FIG. 16. IF THERE IS FIBER DAMAGE OR DELAMINATION, USE THE SAME REPAIRS AS FOR HOLES.	

REPAIR DATA FOR EDGE BANDS OF 350°F (177°C) CURE HONEYCOMB PANELS
TABLE II

**Inlet Cowl - Outer Panel Repair - PW2000 Engine
Figure 201 (Sheet 3 of 3)**

**757-200
STRUCTURAL REPAIR MANUAL**

IDENTIFICATION 1 - INLET COWL STRUCTURE - PW2000 ENGINE

REF DWG
314N3010

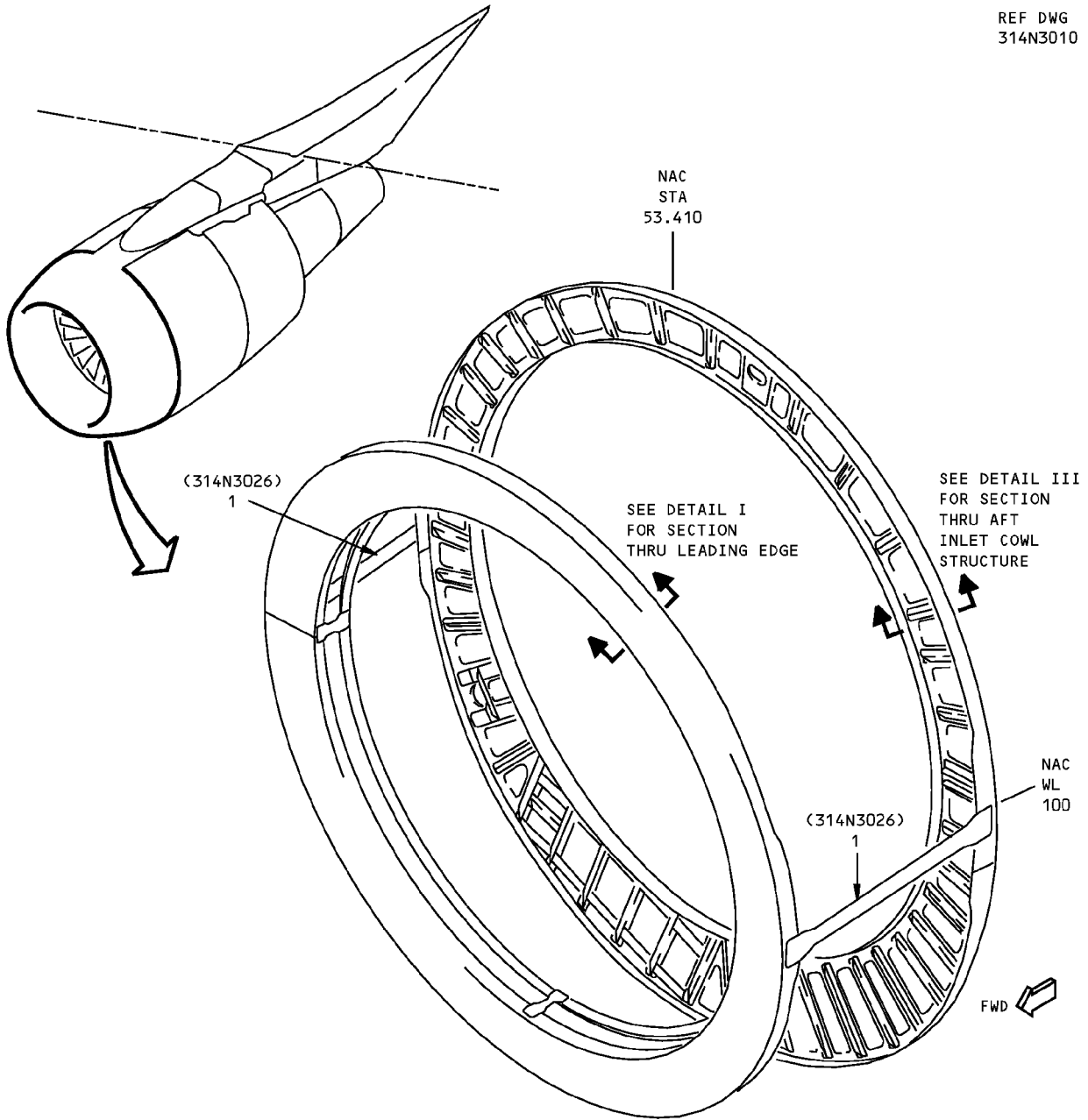

ITEM	DESCRIPTION	GAGE	MATERIAL	EFFECTIVITY
1	TEE		BAC1505-101238 2024-T62	

LIST OF MATERIALS

**Inlet Cowl Structure Identification - PW2000 Engine
Figure 1 (Sheet 1 of 4)**

**757-200
STRUCTURAL REPAIR MANUAL**

REFERENCE DRAWING
314N3020

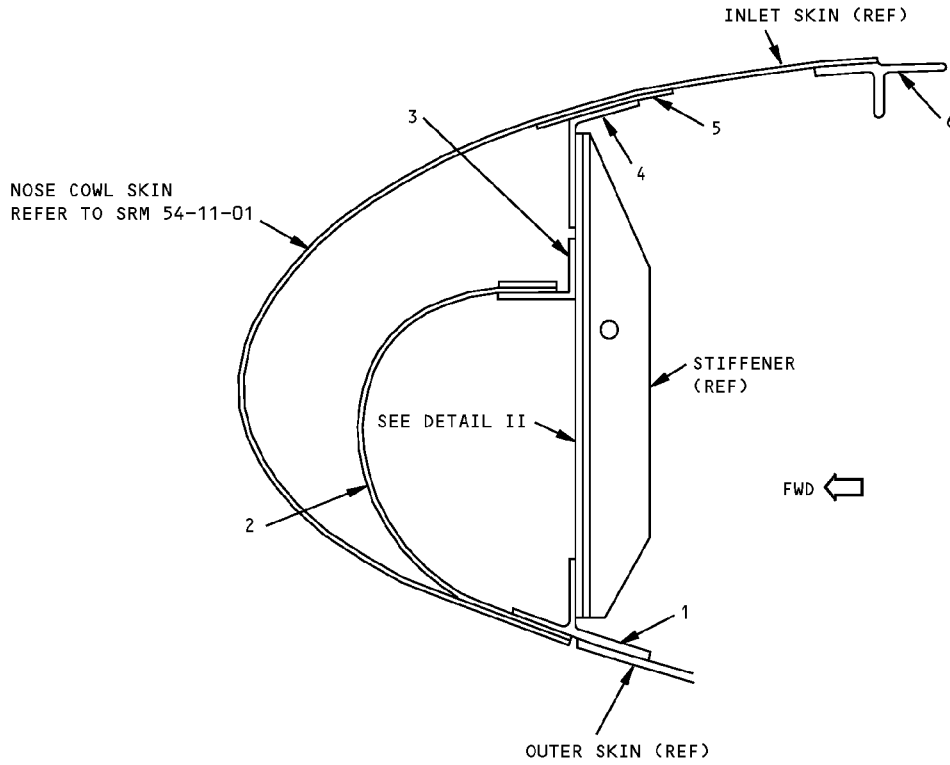

**SECTION THRU LEADING EDGE
DETAIL I**

ITEM	DESCRIPTION	GAGE	MATERIAL	EFFECTIVITY
1	OUTER CHORD		BAC1506-3529 2024-T42	
2	D-DUCT	0.125	CHEM MILLED 2219-T62	
3	D-DUCT ANGLE		BAC1503-100765 2024-T42	
4	INNER CHORD		BAC1514-2630 2024-T42	
5	DOUBLER	0.050	CLAD 2024-T62	
6	RING		BAC1506-3212 2024-T42	

LIST OF MATERIALS FOR DETAIL I

**Inlet Cowl Structure Identification - PW2000 Engine
Figure 1 (Sheet 2 of 4)**

IDENTIFICATION 1
Page 2
May 20/2005

54-11-02

D634N201

**757-200
STRUCTURAL REPAIR MANUAL**

REF DWG
314N3020

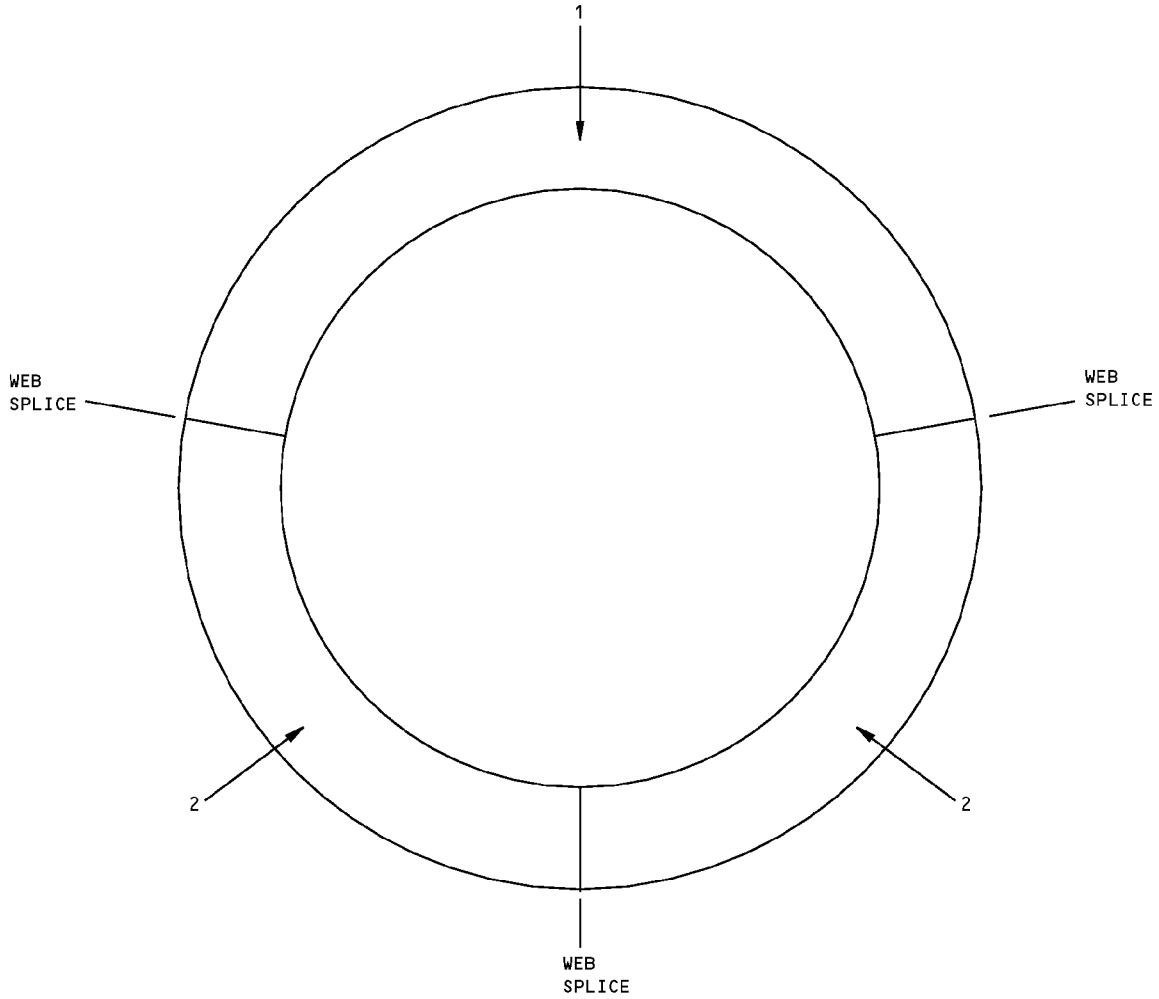

DETAIL II

ITEM	DESCRIPTION	GAGE	MATERIAL	EFFECTIVITY
1	WEB	0.100	CLAD 2024-T81	
2	WEB	0.125	CLAD 2024-T81	

LIST OF MATERIALS FOR DETAIL II

**Inlet Cowl Structure Identification - PW2000 Engine
Figure 1 (Sheet 3 of 4)**

IDENTIFICATION 1
Page 3
May 20/2005

54-11-02

D634N201

**757-200
STRUCTURAL REPAIR MANUAL**

REF DWG
314N3013

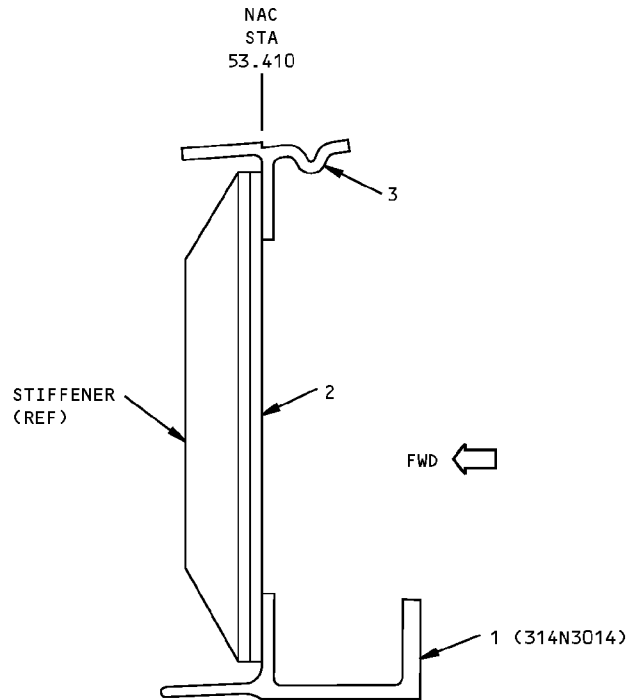

SECTION THRU AFT INLET COWL STRUCTURE
DETAIL III

ITEM	DESCRIPTION	GAGE	MATERIAL	EFFECTIVITY
1	INLET ATTACH RING		7075-T73 FORGED RING	
2	WEB	0.040	CHEM MILLED TI-6AL-4V	
3	CHORD		BAC1506-3551 2024-T42	

LIST OF MATERIALS FOR DETAIL III

**Inlet Cowl Structure Identification - PW2000 Engine
Figure 1 (Sheet 4 of 4)**

IDENTIFICATION 1
Page 4
May 20/2005

54-11-02

D634N201

**757-200
STRUCTURAL REPAIR MANUAL**

ALLOWABLE DAMAGE 1 - INLET COWL STRUCTURE - PW2000 ENGINE

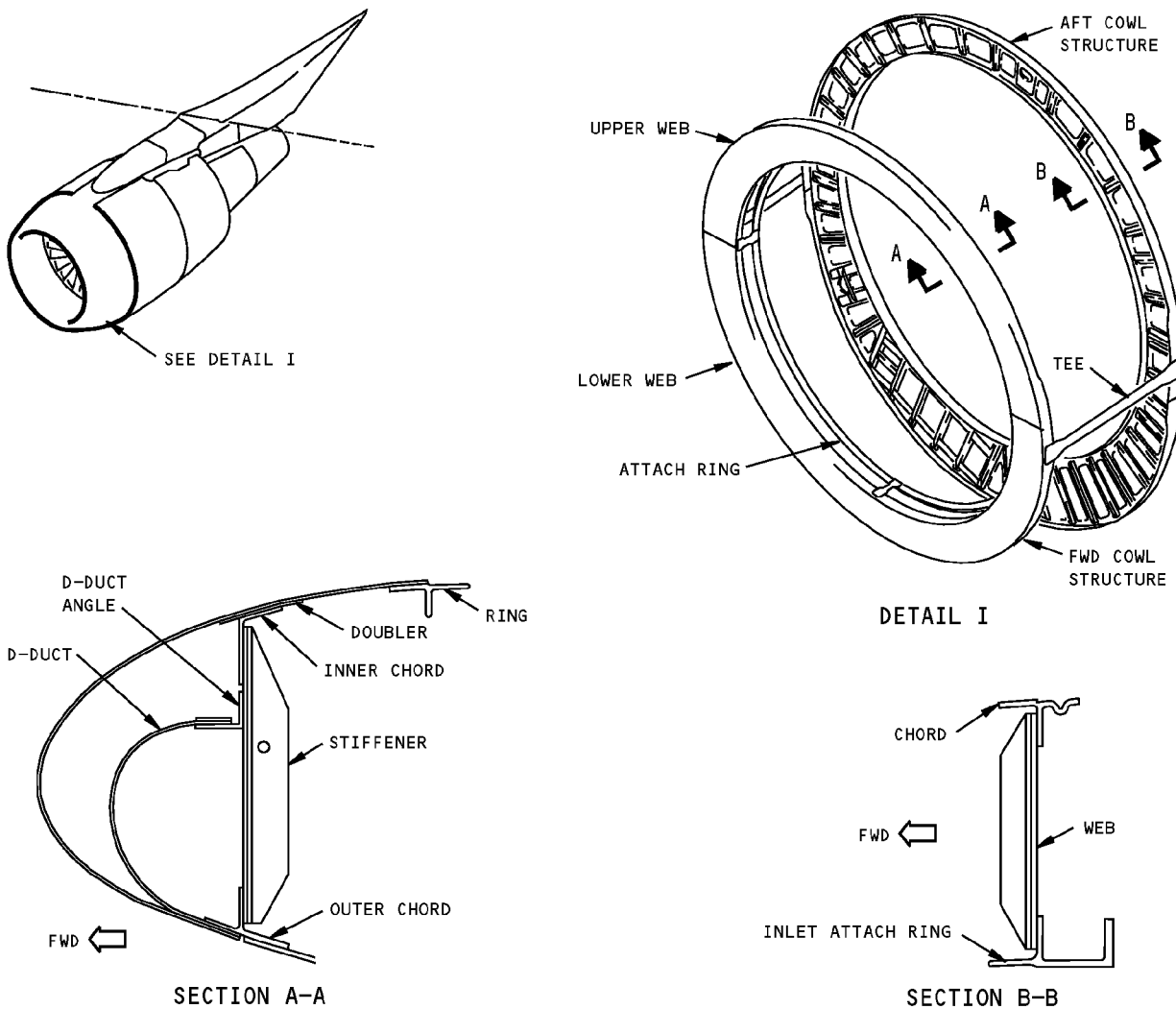

DESCRIPTION		CRACKS	NICKS, GOUGES AND CORROSION	DENTS	HOLES AND PUNCTURES
AFT COWL STRUCTURE	OUTER CHORD	A	B	NOT ALLOWED	NOT ALLOWED
	WEB	A	B	SEE DETAIL III	E
	INLET ATTACH RING F	C	D	NOT ALLOWED	NOT ALLOWED
TEE		A	B	NOT ALLOWED	E STEM ONLY
FWD COWL STRUCTURE	ATTACH RING	A	B	NOT ALLOWED	NOT ALLOWED
	OUTER CHORD	A	B	NOT ALLOWED	NOT ALLOWED
	D-DUCT	A	B	NOT ALLOWED	NOT ALLOWED
	D-DUCT ANGLE	A	B	NOT ALLOWED	NOT ALLOWED
	WEB	A	B	SEE DETAIL III	E

**Inlet Cowl Structure Allowable Damage - PW2000 Engine
Figure 101 (Sheet 1 of 3)**

STRUCTURAL REPAIR MANUAL

NOTES

- REFER TO AMM 51-20 TO REFINISH THE REWORKED AREAS
- REFER TO SRM 51-10-02 FOR INSPECTION AND REMOVAL OF DAMAGE.
- A** CRACKS ARE NOT PERMITTED EXCEPT FOR EDGE CRACKS WHICH MUST BE REMOVED AS SHOWN IN DETAILS II AND VI.
- B** REMOVE DAMAGE AS SHOWN IN DETAILS II, III AND V.
- C** CRACKS ARE NOT PERMITTED EXCEPT FOR EDGE CRACKS WHICH MUST BE REMOVED AS SHOWN IN DETAILS II AND VI.
- D** REMOVE DAMAGE AS SHOWN IN DETAILS II, III AND V.
- E** CLEAN OUT DAMAGE UP TO 0.25 INCH (6.3 mm) MAXIMUM DIAMETER AND NOT CLOSER THAN 1.0 INCH (25 mm) TO FASTENER HOLE OR OTHER DAMAGE. FILL HOLE WITH A 2117-T3 OR T4 ALUMINUM RIVET INSTALLED WET WITH BMS 5-63 SEALANT. ALL OTHER HOLES TO BE REPAIRED.
- F** REFER TO SRM 51-20-06 TO SHOT PEEN THE REWORKED AREAS.

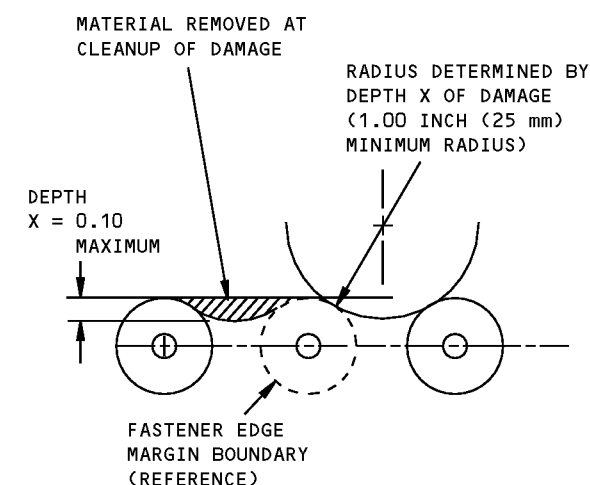

DAMAGE CLEANUP OF EDGES WHERE FASTENER EDGE MARGINS DO NOT OVERLAP

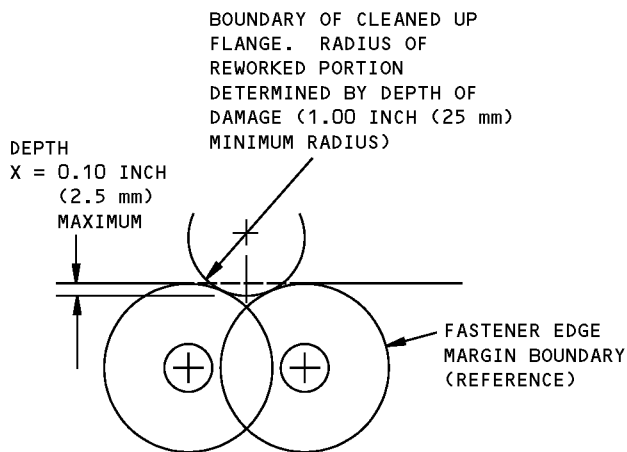

DAMAGE CLEANUP OF EDGES WHERE FASTENER EDGE MARGINS OVERLAP

DETAIL II

Inlet Cowl Structure Allowable Damage - PW2000 Engine
Figure 101 (Sheet 2 of 3)

STRUCTURAL REPAIR MANUAL

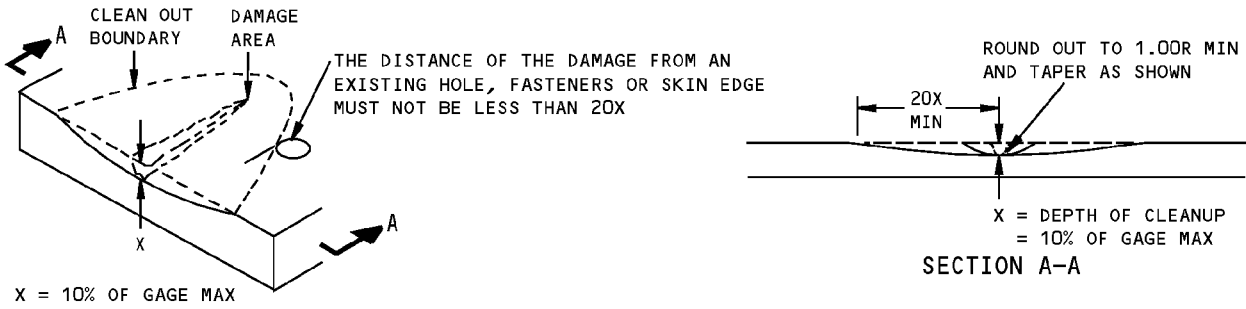

**REMOVAL OF NICK OR GOUGE DAMAGE ON A SURFACE
DETAIL III**

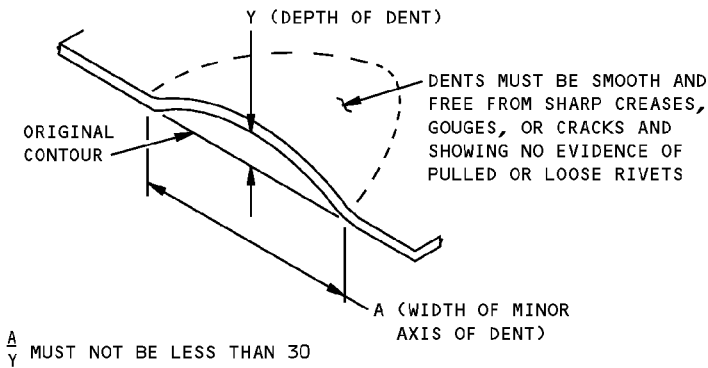

**ALLOWABLE DAMAGE FOR DENT
DETAIL IV**

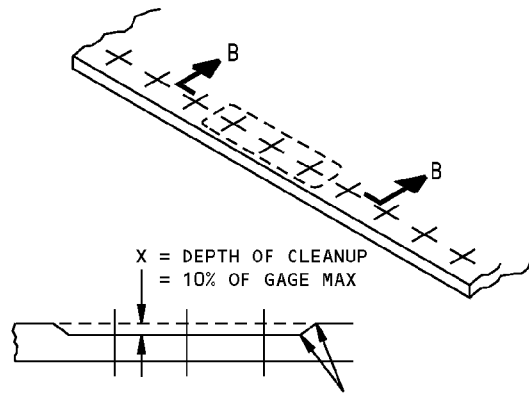

SMOOTH BLEND-OUT RADIUS 0.50 INCH MINIMUM.
CORROSION CLEANUP AROUND ANY THREE
FASTENERS IN TEN IS PERMITTED TO MAX DEPTH

SECTION B-B

**CORROSION CLEANUP
DETAIL V**

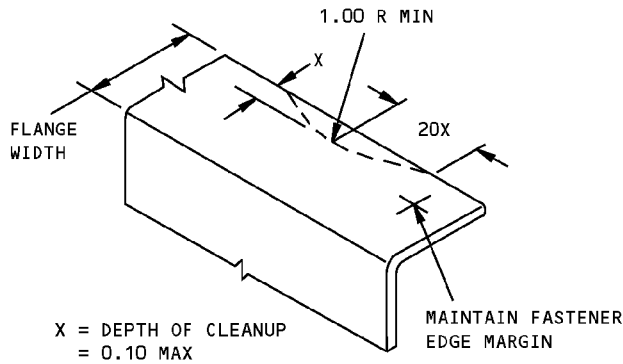

**REMOVAL OF NICK OR CRACK DAMAGE ON AN EDGE
DETAIL VI**

**Inlet Cowl Structure Allowable Damage - PW2000 Engine
Figure 101 (Sheet 3 of 3)**

**757-200
STRUCTURAL REPAIR MANUAL**

REPAIR 1 - INLET COWL STRUCTURE - ATTACH RING REPAIR - PW2000 ENGINE

APPLICABILITY
THIS REPAIR APPLIES TO PW2000 SERIES ENGINE INLET COWL UPPER AND LOWER ATTACH RING ONLY. THIS REPAIR DOES NOT APPLY TO THE UPPER AND LOWER RING SPLICE AREA (SEE DETAIL I).

REPAIR INSTRUCTIONS

1. Remove inlet lip skin and acoustic panel as required to gain access to the inlet attach ring. If skin is damaged, refer to SRM 54-11-01.
2. Cut out the damaged portion of attach ring. Center the cut between initial fastener locations.
3. Make repair parts using the repair material table.
4. Drill fastener holes by fitting parts together and using initial fastener locations in the inlet lip skin and the acoustic panel.
5. Remove all sharp edges, nicks, burrs, and scratches from initial and repair parts.
6. Alodize raw edges and initial surfaces and repair parts.
7. Apply one coat of BMS 10-11, type 1 primer to alodize surfaces of initial and repair parts.
8. Install repair parts and fasteners wet with BMS 5-79 or BMS 5-95.
9. Restore initial finish in accordance with AMM 51-21.

NOTES

- WHEN YOU USE THIS REPAIR REFER TO:
 - AMM 51-21 FOR INTERIOR AND EXTERIOR FINISHES
 - SRM 51-10-01 FOR AERODYNAMIC SMOOTHNESS REQUIREMENTS
 - SRM 51-10-02 FOR INSPECTION AND REMOVAL OF DAMAGE
 - SRM 51-20-01 FOR PROTECTIVE TREATMENT OF METAL
 - SRM 51-20-05 FOR SEALING OF FUSELAGE SKIN REPAIRS
 - SRM 51-40 FOR FASTENER CODE, REMOVAL, INSTALLATION, HOLE SIZES AND EDGE MARGINS.

- A** 3 REQUIRED ON EACH SIDE OF REPAIR SPLICE. CENTER THESE REPAIR FASTENERS BETWEEN THE SKIN ATTACH FASTENER LOCATIONS. INSTALL WET WITH BMS 5-79 OR BMS 5-95. USE WITH BACC30M COLLAR.
- B** 5 REQUIRED ON EACH SIDE OF REPAIR SPLICE. USE INITIAL FASTENER LOCATIONS. INSTALL WET WITH BMS 5-79 OR BMS 5-95. USE WITH BACC30M COLLAR.
- C** THE OUTSIDE BEND RADIUS OF THE REPAIR ANGLE MUST BE LARGER THAN THE RADIUS OF THE NESTING PART. INSIDE BEND RADIUS OF REPAIR ANGLE MUST BE 0.12 INCH (3.0 mm) MINIMUM TO 0.16 INCH (4.0 mm) MAXIMUM.

FASTENER SYMBOLS

- REPAIR FASTENER LOCATION
- INITIAL FASTENER LOCATION

REPAIR MATERIAL			
	PART	QTY	MATERIAL
1	ANGLE	2	0.063 INCH CLAD 2024-0 C HT TR T-42
2	ATTACH RING	1	BAC1506-3212 2024-0 HT TR T42

TABLE I

**Inlet Cowl Structure - Attach Ring Repair - PW2000 Engine
Figure 201 (Sheet 1 of 2)**

**757-200
STRUCTURAL REPAIR MANUAL**

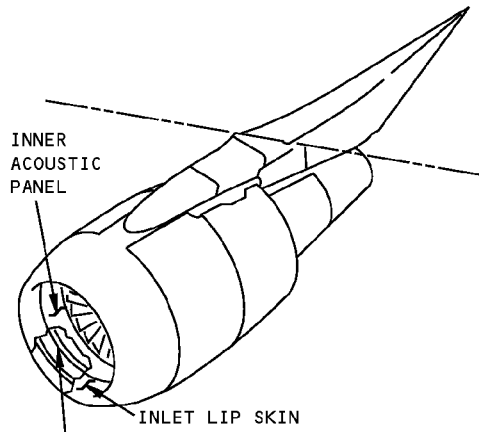

FOR SPLICE LOCATIONS
SEE DETAIL I
FOR ATTACH RING
SEE DETAIL II

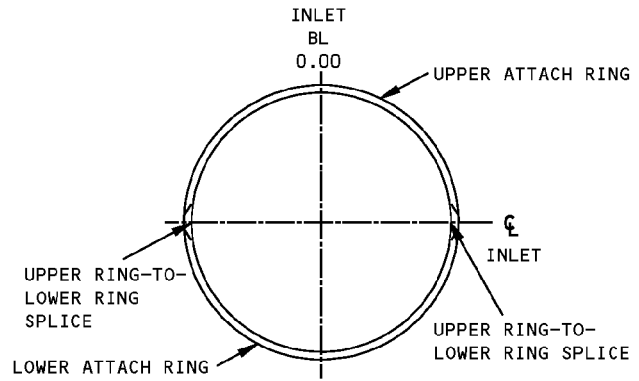

DETAIL I

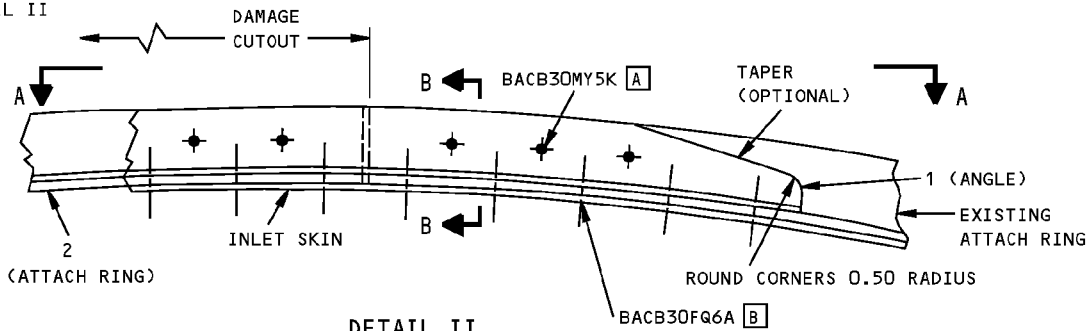

DETAIL II

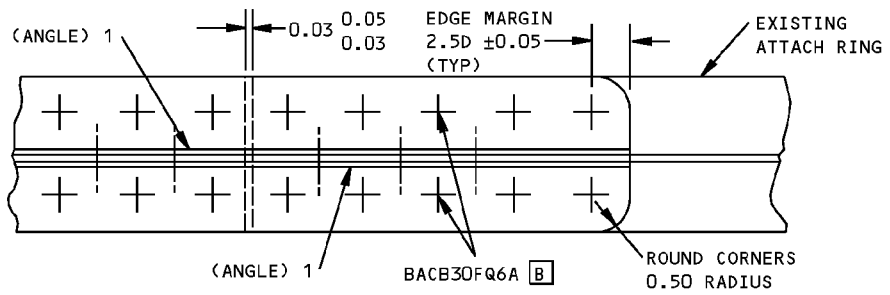

SECTION A-A

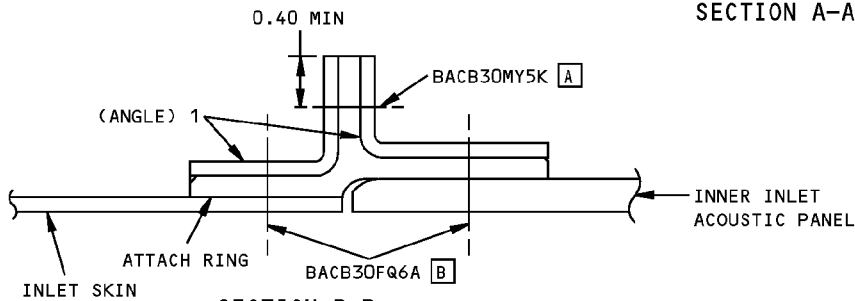

SECTION B-B

**Inlet Cowl Structure - Attach Ring Repair - PW2000 Engine
Figure 201 (Sheet 2 of 2)**

757-200
STRUCTURAL REPAIR MANUAL

IDENTIFICATION 1 - FAN COWL SKIN PANEL - RB211-535E4 ENGINE

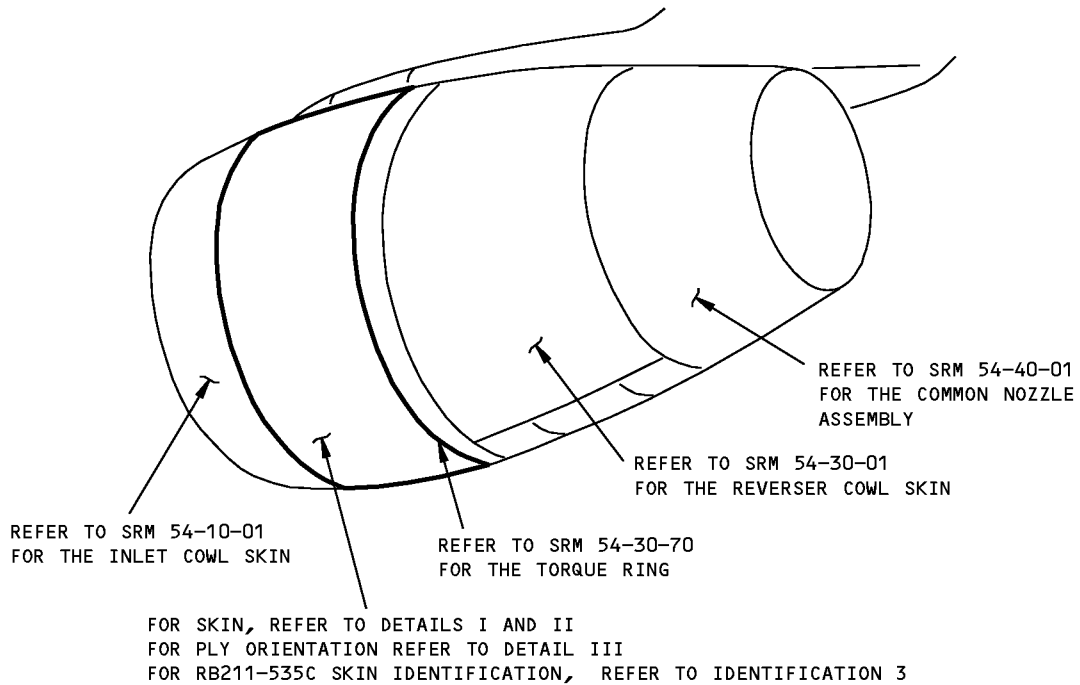

NOTES

- RMS - ROHR MATERIAL SPECIFICATION
- PLY ORIENTATION CONVENTION DEGREES INDICATED IS PARALLEL TO FABRIC WARP DIRECTION.

A GRAPHITE FABRIC A-370-5H/3501-5A

Fan Cowl Skin Panel Identification - RB211-535E4 Engine
Figure 1 (Sheet 1 of 4)

757-200
STRUCTURAL REPAIR MANUAL

REF DWG
LJ75503
(EXCEPT AS NOTED)

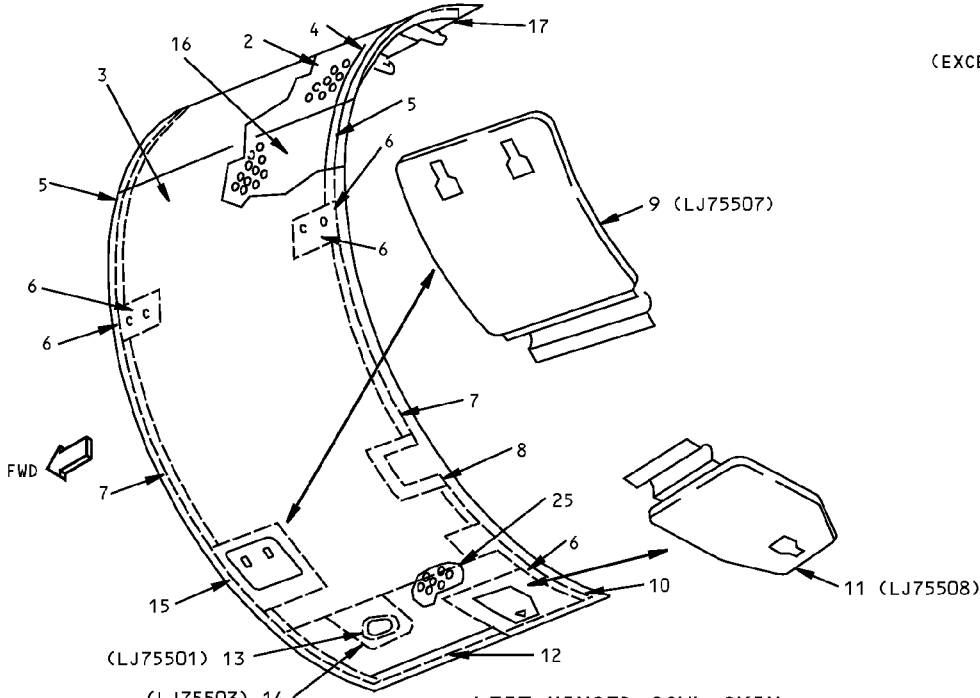

**LEFT HINGED COWL SKIN
DETAIL I**

REF DWG
LJ75504
(EXCEPT AS NOTED)

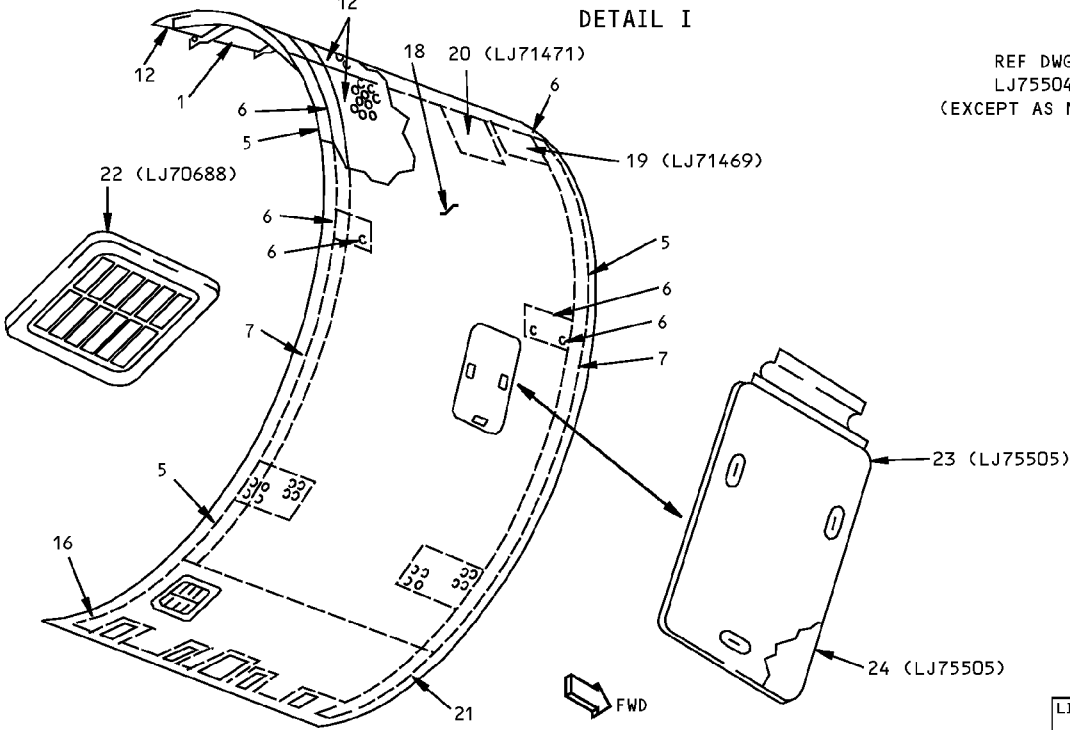

**RIGHT HINGED COWL SKIN
DETAIL II**

LIST OF
MATERIAL

**Fan Cowl Skin Panel Identification - RB211-535E4 Engine
Figure 1 (Sheet 2 of 4)**

757-200
STRUCTURAL REPAIR MANUAL

ITEM	DESCRIPTION	GAGE	MATERIAL	EFFECTIVITY
1	INNER SKIN		GRAPHITE FABRIC RMS060, GROUP 1, TYPE 2, CLASS 1, GRADE 1, 2 PLYS, 0° ORIENTATION [A]	
2	CORE	0.771	5056 ALUMINUM ALLOY HONEYCOMB RMS026 (MIL-A-81596), 22 LBS/CU FT, CLASS 2, TYPE 1	
3	OUTER SKIN		GRAPHITE FABRIC RMS060, GROUP 1, TYPE 2, CLASS 1, GRADE 1, 2 PLYS, 0° ORIENTATION [A]	
4	CORE	0.955	5056 ALUMINUM ALLOY HONEYCOMB RMS026, (MIL-A-81596), 8.1 LBS/CU FT, CLASS 2, TYPE 2	
5	CORE	0.855	5056 ALUMINUM ALLOY HONEYCOMB RMS026, (MIL-A-81596), 8.1 LBS/CU FT, CLASS 2, TYPE 2	
6	CORE	0.771	5056 ALUMINUM ALLOY HONEYCOMB RMS026, (MIL-A-81596), 5.7 LBS/CU FT, CLASS 2, TYPE 2	
7	CORE	0.897	5056 ALUMINUM ALLOY HONEYCOMB RMS026, (MIL-A-81596), 5.7 LBS/CU FT, CLASS 2, TYPE 2	
8	CORE	0.369	5056 ALUMINUM ALLOY HONEYCOMB RMS026, (MIL-A-81596), 5.7 LBS/CU FT, CLASS 2, TYPE 2	
9	DOOR COVER	0.063	2024-T3 CLAD ALUMINUM SHEET QQ-A-250/5, TEMP T-3	
10	CORE	0.355	5056 ALUMINUM ALLOY HONEYCOMB RMS026, (MIL-A-81596), 8.1 LBS/CU FT, CLASS 2, TYPE 2	
11	DOOR SKIN	0.125	2024-O CLAD ALUMINUM SHEET QQ-A-250/5, TEMP O	
12	CORE	0.939	5056 ALUMINUM ALLOY HONEYCOMB RMS026, (MIL-A-81596), 3.1 LBS/CU FT, CLASS 2, TYPE 2	
13	FRAME	0.063	6AL-4V TITANIUM SHEET AMS4911	
14	CORE	0.813	5056 ALUMINUM ALLOY HONEYCOMB RMS026, (MIL-A-81596), 8.1 LBS/CU FT, CLASS 2, TYPE 2	
15	CORE	0.757	5056 ALUMINUM ALLOY HONEYCOMB RMS026, (MIL-A-81596), 8.1 LBS/CU FT, CLASS 2, TYPE 2	
16	CORE	0.939	5056 ALUMINUM ALLOY HONEYCOMB RMS026, (MIL-A-81596), 3.1 LBS/CU FT, CLASS 2, TYPE 2	
17	INNER SKIN		GRAPHITE FABRIC RMS060, GROUP 1, TYPE 2, CLASS 1, GRADE 1, 2 PLYS, 0° ORIENTATION [A]	
18	OUTER SKIN		GRAPHITE FABRIC RMS060, GROUP 1, TYPE 2, CLASS 1, GRADE 1, 2 PLYS, 0° ORIENTATION [A]	
19	PLATE	0.150	302 CRES STEEL SHEET, MIL-S-5059, CONDITION A, FINISH 2D	
20	PLATE	0.150	302 CRES STEEL SHEET, MIL-S-5059, CONDITION A, FINISH 2D	
21	CORE	0.799	5056 ALUMINUM ALLOY HONEYCOMB RMS026, (MIL-A-81596), 8.1 LBS/CU FT, CLASS 2, TYPE 2	
22	LOUVER		RC-1008 40% CARBON REINFORCED NYLON 6/6	
23	SKIN	0.063	2024-O CLAD ALUMINUM SHEET QQ-A-250/5 (HEAT TREAT T-62)	
24	PAN	0.040	2024-O CLAD ALUMINUM SHEET QQ-A-250/5 (HEAT TREAT T-62)	
25	CORE	0.939	5056 ALUMINUM ALLOY HONEYCOMB RMS026, (MIL-A-81596), 2.3 LBS/CU FT, CLASS 2, TYPE 2	

LIST OF MATERIALS FOR DETAILS I AND II

Fan Cowl Skin Panel Identification - RB211-535E4 Engine
Figure 1 (Sheet 3 of 4)

IDENTIFICATION 1
Page 3
May 20/2005

54-20-01

D634N201

757-200
STRUCTURAL REPAIR MANUAL

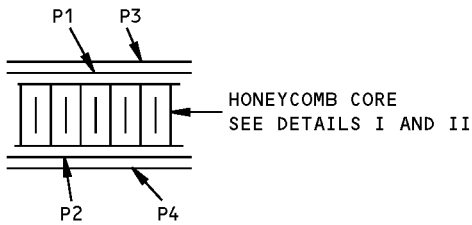
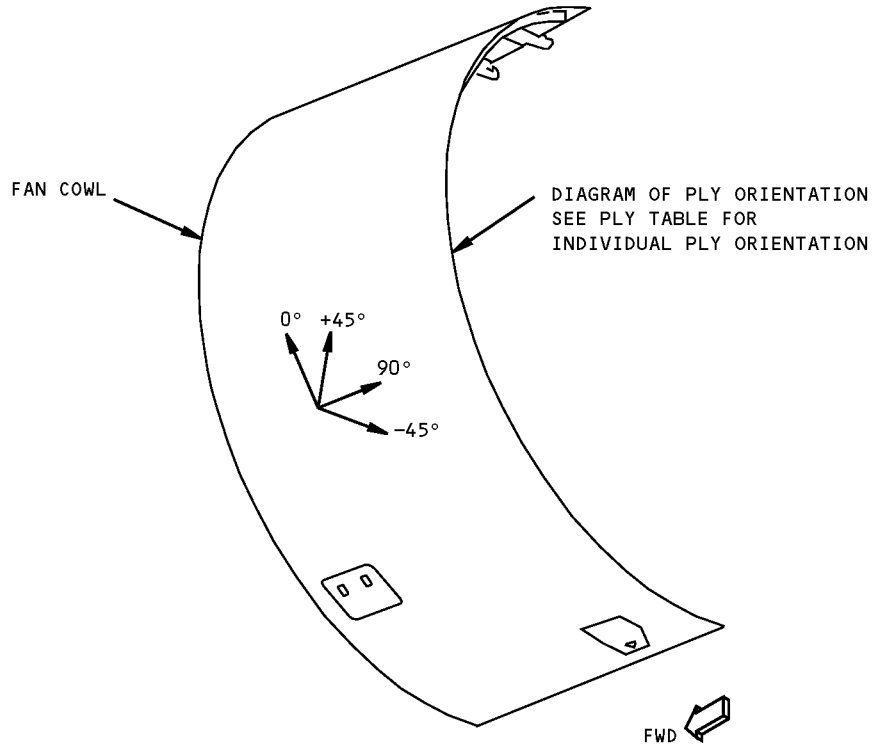

SECTION THRU PANEL

ITEM NUMBER	PLY NUMBER	MATERIAL	PLY ORIENTATION
1,3,17,18	P1,P2,P3,P4	A	0 DEGREES

PLY TABLE

PLY ORIENTATION AND IDENTIFICATION
DETAIL III

Fan Cowl Skin Panel Identification - RB211-535E4 Engine
Figure 1 (Sheet 4 of 4)

757-200
STRUCTURAL REPAIR MANUAL

IDENTIFICATION 2 - R.H FAN COWL SKIN PANEL - RB211-535C ENGINE

REFERENCE DRAWING
LJ71466
(EXCEPT AS NOTED)

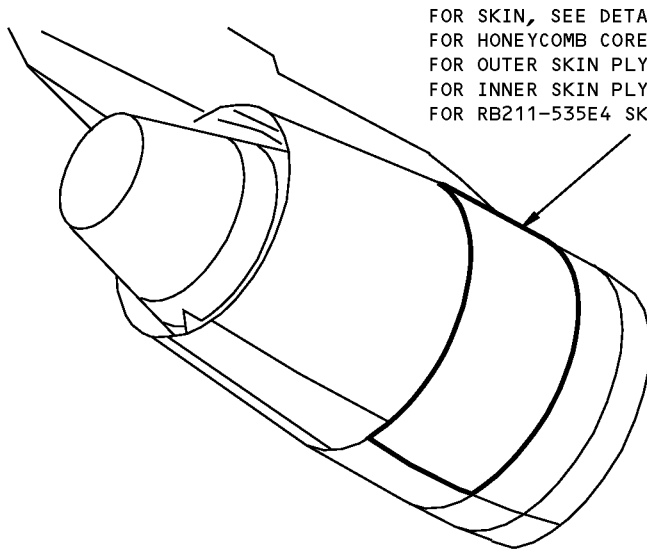

FOR SKIN, SEE DETAIL I
FOR HONEYCOMB CORE, SEE DETAIL II
FOR OUTER SKIN PLY LAYUP, SEE DETAIL III
FOR INNER SKIN PLY LAYUP, SEE DETAIL IV
FOR RB211-535E4 SKIN IDENTIFICATION, REFER TO IDENTIFICATION 1

NOTES

- RMS - ROHR MATERIAL SPECIFICATION

- A** GRAPHITE FABRIC:
- AH-370-5H/3501-5A, AS4 FIBER, V10396
 - CYCOM 985-1, AS4 FIBER, V7945
 - EM 7198, CELION 6K-ST FIBER, V27129
 - R 922-1, CGG 108, CELION 6K FIBER, V30137

Fan Cowl Skin Panel Identification - R.H. Fan Cowl - RB211-535C Engine
Figure 1 (Sheet 1 of 8)

757-200
STRUCTURAL REPAIR MANUAL

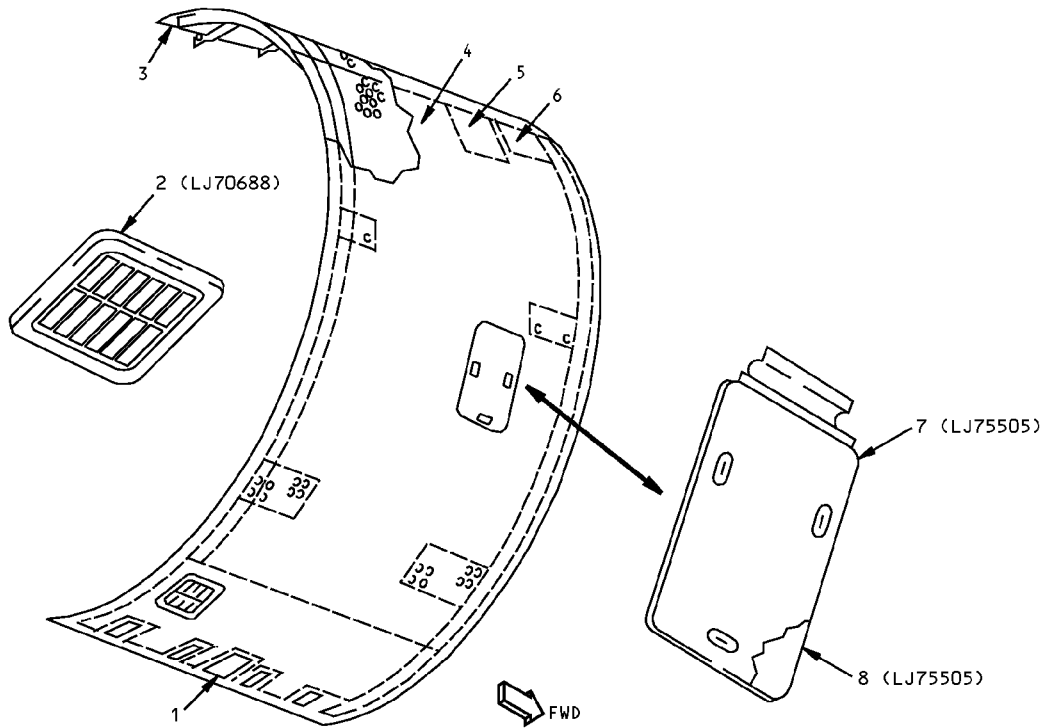

RIGHT HINGED COWL SKIN
DETAIL I

ITEM	DESCRIPTION	GAGE	MATERIAL	EFFECTIVITY
1	DOOR	0.063	2024-O CLAD ALUM SHEET QQ-A-250/5 (HEAT TREAT T-62)	
2	LOUVER		RC-1008 40% CARBON REINFORCED NYLON 6/6	
3	INNER SKIN		GRAPHITE FABRIC RMS60 GROUP 1, TYPE 2, CLASS 1, GRADE 1 [A]	
4	OUTER SKIN		GRAPHITE FABRIC RMS60 GROUP 1, TYPE 2, CLASS 1, GRADE 1 [A]	
5	PLATE	0.150	302 CRES STEEL SHEET, MIL-S-5059, COND. A, FINISH 2D	
6	PLATE	0.150	302 CRES STEEL SHEET, MIL-S-5059, COND. A, FINISH 2D	
7	SKIN	0.063	2024-O CLAD ALUM SHEET QQ-A-250/5 (HEAT TREAT T-62)	
8	PAN	0.040	2024-O CLAD ALUM SHEET QQ-A-250/5 (HEAT TREAT T-62)	

LIST OF MATERIALS FOR DETAIL I

Fan Cowl Skin Panel Identification - R.H. Fan Cowl - RB211-535C Engine
Figure 1 (Sheet 2 of 8)

**757-200
STRUCTURAL REPAIR MANUAL**

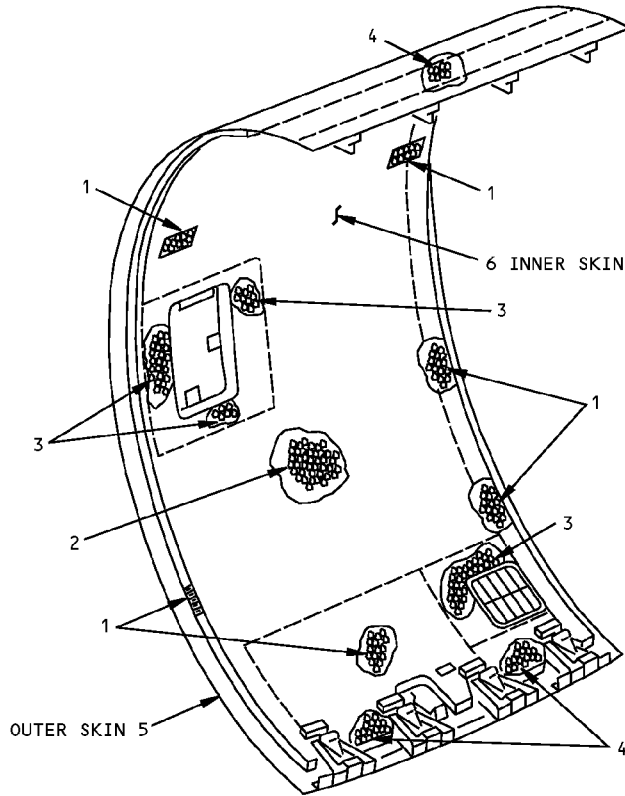

DETAIL II

ITEM	DESCRIPTION	GAGE	MATERIAL	EFFECTIVITY
1	CORE	0.002 FOIL	5056 ALUMINUM ALLOY HONEYCOMB, NONPERFORATED, 3/16 HEXCELL, 5.7 LB/CU FT	
2	CORE	0.001 FOIL	5056 ALUMINUM ALLOY HONEYCOMB, NONPERFORATED, 1/4 HEXCELL, 2.3 LB/CU FT	
3	CORE	0.002 FOIL	5056 ALUMINUM ALLOY HONEYCOMB, NONPERFORATED, 1/8 HEXCELL, 8.1 LB/CU FT	
4	CORE	0.001 FOIL	5056 ALUMINUM ALLOY HONEYCOMB, NONPERFORATED, 3/16 HEXCELL, 3.1 LB/CU FT	
5	INNER SKIN		SEE DETAIL IV	
6	OUTER SKIN		SEE DETAIL III	

LIST OF MATERIALS FOR DETAIL II

**Fan Cowling Skin Panel Identification - R.H. Fan Cowling - RB211-535C Engine
Figure 1 (Sheet 3 of 8)**

D634N201

54-20-01

IDENTIFICATION 2
Page 3
May 20/2005

757-200
STRUCTURAL REPAIR MANUAL

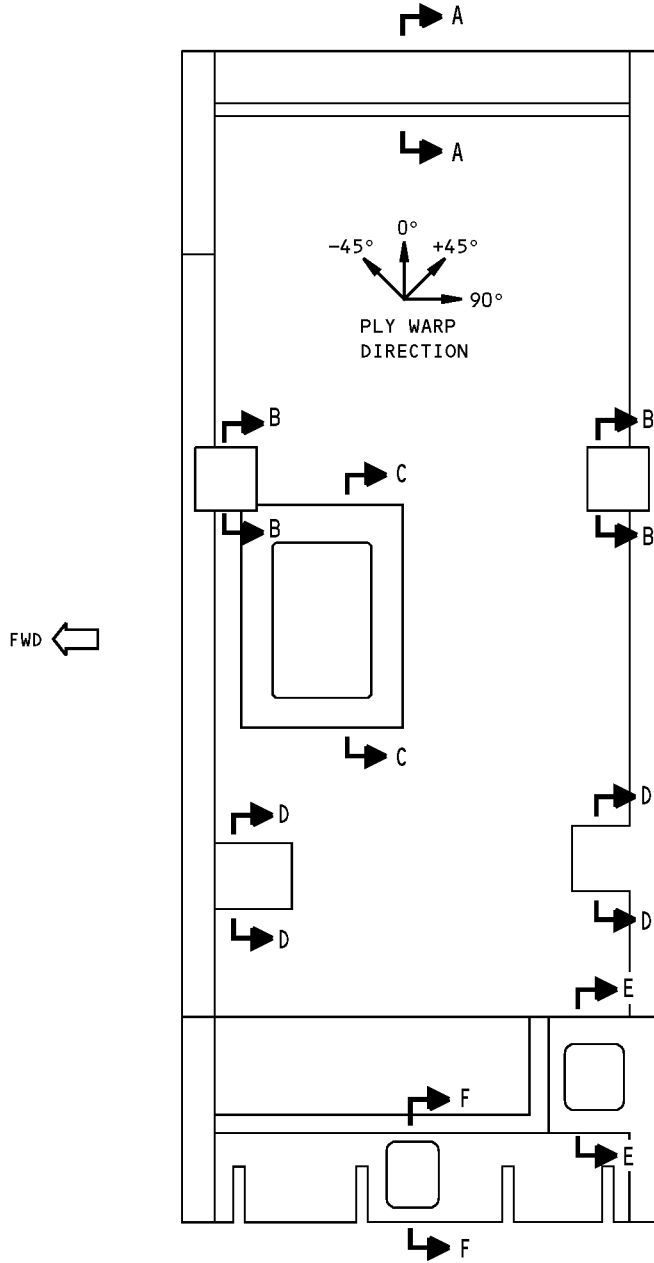

OUTER SKIN LOOKING INBOARD
DETAIL III

55185

Fan Cowl Skin Panel Identification - R.H. Fan Cowl - RB211-535C Engine
Figure 1 (Sheet 4 of 8)

IDENTIFICATION 2
Page 4
May 20/2005

54-20-01

D634N201

757-200
STRUCTURAL REPAIR MANUAL

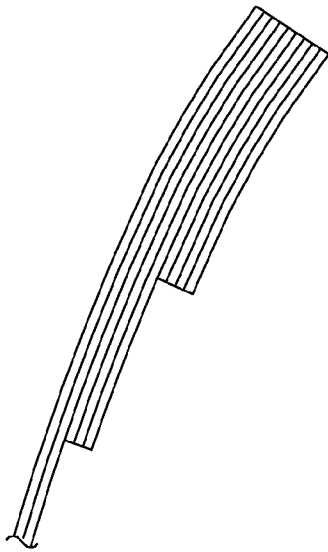

SECTION A-A

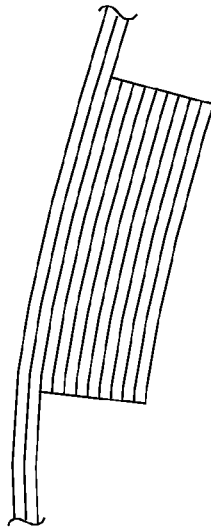

SECTION B-B

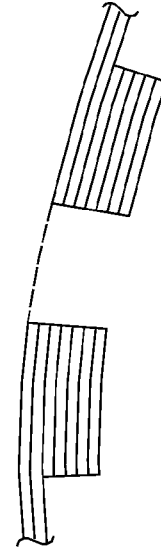

SECTION C-C

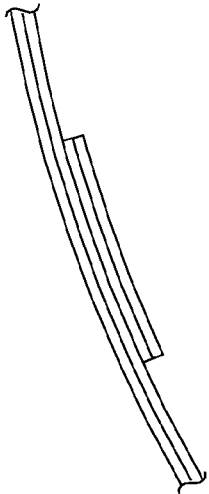

SECTION D-D

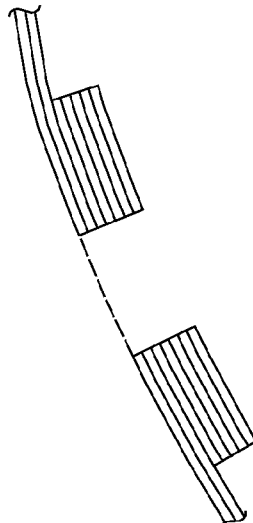

SECTION E-E

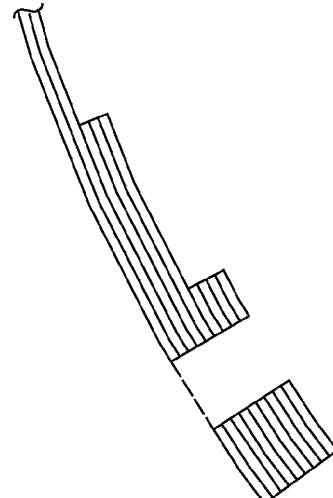

SECTION F-F

ITEM	GAGE	MATERIAL	WARP DIRECTION
SKIN PANEL			
6	0.014	GRAPHITE FABRIC A370-5H/3501-5A	0°

LIST OF MATERIALS FOR SECTION A-A THRU F-F

Fan Cowl Skin Panel Identification - R.H. Fan Cowl - RB211-535C Engine
Figure 1 (Sheet 5 of 8)

757-200
STRUCTURAL REPAIR MANUAL

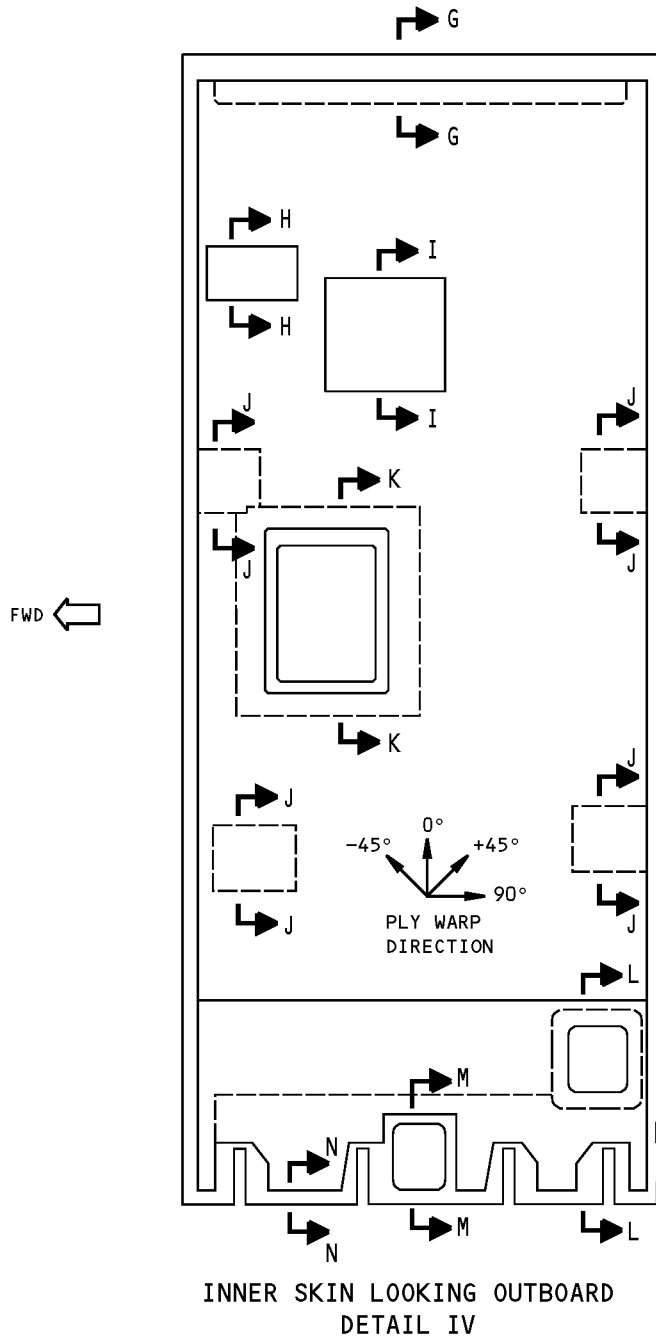

55187

Fan Cowl Skin Panel Identification - R.H. Fan Cowl - RB211-535C Engine
Figure 1 (Sheet 6 of 8)

IDENTIFICATION 2
Page 6
May 20/2005

54-20-01

D634N201

757-200
STRUCTURAL REPAIR MANUAL

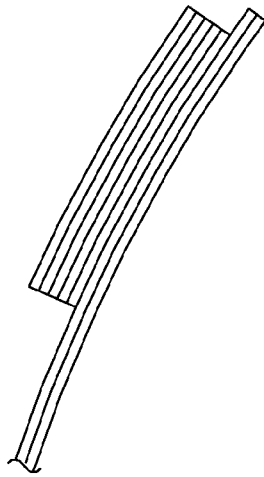

SECTION G-G

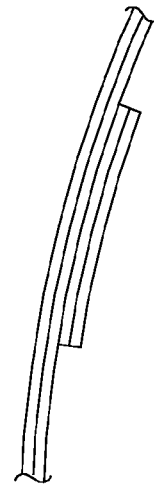

SECTION H-H

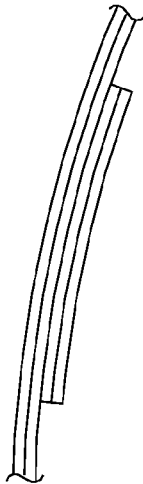

SECTION I-I



SECTION J-J

ITEM	GAGE	MATERIAL	WARP DIRECTION
SKIN PANEL			
6	0.014	GRAPHITE FABRIC A370-5H/3501-5A	0°

LIST OF MATERIALS FOR SECTION G-G THRU J-J

Fan Cowl Skin Panel Identification - R.H. Fan Cowl - RB211-535C Engine
Figure 1 (Sheet 7 of 8)

757-200
STRUCTURAL REPAIR MANUAL

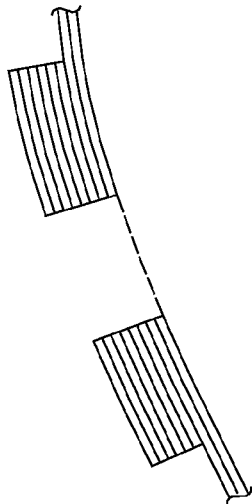

SECTION K-K

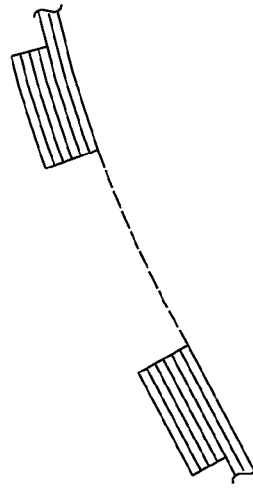

SECTION L-L

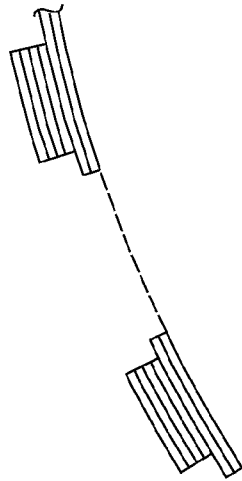

SECTION M-M

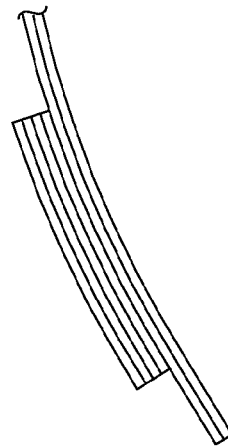

SECTION N-N

ITEM	GAGE	MATERIAL	WARP DIRECTION
SKIN PANEL			
6	0.014	GRAPHITE FABRIC A370-5H/3501-5A	0°

LIST OF MATERIALS FOR SECTION K-K THRU N-N

Fan Cowl Skin Panel Identification - R.H. Fan Cowl - RB211-535C Engine
Figure 1 (Sheet 8 of 8)

757-200
STRUCTURAL REPAIR MANUAL

IDENTIFICATION 3 - L.H. FAN COWL SKIN PANEL - RB211-535C ENGINE

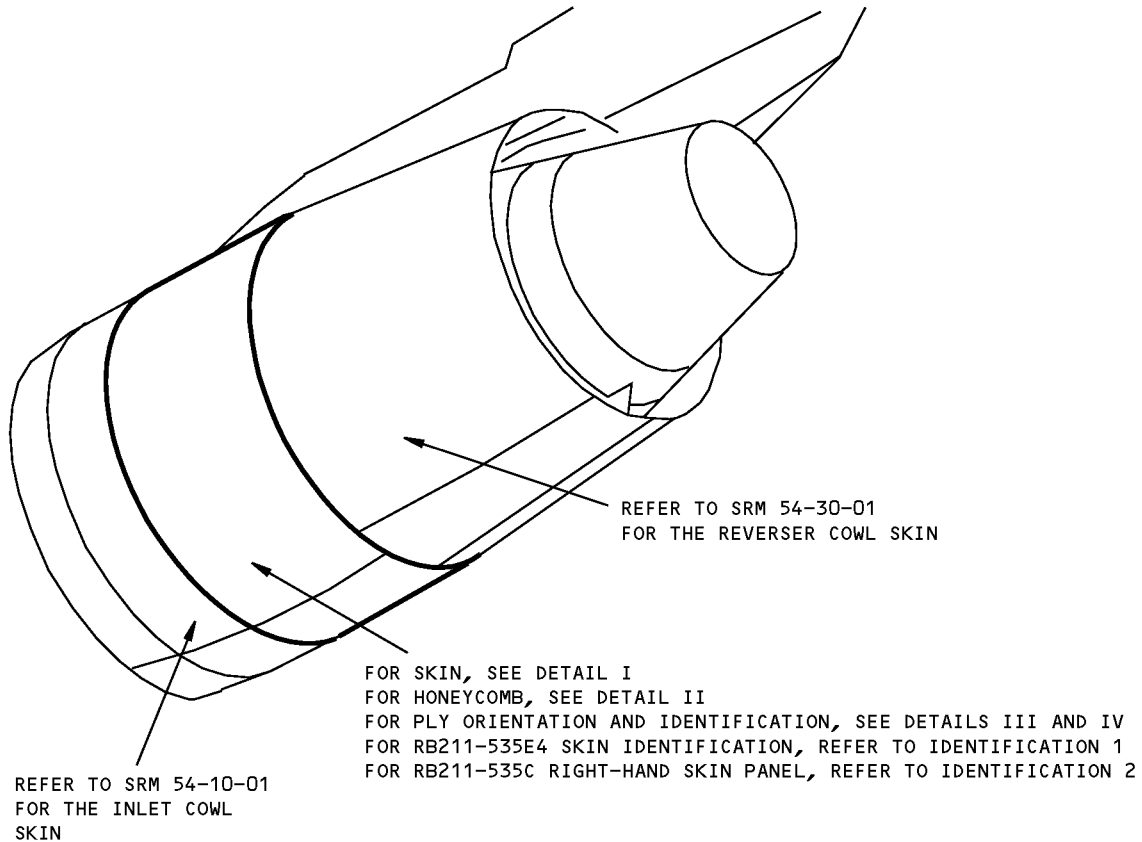

NOTES

- RMS - ROHR MATERIAL SPECIFICATION

- A** GRAPHITE FABRIC:
- AH-370-5H/3501-5A, AS4 FIBER, V10396
 - CYCOM 985-1, AS4 FIBER, V7945
 - EM 7198, CELION 6K-ST FIBER, V27129
 - R 922-1, CGG 108, CELION 6K FIBER, V30137

Fan Cowl Skin Panel Identification - L.H. Fan Cowl - RB211-535C Engine
Figure 1 (Sheet 1 of 10)

**757-200
STRUCTURAL REPAIR MANUAL**

REF DWG
LJ71465
(EXCEPT AS NOTED)

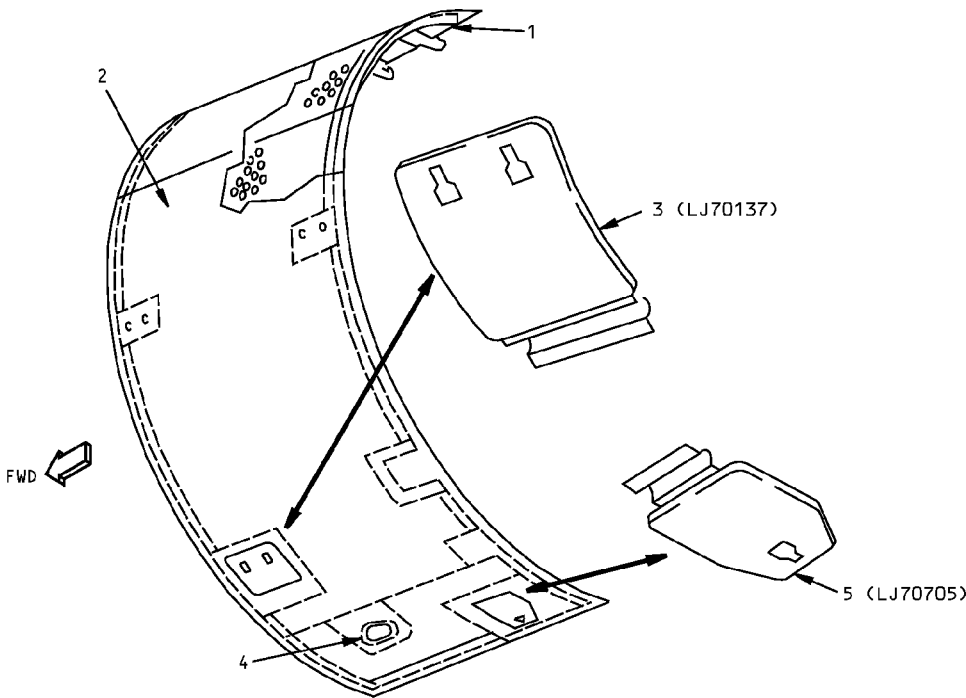

LEFT HINGED COWL SKIN
DETAIL I

LIST OF
MATERIAL

Fan Cowl Skin Panel Identification - L.H. Fan Cowl - RB211-535C Engine
Figure 1 (Sheet 2 of 10)

IDENTIFICATION 3
Page 2
Jan 20/2005

54-20-01

D634N201

757-200
STRUCTURAL REPAIR MANUAL

ITEM	DESCRIPTION	GAGE	MATERIAL	EFFECTIVITY
1	INNER SKIN		GRAPHITE FABRIC RMS60 GROUP 1, TYPE 2, CLASS 1, GRADE 1 A	
2	OUTER SKIN		GRAPHITE FABRIC RMS60 GROUP 1, TYPE 2, CLASS 1, GRADE 1 A	
3	DOOR COVER	0.063	2024-T3 CLAD ALUM SHEET QQ-A-250/5	
4	FRAME	0.063	6AL-4V TITANIUM SHEET AMS4911	
5	DOOR SKIN	0.125	2024-O CLAD ALUM PLATE QQ-A-250/5 (HEAT TREAT T-42)	

LIST OF MATERIALS FOR DETAIL I

Fan Cowl Skin Panel Identification - L.H. Fan Cowl - RB211-535C Engine
Figure 1 (Sheet 3 of 10)

D634N201

54-20-01

IDENTIFICATION 3
Page 3
Jan 20/2005

757-200
STRUCTURAL REPAIR MANUAL

REF DWG
LJ71465

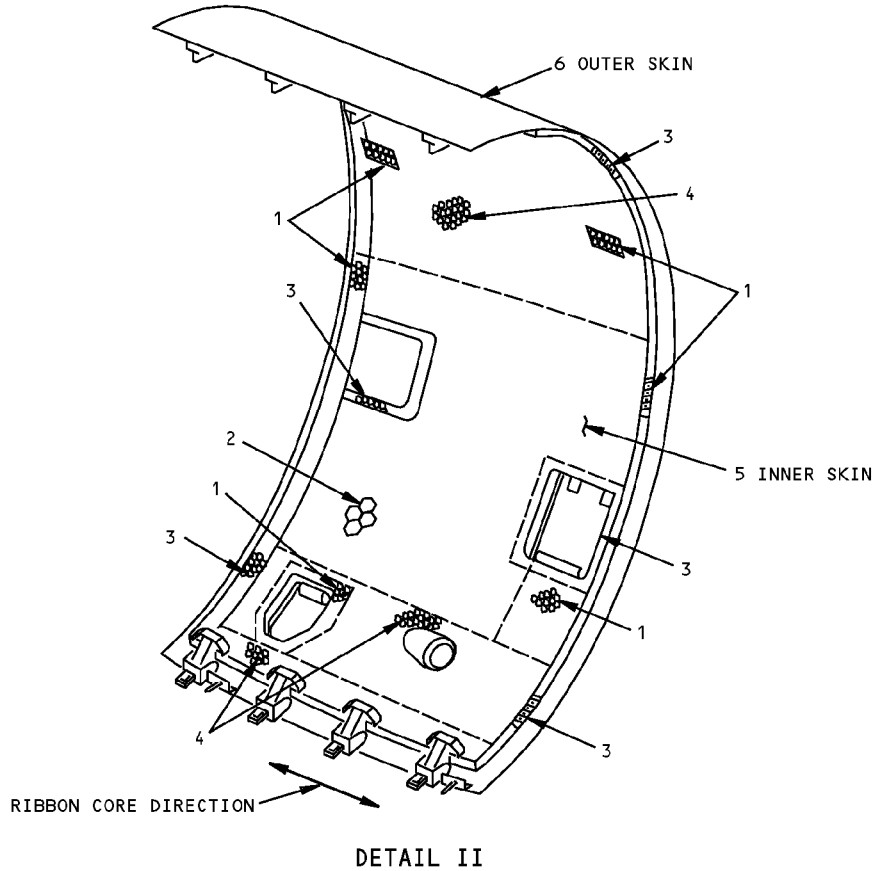

ITEM	DESCRIPTION	GAGE	MATERIAL	EFFECTIVITY
1	CORE	0.002	5056 ALUMINUM ALLOY HONEYCOMB, NONPERFORATED, 3/16 HEXCELL, 5.7 LB/CU FT	
2	CORE	0.001	5056 ALUMINUM ALLOY HONEYCOMB, NONPERFORATED, 1/4 HEXCELL, 2.3 LB/CU FT	
3	CORE	0.002	5056 ALUMINUM ALLOY HONEYCOMB, NONPERFORATED, 1/8 HEXCELL, 8.1 LB/CU FT	
4	CORE	0.001	5056 ALUMINUM ALLOY HONEYCOMB, NONPERFORATED, 3/16 HEXCELL, 3.1 LB/CU FT	
5	INNER SKIN		SEE DETAIL IV	
6	OUTER SKIN		SEE DETAIL III	

LIST OF MATERIALS FOR DETAIL II

Fan Cowling Skin Panel Identification - L.H. Fan Cowling - RB211-535C Engine
Figure 1 (Sheet 4 of 10)

757-200
STRUCTURAL REPAIR MANUAL

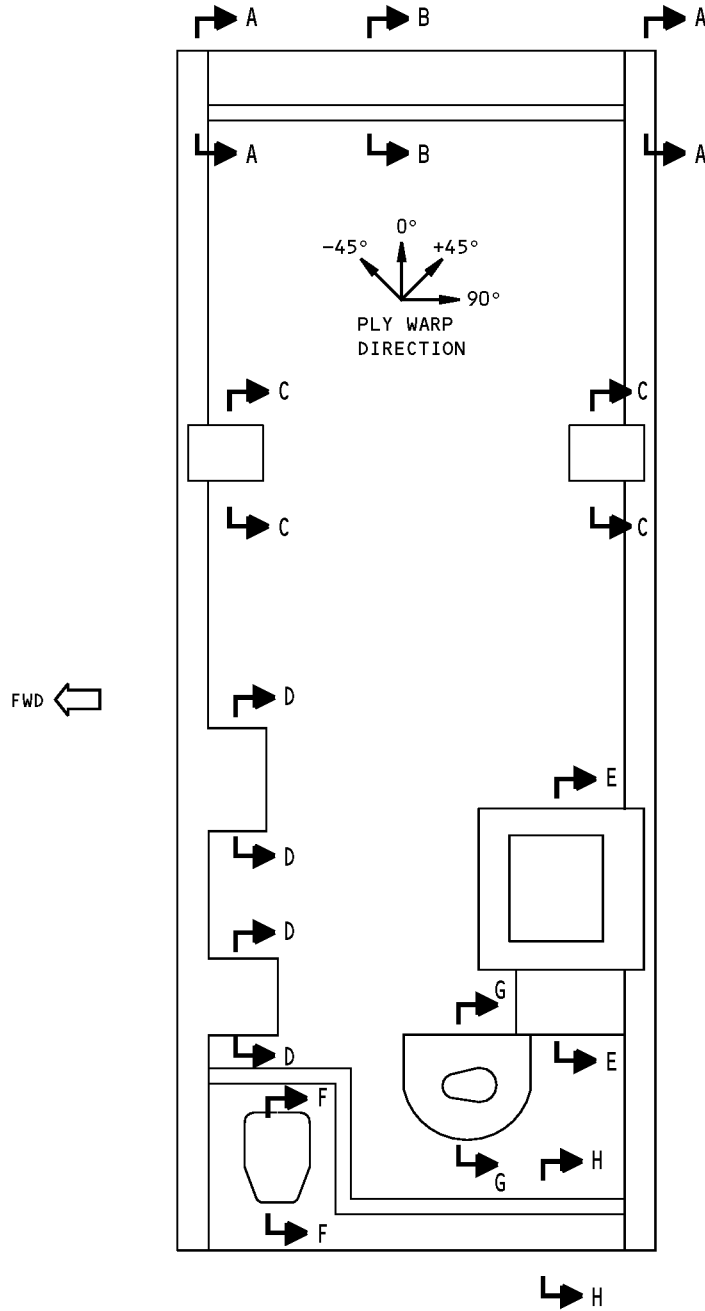

OUTER SKIN LOOKING INBOARD
DETAIL III

55178

Fan Cowl Skin Panel Identification - L.H. Fan Cowl - RB211-535C Engine
Figure 1 (Sheet 5 of 10)

IDENTIFICATION 3
Page 5
Jan 20/2005

54-20-01

D634N201

757-200
STRUCTURAL REPAIR MANUAL

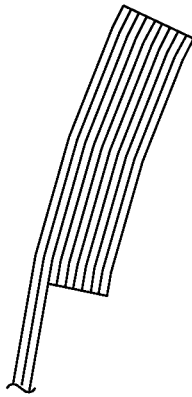

SECTION A-A

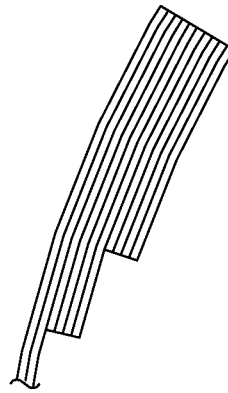

SECTION B-B

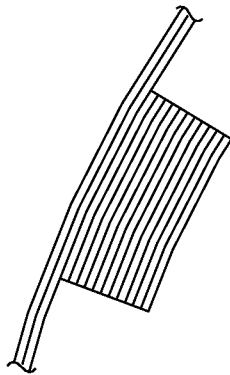

SECTION C-C

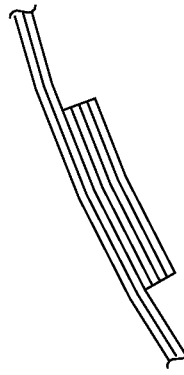

SECTION D-D

ITEM	GAGE	MATERIAL	WARP DIRECTION
SKIN PANEL			
6	0.014	GRAPHITE FABRIC A370-5H/3501-5A	0°

LIST OF MATERIALS FOR SECTION A-A THRU D-D

Fan Cowl Skin Panel Identification - L.H. Fan Cowl - RB211-535C Engine
Figure 1 (Sheet 6 of 10)

757-200
STRUCTURAL REPAIR MANUAL

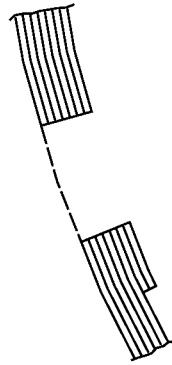

SECTION E-E

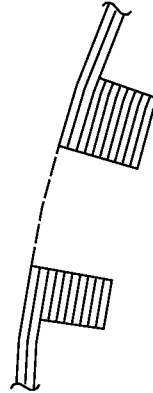

SECTION F-F

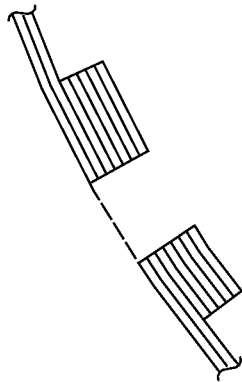

SECTION G-G

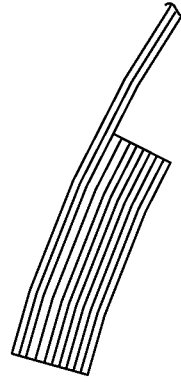

SECTION H-H

ITEM	GAGE	MATERIAL	WARP DIRECTION
SKIN PANEL			
6	0.014	GRAPHITE FABRIC A370-5H/3501-5A	0°

LIST OF MATERIALS FOR SECTION E-E THRU H-H

Fan Cowl Skin Panel Identification - L.H. Fan Cowl - RB211-535C Engine
Figure 1 (Sheet 7 of 10)

757-200
STRUCTURAL REPAIR MANUAL

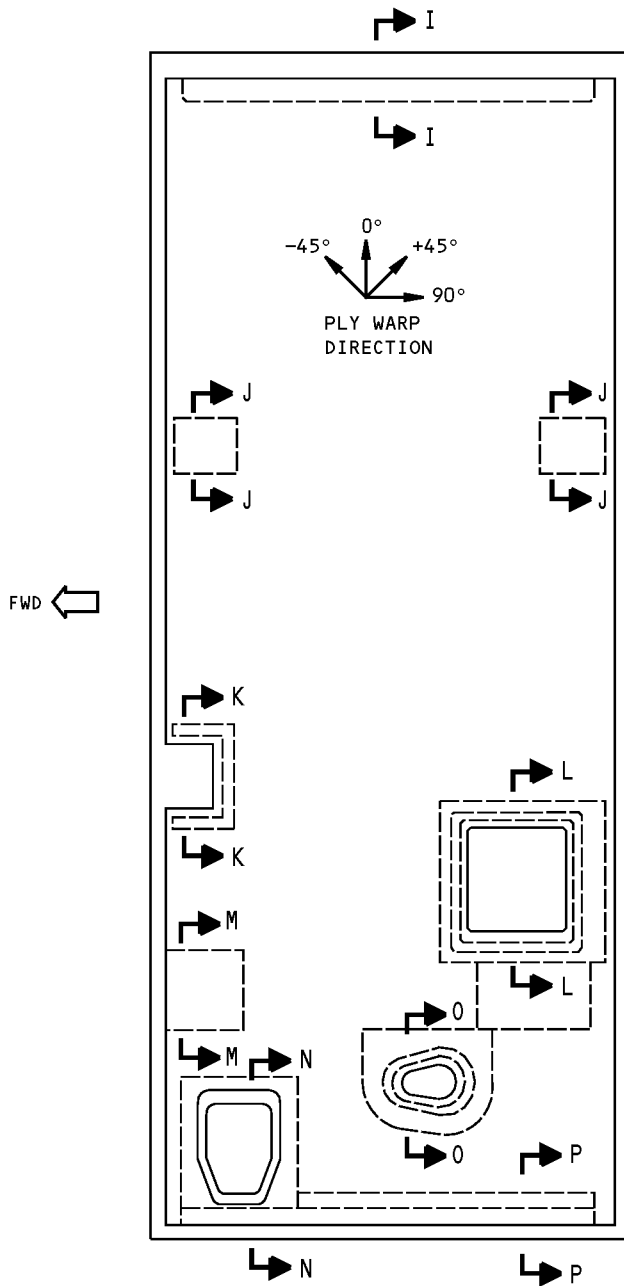

INNER SKIN LOOKING OUTBOARD
DETAIL IV

55181

Fan Cowl Skin Panel Identification - L.H. Fan Cowl - RB211-535C Engine
Figure 1 (Sheet 8 of 10)

IDENTIFICATION 3
Page 8
Jan 20/2005

54-20-01

D634N201

757-200
STRUCTURAL REPAIR MANUAL

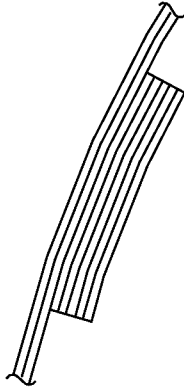

SECTION I-I

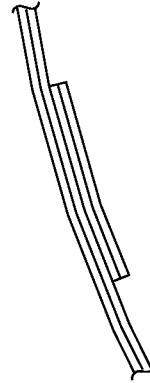

SECTION J-J

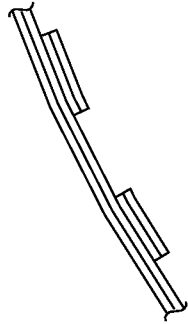

SECTION K-K

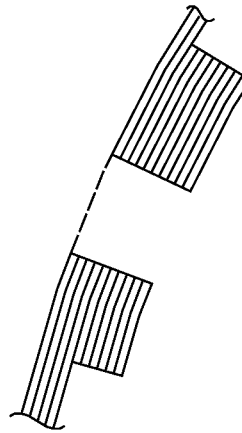

SECTION L-L

ITEM	GAGE	MATERIAL	WARP DIRECTION
SKIN PANEL			
6	0.014	GRAPHITE FABRIC A370-5H/3501-5A	0°

LIST OF MATERIALS FOR SECTION I-I THRU L-L

Fan Cowl Skin Panel Identification - L.H. Fan Cowl - RB211-535C Engine
Figure 1 (Sheet 9 of 10)

757-200
STRUCTURAL REPAIR MANUAL

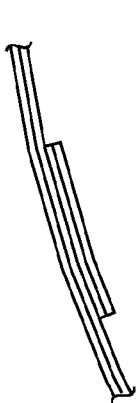

SECTION M-M

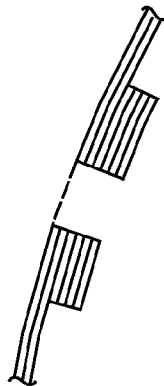

SECTION N-N

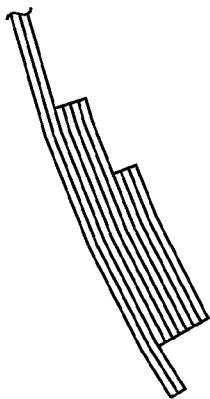

SECTION O-O

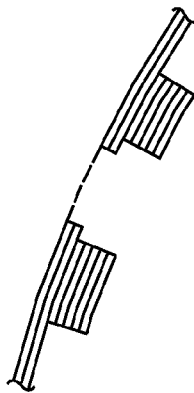

SECTION P-P

ITEM	GAGE	MATERIAL	WARP DIRECTION
SKIN PANEL			
6	0.014	GRAPHITE FABRIC A370-5H/3501-5A	0°

LIST OF MATERIALS FOR SECTION M-M THRU P-P

Fan Cowl Skin Panel Identification - L.H. Fan Cowl - RB211-535C Engine
Figure 1 (Sheet 10 of 10)

757-200
STRUCTURAL REPAIR MANUAL

ALLOWABLE DAMAGE 1 - FAN COWL SKIN - RB211-535 ENGINE

1. Damage Zones (Inner and Outer Skin)

A. Fan Cowl Panels

- (1) Zone 1: Panel flanges.
- (2) Zone 2: Any facing material at panel edges. The panel edges can be either side panel perimeter or edge of access panel cutouts within the panel.
- (3) Zone 3: Any area of panel at attachment of hinges, latches and hold open support strut fixtures.
- (4) Zone 4: All areas not detailed in Zones 1, 2 and 3.

2. Allowable Damage Limits (Inner and Outer Skin)

NOTE: The upper 180 degrees (i.e., 90 degrees on either side of B.L. 0.00) is the fireproof zone for the fan cowl.

CAUTION: ANY PENETRATION OF INNER OR OUTER SKIN IN FIREPROOF ZONE MUST BE REPAIRED PRIOR TO RETURNING PANEL TO FLIGHT STATUS

A. Zone: 1, 2 and 3

- (1) Apparent surface damage or surface imperfections that do not extend into graphite fibers.

B. Zone 4:

- (1) Apparent surface damage or surface imperfections that do not extend into graphite fibers.
- (2) Surface abrasion with a maximum depth of 0.005 inch to an area not greater than 28 sq. inches.
- (3) A maximum of two cuts at a minimum spacing of 10 inches not more than 15 inches in length and 0.005 inch in depth.
- (4) A maximum of two holes at a minimum spacing of 10 inches and 1 inch maximum diameter that pierce the graphite composite skin through to the honeycomb core.

NOTE: The hole or holes must be temporarily covered with aluminum foil tape (Speed Tape) 3M-436 or equivalent. After a maximum of 25 hours, the damaged area must be repaired.

757-200
STRUCTURAL REPAIR MANUAL

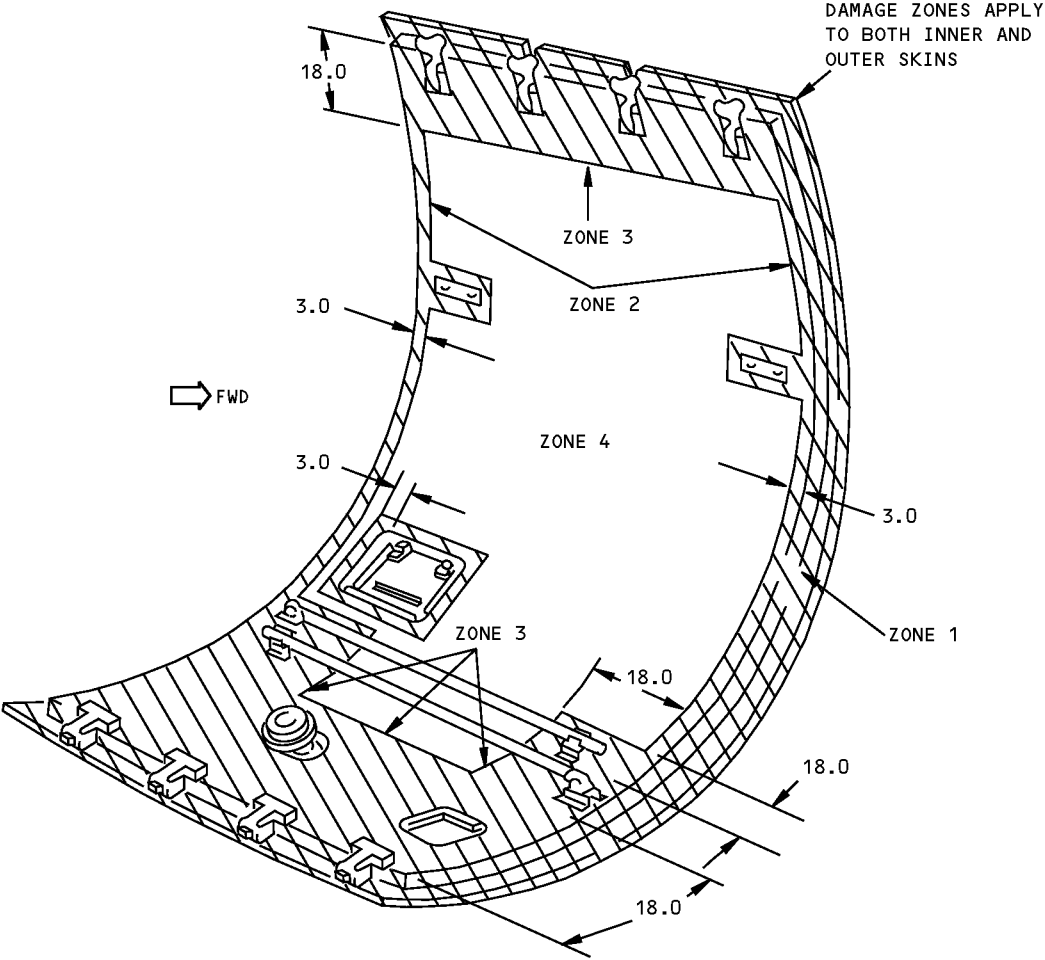

Fan Cowl Skin Allowable Damage - RB211-535 Engine
Figure 101 (Sheet 1 of 2)

757-200
STRUCTURAL REPAIR MANUAL

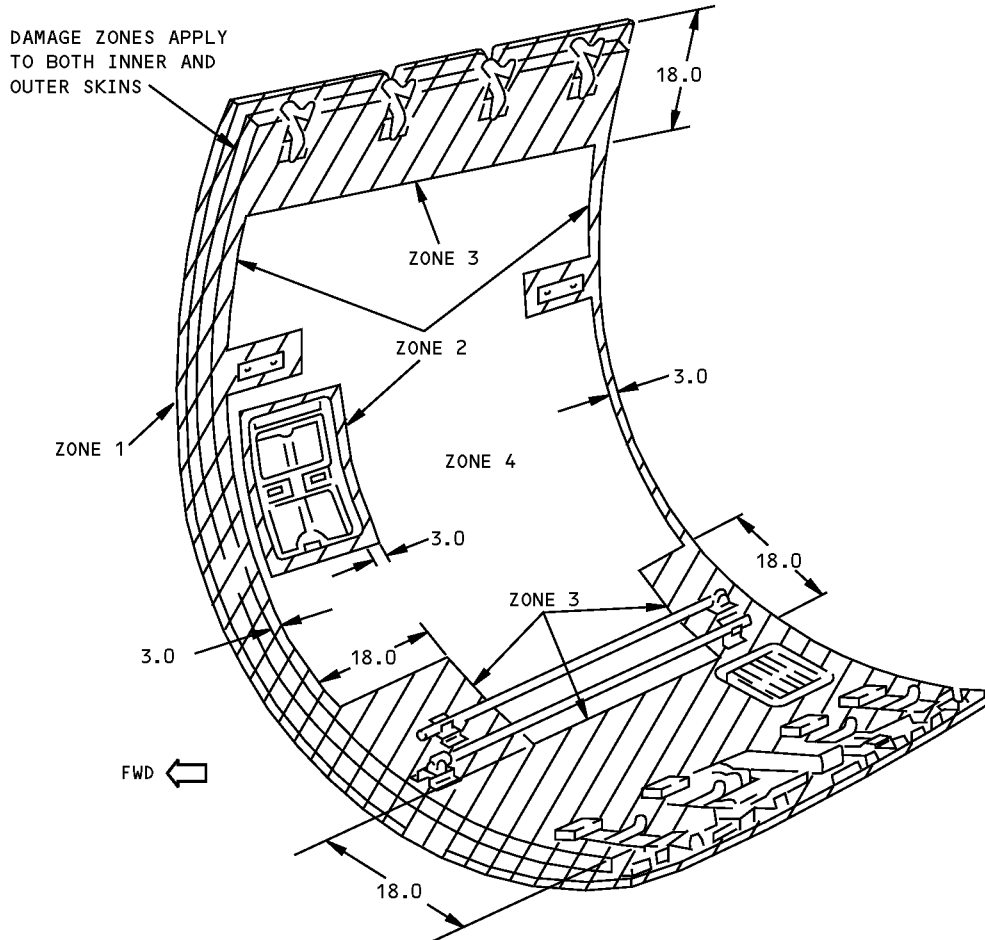

Fan Cowl Skin Allowable Damage - RB211-535 Engine
Figure 101 (Sheet 2 of 2)

STRUCTURAL REPAIR MANUAL

REPAIR 1 - LEFT AND RIGHT FAN COWL PANELS - EDGE EROSION DAMAGE - RB211-535 ENGINE

REPAIR INSTRUCTIONS

1. Remove surface finish using abrasive paper grit size 180 and feather the edge of exterior coating around repair area.
- WARNING:** PROTECTIVE GLOVES SHOULD BE WORN WHEN USING DEGREASERS.
- SMOKING MUST NOT BE ALLOWED WHEN USING DEGREASERS, AS THE VAPOR DECOMPOSES TO FORM PRODUCTS WHICH ARE EXTREMELY TOXIC.
- USE ONLY IN AREAS WITH GOOD VENTILATION.
- VERY FLAMMABLE; KEEP AWAY FROM IGNITION SOURCES.
2. Clean repair area using cheesecloth and MEK. Ensure area wiped dry before solvent evaporates on surface.
- WARNING:** USE EPOXY COMPOUNDS ONLY IN AREAS WITH GOOD VENTILATION.
- TAKE PRECAUTIONS TO PREVENT MATERIAL FROM COMING INTO CONTACT WITH THE SKIN.
3. Mix filler adhesive EA934A in accordance with manufacturers instruction, using weighing equipment 0 to 200 grams.
 4. Apply filler to erosion cavities.
 5. Apply teflon tape over filler area, clamping as necessary, to effect a smooth surface.
 6. Using infrared heat lamps, cure filler at 140°F (60°C) for 1 hour. If heating equipment is not available, cure at room temperature (77°F (25°C)) for 16 hours.
 7. Remove teflon and abrade filler flush with surrounding area.
 8. Touch up exterior paint finish on surface of cowl.
 9. Visually inspect repaired area.

NOTES

- REPAIRS UP TO 0.50 INCH (12.7 mm) LENGTH AND 0.020 INCH (0.51 mm) DEPTH MAY BE EFFECTED ON A DAMAGED PANEL BY FILLING THE EROSION AREA WITH ADHESIVE FILLER
- CARE MUST BE TAKEN NOT TO PENETRATE THE SURFACE OF COMPOSITE WHEN REMOVING EXTERIOR FINISH
- DO NOT PENETRATE THE COMPOSITE MATERIAL SURFACE WHEN ABRADING THE FILLER
- WHEN YOU USE THIS REPAIR, REFER TO:
 - SRM 51-21-01 FOR PROTECTIVE TREATMENT OF NONMETALLIC AND METALLIC
 - SRM 51-31-03 FOR NONMETALLIC MATERIALS LISTING AND SOURCES

**Left and Right Fan Cowl Panels - Repair of Edge Erosion Damage - RB211-535 Engine
Figure 201 (Sheet 1 of 3)**

757-200
STRUCTURAL REPAIR MANUAL

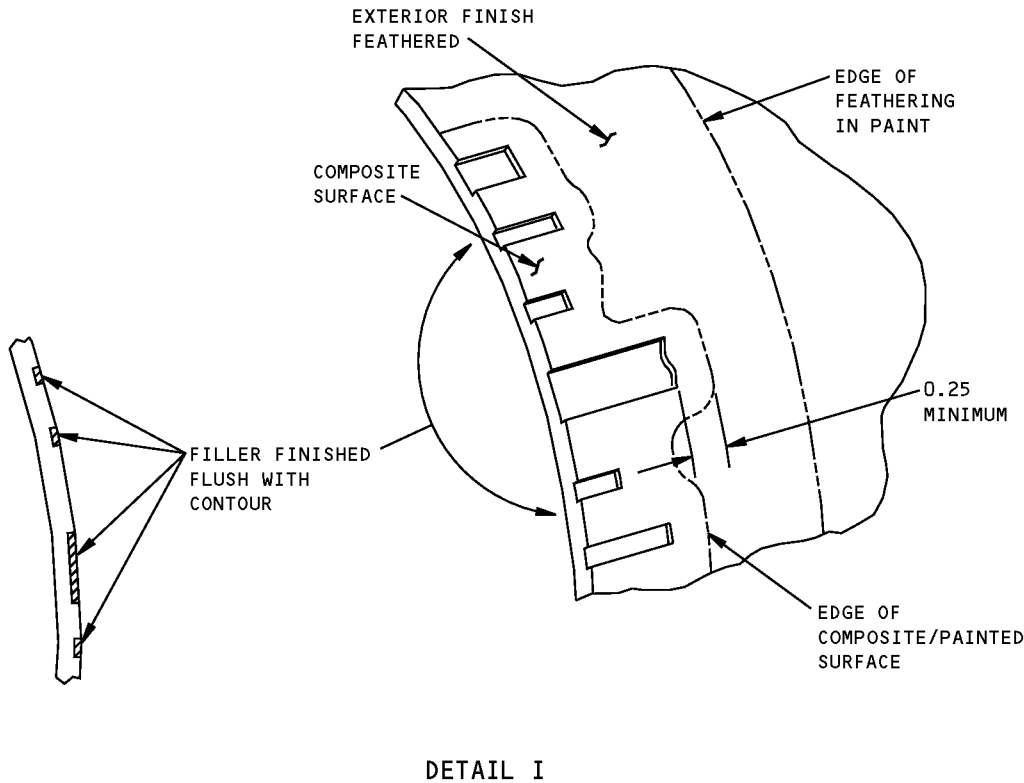
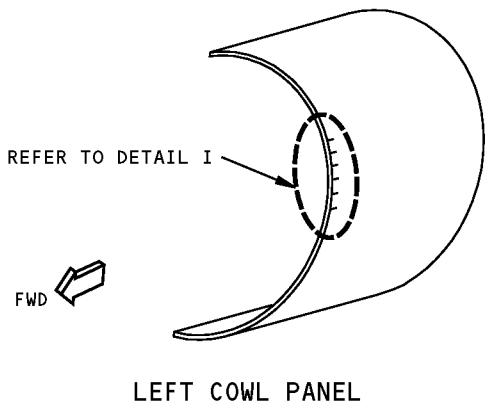

55955

Left and Right Fan Cowl Panels - Repair of Edge Erosion Damage - RB211-535 Engine
Figure 201 (Sheet 2 of 3)

757-200
STRUCTURAL REPAIR MANUAL

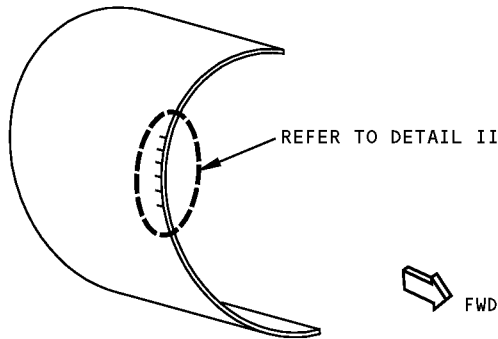

RIGHT COWL PANEL

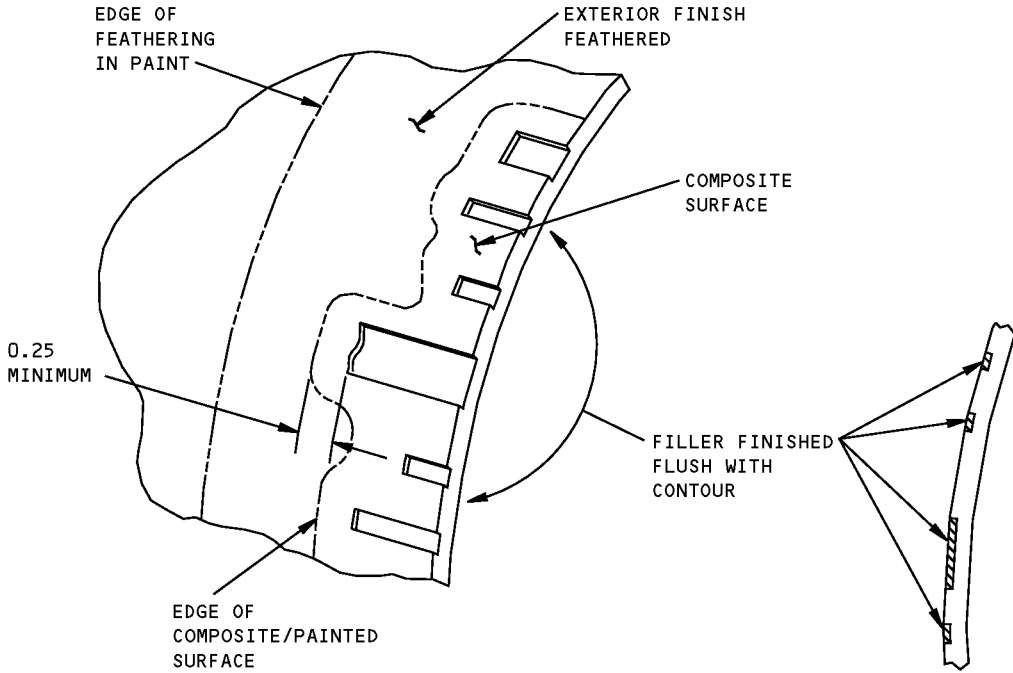

DETAIL II

62048

Left and Right Fan Cowl Panels - Repair of Edge Erosion Damage - RB211-535 Engine
Figure 201 (Sheet 3 of 3)

**757-200
STRUCTURAL REPAIR MANUAL**

REPAIR 2 - FAN COWL SKIN PANEL - RB211-535 ENGINE

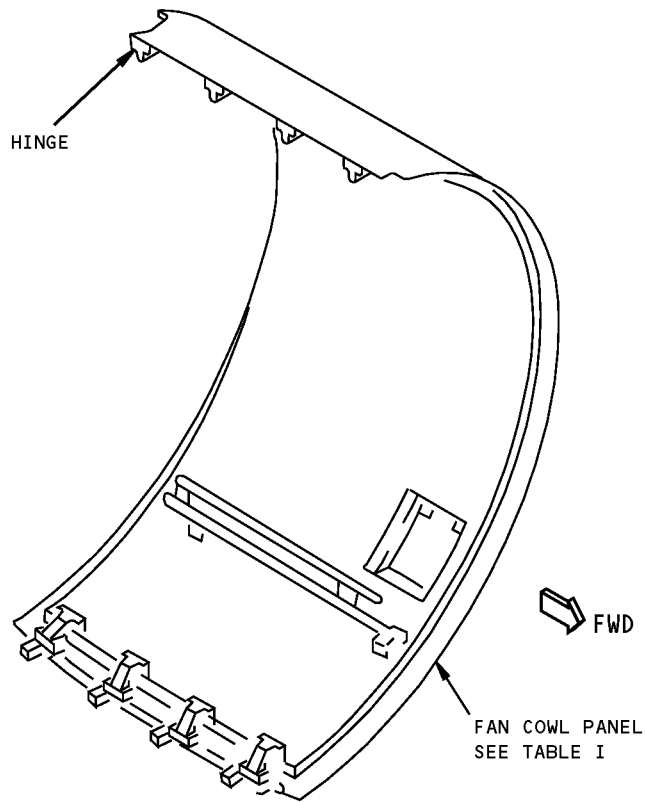
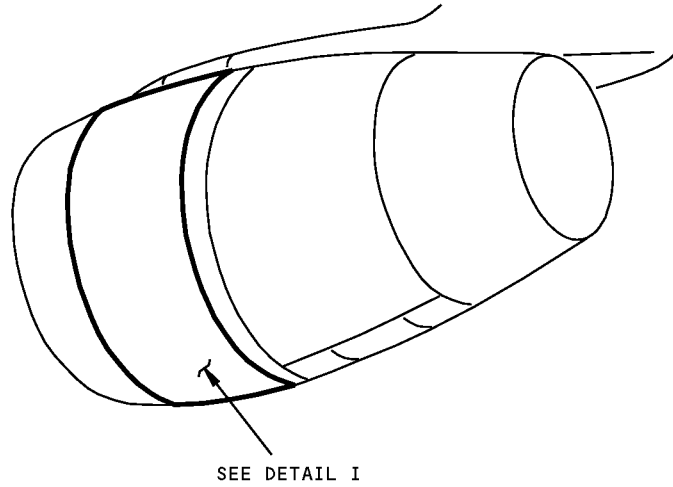

LEFT COWL PANEL SHOWN
RIGHT PANEL SIMILAR
DETAIL I

**Fan Cowl Skin Panel Repairs - RB211-535 Engine
Figure 201 (Sheet 1 of 2)**

757-200
STRUCTURAL REPAIR MANUAL

DAMAGE	PERMANENT REPAIRS	
	WET LAYUP 200° - 230°F (93° - 110°C) CURE (51-71-02)	
CRACKS	CLEAN UP DAMAGE AND REPAIR AS HOLE	CLEAN UP DAMAGE AND REPAIR AS HOLE
HOLES	10.0 INCH MAX DIA NOT TO EXCEED 50% OF SMALLEST DIMENSION ACROSS HONEYCOMB PANEL AT DAMAGE LOCATION. USE TWO EXTRA PLIES PER FACE-SHEET REPAIRED A	NO SIZE LIMIT
DELAMI- NATION	CUT OUT AND REPAIR AS HOLE	
NICKS AND GOUGES	IF FIBER DAMAGE OR DELAMINATION EXISTS, REPAIR AS A HOLE	
DENTS	DENTS RESULT IN FIBER DAMAGE AND DELAMINATION. USE REPAIR DATA TO DETERMINE DENT REPAIR	

REPAIR DATA FOR 350°F (177°C) CURE HONEYCOMB PANELS
TABLE I

NOTES

- REFINISH REWORKED AREAS AS GIVEN IN
AMM 51-20
- REFER TO 51-11-01 FOR AERODYNAMIC
SMOOTHNESS REQUIREMENTS. WHERE THE
REPAIR EXCEEDS THE LIMITS SHOWN IN
51-11-01, CONSIDERATION SHOULD BE GIVEN
TO THE LOSS OF PERFORMANCE
- REFER TO SRM 51-70-16 FOR HOLE DRILLING
AND MACHINING OF COMPOSITE STRUCTURES

A ONE REPAIR PER SQUARE FOOT OF AREA AND A
MINIMUM OF 6.0 INCHES (150 mm) (EDGE TO
EDGE) FROM ANY OTHER DAMAGE, FASTENER
HOLE, OR EDGE OF PANEL

Fan Cowl Skin Panel Repairs - RB211-535 Engine
Figure 201 (Sheet 2 of 2)

STRUCTURAL REPAIR MANUAL

REPAIR 3 - FAN COWL - REPAIR OF SKIN ADJACENT TO LATCHES - RB211-535 ENGINE

APPLICABILITY
THIS REPAIR IS FOR SUPERFICIAL DAMAGE OF SKIN ADJACENT TO LATCHES.

REPAIR INSTRUCTIONS

1. **WARNING:** SANDING OR CUTTING OF COMPOSITE MATERIALS PRODUCES DUST AND FLYING PARTICLES WHICH ARE POTENTIAL HEALTH HAZARD. WEAR PROTECTIVE CLOTHING, GLOVES, DUST MASKS, AND SAFETY GLASSES. AVOID BREATHING OF DUST OR PROLONGED CONTACT OF DUST ON THE SKIN.

Abrade repair area using aluminum oxide abrasive paper (180 grit) to remove all surface protection.

2. **WARNING:** PROTECTIVE GLOVES SHOULD BE WORN WHEN USING DEGREASERS. USE ONLY IN WELL VENTILATED AREAS. VERY FLAMMABLE, KEEP AWAY FROM IGNITION SOURCES.

Clean repair area using clean cotton cloth soaked in MEK. Wipe dry with clean cloth before solvent evaporates.

3. **WARNING:** USE EPOXY COMPOUNDS ONLY IN WELL VENTILATED AREAS. TAKE PRECAUTIONS TO PREVENT MATERIAL FROM COMING INTO CONTACT WITH THE SKIN.

Apply adhesive EA934NA filler to be flush with surrounding area.

4. Cure adhesive filler using (explosion proof) heater lamps for a minimum of 1 hour at 60°C (140°F).

5. **WARNING:** SANDING OR CUTTING OF COMPOSITE MATERIALS PRODUCES DUST AND FLYING PARTICLES WHICH ARE POTENTIAL HEALTH HAZARD. WEAR PROTECTIVE CLOTHING, GLOVES, DUST MASKS, AND SAFETY GLASSES. AVOID BREATHING OF DUST OR PROLONGED CONTACT OF DUST ON THE SKIN.

Abrade using aluminum oxide abrasive paper (180 grit) to make filler flush with surrounding area.

6. **WARNING:** PROTECTIVE GLOVES SHOULD BE WORN WHEN USING DEGREASERS. USE ONLY IN WELL VENTILATED AREAS. VERY FLAMMABLE, KEEP AWAY FROM IGNITION SOURCES.

Clean repair area using clean cotton cloth soaked in MEK. Wipe dry with clean cloth before solvent evaporates.

7. Refinish repaired area as per 51-21-01 of the Structural Repair Manual.
8. Visually inspect the repair area.

NOTE

- THE MAXIMUM DAMAGE DEPTH FOR THIS REPAIR IS 0.005 INS FOR SCRATCHES, CUTS, AND ABRASIONS (NONE EXTENDING INTO THE GRAPHITE FIBERS).

Fan Cowl - Repair of Skin Adjacent to Latches - RB211-535 Engine
Figure 201 (Sheet 1 of 2)

757-200
STRUCTURAL REPAIR MANUAL

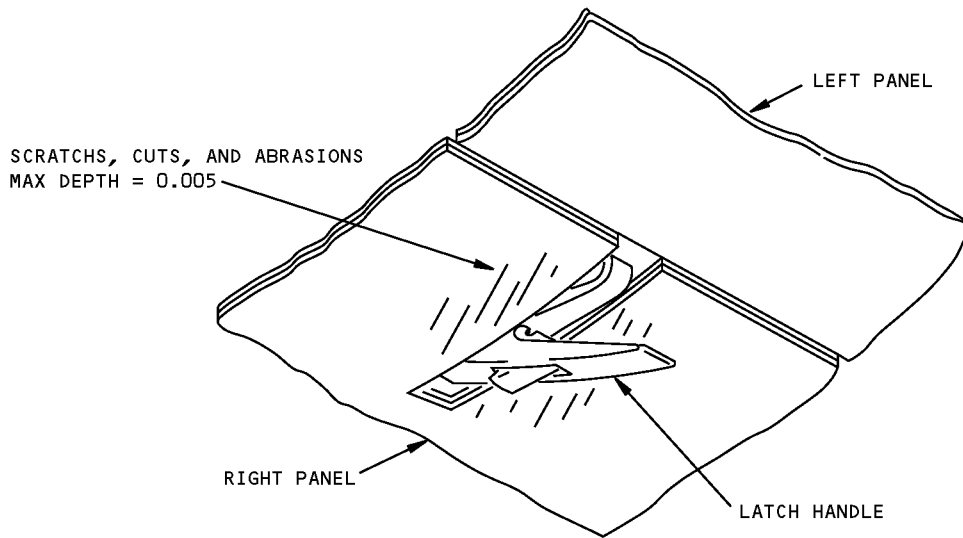
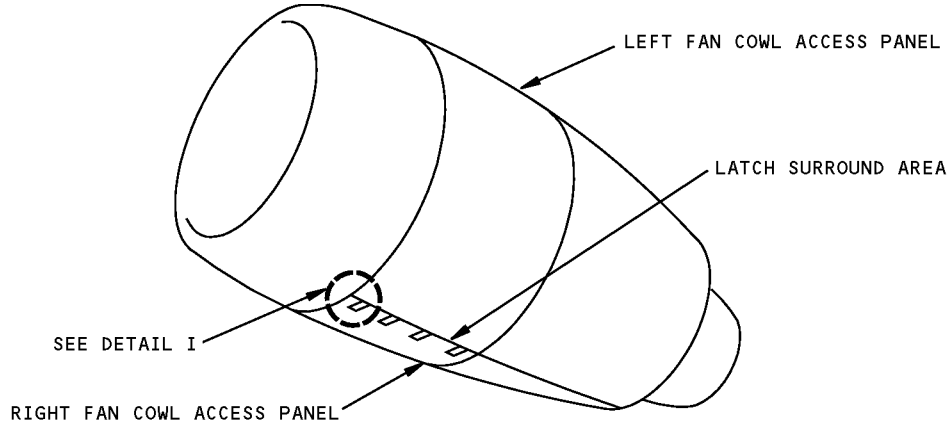

LATCH SURROUND AREA - TYPICAL 4 LOCATIONS
DETAIL I

A7693

Fan Cowl - Repair of Skin Adjacent to Latches - RB211-535 Engine
Figure 201 (Sheet 2 of 2)

STRUCTURAL REPAIR MANUAL

REPAIR 4 - FAN COWL - REPAIR TO CORNERS - EROSION AND IMPACT CORNERS DAMAGE - RB211-535 ENGINE

APPLICABILITY
THIS REPAIR IS FOR EROSION AND IMPACT DAMAGE ON FAN COWL CORNERS. THE DAMAGE MUST NOT EXCEED THE LIMITS SHOWN IN DETAIL I.

REPAIR INSTRUCTIONS

- WARNING:** SANDING OR CUTTING OF COMPOSITE MATERIALS PRODUCES DUST AND FLYING PARTICLES WHICH ARE POTENTIAL HEALTH HAZARD. WEAR PROTECTIVE CLOTHING, GLOVES, DUST MASKS, AND SAFETY GLASSES. AVOID BREATHING OF DUST OR PROLONGED CONTACT OF DUST ON THE SKIN.

Trim inner and outer skin. Abrade repair area using abrasive paper (180 grit). Ensure all surface protection and paint is removed from repair area. See Detail I.

- WARNING:** PROTECTIVE GLOVES SHOULD BE WORN WHEN USING DEGREASERS. SMOKING IS NOT PERMITTED WHEN USING DEGREASERS, AS THE VAPOR DECOMPOSES TO FORM PRODUCTS WHICH ARE EXTREMELY TOXIC. USE ONLY IN WELL VENTILLATED AREAS. VERY FLAMMABLE, KEEP AWAY FROM IGNITION SOURCES.

Clean repair area using clean cotton cloth and methylethyl-ketone. Wipe dry with clean cloth before evaporation of solvent occurs.

- WARNING:** USE EPOXY COMPOUNDS ONLY IN WELL VENTILATED AREAS. TAKE PRECAUTIONS TO PREVENT MATERIAL FROM COMING INTO SKIN CONTACT.

Prepare adhesive mix EA956.

- Layup surface laminate using graphite fabric and fiberglass with EA956 adhesive. See Detail II.
- Apply FEP non-porous parting film and attach clamping block of 0.190 ins thick aluminum plate.
- Layup compound laminate, inner surface laminate and apply parting film using A-370-8H graphite fabric with EA956 adhesive, FEP non-porous parting film, and 0.190 ins thick clamping block with 0.125 ins spacer. See Details III and IV.
- Cure laminate layup for 2 hrs while applying heat and pressure to inner and outer surfaces at 65°-120°C (150°-250°F) with (explosion proof) heater lamps. Remove clamping blocks and parting film.

- WARNING:** SANDING OR CUTTING OF COMPOSITE MATERIALS PRODUCES DUST AND FLYING PARTICLES WHICH ARE POTENTIAL HEALTH HAZARD. WEAR PROTECTIVE CLOTHING, GLOVES, DUST MASKS, AND SAFETY GLASSES. AVOID BREATHING OF DUST OR PROLONGED CONTACT OF DUST ON THE SKIN.

Trim edges of forward panel corners. Chamfer leading edge and smooth area using abrasive paper (180 grit). See Detail V.

- WARNING:** PROTECTIVE GLOVES SHOULD BE WORN WHEN USING DEGREASERS. SMOKING MUST NOT BE ALLOWED WHEN USING DEGREASERS, AS THE VAPOR DECOMPOSES TO FORM PRODUCTS WHICH ARE EXTREMELY TOXIC. USE ONLY IN WELL VENTILLATED AREAS. VERY FLAMMABLE, KEEP AWAY FROM IGNITION SOURCES.

Clean chamfered area using methylethyl-ketone on clean cotton cloth. Wipe dry before evaporation of solvent occurs.

- WARNING:** USE EPOXY COMPOUNDS ONLY IN WELL VENTILATED AREAS. TAKE PRECAUTIONS TO PREVENT MATERIAL FROM COMING INTO CONTACT WITH THE SKIN.

Prepare and apply EA 934NA adhesive to fair chamfered leading edge.

- Cure the repair material for 1 hr at 60°C (140°F).
- WARNING:** PROTECTIVE GLOVES SHOULD BE WORN WHEN USING DEGREASERS. SMOKING MUST NOT BE ALLOWED WHEN USING DEGREASERS, AS THE VAPOR DECOMPOSES TO FORM PRODUCTS WHICH ARE EXTREMELY TOXIC. USE ONLY IN WELL VENTILLATED AREAS. VERY FLAMMABLE, KEEP AWAY FROM IGNITION SOURCES.

Clean repair area using methylethyl-ketone and clean cotton cloth. Wipe dry with clean cotton cloth before evaporation of solvent occurs.

- WARNING:** USE EPOXY COMPOUNDS ONLY IN WELL VENTILATED AREAS. TAKE PRECAUTIONS TO PREVENT MATERIAL FROM COMING INTO SKIN CONTACT.

Restore finish per 51-21-01 of the 757 Structural Repair Manual.

- Visually inspect all repaired areas.

Fan Cowl - Repair to Corners - Erosion and Impact Damage - RB211-535 Engine
Figure 201 (Sheet 1 of 5)

**757-200
STRUCTURAL REPAIR MANUAL**

REPAIR MATERIAL		
PART	QTY	MATERIAL
1	PLY	FIBER TYPE T300 MSRR9305
2	ADHESIVE	EA 956
3	PLY	TYGLASS Y 383/205-T5 0.010 INCH MSRR9048

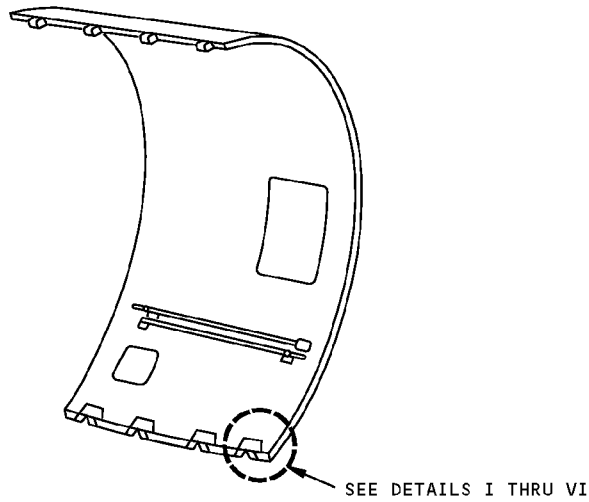

VIEW OF LEFT FAN ACCESS COWL

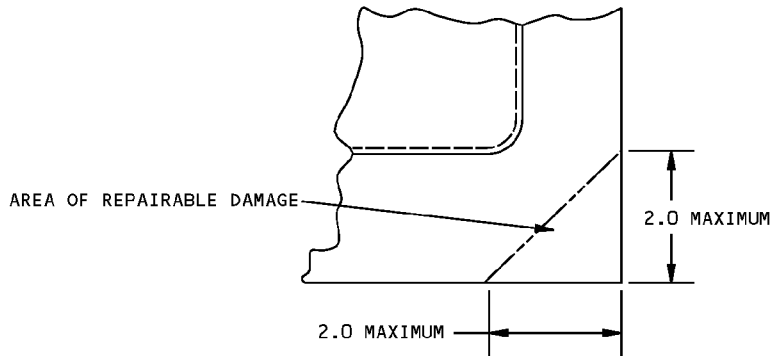

MAXIMUM EXTENT OF REPAIRABLE EROSION AND IMPACT DAMAGE - TYPICAL ALL CORNERS
DETAIL I

A7702

**Fan Cowl - Repair to Corners - Erosion and Impact Damage - RB211-535 Engine
Figure 201 (Sheet 2 of 5)**

757-200
STRUCTURAL REPAIR MANUAL

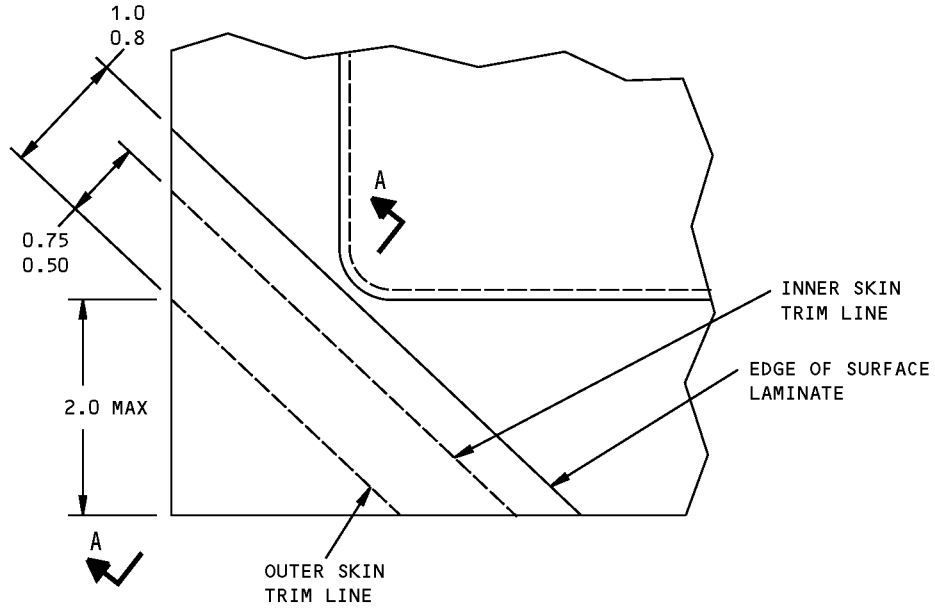

COMPOSITE LAYUP
DETAIL II

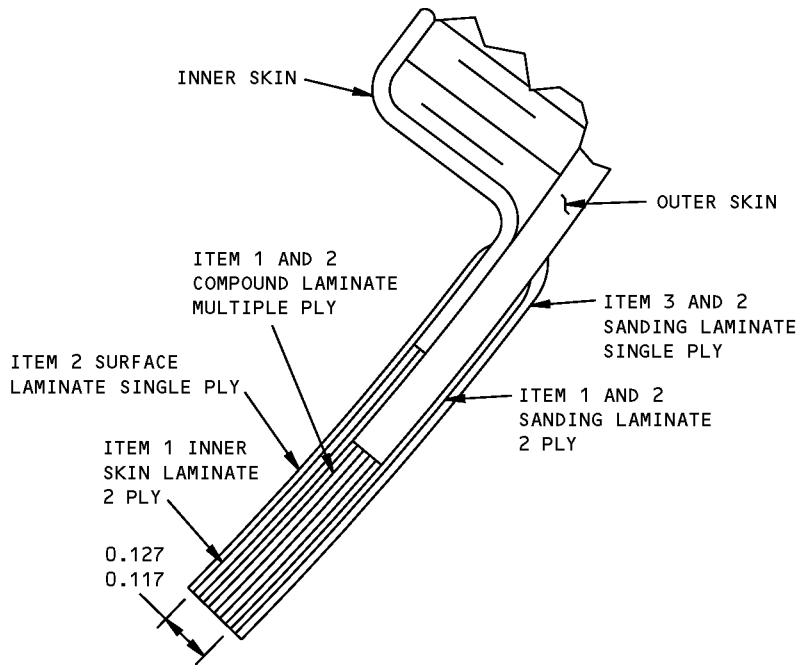

SECTION A-A

A7703A

Fan Cowl - Repair to Corners - Erosion and Impact Damage - RB211-535 Engine
Figure 201 (Sheet 3 of 5)

757-200
STRUCTURAL REPAIR MANUAL

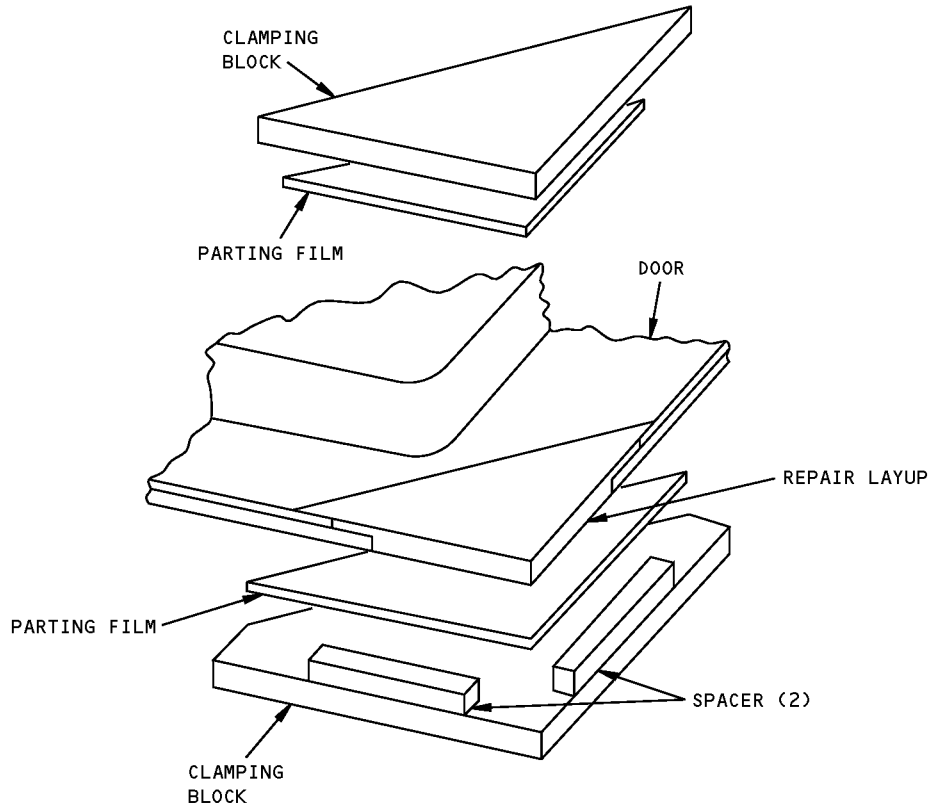

EXPANDED VIEW OF CLAMPUP
CONFIGURATION DURING CURE
DETAIL III

55911

Fan Cowl - Repair to Corners - Erosion and Impact Damage - RB211-535 Engine
Figure 201 (Sheet 4 of 5)

757-200
STRUCTURAL REPAIR MANUAL

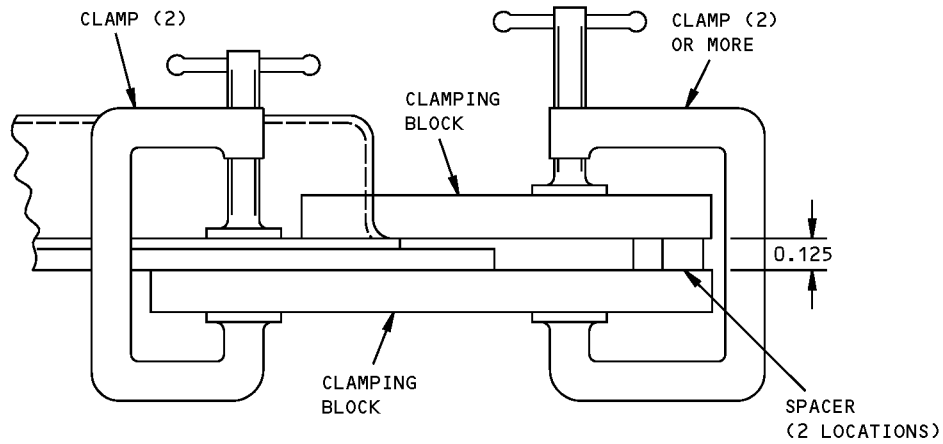

CLAMPUP CONFIGURATION DURING CURE
DETAIL IV

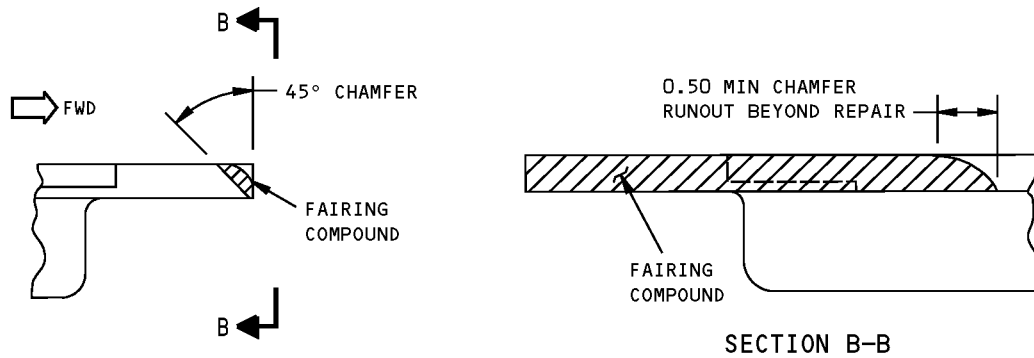

FORWARD CORNERS ONLY
DETAIL V

A7704

Fan Cowl - Repair to Corners - Erosion and Impact Damage - RB211-535 Engine
Figure 201 (Sheet 5 of 5)

STRUCTURAL REPAIR MANUAL

REPAIR 5 - FAN COWL - DELAMINATION CORNERS DAMAGE - RB211-535 ENGINE

APPLICABILITY
THIS REPAIR IS FOR DELAMINATION ON FAN COWL CORNERS. THE DAMAGE MUST NOT EXCEED THE LIMITS SHOWN IN DETAIL I.

REPAIR INSTRUCTIONS

1. **WARNING:** PROTECTIVE GLOVES SHOULD BE WORN WHEN USING DEGREASERS. SMOKING MUST NOT BE ALLOWED WHEN USING DEGREASERS, AS THE VAPOR DECOMPOSES TO FORM PRODUCTS WHICH ARE EXTREMELY TOXIC. USE ONLY IN WELL VENTILLATED AREAS. VERY FLAMMABLE, KEEP AWAY FROM IGNITION SOURCES.

Clean delamination surfaces using methylethyl-ketone. Wipe dry with clean cotton before evaporation occurs.

2. **WARNING:** USE EPOXY COMPOUNDS ONLY IN WELL VENTILATED AREAS. TAKE PRECAUTIONS TO PREVENT MATERIAL FROM COMING INTO CONTACT WITH THE SKIN.

Prepare adhesive mix EA956 and apply to faying surfaces of delamination.

3. Position clamping blocks (0.190 ins thick aluminum plate) and secure. See Detail II.
4. Cure adhesive for 2 hrs while applying heat and pressure at 65-120°C (150-250°F). Use heater lamps (explosion proof).
5. Remove clamping blocks.
6. **WARNING:** SANDING OR CUTTING OF COMPOSITE MATERIALS PRODUCES DUST AND FLYING PARTICLES WHICH ARE POTENTIAL HEALTH HAZARD. WEAR PROTECTIVE CLOTHING, GLOVES, DUST MASKS, AND SAFETY GLASSES. AVOID BREATHING OF DUST OR PROLONGED CONTACT OF DUST ON SKIN.

Trim edges of corner square. Chamfer leading edge of forward corners.

7. **WARNING:** USE EPOXY COMPOUNDS ONLY IN WELL VENTILATED AREAS. TAKE PRECAUTIONS TO PREVENT MATERIAL FROM COMING INTO CONTACT WITH THE SKIN.

Prepare adhesive mix EA934NA and apply to fair chamfered leading edge.

8. Cure fairing repair compound for 1 hr at 60°C (140°F).
9. **WARNING:** PROTECTIVE GLOVES SHOULD BE WORN WHEN USING DEGREASERS. SMOKING MUST NOT BE ALLOWED WHEN USING DEGREASERS, AS THE VAPOR DECOMPOSES TO FORM PRODUCTS WHICH ARE EXTREMELY TOXIC. USE ONLY IN WELL VENTILLATED AREAS. VERY FLAMMABLE, KEEP AWAY FROM IGNITION SOURCES.

Clean repair area using methylethyl-ketone and clean cotton cloth. Wipe dry with clean cotton cloth before evaporation occurs.

10. **WARNING:** USE EPOXY COMPOUNDS ONLY IN WELL VENTILATED AREAS. TAKE PRECAUTIONS TO PREVENT MATERIAL FROM COMING INTO SKIN CONTACT.

Restore finish per 51-21-01 of the 757 Structural Repair Manual.

11. Visually inspect all repaired areas.

**Fan Cowl - Repair to Corners - Delamination Damage - RB211-535 Engine
Figure 201 (Sheet 1 of 2)**

757-200
STRUCTURAL REPAIR MANUAL

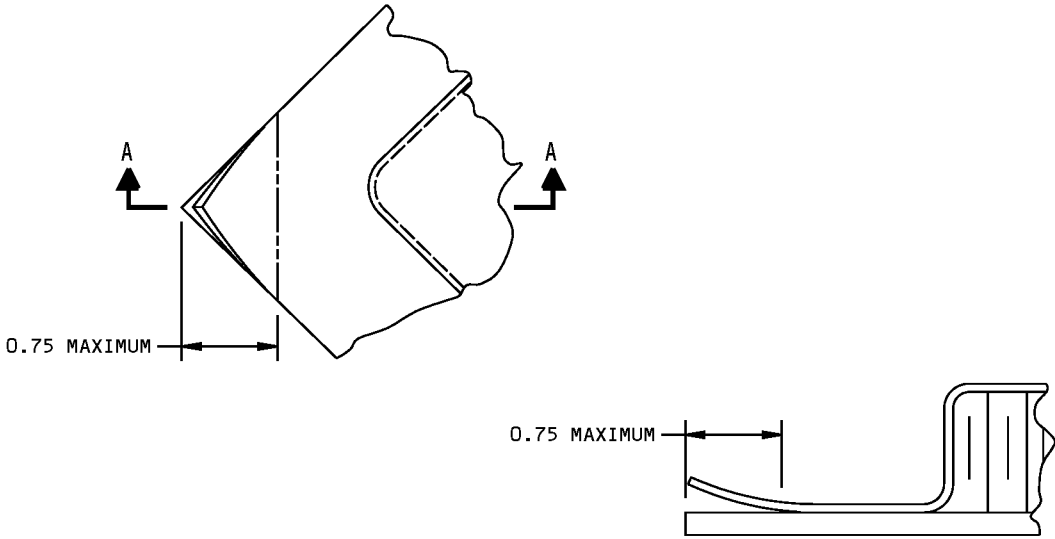

SECTION A-A

TYPICAL ALL CORNERS
MAXIMUM EXTENT OF REPAIRABLE DELAMINATION
DETAIL I

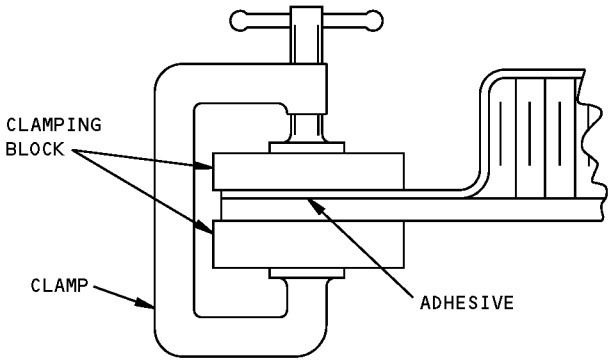

CLAMPUP CONFIGURATION
DURING DELAMINATION CURE
DETAIL II

A7705

Fan Cowl - Repair to Corners - Delamination Damage - RB211-535 Engine
Figure 201 (Sheet 2 of 2)

STRUCTURAL REPAIR MANUAL

REPAIR 6 - FAN COWL - ACCESS PANEL - RB211-535 ENGINE

APPLICABILITY
THIS REPAIR IS FOR DAMAGE REPAIR TO EDGES OF ACCESS PANELS.

REPAIR INSTRUCTIONS

1. Abrade and fair out damage using abrasive paper (150 grit). Maximum damage dimension before blending: 0.50 ins.
2. **WARNING:** PROTECTIVE GLOVES SHOULD BE WORN WHEN USING DEGREASERS. SMOKING MUST NOT BE ALLOWED WHEN USING DEGREASERS, AS THE VAPOR DECOMPOSES TO FORM PRODUCTS WHICH ARE EXTREMELY TOXIC. USE ONLY IN WELL VENTILLATED AREAS. VERY FLAMMABLE, KEEP AWAY FROM IGNITION SOURCES.

Clean abraded area using cheesecloth soaked in MEK. Wipe dry before solvent evaporates.
3. **WARNING:** USE EPOXY COMPOUNDS ONLY IN WELL VENTILATED AREAS. TAKE PRECAUTIONS TO PREVENT MATERIAL FROM COMING INTO CONTACT WITH THE SKIN.

Prepare and mix primer base 463-6-27 and converter X-337 as per manufacturers instructions.

4. Apply primer to repair area.
5. Cure primer for 2 hours at room temperature.
6. Touch up any damage to paint finish on exterior surface of access door as per 51-21-01 of the Structural Repair Manual.
7. Visually inspect the completed repair.

NOTES

- REFINISH REWORKED AREAS PER 71-11-04 OF THE AIRCRAFT MAINTENANCE MANUAL.
 - REFER TO 51-11-01 FOR AERODYNAMIC SMOOTHNESS REQUIREMENTS. WHERE DAMAGE EXCEEDS THE LIMIT SHOWN IN 51-11-01 CONSIDERATION SHOULD BE GIVEN TO LOSS OF PERFORMANCE INVOLVED.
- A** NICKS, CRACKS, SCRATCHES OR GOUGES THAT DO NOT PENETRATE BEYOND THE ALUMINUM CLAD DO NOT REQUIRE REMOVAL.
- B** NICKS OR CRACKS WITHIN THE LIMITATIONS OF DETAIL I SHOULD BE ROUNDED OUT.
- C** SCRATCHES OR GOUGES WITHIN THE LIMITATIONS OF DETAIL II SHOULD BE DRESSED AS INDICATED.
- D** MAXIMUM LENGTH OF SCRATCH OR GOUGE IS 0.5 INS.

Fan Cowl - Repair of Access Panel - RB211-535 Engine
Figure 201 (Sheet 1 of 3)

757-200
STRUCTURAL REPAIR MANUAL

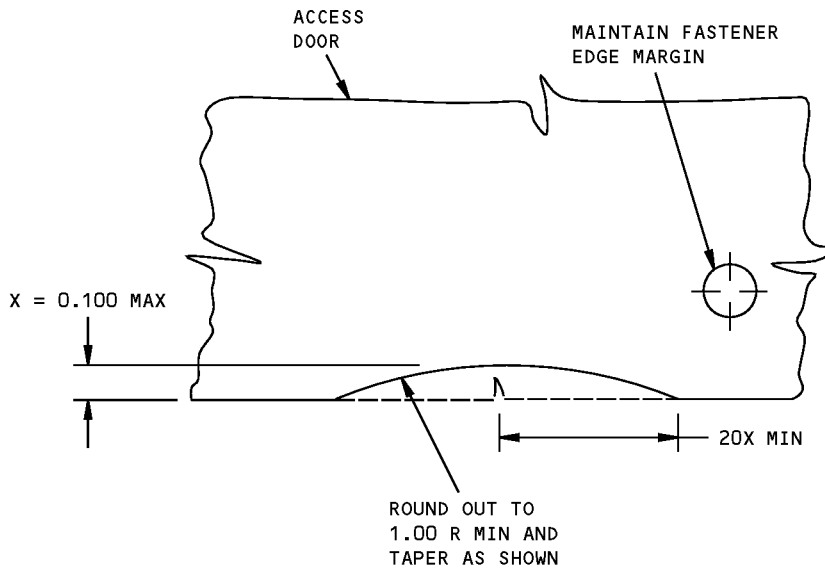
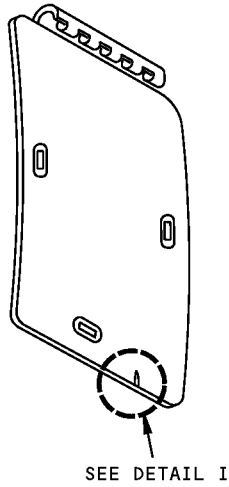

DETAIL OF NICK OR CRACK REMOVED
DETAIL I

A7700

Fan Cowl - Repair of Access Panel - RB211-535 Engine
Figure 201 (Sheet 2 of 3)

757-200
STRUCTURAL REPAIR MANUAL

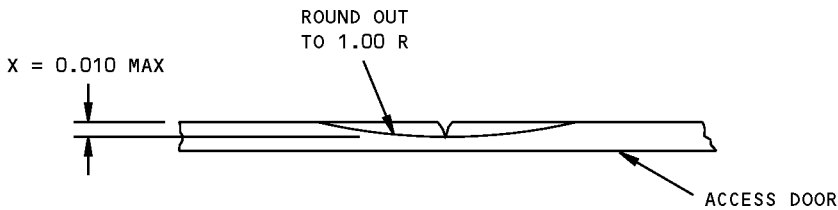
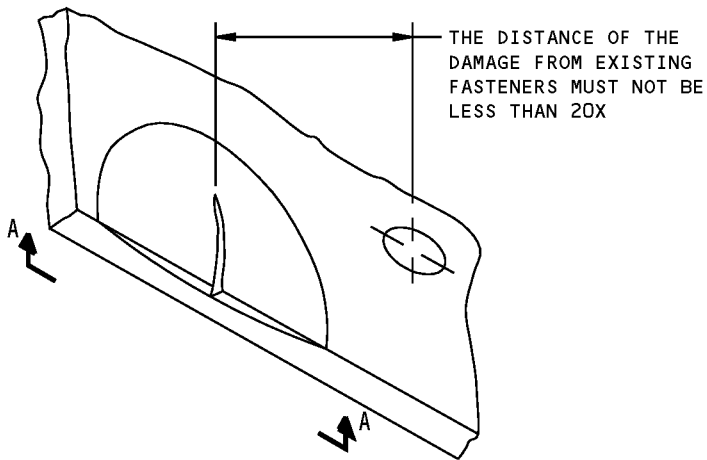
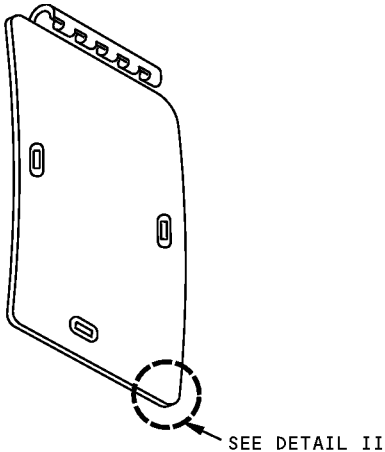

SECTION A-A

DETAIL OF SCRATCH OR GOUGE REMOVED
DETAIL II

A7701

Fan Cowl - Repair of Access Panel - RB211-535 Engine
Figure 201 (Sheet 3 of 3)

757-200
STRUCTURAL REPAIR MANUAL

IDENTIFICATION 1 - FAN COWL SKIN - PW2000 ENGINE

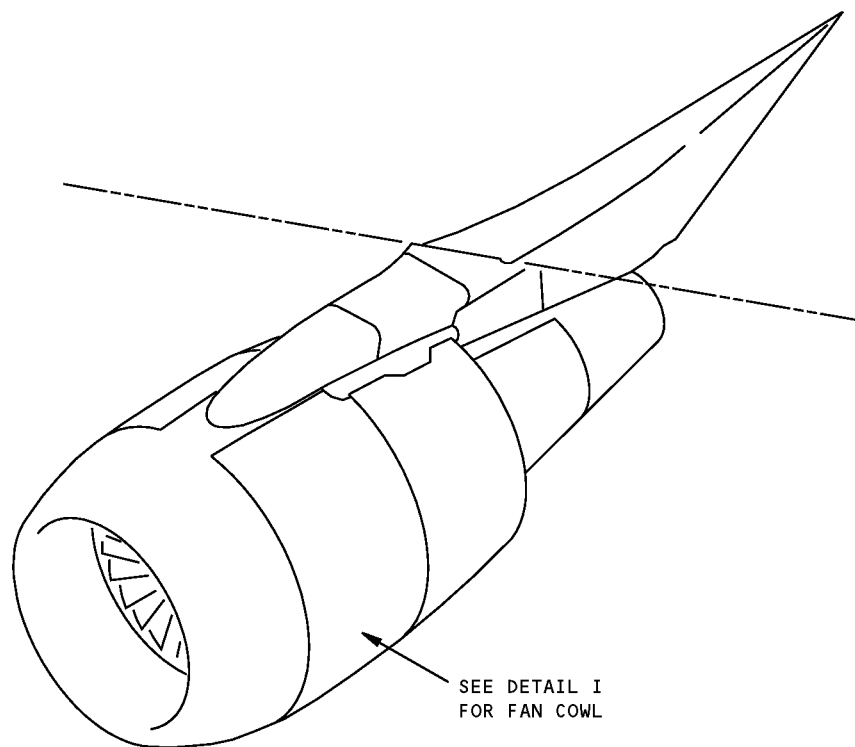

NOTES

- A** PLY ORIENTATION CONVENTION, DEGREES INDICATED, IS PARALLEL TO THE FABRIC WARP DIRECTION
- B** EPOXY IMPREGNATED GRAPHITE FABRIC PER BMS 8-212, TYPE III, CLASS 2, STYLE 3K-135-8H, 350°F (177°C) CURE
- C** EPOXY IMPREGNATED ARAMID FABRIC PER BMS 8-218, STYLE 285, 350°F (177°C) CURE
- D** EPOXY IMPREGNATED GRAPHITE FABRIC PER BMS 8-212, TYPE IV, CLASS 2, STYLE 3K-70-PW, 350°F (177°C) CURE
- E** EPOXY IMPREGNATED FIBERGLASS PER BMS 8-139, TYPE 120, 350°F (177°C) CURE
- F** ALUMINUM FOIL PER BMS 8-289, TYPE 0, CLASS 350, GRADE 2/1100, 350°F (177°C) CURE
- G** MATERIAL AND PLY ORIENTATION SHOWN FOR FIELD AREAS ONLY. SEE BOEING DRAWINGS FOR EDGE BANDS AND AREAS WITH DOUBLERS

Fan Cowl Skin Identification - PW2000 Engine
Figure 1 (Sheet 1 of 2)

**757-200
STRUCTURAL REPAIR MANUAL**

REF DWG
314N3111

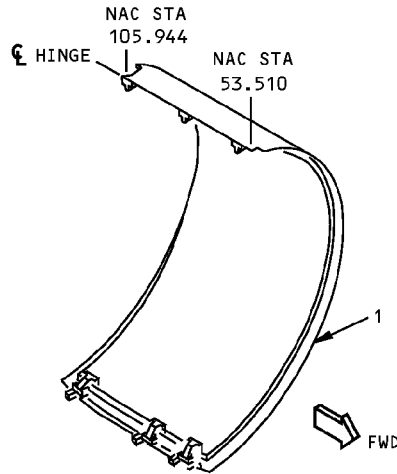

LEFT COWL PANEL SHOWN
RIGHT PANEL SIMILAR

ITEM	DESCRIPTION	GAGE	MATERIAL	EFFECTIVITY
1	PANEL ASSY SKIN CORE		SEE PLY TABLE FOR MATERIAL NONMETALLIC HONEYCOMB PER BMS 8-124, CLASS IV, TYPE I, GRADE 4.0	

LIST OF MATERIALS FOR DETAIL I

ITEM NO.	PLY NO.	MATERIAL	PLY ORIENTATION ^A
1	P1,P24	^B	0° OR 90°
	P14	^C	±45°
	P15	^D	±45°
	P25	^E	0° OR 90°
	P26	^F	----

PLY TABLE ^G

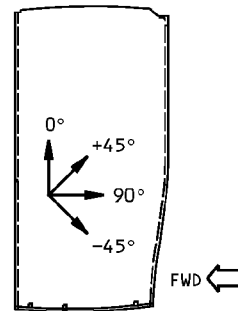

PLY ORIENTATION DIAGRAM

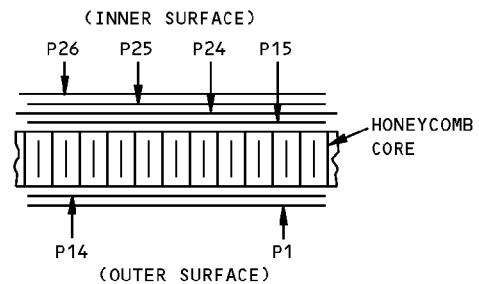

SECTION THRU HONEYCOMB PANEL

DETAIL I

**Fan Cowl Skin Identification - PW2000 Engine
Figure 1 (Sheet 2 of 2)**

IDENTIFICATION 1
Page 2
Jan 20/2005

54-21-01

D634N201

**757-200
STRUCTURAL REPAIR MANUAL**

ALLOWABLE DAMAGE 1 - FAN COWL SKIN - PW2000 ENGINE

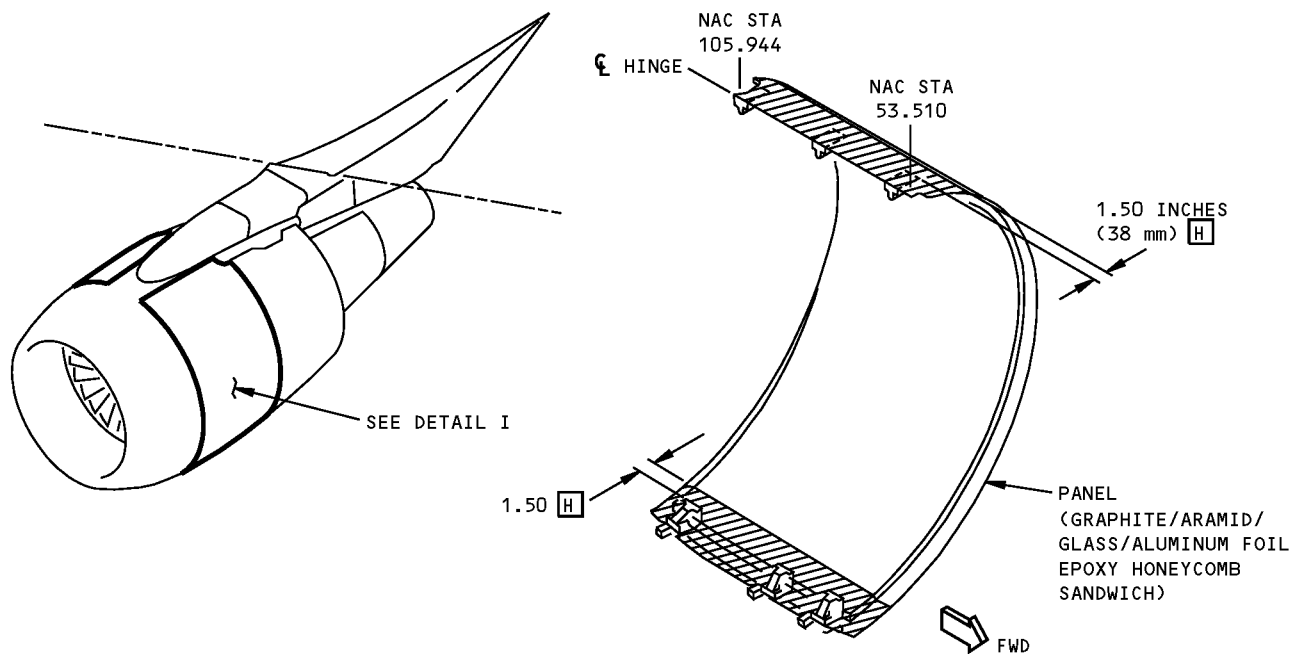

LEFT COWL PANEL IS SHOWN, RIGHT PANEL IS SIMILAR
DETAIL I

DESCRIPTION	CRACKS	NICKS AND GOUGES	EDGE EROSION	DENTS	HOLES AND PUNCTURES	DELAMINATION
PANEL	[B]	[C]	SEE DETAIL IV	[D]	[E]	[F]

NOTES

- THESE ALLOWABLE DAMAGE LIMITS ARE FAA APPROVED CONTINGENT ON ACCOMPLISHMENT OF THE INSPECTIONS AT THE INTERVALS CONTAINED HEREIN.
- REFINISH REWORKED AREAS AS SHOWN IN AMM 51-20.
- REFER TO SRM 51-10-01 FOR AERODYNAMIC SMOOTHNESS REQUIREMENTS. WHERE DAMAGE IS MORE THAN THE LIMITS SHOWN IN SRM 51-10-01. CONSIDERATION SHOULD BE GIVEN TO LOSS OF PERFORMANCE INVOLVED.
- REFER TO SRM 51-10-02 FOR INSPECTION AND REMOVAL OF DAMAGE
- DAMAGE TO PANEL EDGES MAY BE CONFINED TO DELAMINATION OR MAY TAKE A FORM WHICH RESULTS IN DAMAGE TO FIBERS AND A LOSS OF EFFECTIVE CROSS-SECTIONAL AREA. THIS TYPE OF DAMAGE SHOULD BE REMOVED AND THE LIMITATIONS GIVEN FOR CRACKS APPLIED.

- [A] REMOVE MOISTURE FROM DAMAGE AREA. USE OF VACUUM AND HEAT (MAX OF 125°F (52°C)) TO REMOVE MOISTURE FROM HONEYCOMB CELLS IS RECOMMENDED. PROTECT DAMAGE FROM ENTRANCE OF WATER, SUNLIGHT OR OTHER FOREIGN MATTER BY SEALING WITH ALUMINUM FOIL TAPE (SPEED TAPE). RECORD THE LOCATION AND INSPECT EACH AIRPLANE "A" CHECK. REPLACE THE ALUMINUM FOIL TAPE IF ANY PEELING OR DETERIORATION IS EVIDENT. REPAIR NO LATER THAN NEXT AIRPLANE "C" CHECK.
- [B] 1.50 INCHES (38 mm) MAX LENGTH IN HONEYCOMB AREA IS PERMITTED FOR EACH SQUARE FOOT OF AREA. MINIMUM OF 6.0 INCHES (150 mm) FROM ANY OTHER CRACK. REMOVE EDGE CRACKS AS SHOWN IN DETAILS II AND III. [A]
- [C] DAMAGE ALLOWED ON SURFACE RESIN ONLY WITH NO FIBER DAMAGE. CLEAN UP EDGE DAMAGE AS SHOWN IN DETAILS II AND III. REFER TO [E] FOR FIBER DAMAGE IN OTHER AREAS.

**Fan Cowl Skin Allowable Damage - PW2000 Engine
Figure 101 (Sheet 1 of 2)**

ALLOWABLE DAMAGE 1

54-21-01

Page 101
Jan 20/2007

D634N201

STRUCTURAL REPAIR MANUAL

NOTES (CONT)

- [D]** DENTS GENERALLY RESULT IN FIBER DAMAGE OR DELAMINATION. HOWEVER, IF THERE IS NO FIBER DAMAGE OR DELAMINATION, DENTS UP TO 1.0 INCH (25 mm) DIA MAX ARE PERMITTED. ONE DENT PER SQUARE FOOT OF AREA ALLOWED, WHICH MUST BE A MINIMUM OF 6 INCHES (150 mm) FROM ANY OTHER DAMAGE, FASTENER HOLE, OR PANEL EDGE. IF FIBER DAMAGE OR DELAMINATION IS PRESENT, REFER TO APPLICABLE DAMAGE DATA IN TABLE
- [E]** 1.00 INCH (25 mm) MAX DIA PERMITTED PROVIDED DAMAGE IS MIN OF 3.0 INCHES (75 mm) DIAMETER FROM OTHER DAMAGE, NEAREST HOLE, OR MATERIAL EDGE. DO NOT CLEAN UP DAMAGE EXCEPT TO REMOVE RESIN BURRS EXTENDING INTO SURFACE CONTOUR **[A]**
- [F]** 1.00 INCH (25 mm) MAX DIA IS PERMITTED IN HONEYCOMB AREA. A MAXIMUM OF 0.03 INCH (0.76 mm) DELAMINATION FROM EDGE IS PERMITTED. **[A]**

- [G]** DO NOT CHAMFER BEYOND EDGE OF COUNTERSINK AT FASTENER LOCATION. AS AN OPTION TO SEALING WITH SPEED TAPE, THE CHAMFER MAY BE REPAIRED WITHOUT REQUIREMENT FOR "A" CHECK INSPECTIONS AND "C" CHECK REPAIR BY SEALING WITH BMS 5-92 TYPE I OR TYPE III, OR WITH BMS 5-123. CURE BMS 5-92 TYPE I OR TYPE III AT 75°F (24°C) FOR 24 HOURS. CURE BMS 5-123 AT 75°F (24°C) FOR 1 HOUR
- [H]** CRITICAL AREAS (SHADED) TO 1.50 INCHES (38 mm) FROM THE HINGE OR LATCH FITTINGS. EDGE EROSION IS PERMITTED AS GIVEN IN DETAIL IV. EDGE DELAMINATION IS PERMITTED AS GIVEN IN **[F]**. FOR OTHER DAMAGE, CONTACT THE BOEING COMPANY.

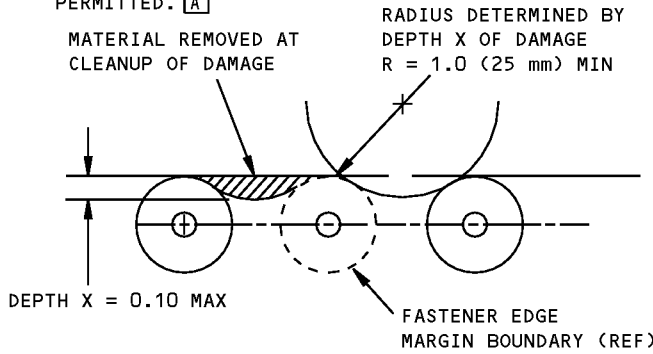

DAMAGE CLEANUP OF EDGES WHERE FASTENER EDGE MARGINS DO NOT OVERLAP

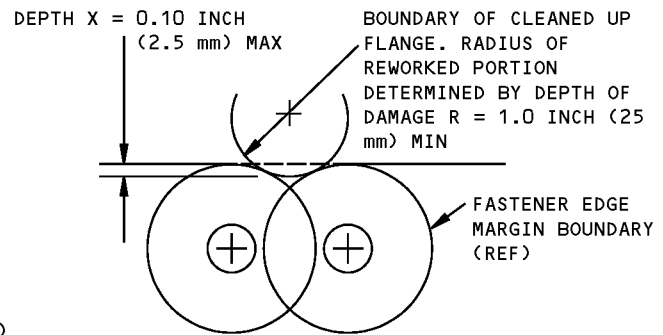

DAMAGE CLEANUP OF EDGES WHERE FASTENER EDGE MARGINS OVERLAP

DETAIL II

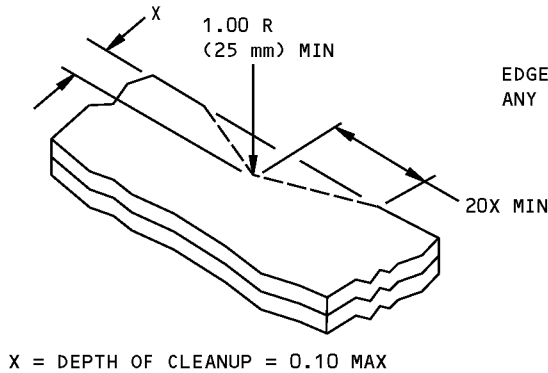

REMOVAL OF NICK OR CRACK DAMAGE ON AN EDGE

DETAIL III

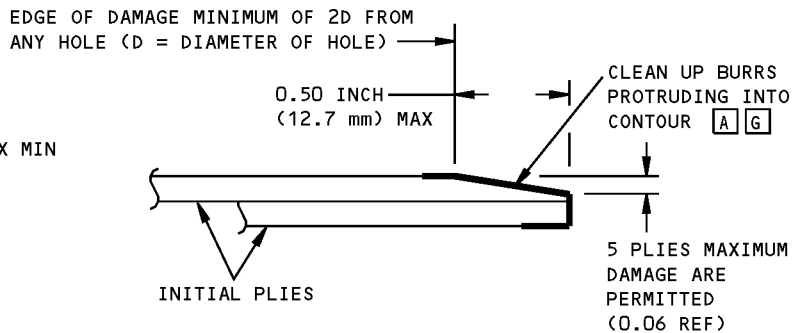

DAMAGE CLEANUP AND SEALING OF EDGE EROSION

DETAIL IV

**Fan Cowl Skin Allowable Damage - PW2000 Engine
Figure 101 (Sheet 2 of 2)**

**757-200
STRUCTURAL REPAIR MANUAL**

REPAIR 1 - FAN COWL SKIN - PW2000 ENGINE

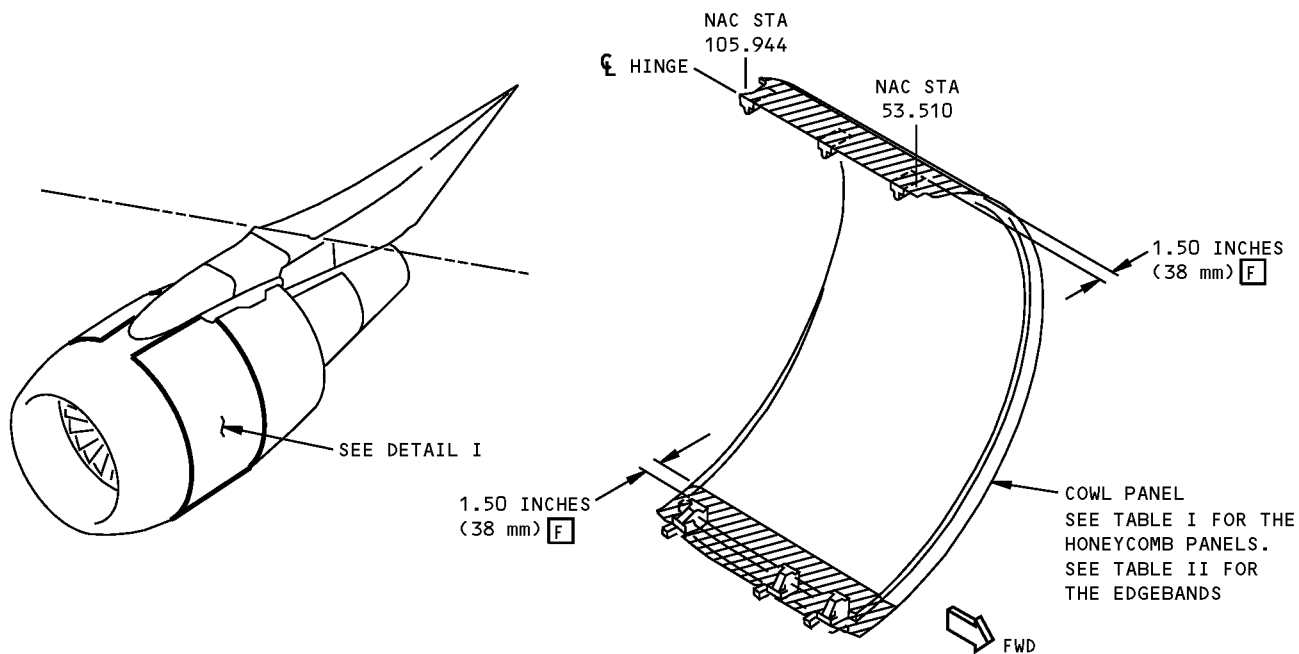

LEFT COWL PANEL IS SHOWN,
RIGHT PANEL IS SIMILAR

DETAIL I

NOTES

- REFINISH WITH ONE COAT OF BMS 10-79 TYPE III PRIMER AND ONE COAT OF BMS 10-60 TYPE II ENAMEL AS GIVEN IN AMM 51-20.
 - REFER TO SRM 51-10-01 FOR AERODYNAMIC SMOOTHNESS REQUIREMENTS. WHERE THE DAMAGE IS MORE THAN THE LIMITS AS GIVEN IN SRM 51-10-01, CONSIDERATION SHOULD BE GIVEN TO THE LOSS OF PERFORMANCE INVOLVED.
- [A] LIMITED TO REPAIR OF DAMAGE TO ONE FACESHEET SKIN AND HONEYCOMB CORE. ONE REPAIR PER SQUARE FOOT OF AREA AND MINIMUM OF 6.0 INCHES (150 mm) (EDGE TO EDGE) FROM ANY OTHER DAMAGE, FASTENER HOLE, OR EDGE OF PANEL.
- [B] INSPECT INTERIM REPAIR USING INSTRUMENTED NDI METHODS OR "TAP" TEST EVERY AIRPLANE "2 A" CHECK. FOR "TAP" TEST, USE A SOLID METAL DISK AND TAP THE REPAIR AREA LIGHTLY BUT FIRMLY. VOID AREAS WILL PRODUCE A DULL SOUND AS OPPOSED TO A SHARP RING ON A SOLID BONDED AREA. PERMANENT REPAIR IS REQUIRED IF ANY DETERIORATION IS EVIDENT. REFER TO SRM 51-70-03, PAR. 4.I. AND THE NONDESTRUCTIVE TEST MANUAL, D634N301. [D]
- [C] ONE REPAIR FOR EACH SQUARE FOOT OF AREA AND A MINIMUM OF 6.0 INCHES (150 mm) (EDGE TO EDGE) FROM ANY OTHER DAMAGE, FASTENER HOLE, OR EDGE OF PANEL.
- [D] THIS REPAIR HAS FAA APPROVAL CONTINGENT ON ACCOMPLISHMENT OF THE INSPECTIONS CONTAINED HEREIN.
- [E] FOR PERMANENT WET LAYUP REPAIRS, USE A 1.0 INCH (25 mm) OVERLAP FOR EACH REPAIR PLY AND CURE AT 230°F (110°C). ALTERNATIVELY, FOR OUTER SKIN REPAIRS ONLY, USE A 0.50 INCH (12.7 mm) OVERLAP FOR EACH REPAIR PLY AND CURE AT 200°F (93°C).
- [F] CRITICAL AREAS (SHADED) TO 1.50 INCHES (38 mm) FROM THE HINGE OR LATCH FITTINGS. REPAIR ONLY EDGE EROSION AND EDGE DELAMINATION. CONTACT THE BOEING COMPANY FOR REPAIR OF OTHER DAMAGE.

**Fan Cowl Skin Repairs - PW2000 Engine
Figure 201 (Sheet 1 of 3)**

STRUCTURAL REPAIR MANUAL

DAMAGE	INTERIM REPAIRS [B]	PERMANENT REPAIRS	
	WET LAYUP 150°F (66°C) CURE (SRM 51-70-03)	WET LAYUP 200°F (93°C) CURE (SRM 51-70-17) [E]	350°F (177°C) CURE (SRM 51-70-04)
CRACKS	UP TO 3.0 INCHES (75 mm) LONG, REPAIR WITH PATCH AS GIVEN IN SRM 51-70-03, PARAGRAPH 5.N. [A]	CLEAN UP DAMAGE AND REPAIR AS A HOLE.	CLEAN UP DAMAGE AND REPAIR AS A HOLE.
HOLES AND PUNCTURES	3.0 INCHES (75 mm) MAXIMUM DIAMETER NOT TO EXCEED 30% OF SMALLEST DIMENSION ACROSS HONEYCOMB PANEL AT THE DAMAGE LOCATION. FILL WITH BMS 5-28, TYPE 7 POTTING COMPOUND AND PATCH AS GIVEN IN SRM 51-70-03, PARAGRAPH 5.N. [A]	12.0 INCHES (300 mm) MAXIMUM DIAMETER NOT TO EXCEED 50% OF SMALLEST DIMENSION ACROSS HONEYCOMB PANEL AT DAMAGE LOCATION. USE TWO EXTRA PILES FOR EACH FACESHEET REPAIRED. [C]	NO SIZE LIMIT
DELAMINATION	3.0 INCHES (75 mm) MAXIMUM DIAMETER NOT TO EXCEED 30% OF SMALLEST DIMENSION ACROSS HONEYCOMB PANEL AT DAMAGE LOCATION. REPAIR AS GIVEN IN SRM 51-70-03, PARAGRAPH 5.A. [A]	12.0 INCHES (300 mm) MAXIMUM DIAMETER NOT TO EXCEED 50% OF SMALLEST DIMENSION ACROSS HONEYCOMB PANEL AT DAMAGE LOCATION. REPAIR AS GIVEN IN SRM 51-70-17, PARAGRAPH 4.A. [C]	NO SIZE LIMIT REPAIR AS GIVEN IN SRM 51-70-04, PARAGRAPH 5.A.
NICKS AND GOUGES	IF THERE IS FIBER DAMAGE OR DELAMINATION, FILL NICKS OR GOUGES AS GIVEN IN SRM 51-70-03. IF YOU FIND FIBER DAMAGE OR DELAMINATION, THEN REPAIR AS A HOLE.		
DENTS	DENTS RESULT IN FIBER DAMAGE AND DELAMINATION. USE REPAIR DATA FOR HOLES AND PUNCTURES TO DETERMINE DENT REPAIR.		

REPAIR DATA FOR 350°F (177°C) CURE HONEYCOMB PANELS
TABLE I

**Fan Cowl Skin Repairs - PW2000 Engine
Figure 201 (Sheet 2 of 3)**

STRUCTURAL REPAIR MANUAL

DAMAGE	INTERIM REPAIRS [B]	PERMANENT REPAIRS	
	WET LAYUP 150°F (66°C) CURE (SRM 51-70-03)	WET LAYUP 200°F (93°C)/230°F (110°C) CURE (SRM 51-70-17) [E]	350°F (177°C) CURE (SRM 51-70-04)
HOLES	REPAIR THE DAMAGE TO THE FASTENER HOLES AS GIVEN IN SRM 51-70-03, FIG. 10. FOR THE LIMITS THAT FOLLOW, REPAIR OTHER DAMAGE AS GIVEN IN SRM 51-70-03, FIG. 9: - AS MAXIMUM OF 15% OF THE AREA OF THE CROSS SECTION THROUGH THE EDGE BAND - A MAXIMUM OF 10% OF THE LENGTH OF THE EDGE BAND FOR EACH SIDE THAT IS DAMAGED.	REPAIR THE DAMAGE TO THE FASTENER HOLES AS GIVEN IN SRM 51-70-17, FIG. 16. REPAIR ALL OTHER DAMAGE AS GIVEN IN SRM 51-70-17, FIG. 15.	REPAIR THE DAMAGE TO THE FASTENER HOLES AS GIVEN IN SRM 51-70-04, FIG. 10. REPAIR ALL OTHER DAMAGE AS GIVEN IN SRM 51-70-04, FIG. 9.
CRACKS	USE THE SAME LIMITS AND REPAIRS AS FOR HOLES.	USE THE SAME REPAIRS AS FOR HOLES.	
DELAMINATION	IF THE DELAMINATION FROM THE PANEL EDGE IS NOT LESS THAN 2D FROM ANY FASTENER HOLE, REPAIR AS GIVEN IN SRM 51-70-03, FIG. 12. FOR ANY OTHER DELAMINATION, USE THE SAME LIMITS AND REPAIRS AS FOR HOLES.	USE THE SAME REPAIRS AS FOR HOLES.	
EDGE EROSION	_____	FOR DAMAGE THAT IS NOT MORE THAN 35% OF EDGE BAND THICKNESS, REPAIR AS GIVEN IN SRM 51-70-03. PARAGRAPH 5.0. FOR GREATER DAMAGE, REPAIR AS GIVEN IN: SRM 51-70-17, PARAGRAPH 4.G. SRM 51-70-04, PARAGRAPH 5.G.	
NICKS AND GOUGES	IF THERE IS FIBER DAMAGE, USE THE SAME REPAIRS AS FOR HOLES. IF THERE IS DELAMINATION, USE THE SAME LIMITS AND REPAIRS AS FOR DELAMINATION.	IF THERE IS NO FIBER DAMAGE OR DELAMINATION, FILL THE NICKS OR GOUGES AS GIVEN IN SRM 51-70-03. IF THERE IS FIBER DAMAGE OR DELAMINATION, USE THE SAME REPAIRS AS FOR HOLES.	
DENTS	IF THERE IS FIBER DAMAGE, USE THE SAME LIMITS AND REPAIRS AS FOR HOLES. IF THERE IS DELAMINATION, USE THE SAME LIMITS AND REPAIRS AS FOR DELAMINATION.	IF THERE IS NO FIBER DAMAGE OR DELAMINATION, FILL THE NICKS OR GOUGES AS GIVEN IN SRM 51-70-03, FIG. 16. IF THERE IS FIBER DAMAGE OR DELAMINATION, USE THE SAME REPAIRS AS FOR HOLES.	

REPAIR OF EDGE BANDS OF 350°F (177°C) CURE HONEYCOMB PANELS
TABLE II

**Fan Cowl Skin Repairs - PW2000 Engine
Figure 201 (Sheet 3 of 3)**

**757-200
STRUCTURAL REPAIR MANUAL**

IDENTIFICATION 1 - FAN COWL STRUCTURE - PW2000 ENGINE

REF DWG
314N3110

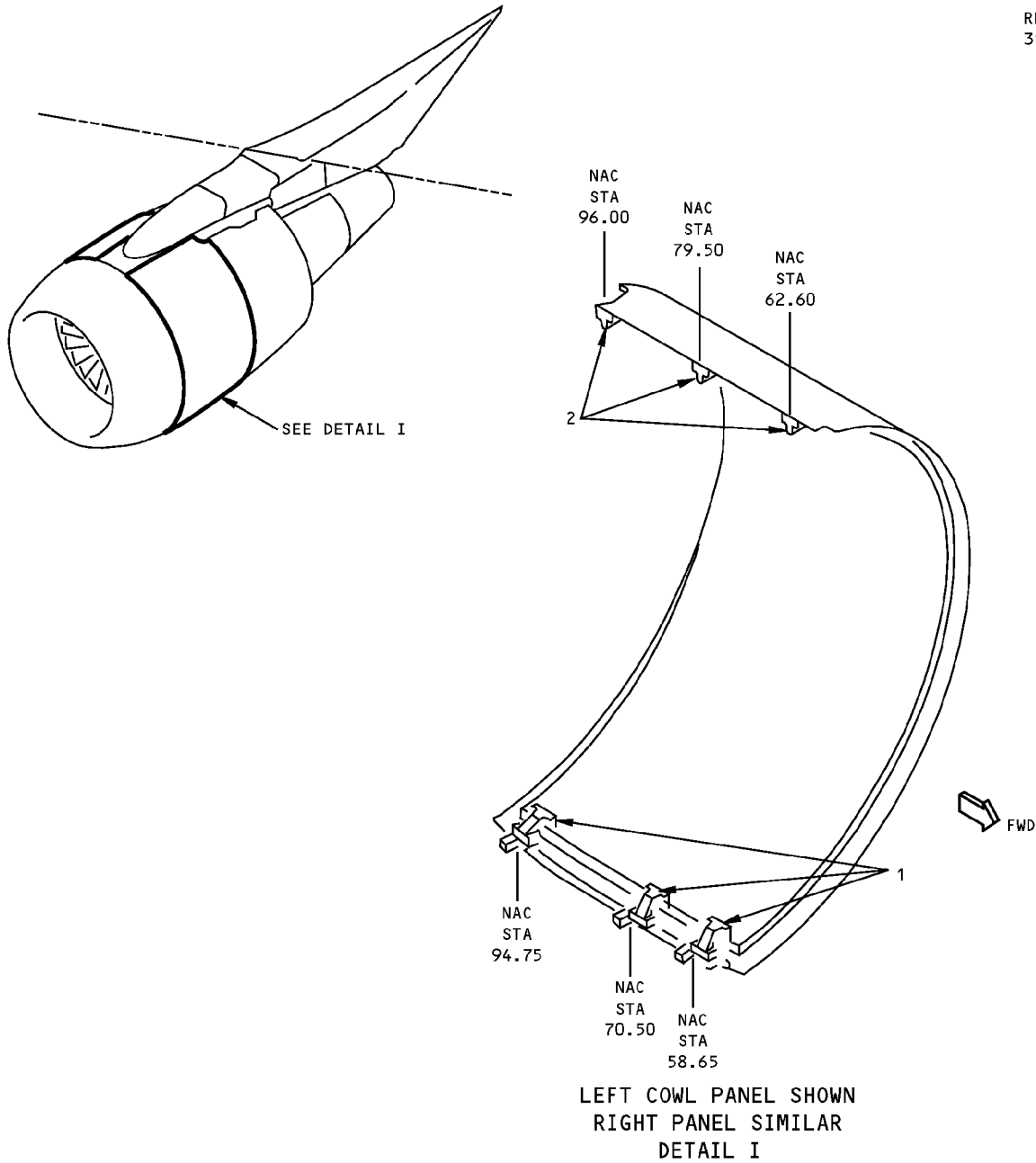

ITEM		GAGE	MATERIAL	EFFECTIVITY
1	LATCH FITTING		7075-T73 FORGING OPTIONAL: 7075-T73 AL BAR	
2	HINGE FITTING		TI-6AL-4V CASTING	

LIST OF MATERIALS FOR DETAIL I

**Fan Cowl Structure Identification - PW2000 Engine
Figure 1**

**757-200
STRUCTURAL REPAIR MANUAL**

ALLOWABLE DAMAGE 1 - FAN COWL STRUCTURE - PW2000 ENGINE

REFERENCE DRAWING
314N3110

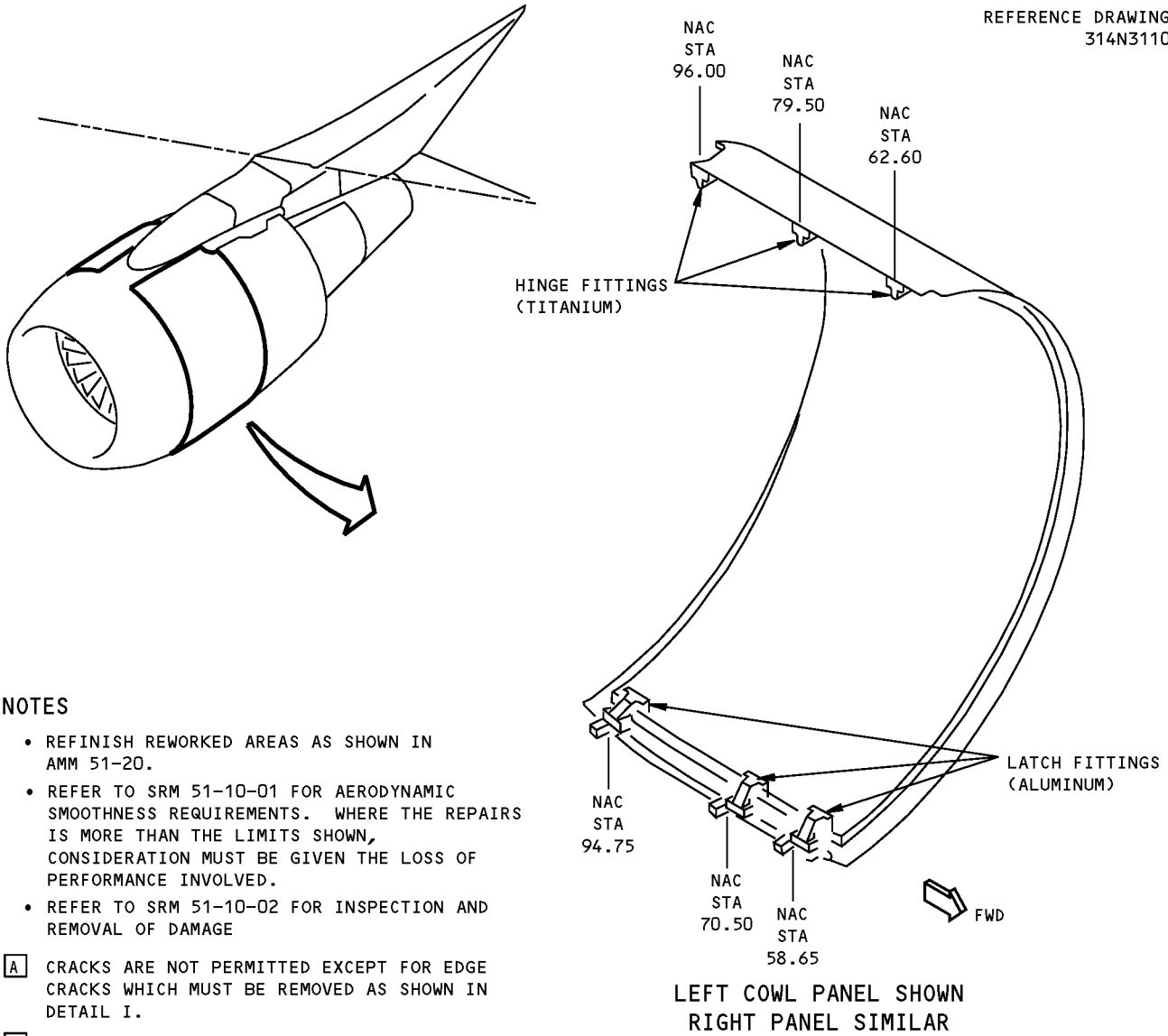

NOTES

- REFINISH REWORKED AREAS AS SHOWN IN AMM 51-20.
- REFER TO SRM 51-10-01 FOR AERODYNAMIC SMOOTHNESS REQUIREMENTS. WHERE THE REPAIRS IS MORE THAN THE LIMITS SHOWN, CONSIDERATION MUST BE GIVEN THE LOSS OF PERFORMANCE INVOLVED.
- REFER TO SRM 51-10-02 FOR INSPECTION AND REMOVAL OF DAMAGE

- A** CRACKS ARE NOT PERMITTED EXCEPT FOR EDGE CRACKS WHICH MUST BE REMOVED AS SHOWN IN DETAIL I.
- B** FOR EDGE DAMAGE SEE DETAIL I, FOR OTHER DAMAGE SEE DETAILS II AND III.

DESCRIPTION	CRACKS	NICKS, GOUGES AND CORROSION	DENTS	HOLES AND PUNCTURES
LATCH FITTING	A	B	NOT PERMITTED	NOT PERMITTED
HINGE FITTING	A	B	NOT PERMITTED	NOT PERMITTED

**Fan Cowl Structure Allowable Damage - PW2000 Engine
Figure 101 (Sheet 1 of 2)**

STRUCTURAL REPAIR MANUAL

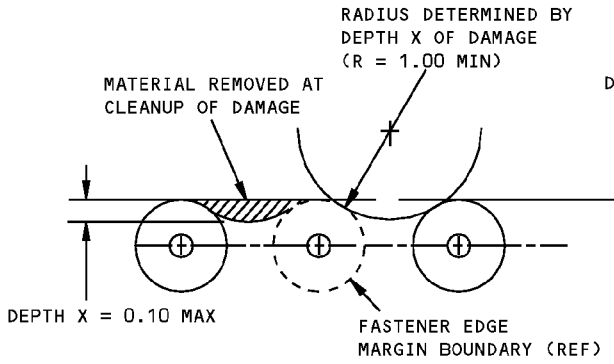

DAMAGE CLEANUP OF EDGES WHERE FASTENER EDGE MARGINS DO NOT OVERLAP

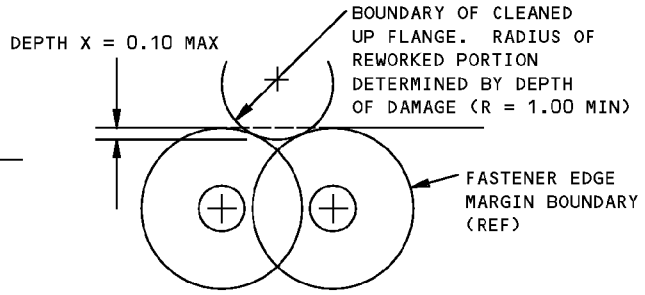

DAMAGE CLEANUP OF EDGES WHERE FASTENER EDGE MARGINS OVERLAP

DETAIL I

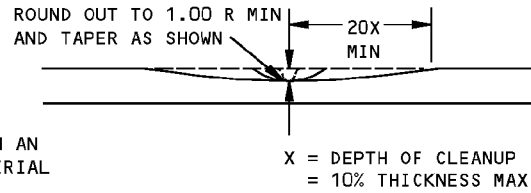
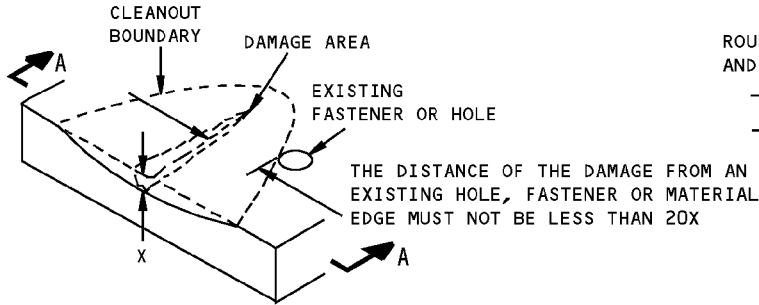

SECTION A-A

REMOVAL OF NICK, GOUGE AND SCRATCH DAMAGE ON A SURFACE

DETAIL II

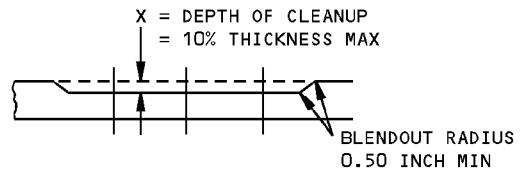
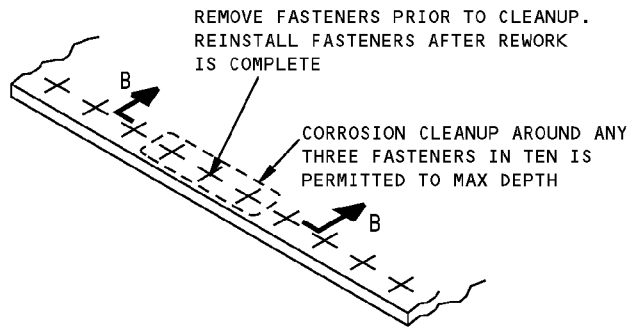

SECTION B-B

CORROSION CLEANUP

DETAIL III

Fan Cowl Structure Allowable Damage - PW2000 Engine
Figure 101 (Sheet 2 of 2)

**757-200
STRUCTURAL REPAIR MANUAL**

REPAIR GENERAL - FAN COWL STRUCTURE - PW2000 ENGINE

REF DWG
314N3110

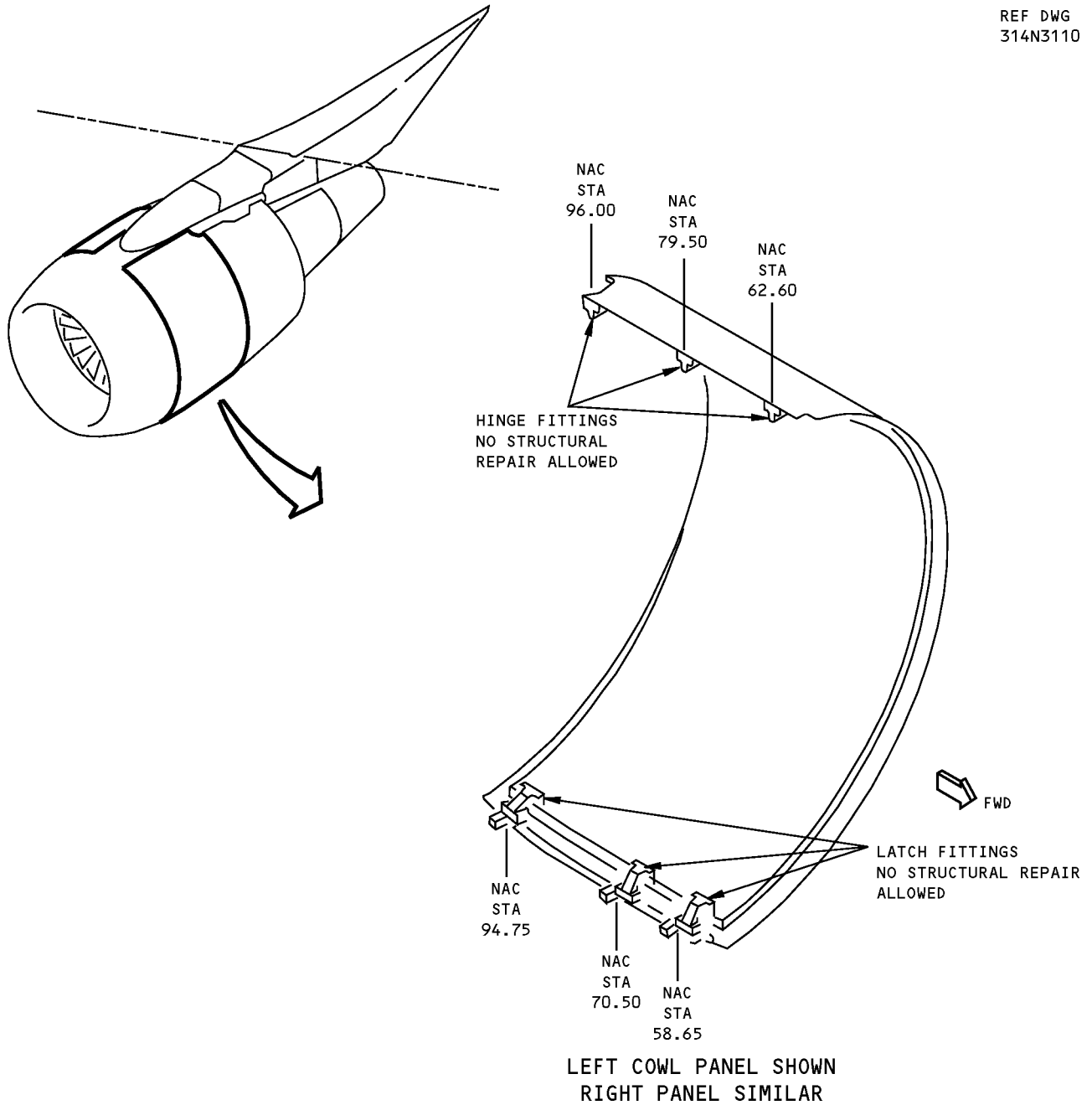

**Fan Cowl Structure Repair - PW2000 Engine
Figure 201**

D634N201

54-21-02

REPAIR GENERAL
Page 201
Jan 20/2005

757-200
STRUCTURAL REPAIR MANUAL

IDENTIFICATION 1 - REVERSER COWL HINGE ACCESS DOOR - RB211-535E4 ENGINE

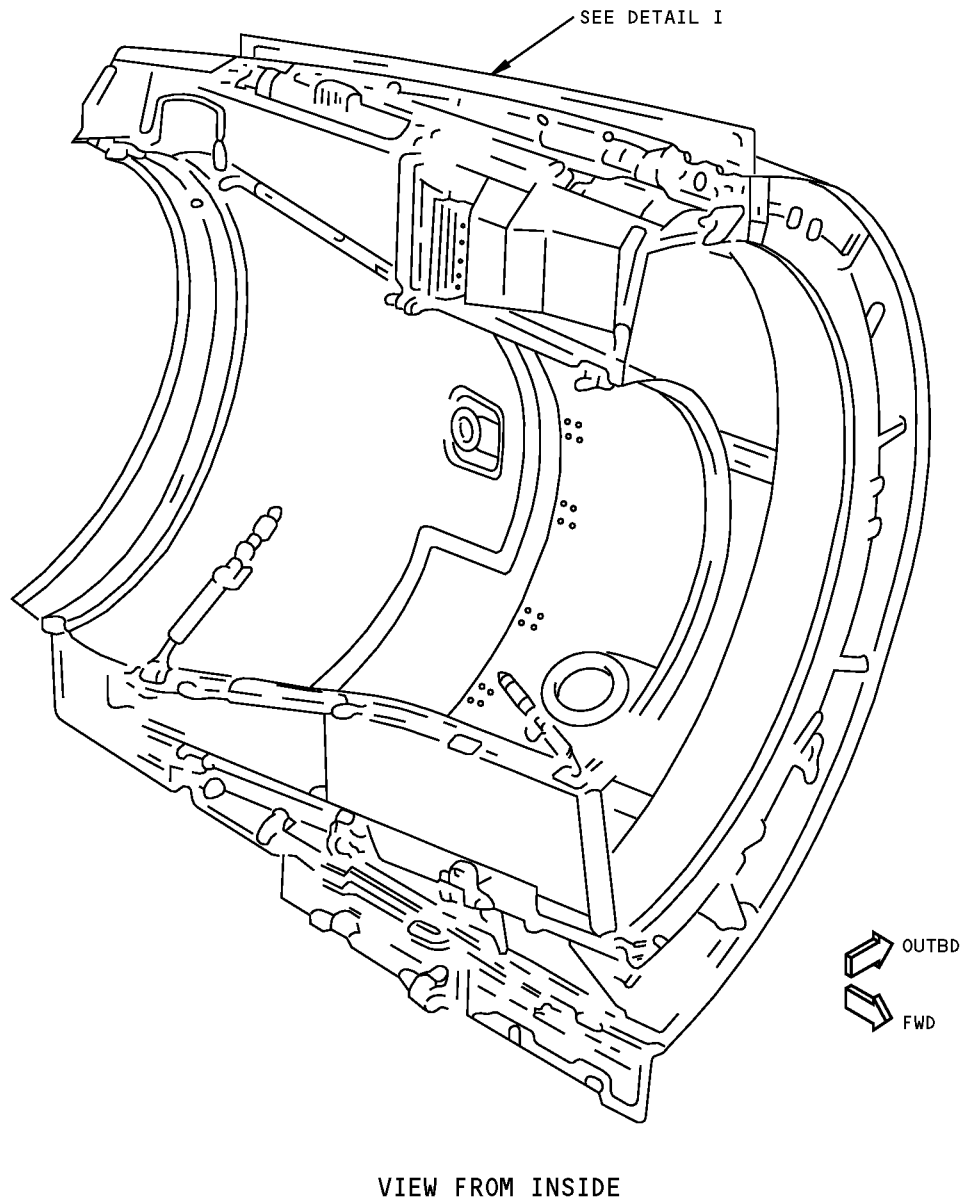

NOTES

- A** PLY ORIENTATION CONVENTION DEGREES INDICATED IS PARALLEL TO THE FABRIC WARP DIRECTION.
- B** GRAPHITE FABRIC, A-370-5H/3501-5A
- C** BONDABLE TEDLAR TYPE 30, 100BG30TR
- D** GRAPHITE TAPE, AS-4/3501-5A

**Reverser Cowl Hinge Access Door Identification - All RB211-535 Engines
Figure 1 (Sheet 1 of 5)**

757-200
STRUCTURAL REPAIR MANUAL

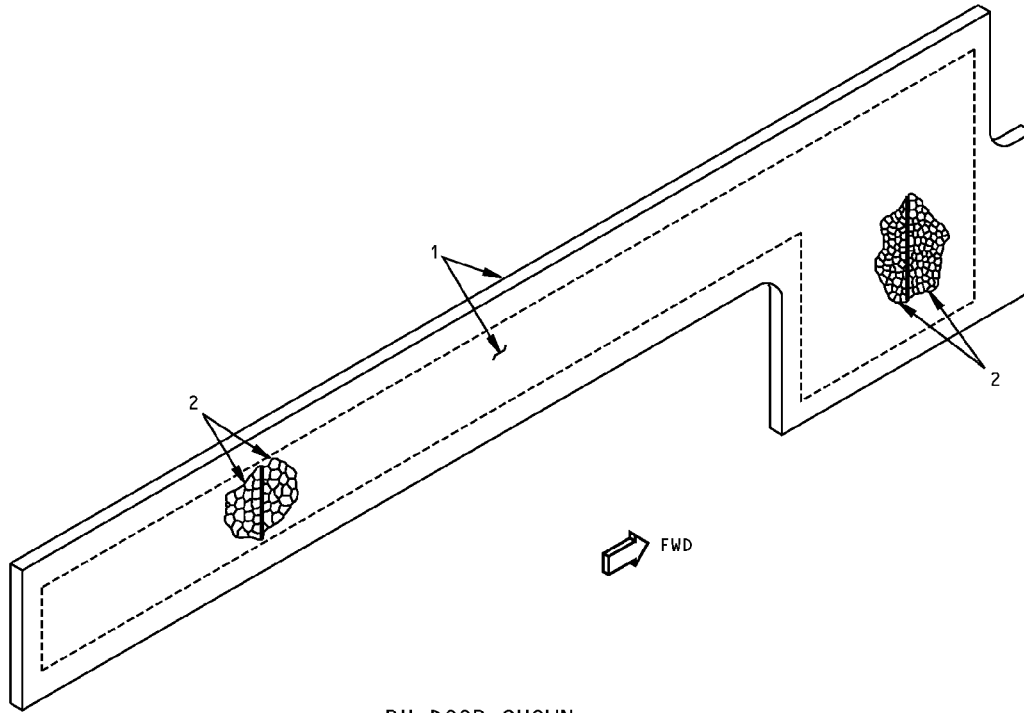

RH DOOR SHOWN
LH DOOR OPPOSITE

DETAIL I

ITEM	DESCRIPTION	GAGE	MATERIAL	EFFECTIVITY
1	PANEL SKIN - INNER AND OUTER		EPOXY/GRAPHITE FABRIC (SEE DETAIL II)	
2	CORE		ALUMINUM HONEYCOMB NONPERFORATED, 1/8 HEX CELL, 0.003 FOIL	

LIST OF MATERIALS FOR DETAIL I

Reverser Cowl Hinge Access Door Identification - All RB211-535 Engines
Figure 1 (Sheet 2 of 5)

IDENTIFICATION 1
Page 2
May 20/2005

54-30-01

D634N201

757-200
STRUCTURAL REPAIR MANUAL

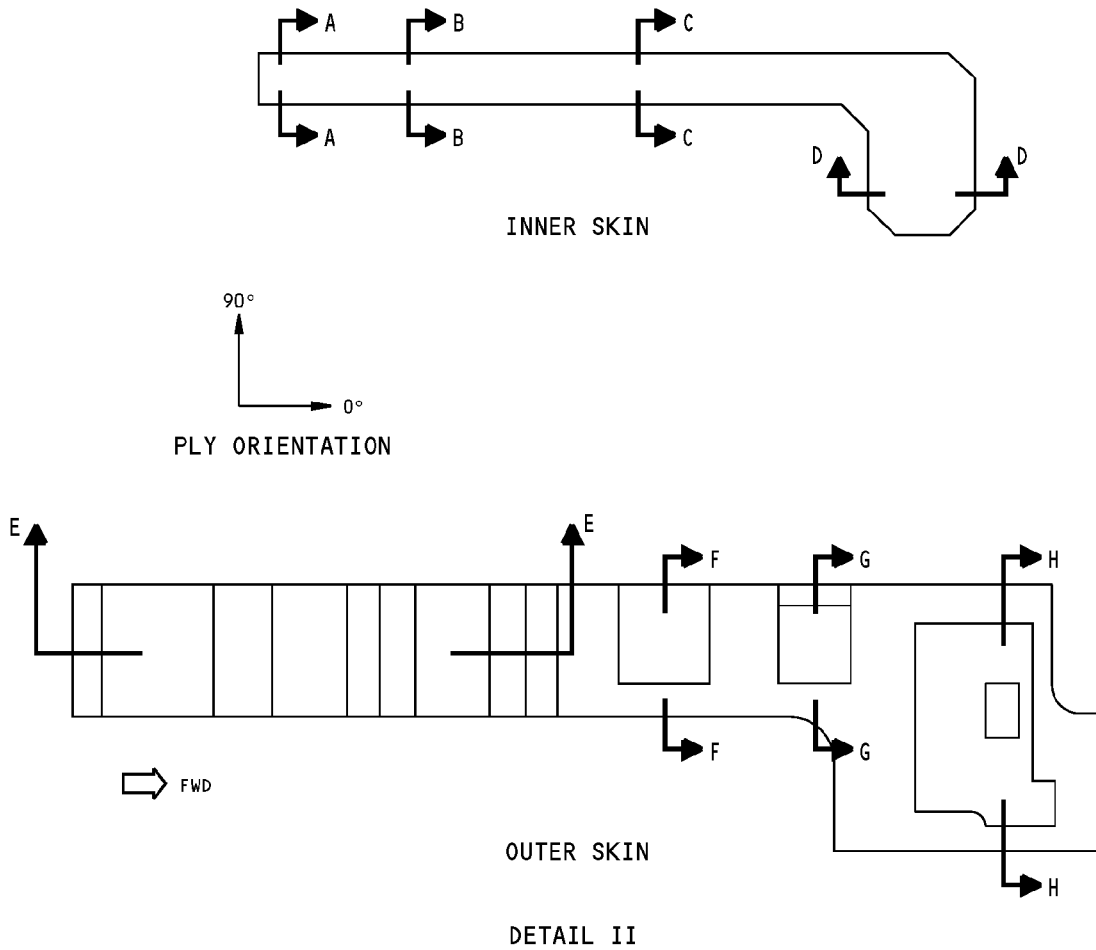

ITEM NO.	PLY NO.	MATERIAL	PLY ORIENTATION ^A
1	F1, F2, F3, F4, F5, F6, F7, F8, F9, F10, F11, F12, F13	^B	0°
	P2	^C	—
	T1, T2, T3, T4, T5, T6, T7, T8, T9, T10, T11, T12	^D	0° AND 90°

PLY TABLE FOR DETAIL II

Reverser Cowl Hinge Access Door Identification - All RB211-535 Engines
Figure 1 (Sheet 3 of 5)

757-200
STRUCTURAL REPAIR MANUAL

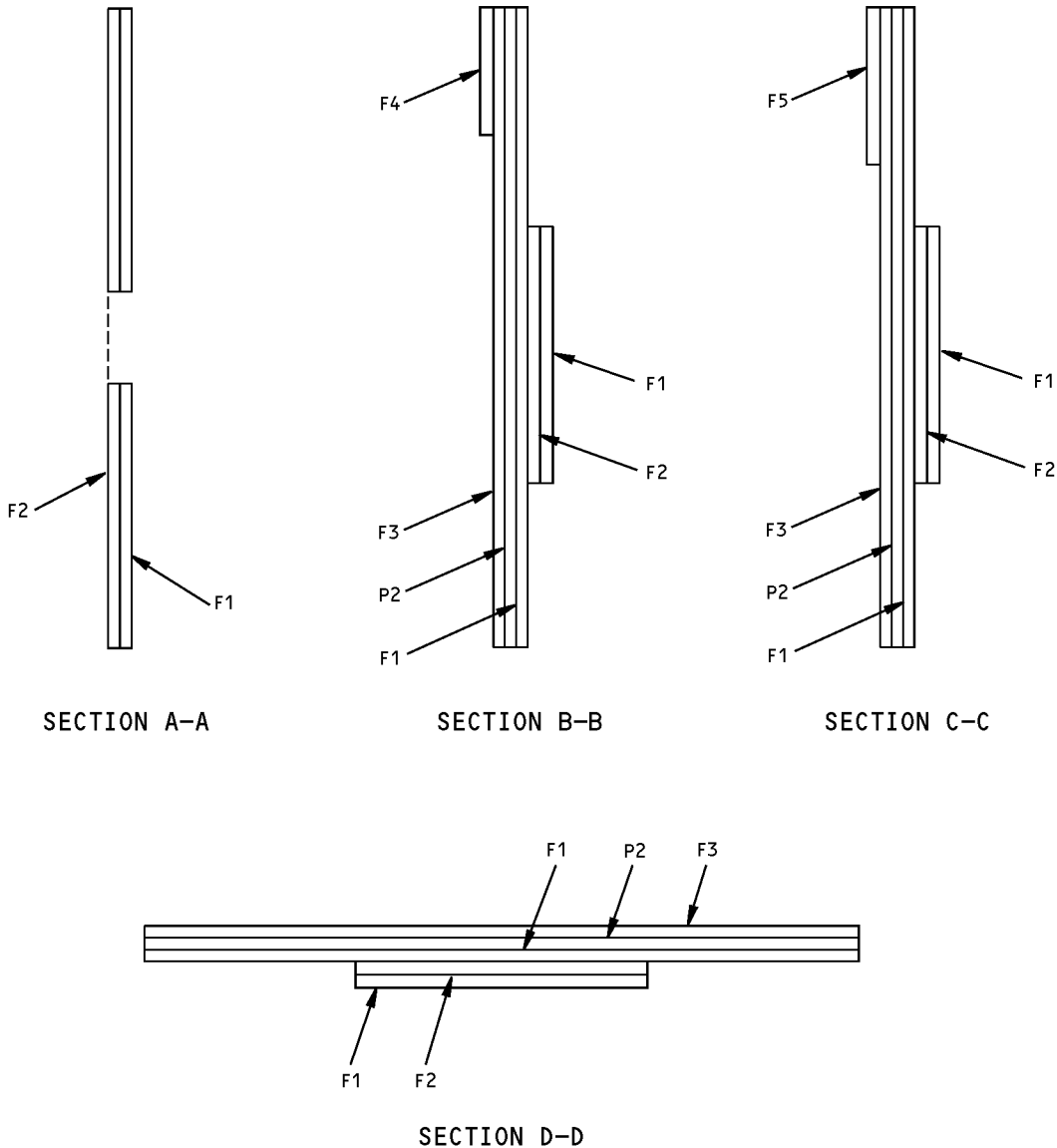

Reverser Cowl Hinge Access Door Identification - All RB211-535 Engines
Figure 1 (Sheet 4 of 5)

757-200
STRUCTURAL REPAIR MANUAL

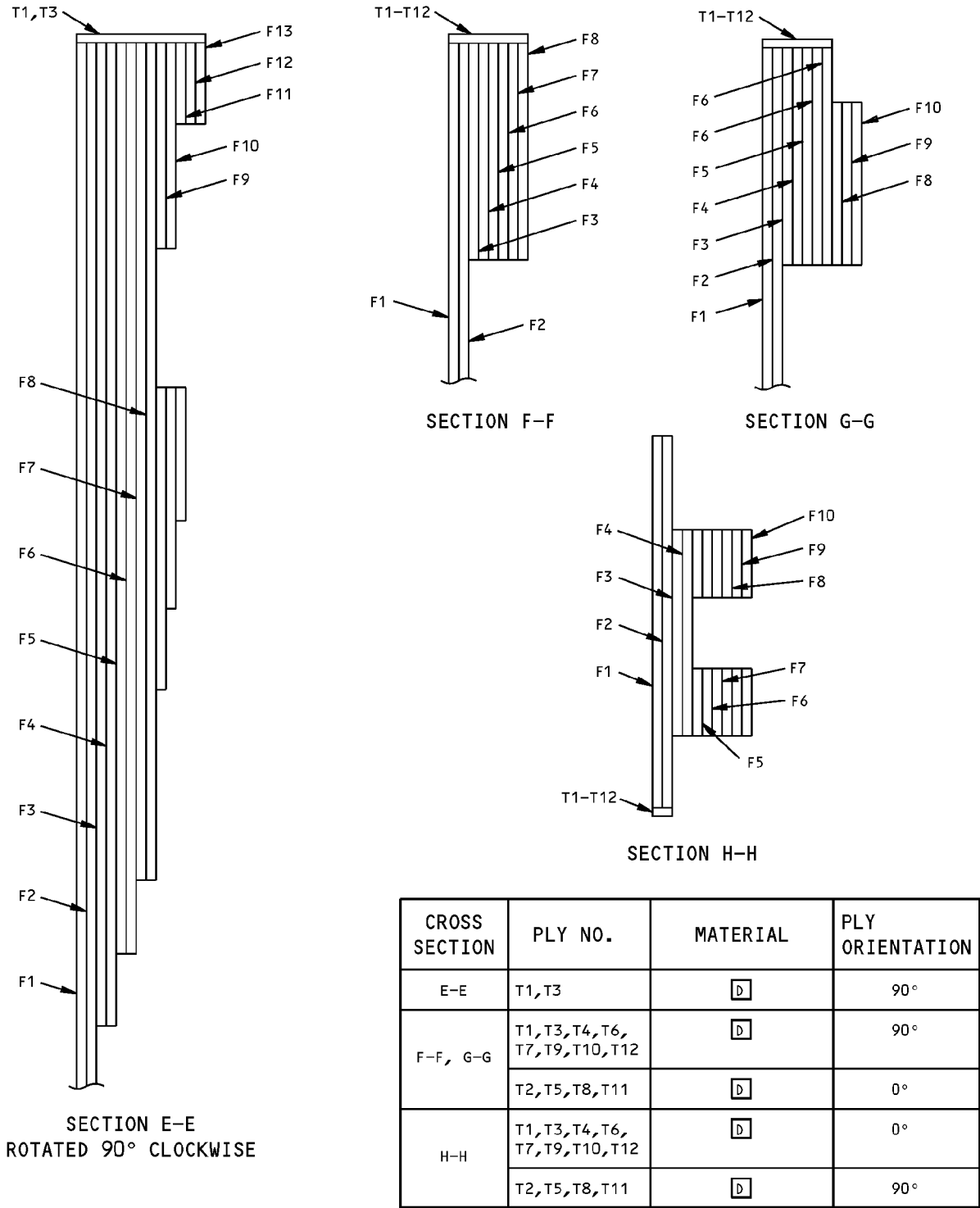

PLY TABLE FOR SECTIONAL VIEWS OF DETAIL II

Reverser Cowl Hinge Access Door Identification - All RB211-535 Engines
Figure 1 (Sheet 5 of 5)

757-200
STRUCTURAL REPAIR MANUAL

IDENTIFICATION 2 - REVERSER COWL SKIN PANEL - RB211-535E4 ENGINE

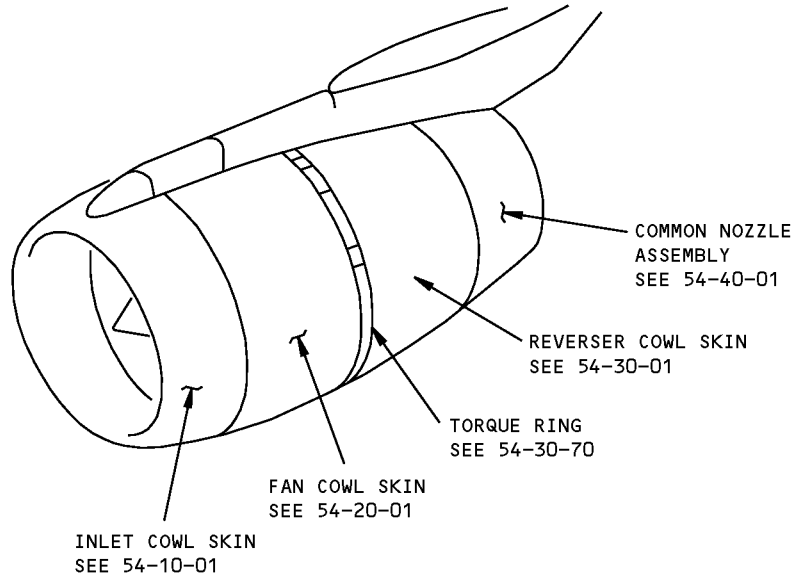

NOTES

- RMS - ROHR MATERIAL SPECIFICATION
- [A] PLY ORIENTATION DEGREES INDICATED IS PARALLEL TO THE FABRIC WARP DIRECTION
- [B] GRAPHITE FABRIC:
 - AH-370-5H/3501-5A, AS4 FIBER, V10396
 - CYCOM 985-1, AS4 FIBER, V7945
 - EM 7198, CELION 6K-ST FIBER, V27129
 - R 922-1, CGG 108, CELION 6K FIBER, V30137

Reverser Cowl Skin Panel Identification - RB211-535E4 Engine
Figure 1 (Sheet 1 of 4)

757-200
STRUCTURAL REPAIR MANUAL

REF DWG
LJ75087
(EXCEPT AS NOTED)

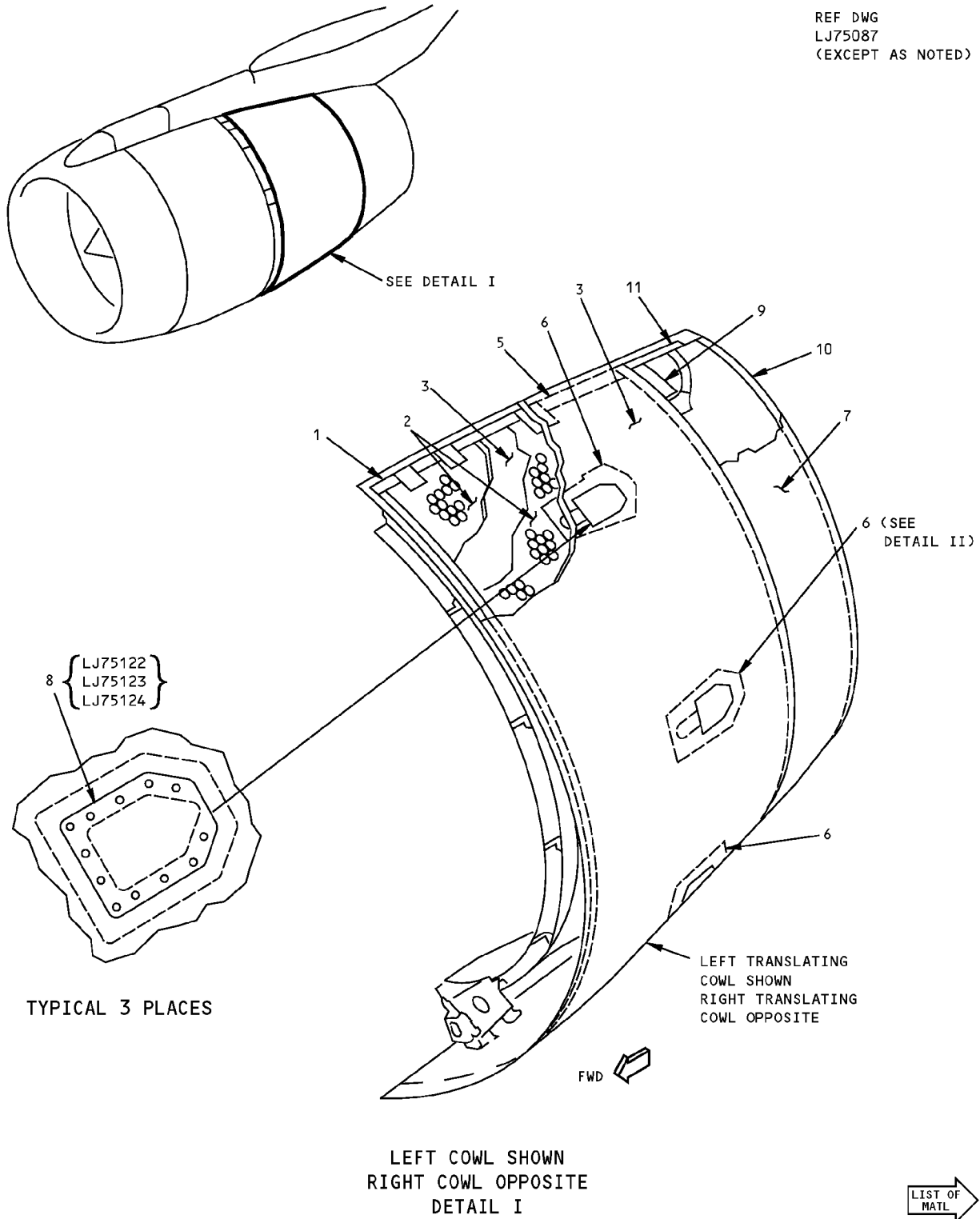

Reverser Cowl Skin Panel Identification - RB211-535E4 Engine
Figure 1 (Sheet 2 of 4)

757-200
STRUCTURAL REPAIR MANUAL

REF DWG
LJ75087
(EXCEPT AS NOTED)

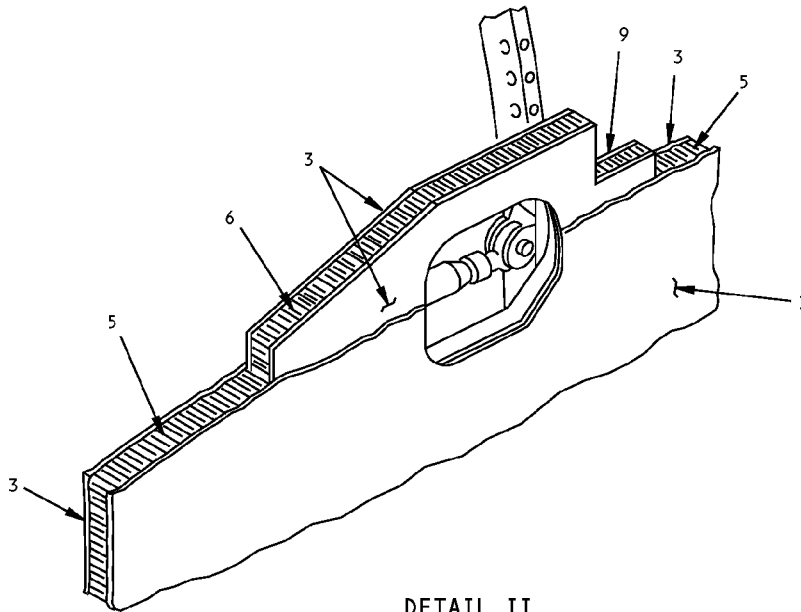

DETAIL II

ITEM	DESCRIPTION	GAGE	MATERIAL	EFFECTIVITY
1	CORE	0.592	5056 ALUM ALLOY HONEYCOMB, 6.1 LB PER CU FT, NONPERFORATED RMS 026 (MIL-A-81596) CLASS 2, TYPE 2	
2	CORE	0.620	5056 ALUM ALLOY HONEYCOMB, 3.1 LB PER CU FT, NONPERFORATED RMS 026 (MIL-A-81596) CLASS 2, TYPE 2	
3	SKIN (INNER/OUTER)		GRAPHITE FABRIC LAMINATE RMS 060 GROUP 1, TYPE 2, CLASS 1, GRADE 1 B SEE DETAIL III	
4	CORE	0.508	5052 ALUM ALLOY HONEYCOMB, 22 LB PER CU FT, NONPERFORATED RMS 026 (MIL-A-81596) CLASS 2, TYPE 1	
5	CORE	0.620	5056 ALUM ALLOY HONEYCOMB, 6.1 LB PER CU FT, NONPERFORATED RMS 026 (MIL-A-81596) CLASS 2, TYPE 2	
6	CORE	0.564	5056 ALUM ALLOY HONEYCOMB, 6.1 LB PER CU FT, NONPERFORATED RMS 026 (MIL-A-81596) CLASS 2, TYPE 2	
7	SKIN	0.080	2024-0 CLAD ALUM SHEET PER QQ-A-250/5 TEMP 0 (HEAT TREAT TO T-62)	
8	PANEL	0.125	2024-T3 CLAD ALUM SHEET PER QQ-A-250/5 (CHEM-MILLED)	
9	CORE	0.480	5052 ALUM ALLOY HONEYCOMB, 22 LB PER CU FT NONPERFORATED RMS 026 (MIL-A-81596) CLASS 2, TYPE 1	
10	TRAILING EDGE	0.135	2024-0 CLAD ALUM SHEET PER QQ-A-200/3 (HEAT TREAT TO T-62)	
11	CLOSURE	0.050	2024-0 CLAD ALUM SHEET PER QQ-A-225/6	

LIST OF MATERIALS FOR DETAILS I AND II

Reverser Cowl Skin Panel Identification - RB211-535E4 Engine
Figure 1 (Sheet 3 of 4)

IDENTIFICATION 2
Page 3
Jan 20/2005

54-30-01

D634N201

757-200
STRUCTURAL REPAIR MANUAL

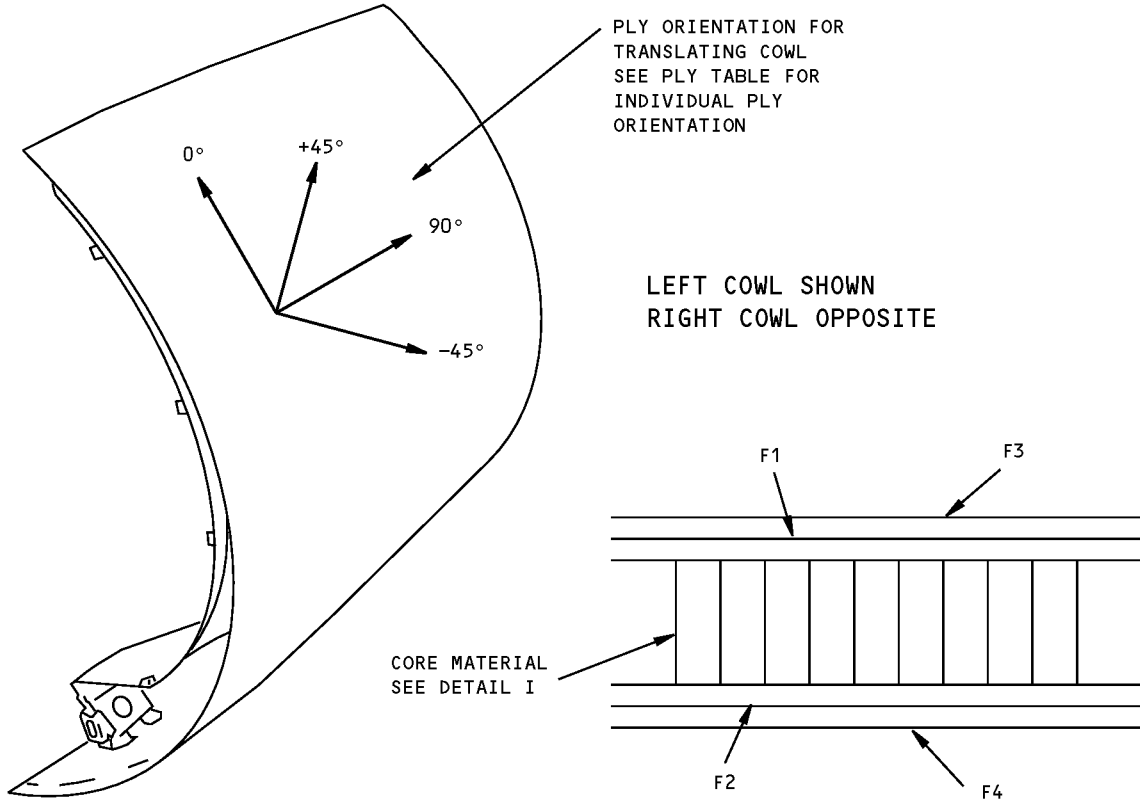

ITEM NO.	PLY NO.	MATERIAL	PLY ORIENTATION ^A
3	F1, F2, F3, F4	^B	0°

PLY TABLE

PLY ORIENTATION AND IDENTIFICATION
DETAIL III

Reverser Cowl Skin Panel Identification - RB211-535E4 Engine
Figure 1 (Sheet 4 of 4)

757-200
STRUCTURAL REPAIR MANUAL

IDENTIFICATION 3 - REVERSER COWL LATCH ACCESS DOORS - RB211-535E4 ENGINE

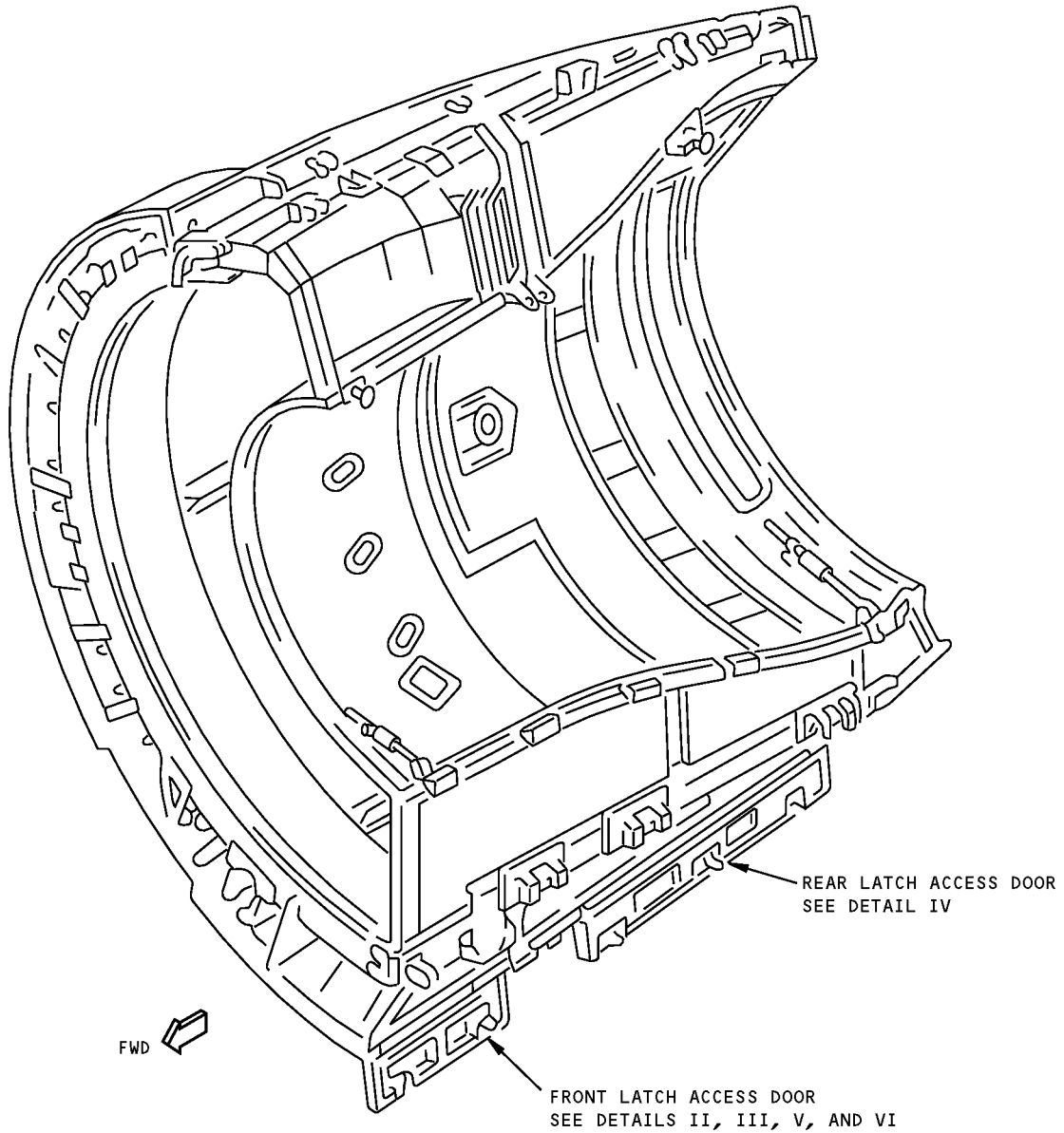

Reverser Cowl Latch Access Doors Identification - RB211-535E4 Engine
Figure 1 (Sheet 1 of 5)

757-200
STRUCTURAL REPAIR MANUAL

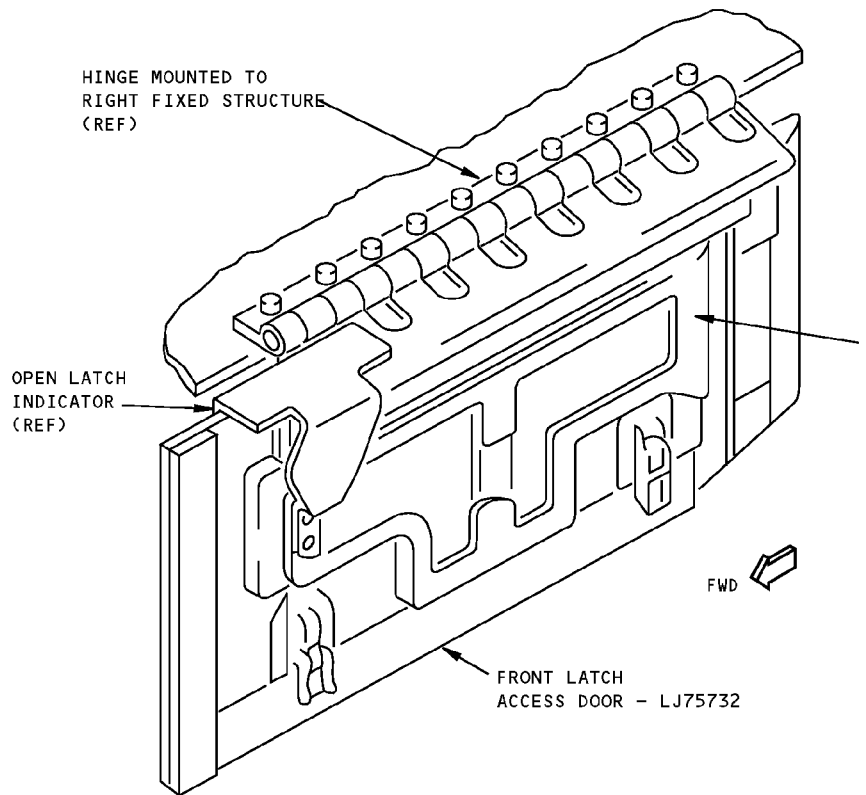

FOR AIRPLANES WITHOUT ROLLS-ROYCE SB 78-8930 INCORPORATED
DETAIL I

ITEM	DESCRIPTION	GAGE	MATERIAL	EFFECTIVITY
1	INNER AND OUTER SKIN PANEL		TITANIUM	

LIST OF MATERIALS FOR DETAIL I

Reverser Cowl Latch Access Doors Identification - RB211-535E4 Engine
Figure 1 (Sheet 2 of 5)

757-200
STRUCTURAL REPAIR MANUAL

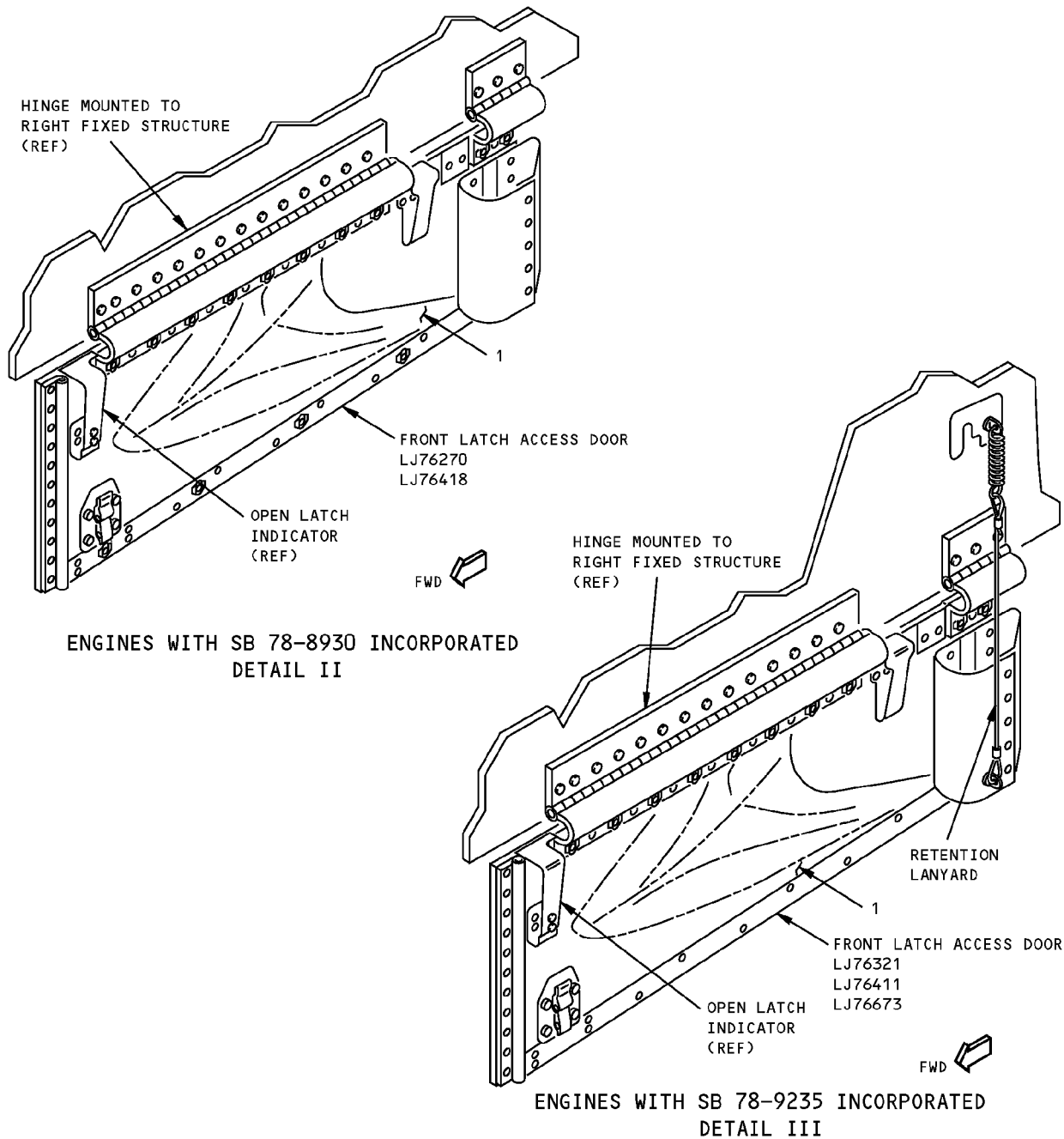

ENGINES WITH SB 78-8930 INCORPORATED
DETAIL II

ENGINES WITH SB 78-9235 INCORPORATED
DETAIL III

ITEM	DESCRIPTION	GAGE	MATERIAL	EFFECTIVITY
1	INNER AND OUTER SKIN PANEL	0.063	2219-0 ALUMINUM SHEET PER QQ-A-250/30 (HEAT TREAT TO -T62)	

LIST OF MATERIALS FOR DETAILS II AND III

Reverser Cowl Latch Access Doors Identification - RB211-535E4 Engine
Figure 1 (Sheet 3 of 5)

757-200
STRUCTURAL REPAIR MANUAL

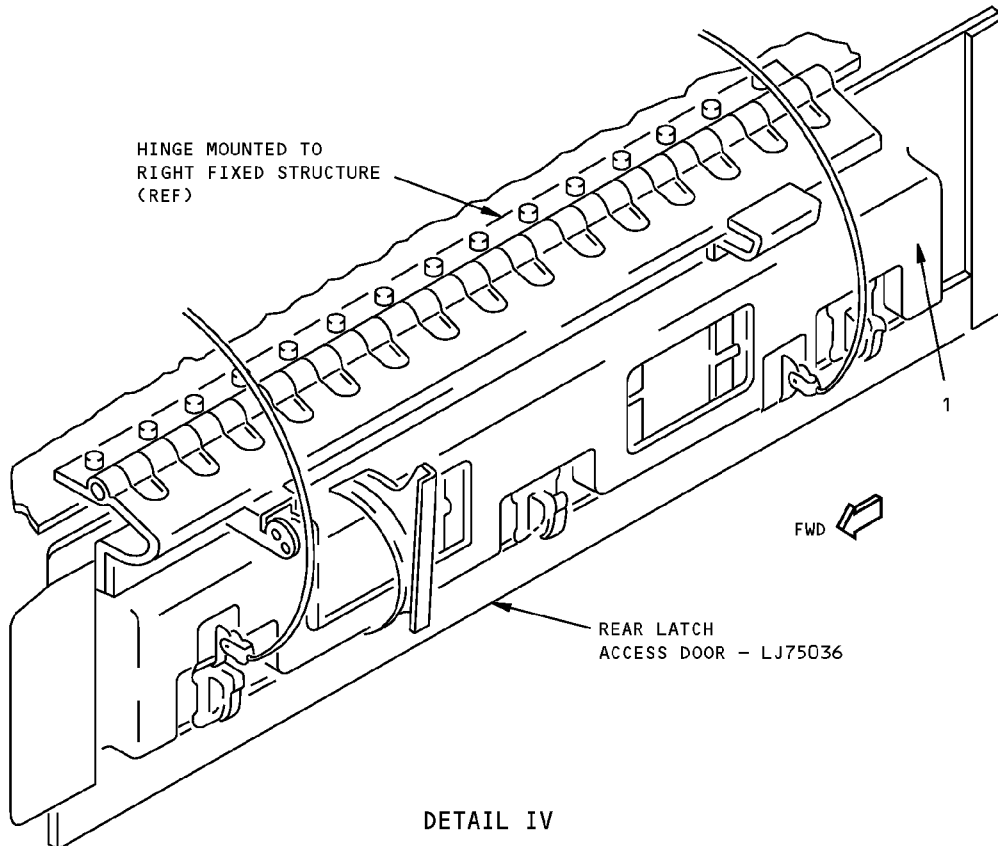

ITEM	DESCRIPTION	GAGE	MATERIAL	EFFECTIVITY
1	INNER AND OUTER SKIN PANEL		TITANIUM	

LIST OF MATERIALS FOR DETAIL IV

Reverser Cowl Latch Access Doors Identification - RB211-535E4 Engine
Figure 1 (Sheet 4 of 5)

757-200
STRUCTURAL REPAIR MANUAL

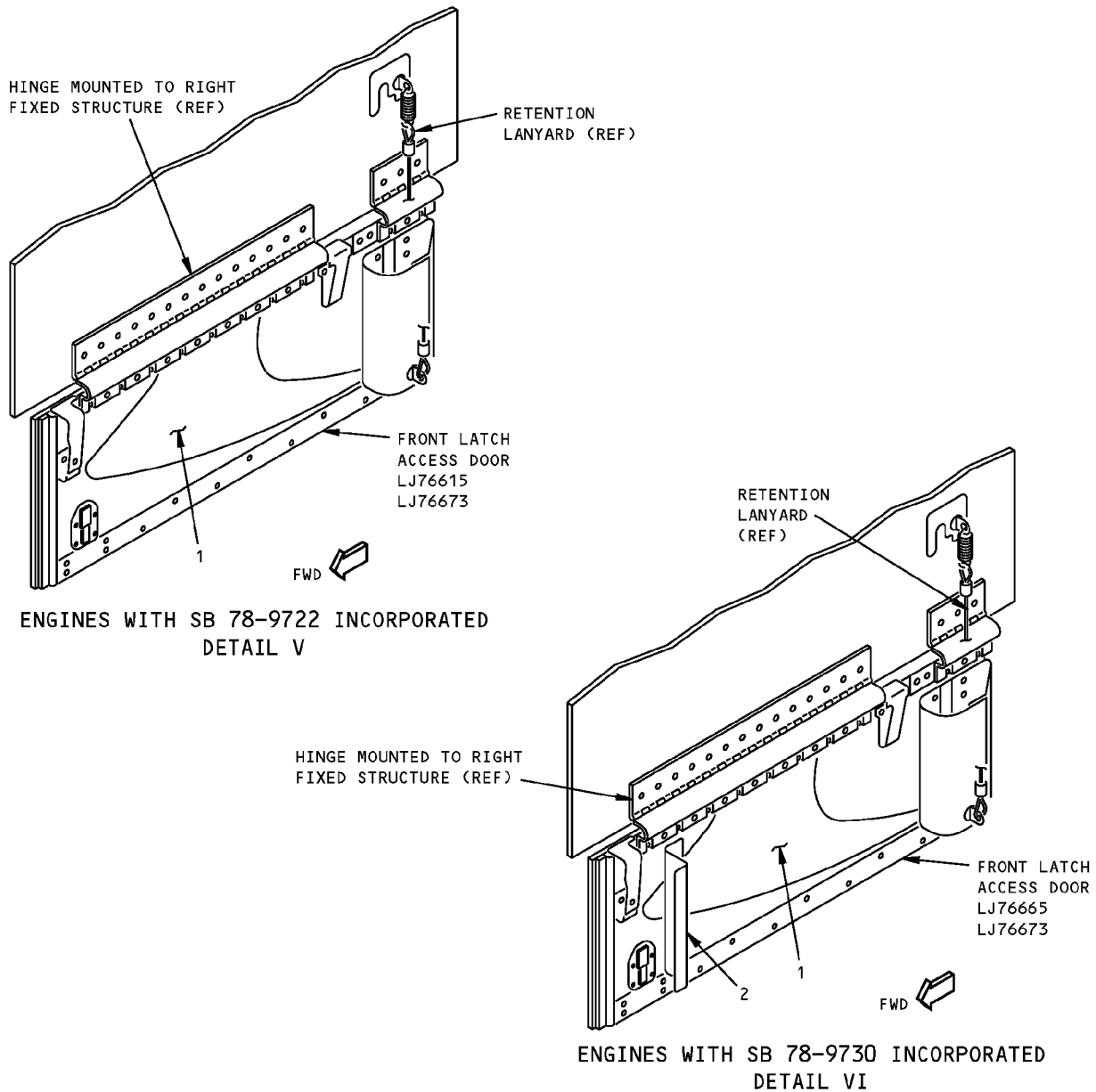

ITEM	DESCRIPTION	GAGE	MATERIAL	EFFECTIVITY
1	INNER AND OUTER SKIN PANEL	0.063	2219-0 ALUMINUM SHEET PER QQ-A-250/30 (HEAT TREAT TO -T62)	
2	STIFFENER		2219-0 ALUMINUM SHEET PER QQ-A-250/30 (HEAT TREAT TO -T62)	

LIST OF MATERIALS FOR DETAILS V AND VI

Reverser Cowl Latch Access Doors Identification - RB211-535E4 Engine
Figure 1 (Sheet 5 of 5)

757-200
STRUCTURAL REPAIR MANUAL

IDENTIFICATION 4 - REVERSER COWL SKIN PANEL - RB211-535C ENGINE

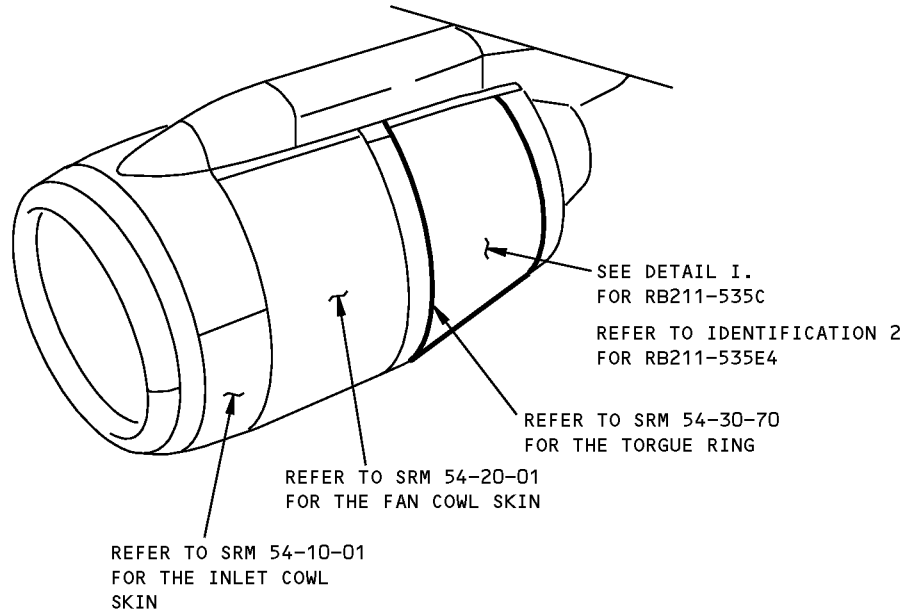

NOTES

- RMS-ROHR MATERIAL SPECIFICATION

- A** PLY ORIENTATION DEGREES INDICATED IS PARALLEL TO THE FABRIC WARP DIRECTION
- B** GRAPHITE FABRIC:
- AH-370-5H/3501-5A, AS4 FIBER, V10396
 - CYCOM 985-1, AS4 FIBER, V7945
 - EM 7198, CELION 6K-ST FIBER, V27129
 - R 922-1, CGG 108, CELION 6K FIBER, V30137

Reverser Cowl Skin Panel Identification - RB211-535C Engine
Figure 1 (Sheet 1 of 8)

757-200
STRUCTURAL REPAIR MANUAL

REF DWG
LJ70087
(EXCEPT AS NOTED)

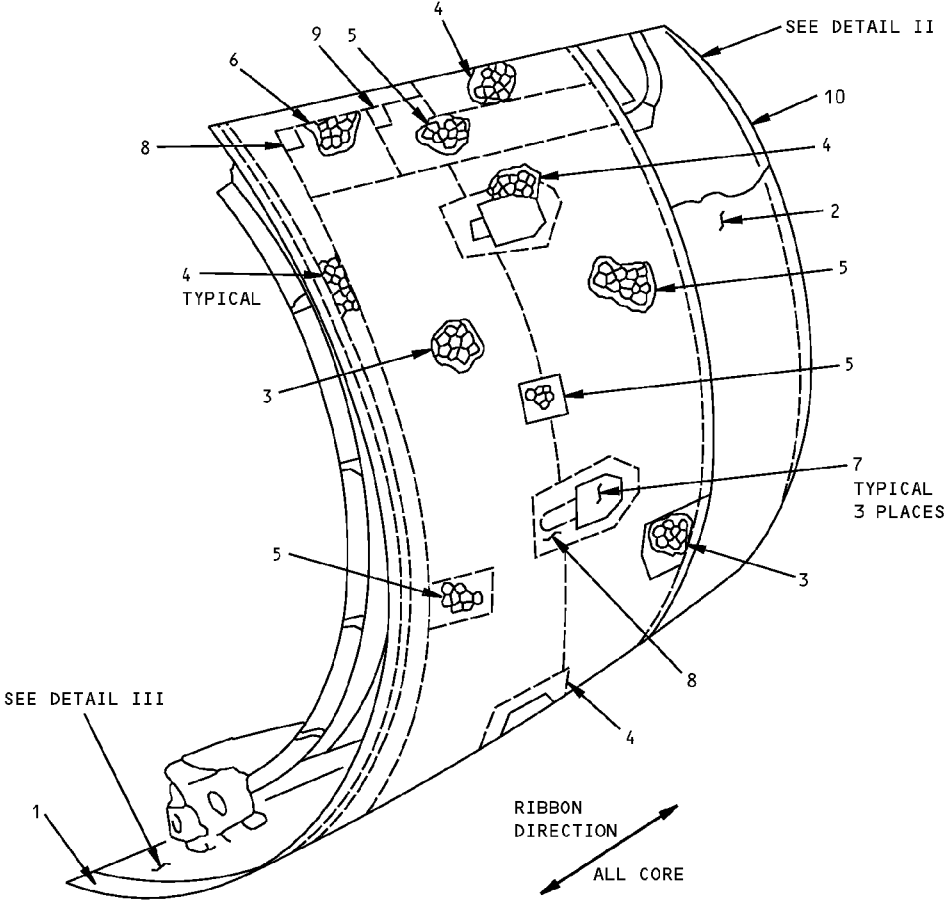

LEFT COWL SHOWN
RIGHT COWL OPPOSITE
DETAIL I



Reverser Cowl Skin Panel Identification - RB211-535C Engine
Figure 1 (Sheet 2 of 8)

IDENTIFICATION 4
Page 2
May 20/2005

54-30-01

D634N201

**757-200
STRUCTURAL REPAIR MANUAL**

ITEM	DESCRIPTION	GAGE	MATERIAL	EFFECTIVITY
1	INNER SKIN		SEE DETAIL III	
2	OUTER SKIN		SEE DETAIL II	
3	CORE	0.001	5056 ALUMINUM HONEYCOMB, NONPERFORATED, 1/4 HEXCELL	
4	CORE	0.002	5056 ALUMINUM HONEYCOMB, NONPERFORATED, 3/16 HEXCELL	
5	CORE	0.002	5056 ALUMINUM HONEYCOMB, NONPERFORATED, 3/8 HEXCELL	
6	CORE	0.002	5056 ALUMINUM HONEYCOMB, NONPERFORATED, 1/8 HEXCELL	
7	PANEL	0.090	2024-T3 CLAD	
8	CORE	0.187	5052 ALUM ALLOY HONEYCOMB 0.002 INCH FOIL, NONPERFORATED, RMS 026 (MIL-A-81596)	
9	POTTING COMPOUND	0.0045	PROSEAL 828 AND PROSEAL 840	
10	TRAILING EDGE		S700E 0327 EXT (ROHR) HT TR T-62	

LIST OF MATERIALS FOR DETAIL I

**Reverser Cowl Skin Panel Identification - RB211-535C Engine
Figure 1 (Sheet 3 of 8)**

D634N201

54-30-01

IDENTIFICATION 4
Page 3
May 20/2005

757-200
STRUCTURAL REPAIR MANUAL

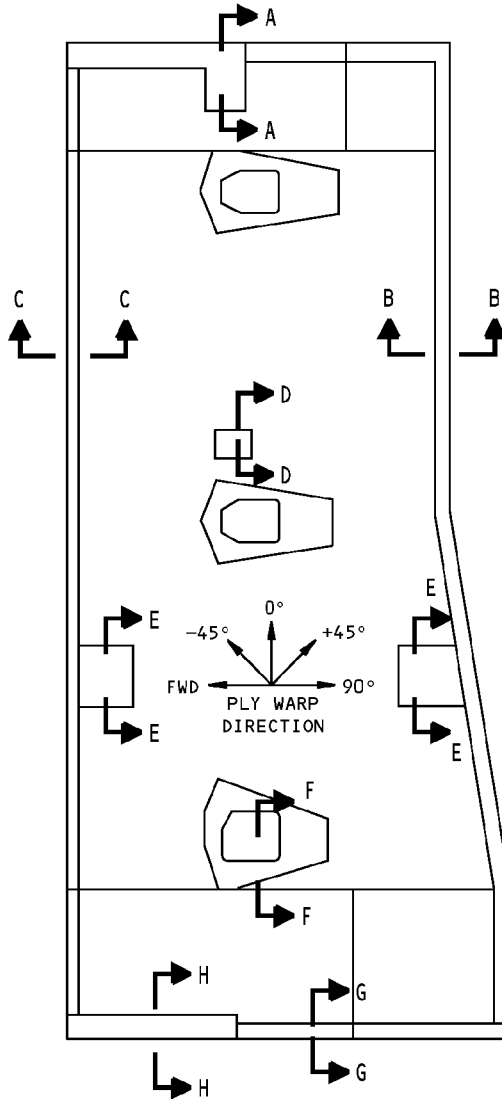

NOTE: SECTION VIEWS DO NOT NECESSARILY REPRESENT ACTUAL PANEL CONTOURS

OUTER SKIN LOOKING INBOARD
DETAIL II

ITEM NO.	PLY NO.	MATERIAL	PLY ORIENTATION ^[A]
2	F1, F3, F4, F5, F6, F7, F8, F9, F10, F11, F12, F13, F14, F15	[B]	0°

PLY TABLE

Reverser Cowl Skin Panel Identification - RB211-535C Engine
Figure 1 (Sheet 4 of 8)

757-200
STRUCTURAL REPAIR MANUAL

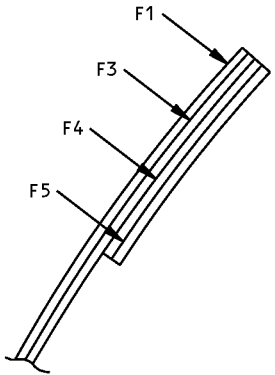

SECTION A-A

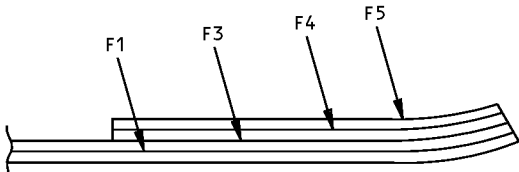

SECTION B-B

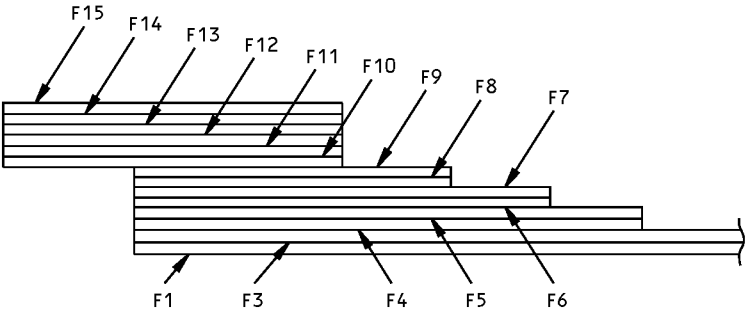

SECTION C-C

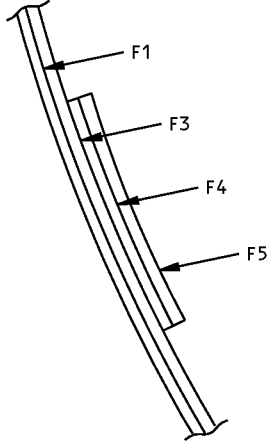

SECTION D-D

Reverser Cowl Skin Panel Identification - RB211-535C Engine
Figure 1 (Sheet 5 of 8)

757-200
STRUCTURAL REPAIR MANUAL

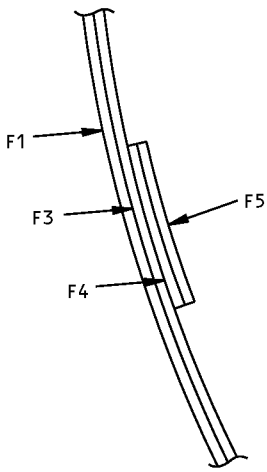

SECTION E-E

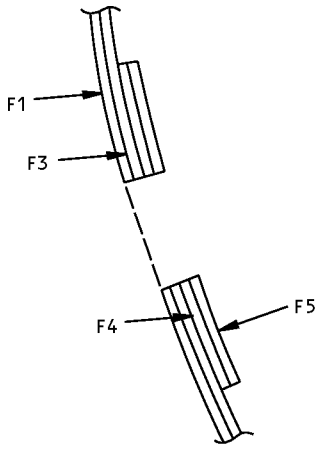

SECTION F-F

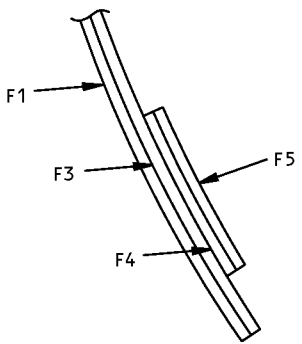

SECTION G-G

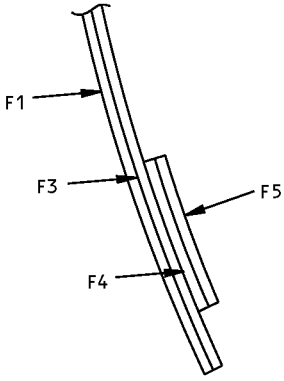

SECTION H-H

ITEM NO.	PLY NO.	MATERIAL	ORIENTATION A
2	F1, F3, F4, F5	B	0°

PLY TABLE

Reverser Cowl Skin Panel Identification - RB211-535C Engine
Figure 1 (Sheet 6 of 8)

757-200
STRUCTURAL REPAIR MANUAL

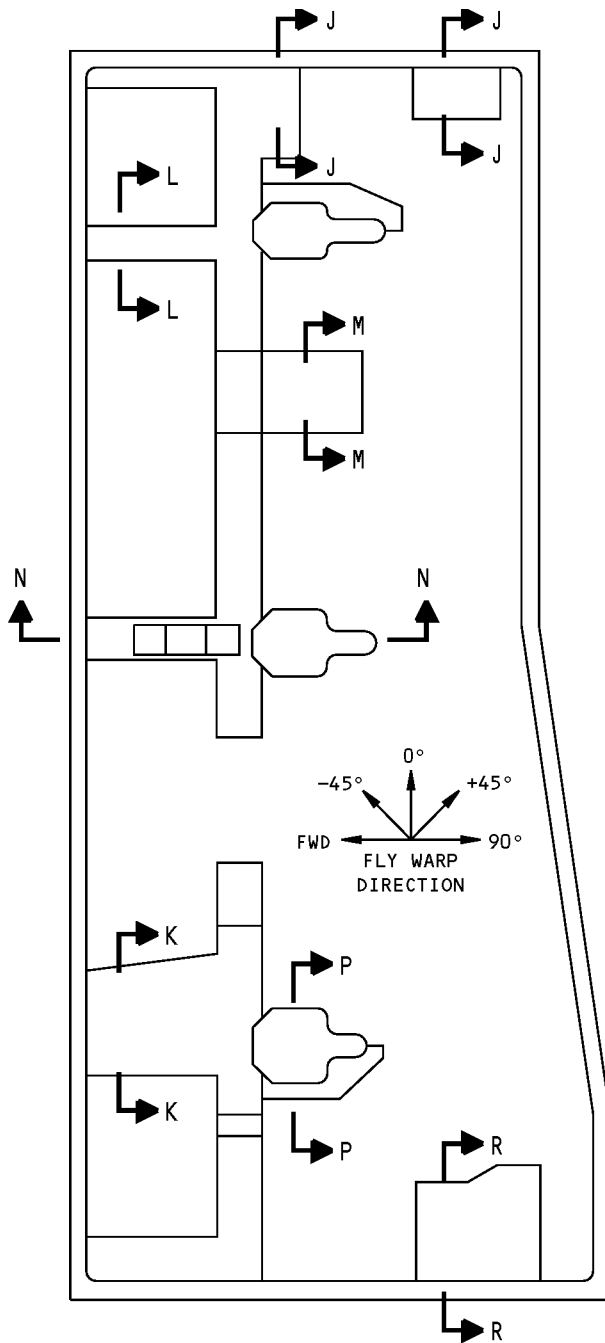

DETAIL III

NOTES

- INNER SKIN LOOKING OUTBOARD
- SECTION VIEWS DO NOT NECESSARILY REPRESENT ACTUAL PANEL CONTOURS

Reverser Cowl Skin Panel Identification - RB211-535C Engine
Figure 1 (Sheet 7 of 8)

757-200
STRUCTURAL REPAIR MANUAL

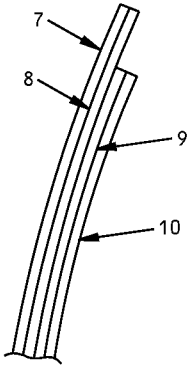

SECTION J-J

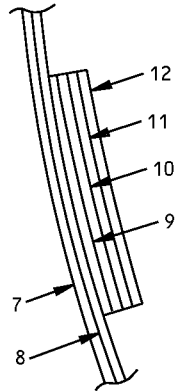

SECTION K-K

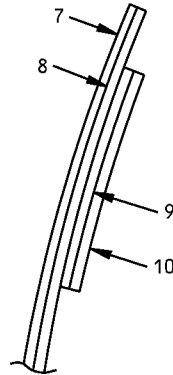

SECTION L-L

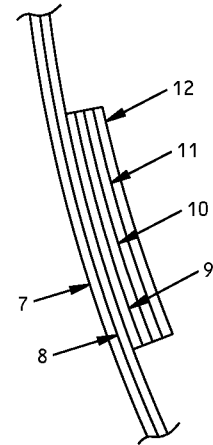

SECTION M-M

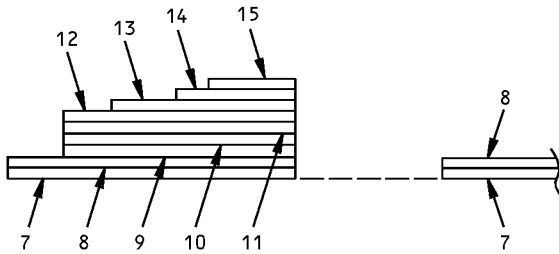

SECTION N-N

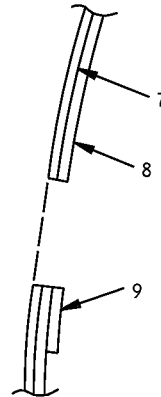

SECTION P-P

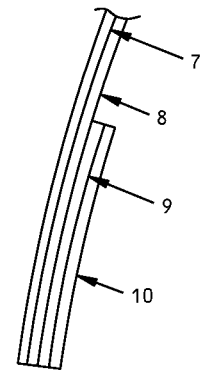

SECTION R-R

Reverser Cowl Skin Panel Identification - RB211-535C Engine
Figure 1 (Sheet 8 of 8)

757-200
STRUCTURAL REPAIR MANUAL

IDENTIFICATION 5 - REVERSER COWL LATCH ACCESS DOORS - RB211-535C ENGINE

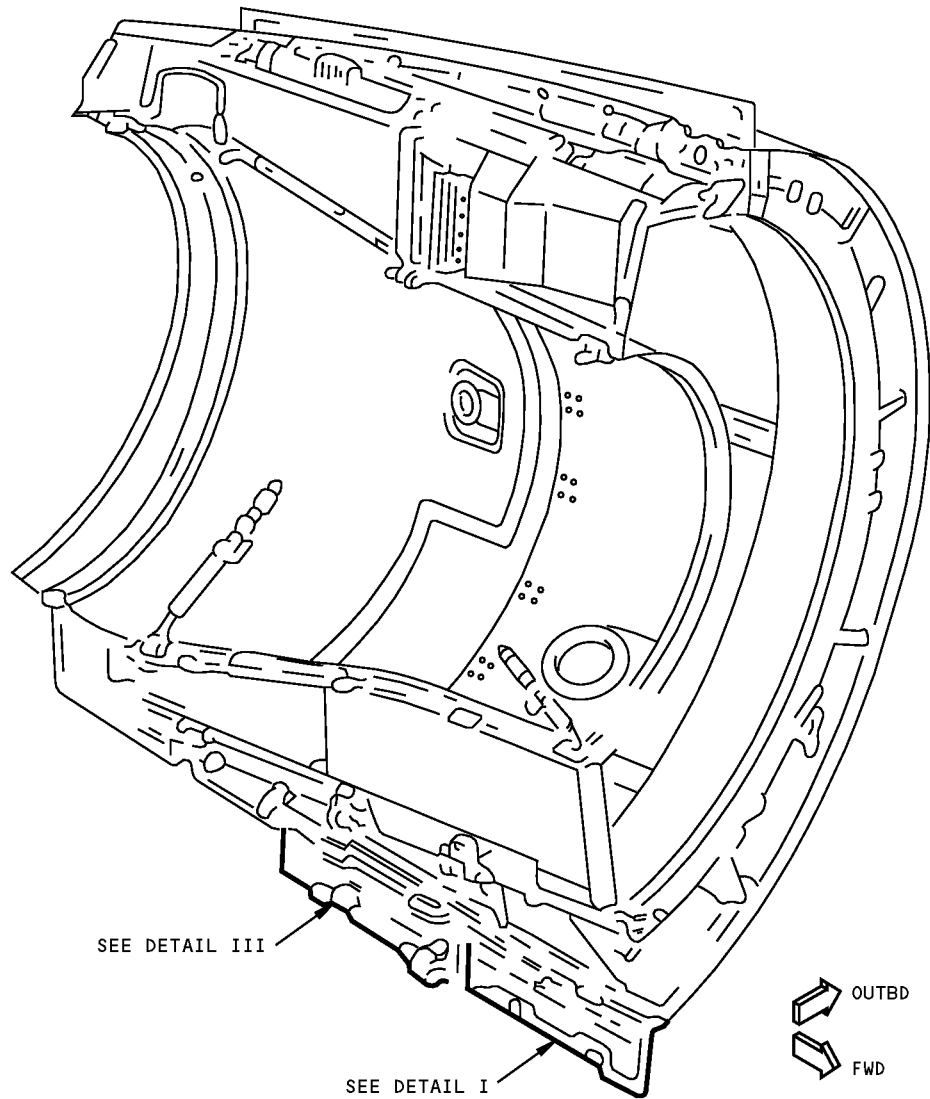

NOTES

- A** PLY ORIENTATION CONVENTION DEGREES INDICATED IS PARALLEL TO THE FABRIC WARP DIRECTION.
- B** GRAPHITE FABRIC, A-370-5H/3501-5A
- C** GRAPHITE TAPE, 3501-5A-AS-4
- D** POTTING COMPOUND PRO SEAL 828 AND PRO SEAL 840

Reverser Cowl Latch Access Doors - RB211-535C Engine
Figure 1 (Sheet 1 of 5)

757-200
STRUCTURAL REPAIR MANUAL

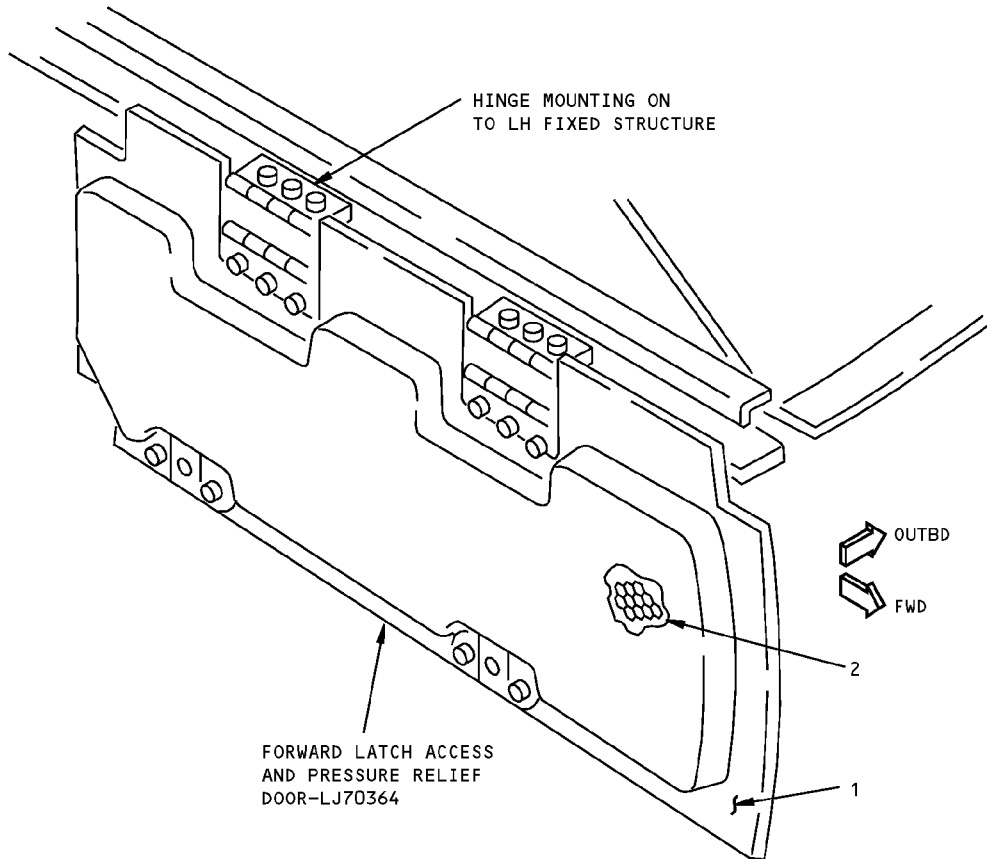

FWD LATCH ACCESS DOOR
DETAIL I

ITEM	DESCRIPTION	GAGE	MATERIAL	EFFECTIVITY
1	INNER AND OUTER SKIN PANEL		EPOXY/GRAPHITE FABRIC (SEE DETAIL II)	
2	CORE		5056 ALUMINUM ALLOY HONEYCOMB 1/2 INCH X 0.002 NONPERFORATED	

LIST OF MATERIALS FOR DETAIL I

Reverser Cowl Latch Access Doors - RB211-535C Engine
Figure 1 (Sheet 2 of 5)

757-200
STRUCTURAL REPAIR MANUAL

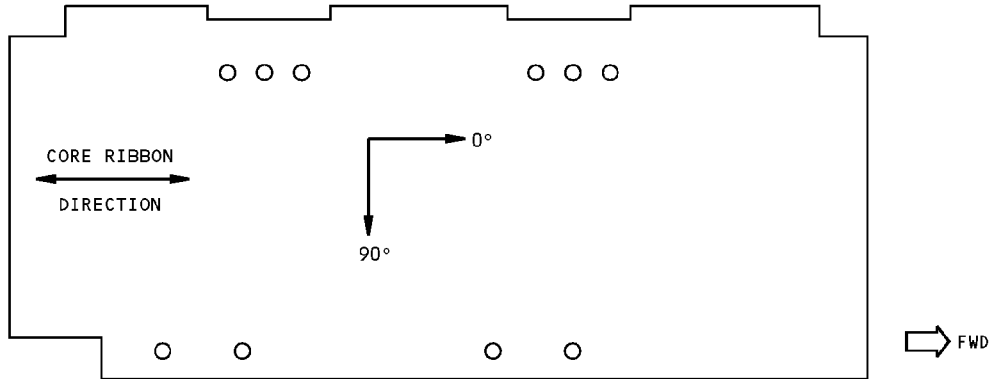
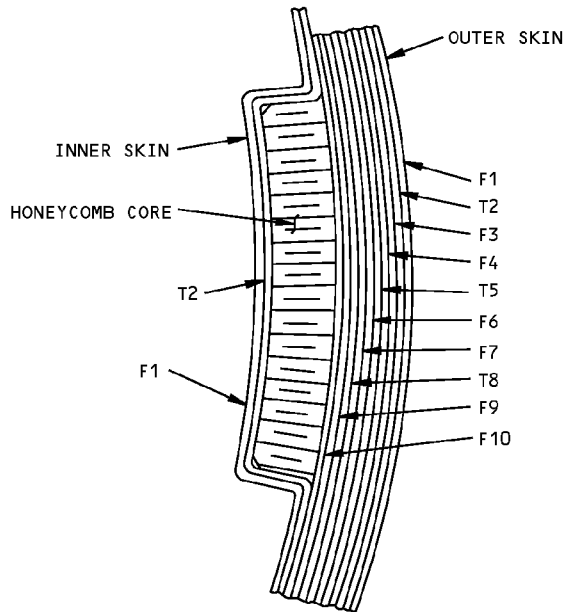

DIAGRAM OF PLY ORIENTATION.
SEE PLY TABLE FOR INDIVIDUAL PLY ORIENTATION AND MATERIAL

FWD LATCH ACCESS PANEL
VIEW ON DOOR PANEL
DETAIL II



SECTION THRU HONEYCOMB

ITEM NO.	PLY NO.	MATERIAL	PLY ORIENTATION ^[A]
1	F1, F3, F4, F6, F7, F9, F10	[B]	0°
	T2, T5, T8	[C]	0°

PLY TABLE FOR DETAIL II

Reverser Cowl Latch Access Doors - RB211-535C Engine
Figure 1 (Sheet 3 of 5)

757-200
STRUCTURAL REPAIR MANUAL

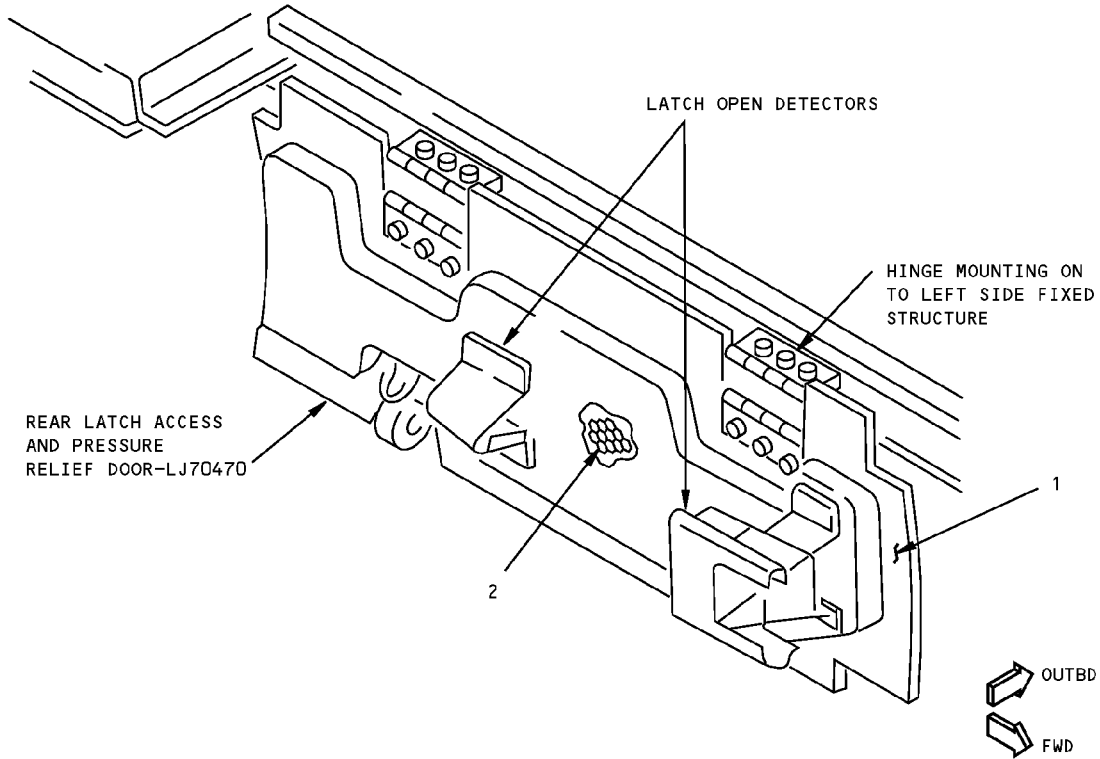

DETAIL III

ITEM	DESCRIPTION	GAGE	MATERIAL	EFFECTIVITY
1	INNER AND OUTER SKIN PANEL		EPOXY/GRAPHITE FABRIC (SEE DETAIL IV)	
2	CORE		5056 ALUMINUM ALLOY HONEYCOMB NONPERFORATED 1/8 HEX CELL	

LIST OF MATERIALS FOR DETAIL III

Reverser Cowl Latch Access Doors - RB211-535C Engine
Figure 1 (Sheet 4 of 5)

757-200
STRUCTURAL REPAIR MANUAL

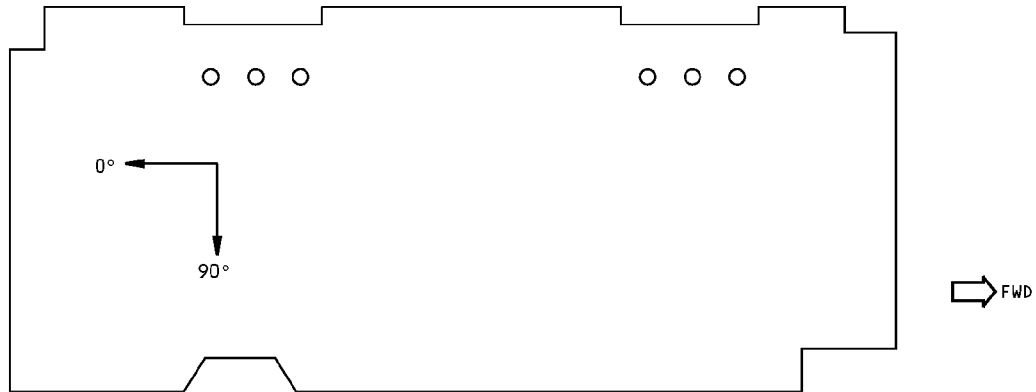
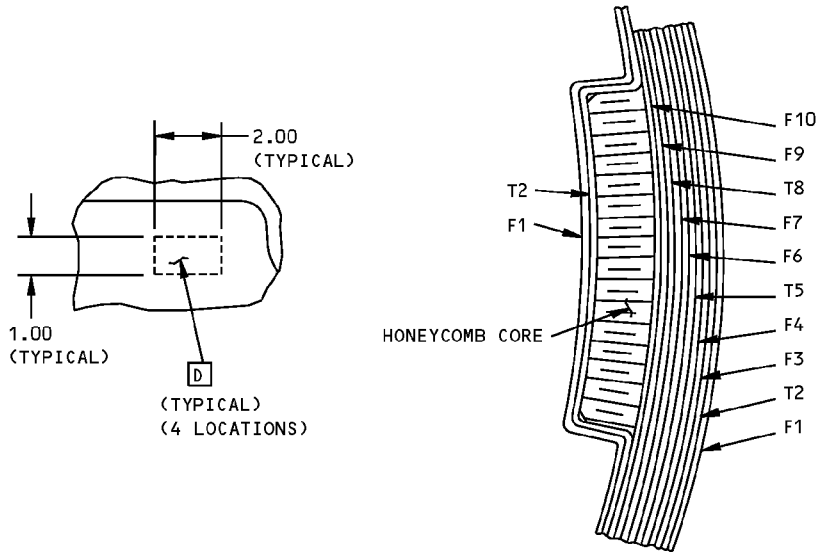

DIAGRAM OF PLY ORIENTATION.
SEE PLY TABLE FOR INDIVIDUAL PLY ORIENTATION AND MATERIAL

VIEW ON DOOR PANEL
DETAIL IV



SECTION THRU HONEYCOMB PANEL

ITEM NO.	PLY NO.	MATERIAL	PLY ORIENTATION ^A
1	F1, F2, F3, F4, F6, F7, F9, F10	^B	0°
	T2, T5, T8	^C	0°

PLY TABLE FOR DETAIL IV

Reverser Cowl Latch Access Doors - RB211-535C Engine
Figure 1 (Sheet 5 of 5)

757-200
STRUCTURAL REPAIR MANUAL

ALLOWABLE DAMAGE 1 - REVERSER COWL SKIN - RB211-535 ENGINE

1. Damage Zones (Inner and Outer Skin)

A. Reverser Cowl Outer Panel

- (1) Zone 1: Panel flanges.
- (2) Zone 2: Any facing material at panel edges. The panel edges can be either outer panel perimeter or edge of access panel cutouts within the panel.
- (3) Zone 3: Areas of panel at attachment of sliders, latches and hold open support strut fixtures.
- (4) Zone 4: All areas not detailed in Zones 1, 2 and 3.

2. Allowable Damage Limits (Inner and Outer Skin)

A. Zone: 1, 2 and 3

- (1) Superficial surface damage not extending into graphite fibers.

B. Zone 4:

- (1) Superficial surface damage not extending into graphite fibers.
- (2) Surface abrasion with a maximum depth of 0.005 inch to an area not greater than 28 sq. inches.
- (3) A maximum of two cuts at a minimum spacing of 10 inches not more than 15 inches in length and 0.005 inch in depth.
- (4) A maximum of two holes at a minimum spacing of 10 inches and 1 inch maximum diameter that pierce the graphite composite skin through to the honeycomb core.

NOTE: The hole or holes must be temporarily covered with aluminum foil tape (Speed Tape) 3M-436 or equivalent. After a maximum of 25 hours, the damaged area must be repaired.

757-200
STRUCTURAL REPAIR MANUAL

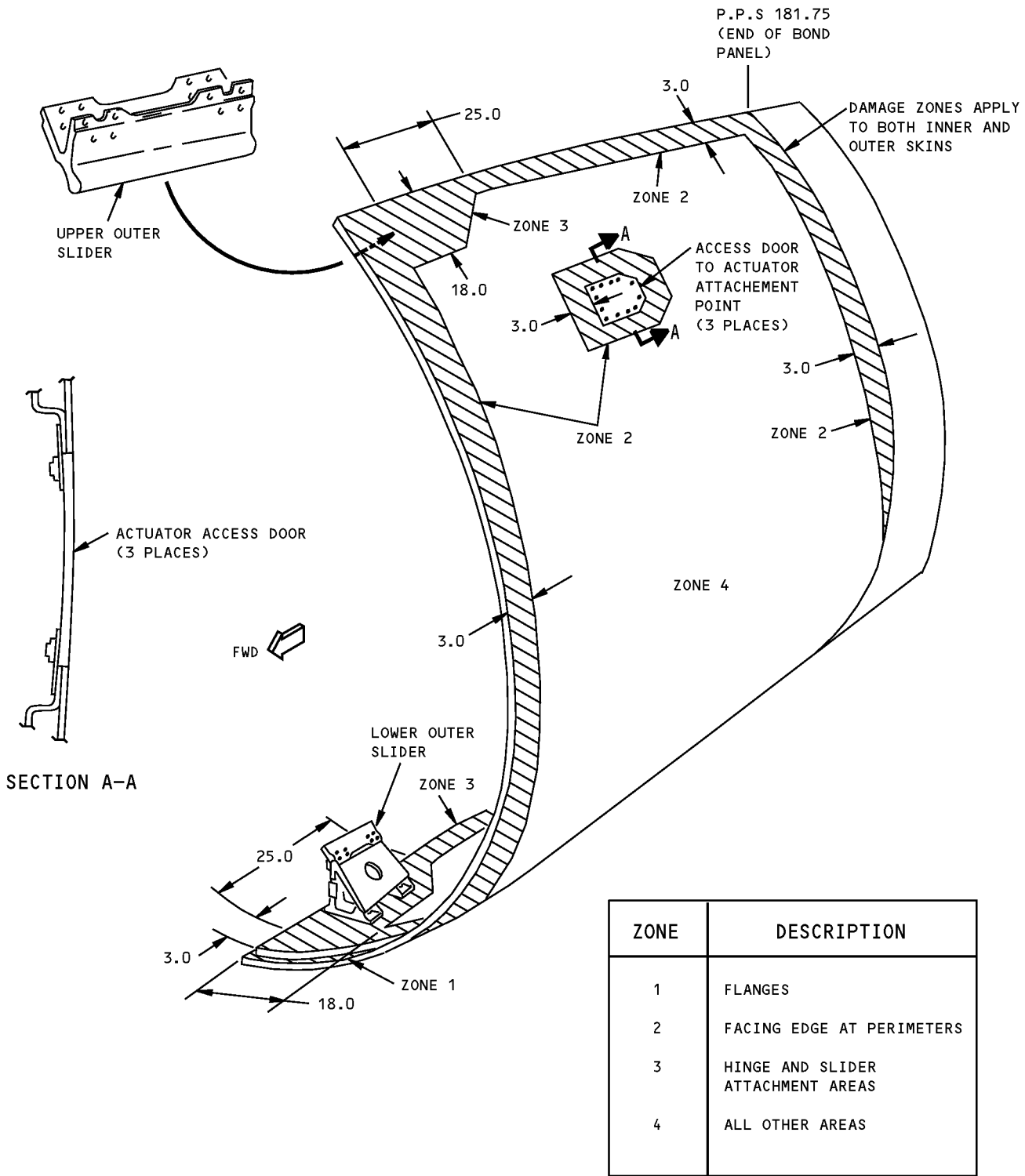

Reverser Cowl Skin Allowable Damage - RB211-535 Engine
Figure 101

757-200
STRUCTURAL REPAIR MANUAL

ALLOWABLE DAMAGE 2 - FAN DUCT NOZZLE - RB211-535 ENGINE

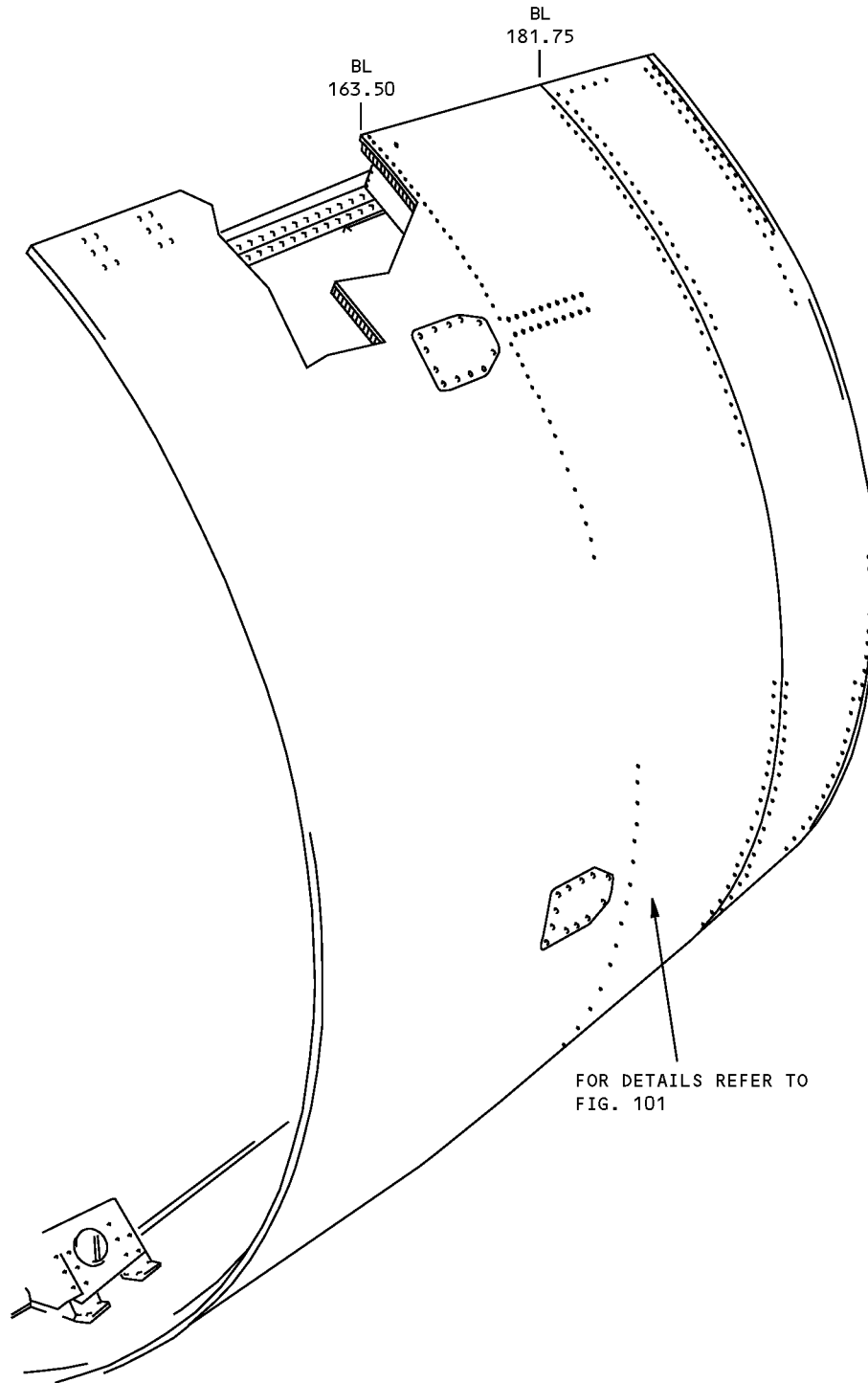

Fan Duct Nozzle Allowable Damage - RB211-535 Engine
Figure 101 (Sheet 1 of 4)

757-200
STRUCTURAL REPAIR MANUAL

DESCRIPTION	CRACKS	NICKS, GOUGES AND CORROSION	DENTS	HOLES AND PUNCTURES
TRAILING EDGE	A	B	SEE DETAIL III	C
ALUMINUM OUTER SKIN	A	B	SEE DETAIL III	C
ALUMINUM INNER SKIN	A	B	SEE DETAIL III	C

NOTES

- REFINISH REWORKED AREAS PER 51-20 OF THE MAINTENANCE MANUAL
- A** CRACKS NOT ALLOWED EXCEPT FOR EDGE CRACKS WHICH MUST BE REMOVED PER DETAILS I AND V
- B** REMOVE DAMAGE PER DETAILS I, II, IV, AND V
- C** CLEAN OUT DAMAGE UP TO 0.25 INCH MAXIMUM DIAMETER AND NOT CLOSER THAN 1.0 INCH TO FASTENER HOLE, MATERIAL EDGE, OR OTHER DAMAGE. FILL HOLE WITH A 2117-T3 OR T4 ALUMINUM RIVET INSTALLED WET WITH BMS 5-95 SEALANT. ALL OTHER HOLES MUST BE REPAIRED

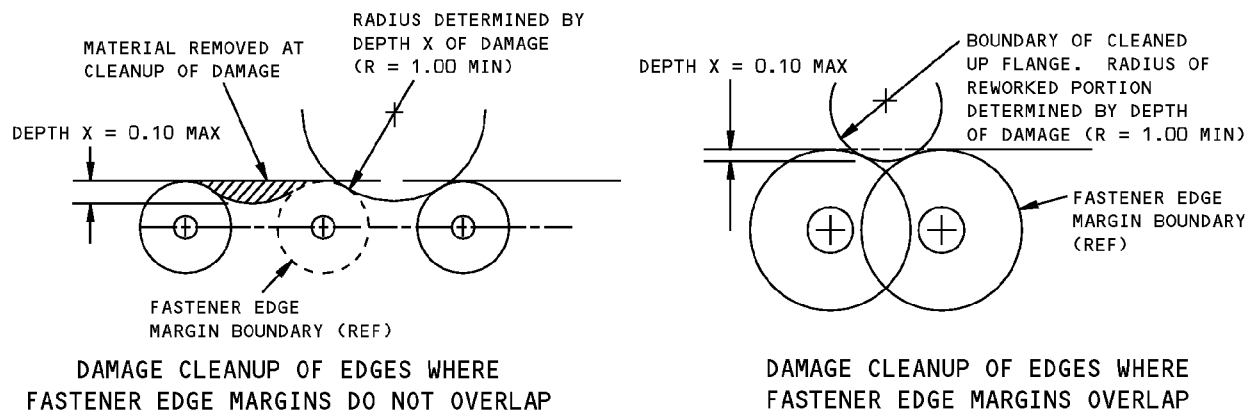

DETAIL I

Fan Duct Nozzle Allowable Damage - RB211-535 Engine
Figure 101 (Sheet 2 of 4)

757-200
STRUCTURAL REPAIR MANUAL

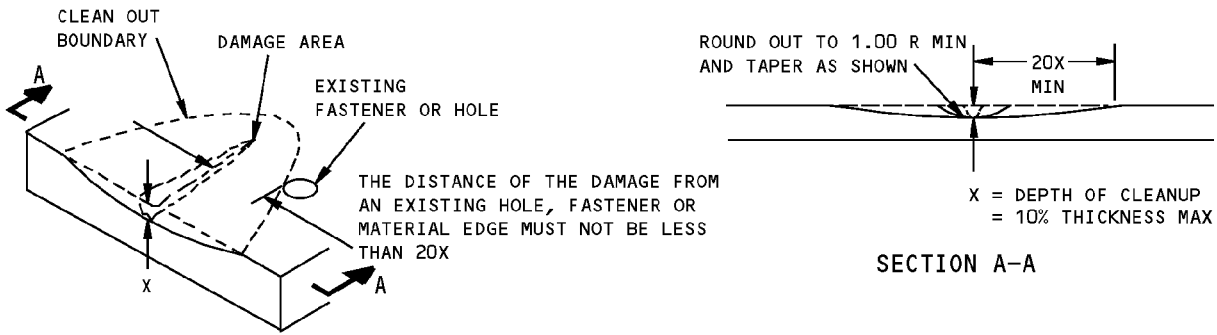

REMOVAL OF NICK, GOUGE AND SCRATCH DAMAGE ON A SURFACE
DETAIL II

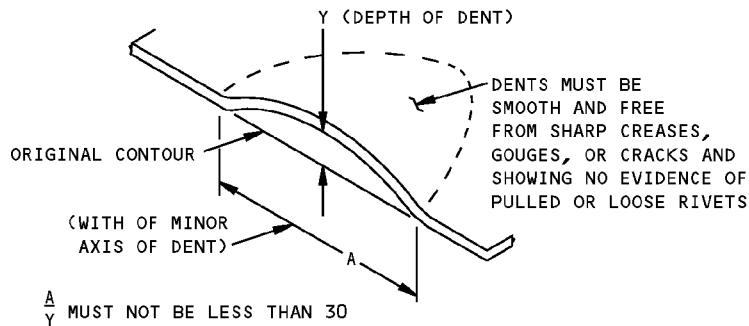

DETAIL III

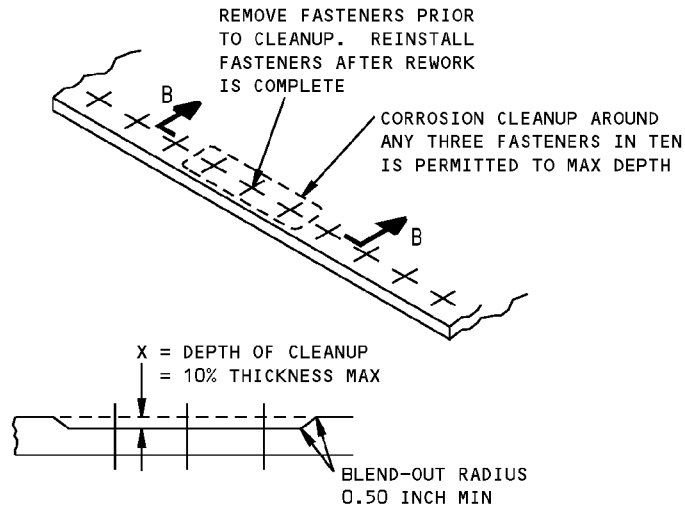

Fan Duct Nozzle Allowable Damage - RB211-535 Engine
Figure 101 (Sheet 3 of 4)

STRUCTURAL REPAIR MANUAL

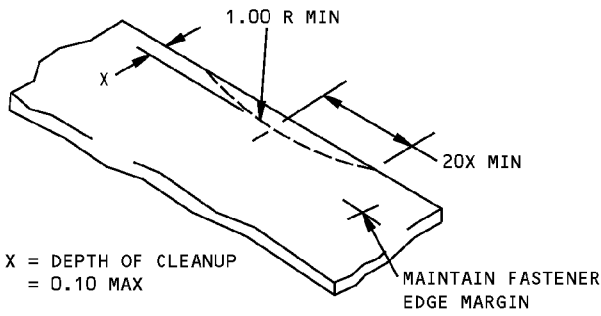

REMOVAL OF NICK OR CRACK DAMAGE ON AN EDGE

DETAIL V

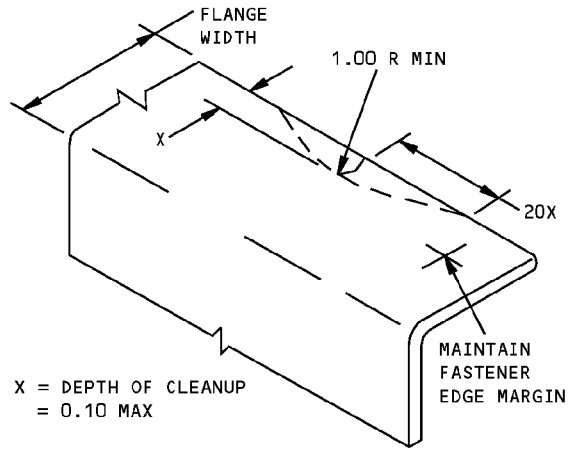

REMOVAL OF NICK OR CRACK DAMAGE ON AN EDGE

DETAIL VI

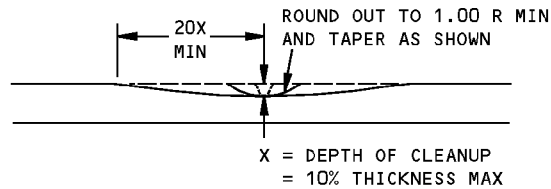
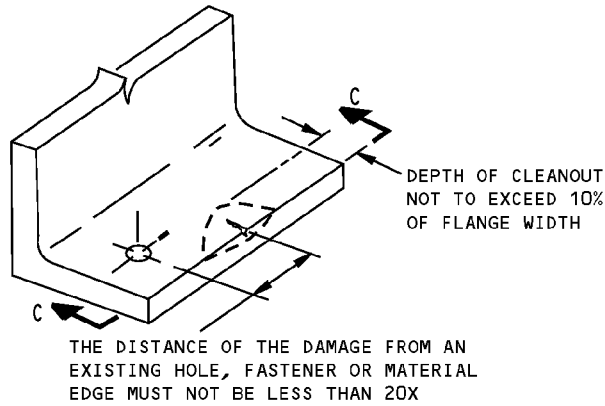

SECTION C-C

REMOVAL OF NICK OR CRACK DAMAGE ON AN EDGE

DETAIL VII

Fan Duct Nozzle Allowable Damage - RB211-535 Engine
Figure 101 (Sheet 4 of 4)

**757-200
STRUCTURAL REPAIR MANUAL**

ALLOWABLE DAMAGE 3 - REVERSER COWL HINGE ACCESS DOORS - RB211-535 ENGINE

REF DWG
LJ75087
(EXCEPT AS NOTED)

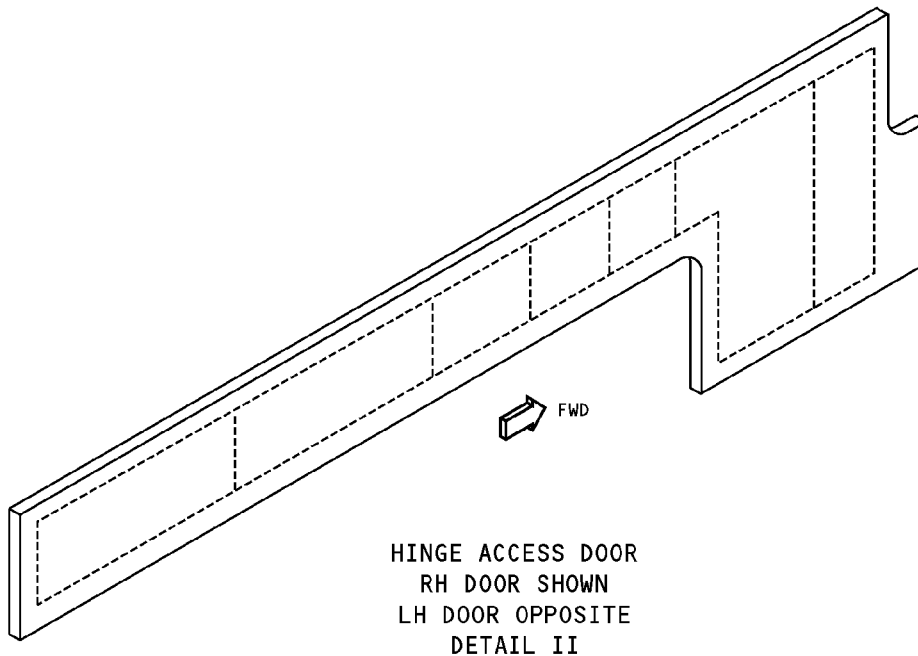
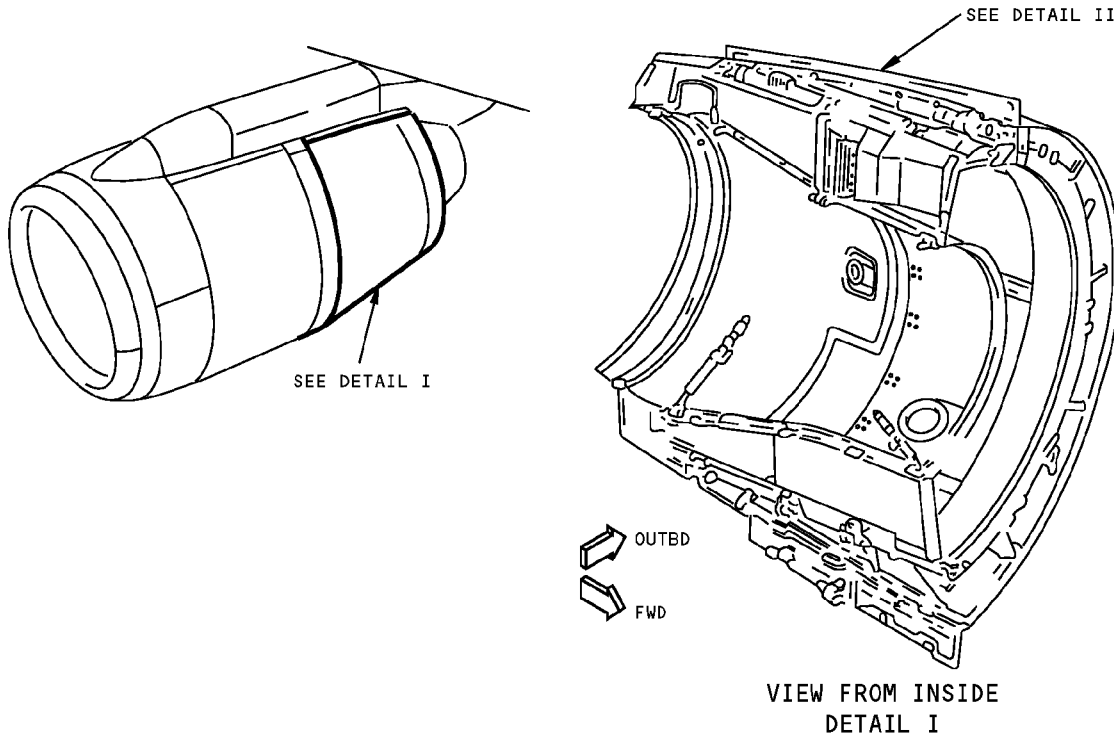

**Reverser Cowl Hinge Access Doors Allowable Damage - RB211-535 Engine
Figure 101 (Sheet 1 of 2)**

STRUCTURAL REPAIR MANUAL

DESCRIPTION	CRACKS	NICKS AND GOUGES	DENTS	HOLES AND PUNCTURES	DELAMINATION
PANEL	NOT PERMITTED	B	C	NOT PERMITTED	D

NOTES

- THESE ALLOWABLE DAMAGE LIMITS ARE FAA APPROVED CONTINGENT ON ACCOMPLISHMENT OF THE INSPECTIONS AT THE INTERVALS CONTAINED HEREIN.
- REFER TO SRM 51-11-01 FOR AERODYNAMIC SMOOTHNESS REQUIREMENTS. WHERE DAMAGE IS MORE THAN THE LIMITS SHOWN IN SRM 51-11-01. CONSIDERATION SHOULD BE GIVEN TO LOSS OF PERFORMANCE INVOLVED.
- REFINISH REWORKED AREAS AS SHOWN IN AMM 51-20.

- A** REMOVE MOISTURE FROM DAMAGE AREA. USE OF VACUUM AND HEAT (MAX OF 125°F (52°C)) TO REMOVE MOISTURE FROM HONEYCOMB CELLS IS RECOMMENDED. PROTECT DAMAGE FROM ENTRANCE OF WATER, SUNLIGHT OR OTHER FOREIGN MATTER BY SEALING WITH ALUMINUM FOIL TAPE (SPEED TAPE) 3M-Y346. RECORD THE LOCATION AND INSPECT EACH AIRPLANE 'A' CHECK. REPLACE THE ALUMINUM FOIL TAPE IF ANY PEELING OR DETERIORATION IS EVIDENT. REPAIR NO LATER THAN NEXT AIRPLANE 'C' CHECK.
- B** DAMAGE IS PERMITTED ON SURFACE RESIN ONLY WITH NO FIBER DAMAGE. CLEAN UP EDGE DAMAGE AS SHOWN IN DETAIL III.

- C** 0.5 INCH (12.7 mm) MAX DIAMETER IS PERMITTED IN THE HONEYCOMB AREA ONLY PROVIDED THERE IS NO DELAMINATION OR FIBER DAMAGE. ONE DENT FOR EACH SQUARE FOOT OF AREA ALLOWED AND A MINIMUM OF 10.0 INCHES (250 mm) FROM ANY OTHER DENT. DENTS GENERALLY INDICATE FIBER DAMAGE OR DELAMINATION. SEE **E** OR **F** IF SUCH DAMAGE IS PRESENT.
- D** 0.50 INCH (12.7 mm) MAX DIA IS PERMITTED IN HONEYCOMB AREA. A MAXIMUM OF 0.10 INCH (2.5 mm) DELAMINATION FROM EDGE IS PERMITTED. REPAIR DELAMINATION IN HONEYCOMB AREA NO LATER THAN THE NEXT 'C' CHECK. PROTECT EDGE DAMAGE AS SHOWN IN **A**.
- E** 0.50 INCH (12.7 mm) MAX DIA PERMITTED PROVIDED DAMAGE IS MIN OF 2.5 D FROM OTHER DAMAGE, NEAREST HOLE, OR MATERIAL EDGE. DO NOT CLEAN UP DAMAGE EXCEPT TO REMOVE RESIN BURRS EXTENDING INTO SURFACE CONTOUR **A**.
- F** 0.50 INCH (12.7 mm) MAX DIAMETER IN HONEYCOMB AREA AND NOT TO EXCEED 25% OF HONEYCOMB CORE LENGTH PER SIDE. A MAXIMUM OF 0.03 INCH (0.76 mm) DELAMINATION FROM EDGE IS ALLOWED. REPAIR DELAMINATION IN THE HONEYCOMB AREA AS SHOWN IN SRM 51-71 AND NO LATER THAN THE NEXT AIRPLANE 'C' CHECK. PROTECT EDGE DAMAGE AS SHOWN IN **A**.

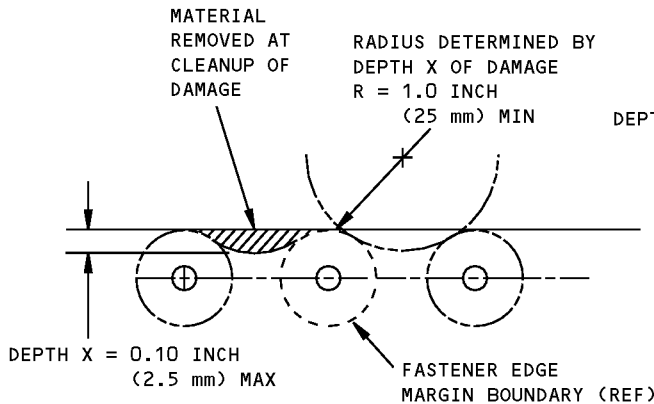

DAMAGE CLEANUP OF EDGES WHERE FASTENER EDGE MARGINS DO NOT OVERLAP

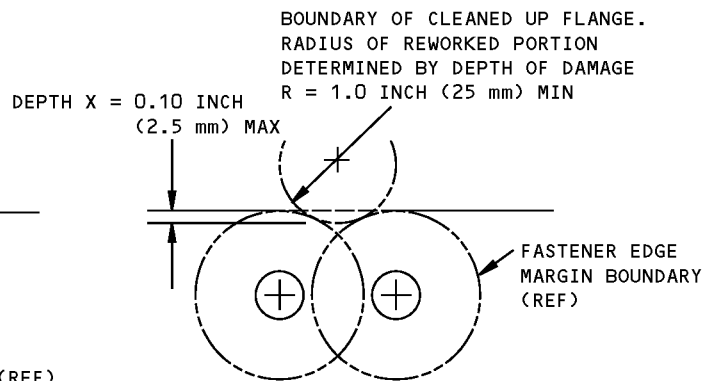

DAMAGE CLEANUP OF EDGES WHERE FASTENER EDGE MARGINS OVERLAP

DETAIL III

Reverser Cowl Hinge Access Doors Allowable Damage - RB211-535 Engine
Figure 101 (Sheet 2 of 2)

757-200
STRUCTURAL REPAIR MANUAL

ALLOWABLE DAMAGE 4 - REVERSER COWL LATCH ACCESS DOORS - RB211-535E4 ENGINE

REF DWG
LJ75087
(EXCEPT AS NOTED)

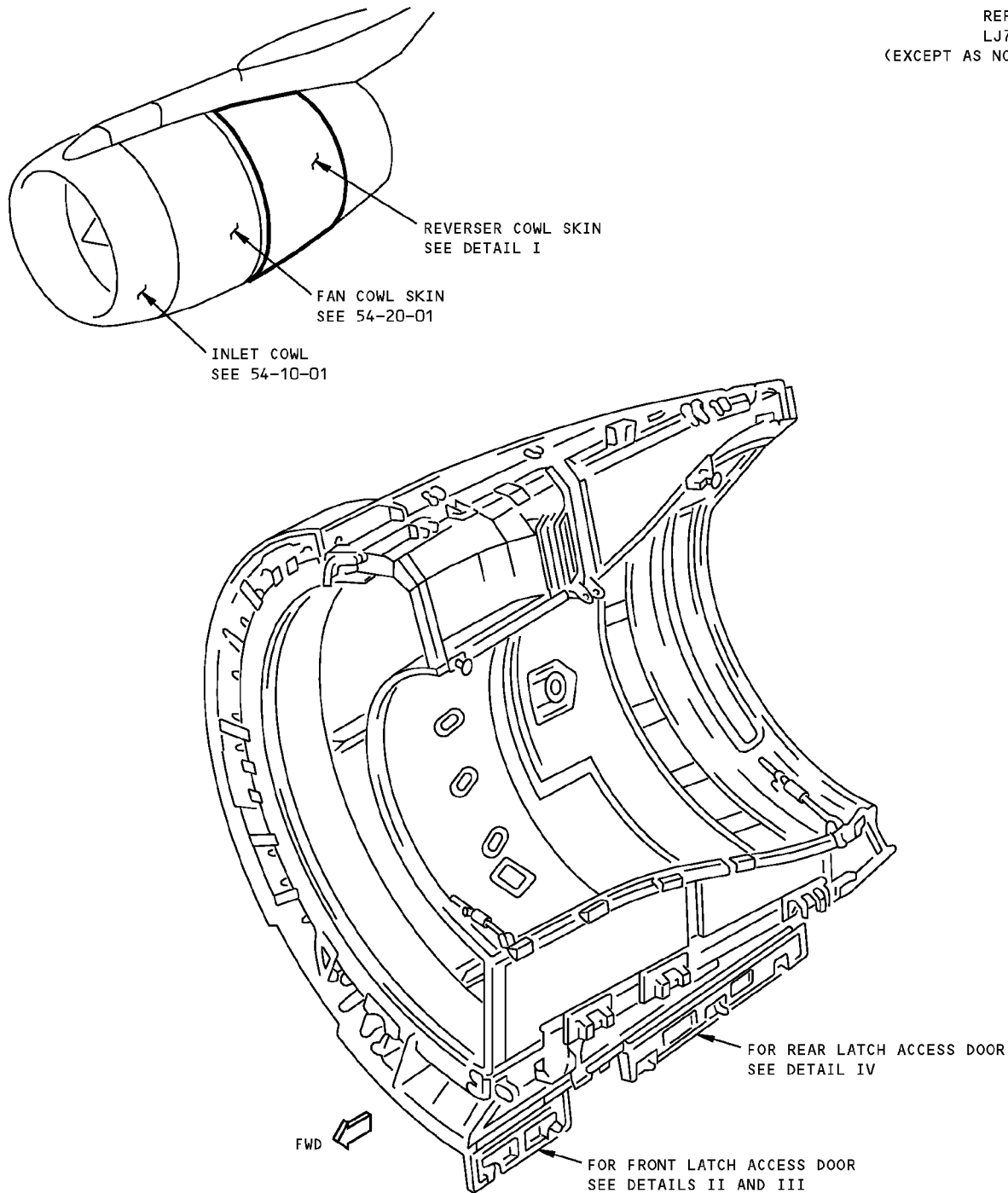

DETAIL I

Reverser Cowl Latch Access Doors Allowable Damage - RB211-535E4 Engine
Figure 101 (Sheet 1 of 4)

ALLOWABLE DAMAGE 4
Page 101
May 20/2005

54-30-01

D634N201

757-200
STRUCTURAL REPAIR MANUAL

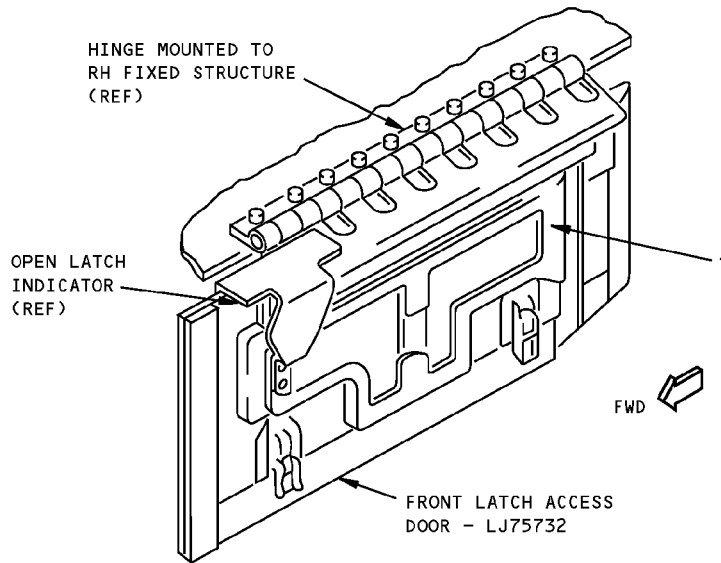

FOR AIRPLANES WITHOUT ROLLS-ROYCE SB 78-8930 INCORPORATED
DETAIL II

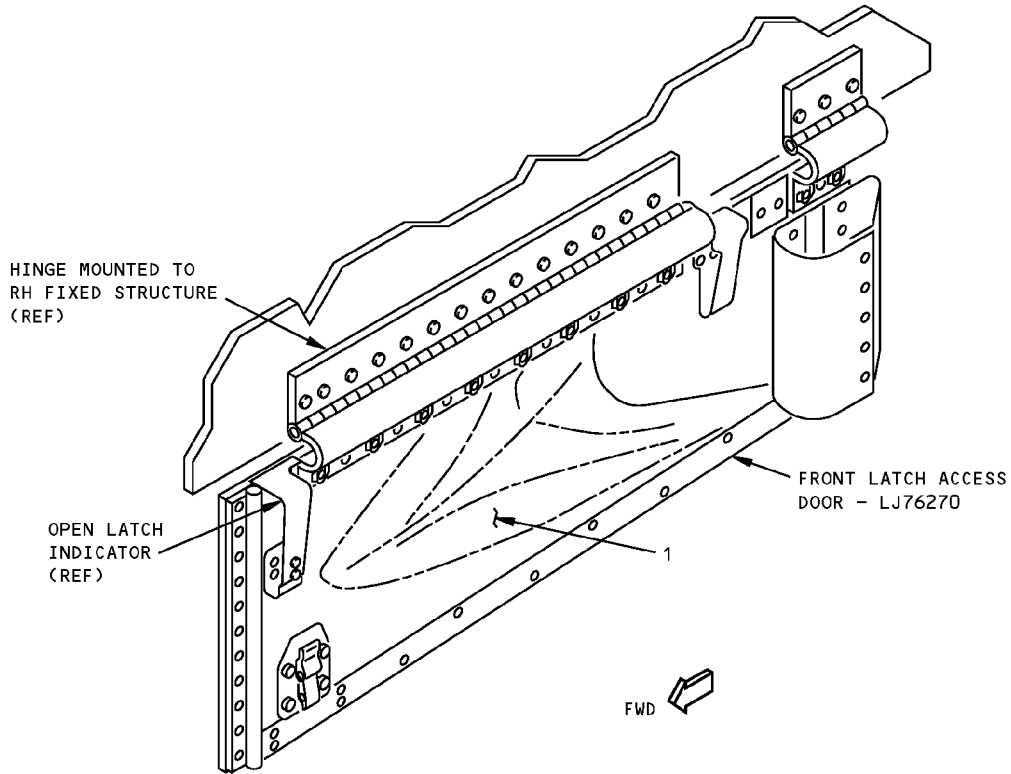

FOR AIRPLANES WITH ROLLS-ROYCE SB 78-8930 INCORPORATED
DETAIL III

Reverser Cowl Latch Access Doors Allowable Damage - RB211-535E4 Engine
Figure 101 (Sheet 2 of 4)

757-200
STRUCTURAL REPAIR MANUAL

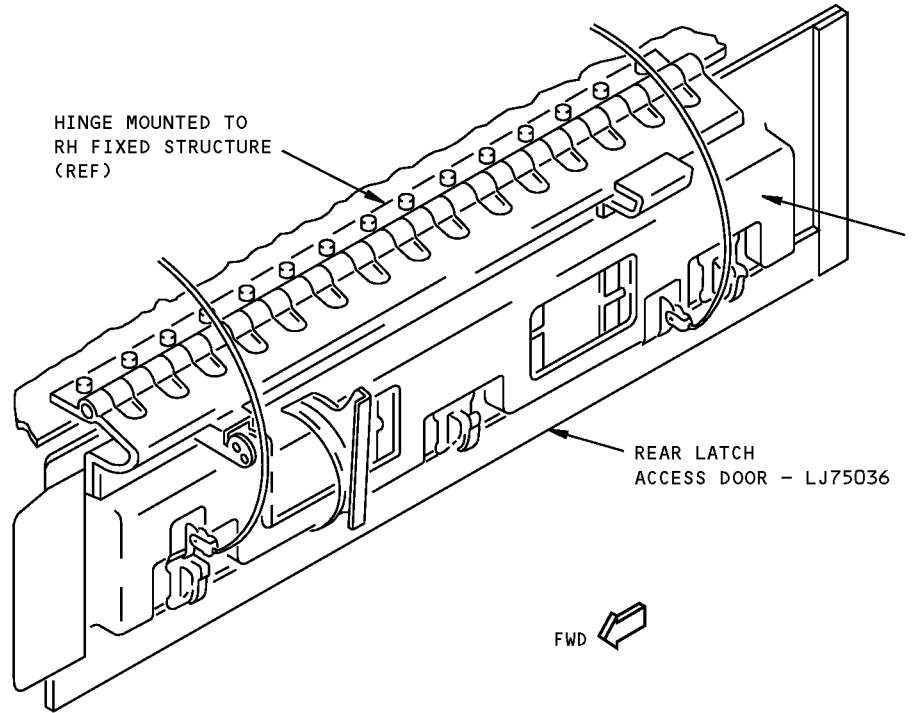

DETAIL IV

Reverser Cowl Latch Access Doors Allowable Damage - RB211-535E4 Engine
Figure 101 (Sheet 3 of 4)

757-200
STRUCTURAL REPAIR MANUAL

Allowable Damage Limits (All Areas of Front and Rear Latch Access Door Skins)

- (1) Superficial surface damage of nicks with a maximum depth of 0.025 inches and a diameter of 0.25 inches.
- (2) Gouges 0.010 maximum depth and maximum length of 4.0 inches long.
- (3) A maximum of three round bottom dents per door 0.080 inches deep.
- (4) A maximum of two cracks per door at a minimum spacing of 5.0 inches, edge to edge, and not more than 1.0 inch long after stop drilling.
- (5) No holes allowed, except for stop drill holes.

Reverser Cowl Latch Access Doors Allowable Damage - RB211-535E4 Engine
Figure 101 (Sheet 4 of 4)

**757-200
STRUCTURAL REPAIR MANUAL**

ALLOWABLE DAMAGE 5 - REVERSER COWL LATCH ACCESS DOORS - RB211-535C ENGINE

REF DWG
LJ75087
(EXCEPT AS NOTED)

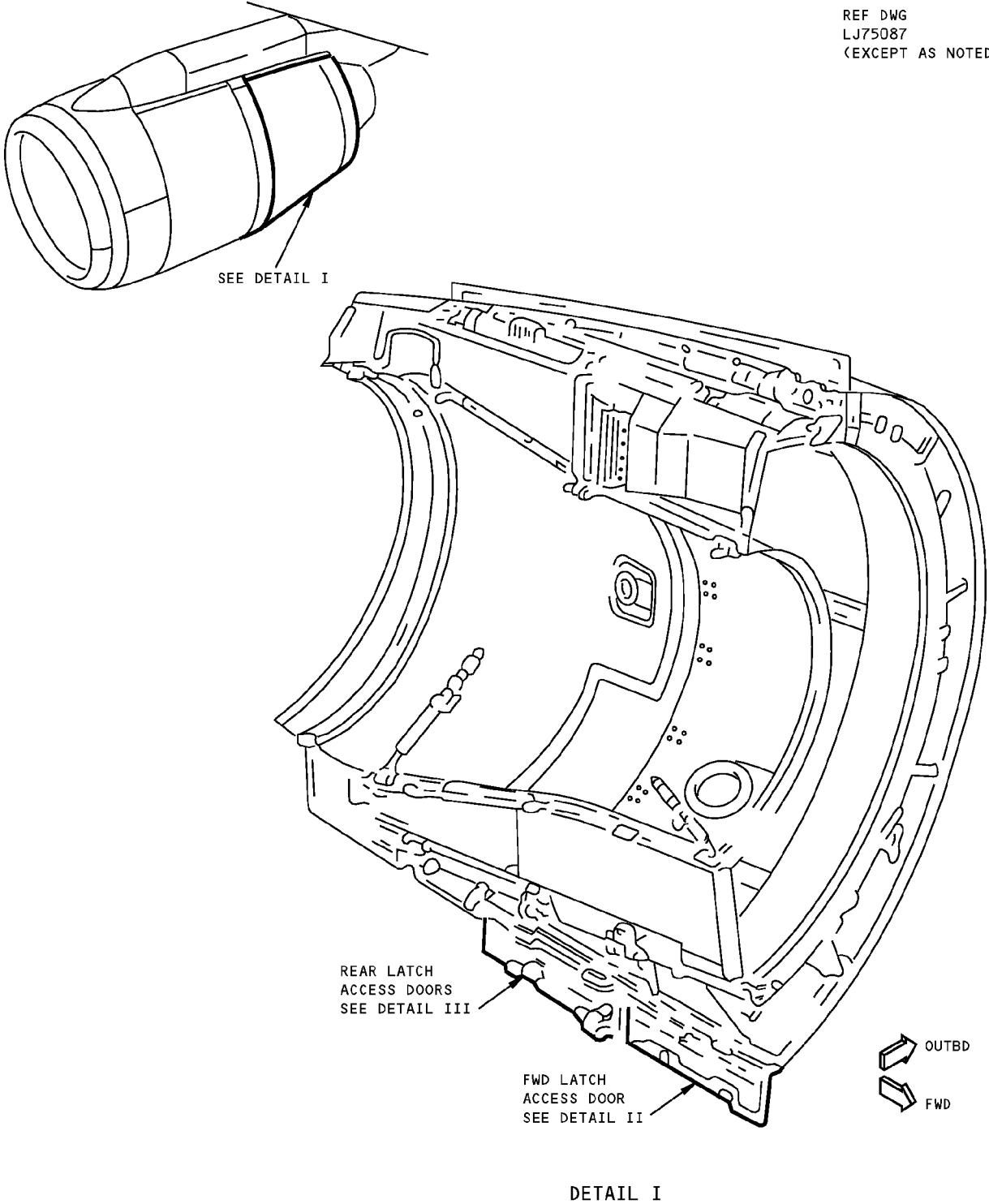

**Reverser Cowl Latch Access Doors Allowable Damage - RB211-535C Engine
Figure 101 (Sheet 1 of 5)**

757-200
STRUCTURAL REPAIR MANUAL

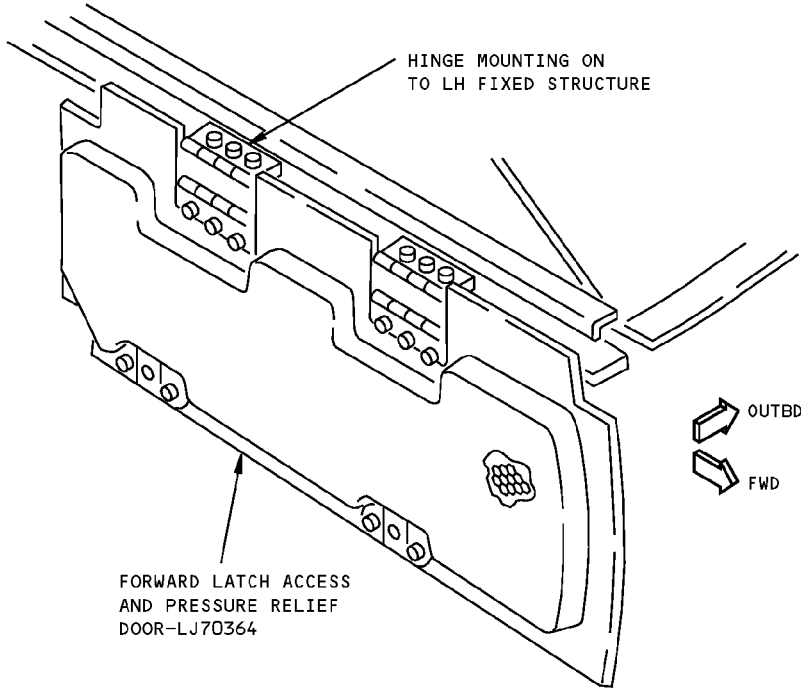

FWD LATCH ACCESS DOOR
DETAIL II

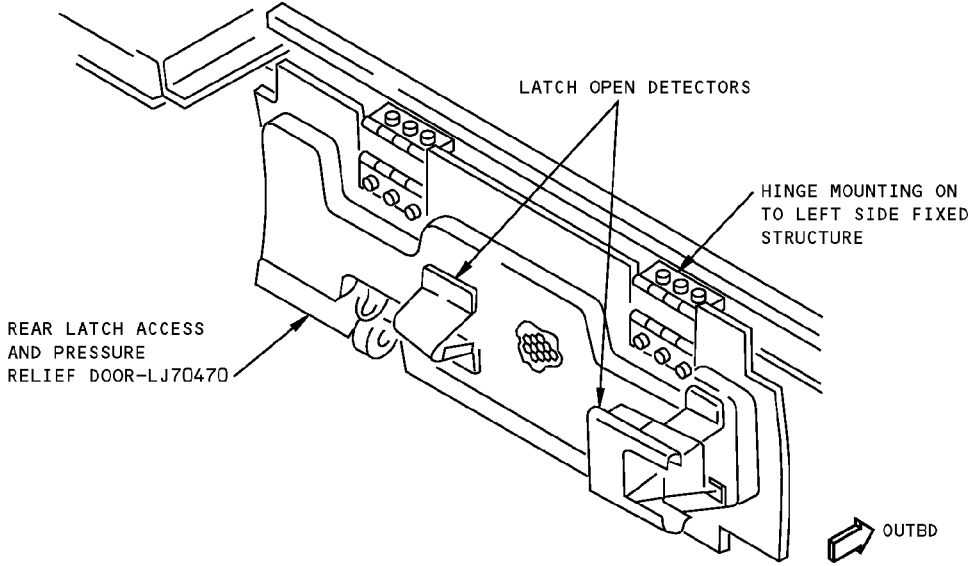

REAR LATCH ACCESS DOOR
DETAIL III

Reverser Cowl Latch Access Doors Allowable Damage - RB211-535C Engine
Figure 101 (Sheet 2 of 5)

STRUCTURAL REPAIR MANUAL

DESCRIPTION	CRACKS	NICKS AND GOUGES	DENTS	HOLES AND PUNCTURES	DELAMINATION
PANEL	[B]	[C]	[D]	[E]	[F]
HINGE FITTINGS	[G]	[H]	NOT ALLOWED	NOT ALLOWED	----

NOTES

- THESE ALLOWABLE DAMAGE LIMITS ARE FAA APPROVED CONTINGENT ON ACCOMPLISHMENT OF THE INSPECTIONS AT THE INTERVALS CONTAINED HEREIN
 - REFER TO SRM 51-10-02 FOR INSPECTION AND REMOVAL OF DAMAGE
 - REFER TO SRM 51-11-01 FOR AERODYNAMIC SMOOTHNESS REQUIREMENTS. WHERE DAMAGE EXCEEDS THE LIMITS SHOWN IN 51-11-01, CONSIDERATION SHOULD BE GIVEN TO LOSS OF PERFORMANCE INVOLVED
 - REFINISH REWORKED AREAS AS GIVEN IN AMM 51-20
- [A] PROTECT DAMAGE FROM ENTRANCE OF WATER, SUNLIGHT OR OTHER FOREIGN MATTER BY SEALING WITH ALUMINUM FOIL TAPE (SPEED TAPE) 3M-Y436. RECORD THE LOCATION AND INSPECT EACH AIRPLANE "A" CHECK. REPLACE THE ALUMINUM FOIL TAPE IF ANY PEELING OR DETERIORATION IS EVIDENT. REPAIR NO LATER THAN NEXT AIRPLANE "C" CHECK
- [B] 0.50 INCH (12.7 mm) MAXIMUM LENGTH IN HONEYCOMB AREA IS ALLOWED FOR EACH SQUARE FOOT (930 SQUARE cm) OF AREA. MINIMUM OF 6.0 INCHES (150 mm) FROM ANY OTHER CRACK. REMOVE EDGE CRACKS AS GIVEN IN DETAILS IV AND VI. [A]
- [C] DAMAGE ALLOWED ON SURFACE RESIN ONLY. DAMAGE TO FIBERS NOT ALLOWED. CLEAN UP EDGE DAMAGE PER DETAILS IV AND VI.
- [D] 1.00 INCH (25 mm) MAXIMUM DIAMETER IS ALLOWED IN HONEYCOMB AREAS ONLY PROVIDED THERE IS NO DELAMINATION OR FIBER DAMAGE. ONE DENT PER SQUARE FOOT (930 SQUARE cm) OF AREA ALLOWED AND A MINIMUM OF 6.0 INCHES (150 mm) FROM ANY OTHER DENT. DENTS GENERALLY INDICATE FIBER DAMAGE OR DELAMINATION. SEE [E] OR [F] IF SUCH DAMAGE IS PRESENT
- [E] 0.50 INCH (12.5 mm) MAX DIAMETER IN HONEYCOMB AREA ONLY PROVIDED DAMAGE IS MINIMUM OF 2.5 D FROM OTHER DAMAGE, NEAREST HOLE, OR MATERIAL EDGE. DO NOT CLEAN UP DAMAGE EXCEPT TO REMOVE RESIN BURRS EXTENDING INTO SURFACE CONTOUR. [A]
- [F] 0.50 INCH (12.5 mm) MAX DIAMETER IN HONEYCOMB AREA AND NOT TO EXCEED 25% OF HONEYCOMB CORE LENGTH PER SIDE. A MAXIMUM OF 0.03 INCH (0.76 mm) DELAMINATION FROM EDGE IS ALLOWED. REPAIR DELAMINATION IN HONEYCOMB AREA PER SRM 51-71 AND NO LATER THAN THE NEXT AIRPLANE "C" CHECK. PROTECT EDGE DAMAGE PER [A]
- [G] CLEAN UP EDGE CRACKS AS GIVEN IN DETAILS IV AND VII. CLEAN UP CORNER CRACKS AS GIVEN IN DETAIL VIII. OTHER CRACKS NOT ALLOWED
- [H] CLEAN UP EDGE DAMAGE PER DETAILS IV AND VI. CLEAN UP CORNER DAMAGE PER DETAIL VIII. CLEAN UP LUG DAMAGE PER DETAIL IX. CLEAN UP OTHER DAMAGE PER DETAIL V.

Reverser Cowl Latch Access Doors Allowable Damage - RB211-535C Engine
Figure 101 (Sheet 3 of 5)

757-200
STRUCTURAL REPAIR MANUAL

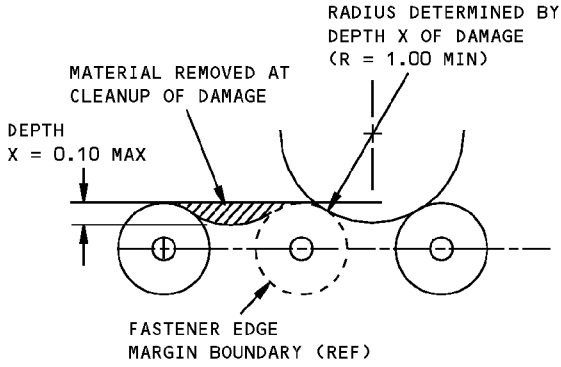

DAMAGE CLEANUP OF EDGES WHERE FASTENER EDGE MARGINS DO NOT OVERLAP

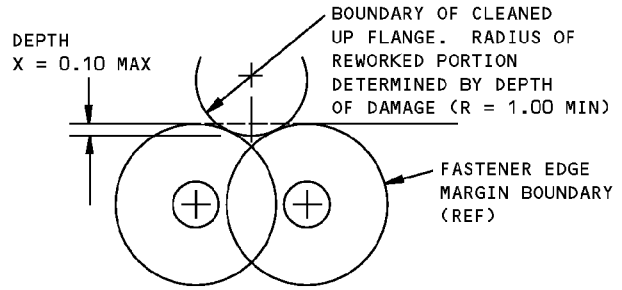

DAMAGE CLEANUP OF EDGES WHERE FASTENER EDGE MARGINS OVERLAP

DETAIL IV

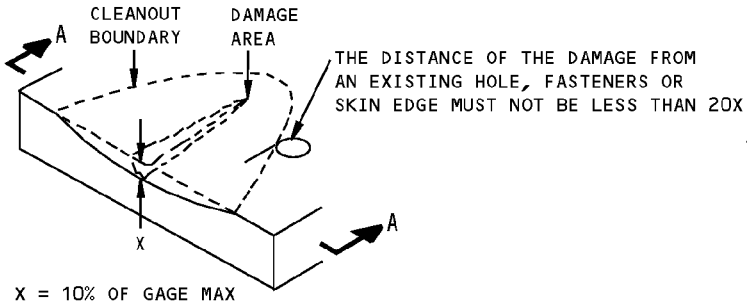

REMOVAL OF NICK OR GOUGE DAMAGE ON A SURFACE
DETAIL V

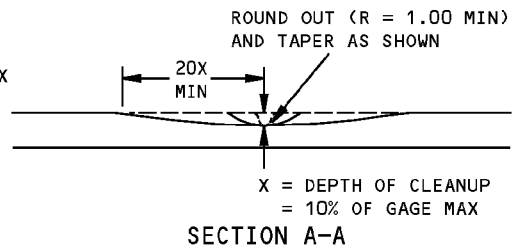

Reverser Cowl Latch Access Doors Allowable Damage - RB211-535C Engine
Figure 101 (Sheet 4 of 5)

757-200
STRUCTURAL REPAIR MANUAL

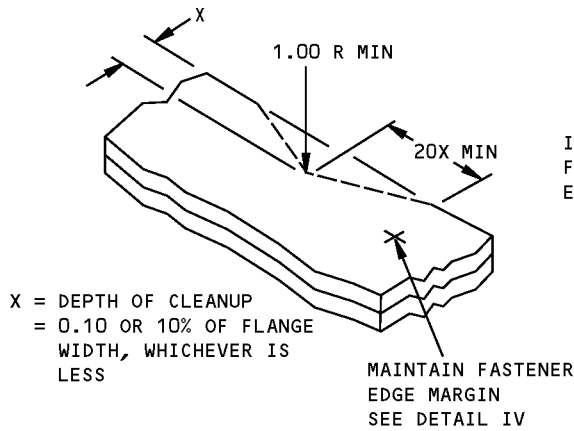

DETAIL VI

IF FASTENER OR
FASTENER PATTERN
EXISTS SEE DETAIL III

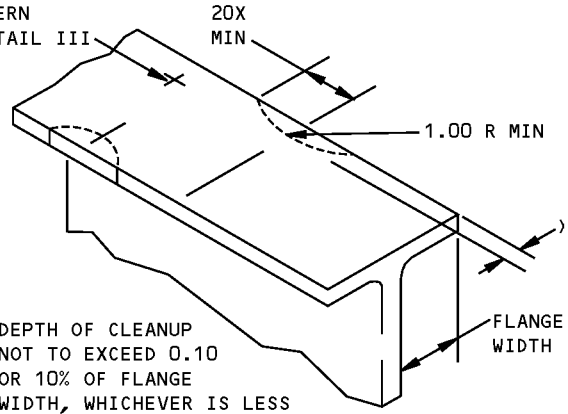

REMOVAL OF DAMAGE ON AN EDGE
DETAIL VII

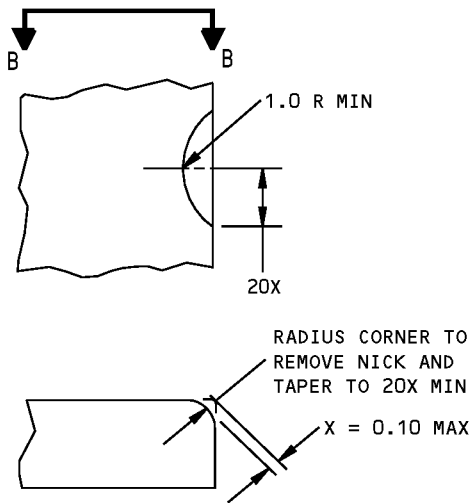

SECTION B-B

DETAIL VIII

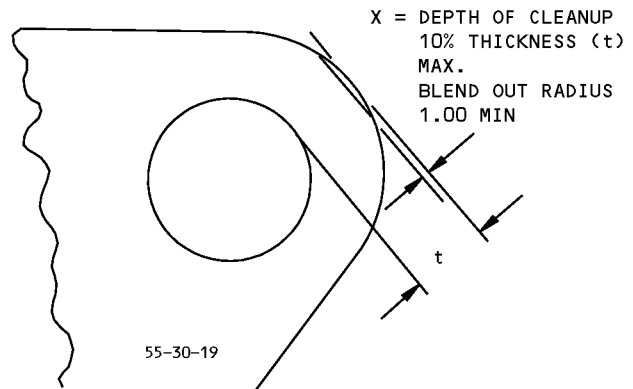

DAMAGE CLEANUP FOR EDGES OF LUG
DETAIL IX

Reverser Cowl Latch Access Doors Allowable Damage - RB211-535C Engine
Figure 101 (Sheet 5 of 5)

757-200
STRUCTURAL REPAIR MANUAL

REPAIR 1 - REVERSER COWL SKIN - RB211-535 ENGINE

DAMAGE	INTERIM REPAIRS [B]		PERMANENT REPAIRS
	WET LAYUP 150°F (66°C) CURE (SRM 51-71-03)	WET LAYUP 200-230°F (93-110°C) CURE (SRM 51-71-02)	350°F (177°C) CURE (SRM 51-71-01)
CRACKS	UP TO 2.0 INCHES (50 mm) LONG REPAIR WITH PATCH AS GIVEN IN SRM 51-71-03 PAR.5.P. [C]	CLEAN UP DAMAGE AND REPAIR AS A HOLE	CLEAN UP DAMAGE AND REPAIR AS A HOLE
HOLES	2.0 INCHES (50 mm) MAXIMUM DIA NOT TO EXCEED 30% OF SMALLEST DIMENSION ACROSS HONEYCOMB PANEL AT THE DAMAGE LOCATION. FILL WITH BMS 5-28 TYPE 7 POTTING COMPOUND PATCH AS GIVEN IN SRM 51-71-03 [A]	10.0 INCHES (250 mm) MAXIMUM DIA NOT TO EXCEED 50% OF SMALLEST DIMENSION ACROSS HONEYCOMB PANEL AT THE DAMAGE LOCATION. USE ONE EXTRA PLY FOR EACH FACESHEET REPAIRED [A]	NO SIZE LIMIT
DELAMI-NATION	CUT OUT AND REPAIR AS A HOLE		
NICKS AND GOUGES	IF THERE IS NO FIBER DAMAGE OR DELAMINATION, FILL NICKS OR GOUGES AS GIVEN IN SRM 51-71-03. IF YOU FIND FIBER DAMAGE OR DELAMINATION, THEN REPAIR AS A HOLE		
DENTS	UP TO 2.0 INCHES (50 mm) DIA WITH NO FIBER DAMAGE OR DELAMINATION, FILL WITH BMS 5-28, TYPE 7 POTTING COMPOUND AND PATCH AS GIVEN IN SRM 51-71-03. [A] OVER 2.0 INCHES (50 mm) DIA OR WITH FIBER DAMAGE OR DELAMINATION, REPAIR AS A HOLE		

REPAIR DATA FOR 350°F (177°C) CURE HONEYCOMB PANELS

NOTES

- [A]** ONE REPAIR FOR EACH SQUARE FOOT OF AREA AND A MINIMUM OF 6.0 INCHES (150 mm) (EDGE TO EDGE) FROM ANY OTHER DAMAGE, FASTENER HOLE, OR EDGE OF PANEL.
- [B]** INSPECT INTERIM REPAIR USING VISUAL AND "TAP" METHODS EVERY AIRPLANE "2A" CHECK. PERMANENT REPAIR IS REQUIRED IF ANY DETERIORATION IS FOUND.
- [C]** LIMIT TO REPAIR OF DAMAGE TO ONE FACESHEET SKIN AND HONEYCOMB CORE. ONE REPAIR FOR EACH SQUARE FOOT OF AREA AND A MINIMUM OF 6.0 INCHES (150 mm) (EDGE OF AREA) FROM ANY OTHER DAMAGE, FASTENER HOLE OR EDGE OF PANEL.

Reverser Cowl Skin Repairs - RB211-535 Engine
Figure 201

D634N201

54-30-01

REPAIR 1
Page 201
Jan 20/2005

757-200
STRUCTURAL REPAIR MANUAL

REPAIR 2 - REVERSER COWL HINGE DOOR - RB211-535 ENGINE

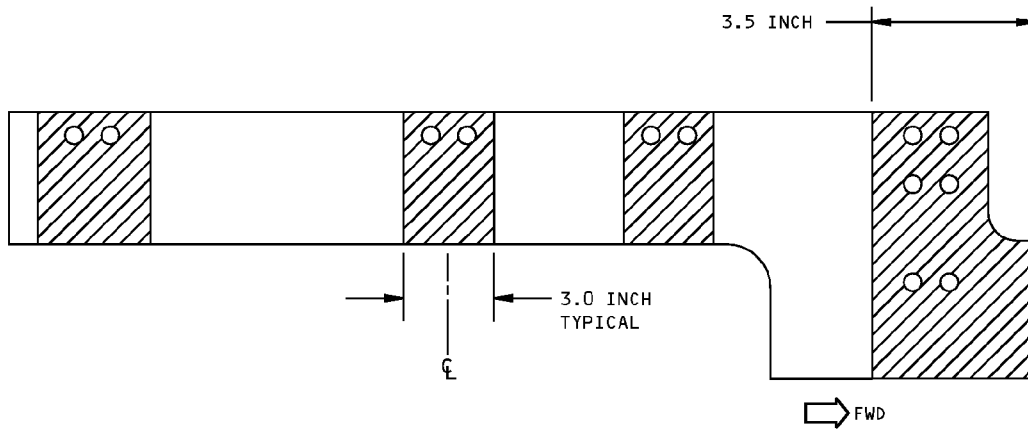
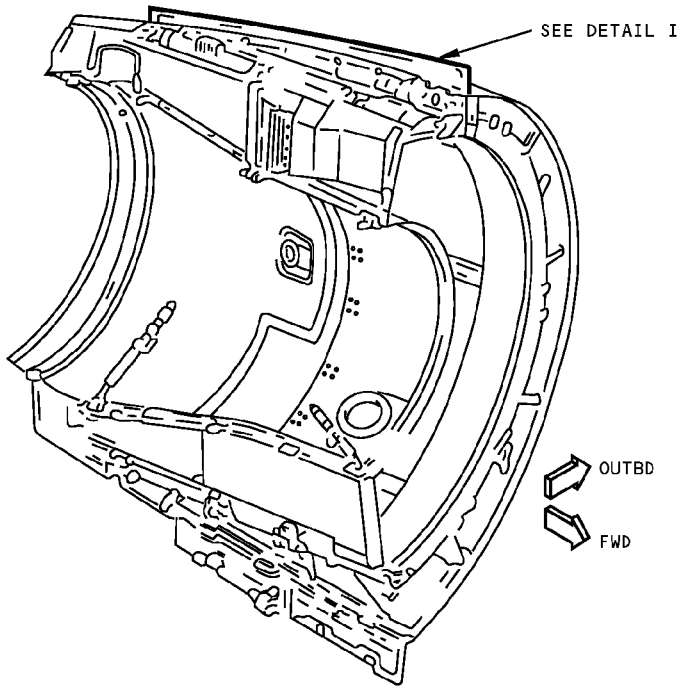

OUTER SKIN
DETAIL I

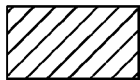

REFER TO THE RB211-535 ENGINE
MANUAL FOR REPAIRS IN THE SHADED
AREA. REPAIRS FROM 51-71-01 OR
51-71-03 ARE NOT ALLOWED IN THE
SHADED AREA

Reverser Cowl Hinge Door Repair - RB211-535 Engine
Figure 201 (Sheet 1 of 2)

757-200
STRUCTURAL REPAIR MANUAL

DAMAGE	INTERIM REPAIRS A	PERMANENT REPAIRS
		WET LAYUP 150°F (66°C) CURE (51-71-03)
CRACKS	UP TO 2.0 LONG. REPAIR WITH PATCH PER 51-71-03 B	CLEAN UP DAMAGE AND REPAIR AS HOLE
HOLES	2.0 MAX DIA NOT TO EXCEED 30% OF SMALLEST DIMENSION ACROSS HONEYCOMB PANEL AT THE DAMAGE LOCATION. FILL WITH BMS 5-28, TYPE 7 POTTING COMPOUND. PATCH PER 51-71-03.	NO SIZE LIMIT. REFER TO 51-71-01
DELAMI- NATION	CUT OUT AND REPAIR AS HOLE	
NICKS AND GOUGES	IF FIBER DAMAGE OR DELAMINATION EXISTS, REPAIR AS HOLE	
DENTS	OVER 1.0 INCH DIAMETER WITH FIBER DAMAGE OR DELAMINATION, REPAIR AS HOLE	

TABLE I

NOTES

- REFINISH REWORKED AREAS PER 51-20 OF THE MAINTENANCE MANUAL.
- REFER TO 51-11-01 FOR AERODYNAMIC SMOOTHNESS REQUIREMENTS. WHERE THE REPAIR EXCEEDS THE LIMITS SHOWN IN 51-11-01, CONSIDERATION SHOULD BE GIVEN TO THE LOSS OF PERFORMANCE.

A INSPECT INTERIM REPAIR USING VISUAL AND "TAP" METHODS EVERY AIRPLANE "2A" CHECK. PERMANENT REPAIR IS REQUIRED IF ANY DETERIORATION IS EVIDENT.

B LIMIT TO REPAIR OF DAMAGE TO ONE FACESHEET SKIN AND HONEYCOMB CORE. ONE REPAIR PER SQUARE FOOT OF AREA AND A MINIMUM OF 6.0 INCHES (EDGE OF AREA) FROM ANY OTHER DAMAGE, FASTENER HOLE OR EDGE OF PANEL.

Reverser Cowl Hinge Door Repair - RB211-535 Engine
Figure 201 (Sheet 2 of 2)

757-200
STRUCTURAL REPAIR MANUAL

REPAIR 3 - REVERSER COWL LATCH ACCESS DOOR - RB211-535C ENGINE

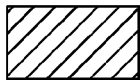
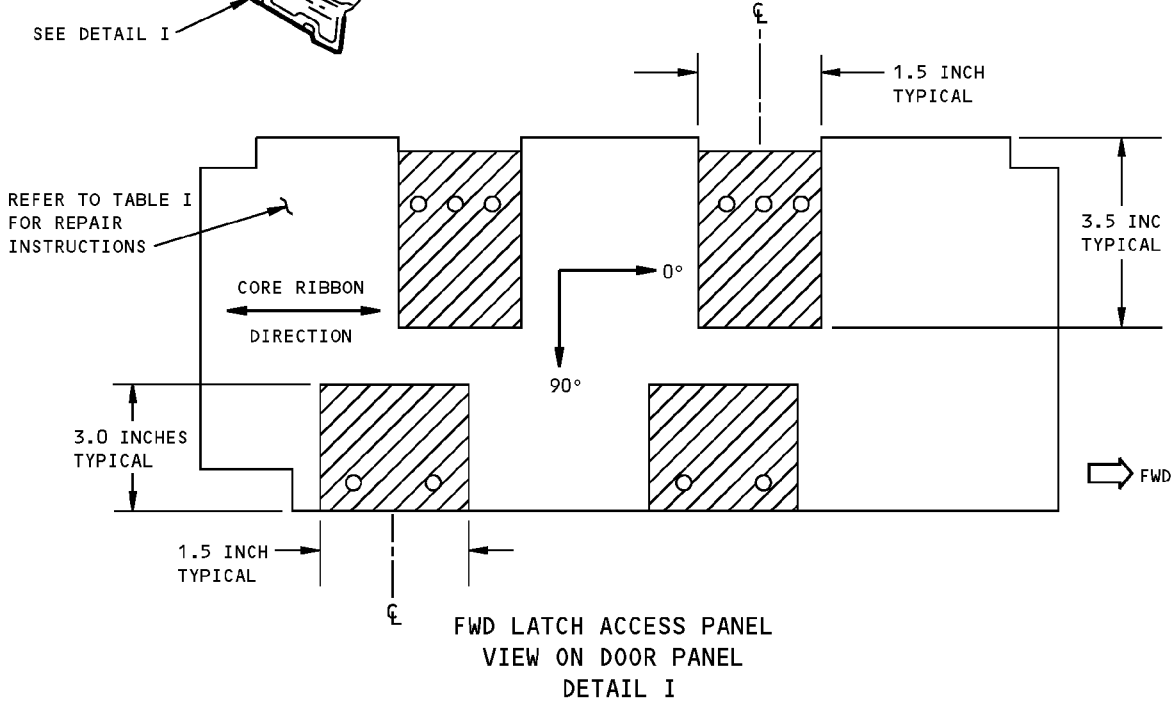
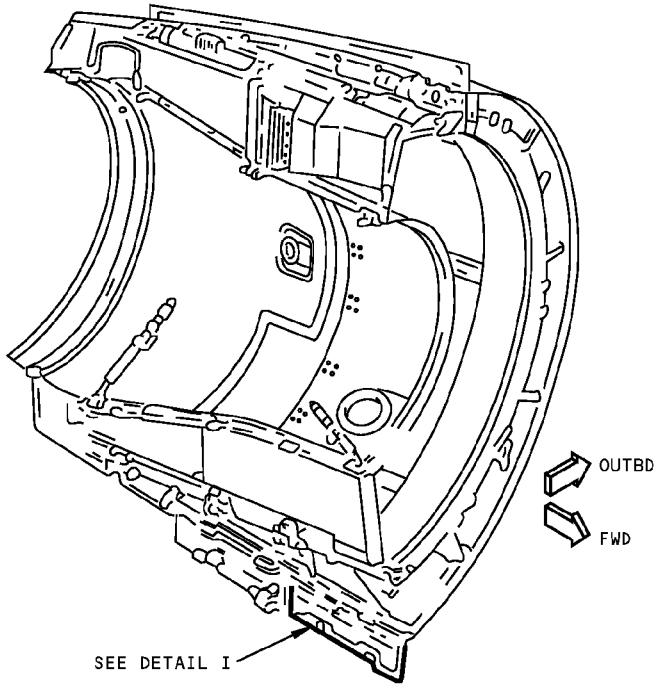

REFER TO THE RB211-535C ENGINE MANUAL FOR REPAIRS IN THE SHADED AREA. REPAIRS FROM 51-71-01 OR 51-71-03 ARE NOT ALLOWED IN THE SHADED AREA

**Reverser Cowl Latch Access Door Repair - RB211-535C Engine
Figure 201 (Sheet 1 of 3)**

757-200
STRUCTURAL REPAIR MANUAL

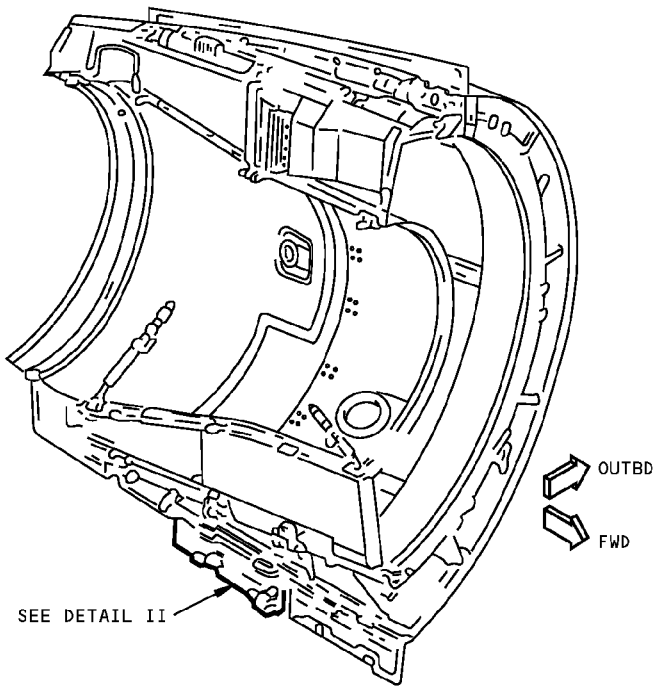

REFER TO TABLE I
FOR REPAIR INSTRUCTIONS

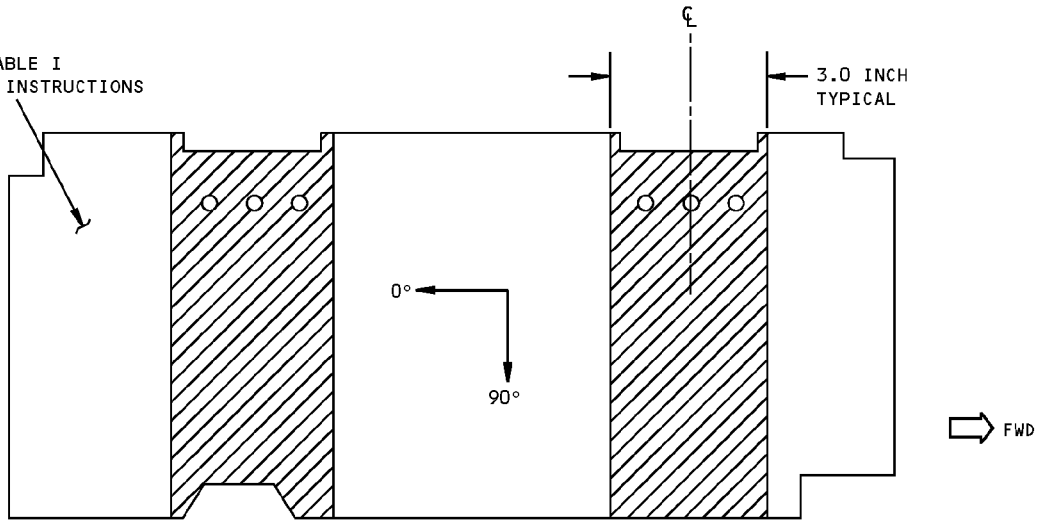

VIEW ON DOOR PANEL
DETAIL II

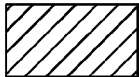

REFER TO THE RB211-535C ENGINE
MANUAL FOR REPAIRS IN THE SHADED
AREA. REPAIRS FROM 51-71-01 OR
51-71-03 ARE NOT ALLOWED IN THE
SHADED AREA

Reverser Cowl Latch Access Door Repair - RB211-535C Engine
Figure 201 (Sheet 2 of 3)

757-200
STRUCTURAL REPAIR MANUAL

DAMAGE	INTERIM REPAIRS ^A	PERMANENT REPAIRS
		WET LAYUP 150°F (66°C) CURE (51-71-03)
CRACKS	UP TO 3.0 LONG. REPAIR WITH PATCH PER 51-71-03	CLEAN UP DAMAGE AND REPAIR AS HOLE
HOLES	3.0 MAX DIA NOT TO EXCEED 30% OF SMALLEST DIMENSION ACROSS HONEYCOMB PANEL AT THE DAMAGE LOCATION. FILL AND PATCH PER 51-71-03.	NO SIZE LIMIT. REFER TO 51-71-01.
DELAMINATION	CUT OUT AND REPAIR AS HOLE	
NICKS AND GOUGES	IF FIBER DAMAGE OR DELAMINATION EXISTS, REPAIR AS HOLE	
DENTS	OVER 1.0 INCH DIAMETER WITH FIBER DAMAGE OR DELAMINATION, REPAIR AS HOLE	

TABLE I

NOTES

- REFINISH REWORKED AREAS PER 51-20 OF THE MAINTENANCE MANUAL.
- REFER TO 51-11-01 FOR AERODYNAMIC SMOOTHNESS REQUIREMENTS. WHERE THE REPAIR EXCEEDS THE LIMITS SHOWN IN 51-11-01, CONSIDERATION SHOULD BE GIVEN TO THE LOSS OF PERFORMANCE.
- REFER TO 51-70-16 FOR HOLE DRILLING AND MACHINING OF COMPOSITE STRUCTURES.

^A INSPECT INTERIM REPAIR USING VISUAL AND "TAP" METHODS EVERY AIRPLANE "2A" CHECK. PERMANENT REPAIR IS REQUIRED IF ANY DETERIORATION IS EVIDENT.

Reverser Cowl Latch Access Door Repair - RB211-535C Engine
Figure 201 (Sheet 3 of 3)

757-200
STRUCTURAL REPAIR MANUAL

IDENTIFICATION 1 - REVERSER COWL RIBS AND STRINGERS - RB211-535E4 ENGINE

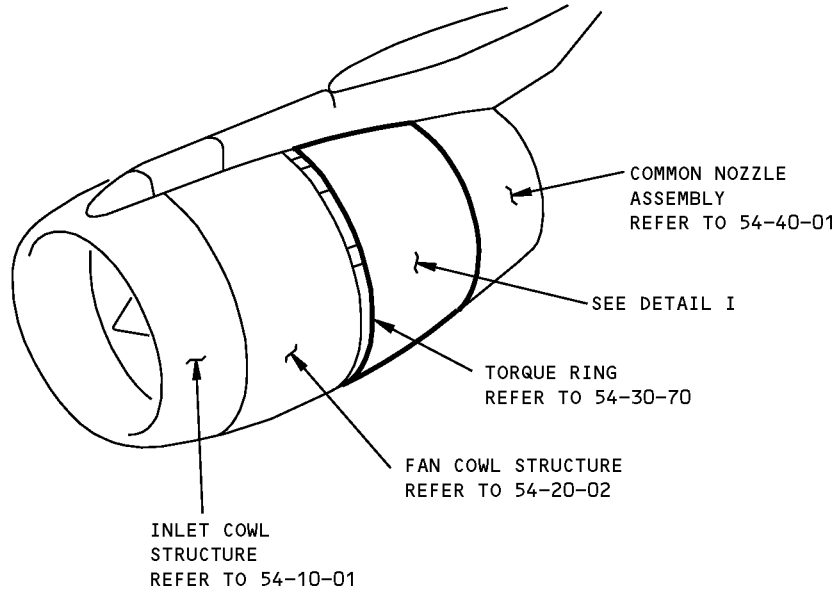

Reverser Cowl Ribs and Stringers Identification - RB211-535E4 Engine
Figure 1 (Sheet 1 of 3)

757-200
STRUCTURAL REPAIR MANUAL

REF DWG
LJ75039
LJ75040

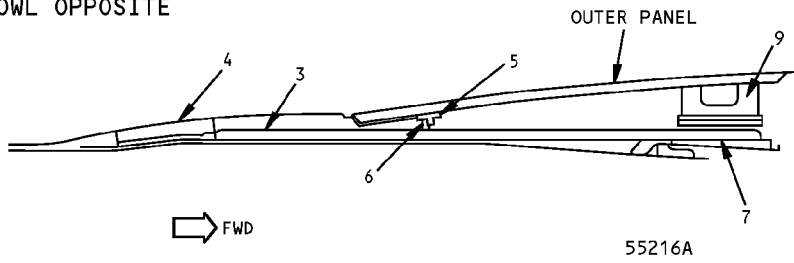
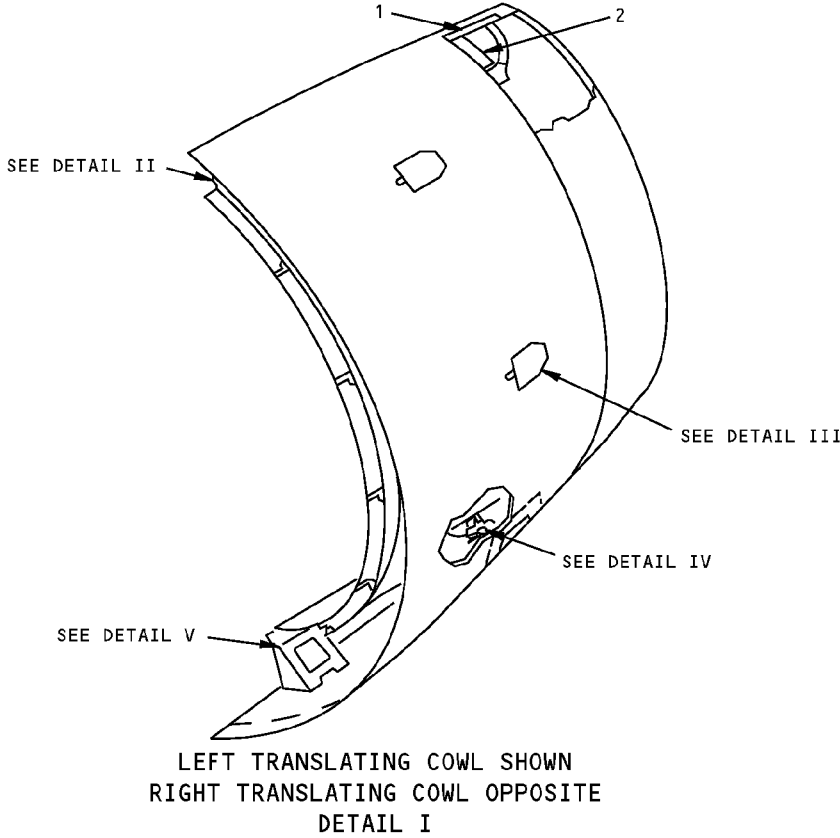

DETAIL II

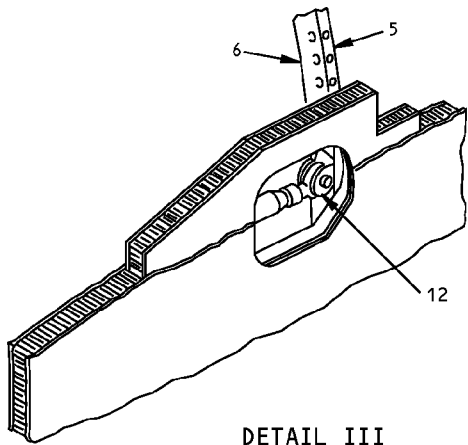

DETAIL III

LIST OF
MATERIAL

Reverser Cowl Ribs and Stringers Identification - RB211-535E4 Engine
Figure 1 (Sheet 2 of 3)

IDENTIFICATION 1
Page 2
Jan 20/2005

54-30-02

D634N201

757-200
STRUCTURAL REPAIR MANUAL

REF DWG
LJ75039
LJ75040

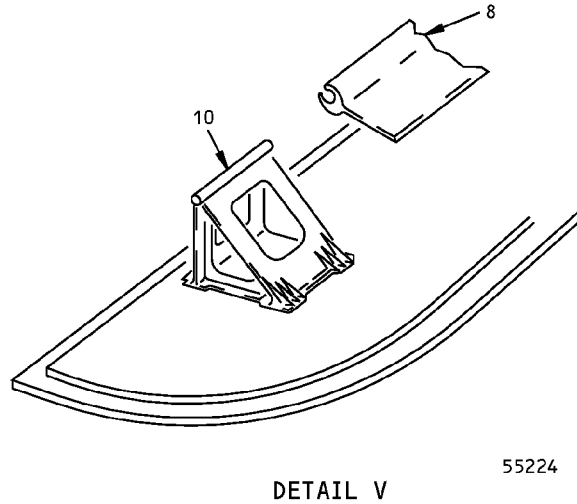
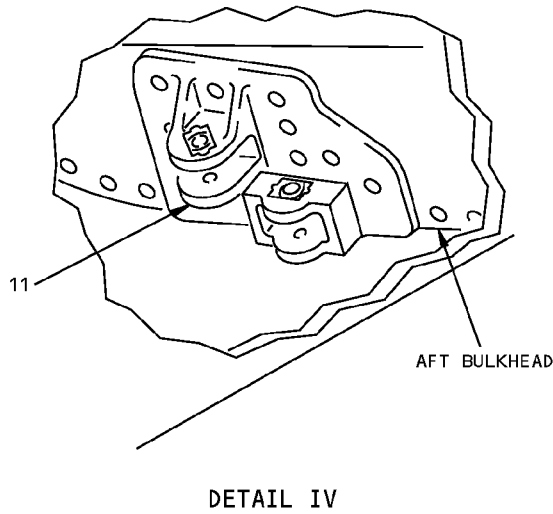

55224

ITEM	DESCRIPTION	GAGE	MATERIAL	EFFECTIVITY
1	SUPPORT, AFT FAIRING	0.050	2024-0 CLAD ALUMINUM SHEET QQ-A-250/5 TEMP-T62	
2	SUPPORT, AFT FAIRING	0.050	2024-0 CLAD ALUMINUM SHEET QQ-A-250/5 TEMP-T62	
3	WEB	0.050	2024-0 CLAD ALUMINUM SHEET QQ-A-250/5 TEMP-T62	
4	WEB	0.050	2024-0 CLAD ALUMINUM SHEET QQ-A-250/5 TEMP-T62	
5	TEE		EXTRUSION S700E0469 (ROHR) 2024-0 H/T TO -T62	
6	FRAME	0.050	2024-0 CLAD ALUMINUM SHEET QQ-A-250/5 TEMP-T62	
7	SLIDER, INNER (UPPER)		EXTRUSION S700E0433 (ROHR) 2024-T3511	
8	SLIDER, INNER (LOWER)		EXTRUSION S700E0433 (ROHR) 2024-T3511	
9	SLIDER, FORWARD (UPPER)		17-4 INVESTMENT CASTING AMS 5344	
10	SLIDER, FORWARD (LOWER)		17-4 INVESTMENT CASTING AMS 5344	
11	BRACKET T/R ACTUATOR		FORGING 2024-T6	
12	BRACKET T/R ACTUATOR		FORGING 2024-T6	

LIST OF MATERIALS FOR DETAILS I, II, III, IV AND V

Reverser Cowl Ribs and Stringers Identification - RB211-535E4 Engine
Figure 1 (Sheet 3 of 3)

IDENTIFICATION 1
Page 3
Jan 20/2005

54-30-02

D634N201

757-200
STRUCTURAL REPAIR MANUAL

IDENTIFICATION 2 - REVERSER COWL RIBS AND STRINGERS - RB211-535C ENGINE

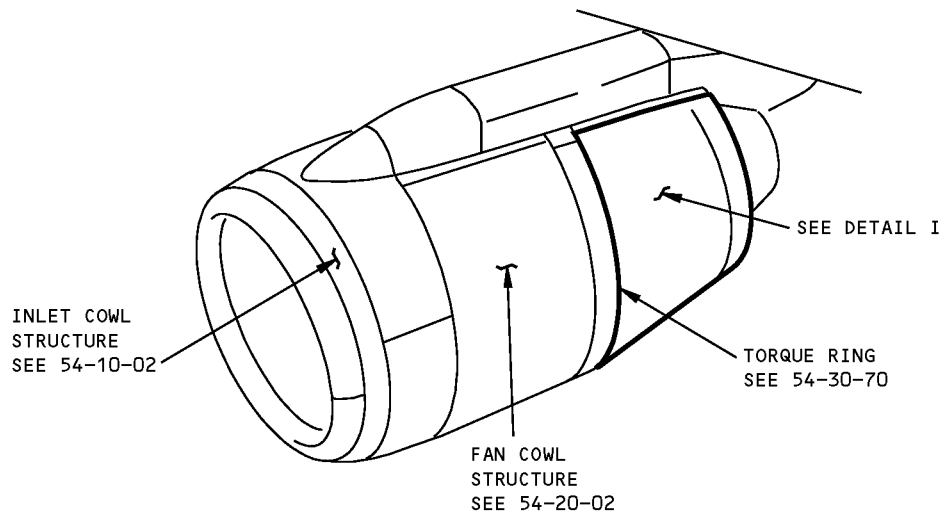

Reverser Cowl Ribs and Stringers Identification - RB211-535C Engine
Figure 1 (Sheet 1 of 5)

**757-200
STRUCTURAL REPAIR MANUAL**

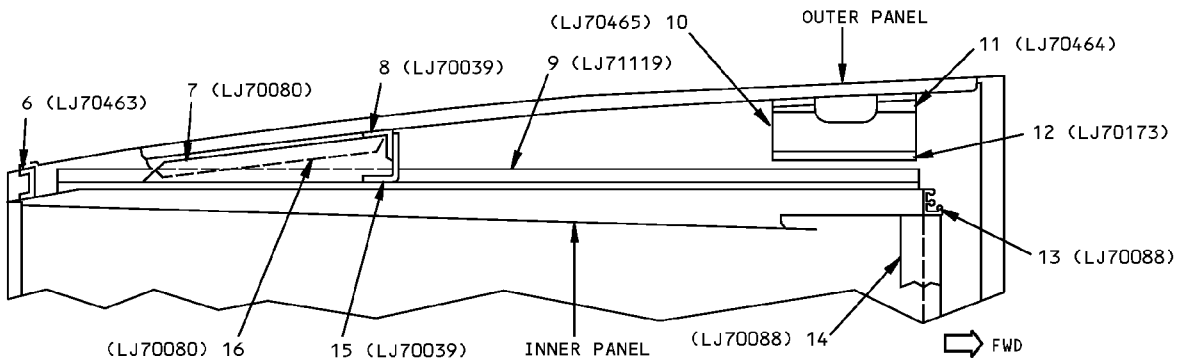
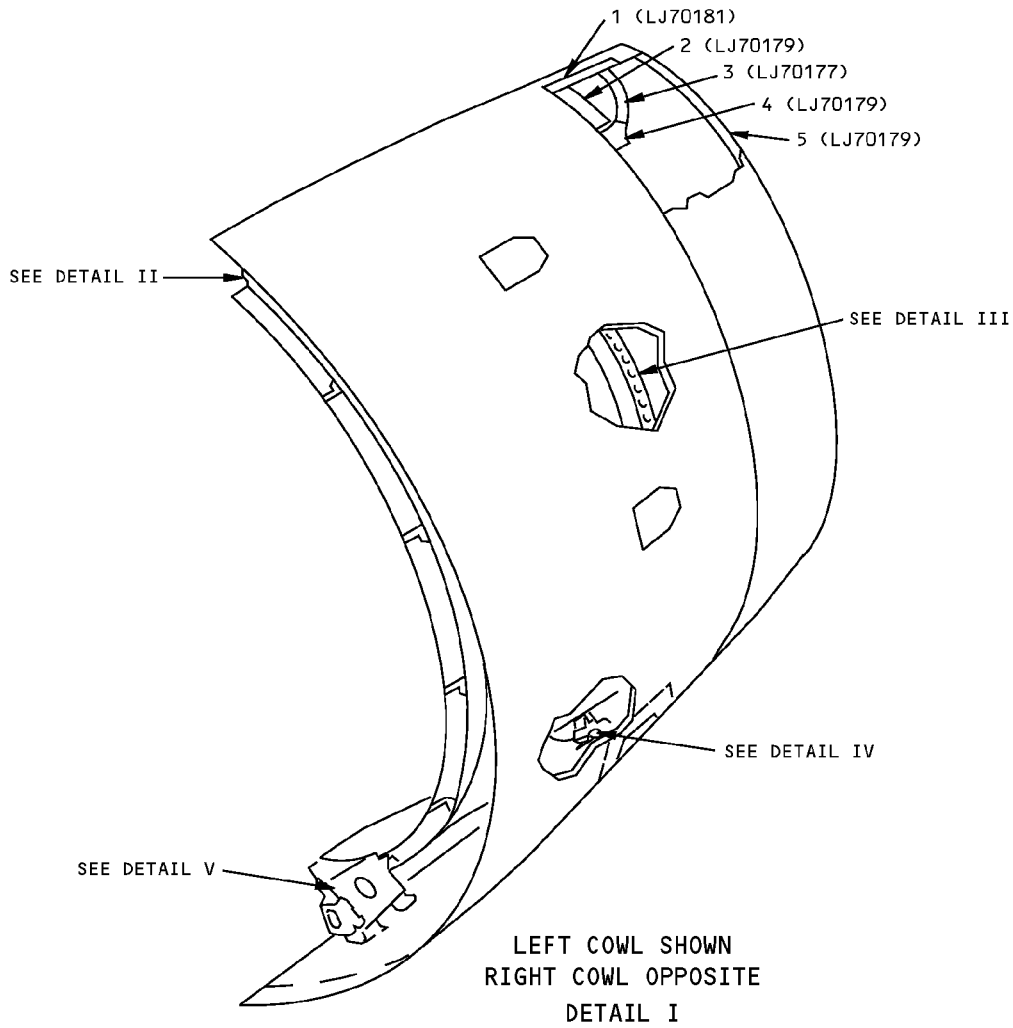

DETAIL II

LIST OF
MATERIAL

**Reverser Cowl Ribs and Stringers Identification - RB211-535C Engine
Figure 1 (Sheet 2 of 5)**

757-200
STRUCTURAL REPAIR MANUAL

ITEM	DESCRIPTION	GAGE	MATERIAL	EFFECTIVITY
1	CLOSURE	1.000	2024-T351 ALUM BAR QQ-A-225/6	
2	UPPER CLOSURE	0.080	2024-0 BARE ALUM SHEET QQ-A-250/4 (HEAT TREAT T-62)	
3	FILLER		A356-T61 ALUM INVESTMENT CASTING, MIL-A-21180, CLASS II	
4	UPPER SLUG		A356-T61 ALUM INVESTMENT CASTING, AMS 4218	
5	TRAILING EDGE		S700E 0327 EXTRUSION (ROHR)(HEAT TREAT T-62)	
6	INTERCOSTAL	0.063	2024-0 CLAD ALUM SHEET QQ-A-250/5 (HEAT TREAT T-42)	
7	WEB	0.050	2024-0 CLAD ALUM SHEET QQ-A-250/5 (HEAT TREAT T-62)	
8	ANGLE	0.063	2024-0 CLAD ALUM SHEET QQ-A-250/5 (HEAT TREAT T-62)	
9	INNER SLIDER		S700 E0213 EXTRUSION (ROHR)	
10	AFT SLIDER BRACKET	2.000	2024-T351 BARE ALUM PLATE QQ-A-250/4 (HEAT TREAT T-851)	
11	FORWARD SLIDER BRACKET	2.000	2024-T351 BARE ALUM PLATE QQ-A-250/4 (HEAT TREAT T-851)	
12	OUTER SLIDER		S700 E0212 EXTRUSION (ROHR)	
13	LEADING EDGE		S700 E0221 EXTRUSION (ROHR)(HEAT TREAT T-42)	
14	DOUBLER	0.025	2024-0 BARE ALUM SHEET QQ-A-250/4 (HEAT TREAT T-42)	
15	WEB	0.063	2024-0 CLAD ALUM SHEET QQ-A-250/5 (HEAT TREAT T-62)	
16	ANGLE	0.050	2024-0 CLAD ALUM SHEET QQ-A-250/5 (HEAT TREAT T-62)	

LIST OF MATERIALS FOR DETAILS I AND II

Reverser Cowl Ribs and Stringers Identification - RB211-535C Engine
Figure 1 (Sheet 3 of 5)

D634N201

54-30-02

IDENTIFICATION 2
Page 3
May 20/2005

757-200
STRUCTURAL REPAIR MANUAL

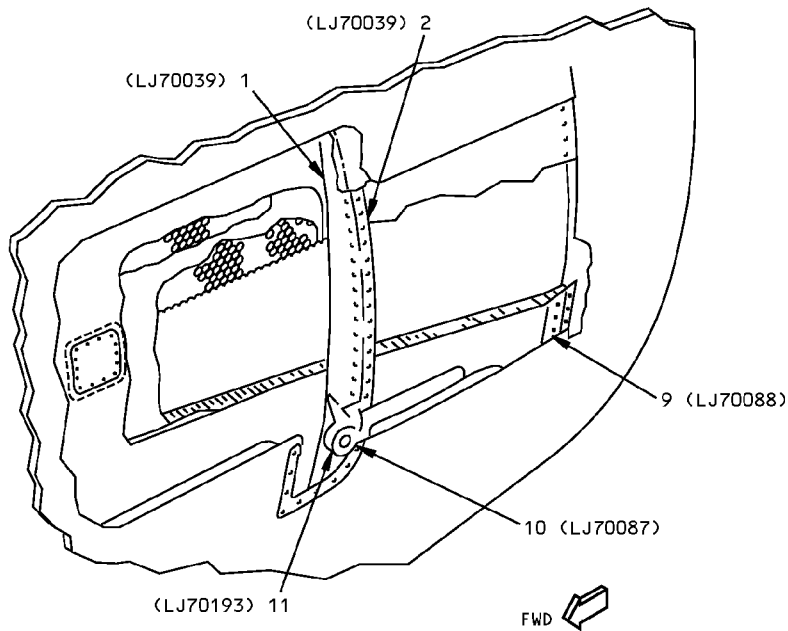

DETAIL III

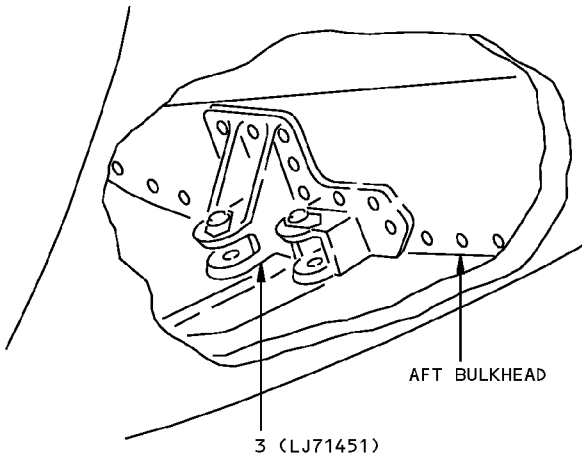

DETAIL IV

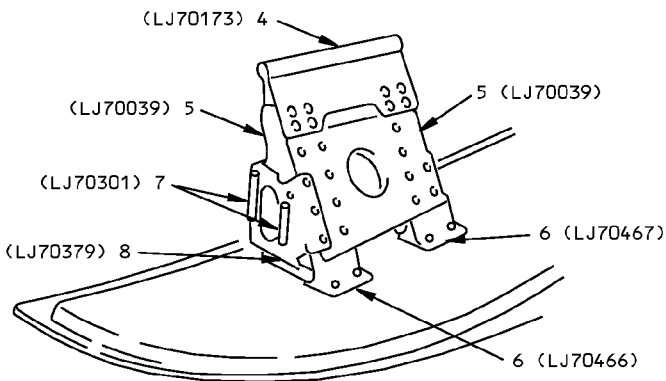

DETAIL V



Reverser Cowl Ribs and Stringers Identification - RB211-535C Engine
Figure 1 (Sheet 4 of 5)

757-200
STRUCTURAL REPAIR MANUAL

ITEM	DESCRIPTION	GAGE	MATERIAL	EFFECTIVITY
1	WEB	0.063	2024-0 CLAD ALUM SHEET QQ-A-250/5 (HEAT TREAT T-62)	
2	ANGLE	0.063	2024-0 CLAD ALUM SHEET QQ-A-250/5 (HEAT TREAT T-62)	
3	BRACKET	4.000	2024-T351 BARE ALUM PLATE QQ-A-250/4 (HEAT TREAT T-851)	
4	OUTER SLIDER		S700 E0212 EXTRUSION (ROHR)	
5	CHANNEL	0.050	2024-0 CLAD ALUM SHEET QQ-A-250/5 (HEAT TREAT T-62)	
6	BRACKET	2.000	2024-T351 BARE ALUM BAR QQ-A-250/4 (HEAT TREAT T-851)	
7	PLATE	0.051	4130 STEEL SHEET, MIL-S-18729 COND N, (CADMIUM PLATE)	
8	BRACKET	0.040	2024-0 CLAD ALUM SHEET QQ-A-250/5 (HEAT TREAT T-42)	
9	DOUBLER	0.025	2024-0 BARE ALUM SHEET 00-A-250/4 (HEAT TREAT T-42)	
10	DOUBLER	0.090	2024-0 CLAD ALUM SHEET QQ-A-250/5 (HEAT TREAT T-62)	
11	BRACKET	3.250	2024-T351 BARE ALUM BAR QQ-A-250/4 (HEAT TREAT T-851)	

LIST OF MATERIALS FOR DETAILS III, IV AND V

Reverser Cowl Ribs and Stringers Identification - RB211-535C Engine
Figure 1 (Sheet 5 of 5)

D634N201

54-30-02

IDENTIFICATION 2
Page 5
May 20/2005

757-200
STRUCTURAL REPAIR MANUAL

ALLOWABLE DAMAGE 1 - REVERSER COWL RIBS AND STRINGERS - RB211-535E4 ENGINE

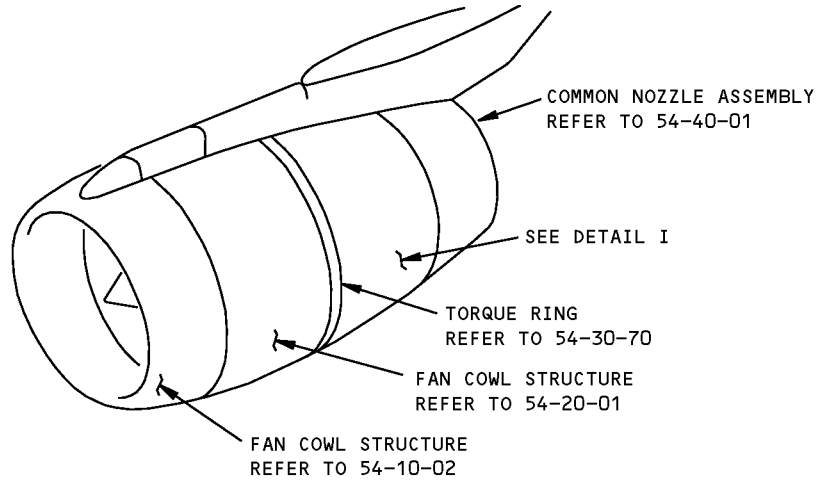

NOTES

- A** CRACKS NOT ALLOWED EXCEPT FOR EDGE CRACKS WHICH MUST BE REMOVED PER DETAIL VI AND XI
- B** REMOVE DAMAGE PER DETAILS VI, VII, AND IX
- C** CRACKS NOT ALLOWED EXCEPT FOR EDGE CRACKS WHICH MUST BE REMOVED PER DETAILS VI AND X

DESCRIPTION	CRACKS	NICKS, GOUGES AND CORROSION	DENTS	HOLES AND PUNCTURES
SUPPORT, AFT FAIRING	A	B	SEE DETAIL VIII	NOT ALLOWED
WEB	A	B	SEE DETAIL VIII	NOT ALLOWED
TEE	A	B	NOT ALLOWED	NOT ALLOWED
SLIDER (INNER)	C	B	NOT ALLOWED	NOT ALLOWED
SLIDER (FORWARD)	A	B	NOT ALLOWED	NOT ALLOWED
FRAME	A	B	SEE DETAIL VIII	NOT ALLOWED
BRACKET T/R ACTUATOR	A	B	NOT ALLOWED	NOT ALLOWED

Reverser Cowl Ribs and Stringers Allowable Damage - RB211-535E4 Engine
Figure 101 (Sheet 1 of 5)

757-200
STRUCTURAL REPAIR MANUAL

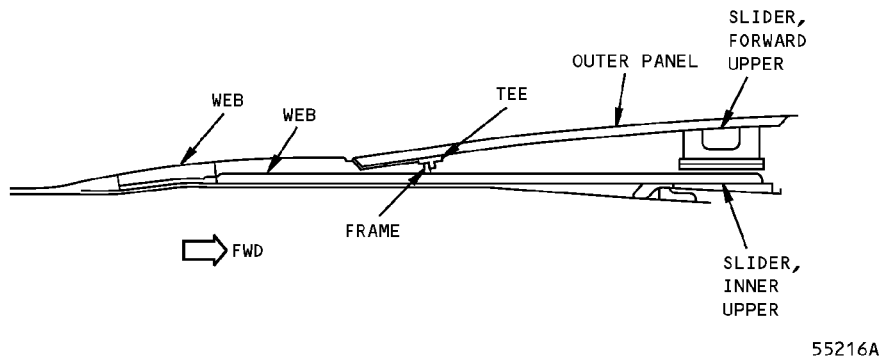
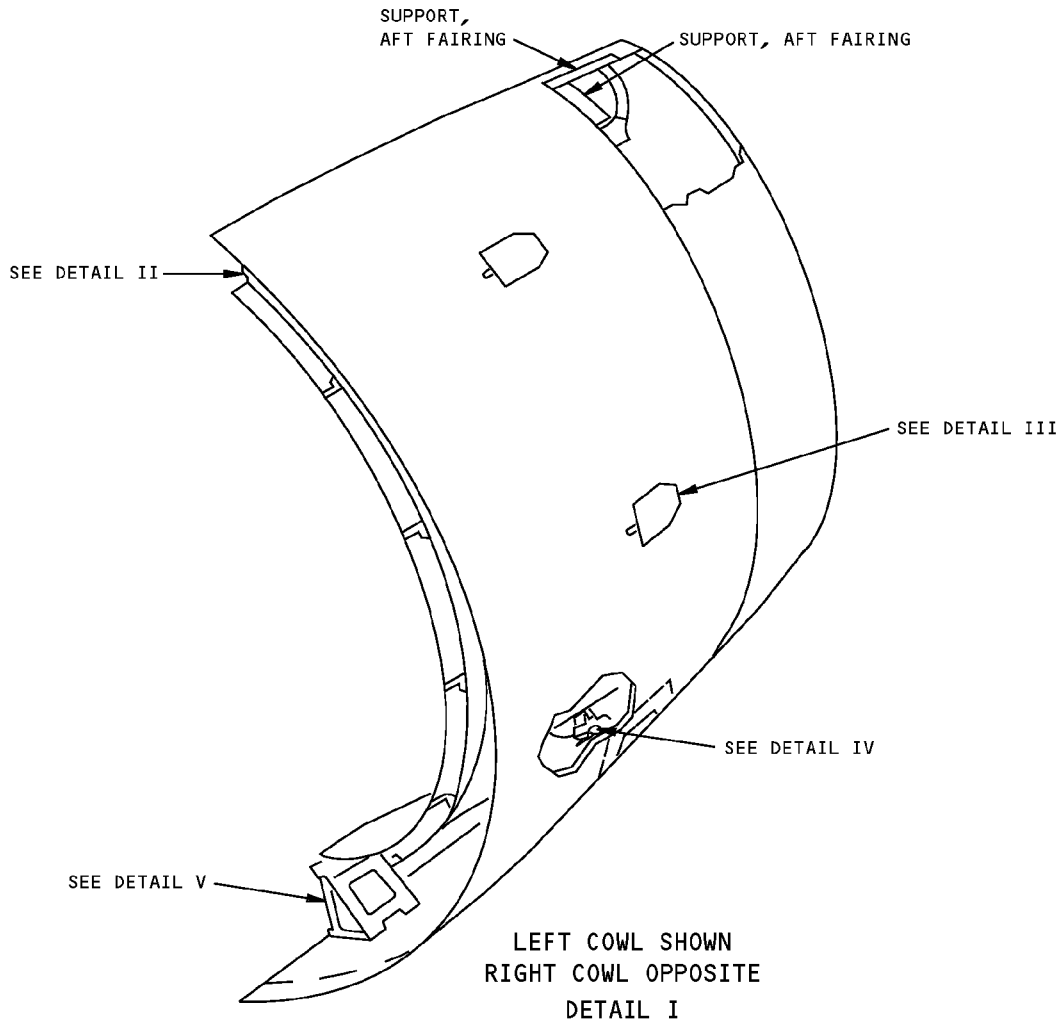

DETAIL II

Reverser Cowl Ribs and Stringers Allowable Damage - RB211-535E4 Engine
Figure 101 (Sheet 2 of 5)

757-200
STRUCTURAL REPAIR MANUAL

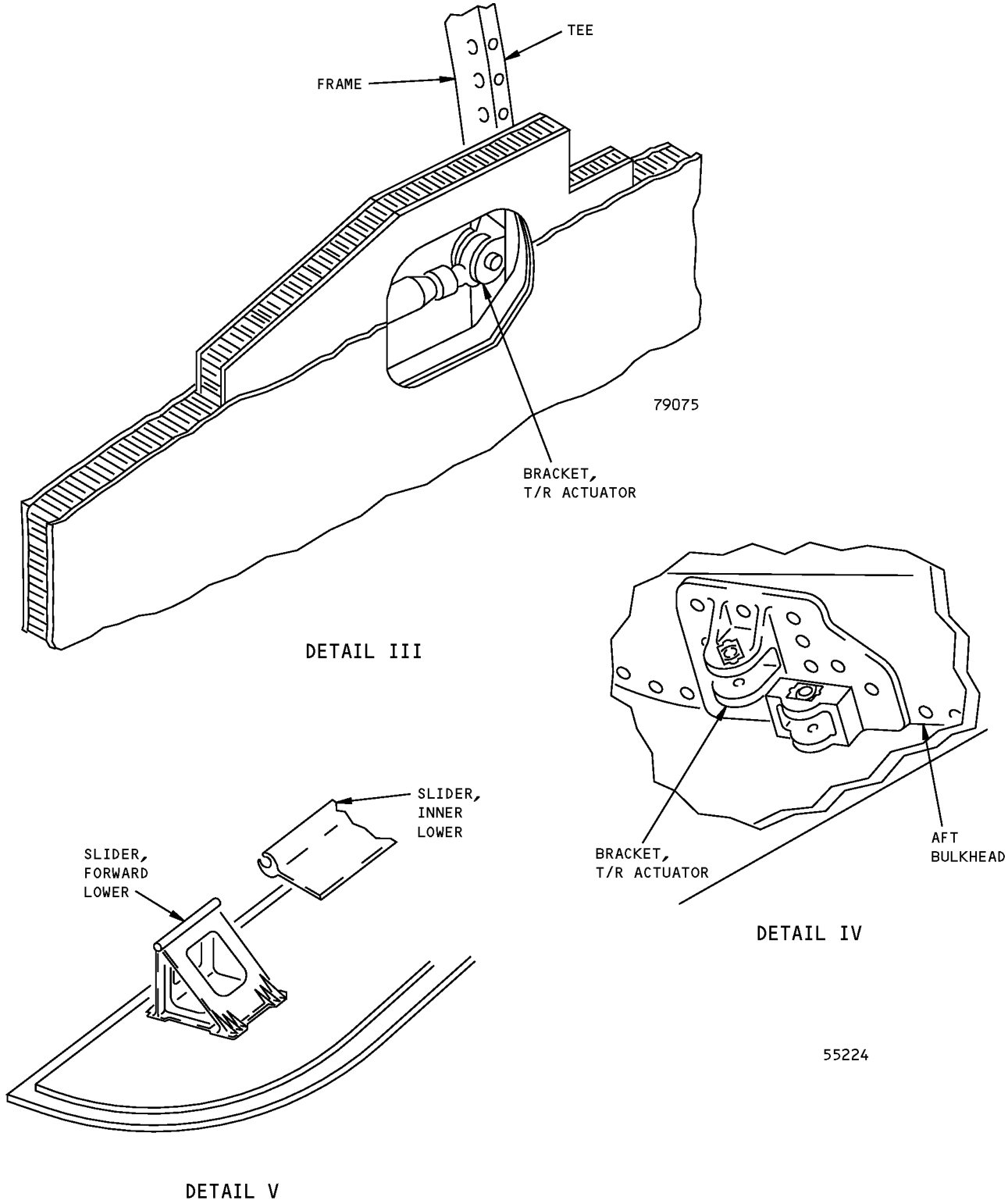

**Reverser Cowl Ribs and Stringers Allowable Damage - RB211-535E4 Engine
Figure 101 (Sheet 3 of 5)**

STRUCTURAL REPAIR MANUAL

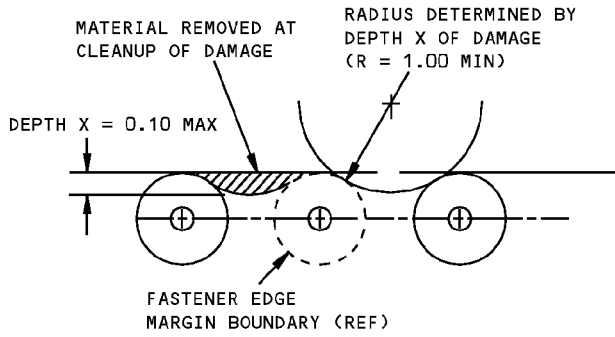

DAMAGE CLEANUP OF EDGES WHERE FASTENER EDGE MARGINS DO NOT OVERLAP

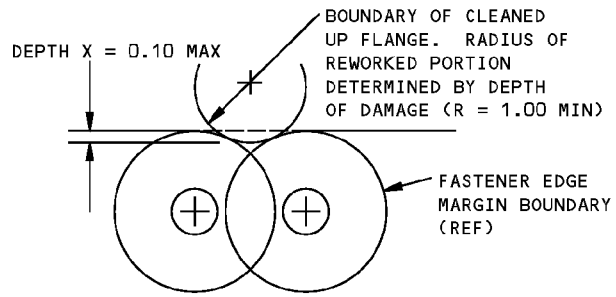

DAMAGE CLEANUP OF EDGES WHERE FASTENER EDGE MARGINS OVERLAP

DETAIL VI

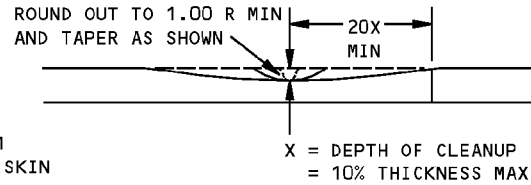
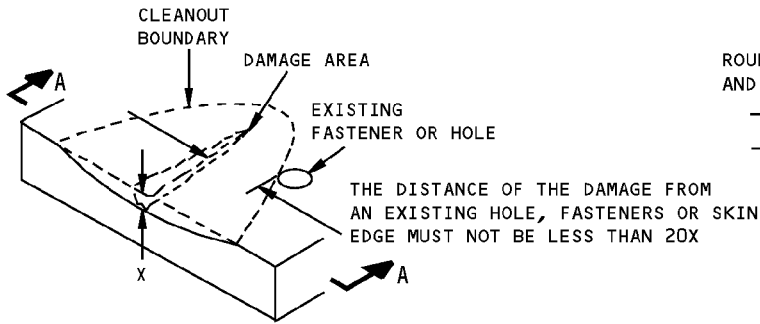

SECTION A-A

REMOVAL OF NICK, GOUGE AND SCRATCH DAMAGE ON A SURFACE

DETAIL VII

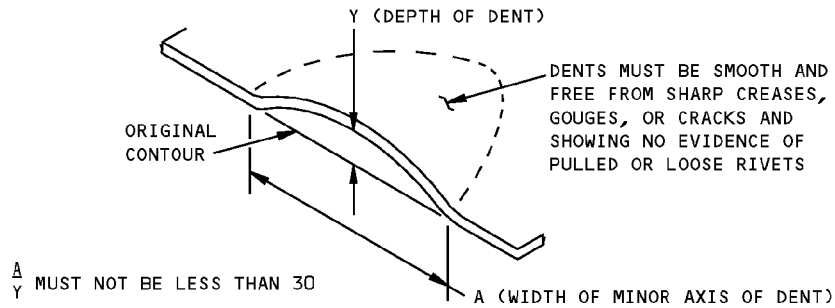

ALLOWABLE DAMAGE FOR DENT

DETAIL VIII

Reverser Cowl Ribs and Stringers Allowable Damage - RB211-535E4 Engine
Figure 101 (Sheet 4 of 5)

757-200
STRUCTURAL REPAIR MANUAL

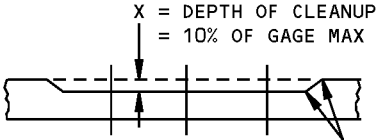
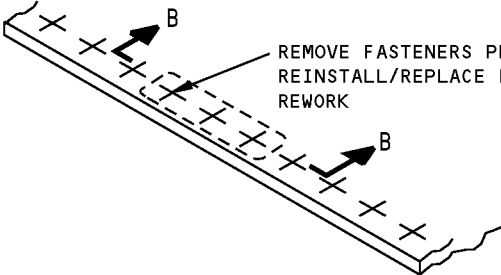

SMOOTH BLENDOUT RADIUS 0.50 INCH MINIMUM. CORROSION CLEANUP AROUND ANY THREE FASTENERS IN TEN IS PERMITTED TO MAX DEPTH

SECTION B-B

CORROSION CLEANUP
DETAIL XI

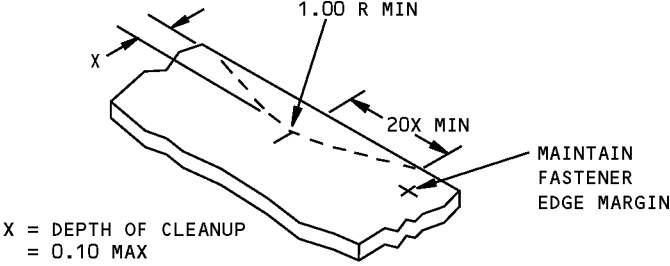

REMOVAL OF NICK OR CRACK DAMAGE ON AN EDGE
DETAIL X

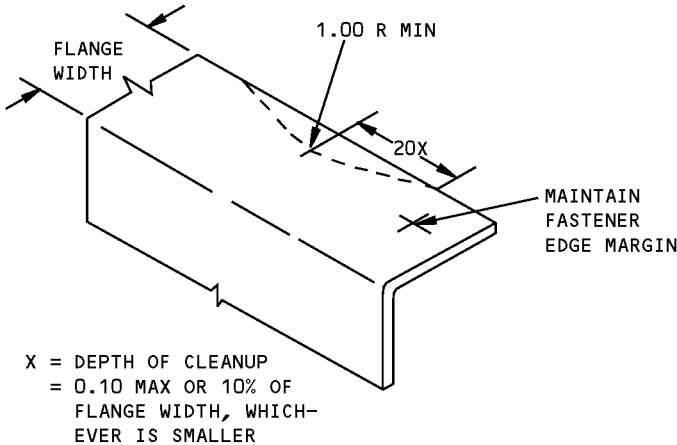

REMOVAL OF NICK OR CRACK DAMAGE ON AN EDGE
DETAIL XI

Reverser Cowl Ribs and Stringers Allowable Damage - RB211-535E4 Engine
Figure 101 (Sheet 5 of 5)

STRUCTURAL REPAIR MANUAL

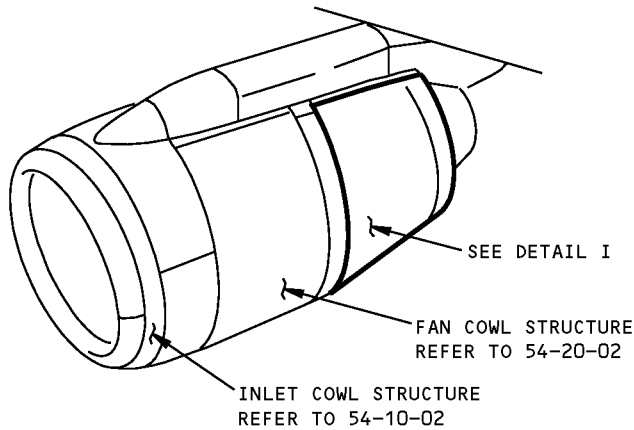
ALLOWABLE DAMAGE 2 - REVERSER COWL RIBS AND STRINGERS - RB211-535C ENGINE

NOTES

- A** CRACKS NOT ALLOWED EXCEPT FOR EDGE CRACKS WHICH MUST BE REMOVED PER DETAIL VI.
- B** REMOVE DAMAGE PER DETAILS VI, VII, AND IX.
- C** CRACKS NOT ALLOWED EXCEPT FOR EDGE CRACKS WHICH MUST BE REMOVED PER DETAILS VI AND X.
- D** CRACKS NOT ALLOWED EXCEPT FOR EDGE CRACKS WHICH MUST BE REMOVED PER DETAILS VI AND XI.

DESCRIPTION	CRACKS	NICKS, GOUGES AND CORROSION	DENTS	HOLES AND PUNCTURES
CLOSURE	C	B	NOT ALLOWED	NOT ALLOWED
UPPER CLOSURE	C	B	NOT ALLOWED	NOT ALLOWED
FILLER	B	B	NOT ALLOWED	NOT ALLOWED
UPPER SLUG	D	B	NOT ALLOWED	NOT ALLOWED
TRAILING EDGE	B	B	NOT ALLOWED	NOT ALLOWED
INTERCOSTAL	A	B	NOT ALLOWED	NOT ALLOWED
WEB	D	B	SEE DETAIL VIII	NOT ALLOWED
ANGLE	D	B	NOT ALLOWED	NOT ALLOWED
INNER SLIDER	C	B	NOT ALLOWED	NOT ALLOWED
AFT SLIDER BRACKET	D	B	NOT ALLOWED	NOT ALLOWED
FORWARD SLIDER BRACKET	D	B	NOT ALLOWED	NOT ALLOWED
OUTER SLIDER	C	B	NOT ALLOWED	NOT ALLOWED
LEADING EDGE	B	B	NOT ALLOWED	NOT ALLOWED
DOUBLER	B	B	NOT ALLOWED	NOT ALLOWED
BRACKET	D	B	NOT ALLOWED	NOT ALLOWED
LOWER SLIDER	C	B	NOT ALLOWED	NOT ALLOWED

Reverser Cowl Ribs and Stringers Allowable Damage - RB211-535C Engine
Figure 101 (Sheet 1 of 5)

757-200
STRUCTURAL REPAIR MANUAL

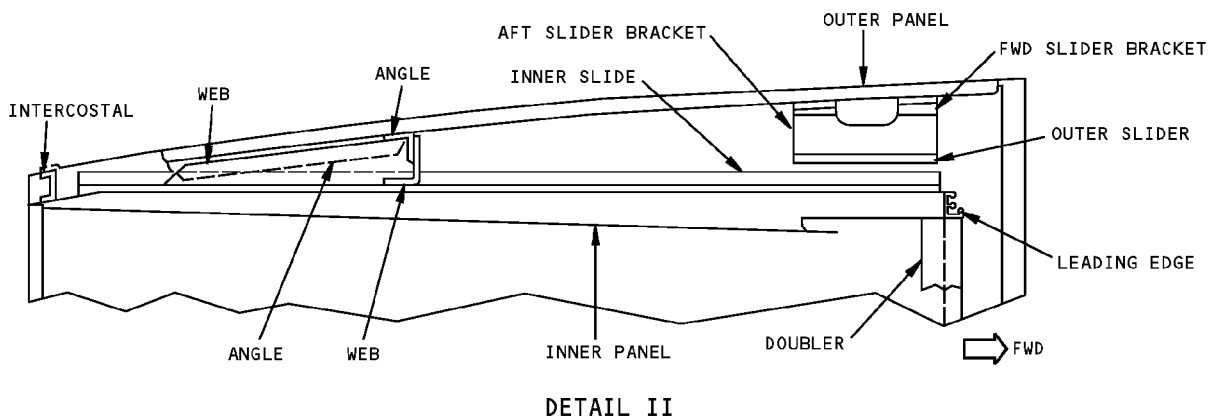
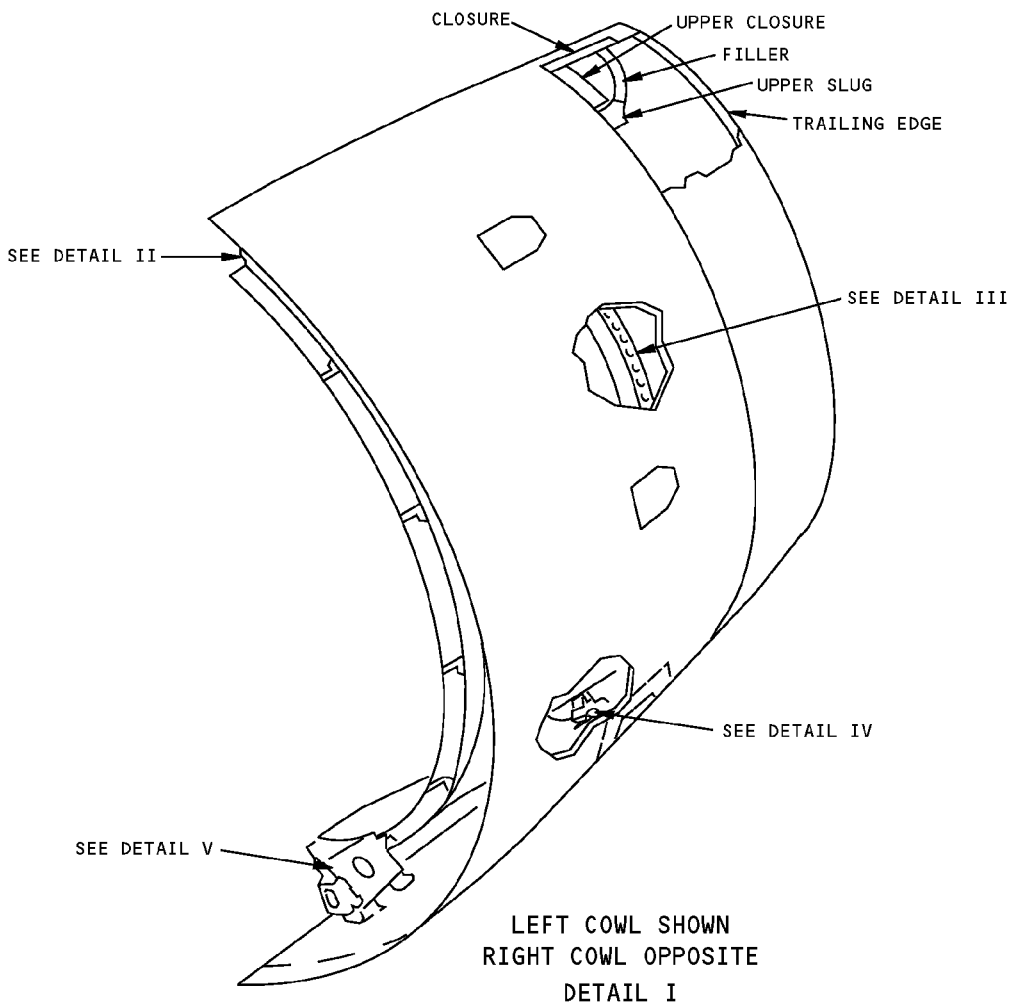

**Reverser Cowl Ribs and Stringers Allowable Damage - RB211-535C Engine
Figure 101 (Sheet 2 of 5)**

757-200
STRUCTURAL REPAIR MANUAL

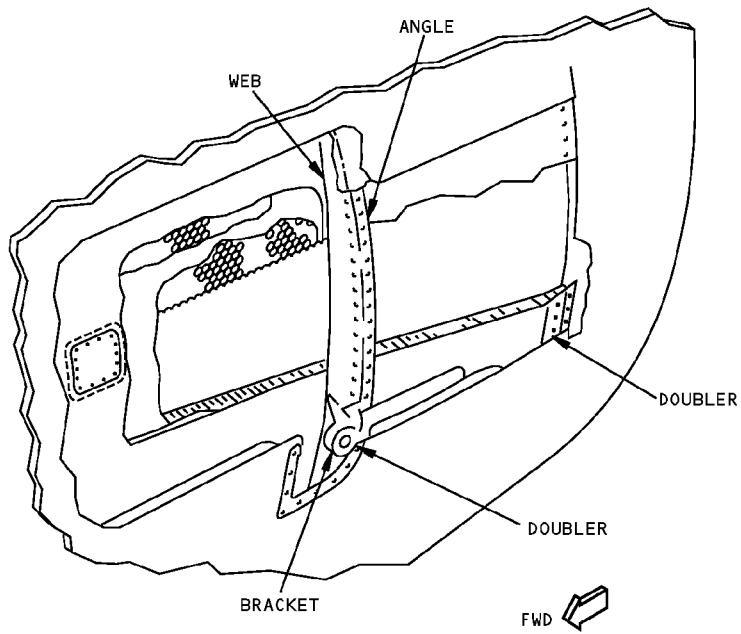

DETAIL III

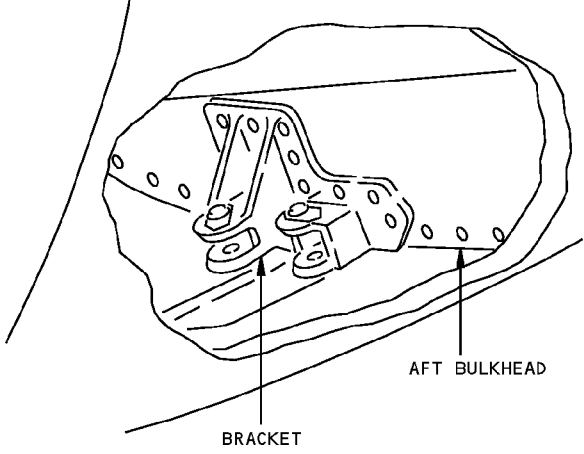

DETAIL IV

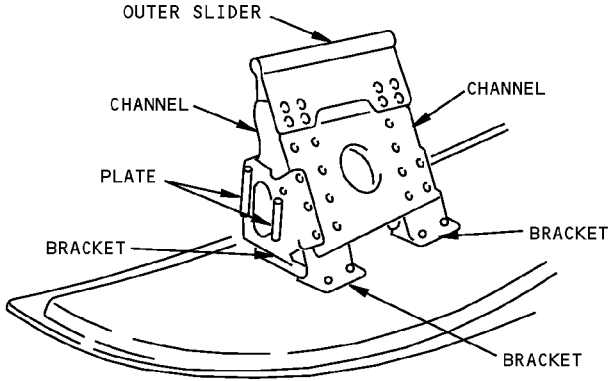

DETAIL V

Reverser Cowl Ribs and Stringers Allowable Damage - RB211-535C Engine
Figure 101 (Sheet 3 of 5)

STRUCTURAL REPAIR MANUAL

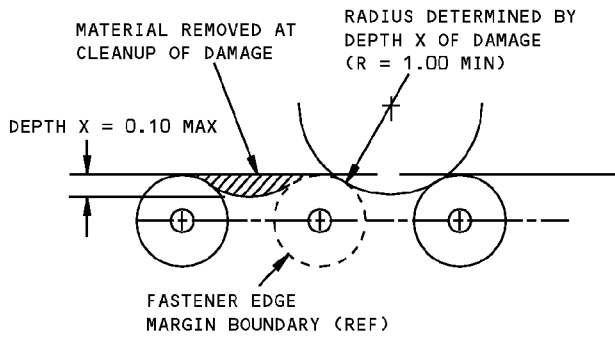

DAMAGE CLEANUP OF EDGES WHERE FASTENER EDGE MARGINS DO NOT OVERLAP

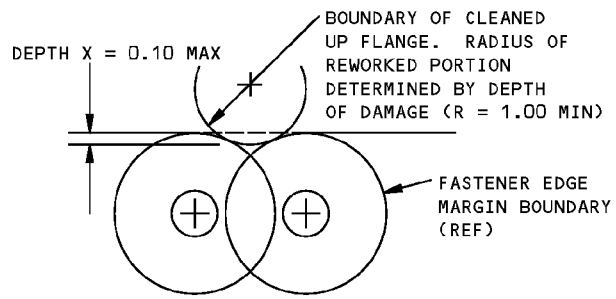

DAMAGE CLEANUP OF EDGES WHERE FASTENER EDGE MARGINS OVERLAP

DETAIL VI

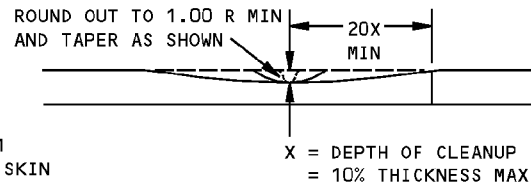
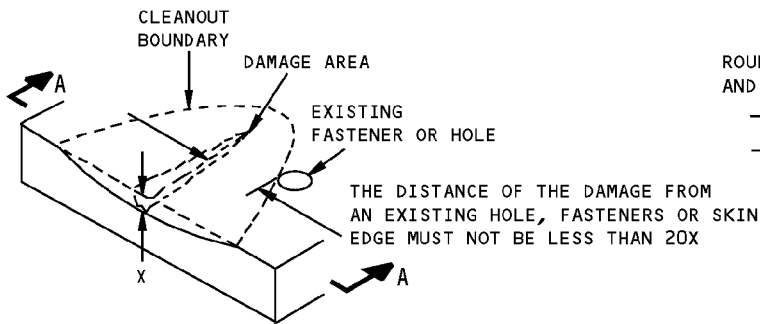

SECTION A-A

REMOVAL OF NICK, GOUGE AND SCRATCH DAMAGE ON A SURFACE

DETAIL VII

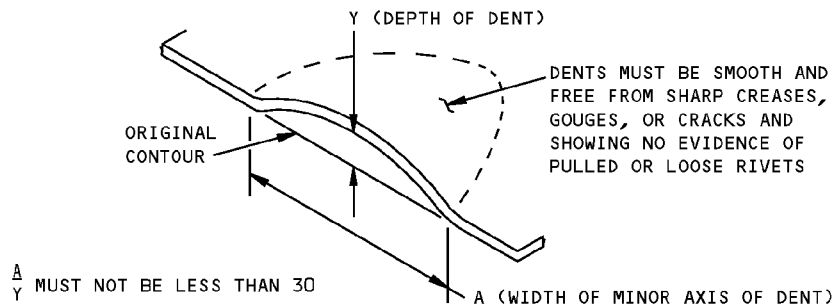

$\frac{A}{Y}$ MUST NOT BE LESS THAN 30

ALLOWABLE DAMAGE FOR DENT

DETAIL VIII

Reverser Cowl Ribs and Stringers Allowable Damage - RB211-535C Engine
Figure 101 (Sheet 4 of 5)

STRUCTURAL REPAIR MANUAL

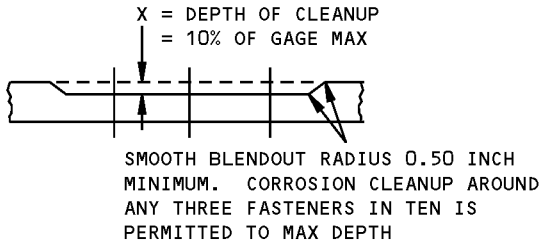
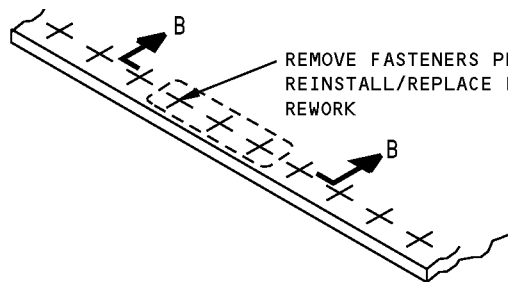

SECTION B-B

**CORROSION CLEANUP
DETAIL IX**

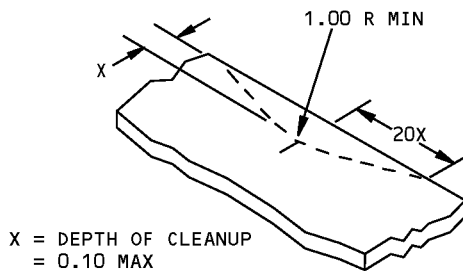

DETAIL X

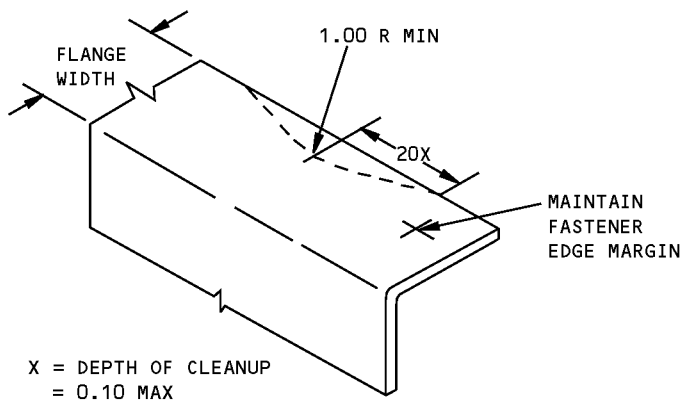

**REMOVAL OF NICK OR CRACK DAMAGE ON AN EDGE
DETAIL XI**

**Reverser Cowl Ribs and Stringers Allowable Damage - RB211-535C Engine
Figure 101 (Sheet 5 of 5)**

757-200
STRUCTURAL REPAIR MANUAL

REPAIR 1 - REVERSER COWL RIBS AND STRINGERS - RB211-535E4 ENGINE

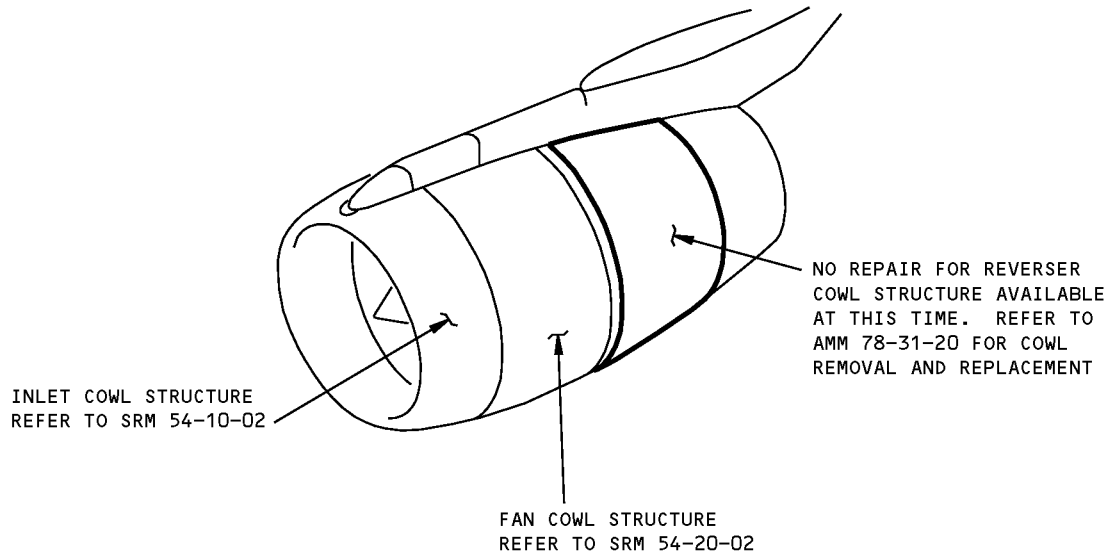

Reverser Cowl Ribs and Stringers Repair - RB211-535E4 Engine
Figure 201

757-200
STRUCTURAL REPAIR MANUAL

REPAIR 2 - REVERSER COWL RIBS AND STRINGERS - RB211-535C ENGINE

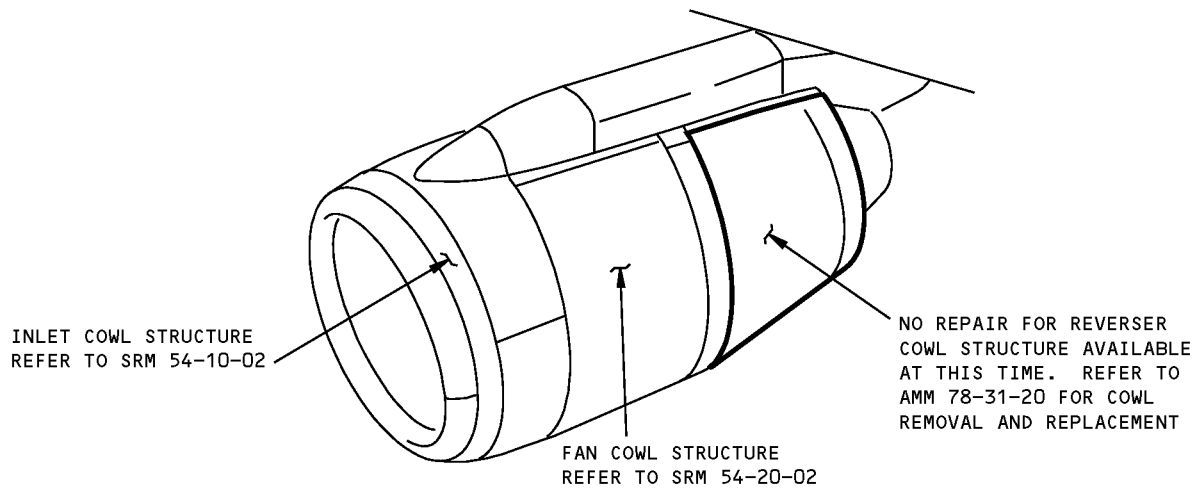

Reverser Cowl Ribs and Stringers Repair - RB211-535C Engine
Figure 201

757-200
STRUCTURAL REPAIR MANUAL

IDENTIFICATION 1 - TORQUE RING OUTER FAIRING - RB211-535E4 ENGINE

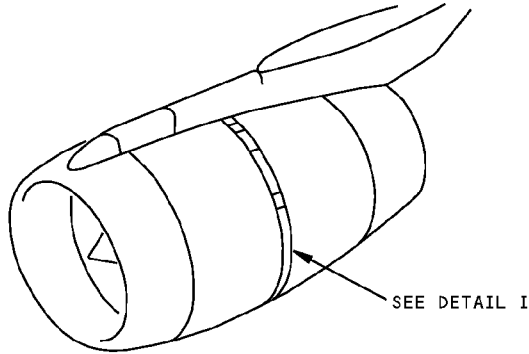

NOTES

- A** PLY ORIENTATION CONVENTION DEGREES INDICATED IS PARALLEL TO THE FABRIC WARP DIRECTION.
- B** GRAPHITE/EPOXY FABRIC RMS060, GROUP I, TYPE 2, CLASS 1, GRADE 1 (AH-370-5H/3501-5A, AS4 FIBER, V10396).
- C** REPAIR PLYS MUST BE ORIENTATED THE SAME AS THE OUTERMOST PLY ON WHICH THE REPAIR WILL BE APPLIED.
- D** FOR ENGINES WITHOUT SB 78-9722.
- E** FOR ENGINES WITH SB 78-9722.

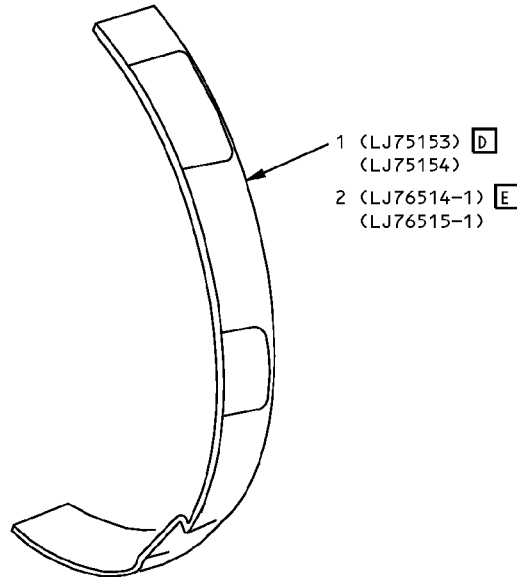

TORQUE RING OUTER FAIRING
LEFT SHOWN, RIGHT OPPOSITE
DETAIL I

ITEM	DESCRIPTION	GAGE	MATERIAL	EFFECTIVITY
1	TORQUE RING OUTER FAIRING		GRAPHITE/EPOXY LAMINATE (SEE DETAIL II)	D
2	TORQUE RING OUTER FAIRING	0.063	2024-O CLAD ALUMINUM	E

LIST OF MATERIALS FOR DETAIL I

**Torque Ring Outer Fairing Identification - RB211-535E4 Engine
Figure 1 (Sheet 1 of 2)**

757-200
STRUCTURAL REPAIR MANUAL

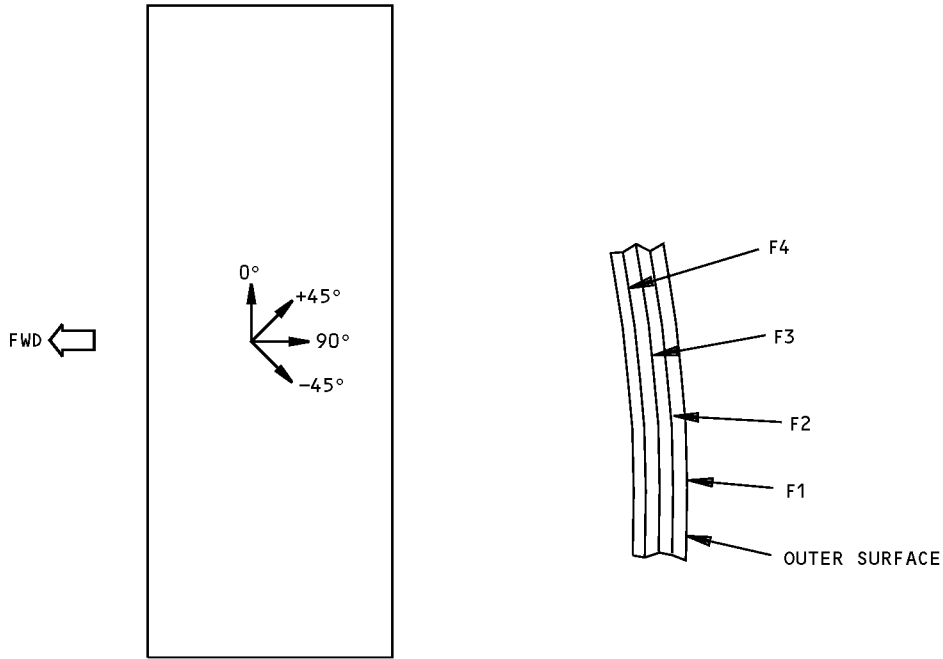

ITEM NO.	PLY NO.	MATERIAL	PLY A C ORIENTATION
1	F1	B	0°
	F2	B	0°
	F3	B	0°
	F4	B	0°

PLY TABLE

CAUTION: PROTECT AGAINST DISSIMILAR MATERIAL CORROSION; USE KEVLAR IN ALL REPAIRS INVOLVING METAL FITTINGS

DETAIL II

**Torque Ring Outer Fairing Identification - RB211-535E4 Engine
Figure 1 (Sheet 2 of 2)**

757-200
STRUCTURAL REPAIR MANUAL

IDENTIFICATION 2 - TORQUE RING OUTER FAIRING - RB211-535C ENGINE

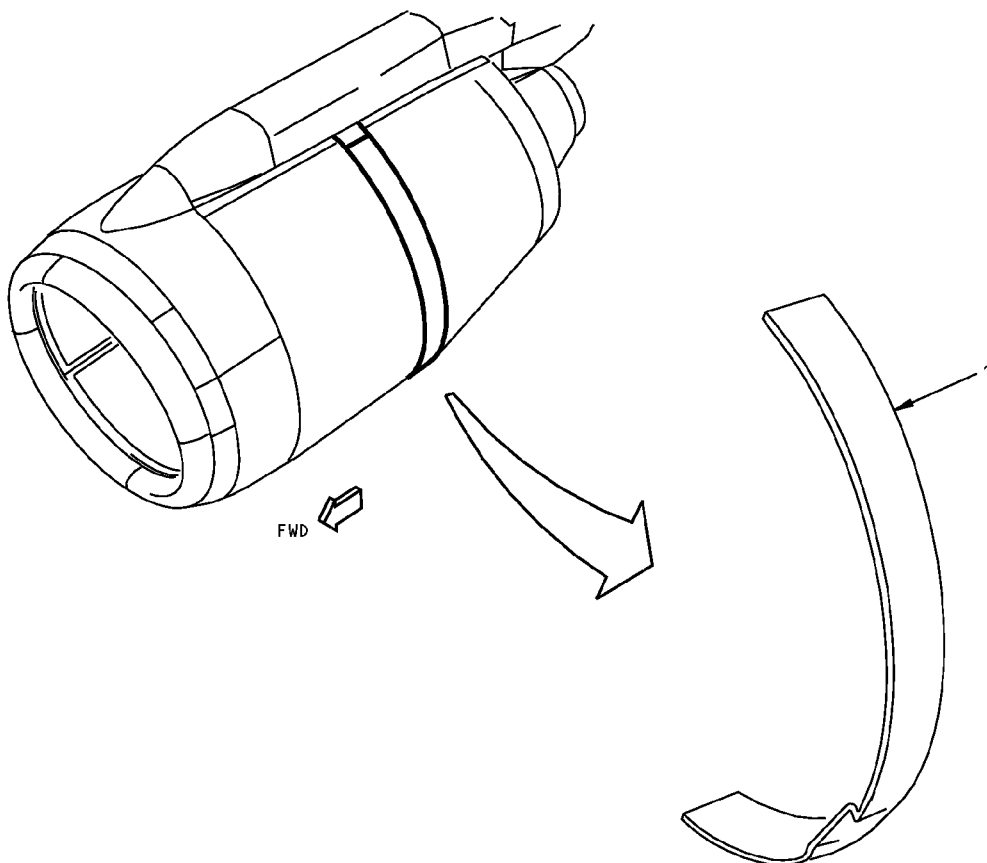

TORQUE RING OUTER FAIRING
LEFT SHOWN, RIGHT OPPOSITE

NOTES

- A** PLY ORIENTATION CONVENTION DEGREES INDICATED IS PARALLEL TO THE FABRIC WARP DIRECTION
- B** ARAMID EPOXY FABRIC PER RMS049 GROUP I, TYPE V (BMS218 STYLE 285)

- C** REPAIR PLIES MUST BE ORIENTATED THE SAME AS THE OUTERMOST PLY ON WHICH THE REPAIR WILL BE APPLIED

ITEM	DESCRIPTION	GAGE	MATERIAL	EFFECTIVITY
1	TORQUE RING OUTER FAIRING		ARAMID/EPOXY LAMINATE (SEE DETAIL I)	

LIST OF MATERIALS

Torque Ring Outer Fairing Identification - RB211-535C Engine
Figure 1

STRUCTURAL REPAIR MANUAL

ALLOWABLE DAMAGE 1 - TORQUE RING OUTER FAIRING - ALL RB211-535 ENGINES

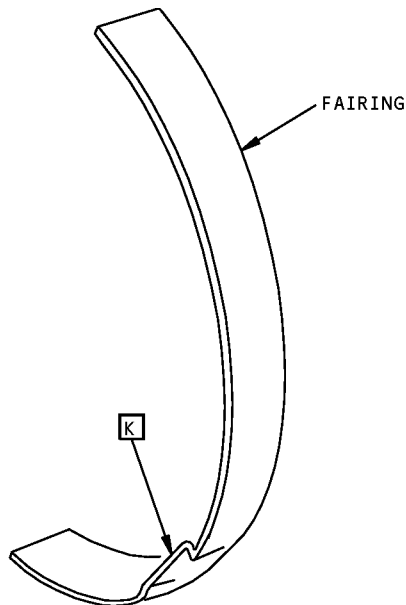
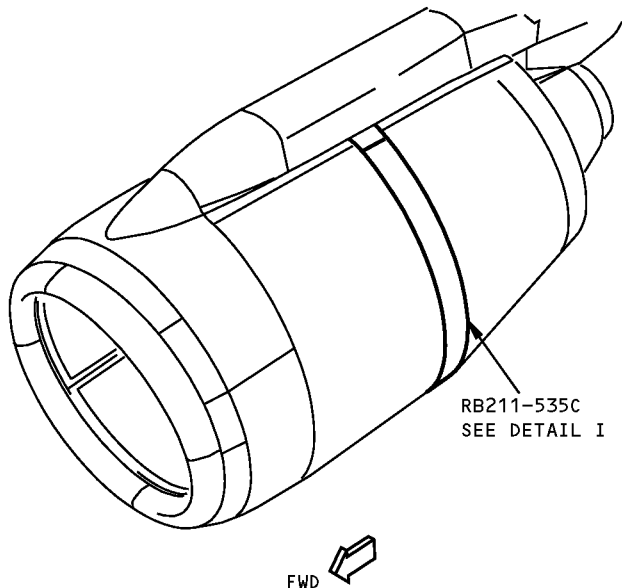

LEFT SIDE IS SHOWN, RIGHT SIDE IS OPPOSITE
TORQUE RING OUTER FAIRING
DETAIL I

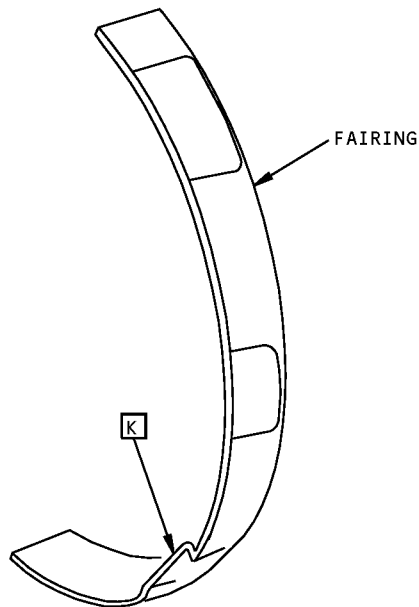
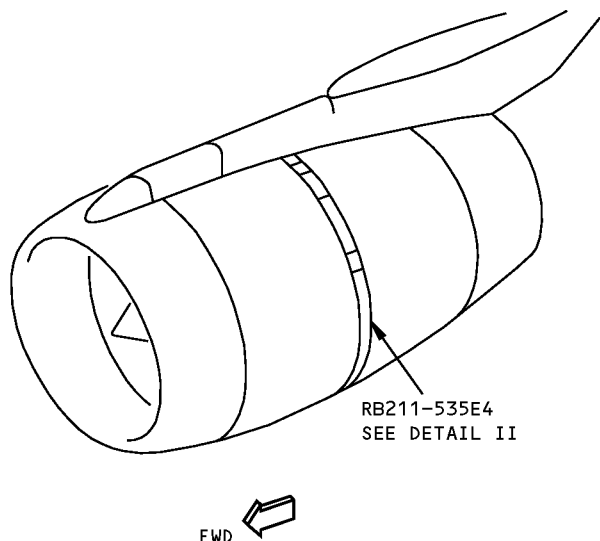

LEFT SIDE IS SHOWN, RIGHT SIDE IS OPPOSITE
TORQUE RING OUTER FAIRING
DETAIL II

**Torque Ring Outer Fairing Allowable Damage - All RB211-535 Engines
Figure 101 (Sheet 1 of 3)**

STRUCTURAL REPAIR MANUAL

DESCRIPTION	CRACKS	NICKS AND GOUGES	DENTS	HOLES AND PUNCTURES	DELAMINATION
FAIRING (GRAPHITE/ARAMID EPOXY LAMINATE)	B	F	E	C	D
FAIRING (ALUMINUM)	G	H	I	J	NOT APPLICABLE

NOTES

- THESE ALLOWABLE DAMAGE LIMITS ARE FAA APPROVED CONTINGENT ON ACCOMPLISHMENT OF THE INSPECTIONS AT THE INTERVALS CONTAINED HEREIN.
- REFER TO SRM 51-11-01 FOR AERODYNAMIC SMOOTHNESS REQUIREMENTS. WHERE DAMAGE IS MORE THAN THE LIMITS SHOWN IN SRM 51-11-01, CONSIDERATION SHOULD BE GIVEN TO LOSS OF PERFORMANCE INVOLVED.
- REFER TO SRM 51-10-02 FOR INSPECTION AND REMOVAL OF DAMAGE
- REFINISH REWORKED AREAS AS GIVEN IN AMM 51-20.
- DAMAGE TO PANEL EDGES MAY BE CONFINED TO DELAMINATION OR MAY TAKE A FORM WHICH RESULTS IN DAMAGE TO FIBERS AND A LOSS OF EFFECTIVE CROSS-SECTIONAL AREA. THIS TYPE OF DAMAGE SHOULD BE REMOVED AND THE LIMITATIONS GIVEN FOR CRACKS APPLIED.
- REFER TO SRM 51-21-05 FOR PROTECTIVE SEALING.
- REFER TO SRM 51-20-07 FOR FREEZE PLUG INSTALLATION.
- REFER TO SRM 51-70-01 FOR REPAIRS FOR MINOR DENTS IN METALLIC SHEET MATERIALS.

- A** PROTECT DAMAGE FROM ENTRANCE OF WATER, SUNLIGHT OR OTHER FOREIGN MATTER BY SEALING WITH ALUMINUM FOIL TAPE (SPEED TAPE) 3M-Y348. APPLY A BMS 5-63 FILLET SEAL TO THE EDGES OF THE TAPE. RECORD THE LOCATION AND INSPECT EACH AIRPLANE "A" CHECK. REPLACE THE ALUMINUM FOIL TAPE IF ANY PEELING OR DETERIORATION IS EVIDENT. REPAIR NO LATER THAN NEXT AIRPLANE "C" CHECK.
- B** 0.125 INCH (3.18 mm) MAXIMUM LENGTH FOR EACH SQUARE FOOT OF AREA AND A MINIMUM OF 10.0 INCHES (250 mm) FROM ANY OTHER DAMAGE. CLEAN UP EDGE CRACKS AS SHOWN IN DETAIL III. CRACKS THROUGH TWO CONSECUTIVE HOLES THROUGH EDGE BAND ARE PERMITTED, PROVIDED SUCH CRACKS ARE NOT LESS THAN 12.0 INCHES (300 mm) APART. **A**
- C** 0.25 INCH (6 mm) MAXIMUM DIAMETER PERMITTED PROVIDED DAMAGE IS MINIMUM OF 10.0 INCHES (250 mm) FROM OTHER DAMAGE, NEAREST HOLE, OR MATERIAL EDGE. DO NOT CLEAN UP DAMAGE EXCEPT TO REMOVE RESIN BURRS EXTENDING INTO SURFACE CONTOUR. **A**

- D** 1.0 INCH (25 mm) MAXIMUM DIAMETER IS PERMITTED. MAXIMUM OF 0.10 INCH (2.5 mm) DELAMINATION FROM EDGE IS PERMITTED. PROTECT EDGE DAMAGE AS GIVEN IN **A**
- E** 1.0 INCH (25 mm) MAXIMUM DIAMETER SMOOTH WITH NO CRACKS. **A**
- F** 0.015 INCH (0.38 mm) MAXIMUM DEPTH, 5.0 INCHES (125 mm) MAXIMUM LENGTH. CLEAN UP EDGE DAMAGE AS AS SHOWN IN DETAIL III. **A**
- G** 1.0 INCH (25 mm) MAXIMUM LENGTH AND 10.0 INCHES (250 mm) MINIMUM SEPARATION BETWEEN ANY TWO ADJACENT CRACKS:
- STOP DRILL EACH END OF THE CRACK AND DO THE STEPS IN **A**
 - AS AN ALTERNATIVE, REPAIR AS A HOLE.
- H** 1.5 INCH (38 mm) MAXIMUM LENGTH, 0.02 INCH (0.5 mm) MAXIMUM DEPTH, AND 0.10 INCH (2.5 mm) MAXIMUM WIDTH AND 3.0 INCH (75 mm) (MINIMUM SEPARATION BETWEEN ANY TWO ADJACENT NICKS OR GOUGES:
- DO THE STEPS IN **A**
 - AS AN ALTERNATIVE, REMOVE DAMAGED SURFACE COATINGS AND FINISHES, FILL DAMAGED AREA WITH AERODYNAMIC FILLER, AND REPAIR SURFACE COATINGS AND FINISHES.
- I** 1.0 INCH (25 mm) MAXIMUM DIAMETER, 0.12 INCH (3.05 mm) MAXIMUM DEPTH AND 10.0 INCHES (250 mm) MINIMUM SEPARATION BETWEEN ANY TWO ADJACENT DENTS:
- DO THE STEPS IN **A**
 - AS AN ALTERNATIVE, REPAIR AS NICK/GOUGE.
- J** 1.0 INCH (25 mm) MAXIMUM DIAMETER, 10.0 INCHES (250 mm) MINIMUM SEPARATION BETWEEN ANY TWO ADJACENT HOLES:
- DO THE STEPS IN **A**
 - AS AN ALTERNATIVE, INSTALL A COUNTERSUNK FREEZE PLUG IN EACH HOLE.
- K** CRACKS ARE NOT PERMITTED IN THE JOGGLED AREA.

Torque Ring Outer Fairing Allowable Damage - All RB211-535 Engines
Figure 101 (Sheet 2 of 3)

757-200
STRUCTURAL REPAIR MANUAL

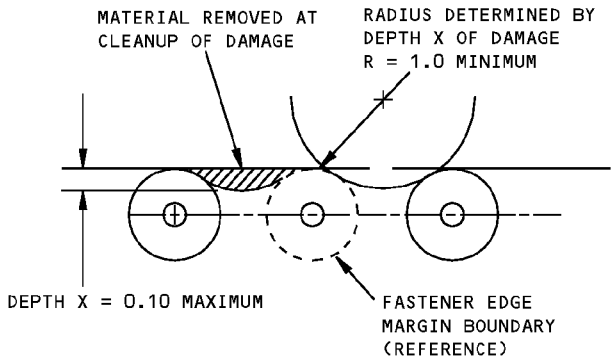

DAMAGE CLEANUP OF EDGES WHERE FASTENER EDGE MARGINS DO NOT OVERLAP

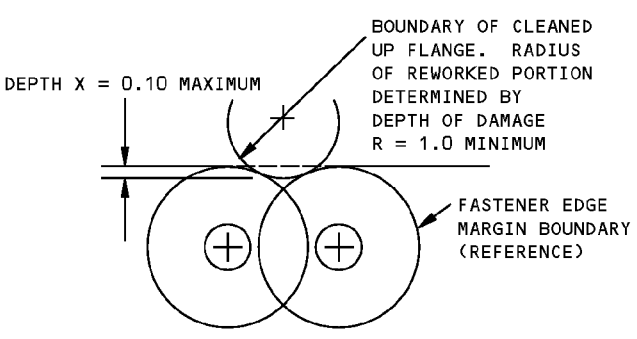

DAMAGE CLEANUP OF EDGES WHERE FASTENER EDGE MARGINS OVERLAP

DETAIL III

Torque Ring Outer Fairing Allowable Damage - All RB211-535 Engines
Figure 101 (Sheet 3 of 3)

757-200
STRUCTURAL REPAIR MANUAL

REPAIR 1 - TYPICAL TORQUE RING OUTER FAIRING - ALL RB211-535 ENGINES

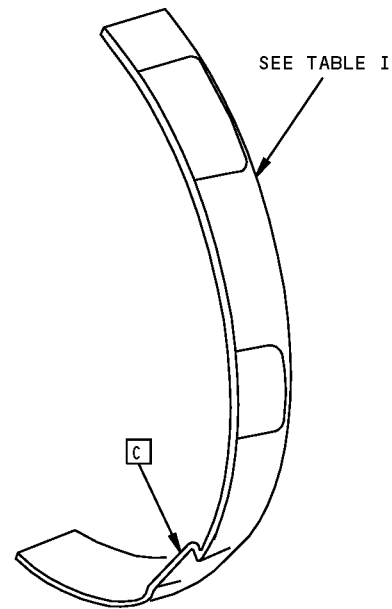
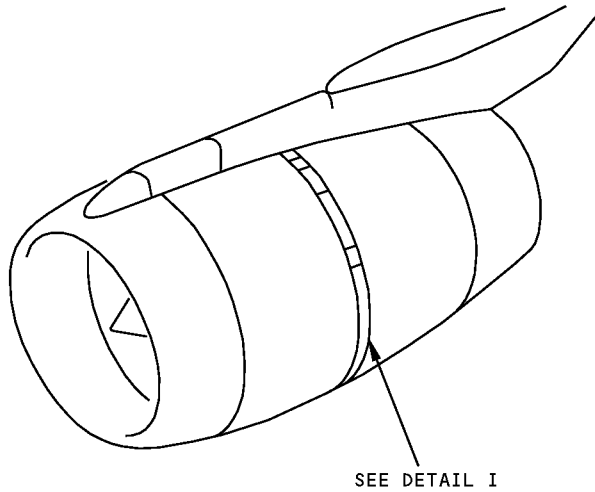

LEFT SIDE IS SHOWN, RIGHT SIDE IS OPPOSITE
TORQUE RING OUTER FAIRING
DETAIL I

NOTES

- A** INSPECT INTERIM REPAIR USING VISUAL AND "TAP" METHODS EVERY AIRPLANE "2A" CHECK. PERMANENT REPAIR IS REQUIRED IF ANY DETERIORATION IS EVIDENT.
- B** ONE REPAIR PER SQUARE FOOT OF AREA AND A MINIMUM OF 6.0 INCHES (EDGE TO EDGE) FROM ANY OTHER DAMAGE OR FASTENER HOLE AND A MINIMUM OF 3.0 INCHES FROM THE EDGE OF THE PANEL.
- C** CRACKS IN THE JOGGLED AREA MUST BE ANALYZED ON A CASE BY CASE BASIS. GET MORE INSTRUCTION FROM BOEING. YOU MUST PROVIDE THE RING SERIAL NUMBER AND GIVE THE EXACT LOCATION AND LENGTH FOR EACH CRACK.

Typical Torque Ring Outer Fairing Repair - All RB211-535 Engines
Figure 201 (Sheet 1 of 2)

STRUCTURAL REPAIR MANUAL

DAMAGE	INTERIM REPAIRS A	PERMANENT REPAIRS	
	WET LAYUP 150°F (66°C) CURE (SRM 51-71-03)	WET LAYUP 200°F (93°C) CURE (SRM 51-71-02)	350°F (177°C) CURE (SRM 51-71-01)
CRACKS	UP TO 3.0 INCHES (75 mm) LONG, REPAIR WITH PATCH AS SHOWN IN SRM 51-71-03 PAR. 5.P.	CLEAN UP DAMAGE AND REPAIR AS HOLE.	CLEAN UP DAMAGE AND REPAIR AS HOLE.
HOLES	3.0 INCHES (75 mm) MAX DIA NOT TO EXCEED 30% OF SMALLEST DIMENSION ACROSS PANEL AT THE DAMAGE LOCATION. FILL AND PATCH AS SHOWN IN SRM 51-71-03 PAR. 5.H.	6.0 INCHES (150 mm) MAXIMUM DIAMETER NOT TO EXCEED 50% OF SMALLEST DIMENSION ACROSS THE PANEL AT THE DAMAGE LOCATION. USE ONE EXTRA PLY FOR EACH FACESHEET REPAIRED. B C	NO SIZE LIMIT. C
DELAMI-NATION	CUT OUT AND REPAIR AS HOLE.		
NICKS AND GOUGES	IF THERE IS NO FIBER DAMAGE OR DELAMINATION, FILL NICKS OR GOUGES AS SHOWN IN SRM 51-71-03. IF THERE IS FIBER DAMAGE OR DELAMINATION, REPAIR AS A HOLE.		
DENTS	UP TO 2.0 INCHES (50 mm) DIA WITH NO FIBER DAMAGE OR DELAMINATION, FILL WITH BMS 5-28, TYPE 7 POTTING COMPOUND AND PATCH AS SHOWN IN SRM 51-71-03 B PAR. 4.M. OVER 2.0 INCHES (50 mm) DIA OR WITH FIBER DAMAGE OR DELAMINATION, REPAIR AS HOLE.		

Typical Torque Ring Outer Fairing Repair - All RB211-535 Engines
Figure 201 (Sheet 2 of 2)

757-200
STRUCTURAL REPAIR MANUAL

REPAIR 2 - TORQUE RING OUTER FAIRING - PATCH REPAIR - ALL RB211-535 ENGINES

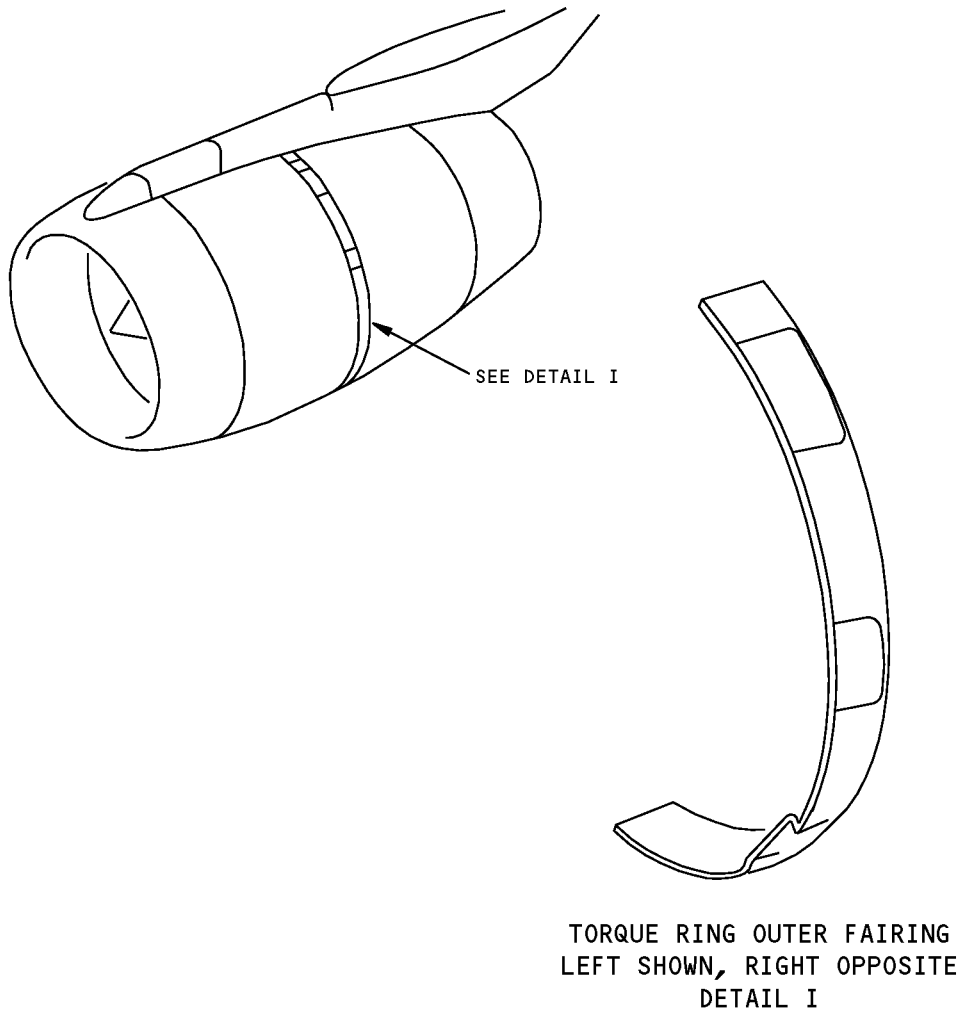

Torque Ring Outer Fairing - Patch Repair- All RB211-535 Engines
Figure 201 (Sheet 1 of 7)

STRUCTURAL REPAIR MANUAL

REPAIR INSTRUCTIONS

1. Prepare the damaged area by removing the metal parts which are closer than 1.25 inches from the edge of the damage. Drill out the fasteners and retain parts for refitment.
2. **WARNING:** PROTECTIVE GLOVES MUST BE WORN WHEN USING DEGREASERS. USE ONLY IN WELL VENTILATED AREAS. VERY INFLAMMABLE. KEEP AWAY FROM IGNITION SOURCES.

Clean around the damage area using clean cotton cloth and methylethylketone. Wipe dry before solvent evaporates.

3. **WARNING:** SANDING OR CUTTING OF COMPOSITE MATERIALS PRODUCES DUST AND FLYING PARTICLES WHICH ARE POTENTIAL HEALTH HAZARDS. WEAR PROTECTIVE CLOTHING, GLOVES, DUST MASKS AND SAFETY GLASSES. AVOID BREATHING DUST AND PROLONGED CONTACT OF DUST ON THE SKIN.

Cut away the damaged fairing. Refer to Details II, III, and IV. If necessary, peel down the edge of the reinforcing plies in the area of the repair.

4. Cut the repair patch from the repair parts for the fairing and rub strip. Refer to Details V and VI.
5. Position the repair patch on the inner surface over the damage cut-out and mark out for fasteners. Refer to Details VI and VII.
6. Drill the fastener holes and deburr.
7. Lightly abrade the faying surfaces using 180 grit abrasive paper in a back and forth motion to matt the surface.
8. **WARNING:** PROTECTIVE GLOVES MUST BE WORN WHEN USING DEGREASERS. USE ONLY IN WELL VENTILATED AREAS. VERY INFLAMMABLE. KEEP AWAY FROM IGNITION SOURCES.

Clean the repair area using clean cotton cloth and methylethylketone. Wipe dry before solvent evaporates. To avoid contamination, handle cleaned parts with cotton fiber gloves.

9. **WARNING:** USE EPOXY COMPOUNDS ONLY IN WELL VENTILATED AREAS. TAKE PRECAUTIONS TO PREVENT MATERIAL FROM COMING INTO CONTACT WITH SKIN.

Using short bristle brush, apply EA956 adhesive to the faying surfaces of repair patch.

10. Clamp the repair patch into position and wet install the blind rivets NAS1739M4-3 and washers AN960C6 using PR-1431-GB-2 sealant. Rivet heads should be flush to 0.004 underflush. Rivet shaving is not allowed.
11. Using explosion proof heat lamps, cure the adhesive at 180-280°F (82-138°C) for 1 hour.
12. **WARNING:** USE SEALANT ONLY IN WELL VENTILATED AREAS. TAKE PRECAUTIONS TO PREVENT MATERIAL FROM COMING INTO CONTACT WITH THE SKIN.
13. Clamp the rub strip into place maintaining 0.005-0.010 inch sealant thickness.
14. Cure the sealant at room temperature for 2 hours, then use explosion proof heat lamps at 170-180°F (72-88°C) for 1 1/2 hours.
15. Clean the remaining adhesive off the metal parts using 180 grit abrasive paper.
16. Lightly abrade the faying surfaces using 180 grit abrasive paper.
17. **WARNING:** PROTECTIVE GLOVES MUST BE WORN WHEN USING DEGREASERS. USE ONLY IN WELL VENTILATED AREAS. VERY INFLAMMABLE. KEEP AWAY FROM IGNITION SOURCES.

Clean the faying surfaces using a clean cotton cloth and methylethylketone. Wipe dry before the solvent evaporates.

18. **WARNING:** USE EPOXY COMPOUNDS ONLY IN WELL VENTILATED AREAS. TAKE PRECAUTIONS TO PREVENT MATERIAL FROM COMING INTO CONTACT WITH THE SKIN.
- Using a short bristle brush, apply adhesive EA934NA to the faying surfaces.
19. Position and clamp the metal parts onto fairing and wet install the blind rivets NAS1739M4-3 and washer AN960C6 using PR1431-GB-2 sealant. Install the rivets flush to 0.004 inch underflush. Rivet shaving is not allowed.
 20. Using explosion proof heat lamps, cure the adhesive at 180-280°F (82-138°C) for 1 hour.
 21. Prepare for surface finish by lightly abrading the faying surface using 180 grit abrasive paper.

**Torque Ring Outer Fairing - Patch Repair- All RB211-535 Engines
Figure 201 (Sheet 2 of 7)**

757-200
STRUCTURAL REPAIR MANUAL

REPAIR INSTRUCTIONS (CONT)

22. **WARNING:** PROTECTIVE GLOVES MUST BE WORN WHEN USING DEGREASERS. USE ONLY IN WELL VENTILATED AREAS. VERY INFLAMMABLE. KEEP AWAY FROM IGNITION SOURCES.

Clean the damage area using a clean cotton cloth and methylethylketone. Wipe dry before the solvent evaporates.

23. **WARNING:** USE EPOXY COMPOUNDS ONLY IN WELL VENTILATED AREAS. TAKE PRECAUTIONS TO PREVENT MATERIAL FROM COMING INTO CONTACT WITH SKIN.

Prepare the adhesive EA956. Add 15% to 20% by weight of chopped fibreglass (1/32-1/16 inch long fibres). Mix until a paste consistency is achieved.

24. Cut a fabric fibreglass 120 style patch the same size as the repair patch.
25. Using adhesive/fibreglass mixture, fill void flush to surface. Refer to Detail VIII.
26. Apply EA956 to fabric patch using a brush to impregnate through fabric. Avoid entrapping air and causing voids.
27. Cure the adhesive 2 hours at room temperature to gel, then use explosion proof heat lamps at 180-280°F (82-183°C) for 1 hour.
28. **WARNING:** SANDING OR CUTTING OF COMPOSITE MATERIALS PRODUCES DUST AND FLYING PARTICLES WHICH ARE POTENTIAL HEALTH HAZARDS. WEAR PROTECTIVE CLOTHING, GLOVES, DUST MASKS, AND SAFETY GLASSES. AVOID BREATHING OF DUST OR PROLONGED CONTACT OF DUST ON THE SKIN.

Lightly abrade the outside surface to a smooth contour using 180 grit abrasive paper.

29. Visually inspect the repair area.
30. Refinish the reworked area per 78-31-20 of the Maintenance Manual.

REPAIR MATERIAL		
PART	QTY	MATERIAL
FAIRING REPAIR PART		ARAMID FIBER (LJ 71835) 535C (LJ 76103) 535E4
RUB STRIP		NYLATRON (LJ 71871)

Torque Ring Outer Fairing - Patch Repair- All RB211-535 Engines
Figure 201 (Sheet 3 of 7)

757-200
STRUCTURAL REPAIR MANUAL

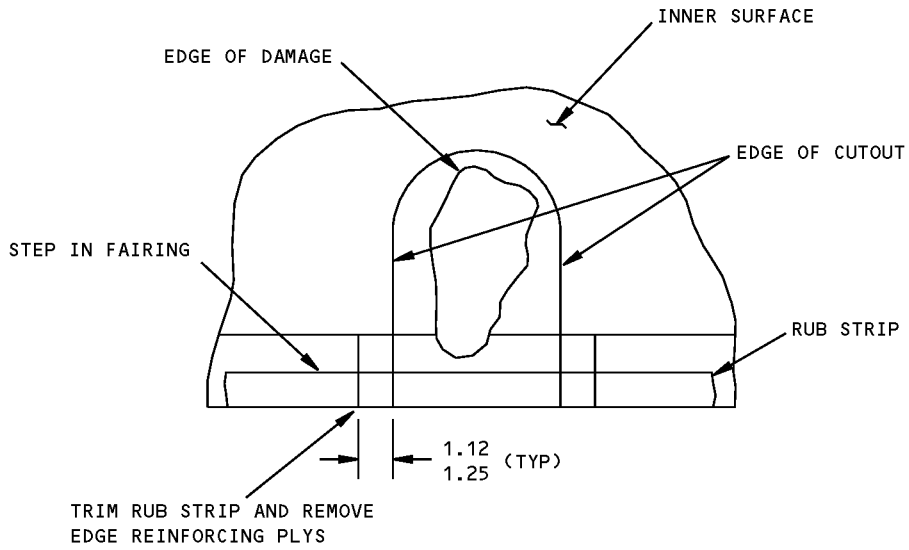
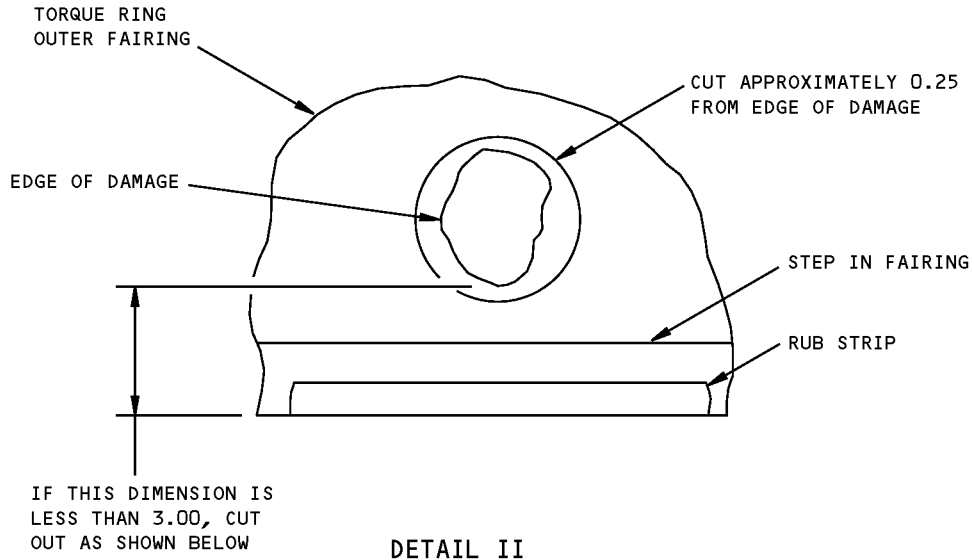

DETAIL III

A9477A

**Torque Ring Outer Fairing - Patch Repair- All RB211-535 Engines
Figure 201 (Sheet 4 of 7)**

757-200
STRUCTURAL REPAIR MANUAL

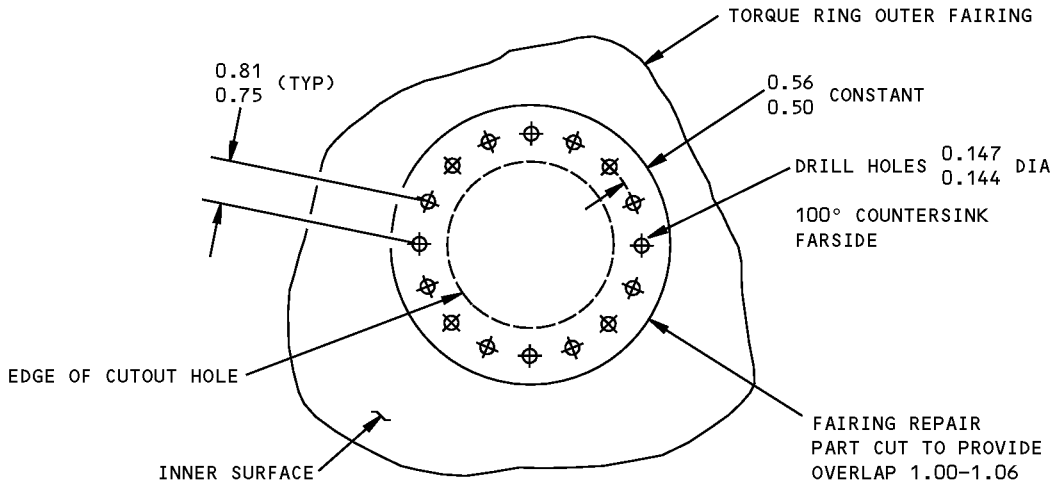

DETAIL IV

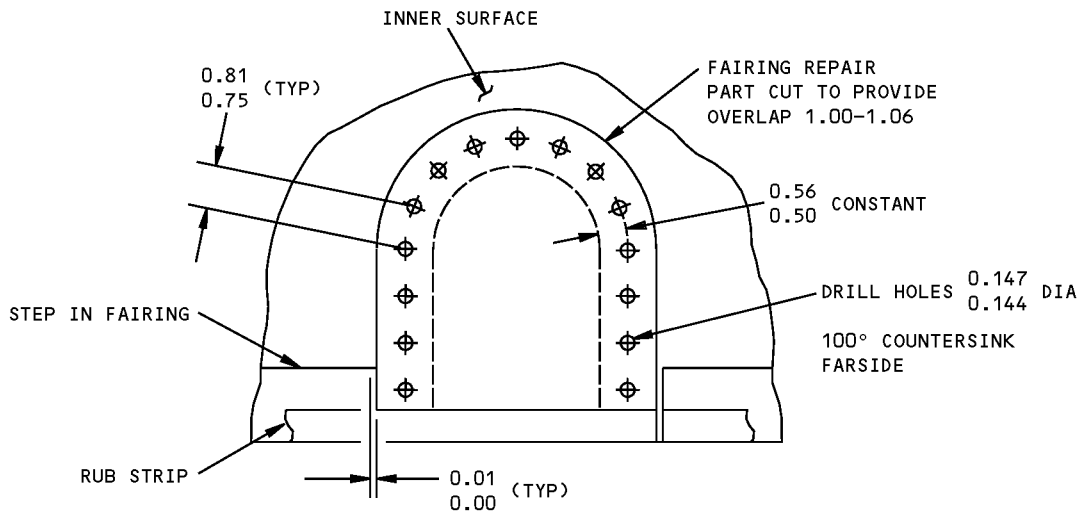

DETAIL V

A9479A

Torque Ring Outer Fairing - Patch Repair- All RB211-535 Engines
Figure 201 (Sheet 5 of 7)

STRUCTURAL REPAIR MANUAL

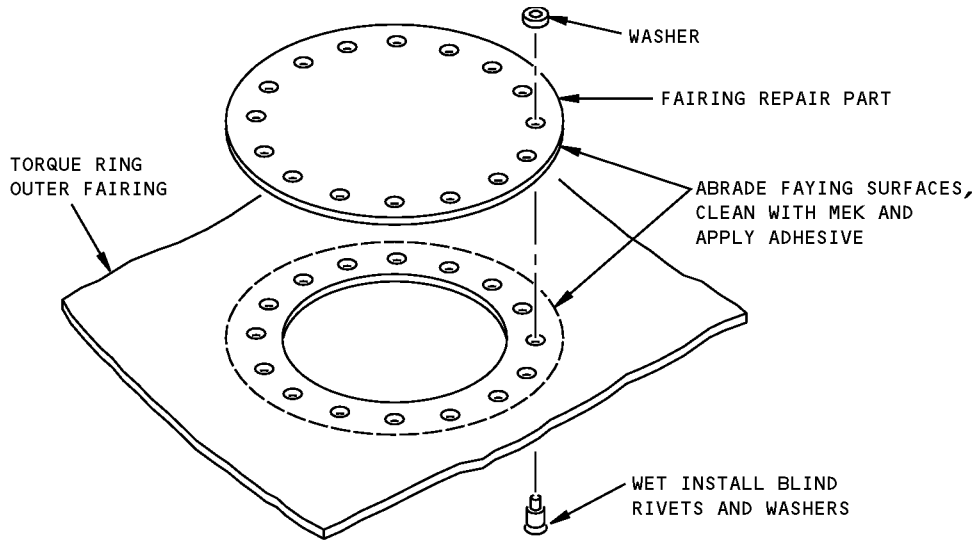

DETAIL VI

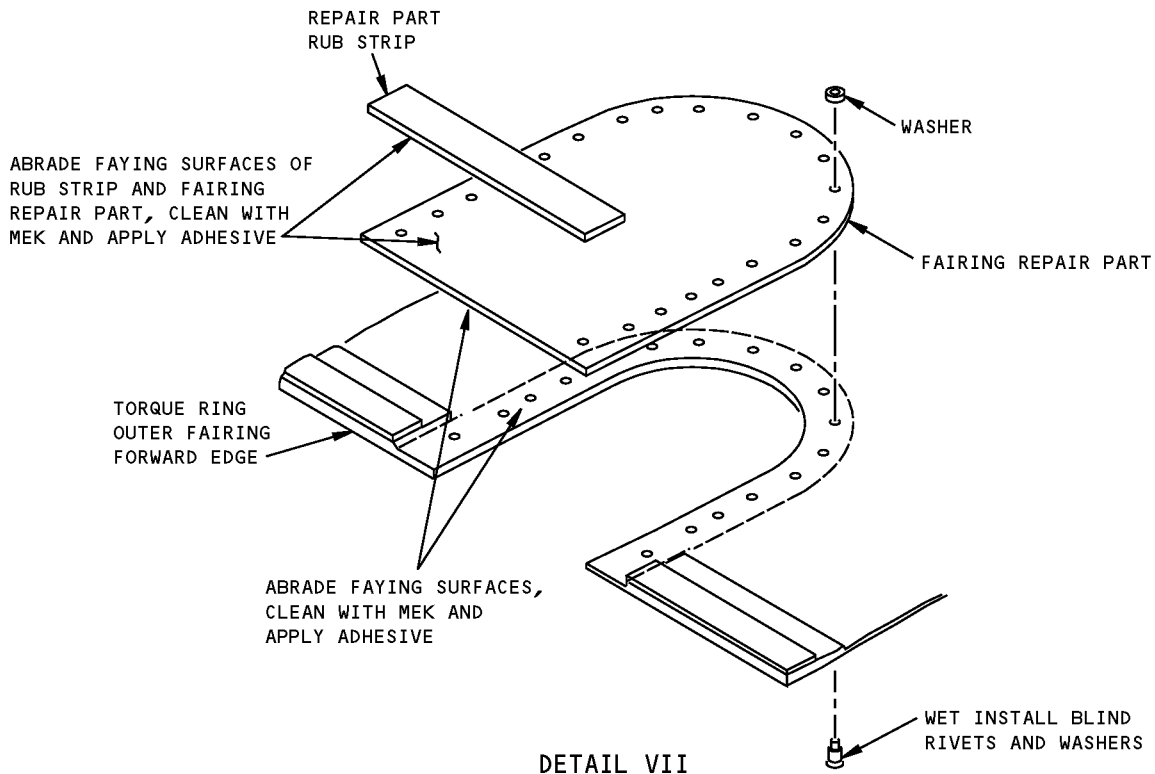

DETAIL VII

A9480A

**Torque Ring Outer Fairing - Patch Repair- All RB211-535 Engines
Figure 201 (Sheet 6 of 7)**

757-200
STRUCTURAL REPAIR MANUAL

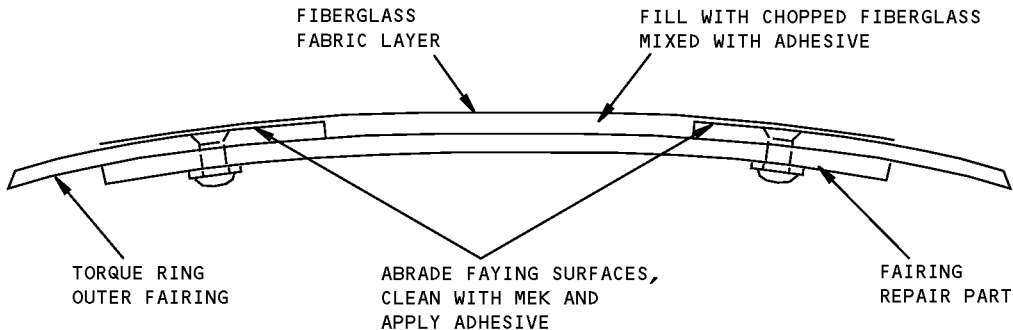

DETAIL VIII

A9481A

Torque Ring Outer Fairing - Patch Repair- All RB211-535 Engines
Figure 201 (Sheet 7 of 7)

**757-200
STRUCTURAL REPAIR MANUAL**

IDENTIFICATION 1 - FAN DUCT COWL AND THRUST REVERSER SKIN - PW2000 ENGINE

REF DWG
315N3001

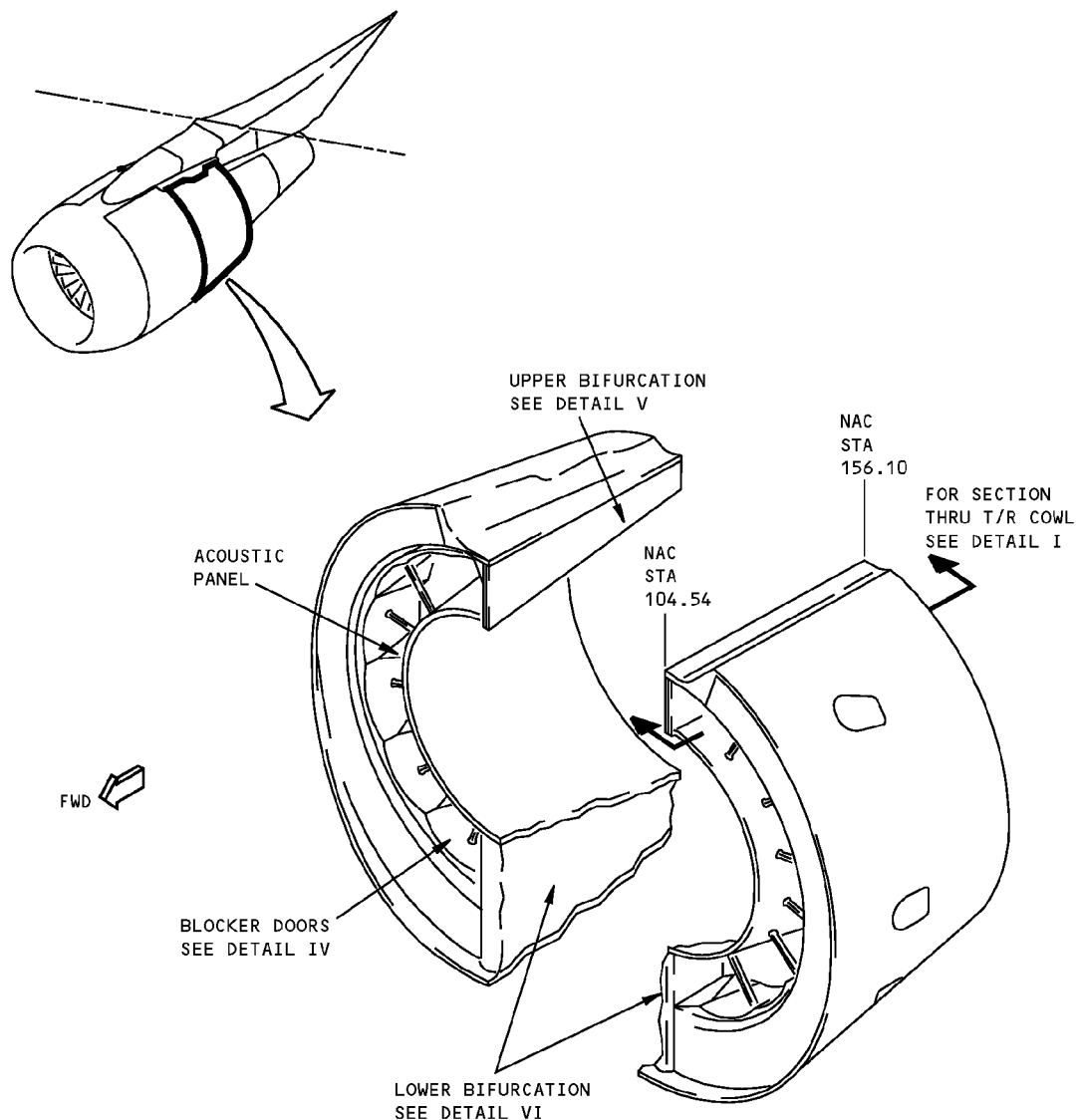

NOTES

- | | |
|--|---|
| <p>A PLY ORIENTATION CONVENTION, DEGREES INDICATED IS PARALLEL TO THE FABRIC WARP DIRECTION</p> <p>B EPOXY IMPREGNATED GRAPHITE FABRIC PER BMS 8-212, TYPE III, CLASS 2, STYLE 3K-135-8H, 350°F (177°C) CURE</p> <p>C EPOXY IMPREGNATED ARAMID FABRIC PER BMS 8-218, STYLE 120, 350°F (177°C) CURE</p> <p>D MATERIAL AND PLY ORIENTATION SHOWN FOR FIELD AREAS ONLY. SEE ENGINEERING DRAWINGS FOR EDGE BANDS AND AREAS WITH DOUBLERS</p> | <p>E HONEYCOMB CORE GRADES VARY THROUGHOUT PANEL. SEE ENGINEERING DRAWINGS FOR DETAILS</p> <p>F EPOXY IMPREGNATED GRAPHITE FABRIC PER BMS 8-212, TYPE IV, CLASS 2, STYLE 3K-70-PW, 350°F (177°C) CURE</p> <p>G FIBERGLASS PREPREG FABRIC PER BMS 8-139, TYPE 120, 350°F (177°C) CURE</p> |
|--|---|

**Fan Duct Cowl and Thrust Reverser Skin Identification - PW2000 Engine
Figure 1 (Sheet 1 of 8)**

**757-200
STRUCTURAL REPAIR MANUAL**

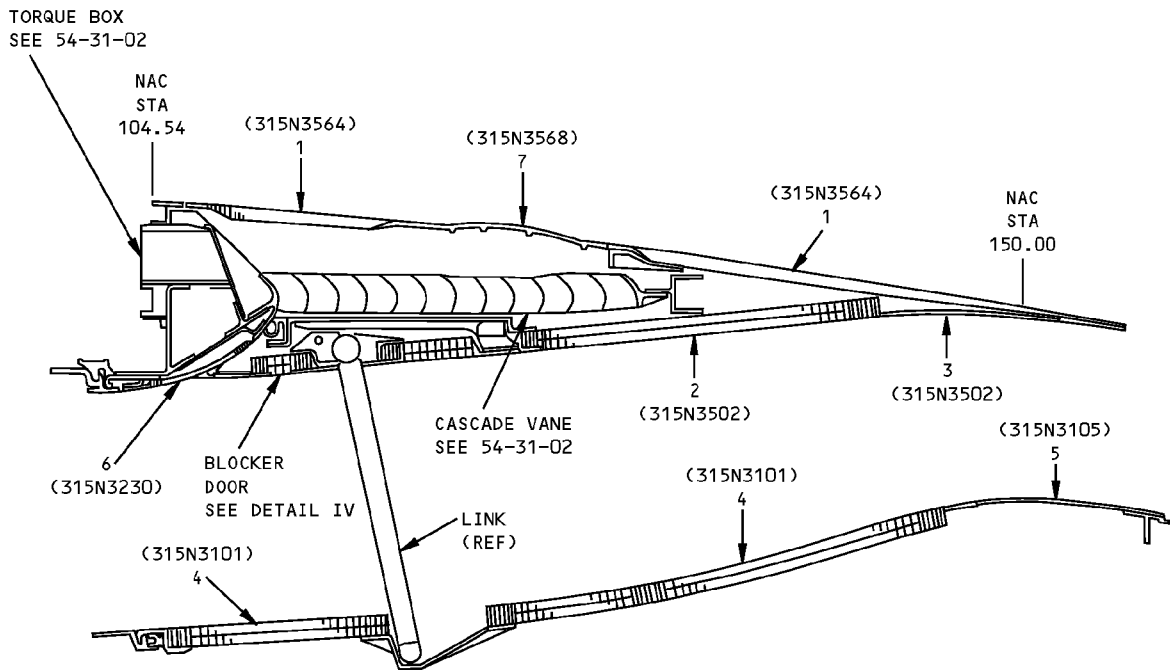

DETAIL I



**Fan Duct Cowl and Thrust Reverser Skin Identification - PW2000 Engine
Figure 1 (Sheet 2 of 8)**

IDENTIFICATION 1
Page 2
Jan 20/2005

54-31-01

D634N201



**757-200
STRUCTURAL REPAIR MANUAL**

ITEM	DESCRIPTION	GAGE	MATERIAL	EFFECTIVITY
1	OUTER COWL PANEL ASSY SKIN CORE		GRAPHITE/ARAMID/EPOXY HONEYCOMB SANDWICH SEE DETAIL II NONMETALLIC HONEYCOMB PER BMS 8-124, CLASS IV, TYPE V [E]	
2	ACOUSTIC PANEL ASSY OUTER SKIN CORE	0.020	2024-T81 ALUMINUM HONEYCOMB PER BMS 4-4, TYPE 6-30N, FORM B	
	INNER SKIN	0.025	PERFORATED SHEET CLAD 2024-T62 PER BMS 7-209, TYPE 1B-25, GRADE 1A, CLASS 50-109	
3	BONDED SKIN ASSY SKIN	0.025	2024-T81	
	DOUBLER	0.071	2024-T81	
4	ACOUSTIC PANEL ASSY OUTER SKIN CORE	0.071	2024-T81 CHEM MILLED ALUMINUM HONEYCOMB PER BMS 4-4, TYPE 6-30N	
	INNER SKIN	0.032	PERFORATED SHEET CLAD 2024-T62, PER BMS 7-209, TYPE 1B-32, GRADE 1B, CLASS 50-109	
5	BONDED SKIN ASSY OUTER SKIN	0.040	2024-T3	
	INNER SKIN	0.032	2024-T3	
6	BULLNOSE PANEL ASSY SKIN CORE		GRAPHITE/FIBERGLASS/EPOXY HONEYCOMB SANDWICH SEE DETAIL III NONMETALLIC HONEYCOMB PER BMS 8-124, TYPE V, CLASS IV, GRADE 3	
7	ACTUATOR ACCESS PANEL		7075-T7351 MACHINED PLATE	

LIST OF MATERIALS FOR DETAIL I

**Fan Duct Cowl and Thrust Reverser Skin Identification - PW2000 Engine
Figure 1 (Sheet 3 of 8)**

D634N201

54-31-01

IDENTIFICATION 1
Page 3
Jan 20/2005

**757-200
STRUCTURAL REPAIR MANUAL**

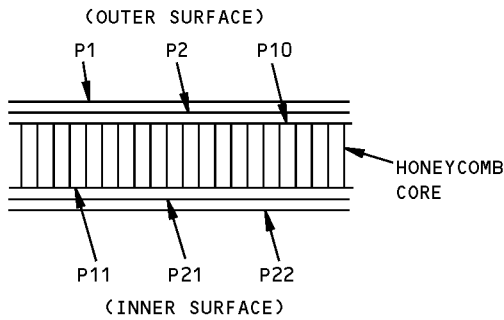

ITEM NO.	PLY NO.	MATERIAL	PLY ORIENTATION ^A
1	P1,P22	^B	0°
	P2,P21	^B	+45°
	P10,P11	^C	-45°

PLY TABLE ^D

SECTION THRU HONEYCOMB PANEL

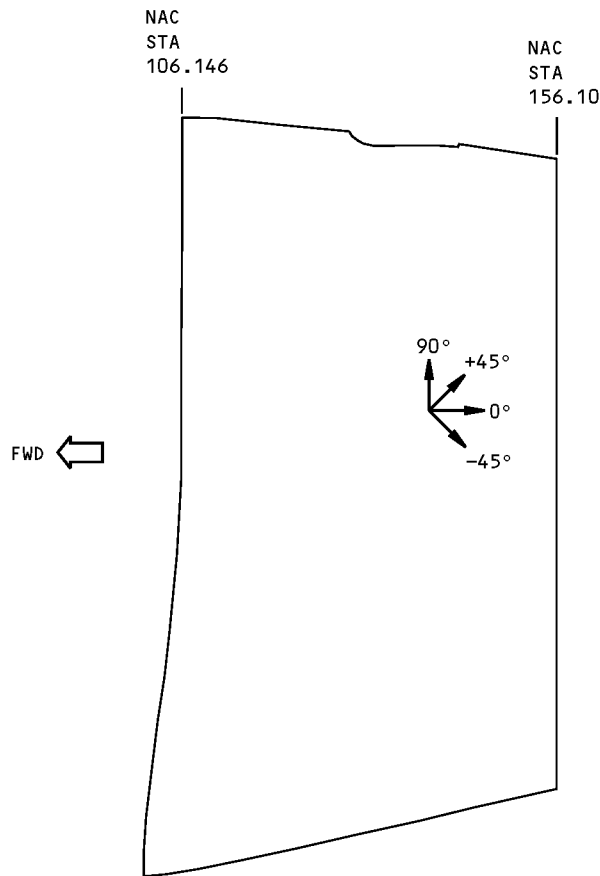

PLY ORIENTATION DIAGRAM ^A
DETAIL II

**Fan Duct Cowl and Thrust Reverser Skin Identification - PW2000 Engine
Figure 1 (Sheet 4 of 8)**

**757-200
STRUCTURAL REPAIR MANUAL**

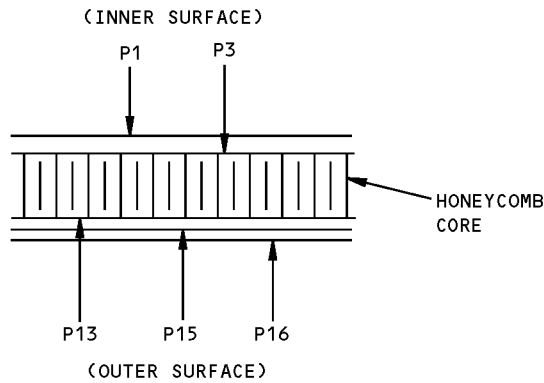

SECTION THRU HONEYCOMB PANEL

ITEM NO.	PLY NO.	MATERIAL	PLY ORIENTATION ^[A]
6	P1,P15	[F]	0° OR 90°
	P3,P13	[F]	±45°
	P16	[G]	±45°

PLY TABLE [E]

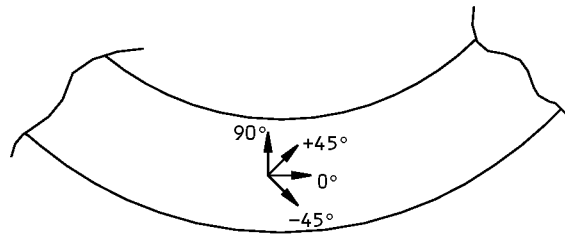

REAR VIEW
DIAGRAM OF PLY ORIENTATION [A]

DETAIL III

**Fan Duct Cowl and Thrust Reverser Skin Identification - PW2000 Engine
Figure 1 (Sheet 5 of 8)**

**757-200
STRUCTURAL REPAIR MANUAL**

REF DWG
315N3500

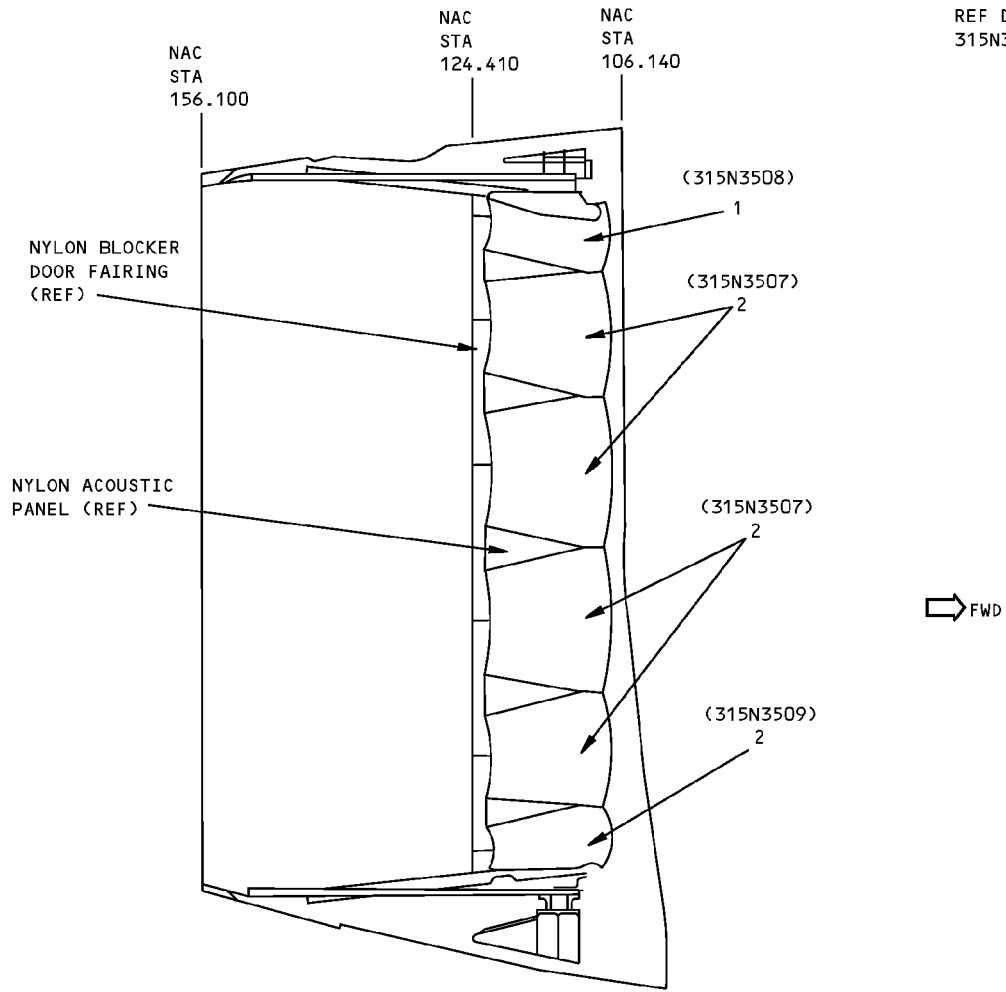

LEFT SIDE SHOWN
RIGHT SIDE OPPOSITE
DETAIL IV

ITEM	DESCRIPTION	GAGE	MATERIAL	EFFECTIVITY
1	BLOCKER DOOR ASSY - UPPER			
	OUTER SKIN CORE	0.025	2024-T81 ALUMINUM HONEYCOMB PER BMS 4-4, TYPE 6-40N, FORM B	
	INNER SKIN	0.025	2024-T62	
2	BLOCKER DOOR ASSY			
	OUTER SKIN CORE	0.025	2024-T81 ALUMINUM HONEYCOMB PER BMS 4-4, TYPE 6-40N, FORM B	
	INNER SKIN	0.050	PERFORATED SHEET CLAD 2024-T62 PER BMS 7-209, TYPE 1B-50, GRADE 1B, CLASS 50-109	

LIST OF MATERIALS FOR DETAIL IV

**Fan Duct Cowl and Thrust Reverser Skin Identification - PW2000 Engine
Figure 1 (Sheet 6 of 8)**

IDENTIFICATION 1
Page 6
Jan 20/2005

54-31-01

D634N201

**757-200
STRUCTURAL REPAIR MANUAL**

REF DWG
315N3300

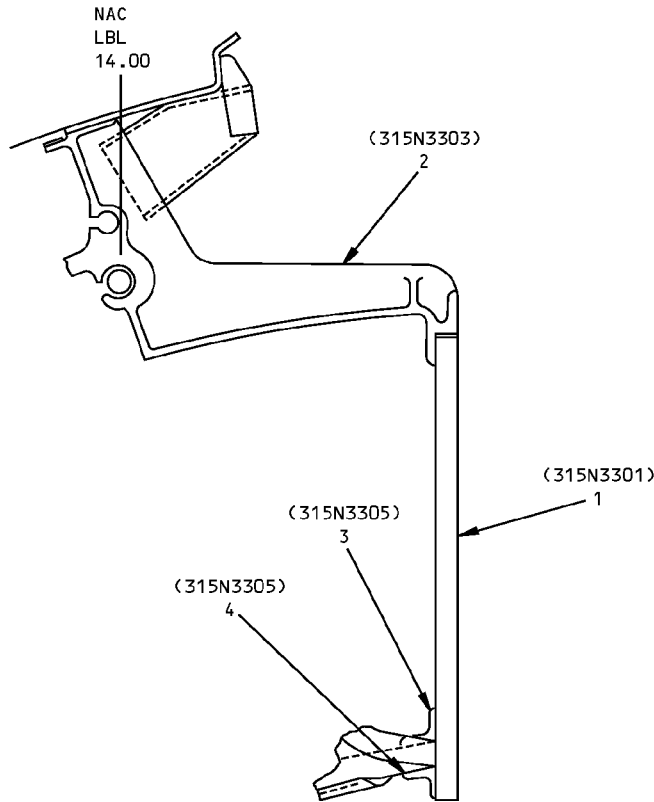

UPPER BIFURCATION PANEL
REAR VIEW
LEFT SIDE SHOWN
RIGHT SIDE OPPOSITE
DETAIL V

ITEM	DESCRIPTION	GAGE	MATERIAL	EFFECTIVITY
1	PANEL ASSY OUTER SKIN CENTER CORE EDGE CORES INNER SKIN	0.040 0.063	PERFORATED CLAD SHEET 2024-T62 PER BMS 7-209, TYPE 1B-40, GRADE 1B, CLASS 50-187 ALUMINUM HONEYCOMB PER BMS 4-4, TYPE 6-30N ALUMINUM HONEYCOMB PER BMS 4-4, TYPE 3-60N, GRADE 11 2024-T81	
2	HINGE FITTING		A357-T61 PREMIUM QUALITY CASTING PER MIL-A-21180 OPTIONAL: HT TR T62	
3	UPPER ATTACH ANGLE		BAC1517-2299 7075-T73	
4	LOWER ATTACH ANGLE		BAC1517-2298 7075-T73	

LIST OF MATERIALS FOR DETAIL V

**Fan Duct Cowl and Thrust Reverser Skin Identification - PW2000 Engine
Figure 1 (Sheet 7 of 8)**

IDENTIFICATION 1
Page 7
Jan 20/2005

54-31-01

D634N201

**757-200
STRUCTURAL REPAIR MANUAL**

REF DWG
315N3400

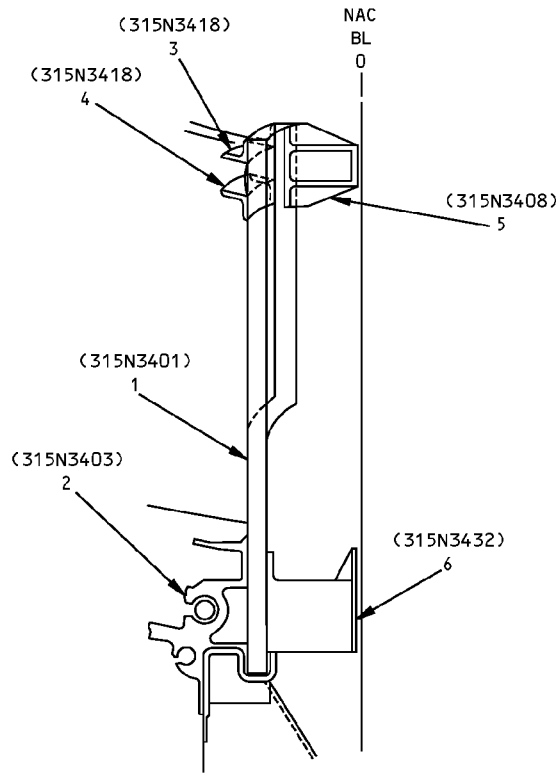

**LOWER BIFURCATION PANEL - REAR VIEW
LEFT SIDE SHOWN, RIGHT SIDE OPPOSITE
DETAIL VI**

ITEM	DESCRIPTION	GAGE	MATERIAL	EFFECTIVITY
1	PANEL ASSY OUTER SKIN CENTER CORE EDGE CORES INNER SKIN	0.025 0.040	PERFORATED CLAD SHEET 2024-T62 PER BMS 7-209, TYPE 1B-25, GRADE 1B, CLASS 50-187 ALUMINUM HONEYCOMB PER BMS 4-4, TYPE 6-30N ALUMINUM HONEYCOMB PER BMS 4-4, TYPE 3-60N, GRADE 2 CHEM MILLED 2024-T81	
2	BEAM FITTING		A357-T61 PREMIUM QUALITY CASTING PER MIL-A-21180 OPTIONAL: HT TR T62	
3	UPPER ATTACH ANGLE		BAC1517-2298 7075-T73	
4	LOWER ATTACH ANGLE		BAC1517-2299 7075-T73	
5	COMPRESSION PAD		7075-T73 FORGED BLOCK	
6	CLOSE OUT FITTING		A357 PREMIUM QUALITY CASTING PER MIL-A-21180, CLASS 10	

LIST OF MATERIALS FOR DETAIL VI

**Fan Duct Cowl and Thrust Reverser Skin Identification - PW2000 Engine
Figure 1 (Sheet 8 of 8)**

IDENTIFICATION 1
Page 8
Jan 20/2005

54-31-01

D634N201

**757-200
STRUCTURAL REPAIR MANUAL**

ALLOWABLE DAMAGE 1 - FAN DUCT COWL AND THRUST REVERSER SKIN - PW2000 ENGINE

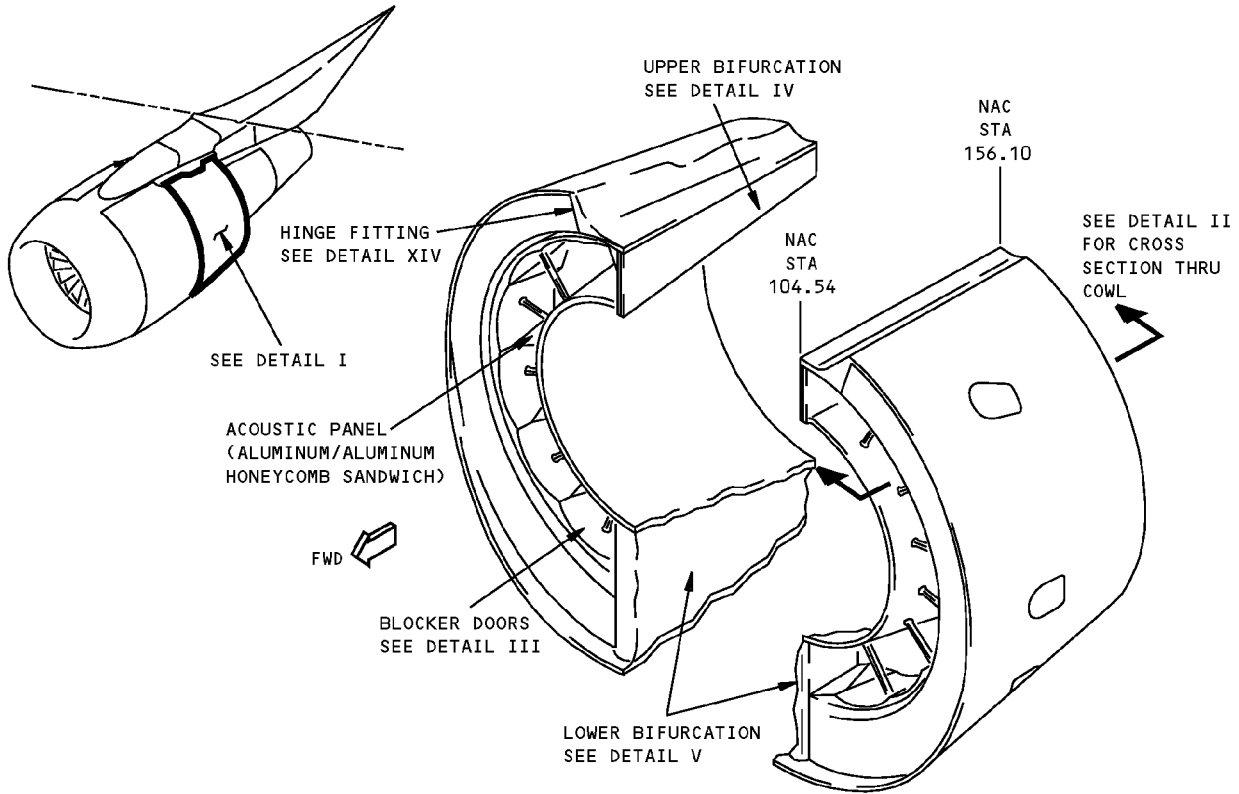

DETAIL I

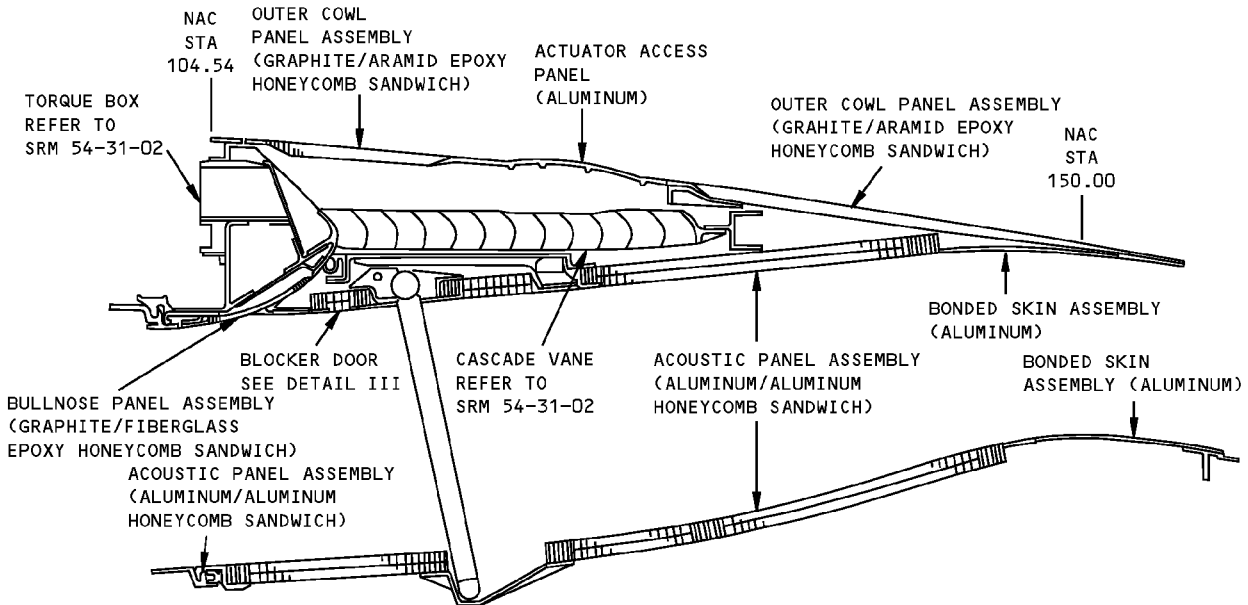

CROSS SECTION THRU THRUST REVERSER COWL

DETAIL II

**Fan Duct Cowl and Thrust Reverser Skin Allowable Damage - PW2000 Engine
Figure 101 (Sheet 1 of 7)**

STRUCTURAL REPAIR MANUAL

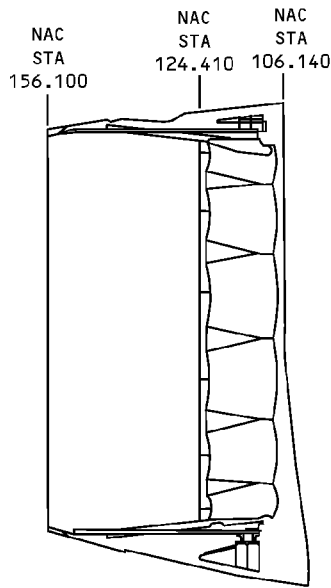

**BLOCKER DOOR ASSEMBLY
(ALUMINUM/ALUMINUM HONEYCOMB SANDWICH)
DETAIL III**

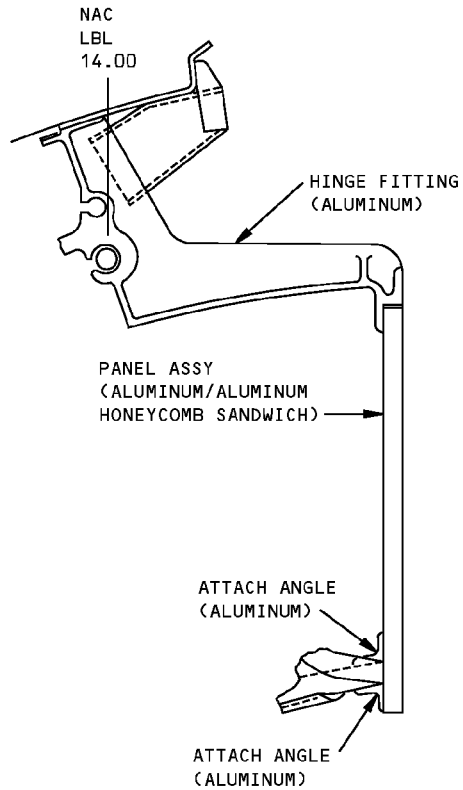

**UPPER BIFURCATION PANEL
REAR VIEW
LEFT SIDE SHOWN - RIGHT SIDE OPPOSITE
DETAIL IV**

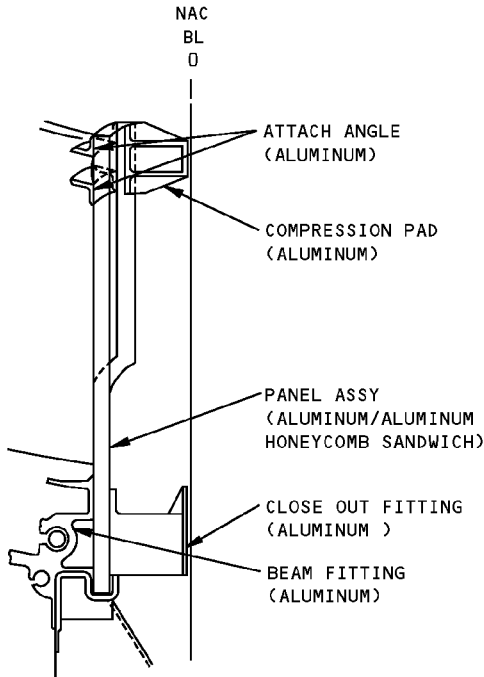

**LOWER BIFURCATION PANEL - REAR VIEW
LEFT SIDE SHOWN - RIGHT SIDE OPPOSITE
DETAIL V**

**Fan Duct Cowl and Thrust Reverser Skin Allowable Damage - PW2000 Engine
Figure 101 (Sheet 2 of 7)**

**757-200
STRUCTURAL REPAIR MANUAL**

DESCRIPTION	CRACKS	NICKS, GOUGES AND CORROSION	DENTS	HOLES AND PUNCTURES	PANEL DELAMINA- TION	EDGE EROSION
ACOUSTIC PANEL	B	C	SEE DETAIL VIII	L	E	--
OUTER COWL PANEL	F	G	H	I	J	SEE DETAIL XIII
ACTUATOR ACCESS PANEL	B	M	SEE DETAIL VIII	D	--	--
BULLNOSE PANEL	F	G	H	I	J	SEE DETAIL XIII
BONDED SKIN	B	M	SEE DETAIL VIII	D	N	--
BLOCKER DOOR ASSEMBLY	F	C	SEE DETAIL VIII	L	E	--
HINGE FITTING	O	K P	NOT PERMITTED	NOT PERMITTED	--	--
ATTACH ANGLE	O	M	NOT PERMITTED	NOT PERMITTED	--	--
BIFURCATION PANEL	F	C	SEE DETAIL VIII	L	E	--
COMPRESSION PAD	O	M	NOT PERMITTED	NOT PERMITTED	--	--
CLOSE OUT FITTING	O	M	NOT PERMITTED	NOT PERMITTED	--	--
BEAM FITTING	O	K	NOT PERMITTED	NOT PERMITTED	--	--

NOTES

- REFINISH REWORKED AREAS AS SHOWN IN AMM 51-20.
 - REFER TO SRM 51-10-01 FOR AERODYNAMIC SMOOTHNESS REQUIREMENTS. WHERE DAMAGE IS MORE THAN THE LIMITS SHOWN IN SRM 51-10-01. CONSIDERATION SHOULD BE GIVEN TO LOSS OF PERFORMANCE INVOLVED.
 - REFER TO SRM 51-10-02 FOR INSPECTION AND REMOVAL OF DAMAGE.
 - DAMAGE TO PANEL EDGES MAY BE CONFINED TO DELAMINATION OR MAY TAKE A FORM WHICH RESULTS IN DAMAGE TO FIBERS AND A LOSS OF EFFECTIVE CROSS-SECTIONAL AREA. THIS TYPE OF DAMAGE SHOULD BE REMOVED AND THE LIMITATIONS GIVEN FOR CRACKS APPLIED.
- A** REMOVE MOISTURE FROM DAMAGE AREA. USE OF VACUUM AND HEAT (MAX OF 125°F (52°C)) TO REMOVE MOISTURE FROM HONEYCOMB CELLS IS RECOMMENDED. PROTECT DAMAGE FROM ENTRANCE OF WATER, SUNLIGHT OR OTHER FOREIGN MATTER BY SEALING WITH ALUMINUM FOIL TAPE (SPEED TAPE). RECORD THE LOCATION AND INSPECT EACH AIRPLANE "A" CHECK. REPLACE THE ALUMINUM FOIL TAPE IF ANY PEELING OR DETERIORATION IS EVIDENT. REPAIR NO LATER THAN NEXT AIRPLANE "C" CHECK.
- B** CRACKS ARE NOT PERMITTED EXCEPT FOR EDGE CRACKS WHICH MUST BE REMOVED AS SHOWN IN DETAILS VI AND X.
- C** REMOVE DAMAGE AS SHOWN IN DETAILS VI, VII AND IX.
- D** CLEAN OUT DAMAGE UP TO 0.25 INCH (6 mm) MAX DIA AND NOT CLOSER THAN 1.0 INCH (25 mm) TO FASTENER HOLE, MATERIAL EDGE, OR OTHER DAMAGE. FILL HOLE WITH A 2117-T3 OR T4 ALUMINUM RIVET INSTALLED WET WITH BMS 5-95 SEALANT. ALL OTHER HOLES TO BE REPAIRED.
- E** DELAMINATION OF SKIN FROM HONEYCOMB UP TO 2.25 SQUARE INCH (1450 SQUARE mm) IS PERMITTED. A MAXIMUM OF 0.50 INCH (12.7 mm) DELAMINATION FROM EDGE IS PERMITTED.
- F** 2.0 INCHES (50 mm) MAX CRACK LENGTH PERMITTED FOR EACH SQUARE FOOT IN HONEYCOMB AREA WHICH MUST BE A MINIMUM OF 4 INCHES FROM OTHER DAMAGE, FASTENER HOLE, PANEL EDGE, OR REINFORCED AREA. CLEAN UP EDGE CRACKS AS SHOWN IN DETAIL VI AND X **A**. DAMAGE MUST NOT BE MORE THAN 10% OF EDGE BAND LENGTH FOR EACH SIDE. NOT MORE THAN ONE CRACKED FASTENER HOLE IN SIX IS PERMITTED.
- G** DAMAGE PERMITTED ON SURFACE RESIN ONLY WITHOUT FIBER DAMAGE. REFER TO **I** WHERE DAMAGE TO FIBER HAS OCCURRED. CLEAN UP EDGE DAMAGE AS SHOWN IN DETAILS VI AND X **A**.

**Fan Duct Cowl and Thrust Reverser Skin Allowable Damage - PW2000 Engine
Figure 101 (Sheet 3 of 7)**

ALLOWABLE DAMAGE 1

54-31-01

Page 103
Jan 20/2005

D634N201

STRUCTURAL REPAIR MANUAL

NOTES (CONT)

- H** DENTS GENERALLY RESULT IN FIBER DAMAGE OR DELAMINATION. HOWEVER, PROVIDED THAT THERE IS NO FIBER DAMAGE OR DELAMINATION, DENTS UP TO 1.50 DIA MAX ARE ALLOWED. ONE DENT PER SQUARE FOOT OF AREA ALLOWED WHICH MUST BE A MINIMUM OF 6 INCHES FROM ANY OTHER DAMAGE, FASTENER HOLE, OR PANEL EDGE. IF FIBER DAMAGE OR DELAMINATION IS PRESENT, REFER TO APPLICABLE DAMAGE DATA IN TABLE.
- I** 1.20 MAX DIA ALLOWED IN HONEYCOMB AREA ONLY PROVIDED DAMAGE IS MINIMUM OF 2.5 D FROM ANY OTHER DAMAGE, NEAREST HOLE OR MATERIAL EDGE. DO NOT CLEAN UP DAMAGE EXCEPT TO REMOVE RESIN BURRS EXTENDING INTO SURFACE CONTOUR **A**.
- J** 4.0 INCH MAX DIA IS ALLOWED IN HONEYCOMB AREA. A MAXIMUM OF 0.10 INCH DELAMINATION FROM EDGE IS ALLOWED. PROTECT EDGE DAMAGE PER **A**. REPAIR DELAMINATION IN HONEYCOMB AREA PER SRM 51-70 NO LATER THAN THE NEXT "C" CHECK.
- K** FOR EDGE DAMAGE SEE DETAIL VI. FOR LUG DAMAGE SEE DETAIL XI. FOR OTHER DAMAGE SEE DETAIL VII. DAMAGE NOT ALLOWED IN VICINITY OF BUSHINGS.
- L** CLEAN OUT DAMAGE UP TO 0.19 DIA MAX PROVIDED DAMAGE IS MINIMUM OF 3D FROM ANY OTHER DAMAGE, NEAREST HOLE, OR MATERIAL EDGE.
- M** FOR EDGE DAMAGE SEE DETAIL VI. FOR OTHER DAMAGE SEE DETAILS VII AND IX.
- N** 2.25 INCH MAX DIA ALLOWED. A MAXIMUM OF 0.50 DELAMINATION FROM EDGE IS ALLOWED.
- O** CRACKS NOT ALLOWED EXCEPT FOR EDGE CRACKS WHICH MUST BE REMOVED PER DETAILS VI AND XII.
- P** FOR HINGE FITTING FORWARD WEB DAMAGE SEE DETAIL XIV.

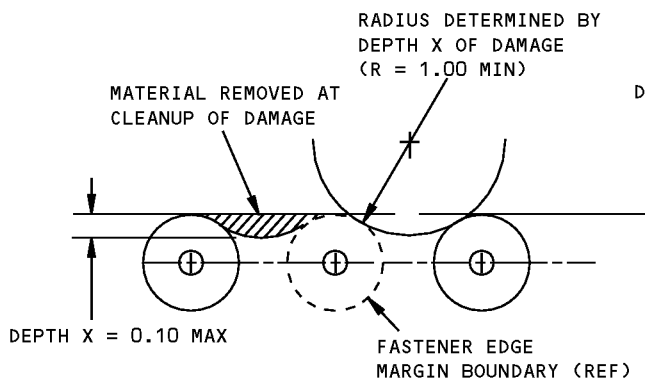

DAMAGE CLEANUP OF EDGES WHERE FASTENER EDGE MARGINS DO NOT OVERLAP

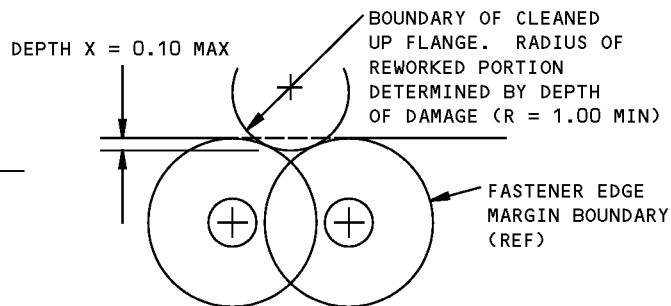

DAMAGE CLEANUP OF EDGES WHERE FASTENER EDGE MARGINS OVERLAP

DETAIL VI

Fan Duct Cowl and Thrust Reverser Skin Allowable Damage - PW2000 Engine
Figure 101 (Sheet 4 of 7)

**757-200
STRUCTURAL REPAIR MANUAL**

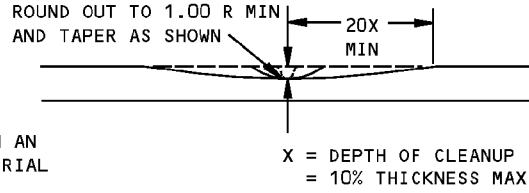
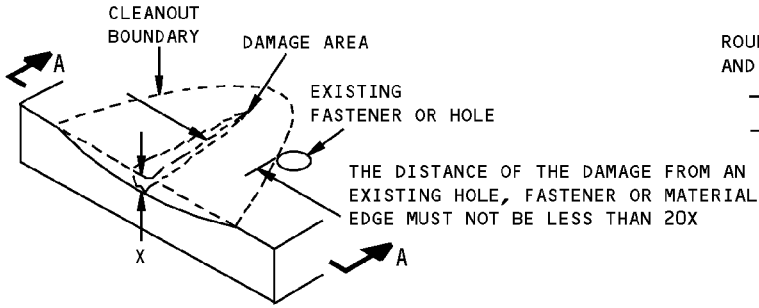

SECTION A-A

**REMOVAL OF NICK, GOUGE AND SCRATCH DAMAGE ON A SURFACE
DETAIL VII**

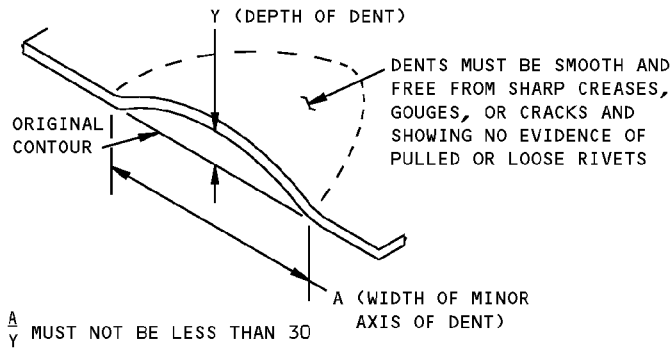

**ALLOWABLE DAMAGE FOR DENT
DETAIL VIII**

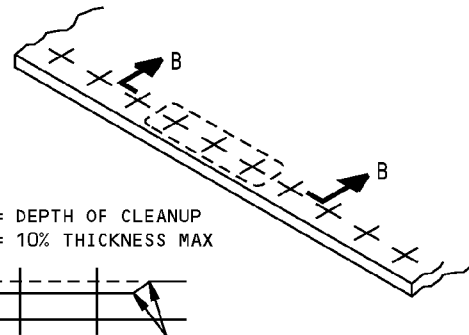

BLEND OUT WITH 0.50 INCH RADIUS MINIMUM. CORROSION CLEANUP AROUND ANY THREE FASTENERS IN TEN IS PERMITTED TO MAX DEPTH

SECTION B-B

**CORROSION CLEANUP
DETAIL IX**

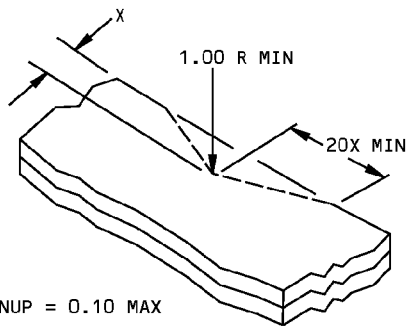

X = DEPTH OF CLEANUP = 0.10 MAX

**REMOVAL OF NICK OR CRACK DAMAGE ON AN EDGE
DETAIL X**

**Fan Duct Cowl and Thrust Reverser Skin Allowable Damage - PW2000 Engine
Figure 101 (Sheet 5 of 7)**

**757-200
STRUCTURAL REPAIR MANUAL**

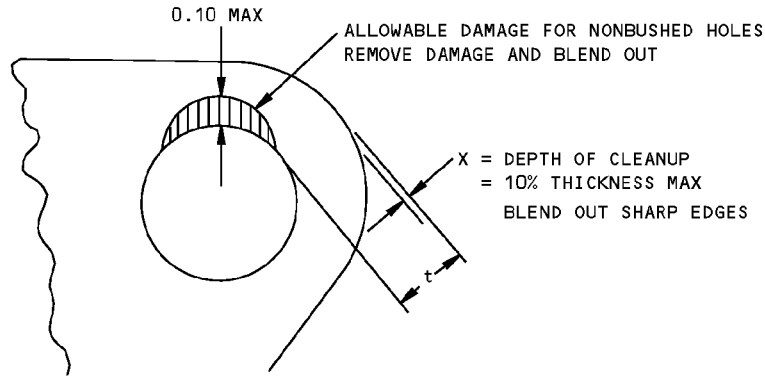

**DAMAGE CLEANUP FOR EDGES OF LUG
DETAIL XI**

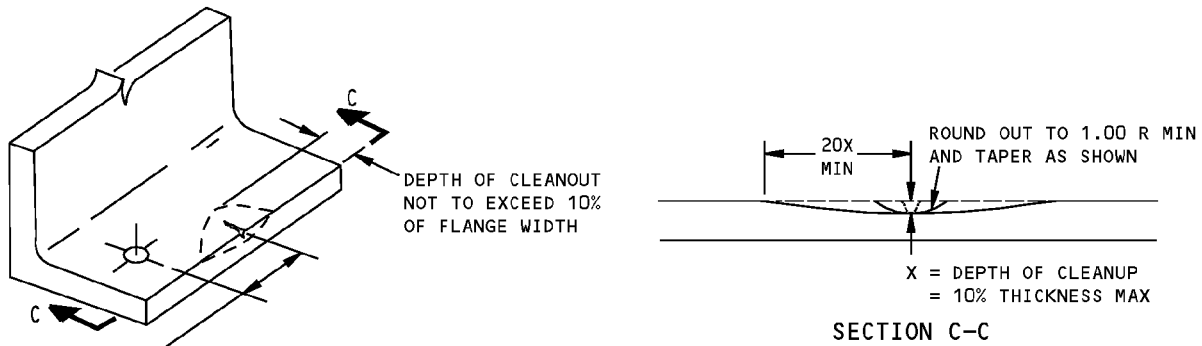

**REMOVAL OF NICK OR CRACK DAMAGE ON AN EDGE
DETAIL XII**

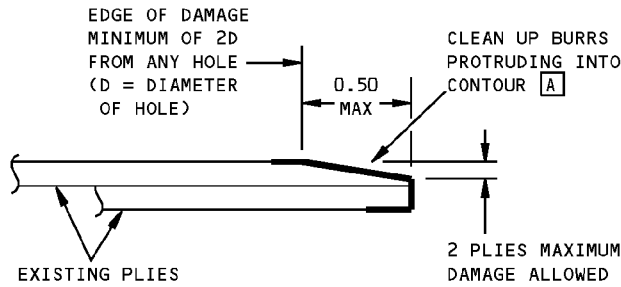

**DAMAGE CLEANUP AND SEALING OF EDGE EROSION
DETAIL XIII**

**Fan Duct Cowl and Thrust Reverser Skin Allowable Damage - PW2000 Engine
Figure 101 (Sheet 6 of 7)**

**757-200
STRUCTURAL REPAIR MANUAL**

REFERENCE DRAWING
315N3303

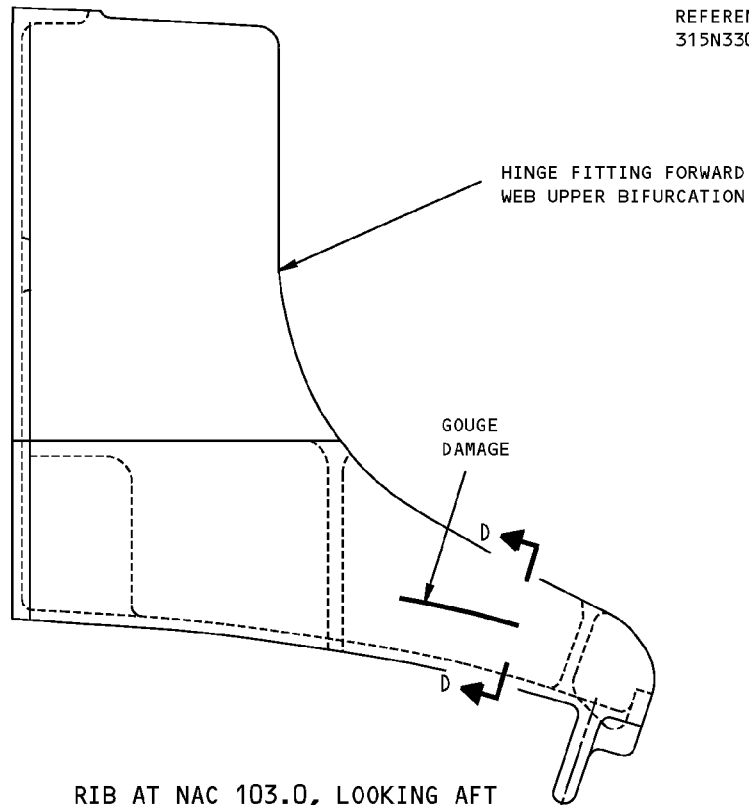

RIB AT NAC 103.0, LOOKING AFT
TYPICAL GOUGE DAMAGE ON FITTING FORWARD RIB
DETAIL XIV

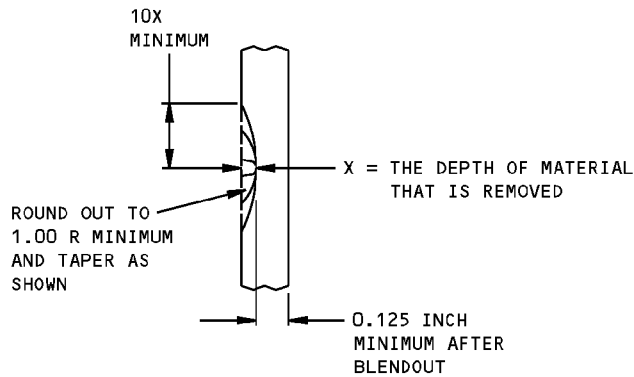

SECTION D-D

NOTE: TRIM THE AFT SIDE OF THE STRUT BULB SEAL RETAINER UP TO 0.050 INCH TO MAKE SURE THERE IS NO MORE DAMAGE.

**Fan Duct Cowl and Thrust Reverser Skin Allowable Damage - PW2000 Engine
Figure 101 (Sheet 7 of 7)**

ALLOWABLE DAMAGE 1
Page 107
Jan 20/2005

54-31-01

D634N201

**757-200
STRUCTURAL REPAIR MANUAL**

REPAIR 1 - FAN DUCT COWL AND THRUST REVERSER SKIN - PW2000 ENGINE

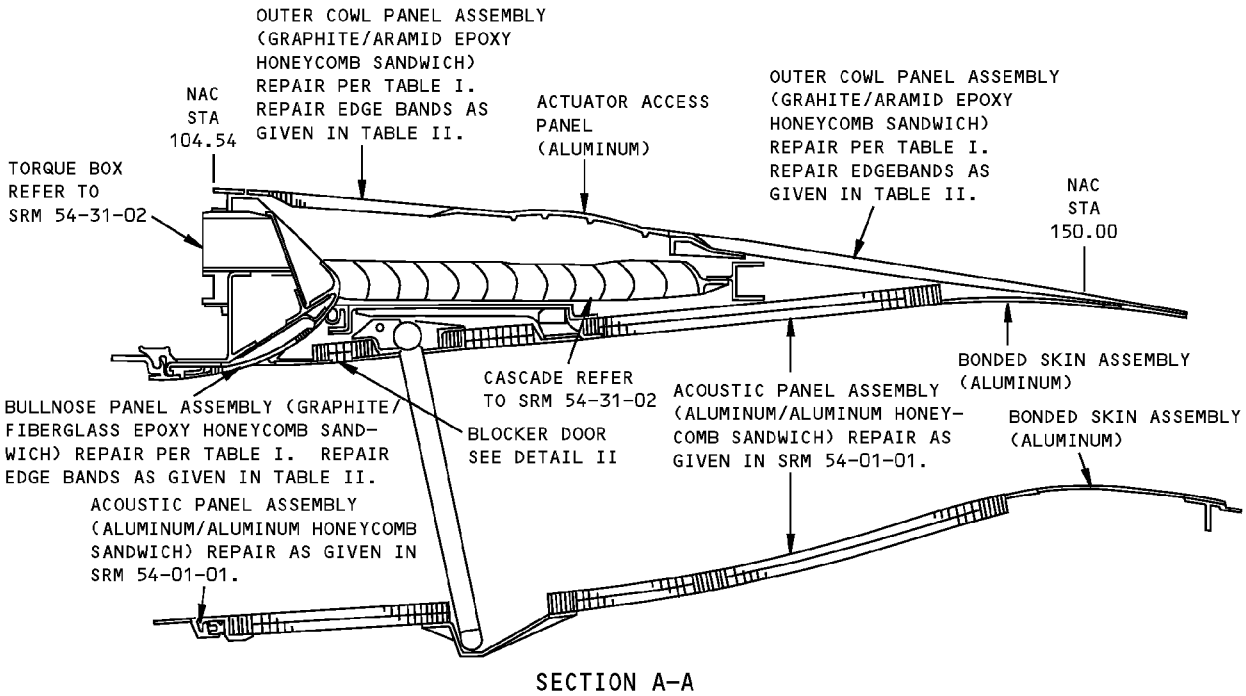
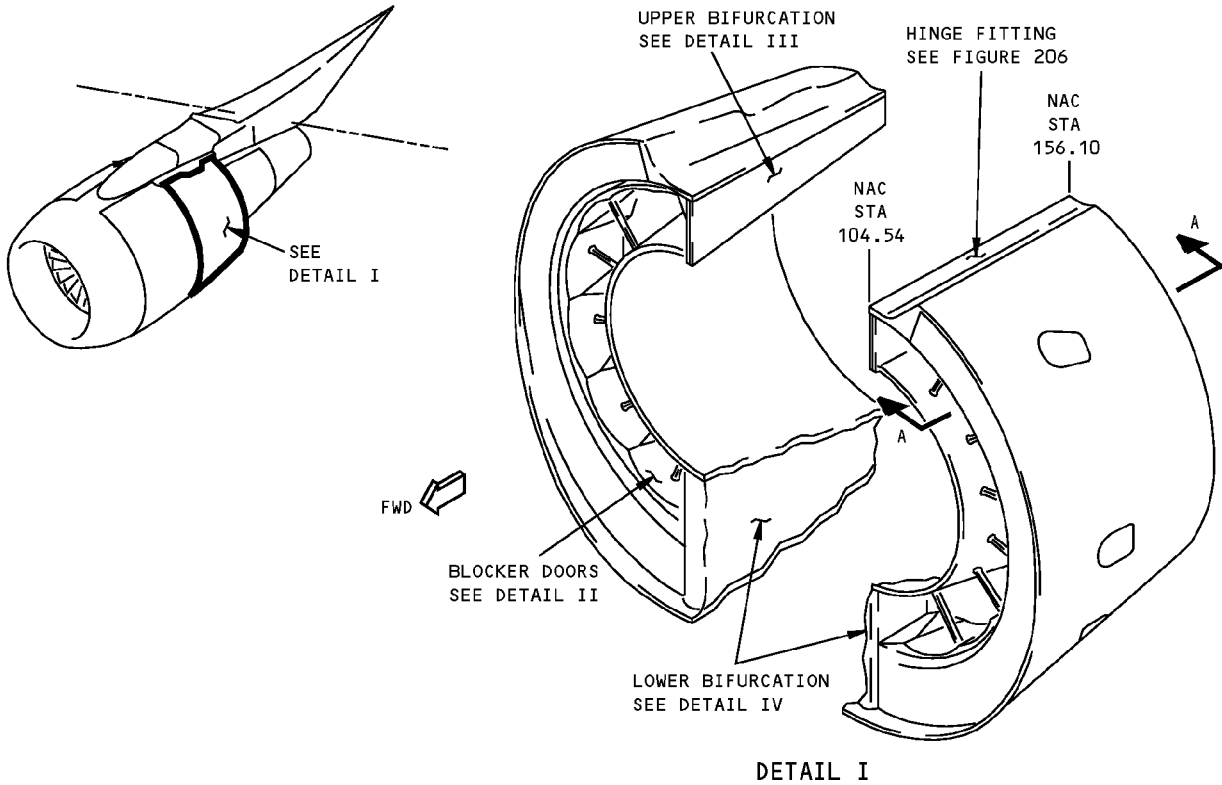

**Fan Duct Cowl and Thrust Reverser Skin Repair - PW2000 Engine
Figure 201 (Sheet 1 of 5)**

STRUCTURAL REPAIR MANUAL

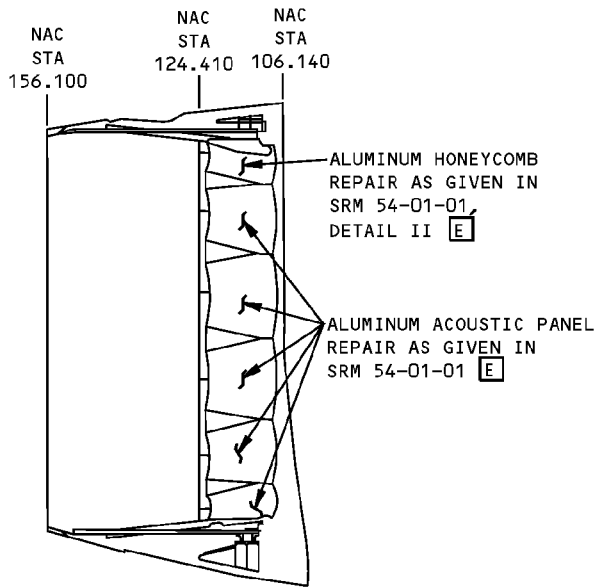

**BLOCKER DOOR ASSY
(ALUMINUM/ALUMINUM HONEYCOMB SANDWICH)
DETAIL II**

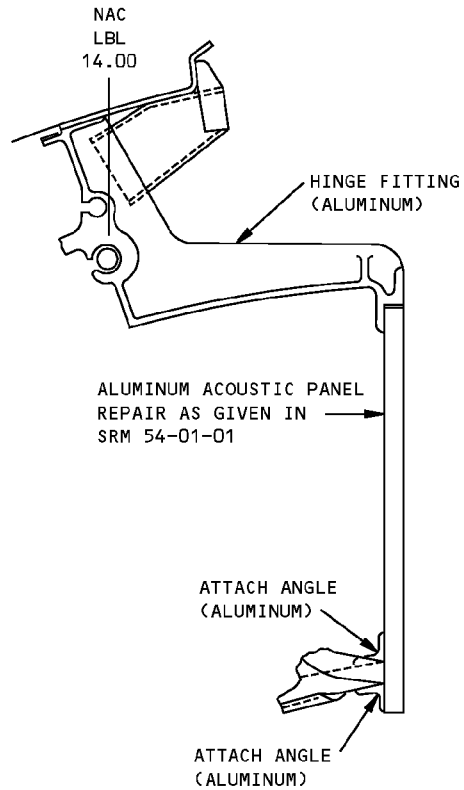

**UPPER BIFURCATION PANEL
REAR VIEW
LEFT SIDE SHOWN - RIGHT SIDE OPPOSITE
DETAIL III**

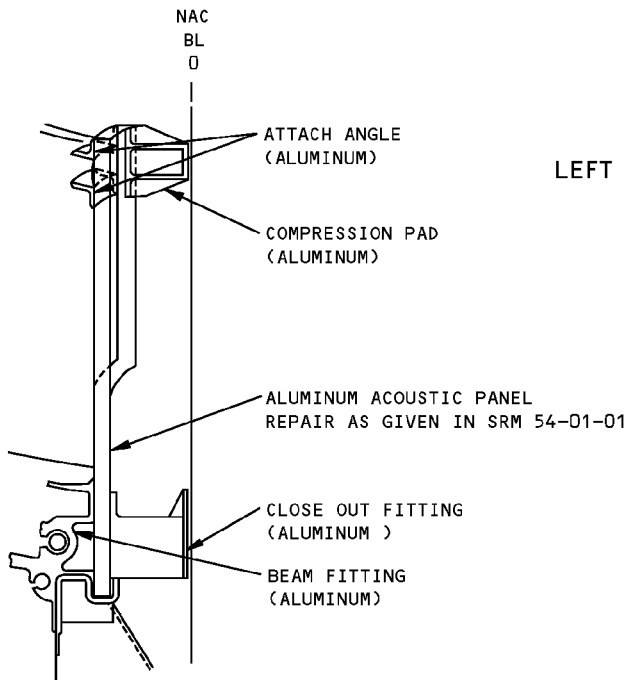

**LOWER BIFURCATION PANEL - REAR VIEW
LEFT SIDE SHOWN - RIGHT SIDE OPPOSITE
DETAIL IV**

**Fan Duct Cowl and Thrust Reverser Skin Repair - PW2000 Engine
Figure 201 (Sheet 2 of 5)**

STRUCTURAL REPAIR MANUAL

NOTES

- FINISH WITH ONE COAT OF BMS 10-79 TYPE III PRIMER AND ONE COAT OF BMS 10-60 TYPE II ENAMEL AS SHOWN IN SRM 51-20.
 - REFER TO SRM 51-10-01 FOR AERODYNAMIC SMOOTHNESS REQUIREMENTS. WHERE THE DAMAGE IS MORE THAN THE LIMITS SHOWN IN SRM 51-10-01, CONSIDERATION SHOULD BE GIVEN TO THE LOSS OF PERFORMANCE INVOLVED.
- [A] LIMITED TO REPAIR OF DAMAGE TO ONE FACE-SHEET SKIN AND HONEYCOMB CORE. ONE REPAIR FOR EACH SQUARE FOOT OF AREA AND MINIMUM OF 6.0 INCHES (150 mm) (EDGE TO EDGE) FROM ANY OTHER DAMAGE, FASTENER HOLE, OR EDGE OF PANEL.
- [B] INSPECT INTERIM REPAIR USING INSTRUMENTED NDI METHODS OR "TAP" TEST EVERY AIRPLANE "2 A" CHECK. FOR "TAP" TEST, USE A SOLID METAL DISK AND TAP THE REPAIR AREA LIGHTLY BUT FIRMLY. VOID AREAS WILL PRODUCE A DULL SOUND AS OPPOSED TO A SHARP RING ON A SOLID BONDED AREA. PERMANENT REPAIR IS REQUIRED IF ANY DETERIORATION IS EVIDENT. REFER TO SRM 51-70-03, PAR. 4.I. AND THE NONDESTRUCTIVE TEST MANUAL [D].
- [C] ONE REPAIR FOR EACH SQUARE FOOT OF AREA AND A MINIMUM OF 6.0 INCHES (150 mm) (EDGE TO EDGE) FROM ANY OTHER DAMAGE, FASTENER HOLE, OR EDGE OR PANEL.
- [D] THIS REPAIR HAS FAA APPROVAL CONTINGENT ON ACCOMPLISHMENT OF THE INSPECTIONS CONTAINED HEREIN.
- [E] 2.0 INCHES (50 mm) MAX DIMENSION NOT TO EXCEED 6 SQUARE INCHES (3870 SQUARE cm) FOR EACH SQUARE FOOT (930 SQUARE cm) IN THE HONEYCOMB AREA. REPAIR MUST NOT INTERFERE WITH OTHER DAMAGE, REINFORCED AREAS, PANEL EDGE, OR FASTENER HOLES.
- [F] FOR PERMANENT WET LAYUP REPAIRS, USE A 1.0 INCH (25 mm) OVERLAP FOR EACH REPAIR PLY AND CURE AT 230°F (110°C). ALTERNATIVELY, FOR OUTER SKIN REPAIRS ONLY, USE A 0.50 INCH (12.7 mm) OVERLAP FOR EACH REPAIR PLY AND CURE AT 200°F (93°C).

Fan Duct Cowl and Thrust Reverser Skin Repair - PW2000 Engine
Figure 201 (Sheet 3 of 5)

**757-200
STRUCTURAL REPAIR MANUAL**

DAMAGE	INTERIM REPAIRS [B]	PERMANENT REPAIRS	
	WET LAYUP 150°F (66°C) CURE (SRM 51-70-03)	WET LAYUP 200°F (93°C) (SRM 51-70-17) [F]	350°F (177°C) CURE (SRM 51-70-04)
CRACKS	UP TO 3.0 INCHES (75 mm) LONG, REPAIR WITH PATCH AS GIVEN IN SRM 51-70-03, PAR. 5.N. [A]	CLEAN UP DAMAGE AND REPAIR AS A HOLE.	CLEAN UP DAMAGE AND REPAIR AS A HOLE.
HOLES AND PUNCTURES	3.0 INCHES (75 mm) MAXIMUM DIAMETER NOT TO EXCEED 30% OF SMALLEST DIMENSION ACROSS HONEYCOMB PANEL AT THE DAMAGE LOCATION. FILL WITH BMS 5-28, TYPE 7 POTTING COMPOUND AND PATCH AS GIVEN IN SRM 51-70-03, PAR. 5.N. [A]	12.0 INCHES (300 mm) MAXIMUM DIAMETER NOT TO EXCEED 50% OF SMALLEST DIMENSION ACROSS HONEYCOMB PANEL AT THE DAMAGE LOCATION. USE TWO EXTRA PLIES FOR EACH FACESHEET REPAIRED. [C]	NO SIZE LIMIT
DELAMINATION	3.0 INCHES (75 mm) MAXIMUM DIAMETER NOT TO EXCEED 30% OF SMALLEST DIMENSION ACROSS HONEYCOMB PANEL AT THE DAMAGE LOCATION. REPAIR AS GIVEN IN SRM 51-70-03, PAR. 5.A. [A]	12.0 INCHES (300 mm) MAXIMUM DIAMETER NOT TO EXCEED 50% OF SMALLEST DIMENSION ACROSS HONEYCOMB PANEL AT THE DAMAGE LOCATION. REPAIR AS GIVEN IN SRM 51-70-17, PAR. 4.A. [C]	NO SIZE LIMIT. REPAIR AS GIVEN IN SRM 51-70-04, PAR. 5.A.
EDGE EROSION	_____	FOR DAMAGE NOT LARGER THAN 35% OF EDGE BAND THICKNESS, REPAIR AS GIVEN IN SRM 51-70-03, PAR. 5.O. FOR LARGER DAMAGE, REPAIR AS GIVEN IN: SRM 51-70-17, PAR. 4.G.	SRM 51-70-04, PAR. 5.G.
NICKS AND GOUGES	IF THERE IS NO FIBER DAMAGE OR DELAMINATION, FILL NICKS OR GOUGES AS GIVEN IN SRM 51-70-03. IF THERE IS FIBER DAMAGE OR DELAMINATION, REPAIR AS A HOLE.		
DENTS	DENTS RESULT IN FIBER DAMAGE AND DELAMINATION. USE REPAIR DATA FOR HOLES AND PUNCTURES TO DETERMINE DENT REPAIR.		

REPAIR DATA FOR 350°F CURE GRAPHITE/EPOXY HONEYCOMB PANELS
TABLE I

**Fan Duct Cowl and Thrust Reverser Skin Repair - PW2000 Engine
Figure 201 (Sheet 4 of 5)**

STRUCTURAL REPAIR MANUAL

DAMAGE	INTERIM REPAIRS B	PERMANENT REPAIRS	
	WET LAYUP 150°F (66°C) CURE (SRM 51-70-03)	WET LAYUP 200°F (93°C)/230°F (110°C) CURE (SRM 51-70-17) F	350°F (177°C) CURE (SRM 51-70-04)
HOLES	REPAIR DAMAGE TO THE FASTENER HOLES AS GIVEN IN SRM 51-70-03, FIG. 10. FOR THE LIMITS THAT FOLLOW REPAIR OTHER DAMAGE AS GIVEN IN SRM 51-70-03, FIG. 9: - A MAXIMUM OF 15% OF THE AREA OF THE CROSS SECTION THROUGH THE EDGE BAND - A MAXIMUM OF 10% OF THE LENGTH OF THE EDGE BAND FOR EACH SIDE THAT IS DAMAGED.	REPAIR THE DAMAGE TO THE FASTENER HOLES AS GIVEN IN SRM 51-70-17, FIG. 16. REPAIR ALL OTHER DAMAGE AS GIVEN IN SRM 51-70-17, FIG. 15.	REPAIR THE DAMAGE TO THE FASTENER HOLES AS GIVEN IN SRM 51-70-04, FIG. 10. REPAIR ALL OTHER DAMAGE AS GIVEN IN SRM 51-70-04, FIG. 9.
CRACKS	USE THE SAME LIMITS AND REPAIRS AS FOR HOLES.	USE THE SAME REPAIRS AS FOR HOLES.	
DELAMINATION	IF DELAMINATION FROM THE PANEL EDGE IS NOT LESS THAN 2D FROM ANY FASTENER HOLE, REPAIR AS GIVEN IN SRM 51-70-03, FIG. 12. FOR ANY OTHER DELAMINATION, USE THE SAME LIMITS AND REPAIRS AS FOR HOLES.	USE THE SAME REPAIRS AS FOR HOLES.	
NICKS AND GOUGES	IF THERE IS FIBER DAMAGE, USE THE SAME REPAIRS AS FOR HOLES. IF THERE IS DELAMINATION, USE THE SAME LIMITS AND REPAIRS AS FOR DELAMINATION.	IF THERE IS NO FIBER DAMAGE OR DELAMINATION, FILL NICKS OR GOUGES AS GIVEN IN SRM 51-70-03. IF THERE IS FIBER DAMAGE OR DELAMINATION, USE THE SAME REPAIRS AS FOR HOLES.	
DENTS	IF THERE IS FIBER DAMAGE, USE THE SAME LIMITS AND REPAIRS AS FOR HOLES. IF THERE IS DELAMINATION, USE THE SAME LIMITS AND REPAIRS AS FOR DELAMINATION.	IF THERE IS NO FIBER DAMAGE OR DELAMINATION, FILL THE NICKS OR GOUGES AS GIVEN IN SRM 51-70-03, FIG. 16. IF THERE IS FIBER DAMAGE OR DELAMINATION, USE SAME REPAIRS AS FOR HOLES.	

REPAIR OF EDGE BANDS OF 350°F (177°C) CURE HONEYCOMB PANELS
TABLE II

Fan Duct Cowl and Thrust Reverser Skin Repair - PW2000 Engine
Figure 201 (Sheet 5 of 5)

STRUCTURAL REPAIR MANUAL

REPAIR 2 - FAN DUCT INNER WALL BONDED SKIN - PW2000 ENGINE

APPLICABILITY

THIS REPAIR IS APPLICABLE TO ALL AREAS OF THE BONDED SKIN ASSEMBLY FOR DELAMINATION OF THE INNER WALL OUTER SKIN FROM THE INNER SKIN.

REPAIR INSTRUCTIONS

1. Get access to the inside of the fan duct at the location of damage.
2. Make the repair doubler as shown in Detail I or Detail II. **B** **D**
3. Locate and mark the fastener holes on the repair doubler.
4. Drill 0.125 inch (3.18 mm) vent holes in the repair doubler.
NOTE: 0.125 inch (3.18 mm) vent holes are required for curing the BMS 5-101 structural adhesive.
5. Clean and prepare the faying surfaces for bonding as given in SRM 51-70-09. Use the HF/Alodine method with Desoto 513-707 CIAP primer.
6. Bond the repair doubler to the fan duct inner wall outer skin with BMS 5-101 structural adhesive and cure as given in SRM 51-70-09.
7. After the cure cycle is complete, drill the fastener holes at the vent hole locations.
8. Install fasteners wet with BMS 5-63 sealant.
NOTE: Ensure that the inner and outer skin panels are drawn tight to close all voids at the delaminated area before fastener installation.
9. Fillet seal the repair doubler with BMS 5-63 sealant.
10. Refinish the doubler surface by alodining as given in SRM 51-20-01 and prime with aluminized epoxy primer (463-6-4 primer; catalyst X-306; Bostik). Spray apply. Mix primer base/catalyst (3/1).

NOTES

- WHEN YOU USE THIS REPAIR, REFER TO:
 - AMM 51-21 FOR INTERIOR AND EXTERIOR FINISHES
 - SRM 51-10-01 FOR AERODYNAMIC SMOOTHNESS REQUIREMENTS
 - SRM 51-10-02 FOR INSPECTION AND REMOVAL OF DAMAGE
 - SRM 51-20-01 FOR PROTECTIVE TREATMENT OF METAL
 - SRM 51-20-05 FOR THE SEALING OF REPAIRS
 - SRM 51-40 FOR FASTENER CODE, REMOVAL, INSTALLATION, HOLE SIZES AND EDGE MARGINS.
- THIS REPAIR HAS FAA APPROVAL CONTINGENT ON THE INSPECTIONS AT THE INTERVALS CONTAINED HEREIN.

- A** USE UP TO 1/32 OVERSIZE FASTENER.
- B** USE DETAIL I TO REPAIR SMALL AREAS OF DELAMINATION. USE DETAIL II TO REPAIR LARGER AREAS OF DELAMINATION WHERE REPAIR DOUBLER EXTENDS TO FRAME AND SPLICE STRAP.
- C** MAINTAIN 2.5D EDGE MARGIN TO ENSURE CONTAINMENT OF DELAMINATION.
- D** THE REPAIR DOUBLER IN DETAIL II WILL NOT BE SQUARE DUE TO OFFSET FASTENER SPACING IN FRAME AND SPLICE STRAP.
- E** THE CRES FIRESHIELD IS LOCATED ONLY ABOVE THE 45° RADIALS ON THE RIGHT AND LEFT SIDES OF THE FAN DUCT.

FASTENER SYMBOLS

- + INITIAL FASTENER LOCATION.
- ✦ REPAIR FASTENER LOCATION. INSTALL A BACR15CE5D RIVET.
- ✦ INITIAL FASTENER LOCATION. INSTALL A BACR15CE6D RIVET. **A**
- ✦ INITIAL FASTENER LOCATION. WHERE HI-LOKS ARE PRESENT, INSTALL A BACB30NW6K HI-LOK WITH BACC30M COLLAR. WHERE RIVETS ARE PRESENT, INSTALL A BACR15CE6D RIVET. **A**

**Fan Duct Inner Wall Bonded Skin Repair - PW2000 Engine
Figure 201 (Sheet 1 of 3)**

**757-200
STRUCTURAL REPAIR MANUAL**

REPAIR MATERIAL			
PART	QTY	MATERIAL	
1	REPAIR DOUBLER	1	0.020 2024-T3

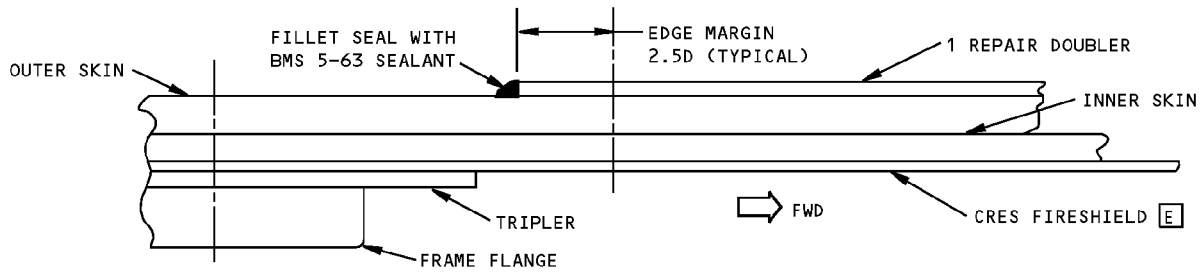
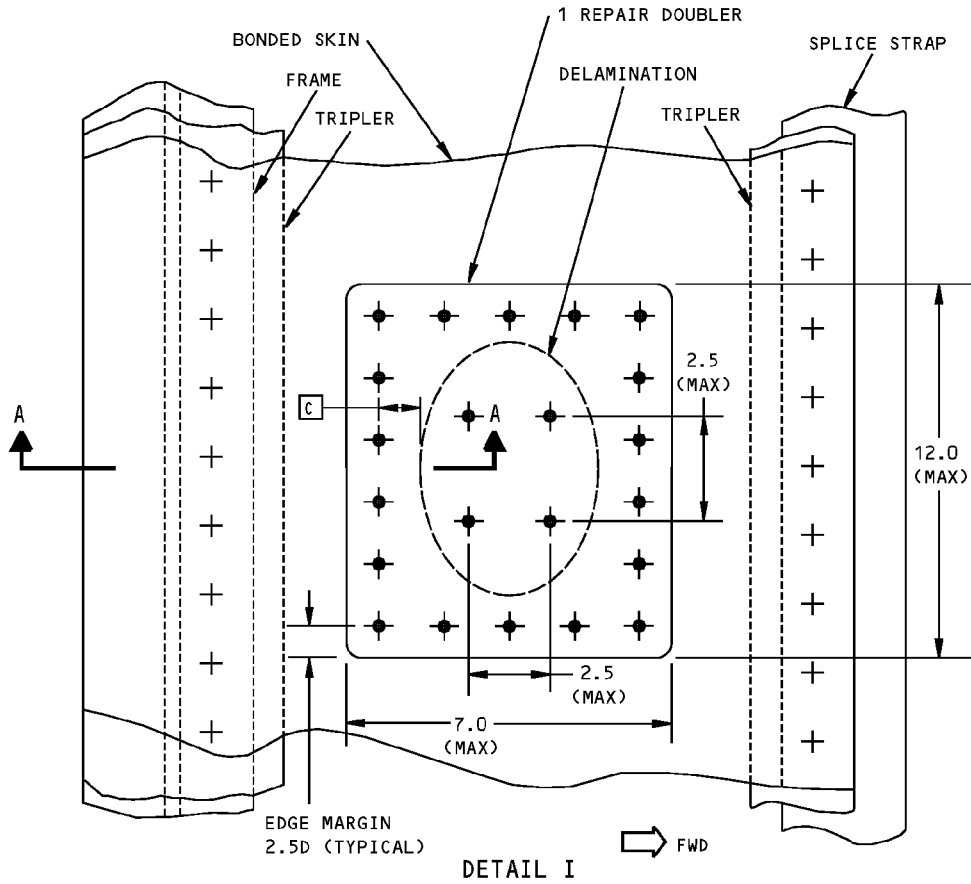

**Fan Duct Inner Wall Bonded Skin Repair - PW2000 Engine
Figure 201 (Sheet 2 of 3)**

**757-200
STRUCTURAL REPAIR MANUAL**

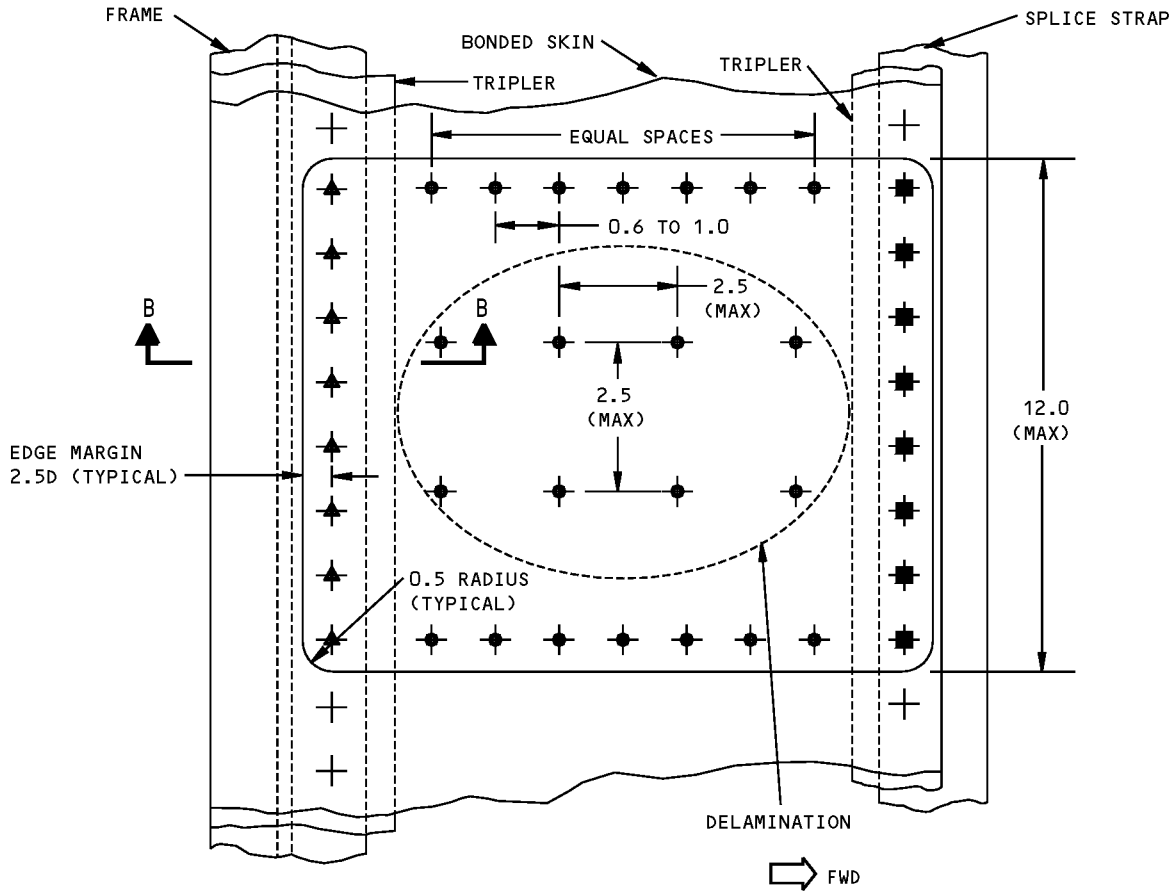

DETAIL II

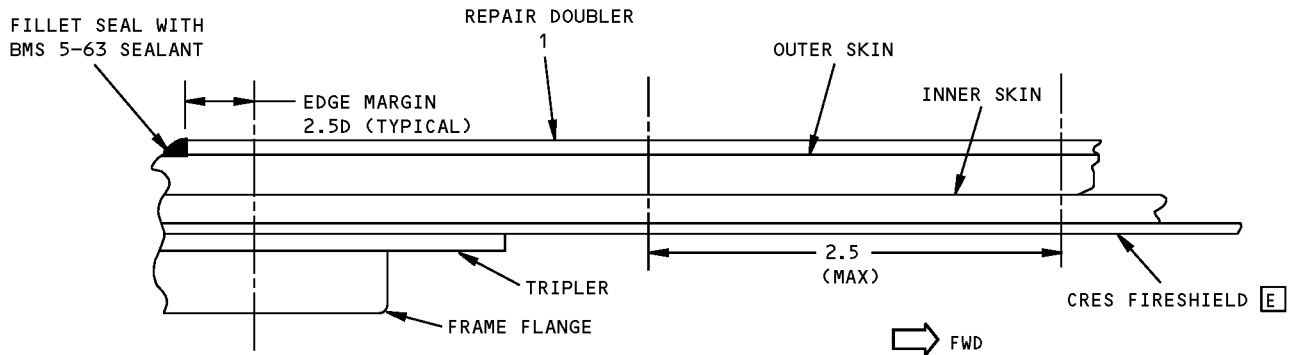

SECTION B-B

**Fan Duct Inner Wall Bonded Skin Repair - PW2000 Engine
Figure 201 (Sheet 3 of 3)**

STRUCTURAL REPAIR MANUAL

REPAIR 3 - FAN DUCT COWL INNER WALL FIRESHIELD DELAMINATION - PW2000 ENGINE

APPLICABILITY
THIS REPAIR IS FOR DELAMINATION OF THE CRES FIRESHIELD FROM THE FAN DUCT COWL INNER WALL BONDED SKIN

REPAIR INSTRUCTIONS

1. Make doubler 1. Refer to Table I and Detail I. Make the repair doubler fit the contour of the cowl.
2. Put doubler 1 in place on the cowl and drill the fastener holes.
3. Remove the nicks, burrs, scratches, gouges, and sharp edges from the cowl and doubler 1.
4. Apply Alodine to the repair doubler.
5. Apply one layer of BAC5710, Type 51 (DeSoto Hi-Temp) primer to the repair doubler and the bare edges of the cowl. Refer to AMM 51-21.
6. Install doubler 1. Make a fay surface seal with BMS 5-63, Type I sealant. Install fasteners wet with BMS 5-63, Type I sealant.
7. Apply a fillet seal all the way around the repair doubler edge with BMS 5-63, Type I sealant.

ALTERNATE REPAIR INSTRUCTIONS

1. Make doubler 2. Refer to Table II and Detail I. Make the repair doubler fit the countour of the cowl.
2. Put doubler 2 in place on the cowl and drill the fastener holes.
3. Remove the nicks, burrs, scratches, gouges, and sharp edges from the cowl and doubler 2.
4. Install doubler 2. Make a fay surface seal with BMS 5-63, Type I sealant. Install fasteners wet with BMS 5-63, Type I sealant.
5. Apply a fillet seal all the way around the repair doubler edge with BMS 5-63, Type I sealant.

NOTES

- WHEN YOU USE THIS REPAIR REFER TO:
 - AMM 51-21 FOR INTERIOR AND EXTERIOR FINISHES
 - SRM 51-10-01 FOR AERODYNAMIC SMOOTHNESS REQUIREMENTS
 - SRM 51-10-02 FOR INSPECTION AND REMOVAL OF DAMAGE
 - SRM 51-20-01 FOR PROTECTIVE TREATMENT OF METAL
 - SRM 51-20-05 FOR SEALING OF REPAIRS
 - SRM 51-30 FOR SOURCE OF REPAIR MATERIALS
 - SRM 51-40-00 FOR FASTENER CODE, INSTALLATION AND REMOVAL, HOLE SIZES, AND EDGE MARGINS
 - SRM 51-40-03 FOR FASTENER SUBSTITUTION
 - SRM 51-40-08 FOR COUNTERSINKING AND USE OF COUNTERSINK REPAIR WASHERS.

A DELAMINATION WHICH EXTENDS THE FULL WIDTH OF THE WALL FROM ONE TRIPLER EDGE TO THE OTHER MAY BE REPAIRED. THE REPAIR DOUBLER MUST FULLY COVER THE DELAMINATION.

FASTENER SYMBOLS

- ⊕ REFERENCE FASTENER LOCATION.
- ⊕ REPAIR FASTENER LOCATION. INSTALL A BACR15CE5M() RIVET COUNTERSUNK ON THE FAR SIDE.

REPAIR MATERIAL			
PART		QTY	MATERIAL
1	DOUBLER	1	0.071 INCH CLAD 2024-T3

TABLE I

REPAIR MATERIAL FOR ALTERNATE REPAIR			
PART		QTY	MATERIAL
2	DOUBLER	1	0.020 INCH 301 CRES 1/2 HARD

TABLE II

**Fan Duct Cowl Inner Wall Fireshield Delamination Repair - PW2000 Engine
Figure 201 (Sheet 1 of 2)**

**757-200
STRUCTURAL REPAIR MANUAL**

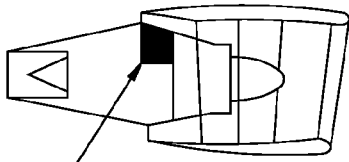

SEE DETAIL I

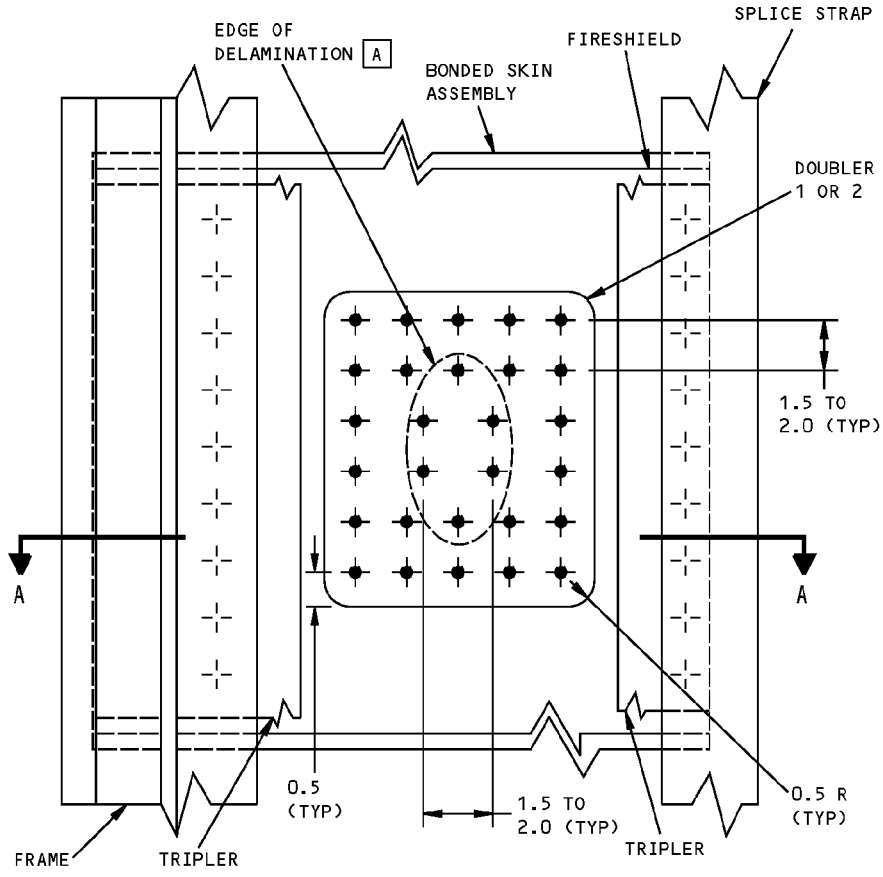

LEFT SIDE OF ENGINE SHOWN
DETAIL I

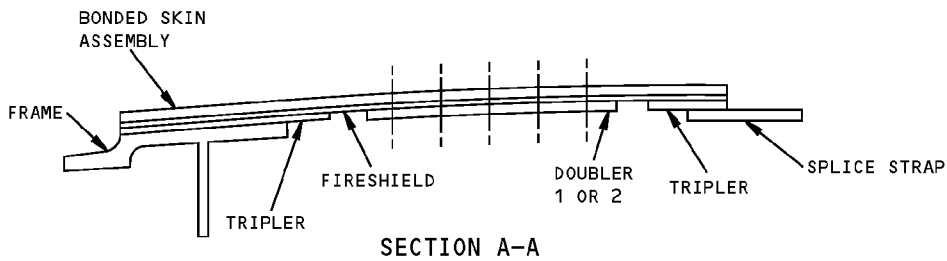

**Fan Duct Cowl Inner Wall Fireshield Delamination Repair - PW2000 Engine
Figure 201 (Sheet 2 of 2)**

STRUCTURAL REPAIR MANUAL

REPAIR 4 - FAN DUCT COWL INNER WALL FIRESHIELD - REPAIR USING ABLATIVE COATING - PW2000 ENGINE**APPLICABILITY**

THIS REPAIR IS FOR DELAMINATION OF THE CRES FIRESHIELD FROM THE FAN DUCT COWL INNER WALL BONDED SKIN.

REPAIR INSTRUCTIONS

1. Remove the fan duct cowl. Refer to AMM 78-31-01.

CAUTION: DO NOT SCRIBE THROUGH THE CRES FIRESHIELD INTO THE DUCT INNER WALL. IF YOU DO, YOU WILL CAUSE DAMAGE TO THE DUCT INNER WALL.

2. Scribe the entire length of the CRES fire- shield along the edge of the tripler. Do not scribe into the duct inner wall. (See Detail I).

3. Remove all of the CRES fireshield from tripler edge to tripler edge and from top to bottom. See Detail I.

4. Remove any loose adhesive that stayed on the bonded skin assembly after you removed the fireshield. Use a scraper that is not metallic.

5. Clean the surface of the tripler and the repair area with a general cleaning solvent (MEK, Naphtha, or equivalent). **A**

6. After the surface of the repair area is dry, make it rough with 240 grit or finer abrasive paper. After you make the surface rough, use compressed air to remove the grit that stayed.

7. Apply DC-1200 primer to the repair area. **A**

WARNING: APPLY MA-25S IN A WELL VENTI- LATED AREA THAT IS NOT NEAR OTHER PAINTING AREAS OR SHOP AREAS. PUT ON GLOVES AND USE EYE AND RESPIRATORY PROTECTION. IF YOU DO NOT FOLLOW THESE PRECAUTIONS, THE MA-25S CAN CAUSE INJURY.

8. Prepare the MA-25S, Type II ablative coating mixture.

NOTE: The MA-25S, Type II material is supplied in kits of part A (base material), part B (catalyst) and part C (thinner for the catalyst). Mix the material and apply it as quickly as possible.

- a. Mix part A by hand with a rigid blade, that is not made from wood, until you get a constant mixture.

- b. Mix one part by weight of part C to one part by weight of part B.

- c. Mix one part by weight of part B, plus part C to 7.77 parts by weight of part A.

9. Apply the MA-25S ablative coating to the repair area with a trowel. Apply it to a thickness of 0.12 to 0.16 inch.

10. Cure the MA-25S ablative coating at 70°F to 90°F (21°C to 32°C) for 30 minutes. Increase the temperature to 120°F to 150°F (39°C to 66°C) and cure for a minimum of 1 hour.

11. Apply the first layer of the ablative coating topcoat.

- a. Add 3% to 5% by weight of silica fibers (HT-100) to a sufficient quantity of RTV60 (which is recommended) or RTV560 topcoat material.

- b. For application with a spray gun, add a quantity of naphtha to the material equal to 30% to 40% by volume of the material. For application with a brush, add a quantity of naphtha to the material equal to 10% to 15% by volume of the material.

- c. Apply the mixture with a spray gun or a brush to the cured MA-25S ablative coating. The thickness must be 0.010 to 0.015 inch.

- d. Cure the topcoat at 70°F to 90°F (21°C to 32°C) for a minimum of 1 hour. Increase the temperature to 140°F (60°C) and cure for 16 to 24 hours, or increase the temperature to 200°F (93°C) and cure for 3 to 4 hours.

**Fan Duct Cowl Inner Wall Fireshield - Repair Using Ablative Coating - PW2000 Engine
Figure 201 (Sheet 1 of 3)**

757-200
STRUCTURAL REPAIR MANUAL

REPAIR INSTRUCTIONS (CONTINUED)

12. Apply the second layer of ablative coating topcoat.
- Add a quantity of naphtha to the RTV60 or RTV560 topcoat material equal to 25% to 45% by volume of the material.
 - Use a spray gun to apply a wet, continuous layer of the topcoat material to the first layer that has cured.
 - Apply non-woven Kevlar 28 mat fabric to the repair area up to the edges of the tripler. Soak the Kevlar mat with the topcoat material.
NOTE: The topcoat material must stay wet while you apply the non-woven Kevlar mat fabric.
 - Apply the topcoat material to the non-woven Kevlar mat and 1 inch of the tripler all around the mat. Apply the topcoat material to a thickness of 0.010 to 0.020 inch (0.3 to 0.5 mm).
 - Cure the topcoat at 70°F to 90°F (21°C to 32°C) for a minimum of 1 hour. Increase the temperature to 140°F (60°C) and cure for 16 to 24 hours, or 200°F (93°C) and cure for 3 to 4 hours.
13. Install the fan duct cowl. Refer to AMM 78-31-01.

NOTES

- WHEN YOU DO THIS REPAIR REFER TO:
 - AMM 78-31-01 FOR REMOVAL AND INSTALLATION OF THE FAN DUCT COWL
 - SRM 51-10-02 FOR INSPECTION AND REMOVAL OF DAMAGE
 - SRM 51-20-01 FOR PROTECTIVE TREATMENT OF METAL
 - SRM 51-30 FOR THE SOURCES OF THE REPAIR MATERIALS.

A THE REPAIR AREA IS DEFINED AS:
THE AREA IN BETWEEN THE FRAME AND SPLICE STRAP FROM THE TOP OF THE PANEL TO THE 45° RADIAL LINE. SEE DETAIL I.

Fan Duct Cowl Inner Wall Fireshield - Repair Using Ablative Coating - PW2000 Engine
Figure 201 (Sheet 2 of 3)

**757-200
STRUCTURAL REPAIR MANUAL**

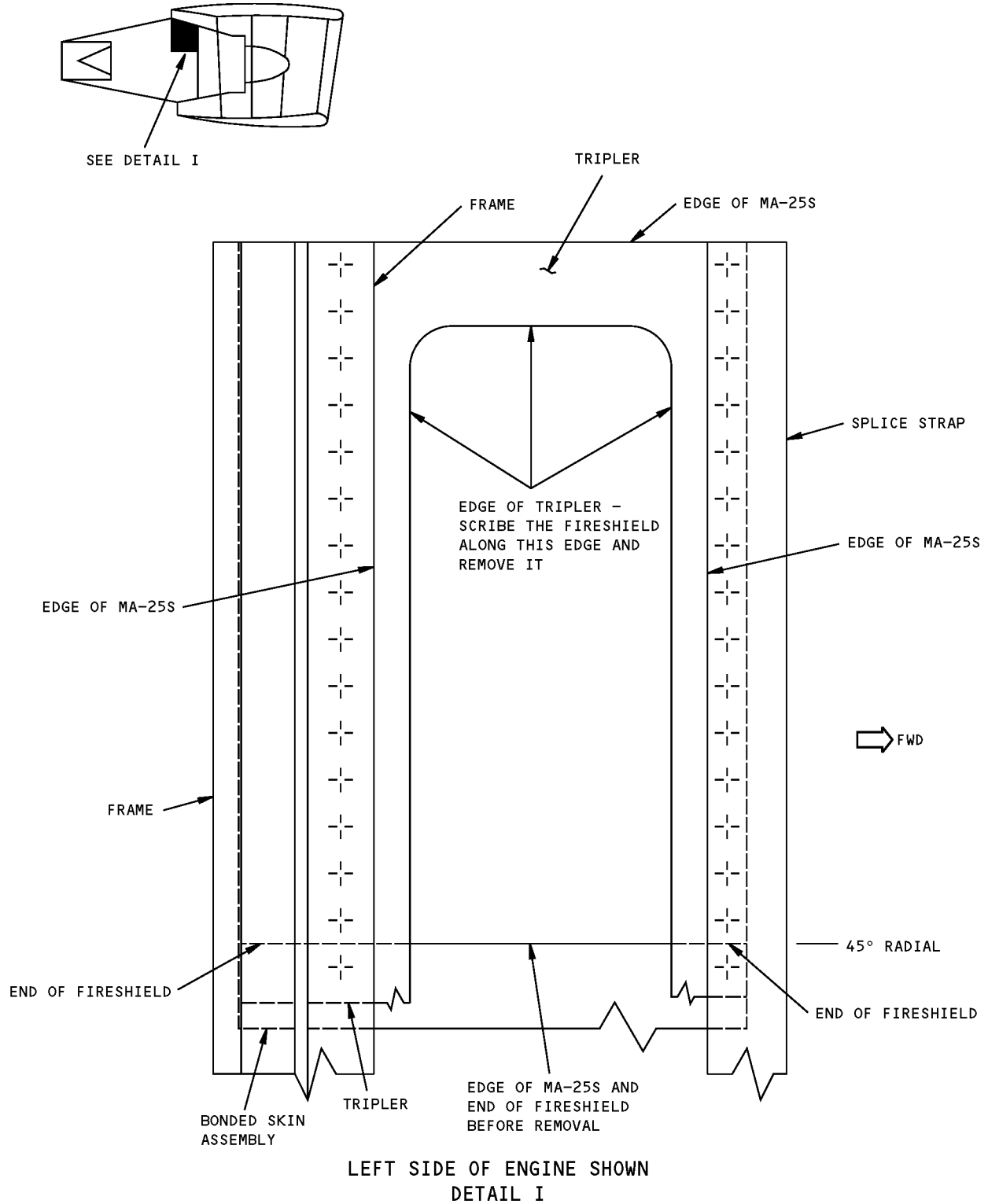

**Fan Duct Cowl Inner Wall Fireshield - Repair Using Ablative Coating - PW2000 Engine
Figure 201 (Sheet 3 of 3)**

STRUCTURAL REPAIR MANUAL

REPAIR 5 - THRUST REVERSER INNER WALL AFT COWL EXTERNAL - PW2000 ENGINE

APPLICABILITY
THIS REPAIR IS APPLICABLE TO THE ALUMINUM SKIN OF THE THRUST REVERSER INNERWALL, AFT COWL.

REPAIR INSTRUCTIONS

- Cut out the damaged part of the skin. Do not remove any of the CRES fireshield. See Details I and II.
- Make the repair parts. Make the repair parts align with the contour of the initial skin. See Table I.
- Assemble the repair parts, drill and countersink the fastener holes.
- Disassemble the repair parts.
Remove the nicks, scratches, gouges, burrs and sharp edges from the repair parts and the initial parts.
Apply a chemical conversion coating to the repair parts and to the bare surfaces of the initial parts.
- Apply one layer of BAC5710, Type 51 high temperature primer (DeSoto Hi-Temp) to parts 2,3,4 and 5. Apply one layer of BAC5710, Type 51 high temperature primer to the outer surface of the initial skin in the repair area and to the inner surface of the Part 1 plate. Let the primer dry.
- Apply one more layer of BAC5710, Type 51 high temperature primer to the mating surfaces of the repair parts and the initial skin.
- Install the repair parts while the primer is wet.
- Install countersink repair washers in the initial fastener holes with BAC5710, Type 51 high temperature primer. Refer to SRM 51-40-08.
- Install the fasteners wet with BAC5710, Type 51 high temperature primer.
- Remove unwanted primer from the outer surface of the skin and part 1 plate with MEK, MIBK, Trichloroethylene, or acetone.



NOTES

- ALL DIMENSIONS ARE IN INCHES UNLESS GIVEN DIFFERENTLY.
- THE DAMAGE LOCATION IS IN A VERY IMPORTANT SONIC ENVIRONMENT. IF CRACKS OR DETERIORATION ARE MORE THAN DAMAGE LIMITS OR OCCUR SUBSEQUENT TO THE REPAIR TELL THE BOEING COMPANY.

- WHEN YOU USE THIS REPAIR REFER TO:
 - AMM 51-21 FOR INTERIOR AND EXTERIOR FINISHES
 - SRM 51-10-01 FOR AERODYNAMIC SMOOTHNESS REQUIREMENTS
 - SRM 51-10-02 FOR INSPECTION AND REMOVAL OF DAMAGE
 - SRM 51-20-01 FOR PROTECTIVE TREATMENT OF METAL
 - SRM 51-20-05 FOR REPAIR SEALING
 - SRM 51-30 FOR THE SOURCES OF REPAIR MATERIALS
 - SRM 51-40-00 FOR FASTENER CODE, REMOVAL, INSTALLATION, HOLE SIZES AND EDGE MARGINS
 - SRM 51-40-03 FOR FASTENER SUBSTITUTION
 - SRM 51-40-08 FOR COUNTERSINKING AND THE USE OF COUNTERSINK REPAIR WASHERS.

A THE DIMENSION SHOWN IN SHEET 4, SECTION C-C IS GIVEN BY THE INITIAL FASTENER LOCATIONS.

FASTENER SYMBOLS

-  REFERENCE FASTENER LOCATION
-  INITIAL FASTENER LOCATION. INSTALL A BACR15CE(6)D RIVET.
-  REPAIR FASTENER LOCATION. INSTALL A BACR15CE(5)D RIVET.

REPAIR MATERIAL			
	PART	QTY	MATERIAL
1	PLATE	1	0.100 INCH CLAD 2024-T3
2	STIFFENER	2	0.071 INCH CLAD 2024-T3
3	SHIM	2	0.140 INCH BARE 2024-T3
4	SHIM	2	0.032 INCH CLAD 2024-T3
5	SHIM	2	0.063 INCH CLAD 2024-T3

TABLE I

**Thrust Reverser Inner Wall Aft Cowl External Repair - PW2000 Engine
Figure 201 (Sheet 1 of 4)**

**757-200
STRUCTURAL REPAIR MANUAL**

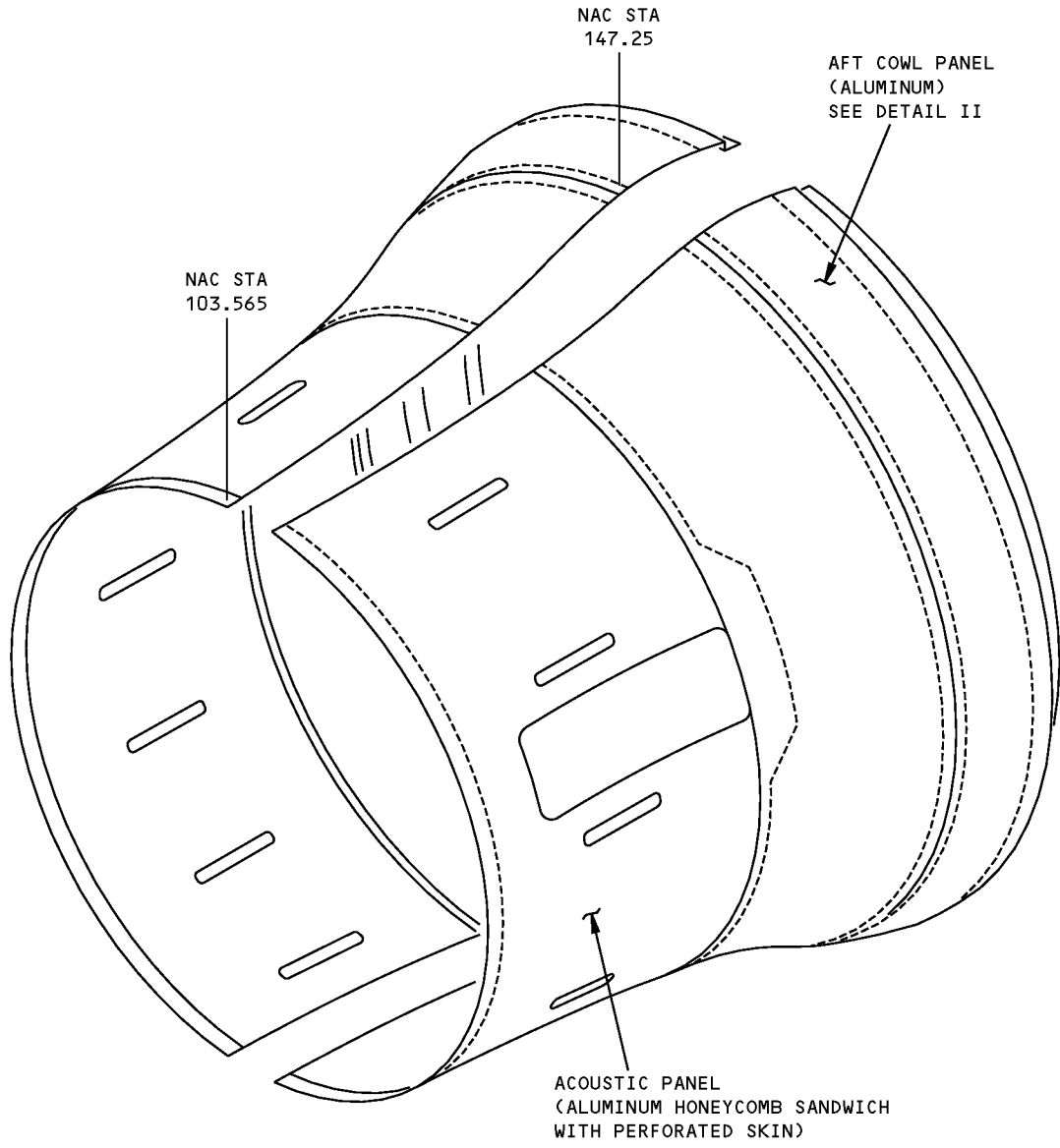

FAN DUCT COWL

DETAIL I

**Thrust Reverser Inner Wall Aft Cowl External Repair - PW2000 Engine
Figure 201 (Sheet 2 of 4)**

**757-200
STRUCTURAL REPAIR MANUAL**

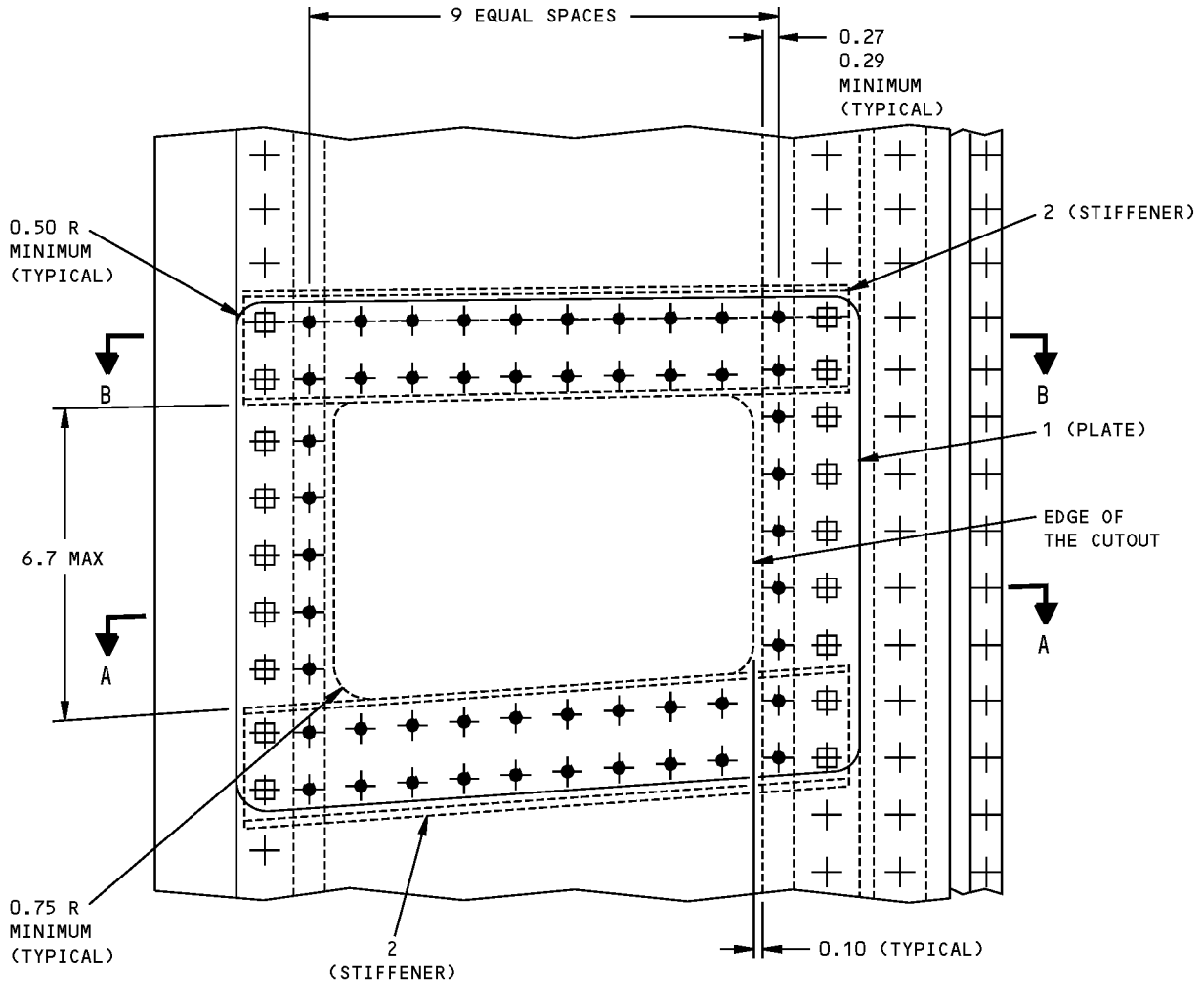

REPAIR OF DAMAGE IN THE OUTER SKIN WITH A BONDED DOUBLER
DETAIL II

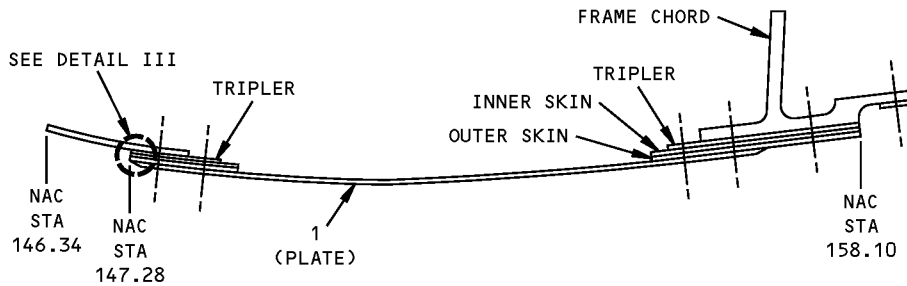

SECTION A-A

Thrust Reverser Inner Wall Aft Cowl External Repair - PW2000 Engine
Figure 201 (Sheet 3 of 4)

**757-200
STRUCTURAL REPAIR MANUAL**

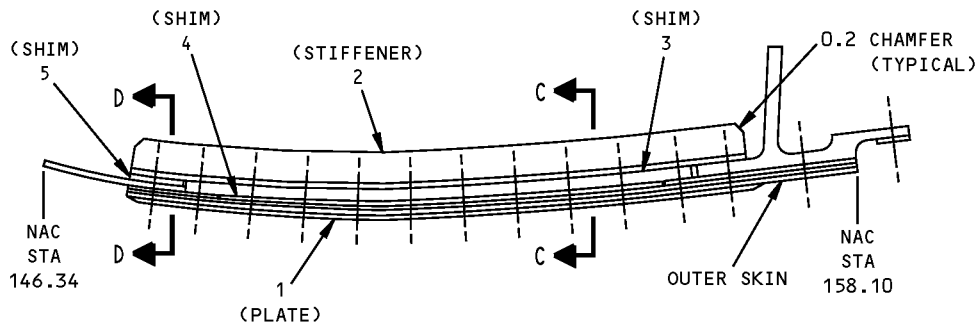

SECTION B-B

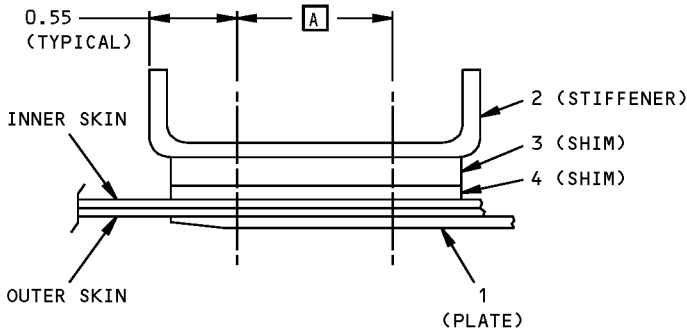

SECTION C-C

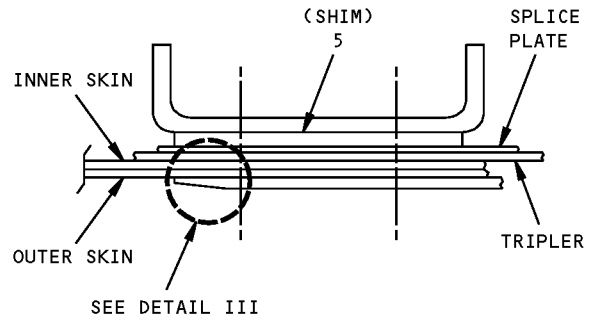

SECTION D-D

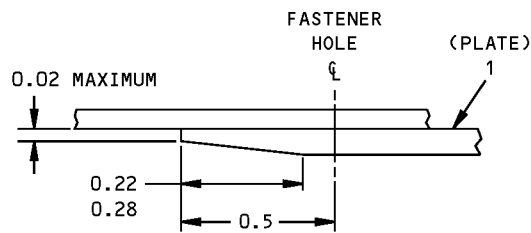

**EDGE CHAMFER TYPICAL ALL EDGES
DETAIL III**

**Thrust Reverser Inner Wall Aft Cowl External Repair - PW2000 Engine
Figure 201 (Sheet 4 of 4)**

STRUCTURAL REPAIR MANUAL

REPAIR 6 - ENGINE THRUST REVERSER HINGE BEAM ACCESS FAIRING - PW2000 ENGINE

APPLICABILITY

THIS REPAIR IS APPLICABLE TO THE GRAPHITE COMPOSITE ACCESS FAIRING IN THE HINGE BEAM OF THE ENGINE THRUST REVERSER. THE REPAIR IS FOR CRACKS AT NAC STA 144 AND CAN BE USED AT 4 LOCATIONS ON THE AIRPLANE. EACH REPAIR WILL HAVE AN ESTIMATE 5.25 LBS TOWG EQUIVALENT EFFECT.

REPAIR INSTRUCTIONS

1. Remove the metal brackets and fasteners adjacent to the hinge door. See Detail I.
2. Remove hinge door at the NAC STA 144.
3. Make a template for the fastener hole locations.
4. Make the reinforcement doubler. See Detail II. Bend the doubler as required to fit the aerodynamic surface of the fairing.
5. Apply one layer of Alodine 1200 and primer BMS 10-79 and one coat of BMS 10-60 to the doubler.
6. Mark a layout of the reinforcement on the external side of the fairing.
7. Repair the cracks on the damaged fairing. Use repair plies with the orientation as shown in Section A-A. Make sure that the extra repair plies extend 0.25 inch (6 mm) minimum past the reinforcement layout. Refer to the SRM 51-70-04 for repair damage and punctures in solid laminate panels.
8. Put an additional repair ply onto the external and internal faces of the panel. Make sure the additional repair plies extend at least 0.50 inch (12.7) beyond the finished repair doubler.
9. Put one isolation ply on the external and internal faces of the panel. Make sure the isolation plies extend 1.0 inch (25 mm) past the repair doubler and the hinge fitting.
10. Drill the fastener holes on the fairing. Use the template for fastener locations. Refer to the SRM 51-70-16 for hole drilling in graphite-to-aluminum structures.
11. Put the reinforcement on the external surface of the fairing. Backdrill the fastener holes onto the reinforcement through the fairing assembly.
12. Remove the nicks, scratches, gouges, burrs, and sharp edges from thr repair parts.
13. Apply a chemical conversion coating to the repair parts and to the bare surfaces of the support angle. Refer to SRM 51-20-01.

14. Apply one layer of BMS 10-11, Type 1 primer to the repair parts and to the bare surfaces of the angle. Refer to SOPM 20-41-02.
15. Install the reinforcement with BMS 5-109, Type II, Class 2 sealant between the mating surfaces, see Detail III. Install special countersink washers BACW10DX() for composite repairs to plug existing countersinks. Fasteners that are not made of aluminum must be installed wet with BMS 5-95 sealant. Use the same fastener type and diameter than the removed fasteners.
16. Apply one layer of BMS 10-11, Type II finish to the repair area. Refer to SOPM 20-41-02.

NOTES

- D = FASTENER DIAMETER.
- KEEP A DISTANCE OF 4D TO 6D BETWEEN THE FASTENERS.
- KEEP THE FASTENER EDGE DISTANCE TO A MINIMUM OF 2D.
- KEEP GAPS TO 0.005 INCH (0.13 mm) OR LESS. USE 2024-T3 CLAD OR 7075-T6 CLAD FILLERS OR LAMINATED SHIM STOCK
- WHEN YOU USE THIS REPAIR REFER TO:
- SOPM 20-41-02 FOR APPLICATION OF FINISHES
 - SRM 51-10-02 FOR INSPECTION AND REMOVAL OF DAMAGE
 - SRM 51-20-01 FOR PROTECTIVE TREATMENT OF METALLIC AND GRAPHITE MATERIALS
 - SRM 51-20-05 FOR REPAIR SEALING
 - SRM 51-40 FOR FASTENER CODE, INSTALLATION AND REMOVAL, HOLE SIZES AND EDGE MARGINS.
 - SRM 51-70-04 GRAPHITE/ARAMID/GLASS REINFORCED EPOXY LAMINATES AND NONMETALLIC HONEYCOMB SANDWICH REPAIRS - 350°F (177°C) CURE
 - SRM 51-70-16 HOLE DRILLING AND MACHINING OF COMPOSITE STRUCTURES

**Engine Thrust Reverser Hinge Beam Access Fairing Repair - PW2000 Engine
Figure 201 (Sheet 1 of 5)**

**757-200
STRUCTURAL REPAIR MANUAL**

FASTENER SYMBOLS

- + REFERENCE FASTENER LOCATION.
- ⊕ INITIAL FASTENER LOCATION. INSTALL A BACR15GA5-() HOLLOW ENDED RIVET.
- ⊕ INITIAL FASTENER LOCATION. INSTALL A BACB30VF4K() BOLT.

REPAIR MATERIAL			
	PART	QTY	MATERIAL
1	DOUBLER	1	0.040 2024-T4
2	REPAIR PLY	AS REQ'D	BMS 8-139, TYPE III, CLASS 2, STYLE 3K-135-8H
3	ISOLATION PLY	AS REQ'D	BMS 8-139, TYPE 120 OR TYPE 1581

TABLE I

**Engine Thrust Reverser Hinge Beam Access Fairing Repair - PW2000 Engine
Figure 201 (Sheet 2 of 5)**

**757-200
STRUCTURAL REPAIR MANUAL**

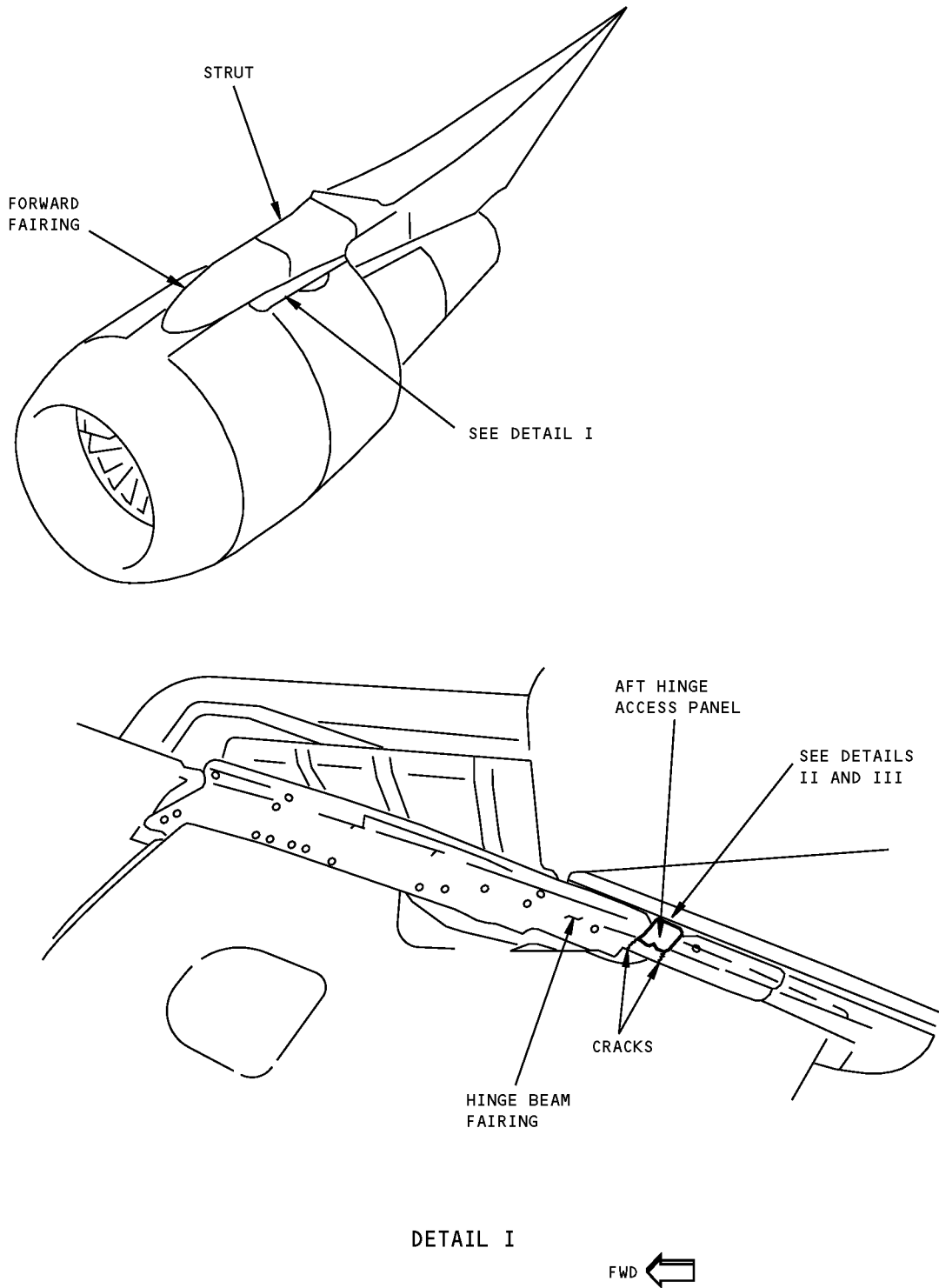

**Engine Thrust Reverser Hinge Beam Access Fairing Repair - PW2000 Engine
Figure 201 (Sheet 3 of 5)**

**757-200
STRUCTURAL REPAIR MANUAL**

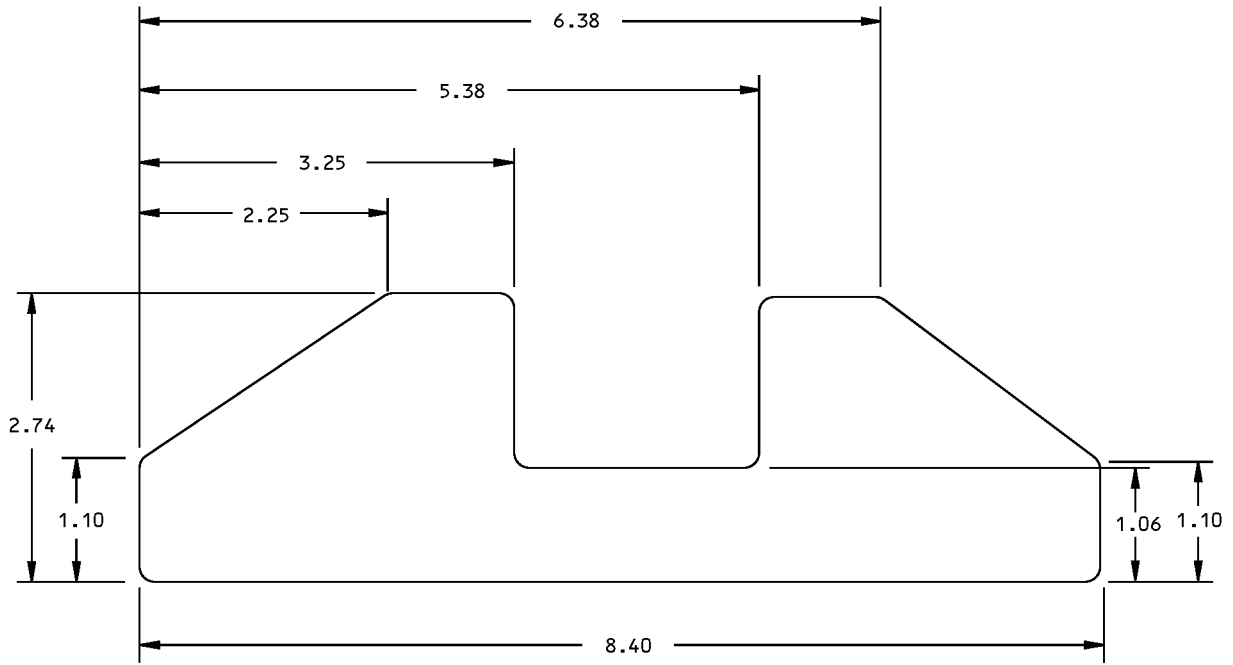

**FLAT PATTERN OF DOUBLER
DETAIL II**

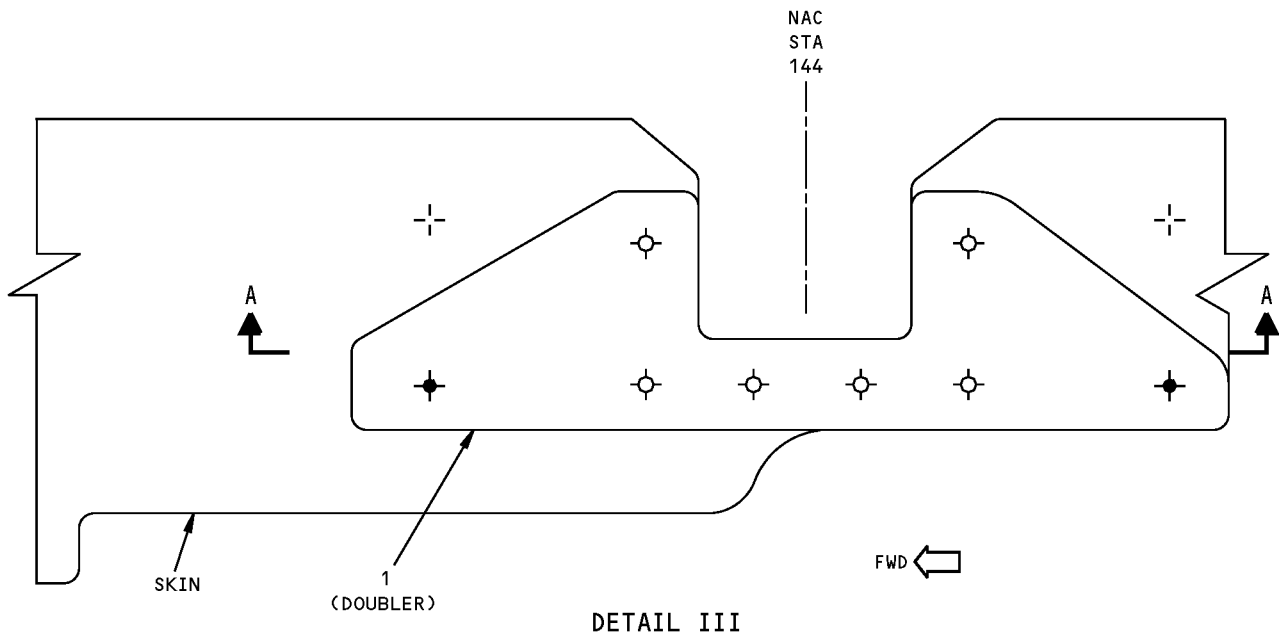

DETAIL III

**Engine Thrust Reverser Hinge Beam Access Fairing Repair - PW2000 Engine
Figure 201 (Sheet 4 of 5)**

**757-200
STRUCTURAL REPAIR MANUAL**

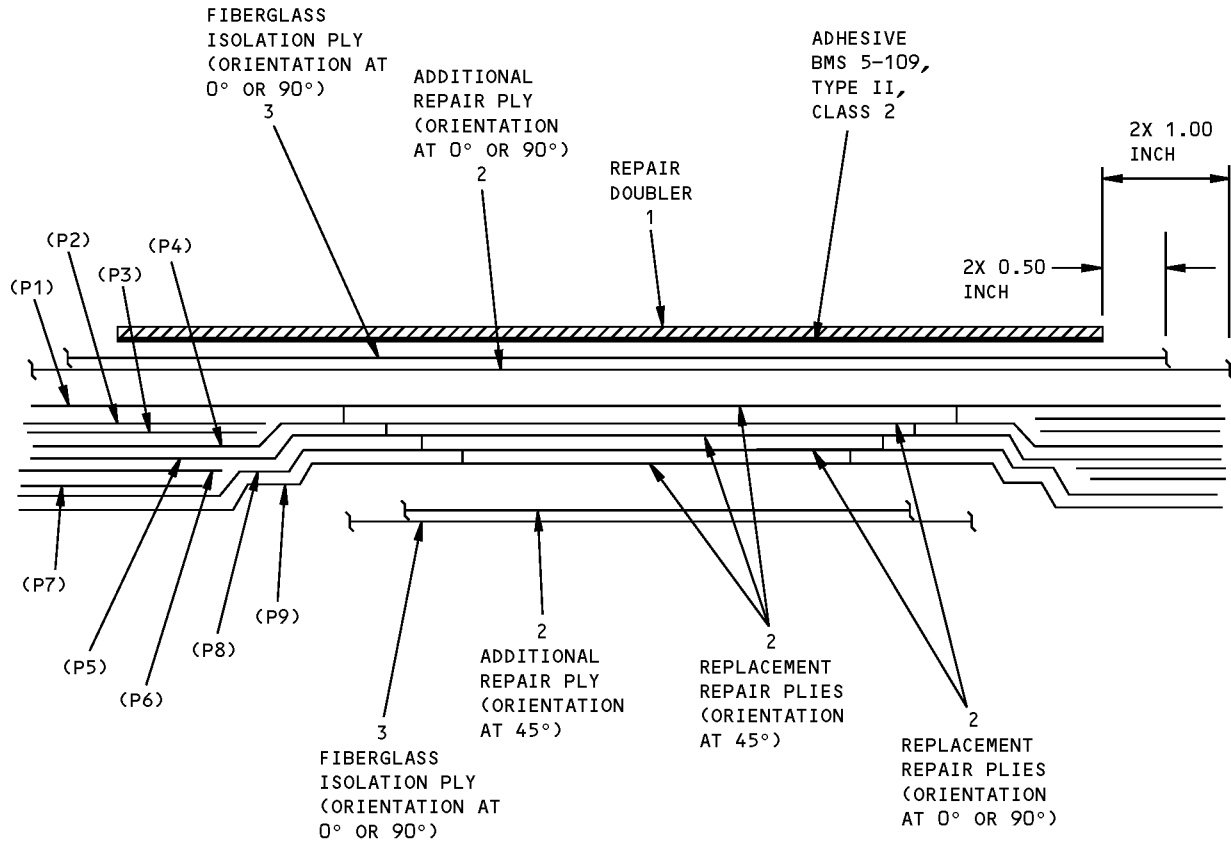

PLY DEFINITION (NO SCALE)

SECTION A-A

**Engine Thrust Reverser Hinge Beam Access Fairing Repair - PW2000 Engine
Figure 201 (Sheet 5 of 5)**

STRUCTURAL REPAIR MANUAL

REPAIR 7 - FAN DUCT COWL AND THRUST REVERSER FORWARD HINGE FITTING RIB - PW2000 ENGINE

APPLICABILITY
THIS REPAIR IS APPLICABLE TO THE HINGE FITTING RIB AT NAC STA 103.00 FOR DAMAGE CAUSED BY THE FIRESEAL INTERFERENCE.

REPAIR INSTRUCTIONS

1. Get access to the damage area.
2. Blend out the damage. See Detail I. Make sure the local rib thickness is not less than 0.070 inch (2 mm) after blend out. Ask Boeing for instructions if the thickness is less than 0.070 inch (2 mm).
3. Do a penetrant inspection to make sure there are no cracks. Refer to SOPM 20-20-02.
4. Trim the angle and zee in the fireseal installation flush with the fireseal retainer. Do not trim more than 0.200 inch (5 mm) measured from the initial edge of the parts. Ask Boeing for instructions if the zee and angle are not flush with the retainer after you removed 0.200 inch (5 mm). See Detail II.
5. Make the repair part. See Table I.
6. Assemble the repair part and drill the fastener holes.
7. Disassemble the repair part.
8. Remove the nicks, scratches, gouges, burrs, and sharp edges from the repair part and the hinge fitting rib.
9. Apply a chemical conversion coating to the bare surfaces of the web and/or the rib of the hinge fitting. Refer to the SRM 51-20-01.
10. Apply two coats of BMS 10-79, Type III primer to the repair part and to the bare surfaces of the web and/or the rib of the hinge fitting. Refer to the SOPM 20-44-04.
11. Fill the blended area with BMS 5-28 Type 6 or Type 25 filler. Cure and sand the cured filler flush with the hinge rib.
12. Install the repair part with BMS 5-63 fire-wall sealant between the mating surfaces. (Optional: DC 93-006 sealant).
13. Install the fasteners wet with BMS 5-63 firewall sealant. (Optional: DC 93-006 sealant).

NOTES

- D = FASTENER DIAMETER
- WHEN YOU USE THIS REPAIR REFER TO:
 - SOPM 20-20-02 FOR PENETRANT INSPECTION PROCEDURES
 - SOPM 20-44-04 FOR APPLICATION OF FINISHES
 - SRM 51-10-02 FOR INSPECTION AND REMOVAL OF DAMAGE
 - SRM 51-20-01 FOR PROTECTIVE TREATMENT OF METAL
 - SRM 51-20-05 FOR REPAIR SEALING
 - SRM 51-40 FOR FASTENER CODE, INSTALLATION AND REMOVAL, HOLE SIZES AND EDGE MARGINS.

- A** BEND IN THE ANNEALED CONDITION AND HEAT TREAT TO 150-170 KSI.
- B** AIRPLANES AFTER LN 852 DO NOT HAVE A ZEE IN THE FIRESEAL INSTALLATION. REFER TO SERVICE BULLETIN 757-54-0033 FOR THE CONFIGURATION WITHOUT A ZEE.

FASTENER SYMBOLS

 REPAIR FASTENER LOCATION. INSTALL A BACR15CE4M() RIVET.

REPAIR MATERIAL			
PART		QTY	MATERIAL
1	DOUBLER	1	0.040 INCH 17-7PH CRES A MIL-S-25043

TABLE I

**Fan Duct Cowl and Thrust Reverser Forward Hinge Fitting Rib Repair - PW2000 Engine
Figure 201 (Sheet 1 of 2)**

**757-200
STRUCTURAL REPAIR MANUAL**

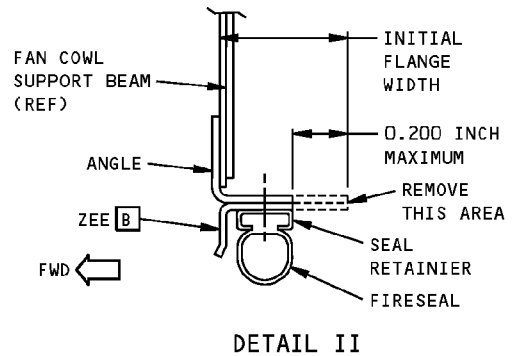
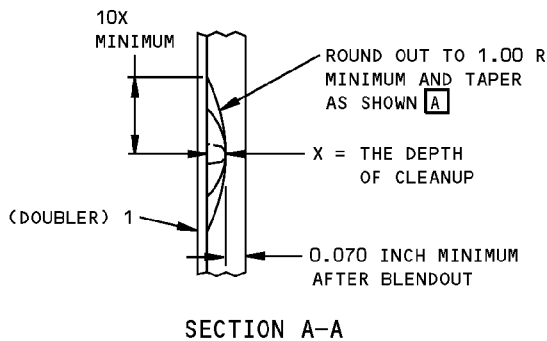
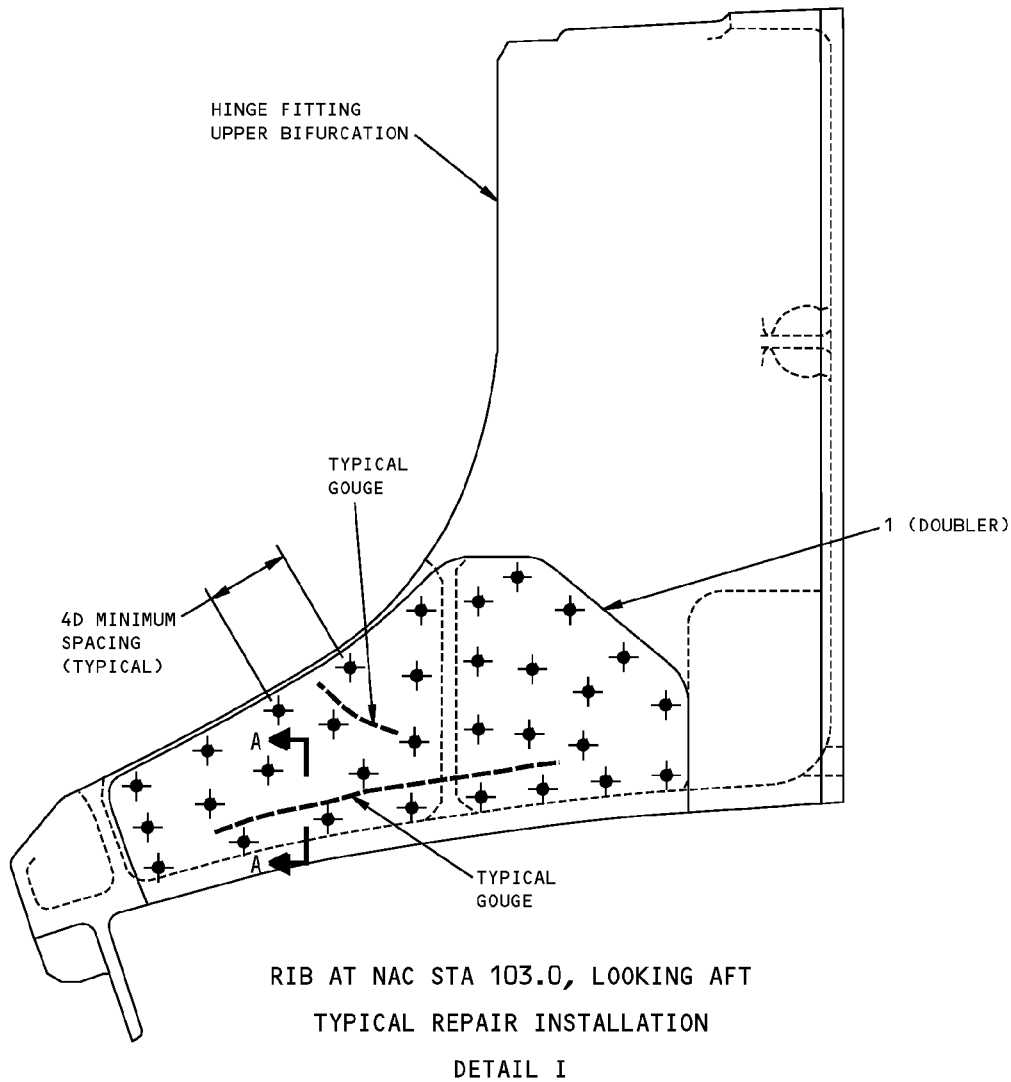

**Fan Duct Cowl and Thrust Reverser Forward Hinge Fitting Rib Repair - PW2000 Engine
Figure 201 (Sheet 2 of 2)**

**757-200
STRUCTURAL REPAIR MANUAL**

IDENTIFICATION 1 - FAN DUCT COWL AND THRUST REVERSER STRUCTURE - PW2000 ENGINE

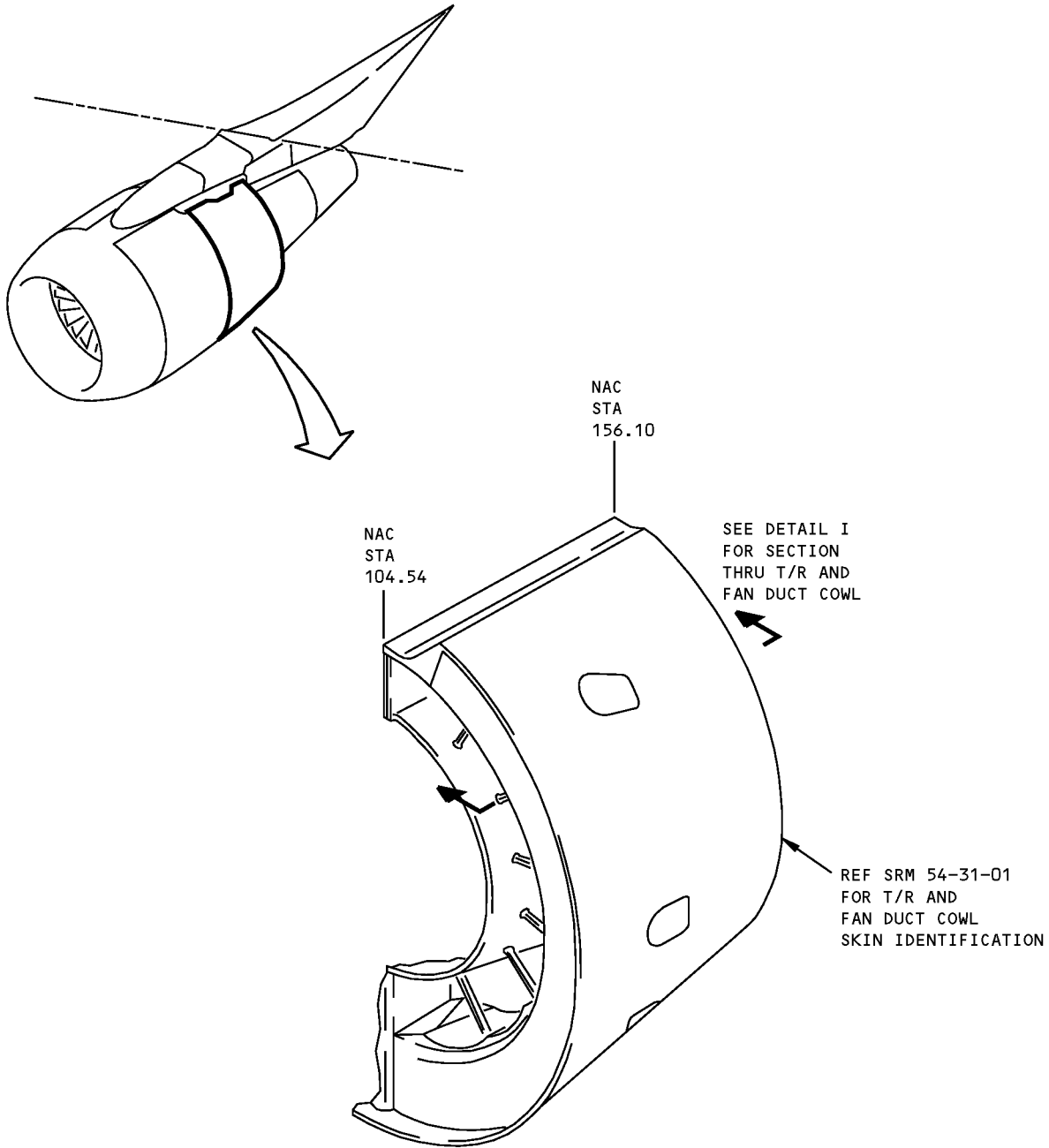

**Fan Duct Cowl and Thrust Reverser Structure Identification - PW2000 Engine
Figure 1 (Sheet 1 of 3)**

**757-200
STRUCTURAL REPAIR MANUAL**

REFERENCE DRAWING
315N3500

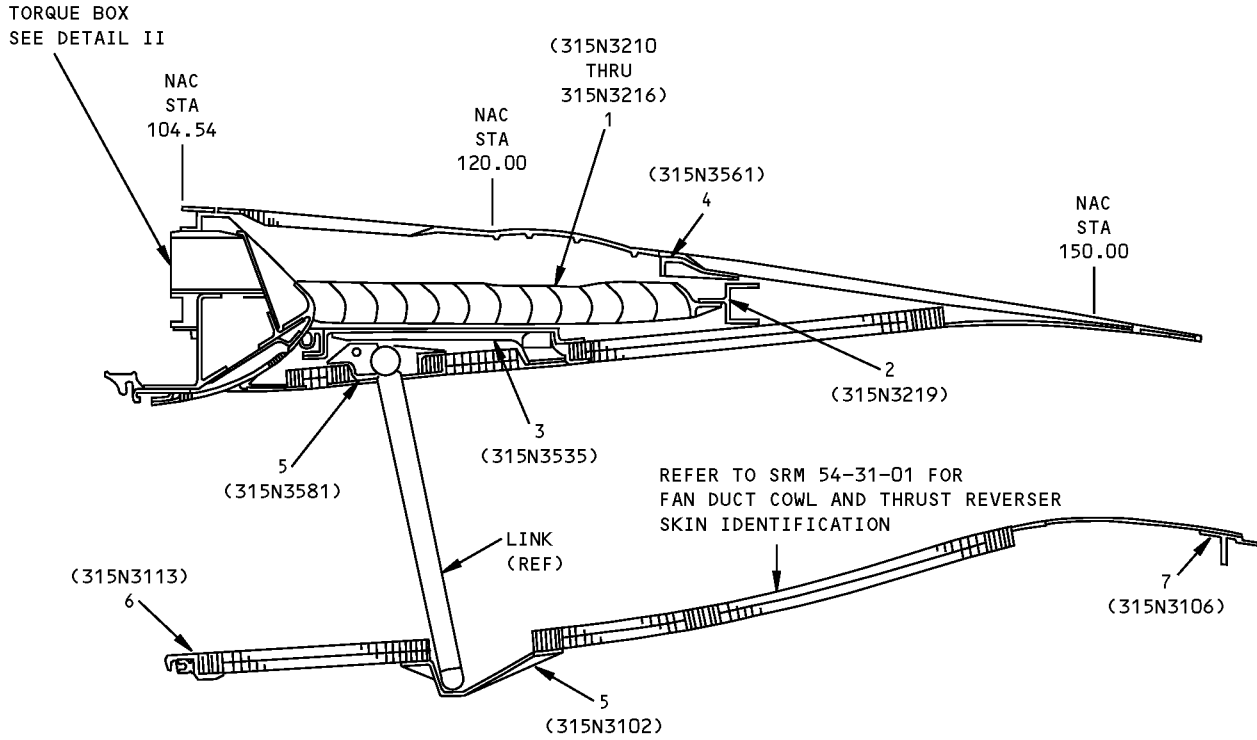

DETAIL I

ITEM	DESCRIPTION	GAGE	MATERIAL	EFFECTIVITY
1	CASCADE VANE		AZ92A-T6 MAGNESIUM CASTING PER MIL-M-46062, CLASS I	
2	SUPPORT RING		BAC1508-264 7075-T73	
3	INTERCOSTAL		AND10137-0709 2024-T42	
4	ACTUATOR FITTING		7075-T73 FORGING	
5	DRAG LINK FITTING		7075-T73 FORGED BLOCK	
6	GROOVE RING		BAC1508-263 7075-T73	
7	FRAME		BAC1506-3522 2219-T62	

LIST OF MATERIALS FOR DETAIL I

**Fan Duct Cowl and Thrust Reverser Structure Identification - PW2000 Engine
Figure 1 (Sheet 2 of 3)**

IDENTIFICATION 1
Page 2
Jan 20/2005

54-31-02

D634N201

**757-200
STRUCTURAL REPAIR MANUAL**

REF DWG
315N3202

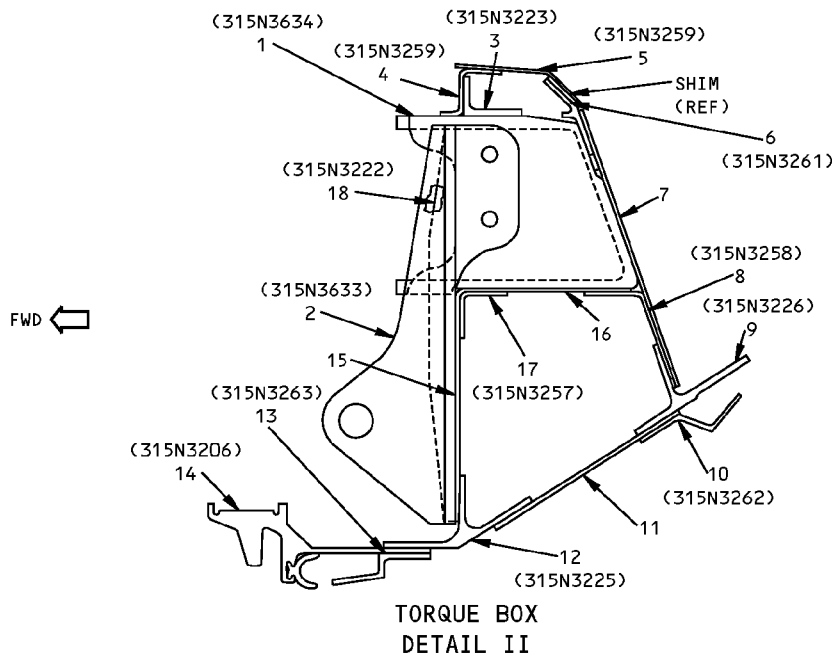

ITEM	DESCRIPTION	GAGE	MATERIAL	EFFECTIVITY
1	ACTUATOR FITTING		7075-T73 FORGING	
2	BRACKET		BAC1505-101231 7075-T73511	
3	FRAME		AND10133-1203 7075-T73	
4	CHORD	0.050	2024-T42 OR INCONEL 625 PER AMS 5599	
5	CHORD	0.040	INCONEL 625 PER AMS 5599	
6	STIFFENER		TI-6AL-4V MACHINED BAR	
7	FIREWALL	0.040	TI-6AL-4V	
8	CHORD	0.063	CLAD 2024-T42	
9	CHORD		BAC1506-3538 2024-T3511	
10	SUPPORT ZEE		BAC1517-2315 7075-T73511	
11	WEB ASSY			
	DOUBLER	0.020	2024-T3	
	DOUBLER	0.020	2024-T3	
	WEB	0.025	2024-T3	
12	CHORD		BAC1506-3513 2024-T3511	
13	SUPPORT ZEE		BAC1517-2304 7075-T73511	
14	VEE GROOVE FITTING		BAC1506-3516 7075-T73511	
15	WEB ASSY			
	DOUBLER	0.016	2024-T3	
	WEB	0.040	2024-T3	
16	WEB	0.040	CLAD 2024-T3	
17	CHORD		BAC1514-2741 2024-T42	
18	STIFFENER		BAC1505-100120 7075-T73511	

LIST OF MATERIALS FOR DETAIL II

**Fan Duct Cowl and Thrust Reverser Structure Identification - PW2000 Engine
Figure 1 (Sheet 3 of 3)**

IDENTIFICATION 1
Page 3
Jan 20/2005

54-31-02

D634N201

ALLOWABLE DAMAGE 1 - FAN DUCT COWL AND THRUST REVERSER STRUCTURE PW2000 ENGINE

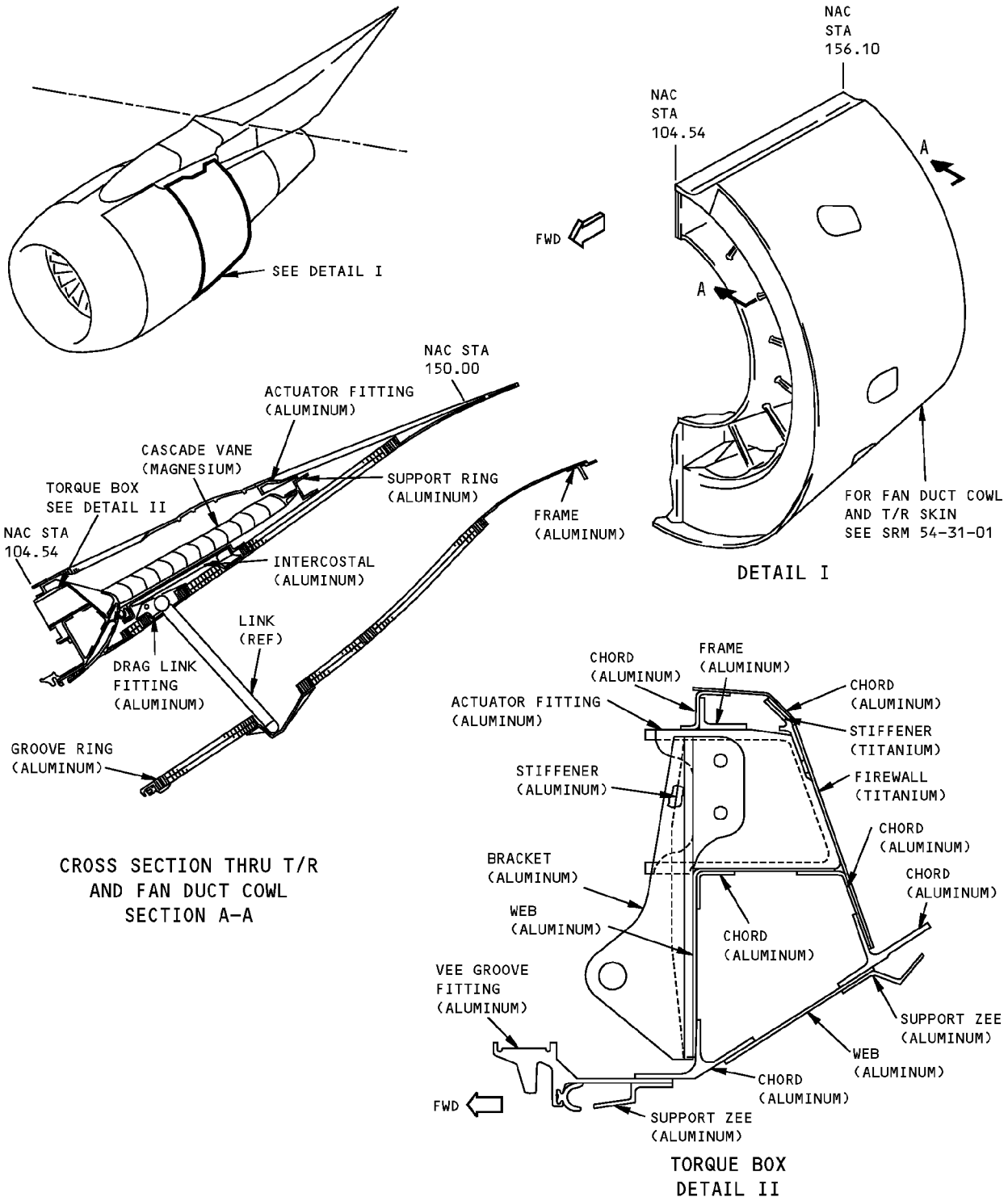

**Fan Duct Cowl and Thrust Reverser Structure Allowable Damage - PW2000 Engine
Figure 101 (Sheet 1 of 5)**

**757-200
STRUCTURAL REPAIR MANUAL**

DESCRIPTION	CRACKS	NICKS, GOUGES AND CORROSION	DENTS	HOLES AND PUNCTURES
CASCADE VANE	[F]	[G]	NOT PERMITTED	NOT PERMITTED
ACTUATOR FITTING [E]	[C]	[B]	NOT PERMITTED	NOT PERMITTED
CHORD	[D]	[B]	NOT PERMITTED	NOT PERMITTED
SUPPORT ZEE	[D]	[B]	NOT PERMITTED	NOT PERMITTED
WEB	[A]	[B]	SEE DETAIL V	NOT PERMITTED
VEE GROOVE FITTING [E]	[C]	[B]	NOT PERMITTED	NOT PERMITTED
STIFFENERS	[D]	[B]	NOT PERMITTED	NOT PERMITTED
SUPPORT RING	[C]	[B]	NOT PERMITTED	NOT PERMITTED
FRAME	[C]	[B]	NOT PERMITTED	NOT PERMITTED
DRAG LINK FITTING [E]	[C]	[B]	NOT PERMITTED	NOT PERMITTED
INTERCOSTAL	[A]	[B]	NOT PERMITTED	NOT PERMITTED
BRACKET	[D]	[B]	NOT PERMITTED	NOT PERMITTED
FIREWALL	[A]	[B]	SEE DETAIL V	NOT PERMITTED
GROOVE RING	[C]	[B]	NOT PERMITTED	NOT PERMITTED

NOTES

- REFINISH REWORKED AREAS AS SHOWN IN AMM 51-20
 - REFER TO SRM 51-10-01 FOR AERODYNAMIC SMOOTHNESS REQUIREMENTS. WHERE THE DAMAGE IS MORE THAN THE LIMITS SHOWN IN SRM 51-10-01, CONSIDERATION SHOULD BE GIVEN TO THE LOSS OF PERFORMANCE INVOLVED.
 - REFER TO SRM 51-10-02 FOR INSPECTION AND REMOVAL OF DAMAGE
- [A] CRACKS ARE NOT PERMITTED EXCEPT FOR EDGE CRACKS WHICH MUST BE REMOVED AS SHOWN IN DETAIL III.
- [B] REMOVE DAMAGE AS SHOWN IN DETAILS III, IV AND VI.
- [C] CRACKS ARE NOT PERMITTED EXCEPT FOR EDGE CRACKS WHICH MUST BE REMOVED AS SHOWN IN DETAILS III AND V.
- [D] CRACKS ARE NOT PERMITTED EXCEPT FOR EDGE CRACKS WHICH MUST BE REMOVED AS SHOWN IN DETAILS III AND VIII.
- [E] SHOT PEEN REWORKED AREA AS SHOWN IN SRM 51-20-06. SHOT PEEN INTENSITIES WILL VARY WITH THE THICKNESS REMAINING AFTER REWORK.
- [F] CRACKS ARE NOT PERMITTED EXCEPT FOR EDGE CRACKS WHICH MUST BE REMOVED AS SHOWN IN DETAILS III, IX AND XI. [H]
- [G] REMOVE DAMAGE AS SHOWN IN DETAILS III, IX AND XI. [H]
- [H] SPECIAL PRECAUTIONS AND PROCEDURES ARE REQUIRED FOR REWORKING MAGNESIUM COMPONENTS. REFER TO SRM 51-10-02 FOR INSPECTION AND REMOVAL OF DAMAGE.

**Fan Duct Cowl and Thrust Reverser Structure Allowable Damage - PW2000 Engine
Figure 101 (Sheet 2 of 5)**

**757-200
STRUCTURAL REPAIR MANUAL**

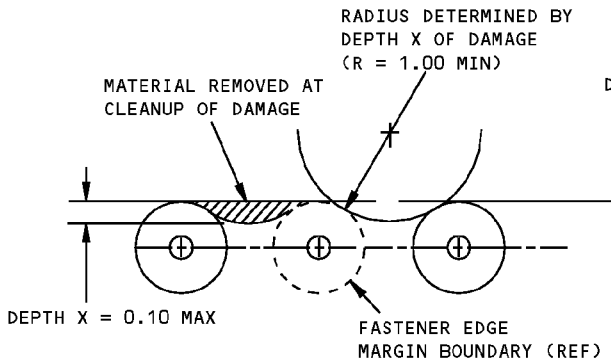

**DAMAGE CLEANUP OF EDGES WHERE
FASTENER EDGE MARGINS DO NOT OVERLAP**

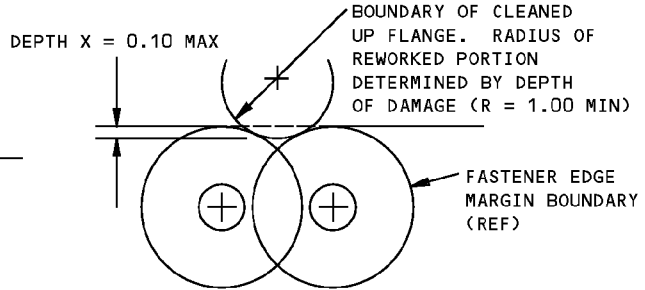

**DAMAGE CLEANUP OF EDGES WHERE
FASTENER EDGE MARGINS OVERLAP**

DETAIL III

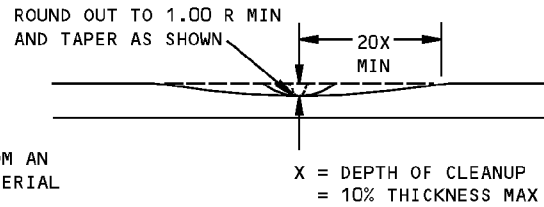
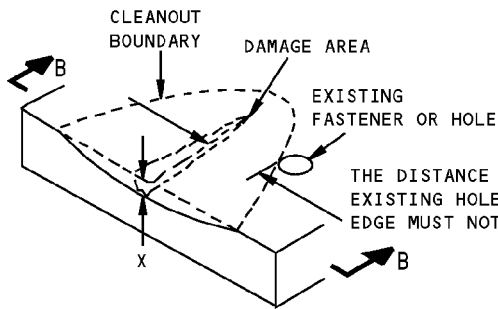

SECTION B-B

REMOVAL OF NICK, GOUGE AND SCRATCH DAMAGE ON A SURFACE

DETAIL IV

**Fan Duct Cowl and Thrust Reverser Structure Allowable Damage - PW2000 Engine
Figure 101 (Sheet 3 of 5)**

**757-200
STRUCTURAL REPAIR MANUAL**

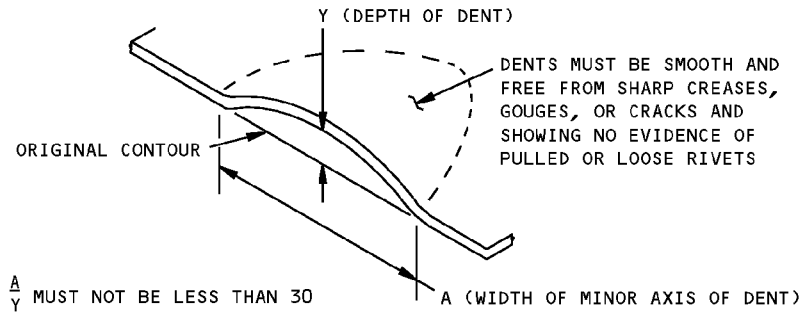

**ALLOWABLE DAMAGE FOR DENT
DETAIL V**

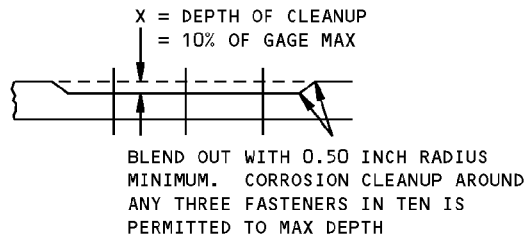
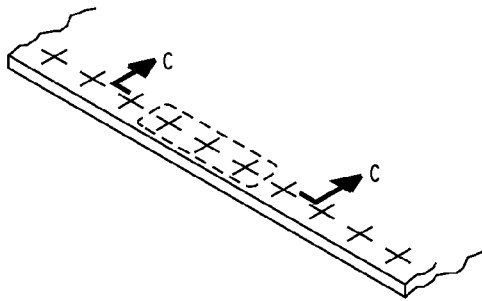

SECTION C-C

**CORROSION CLEANUP
DETAIL VI**

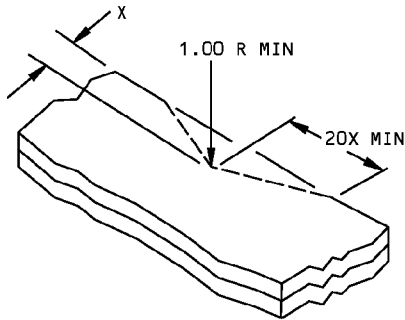

X = DEPTH OF CLEANUP = 0.10 MAX

DETAIL VII

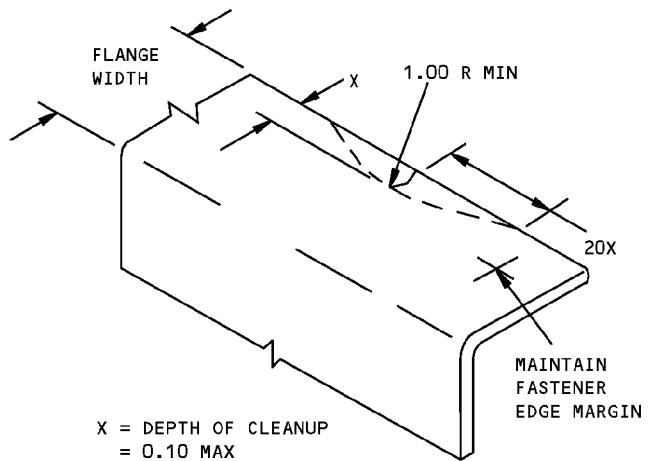

**REMOVAL OF NICK OR CRACK
DAMAGE ON AN EDGE**

DETAIL VIII

**Fan Duct Cowl and Thrust Reverser Structure Allowable Damage - PW2000 Engine
Figure 101 (Sheet 4 of 5)**

**757-200
STRUCTURAL REPAIR MANUAL**

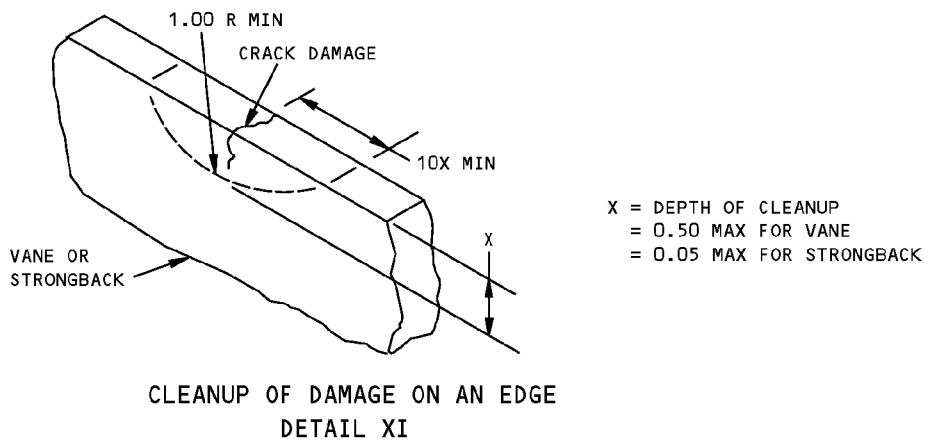
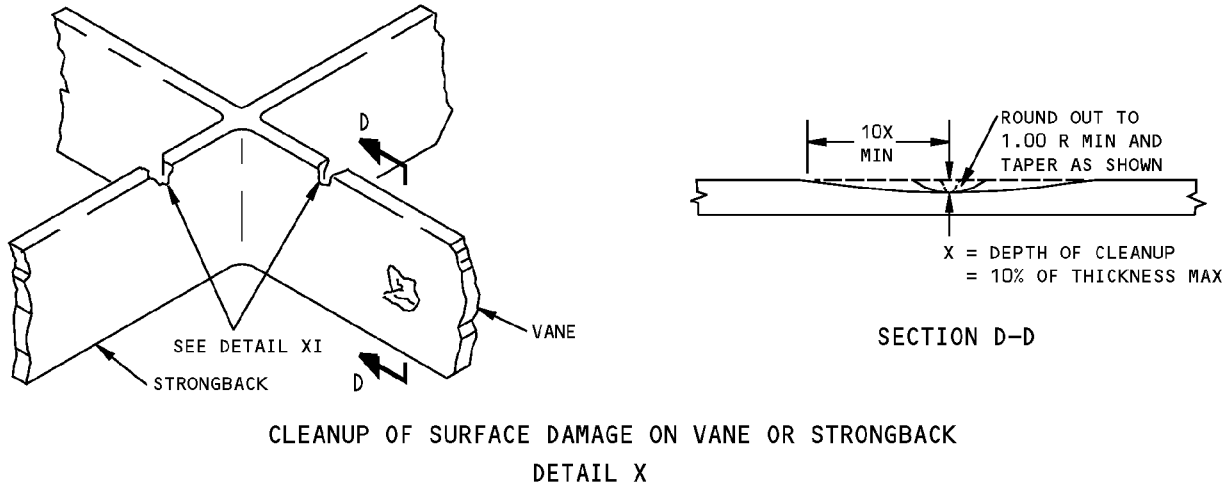
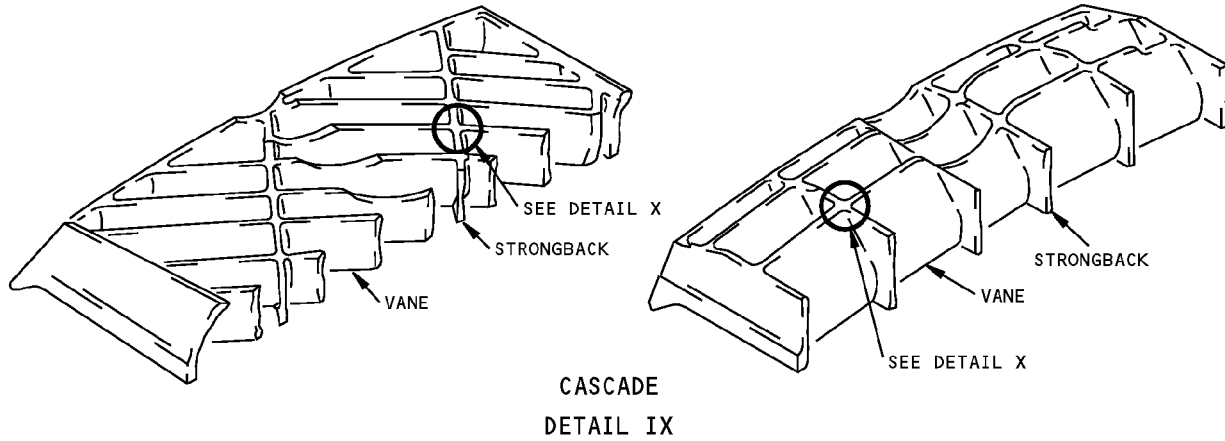

**Fan Duct Cowl and Thrust Reverser Structure Allowable Damage - PW2000 Engine
Figure 101 (Sheet 5 of 5)**

757-200
STRUCTURAL REPAIR MANUAL

IDENTIFICATION 1 - COMMON NOZZLE ASSEMBLY SKIN - RB211-535E4 ENGINE

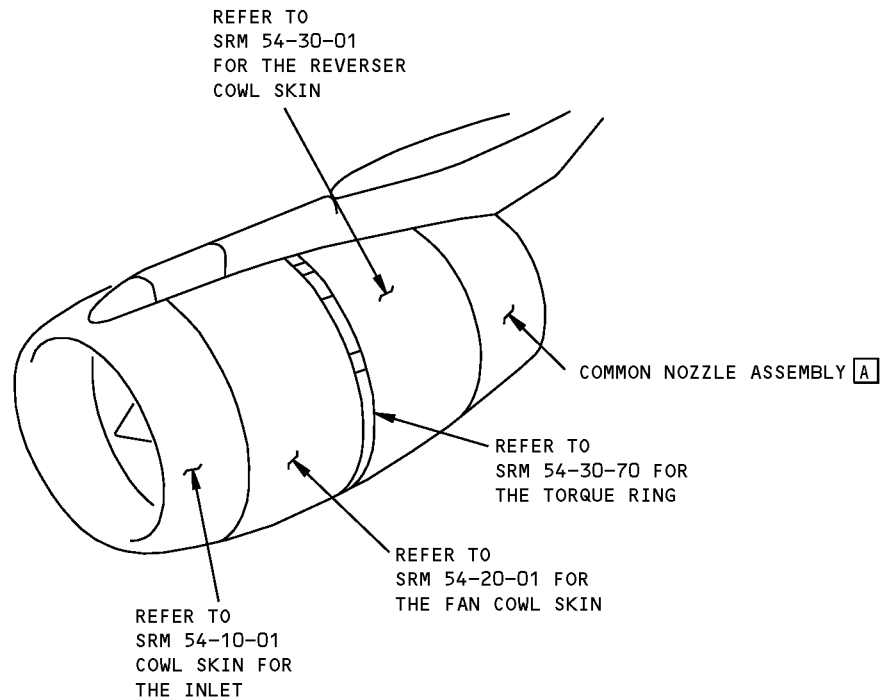

NOTES

- A** REFER TO SRM 54-40-02 IDENTIFICATION 1 FOR COMMON NOZZLE ASSEMBLY STRUCTURE IDENTIFICATION.

Common Nozzle Assembly Skin Identification - RB211-535E4 Engine
Figure 1

STRUCTURAL REPAIR MANUAL

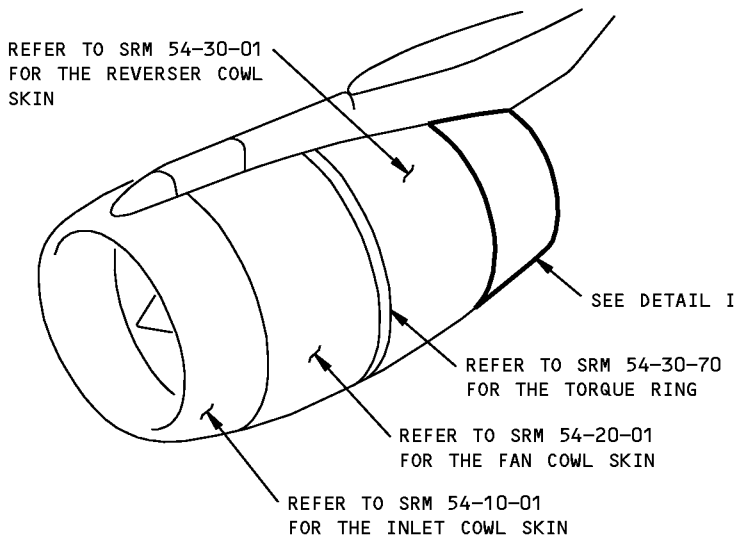
ALLOWABLE DAMAGE GENERAL - COMMON NOZZLE ASSEMBLY SKIN - RB211-535E4 ENGINE

ALLOWABLE DAMAGE - RB211-535E4 COMMON NOZZLE ASSEMBLY

Allowable damage data is intended to permit an operator to ascertain whether a damaged common nozzle assembly may be returned to service without repair. Damage permitted by this data will have no significant effect on strength or fatigue life of the structure, which will still be capable of fulfilling its design function. The types of allowable damage permitted are defined and descriptions are given of cleanup procedures required to prevent damage propagation, or to improve aerodynamic smoothness of a damaged part.

DEFINITIONS

DAMAGE	ALL DAMAGE LIMITS ASSUME THAT EXPOSED EDGES DO NOT PROTRUDE FROM SKIN CONTOUR. SUCH DAMAGE SHOULD BE REWORKED TO REMOVE OR FEATHER PROTRUSIONS. HOLES AND CRACKS IN PRESSURE BOUNDARIES MUST BE SEALED WITH APPROPRIATE TAPE MATERIAL.
ALLOWABLE DAMAGE:	
UNLIMITED USAGE	MINOR DAMAGE NOT AFFECTING THE STRUCTURAL INTEGRITY OR FUNCTIONAL CAPABILITY OF THE COMPONENT AND REQUIRING NO REPAIRS OVER THE AIRCRAFT DESIGN LIMIT.
TIME LIMITED	MINOR DAMAGE NOT AFFECTING THE STRUCTURAL INTEGRITY OF THE COMPONENT IN NORMAL OPERATION, BUT COULD REDUCE THE DESIGN LIFE OF THE COMPONENT. THEREFORE, DAMAGE MUST BE PERMANENTLY REPAIRED NOT LATER THAN THE NEXT MAINTENANCE 'C' CHECK. THE LOCATION AND SIZE OF THE DAMAGE IS TO BE NOTED AND CHECKED AT EACH SUBSEQUENT 'A' CHECK TO ENSURE THAT THE DAMAGE HAS NOT GROWN BEYOND THE TIME LIMITED ALLOWABLE DAMAGE LIMITS.

823608 S0006804606_V2

Common Nozzle Assembly Skin Allowable Damage - RB211-535E4 Engine
Figure 101 (Sheet 1 of 6)

ALLOWABLE DAMAGE GENERAL
 Page 101
54-40-01
 May 20/2008

D634N201

STRUCTURAL REPAIR MANUAL

TYPES OF DAMAGE

GOUGE	A GOUGE IS A DAMAGE AREA OF ANY SIZE WHICH RESULTS IN A CROSS SECTIONAL AREA CHANGE. IT IS USUALLY CAUSED BY CONTACT WITH A RELATIVELY SHARP OBJECT WHICH PRODUCES A CONTINUOUS, SHARP OR SMOOTH CHANNEL-LIKE GROOVE IN THE MATERIAL.
NICK	A NICK IS A LOCAL GOUGE WITH SHARP EDGES. CONSIDER A SERIES OF NICKS IN A LINE TO BE A GOUGE.
SCRATCH	A SCRATCH IS A LINE OF DAMAGE IN THE MATERIAL AND RESULTS IN A CROSS SECTIONAL AREA CHANGE. IT IS USUALLY CAUSED BY CONTACT WITH A VERY SHARP OBJECT.
CRACK	A CRACK IS A PARTIAL FRACTURE OR COMPLETE BREAK IN THE MATERIAL AND PRODUCES A MOST SIGNIFICANT CROSS SECTIONAL AREA CHANGE. IN APPEARANCE, IT IS USUALLY AN IRREGULAR LINE.
DENT	A DENT IS A DAMAGE AREA WHICH IS DEPRESSED WITH RESPECT TO ITS NORMAL CONTOUR. THERE IS NO CROSS SECTIONAL AREA CHANGE IN THE MATERIAL. AREA BOUNDARIES ARE SMOOTH.
HOLE	A HOLE CONSTITUTES A COMPLETE PENETRATION OF THE MATERIAL.
DISBOND	SEPARATION OF THE FACE SHEET FROM THE HONEYCOMB CORE OR A FAYING SURFACE.

NOTES

- ALL DIMENSIONS ARE SHOWN IN INCHES.
- A** MAXIMUM OF 10 LOOSE RIVETS WITH A MINIMUM OF 12 INCH SEPARATION BETWEEN LOOSE RIVETS.
- B** BLEND CORROSION AROUND ANY THREE FASTENERS IN TEN. SEE DETAIL V.
- C** DISBOND IS NOT ALLOWED.
- D** MINIMUM DISTANCE FROM A REINFORCED AREA OR EDGE OF HONEYCOMB.
- E** CRACKS UP TO 0.50 IN LENGTH ARE ALLOWED, PROVIDED THERE IS A MINIMUM OF 3.00 INCH SEPARATION FROM OTHER DAMAGE. A MAXIMUM OF 4 CRACKS ARE ALLOWED. DRILL 0.19 DIAMETER STOP HOLES AT THE ENDS OF CRACK AND REPAIR AT THE NEXT 'A' CHECK. REMOVE EDGE CRACKS PER DETAILS III AND VI.
- F** MUST BE PERMANENTLY REPAIRED AT "A" CHECK.
- G** 1.0 FOR DENTS. NOT MORE THAN 3 DENTS IN ANY ONE LINEAR 16 INCH DISTANCE.
- H** FOR DENTS: 1.5 TIME THE LARGEST DENT DIAMETER
- I** 0.25 INCH FOR NICKS. NOT MORE THAN 4 NICKS PER SQUARE INCH.
- J** MUST BE MONITORED FOR GROWTH AT 'A' CHECKS UNTIL REPAIRED.
- K** NOT WITHIN 1.0 INCH FROM EDGE OF SKIN.
- L** BLEND PER DETAIL IV.

**Common Nozzle Assembly Skin Allowable Damage - RB211-535E4 Engine
Figure 101 (Sheet 2 of 6)**

757-200
STRUCTURAL REPAIR MANUAL

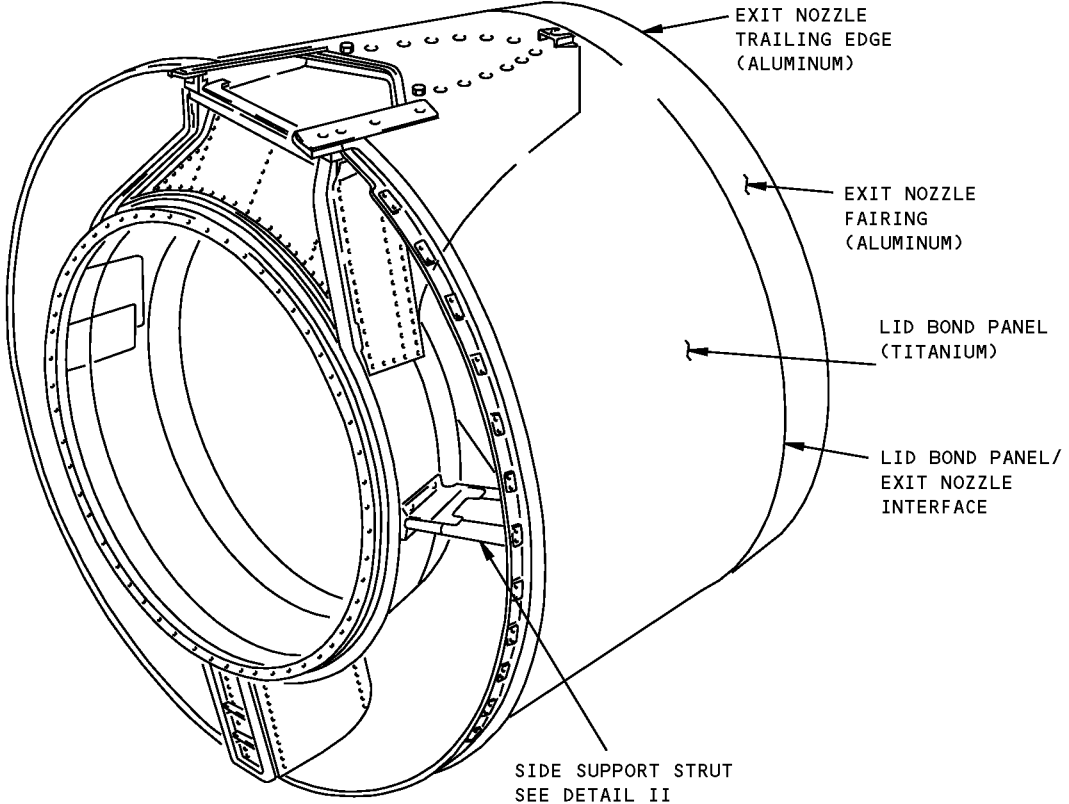

**COMMON NOZZLE ASSEMBLY
DETAIL I**

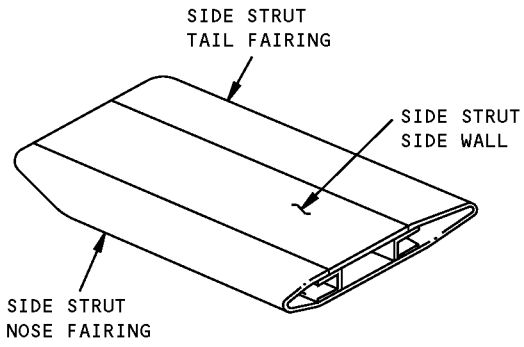

**SIDE SUPPORT STRUT
DETAIL II**

A8557A

**Common Nozzle Assembly Skin Allowable Damage - RB211-535E4 Engine
Figure 101 (Sheet 3 of 6)**

757-200
STRUCTURAL REPAIR MANUAL

DESCRIPTION	NICK	GOUGE/ SCRATCH	CRACKS	HOLES	DENTS	MINIMUM DEFECT SEPARATION	COMMENTS
EXIT NOZZLE TRAILING EDGE	0.20 LONG 0.020 DEEP L	1.50 LONG 0.010 DEEP L	NOT ALLOWED	NOT ALLOWED	NOT ALLOWED	3.0 I	
EXIT NOZZLE FAIRING	0.25 LONG 0.010 DEEP	10.0 LONG 0.010 DEEP	NOT ALLOWED	NOT ALLOWED	2.0 DIA 0.060 DEEP 0.25 R MIN	3.0 I	
LID BOND PANEL	0.75 LONG 0.010 DEEP 1.5 D	MAXIMUM 1.5 LONG 0.007 DEEP 1.5 D	NOT ALLOWED	NOT ALLOWED	2.0 DIA 0.080 DEEP 1.0 D	2.0 G	C
LID BOND PANEL/ EXIT NOZZLE INTERFACE			A CRACK TERMINATING AT 2 ADJACENT FAST- ENERS IS PERMITTED. NO OTHER CRACK IS PERMITTED WITHIN 5.0 OF ANY CRACK TERMINATION			4.0	A B
SIDE STRUT TAIL FAIRING	0.25 LONG 0.010 DEEP	MAXIMUM 10.0 LONG 0.010 DEEP	NOT ALLOWED - EXCEPT EDGE CRACKS. REMOVE DAMAGE PER DETAIL VI	NOT ALLOWED	2.0 DIA 0.060 DEEP K	4.0	
SIDE STRUT SIDE WALL	0.25 LONG 0.010 DEEP	10.0 LONG 0.010 DEEP	SAME AS ABOVE	NOT ALLOWED	2.0 DIA 0.060 DEEP K	4.0	
SIDE STRUT NOSE FAIRING	0.25 LONG 0.010 DEEP	10.0 LONG 0.010 DEEP	SAME AS ABOVE	NOT ALLOWED	2.0 DIA 0.060 DEEP K	4.0	

UNLIMITED USAGE
TABLE I

Common Nozzle Assembly Skin Allowable Damage - RB211-535E4 Engine
Figure 101 (Sheet 4 of 6)

757-200
STRUCTURAL REPAIR MANUAL

DESCRIPTION	NICK	GOUGE/ SCRATCH	CRACKS	HOLES	DENTS	MINIMUM DEFECT SEPARATION	COMMENTS
EXIT NOZZLE TRAILING EDGE				NOT ALLOWED	NOT ALLOWED		
EXIT NOZZLE FAIRING			LESS THAN 1.0 LONG - J . GREATER THAN 1.0, BUT LESS THAN 3.0 - F	NOT ALLOWED	2.0 DIA 0.12 DEEP 0.25 R MIN	2.0	
LID BOND PANEL		MAXIMUM 2.0 LONG X 0.10 WIDE X 0.010 DEEP. MIN 0.05 R J 3.0 D		NOT ALLOWED	5.0 DIA 0.12 DEEP 0.25 R MIN 1.0 D F	3.0 H	
LID BOND PANEL/ EXIT NOZZLE INTERFACE			A CRACK TERMINATING BETWEEN 3 ADJACENT FASTENERS IN JOINT OF 10 OR MORE IS PERMITTED				
SIDE STRUT TAIL FAIRING			E	NOT ALLOWED	2.0 DIA 0.12 DEEP 0.25 R MIN	3.0	
SIDE STRUT SIDE WALL			E	NOT ALLOWED	2.0 DIA 0.12 DEEP 0.25 R MIN	3.0	
SIDE STRUT NOSE FAIRING			E	NOT ALLOWED	2.0 DIA 0.12 DEEP 0.25 R MIN	3.0	

TIME LIMITED USAGE
TABLE II

Common Nozzle Assembly Skin Allowable Damage - RB211-535E4 Engine
Figure 101 (Sheet 5 of 6)

STRUCTURAL REPAIR MANUAL

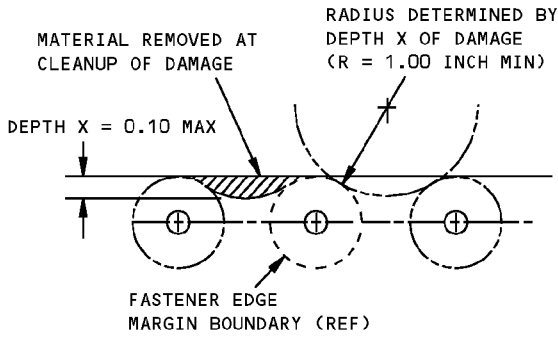

DAMAGE CLEANUP OF EDGES WHERE FASTENER EDGE MARGINS DO NOT OVERLAP

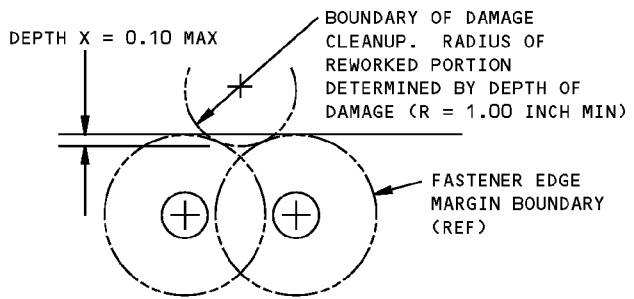

DAMAGE CLEANUP OF EDGES WHERE FASTENER EDGE MARGINS OVERLAP

DETAIL III

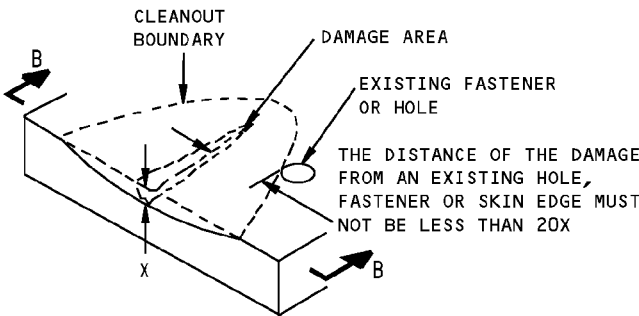

REMOVAL OF NICK, GOUGE, AND SCRATCH DAMAGE ON A SURFACE
DETAIL IV

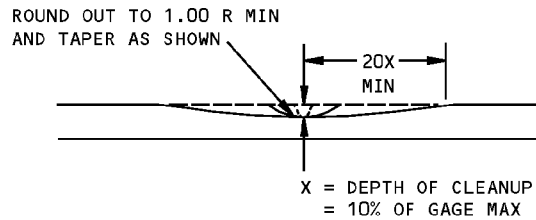

SECTION B-B

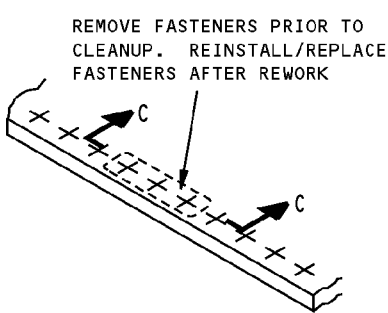

CORROSION CLEANUP
DETAIL V

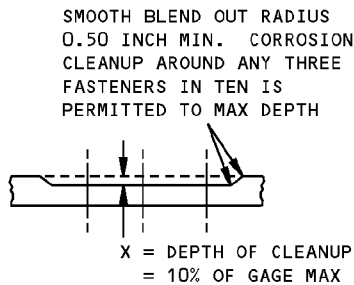

SECTION C-C

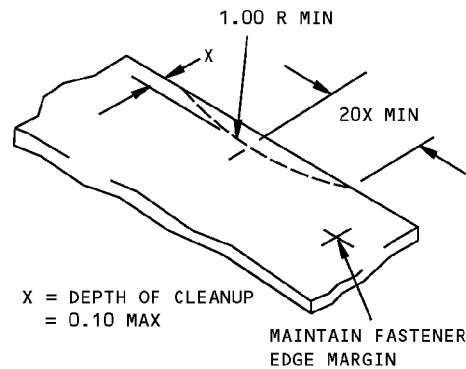

REMOVAL OF NICK OR CRACK
DAMAGE ON AN EDGE
DETAIL VI

Common Nozzle Assembly Skin Allowable Damage - RB211-535E4 Engine
Figure 101 (Sheet 6 of 6)

STRUCTURAL REPAIR MANUAL

REPAIR 1 - COMMON NOZZLE ASSEMBLY CRACK - RB211-535E4 ENGINE

REPAIR INSTRUCTIONS

1. Find the ends of the crack and stop drill 0.177 to 0.197 inch (4.0 to 5.0 mm) dia. holes.
2. Route out the crack to a diameter of 0.08 to 0.093 inch (2.0 to 2.3 mm). The routing tool should not extend into the underlying core by more than 0.10 inch (3 mm).
3. Make the repair part. Refer to Detail I for the distance between fasteners.
4. Put the repair part in place and drill the fastener holes. Drill the holes to match the cell voids in the core.
5. Remove the repair part.
6. Remove all the nicks, scratches, gouges, and sharp edges from the nozzle and the repair part.
7. Wipe the doubler and the repair area on the nozzle with methyl isobutyl ketone (MIBK), methyl ethyl ketone (MEK), or acetone and a clean cotton cloth. Wipe the surfaces dry before the solvent evaporates.
8. Install the repair part with EA934NA adhesive between the faying surfaces. Install the fasteners wet with EA934NA adhesive.
9. Make an aerodynamically smooth fillet around the repair doubler with the excess adhesive.
10. Wipe off the remaining adhesive using a clean cotton cloth.
11. Cure the adhesive.

NOTES

- REFER TO THE FOLLOWING WHEN YOU USE THIS REPAIR:
 - SRM 51-10-02 FOR INSPECTION AND REMOVAL OF DAMAGE
 - SRM 51-11-00 FOR AERODYNAMIC SMOOTHNESS REQUIREMENTS
 - SRM 51-41-00 FOR FASTENER CODE, INSTALLATION AND REMOVAL, HOLE SIZES, EDGE MARGINS, AND COUNTERSINKING
- DIMENSIONS ARE IN INCHES

FASTENER SYMBOLS

- + REPAIR FASTENER LOCATION. INSTALL A CR3555-4-1 UNISINK BLIND RIVET

REPAIR MATERIAL			
PART		QTY	MATERIAL
1	DOUBLER	1	0.020 INCH (0.508 mm) TI 6AL-4V

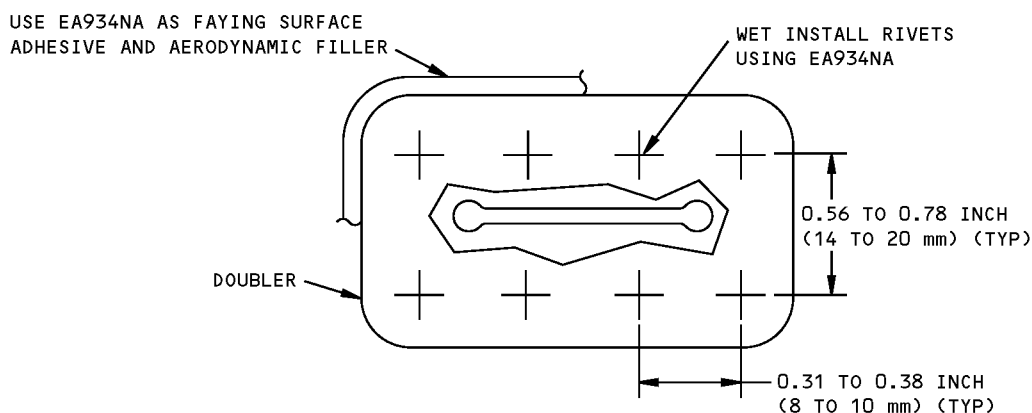

CRACK REPAIR
DETAIL I

Common Nozzle Assembly Crack Repair - RB211-535E4 Engine
Figure 201

757-200
STRUCTURAL REPAIR MANUAL

REPAIR 2 - COMMON NOZZLE ASSEMBLY SCRATCH - RB211-535E4 ENGINE

REPAIR INSTRUCTIONS

1. If the gouge, nick or scratch is no larger than 10.0 inches (250 mm) long, 0.10 inch (2.5 mm) wide or 0.010 (0.25 mm) inch deep then repair as shown in Detail I.
2. If the gouge, nick or scratch does not meet the conditions in Step 1 then repair the damage as a crack. Refer to Repair 1.

NOTES

- REFER TO THE FOLLOWING WHEN YOU USE THIS REPAIR:
 - SRM 51-10-02 FOR INSPECTION AND REMOVAL OF DAMAGE
 - SRM 51-11-00 FOR AERODYNAMIC SMOOTHNESS REQUIREMENTS
 - SRM 51-41-00 FOR FASTENER CODE, INSTALLATION AND REMOVAL, HOLE SIZES, EDGE MARGINS, AND COUNTERSINKING

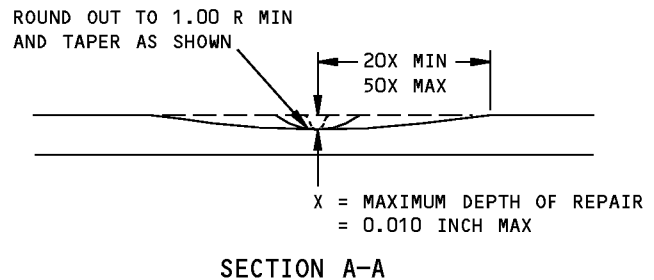
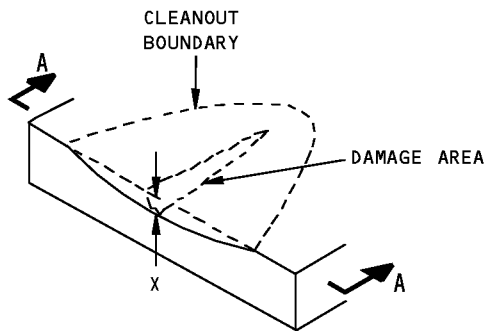

REMOVAL OF NICK, GOUGE, AND SCRATCH DAMAGE ON A SURFACE
DETAIL I

Common Nozzle Assembly Scratch Repair - RB211-535E4 Engine
Figure 201

STRUCTURAL REPAIR MANUAL

REPAIR 3 - COMMON NOZZLE ASSEMBLY DENT - RB211-535E4 ENGINE

REPAIR INSTRUCTIONS

1. Repair dents more than 0.16 inch (4 mm) in depth. Refer to Repair 4. Repair of dents up to 50.0 square inches (320 square mm) is permitted. Refer to Detail I.
2. Make the doubler. Chamfer the edges as shown in Detail II. For edge margins and the distance between fasteners, refer to Detail I.
3. Put the doubler in place and drill the fastener holes.
4. Remove the doubler.
5. Remove all nicks, scratches gouges, sharp edges, and burrs from the nozzle and doubler.
6. Wipe the doubler and the repair area on the nozzle with methyl isobutyl ketone (MIBK), methyl ethyl ketone (MEK), or acetone and a clean cotton cloth. Wipe the surfaces dry before the solvent evaporates.
7. Apply a sufficient amount of adhesive filler EA934NA to the nozzle to fill the dent and provide a faying surface seal between the doubler and the nozzle.
8. Install the doubler with CR3555-4-1 rivets.
9. Make an aerodynamically smooth fillet around the repair doubler with the excess adhesive.
10. Remove any remaining adhesive with a clean cotton cloth.
11. Cure the adhesive.

NOTES

- REFER TO THE FOLLOWING WHEN YOU USE THIS REPAIR:
 - SRM 51-10-02 FOR INSPECTION AND REMOVAL OF DAMAGE
 - SRM 51-11-00 FOR AERODYNAMIC SMOOTHNESS REQUIREMENTS
 - SRM 51-41-00 FOR FASTENER CODE, INSTALLATION AND REMOVAL, HOLE SIZES, EDGE MARGINS, AND COUNTERSINKING
- DIMENSIONS ARE IN INCHES

FASTENER SYMBOLS

- + REPAIR FASTENER LOCATION. INSTALL A CR3555-4-1 UNISINK BLIND RIVET

REPAIR MATERIAL			
PART		QTY	MATERIAL
1	DOUBLER	1	0.020 INCH (0.508 mm) TI 6AL-4V

**Common Nozzle Assembly Dent Repair - RB211-535E4 Engine
Figure 201 (Sheet 1 of 2)**

757-200
STRUCTURAL REPAIR MANUAL

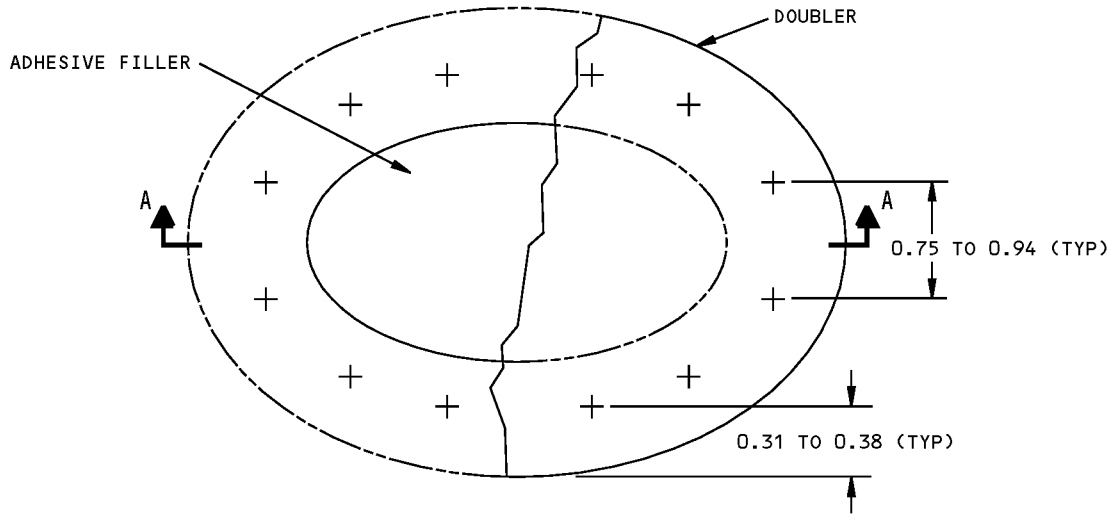

A7301

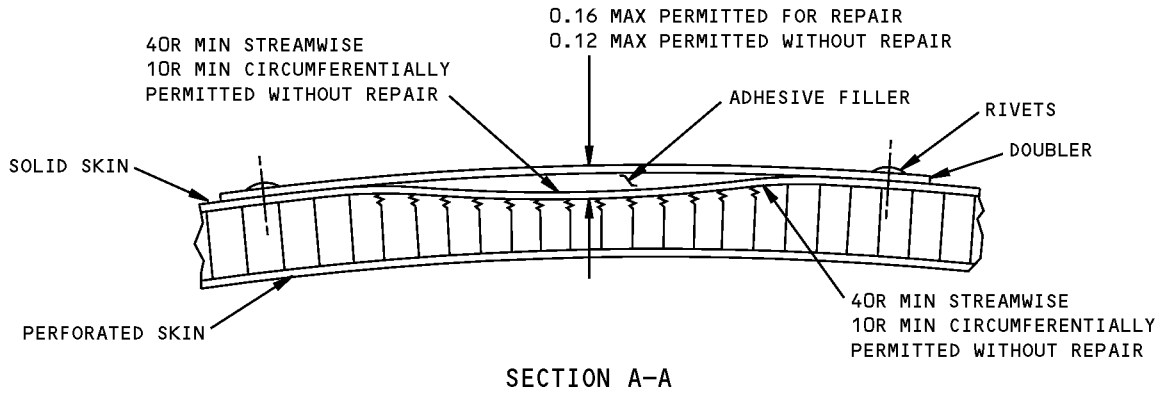

A7302

OUTER SURFACE DENT REPAIR
DETAIL I

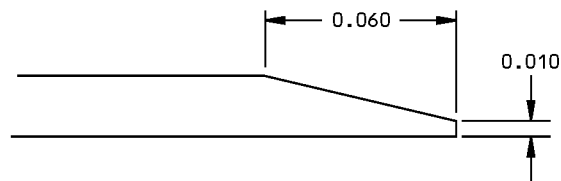

DOUBLER EDGE CHAMFER
DETAIL II

Common Nozzle Assembly Dent Repair - RB211-535E4 Engine
Figure 201 (Sheet 2 of 2)

757-200
STRUCTURAL REPAIR MANUAL**REPAIR 4 - COMMON NOZZLE ASSEMBLY NICK OR PUNCTURE - RB211-535E4 ENGINE****REPAIR INSTRUCTIONS**

1. Drill out damage up to 0.20 inch (5.0 mm) max dia and not closer than 1.0 inch (25 mm) to any other fastener hole, material edge or other damage.
2. Fill the hole with a CR3555 blind rivet installed wet with EA934NA adhesive filler.
3. Cure the adhesive.

NOTES

- REFER TO THE FOLLOWING WHEN YOU USE THIS REPAIR:
 - 51-10-02 FOR INSPECTION AND REMOVAL OF DAMAGE
 - 51-11-00 FOR AERODYNAMIC SMOOTHNESS REQUIREMENTS
 - 51-41-00 FOR FASTENER CODE, INSTALLATION AND REMOVAL, HOLE SIZES, EDGE MARGINS, AND COUNTERSINKING

Common Nozzle Assembly Nick or Puncture Repair - RB211-535E4 Engine
Figure 201

D634N201

54-40-01REPAIR 4
Page 201
May 20/2005

STRUCTURAL REPAIR MANUAL

REPAIR 5 - COMMON NOZZLE ASSEMBLY THROUGH SKIN AND DELAMINATION - RB211-535E4 ENGINE

REPAIR INSTRUCTIONS

1. Damage to honeycomb core panels can be repaired by potting or by honeycomb core replacement.
 - A. The limits for repair by potting are as follows (refer to Detail I):
 - (1) Damage that extends through both face skins and honeycomb core can be repaired if 1.60 inches (40 mm) dia or less.
 - (2) Damage that extends through one face skin and honeycomb core can be repaired if 2.0 square inches (13 square cm) or less or if narrower than 0.75 inch (19 mm).
 - B. The limit for repair by honeycomb core replacement for one face skin and honeycomb core only is up to 20.0 square inches (130 square mm). Refer to Detail II.
2. Remove the damaged skin and honeycomb core with a router and saw.

For repair by potting, the removal of damaged core is not necessary. Fill the damaged core with adhesive.

For repair by honeycomb core replacement, remove the adhesive fillets on the far side skin but do not damage the skin itself. Refer to SRM 51-10-00.
3. Make the repair part(s).

Refer to Detail I or II for edge margins and the distance between fasteners. Chamfer the edges of the doubler(s) as shown in Detail III.

For honeycomb core replacement, the core should fit in the repair hole with contact on all sides.
4. Put the doubler in place and drill the fastener holes.
5. Remove the doubler.
6. Remove all the nicks, scratches, gouges, sharp edges, and burrs from the nozzle and the repair part(s).
7. Wipe the repair area on the nozzle and the repair parts with methyl isobutyl ketone (MIBK), methyl ethyl ketone (MEK) or acetone and a clean cotton cloth. Wipe the surfaces dry before the solvent evaporates.

For repair by honeycomb core replacement, vapor degrease the core. Refer to 20-30-03 of the Standard Overhaul Practices Manual, D6-51702.

8. For repair by potting, fill the damaged core with EA934NA adhesive.

For repair by honeycomb core replacement, install the filler and replacement core. Install the filler with EA934NA adhesive between the faying surfaces. Apply the adhesive to the bottom and sides of the replacement core and install the plug.
9. For repair by potting, install the repair doubler with EA934NA adhesive between the faying surfaces.

For repair by honeycomb core replacement, apply the adhesive to both the top of the replacement core and to the faying surface of the repair doubler and install the doubler.

For repair by honeycomb core replacement and for repair by potting, install the fasteners wet with EA934NA adhesive.
10. Make an aerodynamically smooth fillet around the repair doubler(s) with the excess adhesive.
11. Remove the remaining adhesive with a clean cotton cloth.
12. Cure the repair.

NOTES

- REFER TO THE FOLLOWING WHEN YOU USE THIS REPAIR:
 - SRM 51-10-02 FOR INSPECTION AND REMOVAL OF DAMAGE
 - SRM 51-11-00 FOR AERODYNAMIC SMOOTHNESS REQUIREMENTS
 - SRM 51-41-00 FOR FASTENER CODE, INSTALLATION AND REMOVAL, HOLE SIZES, EDGE MARGINS, AND COUNTERSINKING
 - DIMENSIONS ARE IN INCHES
- A** ONE DOUBLER IS USED FOR REPAIR TO ONE FACE SKIN AND HONEYCOMB CORE. TWO DOUBLERS ARE USED FOR REPAIR TO TWO FACE SKINS AND HONEYCOMB CORE

**Common Nozzle Assembly through Skin and Delamination Repair - RB211-535E4 Engine
Figure 201 (Sheet 1 of 3)**

757-200
STRUCTURAL REPAIR MANUAL

FASTENER SYMBOLS

- + REPAIR FASTENER LOCATION. INSTALL A CR3555-4-1 UNISINK BLIND RIVET
- ⊕ REPAIR FASTENER LOCATED IN A PERFORATION. INSTALL A CR3555-4-1 UNISINK BLIND RIVET
- ◆ REPAIR FASTENER LOCATION. INSTALL A BACB30ND6A REPAIR HI-LOK

REPAIR MATERIAL			
PART		QTY	MATERIAL
1	DOUBLER	A	0.020 TI 6AL-4V
2	FILLER	1	0.020 TI 6AL-4V
3	CORE	1	CRES HONEYCOMB

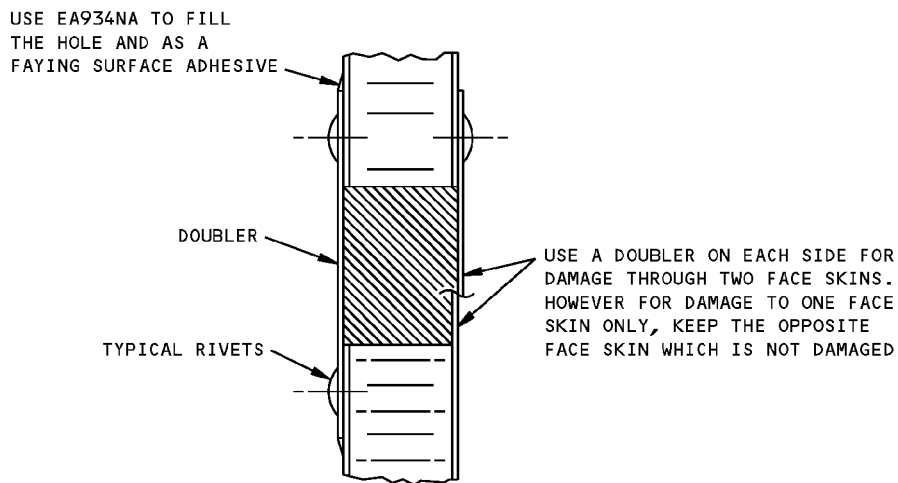
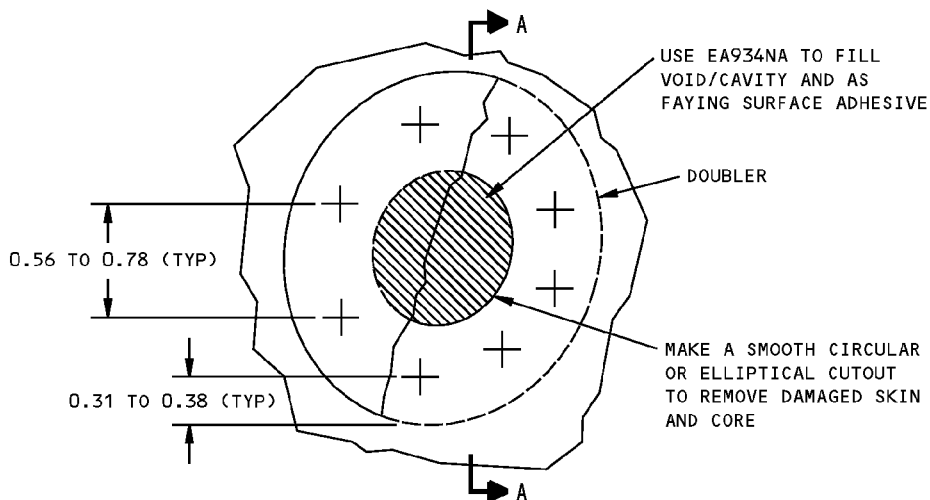

SECTION A-A

A7300

POTTING REPAIR
DETAIL I

Common Nozzle Assembly through Skin and Delamination Repair - RB211-535E4 Engine
Figure 201 (Sheet 2 of 3)

757-200
STRUCTURAL REPAIR MANUAL

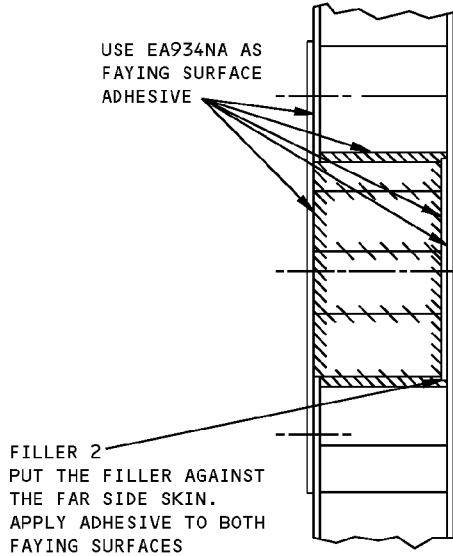
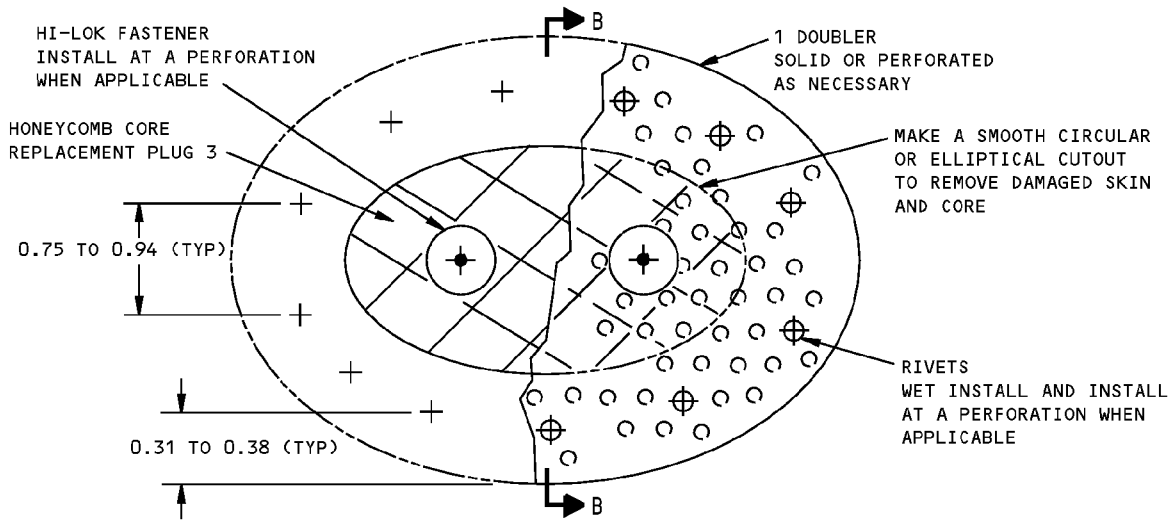

A7301

SECTION B-B

HONEYCOMB CORE REPLACEMENT REPAIR
DETAIL II

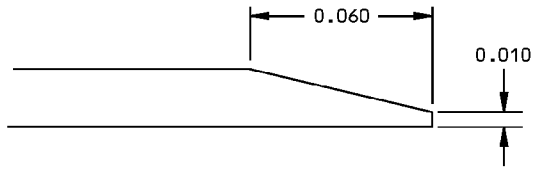

DOUBLER EDGE CHAMFER
DETAIL III

Common Nozzle Assembly through Skin and Delamination Repair - RB211-535E4 Engine
Figure 201 (Sheet 3 of 3)

757-200
STRUCTURAL REPAIR MANUAL

IDENTIFICATION 1 - COMMON NOZZLE ASSEMBLY STRUCTURE - RB211-535E4 ENGINE

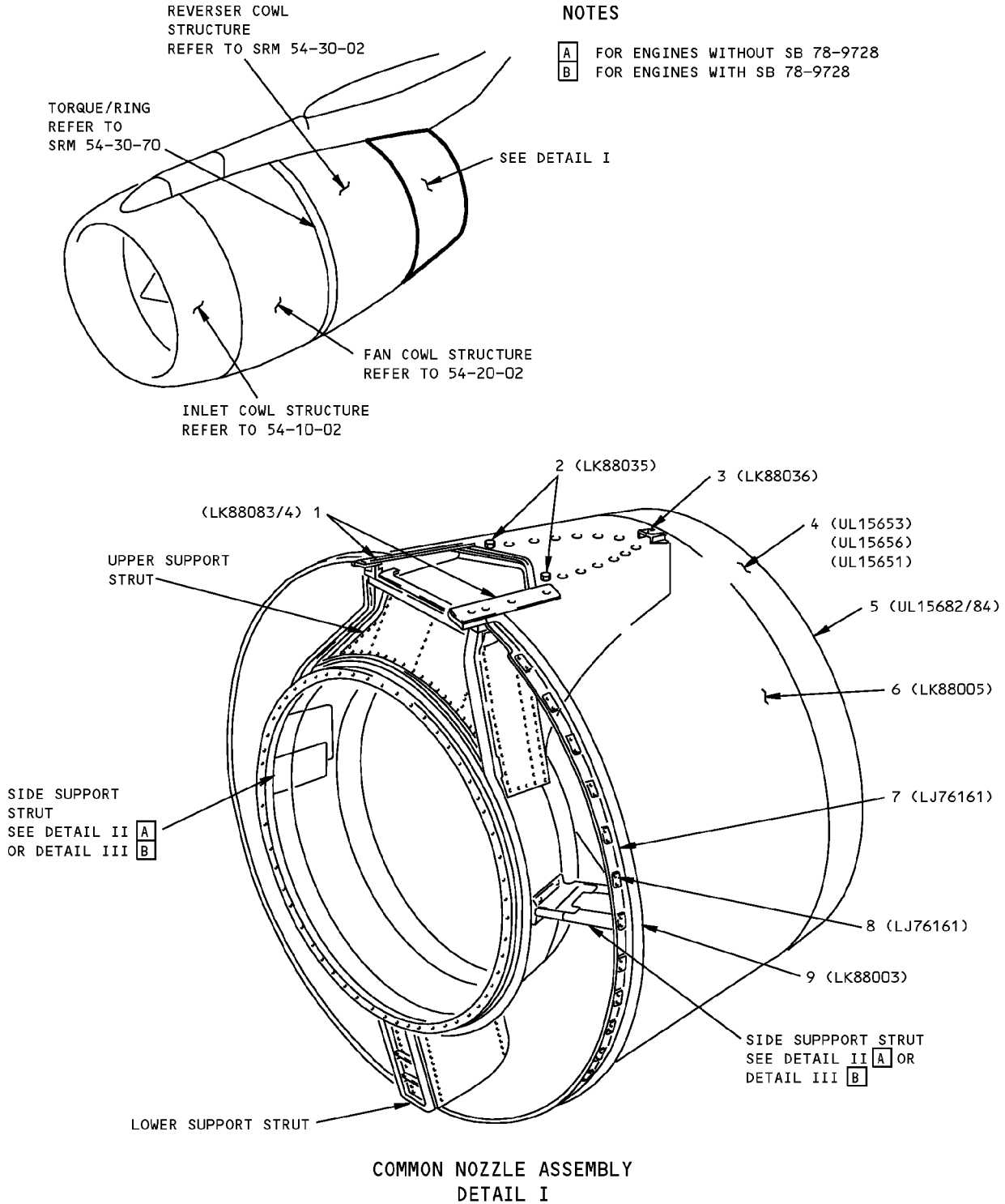

Common Nozzle Assembly Structure Identification - RB211-535E4 Engine
Figure 1 (Sheet 1 of 2)

A8557A

757-200
STRUCTURAL REPAIR MANUAL

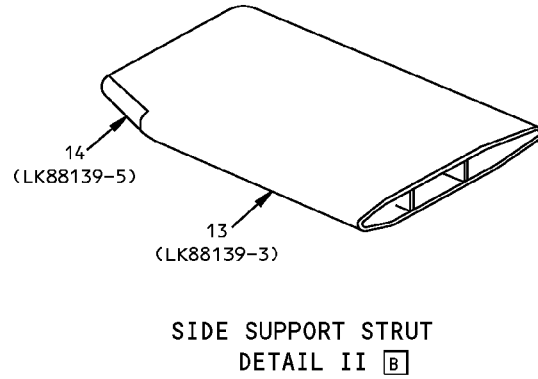
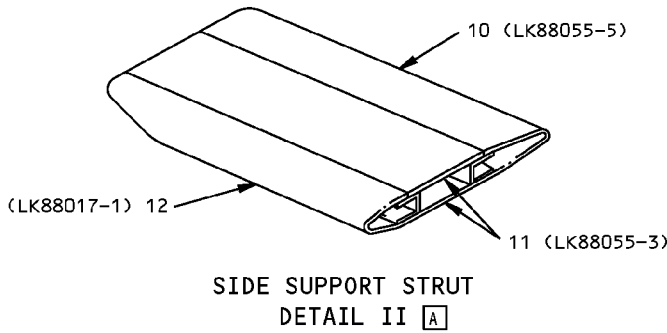

ITEM	DESCRIPTION	GAGE	MATERIAL	EFFECTIVITY
1	SEAL	0.080	AL CLAD 2024-0	
2	PYLON SEAL LOCATION BUSH		AMS 5630	
3	SEAL RETAINER BRACKET		AMS 5646	
4	EXIT NOZZLE FAIRING	0.050	2024-T3	
5	EXIT NOZZLE TRAILING EDGE		EXTRUDED 2024-T4 2024-T4	
6	LID BOND PANEL	0.020	T1-6AL-4V	
7	FAIRING FRAME		2024-0 ALUMINUM	B
8	RUBBING BLOCK		TEFLON AMS 3651	
9	TRANSLATING COWL REAR SEAL		ARM 834 ARM 835	
10	SIDE STRUT TAIL FAIRING	0.063	2024-T42	A
11	SIDE STRUT SIDE WALL	0.063	2024-T3	A
12	SIDE STRUT NOSE FAIRING	0.063	2024-T3	A
13	SIDE STRUT	0.110	6061-0 ALUMINUM SHEET	B
14	SIDE STRUT NOSE EXTENSION	0.100	6061-0 ALUMINUM SHEET	B

LIST OF MATERIALS FOR DETAILS I,II AND III

A8557A

Common Nozzle Assembly Structure Identification - RB211-535E4 Engine
Figure 1 (Sheet 2 of 2)

IDENTIFICATION 1
Page 2
Jan 20/2005

54-40-02

D634N201

**757-200
STRUCTURAL REPAIR MANUAL**

IDENTIFICATION 1 - CORE COWL SKIN - PW2000 ENGINE

REFERENCE DRAWING
314N3210

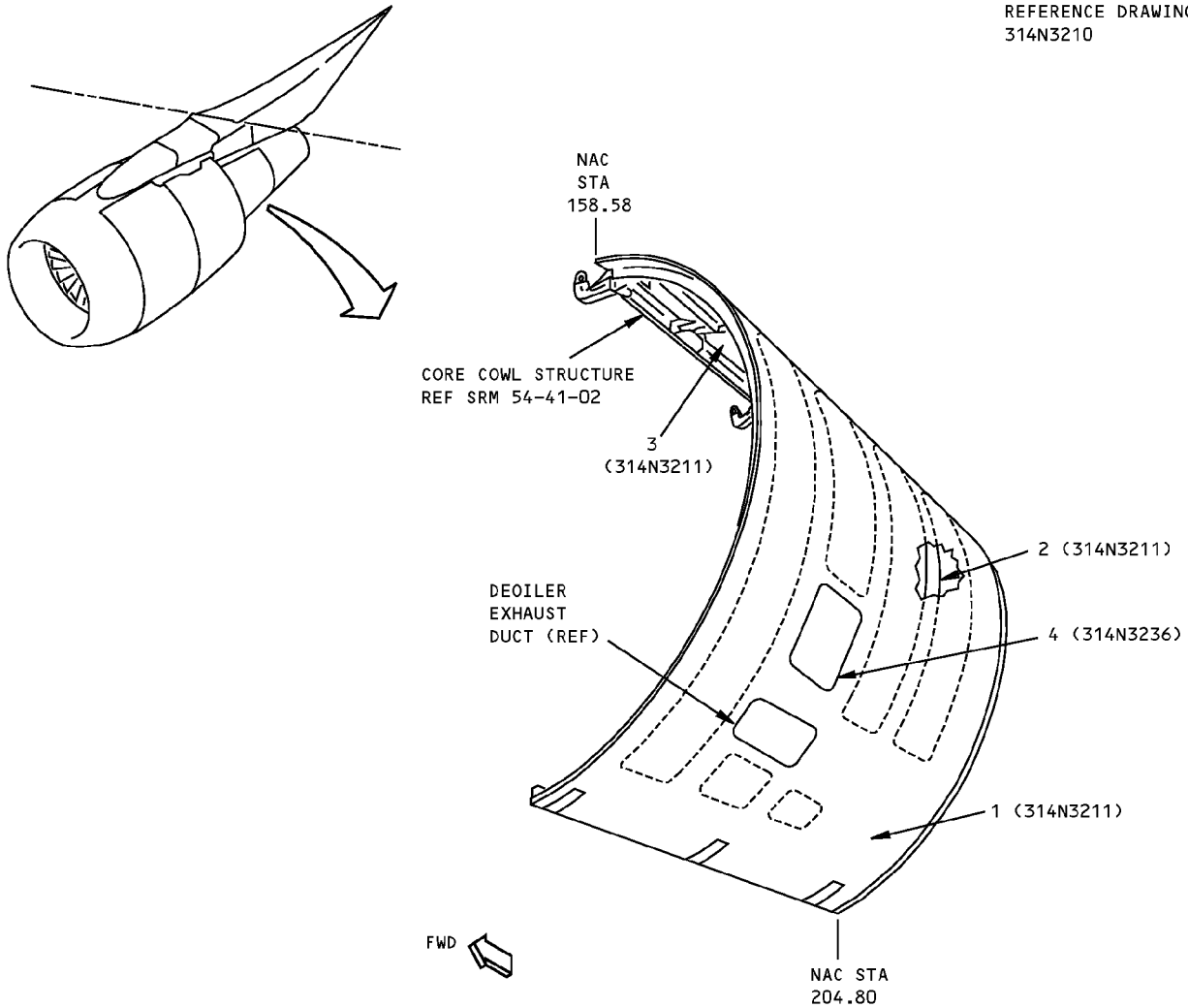

LEFT SIDE SHOWN
RIGHT SIDE SIMILAR

ITEM	DESCRIPTION	GAGE	MATERIAL	EFFECTIVITY
1	SKIN	0.040	CLAD 2024-T3	
2	DOUBLER	0.032	2024-T3	
3	FIRESHIELD	0.005	304 CRES PER MIL-S-5059 ANNEALED SURFACE CONDITION 2D	
4	PRESSURE RELIEF DOOR PANEL	0.250	CLAD 2024-T351 CHEM MILLED	

LIST OF MATERIALS

**Core Cowl Skin Identification - PW2000 Engine
Figure 1**

**757-200
STRUCTURAL REPAIR MANUAL**

ALLOWABLE DAMAGE 1 - CORE COWL SKIN - PW2000 ENGINE

REFERENCE DRAWING
314N3210

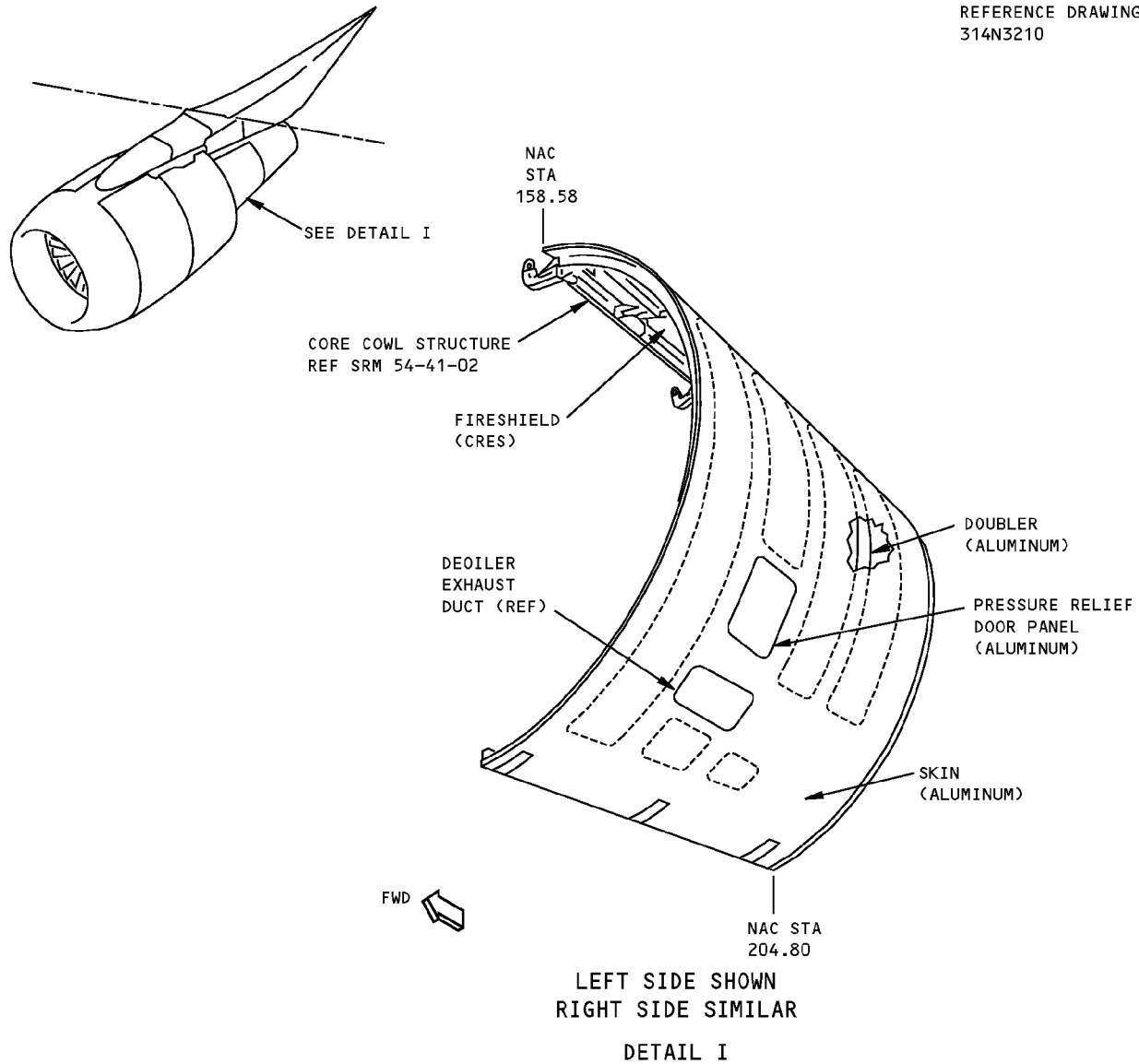

DESCRIPTION	CRACKS	NICKS, GOUGES AND CORROSION	DENTS	HOLES AND PUNCTURES
FIRESHIELD (CRES)	F	B	SEE DETAIL IV	C
DOOR PANEL (ALUMINUM)	E	B	SEE DETAIL IV	D
DOUBLER (ALUMINUM)	A	B	SEE DETAIL IV	D
SKIN (ALUMINUM)	E	B	SEE DETAIL IV	D

**Core Cowl Skin Allowable Damage - PW2000 Engine
Figure 101 (Sheet 1 of 3)**

STRUCTURAL REPAIR MANUAL

NOTES

- REFINISH REWORKED AREAS PER AMM 51-20.
- REFER TO SRM 51-10-01 FOR AERODYNAMIC SMOOTHNESS REQUIREMENTS. WHERE THE DAMAGE IS MORE THAN THE LIMITS SHOWN IN SRM 51-10-01, CONSIDERATION SHOULD BE GIVEN TO THE LOSS OF PERFORMANCE INVOLVED.
- REFER TO SRM 51-10-02 FOR INVESTIGATION AND CLEANUP OF DAMAGE.

- A** CRACKS ARE NOT PERMITTED EXCEPT FOR EDGE CRACKS WHICH MUST BE REMOVED AS SHOWN IN DETAILS II AND VI.
- B** REMOVE DAMAGE AS SHOWN IN DETAILS II, III AND V.
- C** CLEAN OUT DAMAGE UP TO 0.25 INCH (6 mm) MAXIMUM, AND NOT CLOSER THAN 1.0 INCH (25 mm) TO FASTENER HOLE, MATERIAL EDGE, OR OTHER DAMAGE.

- D** CLEAN OUT DAMAGE UP TO 0.25 INCH (6 mm) MAXIMUM DIA AND NOT CLOSER THAN 1.0 INCH (25 mm) TO FASTENER HOLE, MATERIAL EDGE, OR OTHER DAMAGE. FILL HOLE WITH A 2117-T3 OR T4 ALUMINUM RIVET INSTALLED WET WITH BMS 5-95 SEALANT. ALL OTHER HOLES TO BE REPAIRED.
- E** 1.00 (25 mm) MAXIMUM LENGTH CRACK PERMITTED PROVIDED CRACK IS MINIMUM 6.00 INCHES (150 mm) FROM HINGE OR LATCH FITTINGS AND MINIMUM 3.00 INCHES (80 mm) FROM PANEL EDGE OR ADJACENT DAMAGE. DRILL 0.19 INCH (3 mm) STOP HOLES AT ENDS OF CRACK AND REPAIR AT NEXT AIRPLANE "A" CHECK. REMOVE EDGE CRACKS AS SHOWN IN DETAILS II AND VI.
- F** DRILL 0.25 INCH (6 mm) DIA HOLES AT ENDS OF CRACK.

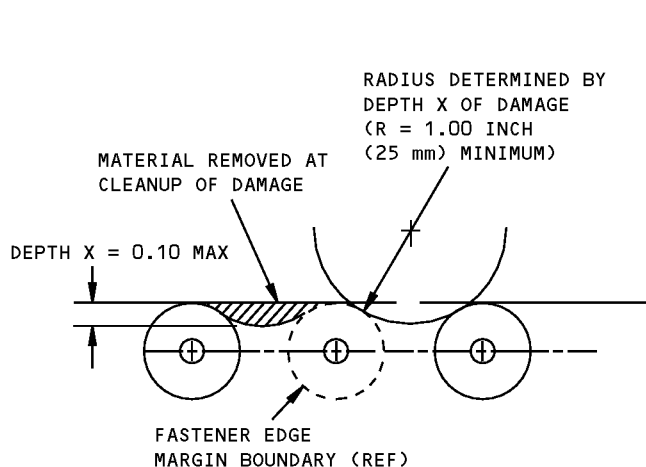

DAMAGE CLEANUP OF EDGES WHERE FASTENER EDGE MARGINS DO NOT OVERLAP

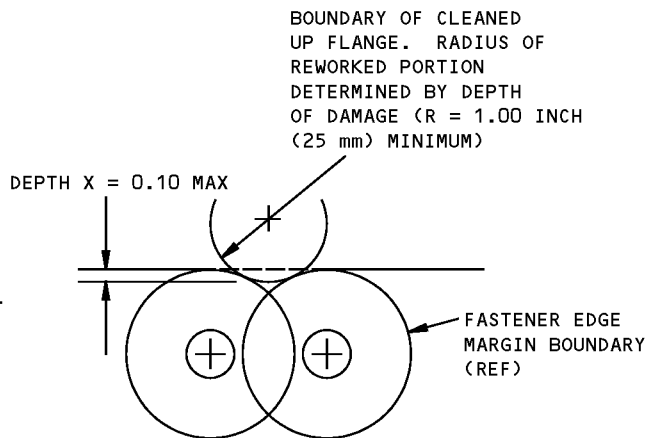

DAMAGE CLEANUP OF EDGES WHERE FASTENER EDGE MARGINS OVERLAP

DETAIL II

Core Cowl Skin Allowable Damage - PW2000 Engine
Figure 101 (Sheet 2 of 3)

**757-200
STRUCTURAL REPAIR MANUAL**

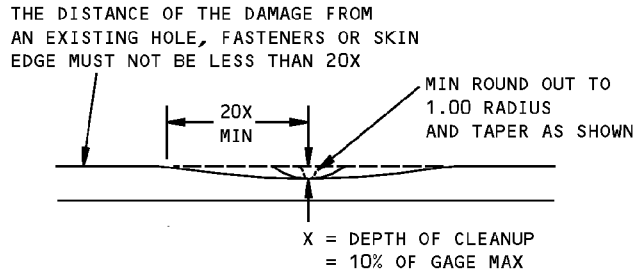
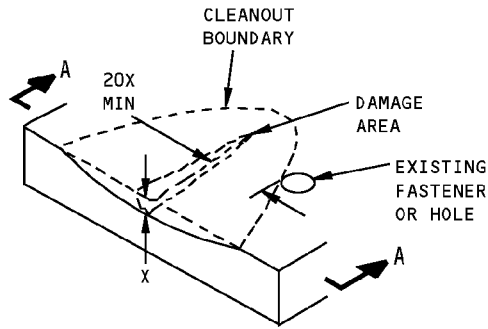

SECTION A-A

**REMOVAL OF NICK, GOUGE OR SCRATCH DAMAGE ON A SURFACE
DETAIL III**

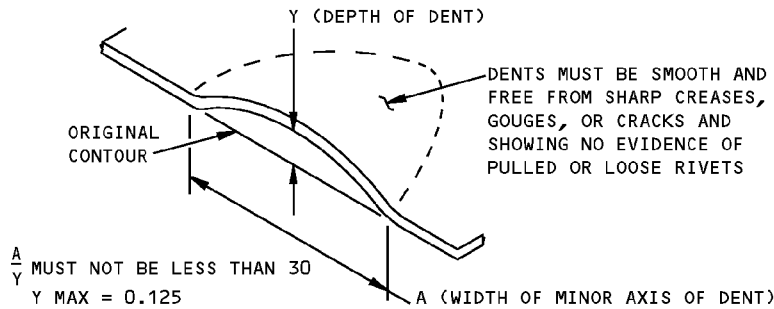

**ALLOWABLE DAMAGE FOR DENT
DETAIL IV**

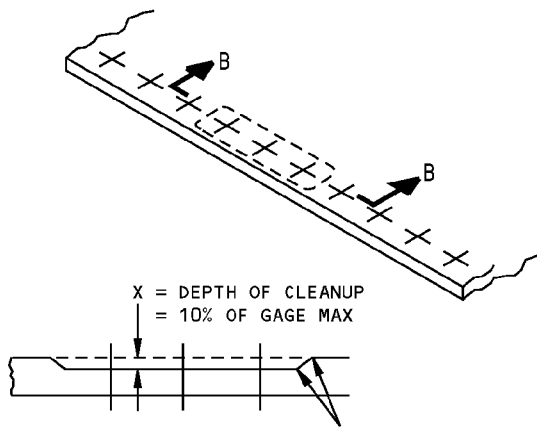

SMOOTH BLEND-OUT RADIUS 0.50 INCH MINIMUM. CORROSION CLEANUP AROUND ANY THREE FASTENERS IN TEN IS PERMITTED TO MAX DEPTH

SECTION B-B

**CORROSION CLEANUP
DETAIL V**

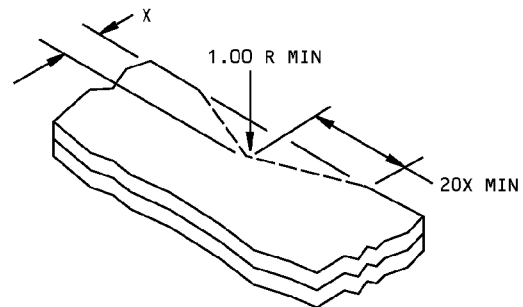

X = DEPTH OF CLEANUP = 0.10 MAX

**REMOVAL OF NICK OR CRACK DAMAGE ON AN EDGE
DETAIL VI**

**Core Cowl Skin Allowable Damage - PW2000 Engine
Figure 101 (Sheet 3 of 3)**



757-200
STRUCTURAL REPAIR MANUAL

REPAIR GENERAL - CORE COWL SKIN - PW2000 ENGINE

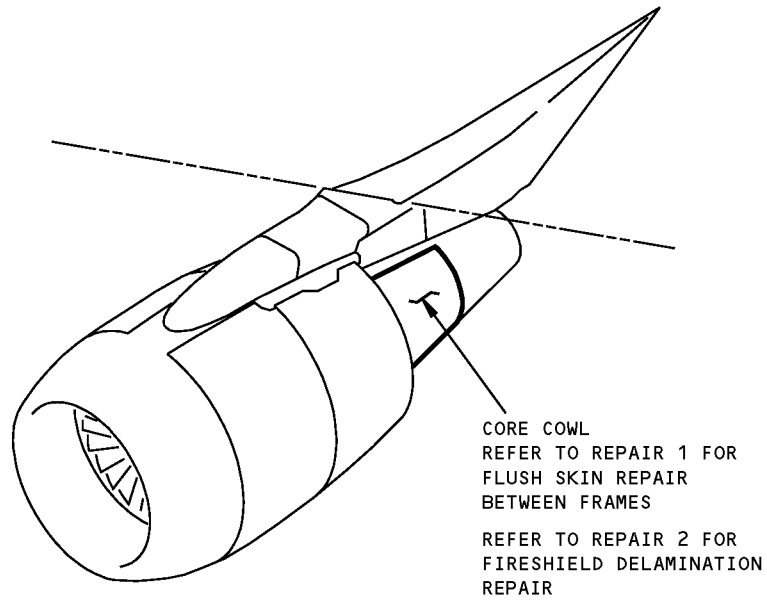

Core Cowl Skin Repair - PW2000 Engine
Figure 201

D634N201

54-41-01

REPAIR GENERAL
Page 201
Jan 20/2005

STRUCTURAL REPAIR MANUAL

REPAIR 1 - CORE COWL SKIN - FLUSH REPAIR BETWEEN FRAMES - PW2000 ENGINE

REPAIR INSTRUCTIONS

1. Cut out damaged skin in a rectangular shape parallel to the frame with a minimum corner radius of 0.50 inch (12.7 mm). The repair must be made between frames and repair parts must not overlap doublers.
2. Return all indented or projecting skin to contour. Remove all burrs, nicks, scratches, sharp edges or corners from the damaged area.
3. Make the repair parts and drill the appropriate fastener holes.
4. Alodize the raw edges of new and existing parts.
5. Apply one coat of BMS 5-42, Type 1, Class 1 primer to repair parts; clad surface is optional.
6. Install the repair parts and fasteners with BMS 5-63 sealant making faying surface seals between all parts in accordance with SRM 51-20-05. A bead of sealant should be apparent all around repair parts after installation. Where there is sufficient sealant squeezed out, it may be formed into a fillet, otherwise an additional fillet seal should be applied.
7. Fill all external gaps with aerodynamic sealant when gaps exceed limits specified in SRM 51-10-01.
8. Restore surface finish in accordance with AMM 51-21.

NOTES

- WHEN YOU USE THIS REPAIR REFER TO:
 - AMM 51-21 FOR INTERIOR AND EXTERIOR FINISHES
 - SRM 51-10-01 FOR AERODYNAMIC SMOOTHNESS REQUIREMENTS
 - SRM 51-10-02 FOR INSPECTION AND REMOVAL OF DAMAGE
 - SRM 51-20-01 FOR PROTECTIVE TREATMENT OF METAL
 - SRM 51-20-05 FOR SEALING OF REPAIRS
 - SRM 51-40 FOR FASTENER CODE, REMOVAL, INSTALLATION, HOLE SIZES AND EDGE MARGINS
 - SRM 51-40-03 FOR FASTENER SUBSTITUTION.
- TO AVOID KNIFE-EDGING OF THE SKIN, DO NOT COUNTERSINK DEEPER THAN 0.030 INCH (0.76 mm). MICROSHAVE HEAD AS SHOWN IN SRM 51-10-01.

FASTENER SYMBOLS

✦ REPAIR FASTENER LOCATION

REPAIR MATERIAL			
	PART	QTY	MATERIAL
1	REPAIR PLATE	1	0.050 INCH (1.3mm) 2024-T3
2	FILLER	1	0.040 INCH (1.0 mm) CLAD 2024-T3

TABLE I

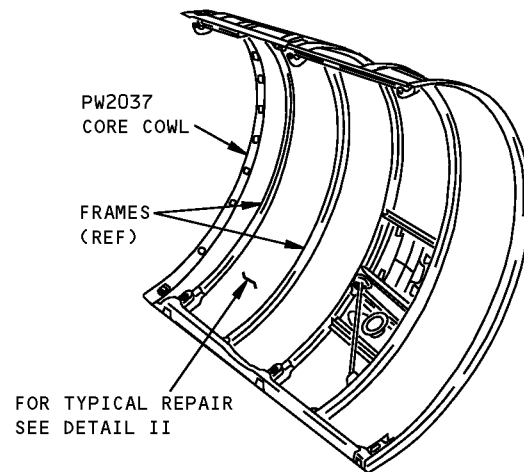
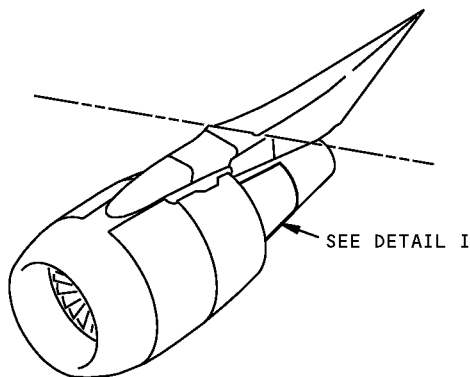

DETAIL I

Core Cowl Skin - Flush Repair Between Frames - PW2000 Engine
Figure 201 (Sheet 1 of 2)

**757-200
STRUCTURAL REPAIR MANUAL**

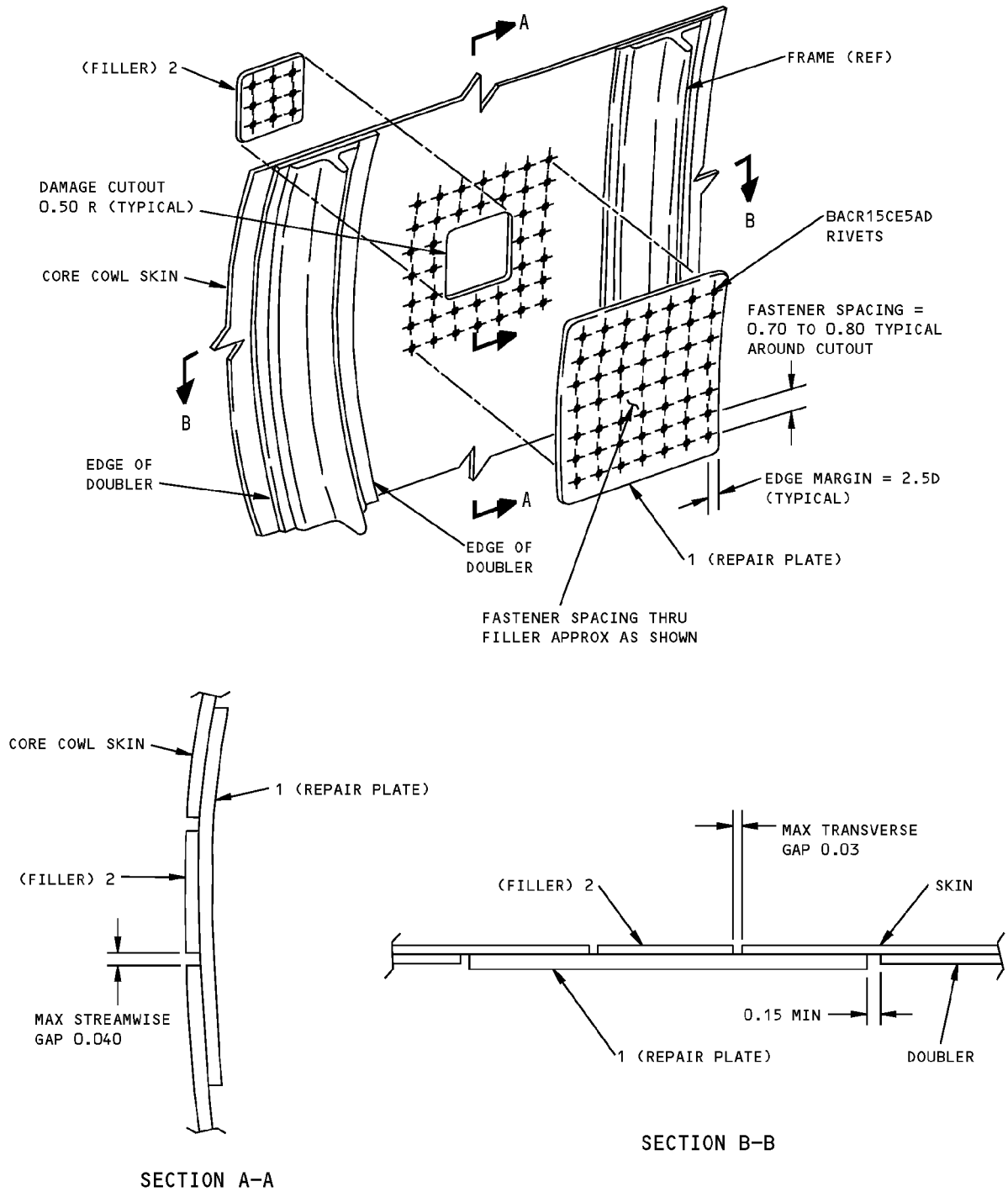

**Core Cowl Skin - Flush Repair Between Frames - PW2000 Engine
Figure 201 (Sheet 2 of 2)**

757-200 STRUCTURAL REPAIR MANUAL

REPAIR 2 - FIRESHIELD DELAMINATION - PW2000 ENGINE

REPAIR INSTRUCTIONS

This repair is for delamination of CRES fireshield from core cowl skin.

1. Make repair part. Form repair plate to fit required contour.
2. Locate, drill and countersink fastener holes.
3. Remove all nicks, scratches, burrs and corners from initial and repair parts.
4. Alodize and apply one coat of BAC5710, Type 51 (De Soto Hi-Temp) Primer to repair part.
5. Rivet repair plate to initial skin using BACR15CE5M fasteners. Fay seal with BMS 5-63 sealant.
6. Fillet seal with BMS 5-63 sealant.

FASTENER SYMBOLS

REPAIR FASTENER LOCATION

REPAIR MATERIAL			
	PART	QTY	MATERIAL
1	PLATE	1	0.071 INCH CLAD 2024-T3

TABLE I

NOTES

- WHEN YOU USE THIS REPAIR REFER TO:
 - AMM 51-21 FOR INTERIOR AND EXTERIOR FINISHES
 - SRM 51-10-01 FOR AERODYNAMIC SMOOTHNESS REQUIREMENTS. WHERE THE DAMAGE IS MORE THAN THE LIMITS SHOWN IN SRM 51-10-01, CONSIDERATION SHOULD BE GIVEN TO THE LOSS OF PERFORMANCE INVOLVED
 - SRM 51-10-02 FOR INSPECTION AND REMOVAL OF DAMAGE
 - SRM 51-20-01 FOR PROTECTIVE TREATMENT OF METAL
 - SRM 51-30 FOR SOURCE OF REPAIR MATERIALS
 - SRM 51-40 FOR FASTENER CODE, REMOVAL, INSTALLATION, HOLE SIZES AND EDGE MARGINS
 - SRM 51-40-03 FOR FASTENER SUBSTITUTION
 - SRM 51-40-08 FOR COUNTERSINKING AND USE OF COUNTERSINK REPAIR WASHERS.

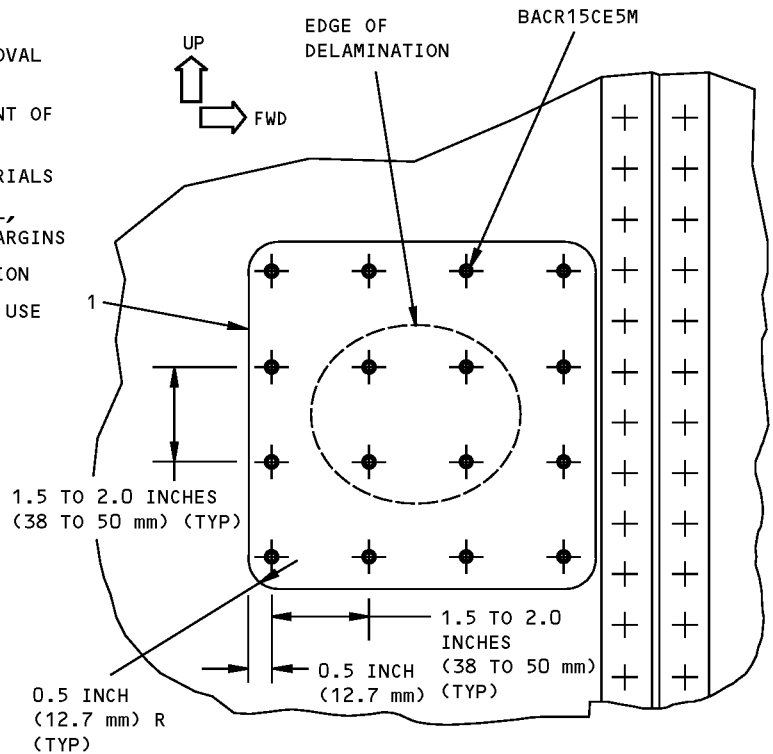

**Fireshield Delamination Repair - PW2000 Engine
Figure 201 (Sheet 1 of 2)**

STRUCTURAL REPAIR MANUAL

ALTERNATE REPAIR INSTRUCTIONS

This repair is for delamination of CRES fireshield from core cowl skin.

1. Make repair part. Form repair plate to fit required contour.
2. Locate, drill and countersink fastener holes.
3. Remove all nicks, scratches, burrs and corners from initial and repair parts.
4. Rivet repair plate to initial skin using BACR15CE5M fasteners. Fay seal with BMS 5-63 sealant.
5. Fillet seal with BMS 5-63 sealant.

FASTENER SYMBOLS

✦ REPAIR FASTENER LOCATION

REPAIR MATERIAL			
PART		QTY	MATERIAL
2	DOUBLER	1	0.020 INCH 301 CRES 1/2 HARD

TABLE I

NOTES

- WHEN YOU USE THIS REPAIR REFER TO:
 - AMM 51-21 FOR INTERIOR AND EXTERIOR FINISHES
 - SRM 51-10-01 FOR AERODYNAMIC SMOOTHNESS REQUIREMENTS. WHERE THE DAMAGE EXCEEDS THE LIMITS SHOWN IN SRM 51-10-01, CONSIDERATION SHOULD BE GIVEN TO THE LOSS OF PERFORMANCE INVOLVED
 - SRM 51-10-02 FOR INSPECTION AND REMOVAL OF DAMAGE
 - SRM 51-20-01 FOR PROTECTIVE TREATMENT OF METAL
 - SRM 51-30 FOR SOURCE OF REPAIR MATERIALS
 - SRM 51-40 FOR FASTENER CODE, REMOVAL, INSTALLATION, HOLE SIZES AND EDGE MARGINS
 - SRM 51-40-03 FOR FASTENER SUBSTITUTION
 - SRM 51-40-08 FOR COUNTERSINKING AND USE OF COUNTERSINK REPAIR WASHERS.

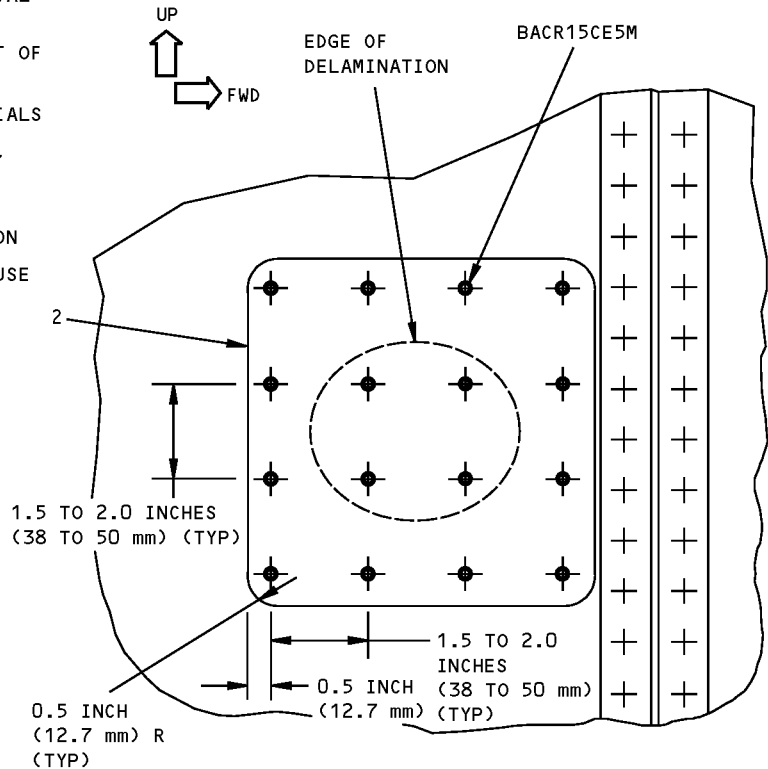

**Fireshield Delamination Repair - PW2000 Engine
Figure 201 (Sheet 2 of 2)**

**757-200
STRUCTURAL REPAIR MANUAL**

IDENTIFICATION 1 - CORE COWL STRUCTURE - PW2000 ENGINE

REFERENCE DRAWING
314N3210

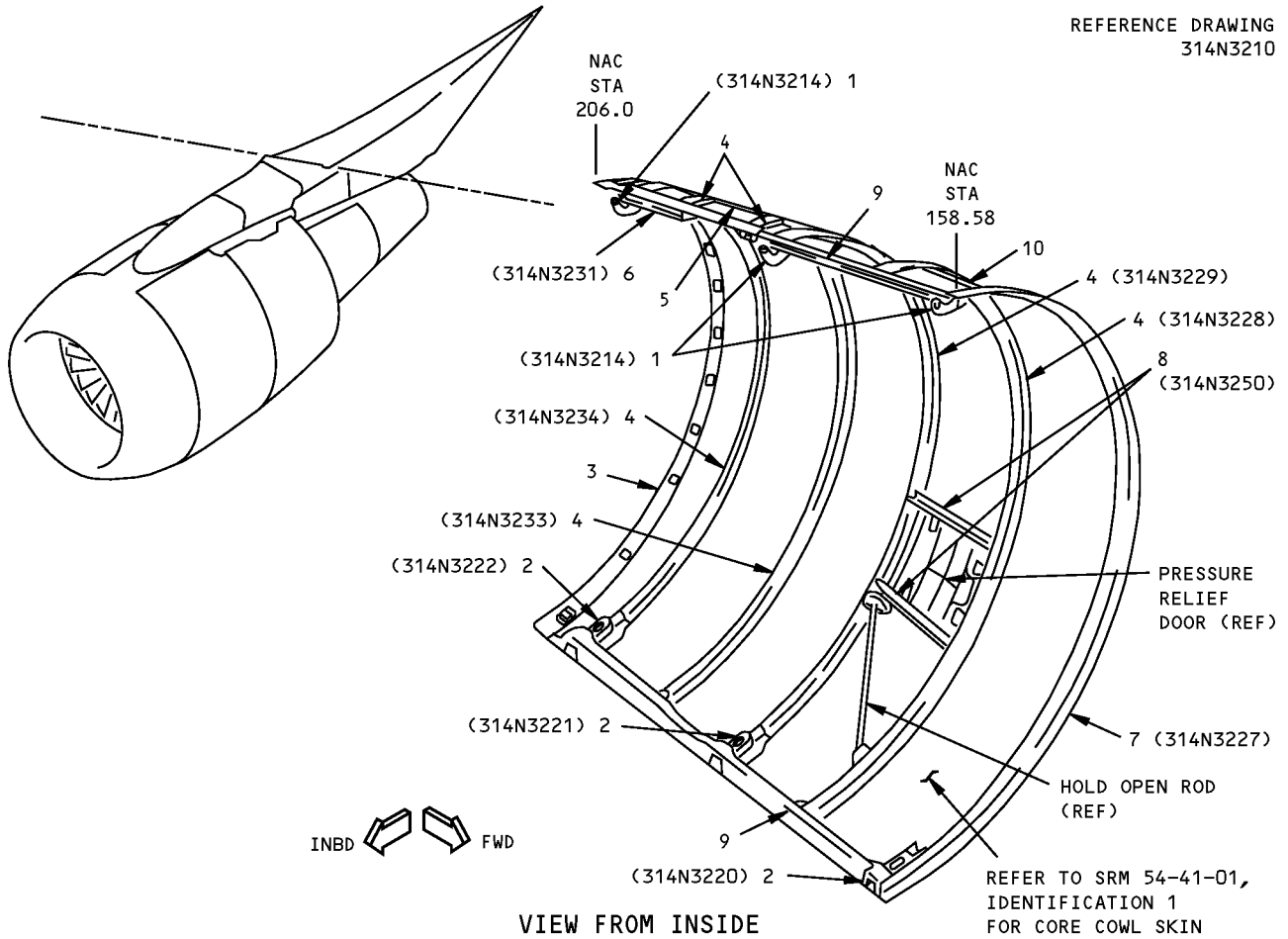

VIEW FROM INSIDE
LEFT SIDE CORE COWL STRUCTURE
RIGHT SIDE OPPOSITE
DETAIL I

ITEM	DESCRIPTION	GAGE	MATERIAL	EFFECTIVITY
1	HINGE FITTING		TI-6AL-4V FORGING	
2	LATCH FITTING		7075-T73 FORGING	
3	TRAILING EDGE FITTING		BAC1513-422 2219-T62	
4	FRAME		BAC1506-3433 2219-T62	
5	INTERCOSTAL		BAC1506-3433 2219-T62	
6	FITTING		FORGING 15-5PH CRES HT TR 180-200 KSI	
7	FRAME		BAC1505-100547 2219-T62	
8	INTERCOSTAL		BAC1505-100351 2219-T62	
9	LONGERON	0.071	CLAD 2219-T62	
10	INTERCOSTAL		BAC1506-2641 2219-T8511 OR 2219-T62	

LIST OF MATERIALS FOR DETAIL I

**Core Cowl Structure Identification - PW2000 Engine
Figure 1**

**757-200
STRUCTURAL REPAIR MANUAL**

ALLOWABLE DAMAGE 1 - CORE COWL STRUCTURE - PW2000 ENGINE

REF DWG
314N3210

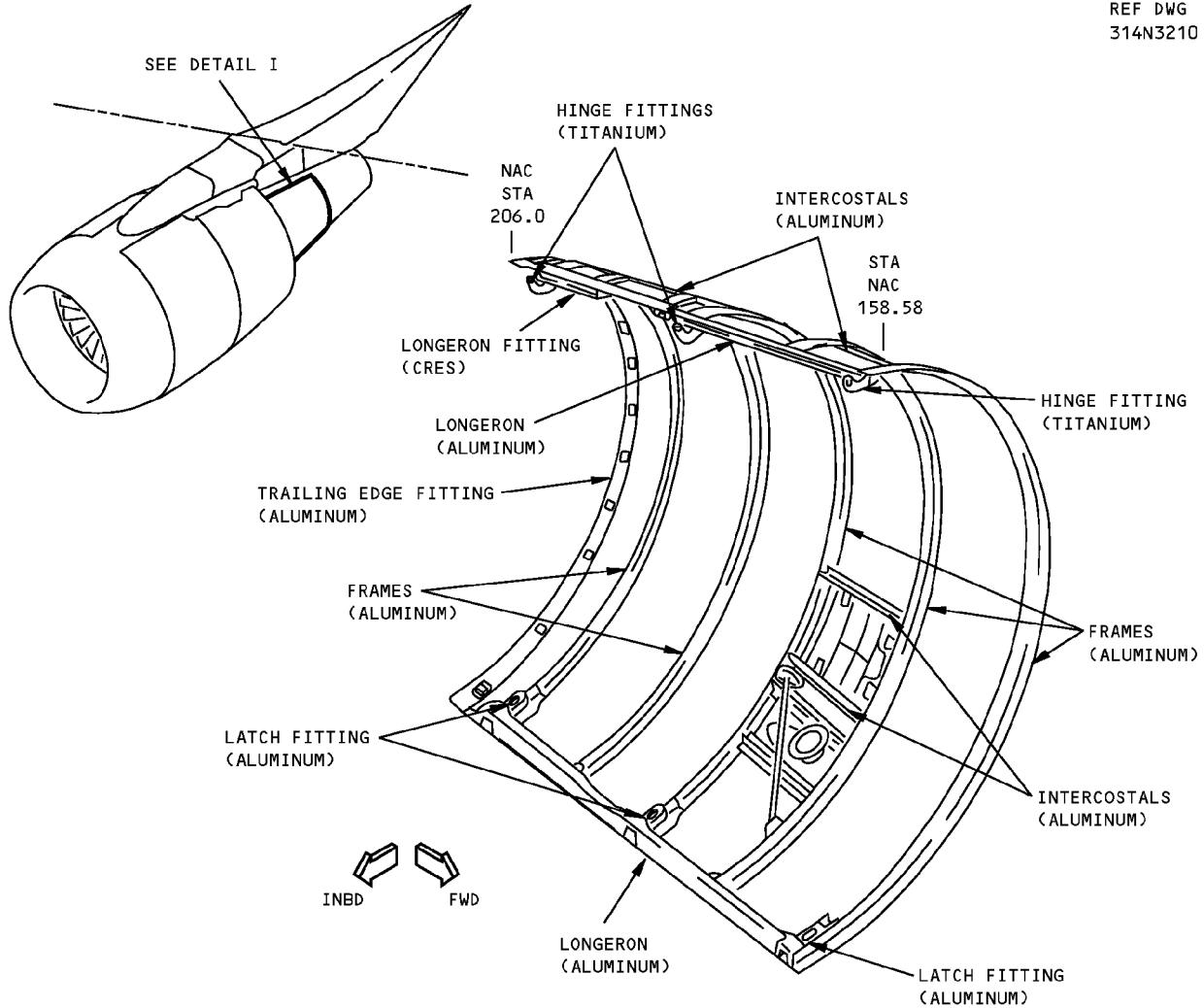

VIEW FROM INSIDE
LEFT SIDE CORE COWL STRUCTURE
DETAIL I

DESCRIPTION	CRACKS	NICKS, GOUGES AND CORROSION	DENTS	HOLES
FRAMES (ALUMINUM)	A	B	NOT ALLOWED	SEE DETAIL IX
INTERCOSTALS (ALUMINUM)	A	B	NOT ALLOWED	SEE DETAIL IX
LONGERONS (ALUMINUM)	D	E	SEE DETAIL VI	G
LONGERON FITTING (CRES)	A	B	NOT ALLOWED	NOT ALLOWED
TRAILING EDGE FITTING (ALUMINUM)	C	F	NOT ALLOWED	NOT ALLOWED
HINGE FITTINGS (TITANIUM)	A	H	NOT ALLOWED	NOT ALLOWED
LATCH FITTINGS (ALUMINUM)	A	B	NOT ALLOWED	NOT ALLOWED

**Core Cowl Structure Allowable Damage - PW2000 Engine
Figure 101 (Sheet 1 of 4)**

ALLOWABLE DAMAGE 1
Page 101
Jan 20/2005

54-41-02

D634N201

STRUCTURAL REPAIR MANUAL

NOTES

- REFER TO SRM 51-10-02 FOR INSECTION AND REMOVAL OF DAMAGE.
- REFINISH REWORKED AREAS AS SHOWN IN AMM 51-20.
- REFER TO SRM 51-10-01 FOR AERODYNAMIC SMOOTHNESS REQUIREMENTS. WHERE THE DAMAGE IS MORE THAN THE LIMITS SHOWN IN SRM 51-10-01, CONSIDERATION SHOULD BE GIVEN TO THE LOSS OF PERFORMANCE INVOLVED.

- A** CRACKS ARE NOT PERMITTED EXCEPT FOR EDGE CRACKS WHICH MUST BE REMOVED AS SHOWN IN DETAIL II.
- B** FOR EDGE DAMAGE SEE DETAIL II. FOR OTHER DAMAGE SEE DETAIL V OR VIII.
- C** CRACKS ARE NOT PERMITTED EXCEPT FOR EDGE CRACKS WHICH MUST BE REMOVED AS SHOWN IN DETAIL III.

- D** CRACKS ARE NOT PERMITTED EXCEPT FOR EDGE CRACKS WHICH MUST BE REMOVED AS SHOWN IN DETAILS II AND IV.
- E** FOR EDGE DAMAGE SEE DETAILS I AND IV. FOR OTHER DAMAGE SEE DETAILS V AND VIII.
- F** FOR EDGE DAMAGE SEE DETAIL III. FOR OTHER DAMAGE SEE DETAIL V OR VIII.
- G** CLEAN OUT DAMAGE UP TO 0.25 INCH (6 mm) MAX DIA AND NOT CLOSER THAN 1.0 INCH (25 mm) TO FASTENER HOLE OR OTHER DAMAGE. FILL HOLE WITH A 2117-T4 OR 2017-13 ALUMINUM PROTRUDING HEAD RIVET INSTALLED WET WITH BMS 5-95 SEALANT. FASTENER EDGE MARGIN MUST BE MAINTAINED IF DAMAGE IS NEAR EDGE OF PART. ALL OTHER HOLES TO BE REPAIRED.
- H** FOR EDGE DAMAGE, SEE DETAIL II. FOR LUG DAMAGE, SEE DETAIL VII. FOR OTHER DAMAGE, SEE DETAIL V AND VIII. DAMAGE IS NOT PERMITTED IN VICINITY OF BUSHINGS.

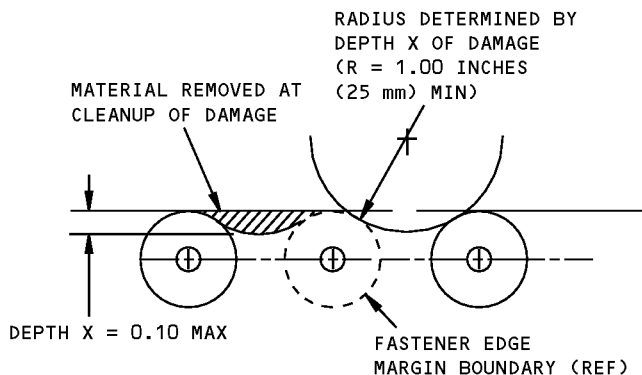

DAMAGE CLEANUP OF EDGES WHERE FASTENER EDGE MARGINS DO NOT OVERLAP

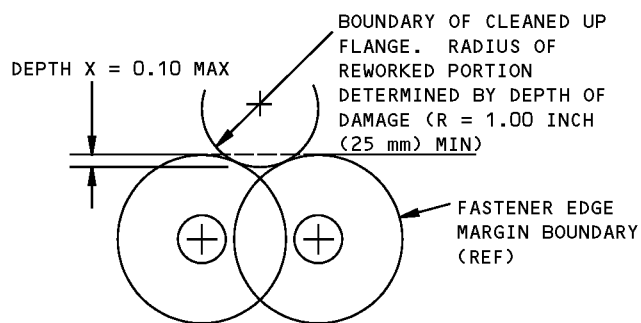

DAMAGE CLEANUP OF EDGES WHERE FASTENER EDGE MARGINS OVERLAP

DETAIL II

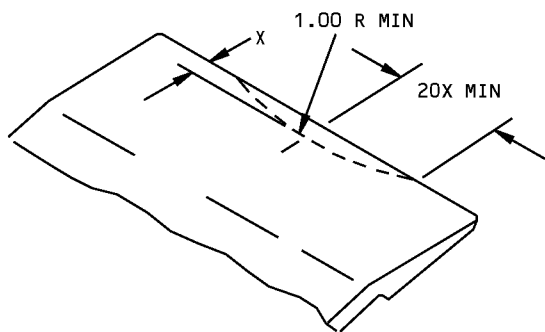

X = DEPTH OF CLEANUP = 0.10 MAX

REMOVAL OF NICK OR CRACK DAMAGE ON AN EDGE

DETAIL III

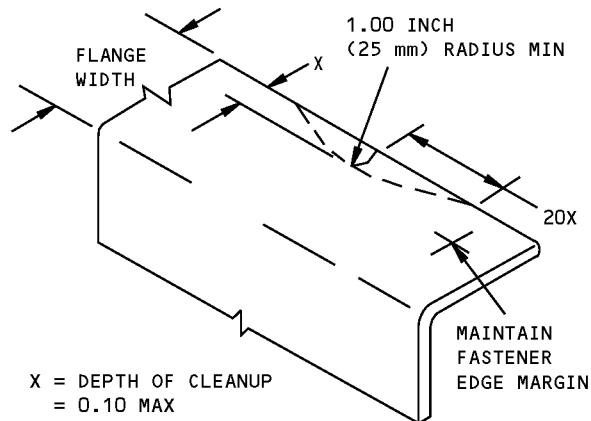

X = DEPTH OF CLEANUP = 0.10 MAX

REMOVAL OF NICK OR CRACK DAMAGE ON AN EDGE

DETAIL IV

Core Cowl Structure Allowable Damage - PW2000 Engine
Figure 101 (Sheet 2 of 4)

**757-200
STRUCTURAL REPAIR MANUAL**

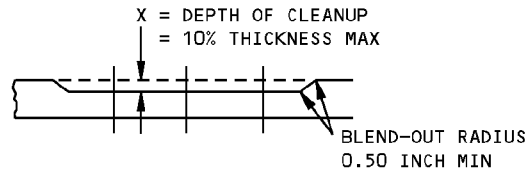
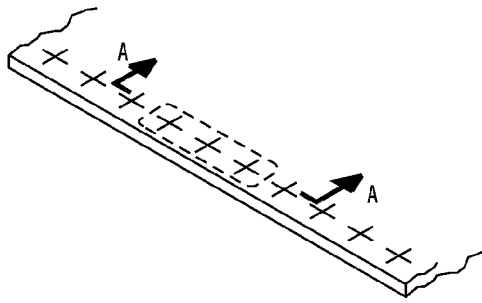

SMOOTH BLEND-OUT RADIUS 0.50 INCH MINIMUM.
CORROSION CLEANUP AROUND ANY THREE FASTENERS
IN TEN IS PERMITTED TO MAX DEPTH

SECTION A-A

CORROSION CLEANUP
DETAIL V

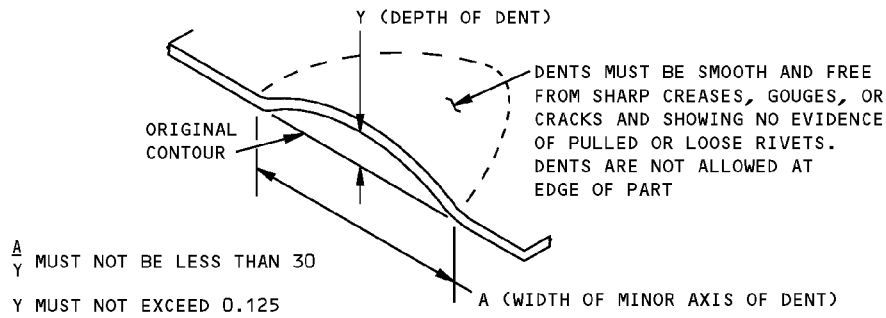

ALLOWABLE DAMAGE FOR DENT
DETAIL VI

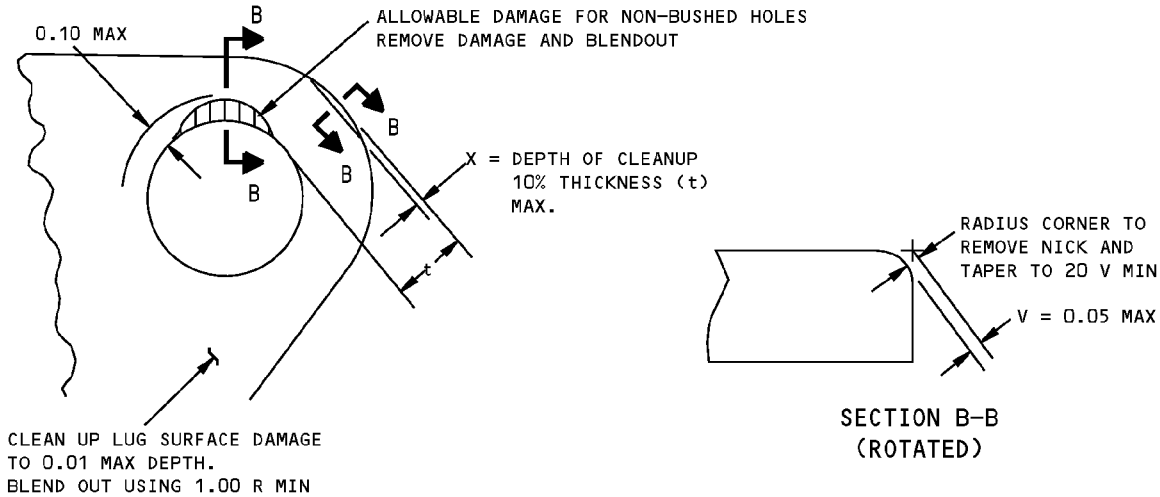

DAMAGE CLEANUP FOR EDGES AND SURFACES OF A LUG
DETAIL VII

Core Cowl Structure Allowable Damage - PW2000 Engine
Figure 101 (Sheet 3 of 4)

**757-200
STRUCTURAL REPAIR MANUAL**

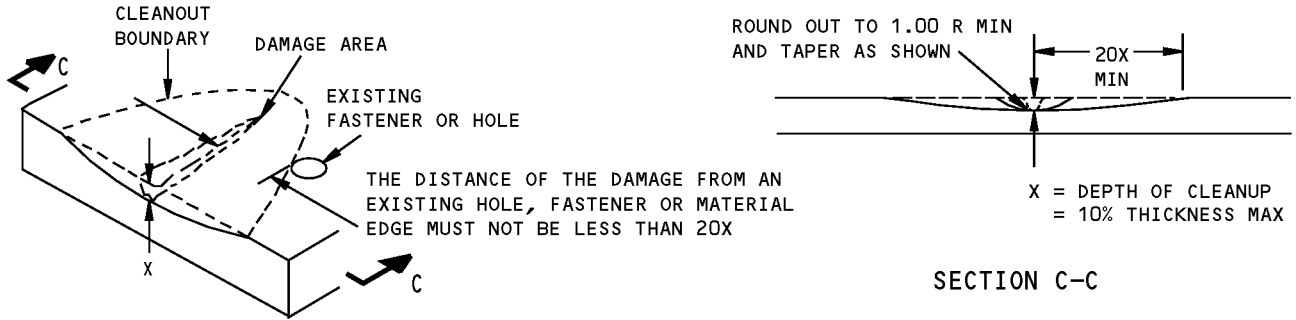

**REMOVAL OF NICK, GOUGE AND SCRATCH DAMAGE ON A SURFACE
DETAIL VIII**

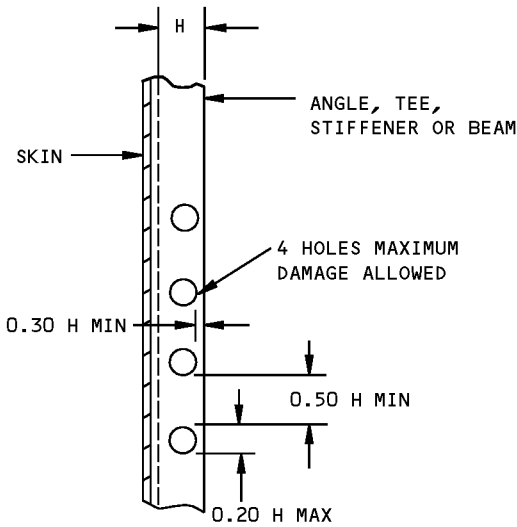

NOTE: NO HOLE DAMAGE ALLOWED IN FLANGES FASTENED TO SKIN. HOLE DAMAGE NOT TO EXCEED 4 PLACES. FILL ALL HOLES WITH 2117-T4 OR 2017-T3 ALUMINUM PROTRUDING HEAD RIVETS INSTALLED WET WITH BMS 5-95. NO HOLE DAMAGE ALLOWED CLOSER THAN 3.5 D TO EXISTING FASTENER. NO HOLE DAMAGE ALLOWED IN SPLICES

H = HEIGHT OF STEM

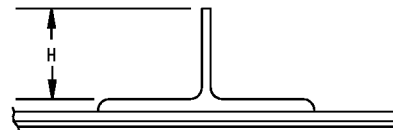

**ALLOWABLE DAMAGE LIMITS FOR HOLES IN FRAMES AND INTERCOSTALS
DETAIL IX**

**Core Cowl Structure Allowable Damage - PW2000 Engine
Figure 101 (Sheet 4 of 4)**

**757-200
STRUCTURAL REPAIR MANUAL**

IDENTIFICATION 1 - PRIMARY EXHAUST - PW2000 ENGINE

REF DWG
333N3000

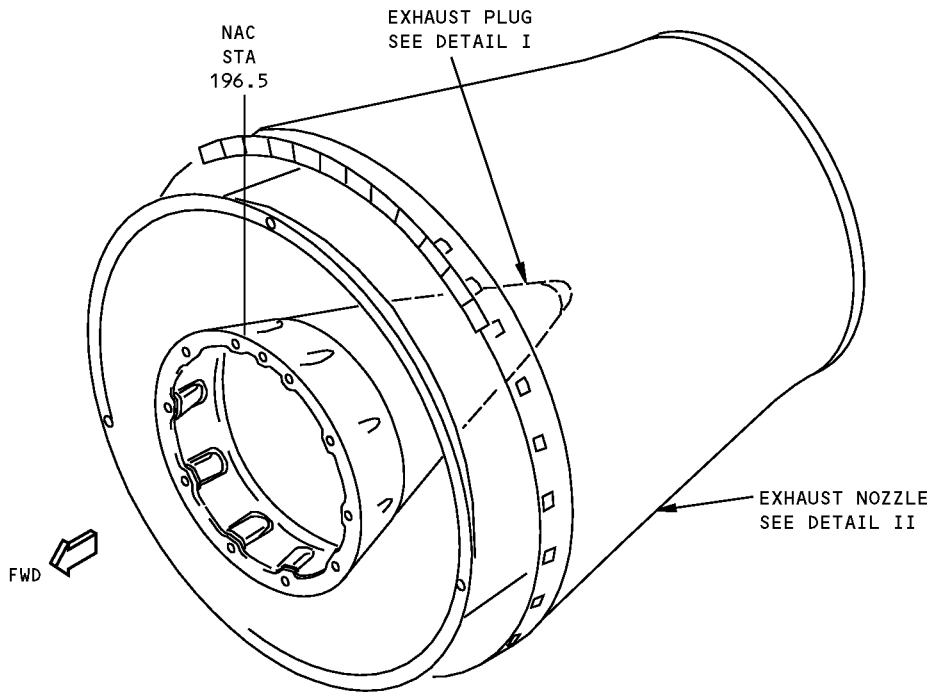
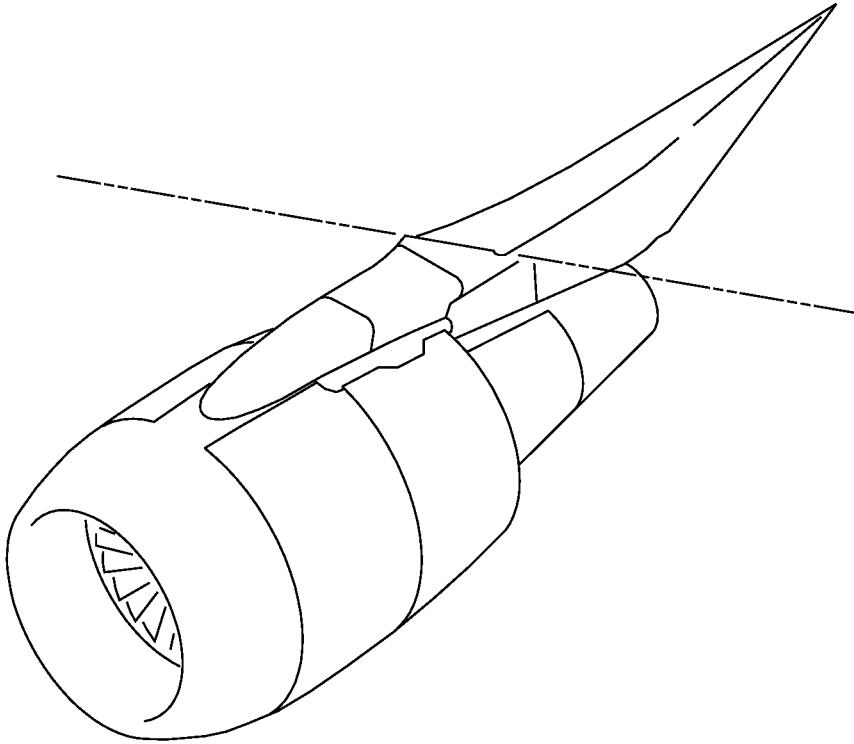

**Primary Exhaust Identification - PW2000 Engine
Figure 1 (Sheet 1 of 3)**

IDENTIFICATION 1
Page 1
Jan 20/2005

54-41-30

D634N201

**757-200
STRUCTURAL REPAIR MANUAL**

REF DWG
314N3310

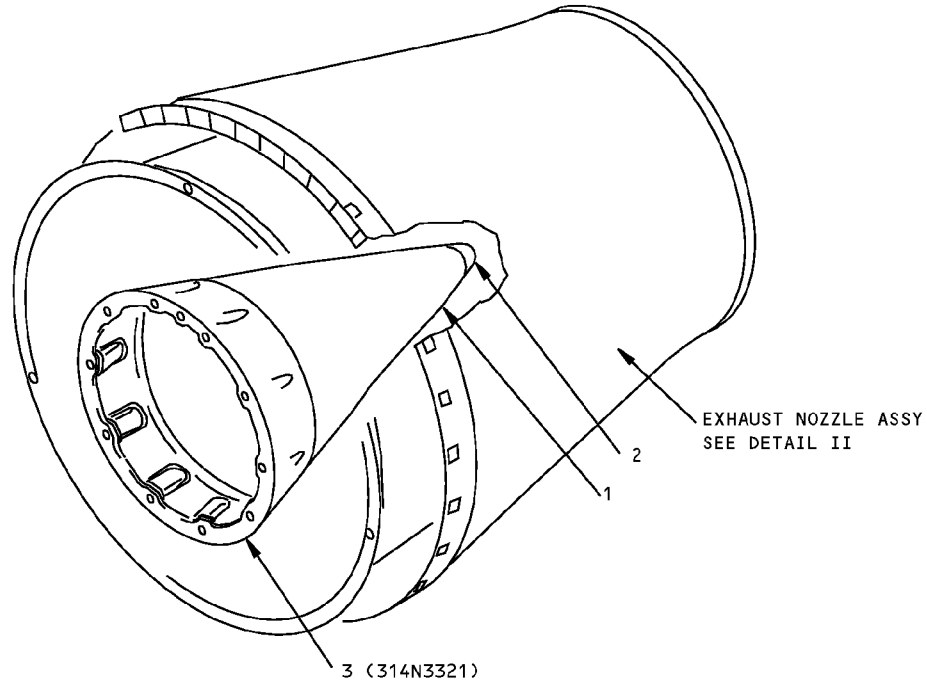

**EXHAUST PLUG
DETAIL I**

ITEM	DESCRIPTION	GAGE	MATERIAL	EFFECTIVITY
1	SKIN	0.040	INCONEL 625	
2	END CAP	0.050	INCONEL 625	
3	FWD MOUNT RING	7/16	INCONEL 625	

LIST OF MATERIALS FOR DETAIL I

**Primary Exhaust Identification - PW2000 Engine
Figure 1 (Sheet 2 of 3)**

IDENTIFICATION 1
Page 2
Jan 20/2005

54-41-30

D634N201

**757-200
STRUCTURAL REPAIR MANUAL**

REF DWG
314N3320

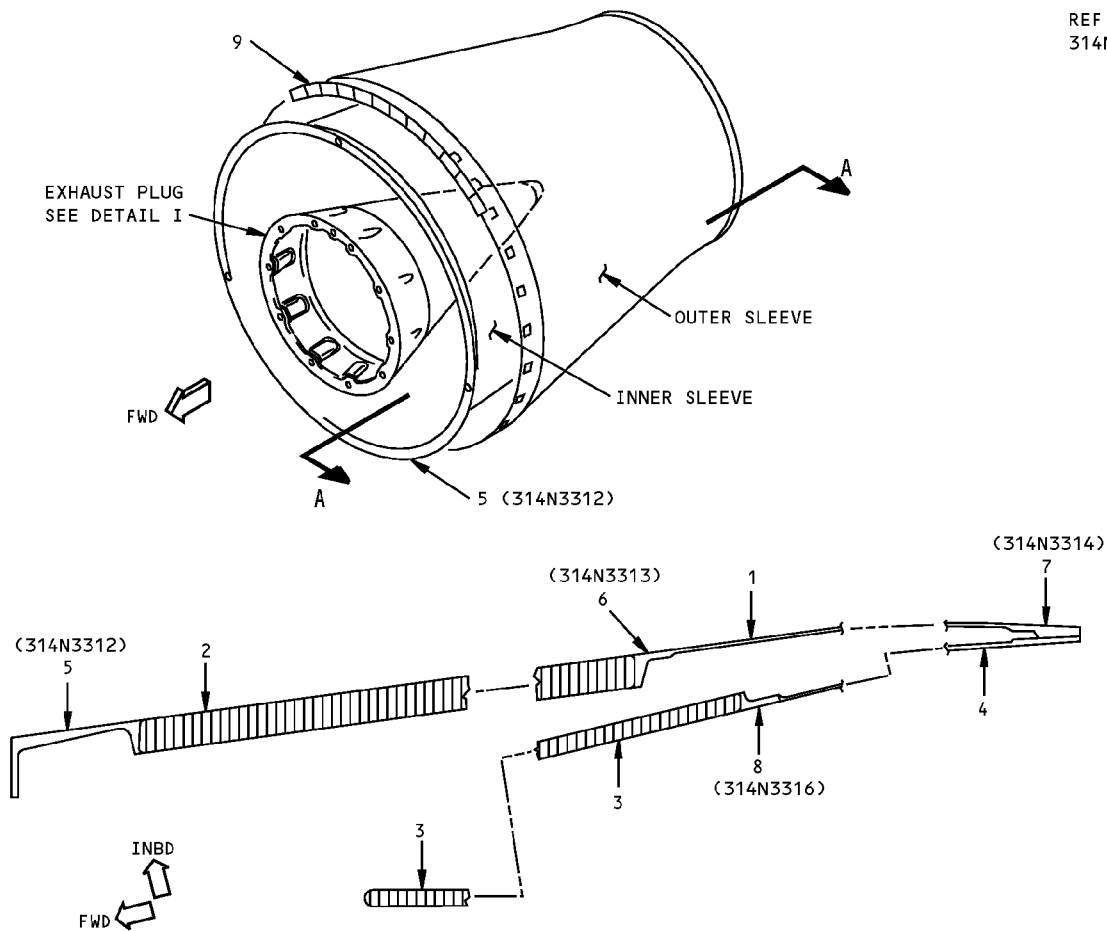

SECTION A-A

PRIMARY EXHAUST - NOZZLE ASSEMBLY
DETAIL II

ITEM	DESCRIPTION	GAGE	MATERIAL	EFFECTIVITY
1	INNER SLEEVE SKIN	0.050	PH15-7MO CRES	
2	INNER SLEEVE PANEL		TRE33001A3/8C-15-7/15-7PX/1820-15-7/50/041	
3	OUTER SLEEVE SKIN		TRE3200-1A-3/8XCN-15-7/15-7/1818-15-7/33/025	
4	OUTER SLEEVE PANEL	0.063	PH15-7MO CRES	
5	FWD MOUNTING RING		PH15-7MO CRES	
6	CLOSURE RING		PH15-7MO CRES	
7	TRAILING EDGE RING		PH15-7MO CRES	
8	CLOSEOUT RING		PH15-7MO CRES	
9	FIRE SEAL	0.030	321/347 CRES	

LIST OF MATERIALS FOR DETAIL II

**Primary Exhaust Identification - PW2000 Engine
Figure 1 (Sheet 3 of 3)**

IDENTIFICATION 1
Page 3
Jan 20/2005

54-41-30

D634N201

**757-200
STRUCTURAL REPAIR MANUAL**

ALLOWABLE DAMAGE 1 - PRIMARY EXHAUST - PW2000 ENGINE

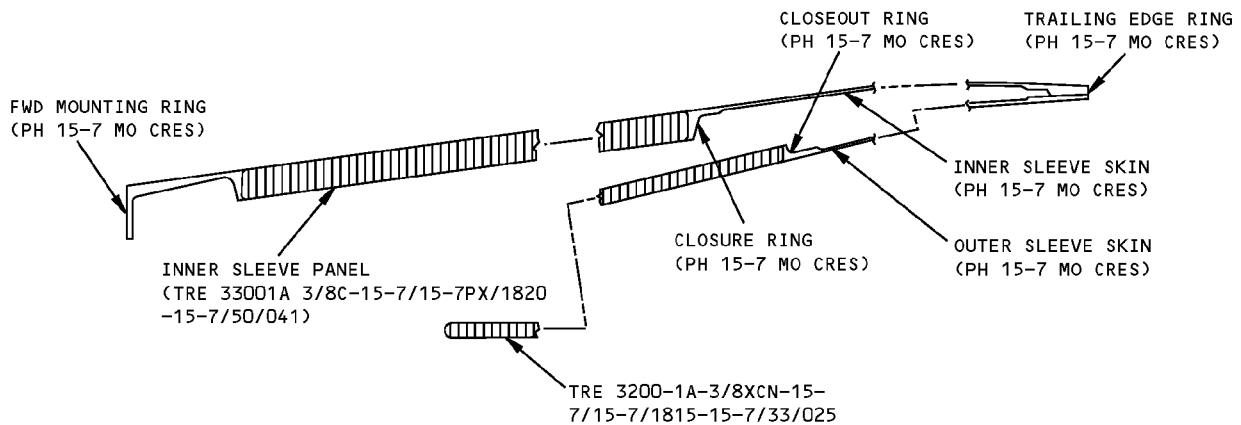
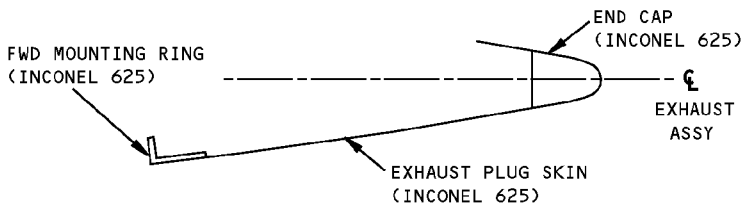
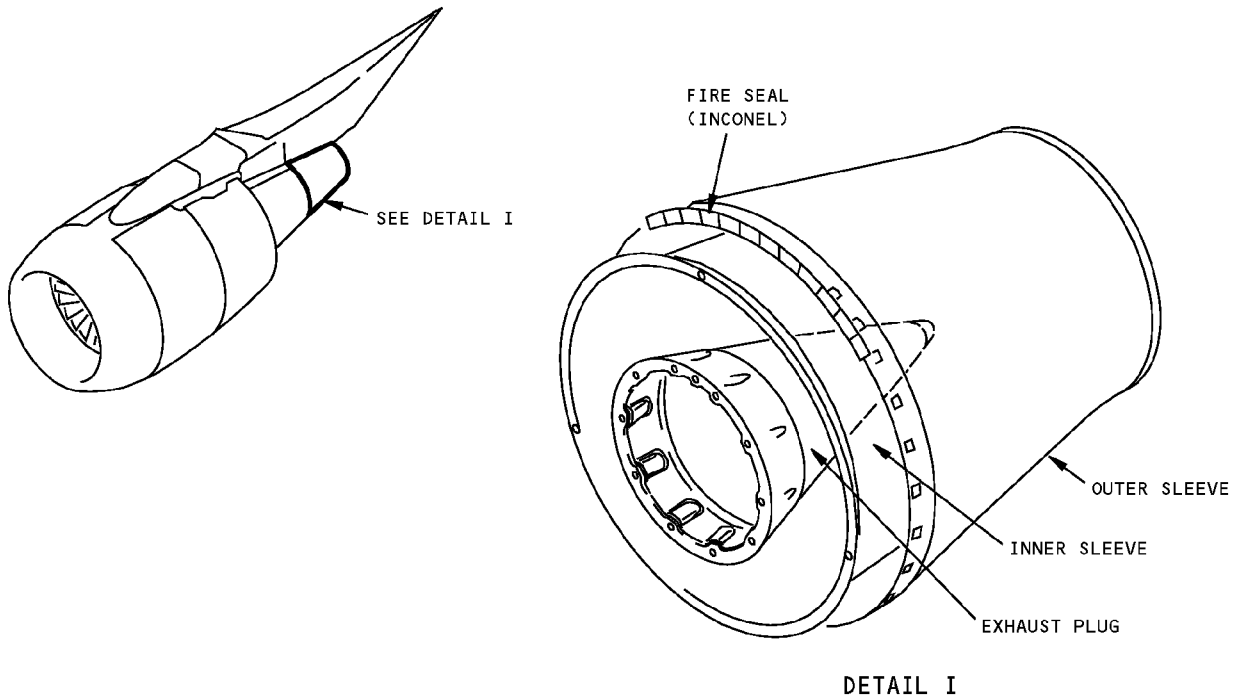

CROSS-SECTIONAL VIEW THRU EXHAUST ASSEMBLY

**Primary Exhaust Allowable Damage - PW2000 Engine
Figure 101 (Sheet 1 of 4)**

**757-200
STRUCTURAL REPAIR MANUAL**

DESCRIPTION	CRACKS	NICKS, GOUGES AND CORROSION	DENTS	HOLES AND PUNCTURES	DELAMINATION
TRAILING EDGE RINGS	A	B	NOT PERMITTED	NOT PERMITTED	
MOUNTING RINGS	A	O	NOT PERMITTED	NOT PERMITTED	
SLEEVE SKIN	NOT PERMITTED	F	C	D	—
PLUG SKIN	NOT PERMITTED	I	C	D	—
INNER SLEEVE HONEYCOMB PANEL	NOT PERMITTED	NOT PERMITTED	C	D	E
PLUG END CAP	NOT PERMITTED	I	C	D	—
FIRE SEAL	A	J	G	NOT PERMITTED	—
CLOSEOUT RING	NOT PERMITTED	NOT PERMITTED	NOT PERMITTED	NOT PERMITTED	—
CLOSURE RING	NOT PERMITTED	H	NOT PERMITTED	NOT PERMITTED	—
PLUG FWD MOUNTING RING	A	J	NOT PERMITTED	NOT PERMITTED	—
OUTER SLEEVE HONEYCOMB PANEL	K N	M	L	D	E

NOTES

- REFER TO SRM 51-10-02 FOR INSPECTION AND REMOVAL OF DAMAGE.

- A** NO CRACKS ARE PERMITTED EXCEPT FOR EDGE CRACKS WHICH MUST BE REMOVED AS GIVEN IN DETAILS II AND IV.
- B** NICKS AND GOUGES ON EDGES MUST BE REMOVED AS GIVEN IN DETAILS III AND IV.
- C** DENTS NOT CLOSER THAN 2.00 INCHES TO EDGE OF PANEL AND WITHOUT CRACKS, SHARP CREASES, WRINKLES, DELAMINATIONS OR HOLES (OTHER THAN MANUFACTURED PERFORATIONS OF ACOUSTIC PANEL) ARE PERMITTED AS GIVEN IN DETAIL V. Y = 0.05 INCH MAXIMUM.

- D** HOLES IN ANY SKIN OR PUNCTURES WHICH COMPLETELY PIERCE THE HONEYCOMB PANELS UP TO 0.10 INCH IN LENGTH OR DIAMETER AFTER CLEANUP ARE PERMITTED. SHARP OR JAGGED EDGES AROUND THE HOLES SHOULD BE SMOOTHED OUT AND ANY SLIT TYPE PUNCTURES SHOULD BE MADE ROUND OR OVAL. HOLES NOT EXCEEDING THE ABOVE LIMITS IN PERFORATED PANELS MAY REMAIN WITHOUT REPAIR IF INSPECTION DOES NOT REVEAL ANY CRACKS, BUT HOLES WHICH COMPLETELY PIERCE THE EXHAUST PLUG SKIN WHERE GAS LEAKAGE MUST BE AVOIDED OR THE OUTER SLEEVE SKINS AWAY FROM THE HONEYCOMB AREA MUST BE PLUGGED BY WELDING THE SOLID FACE. THE NUMBER OF UNREPAIRED HOLES AND PUNCTURES SHALL NOT EXCEED FIVE IN ANY SINGLE HONEYCOMB PANEL. MINIMUM SPACING PERMITTED BETWEEN AN UNREPAIRED HOLE OR PUNCTURE AND ANOTHER HOLE OR PUNCTURE OR THE PANEL EDGE IS 2.00 INCHES.

- E** INNER OR OUTER SKIN-TO-CORE DELAMINATIONS (OR VOIDS) WHICH ARE CONTAINED WITHIN A CIRCLE NOT LARGER THAN 1.00 INCH IN DIAMETER MAY REMAIN, PROVIDED THAT THERE IS A MINIMUM OF 1.00 INCH OF ACCEPTABLE CORE TO THE NEXT DEFECT OR EDGE MEMBER AND THAT THERE ARE NO INCLUDED CRACKS OR THERMAL BUCKLES.

**Primary Exhaust Allowable Damage - PW2000 Engine
Figure 101 (Sheet 2 of 4)**

ALLOWABLE DAMAGE 1

54-41-30

Page 102
Jan 20/2005

D634N201

STRUCTURAL REPAIR MANUAL

NOTES (CONT)

- F** SURFACE NICKS AND GOUGES UP TO 0.10 INCH IN LENGTH OR DIAMETER ARE PERMITTED. CLEAN UP DAMAGE AS GIVEN IN DETAIL III.
- G** DENTS WITHOUT CRACKS, SHARP CREASES, WRINKLES, DELAMINATIONS, OR HOLES ARE PERMITTED AS GIVEN IN DETAIL V.
- H** NICKS AND GOUGES MUST BE REMOVED AS GIVEN IN DETAIL III.
- I** NICKS, GOUGES, AND SCRATCHES UP TO 2.0 INCHES IN LENGTH OR DIAMETER (AFTER CLEANUP) ARE PERMITTED. CLEAN UP DAMAGE AS GIVEN IN DETAIL III.
- J** NICKS, GOUGES, AND SCRATCHES UP TO 0.50 INCH IN LENGTH OR DIAMETER (AFTER CLEANUP) ARE PERMITTED. CLEAN UP DAMAGE AS GIVEN IN DETAIL III.
- K** CRACKS ARE PERMITTED IF:
- THE MAXIMUM LENGTH OF EACH CRACK IS 5.0 INCHES.
 - CRACKS LONGER THAN 5.0 INCHES AND LESS THAN 7.0 INCHES ARE PERMITTED FOR A MAXIMUM OF 300 FLIGHT HOURS.
 - CRACKS LONGER THAN 7.0 INCHES AND LESS THAN 8.5 INCHES ARE PERMITTED FOR A MAXIMUM OF 150 FLIGHT HOURS.
 - THE TOTAL LENGTH OF ALL CRACKS IN EACH FACESHEET IS LESS THAN 20.0 INCHES.
 - THE TOTAL LENGTH OF ALL CRACKS IN EACH FACESHEET IN THE CIRCUMFERENTIAL DIRECTION IS LESS THAN 3.0 INCHES PER QUADRANT.
 - THE DISTANCE BETWEEN A CRACK AND AN EDGE IS AT LEAST ONE HALF THE LENGTH OF THE LONGEST CRACK BUT A MINIMUM OF 1.0 INCH.
 - THE DISTANCE BETWEEN A CRACK AND OTHER DAMAGE ON ONE OF THE TWO FACESHEETS IS AT LEAST TWO TIMES THE LENGTH OF THE LONGEST CRACK. THAT DISTANCE MUST BE A MINIMUM OF 1.0 INCH.
- STOP DRILL THE ENDS OF THE CRACK TO A DIAMETER OF 0.125 INCH AS GIVEN IN SRM 51-10-00. REPAIR THE DAMAGE ON OR BEFORE THE SECOND "A" CHECK.
- L** DENTS, SKIN WRINKLES, SKIN THAT IS PUSHED IN BECAUSE OF HEAT, AND SKIN WAVINESS WHICH DO NOT HAVE SHARP EDGES ARE PERMITTED AS GIVEN IN DETAIL V. DENTS ARE NOT PERMITTED NEARER THAN 2.0 INCHES TO A PANEL EDGE. IF THE DENT HAS A CRACK, USE THE LIMITS FOR A CRACK. IF THE DENT HAS A HOLE, USE THE LIMITS FOR A HOLE. $Y = 0.10$ INCH MAXIMUM.
- M** REMOVE DAMAGE FROM NICKS, GOUGES AND SCRATCHES AS GIVEN IN DETAIL III.
- N** DAMAGE CLEANUP AND REMOVAL OF EDGE CRACKS ARE PERMITTED AS GIVEN IN DETAILS II AND IV.
- O** NICKS AND GOUGES MUST BE REMOVED AS GIVEN IN DETAILS III AND IV. THE MINIMUM FLANGE THICKNESS NECESSARY AFTER DAMAGE REMOVAL ON THE PLUG MOUNTING RING IS 0.115 INCH. THE MINIMUM FLANGE THICKNESS NECESSARY AFTER DAMAGE REMOVAL ON THE OUTER SLEEVE FORWARD MOUNTING RING IS 0.140 INCH.

Primary Exhaust Allowable Damage - PW2000 Engine
Figure 101 (Sheet 3 of 4)

STRUCTURAL REPAIR MANUAL

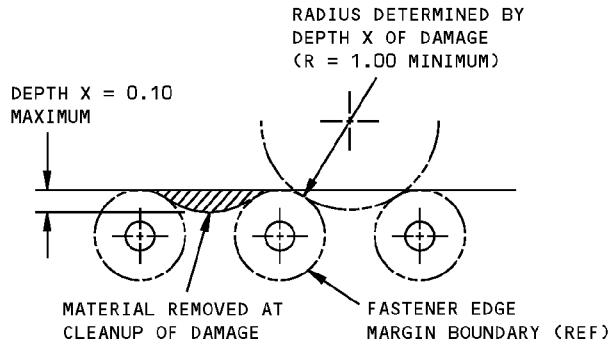

DAMAGE CLEANUP OF EDGES WHERE FASTENER EDGE MARGINS DO NOT OVERLAP

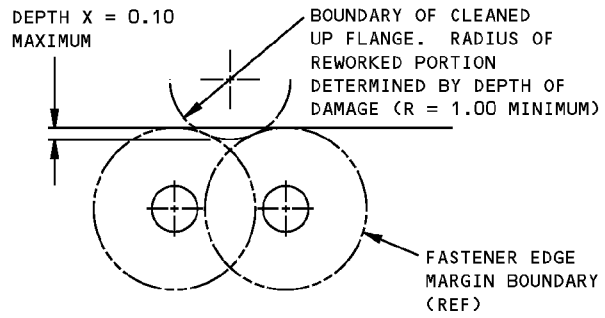

DAMAGE CLEANUP OF EDGES WHERE FASTENER EDGE MARGINS OVERLAP

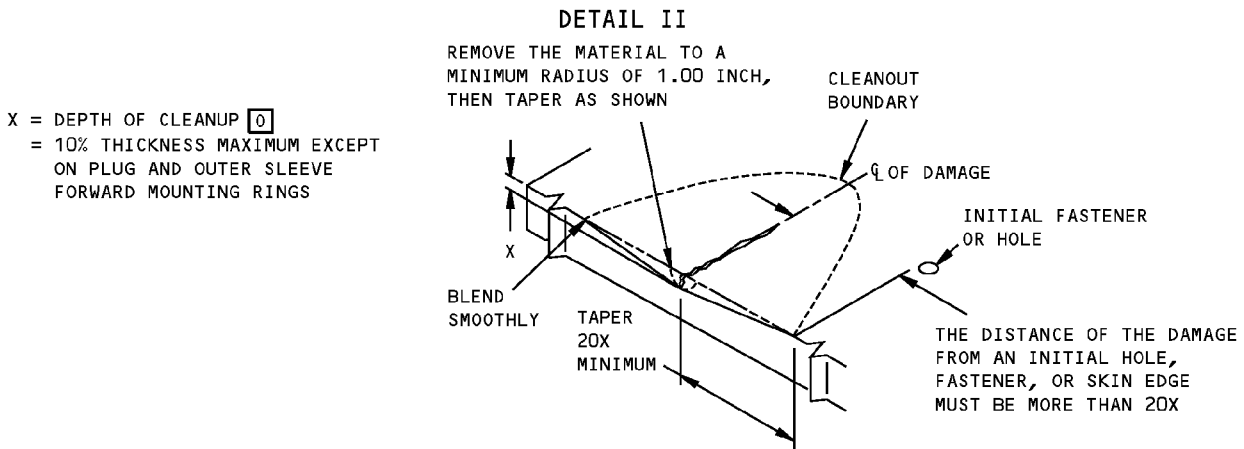

REMOVAL OF NICK, GOUGE AND SCRATCH DAMAGE ON A SURFACE
DETAIL III

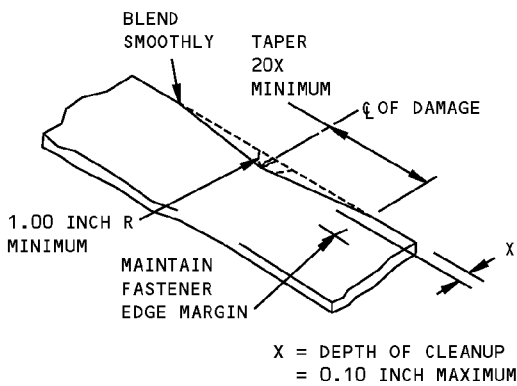

REMOVAL OF NICK OR CRACK DAMAGE ON AN EDGE
DETAIL IV

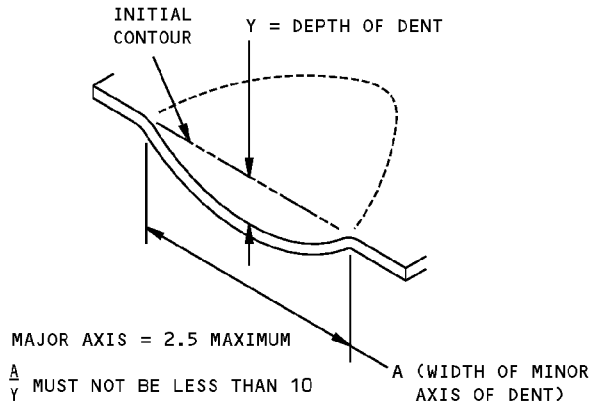

ALLOWABLE DAMAGE FOR A DENT
DETAIL V

Primary Exhaust Allowable Damage - PW2000 Engine
Figure 101 (Sheet 4 of 4)

**757-200
STRUCTURAL REPAIR MANUAL**

REPAIR GENERAL - PRIMARY EXHAUST - PW2000 ENGINE

REFERENCE DRAWING
333N3000

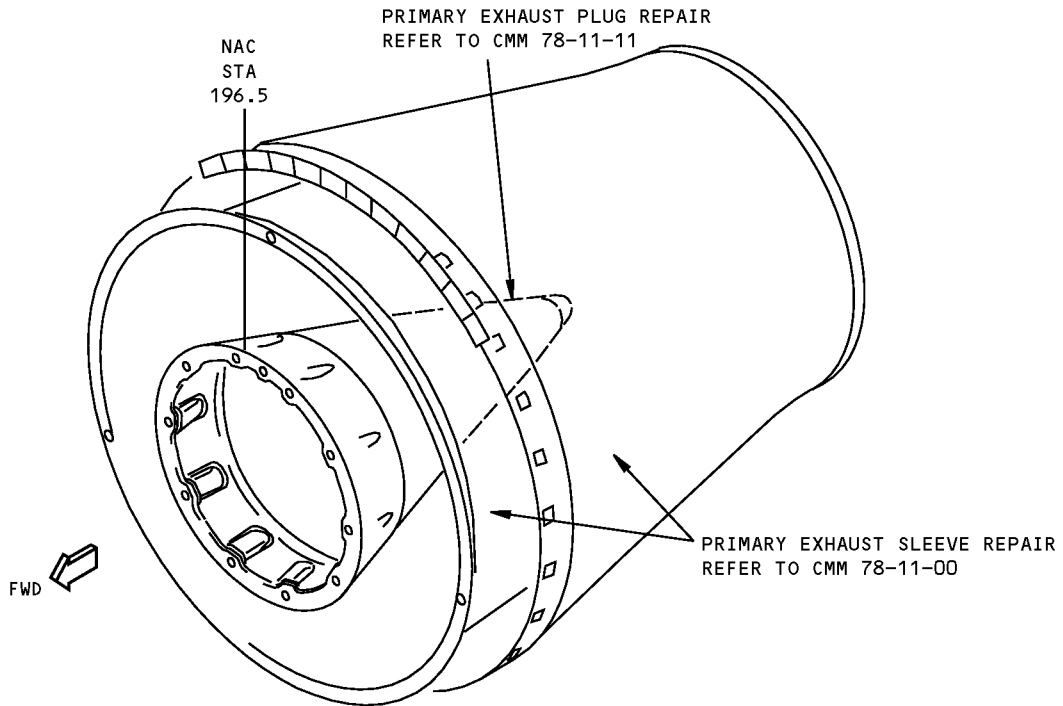
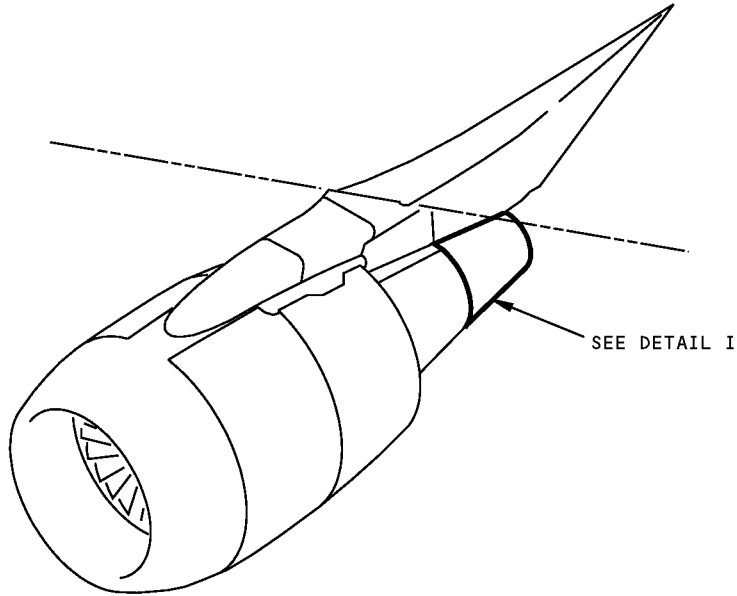

DETAIL I

**Primary Exhaust Repair - PW2000 Engine
Figure 201**

D634N201

54-41-30

REPAIR GENERAL
Page 201
Jan 20/2005

**757-200
STRUCTURAL REPAIR MANUAL**

IDENTIFICATION 1 - STRUT SKIN - RB211-535E4 ENGINE

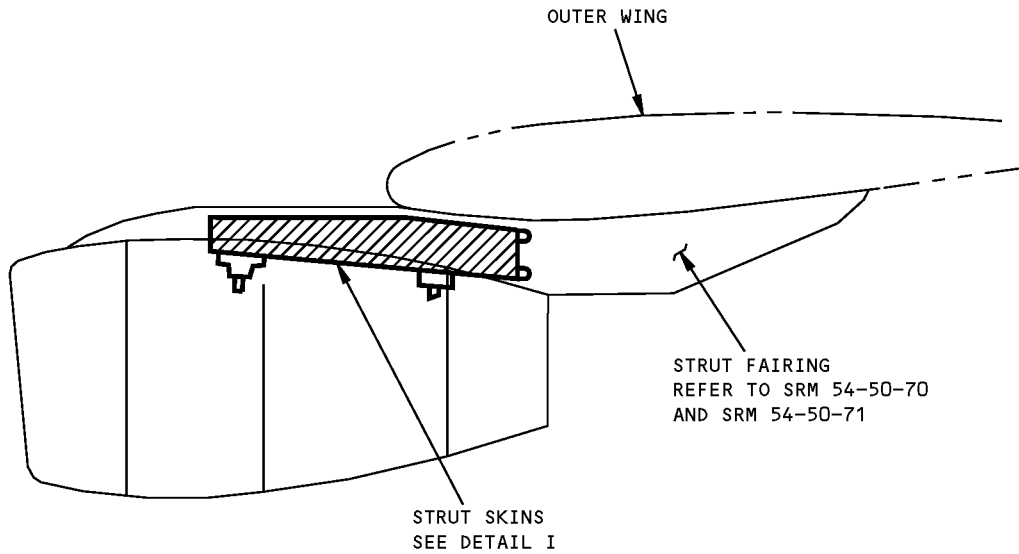

**Strut Skin Identification - RB211-535E4 Engine
Figure 1 (Sheet 1 of 3)**

**757-200
STRUCTURAL REPAIR MANUAL**

REF DWG
311N5002
311N5040
311N5041

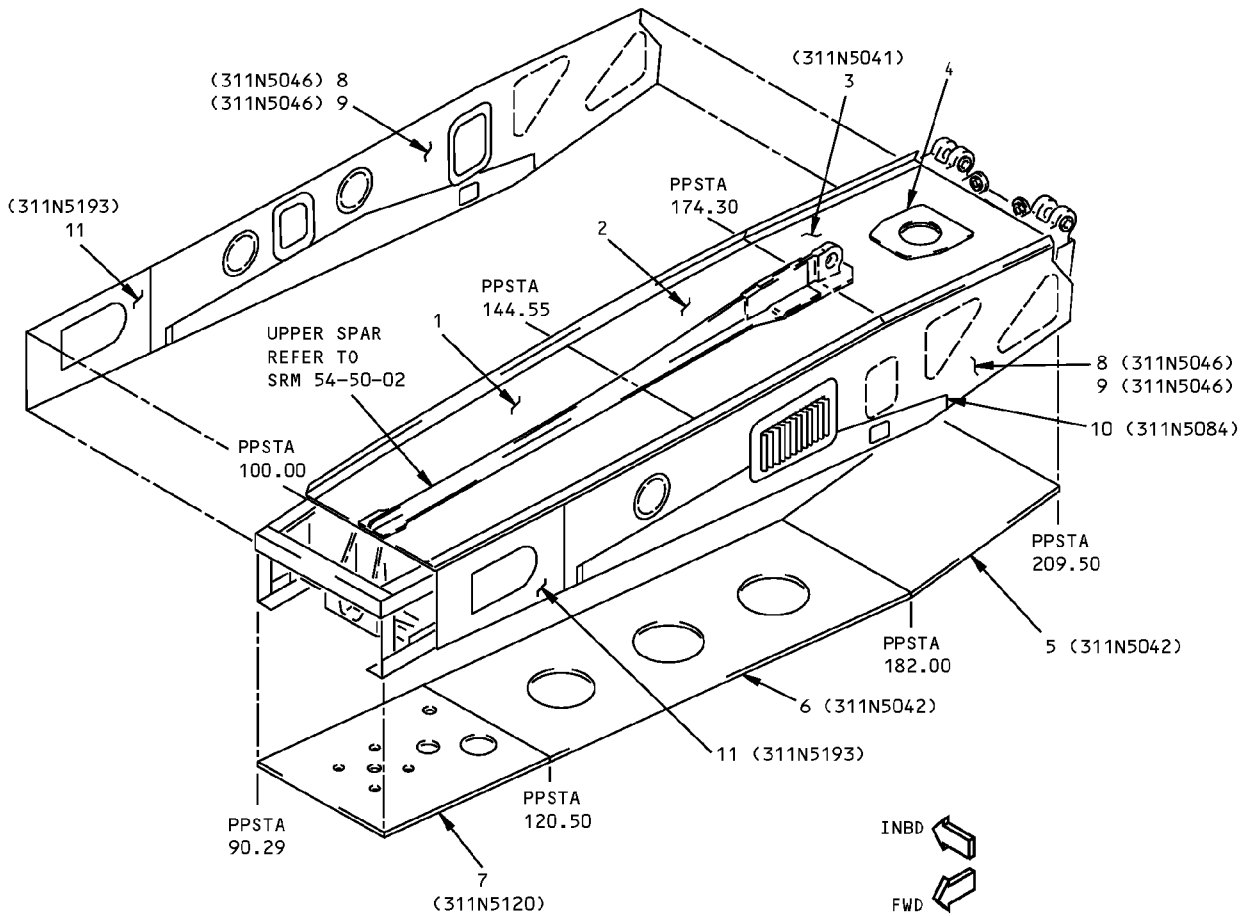

DETAIL I

LIST OF
MATERIAL

**Strut Skin Identification - RB211-535E4 Engine
Figure 1 (Sheet 2 of 3)**

IDENTIFICATION 1
Page 2
Jan 20/2005

54-50-01

D634N201

**757-200
STRUCTURAL REPAIR MANUAL**

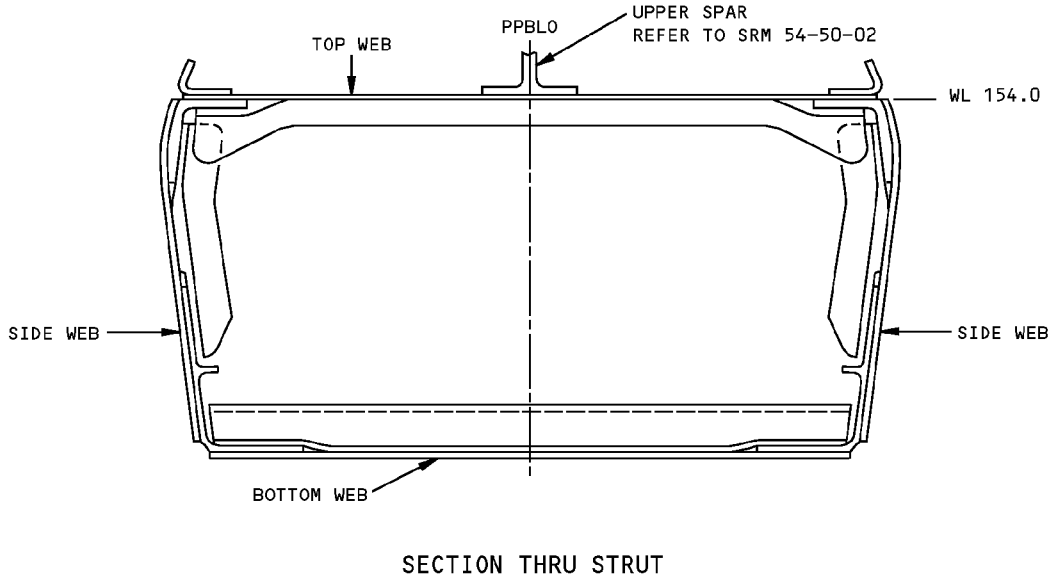

ITEM	DESCRIPTION	GAGE	MATERIAL	EFFECTIVITY
1	FORWARD WEB	0.080	2024-T81	
2	CENTERLINE	0.063	15-5PH CRES HT-TR 180-200 KSI	
3	AFT WEB	0.071	2024-T3	
4	DOUBLER	0.063	2024-T62	
5	LOWER WEB - AFT	0.080	15-5PH CRES HT-TR 180-200 KSI	
6	LOWER WEB - CENTER	0.063	15-5PH CRES HT-TR 180-200 KSI	
7	LOWER WEB - FORWARD	0.063	6AL-4V TITANIUM TYPE III, COMP C	
8	SIDE SKIN	0.090	CLAD 2024-T42	
9	DOUBLER	0.090	2024-T42	
10	HEAT SHIELD	0.057	FIBERGLASS/EPOXY LAMINATE PER BMS 8-139, TYPE 181	
11	SIDE SKIN	1.80	MACHINED TO 0.130 2024-T351	

LIST OF MATERIALS FOR DETAIL I

**Strut Skin Identification - RB211-535E4 Engine
Figure 1 (Sheet 3 of 3)**

D634N201

54-50-01

IDENTIFICATION 1
Page 3
Jan 20/2005

757-200
STRUCTURAL REPAIR MANUAL

IDENTIFICATION 2 - STRUT SKIN - RB211-535C ENGINE

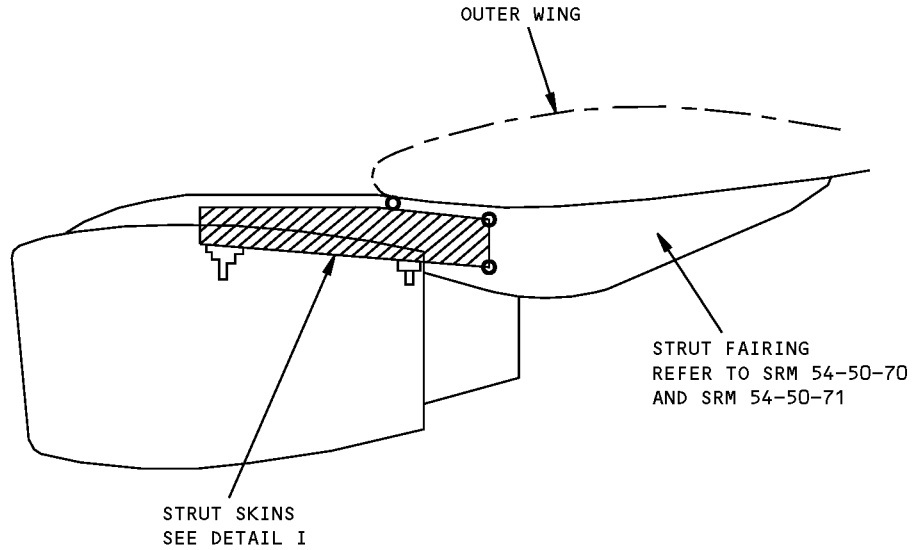

NOTES

- A** FOR AIRPLANES WITH CUM LINE NUMBERS 1 THRU 18
- B** FOR AIRPLANES WITH CUM LINE NUMBERS 19 AND ON
- C** FOR AIRPLANES WITH CUM LINE NUMBERS 1 THRU 30, 32, 33, 34, 36, 50, 51, 52, 54, 56, 57, 58, 63, 77, 78, 81, 89, 90, 93, 98
- D** FOR AIRPLANES NOT INCLUDED IN **C**

Strut Skin Identification - RB211-535C Engine
Figure 1 (Sheet 1 of 3)

**757-200
STRUCTURAL REPAIR MANUAL**

REF DWG
311N5002
311N5040
311N5041

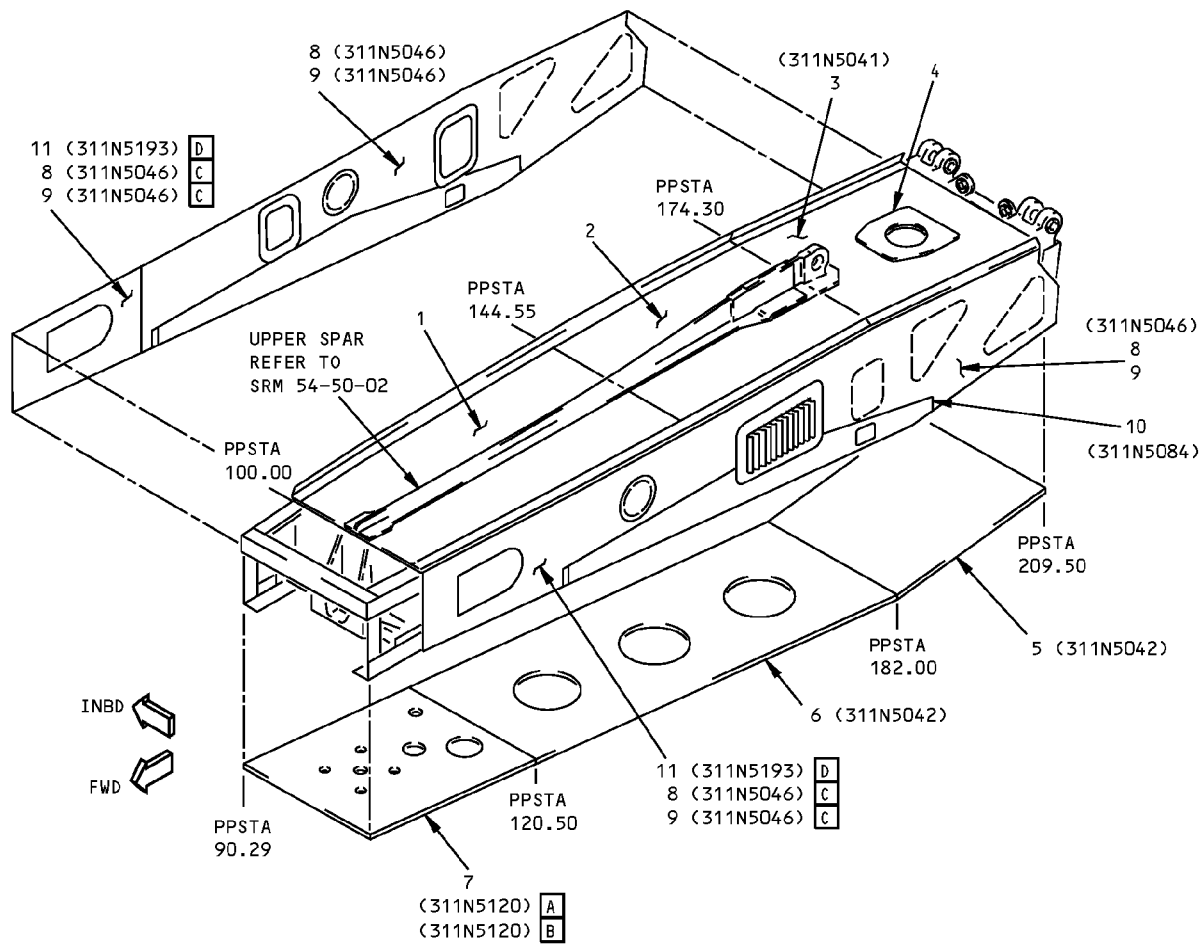

DETAIL I



**Strut Skin Identification - RB211-535C Engine
Figure 1 (Sheet 2 of 3)**

IDENTIFICATION 2
Page 2
Jan 20/2005

54-50-01

D634N201

**757-200
STRUCTURAL REPAIR MANUAL**

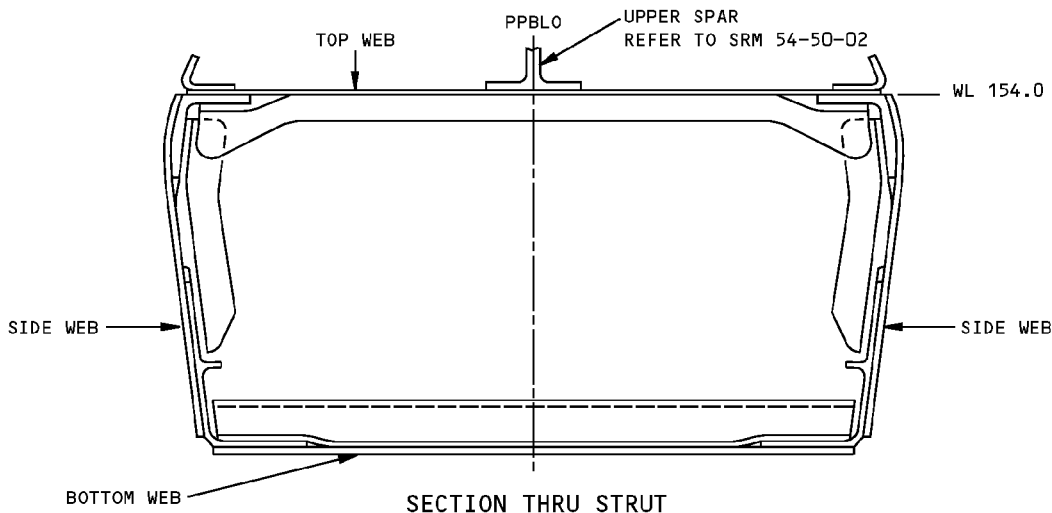

ITEM	DESCRIPTION	GAGE	MATERIAL	EFFECTIVITY
1	FORWARD WEB	0.080	2024-T81	
2	CENTERLINE	0.063	15-5PH CRES HT-TR 180-200 KSI	
3	AFT WEB	0.071	2024-T3	
4	DOUBLER	0.063	2024-T62	
5	LOWER WEB - AFT	0.080	15-5PH CRES HT-TR 180-200 KSI	
6	LOWER WEB - CENTER	0.063	15-5PH CRES HT-TR 180-200 KSI	
7	LOWER WEB - FORWARD	0.063	6AL-4V TITANIUM TYPE III, COMP C	
8	SIDE SKIN	0.090	CLAD 2024-T42	C
9	DOUBLER	0.090	2024-T42	C
10	HEAT SHIELD	0.057	FIBERGLASS/EPOXY LAMINATE PER BMS 8-139, TYPE 181	
11	SIDE SKIN	1.80	MACHINED TO 0.130 2024-T351	D

LIST OF MATERIALS FOR DETAIL I

**Strut Skin Identification - RB211-535C Engine
Figure 1 (Sheet 3 of 3)**

**757-200
STRUCTURAL REPAIR MANUAL**

ALLOWABLE DAMAGE 1 - STRUT SKIN- RB211-535 ENGINE

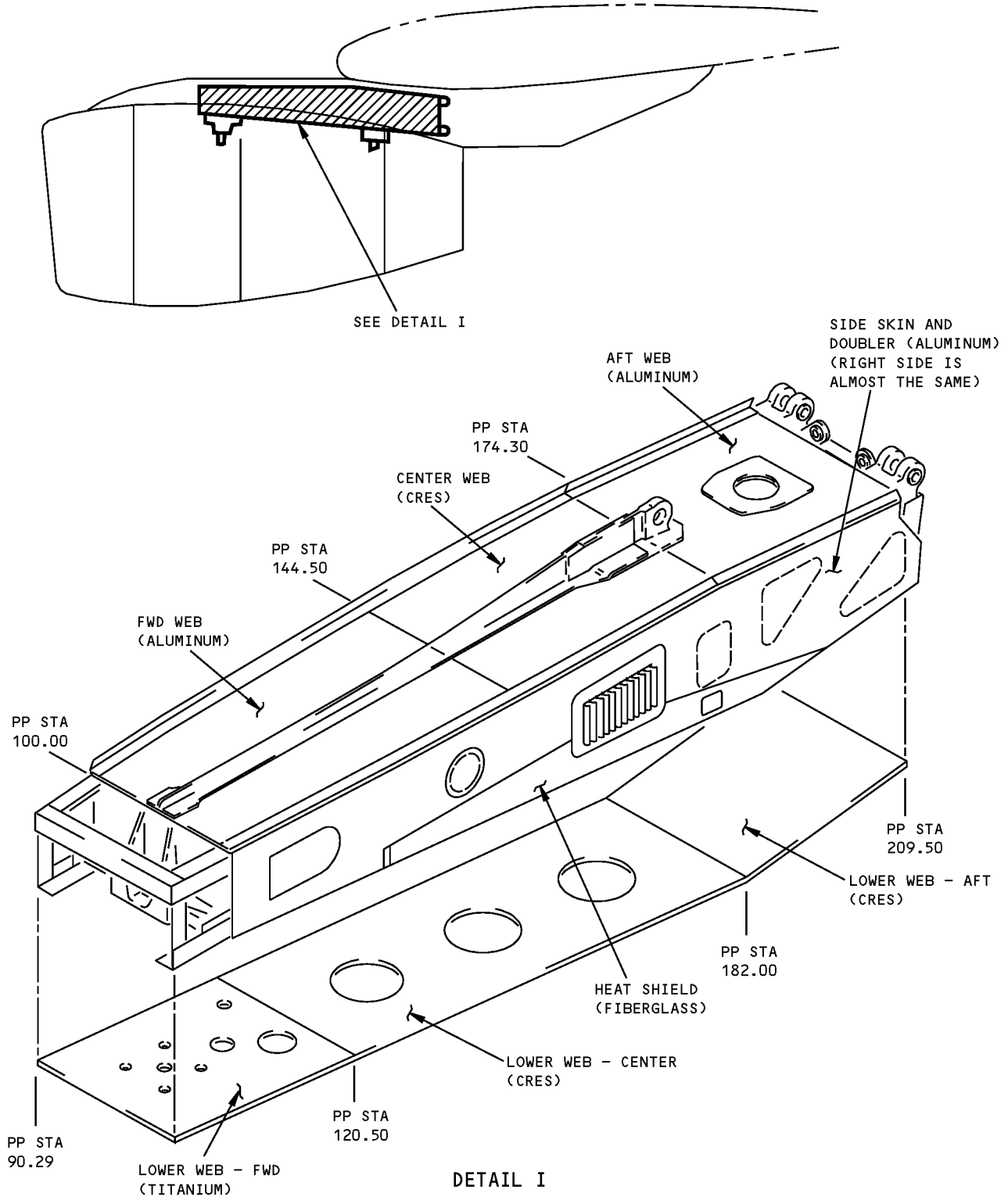

**Strut Skin Allowable Damage - RB211-535 Engine
Figure 101 (Sheet 1 of 4)**



**757-200
STRUCTURAL REPAIR MANUAL**

DESCRIPTION	CRACKS	NICKS, GOUGES AND CORROSION	DENTS	HOLES	DELAMINATION
FWD WEB	A	B	SEE DETAIL IV	C	-----
CENTER WEB	A	B	SEE DETAIL IV	D	-----
AFT WEB	A	B	SEE DETAIL IV	C	-----
SIDE SKIN/DOUBLER	A	B G	SEE DETAIL IV	C	-----
LOWER WEB - FWD	A	B	SEE DETAIL IV	D	-----
LOWER WEB - CENTER	A	B	SEE DETAIL IV	D	-----
LOWER WEB - AFT	A	B	SEE DETAIL IV	D	-----
HEAT SHIELD (FIBERGLASS)	NOT PERMITTED	E	-----	NOT PERMITTED	F

NOTES

- ALL DIMENSIONS ARE SHOWN IN INCHES.
- REFINISH REWORKED AREAS PER AMM 51-20.
- REFER TO SRM 51-10-01 FOR AERODYNAMIC SMOOTHNESS REQUIREMENTS. WHERE THE DAMAGE EXCEEDS THE LIMITS SHOWN IN SRM 51-10-01, CONSIDERATION SHOULD BE GIVEN TO THE LOSS OF PERFORMANCE INVOLVED.

A CRACKS NOT ALLOWED EXCEPT FOR EDGE CRACKS WHICH MUST BE REMOVED PER DETAILS II AND VI.

B REMOVE DAMAGE PER DETAILS II, III, AND V.

C CLEAN OUT DAMAGE UP TO 0.25 MAX DIA AND NOT CLOSER THAN 1.0 INCH TO FASTENER HOLE OR OTHER DAMAGE. FILL HOLE WITH A 2117-T3 OR T4 ALUMINUM RIVET INSTALLED WET WITH BMS 5-95 SEALANT. ALL OTHER HOLES TO BE REPAIRED.

D CLEAN OUT DAMAGE UP TO 0.25 MAX DIA AND NOT CLOSER THAN 1.0 INCH TO FASTENER HOLE OR OTHER DAMAGE. FILL HOLE WITH A MONEL RIVET INSTALLED DRY. ALL OTHER HOLES TO BE REPAIRED.

E DAMAGE IS PERMITTED IF IT DOES NOT GO THROUGH THE OUTER PLY.

F DAMAGE IS PERMITTED IF IT IS NOT MORE THAN 1/3 OF THE LENGTH AND WIDTH OF THE PART.

G REMOVE CORROSION ON THE LOWER EDGE OF THE SIDE SKIN AS GIVEN IN SERVICE BULLETIN 757-54-0022.

**Strut Skin Allowable Damage - RB211-535 Engine
Figure 101 (Sheet 2 of 4)**

STRUCTURAL REPAIR MANUAL

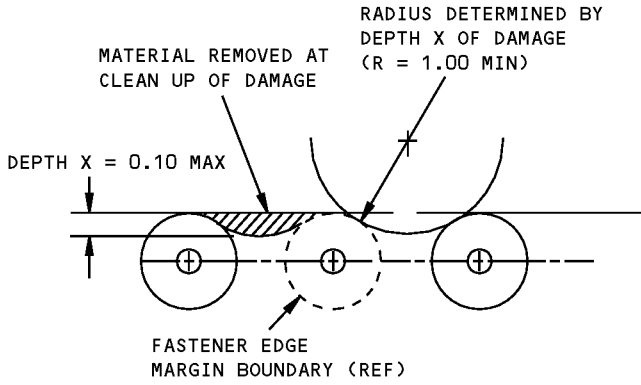

DAMAGE CLEANUP OF EDGES WHERE FASTENER EDGE MARGINS DO NOT OVERLAP

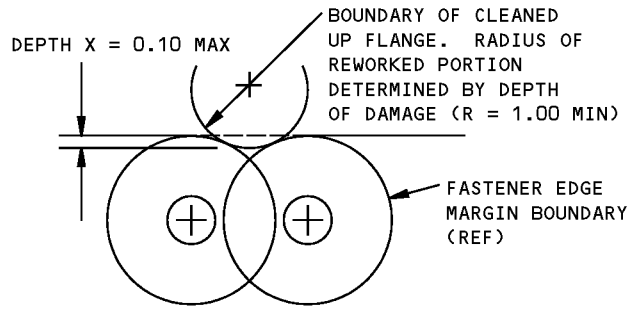

DAMAGE CLEANUP OF EDGES WHERE FASTENER EDGE MARGINS OVERLAP

DETAIL II

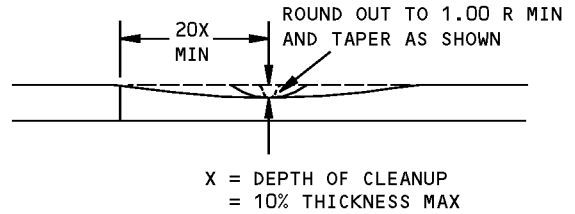
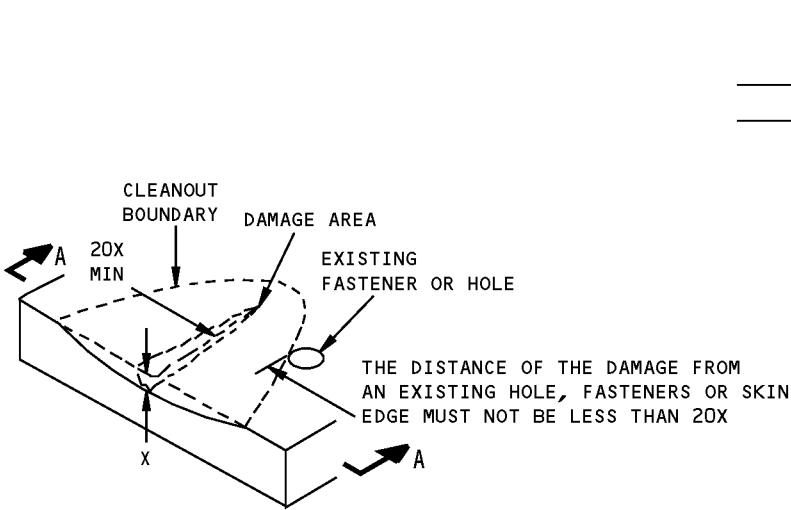

SECTION A-A

REMOVAL OF NICK, GOUGE AND SCRATCH DAMAGE ON A SURFACE

DETAIL III

Strut Skin Allowable Damage - RB211-535 Engine
Figure 101 (Sheet 3 of 4)

STRUCTURAL REPAIR MANUAL

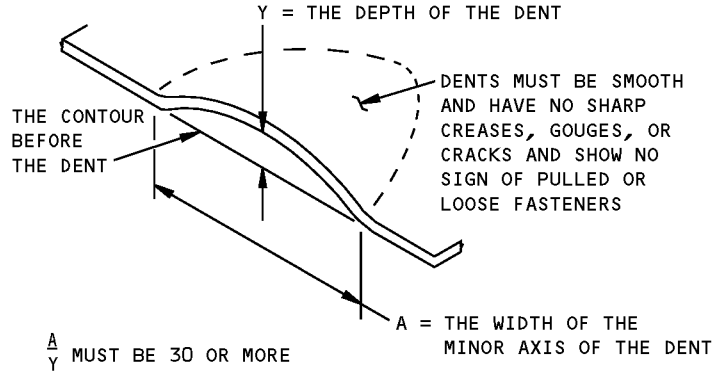

**DENT DAMAGE PERMITTED
DETAIL IV**

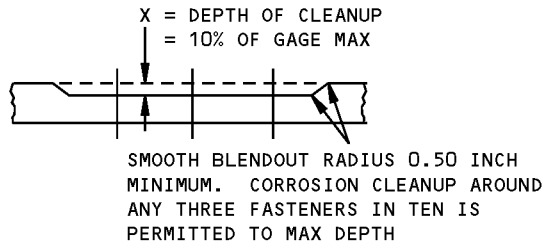
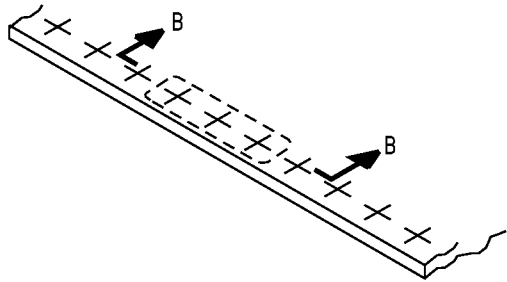

SECTION B-B

**CORROSION CLEANUP
DETAIL V**

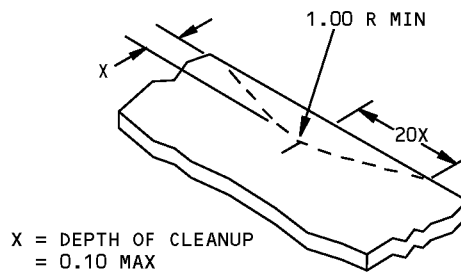

DETAIL VI

**Strut Skin Allowable Damage - RB211-535 Engine
Figure 101 (Sheet 4 of 4)**



757-200
STRUCTURAL REPAIR MANUAL

REPAIR GENERAL - STRUT SKIN - RB211-535 ENGINE - SERVICE BULLETIN LIST

SERVICE BULLETIN REPAIRS

The following Service Bulletins contain repairs which are available for use where specific damage has been encountered. Usually, the Service Bulletin also covers preventive modification data which operators are encouraged to use to eliminate the need for repair.

DAMAGED AREA	CUM LINE NUMBER EFFECTIVITY	SB NUMBER
NACELLES/PYLONS-NACELLE STRUT - STRUT SKIN INSPECTION AND REPAIR	AIRPLANES WITH ROLLS-ROYCE ENGINES, CUM LINE NUMBERS 1 THRU 256	54-0022
NACELLES/PYLONS - SUPPORT BRACKETS FOR HYDRAULIC TUBING - INSPECTION AND REPLACEMENT	AIRPLANES WITH ROLLS-ROYCE ENGINES, CUM LINE NUMBERS 54 THRU 586	54A0030
NACELLES/PYLONS - NACELLE STRUT - INSPECTION AND REPAIR FOR LOWER CHORDS	AIRPLANES WITH ROLLS-ROYCE ENGINES, CUM LINE NUMBERS 1 THRU 736	54-0031

Strut Skin - RB211- 535 Engine
Figure 201

D634N201

54-50-01

REPAIR GENERAL
Page 201
Jan 20/2005

757-200
STRUCTURAL REPAIR MANUAL

REPAIR 1 - STRUT SKIN - RB211-535E4 ENGINE

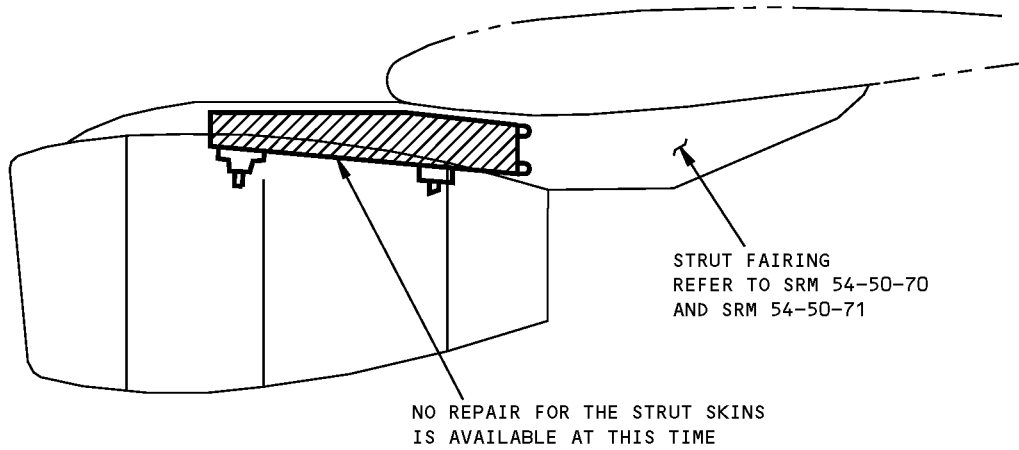

Strut Skin Repairs - RB211-535E4 Engine
Figure 201

D634N201

54-50-01

REPAIR 1
Page 201
Jan 20/2005

757-200
STRUCTURAL REPAIR MANUAL

REPAIR 2 - STRUT SKIN - RB211-535C ENGINE

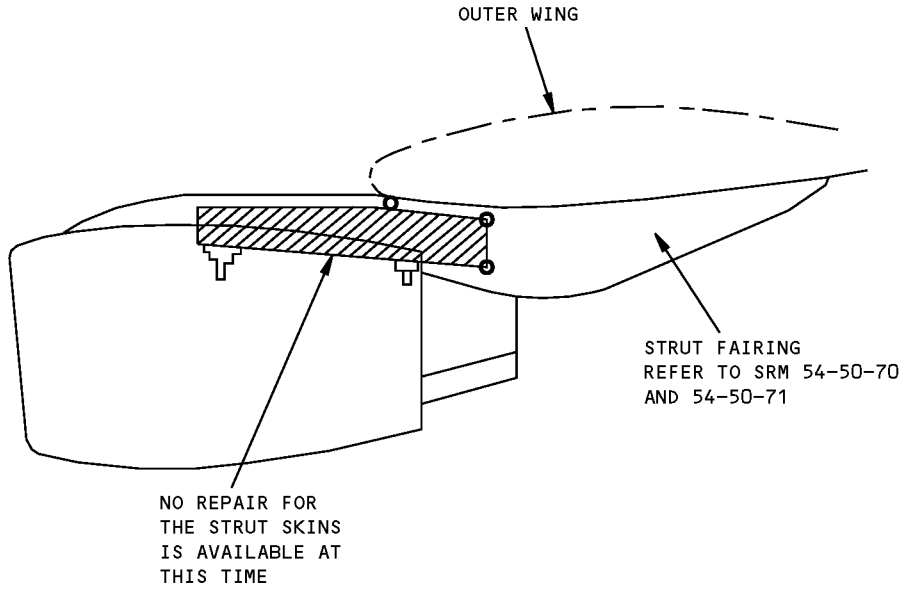

Strut Skin Repairs - RB211-535C Engine
Figure 201

D634N201

54-50-01

REPAIR 2
Page 201
Jan 20/2005

**757-200
STRUCTURAL REPAIR MANUAL**

IDENTIFICATION 1 - STRUT STRUCTURE - RB211-535 ENGINE

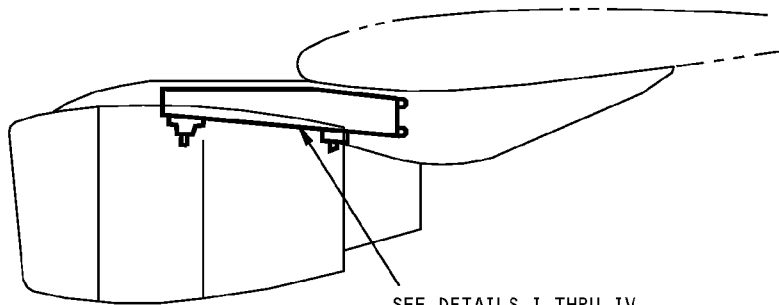

REFERENCE DRAWING
311N0506
311N5040
311N5002

SEE DETAILS I THRU IV

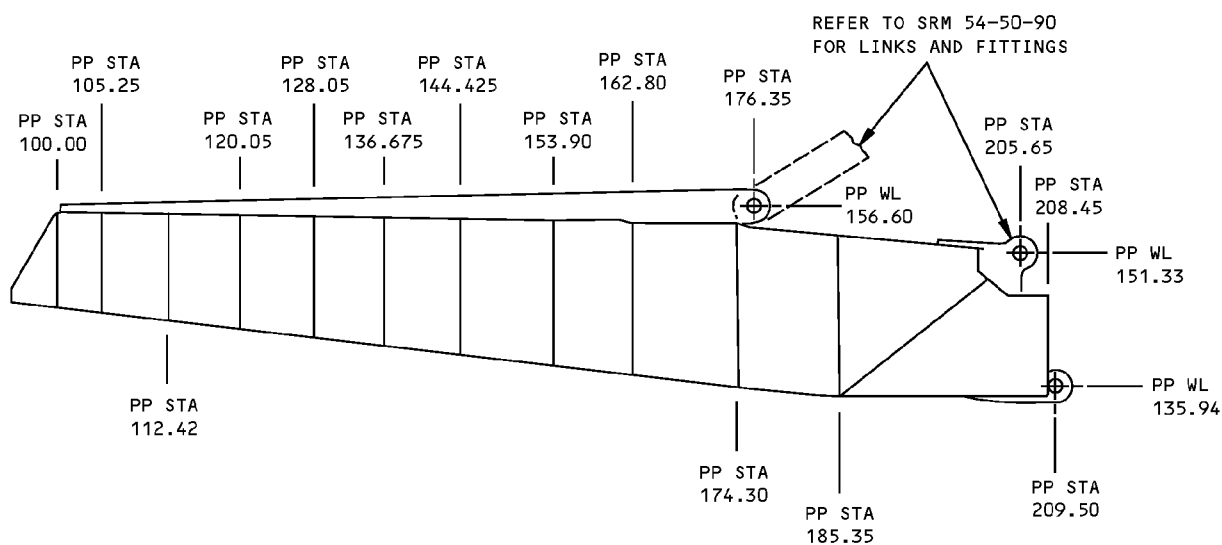

**STRUT STRUCTURE DIAGRAM
DETAIL I**

NOTES

- | | |
|--|---|
| <p>A REFERENCE DRAWING 311N5002</p> <p>B REFERENCE DRAWING 311N5040</p> <p>C FOR AIRPLANES WITH CUM LINE NUMBERS: 2,4,5,9 THRU 13,21,26,114, AND 115 THAT DO NOT HAVE SB 757-54-28 INCORPORATED</p> <p>D FOR AIRPLANES WITH CUM LINE NUMBERS: 31 AND ON</p> <p>E FOR AIRPLANES WITH CUM LINE NUMBERS: 1 THRU 30</p> <p>F FOR AIRPLANES WITH CUM LINE NUMBERS: 1 THRU 18</p> <p>G FOR AIRPLANES WITH CUM LINE NUMBERS: 19 AND ON</p> | <p>H BACK-TO-BACK STIFFENERS FOR AIRPLANES WITH CUM LINE NUMBERS: 31 AND ON, AND FOR AIRPLANES WITH SB 757-54-3 INCORPORATED</p> <p>I FOR AIRPLANES WITH CUM LINE NUMBERS: 1 THRU 115</p> <p>J FOR AIRPLANES WITH CUM LINE NUMBERS: 116 AND ON</p> <p>K FOR AIRPLANES WITH CUM LINE NUMBERS: 737 AND ON, AND FOR AIRPLANES WITH SB 757-54-0035 INCORPORATED</p> <p>L FOR AIRPLANES WITH CUM LINE NUMBERS: 1 THRU 736 WITHOUT SB 757-54-0035 INCORPORATED</p> |
|--|---|

**Strut Structure Identification - RB211-535 Engine
Figure 1 (Sheet 1 of 4)**

**757-200
STRUCTURAL REPAIR MANUAL**

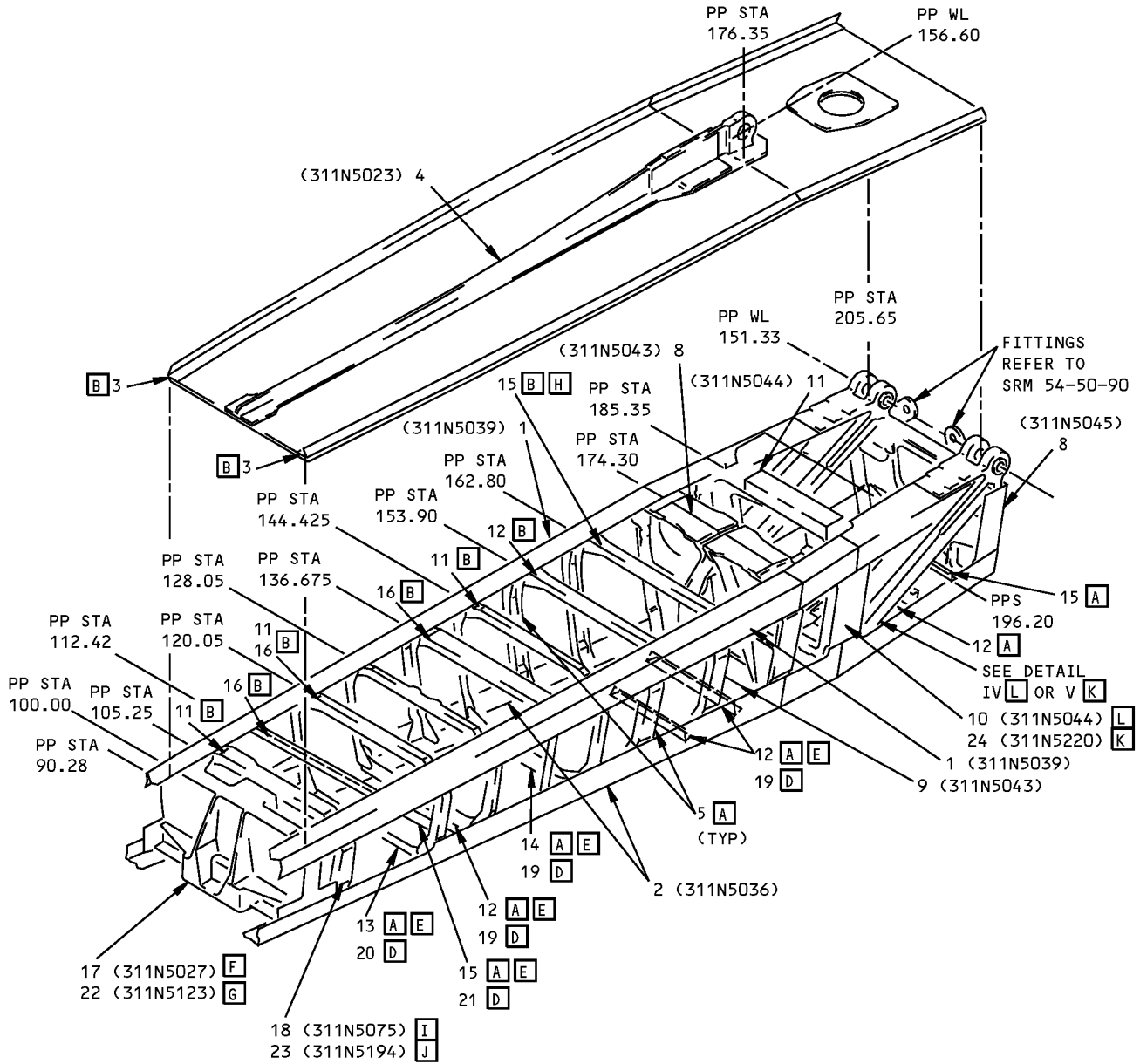

DETAIL II



**Strut Structure Identification - RB211-535 Engine
Figure 1 (Sheet 2 of 4)**

IDENTIFICATION 1
Page 2
Jan 20/2005

54-50-02

D634N201

**757-200
STRUCTURAL REPAIR MANUAL**

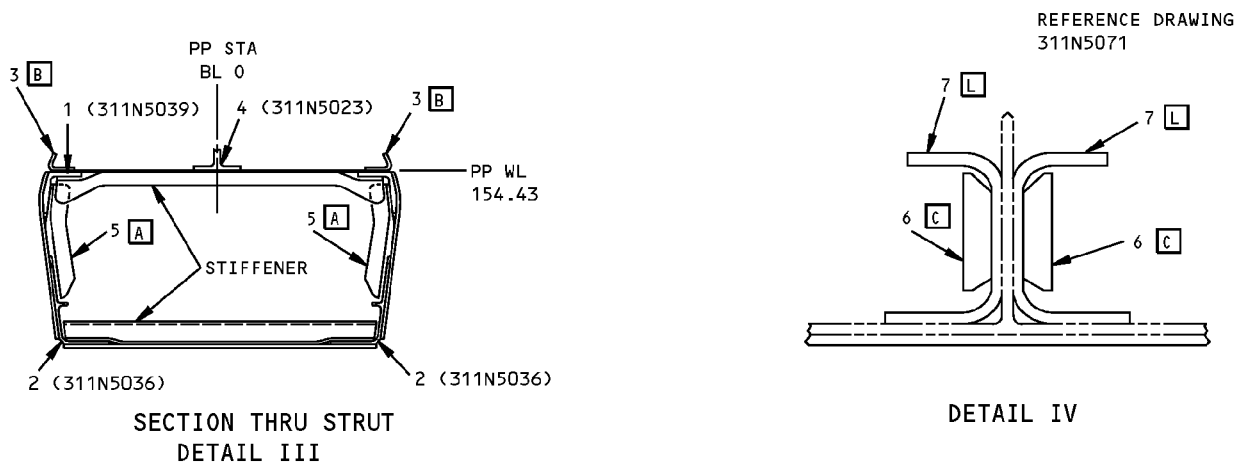

ITEM	DESCRIPTION	GAGE	MATERIAL	EFFECTIVITY
1	UPPER CHORD		BAC1514-2620 EXTRUSION 2024-T8511	
2	LOWER CHORD		FORGING 15-5PH CRES HT-TR 180-200 KSI	
3	ANGLE	0.090	2024-T62	
4	UPPER SPAR		BAC1505-101161 2024-T8511	
5	STIFFENER	0.125	2024-T62	
6	PLATE (2)	0.438	301 CRES 1/4 HARD OPTIONAL: INCONEL 625 PER AMS 5599	[C]
7	CHANNEL (2)	0.190	301 CRES 1/4 HARD OPTIONAL: INCONEL 625 PER AMS 5599	[L]
8	BULKHEAD		FORGING 2219-T6	
9	STIFFENER	0.125	15-5PH CRES HT-TR 180-200 KSI	
10	CHANNEL (2)		BAC1493-184 2024-T62	
11	CHANNEL	0.080	2024-T62	
12	STIFFENER	0.063	15-5PH CRES, HT-TR 180-200 KSI	
13	STIFFENER	0.050	17-7 PH CRES, HT-TR 150-170 KSI	
14	STIFFENER	0.063	17-7 PH CRES, HT-TR 150-170 KSI	
15	STIFFENER	0.080	15-5PH CRES, HT-TR 180-200 KSI	
16	STIFFENER		BAC1505-100583 2024-T62	
17	FITTING, FWD MOUNT		FORGING 7075-T73 OR 2219-T6	[F]
18	STIFFENER		BAC1505-100694 2024-T3511 OPTIONAL: BAR 2024-T8511	[I]
19	STIFFENER	0.063	TI-6AL-4V TYPE III COMP C	
20	STIFFENER	0.050	TI-6AL-4V TYPE III COMP C	
21	STIFFENER	0.080	TI-6AL-4V TYPE III COMP C	
22	FITTING, FWD MOUNT		FORGING 2219-T852 OR 2219-T6	[G]
23	STIFFENER		FORGING 7075-T73	[J]
24	STIFFENER, VERTICAL (2)		ALTER BAC1505-101545 2224-T3511 OPTIONAL: 2024-T3511	[K]

LIST OF MATERIALS FOR DETAILS II THRU IV

**Strut Structure Identification - RB211-535 Engine
Figure 1 (Sheet 3 of 4)**

IDENTIFICATION 1
Page 3
Jan 20/2005

54-50-02

D634N201

**757-200
STRUCTURAL REPAIR MANUAL**

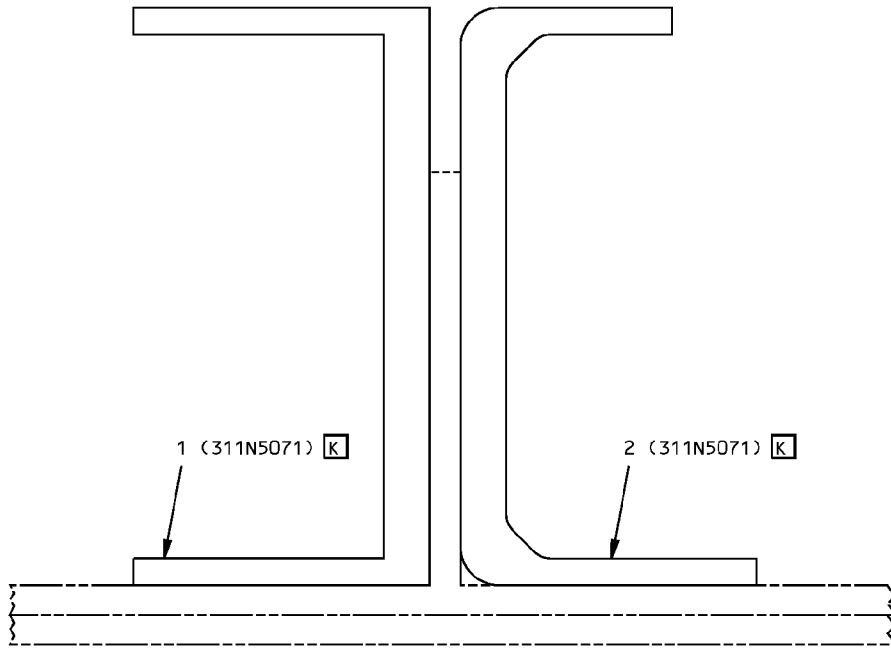

DETAIL V

ITEM	DESCRIPTION	GAGE	MATERIAL	EFFECTIVITY
1	BATHTUB FITTING		15-5PH CRES BAR HT TR 180-200 KSI	[K]
2	CHANNEL-MID CHORD		15-5PH CRES BAR HT TR 180-200 KSI	[K]

LIST OF MATERIALS FOR DETAIL V

**Strut Structure Identification - RB211-535 Engine
Figure 1 (Sheet 4 of 4)**

IDENTIFICATION 1
Page 4
Jan 20/2005

54-50-02

D634N201

**757-200
STRUCTURAL REPAIR MANUAL**

ALLOWABLE DAMAGE 1 - STRUT STRUCTURE - RB211-535 ENGINE

REF DWG
311N0506
311N5040
311N5002

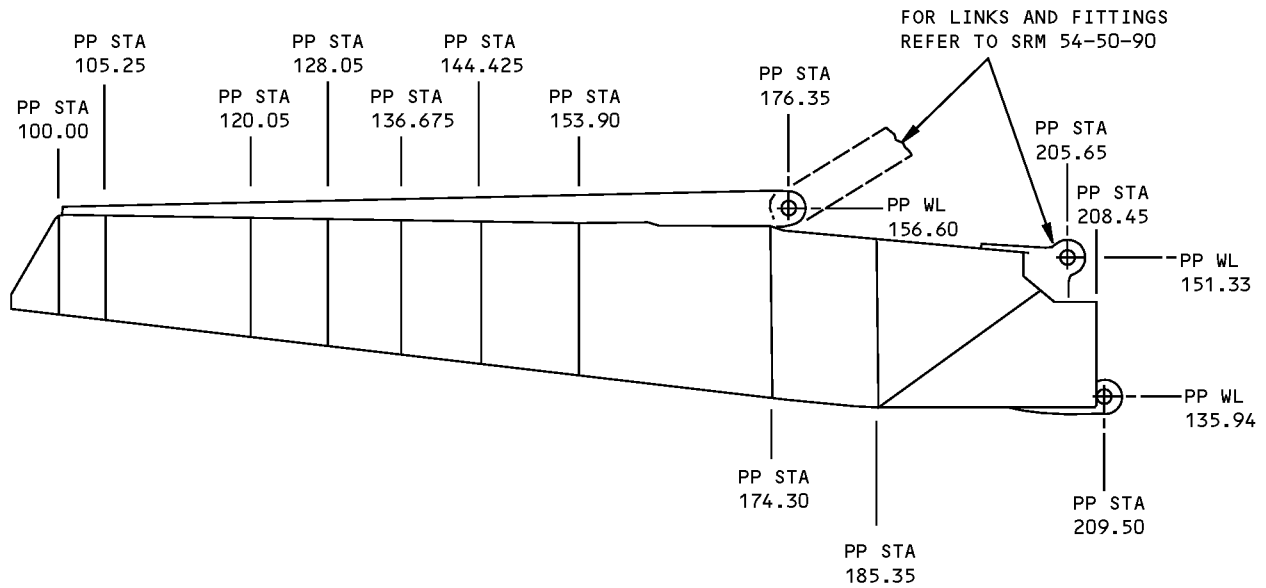
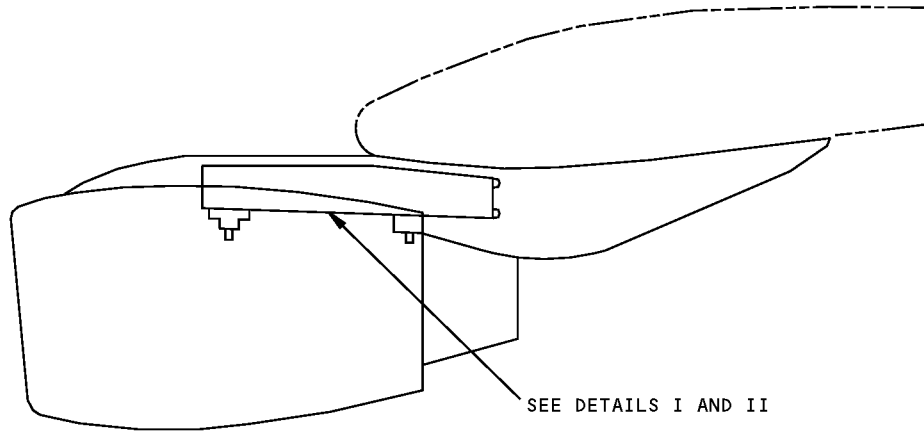

**STRUT STRUCTURE DIAGRAM FOR ALL RB211-535 ENGINES
DETAIL I**

**Strut Structure Allowable Damage - RB211-535 Engine
Figure 101 (Sheet 1 of 6)**

**757-200
STRUCTURAL REPAIR MANUAL**

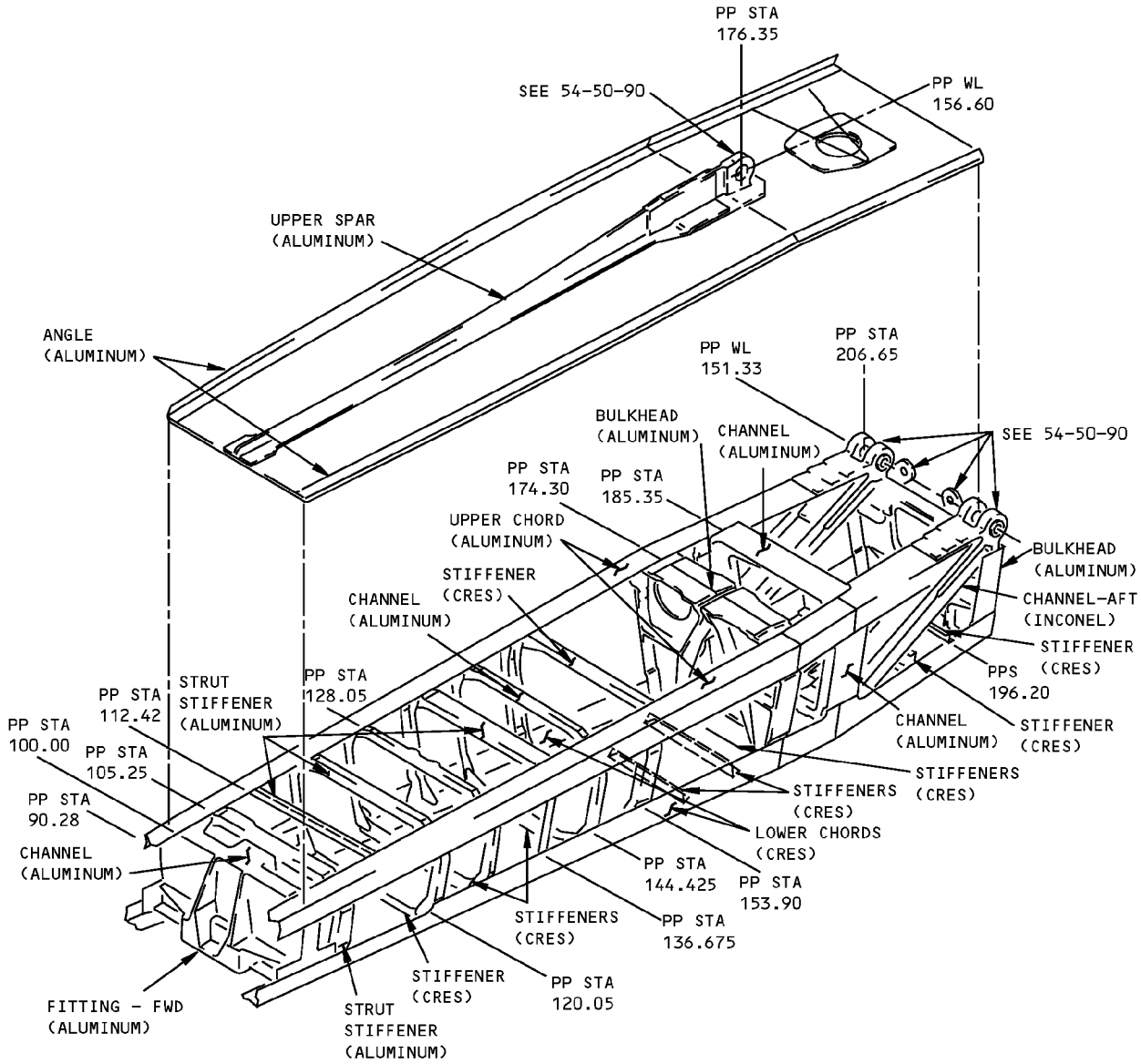

DETAIL II

**Strut Structure Allowable Damage - RB211-535 Engine
Figure 101 (Sheet 2 of 6)**

**757-200
STRUCTURAL REPAIR MANUAL**

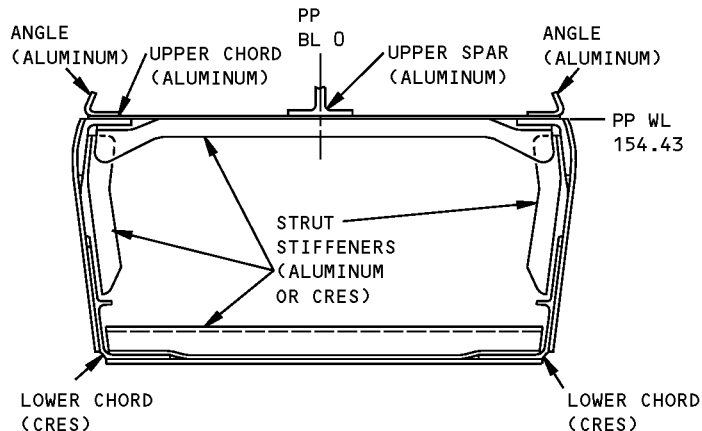

SECTION THRU STRUT
(TYPICAL FOR ALL SUCH STIFFENERS)

DESCRIPTION	CRACKS	NICKS, GOUGES AND CORROSION	DENTS	HOLES AND PUNCTURES
UPPER SPAR [H]	[A]	[C]	NOT ALLOWED	NOT ALLOWED
CHANNELS	[E]	[F]	SEE DETAIL V	NOT ALLOWED
BULKHEADS [H]	[A]	[B]	NOT ALLOWED	NOT ALLOWED
ANGLES	[E]	[F]	SEE DETAIL V	[G]
CHANNEL - AFT	[E]	[F]	SEE DETAIL V	NOT ALLOWED
UPPER CHORD [H]	[A]	[F]	NOT ALLOWED	NOT ALLOWED
STIFFENERS	[A]	[F]	SEE DETAIL V	SEE DETAIL VI
STRUT STIFFENERS [H]	[A]	[F]	SEE DETAIL V	SEE DETAIL VI
LOWER CHORDS [H]	[A]	[F]	NOT ALLOWED	NOT ALLOWED
FITTING - FWD [H]	[D]	[C]	NOT ALLOWED	NOT ALLOWED

**Strut Structure Allowable Damage - RB211-535 Engine
Figure 101 (Sheet 3 of 6)**

STRUCTURAL REPAIR MANUAL

NOTES

- REFINISH REWORKED AREAS AS SHOWN IN AMM 51-20
 - REFER TO SRM 51-10-02 FOR INSPECTION AND REMOVAL OF DAMAGE
- A** CRACKS ARE NOT PERMITTED EXCEPT FOR EDGE CRACKS WHICH MUST BE REMOVED AS SHOWN IN DETAILS III AND VIII.
- B** REMOVE DAMAGE AS SHOWN IN DETAILS III, IV, AND VII.
- C** FOR EDGE DAMAGE SEE DETAIL IX. FOR OTHER DAMAGE SEE DETAIL IV.
- D** CRACKS ARE NOT PERMITTED EXCEPT FOR EDGE CRACKS WHICH MUST BE REMOVED AS SHOWN IN DETAIL IX.
- E** CRACKS ARE NOT PERMITTED EXCEPT FOR EDGE CRACKS WHICH MUST BE REMOVED AS SHOWN IN DETAILS III AND VIII.
- F** REMOVE DAMAGE AS SHOWN IN DETAILS III, IV, AND VIII
- G** CLEAN OUT DAMAGE UP TO 0.25 INCH (6 mm) MAX DIA AND NOT CLOSER THAN 1.0 INCH (25 mm) TO FASTENER HOLE OR OTHER DAMAGE. FILL HOLE WITH A 2117-T3 OR T4 ALUMINUM RIVET INSTALLED WET WITH BMS 5-95 SEALANT. ALL OTHER HOLES TO BE REPAIRED
- H** SHOT PEEN REWORKED AREAS AS SHOWN IN SRM 51-20-06

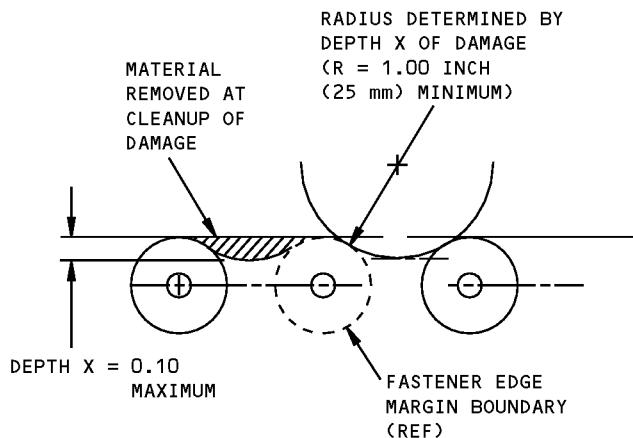

DAMAGE CLEANUP OF EDGES WHERE FASTENER EDGE MARGINS DO NOT OVERLAP

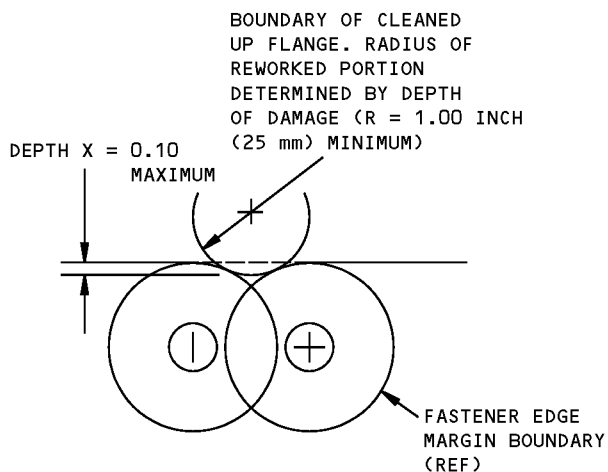

DAMAGE CLEANUP OF EDGES WHERE FASTENER EDGE MARGINS OVERLAP

DETAIL III

Strut Structure Allowable Damage - RB211-535 Engine
Figure 101 (Sheet 4 of 6)

**757-200
STRUCTURAL REPAIR MANUAL**

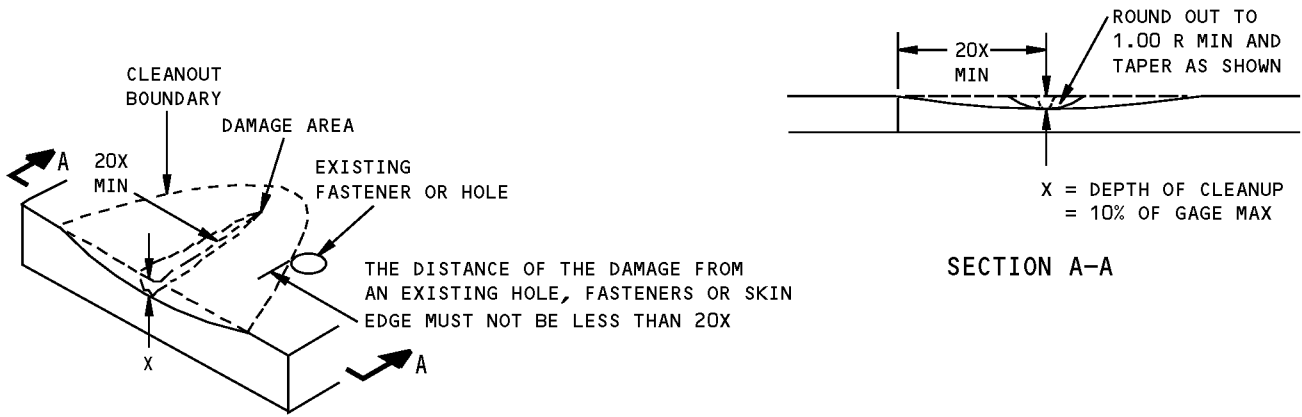

**REMOVAL OF NICK OR GOUGE DAMAGE ON A SURFACE
DETAIL IV**

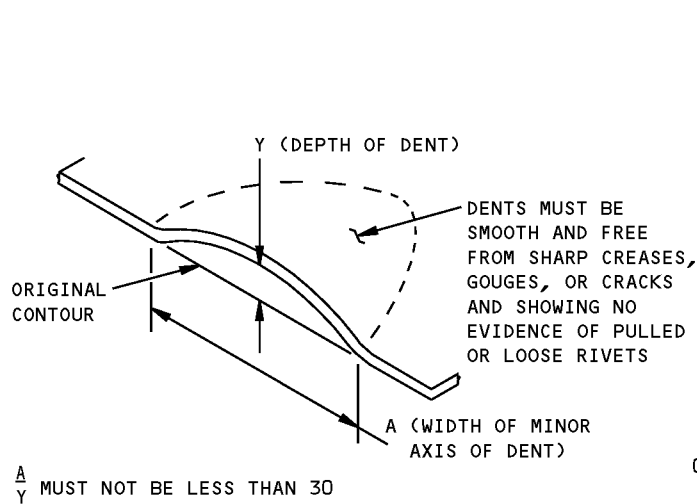

**ALLOWABLE DAMAGE FOR DENT
DETAIL V**

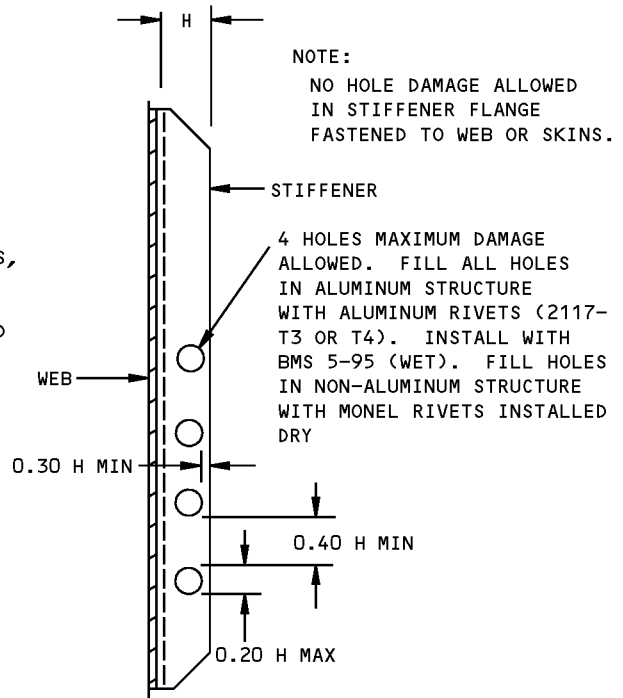

ALLOWABLE DAMAGE LIMITS FOR HOLES IN STIFFENERS

DETAIL VI

**Strut Structure Allowable Damage - RB211-535 Engine
Figure 101 (Sheet 5 of 6)**

**757-200
STRUCTURAL REPAIR MANUAL**

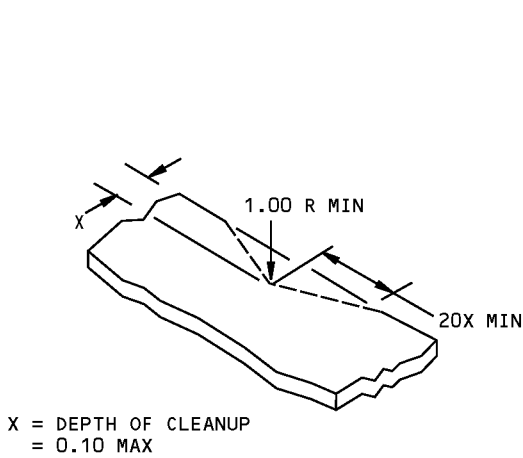

DETAIL VII

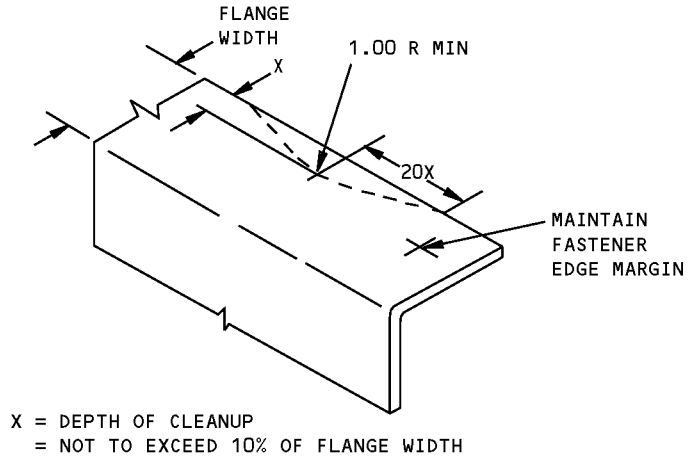

**REMOVAL OF NICK OR CRACK DAMAGE ON AN EDGE
DETAIL VIII**

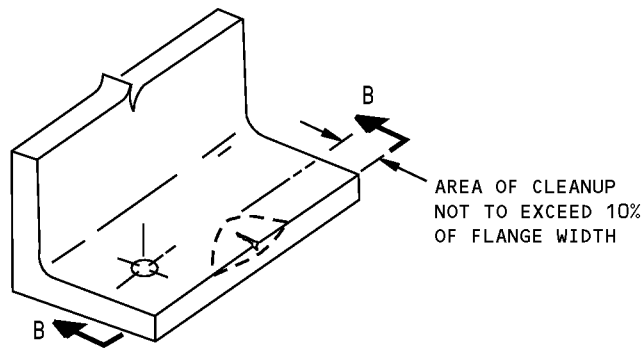

THE DISTANCE OF THE DAMAGE FROM AN EXISTING HOLE, FASTENERS OR EDGE MUST NOT BE LESS THAN 20X

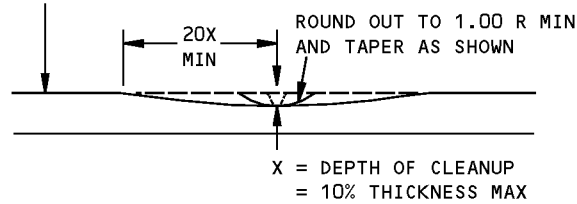

SECTION B-B

DETAIL IX

**Strut Structure Allowable Damage - RB211-535 Engine
Figure 101 (Sheet 6 of 6)**

**757-200
STRUCTURAL REPAIR MANUAL**

IDENTIFICATION 1 - STRUT FAIRING SKIN - RB211-535E4 ENGINE

REF DWG
311N5001

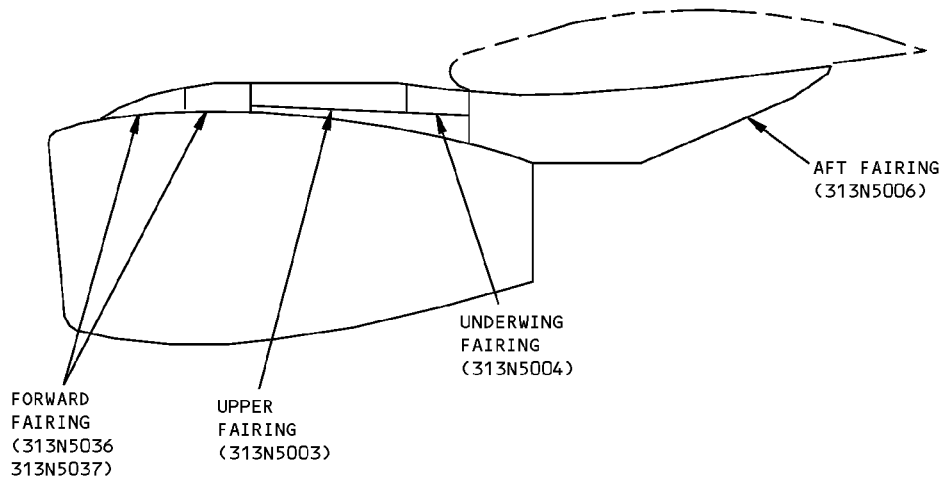

NOTES

- | | |
|--|--|
| <p>A PLY ORIENTATION CONVENTION - DEGREES INDICATED IS PARALLEL TO THE FABRIC WARP DIRECTION</p> <p>B ARAMID/EPOXY PER BMS 8-218, STYLE 285, 350°F (177°C) CURE</p> <p>C FIBERGLASS/EPOXY PER BMS 8-139 TYPE 1581, 350°F (177°C) CURE J</p> <p>D ALL PLYS TO BE LAID IN THE SAME DIRECTION</p> <p>E HEXCEL THORSTRAND FABRIC TEFA-60-F-161</p> <p>F ALUMINUM COATED FIBERGLASS PER BMS8-278, TYPE II, CLASS 350</p> | <p>G MATERIAL AND PLY ORIENTATION SHOWN FOR FIELD AREAS ONLY. SEE BOEING DRAWINGS FOR EDGE BANDS AND AREAS WITH DOUBLERS</p> <p>H FIBERGLASS/EPOXY PER BMS 8-139 TYPE 120, 350°F (177°C) CURE</p> <p>I FIBERGLASS/EPOXY BMS 8-289, TYPE 0, CLASS 350, GRADE 2/1100, 350°F (177°C) CURE</p> <p>J BMS 8-139, TYPE 1581 WAS FORMERLY TYPE 181</p> |
|--|--|

**Strut Fairing Skin Identification - RB211-535E4 Engine
Figure 1 (Sheet 1 of 10)**

**757-200
STRUCTURAL REPAIR MANUAL**

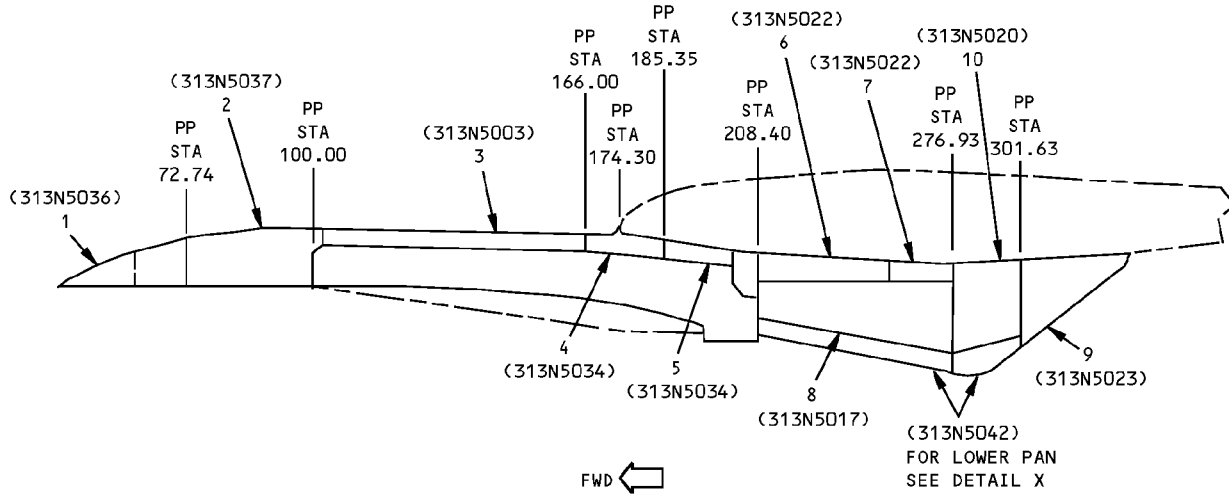

VIEW ON OUTBD SIDE OF LEFT AND RIGHT STRUTS
INBD SIDE SAME EXCEPT AS NOTED

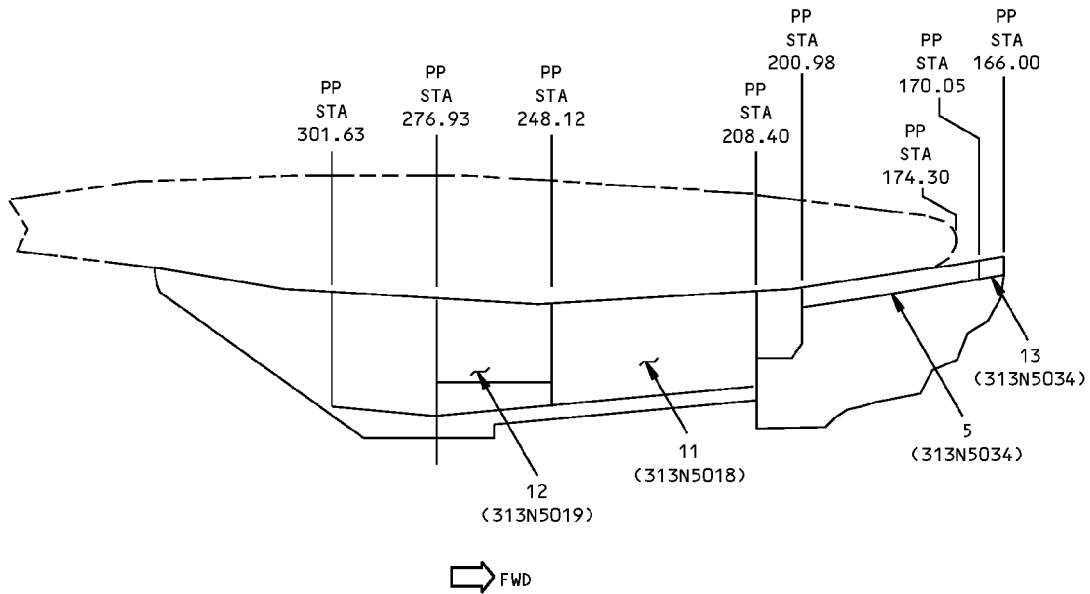

VIEW ON INBD SIDE OF LEFT AND RIGHT STRUTS

LIST OF
MATERIAL

**Strut Fairing Skin Identification - RB211-535E4 Engine
Figure 1 (Sheet 2 of 10)**



**757-200
STRUCTURAL REPAIR MANUAL**

ITEM	DESCRIPTION	GAGE	MATERIAL	EFFECTIVITY
1	SKIN	0.050	CLAD 2024-T42	
2	FAIRING SKIN CORE		ARAMID/FIBERGLASS/EPOXY HONEYCOMB SANDWICH SEE DETAIL I NON-METALLIC HONEYCOMB PER BMS 8-124, CLASS IV, TYPE V GRADE 4.0	
3	FAIRING SKIN CORE		ARAMID/FIBERGLASS/EPOXY HONEYCOMB SANDWICH SEE DETAIL II NON-METALLIC HONEYCOMB PER BMS 8-124, CLASS IV, TYPE V, GRADE 5	
4	FAIRING SKIN CORE		ARAMID/FIBERGLASS/EPOXY HONEYCOMB SANDWICH SEE DETAIL III NON-METALLIC HONEYCOMB PER BMS 8-124, CLASS IV, TYPE V GRADE 5	
5	FAIRING		ARAMID/FIBERGLASS/EPOXY LAMINATE FOR MATERIAL SEE DETAIL IV	
6	SKIN	0.100	CLAD 7075-T6	
7	SKIN	0.063	CLAD 7075-T6	
8	DOOR SKIN CORE		ARAMID/FIBERGLASS/EPOXY HONEYCOMB SANDWICH SEE DETAIL V NON-METALLIC HONEYCOMB PER BMS 8-124, CLASS IV, TYPE V GRADE 5.0	
9	AFT FAIRING SKIN CORE		ARAMID/FIBERGLASS/EPOXY HONEYCOMB SANDWICH SEE DETAIL VI NON-METALLIC HONEYCOMB PER BMS 8-124, CLASS IV, TYPE V GRADE 4.0	
10	PANEL SKIN CORE		ARAMID/FIBERGLASS/EPOXY HONEYCOMB SANDWICH SEE DETAIL VII NON-METALLIC HONEYCOMB PER BMS 8-124, CLASS IV, TYPE V GRADE 5.0	
11	PANEL SKIN CORE		ARAMID/FIBERGLASS/EPOXY HONEYCOMB SANDWICH SEE DETAIL VIII NON-METALLIC HONEYCOMB PER BMS 8-124, CLASS IV, TYPE V GRADE 5.0	
12	PANEL SKIN CORE		ARAMID/FIBERGLASS/EPOXY HONEYCOMB SANDWICH SEE DETAIL IX NON-METALLIC HONEYCOMB PER BMS 8-124, CLASS IV, TYPE V GRADE 5.0	
13	UNDERWING FWD FAIRING		ARAMID/FIBERGLASS/EPOXY LAMINATE FOR MATERIAL SEE DETAIL XI	

LIST OF MATERIALS

**Strut Fairing Skin Identification - RB211-535E4 Engine
Figure 1 (Sheet 3 of 10)**

D634N201

54-50-70

IDENTIFICATION 1
Page 3
Jan 20/2005

**757-200
STRUCTURAL REPAIR MANUAL**

REF DWG
313N5037

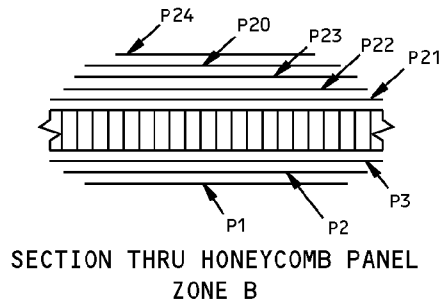
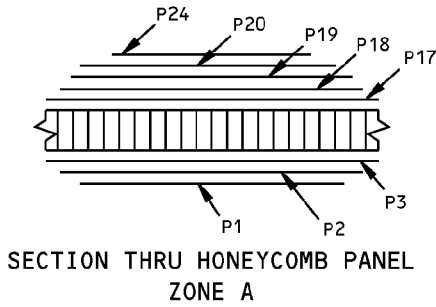

ITEM NO.	PLY NUMBER	MATERIAL	PLY ORIENTATION A
2	P2,P17,P18,P19	C	0° OR 90° D
	P3	H	0° OR 90° D
	P21,P22,P23	B	0° OR 90° D
	P1	E	0° OR 90° D
	P24	I	0° OR 90° D
	P20	H	0° OR 90° D

TABLE I G

DETAIL I

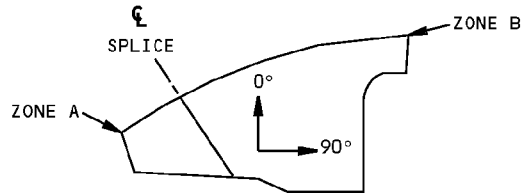

DIAGRAM OF PLY ORIENTATION, SEE TABLE I FOR PLY ORIENTATION AND MATERIAL A

ITEM NO.	PLY NUMBER	MATERIAL	PLY ORIENTATION A
3	1	F	90°
	4,11,13	B	0°
	10,12	B	90°
	2	C	0°
	3,14	H	90°
	15	I	---

TABLE II G

DETAIL II

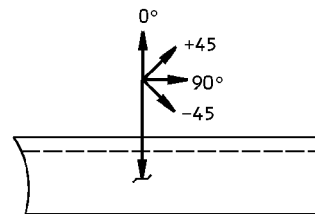
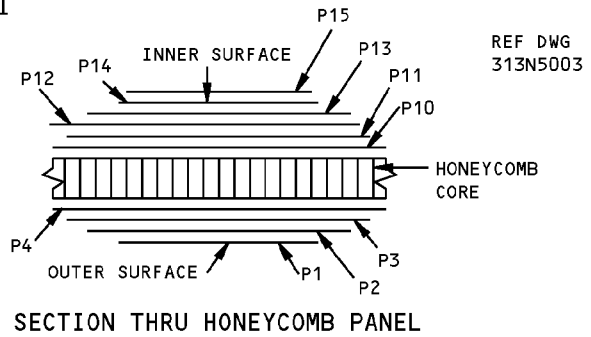

DIAGRAM OF PLY ORIENTATION, SEE TABLE II FOR PLY ORIENTATION AND MATERIAL A

**Strut Fairing Skin Identification - RB211-535E4 Engine
Figure 1 (Sheet 4 of 10)**

IDENTIFICATION 1
Page 4
Jan 20/2005

54-50-70

D634N201

**757-200
STRUCTURAL REPAIR MANUAL**

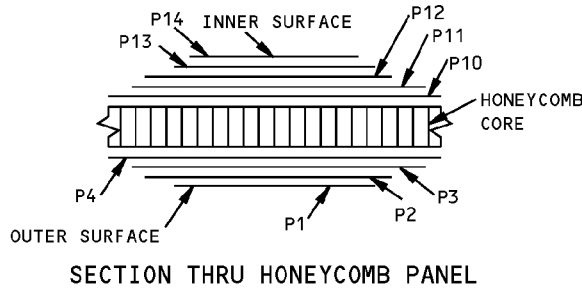

REF DWG
313N5034-1,-2,
-25,-26

ITEM NO.	PLY NUMBER	MATERIAL	PLY ORIENTATION ^A
4	1	F	90°
	10,12	B	0°
	11,13,4	B	90°
	14	H	90°
	2	C	0°
	3	H	90°

TABLE III ^G

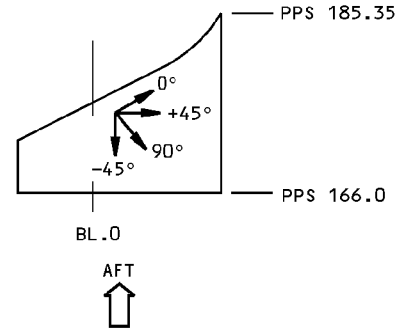

PLAN VIEW
DIAGRAM OF PLY ORIENTATION, SEE
TABLE III FOR PLY ORIENTATION
AND MATERIAL ^A

DETAIL III

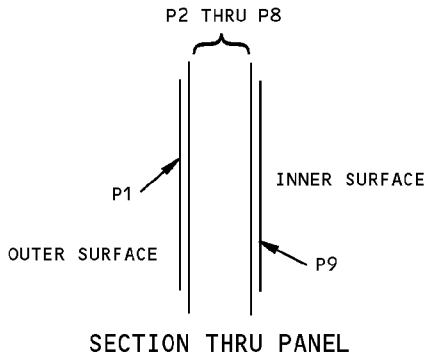

REF DWG
313N5034-5,-6,
-23,-24

ITEM NO.	PLY NUMBER	MATERIAL	PLY ORIENTATION ^A
5	1	C	90°
	5,8	B	0°
	7,9	B	90°
	4,6	B	45°
	2	C	0°
	3	H	90°

TABLE IV ^G

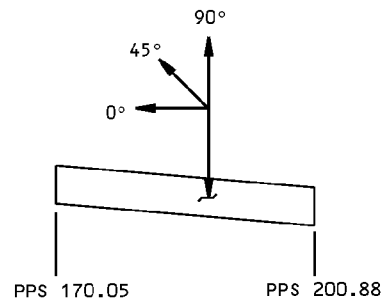

DIAGRAM OF PLY ORIENTATION, SEE
TABLE IV FOR PLY ORIENTATION
AND MATERIAL ^A

DETAIL IV

**Strut Fairing Skin Identification - RB211-535E4 Engine
Figure 1 (Sheet 5 of 10)**

**757-200
STRUCTURAL REPAIR MANUAL**

REF DWG
313N5017

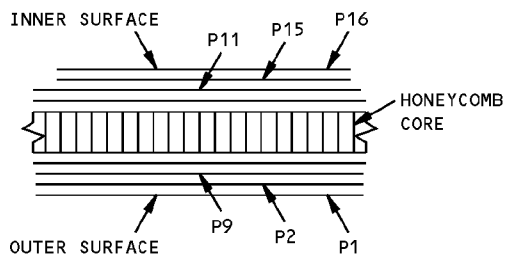

SECTION THRU HONEYCOMB PANEL

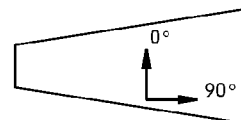

DIAGRAM OF PLY ORIENTATION, SEE
TABLE V FOR PLY ORIENTATION
AND MATERIAL **A**

ITEM NO.	PLY NUMBER	MATERIAL	PLY ORIENTATION A
8	P1,P2,P15,P16	C	0° OR 90°
	P9,P11	B	0° OR 90°

TABLE V **G**

DETAIL V

REF DWG
313N5023

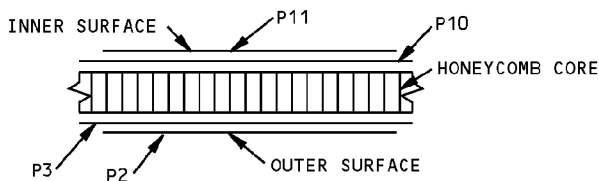

SECTION THRU HONEYCOMB PANEL

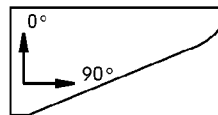

DIAGRAM OF PLY ORIENTATION, SEE
TABLE VI FOR PLY ORIENTATION
AND MATERIAL **A**

ITEM NO.	PLY NUMBER	MATERIAL	PLY ORIENTATION A
9	P2,P3,P10	C	0° OR 90°
	P11	B	0° OR 90° OPTIONAL

TABLE VI **G**

DETAIL VI

**Strut Fairing Skin Identification - RB211-535E4 Engine
Figure 1 (Sheet 6 of 10)**

IDENTIFICATION 1
Page 6
Jan 20/2005

54-50-70

D634N201

**757-200
STRUCTURAL REPAIR MANUAL**

REF DWG
313N5020

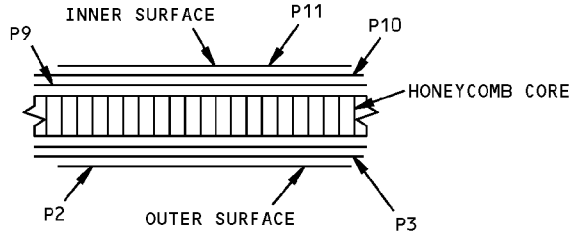

SECTION THRU HONEYCOMB PANEL

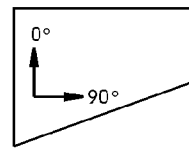

DIAGRAM OF PLY ORIENTATION, SEE TABLE VII FOR PLY ORIENTATION AND MATERIAL **A**

ITEM NO.	PLY NUMBER	MATERIAL	PLY ORIENTATION A
10	P2,P3	C	0° OR 90°
	P9,P10,P11	B	0° OR 90° OPTIONAL

TABLE VII **G**

DETAIL VII

REF DWG
313N5018

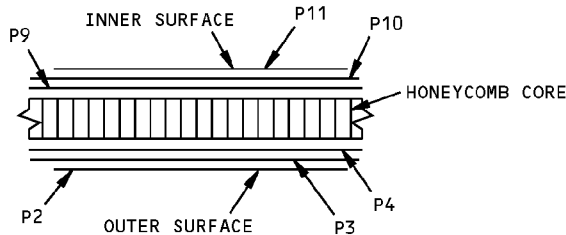

SECTION THRU HONEYCOMB PANEL

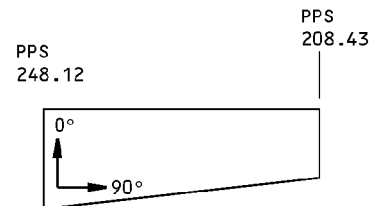

DIAGRAM OF PLY ORIENTATION, SEE TABLE VIII FOR PLY ORIENTATION AND MATERIAL **A**

ITEM NO.	PLY NUMBER	MATERIAL	PLY ORIENTATION A
11	P2,P3	C	0° OR 90°
	P9,P10,P11	B	0° OR 90° OPTIONAL

TABLE VIII **G**

DETAIL VIII

**Strut Fairing Skin Identification - RB211-535E4 Engine
Figure 1 (Sheet 7 of 10)**

IDENTIFICATION 1
Page 7
Jan 20/2005

54-50-70

D634N201

**757-200
STRUCTURAL REPAIR MANUAL**

REF DWG
313N5019

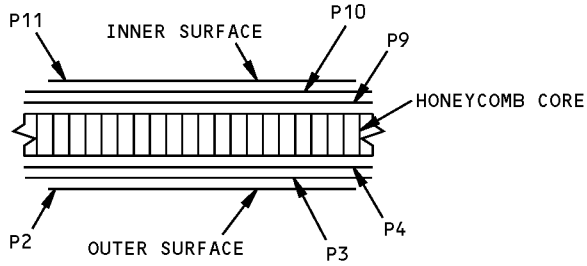

SECTION THRU HONEYCOMB PANEL

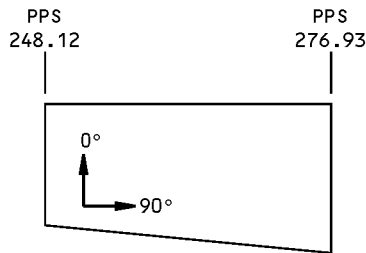

DIAGRAM OF PLY ORIENTATION, SEE
TABLE IX FOR PLY ORIENTATION
AND MATERIAL **A**

ITEM NO.	PLY NUMBER	MATERIAL	PLY ORIENTATION A
12	P2,P3	C	0° OR 90°
	P9,P10,P11	B	0° OR 90° OPTIONAL

TABLE IX

DETAIL IX

**Strut Fairing Skin Identification - RB211-535E4 Engine
Figure 1 (Sheet 8 of 10)**

**757-200
STRUCTURAL REPAIR MANUAL**

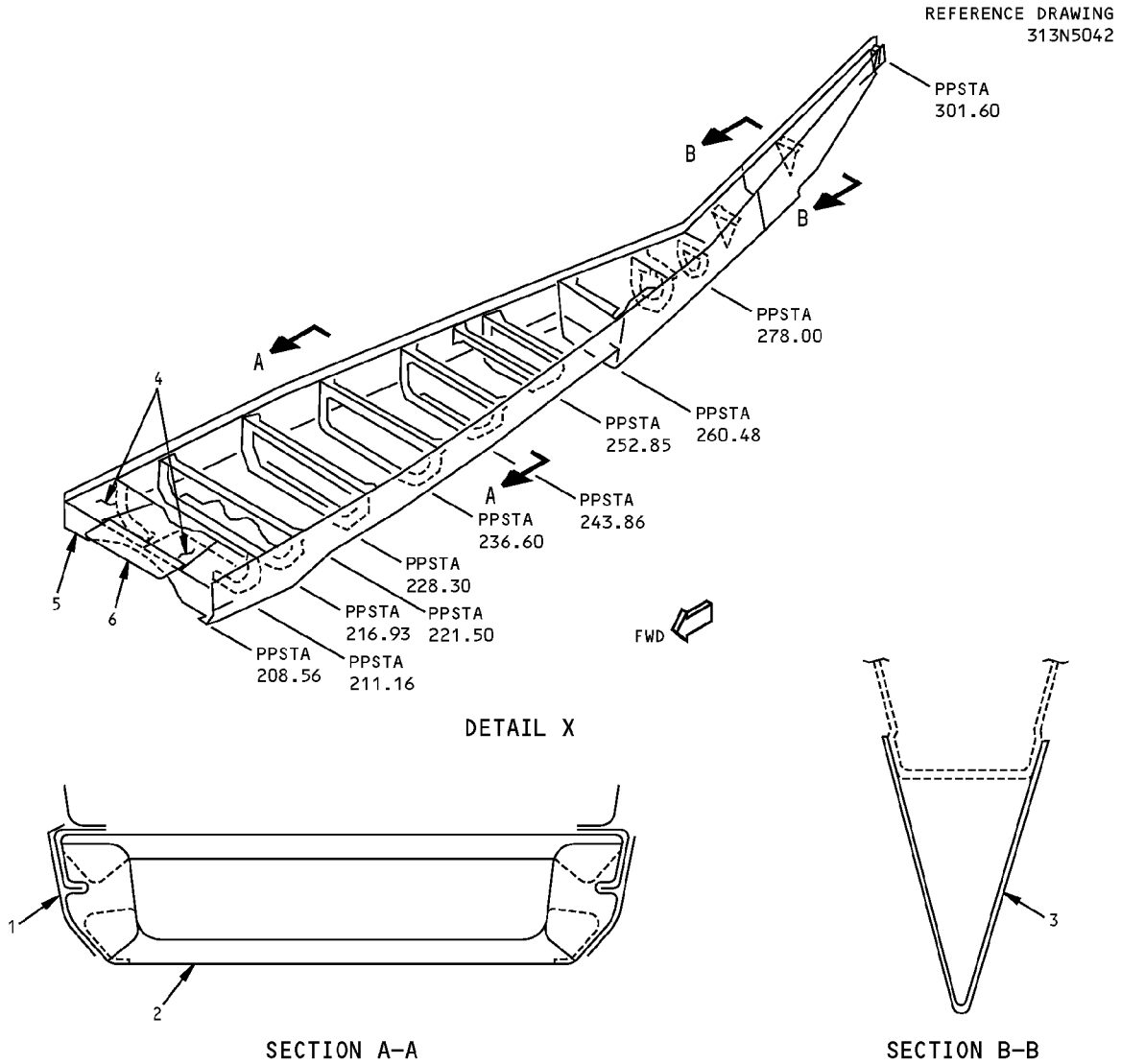

ITEM	DESCRIPTION	GAGE	MATERIAL	EFFECTIVITY
1	SKIN	0.040	STEEL 17-7PH HT-TR 150-170 KSI	
2	PAN	0.050	CLAD 2024-T42	
3	SKIN	0.040	INCONEL 625	
4	COVER	0.040	CLAD 7075-T6	
5	CHANNEL	0.080	CLAD 7075-T6	
6	PLATE	0.090	CLAD 7075-T6	

LIST OF MATERIALS FOR DETAIL X

**Strut Fairing Skin Identification - RB211-535E4 Engine
Figure 1 (Sheet 9 of 10)**

**757-200
STRUCTURAL REPAIR MANUAL**

REF DWG
313N5034-27,-28

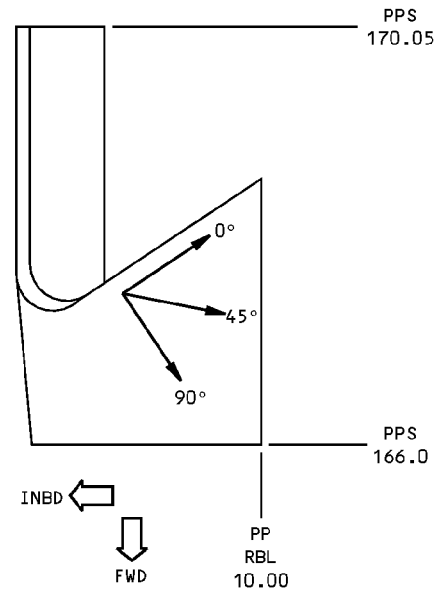
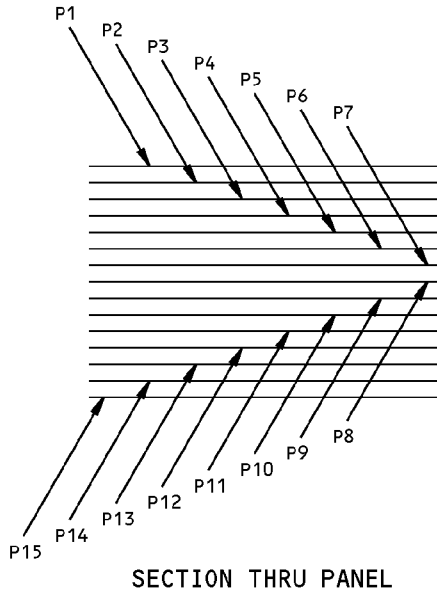

DIAGRAM OF PLY ORIENTATION, SEE
TABLE III FOR PLY ORIENTATION
AND MATERIAL **A**

ITEM NO.	PLY NO.	MATERIAL	PLY ORIENTATION
13	1	F	90°
	4,6,8,10,12	B	0°
	5,7,9,11,13	B	90°
	14	H	0°
	2	C	0°
	3	H	90°
	15	I	---

TABLE XI **G**

DETAIL XI

**Strut Fairing Skin Identification - RB211-535E4 Engine
Figure 1 (Sheet 10 of 10)**

IDENTIFICATION 1
Page 10
Jan 20/2005

54-50-70

D634N201

**757-200
STRUCTURAL REPAIR MANUAL**

IDENTIFICATION 2 - STRUT FAIRING SKIN - RB211-535C ENGINES

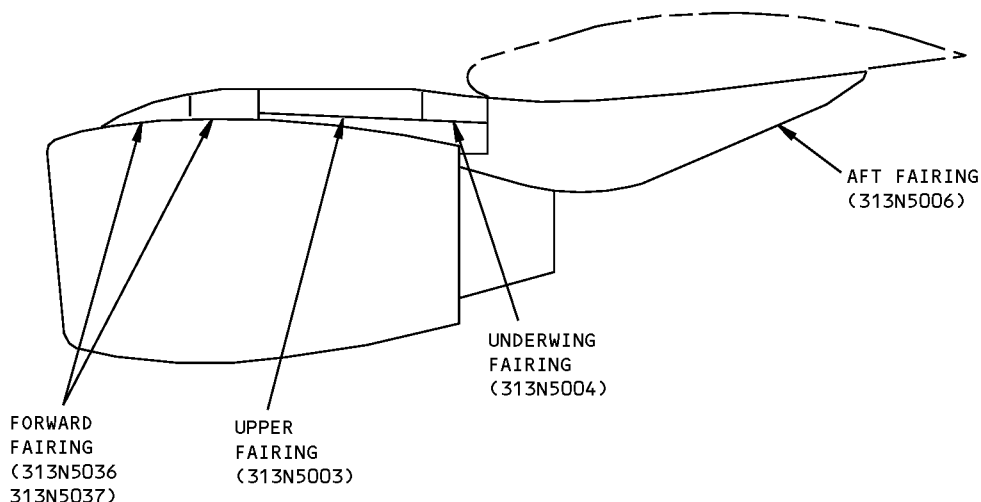

NOTES

- REFER TO IDENTIFICATION 1 FOR RB211-535E4 STRUT FAIRING
- A** PLY ORIENTATION CONVENTION - DEGREES INDICATED IS PARALLEL TO THE FABRIC WARP DIRECTION
- B** ARAMID/EPOXY PER BMS 8-218, STYLE 285, 350°F (177°C) CURE
- C** FIBERGLASS/EPOXY PER BMS 8-139 TYPE 181, 350°F (177°C) CURE
- D** ALL PLYS TO BE LAID IN THE SAME DIRECTION
- E** HEXCEL THORSTRAND FABRIC TEFA-60-F-161
- F** FOR CUM LINE NUMBERS: 1 THRU 30
USE CIBA-GEIGY ALUMINUM (0.002) BONDED TO FIBERGLASS TYPE 120, R8521 RESIN SYSTEM
- G** MATERIAL AND PLY ORIENTATION SHOWN FOR FIELD AREAS ONLY. SEE BOEING DRAWINGS FOR EDGE BANDS AND AREAS WITH DOUBLERS
- H** FIBERGLASS/EPOXY PER BMS 8-139 TYPE 120, 350°F (177°C) CURE
- J** FOR CUM LINE NUMBERS: 30 AND ON
USE FIBERGLASS/EPOXY PER BMS 8-139, TYPE 120 WITH ALUMINUM FOIL PER BMS 8-289, CLASS 350, GRADE 2/1100, 350°F (177°C) CURE
- K** FOR CUM LINE NUMBERS: **K** 1 THRU 29, 34
- L** FOR AIRPLANES NOT IN
- M** FIBERGLASS/EPOXY BMS 8-289, TYPE O, CLASS 350, GRADE 2/1100, 350°F (177°C) CURE
- N** CIBA GEIGY ALUMINUM (0.002) BONDED TO FIBERGLASS TYPE 120 R8521 RESIN SYSTEM
- O** ALUMINUM COATED FIBERGLASS PER BMS8-278, TYPE II, CLASS 350
- P** FOR CUM LINE NUMBERS: 1 THRU 30
- Q** FOR CUM LINE NUMBERS: 1 THRU 30, 32 THRU 34, 36 AND 50
- R** FOR CUM LINE NUMBERS: 51, 52, 54, 57, 58, 63, 77, 78, 81, 89, 90, 93, 98, 116, 123, 145, 160, 166, 168, 175, 179, 210, 211 AND 214

**Strut Fairing Skin Identification - RB211-535C Engines
Figure 1 (Sheet 1 of 10)**

**757-200
STRUCTURAL REPAIR MANUAL**

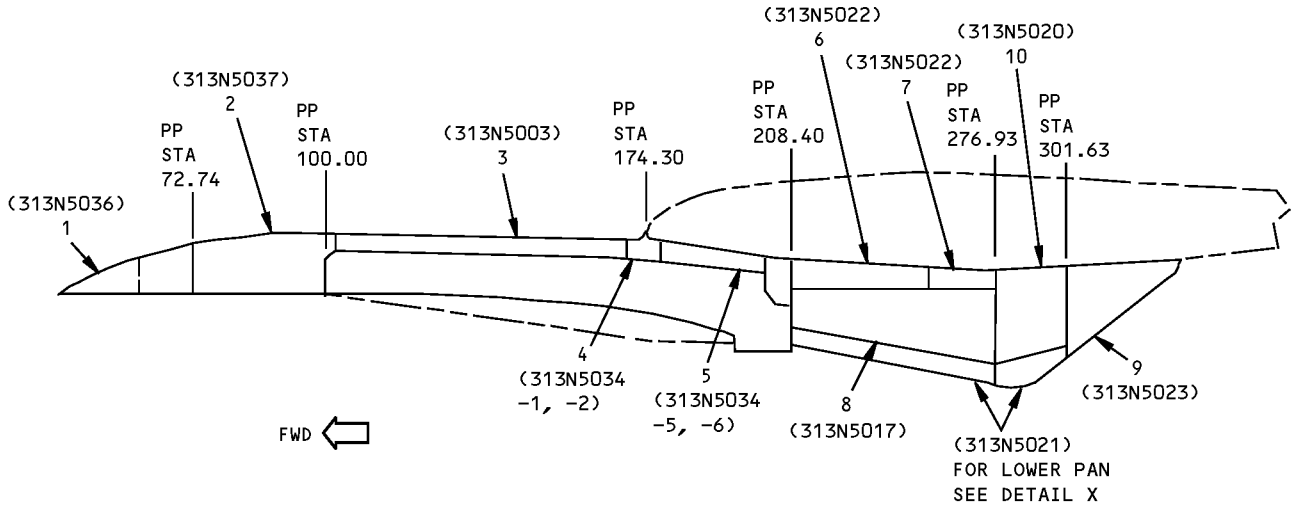

VIEW ON LEFT SIDE OF LEFT AND RIGHT STRUTS
RIGHT SIDE SAME EXCEPT AS NOTED

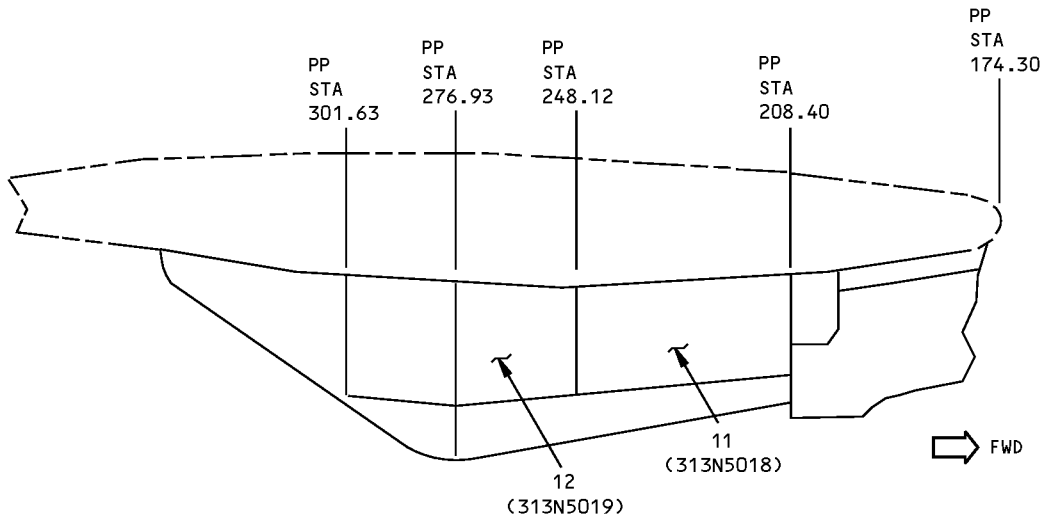

VIEW ON RIGHT SIDE OF LEFT AND RIGHT STRUTS



**Strut Fairing Skin Identification - RB211-535C Engines
Figure 1 (Sheet 2 of 10)**



**757-200
STRUCTURAL REPAIR MANUAL**

ITEM	DESCRIPTION	GAGE	MATERIAL	EFFECTIVITY
1	SKIN	0.050	CLAD 2024-T42	
2	FAIRING SKIN CORE		ARAMID/EPOXY HONEYCOMB SANDWICH SEE DETAIL I NON-METALLIC HONEYCOMB PER BMS 8-124, CLASS IV, TYPE V GRADE 4.0	
3	FAIRING SKIN CORE		ARAMID/EPOXY HONEYCOMB SANDWICH SEE DETAIL II NON-METALLIC HONEYCOMB PER BMS 8-124, CLASS IV, TYPE V, GRADE 5	
4	FAIRING SKIN CORE		ARAMID/EPOXY HONEYCOMB SANDWICH SEE DETAIL III NON-METALLIC HONEYCOMB PER BMS 8-124, CLASS IV, TYPE V GRADE 5	
5	FAIRING		ARAMID/EPOXY LAMINATE FOR MATERIAL SEE DETAIL IV	
6	SKIN	0.100	CLAD 7075-T6	
7	SKIN	0.063	CLAD 7075-T6	
8	DOOR SKIN CORE		ARAMID/EPOXY HONEYCOMB SANDWICH SEE DETAIL V NON-METALLIC HONEYCOMB PER BMS 8-124, CLASS IV, TYPE V GRADE 5.0	
9	AFT FAIRING SKIN CORE		ARAMID/EPOXY HONEYCOMB SANDWICH SEE DETAIL VI NON-METALLIC HONEYCOMB PER BMS 8-124, CLASS IV, TYPE V GRADE 4.0	
10	PANEL SKIN CORE		ARAMID/EPOXY HONEYCOMB SANDWICH SEE DETAIL VII NON-METALLIC HONEYCOMB PER BMS 8-124, CLASS IV, TYPE V GRADE 5.0	
11	PANEL SKIN CORE		ARAMID/EPOXY HONEYCOMB SANDWICH SEE DETAIL VIII NON-METALLIC HONEYCOMB PER BMS 8-124, CLASS IV, TYPE V GRADE 5.0	
12	PANEL SKIN CORE		ARAMID/EPOXY HONEYCOMB SANDWICH SEE DETAIL IX NON-METALLIC HONEYCOMB PER BMS 8-124, CLASS IV, TYPE V GRADE 5.0	
13	UNDERWING FWD FAIRING		ARAMID/FIBERGLASS/EPOXY LAMINATE SEE DETAIL XI	

LIST OF MATERIALS

**Strut Fairing Skin Identification - RB211-535C Engines
Figure 1 (Sheet 3 of 10)**

IDENTIFICATION 2
Page 3
Jan 20/2005

54-50-70

D634N201

**757-200
STRUCTURAL REPAIR MANUAL**

REF DWG
313N5037

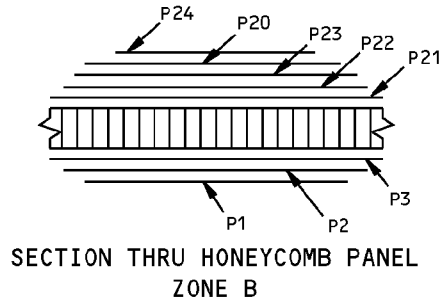
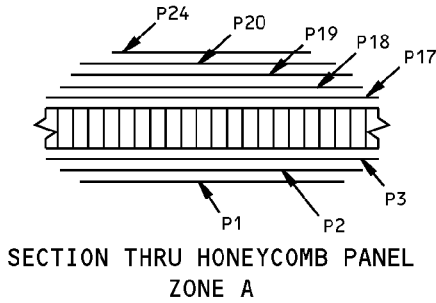

ITEM NO.	PLY NUMBER	MATERIAL	PLY ORIENTATION ^A
2	P2, P17, P18, P19	C	0° OR 90° ^D
	P3	H	0° OR 90° ^D
	P21, P22, P23	B	0° OR 90° ^D
	P1 ^K	E	0° OR 90° ^D
	P1 ^L	O	0° OR 90° ^D
	P24	M	0° OR 90° ^D
	P20 ^K	N	0° OR 90° ^D
	P20 ^L	H	0° OR 90° ^D

TABLE I ^G

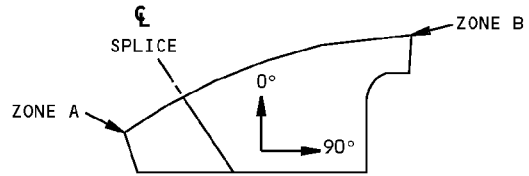

DIAGRAM OF PLY ORIENTATION, SEE TABLE I FOR PLY ORIENTATION AND MATERIAL ^A

DETAIL I

REF DWG
313N5003

ITEM NO.	PLY NUMBER	MATERIAL	PLY ORIENTATION ^A
3	1 ^P	E	90°
	1 ^J	O	90°
	4, 11, 13	B	0°
	10, 12	B	90°
	14 ^P	J	90°
	14 ^J	H	90°
	2	C	0°
	3	H	90°
	15 ^J	M	---

TABLE II ^G

DETAIL II

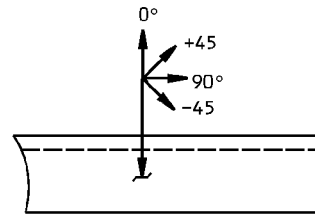
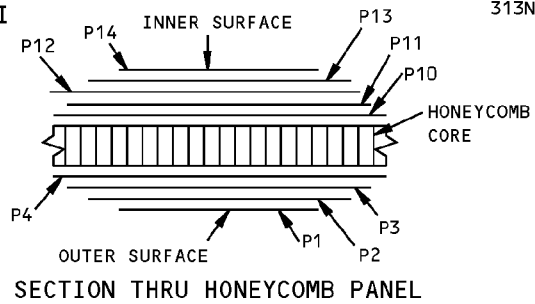

DIAGRAM OF PLY ORIENTATION, SEE TABLE II FOR PLY ORIENTATION AND MATERIAL ^A

**Strut Fairing Skin Identification - RB211-535C Engines
Figure 1 (Sheet 4 of 10)**

IDENTIFICATION 2
Page 4
Jan 20/2005

54-50-70

D634N201

**757-200
STRUCTURAL REPAIR MANUAL**

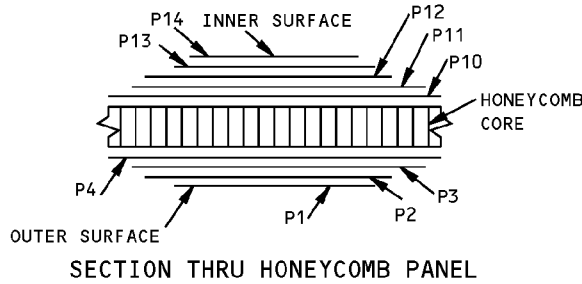

REF DWG
313N5034-1,-2,
-25,-26

ITEM NO.	PLY NUMBER	MATERIAL	PLY ORIENTATION ^[A]
4	1 [P]	[E]	90°
	4, 10, 12	[B]	0°
	11, 13	[B]	90°
	14	[F] [J]	---
	2	[C]	0°
	3	[H]	90°
	1 [J]	[O]	90°
	15 [J]	[M]	---

TABLE III ^[G]

DETAIL III

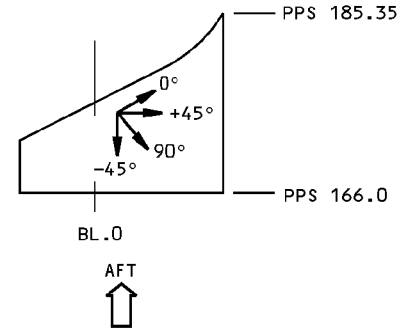

PLAN VIEW
DIAGRAM OF PLY ORIENTATION, SEE
TABLE III FOR PLY ORIENTATION
AND MATERIAL ^[A]

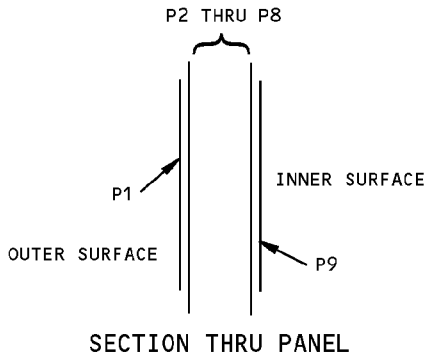

REF DWG
313N5034-5,-6,
-23,-24

ITEM NO.	PLY NUMBER	MATERIAL	PLY ORIENTATION ^[A]
5	1 [P]	[E]	90°
	1 [J]	[C]	90°
	5, 8	[B]	0°
	7, 9	[B]	90°
	4, 6	[B]	45°
	2	[C]	0°
	3	[H]	90°

TABLE IV ^[G]

DETAIL IV

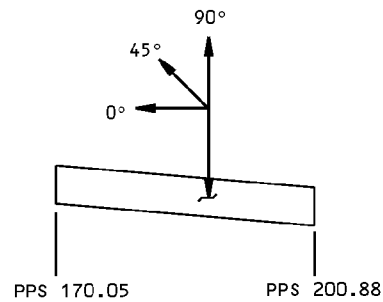
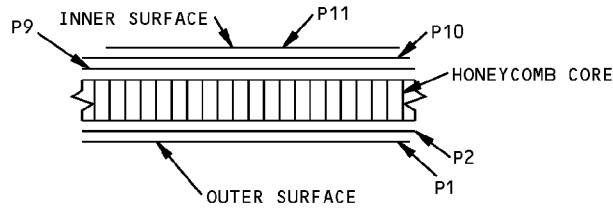

DIAGRAM OF PLY ORIENTATION, SEE
TABLE IV FOR PLY ORIENTATION
AND MATERIAL ^[A]

**Strut Fairing Skin Identification - RB211-535C Engines
Figure 1 (Sheet 5 of 10)**

**757-200
STRUCTURAL REPAIR MANUAL**

REF DWG
313N5017



SECTION THRU HONEYCOMB PANEL

ITEM NO.	PLY NUMBER	MATERIAL	PLY ORIENTATION ^A
8	P1,P2	^C	0° OR 90°
	P9,P10,P11	^B	0° OR 90° OPTIONAL

TABLE V ^G

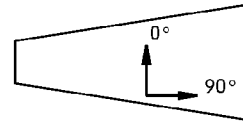
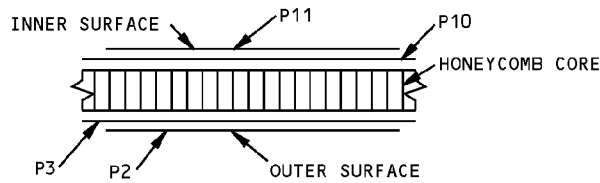

DIAGRAM OF PLY ORIENTATION, SEE
TABLE V FOR PLY ORIENTATION
AND MATERIAL ^A

DETAIL V

REF DWG
313N5023



SECTION THRU HONEYCOMB PANEL

ITEM NO.	PLY NUMBER	MATERIAL	PLY ORIENTATION ^A
9	P2,P3	^C	0° OR 90°
	P11	^B	0° OR 90° OPTIONAL

TABLE VI ^G

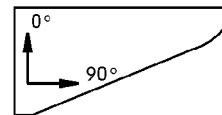

DIAGRAM OF PLY ORIENTATION, SEE
TABLE VI FOR PLY ORIENTATION
AND MATERIAL ^A

DETAIL VI

**Strut Fairing Skin Identification - RB211-535C Engines
Figure 1 (Sheet 6 of 10)**

IDENTIFICATION 2
Page 6
Jan 20/2005

54-50-70

D634N201

**757-200
STRUCTURAL REPAIR MANUAL**

REF DWG
313N5020

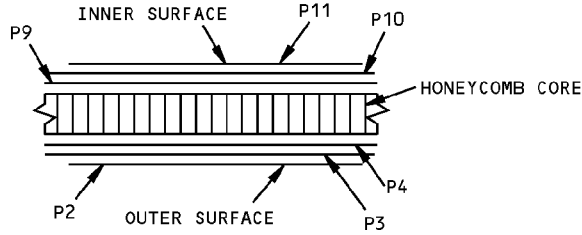

SECTION THRU HONEYCOMB PANEL

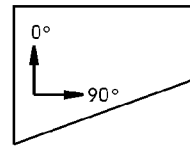

DIAGRAM OF PLY ORIENTATION, SEE
TABLE VII FOR PLY ORIENTATION
AND MATERIAL [A]

ITEM NO.	PLY NUMBER	MATERIAL	PLY ORIENTATION [A]
10	P2,P3	[C]	0° OR 90°
	P9,P10,P11	[B]	0° OR 90° OPTIONAL

TABLE VII [G]

DETAIL VII

REF DWG
313N5018

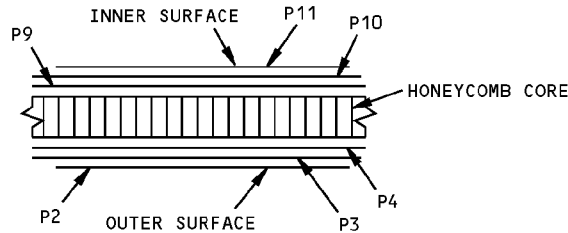

SECTION THRU HONEYCOMB PANEL

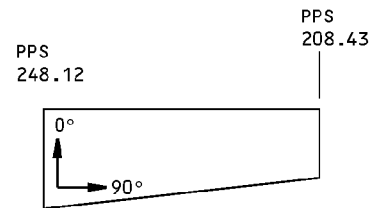

DIAGRAM OF PLY ORIENTATION, SEE
TABLE VIII FOR PLY ORIENTATION
AND MATERIAL [A]

ITEM NO.	PLY NUMBER	MATERIAL	PLY ORIENTATION [A]
11	P2,P3	[C]	0° OR 90°
	P9,P10,P11	[B]	0° OR 90° OPTIONAL

TABLE VIII [G]

DETAIL VIII

**Strut Fairing Skin Identification - RB211-535C Engines
Figure 1 (Sheet 7 of 10)**

IDENTIFICATION 2
Page 7
Jan 20/2005

54-50-70

D634N201

**757-200
STRUCTURAL REPAIR MANUAL**

REF DWG
313N5015

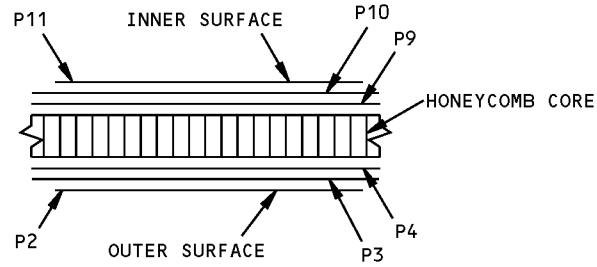

SECTION THRU HONEYCOMB PANEL

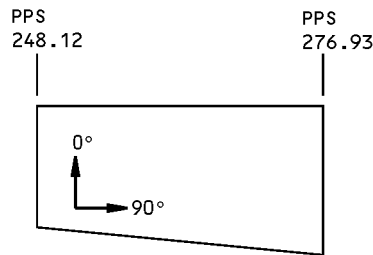

DIAGRAM OF PLY ORIENTATION, SEE
TABLE IX FOR PLY ORIENTATION
AND MATERIAL A

ITEM NO.	PLY NUMBER	MATERIAL	PLY ORIENTATION A
12	P2,P3	C	0° OR 90°
	P9,P10,P11	B	0° OR 90° OPTIONAL

TABLE IX

DETAIL IX

**Strut Fairing Skin Identification - RB211-535C Engines
Figure 1 (Sheet 8 of 10)**

D634N201

54-50-70

IDENTIFICATION 2
Page 8
Jan 20/2005

**757-200
STRUCTURAL REPAIR MANUAL**

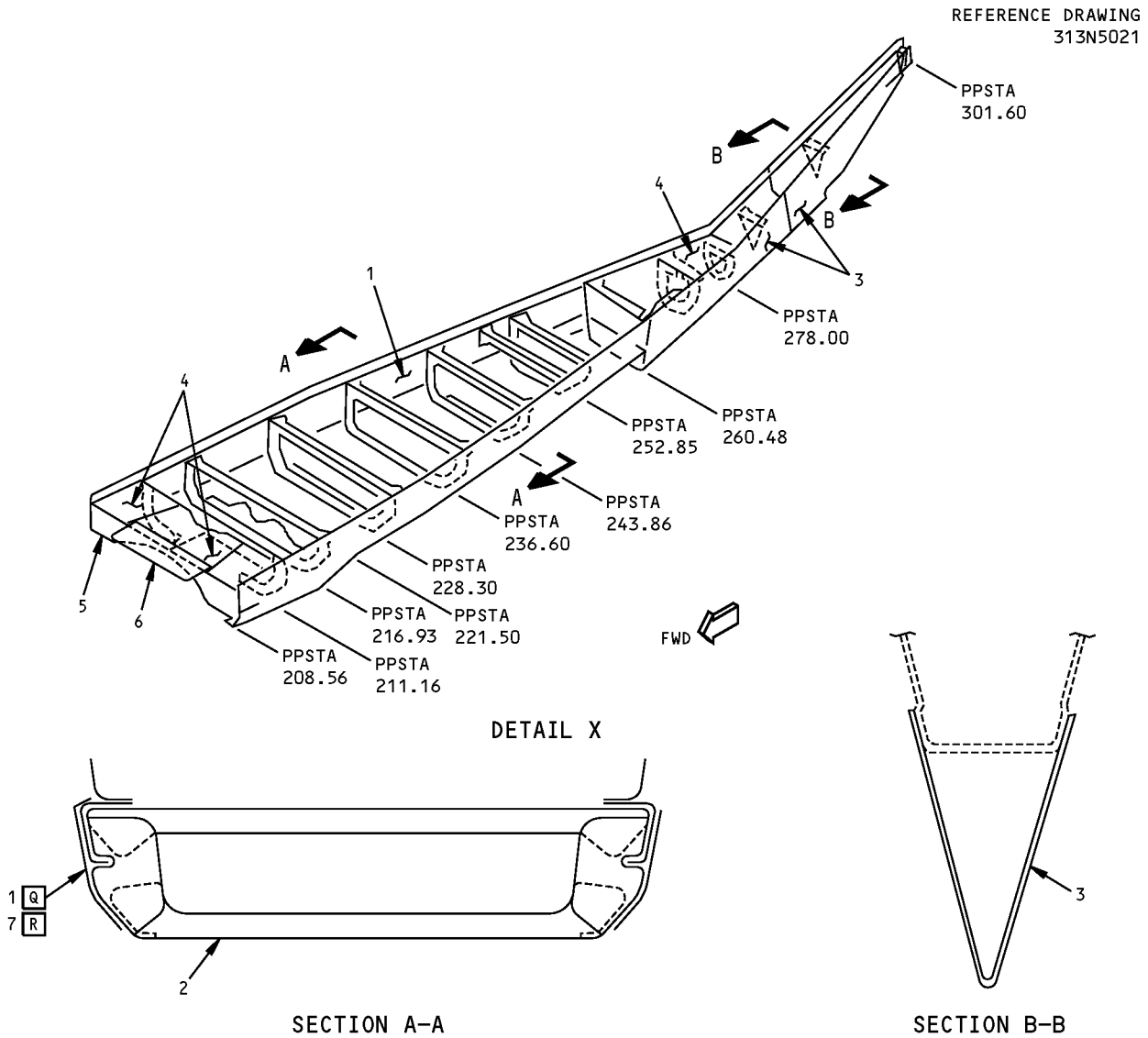

ITEM	DESCRIPTION	GAGE	MATERIAL	EFFECTIVITY
1	SKIN	0.040	STEEL 17-7PH HEAT TREATMENT 150-170 KSI	Q
2	SKIN	0.050	CLAD 7075-T6	
3	SKIN	0.040	INCONEL 625	
4	COVER	0.040	CLAD 7075-T6	
5	CHANNEL	0.080	CLAD 7075-T6	
6	PLATE	0.090	CLAD 7075-T6	
7	SKIN	0.040	CLAD 2024-T42	R

LIST OF MATERIALS FOR DETAIL X

**Strut Fairing Skin Identification - RB211-535C Engines
Figure 1 (Sheet 9 of 10)**

**757-200
STRUCTURAL REPAIR MANUAL**

REF DWG
313N5034-3,-4,-27,-28

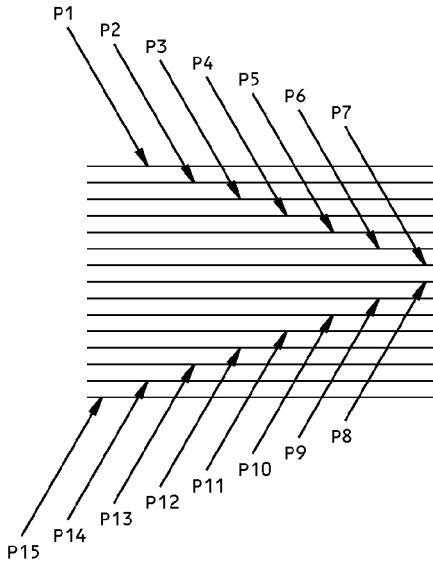

SECTION THRU PANEL

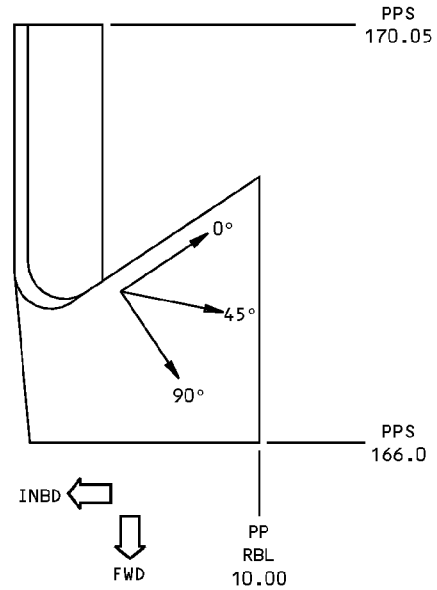

DIAGRAM OF PLY ORIENTATION, SEE
TABLE III FOR PLY ORIENTATION
AND MATERIAL **A**

ITEM NO.	PLY NO.	MATERIAL	PLY ORIENTATION
	1 P	E	90°
	1 J	O	90°
	4,6,8,10,12	B	0°
	5,7,9,11,13	B	90°
	14	H	0°
	2	C	0°
	3	H	90°
	15 J	M	---

DETAIL XI

**Strut Fairing Skin Identification - RB211-535C Engines
Figure 1 (Sheet 10 of 10)**

IDENTIFICATION 2
Page 10
Jan 20/2005

54-50-70

D634N201



757-200
STRUCTURAL REPAIR MANUAL

ALLOWABLE DAMAGE 1 - SRUT FAIRING SKIN - RB211-535E4 ENGINE

REF DWG
311N5001

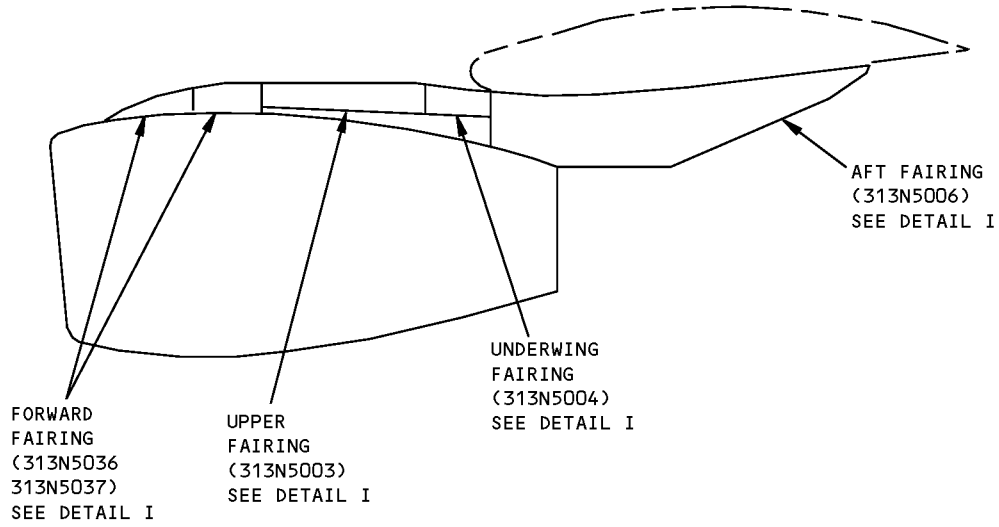

Strut Fairing Skin Allowable Damage - RB211-535E4 Engine
Figure 101 (Sheet 1 of 6)

D634N201

ALLOWABLE DAMAGE 1
Page 101
54-50-70
Jan 20/2007

**757-200
STRUCTURAL REPAIR MANUAL**

REF DWG
311N0506

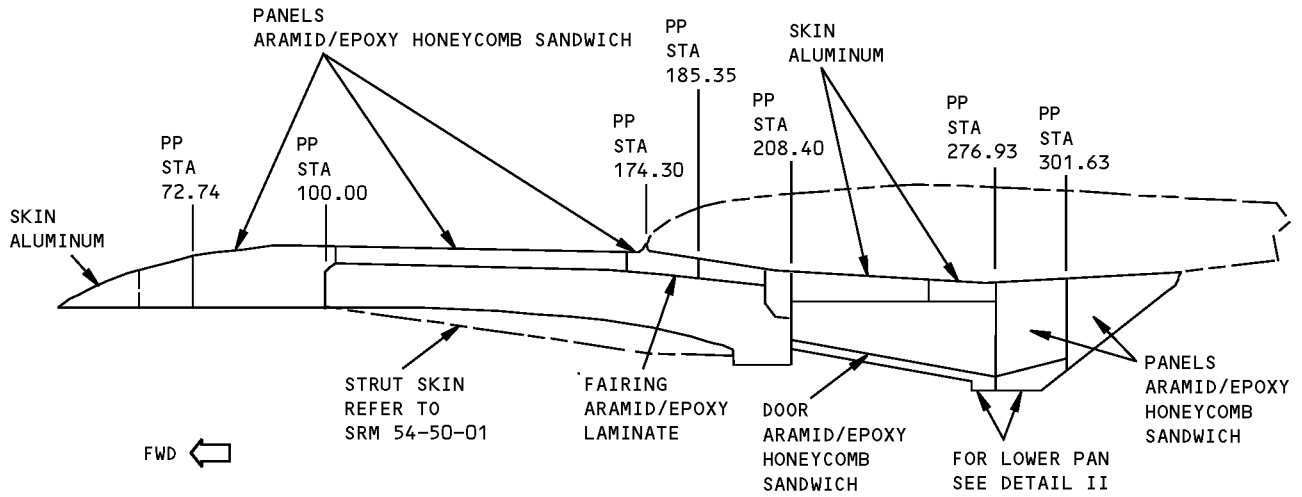

VIEW ON LEFT SIDE OF LEFT AND RIGHT STRUTS
RIGHT SIDE SAME EXCEPT AS NOTED

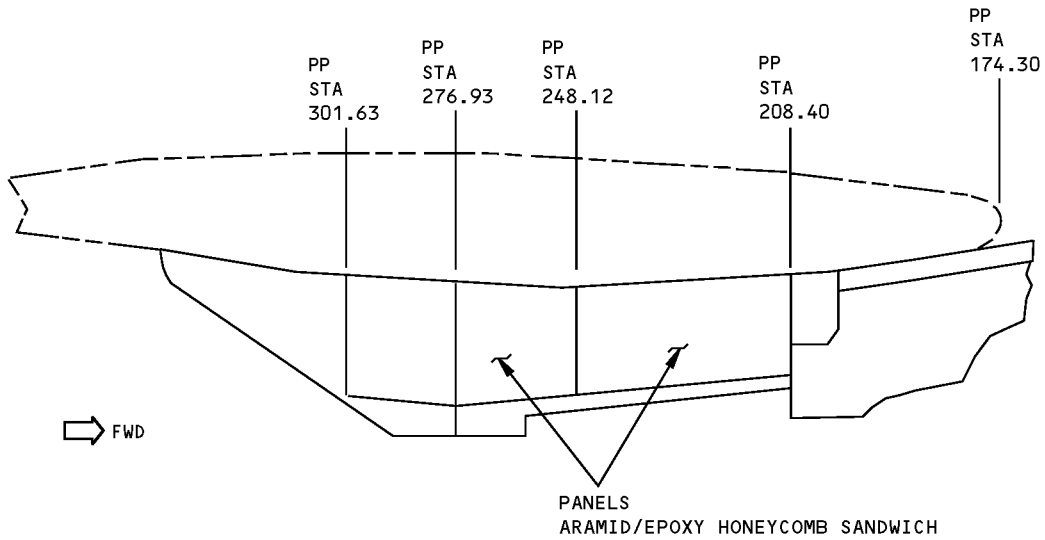

VIEW ON RIGHT SIDE OF LEFT AND RIGHT STRUTS
DETAIL I

**Strut Fairing Skin Allowable Damage - RB211-535E4 Engine
Figure 101 (Sheet 2 of 6)**

ALLOWABLE DAMAGE 1
Page 102
Jan 20/2005

54-50-70

D634N201

**757-200
STRUCTURAL REPAIR MANUAL**

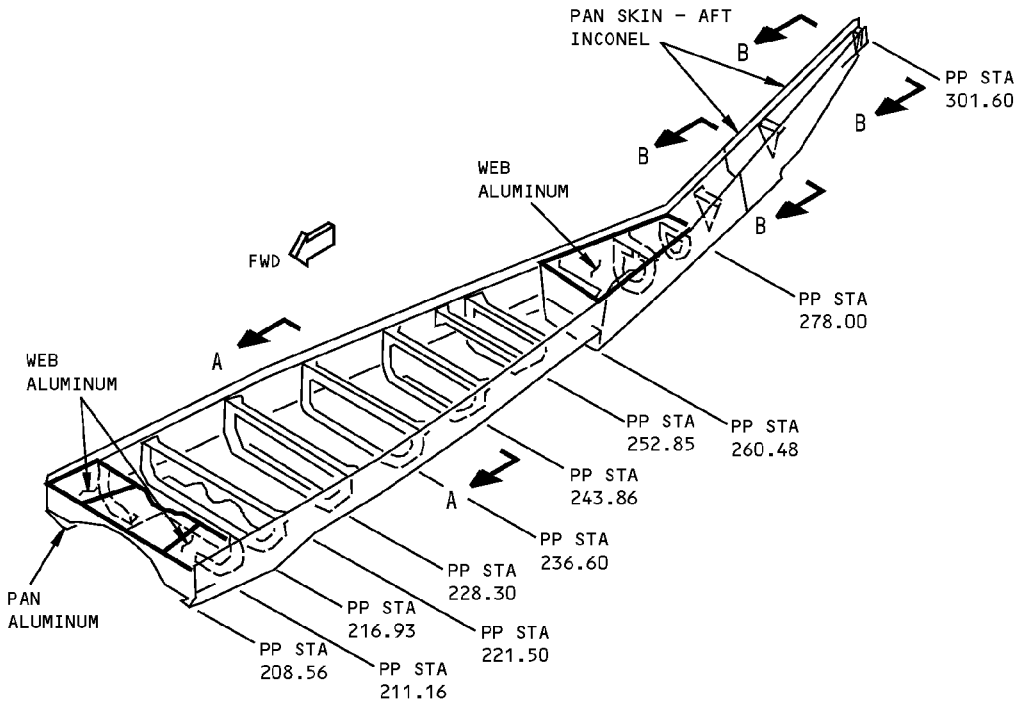

DETAIL II

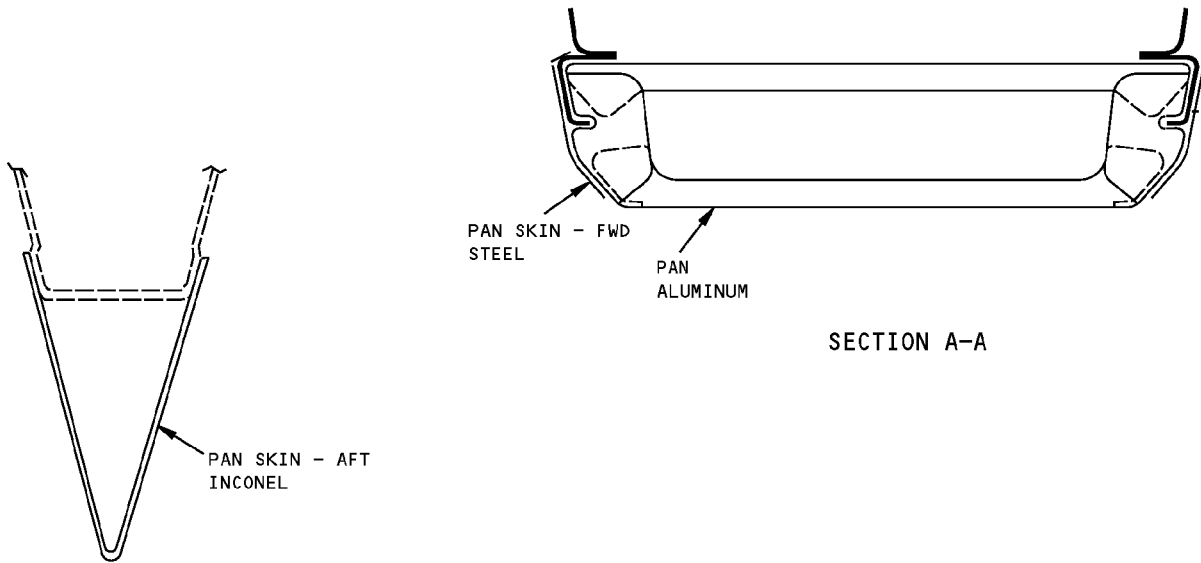

SECTION B-B

SECTION A-A

**Strut Fairing Skin Allowable Damage - RB211-535E4 Engine
Figure 101 (Sheet 3 of 6)**

STRUCTURAL REPAIR MANUAL

DESCRIPTION	CRACKS	NICKS, GOUGES AND CORROSION	DENTS	HOLES AND PUNCTURES	DELAMINATION
ALUMINUM SKIN	B	C	SEE DETAIL V	D	---
PANELS	E	F	G	H	I
FAIRING	E	F	G	H	I
DOOR	E	F	G	H	I
PAN SKIN- AFT	B	C	SEE DETAIL V	J	---
WEB	B	C	SEE DETAIL V	D	---
PAN SKIN - FWD	B	C	SEE DETAIL V	J	---
PAN - ALUMINUM	B	C	SEE DETAIL V	D	---
PAN - STEEL	B	C	SEE DETAIL V	J	---

NOTES

- REFINISH REWORKED AREAS PER AMM 51-20.
- REFER TO SRM 51-10-01 FOR AERODYNAMIC SMOOTHNESS REQUIREMENTS. WHERE THE DAMAGE EXCEEDS THE LIMITS SHOWN IN SRM 51-10-01, CONSIDERATION SHOULD BE GIVEN TO THE LOSS OF PERFORMANCE INVOLVED.
- TYPICAL DAMAGE TO A PANEL EDGE BAND MAY CONSIST OF EDGE CRUSHING, CRACKS OR DELAMINATION. DAMAGE AROUND HOLES MAY CONSIST OF OVALIZATION, FASTENER PULL-THROUGH OR CRACKS OUT OF HOLE. DAMAGE MAY REDUCE THE EFFECTIVE CROSS SECTIONAL AREA OF AN EDGE BAND. DAMAGE TO EDGES SHOULD BE BLENDED OUT TO LIMITATIONS GIVEN FOR COMPONENT.

A PROTECT DAMAGE FROM ENTRANCE OF WATER, SUNLIGHT OR OTHER FOREIGN MATTER BY SEALING WITH ALUMINUM FOIL TAPE (SPEED TAPE) 3M-Y436 OR EQUIVALENT. RECORD LOCATION AND INSPECT AT AIRPLANE 'A' CHECK. REPLACE ALUMINUM FOIL TAPE IF ANY PEELING OR DETERIORATION OF TAPE IS EVIDENT. REPAIR DAMAGE PER SRM 51-70 NO LATER THAN THE NEXT 'C' CHECK.

B CRACKS NOT ALLOWED EXCEPT FOR EDGE CRACKS WHICH MUST BE REMOVED PER DETAILS III AND VII.

C REMOVE DAMAGE PER DETAILS III, IV, AND VI.

D CLEAN OUT DAMAGE UP TO 0.25 INCH MAX DIA AND NOT CLOSER THAN 1.0 INCH TO FASTENER HOLE OR OTHER DAMAGE. FILL HOLE WITH A 2117-T3 OR T4 ALUMINUM RIVET INSTALLED WET WITH BMS 5-95 SEALANT. ALL OTHER HOLES TO BE REPAIRED.

E 2.0 MAX LENGTH IN HONEYCOMB AREA. CLEAN UP EDGE CRACKS PER DETAIL VII. CRACKS THROUGH CONSECUTIVE FASTENERS OR THROUGH THE PANEL EDGE-BAND ARE ALLOWED PROVIDED DAMAGE DOES NOT EXCEED 10% OF EDGE-BAND LENGTH PER SIDE. **A**

F DAMAGE ALLOWED ON SURFACE RESIN ONLY. DAMAGE TO FIBERS NOT ALLOWED. CLEAN UP EDGE DAMAGE PER DETAIL VII. **A**

G DENTS GENERALLY RESULT IN FIBER DAMAGE OR DELAMINATION. HOWEVER, IF THERE IS NO FIBER DAMAGE OR DELAMINATION. DENTS UP TO 2.25 DIA MAX ARE ALLOWED. ONE DENT PER SQUARE FOOT OF AREA ALLOWED WHICH MUST BE A MINIMUM OF 6 INCHES FROM ANY OTHER DAMAGE, FASTENER HOLE, OR PANEL EDGE. SEE **H** OR **I** IF FIBER DAMAGE OR DELAMINATION IS PRESENT.

H 0.25 INCH MAX DIA ALLOWED PROVIDED DAMAGE IS A MINIMUM OF 3.0 D FROM THE NEAREST HOLE OR MATERIAL EDGE AND A MINIMUM OF 6 INCHES FROM OTHER DAMAGE. DO NOT CLEAN UP DAMAGE EXCEPT TO REMOVE RESIN BURRS EXTENDING INTO THE SURFACE CONTOUR. **A**

I 1.00 INCH MAX DIA IS ALLOWED IN HONEYCOMB AREA. A MAXIMUM OF 0.50 INCH DELAMINATION FROM EDGE IS ALLOWED. PROTECT EDGE DAMAGE PER **A**. REPAIR DELAMINATION IN HONEYCOMB AREA PER 51-70 NO LATER THAN THE NEXT 'C' CHECK.

J CLEAN OUT DAMAGE UP TO 0.25 MAX DIA AND NOT CLOSER THAN 1.0 INCH TO FASTENER HOLE OR OTHER DAMAGE. FILL HOLE WITH A MONEL RIVET INSTALLED DRY. ALL OTHER HOLES TO BE REPAIRED.

Strut Fairing Skin Allowable Damage - RB211-535E4 Engine
Figure 101 (Sheet 4 of 6)

**757-200
STRUCTURAL REPAIR MANUAL**

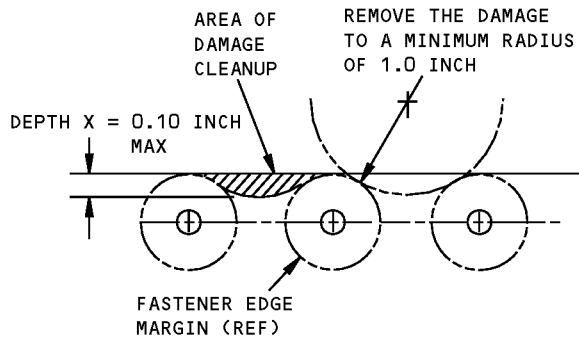

REMOVAL OF DAMAGE AT EDGES WHERE FASTENER EDGE MARGINS DO NOT OVERLAP

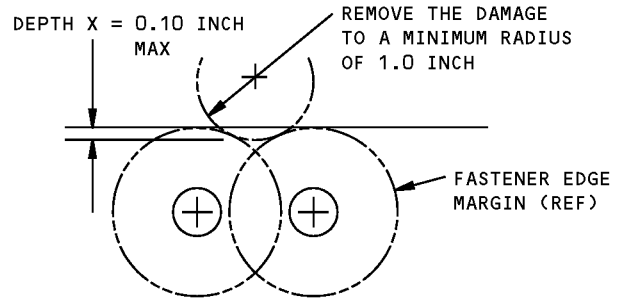

REMOVAL OF DAMAGE AT EDGES WHERE FASTENER EDGE MARGINS OVERLAP

DETAIL III

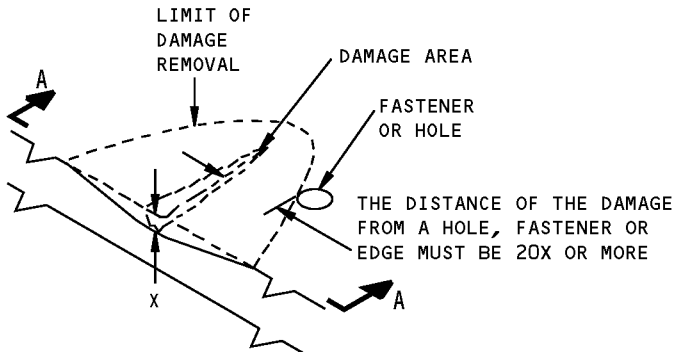

REMOVAL OF NICK, GOUGE AND SCRATCH DAMAGE ON A SURFACE
DETAIL IV

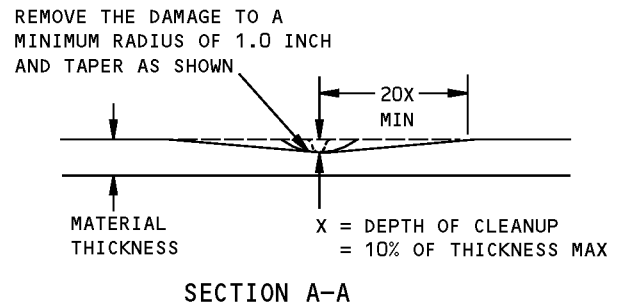

Strut Fairing Skin Allowable Damage - RB211-535E4 Engine
Figure 101 (Sheet 5 of 6)

**757-200
STRUCTURAL REPAIR MANUAL**

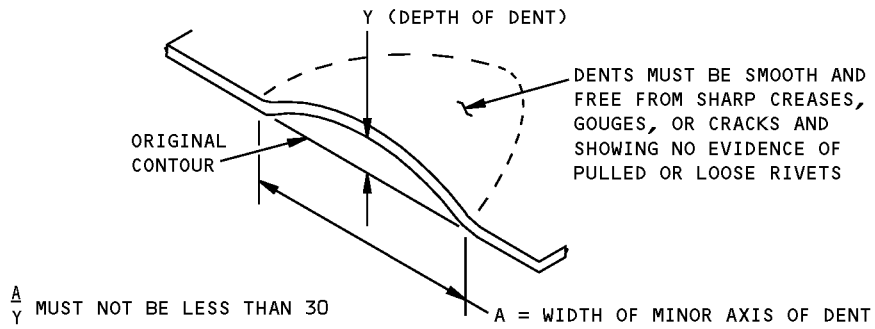

**ALLOWABLE DAMAGE FOR DENT
DETAIL V**

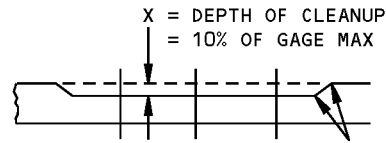
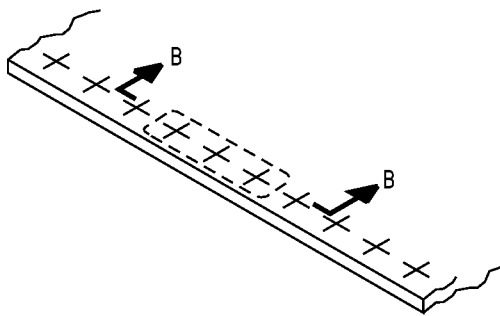

SMOOTH BLENDOUT RADIUS 0.50 INCH MINIMUM. CORROSION CLEANUP AROUND ANY THREE FASTENERS IN TEN IS PERMITTED TO MAX DEPTH

SECTION B-B

**CORROSION CLEANUP
DETAIL VI**

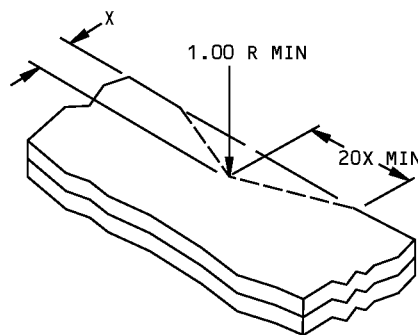

X = DEPTH OF CLEANUP = 0.10 MAX

DETAIL VII

**Strut Fairing Skin Allowable Damage - RB211-535E4 Engine
Figure 101 (Sheet 6 of 6)**

757-200
STRUCTURAL REPAIR MANUAL

ALLOWABLE DAMAGE 2 - STRUT FAIRING SKIN - RB211-535C ENGINE

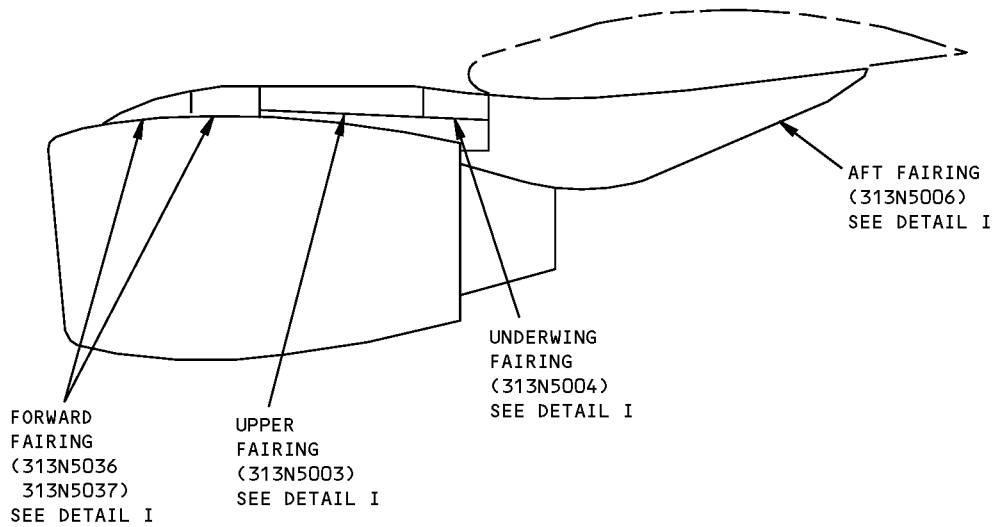

Strut Fairing Skin Allowable Damage - RB211-535C Engine
Figure 101 (Sheet 1 of 6)

**757-200
STRUCTURAL REPAIR MANUAL**

REF DWG
311N0506

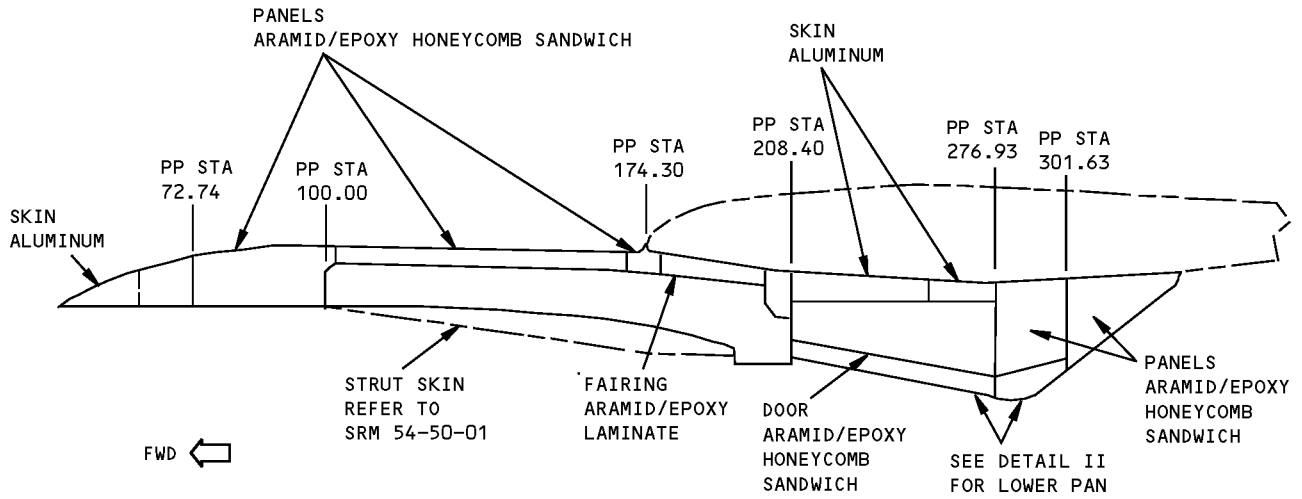

VIEW ON LEFT SIDE OF LEFT AND RIGHT STRUTS
RIGHT SIDE SAME EXCEPT AS NOTED

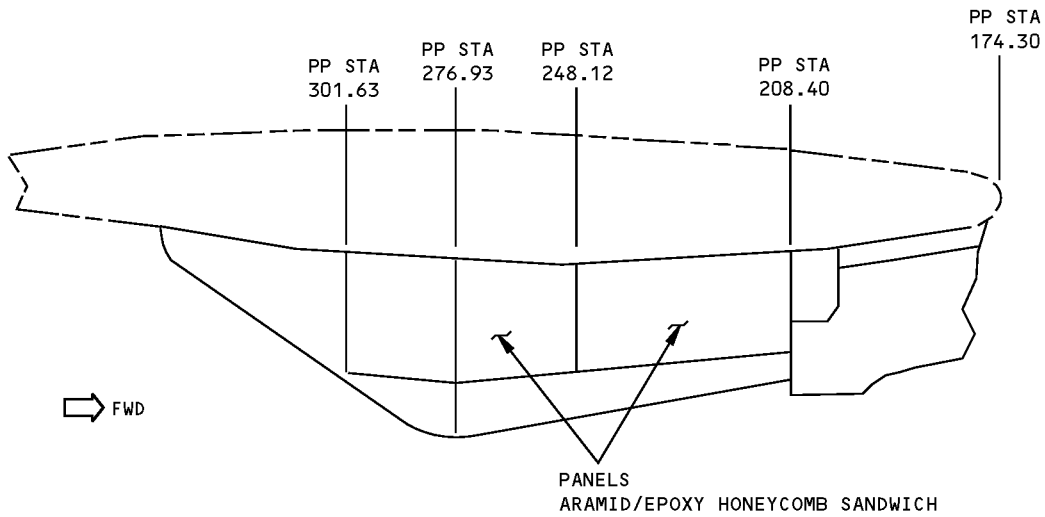

VIEW ON RIGHT SIDE OF LEFT AND RIGHT STRUTS
DETAIL I

**Strut Fairing Skin Allowable Damage - RB211-535C Engine
Figure 101 (Sheet 2 of 6)**

ALLOWABLE DAMAGE 2
Page 102
Jan 20/2005

54-50-70

D634N201

**757-200
STRUCTURAL REPAIR MANUAL**

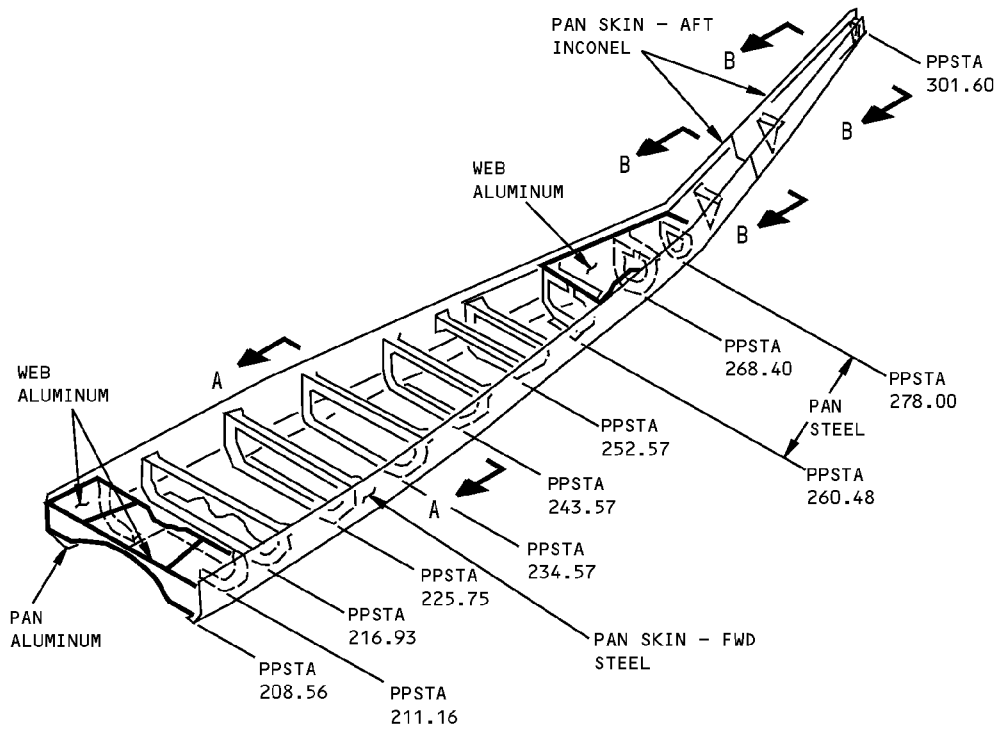

DETAIL II

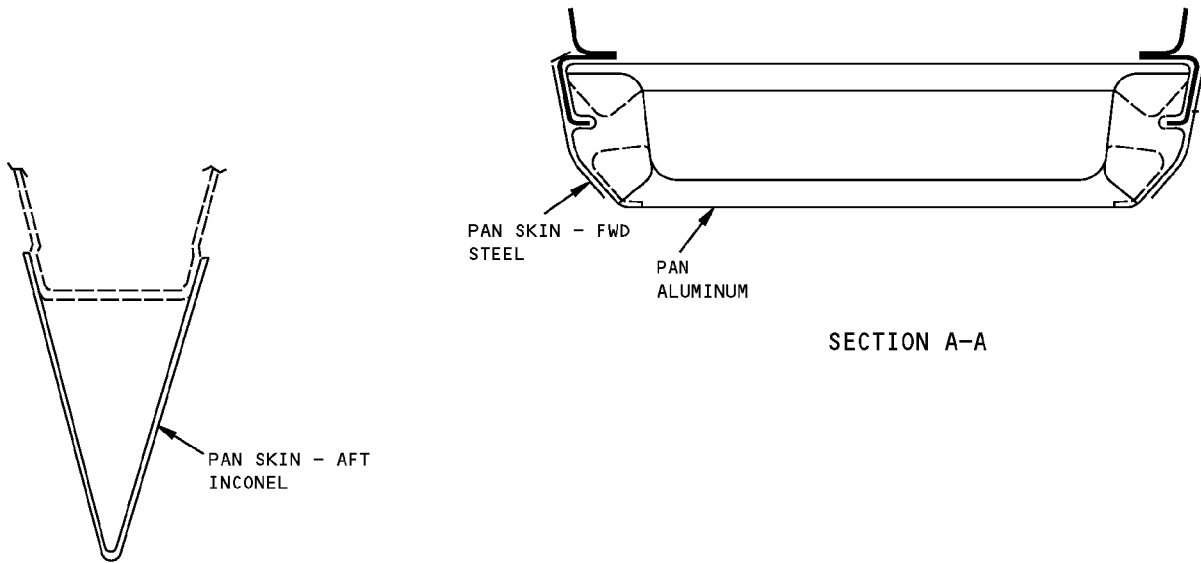

**Strut Fairing Skin Allowable Damage - RB211-535C Engine
Figure 101 (Sheet 3 of 6)**

**757-200
STRUCTURAL REPAIR MANUAL**

DESCRIPTION	CRACKS	NICKS, GOUGES AND CORROSION	DENTS	HOLES AND PUNCTURES	DELAMINATION
ALUMINUM SKIN	B	C	SEE DETAIL V	D	---
PANELS	E	F	G	H	I
FAIRING	E	F	G	H	I
DOOR	E	F	G	H	I
PAN SKIN- AFT	B	C	SEE DETAIL V	J	---
WEB	B	C	SEE DETAIL V	D	---
PAN SKIN - FWD	B	C	SEE DETAIL V	J	---
PAN - ALUMINUM	B	C	SEE DETAIL V	D	---
PAN - STEEL	B	C	SEE DETAIL V	J	---

NOTES

- REFINISH REWORKED AREAS PER AMM 51-20.
- REFER TO SRM 51-10-01 FOR AERODYNAMIC SMOOTHNESS REQUIREMENTS. WHERE THE DAMAGE EXCEEDS THE LIMITS SHOWN IN SRM 51-10-01, CONSIDERATION SHOULD BE GIVEN TO THE LOSS OF PERFORMANCE INVOLVED.
- TYPICAL DAMAGE TO A PANEL EDGE BAND MAY CONSIST OF EDGE CRUSHING, CRACKS OR DELAMINATION. DAMAGE AROUND HOLES MAY CONSIST OF OVALIZATION, FASTENER PULL-THROUGH OR CRACKS OUT OF HOLE. DAMAGE MAY REDUCE THE EFFECTIVE CROSS SECTIONAL AREA OF AN EDGE BAND. DAMAGE TO EDGES SHOULD BE BLENDED OUT TO LIMITATIONS GIVEN FOR COMPONENT.

A PROTECT DAMAGE FROM ENTRANCE OF WATER, SUNLIGHT OR OTHER FOREIGN MATTER BY SEALING WITH ALUMINUM FOIL TAPE (SPEED TAPE) 3M-Y436 OR EQUIVALENT. RECORD LOCATION AND INSPECT AT AIRPLANE 'A' CHECK. REPLACE ALUMINUM FOIL TAPE IF ANY PEELING OR DETERIORATION OF TAPE IS EVIDENT. REPAIR DAMAGE PER SRM 51-70 NO LATER THAN THE NEXT 'C' CHECK.

B CRACKS NOT ALLOWED EXCEPT FOR EDGE CRACKS WHICH MUST BE REMOVED PER DETAILS III AND VII.

C REMOVE DAMAGE PER DETAILS III, IV, AND VI.

D CLEAN OUT DAMAGE UP TO 0.25 INCH MAX DIA AND NOT CLOSER THAN 1.0 INCH TO FASTENER HOLE OR OTHER DAMAGE. FILL HOLE WITH A 2117-T3 OR T4 ALUMINUM RIVET INSTALLED WET WITH BMS 5-95 SEALANT. ALL OTHER HOLES TO BE REPAIRED.

E 2.0 MAX LENGTH IN HONEYCOMB AREA. CLEAN UP EDGE CRACKS PER DETAIL VII. CRACKS THROUGH CONSECUTIVE FASTENERS OR THROUGH THE PANEL EDGE-BAND ARE ALLOWED PROVIDED DAMAGE DOES NOT EXCEED 10% OF EDGE-BAND LENGTH PER SIDE. **A**

F DAMAGE ALLOWED ON SURFACE RESIN ONLY. DAMAGE TO FIBERS NOT ALLOWED. CLEAN UP EDGE DAMAGE PER DETAIL VII. **A**

G DENTS GENERALLY RESULT IN FIBER DAMAGE OR DELAMINATION. HOWEVER, IF THERE IS NO FIBER DAMAGE OR DELAMINATION. DENTS UP TO 2.25 DIA MAX ARE ALLOWED. ONE DENT PER SQUARE FOOT OF AREA ALLOWED WHICH MUST BE A MINIMUM OF 6 INCHES FROM ANY OTHER DAMAGE, FASTENER HOLE, OR PANEL EDGE. SEE **H** OR **I** IF FIBER DAMAGE OR DELAMINATION IS PRESENT.

H 0.25 INCH MAX DIA ALLOWED PROVIDED DAMAGE IS A MINIMUM OF 3.0 D FROM THE NEAREST HOLE OR MATERIAL EDGE AND A MINIMUM OF 6 INCHES FROM OTHER DAMAGE. DO NOT CLEAN UP DAMAGE EXCEPT TO REMOVE RESIN BURRS EXTENDING INTO THE SURFACE CONTOUR. **A**

I 1.00 INCH MAX DIA IS ALLOWED IN HONEYCOMB AREA. A MAXIMUM OF 0.50 INCH DELAMINATION FROM EDGE IS ALLOWED. PROTECT EDGE DAMAGE PER **A**. REPAIR DELAMINATION IN HONEYCOMB AREA PER 51-70 NO LATER THAN THE NEXT 'C' CHECK.

J CLEAN OUT DAMAGE UP TO 0.25 MAX DIA AND NOT CLOSER THAN 1.0 INCH TO FASTENER HOLE OR OTHER DAMAGE. FILL HOLE WITH A MONEL RIVET INSTALLED DRY. ALL OTHER HOLES TO BE REPAIRED.

**Strut Fairing Skin Allowable Damage - RB211-535C Engine
Figure 101 (Sheet 4 of 6)**

**757-200
STRUCTURAL REPAIR MANUAL**

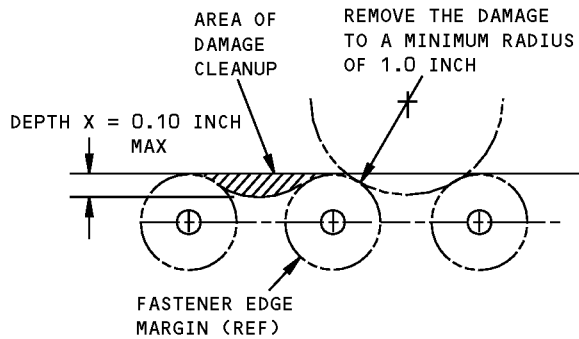

REMOVAL OF DAMAGE AT EDGES WHERE FASTENER EDGE MARGINS DO NOT OVERLAP

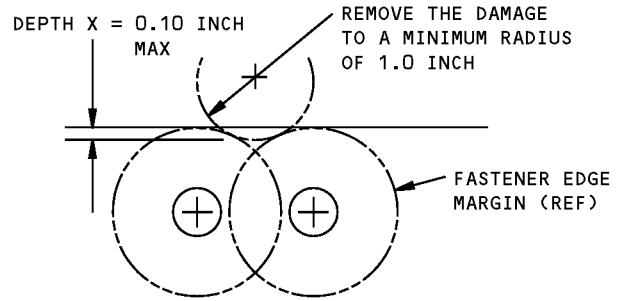

REMOVAL OF DAMAGE AT EDGES WHERE FASTENER EDGE MARGINS OVERLAP

DETAIL III

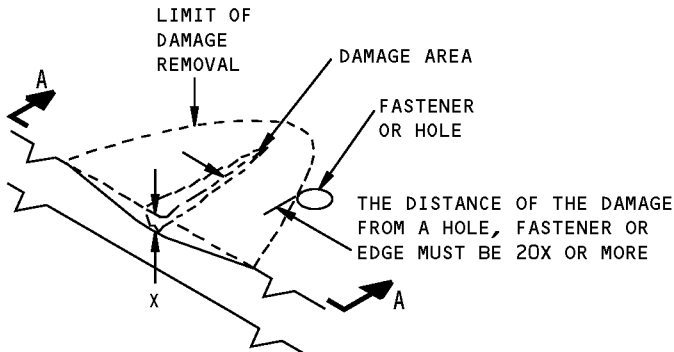

REMOVAL OF NICK, GOUGE AND SCRATCH DAMAGE ON A SURFACE
DETAIL IV

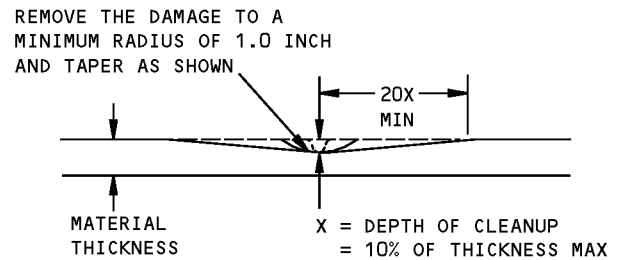

SECTION A-A

**Strut Fairing Skin Allowable Damage - RB211-535C Engine
Figure 101 (Sheet 5 of 6)**

**757-200
STRUCTURAL REPAIR MANUAL**

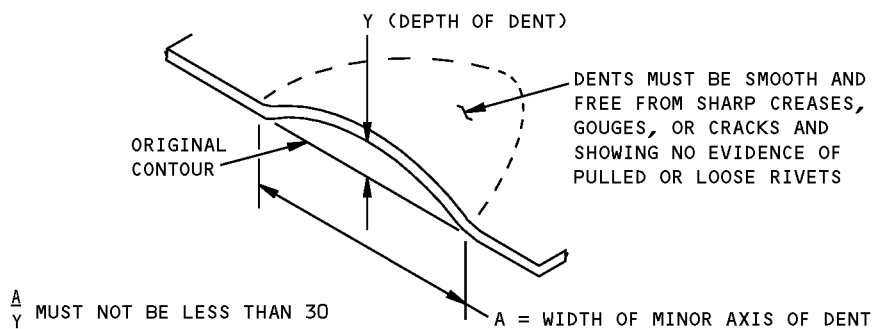

**ALLOWABLE DAMAGE FOR DENT
DETAIL V**

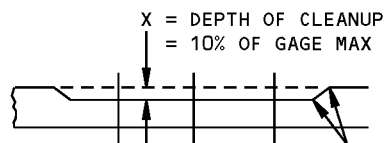
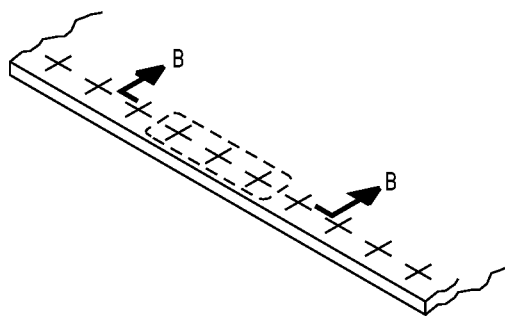

SMOOTH BLENDOUT RADIUS 0.50 INCH MINIMUM. CORROSION CLEANUP AROUND ANY THREE FASTENERS IN TEN IS PERMITTED TO MAX DEPTH

SECTION B-B

**CORROSION CLEANUP
DETAIL VI**

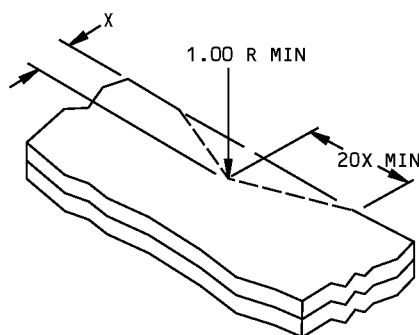

X = DEPTH OF CLEANUP = 0.10 MAX

DETAIL VII

**Strut Fairing Skin Allowable Damage - RB211-535C Engine
Figure 101 (Sheet 6 of 6)**



757-200
STRUCTURAL REPAIR MANUAL

REPAIR GENERAL - STRUT FAIRING SKIN - RB211-535 ENGINE - SERVICE BULLETIN LIST

SERVICE BULLETIN REPAIRS

The following Service Bulletins contain repairs which are available for use where specific damage has been encountered. Usually, the Service Bulletin also covers preventive modification data which operators are encouraged to use to eliminate the need for repair.

DAMAGED AREA	CUM LINE NUMBER EFFECTIVITY	SB NUMBER
NACELLES/PYLONS-STRUT FAIRINGS - INSPECTION AND REPAIR OF TRAILING EDGE SKIN	AIRPLANES WITH ROLLS-ROYCE ENGINES; CUM LINE NUMBERS 1 THRU 399.	54-0024

Strut Fairing Skin - RB211-535 Engine
Figure 201

D634N201

54-50-70

REPAIR GENERAL
Page 201
Jan 20/2005

757-200
STRUCTURAL REPAIR MANUAL

REPAIR 1 - STRUT FAIRING SKIN - RB211-535 ENGINE

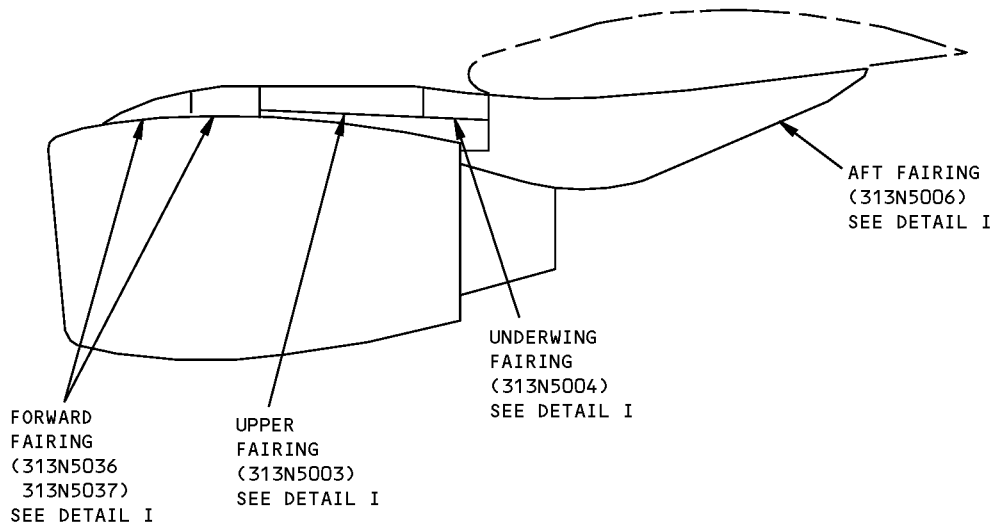

Strut Fairing Skin Repairs - RB211-535 Engine
Figure 201 (Sheet 1 of 3)

**757-200
STRUCTURAL REPAIR MANUAL**

REF DWG
311N0506

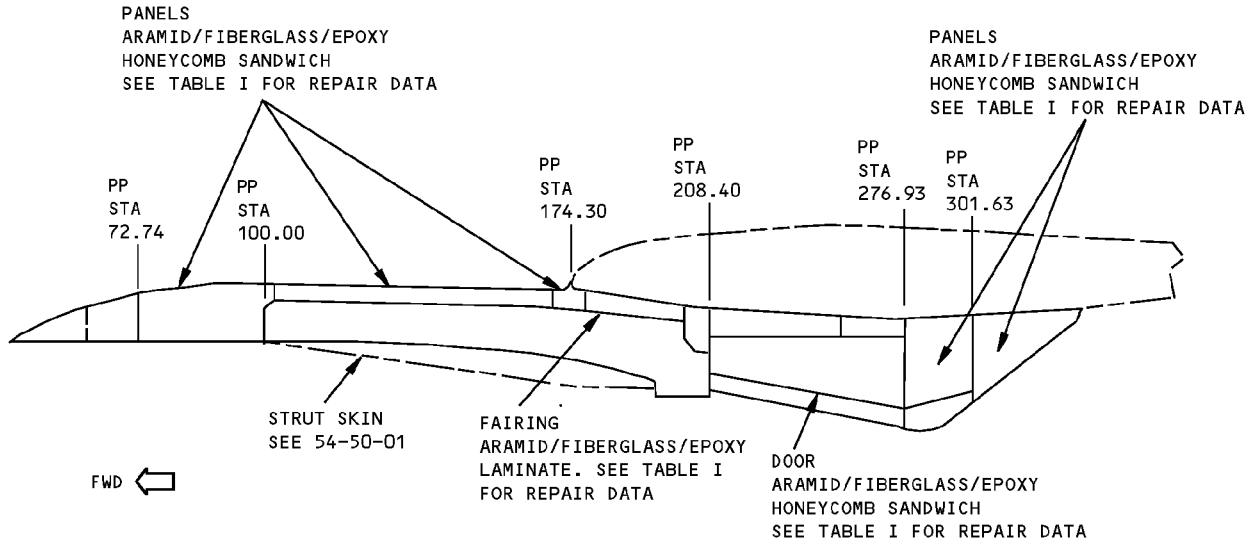

VIEW ON LEFT SIDE OF LEFT AND RIGHT STRUTS
RIGHT SIDE SAME EXCEPT AS NOTED

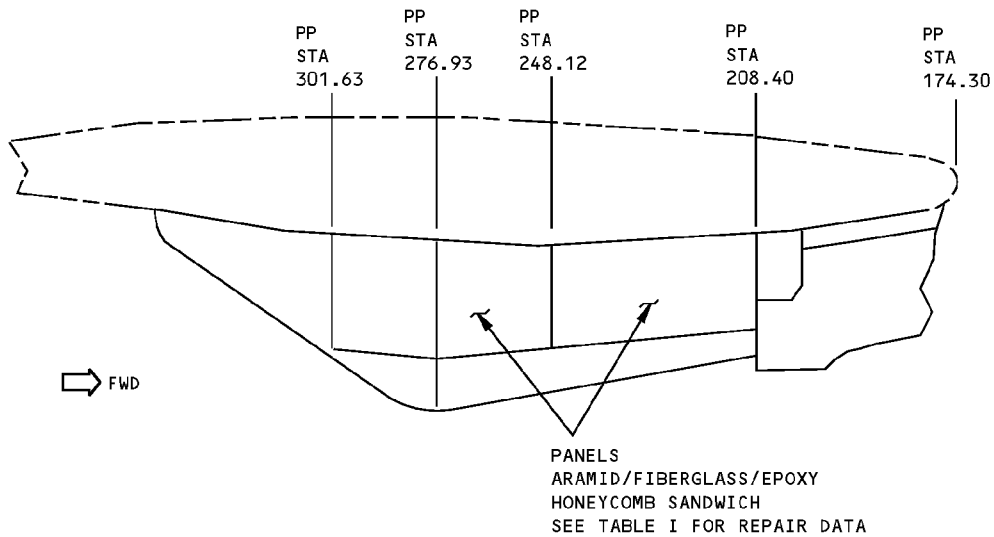

VIEW ON RIGHT SIDE OF LEFT AND RIGHT STRUTS
DETAIL I

**Strut Fairing Skin Repairs - RB211-535 Engine
Figure 201 (Sheet 2 of 3)**

**757-200
STRUCTURAL REPAIR MANUAL**

DAMAGE	INTERIM REPAIRS B	PERMANENT REPAIRS	
	WET LAYUP 150°F (66°C) CURE (SRM 51-70-03)	WET LAYUP 200°F TO 230°F (93°C TO 110°C) CURE (SRM 51-70-17) D	350°F (177°C) CURE (SRM 51-70-04)
CRACKS	UP TO 3.0 INCHES (75 mm) LONG, REPAIR WITH PATCH AS SHOWN IN 51-70-03, PAR. 5.N. A	CLEAN UP DAMAGE AND REPAIR AS HOLE.	CLEAN UP DAMAGE AND REPAIR AS HOLE.
HOLES	3.0 INCHES (75 mm) MAX DIA NOT TO EXCEED 30% OF SMALLEST DIMENSION ACROSS HONEYCOMB PANEL AT THE DAMAGE LOCATION. FILL WITH BMS 5-28, TYPE 7 POTTING COMPOUND AND PATCH AS SHOWN IN SRM 51-70-03, PAR. 5.N. A	12.0 INCHES (300 mm) MAX DIA NOT TO EXCEED 50% OF SMALLEST DIMENSION ACROSS HONEYCOMB PANEL AT THE DAMAGE LOCATION. USE TWO EXTRA PLYS FOR EACH FACESHEET REPAIRED. C	NO SIZE LIMIT
EDGE EROSION		FOR DAMAGE NOT EXCEEDING 35% OF EDGE BAND THICKNESS, REPAIR AS SHOWN IN SRM 51-70-03, PAR. 5.O. FOR GREATER DAMAGE, REPAIR AS SHOWN IN: SRM 51-70-17, PAR. 4.G.	SRM 51-70-04, PAR. 5.G.
DELAMINATION	CUT OUT AND REPAIR AS HOLE.		
NICKS AND GOUGES	IF THERE IS NO FIBER DAMAGE OR DELAMINATION, FILL NICKS OR GOUGES AS SHOWN IN SRM 51-70-03. IF THERE IS FIBER DAMAGE OR DELAMINATION REPAIR AS A HOLE.		
DENTS	UP TO 2.0 INCHES (50 mm) DIA WITH NO FIBER DAMAGE OR DELAMINATION, FILL WITH BMS 5-28, TYPE 7 POTTING COMPOUND AND PATCH AS SHOWN IN SRM 51-70-03, PAR. 5.L. C OVER 2.0 INCHES (50 mm) DIA OR WITH FIBER DAMAGE OR DELAMINATION, REPAIR AS HOLE.		

TABLE I

NOTES

- REFINISH REWORKED AREAS AS SHOWN IN AMM 51-20
 - REFER TO SRM 51-10-01 FOR AERODYNAMIC SMOOTHNESS REQUIREMENTS. WHERE THE REPAIR IS MORE THAN THE LIMITS SHOWN IN SRM 51-10-01, CONSIDERATION SHOULD BE GIVEN TO THE LOSS OF PERFORMANCE.
 - REFER TO SRM 51-70-16 FOR HOLE DRILLING AND MACHINING OF COMPOSITE STRUCTURES.
 - SOME FAIRING PANELS HAVE A CONDUCTIVE COATING. REFER TO SRM 51-70-14 FOR REPAIR OF THE CONDUCTIVE COATING.
- A** LIMITED TO REPAIR OF DAMAGE TO ONE FACE-SHEET SKIN AND HONEYCOMB CORE. ONE REPAIR FOR EACH SQUARE FOOT OF AREA AND MINIMUM OF 6.0 INCHES (150 mm) (EDGE TO EDGE) FROM ANY OTHER DAMAGE, FASTENER HOLE, OR EDGE OF PANEL.
- B** INSPECT INTERIM REPAIR USING INSTRUMENTED NDI METHODS OR "TAP" TEST EVERY AIRPLANE "2A" CHECK. FOR "TAP" TEST, USE A SOLID METAL DISK AND TAP THE REPAIR AREA LIGHTLY BUT FIRMLY. VOID AREAS WILL PRODUCE A DULL SOUND AS OPPOSED TO A SHARP RING ON A SOLID BONDED AREA. PERMANENT REPAIR IS REQUIRED IF ANY DETERIORATION IS EVIDENT. REFER TO SRM 51-70-03, PAR. 4.J. AND THE NONDESTRUCTIVE TEST MANUAL, D634N301.
- C** ONE REPAIR PER SQUARE FOOT OF AREA AND A MINIMUM OF 6.0 INCHES (150 mm) (EDGE TO EDGE) FROM ANY OTHER DAMAGE, FASTENER HOLE, OR EDGE OF PANEL.
- D** FOR WET LAYUP REPAIR, USE 1.0 INCH (25 mm) FOR EACH PLY OVERLAP.

**Strut Fairing Skin Repairs - RB211-535 Engine
Figure 201 (Sheet 3 of 3)**

**757-200
STRUCTURAL REPAIR MANUAL**

IDENTIFICATION 1 - STRUT FAIRING STRUCTURE - RB211-535 ENGINE

REF DWG
313N5003

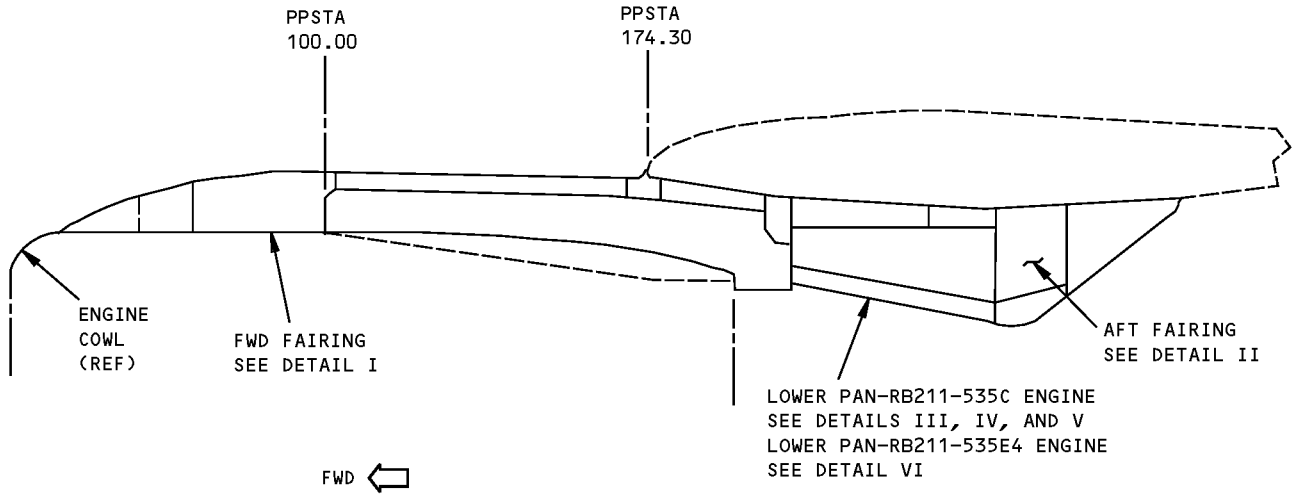

NOTES

- SEE 54-50-70 FOR SKIN PANEL IDENTIFICATION

A FOR CUM LINE NUMBERS:
1 THRU 26

B FOR CUM LINE NUMBERS:
27 THRU 34, 64, 65, 66, 113, 115
(BOEING REF. NA220 THRU NA399,
NA404 THRU NA450)

**Strut Fairing Structure Identification - RB211-535 Engine
Figure 1 (Sheet 1 of 6)**

**757-200
STRUCTURAL REPAIR MANUAL**

REF DWG
313N5036
313N5037

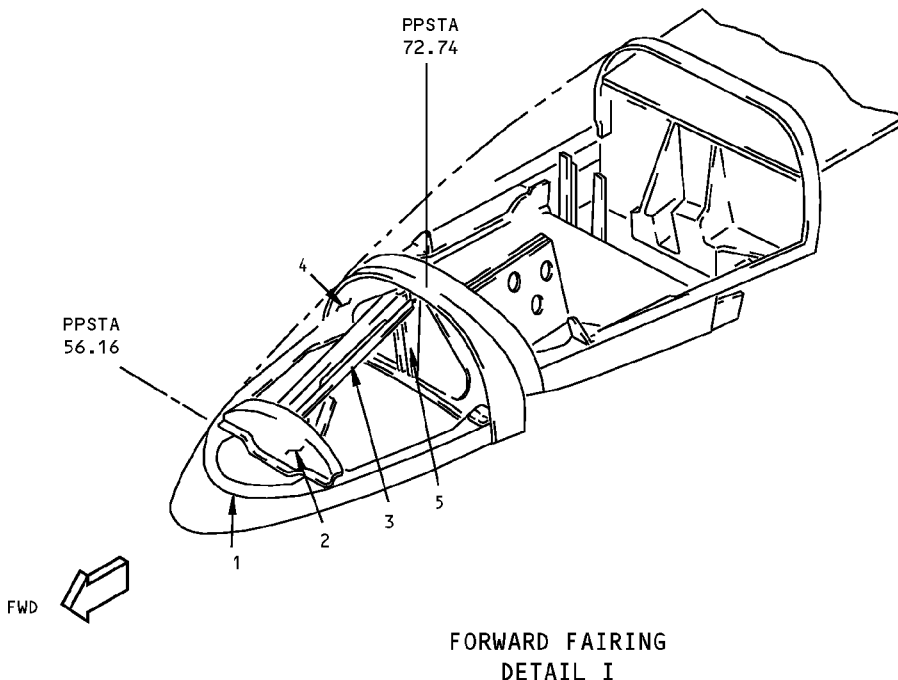

**FORWARD FAIRING
DETAIL I**

ITEM	DESCRIPTION	GAGE	MATERIAL	EFFECTIVITY
1	STIFFENER	0.050	CLAD 2024-T42	
2	BULKHEAD	0.050	CLAD 2024-T42	
3	ANGLE	0.070	CLAD 2024-T42	
4	BULKHEAD	0.040	TITANIUM-6AL-4V TYPE III, COMP C, ANNEALED	
5	ANGLE	0.063	CLAD 2024-T42	

LIST OF MATERIALS FOR DETAIL I

**Strut Fairing Structure Identification - RB211-535 Engine
Figure 1 (Sheet 2 of 6)**

IDENTIFICATION 1
Page 2
Jan 20/2005

54-50-71

D634N201

**757-200
STRUCTURAL REPAIR MANUAL**

REF DWG
313N5033

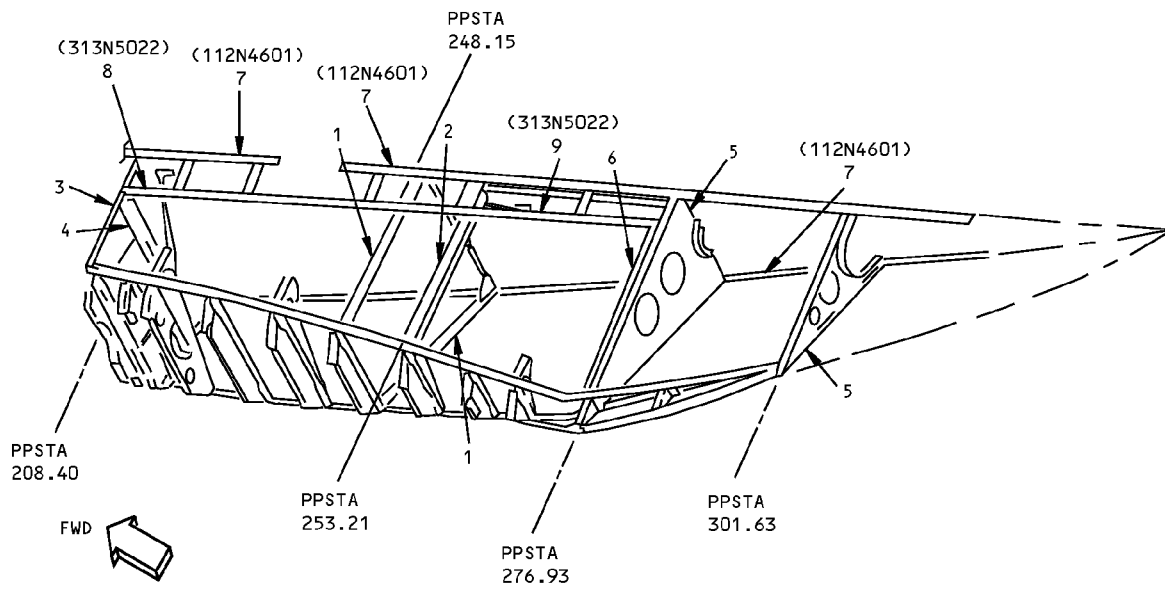

DETAIL II

ITEM	DESCRIPTION	GAGE	MATERIAL	EFFECTIVITY
1	TEE		BAC1506-990 7075-T73	
2	CHANNEL	0.063	CLAD 7075-T6	
3	ANGLE	0.063	CLAD 7075-T6	
4	ANGLE	0.090	CLAD 7075-T6	
5	WEB	0.050	CLAD 7075-T6	
6	CHANNEL	0.090	CLAD 7075-T6	
7	SKATE ANGLE	0.125	2024-T42	
8	ANGLE	0.080	7075-T6	
9	CHANNEL	0.063	7075-T6	

LIST OF MATERIALS FOR DETAIL II

**Strut Fairing Structure Identification - RB211-535 Engine
Figure 1 (Sheet 3 of 6)**

IDENTIFICATION 1
Page 3
Jan 20/2005

54-50-71

D634N201

**757-200
STRUCTURAL REPAIR MANUAL**

REF DWG
313N5021
313N5058
313N5059

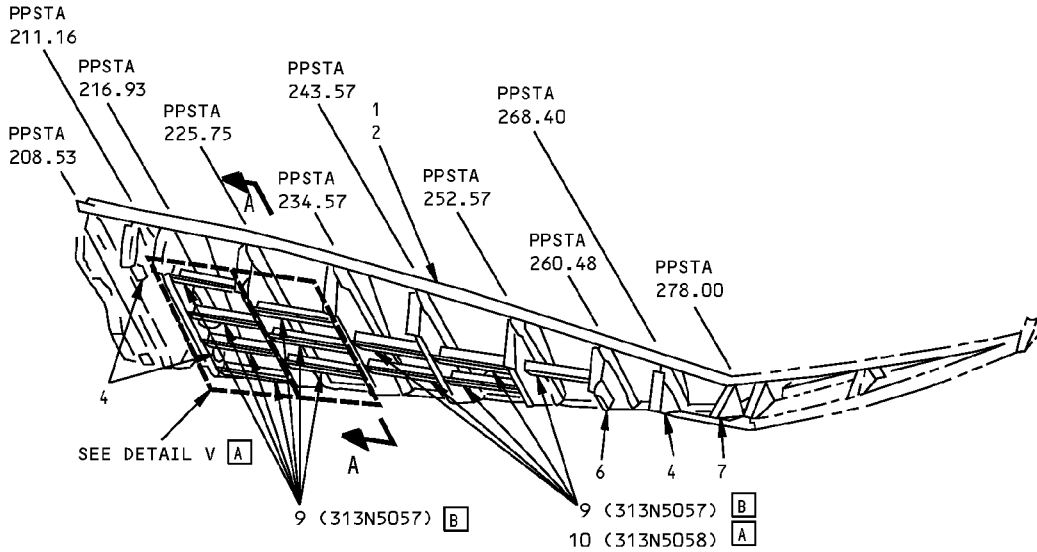

**LOWER PAN - RB211-535C ENGINE
DETAIL III**

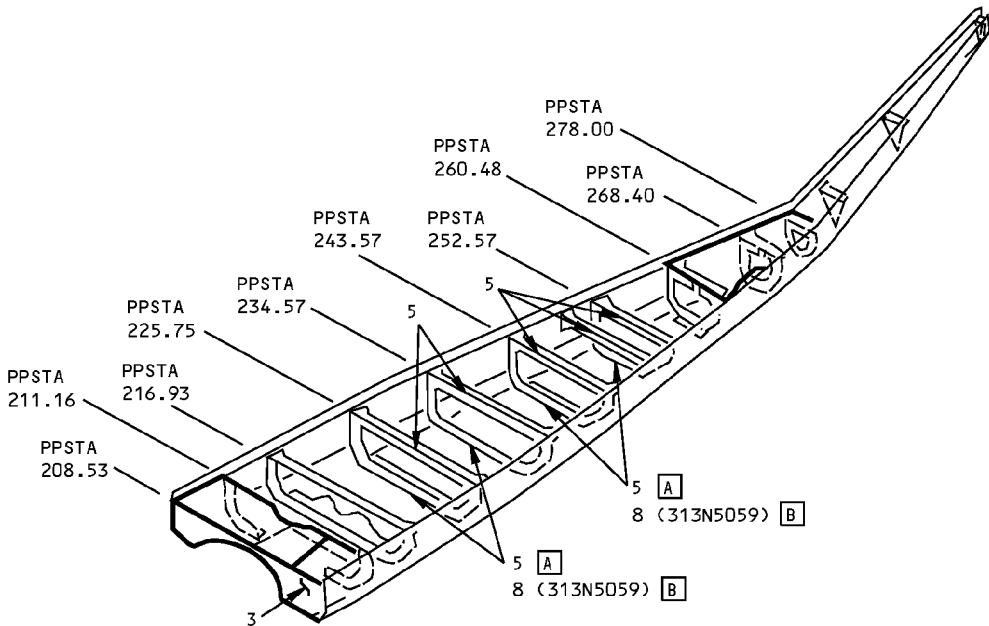

**LOWER PAN - RB211-535C ENGINE
DETAIL IV**

LIST OF
MATL

**Strut Fairing Structure Identification - RB211-535 Engine
Figure 1 (Sheet 4 of 6)**

IDENTIFICATION 1
Page 4
Jan 20/2005

54-50-71

D634N201

**757-200
STRUCTURAL REPAIR MANUAL**

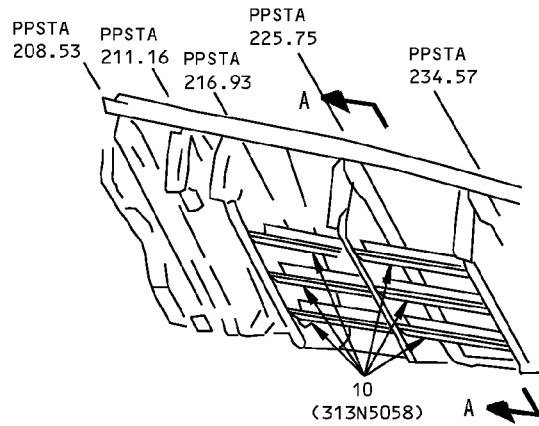

**LOWER PAN - RB211-535C ENGINE
DETAIL V [A]**

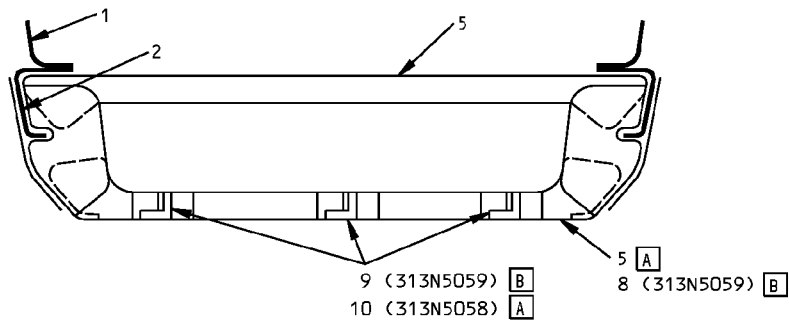

**SECTION AT PPSTA 225.75
OTHER SECTIONS SIMILAR
SECTION A-A**

ITEM	DESCRIPTION	GAGE	MATERIAL	EFFECTIVITY
1	ANGLE	0.063	CLAD 7075-T6	
2	CHORD	0.080	CLAD 7075-T6	
3	CROSS TIE	0.080	CLAD 7075-T6	
4	FRAME	0.040	CLAD 7075-T6	
5	ANGLE	0.040	CLAD 7075-T6	
6	BULKHEAD	0.040	CLAD 7075-T6	
7	FITTING		CASTING 17-4 PH (AISI 630) PER AMS 5344-HT-TR 180 KSI MIN	
8	ANGLE	0.063	CLAD 2024-T42	[B]
9	STIFFENER	0.040	CLAD 2024-T42	[B]
10	STIFFENER	0.040	CLAD 2024-T42	[A]

LIST OF MATERIALS FOR DETAIL III, IV, AND V

**Strut Fairing Structure Identification - RB211-535 Engine
Figure 1 (Sheet 5 of 6)**

**757-200
STRUCTURAL REPAIR MANUAL**

REF DWG
313N5021
313N5058
313N5059

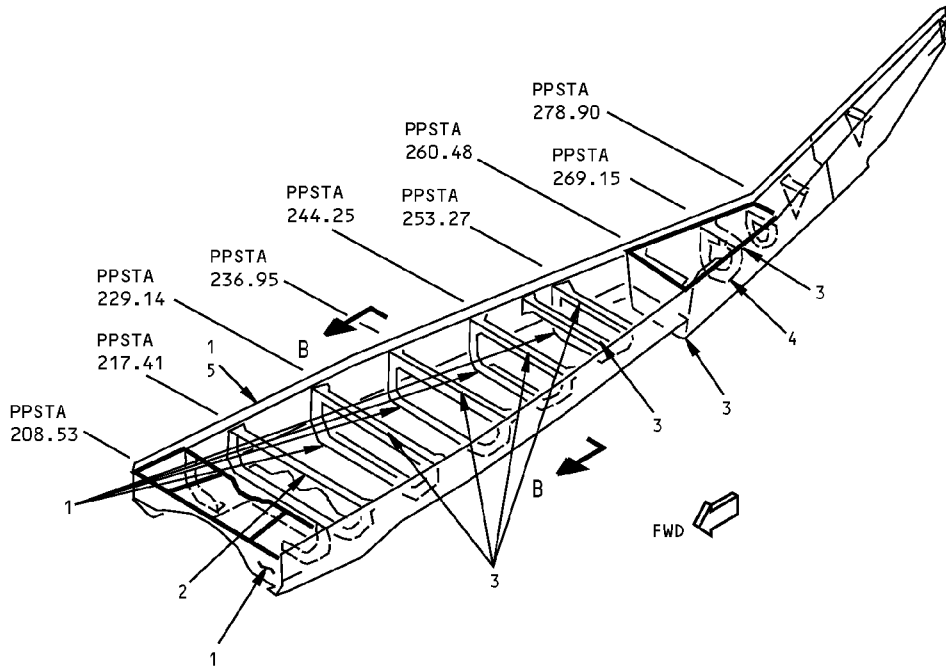

DETAIL VI

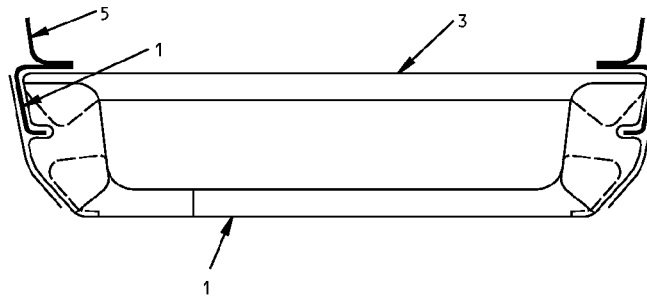

SECTION B-B

ITEM	DESCRIPTION	GAGE	MATERIAL	EFFECTIVITY
1	CHANNEL	0.080	CLAD 7075-T6	
2	BULKHEAD	0.040	CLAD 2024-T42	
3	ANGLE	0.040	CLAD 7075-T6	
4	ANGLE	0.040	17-7 PH, HT TO 150-170 KSI	
5	ANGLE	0.063	CLAD 7075-T6	

LIST OF MATERIALS FOR DETAIL VI

**Strut Fairing Structure Identification - RB211-535 Engine
Figure 1 (Sheet 6 of 6)**

IDENTIFICATION 1
Page 6
Jan 20/2005

54-50-71

D634N201

**757-200
STRUCTURAL REPAIR MANUAL**

ALLOWABLE DAMAGE 1 - STRUT FAIRING STRUCTURE - RB211-535 ENGINE

REFERENCE DRAWING
313N5003

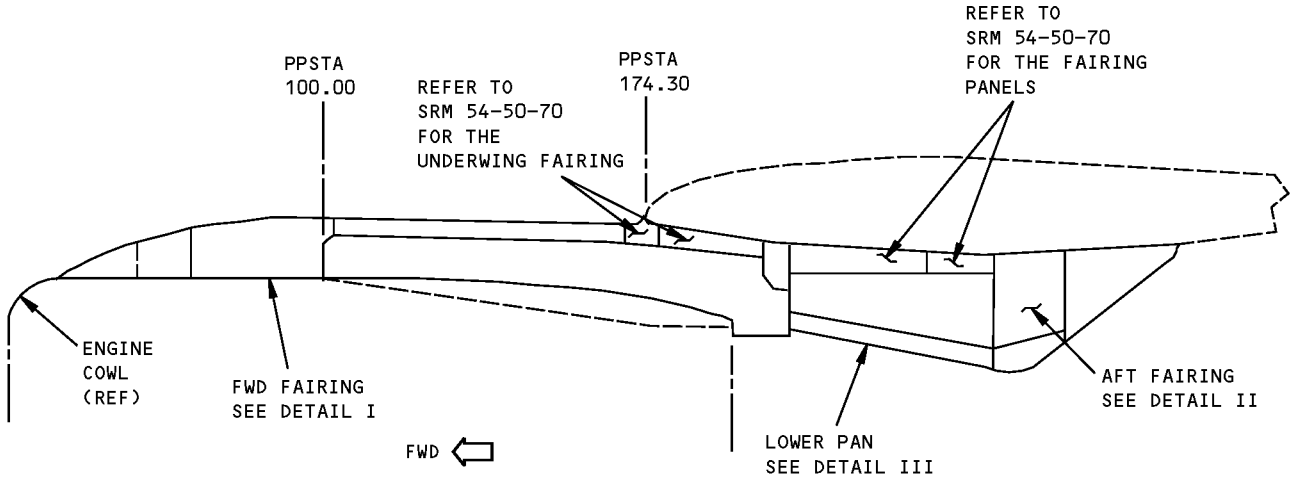

REFERENCE DRAWINGS
313N5036
313N5037

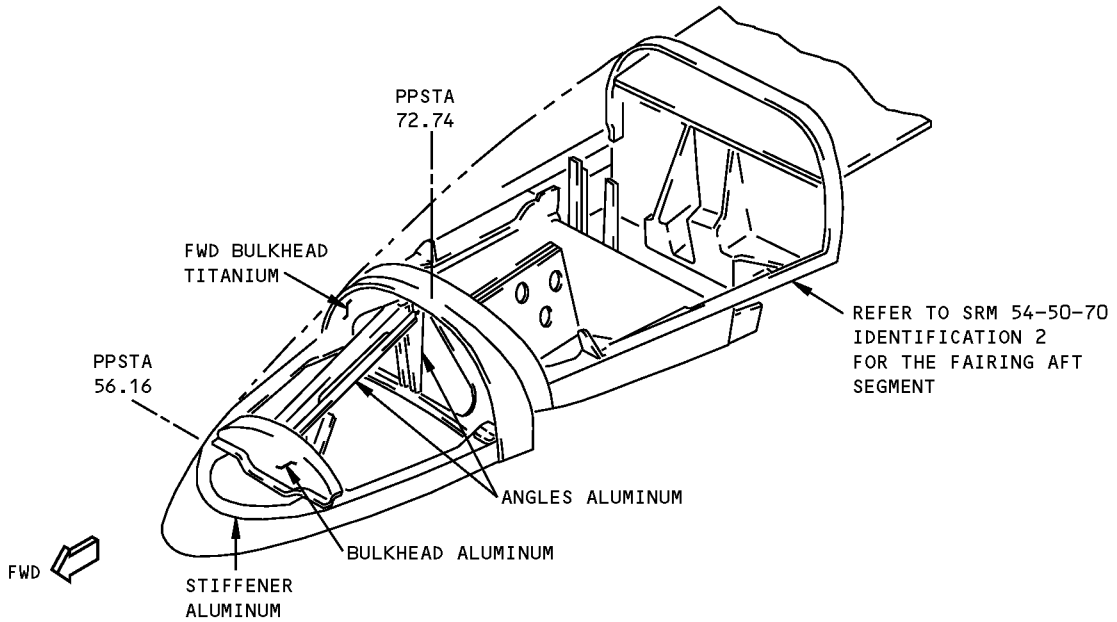

DETAIL I

**Strut Fairing Structure Allowable Damage - RB211-535 Engine
Figure 101 (Sheet 1 of 5)**

**757-200
STRUCTURAL REPAIR MANUAL**

REF DWG
313N5033

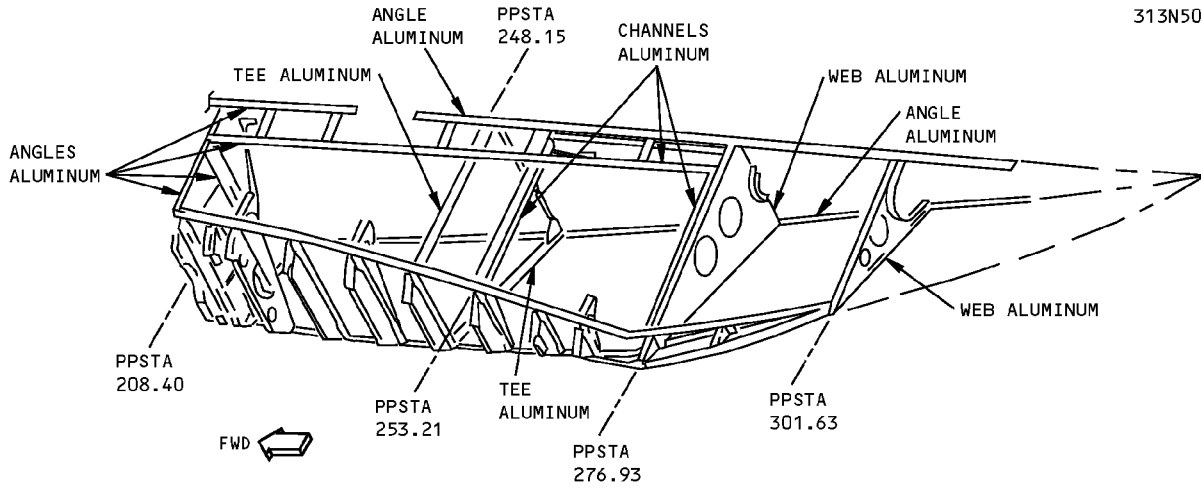

DETAIL II

REF DWG
313N5021

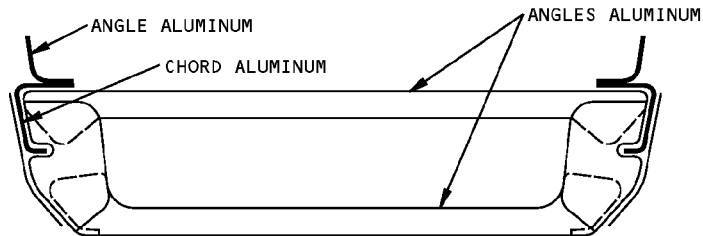
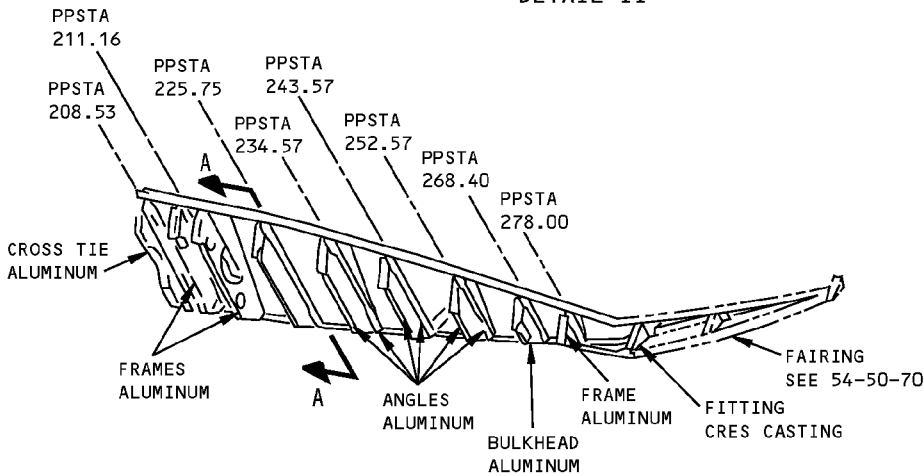

SECTION AT PPSTA 225.75
(TYPICAL)
SECTION A-A
DETAIL III

**Strut Fairing Structure Allowable Damage - RB211-535 Engine
Figure 101 (Sheet 2 of 5)**

ALLOWABLE DAMAGE 1
Page 102
Jan 20/2005

54-50-71

D634N201



**757-200
STRUCTURAL REPAIR MANUAL**

DESCRIPTION	CRACKS	NICKS, GOUGES AND CORROSION	DENTS	HOLES AND PUNCTURES
FWD BULKHEAD	A	B	SEE DETAIL VI	E
STIFFENER	A	B	SEE DETAIL VI	SEE DETAIL X
ANGLES	A	B	SEE DETAIL VI	SEE DETAIL X
BULKHEADS	A	B	SEE DETAIL VI	D
TEES	A	B	SEE DETAIL VI	SEE DETAIL X
CHANNELS	A	B	SEE DETAIL VI	D
WEBS	C	B	SEE DETAIL VI	D
FRAMES	A	B	SEE DETAIL VI	D
CROSS TIE	A	B	SEE DETAIL VI	D
FITTING	A	B	NOT ALLOWED	NOT ALLOWED
CHORD	A	B	SEE DETAIL VI	D

NOTES

- REFINISH REWORKED AREAS PER 51-20 OF THE MAINTENANCE MANUAL
- A CRACKS NOT ALLOWED EXCEPT FOR EDGE CRACKS WHICH MUST BE REMOVED PER DETAILS IV AND IX
- B REMOVE DAMAGE PER DETAILS IV, V, AND VII
- C CRACKS NOT ALLOWED EXCEPT FOR EDGE CRACKS WHICH MUST BE REMOVED PER DETAILS IV AND VIII
- D CLEAN OUT DAMAGE UP TO 0.25 MAX DIA AND NOT CLOSER THAN 1.0 INCH TO FASTENER HOLE OR OTHER DAMAGE. FILL HOLE WITH A 2117-T3 OR T4 ALUMINUM RIVET INSTALLED WET WITH BMS 5-95 SEALANT. ALL OTHER HOLES TO BE REPAIRED
- E CLEAN OUT DAMAGE UP TO 0.25 MAX DIA AND NOT CLOSER THAN 1.0 INCH TO FASTENER HOLE OR OTHER DAMAGE. FILL HOLE WITH A MONEL RIVET INSTALLED DRY. ALL OTHER HOLES TO BE REPAIRED

**Strut Fairing Structure Allowable Damage - RB211-535 Engine
Figure 101 (Sheet 3 of 5)**

STRUCTURAL REPAIR MANUAL

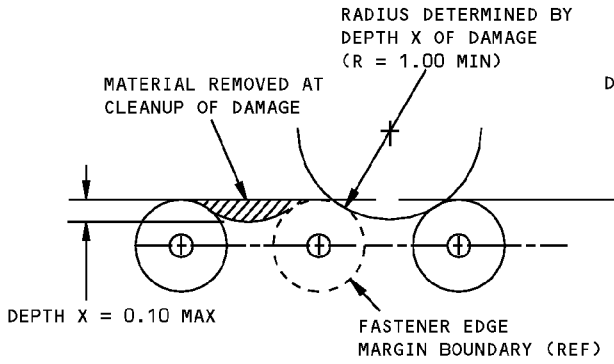

DAMAGE CLEANUP OF EDGES WHERE FASTENER EDGE MARGINS DO NOT OVERLAP

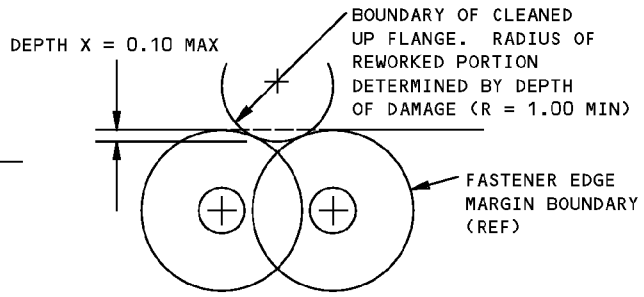

DAMAGE CLEANUP OF EDGES WHERE FASTENER EDGE MARGINS OVERLAP

DETAIL IV

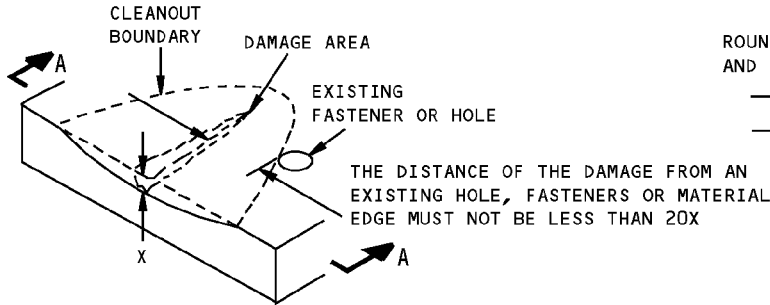

REMOVAL OF NICK, GOUGE AND SCRATCH DAMAGE ON A SURFACE
DETAIL V

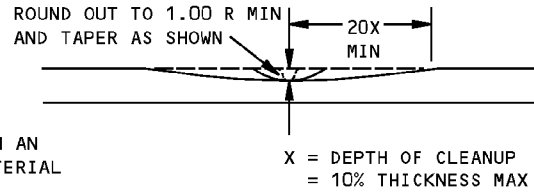

SECTION A-A

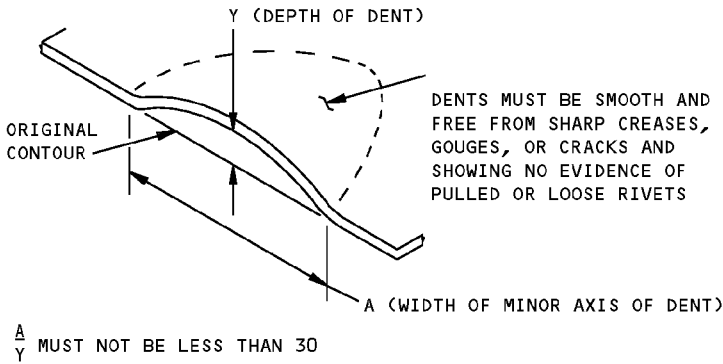

ALLOWABLE DAMAGE FOR DENT
DETAIL VI

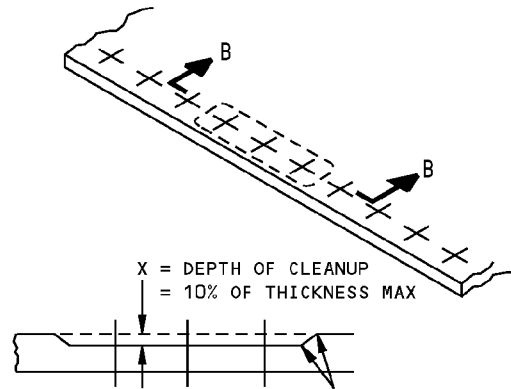

SMOOTH BLENDOUT RADIUS 0.50 INCH MINIMUM. CORROSION CLEANUP AROUND ANY THREE FASTENERS IN TEN IS PERMITTED TO MAX DEPTH

SECTION B-B

CORROSION CLEANUP
DETAIL VII

Strut Fairing Structure Allowable Damage - RB211-535 Engine
Figure 101 (Sheet 4 of 5)

**757-200
STRUCTURAL REPAIR MANUAL**

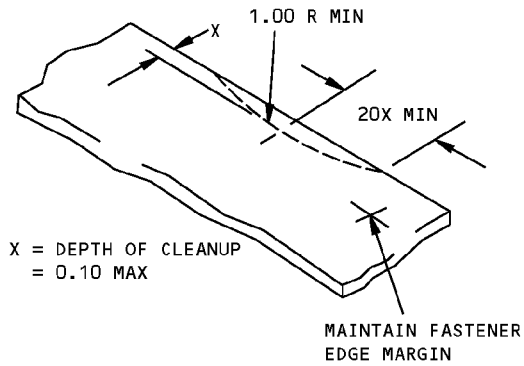

**REMOVAL OF NICK OR CRACK
DAMAGE ON AN EDGE**

DETAIL VIII

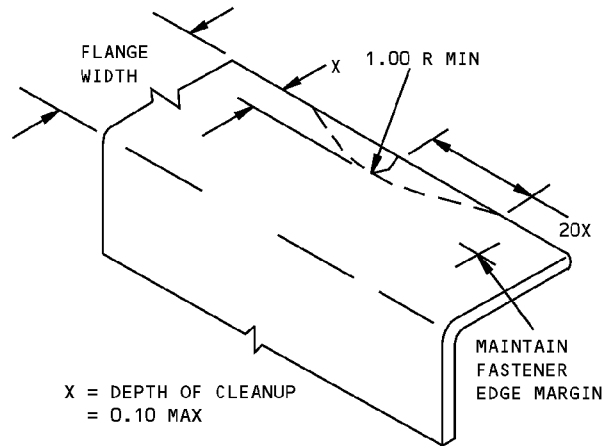

**REMOVAL OF NICK OR CRACK
DAMAGE ON AN EDGE**

DETAIL IX

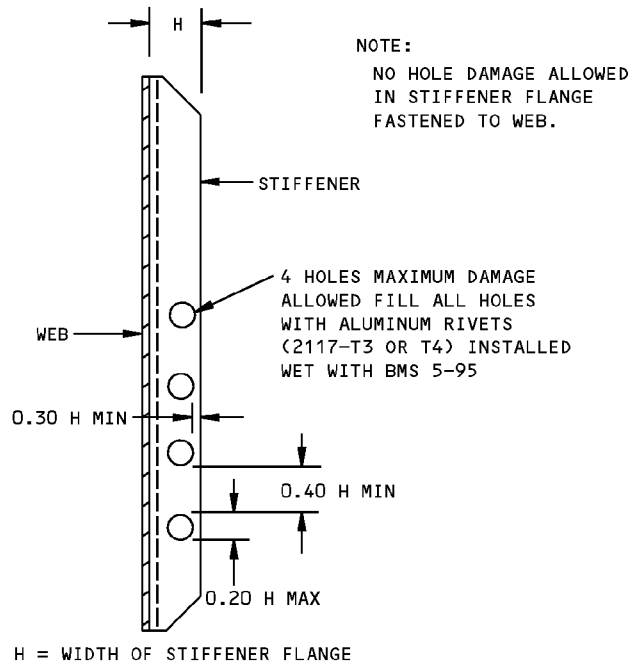

**ALLOWABLE DAMAGE LIMITS FOR
HOLES IN WEB STIFFENERS**

DETAIL X

**Strut Fairing Structure Allowable Damage - RB211-535 Engine
Figure 101 (Sheet 5 of 5)**



757-200
STRUCTURAL REPAIR MANUAL

REPAIR GENERAL - STRUT FAIRING STRUCTURE - RB211-535 ENGINE - SERVICE BULLETIN LIST

SERVICE BULLETIN REPAIRS

The following Service Bulletins contain repairs which are available for use where specific damage has been encountered. Usually, the Service Bulletin also covers preventive modification data which operators are encouraged to use to eliminate the need for repair.

DAMAGED AREA	CUM LINE NUMBER EFFECTIVITY	SB NUMBER
NACELLES/PYLONS - ENGINE TO WING FAIRING - AFT FAIRING PANEL INSPECTION/REPAIR	19 THRU 75 WITH ROLLS-ROYCE ENGINES	54-0006

Strut Fairing Structure - RB211-535 Engine
Figure 201

D634N201

54-50-71

REPAIR GENERAL
Page 201
Jan 20/2005

**757-200
STRUCTURAL REPAIR MANUAL**

REPAIR 1 - STRUT FAIRING STRUCTURE - RB211-535 ENGINE

REFERENCE DRAWING
313N5003

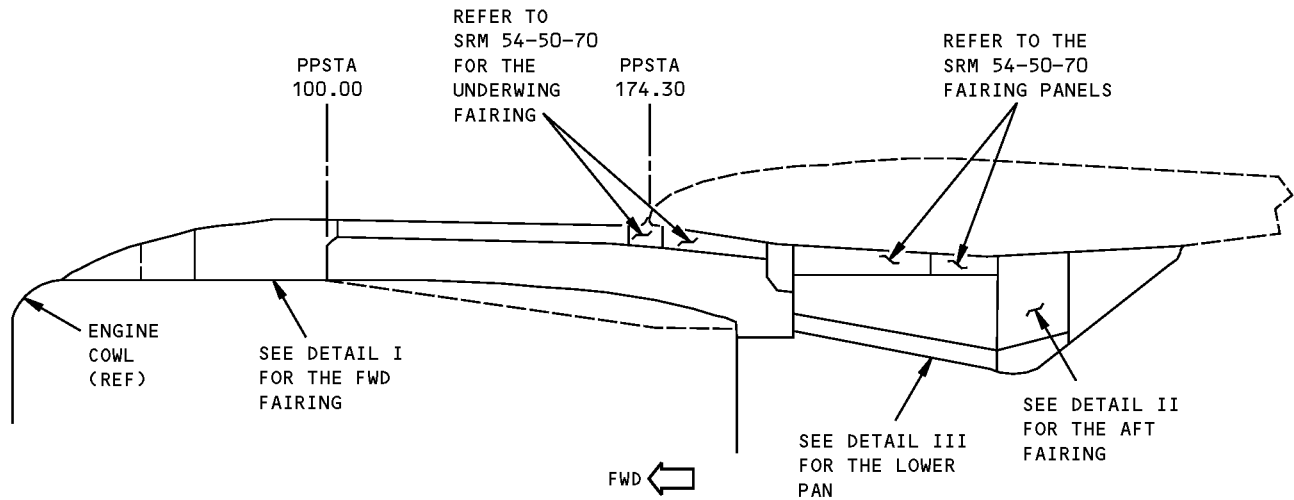

NOTES

- REFINISH REWORKED AREAS AS SHOWN IN AMM 51-21
- REFER TO SRM 51-10-02 FOR INSPECTION AND REMOVAL OF DAMAGE

- A** REFER TO SRM 51-70-11 FOR FORMED SECTION REPAIR
- B** REFER TO SRM 51-70-12 FOR EXTRUDED SECTION REPAIR
- C** REFER TO SRM 51-70-13 FOR WEB REPAIR
- D** NO TYPICAL REPAIRS APPLICABLE. REPAIRS WILL BE BASED ON SERVICE EXPERIENCE

**Strut Fairing Structure Repair - RB211-535 Engine
Figure 201 (Sheet 1 of 3)**

D634N201

54-50-71

REPAIR 1
Page 201
Jan 20/2006

**757-200
STRUCTURAL REPAIR MANUAL**

REFERENCE DRAWINGS
313N5036
313N5037

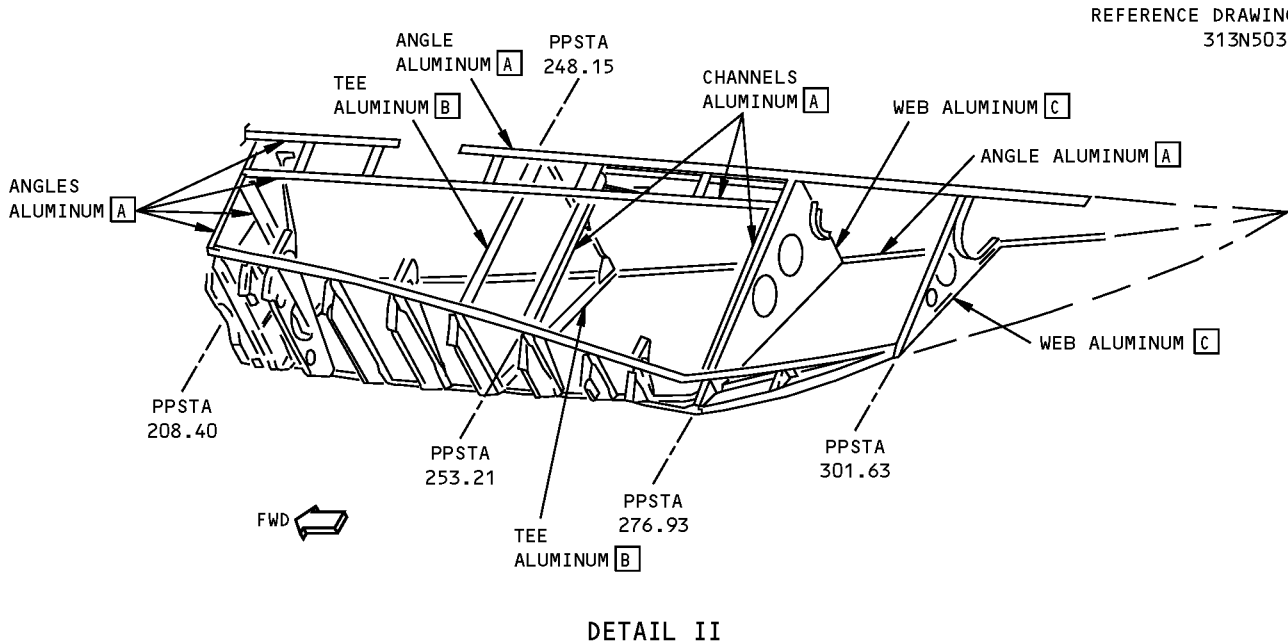
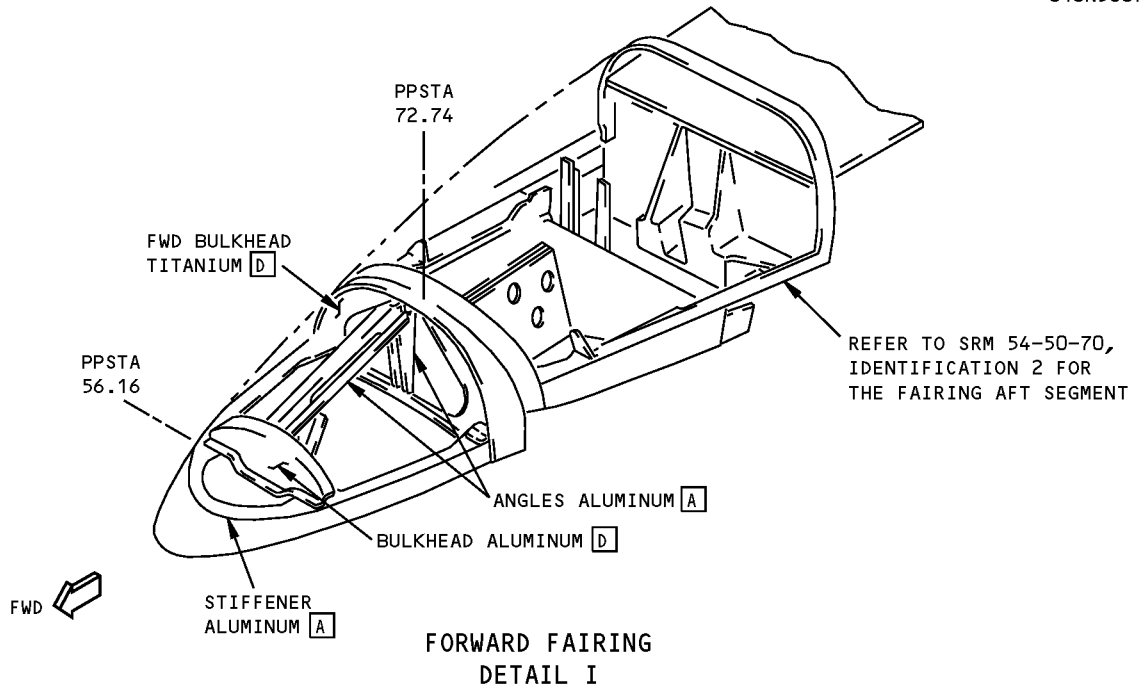

**Strut Fairing Structure Repair - RB211-535 Engine
Figure 201 (Sheet 2 of 3)**

**757-200
STRUCTURAL REPAIR MANUAL**

REF DWG
313N5021

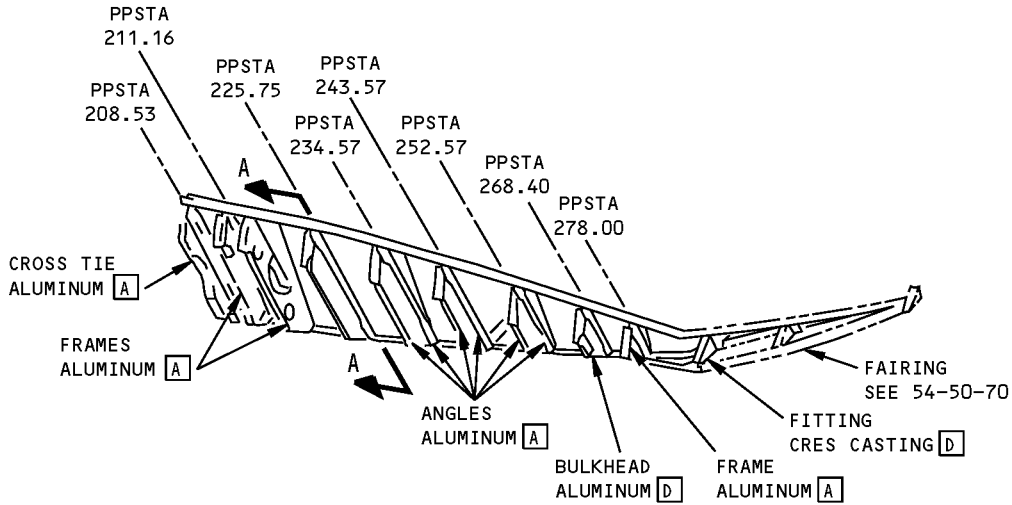

DETAIL III

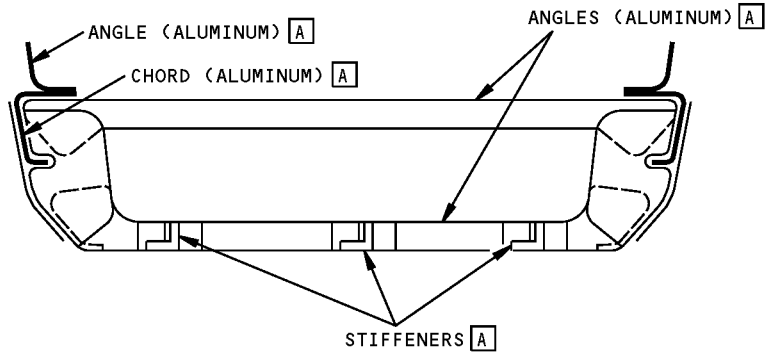

**SECTION AT PPSTA 225.75
OTHER SECTIONS SIMILAR
SECTION A-A**

**Strut Fairing Structure Repair - RB211-535 Engine
Figure 201 (Sheet 3 of 3)**

**757-200
STRUCTURAL REPAIR MANUAL**

IDENTIFICATION 1 - STRUT FITTING - RB211-535 ENGINE

REFER TO IDENTIFICATION 2
FOR THIS ATTACHMENT LINKAGES

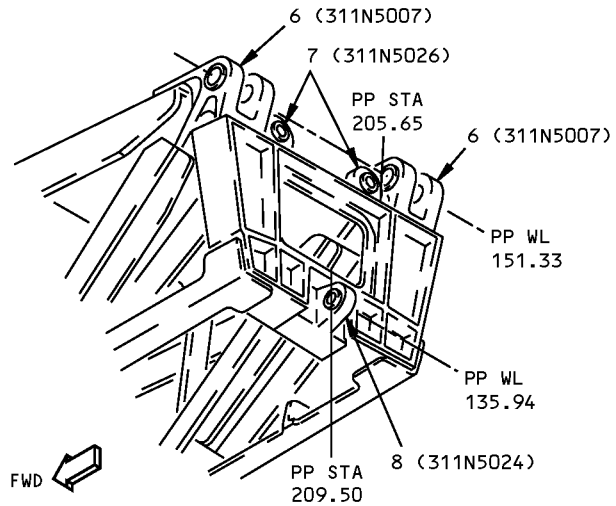
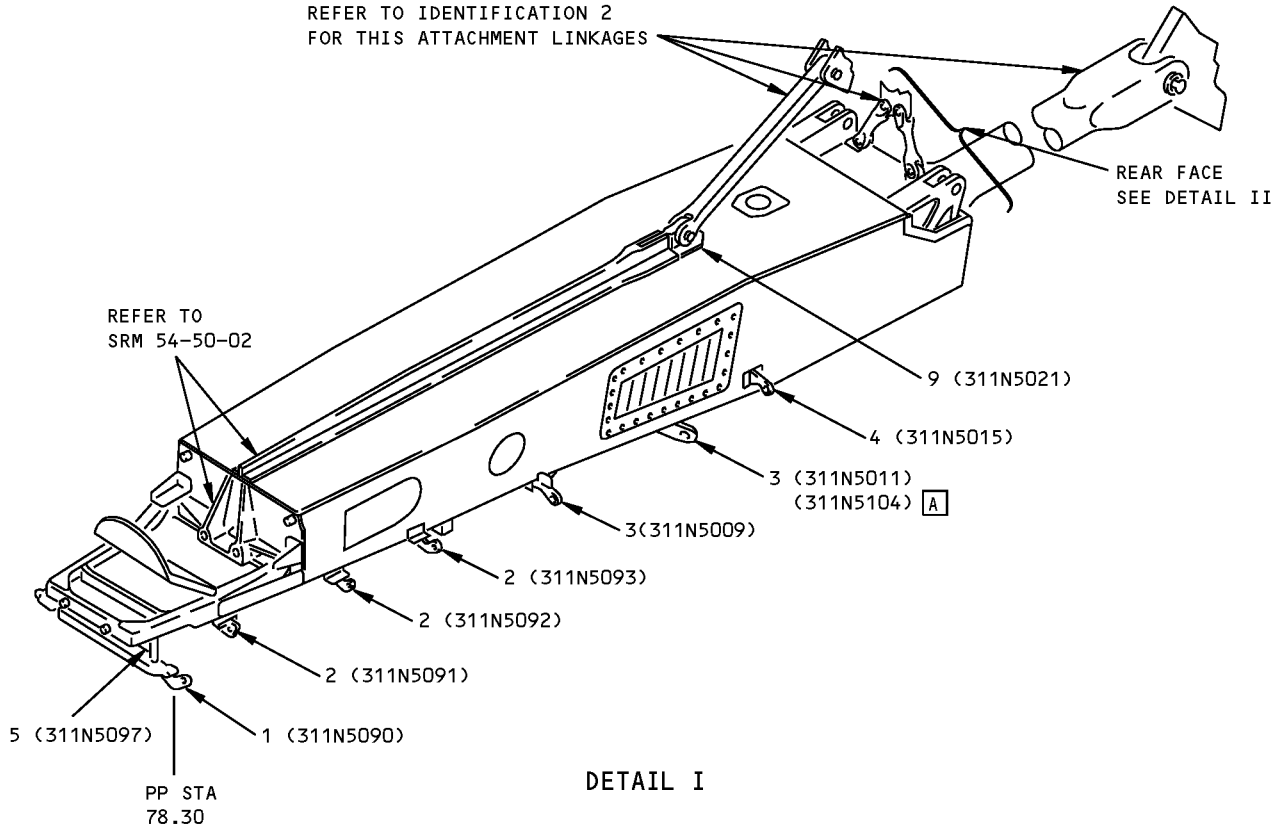

NOTES

- [A] FOR AIRPLANES WITH RB211-535E4 ENGINE
- [B] FOR RB211-535E4 ENGINE STRUTS ON AIRPLANES WITH CUM LINE NUMBERS: 737 AND ON OR WITH SB 757-54-0035 INCORPORATED
- [C] FOR ENGINE STRUTS NOT LISTED IN [B]



**Strut Fitting Identification - RB211-535 Engine
Figure 1 (Sheet 1 of 2)**



**757-200
STRUCTURAL REPAIR MANUAL**

ITEM	DESCRIPTION	GAGE	MATERIAL	EFFECTIVITY
1	HINGE BEAM		BAR OR FORGING TI-6AL-4V ANNEALED	
2	HINGE BEAM		BAR OR CASTING TI-6AL-4V PER BMS 7-181 TYPE I COND A GRADE B	
3	HINGE FITTING		BAR, FORGING, OR CASTING 15-5PH CRES HT TR 180-200 KSI	
4	HINGE FITTING		FORGING 9NI-4CO-.30C HT TR 220 KSI MIN	
5	HINGE LINK	0.250	PLATE TI-6AL-4V TYPE III COMP C	
6	MID SPAR FITTING		FORGING 4330M STEEL HT TR 220-240 KSI FORGING 15-5 PH CRES HT TR 180-200 KSI	C B
7	SIDE LOAD FITTING	1.000 0.625	PLATE 15-5PH CRES HT TR 180-200 KSI PLATE NICKEL ALLOY 718 PER AMS 5596 OPTIONAL: NICKEL ALLOY 718 BAR PER AMS 5662 SOLUTION TREATED, CONDITION II	C B
8	LOWER SPAR FITTING		FORGING TI-6AL-4V ANNEALED	
9	UPPER SPAR FITTING		FORGING 15-5PH CRES HT-TR 180-200 KSI	

LIST OF MATERIALS FOR DETAILS I AND II

**Strut Fitting Identification - RB211-535 Engine
Figure 1 (Sheet 2 of 2)**

D634N201

54-50-90

IDENTIFICATION 1
Page 2
Jan 20/2005

**757-200
STRUCTURAL REPAIR MANUAL**

IDENTIFICATION 2 - ATTACHMENT LINKAGE - RB211-535 ENGINE

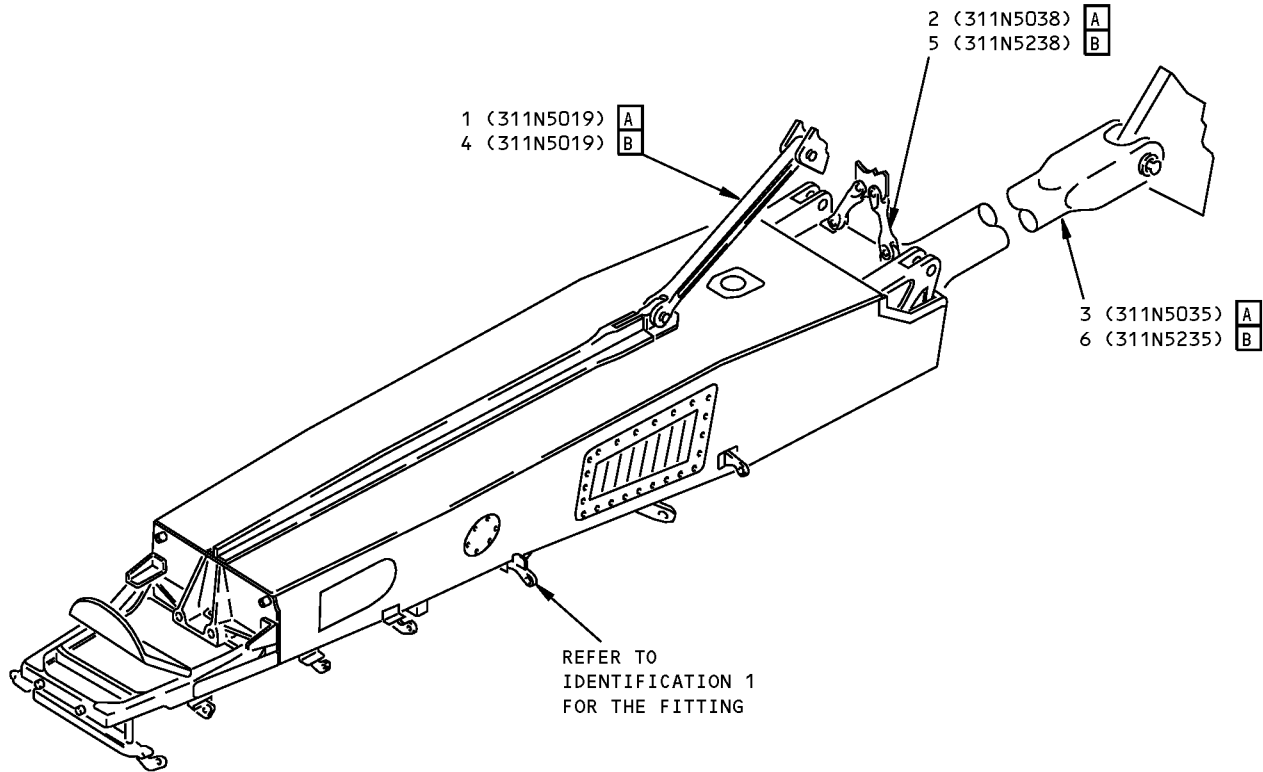

ITEM	DESCRIPTION	GAGE	MATERIAL	EFFECTIVITY
1	UPPER LINK		FORGING 4330M HT TR 220 KSI MIN	A
2	SIDE LINK		BAR 2024-T4	A
3	DIAGONAL BRACE	2.000	TUBE 7.0 DIA 2024-T42	A
4	UPPER LINK		FORGING 9NI-4CO-.30C BMS 7-182, TYPE II, HT TR 220 KSI MINIMUM	B
5	SIDE LINK	0.600	TI-6AL-4V PLATE CODE AB-1, CONDITION A	B
6	DIAGONAL BRACE		FORGING 9NI-4CO-.30C BMS 7-182, TYPE II, HT TR 220 KSI MINIMUM	B

LIST OF MATERIALS

NOTES

- A FOR AIRPLANES WITH CUM LINE NUMBERS: 1 THRU 736 WITHOUT SB 757-54-0035 INCORPORATED
- B FOR AIRPLANES WITH CUM LINE NUMBERS: 737 AND ON, AND FOR AIRPLANES WITH SB 757-54-0035 INCORPORATED

**Attachment Linkage Identification - RB211-535 Engine
Figure 1**

**757-200
STRUCTURAL REPAIR MANUAL**

ALLOWABLE DAMAGE 1 - LINKS AND FITTINGS - RB211-535 ENGINE

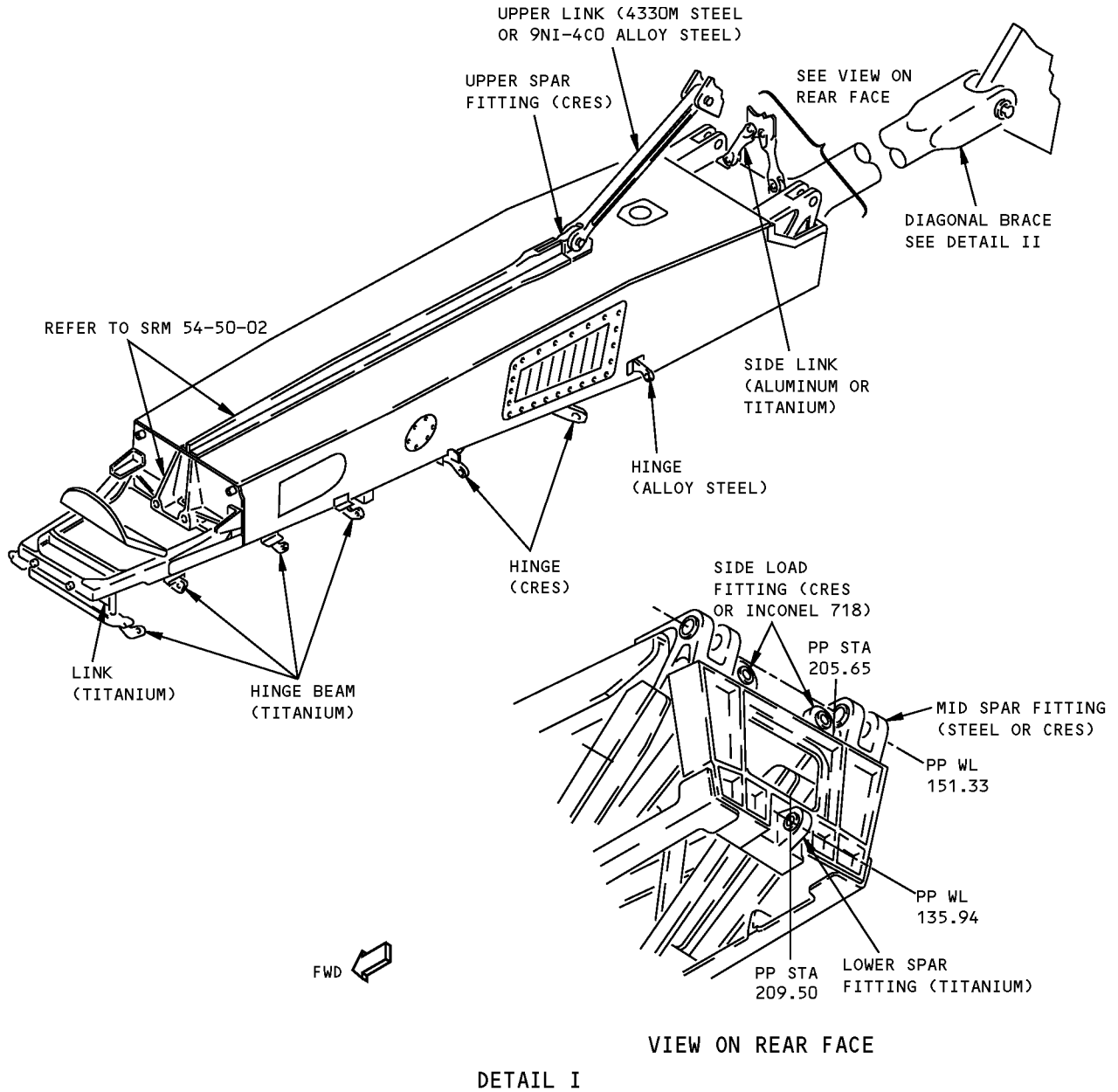

DESCRIPTION [E]	CRACKS	NICKS, GOUGES AND CORROSION	DENTS	HOLES AND PUNCTURES
HINGE	[A]	[A]	NOT ALLOWED	NOT ALLOWED
LINK	[A]	[A]	NOT ALLOWED	NOT ALLOWED
FITTING	[A]	[A] [F]	NOT ALLOWED	NOT ALLOWED

**Links and Fittings Allowable Damage - RB211-535 Engine
Figure 101 (Sheet 1 of 5)**

**757-200
STRUCTURAL REPAIR MANUAL**

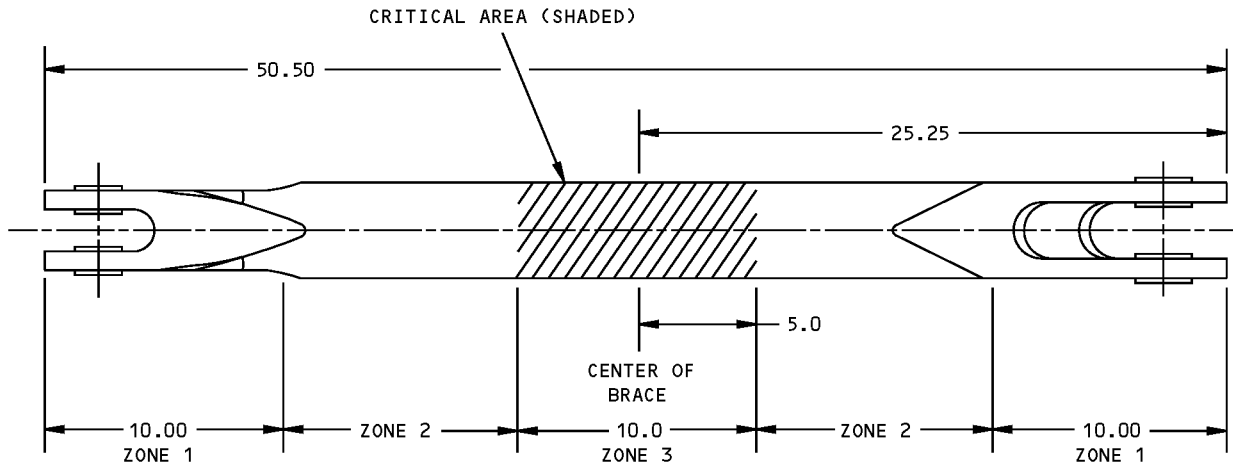

NOTE: MATERIAL IS ALUMINUM TUBING OR 9NI-4CO ALLOY STEEL FORGING.

**DIAGONAL BRACE
DETAIL II**

DESCRIPTION	CRACKS	NICKS, GOUGES, SCRATCHES AND CORROSION	DENTS	HOLES AND PUNCTURES
DIAGONAL BRACE [E]				
ZONE 1	[B]	[C]	NOT ALLOWED	NOT ALLOWED
ZONE 2	[D]	[D]		
ZONE 3 (CRITICAL AREA)	NOT ALLOWED	[D]		

ALLOWABLE DAMAGE FOR DETAIL II

**Links and Fittings Allowable Damage - RB211-535 Engine
Figure 101 (Sheet 2 of 5)**

STRUCTURAL REPAIR MANUAL

NOTES

- REFER TO AMM 51-20 TO APPLY THE FINISH TO THE REWORK AREA.
 - REFER TO SRM 51-10-02 FOR INSPECTION AND REMOVAL OF DAMAGE
 - REFER TO SRM 51-20-00 FOR PROTECTIVE TREATMENT OF METAL PARTS.
- A** FOR EDGE DAMAGE REFER TO DETAIL VI. FOR LUG DAMAGE REFER TO DETAIL V. FOR OTHER DAMAGE REFER TO DETAIL III. DAMAGE NOT ALLOWED IN VICINITY OF BUSHINGS.
- B** CRACKS NOT ALLOWED EXCEPT FOR EDGE CRACKS WHICH MUST BE REMOVED AS GIVEN IN DETAIL IV AND V.
- C** FOR EDGE DAMAGE REFER TO DETAIL IV. FOR LUG DAMAGE REFER TO DETAIL V. FOR OTHER DAMAGE REFER TO DETAIL III. DAMAGE NOT ALLOWED IN VICINITY OF BUSHINGS.
- D** REMOVE DAMAGE AS GIVEN IN DETAIL VII.
- E** SHOT PEEN REWORKED AREAS AS GIVEN IN SRM 51-20-06.
- F** CORROSION OR ABRASIONS ON THE FACE OF THE LUG UNDER THE FLANGE OF THE BUSHING MUST BE REMOVED AS GIVEN IN DETAIL VIII. WHEN YOU REMOVE THE DAMAGE, MAKE SURE THE SPOTFACE IS PERPENDICULAR TO THE BORE. AS A RESULT OF THE SPOTFACE, TRIM 0.01 TO 0.02 INCH (0.25 TO 0.50 mm) FROM THE NON-FLANGED END OF THE BUSHING BEFORE INSTALLATION.

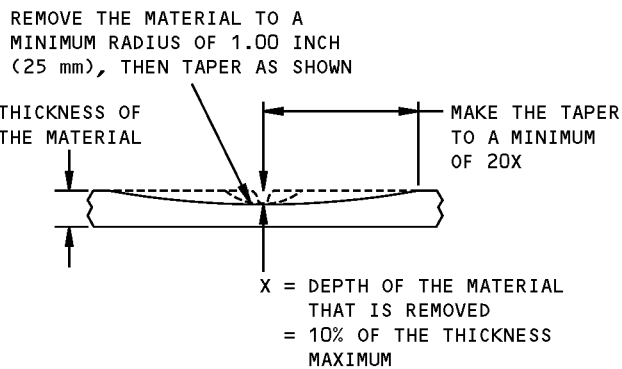
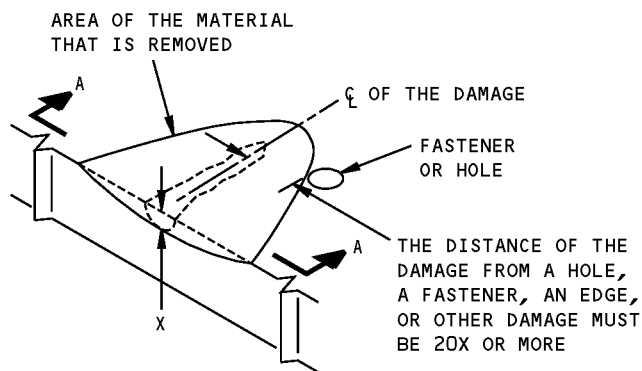

SECTION A-A

REMOVAL OF NICK, GOUGE, CORROSION AND SCRATCH DAMAGE ON A SURFACE
DETAIL III

Links and Fittings Allowable Damage - RB211-535 Engine
Figure 101 (Sheet 3 of 5)

**757-200
STRUCTURAL REPAIR MANUAL**

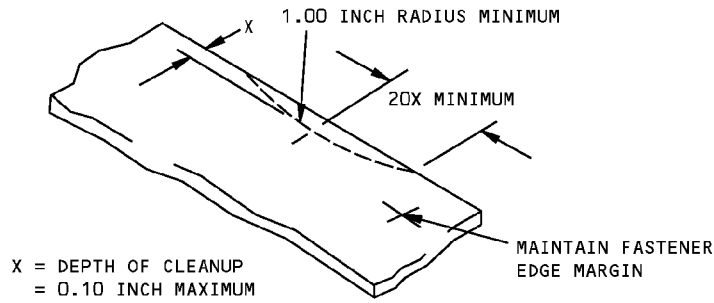

**REMOVAL OF DAMAGE ON AN EDGE
DETAIL IV**

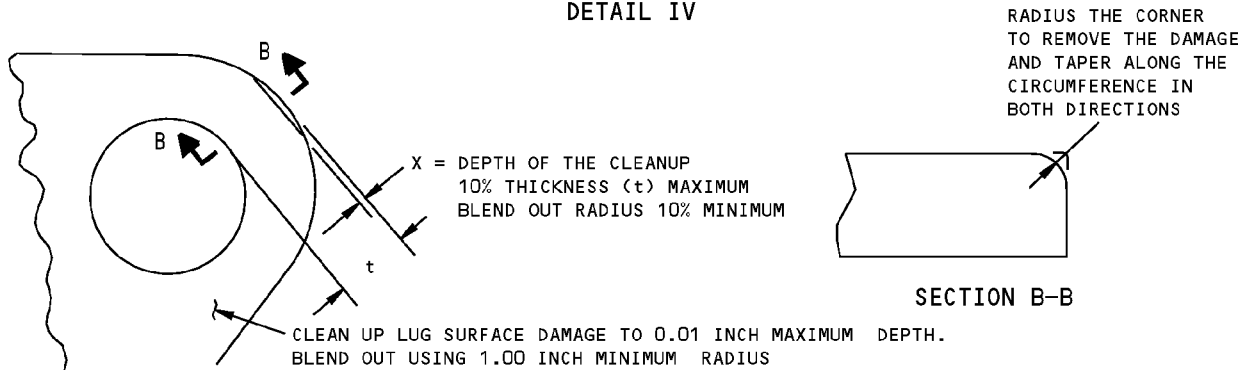

**DAMAGE CLEANUP FOR SURFACES OF LUG
DETAIL V**

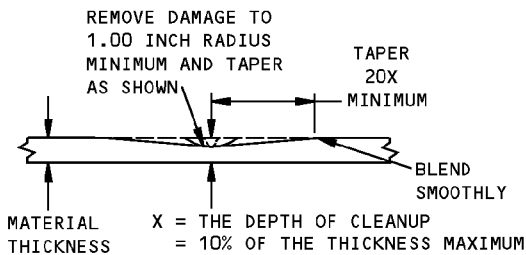
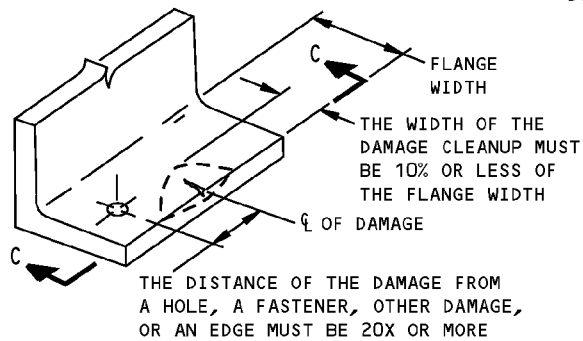

SECTION C-C

**REMOVAL OF NICK OR CRACK DAMAGE ON EDGE
DETAIL VI**

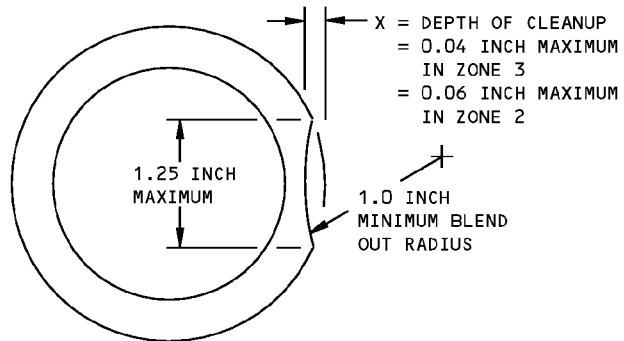

**REMOVAL OF DAMAGE ON A SURFACE
DETAIL VII**

**Links and Fittings Allowable Damage - RB211-535 Engine
Figure 101 (Sheet 4 of 5)**

**757-200
STRUCTURAL REPAIR MANUAL**

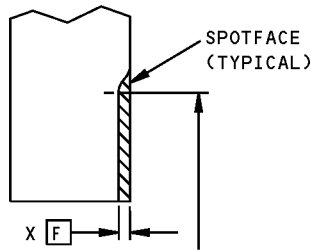
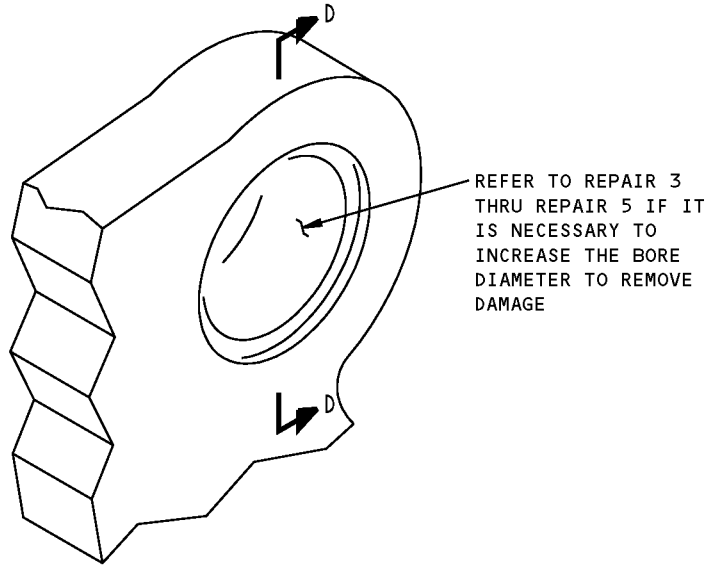

BUSHING FLANGE DIAMETER
+0.01 INCH (0.25 mm)
MAXIMUM

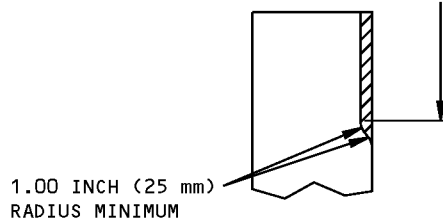

X = 0.010 INCH (25 mm) MAXIMUM

DAMAGE ON LUG FACE
SECTION D-D

REMOVAL OF DAMAGE ON THE LUG FACE UNDER THE FLANGE OF THE BUSHING

DETAIL VIII

 SHADED AREA SHOWS WHERE DAMAGE HAS BEEN REMOVED

**Links and Fittings Allowable Damage - RB211-535 Engine
Figure 101 (Sheet 5 of 5)**



757-200
STRUCTURAL REPAIR MANUAL

REPAIR GENERAL - STRUT ATTACHMENT FITTINGS AND LINKAGE - RB211-535 ENGINE - SERVICE BULLETIN LIST

SERVICE BULLETIN REPAIRS

The following Service Bulletins contain nacelle strut attach structure repairs which are available for use where specific damage has been encountered. Usually, the Service Bulletin also covers preventive modification data which operators are encouraged to use to eliminate the need for repair.

DAMAGED AREA	CUM LINE NUMBER EFFECTIVITY	SB NUMBER
NACELLE STRUT - STRUT-TO-WING ATTACH STRUCTURE IMPROVEMENT	1 THRU 735	757-54-0035
NACELLE STRUT - STRUT-TO-WING ATTACH FITTINGS - INSPECTION OR LUG HOLE OVERSIZING	1 THRU 735	757-54-0038

Strut Attachment Fittings and Linkage - RB211-535 Engine
Figure 201

D634N201

54-50-90

REPAIR GENERAL
Page 201
Jan 20/2005

**757-200
STRUCTURAL REPAIR MANUAL**

REPAIR 1 - STRUT FITTING - RB211-535 ENGINE

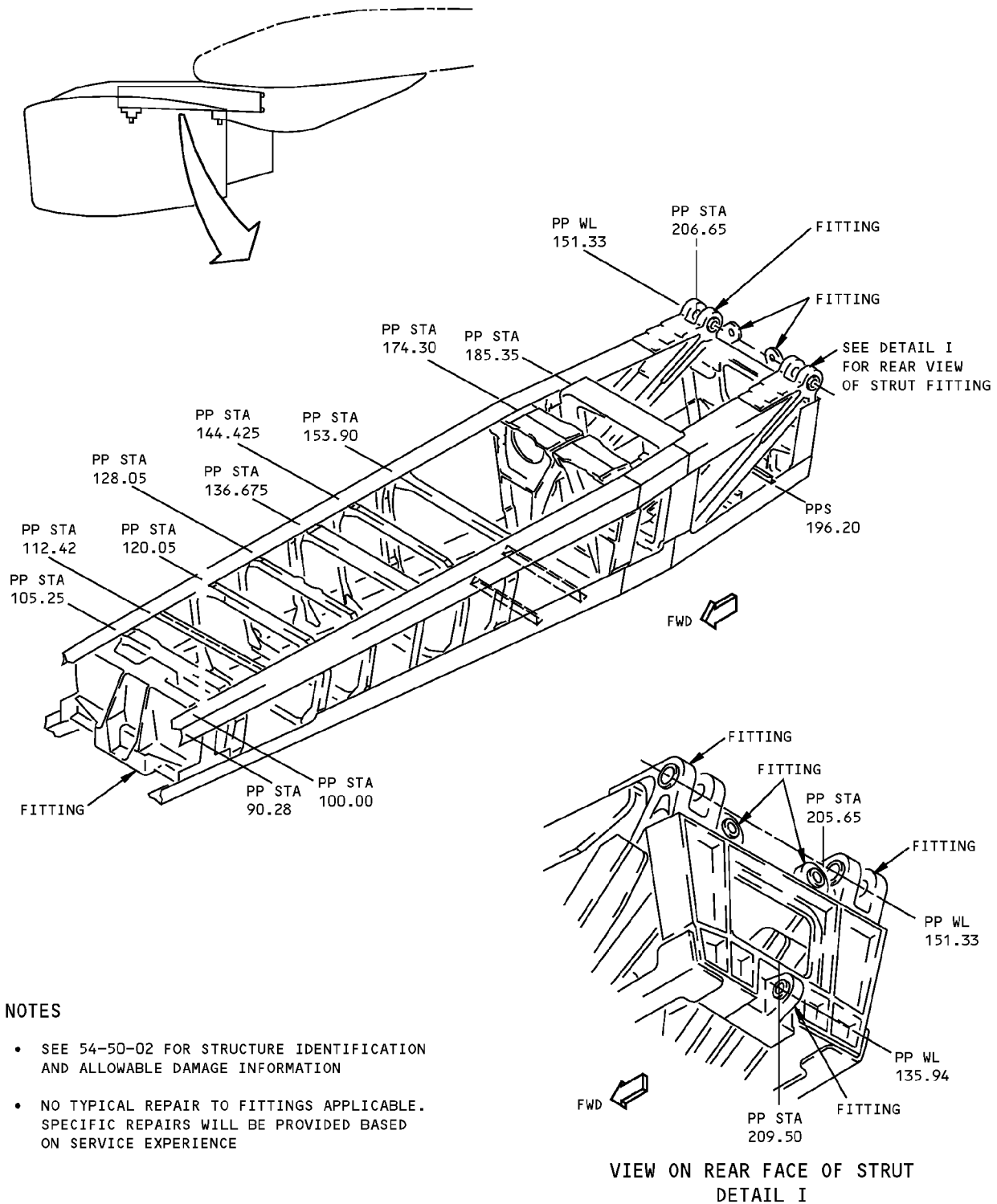

NOTES

- SEE 54-50-02 FOR STRUCTURE IDENTIFICATION AND ALLOWABLE DAMAGE INFORMATION
- NO TYPICAL REPAIR TO FITTINGS APPLICABLE. SPECIFIC REPAIRS WILL BE PROVIDED BASED ON SERVICE EXPERIENCE

**Strut Fitting Repair - RB211-535 Engine
Figure 201**

**757-200
STRUCTURAL REPAIR MANUAL**

REPAIR 2 - ATTACHMENT LINKAGE - RB211-535 ENGINE

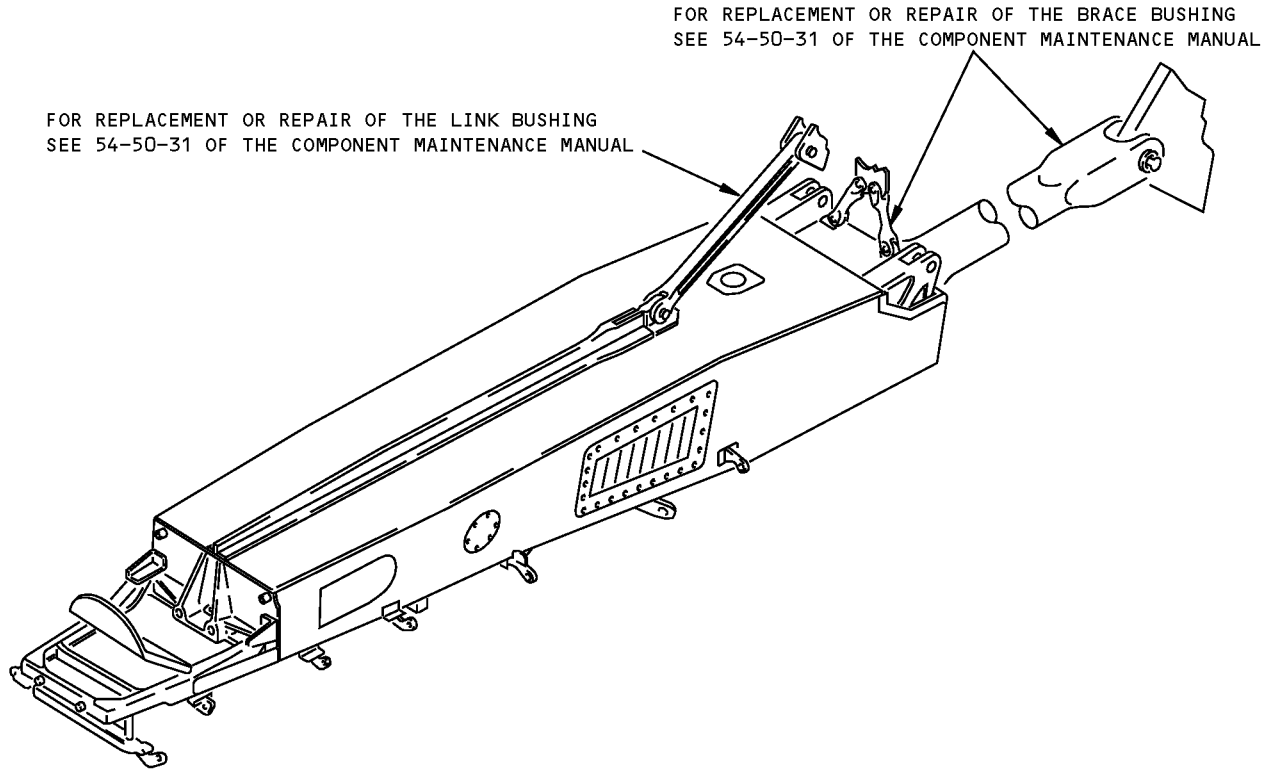

**Attachment Linkage Repair - RB211-535 Engine
Figure 201**

D634N201

54-50-90

REPAIR 2
Page 201
Jan 20/2005

STRUCTURAL REPAIR MANUAL

**REPAIR 3 - FORWARD UPPER SPAR FITTING, LUG HOLE REPAIR WITH INTERFERENCE FIT BUSHING
PROCEDURE - RB211-535 ENGINE**

APPLICABILITY

THIS REPAIR USES THE INTERFERENCE FIT PROCEDURE TO INSTALL THE REPLACEMENT BUSHINGS FOR THE FORWARD UPPER SPAR FITTING ON THE RB211-535 ENGINE. **A**

REPAIR INSTRUCTIONS

PROCEDURE I - REMOVE THE INITIAL BUSHINGS

1. Remove the engine strut from the wing. Refer to AMM 54-51-01.
2. Remove the engine strut access doors. Refer to AMM 54-53-01.
3. Remove the engine strut components as necessary to get access. Refer to AMM 54-51-01.
 - A. Make a record of the position of wire bundles and cables on the two sides of the forward upper spar fitting. Move the wire bundles and cables away from the fitting to make clearance for the repair tools. Disconnect the wires as necessary. If you disconnect electric connections, install caps or plugs at the connection. You can also attach tags that give the location of the connection. This will help you make the connection again.
 - B. Remove tubes, duct, clamps support blocks, and brackets near the fitting as necessary to make clearance for the repair tools.
 - C. Drain the fuel supply line and the hydraulic fluid lines to the engine.
4. Get or make the split bushing removal tool. The Boeing tool number is B54016-1.
5. Remove the two bushings from the lug with the split bushing removal tool.
6. Discard the initial bushings. The bushing material is aluminum-nickel-bronze alloy.

PROCEDURE II - DO AN INSPECTION OF THE LUG HOLE

1. Do an inspection of the inner surface of the hole from which you removed the bushings. Use one of the procedures that follows:
 - Dye penetrant inspection Type I, method C, sensitivity level 3 or higher as specified in SOPM 20-20-02.
 - High Frequency Eddy Current inspection as specified in NDT D6-643N301. Part 6, 51-00-13.
2. If you find damage, you must machine the inner surface of the hole. Continue with the steps given in Procedure III.

3. If no damage is found and the airplane age is more than 15 years, you must machine the inner surface of the hole. Continue with the steps given in Procedure III to remove a minimum of 0.010 inch on the diameter from the inner surface of the hole.
4. If no damage is found and the airplane age is 15 years or less, it is not necessary to machine the inner surface of the hole. Continue with the steps given in Procedure VI.

PROCEDURE III - MACHINE THE LUG HOLE

1. Install the proper diameter reamer or boring tools to machine the hole as necessary to remove damage. Use a temporary sheet cover that is approximately 0.063 inch thick to hold the tools over the hole for the thermal anti-ice duct.

CAUTION: MAKE SURE THE TOOLS USED TO MACHINE THE HOLE ARE CORRECTLY ALIGNED BEFORE YOU MACHINE THE HOLE. IF THE TOOLS ARE NOT CORRECTLY ALIGNED THEN THE HOLE WILL NOT BE CUT IN THE CORRECT LOCATION. IF YOU DO NOT OBEY, THE REPAIR CAN BE UNSATISFACTORY.

2. Machine the hole as necessary to remove the damage.
 - A. The material of the fitting is 15-5PH corrosion resistant steel.
 - B. Do a magnetic particle inspection to make sure all of the damage is removed. If the inspection shows that there is no more damage, machine an insurance cut that is a minimum of 0.010 inch on the diameter.
 - C. The maximum diameter of the hole is 1.9360 inches, see DETAIL II, SECTION A-A. If the diameter of the hole is larger than the maximum, you must get alternative repair instructions from Boeing.
3. Put a 0.020 to 0.030 inch by 45 degree chamfer on the edges of the hole. As an alternative to the chamfer, you can make an equivalent radius.
4. Remove the tools.
5. Remove the sharp edges and burrs from the cut surfaces.

**Forward Upper Spar Fitting, Lug Hole Repair with Interference Fit Bushing Procedure - RB211-535 Engine
Figure 201 (Sheet 1 of 8)**

STRUCTURAL REPAIR MANUAL

6. Do a flap peen procedure to the hole. Use a 3M flapwheel that is 9/16 inch by 1.25 inch to get an Almen intensity of 0.012A and a coverage of 2.0. Refer to SOPM 20-10-03.
7. Hone the hole to the final diameter. Make the finish on the inner surface of the hole 32 microinches R_a or smoother. You can remove a maximum of 0.0012 inch from the radius of the hole to get the necessary surface finish. The maximum diameter of the hole is 1.9360 inches.
8. Use Scotch-Brite to remove sharp edges from the surface of the hole and clean the area with solvent.

PROCEDURE IV – MEASURE THE LUG HOLE DIAMETER

1. Measure and record the diameter of the hole. This is dimension B shown in Detail II, SECTION A-A. Measure the diameter before you apply the primer, sealant, or retaining compound.

PROCEDURE V – CALCULATE THE DIAMETER OF THE OVERSIZED BUSHINGS

1. Calculate the diameter, A, of the oversized bushings with the formula that follows. Refer to Detail III for the definition of the dimension A.

$$A = B + 0.0033 \text{ inch} \pm 0.0005 \text{ inch}$$

PROCEDURE VI – MACHINE THE OVERSIZED BUSHINGS

1. If no damage is found and the airplane age is 15 years or less, use the same diameter dimensions as the initial bushings. Refer to Table I and Detail III. Continue with the steps given in Procedure VIII.
2. Machine the oversized bushings to the necessary outer diameter that you found in Procedure V and the other dimensions given in Detail III.
3. Make the surface finish of the outer diameter of the bushings 32 microinches R_a or smoother. Make the surface finish on the other surfaces 63 microinches R_a or smoother.
4. Remove the sharp edges and burrs from the cut surfaces.

PROCEDURE VII – APPLY THE PRIMER

1. Apply one layer of BMS 10-11, Type I primer to the bare surfaces of the lug. Refer to SOPM 20-41-02.
2. Let the primer fully dry before you install the bushings.

PROCEDURE VIII – APPLY RETAINING COMPOUND (OPTIONAL)

1. Apply Loctite 640 retaining compound (MIL-R-46082, Type II) to the inner surface of the lug hole and to the mating surfaces of the lug. Do the steps in Procedure IX in 15 minutes or less from the time you apply the retaining compound.

Forward Upper Spar Fitting, Lug Hole Repair with Interference Fit Bushing Procedure - RB211-535 Engine
Figure 201 (Sheet 2 of 8)



757-200

STRUCTURAL REPAIR MANUAL

PROCEDURE IX - INSTALL THE OVERSIZED BUSHINGS WITH THE SHRINK FIT METHOD

1. Prepare the bushings for installation with the shrink fit method. Use liquid nitrogen at -320°F (-196°C).

WARNING: LIQUID NITROGEN IS APPROXIMATELY -320°F (-196°C). WEAR PROTECTIVE CLOTHING AND USE IN A VENTILATED AREA TO PREVENT INJURY.

2. Soak the bushings and the installation guide bushing in the liquid nitrogen until the boiling stops. Use the guide bushing from Boeing tool kit MIT012N8729-1 or the equivalent. Refer to SOPM 20-50-03.
3. Install the bushings as quickly as possible. Use the installation tools from Boeing tool kit MIT012N8729-1 or the equivalent.

CAUTION: YOU MUST INSTALL THE BUSHING IMMEDIATELY AFTER YOU REMOVE THE BUSHING FROM THE LIQUID NITROGEN. IF THE BUSHING EXPANDS BEFORE IT IS CORRECTLY INSTALLED IN THE FITTING, THE BUSHING MUST BE REMOVED AND REPLACED.

4. Hold the bushing flange tightly against the face of the lug until the assembly is at room temperature to make sure that the bushing is installed correctly. A press fit can be used to complete the shrink fit installation of the bushings.

PROCEDURE X - MACHINE THE INNER DIAMETER OF THE OVERSIZED BUSHINGS

1. Machine the inner diameter of the bushings to a diameter of 1.6250 to 1.6258 inches as shown in Detail V. Make the surface finish 32 microinches R_a .

PROCEDURE XI - PUT THE AIRPLANE BACK TO THE INITIAL CONDITION

1. Install the components that were removed from engine strut.
2. Connect the wires and cables that were disconnected.
3. Install the engine strut access doors as given in AMM 54-53-01.
4. Install the engine strut on the airplane as given in AMM 54-51-01.

Forward Upper Spar Fitting, Lug Hole Repair with Interference Fit Bushing Procedure - RB211-535 Engine
Figure 201 (Sheet 3 of 8)

D634N201

54-50-90

REPAIR 3
Page 203
Jan 20/2005



**757-200
STRUCTURAL REPAIR MANUAL**

NOTES

- ALL DIMENSIONS ARE IN INCHES, UNLESS GIVEN DIFFERENTLY.
- WHEN YOU USE THE REPAIR REFER TO:
 - AMM 54-51-01 FOR THE REMOVAL AND INSTALLATION OF THE STRUT
 - AMM 54-53-01 FOR THE REMOVAL AND INSTALLATION OF THE STRUT PRESSURE RELIEF AND ACCESS DOORS
 - NDT PART 6, 51-00-13, (D6-643N301) FOR HIGH FREQUENCY EDDY CURRENT INSPECTION
 - SOPM 20-10-02 FOR MACHINING OF ALLOY STEEL
 - SOPM 20-10-03 FOR SHOT PEENING AND FLAP PEENING
 - SOPM 20-20-01 FOR MAGNETIC PARTICLE INSPECTION PROCEDURES
 - SOPM 20-41-02 FOR THE APPLICATION OF CHEMICAL AND SOLVENT RESISTANT FINISHES
 - SOPM 20-50-03 FOR BUSHING REMOVAL AND INSTALLATION.

A AS AN ALTERNATIVE, THE EXPANDED FIT BUSHING INSTALLATION PROCEDURE IS PERMITTED IF THE INSTALLATION REQUIREMENTS LISTED IN SRM 51-20-09 ARE SATISFIED. REFER TO SRM 51-20-09 FOR THE LIST OF EXPANDED FIT BUSHING INSTALLATION GUIDELINES.

REPAIR MATERIAL			
PART		QTY	MATERIAL
1	OVERSIZED BUSHING	2	2.30 INCHES DIAMETER BY 0.80 INCH LONG ALUMINUM-NICKEL-BRONZE BAR AS SPECIFIED IN AMS 4640

TABLE I

**Forward Upper Spar Fitting, Lug Hole Repair with Interference Fit Bushing Procedure - RB211-535 Engine
Figure 201 (Sheet 4 of 8)**

**757-200
STRUCTURAL REPAIR MANUAL**

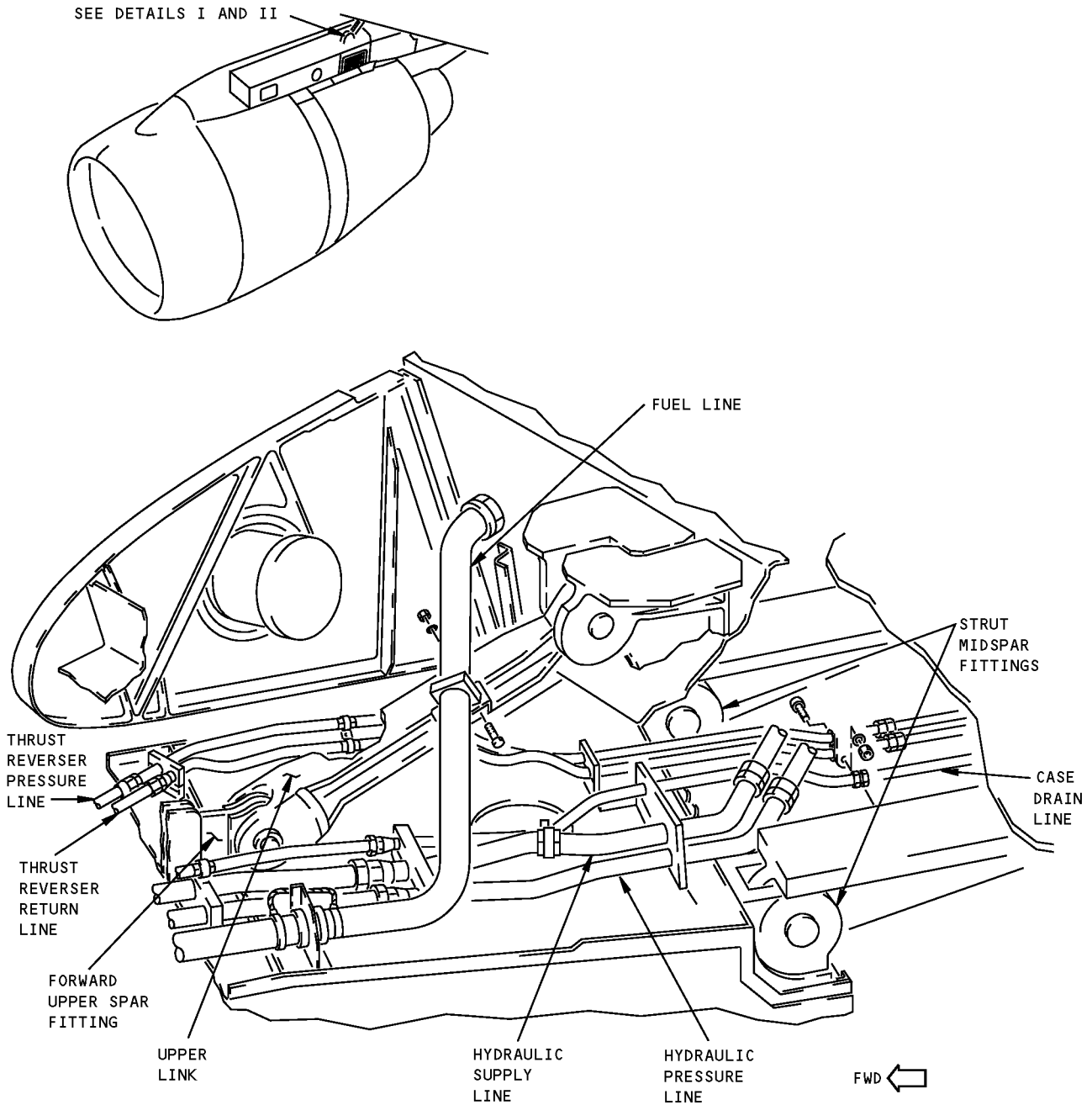

TUBING, DUCT AND FITTING LOCATIONS

DETAIL I

**Forward Upper Spar Fitting, Lug Hole Repair with Interference Fit Bushing Procedure - RB211-535 Engine
Figure 201 (Sheet 5 of 8)**

**757-200
STRUCTURAL REPAIR MANUAL**

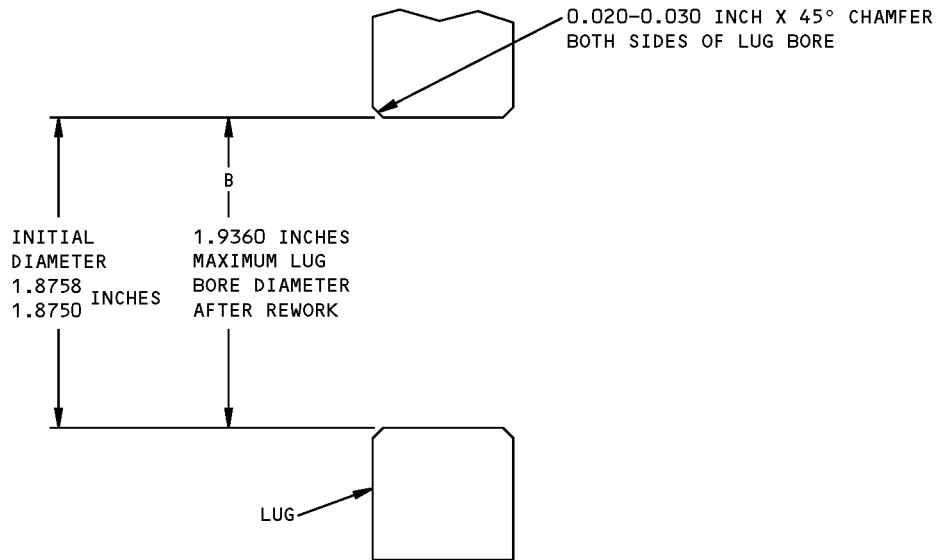
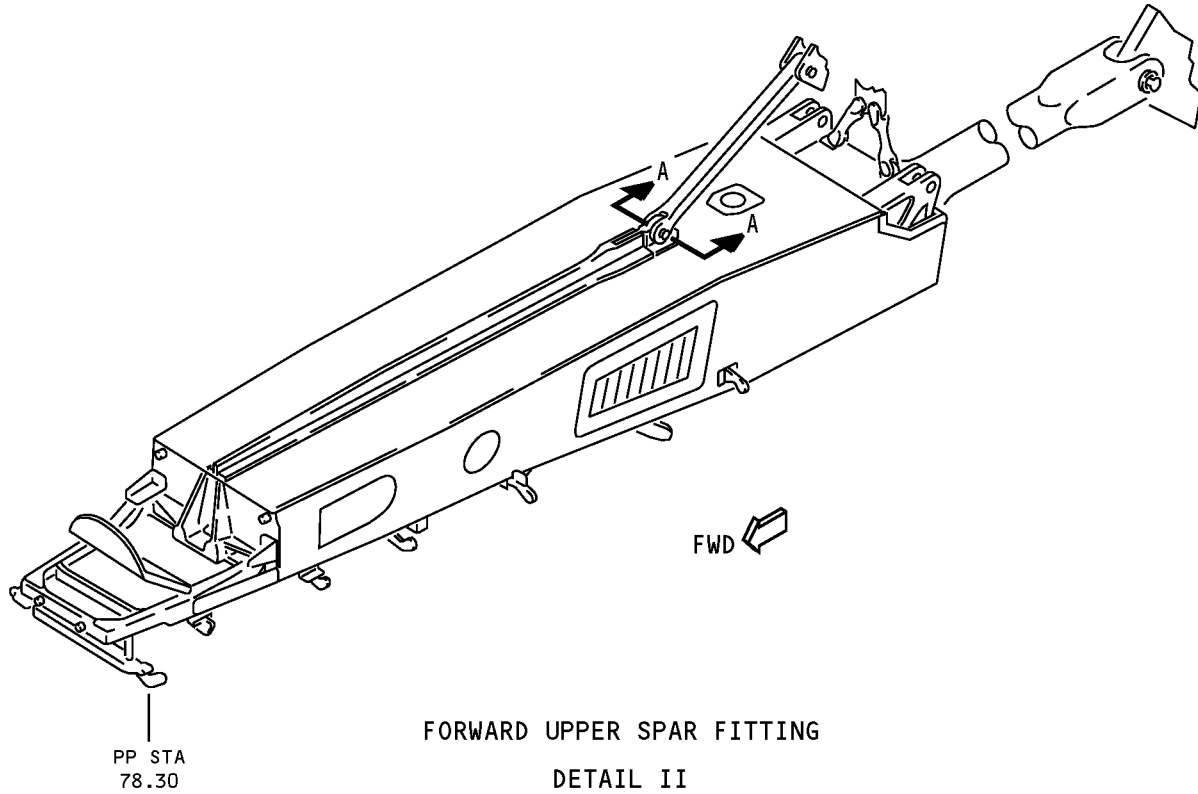

**LUG BORE DIMENSIONS
SECTION A-A**

**Forward Upper Spar Fitting, Lug Hole Repair with Interference Fit Bushing Procedure - RB211-535 Engine
Figure 201 (Sheet 6 of 8)**

**757-200
STRUCTURAL REPAIR MANUAL**

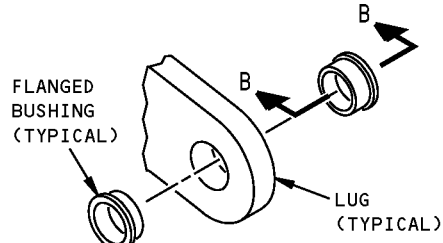

UPPER SPAR FITTING ASSEMBLY

DETAIL III

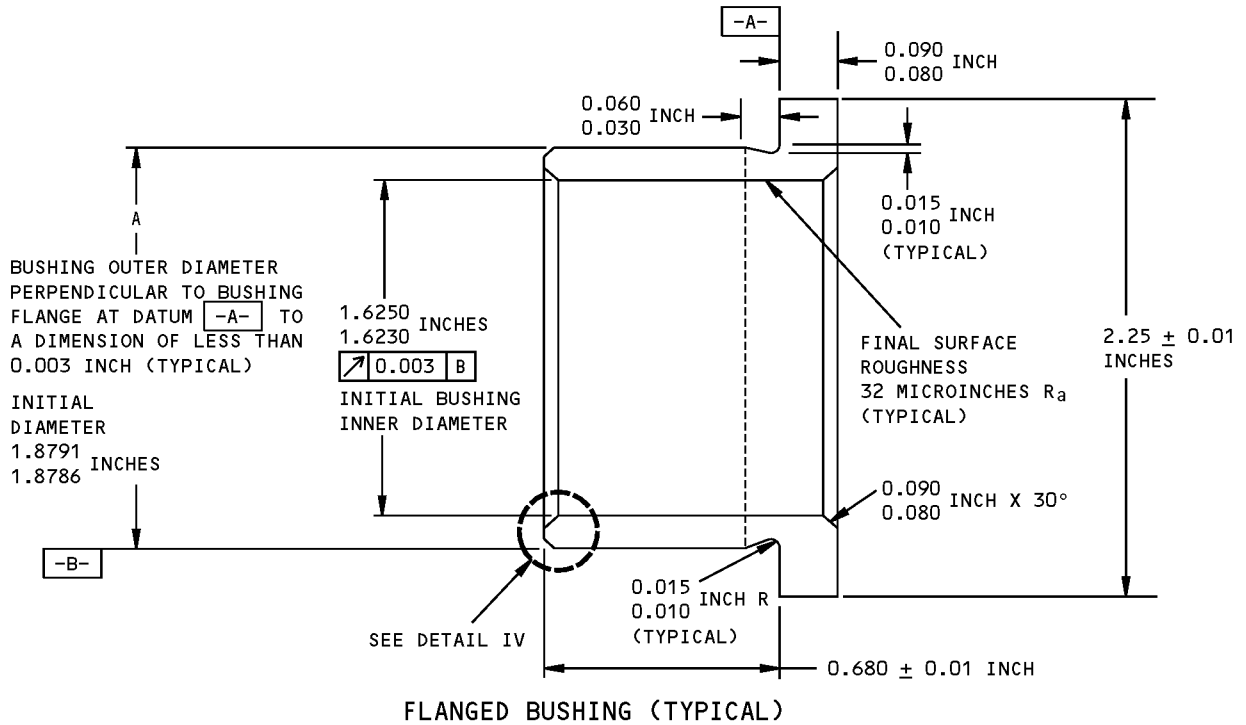

SECTION B-B

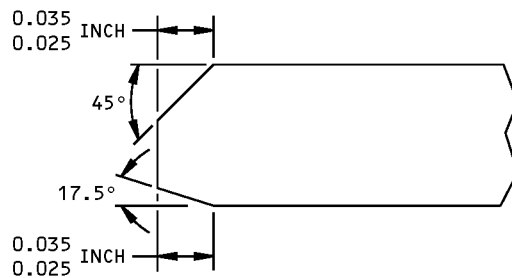

FLANGED BUSHING CHAMFERS

DETAIL IV

**Forward Upper Spar Fitting, Lug Hole Repair with Interference Fit Bushing Procedure - RB211-535 Engine
Figure 201 (Sheet 7 of 8)**

**757-200
STRUCTURAL REPAIR MANUAL**

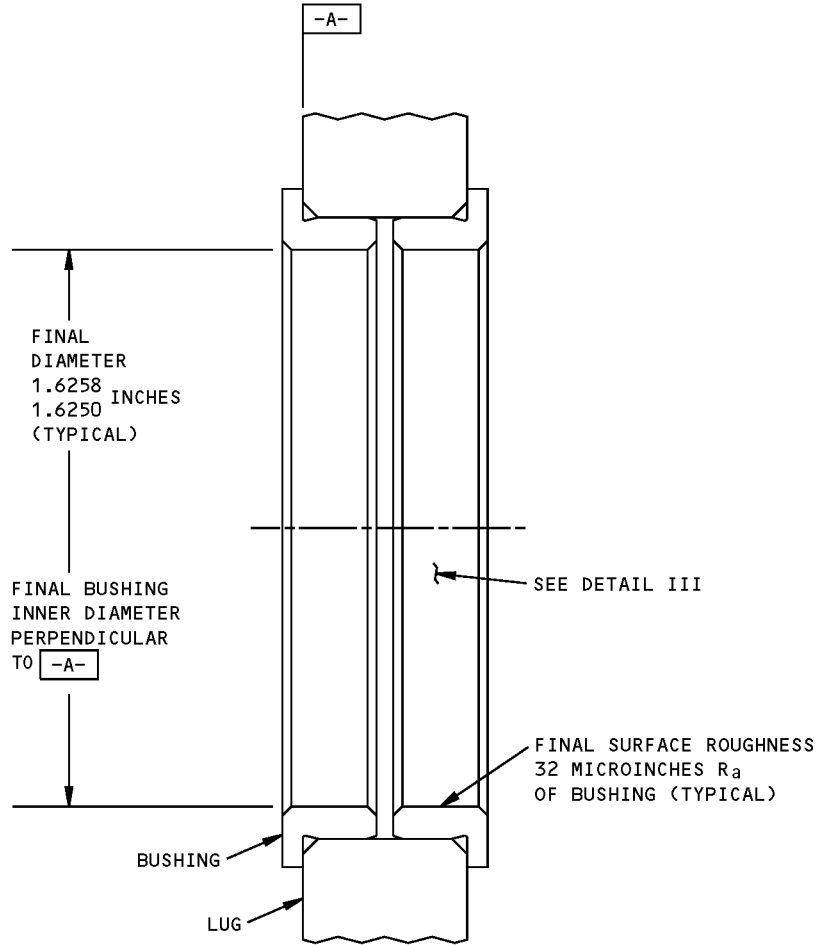

SECTION THROUGH THE CENTER OF THE LUG BORE
BUSHING DIMENSIONS AFTER THE BUSHINGS ARE INSTALLED
DETAIL V

**Forward Upper Spar Fitting, Lug Hole Repair with Interference Fit Bushing Procedure - RB211-535 Engine
Figure 201 (Sheet 8 of 8)**

STRUCTURAL REPAIR MANUAL

REPAIR 4 - MIDSPAR FITTING, LUG HOLE REPAIR WITH INTERFERENCE FIT BUSHING PROCEDURE - RB211-535 ENGINE

APPLICABILITY
THIS REPAIR USES THE INTERFERENCE FIT PROCEDURE TO INSTALL THE REPLACEMENT BUSHINGS FOR THE MIDSPAR FITTING ON THE RB211-535 ENGINE. DIFFERENT REPLACEMENT BUSHINGS ARE USED FOR THE DIFFERENT MATERIAL TYPE FITTINGS, 4330M ALLOY STEEL OR 15-5PH CORROSION RESISTANT STEEL. A

REPAIR INSTRUCTIONS

PROCEDURE I - REMOVE THE INITIAL BUSHINGS

1. Remove the engine strut from the wing. Refer to AMM 54-51-01.
2. Remove the engine strut access doors. Refer to AMM 54-53-01.
3. Remove the engine strut components as necessary to get access. Refer to AMM 54-51-01.
 - A. Make a record of the position of wire bundles and cables near the midspar fitting. Move the wire bundles and cables away from the fitting to make clearance for the repair tools. Disconnect the wires as necessary. If you disconnect electric connections, install caps or plugs at the connection. You can also attach tags that give the location of the connection. This will help you make the connection again.
 - B. Remove tubes, duct, clamps support blocks, and brackets near the fitting as necessary to make clearance for the repair tools.
 - C. Drain the fuel supply line and the hydraulic fluid lines to the engine.
4. Remove the bushing from each lug.
5. Discard the initial bushings. The bushing material is aluminum-nickel-bronze alloy.

PROCEDURE II - DO AN INSPECTION OF THE HOLE FOR EACH LUG

1. Do a magnetic inspection of the inner surface of the hole from which you removed the bushing. Refer to SOPM 20-20-01 for the inspection procedure.
2. If you find damage, you must machine the inner surface of the hole. Continue with the steps given in Procedure III.

3. If no damage is found, it is necessary to remove a minimum of 0.010 inch on the diameter from the inner surface of the hole if the airplane age is:
 - A. 10 years or more for 4330M alloy steel fittings.
 - B. 15 years or more for 15-5PH CRES fittings.

NOTE: The 4330M alloy steel fittings have a cad-ti finish (greenish yellow in color) and the 15-5PH CRES fittings will have a shiny steel color in the bore. If you can not tell the material type of the fitting from the bore, lightly sand off the primer on the side of the lug to expose the cad-ti finish or no finish.

Continue with the steps given in Procedure III.

4. If no damage is found, it is not necessary to machine the inner surface of the hole if the airplane age is:
 - A. Less than 10 years for 4330M fittings.
 - B. Less than 15 years for 15-5PH fittings.

NOTE: The 4330M alloy steel fittings have a cad-ti finish (greenish yellow in color) and the 15-5PH CRES fittings do not. The 15-5PH CRES fittings will have a shiny steel color in the bore. If you can not tell the material type of the fitting from the bore, lightly sand off the primer on the side of the lug to expose the cad-ti finish or no finish.

Continue with the steps given in Procedure VI.

PROCEDURE III - MACHINE THE LUG HOLES

1. Install the proper diameter reamer or boring tools to machine the holes as necessary to remove damage. Use a temporary sheet cover that is approximately 0.063 inch thick to hold the tools over the hole for the thermal anti-ice duct.

**Midspar Fitting, Lug Hole Repair with Interference Fit Bushing Procedure - RB211-535 Engine
Figure 201 (Sheet 1 of 10)**

STRUCTURAL REPAIR MANUAL

PROCEDURE III - MACHINE THE LUG HOLES (CONT)

- CAUTION:** MAKE SURE THE TOOLS USED TO MACHINE THE HOLES ARE CORRECTLY ALIGNED BEFORE YOU MACHINE THE HOLES. IF THE TOOLS ARE NOT CORRECTLY ALIGNED THEN THE HOLES WILL NOT BE CUT IN THE CORRECT LOCATION. IF YOU DO NOT OBEY, THE REPAIR CAN BE UNSATISFACTORY.
2. Machine the holes as necessary to remove the damage for each of the fitting types. Refer to SOPM 20-10-02 for the procedure to machine alloy steel.
 - A. For 4330M alloy steel fittings:
 1. Do a magnetic particle inspection to make sure all of the damage is removed. If the inspection shows that there is no more damage, machine an insurance cut that is a minimum of 0.010 inch on the diameter.
 2. The maximum diameter of each hole is 2.0000 inches, see DETAIL III, SECTION A-A. If the diameter of the hole is larger than the maximum, you must get alternative repair instructions from Boeing.
 - B. For 15-5PH CRES fittings:
 1. Do a magnetic particle inspection to make sure all of the damage is removed. If the inspection shows that there is no more damage, machine an insurance cut that is a minimum of 0.010 inch on the diameter.
 2. The maximum diameter of each hole is 1.8420 inches, see DETAIL III, SECTION A-A. If the diameter of the hole is larger than the maximum, you must get alternative repair instructions from Boeing.
 3. Chamfer the lug hole edges for each of the fitting types.
 - A. For 4330M alloy steel fittings:

Put a 0.045 to 0.055 inch by 45 degree chamfer on the inside of the clevis and 0.020 to 0.040 inch by 45 degree chamfer on the outside of the clevis. See DETAIL III, SECTION A-A. As an alternative to the chamfer, you can make an equivalent radius.
 - B. For 15-5PH CRES fittings:

Put a 0.020 to 0.040 inch by 45 degree chamfer on both the inside and the outside of the clevis. See DETAIL III, SECTION A-A. As an alternative to the chamfer, you can make an equivalent radius.

4. Remove the tools.
5. Remove the sharp edges and burrs from the cut surfaces.
6. For 4330M alloy steel fittings:

Use ammonium persulfate to do a surface etch inspection of each lug hole that has been machined. This inspection examines the temper of the hole to make sure that no damage occurred while the hole was machined. Refer to SOPM 20-10-02 for the surface temper etch inspection procedure.
7. Do a flap peen procedure to each hole. Use a 3M flapwheel that is 9/16 inch by 1.25 inch to get a coverage of 2.0 with an Almen intensity of 0.010A for 4330M alloy steel fittings and 0.008A to 0.013A for 15-5PH CRES fittings. Refer to SOPM 20-10-03.
8. Hone each hole to the final diameter. Make the finish on the inner surface of the holes 32 microinches R_a or smoother.
 - A. For 4330M alloy steel fittings:

You can remove a maximum of 0.0010 inch from the radius of the hole to get the necessary surface finish. The maximum diameter of the hole is 2.0000 inches.
 - B. For 15-5PH CRES fittings:

You can remove a maximum of 0.0013 inch from the radius of the hole to get the necessary surface finish. The maximum diameter of the hole is 1.8420 inches.
9. For 15-5PH CRES fittings:

Use Scotch-Brite to remove sharp edges from the surface of the hole and clean the area with solvent.

PROCEDURE IV - MEASURE THE LUG DIMENSIONS

1. Measure and record the diameter of the hole. This is dimension B shown in Detail III, SECTION A-A. Measure the diameter before you apply the primer, sealant, or retaining compound.

PROCEDURE V - CALCULATE THE DIAMETER OF THE OVERSIZED BUSHINGS

1. Calculate the diameter, A, of the oversized bushings with the formula that follows. Refer to Detail IV or VI for the definition of the dimension A.
 - A. For 4330M alloy steel fittings:
$$A = B + 0.0038 \text{ inch } \pm 0.0005 \text{ inch}$$
 - B. For 15-5PH CRES fittings:
$$A = B + 0.0034 \text{ inch } \pm 0.0005 \text{ inch}$$

**Midspar Fitting, Lug Hole Repair with Interference Fit Bushing Procedure - RB211-535 Engine
Figure 201 (Sheet 2 of 10)**

STRUCTURAL REPAIR MANUAL

PROCEDURE VI - MACHINE THE OVERSIZED BUSHINGS

1. If no damage is found and the airplane age is less than 10 years for 4330M alloy steel fittings or 15 years for 15-5PH, use the same diameter dimensions as the initial bushings. Refer to Table I and Detail IV or VI. Continue with the steps given in Procedure VIII.
2. Machine the oversized bushings to the necessary outer diameter that you found in Procedure V and the other dimensions given in Detail IV or Detail VI.
3. Make the surface finish of the outer diameter of the bushings 32 microinches R_a or smoother. Make the surface finish on the other surfaces 63 microinches R_a or smoother.
4. Remove the sharp edges and burrs from the cut surfaces.

CAUTION: DO NOT CADMIUM PLATE THE INNER SURFACE OF THE BUSHINGS. IF YOU DO NOT OBEY, THE REPAIR WILL BE UNSATISFACTORY.

5. For 4330M alloy steel fittings, apply a stylus cadmium plate that is 0.0003 to 0.0005 inch thick to the outer diameter and the flange of the oversized bushing. Refer to SOPM 20-42-10.

PROCEDURE VII - APPLY THE FINISH TO EACH LUG

1. Apply the finish to the fittings as follows:
 - A. For 4330M alloy steel fittings, Apply cadmium plate that is 0.0003 to 0.0005 inch thick to the lug hole surface.
 - B. For 15-5PH CRES fittings, Apply one layer of BMS 10-11, Type I primer to the bare surfaces of the lug. Refer to SOPM 20-41-02. Let the primer fully dry before you install the bushing.

PROCEDURE VIII - APPLY SEALANT OR OPTIONAL RETAINING COMPOUND TO EACH LUG

1. Apply sealant or optional retaining compound to the fittings as follows:

CAUTION: DO NOT APPLY SEALANT TO THE INNER SURFACE OF THE LUG HOLE OR THE OUTER DIAMETER OF THE BUSHING. IF YOU DO NOT OBEY, THE REPAIR CAN BE UNSATISFACTORY.

- A. For 4330M alloy steel fittings:

- Apply BMS 5-95 sealant to the mating surface of each lug. Do the steps in Procedure IX in 30 minutes or less from the time you apply the sealant. Refer to SRM 51-20-05.
- As an alternative to the sealant, apply Loctite 640 retaining compound (MIL-R-46082, Type II) to the inner surface of the lug hole and to the mating surfaces of the lug. Do the steps in Procedure IX in 15 minutes or less from the time you apply the retaining compound.

NOTE: If you apply the retaining compound, do not apply the BMS 5-95 sealant.

- B. For 15-5PH CRES fittings:

- As an option, apply Loctite 640 retaining compound (MIL-R-46082, Type II) to the inner surface of the lug hole and to the mating surfaces of the lug. Do the steps in Procedure IX in 15 minutes or less from the time you apply the retaining compound.

PROCEDURE IX - INSTALL THE OVERSIZED BUSHINGS WITH THE SHRINK FIT METHOD

1. Prepare the bushings for installation with the shrink fit method. Use liquid nitrogen at -320°F (-196°C).

WARNING: LIQUID NITROGEN IS APPROXIMATELY -320°F (-196°C). WEAR PROTECTIVE CLOTHING AND USE IN A VENTILATED AREA TO PREVENT INJURY.

2. Soak the bushings and the installation guide bushing in the liquid nitrogen until the boiling stops. Use the guide bushing from Boeing tool kit MIT012N8729-1 or the equivalent. Refer to SOPM 20-50-03.
3. Install the bushings as quickly as possible. Use the installation tools from Boeing tool kit MIT012N8729-1 or the equivalent.

CAUTION: YOU MUST INSTALL THE BUSHING IMMEDIATELY AFTER YOU REMOVE THE BUSHING FROM THE LIQUID NITROGEN. IF THE BUSHING EXPANDS BEFORE IT IS CORRECTLY INSTALLED IN THE FITTING, THE BUSHING MUST BE REMOVED AND REPLACED.

Midspar Fitting, Lug Hole Repair with Interference Fit Bushing Procedure - RB211-535 Engine
Figure 201 (Sheet 3 of 10)

**757-200
STRUCTURAL REPAIR MANUAL**

PROCEDURE IX - INSTALL THE OVERSIZED BUSHINGS WITH THE SHRINK FIT METHOD (CONT)

4. Hold the bushing flange tightly against the face of the lug until the assembly is at room temperature to make sure that the bushing is installed correctly. A press fit can be used to complete the shrink fit installation of the bushings.
5. For 4330M alloy steel fittings, anvil swage the bushing to each lug. Refer to SOPM 20-50-03. You can use the roller swage method as an alternative.

PROCEDURE X - MACHINE THE INNER DIAMETER OF THE OVERSIZED BUSHINGS

1. Machine the inner diameter of the bushings to a diameter of 1.5625 to 1.5633 inches as shown in Detail VIII. Make the surface finish 32 microinches R_a .
2. For 4330M alloy steel fittings: Apply a fillet seal of BMS 5-95 sealant between the flanges of the bushings and the lug as shown in Detail VIII. Refer to SRM 51-20-05.

PROCEDURE XI - PUT THE AIRPLANE BACK TO THE INITIAL CONDITION

1. Install the components that were removed from engine strut.
2. Connect the wires and cables that were disconnected.
3. Install the engine strut access doors as given in AMM 54-53-01.
4. Install the engine strut on the airplane as given in AMM 54-51-01.

NOTES

- ALL DIMENSIONS ARE IN INCHES, UNLESS GIVEN DIFFERENTLY.
- WHEN YOU USE THE REPAIR REFER TO:
 - AMM 54-51-01 FOR THE REMOVAL AND INSTALLATION OF THE STRUT
 - AMM 54-53-01 FOR THE REMOVAL AND INSTALLATION OF THE STRUT PRESSURE RELIEF AND ACCESS DOORS
 - SOPM 20-10-02 FOR MACHINING OF ALLOY STEEL AND FOR SURFACE TEMPER ETCH INSPECTION PROCEDURES
 - SOPM 20-10-03 FOR SHOT PEENING AND FLAP PEENING
 - SOPM 20-20-01 FOR MAGNETIC PARTICLE INSPECTION PROCEDURES
 - SOPM 20-41-02 FOR THE APPLICATION OF CHEMICAL AND SOLVENT RESISTANT FINISHES
 - SOPM 20-42-05 FOR CADMIUM PLATING
 - SOPM 20-42-10 FOR LOW HYDROGEN EMBRITTLEMENT STYLUS CADMIUM PLATING
 - SOPM 20-50-03 FOR BUSHING REMOVAL AND INSTALLATION
 - SRM 51-20-05 FOR REPAIR SEALING

A AS AN ALTERNATIVE, THE EXPANDED FIT BUSHING INSTALLATION PROCEDURE IS PERMITTED IF THE INSTALLATION REQUIREMENTS LISTED IN SRM 51-20-09 ARE SATISFIED. REFER TO SRM 51-20-09 FOR THE LIST OF EXPANDED FIT BUSHING INSTALLATION GUIDELINES.

REPAIR MATERIAL			
PART		QTY	MATERIAL
1	OVERSIZED BUSHING	4	2.30 INCHES DIAMETER BY 0.80 INCH LONG ALUMINUM-NICKEL-BRONZE BAR AS SPECIFIED IN AMS 4640

TABLE I

**Midspar Fitting, Lug Hole Repair with Interference Fit Bushing Procedure - RB211-535 Engine
Figure 201 (Sheet 4 of 10)**

**757-200
STRUCTURAL REPAIR MANUAL**

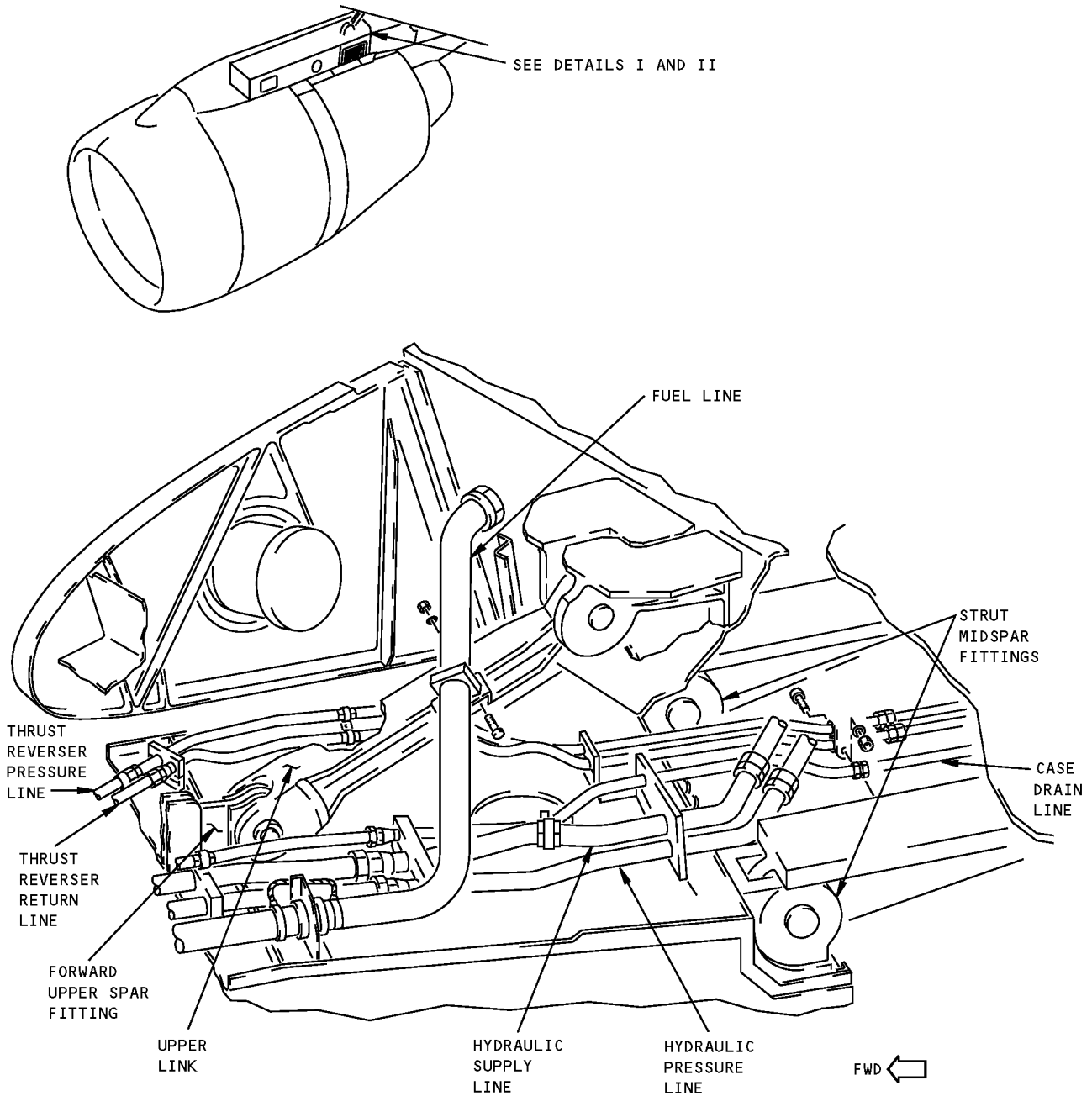

TUBING, DUCT AND FITTING LOCATIONS

DETAIL I

**Midspar Fitting, Lug Hole Repair with Interference Fit Bushing Procedure - RB211-535 Engine
Figure 201 (Sheet 5 of 10)**

**757-200
STRUCTURAL REPAIR MANUAL**

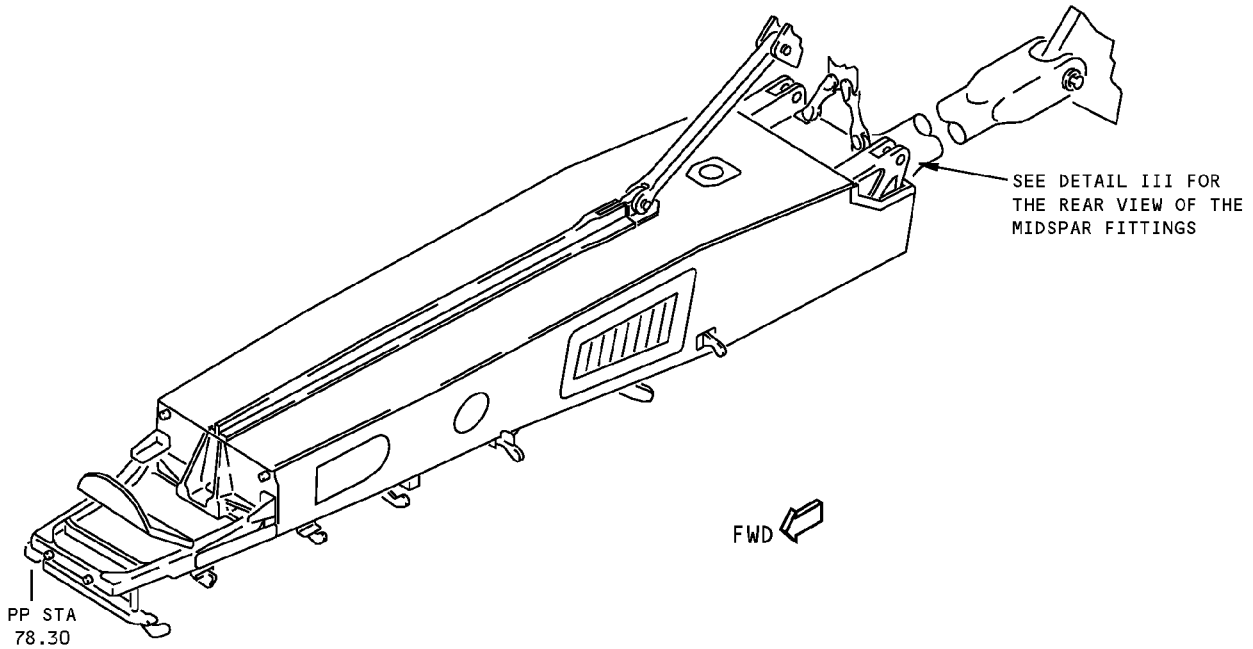

**MIDSPAR FITTINGS
DETAIL II**

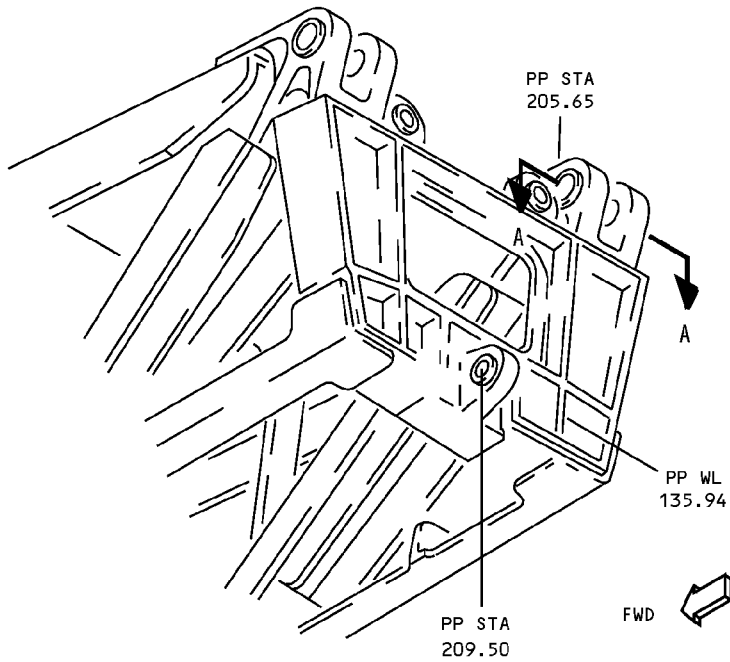

**VIEW ON REAR FACE OF STRUT
DETAIL III**

**Midspar Fitting, Lug Hole Repair with Interference Fit Bushing Procedure - RB211-535 Engine
Figure 201 (Sheet 6 of 10)**

STRUCTURAL REPAIR MANUAL

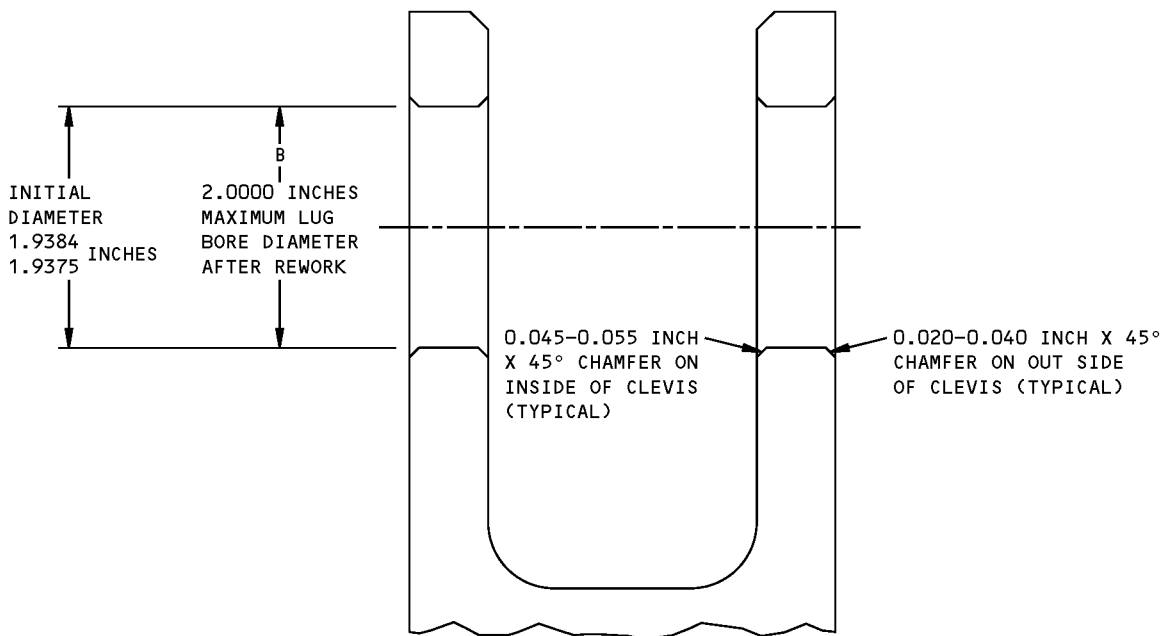

SECTION THROUGH ONE OF THE MIDSPAR CLEVIS FOR FITTINGS WITH 4330M MATERIAL

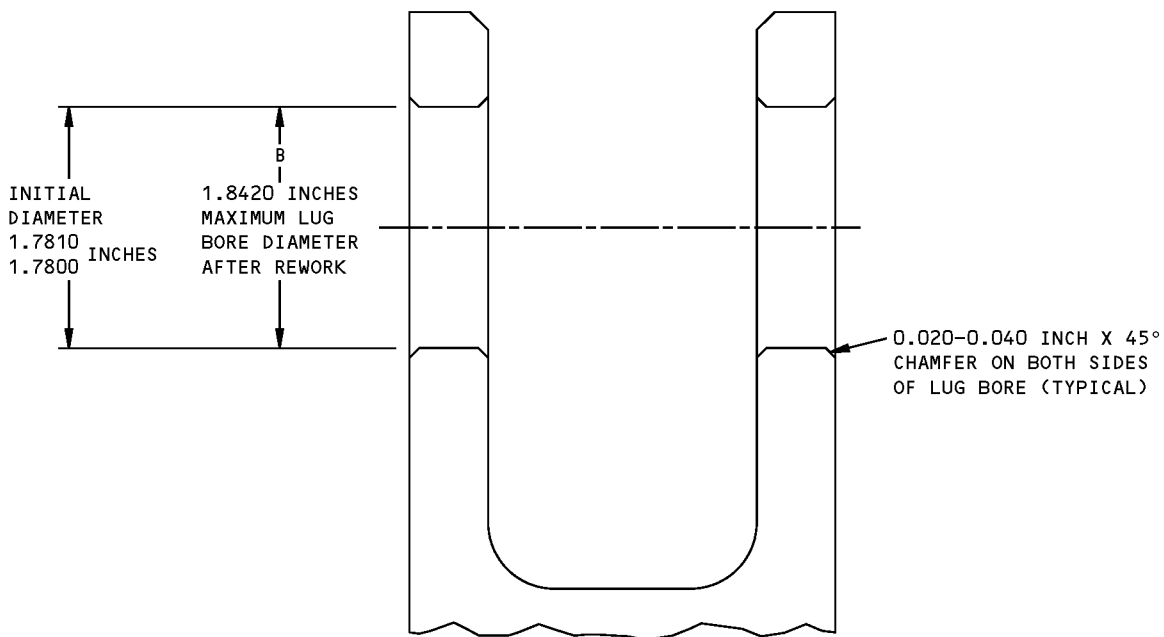

SECTION THROUGH ONE OF THE MIDSPAR CLEVIS FOR FITTINGS WITH 15-5PH MATERIAL

SECTION A-A

Midspar Fitting, Lug Hole Repair with Interference Fit Bushing Procedure - RB211-535 Engine
Figure 201 (Sheet 7 of 10)

**757-200
STRUCTURAL REPAIR MANUAL**

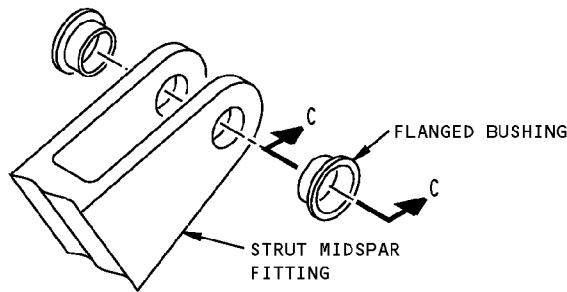

MIDSPAR CLEVIS (TWO LOCATIONS ON EACH STRUT)

DETAIL IV

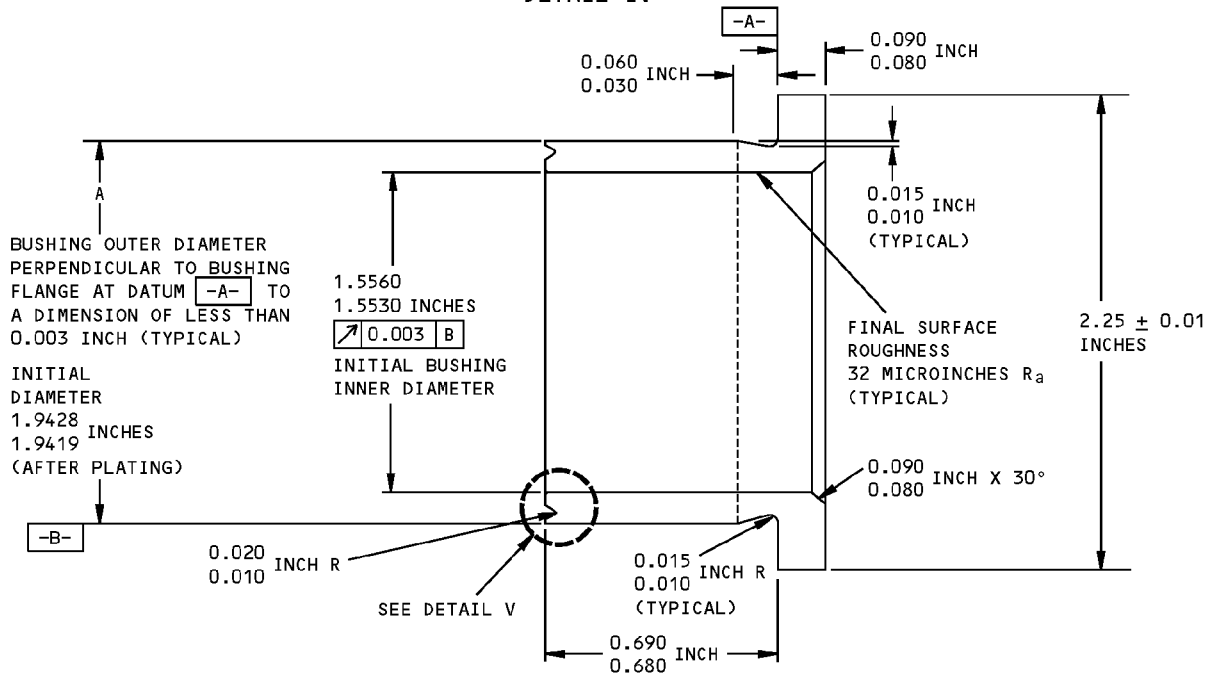

FLANGED BUSHING FOR 4330M FITTINGS (TYPICAL)

SECTION C-C

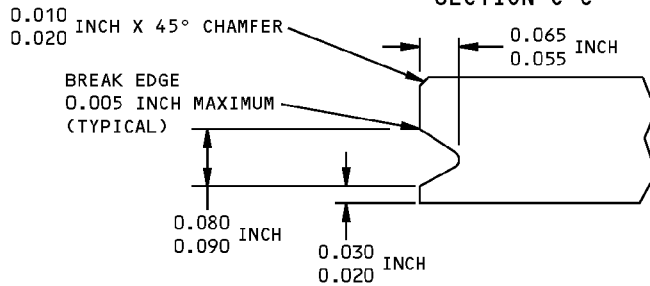

FLANGED BUSHING CHAMFERS

DETAIL V

**Midspar Fitting, Lug Hole Repair with Interference Fit Bushing Procedure - RB211-535 Engine
Figure 201 (Sheet 8 of 10)**

**757-200
STRUCTURAL REPAIR MANUAL**

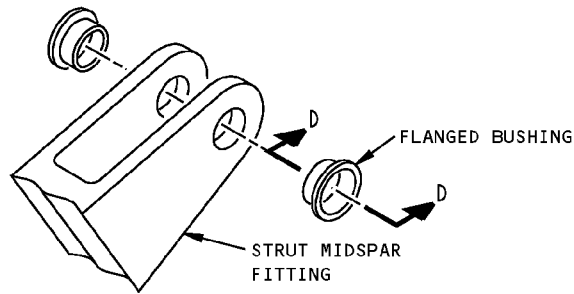

MIDSPAR CLEVIS FOR 15-5PH FITTINGS (TWO LOCATIONS ON EACH STRUT)

DETAIL VI

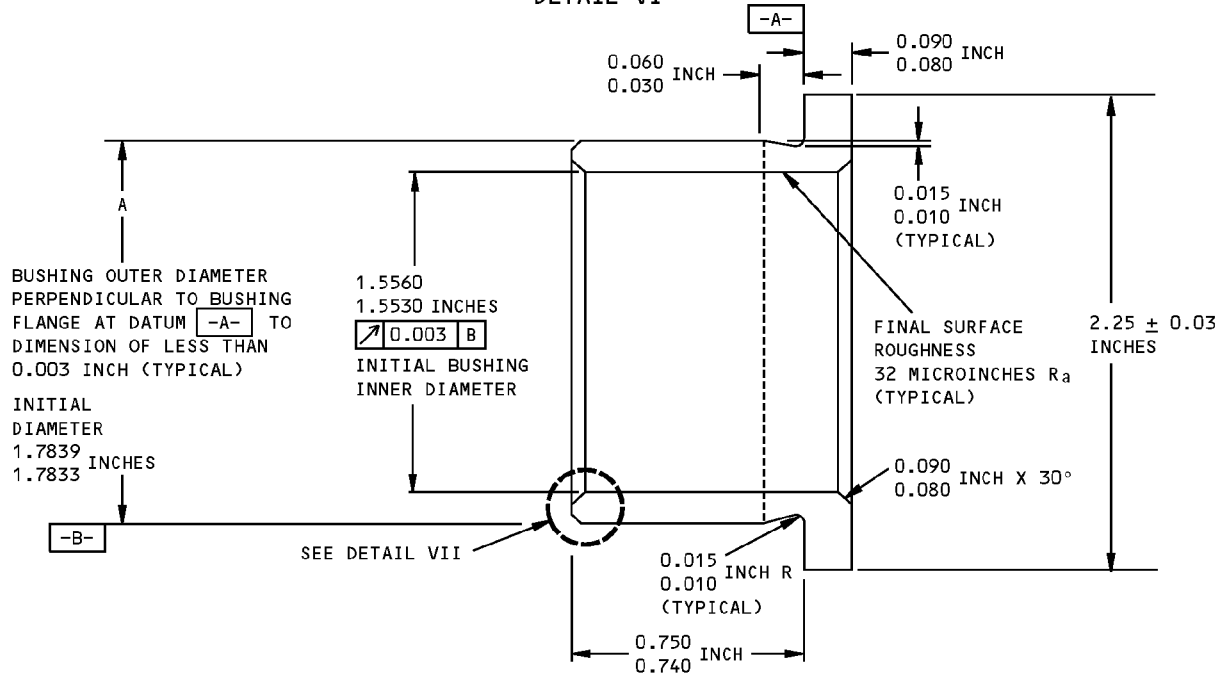

FLANGED BUSHING (TYPICAL)

SECTION D-D

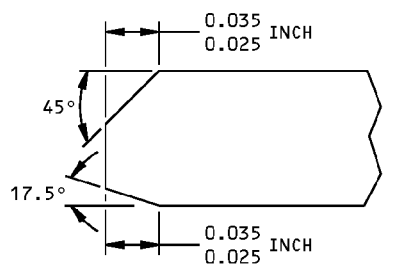

FLANGED BUSHING CHAMFERS

DETAIL VII

**Midspar Fitting, Lug Hole Repair with Interference Fit Bushing Procedure - RB211-535 Engine
Figure 201 (Sheet 9 of 10)**

**757-200
STRUCTURAL REPAIR MANUAL**

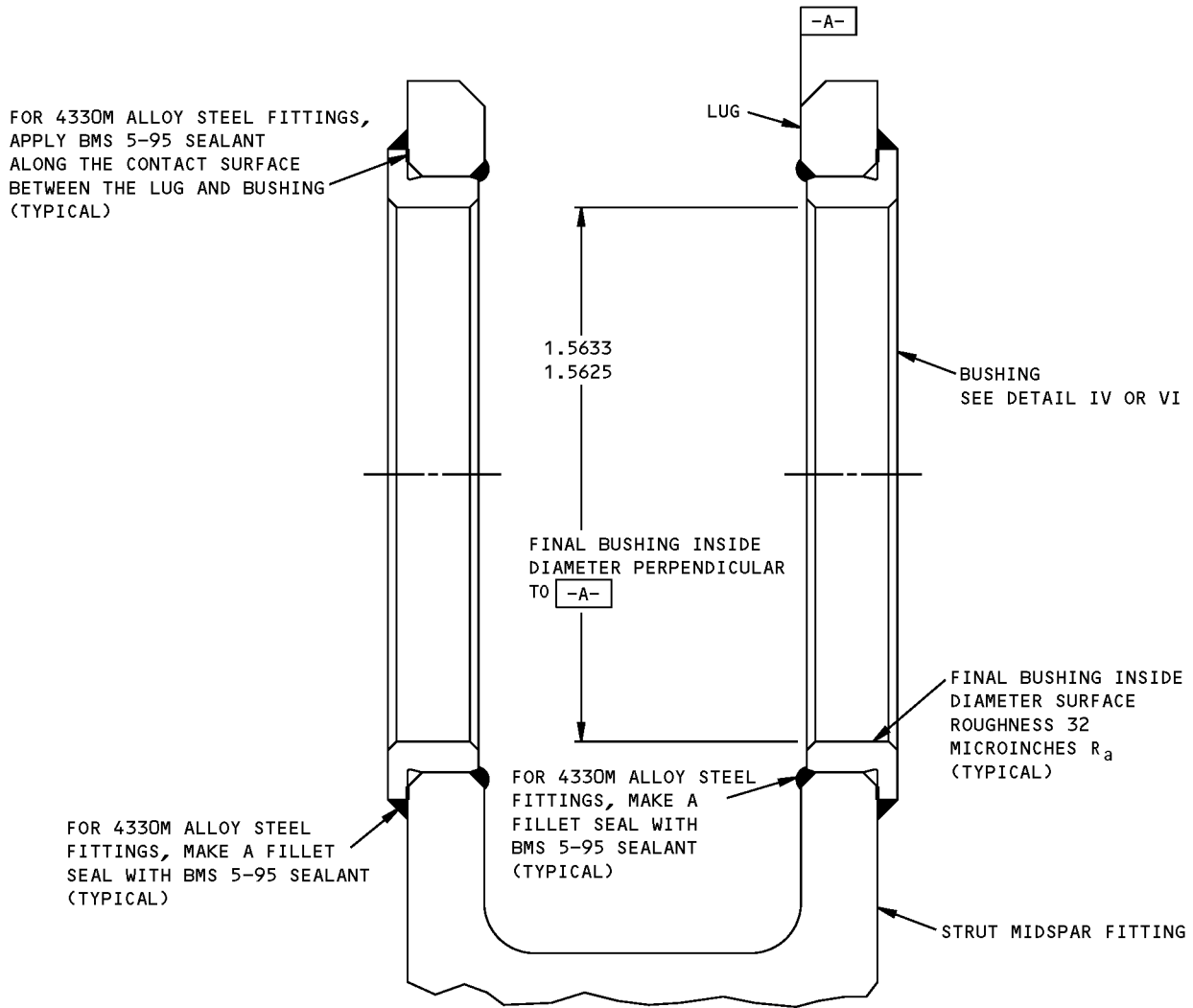

SECTION THROUGH THE MIDSPAR CLEVIS
DIMENSIONS AFTER THE BUSHING IS INSTALLED
DETAIL VIII

Midspar Fitting, Lug Hole Repair with Interference Fit Bushing Procedure - RB211-535 Engine
Figure 201 (Sheet 10 of 10)

STRUCTURAL REPAIR MANUAL

REPAIR 5 - LOWER SPAR FITTING, LUG HOLE REPAIR WITH INTERFERENCE FIT BUSHING PROCEDURE - RB211-535 ENGINE

APPLICABILITY
THIS REPAIR USES THE INTERFERENCE FIT PROCEDURE TO INSTALL THE REPLACEMENT BUSHINGS FOR THE LOWER SPAR FITTING ON THE RB211-535 ENGINE. A

REPAIR INSTRUCTIONS

PROCEDURE I - REMOVE THE INITIAL BUSHINGS

1. Remove the engine strut access doors. Refer to AMM 54-53-01.
2. Remove the engine strut components as necessary to get access. Refer to AMM 54-51-01.
 - A. Make a record of the position of wire bundles and cables near the lower spar fitting. Move the wire bundles and cables away from the fitting to make clearance for the repair tools. Disconnect the wires as necessary. If you disconnect electric connections, install caps or plugs at the connection. You can also attach tags that give the location of the connection. This will help you make the connection again.
 - B. Remove tubes, duct, clamps support blocks, and brackets near the fitting as necessary to make clearance for the repair tools.
 - C. Drain the fuel supply line and the hydraulic fluid lines to the engine.
3. Get or make the split bushing removal tool. The Boeing tool number is B54016-1.
4. Remove the two bushings from the lug with the split bushing removal tool.
5. Discard the initial bushings. The bushing material is aluminum-nickel-bronze alloy.

PROCEDURE II - DO AN INSPECTION OF THE LUG HOLE

1. Do an inspection of the inner surface of the hole from which you removed the bushings. Use one of the procedures that follow:
 - Dye penetrant inspection Type I, method C, sensitivity level 3 or higher as specified in SOPM 20-20-02.
 - High frequency eddy current inspection as specified in NDT, D6-643N301, Part 6, 51-00-13.
2. If you find damage, you must machine the inner surface of the hole. Continue with the steps given in Procedure III.

3. If no damage is found and the airplane age is more than 15 years, you must machine the inner surface of the hole. Continue with the steps given in Procedure III to machine an insurance cut from the inner surface of the hole.
4. If no damage is found and the airplane age is 15 years or less, it is not necessary to machine the inner surface of the hole. Continue with the steps given in Procedure IV.

PROCEDURE III - MACHINE THE LUG HOLE

1. Install the proper diameter reamer of boring tools to machine the hole as necessary to remove damage. Use a temporary sheet cover that is approximately 0.063 inch thick to hold the tools over the hole for the thermal anti-ice duct.

CAUTION: MAKE SURE THE TOOLS USED TO MACHINE THE HOLE ARE CORRECTLY ALIGNED BEFORE YOU MACHINE THE HOLES. IF THE TOOLS ARE NOT CORRECTLY ALIGNED THEN THE HOLE WILL NOT BE CUT IN THE CORRECT LOCATION. IF YOU DO NOT OBEY, THE REPAIR CAN BE UNSATISFACTORY.

2. Machine the hole as necessary to remove the damage.
 - A. The material of the fitting is 6AL-4V titanium alloy. Refer to SOPM 20-10-07 for the procedure to machine titanium alloy.
 - B. Do one of the two inspections given in PROCEDURE II to make sure all of the damage is removed from the inner surface of the lug hole. If the inspection shows that there is no more damage, machine an insurance cut as follows:
 - If the dye penetrant inspection procedure is used, machine a minimum of 0.020 inch on the diameter from the inner surface of the hole.
 - If the high frequency eddy current inspection procedure is used, machine a minimum of 0.030 inch on the diameter from the inner surface of the hole.

**Lower Spar Fitting, Lug Hole Repair with Interference Fit Bushing Procedure - RB211-535 Engine
Figure 201 (Sheet 1 of 8)**

STRUCTURAL REPAIR MANUAL

PROCEDURE III - MACHINE THE LUG HOLE (CONT)

- C. The maximum diameter of the hole is 1.5610 inches, see DETAIL II, SECTION A-A. If the diameter of the hole(s) is larger than the maximum, you must get alternative repair instructions from Boeing.
3. Put a 0.020 to 0.030 inch by 45 degree chamfer on the edges of the hole. As an alternative to the chamfer, you can make an equivalent radius.
4. Remove the tools.
5. Remove the sharp edges and burrs from the cut surfaces.
6. Do a flappeen procedure to the hole. Use a 3M flapwheel that is 9/16 inch by 1.25 inch to get an Almen intensity of 0.008A and a coverage of 2.0. Refer to SOPM 20-10-03.
7. Hone the hole to the final diameter. Make the finish on the inner surface of the hole 32 microinches R_a or smoother. You can remove a maximum of 0.0010 inch from the radius of the hole to get the necessary surface finish. The maximum diameter of the hole is 1.5610 inches.

PROCEDURE IV - MEASURE THE LUG HOLE DIAMETER

1. Measure and record the diameter of the hole. This is dimension B shown in Detail II, SECTION A-A. Measure the diameter before you apply the primer, sealant, or retaining compound.

PROCEDURE V - CALCULATE THE DIAMETER OF THE OVERSIZED BUSHINGS

1. Calculate the diameter, A, of the oversized bushings with the formula that follows. Refer to Detail III for the definition of the dimension A.

$$A = B + 0.0029 \text{ inch } \pm 0.0005 \text{ inch}$$

PROCEDURE VI - MACHINE THE OVERSIZED BUSHINGS

1. If no damage is found and the airplane age is 15 years or less, use the same diameter dimensions as the initial bushings. Refer to Table I and Detail III. Continue with the steps given in Procedure VIII.
2. Machine the oversized bushings to the necessary outer diameter that you found in Procedure V and the other dimensions given in Detail III.
3. Make the surface finish of the outer diameter of the bushings 32 microinches R_a or smoother. Make the surface finish on the other surfaces 63 microinches R_a or smoother.
4. Remove the sharp edges and burrs from the cut surfaces.

PROCEDURE VII - APPLY THE PRIMER

1. Apply one layer of BMS 10-11, Type I primer to the bare surfaces of the lug. Refer to SOPM 20-41-02.
2. Let the primer fully dry before you install the bushings.

PROCEDURE VIII - APPLY RETAINING COMPOUND (OPTIONAL)

1. Apply Loctite 640 retaining compound (MIL-R-46082, Type II) to the inner surface of the lug hole and to the mating surfaces of the lug. Do the steps in Procedure IX in 15 minutes or less from the time you apply the retaining compound.

**Lower Spar Fitting, Lug Hole Repair with Interference Fit Bushing Procedure - RB211-535 Engine
Figure 201 (Sheet 2 of 8)**



757-200

STRUCTURAL REPAIR MANUAL

PROCEDURE IX - INSTALL THE OVERSIZED BUSHINGS WITH THE SHRINK FIT METHOD

1. Prepare the bushings for installation with the shrink fit method. Use liquid nitrogen at -320°F (-196°C).

WARNING: LIQUID NITROGEN IS APPROXIMATELY -320°F (-196°C). WEAR PROTECTIVE CLOTHING AND USE IN A VENTILATED AREA TO PREVENT INJURY.

2. Soak the bushings and the installation guide bushing in the liquid nitrogen until the boiling stops. Use the guide bushing from Boeing tool kit MIT012N8729-1 or the equivalent. Refer to SOPM 20-50-03.
3. Install the bushings as quickly as possible. Use the installation tools from Boeing tool kit MIT012N8729-1 or the equivalent.

CAUTION: YOU MUST INSTALL THE BUSHING IMMEDIATELY AFTER YOU REMOVE THE BUSHING FROM THE LIQUID NITROGEN. IF THE BUSHING EXPANDS BEFORE IT IS CORRECTLY INSTALLED IN THE FITTING, THE BUSHING MUST BE REMOVED AND REPLACED.

4. Hold the bushing flange tightly against the face of the lug until the assembly is at room temperature to make sure that the bushing is installed correctly. A press fit can be used to complete the shrink fit installation of the bushings.

PROCEDURE X - MACHINE THE INNER DIAMETER OF THE OVERSIZED BUSHINGS

1. Machine the inner diameter of the bushings to a diameter of 1.3125 to 1.3133 inches as shown in Detail V. Make the surface finish 32 microinches R_a .

PROCEDURE XI - PUT THE AIRPLANE BACK TO THE INITIAL CONDITION

1. Install the components that were removed from engine strut.
2. Connect the wires and cables that were disconnected.
3. Install the engine strut access doors as given in AMM 54-53-01.

Lower Spar Fitting, Lug Hole Repair with Interference Fit Bushing Procedure - RB211-535 Engine
Figure 201 (Sheet 3 of 8)



**757-200
STRUCTURAL REPAIR MANUAL**

NOTES

- ALL DIMENSIONS ARE IN INCHES, UNLESS GIVEN DIFFERENTLY.
- WHEN YOU USE THE REPAIR REFER TO:
 - AMM 54-53-01 FOR THE REMOVAL AND INSTALLATION OF THE STRUT PRESSURE RELIEF AND ACCESS DOORS
 - NDT, PART 6, 51-00-13 (D6-643N301) EDDY CURRENT INSPECTION PROCEDURES
 - SOPM 20-10-03 FOR SHOT PEENING AND FLAP PEENING
 - SOPM 20-10-07 FOR THE MACHINING OF TITANIUM
 - SOPM 20-20-02 FOR DYE PENETRANT INSPECTION PROCEDURES
 - SOPM 20-41-02 FOR THE APPLICATION OF CHEMICAL AND SOLVENT RESISTANT FINISHES
 - SOPM 20-50-03 FOR BUSHING REMOVAL AND INSTALLATION

A AS AN ALTERNATIVE, THE EXPANDED FIT BUSHING INSTALLATION PROCEDURE IS PERMITTED IF THE INSTALLATION REQUIREMENTS LISTED IN SRM 51-20-09 ARE SATISFIED. REFER TO SRM 51-20-09 FOR THE LIST OF EXPANDED FIT BUSHING INSTALLATION GUIDELINES.

REPAIR MATERIAL			
PART		QTY	MATERIAL
1	OVERSIZED BUSHING	2	2.10 INCHES DIAMETER BY 0.80 INCH LONG ALUMINUM-NICKEL-BRONZE BAR AS SPECIFIED IN AMS 4640

TABLE I

**Lower Spar Fitting, Lug Hole Repair with Interference Fit Bushing Procedure - RB211-535 Engine
Figure 201 (Sheet 4 of 8)**

**757-200
STRUCTURAL REPAIR MANUAL**

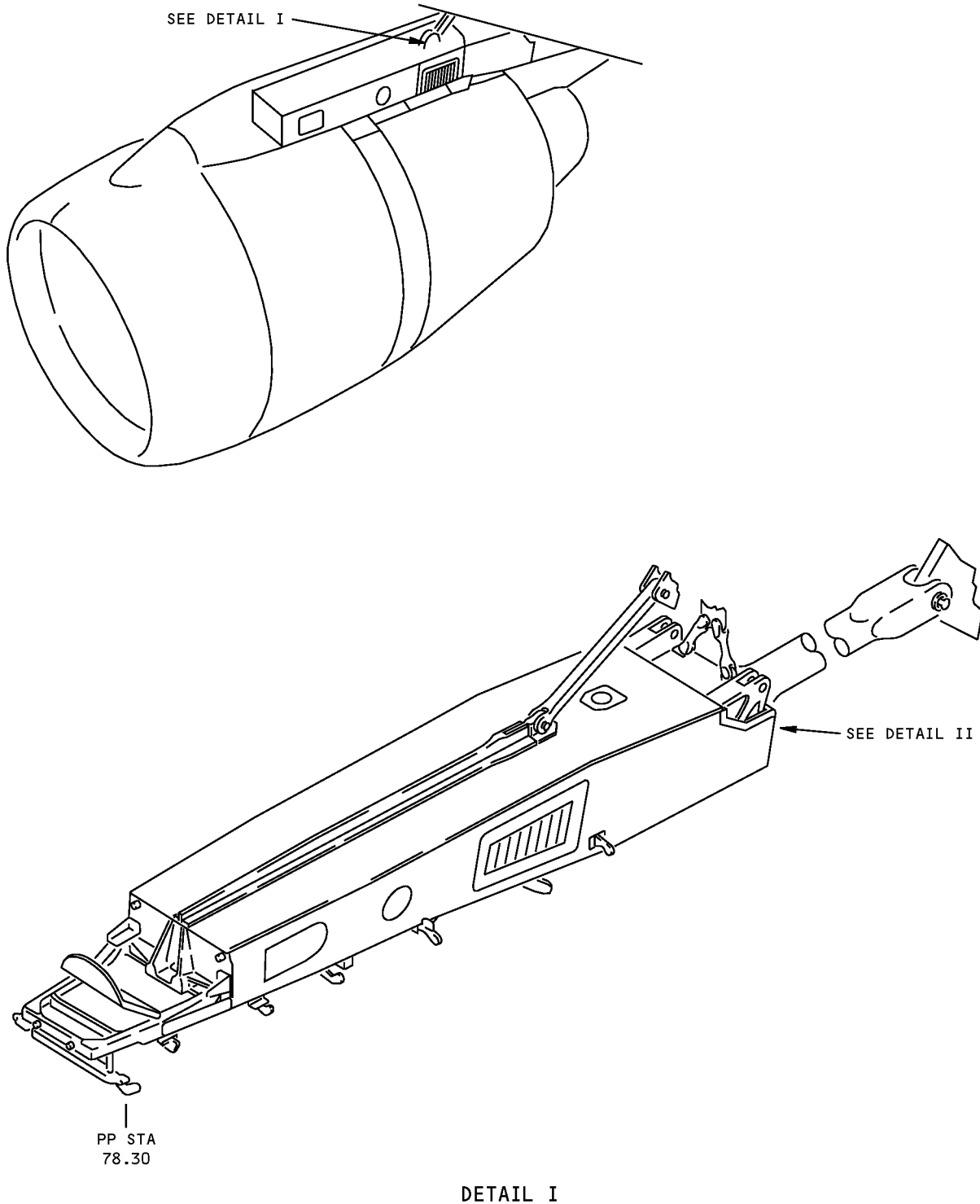

**Lower Spar Fitting, Lug Hole Repair with Interference Fit Bushing Procedure - RB211-535 Engine
Figure 201 (Sheet 5 of 8)**

**757-200
STRUCTURAL REPAIR MANUAL**

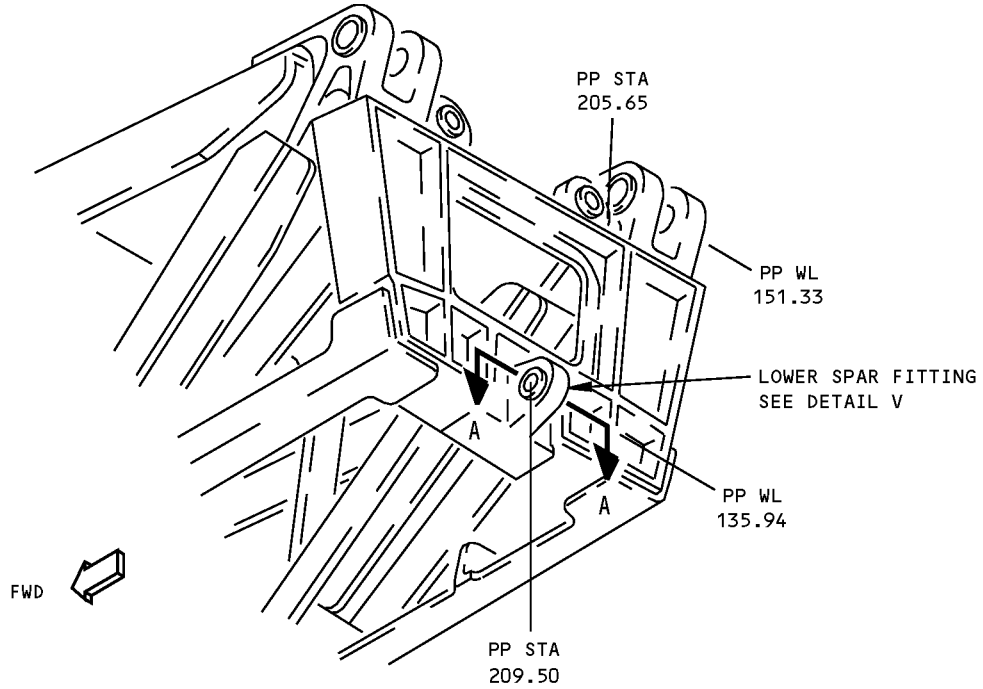

**VIEW ON REAR FACE
DETAIL II**

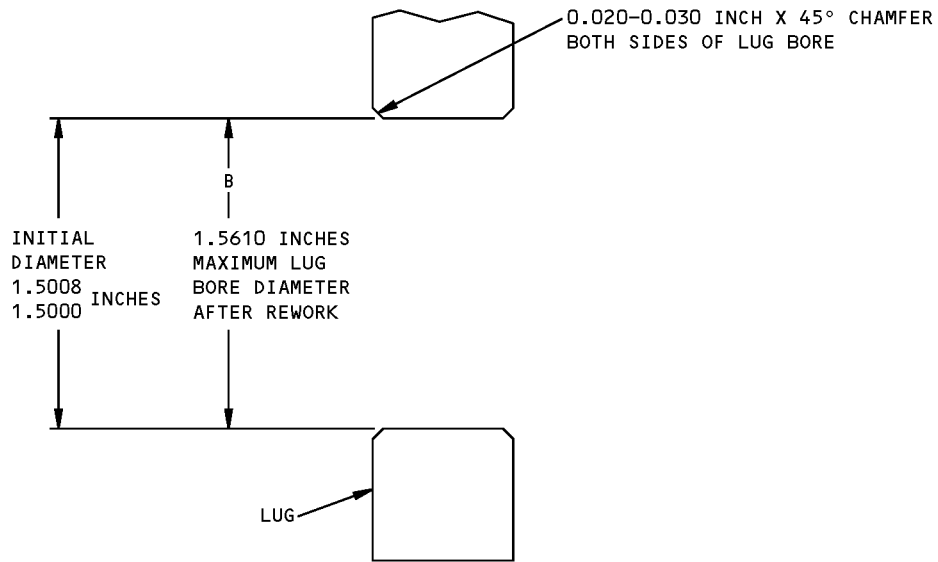

**LUG BORE DIMENSIONS
SECTION A-A**

**Lower Spar Fitting, Lug Hole Repair with Interference Fit Bushing Procedure - RB211-535 Engine
Figure 201 (Sheet 6 of 8)**

757-200
STRUCTURAL REPAIR MANUAL

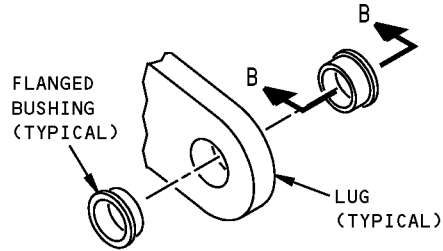

LOWER SPAR FITTING ASSEMBLY

DETAIL III

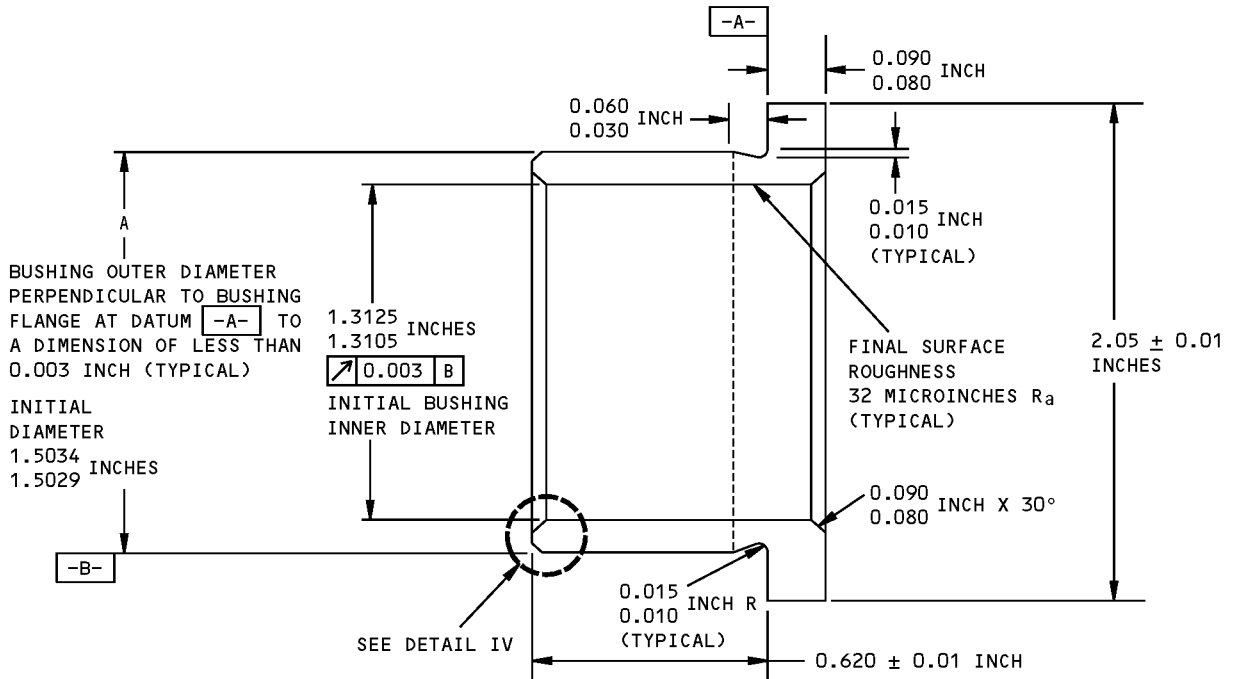

FLANGED BUSHING (TYPICAL)

SECTION B-B

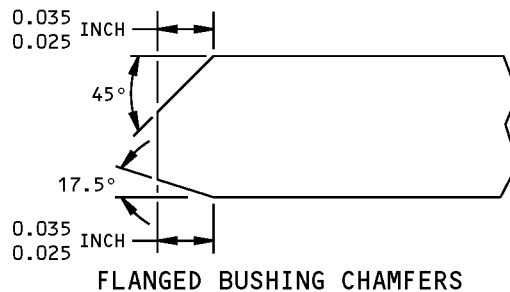

DETAIL IV

Lower Spar Fitting, Lug Hole Repair with Interference Fit Bushing Procedure - RB211-535 Engine
Figure 201 (Sheet 7 of 8)

**757-200
STRUCTURAL REPAIR MANUAL**

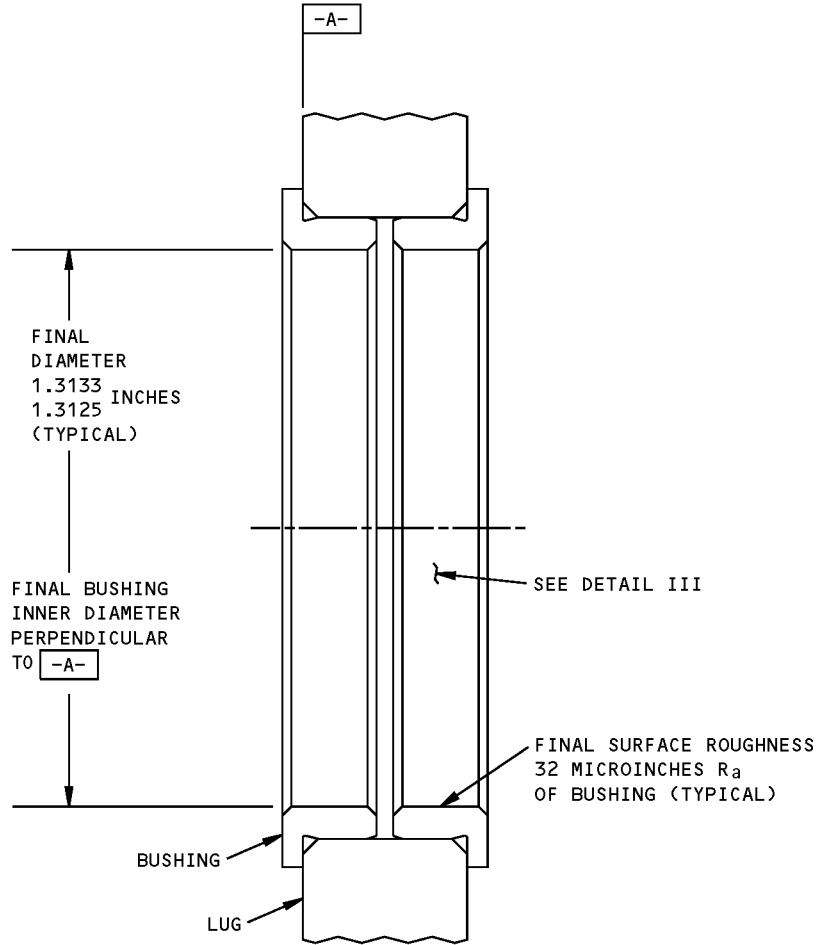

SECTION THROUGH THE CENTER OF THE LUG BORE
BUSHING DIMENSIONS AFTER THE BUSHINGS ARE INSTALLED
DETAIL V

**Lower Spar Fitting, Lug Hole Repair with Interference Fit Bushing Procedure - RB211-535 Engine
Figure 201 (Sheet 8 of 8)**

STRUCTURAL REPAIR MANUAL

REPAIR 6 - PYLON SHIM MIGRATION INSPECTION AND REPLACEMENT - RB211-535 ENGINE

APPLICABILITY
THIS SECTION IS APPLICABLE TO RB211-535 POWERED AIRPLANES AND CONTAINS THE PROCEDURES TO INSPECT AND REPLACE THE SHIMS OF THE STRUT MID-BULKHEAD FITTING.

INSPECTION FOR SHIM MIGRATION

1. Deactivate the wing leading edge slats. Refer to AMM 27-81-00.
2. Remove the mid-strut fairing skins to get access to the shims. Refer to AMM 54-53-01.
3. Do an inspection for migrated shims and measure the total shim migration. See Detail I.

NOTE: Total shim migration for a vertical shim is the sum of the displacements in the forward/aft and the vertical directions. The total shim migration for a horizontal shim is the sum of the displacements in the inboard/outboard and the forward/aft directions. If the total shim migration of both shims is more than 1.60 inches, The Boeing Company recommends immediate replacement of the shims.

4. For total shim migration less than 1.60 inches, but more than 0.250 inch, do one of the following:
 - A. Do a replacement of the shims, or
 - B. Do an inspection for shim migration at each subsequent 3000 flight cycles.
5. For total shim migration of less than 0.25 inch, it is recommended that the shims be inspected at the next 4C check or 12,000 flight cycles, that which occurs first.

CAUTION: DO NOT RE-TORQUE BOLTS THAT ARE COMMON TO THE MIGRATED SHIMS. IF YOU DO NOT OBEY, STRUCTURAL DAMAGE CAN BE THE RESULT.

6. If shim repair or replacement is found to be unnecessary as a result of these inspections, then do the steps that follow:
 - A. Make a record of the amount of shim migration.
 - B. Trim the exposed shim plies and apply BMS 10-11, type 1 primer, or equivalent, to the cut edges.
 - C. Apply a layer of BMS 5-63 or Dow Corning 93-006 sealant to the surrounding surfaces and edges of the shims.

SHIM REPLACEMENT

1. If shim replacement is necessary, do the steps that follow:
 - A. Remove the bolts (1) which are common to the center spar chord, the strut-to-upper link fitting and the shims. Refer to SB 757-54A0039.
 - B. Remove the shims.
2. Do a high frequency eddy current inspection of the fastener holes common to the shims, the strut-to-upper link fitting, and the center spar chord. Refer to NDT Manual, D6-643N301, Part 6, 51-00-17 or 51-00-05.
3. After you remove the shims, measure the gap between the strut-to-upper link fitting and the center spar chord with a feeler gage.
4. Make the new shims from solid 2024-T3 or 7075-T6 material, or BACS40R035C050F laminated shims.
5. Apply a chemical conversion coating followed by BMS 10-11, Type I primer to the shims.
6. Assemble the center spar chord, the strut-to-upper link fitting and the shims, and drill the fastener holes.
 - A. Put the strut-to-upper link fitting and the center spar chord in position.
 - B. Install the shims wet with BMS 5-63 or DC93-006 sealant. Use a small hammer to gently tap the shim grips to put the shim in position.
 - C. The maximum gap permitted at any location with the shim installed is 0.005 inch.
 - D. Drill the fastener holes.
 - E. If necessary, the fastener holes common to the strut-to-upper link fitting and the center spar chord can be drilled to first oversize diameter.
7. Install the fasteners which are common to the center spar chord, the strut-to-upper link fitting and the shims. Use the same type and size as the initial fasteners, or the first oversize, as applicable. Refer to SB 757-54A0039.
8. Install the mid-strut fairing shims. Refer to AMM 54-53-01.
9. Reactivate the wing leading edge slots. Refer to AMM 27-81-00.

**Pylon Shim Migration Inspection and Replacement - RB211-535 Engine
Figure 201 (Sheet 1 of 4)**



757-200
STRUCTURAL REPAIR MANUAL

NOTES

- ALL DIMENSIONS ARE IN INCHES, UNLESS GIVEN DIFFERENTLY.
- WHEN YOU USE THE REPAIR REFER TO:
 - SERVICE BULLETIN 757-54A0039 FOR MORE DATA ON SHIM MIGRATION INSPECTION LOCATIONS
 - AMM 27-81-00 DEACTIVATION/ACTIVATION OF THE WING LEADING EDGE SLAT
 - AMM 54-53-01 FOR THE REMOVAL AND INSTALLATION OF THE STRUT PRESSURE RELIEF AND ACCESS DOORS
 - NDT PART 6, 51-00-17 OR 51-00-05 (D6-643N301) FOR HIGH FREQUENCY EDDY CURRENT INSPECTION
 - SOPM 20-41-02 FOR THE APPLICATION OF CHEMICAL AND SOLVENT RESISTANT FINISHES
 - SRM 51-20-05 FOR REPAIR SEALING

Pylon Shim Migration Inspection and Replacement - RB211-535 Engine
Figure 201 (Sheet 2 of 4)

D634N201

54-50-90

REPAIR 6
Page 202
May 20/2006

**757-200
STRUCTURAL REPAIR MANUAL**

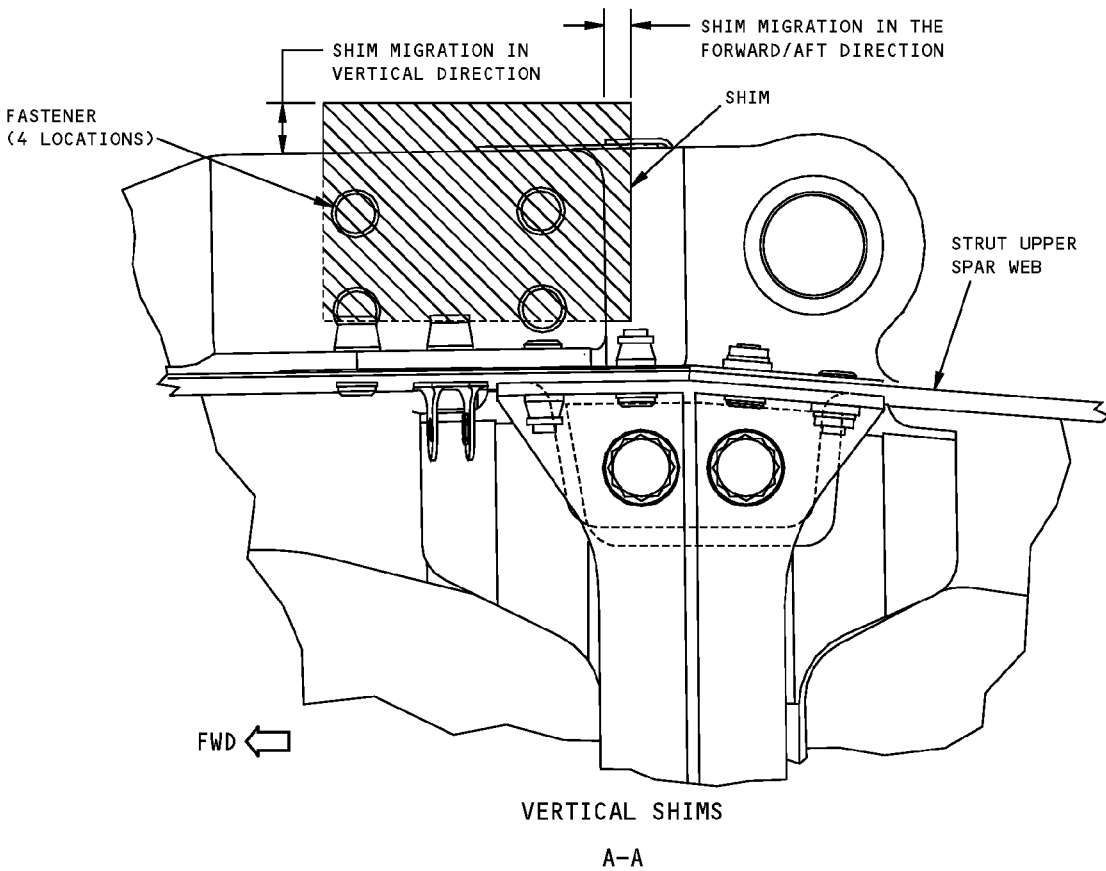
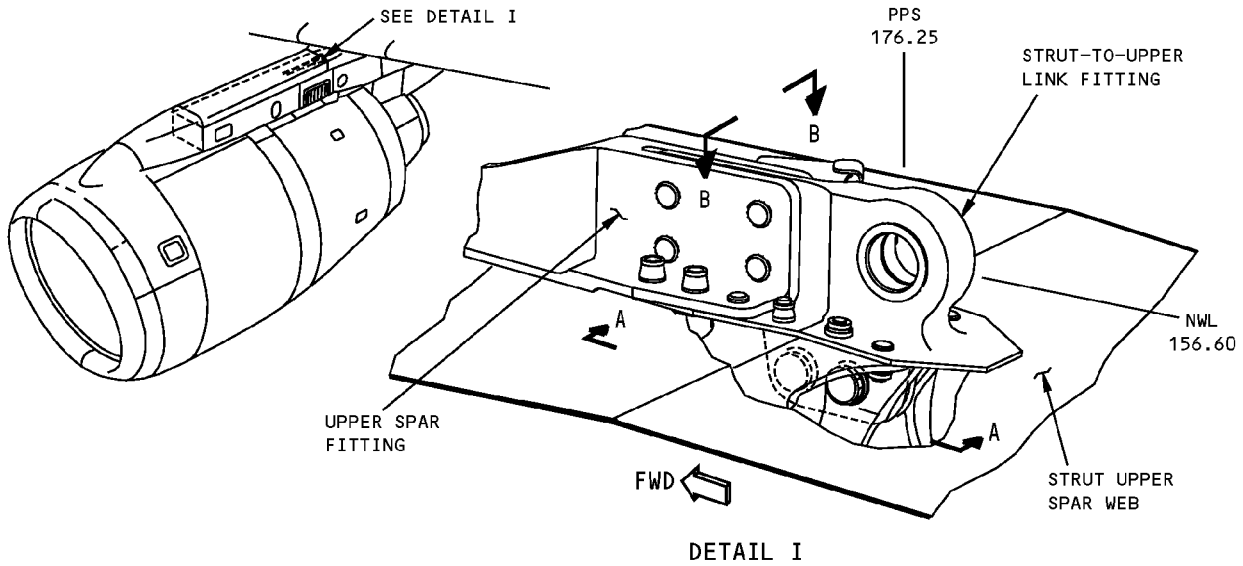

**Pylon Shim Migration Inspection and Replacement - RB211-535 Engine
Figure 201 (Sheet 3 of 4)**

**757-200
STRUCTURAL REPAIR MANUAL**

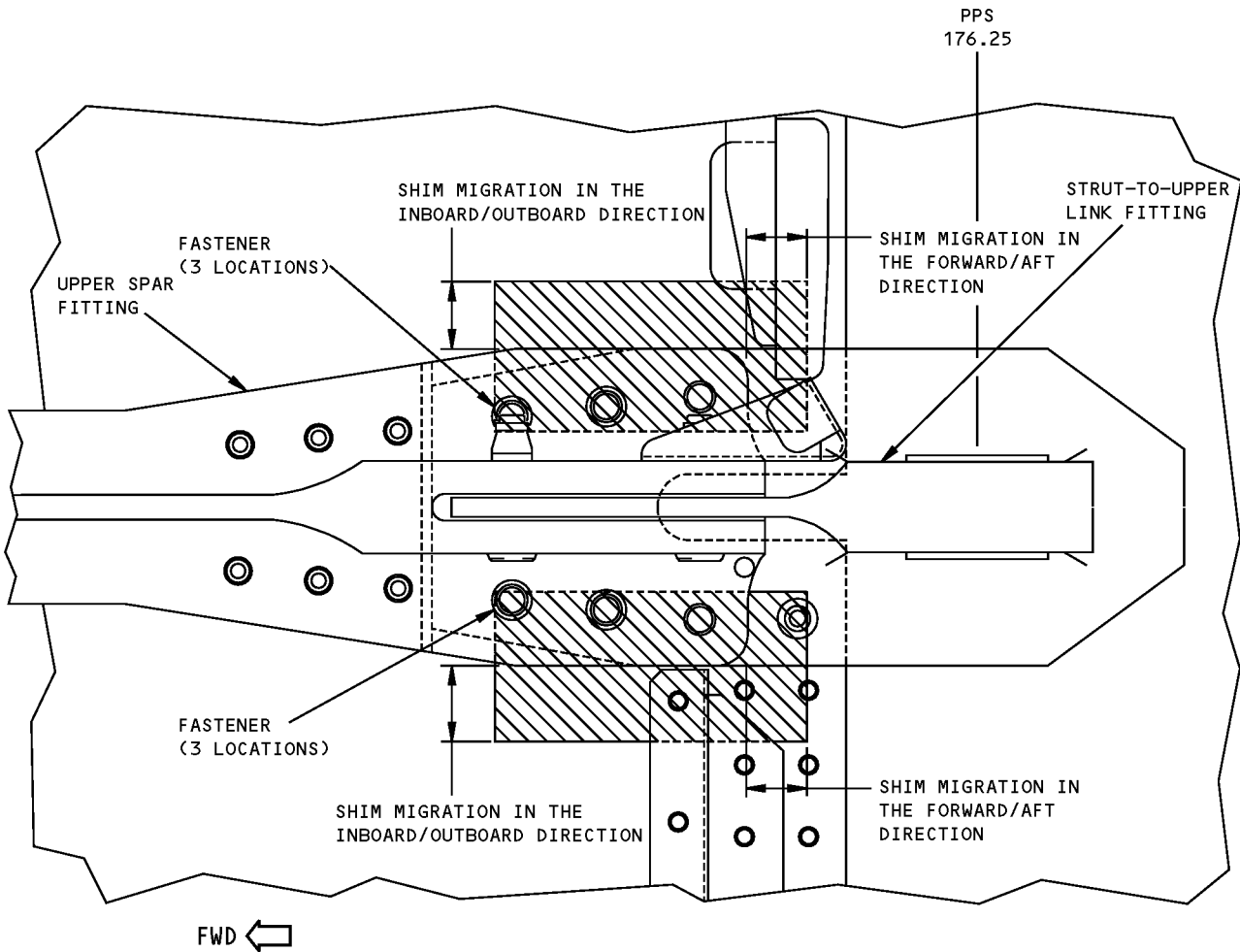

**HORIZONTAL SHIMS
A-A**

**Pylon Shim Migration Inspection and Replacement - RB211-535 Engine
Figure 201 (Sheet 4 of 4)**

757-200
STRUCTURAL REPAIR MANUAL

IDENTIFICATION 1 - STRUT SKIN - PW2000 ENGINE

REFERENCE DRAWING
311N3000

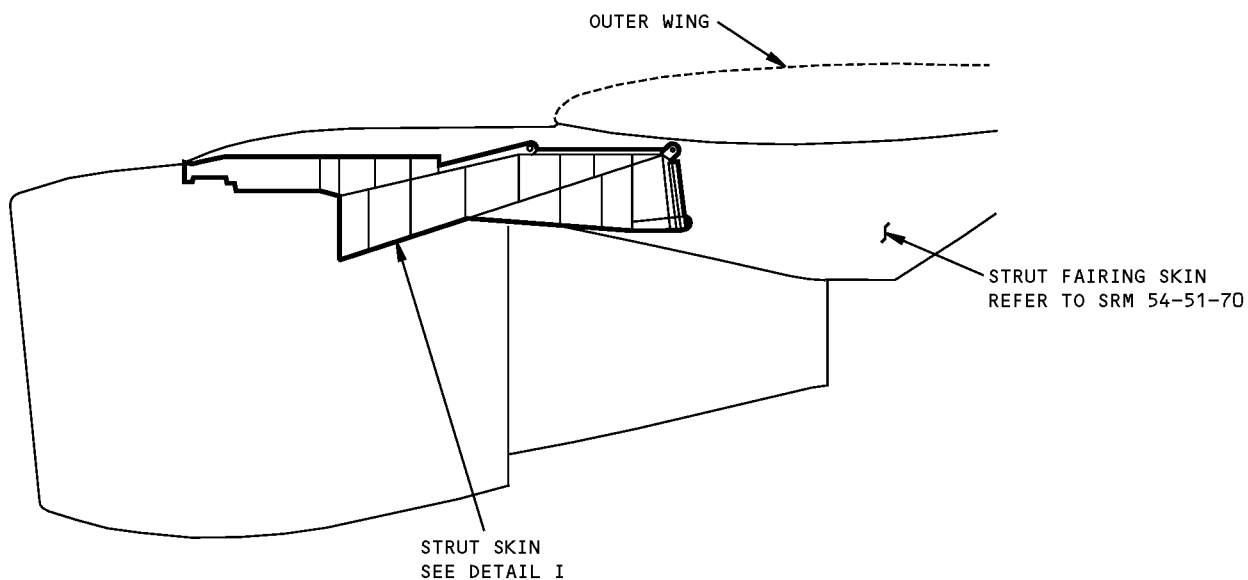

NOTES

- A** FOR CUM LINE NUMBERS:
1 THRU 216 AND HAVING PW2000 SERIES
ENGINES
- B** FOR CUM LINE NUMBERS:
216 AND ON AND HAVING PW2000 SERIES
ENGINES

Strut Skin Identification - PW2000 Engine
Figure 1 (Sheet 1 of 3)

**757-200
STRUCTURAL REPAIR MANUAL**

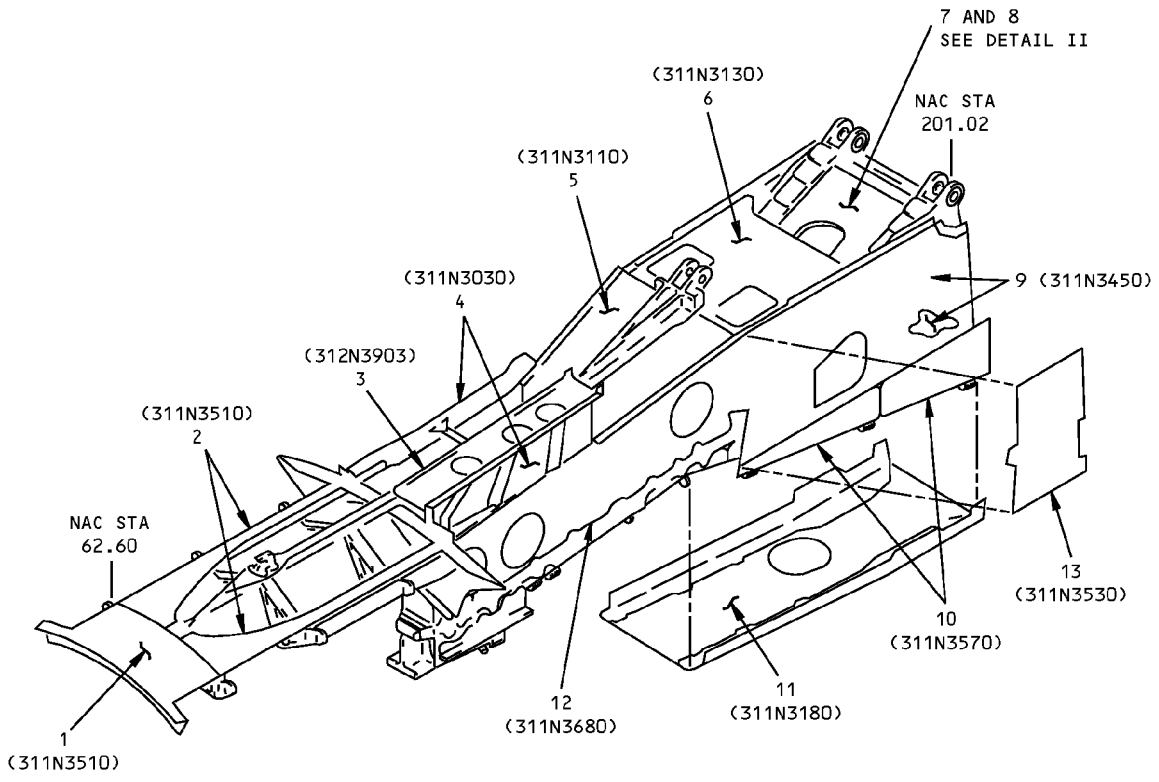

DETAIL I



**Strut Skin Identification - PW2000 Engine
Figure 1 (Sheet 2 of 3)**

IDENTIFICATION 1
Page 2
Jan 20/2005

54-51-01

D634N201

**757-200
STRUCTURAL REPAIR MANUAL**

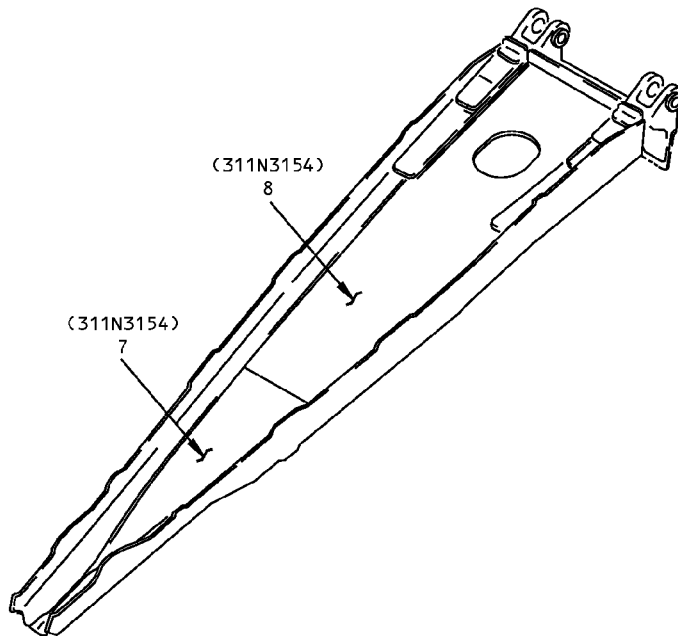

DETAIL II

ITEM	DESCRIPTION	GAGE	MATERIAL	EFFECTIVITY		
1	TOP SKIN, FWD	0.063	TI-6AL-4V TYPE III, COMP C	<table border="1" style="margin: auto;"> <tr><td>A</td></tr> <tr><td>B</td></tr> </table>	A	B
A						
B						
2	TOP SKIN	0.063	CLAD 2024-T3			
3	TRAY	0.063	CLAD 2024-T42			
4	FLUID BARRIER		ARAMID/EPOXY LAMINATE PER BMS 8-218 STYLE 285 POLYETHER ETHER KETONE (PEEK) INJECTION MOLD			
5	WEB, FWD UPR SPAR	0.140	2024-T3			
6	WEB, AFT UPR SPAR	0.063	CLAD 2024-T3			
7	FWD WEB, MIDSPAR	0.187	15-5PH CRES HT-TR 180-200 KSI			
8	AFT WEB, MIDSPAR	0.187	2024-T3			
9	SKIN AND DOUBLERS	0.080	CLAD 2024-T3			
10	CORE COWL SKIRT	0.090	CLAD 2024-T62			
11	WEB, LWR SPAR	0.100	15-5PH CRES HT-TR 180-200 KSI			
12	WEAR STRIP	0.032	301 CRES 1/2 HARD			
13	FAIRING		INJECTION MOULDING - POLYETHER ETHER KETONE			

LIST OF MATERIALS FOR DETAILS I AND II

**Strut Skin Identification - PW2000 Engine
Figure 1 (Sheet 3 of 3)**

D634N201

54-51-01

IDENTIFICATION 1
Page 3
Jan 20/2005

**757-200
STRUCTURAL REPAIR MANUAL**

ALLOWABLE DAMAGE 1 - STRUT SKIN - PW2000 ENGINE

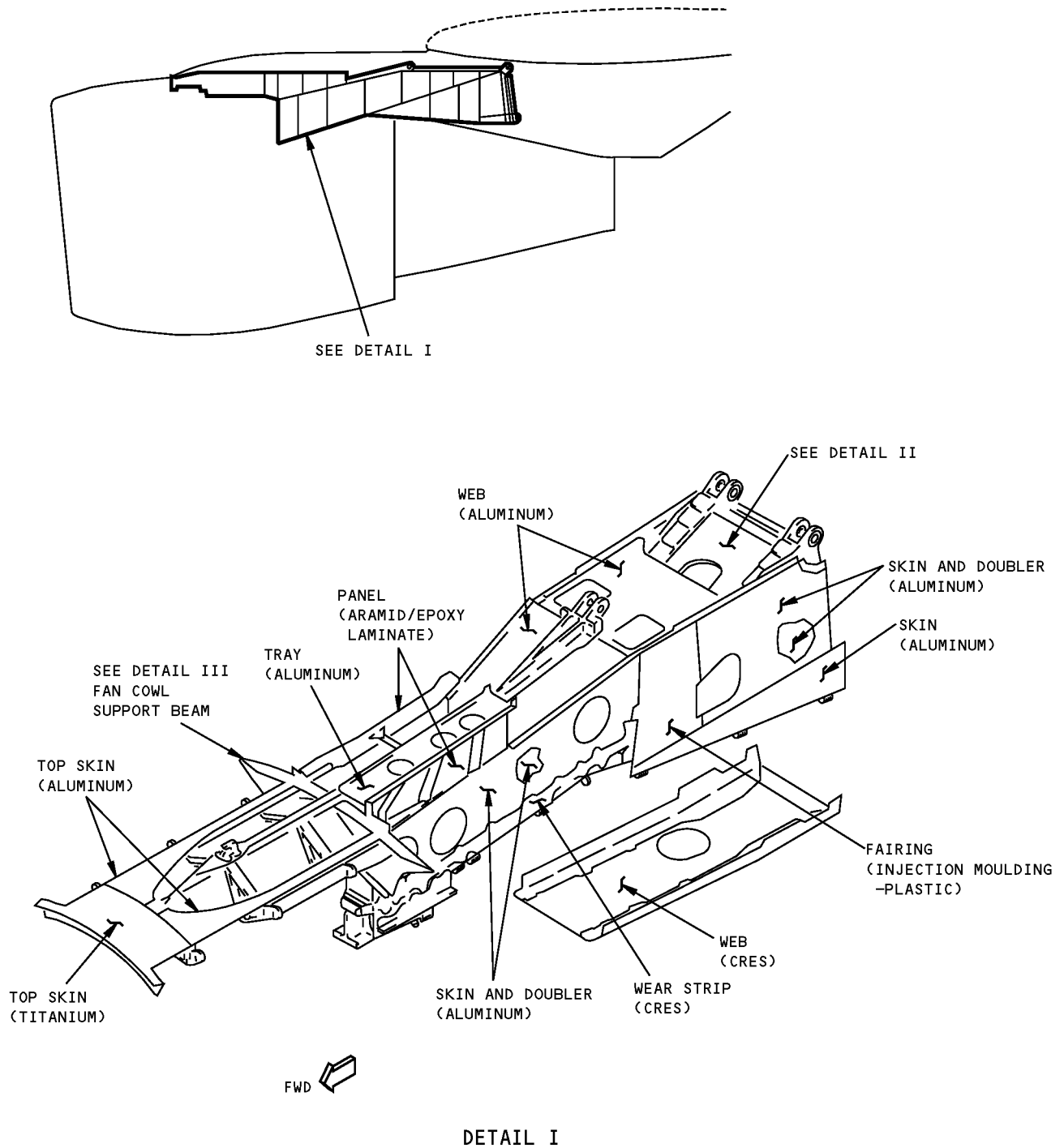

**Strut Skin Allowable Damage- PW2000 Engine
Figure 101 (Sheet 1 of 7)**

**757-200
STRUCTURAL REPAIR MANUAL**

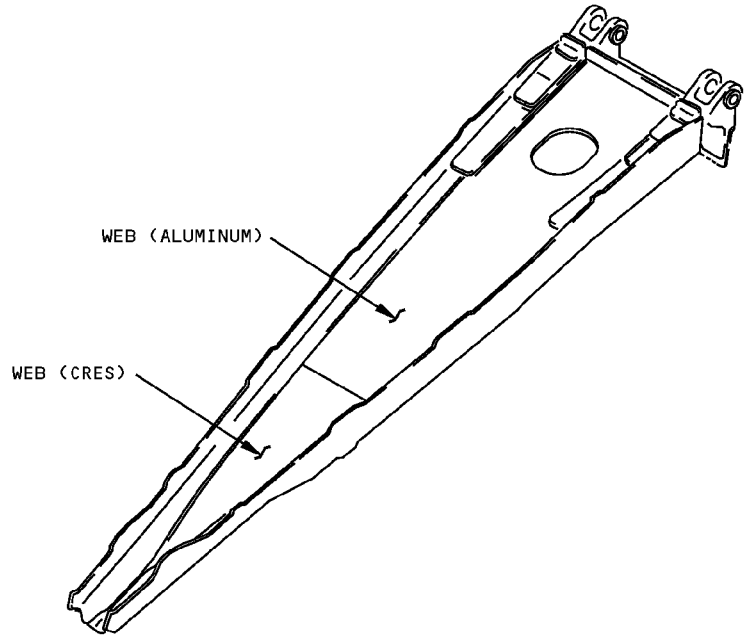

DETAIL II

DESCRIPTION	CRACKS	NICKS, GOUGES AND CORROSION	DENTS	HOLES AND PUNCTURES	DELAMINATION
SKINS AND DOUBLERS	A	B	SEE DETAIL VI	C	—
WEBS	A	B	SEE DETAIL VI	C	—
TRAY AND WEAR STRIP	D	B	SEE DETAIL VI	C	—
FAIRING	D	B	NOT PERMITTED	G	—
PANEL (ARAMID/EPOXY LAMINATE)	A AND H	I	F	E	J

**Strut Skin Allowable Damage- PW2000 Engine
Figure 101 (Sheet 2 of 7)**

**757-200
STRUCTURAL REPAIR MANUAL**

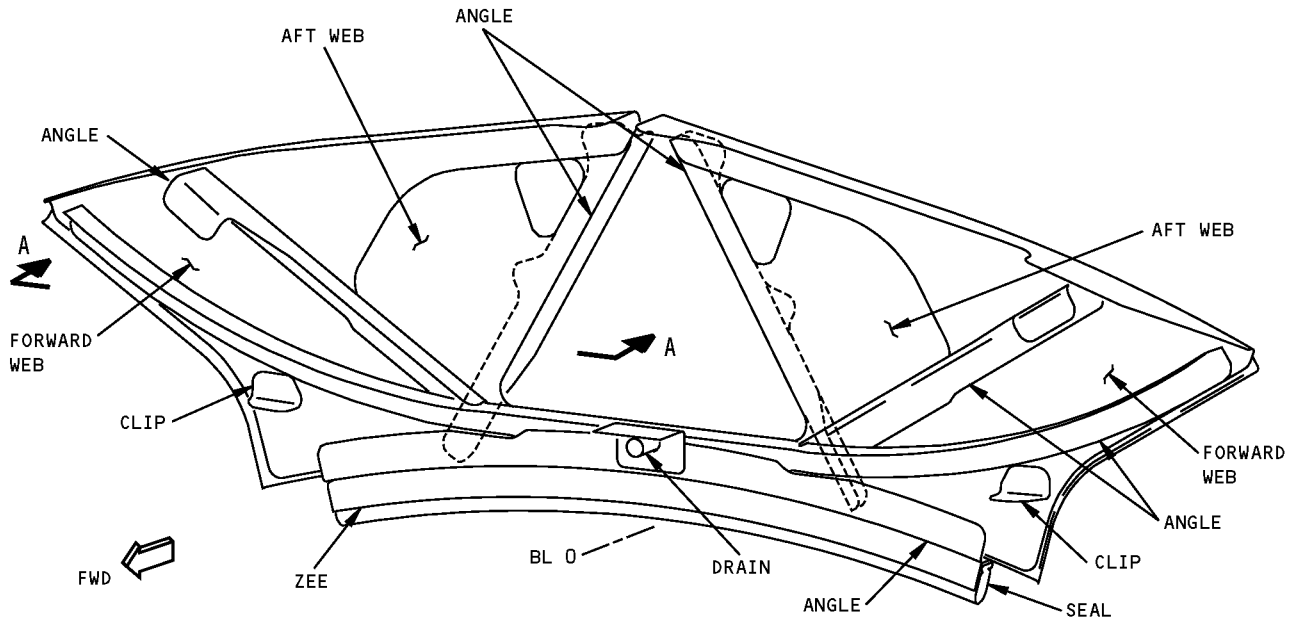

DETAIL III

**Strut Skin Allowable Damage- PW2000 Engine
Figure 101 (Sheet 3 of 7)**

STRUCTURAL REPAIR MANUAL

NOTES

- REFINISH REWORKED AREAS AS SHOWN AMM 51-20.
 - REFER TO SRM 51-10-01 FOR AERODYNAMIC SMOOTHNESS REQUIREMENTS. WHERE THE DAMAGE IS MORE THAN THE LIMITS SHOWN IN SRM 51-10-01, CONSIDERATION SHOULD BE GIVEN TO THE LOSS OF PERFORMANCE INVOLVED.
 - REFER TO SRM 51-10-02 FOR INSPECTION AND REMOVAL OF DAMAGE
 - REFER TO NDT, PART 6, 51-00-13 FOR HIGH FREQUENCY EDDY CURRENT INSPECTION PROCEDURES.
- A** CRACKS NOT PERMITTED EXCEPT FOR EDGE CRACKS WHICH MUST BE REMOVED AS SHOWN IN DETAILS IV AND VIII.
- B** REMOVE DAMAGE AS SHOWN DETAILS IV, V AND VII.
- C** CLEAN OUT DAMAGE UP TO 0.25 INCH (6 mm) MAXIMUM DIAMETER AND NOT CLOSER THAN 1.0 INCH (25 mm) TO FASTENER HOLE, MATERIAL EDGE, FOR OTHER DAMAGE. FILL HOLES IN ALUMINUM WEB OR SKIN WITH A 2117- T3 OR T4 ALUMINUM RIVET INSTALLED WET WITH BMS 5-63 SEALANT. FILL HOLES IN STEEL OR TITANIUM, SKIN OR WEB WITH MONEL RIVET INSTALLED DRY. ALL OTHER HOLES TO BE REPAIRED.
- D** CRACKS UP TO THREE INCHES ARE PERMITTED. DRILL 0.19 INCH (5 mm) DIAMETER HOLE AT EACH END OF CRACK. CLEAN UP EDGE CRACKS AS SHOWN IN DETAILS IV AND VIII.
- CAUTION:** IF THERE IS AN UNDERLYING STRUCTURE, DO NOT DRILL INTO THE UNDERLYING STRUCTURE.
- E** 0.25 INCH (6 mm) MAXIMUM DIAMETER PERMITTED PROVIDED DAMAGE IS MINIMUM OF 3.0 D FROM NEAREST HOLE OR MATERIAL EDGE AND A MINIMUM OF 6 INCHES (150 mm) FROM OTHER DAMAGE. DO NOT CLEAN UP DAMAGE EXCEPT TO REMOVE RESIN BURRS EXTENDING INTO SURFACE CONTOUR. **H**
- F** DENTS GENERALLY RESULT IN FIBER DAMAGE OR DELAMINATION. HOWEVER, IF THERE IS NO FIBER DAMAGE OR DELAMINATION, DENTS UP TO 2.25 INCHES (57 mm) DIAMETER MAXIMUM ARE PERMITTED. ONE DENT FOR EACH SQUARE FOOT OF AREA PERMITTED WHICH MUST BE A MINIMUM OF 6 INCHES (150 mm) FROM ANY OTHER DAMAGE, FASTENER HOLE, OR PANEL EDGE. SEE **E** IF THERE IS A FIBER DAMAGE, OR **J** IF DELAMINATION IS PRESENT.
- G** 0.19 INCH (4.8 mm) MAXIMUM DIAMETER PERMITTED PROVIDED DAMAGE IS MINIMUM OF 3.0 D FROM OTHER DAMAGE, NEAREST HOLE, OR MATERIAL EDGE.
- H** PROTECT DAMAGE FROM ENTRANCE OF WATER, SUNLIGHT OR OTHER FOREIGN MATTER BY SEALING WITH ALUMINUM FOIL TAPE (SPEED TAPE) 3M-Y436 OR EQUIVALENT. RECORD LOCATION AND INSPECT AT AIRPLANE "A" CHECK. REPLACE ALUMINUM FOIL TAPE IF ANY PEELING OR DETERIORATION IS EVIDENT. REPAIR DAMAGE AS SHOWN IN SRM 51-70, NO LATER THAN THE NEXT "C" CHECK.
- I** DAMAGE IS PERMITTED ON SURFACE RESIN ONLY WITHOUT FIBER DAMAGE. REFER TO **E** IF THERE IS FIBER DAMAGE. CLEAN UP EDGE DAMAGE AS SHOWN IN DETAILS IV AND VIII. **H**
- J** 1.00 INCH (25 mm) MAXIMUM DIAMETER (D) IS PERMITTED FOR EACH SQUARE FOOT OF AREA; A MINIMUM OF 6 D (EDGE TO EDGE) FROM ANY OTHER DAMAGE, FASTENER HOLE OR PANEL EDGE. REPAIR AS SHOWN IN SRM 51-70 NO LATER THAN NEXT "C" CHECK. A MAXIMUM OF 0.10 INCH (2.5 mm) DELAMINATION FROM EDGE IS PERMITTED PROTECT EDGE DELAMINATION PER INSTRUCTIONS IN NOTE **H**
- K** ON AIRPLANES BEFORE LINE NUMBER 845: EDGE DAMAGE MAY HAVE OCCURED AT THIS LOCATION. THE DAMAGE IS A RESULT OF INTERFERENCE BETWEEN THE ANGLE AND THE THRUST REVERSER HINGE. IF THERE IS DAMAGE, REMOVE UP TO 0.200 INCH (5 mm) MAXIMUM FROM THE EDGE OF THE ANGLE TO PREVENT FURTHER INTERFERENCE AND DAMAGE. REMOVE THE MATERIAL FROM THE EDGE AS SPECIFIED IN DETAIL VIII, EXCEPT X = 0.200 INCH (5 mm).
- L** ON AIRPLANES BEFORE LINE NUMBER 845: EDGE DAMAGE MAY HAVE OCCURED AT THIS LOCATION. THE DAMAGE IS A RESULT OF INTERFERENCE BETWEEN THE ZEE AND THE THRUST REVERSER HINGE OR THE ENGINE "D" FLANGE. IF THERE IS DAMAGE, REMOVE UP TO 0.200 INCH (5 mm) MAXIMUM FROM THE EDGE OF THE ANGLE AND ZEE TO PREVENT FURTHER INTERFERENCE AND DAMAGE. REMOVE THE MATERIAL FROM THE EDGE AS SPECIFIED IN DETAIL VIII, EXCEPT X = 0.200 INCH (5 mm).
- M** A 4.00 INCHES (100 mm) MAXIMUM LENGTH CRACK IS PERMITTED ALONG THE RADIUS OF THE ANGLE. DRILL 0.19 INCH (4.8 mm) DIAMETER HOLE(S) AT THE END(S) OF THE CRACK. DO A HIGH FREQUENCY EDDY CURRENT (HFEC) OR PENETRANT INSPECTION TO MAKE SURE THE CRACK IS CONTAINED. NO STOP HOLES ARE NECESSARY FOR A CRACK IN THE ANGLE FLANGE IF THE CRACK IS LESS THAN 4.00 INCHES (100 mm) LONG AND STOPS AT A FASTENER. DO A VISUAL INSPECTION EVERY 600 CYCLES FOR CRACKS LESS THAN 2.00 INCHES (50 mm) LONG. DO A VISUAL INSPECTION AT EVERY 300 CYCLES FOR CRACKS BETWEEN 2 (50 mm) AND 4 INCHES (100 mm) LONG. REPLACE THE CRACKED ANGLE WITH A NEW ANGLE AT THE SUBSEQUENT HEAVY MAINTENANCE CHECK.

Strut Skin Allowable Damage- PW2000 Engine
Figure 101 (Sheet 4 of 7)

**757-200
STRUCTURAL REPAIR MANUAL**

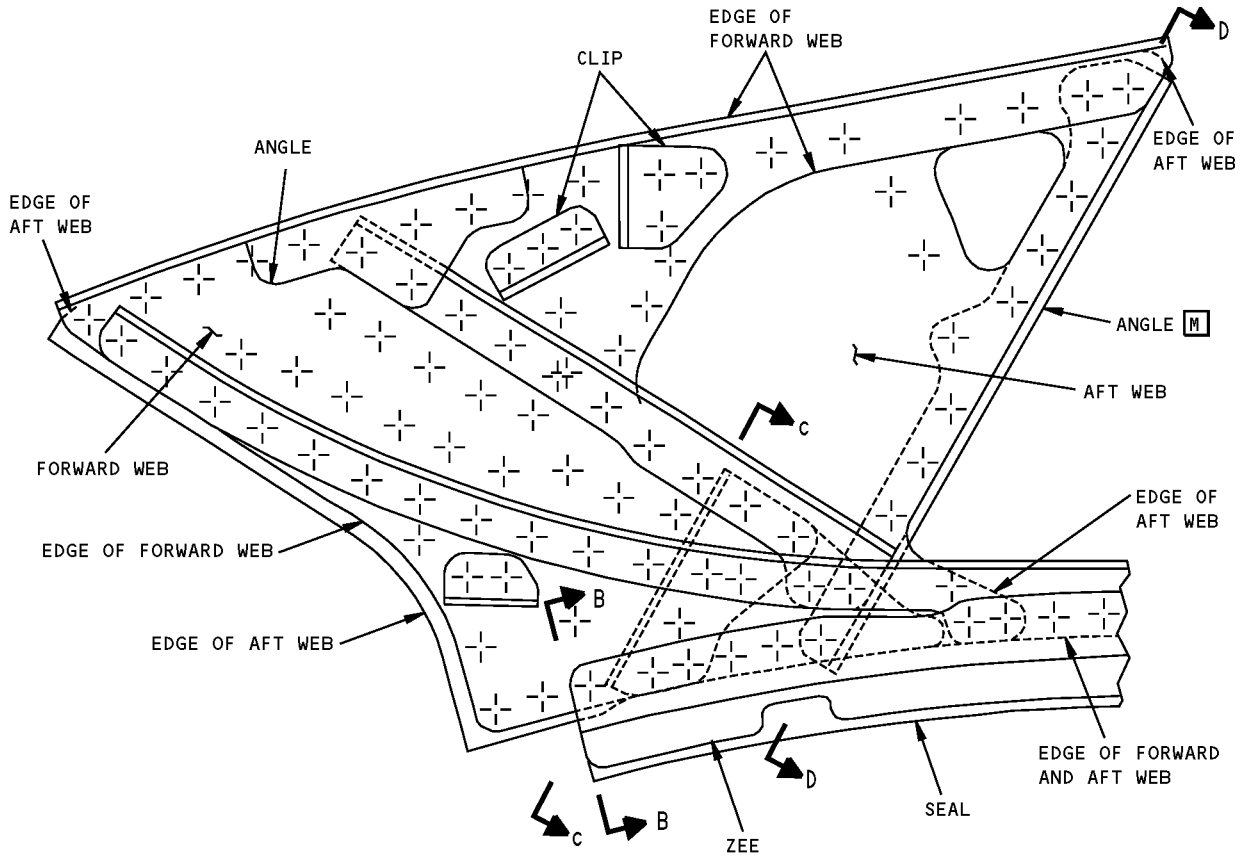

RIGHT SIDE IS SHOWN, LEFT SIDE IS OPPOSITE

VIEW IS LOOKING AFT

VIEW A-A

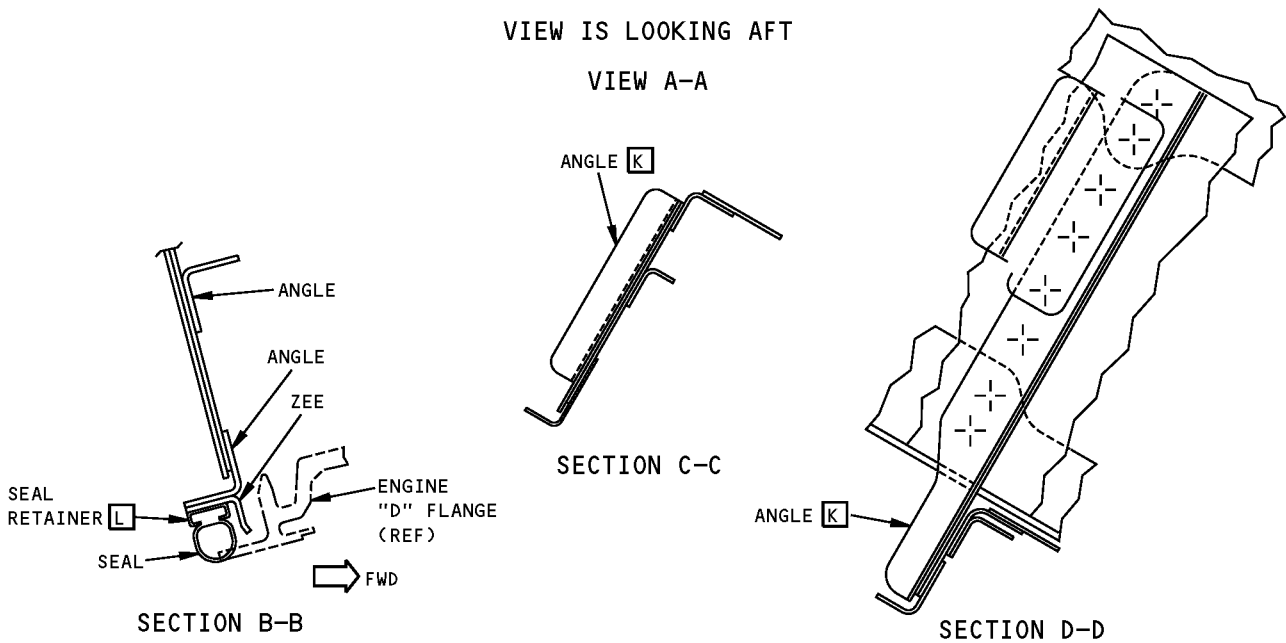

**Strut Skin Allowable Damage- PW2000 Engine
Figure 101 (Sheet 5 of 7)**

**757-200
STRUCTURAL REPAIR MANUAL**

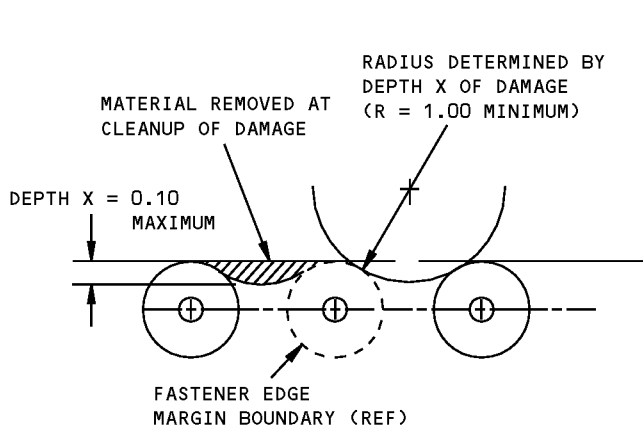

DAMAGE CLEANUP OF EDGES WHERE FASTENER EDGE MARGINS DO NOT OVERLAP

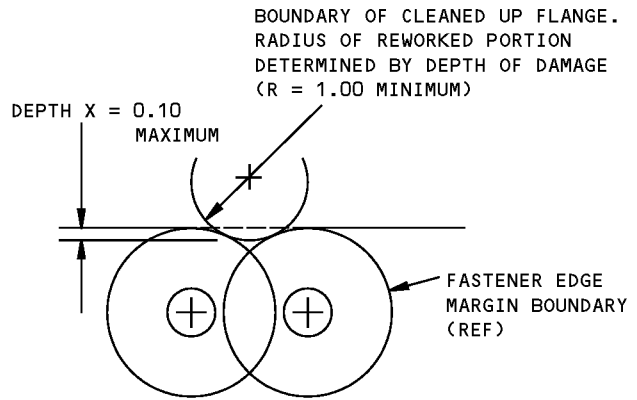

DAMAGE CLEANUP OF EDGES WHERE FASTENER EDGE MARGINS OVERLAP

DETAIL IV

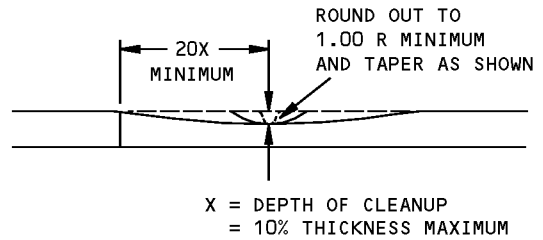

SECTION D-D

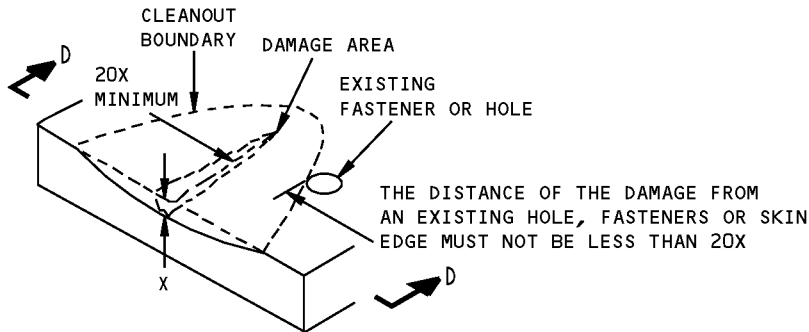

REMOVAL OF NICK, GOUGE AND SCRATCH DAMAGE ON A SURFACE
DETAIL V

**Strut Skin Allowable Damage- PW2000 Engine
Figure 101 (Sheet 6 of 7)**

**757-200
STRUCTURAL REPAIR MANUAL**

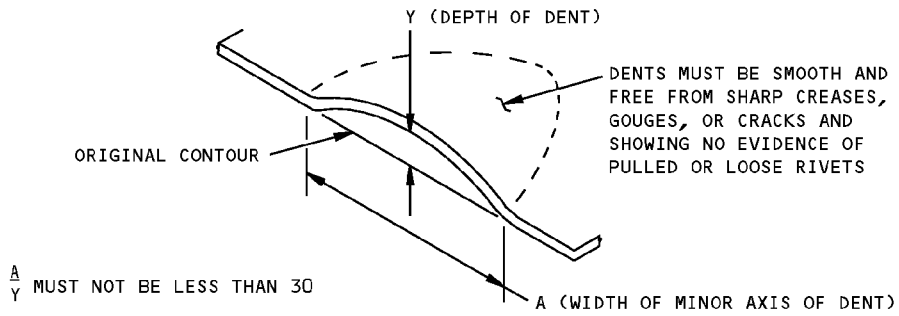

ALLOWABLE DAMAGE FOR DENT

DETAIL VI

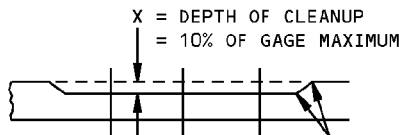
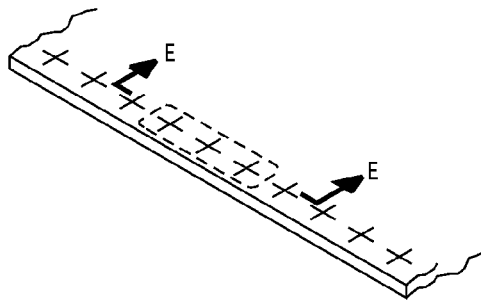

SMOOTH BLENDOUT RADIUS 0.50 INCH MINIMUM.
CORROSION CLEANUP AROUND ANY THREE FASTENERS
IN TEN IS PERMITTED TO MAXIMUM DEPTH

SECTION E-E

CORROSION CLEANUP

DETAIL VII

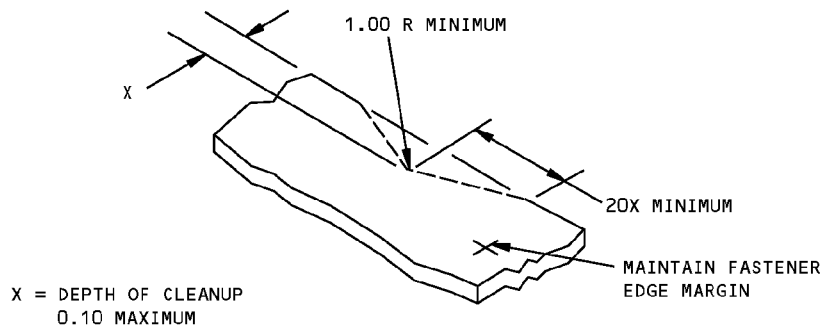

DETAIL VIII

**Strut Skin Allowable Damage- PW2000 Engine
Figure 101 (Sheet 7 of 7)**

**757-200
STRUCTURAL REPAIR MANUAL**

REPAIR 1 - STRUT TOP SKIN REPAIR - PW2000 ENGINE

REPAIR INSTRUCTIONS

1. Clean out damaged area to 1-inch max diameter circle.
2. Fabricate repair part 1.
3. Assemble repair part 1 and drill fastener holes.
4. Remove repair part 1.
5. Break sharp edges of original and repair part. 0.015 R to 0.030 R.
6. Remove all nicks, scratches, burrs, sharp edges and corners from original and repair part.
7. Apply one coat of BMS 10-11, type 1 primer to all of part 1 in accordance with AMM 51-21.
8. Install repair part 1 making a faying surface seal with BMS 5-63 sealant. Install fasteners wet with BMS 5-63.
9. Restore finish.

FASTENER SYMBOLS

✦ REPAIR FASTENER LOCATION

REPAIR MATERIAL			
PART		QTY	MATERIAL
1	PLATE	1	0.063 TI-6AL-4V TYPE III, COMP C OPTIONAL: 0.063 301 CRES 1/2 HARD

TABLE I

NOTES

- WHEN YOU USE THIS REPAIR REFER TO:
 - AMM 51-21 FOR INTERIOR AND EXTERIOR FINISHES
 - AMM 51-31 FOR SEALS AND SEALING
 - SRM 51-20-01 FOR PROTECTIVE TREATMENT OF METAL
 - SRM 51-20-05 FOR SEALING OF REPAIRS
 - SRM 51-40 FOR FASTENER CODE, REMOVAL, INSTALLATION, HOLE SIZES AND EDGE MARGINS
 - SRM 51-40-03 FOR FASTENER SUBSTITUTION.

**Strut Top Skin Repair - PW2000 Engine
Figure 201 (Sheet 1 of 2)**

**757-200
STRUCTURAL REPAIR MANUAL**

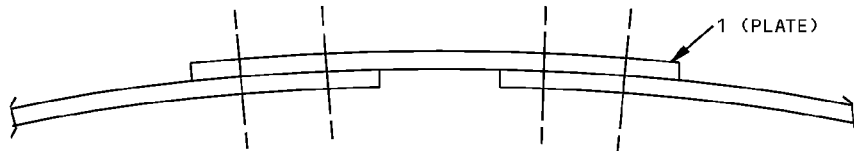
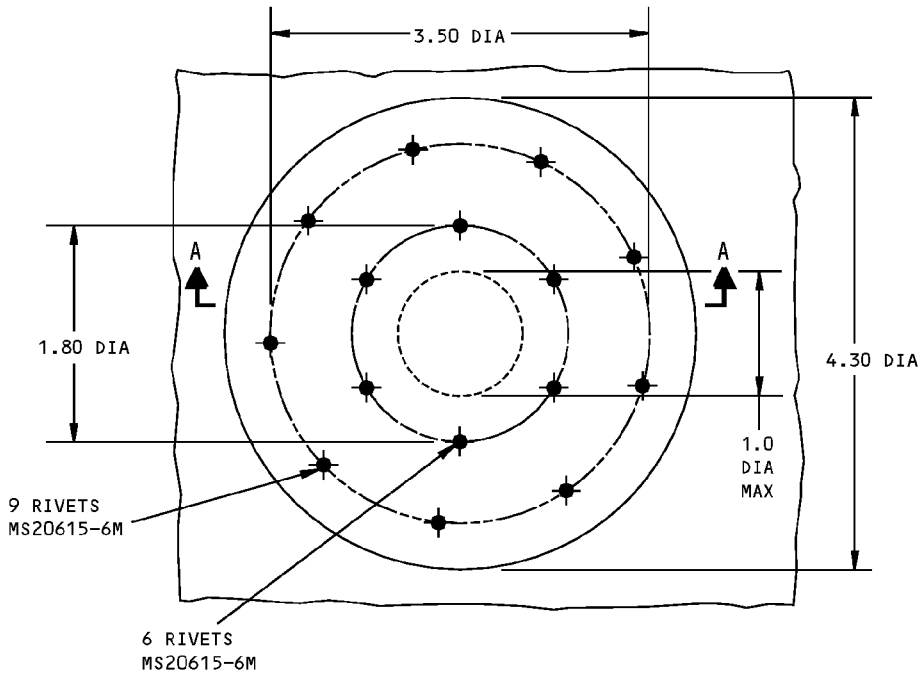
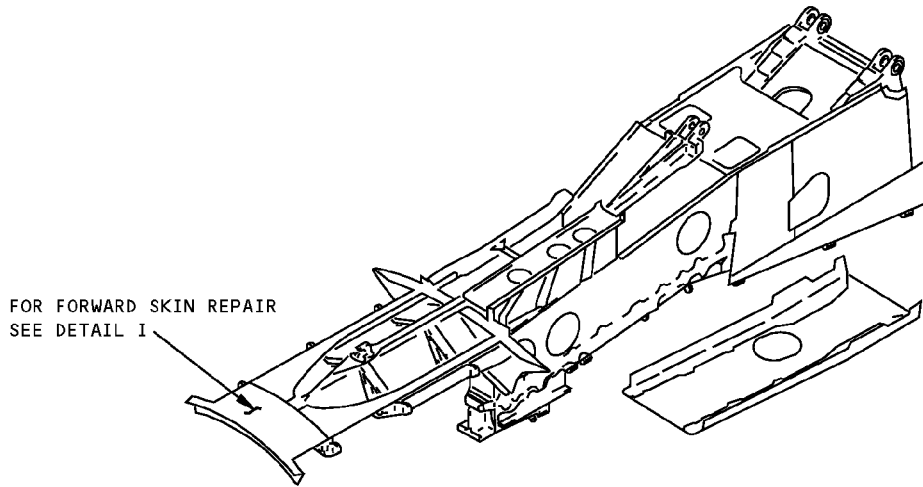

SECTION A-A

**SMALL HOLE OR CRACK REPAIR
DETAIL I**

**Strut Top Skin Repair - PW2000 Engine
Figure 201 (Sheet 2 of 2)**



757-200

STRUCTURAL REPAIR MANUAL

REPAIR 2 - STRUT SIDE SKIN SMALL HOLE OR CRACK - PW2000 ENGINE

REPAIR INSTRUCTIONS

1. Cut out cracked or damaged area to a regular shape.
2. Make the repair plate.
3. Assemble the repair plate and drill fastener holes.

CAUTION: WHEN ESTABLISHING RIVET POSITIONS, ENSURE THAT EDGE MARGINS ARE MAINTAINED ON THE INTERNAL DOUBLER, AND THAT SUFFICIENT CLEARANCE IS AVAILABLE FOR THE FORMATION OF RIVET HEADS ON THE UNDER STRUCTURE.

4. Remove the repair plate.
5. Break sharp edges of original and repair plate 0.015 to 0.030.
6. Remove all nicks, scratches, burrs and corners from original and repair plate.
7. Alodize the raw edges of existing and repair part according to SRM 51-20-01.
8. Apply one coat of BMS 10-11, type 1 primer to faying surfaces of the repair plate, and to the strut skin according to AMM 51-21.
9. Install the repair plate, making a faying surface seal with BMS 5-63 sealant. Install fasteners wet with BMS 5-63.
10. Restore original finishes according to AMM 51-21.

NOTES

- WHEN YOU USE THIS REPAIR REFER TO:
 - AMM 51-21 FOR INTERIOR AND EXTERIOR FINISHES
 - AMM 51-31 FORM SEALS AND SEALING
 - SRM 51-20-01 FOR PROTECTIVE TREATMENT OF METAL
 - SRM 51-20-05 FOR SEALING OF REPAIRS
 - SRM 51-40 FOR FASTENER CODE, REMOVAL, INSTALLATION, HOLE SIZES AND EDGE MARGINS
 - SRM 51-40-03 FOR FASTENER SUBSTITUTION.

A INSIDE OF SKIN IS CHEM-MILLED. MAKE SURE RIVET HEAD CLEARS RADIUS.

FASTENER SYMBOLS

- ◆ REPAIR FASTENER LOCATION
- ✦ ORIGINAL FASTENER LOCATION

REPAIR MATERIAL			
PART		QTY	MATERIAL
1	PLATE	1	0.10 CLAD 2024-T3

TABLE I

**Strut Side Skin Small Hole or Crack Repair - PW2000 Engine
Figure 201 (Sheet 1 of 3)**

D634N201

54-51-01

REPAIR 2
Page 201
Jan 20/2005

**757-200
STRUCTURAL REPAIR MANUAL**

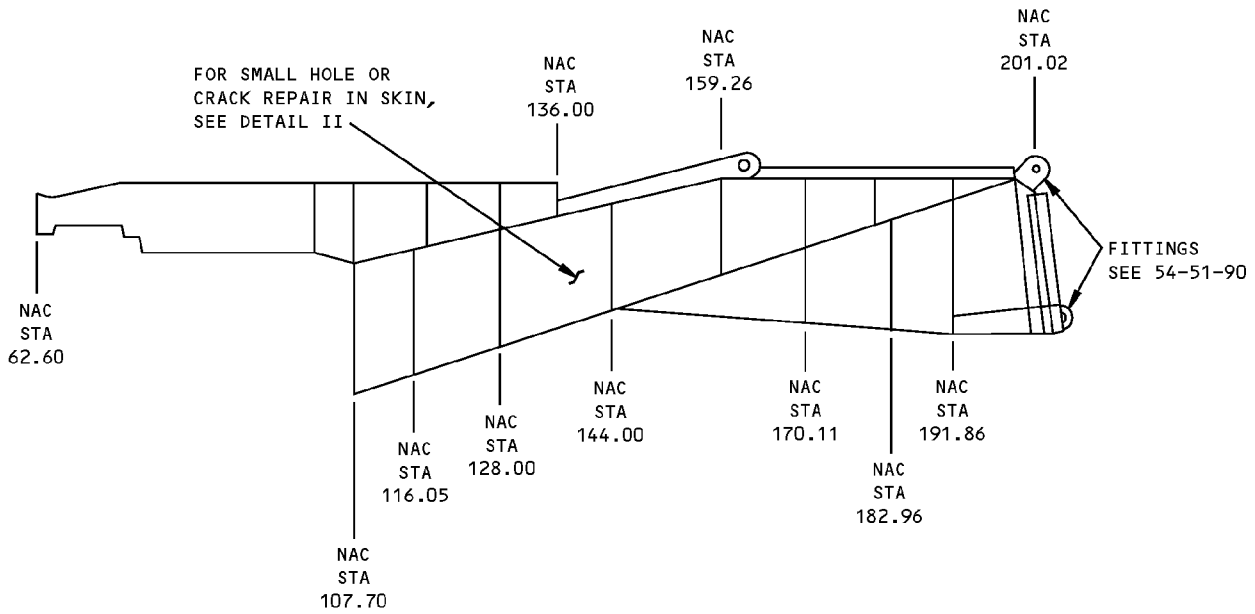
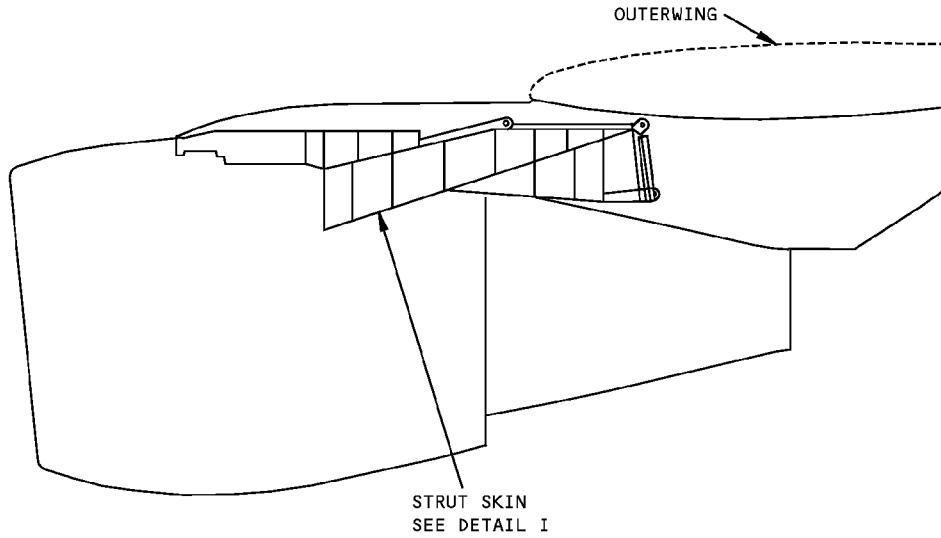

DETAIL I

**Strut Side Skin Small Hole or Crack Repair - PW2000 Engine
Figure 201 (Sheet 2 of 3)**

**757-200
STRUCTURAL REPAIR MANUAL**

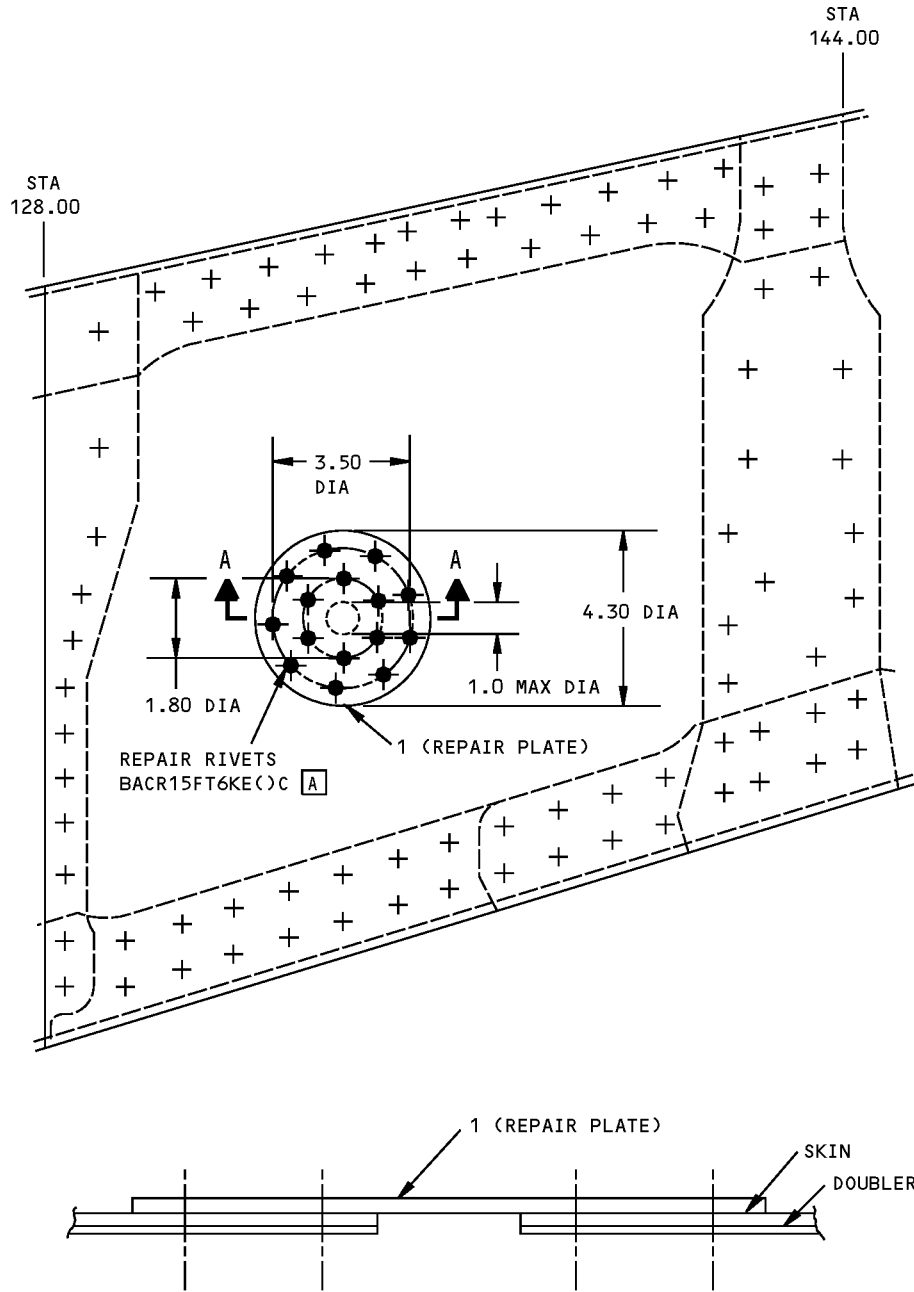

SECTION A-A

**SMALL HOLE OR CRACK REPAIR
DETAIL II**

**Strut Side Skin Small Hole or Crack Repair - PW2000 Engine
Figure 201 (Sheet 3 of 3)**

**757-200
STRUCTURAL REPAIR MANUAL**

IDENTIFICATION 1 - STRUT STRUCTURE - PW2000 ENGINE

REFERENCE DRAWING
311N3000

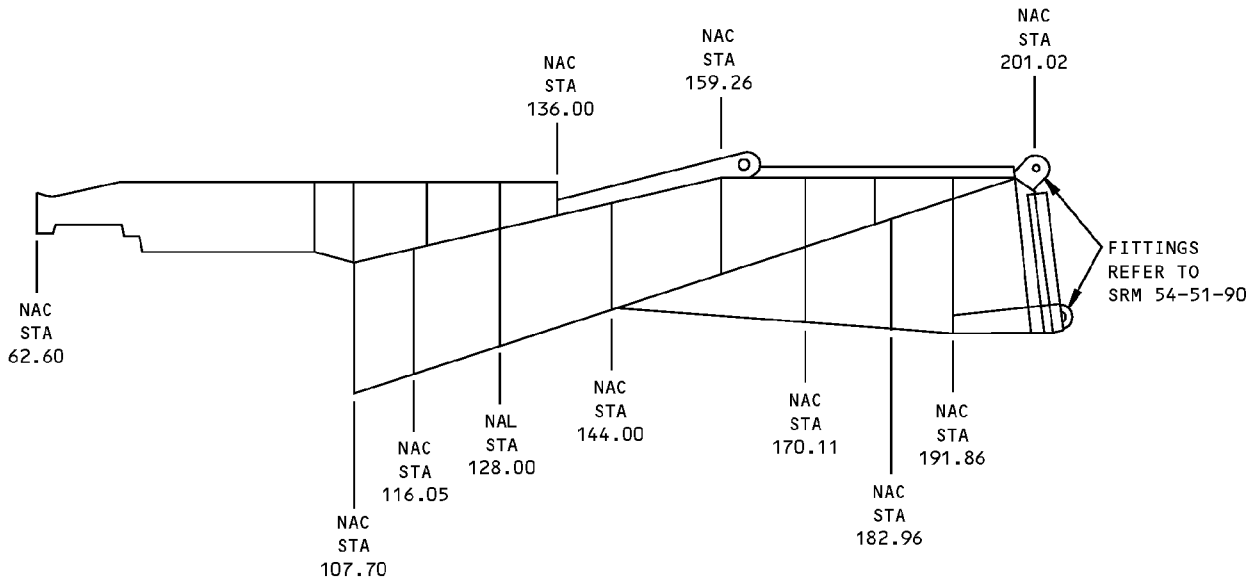
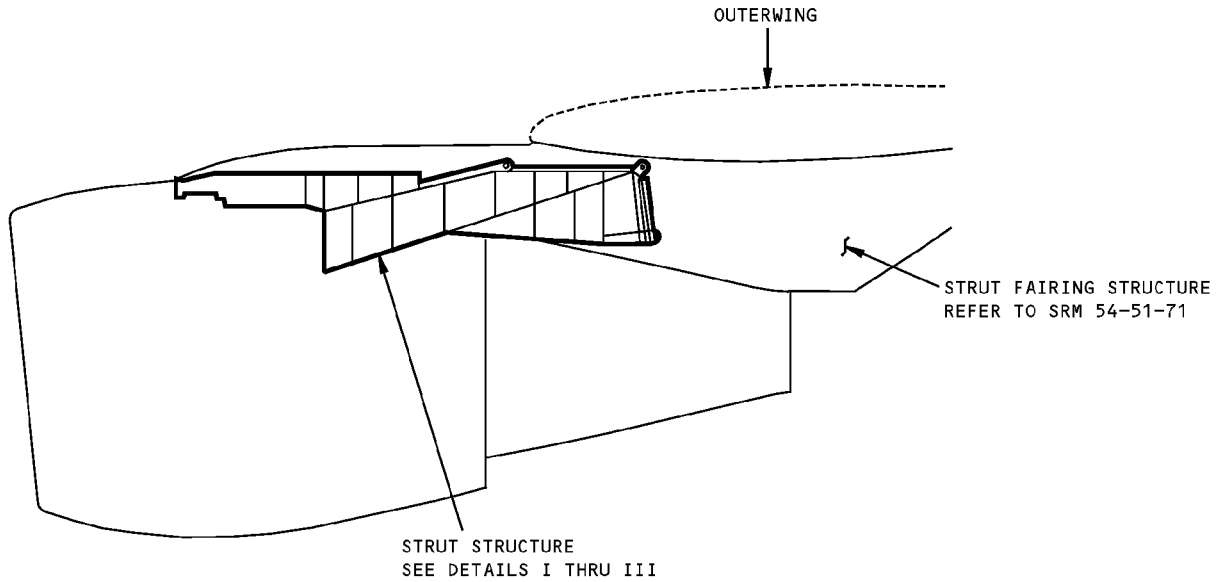

DETAIL I

**Strut Structure Identification - PW2000 Engine
Figure 1 (Sheet 1 of 3)**

**757-200
STRUCTURAL REPAIR MANUAL**

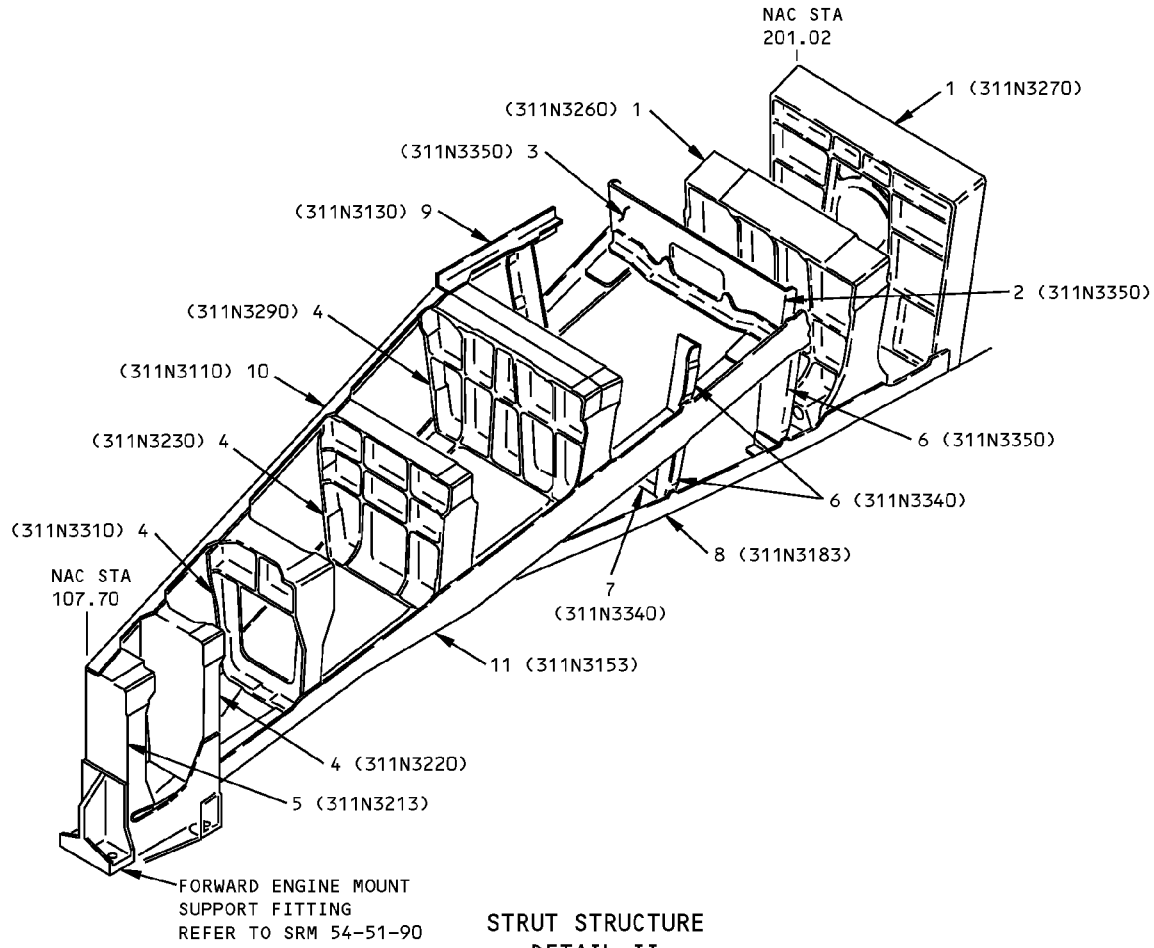

**STRUT STRUCTURE
DETAIL II**

ITEM	DESCRIPTION	GAGE	MATERIAL	EFFECTIVITY
1	BULKHEAD		FORGING 2219-T6	
2	ANGLE	0.063	7075-T62	
3	WEB	0.050	CLAD 2024-T3	
4	BULKHEAD		FORGING 7075-T73	
5	BULKHEAD		FORGING TI-6AL-4V ANNEALED	
6	CHANNEL	0.080	7075-T62	
7	CHANNEL	0.080	15-5PH CRES HT-TR 180-200 KSI	
8	CHORD, LWR SPAR		BAC1527-75 15-5PH CRES HT-TR 180-200 KSI	
9	CHORD, AFT UPR SPAR		BAC1506-3387 7075-T62	
10	CHORD, FWD UPR SPAR		BAC1506-3120 7075-T73	
11	CHORD, MID SPAR		BAC1527-74 15-5PH CRES HT-TR 180-200 KSI	

LIST OF MATERIALS FOR DETAIL II

**Strut Structure Identification - PW2000 Engine
Figure 1 (Sheet 2 of 3)**

**757-200
STRUCTURAL REPAIR MANUAL**

REF DWG
311N3510

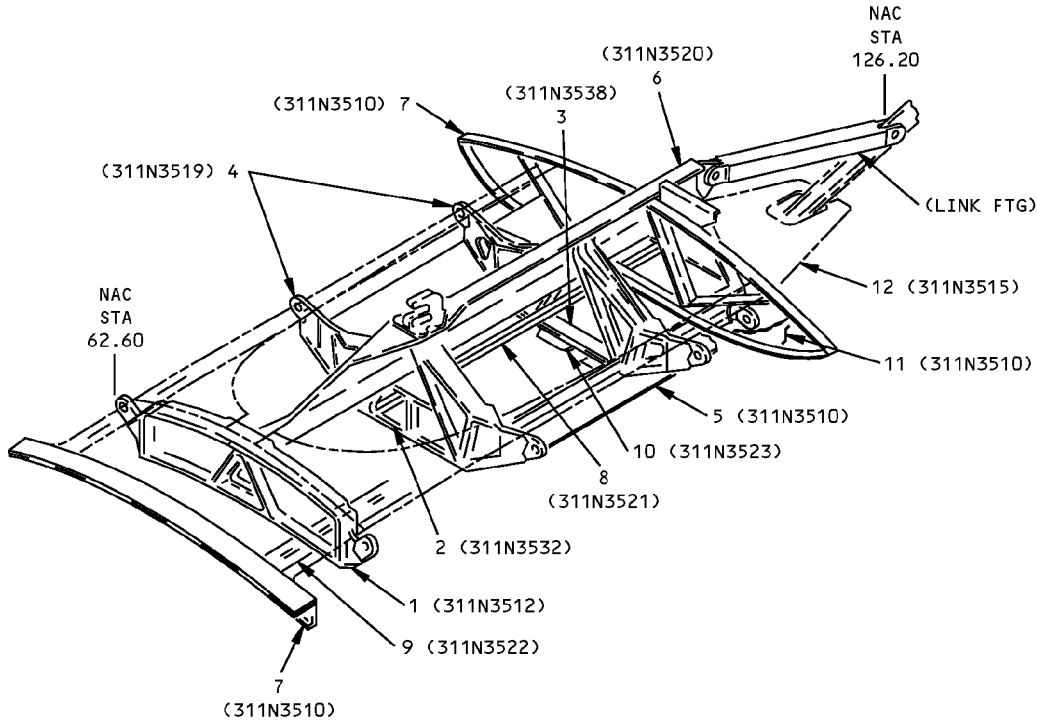

**FAN COWL SUPPORT BEAM
DETAIL III**

ITEM	DESCRIPTION	GAGE	MATERIAL	EFFECTIVITY
1	HINGE FTG		FORGING TI-6AL-4V ANNEALED	
2	HINGE, BACK UP FTG		FORGING TI-6AL-4V ANNEALED	
3	HINGE, BACK UP FTG		FORGING 7075-T73	
4	HINGE FTG		CASTING TI-6AL-4V PER BMS 7-181B TYPE I, COND B GRADE B	
5	FIREWALL	0.063	TI-6AL-4V TYPE III, COMP C	
6	UPR CHORD		BAC1520-2386 7075-T73	
7	ANGLE	0.050	TI-6AL-4V TYPE III, COMP C	
8	LWR CHORD		BAC514-1514 7075-T73	
9	RAIL		BAC1671-201 TI-6AL-4V ANNEALED	
10	DRAIN PAN	0.040	INCONEL 625 ANNEALED	
11	WEB	0.050	TI-6AL-4V TYPE III, COMP C	
12	AFT MOUNT FTG		FORGING 7075-T73	

LIST OF MATERIALS FOR DETAIL III

**Strut Structure Identification - PW2000 Engine
Figure 1 (Sheet 3 of 3)**

IDENTIFICATION 1
Page 3
Jan 20/2005

54-51-02

D634N201

**757-200
STRUCTURAL REPAIR MANUAL**

ALLOWABLE DAMAGE 1 - STRUT STRUCTURE - PW2000 ENGINE

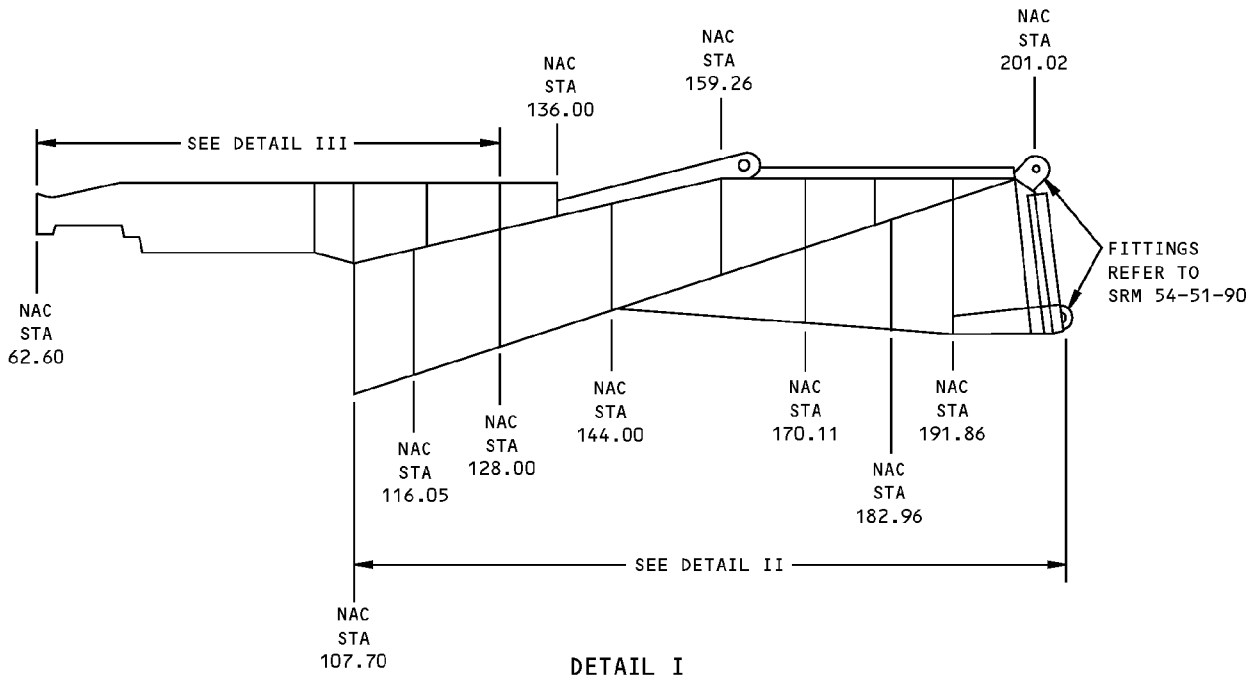
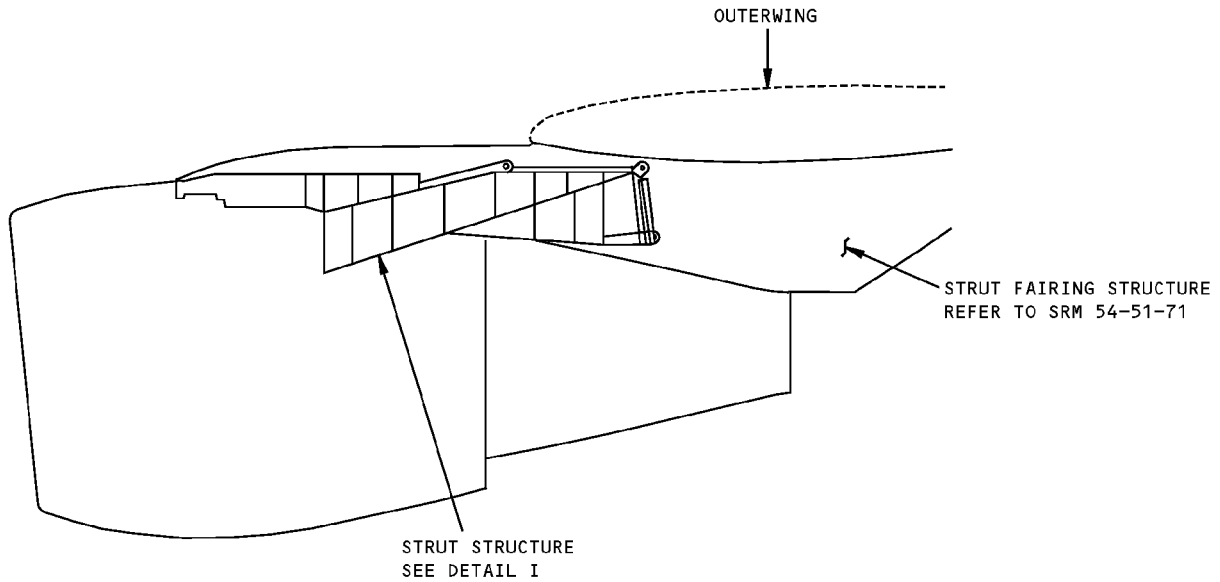

**Strut Structure Allowable Damage- PW2000 Engine
Figure 101 (Sheet 1 of 5)**

**757-200
STRUCTURAL REPAIR MANUAL**

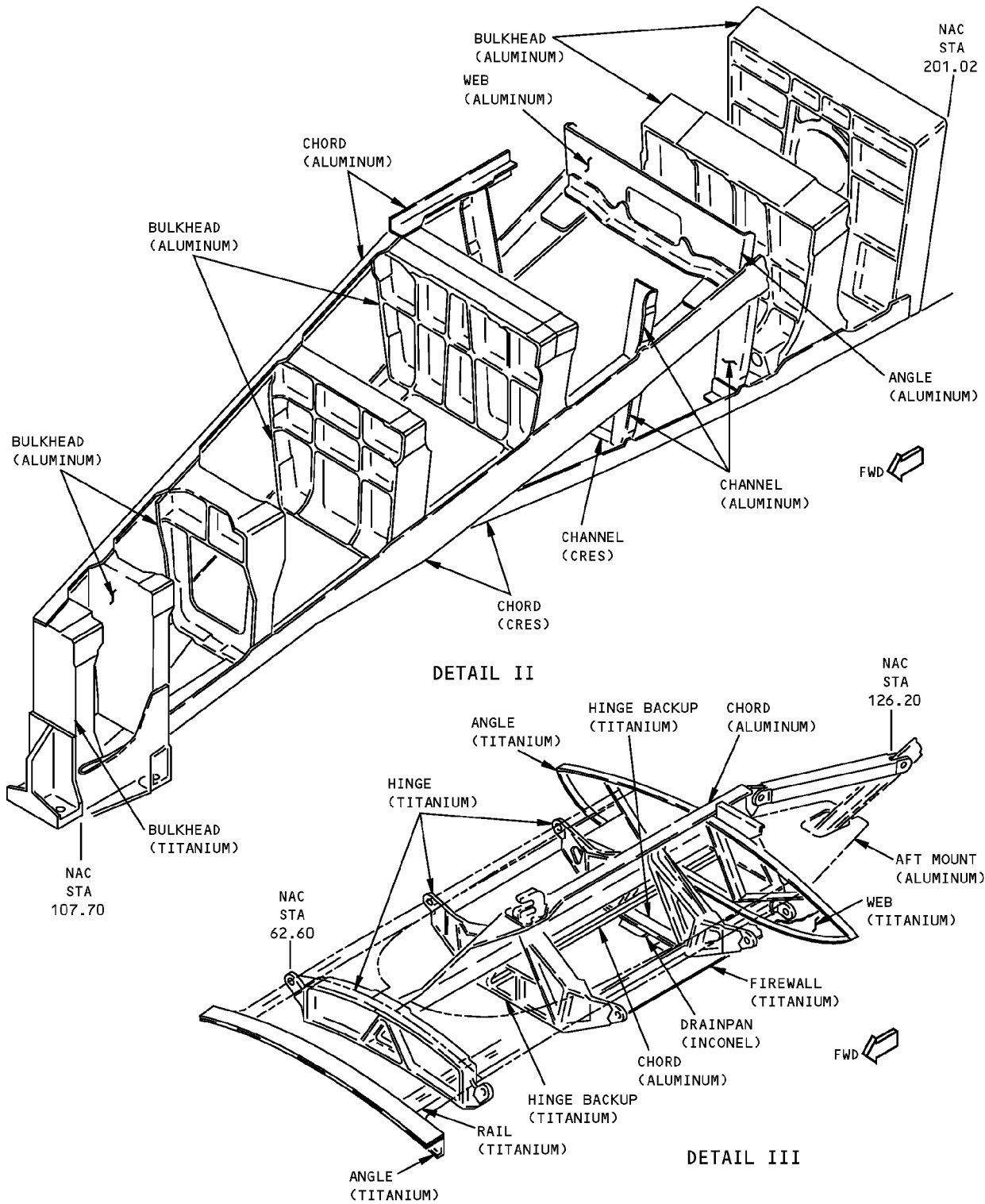

**Strut Structure Allowable Damage- PW2000 Engine
Figure 101 (Sheet 2 of 5)**



757-200
STRUCTURAL REPAIR MANUAL

DESCRIPTION	CRACKS	NICKS, GOUGES AND CORROSION	DENTS	HOLES AND PUNCTURES
BULKHEADS [F]	[A]	[B]	NOT PERMITTED	NOT PERMITTED
CHORDS AND RAILS [F]	[C]	[B]	NOT PERMITTED	NOT PERMITTED
CHANNELS	[C]	[B]	NOT PERMITTED	NOT PERMITTED
ANGLES	[C]	[B]	SEE DETAIL VI	NOT PERMITTED
WEBS	[C]	[B]	SEE DETAIL VI	[D]
HINGES [F]	[E]	[E]	NOT PERMITTED	NOT PERMITTED
HINGE BACKUP [F]	[A]	[B]	NOT PERMITTED	NOT PERMITTED
AFT MOUNT [F]	[A]	[B]	NOT PERMITTED	NOT PERMITTED
FIREWALL	[C]	[B]	SEE DETAIL VI	[D]
DRAINPAN	[C]	[B]	SEE DETAIL VI	[D]

NOTES

- REFINISH REWORKED AREAS AS SHOWN IN AMM 51-20.
- REFER TO SRM 51-10-02 FOR INSPECTION AND REMOVAL OF DAMAGE

[A] CRACKS ARE NOT PERMITTED EXCEPT FOR EDGE CRACKS WHICH MUST BE REMOVED AS SHOWN IN DETAIL XI.

[B] REMOVE DAMAGE AS SHOWN IN DETAILS IV, V AND VII.

[C] CRACKS ARE NOT PERMITTED EXCEPT FOR EDGE CRACKS WHICH MUST BE REMOVED AS SHOWN IN DETAILS IV AND IX.

[D] CLEAN OUT DAMAGE UP TO 0.25 INCH (6 mm) MAX DIA AND NOT CLOSER THAN 1.0 INCH (25 mm) TO FASTENER HOLE, MATERIAL EDGE, FOR OTHER DAMAGE. FILL HOLES IN ALUMINUM WITH A 2117-T3 OR T4 ALUMINUM RIVET INSTALLED WET WITH BMS 5-63 SEALANT. FILL HOLES IN STEEL, INCONEL, OR TITANIUM, WITH MONEL RIVET INSTALLED DRY. ALL OTHER HOLES TO BE REPAIRED

[E] FOR EDGE DAMAGE SEE DETAIL XI. FOR LUG DAMAGE SEE DETAIL X. FOR OTHER DAMAGE SEE DETAIL VIII. DAMAGE IS NOT PERMITTED IN VICINITY OF BUSHINGS.

[F] SHOT PEEN REWORKED AREAS AS SHOWN IN SRM 51-20-06

Strut Structure Allowable Damage- PW2000 Engine
Figure 101 (Sheet 3 of 5)

D634N201

ALLOWABLE DAMAGE 1
54-51-02 Page 103
Jan 20/2005

**757-200
STRUCTURAL REPAIR MANUAL**

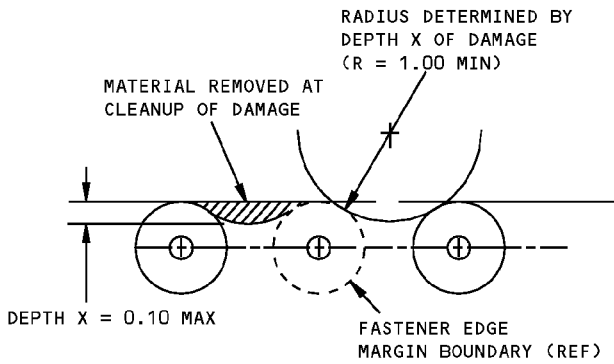

DAMAGE CLEANUP OF EDGES WHERE FASTENER EDGE MARGINS DO NOT OVERLAP

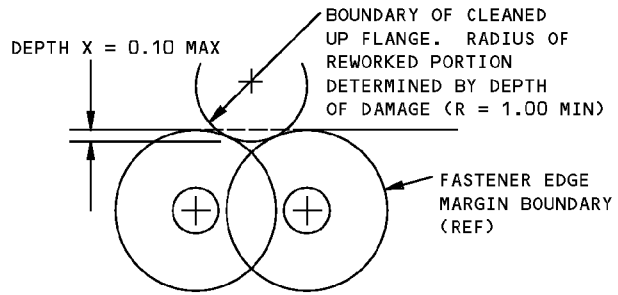

DAMAGE CLEANUP OF EDGES WHERE FASTENER EDGE MARGINS OVERLAP

DETAIL IV

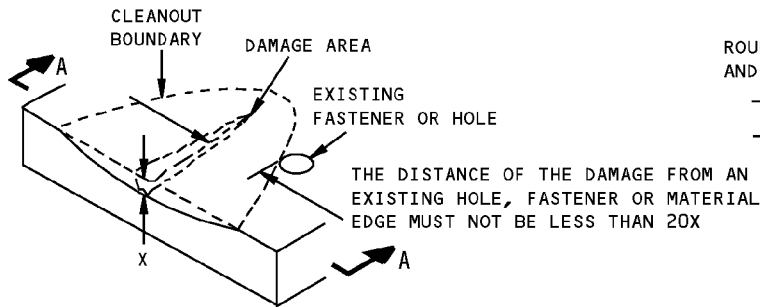

**REMOVAL OF NICK, GOUGE AND SCRATCH DAMAGE ON A SURFACE
DETAIL V**

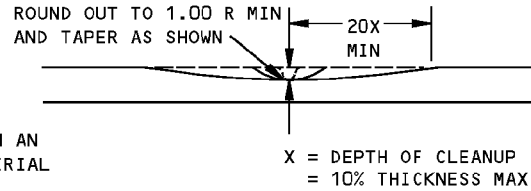

SECTION A-A

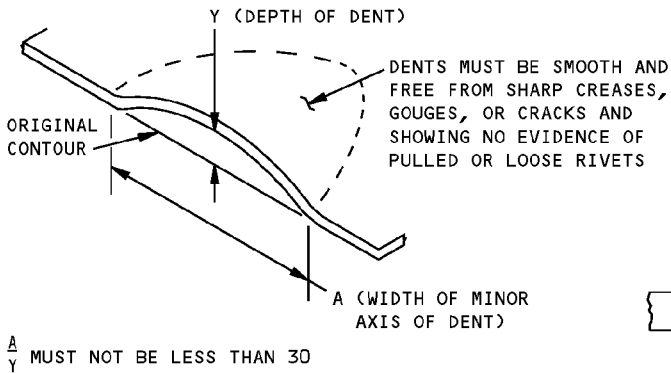

**ALLOWABLE DAMAGE FOR DENT
DETAIL VI**

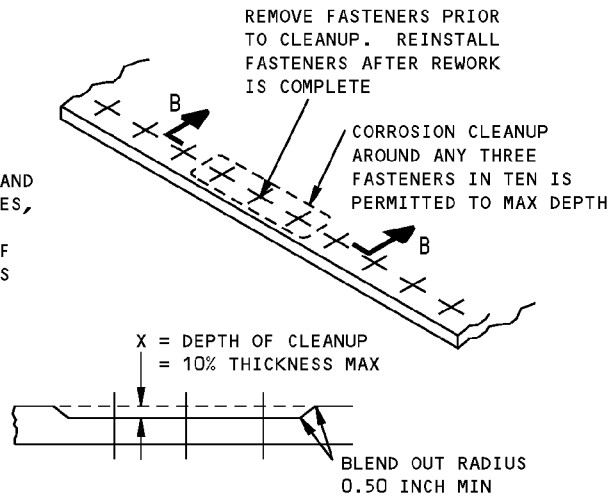

**SECTION B-B
CORROSION CLEANUP
DETAIL VII**

**Strut Structure Allowable Damage- PW2000 Engine
Figure 101 (Sheet 4 of 5)**

**757-200
STRUCTURAL REPAIR MANUAL**

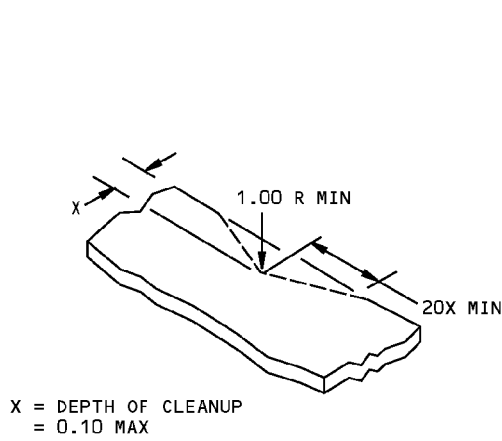

DETAIL VIII

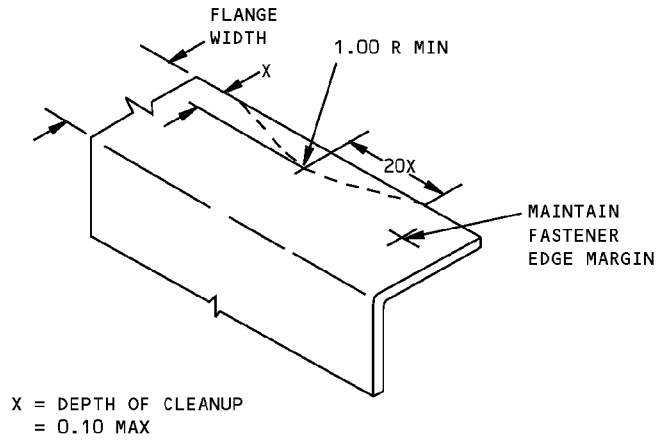

**REMOVAL OF NICK OR CRACK DAMAGE ON AN EDGE
DETAIL IX**

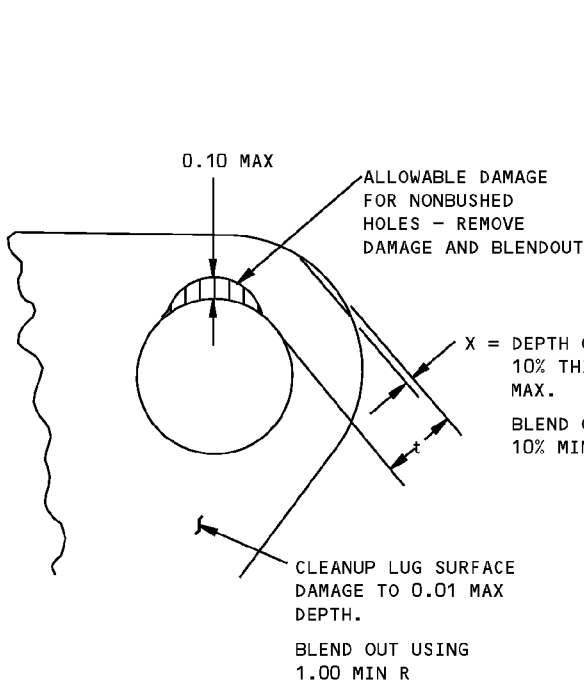

**DAMAGE CLEANUP FOR SURFACES OF LUG
DETAIL X**

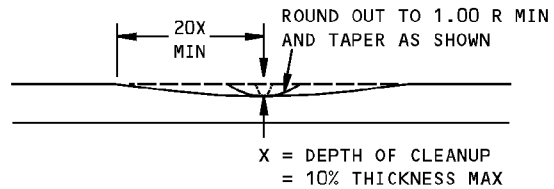
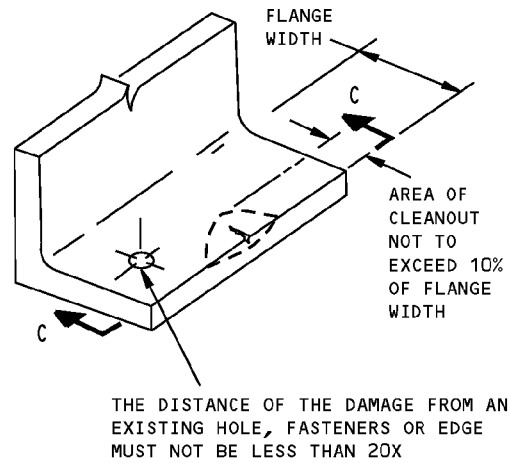

SECTION C-C

**REMOVAL OF NICK OR CRACK DAMAGE ON AN EDGE
DETAIL XI**

**Strut Structure Allowable Damage- PW2000 Engine
Figure 101 (Sheet 5 of 5)**

STRUCTURAL REPAIR MANUAL

REPAIR 1 - FAN COWL SUPPORT BEAM WEB REPAIR - PW2000 ENGINE

REPAIR INSTRUCTIONS



1. Get access to the damaged fan cowl support beam web.
2. Remove clips and angles around the damaged area as necessary. Keep all removed parts so that they can be installed after the repair doubler is in place.
3. Carefully cut and remove the damaged aft web as shown in Detail III, Section A-A. Maintain a minimum of 2D edge margin along the edge of the trim to the initial fastener locations. Make the corner radii a minimum of 0.50 inch (12.7 mm). If the damage is larger than the cutout shown in Detail III, Section A-A, get alternate repair instructions from the Boeing Company.
4. Make the repair doubler and the repair filler. See Table I.
5. Assemble the repair parts and drill the fastener holes. See Detail III, Section A-A.
6. Disassemble the repair parts.
7. Remove the nicks, scratches, gouges, burrs and sharp edges from the repair parts and the web.
8. Prepare the bare surfaces of the web and repair parts as given in the SOPM 20-30-03 for the application of abrasive blasting.
9. Apply one layer of BMS 10-11, Type I primer to the repair parts and the bare surfaces of the web. Refer to SOPM 20-41-02.
10. Install countersink repair washers in the aft web as necessary. See Detail III, Section A-A. Refer to SRM 51-40-08, Figure 3.
11. Install the repair parts with BMS 5-63 sealant between the mating surfaces. Fill all voids with BMS 5-63 sealant.
12. Install hex drive bolts wet with BMS 5-63 sealant. Apply a layer to the threads and under the heads.
13. Apply a fillet seal with BMS 5-63 sealant to the edges of the repair doubler. Refer to SRM 51-20-05.

NOTES

- D = FASTENER DIAMETER.
- REFER TO BOEING DRAWING 311N3510 FOR THE FAN COWL SUPPORT BEAM AREA.
- WHEN YOU USE THIS REPAIR REFER TO:
 - AMM 51-21 FOR INTERIOR AND EXTERIOR FINISHES
 - NDT 51-00-01, PART 6, FIGURE 4 FOR EDDY CURRENT INSPECTION PROCEDURES
 - SOPM 20-30-03 FOR THE APPLICATION OF ABRASIVE BLASTING
 - SOPM 20-41-02 FOR APPLICATION OF FINISHES
 - SRM 51-10-02 FOR INSPECTION AND REMOVAL OF DAMAGE
 - SRM 51-20-01 FOR PROTECTIVE TREATMENT OF METALLIC AND GRAPHITE MATERIALS
 - SRM 51-20-05 FOR REPAIR SEALING
 - SRM 51-40 FOR FASTENER CODE, INSTALLATION AND REMOVAL, HOLE SIZES, AND EDGE MARGINS.
 - SRM 51-40-08, FIGURE 3 FOR COUNTERSINK REPAIR WASHERS.

- A** THIS REPAIR IS SYMMETRICAL ON EACH SIDE OF THE FAN COWL SUPPORT BEAM.
- B** CUT AND REMOVE 0.05 INCH (1.27 mm) OFF THIS FLANGE AND APPLY THE FINISH.

FASTENER SYMBOLS

-  REFERENCE FASTENER LOCATION.
-  INITIAL FASTENER LOCATION. INSTALL A BACB30NW5K() HEX DRIVE BOLT WITH A BACC30M COLLAR.
-  INITIAL FASTENER LOCATION. INSTALL A COUNTERSINK REPAIR WASHER AND INSTALL A BACB30NW5K() HEX DRIVE BOLT WITH A BACC30M COLLAR.

REPAIR MATERIAL			
	PART	QTY	MATERIAL
1	DOUBLER	1	0.050 INCH TI-6AL-4V ANNEALED
2	FILLER	1	0.050 INCH TI-6AL-4V ANNEALED

TABLE I

**Fan Cowl Support Beam Web Repair - PW2000 Engine
Figure 201 (Sheet 1 of 4)**

**757-200
STRUCTURAL REPAIR MANUAL**

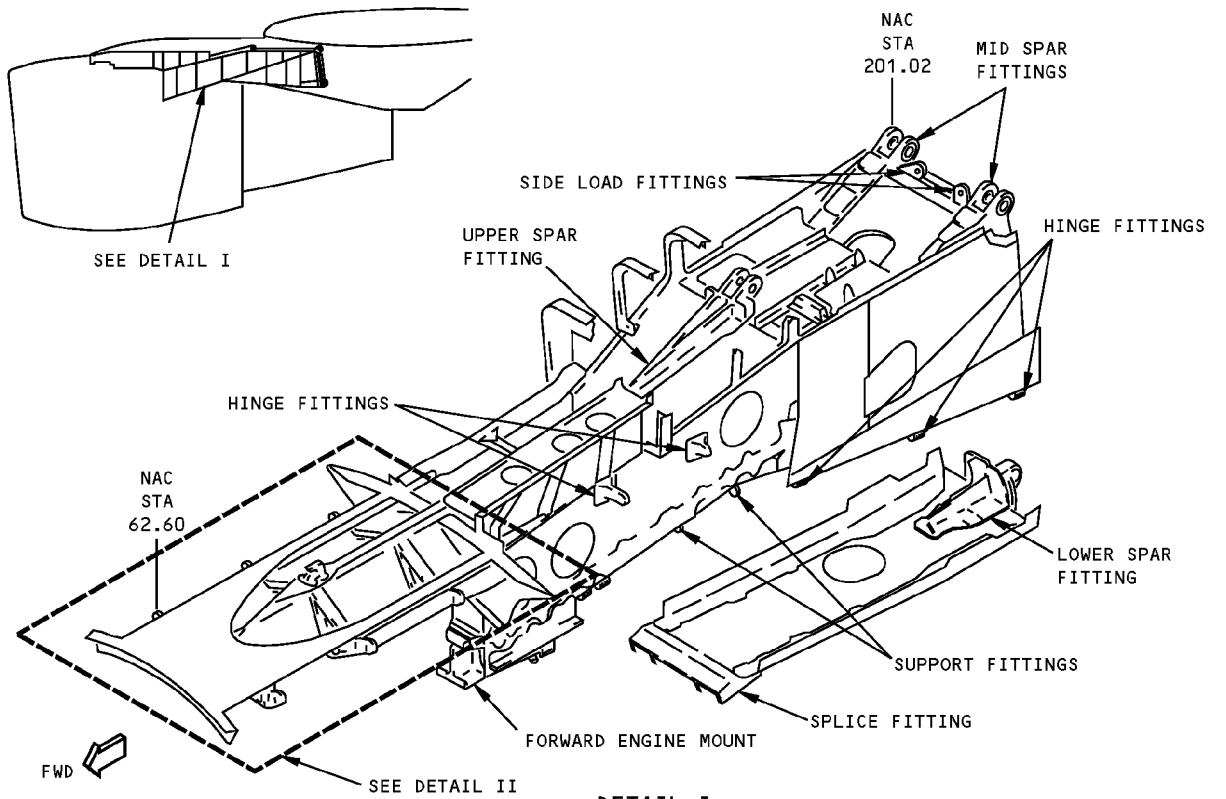

DETAIL I

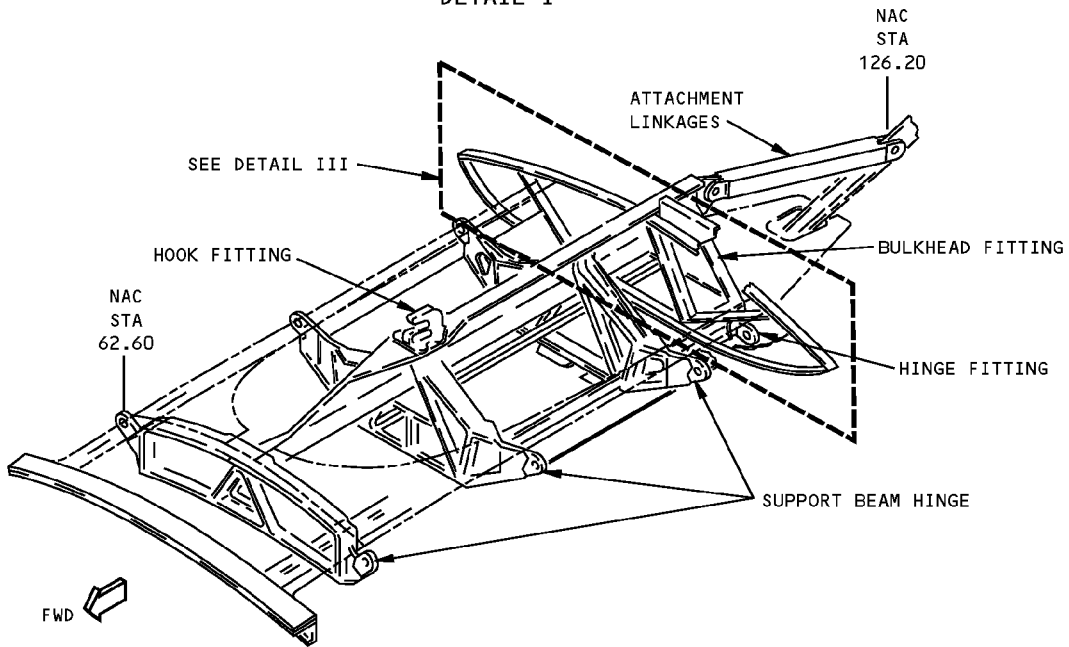

DETAIL II

**Fan Cowl Support Beam Web Repair - PW2000 Engine
Figure 201 (Sheet 2 of 4)**

**757-200
STRUCTURAL REPAIR MANUAL**

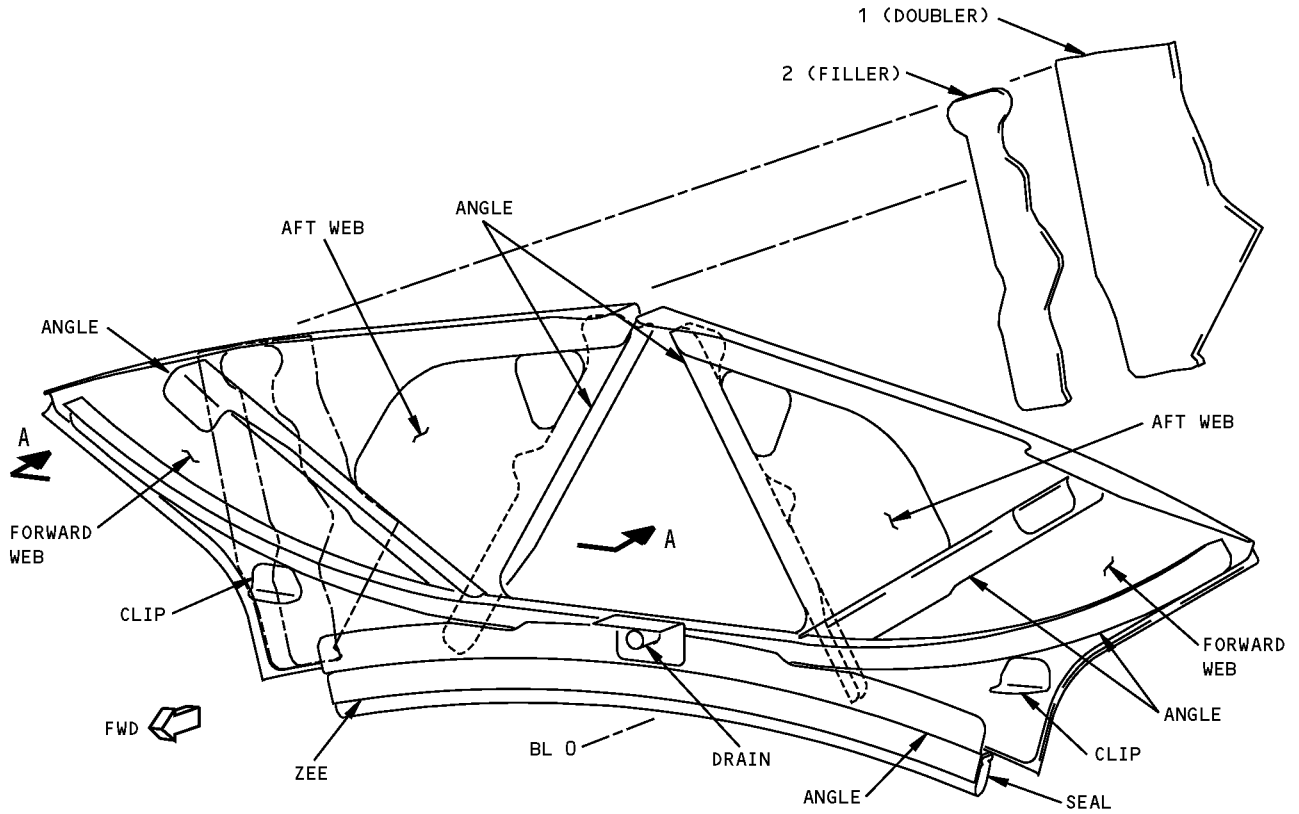

DETAIL III

**Fan Cowl Support Beam Web Repair - PW2000 Engine
Figure 201 (Sheet 3 of 4)**

**757-200
STRUCTURAL REPAIR MANUAL**

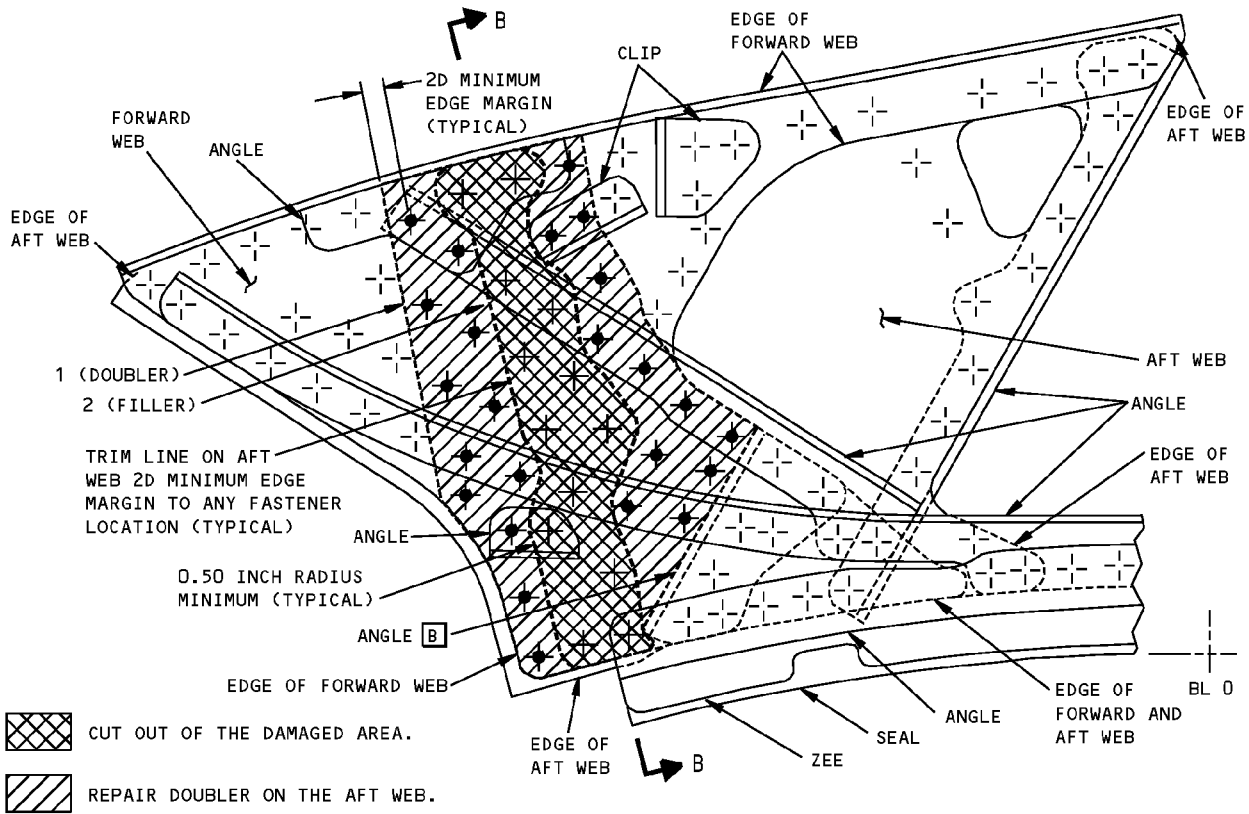

RIGHT SIDE IS SHOWN, LEFT SIDE IS OPPOSITE
VIEW IS LOOKING AFT
SECTION A-A [A]

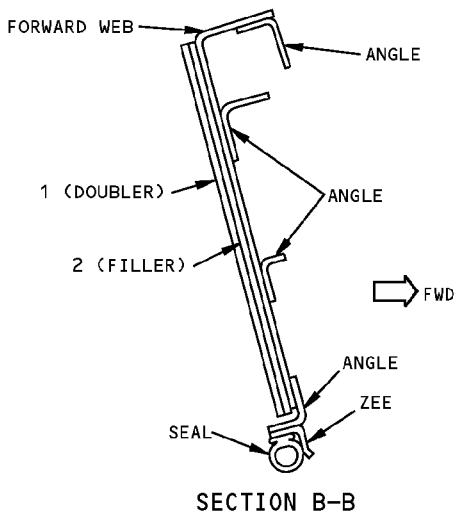

**Fan Cowl Support Beam Web Repair - PW2000 Engine
Figure 201 (Sheet 4 of 4)**

STRUCTURAL REPAIR MANUAL

REPAIR 2 - AFT ENGINE MOUNT ALIGNMENT PIN HOLE - PW2000 ENGINE

APPLICABILITY

THIS REPAIR IS FOR THE AFT ENGINE MOUNT FITTING ALIGNMENT PIN HOLES (2) AT NACELLE STATION 191. THIS REPAIR IS APPLICABLE IF, AFTER BUSHING REMOVAL AND DAMAGE CLEANUP, THE ALIGNMENT PIN BUSHING HOLE DIAMETER IS NOT MORE THAN 1.065 INCHES (27 mm).

REPAIR INSTRUCTIONS

NOTE: If the alignment pin bushing hole diameter becomes more than 1.065 inches (27 mm) during this repair, do not continue. Contact Boeing for repair instructions.

1. Disassemble components, as necessary, to get access to the aft engine mount fitting alignment pin holes.
2. Remove the bushings from the aft engine mount fitting alignment pin holes.
3. Do a penetrant inspection of the alignment pin holes. Refer to SOPM 20-20-02. If no damage is found, go to step (7).
4. Increase the alignment pin hole diameters as necessary to remove the damage.
5. Do a penetrant inspection of the holes. Refer to SOPM 20-20-02.
6. If damage is found, do steps (4) and (5) again.
7. Increase the alignment pin hole diameters by 0.020 inch (0.5 mm).
8. Chamfer the upper side of the alignment pin holes 0.025/0.035 inch (0.6/0.9 mm) by 45 degrees.
9. Hone the alignment pin holes to get a 63 microinch R_a surface finish.
10. Shot peen the alignment pin holes and chamfers. Intensity 0.006A-0.011A, coverage 2.0. Refer to SOPM 20-10-03.
11. Hone the alignment pin holes to get a 32 microinch R_a surface finish. Do not remove more than 0.002 inch (0.05 mm) material from the diameter.
12. Measure the alignment pin hole diameters. If the hole diameter is greater than 1.065 inch (27 mm), contact Boeing for instructions.
13. Apply a chemical conversion coating to the holes and chamfers. Refer to SRM 51-20-01.
14. Make the part 1 repair bushings the same as the 310N3026-38 bushing but the outside diameter before cadmium plating is to be 0.0015/0.0005 inch (0.04/0.01 mm) larger than the alignment pin hole diameter. See Table I.

15. Install the repair bushings using the shrink fit method. Refer to SOPM 20-50-03. Apply BMS 5-63 sealant to the alignment pin holes and the face that contacts the bushing flange.
16. Anvil or roller swage the bushing upper lip. Refer to SOPM 20-50-03.
17. Ream or hone the forward alignment pin hole to 0.7495/0.7505 inch diameter and a 32 microinch R_a surface finish. See Detail I.^a
18. Ream or hone the aft alignment pin hole to 0.7670/0.7680 inch diameter and a 32 microinch R_a surface finish. See Detail I.^a
19. Fillet seal the bushing flange and opposite end of the bushing with BMS 5-63 sealant.
20. Re-install the components that were removed.

NOTES

- WHEN YOU USE THIS REPAIR REFER TO:
 - SOPM 20-10-03 FOR SHOT PEENING
 - SOPM 20-20-02 FOR PENETRANT METHODS OF INSPECTION
 - SOPM 20-41-02 FOR APPLICATION OF FINISHES
 - SOPM 20-42-05 FOR BRIGHT CADMIUM PLATING
 - SOPM 20-50-03 FOR BEARING REMOVAL, INSTALLATION AND RETENTION
 - REFER TO SRM 51-10-02 FOR INSPECTION AND REMOVAL OF DAMAGE
 - SRM 51-20-01 FOR PROTECTIVE TREATMENT OF METALLIC AND GRAPHITE MATERIALS
 - SRM 51-20-05 FOR REPAIR SEALING
 - SRM 51-40 FOR FASTENER CODE, INSTALLATION AND REMOVAL, HOLE SIZES, AND EDGE MARGINS.

REPAIR MATERIAL			
PART		QTY	MATERIAL
1	REPAIR BUSHING	2	15-5 CRES HEAT TREATED TO 140-160 KSI. CADMIUM PLATE PER QQ-P-416, TYPE 2, CLASS 2. REFER TO SOPM 20-42-05. OUTSIDE DIAMETER TO BE 0.0015/0.0005 INCH LARGER THAN ALIGNMENT PIN HOLE DIAMETER

TABLE I

Aft Engine Mount Alignment Pin Hole Repair - PW2000 Engine
Figure 201 (Sheet 1 of 2)

**757-200
STRUCTURAL REPAIR MANUAL**

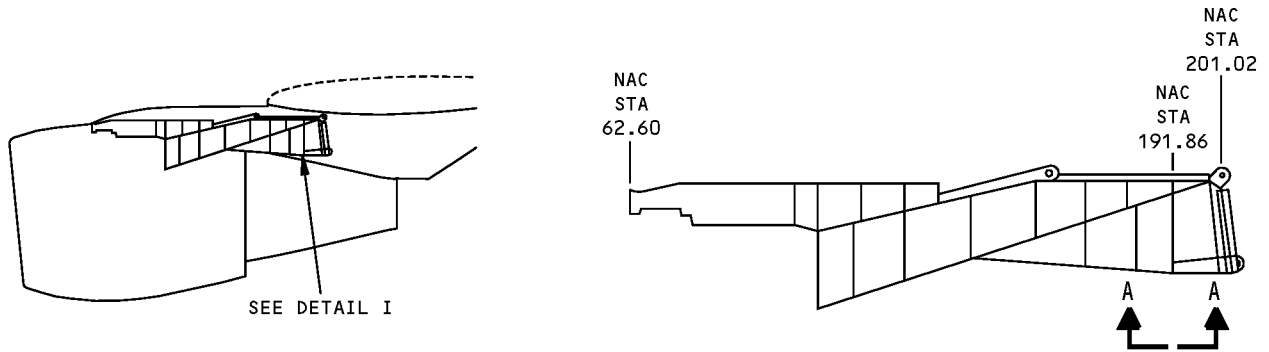

DETAIL I

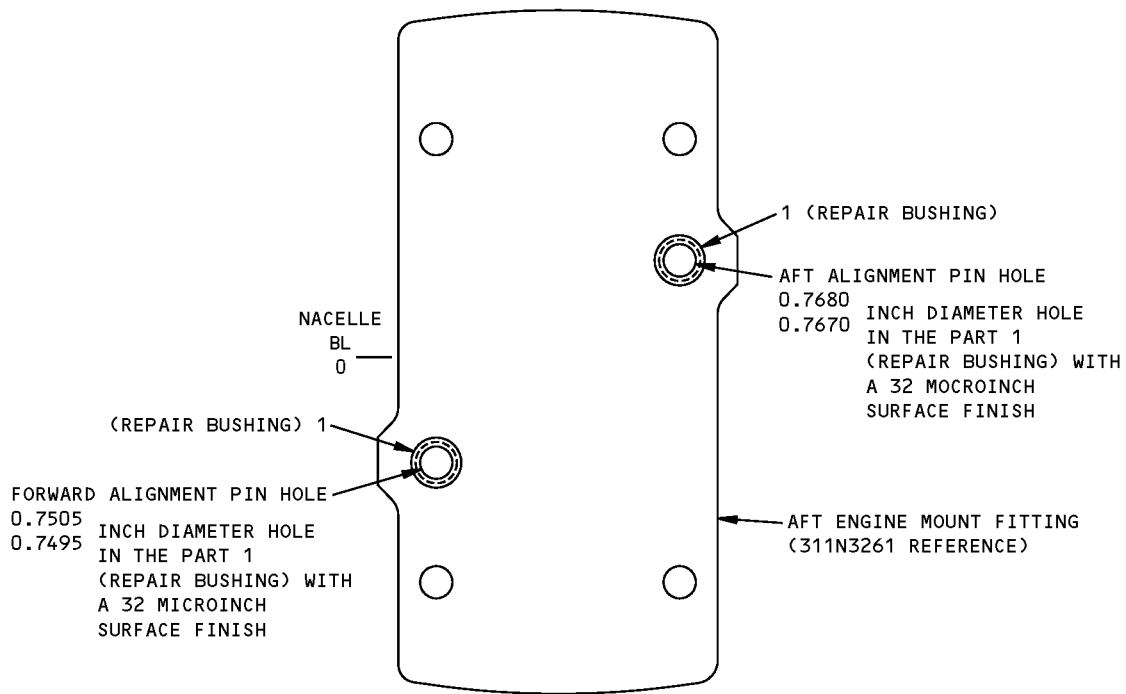

FWD ←

VIEW LOOKING UP

A-A

**Aft Engine Mount Alignment Pin Hole Repair - PW2000 Engine
Figure 201 (Sheet 2 of 2)**

**757-200
STRUCTURAL REPAIR MANUAL**

IDENTIFICATION 1 - STRUT FAIRING SKIN - PW2000 ENGINE

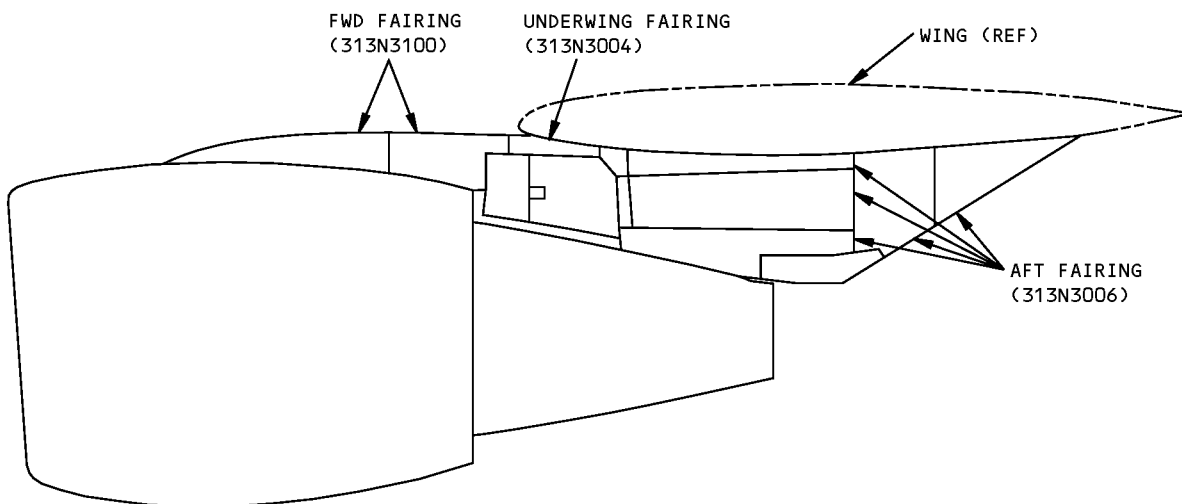

NOTES

- MATERIAL AND PLY ORIENTATION SHOWN FOR FIELD AREAS ONLY. SEE BOEING DRAWINGS FOR EDGE BANDS AND AREAS WITH DOUBLERS

- A** FIBERGLASS/EPOXY PER BMS 8-139, TYPE 181, 350°F (177°C) CURE
- B** ARAMID/EPOXY PER BMS 8-218, STYLE 285, 350°F (177°C) CURE
- C** THORSTRAND PER BMS 8-278, TYPE II CLASS 350, 350°F (177°C) CURE
- D** DENSER NONMETALLIC OR ALUMINUM (5052) HONEYCOMB CORE INSTALLED AT HINGE AND FITTING LOCATIONS
- E** PLY ORIENTATION DEGREES INDICATED IS PARALLEL TO THE FABRIC WARP DIRECTION

F FOR CUM LINE NUMBERS:
68 AND ON

G FOR AIRPLANE NOT LISTED IN **F**

**Strut Fairing Skin Identification - PW2000 Engine
Figure 1 (Sheet 1 of 8)**

**757-200
STRUCTURAL REPAIR MANUAL**

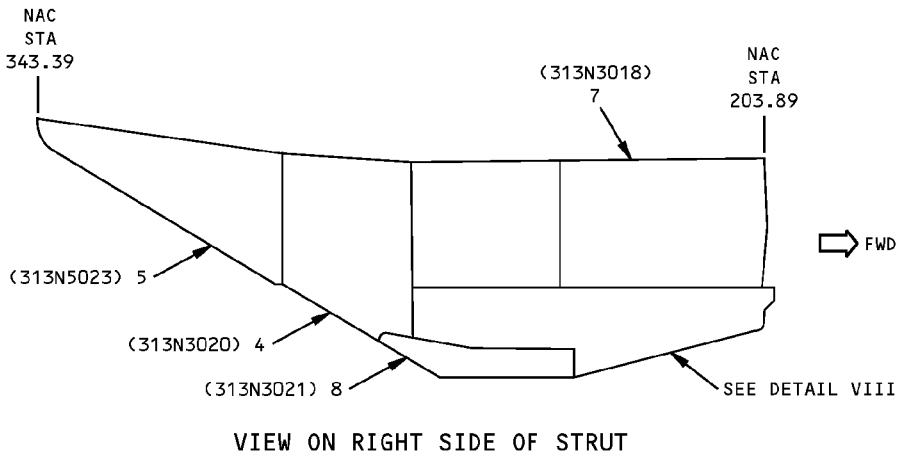
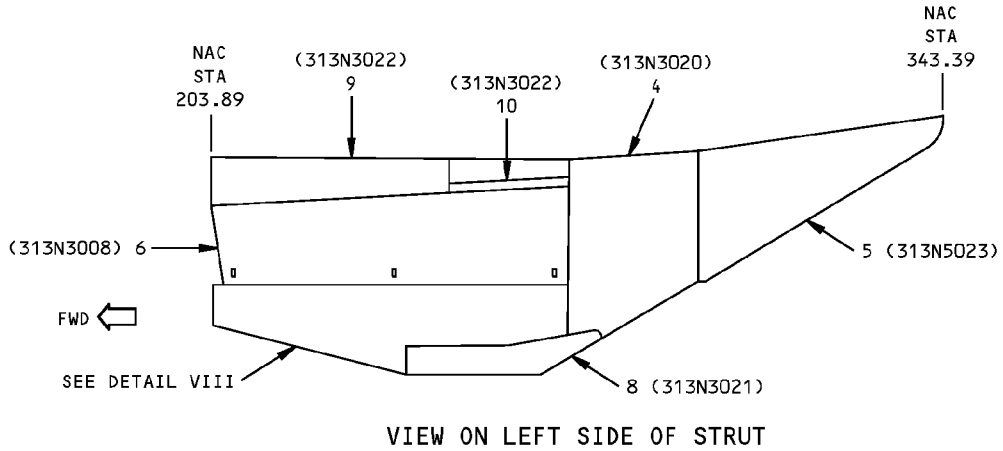
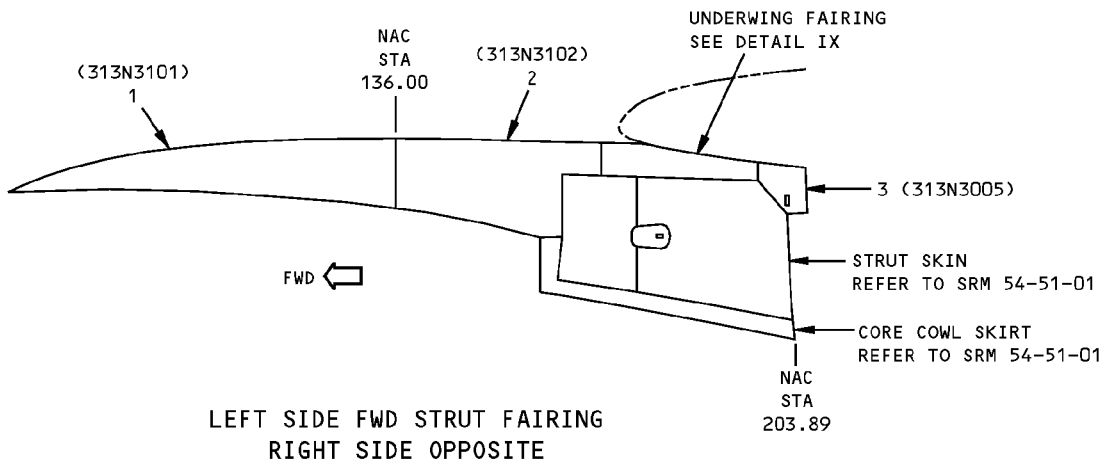

**STRUT FAIRING PANELS
DETAIL I**



**Strut Fairing Skin Identification - PW2000 Engine
Figure 1 (Sheet 2 of 8)**



757-200
STRUCTURAL REPAIR MANUAL

ITEM	DESCRIPTION	GAGE	MATERIAL	EFFECTIVITY
1	PANEL ASSY SKIN CORE		SEE DETAIL II ALUMINUM HONEYCOMB PER BMS 4-6	
2	PANEL ASSY SKIN CORE		SEE DETAIL III 5052/F80-0013-4.3 HEXEL	
3	UNDERWING FAIRING DOOR	0.090	CLAD 2024-T3	
4	PANEL ASSY SKIN CORE	0.50	SEE DETAIL IV NONMETALLIC HONEYCOMB PER BMS 8-124, CLASS IV, TYPE V, GRADE 4.0	
5	PANEL ASSY SKIN CORE		SEE DETAIL V NONMETALLIC HONEYCOMB PER BMS 8-124, CLASS IV, TYPE V, GRADE 4.0	
6	ACCESS DOOR ASSY SKIN CORE		SEE DETAIL VI NONMETALLIC HONEYCOMB PER BMS 8-124 CLASS IV, TYPE V, GRADE 9.0 D	
7	PANEL ASSY SKIN CORE		SEE DETAIL VII NONMETALLIC HONEYCOMB PER BMS 8-124 CLASS IV, TYPE V, GRADE 4.0	
8	LOWER PAN	0.050	INCONEL 625	
9	SKIRT BEAM SKIN	0.100	CLAD 2024-T3	
10	SKIRT BEAM SKIN	0.063	CLAD 7075-T6	

LIST OF MATERIALS FOR DETAIL I

Strut Fairing Skin Identification - PW2000 Engine
Figure 1 (Sheet 3 of 8)

D634N201

54-51-70

IDENTIFICATION 1
Page 3
Jan 20/2005

**757-200
STRUCTURAL REPAIR MANUAL**

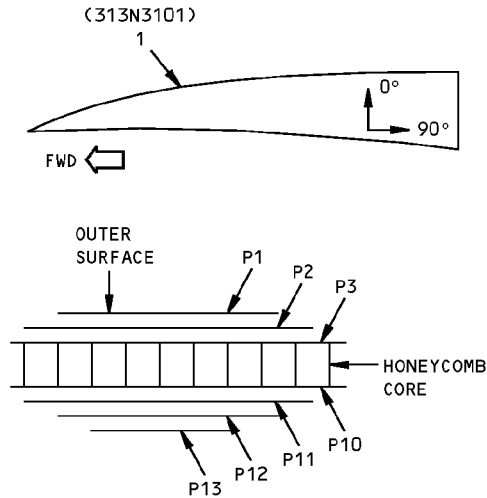

ITEM NO.	PLY NO.	MATERIAL	PLY ORIENTATION [E]
1 [G]	P1	[C]	0° OR 90°
	P2	[A]	0° OR 90°
	P3	[A]	± 45°
	P10, P12, P13	[B]	0° OR 90°
	P11	[B]	± 45°

ITEM NO.	PLY NO.	MATERIAL	PLY ORIENTATION [E]
1 [F]	P1	[C]	0° OR 90°
	P2	[A]	± 45°
	P3	[B]	± 45°
	P10	[B]	± 45°
	P11, P13	[B]	0° OR 90°
	P12	[A]	0° OR 90°

DETAIL II

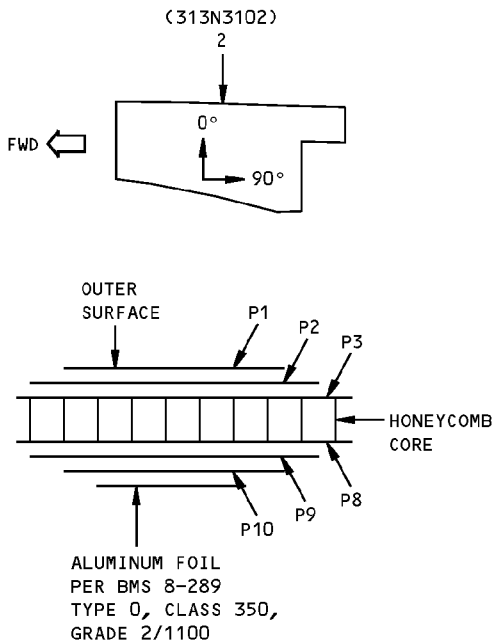

ITEM NO.	PLY NO.	MATERIAL	PLY ORIENTATION [E]
2 [G]	P1	[C]	0° OR 90°
	P2	[A]	0° OR 90°
	P3	[A]	± 45°
	P8, P10	[B]	0° OR 90°
	P9	[B]	± 45°

ITEM NO.	PLY NO.	MATERIAL	PLY ORIENTATION [E]
2 [F]	P1	[C]	0° OR 90°
	P2, P10	[A]	0° OR 90°
	P3, P8	[B]	± 45°
	P9	[B]	0° OR 90°

DETAIL III

**Strut Fairing Skin Identification - PW2000 Engine
Figure 1 (Sheet 4 of 8)**

**757-200
STRUCTURAL REPAIR MANUAL**

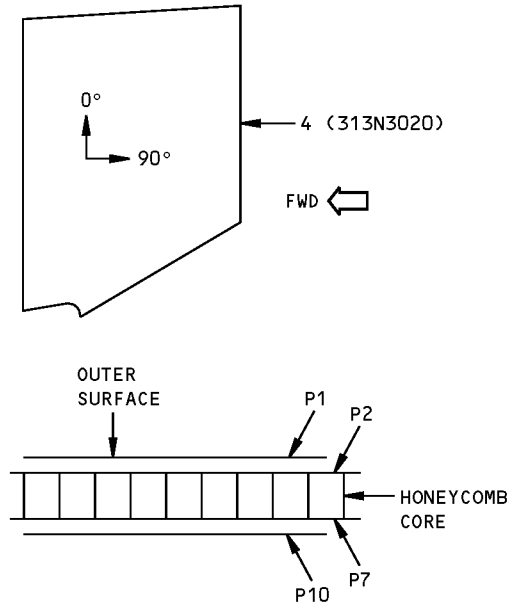

ITEM NO.	PLY NO.	MATERIAL	PLY ORIENTATION [E]
4	P1	[A]	0° OR 90°
	P2	[A]	±45°
	P7	[B]	±45°
	P10	[B]	0° OR 90°

DETAIL IV

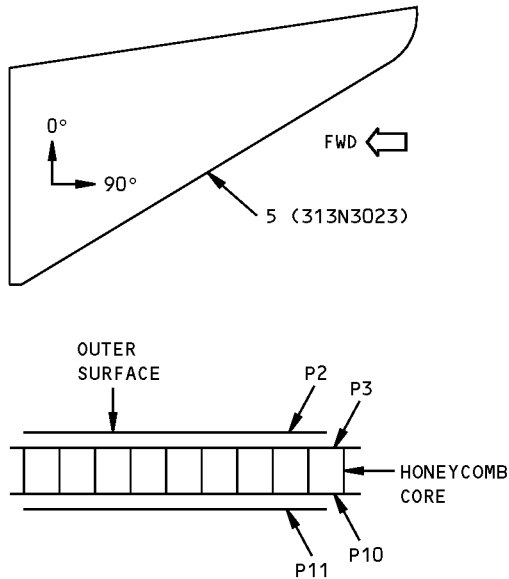

ITEM NO.	PLY NO.	MATERIAL	PLY ORIENTATION [E]
5	P2,P3	[A]	0° OR 90°
	P10,P11	[B]	0° OR 90°

DETAIL V

**Strut Fairing Skin Identification - PW2000 Engine
Figure 1 (Sheet 5 of 8)**

**757-200
STRUCTURAL REPAIR MANUAL**

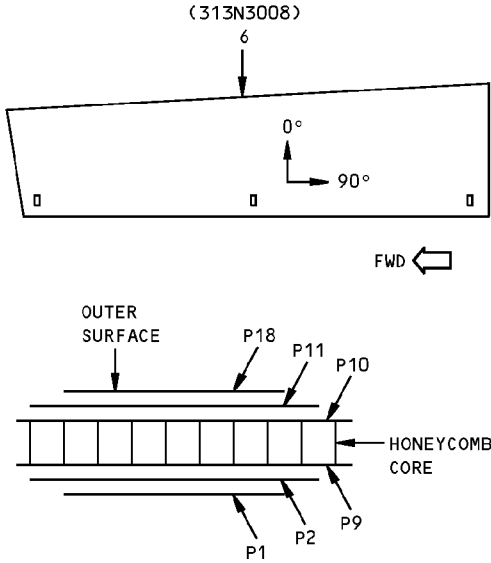

ITEM NO.	PLY NO.	MATERIAL	PLY ORIENTATION [E]
6	P1	[A]	0° OR 90°
	P2	[A]	±45°
	P9, P10, P18	[B]	0° OR 90°
	P11	[B]	±45°

DETAIL VI

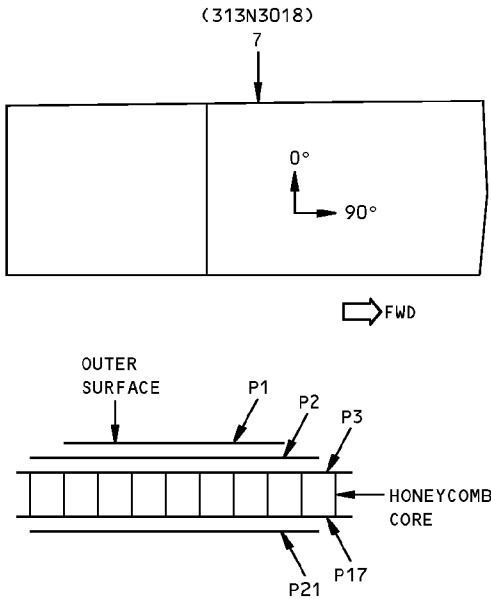

ITEM NO.	PLY NO.	MATERIAL	PLY ORIENTATION [E]
7	P1	[A]	0° OR 90°
	P2	[A]	±45°
	P3, P17	[B]	0° OR 90°
	P21	[B]	±45°

DETAIL VII

**Strut Fairing Skin Identification - PW2000 Engine
Figure 1 (Sheet 6 of 8)**

**757-200
STRUCTURAL REPAIR MANUAL**

REF DWG
313N3050

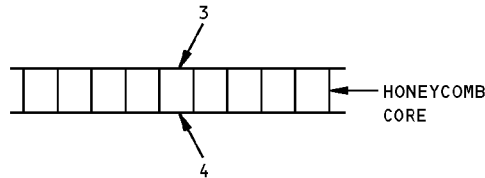
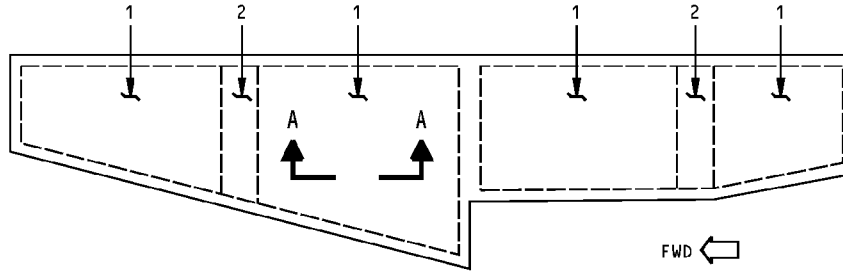

SECTION A-A

DETAIL VIII

ITEM	DESCRIPTION	GAGE	MATERIAL	EFFECTIVITY
1	CORE	0.50	ALUMINUM HONEYCOMB PER BMS 4-4 TYPE 3-15, CLASS N	
2	CORE	0.50	ALUMINUM HONEYCOMB 22.1-1/8-60N (5052) PER MIL-C-7438E	
3	OUTER SKIN	0.016	CLAD 2024-T81	
4	INNER SKIN	0.016	CLAD 2024-T81	

LIST OF MATERIALS FOR DETAIL VIII

**Strut Fairing Skin Identification - PW2000 Engine
Figure 1 (Sheet 7 of 8)**

IDENTIFICATION 1
Page 7
Jan 20/2005

54-51-70

D634N201

**757-200
STRUCTURAL REPAIR MANUAL**

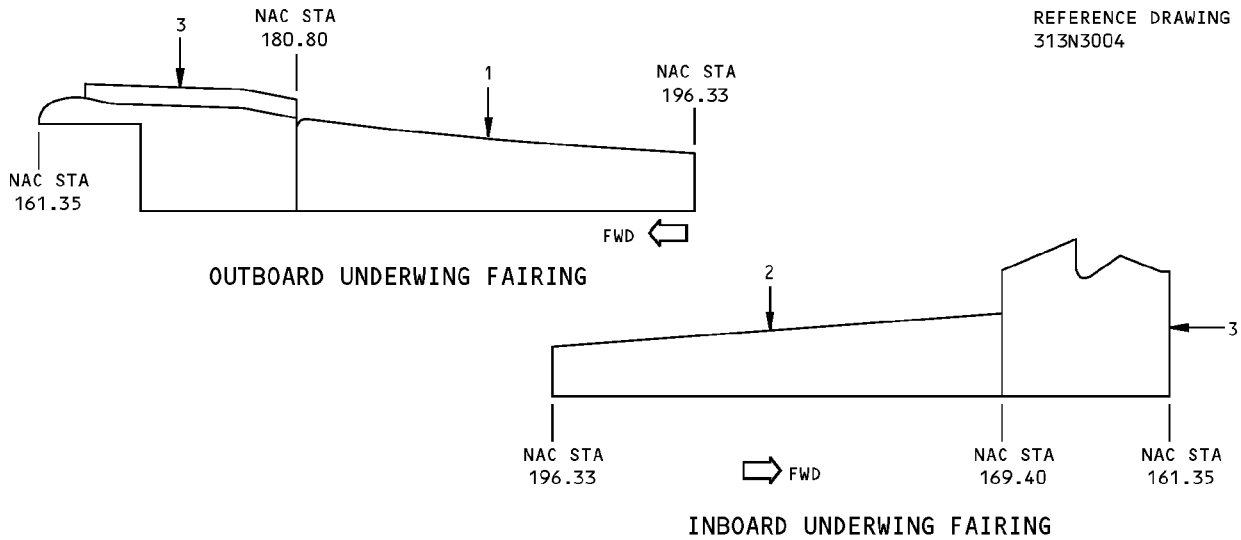

REFERENCE DRAWING
313N3004

DETAIL IX

ITEM	DESCRIPTION	GAGE	MATERIAL	EFFECTIVITY
1	OUTBOARD SKIN PANEL	0.10	CLAD 2024-T42	
2	INBOARD SKIN PANEL	0.10	CLAD 2024-T3	
3	SKIN PANEL		SEE DETAIL X	

LIST OF MATERIALS FOR DETAIL IX

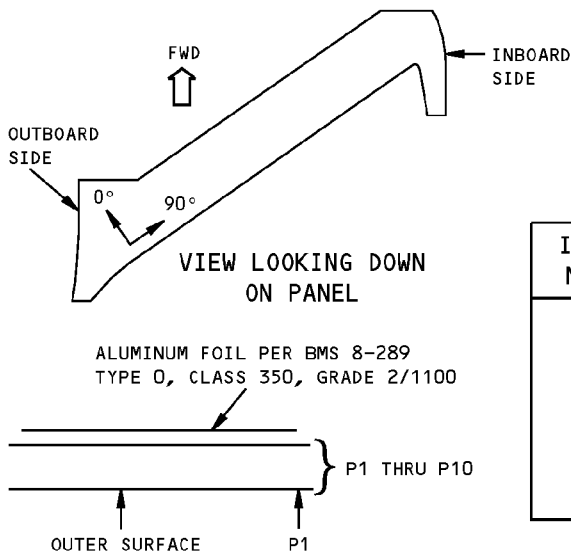

REFERENCE DRAWING
313N3210

ITEM NO.	PLY NO.	MATERIAL	PLY ORIENTATION <input type="checkbox"/> E
3	P1	<input type="checkbox"/> C	0° OR 90°
	P2,P10	<input type="checkbox"/> A	±45°
	P3,P5,P6,P7,P9	<input type="checkbox"/> B	0° OR 90°
	P4,P8	<input type="checkbox"/> B	±45°

DETAIL X

**Strut Fairing Skin Identification - PW2000 Engine
Figure 1 (Sheet 8 of 8)**

**757-200
STRUCTURAL REPAIR MANUAL**

ALLOWABLE DAMAGE 1 - STRUT FAIRING SKIN - PW2000 ENGINE

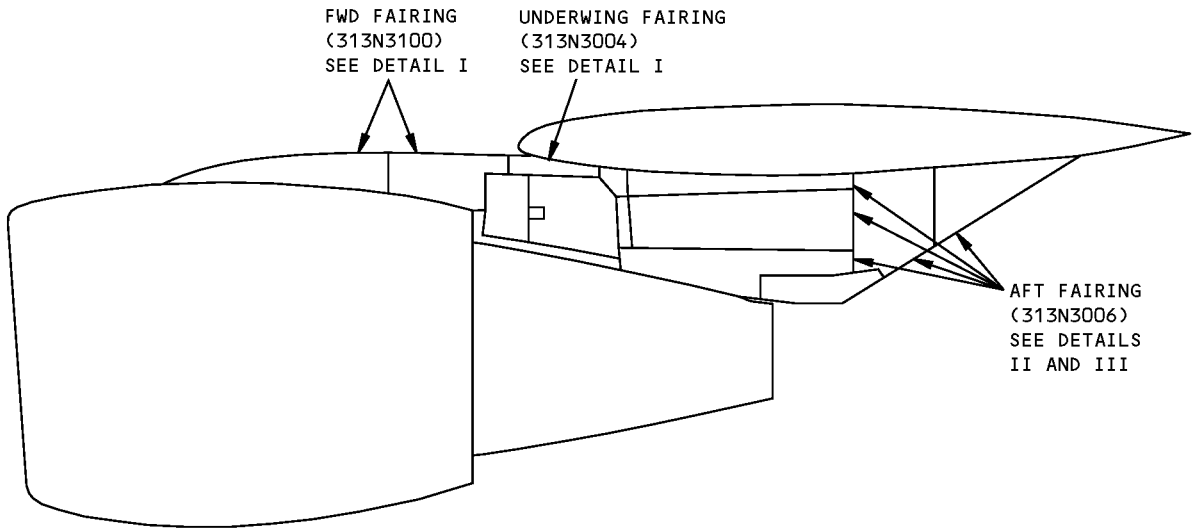

PW2000 SERIES ENGINE FAIRING

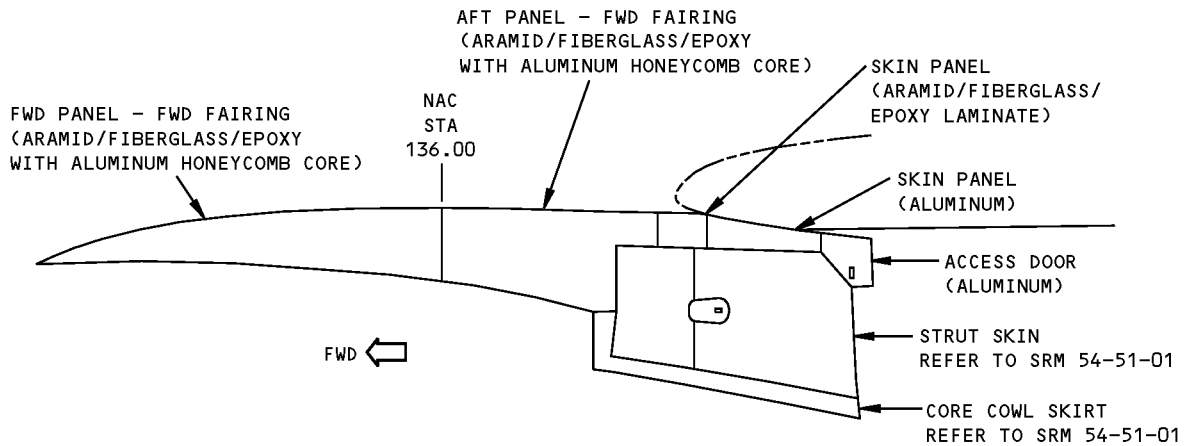

**LEFT SIDE FWD STRUT FAIRING
RIGHT SIDE OPPOSITE**

DETAIL I

**Strut Fairing Skin Allowable Damage - PW2000 Engine
Figure 101 (Sheet 1 of 5)**

**757-200
STRUCTURAL REPAIR MANUAL**

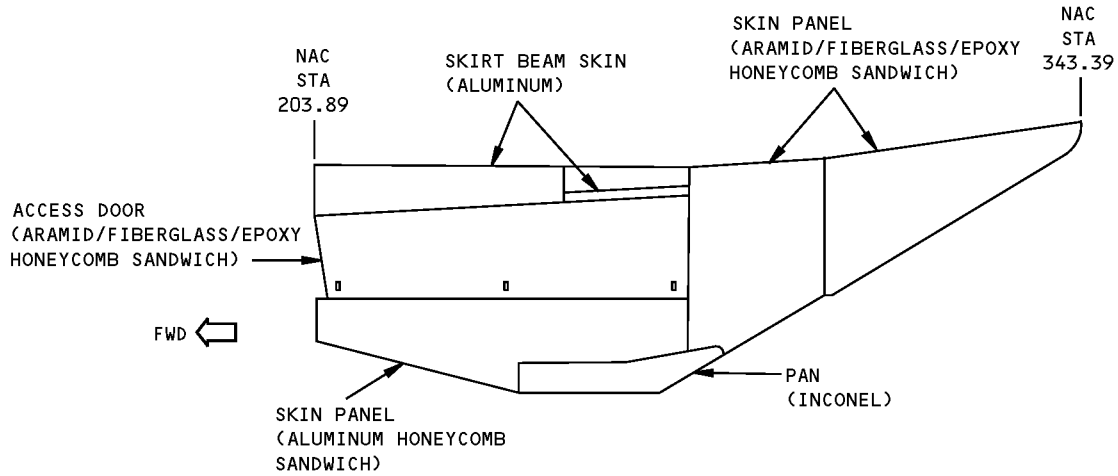

**VIEW ON LEFT SIDE OF STRUT
DETAIL II**

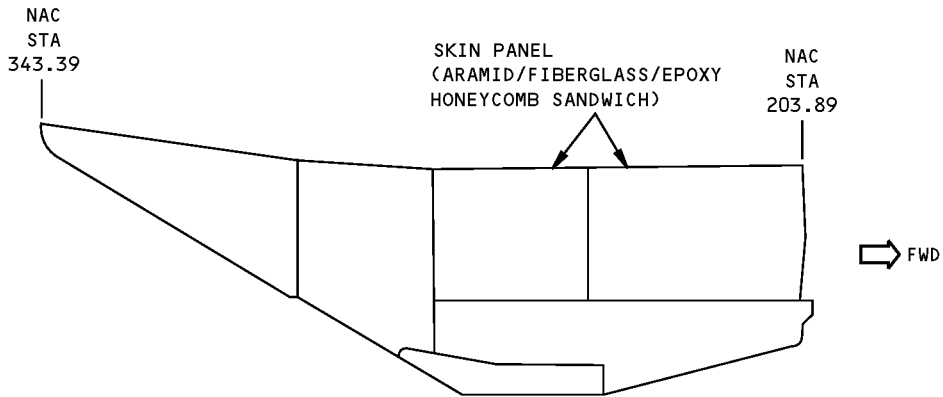

**VIEW ON RIGHT SIDE OF STRUT
STRUT FAIRING PANELS
DETAIL III**

**Strut Fairing Skin Allowable Damage - PW2000 Engine
Figure 101 (Sheet 2 of 5)**

STRUCTURAL REPAIR MANUAL

DESCRIPTION	CRACKS	NICKS, GOUGES AND CORROSION	DENTS	HOLES AND PUNCTURES	PANEL DELAMINATION	EDGE EROSION
SKIN PANELS (ARAMID/GLASS/ALUMINUM CORE)	N	G	H	I	E	SEE DETAIL IX
SKIN PANELS (ALUMINUM)	Q	B	SEE DETAIL VI	C	-----	-----
SKIN PANELS (ARAMID/GLASS/NONMETALLIC CORE)	N	G	H	I	E	SEE DETAIL IX
SKIN PANELS (SOLID LAMINATE)	A	G	H	I	P	SEE DETAIL IX
ACCESS DOOR (ALUMINUM)	L Q	B	SEE DETAIL VI	C	-----	-----
ACCESS DOOR (ARAMID/GLASS/NONMETALLIC CORE)	A	G	H	I	E	SEE DETAIL IX
PAN	A	B	SEE DETAIL VI	M	-----	-----
SKIN PANELS (ALUM/ALUM CORE)	F	K	J	R	P	-----

NOTES

- REFINISH REWORKED AREAS AS SHOWN IN AMM 51-20.
- REFER TO SRM 51-10-01 FOR AERODYNAMIC SMOOTHNESS REQUIREMENTS. WHERE THE DAMAGE IS MORE THAN THE LIMITS SHOWN IN SRM 51-10-01, CONSIDERATION SHOULD BE GIVEN TO THE LOSS OF PERFORMANCE INVOLVED.
- REFER TO SRM 51-10-02 FOR INSPECTION AND REMOVAL OF DAMAGE
- REFER TO SRM 51-70-16 FOR MACHINING OF COMPOSITE STRUCTURES.

- A** CRACKS ARE NOT PERMITTED EXCEPT FOR EDGE CRACKS WHICH MUST BE REMOVED AS SHOWN IN DETAILS V AND VIII.
- B** REMOVE DAMAGE AS SHOWN IN DETAILS IV, V, AND VII.
- C** CLEAN OUT DAMAGE UP TO 0.25 INCH (6 mm) MAX DIAMETER AND NOT CLOSER THAN 1.0 INCH (25 mm) TO FASTENER HOLE OR OTHER DAMAGE. FILL HOLE WITH A 2117-T3 OR T4 ALUMINUM RIVET INSTALLED WET WITH BMS 5-95 SEALANT. ALL OTHER HOLES TO BE REPAIRED.
- D** 1.0 INCH (25 mm) MAX DIAMETER IN HONEYCOMB AREA ONLY AND MIN OF 2.5 D FROM NEAREST HOLE OR MATERIAL EDGE.
- E** 2.0 INCHES (50 mm) MAX DIAMETER IS PERMITTED IN HONEYCOMB AREA. A MAXIMUM OF 0.10 INCH (2.5 mm) DELAMINATION FROM EDGE IS PERMITTED.
- F** 2.0 INCHES (50 mm) MAX LENGTH IN HONEYCOMB AREA AS SHOWN SQUARE FOOT OF AREA AND MINIMUM OF 6.0 INCHES (150 mm) FROM ANY OTHER CRACK. DRILL 0.19 DIA INCH (4.8 mm) STOP HOLES AT END OF CRACK. CLEAN UP EDGE CRACKS AS SHOWN IN DETAILS V AND VIII.
- G** DAMAGE IS PERMITTED ON SURFACE RESIN ONLY. DAMAGE TO FIBERS NOT IS NOT PERMITTED. CLEAN UP EDGE DAMAGE AS SHOWN IN DETAILS V AND VIII.
- H** DENTS GENERALLY RESULT IN FIBER DAMAGE OR DELAMINATION. HOWEVER, IF THERE IS NO FIBER DAMAGE OR DELAMINATION, DENTS UP TO 1.0 INCH (25 mm) DIA MAX ARE PERMITTED. ONE DENT FOR EACH SQUARE FOOT OF AREA IS PERMITTED, WHICH MUST BE A MINIMUM OF 6 INCHES (150 mm) FROM ANY OTHER DAMAGE, FASTENER HOLE, OR PANEL EDGE. SEE **E** OR **I** IF FIBER DAMAGE OR DELAMINATION IS PRESENT.
- I** 0.25 INCH (6 mm) MAX DIAMETER PERMITTED PROVIDED DAMAGE IS MIN OF 3.0 INCHES (75 mm) DIAMETER FROM OTHER DAMAGE, NEAREST HOLE OR MATERIAL EDGE. DO NOT CLEAN UP DAMAGE EXCEPT TO REMOVE RESIN BURRS EXTENDING INTO SURFACE CONTOUR. **O**
- J** 2.0 INCHES (50 mm) DIA IN HONEYCOMB AREA IS PERMITTED PROVIDED THERE IS NO DELAMINATION. ONE DENT PER SQUARE FOOT OF AREA IS PERMITTED AND A MINIMUM OF 6 INCHES (150 mm) FROM ANY OTHER DENT.
- K** REMOVE DAMAGE AS SHOWN IN DETAILS V, VII AND VIII.
- L** NO DAMAGE IS PERMITTED IN AN AREA 1.50 INCHES (38 mm) AROUND HINGE OR LATCH FITTINGS. CONTACT THE BOEING COMPANY FOR ALLOWABLE DAMAGE.
- M** CLEAN OUT DAMAGE UP TO 0.25 INCH (6 mm) MAX DIAMETER AND NOT CLOSER THAN 1.0 INCH (25 mm) TO FASTENER HOLE OR OTHER DAMAGE. FILL HOLE WITH A MONEL RIVET INSTALLED DRY. ALL OTHER HOLES TO BE REPAIRED.

Strut Fairing Skin Allowable Damage - PW2000 Engine
Figure 101 (Sheet 3 of 5)

**757-200
STRUCTURAL REPAIR MANUAL**

NOTES (CONT)

- N** 2.0 MAX LENGTH IN HONEYCOMB AREA PER SQUARE FOOT AND MIN OF 6.0 FROM ANY OTHER CRACK. CLEAN UP EDGE CRACKS PER DETAILS V AND VIII.
- O** REMOVE MOISTURE FROM DAMAGE AREA. USE OF VACUUM AND HEAT (MAX OF 125°F (52°C)) TO REMOVE MOISTURE FROM HONEYCOMB CELLS IS RECOMMENDED. PROTECT DAMAGE FROM ENTRANCE OF WATER, SUNLIGHT OR OTHER FOREIGN MATTER BY SEALING WITH ALUMINUM FOIL TAPE (SPEED TAPE). RECORD THE LOCATION AND INSPECT EACH AIRPLANE "A" CHECK. REPLACE THE ALUMINUM FOIL TAPE IF ANY PEELING OR DETERIORATION IS EVIDENT. REPAIR NO LATER THAN NEXT AIRPLANE "C" CHECK

- P** 1.0 SQUARE INCH ALLOWED WITHOUT REWORK. PROTECT DAMAGE PER **O**
- Q** 2.0 MAX LENGTH ALLOWED AND MINIMUM OF 6.0 FROM ANY OTHER CRACK. DRILL 0.19 STOP HOLES AT END OF CRACK. CLEAN UP EDGE CRACKS PER DETAILS V AND VIII.
- R** 0.25 MAX DIA ALLOWED PROVIDED DAMAGE IS MINIMUM OF 3D FROM OTHER DAMAGE, NEAREST HOLE, OR MATERIAL EDGE

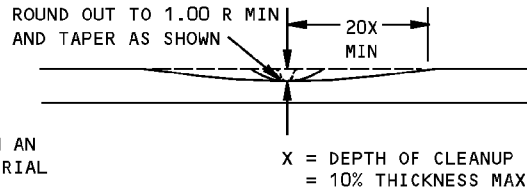
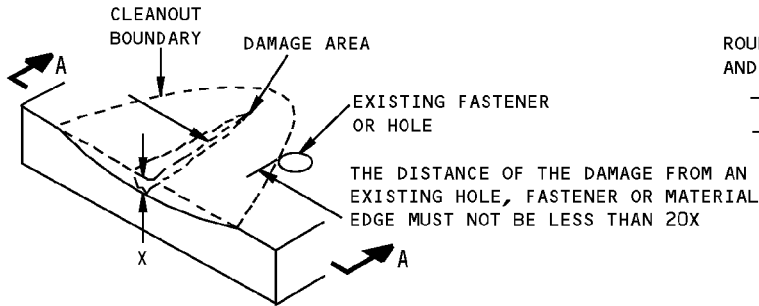

SECTION A-A

**REMOVAL OF NICK, GOUGE AND SCRATCH DAMAGE ON A SURFACE
DETAIL IV**

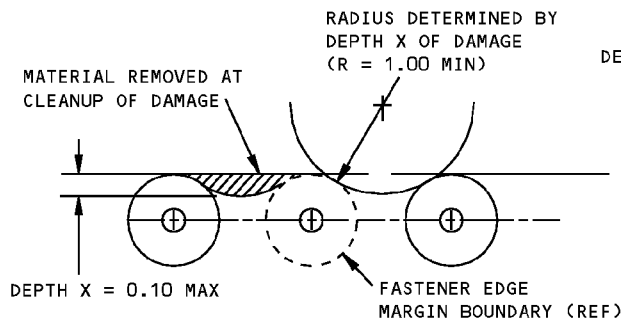

**DAMAGE CLEANUP OF EDGES WHERE
FASTENER EDGE MARGINS DO NOT OVERLAP**

DETAIL V

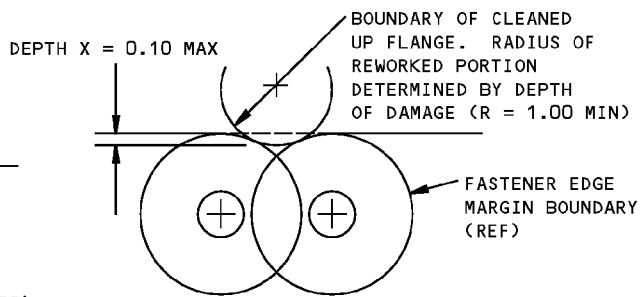

**DAMAGE CLEANUP OF EDGES WHERE
FASTENER EDGE MARGINS OVERLAP**

**Strut Fairing Skin Allowable Damage - PW2000 Engine
Figure 101 (Sheet 4 of 5)**

STRUCTURAL REPAIR MANUAL

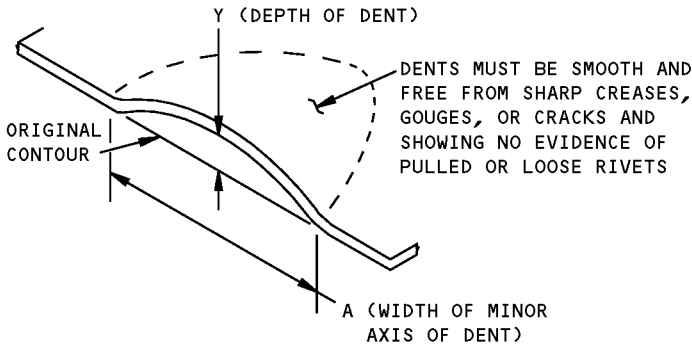

$\frac{A}{Y}$ MUST NOT BE LESS THAN 30
CONTACT BOEING FOR $\frac{A}{Y}$ LESS THAN 30

**ALLOWABLE DAMAGE FOR DENT
DETAIL VI**

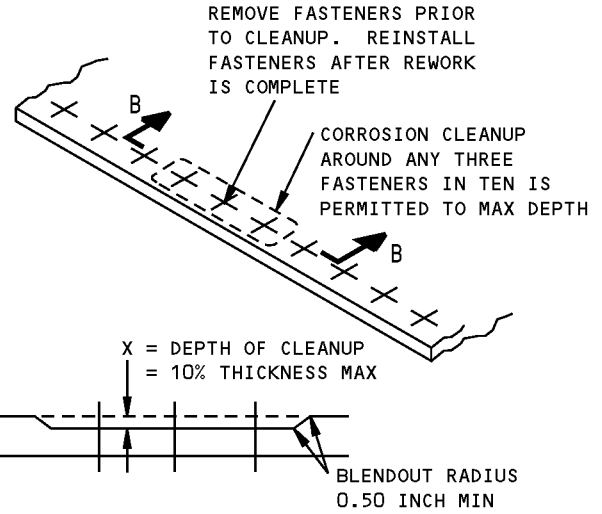

**SECTION B-B
CORROSION CLEANUP
DETAIL VII**

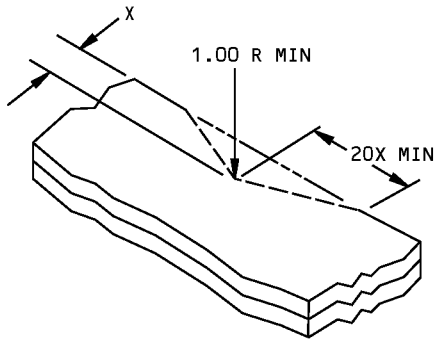

X = DEPTH OF CLEANUP = 0.10 MAX

**REMOVAL OF NICK OR CRACK
DAMAGE ON AN EDGE
DETAIL VIII**

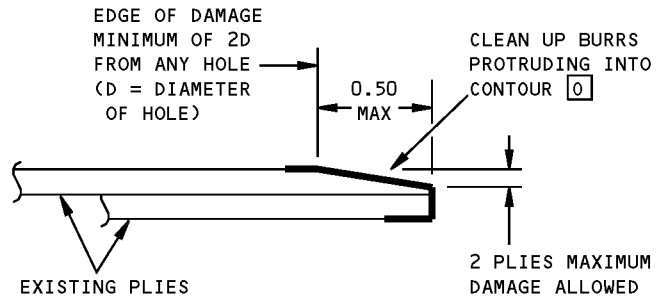

**DAMAGE CLEANUP AND SEALING
OF EDGE EROSION
DETAIL IX**

**Strut Fairing Skin Allowable Damage - PW2000 Engine
Figure 101 (Sheet 5 of 5)**

**757-200
STRUCTURAL REPAIR MANUAL**

REPAIR 1 - STRUT FAIRING SKIN - PW2000 ENGINE

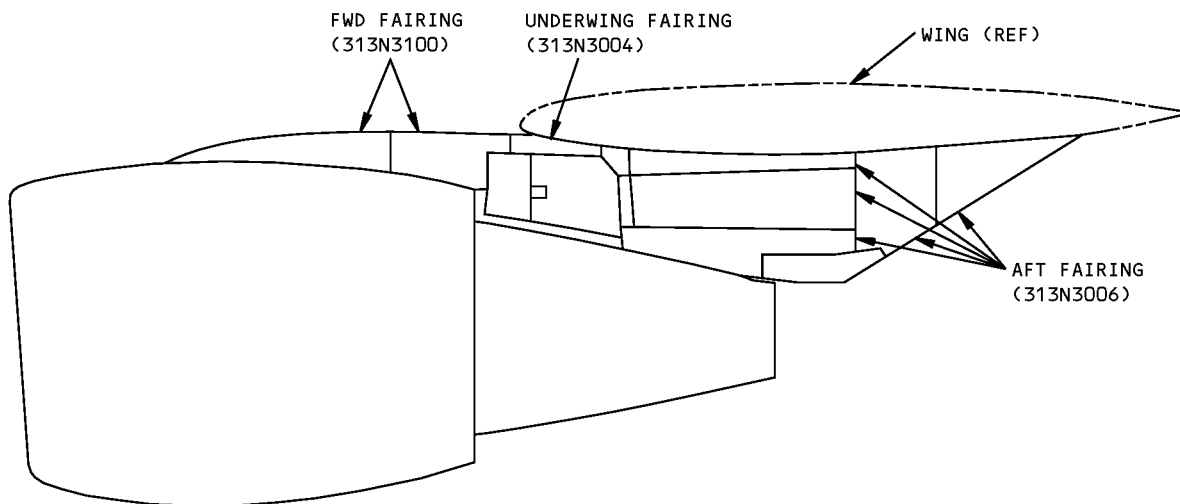

NOTES

- REFINISH REWORKED AREAS PER AMM 51-20.
- REFER TO SRM 51-10-01 FOR AERODYNAMIC SMOOTHNESS REQUIREMENTS. WHERE DAMAGE IS MORE THAN THE LIMITS SHOWN IN SRM 51-10-01. CONSIDERATION SHOULD BE GIVEN TO LOSS OF PERFORMANCE INVOLVED.
- REFER TO SRM 51-10-02 FOR INSPECTION AND REMOVAL OF DAMAGE

A LIMITED TO REPAIR OF DAMAGE TO ONE FACE-SHEET SKIN AND HONEYCOMB CORE. ONE REPAIR FOR EACH SQUARE FOOT OF AREA AND MINIMUM OF 6.0 INCHES (150 mm) (EDGE TO EDGE) FROM ANY OTHER DAMAGE, FASTENER HOLE, OR EDGE OF PANEL.

B INSPECT INTERIM REPAIR USING INSTRUMENTED NDI METHODS OR "TAP" TEST EVERY AIRPLANE "2A" CHECK. FOR "TAP" TEST, USE A SOLID METAL DISK AND TAP THE REPAIR AREA LIGHTLY BUT FIRMLY. VOID AREAS WILL PRODUCE A DULL SOUND AS OPPOSED TO A SHARP RING ON A SOLID BONDED AREA. PERMANENT REPAIR IS REQUIRED IF ANY DETERIORATION IS EVIDENT. REFER TO SRM 51-70-03, PAR. 4.I. AND NDT, D634N301.

F

C ONE REPAIR FOR EACH SQUARE FOOT OF AREA AND A MINIMUM OF 6.0 INCHES (150 mm) (EDGE TO EDGE) FROM ANY OTHER DAMAGE, FASTENER HOLE, OR EDGE OR PANEL.

D CUT OUT AND REPAIR AS A HOLE.

E UP TO 2.0 INCHES (50 mm) LONG REPAIR WITH PATCH AS SHOWN IN SRM 51-70-03, PAR. 5.N.**C**

F THIS REPAIR HAS FAA APPROVAL CONTINGENT ON ACCOMPLISHMENT OF THE INSPECTIONS CONTAINED HEREIN.

**Strut Fairing Skin Repairs - PW2000 Engine
Figure 201 (Sheet 1 of 4)**

**757-200
STRUCTURAL REPAIR MANUAL**

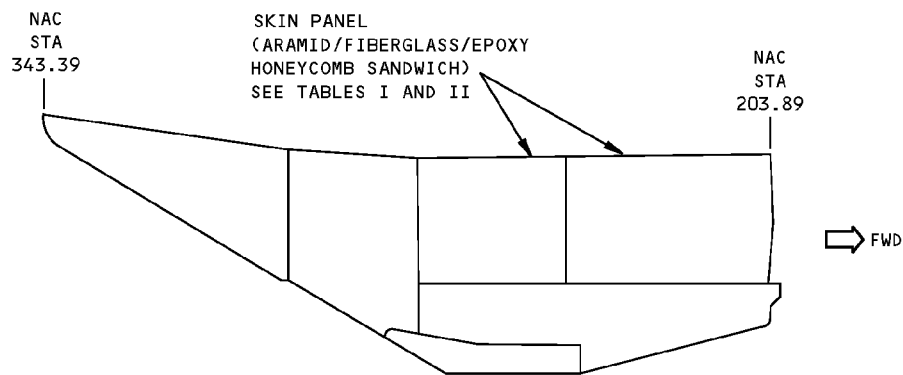
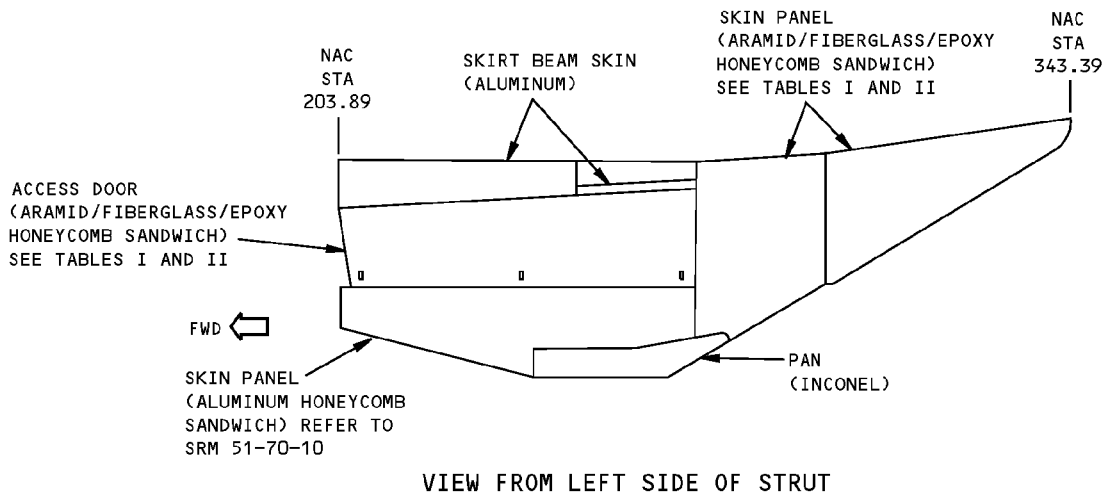
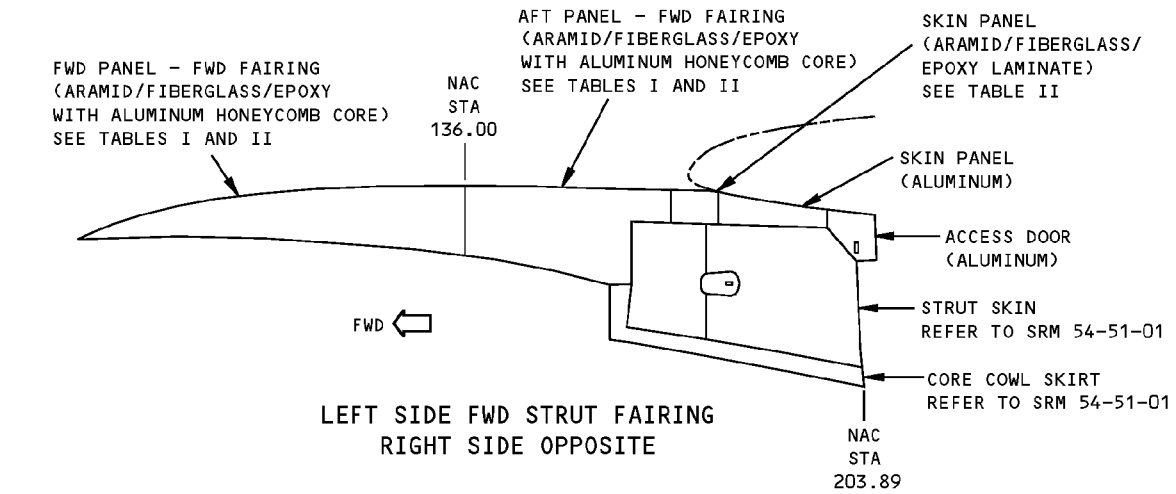

**Strut Fairing Skin Repairs - PW2000 Engine
Figure 201 (Sheet 2 of 4)**

STRUCTURAL REPAIR MANUAL

DAMAGE	INTERIM REPAIRS B	PERMANENT REPAIRS		
	WET LAYUP 150°F CURE (SRM 51-70-03)	WET LAYUP 200°F CURE (SRM 51-70-17)	250°F CURE (SRM 51-70-05)	350°F CURE (SRM 51-70-04)
CRACKS	UP TO 3.0 INCHES (75 mm) LONG, REPAIR WITH PATCH AS GIVEN IN SRM 51-70-03, PAR. 5.N. A	CLEAN UP DAMAGE AND REPAIR AS A HOLE.	CLEAN UP DAMAGE AND REPAIR AS A HOLE.	CLEAN UP DAMAGE AND REPAIR AS A HOLE.
HOLES AND PUNCTURES	3.0 INCHES (75 mm) MAXIMUM DIA NOT TO EXCEED 30% OF SMALLEST DIMENSION ACROSS HONEYCOMB PANEL AT THE DAMAGE LOCATION. FILL WITH BMS 5-28, TYPE 7 POTTING COMPOUND AND PATCH AS GIVEN IN SRM 51-70-03, PAR. 5.N. A	12.0 INCHES (300 mm) MAXIMUM DIA NOT TO EXCEED 50% OF SMALLEST DIMENSION ACROSS HONEYCOMB PANEL AT THE DAMAGE LOCATION. USE TWO EXTRA PLIES FOR EACH FACESHEET REPAIRED. C	6.0 INCHES (150 mm) MAXIMUM DIA NOT TO EXCEED 50% OF SMALLEST DIMENSION ACROSS HONEYCOMB PANEL AT THE DAMAGE LOCATION. USE TWO EXTRA PLIES FOR EACH FACESHEET REPAIRED. C	NO SIZE LIMIT
DELAMINATION	CUT OUT AND REPAIR AS A HOLE.			
NICKS AND GOUGES	IF THERE IS NO FIBER DAMAGE OR DELAMINATION, FILL NICKS OR GOUGES AS GIVEN IN SRM 51-70-03. IF YOU FIND FIBER DAMAGE OR DELAMINATION, THEN REPAIR AS A HOLE.			
DENTS	UP TO 2.0 INCHES (50 mm) DIA WITH NO FIBER DAMAGE OR DELAMINATION, FILL WITH BMS 5-28, TYPE 7 POTTING COMPOUND AND PATCH AS GIVEN IN SRM 51-70-03, PAR. 5.L. OVER 2.0 INCHES (50 mm) DIA OR WITH FIBER DAMAGE OR DELAMINATION, REPAIR AS A HOLE.			

REPAIR DATA FOR 350°F CURE HONEYCOMB PANELS
TABLE I

Strut Fairing Skin Repairs - PW2000 Engine
Figure 201 (Sheet 3 of 4)

STRUCTURAL REPAIR MANUAL

DAMAGE	INTERIM REPAIRS [B]	PERMANENT REPAIRS		
	WET LAYUP 150°F CURE (SRM 51-70-03)	WET LAYUP 200°F CURE (SRM 51-70-17)	250°F CURE (SRM 51-70-05)	350°F CURE (SRM 51-70-04)
CRACKS	FOR EDGE BAND, REFER TO [D] FOR LAMINATE, REFER TO [E].	CLEAN UP DAMAGE AND REPAIR AS A HOLE.	CLEAN UP DAMAGE AND REPAIR AS A HOLE.	CLEAN UP DAMAGE AND REPAIR AS A HOLE.
HOLES AND PUNCTURES	3.0 INCHES (75 mm) MAXIMUM DIA NOT TO EXCEED 15% OF THE CROSS-SECTIONAL AREA THRU LAMINATE OR EDGE BAND OR 10% OF THE EDGE BAND LENGTH FOR EACH SIDE. REPAIR AS GIVEN IN SRM 51-70-03 PAR. 5.G., 5.H., 5.I. OR 5.K. AS APPLICABLE.	10.0 INCHES (250 mm) MAXIMUM DIA NOT TO EXCEED 50% OF CROSS-SECTIONAL AREA OF LAMINATE OR EDGE BAND OR 25% OF THE EDGE BAND LENGTH FOR EACH SIDE. USE TWO EXTRA PLYS FOR EACH FACESHEET.	6.0 INCHES (150 mm) MAXIMUM DIA NOT TO EXCEED 50% OF CROSS-SECTIONAL AREA OF LAMINATE OR EDGE BAND OR 25% OF THE EDGE BAND LENGTH FOR EACH SIDE. USE TWO EXTRA PLYS FOR EACH FACESHEET.	NO SIZE LIMIT
EDGE EROSION	-----	FOR DAMAGE NOT LARGER THAN 35% OF EDGE BAND THICKNESS, REPAIR FOR EACH SRM 51-70-03, PAR. 5.O. FOR LARGER DAMAGE, REPAIR AS GIVEN IN: SRM 51-70-17, PAR. 4.G. SRM 51-70-05, PAR. 5.G. SRM 51-70-04, PAR. 5.G.		
DELAMINATION	CUT OUT AND REPAIR AS A HOLE.			
NICKS AND GOUGES	IF THERE IS NO FIBER DAMAGE OR DELAMINATION, FILL NICKS OR GOUGES AS GIVEN IN SRM 51-70-03. IF YOU FIND FIBER DAMAGE OR DELAMINATION, THEN REPAIR AS A HOLE.			
DENTS	UP TO 2.0 INCHES (50 mm) DIA WITH NO FIBER DAMAGE OR DELAMINATION, FILL WITH BMS 5-28, TYPE 7 POTTING COMPOUND AND PATCH AS GIVEN IN SRM 51-70-03, PAR. 5.L. [C] OVER 2.0 INCHES (50 mm) DIA OR WITH FIBER DAMAGE OR DELAMINATION, REPAIR AS A HOLE.			

REPAIR DATA FOR 350°F CURE LAMINATES AND EDGE BANDS
TABLE II

**Strut Fairing Skin Repairs - PW2000 Engine
Figure 201 (Sheet 4 of 4)**

757-200
STRUCTURAL REPAIR MANUAL

IDENTIFICATION 1 - STRUT FAIRING SUPPORT STRUCTURE - PW2000 ENGINE

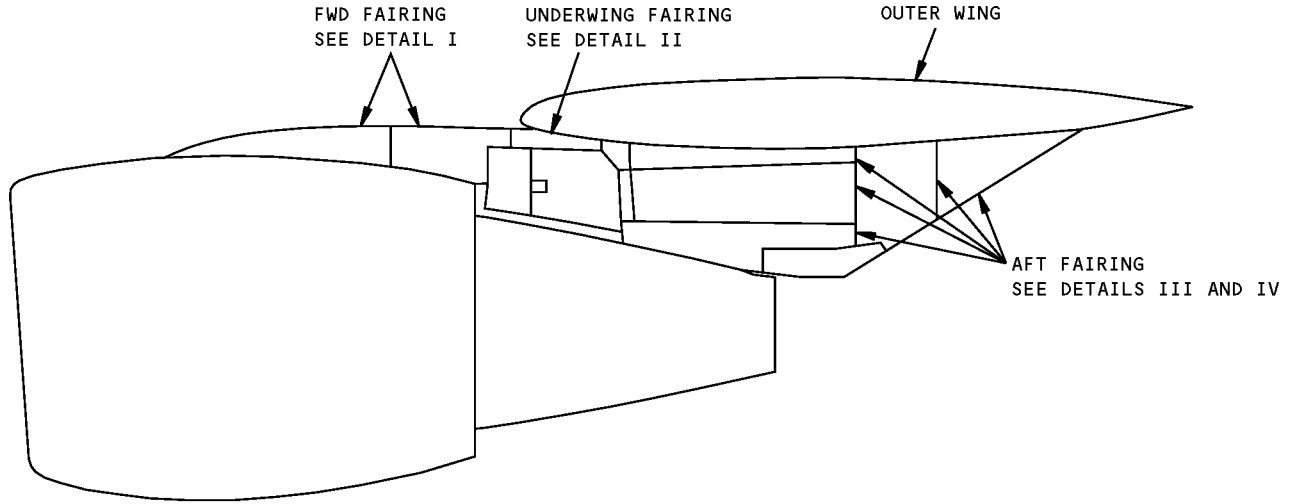

PW2000 SERIES ENGINE FAIRING

NOTES

- A** AIRPLANES WITH SB 54-23.
- B** AIRPLANES NOT LISTED IN **A**.
- C** AIRPLANES WITHOUT 757 SB 57-42.
- D** AIRPLANES WITH 757 SB 57-42.

Strut Fairing Support Structure Identification - PW2000 Engine
Figure 1 (Sheet 1 of 5)

**757-200
STRUCTURAL REPAIR MANUAL**

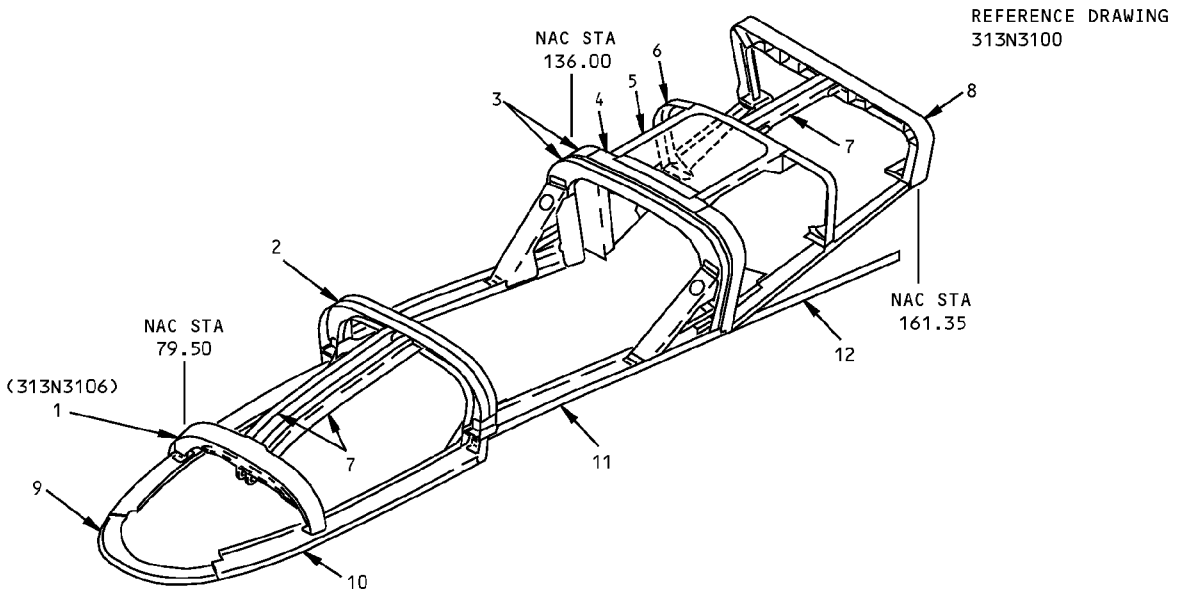

**FORWARD FAIRING STRUCTURE
DETAIL I**

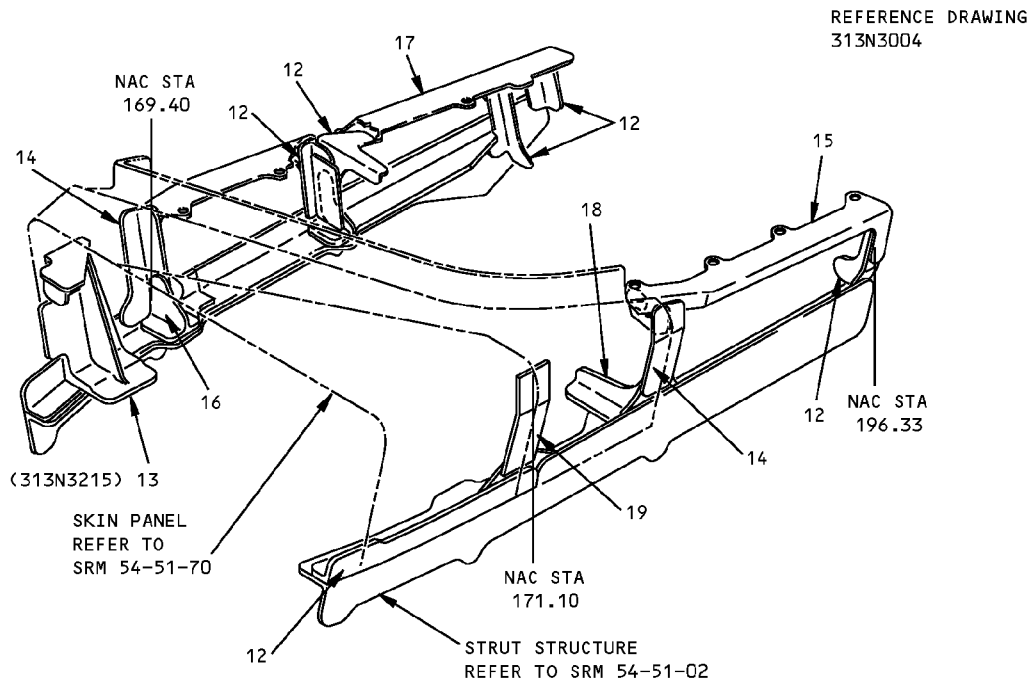

**UNDERWING FAIRING STRUCTURE
DETAIL II**

**Strut Fairing Support Structure Identification - PW2000 Engine
Figure 1 (Sheet 2 of 5)**



757-200
STRUCTURAL REPAIR MANUAL

ITEM	DESCRIPTION	GAGE	MATERIAL	EFFECTIVITY
1	FAIRING ATTACH FITTING		FORGING OR FORGED BLOCK 7075-T73	
2	FRAME	0.063	CLAD 7075-T62	
3	FRAME	0.063	CLAD 2024-T42	
4	FRAME TOP		BAC1506-3384 7075-T62	
5	DOOR FRAME	0.063	CLAD 7075-T62	
6	FRAME ANGLE	0.063	CLAD 7075-T62	
7	ANGLE	0.063	CLAD 2024-T42	
8	FRAME		FORGING OR FORGED BLOCK 7075-T62	
9	PLATE	0.063	CLAD 2024-T42	
10	ZEE LONGERON	0.063	CLAD 2024-T42	
11	LONGERON	0.080	CLAD 7075-T62	
12	ANGLE	0.063	CLAD 2024-T42	
13	SHEAR FITTING		FORGING OR FORGED BLOCK 7075-T73	
14	SPLICE TEE		BAC1505-101193 7075-T6511	
15	FRAME ANGLE	0.080	7075-T62	
16	TEE		BAC1505-101134 7075-T6511	
17	ANGLE	0.063	7075-T62	
18	ANGLE		BAC1514-2616 7075-T6511	
19	SPLICE PLATE	0.080	CLAD 2024-T3	

LIST OF MATERIALS FOR DETAILS I AND II

Strut Fairing Support Structure Identification - PW2000 Engine
Figure 1 (Sheet 3 of 5)

D634N201

54-51-71

IDENTIFICATION 1
Page 3
Jan 20/2005

**757-200
STRUCTURAL REPAIR MANUAL**

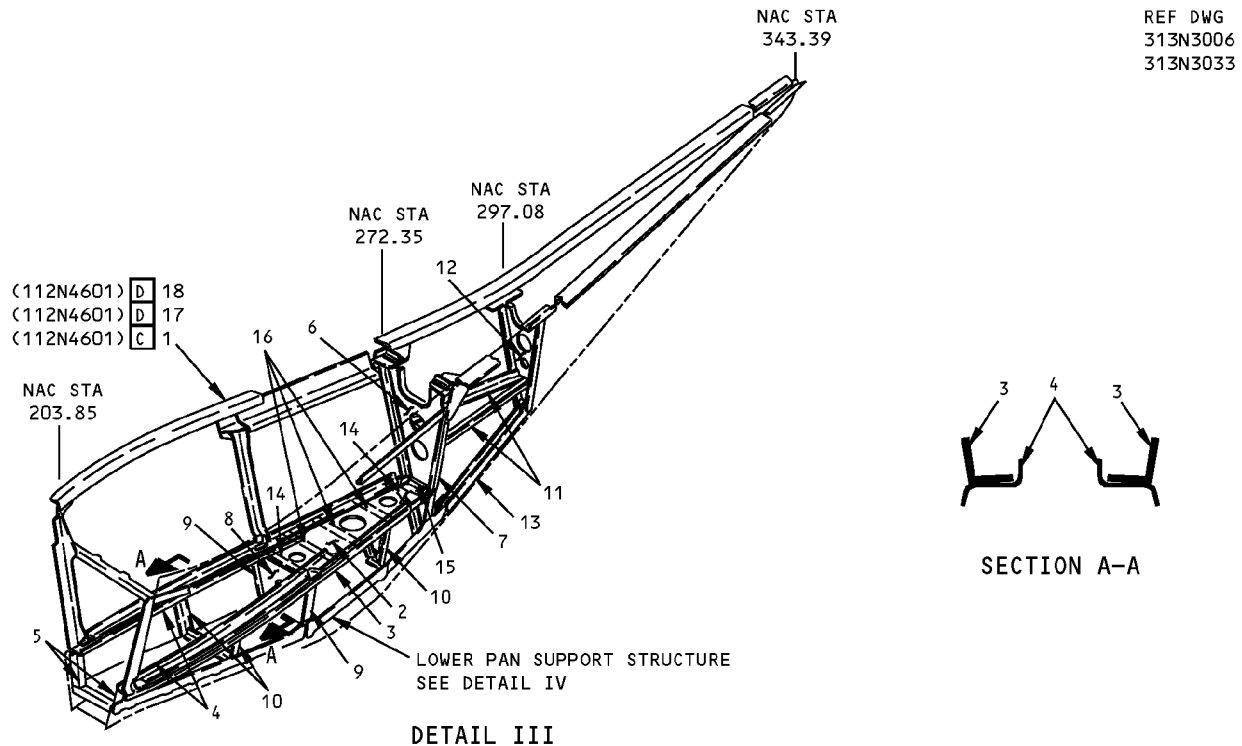

DETAIL III

ITEM	DESCRIPTION	GAGE	MATERIAL	EFFECTIVITY
1	SKATE ANGLE	0.125	2024-T42	C
2	WEB	0.063	CLAD 2024-T42	
3	LATCH STRIKER		BAC1503-100515 7075-T73511	
4	CHORD	0.100	7075-T62	
5	CHANNEL	0.063	2024-T42	
6	WEB	0.063	7075-T62	
7	CHANNEL		BAC1510-1151 7075-T62	
8	WEB	0.050	CLAD 2024-T42	
9	TEE		BAC1506-2643 2024-T42	
10	ANGLE	0.063	CLAD 2024-T42	
11	CHANNEL	0.063	7075-T6	
12	WEB	0.050	CLAD 7075-T6	
13	CLOSURE		BAC1520-2414 2024-T42	
14	ANGLE		BAC1505-100569 2024-T42	
15	ANGLE	0.063	CLAD 7075-T62	
16	CROSS TIE		BAC1505-100913 2024-T42	
17	SKATE ANGLE		AND10133-2401 EXTRUSION 2024-T42	D
18	SKATE ANGLE		BAC1506-588 EXTRUSION 2024-T3511	D

LIST OF MATERIALS FOR DETAIL III

**Strut Fairing Support Structure Identification - PW2000 Engine
Figure 1 (Sheet 4 of 5)**

**757-200
STRUCTURAL REPAIR MANUAL**

REF DWG
313N3021
313N3033

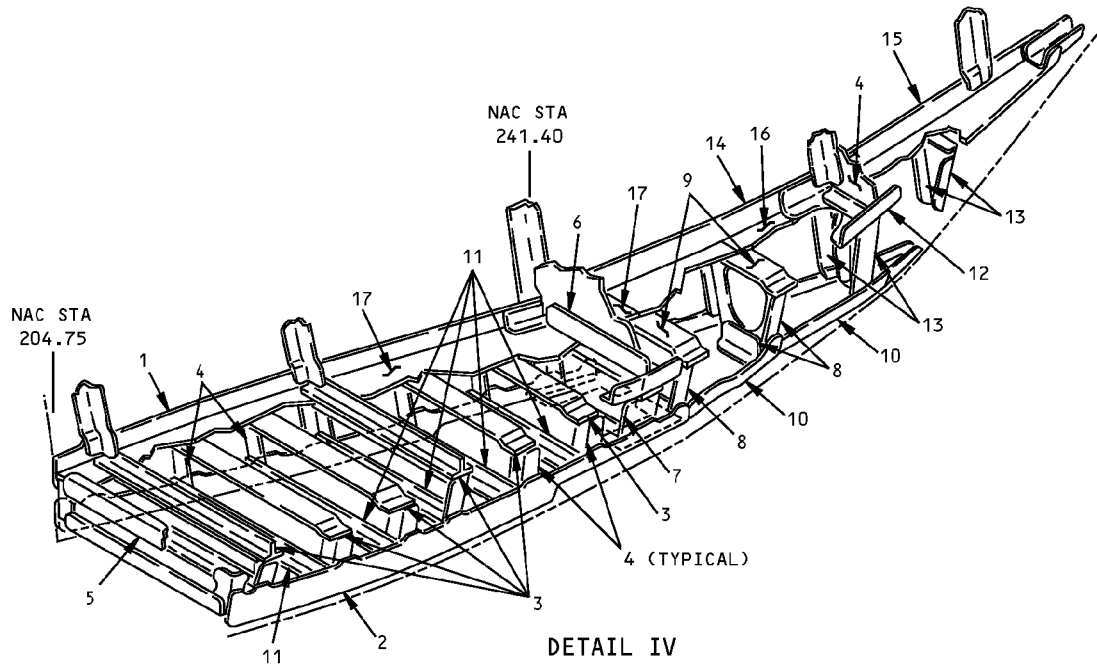

ITEM	DESCRIPTION	GAGE	MATERIAL	EFFECTIVITY
1	FWD CHORD		BAC1506-1990 7075-T73	
2	LOWER CHORD		BAC1506-1990 2024-T42	
3	SPAR STIFFENER		BAC1506-3541 2024-T3511	
4	ANGLE	0.063	CLAD 2024-T42	
5	FWD ATTACH ANGLE	0.063	CLAD 2024-T42	
6	STIFFENER	0.071	CLAD 2024-T42	
7	TEE		BAC1505-10052 2024-T3511	
8	ANGLE	0.050	INCONEL 625 PER AMS5599 ANNEALED	
9	SPAR STIFFENER		BAC1505-100425 2024-T3511	
10	PAN	0.050	INCONEL 625 PER AMS5599 ANNEALED	
11	PAN STIFFENER		BAC1506-3541 2024-T3511	
12	SPLICE CHORD	0.071	CLAD 7075-T6	
13	FRAME	0.050	INCONEL 625 PER AMS5599 ANNEALED	
14	MID CHORD		BAC1506-3540 7075-T73	
15	CHORD STRAP	0.050	CLAD 2024-T42	
16	WEB	0.050	CLAD 2024-T42	
17	WEB ASSEMBLY			
	WEB	0.025	2024-T81	
	DOUBLER	0.050	2024-T81	
	COVER PLATE	0.063	2024-T81	

A
B

LIST OF MATERIALS FOR DETAIL IV

**Strut Fairing Support Structure Identification - PW2000 Engine
Figure 1 (Sheet 5 of 5)**

IDENTIFICATION 1
Page 5
Jan 20/2005

54-51-71

D634N201

**757-200
STRUCTURAL REPAIR MANUAL**

ALLOWABLE DAMAGE 1 - STRUT FAIRING SUPPORT STRUCTURE - PW2000 ENGINE

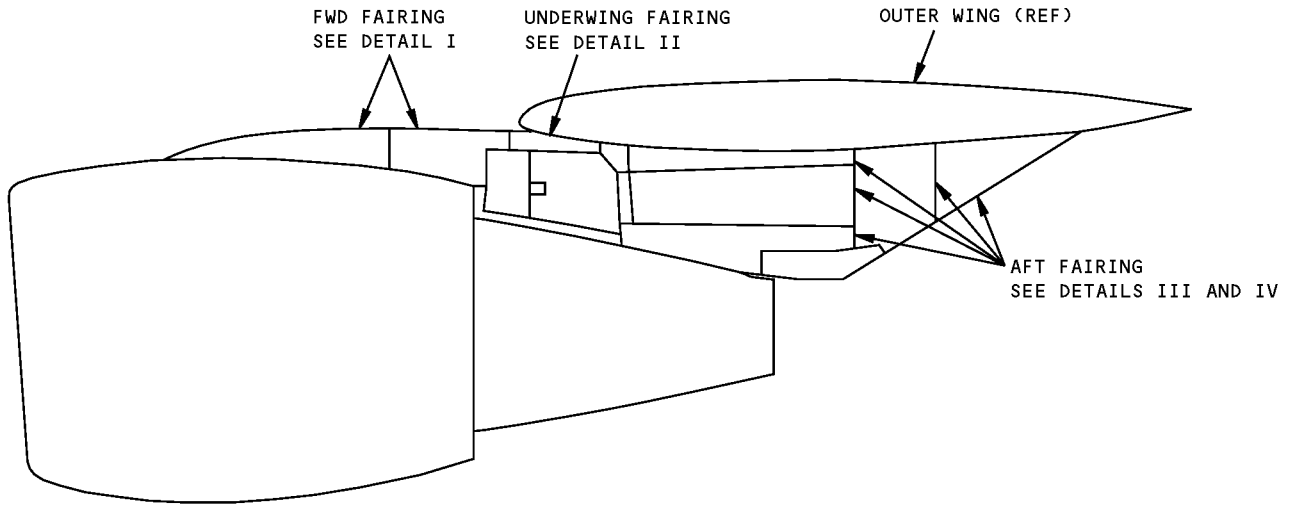

PW2000 SERIES ENGINE FAIRING

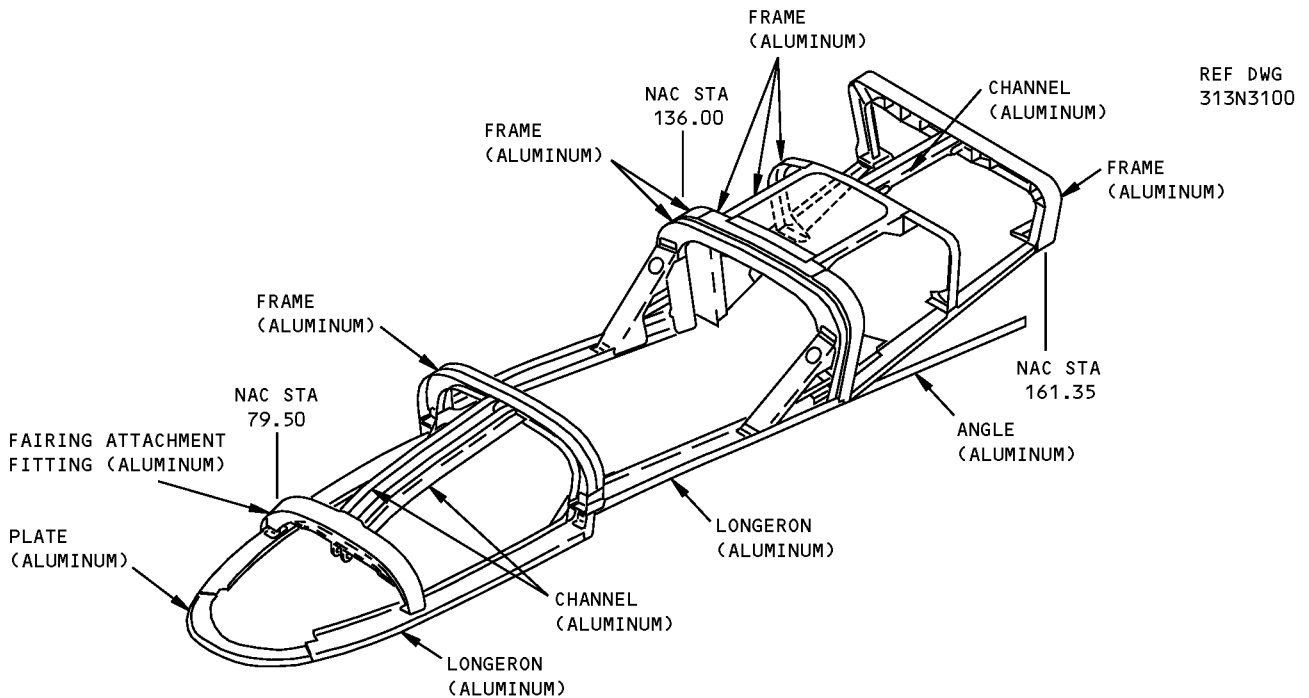

**FORWARD FAIRING STRUCTURE
DETAIL I**

**Allowable Damage - Strut Fairing Support Structure - PW2000 Engine
Figure 101 (Sheet 1 of 6)**

**757-200
STRUCTURAL REPAIR MANUAL**

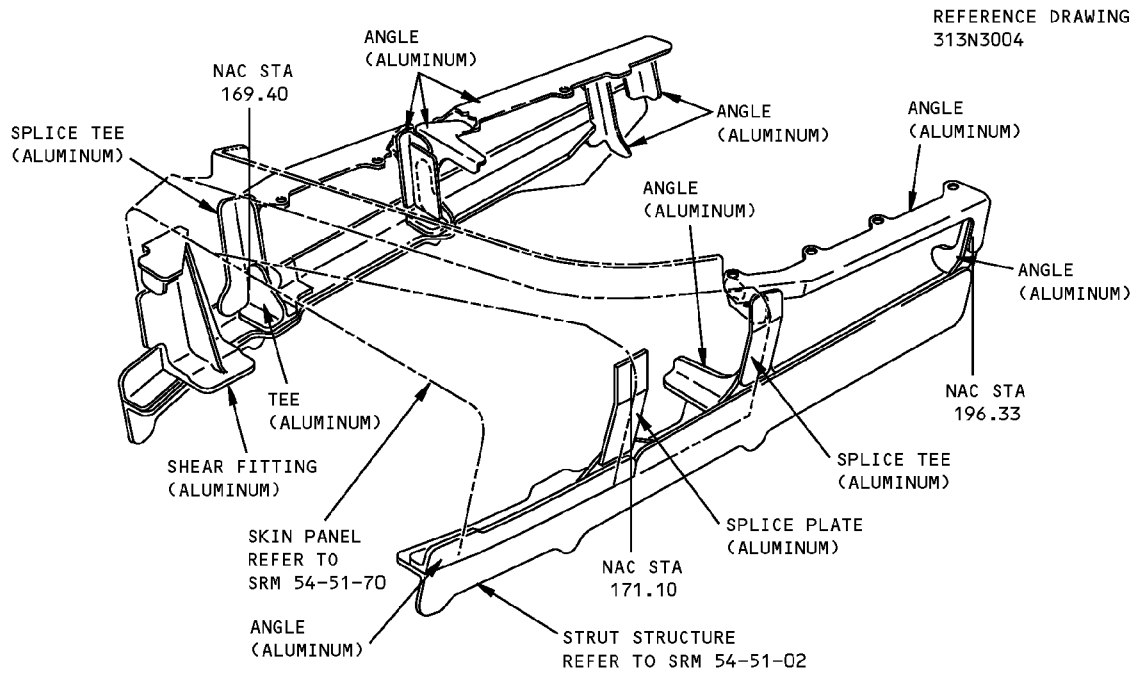

**UNDERWING FAIRING STRUCTURE
DETAIL II**

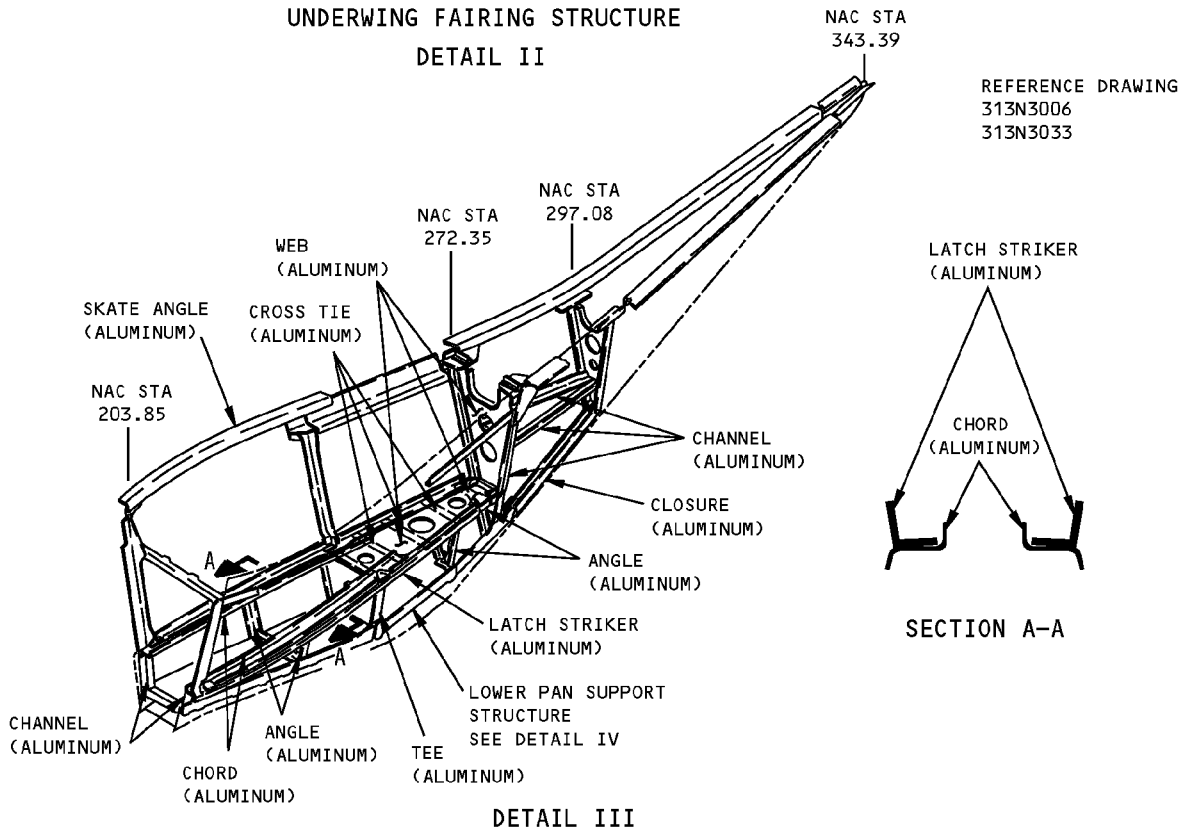

**Allowable Damage - Strut Fairing Support Structure - PW2000 Engine
Figure 101 (Sheet 2 of 6)**

**757-200
STRUCTURAL REPAIR MANUAL**

REF DWG
313N3021
313N3033

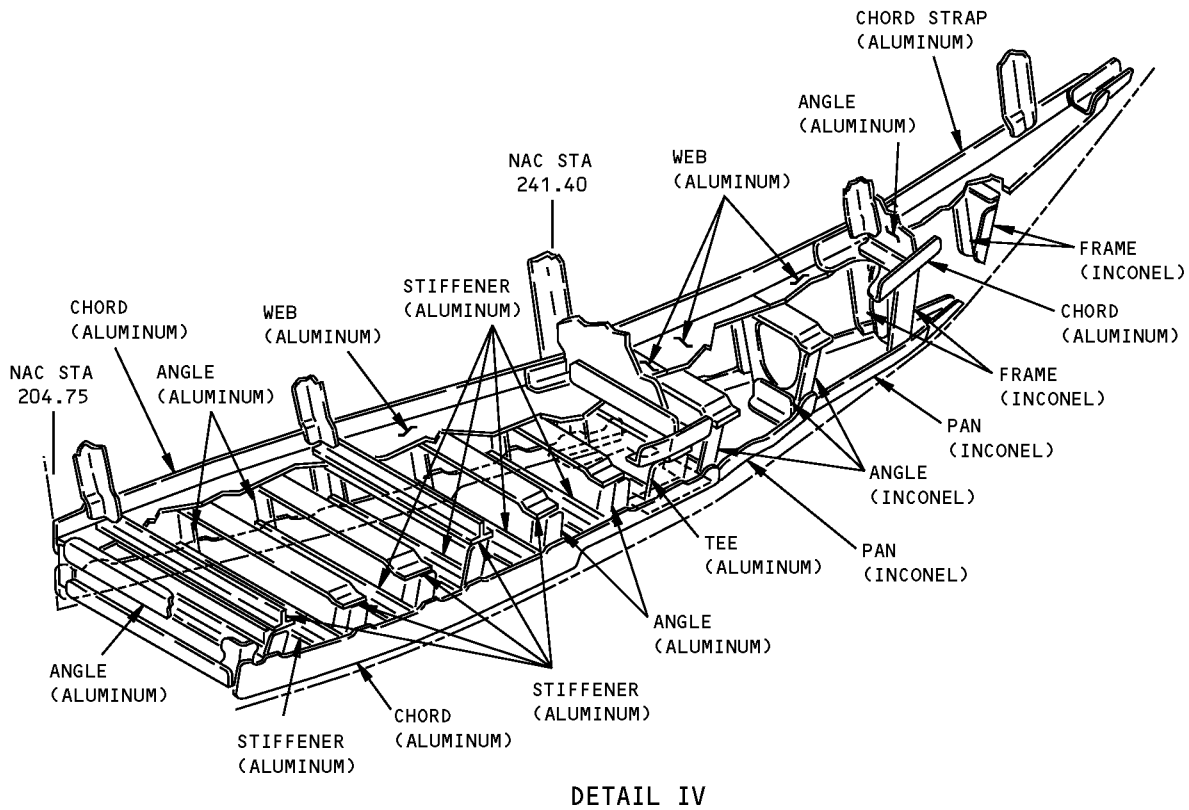

**Allowable Damage - Strut Fairing Support Structure - PW2000 Engine
Figure 101 (Sheet 3 of 6)**

**757-200
STRUCTURAL REPAIR MANUAL**

DESCRIPTION	CRACKS	NICKS, GOUGES AND CORROSION	DENTS	HOLES AND PUNCTURES
SHEAR FITTING	A	B	NOT PERMITTED	NOT PERMITTED
STIFFENERS	A	B	NOT PERMITTED	NOT PERMITTED
ANGLES	A	B	NOT PERMITTED	NOT PERMITTED
PLATES	A	B	NOT PERMITTED	NOT PERMITTED
TEES	A	B	NOT PERMITTED	NOT PERMITTED
CHANNELS	A	B	NOT PERMITTED	NOT PERMITTED
WEBS	C	B	SEE DETAIL VII	C
FRAMES	A	B	NOT PERMITTED	NOT PERMITTED
CROSS TIE	A	B	NOT PERMITTED	NOT PERMITTED
FAIRING ATTACH FITTING	A	B	NOT PERMITTED	NOT PERMITTED
CHORD	A	B	NOT PERMITTED	NOT PERMITTED
LONGERONS	A	B	NOT PERMITTED	NOT PERMITTED
LATCH STRIKERS	A	B	NOT PERMITTED	NOT PERMITTED

NOTES

- REFINISH REWORKED AREAS AS SHOWN IN AMM 51-20.
 - REFER TO SRM 51-10-02 FOR INSPECTION AND REMOVAL OF DAMAGE
- A** CRACKS ARE NOT PERMITTED EXCEPT FOR EDGE CRACKS WHICH MUST BE REMOVED AS SHOWN IN DETAILS V, IX AND X.
- B** REMOVE DAMAGE AS SHOWN IN DETAILS V, VI, VIII, IX AND X.
- C** CLEAN OUT DAMAGE UP TO 0.25 INCH (6 mm) MAX DIA AND NOT CLOSER THAN 1.0 INCH (25 mm) TO FASTENER HOLE OR OTHER DAMAGE. FILL HOLE WITH A 2117-T3 OR T4 ALUMINUM RIVET INSTALLED WET WITH BMS 5-95 SEALANT. ALL OTHER HOLES TO BE REPAIRED.

**Allowable Damage - Strut Fairing Support Structure - PW2000 Engine
Figure 101 (Sheet 4 of 6)**

STRUCTURAL REPAIR MANUAL

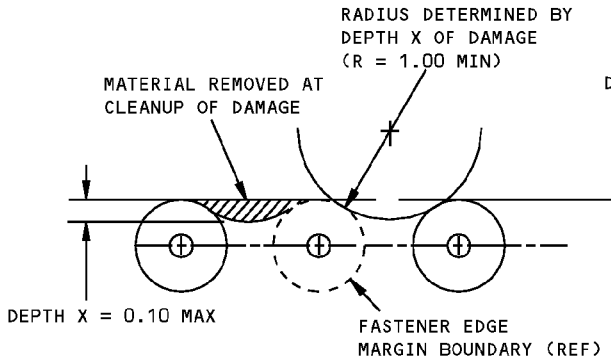

DAMAGE CLEANUP OF EDGES WHERE FASTENER EDGE MARGINS DO NOT OVERLAP

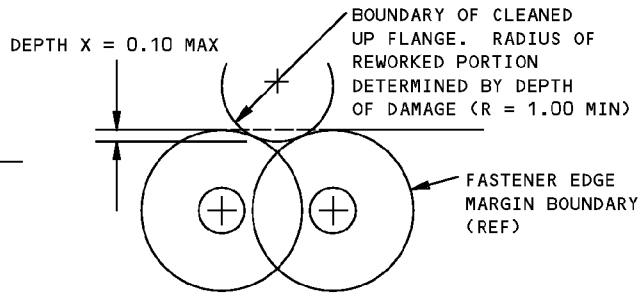

DAMAGE CLEANUP OF EDGES WHERE FASTENER EDGE MARGINS OVERLAP

DETAIL V

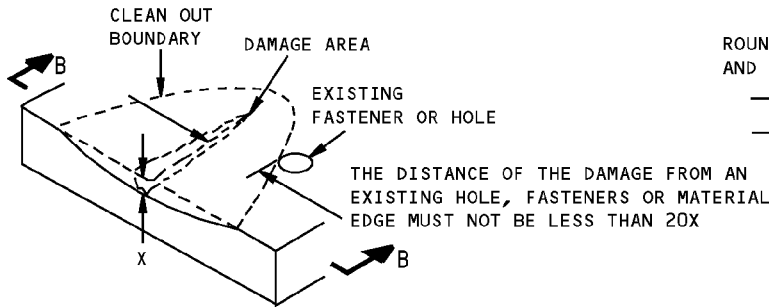

REMOVAL OF NICK, GOUGE AND SCRATCH DAMAGE ON A SURFACE
DETAIL VI

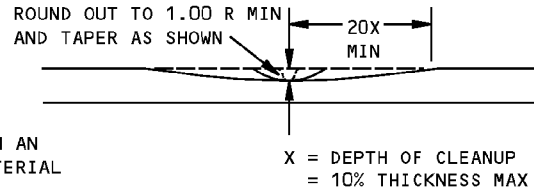

SECTION B-B

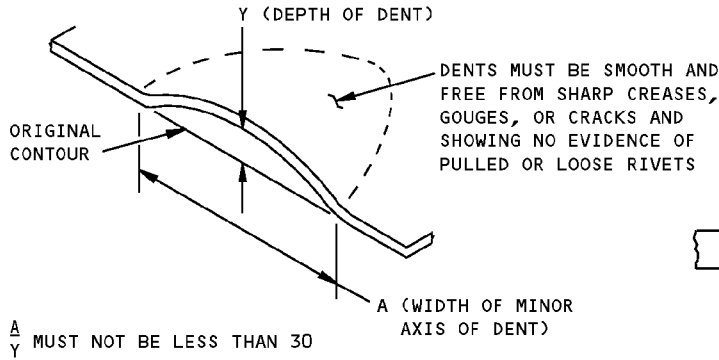

ALLOWABLE DAMAGE FOR DENT
DETAIL VII

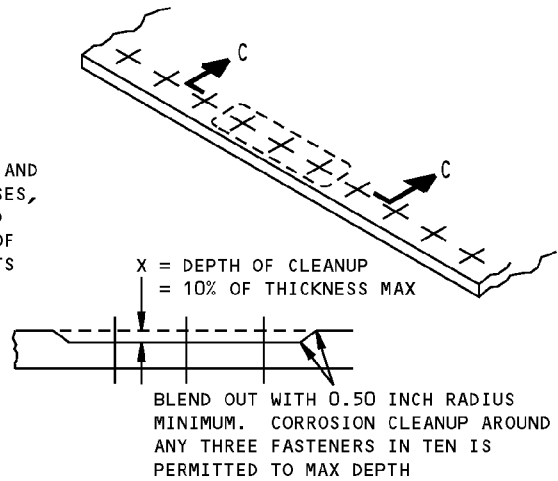

SECTION C-C

CORROSION CLEANUP
DETAIL VIII

Allowable Damage - Strut Fairing Support Structure - PW2000 Engine
Figure 101 (Sheet 5 of 6)

757-200
STRUCTURAL REPAIR MANUAL

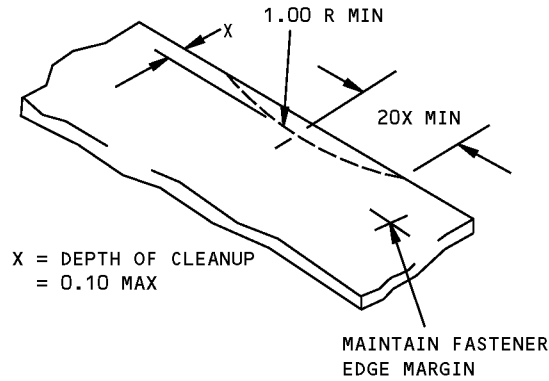

REMOVAL OF NICK OR CRACK DAMAGE ON AN EDGE
DETAIL IX

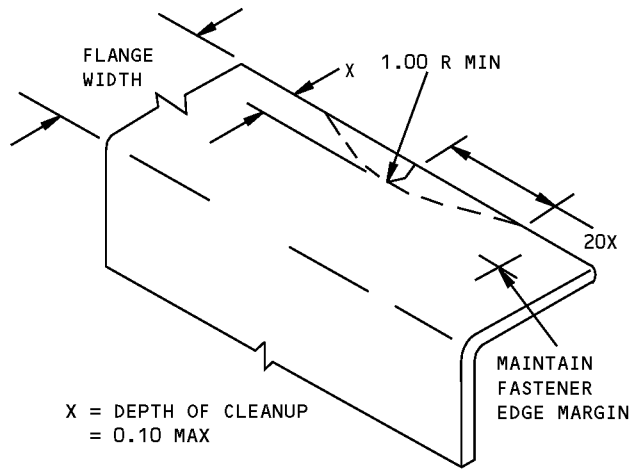

REMOVAL OF NICK OR CRACK DAMAGE ON AN EDGE
DETAIL X

Allowable Damage - Strut Fairing Support Structure - PW2000 Engine
Figure 101 (Sheet 6 of 6)



**757-200
STRUCTURAL REPAIR MANUAL**

REPAIR GENERAL - STRUT FAIRING STRUCTURE - PW2000 ENGINE - SERVICE BULLETIN LIST

SERVICE BULLETIN REPAIRS

The following Service Bulletins contain repairs which are available for use where specific damage has been encountered. Usually, the Service Bulletin also covers preventive modification data which operators are encouraged to use to eliminate the need for repair.

DAMAGED AREA	CUM LINE NUMBER EFFECTIVITY	SB NUMBER
NACELLES/PYLONS - ENGINE TO WING FAIRING - AFT FAIRING PANEL INSPECTION/REPAIR	AIRPLANES WITH PRATT & WHITNEY ENGINES: 37 THRU 496	SB 757-54-0006
NACELLES/PYLONS-STRUT FAIRINGS - INCREASE CLEARANCE BETWEEN STRUT AFT FAIRING LOWER PAN AND ENGINE EXHAUST SLEEVE	AIRPLANES WITH PRATT & WHITNEY ENGINES: 37 THRU 447	SB 757-54-0023
NACELLES/PYLONS - ENGINE TO WING FAIRINGS - AFT INBOARD SKATE ANGLE CHANGE ON THE RIGHT STRUT	AIRPLANES WITH PRATT & WHITNEY ENGINES: 37 THRU 512	SB 757-57-0042
NACELLES/PYLONS - STRUT SIDE SKIN INSPECTION/REPAIR/PREVENTIVE MODIFICATION - PRATT AND WHITNEY POWERED AIRPLANE	AIRPLANES WITH PRATT & WHITNEY ENGINES: 1 THRU 732	SB 757-54-0037

**Strut Fairing Structure - PW2000 Engine
Figure 201**

D634N201

54-51-71

REPAIR GENERAL
Page 201
Jan 20/2005

757-200
STRUCTURAL REPAIR MANUAL

REPAIR 1 - STRUT FAIRING SUPPORT STRUCTURE - PW2000 ENGINE

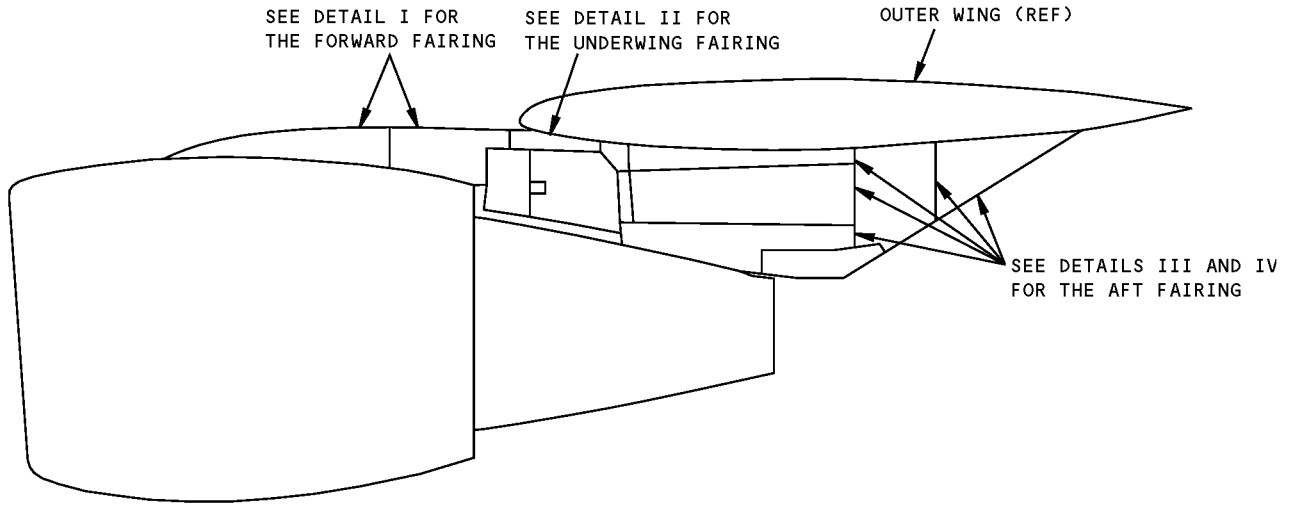

PW2000 SERIES ENGINE FAIRING

NOTES

- REFINISH REWORKED AREAS AS GIVEN IN AMM 51-21.
 - REFER TO SRM 51-10-02 FOR INSPECTION AND REMOVAL OF DAMAGE
- A** REFER TO SRM 51-70-11 FOR FORMED SECTION REPAIR.
- B** REFER TO SRM 51-70-12 FOR EXTRUDED SECTION REPAIR.
- C** REFER TO SRM 51-70-13 FOR WEB REPAIR.
- D** NO TYPICAL REPAIRS ARE AVAILABLE. REPAIRS WILL BE BASED ON SERVICE EXPERIENCE.
- E** FOR AIRPLANES WITHOUT 757 SB 57-42.
- F** FOR AIRPLANES WITH 757 SB 57-42.

Strut Fairing Support Structure Repair - PW2000 Engine
Figure 201 (Sheet 1 of 4)

**757-200
STRUCTURAL REPAIR MANUAL**

REF DWG
313N3100

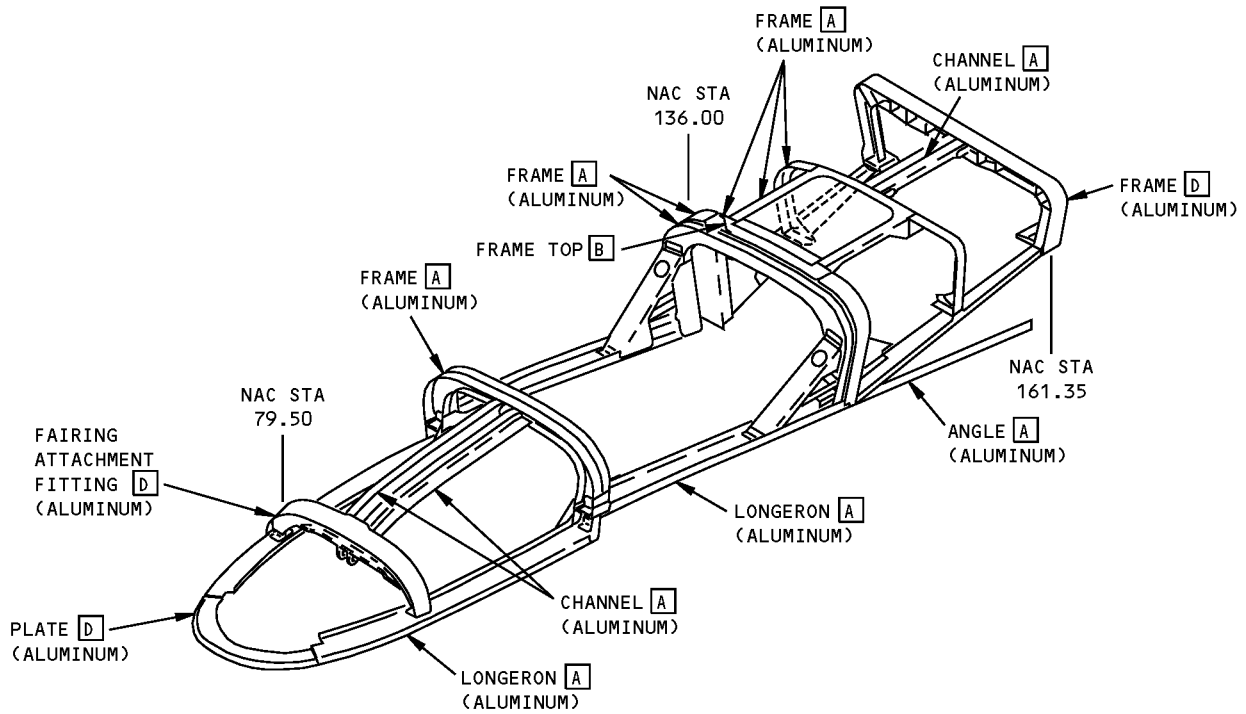

**FORWARD FAIRING STRUCTURE
DETAIL I**

**Strut Fairing Support Structure Repair - PW2000 Engine
Figure 201 (Sheet 2 of 4)**

**757-200
STRUCTURAL REPAIR MANUAL**

REF DWG
313N3004

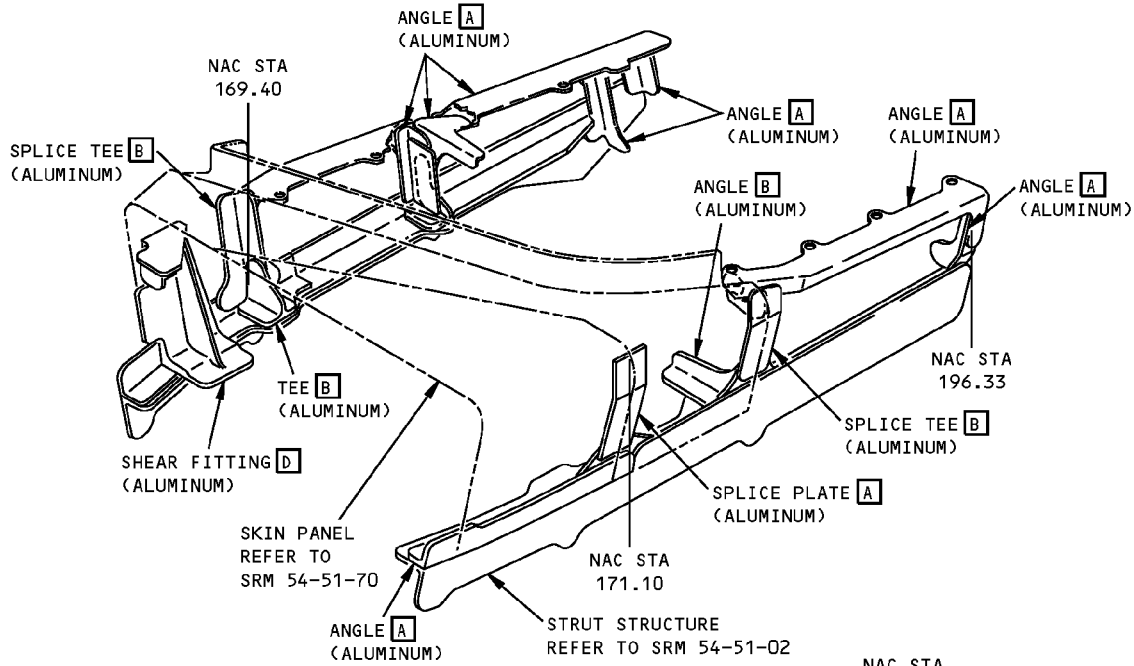

**UNDERWING FAIRING STRUCTURE
DETAIL II**

REF DWG
313N3006
313N3033

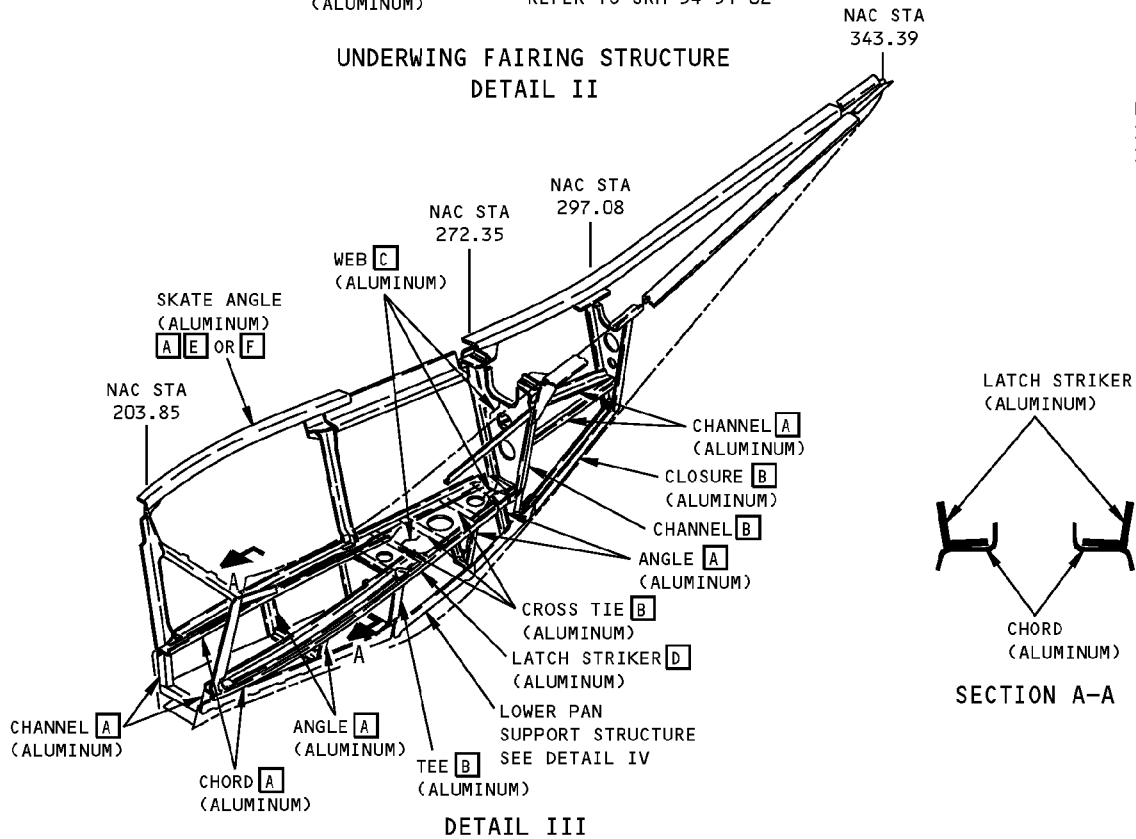

DETAIL III

**Strut Fairing Support Structure Repair - PW2000 Engine
Figure 201 (Sheet 3 of 4)**

REPAIR 1
Page 203
Jan 20/2005

54-51-71

D634N201

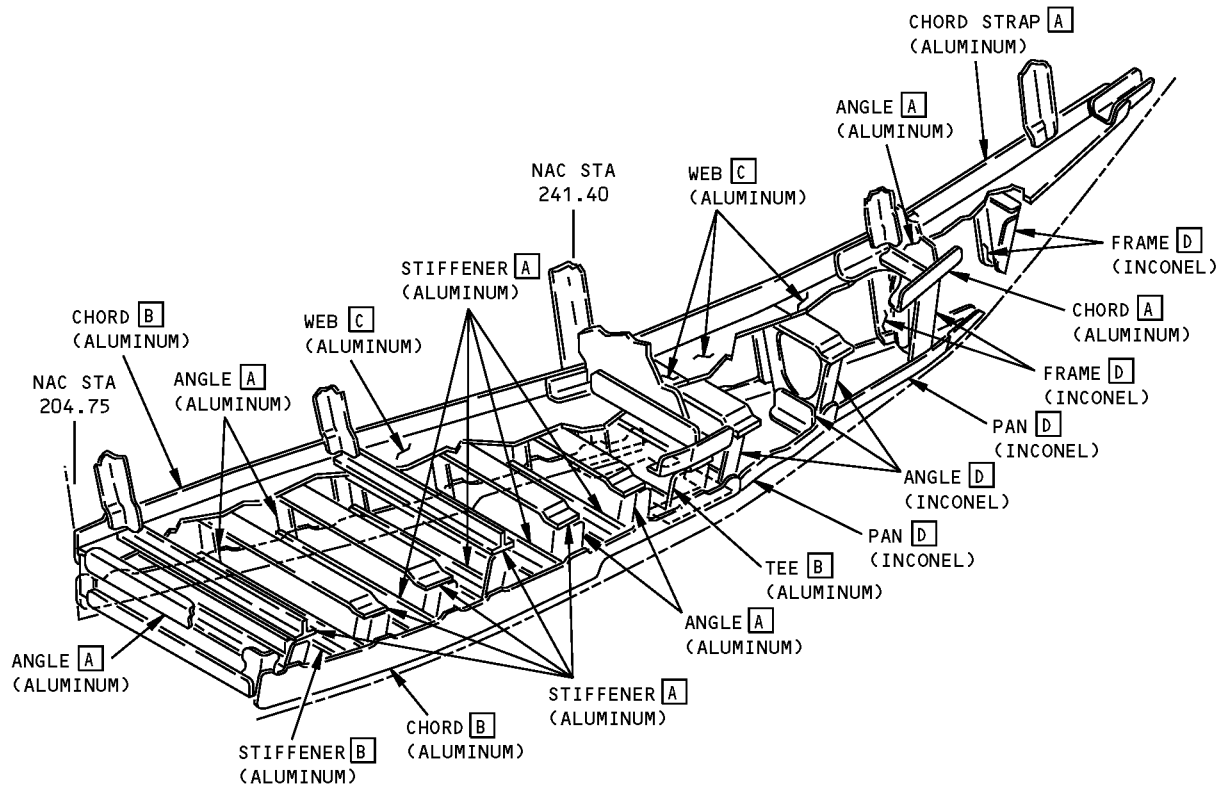

DETAIL IV

**Strut Fairing Support Structure Repair - PW2000 Engine
Figure 201 (Sheet 4 of 4)**

**757-200
STRUCTURAL REPAIR MANUAL**

IDENTIFICATION 1 - STRUT FITTING - PW2000 ENGINE

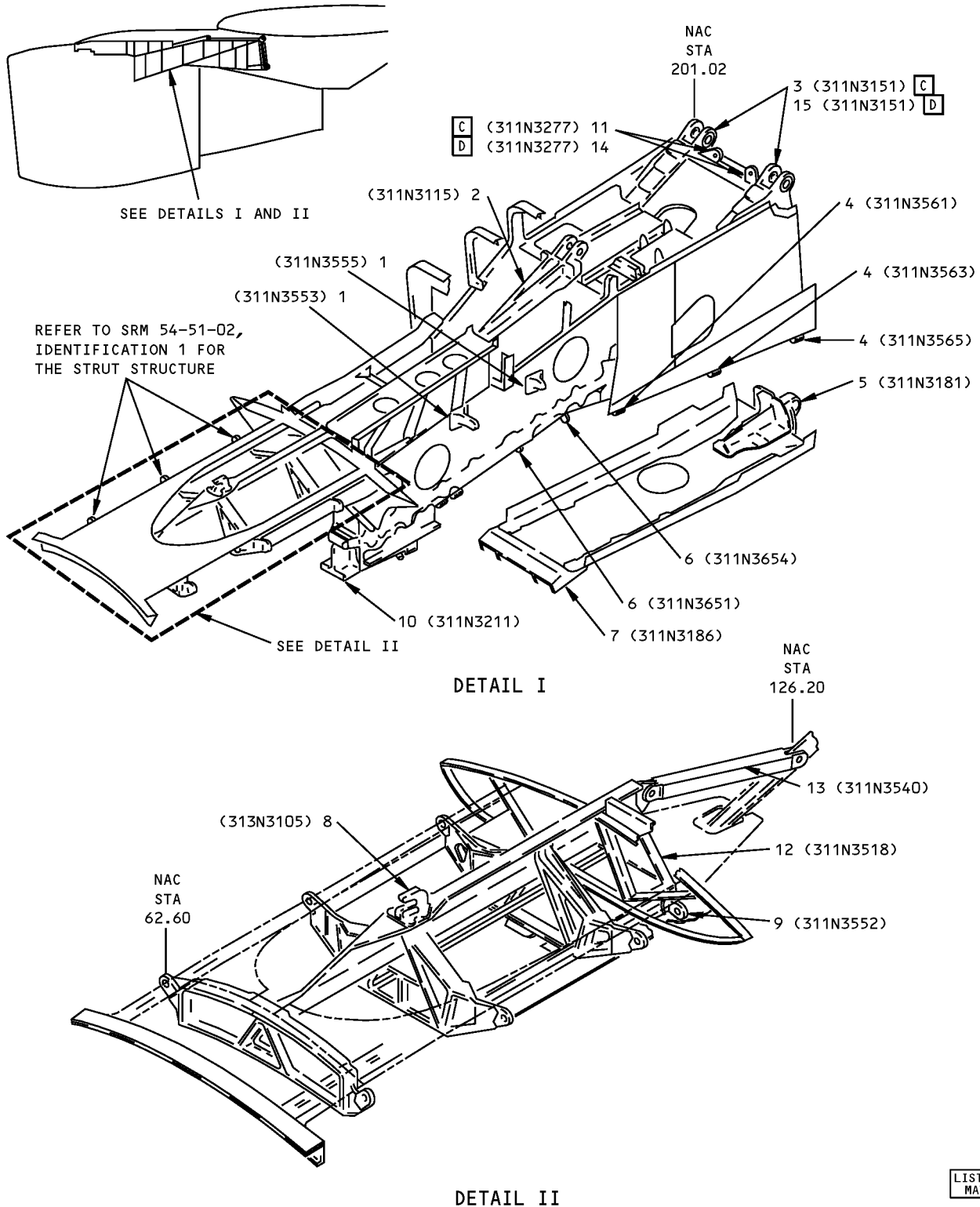

**Strut Fitting Identification - PW2000 Engine
Figure 1 (Sheet 1 of 2)**

DETAIL II

LIST OF
MATL



**757-200
STRUCTURAL REPAIR MANUAL**

ITEM	DESCRIPTION	GAGE	MATERIAL	EFFECTIVITY
1	HINGE FTG		FORGING TI-6AL-4V ANNEALED 15-5PH CRES FORGED BLOCK HT TR 180-200 KSI	A B
2	UPR SPAR FTG		FORGING TI-6AL-4V ANNEALED	
3	MID SPAR FTG		FORGING 4330M STEEL HT TR 220-240 KSI	C
4	HINGE FTG		CASTING TI-6AL-4V PER BMS 7-181 TYPE I, GRADE A, COND B	
5	LWR SPAR FTG		FORGING 15-5PH CRES HT TR 180-200 KSI	
6	SUPPORT FTG		FORGING TI-6AL-4V ANNEALED	
7	SPLICE FTG		FORGING 15-5PH CRES HT TR 180-200 KSI	
8	HOOK FTG		CASTING 17-4PH CRES HT TR 180-200 KSI	
9	HINGE FTG	5.000	FORGING 7075-T73 15-5PH CRES FORGED BLOCK HT TR 180-200 KSI	A B
10	FWD ENGINE MOUNT FTG		FORGING 15-5PH CRES HT TR 180-200 KSI	
11	SIDE LOAD FTG	1.000	15-5PH CRES PLATE HT TR 180-200 KSI	C
12	BULKHEAD FTG		FORGING 7075-T73	
13	LINK FTG		FORGING 7075-T73	
14	SIDE LOAD FTG	1.25	15-5PH CRES PLATE HT TR 180-200 KSI	D
15	MID SPAR FTG		FORGING 15-5PH CRES HT TR 180-200 KSI	D

LIST OF MATERIALS FOR DETAILS I AND II

NOTES

- REFER TO IDENTIFICATION 2 FOR ATTACHMENT LINKAGE

- A** FOR CUM LINE NUMBERS:
1 THRU 210 AND HAVING PW2000 SERIES ENGINES
- B** FOR CUM LINE NUMBERS:
210 AND ON AND HAVING PW2000 SERIES ENGINES
- C** FOR AIRPLANES WITH CUM LINE NUMBERS:
1 THRU 732 PRE-SB 757-54-0034
INCORPORATED
- D** FOR AIRPLANES WITH CUM LINE NUMBERS:
736 AND ON, AND FOR AIRPLANES POST-SB
757-54-0034 INCORPORATED

**Strut Fitting Identification - PW2000 Engine
Figure 1 (Sheet 2 of 2)**

IDENTIFICATION 1
Page 2
Jan 20/2005

54-51-90

D634N201

**757-200
STRUCTURAL REPAIR MANUAL**

IDENTIFICATION 2 - ATTACHMENT LINKAGE - PW2000 ENGINE

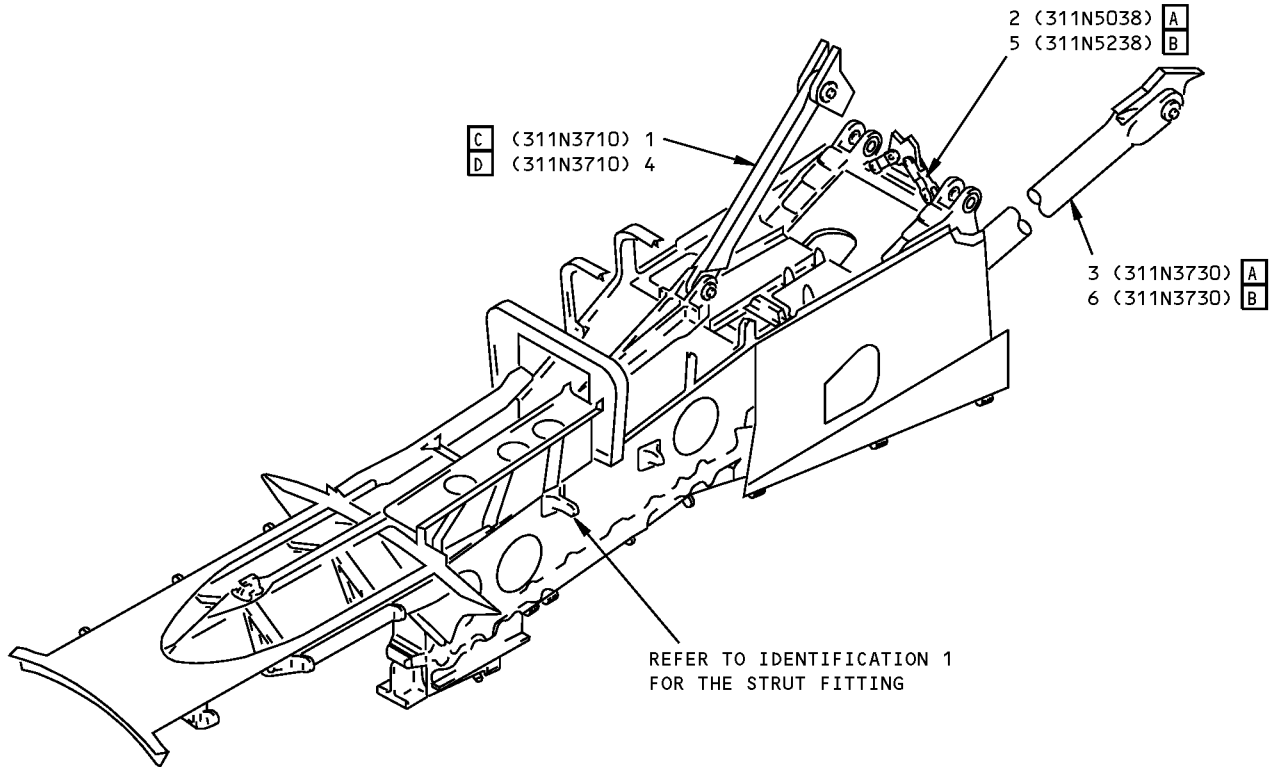

ITEM	DESCRIPTION	GAGE	MATERIAL	EFFECTIVITY
1	UPPER LINK		FORGING 4330M STEEL HT TR 220 KSI MINIMUM	[C]
2	SIDE LINK		BAR 2024-T4	[A]
3	DIAGONAL BRACE		TUBE OR EXTRUDED BAR 7075-T76	[A]
4	UPPER LINK		FORGING 9NI-4CO-.30C BMS 7-182, TYPE II, HT TR 220 KSI MINIMUM	[D]
5	SIDE LINK	0.60	TI-6AL-4V PLATE, MIL-T-9046, CODE AB-1, CONDITION A	[B]
6	DIAGONAL BRACE		TI-6AL-4V BAR, MIL-T-9047 OPTIONAL: TI-6AL-4V BAR, AMS 4928	[B]

LIST OF MATERIALS

NOTES

- [A] FOR AIRPLANES WITH CUM LINE NUMBERS: 1 THRU 732 WITHOUT SB 757-54-0034 INCORPORATED
- [B] FOR AIRPLANES WITH CUM LINE NUMBERS: 736 AND ON, AND FOR AIRPLANES WITH SB 757-54-0034 INCORPORATED

- [C] FOR AIRPLANES WITH CUM LINE NUMBERS: 1 THRU 732 WITHOUT SB 757-54-0036 INCORPORATED
- [D] FOR AIRPLANES WITH CUM LINE NUMBERS: 736 AND ON, AND FOR AIRPLANES WITH SB 757-54-0036 INCORPORATED

**Attachment Linkage Identification - PW2000 Engine
Figure 1**

**757-200
STRUCTURAL REPAIR MANUAL**

ALLOWABLE DAMAGE 1 - STRUT FITTINGS - PW2000 ENGINE

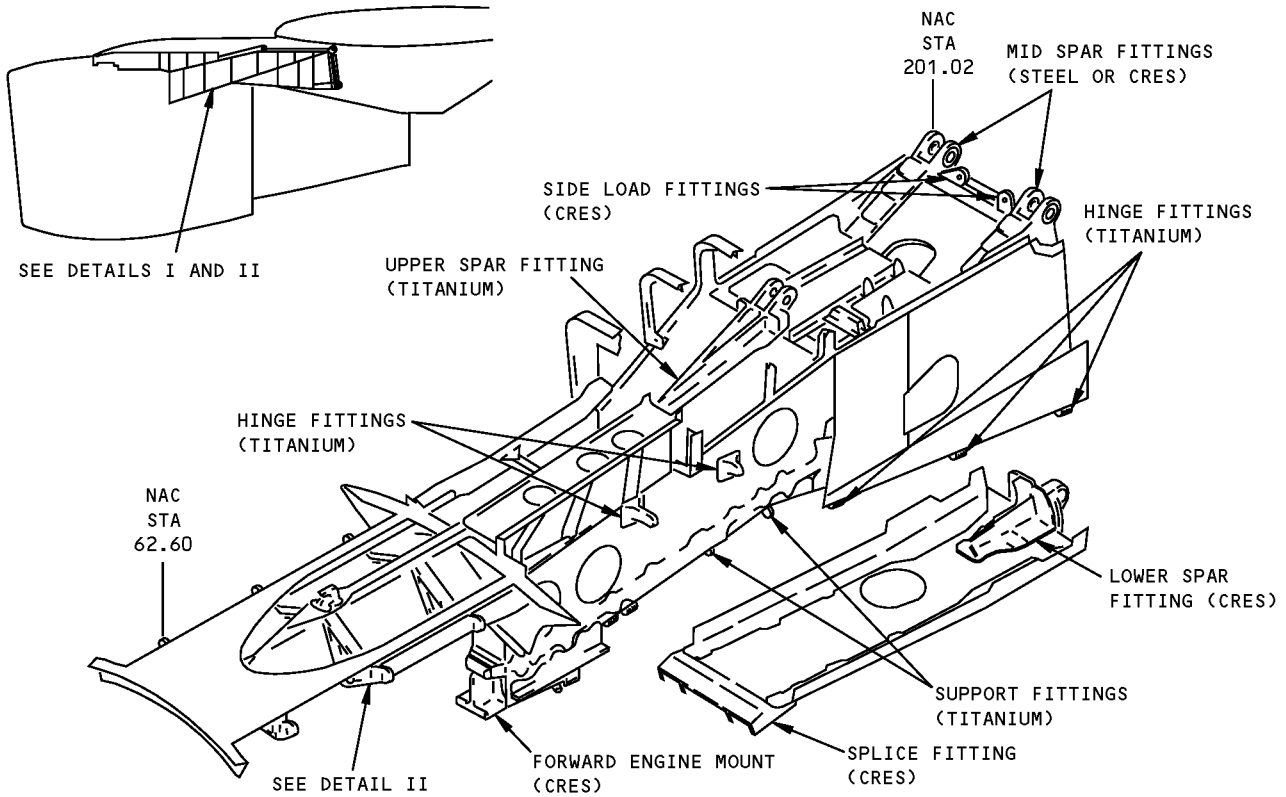

DETAIL I

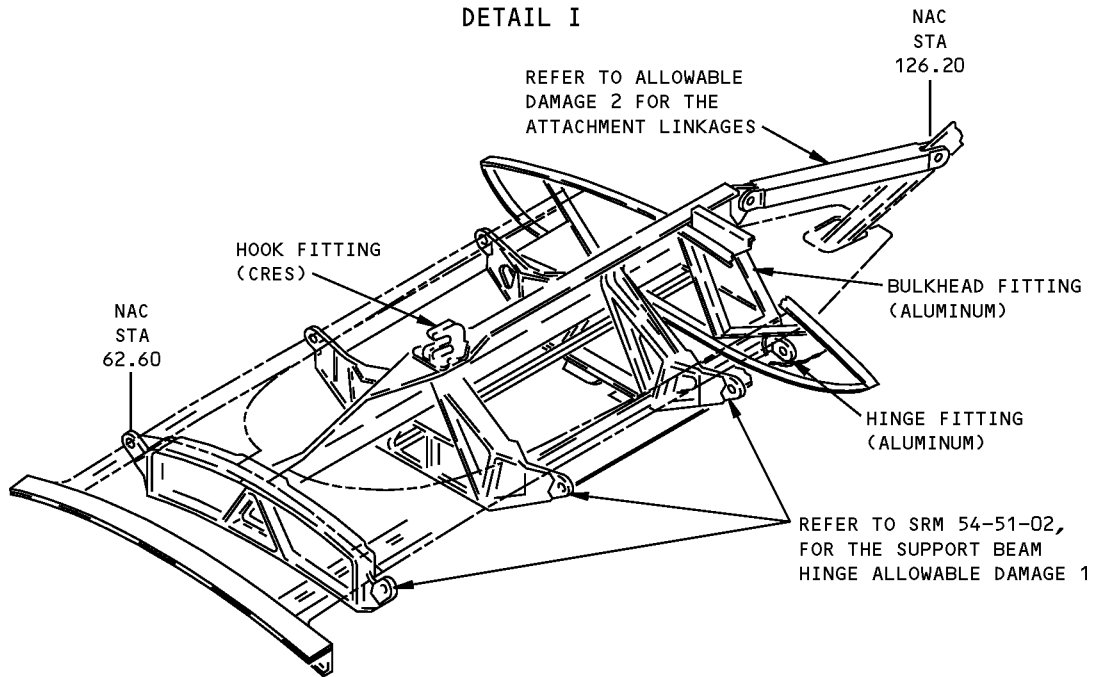

DETAIL II

**Strut Fittings Allowable Damage - PW2000 Engine
Figure 101 (Sheet 1 of 5)**

**757-200
STRUCTURAL REPAIR MANUAL**

DESCRIPTION D	CRACKS	NICKS, GOUGES AND CORROSION	DENTS	HOLES AND PUNCTURES
FWD ENGINE MOUNT AND BULKHEAD FTGS	A	B	NOT PERMITTED	NOT PERMITTED
SPLICE FITTING	A	B	NOT PERMITTED	NOT PERMITTED
SPAR FITTINGS	C	C E	NOT PERMITTED	NOT PERMITTED
SUPPORT FITTINGS	C	C	NOT PERMITTED	NOT PERMITTED
HINGE FITTINGS	C	C	NOT PERMITTED	NOT PERMITTED
HOOK AND SIDE LOAD FTGS	C	C	NOT PERMITTED	NOT PERMITTED

NOTES

- REFER TO AMM 51-20 TO APPLY THE FINISH TO THE REWORK AREA.
- REFER TO SRM 51-10-02 FOR INSPECTION AND REMOVAL OF DAMAGE

- A** CRACKS ARE NOT PERMITTED EXCEPT FOR EDGE CRACKS WHICH MUST BE REMOVED AS GIVEN IN DETAIL VIII.
- B** REMOVE DAMAGE AS GIVEN IN DETAILS V, VI AND VII.
- C** FOR EDGE DAMAGE REFER TO DETAIL VIII. FOR LUG DAMAGE REFER TO DETAIL IX. FOR OTHER DAMAGE REFER TO DETAIL IV. DAMAGE IS NOT PERMITTED IN VICINITY OF BUSHINGS.
- D** SHOT PEEN REWORKED AREAS AS GIVEN IN SRM 51-20-06.
- E** CORROSION OR ABRASIONS ON THE FACE OF THE LUG UNDER THE FLANGE OF THE BUSHING MUST BE REMOVED AS GIVEN IN DETAIL X. WHEN YOU REMOVE THE DAMAGE, MAKE SURE THE SPOTFACE IS PERPENDICULAR TO THE BORE. AS A RESULT OF THE SPOTFACE, TRIM 0.01 TO 0.02 INCH (0.25 TO 0.5 mm) FROM THE NON-FLANGED END OF THE BUSHING BEFORE INSTALLATION.

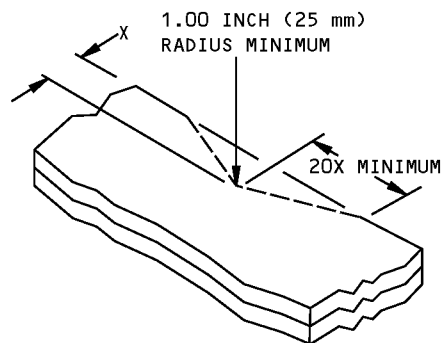

X = DEPTH OF CLEANUP
= 0.10 INCH (2.5 mm) MAXIMUM

DETAIL IV

**Strut Fittings Allowable Damage - PW2000 Engine
Figure 101 (Sheet 2 of 5)**

**757-200
STRUCTURAL REPAIR MANUAL**

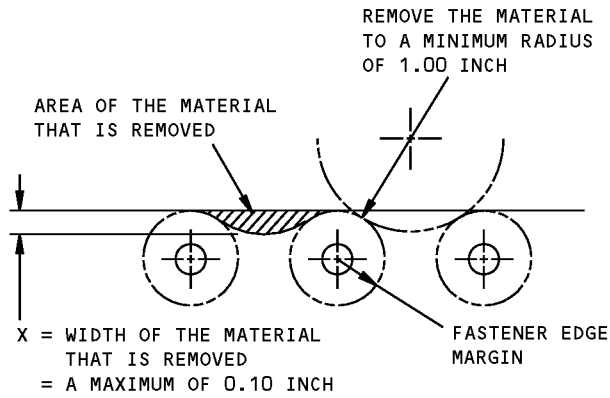

AT A LOCATION WHERE THE FASTENER EDGE MARGINS DO NOT HAVE AN OVERLAP

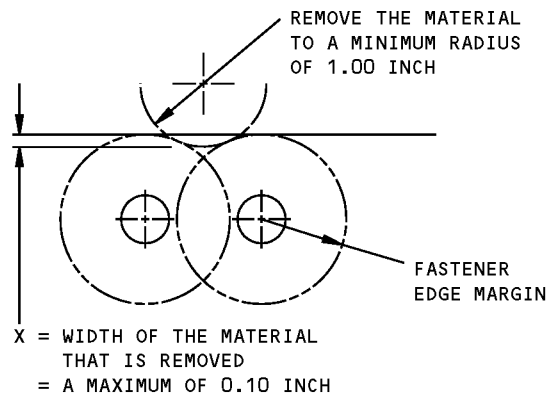

AT A LOCATION WHERE THE FASTENER EDGE MARGINS HAVE AN OVERLAP

**REMOVAL OF DAMAGED MATERIAL ON AN EDGE
DETAIL V**

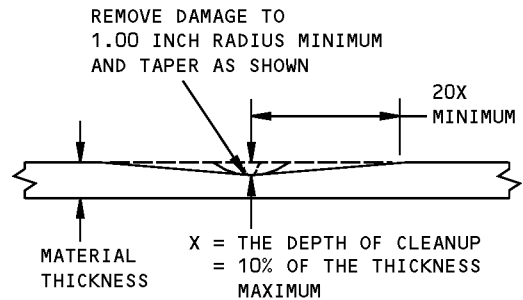
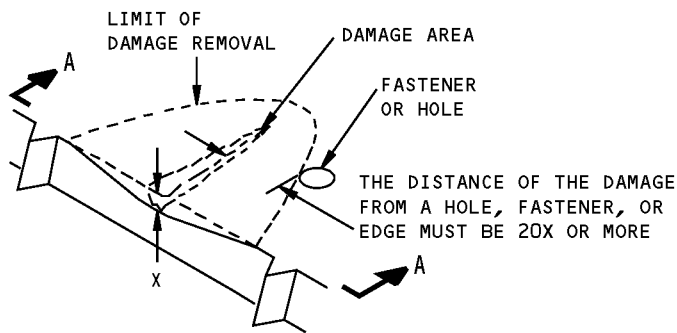

SECTION A-A

**REMOVAL OF NICK, GOUGE, AND SCRATCH DAMAGE ON A SURFACE
DETAIL VI**

**Strut Fittings Allowable Damage - PW2000 Engine
Figure 101 (Sheet 3 of 5)**

STRUCTURAL REPAIR MANUAL

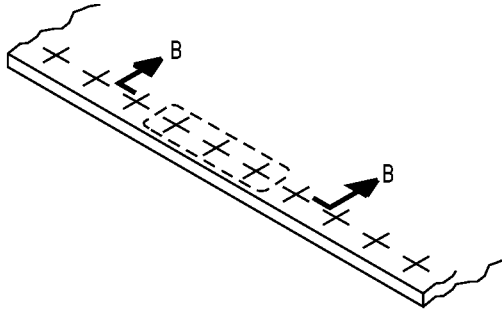

**CORROSION CLEANUP
DETAIL VII**

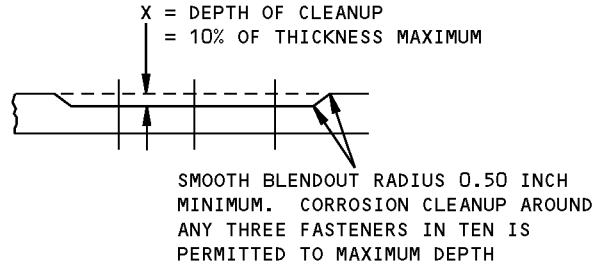

SECTION B-B

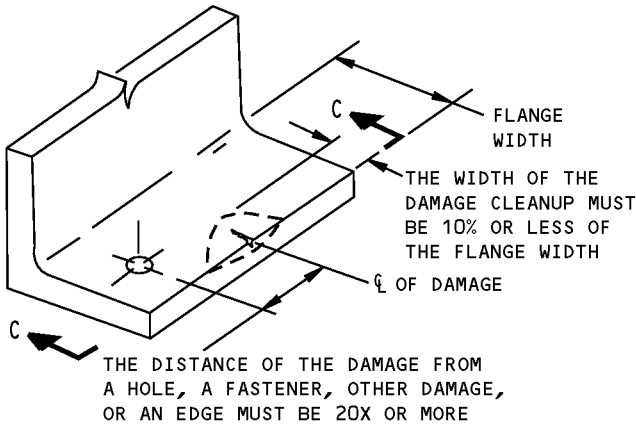

**REMOVAL OF NICK OR CRACK DAMAGE ON AN EDGE
DETAIL VIII**

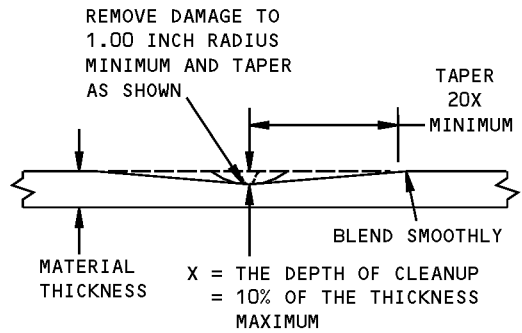

SECTION C-C

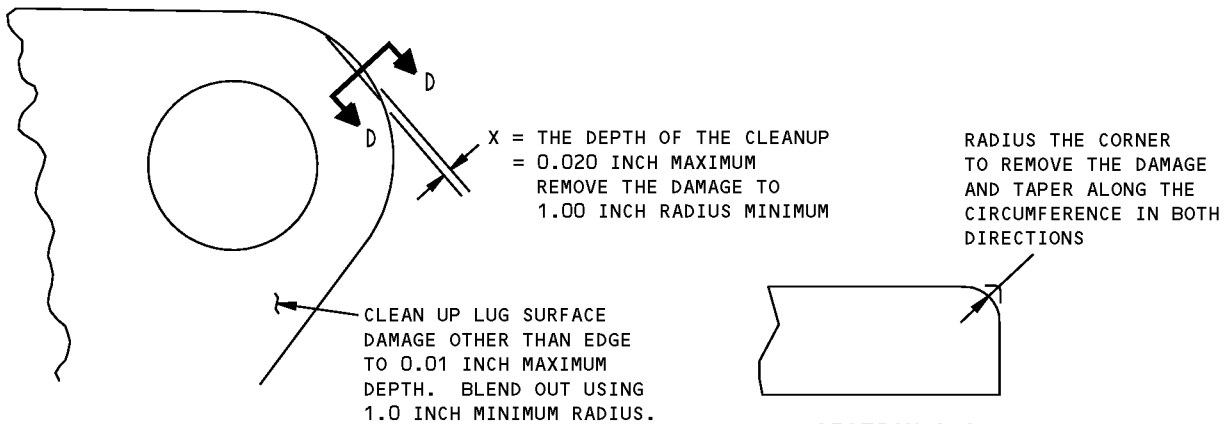

**SECTION D-D
(ROTATED)**

**REMOVAL OF DAMAGE ON A LUG EDGE AND SURFACE
DETAIL IX**

**Strut Fittings Allowable Damage - PW2000 Engine
Figure 101 (Sheet 4 of 5)**

**757-200
STRUCTURAL REPAIR MANUAL**

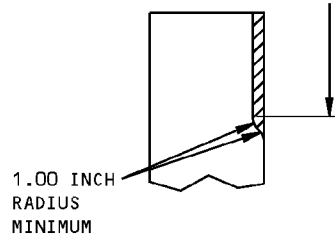
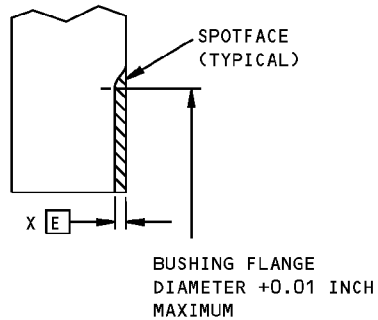
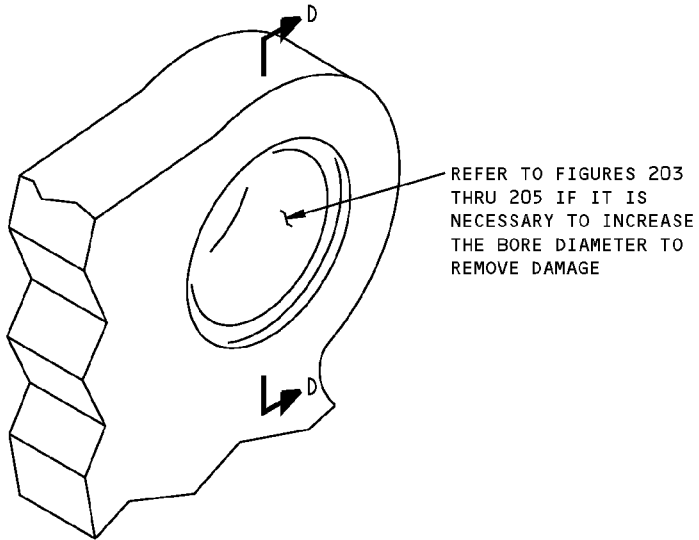

X = 0.010 INCH MAXIMUM

**DAMAGE ON LUG FACE
SECTION D-D**

**REMOVAL OF DAMAGE ON THE LUG FACE UNDER THE FLANGE OF THE BUSHING
DETAIL X**

 SHADED AREA SHOWS WHERE DAMAGE HAS BEEN REMOVED

**Strut Fittings Allowable Damage - PW2000 Engine
Figure 101 (Sheet 5 of 5)**

**757-200
STRUCTURAL REPAIR MANUAL**

ALLOWABLE DAMAGE 2 - ATTACHMENT LINKAGE - PW2000 ENGINE

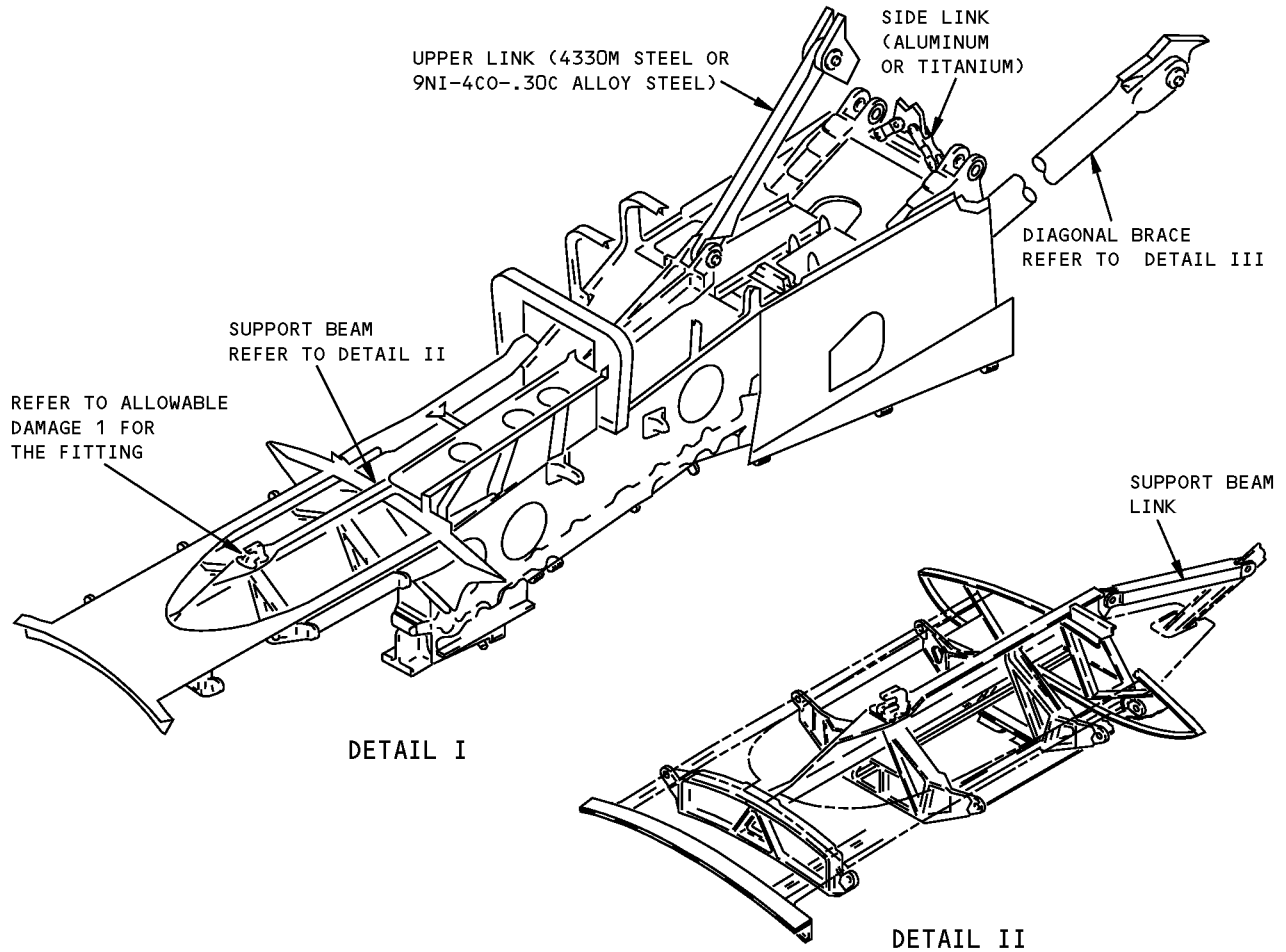

DESCRIPTION	CRACKS	NICKS, GOUGES, SCRATCHES AND CORROSION	DENTS	HOLES AND PUNCTURES
LINK E	A	A	NOT PERMITTED	NOT PERMITTED

ALLOWABLE DAMAGE FOR DETAILS I AND II

NOTES

- REFER TO AMM 51-20 TO APPLY THE FINISH TO THE REWORK AREA.
- REFER TO SRM 51-10-02 FOR INVESTIGATION AND CLEANUP OF DAMAGE.
- REFER TO SRM 51-20-01 FOR PROTECTIVE TREATMENT OF METAL PARTS.

A FOR EDGE DAMAGE REFER TO DETAIL VII. FOR LUG DAMAGE REFER TO DETAIL VI. FOR OTHER DAMAGE REFER TO DETAIL IV. DAMAGE NOT ALLOWED IN THE VICINITY OF BUSHINGS.

B CRACKS ARE NOT PERMITTED EXCEPT FOR EDGE CRACKS WHICH MUST BE REMOVED AS GIVEN IN DETAILS V AND VI.

C FOR EDGE DAMAGE REFER TO DETAIL V. FOR LUG DAMAGE REFER TO DETAIL VI. FOR OTHER DAMAGE REFER TO DETAIL IV. DAMAGE IS NOT PERMITTED IN VICINITY OF BUSHINGS.

D REMOVE DAMAGE AS GIVEN IN DETAIL VIII.

E SHOT PEEN REWORKED AREAS AS GIVEN IN SRM 51-20-06.

**Attachment Linkage Allowable Damage - PW2000 Engine
Figure 101 (Sheet 1 of 3)**

**757-200
STRUCTURAL REPAIR MANUAL**

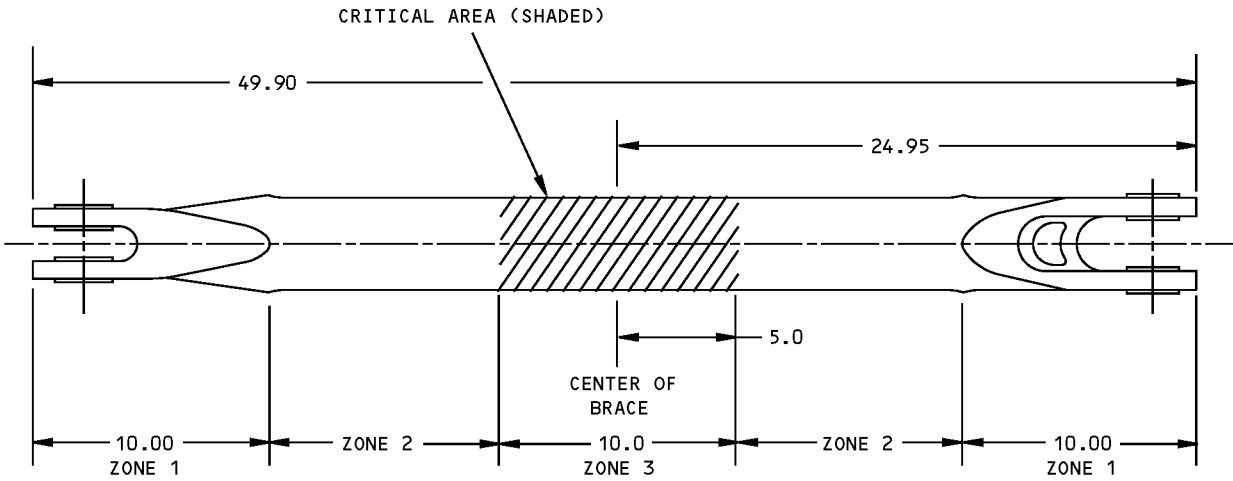

NOTE: MATERIAL IS ALUMINUM TUBING
OR EXTRUDED BAR OR TITANIUM BAR.

**DIAGONAL BRACE
DETAIL III**

DESCRIPTION	CRACKS	NICKS, GOUGES, SCRATCHES AND CORROSION	DENTS	HOLES AND PUNCTURES
DIAGONAL BRACE [E]				
ZONE 1	[B]	[C]	NOT ALLOWED	NOT ALLOWED
ZONE 2	[D]	[D]		
ZONE 3 (CRITICAL AREA)	NOT ALLOWED	[D]		

ALLOWABLE DAMAGE FOR DETAIL III

**Attachment Linkage Allowable Damage - PW2000 Engine
Figure 101 (Sheet 2 of 3)**

**757-200
STRUCTURAL REPAIR MANUAL**

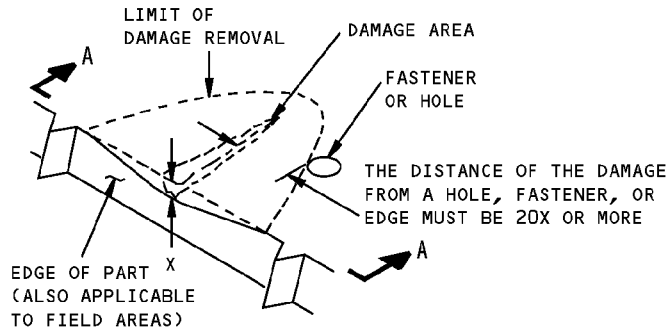

**REMOVAL OF NICK, GOUGE, AND SCRATCH DAMAGE ON A SURFACE
DETAIL IV**

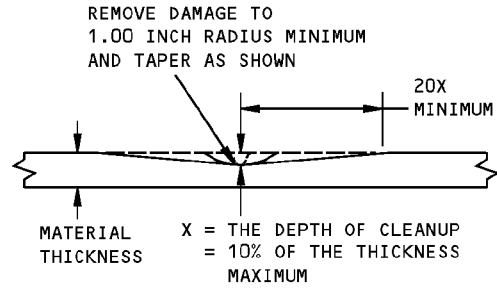

SECTION A-A

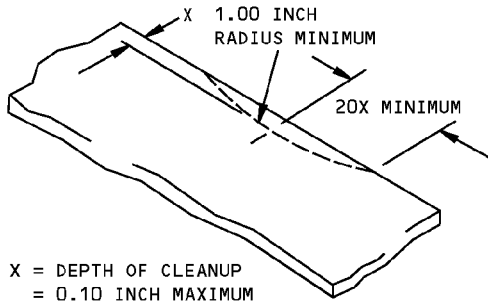

**REMOVAL OF DAMAGE ON AN EDGE
DETAIL V**

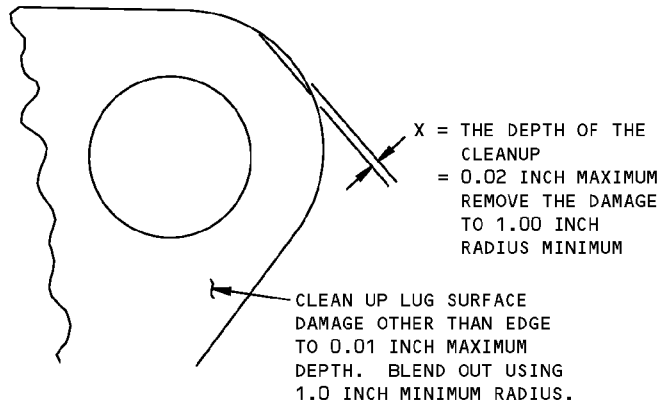

**DAMAGE CLEANUP FOR LUG SURFACE
DETAIL VI**

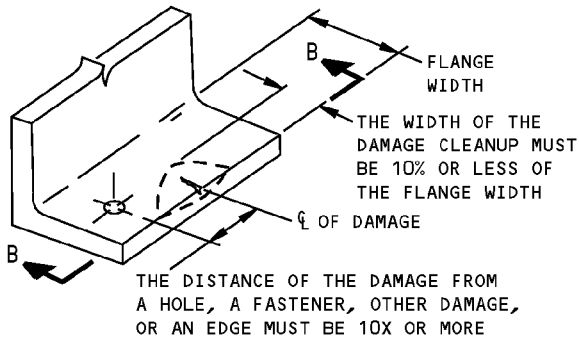

**REMOVAL OF NICK OR CRACK DAMAGE ON EDGE
DETAIL VII**

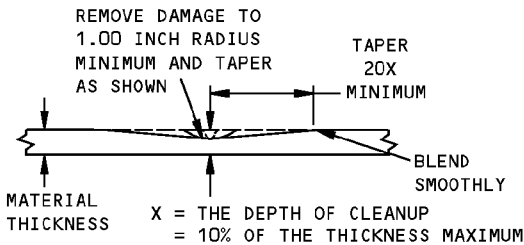

SECTION B-B

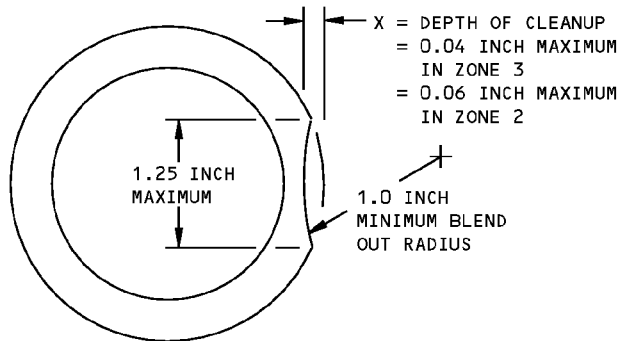

**REMOVAL OF DAMAGE ON A SURFACE
DETAIL VIII**

**Attachment Linkage Allowable Damage - PW2000 Engine
Figure 101 (Sheet 3 of 3)**



**757-200
STRUCTURAL REPAIR MANUAL**

REPAIR GENERAL - STRUT ATTACHMENT FITTINGS - PW2000 ENGINE - SERVICE BULLETIN LIST

SERVICE BULLETIN REPAIRS

The following Service Bulletins contain nacelle strut attach structure repairs which are available for use where specific damage has been encountered. Usually, the Service Bulletin also covers preventive modification data which operators are encouraged to use to eliminate the need for repair.

DAMAGED AREA	CUM LINE NUMBER EFFECTIVITY	SB NUMBER
NACELLE STRUT - STRUT-TO-WING ATTACH STRUCTURE IMPROVEMENT	1 THRU 735	757-54-0034
HYDRAULIC POWER - GENERAL - ENGINE STRUT HYDRAULIC PRESSURE FITTING REPLACEMENT: PAN DOUBLER INSTALLATION	1 THRU 402	757-29-0041

**Strut Attachment Fittings - PW2000 Engine
Figure 201**

D634N201

54-51-90

REPAIR GENERAL
Page 201
Jan 20/2005

**757-200
STRUCTURAL REPAIR MANUAL**

REPAIR 1 - STRUT FITTING - PW2000 ENGINE

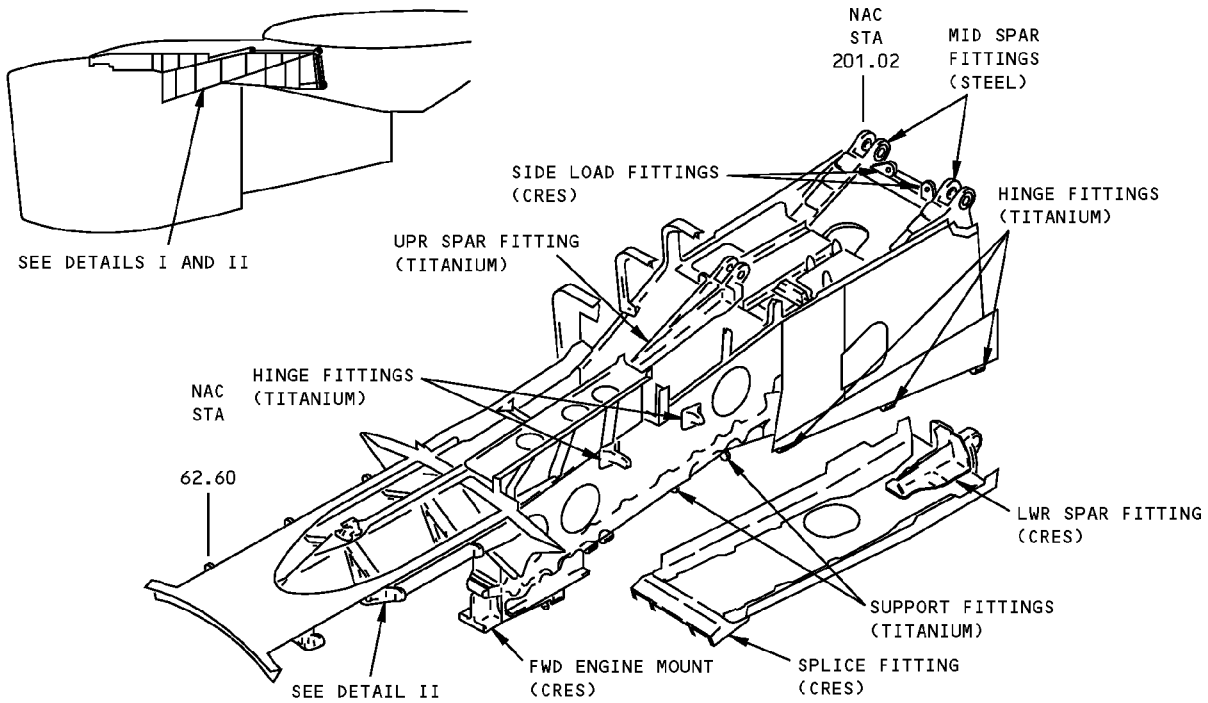

DETAIL I

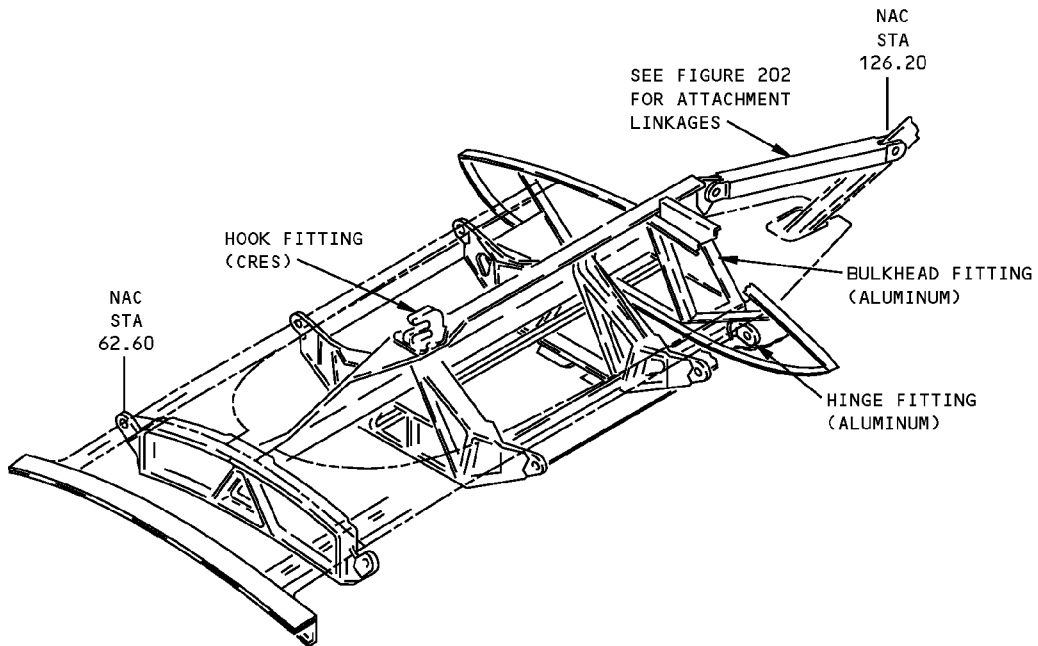

DETAIL II

NOTES

- NO SPECIFIC REPAIRS TO FITTING APPLICABLE. SPECIFIC REPAIRS WILL BE PROVIDED BASED ON SERVICE EXPERIENCE

**Strut Fitting Repair - PW2000 Engine
Figure 201**

**757-200
STRUCTURAL REPAIR MANUAL**

REPAIR 2 - ATTACHMENT LINKAGE - PW2000 ENGINE

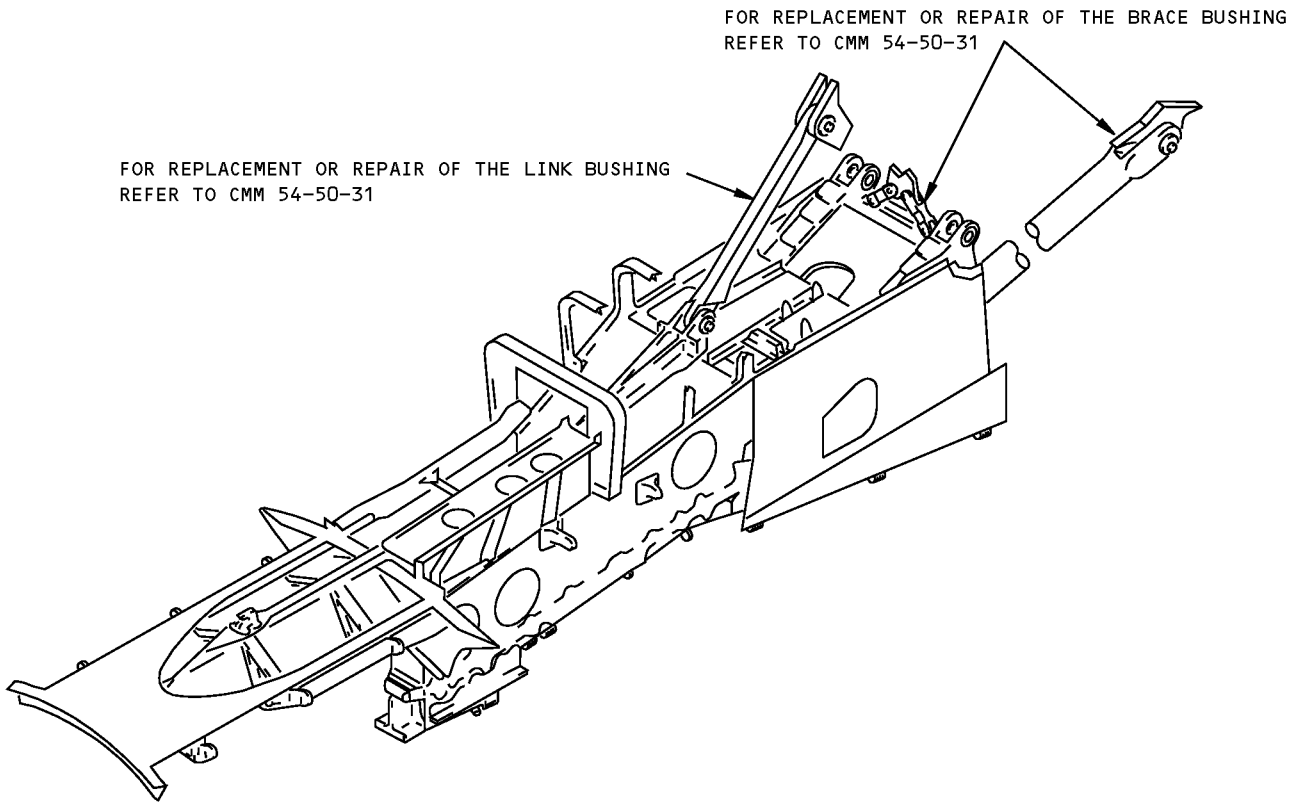

**Attachment Linkage Repair - PW2000 Engine
Figure 201**

D634N201

54-51-90

REPAIR 2
Page 201
Jan 20/2005

STRUCTURAL REPAIR MANUAL

**REPAIR 3 - FORWARD UPPER SPAR FITTING, LUG HOLE REPAIR WITH INTERFERENCE FIT BUSHING
PROCEDURE - PW2000 ENGINE**

APPLICABILITY
THIS REPAIR USES THE INTERFERENCE FIT PROCEDURE TO INSTALL THE REPLACEMENT BUSHINGS FOR THE FORWARD UPPER SPAR FITTING ON THE PW2000 ENGINE. A

REPAIR INSTRUCTIONS

PROCEDURE I - REMOVE THE INITIAL BUSHINGS

1. Remove the engine strut from the wing. Refer to AMM 54-51-01.
2. Remove the engine strut access doors. Refer to AMM 54-53-01.
3. Remove the engine strut components as necessary to get access. Refer to AMM 54-51-01.
 - A. Make a record of the position of wire bundles and cables on the two sides of the forward upper spar fitting. Move the wire bundles and cables away from the fitting to make clearance for the repair tools. Disconnect the wires as necessary. If you disconnect electric connections, install caps or plugs at the connection. You can also attach tags that give the location of the connection. This will help you make the connection again.
 - B. Remove tubes, duct, clamps support blocks, and brackets near the fitting as necessary to make clearance for the repair tools.
 - C. Drain the fuel supply line and the hydraulic fluid lines to the engine.
4. If split bushings are installed in each lug, get or make the split bushing removal tool as necessary. The Boeing tool number is B54016-1.
5. Remove the bushing(s) from each lug. You can use the split bushing removal tool if split bushings are installed in each lug.
6. Discard the initial bushings. The bushing material is aluminum-nickel-bronze alloy.

PROCEDURE II - DO AN INSPECTION OF THE LUG HOLE

1. Do an inspection of the inner surface of the hole from which you removed the bushings. Use one of the procedures that follow:
 - Dye penetrant inspection Type I, method C, sensitivity level 3 or higher as specified in SOPM 20-20-02.
 - High frequency eddy current inspection for titanium parts as specified in NDT, Part 6, 51-00-13.

2. If you find damage, you must machine the inner surface of the hole. Continue with the steps given in Procedure III.
3. If no damage is found and the airplane age is more than 15 years, you must machine the inner surface of the hole. Continue with the steps given in Procedure III to machine an insurance cut from the inner surface of the hole.
4. If no damage is found and the airplane age is 15 years or less, it is not necessary to machine the inner surface of the hole. Continue with the steps given in Procedure VI.

PROCEDURE III - MACHINE THE LUG HOLES

1. Install the proper diameter reamer or boring tools to machine the holes as necessary to remove damage. Use a temporary sheet cover that is approximately 0.063 inch thick to hold the tools over the hole for the thermal anti-ice duct.

CAUTION: MAKE SURE THE TOOLS USED TO MACHINE THE HOLES ARE CORRECTLY ALIGNED BEFORE YOU MACHINE THE HOLE. IF THE TOOLS ARE NOT CORRECTLY ALIGNED THEN THE HOLES WILL NOT BE CUT IN THE CORRECT LOCATION. IF YOU DO NOT OBEY, THE REPAIR CAN BE UNSATISFACTORY.

2. Machine the holes as necessary to remove the damage.
 - A. The material of the fitting is 6AL-4V titanium alloy. Refer to SOPM 20-10-07 for the procedure to machine titanium alloy.
 - B. Do one of the two inspections given in PROCEDURE II to make sure all of the damage is removed from the inner surface of the lug hole. If the inspection shows that there is no more damage, machine an insurance cut as follows:
 - If the dye penetrant inspection procedure is used, machine a minimum of 0.020 inch on the diameter from the inner surface of the hole.
 - If the high frequency eddy current inspection procedure is used, machine a minimum of 0.030 inch on the diameter from the inner surface of the hole.

**Forward Upper Spar Fitting, Lug Hole Repair with Interference Fit Bushing Procedure - PW2000 Engine
Figure 201 (Sheet 1 of 8)**

STRUCTURAL REPAIR MANUAL

PROCEDURE III - MACHINE THE LUG HOLE (CONT)

- C. The maximum diameter of the hole is 1.9340 inches, see DETAIL II, SECTION A-A. If the diameter of the hole(s) is larger than the maximum, you must get alternative repair instructions from Boeing.
3. Put a 0.020 to 0.040 inch by 45 degree chamfer on the edges of the hole. As an alternative to the chamfer, you can make an equivalent radius.
4. Remove the tools.
5. Remove the sharp edges and burrs from the cut surfaces.
6. Do a flap peen procedure to each hole. Use a 3M flapwheel that is 9/16 inch by 1.25 inch to get an Almen intensity of 0.012A and a coverage of 2.0. Refer to SOPM 20-10-03.
7. Hone each hole to the final diameter. Make the finish on the inner surface of the hole 32 microinches R_a or smoother. You can remove a maximum of 0.0012 inch from the radius of the hole to get the necessary surface finish. The maximum diameter of the hole is 1.9340 inches.

PROCEDURE IV - MEASURE THE LUG HOLE DIAMETER

1. Measure and record the diameter of the hole. This is dimension B shown in Detail II, SECTION A-A. Measure the diameter before you apply the primer, sealant, or retaining compound.

PROCEDURE V - CALCULATE THE DIAMETER OF THE OVERSIZED BUSHINGS

1. Calculate the diameter, A, of the oversized bushings with the formula that follows. Refer to Detail III for the definition of the dimension A.

$$A = B + 0.0037 \text{ inch } \pm 0.0005 \text{ inch}$$

PROCEDURE VI - MACHINE THE OVERSIZED BUSHINGS

1. If no damage is found and the airplane age is 15 years or less, use the same diameter dimensions as the initial bushings. Refer to Table I and Detail III. Continue with the steps given in Procedure VIII.
2. Machine the oversized bushings to the necessary outer diameter that you found in Procedure V and the other dimensions given in Detail III.
3. Make the surface finish of the outer diameter of the bushings 32 microinches R_a or smoother. Make the surface finish on the other surfaces 63 microinches R_a or smoother.
4. Remove the sharp edges and burrs from the cut surfaces.

PROCEDURE VII - APPLY THE PRIMER

1. Apply one layer of BMS 10-11, Type I primer to the bare surfaces of the lug. Refer to SOPM 20-41-02.
2. Let the primer fully dry before you install the bushings.

PROCEDURE VIII - APPLY RETAINING COMPOUND (OPTIONAL)

1. Apply Loctite 640 retaining compound (MIL-R-46082, Type II) to the inner surface of the lug hole and to the mating surfaces of the lug. Do the steps in Procedure IX in 15 minutes or less from the time you apply the retaining compound.

**Forward Upper Spar Fitting, Lug Hole Repair with Interference Fit Bushing Procedure - PW2000 Engine
Figure 201 (Sheet 2 of 8)**



757-200

STRUCTURAL REPAIR MANUAL

PROCEDURE IX – INSTALL THE OVERSIZED BUSHINGS WITH THE SHRINK FIT METHOD

1. Prepare the bushings for installation with the shrink fit method. Use liquid nitrogen at -320°F (-196°C).

WARNING: LIQUID NITROGEN IS APPROXIMATELY -320°F (-196°C). WEAR PROTECTIVE CLOTHING AND USE IN A VENTILATED AREA TO PREVENT INJURY.

2. Soak the bushings and the installation guide bushing in the liquid nitrogen until the boiling stops. Use the guide bushing from Boeing tool kit MIT012N8729-1 or the equivalent. Refer to SOPM 20-50-03.
3. Install the bushings as quickly as possible. Use the installation tools from Boeing tool kit MIT012N8729-1 or the equivalent.

CAUTION: YOU MUST INSTALL THE BUSHING IMMEDIATELY AFTER YOU REMOVE THE BUSHING FROM THE LIQUID NITROGEN. IF THE BUSHING EXPANDS BEFORE IT IS CORRECTLY INSTALLED IN THE FITTING, THE BUSHING MUST BE REMOVED AND REPLACED.

4. Hold the bushing flange tightly against the face of the lug until the assembly is at room temperature to make sure that the bushing is installed correctly. A press fit can be used to complete the shrink fit installation of the bushings.

PROCEDURE X – MACHINE THE INNER DIAMETER OF THE OVERSIZED BUSHINGS

1. Machine the inner diameter of the bushings to a diameter of 1.6250 to 1.6258 inches as shown in Detail V. Make the surface finish 32 microinches R_a .

PROCEDURE XI – PUT THE AIRPLANE BACK TO THE INITIAL CONDITION

1. Install the components that were removed from engine strut.
2. Connect the wires and cables that were disconnected.
3. Install the engine strut access doors as given in AMM 54-53-01.
4. Install the engine strut on the airplane as given in AMM 54-51-01.

Forward Upper Spar Fitting, Lug Hole Repair with Interference Fit Bushing Procedure - PW2000 Engine
Figure 201 (Sheet 3 of 8)

D634N201

54-51-90

REPAIR 3
Page 203
Jan 20/2005



**757-200
STRUCTURAL REPAIR MANUAL**

NOTES

- ALL DIMENSIONS ARE IN INCHES, UNLESS GIVEN DIFFERENTLY.
- WHEN YOU USE THE REPAIR REFER TO:
 - AMM 54-51-01 FOR THE REMOVAL AND INSTALLATION OF THE STRUT
 - AMM 54-53-01 FOR THE REMOVAL AND INSTALLATION OF THE STRUT PRESSURE RELIEF AND ACCESS DOORS
 - NDT, PART 6, 51-00-13 FOR HIGH FREQUENCY EDDY CURRENT INSPECTION PROCEDURES
 - SOPM 20-10-03 FOR SHOT PEENING AND FLAP PEENING
 - SOPM 20-10-07 FOR THE MACHINING OF TITANIUM
 - SOPM 20-20-02 FOR DYE PENETRANT INSPECTION PROCEDURES
 - SOPM 20-41-02 FOR THE APPLICATION OF CHEMICAL AND SOLVENT RESISTANT FINISHES
 - SOPM 20-50-03 FOR BUSHING REMOVAL AND INSTALLATION

A AS AN ALTERNATIVE, THE EXPANDED FIT BUSHING INSTALLATION PROCEDURE IS PERMITTED IF THE INSTALLATION REQUIREMENTS LISTED IN SRM 51-20-09 ARE SATISFIED. REFER TO SRM 51-20-09 FOR THE LIST OF EXPANDED FIT BUSHING INSTALLATION GUIDELINES.

REPAIR MATERIAL			
PART		QTY	MATERIAL
1	OVERSIZED BUSHING	2	2.30 INCHES DIAMETER BY 0.80 INCH LONG ALUMINUM-NICKEL-BRONZE BAR AS SPECIFIED IN AMS 4640

TABLE I

**Forward Upper Spar Fitting, Lug Hole Repair with Interference Fit Bushing Procedure - PW2000 Engine
Figure 201 (Sheet 4 of 8)**

**757-200
STRUCTURAL REPAIR MANUAL**

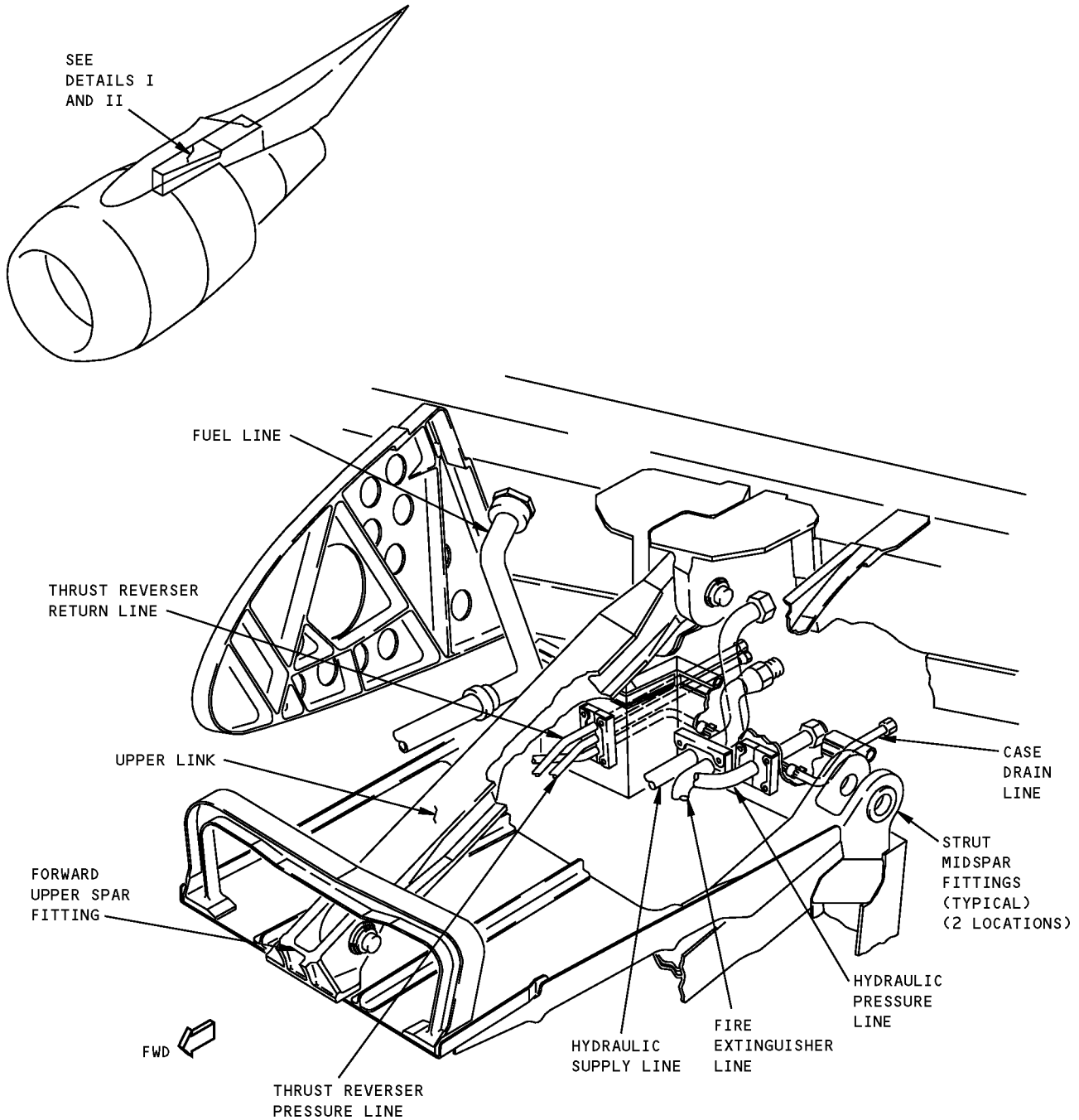

**TUBING, DUCT AND FITTING LOCATIONS
DETAIL I**

**Forward Upper Spar Fitting, Lug Hole Repair with Interference Fit Bushing Procedure - PW2000 Engine
Figure 201 (Sheet 5 of 8)**

**757-200
STRUCTURAL REPAIR MANUAL**

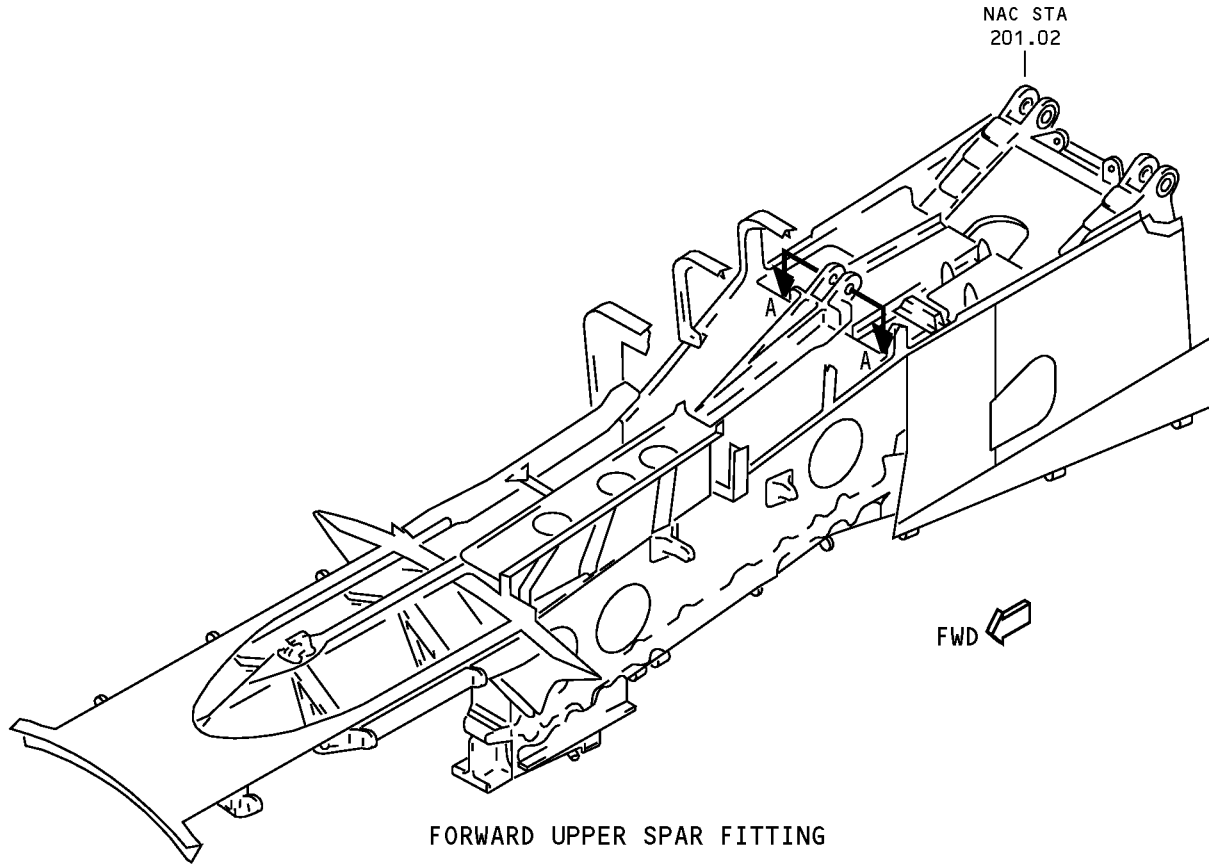

FORWARD UPPER SPAR FITTING

DETAIL II

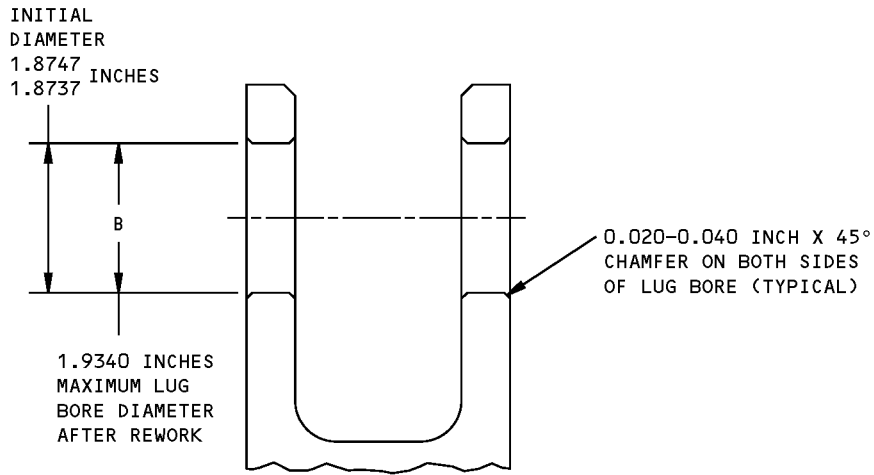

SECTION THROUGH THE FITTING CLEVIS

LUG BORE DIMENSIONS

SECTION A-A

**Forward Upper Spar Fitting, Lug Hole Repair with Interference Fit Bushing Procedure - PW2000 Engine
Figure 201 (Sheet 6 of 8)**

**757-200
STRUCTURAL REPAIR MANUAL**

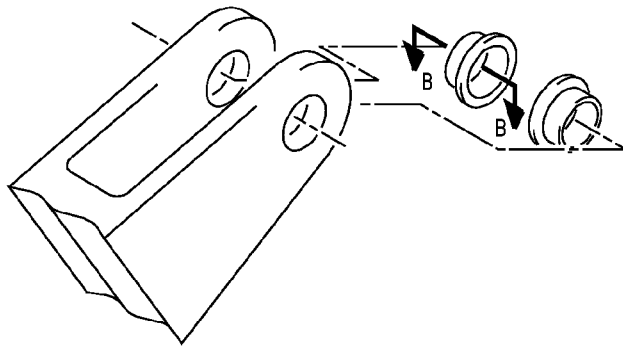

**UPPER SPAR FITTING CLEVIS
DETAIL III**

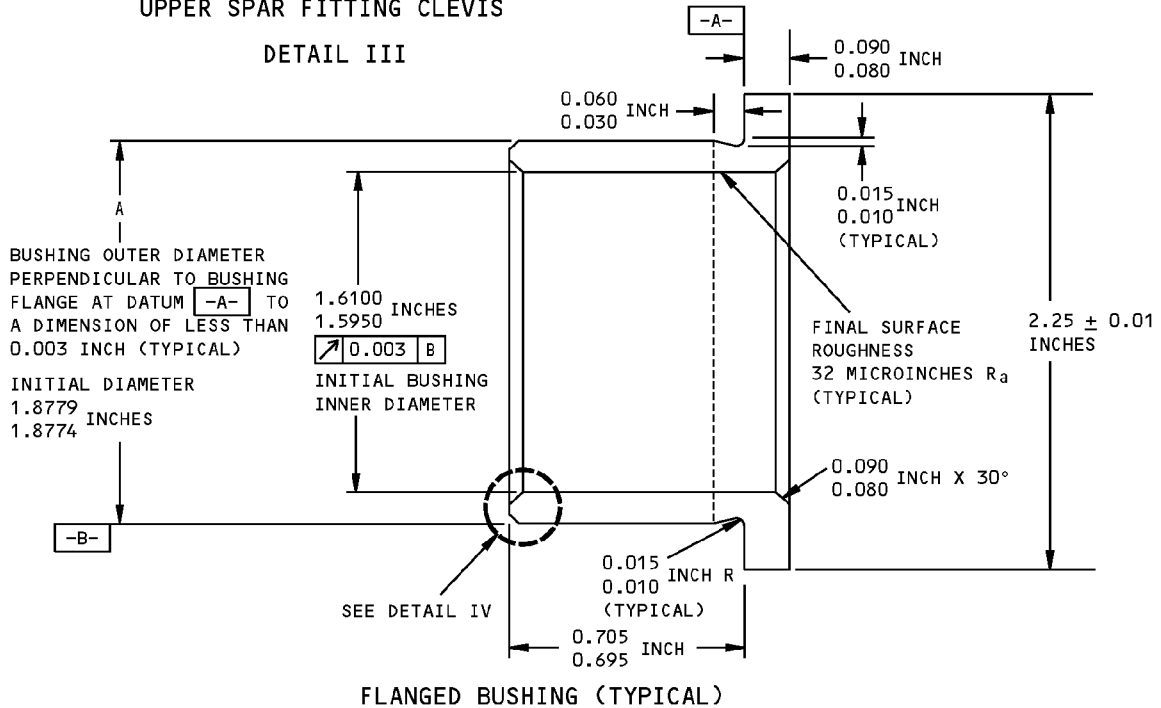

SECTION B-B

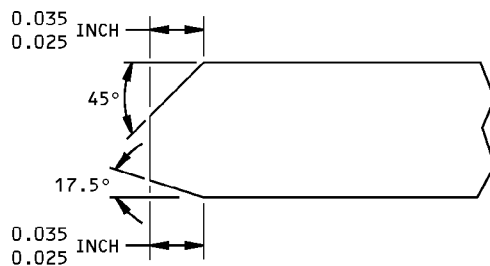

**FLANGED BUSHING CHAMFERS
DETAIL IV**

**Forward Upper Spar Fitting, Lug Hole Repair with Interference Fit Bushing Procedure - PW2000 Engine
Figure 201 (Sheet 7 of 8)**

**757-200
STRUCTURAL REPAIR MANUAL**

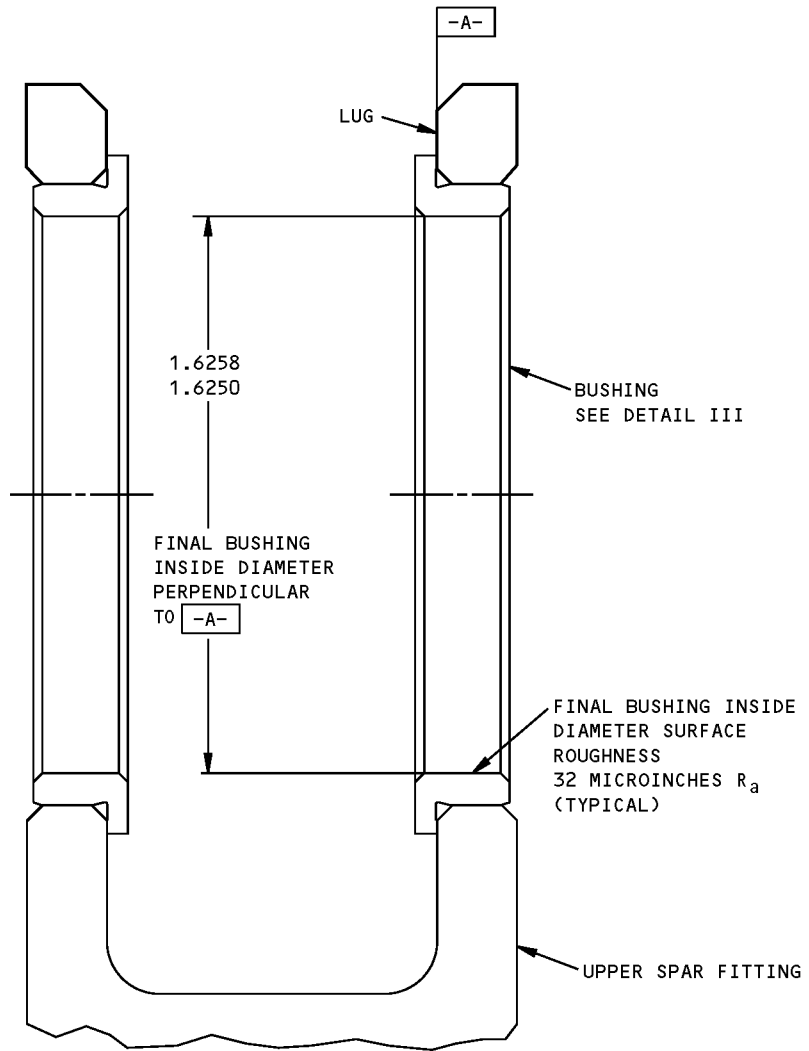

SECTION THROUGH THE UPPER SPAR CLEVIS
DIMENSIONS AFTER THE BUSHING IS INSTALLED

DETAIL V

Forward Upper Spar Fitting, Lug Hole Repair with Interference Fit Bushing Procedure - PW2000 Engine
Figure 201 (Sheet 8 of 8)

STRUCTURAL REPAIR MANUAL

REPAIR 4 - MIDSPAR FITTING, LUG HOLE REPAIR WITH INTERFERENCE FIT BUSHING PROCEDURE - PW2000 ENGINE

APPLICABILITY
<p>THIS REPAIR USES THE INTERFERENCE FIT PROCEDURE TO INSTALL THE REPLACEMENT BUSHINGS FOR THE MIDSPAR FITTING ON THE PW2000 ENGINE. A</p> <p>DIFFERENT REPLACEMENT BUSHINGS ARE USED FOR DIFFERENT STRUT CONFIGURATIONS; THE STRUT IMPROVEMENT CONFIGURATION AND THE PRE-STRUT IMPROVEMENT CONFIGURATION.</p> <p>AIRPLANES WITH SB 757-54-0034 DONE AND AIRPLANE CUM LINE NUMBERS 736 AND ON HAVE THE STRUT IMPROVEMENT CONFIGURATION.</p>

REPAIR INSTRUCTIONS

PROCEDURE I - REMOVE THE INITIAL BUSHINGS

1. Remove the engine strut from the wing. Refer to AMM 54-51-01.
2. Remove the engine strut access doors. Refer to AMM 54-53-01.
3. Remove the engine strut components as necessary to get access. Refer to AMM 54-51-01.
 - A. Make a record of the position of wire bundles and cables near the midspar fitting. Move the wire bundles and cables away from the fitting to make clearance for the repair tools. Disconnect the wires as necessary. If you disconnect electric connections, install caps or plugs at the connection. You can also attach tags that give the location of the connection. This will help you make the connection again.
 - B. Remove tubes, duct, clamps support blocks, and brackets near the fitting as necessary to make clearance for the repair tools.
 - C. Drain the fuel supply line and the hydraulic fluid lines to the engine.
4. Remove the bushing from each lug.
5. Discard the initial bushings. The bushing material is aluminum-nickel-bronze alloy.

PROCEDURE II - DO AN INSPECTION OF THE HOLE FOR EACH LUG

1. Do a magnetic inspection of the inner surface of the hole from which you removed the bushing. Refer to SOPM 20-20-01 for the inspection procedure.
2. If you find damage, you must machine the inner surface of the hole. Continue with the steps given in Procedure III.

3. If no damage is found, it is necessary to remove a minimum of 0.010 inch on the diameter from the inner surface of the hole if the airplane age is:
 - A. 10 years or more for 4330M alloy steel fittings.
 - B. 15 years or more for 15-5PH CRES fittings.

NOTE: The 4330M alloy steel fittings have a cad-ti finish (greenish yellow in color) and the 15-5PH CRES fittings do not. The 15-5PH CRES fittings will have a shiny steel color in the bore. If you can not tell the material type of the fitting from the bore, lightly sand off the primer on the side of the lug to expose the cad-ti finish or no finish.

Continue with the steps given in Procedure III.

4. If no damage is found, it is not necessary to machine the inner surface of the hole if the airplane age is:
 - A. Less than 10 years for 4330M alloy steel fittings.
 - B. Less than 15 years for 15-5PH CRES fittings.

NOTE: The 4330M alloy steel fittings have a cad-ti finish (greenish yellow in color) and the 15-5PH CRES fittings do not. The 15-5PH CRES fittings will have a shiny steel color in the bore. If you can not tell the material type of the fitting from the bore, lightly sand off the primer on the side of the lug to expose the cad-ti finish or no finish.

Continue with the steps given in Procedure VI.

PROCEDURE III - MACHINE THE LUG HOLES

1. Install the proper diameter reamer or boring tools to machine the holes as necessary to remove damage. Use a temporary sheet cover that is approximately 0.063 inch thick to hold the tools over the hole for the thermal anti-ice duct.

**Midspar Fitting, Lug Hole Repair with Interference Fit Bushing Procedure - PW2000 Engine
Figure 201 (Sheet 1 of 10)**

STRUCTURAL REPAIR MANUAL

PROCEDURE III - MACHINE THE LUG HOLES (CONT)

- CAUTION:** MAKE SURE THE TOOLS USED TO MACHINE THE HOLES ARE CORRECTLY ALIGNED BEFORE YOU MACHINE THE HOLES. IF THE TOOLS ARE NOT CORRECTLY ALIGNED THEN THE HOLES WILL NOT BE CUT IN THE CORRECT LOCATION. IF YOU DO NOT OBEY, THE REPAIR CAN BE UNSATISFACTORY.
- Machine the holes as necessary to remove the damage on the fittings. Refer to SOPM 20-10-02 for the procedure to machine alloy steel.
 - Do a magnetic particle inspection to make sure all of the damage is removed. If the inspection shows that there is no damage, machine an insurance cut that is a minimum of 0.010 inch on the diameter.
 - The maximum diameter of each hole is 1.8420 inches, see DETAIL II, SECTION A-A. If the diameter of the hole is larger than the maximum, you must get alternative repair instructions from Boeing.
 - Chamfer the lug hole edges for the fittings. Put a 0.020 to 0.040 inch by 45 degree chamfer on both the inside and the outside of the clevis. See DETAIL II, SECTION A-A. As an alternative to the chamfer, you can make an equivalent radius.
 - Remove the tools.
 - Remove the sharp edges and burrs from the cut surfaces.
 - For 4330M alloy steel fittings: Use ammonium persulfate to do a surface etch inspection of each lug hole that has been machined. This inspection examines the temper of the hole to make sure that no damage occurred while the hole was machined. Refer to SOPM 20-10-02 for the surface temper etch inspection procedure.
 - Do a flap peen procedure to each hole. Use a 3M flapwheel that is 9/16 inch by 1.25 inch to get a coverage of 2.0 with an Almen intensity of 0.008A to 0.013A.
 - Hone each hole to the final diameter. Make the finish on the inner surface of the holes 32 microinches R_a or smoother. You can remove a maximum of 0.0010 inch (or 10 percent of the shot peen intensity that was used) from the radius of the hole to get the necessary surface finish. The maximum diameter of the hole is 1.8420 inches.

PROCEDURE IV - MEASURE THE LUG HOLE DIAMETER

- Measure and record the diameter of the hole. This is dimension B shown in Detail II, SECTION A-A. Measure the diameter before you apply the primer, sealant, or retaining compound.

PROCEDURE V - CALCULATE THE DIAMETER OF THE OVERSIZED BUSHINGS

- Calculate the diameter, A, of the oversized bushings with the formula that follows. Refer to Detail III or V for the definition of the dimension A.

$$A = B + 0.0034 \text{ inch } \pm 0.0005 \text{ inch}$$

PROCEDURE VI - MACHINE THE OVERSIZED BUSHINGS

- If no damage is found and the airplane age is less than 10 years for 4330M alloy steel fittings or 15 years for 15-5PH, use the same diameter dimensions as the initial bushings. Refer to Table I or Table II and Detail III or V. Continue with the steps given in Procedure VIII.
- Machine the oversized bushings to the necessary outer diameter that you found in Procedure V and the other dimensions given in Detail III or Detail V.
- Make the surface finish of the outer diameter of the bushings 32 microinches or smoother. Make the surface finish on the other surfaces 63 microinches R_a or smoother.
- Remove the sharp edges and burrs from the from the cut surfaces.

**Midspar Fitting, Lug Hole Repair with Interference Fit Bushing Procedure - PW2000 Engine
Figure 201 (Sheet 2 of 10)**

STRUCTURAL REPAIR MANUAL

PROCEDURE VI - MACHINE THE OVERSIZED BUSHINGS
(CONT)

CAUTION: DO NOT CADMIUM PLATE THE INNER SURFACE OF THE BUSHINGS. IF YOU DO NOT OBEY, THE REPAIR WILL BE UNSATISFACTORY.

5. For airplane cum line numbers 37 thru 732 without SB 757-54-0034 done, apply a stylus cadmium plate that is 0.0003 to 0.0005 inch thick to the outer diameter and the flange of the oversized bushing. Refer to SOPM 20-42-10.

PROCEDURE VII - APPLY THE FINISH TO EACH LUG

1. Apply the finish to the fittings as follows:

- A. For 4330M alloy steel fittings, Apply cadmium plate that is 0.0003 to 0.0005 inch thick to the lug hole surface.
- B. For 15-5PH CRES fittings, Apply one layer of BMS 10-11, Type I primer to the bare surfaces of the lug. Refer to SOPM 20-41-02. Let the primer fully dry before you install the bushing.

PROCEDURE VIII - APPLY SEALANT OR OPTIONAL RETAINING COMPOUND TO EACH LUG

1. Apply sealant or optional retaining compound to the fittings as follows:

CAUTION: DO NOT APPLY SEALANT TO THE INNER SURFACE OF THE LUG HOLE OR THE OUTER DIAMETER OF THE BUSHING. IF YOU DO NOT OBEY, THE REPAIR CAN BE UNSATISFACTORY.

- A. For 4330M alloy steel fittings:
 - Apply BMS 5-95 sealant to the mating surface of each lug. Do the steps in Procedure IX in 30 minutes or less from the time you apply the sealant. Refer to SRM 51-20-05.
 - As an alternative to the sealant, apply Loctite 640 retaining compound (MIL-R-46082, Type II) to the inner surface of the lug hole and to the mating surfaces of the lug. Do the steps in Procedure IX in 15 minutes or less from the time you apply the retaining compound.

NOTE: If you apply the retaining compound, do not apply the BMS 5-95 sealant.

- B. For 15-5PH CRES fittings:

- As an option, apply Loctite 640 retaining compound (MIL-R-46082, Type II) to the inner surface of the lug hole and to the mating surfaces of the lug. Do the steps in Procedure IX in 15 minutes or less from the time you apply the retaining compound.

PROCEDURE IX - INSTALL THE OVERSIZED BUSHINGS WITH THE SHRINK FIT METHOD

1. Prepare the bushings for installation with the shrink fit method. Use liquid nitrogen at -320°F (-196° C).

WARNING: LIQUID NITROGEN IS APPROXIMATELY -320°F (-196° C). WEAR PROTECTIVE CLOTHING AND USE IN A VENTILATED AREA TO PREVENT INJURY.

2. Soak the bushings and the installation guide bushing in the liquid nitrogen until the boiling stops. Use the guide bushing from Boeing tool kit MIT012N8729-1 or the equivalent. Refer to SOPM 20-50-03.
3. Install the bushings as quickly as possible. Use the installation tools from Boeing tool kit MIT012N8729-1 or the equivalent.

CAUTION: YOU MUST INSTALL THE BUSHING IMMEDIATELY AFTER YOU REMOVE THE BUSHING FROM THE LIQUID NITROGEN. IF THE BUSHING EXPANDS BEFORE IT IS CORRECTLY INSTALLED IN THE FITTING, THE BUSHING MUST BE REMOVED AND REPLACED.

4. Hold the bushing flange tightly against the face of the lug until the assembly is at room temperature to make sure that the bushing is installed correctly. A press fit can be used to complete the shrink fit installation of the bushings.

PROCEDURE X - MACHINE THE INNER DIAMETER OF THE OVERSIZED BUSHINGS

1. Machine the inner diameter of the bushings to a diameter of 1.5625 to 1.5633 inches as shown in Detail VII. Make the surface finish 32 microinches R_a .
2. For 4330M alloy steel fittings: Apply a fillet seal of BMS 5-95 sealant between the flanges of the bushings and the lug as shown in Detail VII. Refer to SRM 51-20-05.

Midspar Fitting, Lug Hole Repair with Interference Fit Bushing Procedure - PW2000 Engine
Figure 201 (Sheet 3 of 10)

**757-200
STRUCTURAL REPAIR MANUAL**

PROCEDURE XI - PUT THE AIRPLANE BACK TO THE INITIAL CONDITION

1. Install the components that were removed from engine strut.
2. Connect the wires and cables that were disconnected.
3. Install the engine strut access doors as given in AMM 54-53-01.
4. Install the engine strut on the airplane as given in AMM 54-51-01.

NOTES

- ALL DIMENSIONS ARE IN INCHES, UNLESS GIVEN DIFFERENTLY.
- WHEN YOU USE THE REPAIR REFER TO:
 - AMM 54-51-01 FOR THE REMOVAL AND INSTALLATION OF THE STRUT
 - AMM 54-53-01 FOR THE REMOVAL AND INSTALLATION OF THE STRUT PRESSURE RELIEF AND ACCESS DOORS
 - SOPM 20-10-02 FOR MACHINING OF ALLOY STEEL AND FOR SURFACE TEMPER ETCH INSPECTION PROCEDURES
 - SOPM 20-10-03 FOR SHOT PEENING AND FLAP PEENING
 - SOPM 20-20-01 FOR MAGNETIC PARTICLE INSPECTION PROCEDURES
 - SOPM 20-41-02 FOR THE APPLICATION OF CHEMICAL AND SOLVENT RESISTANT FINISHES
 - SOPM 20-42-05 FOR CADMIUM PLATING
 - SOPM 20-42-10 FOR LOW HYDROGEN EMBRITTLEMENT STYLUS CADMIUM PLATING
 - SOPM 20-50-03 FOR BUSHING REMOVAL AND INSTALLATION
 - SRM 51-20-05 FOR REPAIR SEALING

A AS AN ALTERNATIVE, THE EXPANDED FIT BUSHING INSTALLATION PROCEDURE IS PERMITTED IF THE INSTALLATION REQUIREMENTS LISTED IN SRM 51-20-09 ARE SATISFIED. REFER TO SRM 51-20-09 FOR THE LIST OF EXPANDED FIT BUSHING INSTALLATION GUIDELINES.

REPAIR MATERIAL		
PART	QTY	MATERIAL
1 OVERSIZED BUSHING	4	2.25 INCHES DIAMETER BY 0.90 INCH LONG ALUMINUM-NICKEL-BRONZE BAR AS SPECIFIED IN AMS 4640

TABLE I

FOR AIRPLANE CUM LINE NUMBERS 37 THRU 732 WITHOUT SB 757-54-0034 DONE

REPAIR MATERIAL		
PART	QTY	MATERIAL
1 OVERSIZED BUSHING	4	2.30 INCHES DIAMETER BY 0.80 INCH LONG ALUMINUM-NICKEL-BRONZE BAR AS SPECIFIED IN AMS 4640

TABLE II

FOR AIRPLANE CUM LINE NUMBERS 736 AND ON OR AIRPLANES WITH SB 757-54-0034 DONE

**Midspar Fitting, Lug Hole Repair with Interference Fit Bushing Procedure - PW2000 Engine
Figure 201 (Sheet 4 of 10)**

**757-200
STRUCTURAL REPAIR MANUAL**

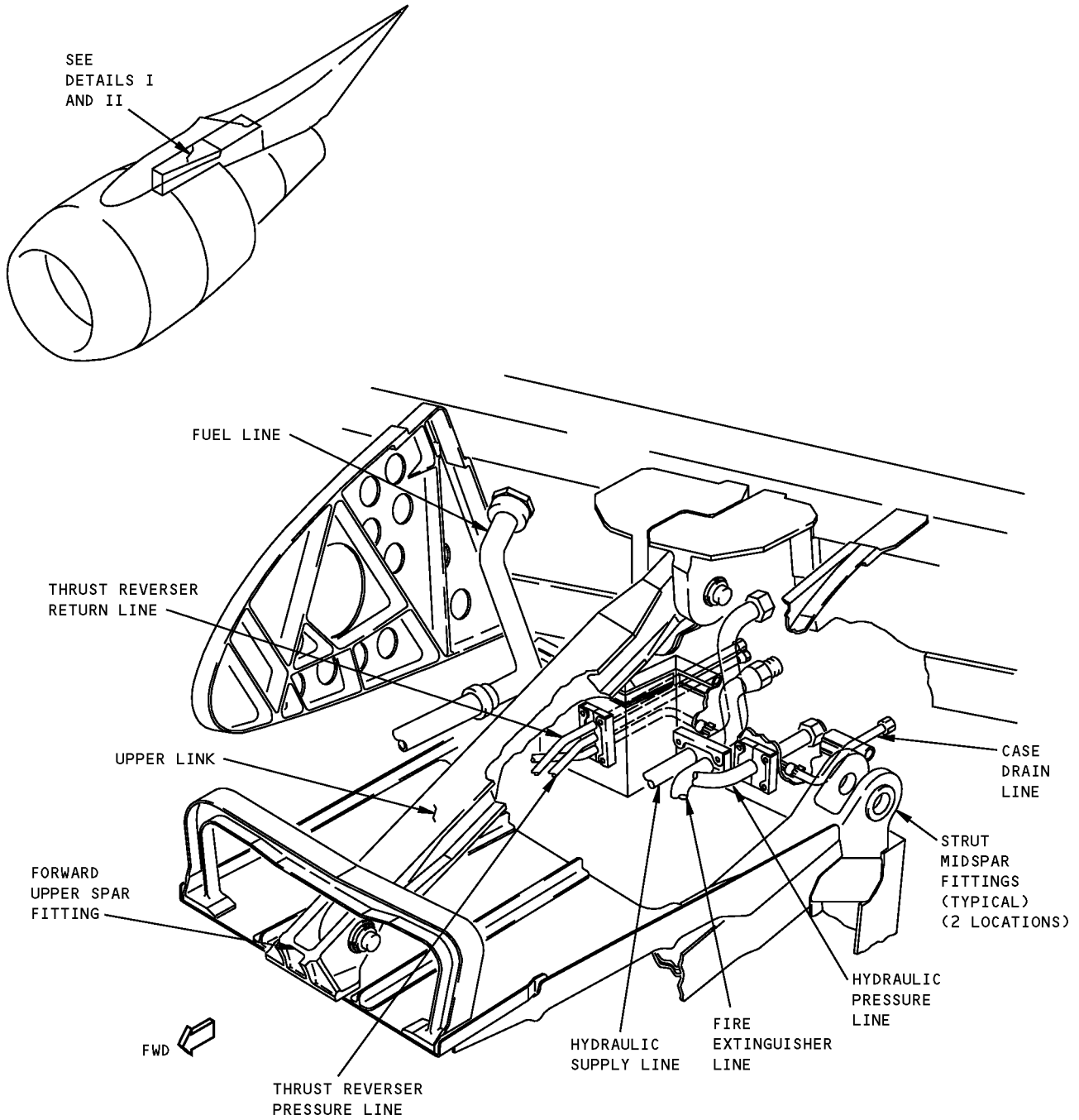

**TUBING, DUCT AND FITTING LOCATIONS
DETAIL I**

**Midspar Fitting, Lug Hole Repair with Interference Fit Bushing Procedure - PW2000 Engine
Figure 201 (Sheet 5 of 10)**

**757-200
STRUCTURAL REPAIR MANUAL**

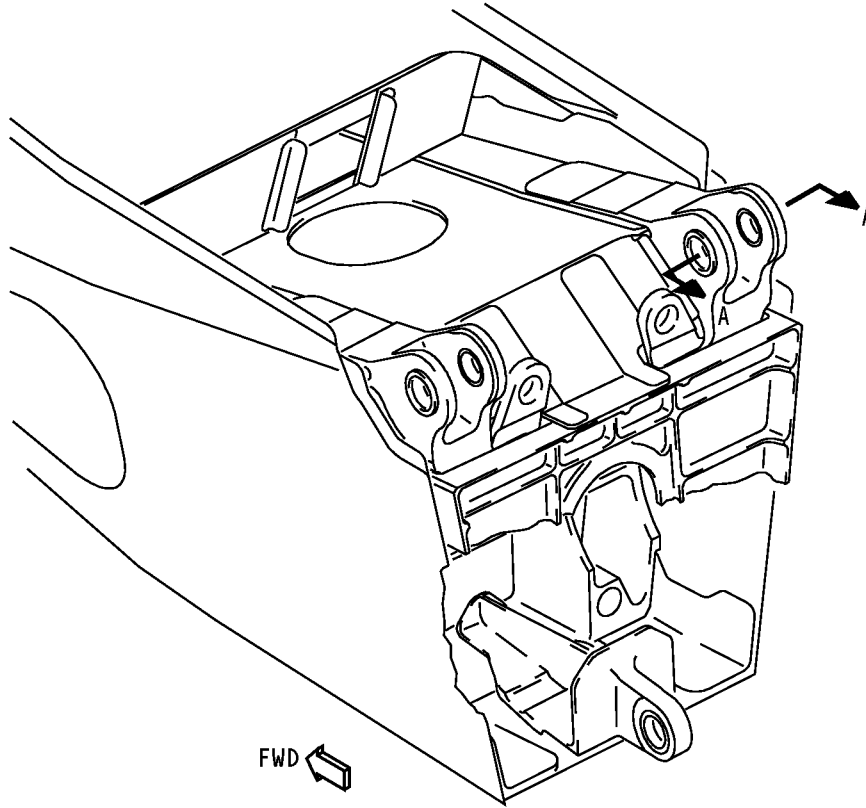

VIEW ON REAR FACE OF STRUT
DETAIL II

**Midspar Fitting, Lug Hole Repair with Interference Fit Bushing Procedure - PW2000 Engine
Figure 201 (Sheet 6 of 10)**

STRUCTURAL REPAIR MANUAL

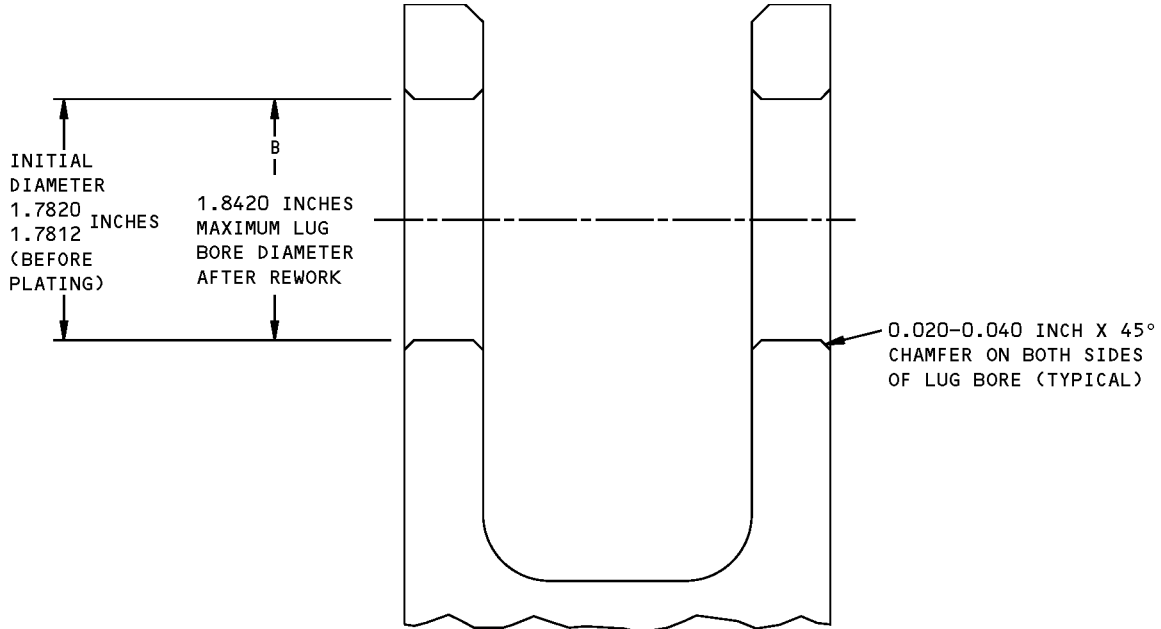

SECTION THROUGH ONE OF THE MIDSPAR CLEVIS FOR AIRPLANE
CUM LINE NUMBERS 37 THRU 732 WITHOUT SB 757-54-0034 DONE

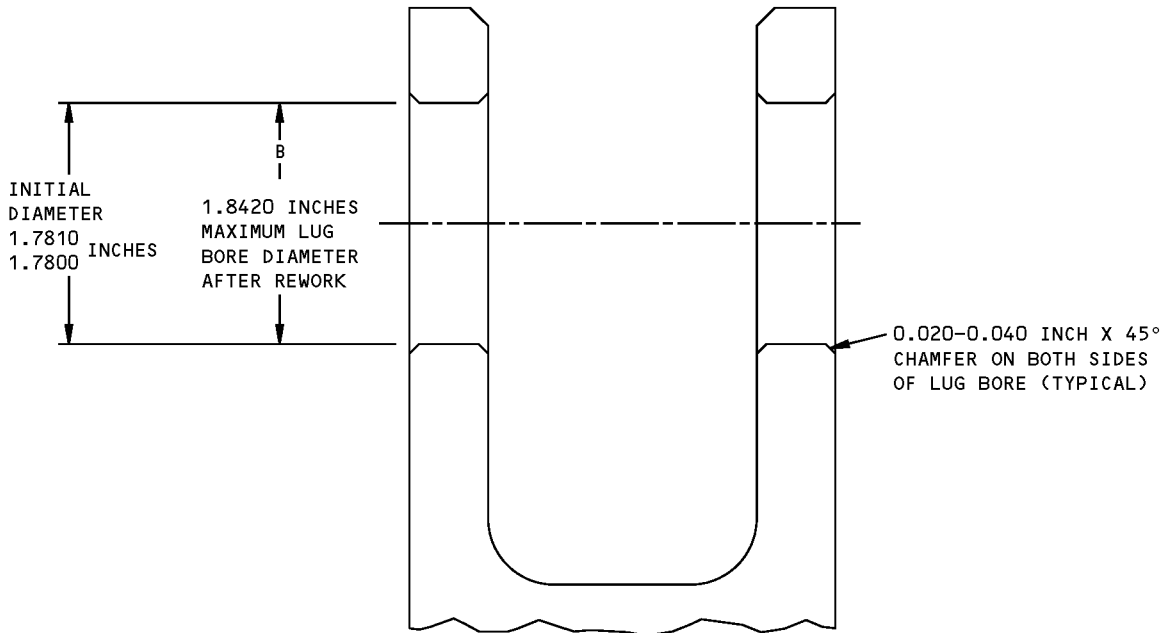

SECTION THROUGH ONE OF THE MIDSPAR CLEVIS FOR AIRPLANE
CUM LINE NUMBERS 736 AND ON OR AIRPLANES WITH SB 757-54-0034 DONE

SECTION A-A

**Midspar Fitting, Lug Hole Repair with Interference Fit Bushing Procedure - PW2000 Engine
Figure 201 (Sheet 7 of 10)**

**757-200
STRUCTURAL REPAIR MANUAL**

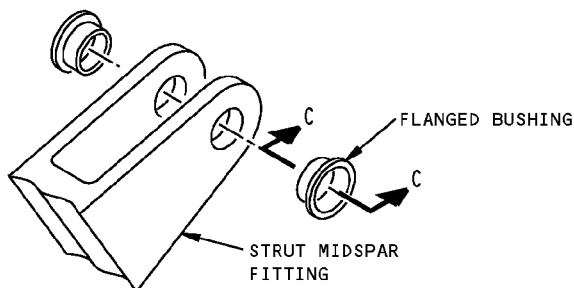

**MIDSPAR CLEVIS FOR AIRPLANE CUM LINE NUMBERS 37 THRU 732
WITHOUT SB 757-54-0034 DONE (TWO LOCATIONS ON EACH STRUT)**

DETAIL III

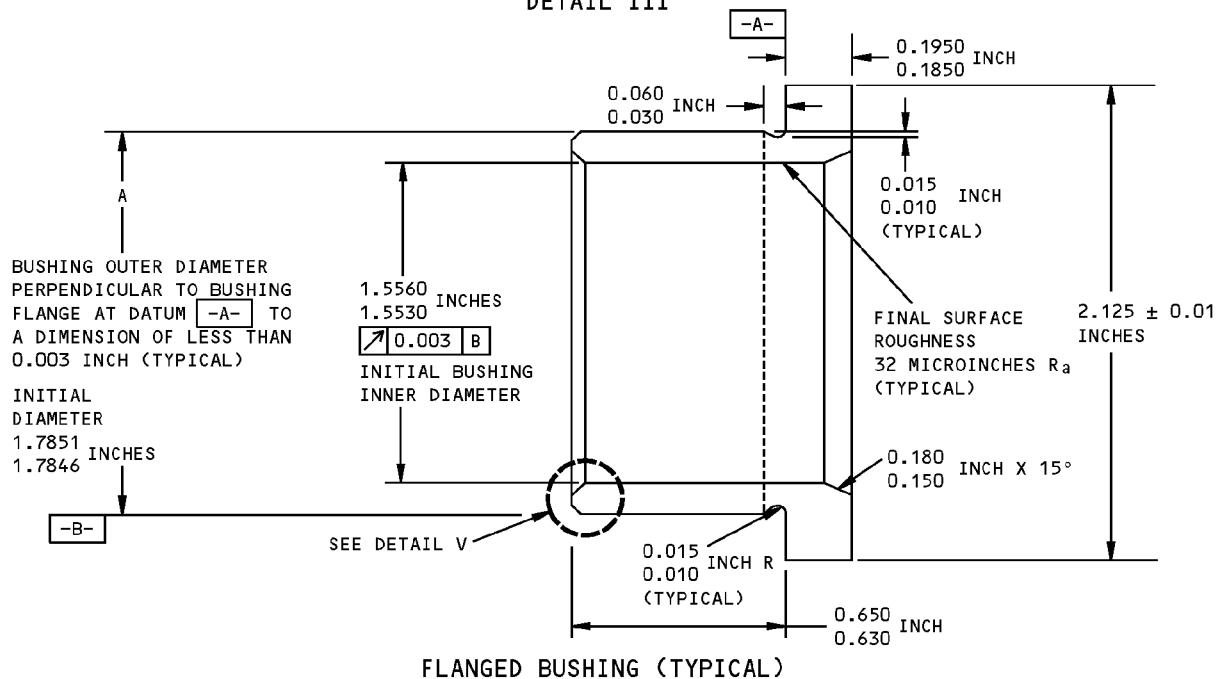

FLANGED BUSHING (TYPICAL)

SECTION C-C

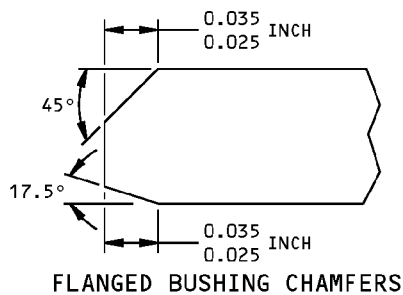

FLANGED BUSHING CHAMFERS

DETAIL IV

**Midspar Fitting, Lug Hole Repair with Interference Fit Bushing Procedure - PW2000 Engine
Figure 201 (Sheet 8 of 10)**

**757-200
STRUCTURAL REPAIR MANUAL**

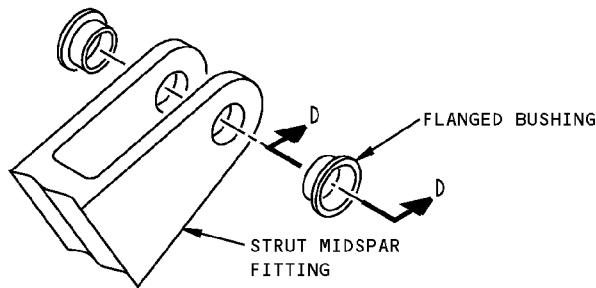

MIDSPAR CLEVIS FOR AIRPLANE CUM LINE NUMBERS 736 AND ON OR AIRPLANES WITH SB 757-54-0034 DONE (TWO LOCATIONS ON EACH STRUT)

DETAIL V

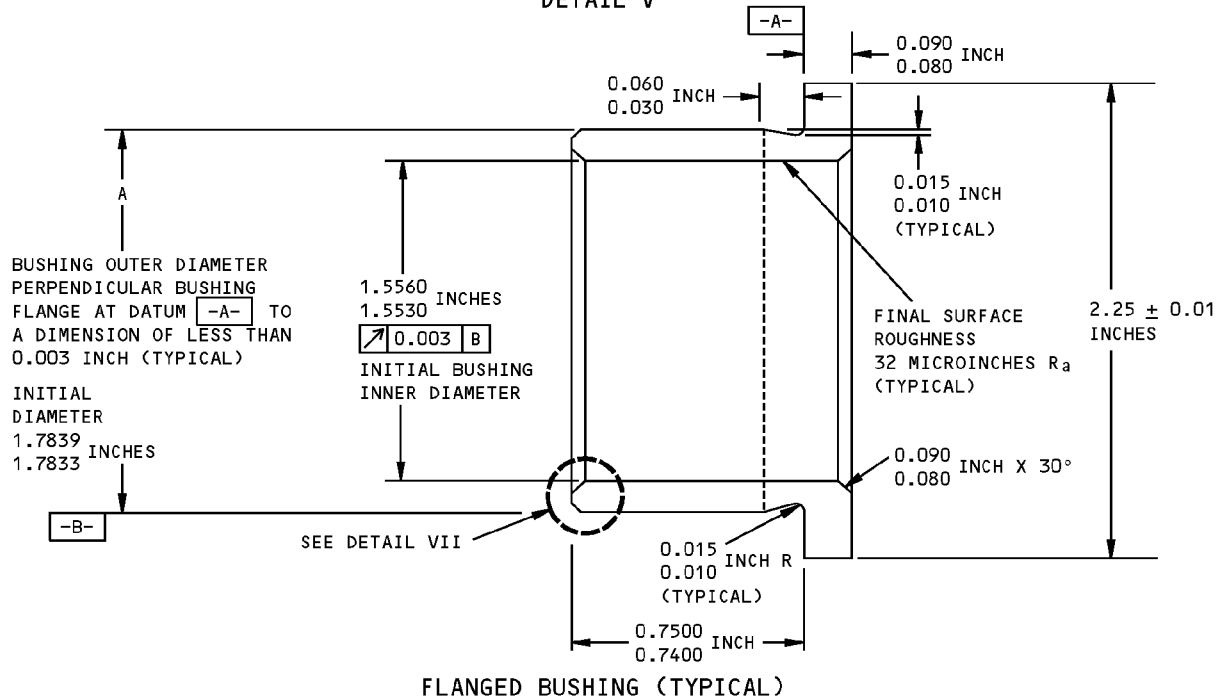

SECTION D-D

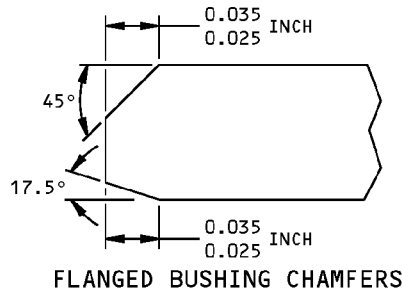

DETAIL VI

**Midspar Fitting, Lug Hole Repair with Interference Fit Bushing Procedure - PW2000 Engine
Figure 201 (Sheet 9 of 10)**

**757-200
STRUCTURAL REPAIR MANUAL**

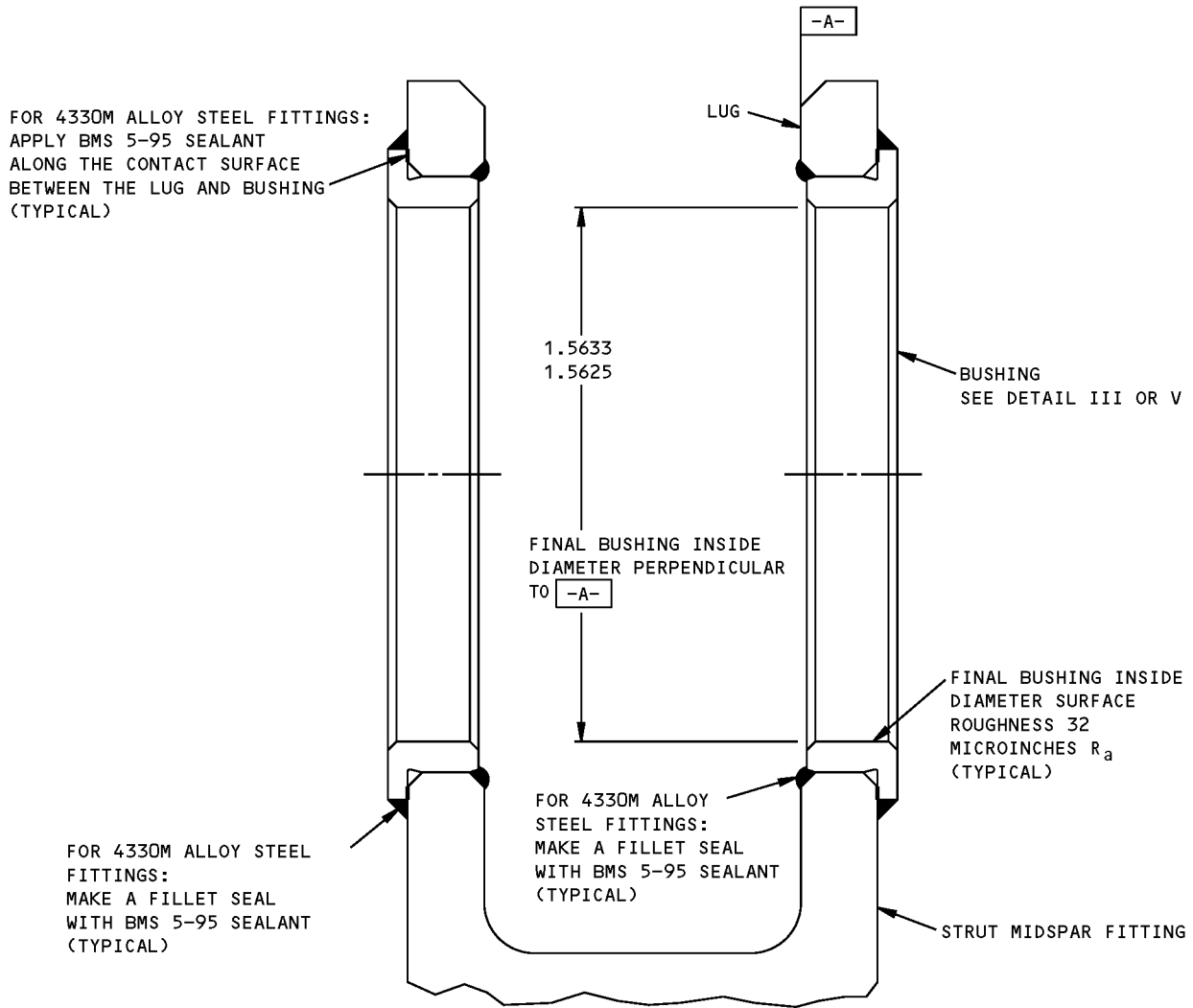

SECTION THROUGH THE MIDSPAR CLEVIS
DIMENSIONS AFTER THE BUSHING IS INSTALLED

DETAIL VII

**Midspar Fitting, Lug Hole Repair with Interference Fit Bushing Procedure - PW2000 Engine
Figure 201 (Sheet 10 of 10)**

STRUCTURAL REPAIR MANUAL

REPAIR 5 - LOWER SPAR FITTING, LUG HOLE REPAIR WITH INTERFERENCE FIT BUSHING PROCEDURE - PW2000 ENGINE

APPLICABILITY
THIS REPAIR USES THE INTERFERENCE FIT PROCEDURE TO INSTALL THE REPLACEMENT BUSHINGS FOR THE LOWER SPAR FITTING ON THE PW2000 ENGINE. A

REPAIR INSTRUCTIONS

PROCEDURE I - REMOVE THE INITIAL BUSHINGS

1. Remove the engine strut access doors. Refer to AMM 54-53-01.
2. Remove the engine strut components as necessary to get access. Refer to AMM 54-51-01.
 - A. Make a record of the position of wire bundles and cables near the lower spar fitting. Move the wire bundles and cables away from the fitting to make clearance for the repair tools. Disconnect the wires as necessary. If you disconnect electric connections, install caps or plugs at the connection. You can also attach tags that give the location of the connection. This will help you make the connection again.
 - B. Remove tubes, duct, clamps support blocks, and brackets near the fitting as necessary to make clearance for the repair tools.
 - C. Drain the fuel supply line and the hydraulic fluid lines to the engine.
3. Get or make the split bushing removal tool. The Boeing tool number is B54016-1.
4. Remove the two bushings from the lug with the split bushing removal tool.
5. Discard the initial bushings. The bushing material is aluminum-nickel-bronze alloy.

PROCEDURE II - DO AN INSPECTION OF THE LUG HOLE

1. Do a magnetic inspection of the inner surface of the hole from which you removed the bushings. Refer to SOPM 20-20-01 for the inspection procedure.
2. If you find damage, you must machine the inner surface of the hole. Continue with the steps given in Procedure III.

3. If no damage is found and the airplane age is more than 15 years, you must machine the inner surface of the hole. Continue with the steps given in Procedure III to remove a minimum of 0.010 inch on the diameter from the inner surface of the hole.
4. If no damage is found and the airplane age is 15 years or less, it is not necessary to machine the inner surface of the hole. Continue with the steps given in Procedure VI.

PROCEDURE III - MACHINE THE LUG HOLE

1. Install the proper diameter reamer or boring tools to machine the hole as necessary to remove damage. Use a temporary sheet cover that is approximately 0.063 inch thick to hold the tools over the hole for the thermal anti-ice duct.

CAUTION: MAKE SURE THE TOOLS USED TO MACHINE THE HOLE ARE CORRECTLY ALIGNED BEFORE YOU MACHINE THE HOLE. IF THE TOOLS ARE NOT CORRECTLY ALIGNED THEN THE HOLE WILL NOT BE CUT IN THE CORRECT LOCATION. IF YOU DO NOT OBEY, THE REPAIR CAN BE UNSATISFACTORY.

2. Machine the hole as necessary to remove the damage.
 - A. The material of the fitting is 15-5PH corrosion resistant steel.
 - B. Do a magnetic particle inspection to make sure all of the damage is removed. If the inspection shows that there is no more damage, machine an insurance cut that is a minimum of 0.010 inch on the diameter.
 - C. The maximum diameter of the hole is 1.8110 inches, see DETAIL II, SECTION A-A. If the diameter of the hole is larger than the maximum, you must get alternative repair instructions from Boeing.
3. Put a 0.020 to 0.040 inch by 45 degree chamfer on the edges of the hole. As an alternative to the chamfer, you can make an equivalent radius.
4. Remove the tools.
5. Remove the sharp edges and burrs from the cut surfaces.

**Lower Spar Fitting, Lug Hole Repair with Interference Fit Bushing Procedure - PW2000 Engine
Figure 201 (Sheet 1 of 8)**

STRUCTURAL REPAIR MANUAL

6. Do a flappeen procedure to the hole. Use a 3M flapwheel that is 9/16 inch by 1.25 inch to get an Almen intensity of 0.016A and a coverage of 2.0. Refer to SOPM 20-10-03.
7. Hone the hole to the final diameter. Make the finish on the inner surface of the hole 32 microinches R_a or smoother. You can remove a maximum of 0.0016 inch from the radius of the hole to get the necessary surface finish. The maximum diameter of the hole is 1.8110 inches.
8. Use Scotch-Brite to remove sharp edges from the surface of the hole and clean the area with solvent.

PROCEDURE IV - MEASURE THE LUG HOLE DIAMETER

1. Measure and record the diameter of the hole. This is dimension B shown in Detail II, SECTION A-A. Measure the diameter before you apply the primer, sealant, or retaining compound.

PROCEDURE V - CALCULATE THE DIAMETER OF THE OVERSIZED BUSHINGS

1. Calculate the diameter, A, of the oversized bushings with the formula that follows. Refer to Detail III for the definition of the dimension A.

$$A = B + 0.0034 \text{ inch } \pm 0.0005 \text{ inch}$$

PROCEDURE VI - MACHINE THE OVERSIZED BUSHINGS

1. If no damage is found and the airplane age is 15 years or less, use the same diameter dimensions as the initial bushings. Refer to Table I and Detail III. Continue with the steps given in Procedure VIII.
2. Machine the oversized bushings to the necessary outer diameter that you found in Procedure V and the other dimensions given in Detail III.
3. Make the surface finish of the outer diameter of the bushings 32 microinches R_a or smoother. Make the surface finish on the other surfaces 63 microinches R_a or smoother.
4. Remove the sharp edges and burrs from the cut surfaces.

PROCEDURE VII - APPLY THE PRIMER

1. Apply one layer of BMS 10-11, Type I primer to the bare surfaces of the lug. Refer to SOPM 20-41-02.
2. Let the primer fully dry before you install the bushings.

PROCEDURE VIII - APPLY RETAINING COMPOUND (OPTIONAL)

1. Apply Loctite 640 retaining compound (MIL-R-46082, Type II) to the inner surface of the lug hole and to the mating surfaces of the lug. Do the steps in Procedure IX in 15 minutes or less from the time you apply the retaining compound.

Lower Spar Fitting, Lug Hole Repair with Interference Fit Bushing Procedure - PW2000 Engine
Figure 201 (Sheet 2 of 8)



757-200

STRUCTURAL REPAIR MANUAL

PROCEDURE IX - INSTALL THE OVERSIZED BUSHINGS WITH THE SHRINK FIT METHOD

1. Prepare the bushings for installation with the shrink fit method. Use liquid nitrogen at -320°F (-196°C).

WARNING: LIQUID NITROGEN IS APPROXIMATELY -320°F (-196°C). WEAR PROTECTIVE CLOTHING AND USE IN A VENTILATED AREA TO PREVENT INJURY.

2. Soak the bushings and the installation guide bushing in the liquid nitrogen until the boiling stops. Use the guide bushing from Boeing tool kit MIT012N8729-1 or the equivalent. Refer to SOPM 20-50-03.
3. Install the bushings as quickly as possible. Use the installation tools from Boeing tool kit MIT012N8729-1 or the equivalent.

CAUTION: YOU MUST INSTALL THE BUSHING IMMEDIATELY AFTER YOU REMOVE THE BUSHING FROM THE LIQUID NITROGEN. IF THE BUSHING EXPANDS BEFORE IT IS CORRECTLY INSTALLED IN THE FITTING, THE BUSHING MUST BE REMOVED AND REPLACED.

4. Hold the bushing flange tightly against the face of the lug until the assembly is at room temperature to make sure that the bushing is installed correctly. A press fit can be used to complete the shrink fit installation of the bushings.

PROCEDURE X - MACHINE THE INNER DIAMETER OF THE OVERSIZED BUSHINGS

1. Machine the inner diameter of the bushings to a diameter of 1.4995 to 1.5010 inches as shown in Detail V. Make the surface finish 32 microinches R_a .

PROCEDURE XI - PUT THE AIRPLANE BACK TO THE INITIAL CONDITION

1. Install the components that were removed from engine strut.
2. Connect the wires and cables that were disconnected.
3. Install the engine strut access doors as given in AMM 54-53-01.

Lower Spar Fitting, Lug Hole Repair with Interference Fit Bushing Procedure - PW2000 Engine
Figure 201 (Sheet 3 of 8)

D634N201

54-51-90

REPAIR 5
Page 203
Jan 20/2005



**757-200
STRUCTURAL REPAIR MANUAL**

NOTES

- ALL DIMENSIONS ARE IN INCHES, UNLESS GIVEN DIFFERENTLY.
- WHEN YOU USE THE REPAIR REFER TO:
 - AMM 54-53-01 FOR THE REMOVAL AND INSTALLATION OF THE STRUT PRESSURE RELIEF AND ACCESS DOORS
 - SOPM 20-10-02 FOR MACHINING OF ALLOY STEEL
 - SOPM 20-10-03 FOR SHOT PEENING AND FLAP PEENING
 - SOPM 20-20-01 FOR MAGNETIC PARTICLE INSPECTION PROCEDURES
 - SOPM 20-41-02 FOR THE APPLICATION OF CHEMICAL AND SOLVENT RESISTANT FINISHES
 - SOPM 20-50-03 FOR BUSHING REMOVAL AND INSTALLATION

A AS AN ALTERNATIVE, THE EXPANDED FIT BUSHING INSTALLATION PROCEDURE IS PERMITTED IF THE INSTALLATION REQUIREMENTS LISTED IN SRM 51-20-09 ARE SATISFIED. REFER TO SRM 51-20-09 FOR THE LIST OF EXPANDED FIT BUSHING INSTALLATION GUIDELINES.

REPAIR MATERIAL			
PART		QTY	MATERIAL
1	OVERSIZED BUSHING	2	2.10 INCHES DIAMETER BY 0.60 INCH LONG ALUMINUM-NICKEL-BRONZE BAR AS SPECIFIED IN AMS 4640

TABLE I

**Lower Spar Fitting, Lug Hole Repair with Interference Fit Bushing Procedure - PW2000 Engine
Figure 201 (Sheet 4 of 8)**

**757-200
STRUCTURAL REPAIR MANUAL**

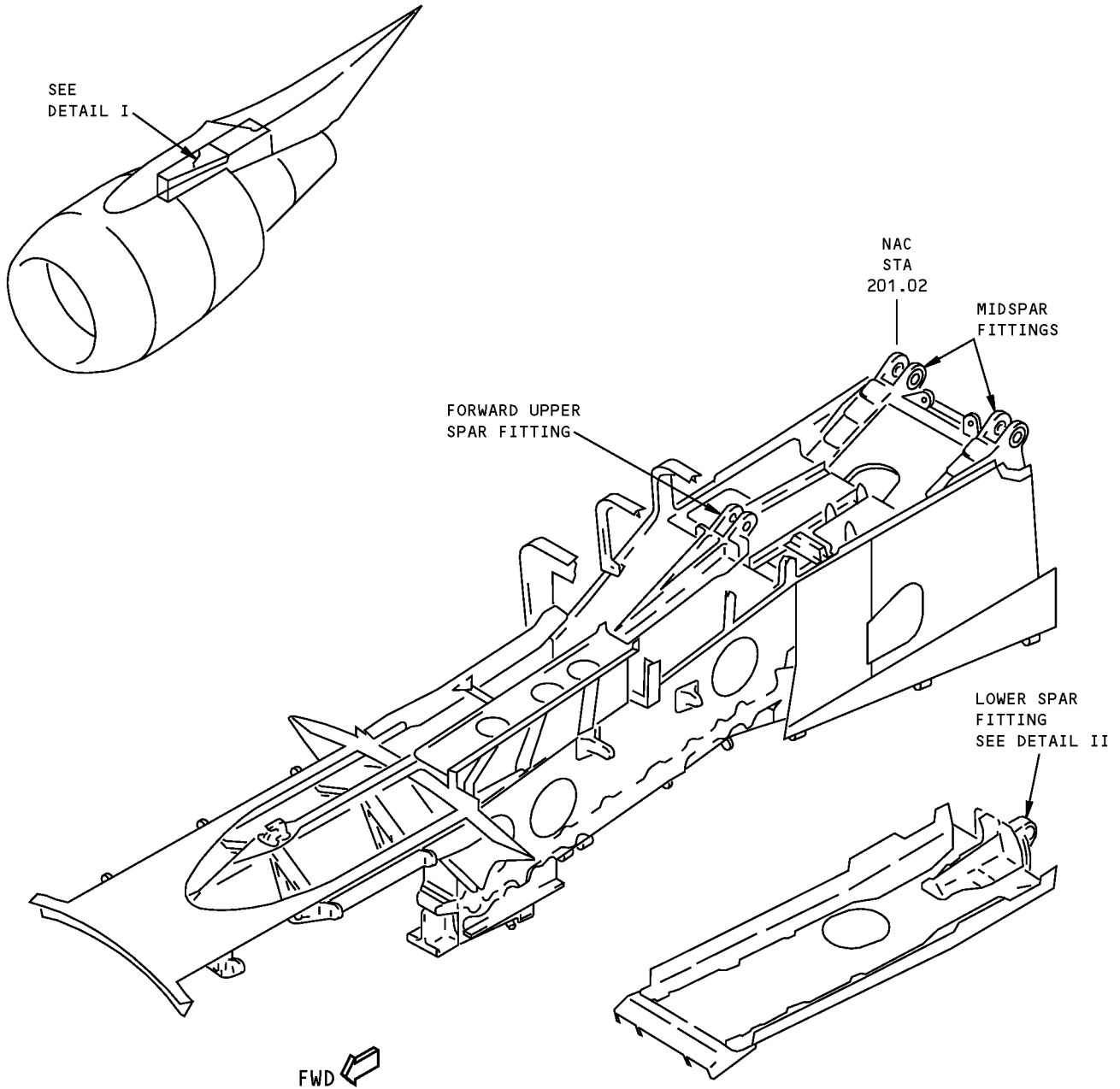

STRUT FITTING LOCATIONS
DETAIL I

**Lower Spar Fitting, Lug Hole Repair with Interference Fit Bushing Procedure - PW2000 Engine
Figure 201 (Sheet 5 of 8)**

**757-200
STRUCTURAL REPAIR MANUAL**

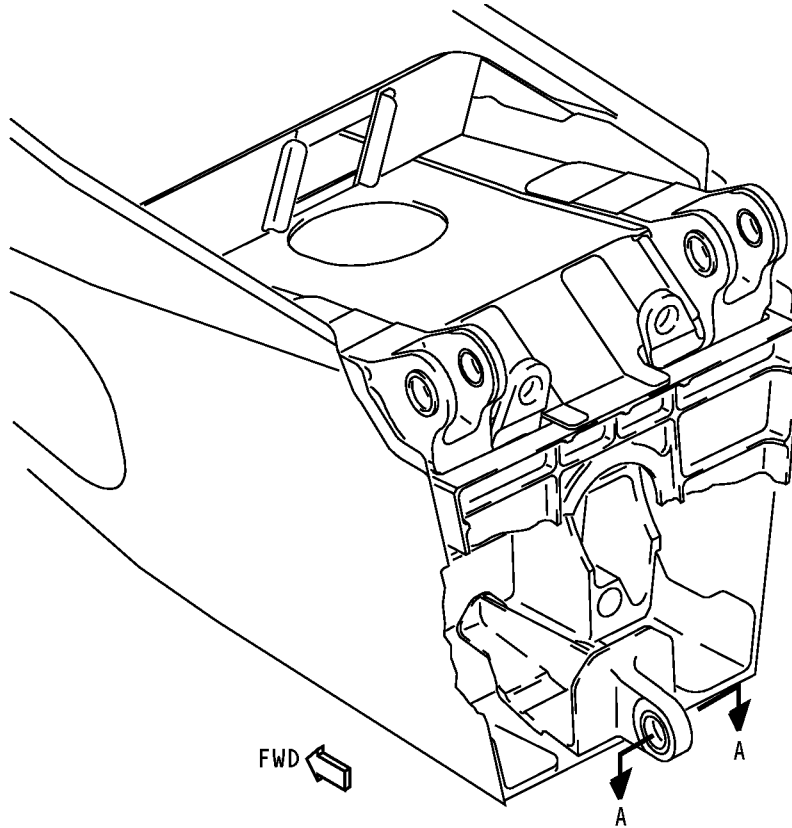

VIEW ON REAR FACE OF STRUT
DETAIL II

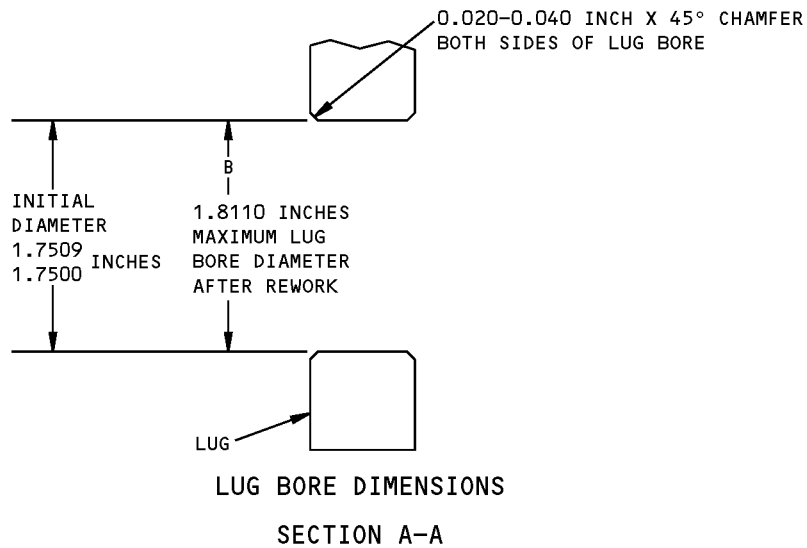

**Lower Spar Fitting, Lug Hole Repair with Interference Fit Bushing Procedure - PW2000 Engine
Figure 201 (Sheet 6 of 8)**

**757-200
STRUCTURAL REPAIR MANUAL**

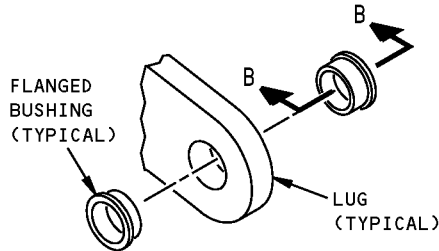

LOWER SPAR FITTING ASSEMBLY

DETAIL III

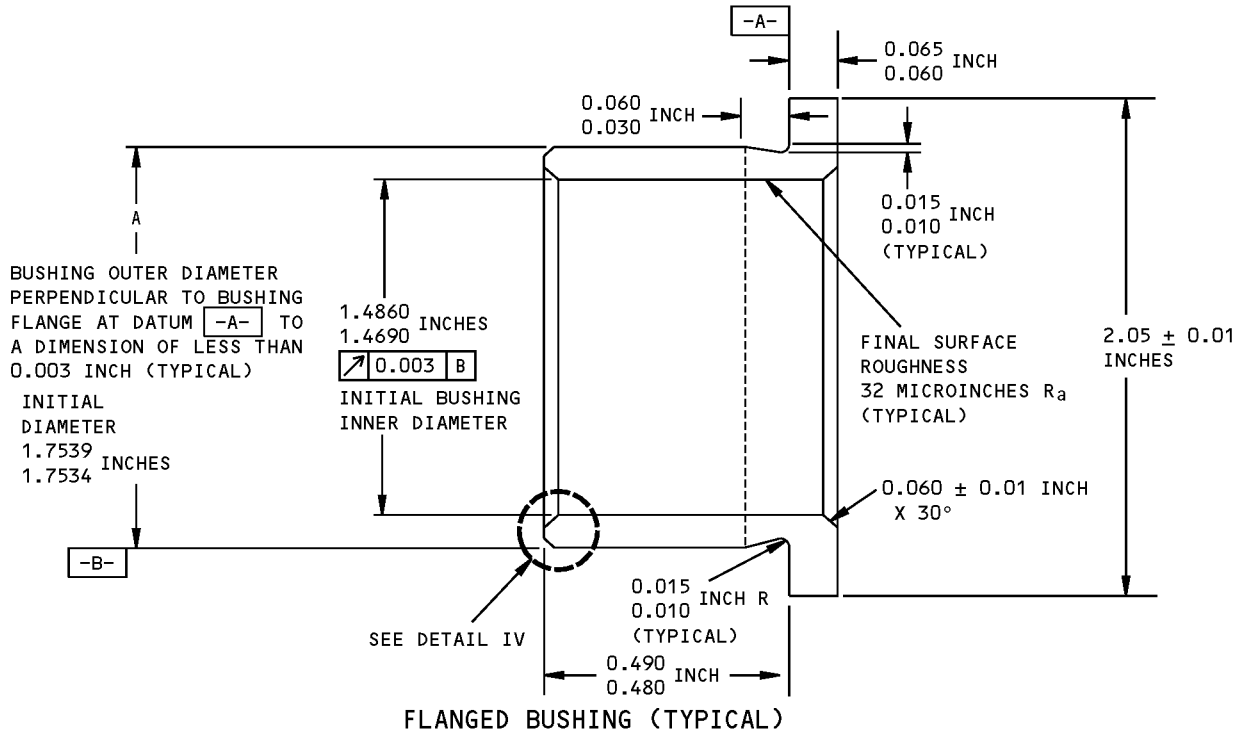

FLANGED BUSHING (TYPICAL)

SECTION B-B

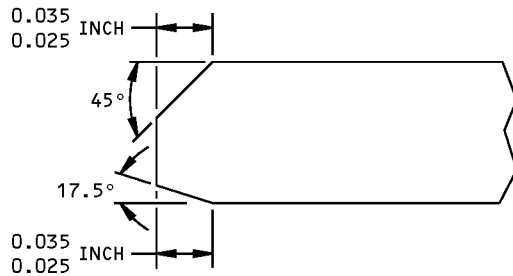

FLANGED BUSHING CHAMFERS

DETAIL IV

**Lower Spar Fitting, Lug Hole Repair with Interference Fit Bushing Procedure - PW2000 Engine
Figure 201 (Sheet 7 of 8)**

**757-200
STRUCTURAL REPAIR MANUAL**

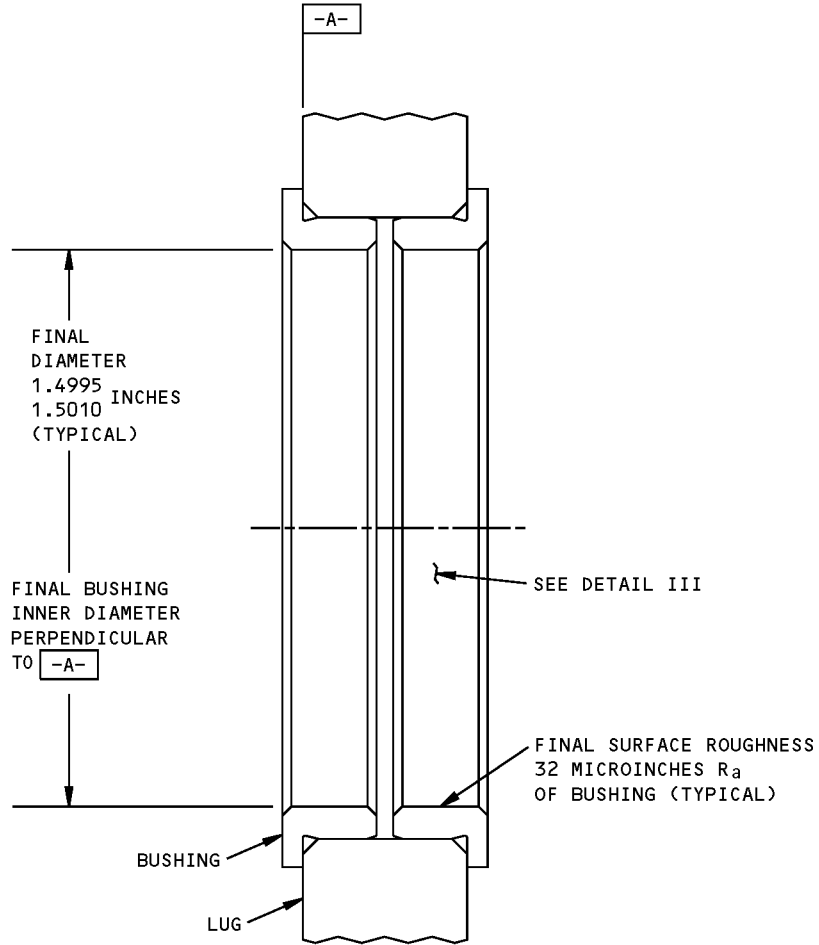

SECTION THROUGH THE CENTER OF THE LUG BORE
BUSHING DIMENSIONS AFTER THE BUSHINGS ARE INSTALLED
DETAIL V

**Lower Spar Fitting, Lug Hole Repair with Interference Fit Bushing Procedure - PW2000 Engine
Figure 201 (Sheet 8 of 8)**

**757-200
STRUCTURAL REPAIR MANUAL**

IDENTIFICATION 1 - FORWARD ENGINE MOUNT BEAM

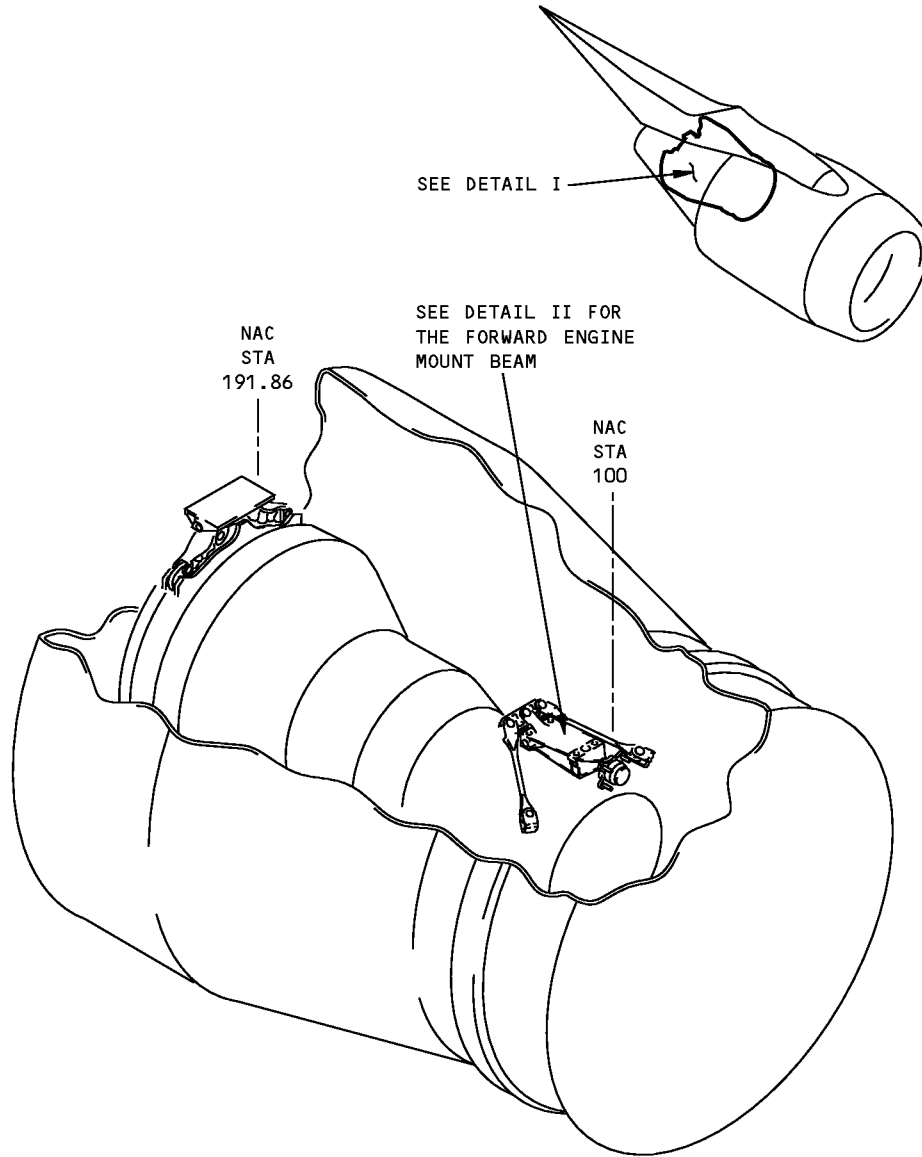

DETAIL I

1470231 S0000266888_V1

**Forward Engine Mount Beam Identification - PW2000 Engine
Figure 1 (Sheet 1 of 2)**

D634N201

54-71-91

IDENTIFICATION 1
Page 1
May 20/2008

**757-200
STRUCTURAL REPAIR MANUAL**

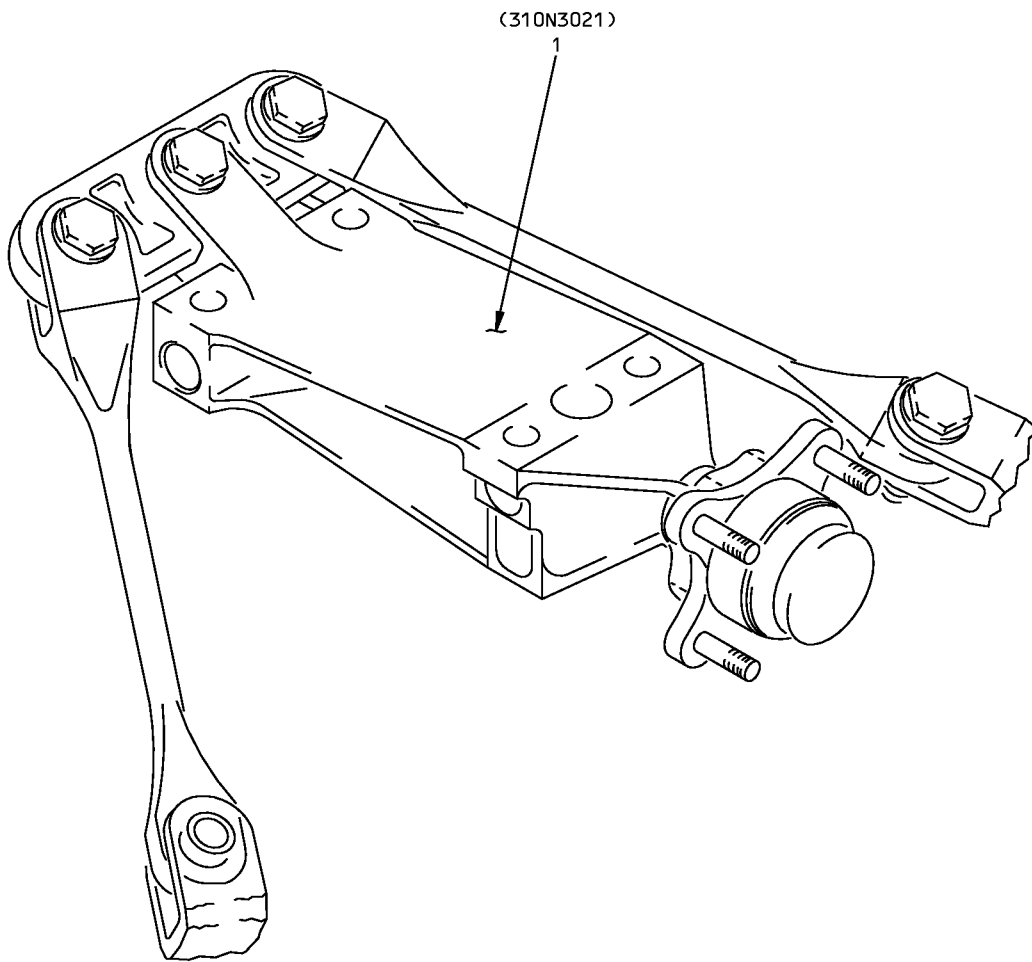

**FORWARD ENGINE MOUNT BEAM
DETAIL II**

1471235 S0000266837_V1

**Forward Engine Mount Beam Identification - PW2000 Engine
Figure 1 (Sheet 2 of 2)**

D634N201

54-71-91

IDENTIFICATION 1
Page 2
May 20/2008



757-200
STRUCTURAL REPAIR MANUAL

ALLOWABLE DAMAGE 1 - FORWARD ENGINE MOUNT BEAM - PW2000 ENGINE

1. Applicability

- A. This section gives the allowable damage limits for the Forward Engine Mount Beam, P/N 310N3021, on PW2000 Engines.
- B. This section specifically addresses wear on the mating surfaces around the tension bolt holes.

2. General

- A. Do an inspection of the engine mounts to find the dimensions of the damage. Refer to INSPECTION AND REMOVAL OF DAMAGE, 51-10-02 for an applicable inspection procedure.
- B. Refer to Table 101/ALLOWABLE DAMAGE 1 for allowable damage limits.
- C. Refer to NONMETALLIC MATERIALS, 51-30-03 for sources of the abrasive and other materials to remove the damage.
- D. Refer to EQUIPMENT AND TOOLS FOR REPAIRS, 51-30-05 for sources of the equipment and other tools to remove the damage.
- E. Remove all permitted damage. Refer to INSPECTION AND REMOVAL OF DAMAGE, 51-10-02 for general instructions and refer to Paragraph 4./ALLOWABLE DAMAGE 1 for the damage removal procedure.
 - (1) Do not remove the material in the zones where damage is not permitted. Refer to Figure 101 (Sheet 1).
- F. Do an inspection of the part.
 - (1) Magnetic particle inspect. Refer to SOPM 20-20-01.
- G. Shot peen with intensity 0.016A, coverage 2.0. Refer to OMH 20-10-03. You may manually peen reworked areas to achieve intensity and coverage required.
- H. Finish and passivate the reworked area. You may clean with scotch brite and solvent wipe.
- I. Apply two coats of BMS 10-11 Type I primer.

**757-200
STRUCTURAL REPAIR MANUAL**

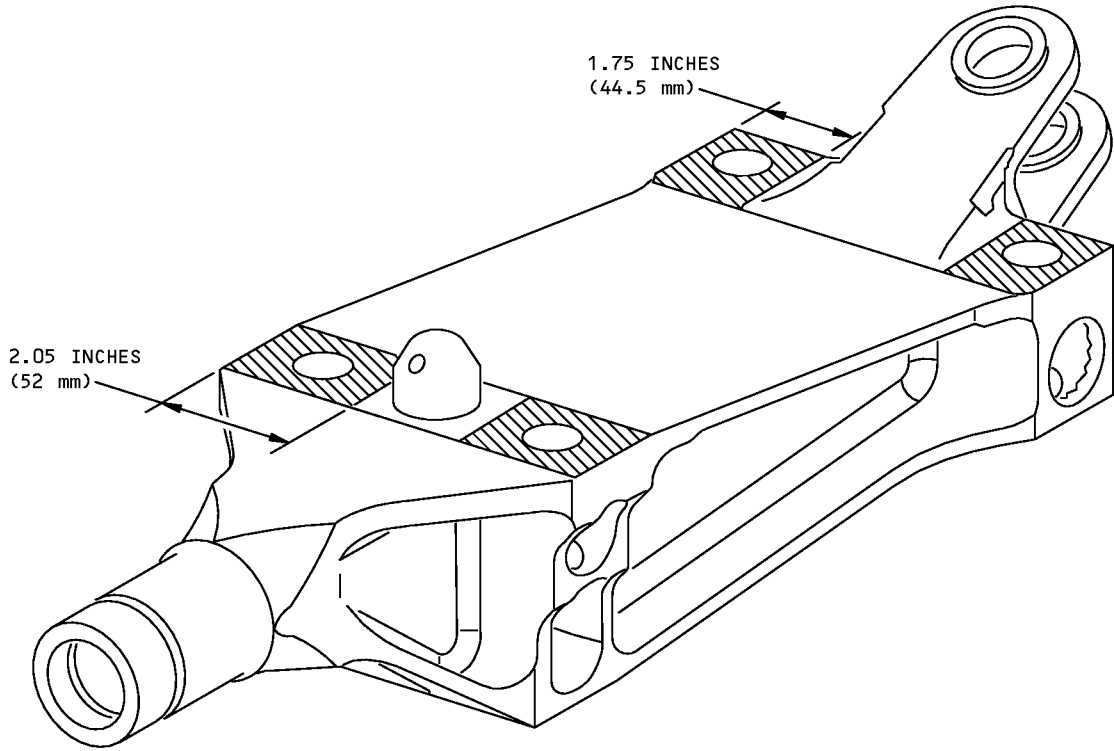

 ALLOWABLE DAMAGE AREAS

DETAIL I

1471338 S0000266838_V1

FORWARD ENGINE MOUNT BEAM - PW2000 ENGINE
Figure 101

D634N201

ALLOWABLE DAMAGE 1
Page 102
54-71-91 May 20/2008



757-200
STRUCTURAL REPAIR MANUAL

3. References

Reference	Title
51-10-02	INSPECTION AND REMOVAL OF DAMAGE
51-30-03	NONMETALLIC MATERIALS
51-30-05	EQUIPMENT AND TOOLS FOR REPAIRS

4. Allowable Damage Limits

A. See Table 101/ALLOWABLE DAMAGE 1 for allowable damage.

Table 101:

DESCRIPTION	CRACKS	NICKS, GOUGES, SCRATCHES, AND CORROSION	DENTS	HOLES AND PUNCTURES
Forward engine mount beam	Not permitted	Up to 0.010 in. (0.254 mm) in depth.	Not permitted	Not permitted

- B. If damage is less than 0.002 in. (0.051 mm), blend out the damage 10:1 to a maximum depth of 0.002 in. (0.051 mm) inches from the initial machined surfaces. (Do NOT blend or machine areas around shear pin.) Surface roughness requirement is 63 microinches RA. Maintain flatness and parallelism requirements for the surfaces that connect to the 311N3211 Forward Mount Fitting Assembly.
- (1) Magnetic particle inspect. Refer to SOPM 20-20-01.
 - (2) Shot peen with intensity 0.016A, coverage 2.0. Refer to OHM 20-10-03. You may manually peen reworked areas to achieve intensity and coverage required.
 - (3) Finish the reworked area, passivate. You may clean with scotch brite and solvent wipe.
 - (4) Apply two coats of BMS 10-11 Type I primer to the allowable damage areas.
- C. If damage exceeds 0.002 in. (0.051 mm) but is less than 0.010 in. (0.254 mm), machine all four surfaces the same amount to a maximum depth of 0.010 in. (0.254 mm) from the initial machined surfaces. (Do NOT blend or machine areas around shear pin.) Surface roughness requirement is 63 microinches RA. Maintain flatness and parallelism requirements for the surfaces that connect to the 311N3211 Forward Mount Fitting Assembly. Minimum fillet radius is 0.125 in. (3.175 mm).
- (1) Magnetic particle inspect. Refer to SOPM 20-20-01.
 - (2) Shot peen with intensity .016A, coverage 2.0. Refer to OHM 20-10-03. Reworked areas may be peened manually to achieve intensity and coverage required.
 - (3) Finish the reworked area, passivate. Cleaning with scotch brite and solvent wipe is permitted.
 - (4) Apply two coats of BMS 10-11 type I primer to the allowable damage areas.