

CHAPTER

57

WINGS



**757-200
STRUCTURAL REPAIR MANUAL**

**CHAPTER 57
WINGS**

Subject/Page	Date	Subject/Page	Date	Subject/Page	Date
EFFECTIVE PAGES		57-00-03 REPAIR 5		57-10-13 IDENTIFICATION 1	
1 thru 7	May 20/2009	201	Jan 20/2005	1	Jan 20/2005
8	BLANK	202	Jan 20/2005	2	Jan 20/2005
57-CONTENTS		203	Jan 20/2005	3	Jan 20/2005
1	Jan 20/2005	204	Jan 20/2005	4	BLANK
2	Jan 20/2006	57-10-01 IDENTIFICATION 1		57-10-13 IDENTIFICATION 2	
3	Jan 20/2006	1	Jan 20/2005	1	Jan 20/2005
4	Jan 20/2005	2	Jan 20/2005	2	Jan 20/2005
5	Feb 20/2005	57-10-01 ALLOWABLE DAMAGE 1		57-10-13 ALLOWABLE DAMAGE 1	
6	Jan 20/2006	101	Jan 20/2007	101	Jan 20/2007
7	Feb 20/2005	102	Jan 20/2005	102	Jan 20/2005
8	BLANK	103	Jan 20/2005	103	Jan 20/2005
57-00-00 GENERAL		104	BLANK	104	Jan 20/2005
1	Jan 20/2005	57-10-03 IDENTIFICATION 1		57-20-01 IDENTIFICATION 1	
2	Jan 20/2005	1	Jan 20/2005	1	Jan 20/2005
57-00-03 ALLOWABLE DAMAGE 1		2	Jan 20/2005	2	BLANK
101	Sep 20/2005	57-10-03 IDENTIFICATION 2		57-20-01 IDENTIFICATION 2	
102	Sep 20/2005	1	Jan 20/2005	1	Jan 20/2005
103	Sep 20/2005	2	Jan 20/2005	2	BLANK
104	BLANK	3	Jan 20/2005	57-20-01 ALLOWABLE DAMAGE 1	
57-00-03 REPAIR 1		4	Jan 20/2005	101	Sep 20/2006
201	Jan 20/2005	5	Jan 20/2005	102	Sep 20/2006
202	Jan 20/2005	6	BLANK	103	Sep 20/2006
203	Jan 20/2005	57-10-03 ALLOWABLE DAMAGE GENERAL		104	Sep 20/2006
204	BLANK	101	Jan 20/2005	105	Sep 20/2006
57-00-03 REPAIR 2		102	BLANK	106	Sep 20/2006
201	Jan 20/2005	57-10-03 REPAIR 1		107	Sep 20/2006
202	Jan 20/2005	201	Jan 20/2005	108	Sep 20/2006
203	Jan 20/2005	202	BLANK	57-20-01 ALLOWABLE DAMAGE 2	
204	Jan 20/2005	57-10-10 IDENTIFICATION 1		101	Jan 20/2005
57-00-03 REPAIR 3		1	Jan 20/2005	102	Jan 20/2005
201	Jan 20/2005	2	Jan 20/2005	57-20-01 REPAIR GENERAL	
202	Jan 20/2005	3	Jan 20/2005	201	Sep 20/2006
203	Jan 20/2005	4	BLANK	202	Sep 20/2006
204	Jan 20/2005	57-10-10 ALLOWABLE DAMAGE 1		57-20-01 REPAIR 1	
57-00-03 REPAIR 4		101	Jan 20/2005	201	Jan 20/2006
201	Jan 20/2005	102	Jan 20/2005	202	Jan 20/2005
202	Jan 20/2005	103	Jan 20/2005	203	Jan 20/2005
203	Jan 20/2005	104	Jan 20/2005	204	BLANK
204	Jan 20/2005				

A = Added, R = Revised, O = Overflow, D = Deleted

57-EFFECTIVE PAGES



**757-200
STRUCTURAL REPAIR MANUAL**

**CHAPTER 57
WINGS**

Subject/Page	Date	Subject/Page	Date	Subject/Page	Date
57-20-01 REPAIR 2		57-20-09 IDENTIFICATION 1 (cont)		57-20-10 IDENTIFICATION 1 (cont)	
201	Jan 20/2005	3	Jan 20/2005	6	Jan 20/2005
202	Jan 20/2005	4	Jan 20/2005	7	Jan 20/2005
203	Jan 20/2005	5	Jan 20/2005	8	BLANK
204	BLANK	6	Jan 20/2005	57-20-10 IDENTIFICATION 2	
57-20-01 REPAIR 3		7	Jan 20/2005	1	Jan 20/2005
201	Jan 20/2005	8	Jan 20/2005	2	Jan 20/2005
202	Jan 20/2005	9	Jan 20/2005	3	Jan 20/2005
203	Jan 20/2005	10	Jan 20/2005	4	Jan 20/2005
204	BLANK	11	Jan 20/2005	5	Jan 20/2005
57-20-01 REPAIR 4		12	Jan 20/2005	6	Jan 20/2005
201	Jan 20/2005	57-20-09 IDENTIFICATION 2		7	Jan 20/2005
202	Jan 20/2005	1	Jan 20/2005	8	BLANK
203	Jan 20/2005	2	Jan 20/2005	57-20-10 ALLOWABLE DAMAGE 1	
204	BLANK	3	Jan 20/2005	101	Sep 20/2006
57-20-01 REPAIR 5		4	BLANK	102	Sep 20/2006
201	Jan 20/2005	57-20-09 ALLOWABLE DAMAGE 1		103	Sep 20/2006
202	Jan 20/2005	101	Sep 20/2006	104	Sep 20/2006
203	Jan 20/2005	102	Sep 20/2006	105	Sep 20/2006
204	Jan 20/2005	103	Sep 20/2006	106	Sep 20/2006
205	Jan 20/2005	104	Sep 20/2006	107	Sep 20/2006
206	Jan 20/2005	105	Sep 20/2006	108	Sep 20/2006
57-20-03 IDENTIFICATION 1		106	BLANK	109	Sep 20/2006
1	Jan 20/2005	57-20-09 ALLOWABLE DAMAGE 2		110	BLANK
2	Jan 20/2005	101	Jan 20/2005	57-20-10 ALLOWABLE DAMAGE 2	
3	Jan 20/2005	102	Jan 20/2005	101	Sep 20/2006
4	BLANK	57-20-09 REPAIR 1		102	Sep 20/2006
57-20-03 IDENTIFICATION 2		201	Jan 20/2005	103	Sep 20/2006
1	Jan 20/2005	202	Jan 20/2005	104	Sep 20/2006
2	Jan 20/2005	203	Jan 20/2005	105	Sep 20/2006
57-20-03 ALLOWABLE DAMAGE GENERAL		204	BLANK	106	Sep 20/2006
101	Jan 20/2007	57-20-09 REPAIR 2		107	Sep 20/2006
102	Sep 20/2006	201	Jan 20/2005	108	BLANK
57-20-03 REPAIR GENERAL		202	Jan 20/2005	57-20-90 IDENTIFICATION 1	
201	Sep 20/2006	57-20-10 IDENTIFICATION 1		1	Jan 20/2005
202	Sep 20/2006	1	Jan 20/2005	2	Jan 20/2005
57-20-09 IDENTIFICATION 1		2	Jan 20/2005	3	Jan 20/2005
1	Jan 20/2005	3	Jan 20/2005	4	Jan 20/2005
2	Jan 20/2005	4	Jan 20/2005	5	Jan 20/2005
		5	Jan 20/2005	6	BLANK

A = Added, R = Revised, O = Overflow, D = Deleted

57-EFFECTIVE PAGES



**757-200
STRUCTURAL REPAIR MANUAL**

**CHAPTER 57
WINGS**

Subject/Page	Date	Subject/Page	Date	Subject/Page	Date
57-20-90 IDENTIFICATION 2		57-30-01 IDENTIFICATION 1 (cont)		57-41-01 ALLOWABLE DAMAGE 1 (cont)	
1	Jan 20/2005	2	BLANK	104	Jan 20/2005
2	Jan 20/2005	57-30-01 ALLOWABLE DAMAGE 1		105	Jan 20/2005
3	Jan 20/2005	101	Sep 20/2006	106	Jan 20/2005
4	BLANK	102	Sep 20/2006	107	Jan 20/2005
57-20-90 IDENTIFICATION 3		103	Sep 20/2006	108	Jan 20/2005
1	Jan 20/2005	104	Sep 20/2006	57-41-01 REPAIR GENERAL	
2	BLANK	57-30-01 REPAIR 1		201	Jan 20/2005
57-20-90 ALLOWABLE DAMAGE 1		201	Sep 20/2006	202	BLANK
101	Jan 20/2005	202	Sep 20/2006	57-41-01 REPAIR 1	
102	Jan 20/2005	203	Sep 20/2006	201	Jan 20/2005
103	Jan 20/2005	204	Sep 20/2006	202	Jan 20/2005
104	Jan 20/2005	57-30-02 IDENTIFICATION 1		203	Jan 20/2005
105	Jan 20/2005	1	Jan 20/2005	204	Jan 20/2005
106	Jan 20/2005	2	BLANK	205	Jan 20/2005
107	Jan 20/2005	57-30-02 ALLOWABLE DAMAGE 1		206	Jan 20/2006
108	Jan 20/2005	101	Sep 20/2006	207	Jan 20/2005
57-20-90 ALLOWABLE DAMAGE 2		102	Sep 20/2006	208	Jan 20/2005
101	Jan 20/2005	103	Sep 20/2006	57-41-09 IDENTIFICATION 1	
102	Jan 20/2005	104	Sep 20/2006	1	Jan 20/2005
103	Jan 20/2005	57-30-02 REPAIR GENERAL		2	Jan 20/2005
104	Jan 20/2005	201	Sep 20/2006	3	Jan 20/2005
57-20-90 ALLOWABLE DAMAGE 3		202	Sep 20/2006	4	Jan 20/2005
101	Jan 20/2005	57-41-01 IDENTIFICATION 1		5	Jan 20/2005
102	Jan 20/2005	1	Jan 20/2005	6	Jan 20/2005
103	Jan 20/2005	2	Jan 20/2005	7	Jan 20/2005
104	Jan 20/2005	3	Jan 20/2005	8	Jan 20/2005
57-20-90 REPAIR 1		4	Jan 20/2005	57-41-09 ALLOWABLE DAMAGE 1	
201	Jan 20/2005	5	Jan 20/2005	101	Jan 20/2007
202	Jan 20/2005	6	Jan 20/2005	102	Jan 20/2005
203	Jan 20/2005	7	Jan 20/2005	103	Jan 20/2005
204	Jan 20/2005	8	Jan 20/2005	104	Jan 20/2005
57-20-90 REPAIR 2		9	Jan 20/2005	105	Jan 20/2005
201	Jan 20/2005	10	Jan 20/2005	106	Jan 20/2005
202	BLANK	11	Jan 20/2005	107	Jan 20/2005
57-20-90 REPAIR 3		12	Jan 20/2005	108	Jan 20/2005
201	Jan 20/2005	57-41-01 ALLOWABLE DAMAGE 1		57-41-13 IDENTIFICATION 1	
202	BLANK	101	Jan 20/2007	1	Jan 20/2005
57-30-01 IDENTIFICATION 1		102	Jan 20/2005	2	Jan 20/2005
1	Jan 20/2005	103	Jan 20/2005		

A = Added, R = Revised, O = Overflow, D = Deleted

57-EFFECTIVE PAGES



**757-200
STRUCTURAL REPAIR MANUAL**

**CHAPTER 57
WINGS**

Subject/Page	Date	Subject/Page	Date	Subject/Page	Date
57-41-13 IDENTIFICATION 1 (cont)		57-43-02 IDENTIFICATION 1		57-51-01 IDENTIFICATION 1 (cont)	
3	Jan 20/2005	1	Jan 20/2005	15	Jan 20/2005
4	Jan 20/2005	2	Jan 20/2005	16	Jan 20/2005
57-41-13 ALLOWABLE DAMAGE 1		3	Jan 20/2005	17	Jan 20/2005
101	Jan 20/2007	4	Jan 20/2005	18	BLANK
102	Jan 20/2005	5	Jan 20/2005	57-51-01 IDENTIFICATION 2	
103	Jan 20/2005	6	Jan 20/2005	1	Jan 20/2005
104	Jan 20/2005	7	Jan 20/2005	2	Jan 20/2005
105	Jan 20/2005	8	Jan 20/2005	3	Jan 20/2005
106	BLANK	9	Jan 20/2005	4	Jan 20/2005
57-41-90 REPAIR GENERAL		10	Jan 20/2005	5	Jan 20/2005
201	Jan 20/2005	11	Jan 20/2005	6	Jan 20/2005
202	Jan 20/2005	12	BLANK	7	Jan 20/2005
203	Jan 20/2005	57-43-02 ALLOWABLE DAMAGE 1		8	Jan 20/2005
204	Jan 20/2005	101	Jan 20/2005	9	Jan 20/2005
205	Jan 20/2005	102	Jan 20/2005	10	Jan 20/2005
206	BLANK	103	Jan 20/2005	11	Jan 20/2005
57-43-01 IDENTIFICATION 1		104	Jan 20/2005	12	Jan 20/2005
1	Jan 20/2005	105	Jan 20/2005	13	Jan 20/2005
2	Jan 20/2005	106	Jan 20/2005	14	Jan 20/2005
3	Jan 20/2005	107	Jan 20/2005	57-51-01 ALLOWABLE DAMAGE 1	
4	Jan 20/2005	108	BLANK	101	Jan 20/2007
57-43-01 ALLOWABLE DAMAGE 1		57-43-02 REPAIR 1		102	Jan 20/2005
101	Jan 20/2007	201	Jan 20/2005	103	Jan 20/2005
102	Jan 20/2005	202	BLANK	104	Jan 20/2005
103	Jan 20/2005	57-51-01 IDENTIFICATION 1		57-51-01 REPAIR GENERAL	
104	Jan 20/2005	1	Jan 20/2005	201	Jan 20/2005
57-43-01 REPAIR GENERAL		2	Jan 20/2005	202	BLANK
201	Jan 20/2005	3	Jan 20/2005	57-51-01 REPAIR 1	
202	BLANK	4	Jan 20/2005	201	Jan 20/2005
57-43-01 REPAIR 1		5	Jan 20/2005	202	Jan 20/2005
201	Jan 20/2005	6	Jan 20/2005	203	Jan 20/2005
202	Jan 20/2005	7	Jan 20/2005	204	Jan 20/2005
203	Jan 20/2005	8	Jan 20/2005	205	Jan 20/2005
204	BLANK	9	Jan 20/2005	206	Jan 20/2005
57-43-01 REPAIR 2		10	Jan 20/2005	57-51-02 IDENTIFICATION 1	
201	Jan 20/2005	11	Jan 20/2005	1	Jan 20/2005
202	Jan 20/2005	12	Jan 20/2005	2	Jan 20/2005
203	Jan 20/2005	13	Jan 20/2005	3	Jan 20/2005
204	BLANK	14	Jan 20/2005	4	Jan 20/2005

A = Added, R = Revised, O = Overflow, D = Deleted

57-EFFECTIVE PAGES



**757-200
STRUCTURAL REPAIR MANUAL**

**CHAPTER 57
WINGS**

Subject/Page	Date	Subject/Page	Date	Subject/Page	Date
57-51-02 IDENTIFICATION 1 (cont)		57-51-70 IDENTIFICATION 0		57-53-01 IDENTIFICATION 1 (cont)	
5	Jan 20/2005	1	Jan 20/2005	7	Jan 20/2005
6	BLANK	2	Jan 20/2005	8	Jan 20/2005
57-51-02 ALLOWABLE DAMAGE 1		3	Jan 20/2005	9	Jan 20/2005
101	Jan 20/2005	4	Jan 20/2005	10	Jan 20/2005
102	Jan 20/2005	5	Jan 20/2005	11	Jan 20/2005
103	Jan 20/2005	6	BLANK	12	Jan 20/2005
104	Jan 20/2005	57-51-70 ALLOWABLE DAMAGE 1		13	Jan 20/2005
105	Jan 20/2005	101	Jan 20/2005	14	BLANK
106	Jan 20/2005	102	Jan 20/2005	57-53-01 ALLOWABLE DAMAGE 1	
107	Jan 20/2005	103	Jan 20/2005	101	Jan 20/2005
108	BLANK	104	BLANK	102	Jan 20/2005
57-51-02 REPAIR GENERAL		57-51-70 REPAIR 1		103	Jan 20/2005
201	Jan 20/2005	201	Jan 20/2005	104	Jan 20/2005
202	BLANK	202	Jan 20/2005	105	Jan 20/2005
57-51-09 IDENTIFICATION 1		203	Jan 20/2005	106	Jan 20/2005
1	Jan 20/2005	204	Jan 20/2005	107	Jan 20/2005
2	Jan 20/2005	205	Jan 20/2005	108	BLANK
3	Jan 20/2005	206	Jan 20/2005	57-53-01 REPAIR 1	
4	Jan 20/2005	57-51-71 IDENTIFICATION 1		201	Jan 20/2005
57-51-09 ALLOWABLE DAMAGE 1		1	Jan 20/2005	202	Jan 20/2006
101	Jan 20/2007	2	BLANK	203	Jan 20/2005
102	Jan 20/2005	57-51-71 ALLOWABLE DAMAGE 1		204	Jan 20/2005
103	Jan 20/2005	101	Jan 20/2005	205	Jan 20/2005
104	Jan 20/2005	102	Jan 20/2005	206	Jan 20/2005
105	Jan 20/2005	103	Jan 20/2005	57-53-01 REPAIR 2	
106	Jan 20/2005	104	Jan 20/2005	201	Jan 20/2005
57-51-14 IDENTIFICATION 1		57-51-90 REPAIR 1		202	Jan 20/2005
1	Jan 20/2005	201	Jan 20/2005	203	Jan 20/2005
2	Jan 20/2005	202	Jan 20/2005	204	BLANK
3	Jan 20/2005	57-51-90 REPAIR 2		57-53-01 REPAIR 3	
4	BLANK	201	Jan 20/2005	201	Jan 20/2005
57-51-14 ALLOWABLE DAMAGE 1		202	BLANK	202	Jan 20/2005
101	Jan 20/2005	57-53-01 IDENTIFICATION 1		203	Jan 20/2005
102	Jan 20/2005	1	Jan 20/2005	204	Jan 20/2005
103	Jan 20/2005	2	Jan 20/2005	57-53-01 REPAIR 4	
104	BLANK	3	Jan 20/2005	201	Feb 20/2005
57-51-14 REPAIR GENERAL		4	Jan 20/2005	202	Feb 20/2005
201	Jan 20/2005	5	Jan 20/2005	203	Feb 20/2005
202	BLANK	6	Jan 20/2005	204	Feb 20/2005

A = Added, R = Revised, O = Overflow, D = Deleted

57-EFFECTIVE PAGES



**757-200
STRUCTURAL REPAIR MANUAL**

**CHAPTER 57
WINGS**

Subject/Page	Date	Subject/Page	Date	Subject/Page	Date
57-53-01 REPAIR 4 (cont)		57-53-70 IDENTIFICATION 1		57-53-90 REPAIR GENERAL	
205	Feb 20/2005	1	Jan 20/2005	201	Jan 20/2005
206	Feb 20/2005	2	Jan 20/2005	202	BLANK
57-53-02 IDENTIFICATION 1		3	May 20/2008	57-60-01 IDENTIFICATION 1	
1	Jan 20/2005	4	Jan 20/2005	1	Jan 20/2005
2	Jan 20/2005	5	Jan 20/2005	2	Jan 20/2005
3	Jan 20/2005	6	Jan 20/2005	3	Jan 20/2005
4	Jan 20/2005	7	Jan 20/2005	4	BLANK
5	Jan 20/2005	8	BLANK	57-60-01 ALLOWABLE DAMAGE 1	
6	Jan 20/2005	57-53-70 ALLOWABLE DAMAGE 1		101	Jan 20/2005
7	Jan 20/2005	101	Jan 20/2005	102	Jan 20/2005
8	Jan 20/2005	102	Jan 20/2005	103	Jan 20/2005
57-53-02 IDENTIFICATION 2		103	Jan 20/2005	104	Jan 20/2005
1	Jan 20/2005	104	Jan 20/2005	57-60-01 REPAIR 1	
2	Sep 20/2007	57-53-70 REPAIR GENERAL		201	Jan 20/2005
3	Jan 20/2005	201	Jan 20/2005	202	Jan 20/2005
4	Jan 20/2005	202	BLANK	203	Jan 20/2005
57-53-02 ALLOWABLE DAMAGE 1		57-53-70 REPAIR 1		204	BLANK
101	Jan 20/2007	201	Jan 20/2005	57-60-02 IDENTIFICATION 1	
102	Jan 20/2005	202	Jan 20/2005	1	Jan 20/2005
103	Jan 20/2005	203	Jan 20/2005	2	Jan 20/2005
104	Jan 20/2005	204	Jan 20/2005	3	Jan 20/2005
105	Jan 20/2005	205	Jan 20/2005	4	BLANK
106	Jan 20/2005	206	Jan 20/2005	57-60-02 ALLOWABLE DAMAGE 1	
107	Jan 20/2005	57-53-71 IDENTIFICATION 1		101	Jan 20/2005
108	Jan 20/2005	1	Jan 20/2005	102	Jan 20/2005
57-53-02 ALLOWABLE DAMAGE 2		2	Jan 20/2005	103	Jan 20/2005
101	Jan 20/2005	3	Jan 20/2005	104	Jan 20/2005
102	Jan 20/2005	4	BLANK	105	Jan 20/2005
103	Jan 20/2005	57-53-71 ALLOWABLE DAMAGE 1		106	BLANK
104	Jan 20/2005	101	Jan 20/2005	57-60-02 REPAIR 1	
105	Jan 20/2005	102	Jan 20/2005	201	Jan 20/2005
106	BLANK	103	Jan 20/2005	202	Jan 20/2005
57-53-02 REPAIR 1		104	Jan 20/2005	203	Jan 20/2005
201	Jan 20/2005	57-53-90 IDENTIFICATION 0		204	BLANK
202	Jan 20/2005	1	Jan 20/2006	57-60-90 IDENTIFICATION 1	
57-53-02 REPAIR 2		2	BLANK	1	Jan 20/2005
201	Jan 20/2005	57-53-90 ALLOWABLE DAMAGE 1		2	BLANK
202	BLANK	101	Jan 20/2005	57-60-90 ALLOWABLE DAMAGE 1	
		102	BLANK	101	Jan 20/2005

A = Added, R = Revised, O = Overflow, D = Deleted

57-EFFECTIVE PAGES



**757-200
STRUCTURAL REPAIR MANUAL**

**CHAPTER 57
WINGS**

Subject/Page	Date	Subject/Page	Date	Subject/Page	Date
57-60-90 ALLOWABLE DAMAGE 1 (cont)		57-70-02 REPAIR 1			
102	BLANK	201	Jan 20/2005		
57-60-90 REPAIR GENERAL		202	Jan 20/2005		
201	Jan 20/2005	57-70-90 IDENTIFICATION 1			
202	BLANK	1	Jan 20/2005		
57-70-01 IDENTIFICATION 1		2	BLANK		
1	Jan 20/2005	57-70-90 ALLOWABLE DAMAGE 1			
2	Jan 20/2005	101	Jan 20/2005		
3	Jan 20/2005	102	BLANK		
4	Jan 20/2005	57-70-90 REPAIR GENERAL			
5	Jan 20/2005	201	Jan 20/2005		
6	Jan 20/2005	202	BLANK		
7	Jan 20/2005				
8	Jan 20/2005				
9	Jan 20/2005				
10	BLANK				
57-70-01 ALLOWABLE DAMAGE 1					
101	Jan 20/2005				
102	Jan 20/2005				
103	Jan 20/2005				
104	Jan 20/2005				
57-70-01 REPAIR 1					
201	Jan 20/2005				
202	Jan 20/2005				
203	Jan 20/2005				
204	BLANK				
57-70-02 IDENTIFICATION 1					
1	Jan 20/2005				
2	Jan 20/2005				
3	Jan 20/2005				
4	Jan 20/2005				
5	Jan 20/2005				
6	BLANK				
57-70-02 ALLOWABLE DAMAGE 1					
101	Jan 20/2005				
102	Jan 20/2005				
103	Jan 20/2005				
104	Jan 20/2005				

A = Added, R = Revised, O = Overflow, D = Deleted

57-EFFECTIVE PAGES



757-200
STRUCTURAL REPAIR MANUAL

CHAPTER 57
WINGS

<u>SUBJECT</u>	<u>CHAPTER SECTION SUBJECT</u>
<u>WINGS - GENERAL</u>	57-00-00
GENERAL - Wings	
<u>WING STRINGERS</u>	57-00-03
ALLOWABLE DAMAGE 1 - Wing Stringers	
REPAIR 1 - Wing Upper Zee Stringer Repair	
REPAIR 2 - Wing Upper "J" Stringer Repair - Skin Splice	
REPAIR 3 - Wing Upper Vent Stringer Repair	
REPAIR 4 - Wing Lower Zee Stringer Repair	
REPAIR 5 - Wing Lower "J" Stringer Repair - Skin Splice	
<u>CENTER WING SKINS</u>	57-10-01
IDENTIFICATION 1 - Center Wing Skin	
ALLOWABLE DAMAGE 1 - Center Wing Skin	
<u>CENTER WING STRINGERS</u>	57-10-03
IDENTIFICATION 1 - Center Wing Upper Stringer	
IDENTIFICATION 2 - Center Wing Lower Stringer	
ALLOWABLE DAMAGE GENERAL - Center Wing Stringers	
REPAIR 1 - Center Wing Stringer Repair	
<u>CENTER WING SPARS</u>	57-10-10
IDENTIFICATION 1 - Center Section Front And Rear Spar	
ALLOWABLE DAMAGE 1 - Wing Center Section Front And Rear Spars	
<u>CENTER WING BEAMS</u>	57-10-13
IDENTIFICATION 1 - Center Section Spanwise Beam	
IDENTIFICATION 2 - Center Wing Lower Internal Beam	
ALLOWABLE DAMAGE 1 - Center Section Spanwise Beam	
<u>OUTER WING SKINS</u>	57-20-01
IDENTIFICATION 1 - Outer Wing Upper Interspar Skin	
IDENTIFICATION 2 - Outer Wing Lower Interspar Skin	

57-CONTENTS



757-200
STRUCTURAL REPAIR MANUAL

CHAPTER 57
WINGS

CHAPTER
SECTION
SUBJECT

SUBJECT

ALLOWABLE DAMAGE 1 - Outer Wing Skin
ALLOWABLE DAMAGE 2 - Impact Resistant Fuel Tank Access Door
REPAIR GENERAL - Outer Wing Skin Panels
REPAIR 1 - Outer Wing Interspar Upper Skin Flush Repair Between Stringers
REPAIR 2 - Outer Wing Interspar Upper Skin Flush Repair at a Stringer
REPAIR 3 - Outer Wing Interspar Lower Skin Flush Repair Between Stringers
REPAIR 4 - Outer Wing Interspar Lower Skin Flush Repair at a Stringer
REPAIR 5 - Wing Skin Lower Surface Corrosion Repair at Fuel Tank Access Door
Cutouts

OUTER WING STRINGERS

57-20-03

IDENTIFICATION 1 - Outer Wing Upper Stringer
IDENTIFICATION 2 - Outer Wing Lower Stringer
ALLOWABLE DAMAGE GENERAL - Outer Wing Stringers
REPAIR GENERAL - Outer Wing Stringers Repair

OUTER WING RIBS

57-20-09

IDENTIFICATION 1 - Outer Wing Rib
IDENTIFICATION 2 - Fuel Dry Bay Barrier
ALLOWABLE DAMAGE 1 - Outer Wing Ribs
ALLOWABLE DAMAGE 2 - Fuel Dry Bay Barrier
REPAIR 1 - Fuel Dry Bay Barrier Repair
REPAIR 2 - Fuel Dry Bay Barrier Repair - Cracks at Door Fastener Holes

OUTER WING SPARS

57-20-10

IDENTIFICATION 1 - Outer Wing Rear Spar
IDENTIFICATION 2 - Outer Wing Front Spar
ALLOWABLE DAMAGE 1 - Outer Wing Rear Spar
ALLOWABLE DAMAGE 2 - Outer Wing Front Spar

OUTER WING ATTACHMENT FITTINGS

57-20-90

IDENTIFICATION 1 - Outer Wing Rear Spar Fitting

57-CONTENTS



757-200
STRUCTURAL REPAIR MANUAL

CHAPTER 57
WINGS

CHAPTER
SECTION
SUBJECT

SUBJECT

IDENTIFICATION 2 - Outer Wing Front Spar Fitting

IDENTIFICATION 3 - Terminal Fitting - BBL 70.50

ALLOWABLE DAMAGE 1 - Outer Wing Rear Spar Fittings

ALLOWABLE DAMAGE 2 - Outer Wing Front Spar Fittings

ALLOWABLE DAMAGE 3 - Terminal Fittings

REPAIR 1 - Outer Wing Rear Spar Fitting Repair

REPAIR 2 - Outer Wing Front Spar Fitting Repair

REPAIR 3 - Terminal Fitting Repair

WING TIP SKIN

57-30-01

IDENTIFICATION 1 - Wing Tip Skin

ALLOWABLE DAMAGE 1 - Wing Tip Skin

REPAIR 1 - Wing Tip Skin Repair

WING TIP STRUCTURE

57-30-02

IDENTIFICATION 1 - Wing Tip Structure

ALLOWABLE DAMAGE 1 - Wing Tip Structure

REPAIR GENERAL - Wing Tip Structure Repair

WING FIXED LEADING EDGE SKIN

57-41-01

IDENTIFICATION 1 - Wing Fixed Leading Edge Skin

ALLOWABLE DAMAGE 1 - Wing Fixed Leading Edge Skin

REPAIR GENERAL - Service Bulletin repair chart

REPAIR 1 - Wing Fixed Leading Edge Skin Repairs

WING FIXED LEADING EDGE RIBS

57-41-09

IDENTIFICATION 1 - Wing Fixed Leading Edge Rib

ALLOWABLE DAMAGE 1 - Wing Fixed Leading Edge Ribs

WING FIXED LEADING EDGE NOSE BEAM

57-41-13

IDENTIFICATION 1 - Wing Fixed Leading Edge Beam

ALLOWABLE DAMAGE 1 - Wing Fixed Leading Edge Beam

57-CONTENTS



757-200
STRUCTURAL REPAIR MANUAL

CHAPTER 57
WINGS

<u>SUBJECT</u>	<u>CHAPTER SECTION SUBJECT</u>
<u>WING FIXED LEADING EDGE RIB FITTING</u>	57-41-90
REPAIR GENERAL - Wing Fixed Leading Edge Rib Fitting Repair	
<u>LEADING EDGE SLAT SKIN</u>	57-43-01
IDENTIFICATION 1 - Leading Edge Slat Skin	
ALLOWABLE DAMAGE 1 - Leading Edge Slat Skin	
REPAIR GENERAL - Service Bulletin Repair Chart	
REPAIR 1 - Leading Edge Slats - Nose Skin Repairs	
REPAIR 2 - Outboard Leading Edge Slat Skin Flush Repair at a Nose Rib Forward of Nose Beam	
<u>LEADING EDGE FLAP STRUCTURE</u>	57-43-02
IDENTIFICATION 1 - Leading Edge Slat Structure	
ALLOWABLE DAMAGE 1 - Leading Edge Slat Structure	
REPAIR 1 - Leading Edge Slat - Trailing Edge Wedge Repairs	
<u>WING TRAILING EDGE SKIN</u>	57-51-01
IDENTIFICATION 1 - Wing Fixed Trailing Edge Skin - Upper Surface	
IDENTIFICATION 2 - Wing Fixed Trailing Edge Skin - Lower Surface	
ALLOWABLE DAMAGE 1 - Wing Fixed Trailing Edge Skin	
REPAIR GENERAL - Service Bulletin Repair Chart	
REPAIR 1 - Wing Fixed Trailing Edge Skin Repairs	
<u>WING TRAILING EDGE STRUCTURE</u>	57-51-02
IDENTIFICATION 1 - Wing Trailing Edge Structure	
ALLOWABLE DAMAGE 1 - Wing Trailing Edge Structure	
REPAIR GENERAL - Service Bulletin Repair Chart	
<u>WING TRAILING EDGE RIBS</u>	57-51-09
IDENTIFICATION 1 - Trailing Edge Rib	
ALLOWABLE DAMAGE 1 - Trailing Edge Rib	
<u>WING LANDING GEAR SUPPORT STRUCTURE</u>	57-51-14
IDENTIFICATION 1 - Main Landing Gear Support Beam	

57-CONTENTS



757-200
STRUCTURAL REPAIR MANUAL

CHAPTER 57
WINGS

<u>SUBJECT</u>	<u>CHAPTER SECTION SUBJECT</u>
ALLOWABLE DAMAGE 1 - Main Landing Gear Support Beam	
REPAIR GENERAL - Main Landing Gear Support Beam Repair	
<u>WING TRUNNION FAIRING SKIN</u>	57-51-70
IDENTIFICATION GENERAL - Trunnion Fairing Skin	
ALLOWABLE DAMAGE 1 - Trunnion Fairing Skin	
REPAIR 1 - Trunnion Fairing Skin Repair	
<u>WING TRUNNION FAIRING STRUCTURE</u>	57-51-71
IDENTIFICATION 1 - Trunnion Fairing Structure	
ALLOWABLE DAMAGE 1 - Trunnion Fairing Structure	
<u>WING TRAILING EDGE ATTACHMENT FITTINGS</u>	57-51-90
REPAIR 1 - Wing Trailing Edge Fitting Repair	
REPAIR 2 - Trunnion Fairing Fitting Repair	
<u>WING TRAILING EDGE FLAP SKIN</u>	57-53-01
IDENTIFICATION 1 - Trailing Edge Flap Skin	
ALLOWABLE DAMAGE 1 - Trailing Edge Flap Skin	
REPAIR 1 - Trailing Edge Flap Composite Skin Repair	
REPAIR 2 - Trailing Edge Flap Skin Aluminum Repair	
REPAIR 3 - Trailing Edge Flap Nose Skin Repair - Area Adjacent to a Nose Rib	
REPAIR 4 - Time Limited Repair - Main Flap - Out Board Trailing Edge - Out Board End Skin Panel	
<u>WING TRAILING EDGE FLAP STRUCTURE</u>	57-53-02
IDENTIFICATION 1 - Trailing Edge Flap Structure	
IDENTIFICATION 2 - Trailing Edge Flap Support Structure Identification	
ALLOWABLE DAMAGE 1 - Trailing Edge Flap Structure	
ALLOWABLE DAMAGE 2 - Trailing Edge Flap Support Structure	
REPAIR 1 - Trailing Edge Flap Structure - Aft Flap Spar Repairs	
REPAIR 2 - Trailing Edge Flap Support Structure Repair	

57-CONTENTS



757-200
STRUCTURAL REPAIR MANUAL

CHAPTER 57
WINGS

<u>SUBJECT</u>	<u>CHAPTER SECTION SUBJECT</u>
<u>WING TRAILING EDGE FLAP TRACK FAIRING SKIN</u>	57-53-70
IDENTIFICATION 1 - Flap Track Fairing Skin	
ALLOWABLE DAMAGE 1 - Flap Track Fairing Skin	
REPAIR GENERAL - Service Bulletin Repair Chart	
REPAIR 1 - Flap Track Fairing Skin Repairs	
<u>WING TRAILING EDGE FLAP TRACK FAIRING STRUCTURE</u>	57-53-71
IDENTIFICATION 1 - Flap Track Fairing Structure	
ALLOWABLE DAMAGE 1 - Flap Track Fairing Structure	
<u>WING TRAILING EDGE FLAP TRACK ATTACHMENT FITTINGS</u>	57-53-90
IDENTIFICATION GENERAL - Flap Track Fairing Fitting	
ALLOWABLE DAMAGE 1 - Flap Track Fairing Fitting	
REPAIR GENERAL - Flap Track Fairing Attachment Fittings Repair	
<u>AILERON SKIN</u>	57-60-01
IDENTIFICATION 1 - Aileron Skin	
ALLOWABLE DAMAGE 1 - Aileron Skin	
REPAIR 1 - Aileron Skin Repairs	
<u>AILERON STRUCTURE</u>	57-60-02
IDENTIFICATION 1 - Aileron Structure	
ALLOWABLE DAMAGE 1 - Aileron Structure	
REPAIR 1 - Aileron Spar and Outboard Closure Rib Repair	
<u>AILERON ATTACHMENT FITTINGS</u>	57-60-90
IDENTIFICATION 1 - Aileron Attachment Fittings	
ALLOWABLE DAMAGE 1 - Aileron Attachment Fittings	
REPAIR GENERAL - Aileron Attachment Fittings	
<u>SPOILER SKIN</u>	57-70-01
IDENTIFICATION 1 - Spoiler Skin	
ALLOWABLE DAMAGE 1 - Spoiler Skin	

57-CONTENTS



757-200
STRUCTURAL REPAIR MANUAL

CHAPTER 57
WINGS

<u>SUBJECT</u>	<u>CHAPTER SECTION SUBJECT</u>
REPAIR 1 - Spoiler Skin	
<u>SPOILER STRUCTURE</u>	57-70-02
IDENTIFICATION 1 - Spoiler Structure	
ALLOWABLE DAMAGE 1 - Spoiler Structure	
REPAIR 1 - Spoiler Spar	
<u>SPOILER ATTACHMENT FITTINGS</u>	57-70-90
IDENTIFICATION 1 - Spoiler Attachment Fittings	
ALLOWABLE DAMAGE 1 - Spoiler Attachment Fittings	
REPAIR GENERAL - Spoiler Attachment Fittings	

57-CONTENTS



757-200
STRUCTURAL REPAIR MANUAL

GENERAL - WINGS

1. General

A. This chapter contains information on allowable damage, identification, and repairs to the structural components of the wing, leading edge slats, trailing edge flaps, spoilers and the aileron.

2. References

Reference	Title
51-21-05, GENERAL	Repair Sealing - RB211-535 Engine Nacelle
51-60	CONTROL SURFACE BALANCING
51-60-01, GENERAL	Aileron Rebalance Procedures

3. Sealing

- A. The outer wing structure between the front and rear spars is sealed to form integral fuel tanks.
- B. Repairs to the wing involving the fuel tank area must be sealed. Refer to 51-21-05, GENERAL for sealing requirements and processes.

4. Control Surface Balancing

- A. Refer to CONTROL SURFACE BALANCING, SECTION/51-60 for general information on control surface balancing.
- B. Refer to 51-60-01, GENERAL for balance requirements and rebalancing instructions for the aileron.

757-200 STRUCTURAL REPAIR MANUAL

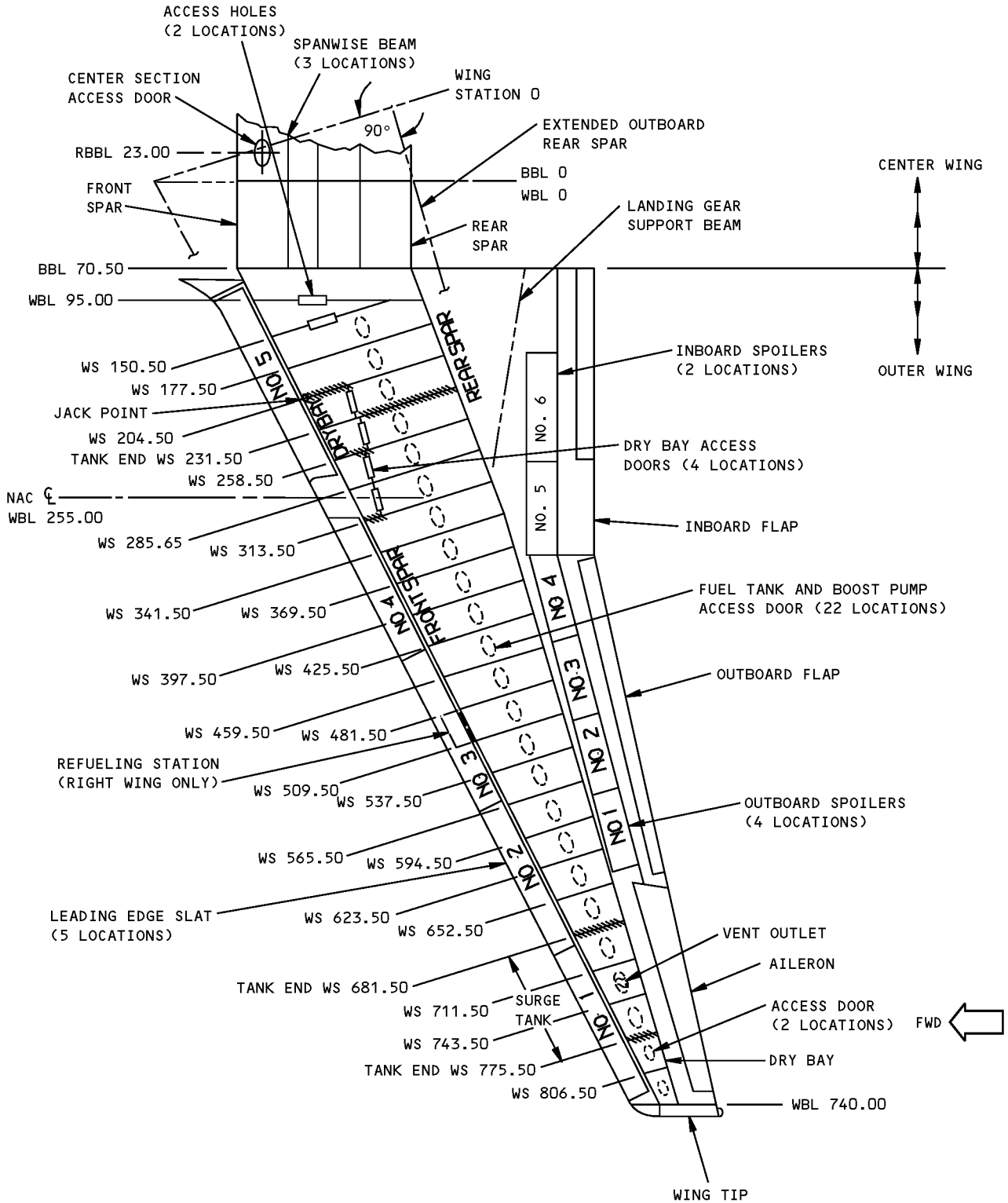

**Wing Station Diagram
Figure 1**

**757-200
STRUCTURAL REPAIR MANUAL**

ALLOWABLE DAMAGE 1 - WING STRINGERS

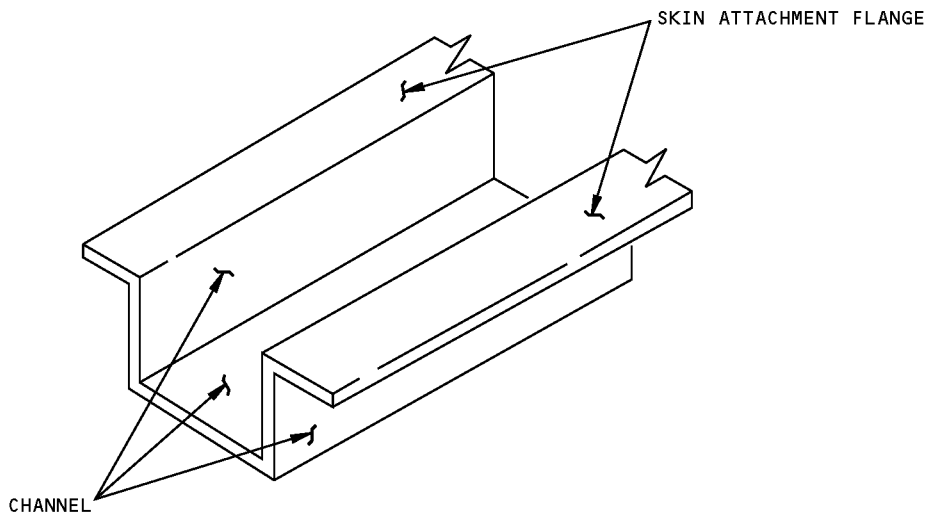
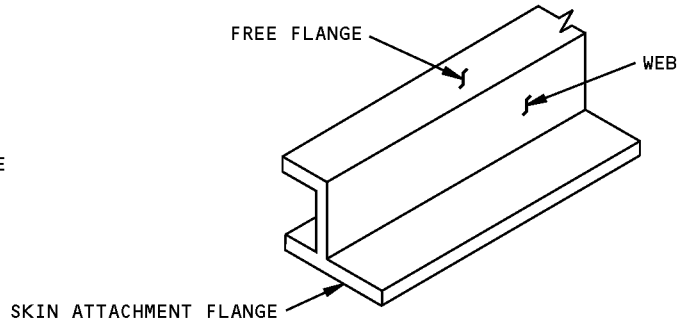
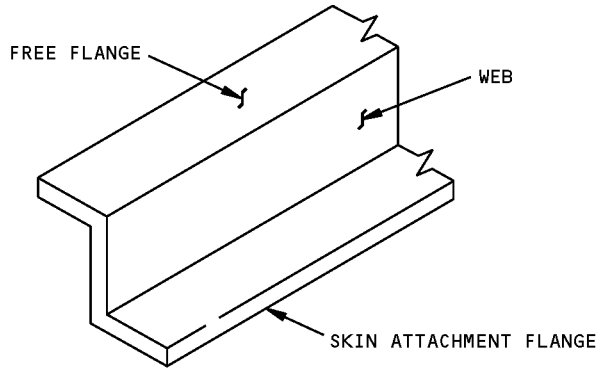

TYPICAL STRINGER SECTIONS

DESCRIPTION	CRACKS	NICKS, GOUGES AND CORROSION	DENTS	HOLES AND PUNCTURES
FREE FLANGE	A	B	NOT ALLOWED	C
SKIN ATTACHMENT FLANGE	A	B	NOT ALLOWED	NOT ALLOWED
WEB	NOT ALLOWED	B	NOT ALLOWED	C
CHANNEL	D	B	NOT ALLOWED	C

**Wing Stringers Allowable Damage
Figure 101 (Sheet 1 of 3)**

STRUCTURAL REPAIR MANUAL

NOTES

WARNING: FUEL VAPORS ARE HAZARDOUS AND EXPLOSIVE. PURGE AND VENTILATE THE FUEL TANKS PER 28-11 OF THE 757 MAINTENANCE MANUAL BEFORE ENTERING FUEL TANKS.

- REFINISH REWORKED AREAS PER 51-20 OF THE MAINTENANCE MANUAL
- SHOT PEEN REWORKED AREAS PER 51-20-06
- THE TOTAL CROSS-SECTIONAL AREA REMOVED BY ANY TYPE OF DAMAGE CLEANUP MUST NOT EXCEED 10 PERCENT OF THE ORIGINAL CROSS-SECTIONAL AREA OF THE STRINGER. SEE DETAIL IV

- A** CRACKS NOT ALLOWED EXCEPT FOR EDGE CRACKS WHICH MUST BE REMOVED PER DETAILS I AND III
- B** REMOVE DAMAGE PER DETAILS I, II AND III
- C** CLEAN OUT DAMAGE UP TO 0.25 DIA (NOMINAL) MAX AND NOT CLOSER THAN 1.0 TO FASTENER HOLE OR OTHER DAMAGE, OR CLOSER THAN 0.50 TO MATERIAL EDGE. COLD WORK HOLES USING LOW INTERFERENCE PROCESS PER 51-40-09. FILL HOLES WITH 2117-T3 OR T4 ALUMINUM RIVET INSTALLED WET WITH BMS 5-95 SEALANT. ALL OTHER HOLES TO BE REPAIRED
- D** CRACKS NOT ALLOWED EXCEPT FOR EDGE CRACKS IN VENT HOLES WHICH MUST BE REMOVED PER DETAILS I AND III

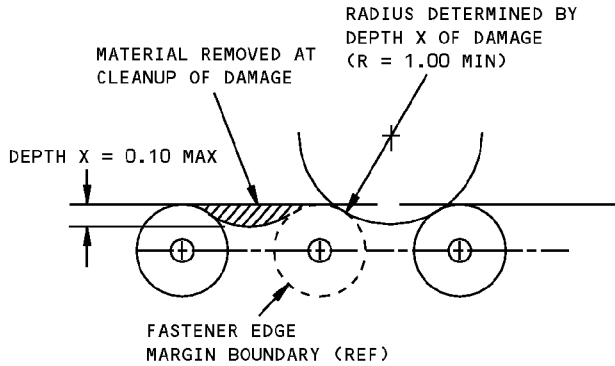

DAMAGE CLEANUP OF EDGES WHERE FASTENER EDGE MARGINS DO NOT OVERLAP

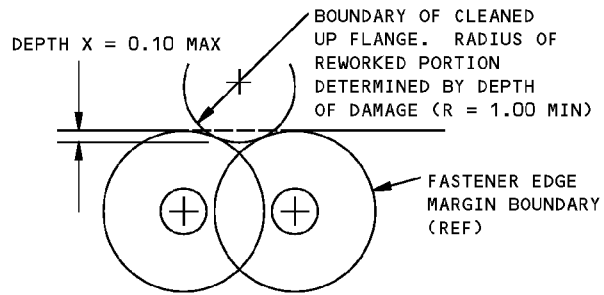

DAMAGE CLEANUP OF EDGES WHERE FASTENER EDGE MARGINS OVERLAP

DETAIL I

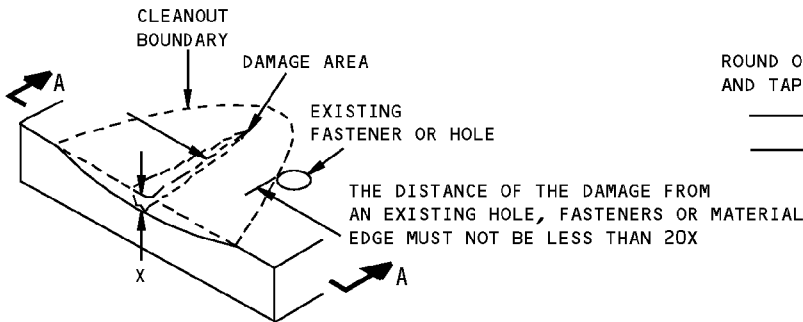

REMOVAL OF NICK, GOUGE AND SCRATCH DAMAGE ON A SURFACE
DETAIL II

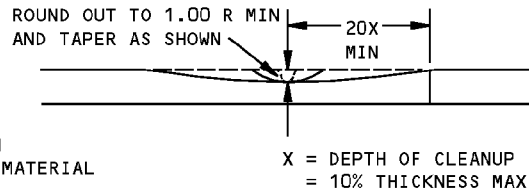

SECTION A-A

Wing Stringers Allowable Damage
Figure 101 (Sheet 2 of 3)

**757-200
STRUCTURAL REPAIR MANUAL**

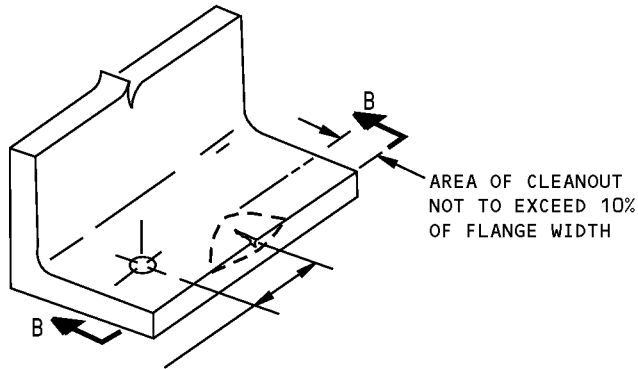

THE DISTANCE OF THE DAMAGE FROM AN EXISTING HOLE, FASTENERS OR EDGE MUST NOT BE LESS THAN 20X

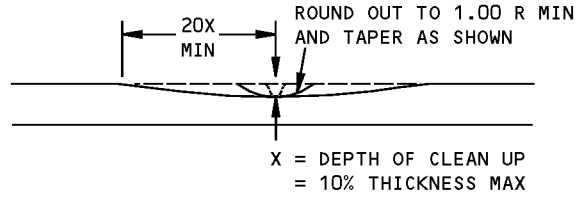

SECTION B-B

**REMOVAL OF NICK OR CRACK DAMAGE ON AN EDGE
DETAIL III**

LOSS IN CROSS-SECTIONAL AREA ALONG ANY LINE A-B OR C-D DUE TO REMOVAL OF ANY TYPE OF DAMAGE MUST NOT EXCEED 10 PERCENT OF ORIGINAL NET CROSS-SECTIONAL AREA OF STRINGER. THIS LOSS OF AREA IS LIMITED TO TWO ADJACENT STRINGERS IF DAMAGE IS LESS THAN 1.5 INCHES APART IN THE SPANWISE DIRECTION

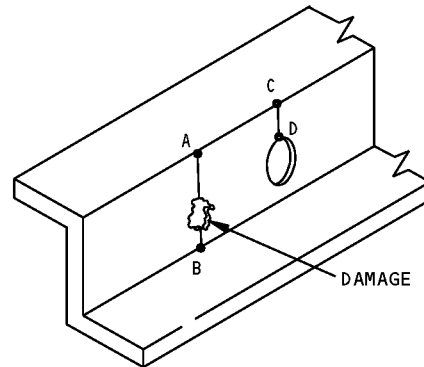

DETAIL IV

**Wing Stringers Allowable Damage
Figure 101 (Sheet 3 of 3)**

757-200
STRUCTURAL REPAIR MANUAL

REPAIR 1 - WING UPPER ZEE STRINGER REPAIR

REPAIR INSTRUCTIONS

WARNING: FUEL VAPORS ARE HAZARDOUS AND EXPLOSIVE. PURGE AND VENTILATE THE FUEL TANKS PER 28-11 OF THE 757 MAINTENANCE MANUAL BEFORE ENTERING FUEL TANKS.

1. Cut and remove damaged portion of stringer. See note **E**. If skin is damaged see 57-10-01 or 57-20-01.
2. Make repair parts.
3. Assemble the repair parts and drill the fastener holes.
4. Remove the repair parts.
5. Break sharp edge of original and repair parts 0.015R to 0.030R.
6. Remove all nicks, scratches, burrs, sharp edges and corners from original and repair parts.
7. Shot peen the cut edges of stringer per 51-20-06.
8. Alodize the repair parts and the cut edges of the original parts per 51-20-01.
9. Apply BMS 10-20, type 2 protective coating to the repair parts and the cut edges of the original parts in accordance with 28-11-00 of the 757 Maintenance Manual.
10. Install the repair parts making a faying surface seal with BMS 5-26 per 51-20-05. Install fasteners wet with BMS 5-26 sealant.
11. Restore original finish per 51-21 of the 757 Maintenance Manual.

NOTES

- REMOVE AND INSTALL ACCESS DOORS PER 28-11 OF THE 757 MAINTENANCE MANUAL
- REFER TO THE FOLLOWING WHEN USING THIS REPAIR:
 - 51-20-01 FOR PROTECTIVE TREATMENT OF METAL
 - 51-20-05 FOR SEALING OF REPAIRS
 - 51-40 FOR FASTENER CODE, REMOVAL, INSTALLATION, HOLE SIZES AND EDGE MARGINS
 - 51-21 OF THE 757 MAINTENANCE MANUAL FOR INTERIOR AND EXTERIOR FINISHES
 - 51-31 OF THE 757 MAINTENANCE MANUAL FOR SEALS AND SEALING
- D = FASTENER DIAMETER
- MACHINE REPAIR PARTS TO 125 MICROINCHES
- A** START TAPER BETWEEN THE FIRST AND SECOND FASTENER FROM THE STRINGER JOINT. TAPER TO 0.07 MIN AT EXTREMITY. TAPER MUST BE 20 TO 1 OR GREATER, I.E., 5% MAX ALLOWABLE SLOPE
- B** MAKE FROM AVAILABLE EXTRUSION. THICKNESS OF REPAIR ANGLES IN THE UNTAPERED AREA MUST BE EQUAL TO OR GREATER THAN THE THICKNESS OF THE ORIGINAL STRINGER
- C** USE SAME SIZE FASTENER AS ORIGINAL. IF FASTENER HOLE IS DAMAGED USE 1/32 OVER-SIZE
- D** USE SAME SIZE FASTENER AS ORIGINAL SKIN FASTENER
- E** USE DETAIL I WHEREVER POSSIBLE. WHERE REPAIR PARTS INTERFERE WITH RIB PADS USE DETAIL II

SYMBOLS

-  REPAIR FASTENER LOCATION

Wing Upper Zee Stringer Repair
Figure 201 (Sheet 1 of 3)

**757-200
STRUCTURAL REPAIR MANUAL**

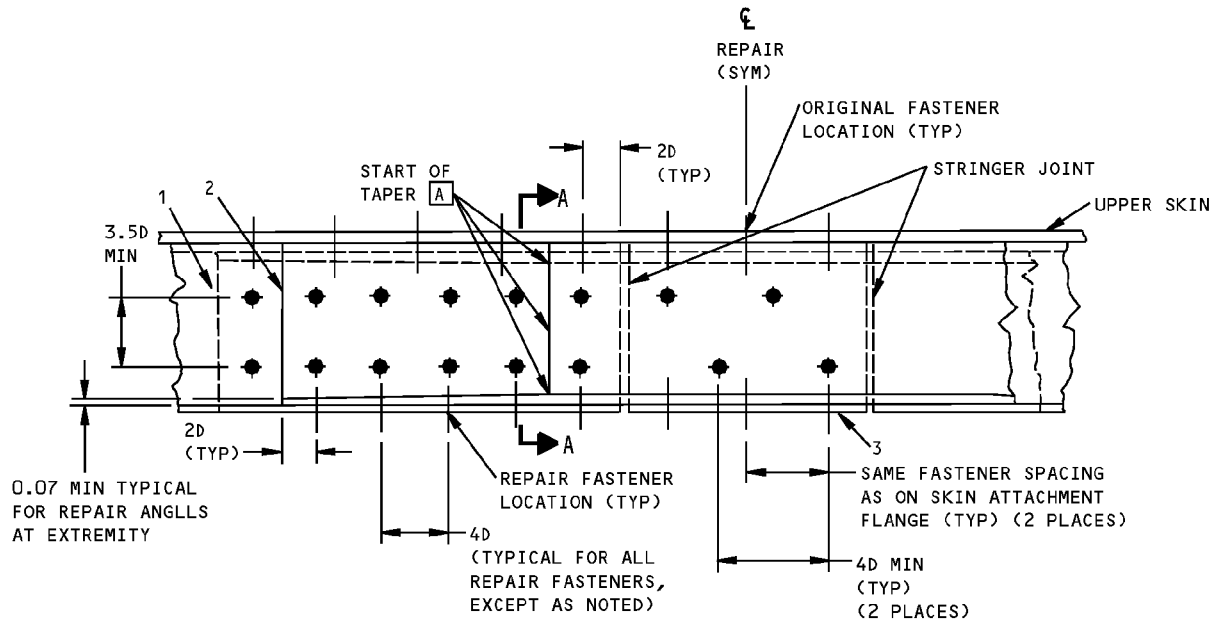

DETAIL I E

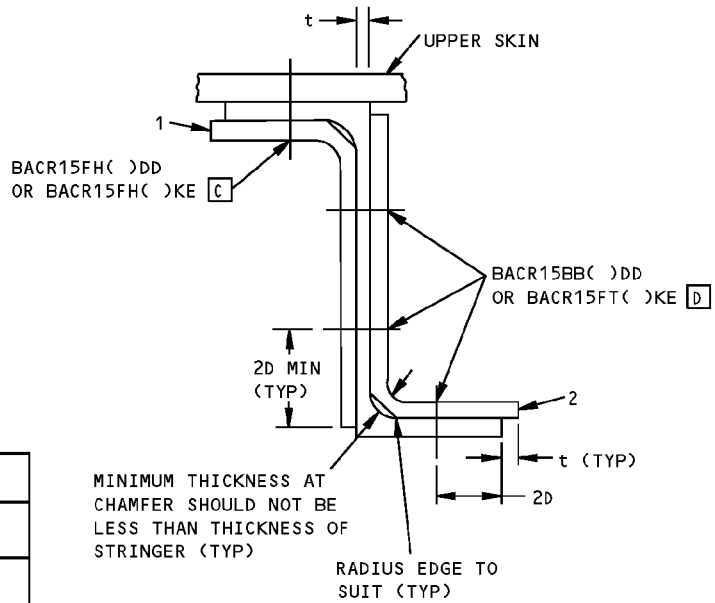

SECTION A-A

REPAIR MATERIAL			
PART	QTY	MATERIAL	
1	ANGLE	1	7150-T76511 B OPT: 7075-T6 OR T651
2	ANGLE	1	7150-T76511 B OPT: 7075-T6 OR T651
3	FILLER	1	SAME AS ORIGINAL STRINGER

**Wing Upper Zee Stringer Repair
Figure 201 (Sheet 2 of 3)**

**757-200
STRUCTURAL REPAIR MANUAL**

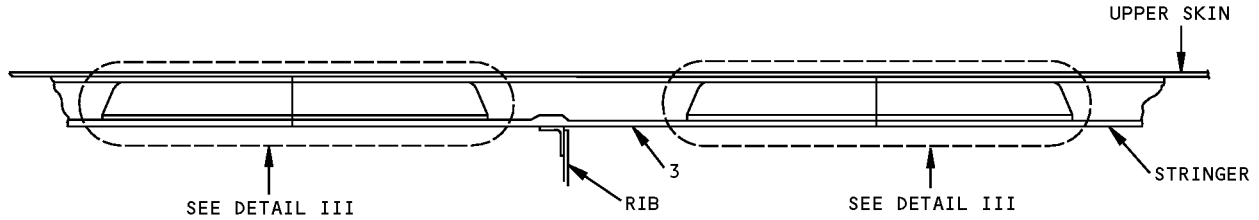

**ALTERNATE REPAIR INSTALLATION FOR
DAMAGE NEAR RIBS
DETAIL II [E]**

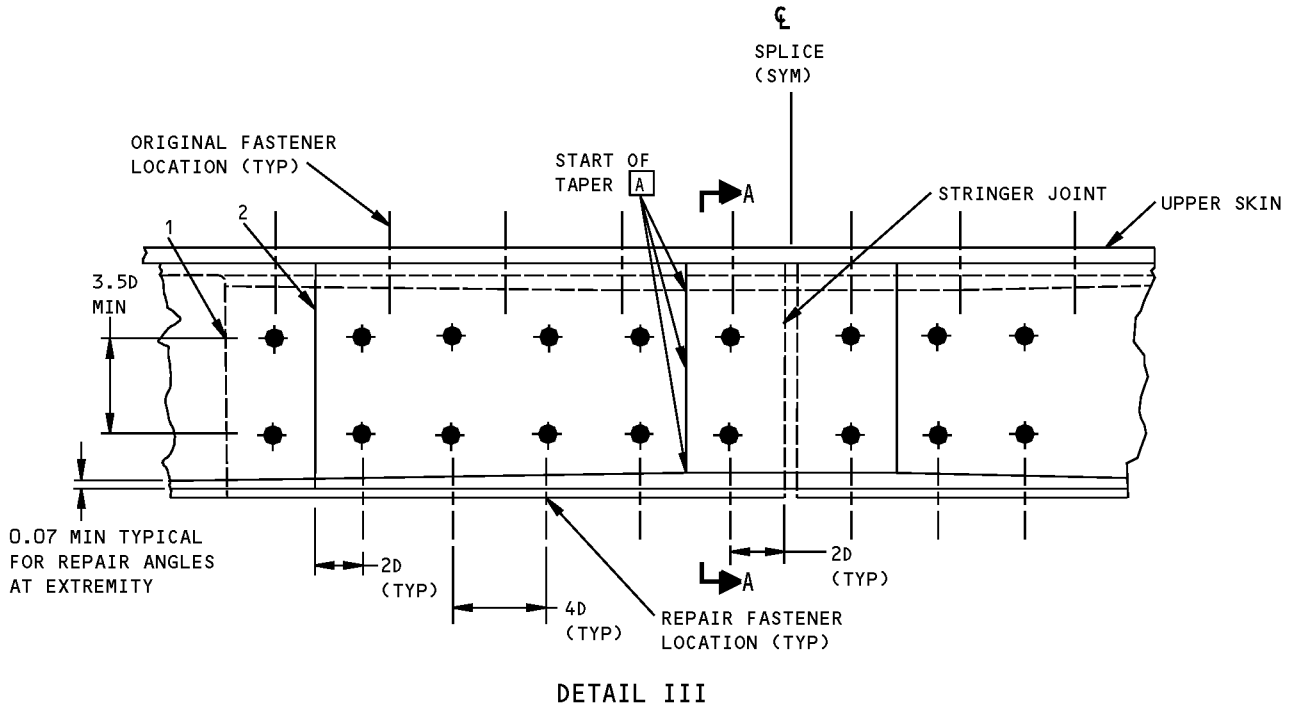

**Wing Upper Zee Stringer Repair
Figure 201 (Sheet 3 of 3)**

757-200
STRUCTURAL REPAIR MANUAL

REPAIR 2 - WING UPPER "J" STRINGER REPAIR - SKIN SPLICE

REPAIR INSTRUCTIONS



WARNING: FUEL VAPORS ARE HAZARDOUS AND EXPLOSIVE. PURGE AND VENTILATE THE FUEL TANKS PER 28-11 OF THE 757 MAINTENANCE MANUAL BEFORE ENTERING FUEL TANKS.

1. Cut and remove damaged portion of stringer. See note **D**. If skin is damaged see 57-10-01 or 57-20-01.
2. Make the repair parts.
3. Assemble the repair parts and drill the fastener holes.
4. Remove the repair parts.
5. Break sharp edge of original and repair parts 0.015R to 0.030R.
6. Remove all nicks, scratches, burrs, sharp edges and corners from original and repair parts.
7. Shot peen the cut edges of stringer per 51-20-06.
8. Alodize the repair parts and the cut edges of the original parts per 51-20-01.
9. Apply BMS 10-20, type 2 protective coating to the repair parts and the cut edges of the original parts in accordance with 28-11-00 of the 757 Maintenance Manual.
10. Install the repair parts making a faying surface seal with BMS 5-26 per 51-20-05. Install fasteners wet with BMS 5-26 sealant. Care must be taken to ensure the channels formed at the stringer joints are kept clear for sealant injection.
11. Seal the repair per 51-20-05.
12. Install the fasteners, in the positions indicated, at the stringer joint lines.
13. Restore the original finish per 51-21 of the 757 Maintenance Manual.

NOTES

- REMOVE AND INSTALL ACCESS DOORS PER 28-11 OF THE 757 MAINTENANCE MANUAL
- D = FASTENER DIAMETER
- MACHINE REPAIR PARTS TO 125 MICROINCHES
- REFER TO THE FOLLOWING WHEN USING THIS REPAIR:
 - 51-20-01 FOR PROTECTIVE TREATMENT OF METAL
 - 51-20-05 FOR SEALING OF REPAIRS
 - 51-40 FOR FASTENER CODE, REMOVAL, INSTALLATION, HOLE SIZES AND EDGE MARGINS
 - 51-21 OF THE 757 MAINTENANCE MANUAL FOR INTERIOR AND EXTERIOR FINISHES
 - 51-31 OF THE 757 MAINTENANCE MANUAL FOR SEALS AND SEALING
- A** START TAPER BETWEEN THE FIRST AND SECOND FASTENER FROM THE STRINGER JOINT. TAPER TO 0.04 AT THE EXTREMITY. TAPER MUST BE 20 TO 1 OR GREATER, I.E., 5% MAX ALLOWABLE SLOPE
- B** BACB30MY8K() WITH BACC30AG8 MAY BE USED AS AN ALTERNATIVE. DO NOT MIX RIVETS AND HI-LOKS IN THE SAME REPAIR
- C** IF FASTENER HOLE IS DAMAGED USE 1/32 OVER-SIZE
- D** USE DETAIL I WHEREVER POSSIBLE. WHERE REPAIR PARTS INTERFERE WITH RIB PADS USE DETAIL II

SYMBOLS

-  ORIGINAL FASTENER LOCATION
-  REPAIR FASTENER LOCATION

Wing Upper "J" Stringer Repair - Skin Splice
Figure 201 (Sheet 1 of 4)

**757-200
STRUCTURAL REPAIR MANUAL**

REPAIR MATERIAL			
PART		QTY	MATERIAL
1	PLATE	1	7150-T6511 OPT: 7075-T6 OR T651
2	PLATE	1	7150-T6511 OPT: 7075-T6 OR T651
3	PLATE	1	0.13 7150-T6511 OPT: 7075-T6 OR T651
4	PLATE	1	0.13 7150-T6511 OPT: 7075-T6 OR T651
5	PLATE	1	0.17 7150-T6511 OPT: 7075-T6 OR T651
6	FILLER	1	SAME AS ORIGINAL STRINGER

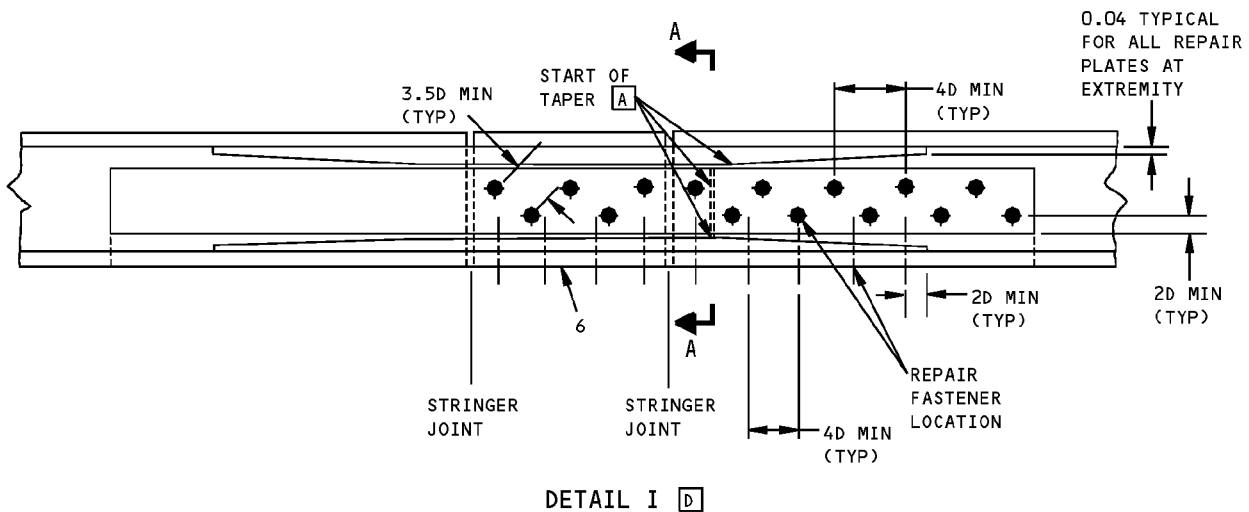

**Wing Upper "J" Stringer Repair - Skin Splice
Figure 201 (Sheet 2 of 4)**

**757-200
STRUCTURAL REPAIR MANUAL**

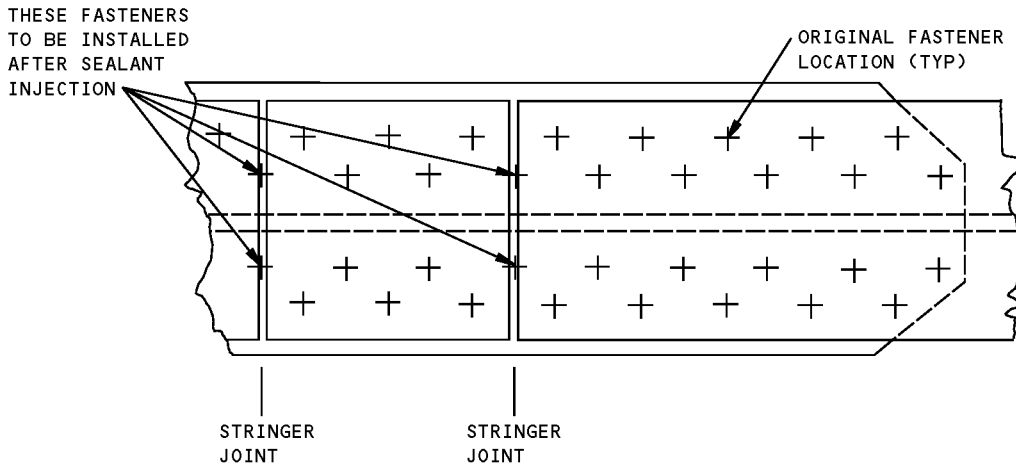

**VIEW OF TOP FLANGE
(SKIN NOT SHOWN)**

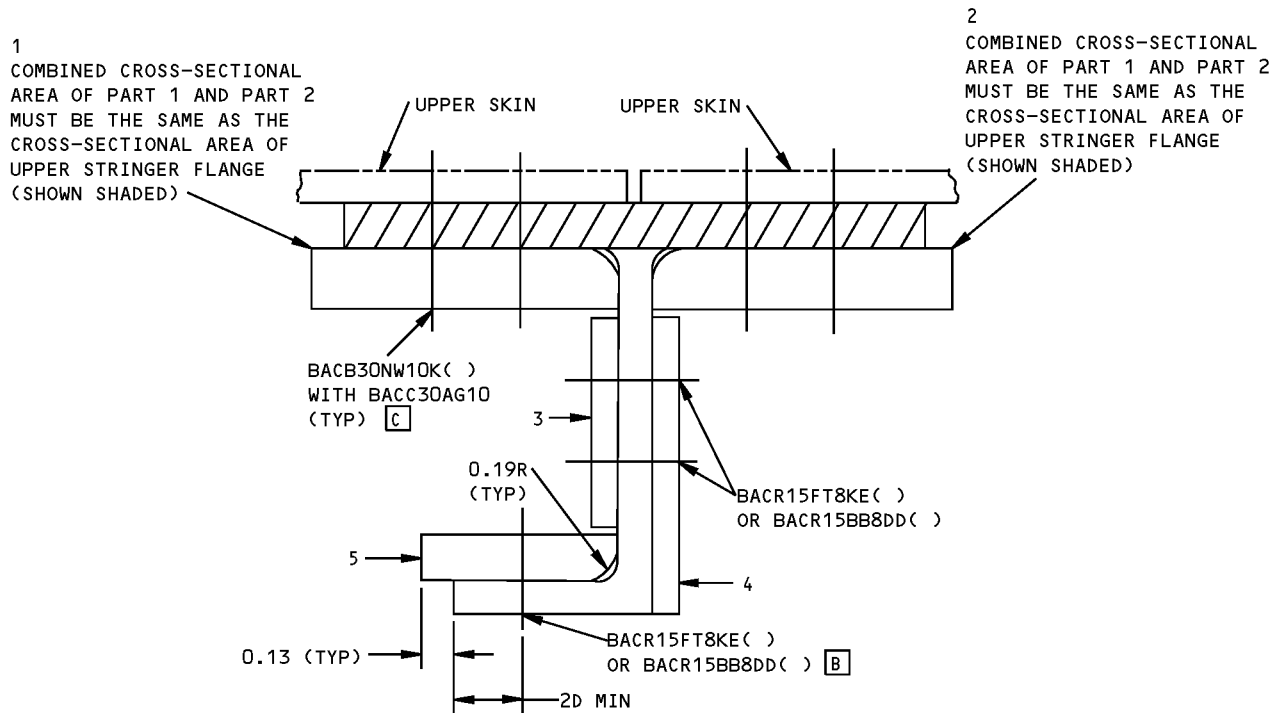

SECTION A-A

**Wing Upper "J" Stringer Repair - Skin Splice
Figure 201 (Sheet 3 of 4)**

**757-200
STRUCTURAL REPAIR MANUAL**

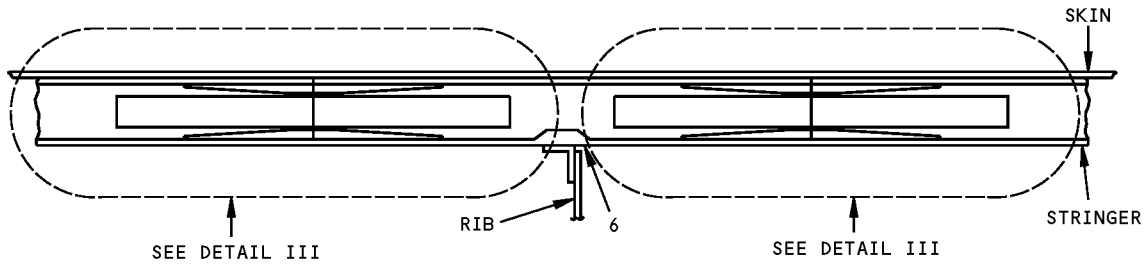

**ALTERNATE REPAIR INSTALLATION FOR
DAMAGE NEAR RIBS**

DETAIL II D

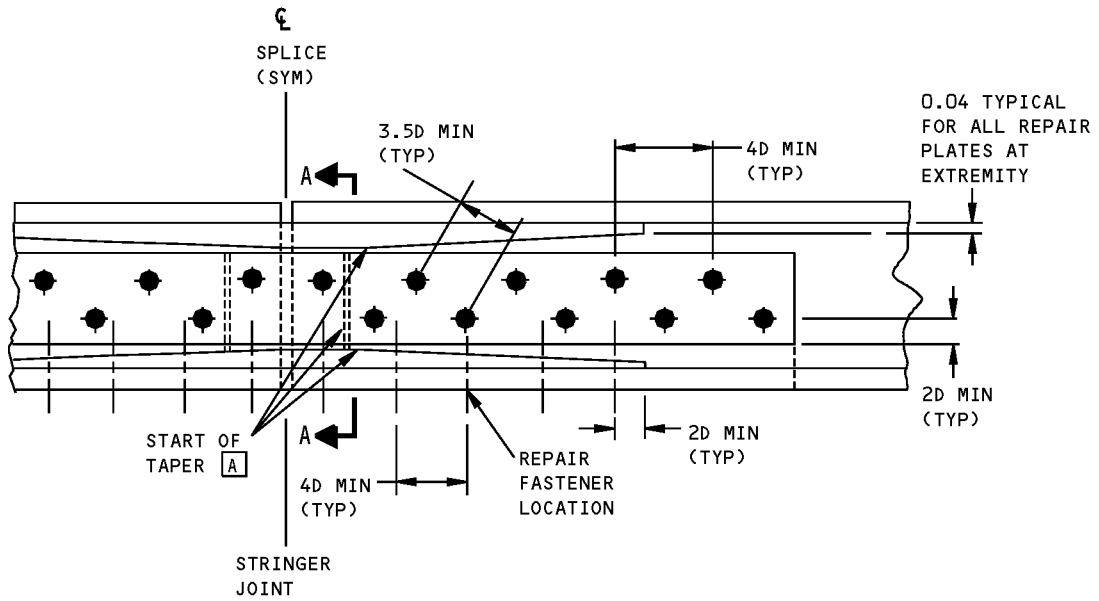

DETAIL III

**Wing Upper "J" Stringer Repair - Skin Splice
Figure 201 (Sheet 4 of 4)**

757-200
STRUCTURAL REPAIR MANUAL

REPAIR 3 - WING UPPER VENT STRINGER REPAIR

REPAIR INSTRUCTIONS

WARNING: FUEL VAPORS ARE HAZARDOUS AND EXPLOSIVE. PURGE AND VENTILATE THE FUEL TANKS PER 28-11 OF THE 757 MAINTENANCE MANUAL BEFORE ENTERING FUEL TANKS.

1. Cut and remove the damaged portion of stringer. If skin is damaged refer to 57-10-01 or 57-20-01.
2. Make the repair parts.
3. Assemble the repair parts and drill the fastener holes.
4. Remove the repair parts.
5. Break sharp edges of original and repair parts 0.015R to 0.030R.
6. Remove all nicks, scratches, burrs, sharp edges and corners from original and repair parts.
7. Shot peen the cut edges of stringer per 51-20-06.
8. Alodize the repair parts and the cut edges of the original parts per 51-20-01.
9. Apply BMS 10-20, type 2 protective coating to the repair parts and the cut edges of the original parts in accordance with 28-11-00 of the 757 Maintenance Manual.
10. Install the repair parts making a faying surface seal with BMS 5-26. Install the fasteners wet with BMS 5-26.
11. Seal the repair per 51-20-05.
12. Restore the original finish per 51-21 of the 757 Maintenance Manual.

- REFER TO THE FOLLOWING WHEN USING THIS REPAIR:
 - 51-20-01 FOR PROTECTIVE TREATMENT OF METAL
 - 51-20-05 FOR SEALING OF REPAIRS
 - 51-40 FOR FASTENER CODE, REMOVAL, INSTALLATION, HOLE SIZES AND EDGE MARGINS
 - 51-21 OF THE 757 MAINTENANCE MANUAL FOR INTERIOR AND EXTERIOR FINISHES
 - 51-31 OF THE 757 MAINTENANCE MANUAL FOR SEALS AND SEALING

- A** START TAPER BETWEEN THE FIRST AND SECOND FASTENER FROM THE STRINGER JOINT. TAPER TO 0.04 MIN AT THE EXTREMITY. TAPER MUST BE 20 TO 1 OR GREATER, I.E., 5% MAX SLOPE ALLOWABLE
- B** USE SAME SIZE FASTENER AS ORIGINAL. IF FASTENER HOLE IS DAMAGED, USE 1/32 OVERSIZE
- C** USE SAME SIZE FASTENER AS ORIGINAL SKIN TO STRINGER ATTACHMENT FASTENER

SYMBOLS

- + ORIGINAL FASTENER LOCATION
- ⊕ REPAIR FASTENER LOCATION

NOTES

- REMOVE AND INSTALL ACCESS DOORS PER 28-11 OF THE MAINTENANCE MANUAL
- D = FASTENER DIAMETER
- MACHINE REPAIR PARTS TO 125 MICROINCHES AA

Wing Upper Vent Stringer Repair
Figure 201 (Sheet 1 of 4)



757-200
STRUCTURAL REPAIR MANUAL

REPAIR MATERIAL			
PART		QTY	MATERIAL
1	PLATE	1	7150-T6511 OPT: 7075-T6 OR T651
2	PLATE	1	7150-T6511 OPT: 7075-T6 OR T651
3	PLATE	1	7150-T6511 OPT: 7075-T6 OR T651
4	PLATE	1	7150-T6511 OPT: 7075-T6 OR T651
5	PLATE	1	7150-T6511 OPT: 7075-T6 OR T651
6	FILLER	1	SAME AS ORIGINAL STRINGER

Wing Upper Vent Stringer Repair
Figure 201 (Sheet 2 of 4)

D634N201

57-00-03

REPAIR 3
Page 202
Jan 20/2005

STRUCTURAL REPAIR MANUAL

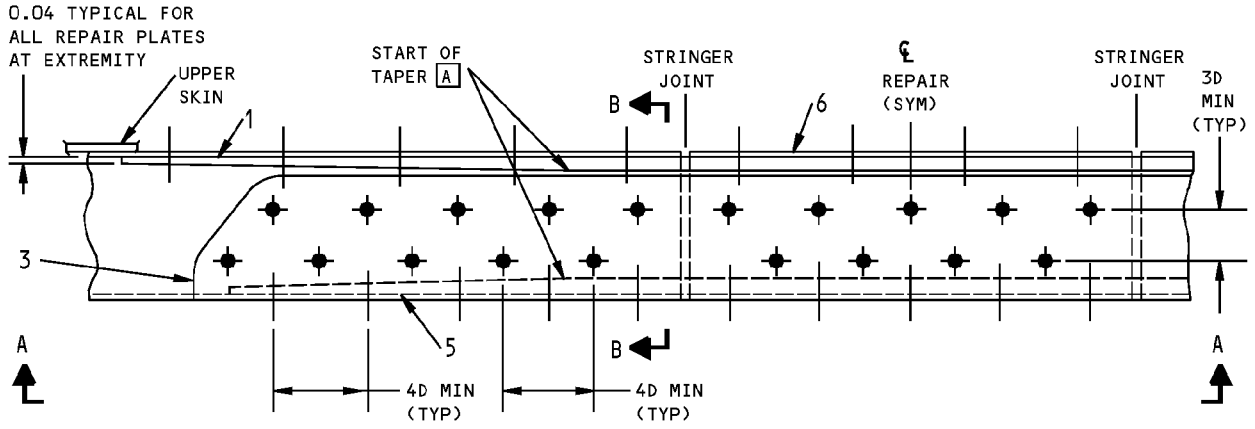

DETAIL I

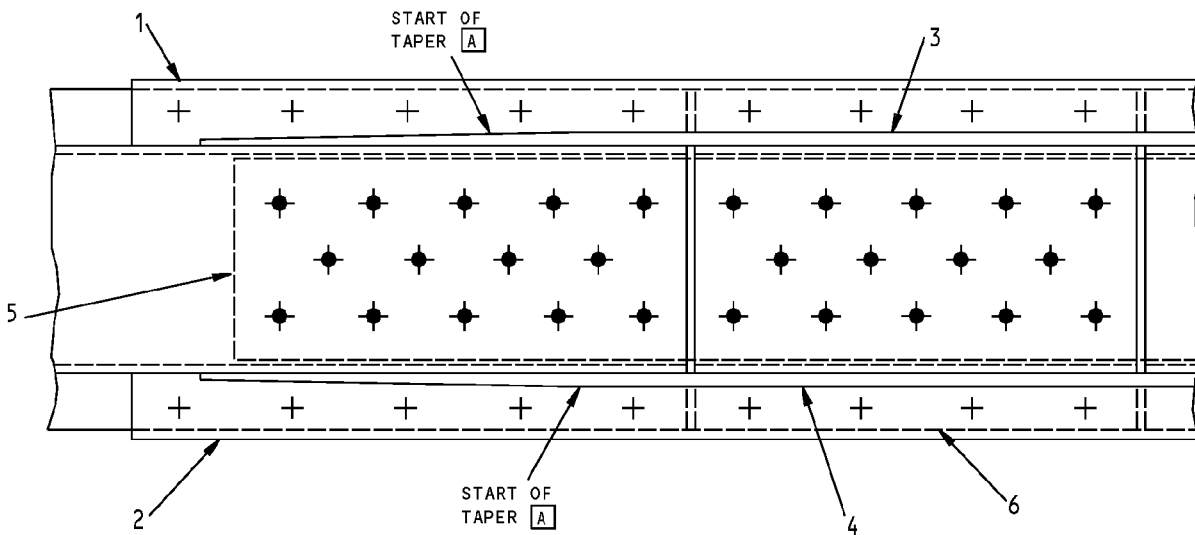

SECTION A-A

**Wing Upper Vent Stringer Repair
Figure 201 (Sheet 3 of 4)**

**757-200
STRUCTURAL REPAIR MANUAL**

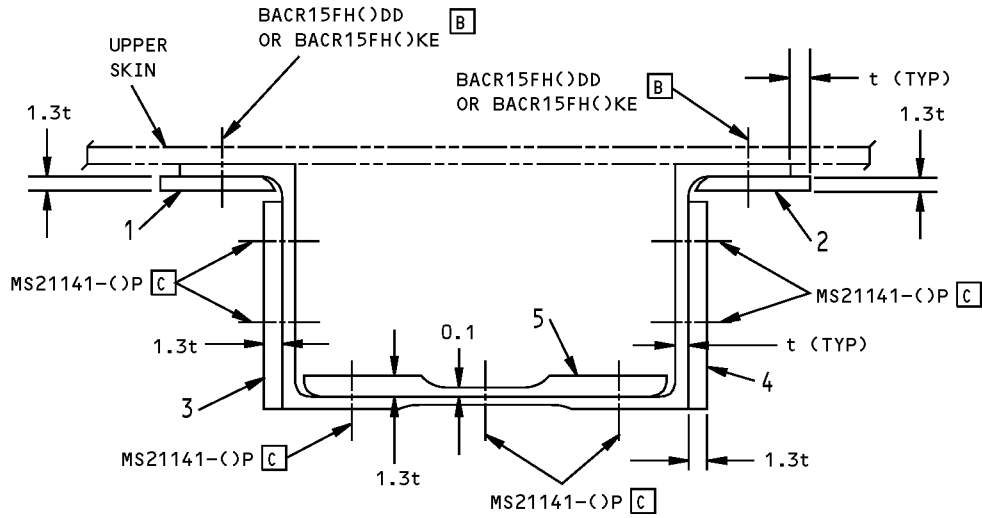

TYPICAL SECTION THROUGH REPAIR IN UNTAPERED AREA
(FOR SECTION OF STRINGER WITH RIB ATTACHMENT TAB, SEE DETAIL II)

SECTION B-B

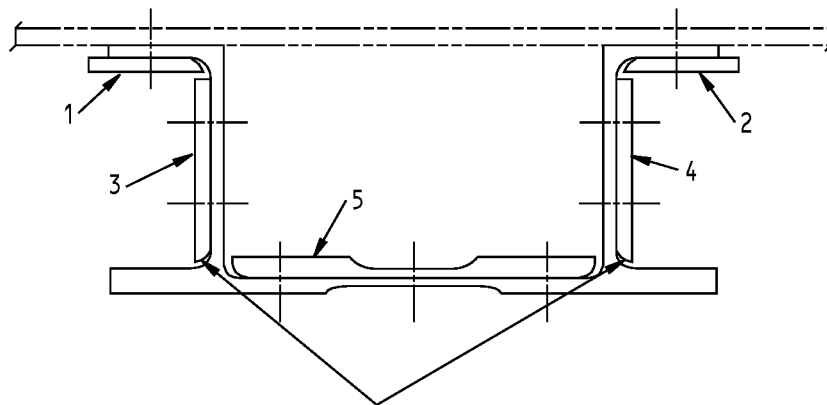

TRIM REPAIR PARTS 3 AND 4 TO
FIT AROUND RIB ATTACHMENT TAB

DETAIL II

**Wing Upper Vent Stringer Repair
Figure 201 (Sheet 4 of 4)**

STRUCTURAL REPAIR MANUAL

REPAIR 4 - WING LOWER ZEE STRINGER REPAIR

REPAIR INSTRUCTIONS

WARNING: FUEL VAPORS ARE HAZARDOUS AND EXPLOSIVE. PURGE AND VENTILATE THE FUEL TANKS PER 28-11 OF THE 757 MAINTENANCE MANUAL BEFORE ENTERING FUEL TANKS.

1. Cut and remove damaged portion of stringer. See note [H]. If skin is damaged, refer to 57-10-01 or 57-20-01.
2. Establish the maximum section of the portion removed (ignore pads at rib stations) and calculate the dimensions of the repair parts.
3. Make the repair parts.
4. Assemble the repair parts and drill the fastener holes. Determine the fastener type from the 2.5 D maximum stackup requirement. [D]
5. Remove the repair parts.
6. Break sharp edges of original and repair parts 0.015R to 0.030R.
7. Remove all nicks, scratches, burrs, sharp edges and corners from original and repair parts.
8. Alodize the repair parts and the cut edges of the original parts per 51-20-01.
9. Apply BMS 10-20, type 2 protective coating to the repair parts and the cut edges of the original parts in accordance with 28-11-00 of the 757 Maintenance Manual.
10. Install the repair parts making faying surface seals with BMS 5-26. Install fasteners wet with BMS 5-26.
11. Seal the repair per 51-20-05.
12. Restore original finish per 51-21 of the 757 Maintenance Manual.

- D = FASTENER DIAMETER
- MACHINE REPAIR PARTS TO 125 MICROINCHES AA
- REFER TO THE FOLLOWING WHEN USING THIS REPAIR:
 - 51-20-01 FOR PROTECTIVE TREATMENT OF METAL
 - 51-20-05 FOR SEALING OF REPAIRS
 - 51-40 FOR FASTENER CODE, REMOVAL, INSTALLATION, HOLE SIZES AND EDGE MARGINS
 - 51-21 OF THE 757 MAINTENANCE MANUAL FOR INTERIOR AND EXTERIOR FINISHES
 - 51-31 OF THE 757 MAINTENANCE MANUAL FOR SEALS AND SEALING

- [A] START TAPER BETWEEN THE FIRST AND SECOND FASTENER FROM THE STRINGER JOINT. TAPER TO 0.04 MIN AT THE EXTREMITY. TAPER MUST BE 20 TO 1 OR GREATER, I.E., 5% MAX SLOPE ALLOWABLE
- [B] NET CROSS-SECTIONAL AREA OF REPAIR PART MUST BE 1.0 X CROSS-SECTIONAL AREA OF STRINGER FLANGE (SHOWN SHADED). IF 2024 MATERIAL IS USED, NET CROSS-SECTIONAL AREA OF REPAIR PART MUST BE 1.8 X CROSS-SECTIONAL AREA OF STRINGER FLANGE
- [C] NET CROSS-SECTIONAL AREA OF REPAIR PART MUST BE 0.50 X CROSS-SECTIONAL AREA OF STRINGER WEB (SHOWN SHADED). IF 2024 MATERIAL IS USED, NET CROSS-SECTIONAL AREA OF REPAIR PART MUST BE 0.54 X CROSS-SECTIONAL AREA OF STRINGER WEB
- [D] BACB30MY()K WITH BACC30AG() OPTIONAL. WHERE THICKNESS TO BE FASTENED IS GREATER THAN 2.5 D, BACB30MY()K WITH BACC30AG() MUST BE USED. DO NOT MIX RIVETS AND HI-LOKS IN THE SAME REPAIR PLATE
- [E] USE 1/32 OVERSIZE FASTENER. IF THICKNESS TO BE FASTENED IS GREATER THAN 2.5 D, USE BACB30NY()K()Y (1/32 OVERSIZE) PLUS BACC30AG() (100°CSK)
- [F] REPLACE 3/8 DIA RIVETS WITH BACB30NY12K()Y (1/32 OVERSIZE) PLUS BACC30AG12 (100° CSK)
- [G] LOCALLY CHAMFER OR SPOT FACE PLATE TO ELIMINATE COLLAR INTERFERENCE WITH PLATE, IF NECESSARY

NOTES

- REMOVE AND INSTALL ACCESS DOORS PER 28-11 OF THE 757 MAINTENANCE MANUAL
- THIS REPAIR CAN BE USED ON TAPERED STRINGERS PROVIDED THE TAPER IS GRADUAL, THE REPLACEMENT STRINGER IS IDENTICAL IN TAPER TO THE DAMAGED PORTION OF THE STRINGER REMOVED AND ALL REPAIR PART DIMENSIONS ARE DETERMINED AT THE CUTIN STRINGER WHERE THE THICKNESS OF THE FLANGES AND WEB IS THE LARGEST

**Wing Lower Zee Stringer Repair
Figure 201 (Sheet 1 of 4)**

**757-200
STRUCTURAL REPAIR MANUAL**

NOTES (Cont)

- H** USE DETAIL I WHEREVER POSSIBLE. WHERE REPAIR PARTS INTERFERE WITH RIB PADS USE DETAIL II
- I** USE 1/4 DIA FASTENER IF ORIGINAL SKIN FASTENER IS 1/4 DIA. USE 5/16 DIA FASTENER IF ORIGINAL SKIN FASTENER IS 5/16 OR 3/8 DIA

SYMBOLS

 REPAIR FASTENER LOCATION

REPAIR MATERIAL			
PART		QTY	MATERIAL
1	PLATE	1	2224-T3511 OPT: 2024-T3 OR T351
2	PLATE	1	2224-T3511 OPT: 2024-T3 OR T351
3	PLATE	1	2224-T3511 OPT: 2024-T3 OR T351
4	PLATE	1	2224-T3511 OPT: 2024-T3 OR T351
5	FILLER	1	2224-T3511

**Wing Lower Zee Stringer Repair
Figure 201 (Sheet 2 of 4)**

**757-200
STRUCTURAL REPAIR MANUAL**

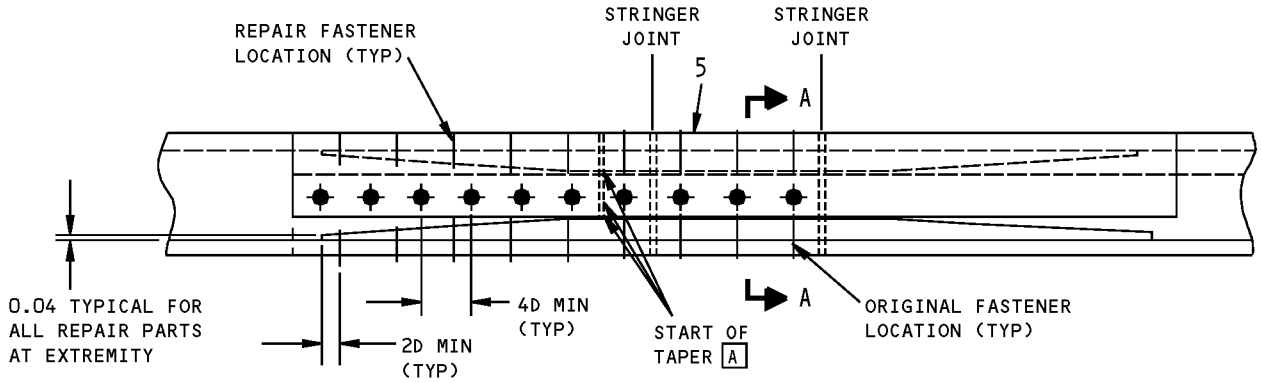

DETAIL I H

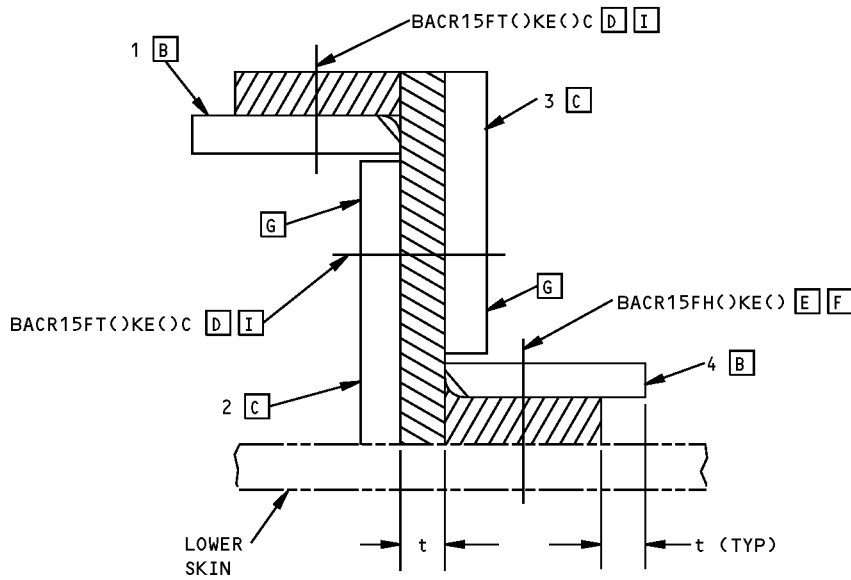

SECTION A-A

**Wing Lower Zee Stringer Repair
Figure 201 (Sheet 3 of 4)**

**757-200
STRUCTURAL REPAIR MANUAL**

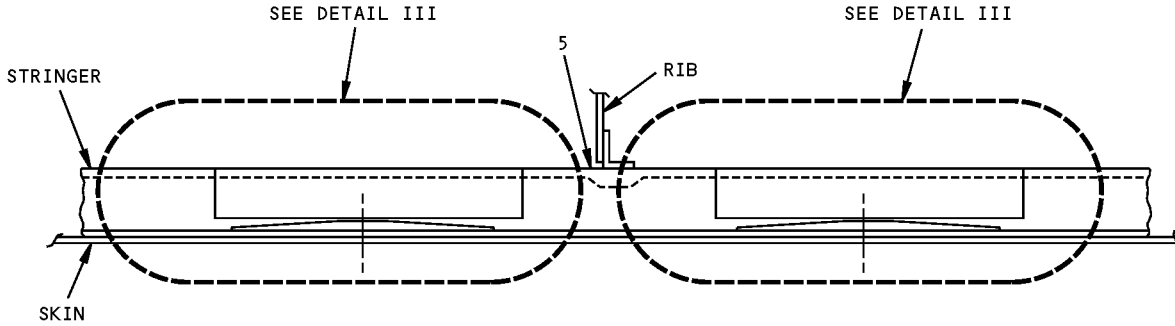

ALTERNATE REPAIR INSTALLATION FOR DAMAGE NEAR RIBS

DETAIL II H

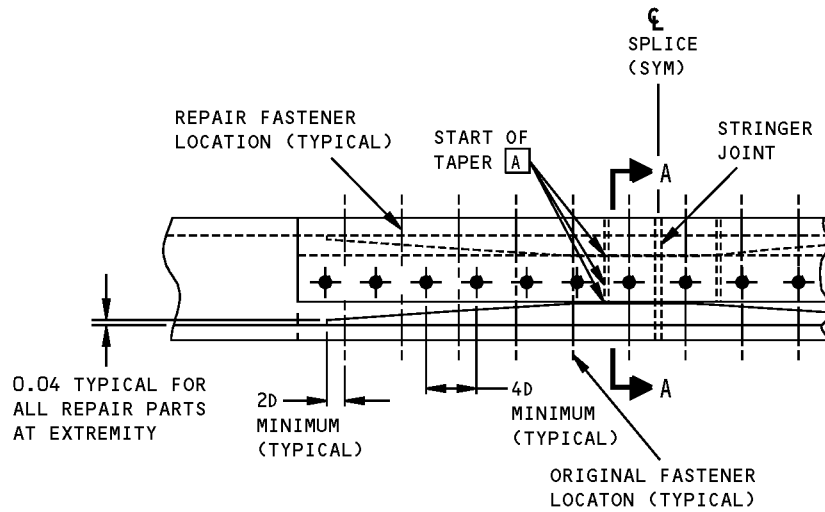

DETAIL III

**Wing Lower Zee Stringer Repair
Figure 201 (Sheet 4 of 4)**

STRUCTURAL REPAIR MANUAL

REPAIR 5 - WING LOWER "J" STRINGER REPAIR - SKIN SPLICE

REPAIR INSTRUCTIONS

- WARNING:** FUEL VAPORS ARE HAZARDOUS AND EXPLOSIVE. PURGE AND VENTILATE THE FUEL TANKS PER 28-11 OF THE 757 MAINTENANCE MANUAL BEFORE ENTERING FUEL TANKS.
1. Cut and remove damaged portion of stringer. See note **H**. If skin is damaged, refer to 57-10-01 or 57-20-01.
 2. Establish the maximum section of the portion removed (ignore pads at rib stations) and calculate the dimensions of the repair parts.
 3. Make the repair parts.
 4. Assemble the repair parts and drill the fastener holes. Determine the fastener type from the 2.5 D maximum stackup requirement. **F**
 5. Remove the repair parts.
 6. Break sharp edges of original and repair parts 0.015R to 0.030R.
 7. Remove all nicks, scratches, burrs, sharp edges and corners from original and repair parts.
 8. Alodize the repair parts and the cut edges of the original parts per 51-20-01.
 9. Apply BMS 10-20, type 2 protective coating to the repair parts and the cut edges of the original parts in accordance with 28-11-00 of the 757 Maintenance Manual.
 10. Install the repair parts making faying surface seals with BMS 5-26. Install fasteners wet with BMS 5-26. Care must be taken to ensure that channels formed at the stringer joints are kept clear for sealant injection.
 11. Seal the repair per 51-20-05.
 12. Install the fasteners, in the positions indicated, at the stringer joint lines.
 13. Restore original finish per 51-21 of the 757 Maintenance Manual.

NOTES

- REMOVE AND INSTALL ACCESS DOORS PER 28-11 OF THE 757 MAINTENANCE MANUAL
 - THIS REPAIR CAN BE USED ON TAPERED STRINGERS PROVIDED THE TAPER IS GRADUAL, THE REPLACEMENT STRINGER IS IDENTICAL IN TAPER TO THE DAMAGED PORTION OF THE STRINGER REMOVED AND ALL REPAIR PART DIMENSIONS ARE DETERMINED AT THE CUTIN STRINGER WHERE THE THICKNESS OF THE FLANGES AND WEB IS THE LARGEST
 - D = FASTENER DIAMETER
 - MACHINE REPAIR PARTS TO 125 MICROINCHES AA
 - REFER TO THE FOLLOWING WHEN USING THIS REPAIR:
 - 51-20-01 FOR PROTECTIVE TREATMENT OF METAL
 - 51-20-05 FOR SEALING OF REPAIRS
 - 51-40 FOR FASTENER CODE, REMOVAL, INSTALLATION, HOLE SIZES AND EDGE MARGINS
 - 51-21 OF THE 757 MAINTENANCE MANUAL FOR INTERIOR AND EXTERIOR FINISHES
 - 51-31 OF THE 757 MAINTENANCE MANUAL FOR SEALS AND SEALING
- A** START TAPER BETWEEN THE FIRST AND SECOND FASTENER FROM THE STRINGER JOINT. TAPER TO 0.04 MIN AT THE EXTREMITY. TAPER MUST BE 20 TO 1 OR GREATER, I.E., 5% MAX SLOPE ALLOWABLE
- B** NET CROSS-SECTIONAL AREA OF REPAIR PART 1 MUST BE 1.0 X CROSS-SECTIONAL AREA OF STRINGER UPPER FLANGE (SHOWN SHADED). IF 2024 MATERIAL IS USED, NET CROSS-SECTIONAL AREA OF REPAIR PART 1 MUST BE 1.08 X CROSS-SECTIONAL AREA OF STRINGER UPPER FLANGE
- C** NET CROSS-SECTIONAL AREA OF REPAIR PART 2 MUST BE 0.47 X CROSS-SECTIONAL AREA OF STRINGER WEB (SHOWN SHADED). IF 2024 MATERIAL IS USED, NET CROSS-SECTIONAL AREA OF REPAIR PART 2 MUST BE 0.51 X CROSS-SECTIONAL AREA OF STRINGER WEB
- D** NET CROSS-SECTIONAL AREA OF REPAIR PART 3 MUST BE 0.53 X CROSS-SECTIONAL AREA OF STRINGER WEB (SHOWN SHADED). IF 2024 MATERIAL IS USED, NET CROSS-SECTIONAL AREA OF REPAIR PART 3 MUST BE 0.58 X CROSS-SECTIONAL AREA OF STRINGER WEB

**Wing Lower "J" Stringer Repair - Skin Splice
Figure 201 (Sheet 1 of 4)**



**757-200
STRUCTURAL REPAIR MANUAL**

NOTES (Cont)

- [E]** COMBINED NET CROSS-SECTIONAL AREA OF REPAIR PARTS 4 AND 5 MUST BE 1.0 X CROSS-SECTIONAL AREA OF STRINGER LOWER FLANGE (SHOWN SHADED). IF 2024 MATERIAL IS USED, COMBINED NET CROSS-SECTIONAL AREA OF REPAIR PARTS 4 AND 5 MUST BE 1.08 X CROSS-SECTIONAL AREA OF STRINGER LOWER FLANGE
- [F]** BACB30MY()K WITH BACC30AG() OPTIONAL. WHERE THICKNESS TO BE FASTENED IS GREATER THAN 2.5 D, BACB30MY()K WITH BACC30AG() MUST BE USED. DO NOT MIX RIVETS AND HI-LOKS IN THE SAME REPAIR PLATE
- [G]** USE SAME SIZE FASTENER AS ORIGINAL SKIN FASTENER
- [H]** USE DETAIL I WHEREVER POSSIBLE. WHERE REPAIR PARTS INTERFERE WITH RIB PADS USE DETAIL II
- [I]** USE SAME TYPE FASTENER AS ORIGINAL, 1/32 OVERSIZE
 FOR HI-LOK BOLTS USE BACB30NW()K() WITH BACC30AG()
 FOR 70° LEAD IN HEAD BOLTS, USE BACB30PT()K()L WITH BACN10MT() AND BACW10AU()
 FOR RIVETS USE BACR15FH()KE() **[J]**
- [J]** BACB30NY()K()Y (1/32 OVERSIZE) WITH BACC30AG() OPTIONAL (100° CSK). WHERE THICKNESS TO BE FASTENED IS GREATER THAN 2.5 D, BACB30NY()K()Y WITH BACC30AG() MUST BE USED. DO NOT MIX RIVET AND HI-LOKS IN THE SAME REPAIR PLATE

REPAIR MATERIAL			
PART		QTY	MATERIAL
1	PLATE	1	2224-T3511 OPT: 2024-T3 OR T351
2	PLATE	1	2224-T3511 OPT: 2024-T3 OR T351
3	PLATE	1	2224-T3511 OPT: 2024-T3 OR T351
4	PLATE	1	2224-T3511 OPT: 2024-T3 OR T351
5	PLATE	1	2224-T3511 OPT: 2024-T3 OR T351
6	FILLER	1	2224-T3511

SYMBOLS

-  ORIGINAL FASTENER LOCATION
-  REPAIR FASTENER LOCATION

**Wing Lower "J" Stringer Repair - Skin Splice
Figure 201 (Sheet 2 of 4)**

**757-200
STRUCTURAL REPAIR MANUAL**

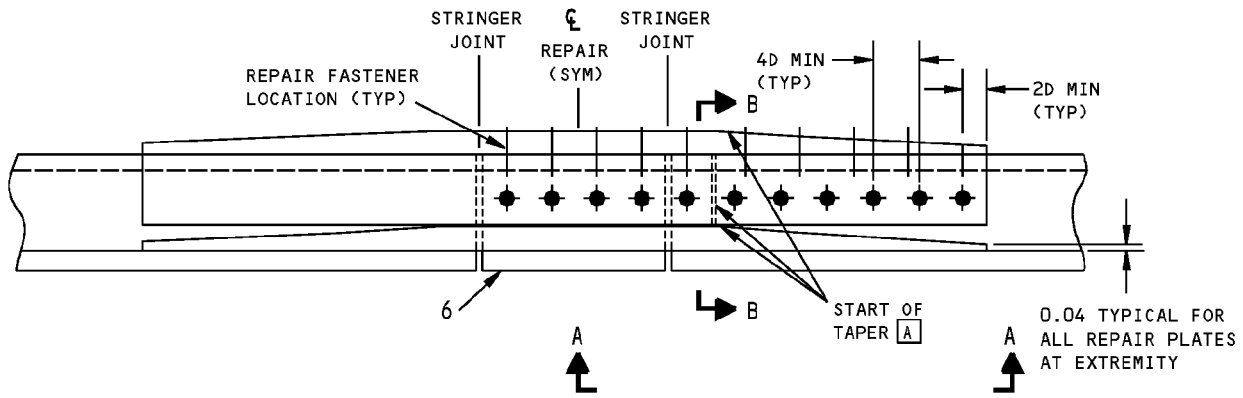

DETAIL I [H]

INSTALL THESE FASTENERS AFTER SEALANT INJECTION. USE BACB30NY()K()Y (100° CSK) WITH BACC30AG() AT THESE LOCATIONS

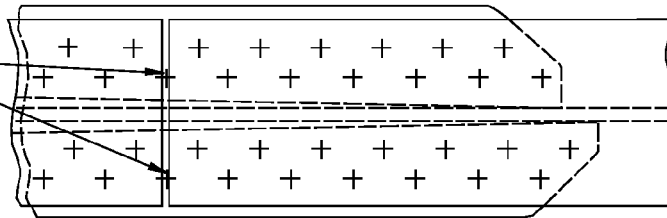

(SKIN NOT SHOWN)
SECTION A-A

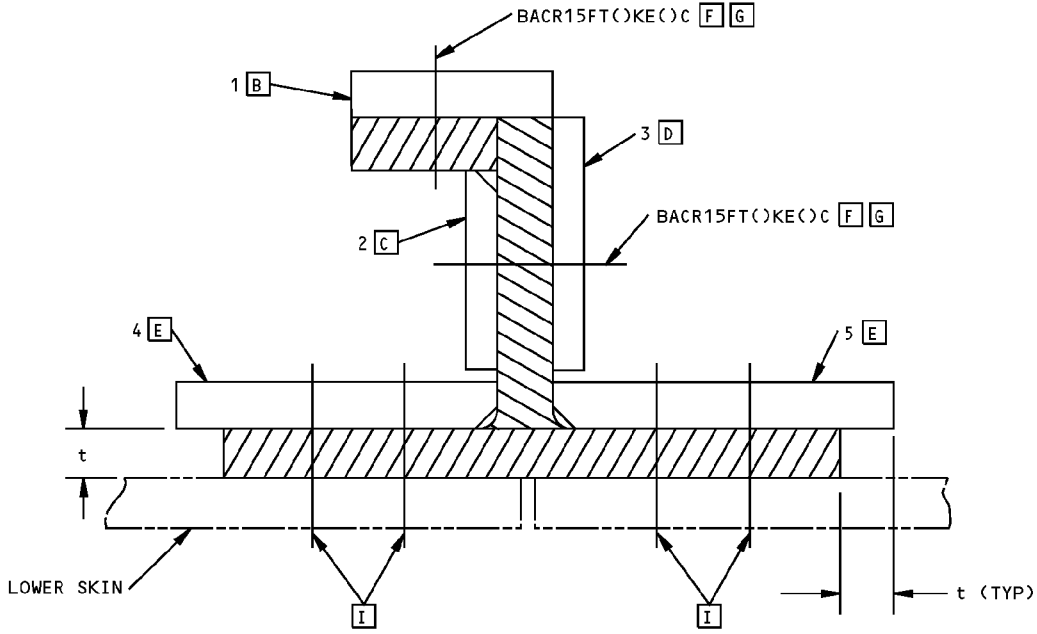

SECTION B-B

**Wing Lower "J" Stringer Repair - Skin Splice
Figure 201 (Sheet 3 of 4)**

**757-200
STRUCTURAL REPAIR MANUAL**

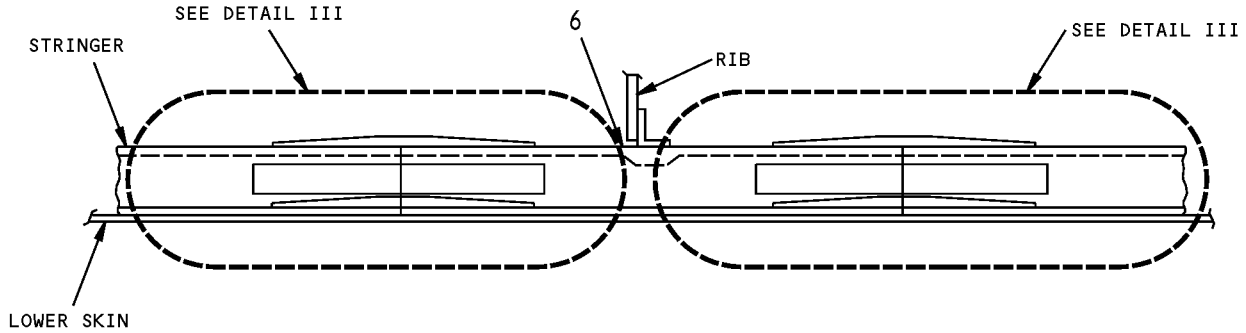

**ALTERNATE REPAIR INSTALLATION FOR
DAMAGE NEAR RIBS**

DETAIL II H

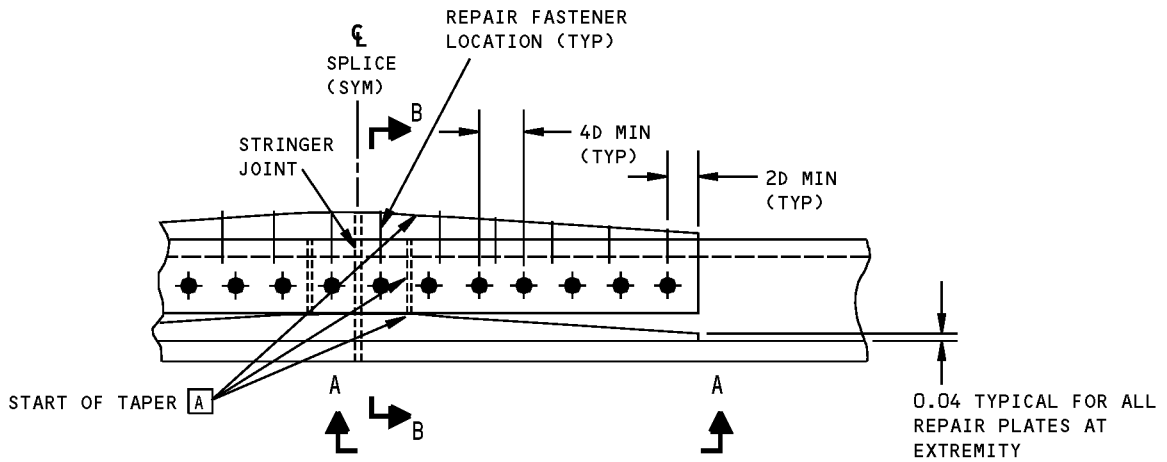

DETAIL III

**Wing Lower "J" Stringer Repair - Skin Splice
Figure 201 (Sheet 4 of 4)**

**757-200
STRUCTURAL REPAIR MANUAL**

IDENTIFICATION 1 - CENTER WING SKIN

REF DWG
111N3001

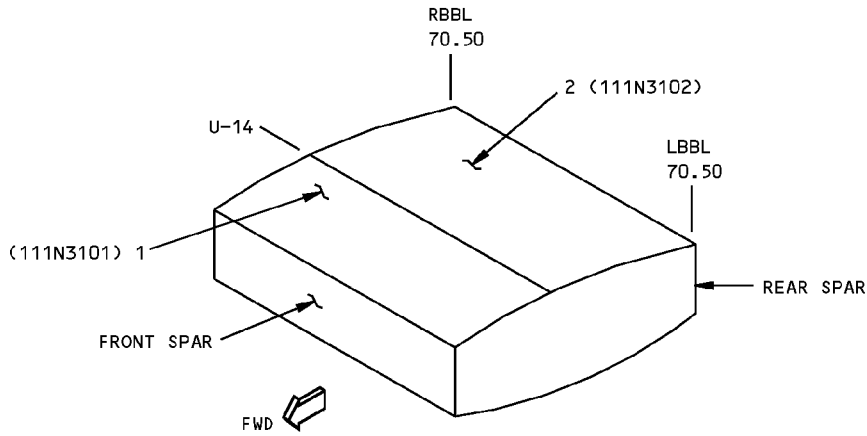
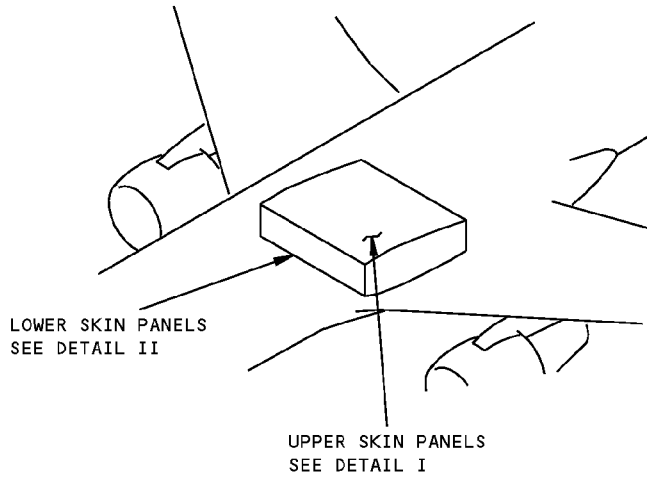

**UPPER SKIN PANELS
DETAIL I**

ITEM	DESCRIPTION	GAGE	MATERIAL	EFFECTIVITY
1	SKIN PANEL NO. 1	0.55	7150-T651 (MACHINED TO 0.200 MIN)	
2	SKIN PANEL NO. 2	0.55	7150-T651 (MACHINED TO 0.232 MIN)	

LIST OF MATERIALS FOR DETAIL I

**Center Wing Skin Identification
Figure 1 (Sheet 1 of 2)**

IDENTIFICATION 1
Page 1
Jan 20/2005

57-10-01

D634N201

**757-200
STRUCTURAL REPAIR MANUAL**

REF DWG
111N4001

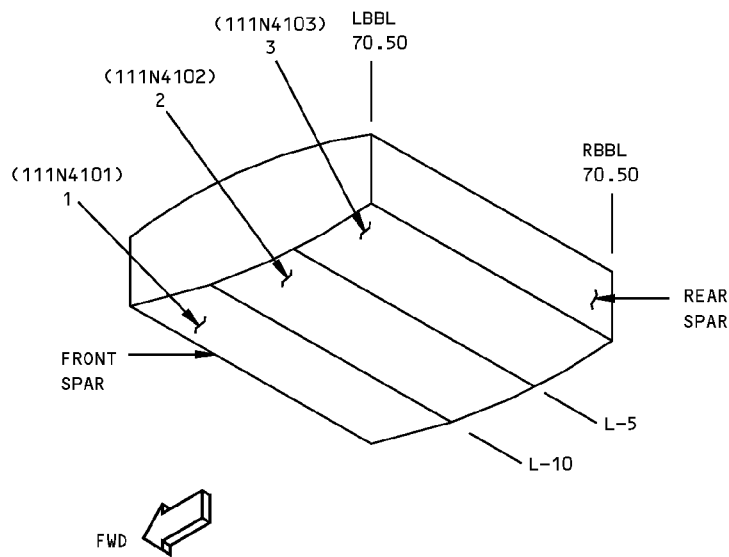

**LOWER SKIN PANELS
DETAIL II**

ITEM	DESCRIPTION	GAGE	MATERIAL	EFFECTIVITY
1	SKIN PANEL NO. 1	0.75	2324-T39 (MACHINED TO 0.200 MIN)	
2	SKIN PANEL NO. 2	0.84	2324-T39 (MACHINED TO 0.232 MIN)	
3	SKIN PANEL NO. 3	0.88	2324-T39 (MACHINED TO 0.232 MIN)	

LIST OF MATERIALS FOR DETAIL II

**Center Wing Skin Identification
Figure 1 (Sheet 2 of 2)**

IDENTIFICATION 1
Page 2
Jan 20/2005

57-10-01

D634N201

**757-200
STRUCTURAL REPAIR MANUAL**

ALLOWABLE DAMAGE 1 - CENTER WING SKIN

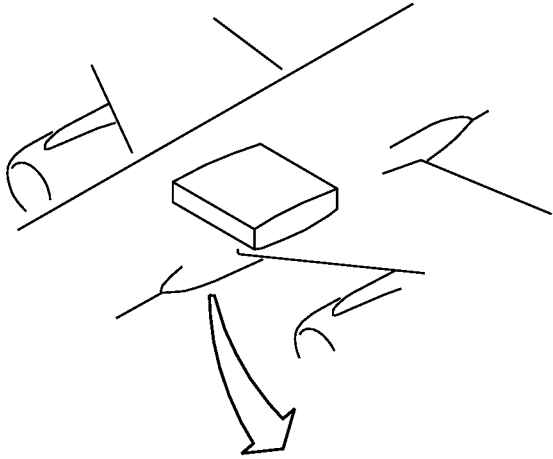

REF DWG
111N3001

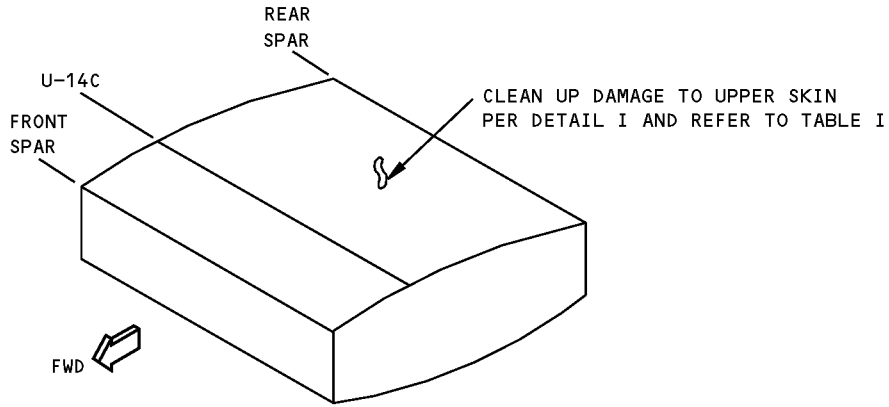

REF DWG
111N4001

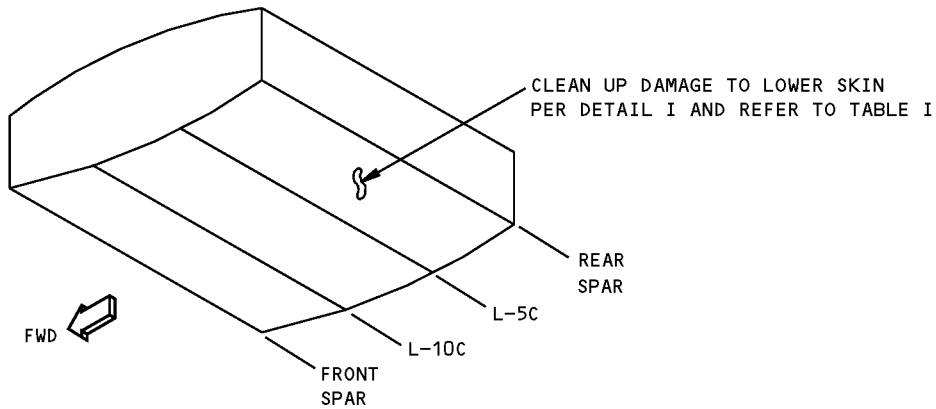

**Center Wing Skin Allowable Damage
Figure 101 (Sheet 1 of 3)**

**757-200
STRUCTURAL REPAIR MANUAL**

ZONE	ALLOWABLE DAMAGE ^A		
	MAX DEPTH OF DAMAGE AFTER CLEANUP (IN)	MAX LOSS OF CROSS-SECTIONAL AREA BETWEEN ADJACENT STIFFENERS OR BETWEEN SPAR AND STIFFENER (SQ IN) ^B	TOTAL MAX LOSS OF CROSS-SECTIONAL AREA BETWEEN FRONT SPAR AND REAR SPAR (SQ IN) ^B
UPPER SKIN	0.028	0.016	0.25
LOWER SKIN FRONT SPAR TO L-10C	0.055	0.065	0.60
LOWER SKIN L-10C TO L-5C	0.055	0.065	0.60
LOWER SKIN L-5C TO REAR SPAR	0.050	0.045	0.60

TABLE I ^C

NOTES

- DAMAGE TO CENTER WING SKINS BY NICKS, SCRATCHES, GOUGES, CRACKS, ABRASIONS AND CORROSION IS ALLOWABLE PROVIDED THAT NONE OF THE LIMITATIONS IN TABLE I ARE EXCEEDED. DAMAGE DEPTH AND LOSS OF CROSS-SECTIONAL AREA ARE TO BE DETERMINED AFTER CLEANUP (SEE DETAIL I)
- THESE ALLOWABLE DAMAGE LIMITS ARE NOT APPLICABLE IF THERE IS UNREPAIRED DAMAGE TO ANY STIFFENER IN THE SAME AREA
- REFER TO SRM 57-20-01 FOR A TYPICAL SAMPLE CALCULATION

^B LOSS OF CROSS-SECTIONAL AREA ON A LINE PERPENDICULAR TO THE REAR SPAR. MULTIPLE AREAS OF DAMAGE ARE TO BE CONSIDERED ON THE SAME LINE IF LESS THAN 1.50 INCHES (38 mm) FROM EACH OTHER MEASURED SPANWISE (SEE DETAIL II)

^C REFER TO SOPM 20-10-03 FOR SHOT PEENING AT REWORKED AREAS WITH SHOT NO. 230, 0.004A/0.007A INTENSITY

^A ALLOWABLE DAMAGE LIMITATIONS ARE NOT APPLICABLE IN THE FOLLOWING AREAS (CONSULT THE BOEING COMPANY FOR SPECIFIC INSTRUCTIONS)

1. WITHIN 1.50 INCHES (38 mm) OF ANY CHORDWISE ROW OF FASTENERS
2. FORWARD OF A LINE 1.50 INCHES (38 mm) AFT OF THE AFT ROW OF FASTENERS ATTACHING THE SKIN TO THE FRONT SPAR
3. AFT OF A LINE 1.50 INCHES (38 mm) FORWARD OF THE FORWARD ROW OF FASTENERS ATTACHING THE SKIN TO THE REAR SPAR
4. WITHIN 1.50 INCHES (38 mm) OF FASTENERS IN THE SPANWISE SKIN SPLICES

**Center Wing Skin Allowable Damage
Figure 101 (Sheet 2 of 3)**

**757-200
STRUCTURAL REPAIR MANUAL**

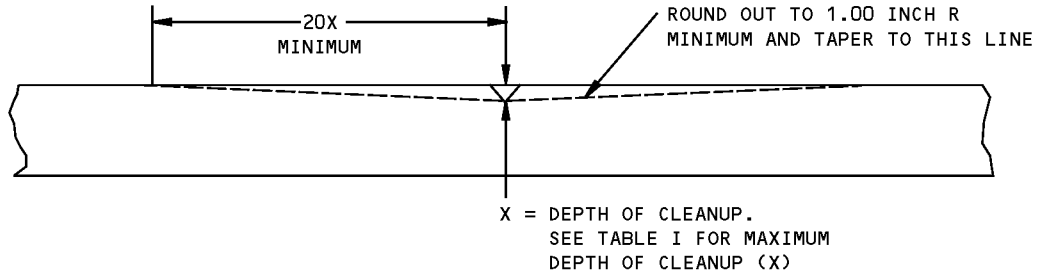

**SECTION THROUGH CLEANED UP DAMAGE
DETAIL I**

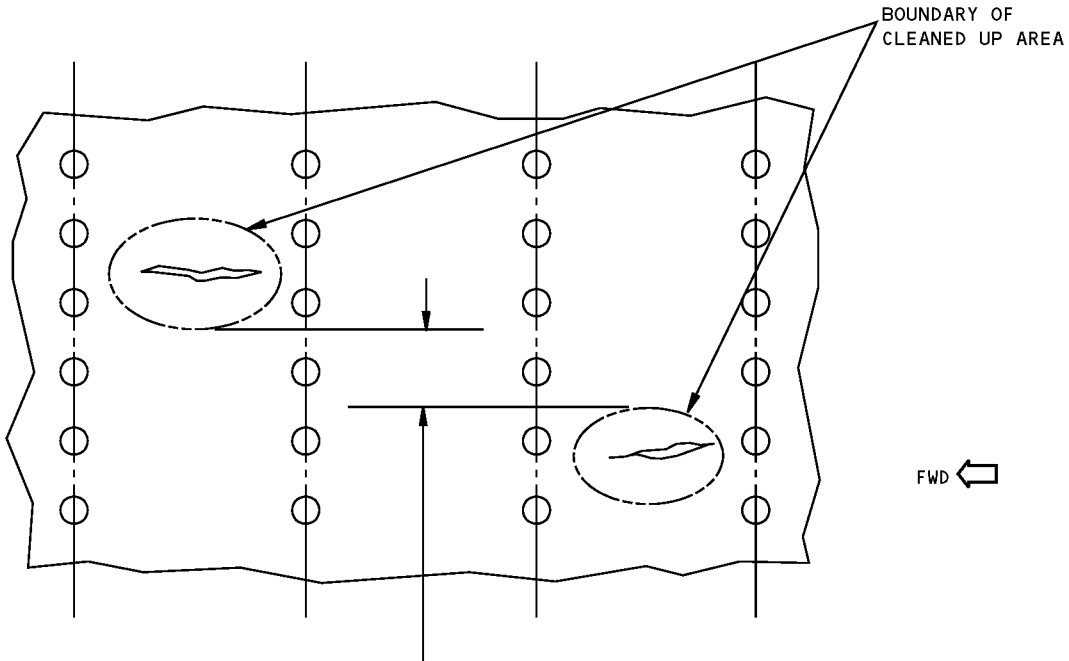

IF THIS DIMENSION IS LESS THAN 1.50 INCHES BOTH AREAS OF DAMAGE ARE CONSIDERED TO BE ON THE SAME CROSS SECTION

**ADDITIVE DAMAGE
DETAIL II**

**Center Wing Skin Allowable Damage
Figure 101 (Sheet 3 of 3)**



757-200
STRUCTURAL REPAIR MANUAL

IDENTIFICATION 1 - CENTER WING UPPER STRINGER

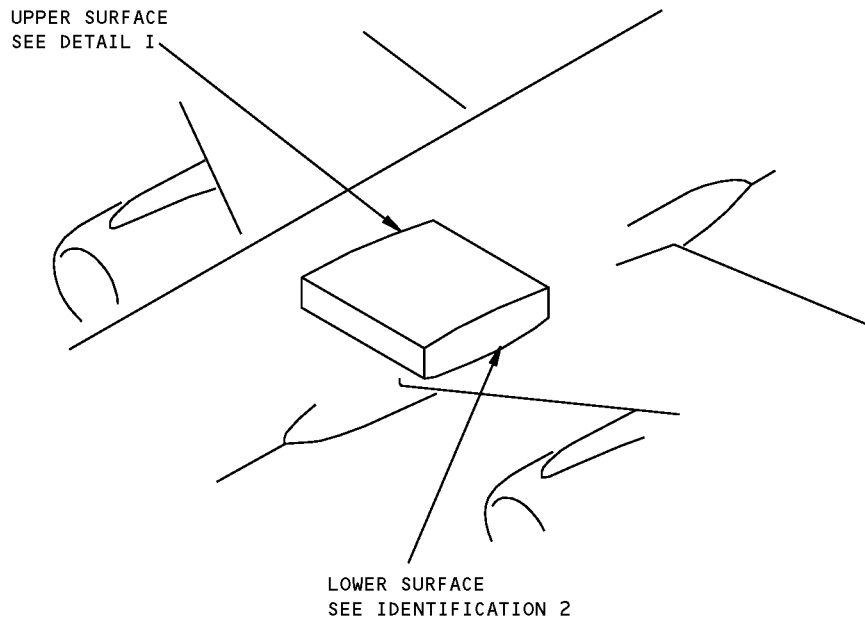

Center Wing Upper Stringer Identification
Figure 1 (Sheet 1 of 2)

D634N201

57-10-03

IDENTIFICATION 1
Page 1
Jan 20/2005

757-200 STRUCTURAL REPAIR MANUAL

REF DWG
111N3201
THRU
111N3211

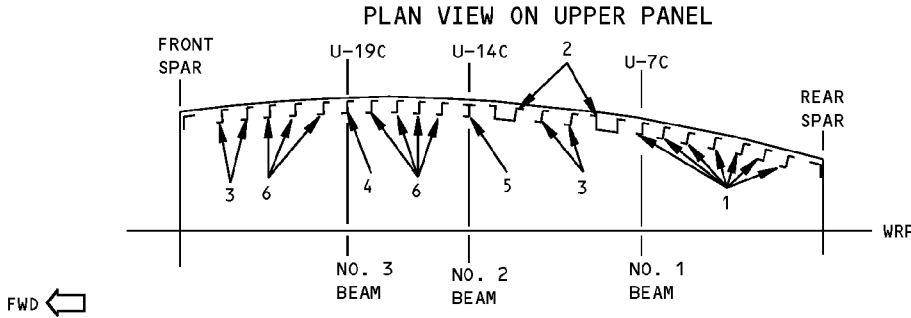
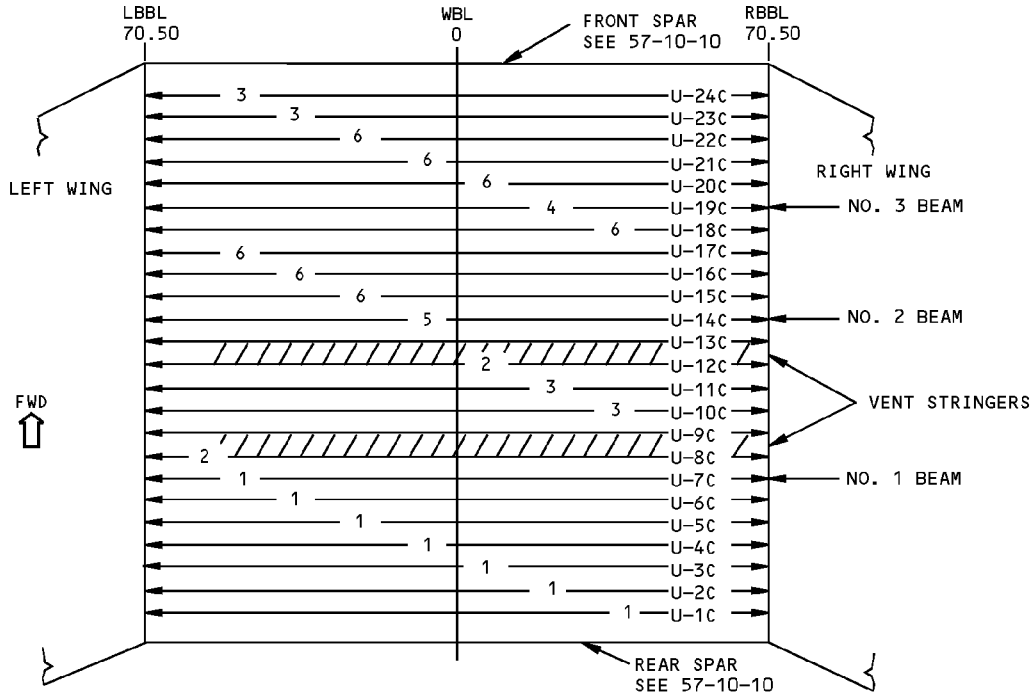

ITEM	DESCRIPTION	MATERIAL	TYPE	EFFECTIVITY
1	STRINGER	BAC1518-874 7150-T6511 OPTIONAL: BAC1518-697 7150-T6511	I	
2	STRINGER-VENT	BAC1510-1109 7150-T6511 OPTIONAL: BAC1518-1064 7150-T6511	II	
3	STRINGER	BAC1518-697 7150-T6511	I	
4	STRINGER	BAC1518-747 7150-T6511	I	
5	STRINGER	BAC1518-876 7150-T6511 OPTIONAL: BAC1518-696 7150-T6511	I	
6	STRINGER	BAC1518-697 7150-T6511 OPTIONAL: BAC1518-747 7150-T6511	I	

LIST OF MATERIALS FOR DETAIL I

Center Wing Upper Stringer Identification Figure 1 (Sheet 2 of 2)

IDENTIFICATION 1
Page 2
Jan 20/2005

57-10-03

D634N201



757-200
STRUCTURAL REPAIR MANUAL

IDENTIFICATION 2 - CENTER WING LOWER STRINGER

REFERENCE DRAWINGS
111N4201
THRU
111N4208

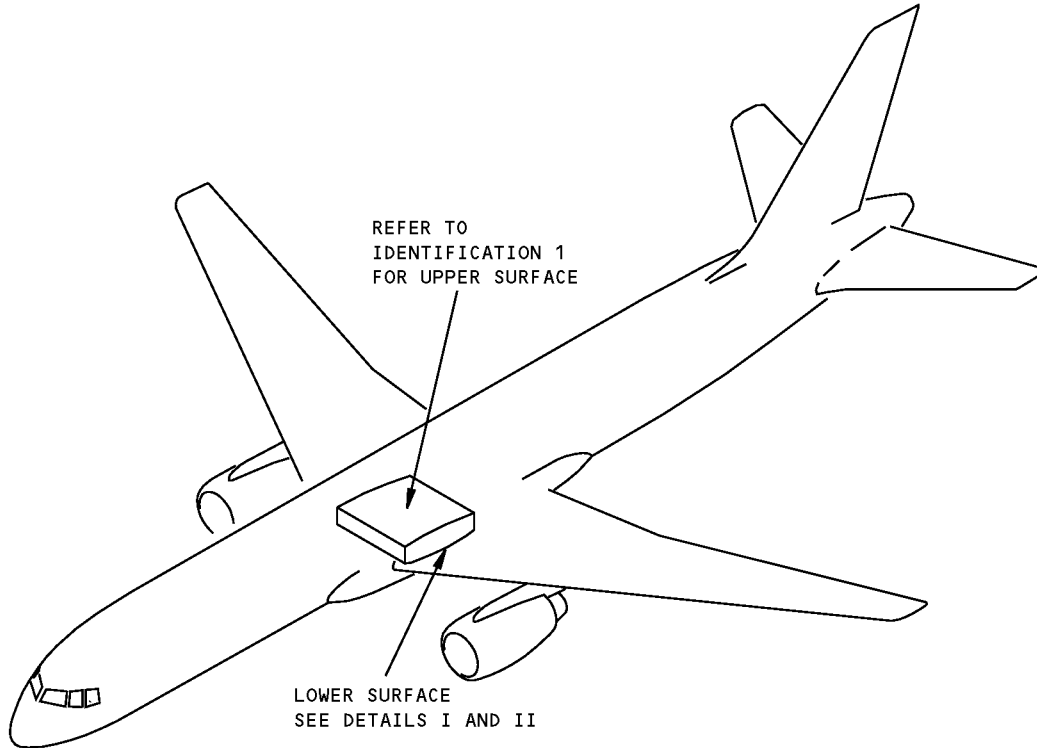

NOTES

A FOR AIRPLANE WITH STRUCTURAL PROVISIONS
FOR MAXIMUM DESIGN TAXI WEIGHT OF 241,000
POUNDS AND MAXIMUM DESIGN TAKEOFF WEIGHT
OF 240,000 POUNDS

B FOR ALL AIRPLANES OTHER THAN THOSE IN **A**



Center Wing Lower Stringer Identification
Figure 1 (Sheet 1 of 5)

D634N201

57-10-03

IDENTIFICATION 2
Page 1
Jan 20/2005

**757-200
STRUCTURAL REPAIR MANUAL**

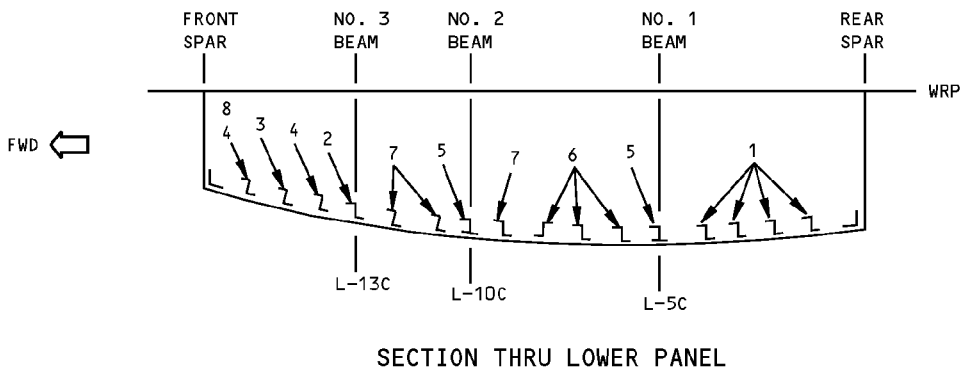
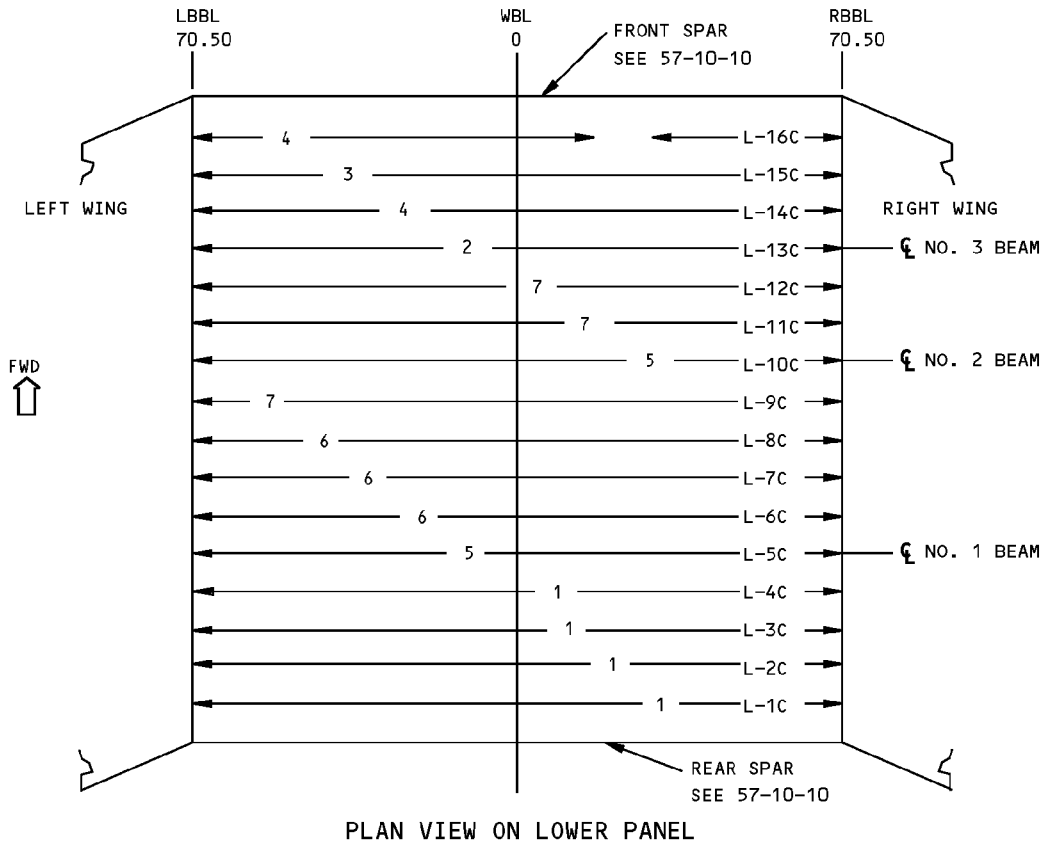

DETAIL I [A]



**Center Wing Lower Stringer Identification
Figure 1 (Sheet 2 of 5)**



757-200
STRUCTURAL REPAIR MANUAL

ITEM	DESCRIPTION	MATERIAL	TYPE	EFFECTIVITY
1	STRINGER	BAC1517-2272 2224-T3511 OPTIONAL: BAC1517-2114 2224-T3511	I I	
2	STRINGER	BAC1517-2269 2224-T3511 OPTIONAL: BAC1517-2136 2224-T3511	I I	
3	STRINGER	BAC1506-3461 2224-T3511 OPTIONAL: BAC1506-3199 2224-T3511	I I	
4	STRINGER	BAC1517-2268 2224-T3511 OPTIONAL: BAC1517-2136 2224-T3511	I I	
5	STRINGER	BAC1506-3462 2224-T3511 OPTIONAL: BAC1506-3199 2224-T3511	I I	
6	STRINGER	BAC1517-2271 2224-T3511 OPTIONAL: BAC1517-2114 2224-T3511	I I	
7	STRINGER	BAC1517-2270 2224-T3511 OPTIONAL: BAC1517-2114 2224-T3511	I I	
8	STRINGER	BAC1506-3460 2224-T3511 OPTIONAL: BAC1506-3199 2224-T3511	I I	

LIST OF MATERIALS FOR DETAIL I A

Center Wing Lower Stringer Identification
Figure 1 (Sheet 3 of 5)

D634N201

57-10-03

IDENTIFICATION 2
Page 3
Jan 20/2005

**757-200
STRUCTURAL REPAIR MANUAL**

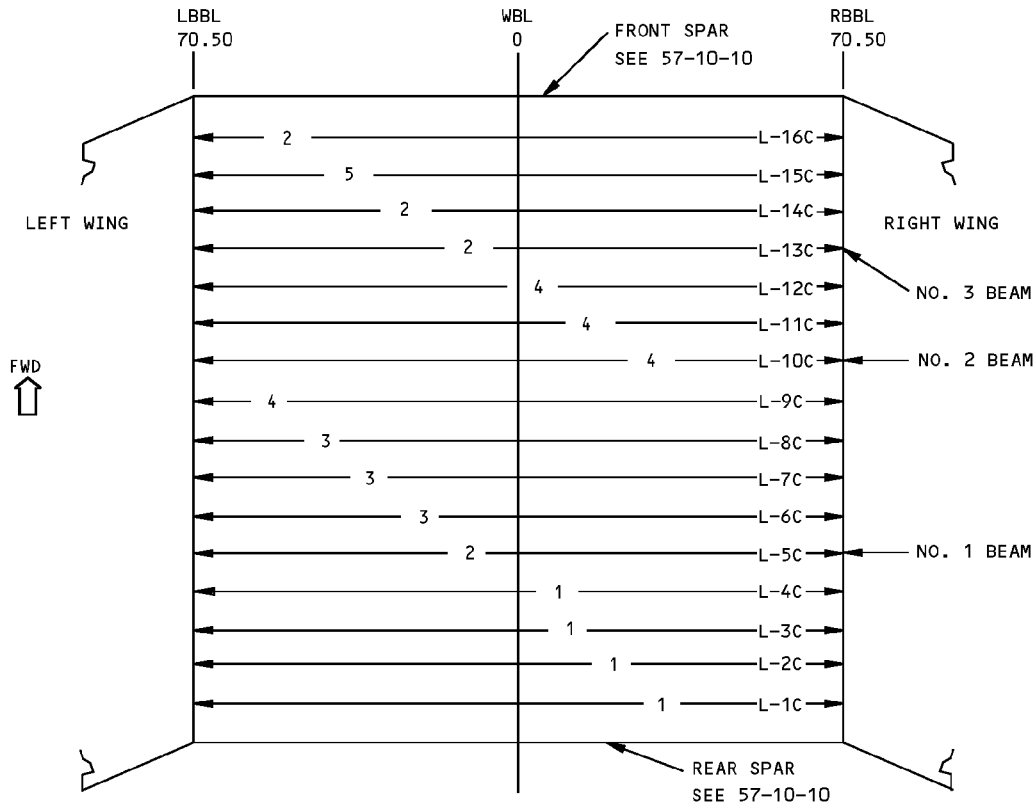

PLAN VIEW ON LOWER PANEL

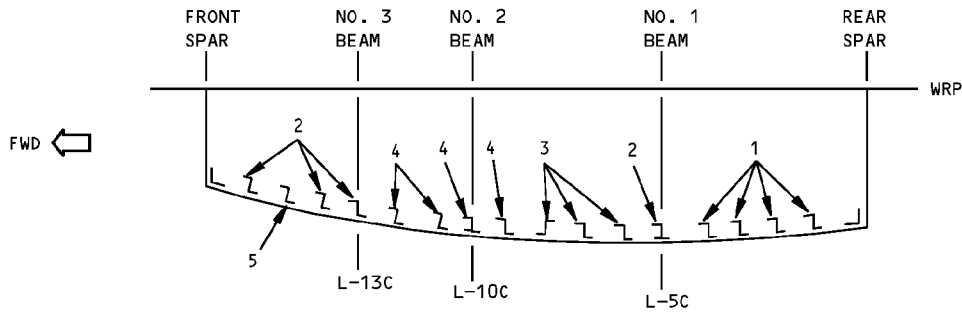

SECTION THRU LOWER PANEL

DETAIL II **B**



**Center Wing Lower Stringer Identification
Figure 1 (Sheet 4 of 5)**



757-200
STRUCTURAL REPAIR MANUAL

ITEM	DESCRIPTION	MATERIAL	TYPE	EFFECTIVITY
1	STRINGER	BAC1517-2267 2224-T3511 OPTIONAL: BAC1517-2114 2224-T3511	I	
2	STRINGER	BAC1517-2114 2224-T3511	I	
3	STRINGER	BAC1506-3145 2224-T3511	I	
4	STRINGER	BAC1517-2115 2224-T3511	I	
5	STRINGER	BAC1517-2226 2224-T3511 OPTIONAL: BAC1517-2114 2224-T3511	I	

LIST OF MATERIALS FOR DETAIL II **B**

Center Wing Lower Stringer Identification
Figure 1 (Sheet 5 of 5)

D634N201

57-10-03

IDENTIFICATION 2
Page 5
Jan 20/2005



757-200
STRUCTURAL REPAIR MANUAL

ALLOWABLE DAMAGE GENERAL - CENTER WING STRINGERS

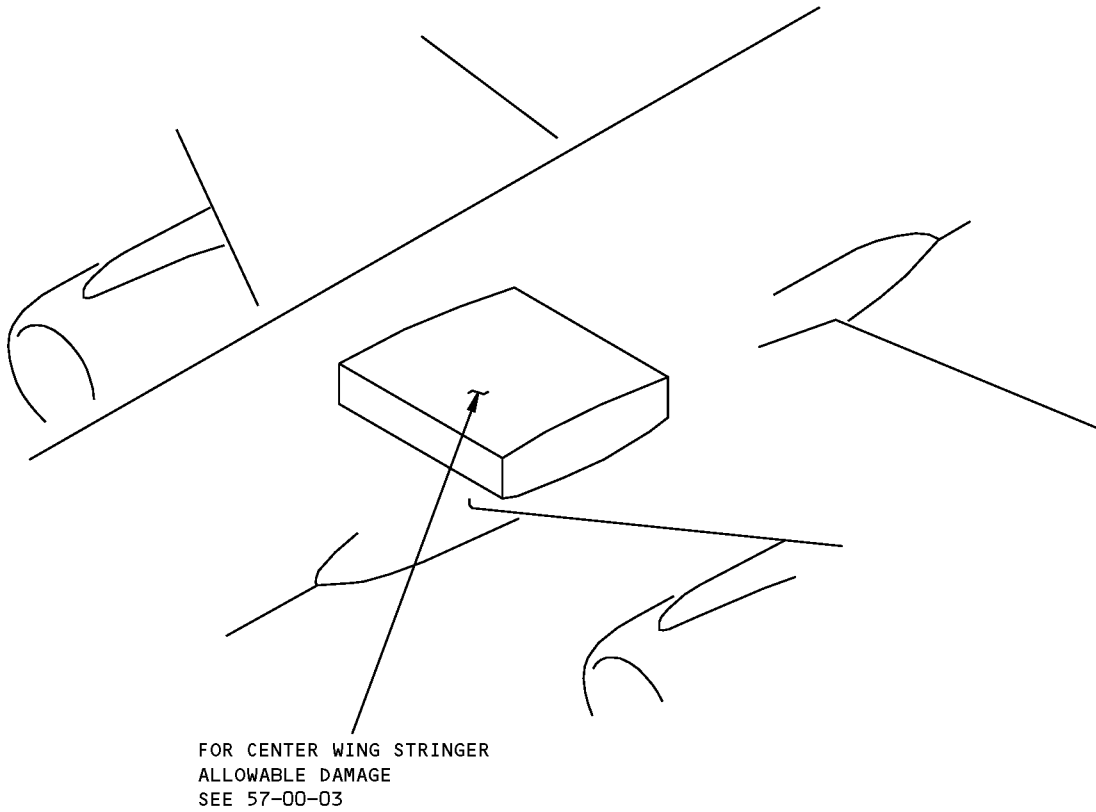

Center Wing Stringers Allowable Damage
Figure 101

D634N201

ALLOWABLE DAMAGE GENERAL
Page 101
57-10-03 Jan 20/2005



757-200
STRUCTURAL REPAIR MANUAL

REPAIR 1 - CENTER WING STRINGER REPAIR

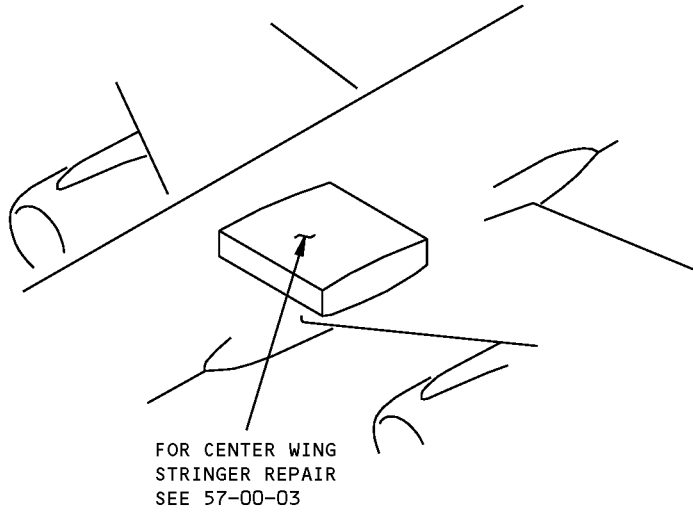

Center Wing Stringer Repair
Figure 201

D634N201

57-10-03

REPAIR 1
Page 201
Jan 20/2005

**757-200
STRUCTURAL REPAIR MANUAL**

IDENTIFICATION 1 - CENTER SECTION FRONT AND REAR SPAR

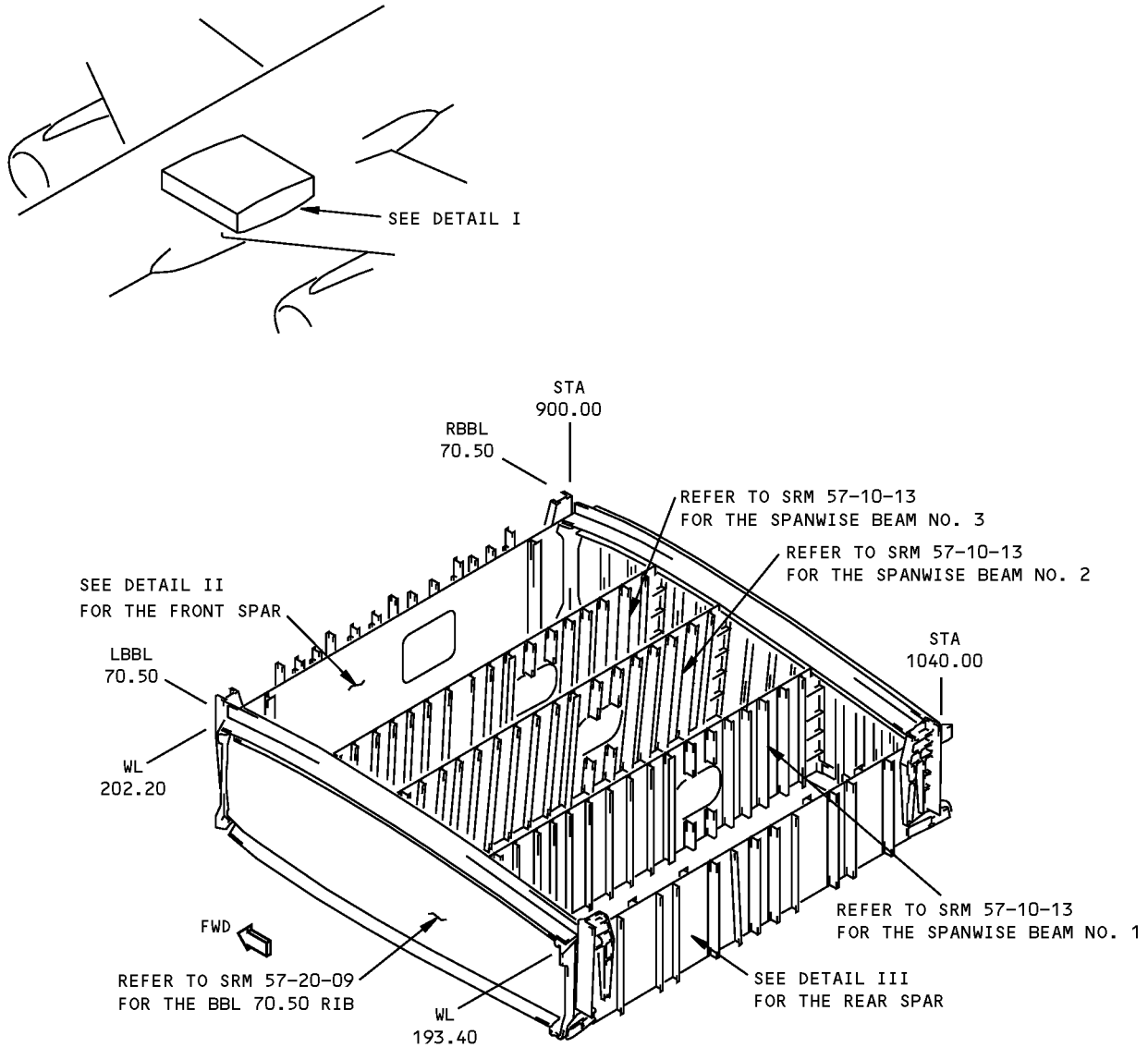

DETAIL I

NOTES

A FOR CUM LINE NUMBERS:
1 THRU 20

B FOR CUM LINE NUMBERS:
1 THRU 13

C FOR CUM LINE NUMBERS:
14 AND ON

D FOR CUM LINE NUMBERS:
1 THRU 241

E FOR CUM LINE NUMBERS:
242 AND ON

**Center Section Front and Rear Spar Identification
Figure 1 (Sheet 1 of 3)**



**757-200
STRUCTURAL REPAIR MANUAL**

ITEM	DESCRIPTION	GAGE	MATERIAL	EFFECTIVITY
1	STIFFENER		BAC1517-2196 7075-T6511	
2	STIFFENER		BAC1517-2198 7075-T6511	
3	STIFFENER		BAC1506-3353 7075-T6511 BAC1506-915 7075-T6511	D E
4	STIFFENER		BAC1506-3354 7075-T6511	
5	STIFFENER		BAC1518-2199 7075-T6511	
6	UPPER CHORD		BAC1514-2581 7075-T7351	
7	FRONT SPAR WEB	0.430	2024-T351 MACHINED TO 0.050 MIN	
8	LOWER CHORD		BAC1514-2580 2224-T3511	
9	MANUFACTURING DOOR	0.160	SHEET 2024-T351	
10	FRONT SPAR - BODY CHORD		BAC1514-2619 2024-T42	
11	STIFFENER		BAC1517-2242 7075-T6511 OPTIONAL: BAC1517-2200 7075-T6511	A
12	STIFFENER		BAC1517-2241 7075-T73511 BAC1517-2288 7075-T73511	B C
13	STIFFENER		BAC1517-2242 7075-T6511 BAC1517-2287 7075-T6511	B C
14	STIFFENER		BAC1506-3413 7075-T6511 BAC1506-3482 7075-T6511	B C
15	STIFFENER		FORGING 7075-T73	
16	UPPER CHORD		BAC1514-2583 7075-T6511	
17	REAR SPAR WEB	0.750	2324-T39 MACHINED TO 0.110 MIN	
18	LOWER CHORD		BAC1514-2582 2224-T3511	
19	BEAM		FORGING 7075-T73	

LIST OF MATERIALS FOR DETAILS II AND III

**Center Section Front and Rear Spar Identification
Figure 1 (Sheet 3 of 3)**

IDENTIFICATION 1
Page 3
Jan 20/2005

57-10-10

D634N201

**757-200
STRUCTURAL REPAIR MANUAL**

ALLOWABLE DAMAGE 1 - WING CENTER SECTION FRONT AND REAR SPARS

REF DWG
111N2001
111N1001

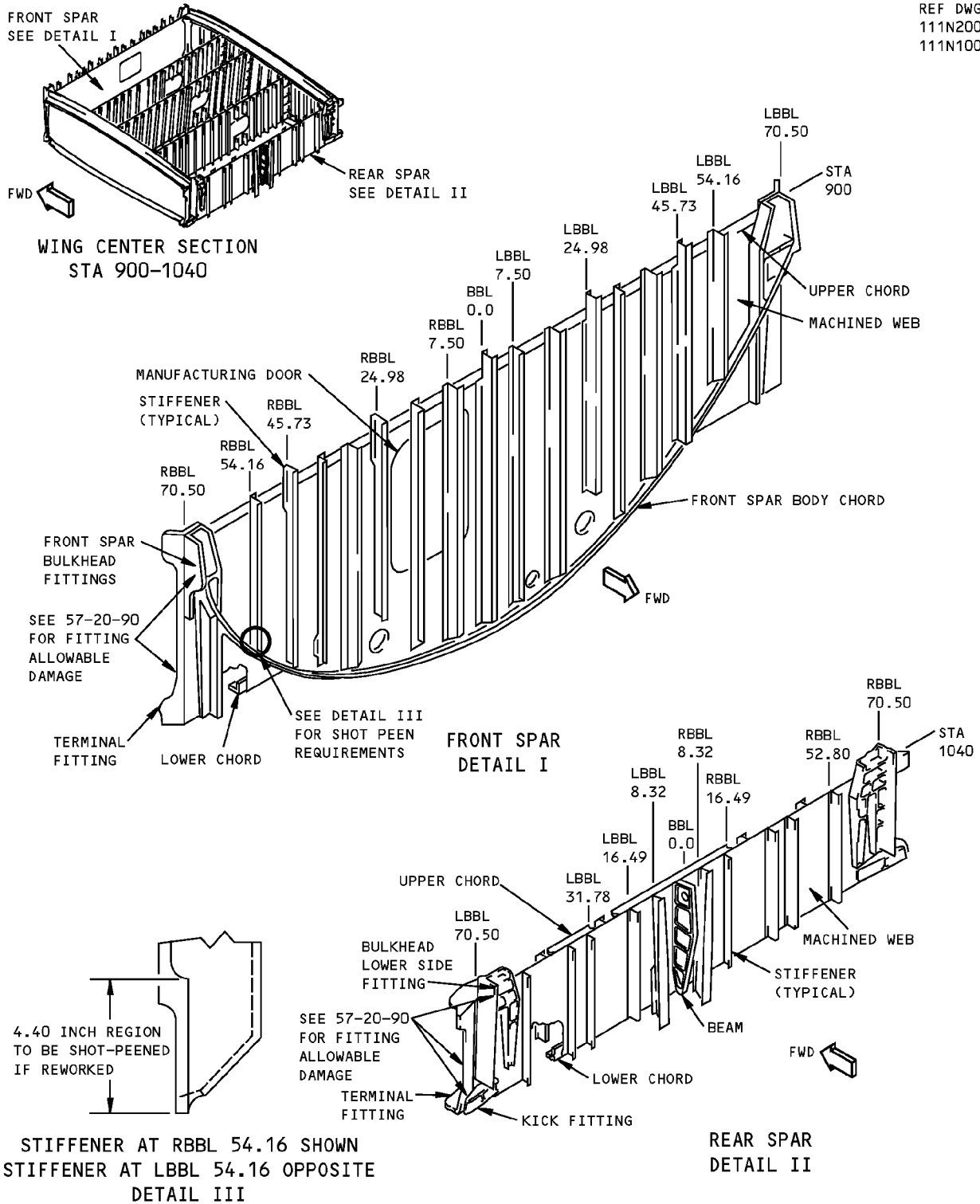

**Wing Center Section Front and Rear Spars Allowable Damage
Figure 101 (Sheet 1 of 4)**

STIFFENER AT RBBL 54.16 SHOWN
STIFFENER AT LBBL 54.16 OPPOSITE
DETAIL III

REAR SPAR
DETAIL II

**757-200
STRUCTURAL REPAIR MANUAL**

DESCRIPTION	CRACKS	NICKS, GOUGES AND CORROSION	DENTS	HOLES AND PUNCTURES
<u>FRONT SPAR</u>				
UPPER & LOWER CHORD	C	D	NOT ALLOWED	NOT ALLOWED
MACHINED WEB	E	D	SEE DETAIL VI	G
BODY CHORD	A	B	NOT ALLOWED	NOT ALLOWED
MANUFACTURING DOOR	E	D	SEE DETAIL VI	G
STIFFENER AT BBL 541.6	H	J	NOT ALLOWED	SEE DETAIL X
STIFFENER (TYPICAL)	A	B	NOT ALLOWED	SEE DETAIL X
<u>REAR SPAR</u>				
UPPER & LOWER CHORDS	C	D	NOT ALLOWED	NOT ALLOWED
MACHINED WEB	C	D	SEE DETAIL VI	G
STIFFENER AT BBL 8.32	C	D	NOT ALLOWED	SEE DETAIL X
STIFFENER (TYPICAL)	A	B	NOT ALLOWED	SEE DETAIL X
BEAM	C	F	NOT ALLOWED	NOT ALLOWED

NOTES

WARNING: PRESENCE OF FUEL VAPORS IN FUEL TANKS CREATES EXPLOSIVE AND TOXIC CONDITIONS. REFER TO 28-11-00 OF THE MAINTENANCE MANUAL FOR FUEL TANK MAINTENANCE PRACTICES AND ENTRY PROCEDURES

- REFINISH REWORKED AREAS AS GIVEN IN AMM 51-20.
- REFER TO 51-10-02 FOR INSPECTION AND REMOVAL OF DAMAGE

A CRACKS NOT ALLOWED EXCEPT FOR EDGE CRACKS WHICH MUST BE REMOVED PER DETAILS IV AND IX

B REMOVE DAMAGE PER DETAILS IV, V AND VII

C CRACKS NOT ALLOWED EXCEPT FOR EDGE CRACKS WHICH MUST BE REMOVED PER DETAILS IV AND IX **K**

D REMOVE DAMAGE PER DETAILS IV, V AND VII **K**

E CRACKS NOT ALLOWED EXCEPT FOR EDGE CRACKS WHICH MUST BE REMOVED PER DETAILS IV AND VIII **K**

F FOR EDGE DAMAGE SEE DETAILS IV AND VII. FOR LUG DAMAGE SEE DETAIL XI. FOR OTHER DAMAGE SEE DETAIL V. DAMAGE NOT ALLOWED IN VICINITY OF BUSHINGS **K**

G CLEAN PUNCTURE OUT WITH 0.25 INCH (6 mm) MAX DIA HOLE AND NOT CLOSER THAN 1.0 INCH (25 mm) TO FASTENER HOLE OR OTHER DAMAGE. HOLES ALLOWED IN UNPADDED AREAS OF WEBS ONLY, AWAY FROM RADIUS. FILL HOLES WITH A 2117-T3 OR T4 ALUMINUM PROTRUDING HEAD RIVET INSTALLED WET WITH BMS 5-26 SEALANT. ALL OTHER HOLES TO BE REPAIRED

H CRACKS NOT ALLOWED EXCEPT FOR EDGE CRACKS WHICH MUST BE REMOVED PER DETAILS IV AND IX. SHOT PEEN REWORKED AREA DIMENSIONED IN DETAIL III PER **K**

I NO HOLE DAMAGE ALLOWED IN FREE FLANGES OF "Z" OR "J" SECTION AS WELL AS IN FLANGES FASTENED TO WEBS. HOLE DAMAGE NOT TO EXCEED 4 PLACES. FILL ALL HOLES WITH 2117-T3 OR 2017-T4 ALUMINUM RIVETS INSTALLED WEB WITH BMS 5-26 SEALANT

J REMOVE DAMAGE PER DETAILS IV, V AND VII. SHOT PEEN REWORKED AREA DIMENSIONED IN DETAIL III PER **K**

K SHOT PEEN REWORKED AREAS PER SRM 51-20-06

**Wing Center Section Front and Rear Spars Allowable Damage
Figure 101 (Sheet 2 of 4)**

STRUCTURAL REPAIR MANUAL

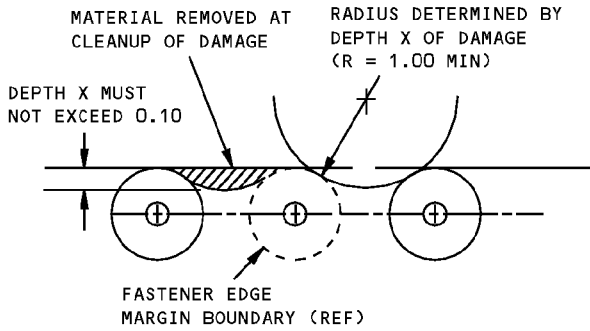

DAMAGE CLEANUP OF EDGES WHERE FASTENER EDGE MARGINS DO NOT OVERLAP

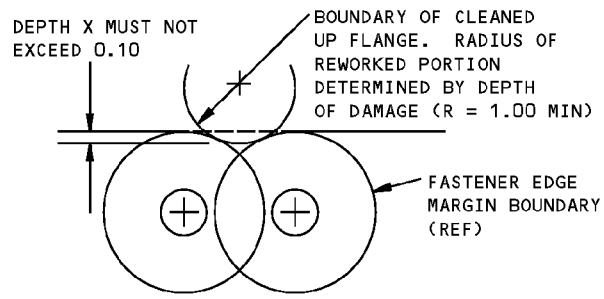

DAMAGE CLEANUP OF EDGES WHERE FASTENER EDGE MARGINS OVERLAP

DETAIL IV

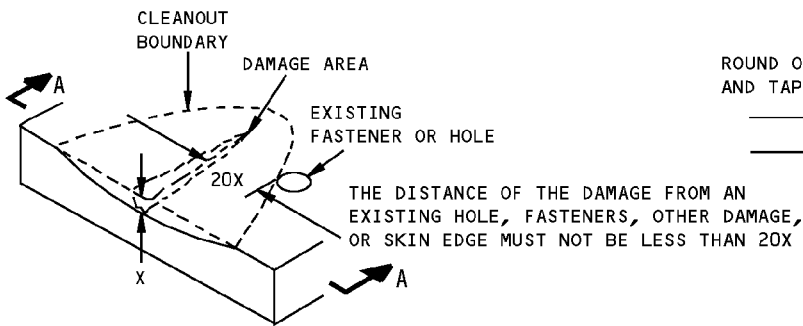

REMOVAL OF NICK, GOUGE AND SCRATCH DAMAGE ON A SURFACE
DETAIL V

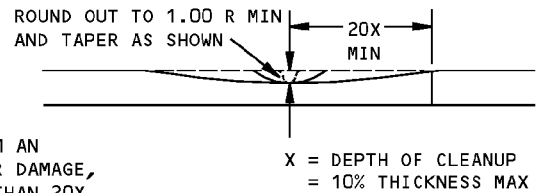

SECTION A-A

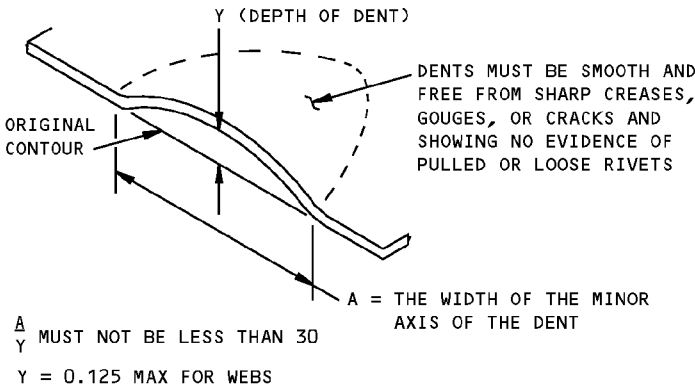

$\frac{A}{Y}$ MUST NOT BE LESS THAN 30
Y = 0.125 MAX FOR WEBS

ALLOWABLE DAMAGE FOR DENT
DETAIL VI

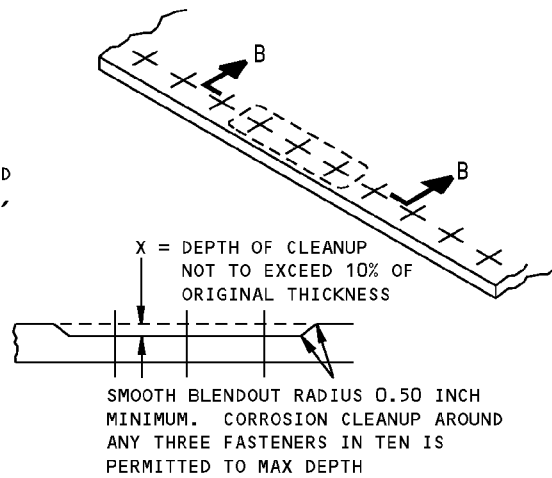

SECTION B-B

CORROSION CLEANUP
DETAIL VII

Wing Center Section Front and Rear Spars Allowable Damage
Figure 101 (Sheet 3 of 4)

STRUCTURAL REPAIR MANUAL

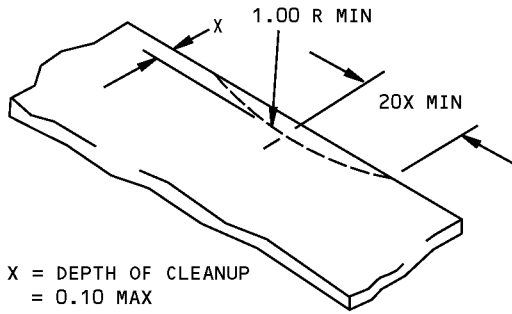

X = DEPTH OF CLEANUP
= 0.10 MAX

**REMOVAL OF NICK OR CRACK
DAMAGE ON AN EDGE
DETAIL VIII**

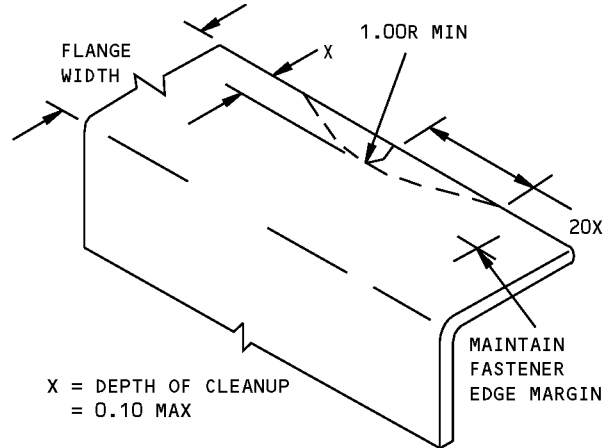

X = DEPTH OF CLEANUP
= 0.10 MAX

**REMOVAL OF NICK OR CRACK
DAMAGE ON AN EDGE
DETAIL IX**

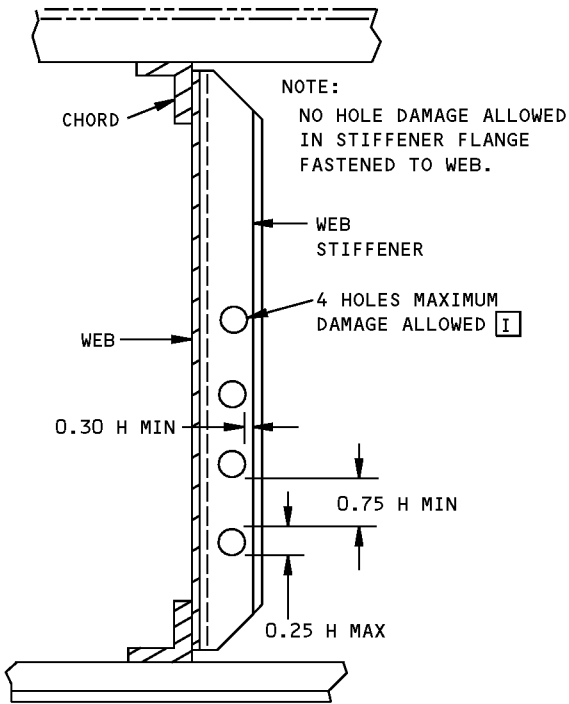

NOTE:
NO HOLE DAMAGE ALLOWED
IN STIFFENER FLANGE
FASTENED TO WEB.

4 HOLES MAXIMUM
DAMAGE ALLOWED **I**

0.30 H MIN

0.75 H MIN

0.25 H MAX

**ALLOWABLE DAMAGE LIMITS FOR
HOLES IN WEB STIFFENERS
DETAIL X**

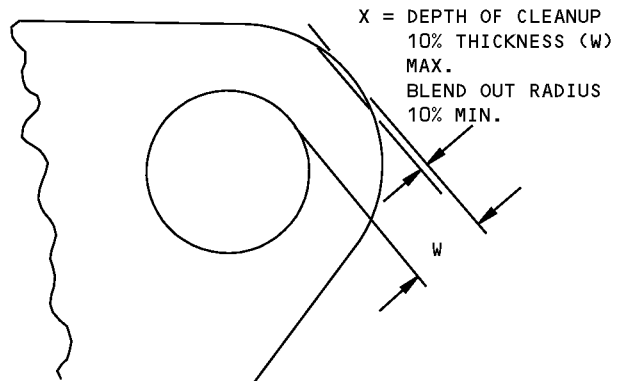

**DAMAGE CLEANUP FOR EDGES OF LUG
DETAIL XI**

**Wing Center Section Front and Rear Spars Allowable Damage
Figure 101 (Sheet 4 of 4)**

**757-200
STRUCTURAL REPAIR MANUAL**

IDENTIFICATION 1 - CENTER SECTION SPANWISE BEAM

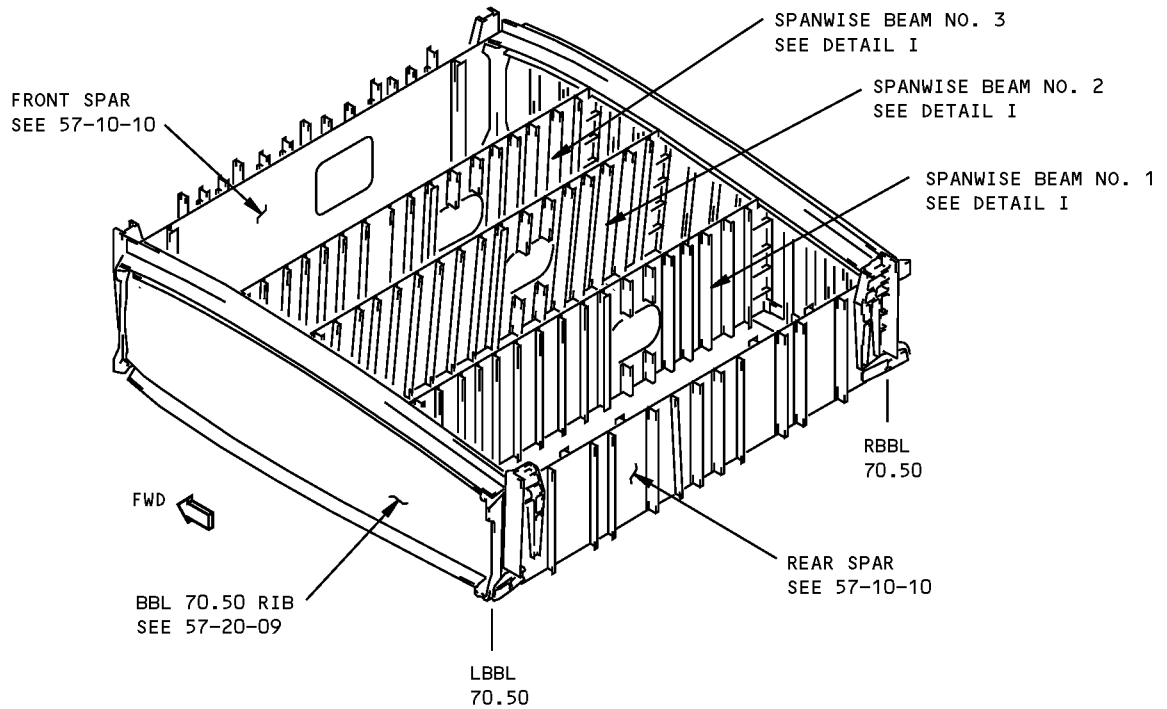
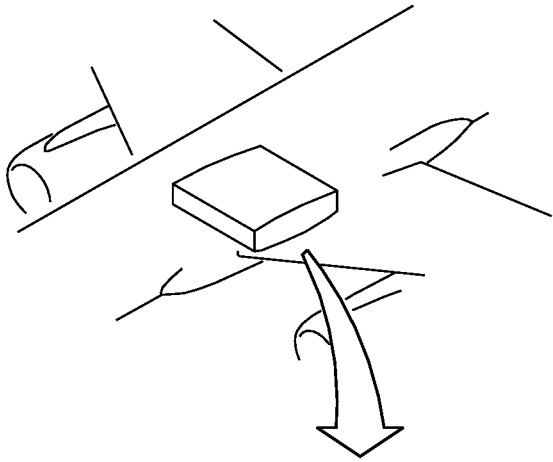

NOTES

- SEE 57-10-03 FOR LOCATION OF BEAMS

**Center Section Spanwise Beam Identification
Figure 1 (Sheet 1 of 3)**

**757-200
STRUCTURAL REPAIR MANUAL**

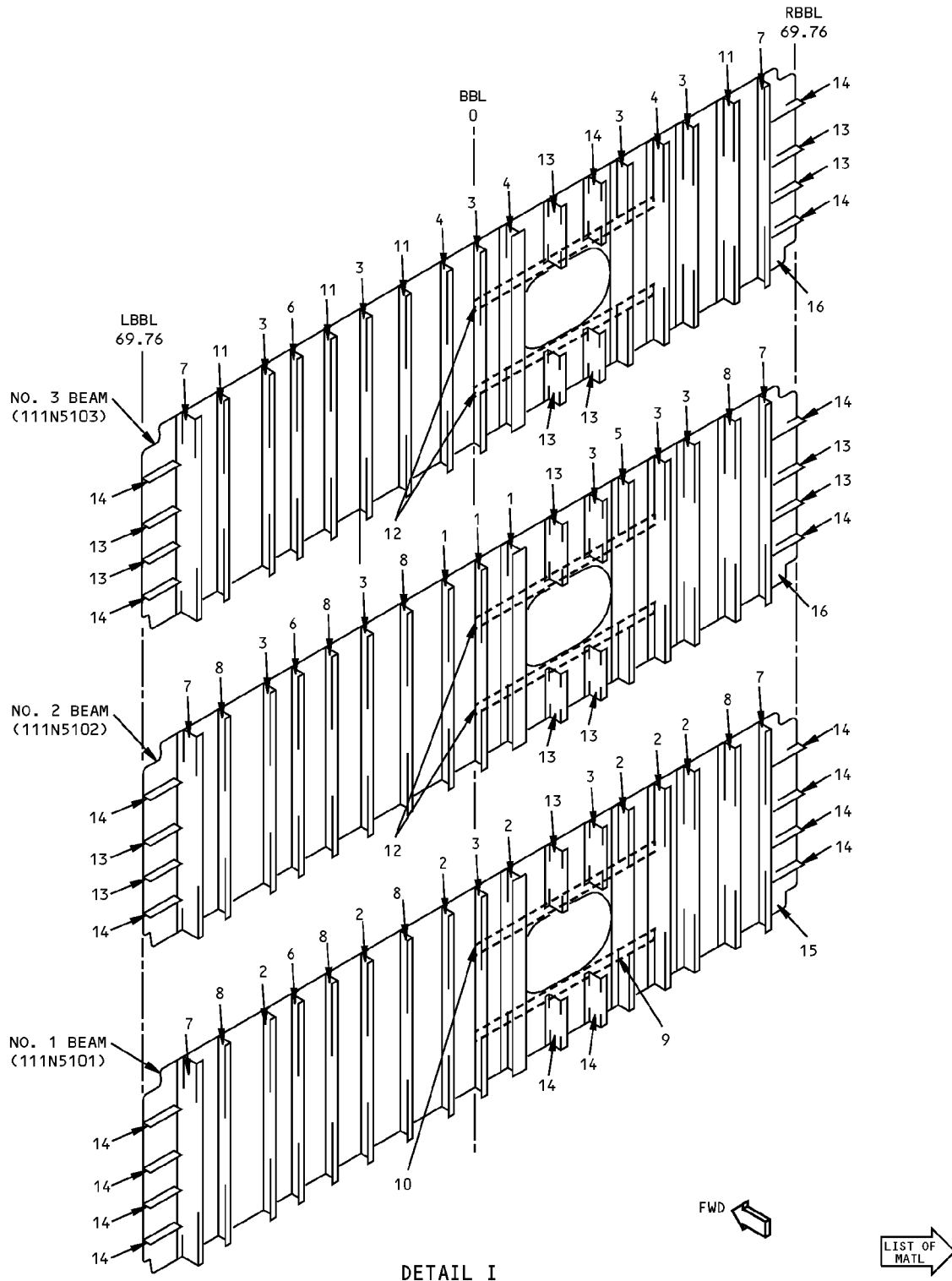

**Center Section Spanwise Beam Identification
Figure 1 (Sheet 2 of 3)**



757-200
STRUCTURAL REPAIR MANUAL

ITEM	DESCRIPTION	GAGE	MATERIAL	EFFECTIVITY
1	STIFFENER		BAC1518-808 7075-T6511	
2	STIFFENER		BAC1518-809 7075-T6511	
3	STIFFENER		BAC1518-810 7075-T6511	
4	STIFFENER		BAC1518-811 7075-T6511	
5	STIFFENER		BAC1518-812 7075-T6511	
6	STIFFENER		BAC1518-813 7075-T6511	
7	STIFFENER		BAC1518-815 7075-T6511	
8	STIFFENER		BAC1506-3347 7075-T6511	
9	STIFFENER		BAC1506-3348 7075-T6511	
10	STIFFENER		BAC1506-3349 7075-T6511	
11	STIFFENER		BAC1506-3350 7075-T6511	
12	STIFFENER		BAC1506-3351 7075-T6511	
13	STIFFENER		BAC1517-2230 7075-T6511	
14	STIFFENER		BAC1517-2231 7075-T6511	
15	MACHINED WEB	0.37	PLATE 2024-T351	
16	MACHINED WEB	0.32	PLATE 2024-T351	

LIST OF MATERIALS

Center Section Spanwise Beam Identification
Figure 1 (Sheet 3 of 3)

D634N201

57-10-13

IDENTIFICATION 1
Page 3
Jan 20/2005

**757-200
STRUCTURAL REPAIR MANUAL**

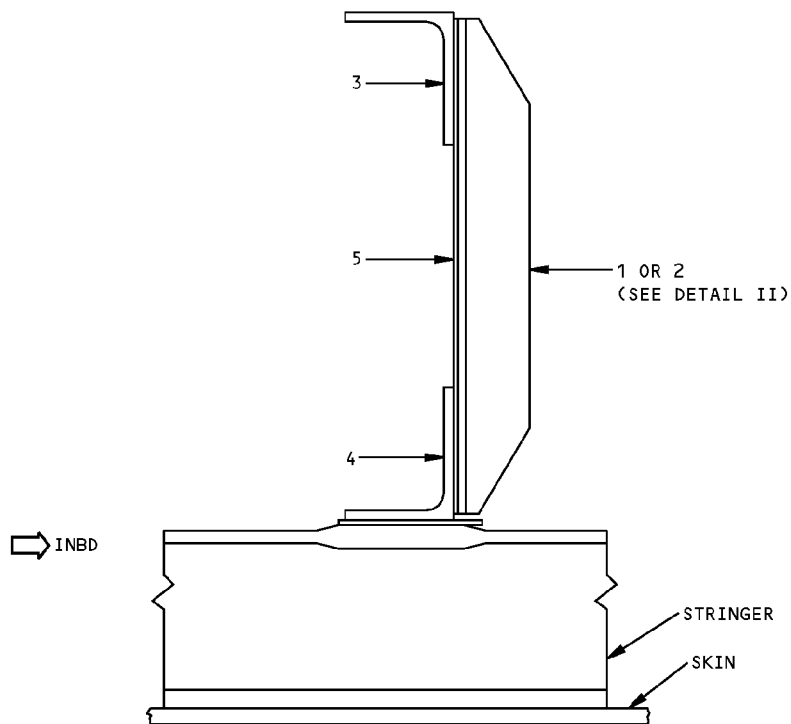

SECTION A-A

ITEM	DESCRIPTION	GAGE	MATERIAL	EFFECTIVITY
1	STIFFENER		AND10133-0602 7075-T6511	
2	STIFFENER		AND10133-1002 7075-T6511	
3	UPR CHORD		BAC1503-100382 7075-T6511	
4	LWR CHORD		AND10133-2002 7075-T6	
5	WEB	0.050	2024-T3	
6	HINGE PLATE	0.310	7075-T7351	

MATERIAL LIST FOR DETAIL II AND SECTION A-A

**Center Wing Lower Internal Beam Identification
Figure 1 (Sheet 2 of 2)**

**757-200
STRUCTURAL REPAIR MANUAL**

ALLOWABLE DAMAGE 1 - CENTER SECTION SPANWISE BEAM

REF DWG
111N0001

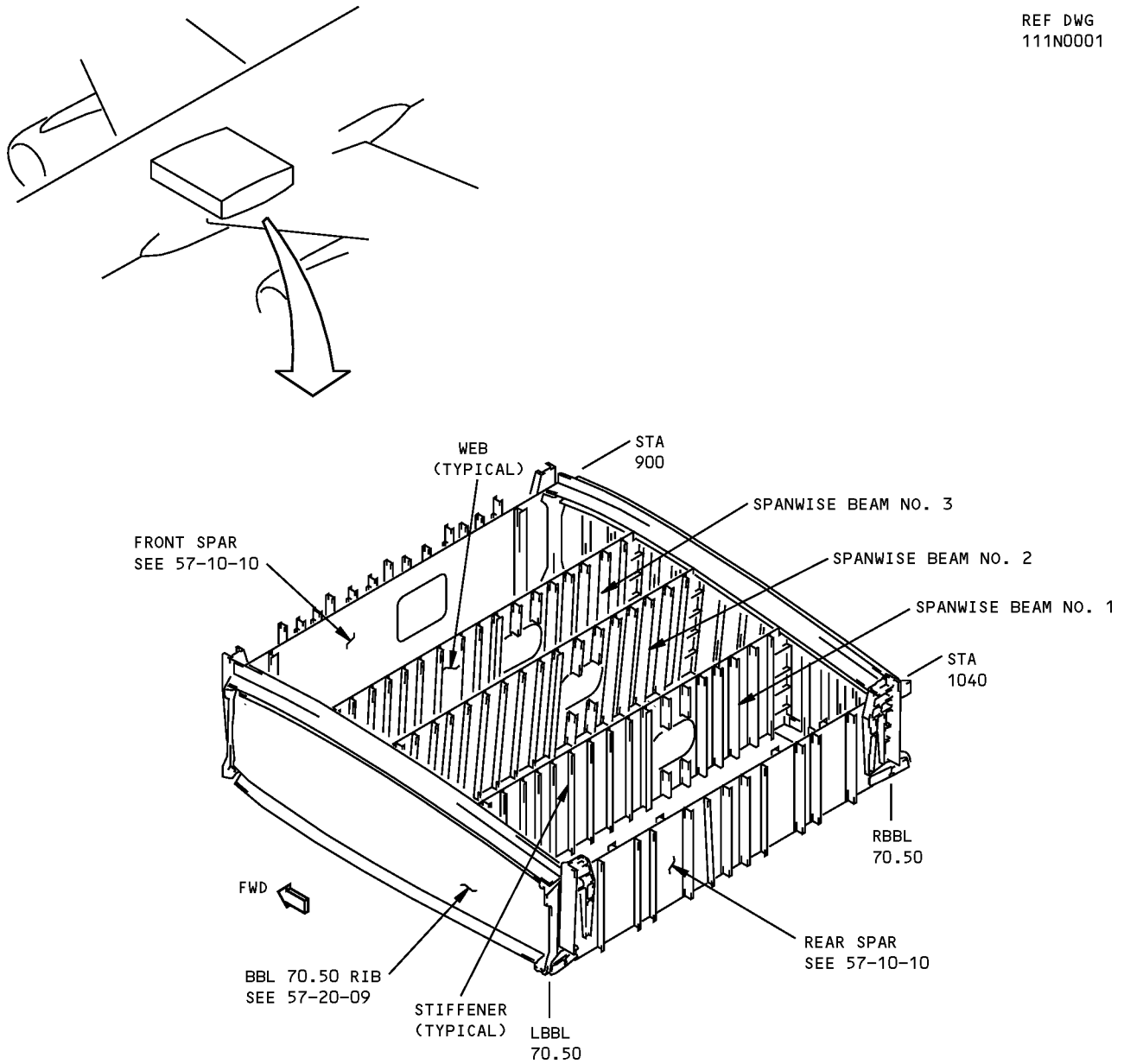

**Center Section Spanwise Beam Allowable Damage
Figure 101 (Sheet 1 of 4)**

ALLOWABLE DAMAGE 1
Page 101
Jan 20/2007

57-10-13

D634N201

**757-200
STRUCTURAL REPAIR MANUAL**

DESCRIPTION	CRACKS	NICKS, GOUGES AND CORROSION	DENTS	HOLES AND PUNCTURES
WEBS BEAM NO. 1	A	D	SEE DETAIL III	H
BEAMS NO. 2 AND 3	B	E	SEE DETAIL III	H
STIFFENERS	C	F	NOT ALLOWED	SEE DETAIL VII

NOTES

- REFINISH REWORKED AREAS PER 51-20 OF THE MAINTENANCE MANUAL

A CRACKS NOT ALLOWED EXCEPT FOR EDGE CRACKS WHICH MUST BE REMOVED PER DETAILS I AND V. SHOT PEEN REWORKED AREAS PER 20-10-03 OF THE COMPONENT MAINTENANCE MANUAL WITH SHOT NO. 230-330, INTENSITY .003A-.005A, OPTIONAL GLASS BEAD PEEN WITH BEAD SIZE 165-331, INTENSITY .003A-.005A **G**

B CRACKS NOT ALLOWED EXCEPT FOR EDGE CRACKS WHICH MUST BE REMOVED PER DETAILS I AND V. SHOT PEEN REWORKED AREAS PER 20-10-03 OF THE COMPONENT MAINTENANCE MANUAL WITH SHOT NO. 230-330, INTENSITY .004A-.006A **G**

C CRACKS NOT ALLOWED EXCEPT FOR EDGE CRACKS WHICH MUST BE REMOVED PER DETAILS I AND VI

D REMOVE DAMAGE PER DETAILS I,II, AND IV. MAX DEPTH 10% OF GAGE. SHOT PEEN REWORKED AREAS PER 20-10-03 OF THE COMPONENT MAINTENANCE MANUAL WITH SHOT NO. 230-330, INTENSITY .003A-.005A. OPTIONAL GLASS BEAD PEEN WITH BEAD SIZE 165-331, INTENSITY .003A-.005A **G**

E REMOVE DAMAGE PER DETAILS I,II, AND IV. MAX DEPTH 10% OF GAGE. SHOT PEEN REWORKED AREAS PER 20-10-03 OF THE COMPONENT MAINTENANCE MANUAL WITH SHOT NO. 230-330, INTENSITY .004A-.006A **G**

F REMOVE DAMAGE PER DETAILS I,II, AND IV. MAX DEPTH 10% OF GAGE

G SHOT PEEN INTENSITIES SHOWN FOR MANUFACTURED COMPONENTS. SEE 51-20-06 FOR SHOT PEEN INTENSITIES REQUIRED DUE TO THICKNESS REDUCTION RESULTING FROM REWORK

H CLEAN OUT DAMAGE UP TO 0.25 MAX DIA AND NOT CLOSER THAN 1.0 INCH TO FASTENER HOLE OR OTHER DAMAGE. HOLES ALLOWED IN UNPADDED AREAS OF WEB ONLY, AWAY FROM RADIUS. FILL HOLE WITH A 2117-T3 OR T4 ALUMINUM PROTRUDING HEAD RIVET INSTALLED WET WITH BMS 5-95 SEALANT. ALL OTHER HOLES TO BE REPAIRED

**Center Section Spanwise Beam Allowable Damage
Figure 101 (Sheet 2 of 4)**

STRUCTURAL REPAIR MANUAL

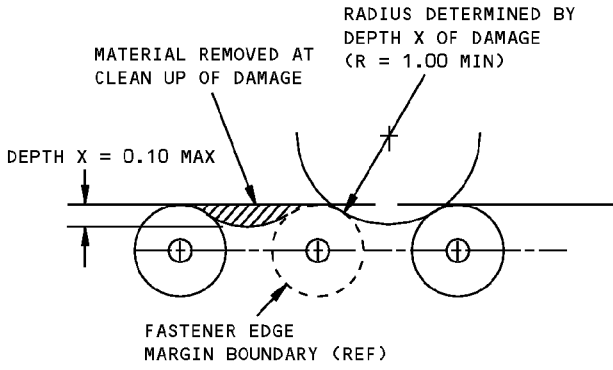

DAMAGE CLEANUP OF EDGES WHERE FASTENER EDGE MARGINS DO NOT OVERLAP

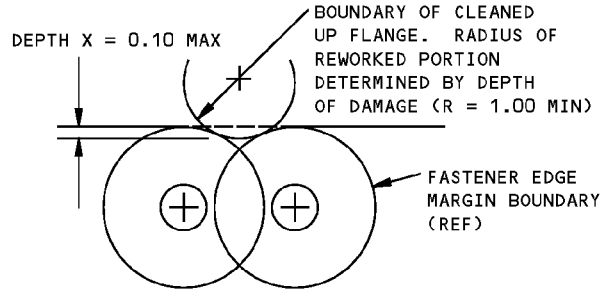

DAMAGE CLEANUP OF EDGES WHERE FASTENER EDGE MARGINS OVERLAP

DETAIL I

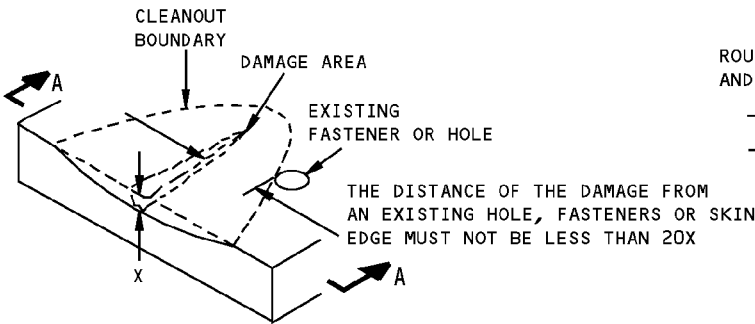

REMOVAL OF NICK, GOUGE AND SCRATCH DAMAGE ON A SURFACE
DETAIL II

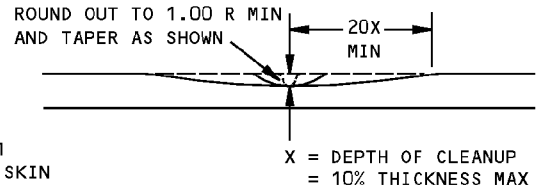

SECTION A-A

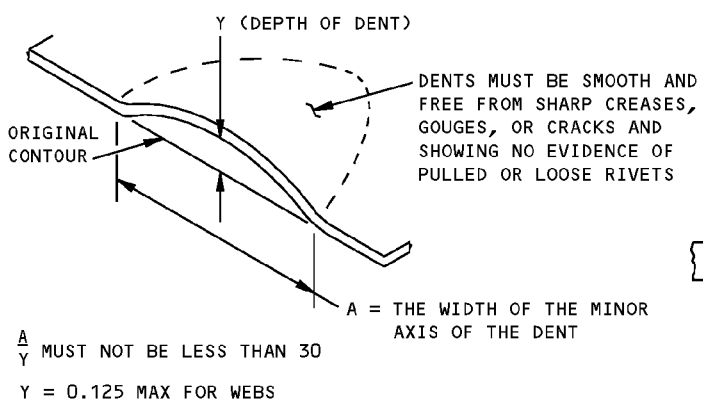

$\frac{A}{Y}$ MUST NOT BE LESS THAN 30
Y = 0.125 MAX FOR WEBS

ALLOWABLE DAMAGE FOR DENT
DETAIL III

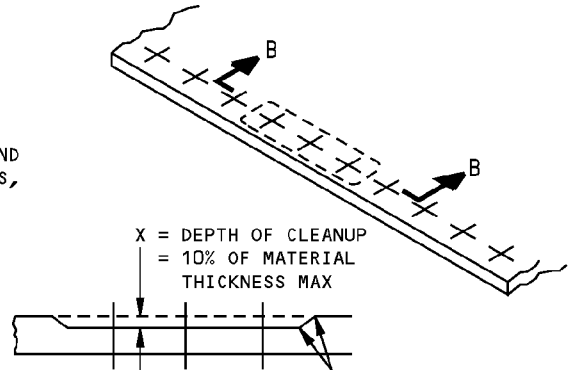

SECTION B-B

CORROSION CLEANUP
DETAIL IV

Center Section Spanwise Beam Allowable Damage
Figure 101 (Sheet 3 of 4)

**757-200
STRUCTURAL REPAIR MANUAL**

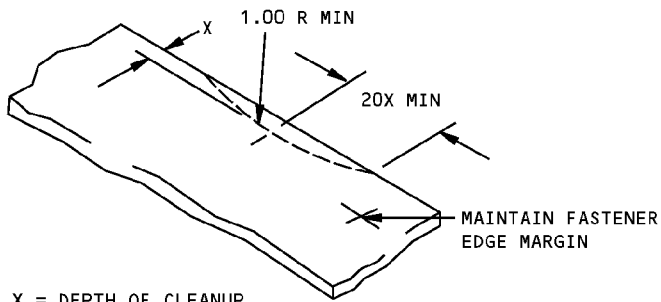

X = DEPTH OF CLEANUP
= 0.10 MAX

**REMOVAL OF NICK OR CRACK
DAMAGE ON AN EDGE
DETAIL V**

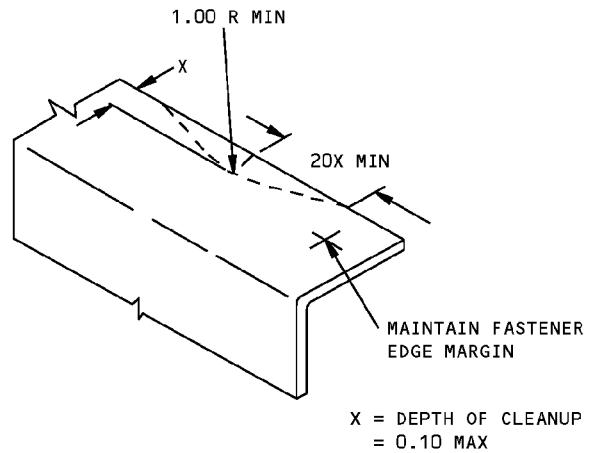

X = DEPTH OF CLEANUP
= 0.10 MAX

**REMOVAL OF NICK OR CRACK
DAMAGE ON AN EDGE
DETAIL VI**

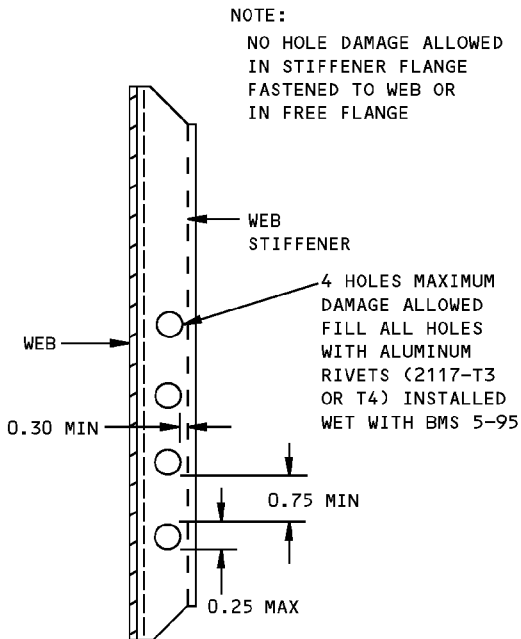

NOTE:
NO HOLE DAMAGE ALLOWED
IN STIFFENER FLANGE
FASTENED TO WEB OR
IN FREE FLANGE

**ALLOWABLE DAMAGE LIMITS FOR
HOLES IN WEB STIFFENERS
DETAIL VII**

**Center Section Spanwise Beam Allowable Damage
Figure 101 (Sheet 4 of 4)**

**757-200
STRUCTURAL REPAIR MANUAL**

IDENTIFICATION 1 - OUTER WING UPPER INTERSPAR SKIN

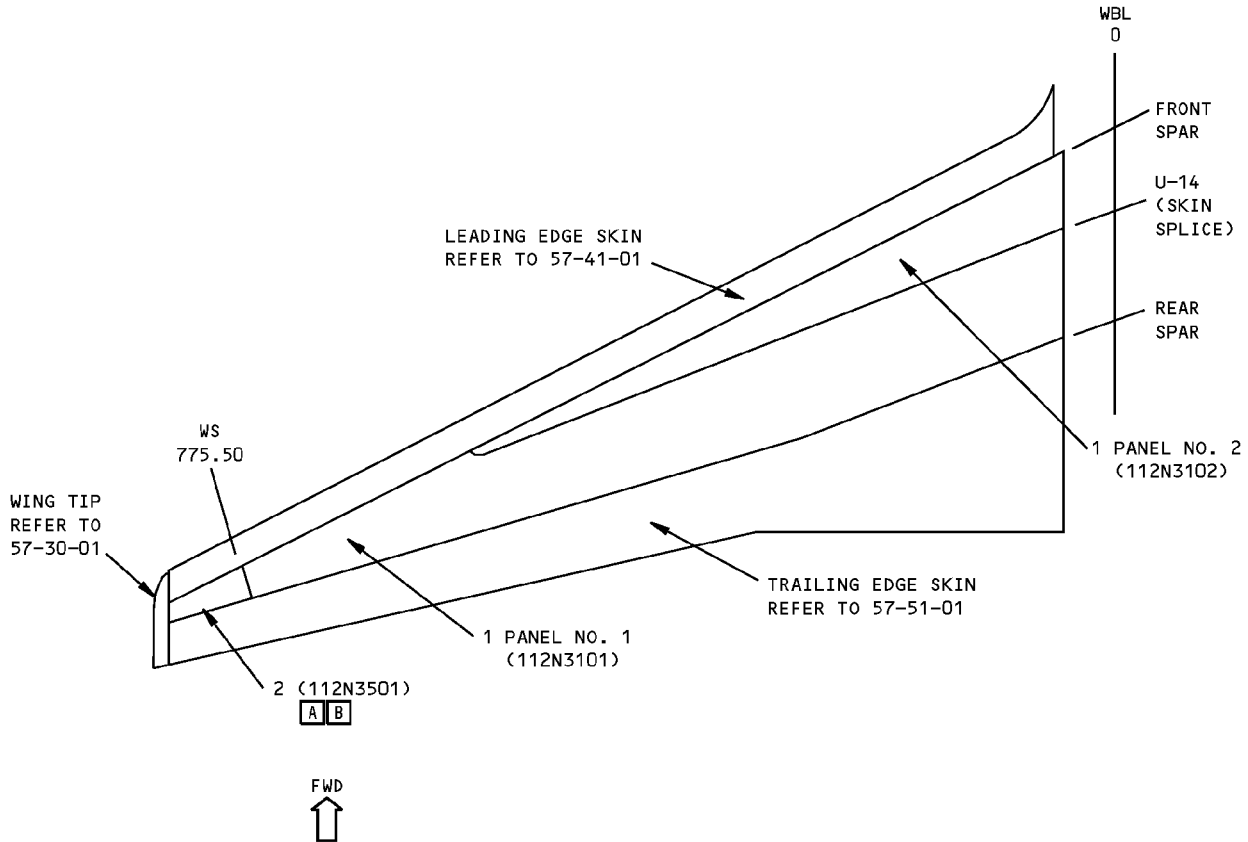

PLAN VIEW
LEFT WING SHOWN
RIGHT WING OPPOSITE

NOTES

- A** FOR AIRPLANE CUM LINE NUMBERS: 1 THRU 1009
- B** FOR AIRPLANE CUM LINE NUMBERS: 1010 AND ON

ITEM	DESCRIPTION	GAGE	MATERIAL	EFFECTIVITY
1	SKIN	0.75 0.90	7150-T651 OR 7150-T651	
2	HONEYCOMB PANEL ASSY OUTER SKIN	0.500 0.375	7075-T6511 (CHEM-MILLED TO 0.025 MINIMUM) 7075-T6 (CHEM-MILLED TO 0.025 MINIMUM)	B A
	CORE, OUTBOARD	0.500	BMS 4-4 5052 TYPE 4-15N FORM B	
	CORE, INBOARD	0.625	BMS 4-4 5052 TYPE 4-15N FORM B	
	INNER SKIN	0.016	7075-T6	

LIST OF MATERIALS

**Outer Wing Upper Interspar Skin Identification
Figure 1**

**757-200
STRUCTURAL REPAIR MANUAL**

IDENTIFICATION 2 - OUTER WING LOWER INTERSPAR SKIN

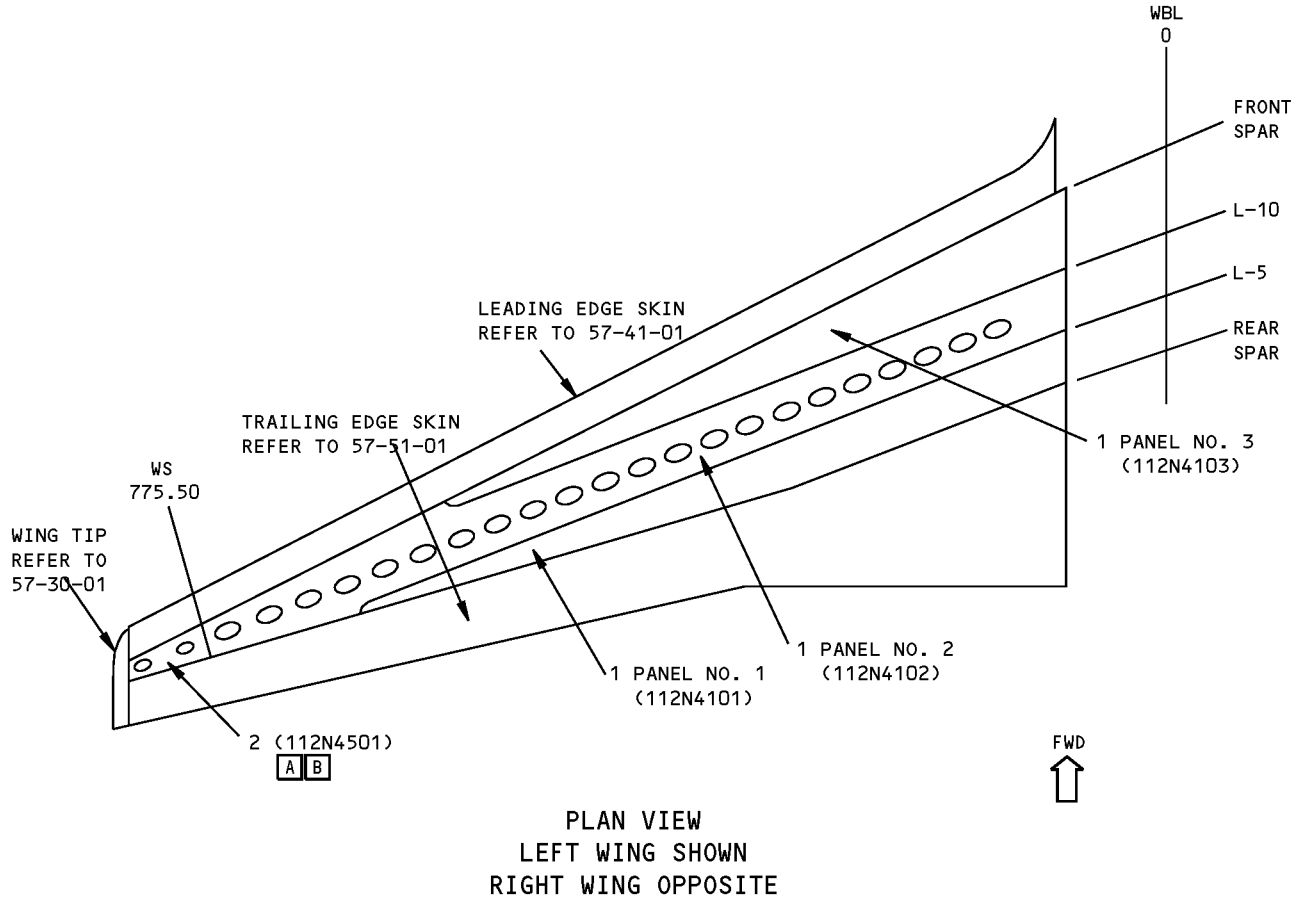

NOTES

- A** FOR AIRPLANE CUM LINE NUMBERS: 1 THRU 1009
- B** FOR AIRPLANE CUM LINE NUMBERS: 1010 AND ON

ITEM	DESCRIPTION	GAGE	MATERIAL	EFFECTIVITY
1	SKIN	1.08 1.26	2324-T39 OPTIONAL: 2324-T39	
2	HONEYCOMB PANEL ASSY OUTER SKIN CORE, OUTBOARD INNER SKIN, OUTBOARD CORE, INBOARD INNER SKIN, INBOARD	0.312 0.500 0.016 0.020 0.625 0.020	2024-T351 (CHEM-MILLED TO 0.032 MIN) BMS 4-4 5052 TYPE 4-15N FORM B 2024-T3 2024-T3 BMS 4-4 5052 TYPE 4-15N FORM B 2024-T3	A B

LIST OF MATERIALS

**Outer Wing Lower Interspar Skin Identification
Figure 1**



757-200

STRUCTURAL REPAIR MANUAL

ALLOWABLE DAMAGE 1 - OUTER WING SKIN

This subject gives the allowable damage limits for the outer wing skin, as shown in Figure 101 of Allowable Damage 1.

Allowable Damage 1 is applicable to airplanes that have not had winglets installed.

Allowable Damage 1 is not applicable to airplanes that have had winglets installed after production of the airplane. Refer to Aviation Partners Boeing (APB) document AP57.2-0602 for the winglet data.

**Outer Wing Skin Allowable Damage
Figure 101 (Sheet 1 of 8)**

D634N201

ALLOWABLE DAMAGE 1
Page 101
57-20-01
Sep 20/2006

**757-200
STRUCTURAL REPAIR MANUAL**

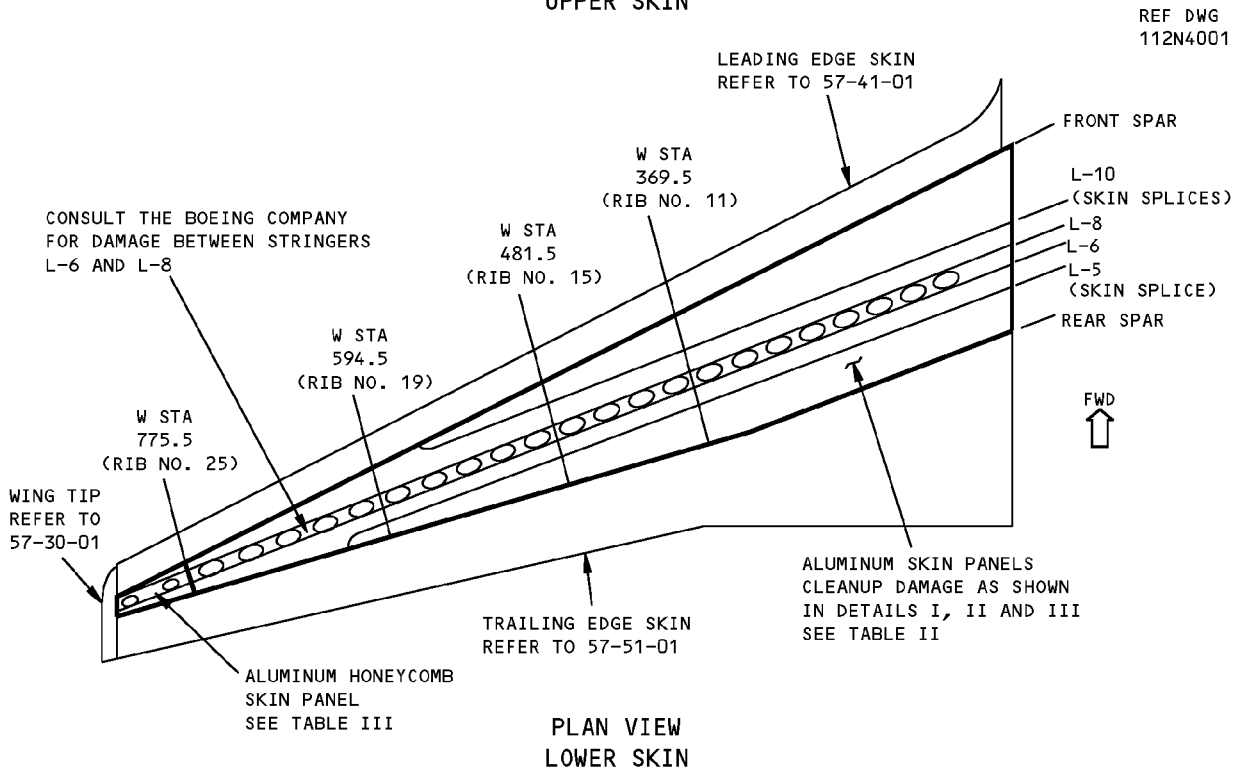
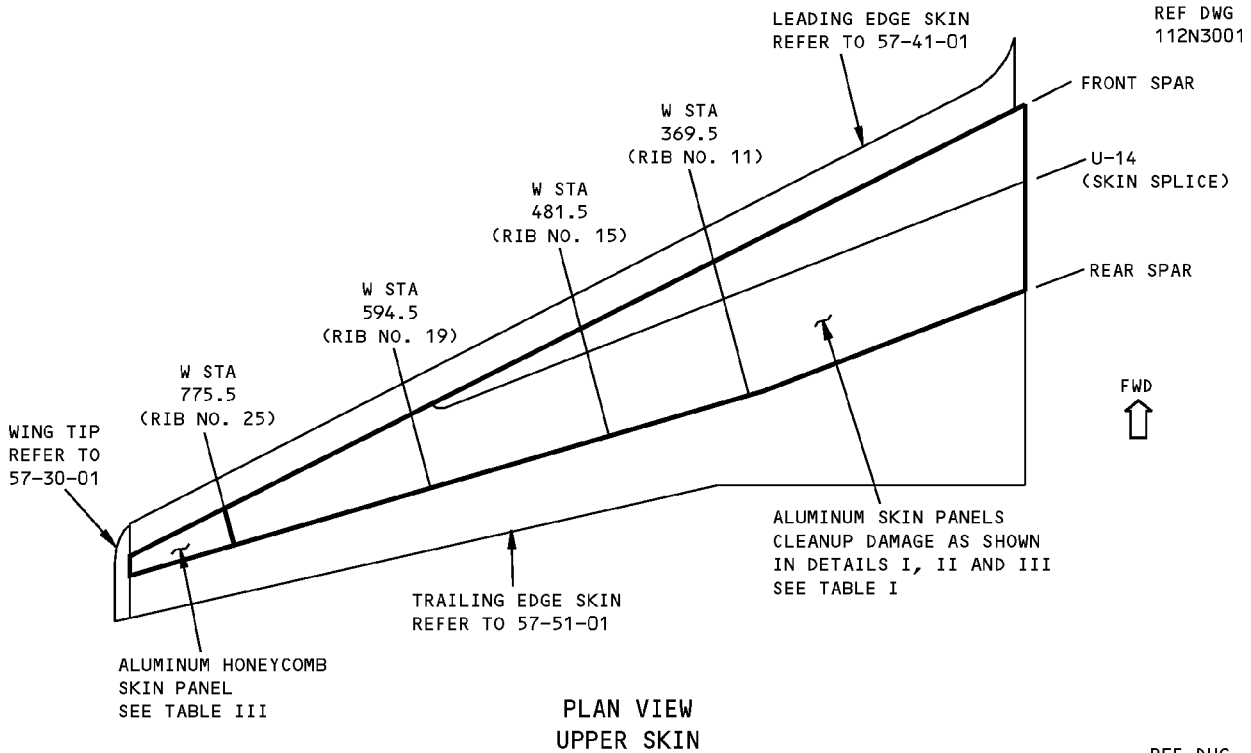

**Outer Wing Skin Allowable Damage
Figure 101 (Sheet 2 of 8)**



**757-200
STRUCTURAL REPAIR MANUAL**

ZONE	ALLOWABLE DAMAGE A		
	MAX DEPTH OF DAMAGE AFTER CLEANUP (IN)	MAX LOSS OF CROSS-SECTIONAL AREA BETWEEN ADJACENT STIFFENERS OR BETWEEN SPAR AND STIFFENER (SQ IN) B C	TOTAL MAX LOSS OF CROSS-SECTIONAL AREA BETWEEN FRONT SPAR AND REAR SPAR (SQ IN) B
INBD OF WS 369.5	0.025	0.018	0.21
WS 369.5 TO WS 481.5	0.030	0.020	0.15
WS 481.5 TO WS 594.5	0.030	0.018	0.12
WS 594.5 TO WS 775.5	0.020	0.010	0.04

ALLOWABLE DAMAGE – UPPER SKIN D
TABLE I

ZONE	ALLOWABLE DAMAGE A		
	MAX DEPTH OF DAMAGE AFTER CLEANUP (IN)	MAX LOSS OF CROSS-SECTIONAL AREA BETWEEN ADJACENT STIFFENERS OR BETWEEN SPAR AND STIFFENER (SQ IN) B C	TOTAL MAX LOSS OF CROSS-SECTIONAL AREA BETWEEN FRONT SPAR AND REAR SPAR (SQ IN) B
INBD OF WS 369.5	0.050	0.050	0.50
WS 369.5 TO WS 481.5	0.050	0.050	0.34
WS 481.5 TO WS 594.5	0.045	0.043	0.20
WS 594.5 TO WS 775.5	0.040	0.030	0.10

ALLOWABLE DAMAGE – LOWER SKIN D
TABLE II

DESCRIPTION	EDGE CRACKS	NICKS, GOUGES AND CORROSION	DENTS	HOLES AND PUNCTURES	DELAMINATION
ALUMINUM SANDWICH SKIN PANEL, UPPER AND LOWER SKIN	G	H	I	J	F

ALLOWABLE DAMAGE – ALUMINUM HONEYCOMB PANEL
TABLE III

**Outer Wing Skin Allowable Damage
Figure 101 (Sheet 3 of 8)**

STRUCTURAL REPAIR MANUAL

NOTES

- REFINISH REWORKED AREAS AS GIVEN IN AMM 51-20
- REFER TO SRM 51-10-02 FOR INSPECTION AND REMOVAL OF DAMAGE
- REFER TO SRM 51-10-01 FOR AERODYNAMIC SMOOTHNESS REQUIREMENTS. WHERE DAMAGE EXCEEDS THE LIMITS SHOWN IN SRM 51-10-01, CONSIDERATION SHOULD BE GIVEN TO LOSS OF PERFORMANCE INVOLVED.
- DAMAGE TO INSPAR WING SKINS BY NICKS, SCRATCHES, GOUGES, CRACKS, ABRASIONS AND CORROSION IS ALLOWABLE PROVIDED THAT ALL OF THE LIMITATIONS IN TABLE I OR TABLE II ARE NOT EXCEEDED. DAMAGE DEPTH AND LOSS OF CROSS-SECTIONAL AREA ARE TO BE DETERMINED AFTER CLEANUP (SEE DETAIL I).
- THESE ALLOWABLE DAMAGE LIMITS ARE NOT APPLICABLE IF THERE IS UNREPAIRED DAMAGE TO ANY STIFFENER IN THE SAME AREA.
- REFER TO SAMPLE CALCULATION SHOWING THE USE OF THE TABULATED LIMITATIONS.

- A** ALLOWABLE DAMAGE LIMITATIONS ARE NOT APPLICABLE IN THE FOLLOWING AREAS (CONSULT THE BOEING COMPANY FOR SPECIFIC INSTRUCTIONS):
1. WITHIN 1.50 INCHES (38 mm) OF ANY CHORDWISE ROW OF FASTENERS
 2. FORWARD OF A LINE 1.50 INCHES (38 mm) AFT OF THE AFT ROW OF FASTENERS ATTACHING THE SKIN TO THE FRONT SPAR
 3. AFT OF A LINE 1.50 INCHES (38 mm) FORWARD OF THE FORWARD ROW OF FASTENERS ATTACHING THE SKIN OF THE REAR SPAR
 4. WITHIN 1.50 INCHES (38 mm) OF FASTENERS IN THE SPANWISE SKIN SPLICES.

- B** LOSS OF CROSS-SECTIONAL AREA ON A LINE PERPENDICULAR TO THE REAR SPAR. MULTIPLE AREAS OF DAMAGE ARE TO BE CONSIDERED ON THE SAME LINE IF LESS THAN 1.50 INCHES (38 mm) FROM EACH OTHER MEASURED SPANWISE (SEE DETAIL II).

- C** WHERE THE STIFFENER ADJACENT TO A SPAR FORMS A TAPERED PANEL WITH THE SPAR, THE ALLOWABLE DAMAGE LIMITATIONS APPLY TO THE AREA BETWEEN THE SPAR AND THE SECOND STIFFENER, UNLESS THE DISTANCE BETWEEN THE SPAR AND ADJACENT STIFFENER IS EQUIVALENT TO LOCAL STIFFENER SPACING.

- D** SHOT PEEN REWORKED AREAS PER SRM 51-20-06. SHOT PEEN INTENSITIES WILL VARY WITH THE THICKNESS REMAINING AFTER REWORK.

- E** REMOVE MOISTURE FROM THE DAMAGED AREA. USE A VACUUM AND HEAT (A MAXIMUM OF 125°F [52°C]) TO REMOVE MOISTURE FROM THE HONEYCOMB CELLS. SEAL THE DAMAGED AREA WITH ALUMINUM FOIL TAPE (SPEED TAPE). KEEP A RECORD OF THE LOCATION AND MAKE AN INSPECTION EVERY AIRPLANE "A" CHECK. REPLACE THE TAPE IF ANY DETERIORATION IS FOUND. REPAIR THE DAMAGE NO LATER THAN THE NEXT AIRPLANE "C" CHECK.

- F** SEE DETAIL VIII. PROTECT THE DAMAGE AS SPECIFIED IN **E**.

- G** REMOVE EDGE CRACKS AS SHOWN IN DETAIL IV. OTHER CRACKS ARE NOT PERMITTED.

- H** REMOVE DAMAGE AS SHOWN IN DETAILS IV, V, AND VII. ONLY ONE DAMAGE CLEANUP IS PERMITTED IN AN AREA OF 15 SQUARE INCHES (97 SQUARE cm).

- I** DENT DAMAGE OF 1.5 SQUARE INCHES (9.7 SQUARE cm) IS PERMITTED IN AN AREA OF ONE SQUARE FOOT. THE DISTANCE FROM THE DAMAGE TO AN EDGE, A HOLE, OR OTHER DAMAGE MUST BE MORE THAN 4A. SEE DETAIL VI.

- J** HOLES IN THE EDGE BAND ARE NOT PERMITTED. IN THE HONEYCOMB AREA, HOLES ARE PERMITTED TO A MAXIMUM DIAMETER OF 0.25 INCH (6 mm). HOLES MUST BE MORE THAN 1.0 INCH (25 mm) FROM AN EDGE, ANOTHER HOLE, OR OTHER TYPE OF DAMAGE. ONE HOLE IS PERMITTED IN AN AREA OF 15 SQUARE INCHES (97 SQUARE cm). PROTECT THE DAMAGE AS SPECIFIED IN **E**.

- K** THE THICKNESS OF THE TOP SHEET IS NOT CONSTANT. USE THE THINNEST SKIN THICKNESS IN THE DAMAGE AREA TO FIND "X".

**Outer Wing Skin Allowable Damage
Figure 101 (Sheet 4 of 8)**

**757-200
STRUCTURAL REPAIR MANUAL**

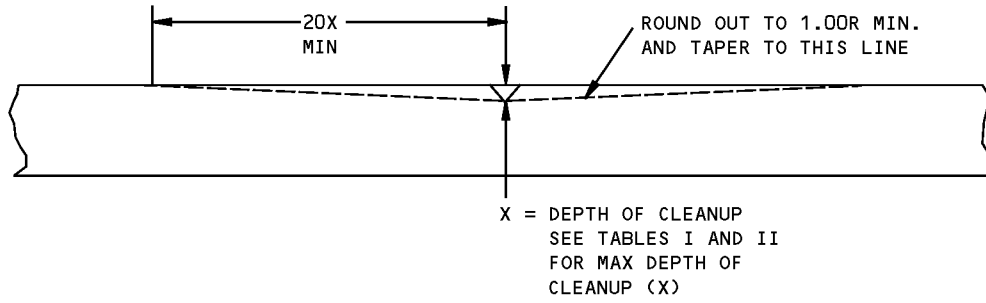

**SECTION THROUGH CLEANED UP DAMAGE
DETAIL I**

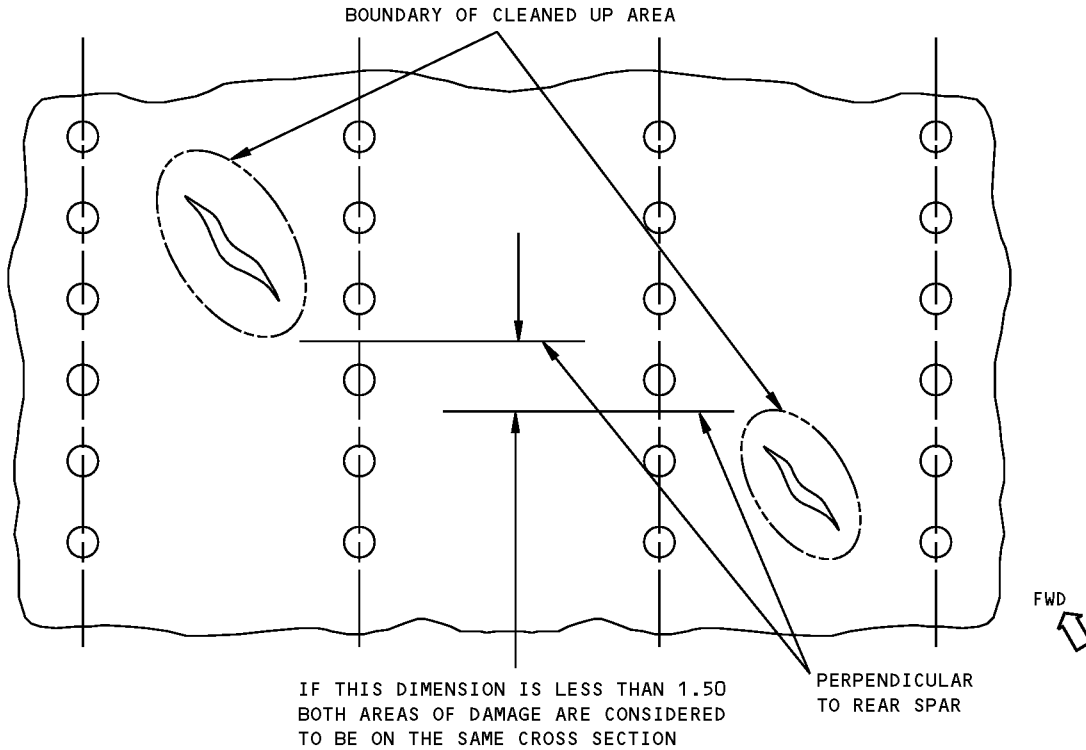

**ADDITIVE DAMAGE
DETAIL II**

**Outer Wing Skin Allowable Damage
Figure 101 (Sheet 5 of 8)**

**757-200
STRUCTURAL REPAIR MANUAL**

SAMPLE CALCULATION

ASSUME THE DAMAGE IS TWO ABRASIONS
LOCATED AS SHOWN ON THE LOWER SKIN:

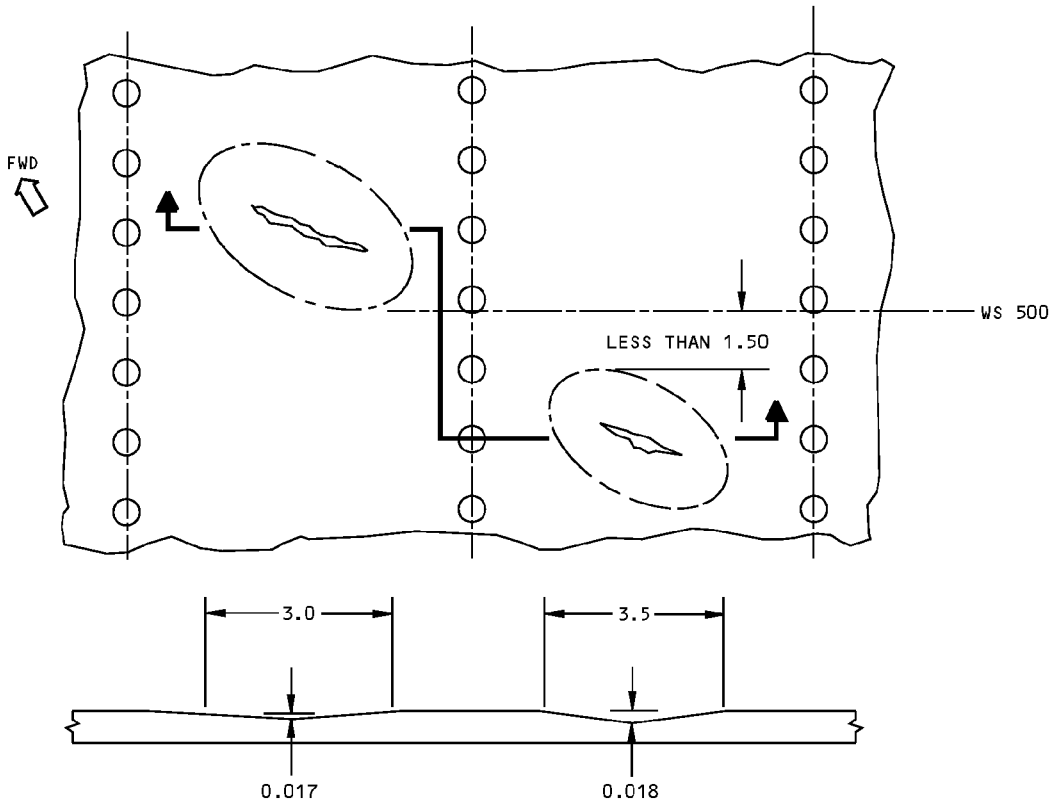

SECTION THROUGH DAMAGE AFTER CLEANUP PERPENDICULAR TO REAR SPAR

STEP 1 - CHECK DEPTH OF DAMAGE. FROM TABLE II, PERMITTED DEPTH OF DAMAGE BETWEEN WS 481.5 AND WS 594.5 IS 0.045. BOTH AREAS OF DAMAGE ARE WITHIN THIS LIMITATION.

STEP 2 - CHECK LOSS IN AREA BETWEEN STIFFENERS.

LOSS IN AREA OF FORWARD DAMAGE PERPENDICULAR TO REAR SPAR =

$$\frac{3.0}{2} \times 0.017 = 0.025 \text{ SQ. IN.}$$

LOSS IN AREA OF AFT DAMAGE =

$$\frac{3.5}{2} \times 0.018 = 0.032 \text{ SQ. IN.}$$

THESE ARE BOTH WITHIN THE 0.043 LIMITATION OF TABLE II.

STEP 3 - CHECK THE TOTAL LOSS IN AREA BETWEEN FRONT AND REAR SPARS. AS THE TWO AREAS ARE LESS THAN 1.50 APART (PERPENDICULAR TO REAR SPAR) THE DAMAGE IS CUMULATIVE. $0.025 + 0.032 = 0.057$ SQUARE INCHES. THIS IS WITHIN THE 0.20 LIMITATION OF TABLE II.

AS ALL OF THE CRITERIA ARE WITHIN TABLE II LIMITATIONS, THE DAMAGE SHOWN WOULD BE ACCEPTABLE.

DETAIL III

**Outer Wing Skin Allowable Damage
Figure 101 (Sheet 6 of 8)**

STRUCTURAL REPAIR MANUAL

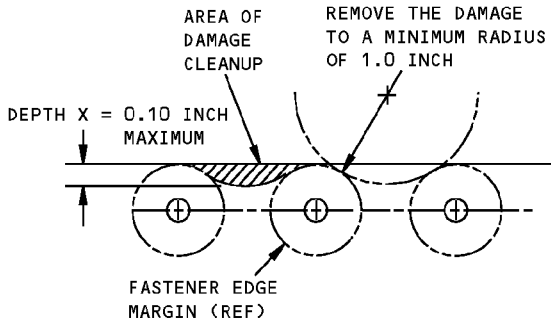

REMOVAL OF DAMAGE AT EDGES WHERE FASTENER EDGE MARGINS DO NOT OVERLAP

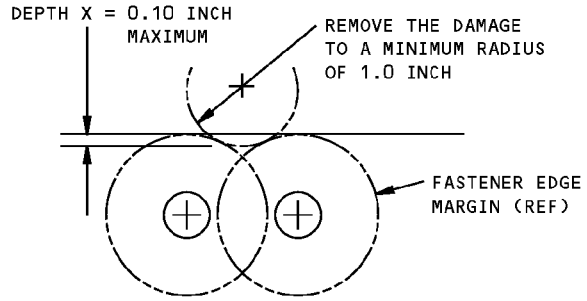

REMOVAL OF DAMAGE AT EDGES WHERE FASTENER EDGE MARGINS OVERLAP

DETAIL IV

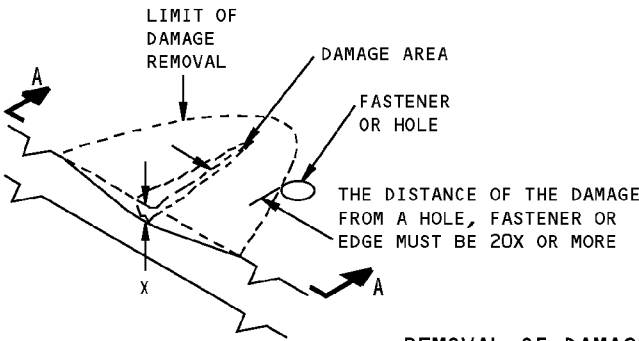

REMOVAL OF DAMAGE ON A SURFACE
DETAIL V

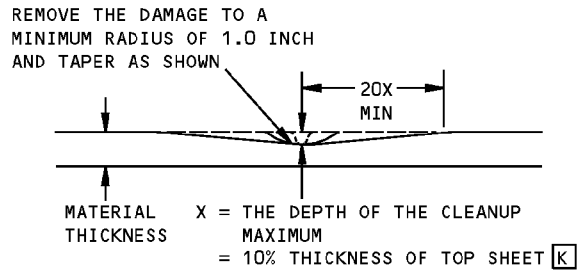

SECTION A-A

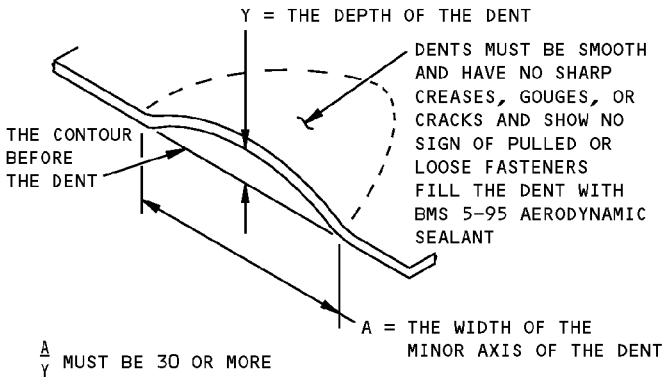

DENT DAMAGE PERMITTED
DETAIL VI

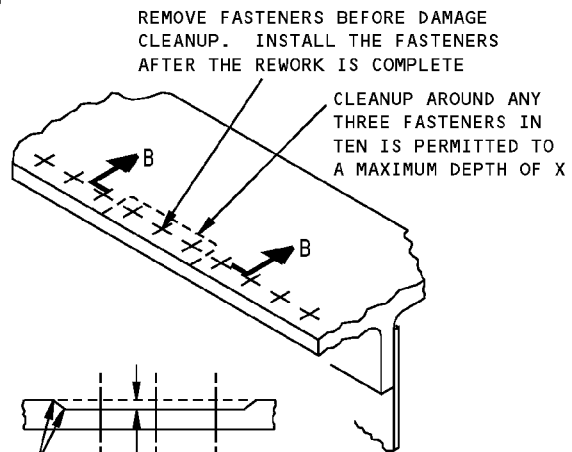

SECTION B-B
REMOVAL OF CORROSION DAMAGE
DETAIL VII

**Outer Wing Skin Allowable Damage
Figure 101 (Sheet 7 of 8)**

**757-200
STRUCTURAL REPAIR MANUAL**

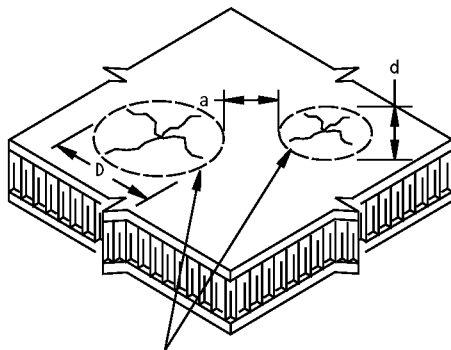

ADJACENT DAMAGE AREAS ON SURFACE OF ALUMINUM SANDWICH PANEL

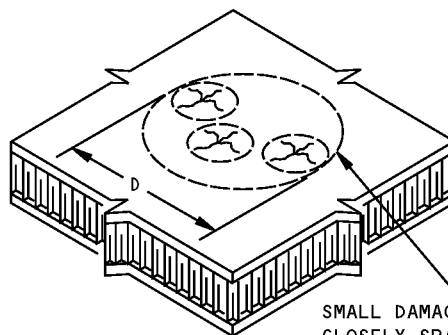

SMALL DAMAGE AREAS THAT ARE CLOSELY SPACED MAY BE GROUPED TOGETHER AND CONSIDERED AS ONE DAMAGE AREA

- DAMAGE TO ALUMINUM SANDWICH PANELS EXPOSED TO MULTIPLE IMPACTS, I.E., HAIL DAMAGE, CAN BE DETECTED BY USING INSTRUMENTED NON-DESTRUCTIVE INSPECTION METHODS OR BY TAPPING THE SUSPECTED DAMAGE AREA WITH A SMALL METALLIC DISK OBJECT. INSPECTION SHOULD COVER THE AREA WITHIN 3 DIAMETERS AROUND THE EDGE OF THE VISIBLE DAMAGE SITE. FOR TAP TEST, USE A SOLID METAL DISK AND TAP THE DAMAGE AREA LIGHTLY BUT FIRMLY. VOID AREAS SHOULD PRODUCE A DULL SOUND AS OPPOSED TO A SHARP RING ON A SOLID BONDED AREA
- A DAMAGE AREA IS ANY SINGLE AREA OF DELAMINATION. SMALL DAMAGE AREAS THAT ARE CLOSELY SPACED MAY BE GROUPED TOGETHER AND CONSIDERED AS ONE DAMAGE AREA.
- "d" IS THE LARGER DIAMETER OF TWO ADJACENT DAMAGE AREAS AND CAN BE A MAXIMUM OF 2.0 INCHES.
- "a" IS THE DISTANCE BETWEEN TWO ADJACENT DAMAGE AREAS.
- "d" IS THE MAXIMUM DIMENSION OF THE SMALLER OF TWO ADJACENT DAMAGE AREAS.
- a/d MUST BE A MINIMUM OF 3.0. CALCULATE a/d BY DIVIDING DISTANCE "a" BY DIAMETER "d".

**DELAMINATION SIZE AND SPACING DATA
FOR ALUMINUM SANDWICH PANELS
DETAIL VIII**

**Outer Wing Skin Allowable Damage
Figure 101 (Sheet 8 of 8)**

**757-200
STRUCTURAL REPAIR MANUAL**

ALLOWABLE DAMAGE 2 - IMPACT RESISTANT FUEL TANK ACCESS DOOR

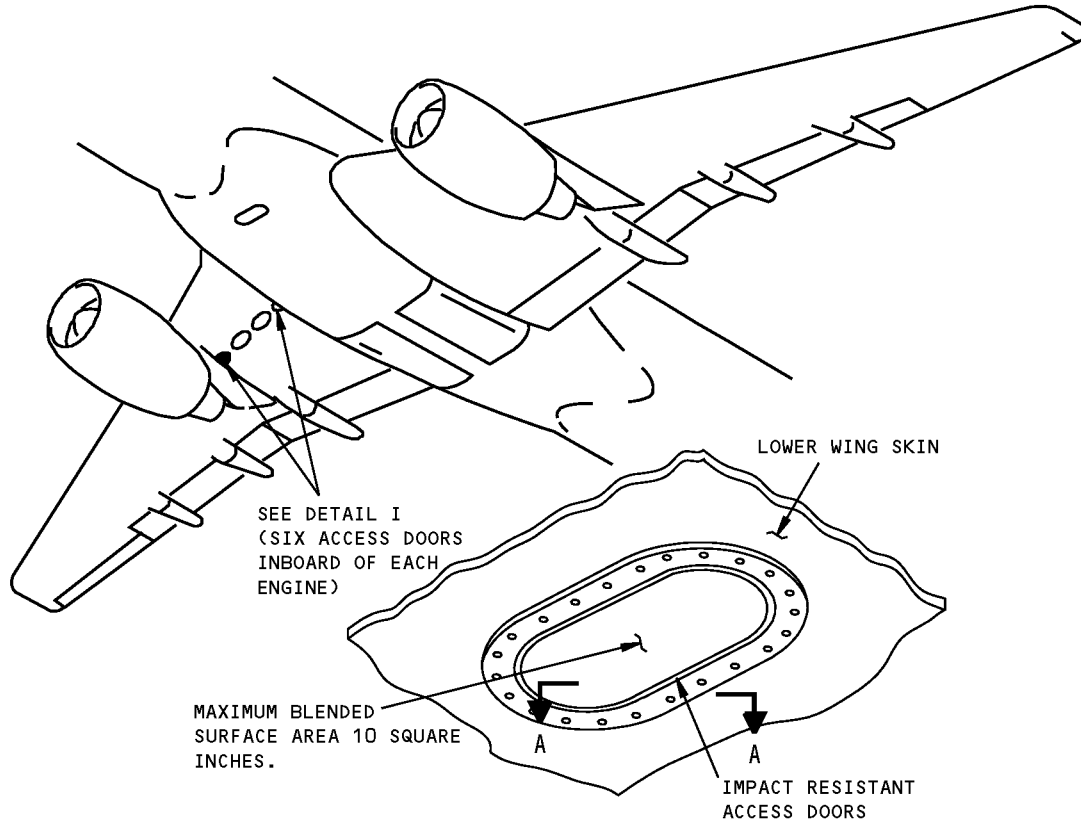

DETAIL I

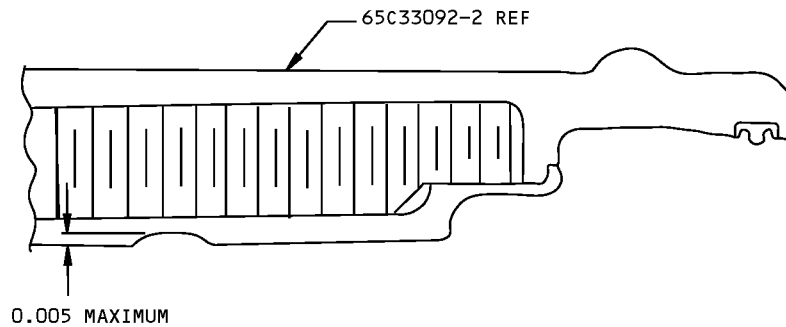

A - A

DESCRIPTION	CRACKS	NICKS, GOUGES AND CORROSION	DENTS	HOLES AND PUNCTURES
IMPACT RESISTANT ACCESS DOOR	NOT PERMITTED	A	NOT PERMITTED	NOT PERMITTED

**Impact Resistant Fuel Tank Access Door Allowable Damage
Figure 101 (Sheet 1 of 2)**



757-200
STRUCTURAL REPAIR MANUAL

NOTES

- A** REMOVE DAMAGE ON ACCESS DOOR OUTER PANEL AS GIVEN IN DETAIL I. THE MAXIMUM DEPTH OF BLENDING PERMITTED IS 0.005 INCH AND THE MAXIMUM BLENDED SURFACE AREA IS 10 SQUARE INCHES.
- SMOOTHLY BLEND OUT CHAFING DAMAGE AT 20 TO 1 RATIO. MAKE THE SURFACE FINISH 125 MICRO INCHES Ra OR BETTER.
 - APPLY A CHEMICAL CONVERSION COATING TO THE BARE SURFACES OF THE ACCESS DOOR. REFER TO SRM 51-20-01.
 - APPLY TWO LAYERS OF BMS 10-11, TYPE 1 FINISH TO THE REWORKED AREA. REFER TO SOPM 20-41-02.

Impact Resistant Fuel Tank Access Door Allowable Damage
Figure 101 (Sheet 2 of 2)

D634N201

57-20-01
ALLOWABLE DAMAGE 2
Page 102
Jan 20/2005



757-200

STRUCTURAL REPAIR MANUAL

REPAIR GENERAL - OUTER WING SKIN PANELS

This subject gives the repair data for the outer wing skin panels, as shown in Figure 201 of Repair General.

Repair General is applicable to airplanes that have not had winglets installed.

Repair General is not applicable to airplanes that have had winglets installed after production of the airplane. Refer to Aviation Partners Boeing (APB) document AP57.2-0602 for the winglet data.

**Outer Wing Skin Panel Repair
Figure 201 (Sheet 1 of 2)**

D634N201

57-20-01

REPAIR GENERAL
Page 201
Sep 20/2006

**757-200
STRUCTURAL REPAIR MANUAL**

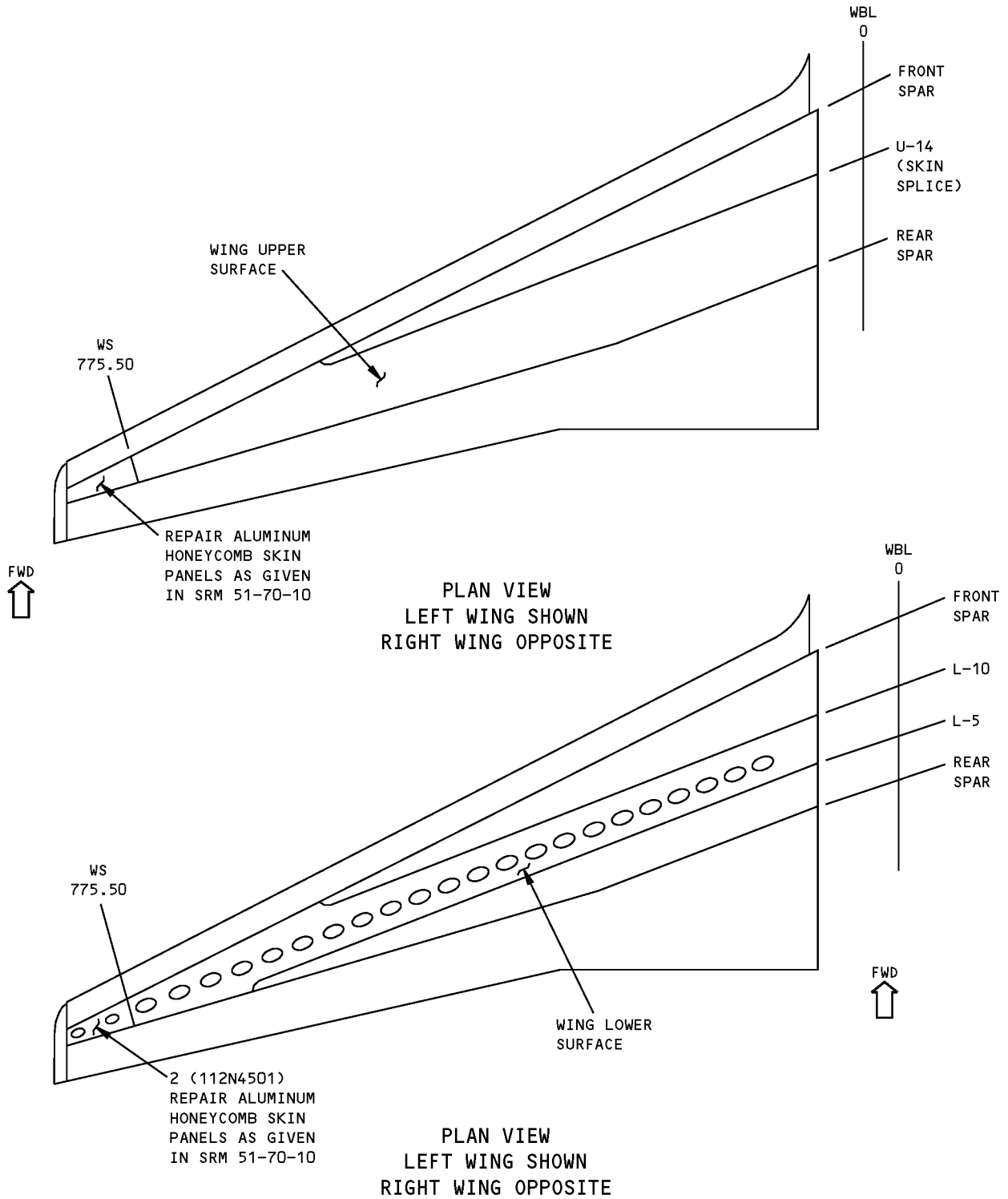

**Outer Wing Skin Panel Repair
Figure 201 (Sheet 2 of 2)**

757-200 STRUCTURAL REPAIR MANUAL

REPAIR 1 - OUTER WING INTERSPAR UPPER SKIN FLUSH REPAIR BETWEEN STRINGERS

REPAIR INSTRUCTIONS

WARNING: FUEL VAPORS ARE HAZARDOUS AND EXPLOSIVE. PURGE AND VENTILATE THE FUEL TANKS PER 28-11 OF THE 757 MAINTENANCE MANUAL BEFORE ENTERING FUEL TANKS.

1. Cut out damaged portion of skin to give a hole with the major axis parallel to the stringers.
2. Make the repair parts.
3. Assemble the repair parts and drill the fastener holes.
4. Remove the repair parts.
5. Break sharp edges of original and repair parts 0.015R to 0.030R.
6. Remove all nicks, scratches, burrs, sharp edges and corners from original and repair parts.
7. Rotary peen all edges of skin cutout per 20-10-03 of the 757 Component Maintenance Manual.
8. Prepare repair parts 1 thru 4 for bonding in accordance with 51-70.
9. Assemble repair parts 1 thru 4, bonding in accordance with 51-70.
10. Alodize the bonded assembly (repair parts 1 thru 4), the cut edges of repair part 5 and the cut edges of the original parts per 51-20-01.
11. Apply BMS 10-20, type 2 protective coating to the bonded assembly (repair parts 1 thru 4), repair part 5 and the cut edges of the original parts in accordance with 28-11-00 of the 757 Maintenance Manual.
12. Install the repair parts making a faying surface seal between the bonded assembly and the skin with BMS 5-26. Install fasteners wet with BMS 5-26 sealant.
13. Apply a fillet seal with BMS 5-26 sealant in accordance with 51-20-05.
14. Apply BMS 10-20, type 2 protective coating to sealant.
15. Fill gap between parts with aerodynamic smoother (BMS 5-79 or BMS 5-95).
16. Restore original finish per 51-21 of the 757 Maintenance Manual.

NOTES

- REFER TO THE FOLLOWING WHEN USING THIS REPAIR:
 - 51-10-01 FOR AERODYNAMIC SMOOTHNESS REQUIREMENTS
 - 51-20-01 FOR PROTECTIVE TREATMENT OF METAL
 - 51-20-05 FOR SEALING OF REPAIRS
 - 51-40 FOR FASTENER CODE, REMOVAL, INSTALLATION, HOLE SIZES AND EDGE MARGINS
 - 51-21 OF THE 757 MAINTENANCE MANUAL FOR INTERIOR AND EXTERIOR FINISHES
 - 51-31 OF THE 757 MAINTENANCE MANUAL FOR SEALS AND SEALING
- REMOVE AND INSTALL ACCESS DOORS PER 28-11 OF THE 757 MAINTENANCE MANUAL

- A** FOR MATERIAL GAGES SEE TABLE I
- B** SAME THICKNESS AS SKIN
- C** FOR REPAIR FASTENER SIZE SEE TABLE I

FASTENER SYMBOLS

-  REPAIR FASTENER LOCATIONS

**Outer Wing Interspar Upper Skin Flush Repair Between Stringers
Figure 201 (Sheet 1 of 3)**



**757-200
STRUCTURAL REPAIR MANUAL**

REPAIR MATERIAL			
PART		QTY	MATERIAL
1	PLATE	1	7150-T651 A OPTIONAL; 7075-T6
2	PLATE	1	7150-T651 A OPTIONAL; 7075-T6
3	PLATE	1	7150-T651 A OPTIONAL; 7075-T6
4	PLATE	1	7150-T651 A OPTIONAL; 7075-T6
5	FILLER	1	CLAD 7075-T6 B

SKIN THICKNESS	REPAIR PLATE GAGE				REPAIR FASTENER DIAMETER
	PLATE 1	PLATE 2	PLATE 3	PLATE 4	
0.100 THRU 0.125	0.040	0.040	0.040	0.040	3/16
OVER 0.125 THRU 0.160	0.050	0.050	0.050	0.050	1/4
OVER 0.160 THRU 0.190	0.050	0.050	0.050	0.080	1/4
OVER 0.190 THRU 0.210	0.063	0.063	0.063	0.080	1/4

TABLE I

**Outer Wing Interspar Upper Skin Flush Repair Between Stringers
Figure 201 (Sheet 2 of 3)**

D634N201

57-20-01

REPAIR 1
Page 202
Jan 20/2005

**757-200
STRUCTURAL REPAIR MANUAL**

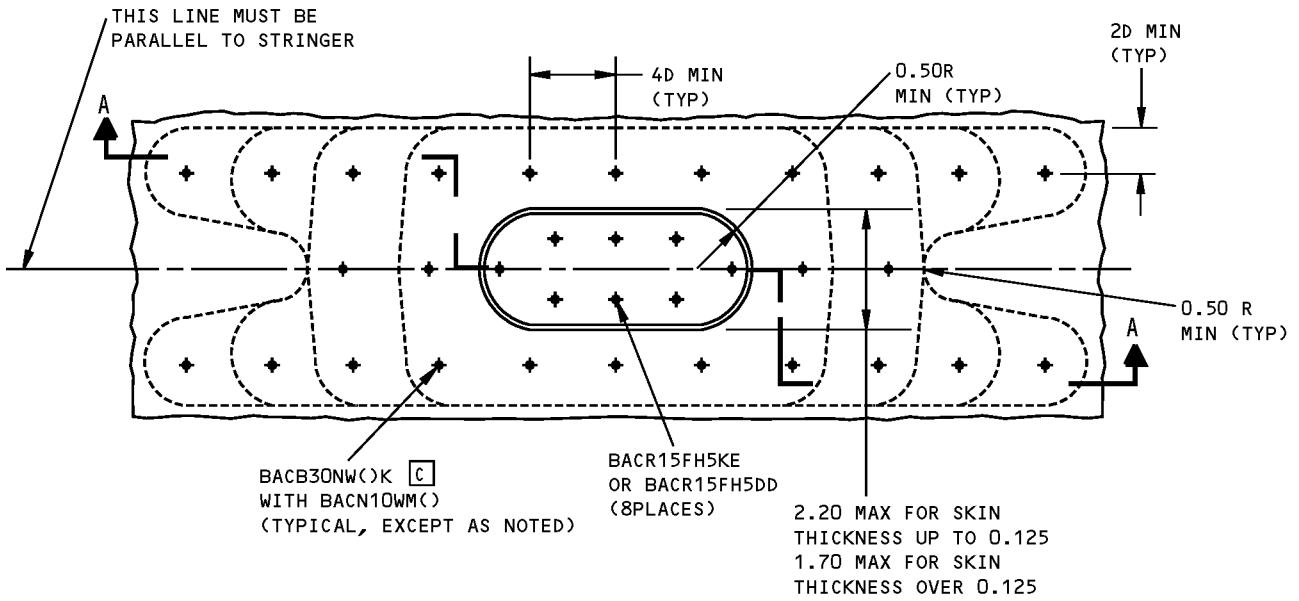

DETAIL I

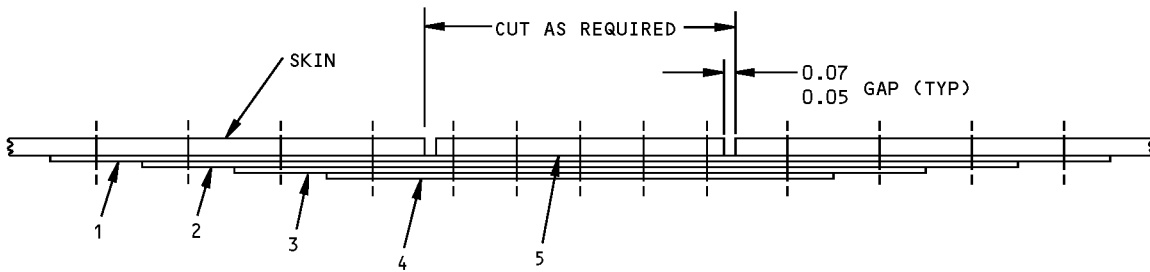

SECTION A-A

**Outer Wing Interspar Upper Skin Flush Repair Between Stringers
Figure 201 (Sheet 3 of 3)**

STRUCTURAL REPAIR MANUAL

REPAIR 2 - OUTER WING INTERSPAR UPPER SKIN FLUSH REPAIR AT A STRINGER

REPAIR INSTRUCTIONS

WARNING: FUEL VAPORS ARE HAZARDOUS AND EXPLOSIVE. PURGE AND VENTILATE THE FUEL TANKS PER 28-11 OF THE 757 MAINTENANCE MANUAL BEFORE ENTERING FUEL TANKS.

1. Cut out damaged portion of skin to give a rectangular hole with radiused corners. Do not cut into stringer. If stringer is damaged, see 57-20-03.
2. Drill out existing fasteners in the skin to stringer attachment as required.
3. Make the repair parts.
4. Assemble the repair parts and drill the fastener holes.
5. Remove the repair parts.
6. Break sharp edges of original and repair parts 0.015R to 0.030R.
7. Remove all nicks, scratches, burrs, sharp edges and corners from original and repair parts.
8. Rotary peen all edges of skin cutout per 20-10-03 of the 757 Component Maintenance Manual.
9. Prepare repair parts 1 thru 4 for bonding in accordance with 51-70.
10. Assemble repair parts 1 thru 4, bonding in accordance with 51-70.
11. Alodize the bonded assembly (repair parts 1 thru 4), repair part 5 and the cut edges of the original parts per 51-20-01.
12. Apply BMS 10-20, type 2 protective coating to the bonded assembly (repair parts 1 thru 4), repair part 5 and the cut edges of the original parts in accordance with 28-11-00 of the 757 Maintenance Manual.
13. Install the repair parts making a faying surface seal between the bonded assembly and the skin with BMS 5-26. Install fasteners wet with BMS 5-26 sealant.
14. Apply a fillet seal with BMS 5-26 sealant in accordance with 51-20-05.
15. Apply BMS 10-20, type 2 protective coating to sealant.
16. Fill gap between parts with aerodynamic smoother (BMS 5-79 or BMS 5-95).
17. Restore original finish per 51-21 of the 757 Maintenance Manual.

NOTES

- REFER TO THE FOLLOWING WHEN USING THIS REPAIR:
 - 51-10-01 FOR AERODYNAMIC SMOOTHNESS REQUIREMENTS
 - 51-20-01 FOR PROTECTIVE TREATMENT OF METAL
 - 51-20-05 FOR SEALING OF REPAIRS
 - 51-40 FOR FASTENER CODE, REMOVAL, INSTALLATION, HOLE SIZES AND EDGE MARGINS
 - 51-21 OF THE 757 MAINTENANCE MANUAL FOR INTERIOR AND EXTERIOR FINISHES
 - 51-31 OF THE 757 MAINTENANCE MANUAL FOR SEALS AND SEALING
- REMOVE AND INSTALL ACCESS DOORS PER 28-11 OF THE 757 MAINTENANCE MANUAL

- A** FOR MATERIAL GAGES SEE TABLE I
- B** SAME THICKNESS AS SKIN
- C** FOR REPAIR FASTENER SIZE SEE TABLE I
- D** USE SAME SIZE FASTENER AS ORIGINAL. IF FASTENER HOLE IN STRINGER IS DAMAGED, USE 1/32 OVERSIZE

FASTENER SYMBOLS

- ✚ EXISTING FASTENER LOCATIONS
- ✚ REPAIR FASTENER LOCATIONS

**Outer Wing Interspar Upper Skin Flush Repair at a Stringer
Figure 201 (Sheet 1 of 3)**



**757-200
STRUCTURAL REPAIR MANUAL**

REPAIR MATERIAL				
PART		QTY	MATERIAL	
1	PLATE	2	7150-T651 A	OPTIONAL; 7075-T6
2	PLATE	2	7150-T651 A	OPTIONAL; 7075-T6
3	PLATE	2	7150-T651 A	OPTIONAL; 7075-T6
4	PLATE	2	7150-T651 A	OPTIONAL; 7075-T6
5	FILLER	1	7075-T6	B

SKIN THICKNESS	REPAIR PLATE GAGE				REPAIR FASTENER DIAMETER
	PLATE 1	PLATE 2	PLATE 3	PLATE 4	
0.100 THRU 0.125	0.040	0.040	0.040	0.050	3/16
OVER 0.125 THRU 0.160	0.050	0.050	0.050	0.050	1/4
OVER 0.160 THRU 0.190	0.050	0.050	0.050	0.080	1/4
OVER 0.190 THRU 0.210	0.063	0.063	0.063	0.080	1/4

TABLE I

**Outer Wing Interspar Upper Skin Flush Repair at a Stringer
Figure 201 (Sheet 2 of 3)**

**757-200
STRUCTURAL REPAIR MANUAL**

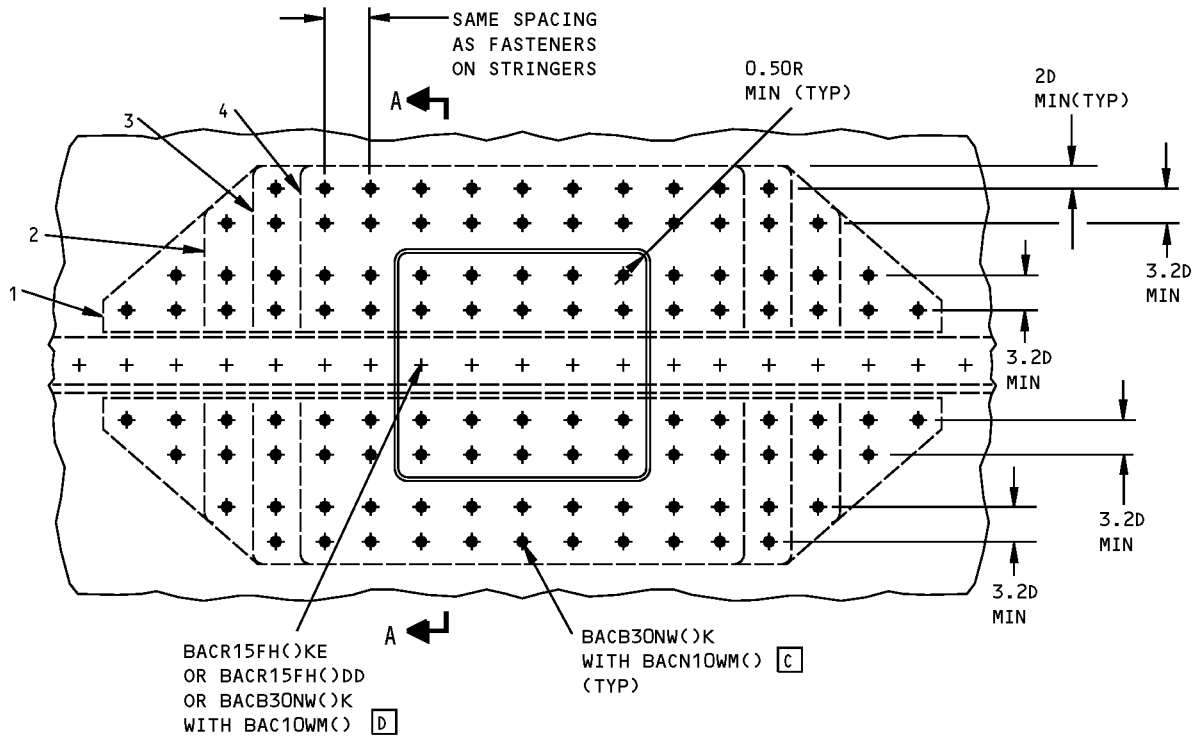

DETAIL I

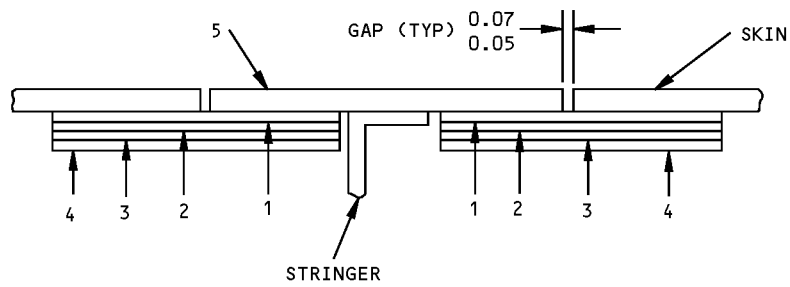

SECTION A-A
ROTATED 90° CW

Outer Wing Interspar Upper Skin Flush Repair at a Stringer
Figure 201 (Sheet 3 of 3)

757-200 STRUCTURAL REPAIR MANUAL

REPAIR 3 - OUTER WING INTERSPAR LOWER SKIN FLUSH REPAIR BETWEEN STRINGERS

REPAIR INSTRUCTIONS

1. Cut out damaged portion of skin to give a hole with the major axis parallel to the stringers.
2. Make the repair parts.
3. Assemble the repair parts and drill the fastener holes.
4. Remove the repair parts.
5. Break sharp edges of original and repair parts 0.015R to 0.030R.
6. Remove all nicks, scratches, burrs, sharp edges and corners from original and repair parts.
7. Rotary peen all edges of skin cutout per 20-10-03 of the 757 Component Maintenance Manual.
8. Alodize repair parts 1 thru 4, the cut edges of repair part 5 and the cut edges of the original parts per 51-20-01.
9. Apply BMS 10-20, type 2 protective coating to the repair parts and the cut edges of the original parts in accordance with 28-11-00 of the 757 Maintenance Manual.
10. Install the repair parts making faying surface seals with BMS 5-26. Install fasteners wet with BMS 5-26 sealant.
11. Apply a fillet seal with BMS 5-26 sealant in accordance with 51-20-05.
12. Apply BMS 10-20, type 2 protective coating to sealant.
13. Fill gap between parts with aerodynamic smoother (BMS 5-79 or BMS 5-95).
14. Restore original finish per 51-21 of the 757 Maintenance Manual.

NOTES

- REFER TO THE FOLLOWING WHEN USING THIS REPAIR:
 - 51-10-01 FOR AERODYNAMIC SMOOTHNESS REQUIREMENTS
 - 51-20-01 FOR PROTECTIVE TREATMENT OF METAL
 - 51-20-05 FOR SEALING OF REPAIRS
 - 51-40 FOR FASTENER CODE, REMOVAL, INSTALLATION, HOLE SIZES AND EDGE MARGINS
 - 51-21 OF THE 757 MAINTENANCE MANUAL FOR INTERIOR AND EXTERIOR FINISHES
 - 51-31 OF THE 757 MAINTENANCE MANUAL FOR SEALS AND SEALING
- REMOVE AND INSTALL ACCESS DOORS PER 28-11 OF THE 757 MAINTENANCE MANUAL
- D = FASTENER DIAMETER

A FOR MATERIAL GAGES SEE TABLE I

B GAGE TO SUIT, I.E., GAGE OF PART 5 PLUS GAGE OF PART 6 MUST EQUAL ORIGINAL SKIN THICKNESS

C FOR REPAIR FASTENER SIZE SEE TABLE I

FASTENER SYMBOLS

 REPAIR FASTENER LOCATION

Outer Wing Interspar Lower Skin Flush Repair Between Stringers
Figure 201 (Sheet 1 of 3)



**757-200
STRUCTURAL REPAIR MANUAL**

REPAIR MATERIAL			
PART		QTY	MATERIAL
1	PLATE	1	2324-T39 A OPTIONAL: 2024-T3
2	PLATE	1	2324-T39 A OPTIONAL: 2024-T3
3	PLATE	1	2324-T39 A OPTIONAL: 2024-T3
4	PLATE	1	2324-T39 A OPTIONAL: 2024-T3
5	FILLER	1	0.10 CLAD 2024-T3
6	FILLER	AS REQ'D	2024-T3 B

SKIN THICKNESS	REPAIR PLATE GAGE				REPAIR FASTENER DIAMETER
	PLATE 1	PLATE 2	PLATE 3	PLATE 4	
0.140 THRU 0.170	0.050	0.050	0.063	NOT REQUIRED	1/4
OVER 0.170 THRU 0.190	0.050	0.050	0.050	0.063	5/16
OVER 0.190 THRU 0.240	0.050	0.050	0.050	0.080	5/16

TABLE I

**Outer Wing Interspar Lower Skin Flush Repair Between Stringers
Figure 201 (Sheet 2 of 3)**

D634N201

57-20-01

REPAIR 3
Page 202
Jan 20/2005

**757-200
STRUCTURAL REPAIR MANUAL**

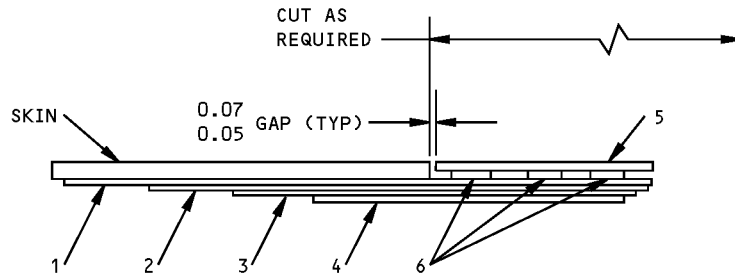
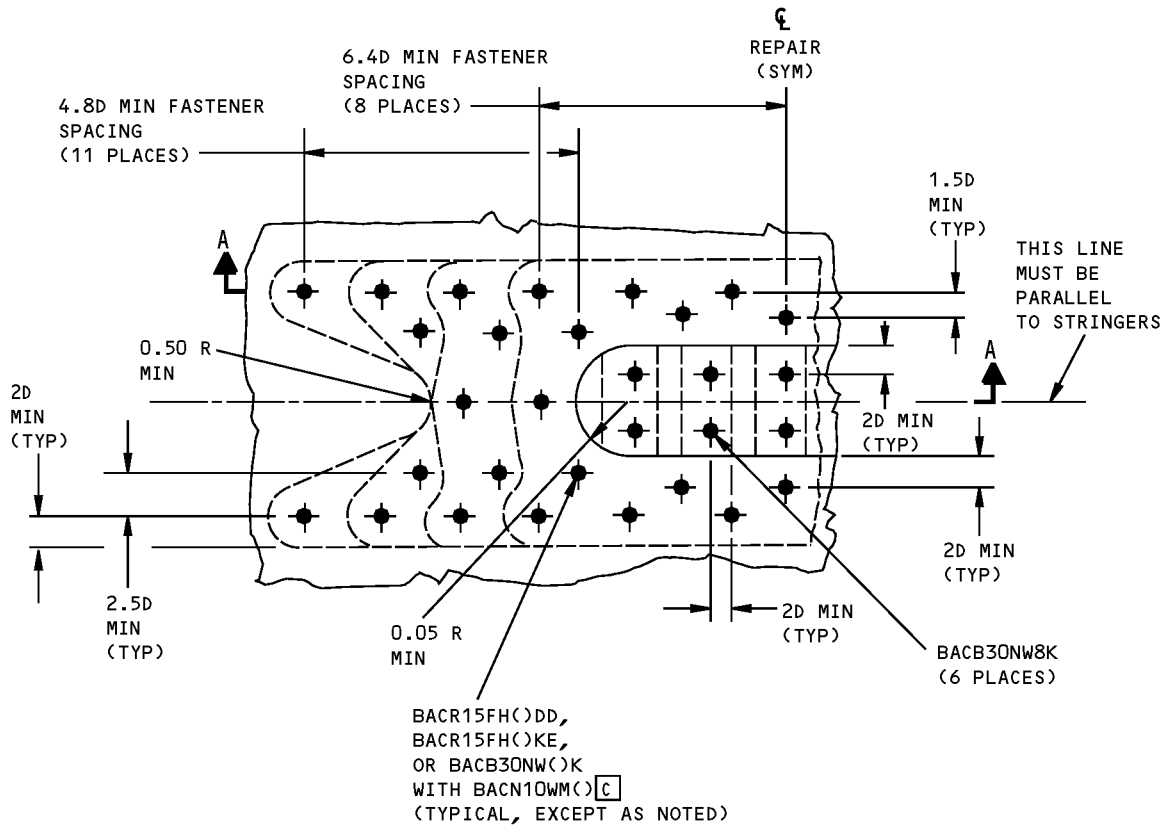

SECTION A-A

**Outer Wing Interspar Lower Skin Flush Repair Between Stringers
Figure 201 (Sheet 3 of 3)**

STRUCTURAL REPAIR MANUAL**REPAIR 4 - OUTER WING INTERSPAR LOWER SKIN FLUSH REPAIR AT A STRINGER****REPAIR INSTRUCTIONS**

1. Cut out damaged portion of skin to give a rectangular hole with radiused corners. Do not cut into stringer. If stringer is damaged, see 57-20-03.
2. Drill out existing fasteners in the skin to stringer attachment as required.
3. Make the repair parts.
4. Assemble the repair parts and drill the fastener holes.
5. Remove the repair parts.
6. Break sharp edges of original and repair parts 0.015R to 0.030R.
7. Remove all nicks, scratches, burrs, sharp edges and corners from original and repair parts.
8. Rotary peen all edges of skin cutout per 20-10-03 of the 757 Component Maintenance Manual.
9. Alodize the repair parts and the cut edges of the original parts per 51-20-01.
10. Apply BMS 10-20, type 2 protective coating to the repair parts and the cut edges of the original parts in accordance with 28-11-00 of the 757 Maintenance Manual.
11. Install the repair parts making faying surface seals with BMS 5-26. Install fasteners wet with BMS 5-26 sealant.
12. Apply a fillet seal with BMS 5-26 sealant in accordance with 51-20-05.
13. Apply BMS 10-20, type 2 protective coating to sealant.
14. Fill gap between parts with aerodynamic smoother (BMS 5-79 or BMS 5-95).
15. Restore original finish per 51-21 of the 757 Maintenance Manual.

NOTES

- REFER TO THE FOLLOWING WHEN USING THIS REPAIR:
 - 51-10-01 FOR AERODYNAMIC SMOOTHNESS REQUIREMENTS
 - 51-20-01 FOR PROTECTIVE TREATMENT OF METAL
 - 51-20-05 FOR SEALING OF REPAIRS
 - 51-40 FOR FASTENER CODE, REMOVAL, INSTALLATION, HOLE SIZES AND EDGE MARGINS
 - 51-21 OF THE 757 MAINTENANCE MANUAL FOR INTERIOR AND EXTERIOR FINISHES
 - 51-31 OF THE 757 MAINTENANCE MANUAL FOR SEALS AND SEALING
 - REMOVE AND INSTALL ACCESS DOORS PER 28-11 OF THE 757 MAINTENANCE MANUAL
 - D = FASTENER DIAMETER
- A** FOR MATERIAL GAGES SEE TABLE I
- B** SAME THICKNESS AS SKIN
- C** FOR REPAIR FASTENER SIZE SEE TABLE I
- D** USE SAME SIZE FASTENER AS ORIGINAL. IF FASTENER HOLE IN STRINGER IS DAMAGED, USE 1/32 OVERSIZE

FASTENER SYMBOLS

- + EXISTING FASTENER LOCATION
- ◆ REPAIR FASTENER LOCATION

**Outer Wing Interspar Lower Skin Flush Repair at a Stringer
Figure 201 (Sheet 1 of 3)**



**757-200
STRUCTURAL REPAIR MANUAL**

REPAIR MATERIAL			
PART		QTY	MATERIAL
1	PLATE	2	2324-T39 A OPTIONAL: 2024-T3
2	PLATE	2	2324-T39 A OPTIONAL: 2024-T3
3	PLATE	2	2324-T39 A OPTIONAL: 2024-T3
4	PLATE	2	2324-T39 A OPTIONAL: 2024-T3
5	FILLER	1	2024-T3 B

SKIN THICKNESS	REPAIR PLATE GAGE				REPAIR FASTENER DIAMETER
	PLATE 1	PLATE 2	PLATE 3	PLATE 4	
0.140 THRU 0.170	0.050	0.050	0.050	0.063	1/4
OVER 0.170 THRU 0.190	0.050	0.050	0.050	0.063	5/16
OVER 0.190 THRU 0.240	0.050	0.050	0.050	0.080	5/16

TABLE I

**Outer Wing Interspar Lower Skin Flush Repair at a Stringer
Figure 201 (Sheet 2 of 3)**

D634N201

57-20-01

REPAIR 4
Page 202
Jan 20/2005

**757-200
STRUCTURAL REPAIR MANUAL**

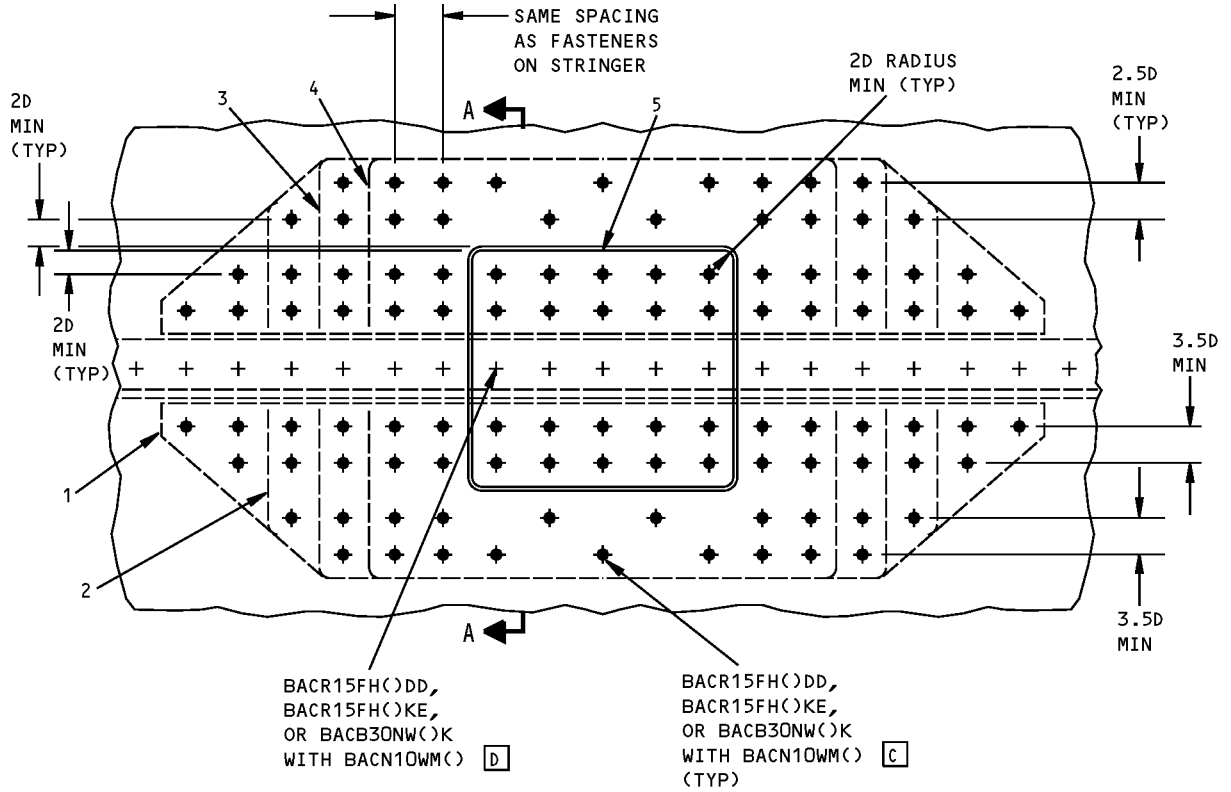

DETAIL I

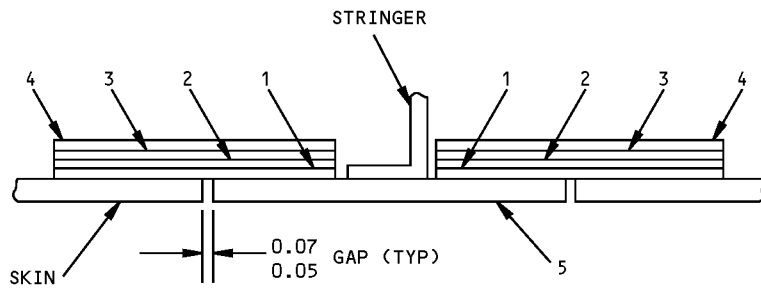

**SECTION A-A
(ROTATED 90° CCW)**

**Outer Wing Interspar Lower Skin Flush Repair at a Stringer
Figure 201 (Sheet 3 of 3)**

STRUCTURAL REPAIR MANUAL

REPAIR 5 - WING SKIN LOWER SURFACE CORROSION REPAIR AT FUEL TANK ACCESS DOOR CUTOUTS

APPLICABILITY
THIS REPAIR IS APPLICABLE TO FUEL TANK ACCESS DOORS AND CUTOUTS FOR DOOR SIZES OF 18 X 10 AND 18 X 8 ONLY.

REPAIR INSTRUCTIONS

WARNING: FAILURE TO PURGE AND VENTILATE THE FUEL TANKS WILL RESULT IN HAZARDOUS AND EXPLOSIVE FUEL VAPORS.

1. Purge and ventilate the fuel tanks in the repair area. Refer to AMM 28-11-00.
2. Remove the fuel tank access door.
3. Clean the edge of the skin cutout, and the door and wing skin lower surfaces which contact the clamp ring.
CAUTION: WHEN YOU BLEND OUT DAMAGE, MAKE SURE THE FUNCTIONALITY OF THE DOOR IS NOT AFFECTED.
4. Remove damage at the edge of the skin cutout per Details I and II [C]. See Detail IV for electrical bonding requirements [A].
5. Remove corrosion and fretting damage on the milled step of the skin and fuel tank access door per Details I and III [C][H]. Remove corrosion and fretting damage on the clamp ring as given in Details I and VI [C][H]. Do not fill the blendouts. See Detail IV for electrical bonding requirements [A].
6. Do a 10X visual inspection of the reworked area to make sure that all corroded material is removed. As an alternative, do a dye penetrant inspection. Refer to SOPM 20-20-02.
7. For wing skin cutouts only, shot peen the damaged area using self-contained equipment to an intensity of 0.004A, coverage 2.0. As an alternative, shot peen the damaged area using standard shot peening equipment (No. 170 to 550 cast shot or 20 to 62 cutwire shot and an intensity of 0.004A to 0.007A, coverage 1.0 automatic or 2.0 manual peening). Refer to SOPM 20-10-03.
8. Smooth the reworked areas to a surface finish of 63 microinches AA. Do not go below the peen valleys.
9. Apply a chemical conversion coating to the reworked surfaces. Refer to SRM 51-20-01.
10. Apply one layer of BMS 10-20, Type II primer to the reworked surfaces. Refer to AMM 28-11-00 and Detail IV and V [E].
11. Do a visual inspection of the bond surface between the fuel tank access door, clamp ring, and the wing lower skin. Make sure a minimum of 50% of the bond surface remains after damage removal. See Detail IV [A].

NOTES

- REFER TO SRM 57-00-00 FOR FUEL TANK ACCESS DOOR LOCATIONS.
- WHEN YOU USE THIS REPAIR, REFER TO:
 - AMM 51-21 FOR INTERIOR AND EXTERIOR FINISHES
 - SOPM 20-10-03 D6-51702, FOR SHOT PEENING
 - SOPM 20-20-02 D6-51702, FOR PENETRANT INSPECTION METHODS
 - SRM 51-10-01 FOR AERODYNAMIC SMOOTHNESS REQUIREMENTS
 - SRM 51-10-02 FOR INSPECTION AND REMOVAL OF DAMAGE
 - SRM 51-20-01 FOR PROTECTIVE TREATMENT OF METALLIC AND GRAPHITE MATERIALS AND CLAMP RING.

- [A] THE FUEL TANK ACCESS DOOR AND CLAMP RING MUST BE ELECTRICALLY BONDED TO THE WING SKIN TO PREVENT DIRECT LIGHTNING ATTACHMENT CURRENT FROM CAUSING ARCING IN THE FUEL TANK.
- [B] THE REPAIR OF A FUEL TANK ACCESS DOOR WITH DAMAGE AT THE DOOR-SKIN FAYING SURFACE SHOWN IN DETAIL I IS NOT ALLOWED. THE DAMAGED DOOR MUST BE REPLACED WITH A NEW DOOR.
- [C] REPAIRS TO COMPOSITE DOORS ARE NOT ALLOWED. A DAMAGED COMPOSITE DOOR MUST BE REPLACED WITH A NEW COMPOSITE DOOR.
- [D] A NEW KNITTED ALUMINUM GASKET (PART NO. 65C33095-XX OR 65C33161-XX) MUST BE INSTALLED WITH AERO SHELL NO. 14 GREASE IMPREGNATED INTO THE GASKET CONTINUOUSLY AND EVENLY THROUGHOUT THE KNIT. DO NOT RE-USE THE EXISTING GASKET.
- [E] DO NOT APPLY PRIMER TO THE LOWER SURFACE OF THE DOOR OR LOWER SKIN, OR THE UPPER SURFACE OF THE CLAMP RING IN THIS AREA (TYPICAL AROUND THE SKIN CUTOUT AND THE DOOR). IF PRIMER IS APPLIED IN THIS AREA, IT MUST BE REMOVED. THE UNPRIMED SURFACES ARE REQUIRED FOR ELECTRICAL BONDING.
- [F] AS AN ALTERNATE, APPLY TWO COATS OF BMS 10-79, TYPE III PRIMER TO THE SURFACE. REFER TO SOPM 20-44-04.
- [G] REPAIRED DOORS MUST BE MARKED "REPAIRED PER 757 SRM 57-20-01 REPAIR 5".
- [H] REMOVAL OF IMPRESSIONS CAUSED BY THE KNITTED ALUMINUM GASKET IS NOT NECESSARY IF THE IMPRESSIONS ARE NOT MORE THAN 0.005 INCH DEEP. THIS IS APPLICABLE TO THE FUEL TANK ACCESS DOORS, CLAMP RINGS AND THE MILLED STEP OF THE SKIN.

**Wing Skin Lower Surface Corrosion Repair at Fuel Tank Access Door Cutouts
Figure 201 (Sheet 1 of 6)**

**757-200
STRUCTURAL REPAIR MANUAL**

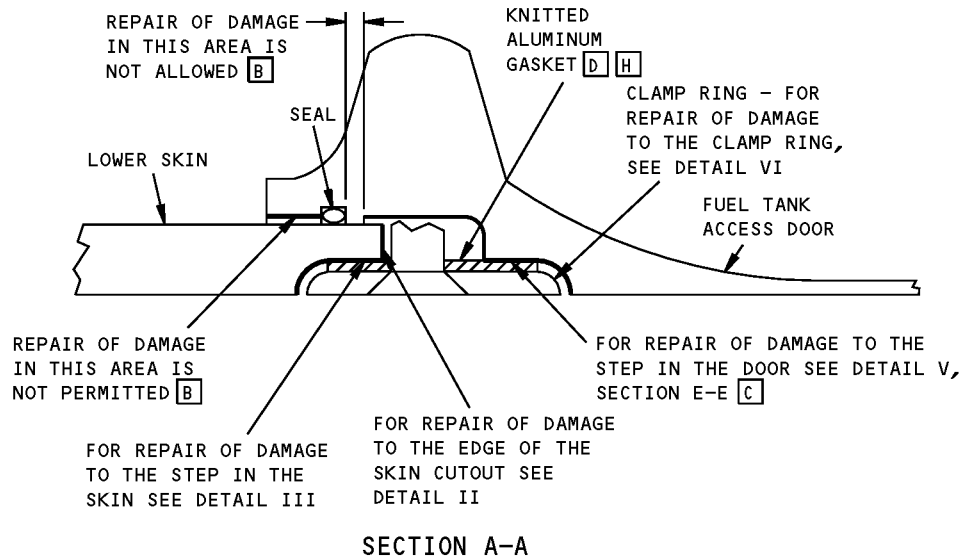
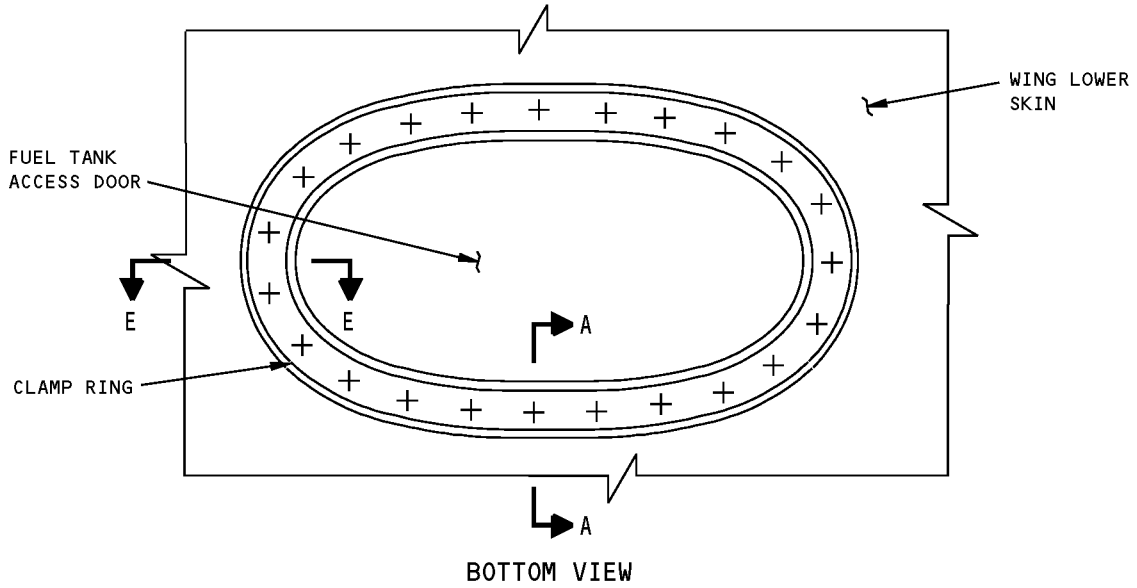

NOTE: FOR DAMAGE TO THE DOOR IN AREAS NOT SHOWN CONTACT THE BOEING COMPANY FOR ALLOWABLE DAMAGE LIMITS. [C]
SEE DETAIL IV FOR ELECTRICAL BONDING REQUIREMENTS.

**FUEL TANK ACCESS DOOR
DETAIL I**

**Wing Skin Lower Surface Corrosion Repair at Fuel Tank Access Door Cutouts
Figure 201 (Sheet 2 of 6)**

**757-200
STRUCTURAL REPAIR MANUAL**

SEE DETAIL VI FOR THE REPAIR OF DAMAGE TO THE CLAMP RING

BLEND OUT DAMAGE
20X MINIMUM

WING
LOWER SKIN

SEE DETAIL III FOR THE REPAIR OF DAMAGE TO THE MILLEDSTEP IN THE SKIN

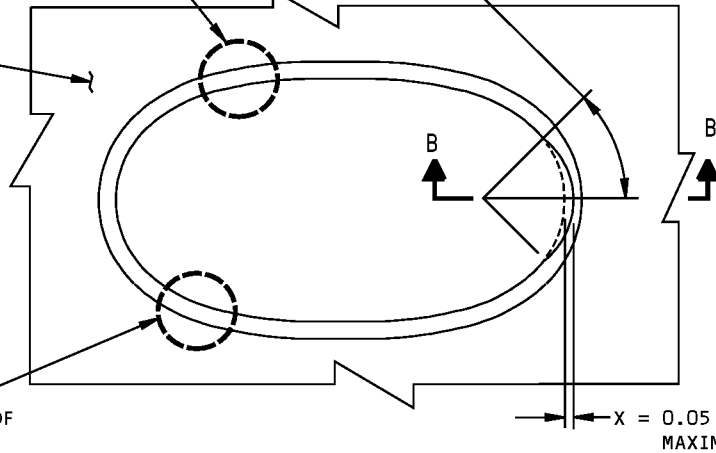

BOTTOM VIEW - DOOR NOT SHOWN

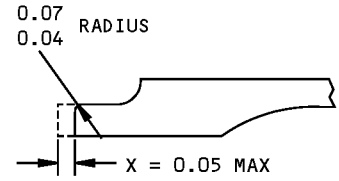

TYPICAL BLENDOUT AROUND DOOR CUTOUT PERIPHERY SECTION B-B

**DAMAGE REMOVAL AT THE EDGE OF THE SKIN CUTOUT
DETAIL II**

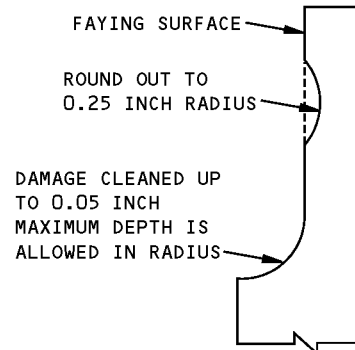
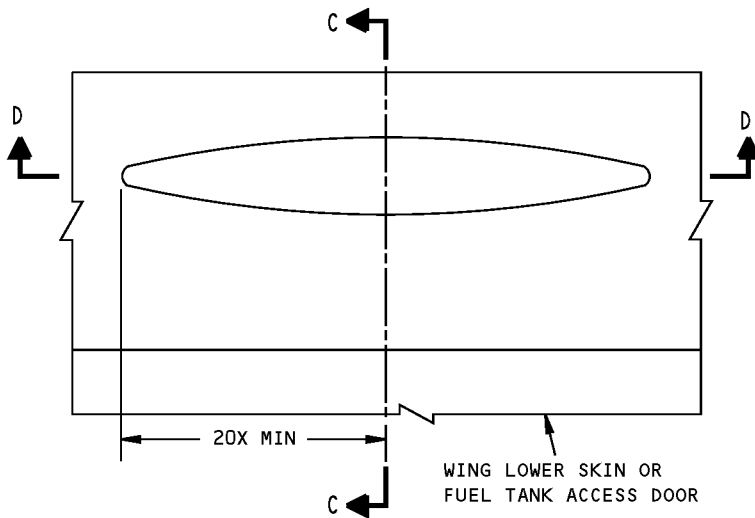

SECTION C-C

DAMAGE REMOVAL ON THE MILLED STEP IN THE SKIN

DETAIL III [H]

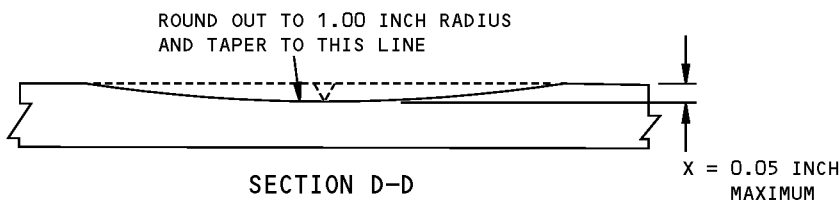

SECTION D-D

**Wing Skin Lower Surface Corrosion Repair at Fuel Tank Access Door Cutouts
Figure 201 (Sheet 3 of 6)**

**757-200
STRUCTURAL REPAIR MANUAL**

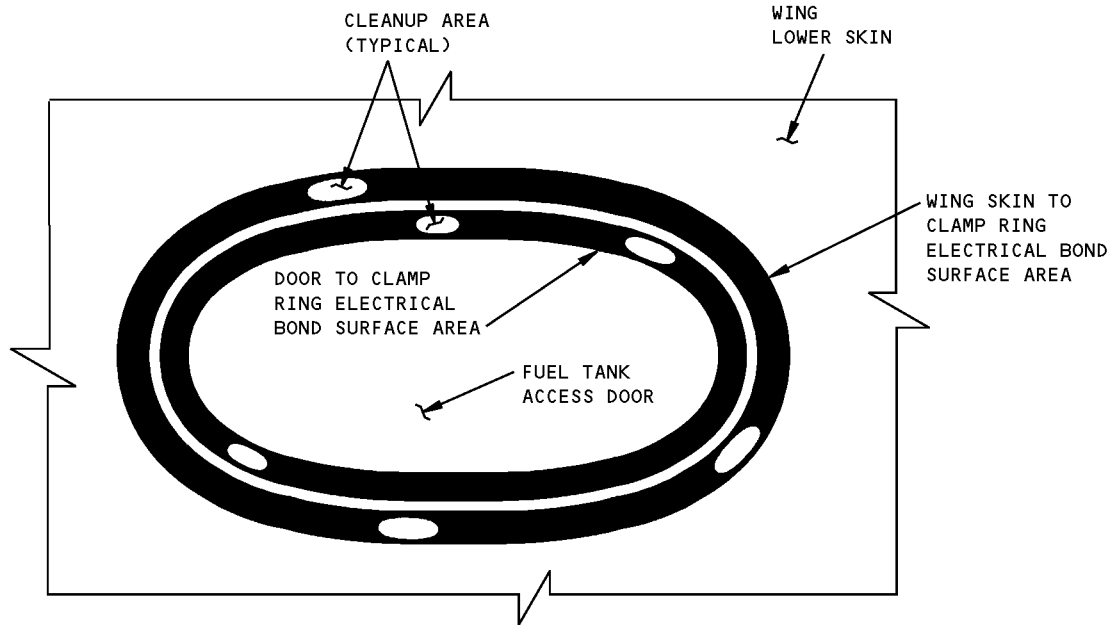

NOTE: 50% OF THE TOTAL ELECTRICAL BOND SURFACE AREA MUST REMAIN INTACT. FOR ELECTRICAL BOND SURFACE AREA LOSS GREATER THAN 50%, CONTACT THE BOEING COMPANY.

BOTTOM VIEW - CLAMP RING NOT SHOWN

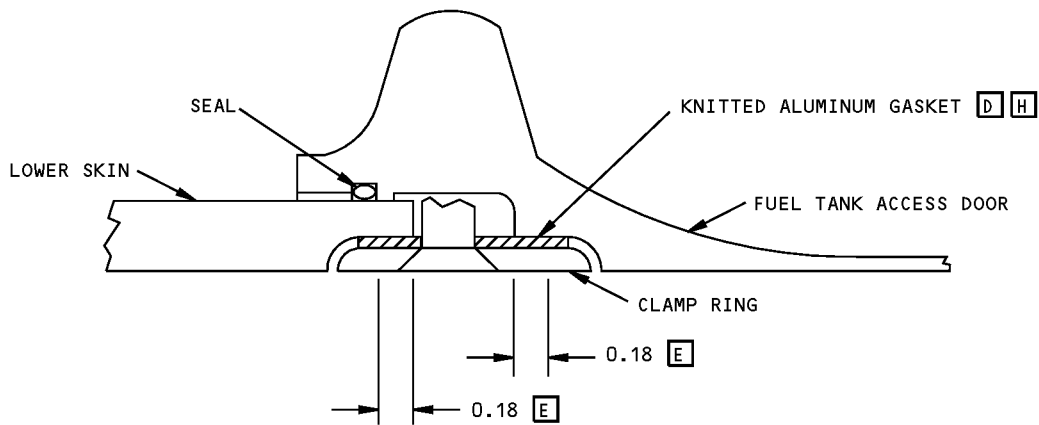

**REQUIREMENTS FOR ELECTRICAL BONDING
DETAIL IV A**

**Wing Skin Lower Surface Corrosion Repair at Fuel Tank Access Door Cutouts
Figure 201 (Sheet 4 of 6)**

**757-200
STRUCTURAL REPAIR MANUAL**

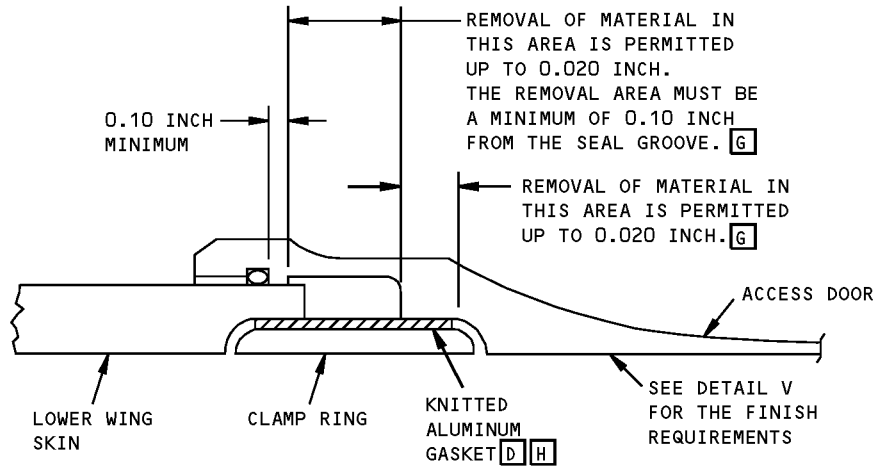

SECTION E-E

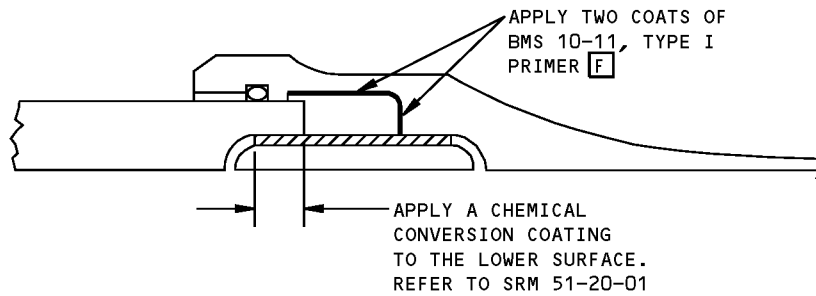

FINISH REQUIREMENTS FOR ACCESS DOOR AND LOWER SKIN
DETAIL V

**Wing Skin Lower Surface Corrosion Repair at Fuel Tank Access Door Cutouts
Figure 201 (Sheet 5 of 6)**

**757-200
STRUCTURAL REPAIR MANUAL**

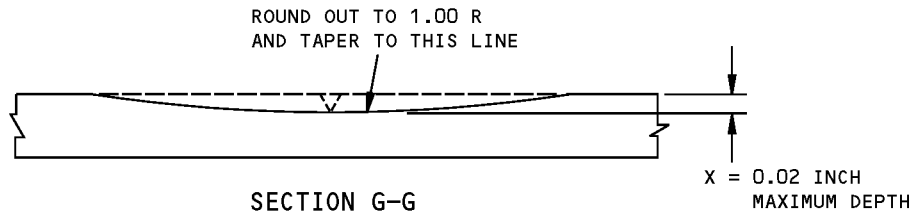
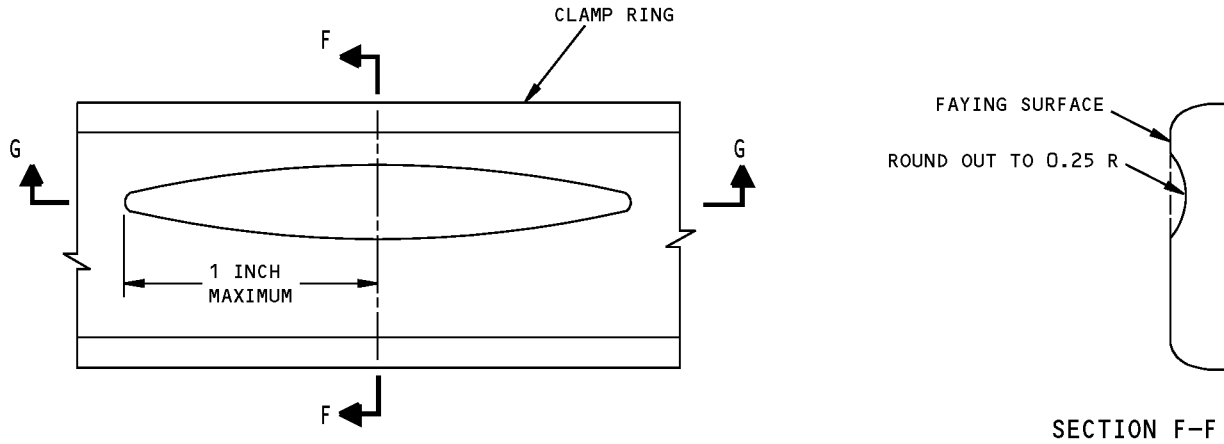

**DAMAGE REMOVAL ON THE CLAMP RING
DETAIL VI H**

**Wing Skin Lower Surface Corrosion Repair at Fuel Tank Access Door Cutouts
Figure 201 (Sheet 6 of 6)**



757-200
STRUCTURAL REPAIR MANUAL

IDENTIFICATION 1 - OUTER WING UPPER STRINGER

REFERENCE DRAWINGS
112N3001
112N3201
THRU
112N3224

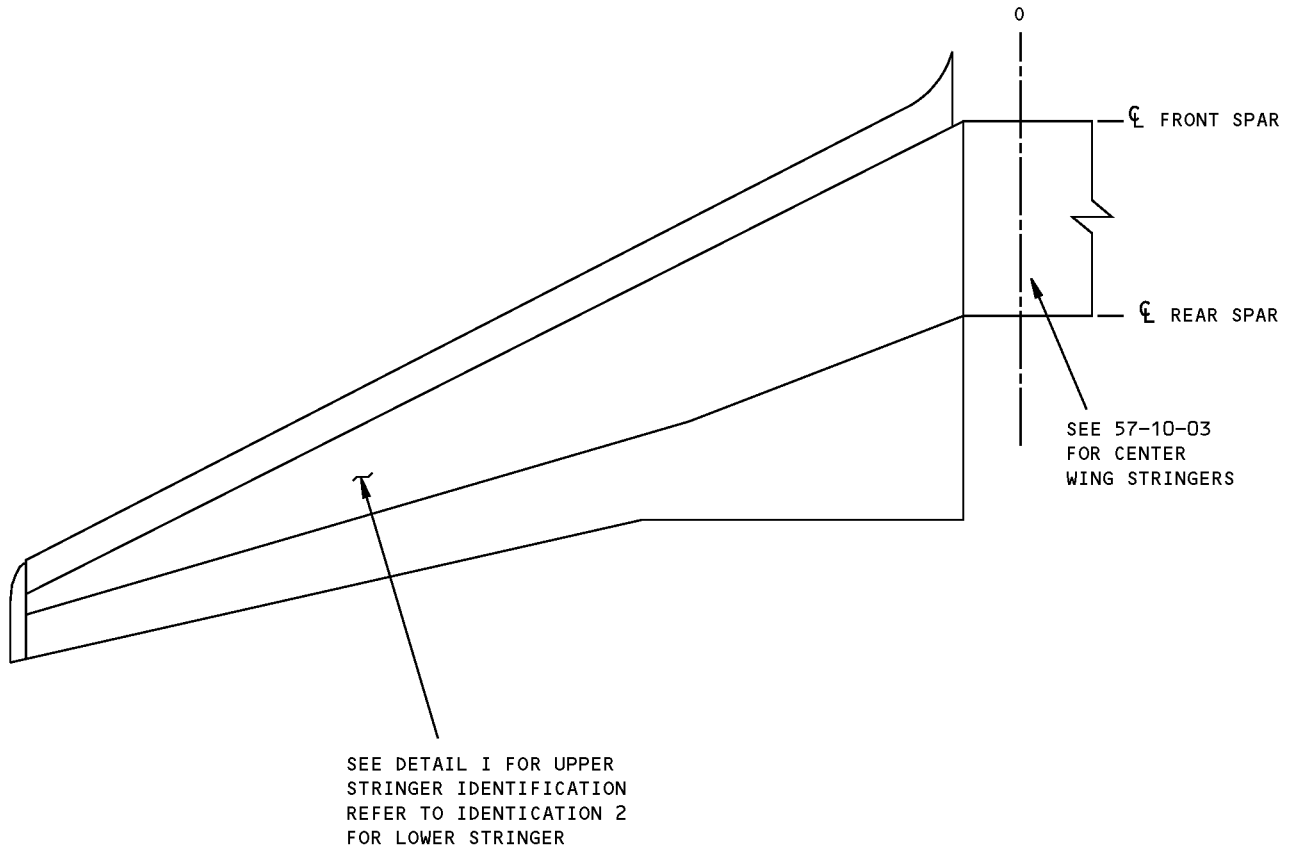

Outer Wing Upper Stringer Identification
Figure 1 (Sheet 1 of 3)

D634N201

57-20-03

IDENTIFICATION 1
Page 1
Jan 20/2005

**757-200
STRUCTURAL REPAIR MANUAL**

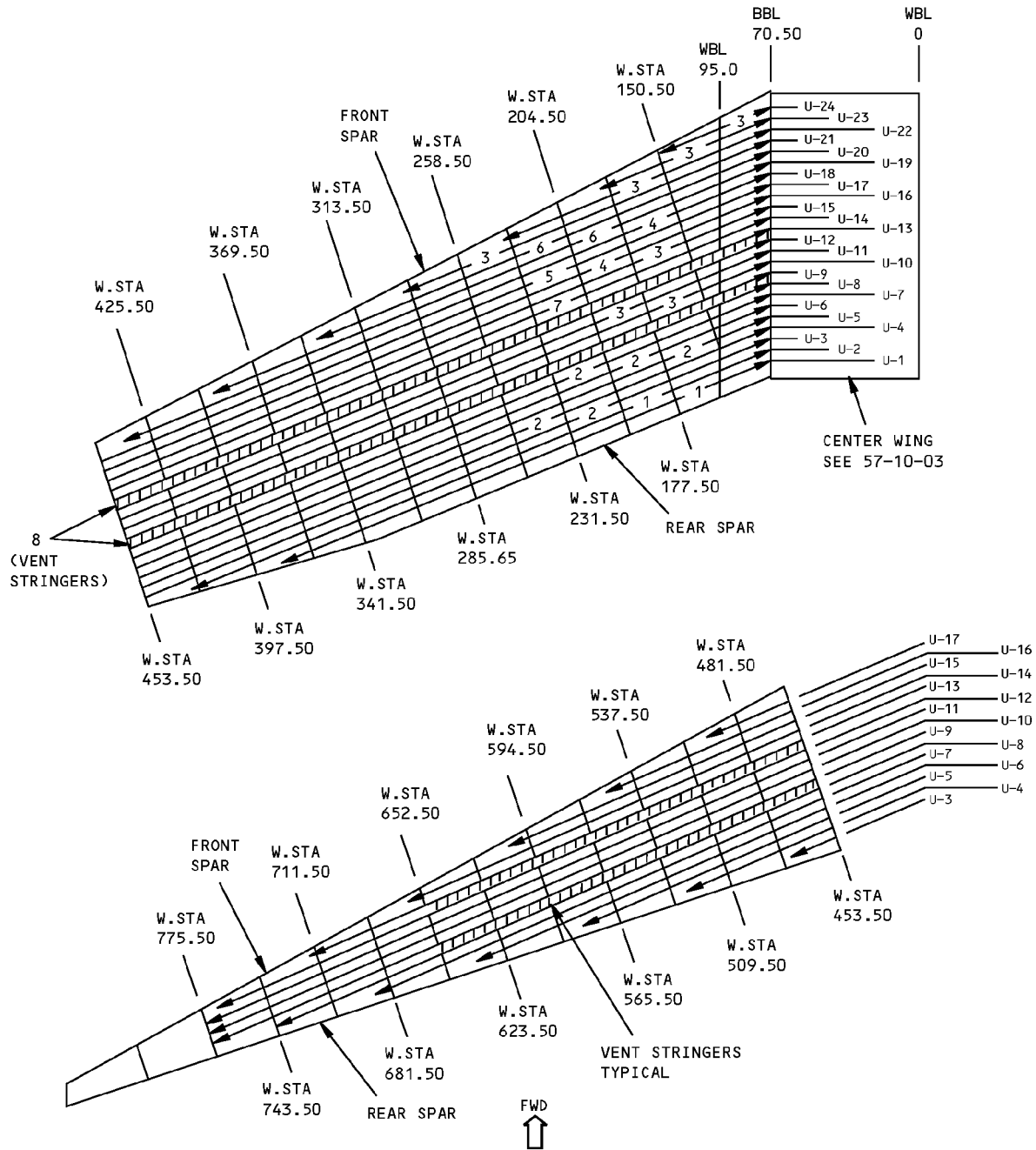

PLAN VIEW UPPER SURFACE
LEFT WING SHOWN
RIGHT WING OPPOSITE
DETAIL I



**Outer Wing Upper Stringer Identification
Figure 1 (Sheet 2 of 3)**

**757-200
STRUCTURAL REPAIR MANUAL**

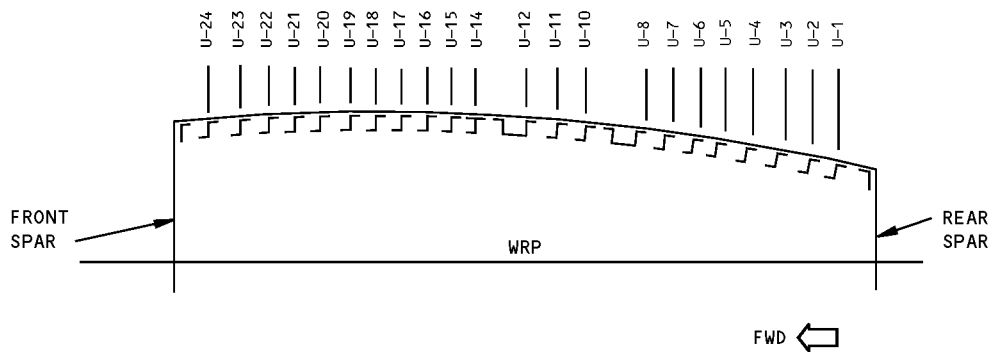

SECTION THRU
UPPER PANEL

ITEM	DESCRIPTION	MATERIAL	TYPE	EFFECTIVITY
1	STRINGER	BAC1518-726 7150-T6511	I	
2	STRINGER	BAC1518-697 7150-T6511	I	
3	STRINGER	BAC1518-880 7150-T6511 OPTIONAL: BAC1518-697 7150-T6511	I	
4	STRINGER	BAC1518-879 7150-T6511 OPTIONAL: BAC1518-697 7150-T6511	I	
5	STRINGER	BAC1518-879 7150-T6511 OPTIONAL: BAC158-697, -726 7150-T6511	I	
6	STRINGER	BAC1518-878 7150-T6511 OPTIONAL: BAC 1518-726 7150-T6511	I	
7	STRINGER	BAC 1513-881 7150-T6511 OPTIONAL: BAC 1518-697 7150-T6511	I	
8	STRINGER-VENT	BAC 1510-1108 7150-T6511 OPTIONAL: BAC1510-1060 7150-T6511	II	

LIST OF MATERIALS FOR DETAIL I

**Outer Wing Upper Stringer Identification
Figure 1 (Sheet 3 of 3)**

**757-200
STRUCTURAL REPAIR MANUAL**

IDENTIFICATION 2 - OUTER WING LOWER STRINGER

REF DWG
112N4001

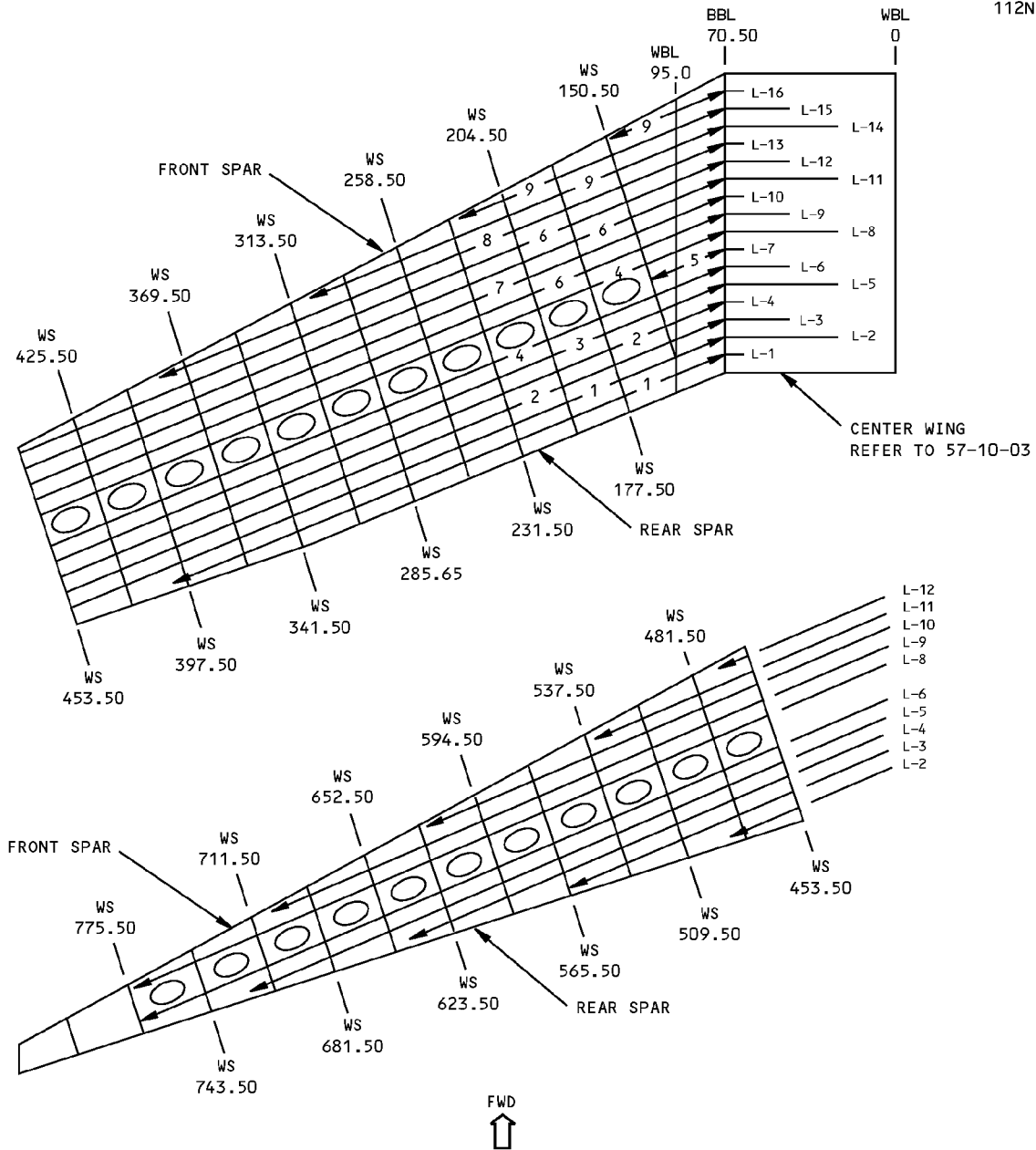

PLAN VIEW LOWER SURFACE
LEFT WING SHOWN
RIGHT WING OPPOSITE
DETAIL I

LIST OF
MATERIAL

**Outer Wing Lower Stringer Identification
Figure 1 (Sheet 1 of 2)**

**757-200
STRUCTURAL REPAIR MANUAL**

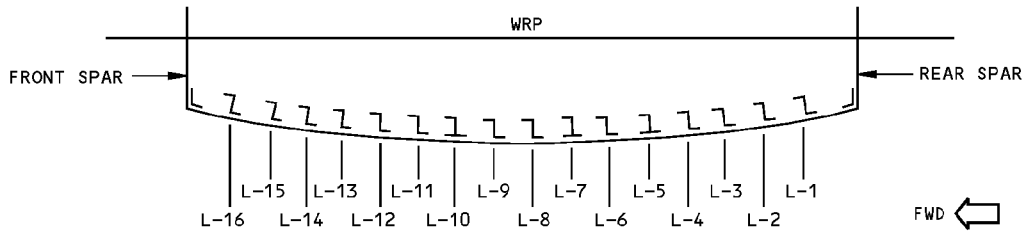

SECTION THRU LOWER PANEL

ITEM	DESCRIPTION	MATERIAL	TYPE	EFFECTIVITY
1	STRINGER (L-1,L-2)	BAC1517-2267 2224-T3511 OPTIONAL: BAC1517-2114 2224-T3511	┌	
2	STRINGER (L-3,L-4)	BAC1517-2266 2224-T3511 OPTIONAL: BAC1517-2114 2224-T3511	┌	
3	STRINGER (L-5)	BAC1506-3458 2224-T3511 OPTIONAL: BAC1506-3145 2224-T3511	└	
4	STRINGER (L-6,L-8)	BAC1517-2265 2224-T3511 OPTIONAL: BAC1517-2115 2224-T3511	┌	
5	STRINGER (L-7)	BAC1506-3460 2224-T3511 OPTIONAL: BAC1506-3145 2224-T3511	└	
6	STRINGER (L-9,L-11,L-12)	BAC1517-2264 2224-T3511 OPTIONAL: BAC1517-2114 2224-T3511	┌	
7	STRINGER (L-10)	BAC1506-3459 2224-T3511 OPTIONAL: BAC1506-3145 2224-T3511	└	
8	STRINGER (L-13)	BAC1517-2263 2224-T3511 OPTIONAL: BAC1517-2114 2224-T3511	┌	
9	STRINGER (L-14,L-15,L-16)	BAC1517-2262 2224-T3511 OPTIONAL: BAC1517-2114 2224-T3511	┌	

LIST OF MATERIALS FOR DETAIL I

**Outer Wing Lower Stringer Identification
Figure 1 (Sheet 2 of 2)**



757-200

STRUCTURAL REPAIR MANUAL

ALLOWABLE DAMAGE GENERAL - OUTER WING STRINGERS

This subject refers to the allowable damage limits for the outer wing stringers, as shown in SRM 57-00-03, Allowable Damage 1.

Allowable Damage 1 is applicable to airplanes that have not had winglets installed.

Allowable Damage 1 is not applicable to airplanes that have had winglets installed after production of the airplane. Refer to Aviation Partners Boeing (APB) document AP57.2-0602 for the winglet data.

**Outer Wing Stringers Allowable Damage
Figure 101 (Sheet 1 of 2)**

D634N201

ALLOWABLE DAMAGE GENERAL
57-20-03
Page 101
Jan 20/2007



757-200
STRUCTURAL REPAIR MANUAL

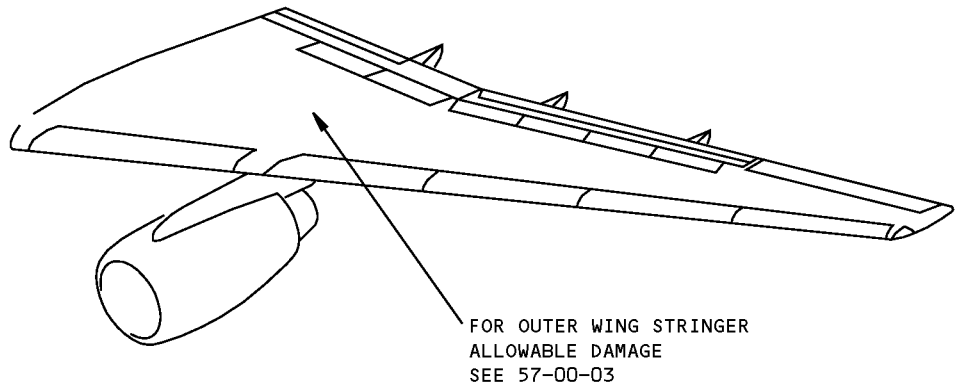

Outer Wing Stringers Allowable Damage
Figure 101 (Sheet 2 of 2)

D634N201

ALLOWABLE DAMAGE GENERAL
57-20-03
Page 102
Sep 20/2006



757-200
STRUCTURAL REPAIR MANUAL

REPAIR GENERAL - OUTER WING STRINGERS REPAIR

This subject refers to the repair data for the outer wing stringers, as shown in SRM 57-00-03, Wing Stringer Repairs.

These Wing Stringer Repairs are applicable to airplanes that have not had winglets installed.

These Wing Stringer Repairs are not applicable to airplanes that have had winglets installed after production of the airplane. Refer to Aviation Partners Boeing (APB) document AP57.2-0602 for the winglet data.

Outer Wing Stringers Repair
Figure 201 (Sheet 1 of 2)

D634N201

57-20-03

REPAIR GENERAL
Page 201
Sep 20/2006



757-200
STRUCTURAL REPAIR MANUAL

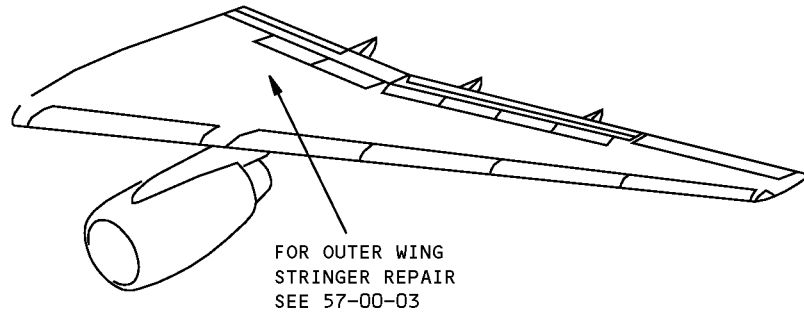

Outer Wing Stringers Repair
Figure 201 (Sheet 2 of 2)

D634N201

57-20-03

REPAIR GENERAL
Page 202
Sep 20/2006

**757-200
STRUCTURAL REPAIR MANUAL**

IDENTIFICATION 1 - OUTER WING RIB

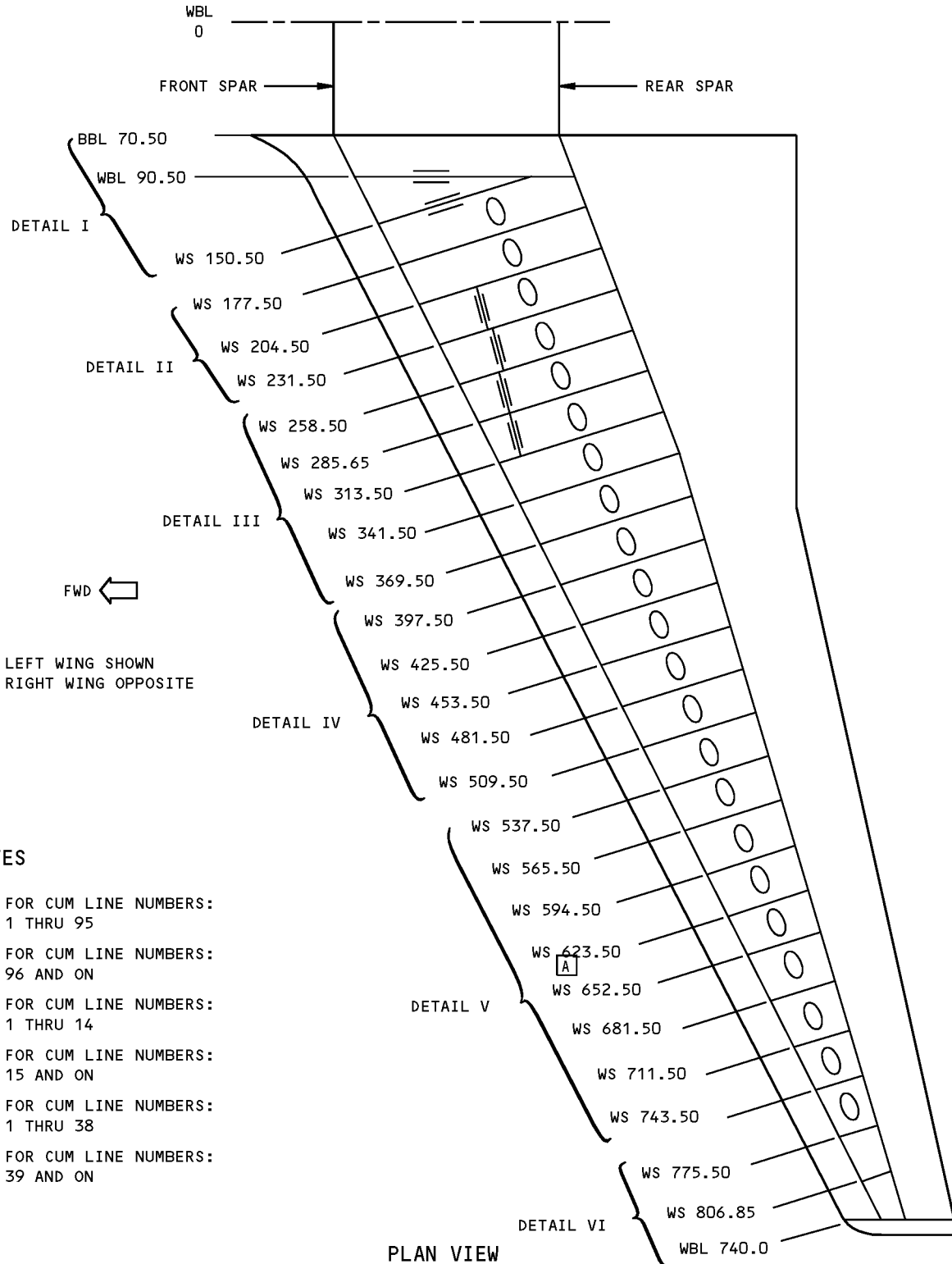

NOTES

- A** FOR CUM LINE NUMBERS: 1 THRU 95
- B** FOR CUM LINE NUMBERS: 96 AND ON
- C** FOR CUM LINE NUMBERS: 1 THRU 14
- D** FOR CUM LINE NUMBERS: 15 AND ON
- E** FOR CUM LINE NUMBERS: 1 THRU 38
- F** FOR CUM LINE NUMBERS: 39 AND ON

**Outer Wing Rib Identification
Figure 1 (Sheet 1 of 12)**

**757-200
STRUCTURAL REPAIR MANUAL**

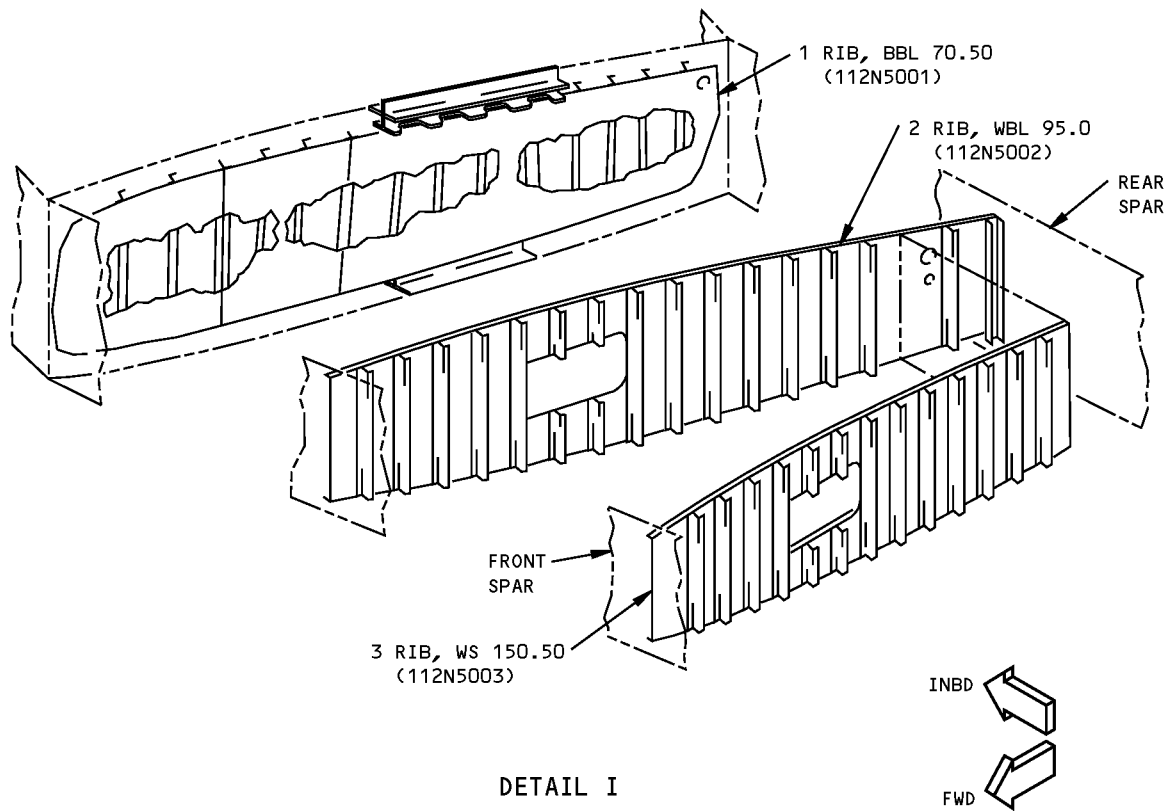

LIST OF
MATL

**Outer Wing Rib Identification
Figure 1 (Sheet 2 of 12)**



**757-200
STRUCTURAL REPAIR MANUAL**

ITEM	DESCRIPTION	GAGE	MATERIAL	EFFECTIVITY
1	RIB			
	UPPER CHORD		BAC1520-2166 7075-T73	
	FORWARD WEB	0.40	7075-T651	
	CENTER WEB	0.45	7075-T651	
	AFT WEB	0.80	7075-T651	
	LOWER CHORD		BAC1520-2342 2024-T3511 OPTIONAL: BAC1520-2191 2024-T3511	
2	RIB			
	UPPER CHORD		AND10134-2404 7075-T6	
	FORWARD WEB	0.063	CLAD 2024-T3	
	CENTER-FORWARD WEB	0.050	CLAD 2024-T3	
	UPPER WEB	0.040	CLAD 2024-T3	
	LOWER WEB	0.040	CLAD 2024-T3	
	AFT WEB	0.063	CLAD 2024-T3	
	CENTER WEB	0.040	CLAD 2024-T3	
	LOWER CHORD		AND10134-2404 7075-T6	
3	RIB			
	UPPER CHORD		AND10134-2403 7075-T6	
	WEBS	0.040	CLAD 2024-T3	
	LOWER CHORD		AND10134-2403 7075-T6	

LIST OF MATERIALS FOR DETAIL I

**Outer Wing Rib Identification
Figure 1 (Sheet 3 of 12)**

D634N201

57-20-09

IDENTIFICATION 1
Page 3
Jan 20/2005

**757-200
STRUCTURAL REPAIR MANUAL**

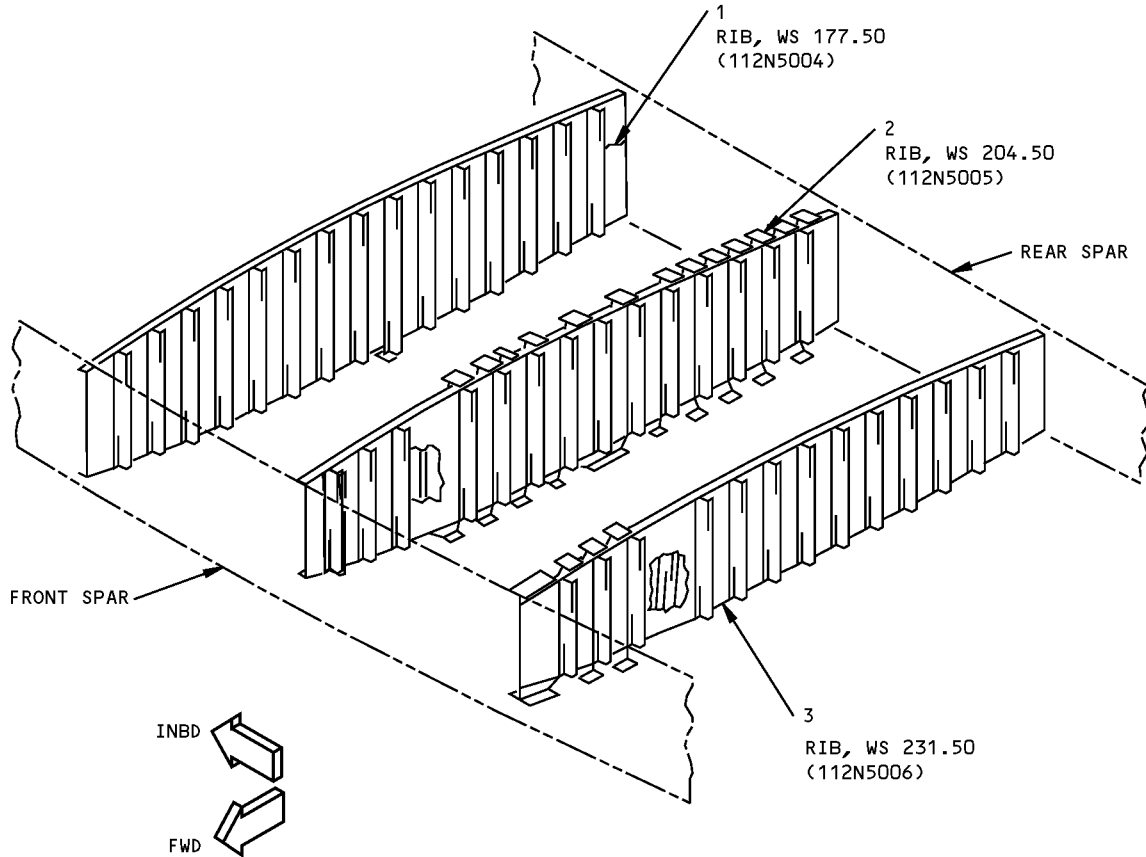

DETAIL II



**Outer Wing Rib Identification
Figure 1 (Sheet 4 of 12)**



**757-200
STRUCTURAL REPAIR MANUAL**

ITEM	DESCRIPTION	GAGE	MATERIAL	EFFECTIVITY
1	RIB			
	UPPER CHORD		AND10134-2403 7075-T6	
	WEB	0.40	CLAD 2024-T3	
	LOWER CHORD		AND10134-2403 7075-T6	
2	RIB			
	UPPER CHORD		BAC1520-2226 7075-T73	
	WEB	0.625	7075-T651 (MACHINED TO 0.080 MIN)	C
		0.50	7075-T651 (MACHINED TO 0.060 MIN)	D
	LOWER CHORD		BAC1520-2296 7075-T73 OPTIONAL: BAC1520-2225 7075-T73	
3	RIB			
	UPPER CHORD		BAC1520-2226 7075-T73	
	WEB	0.375	7075-T651 (MACHINED TO 0.060 MIN)	
	LOWER CHORD		BAC1520-2296 7075-T73 OPTIONAL: BAC1520-2226 7075-T73	

LIST OF MATERIALS FOR DETAIL II

**Outer Wing Rib Identification
Figure 1 (Sheet 5 of 12)**

D634N201

57-20-09

IDENTIFICATION 1
Page 5
Jan 20/2005

**757-200
STRUCTURAL REPAIR MANUAL**

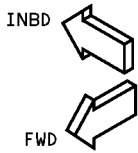
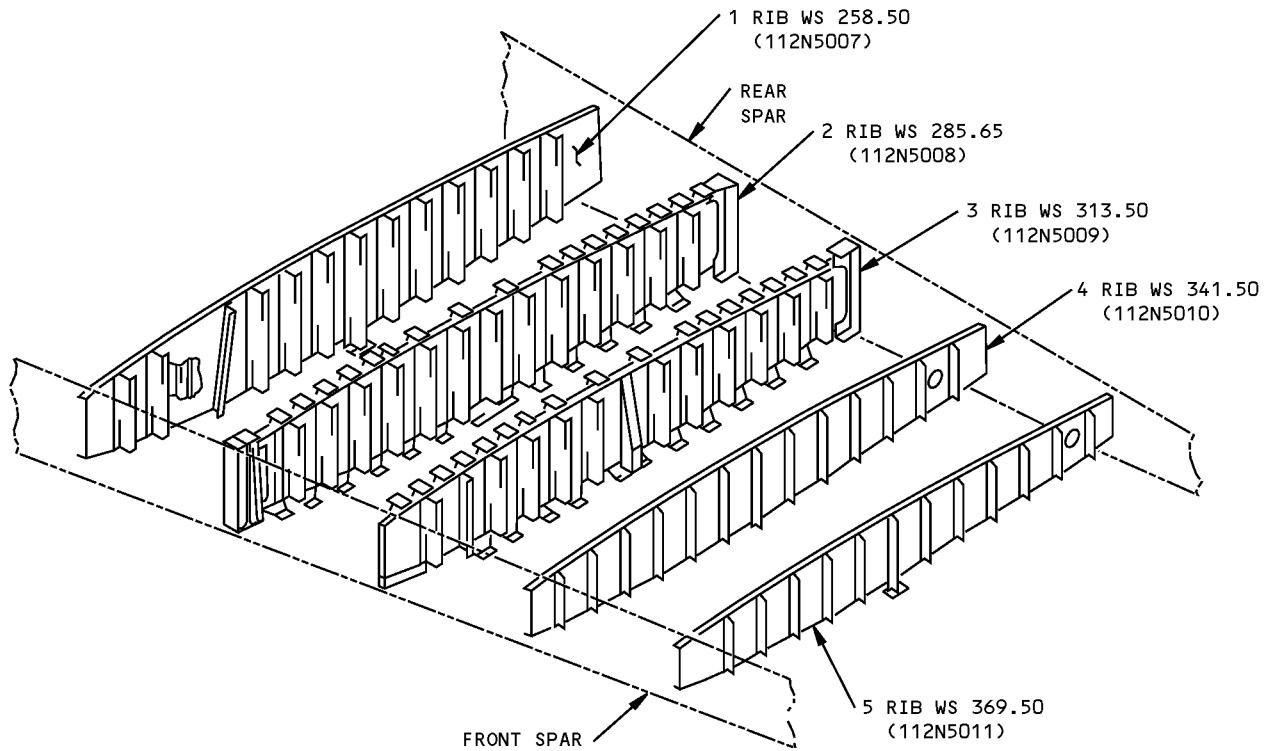

DETAIL III



**Outer Wing Rib Identification
Figure 1 (Sheet 6 of 12)**



**757-200
STRUCTURAL REPAIR MANUAL**

ITEM	DESCRIPTION	GAGE	MATERIAL	EFFECTIVITY
1	RIB			
	UPPER CHORD		AND10134-2403 7075-T6	
	FORWARD WEB	0.050	CLAD 2024-T3	
	CENTER WEB	0.040	CLAD 2024-T3	
	AFT WEB	0.050	CLAD 2024-T3	
	LOWER CHORD		AND10134-2403 7075-T6	
2	RIB			
	UPPER CHORD		BAC1520-2295 7075-T73 OPTIONAL: BAC1520-2222 7075-T73	
	WEB	0.50	7075-T651 (MACHINED TO 0.060 MIN)	
	LOWER CHORD		BAC1520-2296 7075-T73 OPTIONAL: BAC1520-2221 7075-T73	
3	RIB			
	UPPER CHORD		BAC1520-2295 7075-T73 OPTIONAL: BAC1520-2222 7075-T73	
	WEB	0.75 0.50	7075-T651 (MACHINED TO 0.070 MIN) 7075-T651 (MACHINED TO 0.070 MIN)	E F
	LOWER CHORD		BAC1520-2295 7075-T73 OPTIONAL: BAC1520-2221 7075-T73	
4	RIB			
	UPPER CHORD		AND10134-2404 7075-T62	
	FORWARD WEB	0.050	CLAD 2024-T3	
	CENTER WEB	0.040	CLAD 2024-T3	
	AFT WEB	0.050	CLAD 2024-T3	
	LOWER CHORD		AND10134-2404 7075-T62	
5	RIB			
	UPPER CHORD		AND10134-2404 7075-T6	
	FORWARD WEB	0.050	CLAD 2024-T3	
	CENTER WEB	0.040	CLAD 2024-T3	
	AFT WEB	0.060	CLAD 2024-T3	
	LOWER CHORD		AND10134-2404 7075-T6	

LIST OF MATERIALS FOR DETAIL III

**Outer Wing Rib Identification
Figure 1 (Sheet 7 of 12)**

D634N201

57-20-09

IDENTIFICATION 1
Page 7
Jan 20/2005

**757-200
STRUCTURAL REPAIR MANUAL**

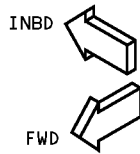
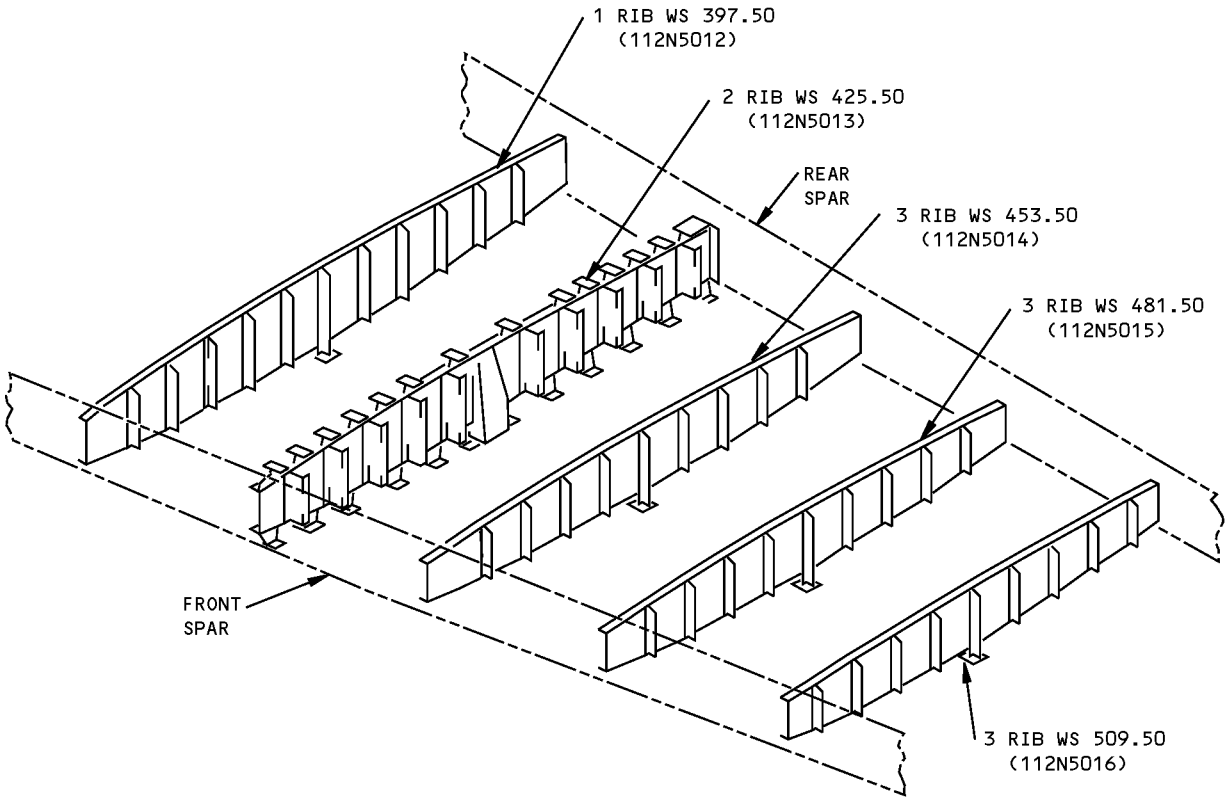

DETAIL IV



**Outer Wing Rib Identification
Figure 1 (Sheet 8 of 12)**



**757-200
STRUCTURAL REPAIR MANUAL**

ITEM	DESCRIPTION	GAGE	MATERIAL	EFFECTIVITY
1	RIB			
	UPPER CHORD		AND10134-2404 7075-T6	
	FORWARD WEB	0.050	CLAD 2024-T3	
	CENTER WEB	0.040	CLAD 2024-T3	
	AFT WEB	0.050	CLAD 2024-T3	
	LOWER CHORD		AND10134-2404 7075-T6	
2	RIB			
	UPPER CHORD		BAC1520-2294 7075-T73 OPTIONAL: BAC1520-2223 7075-T73	
	WEB	0.75	2024-T351	
	LOWER CHORD		BAC1520-2293 7075-T73 OPTIONAL: BAC1520-2224 7075-T73	
3	RIB			
	UPPER CHORD		AND10134-2403 7075-T6	
	FORWARD WEB	0.040	CLAD 2024-T3	
	CENTER WEB	0.032	CLAD 2024-T3	
	AFT WEB	0.040	CLAD 2024-T3	
	LOWER CHORD		AND10134-2403 7075-T6	

LIST OF MATERIALS FOR DETAIL IV

**Outer Wing Rib Identification
Figure 1 (Sheet 9 of 12)**

D634N201

57-20-09

IDENTIFICATION 1
Page 9
Jan 20/2005

**757-200
STRUCTURAL REPAIR MANUAL**

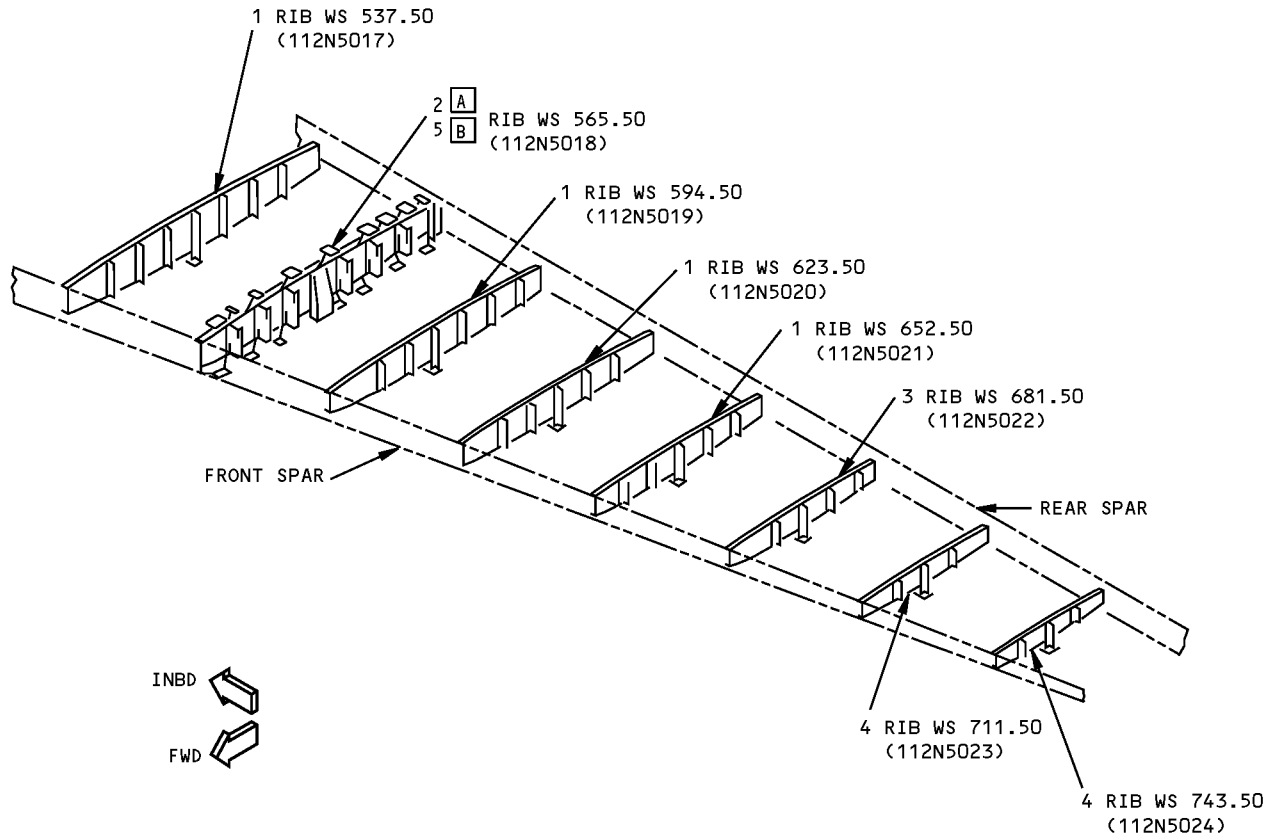

DETAIL V



**Outer Wing Rib Identification
Figure 1 (Sheet 10 of 12)**



**757-200
STRUCTURAL REPAIR MANUAL**

ITEM	DESCRIPTION	GAGE	MATERIAL	EFFECTIVITY
1	RIB			
	UPPER CHORD		AND10134-2006 7075-T6	
	FORWARD WEB	0.040	CLAD 2024-T3	
	CENTER WEB	0.032	CLAD 2024-T3	
	AFT WEB	0.040	CLAD 2024-T3	
	LOWER CHORD		AND10134-2006 7075-T6	
2	RIB			A
	UPPER CHORD		BAC1520-11190 7075-T73 OPTIONAL: BAC1520-2223 7075-T73	
	WEB	0.50	2024-T351 (MACHINED TO 0.050 MIN)	
	LOWER CHORD		BAC1503-11190 7075-T73 OPTIONAL: BAC1520-2224 7075-T73	
3	RIB			
	UPPER CHORD		AND10133-2001 7075-T6	
	WEB	0.050	CLAD 2024-T3	
	LOWER CHORD		AND10133-2001 7075-T6	
4	RIB			
	UPPER CHORD		AND10133-2001 7075-T6	
	WEB	0.032	CLAD 2024-T3	
	LOWER CHORD		AND10133-2001 7075-T6	
5	RIB			B
	UPPER CHORD		BAC1520-2294 7075-T73	
	WEB, FWD	0.050	CLAD 2024-T3	
	WEB, AFT	0.100	2024-T3	
	LOWER CHORD		BAC1520-2293 7075-T73	

LIST OF MATERIALS FOR DETAIL V

**Outer Wing Rib Identification
Figure 1 (Sheet 11 of 12)**

**757-200
STRUCTURAL REPAIR MANUAL**

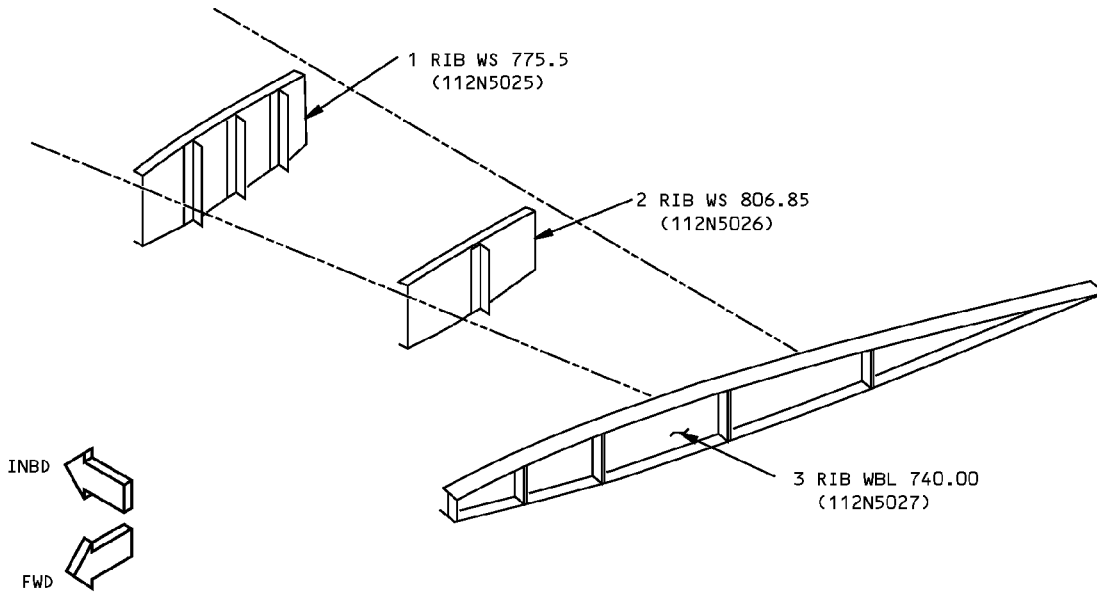

DETAIL VI

ITEM	DESCRIPTION	GAGE	MATERIAL	EFFECTIVITY
1	RIB	0.050	BAC1505-100172 2024-T42 CLAD 2024-T3 BAC1505-100172 2024T42	
	UPPER CHORD			
	WEB			
2	RIB	0.032	AND10133-2001 7075-T6 CLAD 2024-T3 AND10133-2001 7075-T6	
	UPPER CHORD			
	WEB			
3	RIB	0.040	AND10134-1204 7075-T6 CLAD 2024-T3 AND10134-1204 7075-T6	
	UPPER CHORD			
	WEB			
	LOWER CHORD			

LIST OF MATERIALS FOR DETAIL VI

**Outer Wing Rib Identification
Figure 1 (Sheet 12 of 12)**

**757-200
STRUCTURAL REPAIR MANUAL**

IDENTIFICATION 2 - FUEL DRY BAY BARRIER

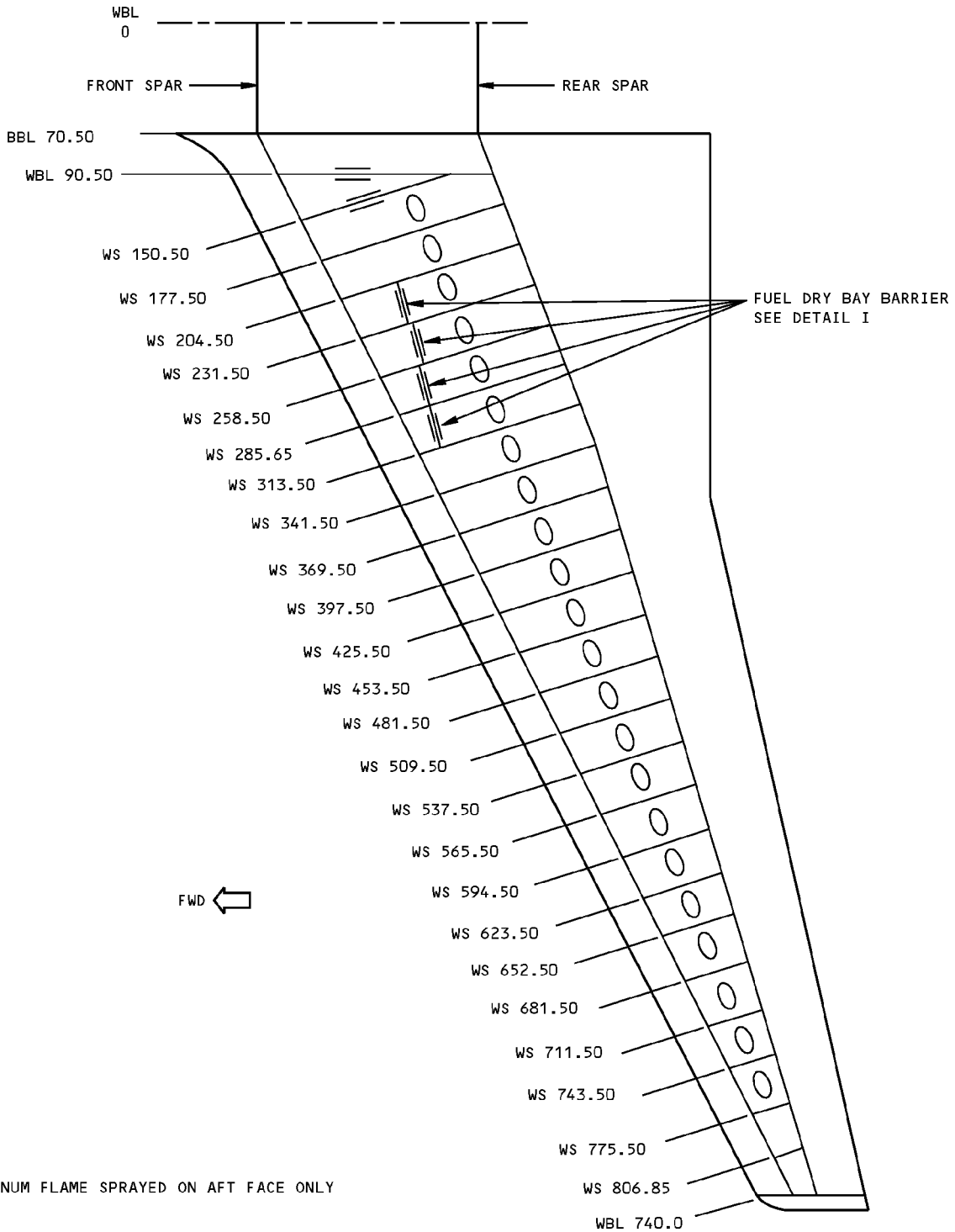

NOTES

A ALUMINUM FLAME SPRAYED ON AFT FACE ONLY

PLAN VIEW

**Fuel Dry Bay Barrier Identification
Figure 1 (Sheet 1 of 3)**

**757-200
STRUCTURAL REPAIR MANUAL**

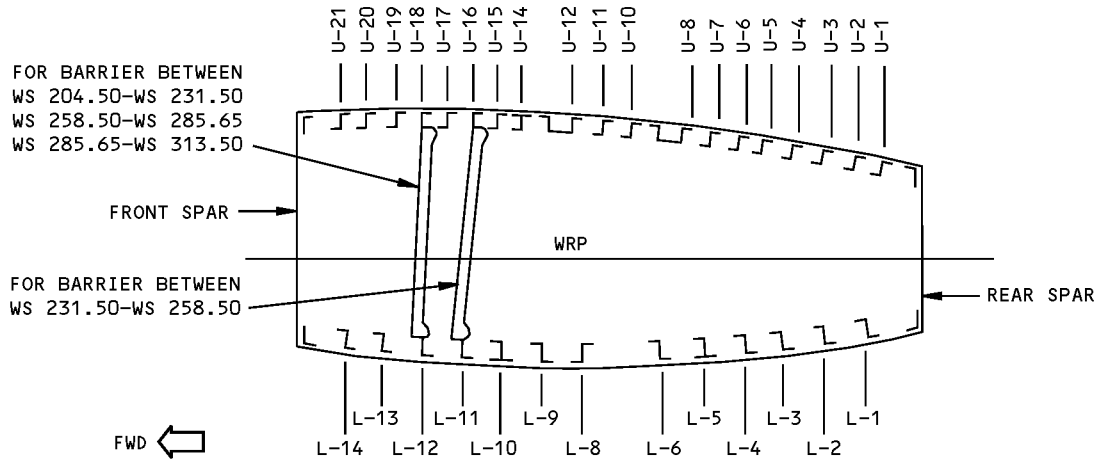
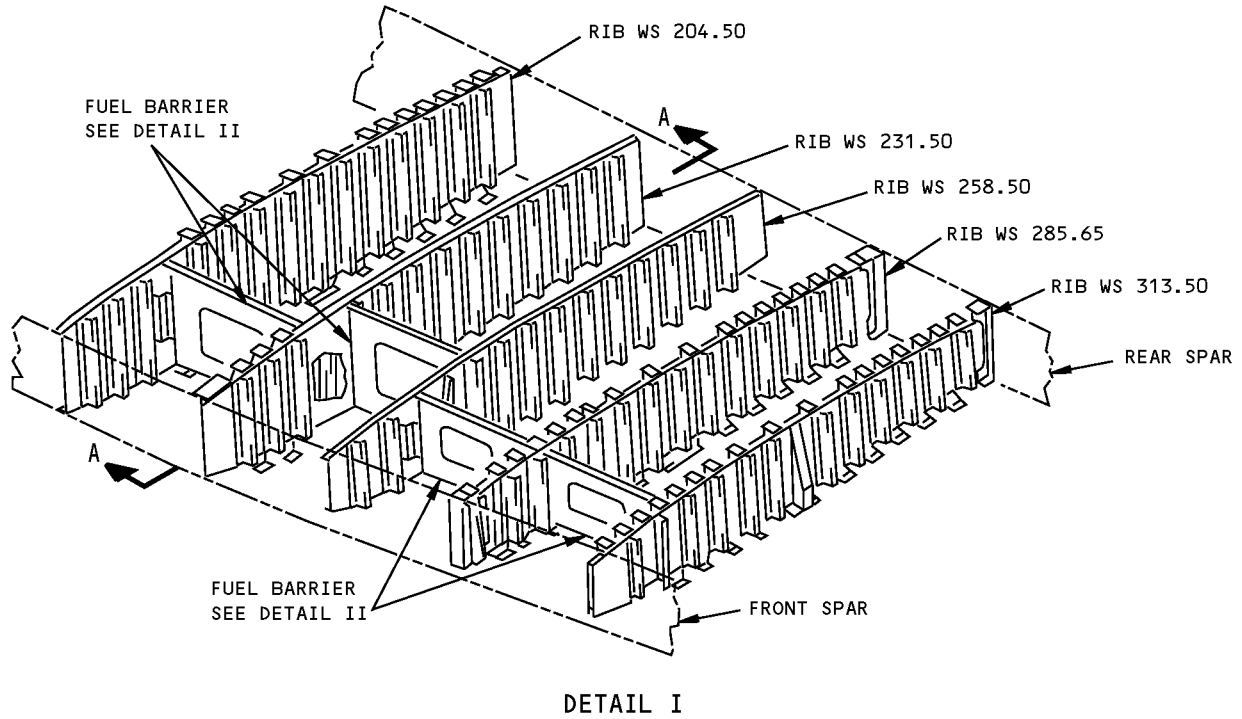

SECTION THRU WING AT WS 231.50
WS 204.50, WS 258.50, WS 285.65 AND WS 313.50 SIMILAR
SECTION A-A

**Fuel Dry Bay Barrier Identification
Figure 1 (Sheet 2 of 3)**

**757-200
STRUCTURAL REPAIR MANUAL**

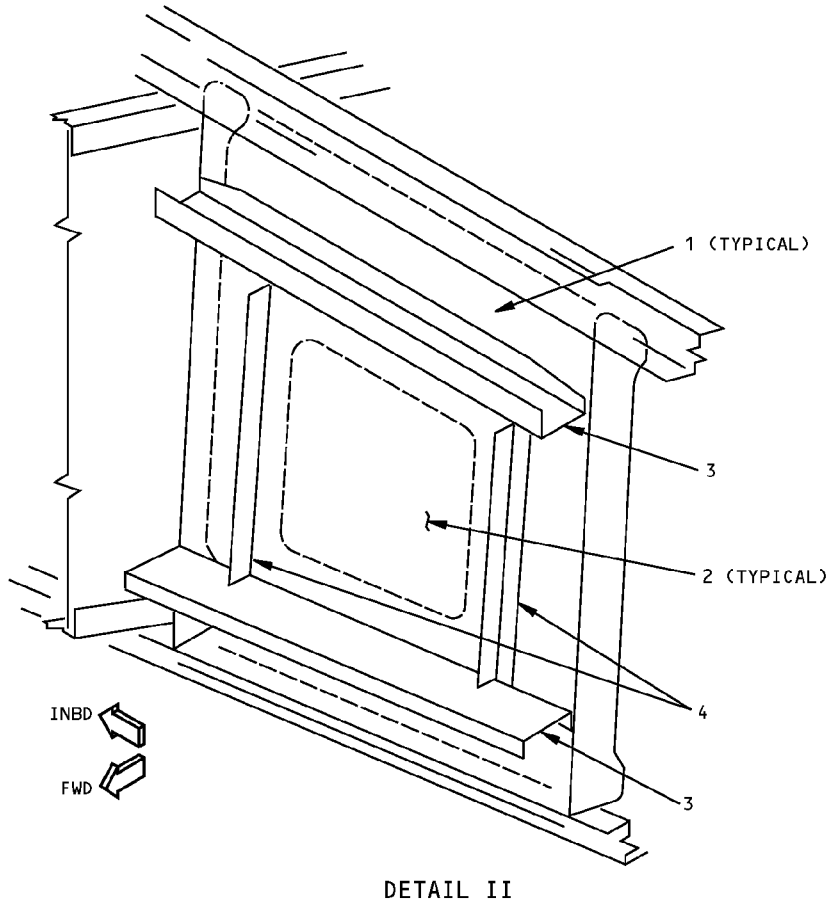

ITEM	DESCRIPTION	GAGE	MATERIAL	EFFECTIVITY
1	DRY BAY BARRIER		FIBERGLASS EPOXY PER BMS 8-79, CLASS III, GRADE 1.0 TYPE 1581	
2	ACCESS DOOR - DRY BAY BARRIER SKINS CORE		FIBERGLASS EPOXY PER BMS 8-79, CLASS III, GRADE 1.0 TYPE 1581 HONEYCOMB CORE PER BMS 8-124, CLASS IV, TYPE 1, GRADE 4.0	
3	CHANNEL		BAC1509-100490 7075-T6511	
4	STIFFENER		BAC1503-100126 2024-T3511	

LIST OF MATERIALS FOR DETAIL II

**Fuel Dry Bay Barrier Identification
Figure 1 (Sheet 3 of 3)**

IDENTIFICATION 2
Page 3
Jan 20/2005

57-20-09

D634N201



757-200

STRUCTURAL REPAIR MANUAL

ALLOWABLE DAMAGE 1 - OUTER WING RIBS

This subject gives the allowable damage limits for the outer wing ribs, as shown in Figure 101 of Allowable Damage 1.

Allowable Damage 1 is applicable to airplanes that have not had winglets installed.

Allowable Damage 1 is not applicable to airplanes that have had winglets installed after production of the airplane. Refer to Aviation Partners Boeing (APB) document AP57.2-0602 for the winglet data.

**Outer Wing Ribs Allowable Damage
Figure 101 (Sheet 1 of 5)**

D634N201

ALLOWABLE DAMAGE 1
Page 101
57-20-09 Sep 20/2006

757-200 STRUCTURAL REPAIR MANUAL

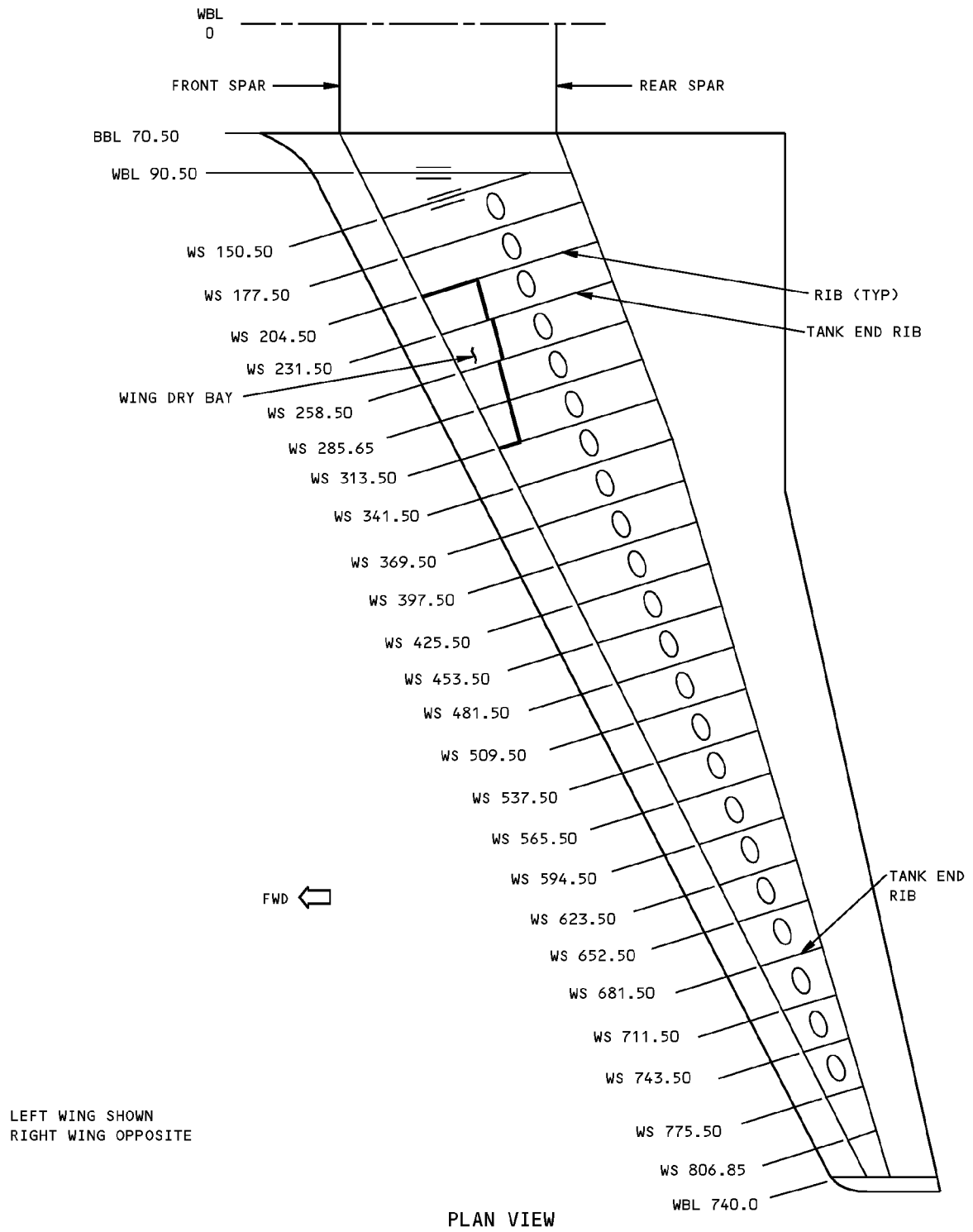

**Outer Wing Ribs Allowable Damage
Figure 101 (Sheet 2 of 5)**



757-200
STRUCTURAL REPAIR MANUAL

DESCRIPTION	CRACKS	NICKS, GOUGES AND CORROSION	DENTS	HOLES AND PUNCTURES
WEBS	A	CLEAN UP PER DETAILS I, II AND IV	D	E
CHORDS	B	C	NOT ALLOWED	NOT ALLOWED
STIFFENERS	B	C	NOT ALLOWED	SEE DETAIL V

NOTES

WARNING: PRESENCE OF FUEL VAPORS IN FUEL TANKS CREATES EXPLOSIVE AND TOXIC CONDITIONS. REFER TO 28-11-00 OF THE MAINTENANCE MANUAL FOR FUEL TANK MAINTENANCE PRACTICES AND ENTRY PROCEDURES.

- REFINISH REWORKED AREAS PER 51-20 OF THE MAINTENANCE MANUAL

- A CLEAN UP EDGE CRACKS PER DETAIL I. OTHER CRACKS NOT ALLOWED
- B CLEAN UP EDGE CRACKS PER DETAILS I AND VI. OTHER CRACKS NOT ALLOWED
- C NICKS, GOUGES OR SCRATCH DAMAGE REMOVED ACCORDING TO DETAILS I, II, IV AND VI IS ALLOWED PROVIDED THE MAXIMUM PERMISSIBLE DEPTH IS NOT EXCEEDED

D DENT DAMAGE IS ALLOWED PROVIDED DEPTH Y DOES NOT EXCEED 0.050, A/Y IS NOT LESS THAN 30, AND THERE IS NO EVIDENCE OF PULLED OR LOOSE RIVETS, SHARP CREASES, GOUGES, SCRATCHES OR CRACKING. SEE DETAIL III

E HOLES UP TO 0.25 DIAMETER ARE ALLOWED PROVIDED THEY ARE LOCATED 4.0D FROM ANY OTHER HOLE, FASTENER, PART EDGE, OR OTHER DAMAGE AND ARE FILLED WITH 2117-T4 OR -T3 ALUMINUM RIVETS. INSTALL RIVETS WET WITH BMS 5-26 SEALANT. SEAL RIVETS INSTALLED IN TANK END RIBS PER 51-20-05. ONE HOLE ALLOWED PER WEB BAY

Outer Wing Ribs Allowable Damage
Figure 101 (Sheet 3 of 5)

STRUCTURAL REPAIR MANUAL

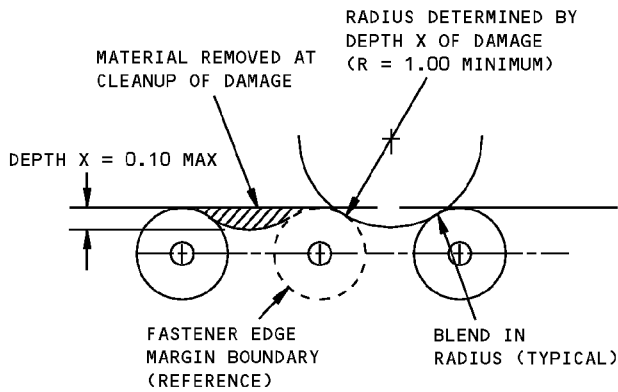

DAMAGE CLEANUP OF EDGES WHERE FASTENER EDGE MARGINS DO NOT OVERLAP

DETAIL I

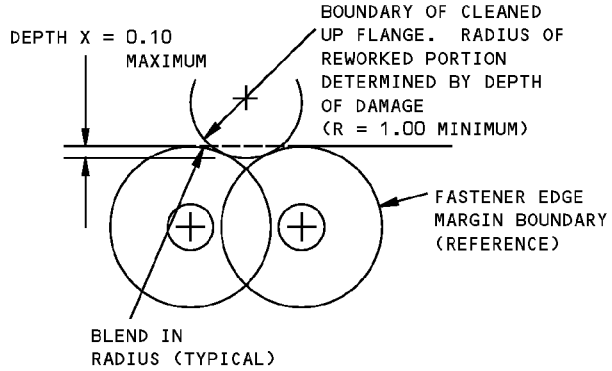

DAMAGE CLEANUP OF EDGES WHERE FASTENER EDGE MARGINS OVERLAP

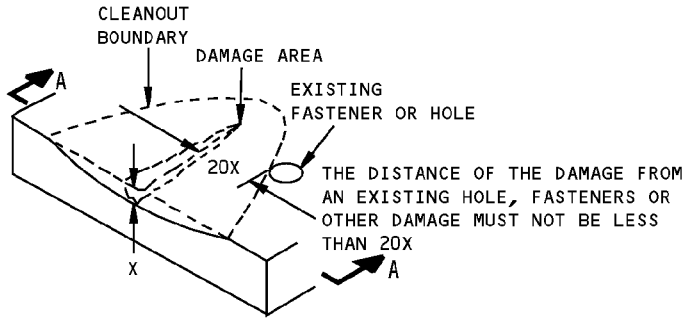

REMOVAL OF NICK, GOUGE AND SCRATCH DAMAGE ON A SURFACE
DETAIL II

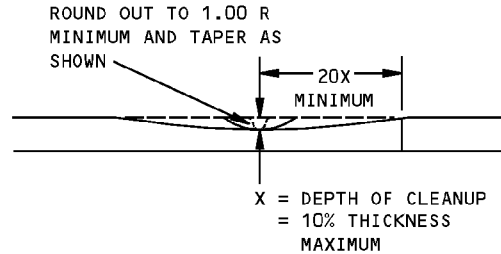

THE MAXIMUM AREA REMOVED FOR CLEANUP SHALL NOT EXCEED 4% OF ORIGINAL CROSS-SECTIONAL AREA

SECTION A-A

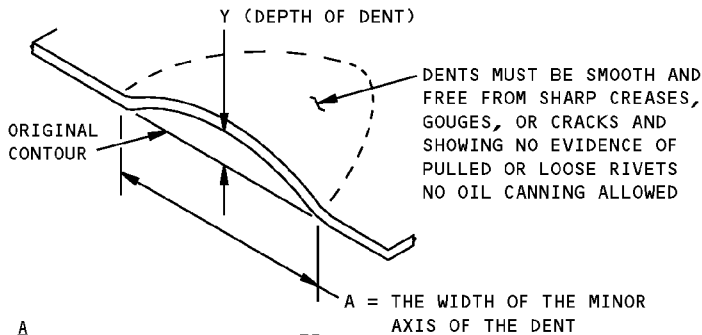

$\frac{A}{Y}$ MUST NOT BE LESS THAN 30
Y = 0.05 MAXIMUM FOR WEBS AND FLANGES OF CHORDS AND STIFFENERS

ALLOWABLE DAMAGE FOR DENT
DETAIL III

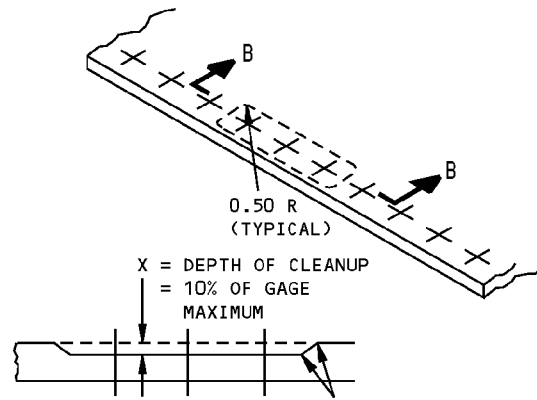

CORROSION CLEANUP
DETAIL IV

Outer Wing Ribs Allowable Damage
Figure 101 (Sheet 4 of 5)

**757-200
STRUCTURAL REPAIR MANUAL**

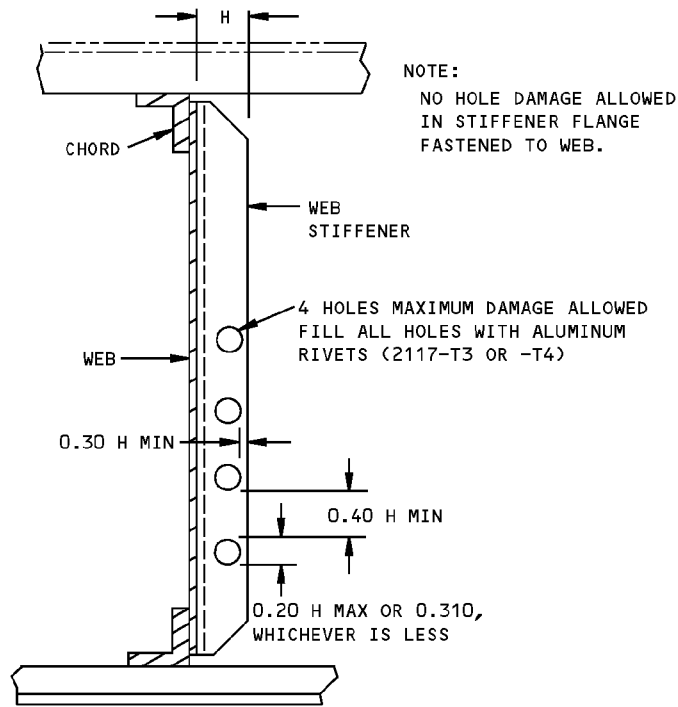

H = WIDTH OF STIFFENER FLANGE

**ALLOWABLE DAMAGE LIMITS FOR
HOLES IN WEB STIFFENERS
DETAIL V**

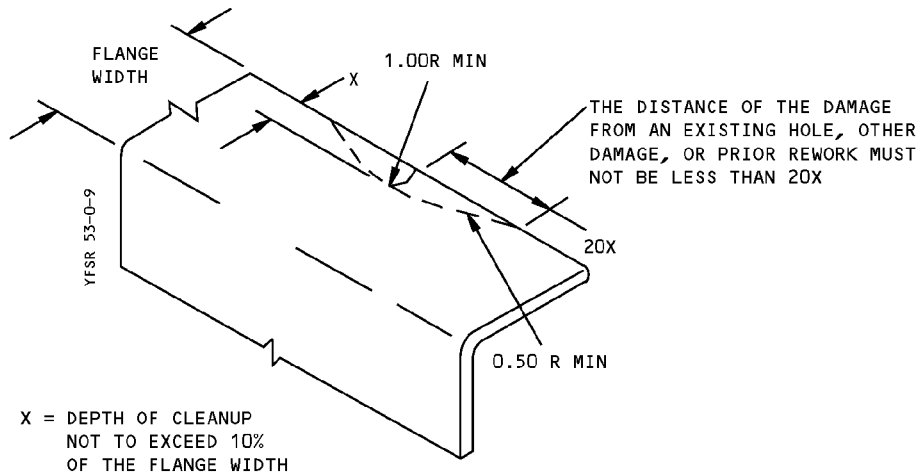

**DAMAGE CLEANUP OF FREE
FLANGE WITHOUT FASTENERS
DETAIL VI**

**Outer Wing Ribs Allowable Damage
Figure 101 (Sheet 5 of 5)**

**757-200
STRUCTURAL REPAIR MANUAL**

ALLOWABLE DAMAGE 2 - FUEL DRY BAY BARRIER

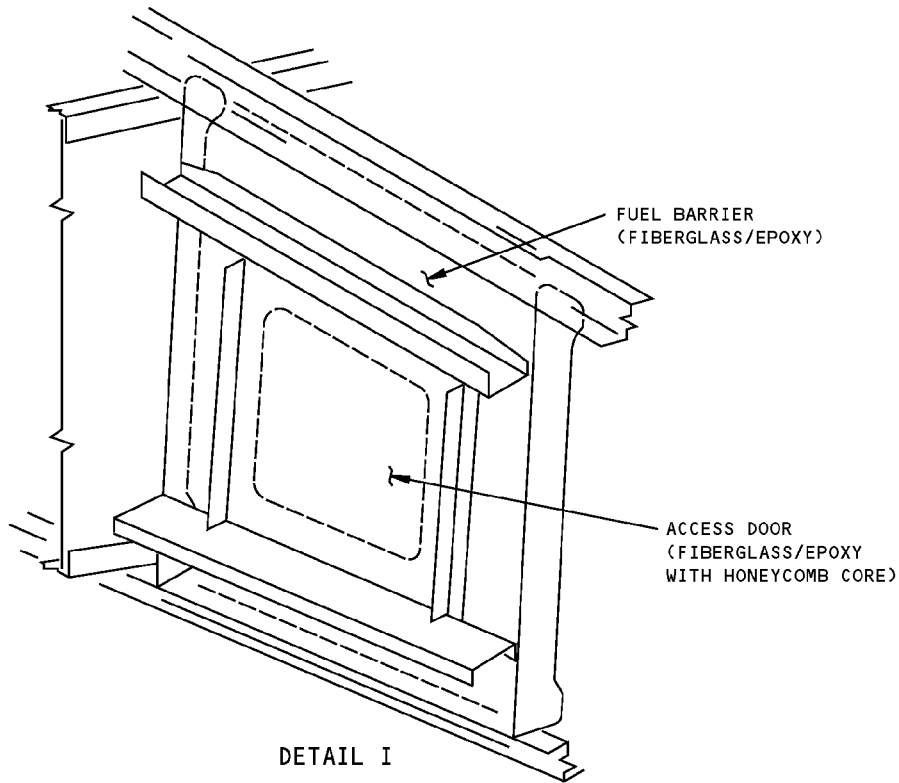
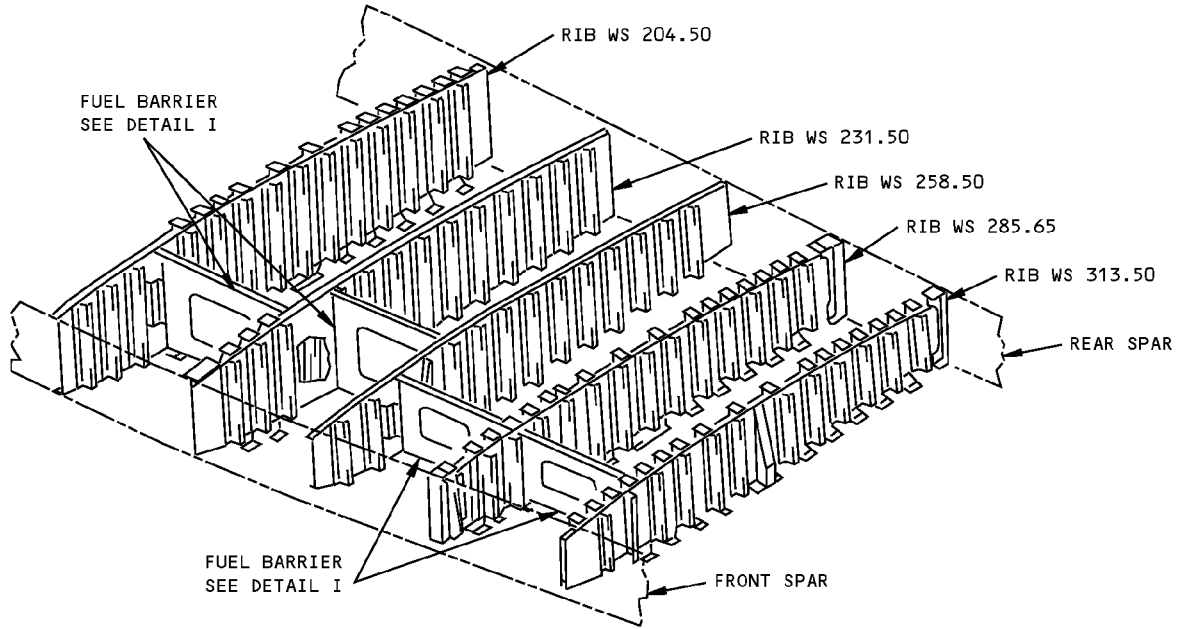

**Fuel Dry Bay Barrier Allowable Damage
Figure 101 (Sheet 1 of 2)**



757-200

STRUCTURAL REPAIR MANUAL

LOCATION	CRACKS	NICKS, GOUGES AND CORROSION	DENTS	HOLES AND PUNCTURES	DELAMINATION
FUEL BARRIER	NOT ALLOWED	A	NOT ALLOWED	NOT ALLOWED	NOT ALLOWED
ACCESS DOOR					

NOTES

WARNING: REMOVE ALL THE FUEL AND OPEN THE FUEL TANKS TO THE AIR BEFORE YOU GO INTO THE FUEL TANKS. REFER TO SRM 28-11 FOR INSTRUCTIONS. FUEL VAPORS ARE EXPLOSIVE AND DANGEROUS.

- DAMAGE IS ALLOWED ON THE FORWARD DRY SIDE OF THE FUEL DRY BAY BARRIER ONLY. REPAIR ANY DAMAGE ON THE AFT SIDE AS GIVEN IN REPAIR 1
- IF THE DAMAGE TO THE FORWARD SIDE IS MORE THAN THE ALLOWABLE DAMAGE LIMITS, REPAIR DAMAGE ACCORDING TO REPAIR 1
- REFER TO SRM 51-10-02 FOR INSPECTION AND REMOVAL OF DAMAGE
- REFER TO SRM 51-70-14 PAR. 3 FOR ALLOWABLE DAMAGE TO ALUMINUM FLAME SPRAYED COATINGS B
- REFINISH REWORKED AREAS PER AMM 51-20
- RESTORE DAMAGED FILLET SEALS WITH BMS 5-26 PER SRM 51-20-06 AND APPLY BMS 10-20, TYPE 2 PROTECTIVE COATING TO SEALANT

A DAMAGE ALLOWED ON SURFACE RESIN ONLY. DAMAGE TO FIBERS NOT ALLOWED B

- B DO NOT LET WATER, FUEL OR OTHER UNWANTED MATERIAL GET INTO THE DAMAGED SURFACE.
- 1) CLEAN THE DAMAGED SURFACE AND THE AREA AROUND THE DAMAGED SURFACE WITH MIBK (METHYL ISOBUTYL KETONE), MEK (METHYL ETHYL KETONE), TRICHLOROETHANE OR ACETONE
 - 2) LET THE DAMAGED SURFACE BECOME DRY
 - 3) SEAL THE DAMAGED SURFACE WITH ALUMINUM FOIL (SPEED TAPE) 3M-Y436 OR EQUIVALENT
 - 4) APPLY BMS 10-20, TYPE 2 PROTECTIVE COATING TO THE SURFACE OF THE SPEED TAPE AND THE AREA AROUND THE SPEED TAPE

Fuel Dry Bay Barrier Allowable Damage
Figure 101 (Sheet 2 of 2)

ALLOWABLE DAMAGE 2

57-20-09

Page 102
Jan 20/2005

D634N201

**757-200
STRUCTURAL REPAIR MANUAL**

REPAIR 1 - FUEL DRY BAY BARRIER REPAIR

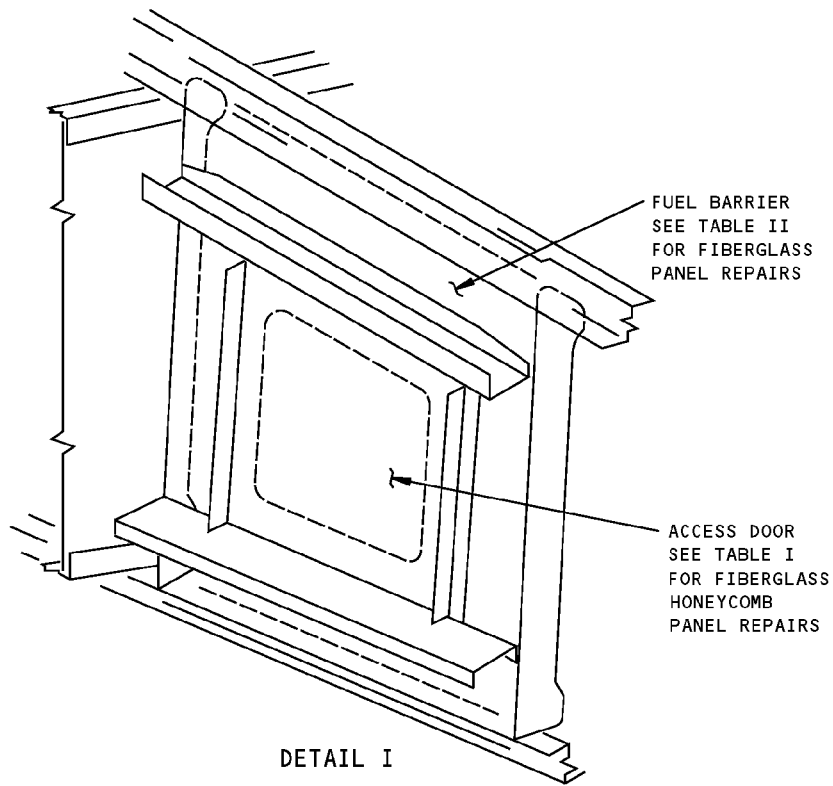
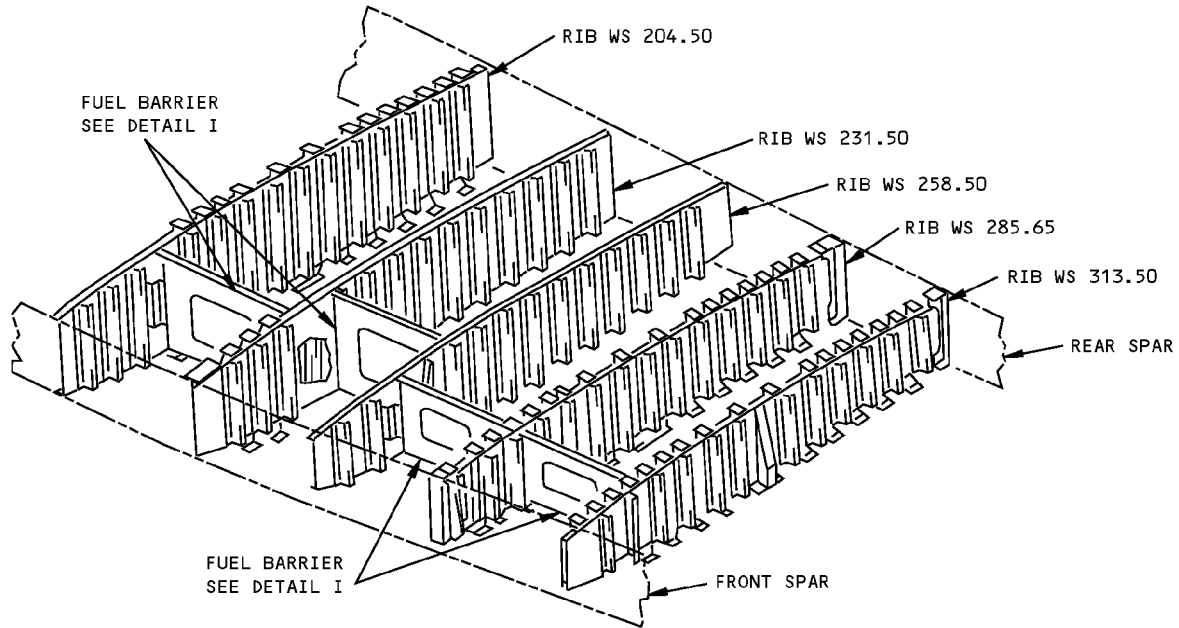

**Fuel Dry Bay Barrier Repair
Figure 201 (Sheet 1 of 3)**

**757-200
STRUCTURAL REPAIR MANUAL**

DAMAGE	PERMANENT REPAIRS [C]		
	WET LAYUP 150°F (66°C) CURE (SRM 51-70-06) [A]	WET LAYUP 200°F (93°C) CURE (SRM 51-70-17)	250°F (121°C) CURE (SRM 51-70-07)
CRACKS	CLEAN UP DAMAGE AND REPAIR AS A HOLE	CLEAN UP DAMAGE AND REPAIR AS A HOLE	CLEAN UP DAMAGE AND REPAIR AS A HOLE
HOLES AND PUNCTURES	4.0 INCHES (100 mm) MAXIMUM DIA NOT TO EXCEED 50% OF SMALLEST DIMENSION ACROSS HONEYCOMB PANEL AT THE DAMAGE LOCATION. USE TWO EXTRA PLYS FOR EACH SIDE [B]	8.0 INCHES (200 mm) MAXIMUM DIA NOT TO EXCEED 50% OF SMALLEST DIMENSION ACROSS HONEYCOMB PANEL AT THE DAMAGE LOCATION. USE TWO EXTRA PLYS FOR EACH SIDE [B]	NO SIZE LIMIT
DELAMINATION	CUT OUT AND REPAIR AS A HOLE		
NICKS AND GOUGES	IF THERE IS NO FIBER DAMAGE OR DELAMINATION, FILL NICKS OR GOUGES AS GIVEN IN SRM 51-70-06 IF YOU FIND FIBER DAMAGE OR DELAMINATION, THEN REPAIR AS A HOLE		
DENTS	UP TO 2.0 INCHES (50 mm) DIA WITH NO FIBER DAMAGE OR DELAMINATION, FILL WITH BMS 5-28, TYPE 7 POTTING COMPOUND AND PATCH AS GIVEN IN SRM 51-70-06, PAR. 5.L. [B] OVER 2.0 INCHES (50 mm) DIA OR WITH FIBER DAMAGE OR DELAMINATION, REPAIR AS A HOLE		
DAMAGE TO ALUMINUM FLAME SPRAY	REPAIR THE DAMAGE AS GIVEN IN SRM 51-70-14, PAR. 10.B OR 10.C. INSTALL THE ACCESS DOOR WITH A FILLET SEAL AROUND THE DOOR AND THE FASTENERS. <u>NOTE:</u> A FAY SURFACE SEAL BETWEEN THE ACCESS DOOR AND THE DRY BAY PANEL IS NOT NECESSARY.		

**REPAIR DATA FOR 250°F CURE HONEYCOMB PANELS (FIBERGLASS)
TABLE I**

REPAIR INSTRUCTIONS

WARNING: REMOVE ALL THE FUEL AND OPEN THE FUEL TANKS TO THE AIR BEFORE YOU GO INTO THE FUEL TANKS. REFER TO AMM 28-11 FOR INSTRUCTIONS. FUEL VAPORS ARE EXPLOSIVE AND DANGEROUS.

DO NOT USE A TEMPERATURE HIGHER THAN 150°F (66°C) TO CURE THIS REPAIR UNLESS YOU REMOVE ALL THE FUEL AND KEEP THE FUEL TANK OPEN FOR VENTILATION. FUEL VAPORS CAN BE EXPLOSIVE AT A TEMPERATURE AS LOW AS 180°F (82°C).

NOTES

- REFER TO SRM 51-10-02 FOR INSPECTION AND REMOVAL OF DAMAGE
- REFINISH REWORKED AREAS WITH BMS 10-20, TYPE 2 PROTECTIVE COATING AS GIVEN IN 51-20 OF THE 757 MAINTENANCE MANUAL
- RESTORE DAMAGED TEDLAR SURFACES AS GIVEN IN SRM 51-70-14 PAR. 15
- RESTORE FILLET SEALS WITH BMS 5-26 AS GIVEN IN SRM 51-20-05

- [A] LIMITED TO REPAIR OF DAMAGE TO ONE FACESHEET SKIN AND HONEYCOMB CORE. ONE REPAIR FOR EACH SQUARE FOOT OF AREA AND MINIMUM OF 6.0 INCHES (150 mm) (EDGE TO EDGE) FROM ANY OTHER DAMAGE, FASTENER HOLE, OR EDGE OF PANEL
- [B] ONE REPAIR FOR EACH SQUARE FOOT OF AREA AND A MINIMUM OF 6.0 INCHES (150 mm) (EDGE TO EDGE) FROM ANY OTHER DAMAGE, FASTENER HOLE, OR EDGE OR PANEL
- [C] REMOVE MOISTURE AND FUEL CONTAMINATION FROM DAMAGE AREA. USE OF VACUUM AND HEAT (MAXIMUM OF 125°F [52°C]) TO REMOVE MOISTURE FROM HONEYCOMB CELLS IS RECOMMENDED
- [D] ONE REPAIR FOR EACH SQUARE FOOT OF AREA AND A MINIMUM OF 3.0 INCHES (75 mm) (EDGE TO EDGE) FROM ANY OTHER DAMAGE, FASTENER HOLE OR EDGE OF PANEL

**Fuel Dry Bay Barrier Repair
Figure 201 (Sheet 2 of 3)**



**757-200
STRUCTURAL REPAIR MANUAL**

DAMAGE	PERMANENT REPAIRS C		
	WET LAYUP 150°F (66°C) CURE (SRM 51-70-06)	WET LAYUP 200°F (93°C) CURE (SRM 51-70-17)	250°F (121°C) CURE (SRM 51-70-07)
CRACKS	CLEAN UP DAMAGE AND REPAIR AS A HOLE	CLEAN UP DAMAGE AND REPAIR AS A HOLE	CLEAN UP DAMAGE AND REPAIR AS A HOLE
HOLES AND PUNCTURES	1.0 INCH (25 mm) MAXIMUM DIA NOT TO EXCEED 50% OF CROSS-SECTIONAL AREA OF LAMINATE OR EDGE BAND OR 25% OF THE EDGE BAND LENGTH FOR EACH SIDE. USE TWO EXTRA PLYS D	2.0 INCH (50 mm) MAXIMUM DIA NOT TO EXCEED 50% OF CROSS-SECTIONAL AREA OF LAMINATE OR EDGE BAND OR 25% OF THE EDGE BAND LENGTH FOR EACH SIDE. USE TWO EXTRA PLYS	NO SIZE LIMIT
EDGE EROSION	FOR DAMAGE THAT IS NOT LARGER THAN 35% OF THE EDGE BAND THICKNESS, REPAIR AS GIVEN IN SRM 51-70-06 PAR. 5.O. FOR LARGER DAMAGE, REPAIR AS GIVEN IN:		
	SRM 51-70-06 PAR. 5.G.	SRM 51-70-17 PAR. 4.G.	SRM 51-70-07 PAR. 5.G.
DELAMINATION	CUT OUT AND REPAIR AS A HOLE		
NICKS AND GOUGES	IF THERE IS NO FIBER DAMAGE OR DELAMINATION, FILL NICKS OR GOUGES AS GIVEN IN SRM 51-70-06 IF YOU FIND FIBER DAMAGE OR DELAMINATION, THEN REPAIR AS A HOLE		
DENTS	UP TO 1.0 INCH (25 mm) DIA WITH NO FIBER DAMAGE OR DELAMINATION, FILL WITH BMS 5-28, TYPE 7 POTTING COMPOUND AND PATCH AS GIVEN IN SRM 51-70-06, PAR. 5.L. OVER 1.0 INCH (25 mm) DIA OR WITH FIBER DAMAGE OR DELAMINATION, REPAIR AS A HOLE		
DAMAGE TO ALUMINUM FLAME SPRAY	REPAIR THE DAMAGE AS GIVEN IN SRM 51-70-14, PAR. 10.B OR 10.C. INSTALL THE ACCESS DOOR WITH A FILLET SEAL AROUND THE DOOR AND THE FASTENERS. <u>NOTE:</u> A FAY SURFACE SEAL BETWEEN THE ACCESS DOOR AND THE DRY BAY PANEL IS NOT NECESSARY.		

REPAIR DATA FOR 250°F CURE LAMINATES AND EDGE BANDS (FIBERGLASS)
TABLE II

**Fuel Dry Bay Barrier Repair
Figure 201 (Sheet 3 of 3)**

D634N201

57-20-09

REPAIR 1
Page 203
Jan 20/2005



757-200

STRUCTURAL REPAIR MANUAL

REPAIR 2 - FUEL DRY BAY BARRIER REPAIR - CRACKS AT DOOR FASTENER HOLES

REPAIR INSTRUCTIONS

WARNING: REMOVE ALL THE FUEL AND OPEN THE FUEL TANKS TO THE AIR BEFORE YOU GO INTO THE FUEL TANKS. REFER TO 28-11 OF THE 757 MAINTENANCE MANUAL FOR INSTRUCTIONS. FUEL VAPORS ARE EXPLOSIVE AND DANGEROUS.

DO NOT USE A TEMPERATURE HIGHER THAN 150°F (66°C) TO CURE THIS REPAIR UNLESS YOU REMOVE ALL THE FUEL AND OPEN THE FUEL TANK TO THE AIR. FUEL VAPORS CAN BE EXPLOSIVE AT A TEMPERATURE AS LOW AS 180°F (82°C).

1. Stop drill the ends of the cracks to a diameter of 0.25 inch (6 mm).
2. Cut out 3 pieces of fiberglass cloth to make a pictureframe doubler. Refer to Detail I.
3. Layup and cure the doubler. Refer to any one of the following 3 for layup and curing instructions.
 - A) 51-70-06 for 150°F (66°C) wet layup
or
 - B) 51-70-17 for 200°F (93°C) wet layup
or
 - C) 51-70-07 for 250°F (121°C) cure

NOTES

- REFER TO 51-10-02 FOR INSPECTION AND REMOVAL OF DAMAGE
- REFINISH REWORKED AREAS WITH BMS 10-20, TYPE 2 PROTECTIVE COATING PER 51-20 OF THE 757 MAINTENANCE MANUAL
- RESTORE DAMAGED ALUMINUM FLAME SPRAY AS GIVEN IN 51-70-14 PAR. 10.B OR 10.C AND TEDLAR SURFACE AS GIVEN IN PAR. 17
- RESTORE FILLET SEALS WITH BMS 5-26 PER 51-20-05

Fuel Dry Bay Barrier Repair - Cracks at Door Fastener Holes
Figure 201 (Sheet 1 of 2)

D634N201

57-20-09

REPAIR 2
Page 201
Jan 20/2005

**757-200
STRUCTURAL REPAIR MANUAL**

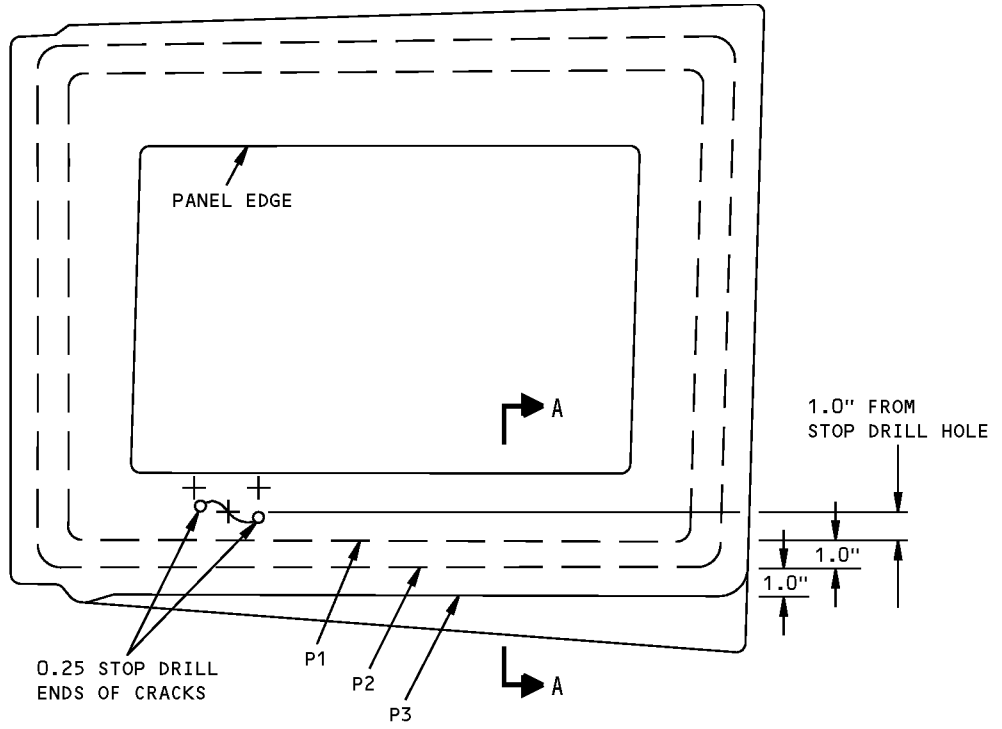

DETAIL I

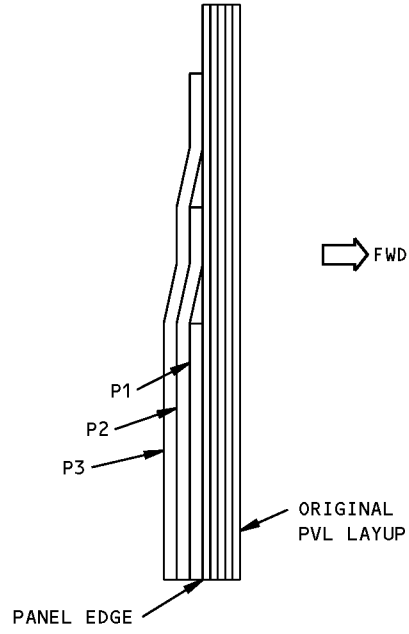

SECTION A-A

**Fuel Dry Bay Barrier Repair - Cracks at Door Fastener Holes
Figure 201 (Sheet 2 of 2)**

**757-200
STRUCTURAL REPAIR MANUAL**

IDENTIFICATION 1 - OUTER WING REAR SPAR

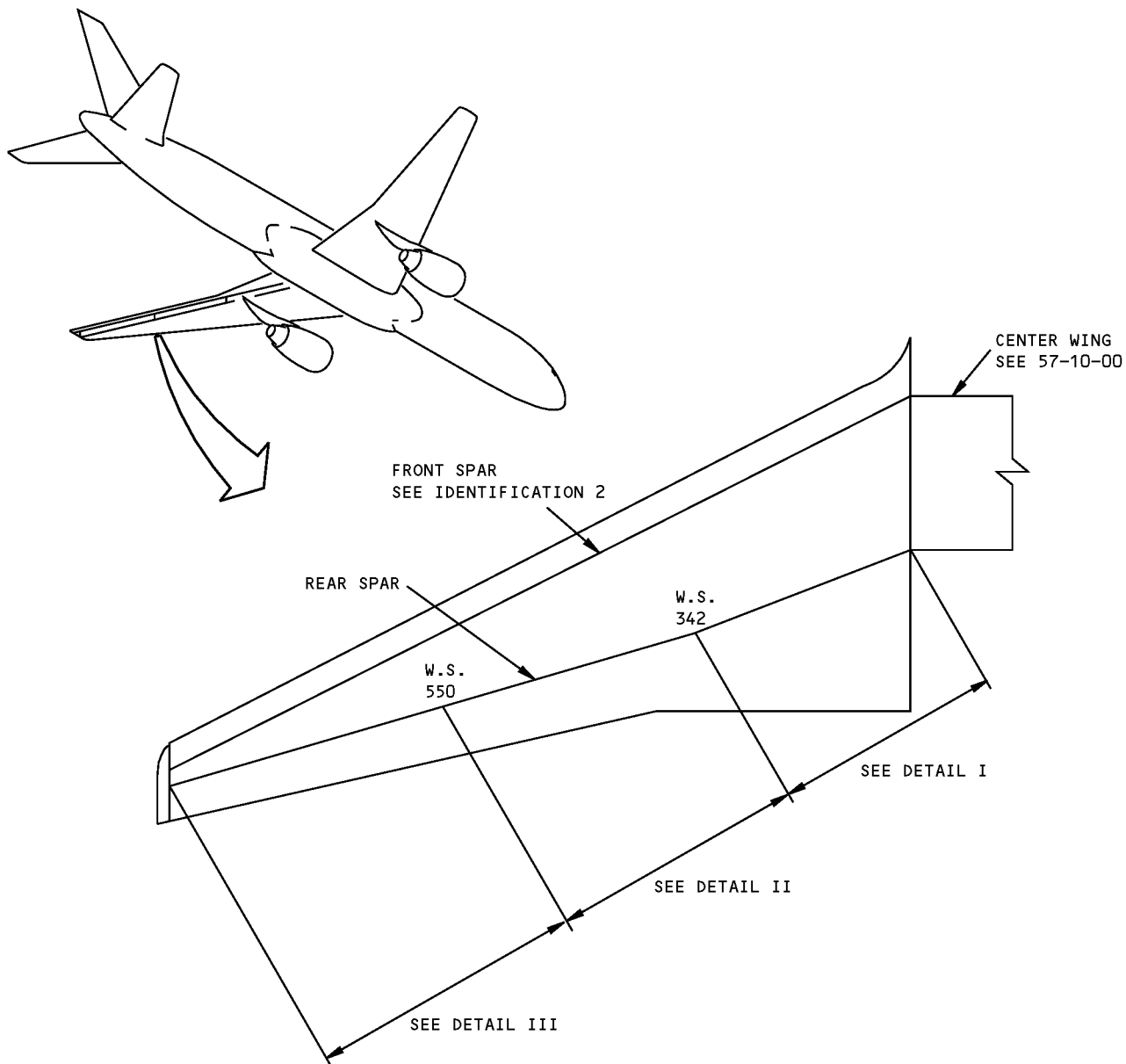

NOTES

- SEE 57-20-90 FOR FITTING IDENTIFICATION
- A** FOR CUM LINE NUMBERS: 1 THRU 36
- B** FOR CUM LINE NUMBERS: 37 AND ON
- C** FOR CUM LINE NUMBERS: 1 THRU 46
- D** FOR CUM LINE NUMBERS: 47 AND ON

**Outer Wing Rear Spar Identification
Figure 1 (Sheet 1 of 7)**

**757-200
STRUCTURAL REPAIR MANUAL**

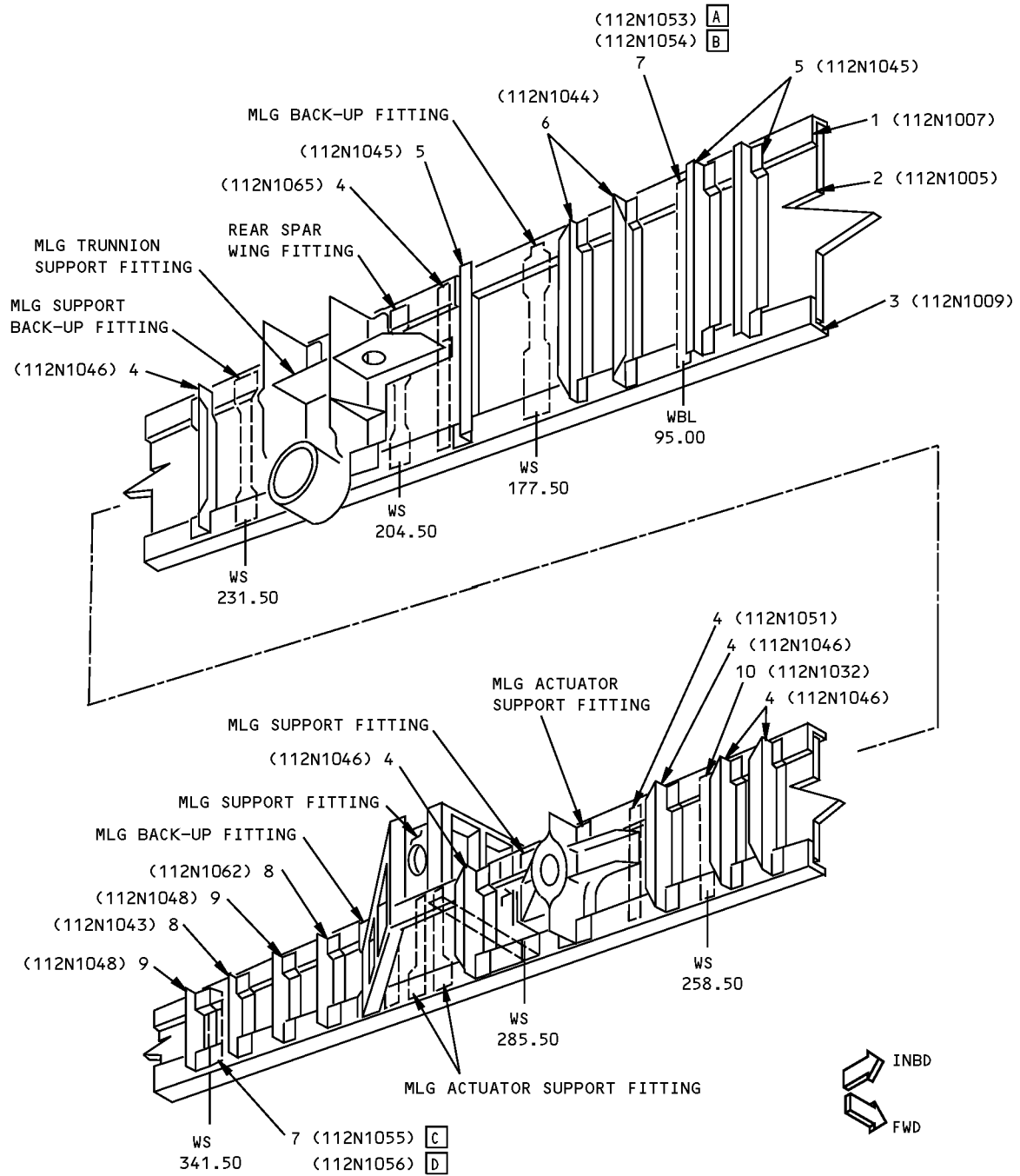

DETAIL I

LIST OF
MATERIAL

**Outer Wing Rear Spar Identification
Figure 1 (Sheet 2 of 7)**



757-200
STRUCTURAL REPAIR MANUAL

ITEM	DESCRIPTION	GAGE	MATERIAL	EFFECTIVITY		
1	UPPER CHORD		BAC1514-2561 7075-T73511			
2	WEB	1.00 1.13	PLATE 2324-T39 OPTIONAL: PLATE 2324-T39			
3	LOWER CHORD		BAC1514-2562 2024-T3511			
4	STIFFENER		BAC1517-2209 7075-T73511			
5	STIFFENER		BAC1514-2193 7075-T73511			
6	STIFFENER		BAC1509-100485 7075-T73511			
7	RIB POST		FORGING 7175-T736 FORGED BLOCK 7175-T736	<table border="1"><tr><td>D</td></tr><tr><td>C</td></tr></table>	D	C
D						
C						
8	STIFFENER		BAC1503-100682 7075-T73511			
9	STIFFENER		BAC1509-100485 7075-T73511			
10	RIB POST		BAC1517-2222 7075-T73511			

LIST OF MATERIALS FOR DETAIL I

Outer Wing Rear Spar Identification
Figure 1 (Sheet 3 of 7)

D634N201

57-20-10

IDENTIFICATION 1
Page 3
Jan 20/2005

**757-200
STRUCTURAL REPAIR MANUAL**

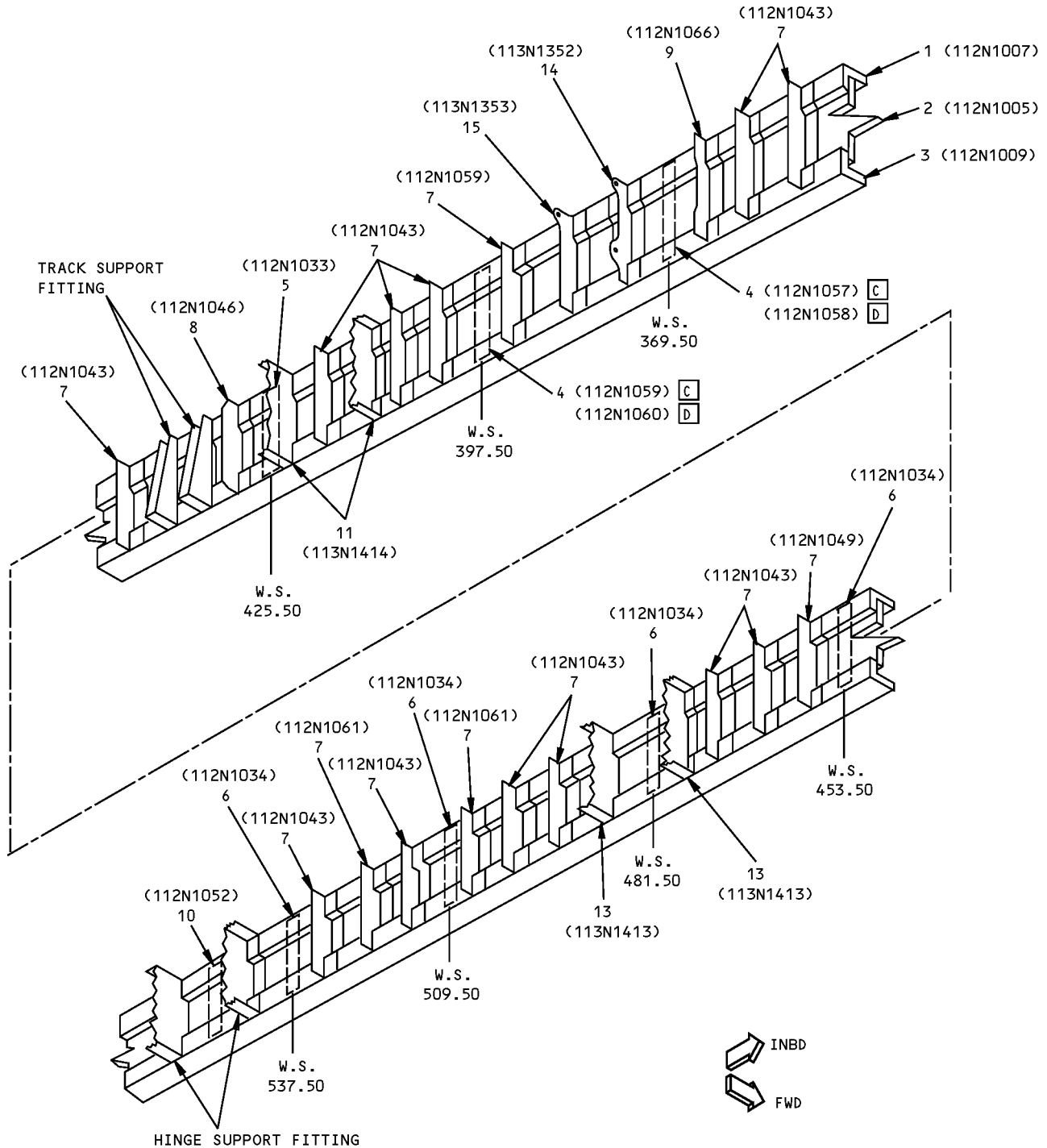

DETAIL II



**Outer Wing Rear Spar Identification
Figure 1 (Sheet 4 of 7)**



**757-200
STRUCTURAL REPAIR MANUAL**

ITEM	DESCRIPTION	GAGE	MATERIAL	EFFECTIVITY
1	UPPER CHORD		BAC1514-2561 7075-T73511	
2	WEB	1.00 1.13	PLATE 2324-T39 OPTIONAL: PLATE 2324-T39	
3	LOWER CHORD		BAC1514-2562 2024-T3511	
4	RIB POST		FORGED BLOCK 7175-T736 FORGING 7175-T736	C D
5	RIB POST		BAC1514-2629 7075-T6511	
6	RIB POST		BAC1517-2224 7075-T73511	
7	STIFFENER		BAC1503-100682 7075-T73511	
8	STIFFENER		BAC1517-100485 7075-T73511	
9	STIFFENER		BAC1514-2625 7075-T73511	
10	STIFFENER		BAC1503-100685 7075-T6511 OPTIONAL: BAC1503-100685 7075-T73511	
11	ACTUATOR SUPPORT RIB ASSEMBLY		FORGING 7075-T73	
12	ACTUATOR SUPPORT RIB ASSEMBLY		FORGING 7075-T73	
13	BEAM SUPPORT ASSEMBLY		7075-T7351	
14	BEAM SUPPORT ASSEMBLY		7075-T7351	

LIST OF MATERIALS FOR DETAIL II

**Outer Wing Rear Spar Identification
Figure 1 (Sheet 5 of 7)**

D634N201

57-20-10

IDENTIFICATION 1
Page 5
Jan 20/2005

**757-200
STRUCTURAL REPAIR MANUAL**

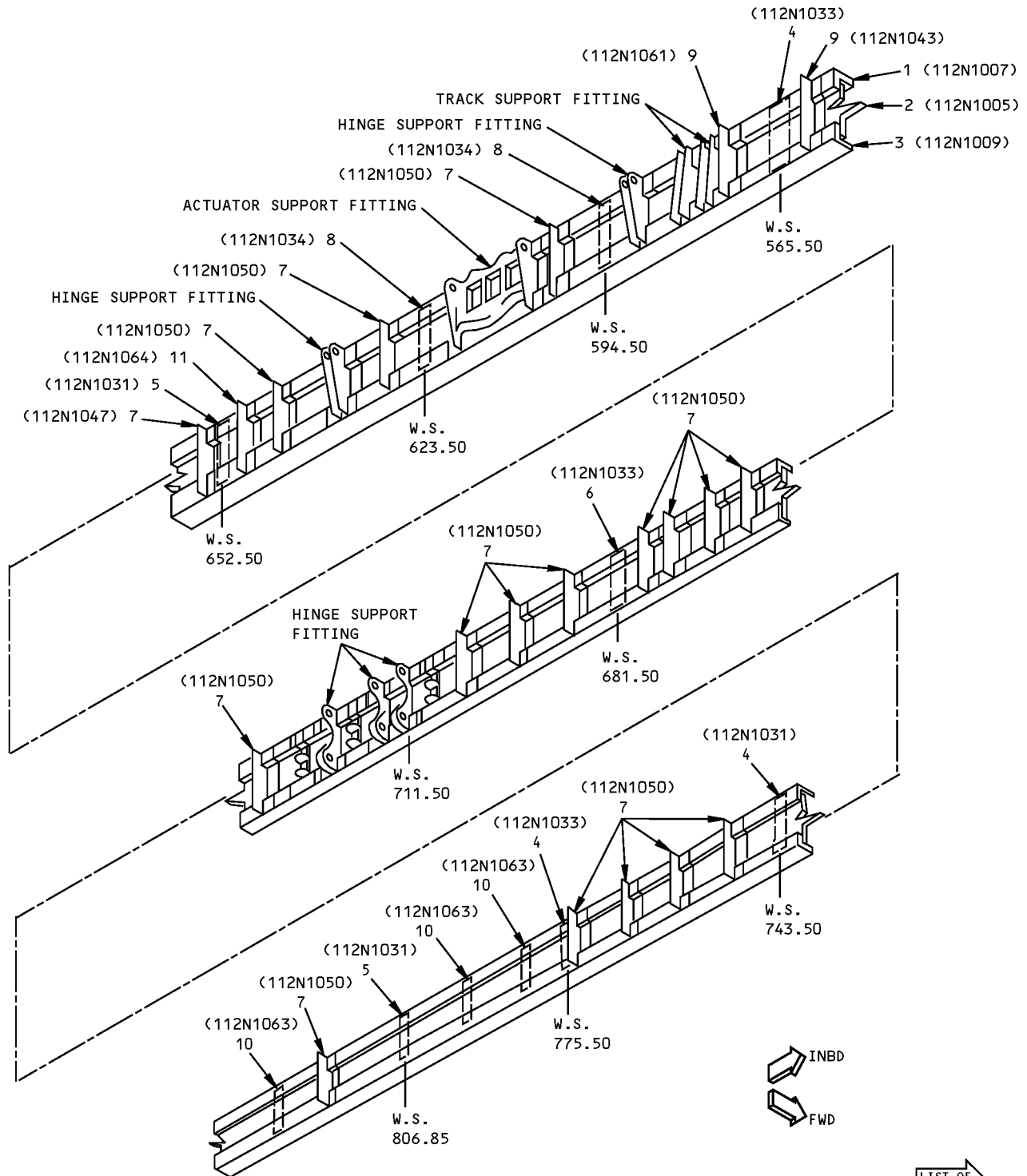

LIST OF
MATERIAL

DETAIL III

**Outer Wing Rear Spar Identification
Figure 1 (Sheet 6 of 7)**



757-200
STRUCTURAL REPAIR MANUAL

ITEM	DESCRIPTION	GAGE	MATERIAL	EFFECTIVITY
1	UPPER CHORD		BAC1514-2561 7075-T73511	
2	WEB	1.00 1.13	PLATE 2324-T39 OPTIONAL: PLATE 2324-T39	
3	LOWER CHORD		BAC1514-2562 2024-T3511	
4	RIB POST		BAC1505-101233 7075-T6511	
5	RIB POST		BAC1514-2628 7075-T6511	
6	RIB POST		BAC1505-101236 7075-T6511	
7	STIFFENER		BAC1503-100685 7075-T73511	
8	RIB POST		BAC1517-2223 7075-T73511	
9	STIFFENER		BAC1503-100682 7075-T73511	
10	STIFFENER		BAC1503-100457 7075-T6511	
11	STIFFENER		BAC1514-2626 7075-T73511	

LIST OF MATERIALS FOR DETAIL III

Outer Wing Rear Spar Identification
Figure 1 (Sheet 7 of 7)

D634N201

57-20-10

IDENTIFICATION 1
Page 7
Jan 20/2005

**757-200
STRUCTURAL REPAIR MANUAL**

IDENTIFICATION 2 - OUTER WING FRONT SPAR

REFERENCE DRAWING
112N1202

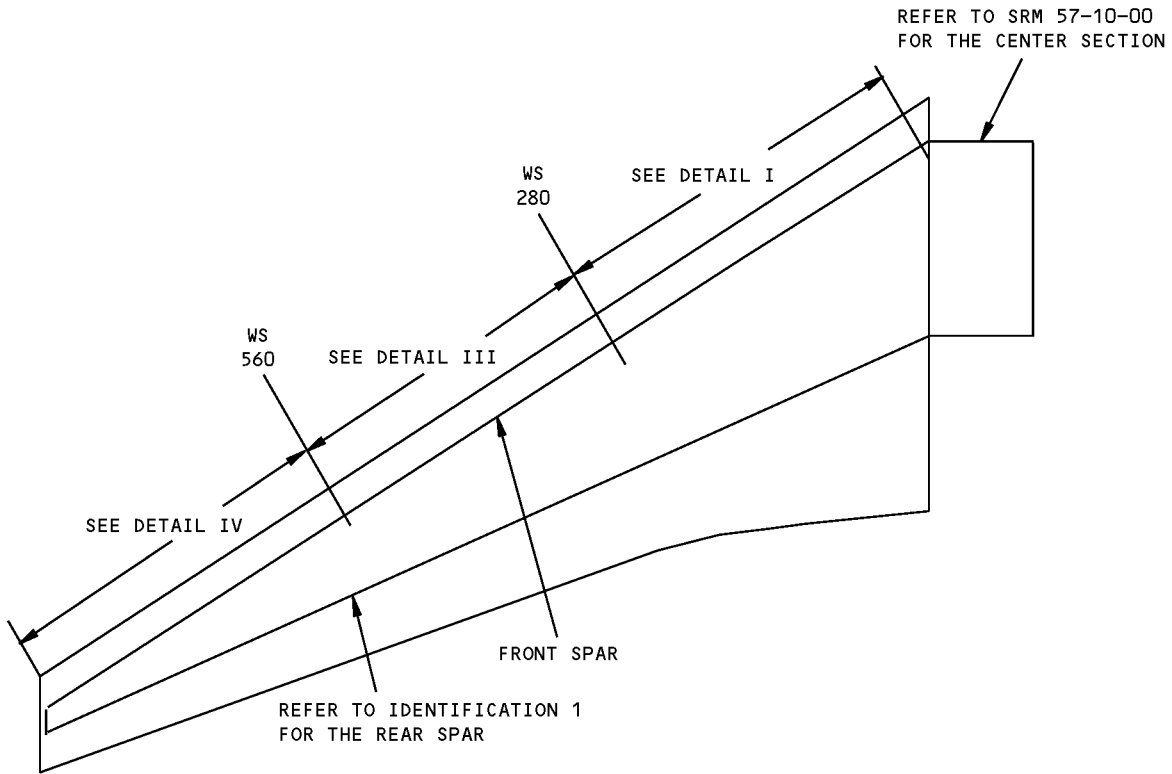

NOTES

- | | |
|---|--|
| <p>A FOR CUM LINE NUMBERS:
1 THRU 14</p> <p>B FOR CUM LINE NUMBERS:
15 AND ON</p> <p>C FOR CUM LINE NUMBERS:
1 THRU 36</p> <p>D FOR CUM LINE NUMBERS:
37 AND ON</p> <p>E FOR CUM LINE NUMBERS:
1 THRU 46</p> | <p>F FOR CUM LINE NUMBERS:
47 AND ON</p> <p>G FOR CUM LINE NUMBERS:
1 THRU 49</p> <p>H FOR CUM LINE NUMBERS:
50 THRU 1009</p> <p>I FOR CUM LINE NUMBERS:
1 THRU 1009</p> <p>J FOR CUM LINE NUMBERS:
1010 AND ON</p> |
|---|--|

**Outer Wing Front Spar Identification
Figure 1 (Sheet 1 of 7)**

**757-200
STRUCTURAL REPAIR MANUAL**

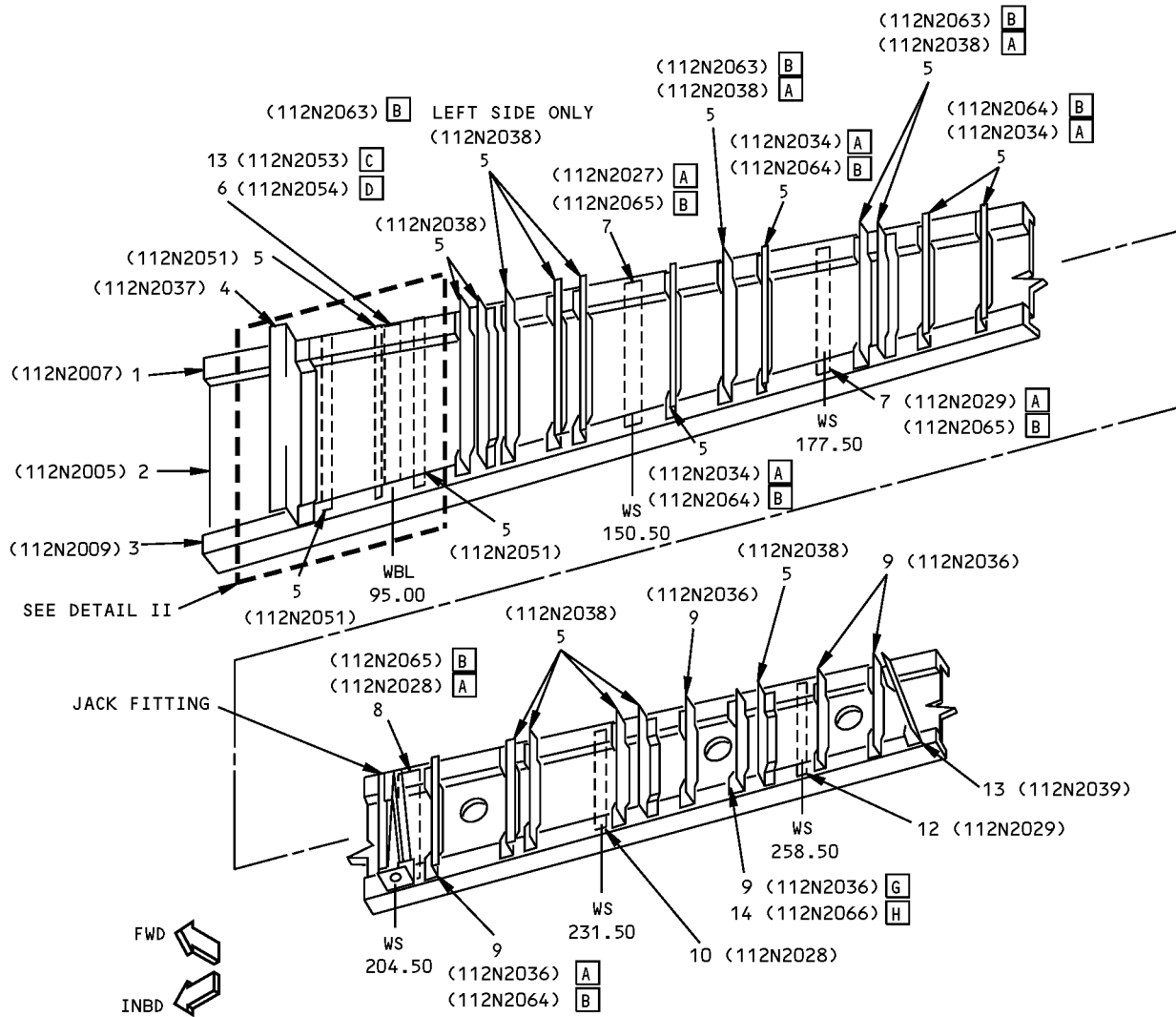

LEFT SIDE SHOWN
RIGHT SIDE OPPOSITE
EXCEPT AS NOTED

**FRONT VIEW
DETAIL I**

LIST OF
MATL

**Outer Wing Front Spar Identification
Figure 1 (Sheet 2 of 7)**

**757-200
STRUCTURAL REPAIR MANUAL**

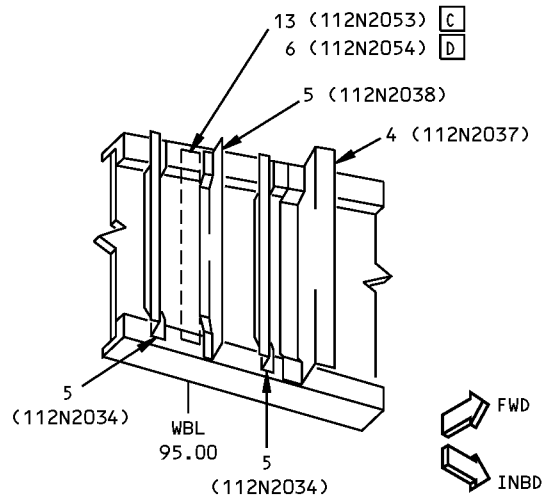

(RIGHT WING ONLY)
FRONT VIEW
DETAIL II

ITEM	DESCRIPTION	GAGE	MATERIAL	EFFECTIVITY
1	UPPER CHORD		BAC1514-2559 7075-T73511	
2	WEB	0.75 0.88 1.12	PLATE 2324-T39 OPTIONAL: PLATE 2324-T39 PLATE 2324-T39	I I J
3	LOWER CHORD		BAC1514-2560 2224-T3511	
4	STIFFENER		BAC1503-100681 7075-T73511	
5	STIFFENER		BAC1517-2194 7075-T73511	
6	RIB POST		FORGING 7175-T736	D
7	RIB POST		BAC1517-2203 7075-T73511	
8	RIB POST		BAC1505-101225 7075-T6511	
9	STIFFENER		BAC1503-100681 7075-T73511	G
10	RIB POST		BAC1517-2205 7075-T73511	
11	RIB POST		BAC1517-2206 7075-T73511	
12	STIFFENER		BAC1514-2612 7075-T73511	
13	RIB POST		FORGED BLOCK 7175-T736	C
14	STIFFENER		BAC1509-100543 7075-T73511 OPTIONAL: 7075-T73511 BAR OR 7075-T7351 PLATE PLATE 7050-7451, AMS4050 OR BMS 7-323	H J

LIST OF MATERIALS FOR DETAILS I AND II

**Outer Wing Front Spar Identification
Figure 1 (Sheet 3 of 7)**

**757-200
STRUCTURAL REPAIR MANUAL**

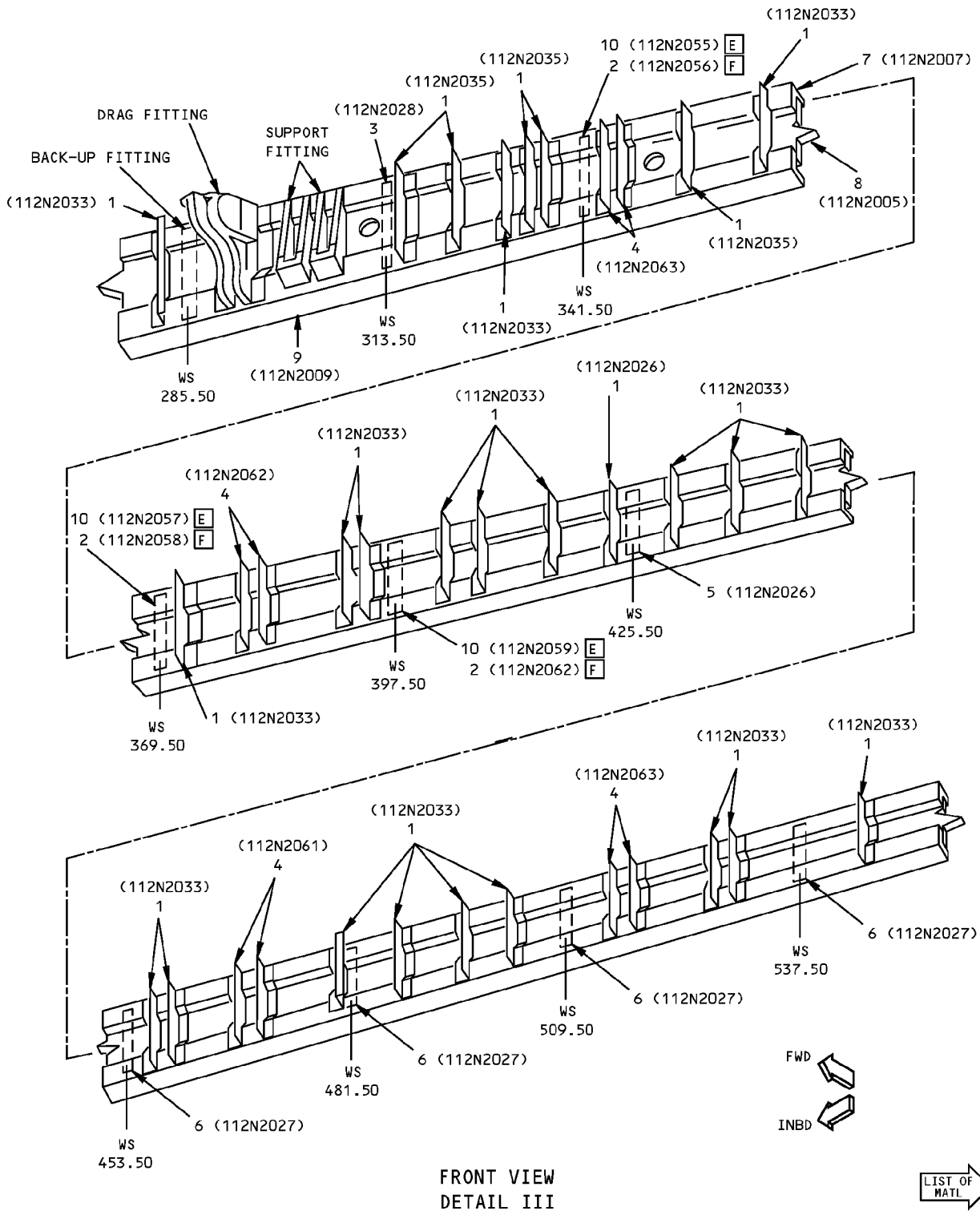

**FRONT VIEW
DETAIL III**

**Outer Wing Front Spar Identification
Figure 1 (Sheet 4 of 7)**





757-200
STRUCTURAL REPAIR MANUAL

ITEM	DESCRIPTION	GAGE	MATERIAL	EFFECTIVITY
1	STIFFENER		BAC1503-100682 7075-T73511	
2	RIB POST		FORGING 7175-T736	
3	RIB POST		BAC1505-101224 7075-T6511	
4	STIFFENER	1.50	PLATE 7075-T7351 OPTIONAL: FORGING 7075-T73	
5	RIB POST		BAC1514-2622 7075-T6511	
6	RIB POST		BAC1517-2203 7075-T73511	
7	UPPER CHORD		BAC1514-2559 7075-T73511	
8	WEB	0.75 0.88 1.12	PLATE 2324-T39 OPTIONAL: PLATE 2324-T39 PLATE 2324-T39	I I J
9	LOWER CHORD		BAC1514-2560 2224-T3511	
10	RIB POST		FORGED BLOCK 7175-T736	E

LIST OF MATERIALS FOR DETAIL III

Outer Wing Front Spar Identification
Figure 1 (Sheet 5 of 7)

D634N201

57-20-10

IDENTIFICATION 2
Page 5
Jan 20/2005

**757-200
STRUCTURAL REPAIR MANUAL**

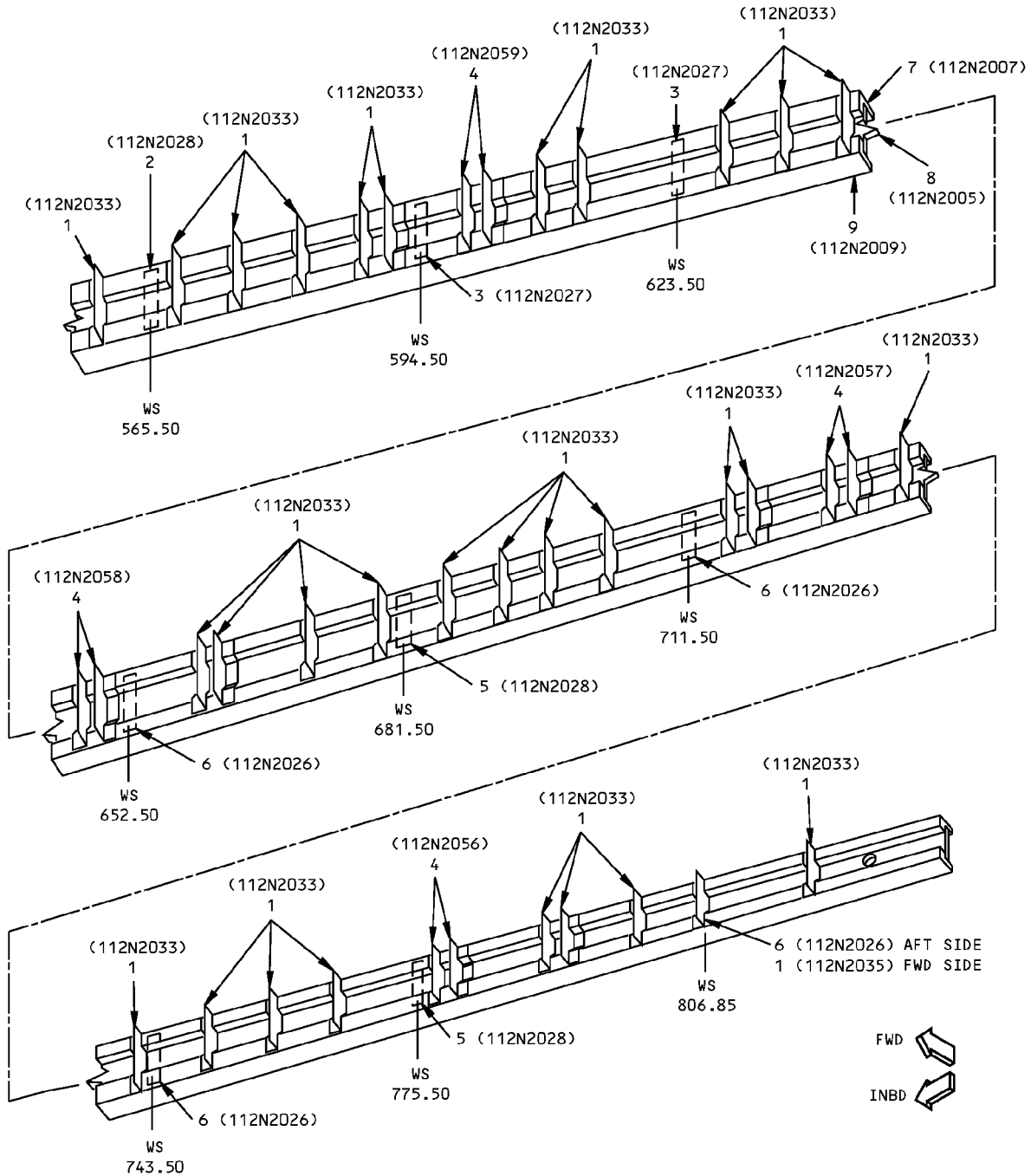

FRONT VIEW
DETAIL IV



**Outer Wing Front Spar Identification
Figure 1 (Sheet 6 of 7)**



757-200
STRUCTURAL REPAIR MANUAL

ITEM	DESCRIPTION	GAGE	MATERIAL	EFFECTIVITY
1	STIFFENER		BAC1503-100682 7075-T73511	
2	RIB POST		BAC1505-10123 7075-T6511	
3	RIB POST		BAC1517-2203 7075-T73511	
4	STIFFENER	1.30	PLATE 7075-T7351 OPTIONAL: FORGING 7075-T73	
5	RIB POST	2.50	BAC1505-101223 7075-T6511 OPTIONAL: EXTRUDED BAR 7075-T6511	
6	RIB POST		BAC1514-2622 7075-T6511	
7	UPPER CHORD		BAC1514-2559 7075-T73511	
8	WEB	0.75	PLATE 2324-T39 OPTIONAL:	I
		0.88	PLATE 2324-T39	J
		1.12	PLATE 2324-T39	I
9	LOWER CHORD		BAC1514-2560 2224-T3511	

LIST OF MATERIALS FOR DETAIL IV

Outer Wing Front Spar Identification
Figure 1 (Sheet 7 of 7)

D634N201

57-20-10

IDENTIFICATION 2
Page 7
Jan 20/2005



757-200

STRUCTURAL REPAIR MANUAL

ALLOWABLE DAMAGE 1 - OUTER WING REAR SPAR

This subject gives the allowable damage limits for the outer wing rear spar, as shown in Figure 101 of Allowable Damage 1.

Allowable Damage 1 is applicable to airplanes that have not had winglets installed.

Allowable Damage 1 is not applicable to airplanes that have had winglets installed after production of the airplane. Refer to Aviation Partners Boeing (APB) document AP57.2-0602 for the winglet data.

**Outer Wing Rear Spar Allowable Damage
Figure 101 (Sheet 1 of 9)**

D634N201

ALLOWABLE DAMAGE 1
Page 101
57-20-10 Sep 20/2006

**757-200
STRUCTURAL REPAIR MANUAL**

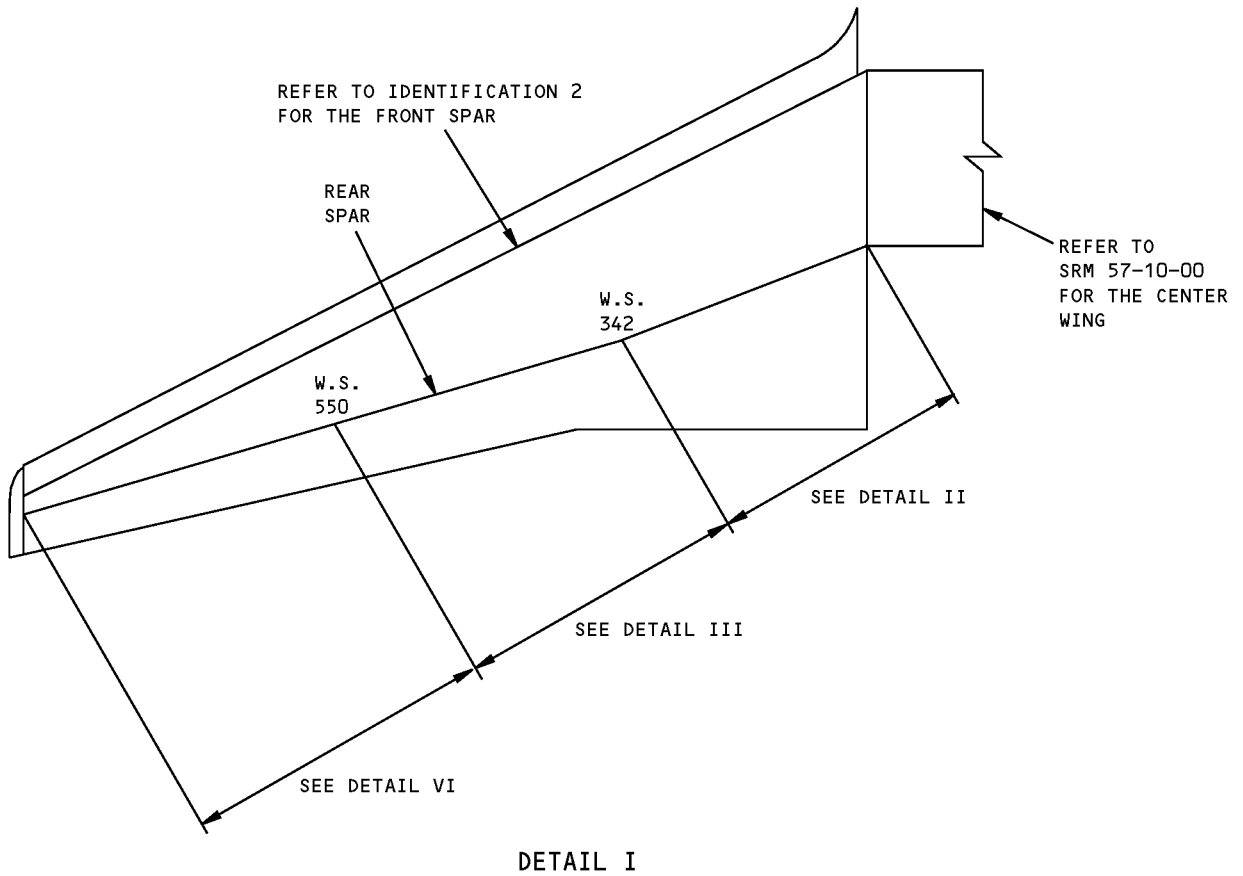
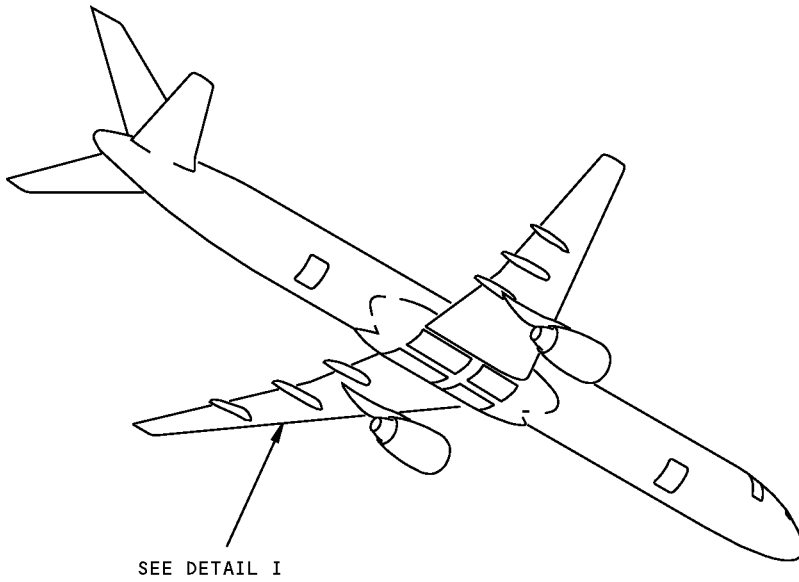

**Outer Wing Rear Spar Allowable Damage
Figure 101 (Sheet 2 of 9)**

**757-200
STRUCTURAL REPAIR MANUAL**

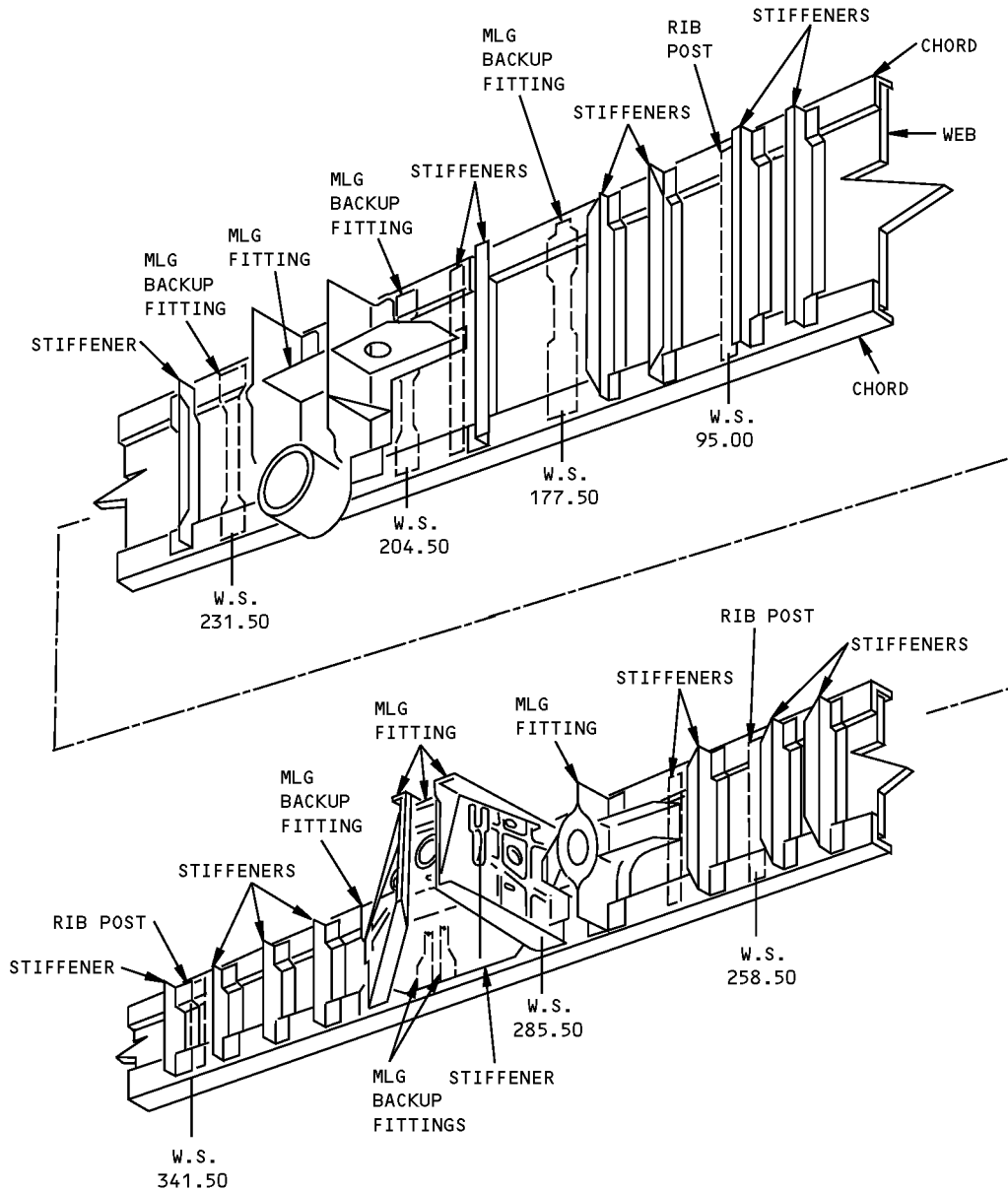

DETAIL I

SEE 57-20-90 FIGURE 101 FOR ALLOWABLE DAMAGE-FITTINGS

**Outer Wing Rear Spar Allowable Damage
Figure 101 (Sheet 3 of 9)**

**757-200
STRUCTURAL REPAIR MANUAL**

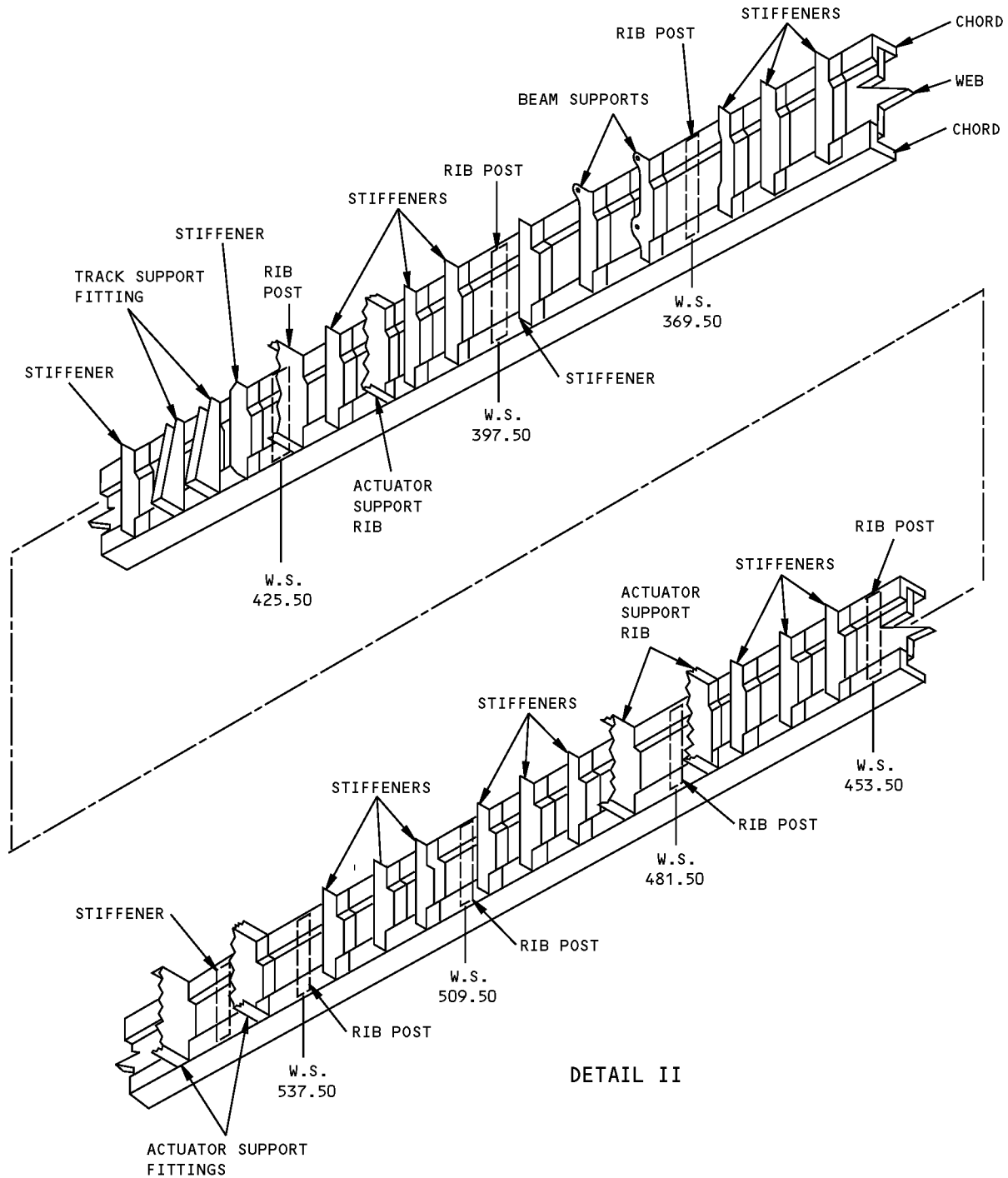

**Outer Wing Rear Spar Allowable Damage
Figure 101 (Sheet 4 of 9)**

**757-200
STRUCTURAL REPAIR MANUAL**

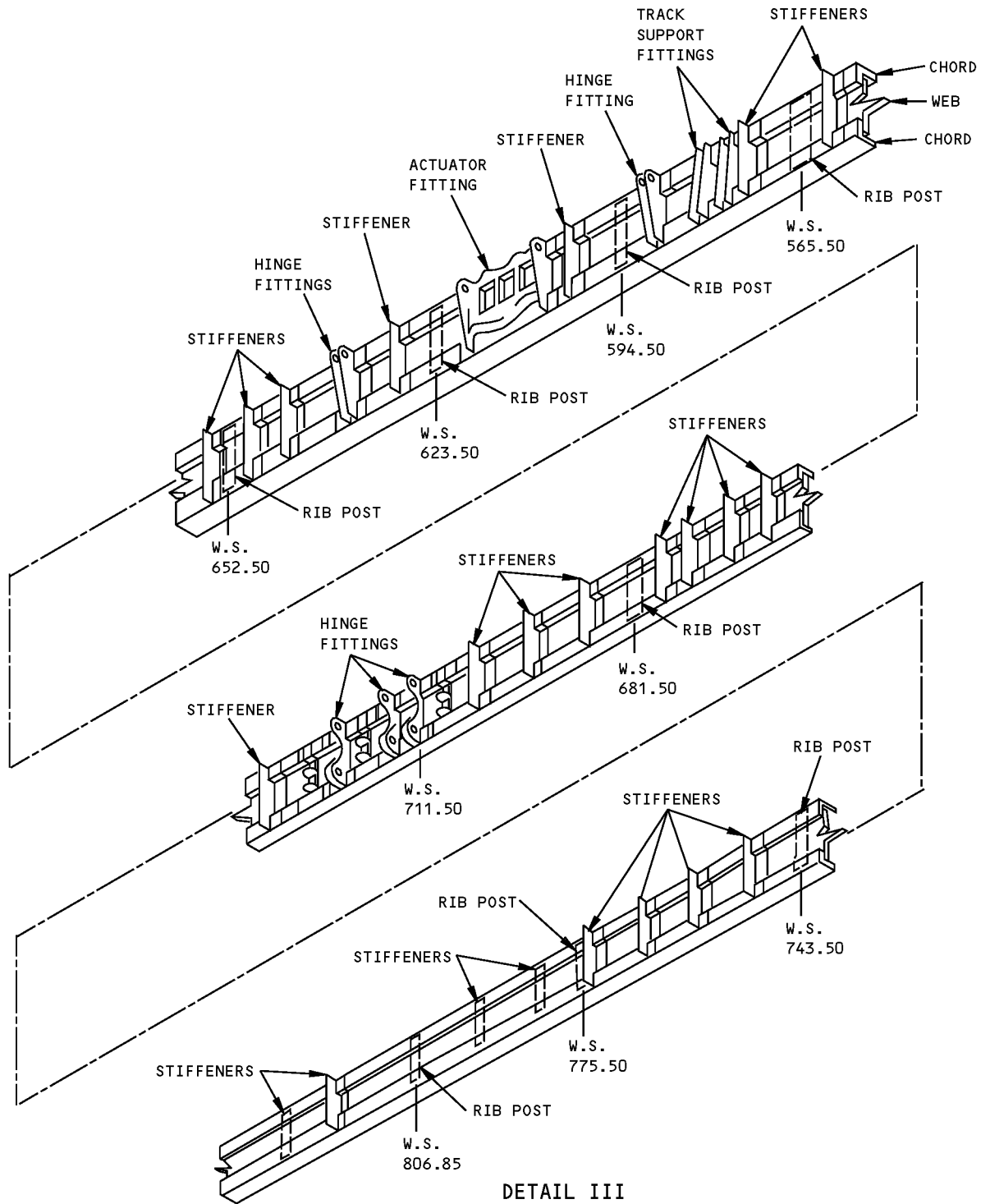

**Outer Wing Rear Spar Allowable Damage
Figure 101 (Sheet 5 of 9)**



**757-200
STRUCTURAL REPAIR MANUAL**

LOCATION	CRACKS	NICKS, GOUGES AND CORROSION	DENTS	HOLES AND PUNCTURES
CHORDS [F]	[A]	[C]	NOT ALLOWED	NOT ALLOWED
WEB	[G]	[C]	SEE DETAIL XI	[H]
STIFFENERS	[A]	[C]	NOT ALLOWED	SEE DETAIL X
RIB POSTS [I]	[B]	[E]	NOT ALLOWED	NOT ALLOWED
BEAM SUPPORTS [F]	[B]	[D]	NOT ALLOWED	NOT ALLOWED
ACTUATOR SUPPORT RIBS [F]	[B]	[D]	NOT ALLOWED	NOT ALLOWED

**Outer Wing Rear Spar Allowable Damage
Figure 101 (Sheet 6 of 9)**

D634N201

ALLOWABLE DAMAGE 1
57-20-10
Page 106
Sep 20/2006

757-200
STRUCTURAL REPAIR MANUAL

NOTES

WARNING:

PRESENCE OF FUEL VAPORS IN FUEL TANKS CREATES EXPLOSIVE AND TOXIC CONDITIONS. REFER TO 28-11-00 OF THE MAINTENANCE MANUAL FOR FUEL TANK MAINTENANCE PRACTICES AND ENTRY PROCEDURES

- REFINISH REWORKED AREAS PER 51-20 OF THE MAINTENANCE MANUAL
- REMOVE ALL SHARP EDGES IN REWORK AREA. 0.50R MIN BLEND OUT RADIUS TYPICAL FOR ALL DAMAGE CLEANUP EXCEPT WHERE NOTED

- A** CRACKS NOT ALLOWED EXCEPT FOR EDGE CRACKS, WHICH MUST BE REMOVED PER DETAILS IV AND IX
- B** CRACKS NOT ALLOWED EXCEPT FOR EDGE CRACKS, WHICH MUST BE REMOVED PER DETAIL VII
- C** REMOVE DAMAGE PER DETAILS IV, V, AND VI. MAX DEPTH 10% OF GAGE
- D** FOR EDGE DAMAGE, SEE DETAIL IV. FOR OTHER DAMAGE, SEE DETAIL V. FOR LUG DAMAGE, SEE DETAIL VIII. DAMAGE NOT ALLOWED IN VICINITY OF BUSHINGS

E FOR EDGE DAMAGE, SEE DETAIL IV. FOR OTHER DAMAGE, SEE DETAIL V

F SHOT PEEN INTENSITIES MAY VARY WITH THICKNESS REMAINING AFTER REWORK. REFER TO 51-20-06

G CRACKS NOT ALLOWED EXCEPT FOR EDGE CRACKS, WHICH MUST BE REMOVED PER DETAIL IV

H CLEAN OUT DAMAGE UP TO 0.25 MAX DIA AND NOT CLOSER THAN 1.0 INCH TO FASTENER HOLE, WEB CUT-OUT OR OTHER DAMAGE. FILL HOLE WITH A 2117-T3 OR T4 ALUMINUM RIVET INSTALLED WET WITH BMS 5-26 SEALANT AND SEAL PER 51-20-05. ALL OTHER HOLES TO BE REPAIRED

I SHOT PEEN REWORKED AREAS OF RIB POSTS AT WS 95.00, WS 341.50, WS 369.50, WS 397.50 AND WS 425.50 PER 51-20-06

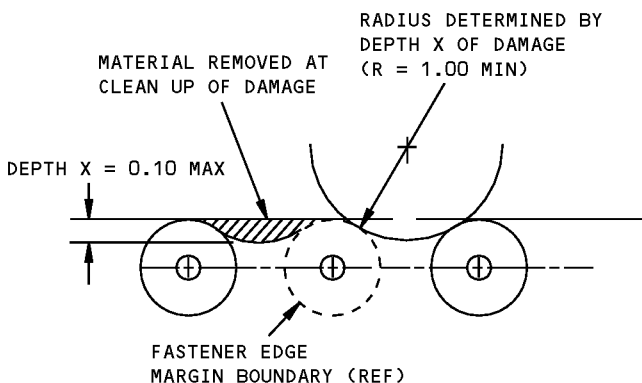

DAMAGE CLEAN UP OF EDGES WHERE FASTENER EDGE MARGINS DO NOT OVERLAP

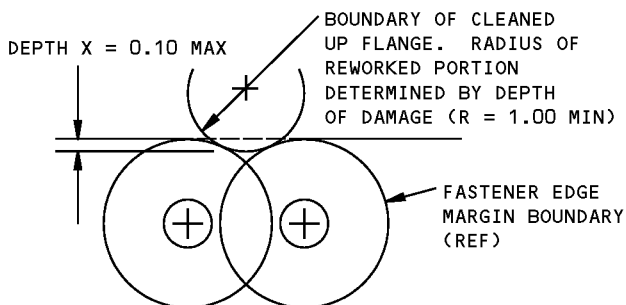

DAMAGE CLEAN UP OF EDGES WHERE FASTENER EDGE MARGINS OVERLAP

DETAIL IV

Outer Wing Rear Spar Allowable Damage
Figure 101 (Sheet 7 of 9)

**757-200
STRUCTURAL REPAIR MANUAL**

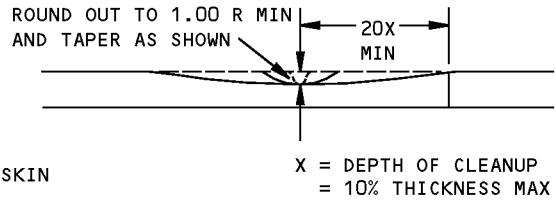
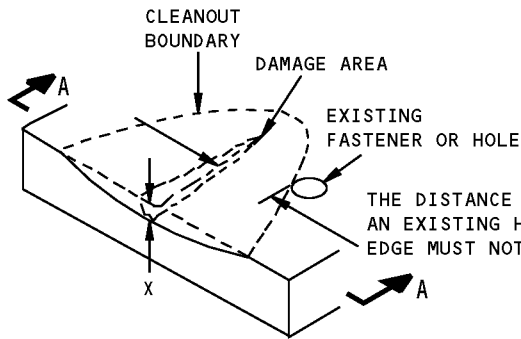

SECTION A-A

**REMOVAL OF NICK, GOUGE AND SCRATCH DAMAGE ON A SURFACE
DETAIL V**

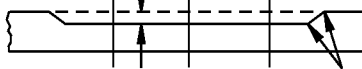
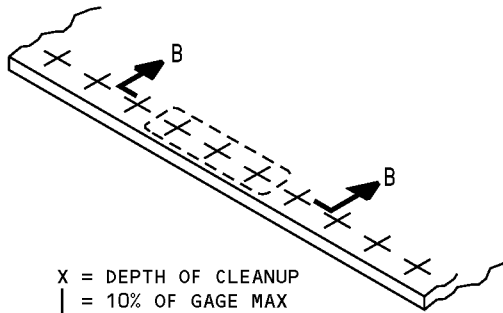

SMOOTH BLENDOUT RADIUS 0.50 INCH MINIMUM. CORROSION CLEANUP AROUND ANY THREE FASTENERS IN TEN IS PERMITTED TO MAX DEPTH

SECTION B-B

**CORROSION CLEANUP
DETAIL VI**

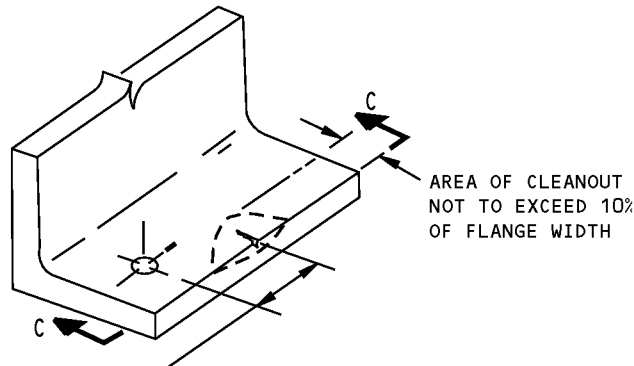

THE DISTANCE OF THE DAMAGE FROM AN EXISTING HOLE, FASTENERS OR EDGE MUST NOT BE LESS THAN 20X

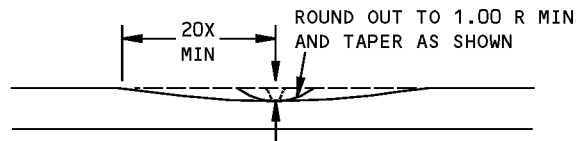

X = DEPTH OF CLEANUP = 10% THICKNESS MAX

SECTION C-C

**REMOVAL OF NICK OR CRACK
DAMAGE ON AN EDGE
DETAIL VII**

**Outer Wing Rear Spar Allowable Damage
Figure 101 (Sheet 8 of 9)**

STRUCTURAL REPAIR MANUAL

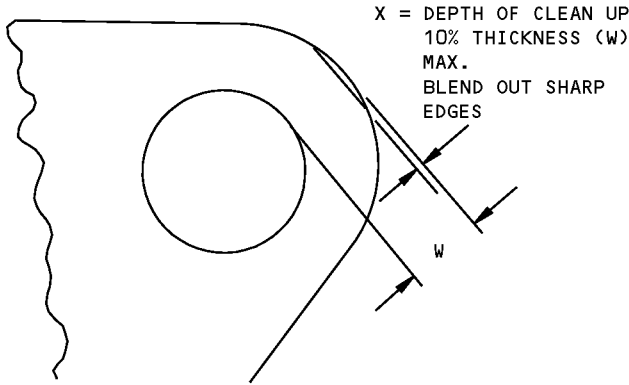

**DAMAGE CLEAN UP FOR EDGES OF LUG
DETAIL VIII**

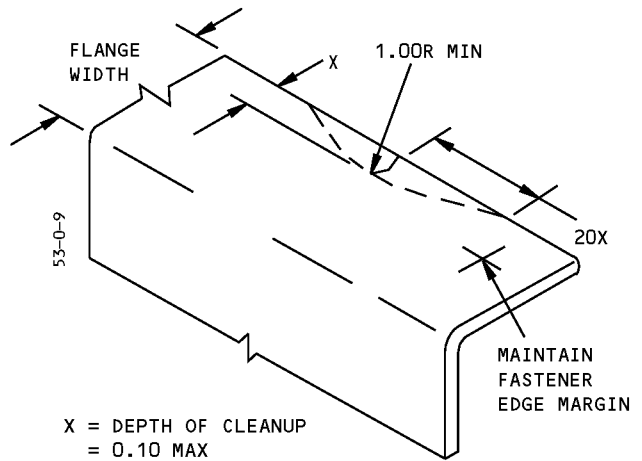

**REMOVAL OF NICK OR CRACK
DAMAGE ON AN EDGE
DETAIL IX**

H = WIDTH OF STIFFENER FLANGE
FOR H ≥ 1.750, USE H = 1.750

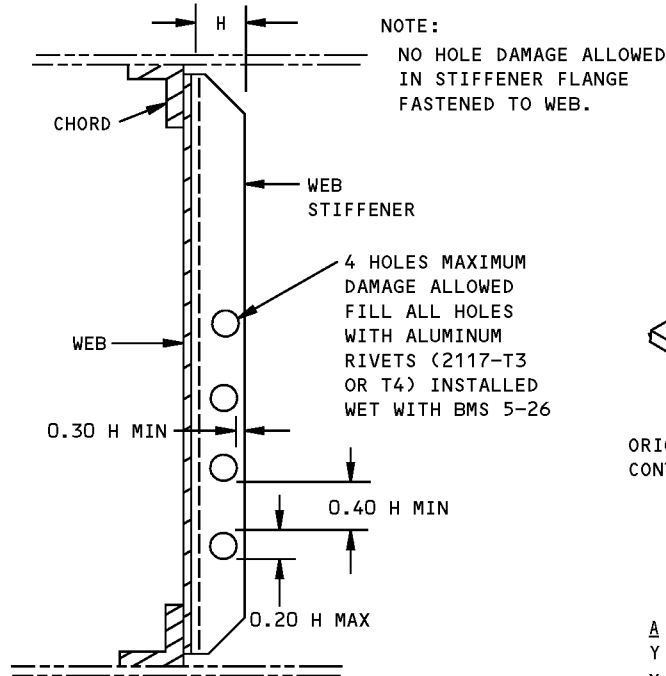

**ALLOWABLE DAMAGE LIMITS FOR
HOLES IN WEB STIFFENERS
DETAIL X**

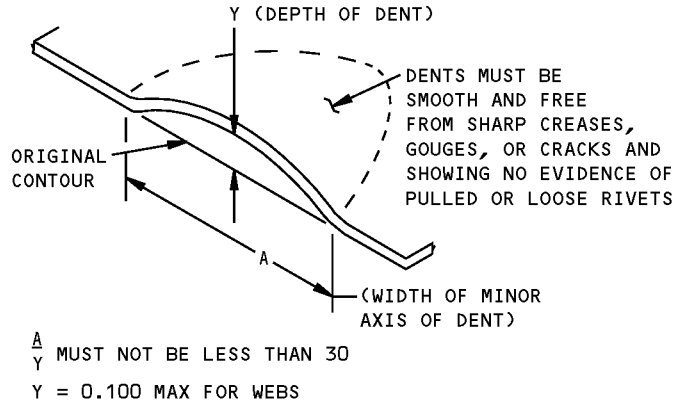

**ALLOWABLE DAMAGE FOR DENT
DETAIL XI**

**Outer Wing Rear Spar Allowable Damage
Figure 101 (Sheet 9 of 9)**



757-200

STRUCTURAL REPAIR MANUAL

ALLOWABLE DAMAGE 2 - OUTER WING FRONT SPAR

This subject gives the allowable damage limits for the outer wing front spar, as shown in Figure 101 of Allowable Damage 2.

Allowable Damage 2 is applicable to airplanes that have not had winglets installed.

Allowable Damage 2 is not applicable to airplanes that have had winglets installed after production of the airplane. Refer to Aviation Partners Boeing (APB) document AP57.2-0602 for the winglet data.

**Outer Wing Front Spar Allowable Damage
Figure 101 (Sheet 1 of 7)**

D634N201

ALLOWABLE DAMAGE 2
Page 101
57-20-10
Sep 20/2006

**757-200
STRUCTURAL REPAIR MANUAL**

REFERENCE DRAWING
112N2001

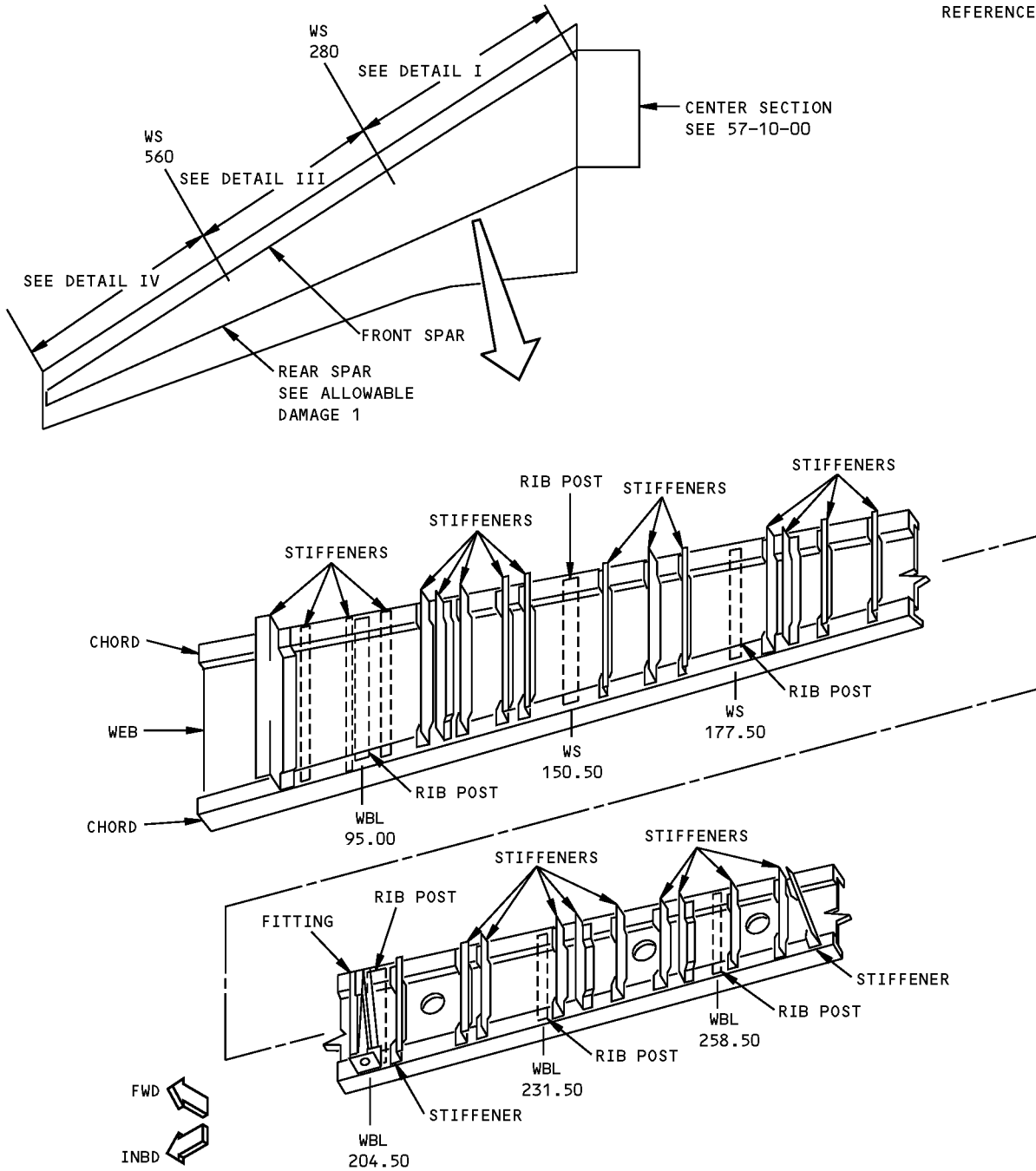

MATERIAL: ALUMINUM

LEFT SIDE SHOWN
RIGHT SIDE SIMILAR
DETAIL I

**Outer Wing Front Spar Allowable Damage
Figure 101 (Sheet 2 of 7)**

**757-200
STRUCTURAL REPAIR MANUAL**

REF DWG
112N2001

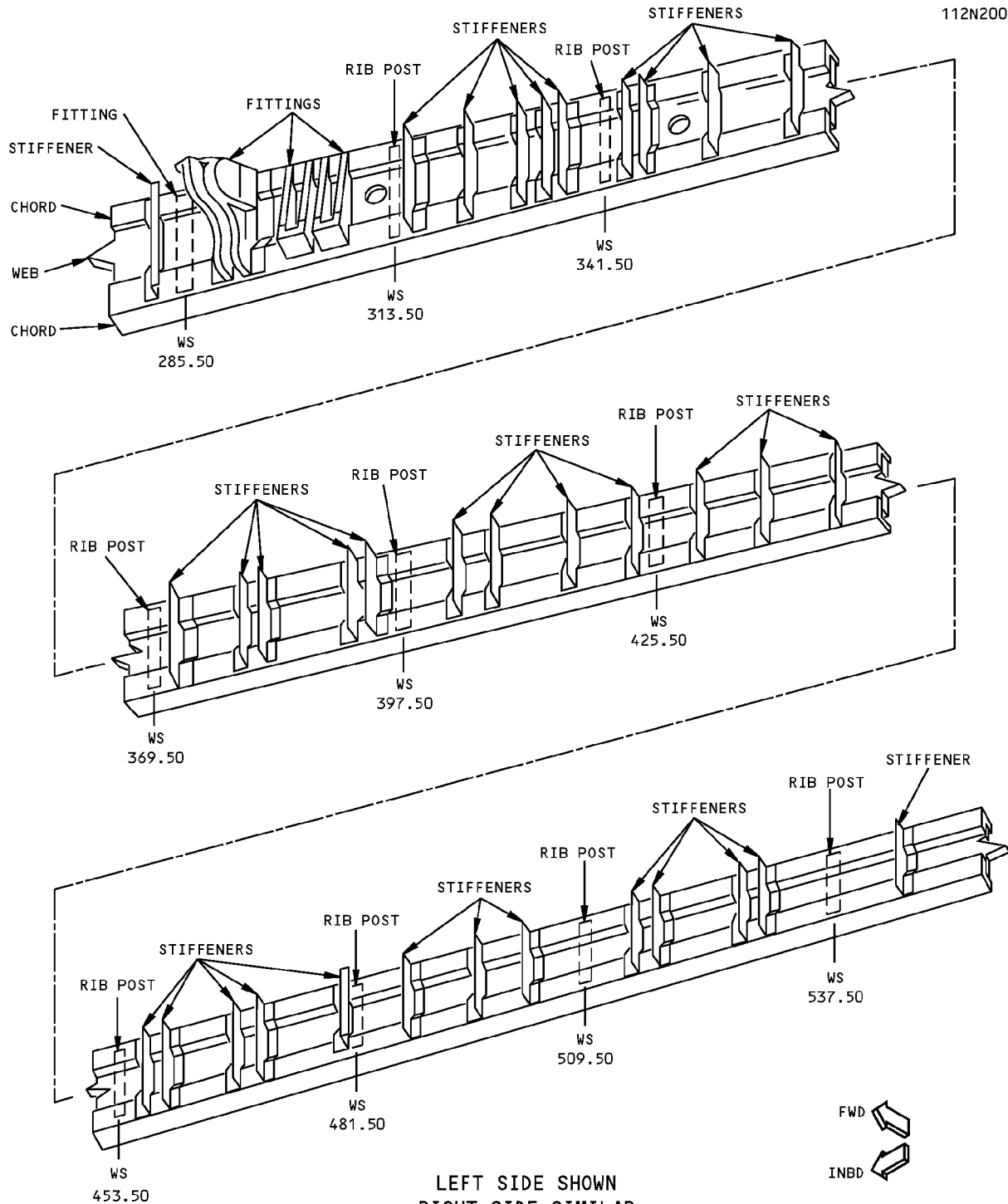

MATERIAL: ALUMINUM

LEFT SIDE SHOWN
RIGHT SIDE SIMILAR
DETAIL II

**Outer Wing Front Spar Allowable Damage
Figure 101 (Sheet 3 of 7)**

**757-200
STRUCTURAL REPAIR MANUAL**

REF DWG
112N2001

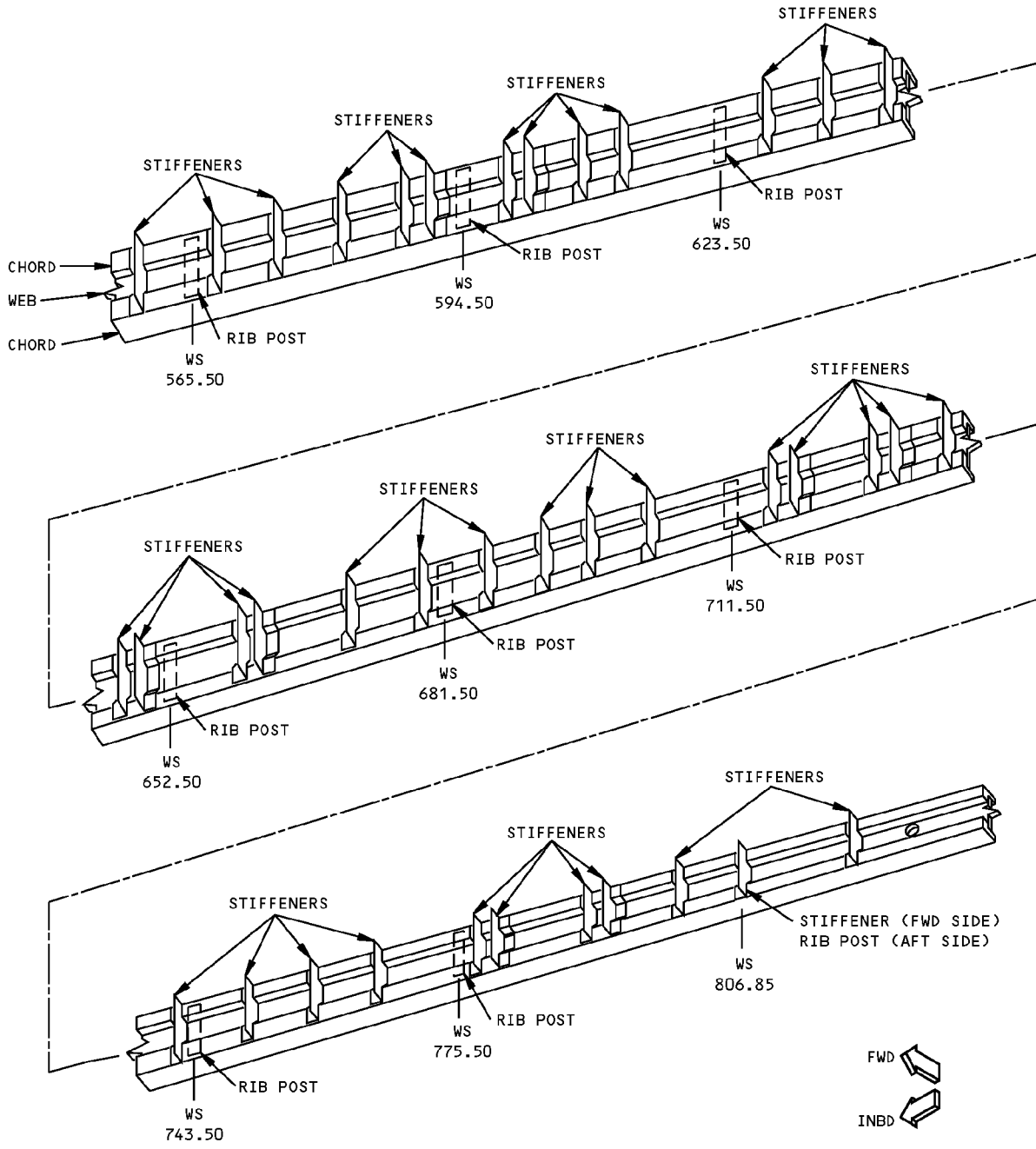

MATERIAL: ALUMINUM

LEFT SIDE SHOWN
RIGHT SIDE SIMILAR
DETAIL III

**Outer Wing Front Spar Allowable Damage
Figure 101 (Sheet 4 of 7)**



**757-200
STRUCTURAL REPAIR MANUAL**

DESCRIPTION	CRACKS	NICKS, GOUGES AND CORROSION	DENTS	HOLES AND PUNCTURES
CHORDS [G]	[A]	[D]	NOT ALLOWED	NOT ALLOWED
WEBS [G]	[B]	[D]	SEE DETAIL VI	[F]
STIFFENERS	[A]	[D]	NOT ALLOWED	SEE DETAIL X
RIB POSTS [H]	[C]	[E]	NOT ALLOWED	NOT ALLOWED

NOTES

WARNING: PRESENCE OF FUEL VAPORS IN FUEL TANKS CREATES EXPLOSIVE AND TOXIC CONDITIONS. REFER TO 28-11-00 OF THE MAINTENANCE MANUAL FOR FUEL TANK MAINTENANCE PRACTICES AND ENTRY PROCEDURES

- REFINISH REWORKED AREAS PER 51-20 OF THE MAINTENANCE MANUAL
- REMOVE ALL SHARP EDGES IN REWORK AREA. 0.50R MIN BLEND OUT RADIUS TYPICAL FOR ALL DAMAGE CLEANUP EXCEPT WHERE NOTED

[A] CRACKS NOT ALLOWED EXCEPT FOR EDGE CRACKS WHICH MUST BE REMOVED PER DETAILS IV AND VIII

[B] CRACKS NOT ALLOWED EXCEPT FOR EDGE CRACKS WHICH MUST BE REMOVED PER DETAIL IV

[C] CRACKS NOT ALLOWED EXCEPT FOR EDGE CRACKS WHICH MUST BE REMOVED PER DETAIL IX

[D] REMOVE DAMAGE PER DETAILS IV, V AND VII. MAX DEPTH 10% OF THICKNESS

[E] FOR EDGE DAMAGE, SEE DETAIL IV. FOR OTHER DAMAGE, SEE DETAIL V

[F] CLEAN OUT DAMAGE UP TO 0.25 MAX DIA AND NOT CLOSER THAN 1.0 TO FASTENER HOLE, WEB CUT-OUT OR OTHER DAMAGE. FILL HOLE WITH A 2117-T3 OR T4 ALUMINUM RIVET INSTALLED WET WITH BMS 5-26 SEALANT AND SEAL PER 51-20-05. ALL OTHER HOLES TO BE REPAIRED

[G] SHOT PEEN REWORKED AREAS PER 51-20-06

[H] SHOT PEEN REWORKED AREAS OF RIB POSTS AT WBL 95.00, WS 341.50, WS 369.50 AND WS 397.50 PER 51-20-06

**Outer Wing Front Spar Allowable Damage
Figure 101 (Sheet 5 of 7)**

**757-200
STRUCTURAL REPAIR MANUAL**

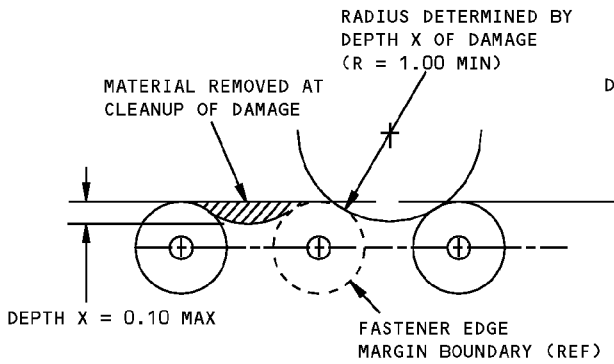

DAMAGE CLEANUP OF EDGES WHERE FASTENER EDGE MARGINS DO NOT OVERLAP

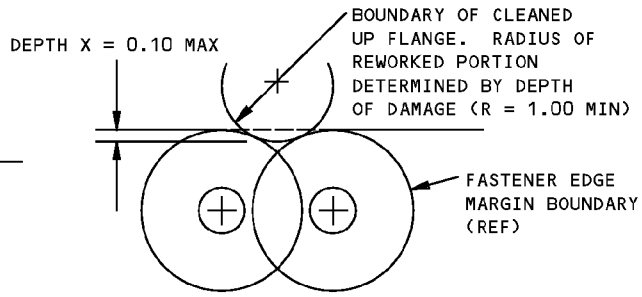

DAMAGE CLEANUP OF EDGES WHERE FASTENER EDGE MARGINS OVERLAP

DETAIL IV

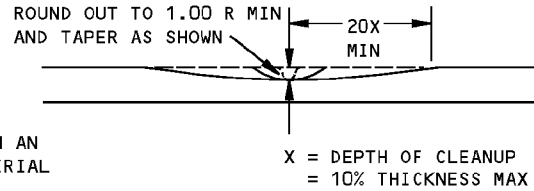
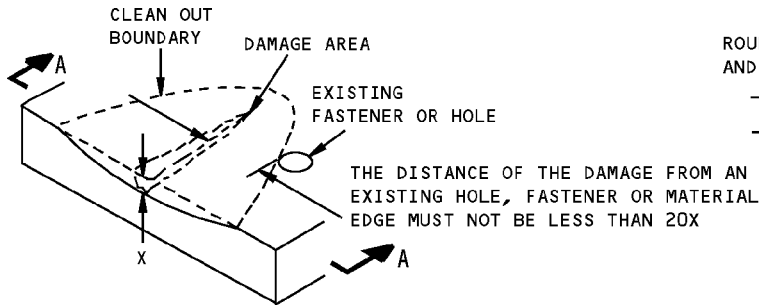

SECTION A-A

**REMOVAL OF NICK, GOUGE AND SCRATCH DAMAGE ON A SURFACE
DETAIL V**

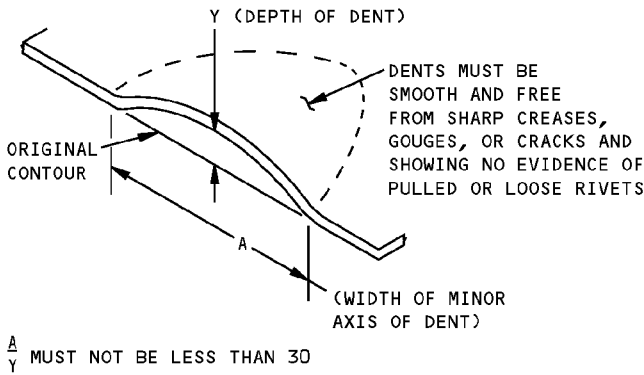

**ALLOWABLE DAMAGE FOR DENT
DETAIL VI**

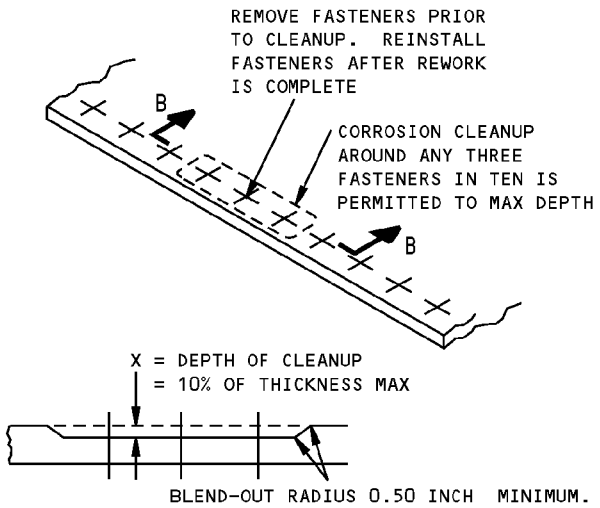

**SECTION B-B
CORROSION CLEANUP
DETAIL VII**

**Outer Wing Front Spar Allowable Damage
Figure 101 (Sheet 6 of 7)**

**757-200
STRUCTURAL REPAIR MANUAL**

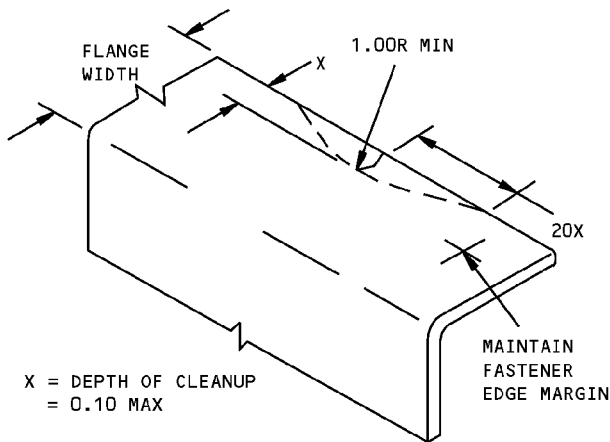

X = DEPTH OF CLEANUP
= 0.10 MAX

**REMOVAL OF NICK OR CRACK
DAMAGE ON AN EDGE
DETAIL VIII**

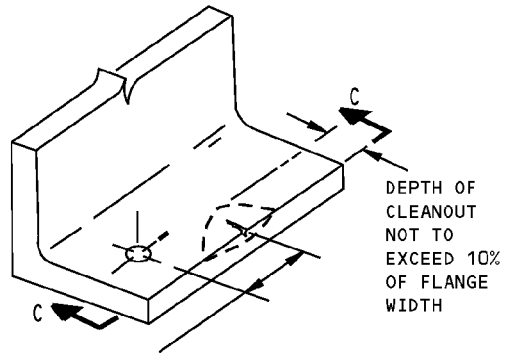

DEPTH OF
CLEANOUT
NOT TO
EXCEED 10%
OF FLANGE
WIDTH

THE DISTANCE OF THE DAMAGE FROM AN
EXISTING HOLE, FASTENERS OR EDGE
MUST NOT BE LESS THAN 20X

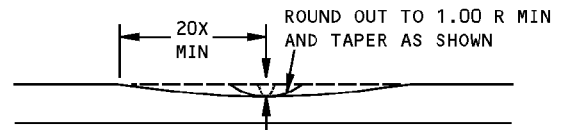

X = DEPTH OF CLEAN UP
= 10% THICKNESS MAX

**SECTION C-C
REMOVAL OF NICK OR CRACK
DAMAGE ON AN EDGE
DETAIL IX**

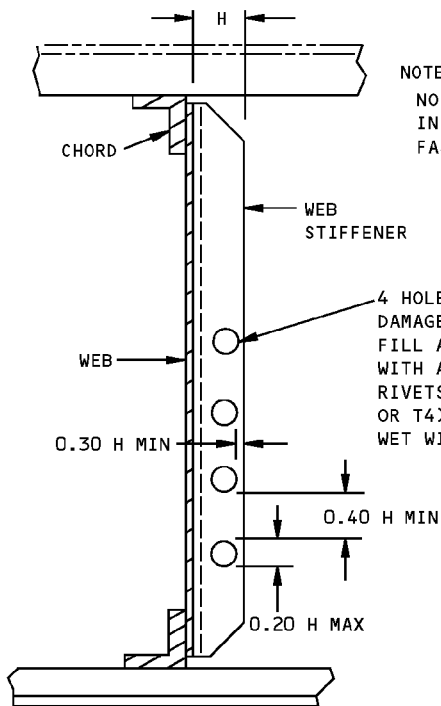

NOTE:
NO HOLE DAMAGE ALLOWED
IN STIFFENER FLANGE
FASTENED TO WEB.

4 HOLES MAXIMUM
DAMAGE ALLOWED
FILL ALL HOLES
WITH ALUMINUM
RIVETS (2117-T3
OR T4) INSTALLED
WET WITH BMS 5-26

H = WIDTH OF STIFFENER FLANGE
FOR $H \leq 1.750$, USE $H = 1.750$

**ALLOWABLE DAMAGE LIMITS FOR
HOLES IN WEB STIFFENERS
DETAIL X**

**Outer Wing Front Spar Allowable Damage
Figure 101 (Sheet 7 of 7)**

**757-200
STRUCTURAL REPAIR MANUAL**

IDENTIFICATION 1 - OUTER WING REAR SPAR FITTING

REFERENCE DRAWING
112N1001

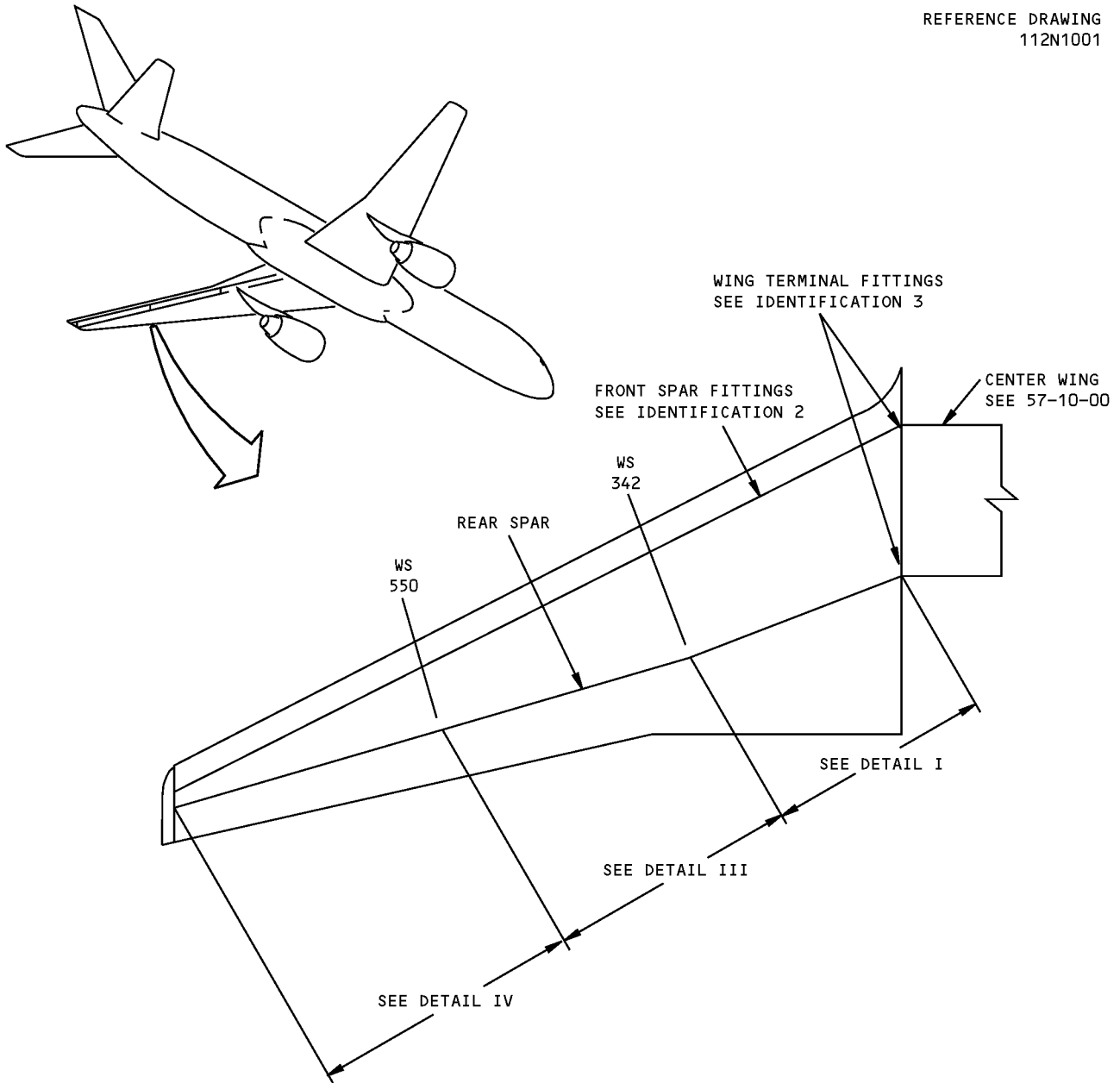

NOTES

A FOR CUM LINE NUMBERS:
1 THRU 28

B FOR CUM LINE NUMBERS:
29 AND ON

**Outer Wing Rear Spar Fitting Identification
Figure 1 (Sheet 1 of 5)**

**757-200
STRUCTURAL REPAIR MANUAL**

REF DWGS
112N1001
113N1001

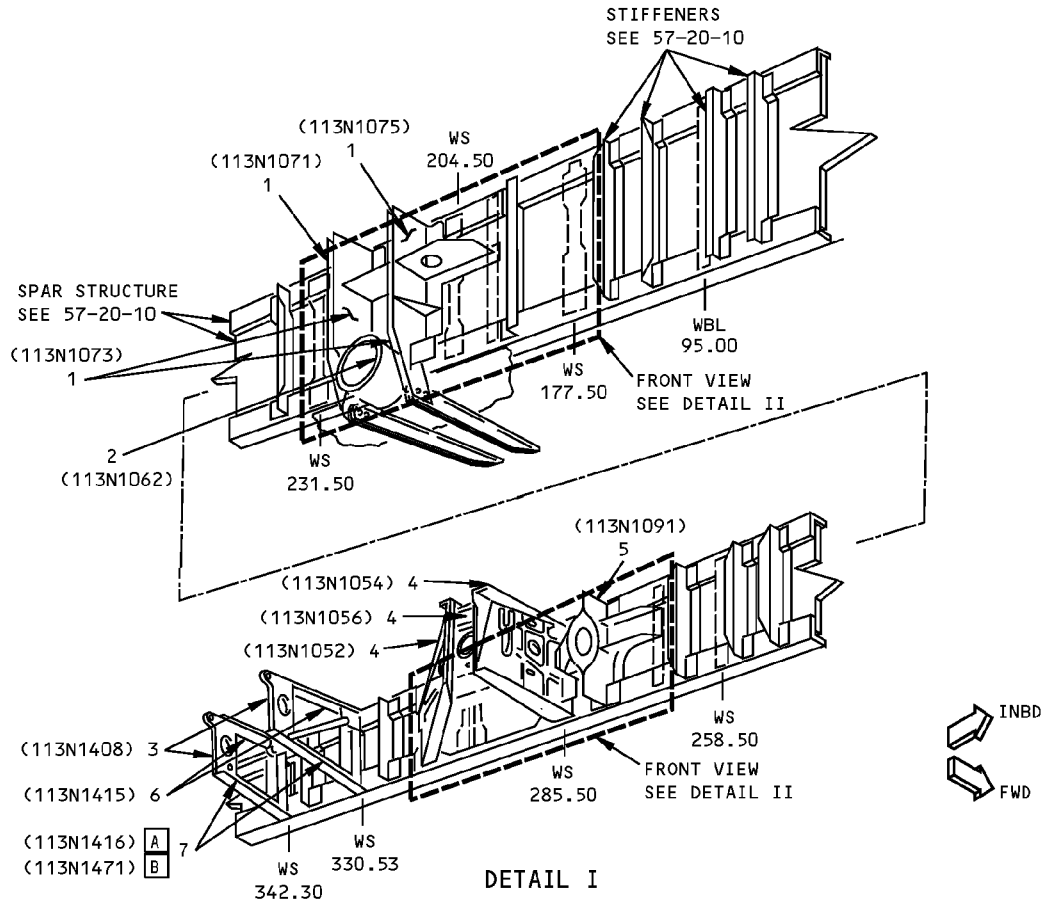

ITEM	DESCRIPTION	GAGE	MATERIAL	EFFECTIVITY
1	MLG TRUNNION SUPPORT FITTING - OUTBD - CTR - INBD		FORGING 7075-T73 FORGING 7075-T73 FORGING 7075-T73	
2	MLG TRUNNION SUPPORT BEARING HOUSING		TI-10V-2FE-3AL	
3	SPOILER ACTUATOR SUPPORT FITTING		FORGING 7075-T73	
4	MLG SUPPORT FITTING - OUTBD - CTR - INBD		FORGING 7075-T73 FORGING 7075-T73 FORGING 7075-T73	
5	MLG ACTUATOR SUPPORT FITTING		FORGING 7075-T73	
6	BEAM		BAC1506-1489 7075-T73	
7	BEAM		BAC1506-3166 7075-T73511 BAC1506-3261 7075-T73511	A B

LIST OF MATERIALS FOR DETAIL I

**Outer Wing Rear Spar Fitting Identification
Figure 1 (Sheet 2 of 5)**

IDENTIFICATION 1
Page 2
Jan 20/2005

57-20-90

D634N201

**757-200
STRUCTURAL REPAIR MANUAL**

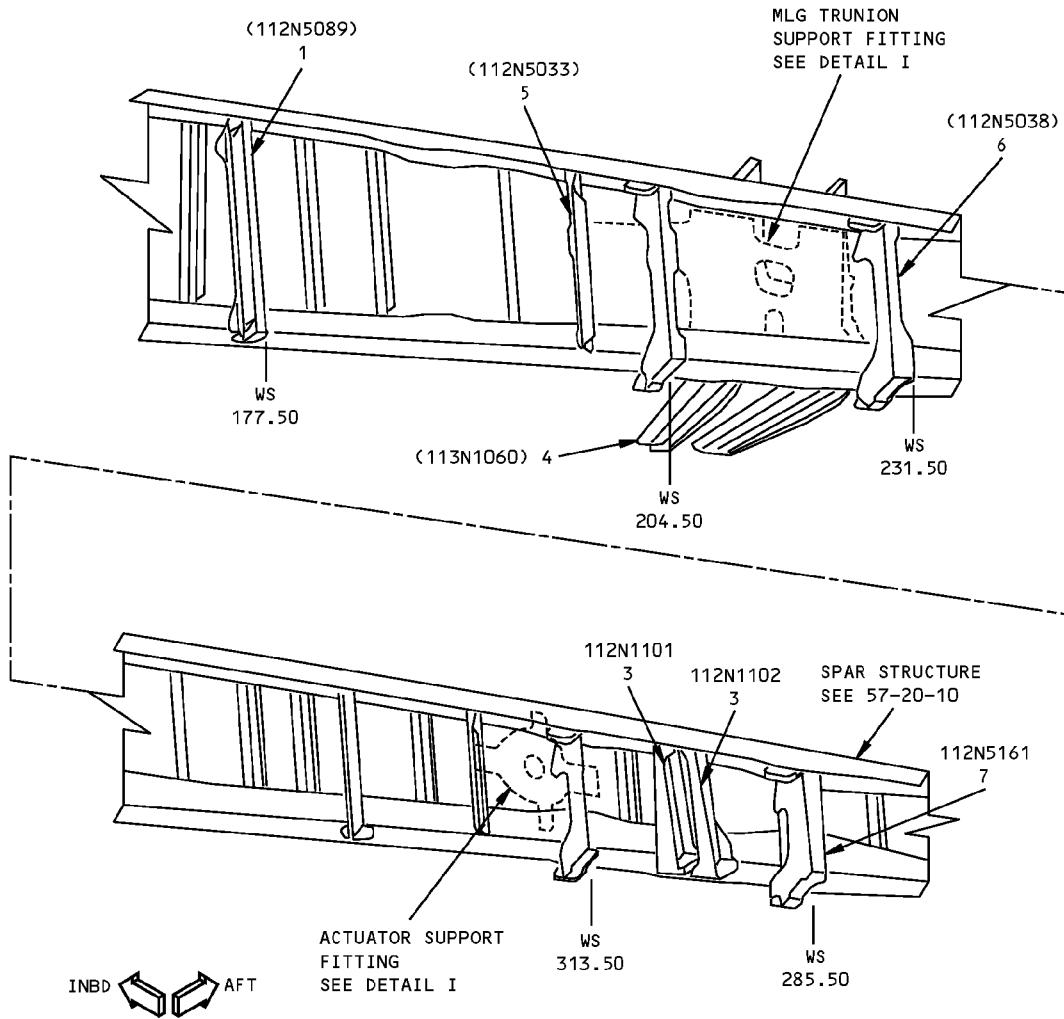

**REAR SPAR FRONT VIEW
DETAIL II**

ITEM	DESCRIPTION	GAGE	MATERIAL	EFFECTIVITY
1	RIB SUPPORT		7075-T73 FORGED BLOCK OR DIE FORGING	
2	MLG SUPPORT FITTING		7075-T73 FORGED BLOCK OR DIE FORGING	
3	BACKUP FITTING		7075-T73 FORGED BLOCK OR DIE FORGING	
4	DRAG FITTING		7075-T73 FORGED BLOCK OR DIE FORGING	

LIST OF MATERIALS FOR DETAIL II

**Outer Wing Rear Spar Fitting Identification
Figure 1 (Sheet 3 of 5)**

**757-200
STRUCTURAL REPAIR MANUAL**

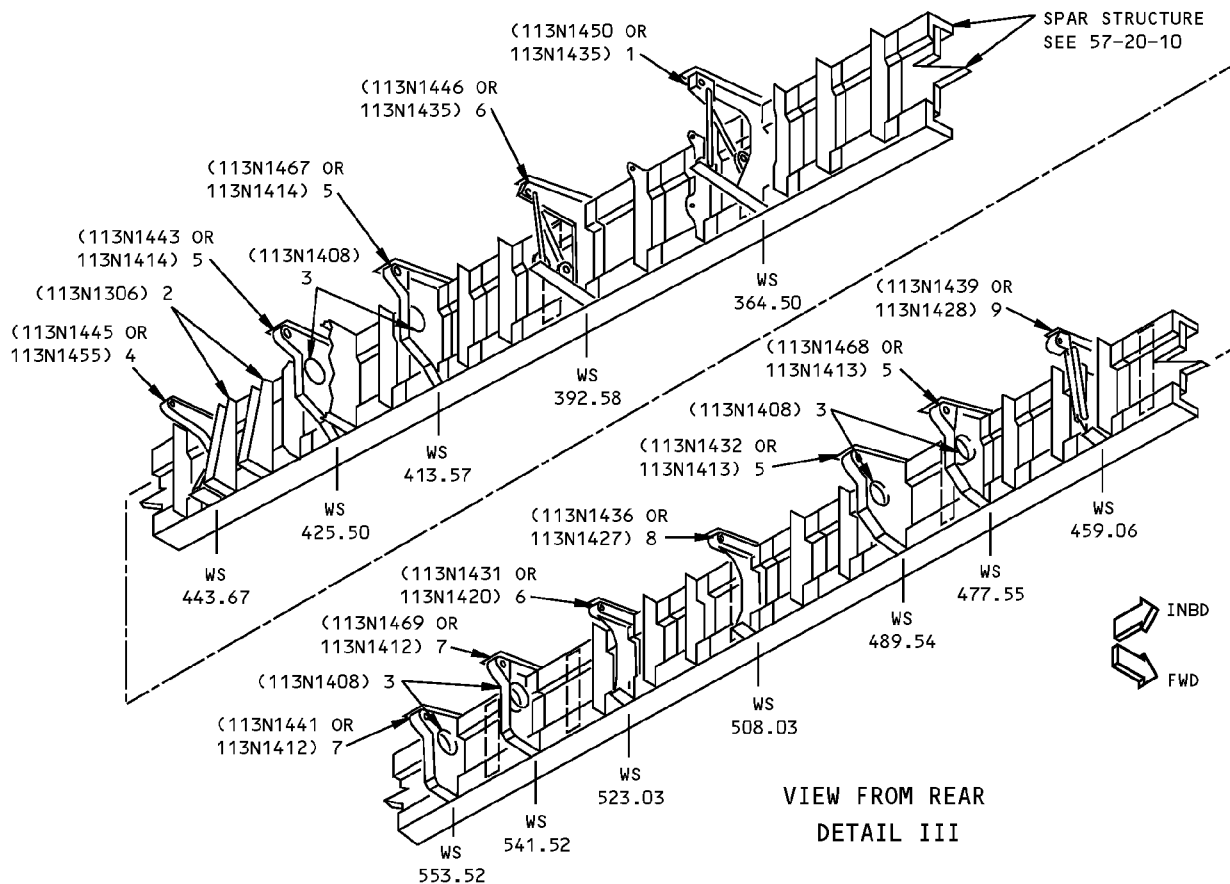

**VIEW FROM REAR
DETAIL III**

ITEM	DESCRIPTION	GAGE	MATERIAL	EFFECTIVITY
1	SUPPORT FITTING	2.70	7075-T73 FORGING OR 7075-T73 FORGED BLOCK	
2	TRACK SUPPORT FITTING		7075-T73 FORGED BLOCK	
3	ACTUATOR SUPPORT FITTING	3.3	7075-T73 FORGED BLOCK	
4	SUPPORT FITTING	3.10	7075-T73 FORGING OR 7075-T73 FORGED BLOCK	
5	SUPPORT FITTING	3.90	7075-T73 FORGING OR 7075-T73 FORGED BLOCK	
6	SUPPORT FITTING	2.80	7075-T73 FORGING OR 7075-T73 FORGED BLOCK	
7	SUPPORT FITTING	4.00	7075-T73 FORGING OR 7075-T73 FORGED BLOCK	
8	SUPPORT FITTING	3.25	7075-T73 FORGING OR 7075-T73 FORGED BLOCK	
9	SUPPORT FITTING	3.00	7075-T73 FORGING OR 7075-T73 FORGED BLOCK	

LIST OF MATERIALS FOR DETAIL III

**Outer Wing Rear Spar Fitting Identification
Figure 1 (Sheet 4 of 5)**

**757-200
STRUCTURAL REPAIR MANUAL**

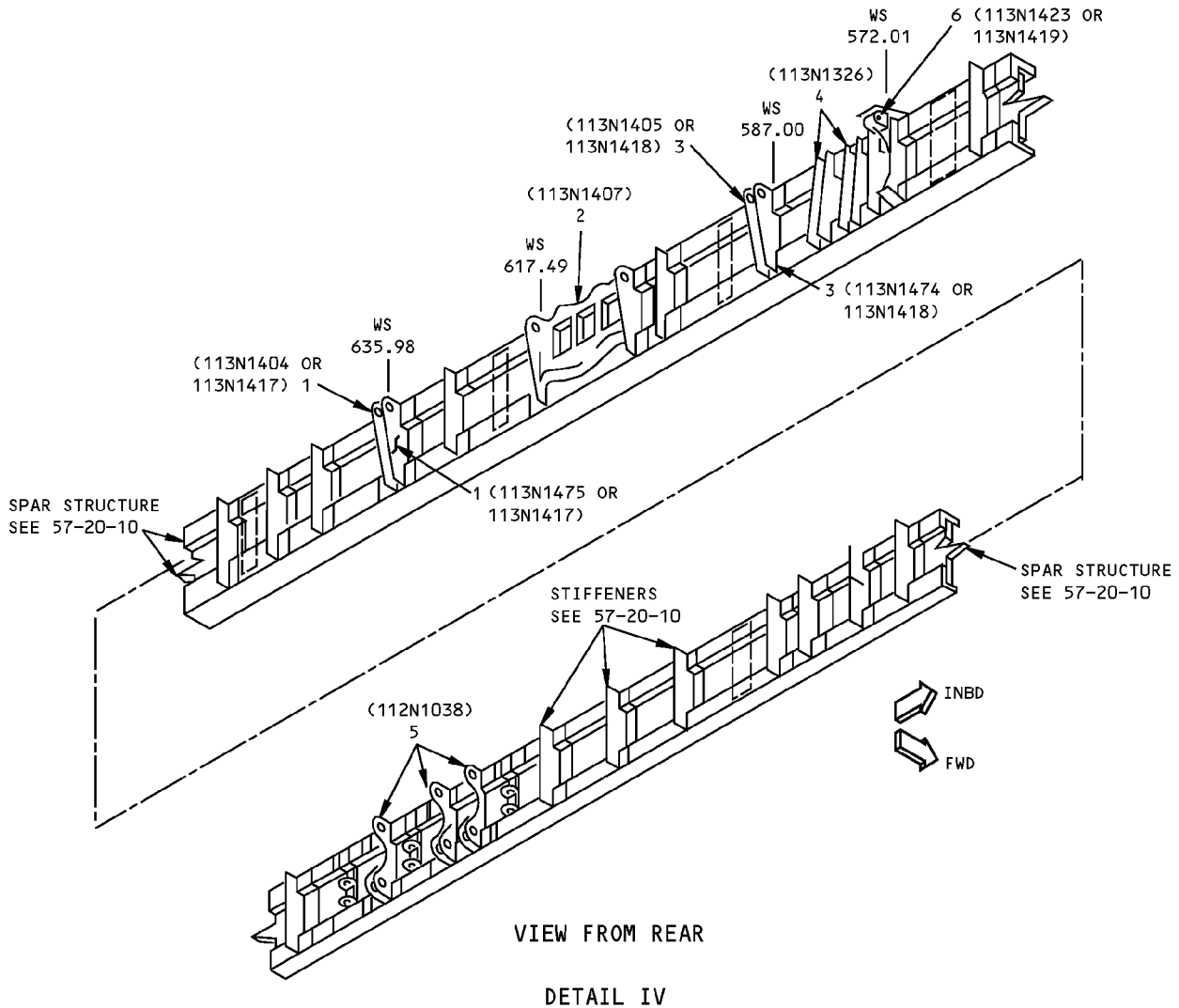

ITEM	DESCRIPTION	GAGE	MATERIAL	EFFECTIVITY
1	SUPPORT FITTING	1.45	7075-T73 FORGING OR 7075-T351 PLATE OR 7075-T73 FORGED BLOCK	
2	SUPPORT FITTING		7075-T73 FORGED BLOCK	
3	SUPPORT FITTING	1.40	7075-T73 FORGING OR 7075-T7351 PLATE OR 7075-T73 FORGED BLOCK	
4	TRACK SUPPORT FITTING		7075-T73 FORGED BLOCK	
5	HINGE SUPPORT FITTINGS		7075-T7351 FORGING	
6	SUPPORT FITTING	2.80	7075-T73 FORGING OR 7075-T73 FORGED BLOCK	

LIST OF MATERIALS FOR DETAIL IV

**Outer Wing Rear Spar Fitting Identification
Figure 1 (Sheet 5 of 5)**

**757-200
STRUCTURAL REPAIR MANUAL**

IDENTIFICATION 2 - OUTER WING FRONT SPAR FITTING

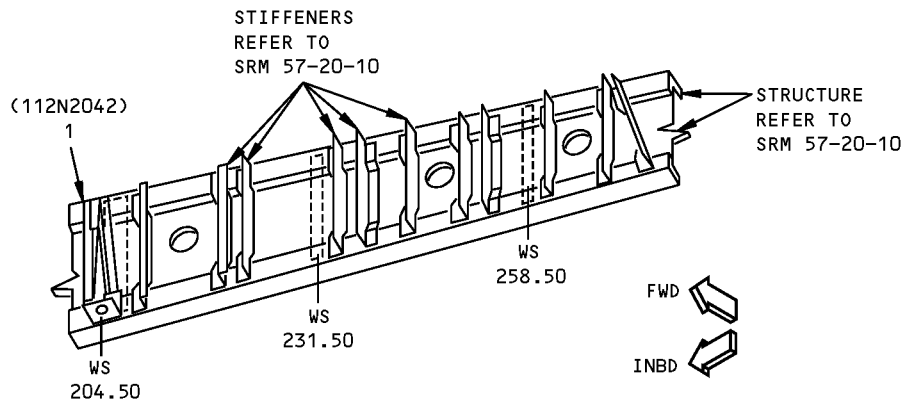
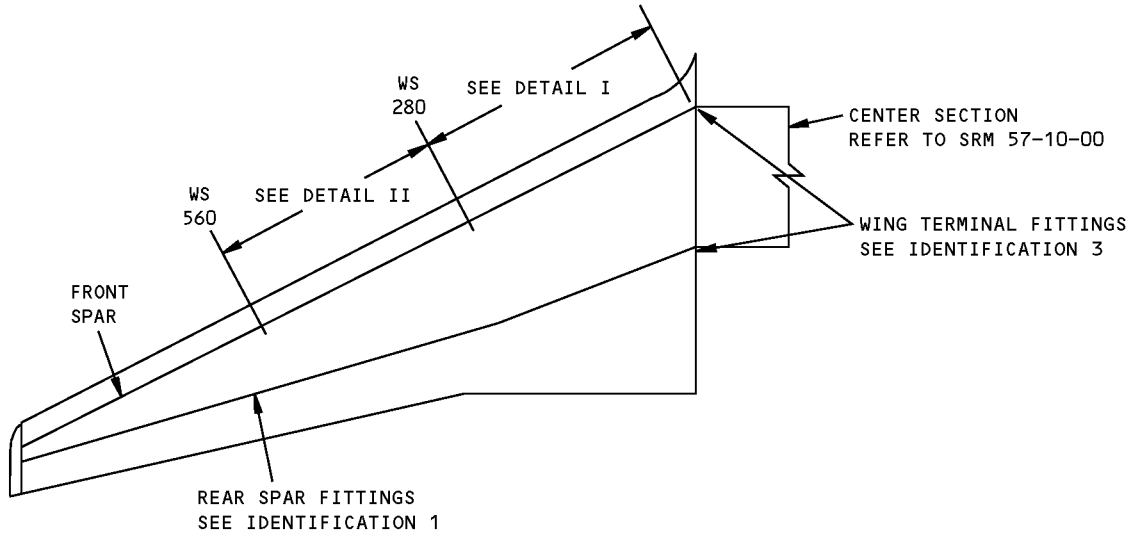

DETAIL I

NOTES

- A** FOR AIRPLANES WITH CUM LINE NUMBERS: 2 THRU 609
- B** FOR AIRPLANES WITH CUM LINE NUMBERS: 610 THRU 665
- C** FOR AIRPLANES NOT LISTED IN **A**, **B** AND **F**
- D** FOR AIRPLANES WITH CUM LINE NUMBERS: 1 THRU 736 WITHOUT SB 757-54-0034 OR SB 757-54-0035 INCORPORATED
- E** FOR AIRPLANES WITH CUM LINE NUMBERS: 737 AND ON, AND FOR AIRPLANES WITH SB 757-54-0034 OR SB 757-54-0035 INCORPORATED
- F** FOR AIRPLANES WITH CUM LINE NUMBERS: 737 AND ON
- G** FOR AIRPLANES WITH CUM LINE NUMBERS: 1010 AND ON

ITEM	DESCRIPTION	GAGE	MATERIAL	EFFECTIVITY
1	JACK FITTING		FORGING 7075-T73	

LIST OF MATERIALS FOR DETAIL I

**Outer Wing Front Spar Fitting Identification
Figure 1 (Sheet 1 of 3)**

757-200 STRUCTURAL REPAIR MANUAL

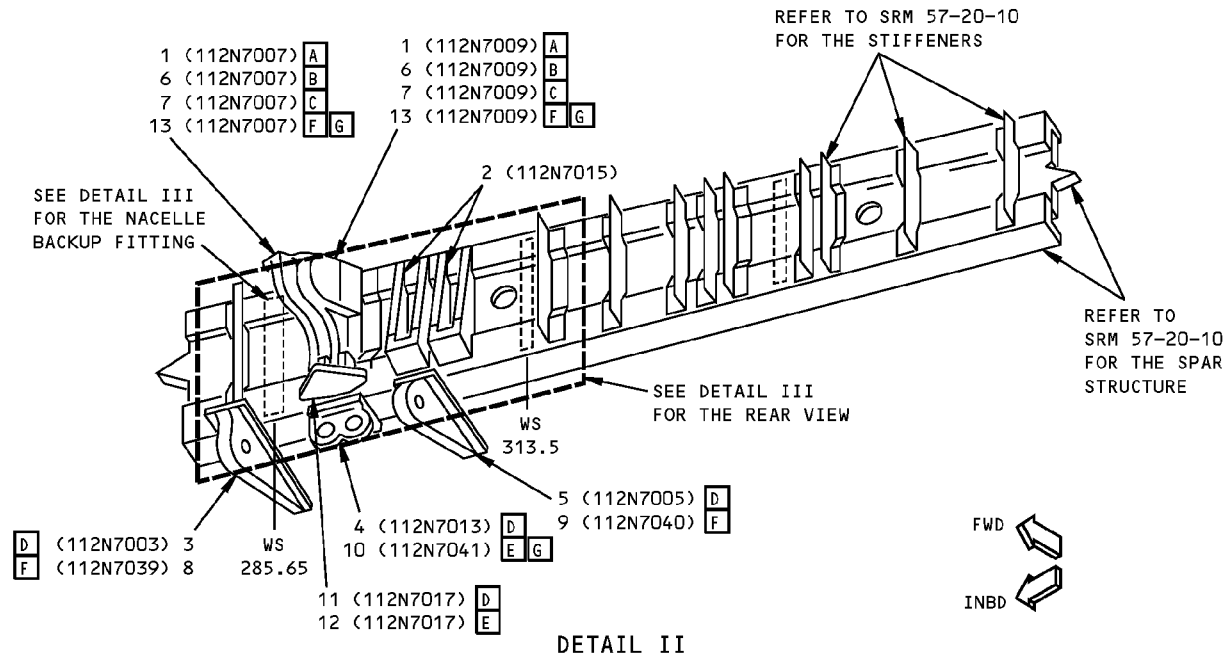

ITEM	DESCRIPTION	GAGE	MATERIAL	EFFECTIVITY
1	DRAG FITTING		7075-T73 FORGING	A
2	NACELLE SUPPORT FITTING		7075-T73 FORGING	
3	INBOARD SIDE LOAD FITTING		7075-T73 FORGING	D
4	SIDE LINK ATTACH FITTING		7075-T73511 BAC1506-3412 EXTRUSION (OPTIONAL: 7075-T73 FORGING)	D
5	OUTBOARD SIDE LOAD FITTING		7075-T73 FORGING	D
6	DRAG FITTING		7075-T73 FORGING (OPTIONAL: 7050-T74 FORGING)	B
7	DRAG FITTING		7050-T7452 FORGING (OPTIONAL: 7075-T73 OR 7050-T74 FORGING)	C
8	INBOARD SIDE LOAD FITTING	3.0	7050-T7451 PLATE (OPTIONAL: 7050-T7452 FORGING)	F
9	OUTBOARD SIDE LOAD FITTING	3.0	7050-T7451 PLATE (OPTIONAL: 7050-T7452 FORGING)	F
10	SIDE LINK ATTACH FITTING	7.0	7050-T7451 PLATE	E G
11	SHEAR TIE		BAC1508-236 7075-T73 (OPTIONAL: 7075-T73 PLATE)	D
12	SHEAR TIE	4.0	7050-T7451 PLATE	E
13	DRAG FITTING		7050-T7451 PLATE	F G

LIST OF MATERIALS FOR DETAIL II

**Outer Wing Front Spar Fitting Identification
Figure 1 (Sheet 2 of 3)**

**757-200
STRUCTURAL REPAIR MANUAL**

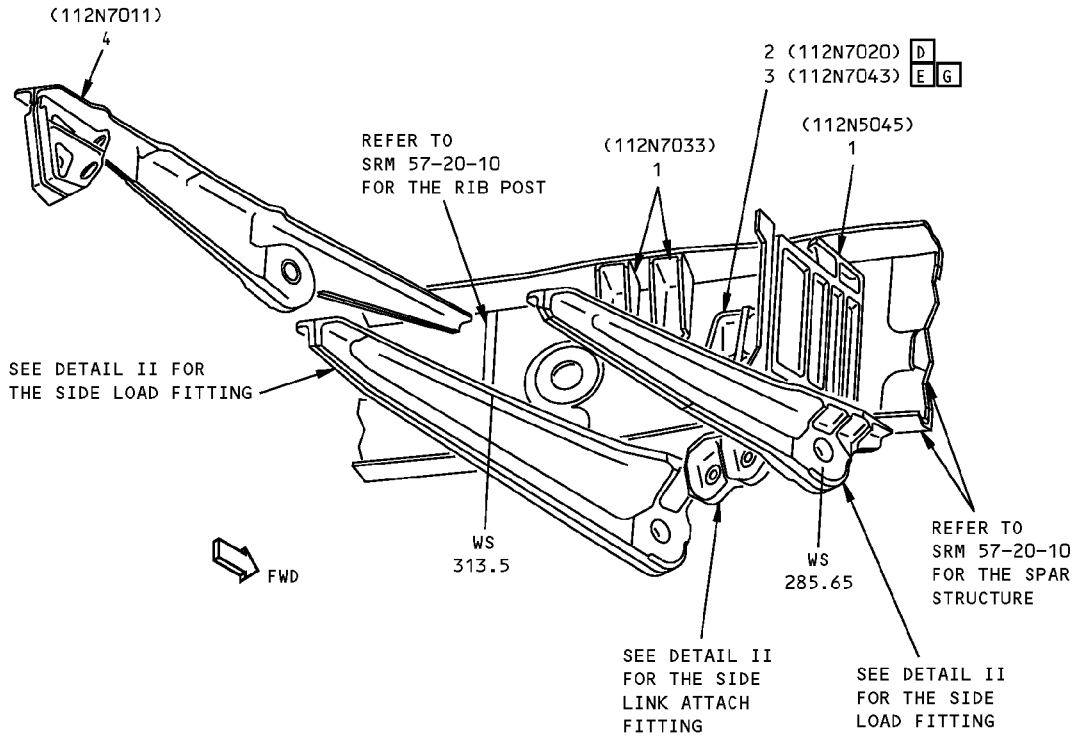

**REAR VIEW
DETAIL III**

ITEM	DESCRIPTION	GAGE	MATERIAL	EFFECTIVITY
1	NACELLE BACKUP FITTING		7075-T73 FORGING OR 7075-T73 FORGED BLOCK	
2	SUPPORT FITTING, SIDE LINK ATTACH		7075-T73 FORGING	D
3	SUPPORT FITTING, SIDE LINK ATTACH	5.0	7075-T7451 PLATE	E G
4	AFT DRAG FITTING		7075-T73 FORGING	

LIST OF MATERIALS FOR DETAIL III

**Outer Wing Front Spar Fitting Identification
Figure 1 (Sheet 3 of 3)**

**757-200
STRUCTURAL REPAIR MANUAL**

IDENTIFICATION 3 - TERMINAL FITTING - BBL 70.50

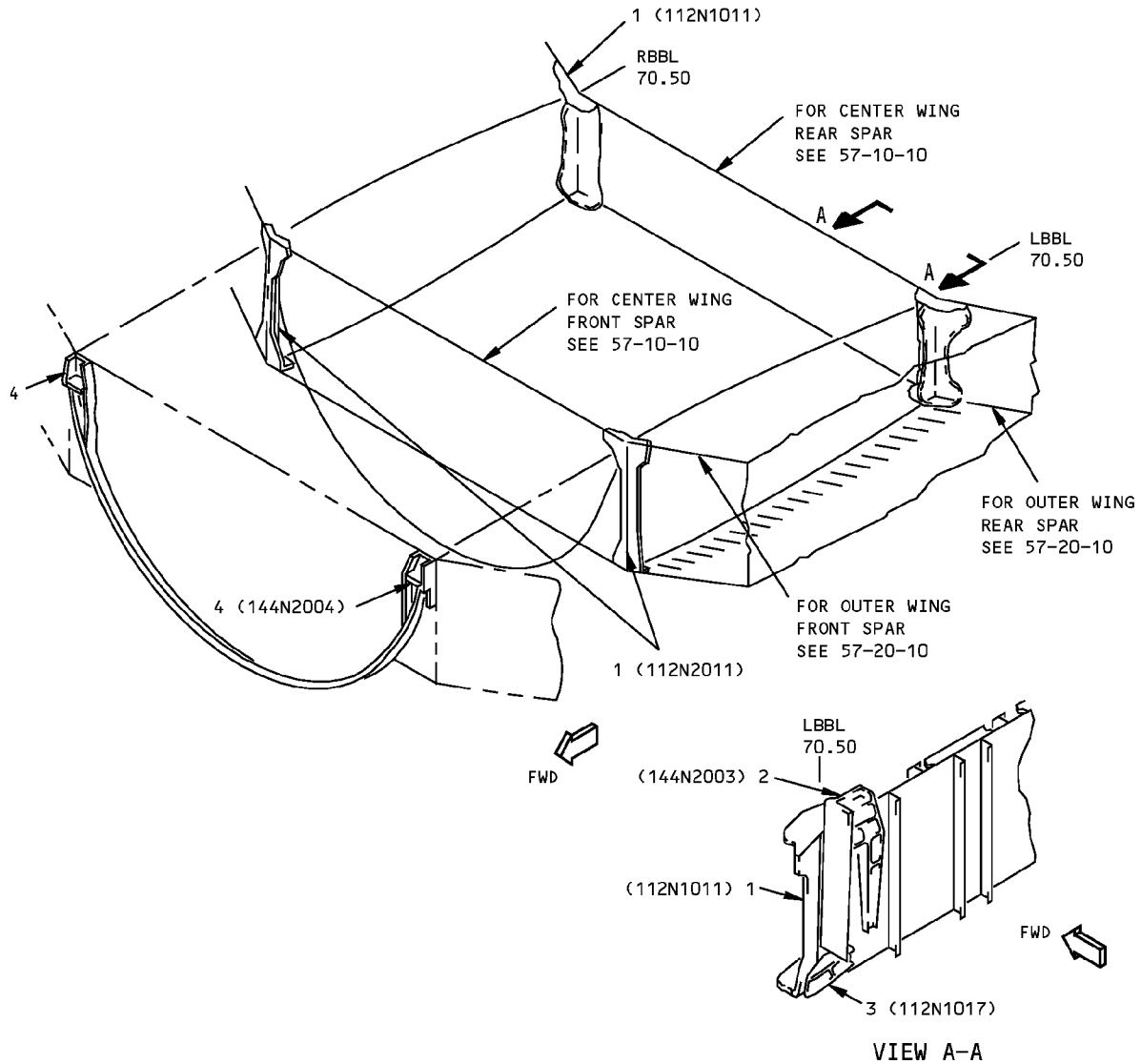

ITEM	DESCRIPTION	GAGE	MATERIAL	EFFECTIVITY
1	TERMINAL FITTING		FORGING 7075-T73	
2	BULKHEAD LOWER SIDE FITTING		FORGING 7175-T736	
3	LOWER KICK FITTING		EXTRUDED BAR 2024-T3511	
4	BULKHEAD LOWER SIDE FITTING		FORGING 7075-T73	

LIST OF MATERIALS

**Terminal Fitting Identification - BBL 70.50
Figure 1**

**757-200
STRUCTURAL REPAIR MANUAL**

ALLOWABLE DAMAGE 1 - OUTER WING REAR SPAR FITTINGS

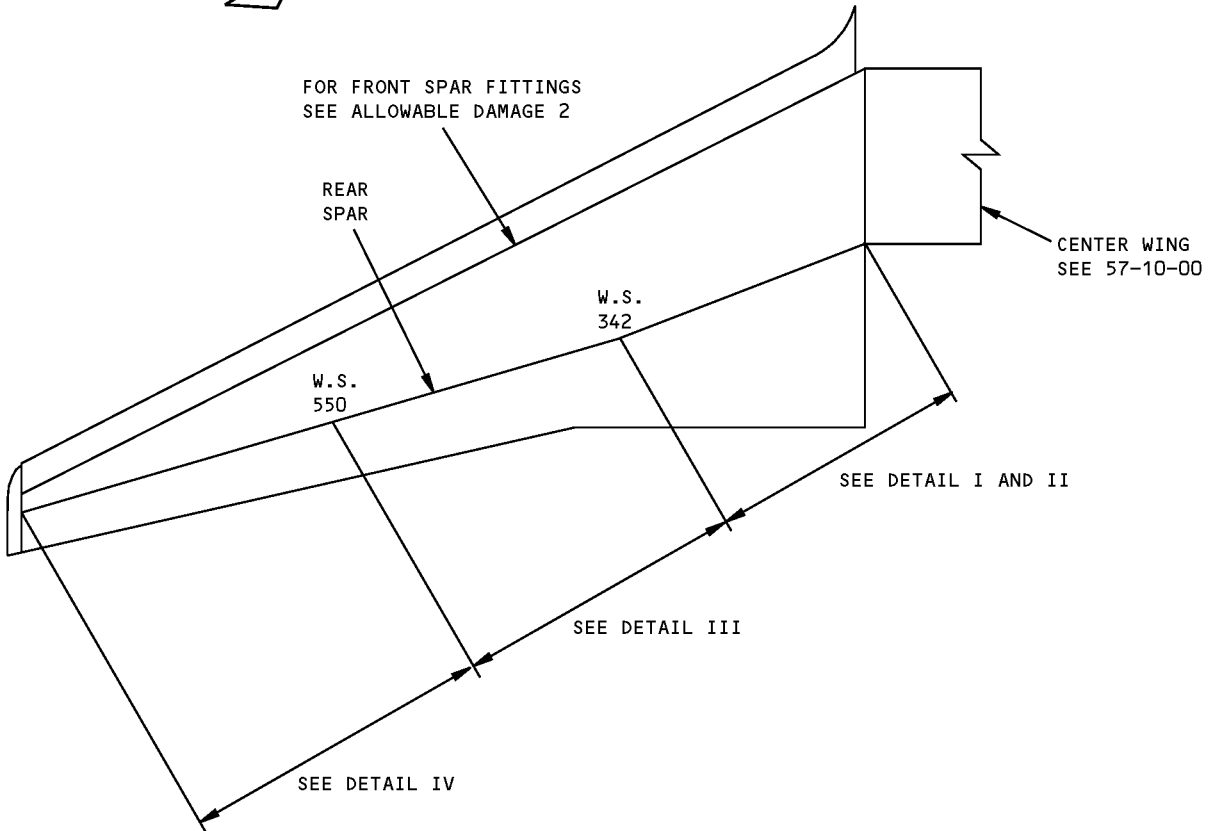
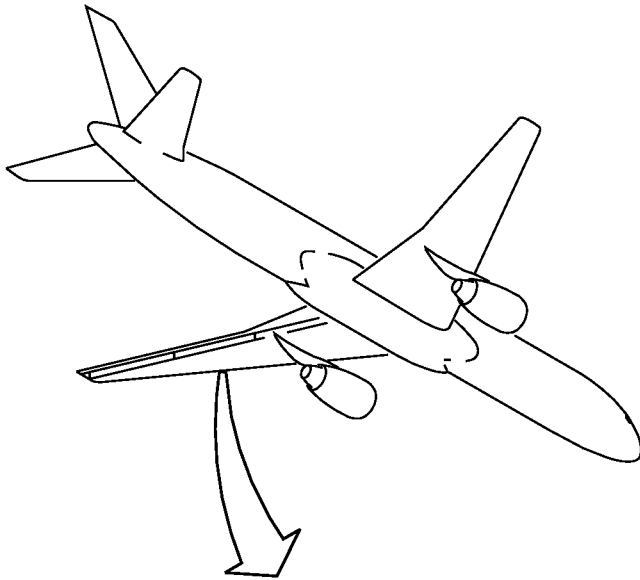

**Outer Wing Rear Spar Fittings Allowable Damage
Figure 101 (Sheet 1 of 8)**

**757-200
STRUCTURAL REPAIR MANUAL**

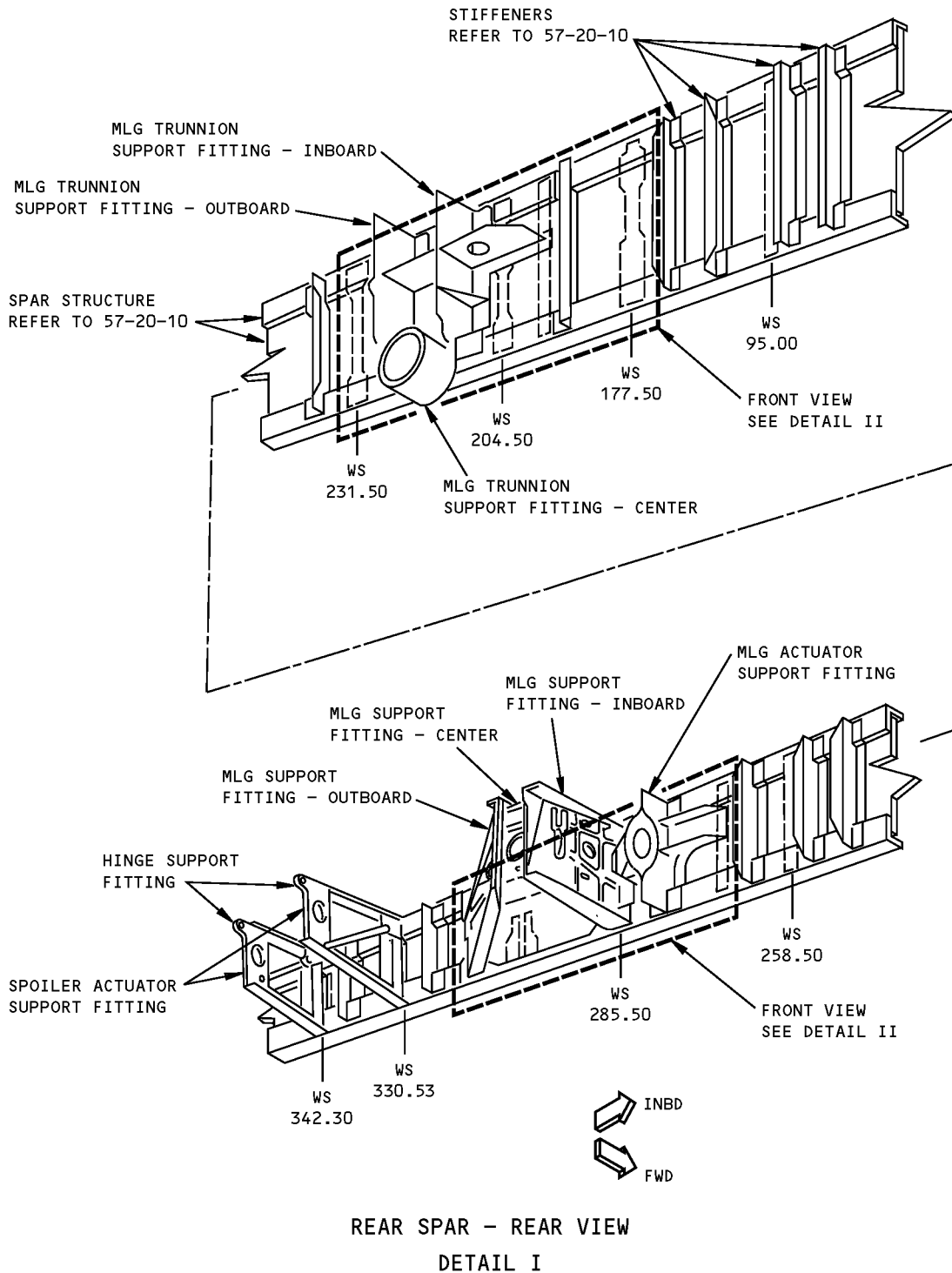

**Outer Wing Rear Spar Fittings Allowable Damage
Figure 101 (Sheet 2 of 8)**

**757-200
STRUCTURAL REPAIR MANUAL**

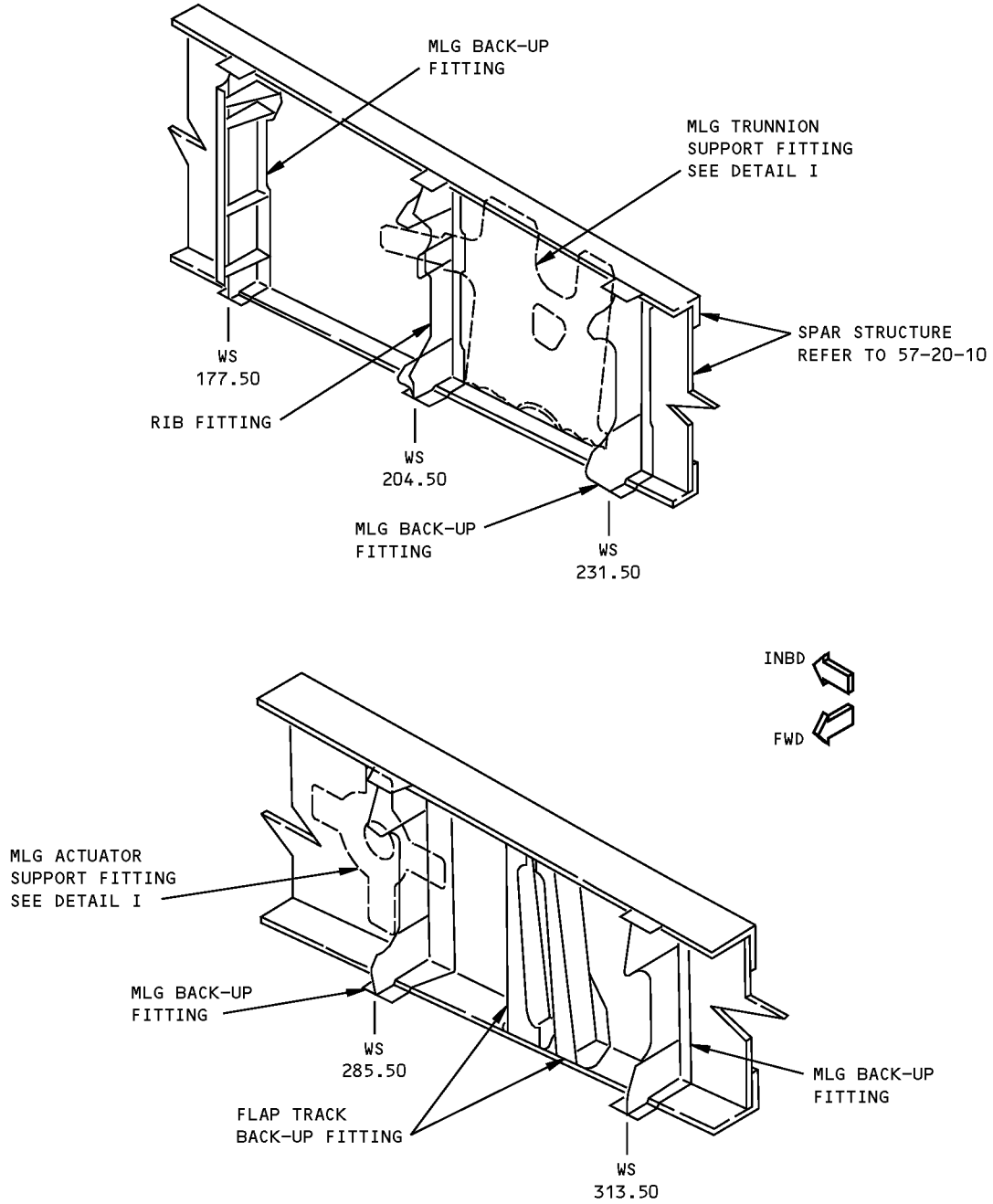

**REAR SPAR - FRONT VIEW
DETAIL II**

**Outer Wing Rear Spar Fittings Allowable Damage
Figure 101 (Sheet 3 of 8)**

**757-200
STRUCTURAL REPAIR MANUAL**

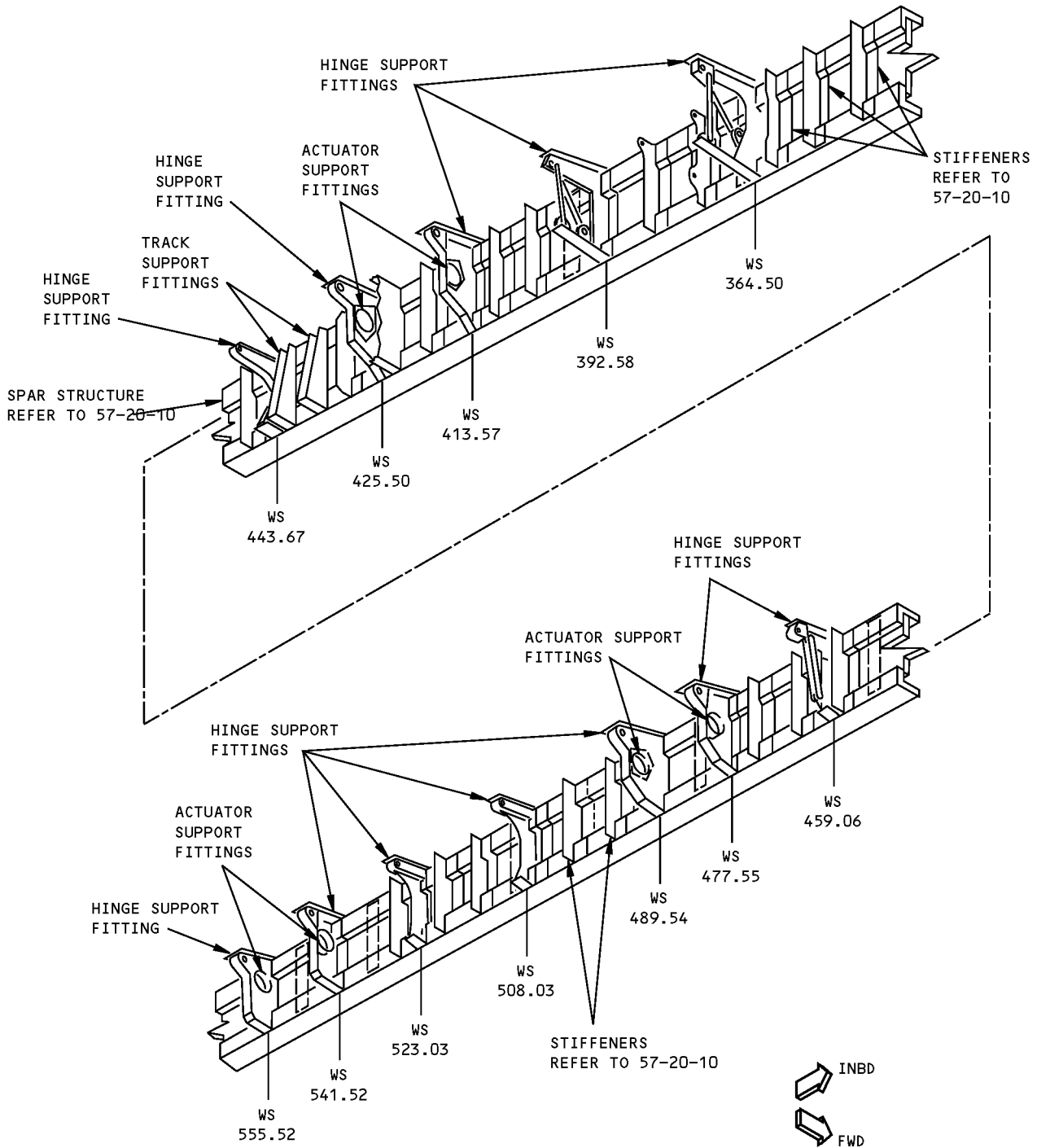

**REAR SPAR - REAR VIEW
DETAIL III**

**Outer Wing Rear Spar Fittings Allowable Damage
Figure 101 (Sheet 4 of 8)**

**757-200
STRUCTURAL REPAIR MANUAL**

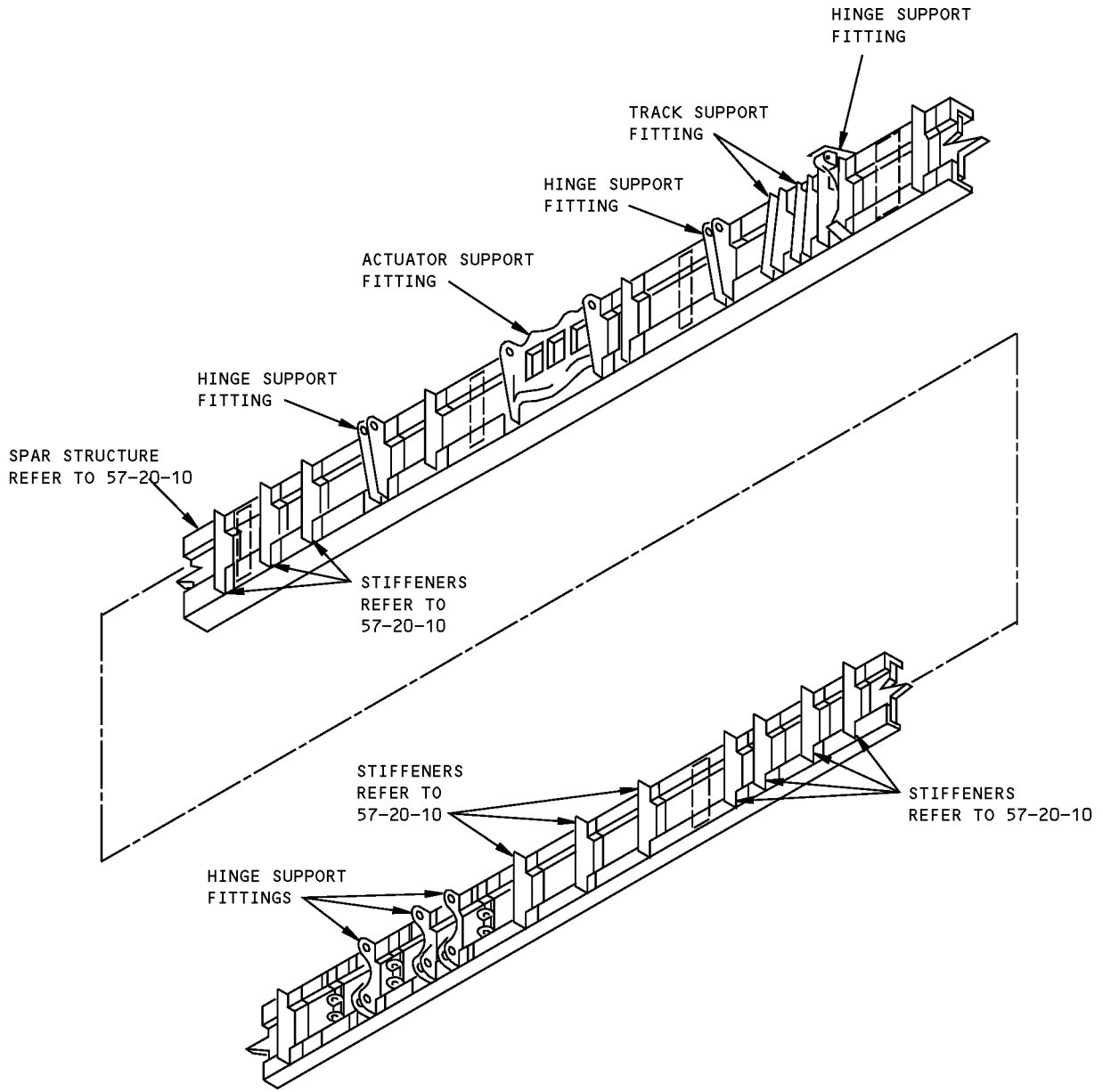

REAR SPAR – REAR VIEW
DETAIL IV

**Outer Wing Rear Spar Fittings Allowable Damage
Figure 101 (Sheet 5 of 8)**



757-200
STRUCTURAL REPAIR MANUAL

DESCRIPTION	CRACKS	NICKS, GOUGES AND CORROSION	DENTS	HOLES AND PUNCTURES
MLG TRUNNION SUPPORT FITTING - OUTBD D	A	C	NOT ALLOWED	NOT ALLOWED
MLG TRUNNION SUPPORT FITTING - INBD D	A	C	NOT ALLOWED	NOT ALLOWED
MLG TRUNNION SUPPORT FITTING - CTR D	A	B	NOT ALLOWED	NOT ALLOWED
MLG SUPPORT FITTING - INBD AND OUTBD D	A	C	NOT ALLOWED	NOT ALLOWED
MLG SUPPORT FITTING - CTR D	A	B	NOT ALLOWED	NOT ALLOWED
ACTUATOR SUPPORT FITTING D	A	B	NOT ALLOWED	NOT ALLOWED
BACK-UP FITTING D	A	C	NOT ALLOWED	NOT ALLOWED
HINGE SUPPORT FITTINGS D	A	B	NOT ALLOWED	NOT ALLOWED
RIB FITTING D	A	C	NOT ALLOWED	NOT ALLOWED

Outer Wing Rear Spar Fittings Allowable Damage
Figure 101 (Sheet 6 of 8)

**757-200
STRUCTURAL REPAIR MANUAL**

NOTES

- REFINISH REWORKED AREAS AS GIVEN IN AMM 51-20
- REFER TO SRM 51-10-02 FOR INSPECTION AND REMOVAL OF DAMAGE
- A** CRACKS NOT ALLOWED EXCEPT FOR EDGE CRACKS WHICH MUST BE REMOVED PER DETAIL V.
- B** FOR EDGE DAMAGE SEE DETAIL V. FOR LUG DAMAGE SEE DETAIL VII. FOR OTHER DAMAGE SEE DETAIL VI. DAMAGE NOT ALLOWED IN VICINITY OF BUSHINGS.
- C** FOR EDGE DAMAGE SEE DETAIL V. FOR OTHER DAMAGE SEE DETAIL VI.
- D** SHOT PEEN REWORKED AREAS PER 51-20-06. SHOT PEEN INTENSITIES MAY VARY WITH THICKNESS REMAINING AFTER REWORK.

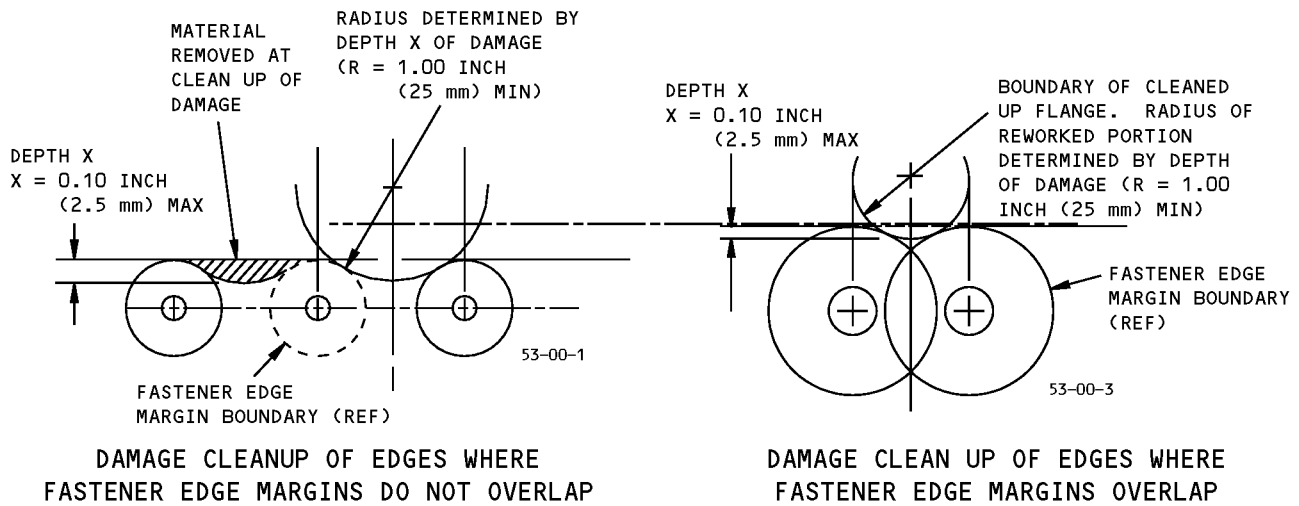

DETAIL V

**Outer Wing Rear Spar Fittings Allowable Damage
Figure 101 (Sheet 7 of 8)**

**757-200
STRUCTURAL REPAIR MANUAL**

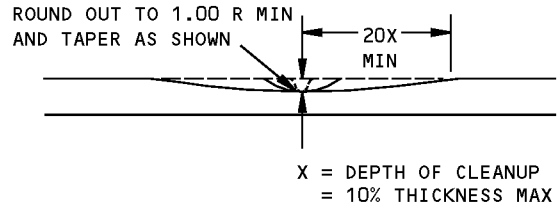
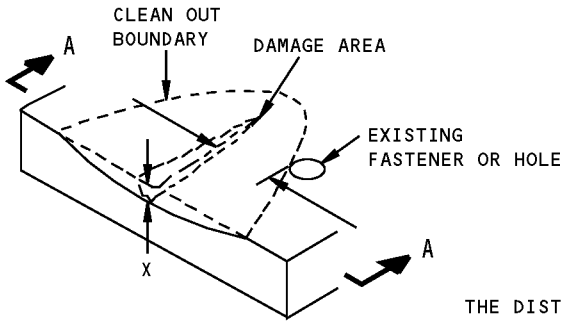

SECTION A-A

THE DISTANCE OF THE DAMAGE FROM AN EXISTING HOLE, FASTENERS OR SKIN EDGE MUST NOT BE LESS THAN 20X

**REMOVAL OF NICK, GOUGE AND SCRATCH DAMAGE ON A SURFACE
DETAIL VI**

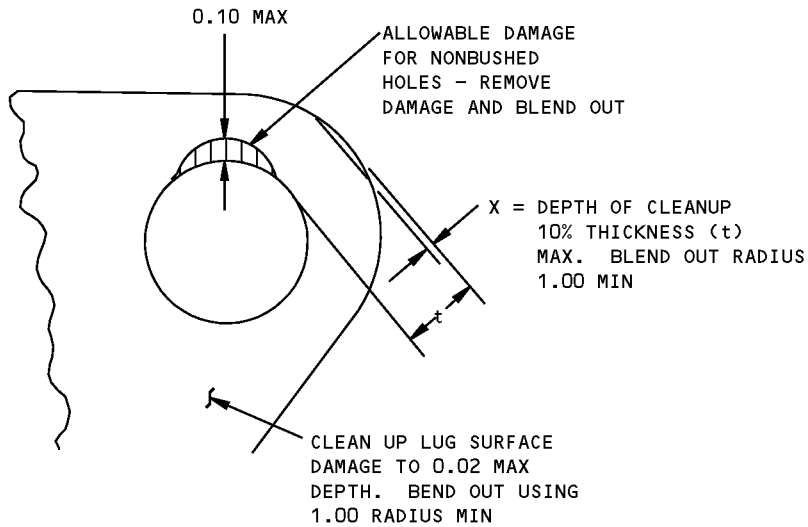

**DAMAGE CLEANUP FOR SURFACES OF LUG
DETAIL VII**

**Outer Wing Rear Spar Fittings Allowable Damage
Figure 101 (Sheet 8 of 8)**

**757-200
STRUCTURAL REPAIR MANUAL**

ALLOWABLE DAMAGE 2 - OUTER WING FRONT SPAR FITTINGS

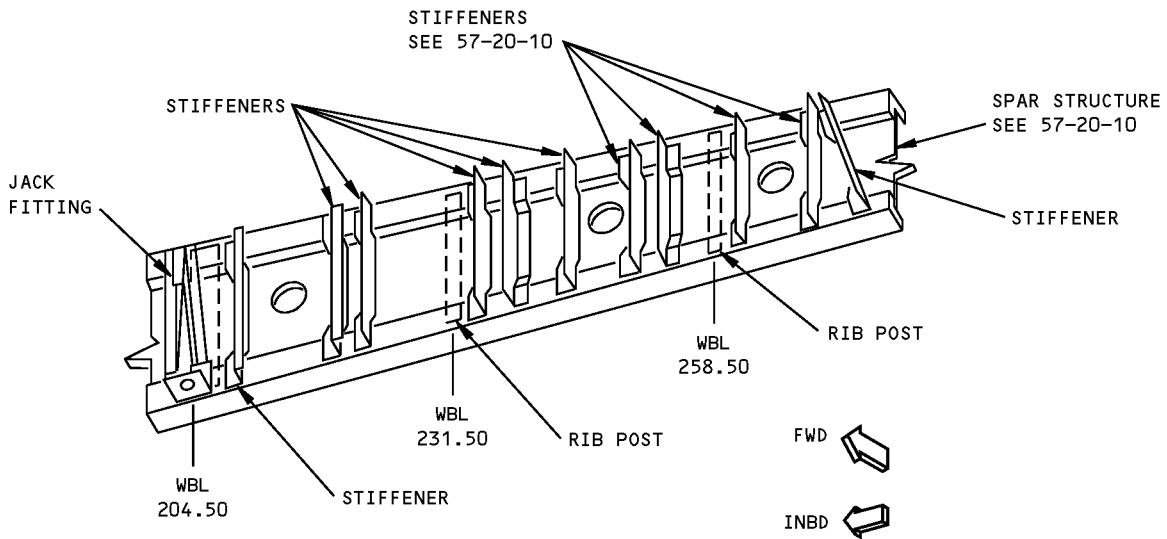
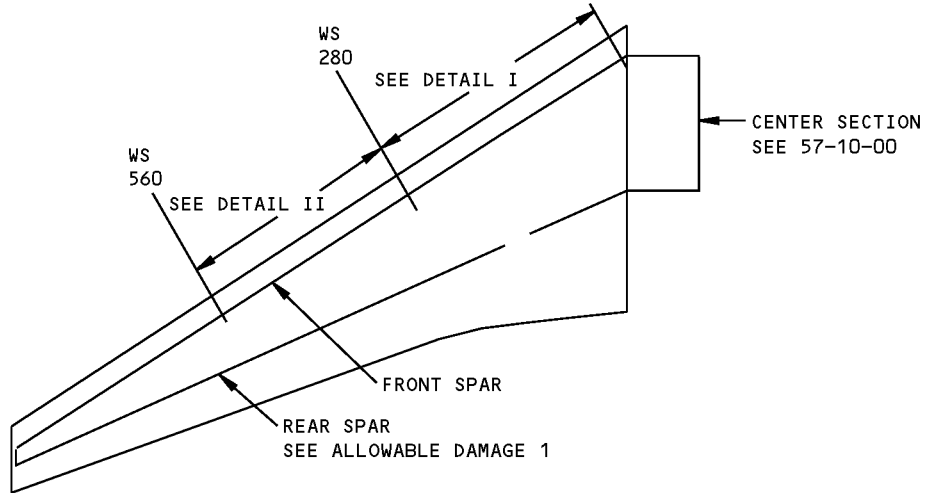

DETAIL I

**Outer Wing Front Spar Fittings Allowable Damage
Figure 101 (Sheet 1 of 4)**

**757-200
STRUCTURAL REPAIR MANUAL**

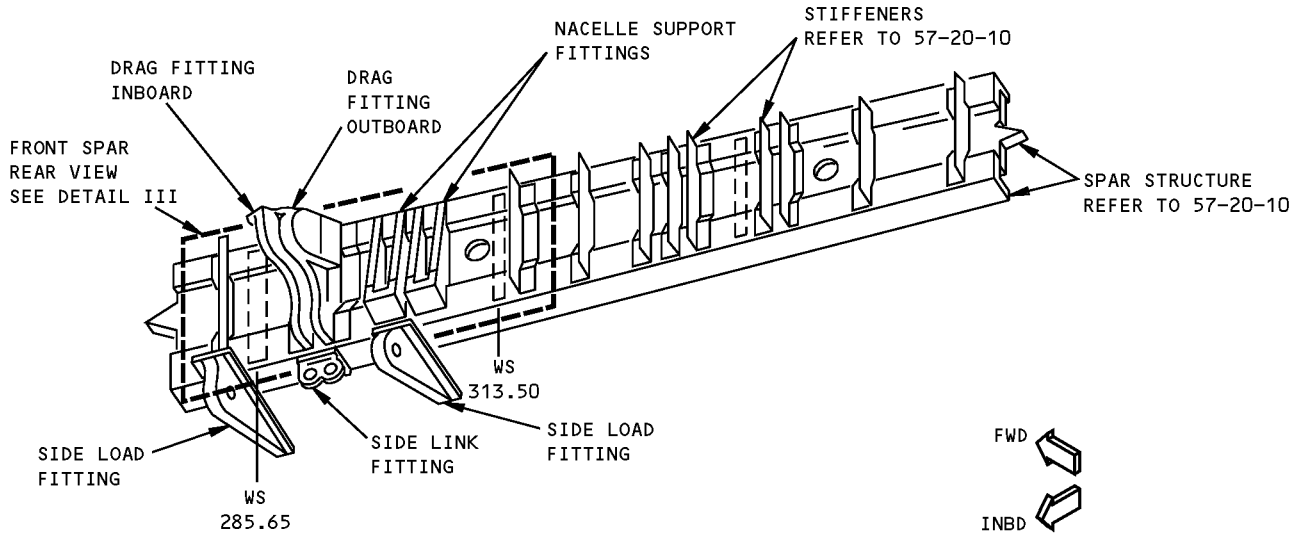

DETAIL II

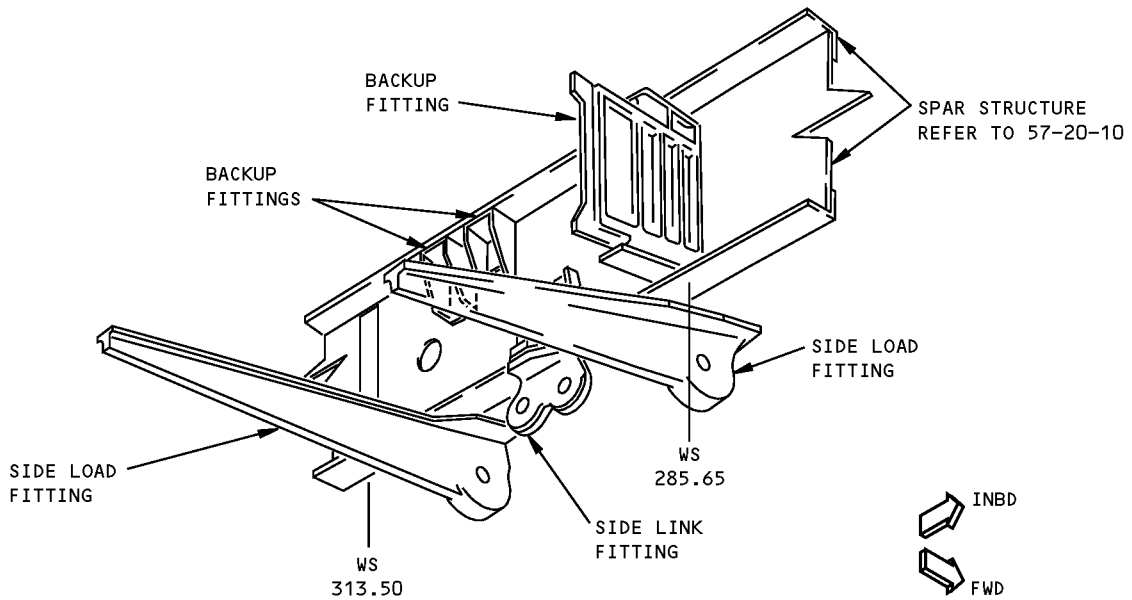

**FRONT SPAR - REAR VIEW
DETAIL III**

**Outer Wing Front Spar Fittings Allowable Damage
Figure 101 (Sheet 2 of 4)**

**757-200
STRUCTURAL REPAIR MANUAL**

DESCRIPTION	CRACKS	NICKS, GOUGES AND CORROSION	DENTS	HOLES AND PUNCTURES
JACK FITTING D	A	C	NOT PERMITTED	NOT PERMITTED
DRAG FITTINGS D	A	C	NOT PERMITTED	NOT PERMITTED
SIDE LOAD FITTINGS D	A	B	NOT PERMITTED	NOT PERMITTED
BACK-UP FITTINGS D	A	C	NOT PERMITTED	NOT PERMITTED
SIDE LINK FITTING D	A	B	NOT PERMITTED	NOT PERMITTED

NOTES

- REFINISH THE REWORKED AREAS AS GIVEN IN AMM 51-20
 - REFER TO SRM 51-10-02 FOR INSPECTION AND REMOVAL OF DAMAGE
- A** EDGE CRACKS MUST BE REMOVED AS GIVEN IN DETAIL IV. OTHER CRACKS ARE NOT PERMITTED.
- B** FOR EDGE DAMAGE, SEE DETAIL IV. FOR LUG DAMAGE, SEE DETAIL VI. FOR OTHER DAMAGE, SEE DETAIL V. DAMAGE IS NOT PERMITTED IN THE VICINITY OF THE BUSHINGS.
- C** FOR EDGE DAMAGE, SEE DETAIL IV. FOR OTHER DAMAGE, SEE DETAIL V.
- D** SHOT PEEN THE REWORKED AREAS AS GIVEN IN SRM 51-20-06. SHOT PEEN INTENSITIES CAN VARY WITH THE THICKNESS REMAINING AFTER THE REWORK.

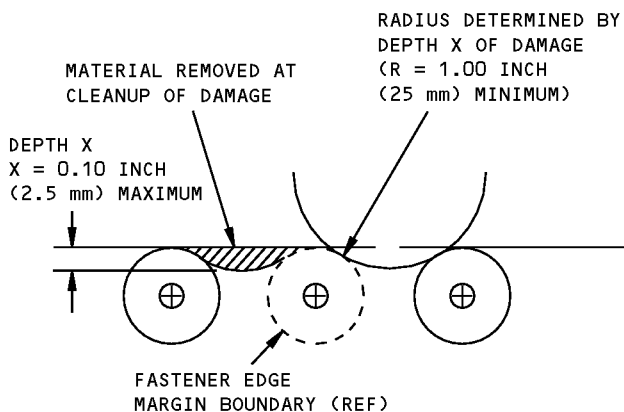

DAMAGE CLEANUP OF EDGES WHERE FASTENER EDGE MARGINS DO NOT OVERLAP

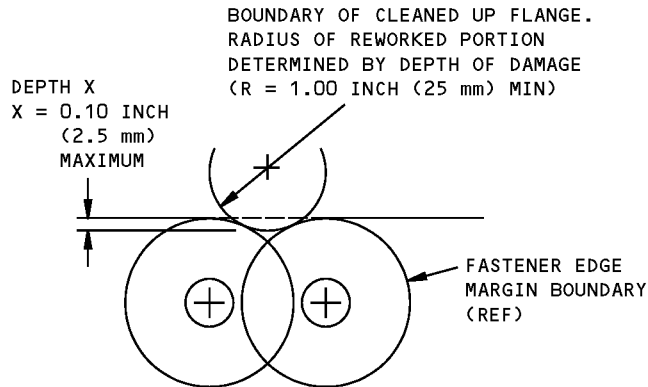

DAMAGE CLEANUP OF EDGES WHERE FASTENER EDGE MARGINS OVERLAP

DETAIL IV

**Outer Wing Front Spar Fittings Allowable Damage
Figure 101 (Sheet 3 of 4)**

**757-200
STRUCTURAL REPAIR MANUAL**

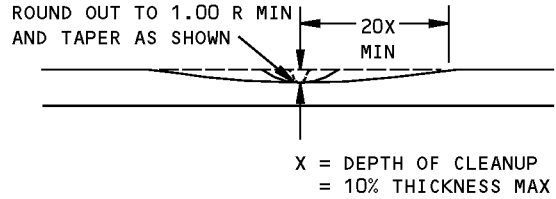
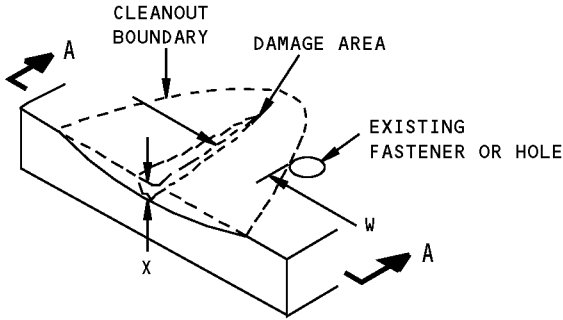

SECTION A-A

W = THE DISTANCE OF THE DAMAGE FROM AN EXISTING HOLE, FASTENERS OR SKIN EDGE MUST NOT BE LESS THAN 20X

**REMOVAL OF NICK, GOUGE AND SCRATCH DAMAGE ON A SURFACE
DETAIL V**

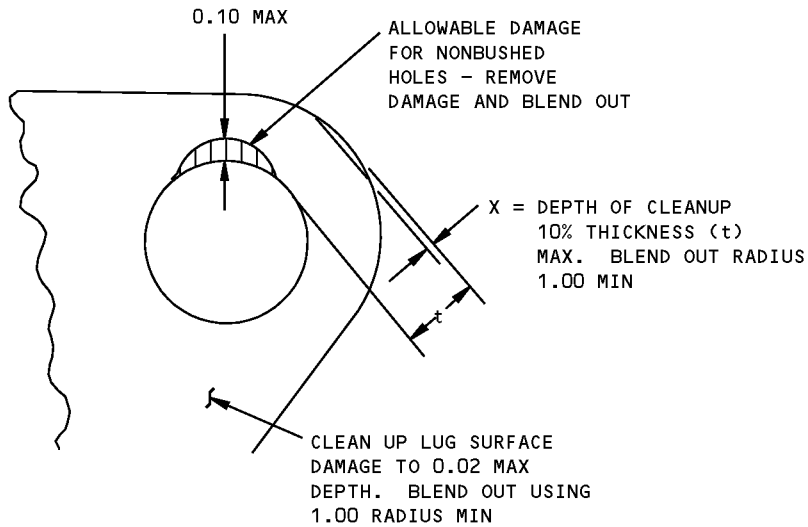

**DAMAGE CLEANUP FOR SURFACES OF LUG
DETAIL VI**

**Outer Wing Front Spar Fittings Allowable Damage
Figure 101 (Sheet 4 of 4)**

757-200
STRUCTURAL REPAIR MANUAL

ALLOWABLE DAMAGE 3 - TERMINAL FITTINGS

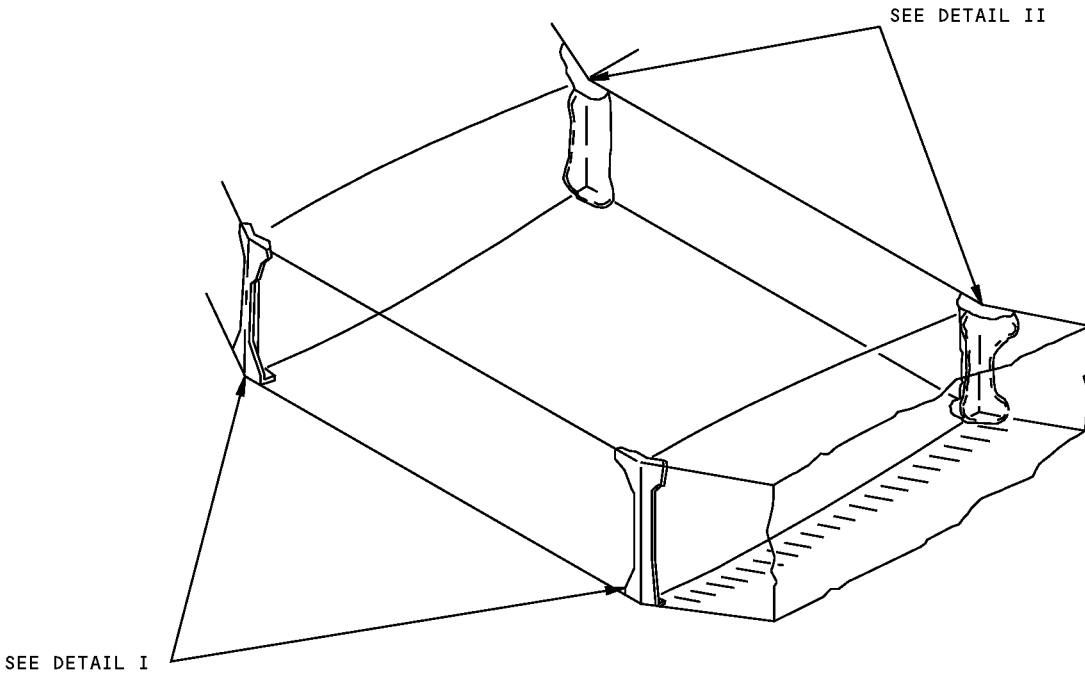
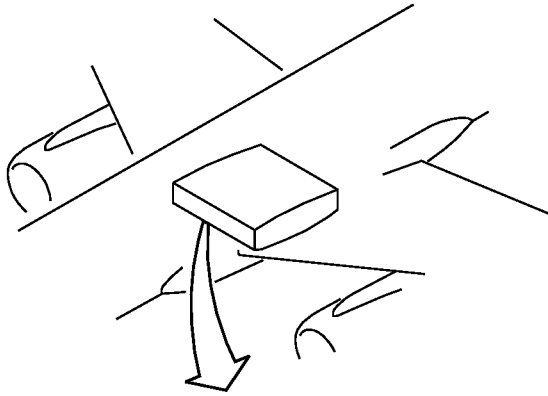

Terminal Fittings Allowable Damage
Figure 101 (Sheet 1 of 4)

**757-200
STRUCTURAL REPAIR MANUAL**

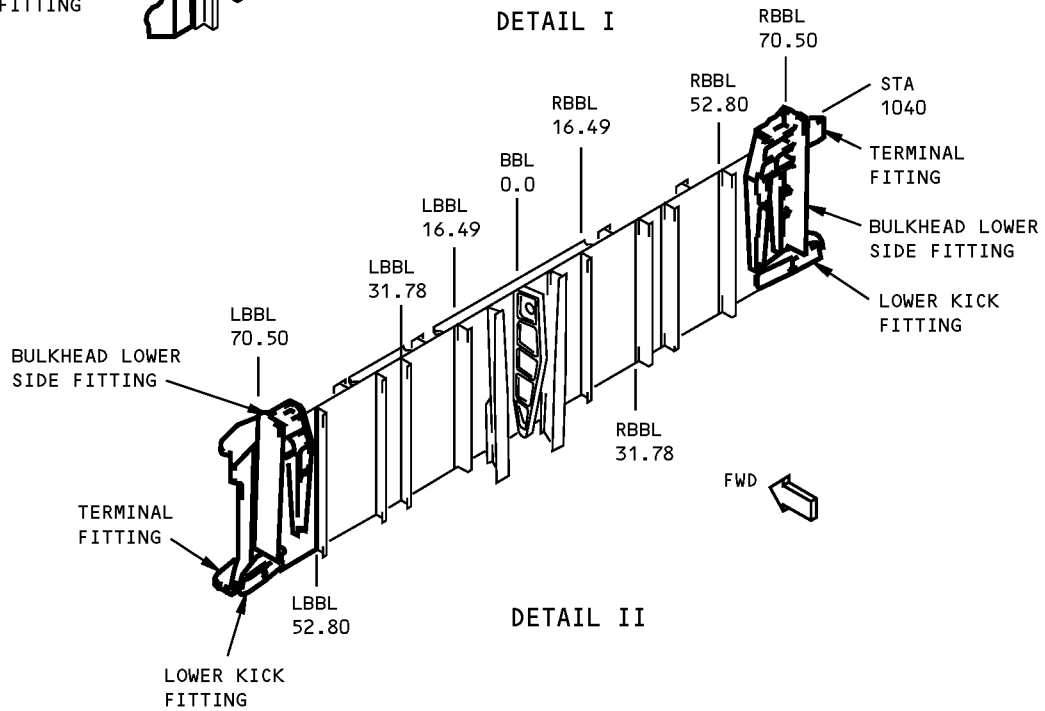
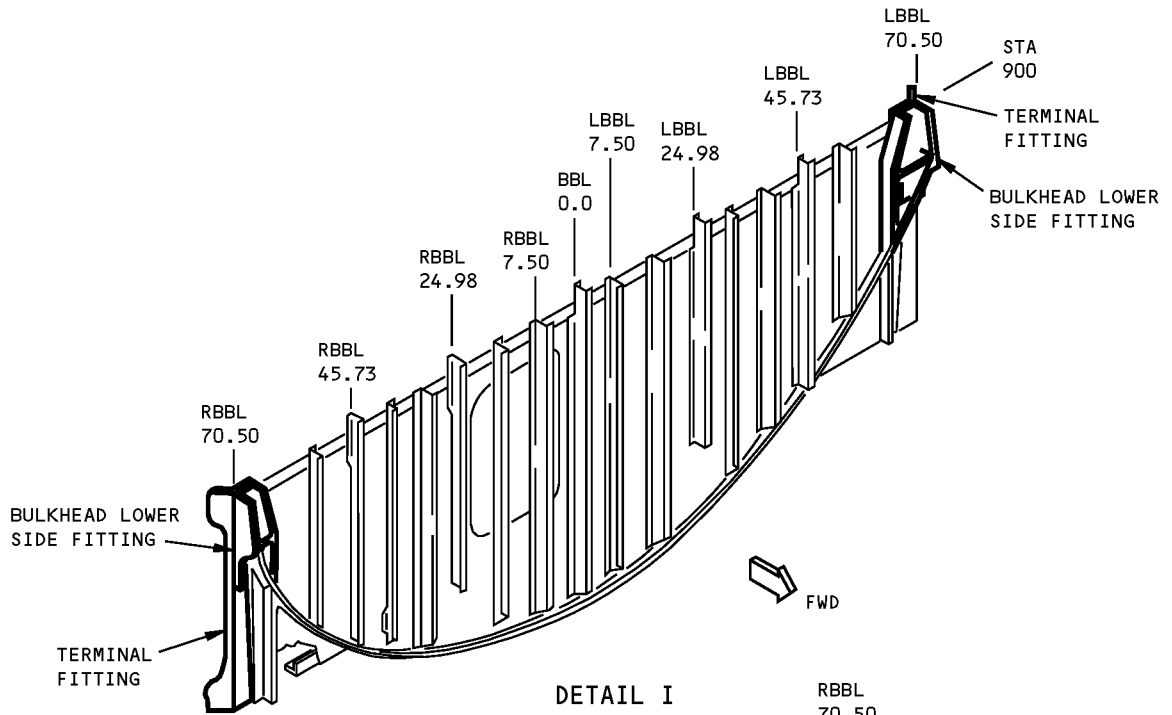

**Terminal Fittings Allowable Damage
Figure 101 (Sheet 2 of 4)**

**757-200
STRUCTURAL REPAIR MANUAL**

DESCRIPTION	CRACKS	NICKS, GOUGES, SCRATCHES AND CORROSION	DENTS	HOLES AND PUNCTURES
BULKHEAD FITTINGS D	A	B	NOT ALLOWED	NOT ALLOWED
TERMINAL FITTING D		C	NOT ALLOWED	NOT ALLOWED
LOWER KICK FITTING D		B	NOT ALLOWED	NOT ALLOWED

NOTES

WARNING: PRESENCE OF FUEL VAPORS IN FUEL TANKS CREATES EXPLOSIVE AND TOXIC CONDITIONS. REFER TO 28-11-00 OF THE MAINTENANCE MANUAL FOR FUEL TANK MAINTENANCE PRACTICES AND ENTRY PROCEDURES.

- REFINISH REWORKED AREAS AS GIVEN IN AMM 51-20
- REFER TO SRM 51-10-02 FOR INSPECTION AND REMOVAL OF DAMAGE

- A** CRACKS NOT ALLOWED EXCEPT FOR EDGE CRACKS WHICH MUST BE REMOVED PER DETAILS III AND VI
- B** REMOVE DAMAGE PER DETAILS III, IV AND V
- C** REMOVE DAMAGE PER DETAIL III, IV, V, AND VII
- D** SHOT PEEN REWORKED AREAS PER 51-20-06

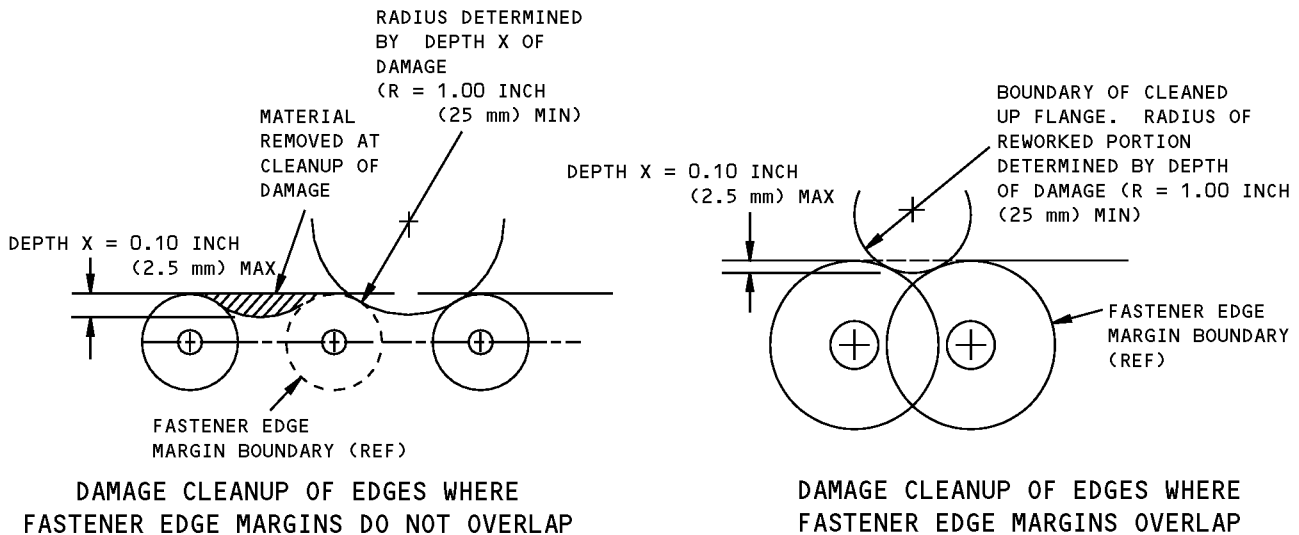

**Terminal Fittings Allowable Damage
Figure 101 (Sheet 3 of 4)**

**757-200
STRUCTURAL REPAIR MANUAL**

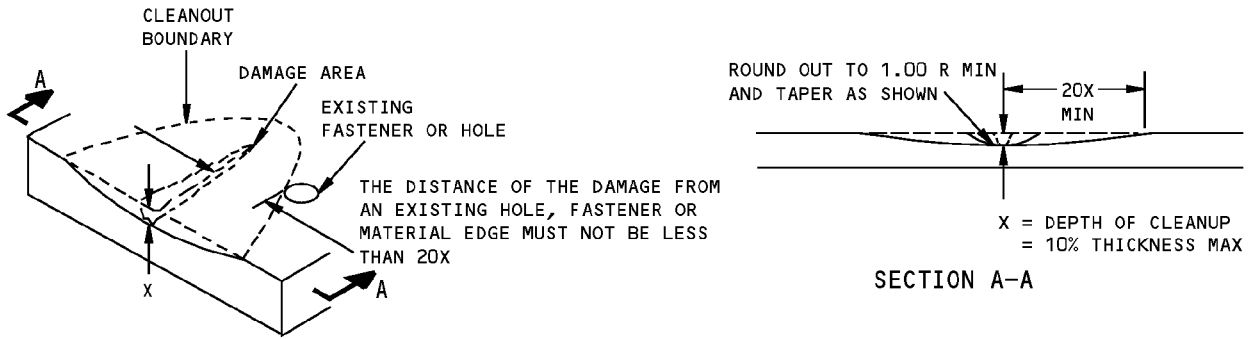

**REMOVAL OF NICK, GOUGE AND SCRATCH DAMAGE ON A SURFACE
DETAIL IV**

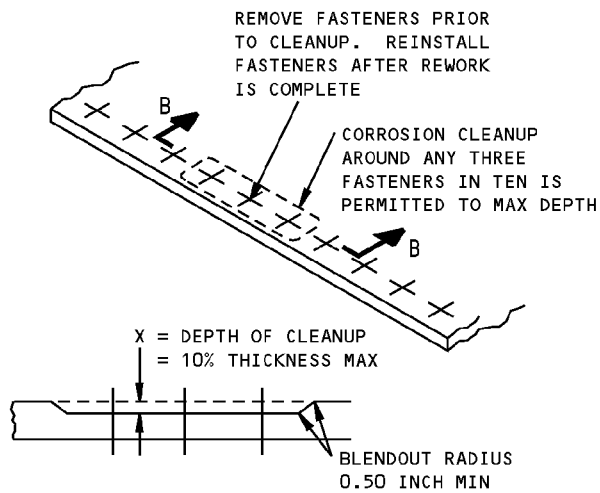

**SECTION B-B
CORROSION CLEANUP
DETAIL V**

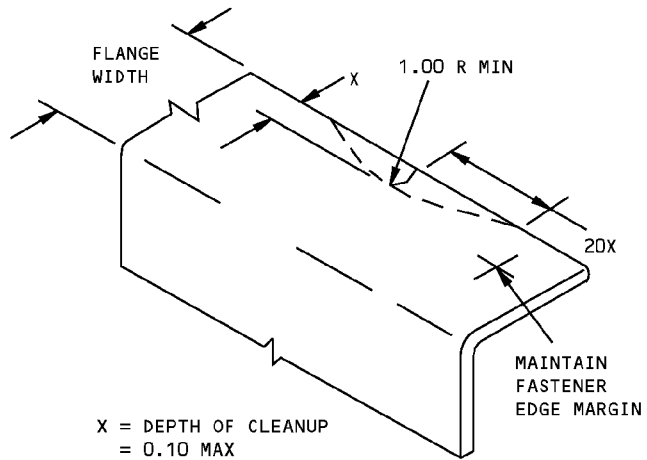

**REMOVAL OF NICK OR CRACK
DAMAGE ON AN EDGE
DETAIL VI**

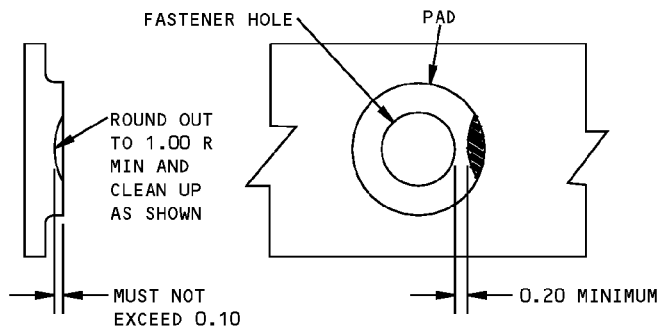

**DAMAGE CLEANUP FOR REAR SPAR
TERMINAL FITTING PADS
DETAIL VII**

**Terminal Fittings Allowable Damage
Figure 101 (Sheet 4 of 4)**

**757-200
STRUCTURAL REPAIR MANUAL**

REPAIR 1 - OUTER WING REAR SPAR FITTING REPAIR

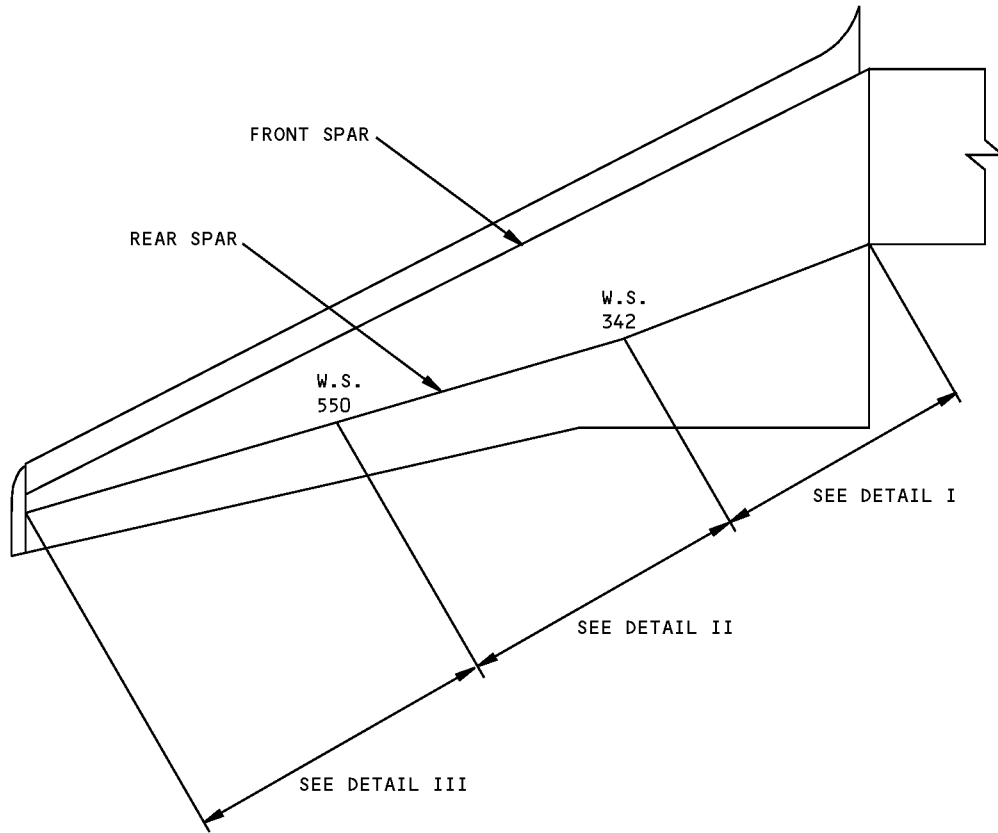
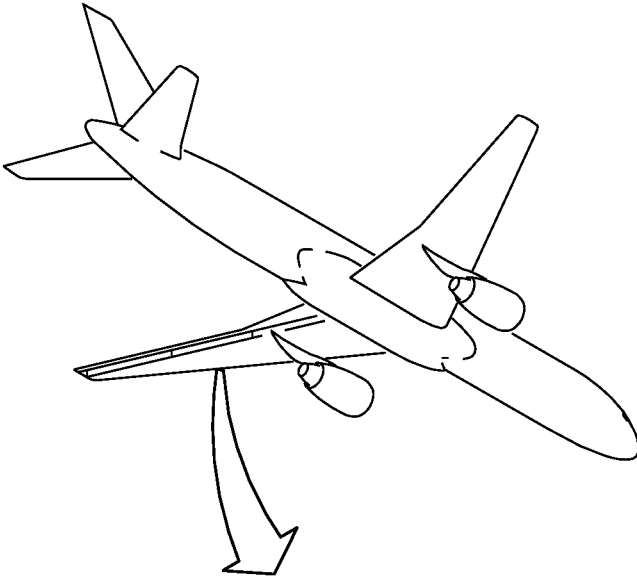

**Outer Wing Rear Spar Fitting Repair
Figure 201 (Sheet 1 of 4)**

**757-200
STRUCTURAL REPAIR MANUAL**

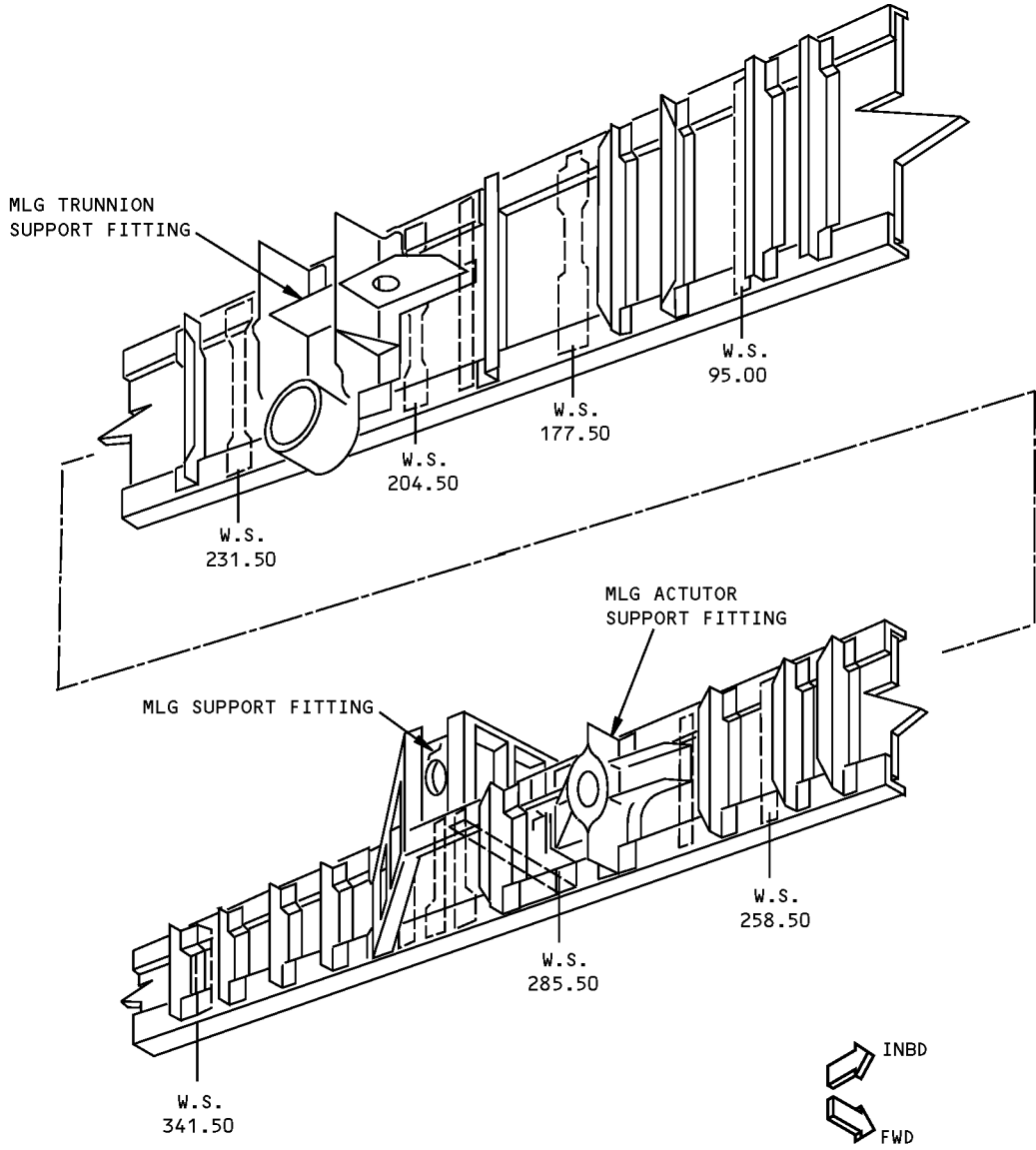

DETAIL I

NOTES

- NO TYPICAL REPAIRS TO FITTINGS APPLICABLE. SPECIFIC REPAIRS TO FITTINGS WILL BE PROVIDED BASED ON SERVICE EXPERIENCE
- SEE 57-20-10 FOR MATERIAL IDENTIFICATION AND ALLOWABLE DAMAGE DATA

**Outer Wing Rear Spar Fitting Repair
Figure 201 (Sheet 2 of 4)**

**757-200
STRUCTURAL REPAIR MANUAL**

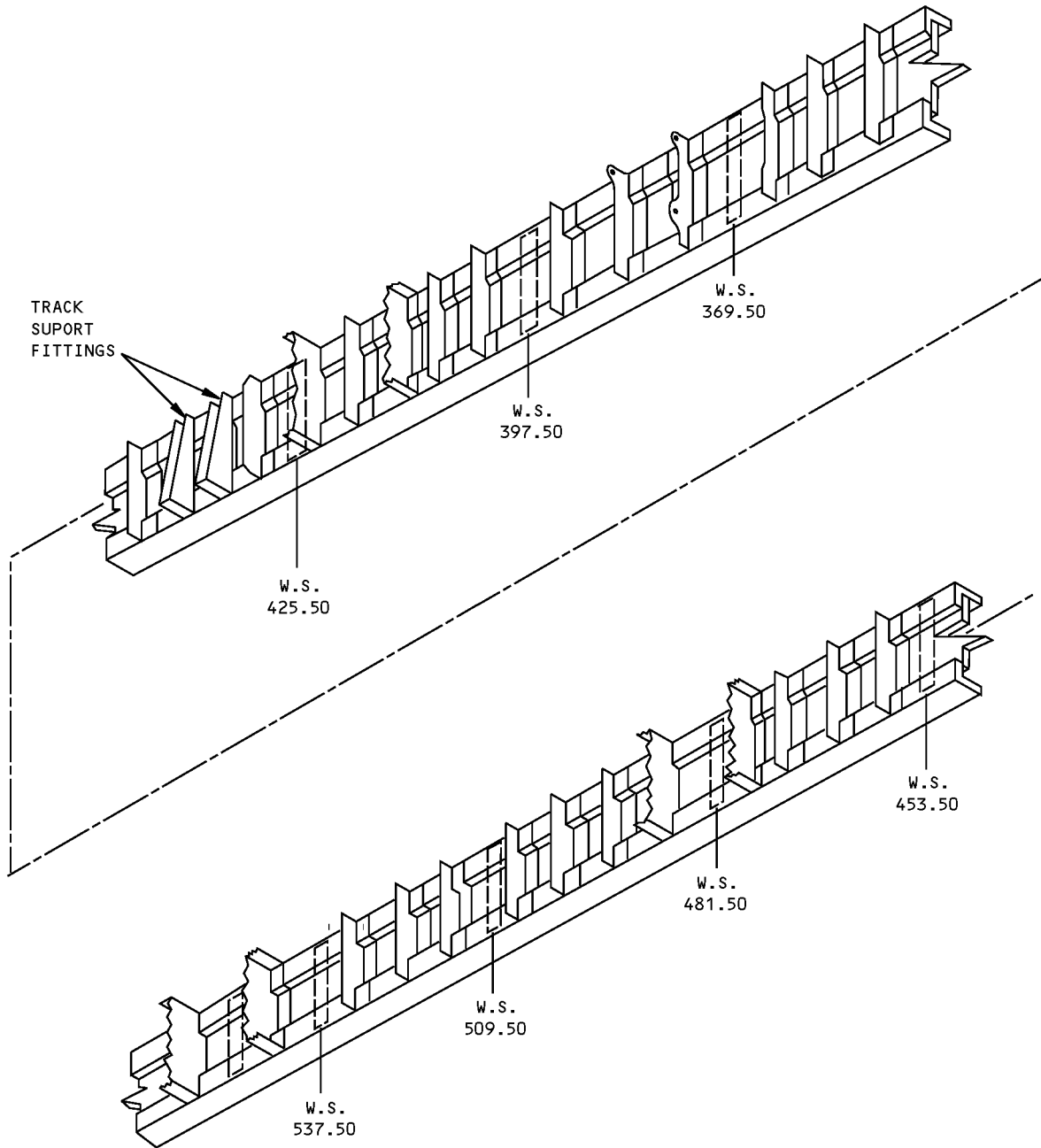

DETAIL II

**Outer Wing Rear Spar Fitting Repair
Figure 201 (Sheet 3 of 4)**

**757-200
STRUCTURAL REPAIR MANUAL**

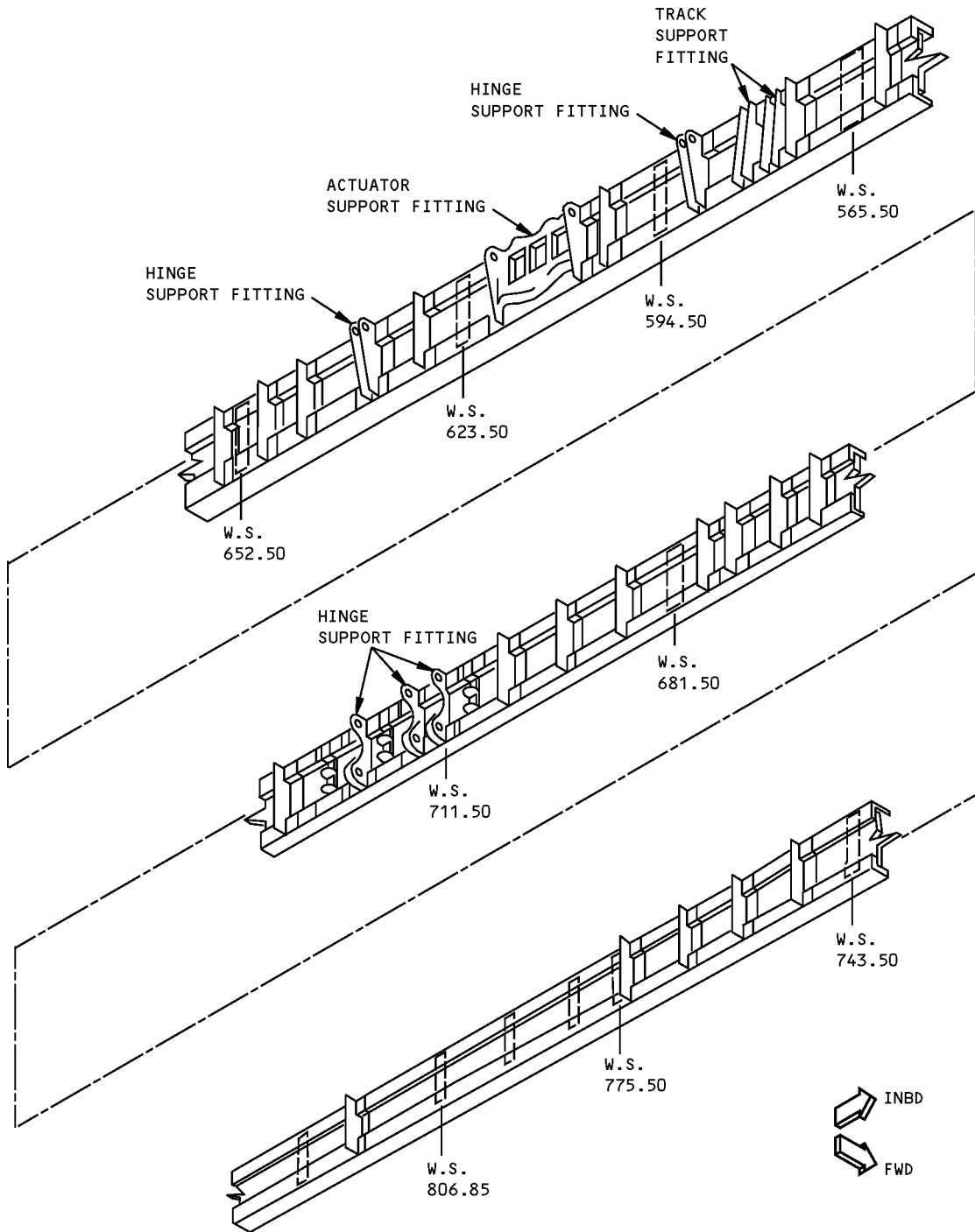

DETAIL III

**Outer Wing Rear Spar Fitting Repair
Figure 201 (Sheet 4 of 4)**

**757-200
STRUCTURAL REPAIR MANUAL**

REPAIR 2 - OUTER WING FRONT SPAR FITTING REPAIR

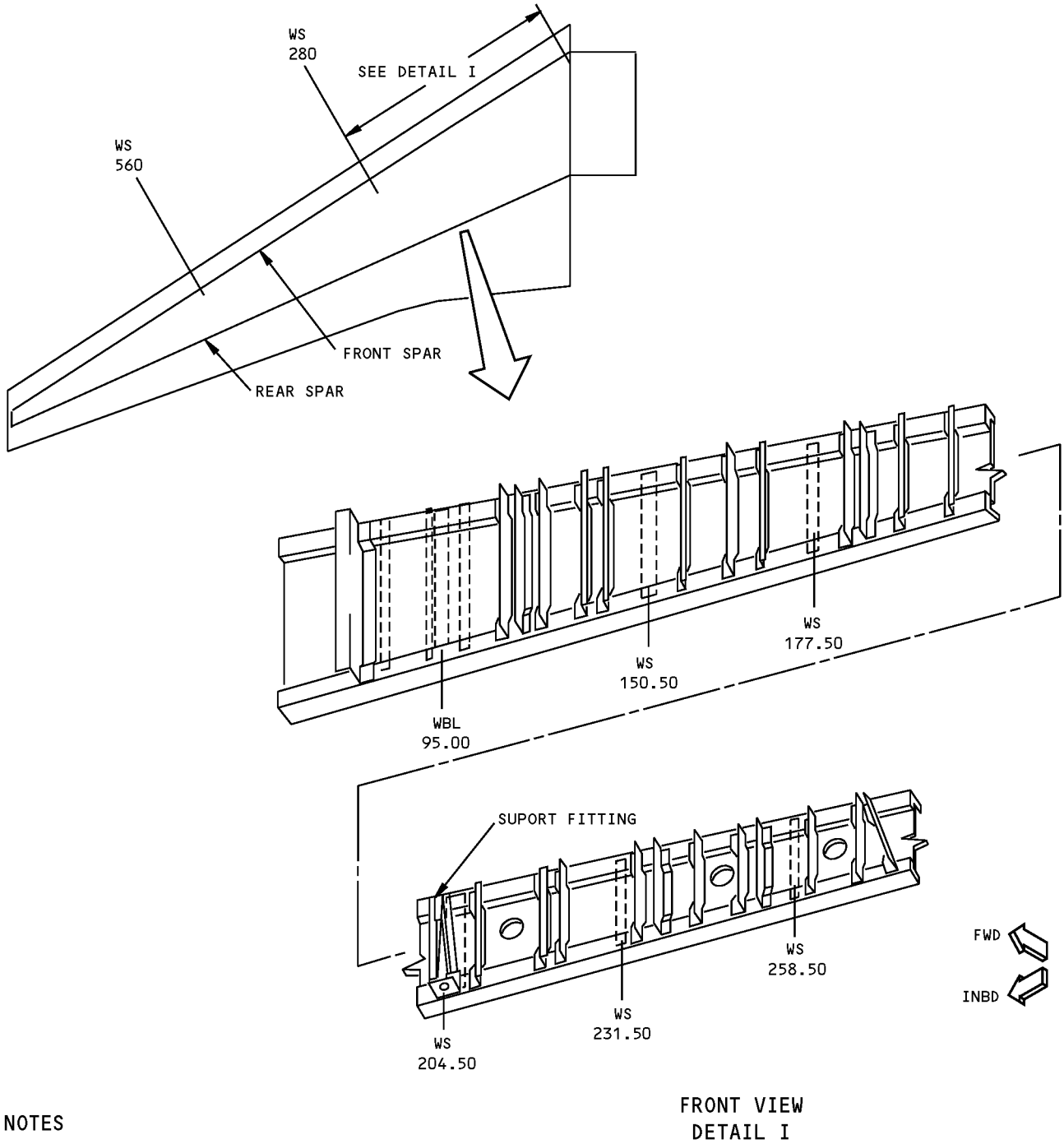

NOTES

- SEE 57-20-10 FOR STRUCTURE IDENTIFICATION AND ALLOWABLE DAMAGE INFORMATION
- NO TYPICAL REPAIR TO FITTINGS APPLICABLE. SPECIFIC REPAIRS TO FITTINGS WILL BE PROVIDED BASED ON SERVICE EXPERIENCE

**Outer Wing Front Spar Fitting Repair
Figure 201**

D634N201

57-20-90

REPAIR 2
Page 201
Jan 20/2005

**757-200
STRUCTURAL REPAIR MANUAL**

REPAIR 3 - TERMINAL FITTING REPAIR

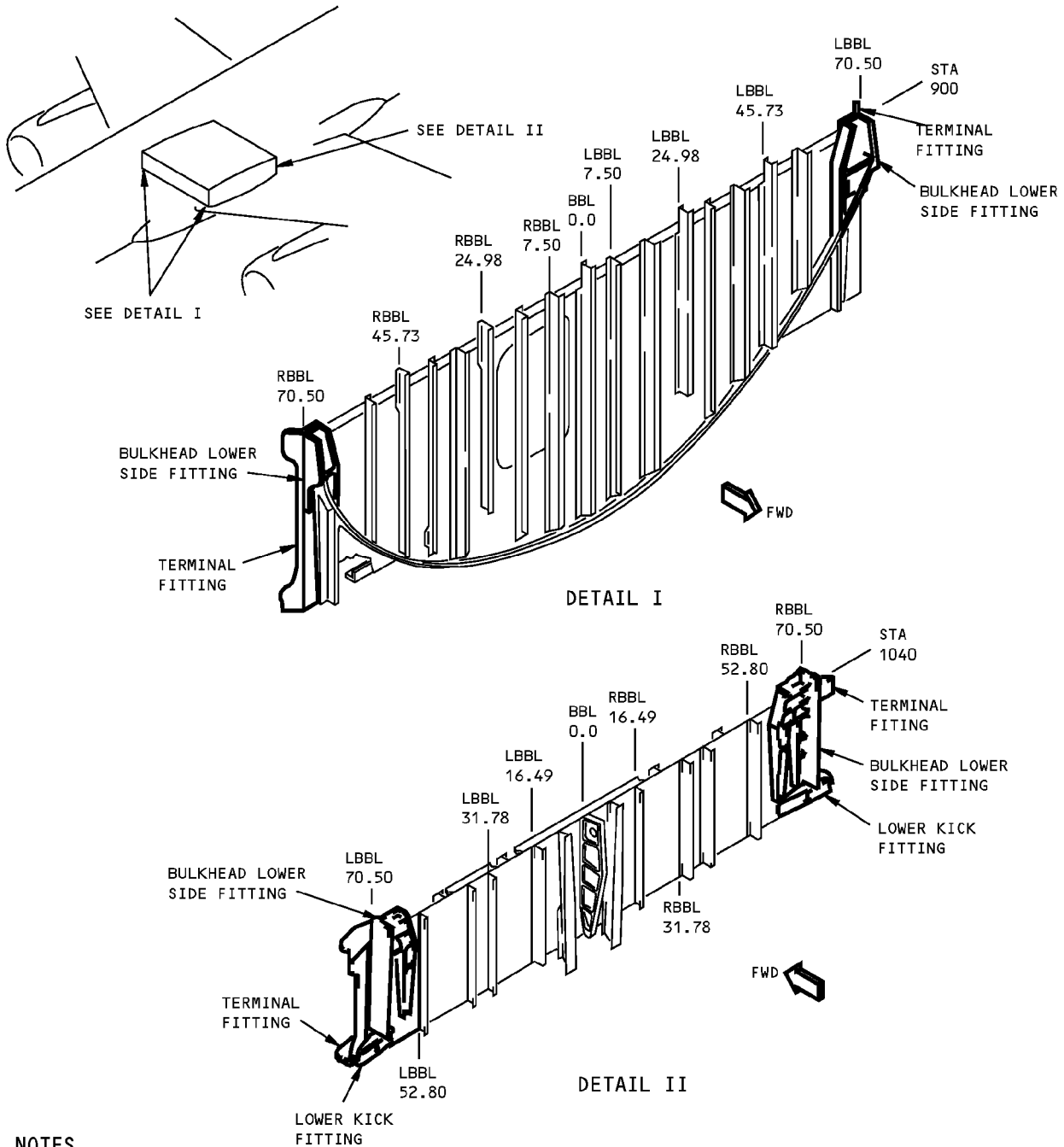

NOTES

- SEE 57-10-10 FOR STRUCTURE IDENTIFICATION AND ALLOWABLE DAMAGE INFORMATION
- NO TYPICAL REPAIR TO FITTINGS APPLICABLE. SPECIFIC REPAIR TO FITTINGS WILL BE PROVIDED BASED ON SERVICE EXPERIENCE

**Terminal Fitting Repair
Figure 201**

**757-200
STRUCTURAL REPAIR MANUAL**

IDENTIFICATION 1 - WING TIP SKIN

REF DWG
119N002
119N003

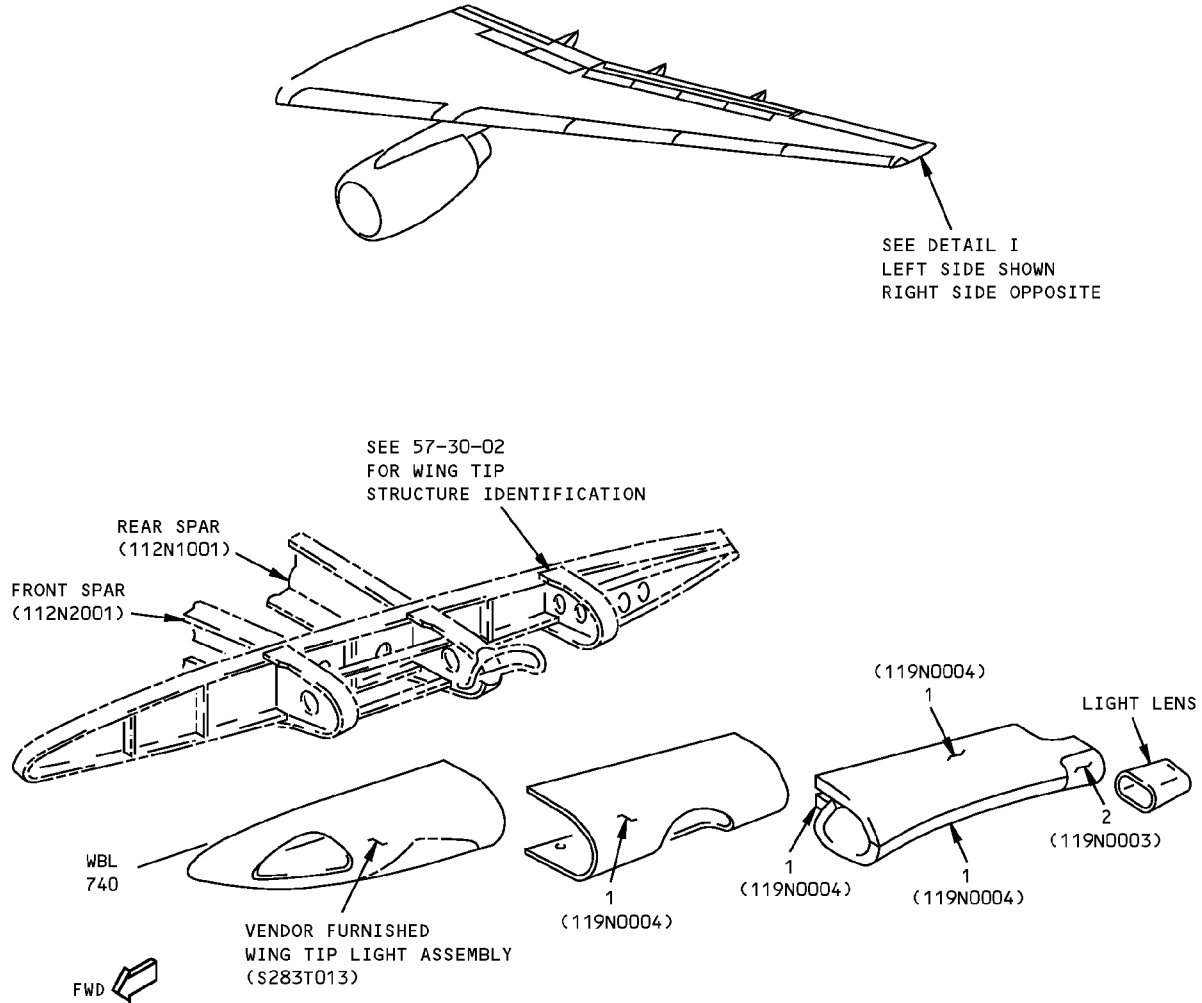

DETAIL I

ITEM	DESCRIPTION	GAGE	MATERIAL	EFFECTIVITY
1	SKIN PANEL	0.10	CLAD 2024-T42 (CHEM-MILLED TO 0.060 MIN)	
2	ACCESS DOOR	0.10	CLAD 2024-T42	

LIST OF MATERIALS FOR DETAIL I

**Wing Tip Skin Identification
Figure 1**



757-200

STRUCTURAL REPAIR MANUAL

ALLOWABLE DAMAGE 1 - WING TIP SKIN

This subject gives the allowable damage limits for the outer wing tip skin, as shown in Figure 101 of Allowable Damage 1.

Allowable Damage 1 is applicable to airplanes that have not had winglets installed.

Allowable Damage 1 is not applicable to airplanes that have had winglets installed after production of the airplane. Refer to Aviation Partners Boeing (APB) document AP57.2-0602 for the winglet data.

**Wing Tip Skin Allowable Damage
Figure 101 (Sheet 1 of 4)**

D634N201

ALLOWABLE DAMAGE 1
Page 101
57-30-01
Sep 20/2006

**757-200
STRUCTURAL REPAIR MANUAL**

REF DWG
119N002
119N003

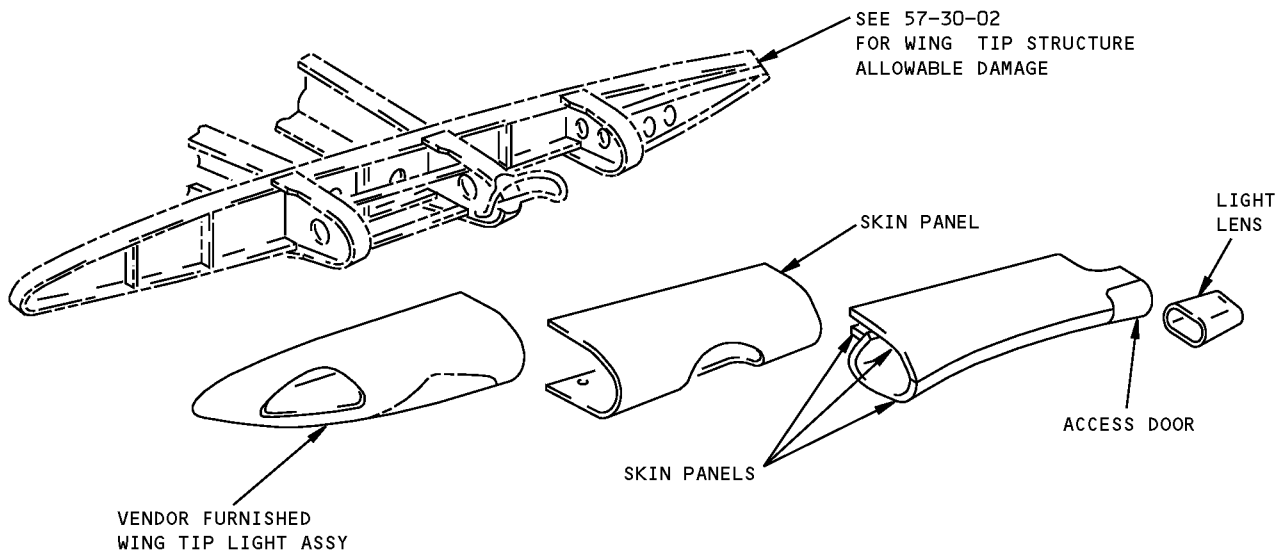
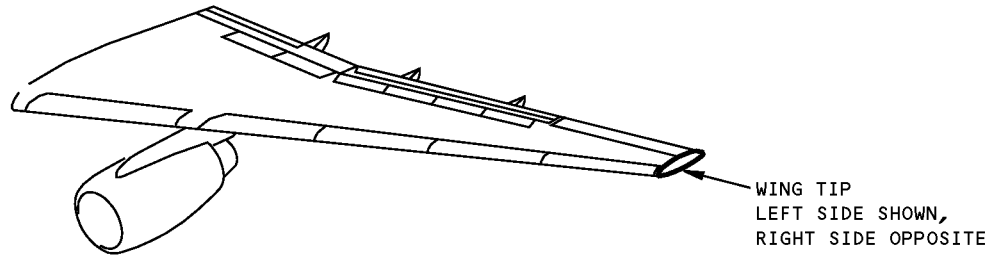

SKIN PANELS AND ACCESS DOOR ARE ALUMINUM

ITEM	CRACKS	NICKS, GOUGES AND CORROSION	DENTS	HOLES AND PUNCTURES
SKIN PANEL	A	B	SEE DETAIL III	C
ACCESS DOOR	A	B	SEE DETAIL III	C

**Wing Tip Skin Allowable Damage
Figure 101 (Sheet 2 of 4)**

757-200 STRUCTURAL REPAIR MANUAL

NOTES

- REFINISH REWORKED AREAS PER 51-20 OF THE MAINTENANCE MANUAL
- REFER TO 51-10-01 FOR AERODYNAMIC SMOOTHNESS REQUIREMENTS. WHERE THE DAMAGE EXCEEDS THE LIMITS SHOWN IN 51-10-01, CONSIDERATION SHOULD BE GIVEN TO THE LOSS OF PERFORMANCE INVOLVED

- A** CRACKS NOT ALLOWED EXCEPT FOR EDGE CRACKS WHICH MUST BE REMOVED PER DETAILS I AND V.
- B** REMOVE DAMAGE PER DETAILS II AND IV.
- C** CLEAN OUT DAMAGE UP TO 0.25 MAX DIA AND NOT CLOSER THAN 1.0 INCH TO FASTENER HOLE OR OTHER DAMAGE. FILL HOLE WITH A 2117-T3 OR T4 ALUMINUM RIVET INSTALLED WET WITH BMS 5-95 SEALANT. ALL OTHER HOLES TO BE REPAIRED.

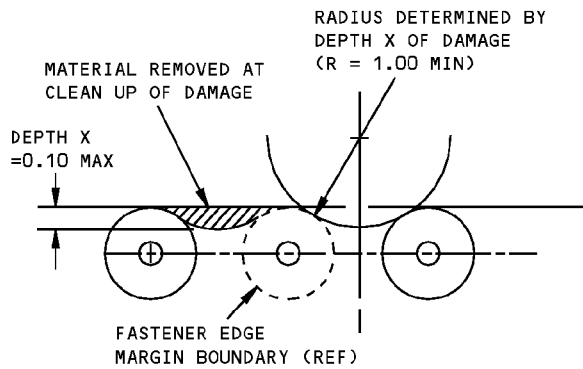

DAMAGE CLEAN UP OF EDGES WHERE FASTENER EDGE MARGINS DO NOT OVERLAP

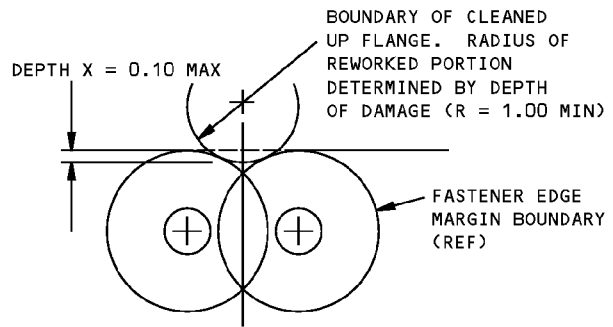

DAMAGE CLEAN UP OF EDGES WHERE FASTENER EDGE MARGINS OVERLAP

DETAIL I

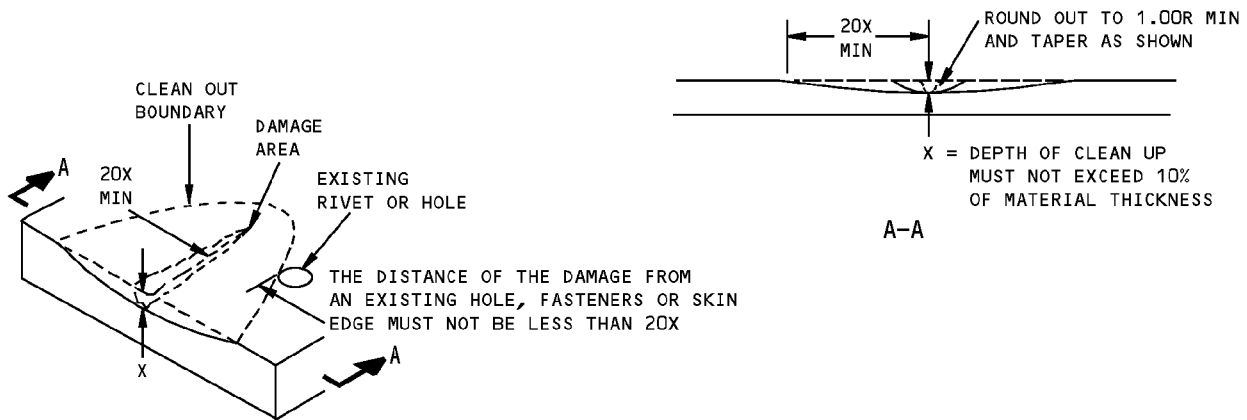

REMOVAL OF NICK OR GOUGE DAMAGE ON A SURFACE
DETAIL II

**Wing Tip Skin Allowable Damage
Figure 101 (Sheet 3 of 4)**

**757-200
STRUCTURAL REPAIR MANUAL**

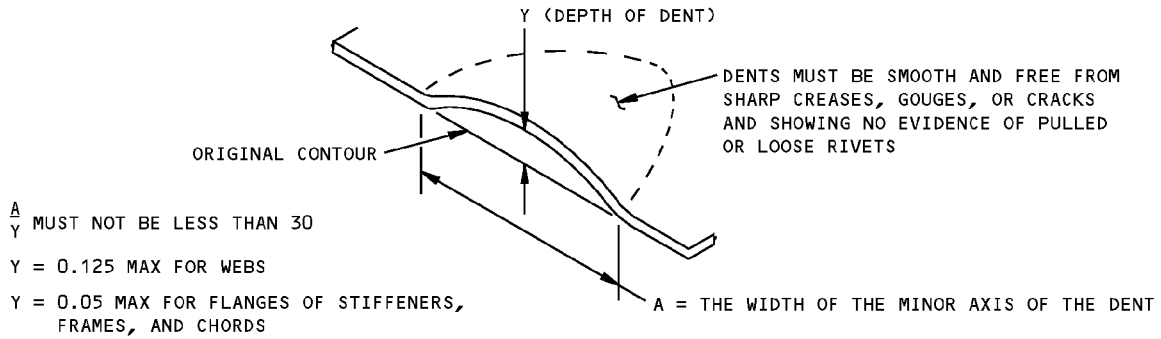

**ALLOWABLE DAMAGE FOR DENT
DETAIL III**

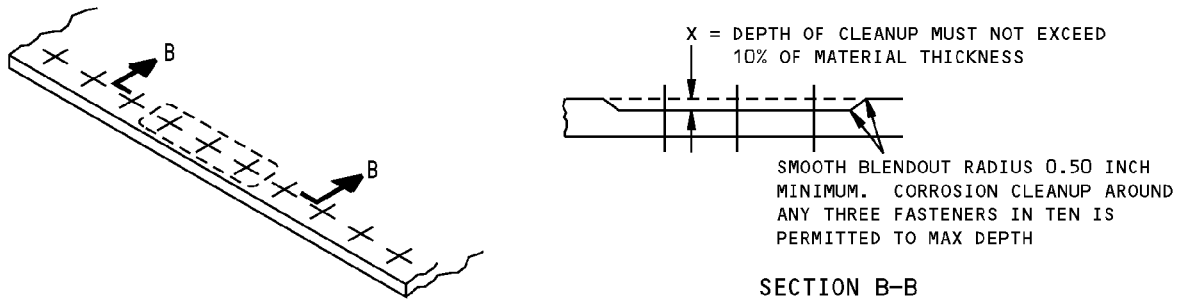

**CORROSION CLEANUP
DETAIL IV**

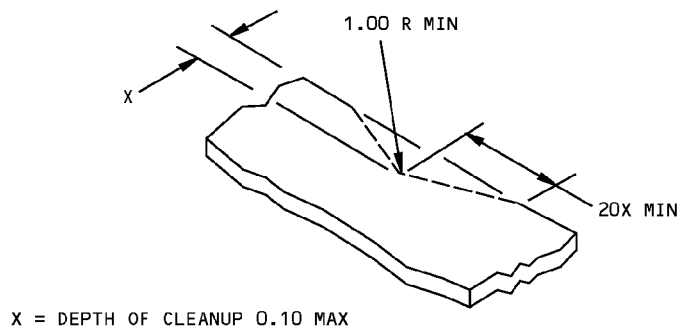

DETAIL V

**Wing Tip Skin Allowable Damage
Figure 101 (Sheet 4 of 4)**



757-200
STRUCTURAL REPAIR MANUAL

REPAIR 1 - WING TIP SKIN REPAIR

This subject gives the repair data for the wing tip skin, as shown in Figure 201 of Repair 1.

Repair 1 is applicable to airplanes that have not had winglets installed.

Repair 1 is not applicable to airplanes that have had winglets installed after production of the airplane. Refer to Aviation Partners Boeing (APB) document AP57.2-0602 for the winglet data.

Wing Tip Skin Repair
Figure 201 (Sheet 1 of 4)

D634N201

57-30-01

REPAIR 1
Page 201
Sep 20/2006

**757-200
STRUCTURAL REPAIR MANUAL**

REF DWG
119N002
119N003

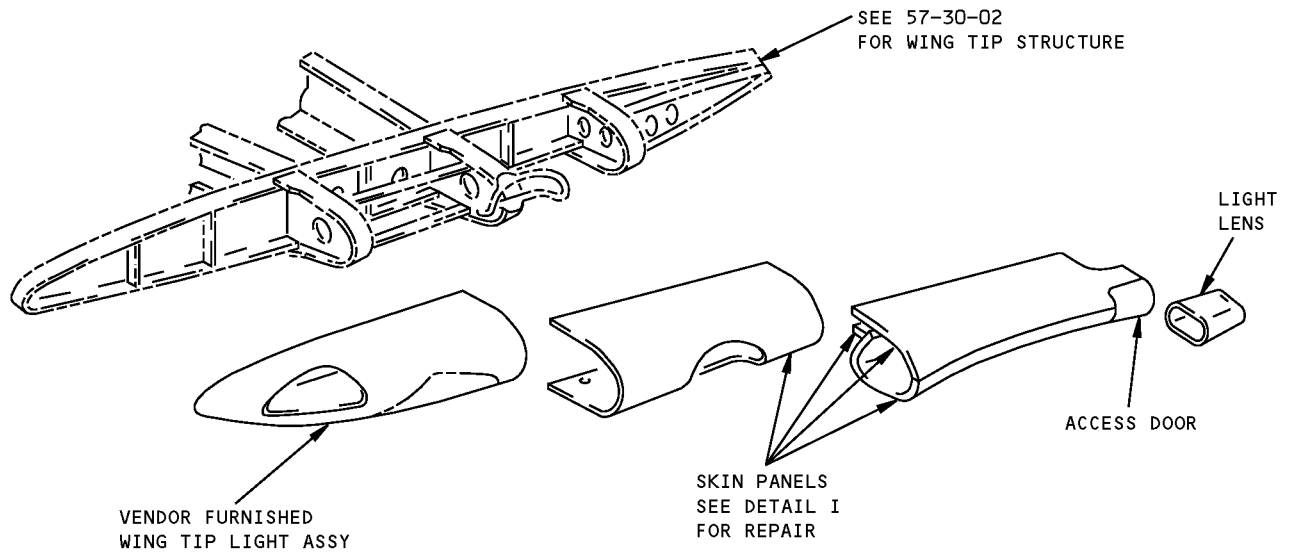
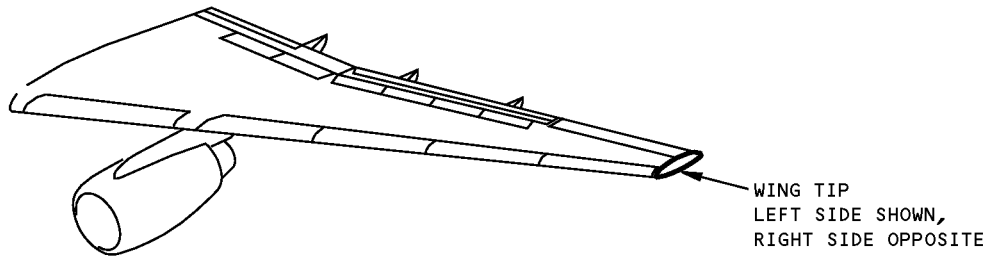

**Wing Tip Skin Repair
Figure 201 (Sheet 2 of 4)**



**757-200
STRUCTURAL REPAIR MANUAL**

REPAIR INSTRUCTIONS

1. Remove wing tip cap by removing attachment screws.
2. Cut out damaged area.
3. Make part 1 to suit inside contour of damaged area.
4. Make part 2 to suit original contour of damaged area.
5. Remove sharp edges and burrs from parts 1 and 2 and at damage area cutout.
6. Prior to assembly and installation of repair parts, alodize all raw edges of repair parts and damage cutout area per 51-20-01.
7. Install repair parts 1 and 2 with faying surface sealant BMS 5-95. Install fasteners wet with BMS 5-95 sealant.
8. In aerodynamic smoothness critical areas apply aerodynamic smoother BMS 5-79 per 51-10-01.
9. Restore original exterior finish per 757 Maintenance Manual, 51-21.
10. Replace wing tip cap.

SYMBOLS

◆ REPAIR FASTENER LOCATIONS

REPAIR MATERIAL			
PART		QTY	MATERIAL
1	DOUBLER	1	0.060 CLAD 2024-T4
2	FILLER	1	0.060 CLAD 2024-T4

NOTES

- REFER TO 51-40 FOR FASTENER CODE, REMOVAL AND INSTALLATION, HOLE SIZES AND EDGE MARGINS
- REFER TO 51-20-05 FOR SEALING OF REPAIRS

**Wing Tip Skin Repair
Figure 201 (Sheet 3 of 4)**

**757-200
STRUCTURAL REPAIR MANUAL**

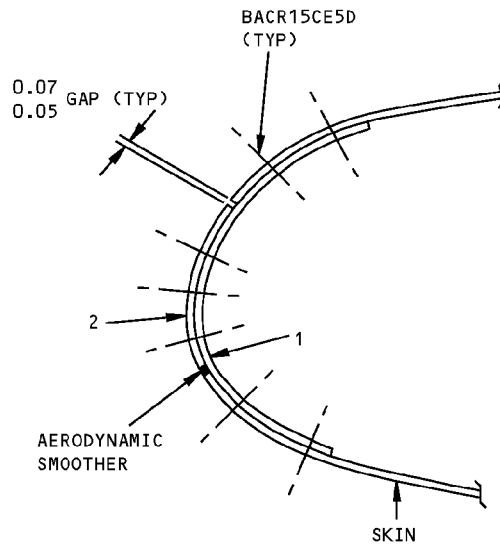
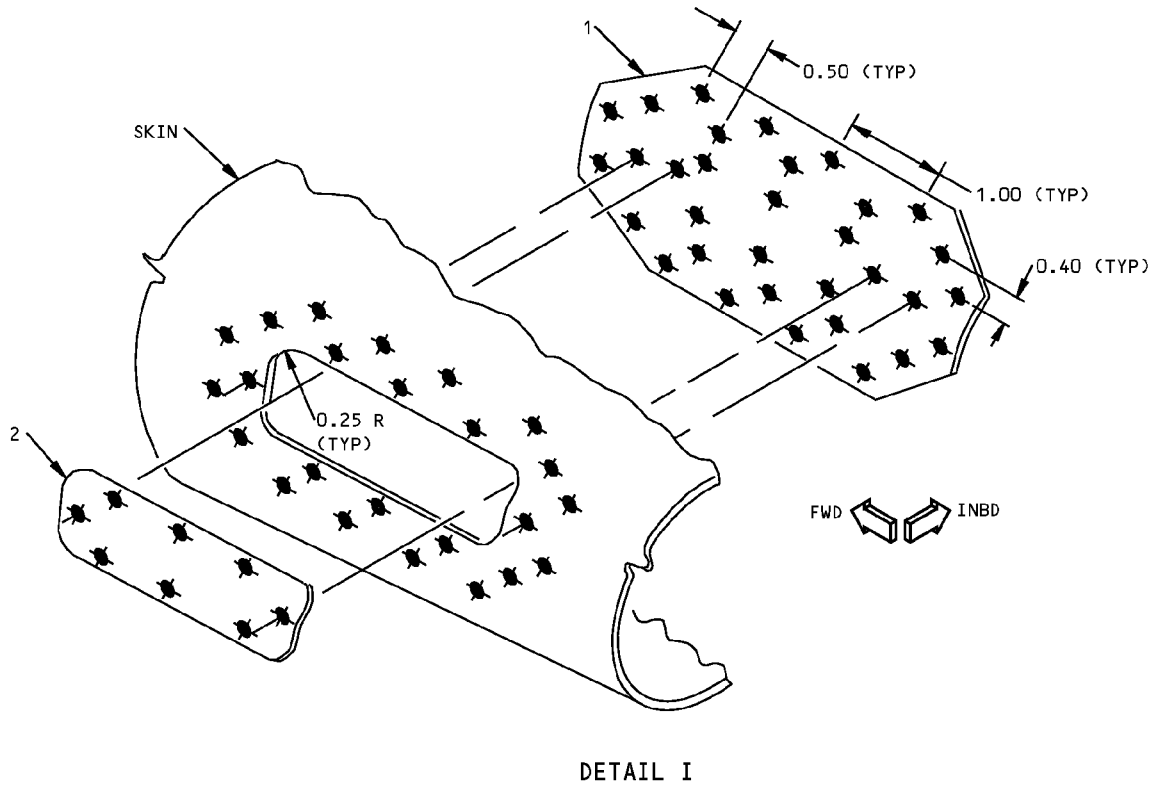

**Wing Tip Skin Repair
Figure 201 (Sheet 4 of 4)**

**757-200
STRUCTURAL REPAIR MANUAL**

IDENTIFICATION 1 - WING TIP STRUCTURE

REF DWG
119N0002
119N0003

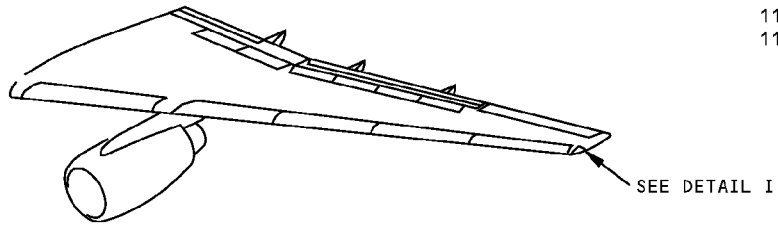

LEFT WING SHOWN,
RIGHT WING OPPOSITE

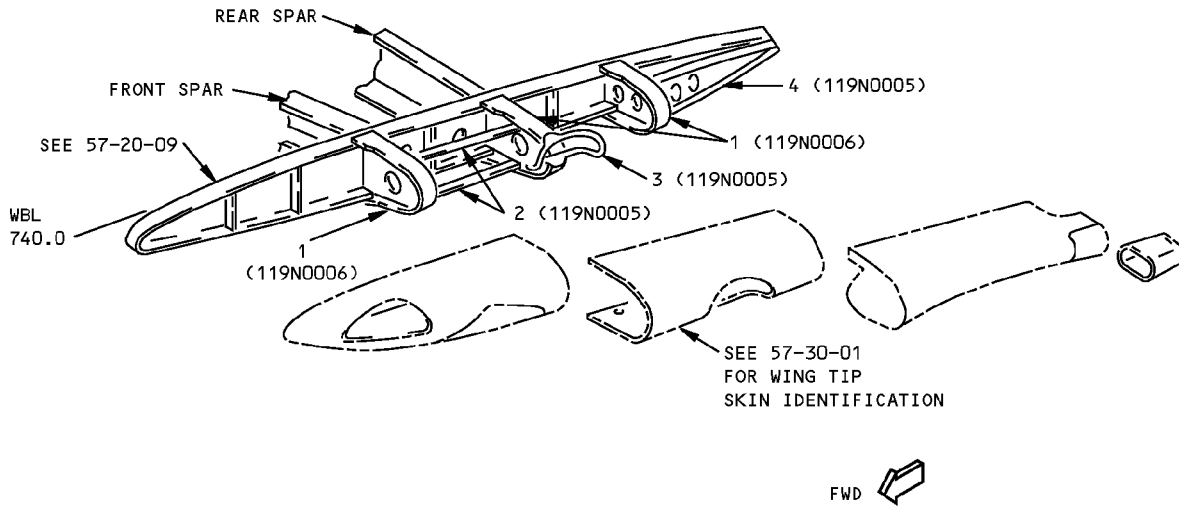

DETAIL I

ITEM	DESCRIPTION	GAGE	MATERIAL	EFFECTIVITY
1	RIB	0.040	CLAD 2024-T42	
2	INTERCOSTAL	0.063	CLAD 2024-T42	
3	STRAP	0.063	CLAD 2024-T42	
4	WEB	0.063	CLAD 2024-T42	

LIST OF MATERIALS FOR DETAIL I

**Wing Tip Structure Identification
Figure 1**



757-200

STRUCTURAL REPAIR MANUAL

ALLOWABLE DAMAGE 1 - WING TIP STRUCTURE

This subject gives the allowable damage limits for the outer wing tip structure, as shown in Figure 101 of Allowable Damage 1.

Allowable Damage 1 is applicable to airplanes that have not had winglets installed.

Allowable Damage 1 is not applicable to airplanes that have had winglets installed after production of the airplane. Refer to Aviation Partners Boeing (APB) document AP57.2-0602 for the winglet data.

**Wing Tip Structure Allowable Damage
Figure 101 (Sheet 1 of 4)**

D634N201

ALLOWABLE DAMAGE 1
Page 101
57-30-02 Sep 20/2006

**757-200
STRUCTURAL REPAIR MANUAL**

REF DWG
119N0002
119N0003

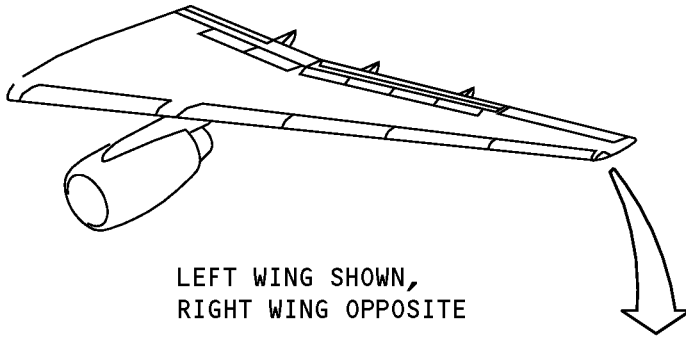

LEFT WING SHOWN,
RIGHT WING OPPOSITE

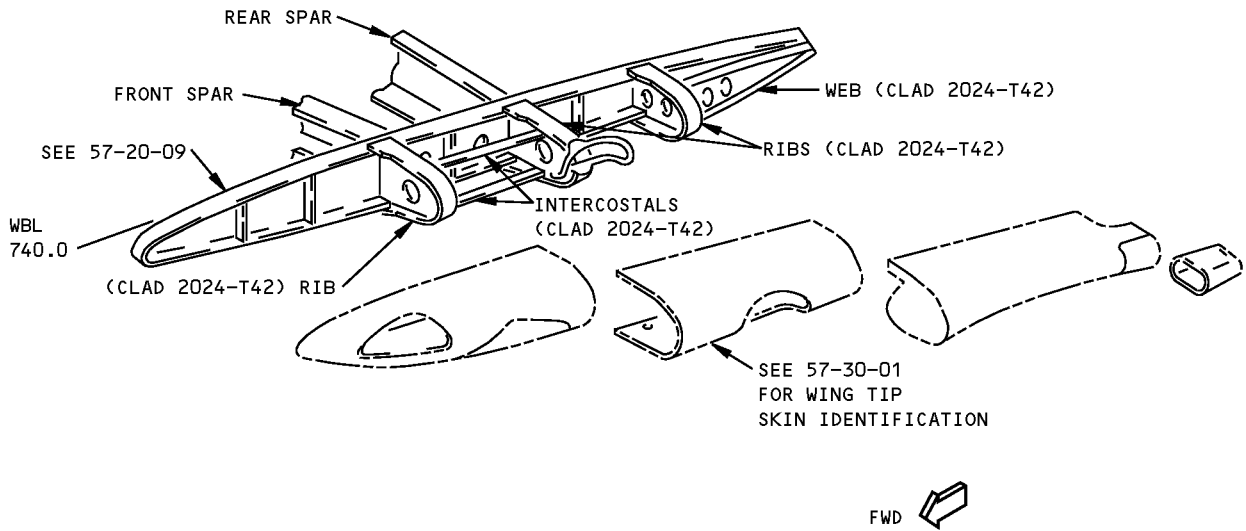

ITEM	CRACKS	NICKS, GOUGES AND CORROSION	DENTS	HOLES AND PUNCTURES
RIB	B	C	SEE DETAIL III	E
INTERCOSTAL	B	C	SEE DETAIL III	E
WEB	A	D	SEE DETAIL III	E

**Wing Tip Structure Allowable Damage
Figure 101 (Sheet 2 of 4)**

**757-200
STRUCTURAL REPAIR MANUAL**

NOTES

- REFINISH REWORKED AREAS PER 51-20 OF THE MAINTENANCE MANUAL.
- A** CRACKS NOT ALLOWED EXCEPT FOR EDGE CRACKS WHICH MUST BE REMOVED PER DETAILS I AND V.
- B** CRACKS NOT ALLOWED EXCEPT FOR EDGE CRACKS WHICH MUST BE REMOVED PER DETAILS I AND VI.
- C** REMOVE DAMAGE PER DETAILS II AND IV.
- D** REMOVE DAMAGE PER DETAILS II, IV, AND V.
- E** CLEAN PUNCTURE OUT WITH 0.25 MAX DIA HOLE AND NOT CLOSER THAN 1.0 INCH TO FASTENER HOLE OR OTHER DAMAGE. FILL HOLE WITH A 2117-T3 OR T4 ALUMINUM RIVET INSTALLED WET WITH BMS 5-95 SEALANT. ALL OTHER HOLES TO BE REPAIRED.

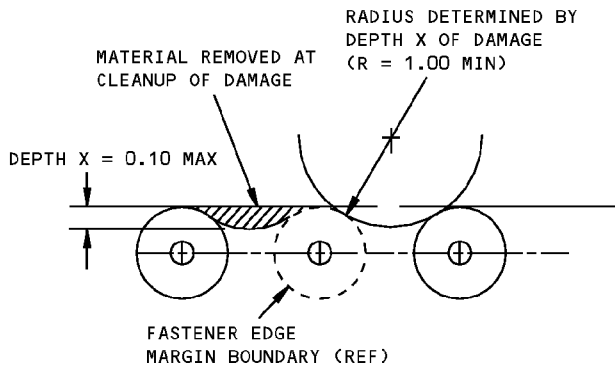

DAMAGE CLEANUP OF EDGES WHERE FASTENER EDGE MARGINS DO NOT OVERLAP

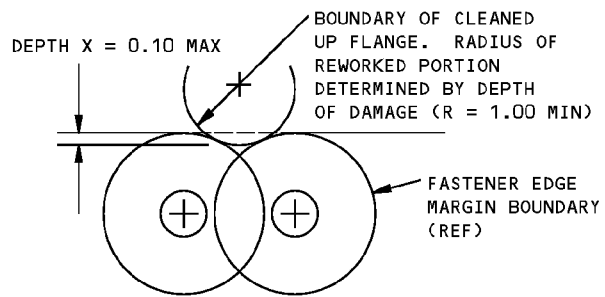

DAMAGE CLEANUP OF EDGES WHERE FASTENER EDGE MARGINS OVERLAP

DETAIL I

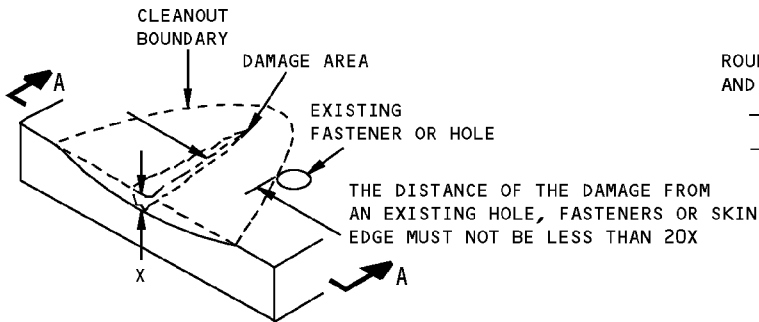

**REMOVAL OF NICK, GOUGE AND SCRATCH DAMAGE ON A SURFACE
DETAIL II**

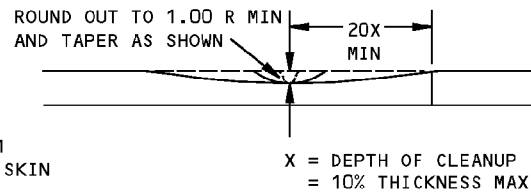

SECTION A-A

**Wing Tip Structure Allowable Damage
Figure 101 (Sheet 3 of 4)**

**757-200
STRUCTURAL REPAIR MANUAL**

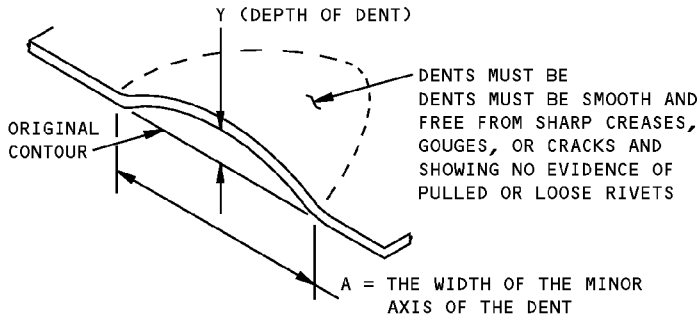

$\frac{A}{Y}$ MUST NOT BE LESS THAN 30

**ALLOWABLE DAMAGE FOR DENT
DETAIL III**

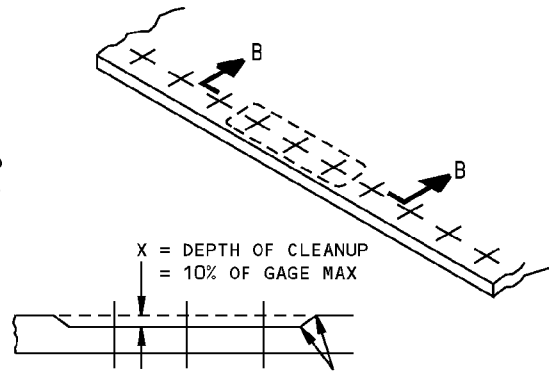

SECTION B-B

**CORROSION CLEANUP
DETAIL IV**

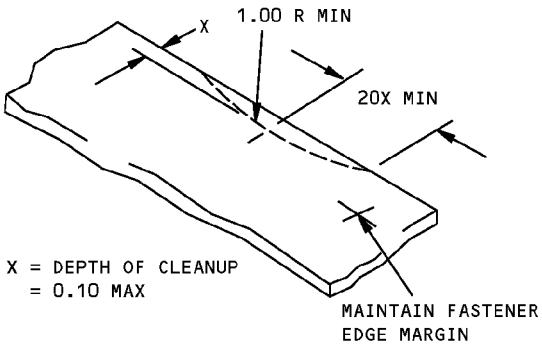

**REMOVAL OF NICK OR CRACK
DAMAGE ON AN EDGE
DETAIL V**

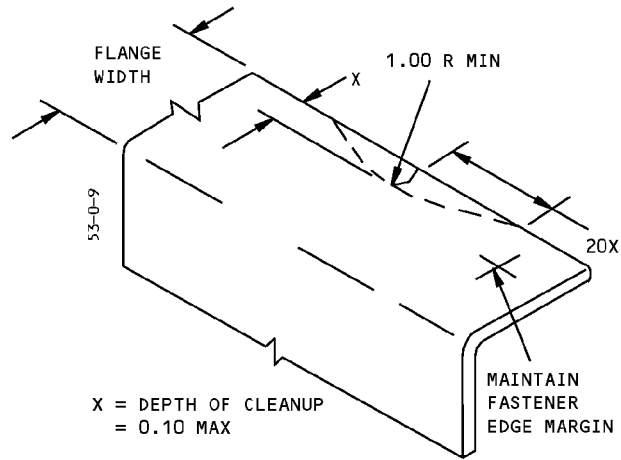

**REMOVAL OF NICK OR CRACK
DAMAGE ON AN EDGE
DETAIL VI**

**Wing Tip Structure Allowable Damage
Figure 101 (Sheet 4 of 4)**



757-200

STRUCTURAL REPAIR MANUAL

REPAIR GENERAL - WING TIP STRUCTURE REPAIR

This subject gives the repair data for the wing tip structure, as shown in Figure 201 of Repair 1.

Repair 1 is applicable to airplanes that have not had winglets installed.

Repair 1 is not applicable to airplanes that have had winglets installed after production of the airplane. Refer to Aviation Partners Boeing (APB) document AP57.2-0602 for the winglet data.

**Wing Tip Structure Repair
Figure 201 (Sheet 1 of 2)**

D634N201

57-30-02

REPAIR GENERAL
Page 201
Sep 20/2006

**757-200
STRUCTURAL REPAIR MANUAL**

REF DWG
119N0002
119N0003

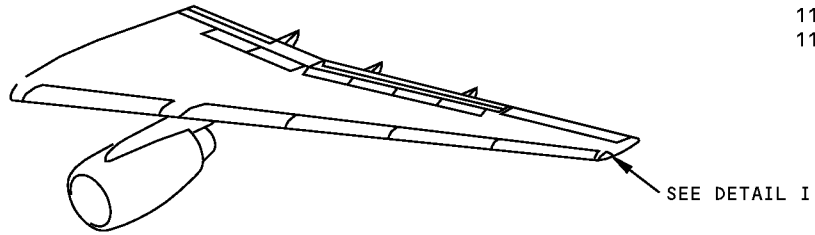

LEFT WING SHOWN,
RIGHT WING OPPOSITE

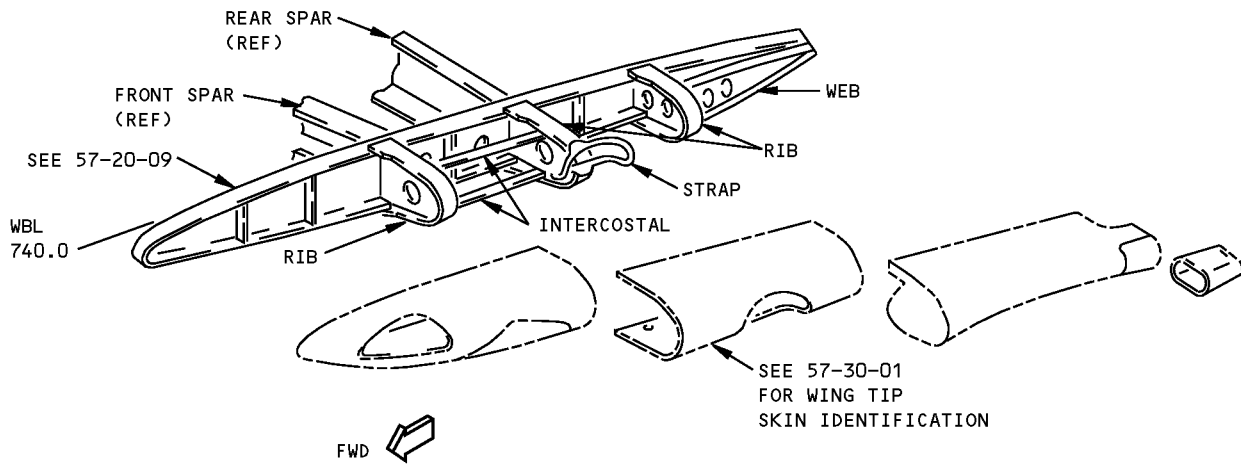

DETAIL I

NOTES

- SEE 51-70-11 FOR FORMED SECTION REPAIRS
- SEE 51-70-13 FOR WEB REPAIRS

**Wing Tip Structure Repair
Figure 201 (Sheet 2 of 2)**

D634N201

REPAIR GENERAL
Page 202
57-30-02
Sep 20/2006

**757-200
STRUCTURAL REPAIR MANUAL**

IDENTIFICATION 1 - WING FIXED LEADING EDGE SKIN

REFERENCE DRAWINGS
114N1001
114N2001

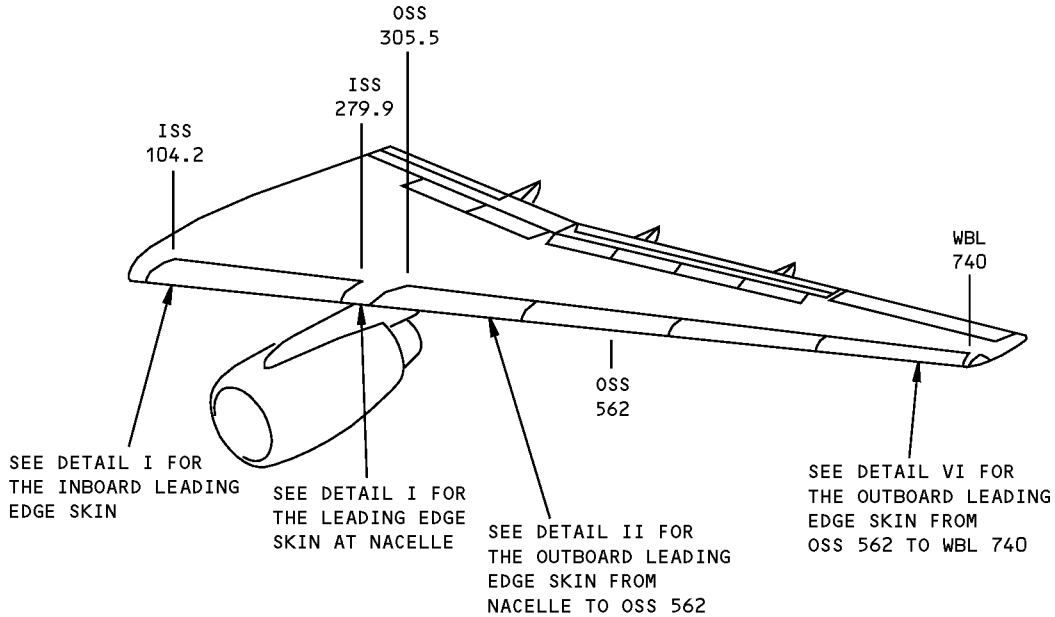

LEFT SIDE IS SHOWN, RIGHT SIDE IS OPPOSITE, UNLESS OTHERWISE GIVEN

NOTES:

- | | |
|---|--|
| <p>A RIGHT SIDE ONLY</p> <p>B FOR AIRPLANES WITH CUM LINE NUMBERS 1 THRU 40, 42</p> <p>C FOR AIRPLANES NOT IN B</p> <p>D FOR CUM LINE NUMBERS: 1 THRU 768.</p> <p>E FOR CUM LINE NUMBERS: 769 THRU 949.</p> <p>F FOR CUM LINE NUMBERS: 950 AND ON.</p> | <p>G PLY ORIENTATION CONVENTION, DEGREES INDICATED IS PARALLEL TO THE FABRIC WARP DIRECTION</p> <p>H FIBERGLASS/EPOXY FABRIC AS GIVEN IN BMS 8-79, CLASS III, GRADE B, TYPE 1581</p> <p>I FIBERGLASS/EPOXY FABRIC AS GIVEN IN BMS 8-79, CLASS III, GRADE B, TYPE 7781 (OPTIONAL: 1581)</p> <p>J 2 MIL GRAY TEDLAR AS GIVEN IN BAC 5317-2 TO INTERIOR SURFACE</p> |
|---|--|

**Wing Fixed Leading Edge Skin Identification
Figure 1 (Sheet 1 of 12)**

**757-200
STRUCTURAL REPAIR MANUAL**

REF DWG
114N1601
114N1501
114N1801

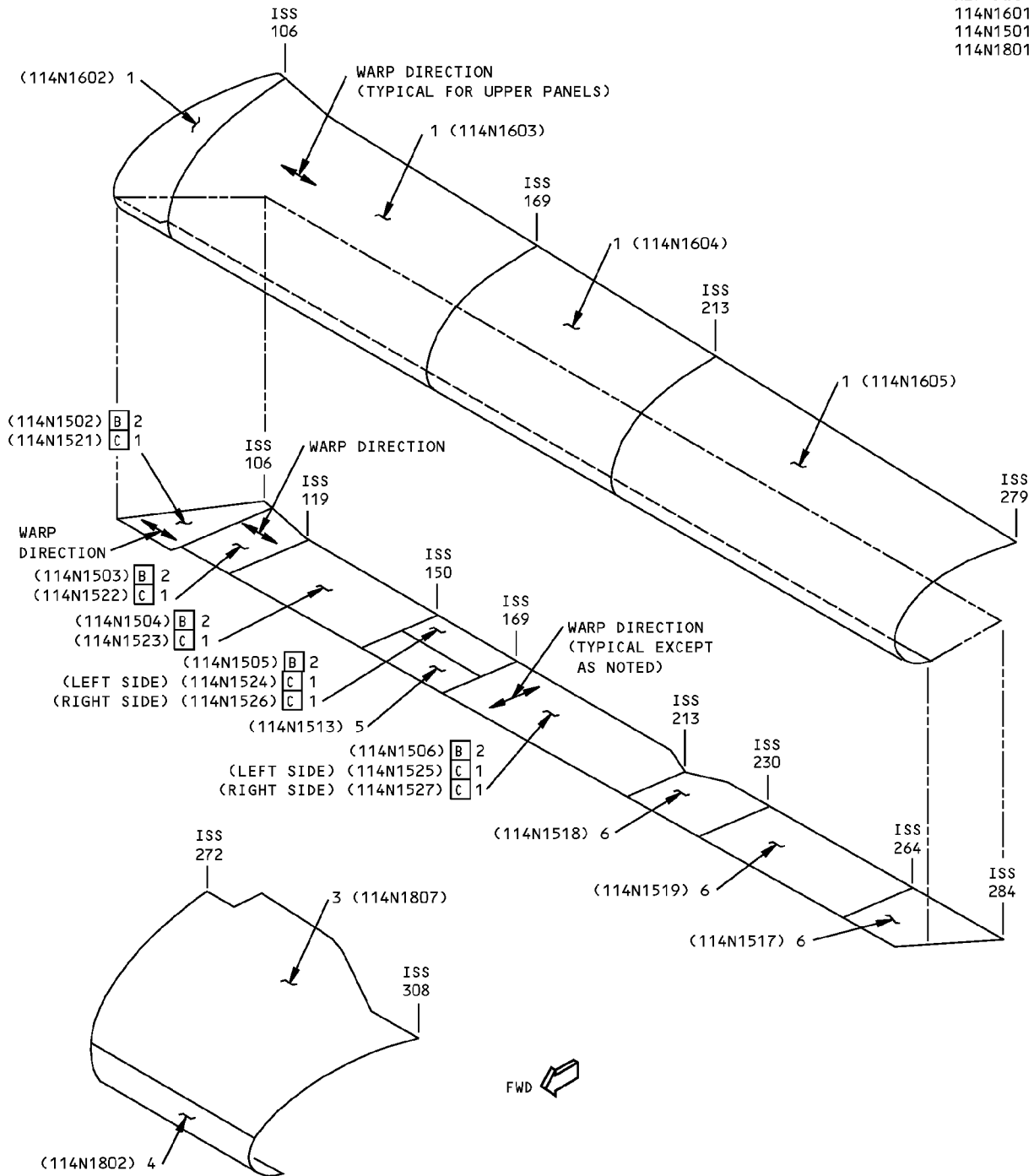

LEADING EDGE SKIN AT NACELLE

DETAIL I



**Wing Fixed Leading Edge Skin Identification
Figure 1 (Sheet 2 of 12)**

IDENTIFICATION 1
Page 2
Jan 20/2005

57-41-01

D634N201



**757-200
STRUCTURAL REPAIR MANUAL**

ITEM	DESCRIPTION	GAGE	MATERIAL	EFFECTIVITY
1	PANEL ASSY SKIN		GLASS FABRIC HONEYCOMB SANDWICH GLASS FABRIC REINFORCED EPOXY PER BMS 8-139, TYPE 181, 350°F (177°C) CURE, 2 PLIES ON EACH SURFACE. INTERIOR SURFACE OF GRAY TEDLAR FILM PLUS SCOTCH BRAND ALUMINUM FOIL TAPE (Y-427) OR BMS 8-289, TYPE 0/350/2/1100/025	
	CORE		NONMETALLIC HONEYCOMB PER BMS 8-124, CLASS 5, TYPE V, GRADE 3.0	
2	PANEL ASSY SKIN		ARAMID/EPOXY HONEYCOMB SANDWICH ARAMID REINFORCED EPOXY FABRIC PER BMS 8-218 STYLE 285, 350°F (177°C) CURE, 2 PLIES ON EACH SURFACE	
	CORE		NONMETALLIC HONEYCOMB BMS 8-124, CLASS 5, TYPE V, GRADE 3.0	
3	PANEL ASSY SKIN		GLASS FABRIC/EPOXY HONEYCOMB SANDWICH GLASS FABRIC REINFORCED EPOXY PER BMS 8-139, TYPE 181, 350°F (177°C) CURE, 2 PLIES ON EACH SURFACE	
	CORE	1.0	NONMETALLIC HONEYCOMB PER BMS 8-124, CLASS 5, TYPE V, GRADE 3.0	
4	NOSE SKIN	0.063	7075-T6	
5	BLOW OUT PANEL ASSY SKIN		GLASS FABRIC HONEYCOMB SANDWICH GLASS FABRIC REINFORCED EPOXY PER BMS 8-139, TYPE 181, 350°F (177°C) CURE, 2 PLIES ON EACH SURFACE	
	CORE		NONMETALLIC HONEYCOMB PER BMS 8-124, CLASS 5, TYPE V, GRADE 3.0	
6	PANEL ASSY SKIN		GLASS FABRIC HONEYCOMB SANDWICH GLASS FABRIC REINFORCED EPOXY PER BMS 8-139, TYPE 181, 350°F (177°C) CURE, 2 PLIES ON EACH SURFACE	
	CORE		NONMETALLIC HONEYCOMB PER BMS 8-124, CLASS 5, TYPE V, GRADE 3.0	

LIST OF MATERIALS FOR DETAIL I

**Wing Fixed Leading Edge Skin Identification
Figure 1 (Sheet 3 of 12)**

IDENTIFICATION 1
Page 3
Jan 20/2005

57-41-01

D634N201

757-200 STRUCTURAL REPAIR MANUAL

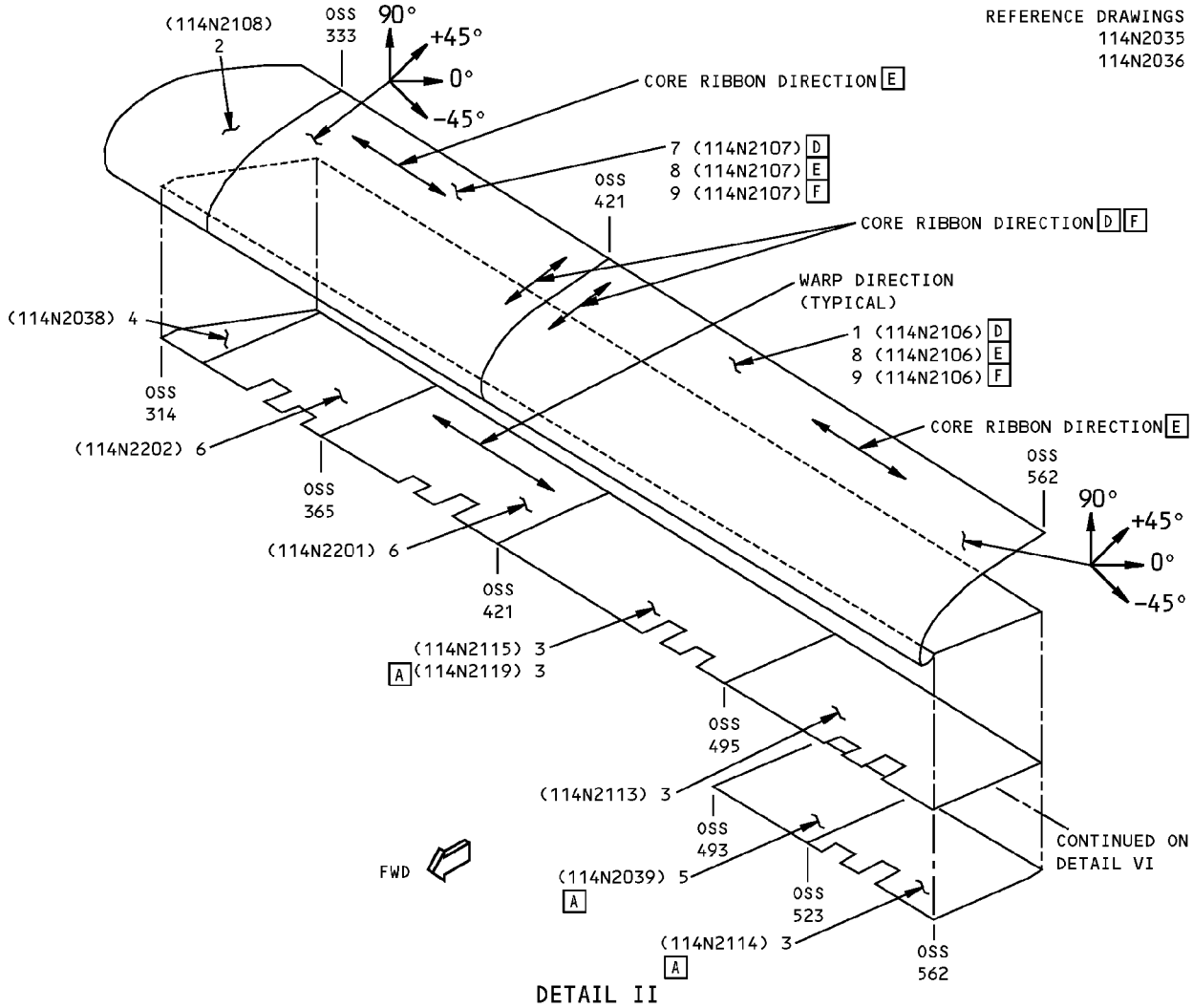

DETAIL II

ITEM	DESCRIPTION	GAGE	MATERIAL	EFFECTIVITY
1	PANEL ASSEMBLY OUTER SKIN CORE INNER SKIN		GLASS FABRIC HONEYCOMB SANDWICH OUTER PLY (2 PLY) - GLASS FABRIC REINFORCED EPOXY PER BMS 8-79, TYPE 120, 250°F (121°C) CURE INNER PLY (1 PLY) - GLASS FABRIC REINFORCED EPOXY PER BMS 8-79, TYPE 1581, 250°F (121°C) CURE NONMETALLIC HONEYCOMB PER BMS 8-124, CLASS 4, TYPE V, GRADE 3.0 GLASS FABRIC REINFORCED EPOXY PER BMS 8-79, TYPE 1581 (2 PLIES), 250°F (121°C) CURE	[D]

LIST OF MATERIALS FOR DETAIL II (CONT)

Wing Fixed Leading Edge Skin Identification
Figure 1 (Sheet 4 of 12)



**757-200
STRUCTURAL REPAIR MANUAL**

ITEM	DESCRIPTION	GAGE	MATERIAL	EFFECTIVITY
2	PANEL ASSEMBLY OUTER SKIN CORE INNER SKIN		GLASS FABRIC HONEYCOMB SANDWICH OUTER PLY (2 PLY) - GLASS FABRIC REINFORCED EPOXY PER BMS 8-139, TYPE 120, 350°F (177°C) CURE INNER PLY (1 PLY) - GLASS FABRIC REINFORCED EPOXY PER BMS 8-139, TYPE 181, 350°F (177°C) CURE NONMETALLIC HONEYCOMB PER BMS 8-124, CLASS 5, TYPE V, GRADE 3.0 GLASS FABRIC REINFORCED EPOXY PER BMS 8-139, TYPE 181 (2 PLY), 350°F (177°C) CURE INTERIOR SURFACE OF GRAY TEDLAR FILM PLUS SCOTCH BRAND ALUMINUM FOIL TAPE (Y-427) OR BMS 8-289 TYPE 0/350/2/1100/025	
3	PANEL ASSEMBLY INNER AND OUTER SKIN CORE		FIBERGLASS/ARAMID/EPOXY HONEYCOMB SANDWICH OUTER PLIES (ONE ON EACH SURFACE) GLASS EPOXY FABRIC PER BMS 8-79, TYPE 120, 250°F (121°C) CURE CENTER PLIES (ONE ON EACH SURFACE) ARAMID EPOXY FABRIC PER BMS 8-219, STYLE 120, 250°F (121°C) CURE BOND PLIES (ONE ON EACH SURFACE) ARAMID EPOXY FABRIC PER BMS 8-219, SYLE 285, 250°F (121°C) CURE NONMETALLIC HONEYCOMB PER BMS 8-124, CLASS 4, TYPE V, GRADE 3.0	
4	DOOR	0.090	CLAD 7075-T6	
5	DOOR PANEL	0.100	2024-T3 - CHEM MILLED	
6	PANEL ASSEMBLY INNER AND OUTER SKIN CORE		GLASS FABRIC HONEYCOMB SANDWICH GLASS FABRIC REINFORCED EPOXY BMS 8-79, TYPE 120, 250°F (121°C) CURE (3 PLIES EACH SIDE) NONMETALLIC HONEYCOMB PER BMS 8-124, CLASS 4, TYPE V, GRADE 3.0 INTERIOR SURFACE OF GRAY TEDLAR FILM PLUS SCOTCH BRAND ALUMINUM FOIL TAPE (Y-427) OR BMS 8-289 TYPE 0/350/2/1100/025	
7	PANEL ASSEMBLY OUTER SKIN CORE INNER SKIN		GLASS FABRIC HONEYCOMB SANDWICH OUTER PLY (2 PLY)) - GLASS FABRIC REINFORCED EPOXY PER BMS 8-79, TYPE 120, 250°F (121°C) CURE INNER PLY (1 PLY) - GLASS FABRIC REINFORCED EPOXY PER BMS 8-79, TYPE 1581, 250°F (121°C) CURE NONMETALLIC HONEYCOMB PER BMS 8-124, CLASS 4, TYPE V, GRADE 3.0 GLASS FABRIC REINFORCED EPOXY PER BMS 8-79, TYPE 1581, 250°F (121°C) CURE (2 PLIES) INTERIOR SURFACE OF GRAY TEDLAR FILM PLUS SCOTCH BRAND ALUMINUM FOIL TAPE (Y-427) OR BMS 8-289 TYPE 0/350/2/1100/025	D

LIST OF MATERIALS FOR DETAIL II

**Wing Fixed Leading Edge Skin Identification
Figure 1 (Sheet 5 of 12)**

IDENTIFICATION 1
Page 5
Jan 20/2005

57-41-01

D634N201



757-200
STRUCTURAL REPAIR MANUAL

ITEM	DESCRIPTION	GAGE	MATERIAL	EFFECTIVITY
8	PANEL ASSEMBLY SKIN CORE		SEE DETAIL III NONMETALLIC HONEYCOMB AS GIVEN IN BMS 8-124, CLASS 4, TYPE V, GRADE 3.0	E
9	PANEL ASSEMBLY SKIN CORE		SEE DETAIL IV AND V NONMETALLIC HONEYCOMB AS GIVEN IN BMS 8-124, CLASS 4, TYPE V, GRADE 3.0	F

LIST OF MATERIALS FOR DETAIL II (CONT)

Wing Fixed Leading Edge Skin Identification
Figure 1 (Sheet 6 of 12)

D634N201

57-41-01

IDENTIFICATION 1
Page 6
Jan 20/2005

**757-200
STRUCTURAL REPAIR MANUAL**

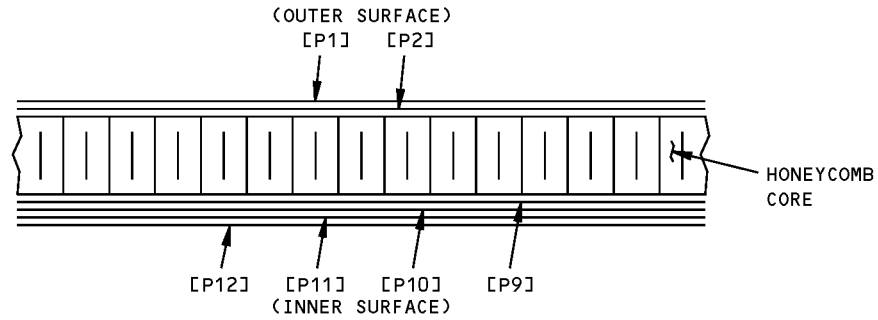

ITEM NO.	PLY NO.	MATERIAL	PLY ORIENTATION G
8	P1, P2, P9, P10, P11, P12	I	0° OR 90°

PLY TABLE **E**

DETAIL III

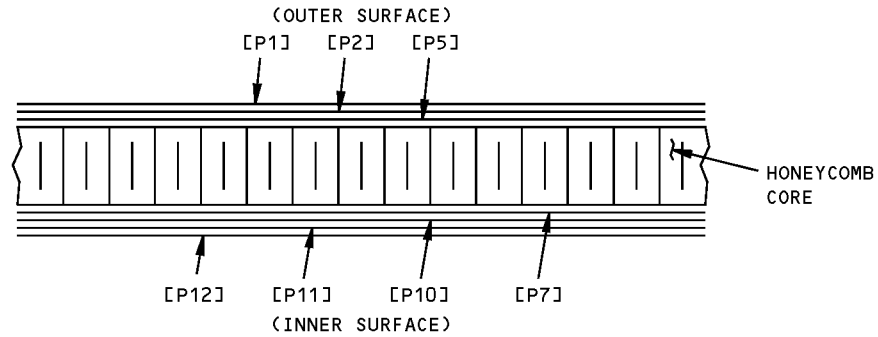

ITEM NO.	PLY NO.	MATERIAL	PLY ORIENTATION G
9	P1, P3, P7, P11	I	0° OR 90°
	P2, P10	I	+45° OR -45°
	P12	J	N/A

PLY TABLE **F**

(BETWEEN OSS 453.60 AND OSS 562.10)

DETAIL IV

**Wing Fixed Leading Edge Skin Identification
Figure 1 (Sheet 7 of 12)**

**757-200
STRUCTURAL REPAIR MANUAL**

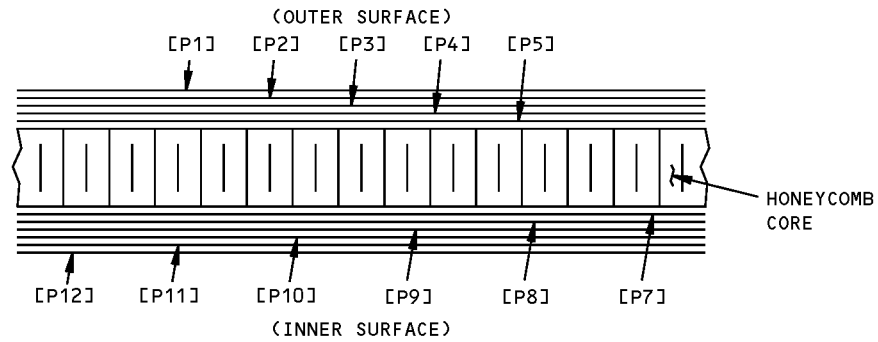

ITEM NO.	PLY NO.	MATERIAL	PLY ORIENTATION [G]
9	P1, P3, P4, P5, P7, P8, P9, P11	[I]	0° OR 90°
	P2, P10	[I]	+45° OR -45°
	P12	[J]	N/A

PLY TABLE [F]
(BETWEEN OSS 421.90 AND OSS 453.60)

DETAIL V

**Wing Fixed Leading Edge Skin Identification
Figure 1 (Sheet 8 of 12)**

**757-200
STRUCTURAL REPAIR MANUAL**

REFERENCE DRAWINGS
114N203E
114N203E

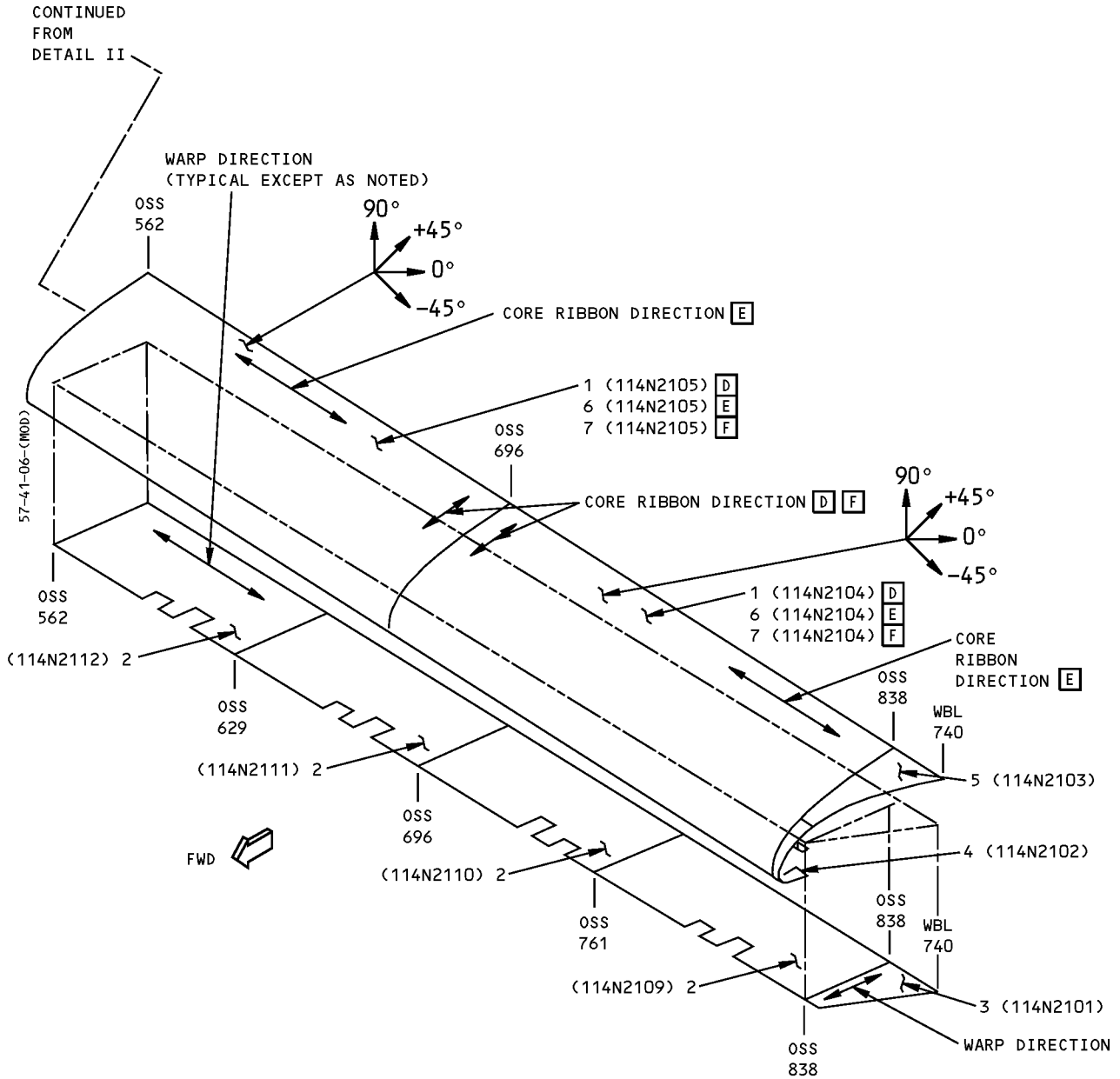

DETAIL VI



**Wing Fixed Leading Edge Skin Identification
Figure 1 (Sheet 9 of 12)**

IDENTIFICATION 1
Page 9
Jan 20/2005

57-41-01

D634N201



757-200
STRUCTURAL REPAIR MANUAL

ITEM	DESCRIPTION	GAGE	MATERIAL	EFFECTIVITY
1	PANEL ASSEMBLY OUTER SKIN CORE INNER SKIN		GLASS FABRIC HONEYCOMB SANDWICH OUTER PLY (2 PLY) - GLASS FABRIC REINFORCED EPOXY PER BMS 8-79, TYPE 120, 250°F (121°C) CURE INNER PLY (1 PLY) - GLASS FABRIC REINFORCED EPOXY PER BMS 8-79, TYPE 1581, 250°F (121°C) CURE NONMETALLIC HONEYCOMB PER BMS 8-124, CLASS 4, TYPE V, GRADE 3.0. GLASS FABRIC REINFORCED EPOXY PER BMS 8-79, TYPE 1581, 250°F (121°C) CURE (2 PLIES).	D
2	PANEL ASSEMBLY OUTER SKIN INNER SKIN CORE		FIBERGLASS/ARAMID/EPOXY HONEYCOMB SANDWICH OUTER PLY, PREIMPREGNATED FIBERGLASS EPOXY PER BMS 8-79, TYPE 120, 250°F (121°C) CURE CENTER PLY, ARAMID REINFORCED EPOXY FABRIC PER BMS 8-219, STYLE 120, 250°F (121°C) CURE BOND PLY, ARAMID REINFORCED EPOXY FABRIC PER BMS 8-219, STYLE 285, 250°F (121°C) CURE NONMETALLIC HONEYCOMB PER BMS 8-124, CLASS 4, TYPE V, GRADE 3.0.	
3	PANEL ASSEMBLY OUTER SKIN INNER SKIN CORE		FIBERGLASS/ARAMID/EPOXY HONEYCOMB SANDWICH OUTER PLY, ALUMINUM COATED FIBERGLASS/EPOXY FABRIC PER BMS 8-278, TYPE I CLASS 250 OUTER PLY, PREIMPREGNATED FIBERGLASS EPOXY PER BMS 8-79, TYPE 120, 250°F (121°C) CURE CENTER PLY, ARAMID REINFORCED EPOXY FABRIC PER BMS 8-219, STYLE 120, 250°F (121°C) CURE BOND PLY, ARAMID REINFORCED EPOXY FABRIC PER BMS 8-219, STYLE 285, 250°F (121°C) CURE OUTER PLY, INDUSTRIAL TAPE 3M 425(Y-427) OUTER PLY, PEIMPREGNATED FIBERGLASS EPOXY PER BMS 8-79, TYPE 120, 250°F (121°C) CURE CENTER PLY, ARAMID REINFORCED EPOXY FABRIC PER BMS 8-219, STYLE 120, 250°F (121°C) CURE BOND PLY, ARAMID REINFORCED EPOXY FABRIC PER BMS 8-219, STYLE 285, 250°F (121°C) CURE NONMETALLIC HONEYCOMB PER BMS 8-124, CLASS 4, TYPE V, GRADE 3.0.	
4	NOSE SKIN	0.063	7075-T62	
5	PANEL ASSEMBLY OUTER SKIN INNER SURFACE CORE		GLASS FABRIC HONEYCOMB SANDWICH OUTER PLY, ALUMINUM COATED FIBERGLASS/EPOXY FABRIC PER BMS 8-278, TYPE I, CLASS 250. INNER PLY, GLASS FABRIC REINFORCED EPOXY PER BMS 8-79, TYPE 1581, 250°F (121°C) CURE OUTER SURFACE, ALUMINUM FOIL SCOTCH BRAND TAPE 425(Y-427) OUTER PLY, GLASS FABRIC REINFORCED EPOXY PER BMS 8-79, TYPE 1581, 250°F (121°C) CURE INNER PLY, GLASS FABRIC REINFORCED EPOXY PER BMS 8-79, TYPE 1581, 250°F (121°C) CURE NONMETALLIC HONEYCOMB PER BMS 8-124, CLASS 4, TYPE V, GRADE 3.0.	

LIST OF MATERIALS FOR DETAIL VI

Wing Fixed Leading Edge Skin Identification
Figure 1 (Sheet 10 of 12)

IDENTIFICATION 1
Page 10
Jan 20/2005

57-41-01

D634N201

**757-200
STRUCTURAL REPAIR MANUAL**

ITEM	DESCRIPTION	GAGE	MATERIAL	EFFECTIVITY
6	PANEL ASSEMBLY SKIN CORE		SEE DETAIL VII NONMETALLIC HONEYCOMB AS GIVEN IN BMS 8-124, CLASS 4, TYPE V, GRADE 3.0.	E
7	PANEL ASSEMBLY SKIN CORE		SEE DETAILS VIII AND IX NONMETALLIC HONEYCOMB AS GIVEN IN BMS 8-124, CLASS 4, TYPE V, GRADE 3.0.	F

LIST OF MATERIALS FOR DETAIL VI (CONT)

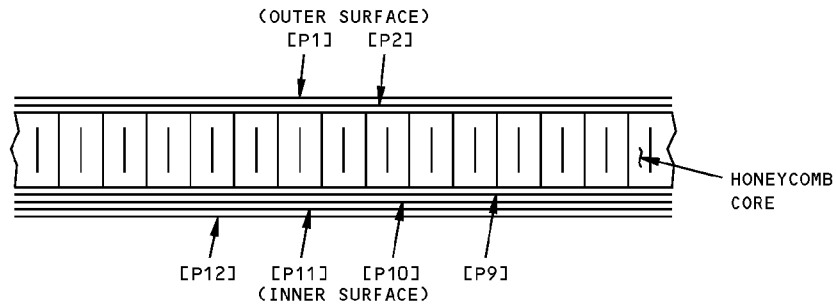

ITEM NO.	PLY NO.	MATERIAL	PLY ORIENTATION G
6	P1, P2, P9, P10, P11, P12	H	0° OR 90°

PLY TABLE E

DETAIL VII

**Wing Fixed Leading Edge Skin Identification
Figure 1 (Sheet 11 of 12)**

**757-200
STRUCTURAL REPAIR MANUAL**

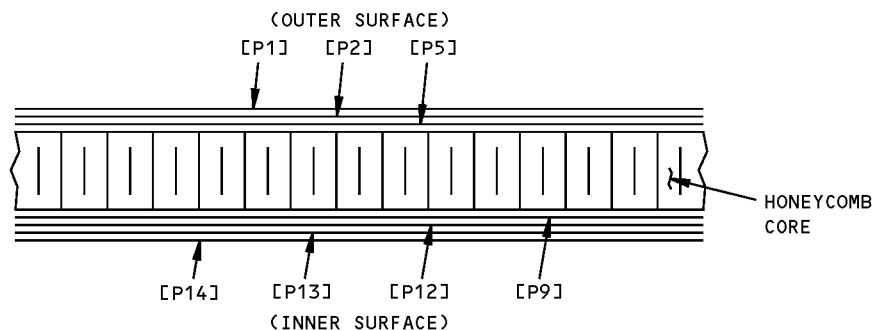

ITEM NO.	PLY NO.	MATERIAL	PLY ORIENTATION G
7	P1, P5, P9, P13	I	0° OR 90°
	P2, P12	I	+45° OR -45°
	P14	J	N/A

PLY TABLE F
(BETWEEN OSS 583.30 AND WBL 740)

DETAIL VIII

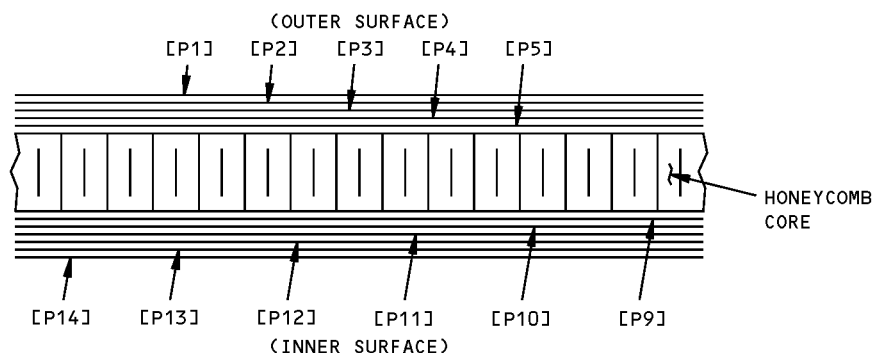

ITEM NO.	PLY NO.	MATERIAL	PLY ORIENTATION G
8	P1, P3, P4, P5, P9, P11, P13	I	0° OR 90°
	P2, P10, P12	I	+45° OR -45°
	P14	J	N/A

PLY TABLE F
(BETWEEN OSS 562.10 AND OSS 583.30)

DETAIL IX

**Wing Fixed Leading Edge Skin Identification
Figure 1 (Sheet 12 of 12)**



757-200
STRUCTURAL REPAIR MANUAL

ALLOWABLE DAMAGE 1 - WING FIXED LEADING EDGE SKIN

REF DWG
 114N1001
 114N2001

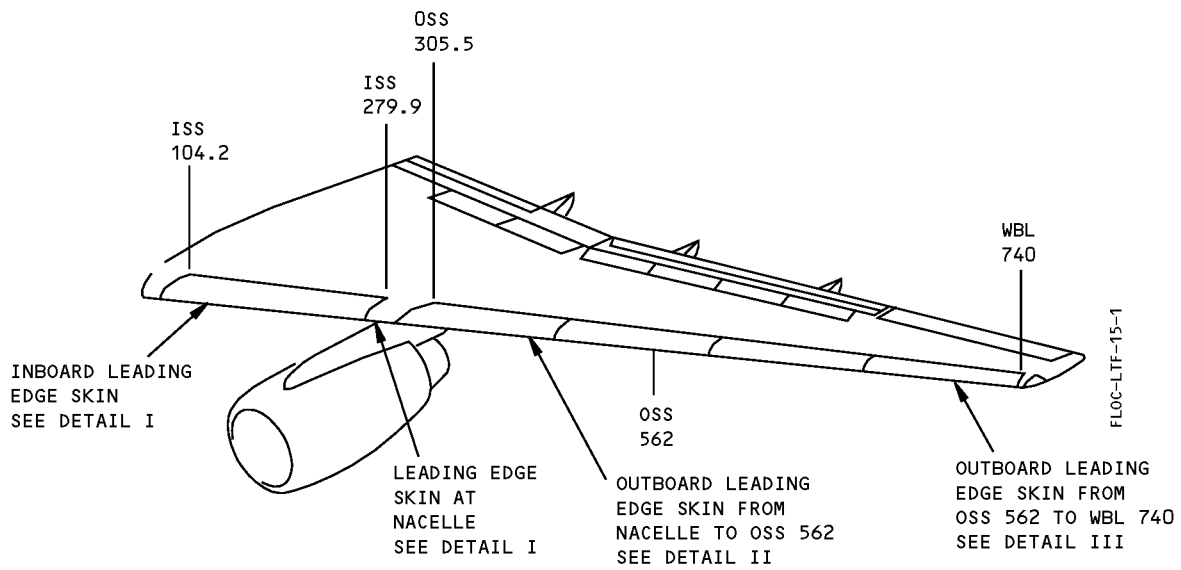

LEFT SIDE SHOWN
 RIGHT SIDE OPPOSITE
 EXCEPT AS NOTED

Wing Fixed Leading Edge Skin Allowable Damage
Figure 101 (Sheet 1 of 8)

D634N201

ALLOWABLE DAMAGE 1
 Page 101
 Jan 20/2007

57-41-01

**757-200
STRUCTURAL REPAIR MANUAL**

REF DWG
114N1601
114N1501
114N1801

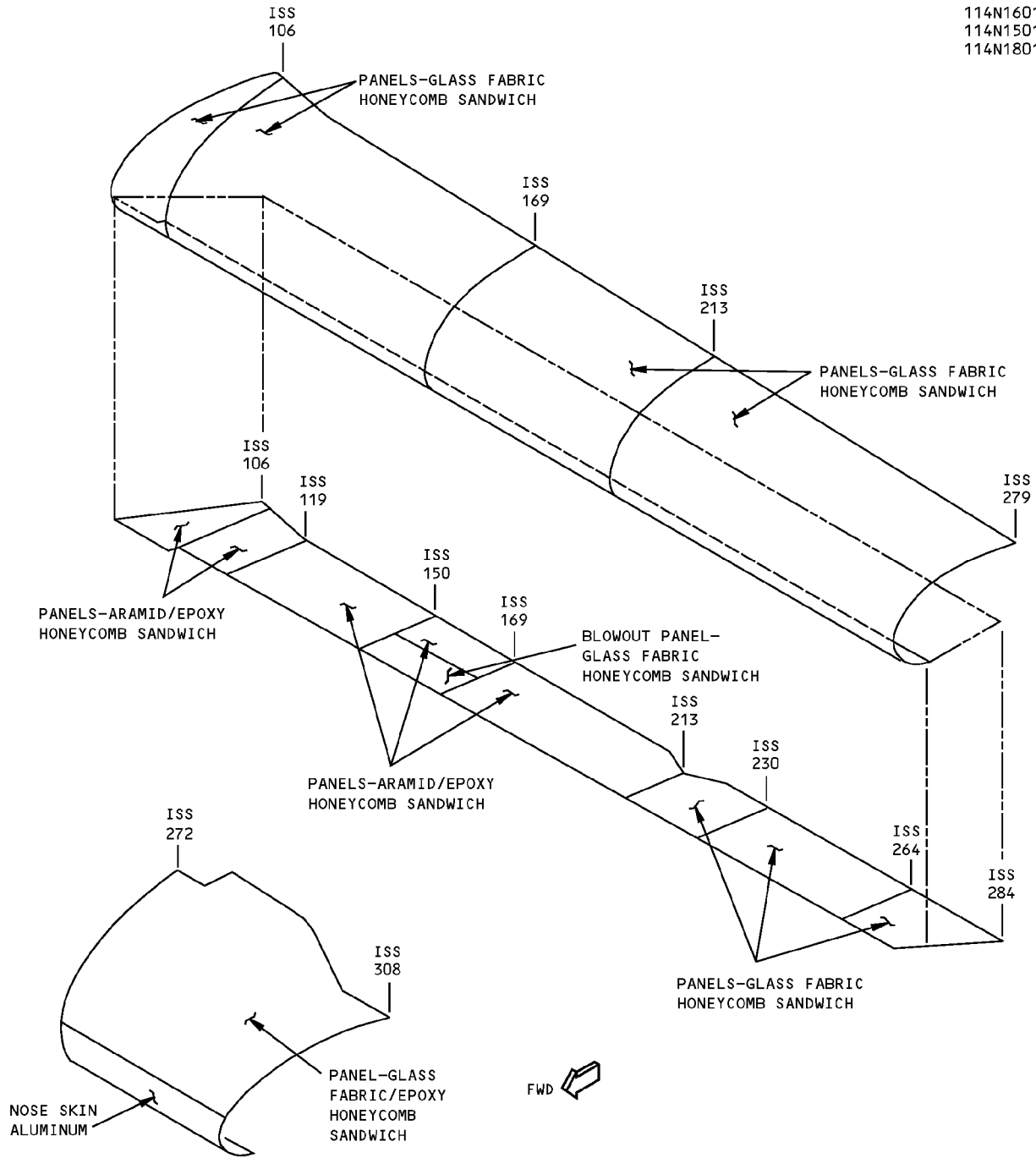

LEADING EDGE SKIN AT NACELLE

DETAIL I

**Wing Fixed Leading Edge Skin Allowable Damage
Figure 101 (Sheet 2 of 8)**

ALLOWABLE DAMAGE 1

57-41-01

Page 102
Jan 20/2005

D634N201

**757-200
STRUCTURAL REPAIR MANUAL**

REF DWG
114N2035
114N2036

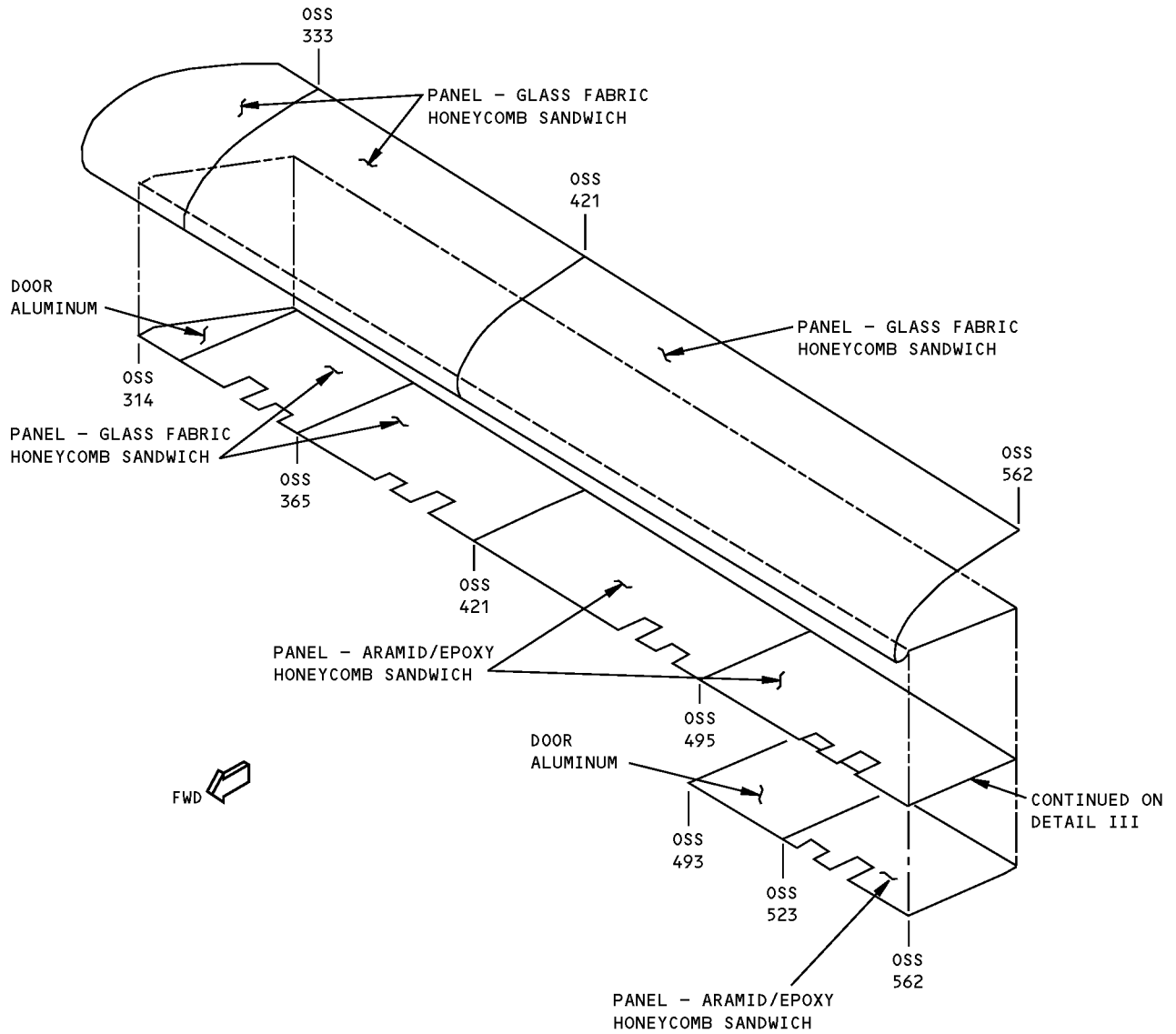

DETAIL II

**Wing Fixed Leading Edge Skin Allowable Damage
Figure 101 (Sheet 3 of 8)**

**757-200
STRUCTURAL REPAIR MANUAL**

REF DWG
114N2035
114N2036

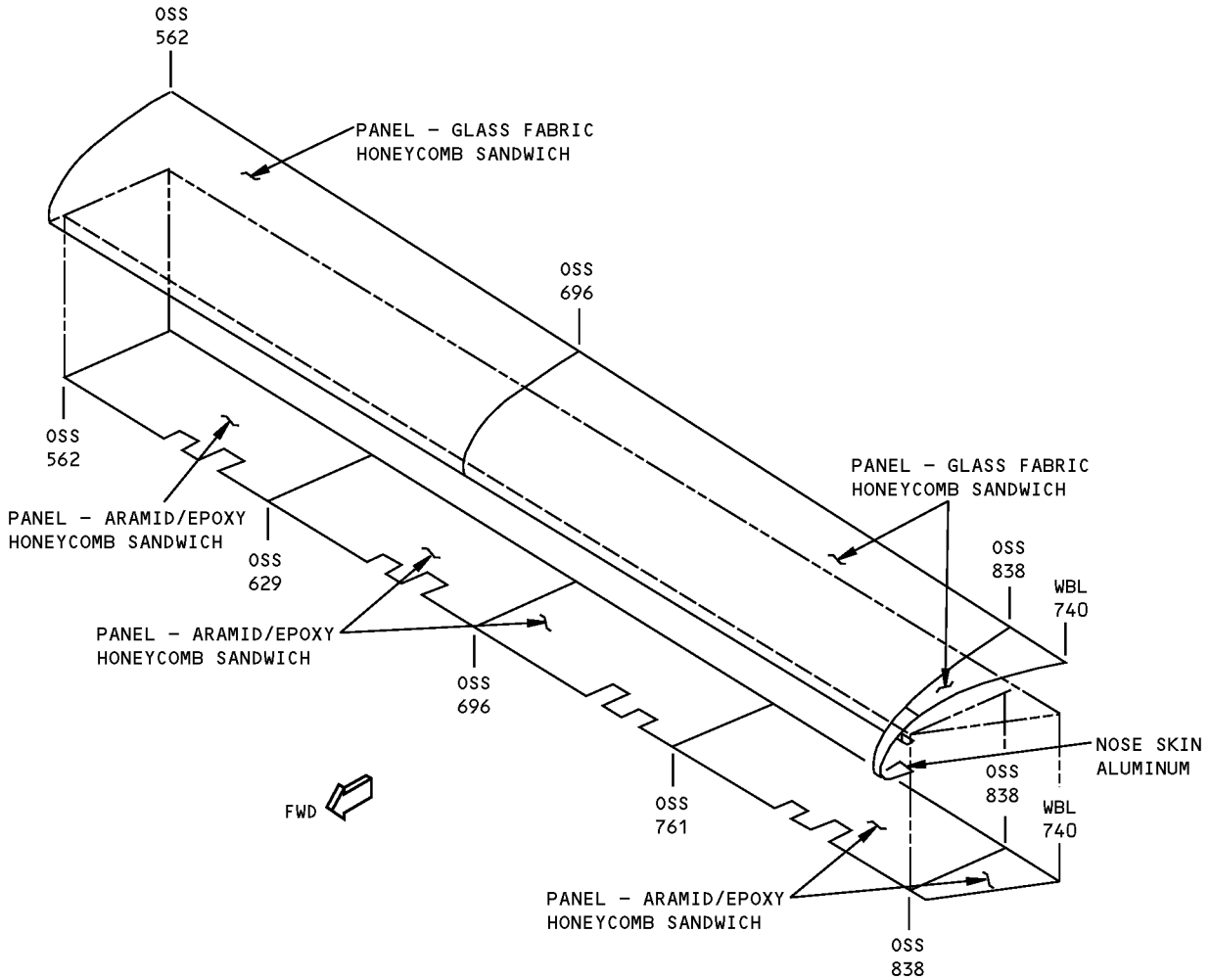

DETAIL III

**Wing Fixed Leading Edge Skin Allowable Damage
Figure 101 (Sheet 4 of 8)**

**757-200
STRUCTURAL REPAIR MANUAL**

DESCRIPTION	CRACKS	NICKS, GOUGES AND COR- ROSION	DENTS	HOLES AND PUNCTURES	DELAMI- NATION	EDGE EROSION
PANELS	A	B	C	A	A	SEE DETAIL IX
NOSE SKIN	G	E	SEE DETAIL VI	F	---	---
DOOR	G	E	SEE DETAIL VI	F	---	---

TABLE I

NOTES

- REFINISH REWORKED AREAS AS GIVEN IN AMM 51-20
- REFER TO 51-10-02 FOR INSPECTION AND REMOVAL OF DAMAGE
- REFER TO SRM 51-10-01 FOR AERODYNAMIC SMOOTHNESS REQUIREMENTS. WHERE THE DAMAGE EXCEEDS THE LIMITS SHOWN IN SRM 51-10-01, CONSIDERATION SHOULD BE GIVEN TO THE LOSS OF PERFORMANCE INVOLVED

- A** DAMAGE TO SKIN PANEL EDGES MAY BE A COMBINATION OF EDGE DELAMINATION AND/OR CRACKS, GOUGES, ETC. WHICH CAN RESULT IN FIBER DAMAGE AND A LOSS OF CROSS-SECTIONAL AREA. REMOVE EDGE DAMAGE AS GIVEN IN DETAILS IV AND VIII. NOT MORE THAN 1 FASTENER HOLE IN SIX MAY BE CRACKED OR DAMAGED. DAMAGE MUST NOT EXCEED 10 PERCENT OF THE EDGE BAND LENGTH FOR EACH SIDE. 2.0 INCH (51 mm) MAXIMUM DIAMETER ALLOWED FOR SINGLE DAMAGE SITE IN HONEYCOMB AREA. MULTIPLE DAMAGE SITES MUST NOT BE CLOSER THAN A MINIMUM OF a/D = 3.0. SEE DETAIL X FOR DAMAGE CRITERIA. DAMAGE ALLOWED TO ONE SURFACE AND HONEYCOMB CORE ONLY. PROTECT DAMAGE NOT REWORKED AS GIVEN IN **D**
- B** DAMAGE ALLOWED ON SURFACE RESIN ONLY WITH NO FIBER DAMAGE. CLEAN UP EDGE DAMAGE AS SHOWN IN DETAILS IV AND V. REFER TO **A** FOR FIBER DAMAGE IN OTHER AREAS.
- C** DENTS RESULT IN DELAMINATION AND FIBER DAMAGE AND MUST BE TREATED AS A HOLE OR PUNCTURE

- D** REMOVE MOISTURE FROM DAMAGE AREA. USE OF VACUUM AND HEAT (MAX OF 125°F [52°C]) TO REMOVE MOISTURE FROM HONEYCOMB CELLS IS RECOMMENDED. PROTECT DAMAGE FROM ENTRANCE OF WATER, SUNLIGHT OR OTHER FOREIGN MATTER BY SEALING WITH ALUMINUM FOIL TAPE (SPEED TAPE). RECORD THE LOCATION AND INSPECT EVERY AIRPLANE "A" CHECK. REPLACE THE ALUMINUM FOIL TAPE IF ANY PEELING OR DETERIORATION EVIDENT. REPAIR NO LATER THAN NEXT AIRPLANE "C" CHECK
- E** REMOVE DAMAGE AS SHOWN IN DETAILS IV, V, AND VII
- F** CLEAN OUT DAMAGE UP TO 0.25 INCH (6 mm) MAXIMUM DIAMETER AND NOT CLOSER THAN 1.0 INCH (25 mm) TO FASTENER HOLE OR OTHER DAMAGE. FILL HOLE WITH A 2117-T3 OR T4 ALUMINUM RIVET INSTALLED WET WITH BMS 5-95 SEALANT. ALL OTHER HOLES TO BE REPAIRED
- G** CRACKS NOT ALLOWED EXCEPT FOR EDGE CRACKS WHICH MUST BE REMOVED AS SHOWN IN DETAILS IV AND VIII
- H** THESE ALLOWABLE DAMAGE LIMITS HAVE FAA APPROVAL CONTINGENT ON ACCOMPLISHMENT OF THE INSPECTION CONTAINED HEREIN

**Wing Fixed Leading Edge Skin Allowable Damage
Figure 101 (Sheet 5 of 8)**

**757-200
STRUCTURAL REPAIR MANUAL**

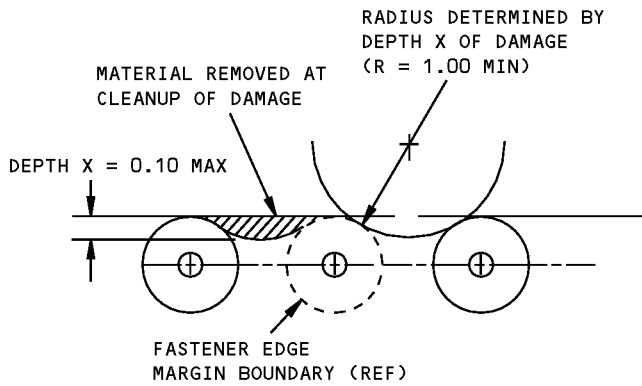

DAMAGE CLEANUP OF EDGES WHERE FASTENER EDGE MARGINS DO NOT OVERLAP

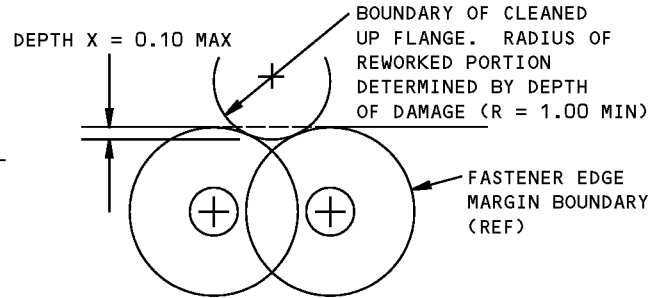

DAMAGE CLEANUP OF EDGES WHERE FASTENER EDGE MARGINS OVERLAP

DETAIL IV

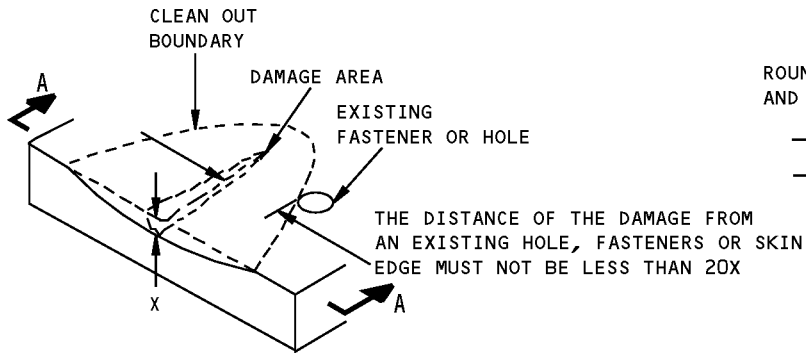

**REMOVAL OF NICK, GOUGE AND SCRATCH DAMAGE ON A SURFACE
DETAIL V**

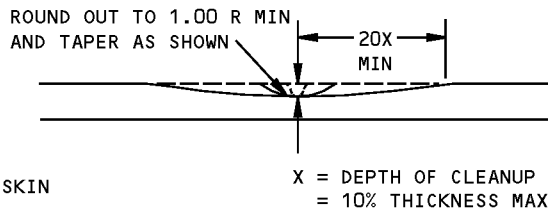

SECTION A-A

**Wing Fixed Leading Edge Skin Allowable Damage
Figure 101 (Sheet 6 of 8)**

**757-200
STRUCTURAL REPAIR MANUAL**

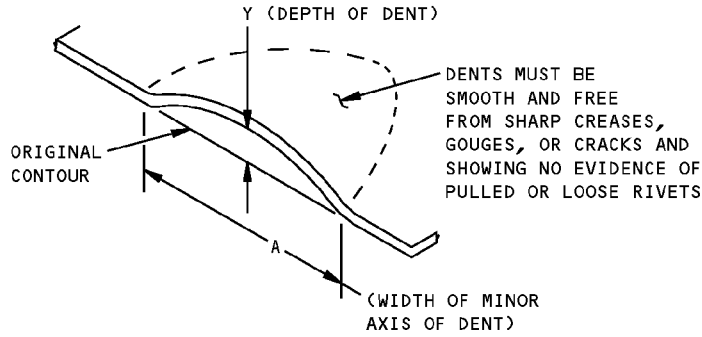

$\frac{A}{Y}$ MUST NOT BE LESS THAN 30

**ALLOWABLE DAMAGE FOR DENT
DETAIL VI**

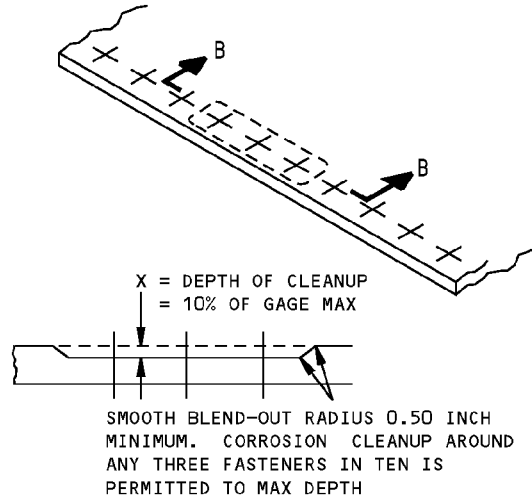

SECTION B-B

**CORROSION CLEANUP
DETAIL VII**

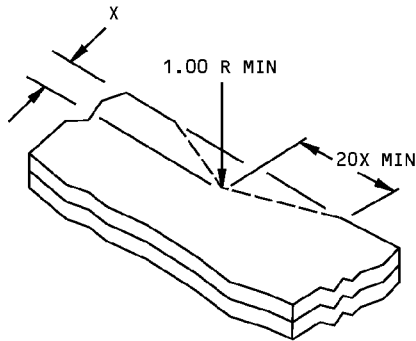

X = DEPTH OF CLEANUP = 0.10 MAX

**REMOVAL OF NICK OR CRACK
DAMAGE OF AN EDGE
DETAIL VIII**

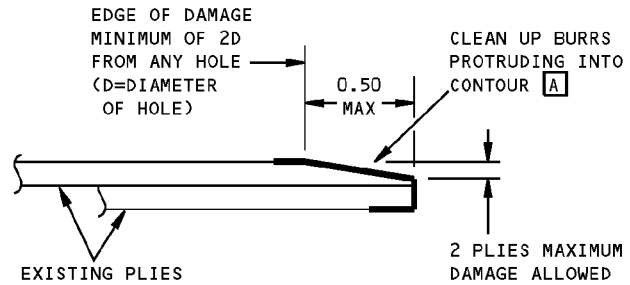

**DAMAGE CLEANUP AND SEALING
OF EDGE EROSION
DETAIL IX**

**Wing Fixed Leading Edge Skin Allowable Damage
Figure 101 (Sheet 7 of 8)**

**757-200
STRUCTURAL REPAIR MANUAL**

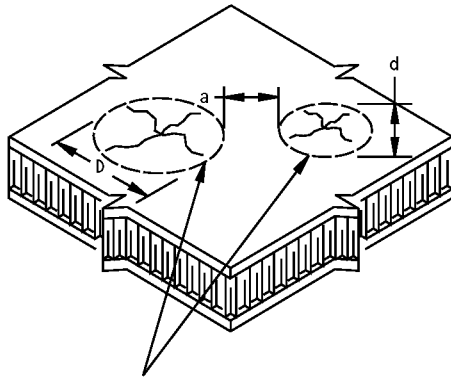

ADJACENT DAMAGE SITES ON SURFACE OF COMPOSITE PANEL

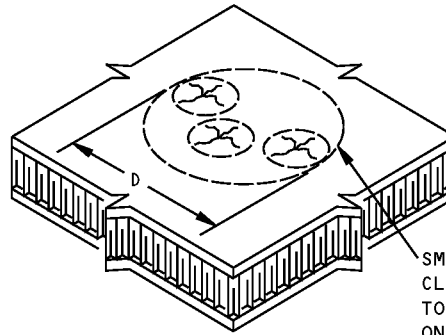

SMALL DAMAGE SITES THAT ARE CLOSELY SPACED MAY BE GROUPED TOGETHER AND CONSIDERED AS ONE DAMAGE SITE

- DAMAGE TO COMPOSITE PANELS EXPOSED TO MULTIPLE IMPACTS, I.E., HAIL DAMAGE, CAN BE DETECTED BY USING INSTRUMENTED NON-DESTRUCTIVE INSPECTION METHODS OR BY TAPPING THE SUSPECTED DAMAGE AREA WITH A SMALL METALLIC DISK OBJECT. INSPECTION SHOULD COVER THE AREA WITHIN 3 DIAMETERS AROUND THE EDGE OF THE VISIBLE DAMAGE SITE. FOR TAP TEST, USE A SOLID METAL DISK AND TAP THE DAMAGE AREA LIGHTLY BUT FIRMLY. VOID AREAS SHOULD PRODUCE A DULL SOUND AS OPPOSED TO A SHARP RING ON A SOLID BONDED AREA
- DAMAGE SITE IS ANY SINGLE AREA OF A PANEL WHERE A DENT, CRACK, DELAMINATION, PUNCTURE OR ANY COMBINATION OF THESE EXIST. SMALL DAMAGE SITES THAT ARE CLOSELY SPACED MAY BE GROUPED TOGETHER AND CONSIDERED AS ONE DAMAGE SITE
- "D" IS DETERMINED BY MEASURING THE MAX DIMENSION OF A DENT, CRACK, OR OTHER DAMAGE, WHICHEVER IS GREATER
- "a" IS THE DISTANCE BETWEEN TWO ADJACENT DAMAGE SITES
- "d" IS THE MAX DIMENSION OF THE SMALLER OF TWO ADJACENT DAMAGE SITES
- CALCULATE a/D BY DIVIDING DISTANCE "a" BY DIMENSION "D"
- DAMAGE IS ALLOWED WHEN "D" IS EQUAL TO OR LESS THAN THE MAXIMUM ALLOWABLE "D" FROM TABLE I AND WHEN a/D IS EQUAL TO OR GREATER THAN THE MINIMUM a/D GIVEN IN TABLE I

**DAMAGE SIZING AND SPACING DATA
FOR COMPOSITE PANELS
DETAIL X**

**Wing Fixed Leading Edge Skin Allowable Damage
Figure 101 (Sheet 8 of 8)**



757-200
STRUCTURAL REPAIR MANUAL

REPAIR GENERAL - SERVICE BULLETIN REPAIR CHART

SERVICE BULLETIN REPAIRS - WING FIXED LEADING EDGE

The following Service Bulletins contain repairs which are available for use where specific damage has been encountered. Usually, the Service Bulletin also covers preventive modification data which operators are encouraged to use to eliminate the need for repair.

DAMAGED AREA	CUM LINE NUMBER EFFECTIVITY	SB NUMBER
WING - OUTBOARD FIXED LEADING EDGE UPPER SKIN PANELS - INSPECTION AND REPAIR	1 THRU 870	757-57-0052

Service Bulletin repair chart
Figure 201

**757-200
STRUCTURAL REPAIR MANUAL**

REPAIR 1 - WING FIXED LEADING EDGE SKIN REPAIRS

REF DWG
114N1001
114N2001

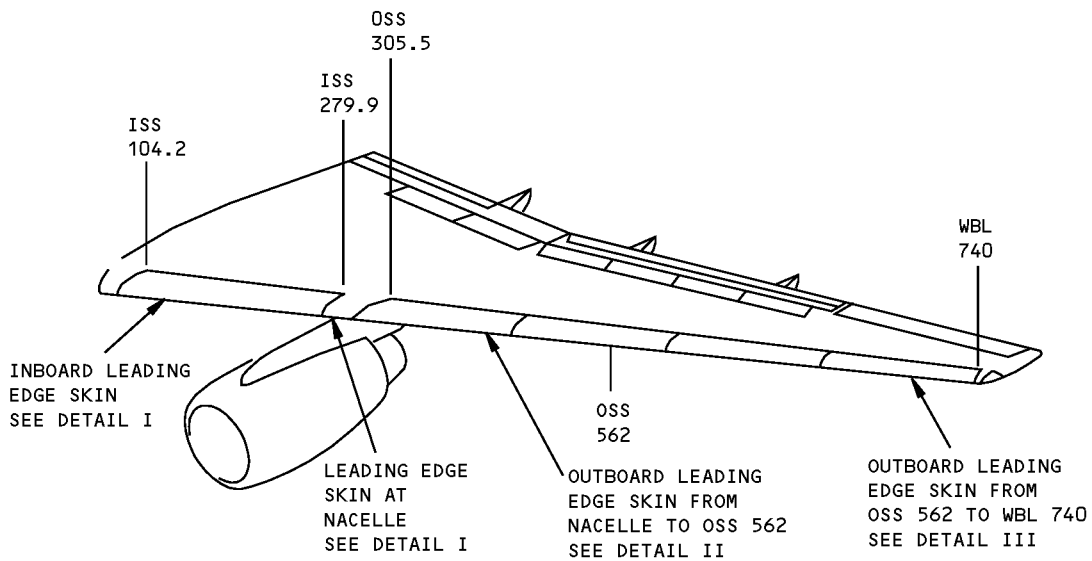

LEFT SIDE SHOWN
RIGHT SIDE OPPOSITE
EXCEPT AS NOTED

**Wing Fixed Leading Edge Skin Repairs
Figure 201 (Sheet 1 of 8)**

**757-200
STRUCTURAL REPAIR MANUAL**

REF DWG
114N1601
114N1501
114N1801

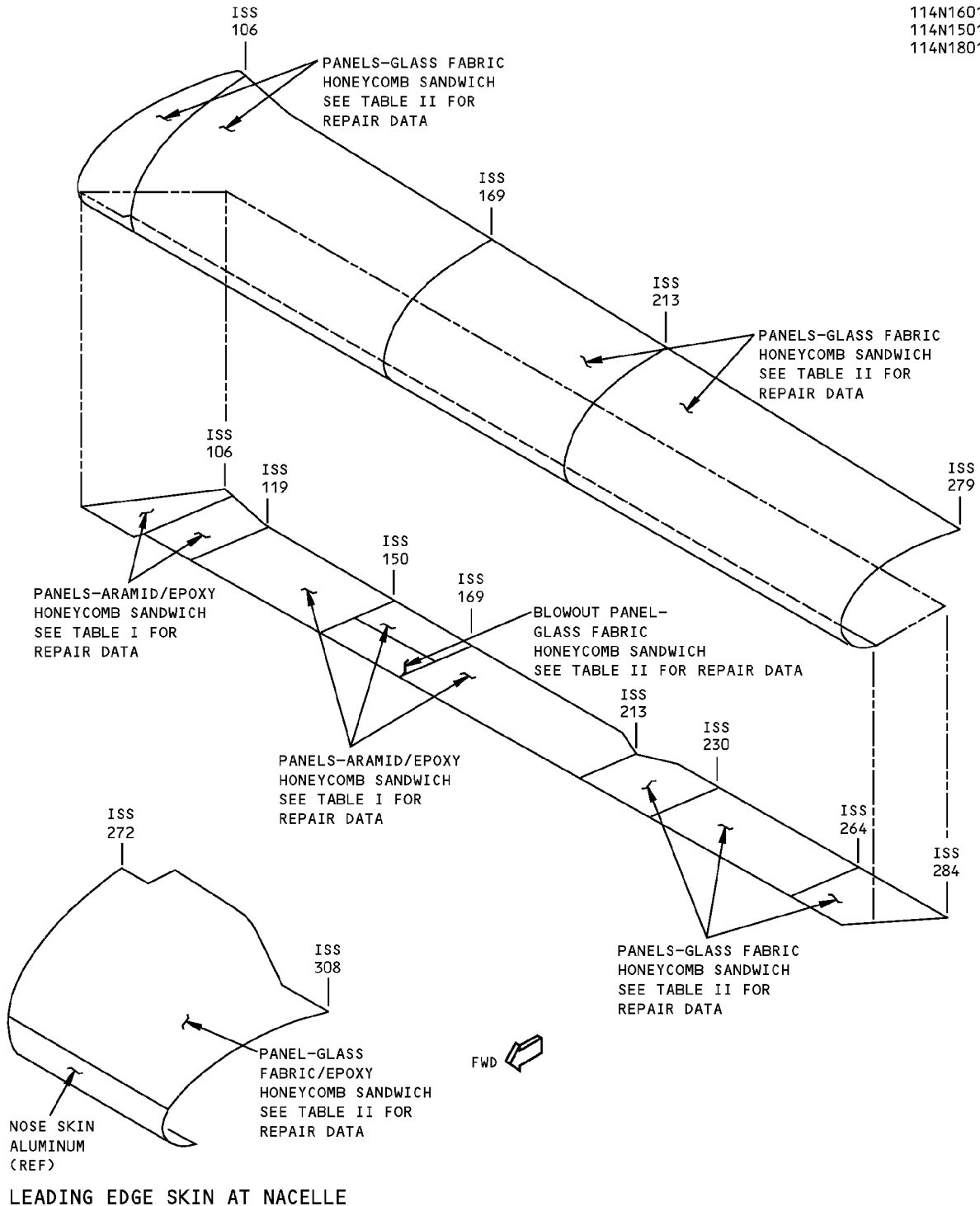

**Wing Fixed Leading Edge Skin Repairs
Figure 201 (Sheet 2 of 8)**

**757-200
STRUCTURAL REPAIR MANUAL**

REFERENCE DRAWINGS
114N2035
114N2036

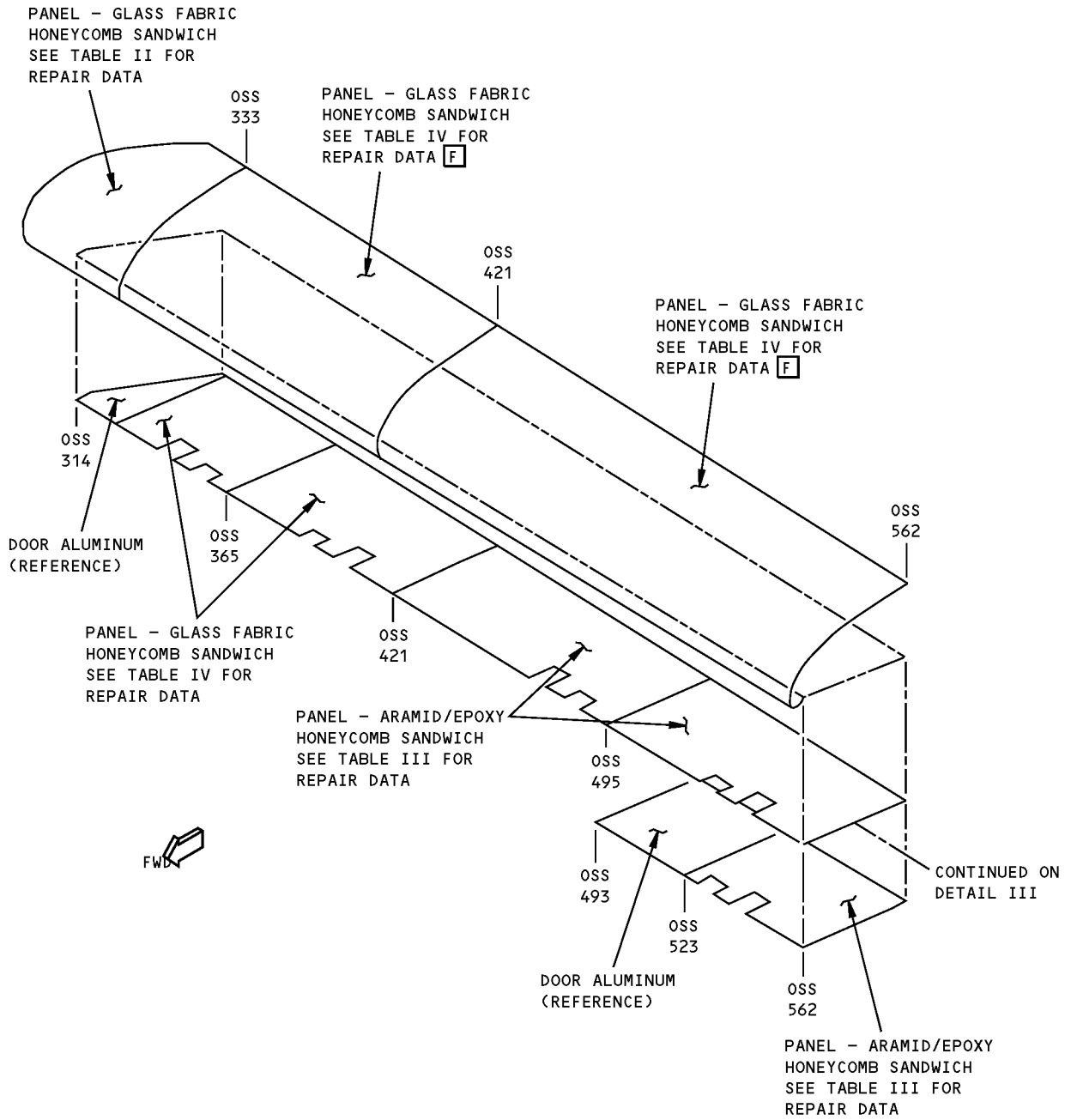

DETAIL II

**Wing Fixed Leading Edge Skin Repairs
Figure 201 (Sheet 3 of 8)**

**757-200
STRUCTURAL REPAIR MANUAL**

REFERENCE DRAWINGS
114N2035
114N2036

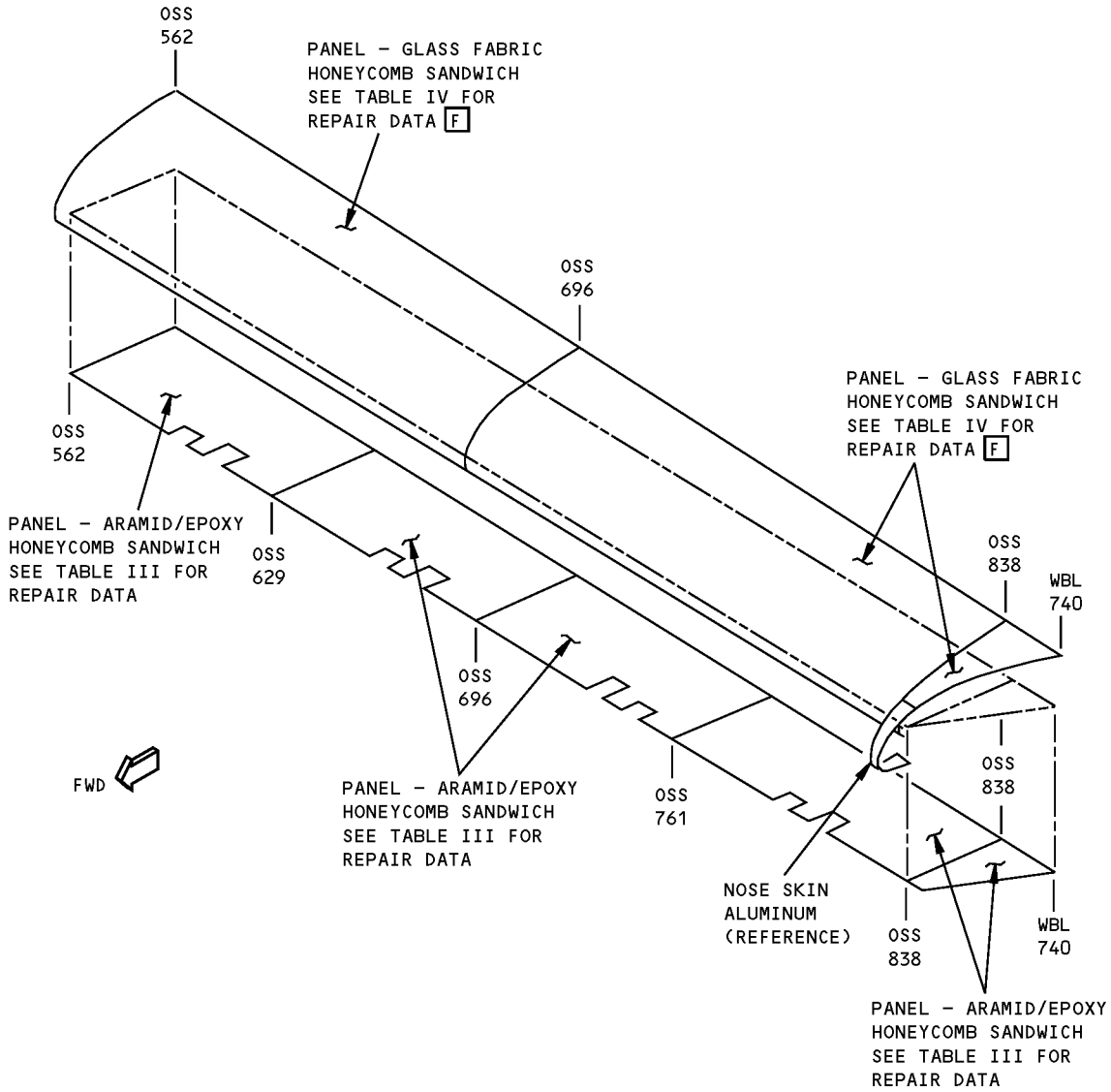

DETAIL III

**Wing Fixed Leading Edge Skin Repairs
Figure 201 (Sheet 4 of 8)**

**757-200
STRUCTURAL REPAIR MANUAL**

DAMAGE	INTERIM REPAIRS D	PERMANENT REPAIRS	
	WET LAYUP 150°F (66°C) CURE (SRM 51-70-03)	WET LAYUP 200°F (93°C) CURE (SRM 51-70-17) B	350°F (177°C) CURE (SRM 51-70-04)
CRACKS	UP TO 3.0 INCHES (75 mm) LONG, REPAIR WITH PATCH AS SHOWN IN SRM 51-70-03, PAR. 5.N. A	CLEAN UP DAMAGE AND REPAIR AS A HOLE.	CLEAN UP DAMAGE AND REPAIR AS A HOLE.
HOLES	3.0 INCHES (75 mm) MAXIMUM DIAMETER NOT TO EXCEED 30% OF SMALLEST DIMENSION ACROSS HONEYCOMB PANEL AT DAMAGE LOCATION. FILL WITH BMS 5-28, TYPE 7 POTTING COMPOUND AND PATCH AS SHOWN IN SRM 51-70-03, PAR. 5.N. A	12.0 INCHES (300 mm) MAXIMUM DIAMETER NOT TO EXCEED 50% OF SMALLEST DIMENSION ACROSS HONEYCOMB PANEL AT THE DAMAGE LOCATION. USE TWO EXTRA PLYS FOR EACH FACESHEET REPAIRED. C	NO SIZE LIMIT
EDGE EROSION	_____	FOR DAMAGE THAT IS NOT LARGER THAN 35% OF EDGE BAND THICKNESS, REPAIR AS SHOWN IN SRM 51-70-03, PAR. 5.O. FOR LARGER DAMAGE, REPAIR AS SHOWN IN: SRM 51-70-17, PAR. 4.G.	SRM 51-70-04, PAR. 5.G.
DELAMINATION	CUT OUT AND REPAIR AS A HOLE.		
NICKS AND GOUGES	IF THERE IS NO FIBER DAMAGE OR DELAMINATION, FILL NICKS OR GOUGES AS SHOWN IN SRM 51-70-03. IF YOU FIND FIBER DAMAGE OR DELAMINATION, THEN REPAIR AS A HOLE.		
DENTS	UP TO 2.0 INCHES (50 mm) DIAMETER WITH NO FIBER DAMAGE OR DELAMINATION, FILL WITH BMS 5-28, TYPE 7 POTTING COMPOUND AND PATCH AS SHOWN IN SRM 51-70-03, PAR. 5.L. C OVER 2.0 INCHES (50 mm) DIAMETER OR WITH FIBER DAMAGE OR DELAMINATION, REPAIR AS A HOLE.		

**REPAIR DATA FOR 350°F (177°C) CURE HONEYCOMB PANELS (ARAMID)
TABLE I**

NOTES

- WHEN YOU USE THIS REPAIR, REFER TO:
 - AMM 51-21-01 FOR APPLICATION OF FINISHES
 - SRM 51-10-01, FOR AERODYNAMIC SMOOTHNESS REQUIREMENTS. WHERE THE DAMAGE IS MORE THAN THE LIMITS GIVEN IN SRM 51-10-01, THOUGHT SHOULD BE GIVEN TO THE LOSS OF PERFORMANCE THAT MAY OCCUR
 - SRM 51-10-02 FOR INSPECTION AND REMOVAL OF DAMAGE.

A LIMITED TO REPAIR OF DAMAGE TO ONE FACE-SHEET SKIN AND HONEYCOMB CORE. ONE REPAIR FOR EACH SQUARE FOOT OF AREA AND MINIMUM OF 6.0 INCHES (EDGE TO EDGE) FROM ANY OTHER DAMAGE, FASTENER HOLE, OR EDGE OF PANEL

B MAKE AN OVERLAP OF 1.0 INCH (25 mm) FOR EACH REPAIR PLY.

C ONE REPAIR FOR EACH SQUARE FOOT OF AREA AND A MINIMUM OF 6.0 INCHES (150 mm) (EDGE TO EDGE) FROM ANY OTHER DAMAGE, FASTENER HOLE, OR EDGE OR PANEL

D INSPECT INTERIM REPAIR USING INSTRUMENTED NDT METHODS OR "TAP" TEST EVERY AIRPLANE "2A" CHECK. FOR "TAP" TEST, USE A SOLID METAL DISK AND TAP THE REPAIR AREA LIGHTLY BUT FIRMLY. VOID AREAS WILL GIVE A DULL SOUND INSTEAD OF A SHARP RING THAT YOU WILL HEAR ON A SOLID BONDED AREA. PERMANENT REPAIR IS REQUIRED IF ANY DETERIORATION IS FOUND. REFER TO SRM 51-70-03, PAR. 4.I. AND THE NONDESTRUCTIVE TEST MANUAL **E**

E THESE REPAIRS HAVE FAA APPROVAL ONLY IF YOU DO THE INSPECTIONS GIVEN IN THIS REPAIR

F YOU CAN REPAIR CRACKS AND DELAMINATION IN THE UPPER PANELS AS GIVEN IN SB 757-57-0052. THE LIMITATIONS IN SB 757-57-0052 SUPERSEDE THE LIMITATIONS IN TABLE IV.

**Wing Fixed Leading Edge Skin Repairs
Figure 201 (Sheet 5 of 8)**



**757-200
STRUCTURAL REPAIR MANUAL**

DAMAGE	INTERIM REPAIRS D	PERMANENT REPAIRS	
	WET LAYUP 150°F (66°C) CURE (SRM 51-70-06)	WET LAYUP 200°F (93°C) CURE (SRM 51-70-17) B	350°F (177°C) CURE (SRM 51-70-08)
CRACKS	UP TO 3.0 INCHES (75 mm) LONG, REPAIR WITH PATCH AS GIVEN IN SRM 51-70-06, PAR. 5.N. A	CLEAN UP DAMAGE AND REPAIR AS A HOLE.	CLEAN UP DAMAGE AND REPAIR AS A HOLE.
HOLES	3.0 INCHES (75 mm) MAXIMUM DIA NOT TO EXCEED 30% OF SMALLEST DIMENSION ACROSS HONEYCOMB PANEL AT DAMAGE LOCATION. FILL WITH BMS 5-28, TYPE 7 POTTING COMPOUND AND PATCH AS GIVEN IN SRM 51-70-06, PAR. 5.N. A	12.0 INCHES (300 mm) MAXIMUM DIA NOT TO EXCEED 50% OF SMALLEST DIMENSION ACROSS HONEYCOMB PANEL AT THE DAMAGE LOCATION. USE TWO EXTRA PLIES FOR EACH FACESHEET REPAIRED. C	NO SIZE LIMIT
EDGE EROSION	_____	FOR DAMAGE THAT IS NOT LARGER THAN 35% OF EDGE BAND THICKNESS, REPAIR AS GIVEN IN SRM 51-70-06 PAR. 5.O. FOR LARGER DAMAGE, REPAIR AS GIVEN IN: SRM 51-70-17 PAR. 4.G.	SRM 51-70-08 PAR. 5.G.
DELAMINATION	CUT OUT AND REPAIR AS A HOLE.		
NICKS AND GOUGES	IF THERE IS NO FIBER DAMAGE OR DELAMINATION, FILL NICKS OR GOUGES AS GIVEN IN SRM 51-70-06. IF YOU FIND FIBER DAMAGE OR DELAMINATION, THEN REPAIR AS A HOLE.		
DENTS	UP TO 2.0 INCHES (50 mm) DIA WITH NO FIBER DAMAGE OR DELAMINATION, FILL WITH BMS 5-28, TYPE 7 POTTING COMPOUND AND PATCH AS GIVEN IN SRM 51-70-06, PAR. 5.L. C OVER 2.0 INCHES (50 mm) DIA OR WITH FIBER DAMAGE OR DELAMINATION, REPAIR AS A HOLE.		

REPAIR DATA FOR 350°F CURE HONEYCOMB PANELS (FIBERGLASS)
TABLE II

**Wing Fixed Leading Edge Skin Repairs
Figure 201 (Sheet 6 of 8)**



**757-200
STRUCTURAL REPAIR MANUAL**

DAMAGE	INTERIM REPAIRS D	PERMANENT REPAIRS		
	WET LAYUP ROOM TEMP (SRM 51-70-06)	WET LAYUP 150°F (66°C) CURE (SRM 51-70-03) B	WET LAYUP 200°F (93°C) CURE (SRM 51-70-17) B	250°F (121°C) CURE (SRM 51-70-05)
CRACKS	UP TO 4.0 INCHES (100 mm) LONG, REPAIR WITH PATCH AS SHOWN IN SRM 51-70-03, PAR. 5.N. A	CLEAN UP DAMAGE AND REPAIR AS A HOLE.	CLEAN UP DAMAGE AND REPAIR AS A HOLE.	CLEAN UP DAMAGE AND REPAIR AS A HOLE.
HOLES	4.0 INCHES (100 mm) MAXIMUM DIAMETER NOT TO EXCEED 30% OF SMALLEST DIMENSION ACROSS HONEYCOMB PANEL AT THE DAMAGE LOCATION. FILL WITH BMS 5-28, TYPE 7 POTTING COMPOUND AND PATCH AS SHOWN IN SRM 51-70-03, PAR. 5.N. A	8.0 INCH (200 mm) MAXIMUM DIAMETER NOT TO EXCEED 50% OF SMALLEST DIMENSION ACROSS HONEYCOMB PANEL AT THE DAMAGE LOCATION. USE TWO EXTRA PLIES FOR EACH FACESHEET REPAIRED. C	12.0 INCH (300 mm) MAXIMUM DIAMETER NOT TO EXCEED 50% OF SMALLEST DIMENSION ACROSS HONEYCOMB PANEL AT THE DAMAGE LOCATION. USE TWO EXTRA PLIES FOR EACH FACESHEET REPAIRED. C	NO SIZE LIMIT
EDGE EROSION		FOR DAMAGE THAT IS NOT LARGER THAN 35% OF EDGE BAND THICKNESS, REPAIR AS SHOWN IN SRM 51-70-06, PAR. 5.0. FOR LARGER DAMAGE, REPAIR AS SHOWN IN: SRM 51-70-03 PAR. 5.G. SRM 51-70-17 PAR. 4.G. SRM 51-70-05 PAR. 5.G.		
DELAMINATION	CUT OUT AND REPAIR AS A HOLE.			
NICKS AND GOUGES	IF THERE IS NO FIBER DAMAGE OR DELAMINATION, FILL NICKS OR GOUGES AS SHOWN IN SRM 51-70-03. IF YOU FIND FIBER DAMAGE OR DELAMINATION, THEN REPAIR AS A HOLE.			
DENTS	UP TO 2.0 INCHES (50 mm) DIAMETER WITH NO FIBER DAMAGE OR DELAMINATION, FILL WITH BMS 5-28, TYPE 7 POTTING COMPOUND AND PATCH AS SHOWN IN SRM 51-70-03, PAR. 5.L. C OVER 2.0 INCHES (50 mm) DIAMETER OR WITH FIBER DAMAGE OR DELAMINATION, REPAIR AS A HOLE.			

REPAIR DATA FOR 250°F CURE HONEYCOMB PANELS (ARAMID)
TABLE III

**Wing Fixed Leading Edge Skin Repairs
Figure 201 (Sheet 7 of 8)**



**757-200
STRUCTURAL REPAIR MANUAL**

DAMAGE	INTERIM REPAIRS D	PERMANENT REPAIRS		
	WET LAYUP ROOM TEMP (SRM 51-70-06)	WET LAYUP 150°F (66°C) CURE (SRM 51-70-06) B	WET LAYUP 200°F (93°C) CURE (SRM 51-70-17) B	250°F (121°C) CURE (SRM 51-70-07)
CRACKS	UP TO 4.0 INCHES (100 mm) LONG, REPAIR WITH PATCH AS SHOWN IN SRM 51-70-06, PAR. 5.N. A	CLEAN UP DAMAGE AND REPAIR AS A HOLE.	CLEAN UP DAMAGE AND REPAIR AS A HOLE.	CLEAN UP DAMAGE AND REPAIR AS A HOLE. NO SIZE LIMIT
HOLES	4.0 INCHES (100 mm) MAXIMUM DIAMETER NOT TO EXCEED 30% OF SMALLEST DIMENSION ACROSS HONEYCOMB PANEL AT THE DAMAGE LOCATION. FILL WITH BMS 5-28, TYPE 7 POTTING COMPOUND AND PATCH AS SHOWN IN SRM 51-70-06, PAR. 5.N. A	8.0 INCHES (200 mm) MAXIMUM DIAMETER NOT TO EXCEED 50% OF SMALLEST DIMENSION ACROSS HONEYCOMB PANEL AT THE DAMAGE LOCATION. USE TWO EXTRA PLYS FOR EACH FACESHEET REPAIRED. C	12.0 INCHES (300 mm) MAXIMUM DIAMETER NOT TO EXCEED 50% OF SMALLEST DIMENSION ACROSS HONEYCOMB PANEL AT THE DAMAGE LOCATION. USE TWO EXTRA PLYS FOR EACH FACESHEET REPAIRED. C	
EDGE EROSION		FOR DAMAGE THAT IS NOT LARGER THAN 35% OF EDGE BAND THICKNESS, REPAIR AS SHOWN IN SRM 51-70-06, PAR. 5.O. FOR LARGER DAMAGE, REPAIR AS SHOWN IN: SRM 51-70-06, PAR. 5.G. SRM 51-70-17, PAR. 4.G. SRM 51-70-07, PAR. 5.G.		
DELAMINATION	CUT OUT AND REPAIR AS A HOLE.			
NICKS AND GOUGES	IF THERE IS NO FIBER DAMAGE OR DELAMINATION, FILL NICKS OR GOUGES AS SHOWN IN SRM 51-70-06. IF YOU FIND FIBER DAMAGE OR DELAMINATION, THEN REPAIR AS A HOLE.			
DENTS	UP TO 2.0 INCHES (50 mm) DIAMETER WITH NO FIBER DAMAGE OR DELAMINATION, FILL WITH BMS 5-28, TYPE 7 POTTING COMPOUND AND PATCH AS SHOWN IN SRM 51-70-06, PAR. 5.L. C OVER 2.0 INCHES (50 mm) DIAMETER OR WITH FIBER DAMAGE OR DELAMINATION, REPAIR AS A HOLE.			

REPAIR DATA FOR 250°F (121°C) CURE HONEYCOMB PANELS (FIBERGLASS)
TABLE IV

**Wing Fixed Leading Edge Skin Repairs
Figure 201 (Sheet 8 of 8)**

757-200
STRUCTURAL REPAIR MANUAL

IDENTIFICATION 1 - WING FIXED LEADING EDGE RIB

REFERENCE DRAWING
114N1001

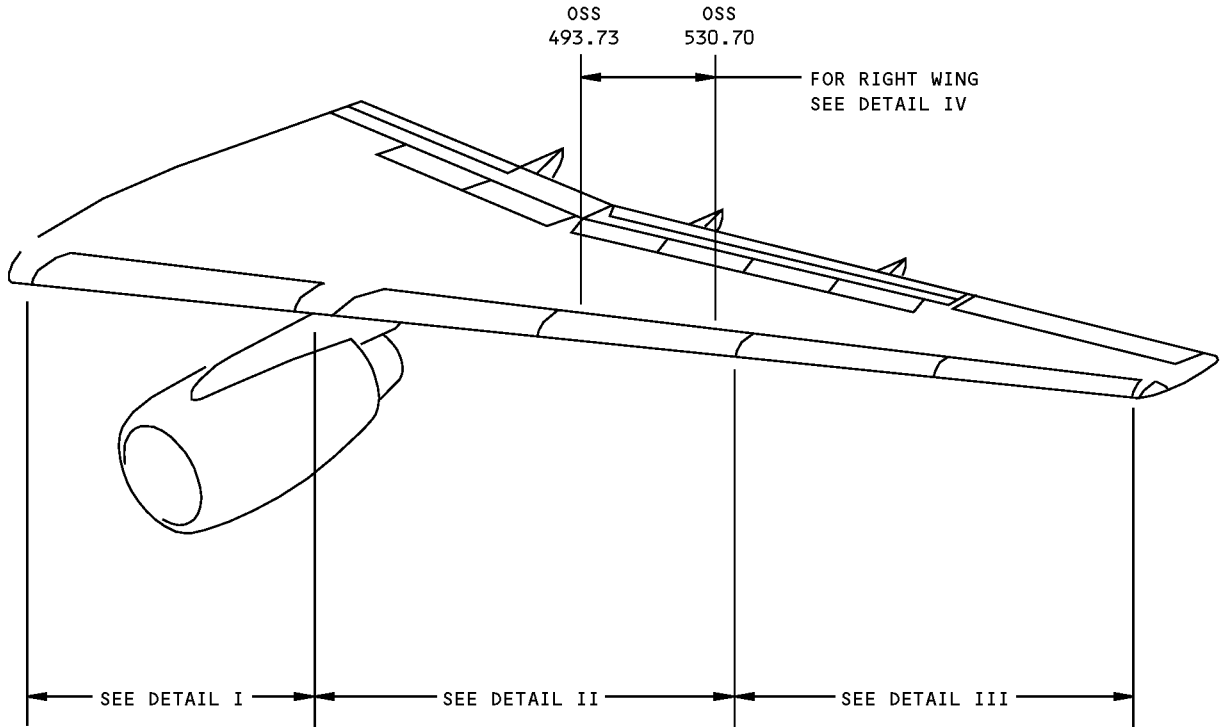

LEFT WING SHOWN
RIGHT WING OPPOSITE
EXCEPT AS NOTED

NOTES

- A** OPTIONAL FOR CUM LINE NUMBERS:
1 THRU 28
- B** FOR AIRPLANE CUM LINE NUMBERS:
1 THRU 28
- C** FOR AIRPLANE CUM LINE NUMBERS:
29 THRU 1009

- D** FOR CUM LINE NUMBERS:
1 THRU 25
- E** FOR CUM LINE NUMBERS:
26 AND ON
- F** FOR CUM LINE NUMBERS:
1010 AND ON

Wing Fixed Leading Edge Rib Identification
Figure 1 (Sheet 1 of 8)

**757-200
STRUCTURAL REPAIR MANUAL**

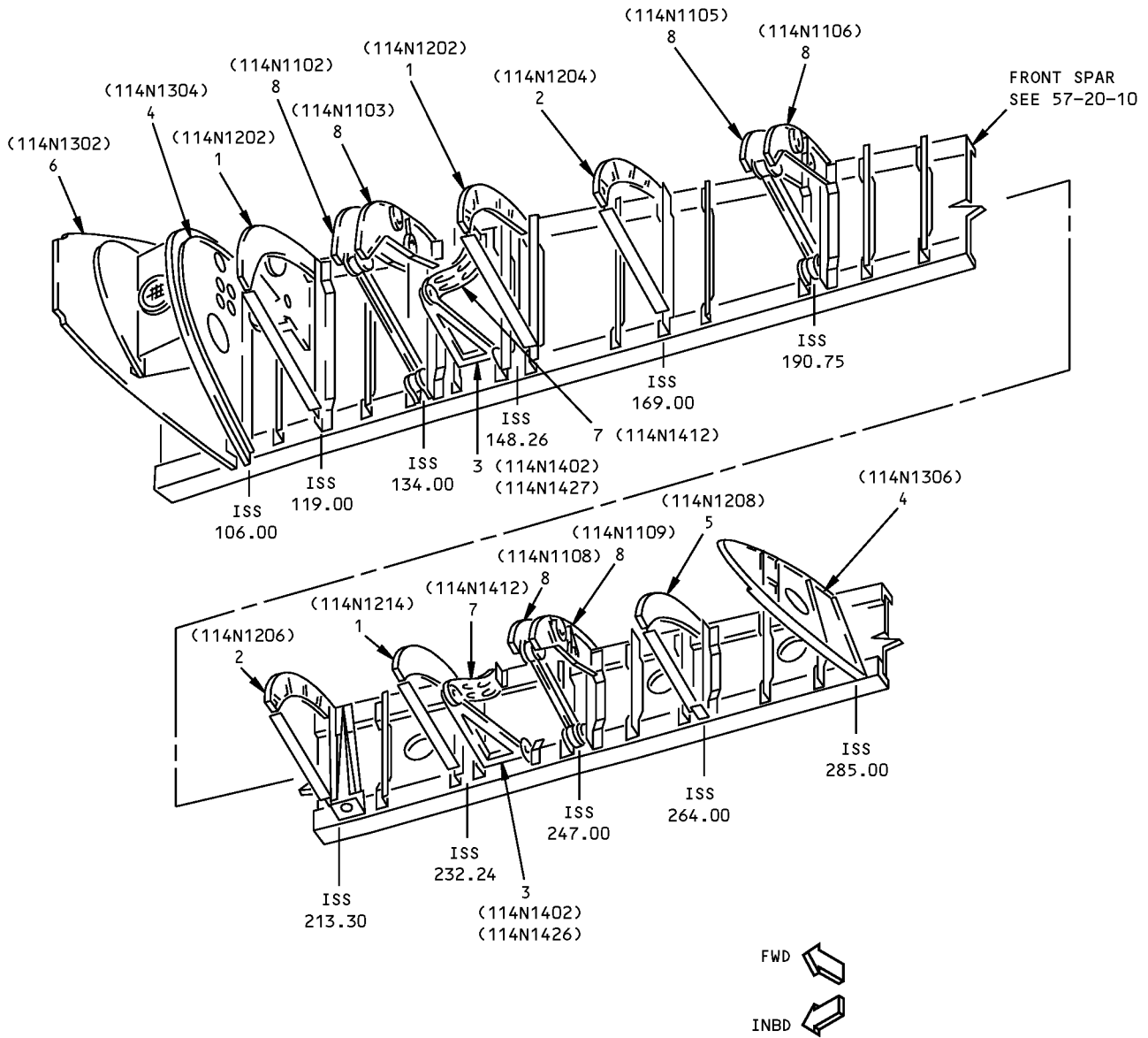

DETAIL I

LIST OF
MATL

**Wing Fixed Leading Edge Rib Identification
Figure 1 (Sheet 2 of 8)**

IDENTIFICATION 1
Page 2
Jan 20/2005

57-41-09

D634N201



757-200
STRUCTURAL REPAIR MANUAL

ITEM	DESCRIPTION	GAGE	MATERIAL	EFFECTIVITY
1	AIRLOAD RIB	0.90	7075-T7351 PLATE OPTIONAL: FORGING 7075-T7352	
2	AIRLOAD RIB	2.00	7075-T7351 PLATE OPTIONAL: FORGING 7075-T7352	
3	YOKE	1.70	7075-T7351 PLATE OPTIONAL: FORGING 7075-T7352 7075-T73 DIE FORGING	A
4	SEAL RIB	2.50	7075-T7351 PLATE OPTIONAL: FORGING 7075-T7352 CASTING 15-5PH CRES 180-200 KSI	D E
5	AIRLOAD RIB	1.00	7075-T7351 PLATE OPTIONAL: FORGING 7075-T7352	
6	END RIB	1.50	7075-T7351 PLATE OPTIONAL: FORGING 7075-T7352	
7	TRACK	0.75	4330M STEEL BAR HT TR 220-240 KSI	
8	TRACK SUPPORT RIB	2.25	7075-T7351 PLATE OPTIONAL: FORGING 7075-T7352	

LIST OF MATERIALS FOR DETAIL I

Wing Fixed Leading Edge Rib Identification
Figure 1 (Sheet 3 of 8)

D634N201

57-41-09

IDENTIFICATION 1
Page 3
Jan 20/2005

**757-200
STRUCTURAL REPAIR MANUAL**

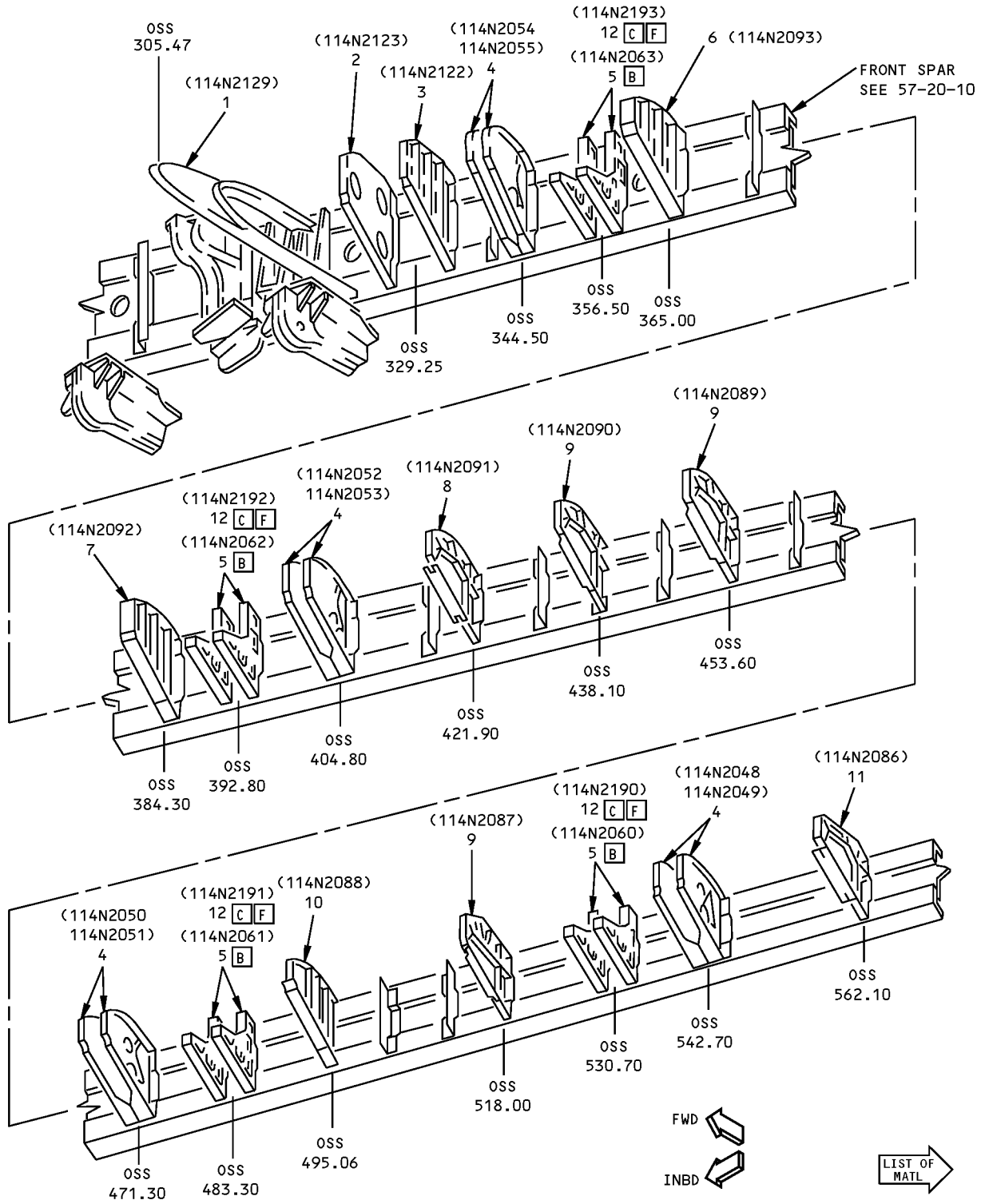

DETAIL II

**Wing Fixed Leading Edge Rib Identification
Figure 1 (Sheet 4 of 8)**



**757-200
STRUCTURAL REPAIR MANUAL**

ITEM	DESCRIPTION	GAGE	MATERIAL	EFFECTIVITY
1	CLOSURE RIB	3.00	7075-T7351 AS GIVEN IN QQ-A-250/12 OPTIONAL: FORGING 7075-T73 AS GIVEN IN BMS-186	
2	TRACK SUPPORT RIB	1.50	7050-T7451 PLATE AS GIVEN IN AMS 4050 OPTIONAL: FORGING 7075-T73 AS GIVEN IN BMS-186, OR 7075-T7351 PLATE AS GIVEN IN QQ-A-250/12	
3	TRACK SUPPORT RIB	2.50	7050-T7451 PLATE AS GIVEN IN AMS 4050 OPTIONAL: FORGING 7075-T73 AS GIVEN IN BMS-186, OR 7075-T7351 PLATE AS GIVEN IN QQ-A-250/12	
4	TRACK SUPPORT RIB	3.00	7050-T7451 PLATE AS GIVEN IN AMS 4050 OPTIONAL: FORGING 7075-T73 AS GIVEN IN BMS-186, OR 7075-T7351 PLATE AS GIVEN IN QQ-A-250/12	
5	TRACK SUPPORT RIB	1.50	7050-T7351 PLATE AS GIVEN IN QQ-A-250/12 OPTIONAL: FORGING 7075-T73 AS GIVEN IN BMS-186	B
6	AIRLOAD RIB	2.75	7050-T7451 PLATE AS GIVEN IN AMS 4050 OPTIONAL: FORGING 7075-T73 AS GIVEN IN BMS-186, OR 7075-T7351 PLATE AS GIVEN IN QQ-A-250/12	
7	AIRLOAD RIB	1.50	7050-T7451 PLATE AS GIVEN IN AMS 4050 OPTIONAL: FORGING 7075-T73 AS GIVEN IN BMS-186, OR 7075-T7351 PLATE AS GIVEN IN QQ-A-250/12	
8	AIRLOAD RIB	2.40	7050-T7451 PLATE AS GIVEN IN AMS 4050 OPTIONAL: FORGING 7075-T73 AS GIVEN IN BMS-186, OR 7075-T7351 PLATE AS GIVEN IN QQ-A-250/12	
9	AIRLOAD RIB	1.50	7050-T7451 PLATE AS GIVEN IN AMS 4050 OPTIONAL: FORGING 7075-T73 AS GIVEN IN BMS-186, OR 7075-T7351 PLATE AS GIVEN IN QQ-A-250/12	
10	AIRLOAD RIB	2.60	7050-T7451 PLATE AS GIVEN IN AMS 4050 OPTIONAL: FORGING 7075-T73 AS GIVEN IN BMS-186, OR 7075-T7351 PLATE AS GIVEN IN QQ-A-250/12	
11	AIRLOAD RIB	2.50	7050-T7451 PLATE AS GIVEN IN AMS 4050 OPTIONAL: FORGING 7075-T73 AS GIVEN IN BMS-186, OR 7075-T7351 PLATE AS GIVEN IN QQ-A-250/12	
12	TRACK SUPPORT RIB	1.50	7050-T7351 AS GIVEN IN QQ-A-250/12 OPTIONAL: FORGING 7075-T73 AS GIVEN IN BMS-186	C
13	TRACK SUPPORT RIB	1.50	7050-T7451 PLATE AS GIVEN IN AMS 4050	F

LIST OF MATERIALS FOR DETAIL II

**Wing Fixed Leading Edge Rib Identification
Figure 1 (Sheet 5 of 8)**

**757-200
STRUCTURAL REPAIR MANUAL**

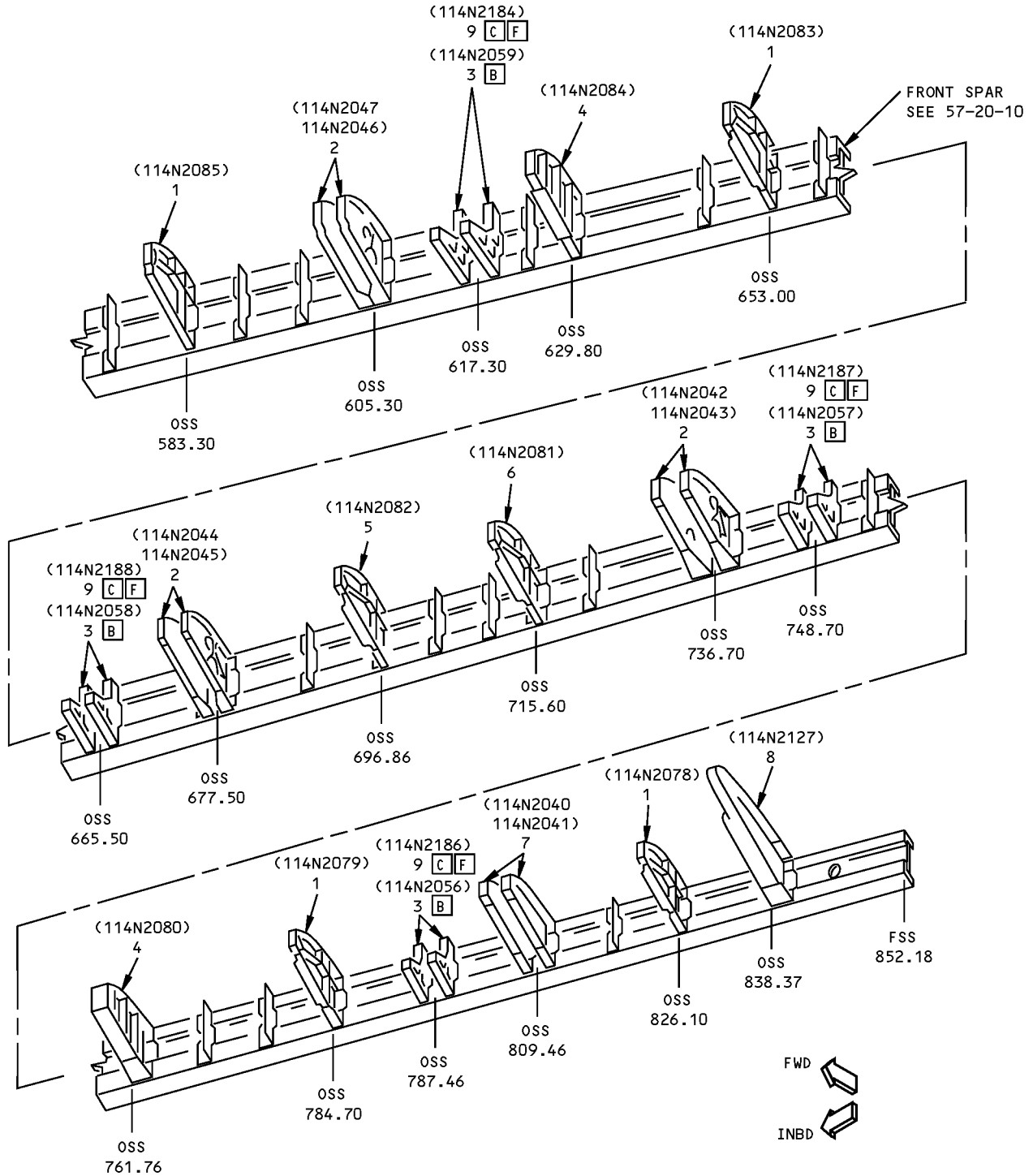

DETAIL III



**Wing Fixed Leading Edge Rib Identification
Figure 1 (Sheet 6 of 8)**



757-200
STRUCTURAL REPAIR MANUAL

ITEM	DESCRIPTION	GAGE	MATERIAL	EFFECTIVITY
1	AIRLOAD RIB	1.50	7075-T7351 PLATE OPTIONAL: FORGING 7075-T73	
2	TRACK SUPPORT RIB	3.00	7075-T7351 PLATE OPTIONAL: FORGING 7075-T73	
3	TRACK SUPPORT FITTING	1.30	7075-T7351 PLATE OPTIONAL: FORGING 7075-T73	B
4	AIRLOAD RIB	2.80	7075-T7351 PLATE OPTIONAL: FORGING 7075-T73	
5	AIRLOAD RIB	2.00	7075-T7351 PLATE OPTIONAL: FORGING 7075-T73	
6	AIRLOAD RIB	1.25	7075-T7351 PLATE OPTIONAL: FORGING 7075-T73	
7	TRACK SUPPORT RIB	0.500	7075-T7351 PLATE OPTIONAL: FORGING 7075-T73	
8	CLOSURE RIB	2.50	7075-T7351 PLATE OPTIONAL: FORGING 7075-T73	
9	TRACK SUPPORT FITTING		FORGING 7075-T73 7050-T7451 PLATE AS GIVEN IN AMS 4050	C F

LIST OF MATERIALS FOR DETAIL III

Wing Fixed Leading Edge Rib Identification
Figure 1 (Sheet 7 of 8)

D634N201

57-41-09

IDENTIFICATION 1
Page 7
Jan 20/2005

**757-200
STRUCTURAL REPAIR MANUAL**

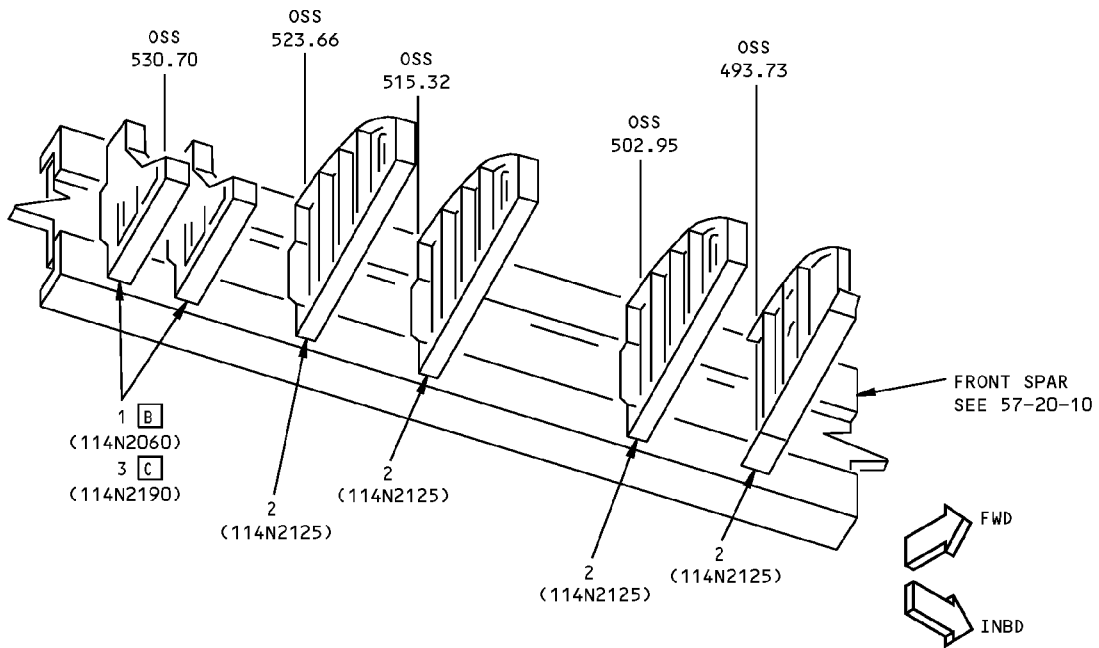
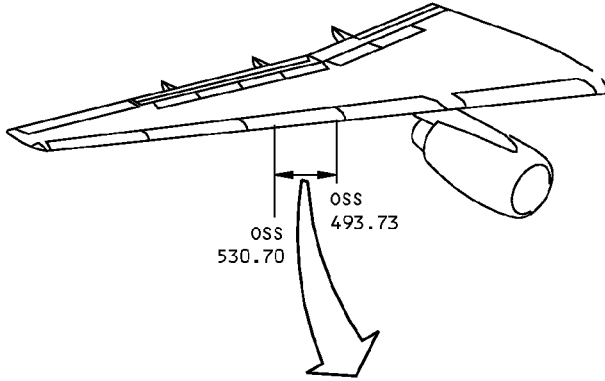

DETAIL IV

ITEM	DESCRIPTION	GAGE	MATERIAL	EFFECTIVITY
1	TRACK SUPPORT FITTING	1.50	7075-T7351 PLATE OPTIONAL: FORGING 7075-T73	
2	AIRLOAD RIB	1.50	7075-T7351 PLATE OPTIONAL: FORGING 7075-T73	[B]
3	TRACK SUPPORT FITTING		FORGING 7075-T73	[C]

LIST OF MATERIALS FOR DETAIL IV

**Wing Fixed Leading Edge Rib Identification
Figure 1 (Sheet 8 of 8)**



757-200
STRUCTURAL REPAIR MANUAL

ALLOWABLE DAMAGE 1 - WING FIXED LEADING EDGE RIBS

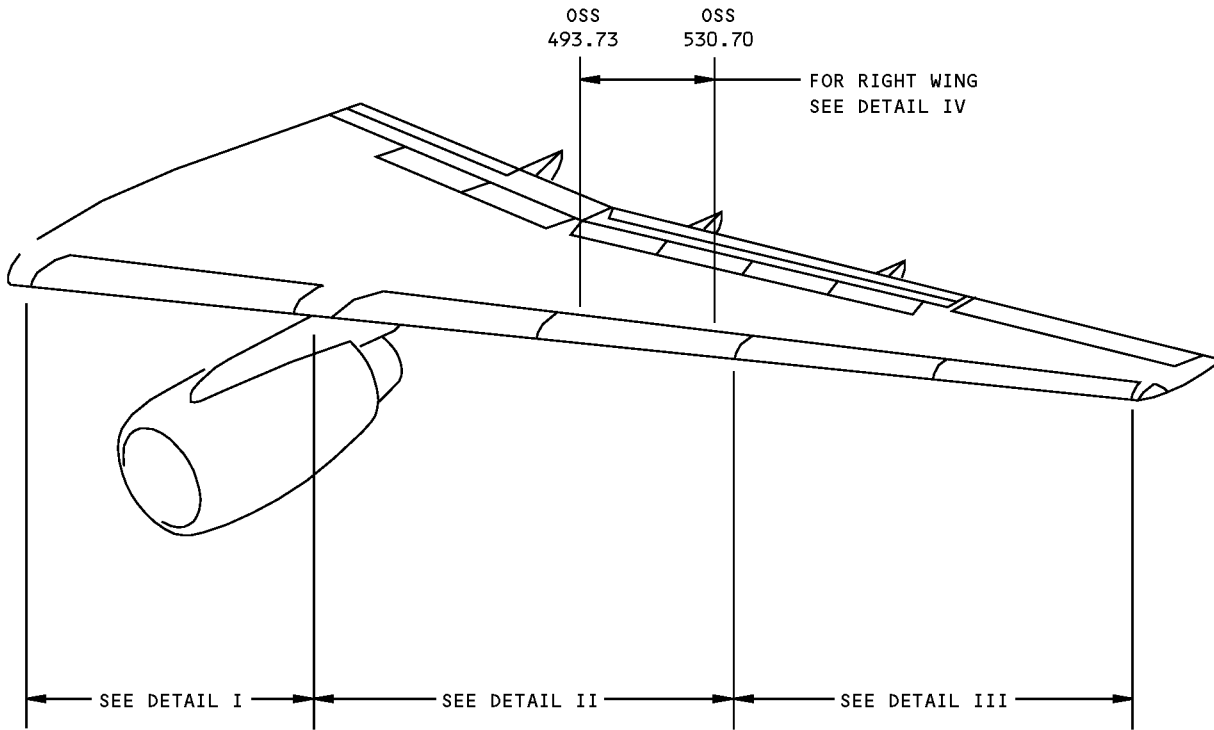

LEFT WING SHOWN
RIGHT WING OPPOSITE
EXCEPT AS NOTED

Wing Fixed Leading Edge Ribs Allowable Damage
Figure 101 (Sheet 1 of 8)

D634N201

ALLOWABLE DAMAGE 1
Page 101
57-41-09 Jan 20/2007

**757-200
STRUCTURAL REPAIR MANUAL**

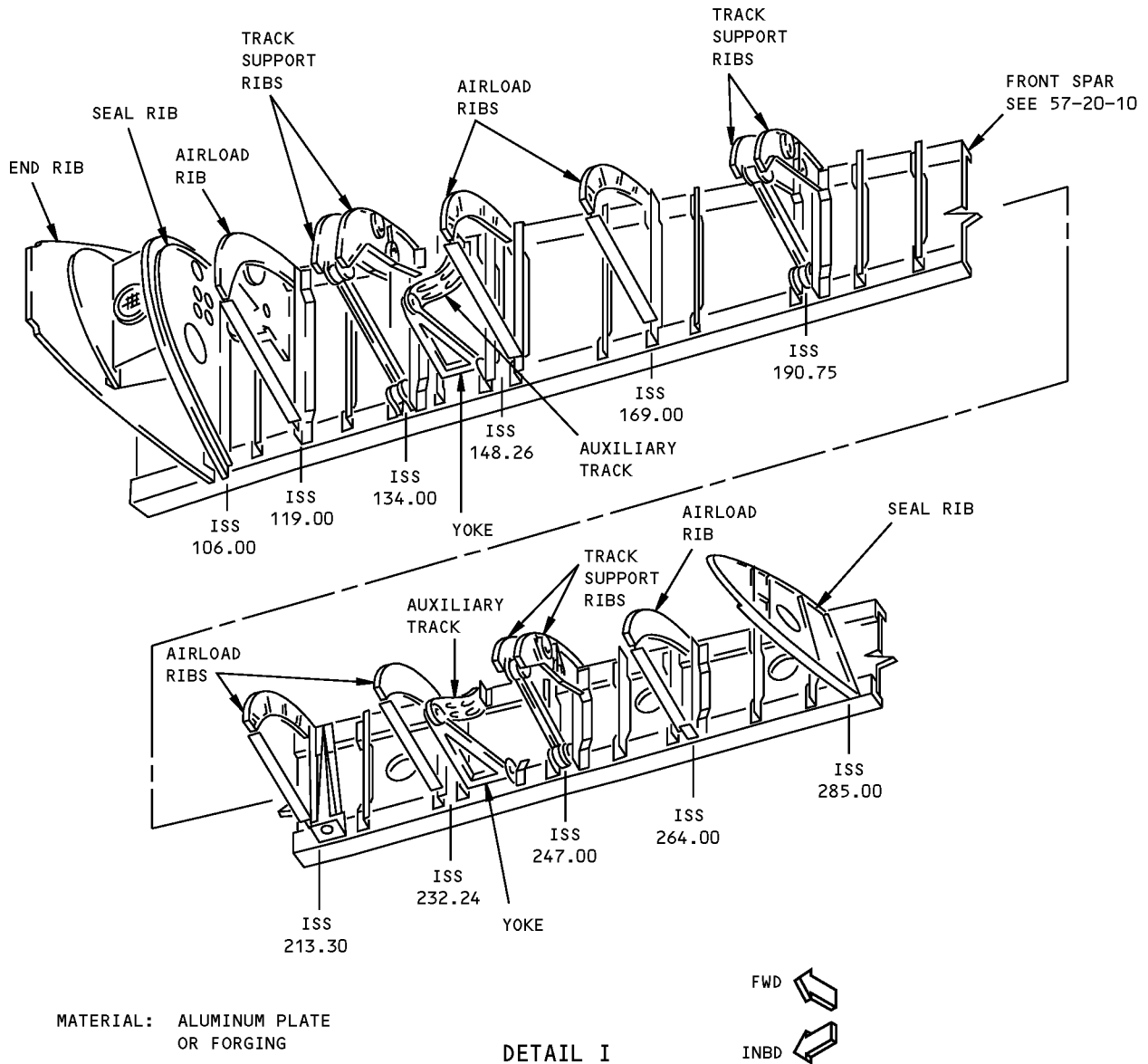

**Wing Fixed Leading Edge Ribs Allowable Damage
Figure 101 (Sheet 2 of 8)**

**757-200
STRUCTURAL REPAIR MANUAL**

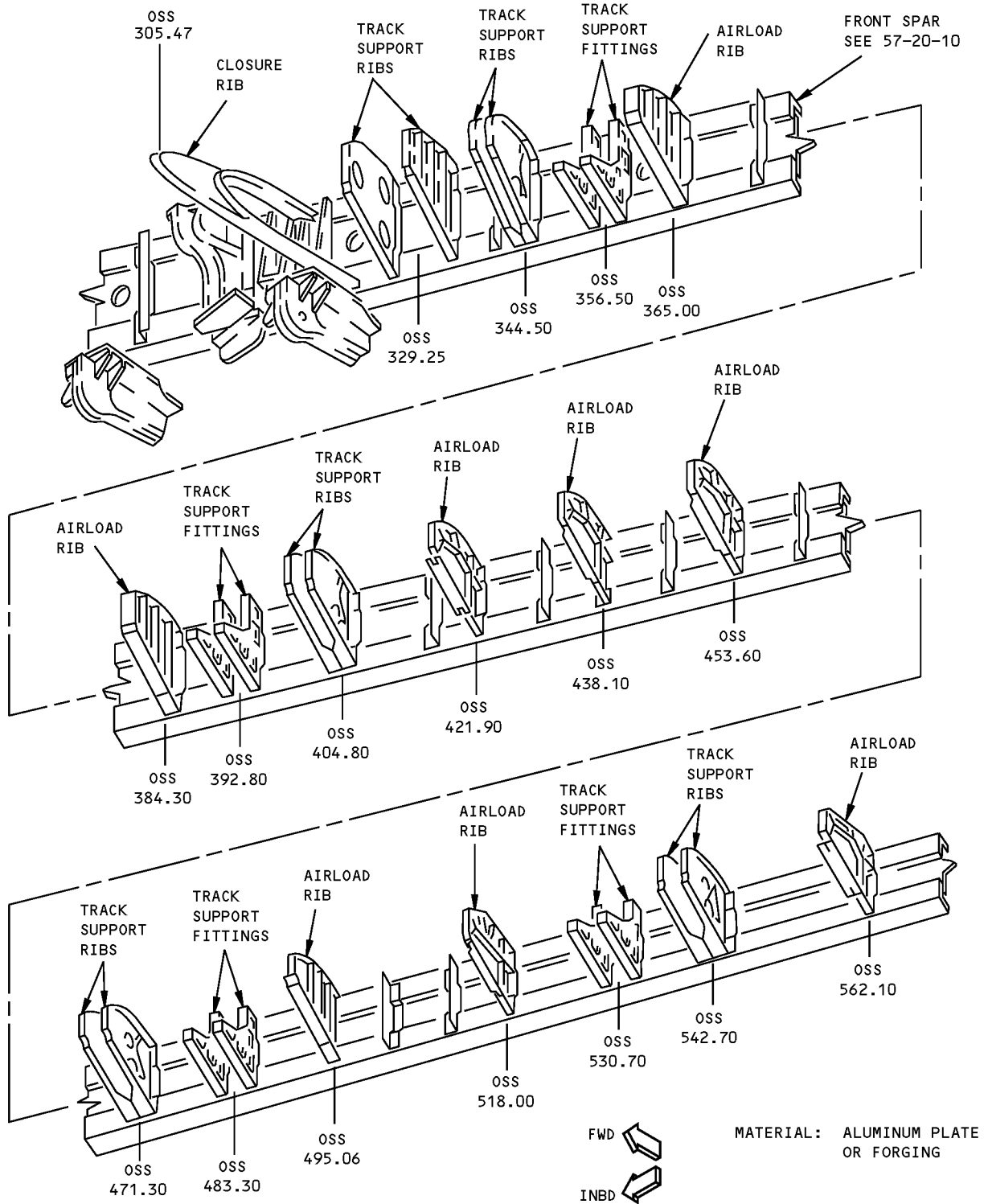

DETAIL II

**Wing Fixed Leading Edge Ribs Allowable Damage
Figure 101 (Sheet 3 of 8)**

**757-200
STRUCTURAL REPAIR MANUAL**

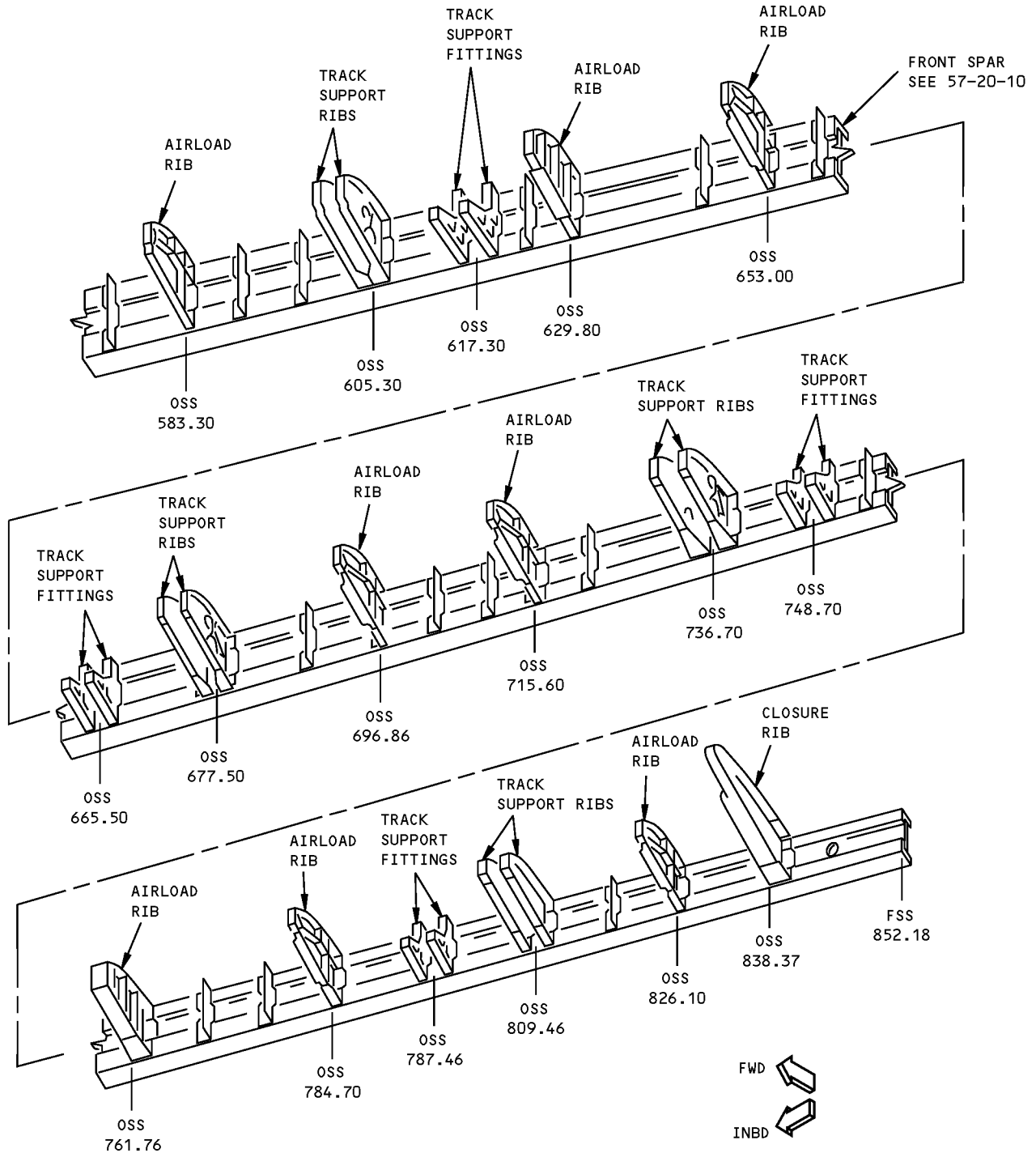

DETAIL III

**Wing Fixed Leading Edge Ribs Allowable Damage
Figure 101 (Sheet 4 of 8)**

ALLOWABLE DAMAGE 1

57-41-09

Page 104
Jan 20/2005

D634N201

**757-200
STRUCTURAL REPAIR MANUAL**

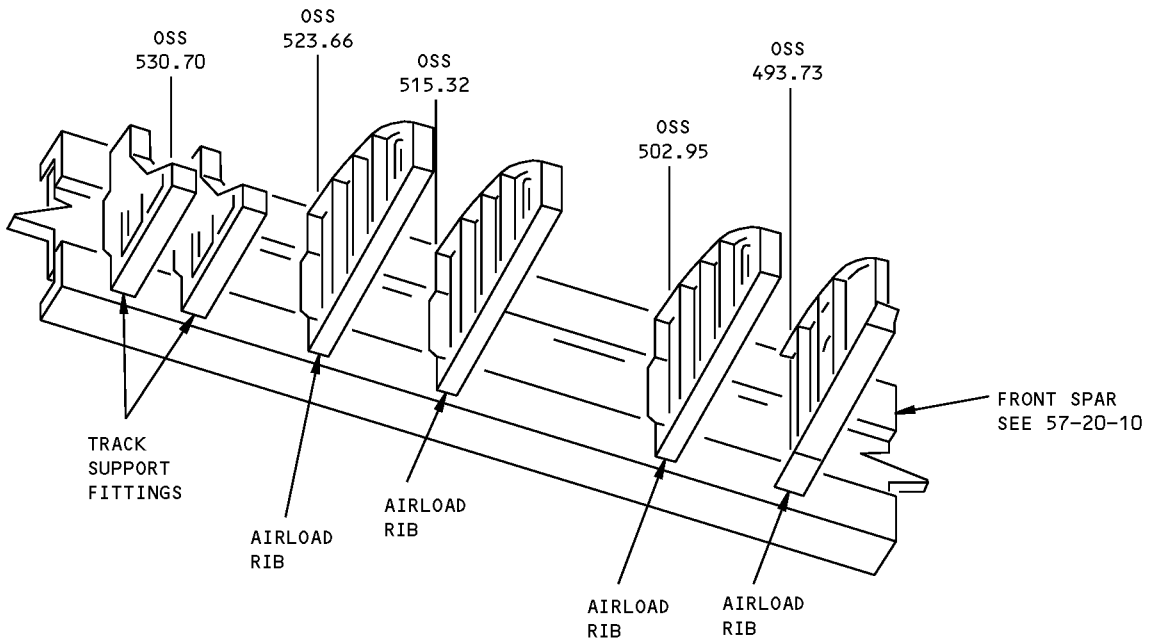
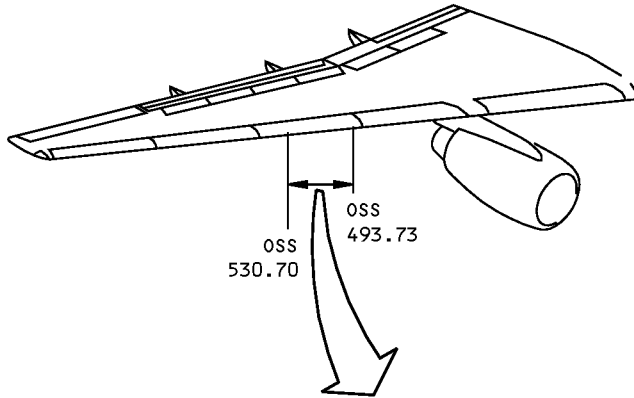

**RIGHT WING ONLY
DETAIL IV**

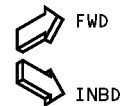

**Wing Fixed Leading Edge Ribs Allowable Damage
Figure 101 (Sheet 5 of 8)**



**757-200
STRUCTURAL REPAIR MANUAL**

DESCRIPTION	CRACKS	NICKS, GOUGES AND CORROSION	DENTS	HOLES AND PUNCTURES
RIBS				
CHORDS	A	B	NOT ALLOWED	NOT ALLOWED
WEBS	C	B	SEE DETAIL VII	D
FITTINGS	E	F	NOT ALLOWED	NOT ALLOWED
TRACK	A	F	NOT ALLOWED	NOT ALLOWED
YOKE	A	F	NOT ALLOWED	NOT ALLOWED
TRACK SUPPORT FITTINGS	E	F	NOT ALLOWED	NOT ALLOWED

NOTES

- REFINISH REWORKED AREAS PER 51-20 OF THE MAINTENANCE MANUAL
- A CRACKS NOT ALLOWED EXCEPT FOR EDGE CRACKS WHICH MUST BE REMOVED PER DETAILS V AND X. REFER TO G FOR SHOT PEEN REQUIREMENTS
- B REMOVE DAMAGE PER DETAILS V, VI AND VIII. REFER TO G FOR SHOT PEEN REQUIREMENTS
- C CRACKS NOT ALLOWED EXCEPT FOR EDGE CRACKS WHICH MUST BE REMOVED PER DETAILS V AND IX. REFER TO G FOR SHOT PEEN REQUIREMENTS
- D CLEAN OUT DAMAGE UP TO 0.25 MAX DIA AND NOT CLOSER THAN 1.0 INCH TO FASTENER HOLE OR OTHER DAMAGE. FILL HOLE WITH A 2117-T3 OR T4 ALUMINUM RIVET INSTALLED WET WITH BMS 5-95 SEALANT. ALL OTHER HOLES TO BE REPAIRED
- E CRACKS NOT ALLOWED EXCEPT FOR EDGE CRACKS WHICH MUST BE REMOVED PER DETAILS XII. REFER TO G FOR SHOT PEEN REQUIREMENTS
- F FOR EDGE DAMAGE SEE DETAIL XII. FOR LUG DAMAGE SEE DETAIL XI. FOR OTHER DAMAGE SEE DETAIL VI. DAMAGE NOT ALLOWED IN VICINITY OF BUSHINGS. REFER TO G FOR SHOT PEEN REQUIREMENTS
- G SHOT PEEN REWORKED AREA PER 20-10-03 OF THE COMPONENT MAINTENANCE MANUAL. REFER TO 51-20-06 FOR SHOT PEEN REQUIREMENTS

**Wing Fixed Leading Edge Ribs Allowable Damage
Figure 101 (Sheet 6 of 8)**

**757-200
STRUCTURAL REPAIR MANUAL**

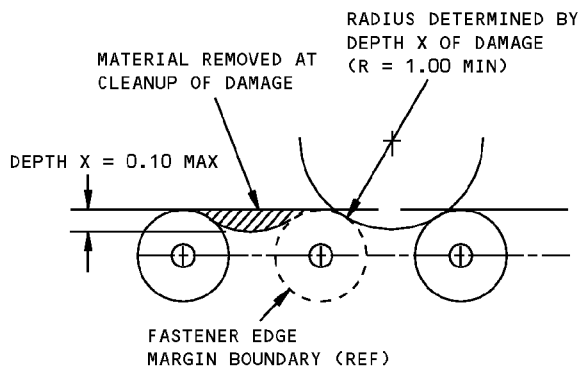

DAMAGE CLEANUP OF EDGES WHERE FASTENER EDGE MARGINS DO NOT OVERLAP

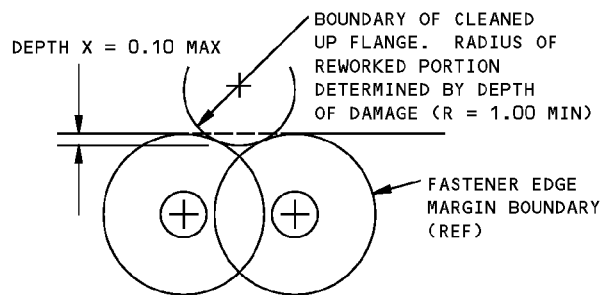

DAMAGE CLEANUP OF EDGES WHERE FASTENER EDGE MARGINS OVERLAP

DETAIL V

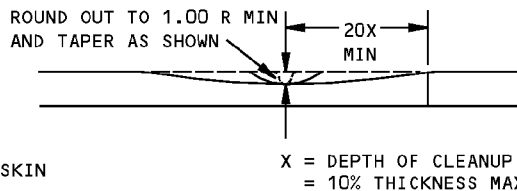
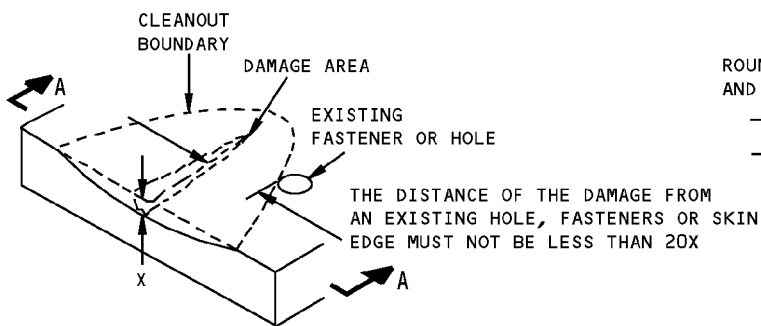

SECTION A-A

**REMOVAL OF NICK, GOUGE AND SCRATCH DAMAGE ON A SURFACE
DETAIL VI**

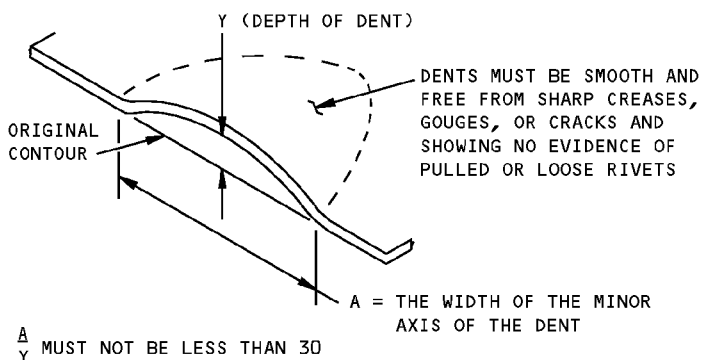

**ALLOWABLE DAMAGE FOR DENT
DETAIL VII**

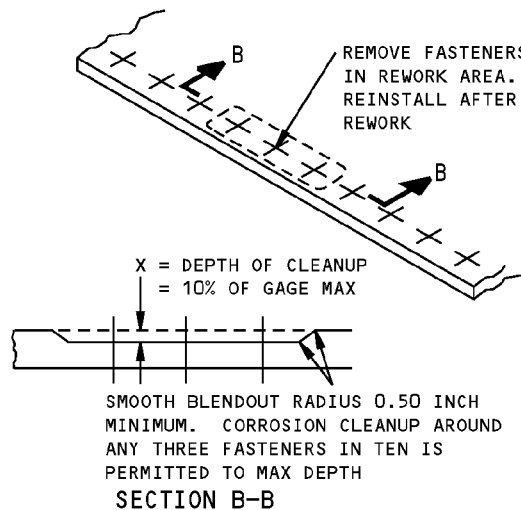

**CORROSION CLEANUP
DETAIL VIII**

**Wing Fixed Leading Edge Ribs Allowable Damage
Figure 101 (Sheet 7 of 8)**

**757-200
STRUCTURAL REPAIR MANUAL**

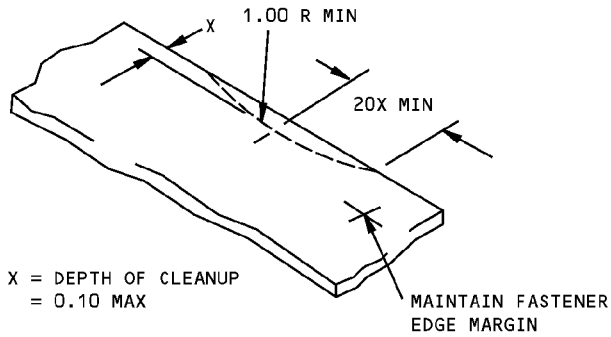

**REMOVAL OF NICK OR CRACK
DAMAGE ON AN EDGE
DETAIL IX**

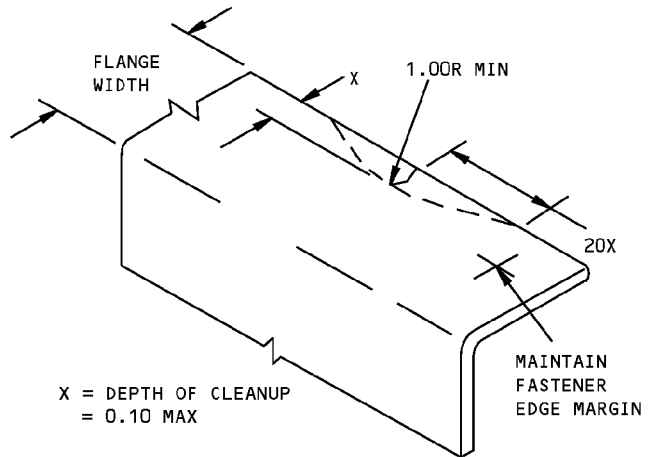

**REMOVAL OF NICK OR CRACK
DAMAGE ON AN EDGE
DETAIL X**

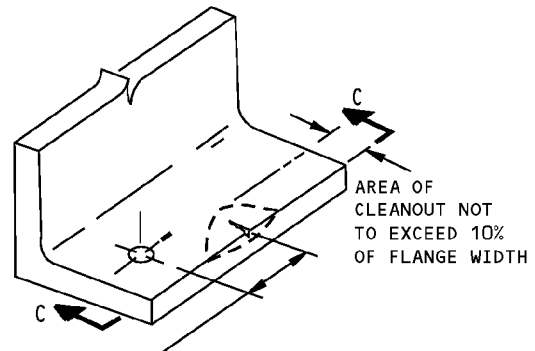

THE DISTANCE OF THE DAMAGE FROM AN
EXISTING HOLE, FASTENERS OR EDGE
MUST NOT BE LESS THAN 20X

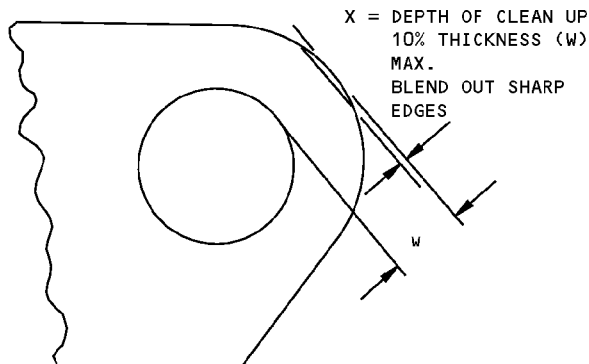

**DAMAGE CLEAN UP FOR EDGES OF LUG
DETAIL XI**

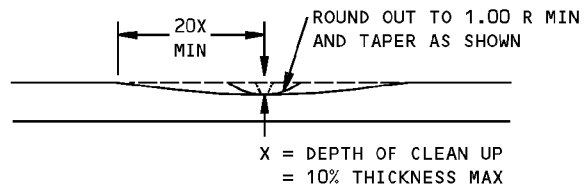

SECTION C-C

**REMOVAL OF NICK OR CRACK
DAMAGE ON AN EDGE
DETAIL XII**

**Wing Fixed Leading Edge Ribs Allowable Damage
Figure 101 (Sheet 8 of 8)**



757-200
STRUCTURAL REPAIR MANUAL

IDENTIFICATION 1 - WING FIXED LEADING EDGE BEAM

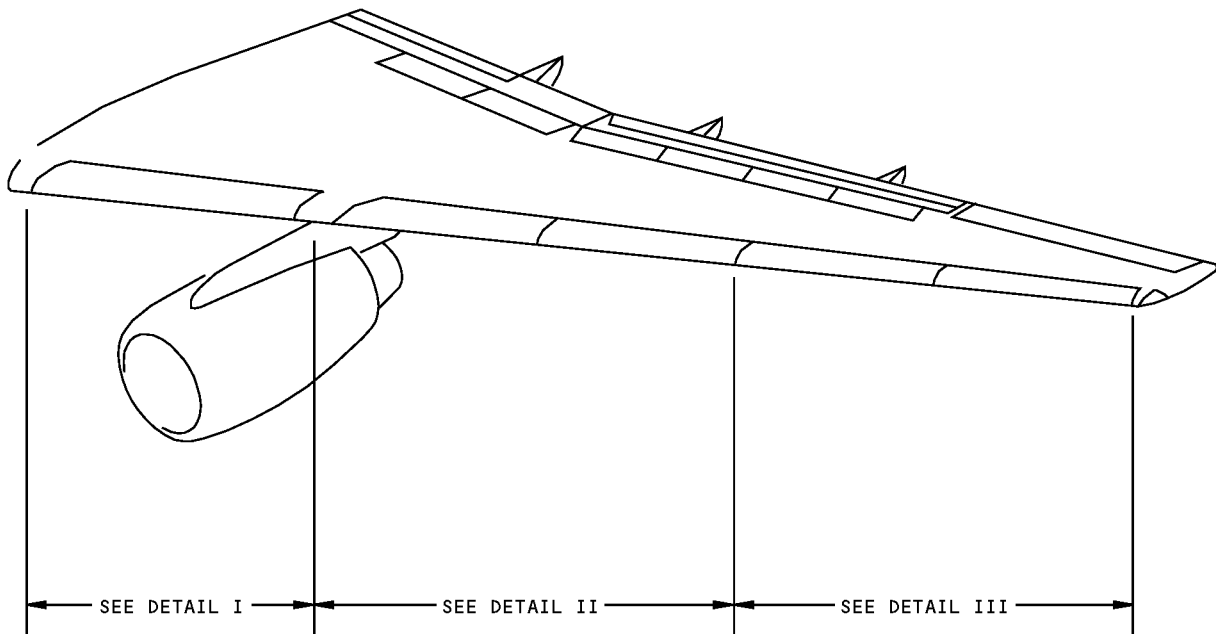

LEFT WING SHOWN
RIGHT WING OPPOSITE
EXCEPT AS NOTED

NOTES

- A** FOR CUM LINE NUMBERS:
1 THRU 53
- B** FOR ALL AIRPLANES NOT IN **A**

Wing Fixed Leading Edge Beam Identification
Figure 1 (Sheet 1 of 4)

D634N201

57-41-13

IDENTIFICATION 1
Page 1
Jan 20/2005

**757-200
STRUCTURAL REPAIR MANUAL**

REF DWG
114N1606

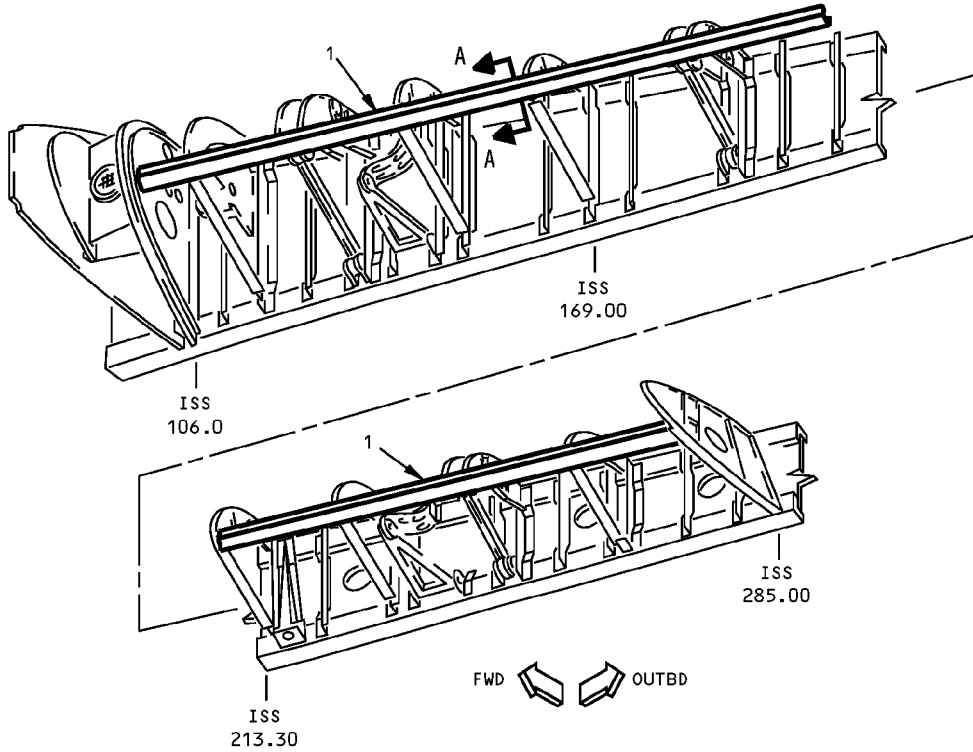

DETAIL I

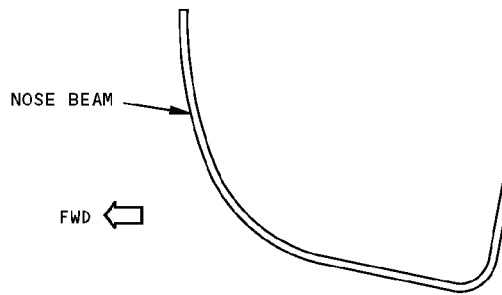

**CROSS-SECTIONAL VIEW OF NOSE BEAM
SECTION A-A**

ITEM	DESCRIPTION	GAGE	MATERIAL	EFFECTIVITY
1	NOSE BEAM	0.10 0.10	7075-T6 2024-T42	A B

LIST OF MATERIALS FOR DETAIL I

**Wing Fixed Leading Edge Beam Identification
Figure 1 (Sheet 2 of 4)**

IDENTIFICATION 1
Page 2
Jan 20/2005

57-41-13

D634N201

**757-200
STRUCTURAL REPAIR MANUAL**

REF DWG
114N2034

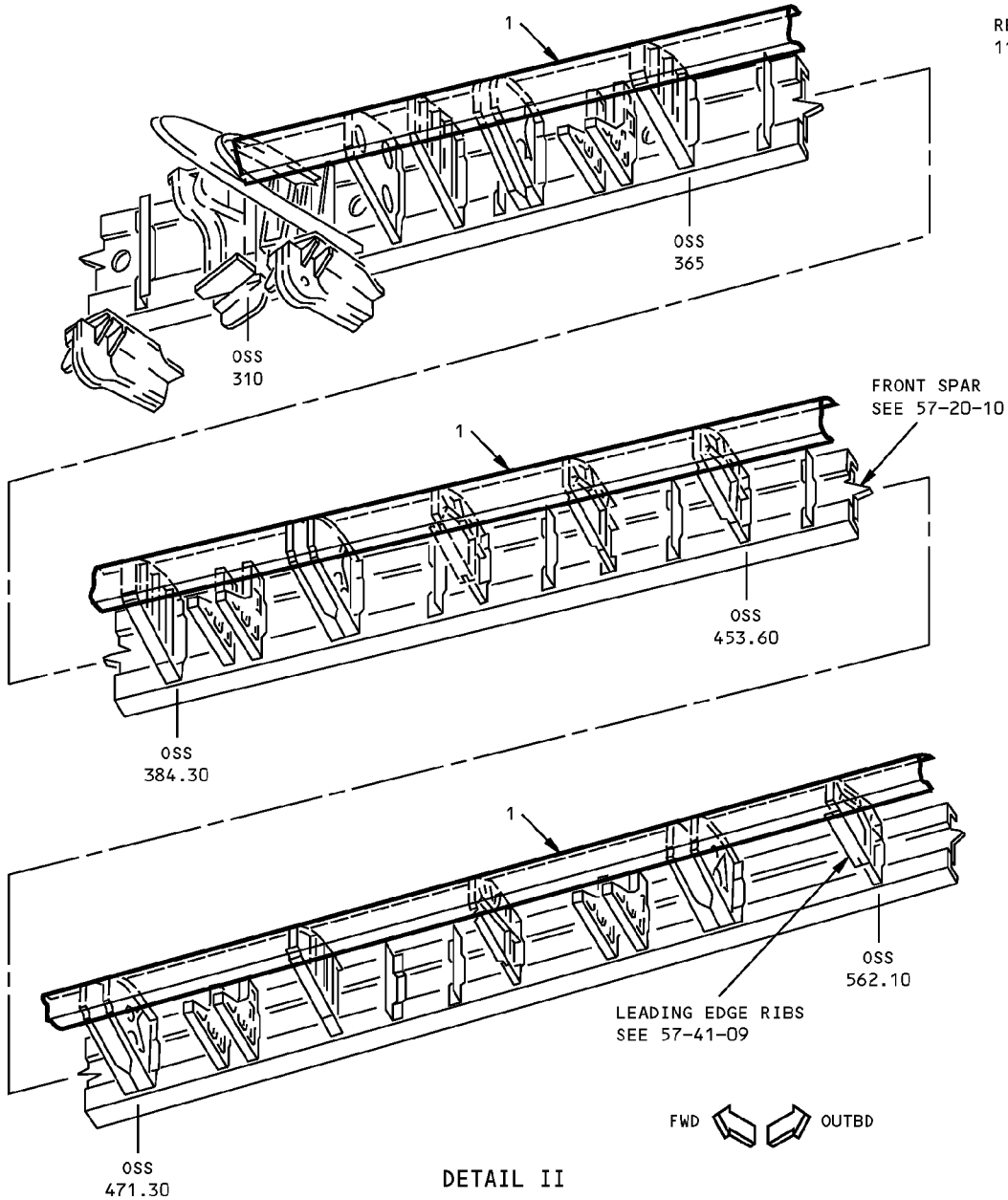

ITEM	DESCRIPTION	GAGE	MATERIAL	EFFECTIVITY
1	SPANWISE BEAM ASSY BEAM ANGLE	0.050 0.050	2024-T42 2024-T42	

LIST OF MATERIALS FOR DETAIL II

**Wing Fixed Leading Edge Beam Identification
Figure 1 (Sheet 3 of 4)**

IDENTIFICATION 1
Page 3
Jan 20/2005

57-41-13

D634N201

**757-200
STRUCTURAL REPAIR MANUAL**

REF DWG
114N2034

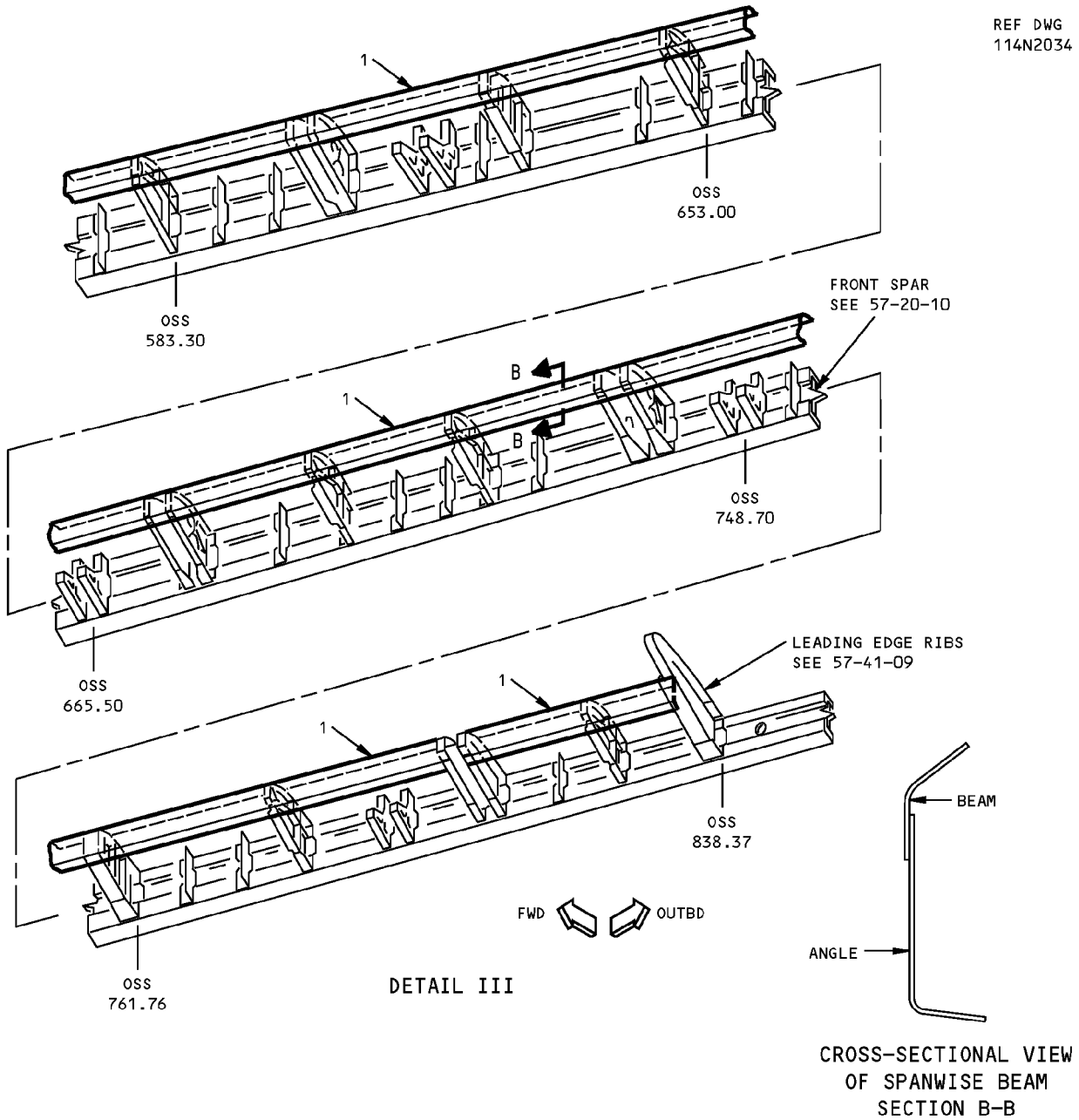

ITEM	DESCRIPTION	GAGE	MATERIAL	EFFECTIVITY
1	SPANWISE BEAM ASSY BEAM ANGLE	0.050 0.050	2024-T42 2024-T42	

LIST OF MATERIALS FOR DETAIL III

**Wing Fixed Leading Edge Beam Identification
Figure 1 (Sheet 4 of 4)**

IDENTIFICATION 1
Page 4
Jan 20/2005

57-41-13

D634N201



757-200
STRUCTURAL REPAIR MANUAL

ALLOWABLE DAMAGE 1 - WING FIXED LEADING EDGE BEAM

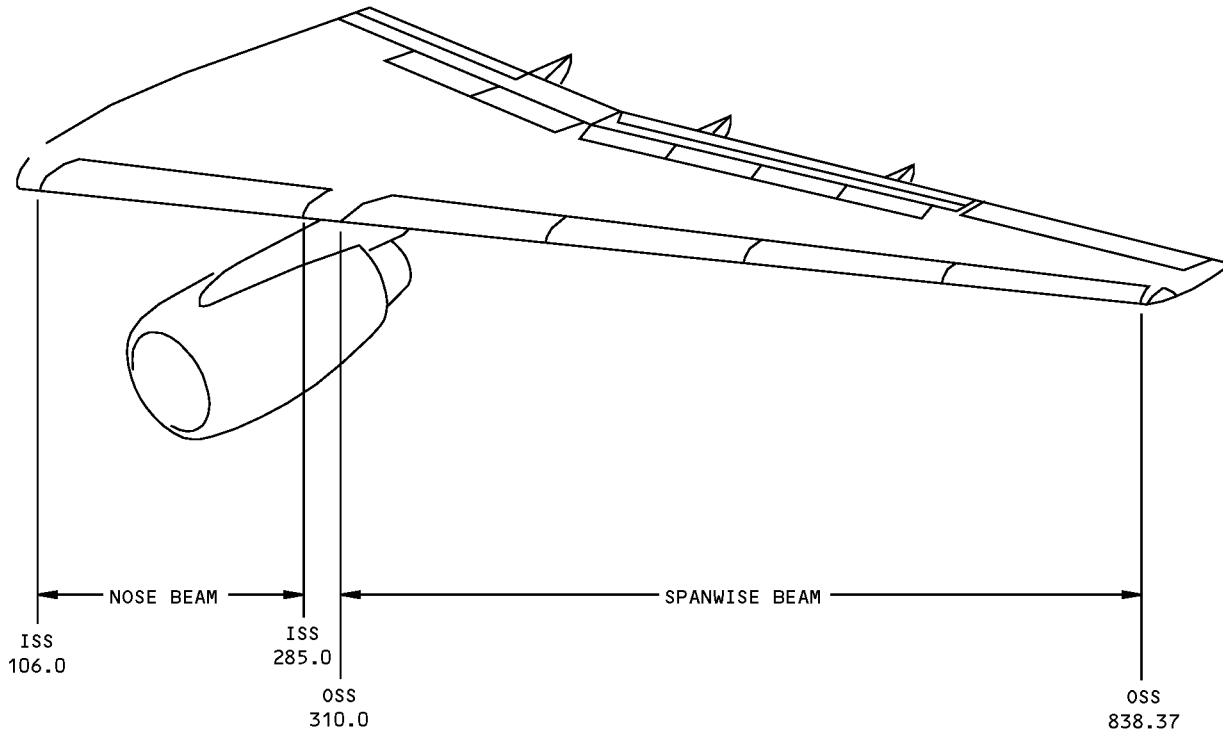

LEFT WING SHOWN
RIGHT WING OPPOSITE EXCEPT AS NOTED

Wing Fixed Leading Edge Beam Allowable Damage
Figure 101 (Sheet 1 of 5)

**757-200
STRUCTURAL REPAIR MANUAL**

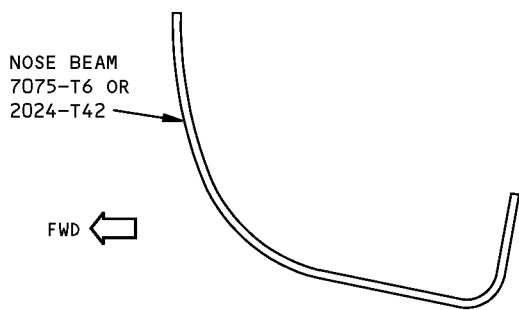
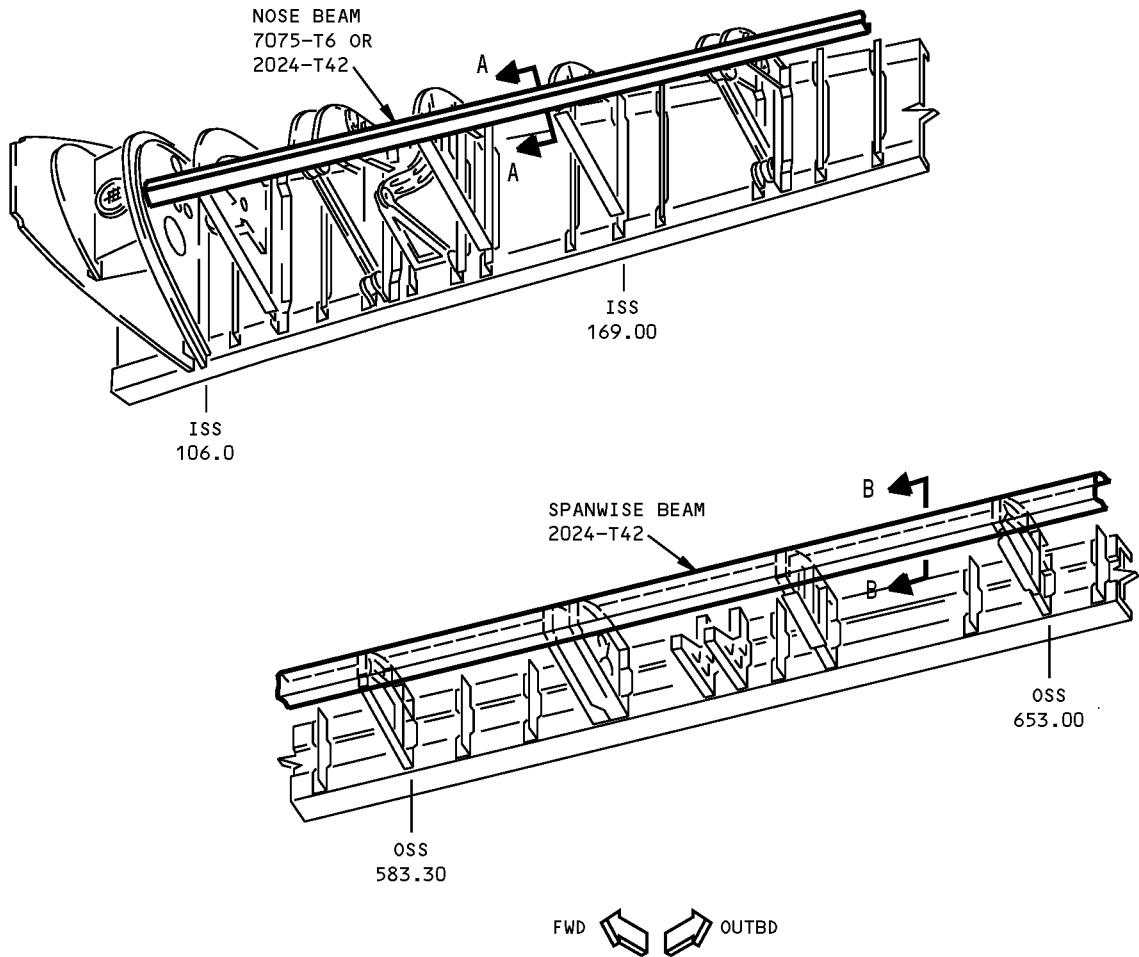

CROSS-SECTIONAL VIEW OF NOSE BEAM
TYPICAL FOR ISS 106.0 THRU ISS 285.0
SECTION A-A

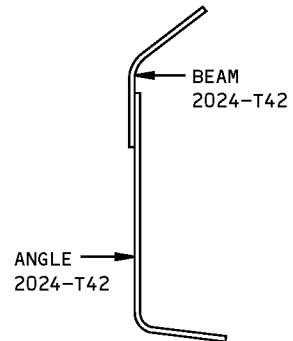

CROSS-SECTIONAL VIEW OF SPANWISE BEAM
TYPICAL FOR OSS 310.0 THRU OSS 838.37
SECTION B-B

**Wing Fixed Leading Edge Beam Allowable Damage
Figure 101 (Sheet 2 of 5)**



757-200
STRUCTURAL REPAIR MANUAL

DESCRIPTION	CRACKS	NICKS, GOUGES AND CORROSION	DENTS	HOLES AND PUNCTURES
NOSE BEAM	A	B	SEE DETAIL III	C
SPANWISE BEAM ASSY			SEE DETAIL III	
BEAM	A	B		C
ANGLE	D	E	SEE DETAIL III	C

NOTES

- REFER TO IDENTIFICATION 1 FOR LOCATIONS OF LEADING EDGE BEAMS AND FOR MATERIAL EFFECTIVITY
- REFINISH REWORKED AREAS PER 51-20 OF THE MAINTENANCE MANUAL
- REFER TO 51-10-02 FOR INSPECTION AND REMOVAL OF DAMAGE

- A CRACKS NOT ALLOWED EXCEPT FOR EDGE CRACKS WHICH MUST BE REMOVED PER DETAIL I
- B REMOVE EDGE DAMAGE PER DETAIL I. BLEND OUT SURFACE DAMAGE PER DETAILS II AND IV
- C CLEAN OUT DAMAGE UP TO 0.25 INCH (6 mm) MAX DIA AND NOT CLOSER THAN 1.5 INCHES (38 mm) TO FASTENER HOLE, MATERIAL EDGE, OR OTHER DAMAGE. FILL HOLE WITH 2117-T3 OR T4 ALUMINUM RIVET INSTALLED WET WITH BMS 5-95 SEALANT. ALL OTHER HOLES TO BE REPAIRED
- D CRACKS NOT ALLOWED EXCEPT FOR EDGE CRACKS WHICH MUST BE REMOVED PER DETAILS I AND V
- E REMOVE EDGE DAMAGE PER DETAILS I AND V. BLEND OUT SURFACE DAMAGE PER DETAIL II AND IV

Wing Fixed Leading Edge Beam Allowable Damage
Figure 101 (Sheet 3 of 5)

STRUCTURAL REPAIR MANUAL

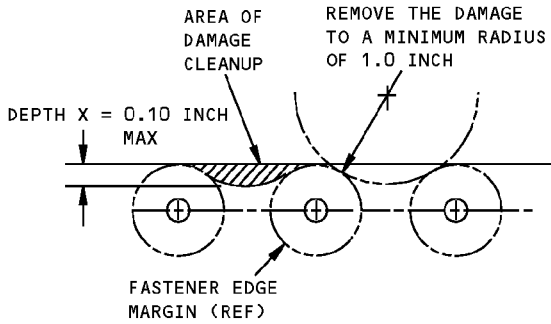

REMOVAL OF DAMAGE AT EDGES WHERE FASTENER EDGE MARGINS DO NOT OVERLAP

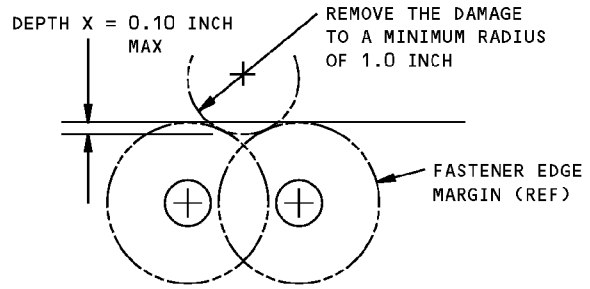

REMOVAL OF DAMAGE AT EDGES WHERE FASTENER EDGE MARGINS OVERLAP

DETAIL I

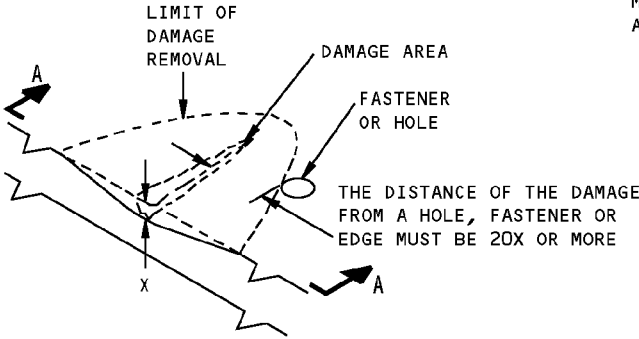

REMOVE THE DAMAGE TO A MINIMUM RADIUS OF 1.0 INCH AND TAPER AS SHOWN

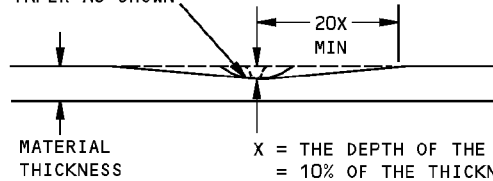

NOTE: THE MAXIMUM AREA REMOVED FOR CLEANUP MUST NOT BE LARGER THAN 4% OF THE CROSS-SECTIONAL AREA.

SECTION A-A

REMOVAL OF DAMAGE ON A SURFACE
DETAIL II

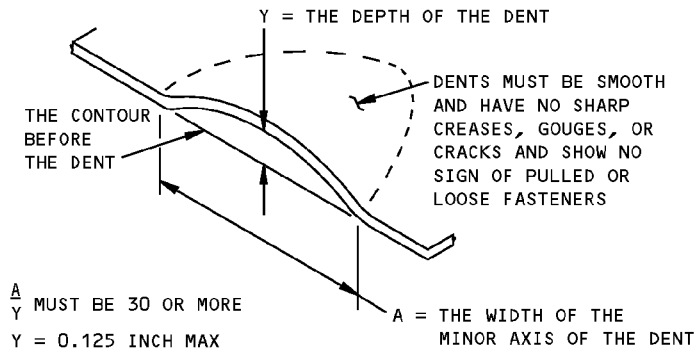

DENT DAMAGE PERMITTED
DETAIL III

**Wing Fixed Leading Edge Beam Allowable Damage
Figure 101 (Sheet 4 of 5)**

**757-200
STRUCTURAL REPAIR MANUAL**

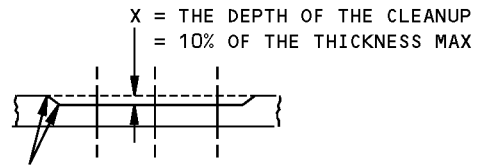
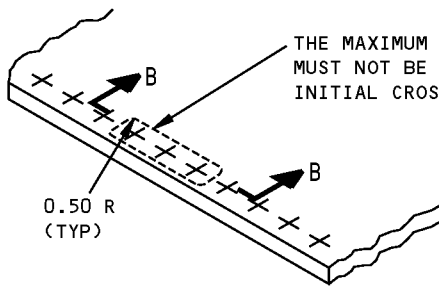

SMOOTH THE BLENDOUT RADIUS TO 0.50 INCH MINIMUM.
CLEANUP AROUND ANY THREE FASTENERS IN TEN IS PERMITTED TO THE MAXIMUM DEPTH

SECTION B-B

**DAMAGE CLEANUP AROUND FASTENERS
DETAIL IV**

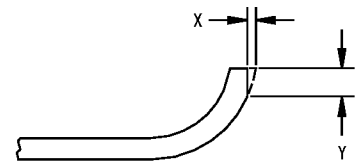
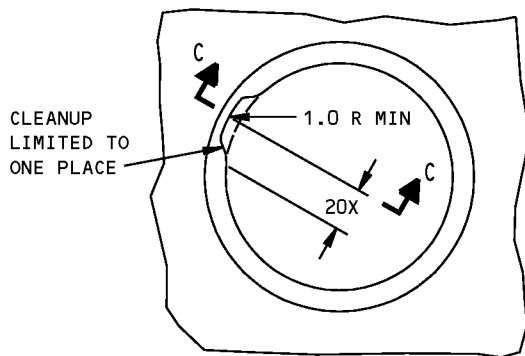

SECTION C-C

X = THE DEPTH OF THE CLEANUP
X MAX = 10% OF THE FLANGE THICKNESS
Y = THE LENGTH OF THE CLEANUP
Y MAX = 0.10 OR 1/2 OF THE FLANGE HEIGHT,
WHICHEVER IS LESS

**FLANGED HOLE EDGE DAMAGE CLEANUP
DETAIL V**

**Wing Fixed Leading Edge Beam Allowable Damage
Figure 101 (Sheet 5 of 5)**

757-200
STRUCTURAL REPAIR MANUAL

REPAIR GENERAL - WING FIXED LEADING EDGE RIB FITTING REPAIR

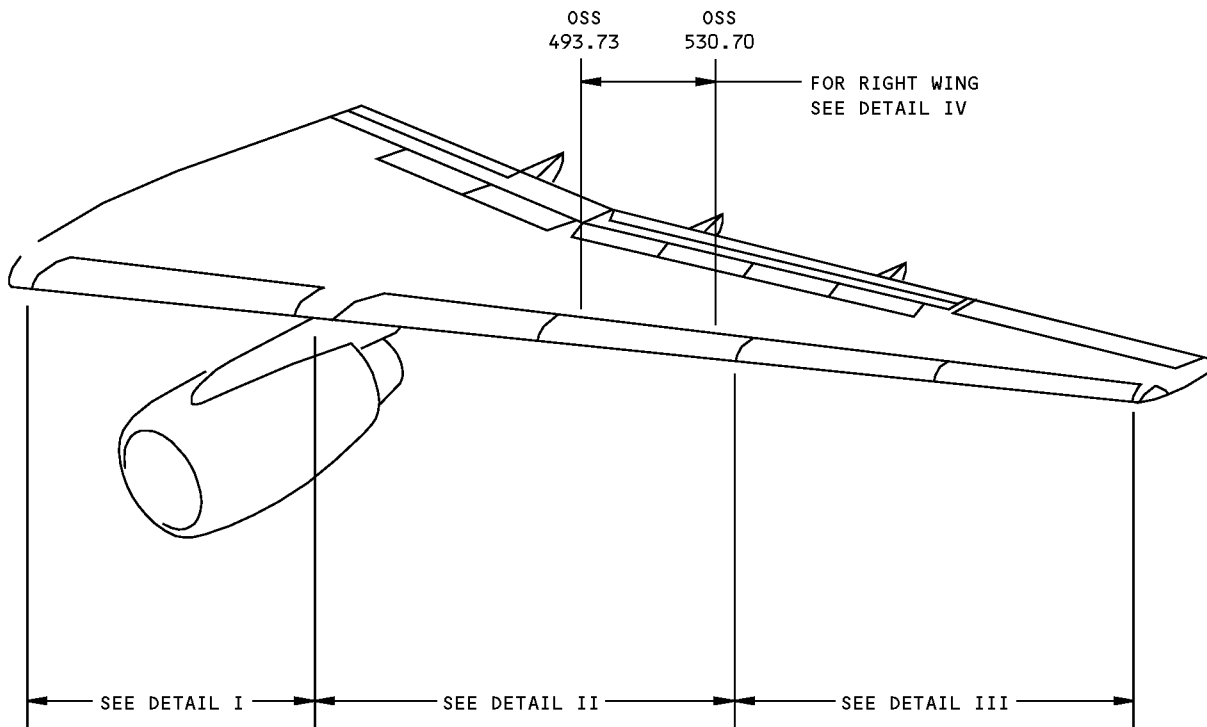

NOTES

- SEE 57-41-09 FOR STRUCTURE IDENTIFICATION AND ALLOWABLE DAMAGE INFORMATION
- NO TYPICAL REPAIR TO FITTINGS AND FORGINGS APPLICABLE. SPECIFIC REPAIRS TO FITTINGS AND FORGINGS WILL BE PROVIDED BASED ON SERVICE EXPERIENCE

Wing Fixed Leading Edge Rib Fitting Repair
Figure 201 (Sheet 1 of 5)

**757-200
STRUCTURAL REPAIR MANUAL**

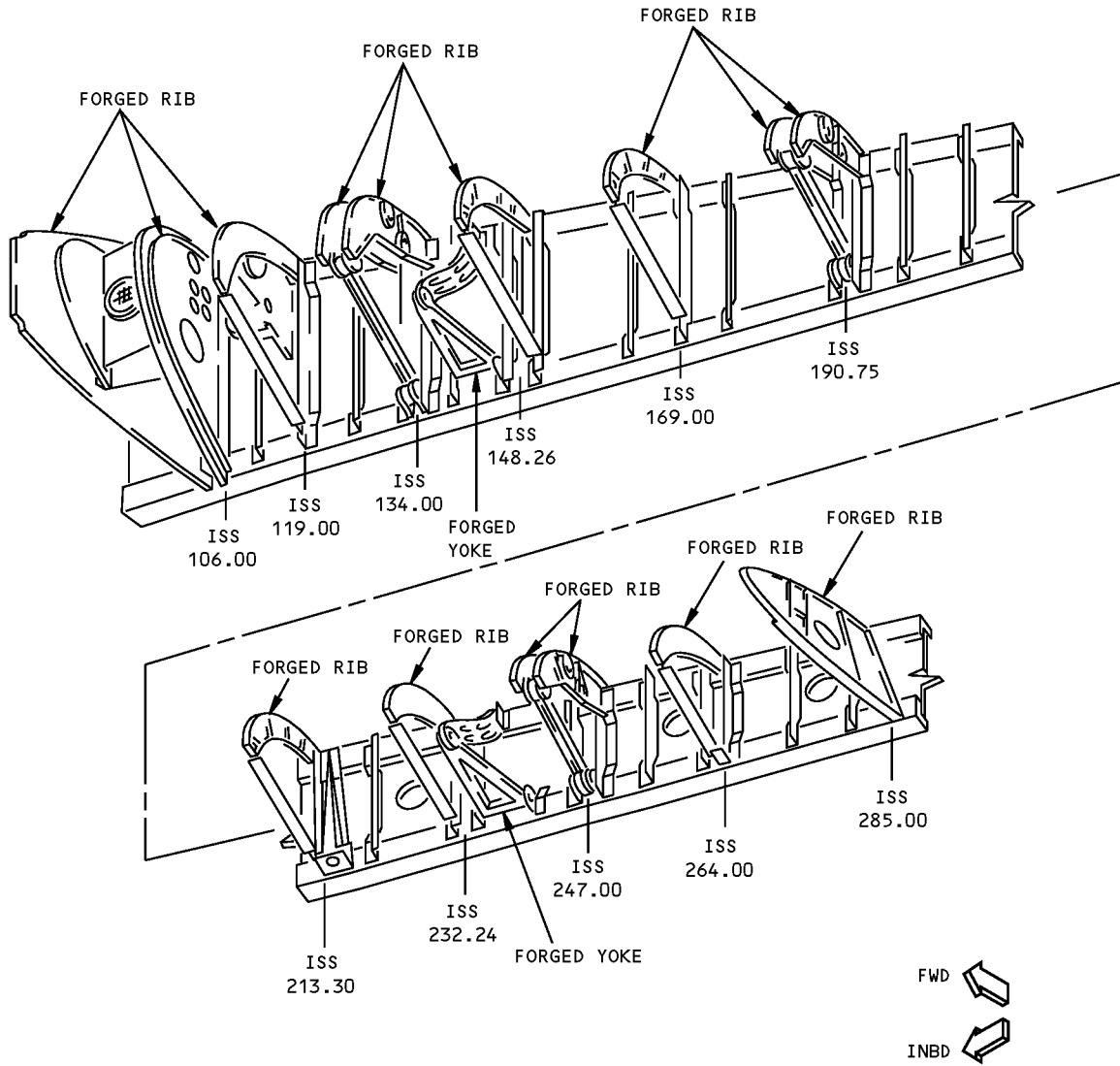

DETAIL I

**Wing Fixed Leading Edge Rib Fitting Repair
Figure 201 (Sheet 2 of 5)**

**757-200
STRUCTURAL REPAIR MANUAL**

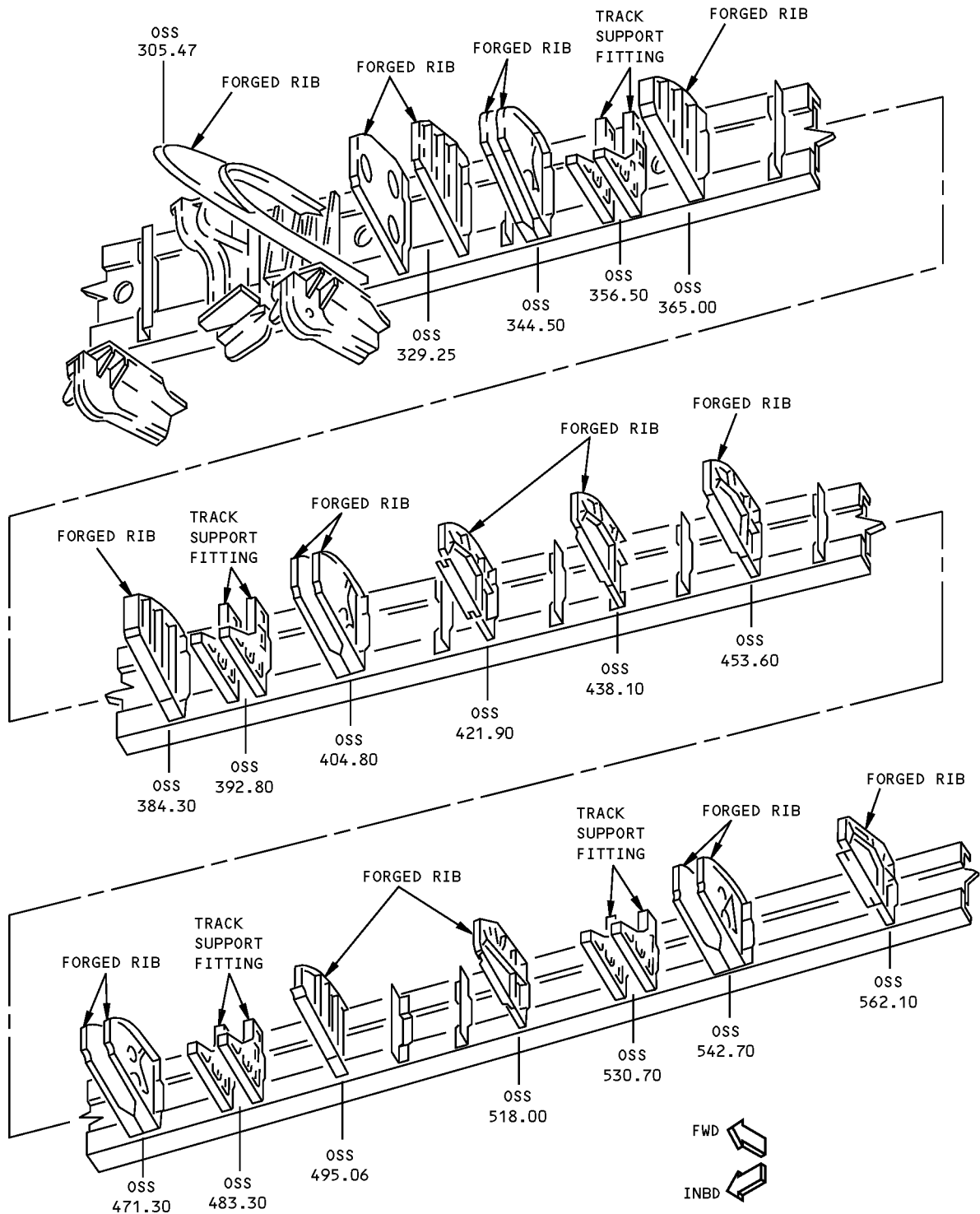

DETAIL II

**Wing Fixed Leading Edge Rib Fitting Repair
Figure 201 (Sheet 3 of 5)**

**757-200
STRUCTURAL REPAIR MANUAL**

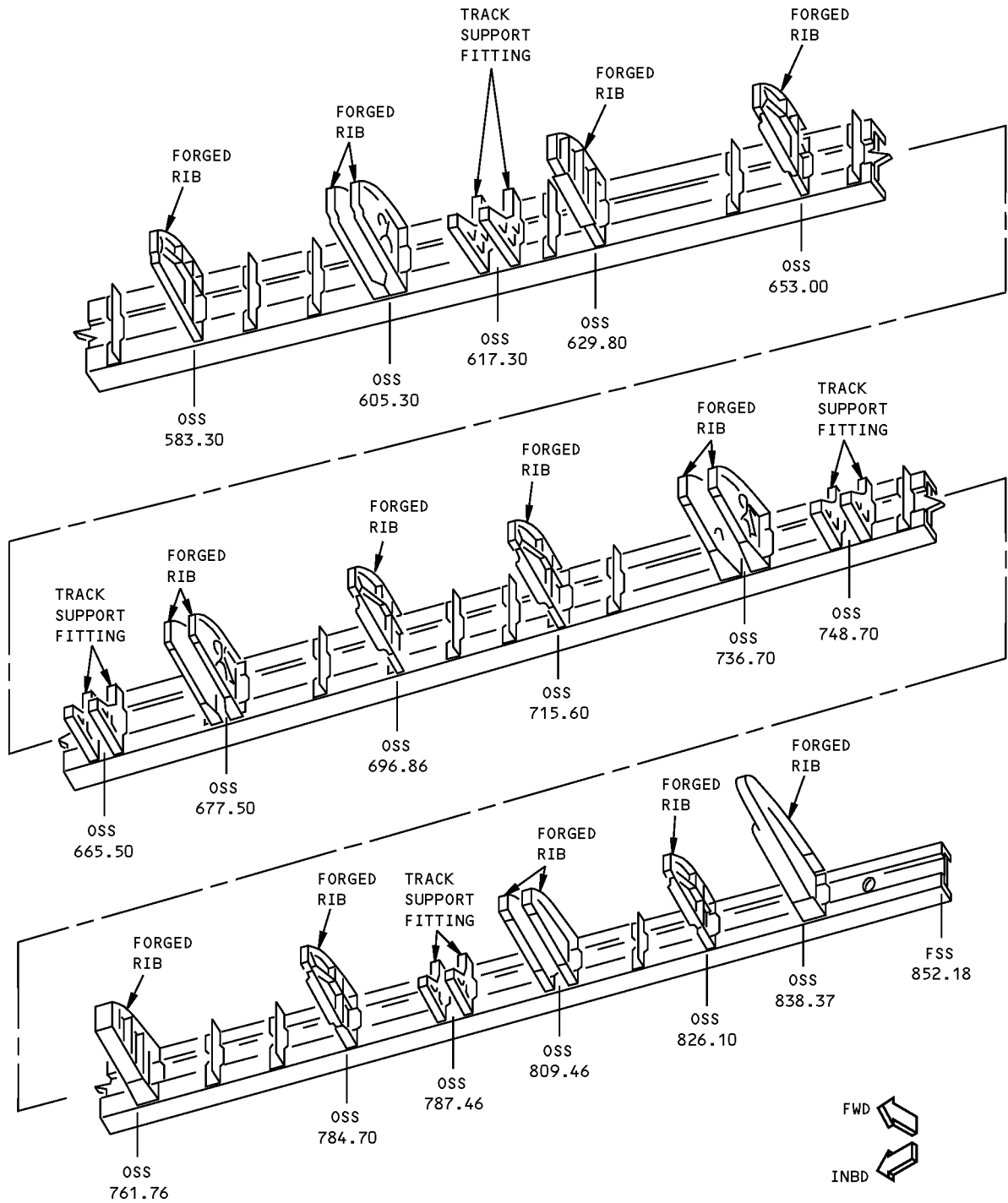

DETAIL III

**Wing Fixed Leading Edge Rib Fitting Repair
Figure 201 (Sheet 4 of 5)**

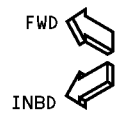

**757-200
STRUCTURAL REPAIR MANUAL**

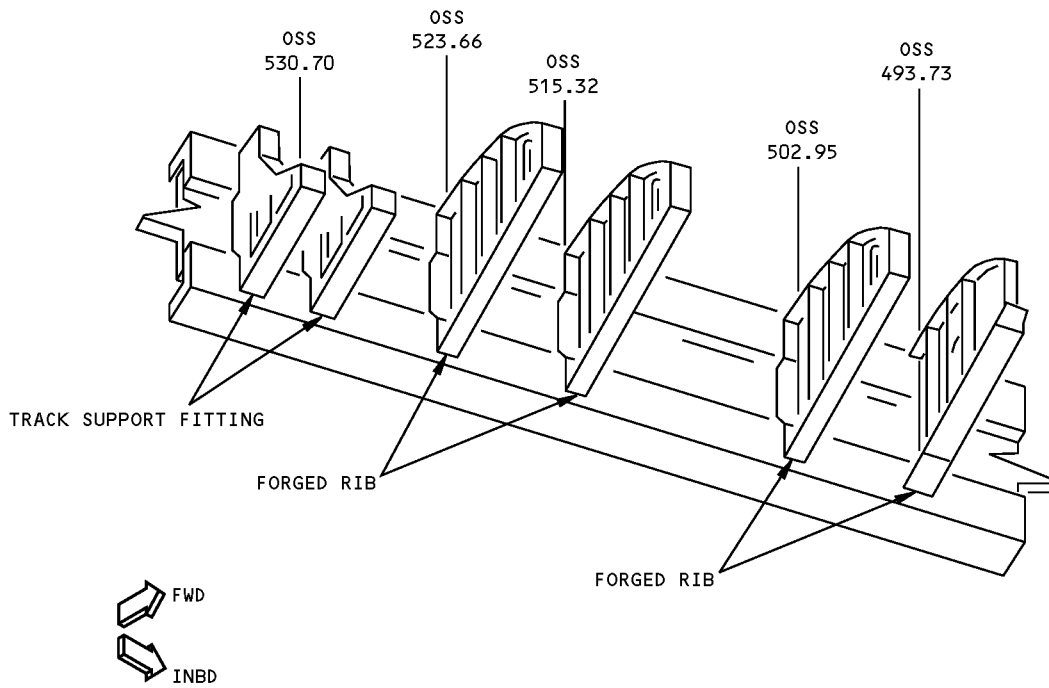

DETAIL IV

**Wing Fixed Leading Edge Rib Fitting Repair
Figure 201 (Sheet 5 of 5)**

757-200
STRUCTURAL REPAIR MANUAL

IDENTIFICATION 1 - LEADING EDGE SLAT SKIN

REF DWG
114N3002
114N4002
114N4003
114N4004
114N4005

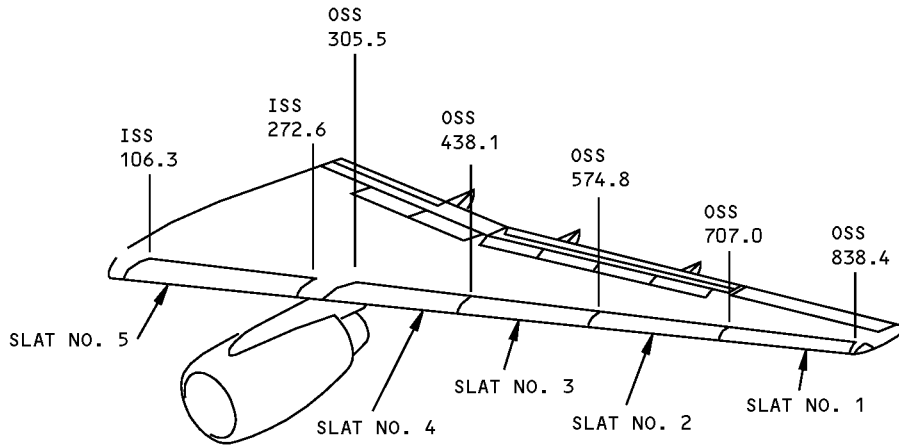

SEE DETAIL I FOR SLATS 1 THRU 4
SEE DETAIL II FOR SLAT 5



LEFT SIDE SHOWN,
RIGHT SIDE OPPOSITE

NOTES

- A** FOR CUM LINE NUMBERS:
1 THRU 3
ITEM 3 OPTIONAL
- B** FOR ALL AIRPLANES NOT LISTED IN **A**
- C** FOR SLAT NO. 3 ON AIRPLANES WITH
251,000 LB MTGW

Leading Edge Slat Skin Identification
Figure 1 (Sheet 1 of 4)

**757-200
STRUCTURAL REPAIR MANUAL**

REF DWG
114N4002
114N4003
114N4004
114N4005

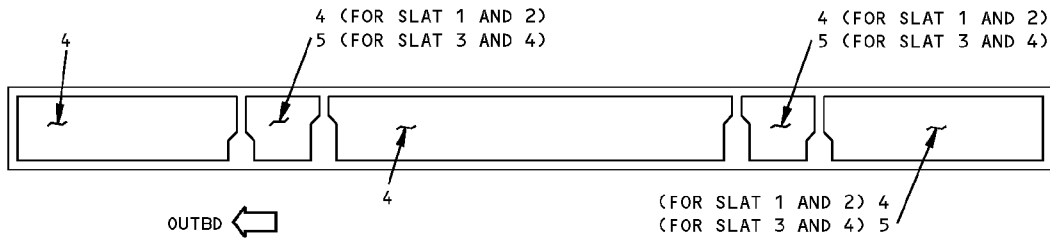
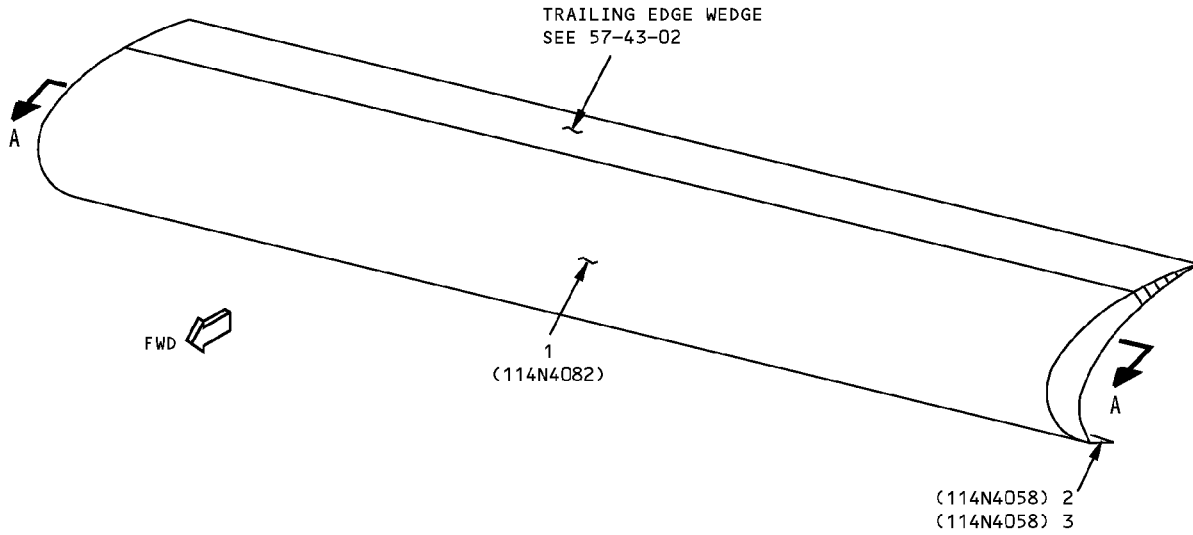

REF DWG
SLAT NO. 1 114N4075
SLAT NO. 2 114N4076
SLAT NO. 3 114N4077
SLAT NO. 4 114N4078

REAR VIEW
A-A

SLATS 1 THRU 4
DETAIL I



**Leading Edge Slat Skin Identification
Figure 1 (Sheet 2 of 4)**

IDENTIFICATION 1
Page 2
Jan 20/2005

57-43-01

D634N201



757-200
STRUCTURAL REPAIR MANUAL

ITEM	DESCRIPTION	GAGE	MATERIAL	EFFECTIVITY
1	NOSE SKIN	0.063 0.071	7075-T6 7075-T6	<input type="checkbox"/> C
2	CLOSURE PANEL		FIBERGLASS/EPOXY PER BMS 8-79, TYPE 1581 OR TYPE 7781 LAMINATE, 250°F (121°C) CURE	<input type="checkbox"/> A
3	CLOSURE PANEL OUTER PLYS DOUBLER AND FILLER PLYIS		FIBERGLASS/ARAMID/EPOXY LAMINATE FIBERGLASS/EPOXY FABRIC PER BMS 8-79, TYPE 120, 250°F (121°C) CURE ARAMID/EPOXY FABRIC PER BMS 8-219, STYLE 285, 250°F (121°C) CURE	<input type="checkbox"/> B
4	COVE SKIN	0.050	CLAD 7075-T6	
5	COVE SKIN	0.056	CLAD 7075-T6	

LIST OF MATERIALS FOR DETAIL I

Leading Edge Slat Skin Identification
Figure 1 (Sheet 3 of 4)

D634N201

57-43-01

IDENTIFICATION 1
Page 3
Jan 20/2005

**757-200
STRUCTURAL REPAIR MANUAL**

REF DWG
114N3002

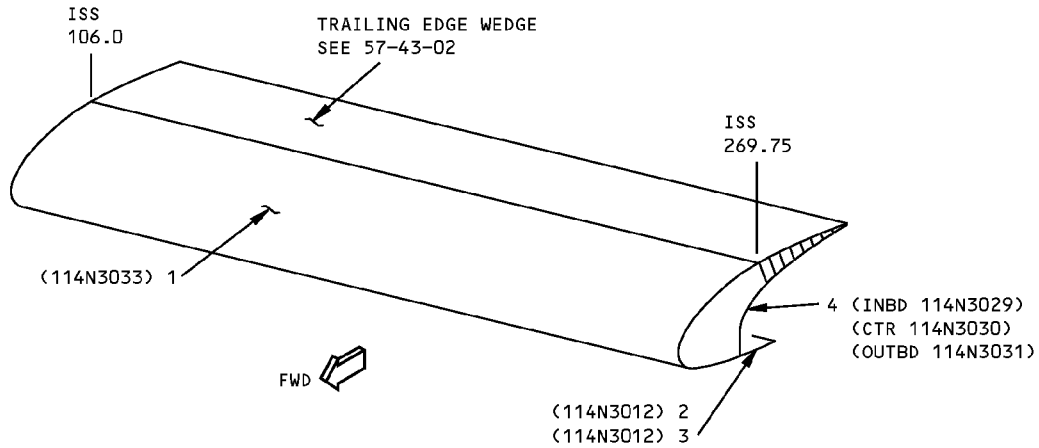

**SLAT NO. 5
DETAIL II**

ITEM	DESCRIPTION	GAGE	MATERIAL	EFFECTIVITY
1	NOSE SKIN	0.080	7075-T6 (CHEM-MILLED TO 0.060 MIN)	
2	CLOSURE PANEL		FIBERGLASS/EPOXY PER BMS 8-79, TYPE 1581 OR TYPE 7781, 250°F (121°C) CURE	[A]
3	CLOSURE PANEL OUTER PLYS DOUBLER AND FILLER PLYS		FIBERGLASS/ARAMID/EPOXY LAMINATE FIBERGLASS/EPOXY FABRIC PER BMS 8-79, TYPE 120, 250°F (121°C) CURE ARAMID/EPOXY FABRIC PER BMS 8-219, STYLE 285, 250°F (121°C) CURE	[B]
4	COVE PANEL OUTER SKIN CORE INNER SKIN	0.040 0.011	ALUMINUM HONEYCOMB SANDWICH 2024-T3 HONEYCOMB PER BMS 4-4, TYPE 3-10N FORM B (5052) 2024-T3	

LIST OF MATERIALS FOR DETAIL II

**Leading Edge Slat Skin Identification
Figure 1 (Sheet 4 of 4)**

IDENTIFICATION 1
Page 4
Jan 20/2005

57-43-01

D634N201

**757-200
STRUCTURAL REPAIR MANUAL**

ALLOWABLE DAMAGE 1 - LEADING EDGE SLAT SKIN

REF DWG
114N3002
114N4002
114N4003
114N4004
114N4005

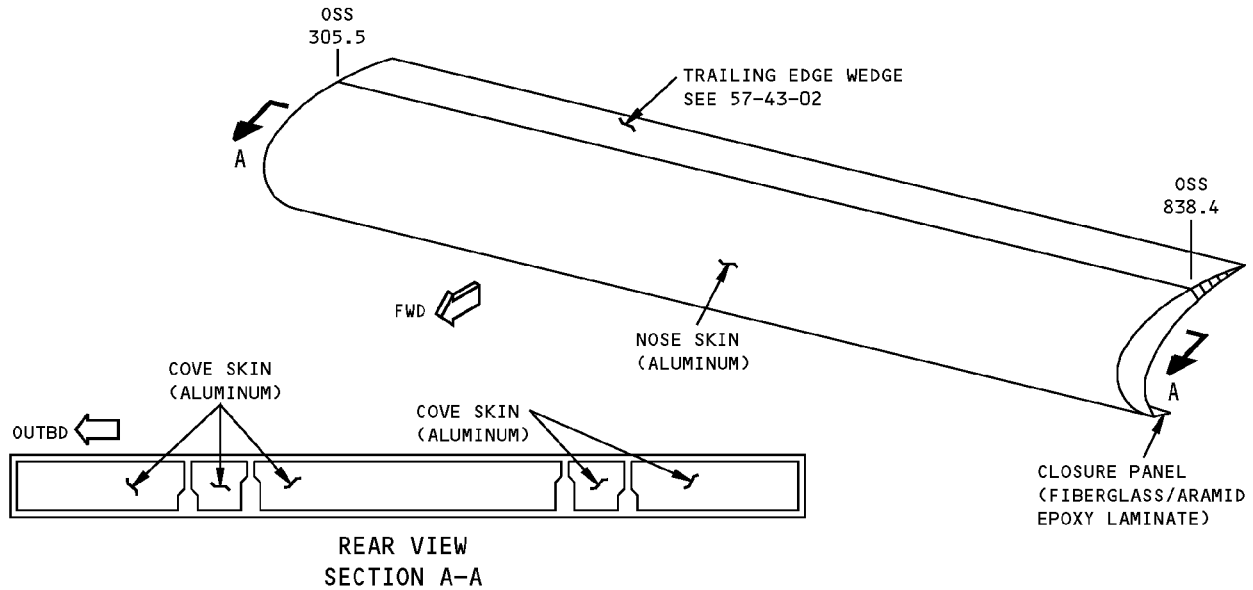
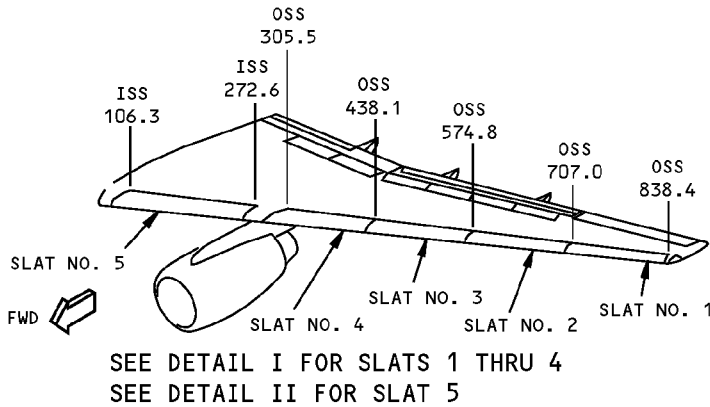

SLATS NO. 1 THRU NO. 4
DETAIL I

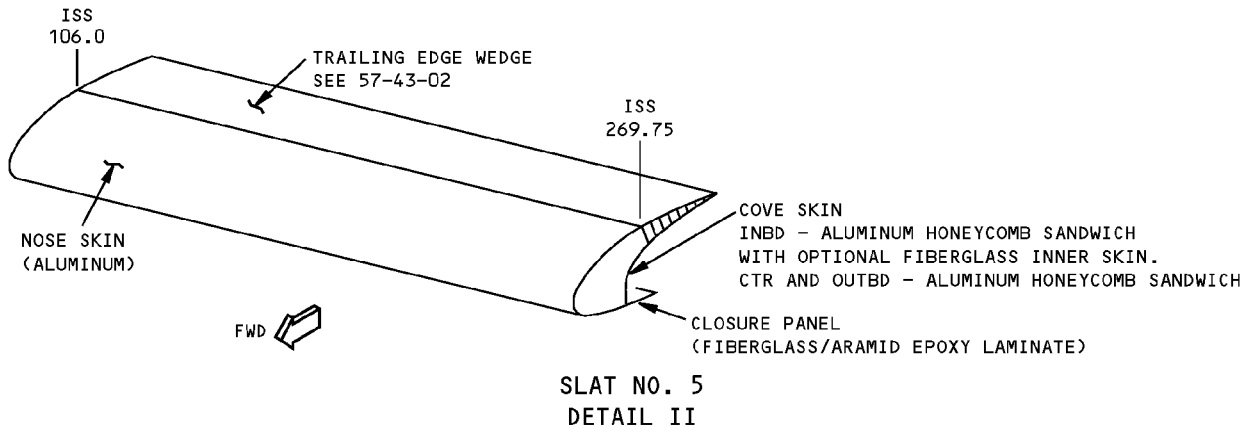

**Leading Edge Slat Skin Allowable Damage
Figure 101 (Sheet 1 of 4)**

STRUCTURAL REPAIR MANUAL

DESCRIPTION	CRACKS	NICKS, GOUGES AND CORROSION	DENTS	HOLES AND PUNCTURES	DELAMINATION
NOSE SKIN	[B]	[C]	[M]	[D]	—
CLOSURE PANEL	[E]	[F]	[G]	[H]	[I]
COVE PANEL - INBD	[B]	[C]	[G]	[J]	[K]
COVE PANEL - OUTBD AND CTR	[B]	[C]	SEE DETAIL VII	[J]	[K]

NOTES

- REFINISH REWORKED AREAS PER AMM 51-20.
- REFER TO SRM 51-10-02 FOR INSPECTION AND REMOVAL OF DAMAGE.
- REFER TO SRM 51-10-01 FOR AERODYNAMIC SMOOTHNESS REQUIREMENTS. WHERE DAMAGE EXCEEDS THE LIMITS SHOWN IN SRM 51-10-01. CONSIDERATION SHOULD BE GIVEN TO LOSS OF PERFORMANCE INVOLVED.
- TYPICAL DAMAGE TO A PANEL EDGE BAND MAY CONSIST OF EDGE CRUSHING, CRACKS OR DELAMINATION. DAMAGE AROUND HOLES MAY CONSIST OF OVALIZATION, FASTENER PULL-THRU OR CRACKS OUT OF HOLE. DAMAGE MAY REDUCE THE EFFECTIVE CROSS-SECTIONAL AREA OF AN EDGE BAND. DAMAGE TO EDGES SHOULD BE BLENDED OUT TO LIMITATIONS GIVEN FOR COMPONENT.

[A] REMOVE MOISTURE FROM DAMAGE AREA. USE OF VACUUM AND HEAT (MAX OF 125°F (52°C)) TO REMOVE MOISTURE FROM HONEYCOMB CELLS IS RECOMMENDED. PROTECT DAMAGE FROM ENTRANCE OF WATER, SUNLIGHT OR OTHER FOREIGN MATTER BY SEALING WITH ALUMINUM FOIL TAPE (SPEED TAPE). RECORD THE LOCATION AND INSPECT EACH AIRPLANE "A" CHECK. REPLACE THE ALUMINUM FOIL TAPE IF ANY PEELING OR DETERIORATION IS EVIDENT. REPAIR NO LATER THAN NEXT AIRPLANE "C" CHECK. [L]

[B] CRACKS NOT ALLOWED EXCEPT FOR EDGE CRACKS THAT MUST BE REMOVED PER DETAILS III AND IV.

[C] REMOVE DAMAGE PER DETAILS III, V AND VI.

[D] CLEAN OUT DAMAGE UP TO 0.25 INCH (6 mm) MAX DIA AND NOT CLOSER THAN 1.0 INCH (25 mm) TO FASTENER HOLE OR OTHER DAMAGE. FILL HOLE WITH A 2117-T3 OR T4 ALUMINUM RIVET INSTALLED WET WITH BMS 5-95 SEALANT. ALL OTHER HOLES TO BE REPAIRED.

[E] 2.0 INCH (50 mm) MAX LENGTH ALLOWED PER SQUARE FOOT AREA AND A MINIMUM OF 6.0 INCHES (150 mm) FROM ANY OTHER CRACK. CLEAN UP EDGE CRACKS PER DETAILS III AND IV. CRACKS THRU CONSECUTIVE FASTENERS OR THRU THE PANEL EDGE BAND ARE ALLOWED PROVIDED DAMAGE DOES NOT EXCEED 10% OF EDGE BAND LENGTH PER SIDE. [A]

[F] DAMAGE ALLOWED ON SURFACE RESIN ONLY. DAMAGE TO FIBERS NOT ALLOWED. CLEAN UP EDGE DAMAGE PER DETAIL III. [A]

[G] DENTS GENERALLY RESULT IN FIBER DAMAGE OR DELAMINATION. HOWEVER, IF THERE IS NO FIBER DAMAGE OR DELAMINATION, DENTS UP TO 2.0 INCHES (50 mm) DIAMETER MAX ARE ALLOWED. ONE DENT PER SQUARE FOOT OF AREA ALLOWED THAT MUST BE A MINIMUM OF 6 INCHES (150 mm) FROM ANY OTHER DAMAGE, FASTENER HOLE, OR PANEL EDGE. SEE [H] OR [I] IF FIBER DAMAGE OR DELAMINATION IS PRESENT.

[H] 2.0 INCHES (50 mm) MAX DIMENSION (D) ALLOWED PER SQUARE FOOT AREA AND A MINIMUM OF 6D (EDGE TO EDGE) FROM ANY OTHER DAMAGE, FASTENER HOLE, OR PANEL EDGE. DO NOT CLEAN UP DAMAGE EXCEPT TO RESIN BURRS EXTENDING INTO SURFACE CONTOUR. [A]

[I] 2.0 INCHES (50 mm) MAX DIMENSION (D) IS ALLOWED PER SQUARE FOOT OF AREA AND A MINIMUM OF 6 D (EDGE TO EDGE) FROM ANY OTHER DAMAGE, FASTENER HOLE OR PANEL EDGE. A MAXIMUM OF 0.10 INCH (2.5 mm) DELAMINATION FROM EDGE IS ALLOWED. PROTECT EDGE DAMAGE PER [A]. REPAIR DELAMINATION PER SRM 51-70 NO LATER THAN NEXT "C" CHECK.

[J] HOLE UP TO 0.25 INCH (6 mm) DIAMETER NO CLOSER THAN 1.0 INCH (25 mm) TO ANY ADJACENT HOLE. CLEAN PUNCTURE UP TO 0.25 INCH (6 mm) DIAMETER MAX. [A]

[K] 1.50 SQUARE INCHES (9.7 SQUARE cm) OF DELAMINATION IN HONEYCOMB AREA IS ALLOWED PER SQUARE FOOT OF PANEL PROVIDING DAMAGE IS 4D FROM ANY HOLES, PANEL EDGE OR OTHER DAMAGE. REPAIR DELAMINATION NO LATER THAN THE NEXT "C" CHECK.

[L] THESE ALLOWABLE DAMAGE LIMITS HAVE FAA APPROVAL CONTINGENT OF ACCOMPLISHMENT ON THE INSPECTIONS CONTAINED HEREIN.

**Leading Edge Slat Skin Allowable Damage
Figure 101 (Sheet 2 of 4)**



757-200
STRUCTURAL REPAIR MANUAL

NOTES (CONTINUED)

M DENTS ARE PERMITTED AS GIVEN IN DETAIL VII. REFER TO SRM 51-70-01 TO FILL, REPAIR, OR REWORK DENTS THAT ARE NOT LARGER THAN THE LIMITS GIVEN IN DETAIL VII.

THE DISTANCE BETWEEN DENTS THAT ARE NOT FILLED MUST BE ONE-HALF THE MAXIMUM DIMENSION OF THE LARGER DAMAGED AREA OR MORE. THE DISTANCE BETWEEN A DENT THAT IS NOT FILLED AND A DIFFERENT DAMAGED AREA MUST BE ONE-HALF THE MAXIMUM DIMENSION OF THE LARGER DAMAGED AREA OR MORE.

THE DEPTH OF A DENT (Y) FORWARD OF THE NOSE BEAM MUST NOT BE LARGER THAN 0.06 INCH. THE DEPTH OF A DENT (Y) AFT OF THE NOSE BEAM MUST NOT BE LARGER THAN 0.12 INCH.

THE MAXIMUM NUMBER OF DENTS PERMITTED IN EACH SLAT FORWARD OF THE NOSE BEAM IS 10. THE MAXIMUM NUMBER OF DENTS PERMITTED IN EACH SLAT AFT OF THE NOSE BEAM IS 10.

Leading Edge Slat Skin Allowable Damage
Figure 101 (Sheet 3 of 4)

D634N201

ALLOWABLE DAMAGE 1
57-43-01
Page 103
Jan 20/2005

STRUCTURAL REPAIR MANUAL

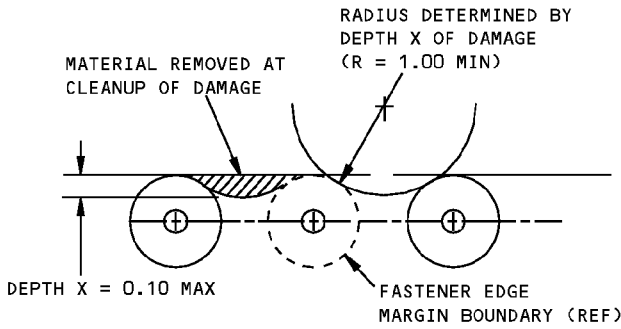

DAMAGE CLEANUP OF EDGES WHERE FASTENER EDGE MARGINS DO NOT OVERLAP

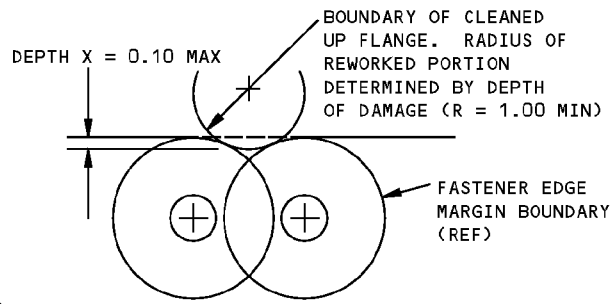

DAMAGE CLEANUP OF EDGES WHERE FASTENER EDGE MARGINS OVERLAP

DETAIL III

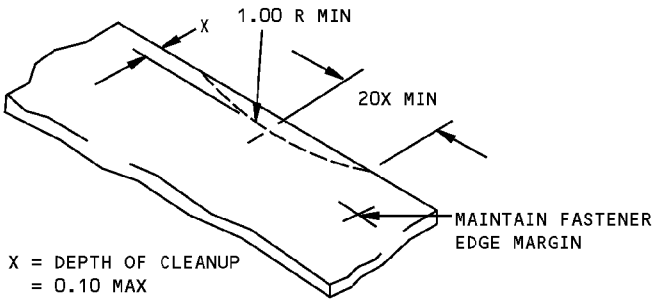

**REMOVAL OF NICK OR CRACK DAMAGE ON AN EDGE
DETAIL IV**

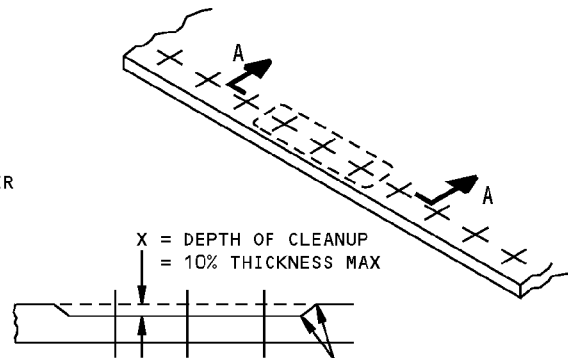

SECTION A-A

**CORROSION CLEANUP
DETAIL V**

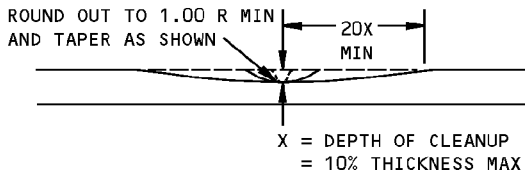
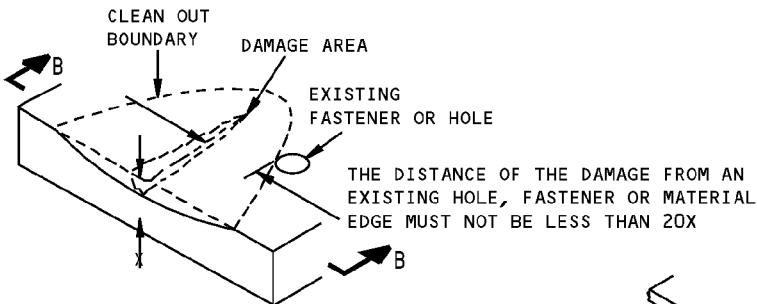

SECTION B-B

**REMOVAL OF NICK, GOUGE AND SCRATCH DAMAGE ON A SURFACE
DETAIL VI**

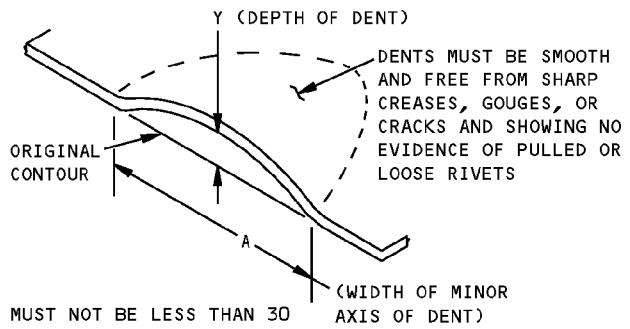

**ALLOWABLE DAMAGE FOR DENT
DETAIL VII**

**Leading Edge Slat Skin Allowable Damage
Figure 101 (Sheet 4 of 4)**



757-200
STRUCTURAL REPAIR MANUAL

REPAIR GENERAL - SERVICE BULLETIN REPAIR CHART

SERVICE BULLETIN REPAIRS - LEADING EDGE SLATS

The following Service Bulletins contain repairs which are available for use where specific damage has been encountered. Usually, the Service Bulletin also covers preventive modification data which operators are encouraged to use to eliminate the need for repair.

DAMAGED AREA	CUM LINE NUMBER EFFECTIVITY	SB NUMBER
WINGS - OUTBOARD LEADING EDGE SLATS - TRAILING EDGE WEDGE SKIN INSPECTION AND REPAIR	140 THRU 348	757-57A-45

Service Bulletin Repair Chart
Figure 201

**757-200
STRUCTURAL REPAIR MANUAL**

REPAIR 1 - LEADING EDGE SLATS - NOSE SKIN REPAIRS

APPLICABILITY
THIS REPAIR IS FOR THE NOSE SKINS OF SLATS NO. 1 THRU 5 BETWEEN THE RIBS. C D

REPAIR INSTRUCTIONS

1. Carefully cut and remove the damaged part of the skin. Make the cut a rectangular shape with the primary axis parallel to the wing spar. Make all corner radii 0.50 inches or more.
2. Make the repair parts and form them to the contour of the skin. See Table I and Detail I.
3. Assemble the repair parts and drill and countersink the fastener holes.
4. Remove the repair parts.
5. Remove all the nicks, scratches, gouges, burrs and sharp edges from the skin and the repair parts.
6. Apply Alodine to the repair parts and to the bare edges of the skin. Refer to 51-20-01.
7. Apply one layer of BMS 10-79, Type III primer to the repair parts and the bare edges of the skin.
8. Install the doublers (items 2 and 3) and the straps (item 4) through the rectangular hole. Install them with BMS 5-95 sealant between the faying surfaces. Install the BACR15CE5D rivets dry.
9. Install the repair plate (item 1) with BMS 5-95 sealant between the faying surfaces. Install the NAS1739E5 blind rivets wet with BMS 5-95 sealant.
10. Fill the gap between the skin and the repair plate (item 1) with BMS 5-95.
11. Apply the finish to the repair area. Refer to 51-21 of the Maintenance Manual.

NOTES

- D = FASTENER DIAMETER
- WHEN YOU USE THIS REPAIR REFER TO:
 - 51-10-01 FOR AERODYNAMIC SMOOTHNESS
 - 51-20-01 FOR PROTECTIVE TREATMENT OF METAL
 - 51-20-05 FOR REPAIR SEALING
 - 51-40 FOR FASTENER CODE, INSTALLATION AND REMOVAL, HOLE SIZES, EDGE MARGINS, AND COUNTERSINKING
 - 51-21 OF THE MAINTENANCE MANUAL FOR INTERIOR AND EXTERIOR FINISHES.

- A** FOR THE REPAIR PLATE, USE THE SAME GAGE AS THE SKIN. FOR THE DOUBLERS AND THE STRAPS, USE ONE GAGE LARGER THAN THE SKIN.
- B** COUNTERSINK AS REQUIRED TO ACCOMMODATE THE FASTENER HEAD DEPTH. DO NOT COUNTERSINK MORE THAN 70% OF THE SKIN THICKNESS TO PREVENT KNIFE-EDGING OF THE SKIN.
- C** FOR RIB LOCATIONS, SEE 57-43-02.
- D** REPAIRS TO SLAT NO. 5 ARE LIMITED TO AREAS OF CONSTANT SKIN THICKNESS ONLY.
- E** FILL THE GAP BETWEEN THE SKIN AND THE REPAIR PLATE WITH BMS 5-95 SEALANT. REFER TO 51-10-01 FOR AERODYNAMIC SMOOTHNESS.
- F** HEAT TREAT THE REPAIR PART TO THE T6 CONDITION AFTER FORMING IT.

SYMBOLS

- + REPAIR FASTENER LOCATION. INSTALL A BACR15CE5D SOLID RIVET.
- ◆ REPAIR FASTENER LOCATION. INSTALL A NAS1739E5 BLIND RIVET.

**Leading Edge Slats - Nose Skin Repairs
Figure 201 (Sheet 1 of 3)**

**757-200
STRUCTURAL REPAIR MANUAL**

REPAIR MATERIAL			
PART	QTY	MATERIAL	
1	REPAIR PLATE	1	7075-T6 A F
2	DOUBLER	1	7075-T6 A F
3	DOUBLER	1	7075-T6 A F
4	STRAP	2	7075-T6 A

TABLE I

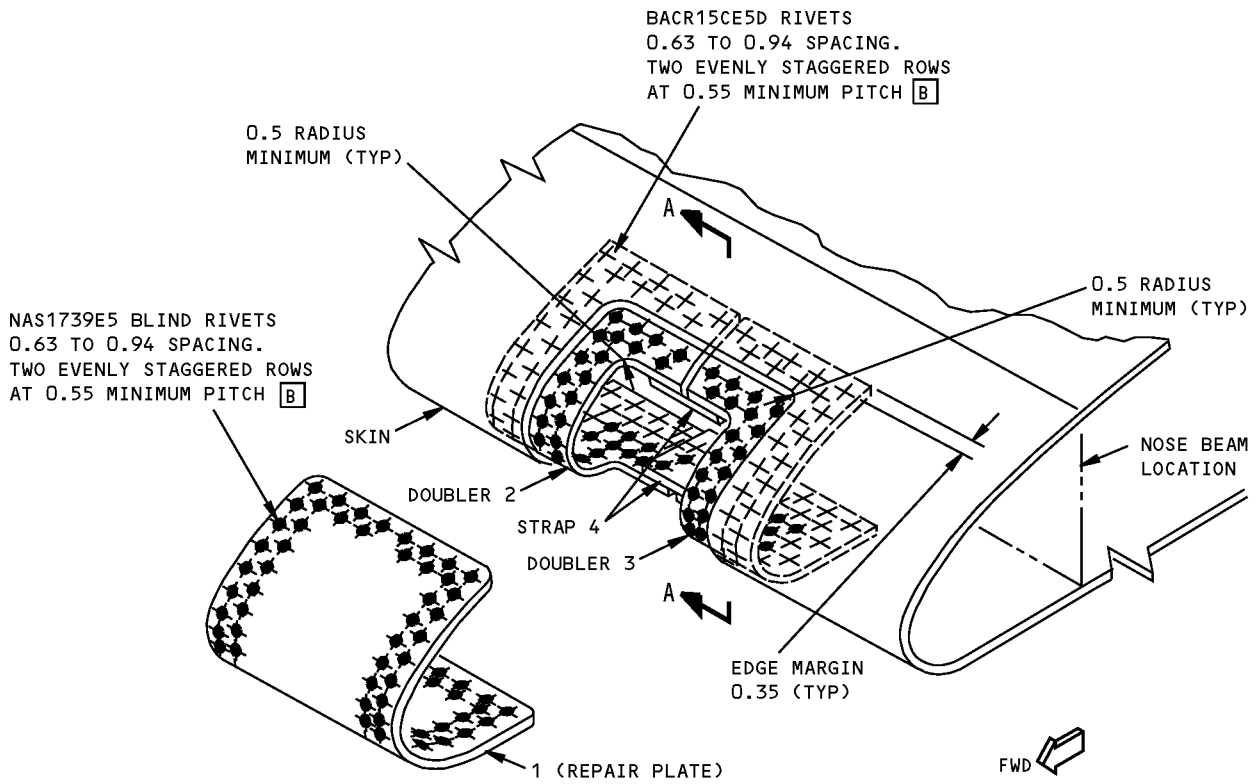

DETAIL I

**Leading Edge Slats - Nose Skin Repairs
Figure 201 (Sheet 2 of 3)**

**757-200
STRUCTURAL REPAIR MANUAL**

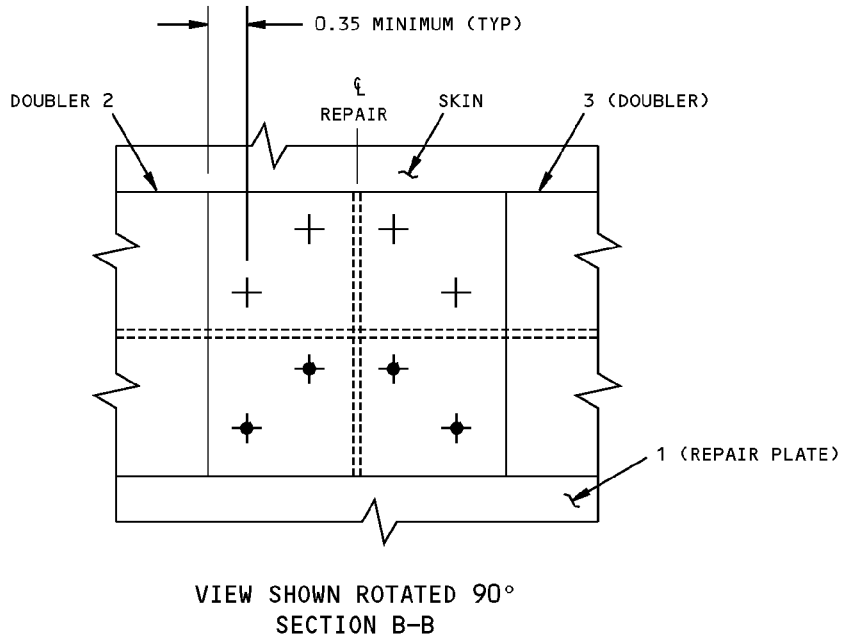
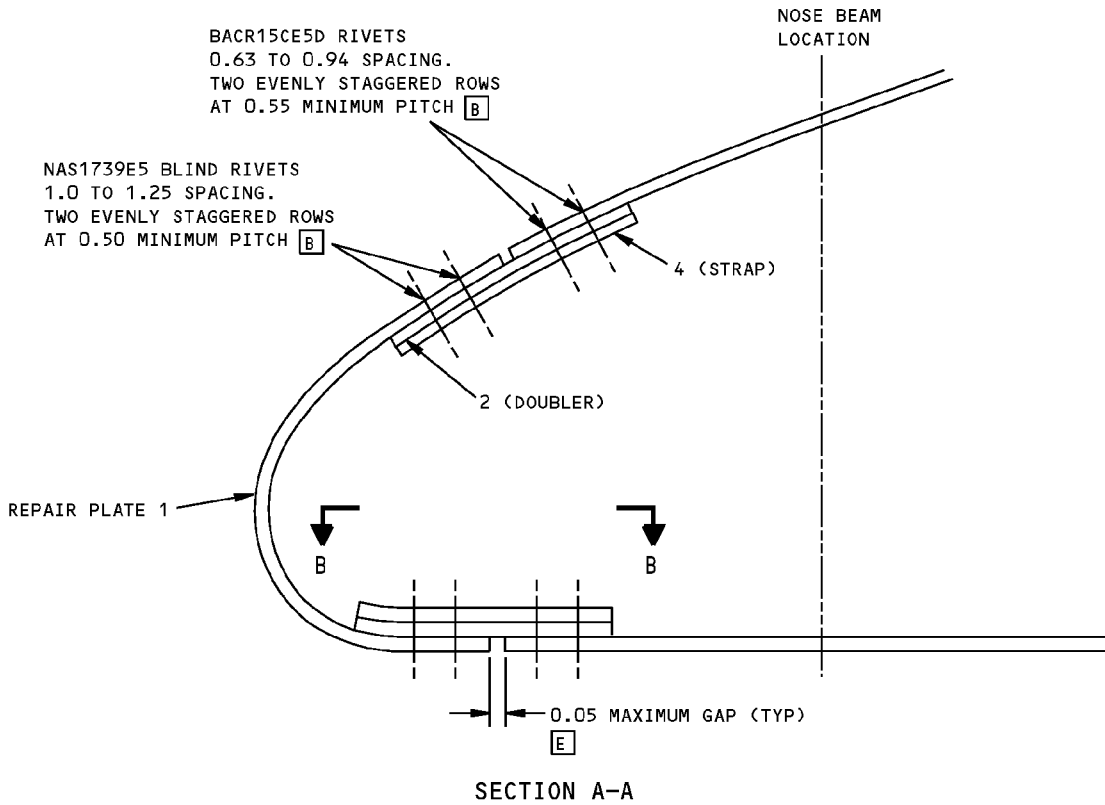

**Leading Edge Slats - Nose Skin Repairs
Figure 201 (Sheet 3 of 3)**

STRUCTURAL REPAIR MANUAL

REPAIR 2 - OUTBOARD LEADING EDGE SLAT SKIN FLUSH REPAIR AT A NOSE RIB FORWARD OF NOSE BEAM**REPAIR INSTRUCTIONS**

1. Get access to the damaged area.
2. Carefully cut and remove the damaged part of the slat skin.
NOTE: Do not damage the structure below the slat skin. Make the cut a rectangular shape with the corner radii 0.50 inch (12.7 mm) or more.
3. Make the repair parts. Make the repair parts the same contour as the slat skin. See Table I and Detail I.
4. Assemble the repair parts and drill the repair fastener holes.
5. Disassemble the repair parts.
6. Remove the nicks, scratches, gouges, burrs and sharp edges from the repair parts and the slat skin.
7. Apply a chemical conversion coating to the repair parts and to the bare surfaces of the slat skin. Refer to SRM 51-20-01.
8. Apply one layer of BMS 10-79, Type III primer to the repair parts and to the bare surfaces of the slat skin. Refer to SOPM 20-44-04.
9. Install the part 2 and part 3 doublers through the rectangular hole. Install the doublers with Dow Corning 93-006 sealant between the mating surfaces. Install the BACR15CE5D rivets dry. Use the access hole in the nose rib to install the BACR15CE5D rivets.
10. Install the part 1 repair plate to the repair doublers with Dow Corning 93-006 sealant between the mating surfaces. Install the NAS1739E5 blind rivets wet with Dow Corning 93-006 sealant.
11. Install the initial solid nose rib-to-skin fasteners wet with Dow Corning 93-006 sealant. Install the nose rib-to-repair plate fasteners (NAS1739E6 blind rivets) wet with Dow Corning 93-006 sealant.
12. Fill the space between the edges of the slat skin and the part 1 repair plate with BMS 5-95 sealant. Refer to SRM 51-10-01.
13. Apply one layer of BMS 10-11, Type II enamel to the repair area. Refer to SOPM 20-41-02.

NOTES

- ALL DIMENSIONS ARE IN INCHES UNLESS SHOWN DIFFERENTLY.
 - D = THE DIAMETER OF THE FASTENER
 - EXAMINE THE BLIND RIVETS 3000 FLIGHT CYCLES AFTER INSTALLATION, AND EACH 2500 FLIGHT CYCLES AFTER THAT.
 - WHEN YOU USE THE REPAIR REFER TO:
 - SOPM 20-41-02 FOR APPLICATION OF CHEMICAL AND SOLVENT RESISTANT FINISHES
 - SOPM 20-44-04 FOR APPLICATION OF URETHANE COMPATIBLE PRIMER
 - SRM 51-10-02 FOR INSPECTION AND REMOVAL OF DAMAGE
 - SRM 51-20-01 FOR PROTECTIVE TREATMENT OF METAL
 - SRM 51-20-05 FOR SEALING OF REPAIRS
 - SRM 51-40 FOR FASTENER CODE, REMOVAL AND INSTALLATION, HOLE SIZES AND EDGE MARGINS.
- A** IF NECESSARY, INSTALL A 1/32 INCH OVERSIZE FASTENER OF THE SAME TYPE AS THE INITIAL FASTENER.

**Outboard Leading Edge Slat Skin Flush Repair at a Nose Rib Forward of Nose Beam
Figure 201 (Sheet 1 of 3)**

**757-200
STRUCTURAL REPAIR MANUAL**

FASTENER SYMBOLS

- ▲ INITIAL FASTENER LOCATION. INSTALL A BACR15CE6D RIVET. **A**
- ⊕ REPAIR FASTENER LOCATION. INSTALL A BACR15CE5D SOLID RIVET.
- ◆ REPAIR FASTENER LOCATION. INSTALL A NAS1739E5 BLIND RIVET.
- INITIAL FASTENER LOCATION. INSTALL A NAS1739E6 BLIND RIVET.

REPAIR MATERIAL			
PART	QTY	MATERIAL	
1	REPAIR PLATE	1	USE THE SAME MATERIAL, HEAT TREAT AND GAGE AS THE INITIAL SKIN. FORM THE REPAIR PLATE IN THE "O" CONDITION. B
2	DOUBLER	1	USE THE SAME MATERIAL, HEAT TREAT AND ONE GAGE LARGER THAN THE INITIAL SKIN. FORM THE DOUBLER IN THE "O" CONDITION. B
3	DOUBLER	1	USE THE SAME MATERIAL, HEAT TREAT AND ONE GAGE LARGER THAN THE INITIAL SKIN. FORM THE DOUBLER IN THE "O" CONDITION. B

TABLE I

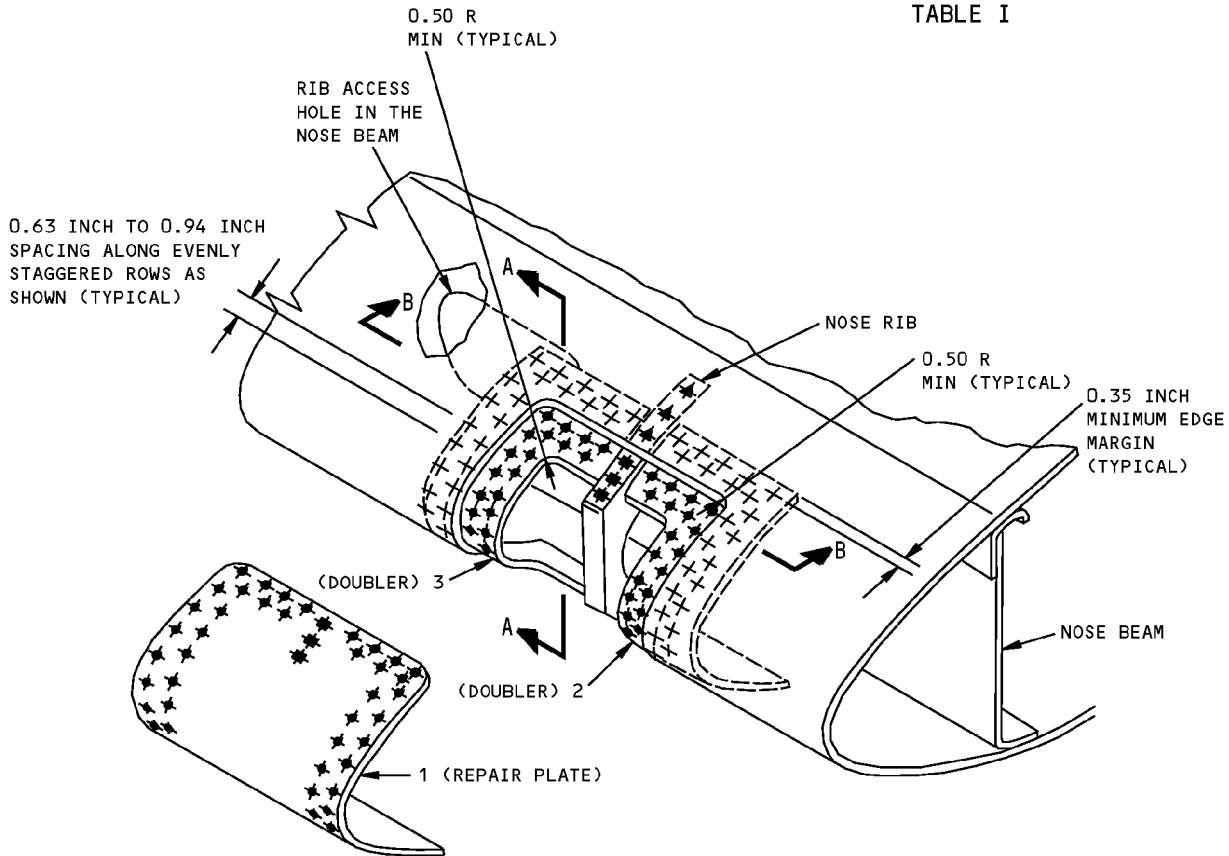

DETAIL I

**Outboard Leading Edge Slat Skin Flush Repair at a Nose Rib Forward of Nose Beam
Figure 201 (Sheet 2 of 3)**

**757-200
STRUCTURAL REPAIR MANUAL**

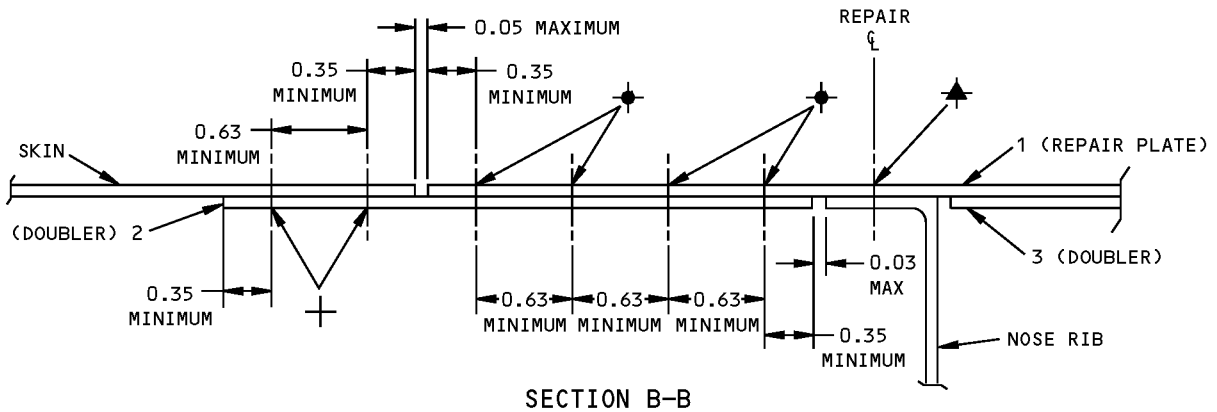
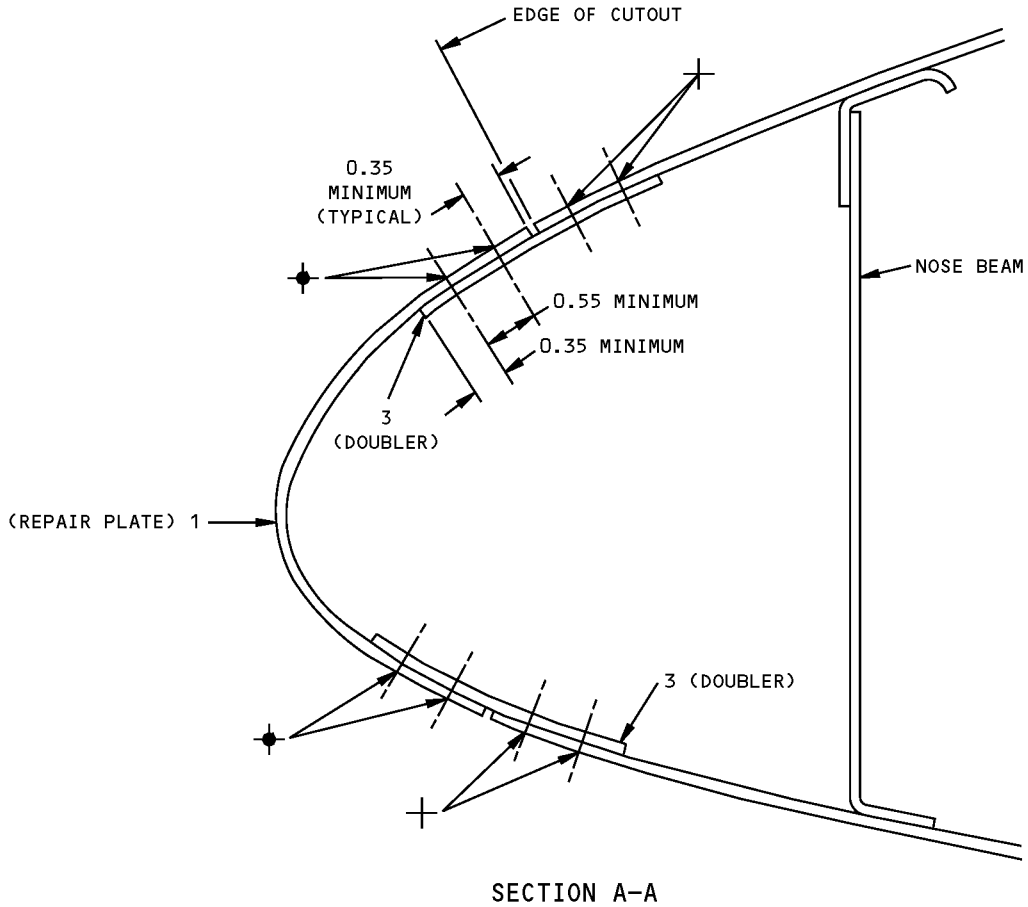

**Outboard Leading Edge Slat Skin Flush Repair at a Nose Rib Forward of Nose Beam
Figure 201 (Sheet 3 of 3)**



757-200
STRUCTURAL REPAIR MANUAL

IDENTIFICATION 1 - LEADING EDGE SLAT STRUCTURE

REF DWG
114N4002
114N4003
114N4004
114N4005
114N3002

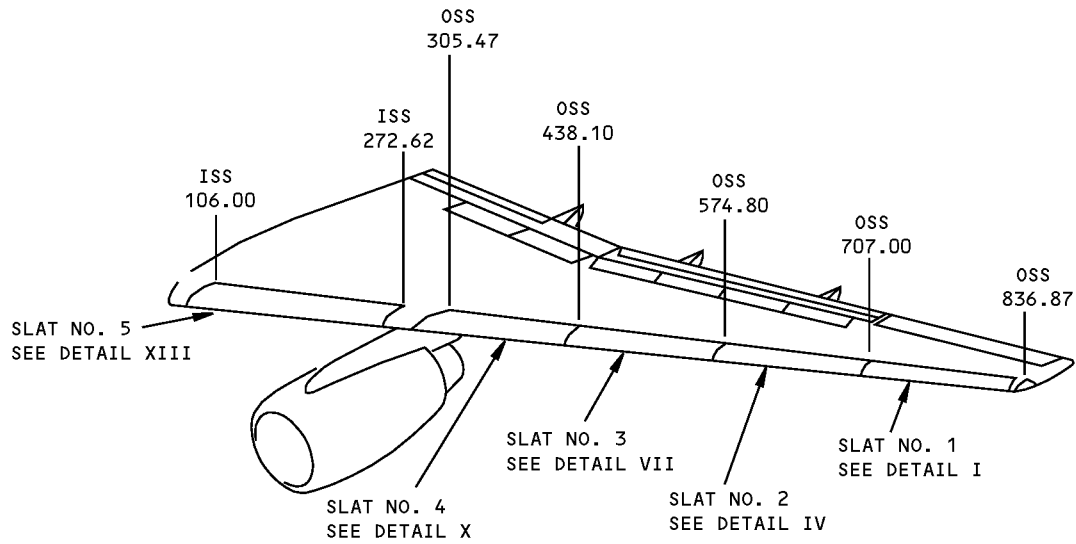

LEFT SIDE SHOWN,
RIGHT SIDE OPPOSITE

Leading Edge Slat Structure Identification
Figure 1 (Sheet 1 of 11)

**757-200
STRUCTURAL REPAIR MANUAL**

REF DWG
114N4002

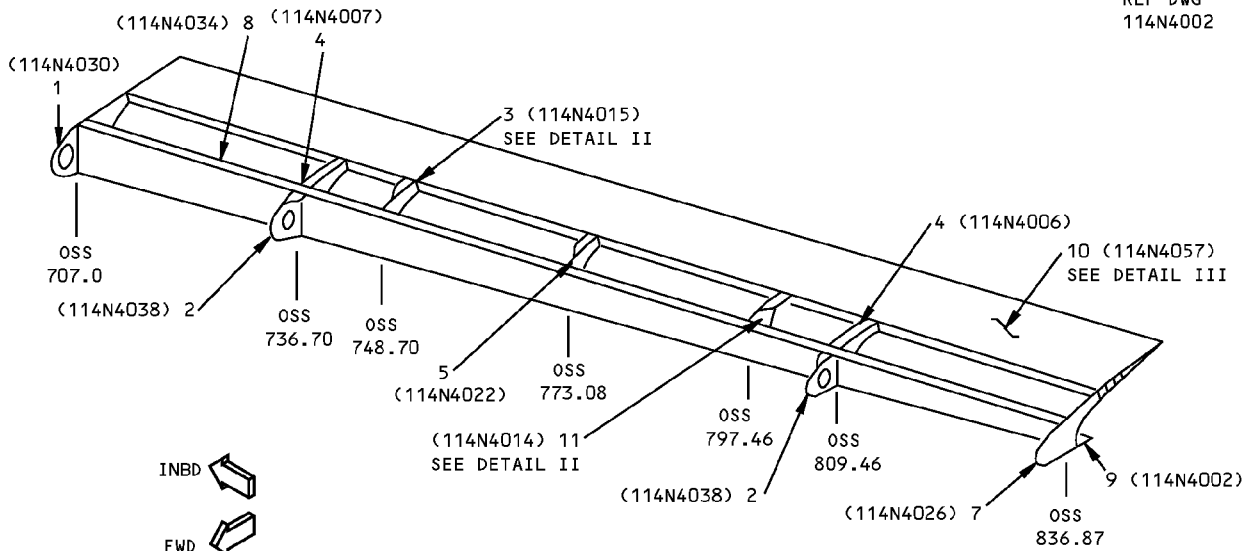

**SLAT NO. 1
DETAIL I**

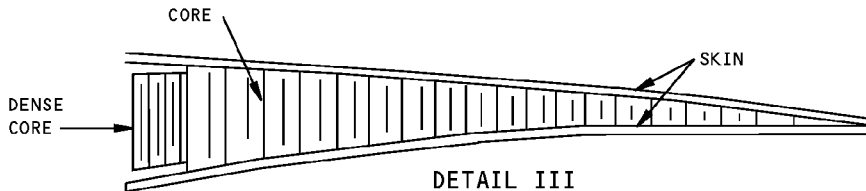
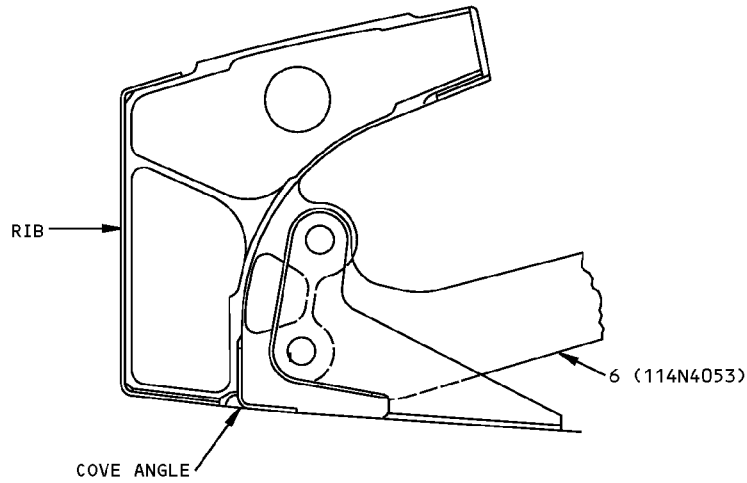

LIST OF
MATL

**Leading Edge Slat Structure Identification
Figure 1 (Sheet 2 of 11)**

IDENTIFICATION 1
Page 2
Jan 20/2005

57-43-02

D634N201



**757-200
STRUCTURAL REPAIR MANUAL**

ITEM	DESCRIPTION	GAGE	MATERIAL	EFFECTIVITY
1	END RIB	1.50	7075-T7351 OPTIONAL: FORGING 7075-T73	
2	NOSE RIB	2.00	7075-T7351 OPTIONAL: FORGING 7075-T73	
3	AUXILIARY ARM RIB	4.0	FORGED BLOCK 7075-T73 OR 7050-T7651 OR T73651	
4	MAIN TRACK RIB	4.0	FORGED BLOCK 7075-T73 OPTIONAL: 7050-T7451 OR T73651	
5	AIRLOAD RIB	2.0	7075-T7351 OPTIONAL: FORGING 7075-T73	
6	AUXILIARY ARM	0.70	FORGING 7075-T73 OPTIONAL: 7075-T7351	
7	END RIB	2.5	7075-T7351 OPTIONAL: FORGING 7075-T73	
8	NOSE BEAM BEAM STIFFENER	0.056	CLAD 7075-T6 AND10133-0501 7075-T6511	
9	COVE ANGLE	0.063	7075-T6	
10	TE WEDGE ASSEMBLY SKIN CORE	0.016 1.5	2024-T3 HONEYCOMB PER BMS 4-4, TYPE 3-10N FORM B OPTIONAL FORM C	
	DENSE CORE	1.5	HONEYCOMB PER MIL-C-7438 12.0 - 1/8-30 (5052)T	
11	AUX ARM RIB	4.0	FORGED BLOCK 7075-T73	

LIST OF MATERIALS FOR DETAIL I AND II

**Leading Edge Slat Structure Identification
Figure 1 (Sheet 3 of 11)**

IDENTIFICATION 1
Page 3
Jan 20/2005

57-43-02

D634N201

**757-200
STRUCTURAL REPAIR MANUAL**

REF DWG
114N4003

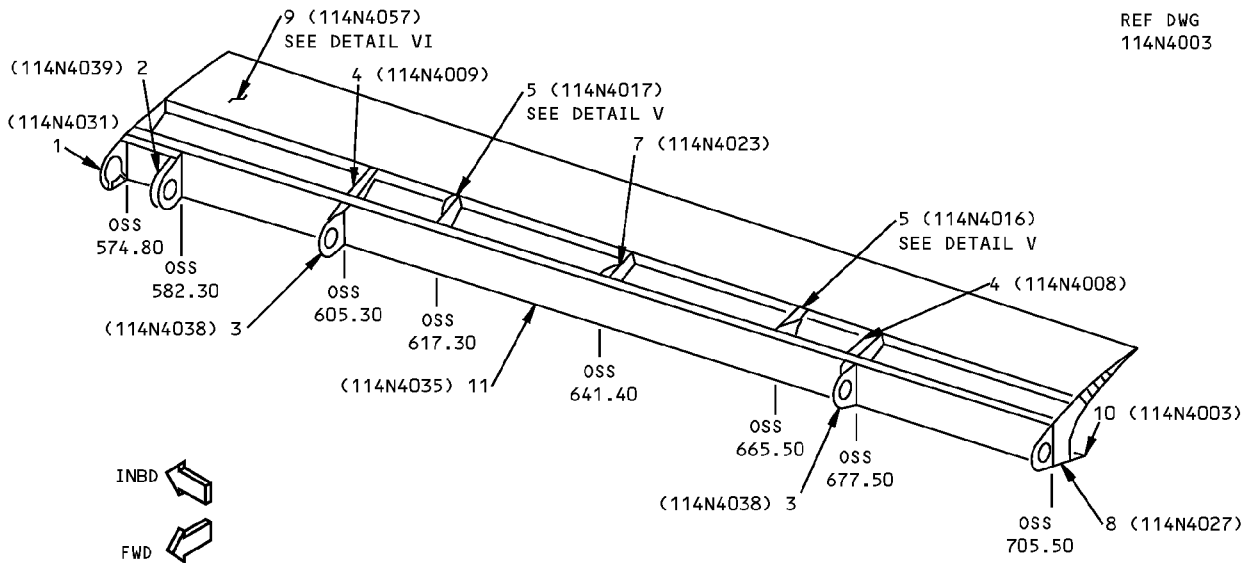

**SLAT NO. 2
DETAIL IV**

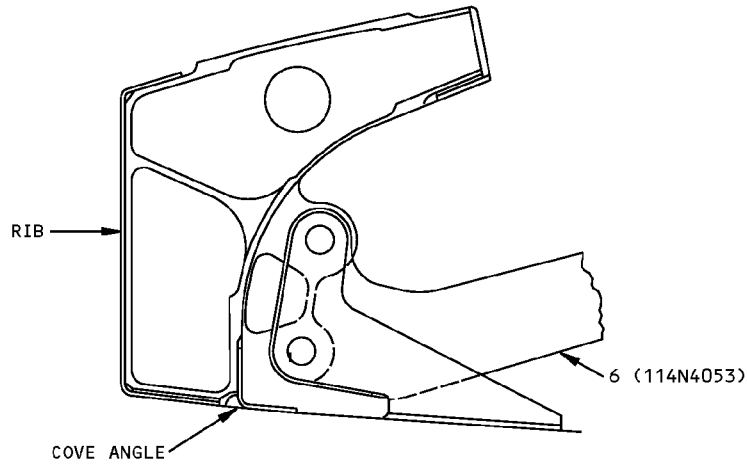

DETAIL V

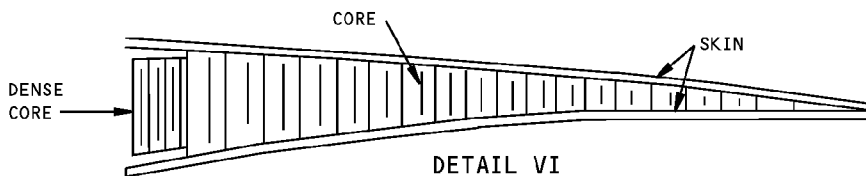

DETAIL VI

LIST OF
MATL

**Leading Edge Slat Structure Identification
Figure 1 (Sheet 4 of 11)**

IDENTIFICATION 1
Page 4
Jan 20/2005

57-43-02

D634N201



**757-200
STRUCTURAL REPAIR MANUAL**

ITEM	DESCRIPTION	GAGE	MATERIAL	EFFECTIVITY
1	END RIB	1.12	7075-T7351 OPTIONAL: FORGED BLOCK 7075-T73	
2	NOSE RIB	2.50	7075-T7351 OPTIONAL: FORGING 7075-T73	
3	NOSE RIB	2.00	7075-T7351 OPTIONAL: FORGING 7075-T73	
4	MAIN TRACK RIB	4.0	FORGED BLOCK 7075-T73 OPTIONAL: 7050-T7451 OR T73651	
5	AUXILIARY ARM RIB	4.0	FORGED BLOCK 7075-T73 OR 7050-T7651 OR T73651	
6	AUXILIARY ARM	0.70	FORGING 7075-T73 OPTIONAL: 7075-T7351	
7	AIR LOAD RIB	2.0	7075-T7351 OPTIONAL: FORGING 7075-T73	
8	END RIB	2.50	7075-T7351 OPTIONAL: FORGING 7075-T73	
9	TE WEDGE ASSEMBLY			
	SKIN	0.016	2024-T81	
	CORE	1.5	HONEYCOMB PER BMS 4-4, TYPE 3-10N FORM B OPTIONAL FORM C	
	DENSE CORE	1.5	HONEYCOMB PER MIL-C-7438 12.0-1/8-30 (5052)T	
10	COVE ANGLE	0.063	7075-T6	
11	NOSE BEAM ASSEMBLY			
	BEAM	0.056	CLAD 7075-T6	
	STIFFENERS		AND10133-0501 7075-T6511	

LIST OF MATERIALS FOR DETAILS IV AND V

**Leading Edge Slat Structure Identification
Figure 1 (Sheet 5 of 11)**

**757-200
STRUCTURAL REPAIR MANUAL**

REF DWG
114N4004

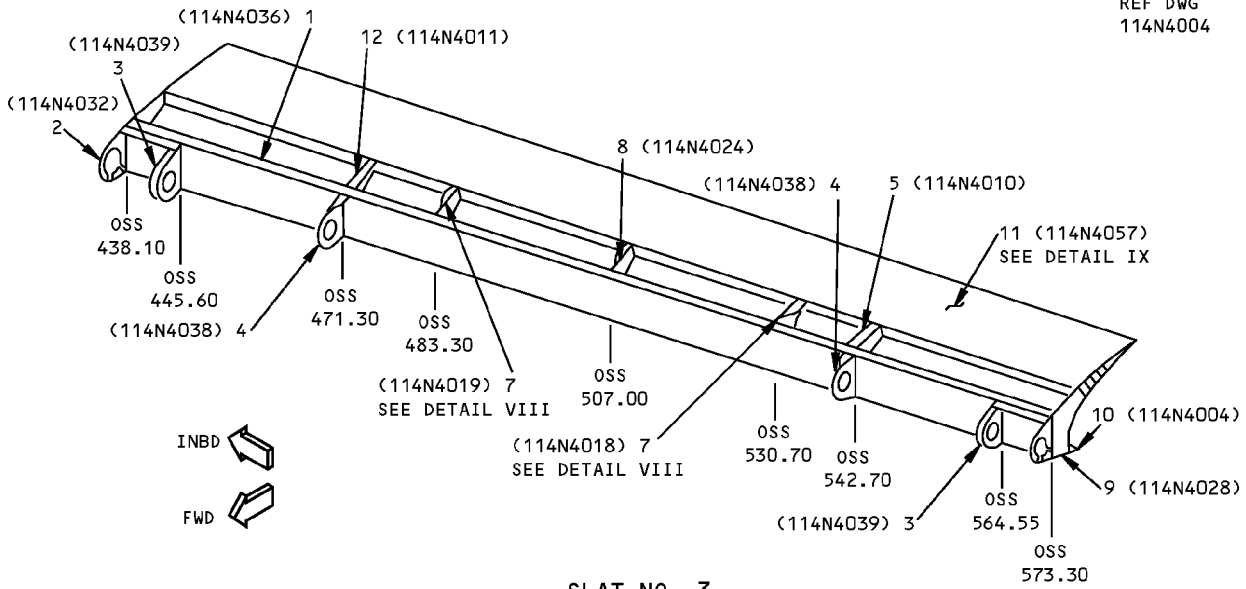

**SLAT NO. 3
DETAIL VII**

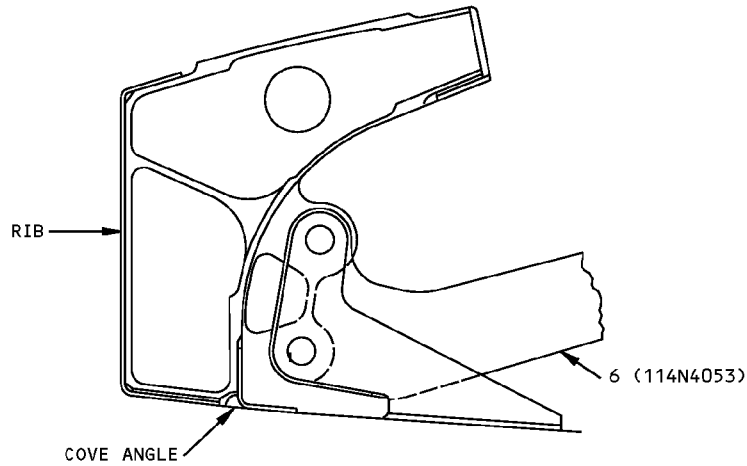

DETAIL VIII

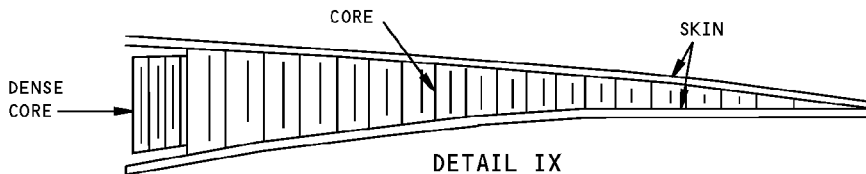

DETAIL IX

LIST OF
MATL

**Leading Edge Slat Structure Identification
Figure 1 (Sheet 6 of 11)**

IDENTIFICATION 1
Page 6
Jan 20/2005

57-43-02

D634N201



**757-200
STRUCTURAL REPAIR MANUAL**

ITEM	DESCRIPTION	GAGE	MATERIAL	EFFECTIVITY
1	NOSE BEAM ASSY BEAM STIFFENERS	0.056	CLAD 7075-T62 AND10133-0501 7075-T6511	
2	END RIB	1.12	7075-T7351 OPTIONAL: FORGING 7075-T73	
3	NOSE RIB	2.5	7075-T7351 OPTIONAL: FORGING 7075-T73	
4	NOSE RIB	2.00	7075-T7351 OPTIONAL: FORGING 7075-T73	
5	MAIN TRACK RIB	4.0	FORGED BLOCK 7075-T73	
6	AUXILIARY ARM	0.70	FORGING 7075-T73 OPTIONAL: 7075-T7351	
7	AUXILIARY ARM RIB	4.0	FORGED BLOCK 7075-T73 OR 7050-T7651 OR T73651	
8	AIRLOAD RIB	2.0	7075-T7351 OPTIONAL: FORGING 7075-T73	
9	END RIB	2.50	7075-T7351 OPTIONAL: 7075-T73	
10	COVE ANGLE	0.063	7075-T6	
11	TE WEDGE ASSEMBLY SKIN CORE	0.016 1.5	2024-T3 HONEYCOMB PER BMS 4-4, TYPE 3-10N FORM B OPTIONAL FORM C	
	DENSE CORE	1.5	HONEYCOMB PER MIL-C-7438 12.0-1/8-30 (5052)T	
12	MAIN TRACK RIB	4.0	FORGED BLOCK 7075-T73 OPTIONAL: 7050-T7451 OR T73651	

LIST OF MATERIALS FOR DETAILS VII AND VIII

**Leading Edge Slat Structure Identification
Figure 1 (Sheet 7 of 11)**

IDENTIFICATION 1
Page 7
Jan 20/2005

57-43-02

D634N201

**757-200
STRUCTURAL REPAIR MANUAL**

REF DWG
114N4005

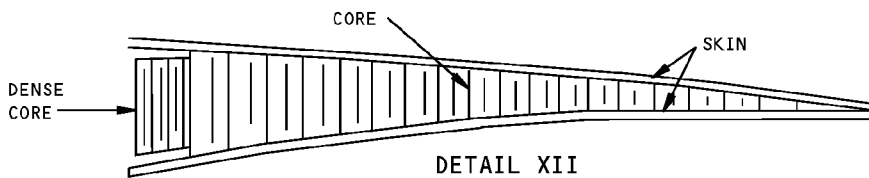
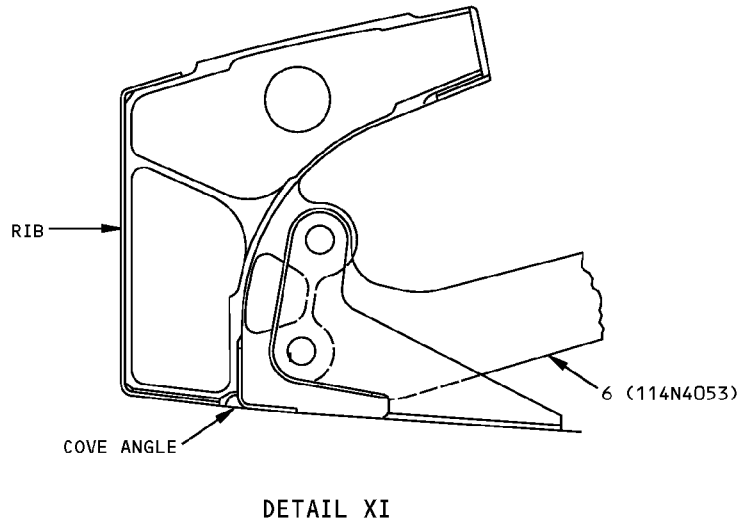
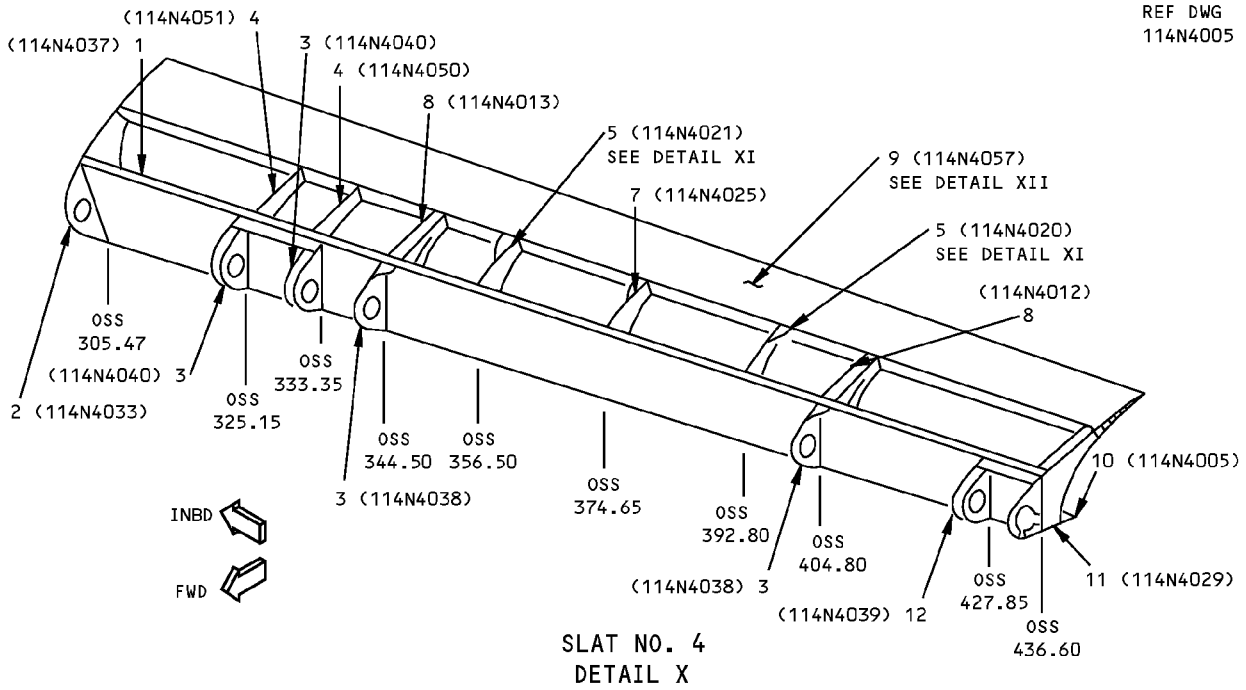

LIST OF
MATL

**Leading Edge Slat Structure Identification
Figure 1 (Sheet 8 of 11)**

IDENTIFICATION 1
Page 8
Jan 20/2005

57-43-02

D634N201



**757-200
STRUCTURAL REPAIR MANUAL**

ITEM	DESCRIPTION	GAGE	MATERIAL	EFFECTIVITY
1	NOSE BEAM ASSY BEAM STIFFENERS	0.056	CLAD 7075-T62 AND10133-0501 7075-T6511	
2	END RIB		7075-T7351 OPTIONAL: FORGING 7075-T73	
3	NOSE RIB	2.0	7075-T7351 OPTIONAL: FORGING 7075-T73	
4	DUCT RIB	1.0	7075-T7351 OPTIONAL: FORGING 7075-T73	
5	AUXILIARY ARM RIB	4.0	FORGED BLOCK 7075-T73 OR 7050-T7651 OR T73651	
6	AUXILIARY ARM	0.70	FORGING 7075-T73 OPTIONAL: 7075-T7351	
7	AIRLOAD RIB	2.0	7075-T7351 OPTIONAL: FORGING 7075-T73	
8	MAIN TRACK RIB	4.0	FORGED BLOCK 7075-T73 OPTIONAL: 7050-T7451 OR T73651	
9	TE WEDGE ASSEMBLY SKIN CORE	0.016 1.5	2024-T81 HONEYCOMB PER BMS 4-4, TYPE 3-10N FORM B OPTIONAL FORM C	
	DENSE CORE	1.5	HONEYCOMB PER MIL-C-7438 12.0-1/8-30 (5052)T	
10	COVE ANGLE	0.063	7075-T6	
11	END RIB	2.50	7075-T7351 OPTIONAL: FORGING 7075-T73	
12	NOSE RIB	2.5	7075-T7351 OPTIONAL: FORGING 7075-T73	

LIST OF MATERIALS FOR DETAILS X AND XI

**Leading Edge Slat Structure Identification
Figure 1 (Sheet 9 of 11)**

IDENTIFICATION 1
Page 9
Jan 20/2005

57-43-02

D634N201

**757-200
STRUCTURAL REPAIR MANUAL**

REF DWG
114N3002

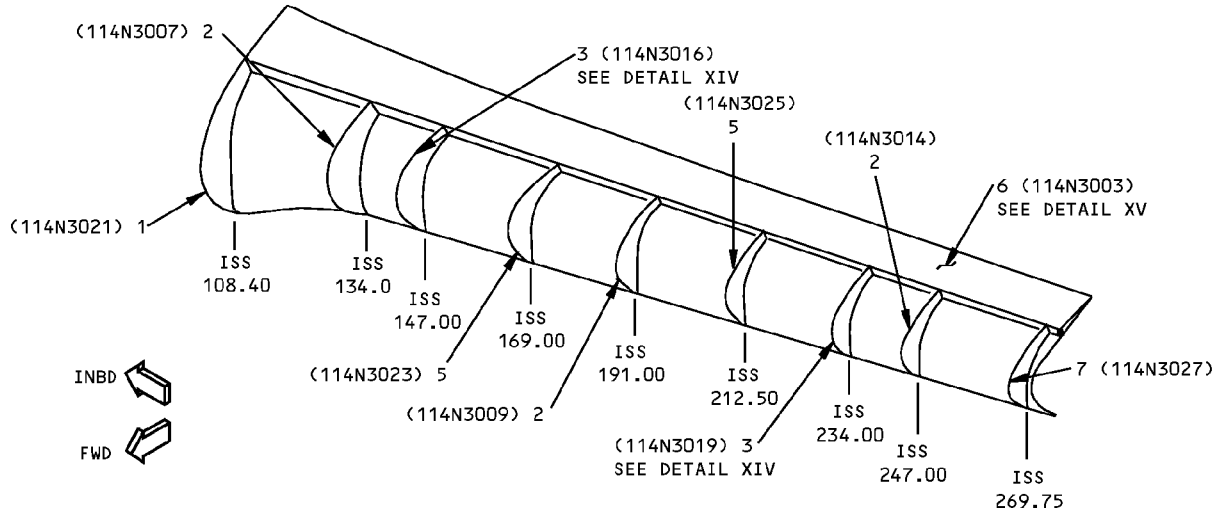

**SLAT NO. 5
DETAIL XIII**

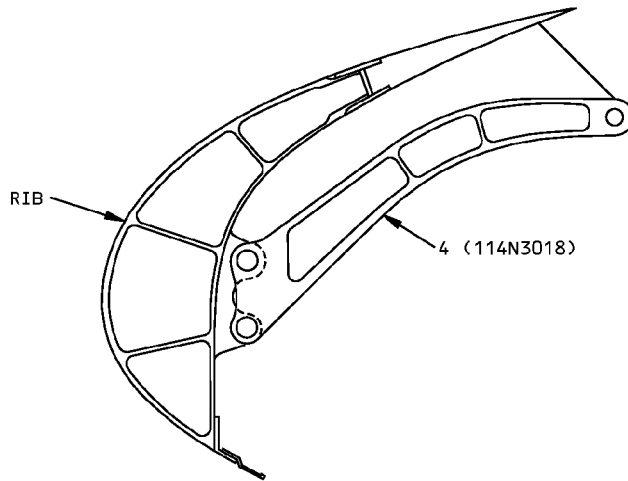

DETAIL XIV

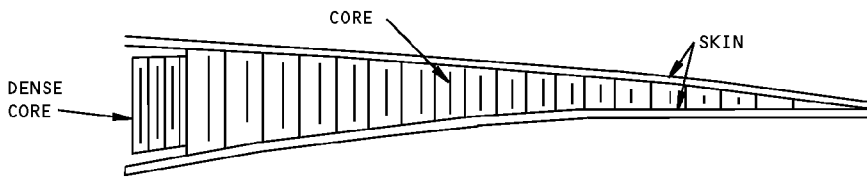

DETAIL XV

LIST OF
MATL →

**Leading Edge Slat Structure Identification
Figure 1 (Sheet 10 of 11)**

IDENTIFICATION 1
Page 10
Jan 20/2005

57-43-02

D634N201



757-200
STRUCTURAL REPAIR MANUAL

ITEM	DESCRIPTION	GAGE	MATERIAL	EFFECTIVITY
1	SUPPORT RIB	1.60	FORGED BLOCK 7075-T73 OPTIONAL: 7075-T7351	
2	MAIN TRACK SUPPORT RIB	2.75	FORGED BLOCK 7075-T73	
3	AUXILIARY TRACK SUPPORT RIB	3.10	FORGED BLOCK 7075-T73 OR 7050-T73	
4	AUXILIARY ARM	0.90	7075-T7351 OR FORGED BLOCK 7075-T73	
5	SUPPORT RIB	1.00	FORGED BLOCK 7075-T73 OPTIONAL: 7075-T7351	
6	TE WEDGE ASSY SKIN CORE DENSE CORE	0.016 1.5 1.5	2024-T3 HONEYCOMB PER BMS 4-4 TYPE 3-10N FORM B OR C HONEYCOMB PER MIL-C-7438, 12.0-1/8-30 GRADE B, CLASS 2	
7	SUPPORT RIB	2.00	FORGED BLOCK 7075-T73 OPTIONAL: 7075-T7351	

LIST OF MATERIALS FOR DETAILS XIII AND XIV

Leading Edge Slat Structure Identification
Figure 1 (Sheet 11 of 11)

D634N201

57-43-02

IDENTIFICATION 1
Page 11
Jan 20/2005

**757-200
STRUCTURAL REPAIR MANUAL**

ALLOWABLE DAMAGE 1 - LEADING EDGE SLAT STRUCTURE

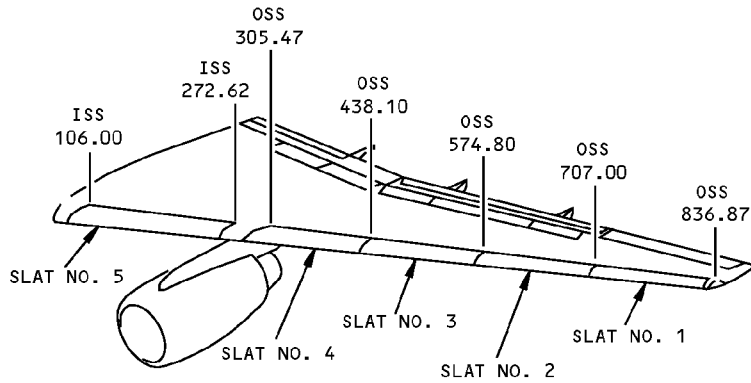

REFERENCE DRAWING
114N4002
114N4003
114N4004
114N4005
114N3002

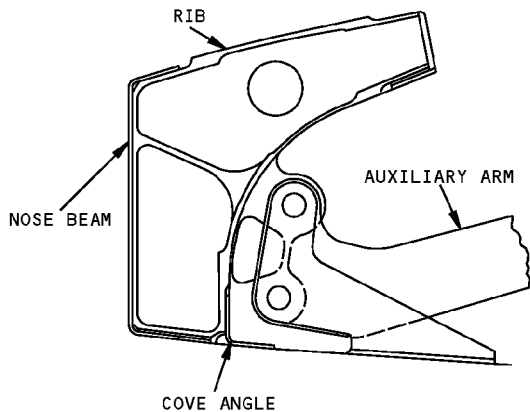
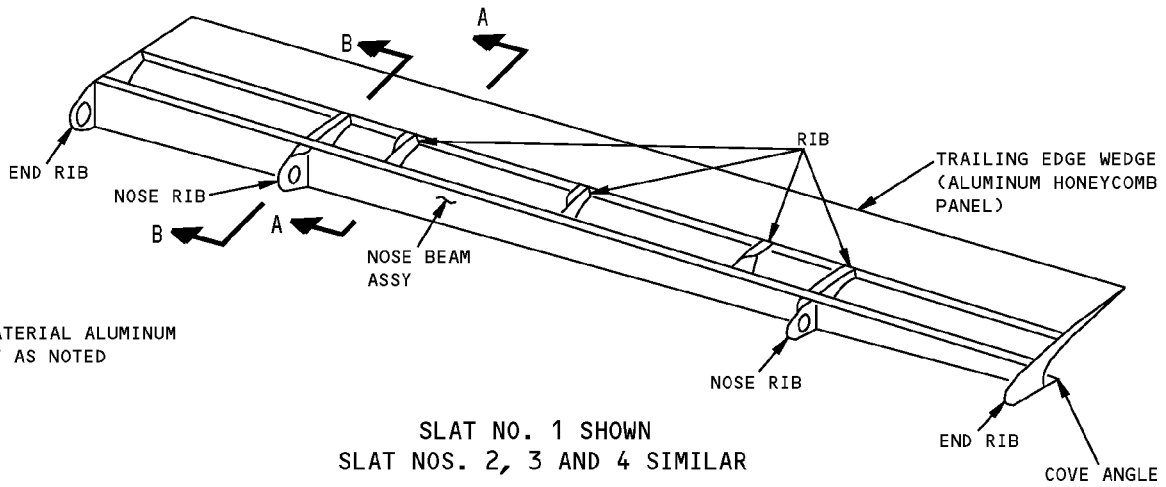

SECTION A-A

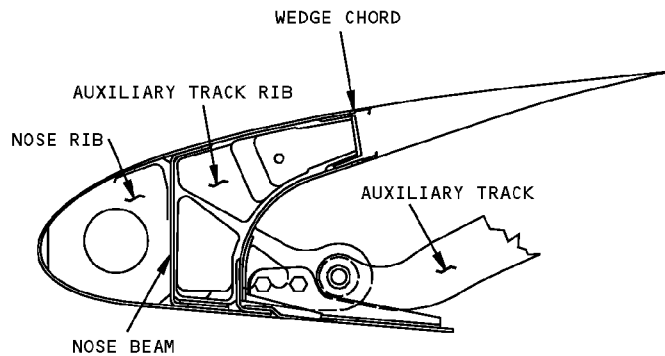

SECTION B-B

**Leading Edge Slat Structure Allowable Damage
Figure 101 (Sheet 1 of 7)**

**757-200
STRUCTURAL REPAIR MANUAL**

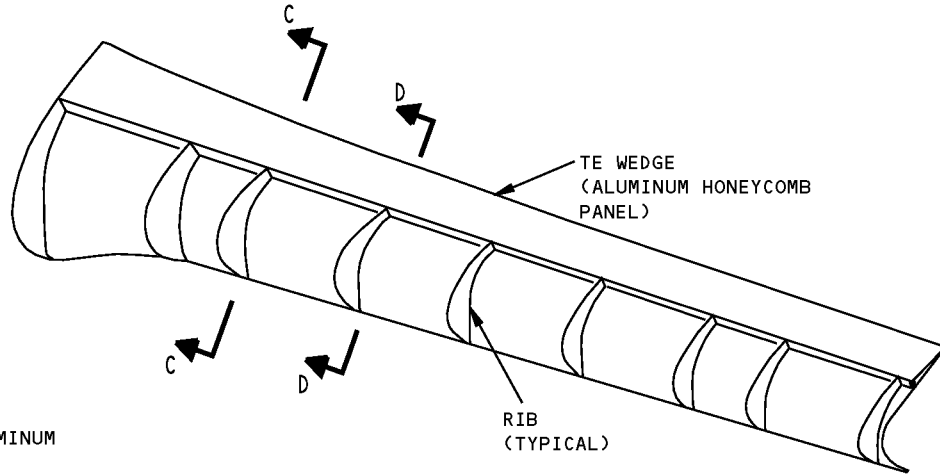

ALL MATERIAL ALUMINUM
EXCEPT AS NOTED

SLAT NO. 5

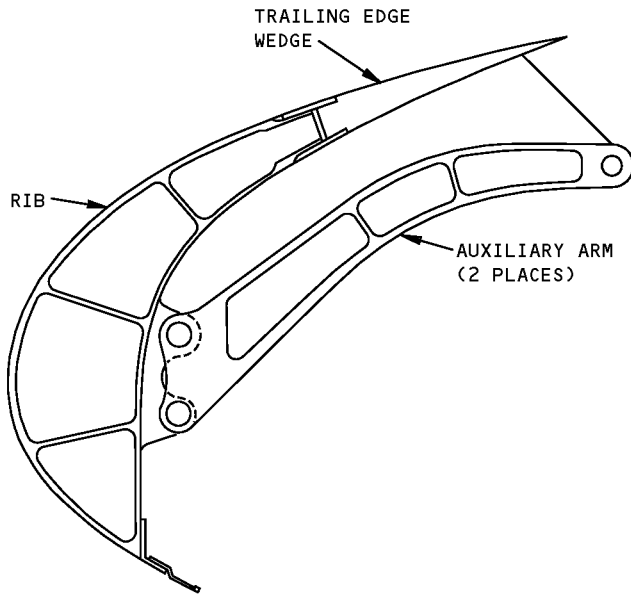

SECTION C-C

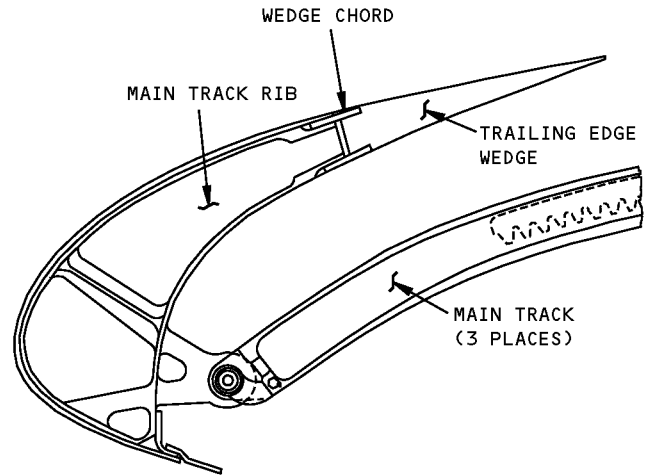

SECTION D-D

**Leading Edge Slat Structure Allowable Damage
Figure 101 (Sheet 2 of 7)**

**757-200
STRUCTURAL REPAIR MANUAL**

ITEM	CRACKS	NICKS, GOUGES AND CORROSION	DENTS	HOLES AND PUNCTURES	DELAMINATION
NOSE RIB [B]	[A]	SEE DETAIL V	NOT ALLOWED	NOT ALLOWED	---
END RIB [B]	[A]	SEE DETAIL V	NOT ALLOWED	NOT ALLOWED	---
RIB (TYPICAL) [B]	[A]	[C]	NOT ALLOWED	NOT ALLOWED	---
COVE ANGLE	[D]	[C]	SEE DETAIL III	[E]	---
NOSE BEAM ASSEMBLY					
BEAM	[D]	[F]	SEE DETAIL III	[E]	---
STIFFENERS	[D]	[C]	NOT ALLOWED	SEE DETAIL VIII	---
AUXILIARY ARM [B]	[A]	[F]	NOT ALLOWED	NOT ALLOWED	---
MAIN TRACK [B]	SEE DETAIL IX	SEE DETAIL IX	NOT ALLOWED	NOT ALLOWED	---
TE WEDGE	[H]	[J]	[K]	[L]	[M]

NOTES

- REFINISH REWORKED AREAS AS GIVEN IN AMM 51-20.
 - REFER TO SRM 51-10-01 FOR AERODYNAMIC SMOOTHNESS REQUIREMENTS. WHERE THE DAMAGE EXCEEDS THE LIMITS SHOWN IN SRM 51-10-01, CONSIDERATION SHOULD BE GIVEN TO THE LOSS OF PERFORMANCE INVOLVED.
- [A] CLEAN UP EDGE CRACKS AS GIVEN IN DETAILS I AND II. OTHER CRACKS MUST BE REPAIRED.
- [B] SHOT PEEN REWORKED AREAS AS GIVEN IN SRM 51-20-06.
- [C] REMOVE DAMAGE AS GIVEN IN DETAILS II, IV AND VI.
- [D] CRACKS NOT ALLOWED EXCEPT FOR EDGE CRACKS WHICH MUST BE REMOVED AS GIVEN IN DETAILS I AND VII.
- [E] CLEAN OUT DAMAGE UP TO 0.25 MAX DIA AND NOT CLOSER THAN 2.0 INCH TO FASTENER HOLE, EDGE OR OTHER DAMAGE. FILL HOLE WITH A 2117-T3 OR T4 ALUMINUM RIVET INSTALLED WET WITH BMS 5-95 SEALANT. ALL OTHER HOLES TO BE REPAIRED.
- [F] REMOVE DAMAGE AS GIVEN IN DETAILS I, II, IV AND VII.
- [G] REMOVE MOISTURE FROM DAMAGE AREA. USE OF VACUUM AND HEAT (MAX OF 125°F (52°C)) TO REMOVE MOISTURE FROM HONEYCOMB CELLS IS RECOMMENDED. PROTECT DAMAGE FROM ENTRANCE OF WATER, SUNLIGHT OR OTHER FOREIGN MATTER BY SEALING WITH ALUMINUM FOIL TAPE (SPEED TAPE). RECORD THE LOCATION AND INSPECT EVERY AIRPLANE "A" CHECK. REPLACE THE ALUMINUM FOIL TAPE IF ANY PEELING OR DETERIORATION EVIDENT. REPAIR NO LATER THAN NEXT AIRPLANE "C" CHECK [D].

**Leading Edge Slat Structure Allowable Damage
Figure 101 (Sheet 3 of 7)**

STRUCTURAL REPAIR MANUAL

NOTES (CONT)

- H** CLEAN UP EDGE CRACKS AS GIVEN IN DETAILS I AND VII. 1.50 MAX LENGTH CRACK ALLOWED IN HONEYCOMB AREA. STOP DRILL ENDS OF CRACK WITH 0.19 DIA HOLE **G**.
- J** REMOVE DAMAGE AS GIVEN IN DETAILS II AND IV.
- K** MAXIMUM ALLOWABLE DENT DIAMETER IS 2.0 INCHES. DENTS ARE NOT PERMITTED ON THE WEDGE CHORDS AT THE FORWARD EDGE. IF THE EDGE OF A DENT IS LESS THAN 2.0 INCHES FROM THE EDGE OF A PANEL, THE DENT MUST BE A DEPTH OF 0.040 INCH OR LESS. IF THE EDGE OF A DENT IS 2.0 INCHES OR MORE FROM THE EDGE OF THE PANEL, THEN THE DENT MUST BE A DEPTH OF 0.120 INCH OR LESS. THE MINIMUM A/Y RATIO FOR ALL DENTS IS 10. THE MINIMUM DISTANCE BETWEEN THE EDGE OF A DENT AND THE EDGE OF ANOTHER DENT OR OTHER DAMAGE MUST NOT BE LESS THAN THE DIAMETER OF THE LARGER DENT. IF A DENT HAS A DEPTH MORE THAN 0.120 INCH, AND IS SATISFACTORY TO ALL OF THE OTHER ALLOWABLE DENT LIMITS, IT MUST BE FILLED AND MADE SMOOTH WITH BMS 5-28, TYPE 3 POTTING COMPOUND. REFER TO SRM 51-70-01. THE FILLED DAMAGE MUST BE INSPECTED AT EACH AIRPLANE "A" CHECK AND REPAIRED BY THE NEXT "C" CHECK. SEE DETAIL III.
- L** CLEAN UP DAMAGE TO 0.25 MAX DIA HOLE AND NOT CLOSER THAN 1.0 INCH TO FASTENER HOLE, EDGE OF PART OF OTHER DAMAGE. ONE HOLE PER 15.0 SQUARE INCHES OF PANEL ALLOWED **G**.
- M** DAMAGE TO A MAXIMUM DIMENSION (D) OF 1.50 INCH IS PERMITTED IN THE HONEYCOMB AREA. THE DAMAGE MUST BE A MINIMUM OF 4D EDGE TO EDGE FROM OTHER DAMAGE. THE DAMAGE MUST ALSO BE A MINIMUM OF 1.0 INCH FROM THE EDGE OF A PANEL. A MAXIMUM DELAMINATION OF 0.10 INCH IS PERMITTED ON THE EDGES OF A PANEL. SEAL THE DAMAGE ON THE EDGE AS GIVEN IN **G**. REPAIR THE DELAMINATION IN THE HONEYCOMB AREA AS GIVEN IN SRM 51-70 AT OR BEFORE THE NEXT "C" CHECK.
- N** CADMIUM PLATE REWORKED SURFACES OF STEEL PARTS AS GIVEN IN SOPM 20-42-10, DOCUMENT D6-51702.
- O** THESE ALLOWABLE DAMAGE LIMITS HAVE APPROVAL ON ACCOMPLISHMENT OF THE INSPECTIONS CONTAINED HEREIN.

Leading Edge Slat Structure Allowable Damage
Figure 101 (Sheet 4 of 7)

STRUCTURAL REPAIR MANUAL

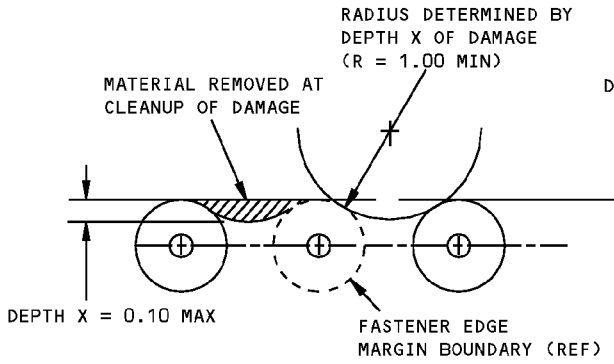

DAMAGE CLEANUP OF EDGES WHERE FASTENER EDGE MARGINS DO NOT OVERLAP

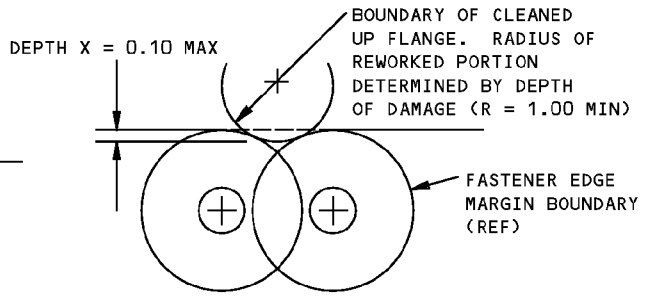

DAMAGE CLEANUP OF EDGES WHERE FASTENER EDGE MARGINS OVERLAP

DETAIL I

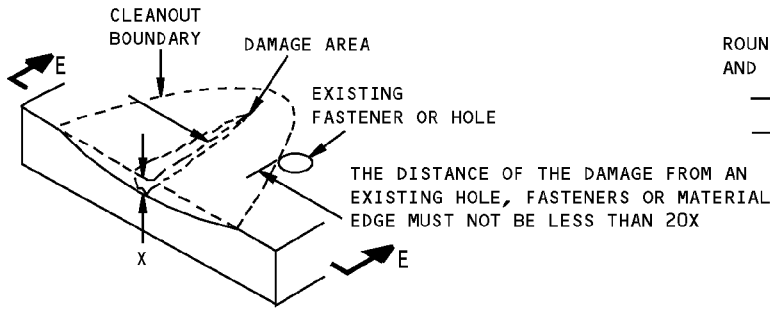

REMOVAL OF NICK, GOUGE AND SCRATCH DAMAGE ON A SURFACE
DETAIL II

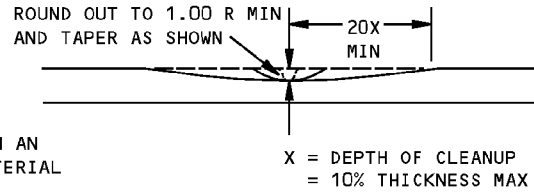

SECTION E-E

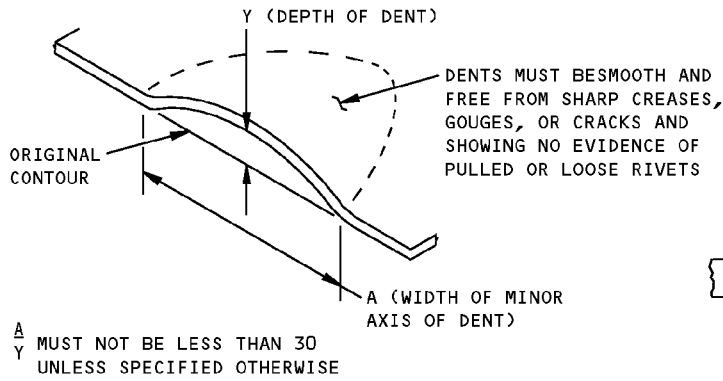

ALLOWABLE DAMAGE FOR DENT
DETAIL III

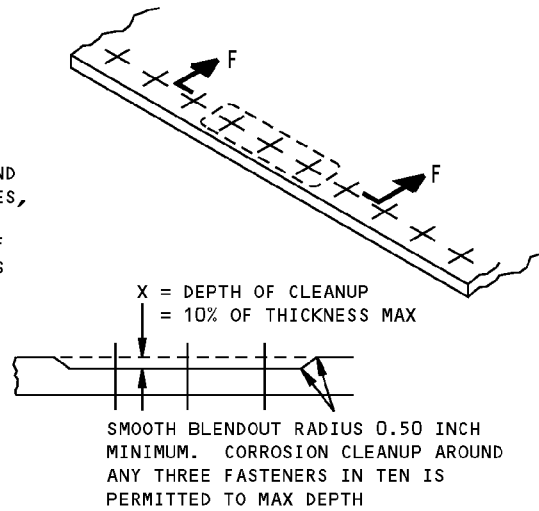

SECTION F-F
CORROSION CLEANUP
DETAIL IV

**Leading Edge Slat Structure Allowable Damage
Figure 101 (Sheet 5 of 7)**

**757-200
STRUCTURAL REPAIR MANUAL**

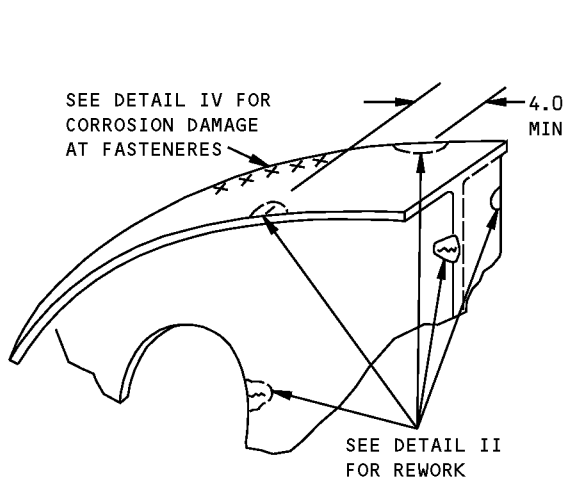

**REMOVAL OF DAMAGE ON NOSE RIB AND END RIB
DETAIL V**

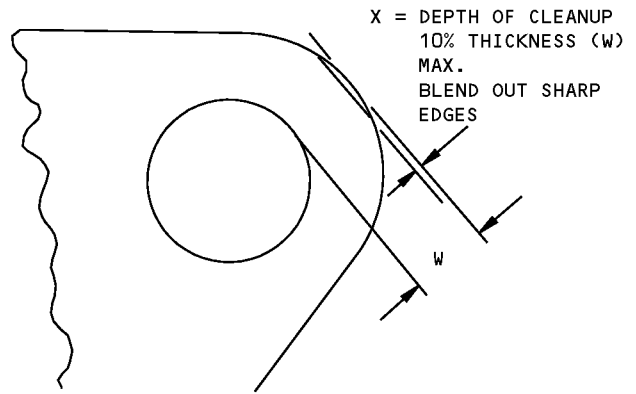

**DAMAGE CLEANUP FOR EDGES OF LUG
DETAIL VI**

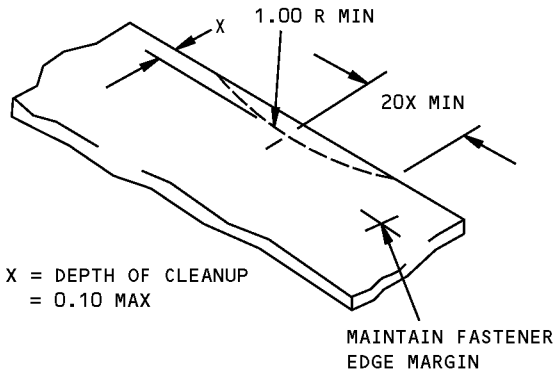

**REMOVAL OF NICK OR CRACK
DAMAGE ON AN EDGE
DETAIL VII**

NOTE:
NO HOLE DAMAGE ALLOWED IN STIFFENER FLANGE FASTENED TO NOSE BEAM

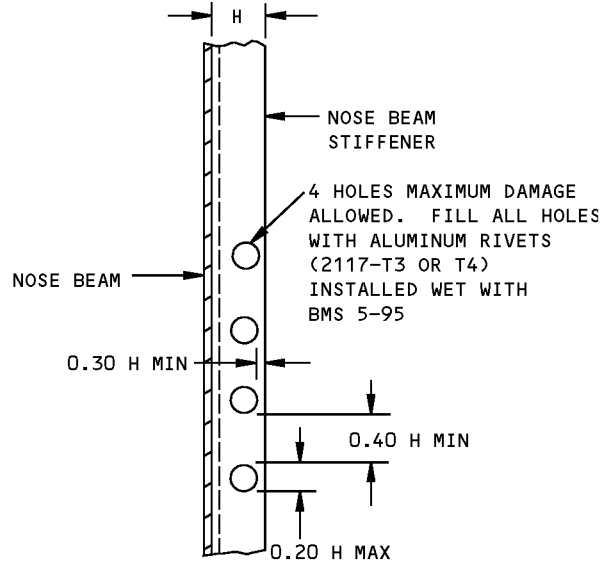

H = WIDTH OF STIFFENER FLANGE

**ALLOWABLE DAMAGE LIMITS FOR HOLES IN NOSE BEAM STIFFENERS
DETAIL VIII**

**Leading Edge Slat Structure Allowable Damage
Figure 101 (Sheet 6 of 7)**

**757-200
STRUCTURAL REPAIR MANUAL**

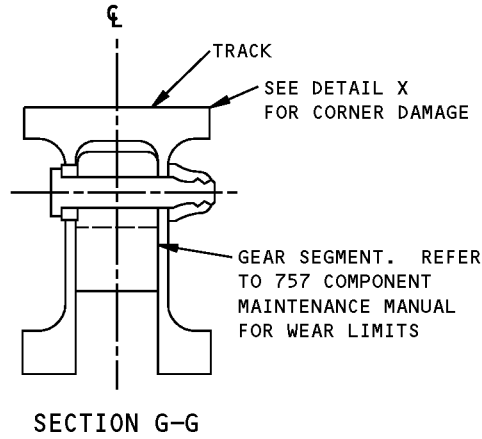
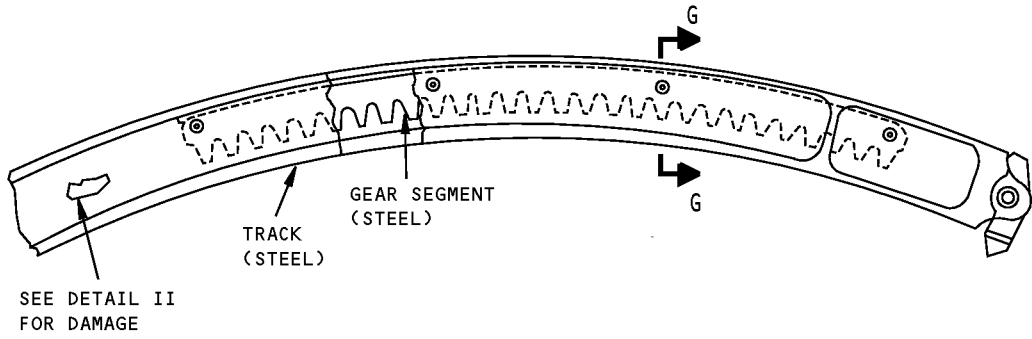

**MAIN TRACK ASSEMBLY
DETAIL IX [N]**

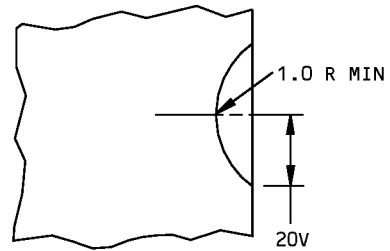
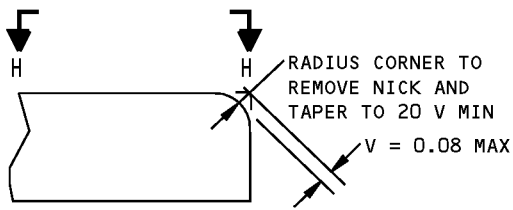

DETAIL X [N]

**Leading Edge Slat Structure Allowable Damage
Figure 101 (Sheet 7 of 7)**

**757-200
STRUCTURAL REPAIR MANUAL**

REPAIR 1 - LEADING EDGE SLAT - TRAILING EDGE WEDGE REPAIRS

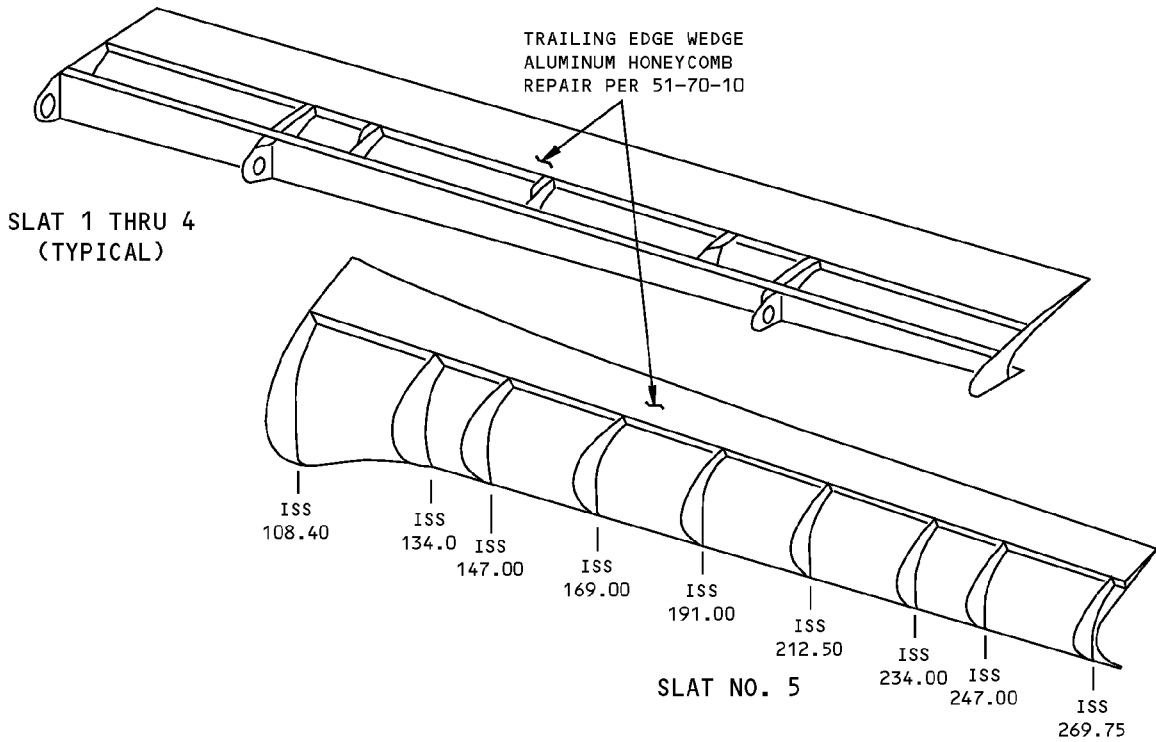
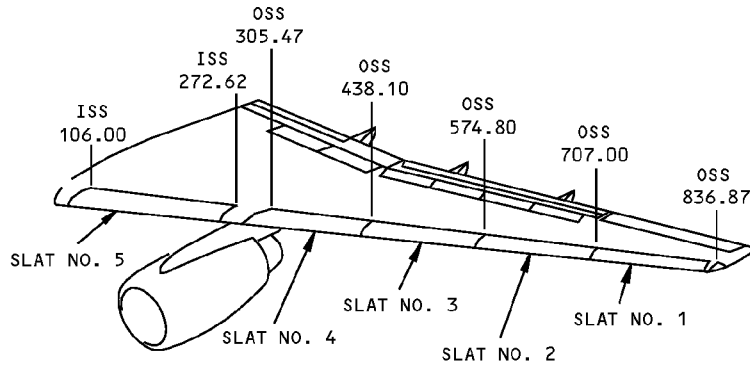

NOTES

- REPAIR ALUMINUM HONEYCOMB TRAILING EDGE WEDGE PER 51-70-10
- REPLACE FLEX CORE WITH FLEX CORE AND DENSE CORE WITH DENSE CORE

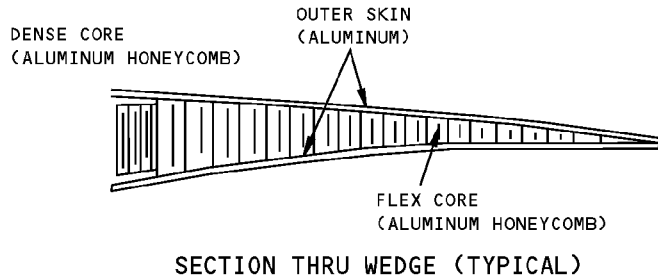

**Leading Edge Slat - Trailing Edge Wedge Repairs
Figure 201**

**757-200
STRUCTURAL REPAIR MANUAL**

IDENTIFICATION 1 - WING FIXED TRAILING EDGE SKIN - UPPER SURFACE

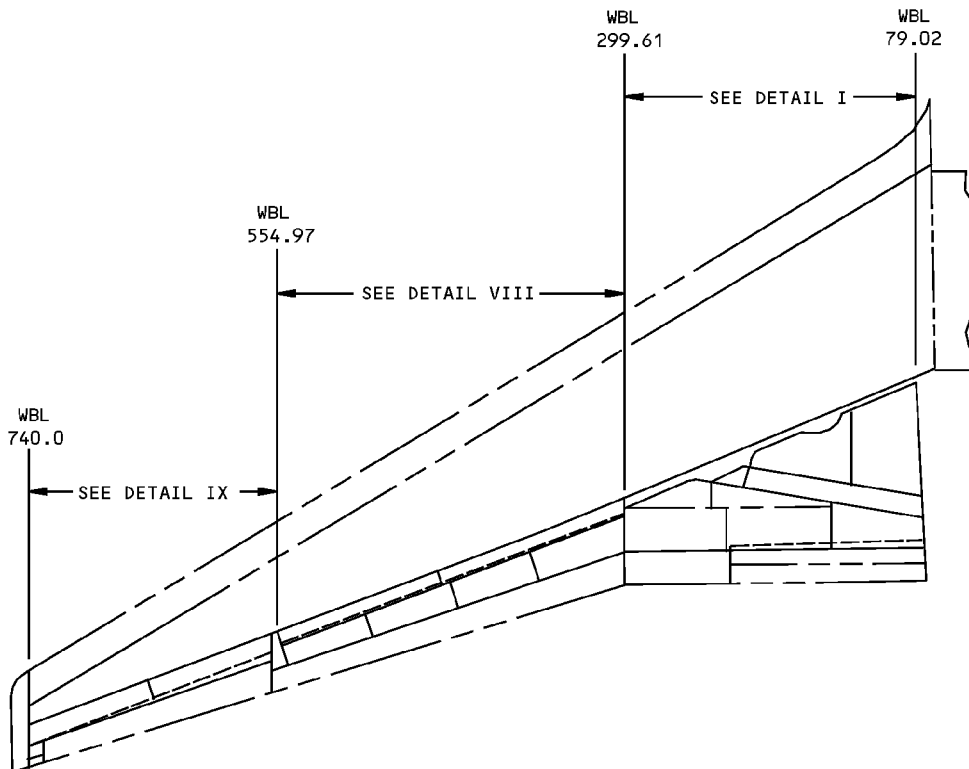

NOTES

- | | |
|---|---|
| <p>[A] PLY ORIENTATION CONVENTION, DEGREES INDICATED IS PARALLEL TO THE FABRIC WARP DIRECTION</p> <p>[B] MATERIAL AND PLY ORIENTATION SHOWN FOR FIELD AREAS ONLY. SEE BOEING DRAWINGS FOR EDGE BANDS AND AREAS WITH DOUBLERS</p> <p>[C] DIAGRAM OF PLY ORIENTATION, SEE PLY TABLE FOR PLY ORIENTATION AND MATERIAL</p> <p>[D] ARAMID/EPOXY FABRIC PER BMS 8-219, STYLE 285, 250°F (121°C) CURE</p> <p>[E] GRAPHITE/EPOXY TAPE PER BMS 8-168, TYPE II, CLASS 1, GRADE 145, 250°F (121°C) CURE</p> <p>[F] GRAPHITE/EPOXY FABRIC PER BMS 8-168, TYPE II, CLASS 2, STYLE 3K-70-PW, 250°F (121°C) CURE</p> <p>[G] FIBERGLASS/EPOXY FABRIC PER BMS 8-79, CLASS III, GRADE 1, TYPE 120, 250°F (121°C) CURE</p> <p>[H] ARAMID/EPOXY FABRIC PER BMS 8-219, STYLE 120, 250°F (121°C) CURE</p> | <p>[I] GRAPHITE/EPOXY TAPE PER BMS 8-168, TYPE II, CLASS 1, GRADE 95, 250°F (121°C) CURE</p> <p>[J] ARAMID/EPOXY FABRIC PER BMS 8-219, STYLE 285 OR ADD ARAMID/EPOXY FABRIC PER BMS 8-219, STYLE 120 AS REQUIRED TO MEET THICKNESS REQUIREMENTS</p> <p>[K] FIBERGLASS/EPOXY FABRIC PER BMS 8-79 CLASS III, GRADE 1, TYPE 1581, 250°F (121°C) CURE</p> <p>[L] GRAPHITE/EPOXY TAPE PER BMS 8-168, TYPE II, CLASS 1, GRADE 190, 250°F (121°C) CURE. NUMBER OF PLYS WILL VARY. SEE BOEING DRAWINGS</p> <p>[M] FOR CUM LINE NUMBERS: 1 THRU 67</p> <p>[N] FOR CUM LINE NUMBERS: 68 AND ON</p> <p>[O] FOR CUM LINE NUMBERS: 1 THRU 40</p> <p>[P] FOR AIRPLANES NOT LISTED IN [O]</p> |
|---|---|

**Wing Fixed Trailing Edge Skin Identification - Upper Surface
Figure 1 (Sheet 1 of 17)**

757-200 STRUCTURAL REPAIR MANUAL

NOTES (CONT)

- | | |
|---|--|
| <p>Q FOR CUM LINE NUMBER:
1</p> <p>R FOR CUM LINE NUMBERS:
2 AND ON</p> <p>S FOR CUM LINE NUMBERS:
2 THRU 141</p> <p>T FOR CUM LINE NUMBERS:
142 AND ON</p> | <p>U FOR CUM LINE NUMBERS:
1 THRU 141</p> <p>V FOR CUM LINE NUMBERS:
33 AND ON</p> <p>W FOR CUM LINE NUMBERS:
142 THRU 371</p> <p>X FOR CUM LINE NUMBERS:
372 AND ON</p> |
|---|--|

REF DWG
113N1610

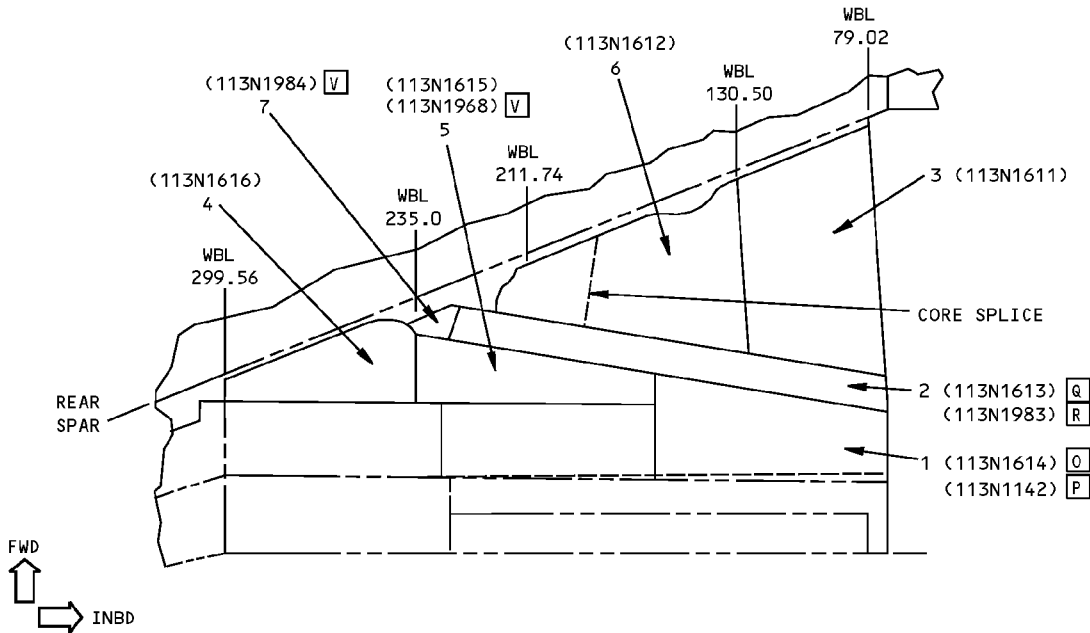

DETAIL I



**Wing Fixed Trailing Edge Skin Identification - Upper Surface
Figure 1 (Sheet 2 of 17)**

IDENTIFICATION 1
Page 2
Jan 20/2005

57-51-01

D634N201



757-200

STRUCTURAL REPAIR MANUAL

ITEM	DESCRIPTION	GAGE	MATERIAL	EFFECTIVITY
1	SKIN PANEL SKIN CORE		ARAMID/GRAPHITE/EPOXY HONEYCOMB SANDWICH OR FIBERGLASS/GRAPHITE/EPOXY HONEYCOMB SANDWICH SEE DETAIL II NOMEX HONEYCOMB PER BMS 8-124, CLASS IV, TYPE V, GRADE 3.0	
2	SKIN PANEL SKIN CORE		ARAMID/GRAPHITE/EPOXY HONEYCOMB SANDWICH OR FIBERGLASS/EPOXY HONEYCOMB SANDWICH SEE DETAIL III NOMEX HONEYCOMB PER BMS 8-124, CLASS IV, TYPE V, GRADE 3.0	
3	SKIN PANEL SKIN CORE		ARAMID/GRAPHITE/EPOXY HONEYCOMB SANDWICH OR FIBERGLASS/EPOXY HONEYCOMB SANDWICH SEE DETAIL IV NOMEX HONEYCOMB PER BMS 8-124, CLASS IV, TYPE V, GRADE 3.0	
4	SKIN PANEL SKIN CORE		ARAMID/GRAPHITE/EPOXY HONEYCOMB SANDWICH OR FIBERGLASS/EPOXY HONEYCOMB SANDWICH SEE DETAIL V NOMEX HONEYCOMB PER BMS 8-124, CLASS IV, TYPE V, GRADE 3.0	
5	SKIN PANEL SKIN CORE		ARAMID/GRAPHITE/EPOXY HONEYCOMB SANDWICH OR FIBERGLASS/EPOXY HONEYCOMB SANDWICH SEE DETAIL VI NOMEX HONEYCOMB PER BMS 8-124, CLASS IV, TYPE V, GRADE 3.0	
6	SKIN PANEL SKIN CORE		ARAMID/GRAPHITE/EPOXY HONEYCOMB SANDWICH OR FIBERGLASS/EPOXY HONEYCOMB SANDWICH SEE DETAIL VII NOMEX HONEYCOMB PER BMS 8-124, CLASS IV, TYPE V, GRADE 3.0	
7	SKIN PANEL SKIN		FIBERGLASS/EPOXY LAMINATE BMS 8-79 TYPE 1581 OR 7781, PLIES ORIENTATED PARALLEL TO REAR SPAR	

LIST OF MATERIALS FOR DETAIL I

Wing Fixed Trailing Edge Skin Identification - Upper Surface
Figure 1 (Sheet 3 of 17)

IDENTIFICATION 1
Page 3
Jan 20/2005

57-51-01

D634N201

**757-200
STRUCTURAL REPAIR MANUAL**

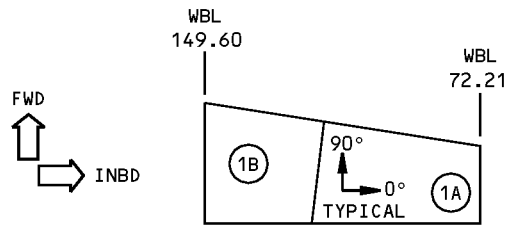

VIEW ON PANEL **C**

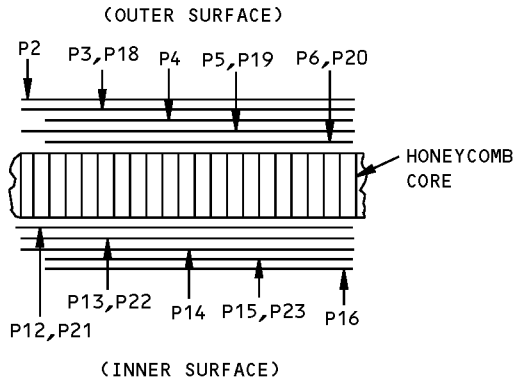

SECTION THRU PANEL **O**

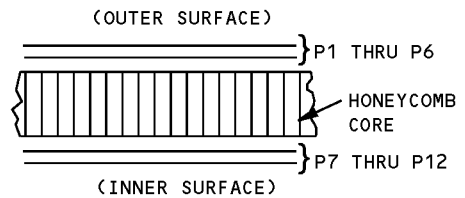

SECTION THRU PANEL **P**

ITEM NO.	PLY NO.	MATERIAL	PLY ORIENTATION A
1	1A P2,P4, P14,P16	D	0° OR 90°
		F	0° OR 90°
	1B P2,P4, P14,P16	D	0° OR 90°
		F	0° OR 90°

PLY TABLE **B O**

ITEM NO.	PLY NO.	MATERIAL	PLY ORIENTATION A	
7	1A AND 1B	P1,P2,	G	OPTIONAL
		P11,P12	K	OPTIONAL
	P3,P5,P6 P7,P8,P10	F	0° OR 90°	
	P4,P9	F	±45°	

PLY TABLE **B P**

DETAIL II

**Wing Fixed Trailing Edge Skin Identification - Upper Surface
Figure 1 (Sheet 4 of 17)**

**757-200
STRUCTURAL REPAIR MANUAL**

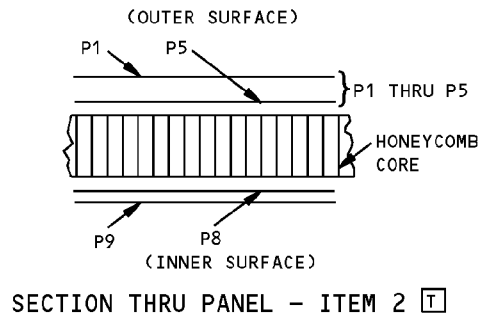
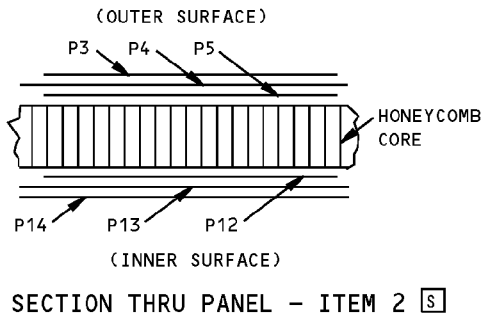
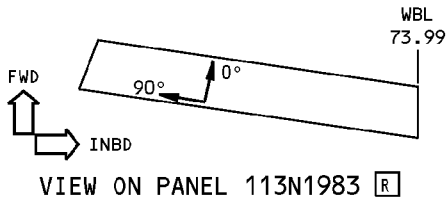
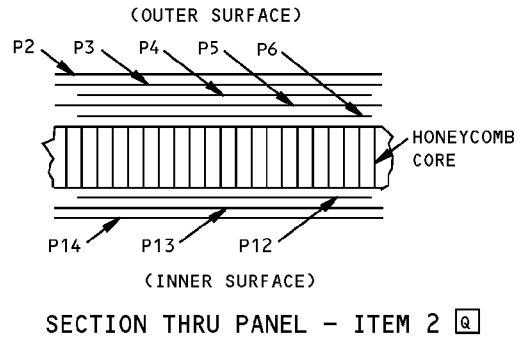
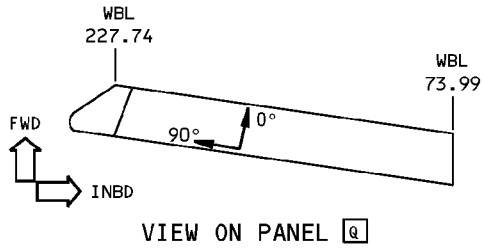

ITEM NO.	PLY NO.	MATERIAL	PLY ORIENTATION A
2 Q	P2,P4, P13,P14	D	0° OR 90°
	P3,P5, P6,P12	E	0°
2 S	P13	D	0° OR 90°
	P3,P5, P6,P12	E	0°
2 T	P1,P3,P5	K	0° OR 90°
	P2,P9	K	±45°

PLY TABLE **B**

DETAIL III

**Wing Fixed Trailing Edge Skin Identification - Upper Surface
Figure 1 (Sheet 5 of 17)**

**757-200
STRUCTURAL REPAIR MANUAL**

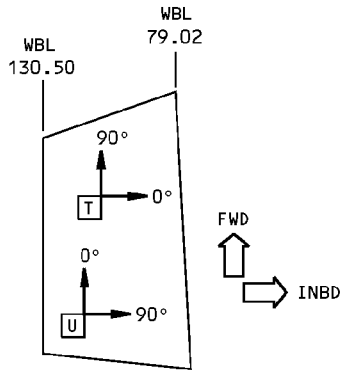

VIEW ON PANEL **C**

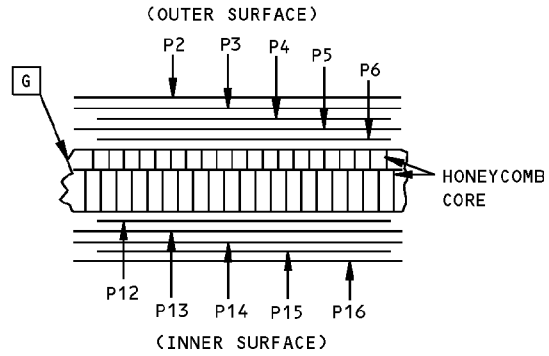

SECTION THRU PANEL - ITEM 3 **U**

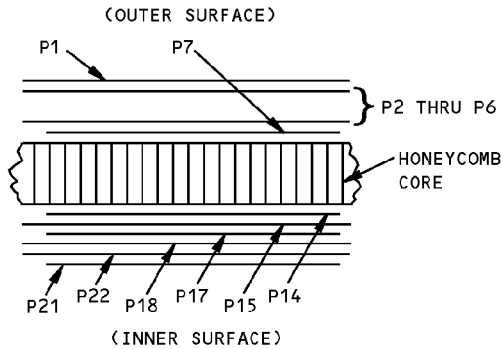

SECTION THRU PANEL - ITEM 3 **W**

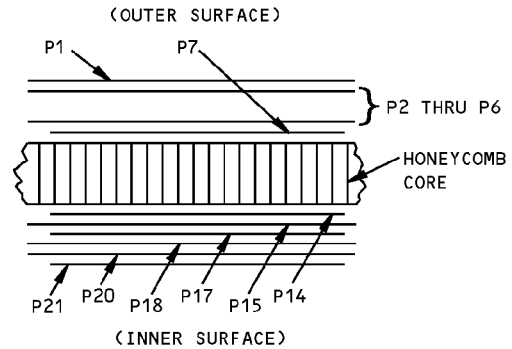

SECTION THRU PANEL - ITEM 3 **X**

ITEM NO.	PLY NO.	MATERIAL	PLY ORIENTATION A
3 U	P2,P4,P14,P16	D	0° OR 90°
	P3,P5,P6,P12,P13,P15	E	0°
3 W	P3,P18	K	±45°
	P1,P5,P7,P22	K	0° OR 90°
	P2,P4,P6,P14,P17,P21	E	0°
	P15	G	±45°
3 X	P13,P18	K	±45°
	P1,P5,P7,P21	K	0° OR 90°
	P2,P4,P6,P14,P17,P20	E	0°
	P15	G	±45°

PLY TABLE **B**

DETAIL IV

**Wing Fixed Trailing Edge Skin Identification - Upper Surface
Figure 1 (Sheet 6 of 17)**

**757-200
STRUCTURAL REPAIR MANUAL**

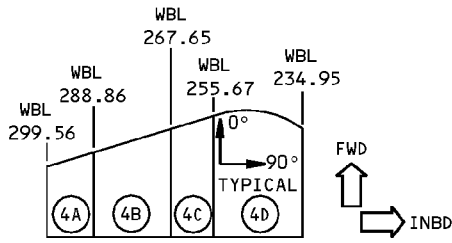

VIEW ON PANEL **C U**

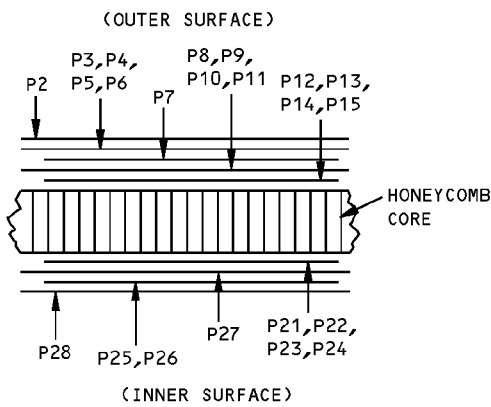

SECTION THRU PANEL - ITEM **4 U**

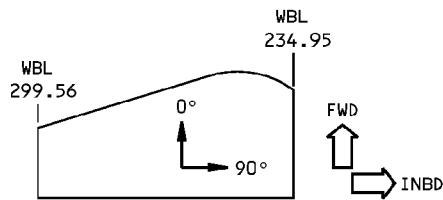

VIEW ON PANEL **C T**

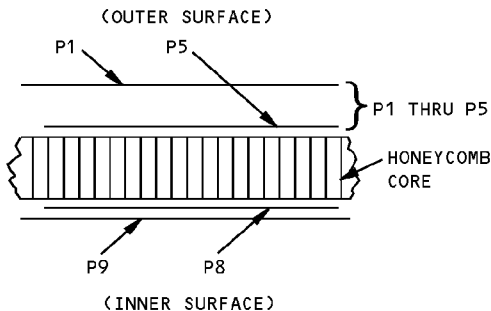

SECTION THRU PANEL - ITEM **4 T**

DETAIL V

**Wing Fixed Trailing Edge Skin Identification - Upper Surface
Figure 1 (Sheet 7 of 17)**

ITEM NO.	PLY NO.	MATERIAL	PLY ORIENTATION A
4 A	P2, P7, P27, P28	D	0° OR 90°
	P6, P11, P15, P24	E	0°
4 B	P2, P7, P27, P28	D	0° OR 90°
	P5, P10, P14, P23	E	0°
4 C	P2, P7, P27, P28	D	0° OR 90°
	P4, P9, P13, P22, P26	E	0°
4 D	P2, P7, P27, P28	D	0° OR 90°
	P3, P8, P12, P21, P25	E	0°
4 T	P1, P3, P4, P5, P8, P10	K	0° OR 90°
	P2, P9	K	±45°

PLY TABLE **B**

**757-200
STRUCTURAL REPAIR MANUAL**

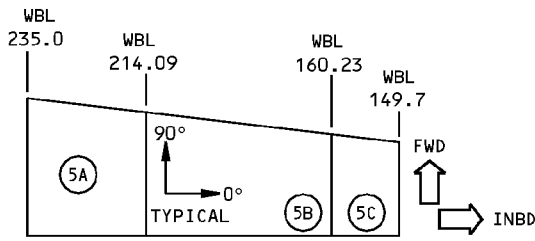

VIEW ON PANEL **C U**

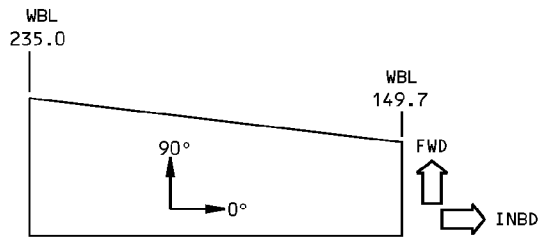

VIEW ON PANEL **C T**

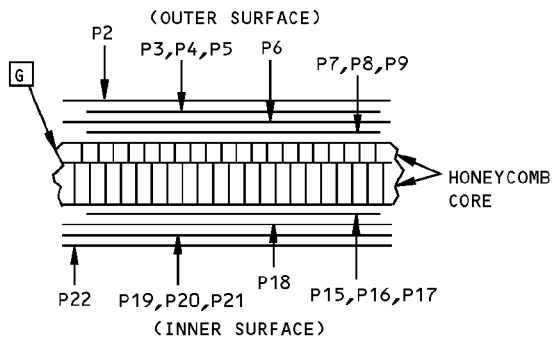

SECTION THRU PANEL - ITEM 5 **U**

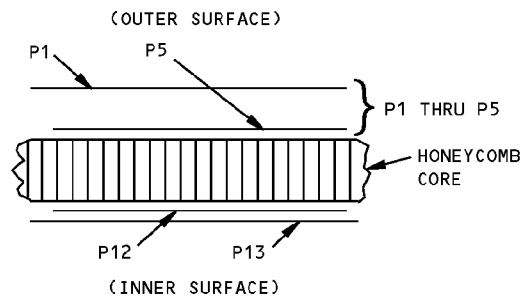

SECTION THRU PANEL - ITEM 5 **T**

ITEM NO.	PLY NO.	MATERIAL	PLY ORIENTATION A
5 U	5A	P2, P6, P18, P22	D 0° OR 90°
		P3, P7, P15, P19	F 0° OR 90°
	5B	P2, P6, P18, P22	D 0° OR 90°
		P4, P8, P16, P20	F 0° OR 90°
	5C	P2, P6, P18, P22	D 0° OR 90°
		P5, P9, P17, P21	F 0° OR 90°
5 T	P1, P3, P4, P5, P12	K 0° OR 90°	
	P2, P13	K ±45°	

PLY TABLE **B**

DETAIL VI

**Wing Fixed Trailing Edge Skin Identification - Upper Surface
Figure 1 (Sheet 8 of 17)**

**757-200
STRUCTURAL REPAIR MANUAL**

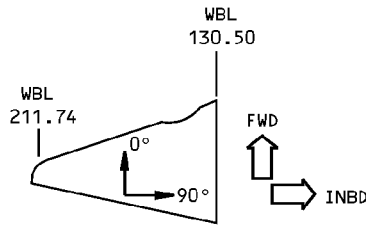

VIEW ON PANEL **C**

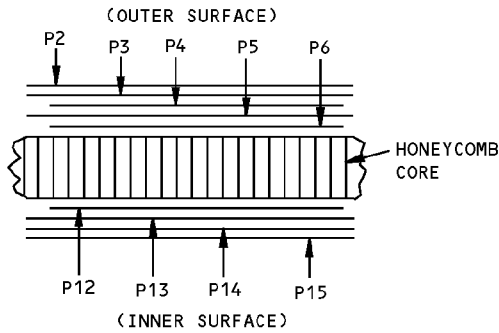

SECTION THRU PANEL - ITEM 6 **U**

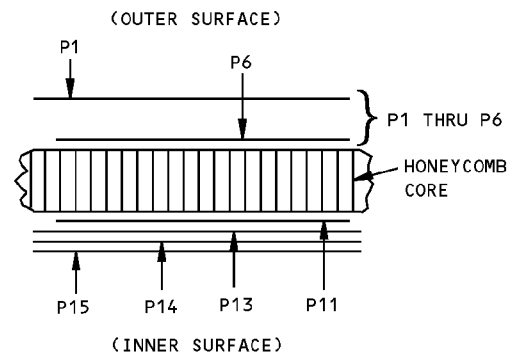

SECTION THRU PANEL - ITEM 6 **T**

ITEM NO.	PLY NO.	MATERIAL	PLY ORIENTATION A
6 U	P2,P4, P13,P15	D	0° OR 90°
	P3,P5,P6, P12,P14	E	0°
6 T	P1,P6,P11	K	0° OR 90°
	P2,P4,P5, P13,P14	E	0°
	P3,P15	K	±45°

PLY TABLE **B**

DETAIL VII

**Wing Fixed Trailing Edge Skin Identification - Upper Surface
Figure 1 (Sheet 9 of 17)**

**757-200
STRUCTURAL REPAIR MANUAL**

REF DWG
113N1640

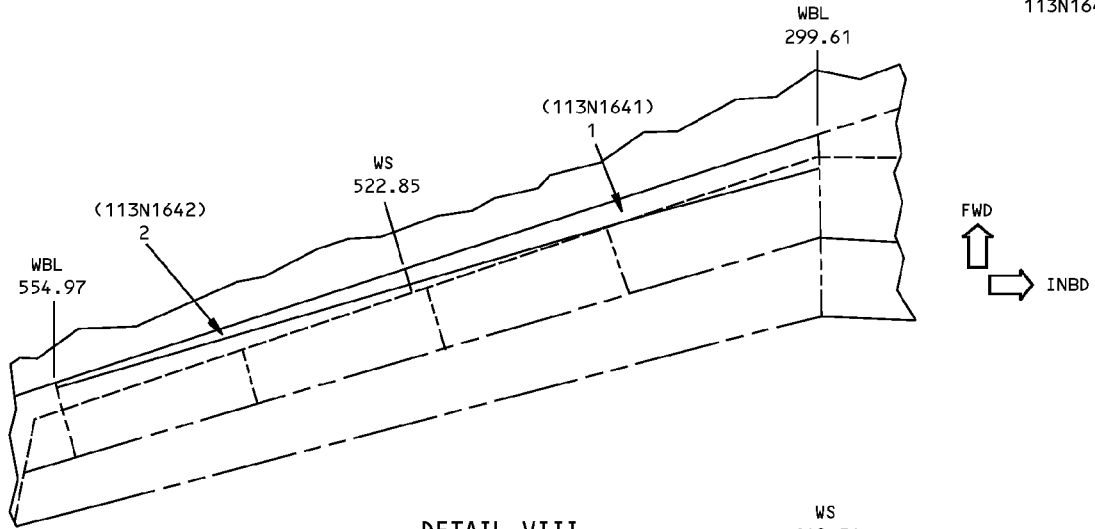

DETAIL VIII

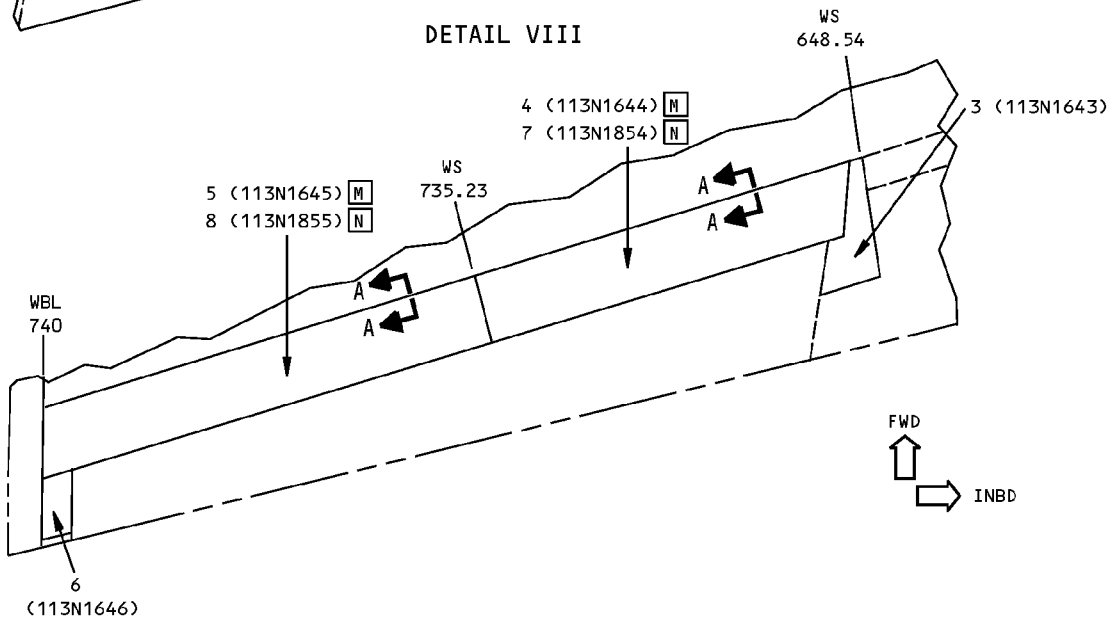

DETAIL IX

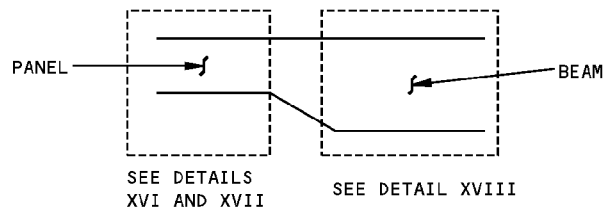

SECTION A-A N

LIST OF
MATL

**Wing Fixed Trailing Edge Skin Identification - Upper Surface
Figure 1 (Sheet 10 of 17)**

IDENTIFICATION 1
Page 10
Jan 20/2005

57-51-01

D634N201



**757-200
STRUCTURAL REPAIR MANUAL**

ITEM	DESCRIPTION	GAGE	MATERIAL	EFFECTIVITY
1	SKIN PANEL SKIN CORE		ARAMID/EPOXY HONEYCOMB SANDWICH OR FIBERGLASS/EPOXY HONEYCOMB SANDWICH SEE DETAIL X NOMEX HONEYCOMB PER BMS 8-124 CLASS IV, TYPE V, GRADE 3.0	
2	SKIN PANEL		SEE DETAIL XI	
3	SKIN PANEL SKIN CORE		ARAMID/EPOXY HONEYCOMB SANDWICH OR FIBERGLASS/EPOXY HONEYCOMB SANDWICH SEE DETAIL XII NOMEX HONEYCOMB PER BMS 8-124 CLASS IV, TYPE V, GRADE 3.0	
4	SKIN PANEL SKIN CORE		ARAMID/GRAPHITE/EPOXY HONEYCOMB SANDWICH SEE DETAIL XIII NOMEX HONEYCOMB PER BMS 8-124 CLASS IV, TYPE V, GRADE 3.0	M
5	SKIN PANEL SKIN CORE		ARAMID/GRAPHITE/EPOXY HONEYCOMB SANDWICH SEE DETAIL XIV NOMEX HONEYCOMB PER BMS 8-124 CLASS IV, TYPE V, GRADE 3.0	M
6	SKIN PANEL SKIN CORE		ARAMID/EPOXY HONEYCOMB SANDWICH OR FIBERGLASS/EPOXY HONEYCOMB SANDWICH SEE DETAIL XV NOMEX HONEYCOMB PER BMS 8-129 CLASS IV, TYPE V, GRADE 3.0	
7	SKIN PANEL/BEAM SKIN CORE		GLASS FIBER/GRAPHITE/EPOXY HONEYCOMB SANDWICH SEE DETAIL XVI NOMEX HONEYCOMB PER BMS 8-124 CLASS IV, TYPE V, GRADE 3.0	N
8	SKIN PANEL/BEAM SKIN CORE		GLASS FIBER/GRAPHITE/EPOXY HONEYCOMB SANDWICH SEE DETAIL XVII NOMEX HONEYCOMB PER BMS 8-124 CLASS IV, TYPE V, GRADE 3.0	N

LIST OF MATERIALS FOR DETAILS VIII AND IX

**Wing Fixed Trailing Edge Skin Identification - Upper Surface
Figure 1 (Sheet 11 of 17)**

IDENTIFICATION 1
Page 11
Jan 20/2005

57-51-01

D634N201

**757-200
STRUCTURAL REPAIR MANUAL**

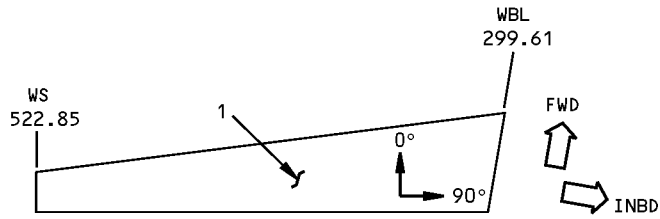

VIEW ON PANEL **C**

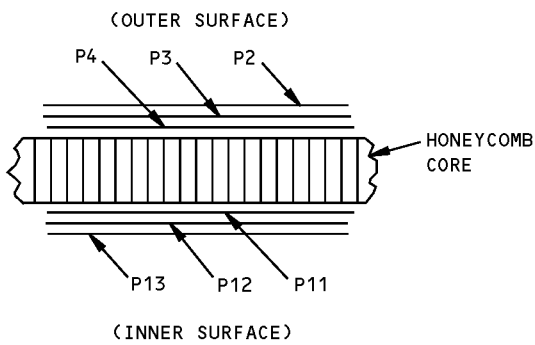

SECTION THRU PANEL - ITEM 1 **M**

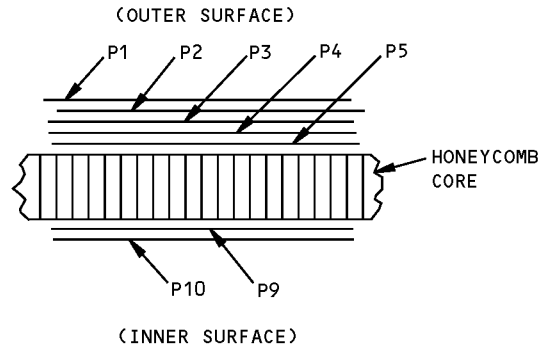

SECTION THRU PANEL - ITEM 1 **N**

ITEM NO.	PLY NO.	MATERIAL	PLY ORIENTATION A
1 M	P2, P3, P4, P11, P12, P13	H	0° OR 90°
1 N	P1, P3, P4, P5, P9	K	0° OR 90°
	P2, P10	K	±45°

PLY TABLE **B**

DETAIL X

**Wing Fixed Trailing Edge Skin Identification - Upper Surface
Figure 1 (Sheet 12 of 17)**

**757-200
STRUCTURAL REPAIR MANUAL**

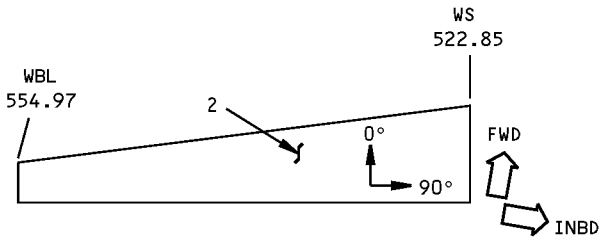

VIEW ON PANEL **C U**

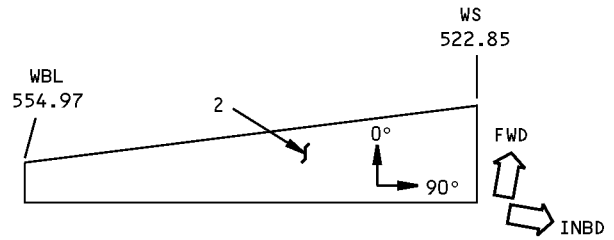

VIEW ON PANEL **C T**

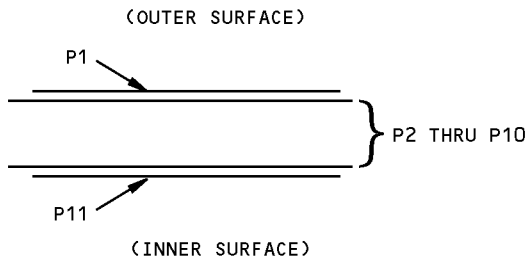

SECTION THRU PANEL - ITEM 2 **U**

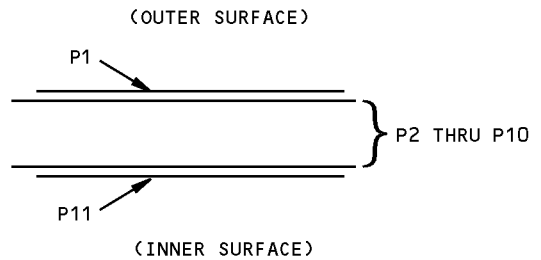

SECTION THRU PANEL - ITEM 2 **T**

ITEM NO.	PLY NO.	MATERIAL	PLY ORIENTATION A
2 U	P1,P11	G	0° OR 90°
	P2 THRU P10	J	OPTIONAL
2 T	P1,P11	G	0° OR 90°
	P2 THRU P9	K	OPTIONAL

PLY TABLE **B**

DETAIL XI

**Wing Fixed Trailing Edge Skin Identification - Upper Surface
Figure 1 (Sheet 13 of 17)**

IDENTIFICATION 1
Page 13
Jan 20/2005

57-51-01

D634N201

**757-200
STRUCTURAL REPAIR MANUAL**

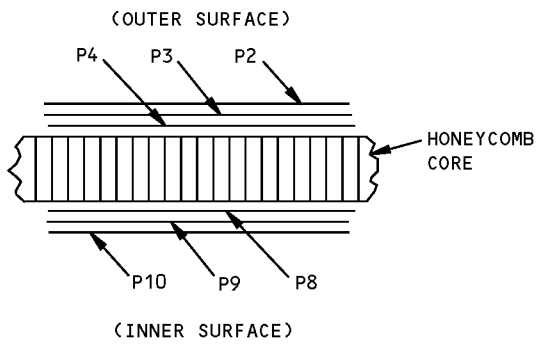
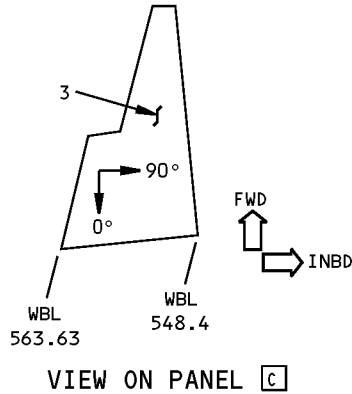

SECTION THRU PANEL - ITEM 3 **M**

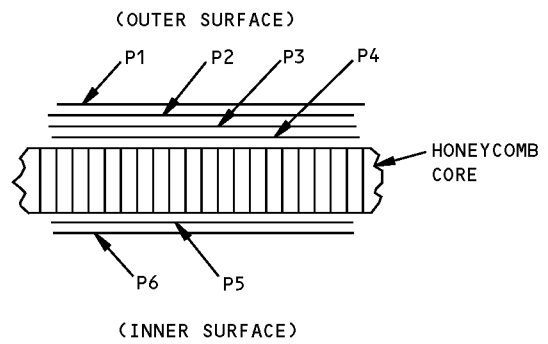

SECTION THRU PANEL - ITEM 3 **N**

ITEM NO.	PLY NO.	MATERIAL	PLY ORIENTATION A
3 M	P2, P3, P4, P8, P9, P10	D	0° OR 90°
3 N	P2 THRU P6	K	0° OR 90°
	P1	G	0° OR 90°

PLY TABLE **B**

DETAIL XII

**Wing Fixed Trailing Edge Skin Identification - Upper Surface
Figure 1 (Sheet 14 of 17)**

**757-200
STRUCTURAL REPAIR MANUAL**

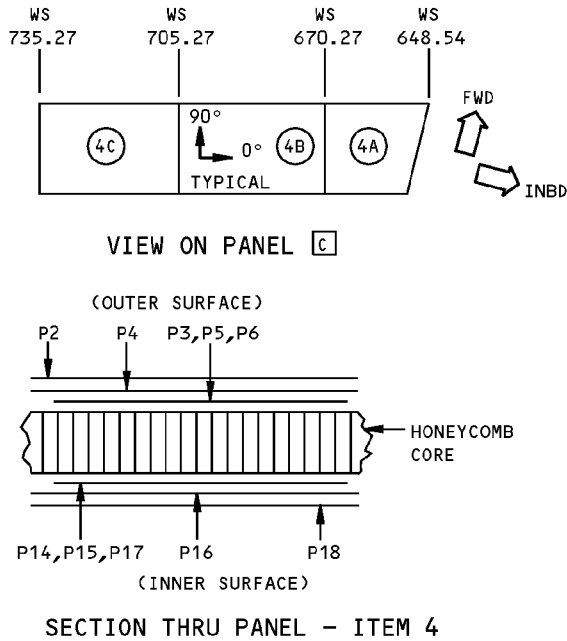

ITEM NO.	PLY NO.	MATERIAL	PLY ORIENTATION [A]	
4	4A	P2,P18	D	0° OR 90°
		P3,P15	I	90°
	4B	P2,P18	D	0° OR 90°
		P4,P16	E	90°
		P6,P14	I	90°
	4C	P2,P18	D	0° OR 90°
P5,P17		I	90°	

PLY TABLE B

DETAIL XIII

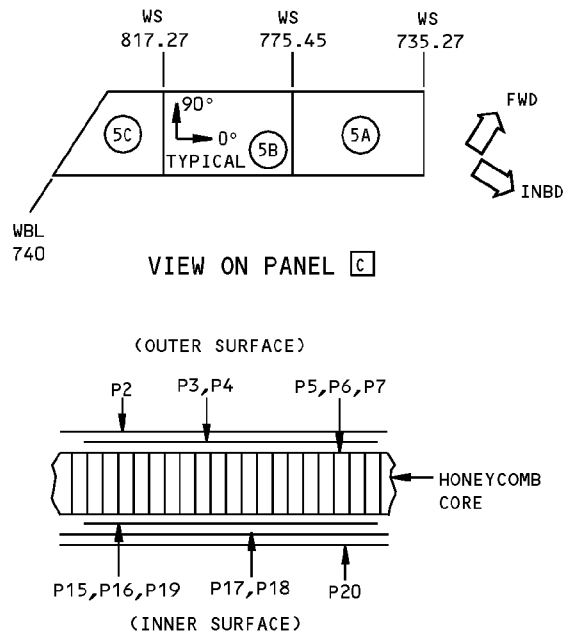

ITEM NO.	PLY NO.	MATERIAL	PLY ORIENTATION [A]	
5	5A	P2,P20	D	0° OR 90°
		P3,P17	I	90°
		P6,P15	E	90°
	5B	P2,P20	D	0° OR 90°
		P4,P18	I	90°
		P7,P16	E	90°
5C	P2,P20	D	0° OR 90°	
	P5,P19	I	90°	

PLY TABLE B

DETAIL XIV

**Wing Fixed Trailing Edge Skin Identification - Upper Surface
Figure 1 (Sheet 15 of 17)**

**757-200
STRUCTURAL REPAIR MANUAL**

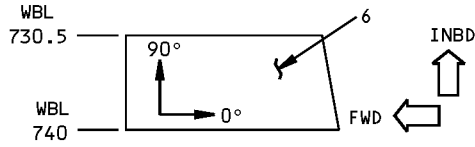

VIEW ON PANEL **C**

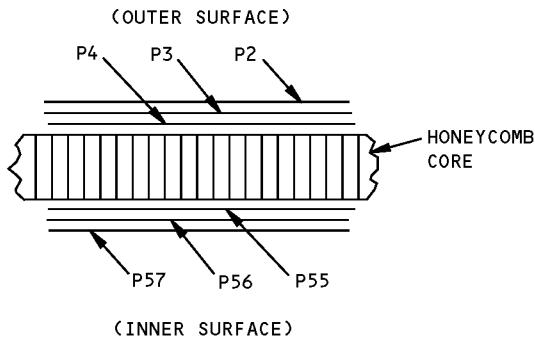

SECTION THRU PANEL - ITEM 6 **M**

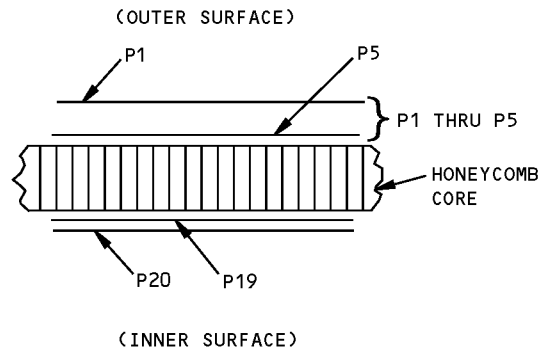

SECTION THRU PANEL - ITEM 6 **N**

ITEM NO.	PLY NO.	MATERIAL	PLY ORIENTATION A
6 M	P2, P3, P4, P55, P56, P57	H	0° OR 90°
6 N	P2	G	±45°
	P1, P3, P4, P5, P20	K	0° OR 90°
	P19	K	±45°

PLY TABLE **B**

DETAIL XV

**Wing Fixed Trailing Edge Skin Identification - Upper Surface
Figure 1 (Sheet 16 of 17)**

**757-200
STRUCTURAL REPAIR MANUAL**

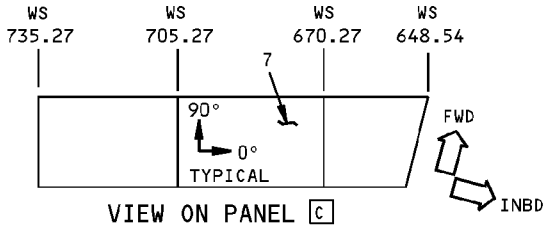

VIEW ON PANEL **C**

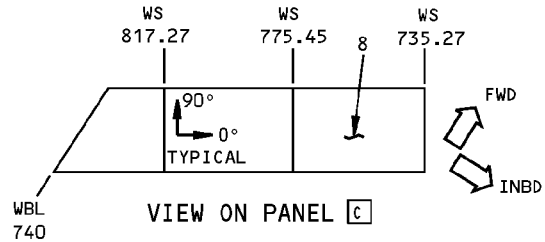

VIEW ON PANEL **C**

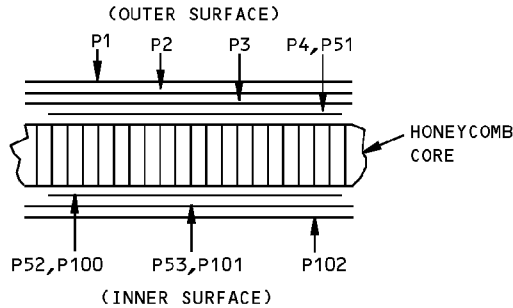

SECTION THRU PANEL - ITEM 7
DETAIL XVI

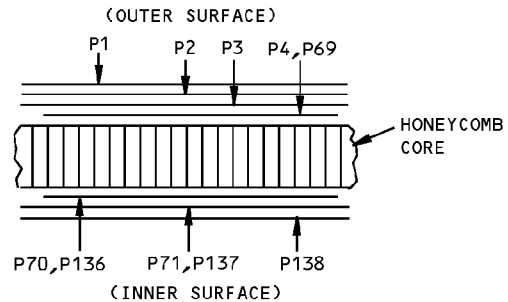

SECTION THRU PANEL - ITEM 8
DETAIL XVII

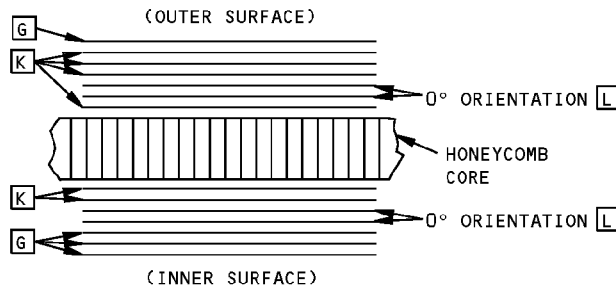

SECTION THRU BEAM
DETAIL XVIII

ITEM NO.	PLY NO.	MATERIAL	PLY ORIENTATION A
7	P1, P100, P102	G	0° OR 90°
	P101	G	±45°
	P3	K	±45°
	P2, P4 P51, P52, P53	K	0° OR 90°
8	P1, P136, P138	G	0° OR 90°
	P137	G	±45°
	P3	K	±45°
	P2, P4 P69, P70, P71	K	0° OR 90°

PLY TABLE FOR DETAILS XVI, XVII, AND XVIII **B**

**Wing Fixed Trailing Edge Skin Identification - Upper Surface
Figure 1 (Sheet 17 of 17)**

**757-200
STRUCTURAL REPAIR MANUAL**

IDENTIFICATION 2 - WING FIXED TRAILING EDGE SKIN - LOWER SURFACE

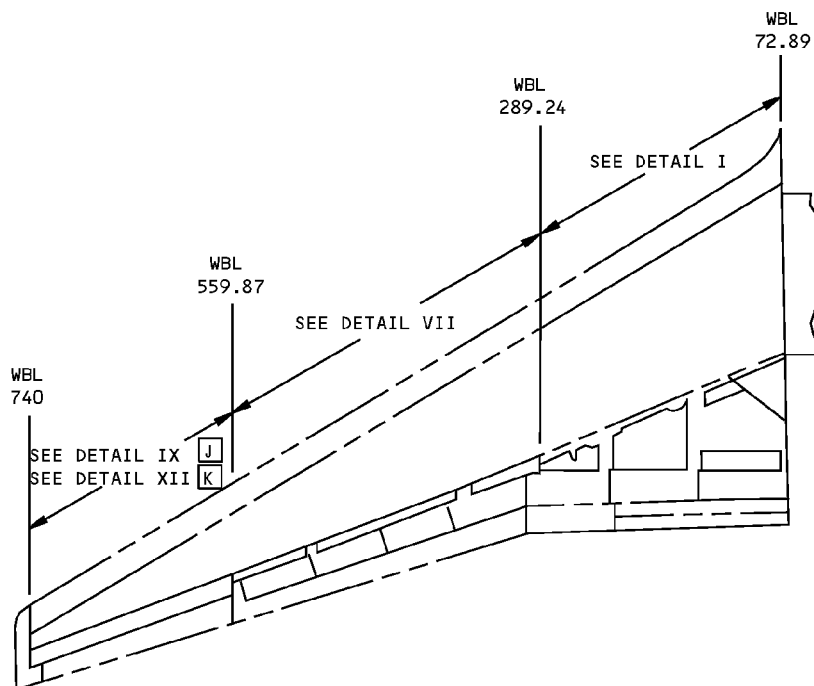

LOWER SURFACE SHOWN
SEE FIG. 1 FOR UPPER SURFACE

NOTES

- | | |
|--|--|
| <p>A PLY ORIENTATION CONVENTION, DEGREES INDICATED IS PARALLEL TO THE FABRIC WARP DIRECTION</p> <p>B MATERIAL AND PLY ORIENTATION SHOWN FOR FIELD AREAS ONLY. SEE BOEING DRAWINGS FOR EDGE BANDS AND AREAS WITH DOUBLERS</p> <p>C DIAGRAM OF PLY ORIENTATION, SEE PLY TABLE FOR PLY ORIENTATION</p> <p>D ARAMID/EPOXY FABRIC PER BMS 8-219, STYLE 285, (250°F (121°C) CURE)</p> <p>E GRAPHITE/EPOXY TAPE PER BMS 8-168, TYPE II, CLASS 1, GRADE 145, (250°F (121°C) CURE)</p> <p>F GRAPHITE/EPOXY FABRIC PER BMS 8-168, TYPE II, CLASS 2, GRADE 3K-70-PW, (250°F (121°C) CURE)</p> | <p>G ARAMID/EPOXY FABRIC PER BMS 8-219, STYLE 120, (250°F (121°C) CURE)</p> <p>H GRAPHITE/EPOXY TAPE PER BMS 8-168, TYPE II, CLASS 1, GRADE 95, (250°F (121°C) CURE)</p> <p>I LIMITED FIELD AREA, SEE BOEING DRAWINGS</p> <p>J FOR CUM LINE NUMBERS: 1 THRU 10</p> <p>K FOR CUM LINE NUMBERS: 11 AND ON</p> |
|--|--|

**Wing Fixed Trailing Edge Skin Identification - Lower Surface
Figure 1 (Sheet 1 of 14)**

**757-200
STRUCTURAL REPAIR MANUAL**

REF DWG
113N1620

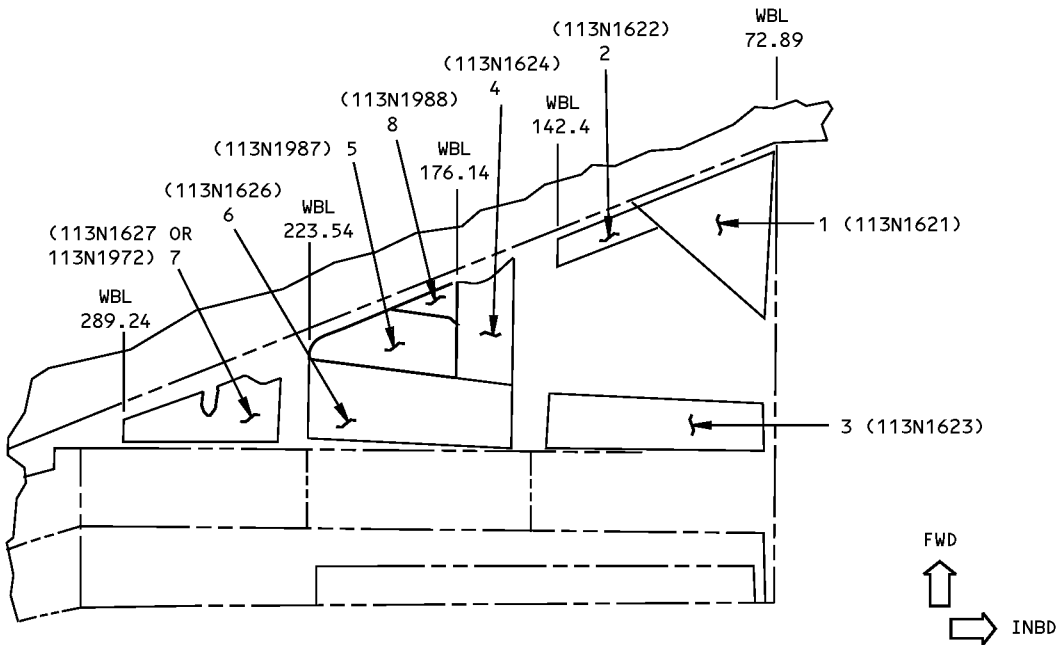

DETAIL I

**Wing Fixed Trailing Edge Skin Identification - Lower Surface
Figure 1 (Sheet 2 of 14)**

IDENTIFICATION 2
Page 2
Jan 20/2005

57-51-01

D634N201



757-200
STRUCTURAL REPAIR MANUAL

ITEM	DESCRIPTION	GAGE	MATERIAL	EFFECTIVITY
1	SKIN PANEL SKIN CORE		ARAMID/GRAPHITE/EPOXY HONEYCOMB SANDWICH SEE DETAIL II NOMEX HONEYCOMB PER BMS 8-124 CLASS IV, TYPE V, GRADE 3.0	
2	SKIN PANEL SKIN CORE		ARAMID/GRAPHITE/EPOXY HONEYCOMB SANDWICH SEE DETAIL II NOMEX HONEYCOMB PER BMS 8-124 CLASS IV, TYPE V, GRADE 3.0	
3	SKIN PANEL SKIN CORE		ARAMID/GRAPHITE/EPOXY HONEYCOMB SANDWICH SEE DETAIL III NOMEX HONEYCOMB PER BMS 8-124 CLASS IV, TYPE V, GRADE 3.0	
4	SKIN PANEL SKIN CORE		ARAMID/GRAPHITE/EPOXY HONEYCOMB SANDWICH SEE DETAIL IV NOMEX HONEYCOMB PER BMS 8-124 CLASS IV, TYPE V, GRADE 3.0	
5	SKIN PANEL SKIN CORE		ARAMID/GRAPHITE/EPOXY HONEYCOMB SANDWICH SEE DETAIL II NOMEX HONEYCOMB PER BMS 8-124 CLASS IV, TYPE V, GRADE 3.0	
6	SKIN PANEL SKIN CORE		ARAMID/GRAPHITE/EPOXY HONEYCOMB SANDWICH SEE DETAIL V NOMEX HONEYCOMB PER BMS 8-124 CLASS IV, TYPE V, GRADE 3.0	
7	SKIN PANEL SKIN CORE		ARAMID/GRAPHITE/EPOXY HONEYCOMB SANDWICH SEE DETAIL VI NOMEX HONEYCOMB PER BMS 8-124 CLASS IV, TYPE V, GRADE 3.0	
8	PANEL	0.10	7075-T651 CHEM-MILLED	

LIST OF MATERIALS FOR DETAIL I

Wing Fixed Trailing Edge Skin Identification - Lower Surface
Figure 1 (Sheet 3 of 14)

D634N201

57-51-01

IDENTIFICATION 2
Page 3
Jan 20/2005

**757-200
STRUCTURAL REPAIR MANUAL**

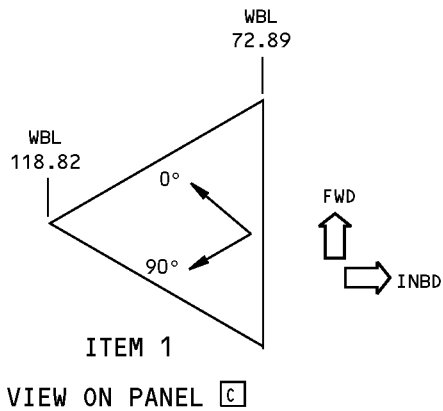
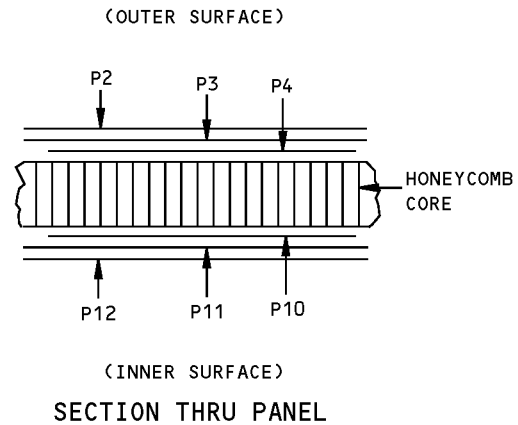
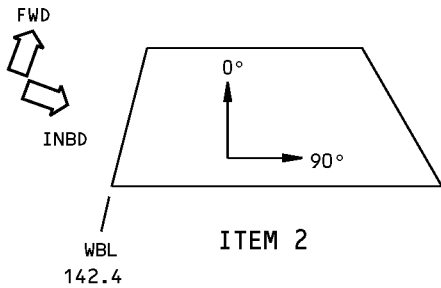
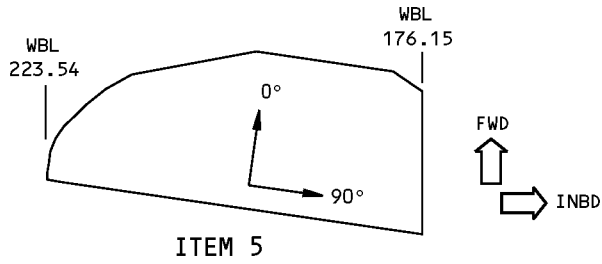

ITEM NO.	PLY NO.	MATERIAL	PLY ORIENTATION A
1, 2, 5	P2, P3 P11, P12	D	0° OR 90°
	P4, P10	E	0°

PLY TABLE **B**

DETAIL II

**Wing Fixed Trailing Edge Skin Identification - Lower Surface
Figure 1 (Sheet 4 of 14)**

**757-200
STRUCTURAL REPAIR MANUAL**

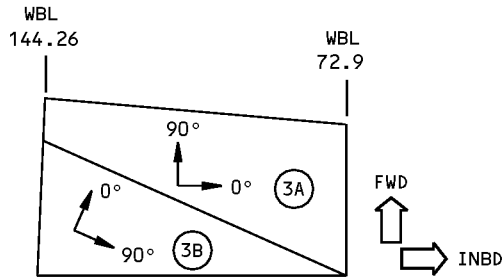

VIEW ON PANEL **C**

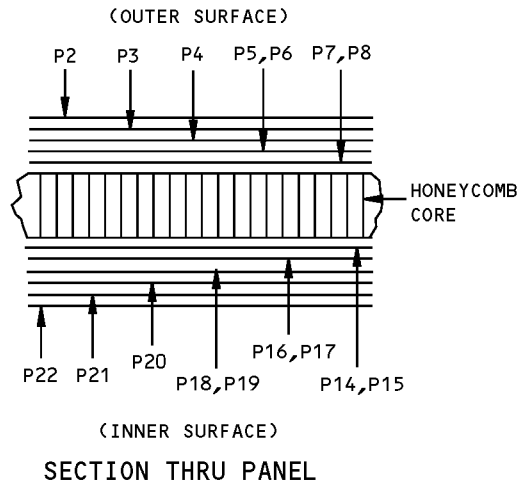

ITEM NO.	PLY NO.	MATERIAL	PLY ORIENTATION A
3	3A	P2,P3 P21,P22	D 0° OR 90°
		P4,P20	E 0°
		P6,P8,P15, P17,P19	E 90°
	3B	P2,P3 P21,P22	D 0° OR 90°
		P4,P20	E 0°
		P5,P7,P14, P16,P18	E 90°

PLY TABLE **B**

DETAIL III

**Wing Fixed Trailing Edge Skin Identification - Lower Surface
Figure 1 (Sheet 5 of 14)**

**757-200
STRUCTURAL REPAIR MANUAL**

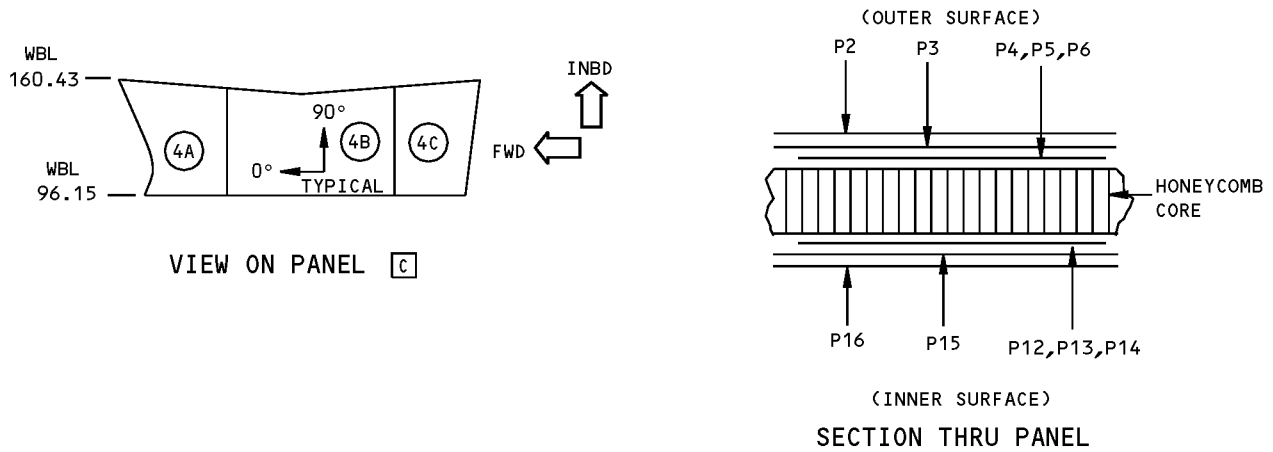

ITEM NO.	PLY NO.	MATERIAL	PLY ORIENTATION A
4	(4A)	P2, P3 P15, P16	G 0° OR 90°
		P6, P14	E 0°
	(4B)	P2, P3, P15, P16	G 0° OR 90°
		P5, P13	E 0°
	(4C)	P2, P3 P15, P16	G 0° OR 90°
		P4, P12	E 0°

PLY TABLE B

DETAIL IV

**Wing Fixed Trailing Edge Skin Identification - Lower Surface
Figure 1 (Sheet 6 of 14)**

**757-200
STRUCTURAL REPAIR MANUAL**

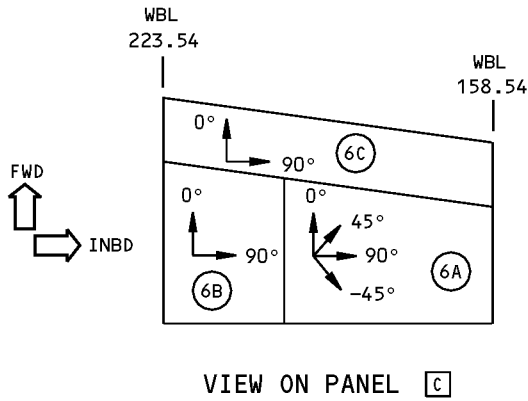

VIEW ON PANEL **C**

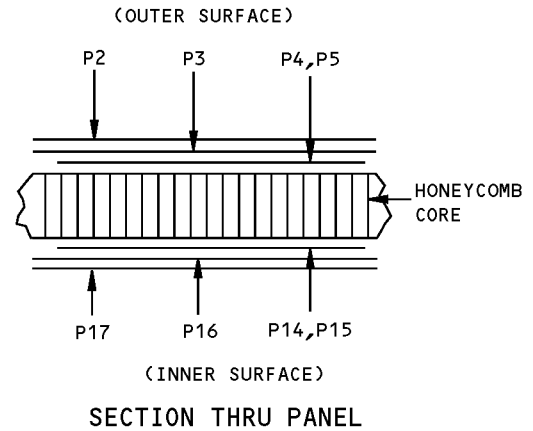

SECTION THRU PANEL

ITEM NO.	PLY NO.	MATERIAL	PLY ORIENTATION A
6	6A	P2,P3 P16,P17	D 0° OR 90°
		P4,P15	F ±45°
	6B	P2,P3, P16,P17	D 0° OR 90°
	6C	P2,P3 P16,P17	D 0° OR 90°
P5,P14		E 0°	

PLY TABLE **B**

DETAIL V

**Wing Fixed Trailing Edge Skin Identification - Lower Surface
Figure 1 (Sheet 7 of 14)**

**757-200
STRUCTURAL REPAIR MANUAL**

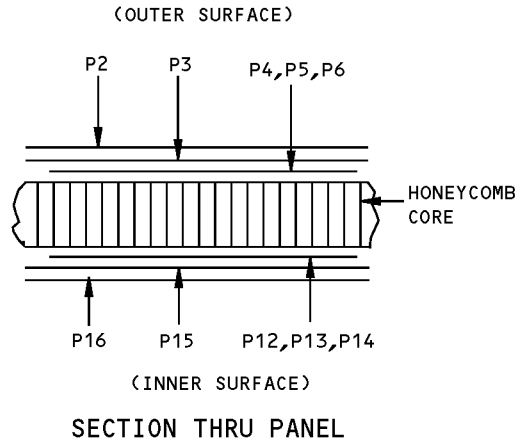
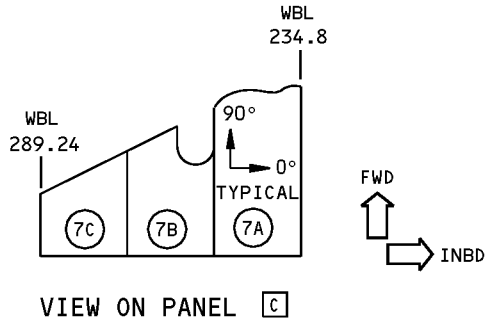

ITEM NO.	PLY NO.	MATERIAL	PLY ORIENTATION
7	7A	P2,P3 P15,P16	D
		P6,P14	E
	7B	P2,P3 P15,P16	D
		P5,P13	E
	7C	P2,P3 P15,P16	D
		P4,P12	E

PLY TABLE B

DETAIL VI

**Wing Fixed Trailing Edge Skin Identification - Lower Surface
Figure 1 (Sheet 8 of 14)**

**757-200
STRUCTURAL REPAIR MANUAL**

REF DWG
113N1650

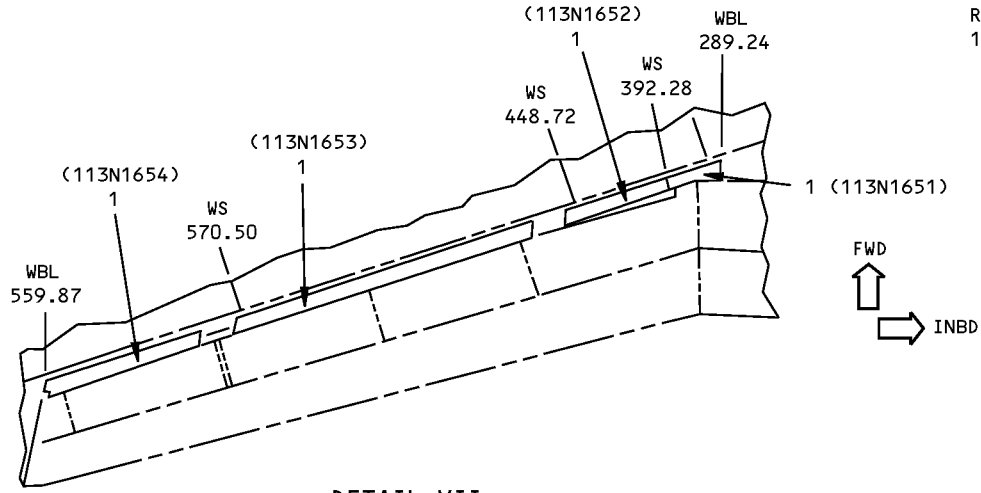

DETAIL VII

ITEM	DESCRIPTION	GAGE	MATERIAL	EFFECTIVITY
1	SKIN PANEL SKIN CORE		ARAMID/EPOXY HONEYCOMB SANDWICH SEE DETAIL VIII NOMEX HONEYCOMB PER BMS 8-124 CLASS IV, TYPE V, GRADE 3.0	

LIST OF MATERIALS FOR DETAIL VII

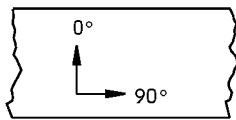

VIEW ON PANEL [C]

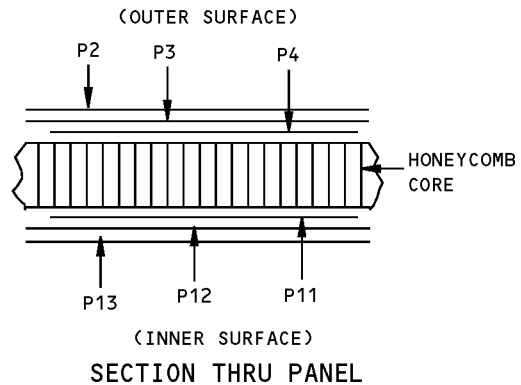

ITEM NO.	PLY NO.	MATERIAL	PLY ORIENTATION [A]
1	P2,P3,P4 P11,P12,P13	[G]	0° OR 90°

PLY TABLE [B]

DETAIL VIII

**Wing Fixed Trailing Edge Skin Identification - Lower Surface
Figure 1 (Sheet 9 of 14)**

IDENTIFICATION 2
Page 9
Jan 20/2005

57-51-01

D634N201

**757-200
STRUCTURAL REPAIR MANUAL**

REF DWG
113N1650

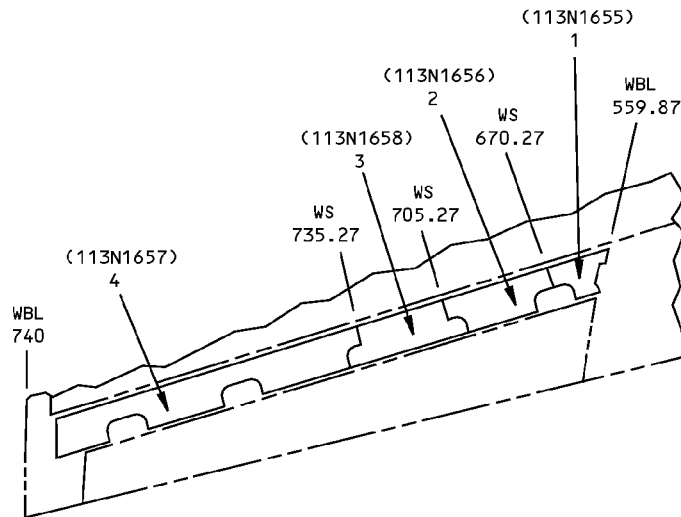

DETAIL IX J

ITEM	DESCRIPTION	GAGE	MATERIAL	EFFECTIVITY
1	SKIN PANEL SKIN CORE		ARAMID/GRAPHITE/EPOXY HONEYCOMB SANDWICH SEE DETAIL X NOMEX HONEYCOMB PER BMS 8-124 CLASS IV, TYPE V, GRADE 3.0	
2	SKIN PANEL SKIN CORE		ARAMID/GRAPHITE/EPOXY HONEYCOMB SANDWICH SEE DETAIL X NOMEX HONEYCOMB PER BMS 8-124 CLASS IV, TYPE V, GRADE 3.0	
3	SKIN PANEL SKIN I FWD CORE CENTER CORE AFT CORE		ARAMID/GRAPHITE/EPOXY HONEYCOMB SANDWICH ARAMID/GRAPHITE HYBRID SKIN NOMEX HONEYCOMB PER BMS 8-124 CLASS IV, TYPE V, GRADE 3.0 FIBERGLASS HONEYCOMB PER BMS 8-124 CLASS I, TYPE I, GRADE 12.0 NOMEX HONEYCOMB PER BMS 8-124 CLASS IV, TYPE V, GRADE 4.0	
4	SKIN PANEL SKIN CORE		ARAMID/GRAPHITE/EPOXY HONEYCOMB SANDWICH SEE DETAIL XI NOMEX HONEYCOMB PER BMS 8-124 CLASS IV, TYPE V, GRADE 3.0	

LIST OF MATERIALS FOR DETAIL IX

**Wing Fixed Trailing Edge Skin Identification - Lower Surface
Figure 1 (Sheet 10 of 14)**

IDENTIFICATION 2
Page 10
Jan 20/2005

57-51-01

D634N201

**757-200
STRUCTURAL REPAIR MANUAL**

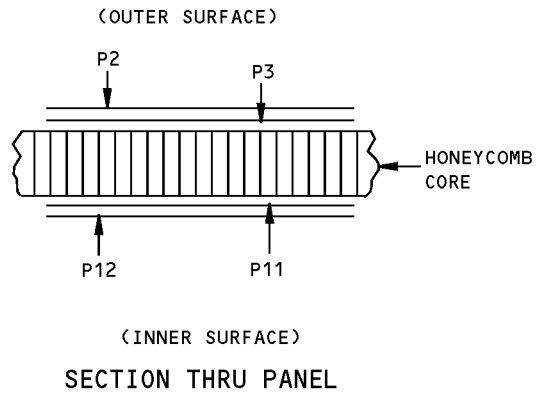
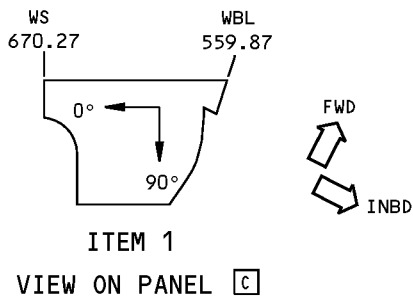
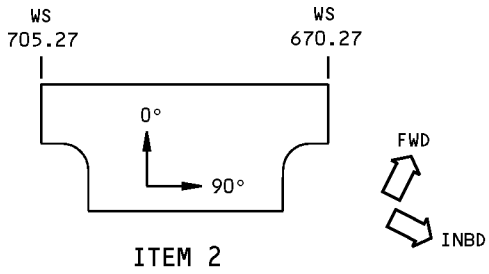

ITEM NO.	PLY NO.	MATERIAL	PLY ORIENTATION A
1	P2,P12	G	0° OR 90°
	P3,P11	H	90°
2	P2,P12	D	0° OR 90°
	P3,P11	H	0°

PLY TABLE **B**

DETAIL X

**Wing Fixed Trailing Edge Skin Identification - Lower Surface
Figure 1 (Sheet 11 of 14)**

**757-200
STRUCTURAL REPAIR MANUAL**

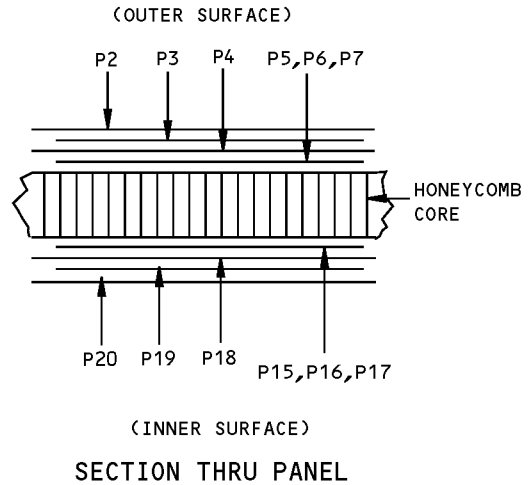
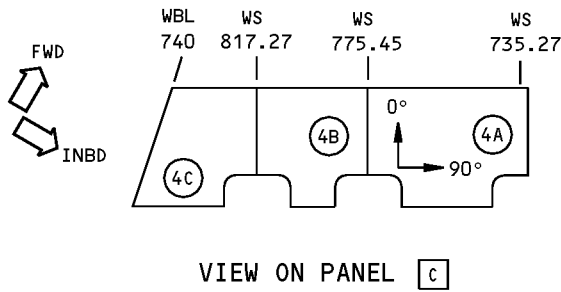

ITEM NO.	PLY NO.	MATERIAL	PLY ORIENTATION A
4	4A	P2,P3,P4, P18,P19,P20	G 0° OR 90°
		P7,P17	H 0°
	4B	P2,P3,P4, P18,P19,P20	G 0° OR 90°
		P6,P16	H 0°
	4C	P2,P3,P4, P18,P19,P20	G 0° OR 90°
		P5,P15	H 0°

PLY TABLE **B**

DETAIL XI

**Wing Fixed Trailing Edge Skin Identification - Lower Surface
Figure 1 (Sheet 12 of 14)**

**757-200
STRUCTURAL REPAIR MANUAL**

REF DWG
113N1650

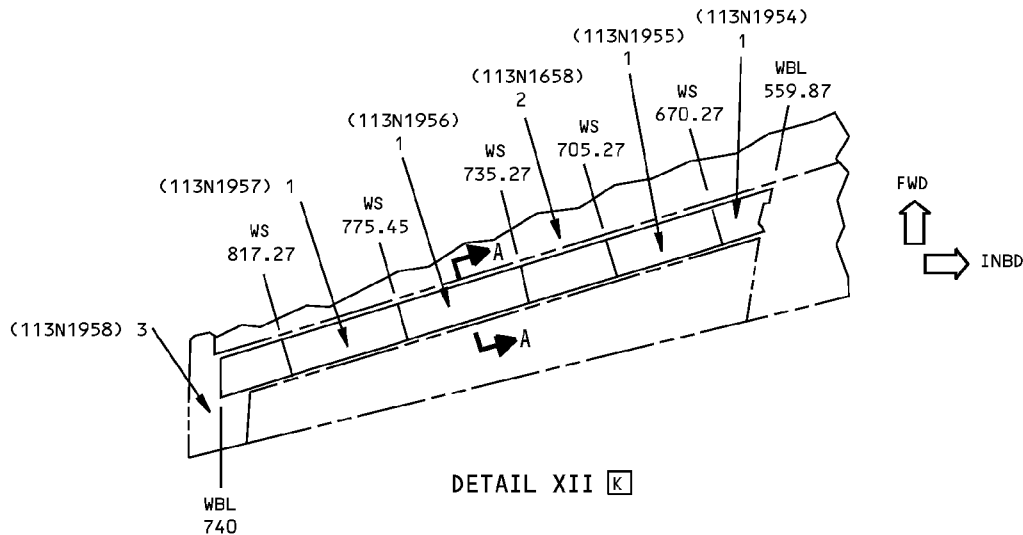

DETAIL XII **K**

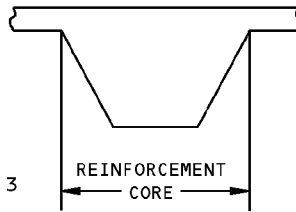

NOTE:
TYPICAL FOR
PANELS 1 AND 3

SECTION A-A

ITEM	DESCRIPTION	GAGE	MATERIAL	EFFECTIVITY
1	SKIN PANEL SKIN CORE REINFORCEMENT CORE		ARAMID/GRAPHITE/EPOXY HONEYCOMB SANDWICH SEE DETAIL XIII NOMEX HONEYCOMB PER BMS 8-124 CLASS IV, TYPE V, GRADE 3.0 NOMEX HONEYCOMB PER BMS 8-124 CLASS IV, TYPE V, GRADE 8.0	
2	SKIN PANEL SKIN I FWD CORE CENTER CORE AFT CORE		ARAMID/GRAPHITE/EPOXY HONEYCOMB SANDWICH ARAMID/GRAPHITE HYBRID SKIN NOMEX HONEYCOMB PER BMS 8-124 CLASS IV, TYPE V, GRADE 3.0 FIBERGLASS HONEYCOMB PER BMS 8-124 CLASS I, TYPE I, GRADE 12.0 NOMEX HONEYCOMB PER BMS 8-124 CLASS IV, TYPE V, GRADE 4.0	
3	SKIN PANEL SKIN CORE REINFORCEMENT CORE		ARAMID/GRAPHITE/EPOXY HONEYCOMB SANDWICH SEE DETAIL XIII NOMEX HONEYCOMB PER BMS 8-124 CLASS IV, TYPE V, GRADE 3.0 NOMEX HONEYCOMB PER BMS 8-124 CLASS IV, TYPE V, GRADE 8.0	

LIST OF MATERIALS FOR DETAIL XII

**Wing Fixed Trailing Edge Skin Identification - Lower Surface
Figure 1 (Sheet 13 of 14)**

IDENTIFICATION 2
Page 13
Jan 20/2005

57-51-01

D634N201

**757-200
STRUCTURAL REPAIR MANUAL**

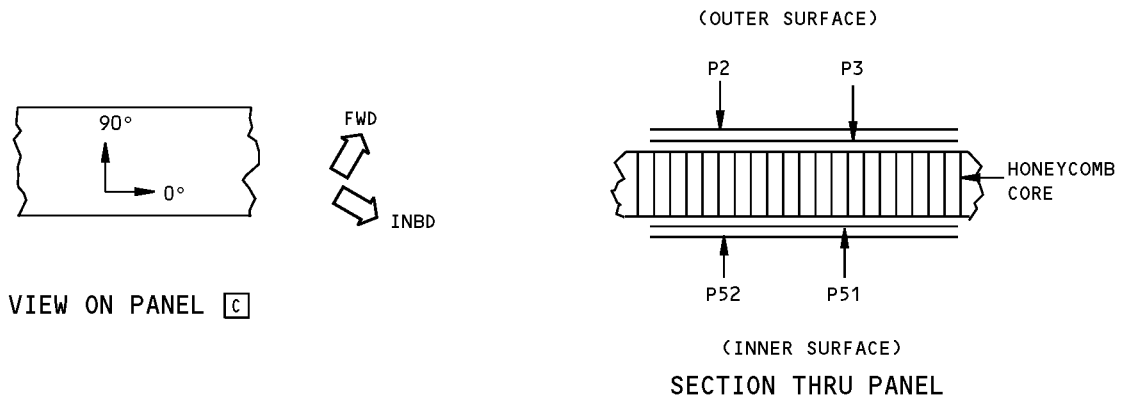

ITEM NO.	PLY NO.	MATERIAL	PLY ORIENTATION A
1	P2,P52	D	0° OR 90°
	P3,P51	H	90°
3	P2,P52	D	0° OR 90°
	P3,P51	H	0°

PLY TABLE **B**

DETAIL XIII

**Wing Fixed Trailing Edge Skin Identification - Lower Surface
Figure 1 (Sheet 14 of 14)**

**757-200
STRUCTURAL REPAIR MANUAL**

ALLOWABLE DAMAGE 1 - WING FIXED TRAILING EDGE SKIN

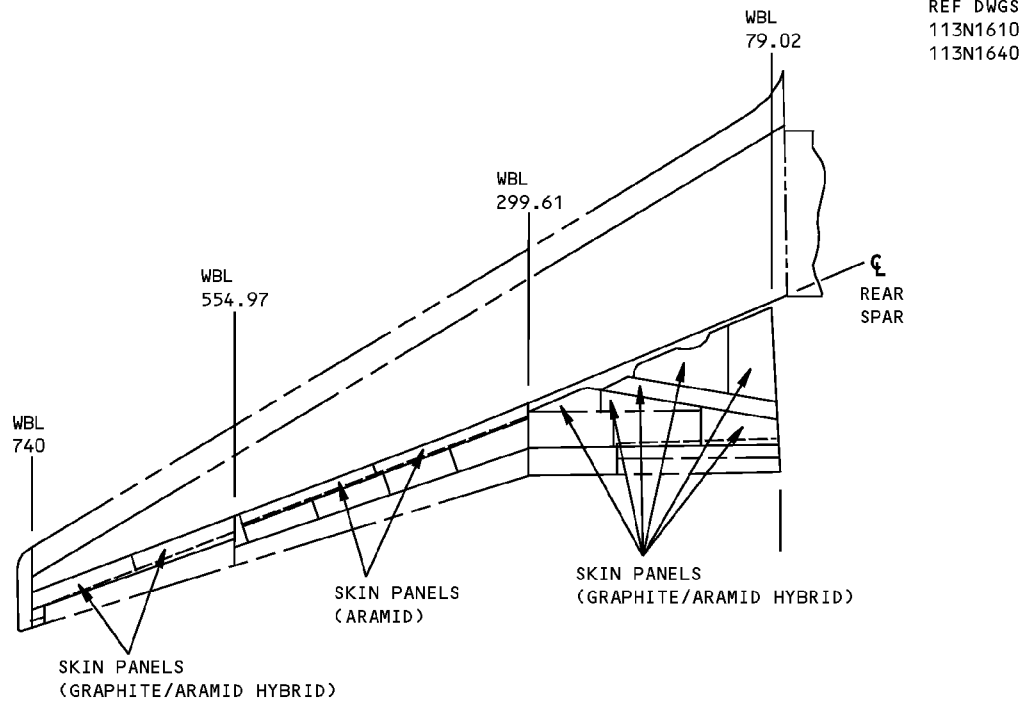

REF DWGS
113N1610
113N1640

UPPER SURFACE

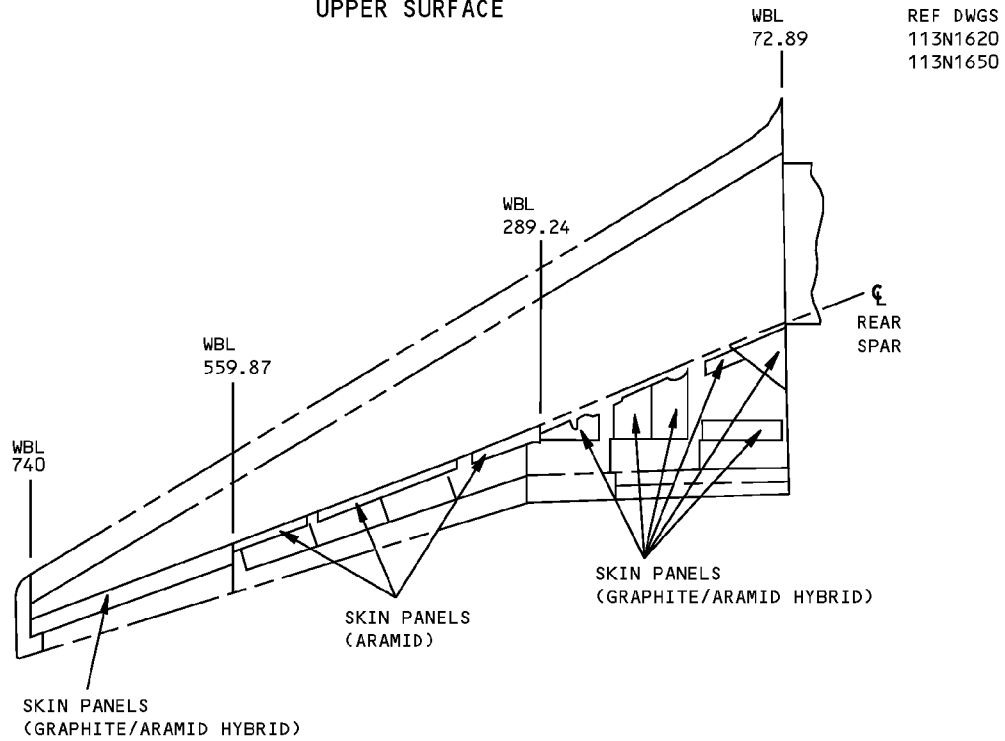

REF DWGS
113N1620
113N1650

LOWER SURFACE

**Wing Fixed Trailing Edge Skin Allowable Damage
Figure 101 (Sheet 1 of 4)**



**757-200
STRUCTURAL REPAIR MANUAL**

DESCRIPTION	CRACKS	NICKS, GOUGES AND CORROSION	DENTS	HOLES AND PUNCTURES	PANEL DELAMINATION
SKIN PANEL	A	B	C	A	A

TABLE I

NOTES

- REFINISH REWORKED AREAS PER 51-20 OF THE MAINTENANCE MANUAL
 - REFER TO 51-10-02 FOR INSPECTION AND REMOVAL OF DAMAGE
 - REFER TO 51-10-01 FOR AERODYNAMIC SMOOTHNESS REQUIREMENTS. WHERE DAMAGE EXCEEDS THE LIMITS SHOWN IN 51-10-01, CONSIDERATION SHOULD BE GIVEN TO LOSS OF PERFORMANCE INVOLVED
- A** DAMAGE TO SKIN PANEL EDGES MAY BE A COMBINATION OF EDGE DELAMINATION AND/OR CRACKS, GOUGES, ETC. WHICH CAN RESULT IN FIBER DAMAGE AND A LOSS OF CROSS-SECTIONAL AREA. REMOVE EDGE DAMAGE PER DETAILS I AND II. 2.0 INCH (50 mm) MAX DIMENSION ALLOWED FOR SINGLE DAMAGE SITE IN HONEYCOMB AREA. MULTIPLE DAMAGE SITES MUST NOT BE CLOSER THAN A MINIMUM OF $a/D = 3.0$. 2.0 INCH (50 mm) MAX DIMENSION (D) IN HONEYCOMB AREA IS ALLOWED PER SQUARE FOOT OF AREA AND A MINIMUM OF 3D (EDGE TO EDGE) FROM ANY OTHER DAMAGE, FASTENER HOLE, OR PANEL EDGE. SEE DETAIL IV FOR DAMAGE CRITERIA. DAMAGE ALLOWED TO ONE SURFACE AND HONEYCOMB CORE ONLY. PROTECT DAMAGE NOT REWORKED PER **D**
- B** DAMAGE ALLOWED ON SURFACE RESIN ONLY WITH NO FIBER DAMAGE. CLEAN UP EDGE DAMAGE PER DETAILS I AND II. FIBER DAMAGE MUST BE TREATED AS A HOLE OR PUNCTURE DAMAGE
- C** DENTS RESULT IN DELAMINATION AND FIBER DAMAGE AND MUST BE TREATED AS A HOLE OR PUNCTURE DAMAGE
- D** REMOVE MOISTURE FROM DAMAGE AREA. USE OF VACUUM AND HEAT (MAX OF 125°F (52°C)) TO REMOVE MOISTURE FROM HONEYCOMB CELLS IS RECOMMENDED. PROTECT DAMAGE FROM ENTRANCE OF WATER, SUNLIGHT OR OTHER FOREIGN MATTER BY SEALING WITH ALUMINUM FOIL TAPE (SPEED TAPE). RECORD THE LOCATION AND INSPECT EVERY AIRPLANE "A" CHECK. REPLACE THE ALUMINUM FOIL TAPE IF ANY PEELING OR DETERIORATION IS EVIDENT. REPAIR NO LATER THAN NEXT AIRPLANE "C" CHECK **E**
- E** THIS ALLOWABLE DAMAGE HAS FAA APPROVAL CONTINGENT ON ACCOMPLISHMENT OF THE INSPECTIONS CONTAINED HEREIN

**Wing Fixed Trailing Edge Skin Allowable Damage
Figure 101 (Sheet 2 of 4)**

**757-200
STRUCTURAL REPAIR MANUAL**

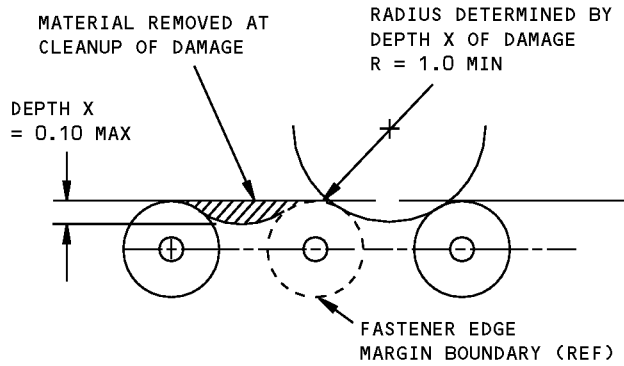

**DAMAGE CLEANUP OF EDGES WHERE
FASTENER EDGE MARGINS DO NOT OVERLAP**

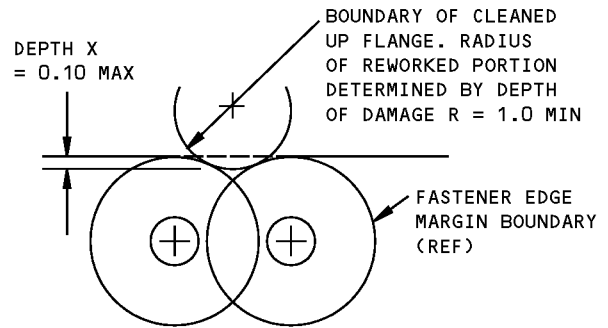

**DAMAGE CLEANUP OF EDGES WHERE
FASTENER EDGE MARGINS OVERLAP**

DETAIL I

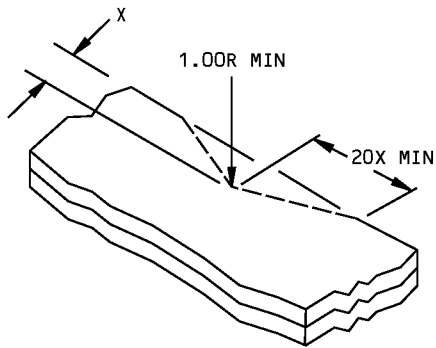

X = DEPTH OF CLEANUP = 0.10 MAX

DETAIL II

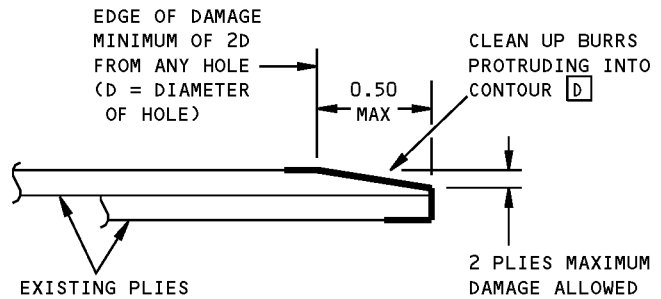

**DAMAGE CLEANUP AND SEALING
OF EDGE EROSION**

DETAIL III

**Wing Fixed Trailing Edge Skin Allowable Damage
Figure 101 (Sheet 3 of 4)**

**757-200
STRUCTURAL REPAIR MANUAL**

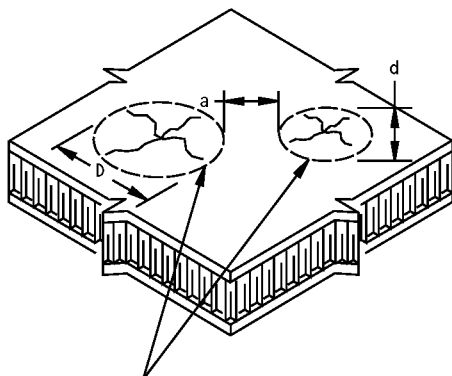

ADJACENT DAMAGE SITES ON SURFACE OF COMPOSITE PANEL

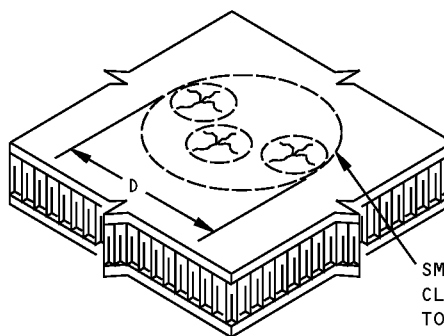

SMALL DAMAGE SITES THAT ARE CLOSELY SPACED MAY BE GROUPED TOGETHER AND CONSIDERED AS ONE DAMAGE SITE

- DAMAGE TO COMPOSITE PANELS EXPOSED TO MULTIPLE IMPACTS, I.E., HAIL DAMAGE, CAN BE DETECTED BY USING INSTRUMENTED NON-DESTRUCTIVE INSPECTION METHODS OR BY TAPPING THE SUSPECTED DAMAGE AREA WITH A SMALL METALLIC DISK OBJECT. INSPECTION SHOULD COVER THE AREA WITHIN 3 DIAMETERS AROUND THE EDGE OF THE VISIBLE DAMAGE SITE. FOR TAP TEST, USE A SOLID METAL DISK AND TAP THE DAMAGE AREA LIGHTLY BUT FIRMLY. VOID AREAS SHOULD PRODUCE A DULL SOUND AS OPPOSED TO A SHARP RING ON A SOLID BONDED AREA
- DAMAGE SITE IS ANY SINGLE AREA OF A PANEL WHERE A DENT, CRACK, DELAMINATION, PUNCTURE OR ANY COMBINATION OF THESE EXIST. SMALL DAMAGE SITES THAT ARE CLOSELY SPACED MAY BE GROUPED TOGETHER AND CONSIDERED AS ONE DAMAGE SITE
- "D" IS DETERMINED BY MEASURING THE MAX DIMENSION OF A DENT, CRACK, OR OTHER DAMAGE, WHICHEVER IS GREATER
- "a" IS THE DISTANCE BETWEEN TWO ADJACENT DAMAGE SITES
- "d" IS THE MAX DIMENSION OF THE SMALLER OF TWO ADJACENT DAMAGE SITES
- CALCULATE a/D BY DIVIDING DISTANCE "a" BY DIMENSION "D"
- DAMAGE IS ALLOWED WHEN "D" IS EQUAL TO OR LESS THAN THE MAXIMUM ALLOWABLE "D" FROM TABLE I AND WHEN a/D IS EQUAL TO OR GREATER THAN THE MINIMUM a/D GIVEN IN TABLE I

**DAMAGE SIZING AND SPACING DATA
FOR COMPOSITE PANELS
DETAIL IV**

**Wing Fixed Trailing Edge Skin Allowable Damage
Figure 101 (Sheet 4 of 4)**



757-200
STRUCTURAL REPAIR MANUAL

REPAIR GENERAL - SERVICE BULLETIN REPAIR CHART

SERVICE BULLETIN REPAIRS

The following Service Bulletins contain repairs which are available for use where specific damage has been encountered. Usually, the Service Bulletin also covers preventive modification data which operators are encouraged to use to eliminate the need for repair.

DAMAGED AREA	CUM LINE NUMBER EFFECTIVITY	SB NUMBER
OUTER SURFACE, UPPER FIXED TRAILING EDGE PANELS INBOARD TRAILING EDGE FIXED UPPER PANEL INSPECTION AND REPAIR	1 THRU 36, 38 THRU 52	51-0003
	1 THRU 371	57-0036

Service Bulletin Repair Chart
Figure 201

D634N201

57-51-01

REPAIR GENERAL
Page 201
Jan 20/2005

REPAIR 1 - WING FIXED TRAILING EDGE SKIN REPAIRS

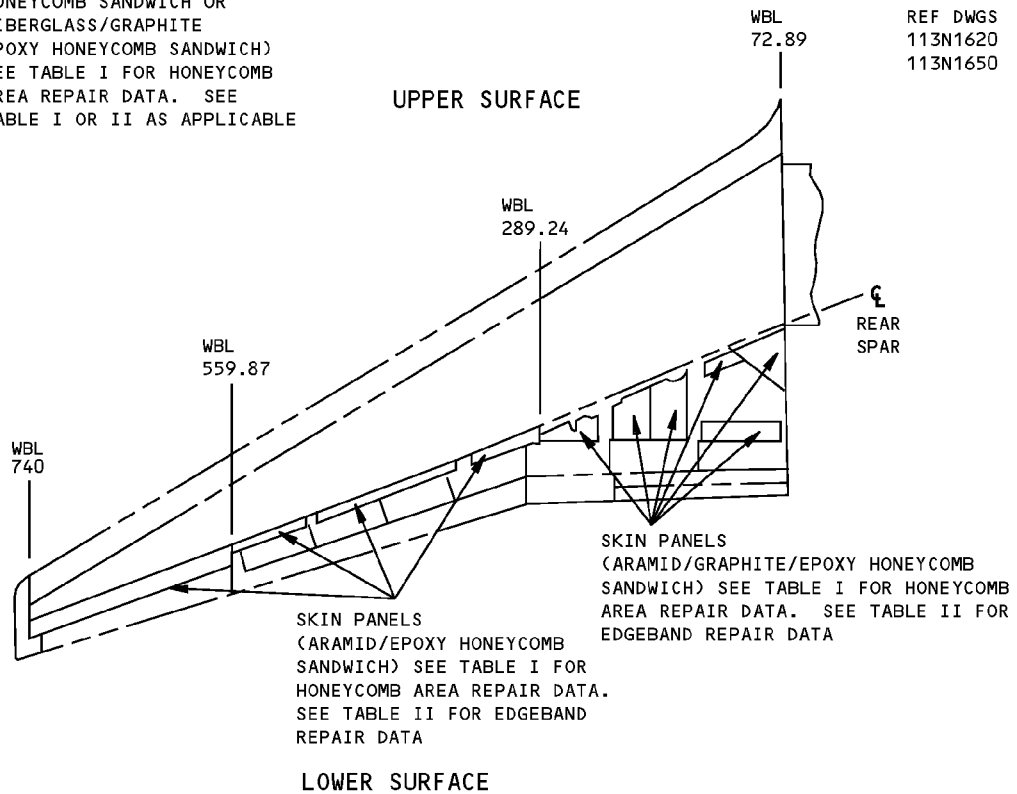
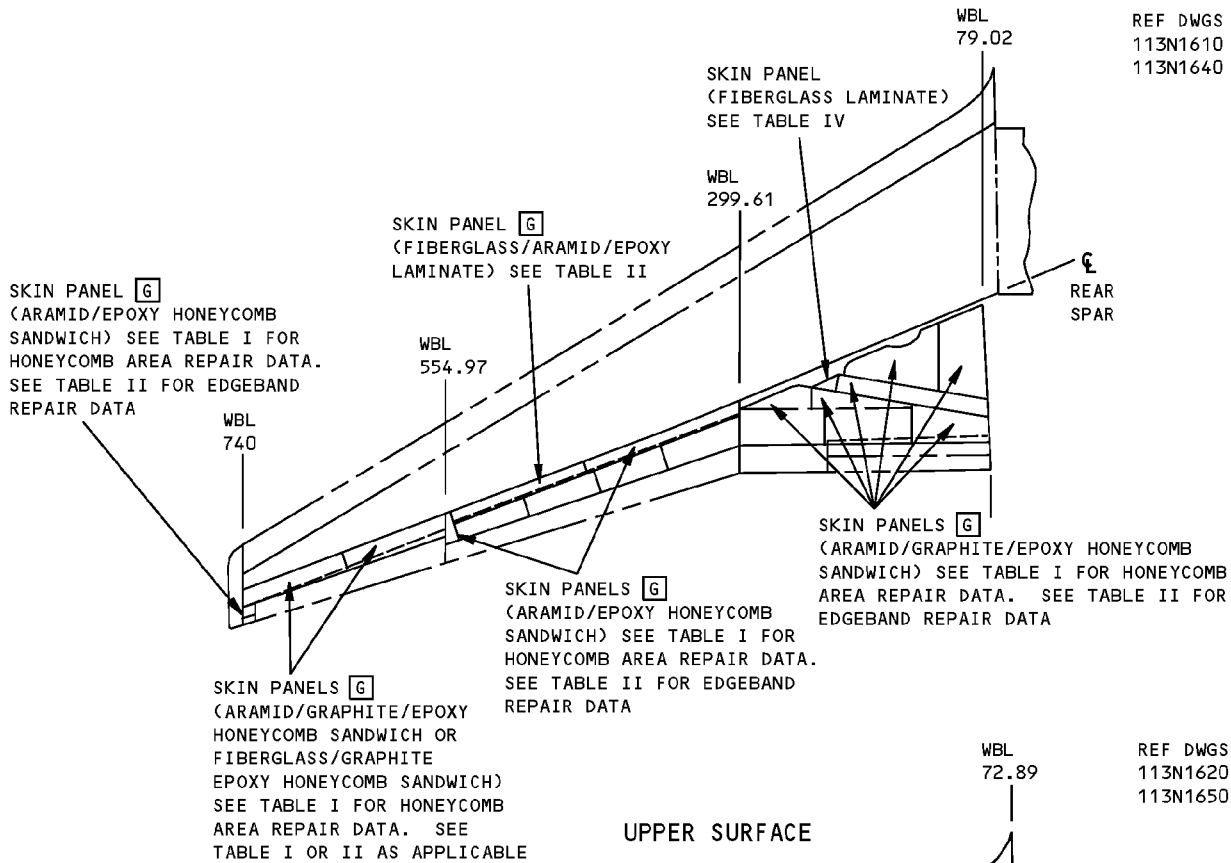

**Wing Fixed Trailing Edge Skin Repairs
Figure 201 (Sheet 1 of 6)**

STRUCTURAL REPAIR MANUAL

NOTES

- REFINISH REWORKED AREAS PER 51-20 OF THE MAINTENANCE MANUAL
- REFER TO SRM 51-10-01 FOR AERODYNAMIC SMOOTHNESS REQUIREMENTS. WHERE THE DAMAGE EXCEEDS THE LIMITS SHOWN IN SRM 51-10-01, CONSIDERATION SHOULD BE GIVEN TO THE LOSS OF PERFORMANCE INVOLVED.
- REFER TO SRM 51-10-02 FOR INSPECTION AND REMOVAL OF DAMAGE.

A LIMITED TO REPAIR OF DAMAGE TO ONE FACE-SHEET SKIN AND HONEYCOMB CORE. ONE REPAIR PER SQUARE FOOT (930 SQUARE cm) OF AREA AND MINIMUM OF 6.0 INCHES (150 mm) (EDGE TO EDGE) FROM ANY OTHER DAMAGE, FASTENER HOLE, OR EDGE OF PANEL.

B ONE REPAIR PER SQUARE FOOT (930 SQUARE cm) OF AREA AND A MINIMUM OF 6.0 INCHES (150 mm) (EDGE TO EDGE) FROM ANY OTHER DAMAGE, FASTENER HOLE, OR EDGE OF PANEL.

C INSPECT INTERIM REPAIR USING INSTRUMENTED NDT METHODS OR "TAP" TEST EVERY AIRPLANE "2A" CHECK. FOR "TAP" TEST, USE A SOLID METAL DISK AND TAP THE REPAIR AREA LIGHTLY BUT FIRMLY. VOID AREAS WILL PRODUCE A DULL SOUND AS OPPOSED TO A SHARP RING ON A SOLID BONDED AREA. PERMANENT REPAIR IS REQUIRED IF ANY DETERIORATION IS EVIDENT. REFER TO SRM 51-70-03 OR SRM 51-70-06 FOR FIBERGLASS, PAR. 4.I. AND THE NDT MANUAL **H**

D FOR EDGE BAND, CUT OUT DAMAGE AND REPAIR AS A HOLE.

E FOR LAMINATE, UP TO 2.0 INCHES (50 mm) LONG REPAIR WITH PATCH AS SHOWN IN SRM 51-70-03 PAR. 5.I. ONE REPAIR PER SQUARE FOOT (930 SQUARE cm) OF AREA AND A MINIMUM OF 3.0 INCHES (75 mm) (EDGE-TO-EDGE) FROM ANY OTHER DAMAGE, FASTENER HOLE, OR EDGE OF PANEL

F FOR LAMINATE UP TO 2.0 INCHES (50 mm) LONG REPAIR WITH PATCH AS SHOWN IN SRM 51-70-06 PAR. 5.I. ONE REPAIR PER SQUARE FOOT (930 SQUARE cm) OF AREA AND A MINIMUM OF 3.0 INCHES (75 mm) (EDGE-TO-EDGE) FROM ANY OTHER DAMAGE, FASTENER HOLE, OR EDGE OF PANEL

G FOR ADDED PROTECTION AGAINST MOISTURE INGESTION, INCORPORATION OF SB 757-51-0003 IS RECOMMENDED. FOR PANELS WITH EXISTING MOISTURE BARRIER COATING, REAPPLY BMS5-95 SEALANT ON REWORKED AREAS PRIOR TO THE APPLICATION OF THE ENAMEL FINISH. REFER TO AMM 51-21-12

H THIS REPAIR HAS FAA APPROVAL CONTINGENT ON ACCOMPLISHMENT OF THE INSPECTIONS CONTAINED HEREIN

Wing Fixed Trailing Edge Skin Repairs
Figure 201 (Sheet 2 of 6)

**757-200
STRUCTURAL REPAIR MANUAL**

DAMAGE	INTERIM REPAIRS C	PERMANENT REPAIRS		
	WET LAYUP ROOM TEMP (SRM 51-70-03)	WET LAYUP 150°F (66° C) CURE (SRM 51-70-03)	WET LAYUP 200°F (93°C CURE (SRM 51-70-17)	250°F (121°C CURE (SRM 51-70-05)
CRACKS	UP TO 4.0 INCHES (100 mm) LONG, REPAIR WITH PATCH AS GIVEN IN SRM 51-70-03, PAR. 5.N. A	CLEAN UP DAMAGE AND REPAIR AS A HOLE	CLEAN UP DAMAGE AND REPAIR AS A HOLE	CLEAN UP DAMAGE AND REPAIR AS A HOLE
HOLES AND PUNCTURES	4.0 INCHES (100 mm) MAXIMUM DIA NOT TO EXCEED 30% OF SMALLEST DIMENSION ACROSS HONEYCOMB PANEL AT THE DAMAGE LOCATION. FILL WITH BMS 5-28, TYPE 7 POTTING COMPOUND AND PATCH AS GIVEN IN SRM 51-70-03, PAR. 5.N. A	8.0 INCHES (200 mm) MAXIMUM DIA NOT TO EXCEED 50% OF SMALLEST DIMENSION ACROSS HONEYCOMB PANEL AT THE DAMAGE LOCATION. USE TWO EXTRA PLIES FOR EACH FACESHEET REPAIRED B	12.0 INCHES (300 mm) MAXIMUM DIA NOT TO EXCEED 50% OF SMALLEST DIMENSION ACROSS HONEYCOMB PANEL AT THE DAMAGE LOCATION. USE TWO EXTRA PLIES FOR EACH FACESHEET REPAIRED B	NO SIZE LIMIT
DELAMINATION	CUT OUT AND REPAIR AS A HOLE			
NICKS AND GOUGES	IF THERE IS NO FIBER DAMAGE OR DELAMINATION, FILL NICKS OR GOUGES AS GIVEN IN SRM 51-70-03 IF YOU FIND FIBER DAMAGE OR DELAMINATION, THEN REPAIR AS A HOLE			
DENTS	UP TO 2.0 INCHES (50 mm) DIA WITH NO FIBER DAMAGE OR DELAMINATION, FILL WITH BMS 5-28, TYPE 7 POTTING COMPOUND AND PATCH AS GIVEN IN SRM 51-70-03, PAR. 5.L. B OVER 2.0 INCHES (50 mm) DIA OR WITH FIBER DAMAGE OR DELAMINATION, REPAIR AS A HOLE			

REPAIR DATA FOR 250°F CURE HONEYCOMB PANELS (ARAMID/GRAPHITE) **G**
TABLE I

**Wing Fixed Trailing Edge Skin Repairs
Figure 201 (Sheet 3 of 6)**

STRUCTURAL REPAIR MANUAL

DAMAGE	INTERIM REPAIRS [C]	PERMANENT REPAIRS		
	WET LAYUP ROOM TEMP (SRM 51-70-03)	WET LAYUP 150°F (66°C) CURE (SRM 51-70-03)	WET LAYUP 200°F (93°C) CURE (SRM 51-70-17)	250°F (121°C) CURE (SRM 51-70-05)
CRACKS	FOR EDGE BAND, REFER TO [D] FOR LAMINATE, REFER TO [E]	CLEAN UP DAMAGE AND REPAIR AS A HOLE	CLEAN UP DAMAGE AND REPAIR AS A HOLE	CLEAN UP DAMAGE AND REPAIR AS A HOLE
HOLES AND PUNCTURES	2.0 INCHES (50 mm) MAXIMUM DIA NOT TO EXCEED 15% OF CROSS-SECTIONAL AREA OF LAMINATE OR EDGE BAND OR 10% OF THE EDGE BAND LENGTH FOR EACH SIDE. REPAIR AS GIVEN IN SRM 51-70-03 PAR. 5.G., 5.H., 5.I., OR 5.K. AS APPLICABLE [A]	5.0 MAXIMUM DIA NOT TO EXCEED 50% OF CROSSSECTIONAL AREA OF LAMINATE OR EDGE BAND OR 25% OF THE EDGE BAND LENGTH FOR EACH SIDE. USE TWO EXTRA PLYS FOR EACH SIDE [B]	10.0 MAXIMUM DIA NOT TO EXCEED 50% OF CROSSSECTIONAL AREA OF LAMINATE OR EDGE BAND OR 25% OF THE EDGE BAND LENGTH FOR EACH SIDE. USE TWO EXTRA PLYS FOR EACH SIDE	NO SIZE LIMIT
EDGE EROSION	_____	FOR DAMAGE THAT IS NOT LARGER THAN 35% OF THE EDGE BAND THICKNESS, REPAIR AS GIVEN IN SRM 51-70-03 PAR. 5.O. FOR LARGER DAMAGE, REPAIR AS GIVEN IN : SRM 51-70-03 PAR. 5.G. SRM 51-70-17 PAR. 4.G. SRM 51-70-05 PAR. 5.G.		
DELAMINATION	CUT OUT AND REPAIR AS A HOLE			
NICKS AND GOUGES	IF THERE IS NO FIBER DAMAGE OR DELAMINATION, FILL NICKS OR GOUGES AS GIVEN IN SRM 51-70-03 IF YOU FIND FIBER DAMAGE OR DELAMINATION, THEN REPAIR AS A HOLE			
DENTS	UP TO 2.0 INCHES (50 mm) DIA WITH NO FIBER DAMAGE OR DELAMINATION, FILL WITH BMS 5-28, TYPE 7 POTTING COMPOUND AND PATCH AS GIVEN IN SRM 51-70-03, PAR. 5.L. OVER 2.0 INCHES (50 mm) DIA OR WITH FIBER DAMAGE OR DELAMINATION, REPAIR AS A HOLE			

REPAIR DATA FOR 250°F (121°C) CURE HONEYCOMB PANELS (ARAMID/GRAPHITE) [G]
TABLE II

**Wing Fixed Trailing Edge Skin Repairs
Figure 201 (Sheet 4 of 6)**

STRUCTURAL REPAIR MANUAL

DAMAGE	INTERIM REPAIRS [C]	PERMANENT REPAIRS		
	WET LAYUP ROOM TEMP (SRM 51-70-06)	WET LAYUP 150°F (66°C) CURE (SRM 51-70-03)	WET LAYUP 200°F (93°C) CURE (SRM 51-70-17)	250°F (121°C) CURE (SRM 51-70-05)
CRACKS	UP TO 2.0 INCHES (50 mm) LONG, REPAIR WITH PATCH AS GIVEN IN SRM 51-70-06, PAR. 5.N. [A]	CLEAN UP DAMAGE AND REPAIR AS A HOLE	CLEAN UP DAMAGE AND REPAIR AS A HOLE	CLEAN UP DAMAGE AND REPAIR AS A HOLE
HOLES AND PUNCTURES	4.0 INCHES (100 mm) MAXIMUM DIA NOT TO EXCEED 30% OF SMALLEST DIMENSION ACROSS HONEYCOMB PANEL AT THE DAMAGE LOCATION. FILL WITH BMS 5-28, TYPE 7 POTTING COMPOUND AND PATCH AS GIVEN IN SRM 51-70-06, PAR. 5.N. [A]	8.0 INCHES (200 mm) MAXIMUM DIA NOT TO EXCEED 50% OF SMALLEST DIMENSION ACROSS HONEYCOMB PANEL AT THE DAMAGE LOCATION. USE TWO EXTRA PLIES FOR EACH SIDE [B]	12.0 INCHES (300 mm) MAXIMUM DIA NOT TO EXCEED 50% OF SMALLEST DIMENSION ACROSS HONEYCOMB PANEL AT THE DAMAGE LOCATION. USE TWO EXTRA PLIES FOR EACH SIDE [B]	NO SIZE LIMIT
DELAMINATION	CUT OUT AND REPAIR AS A HOLE			
NICKS AND GOUGES	IF THERE IS NO FIBER DAMAGE OR DELAMINATION, FILL NICKS OR GOUGES AS GIVEN IN SRM 51-70-06 IF YOU FIND FIBER DAMAGE OR DELAMINATION, THEN REPAIR AS A HOLE			
DENTS	UP TO 2.0 INCHES (50 mm) DIA WITH NO FIBER DAMAGE OR DELAMINATION, FILL WITH BMS 5-28, TYPE 7 POTTING COMPOUND AND PATCH AS GIVEN IN SRM 51-70-06, PAR. 5.L. [B] OVER 2.0 INCHES (50 mm) DIA OR WITH FIBER DAMAGE OR DELAMINATION, REPAIR AS A HOLE			

REPAIR DATA FOR 250°F (121°C) CURE HONEYCOMB PANELS (FIBERGLASS)
TABLE III

Wing Fixed Trailing Edge Skin Repairs
Figure 201 (Sheet 5 of 6)



757-200

STRUCTURAL REPAIR MANUAL

DAMAGE	INTERIM REPAIRS C	PERMANENT REPAIRS		
	WET LAYUP ROOM TEMP (SRM 51-70-06)	WET LAYUP 150°F (66°C) CURE (SRM 51-70-06)	WET LAYUP 200°F (93°C) CURE (SRM 51-70-17)	250°F (121°C) CURE (SRM 51-70-07)
CRACKS	FOR EDGE BAND, REFER TO D FOR LAMINATE, REFER TO F	CLEAN UP DAMAGE AND REPAIR AS A HOLE	CLEAN UP DAMAGE AND REPAIR AS A HOLE	CLEAN UP DAMAGE AND REPAIR AS A HOLE
HOLES AND PUNCTURES	2.0 INCHES (50 mm) MAXIMUM DIA NOT TO EXCEED 15% OF CROSS-SECTIONAL AREA OF LAMINATE OR EDGE BAND OR 10% OF THE EDGE BAND LENGTH FOR EACH SIDE. REPAIR AS GIVEN IN SRM 51-70-03 PAR. 5.G., 5.H., 5.I., OR 5.K. AS APPLICABLE A	5.0 INCHES (50 mm) MAXIMUM DIA NOT TO EXCEED 50% OF CROSS-SECTIONAL AREA OF LAMINATE OR EDGE BAND OR 25% OF THE EDGE BAND LENGTH FOR EACH SIDE. USE TWO EXTRA PLIES FOR EACH FACESHEET B	10.0 INCHES (250 mm) MAXIMUM DIA NOT TO EXCEED 50% OF CROSS-SECTIONAL AREA OF LAMINATE OR EDGE BAND OR 25% OF THE EDGE BAND LENGTH FOR EACH SIDE. USE TWO EXTRA PLIES FOR EACH FACESHEET	NO SIZE LIMIT
EDGE EROSION	_____	FOR DAMAGE THAT IS NOT LARGER THAN 35% OF THE EDGE BAND THICKNESS, REPAIR AS GIVEN IN SRM 51-70-06 PAR. 5.O. FOR LARGER DAMAGE, REPAIR AS GIVEN IN: SRM 51-70-06 PAR. 5.G. SRM 51-70-17 PAR. 4.G. SRM 51-70-07 PAR. 5.G.		
DELAMINATION	CUT OUT AND REPAIR AS A HOLE			
NICKS AND GOUGES	IF THERE IS NO FIBER DAMAGE OR DELAMINATION, FILL NICKS OR GOUGES AS GIVEN IN SRM 51-70-06 IF YOU FIND FIBER DAMAGE OR DELAMINATION, THEN REPAIR AS A HOLE			
DENTS	UP TO 2.0 INCHES (50 mm) DIA WITH NO FIBER DAMAGE OR DELAMINATION, FILL WITH BMS 5-28, TYPE 7 POTTING COMPOUND AND PATCH AS GIVEN IN SRM 51-70-06, PAR. 5.L. OVER 2.0 INCHES (50 mm) DIA OR WITH FIBER DAMAGE OR DELAMINATION, REPAIR AS A HOLE			

REPAIR DATA FOR 250°F CURE LAMINATES AND EDGE BANDS (FIBERGLASS)
TABLE IV

**Wing Fixed Trailing Edge Skin Repairs
Figure 201 (Sheet 6 of 6)**

D634N201

57-51-01

REPAIR 1
Page 206
Jan 20/2005

757-200
STRUCTURAL REPAIR MANUAL

IDENTIFICATION 1 - WING TRAILING EDGE STRUCTURE

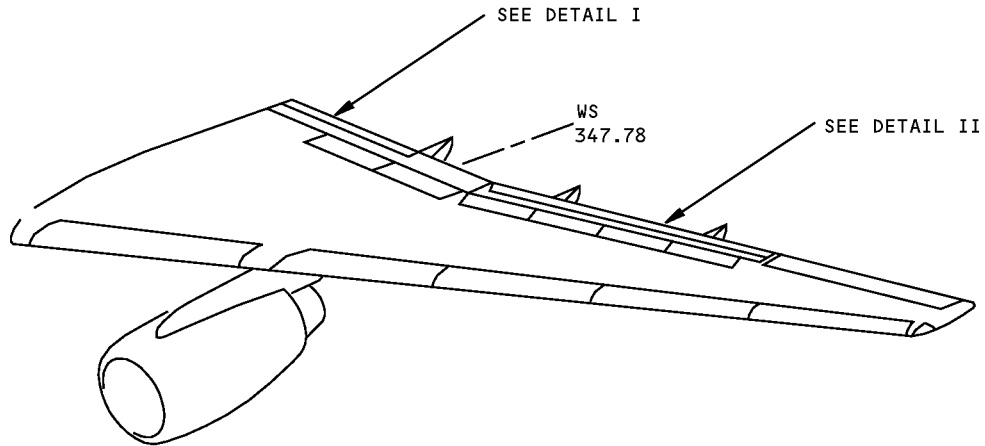

NOTES

- A** FOR CUM LINE NUMBERS:
1 THRU 10
- B** FOR CUM LINE NUMBERS:
1 THRU 67
- C** FOR CUM LINE NUMBERS:
144,147,149 THRU 200
(REF: BOEING N0111-N2699,
N2701-N2999,N3037-N9999)

Wing Trailing Edge Structure Identification
Figure 1 (Sheet 1 of 5)

**757-200
STRUCTURAL REPAIR MANUAL**

REF DWG
113N1630

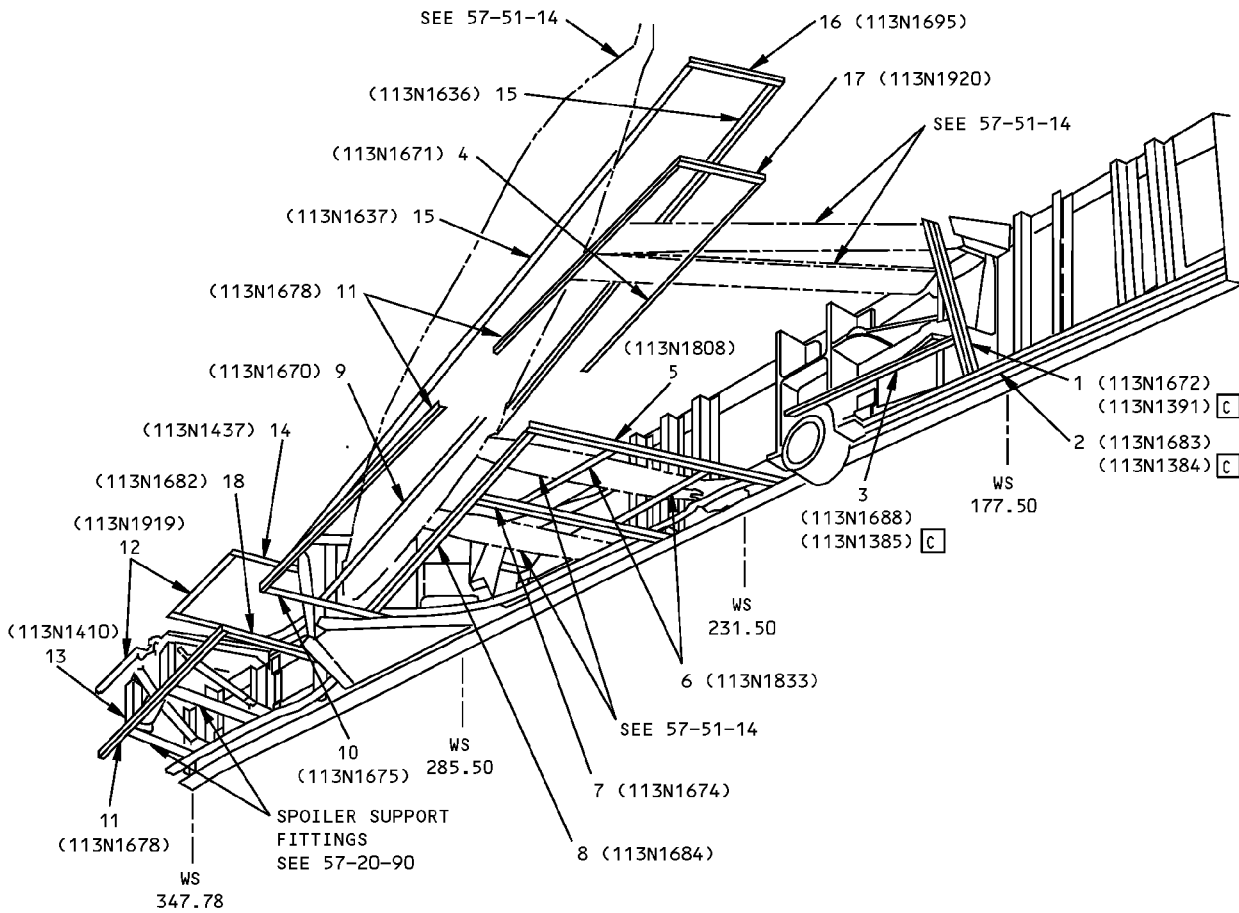

LEFT SIDE SHOWN
RIGHT SIDE OPPOSITE

DETAIL I



**Wing Trailing Edge Structure Identification
Figure 1 (Sheet 2 of 5)**

IDENTIFICATION 1
Page 2
Jan 20/2005

57-51-02

D634N201



**757-200
STRUCTURAL REPAIR MANUAL**

ITEM	DESCRIPTION	GAGE	MATERIAL	EFFECTIVITY
1	PANEL SUPPORT BEAM	0.063	BAC1517-1832 7075-T73 2024-T3	C
2	PANEL SUPPORT BEAM	0.10	7075-T73 AND10137-1111 7075-T73	C
3	PANEL STIFFENER		BAC1506-10133 7075-T73	
4	PANEL SUPPORT BEAM		AND10134-2001 7075-T73	
5	TRUNNION DOOR SUPPORT BEAM		7075-T73 FORGED BLOCK OR DIE FORGING	
6	SUPPORT CHANNEL	1.25	7075-T7351 (OR 7075-T73 DIE FORGING)	
7	PANEL SUPPORT BEAM		BAC1506-2390 7075-T73 OPTIONAL: BAC1506-2390 7075-T6	
8	PANEL SUPPORT BEAM		BAC1506-1762 7075-T73	
9	SUPPORT CHANNEL		BAC1509-100423 7075-T73	
10	PANEL SUPPORT BEAM		AND10136-2401 7075-T73	
11	PANEL SUPPORT BEAM	0.10	CLAD 7075-T6	
12	PANEL SUPPORT BEAM		BAC1503-100019 7075-T73	
13	ACTUATOR RIB		7075-T73 FORGED BLOCK	
14	HINGE FITTING		7075-T73 FORGED BLOCK	
15	PANEL SUPPORT BEAM		BAC1506-1831 7075-T73	
16	PANEL SUPPORT BEAM	0.063	CLAD 7075-T73	
17	SUPPORT ANGLE		AND10134-1403 7075-T73511	
18	FAIRING TRACK RIB		7075-T73 FORGED BLOCK	

LIST OF MATERIALS FOR DETAIL I

**Wing Trailing Edge Structure Identification
Figure 1 (Sheet 3 of 5)**

IDENTIFICATION 1
Page 3
Jan 20/2005

57-51-02

D634N201

**757-200
STRUCTURAL REPAIR MANUAL**

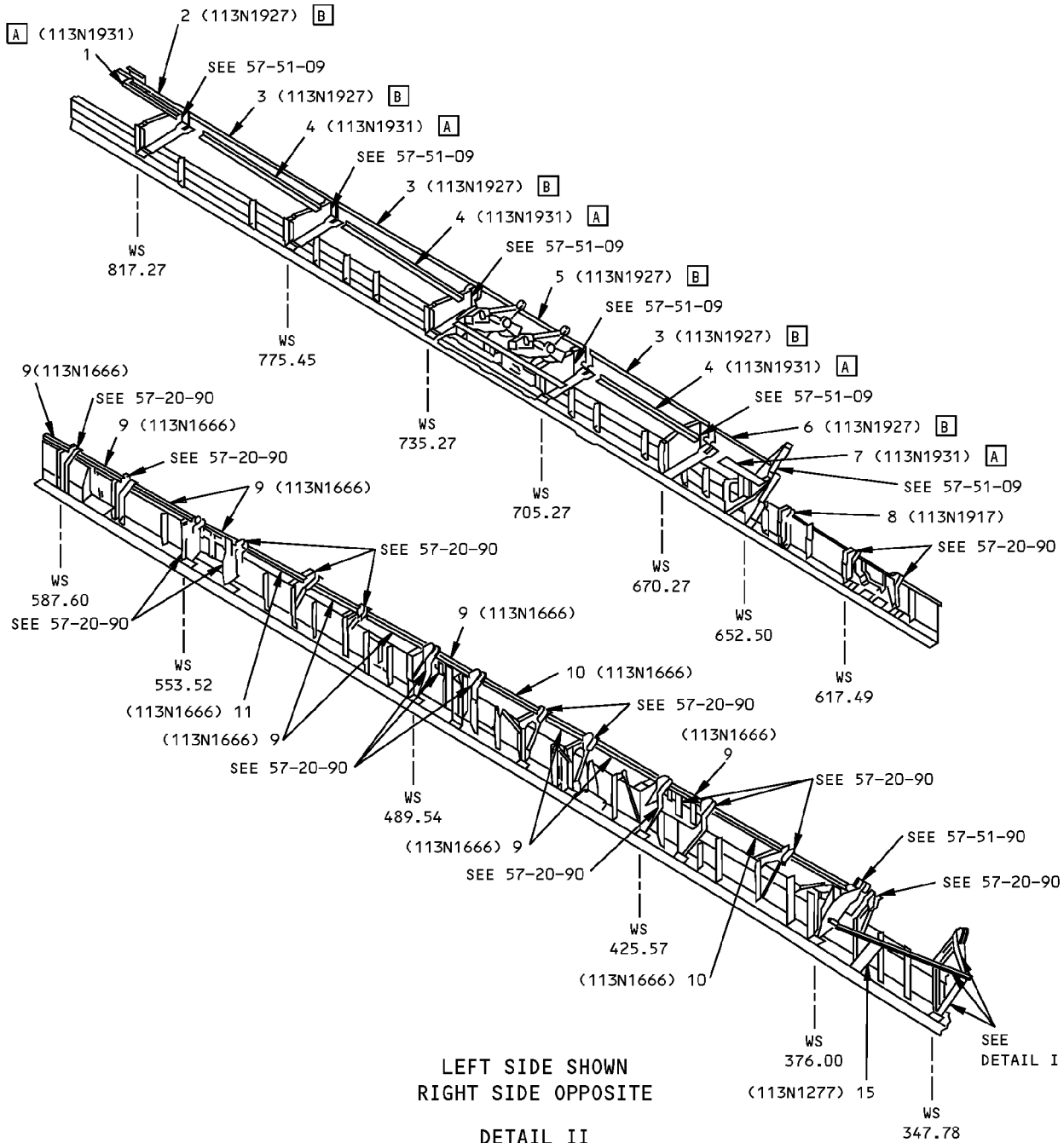

LIST OF
MATERIAL

**Wing Trailing Edge Structure Identification
Figure 1 (Sheet 4 of 5)**



757-200
STRUCTURAL REPAIR MANUAL

ITEM	DESCRIPTION	GAGE	MATERIAL	EFFECTIVITY
1	PANEL STIFFENER		AND10133-2002 7075-T73511	A
2	PANEL STIFFENER		AND10134-2010 7075-T73511	B
3	PANEL STIFFENER	1.00	TI-6AL-4V	B
4	PANEL STIFFENER	0.090	7075-T7351	A
5	PANEL STIFFENER	0.625	7075-T7351	
6	PANEL STIFFENER		AND10134-1407 7075-T73511	B
7	PANEL STIFFENER		AND10134-1402 7075-T73511	A
8	HINGE FITTING	1.45	7075-T7351 PLATE OPTIONAL: FORGING 7075-T73	
9	STRINGER		BAC1503-100096 7075-T73511	
10	STRINGER		AND10133-1002 7075-T73511	
11	STRINGER		AND10136-2402 7075-T73511	

LIST OF MATERIALS FOR DETAIL II

Wing Trailing Edge Structure Identification
Figure 1 (Sheet 5 of 5)

D634N201

57-51-02

IDENTIFICATION 1
Page 5
Jan 20/2005



757-200
STRUCTURAL REPAIR MANUAL

ALLOWABLE DAMAGE 1 - WING TRAILING EDGE STRUCTURE

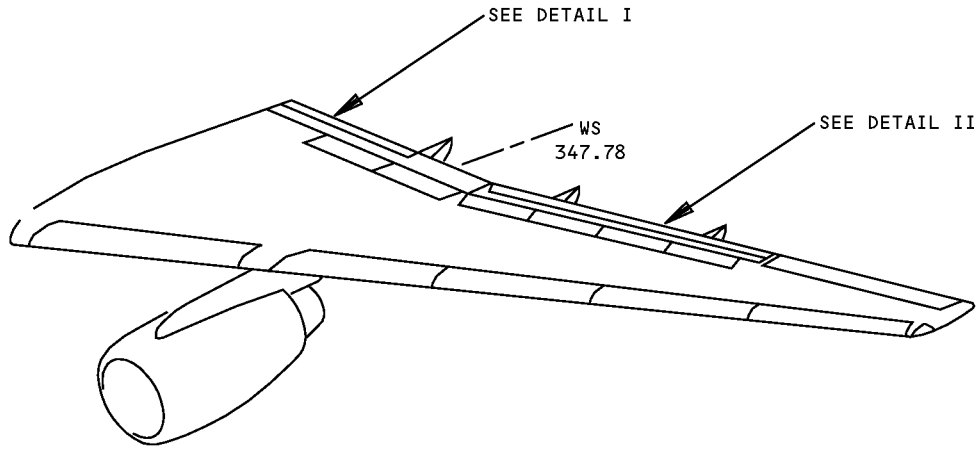

Wing Trailing Edge Structure Allowable Damage
Figure 101 (Sheet 1 of 7)

D634N201

ALLOWABLE DAMAGE 1
Page 101
57-51-02 Jan 20/2005

**757-200
STRUCTURAL REPAIR MANUAL**

REF DWG
113N1630

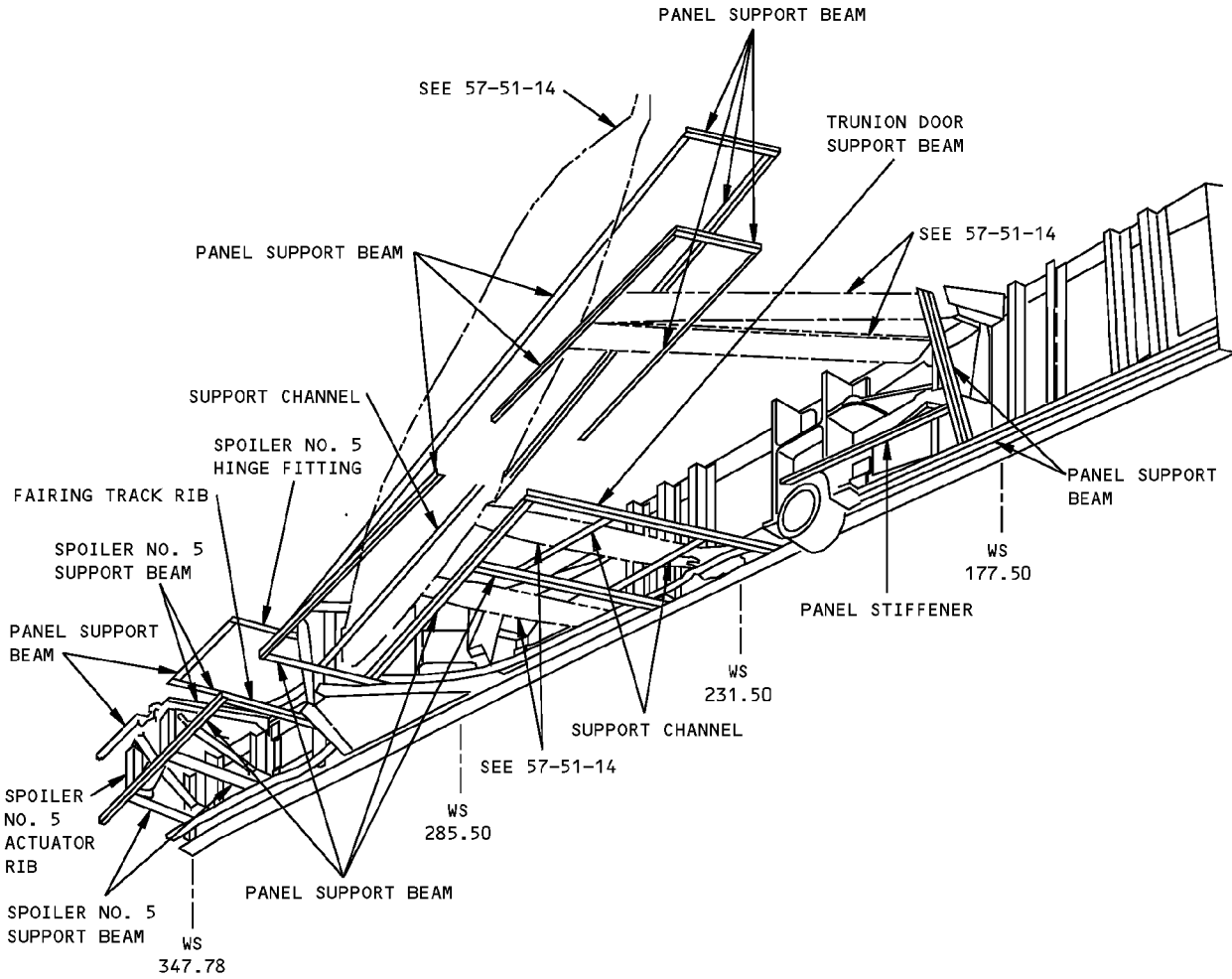

MATERIAL: ALUMINUM

INBOARD STRUCTURE
LEFT SIDE SHOWN
RIGHT SIDE OPPOSITE
DETAIL I

**Wing Trailing Edge Structure Allowable Damage
Figure 101 (Sheet 2 of 7)**

D634N201

ALLOWABLE DAMAGE 1
57-51-02
Page 102
Jan 20/2005

**757-200
STRUCTURAL REPAIR MANUAL**

REF DWG
113N1630

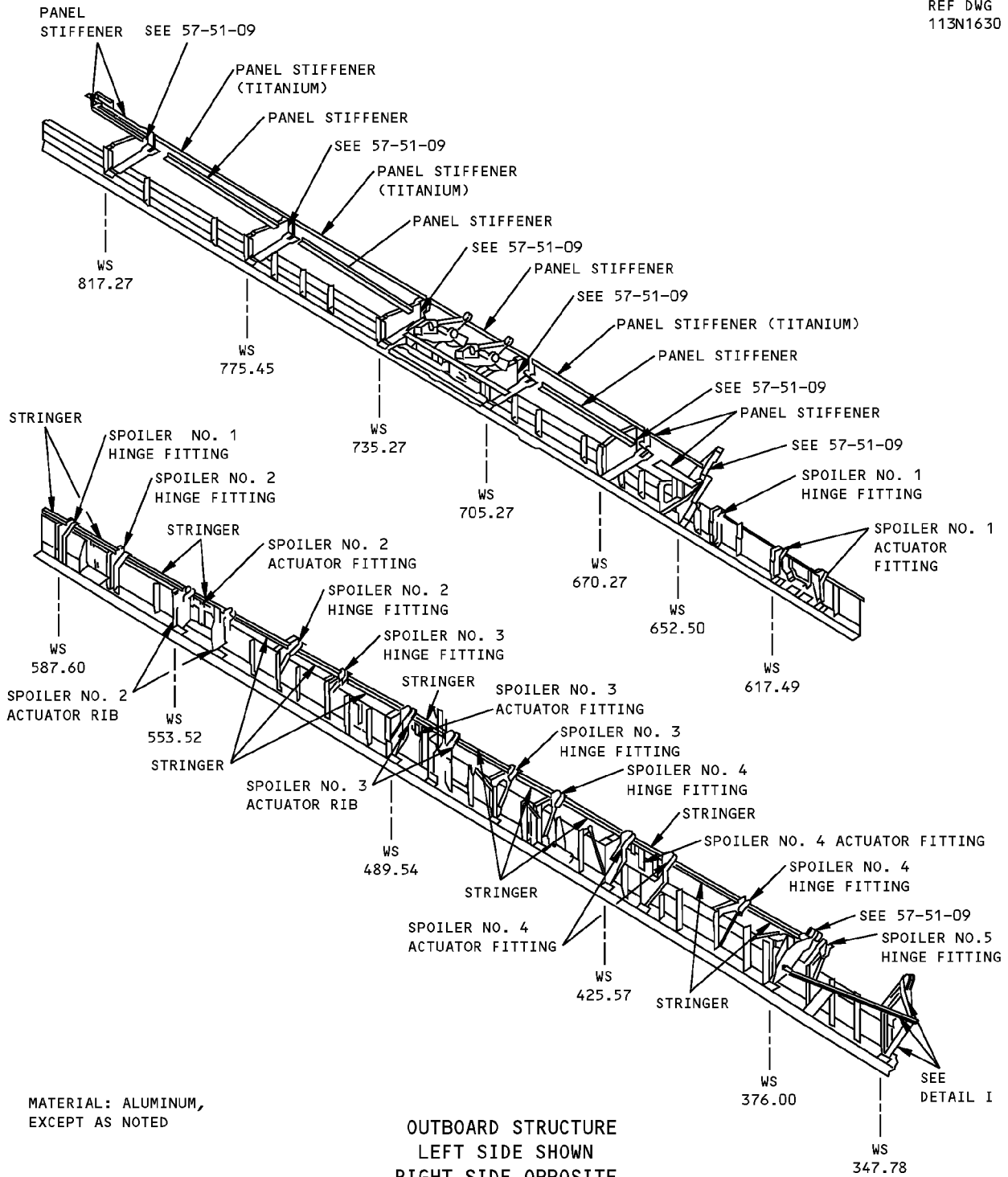

MATERIAL: ALUMINUM,
EXCEPT AS NOTED

OUTBOARD STRUCTURE
LEFT SIDE SHOWN
RIGHT SIDE OPPOSITE
DETAIL II

**Wing Trailing Edge Structure Allowable Damage
Figure 101 (Sheet 3 of 7)**

ALLOWABLE DAMAGE 1
Page 103
Jan 20/2005

57-51-02

D634N201



**757-200
STRUCTURAL REPAIR MANUAL**

DESCRIPTION	CRACKS	NICKS, GOUGES AND CORROSION	DENTS	HOLES AND PUNCTURES
PANEL SUPPORT BEAMS	A	C	NOT ALLOWED	NOT ALLOWED
PANEL STIFFENERS (ALUMINUM)				
LWR STIFFENERS WS 670.27 TO WS 817.27	D	E	NOT ALLOWED	F
ALL OTHER STIFFENERS	A	C	NOT ALLOWED	F
PANEL STIFFENERS (TITANIUM)	A	C	NOT ALLOWED	G
TRUNNION DOOR SUPPORT BEAM	A	C	NOT ALLOWED	NOT ALLOWED
SPOILER NO. 5 SUPPORT BEAMS	D	E	NOT ALLOWED	NOT ALLOWED
STRINGERS	A	B	NOT ALLOWED	NOT ALLOWED
SUPPORT CHANNELS	A	C	SEE DETAIL V	NOT ALLOWED
ACTUATOR RIBS	H	I	NOT ALLOWED	NOT ALLOWED
ACTUATOR FITTINGS	H	J	NOT ALLOWED	NOT ALLOWED
HINGE FITTINGS	H	I	NOT ALLOWED	NOT ALLOWED
FAIRING TRACK RIB	H	J	NOT ALLOWED	NOT ALLOWED

**Wing Trailing Edge Structure Allowable Damage
Figure 101 (Sheet 4 of 7)**



757-200

STRUCTURAL REPAIR MANUAL

NOTES

- REFINISH REWORKED AREAS PER 51-20 OF THE MAINTENANCE MANUAL
- A** CRACKS NOT ALLOWED EXCEPT FOR EDGE CRACKS, WHICH MUST BE REMOVED PER DETAILS III AND VII
- B** REMOVE DAMAGE PER DETAILS III, IV AND VII. MAX DEPTH 5% OF GAGE
- C** REMOVE DAMAGE PER DETAILS III, IV AND VI. MAX DEPTH 10% OF GAGE
- D** CRACKS NOT ALLOWED EXCEPT FOR EDGE CRACKS, WHICH MUST BE REMOVED PER DETAILS III AND VII. SHOT PEEN REWORKED AREAS PER 20-10-03 OF THE COMPONENT MAINTENANCE MANUAL WITH SHOT NO. 230-550. **K**
- E** REMOVE DAMAGE PER DETAILS III, IV AND VI. MAX DEPTH OF 10% OF GAGE. SHOT PEEN REWORKED AREAS PER 20-10-03 OF THE COMPONENT MAINTENANCE MANUAL WITH SHOT NO. 230-550. **K**
- F** CLEAN OUT DAMAGE UP TO 0.25 MAX DIA AND NOT CLOSER THAN 1.0 INCH TO FASTENER HOLE OR OTHER DAMAGE. FILL HOLE WITH A 2117-T3 OR T4 ALUMINUM RIVET INSTALLED WET WITH BMS 5-95 SEALANT. ALL OTHER HOLES TO BE REPAIRED
- G** CLEAN OUT DAMAGE UP TO 0.25 MAX DIA AND NOT CLOSER THAN 1.0 INCH TO FASTENER HOLE OR OTHER DAMAGE. FILL HOLE WITH A MONEL RIVET INSTALLED DRY. ALL OTHER HOLES TO BE REPAIRED
- H** CRACKS NOT ALLOWED EXCEPT FOR EDGE CRACKS, WHICH MUST BE REMOVED PER DETAIL VIII. SHOT PEEN REWORKED AREAS PER 20-10-03 OF THE COMPONENT MAINTENANCE MANUAL WITH SHOT NO. 230-550. **K**
- I** FOR EDGE DAMAGE SEE DETAIL III. FOR LUG DAMAGE SEE DETAIL IX. FOR OTHER DAMAGE SEE DETAIL IV. DAMAGE NOT ALLOWED IN VICINITY OF BUSHINGS. SHOT PEEN REWORKED AREAS PER 20-10-03 OF THE COMPONENT MAINTENANCE MANUAL WITH SHOT NO. 230-550. **K**
- J** FOR EDGE DAMAGE SEE DETAIL III. FOR OTHER DAMAGE SEE DETAIL IV. SHOT PEEN REWORKED AREAS PER 20-10-03 OF THE COMPONENT MAINTENANCE MANUAL WITH SHOT NO. 230-550. **K**
- K** SHOT PEEN INTENSITIES MAY VARY WITH THICKNESS LEFT AFTER REWORK. REFER TO 51-20-06

**Wing Trailing Edge Structure Allowable Damage
Figure 101 (Sheet 5 of 7)**

D634N201

ALLOWABLE DAMAGE 1
57-51-02
Page 105
Jan 20/2005

STRUCTURAL REPAIR MANUAL

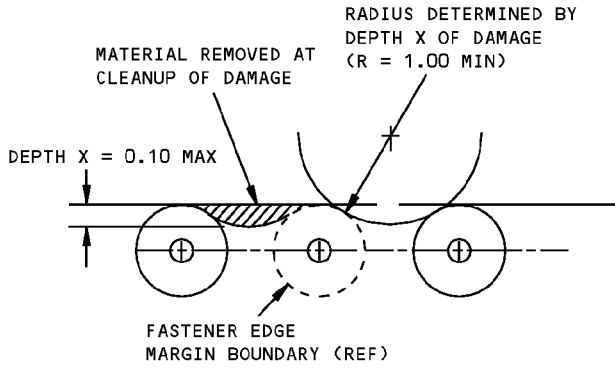

DAMAGE CLEANUP OF EDGES WHERE FASTENER EDGE MARGINS DO NOT OVERLAP

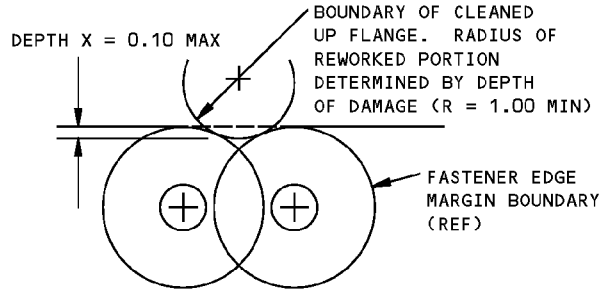

DAMAGE CLEANUP OF EDGES WHERE FASTENER EDGE MARGINS OVERLAP

DETAIL III

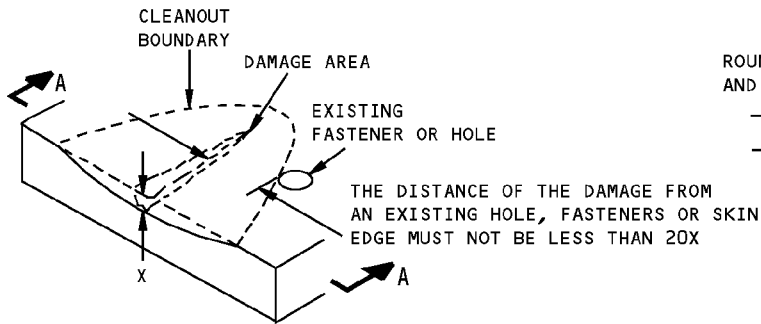

REMOVAL OF NICK, GOUGE AND SCRATCH DAMAGE ON A SURFACE
DETAIL IV

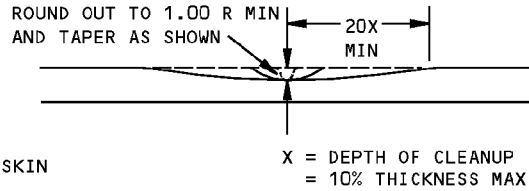

SECTION A-A

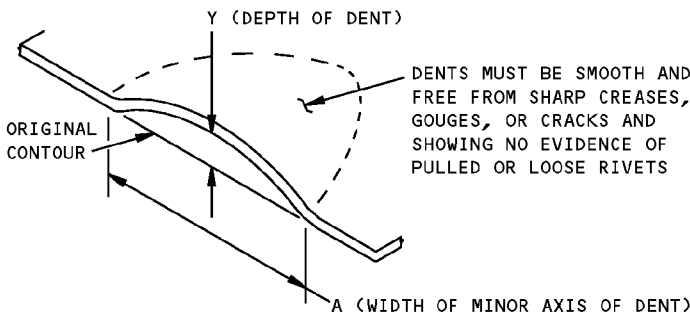

$\frac{A}{Y}$ MUST NOT BE LESS THAN 30

ALLOWABLE DAMAGE FOR DENT
DETAIL V

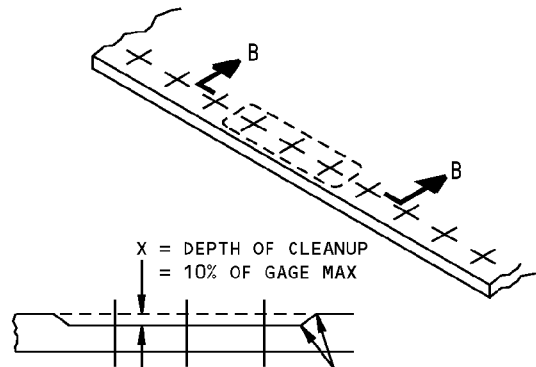

SMOOTH BLENDOUT RADIUS 0.50 INCH MINIMUM. CORROSION CLEANUP AROUND ANY THREE FASTENERS IN TEN IS PERMITTED TO MAX DEPTH

SECTION B-B

CORROSION CLEANUP
DETAIL VI

**Wing Trailing Edge Structure Allowable Damage
Figure 101 (Sheet 6 of 7)**

**757-200
STRUCTURAL REPAIR MANUAL**

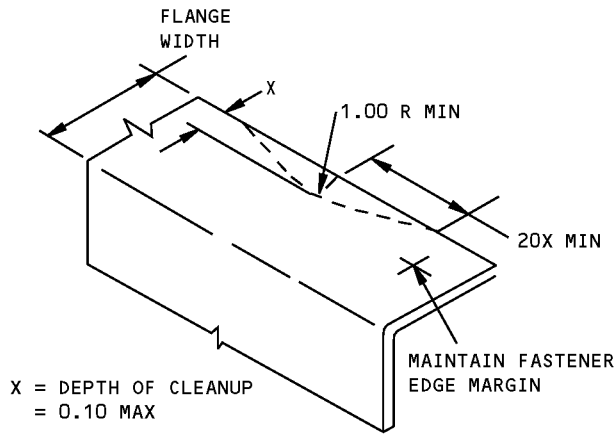

**REMOVAL OF NICK OR CRACK
DAMAGE ON AN EDGE
DETAIL VII**

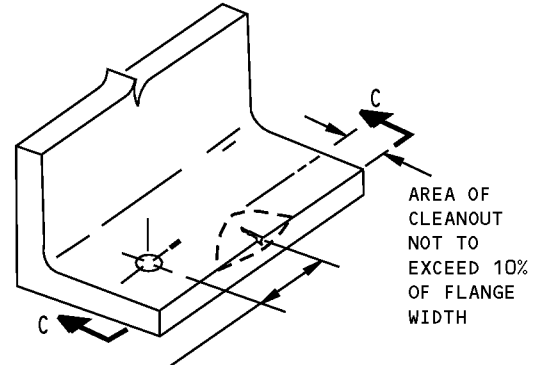

THE DISTANCE OF THE DAMAGE FROM AN EXISTING HOLE, FASTENERS OR EDGE MUST NOT BE LESS THAN 20X

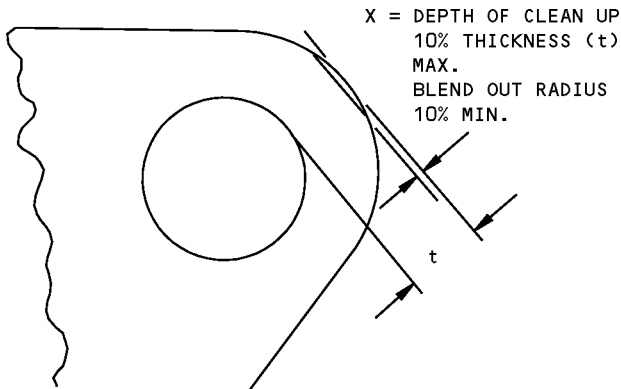

**DAMAGE CLEAN UP FOR EDGES OF LUG
DETAIL IX**

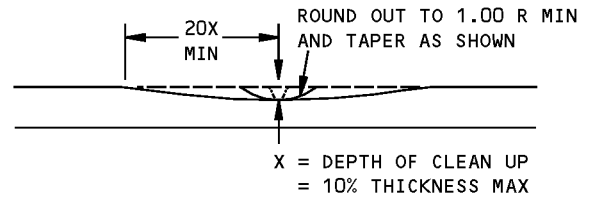

**SECTION C-C
REMOVAL OF NICK OR CRACK
DAMAGE ON AN EDGE
DETAIL VIII**

**Wing Trailing Edge Structure Allowable Damage
Figure 101 (Sheet 7 of 7)**



757-200
STRUCTURAL REPAIR MANUAL

REPAIR GENERAL - SERVICE BULLETIN REPAIR CHART

SERVICE BULLETIN REPAIRS

The following Service Bulletins contain repairs which are available for use where specific damage has been encountered. Usually, the Service Bulletin also covers preventive modification data which operators are encouraged to use to eliminate the need for repair.

DAMAGED AREA	CUM LINE NUMBER EFFECTIVITY	SB NUMBER
WINGS - WING TRAILING EDGE-FIXED UPPER PANEL SUPPORT BEAM CLIP INSPECTION AND REPLACEMENT	1 THRU 387	57-0027

Service Bulletin Repair Chart
Figure 201

D634N201

57-51-02

REPAIR GENERAL
Page 201
Jan 20/2005

**757-200
STRUCTURAL REPAIR MANUAL**

IDENTIFICATION 1 - TRAILING EDGE RIB

REF DWG
113N1001

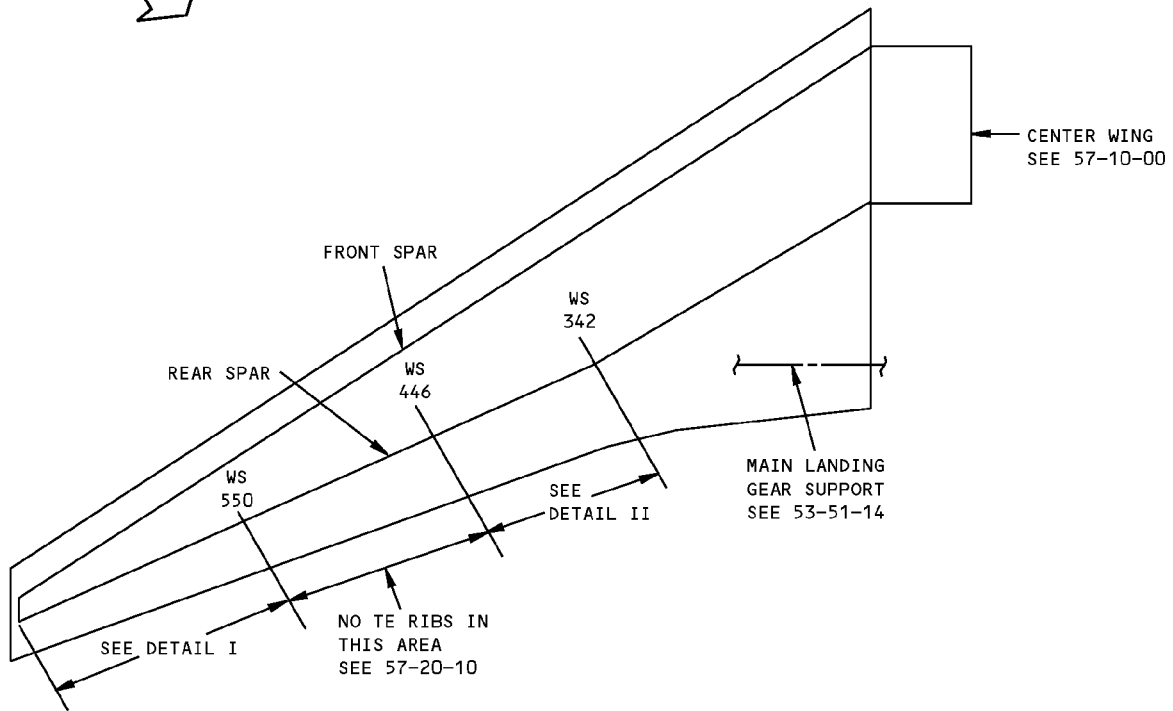
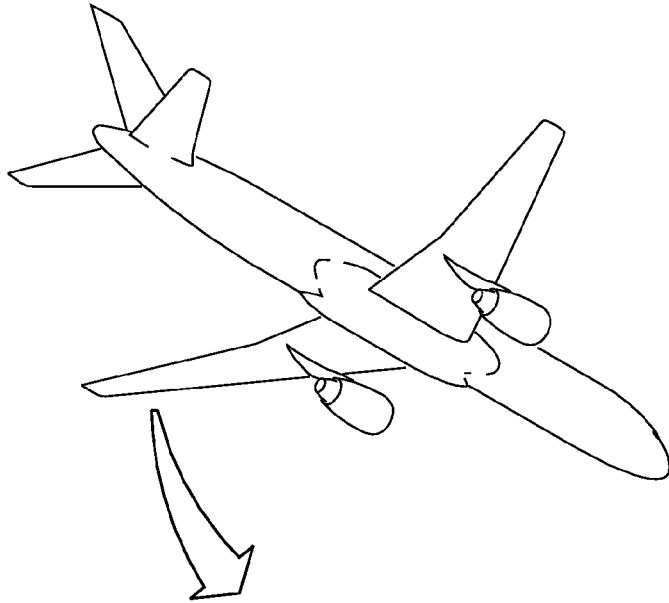

NOTES

- A** OPTIONAL FOR CUM LINE NUMBERS:
1 THRU 22
- B** OPTIONAL FOR CUM LINE NUMBERS:
1 THRU 36

**Trailing Edge Rib Identification
Figure 1 (Sheet 1 of 4)**

**757-200
STRUCTURAL REPAIR MANUAL**

REF DWG
112N1001

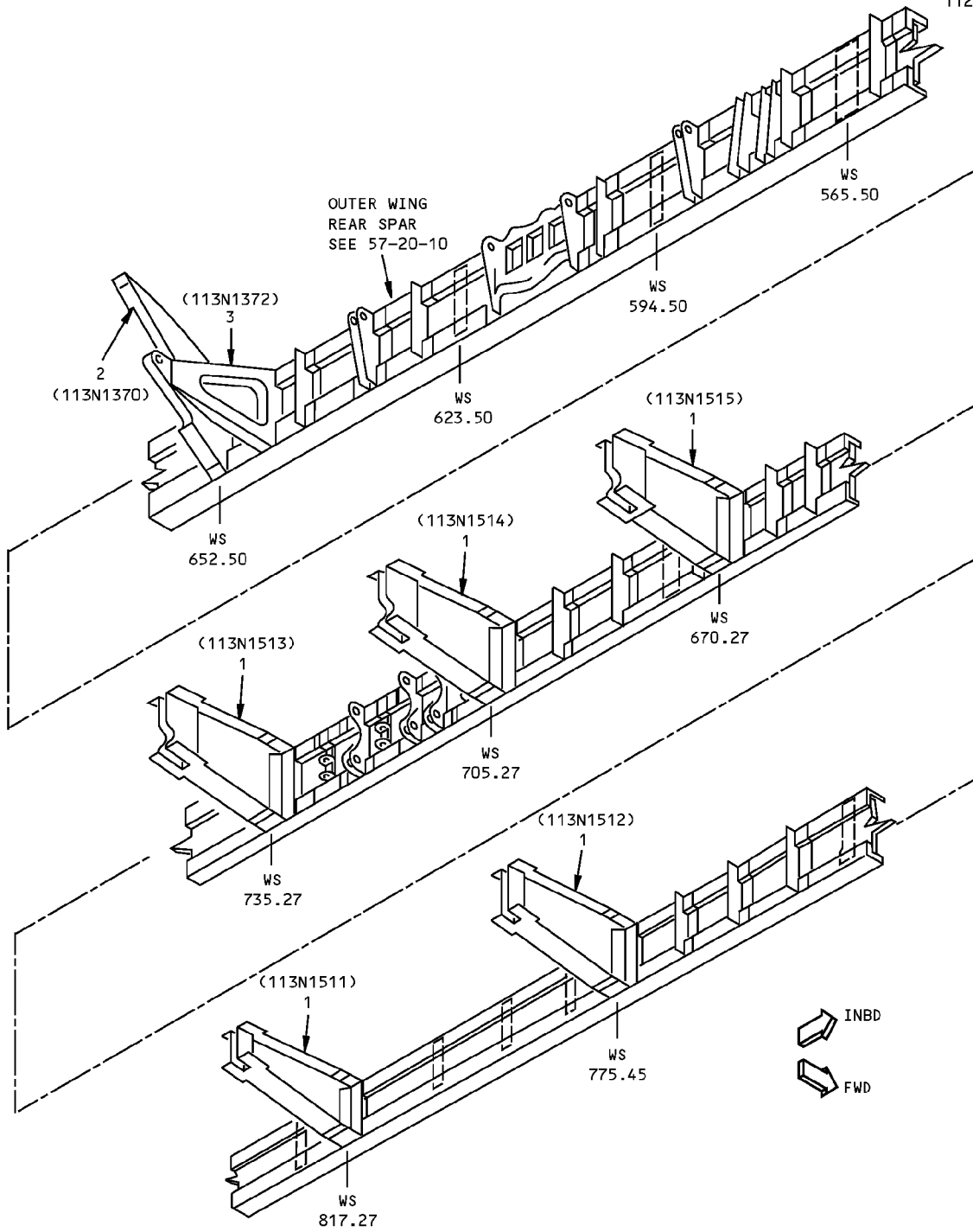

DETAIL I

**Trailing Edge Rib Identification
Figure 1 (Sheet 2 of 4)**

LIST OF
MATL



757-200
STRUCTURAL REPAIR MANUAL

ITEM	DESCRIPTION	GAGE	MATERIAL	EFFECTIVITY
1	RIB		FORGING 7075-T73 OPTIONAL: FORGED BLOCK 7075-T73	
2	RIB TRACK SUPPORT UPR TRACK	2.75 1.75	7075-T7351 4330M STEEL DIE FORGING HT TR 220-240 KSI 4330M STEEL HT TR 220-240 KSI	A
	LWR TRACK	2.0	4330M STEEL HT TR 220-240 KSI	
3	AUX RIB	2.0	7075-T7351	

LIST OF MATERIALS FOR DETAIL I

Trailing Edge Rib Identification
Figure 1 (Sheet 3 of 4)

D634N201

57-51-09

IDENTIFICATION 1
Page 3
Jan 20/2005

**757-200
STRUCTURAL REPAIR MANUAL**

REF DWG
112N1001

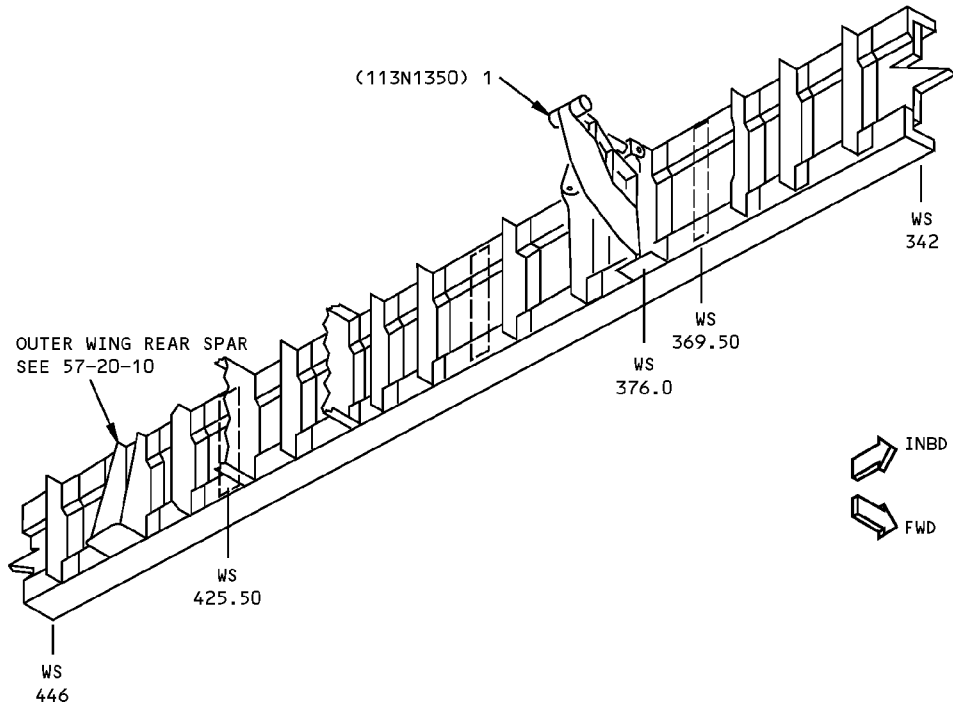

DETAIL II

ITEM	DESCRIPTION	GAGE	MATERIAL	EFFECTIVITY
1	DEFLECTION CONTROL RIB BEAM		7075-T73 DIE FORGING	
	BEAM SUPPORT		FORGED BLOCK 7075-T73	B
	SIDE BRACE		7075-T73 DIE FORGING FORGED BLOCK 7075-T73 MACHINED BAR 7075-T7351	B

LIST OF MATERIALS FOR DETAIL II

**Trailing Edge Rib Identification
Figure 1 (Sheet 4 of 4)**

IDENTIFICATION 1
Page 4
Jan 20/2005

57-51-09

D634N201

**757-200
STRUCTURAL REPAIR MANUAL**

ALLOWABLE DAMAGE 1 - TRAILING EDGE RIB

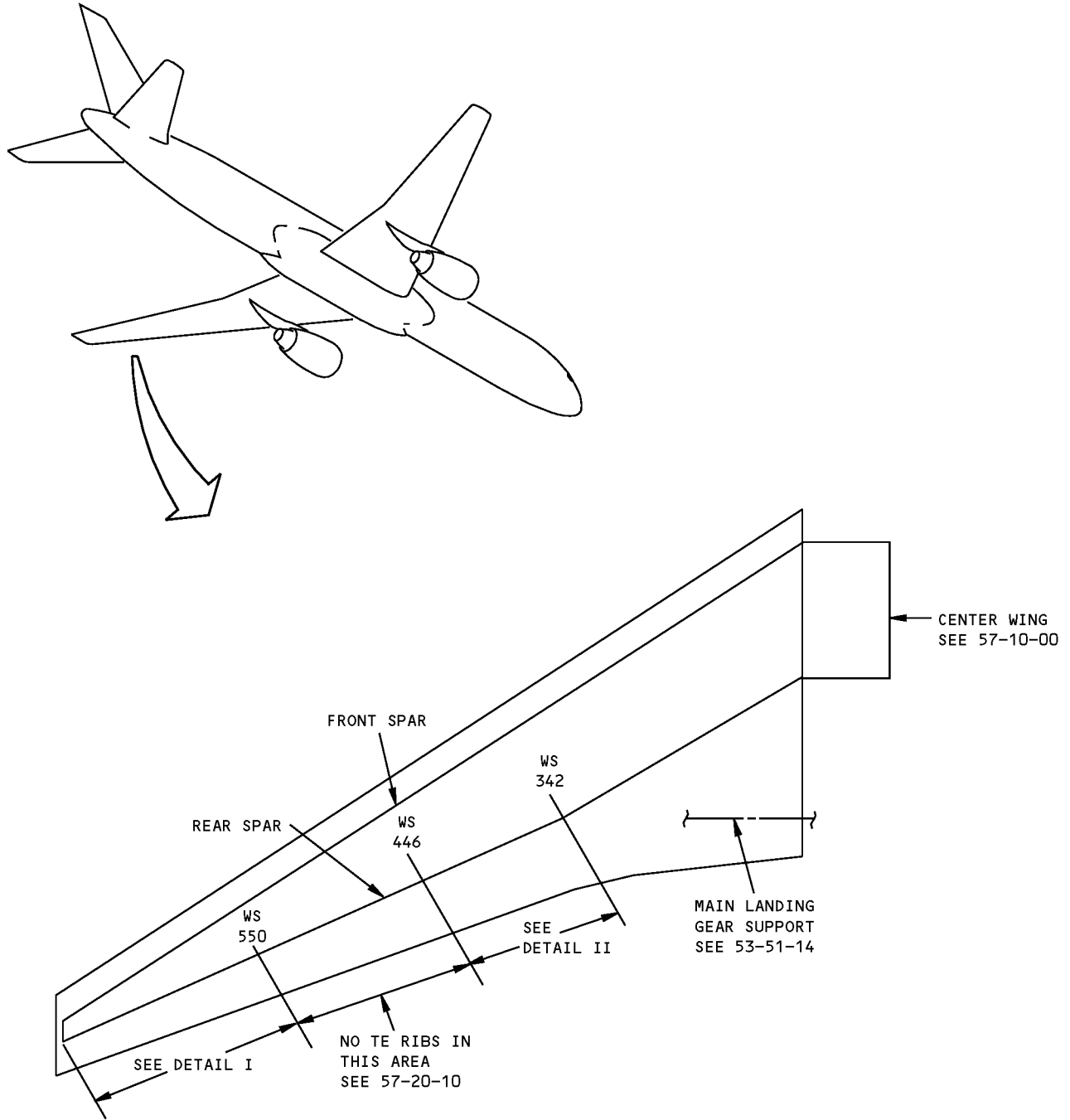

**Trailing Edge Rib Allowable Damage
Figure 101 (Sheet 1 of 6)**

**757-200
STRUCTURAL REPAIR MANUAL**

REF DWG
112N1001

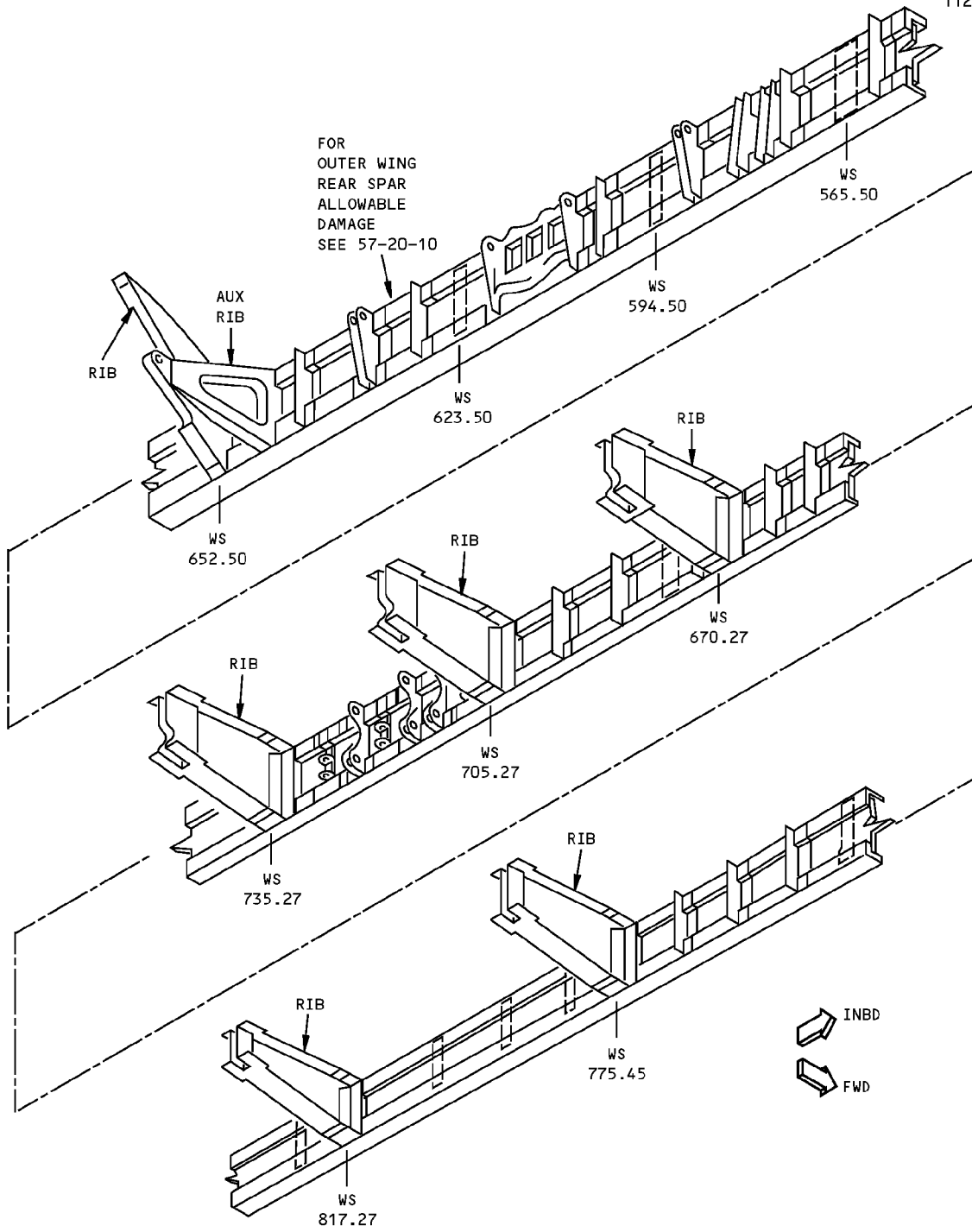

MATERIAL: ALUMINUM

DETAIL I

**Trailing Edge Rib Allowable Damage
Figure 101 (Sheet 2 of 6)**

D634N201

ALLOWABLE DAMAGE 1
57-51-09
Page 102
Jan 20/2005

**757-200
STRUCTURAL REPAIR MANUAL**

REF DWG
112N1001

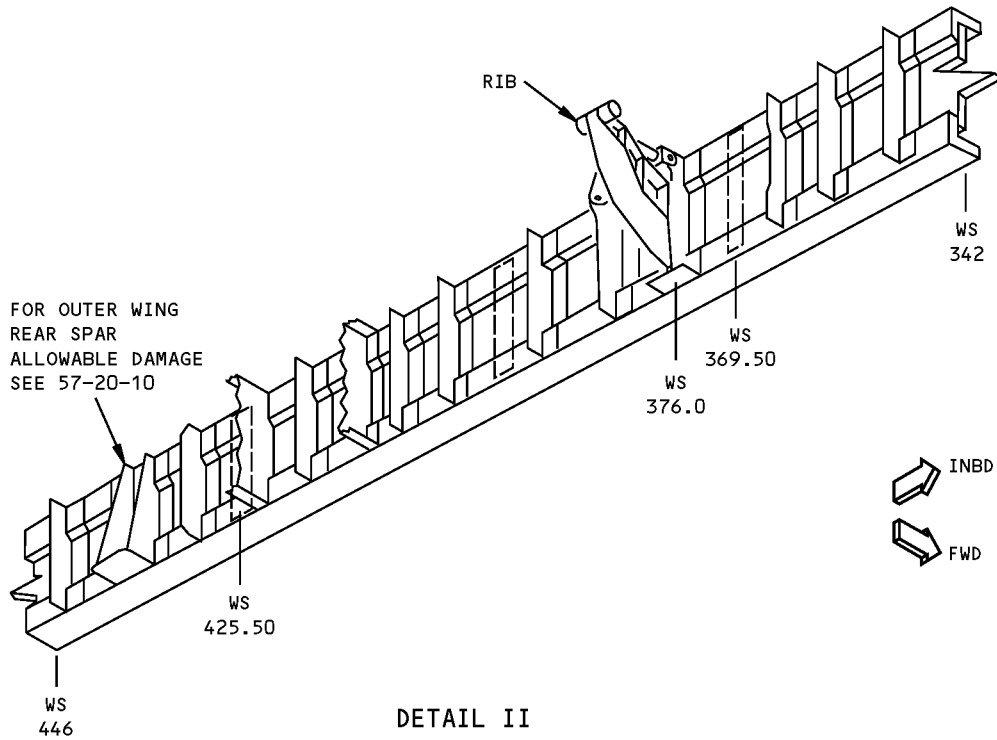

MATERIAL: ALUMINUM

**Trailing Edge Rib Allowable Damage
Figure 101 (Sheet 3 of 6)**

D634N201

ALLOWABLE DAMAGE 1
Page 103
57-51-09
Jan 20/2005



757-200
STRUCTURAL REPAIR MANUAL

DESCRIPTION	CRACKS	NICKS, GOUGES AND CORROSION	DENTS	HOLES AND PUNCTURES
RIB - WS 376.00 BEAM	A	G	NOT ALLOWED	NOT ALLOWED
BEAM SUPPORT	B	H	NOT ALLOWED	NOT ALLOWED
SIDE BRACE	B	H	NOT ALLOWED	NOT ALLOWED
RIB - WS 652.50 UPPER AND LOWER TRACK (STEEL)	C	I	NOT ALLOWED	NOT ALLOWED
TRACK SUPPORT (ALUMINUM)	D	J	NOT ALLOWED	NOT ALLOWED
AUX RIB (ALUMINUM)	D	J	NOT ALLOWED	NOT ALLOWED
RIB - WS 817.27	E	K	NOT ALLOWED	NOT ALLOWED
ALL OTHER RIBS	F	L	NOT ALLOWED	NOT ALLOWED

Trailing Edge Rib Allowable Damage
Figure 101 (Sheet 4 of 6)

STRUCTURAL REPAIR MANUAL

NOTES

- REFINISH REWORKED AREAS AS GIVEN IN AMM 51-20

- [A] CRACKS NOT ALLOWED EXCEPT FOR EDGE CRACKS, WHICH MUST BE REMOVED. SEE DETAILS III AND V. SHOT PEEN REWORKED AREAS AS GIVEN IN SOPM 20-10-03 WITH SHOT NO. 230-550, INTENSITY 0.006A TO 0.008A [M]
- [B] CRACKS NOT ALLOWED EXCEPT FOR EDGE CRACKS, WHICH MUST BE REMOVED. SEE DETAILS III AND V. SHOT PEEN REWORKED AREAS AS GIVEN IN SOPM 20-10-03 WITH SHOT NO. 230-550, INTENSITY 0.008A TO 0.010A [M]
- [C] CRACKS NOT ALLOWED EXCEPT FOR EDGE CRACKS, WHICH MUST BE REMOVED. SEE DETAILS III AND V. SHOT PEEN REWORKED AREAS AS GIVEN IN SOPM 20-10-03 WITH SHOT NO. 170-460, INTENSITY 0.006A [M]
- [D] CRACKS NOT ALLOWED EXCEPT FOR EDGE CRACKS, WHICH MUST BE REMOVED. SEE DETAILS III AND V. SHOT PEEN REWORKED AREAS AS GIVEN IN SOPM 20-10-03 WITH SHOT NO. 230-550, INTENSITY 0.004A TO 0.007A [M]
- [E] CRACKS NOT ALLOWED EXCEPT FOR EDGE CRACKS, WHICH MUST BE REMOVED. SEE DETAILS III AND V. SHOT PEEN REWORKED AREAS AS GIVEN IN SOPM 20-10-03 WITH SHOT NO. 230-280, INTENSITY 0.003A TO 0.005A [M]
- [F] CRACKS NOT ALLOWED EXCEPT FOR EDGE CRACKS, WHICH MUST BE REMOVED. SEE DETAILS III AND V. SHOT PEEN REWORKED AREAS AS GIVEN IN SOPM 20-10-03 WITH SHOT NO. 230-280, INTENSITY 0.006A TO 0.008A [M]
- [G] FOR EDGE DAMAGE, SEE DETAIL III. FOR OTHER DAMAGE, SEE DETAILS IV AND VI. SHOT PEEN REWORKED AREAS AS GIVEN IN SOPM 20-10-03 WITH SHOT NO. 230-550, INTENSITY 0.006A TO 0.008A [M]
- [H] FOR EDGE DAMAGE, SEE DETAIL III. FOR OTHER DAMAGE, SEE DETAILS IV AND VI. SHOT PEEN REWORKED AREAS AS GIVEN IN SOPM 20-10-03 WITH SHOT NO. 230-550, INTENSITY 0.006A TO 0.010A [M]
- [I] FOR EDGE DAMAGE, SEE DETAIL III. FOR OTHER DAMAGE, SEE DETAILS IV AND VI. SHOT PEEN REWORKED AREAS AS GIVEN IN SOPM 20-10-03 WITH SHOT NO. 170-460, INTENSITY 0.006A [M]
- [J] FOR EDGE DAMAGE, SEE DETAIL III. FOR OTHER DAMAGE, SEE DETAILS IV AND VI. SHOT PEEN REWORKED AREAS AS GIVEN IN SOPM 20-10-03 WITH SHOT NO. 230-550, INTENSITY 0.004A TO 0.007A [M]

- [K] FOR EDGE DAMAGE, SEE DETAIL III. FOR OTHER DAMAGE, SEE DETAILS IV AND VI. SHOT PEEN REWORKED AREAS AS GIVEN IN SOPM 20-10-03 WITH SHOT NO. 230-280, INTENSITY 0.003A TO 0.005A [M]
- [L] FOR EDGE DAMAGE, SEE DETAIL III. FOR OTHER DAMAGE, SEE DETAILS IV AND VI. SHOT PEEN REWORKED AREAS AS GIVEN IN SOPM 20-10-03 WITH SHOT NO. 230-280, INTENSITY 0.006A TO 0.008A [M]
- [M] SHOT PEEN INTENSITIES SHOWN FOR MANUFACTURED COMPONENTS. REFER TO SRM 51-20-06 FOR SHOT PEEN INTENSITIES REQUIRED DUE TO THICKNESS REDUCTION RESULTING FROM REWORK.

Trailing Edge Rib Allowable Damage
Figure 101 (Sheet 5 of 6)

STRUCTURAL REPAIR MANUAL

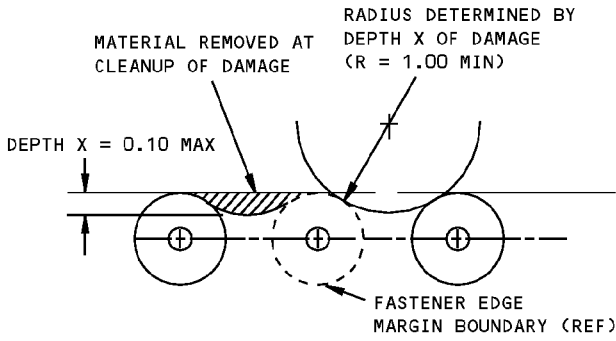

DAMAGE CLEANUP OF EDGES WHERE FASTENER EDGE MARGINS DO NOT OVERLAP

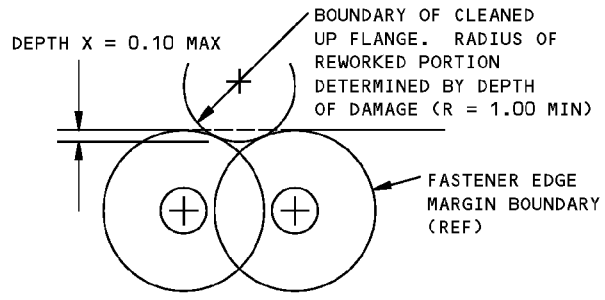

DAMAGE CLEANUP OF EDGES WHERE FASTENER EDGE MARGINS OVERLAP

DETAIL III

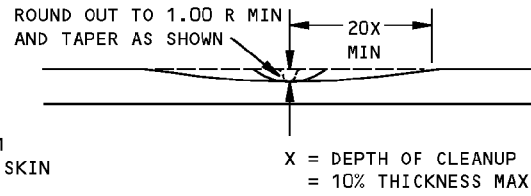
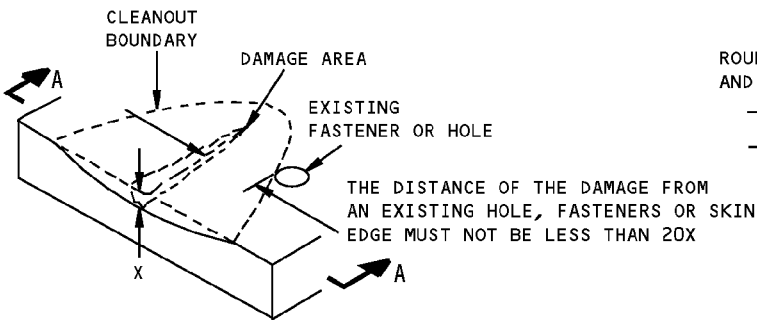

SECTION A-A

REMOVAL OF NICK, GOUGE AND SCRATCH DAMAGE ON A SURFACE

DETAIL IV

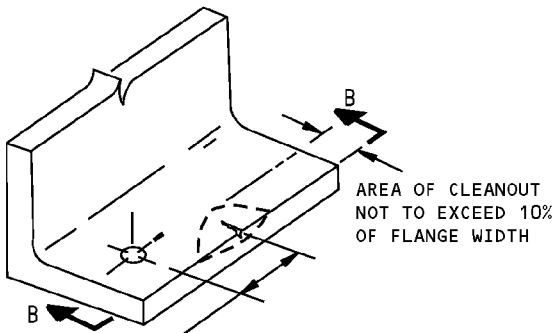

THE DISTANCE OF THE DAMAGE FROM AN EXISTING HOLE, FASTENERS OR EDGE MUST NOT BE LESS THAN 20X

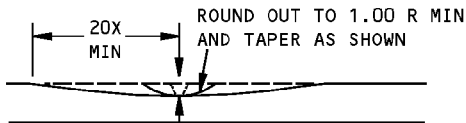

X = DEPTH OF CLEANUP = 10% THICKNESS MAX

SECTION B-B

REMOVAL OF NICK OR CRACK DAMAGE ON AN EDGE

DETAIL V

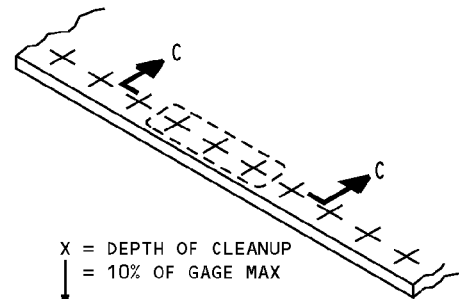

X = DEPTH OF CLEANUP = 10% OF GAGE MAX

SMOOTH BLENDOUT RADIUS 0.50 INCH MINIMUM. CORROSION CLEANUP AROUND ANY THREE FASTENERS IN TEN IS PERMITTED TO MAX DEPTH

SECTION C-C

CORROSION CLEANUP

DETAIL VI

**Trailing Edge Rib Allowable Damage
Figure 101 (Sheet 6 of 6)**



757-200
STRUCTURAL REPAIR MANUAL

IDENTIFICATION 1 - MAIN LANDING GEAR SUPPORT BEAM

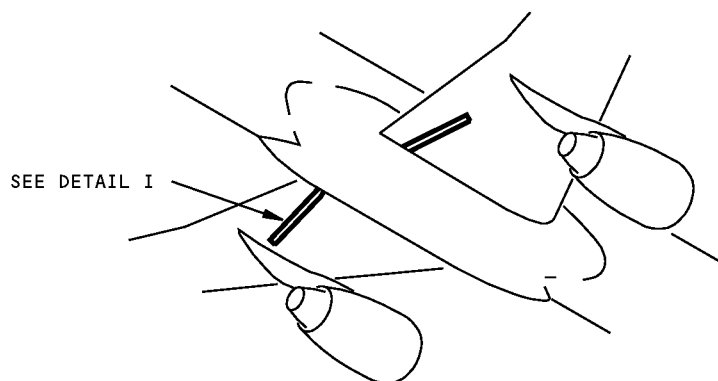

NOTES

A FOR CUM LINE NUMBERS: 1 THRU 12
OPTIONAL FOR CUM LINE NUMBER: 13
BEAM IS MADE OF TWO PIECES

B OPTIONAL FOR CUM LINE NUMBERS:
1 THRU 21
(BOEING REF: N0022 THRU N0057,
N3001 THRU N3010)

Main Landing Gear Support Beam Identification
Figure 1 (Sheet 1 of 3)

D634N201

57-51-14

IDENTIFICATION 1
Page 1
Jan 20/2005

**757-200
STRUCTURAL REPAIR MANUAL**

REF DWG
113N1001

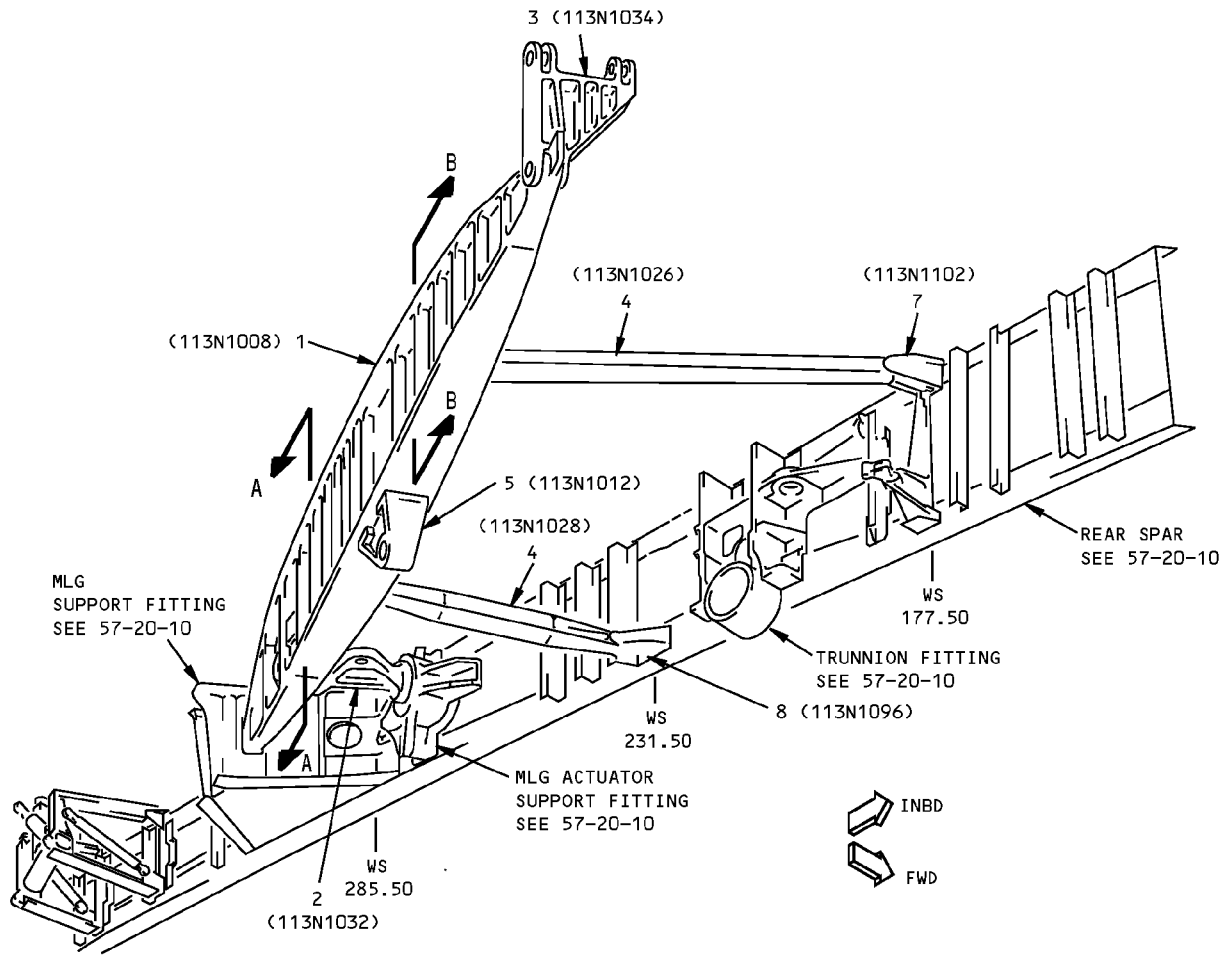

LEFT SIDE SHOWN
RIGHT SIDE SIMILAR
DETAIL I

LIST OF
MATL

**Main Landing Gear Support Beam Identification
Figure 1 (Sheet 2 of 3)**

IDENTIFICATION 1
Page 2
Jan 20/2005

57-51-14

D634N201

**757-200
STRUCTURAL REPAIR MANUAL**

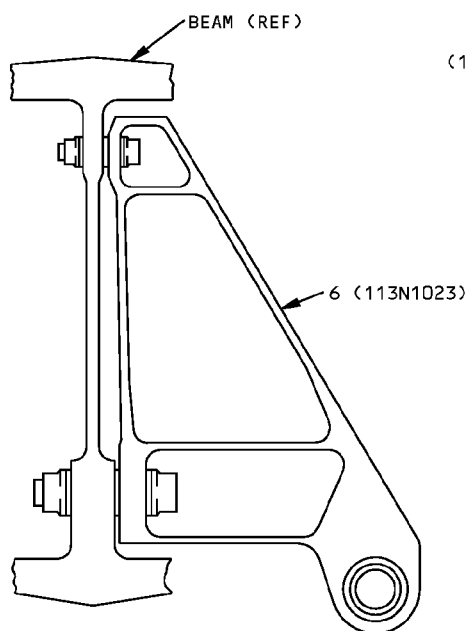

SECTION A-A

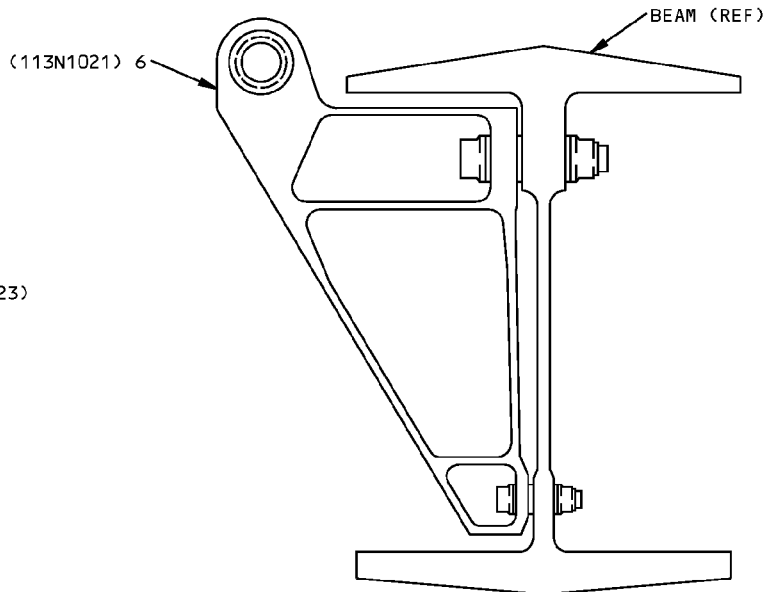

SECTION B-B

ITEM	DESCRIPTION	GAGE	MATERIAL	EFFECTIVITY
1	BEAM		TI-6AL-4V DIE FORGING	A
2	YOKE		TI-6AL-4V FORGED BLOCK OR DIE FORGING	
3	SUPPORT LINK		7050-T73652 FORGED BLOCK OR DIE FORGING OR 7050-T74 FORGING	B
4	STABILIZING LINK		TI-6AL-4V FORGED BLOCK OR DIE FORGING	
5	TRUNNION SUPPORT FITTING		TI-6AL-4V FORGED BLOCK OR DIE FORGING	
6	STABILIZER SUPPORT FITTING		TI-6AL-4V FORGED BLOCK OR DIE FORGING	
7	JURY PIVOT FITTING		7075-T73 FORGED BLOCK OR DIE FORGING	
8	STABILIZING SUPPORT FITTING		TI-6AL-4V FORGED BLOCK	

LIST OF MATERIALS FOR DETAIL I

**Main Landing Gear Support Beam Identification
Figure 1 (Sheet 3 of 3)**

**757-200
STRUCTURAL REPAIR MANUAL**

ALLOWABLE DAMAGE 1 - MAIN LANDING GEAR SUPPORT BEAM

REF DWG
113N1001

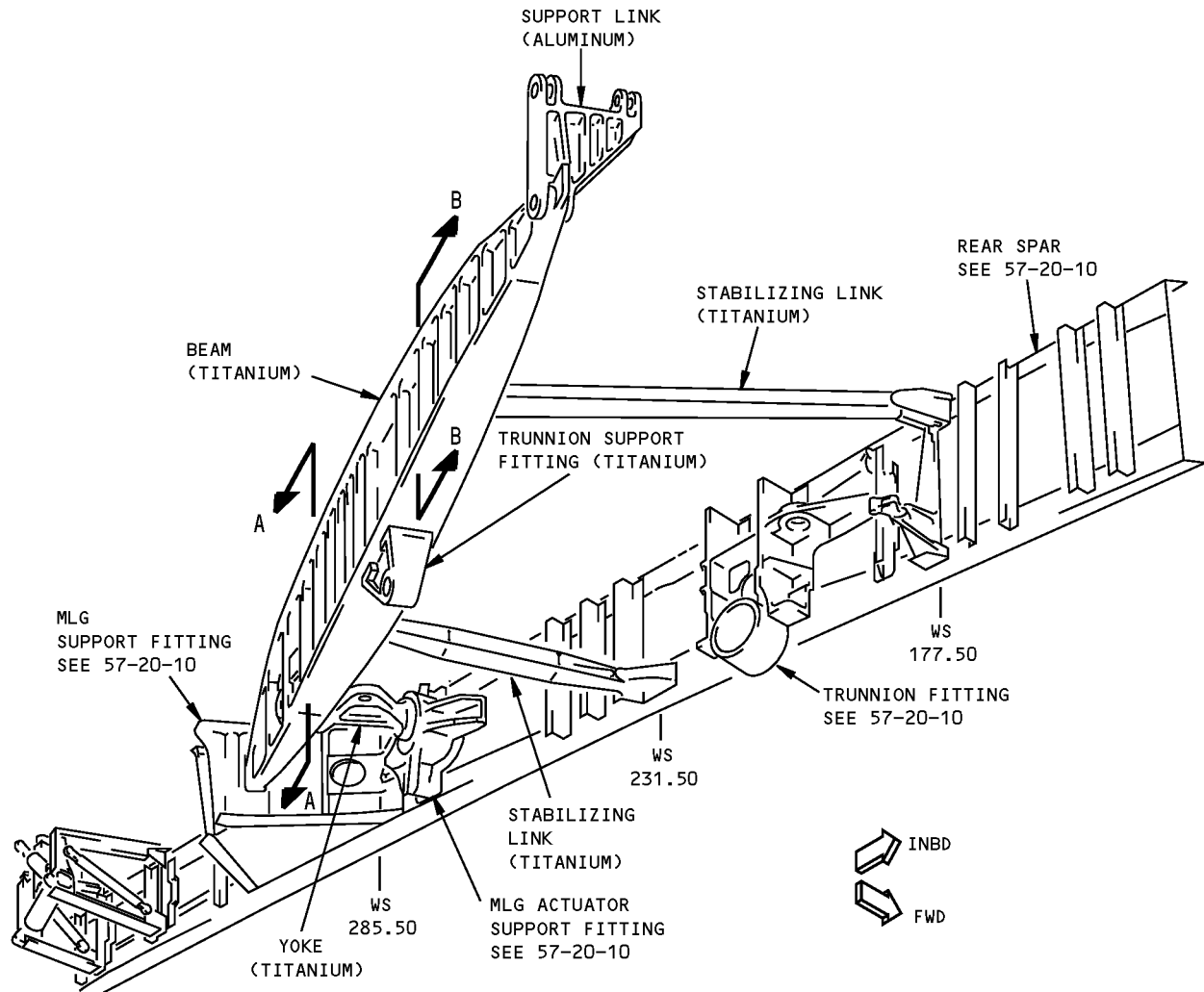
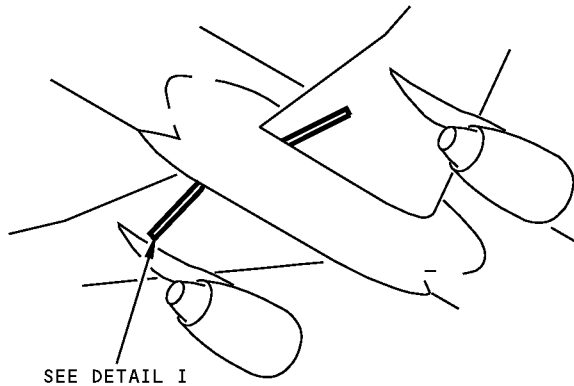

DETAIL I

**Main Landing Gear Support Beam Allowable Damage
Figure 101 (Sheet 1 of 3)**

**757-200
STRUCTURAL REPAIR MANUAL**

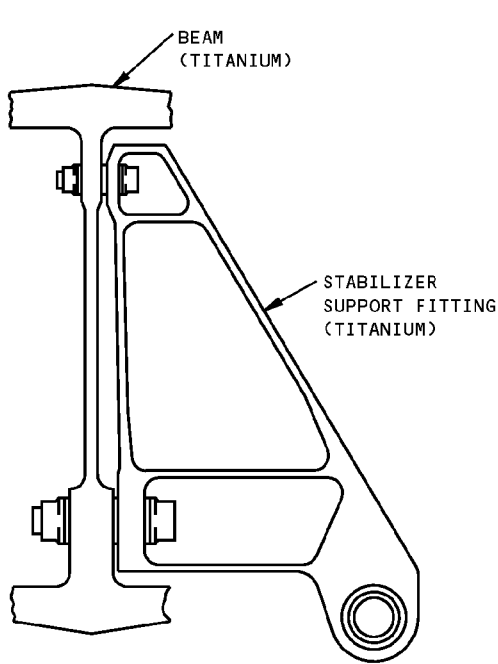

SECTION A-A

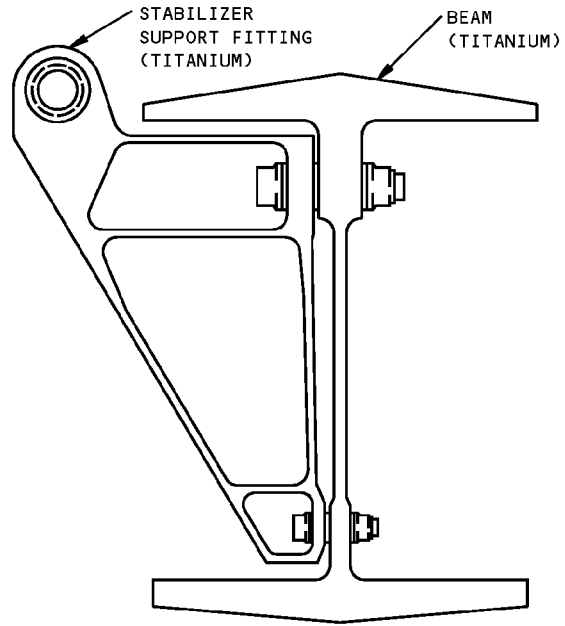

SECTION B-B

DESCRIPTION	CRACKS	NICKS, GOUGES AND CORROSION	DENTS	HOLES AND PUNCTURES
BEAM	A	B	NOT PERMITTED	NOT PERMITTED
SUPPORT LINK	A	B	NOT PERMITTED	NOT PERMITTED
YOKE	A	B	NOT PERMITTED	NOT PERMITTED
TRUNNION SUPPORT FTG	A	B	NOT PERMITTED	NOT PERMITTED
STABILIZER SUPPORT FTG	A	B	NOT PERMITTED	NOT PERMITTED
STABILIZING LINK	A	B	NOT PERMITTED	NOT PERMITTED

NOTES

- SHOT PEEN REWORKED AREAS PER AS GIVEN IN SRM 51-20-06.
- REFINISH REWORKED AREAS AS GIVEN IN AMM 51-20.

A CRACKS NOT ALLOWED EXCEPT FOR EDGE CRACKS WHICH MUST BE REMOVED AS SHOWN IN DETAIL IV.

B FOR EDGE DAMAGE SEE DETAIL IV. FOR LUG DAMAGE SEE DETAIL III. FOR OTHER DAMAGE SEE DETAIL II. 0.01 MAX DAMAGE CLEANUP IS ALLOWED IN VICINITY OF BUSHINGS.

**Main Landing Gear Support Beam Allowable Damage
Figure 101 (Sheet 2 of 3)**

**757-200
STRUCTURAL REPAIR MANUAL**

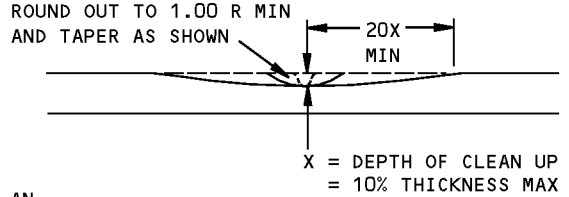
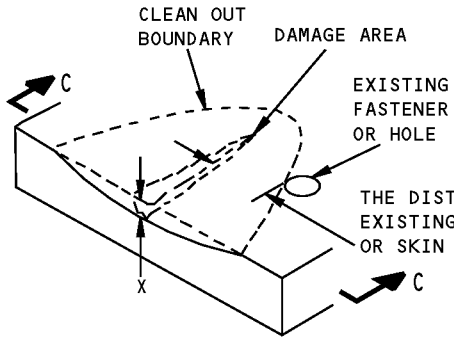

SECTION C-C

THE AREA REMOVED FOR CLEAN UP MUST NOT EXCEED 4% OF THE CROSS SECTIONAL AREA

**REMOVAL OF NICK, GOUGE AND SCRATCH DAMAGE ON A SURFACE
DETAIL II**

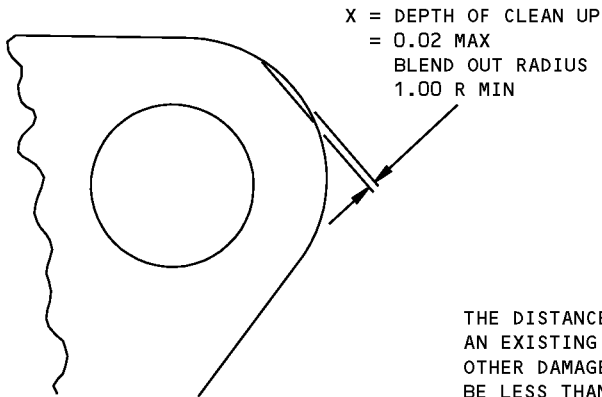

**DAMAGE CLEAN UP FOR EDGES OF LUG
DETAIL III**

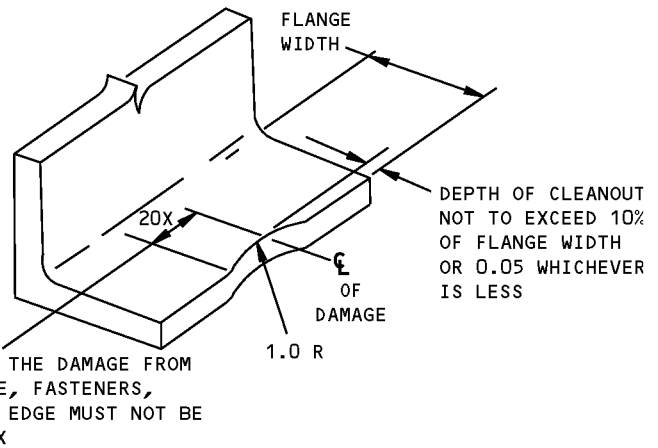

**REMOVAL OF EDGE DAMAGE FROM
FREE FLANGE WITHOUT FASTENERS
DETAIL IV**

**Main Landing Gear Support Beam Allowable Damage
Figure 101 (Sheet 3 of 3)**

ALLOWABLE DAMAGE 1

57-51-14

Page 103
Jan 20/2005

D634N201

**757-200
STRUCTURAL REPAIR MANUAL**

REPAIR GENERAL - MAIN LANDING GEAR SUPPORT BEAM REPAIR

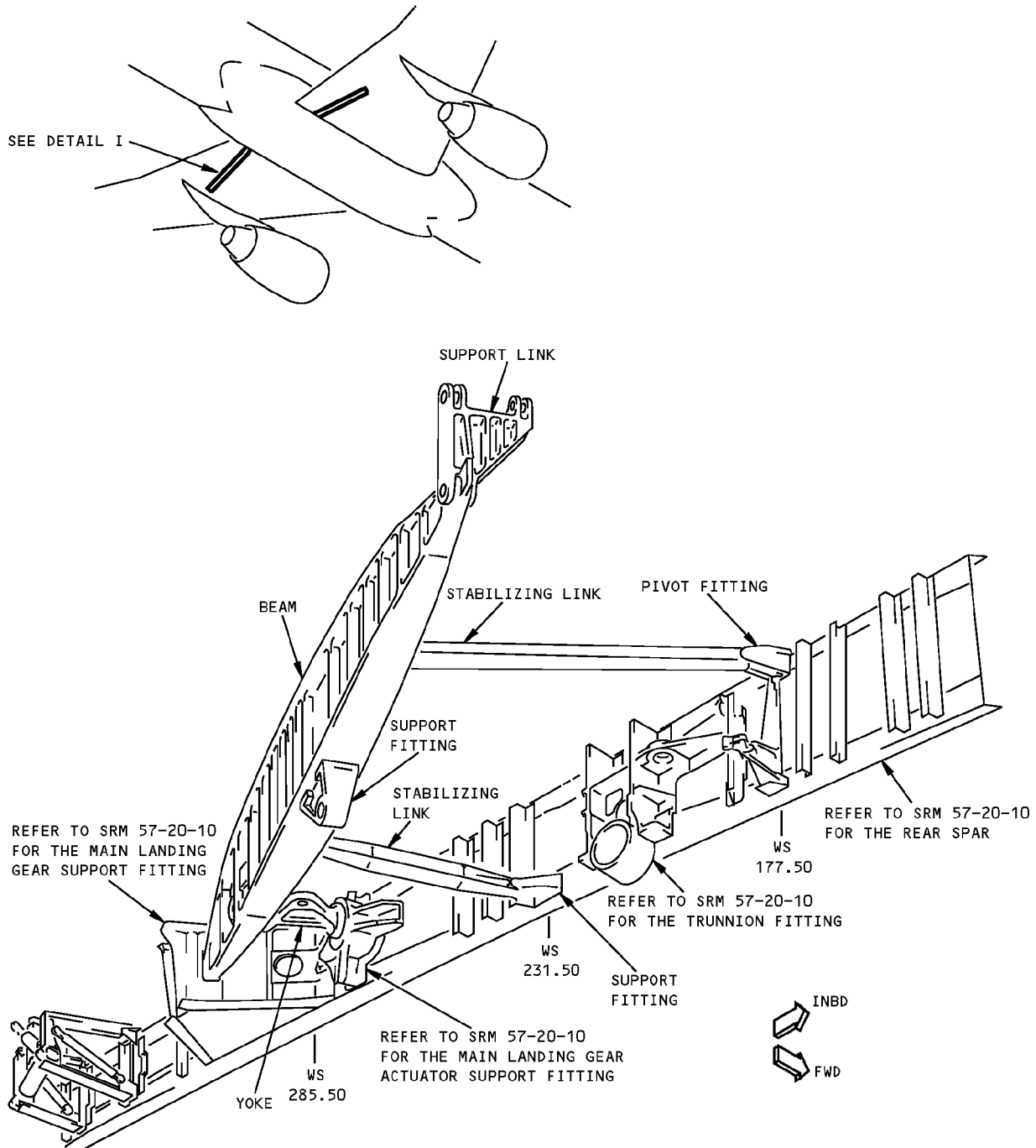

LEFT SIDE IS SHOWN, RIGHT SIDE IS SIMILAR
DETAIL I

NOTES

- NO REPAIRS ARE PERMITTED TO FITTINGS OR OTHER FORGED STRUCTURAL ITEMS

**Main Landing Gear Support Beam Repair
Figure 201**



757-200
STRUCTURAL REPAIR MANUAL

IDENTIFICATION GENERAL - TRUNNION FAIRING SKIN

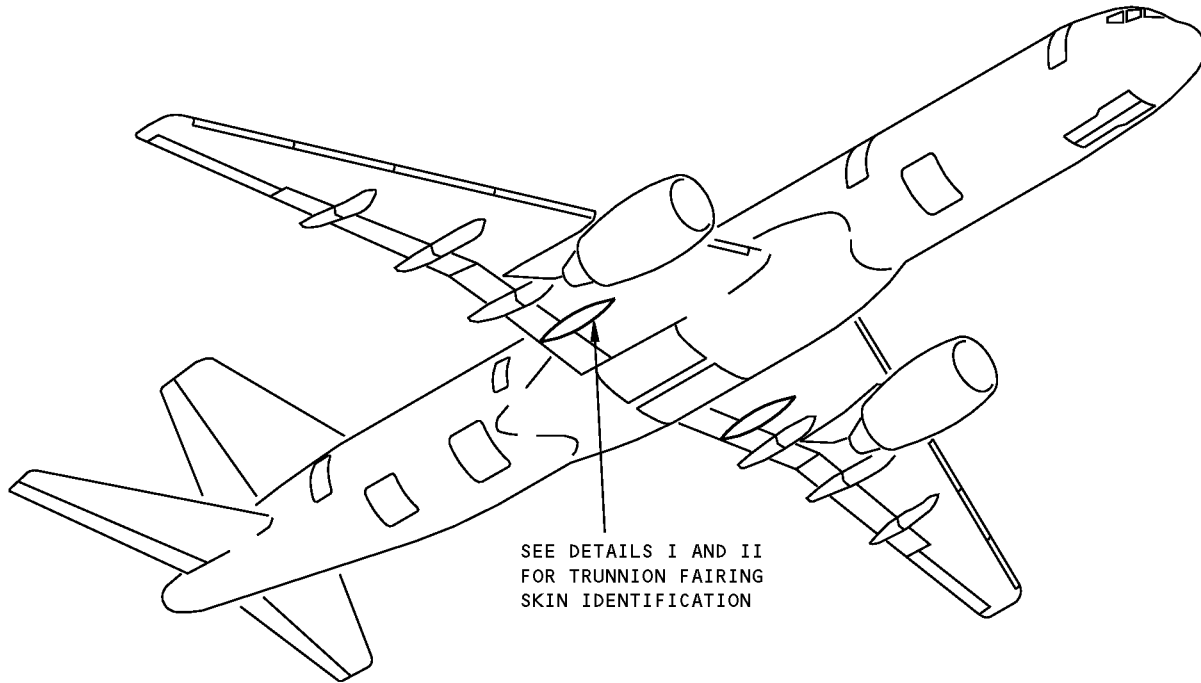

NOTES

- | | |
|--|--|
| A PLY ORIENTATION CONVENTION, DEGREES INDICATED, IS PARALLEL TO THE FABRIC WARP DIRECTION | E GLASS FABRIC PER BMS 9-3, TYPE D, STYLE 120, WITH RESIN PER BMS 8-201, ROOM TEMP CURE |
| B GLASS FABRIC PER BMS 8-79, CLASS III, GRADE 1, TYPE 120, 250°F (121°C) CURE | F GLASS FABRIC PER BMS 8-79, CLASS III, GRADE 1, TYPE 1581, 250°F (121°C) CURE |
| C GRAPHITE FABRIC PER BMS 8-168, CLASS II, TYPE II, STYLE 3K-70-PW, 250°F (121°C) CURE | G FOR CUM LINE NUMBERS:
1 THRU 54 |
| D KEVLAR FABRIC PER BMS 8-219, STYLE 285, 250°F (121°C) CURE | H FOR CUM LINE NUMBERS:
55 AND ON |

Trunnion Fairing Skin Identification
Figure 1 (Sheet 1 of 5)

**757-200
STRUCTURAL REPAIR MANUAL**

REF DWG
113N1800

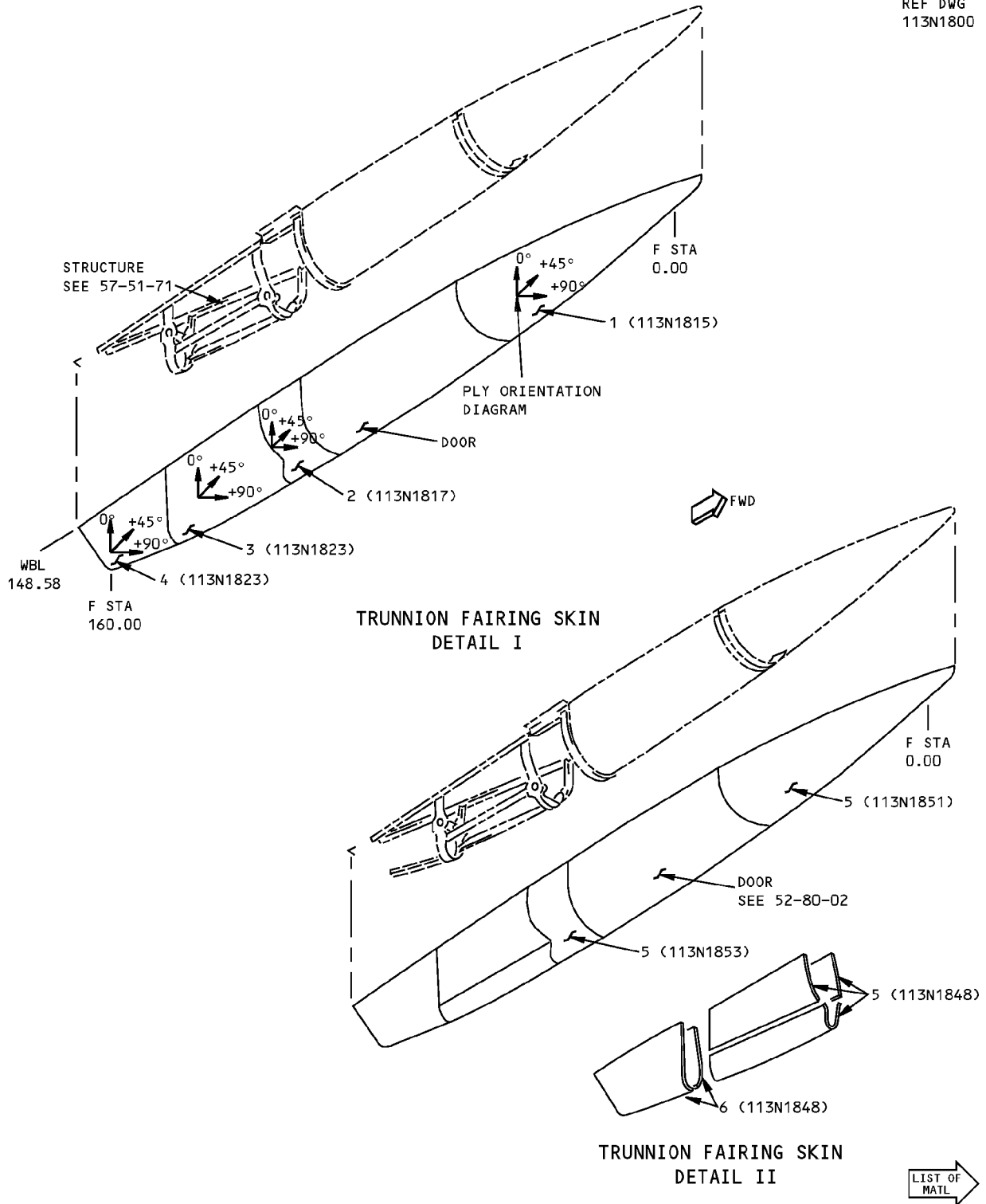

**Trunnion Fairing Skin Identification
Figure 1 (Sheet 2 of 5)**

IDENTIFICATION GENERAL

57-51-70

Page 2
Jan 20/2005

D634N201



**757-200
STRUCTURAL REPAIR MANUAL**

ITEM	DESCRIPTION	GAGE	MATERIAL	EFFECTIVITY
1	FORWARD PANEL SKIN CORE		GLASS FABRIC/GRAPHITE EPOXY HONEYCOMB SANDWICH SEE DETAIL III NOMEX HONEYCOMB PER BMS 8-124, CLASS IV, TYPE V, GRADE 3.0	G
2	MID PANEL SKIN CORE		KEVLAR/GRAPHITE EPOXY HONEYCOMB SANDWICH SEE DETAIL IV NOMEX HONEYCOMB PER BMS 8-124, CLASS IV, TYPE V, GRADE 3.0	G
3	MID PANEL SKIN CORE		KEVLAR/GRAPHITE EPOXY HONEYCOMB SANDWICH SEE DETAIL V NOMEX HONEYCOMB PER BMS 8-124, CLASS IV, TYPE V, GRADE 3.0	G
4	AFT PANEL SKIN		ARAMID/GRAPHITE/EPOXY LAMINATE SEE DETAIL V	G
5	PANEL SKIN CORE LEADING EDGE INSERT	0.063	GLASS FABRIC EPOXY HONEYCOMB SANDWICH SEE DETAIL V NOMEX HONEYCOMB PER BMS 8-124, CLASS IV, TYPE V, GRADE 3.0 5052-H34	H
6	PANEL SKIN CORE		GLASS FABRIC EPOXY HONEYCOMB SANDWICH SEE DETAIL V NOMEX HONEYCOMB PER BMS 8-124, CLASS IV, TYPE V, GRADE 3.0	H

LIST OF MATERIALS FOR DETAILS I AND II

**Trunnion Fairing Skin Identification
Figure 1 (Sheet 3 of 5)**

IDENTIFICATION GENERAL

57-51-70

Page 3
Jan 20/2005

D634N201

**757-200
STRUCTURAL REPAIR MANUAL**

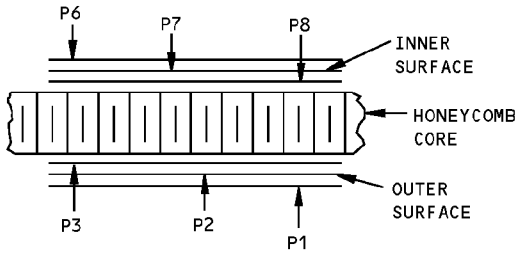

**ITEM NO. 1
SECTION THRU HONEYCOMB PANEL**

ITEM NO.	PLY NO.	MATERIAL	PLY ORIENTATION ^A
1	1	D	0° OR 90°
	2	D	
	3	C	
	6	D	
	7	D	
	8	C	

MATERIAL AND PLY ORIENTATION SHOWN FOR FIELD AREAS ONLY. SEE BOEING DRAWINGS FOR EDGE BANDS AND AREAS WITH DOUBLERS. SEE DETAIL I FOR PLY ORIENTATION

DETAIL III

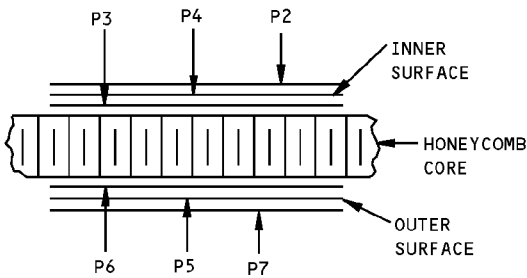

**ITEM NO. 2
SECTION THRU HONEYCOMB PANEL**

ITEM NO.	PLY NO.	MATERIAL	PLY ORIENTATION ^A
2	2	D	0° OR 90°
	3	C	
	4	D	
	5	D	
	6	C	
	7	D	

MATERIAL AND PLY ORIENTATION SHOWN FOR FIELD AREAS ONLY. SEE BOEING DRAWINGS FOR EDGE BANDS AND AREAS WITH DOUBLERS. SEE DETAIL I FOR PLY ORIENTATION

DETAIL IV

**Trunnion Fairing Skin Identification
Figure 1 (Sheet 4 of 5)**

IDENTIFICATION GENERAL

57-51-70

Page 4
Jan 20/2005

D634N201

**757-200
STRUCTURAL REPAIR MANUAL**

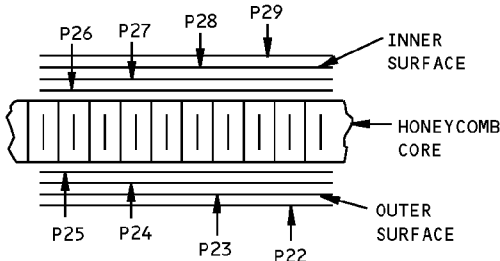

**ITEM NO. 3
SECTION THRU HONEYCOMB PANEL**

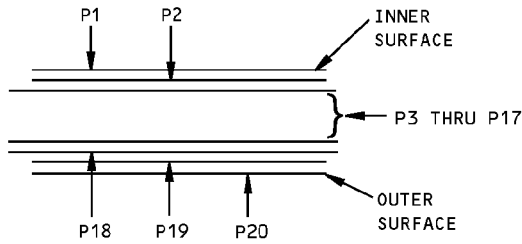

**ITEM NO. 4
SECTION THRU LAMINATE**

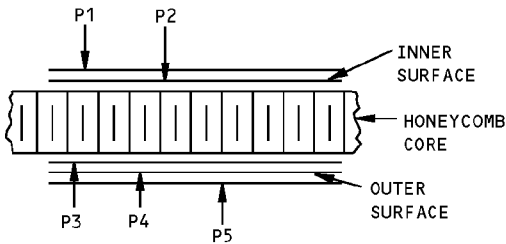

**ITEM NO. 5
SECTION THRU HONEYCOMB PANEL**

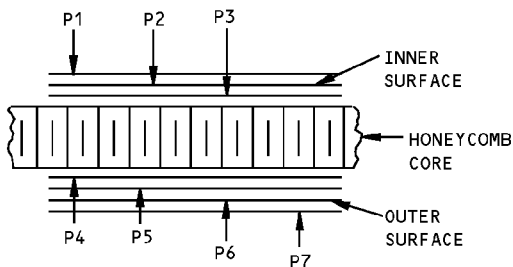

**ITEM NO. 6
SECTION THRU HONEYCOMB PANEL**

ITEM NO.	PLY NO.	MATERIAL	PLY ORIENTATION ^[A]
3	22	D	0° OR 90°
	23	C	
	24	C	± 45°
	25	C	0° OR 90°
	26	C	
	27	C	± 45°
	28	C	0° OR 90°
29	D		
4	1	B	0° OR 90°
	2	D	
	P3 THRU P17	C	
	18	D	
	19	E	
5	1	F	0° OR 90°
	2	F	
	3	F	
	4	F	
	5	B	
6	1	F	0° OR 90°
	2	F	
	3	F	
	4	F	
	5	F	
	6	F	
	7	B	

MATERIAL AND PLY ORIENTATION SHOWN FOR FIELD AREAS ONLY. SEE BOEING DRAWINGS FOR EDGE BANDS AND AREAS WITH DOUBLERS. SEE DETAIL I FOR PLY ORIENTATION

DETAIL V

**Trunnion Fairing Skin Identification
Figure 1 (Sheet 5 of 5)**

IDENTIFICATION GENERAL

57-51-70

Page 5
Jan 20/2005

D634N201

**757-200
STRUCTURAL REPAIR MANUAL**

ALLOWABLE DAMAGE 1 - TRUNNION FAIRING SKIN

REF DWG
113N1800

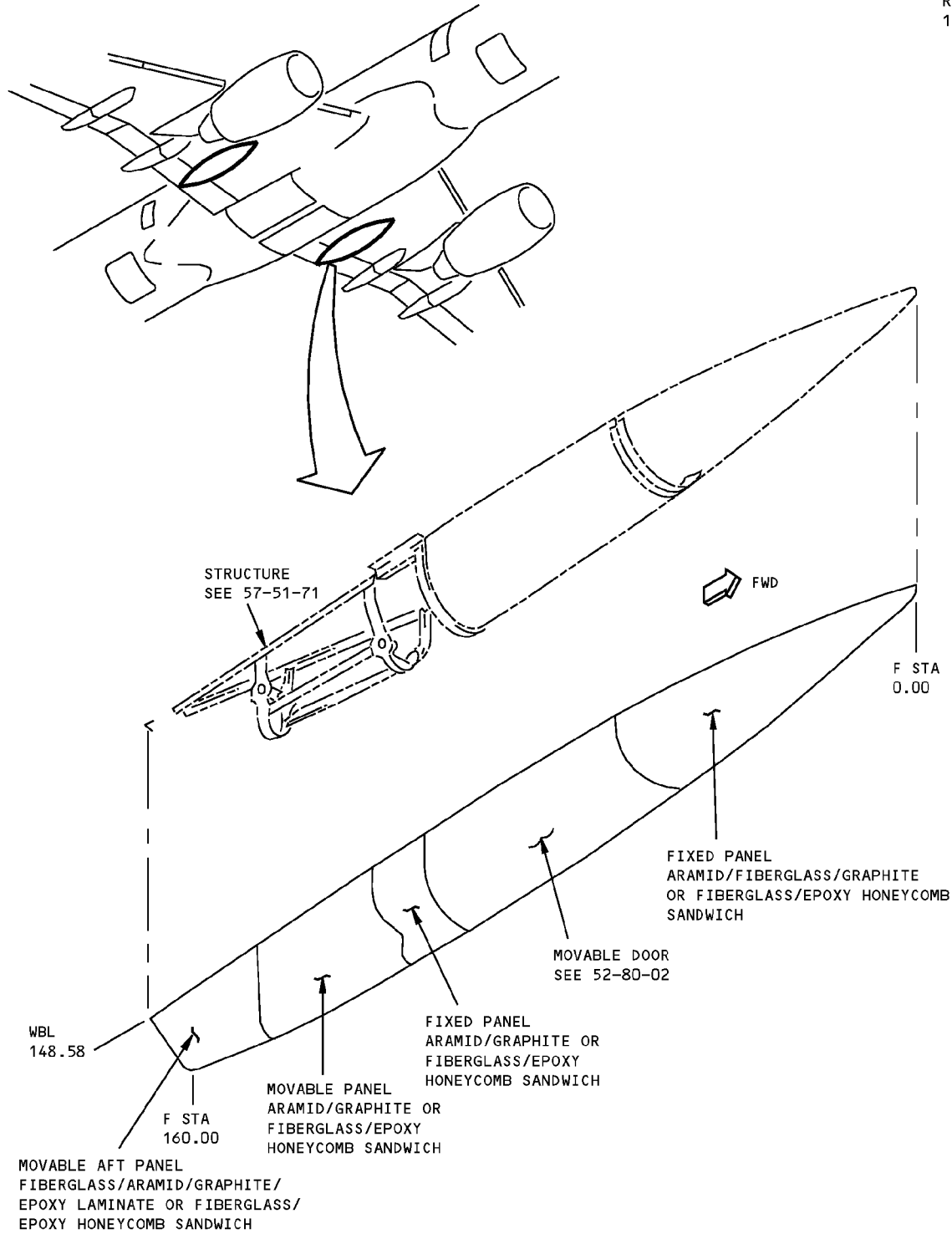

**Trunnion Fairing Skin Allowable Damage
Figure 101 (Sheet 1 of 3)**

STRUCTURAL REPAIR MANUAL

DESCRIPTION	CRACKS	NICKS, GOUGES AND CORROSION	DENTS	HOLES AND PUNCTURES	PANEL DELAMINATION	EDGE EROSION
FIXED PANEL	[B]	[C]	[D]	[E]	[F]	SEE DETAIL III
MOVABLE PANEL	[G]	[C]	[D]	[E]	[F]	SEE DETAIL III
AFT PANEL	[G]	[C]	[D]	[E]	[H]	SEE DETAIL III

NOTES

- REFINISH REWORKED AREAS PER AMM 51-20.
- REFER TO SRM 51-10-02 FOR INSPECTION AND REMOVAL OF DAMAGE.

REFER TO SRM 51-10-01 FOR AERODYNAMIC SMOOTHNESS REQUIREMENTS. WHERE THE DAMAGE EXCEEDS THE LIMITS SHOWN IN SRM 51-10-01, CONSIDERATION SHOULD BE GIVEN TO THE LOSS OF PERFORMANCE INVOLVED.
- TYPICAL DAMAGE TO A PANEL EDGE BAND MAY CONSIST OF EDGE CRUSHING, CRACKS OR DELAMINATION. DAMAGE AROUND HOLES MAY CONSIST OF OVALIZATION, FASTENER PULL-THROUGH OR CRACKS OUT OF HOLE. DAMAGE MAY REDUCE THE EFFECTIVE CROSS SECTIONAL AREA OF AN EDGE BAND. DAMAGE TO EDGES SHOULD BE BLENDED OUT TO LIMITATIONS GIVEN FOR COMPONENT.

- [A] REMOVE MOISTURE FROM DAMAGE AREA. USE OF VACUUM AND HEAT (MAX OF 125°F (52°C)) TO REMOVE MOISTURE FROM HONEYCOMB CELLS IS RECOMMENDED. PROTECT DAMAGE FROM ENTRANCE OF WATER, SUNLIGHT OR OTHER FOREIGN MATTER BY SEALING WITH ALUMINUM FOIL TAPE (SPEED TAPE). RECORD THE LOCATION AND INSPECT EVERY AIRPLANE "A" CHECK. REPLACE THE ALUMINUM FOIL TAPE IF ANY PEELING OR DETEIORATION EVIDENT. REPAIR NO LATER THAN NEXT AIRPLANE "C" CHECK. [I]
- [B] 1.0 INCH (25 mm) MAX LENGTH ALLOWED IN HONEYCOMB AREA PER SQUARE FOOT OF AREA AND A MINIMUM OF 6 INCHES FROM ANY OTHER CRACK. CLEAN UP EDGE CRACKS PER DETAILS I AND II. CRACKS THROUGH CONSECUTIVE FASTENERS OR THROUGH THE PANEL EDGE-BAND ARE ALLOWED PROVIDED DAMAGE DOES NOT EXCEED 10% OF EDGE-BAND LENGTH PER SIDE. [A]
- [C] DAMAGE ALLOWED ON SURFACE RESIN ONLY. DAMAGE TO FIBERS NOT ALLOWED. CLEAN UP EDGE DAMAGE PER DETAILS I AND II. [A]

- [D] DENTS GENERALLY RESULT IN FIBER DAMAGE OR DELAMINATION. HOWEVER, IF THERE IS NO FIBER DAMAGE OR DELAMINATION, DENTS UP TO 1.50 INCH (38 mm) DIA MAX ARE ALLOWED. ONE DENT PER SQUARE FOOT OF AREA ALLOWED WHICH MUST BE A MINIMUM OF 6 INCHES (150 mm) FROM ANY OTHER DAMAGE, FASTENER HOLE, OR PANEL EDGE. SEE [E], [F] OR [H] IF FIBER DAMAGE OR DELAMINATION IS PRESENT.
- [E] 1.0 (25 mm) MAX DIA ALLOWED PROVIDED DAMAGE IS MIN OF 2.5 INCHES (63 mm) DIA FROM OTHER DAMAGE, NEAREST HOLE, OR MATERIAL EDGE. DO NOT CLEAN UP DAMAGE EXCEPT TO REMOVE RESIN BURRS EXTENDING INTO SURFACE CONTOUR. [A]
- [F] 1.0 INCH (25 mm) MAX DIA IS ALLOWED IN HONEYCOMB AREA. A MAXIMUM OF 0.10 INCH (2.5 mm) DELAMINATION FROM EDGE IS ALLOWED. REPAIR DELAMINATION IN HONEYCOMB AREA PER 51-70 NO LATER THAN THE NEXT "C" CHECK. PROTECT EDGE DAMAGE PER [A].
- [G] CRACKS NOT ALLOWED EXCEPT FOR EDGE CRACKS WHICH MUST BE REMOVED PER DETAILS I AND II. MAINTAIN EDGE MARGIN SHOWN. REFINISH OR [A].
- [H] FOR LAMINATE STRUCTURE, 1.0 SQUARE INCH (6.5 SQUARE cm) IS ALLOWED WITHOUT REWORK. PROTECT EDGE DAMAGE PER [A]. SEE [F] FOR HONEYCOMB SANDWICH CONFIGURATION.
- [I] THIS REPAIR HAS FAA APPROVAL CONTINGENT ON ACCOMPLISHMENT OF THE INSPECTIONS CONTAINED HEREIN.

**Trunnion Fairing Skin Allowable Damage
Figure 101 (Sheet 2 of 3)**

**757-200
STRUCTURAL REPAIR MANUAL**

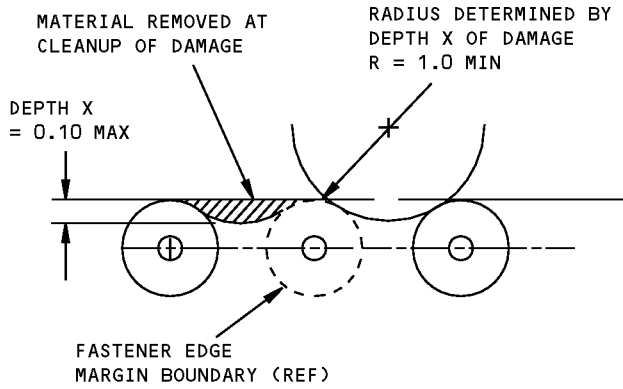

DAMAGE CLEANUP OF EDGES WHERE FASTENER EDGE MARGINS DO NOT OVERLAP

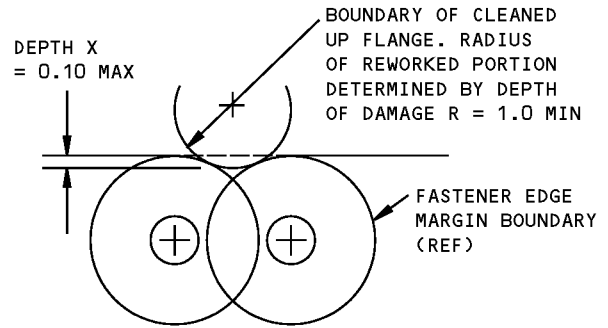

DAMAGE CLEANUP OF EDGES WHERE FASTENER EDGE MARGINS OVERLAP

DETAIL I

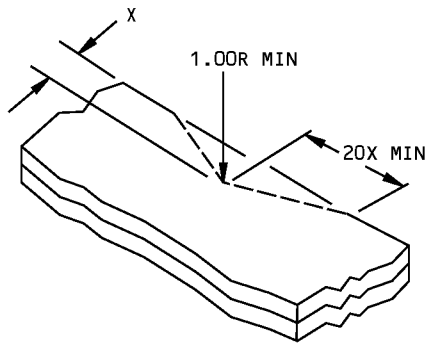

X = DEPTH OF CLEANUP = 0.10 MAX

DETAIL II

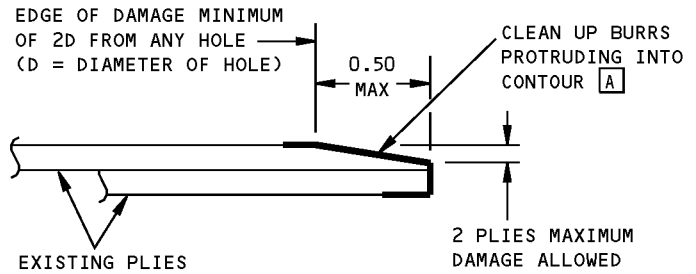

DAMAGE CLEANUP AND SEALING OF EDGE EROSION
DETAIL III

**Trunion Fairing Skin Allowable Damage
Figure 101 (Sheet 3 of 3)**

**757-200
STRUCTURAL REPAIR MANUAL**

REPAIR 1 - TRUNNION FAIRING SKIN REPAIR

REF DWG
113N1800

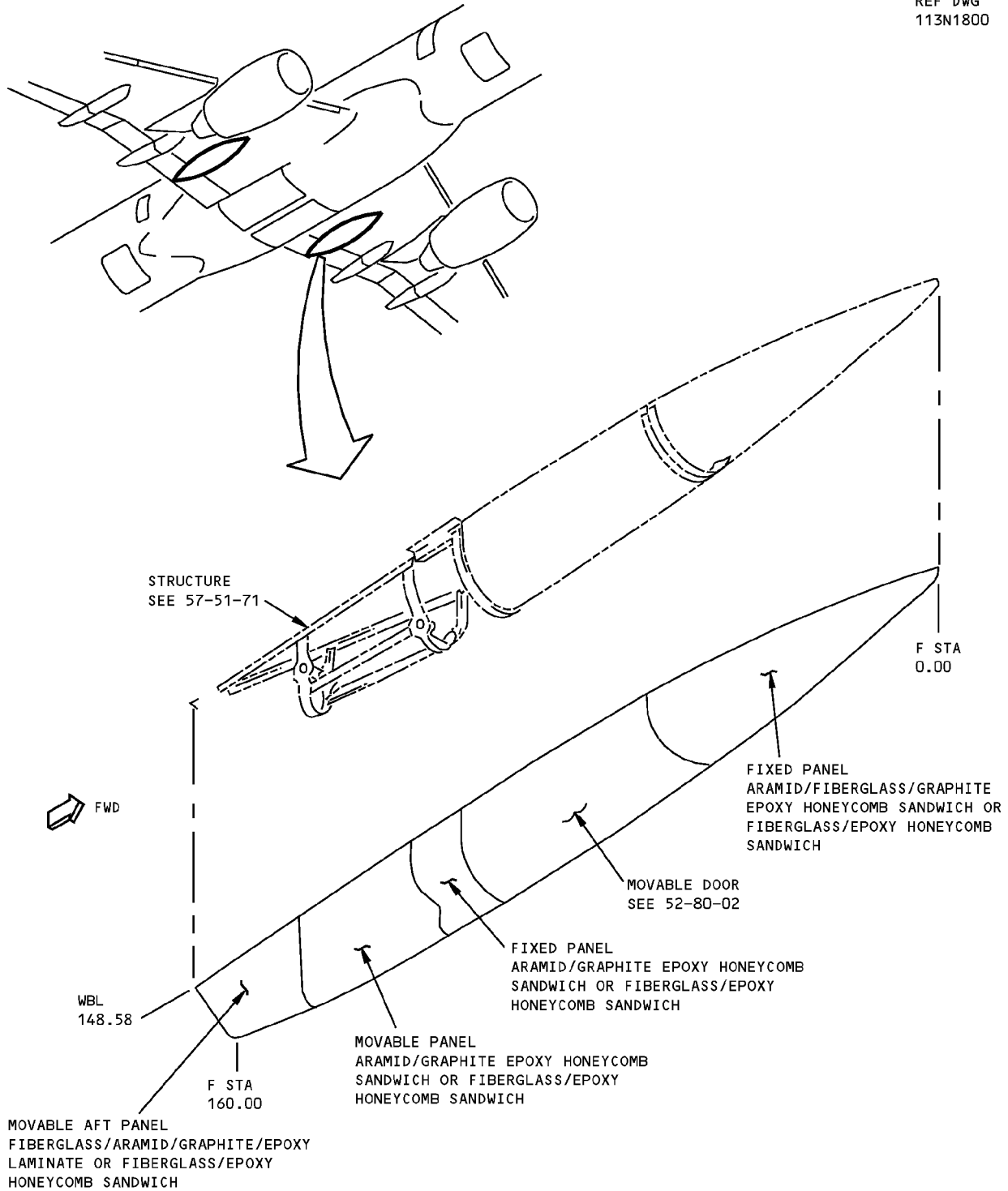

**Trunnion Fairing Skin Repairs
Figure 201 (Sheet 1 of 6)**

STRUCTURAL REPAIR MANUAL

DAMAGE	INTERIM REPAIRS B	PERMANENT REPAIRS		
	WET LAYUP ROOM TEMP (SRM 51-70-03) E	WET LAYUP 150°F (66°C) CURE (SRM 51-70-03)	WET LAYUP 200°F (93°C) CURE (SRM 51-70-17)	250°F (121°C) CURE (SRM 51-70-05)
CRACKS	UP TO 4.0 INCHES (100 mm) LONG, REPAIR WITH PATCH AS GIVEN IN SRM 51-70-03, PAR. 5.N. A	CLEAN UP DAMAGE AND REPAIR AS A HOLE	CLEAN UP DAMAGE AND REPAIR AS A HOLE	CLEAN UP DAMAGE AND REPAIR AS A HOLE
HOLES AND PUNCTURES	4.0 INCHES (100 mm) MAXIMUM DIA NOT TO EXCEED 30% OF SMALLEST DIMENSION ACROSS HONEYCOMB PANEL AT THE DAMAGE LOCATION. FILL WITH BMS 5-28, TYPE 7 POTTING COMPOUND AND PATCH AS GIVEN IN SRM 51-70-03, PAR. 5.N. A	8.0 INCHES (200 mm) MAXIMUM DIA NOT TO EXCEED 50% OF SMALLEST DIMENSION ACROSS HONEYCOMB PANEL AT THE DAMAGE LOCATION. USE TWO EXTRA PLIES FOR EACH FACESHEET REPAIRED C	12.0 INCHES (200 mm) MAXIMUM DIA NOT TO EXCEED 50% OF SMALLEST DIMENSION ACROSS HONEYCOMB PANEL AT THE DAMAGE LOCATION. USE TWO EXTRA PLIES FOR EACH FACESHEET REPAIRED C	NO SIZE LIMIT
DELAMINATION	CUT OUT AND REPAIR AS A HOLE			
NICKS AND GOUGES	IF THERE IS NO FIBER DAMAGE OR DELAMINATION, FILL NICKS OR GOUGES AS GIVEN IN SRM 51-70-03 IF YOU FIND FIBER DAMAGE OR DELAMINATION, THEN REPAIR AS A HOLE			
DENTS	UP TO 2.0 INCHES (50 mm) DIA WITH NO FIBER DAMAGE OR DELAMINATION, FILL WITH BMS 5-28, TYPE 7 POTTING COMPOUND AND PATCH AS GIVEN IN SRM 51-70-03, PAR. 5.L. C OVER 2.0 INCHES (50 mm) DIA OR WITH FIBER DAMAGE OR DELAMINATION, REPAIR AS A HOLE			

REPAIR DATA FOR 250°F (121°C) CURE HONEYCOMB PANELS (ARAMID/GRAPHITE)
(SEE TABLE III FOR EDGE BANDS)

NOTES

TABLE I

- WHEN YOU USE THIS REPAIR, REFER TO:
 - AMM 51-21-01 FOR APPLICATION OF FINISHES
 - SRM 51-10-01, FOR AERODYNAMIC SMOOTHNESS REQUIREMENTS. WHERE THE DAMAGE IS MORE THAN THE LIMITS GIVEN IN SRM 51-10-01, THOUGHT SHOULD BE GIVEN TO THE LOSS OF PERFORMANCE THAT MAY OCCUR
 - SRM 51-10-02 FOR INSPECTION AND REMOVAL OF DAMAGE.

A LIMITED TO REPAIR OF DAMAGE TO ONE FACE-SHEET SKIN AND HONEYCOMB CORE. ONE REPAIR FOR EACH SQUARE FOOT OF AREA AND MINIMUM OF 6.0 INCHES (150 mm) (EDGE TO EDGE) FROM ANY OTHER DAMAGE, FASTENER HOLE, OR EDGE OF PANEL

- B** INSPECT INTERIM REPAIR USING INSTRUMENTED NDT METHODS OR "TAP" TEST EVERY AIRPLANE "2A" CHECK. FOR "TAP" TEST, USE A SOLID METAL DISK AND TAP THE REPAIR AREA LIGHTLY BUT FIRMLY. VOID AREAS WILL GIVE A DULL SOUND INSTEAD OF A SHARP RING THAT YOU WILL HEAR ON A SOLID BONDED AREA. PERMANENT REPAIR IS REQUIRED IF ANY DETERIORATION IS EVIDENT. REFER TO SRM 51-70-03, PAR. 4.I. AND THE NONDESTRUCTIVE TEST MANUAL **F**
- C** ONE REPAIR FOR EACH SQUARE FOOT OF AREA AND A MINIMUM OF 6.0 INCHES (150 mm) (EDGE TO EDGE) FROM ANY OTHER DAMAGE, FASTENER HOLE, OR EDGE OF PANEL
- D** ONE REPAIR FOR EACH SQUARE FOOT OF AREA AND A MINIMUM OF 3.0 INCHES (75 mm) (EDGE TO EDGE) FROM ANY OTHER DAMAGE, FASTENER HOLE, OR EDGE OF PANEL
- E** MAXIMUM PROPERTIES IN SRM 51-70-03 MAY BE OBTAINED BY CURING AT 150°F (66°C)
- F** THIS REPAIR HAS FAA APPROVAL ONLY IF YOU DO THE INSPECTIONS GIVEN IN THIS REPAIR

Trunnion Fairing Skin Repairs
Figure 201 (Sheet 2 of 6)

STRUCTURAL REPAIR MANUAL

DAMAGE	INTERIM REPAIRS B	PERMANENT REPAIRS		
	WET LAYUP ROOM TEMP (SRM 51-70-03) E	WET LAYUP 150°F (66°C) CURE (SRM 51-70-03)	WET LAYUP 200°F (93°C) CURE (SRM 51-70-17)	250°F (121°C) CURE (SRM 51-70-05)
CRACKS	UP TO 2.0 INCHES (50 mm) LONG, REPAIR WITH PATCH AS GIVEN IN SRM 51-70-03, PAR. 5.N. D	CLEAN UP DAMAGE AND REPAIR AS A HOLE	CLEAN UP DAMAGE AND REPAIR AS A HOLE	CLEAN UP DAMAGE AND REPAIR AS A HOLE
HOLES	2.0 INCHES (50 mm) MAXIMUM DIA NOT TO EXCEED 30% OF SMALLEST DIMENSION ACROSS LAMINATE PANEL AT THE DAMAGE LOCATION. FILL WITH BMS 5-28, TYPE 7 POTTING COMPOUND AND PATCH AS GIVEN IN SRM 51-70-03, PAR. 5.N. D	5.0 INCHES (125 mm) MAXIMUM DIA NOT TO EXCEED 50% OF SMALLEST DIMENSION ACROSS LAMINATE PANEL AT THE DAMAGE LOCATION. USE TWO EXTRA PLIES FOR EACH SIDE D	10.0 INCHES (250 mm) MAXIMUM DIA NOT TO EXCEED 50% OF SMALLEST DIMENSION ACROSS LAMINATE PANEL AT THE DAMAGE LOCATION. USE TWO EXTRA PLIES FOR EACH SIDE	NO SIZE LIMIT
DELAMINATION	CUT OUT AND REPAIR AS A HOLE			
NICKS AND GOUGES	IF THERE IS NO FIBER DAMAGE OR DELAMINATION, FILL NICKS OR GOUGES AS GIVEN IN SRM 51-70-03 IF YOU FIND FIBER DAMAGE OR DELAMINATION, THEN REPAIR AS A HOLE			
DENTS	UP TO 2.0 INCHES (50 mm) DIA WITH NO FIBER DAMAGE OR DELAMINATION, FILL WITH BMS 5-28, TYPE 7 POTTING COMPOUND AND PATCH AS GIVEN IN SRM 51-70-03, PAR. 5.L. D OVER 2.0 INCHES (50 mm) DIA OR WITH FIBER DAMAGE OR DELAMINATION, REPAIR AS A HOLE			

REPAIR DATA FOR 250°F CURE LAMINATES (ARAMID/GRAPHITE)
(SEE TABLE III FOR EDGE BANDS)
TABLE II

Trunnion Fairing Skin Repairs
Figure 201 (Sheet 3 of 6)



**757-200
STRUCTURAL REPAIR MANUAL**

DAMAGE	INTERIM REPAIRS B	PERMANENT REPAIRS	
	ROOM TEMP (SRM 51-70-03) E	WET LAYUP 200°F (93°C) CURE (SRM 51-70-17)	250°F (121°C) CURE (SRM 51-70-05)
HOLES AND PUNCTURES	REPAIR DAMAGE TO FASTENER HOLES AS GIVEN IN SRM 51-70-03, PAR. 5.K. FOR ALL OTHER DAMAGE UP TO 15% OF CROSS-SECTIONAL AREA THRU THE EDGE BAND OR 10% OF THE EDGE BAND LENGTH FOR EACH AFFECTED SIDE, REPAIR AS GIVEN IN SRM 51-70-03, PAR. 5.G.	REPAIR DAMAGE TO FASTENER HOLES AS GIVEN IN SRM 51-70-17, PAR. 4.K. FOR ALL OTHER DAMAGE, REPAIR AS GIVEN IN SRM 51-70-17, PAR. 4.G.	REPAIR DAMAGE TO FASTENER HOLES AS GIVEN IN SRM 51-70-05, PAR. 5.K. FOR ALL OTHER DAMAGE, REPAIR AS GIVEN IN SRM 51-70-05, PAR. 5.G.
DELAMINATION	IF DELAMINATION FROM PANEL EDGE IS NO LESS THAN 2D FROM ANY FASTENER HOLE, REPAIR AS GIVEN IN SRM 51-70-03, PAR. 5.A.(2). ANY OTHER DELAMINATION MUST BE CUT OUT AND REPAIRED AS A HOLE	CUT OUT AND REPAIR AS A HOLE	CUT OUT AND REPAIR AS A HOLE
EDGE EROSION	_____	FOR DAMAGE THAT IS NOT LARGER THAN 35% OF EDGE BAND THICKNESS, REPAIR AS GIVEN IN SRM 51-70-03 PAR. 5.O. FOR LARGER DAMAGE, REPAIR AS GIVEN IN: SRM 51-70-17 PAR. 4.G.	SRM 51-70-05 PAR. 5.G.
CRACKS	REPAIR AS A HOLE		
NICKS AND GOUGES	IF THERE IS NO FIBER DAMAGE OR DELAMINATION, FILL NICKS OR GOUGES AS GIVEN IN SRM 51-70-03 IF YOU FIND FIBER DAMAGE OR DELAMINATION, THEN REPAIR AS A HOLE OR DELAMINATION, WHICHEVER IS APPLICABLE		
DENTS	IF THERE IS NO FIBER DAMAGE OR DELAMINATION, FILL DENTS AS GIVEN IN SRM 51-70-03 IF YOU FIND FIBER DAMAGE OR DELAMINATION, THEN REPAIR AS A HOLE OR DELAMINATION, WHICHEVER IS APPLICABLE		

REPAIR DATA FOR EDGE BANDS OF 250°F CURE LAMINATES AND
HONEYCOMB PANELS (ARAMID/GRAPHITE)
TABLE III

**Trunnion Fairing Skin Repairs
Figure 201 (Sheet 4 of 6)**

D634N201

57-51-70

REPAIR 1
Page 204
Jan 20/2005

STRUCTURAL REPAIR MANUAL

DAMAGE	INTERIM REPAIRS B	PERMANENT REPAIRS		
	WET LAYUP E ROOM TEMP (SRM 51-70-06)	WET LAYUP 150°F (66°C) CURE (SRM 51-70-06)	WET LAYUP 200°F (93°C) CURE (SRM 51-70-17)	250°F (121°C) CURE (SRM 51-70-07)
CRACKS	UP TO 4.0 INCHES (100 mm) LONG, REPAIR WITH PATCH AS GIVEN IN SRM 51-70-06, PAR. 5.N. A	CLEAN UP DAMAGE AND REPAIR AS A HOLE	CLEAN UP DAMAGE AND REPAIR AS A HOLE	CLEAN UP DAMAGE AND REPAIR AS A HOLE
HOLES AND PUNCTURES	4.0 INCHES (100 mm) MAXIMUM DIA NOT TO EXCEED 30% OF SMALLEST DIMENSION ACROSS HONEYCOMB PANEL AT THE DAMAGE LOCATION. FILL WITH BMS 5-28, TYPE 7 POTTING COMPOUND AND PATCH AS GIVEN IN SRM 51-70-06, PAR. 5.N. A	8.0 INCHES (200 mm) MAXIMUM DIA NOT TO EXCEED 50% OF SMALLEST DIMENSION ACROSS HONEYCOMB PANEL AT THE DAMAGE LOCATION. USE TWO EXTRA PLIES FOR EACH FACESHEET REPAIRED C	12.0 INCHES (300 mm) MAXIMUM DIA NOT TO EXCEED 50% OF SMALLEST DIMENSION ACROSS HONEYCOMB PANEL AT THE DAMAGE LOCATION. USE TWO EXTRA PLIES FOR EACH FACESHEET C REPAIRED	NO SIZE LIMIT
DELAMINATION	CUT OUT AND REPAIR AS A HOLE			
NICKS AND GOUGES	IF THERE IS NO FIBER DAMAGE OR DELAMINATION, FILL NICKS OR GOUGES AS GIVEN IN SRM 51-70-03 IF YOU FIND FIBER DAMAGE OR DELAMINATION, THEN REPAIR AS A HOLE			
DENTS	UP TO 2.0 INCHES (50 mm) DIA WITH NO FIBER DAMAGE OR DELAMINATION, FILL WITH BMS 5-28, TYPE 7 POTTING COMPOUND AND PATCH AS GIVEN IN SRM 51-70-06, PAR. 5.L. C OVER 2.0 INCHES (50 mm) DIA OR WITH FIBER DAMAGE OR DELAMINATION, REPAIR AS A HOLE			

REPAIR DATA FOR 250°F (121°C) CURE HONEYCOMB PANELS (FIBERGLASS)
(SEE TABLE V FOR EDGE BANDS)
TABLE IV

Trunnion Fairing Skin Repairs
Figure 201 (Sheet 5 of 6)

**757-200
STRUCTURAL REPAIR MANUAL**

DAMAGE	INTERIM REPAIRS B	PERMANENT REPAIRS	
	ROOM TEMP (SRM 51-70-06)	WET LAYUP 200°F (93°C) CURE (SRM 51-70-17)	250°F (121°C) CURE (SRM 51-70-05)
HOLES AND PUNCTURES	REPAIR DAMAGE TO FASTENER HOLES AS GIVEN IN SRM 51-70-06, PAR. 5.K. FOR ALL OTHER DAMAGE UP TO 15% OF CROSS-SECTIONAL AREA THRU THE EDGE BAND OR 10% OF THE EDGE BAND LENGTH FOR EACH AFFECTED SIDE, REPAIR AS GIVEN IN SRM 51-70-06, PAR. 5.G.	REPAIR DAMAGE TO FASTENER HOLES AS GIVEN SRM 51-70-17, PAR. 4.K. FOR ALL OTHER DAMAGE, REPAIR AS GIVEN IN SRM 51-70-17, PAR. 4.G.	REPAIR DAMAGE TO FASTENER HOLES AS GIVEN IN SRM 51-70-07, PAR. 5.K. FOR ALL OTHER DAMAGE, REPAIR AS GIVEN IN SRM 51-70-07, PAR. 5.G.
DELAMINATION	IF DELAMINATION FROM PANEL EDGE IS NO LESS THAN 2D FROM ANY FASTENER HOLE, REPAIR AS GIVEN IN SRM 51-70-06, PAR. 5.A.(2). ANY OTHER DELAMINATION MUST BE CUT OUT AND REPAIRED AS A HOLE	CUT OUT AND REPAIR AS A HOLE	CUT OUT AND REPAIR AS A HOLE
EDGE EROSION	—————	FOR DAMAGE THAT IS NOT LARGER THAN 35% OF EDGE BAND THICKNESS, REPAIR AS GIVEN IN SRM 51-70-06 PAR. 5.O. FOR LARGER DAMAGE, REPAIR AS GIVEN IN: SRM 51-70-17 PAR. 4.G.	SRM 51-70-07 PAR. 5.G.
CRACKS	REPAIR AS A HOLE		
NICKS AND GOUGES	IF THERE IS NO FIBER DAMAGE OR DELAMINATION, FILL NICKS OR GOUGES AS GIVEN IN SRM 51-70-06 IF YOU FIND FIBER DAMAGE OR DELAMINATION, THEN REPAIR AS A HOLE OR DELAMINATION, WHICHEVER IS APPLICABLE		
DENTS	IF THERE IS NO FIBER DAMAGE OR DELAMINATION, FILL DENTS AS GIVEN IN SRM 51-70-06 IF YOU FIND FIBER DAMAGE OR DELAMINATION, THEN REPAIR AS A HOLE OR DELAMINATION, WHICHEVER IS APPLICABLE		

REPAIR DATA FOR EDGE BANDS OF 250°F CURE HONEYCOMB PANELS (FIBERGLASS)

**Trunnion Fairing Skin Repairs
Figure 201 (Sheet 6 of 6)**

**757-200
STRUCTURAL REPAIR MANUAL**

IDENTIFICATION 1 - TRUNNION FAIRING STRUCTURE

REF DWG
113N1800

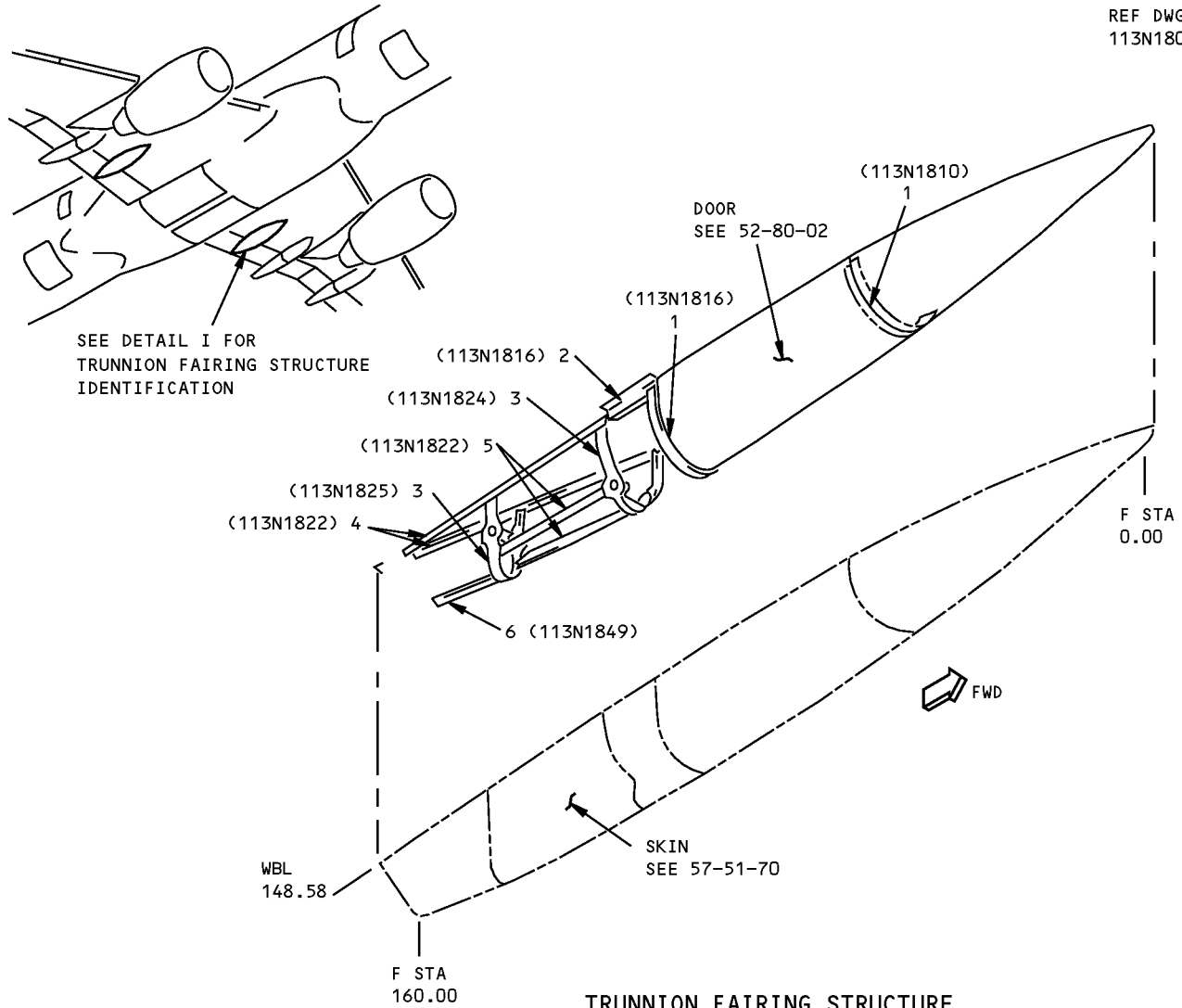

**TRUNNION FAIRING STRUCTURE
DETAIL I**

NOTES

A FOR CUM LINE NUMBERS 55 AND ON

ITEM	DESCRIPTION	GAGE	MATERIAL	EFFECTIVITY
1	SUPPORT	0.063	CLAD 2024-T42	
2	ANGLE	0.063	CLAD 2024-T42	
3	FITTING		7075-T73 FORGED BLOCK OR DIE FORGING	
4	ANGLE	0.112	CLAD 7075-T6	
5	BEAM	0.090	CLAD 7075-T6 (2 BACK-TO-BACK ANGLES)	
6	SPLICE ANGLE	0.063	CLAD 7075-T6	A

LIST OF MATERIALS FOR DETAIL I

**Trunnion Fairing Structure Identification
Figure 1**

**757-200
STRUCTURAL REPAIR MANUAL**

ALLOWABLE DAMAGE 1 - TRUNNION FAIRING STRUCTURE

REF DWG
113N1800

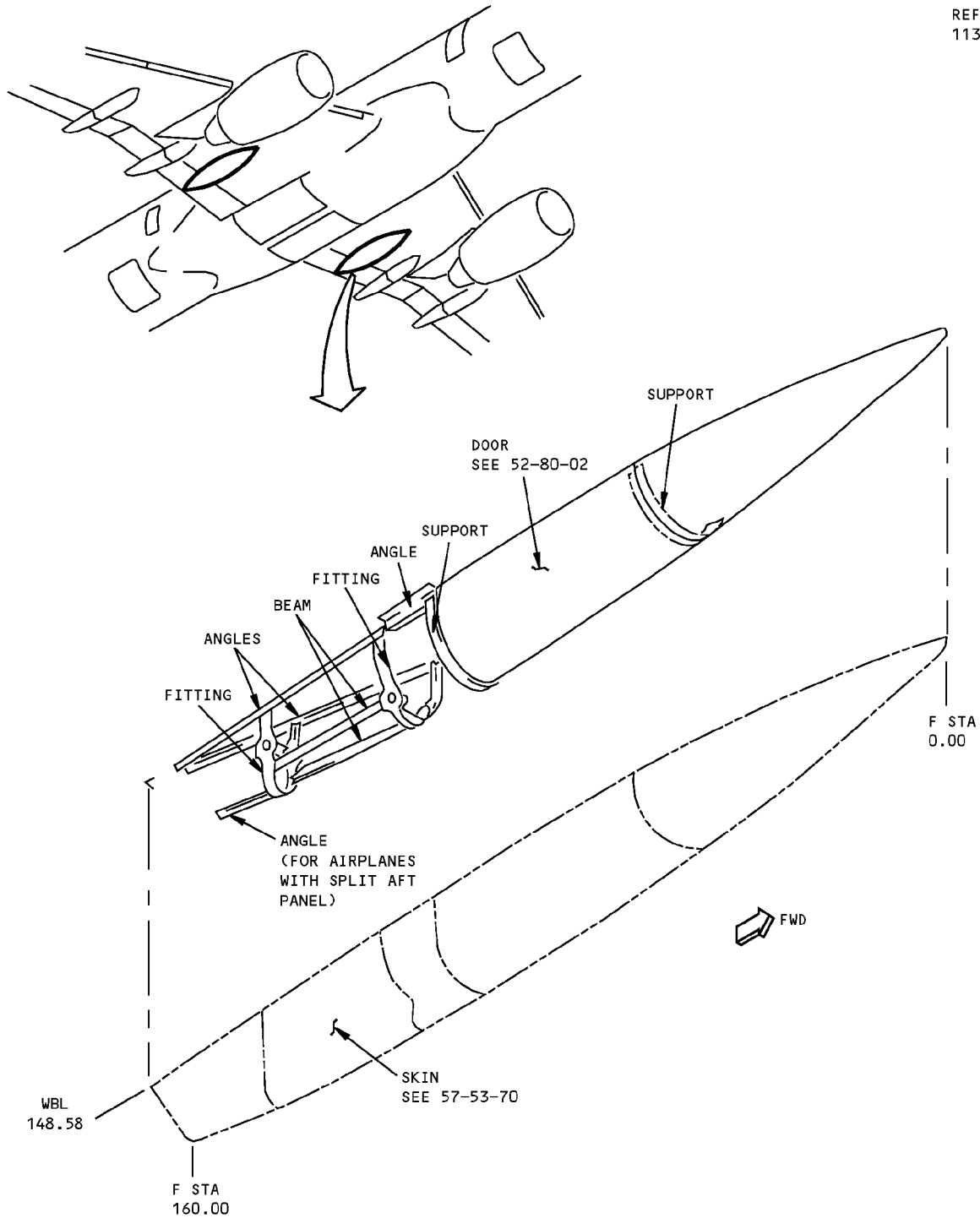

MATERIAL: ALUMINUM

**Trunnion Fairing Structure Allowable Damage
Figure 101 (Sheet 1 of 4)**

D634N201

ALLOWABLE DAMAGE 1
Page 101
57-51-71
Jan 20/2005

**757-200
STRUCTURAL REPAIR MANUAL**

DESCRIPTION	CRACKS	NICKS, GOUGES AND CORROSION	DENTS	HOLES AND PUNCTURES
SUPPORTS	A	B	SEE DETAIL III	C
ANGLES	A	B	NOT ALLOWED	C
FITTINGS F	D	E	NOT ALLOWED	NOT ALLOWED
BEAMS	A	B	NOT ALLOWED	C

NOTES

- REFINISH REWORKED AREAS PER 51-20 OF THE MAINTENANCE MANUAL
- A CRACKS NOT ALLOWED EXCEPT FOR EDGE CRACKS WHICH MUST BE REMOVED PER DETAILS I AND VI
- B REMOVE DAMAGE PER DETAILS I, II, AND IV
- C NOT CLOSER THAN 1.0 INCH TO FASTENER HOLE, OR OTHER DAMAGE AND NOT CLOSER THAN 2D TO MATERIAL EDGE. FILL HOLE WITH A 2117-T3 OR T4 ALUMINUM RIVET INSTALLED WET WITH BMS 5-95 SEALANT. ALL OTHER HOLES TO BE REPAIRED
- D CRACKS NOT ALLOWED EXCEPT FOR EDGE CRACKS WHICH MUST BE REMOVED PER DETAILS I AND V
- E FOR EDGE DAMAGE SEE DETAIL VIII. FOR LUG DAMAGE SEE DETAIL VII. FOR OTHER DAMAGE SEE DETAIL II. DAMAGE NOT ALLOWED IN VICINITY OF BUSHINGS.
- F SHOT PEEN REWORKED AREAS PER 51-20-06

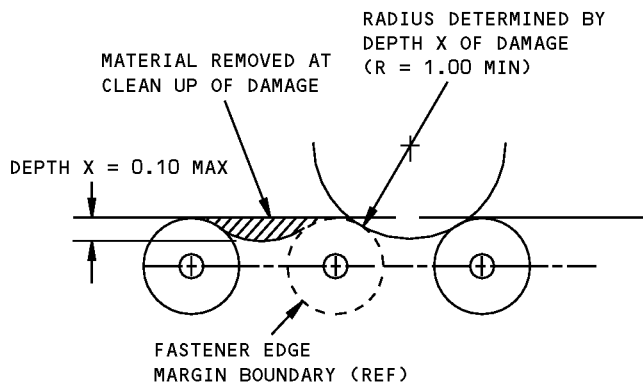

DAMAGE CLEAN UP OF EDGES WHERE FASTENER EDGE MARGINS DO NOT OVERLAP

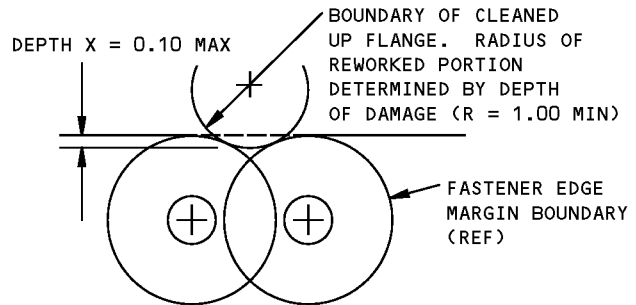

DAMAGE CLEAN UP OF EDGES WHERE FASTENER EDGE MARGINS OVERLAP

DETAIL I

**Trunnion Fairing Structure Allowable Damage
Figure 101 (Sheet 2 of 4)**

**757-200
STRUCTURAL REPAIR MANUAL**

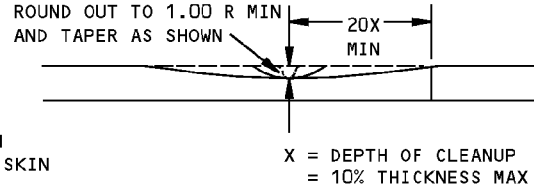
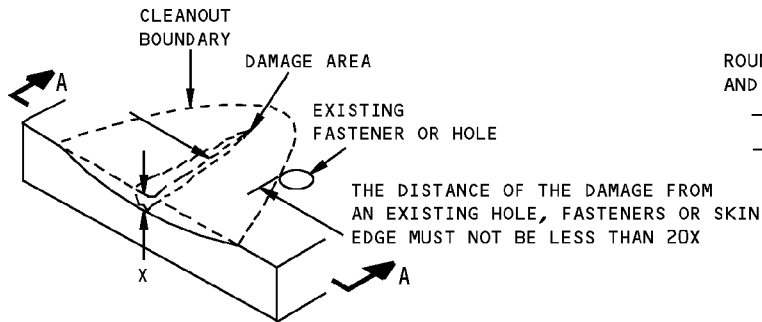

SECTION A-A

**REMOVAL OF NICK, GOUGE AND SCRATCH DAMAGE ON A SURFACE
DETAIL II**

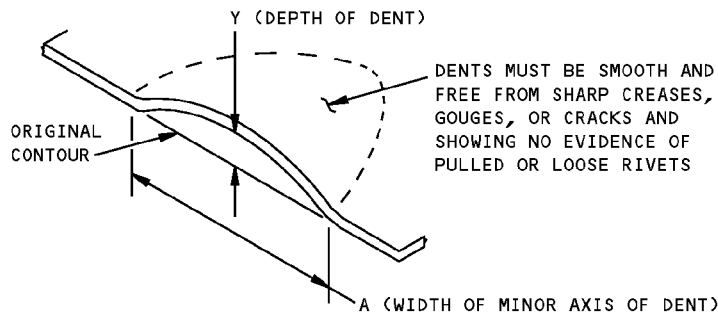

$\frac{A}{Y}$ MUST NOT BE LESS THAN 30

**ALLOWABLE DAMAGE FOR DENT
DETAIL III**

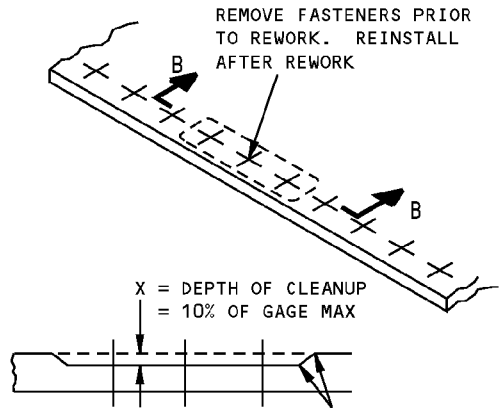

SMOOTH BLENDOUT RADIUS 0.50 INCH MINIMUM. CORROSION CLEANUP AROUND ANY THREE FASTENERS IN TEN IS PERMITTED TO MAX DEPTH

SECTION B-B

**CORROSION CLEANUP
DETAIL IV**

**Trunnion Fairing Structure Allowable Damage
Figure 101 (Sheet 3 of 4)**

**757-200
STRUCTURAL REPAIR MANUAL**

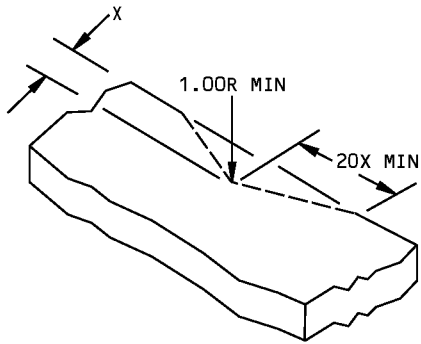

X = DEPTH OF CLEANUP = 0.10 MAX

DETAIL V

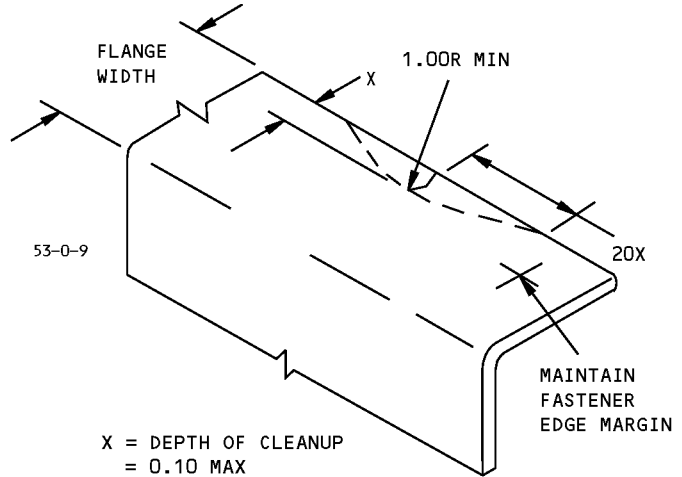

X = DEPTH OF CLEANUP = 0.10 MAX

**REMOVAL OF NICK OR CRACK
DAMAGE ON AN EDGE
DETAIL VI**

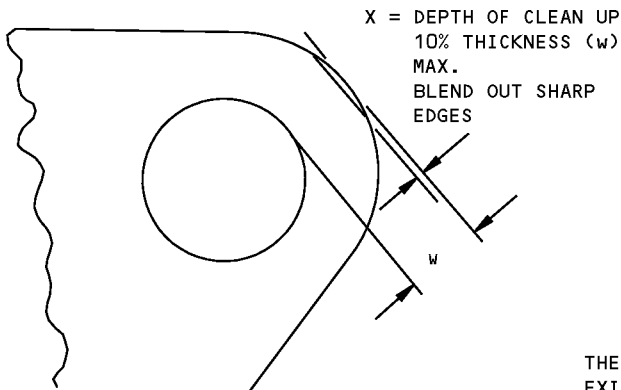

**DAMAGE CLEAN UP FOR EDGES OF LUG
DETAIL VII**

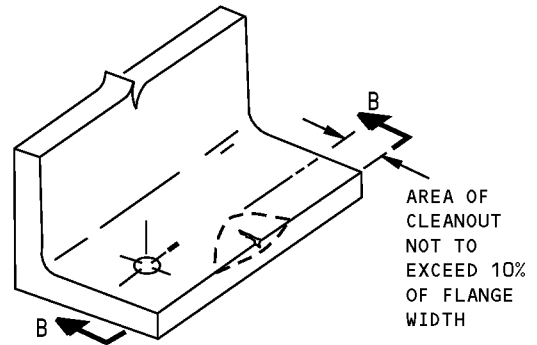

THE DISTANCE OF THE DAMAGE FROM AN EXISTING HOLE, FASTENERS OR EDGE MUST NOT BE LESS THAN 20X

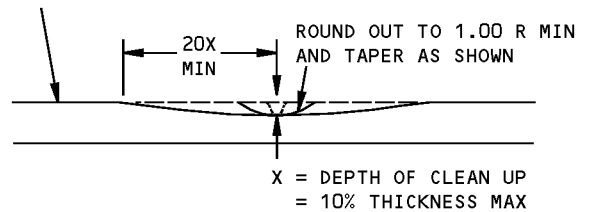

**SECTION B-B
DETAIL VIII**

**Trunnion Fairing Structure Allowable Damage
Figure 101 (Sheet 4 of 4)**

757-200
STRUCTURAL REPAIR MANUAL

REPAIR 1 - WING TRAILING EDGE FITTING REPAIR

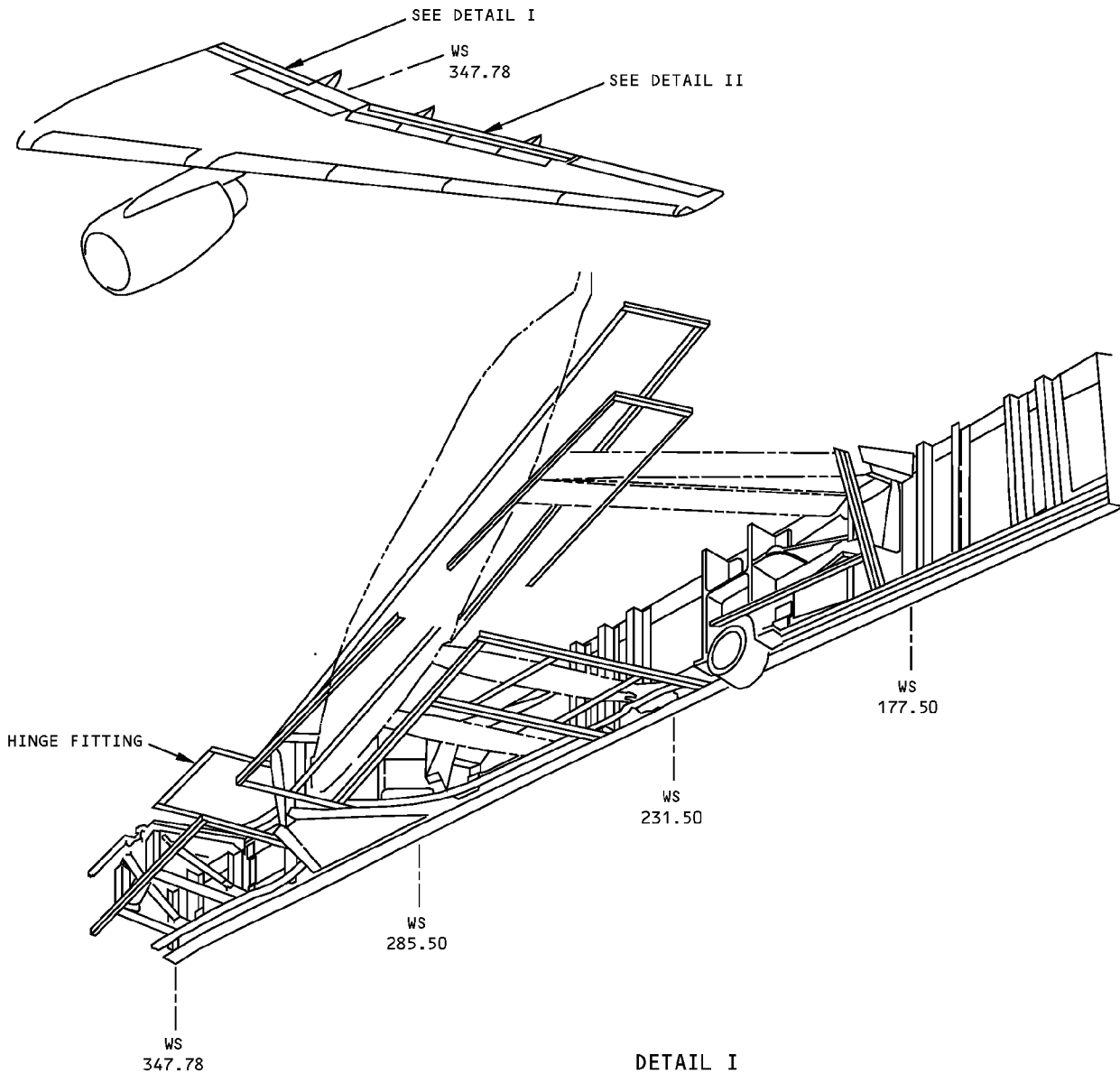

NOTES

- SEE 57-51-02 FOR STRUCTURE IDENTIFICATION AND ALLOWABLE DAMAGE INFORMATION
- NO TYPICAL REPAIR TO FITTINGS APPLICABLE. SPECIFIC REPAIRS TO FITTINGS WILL BE PROVIDED BASED ON SERVICE EXPERIENCE

Wing Trailing Edge Fitting Repair
Figure 201 (Sheet 1 of 2)

**757-200
STRUCTURAL REPAIR MANUAL**

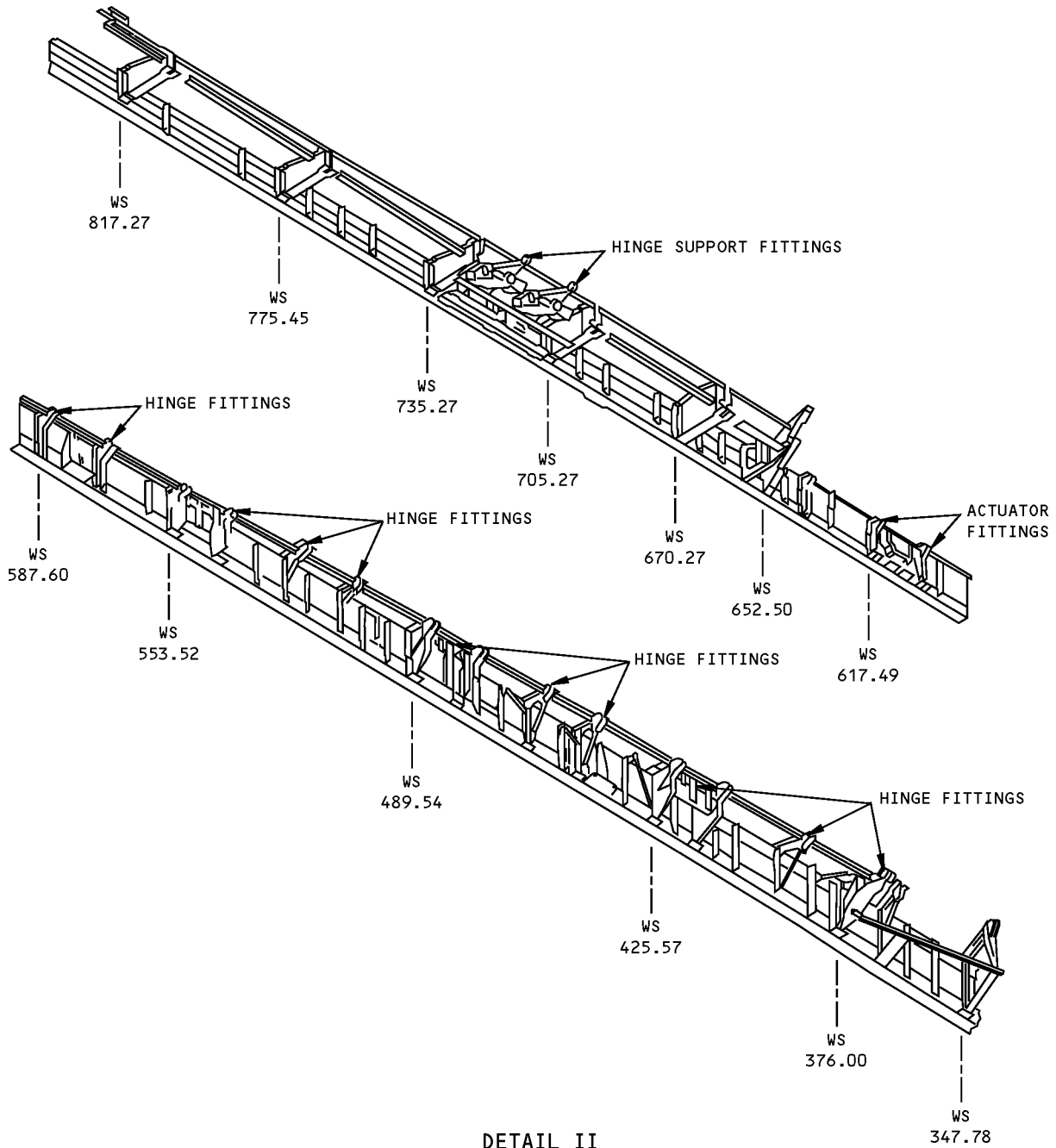

**Wing Trailing Edge Fitting Repair
Figure 201 (Sheet 2 of 2)**

**757-200
STRUCTURAL REPAIR MANUAL**

REPAIR 2 - TRUNNION FAIRING FITTING REPAIR

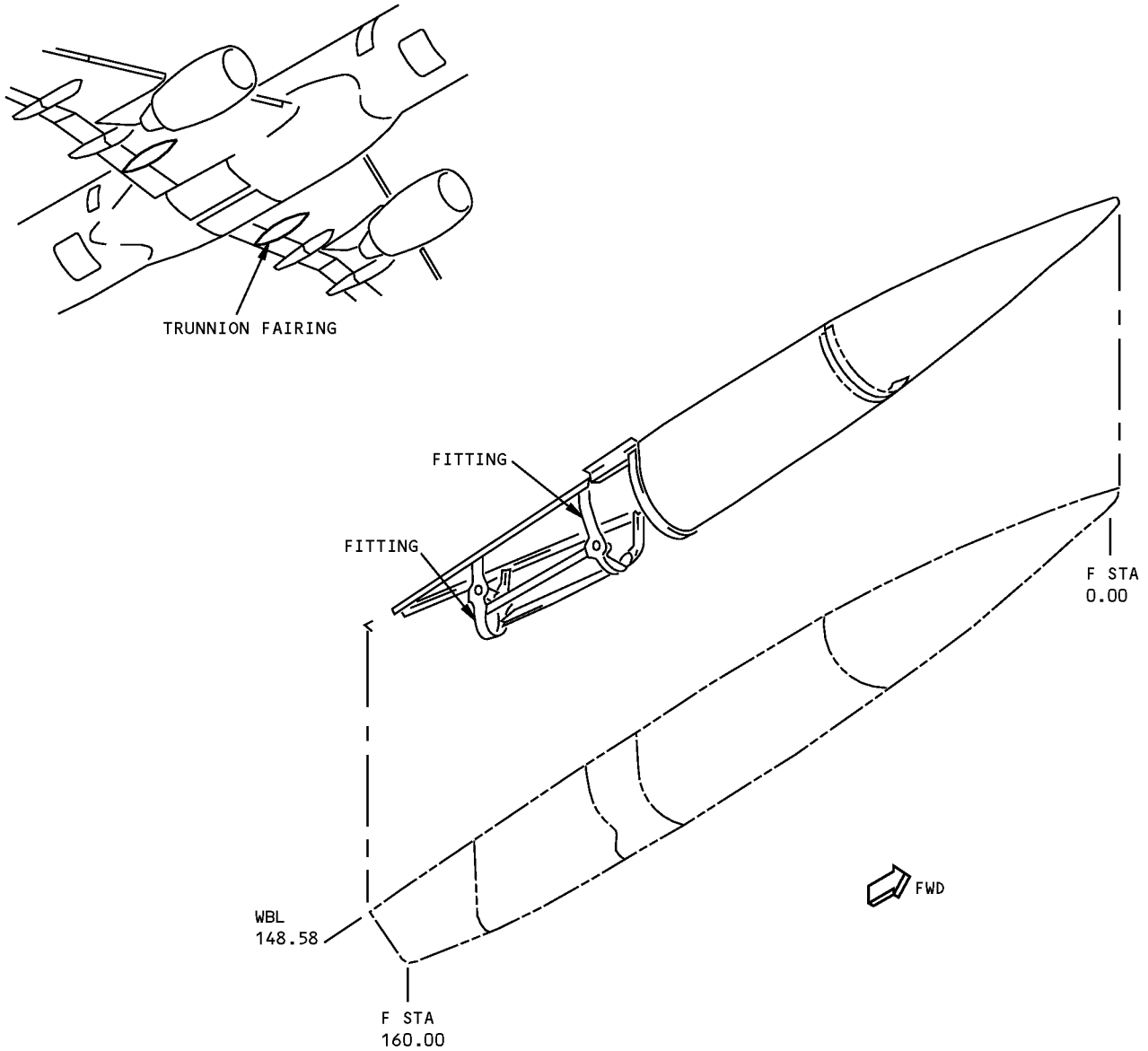

NOTES

- SEE 57-51-71 FOR STRUCTURE IDENTIFICATION AND ALLOWABLE DAMAGE INFORMATION
- NO TYPICAL REPAIR TO FITTINGS APPLICABLE. SPECIFIC REPAIRS TO FITTINGS WILL BE PROVIDED BASED ON SERVICE EXPERIENCE

**Trunnion Fairing Fitting Repair
Figure 201**



757-200
STRUCTURAL REPAIR MANUAL

IDENTIFICATION 1 - TRAILING EDGE FLAP SKIN

REF DWG
113N2001
113N3001

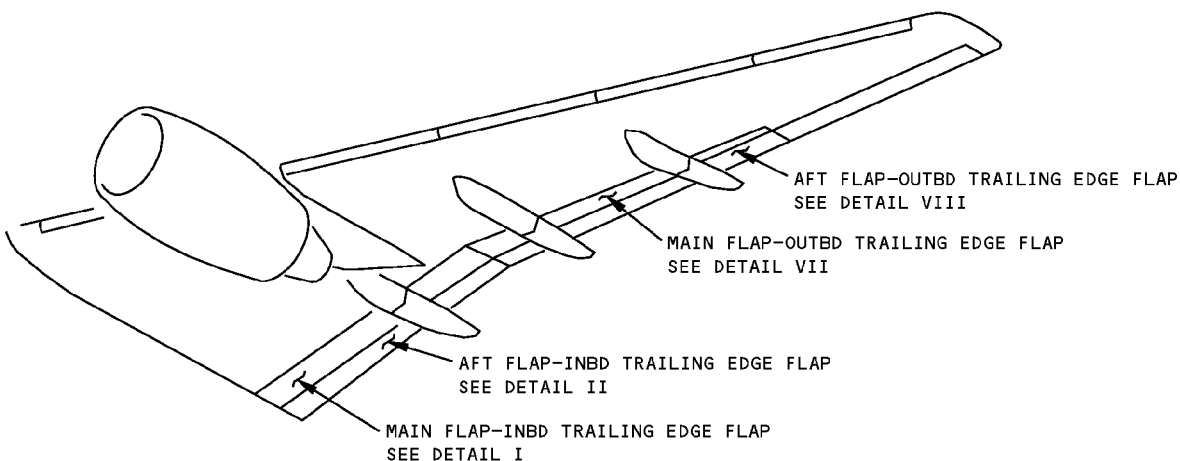

LEFT SIDE SHOWN
RIGHT SIDE OPPOSITE

NOTES

- A** PLY ORIENTATION CONVENTION, DEGREES INDICATED, IS PARALLEL TO THE FABRIC WARP DIRECTION
- B** GRAPHITE/EPOXY FABRIC PER BMS 8-212, TYPE IV, CLASS 2, STYLE 3K-70-PW, 350°F (177°C) CURE
- C** ARAMID/EPOXY FABRIC PER BMS 8-218, STYLE 285. 350°F (177°C) CURE
- D** GRAPHITE/EPOXY FABRIC PER BMS 8-256, CLASS 2, STYLE 3K-70-PW, 350°F (177°C) CURE
- E** MATERIAL AND PLY ORIENTATION SHOWN FOR FIELD AREAS ONLY. SEE BOEING DRAWINGS FOR EDGE BANDS AND AREAS WITH DOUBLERS

Trailing Edge Flap Skin Identification
Figure 1 (Sheet 1 of 13)

D634N201

57-53-01

IDENTIFICATION 1
Page 1
Jan 20/2005

**757-200
STRUCTURAL REPAIR MANUAL**

REF DWG
113N2003

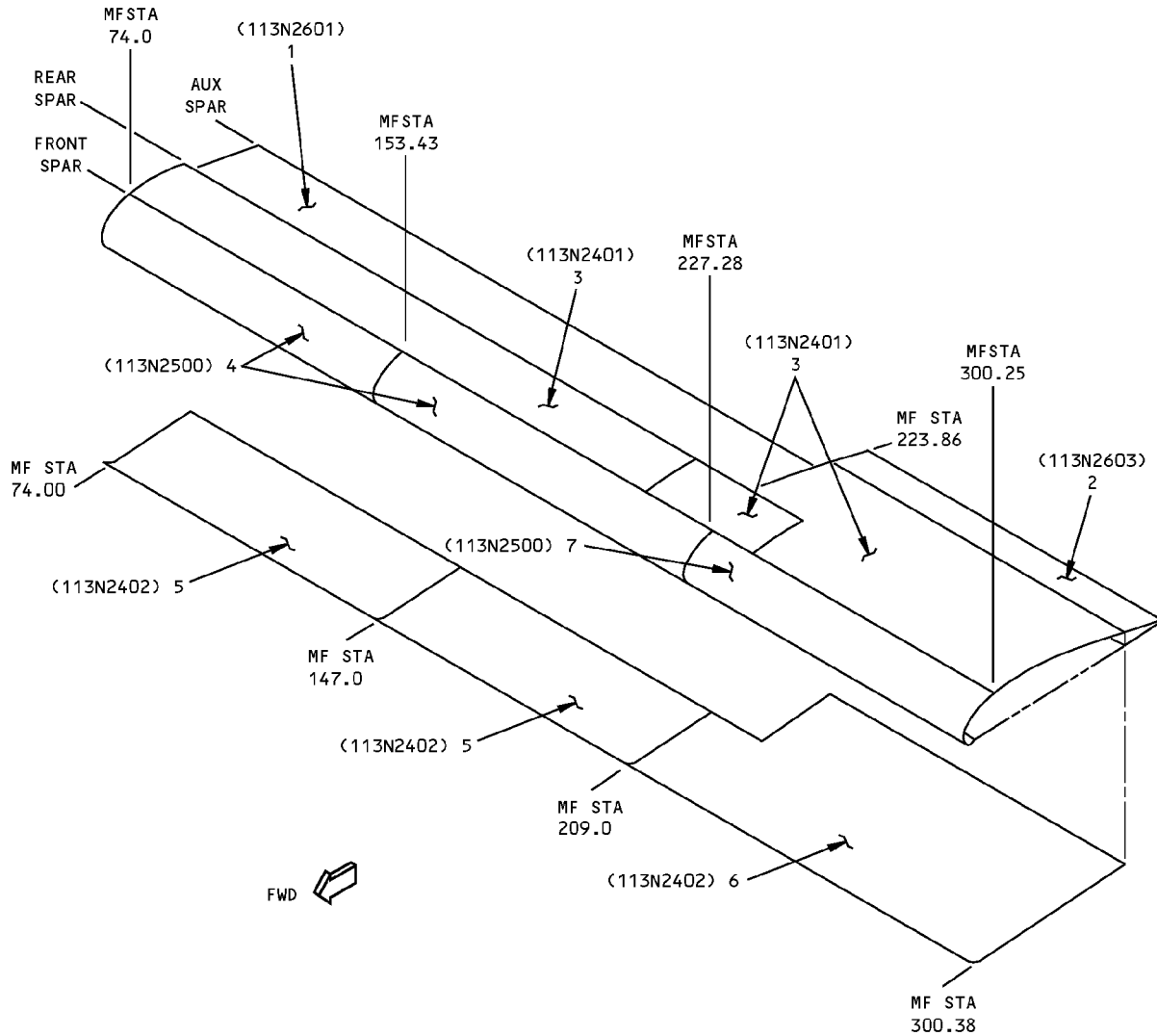

**MAIN FLAP - INBOARD TRAILING EDGE FLAP
DETAIL I**



**Trailing Edge Flap Skin Identification
Figure 1 (Sheet 2 of 13)**

IDENTIFICATION 1
Page 2
Jan 20/2005

57-53-01

D634N201



**757-200
STRUCTURAL REPAIR MANUAL**

ITEM	DESCRIPTION	GAGE	MATERIAL	EFFECTIVITY
1	PANEL ASSEMBLY SKIN CORE	0.75	FIBERGLASS/EPOXY HONEYCOMB SANDWICH FIBERGLASS FABRIC PER BMS 8-79, STYLE 7781 (STYLE 1581 OPTIONAL) CLASS III, 250°F (121°C) CURE PLY ORIENTATION LENGTHWISE AT 0/90° A NOMEX HONEYCOMB CORE PER BMS 8-124, CLASS 4, TYPE V, GRADE 3.0.	
2	PANEL ASSEMBLY SKIN UPPER SKIN LOWER CORE	0.016 0.020	ALUMINUM HONEYCOMB SANDWICH 2024-T81 2024-T81 HONEYCOMB PER BMS 4-4, TYPE 3-10N, FORM B	
3	PANEL ASSEMBLY OUTER SKIN INNER SKIN CORE	0.125 0.012 0.50	ALUMINUM HONEYCOMB SANDWICH 2024-T3 2024-T3 ALUMINUM HONEYCOMB BMS 4-4, TYPE 3-10N	
4	PANEL ASSEMBLY SKIN SKIN OUTER PLY	0.080	2024-T6 FIBERGLASS FABRIC PER BMS 8-79 STYLE 1581- (ONE PLY) PLY ORIENTATION LENGTHWISE AT 0/90° A	
5	PANEL ASSEMBLY OUTER SKIN INNER SKIN CORE	0.125 0.012 0.31	ALUMINUM HONEYCOMB SANDWICH 2024-T3 (CHEM-MILLED TO 0.032 MIN) 2024-T3 ALUMINUM HONEYCOMB BMS 4-4, TYPE 3-10N	
6	PANEL ASSEMBLY OUTER SKIN INNER SKIN CORE	0.125 0.012 0.31	2024-T3 (CHEM-MILLED TO 0.045 MIN) 2024-T3 ALUMINUM HONEYCOMB BMS 4-4, TYPE 3-10N	
7	PANEL ASSEMBLY SKIN	0.080	2024-T6	

LIST OF MATERIALS FOR DETAIL I

**Trailing Edge Flap Skin Identification
Figure 1 (Sheet 3 of 13)**

IDENTIFICATION 1
Page 3
Jan 20/2005

57-53-01

D634N201

**757-200
STRUCTURAL REPAIR MANUAL**

REF DWG
113N2800

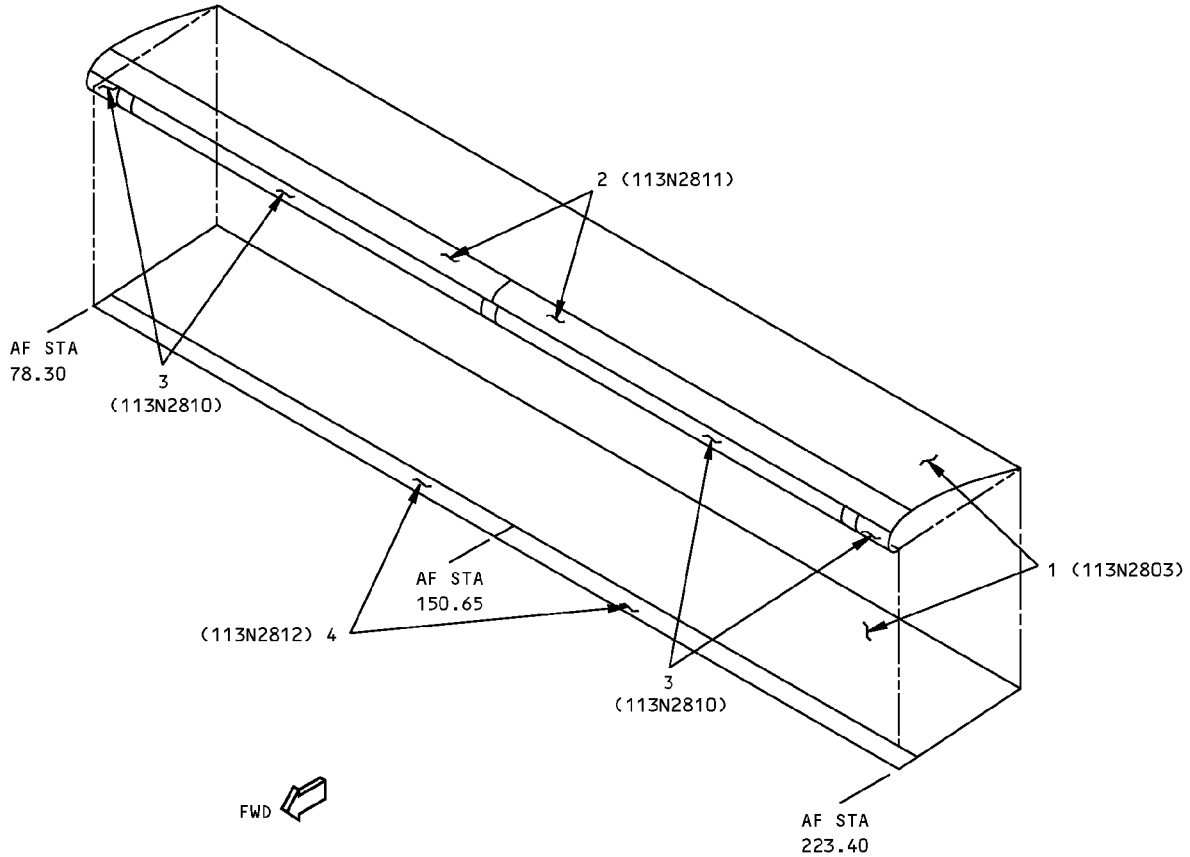

**AFT FLAP-INBD TRAILING EDGE FLAP
DETAIL II**



**Trailing Edge Flap Skin Identification
Figure 1 (Sheet 4 of 13)**

IDENTIFICATION 1
Page 4
Jan 20/2005

57-53-01

D634N201



757-200
STRUCTURAL REPAIR MANUAL

ITEM	DESCRIPTION	GAGE	MATERIAL	EFFECTIVITY
1	TE WEDGE SKIN CORE		ARAMID/GRAPHITE/EPOXY HONEYCOMB SANDWICH SEE DETAIL III NOMEX HONEYCOMB PER BMS 8-124, CLASS 4, TYPE V, GRADE 3.0.	
2	UPR LE PANEL SKIN CORE		GRAPHITE/EPOXY HONEYCOMB SANDWICH SEE DETAIL IV NOMEX HONEYCOMB PER BMS 8-124, CLASS 4, TYPE V, GRADE 3.0.	
3	LE NOSE PANEL SKIN		SEE DETAIL V	
4	LWR LE PANEL SKIN CORE		SEE DETAIL VI NOMEX HONEYCOMB PER BMS 8-124, CLASS 4, TYPE V, GRADE 3.0.	

LIST OF MATERIALS FOR DETAIL II

Trailing Edge Flap Skin Identification
Figure 1 (Sheet 5 of 13)

D634N201

57-53-01

IDENTIFICATION 1
Page 5
Jan 20/2005

**757-200
STRUCTURAL REPAIR MANUAL**

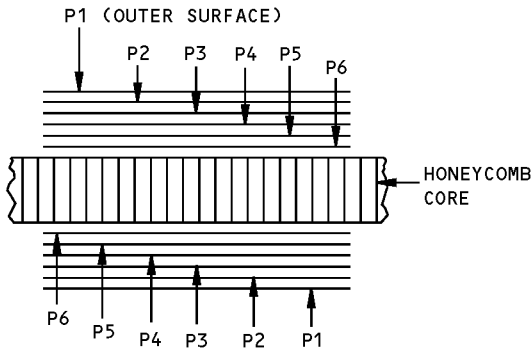

SECTION THRU THE WEDGE HONEYCOMB PANEL

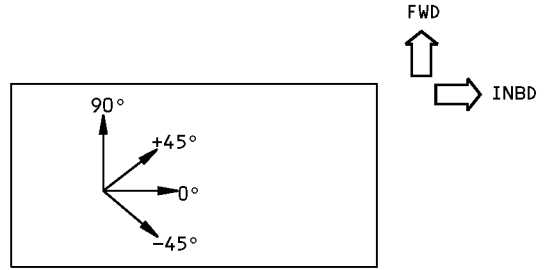

PLY ORIENTATION DIAGRAM
SEE TABLE I FOR INDIVIDUAL
PLY ORIENTATION AND MATERIALS

ITEM NO.	PLY NO.	MATERIAL	PLY ORIENTATION A
1 UPR SURFACE	P1	B	0°
	P2,P4	B	45°
	P3,P5, P6	B	0° OR 90°
1 LWR SURFACE	P1	C	0°
	P2	B	0°
	P3,P5	B	45°
	P4,P6	B	0° OR 90°

TABLE I E
DETAIL III

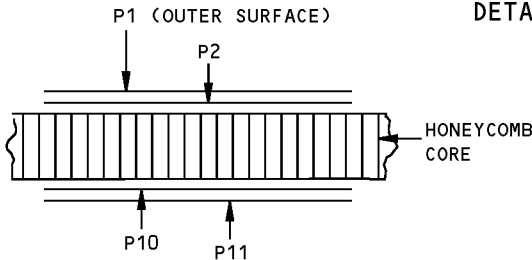

SECTION THRU HONEYCOMB UPPER PANEL

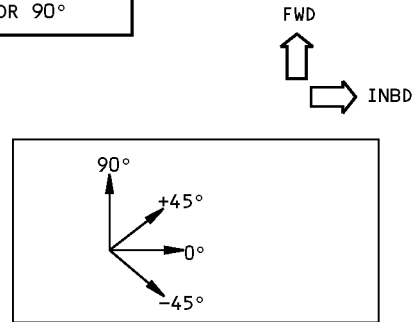

PLY ORIENTATION DIAGRAM
SEE TABLE II FOR INDIVIDUAL
PLY ORIENTATION AND MATERIALS

ITEM NO.	PLY NO.	MATERIAL	PLY ORIENTATION A
2	P1,P11	D	0°
	P2,P10	D	45°

TABLE II E
DETAIL IV

**Trailing Edge Flap Skin Identification
Figure 1 (Sheet 6 of 13)**

**757-200
STRUCTURAL REPAIR MANUAL**

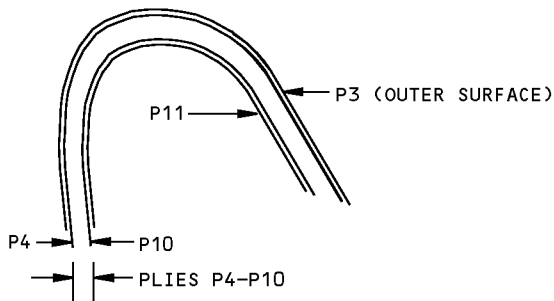

SECTION THRU NOSE PANEL

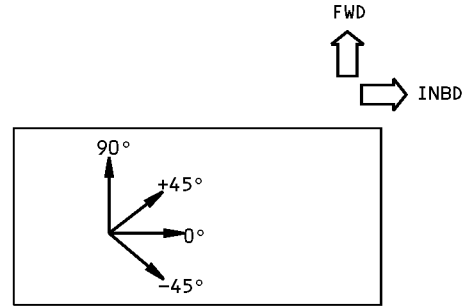

PLY ORIENTATION DIAGRAM
SEE TABLE III FOR INDIVIDUAL
PLY ORIENTATION AND MATERIALS

ITEM NO.	PLY NO.	MATERIAL	PLY ORIENTATION ^[A]
3	P3, P4, P6, P7, P9, P10	[B]	0°
	P5, P8, P11	[B]	±45°

TABLE III [E]

DETAIL V

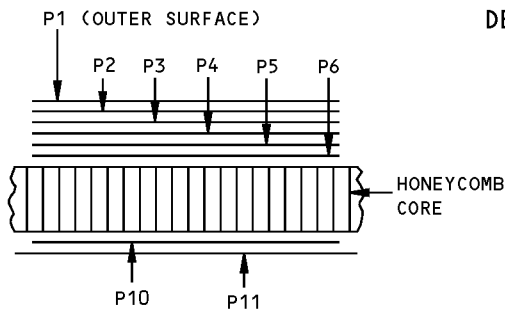

SECTION THRU HONEYCOMB LOWER PANEL

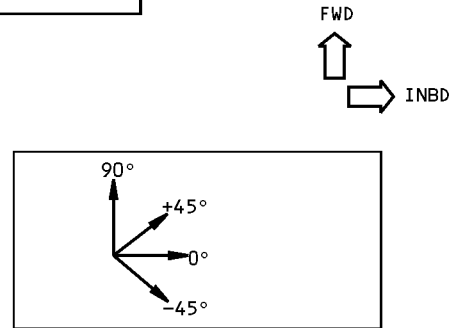

PLY ORIENTATION DIAGRAM
SEE TABLE IV FOR INDIVIDUAL
PLY ORIENTATION AND MATERIALS

ITEM NO.	PLY NO.	MATERIAL	PLY ORIENTATION ^[A]
4	P1	[C]	0°
	P2, P11	[D]	0°
	P3, P5, P10	[D]	45°
	P4, P6	[D]	0° OR 90°

TABLE IV [E]

DETAIL VI

**Trailing Edge Flap Skin Identification
Figure 1 (Sheet 7 of 13)**

**757-200
STRUCTURAL REPAIR MANUAL**

REFERENCE DRAWING
113N3003

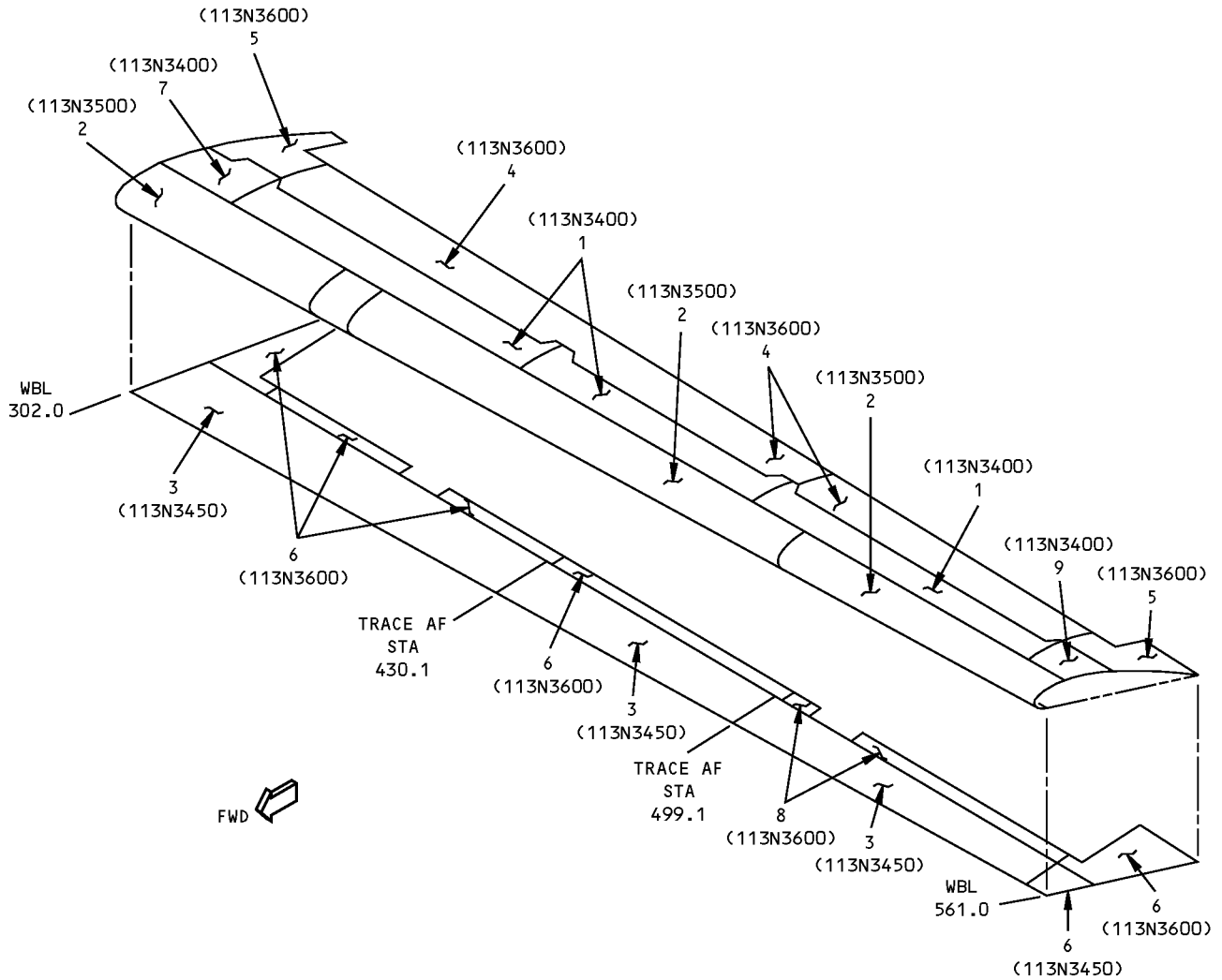

**MAIN FLAP - OUTBOARD TRAILING EDGE FLAP
DETAIL VII**



**Trailing Edge Flap Skin Identification
Figure 1 (Sheet 8 of 13)**

IDENTIFICATION 1
Page 8
Jan 20/2005

57-53-01

D634N201



**757-200
STRUCTURAL REPAIR MANUAL**

ITEM	DESCRIPTION	GAGE	MATERIAL	EFFECTIVITY
1	UPR PANEL ASSY OUTER SKIN	0.125	ALUMINUM HONEYCOMB SANDWICH 7075-T76 OPTIONAL: 7075-T73 (CHEM-MILLED TO 0.020 MIN)	
	INNER SKIN	0.016	7075-T6	
	CORE	0.50	ALUMINUM HONEYCOMB PER BMS 4-4, TYPE 3-10, CLASS-N	
2	NOSE SKIN	0.080	2024-T3 (CHEM-MILLED TO 0.045 MIN)	
3	LWR PANEL ASSY OUTER SKIN	0.080	ALUMINUM HONEYCOMB SANDWICH 2024-T3 (CHEM-MILLED TO 0.040 MIN)	
	INNER SKIN	0.016	2024-T3	
	CORE	0.50	ALUMINUM HONEYCOMB PER BMS 4-4, TYPE 3-10, CLASS-N	
4	UPR TE PANEL SKIN		GLASS FABRIC REINFORCED HONEYCOMB SANDWICH FIBERGLASS/EPOXY PER BMS 8-79, TYPE 1581, CLASS III, 250°F (121°C) CURE PLY ORIENTATION LENGTHWISE AT 0/90° A	
	CORE	0.75	NOMEX HONEYCOMB PER BMS 8-124, CLASS 4, TYPE V, GRADE 3.0.	
5	TE END PANEL	0.125	7075-T73 OPTIONAL: 7075-T76 (CHEM-MILLED TO 0.040 MIN)	
6	LWR TE PANEL	0.08	2024-T3 (CHEM-MILLED TO 0.040 MIN)	
7	TE END PANEL	0.125	7075-T76 OPTIONAL: 7075-T73 (CHEM-MILLED TO 0.080 MIN)	
8	LWR TE PANEL	0.08	2024-T3	
9	TE END PANEL	0.125	7075-T76 OPTIONAL: 7075-T73 (CHEM-MILLED TO 0.060 MIN)	

LIST OF MATERIALS FOR DETAIL VII

**Trailing Edge Flap Skin Identification
Figure 1 (Sheet 9 of 13)**

IDENTIFICATION 1
Page 9
Jan 20/2005

57-53-01

D634N201

**757-200
STRUCTURAL REPAIR MANUAL**

REF DWG
113N3800

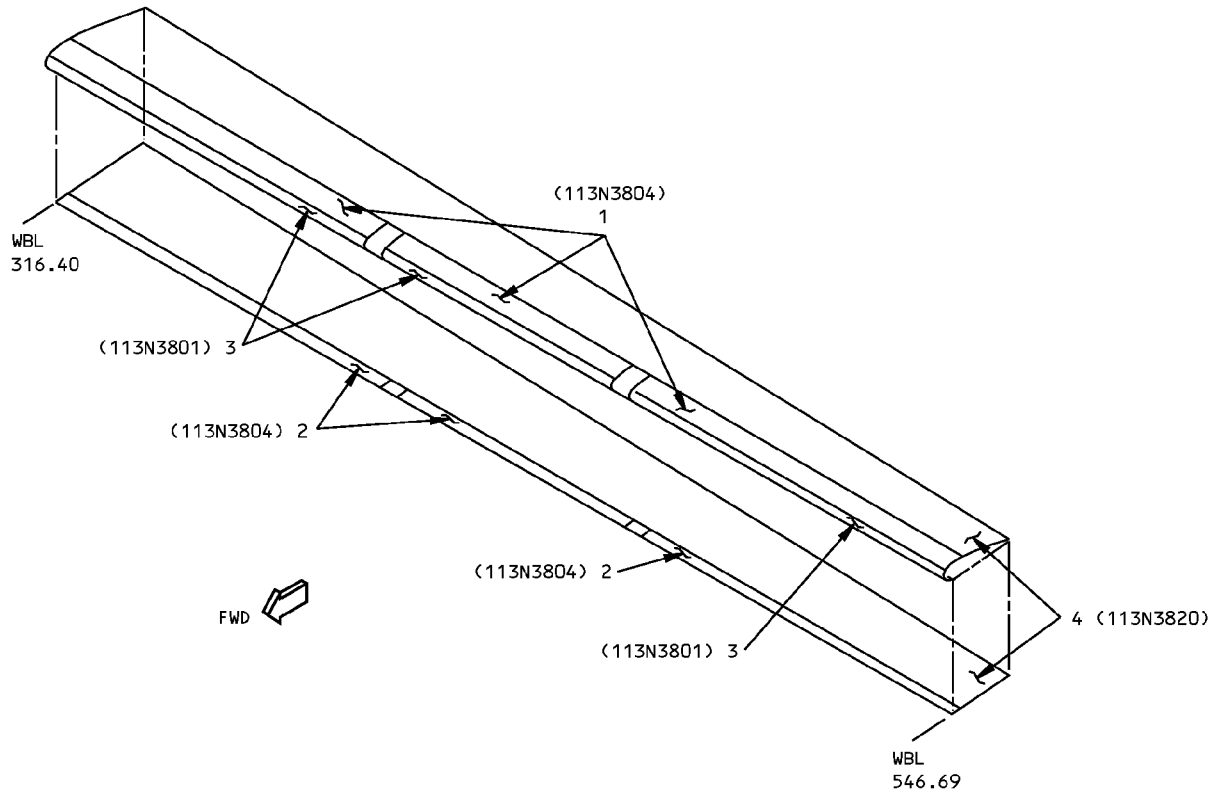

**AFT FLAP – OUTBD TRAILING EDGE FLAP
DETAIL VIII**



**Trailing Edge Flap Skin Identification
Figure 1 (Sheet 10 of 13)**

IDENTIFICATION 1
Page 10
Jan 20/2005

57-53-01

D634N201



757-200
STRUCTURAL REPAIR MANUAL

ITEM	DESCRIPTION	GAGE	MATERIAL	EFFECTIVITY
1	LE SKIN AFT FLAP SKIN CORE	0.15	GRAPHITE/EPOXY HONEYCOMB SANDWICH SEE DETAIL IX NOMEX HONEYCOMB PER BMS 8-124, CLASS 4, TYPE V, GRADE 3.0.	
2	LE SKIN AFT FLAP SKIN CORE	0.15	GRAPHITE/EPOXY HONEYCOMB SANDWICH SEE DETAIL X NOMEX HONEYCOMB PER BMS 8-124, CLASS 4, TYPE V, GRADE 3.0.	
3	NOSE CAP SKIN		SEE DETAIL XI	
4	TE WEDGE SKIN CORE	3.0	SEE DETAIL XII NOMEX HONEYCOMB PER BMS 8-124, CLASS 4, TYPE V, GRADE 3.0.	

LIST OF MATERIALS FOR DETAIL VIII

Trailing Edge Flap Skin Identification
Figure 1 (Sheet 11 of 13)

D634N201

57-53-01

IDENTIFICATION 1
Page 11
Jan 20/2005

**757-200
STRUCTURAL REPAIR MANUAL**

OPTIONAL PLY: BMS 8-245,
CLASS 1, TYPE II, GRADE 3.0.

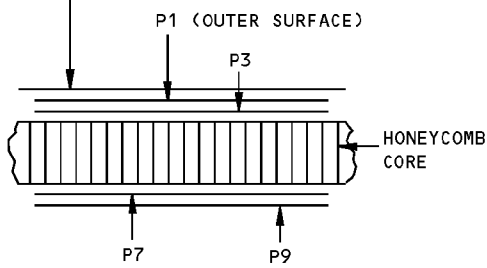

SECTION THRU UPPER HONEYCOMB PANEL

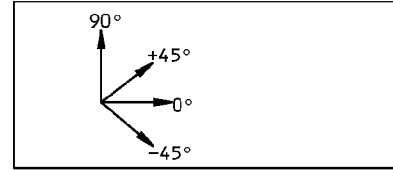
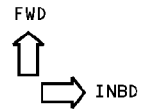

PLY ORIENTATION DIAGRAM
SEE TABLE V FOR INDIVIDUAL
PLY ORIENTATION AND MATERIALS

ITEM NO.	PLY NO.	MATERIAL	PLY ORIENTATION A
1	P1,P9	D	$\pm 45^\circ$
	P3,P7	D	0° OR 90°

TABLE V E

DETAIL IX

OPTIONAL PLY: BMS 8-245,
CLASS 1, TYPE II, GRADE 3.0.

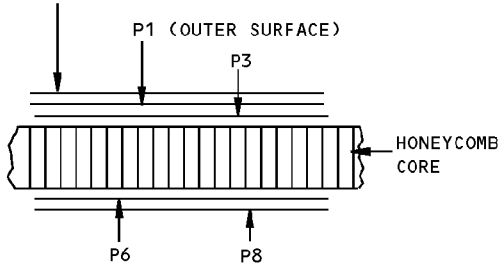

SECTION THRU LOWER HONEYCOMB PANEL

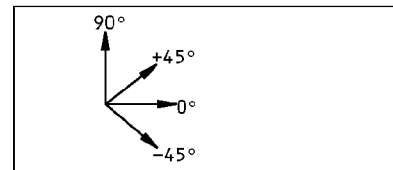
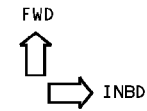

PLY ORIENTATION DIAGRAM
SEE TABLE VI FOR INDIVIDUAL
PLY ORIENTATION AND MATERIALS

ITEM NO.	PLY NO.	MATERIAL	PLY ORIENTATION A
2	P1,P8	D	$\pm 45^\circ$
	P3,P6	D	0° OR 90°

TABLE VI E

DETAIL X

**Trailing Edge Flap Skin Identification
Figure 1 (Sheet 12 of 13)**

**757-200
STRUCTURAL REPAIR MANUAL**

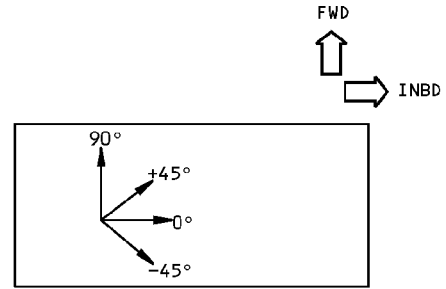
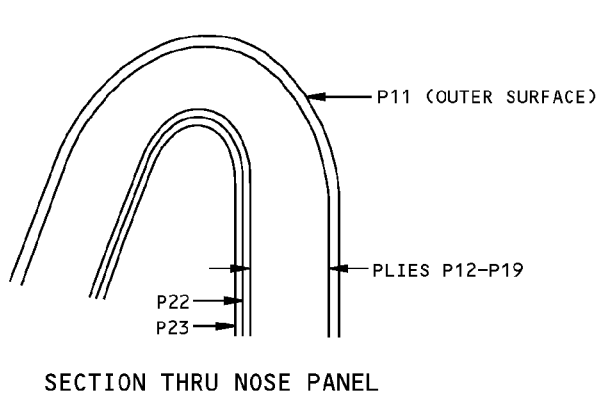

PLY ORIENTATION DIAGRAM
SEE TABLE VII FOR INDIVIDUAL
PLY ORIENTATION AND MATERIALS

ITEM NO.	PLY NO.	MATERIAL	PLY ORIENTATION ^A
3	P11, P13, P16, P18, P22	^B	±45°
	P12, P14, P15, P17, P19, P23	^B	0° OR 90°

TABLE VII ^E
DETAIL XI

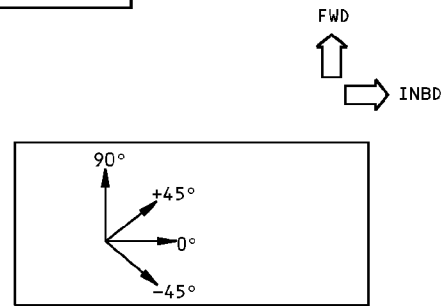
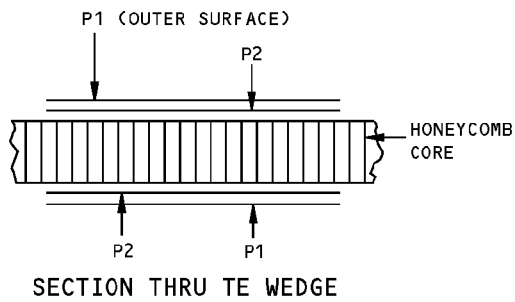

PLY ORIENTATION DIAGRAM
SEE TABLE VIII FOR INDIVIDUAL
PLY ORIENTATION AND MATERIALS

ITEM NO.	PLY NO.	MATERIAL	PLY ORIENTATION ^A
4	P1	^B	0° OR 90°
	P2	^B	45°

TABLE VIII ^E
DETAIL XII

**Trailing Edge Flap Skin Identification
Figure 1 (Sheet 13 of 13)**

**757-200
STRUCTURAL REPAIR MANUAL**

ALLOWABLE DAMAGE 1 - TRAILING EDGE FLAP SKIN

REF DWG
113N2003

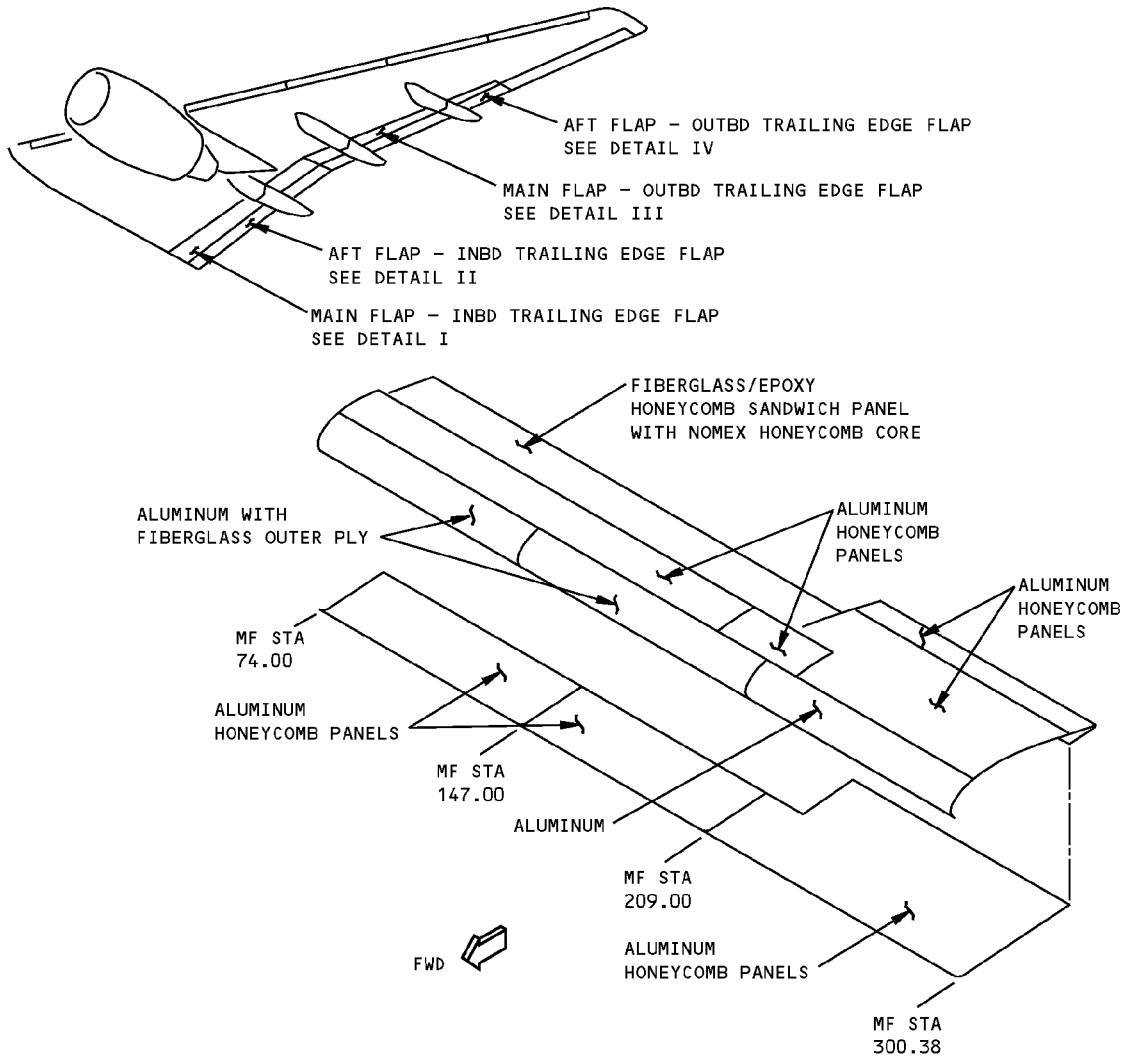

DESCRIPTION	CRACKS	NICKS, GOUGES AND CORROSION	DENTS	HOLES AND PUNCTURES	PANEL DELAMINA- TION	EDGE EROSION
ALUMINUM HONEYCOMB PANELS	H	F	G	I	L	--
ALUMINUM WITH FIBERGLASS OUTER PLY	M	N	O	P	Q	E
FIBERGLASS/EPOXY HONEYCOMB SANDWICH PANEL WITH NOMEX HONEYCOMB CORE	A	B	C	A	A	SEE DETAIL X
ALUMINUM	K	F	G	J	--	--

**MAIN FLAP - INBD TRAILING EDGE FLAP
DETAIL I**

**Trailing Edge Flap Skin Allowable Damage
Figure 101 (Sheet 1 of 7)**

**757-200
STRUCTURAL REPAIR MANUAL**

REF DWG
113N2800

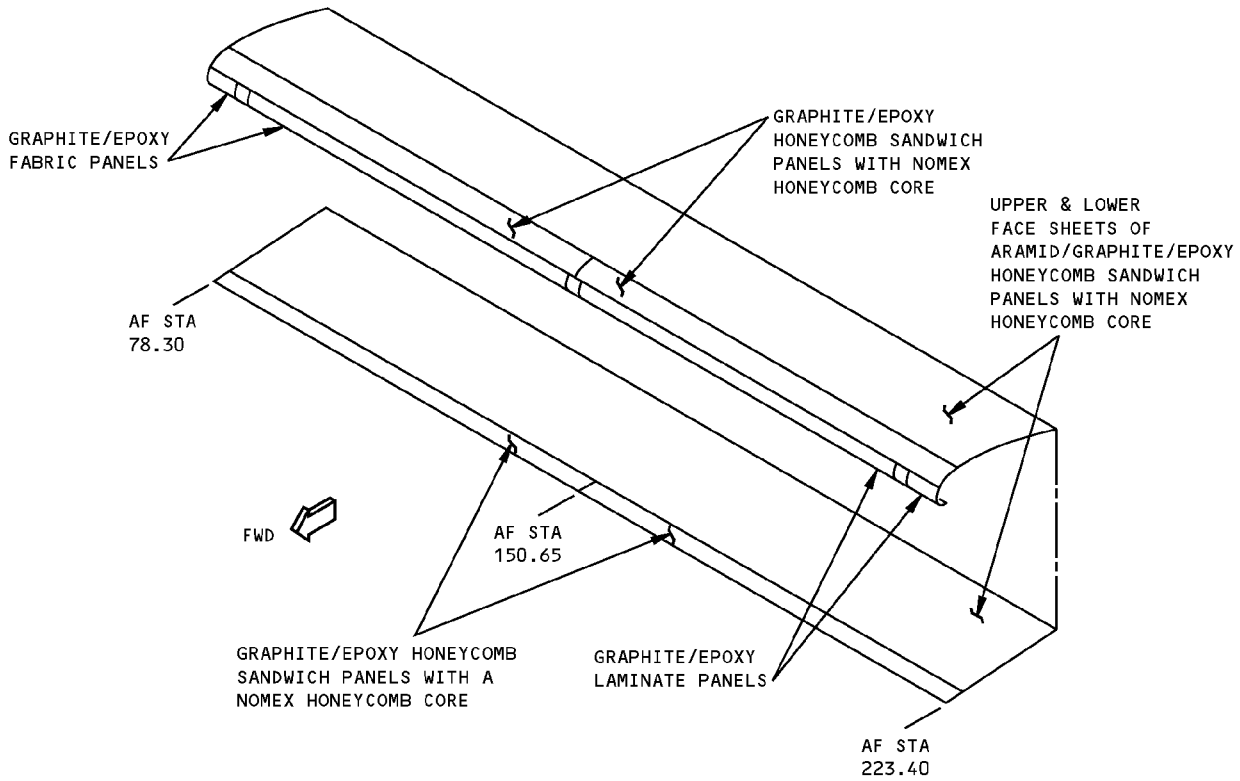

DESCRIPTION	CRACKS	NICKS, GOUGES AND CORROSION	DENTS	HOLES AND PUNCTURES	PANEL DELAMINA- TION	EDGE EROSION
GRAPHITE/EPOXY HONEYCOMB SANDWICH PANELS WITH NOMEX HONEYCOMB CORE	A	B	C	A	A	SEE DETAIL X
GRAPHITE/EPOXY LAMINATE PANELS	A	B	C	A	A	SEE DETAIL X

AFT FLAP - INBD TRAILING EDGE FLAP
DETAIL II

**Trailing Edge Flap Skin Allowable Damage
Figure 101 (Sheet 2 of 7)**

**757-200
STRUCTURAL REPAIR MANUAL**

REFERENCE DRAWING
113N3003

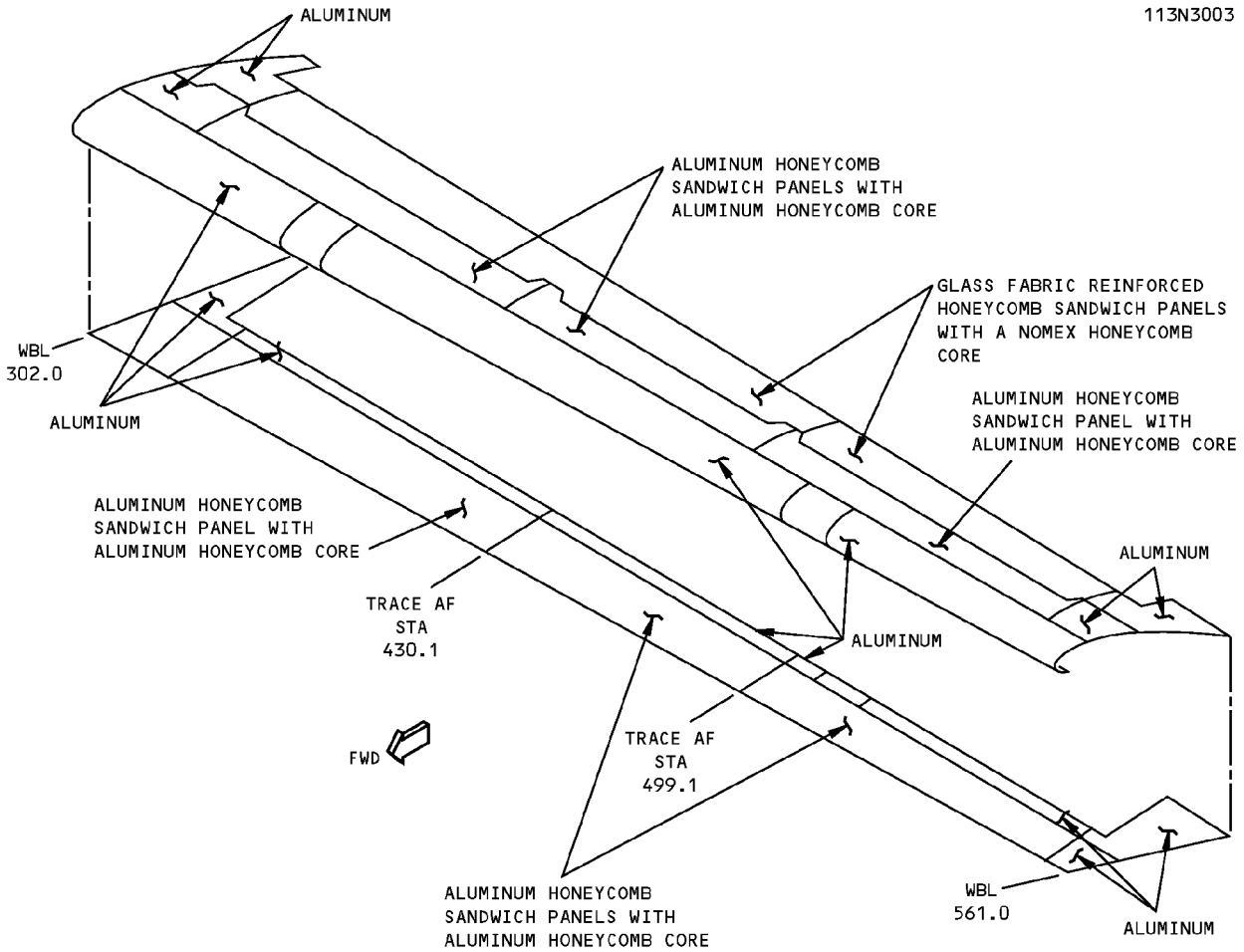

DESCRIPTION	CRACKS	NICKS, GOUGES AND CORROSION	DENTS	HOLES AND PUNCTURES	PANEL DELAMINA- TION	EDGE EROSION
ALUMINUM	K	F	G	J	--	--
ALUMINUM HONEYCOMB SANDWICH PANEL WITH ALUMINUM HONEYCOMB CORE	H	F	G	I	L	--
GLASS FABRIC HONEYCOMB PANELS WITH A NOMEX HONEYCOMB CORE	A	B	C	A	A	SEE DETAIL X

MAIN FLAP – OUTBOARD TRAILING EDGE FLAP
DETAIL III

**Trailing Edge Flap Skin Allowable Damage
Figure 101 (Sheet 3 of 7)**

**757-200
STRUCTURAL REPAIR MANUAL**

REF DWG
113N3800

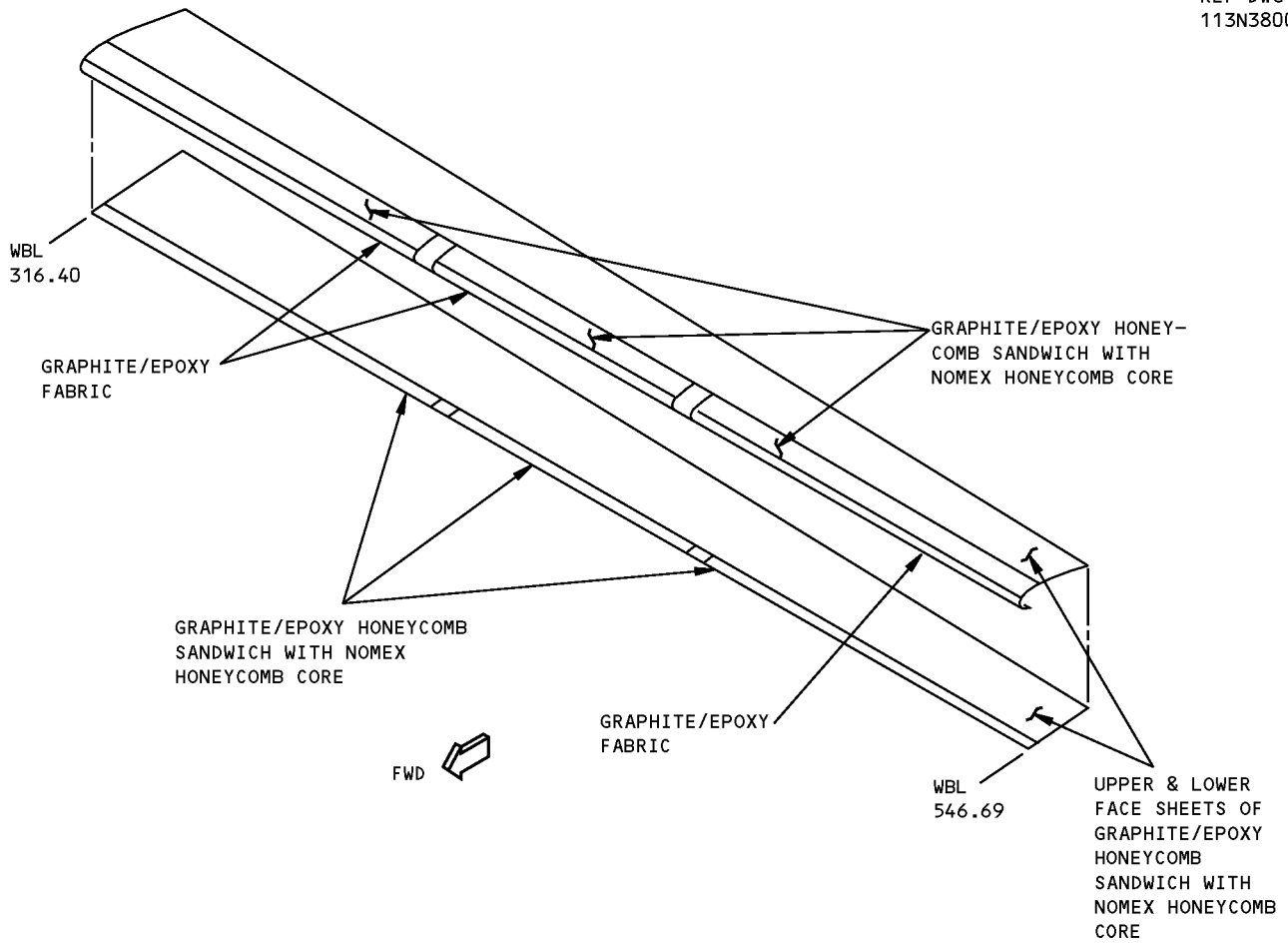

DESCRIPTION	CRACKS	NICKS, GOUGES AND CORROSION	DENTS	HOLES AND PUNCTURES	PANEL DELAMINA- TION	EDGE EROSION
GRAPHITE/EPOXY HONEYCOMB SANDWICH WITH NOMEX HONEYCOMB CORE	A	B	C	A	A	SEE DETAIL X
GRAPHITE/EPOXY FABRIC PANELS	A	B	C	A	A	SEE DETAIL X

**AFT FLAP – OUTBD TRAILING EDGE FLAP
DETAIL IV**

**Trailing Edge Flap Skin Allowable Damage
Figure 101 (Sheet 4 of 7)**

STRUCTURAL REPAIR MANUAL

NOTES

- REFINISH REWORKED AREAS PER 51-20 OF THE MAINTENANCE MANUAL.
 - REFER TO SRM 51-10-01 FOR AERODYNAMIC SMOOTHNESS REQUIREMENTS. WHERE DAMAGE EXCEEDS THE LIMITS SHOWN IN SRM 51-10-01. CONSIDERATION SHOULD BE GIVEN TO LOSS OF PERFORMANCE INVOLVED.
 - REFER TO SRM 51-10-02 FOR INSPECTION AND REMOVAL OF DAMAGE.
- A** DAMAGE TO SKIN PANEL EDGES MAY BE A COMBINATION OF EDGE DELAMINATION AND/OR CRACKS, GOUGES, ETC. WHICH CAN RESULT IN FIBER DAMAGE AND A LOSS OF CROSS-SECTIONAL AREA. REMOVE EDGE DAMAGE PER DETAILS V AND VI. NOT MORE THAN 1 FASTENER HOLE IN SIX MAY BE CRACKED OR DAMAGED. DAMAGE MUST NOT EXCEED 10% OF THE EDGE BAND LENGTH PER SIDE. 2.0 INCHES (50 mm) MAX DIA ALLOWED FOR SINGLE DAMAGE SITE IN HONEYCOMB AREA. MULTIPLE DAMAGE SITES MUST NOT BE CLOSER THAN A MINIMUM OF $a/d = 3.0$ SEE DETAIL IX FOR DAMAGE CRITERIA. DAMAGE ALLOWED TO ONE SURFACE AND HONEYCOMB CORE ONLY. PROTECT DAMAGE NOT REWORKED PER **D**.
 - B** DAMAGE ALLOWED ON SURFACE RESIN ONLY WITH NO FIBER DAMAGE. CLEAN UP EDGE DAMAGE PER DETAILS V AND VI. REFER TO **A** FOR FIBER DAMAGE IN OTHER AREAS.
 - C** DENTS RESULT IN DELAMINATION AND FIBER DAMAGE AND MUST BE TREATED AS A HOLE OR PUNCTURE DAMAGE.
 - D** REMOVE MOISTURE FROM DAMAGE AREA. USE OF VACUUM AND HEAT (MAX OF 125°F (52°C)) TO REMOVE MOISTURE FROM HONEYCOMB CELLS IS RECOMMENDED. PROTECT DAMAGE FROM ENTRANCE OF WATER, SUNLIGHT OR OTHER FOREIGN MATTER BY SEALING WITH ALUMINUM FOIL TAPE (SPEED TAPE). RECORD THE LOCATION AND INSPECT EVERY AIRPLANE "A" CHECK. REPLACE THE ALUMINUM FOIL TAPE IF ANY PEELING OR DETErioration EVIDENT. REPAIR NO LATER THAN NEXT AIRPLANE "C" CHECK. **R**
 - E** TREAT EDGE EROSION PER DETAIL X EXCEPT ONLY ONE EXISTING PLY.
 - F** REMOVE DAMAGE PER DETAILS V, VI AND VIII.
 - G** SEE DETAIL VII.
 - H** 1.0 INCH (25 mm) MAX LENGTH IN HONEYCOMB AREA. STOP DRILL ENDS OF CRACK WITH 0.25 INCH (6 mm) DIA HOLE, CLEAN UP EDGE CRACKS PER DETAILS V AND VI. CRACKS THROUGH CONSECUTIVE FASTENERS OR THROUGH THE PANEL EDGE BAND ARE ALLOWED PROVIDED DAMAGE DOES NOT EXCEED 10% OF EDGE BAND LENGTH PER SIDE. **D**
 - I** 0.25 INCH (6 mm) MAX DIA ALLOWED PROVIDED DAMAGE IS MIN OF 3D FROM OTHER DAMAGE, NEAREST HOLE, OR MATERIAL EDGE. **D**
 - J** CLEAN OUT DAMAGE UP TO 0.25 INCH (6 mm) MAX DIA AND NOT CLOSER THAN 1.0 INCH (25 mm) TO FASTENER HOLE, MATERIAL EDGE, EXISTING HOLES OR OTHER DAMAGE. FILL HOLE WITH A 2117-T3 OR T4 ALUMINUM RIVET INSTALLED WET WITH BMS 5-95 SEALANT. ALL OTHER HOLES TO BE REPAIRED.
 - K** CRACKS NOT ALLOWED EXCEPT FOR EDGE CRACKS WHICH MUST BE REMOVED PER DETAIL V AND VI.
 - L** 1.0 INCH (25 mm) MAX DIA ALLOWED WITHOUT REWORK.
 - M** CRACKS NOT ALLOWED IN ALUMINUM SKIN EXCEPT FOR EDGE CRACKS WHICH MUST BE REMOVED PER DETAILS V AND VI. TREAT DAMAGE TO OUTER FIBERGLASS PLY PER **A**.
 - N** REMOVE DAMAGE IN ALUMINUM SKIN PER DETAIL V, VI, AND VIII. TREAT DAMAGE TO FIBERGLASS PLY PER **B**.
 - O** SEE DETAIL VII FOR DENT DAMAGE IN ALUMINUM SKIN AND **C** FOR DAMAGE TO FIBERGLASS PLY.
 - P** CLEAN OUT DAMAGE IN ALUMINUM SKIN UP TO 0.25 INCH (6 mm) MAX DIA AND NOT CLOSER THAN 1.0 INCH (25 mm) TO FASTENER HOLES, MATERIAL EDGE, OR OTHER DAMAGE. FILL HOLE WITH A 2117-T3 OR T4 ALUMINUM RIVET INSTALLED WET WITH BMS 5-95 SEALANT. ALL OTHER HOLES TO BE REPAIRED. SEE **A** FOR HOLES TO FIBERGLASS OUTER PLY.
 - Q** FOR DELAMINATION OF OUTER FIBERGLASS PLY, SEE **A**.
 - R** THIS ALLOWABLE DAMAGE HAS FAA APPROVAL CONTINGENT ON ACCOMPLISHMENT OF THE INSPECTIONS CONTAINED HEREIN.

Trailing Edge Flap Skin Allowable Damage
Figure 101 (Sheet 5 of 7)

**757-200
STRUCTURAL REPAIR MANUAL**

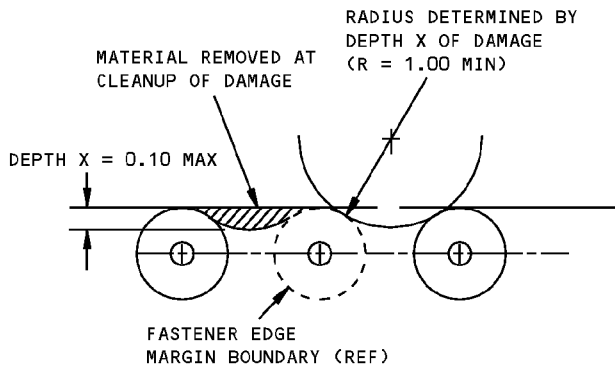

DAMAGE CLEANUP OF EDGES WHERE FASTENER EDGE MARGINS DO NOT OVERLAP

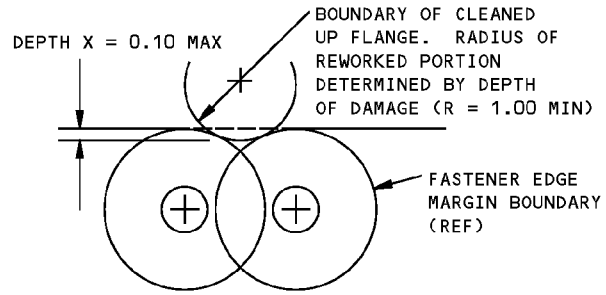

DAMAGE CLEANUP OF EDGES WHERE FASTENER EDGE MARGINS OVERLAP

DETAIL V

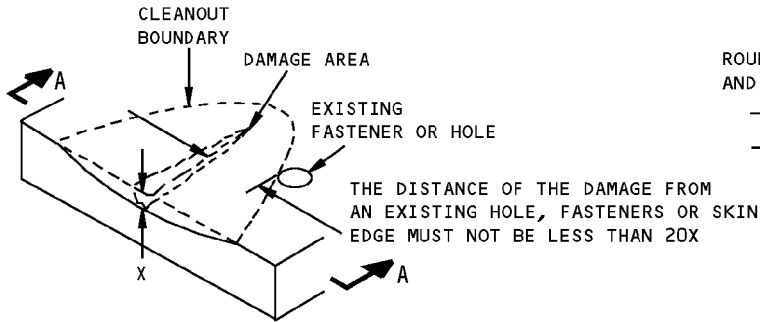

**REMOVAL OF NICK, GOUGE AND SCRATCH DAMAGE ON A SURFACE
DETAIL VI**

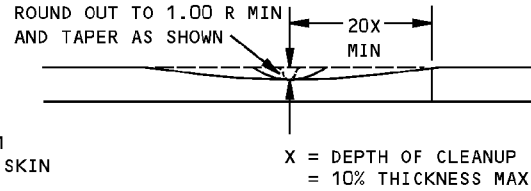

SECTION A-A

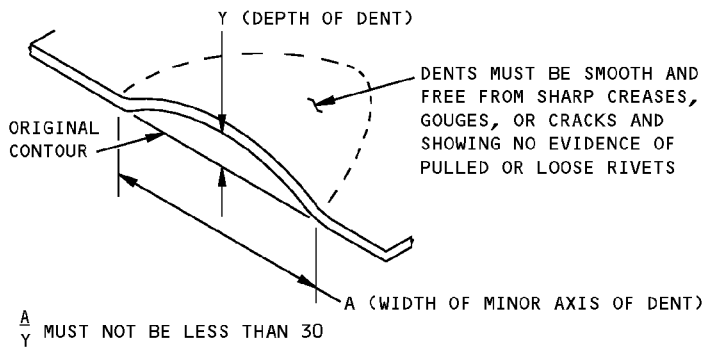

**ALLOWABLE DAMAGE FOR DENT
DETAIL VII**

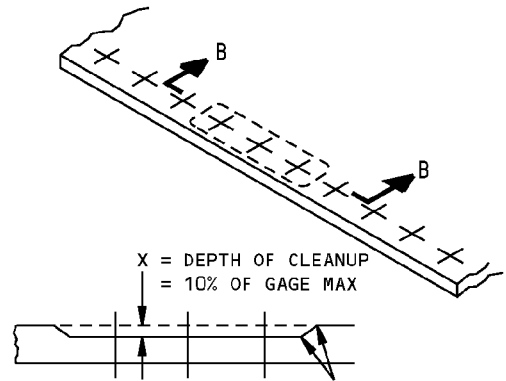

**SECTION B-B
CORROSION CLEANUP
DETAIL VIII**

**Trailing Edge Flap Skin Allowable Damage
Figure 101 (Sheet 6 of 7)**

STRUCTURAL REPAIR MANUAL

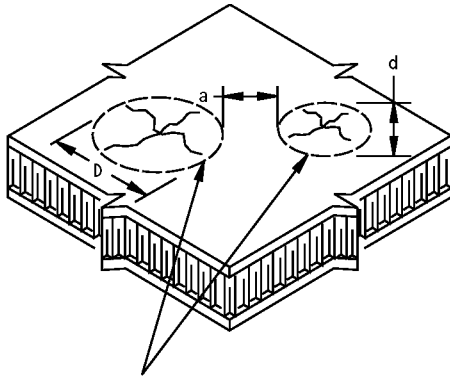

ADJACENT DAMAGE SITES ON SURFACE OF COMPOSITE PANEL

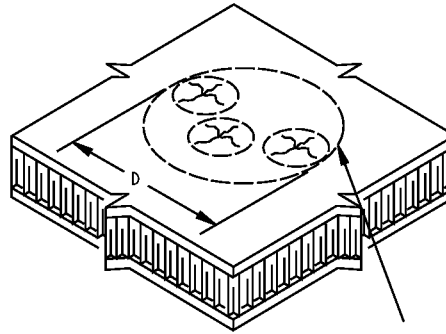

SMALL DAMAGE SITES THAT ARE CLOSELY SPACED MAY BE GROUPED TOGETHER AND CONSIDERED AS ONE DAMAGE SITE

- DAMAGE TO COMPOSITE PANELS EXPOSED TO MULTIPLE IMPACTS, I.E., HAIL DAMAGE, CAN BE DETECTED BY USING INSTRUMENTED NON-DESTRUCTIVE INSPECTION METHODS OR BY TAPPING THE SUSPECTED DAMAGE AREA WITH A SMALL METALLIC DISK OBJECT. INSPECTION SHOULD COVER THE AREA WITHIN 3 DIAMETERS AROUND THE EDGE OF THE VISIBLE DAMAGE SITE. FOR TAP TEST, USE A SOLID METAL DISK AND TAP THE DAMAGE AREA LIGHTLY BUT FIRMLY. VOID AREAS SHOULD PRODUCE A DULL SOUND AS OPPOSED TO A SHARP RING ON A SOLID BONDED AREA.
- DAMAGE SITE IS ANY SINGLE AREA OF A PANEL WHERE A DENT, CRACK, DELAMINATION, PUNCTURE OR ANY COMBINATION OF THESE EXIST. SMALL DAMAGE SITES THAT ARE CLOSELY SPACED MAY BE GROUPED TOGETHER AND CONSIDERED AS ONE DAMAGE SITE.
- "D" IS DETERMINED BY MEASURING THE MAX DIMENSION OF A DENT, CRACK, OR OTHER DAMAGE, WHICHEVER IS GREATER
- "a" IS THE DISTANCE BETWEEN TWO ADJACENT DAMAGE SITES
- "d" IS THE MAX DIMENSION OF THE SMALLER OF TWO ADJACENT DAMAGE SITES
- CALCULATE a/D BY DIVIDING DISTANCE "a" BY DIMENSION "D"
- DAMAGE IS ALLOWED WHEN "D":
 - IS EQUAL TO OR LESS THAN THE MAXIMUM ALLOWABLE "D" GIVEN IN THE NOTES IN DETAILS I THROUGH IV AND
 - WHEN a/D IS EQUAL TO OR GREATER THAN THE MINIMUM a/D GIVEN IN THE NOTES IN DETAILS I THROUGH IV.

DAMAGE SIZING AND SPACING DATA FOR COMPOSITE PANELS
DETAIL IX

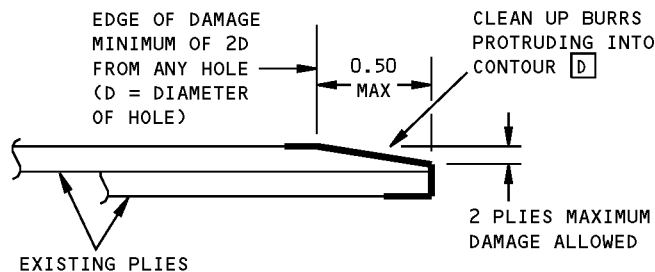

DAMAGE CLEANUP AND SEALING OF EDGE EROSION
DETAIL X

Trailing Edge Flap Skin Allowable Damage
Figure 101 (Sheet 7 of 7)

757-200
STRUCTURAL REPAIR MANUAL

REPAIR 1 - TRAILING EDGE FLAP COMPOSITE SKIN REPAIR

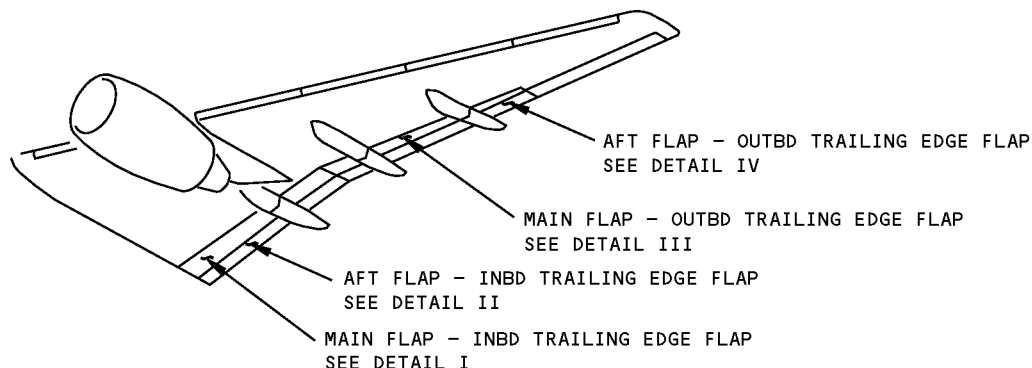

NOTES

- REFINISH REWORKED AREAS PER AMM 51-20
- REFER TO SRM 51-10-01 FOR AERODYNAMIC SMOOTHNESS REQUIREMENTS. WHERE THE DAMAGE EXCEEDS THE LIMITS SHOWN IN SRM 51-10-01, CONSIDERATION SHOULD BE GIVEN TO THE LOSS OF PERFORMANCE INVOLVED.
- REFER TO SRM 51-10-02 FOR INSPECTION AND REMOVAL OF DAMAGE.

- A** LIMITED TO REPAIR OF DAMAGE TO ONE FACE-SHEET SKIN AND HONEYCOMB CORE. ONE REPAIR PER SQUARE FOOT OF AREA AND MINIMUM OF 6.0 INCHES (150 mm) (EDGE TO EDGE) FROM ANY OTHER DAMAGE, FASTENER HOLE, OR EDGE OF PANEL.
- B** INSPECT INTERIM REPAIR USING INSTRUMENTED NDI METHODS OR "TAP" TEST EVERY AIRPLANE "2A" CHECK. FOR "TAP" TEST, USE A SOLID METAL DISK AND TAP THE REPAIR AREA LIGHTLY BUT FIRMLY. VOID AREAS WILL PRODUCE A DULL SOUND AS OPPOSED TO A SHARP RING ON A SOLID BONDED AREA. PERMANENT REPAIR IS REQUIRED IF ANY DETERIORATION IS EVIDENT. REFER TO SRM 51-70-03, PAR. 4.I. AND THE NONDESTRUCTIVE TEST MANUAL **D**.
- C** ONE REPAIR IS PERMITTED FOR EACH SQUARE FOOT OF AREA. THE REPAIR MUST BE A MINIMUM OF 6.0 INCHES (150 mm) (EDGE TO EDGE) FROM THE NEAREST FASTENER HOLE OR DAMAGED AREA. THE REPAIR MUST BE A MINIMUM OF 3.0 INCHES (75 mm) FROM THE SPAR. THE REPAIR MUST BE A MINIMUM OF 4.0 INCHES (100 mm) FROM THE TRAILING EDGE. THE REPAIR MUST BE A MINIMUM DISTANCE FROM THE INBOARD AND OUTBOARD ENDS OF THE PANEL. THIS DISTANCE IS EQUAL TO THE LARGEST DIMENSION OF THE REPAIR. THE REPAIR MUST BE A MINIMUM OF 1.0 INCH (25 mm) FROM THE INBOARD AND OUTBOARD ENDS OF THE PANEL. IF THE REPAIR IS LESS THAN 1.0 INCH (25 mm) FROM THE INBOARD AND OUTBOARD ENDS OF THE PANEL, REFER TO SRM 51-70-05 FOR THE REPAIR. APPLY BMS 5-95 TO THE ENDS OF THE AFT FLAP.

- D** THIS REPAIR HAS FAA APPROVAL CONTINGENT ON ACCOMPLISHMENT OF THE INSPECTIONS CONTAINED HEREIN.
- E** FOR THE AREA BETWEEN THE FRONT SPAR AND REAR SPAR OF THE INBOARD MAIN FLAP ONLY:
- YOU CAN PUT EXTERNAL REPAIRS ON THE UPPER PANELS IF THE THICKNESS OF THE REPAIR IS 0.050 INCH (12.7 mm) OR LESS
 - IF YOU MAKE A REPAIR OF MORE THAN 0.050 INCH (12.7 mm) THICKNESS, THE REPAIR CAN HIT THE LOWER SURFACE OF THE SPOILER.
- F** FOR THE AREA BETWEEN THE FRONT SPAR AND REAR SPAR OF THE OUTBOARD MAIN FLAP ONLY:
- DO NOT PUT EXTERNAL REPAIRS ON THE UPPER PANELS
 - IF YOU MAKE A REPAIR THAT IS NOT FLUSH IN THIS AREA, THE REPAIR WILL HIT THE LOWER SURFACE OF THE SPOILER.

Trailing Edge Flap Composite Skin Repair
Figure 201 (Sheet 1 of 6)

**757-200
STRUCTURAL REPAIR MANUAL**

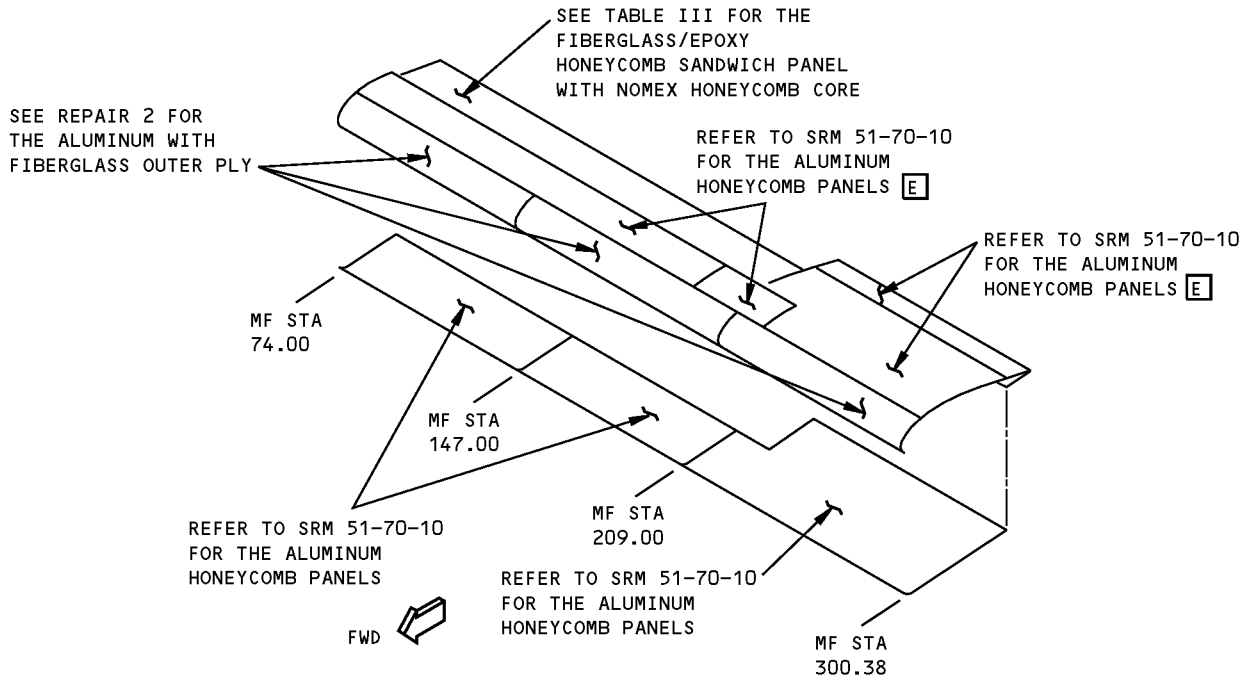

**MAIN FLAP - INBD TRAILING EDGE FLAP
DETAIL I**

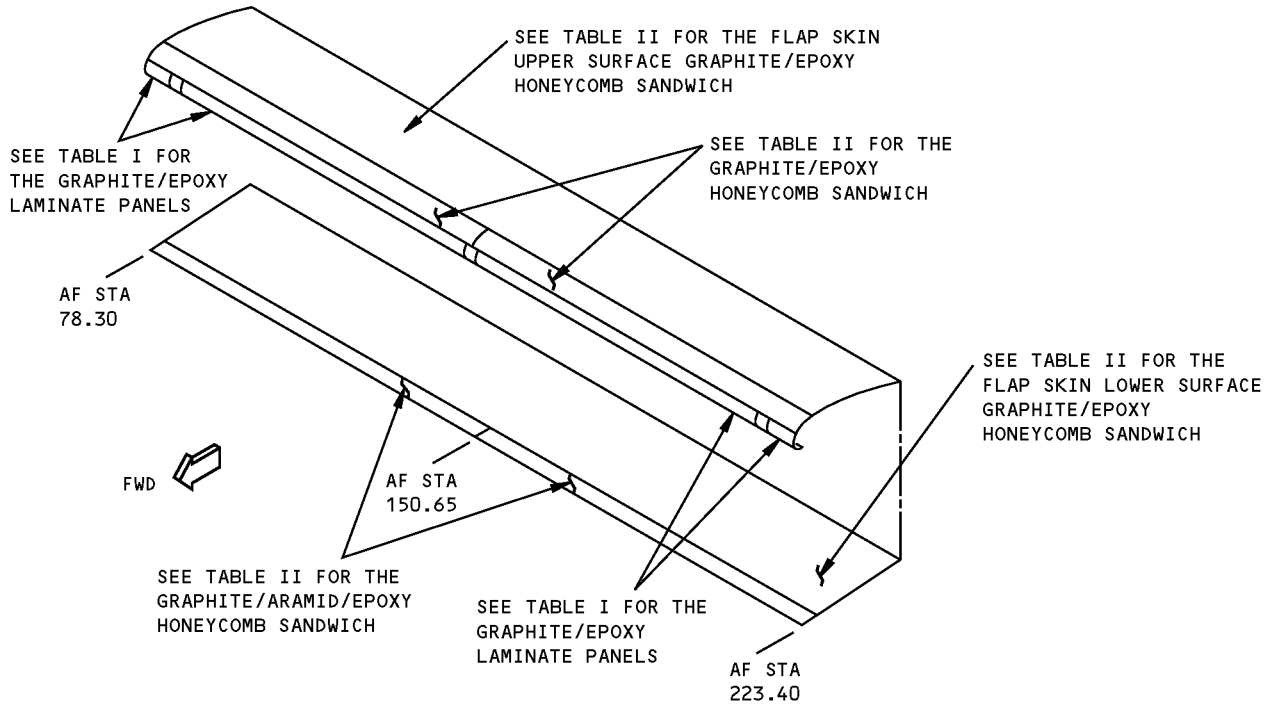

**AFT FLAP - INBD TRAILING EDGE FLAP
DETAIL II**

**Trailing Edge Flap Composite Skin Repair
Figure 201 (Sheet 2 of 6)**

STRUCTURAL REPAIR MANUAL

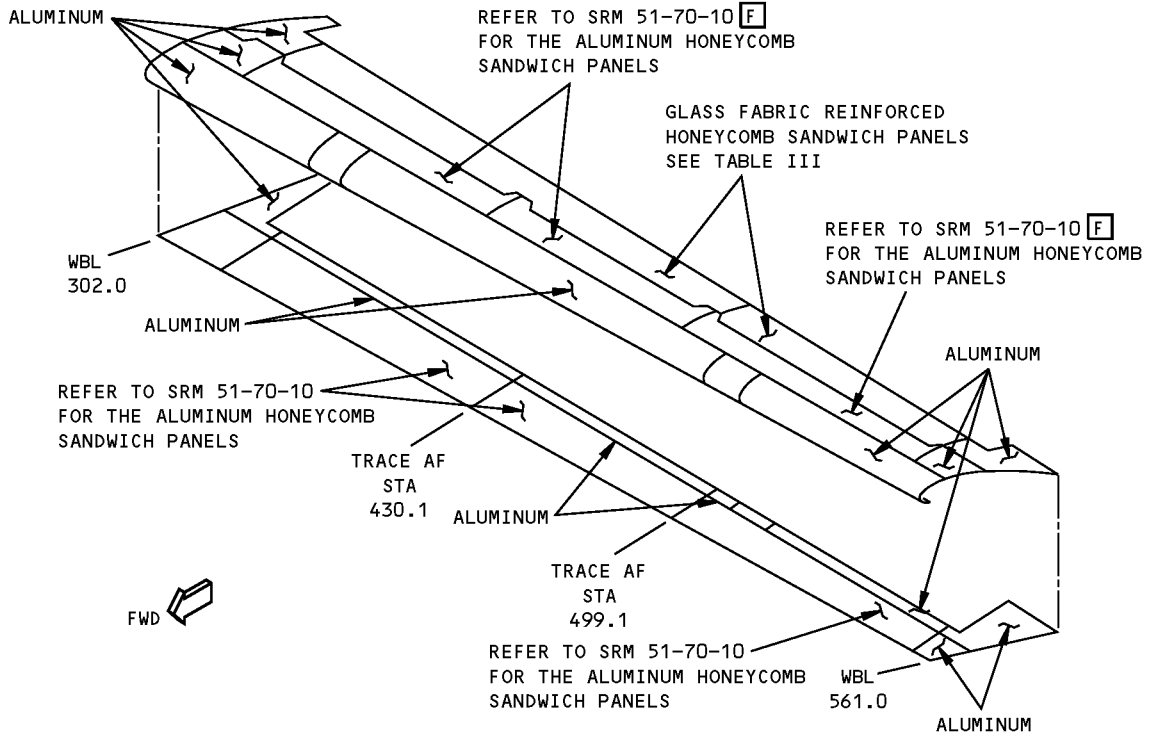

**MAIN FLAP - OUTBOARD TRAILING EDGE FLAP
DETAIL III**

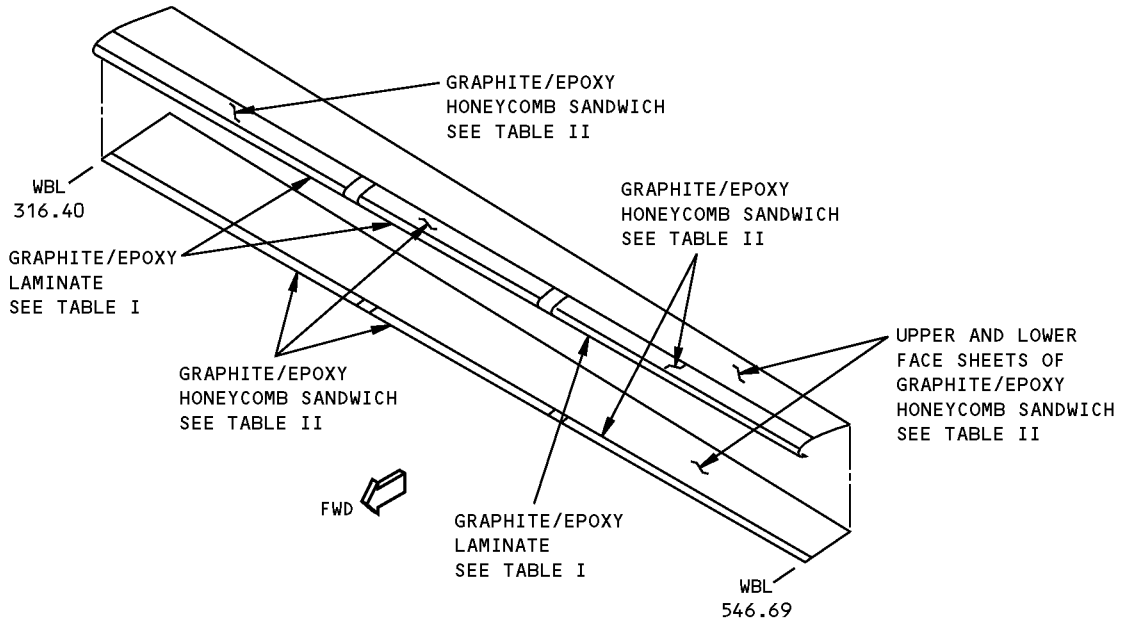

**AFT FLAP - OUTBOARD TRAILING EDGE FLAP
DETAIL IV**

**Trailing Edge Flap Composite Skin Repair
Figure 201 (Sheet 3 of 6)**

STRUCTURAL REPAIR MANUAL

DAMAGE	INTERIM REPAIRS B	PERMANENT REPAIRS		
	WET LAYUP 150°F (66°C) CURE (SRM 51-70-03)	WET LAYUP 200°F (93°C) CURE (SRM 51-70-17)	250°F (121°C) CURE (SRM 51-70-05)	350°F (177°C) CURE (SRM 51-70-04)
CRACKS	UP TO 3.0 INCHES (75 mm) LONG, REPAIR WITH PATCH AS GIVEN IN SRM 51-70-03, PAR. 5.N. A	CLEAN UP DAMAGE AND REPAIR AS A HOLE.	CLEAN UP DAMAGE AND REPAIR AS A HOLE.	CLEAN UP DAMAGE AND REPAIR AS A HOLE.
HOLES AND PUNCTURES	3.0 INCHES (75 mm) MAXIMUM DIA NOT TO EXCEED 30% OF SMALLEST DIMENSION ACROSS LAMINATE PANEL AT THE DAMAGE LOCATION. FILL WITH BMS 5-28, TYPE 7 POTTING COMPOUND AND PATCH AS GIVEN IN SRM 51-70-03, PAR. 5.N. A	12.0 INCHES (300 mm) MAXIMUM DIA NOT TO EXCEED 50% OF SMALLEST DIMENSION ACROSS LAMINATE PANEL AT THE DAMAGE LOCATION. USE TWO EXTRA PLIES FOR EACH FACESHEET REPAIRED. C	6.0 INCHES (150 mm) MAXIMUM DIA NOT TO EXCEED 50% OF SMALLEST DIMENSION ACROSS LAMINATE PANEL AT THE DAMAGE LOCATION. USE TWO EXTRA PLIES FOR EACH FACESHEET REPAIRED. C	NO SIZE LIMIT
EDGE EROSION	_____	FOR DAMAGE THAT IS NOT LARGER THAN 35% OF EDGE BAND THICKNESS, REPAIR AS GIVEN IN SRM 51-70-03, PAR. 5.O. FOR LARGER DAMAGE, REPAIR AS GIVEN IN: SRM 51-70-17, PAR. 4.G. SRM 51-70-05, PAR. 5.G. SRM 51-70-04, PAR. 5.G.		
DELAMINATION	CUT OUT AND REPAIR AS A HOLE.			
NICKS AND GOUGES	IF THERE IS NO FIBER DAMAGE OR DELAMINATION, FILL NICKS OR GOUGES AS GIVEN IN SRM 51-70-03. IF YOU FIND FIBER DAMAGE OR DELAMINATION THEN, REPAIR AS A HOLE.			
DENTS	UP TO 2.0 INCHES (50 mm) DIA WITH NO FIBER DAMAGE OR DELAMINATION, FILL WITH BMS 5-28, TYPE 7 POTTING COMPOUND AND PATCH AS GIVEN IN SRM 51-70-03, PAR. 5.L. C OVER 2.0 INCHES (50 mm) DIA OR WITH FIBER DAMAGE OR DELAMINATION, REPAIR AS A HOLE.			

REPAIR DATA FOR 350°F CURE LAMINATE PANELS (GRAPHITE/ARAMID)
TABLE I

Trailing Edge Flap Composite Skin Repair
Figure 201 (Sheet 4 of 6)



**757-200
STRUCTURAL REPAIR MANUAL**

DAMAGE	INTERIM REPAIRS B	PERMANENT REPAIRS		
	WET LAYUP 150°F (66°C) CURE (SRM 51-70-03)	WET LAYUP 200°F (93°C) CURE (SRM 51-70-17)	250°F (121°C) CURE (SRM 51-70-05)	350°F (177°C) CURE (SRM 51-70-04)
CRACKS	UP TO 3.0 INCHES (76 mm) LONG, REPAIR WITH PATCH AS GIVEN IN SRM 51-70-03, PAR. 5.N. A	CLEAN UP DAMAGE AND REPAIR AS A HOLE.	CLEAN UP DAMAGE AND REPAIR AS A HOLE.	CLEAN UP DAMAGE AND REPAIR AS A HOLE.
HOLES AND PUNCTURES	3.0 INCHES (75 mm) MAXIMUM DIA NOT TO EXCEED 30% OF SMALLEST DIMENSION ACROSS HONEYCOMB PANEL AT THE DAMAGE LOCATION. FILL WITH BMS 5-28, TYPE 7 POTTING COMPOUND AND PATCH AS GIVEN IN SRM 51-70-03, PAR. 5.N. A	12.0 INCHES (300 mm) MAXIMUM DIA NOT TO EXCEED 50% OF SMALLEST DIMENSION ACROSS HONEYCOMB PANEL AT THE DAMAGE LOCATION. USE TWO EXTRA PLIES FOR EACH FACESHEET REPAIRED. C	6.0 INCHES (150 mm) MAXIMUM DIA NOT TO EXCEED 50% OF SMALLEST DIMENSION ACROSS HONEYCOMB PANEL AT THE DAMAGE LOCATION. USE TWO EXTRA PLIES FOR EACH FACESHEET REPAIRED. C	NO SIZE LIMIT
EDGE EROSION	_____	FOR DAMAGE THAT IS NOT LARGER THAN 35% OF EDGE BAND THICKNESS, REPAIR AS GIVEN IN SRM 51-70-03, PAR. 5.O. FOR LARGER DAMAGE, REPAIR AS GIVEN IN: SRM 51-70-17, PAR. 4.G. SRM 51-70-05, PAR. 5.G. SRM 51-70-04, PAR. 5.G.		
DELAMINATION	CUT OUT AND REPAIR AS A HOLE.			
NICKS AND GOUGES	IF THERE IS NO FIBER DAMAGE OR DELAMINATION, FILL NICKS OR GOUGES AS GIVEN IN SRM 51-70-03. IF YOU FIND FIBER DAMAGE OR DELAMINATION, THEN REPAIR AS A HOLE.			
DENTS	UP TO 2.0 INCHES (50 mm) DIA WITH NO FIBER DAMAGE OR DELAMINATION, FILL WITH BMS 5-28, TYPE 7 POTTING COMPOUND AND PATCH AS GIVEN IN SRM 51-70-03, PAR. 5.L. C OVER 2.0 INCHES (50 mm) DIA OR WITH FIBER DAMAGE OR DELAMINATION, REPAIR AS A HOLE.			

REPAIR DATA FOR 350°F (177°C) CURE HONEYCOMB PANELS (GRAPHITE/ARAMID)
TABLE II

**Trailing Edge Flap Composite Skin Repair
Figure 201 (Sheet 5 of 6)**



**757-200
STRUCTURAL REPAIR MANUAL**

DAMAGE	INTERIM REPAIRS B	PERMANENT REPAIRS		
	WET LAYUP ROOM TEMP CURE (SRM 51-70-06)	WET LAYUP 150°F (66°C) CURE (SRM 51-70-06)	WET LAYUP 200°F (93°C) CURE (SRM 51-70-17)	250°F (121°C) CURE (SRM 51-70-07)
CRACKS	UP TO 3.0 INCHES (75 mm) LONG, REPAIR WITH PATCH AS GIVEN IN SRM 51-70-06, PAR. 5.N. A	CLEAN UP DAMAGE AND REPAIR AS A HOLE.	CLEAN UP DAMAGE AND REPAIR AS A HOLE.	CLEAN UP DAMAGE AND REPAIR AS A HOLE.
HOLES AND PUNCTURES	4.0 INCHES (100 mm) MAXIMUM DIA NOT TO EXCEED 30% OF SMALLEST DIMENSION ACROSS HONEYCOMB PANEL AT THE DAMAGE LOCATION. FILL WITH BMS 5-28, TYPE 7 POTTING COMPOUND AND PATCH AS GIVEN IN SRM 51-70-06, PAR. 5.N. A	8.0 INCHES (200 mm) MAXIMUM DIA NOT TO EXCEED 50% OF SMALLEST DIMENSION ACROSS HONEYCOMB PANEL AT THE DAMAGE LOCATION. USE TWO EXTRA PLIES FOR EACH FACESHEET REPAIRED. C	12.0 INCHES (300 mm) MAXIMUM DIA NOT TO EXCEED 50% OF SMALLEST DIMENSION ACROSS HONEYCOMB PANEL AT THE DAMAGE LOCATION. USE TWO EXTRA PLIES FOR EACH FACESHEET REPAIRED. C	NO SIZE LIMIT
EDGE EROSION	_____	FOR DAMAGE THAT IS NOT LARGER THAN 35% OF EDGE BAND THICKNESS, REPAIR AS GIVEN IN SRM 51-70-06, PAR. 5.O. FOR LARGER DAMAGE, REPAIR AS GIVEN IN: SRM 51-70-06, PAR. 5.G. SRM 51-70-17, PAR. 4.G. SRM 51-70-07, PAR. 5.G.		
DELAMINATION	CUT OUT AND REPAIR AS A HOLE.			
NICKS AND GOUGES	IF THERE IS NO FIBER DAMAGE OR DELAMINATION, FILL NICKS OR GOUGES AS GIVEN IN SRM 51-70-03. IF YOU FIND FIBER DAMAGE OR DELAMINATION THEN, REPAIR AS A HOLE.			
DENTS	UP TO 2.0 INCHES (50 mm) DIA WITH NO FIBER DAMAGE OR DELAMINATION, FILL WITH BMS 5-28, TYPE 7 POTTING COMPOUND AND PATCH AS GIVEN IN SRM 51-70-06, PAR. 5.L. C OVER 2.0 INCHES (50 mm) DIA OR WITH FIBER DAMAGE OR DELAMINATION, REPAIR AS A HOLE.			

REPAIR DATA FOR 250°F (121°C) CURE HONEYCOMB PANELS (FIBERGLASS)
TABLE III

**Trailing Edge Flap Composite Skin Repair
Figure 201 (Sheet 6 of 6)**

STRUCTURAL REPAIR MANUAL

REPAIR 2 - TRAILING EDGE FLAP SKIN ALUMINUM REPAIR

REPAIR INSTRUCTIONS

1. Cut out damaged portion of skin in a rectangular shape with the major axis parallel to wing spar. Round corners to 0.5 inch (12.7) radius.
2. Make repair parts. Form to contour of skin.
3. Break all sharp edges of original and repair parts 0.015 to 0.030 (0.4 to 0.8 mm) radius.
4. Locate, drill, and countersink the fastener holes.
5. Remove all nicks, burrs, and scratches from original and repair parts.
6. Alodize the repair parts.
7. Apply one coat of BMS 10-11 primer to surfaces of repair parts.

NOTE: FOR SKIN HAVING FIBERGLASS OUTER PLY, DO NOT PRIME REPAIR PLATE OUTER SURFACE.

8. Fit doublers and straps through the rectangular hole. Apply a faying surface seal with BMS 5-95 to all mating surfaces. Install BACR15CE5D() fasteners wet with BMS 5-95.
9. Fit repair plate onto doublers. Use a faying surface seal with BMS 5-95 and NAS1399D5() rivets.
NOTE: For skins having a fiberglass outer ply, omit steps 10 and 11.
10. Fill gaps between skin and repair plate with BMS 5-95.
11. Restore original finish.
NOTE: Steps 12 thru 15 are for skin with fiberglass outer ply only (main flap - inboard TE flap). Refer to SRM 51-70-06 for fiberglass repair data.
12. Cut fiberglass repair ply with a one inch overlap.
13. Remove paint from original fiberglass ply in the overlap area.
14. Clean repair area and complete repair as given in SRM 51-70-06, par. 3, using one ply of Type H, H-2, or H-3 any Class except Class 7 glass fabric.
NOTE: Extra plies are not required for this repair.
15. Restore original finish as given in AMM 51-20.

NOTES

- THIS REPAIR APPLIES ONLY TO AREAS BETWEEN SPAR CHORDS AND RIBS WHERE SKIN IS CONSTANT THICKNESS. DOUBLERS MUST NOT RIDE A CHEM-MILLED RADIUS
- WHEN YOU USE THIS REPAIR REFER TO:
REFER TO SRM 51-10-02 FOR INSPECTION AND REMOVAL OF DAMAGE.

SRM 51-10-01 FOR AERODYNAMIC SMOOTHNESS REQUIREMENTS. WHERE THE REPAIR EXCEEDS THE LIMITS, CONSIDERATION SHOULD BE GIVEN TO THE LOSS OF PERFORMANCE INVOLVED



SRM 51-10-05 FOR SEALING OF REPAIRS

SRM 51-20-01 FOR PROTECTIVE TREATMENT OF METAL

SRM 51-40 FOR FASTENER CODE, REMOVAL, INSTALLATION, HOLE SIZES, AND EDGE MARGINS.

- A** FOR REPAIR PLATE, USE SAME GAGE AS ORIGINAL SKIN, TO A MINIMUM THICKNESS OF 0.071 INCH. ORIGINAL SKIN THICKNESS MUST BE MEASURED IN CHEM-MILLED AREAS.
- B** FOR DOUBLERS AND STRAPS, USE ONE GAGE THICKER THAN THE INITIAL SKIN. MEASURE THE INITIAL SKIN THICKNESS IN CHEM-MILLED AREAS.
- C** CHAMFER ALL THE EDGES OF PART 1 (REPAIR PLATE) IF PART 1 IS THICKER THAN THE ADJACENT SKIN.

SYMBOLS

-  BLIND RIVET REPAIR FASTENERS.
-  SOLID RIVET REPAIR FASTENERS.

Trailing Edge Flap Skin Aluminum Repair
Figure 201 (Sheet 1 of 3)

**757-200
STRUCTURAL REPAIR MANUAL**

REPAIR MATERIAL			
PART	QTY	MATERIAL	
1	REPAIR PLATE	1	2024-T3 A
2	DOUBLER	1	2024-T3 B
3	DOUBLER	1	2024-T3 B
4	STRAP	2	2024-T3 B
5	FIBERGLASS SKIN	1	BMS 8-79 TYPE 1581

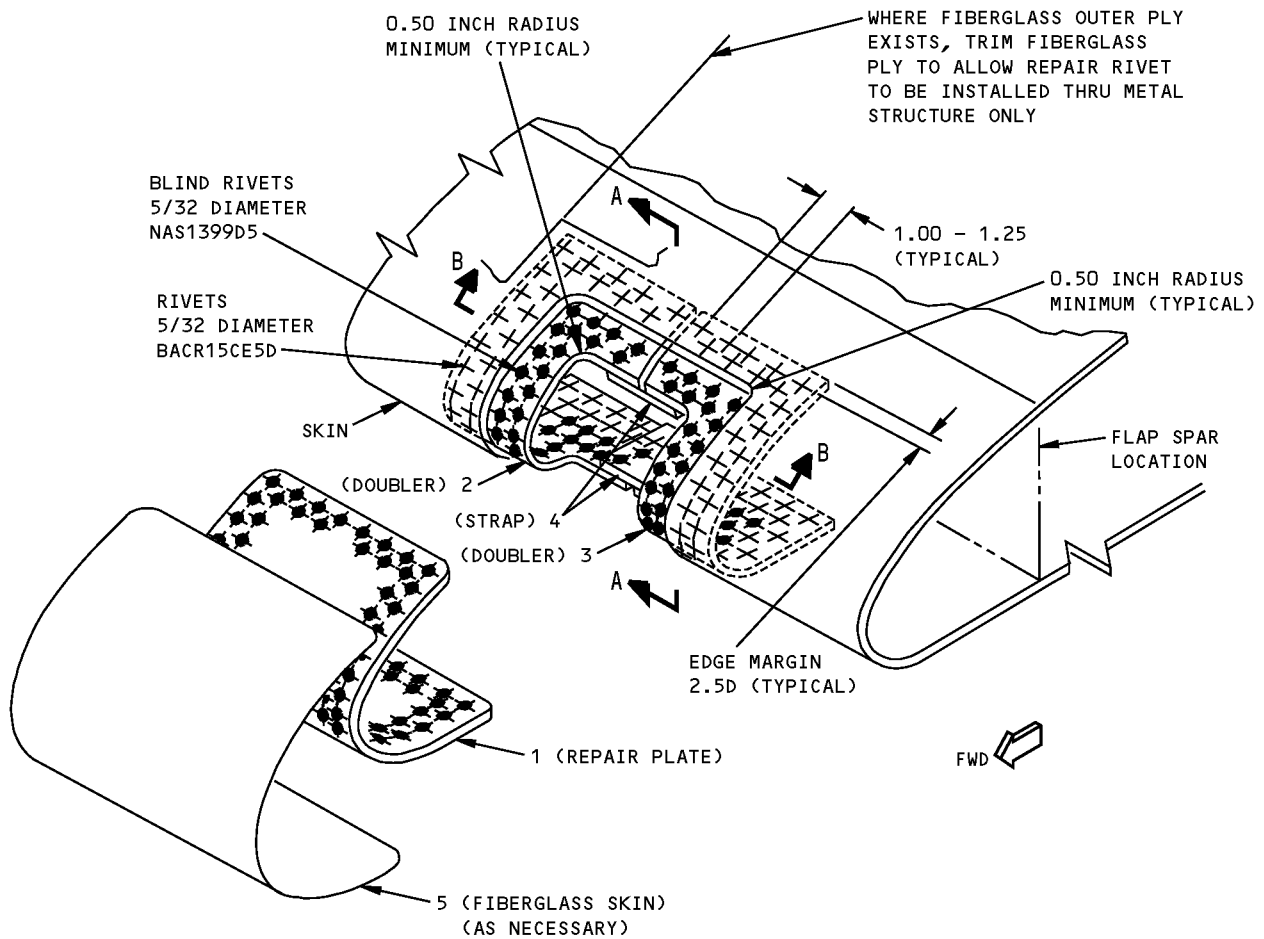

**Trailing Edge Flap Skin Aluminum Repair
Figure 201 (Sheet 2 of 3)**

**757-200
STRUCTURAL REPAIR MANUAL**

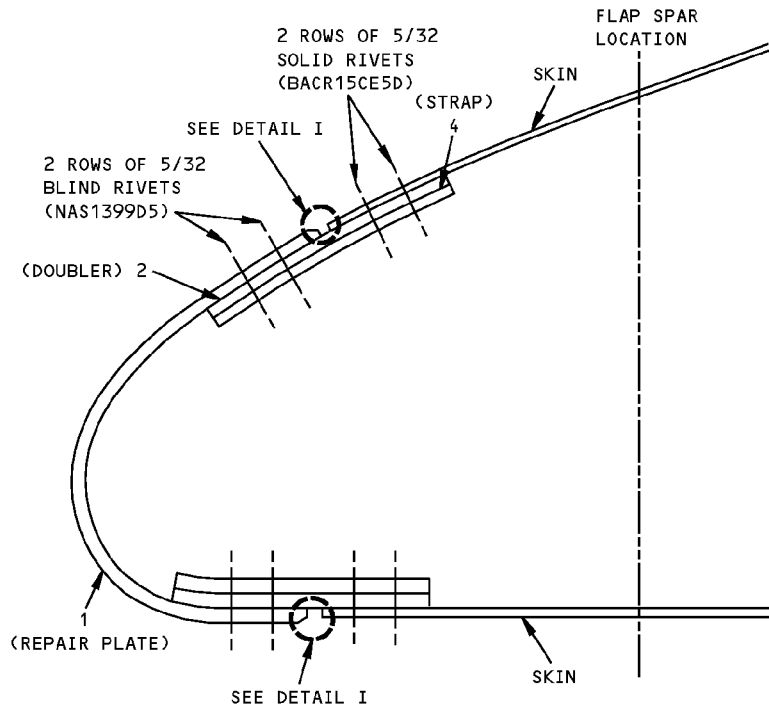

SECTION A-A

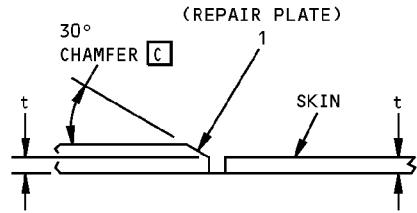

**(TYPICAL)
DETAIL I**

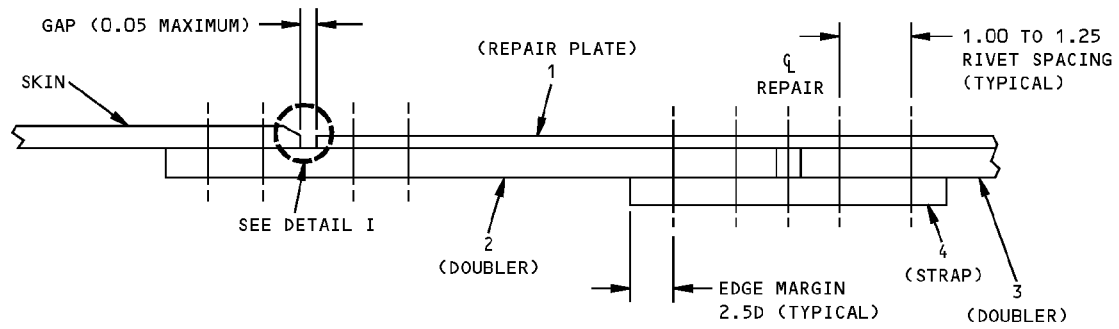

SECTION B-B

**Trailing Edge Flap Skin Aluminum Repair
Figure 201 (Sheet 3 of 3)**

STRUCTURAL REPAIR MANUAL

REPAIR 3 - TRAILING EDGE FLAP NOSE SKIN REPAIR - AREA ADJACENT TO A NOSE RIB

APPLICABILITY
THIS REPAIR IS APPLICABLE TO DAMAGED LEADING EDGE AREAS ADJACENT TO A NOSE RIB OF THE FLAP. THE DAMAGED AREA CAN BE ALL ALUMINUM SKIN, OR ALUMINUM SKIN COVERED WITH A FIBERGLASS OUTER PLY. STEPS 15 THROUGH 18 APPLY TO ALUMINUM SKIN COVERED WITH A FIBERGLASS OUTER PLY.

REPAIR INSTRUCTIONS

1. Get access to the damaged area.
2. Cut and remove the damaged part of the flap leading edge skin. Make a cut of a rectangular shape with the long edge parallel to the flap spar. Do not cut into the nose rib at the intersection of the skin and rib. See Detail I.
3. Make the aluminum repair parts. Form the parts to the flap leading edge skin contour. See Table I.
4. Assemble the repair parts and drill the fastener holes. Use shims if necessary, Refer to SRM 51-30-01.
5. Disassemble the repair parts.
6. Remove the nicks, scratches, gouges, burrs, and sharp edges from the repair parts and the flap leading edge skin.
7. Apply a chemical conversion coating to the repair parts and to the bare surfaces of the flap leading edge. Refer to the SRM 51-20-01.
8. Apply one layer of BMS 10-11, Type I primer to the repair parts and to the bare surfaces of the flap leading edge.

NOTE: DO NOT PRIME THE OUTER SURFACE OF THE PART 3 (SKIN), IF THE LEADING EDGE SKIN HAS FIBERGLASS.
9. Install the part 1 (doubler), part 2 (doubler) and shims (if used) through the rectangular hole. Install the parts with BMS 5-95 sealant between the mating surfaces.
10. Install the part 3 (skin) with BMS 5-95 sealant between the mating surfaces.
11. Fill the gaps between the skin and the part 3 (skin) with BMS 5-95 sealant.

12. If the initial leading edge is aluminum only, apply one layer of BMS 10-11, Type II finish to the repair area. Refer to SOPM 20-41-02.

NOTE: DO STEPS 15 THROUGH 18 ONLY IF THE LEADING EDGE HAS A FIBERGLASS OUTER PLY (MAIN FLAP-INBOARD TRAILING EDGE FLAP).

13. Remove the paint from the initial fiberglass ply in the overlap area **E**.
14. Cut part 4 (fiberglass ply) **E**.
15. Clean repair area and complete repair. Refer to SRM 51-70-06, para. 3 using one ply of Type H-2 fiberglass. You can use any Class fiberglass, but not Class 7.
16. Put back the initial finish. Refer to AMM 51-20.

NOTES

- DO NOT LET THE PART 1 (DOUBLER) OR PART 2 (DOUBLER) TOUCH (RIDE) A CHEMICALLY MILLED RADIUS ON THE INITIAL SKIN.

D = FASTENER DIAMETER.

ALL DIMENSIONS ARE IN INCHES.
- EXAMINE THE BLIND RIVETS AT 2500 FLIGHT CYCLE INTERVALS.
- WHEN YOU USE THIS REPAIR REFER TO:
 - AMM 51-20 FOR STRUCTURE FINISH
 - SOPM 20-41-02 FOR APPLICATION OF FINISHES
 - REFER TO SRM 51-10-02 FOR INSPECTION AND REMOVAL OF DAMAGE.
 - SRM 51-10-01 FOR AERODYNAMIC SMOOTHNESS REQUIREMENTS. WHERE THE REPAIR EXCEEDS THE LIMITS, CONSIDER THE LOSS IN PERFORMANCE
 - SRM 51-20-05 FOR REPAIR SEALING
 - SRM 51-30-01 FOR SHIM INSTALLATION
 - SRM 51-40 FOR FASTENER CODE, INSTALLATION AND REMOVAL, HOLE SIZES AND EDGE MARGINS
 - SRM 51-70-06 FOR FIBERGLASS REPAIRS

**Trailing Edge Flap Nose Skin Repair - Area Adjacent to a Nose Rib
Figure 201 (Sheet 1 of 4)**

**757-200
STRUCTURAL REPAIR MANUAL**





NOTES (CONT)

- A** INSTALL THE REPAIR RIVETS IN METAL ONLY. IF THE LEADING EDGE HAS GLASS FABRIC, CUT IT AS NECESSARY.
- B** ONE GAGE THICKER THAN THE LOCAL THICKNESS OF THE DAMAGED SKIN. THE INITIAL SKIN THICKNESS MUST BE MEASURED IN THE CHEMICALLY MILLED AREAS.
- C** FORM IN THE ANNEALED CONDITION. HEAT TREAT TO THE T4 CONDITION AFTER THE PART IS FORMED.
- D** IF THE PART 3 (SKIN) IS THICKER THAN THE ADJACENT SKIN, CHAMFER ALL THE EDGES AROUND AS SHOWN IN DETAIL II.
- E** A ONE INCH OVERLAP IS NECESSARY ON THE AREA OF FIBERGLASS REMOVED BY THE CUT. **A**

REPAIR MATERIAL			
PART		QTY	MATERIAL
1	DOUBLER	1	2024-0 B C
2	DOUBLER	1	2024-0 B C
3	SKIN	1	2024-0 0.080 C
4	FIBERGLASS PLY	1	BMS 8-79 TYPE 1581 E

TABLE I

FASTENER SYMBOLS

-  REFERENCE FASTENER LOCATION.
-  REPAIR FASTENER LOCATION. INSTALL A BACR15CE5D() RIVET.
-  REPAIR FASTENER LOCATION. INSTALL A NAS1399D5() BLIND RIVET.
-  INITIAL FASTENER LOCATION. INSTALL A NAS1399D6() BLIND RIVET.

**Trailing Edge Flap Nose Skin Repair - Area Adjacent to a Nose Rib
Figure 201 (Sheet 2 of 4)**

**757-200
STRUCTURAL REPAIR MANUAL**

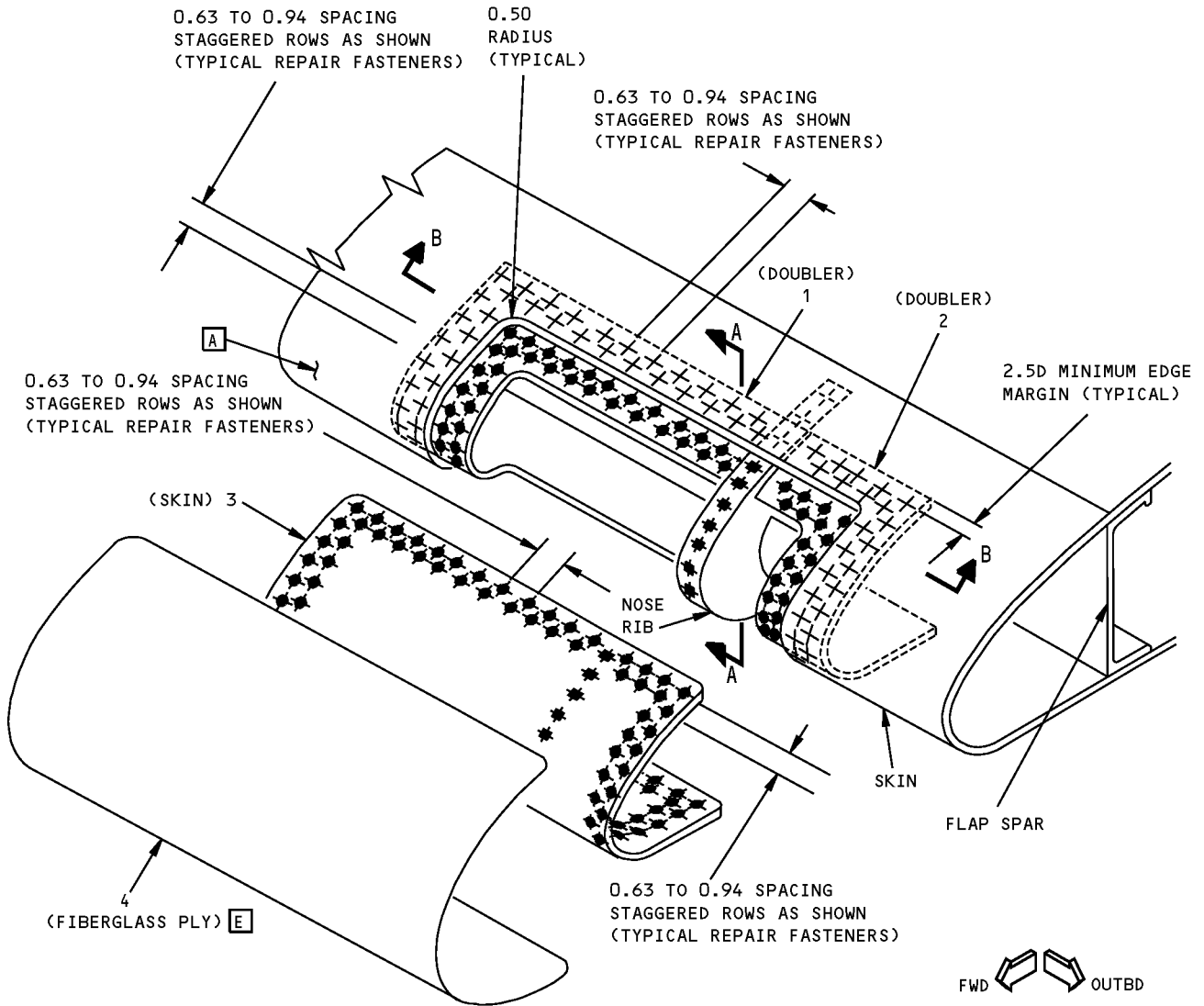

DETAIL I

**Trailing Edge Flap Nose Skin Repair - Area Adjacent to a Nose Rib
Figure 201 (Sheet 3 of 4)**

**757-200
STRUCTURAL REPAIR MANUAL**

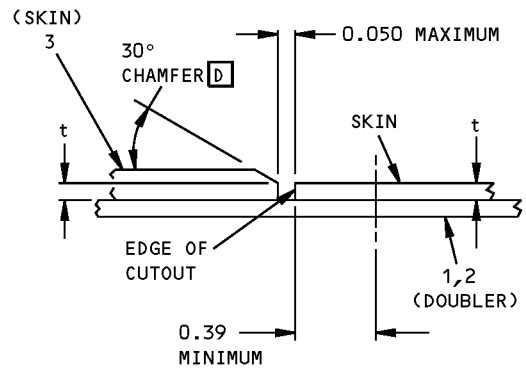
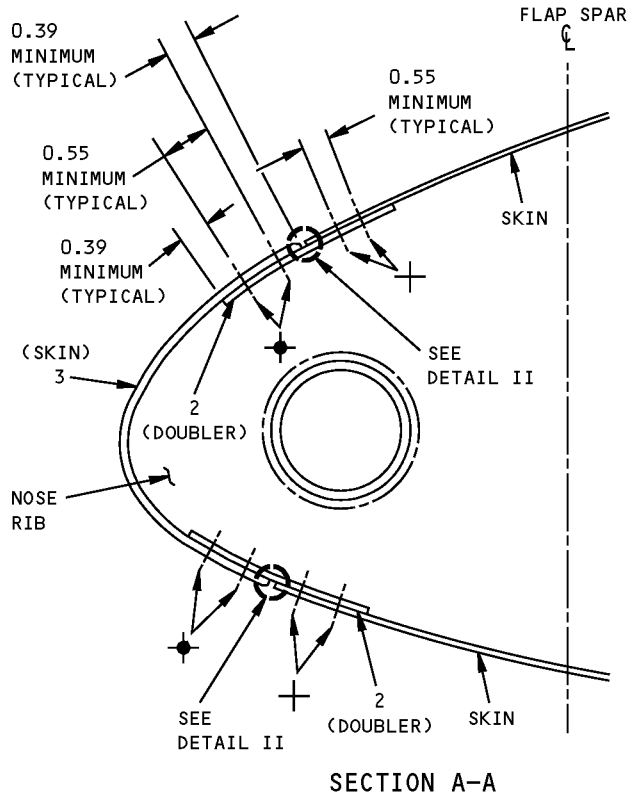

DETAIL II

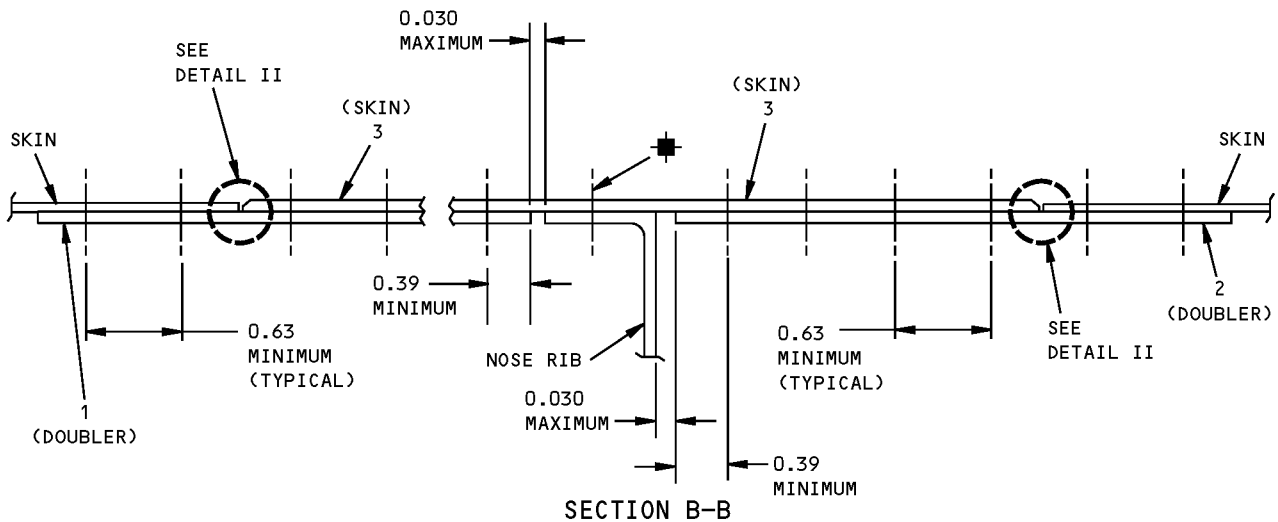

**Trailing Edge Flap Nose Skin Repair - Area Adjacent to a Nose Rib
Figure 201 (Sheet 4 of 4)**

STRUCTURAL REPAIR MANUAL

REPAIR 4 - TIME LIMITED REPAIR - MAIN FLAP - OUT BOARD TRAILING EDGE - OUT BOARD END SKIN PANEL

APPLICABILITY
THIS TIME LIMITED REPAIR IS APPLICABLE TO THE UPPER AND LOWER END PANELS OF THE MAIN FLAP OUTBOARD TRAILING EDGE FLAP. SEE DETAIL I.

REPAIR INSTRUCTIONS

1. Get access to the damaged area.
2. Cut and remove the damaged part of the trailing edge end panel.
NOTE: Keep a minimum 0.50 inch (12.7mm) radius at the corners and a 2D minimum edge distance to the initial fasteners.
3. Do a penetrant inspection to make sure all cracks have been removed. Refer to SOPM 20-20-02.
4. Make the repair parts. See Table I.
5. Assemble the repair parts, drill and countersink the fastener holes.
6. Disassemble the repair parts.
7. Remove the nicks, scratches, gouges, burrs, and sharp edges from the repair parts and the cut edge of the panel.
8. Apply a chemical conversion coating to the repair parts and the bare surfaces of the initial parts. Refer to SRM 51-20-01.
9. Apply one layer of BMS 10-11, Type I primer to the repair parts and to the bare surfaces of the initial parts. Refer to SOPM 20-41-02.
10. Install filler and doubler. Apply a faying surface seal of BMS 5-95 to all mating surfaces.
11. Install the BACR15GF6D() and NAS1399D6() fasteners wet with BMS 5-95 sealant.
12. Put the initial finish back as given in AMM 51-20

NOTES



- BLIND RIVET REPAIRS MUST BE INSPECTED EVERY 3000 FLIGHT CYCLES. IF THERE IS ANY EVIDENCE OF PULLED OR LOOSE RIVETS, THE RIVETS MUST BE REPLACED. **D**

PANEL

- WHEN YOU USE THIS REPAIR REFER TO :
 - SRM 51-10-01 FOR AERODYNAMIC SMOOTHNESS REQUIREMENTS. WHERE THE REPAIR IS MORE THAN THE LIMITS, CONSIDERATION SHOULD BE GIVEN THE LOSS OF PERFORMANCE INVOLVED
 - SRM 51-10-02 FOR INVESTIGATION AND CLEANUP OF DAMAGE
 - SRM 51-20-01 FOR PROTECTIVE TREATMENT OF METALLIC MATERIALS
 - SRM 51-20-05 FOR REPAIR SEALING
 - SRM 51-40 FOR FASTENER CODE, INSTALLATION AND REMOVAL, HOLE SIZES AND EDGE MARGINS.

- A** FOR FILLER, USE SAME GAGE AS THE INITIAL SKIN. THE INITIAL SKIN THICKNESS MUST BE MEASURED IN FULL THICKNESS AREAS AT THE FASTENERS.
- B** FOR DOUBLER, USE ONE GAGE THICKER THAN THE INITIAL SKIN. MEASURE THE INITIAL SKIN THICKNESS IN FULL THICKNESS AREA AT THE FASTENERS.
- C** CHAMFER ALL EDGES OF THE PART 2 (DOUBLER).
- D** THIS REPAIR HAS FAA APPROVAL CONTINGENT ON ACCOMPLISHMENT OF THE INSPECTIONS AT THE INTERVAL CONTAINED HEREIN.

FASTENER SYMBOLS

-  REFERENCE FASTENER LOCATION
-  REPAIR FASTENER LOCATION. INSTALL A NAS1399D6() BLIND RIVET.
-  INITIAL FASTENER LOCATION. INSTALL A BACRCE6D() SOLID RIVET.

REPAIR MATERIAL			
	PART	QTY	MATERIAL
1	FILLER	1	2024-T3 A
2	DOUBLER	1	2024-T3 B

TABLE I

**Time Limited Repair - Main Flap - Out Board Trailing Edge - Out Board End Skin Panel
Figure 201 (Sheet 1 of 6)**

**757-200
STRUCTURAL REPAIR MANUAL**

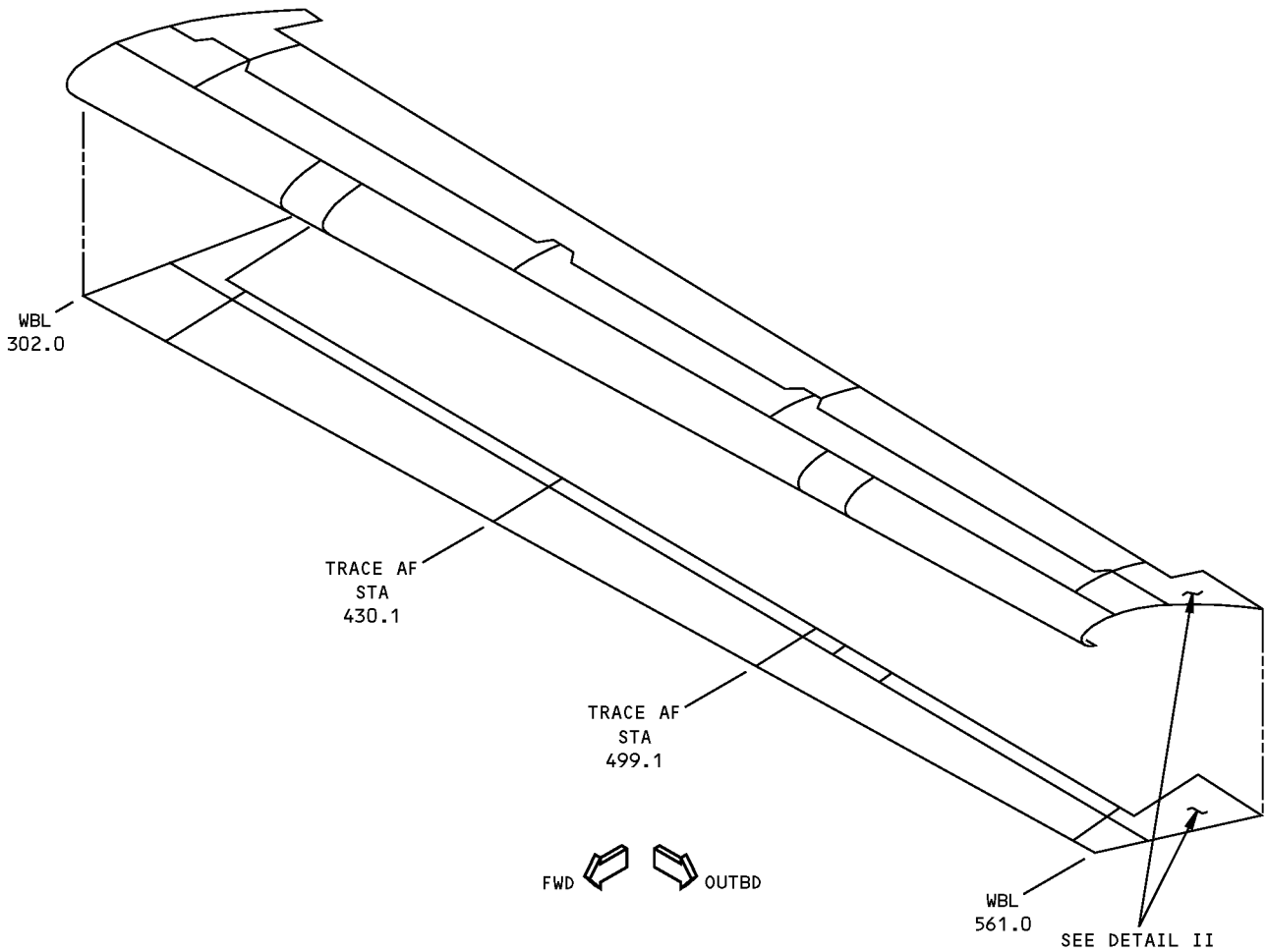
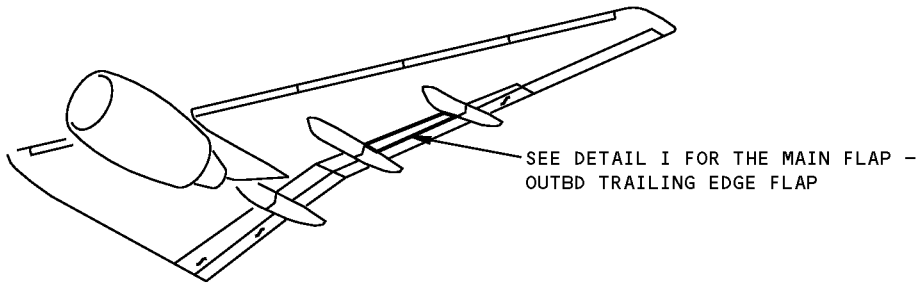

**MAIN FLAP - OUTBOARD TRAILING EDGE FLAP
DETAIL I**

**Time Limited Repair - Main Flap - Out Board Trailing Edge - Out Board End Skin Panel
Figure 201 (Sheet 2 of 6)**

**757-200
STRUCTURAL REPAIR MANUAL**

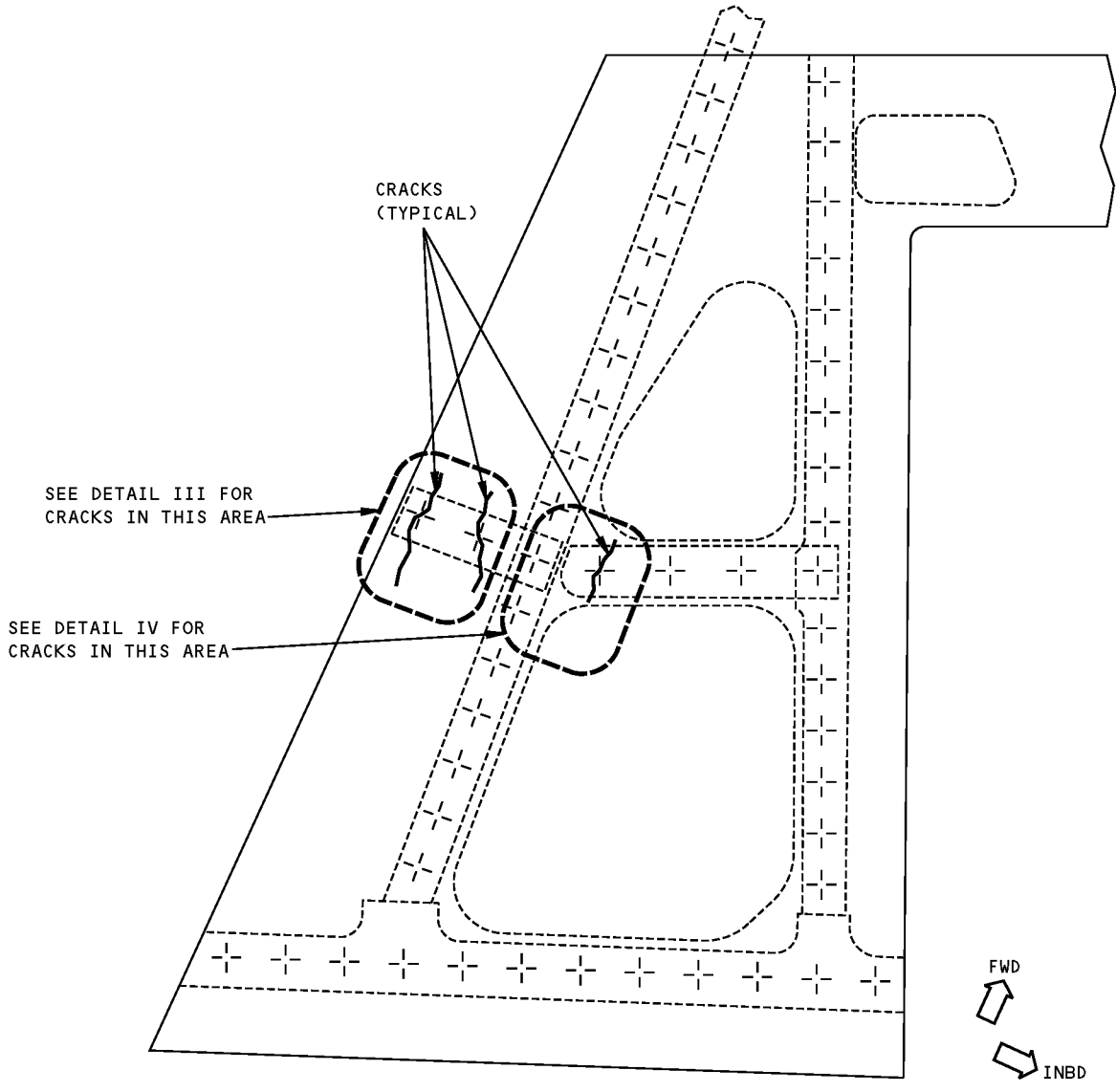

DETAIL II

**Time Limited Repair - Main Flap - Out Board Trailing Edge - Out Board End Skin Panel
Figure 201 (Sheet 3 of 6)**

**757-200
STRUCTURAL REPAIR MANUAL**

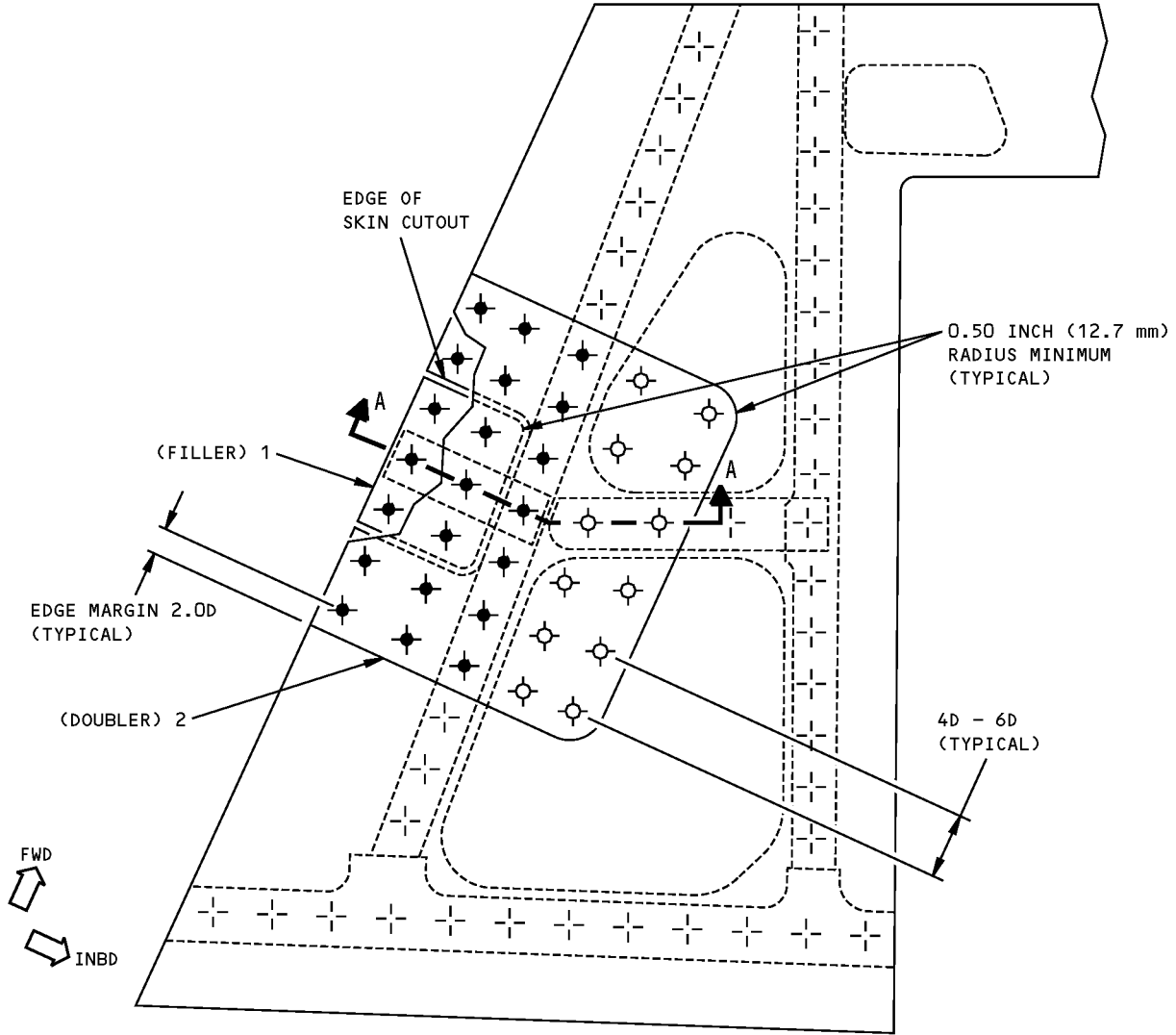

DETAIL III

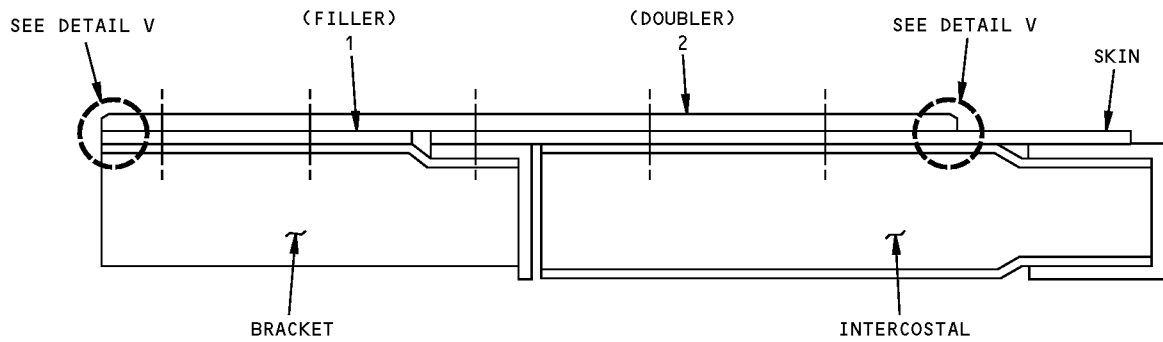

SECTION A-A

**Time Limited Repair - Main Flap - Out Board Trailing Edge - Out Board End Skin Panel
Figure 201 (Sheet 4 of 6)**

**757-200
STRUCTURAL REPAIR MANUAL**

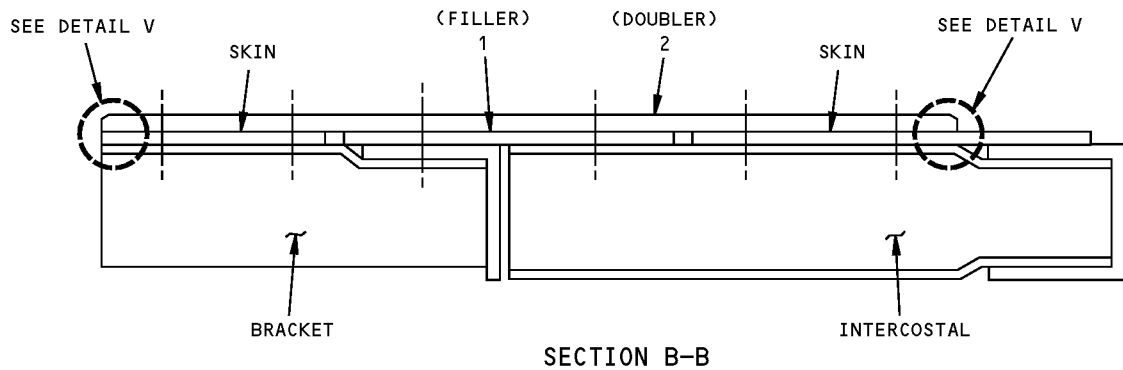
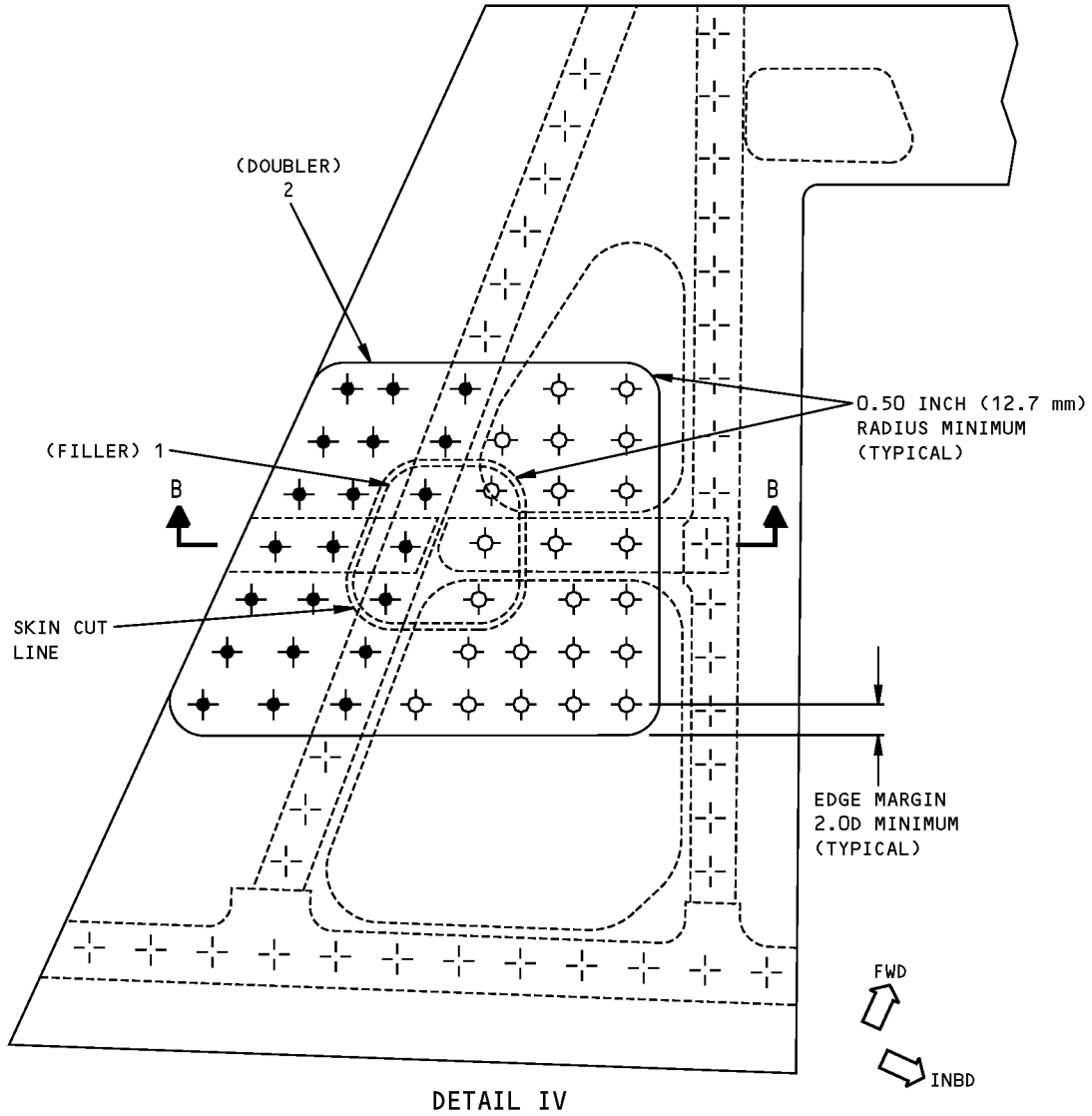

**Time Limited Repair - Main Flap - Out Board Trailing Edge - Out Board End Skin Panel
Figure 201 (Sheet 5 of 6)**

757-200
STRUCTURAL REPAIR MANUAL

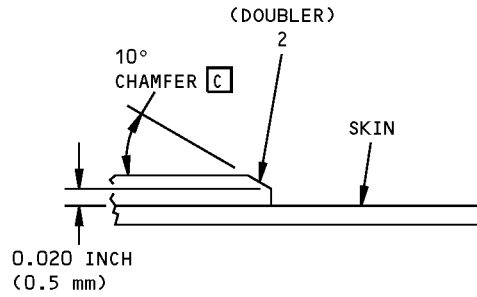

DETAIL V
(TYPICAL)

Time Limited Repair - Main Flap - Out Board Trailing Edge - Out Board End Skin Panel
Figure 201 (Sheet 6 of 6)

**757-200
STRUCTURAL REPAIR MANUAL**

IDENTIFICATION 1 - TRAILING EDGE FLAP STRUCTURE

REFERENCE DRAWING
113N2001
113N3001

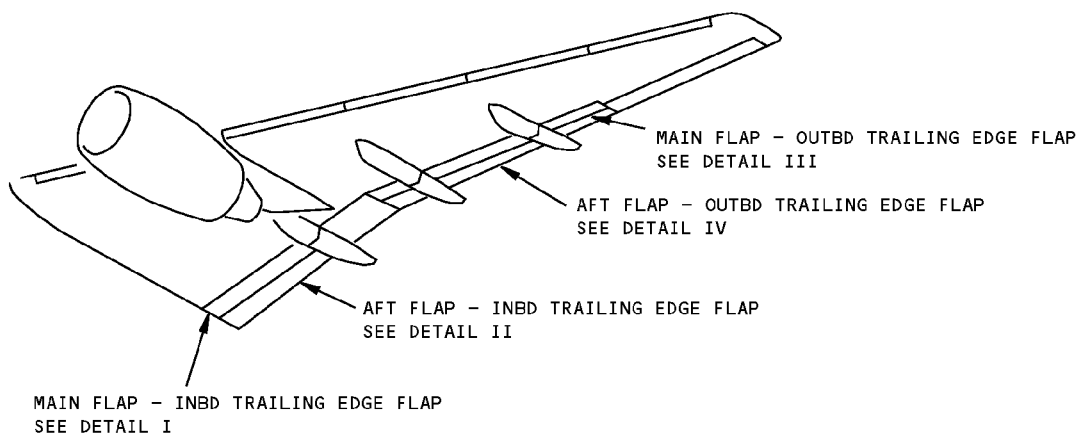

LEFT SIDE SHOWN,
RIGHT SIDE OPPOSITE

NOTES

- | | |
|---|--|
| <p>A FOR CUM LINE NUMBERS:
1 THRU 3</p> <p>B FOR CUM LINE NUMBERS:
4 AND ON</p> <p>C GRAPHITE/EPOXY PREPREG FABRIC PER BMS 8-212,
TYPE IV, CLASS 2, STYLE 3K-70-PW,
350°F (177°C) CURE.</p> <p>D IN THIS AREA THERE IS A SINGLE PLY OF
FIBERGLASS PREPREG FABRIC PER BMS 8-139,
TYPE 120, 350°F (177°C) CURE, BONDED TO
INSIDE OF SPAR.</p> | <p>E PLY ORIENTATION CONVENTION, DEGREES
INDICATED, IS PARALLEL TO THE FABRIC WARP
DIRECTION.</p> <p>F FIBERGLASS EPOXY PREPREG PER BMS 8-139,
TYPE 120, 350°F (177°C) CURE.</p> <p>G FOR CUM LINE NUMBERS:
1 THRU 764</p> <p>H FOR CUM LINE NUMBERS:
765 AND ON</p> |
|---|--|

**Trailing Edge Flap Structure Identification
Figure 1 (Sheet 1 of 8)**

IDENTIFICATION 1
Page 1
Jan 20/2005

57-53-02

D634N201

**757-200
STRUCTURAL REPAIR MANUAL**

REF DWG
113N2003

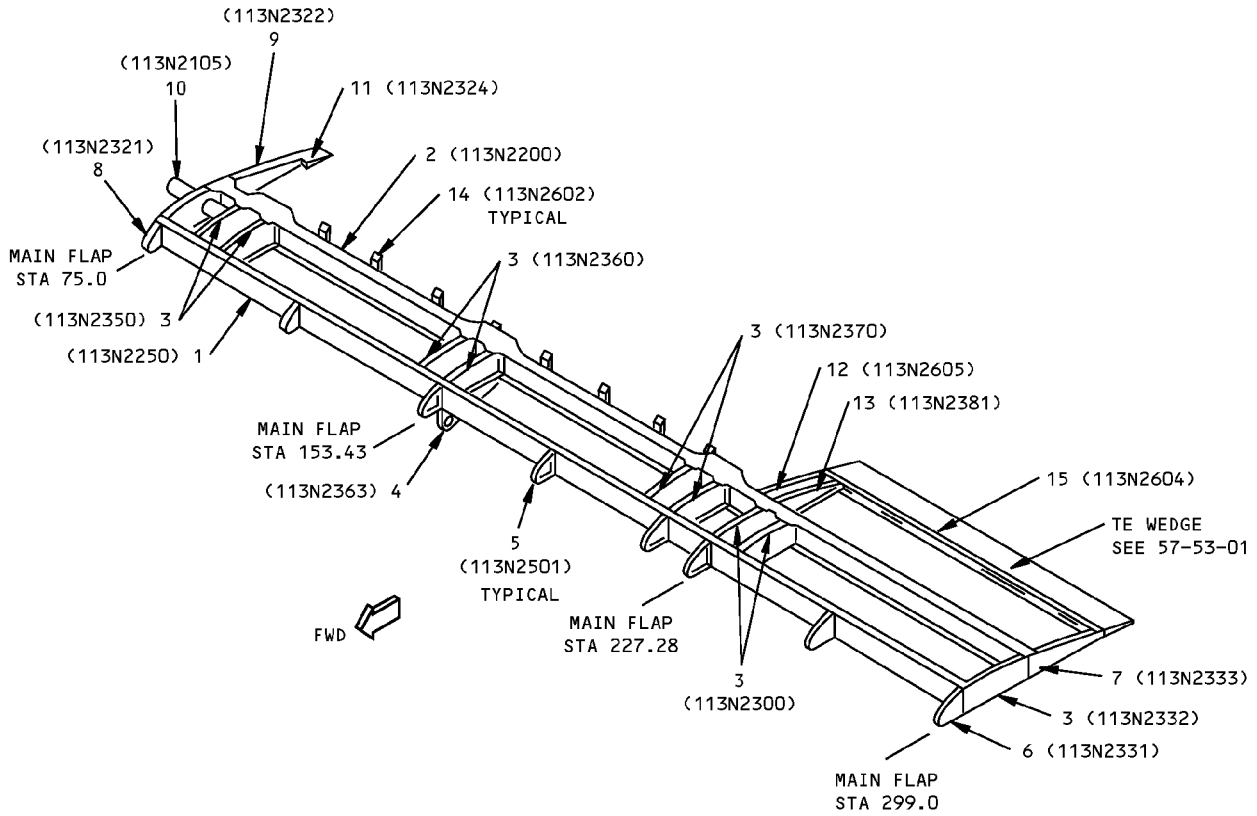

MAIN FLAP - INBD TRAILING EDGE FLAP
DETAIL I



Trailing Edge Flap Structure Identification
Figure 1 (Sheet 2 of 8)

IDENTIFICATION 1
Page 2
Jan 20/2005

57-53-02

D634N201



**757-200
STRUCTURAL REPAIR MANUAL**

ITEM	DESCRIPTION	GAGE	MATERIAL	EFFECTIVITY
1	FRONT SPAR ASSY WEB STIFFENER UPR CHORD LWR CHORD	0.040	2024-T3 AND10113 7075-T73511 BAC1514-2539 2024-T42 BAC1514-2541 2024-T42	
2	REAR SPAR ASSY UPR AND LWR CHORDS FAILSAFE STRAPS WEB WEB STIFFENER STIFFENER	0.224 0.040 0.10	BAC1514-2540 2024-T42 BAC1511-10013 2024-T3511 OPTIONAL: 2024-T3 CLAD 2024-T3 2024-T3 AND10134 7075-T73511 AND10133 7075-T73511	B A
3	OUTBD CLOSURE RIB		FORGED BLOCK 7075-T73	
4	BEAM BELLCRANK SUPPORT		FORGED BLOCK 7075-T73	
5	NOSE RIB	0.063	CLAD 2024-T42	
6	OUTBD CLOSURE RIB		FORGED BLOCK 7075-T73 OR 7075-T7351	
7	OUTBD CLOSURE RIB		FORGED BLOCK 7075-T73 OR 7075-T7351	
8	INBD CLOSURE RIB		FORGED BLOCK 7075-T73	
9	INBD CLOSURE RIB		MACHINED BLOCK 7075-T7351 OPTIONAL: FORGED BLOCK 7075-T73	
10	TORQUE TUBE		4330M STEEL PER BMS 7-122 HT TR 220-240 KSI	
11	TE WEDGE BOND CHANNEL UPR SKIN LWR SKIN CORE	0.063 0.020 0.020	2024-T42 2024-T3 2024-T3 HONEYCOMB PER BMS 4-4, TYPE 3-10N	
12	SPLICE TEE		AND10136 7075-T73511	
13	RIB		MACHINED BLOCK 7075-T7351 OR FORGED BLOCK 7075-T73	
14	STRUT		MACHINED BLOCK 7075-T73	
15	AUX SPAR		BAC1509-100468 2024-T8511	

LIST OF MATERIALS FOR DETAIL I

**Trailing Edge Flap Structure Identification
Figure 1 (Sheet 3 of 8)**

D634N201

57-53-02

IDENTIFICATION 1
Page 3
Jan 20/2005

**757-200
STRUCTURAL REPAIR MANUAL**

REF DWG
113N2800

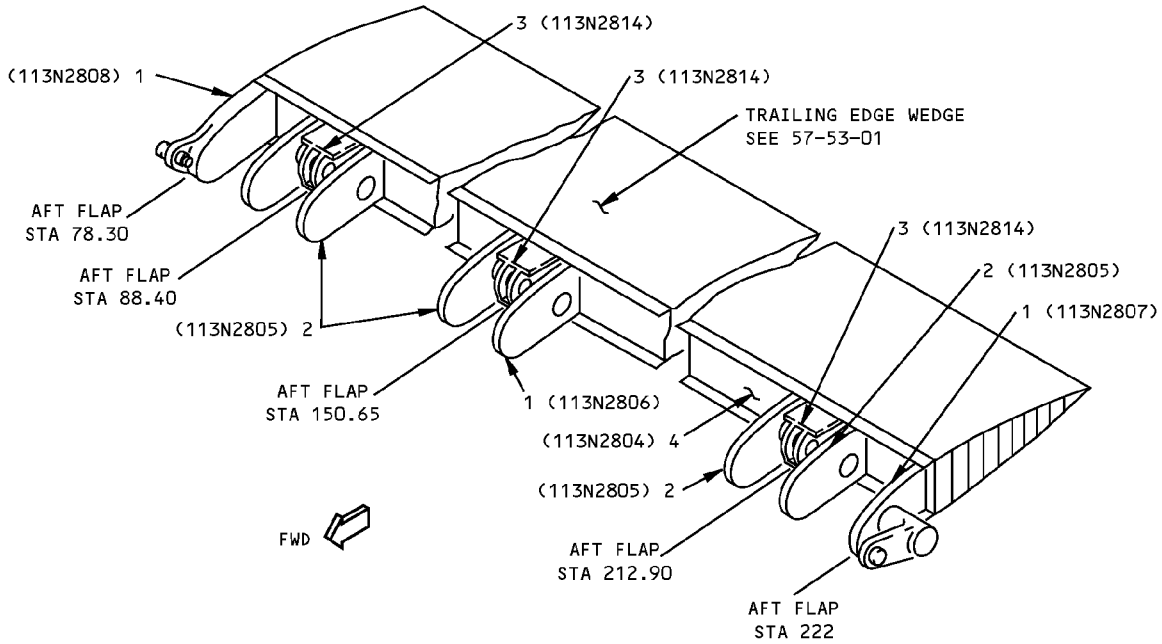

**AFT FLAP - INBD TRAILING EDGE FLAP
DETAIL II**

ITEM	DESCRIPTION	GAGE	MATERIAL	EFFECTIVITY
1	RIB		FORGING 7075-T73	
2	RIB		FORGING 7075-T73 OR 7075-T7351	
3	FLAP TRACK ATTACH FITTING		7075-T73 FORGED BLOCK	
4	SPAR ASSY BACKING PLATE BOND ASSY	0.032	TI-COM-PURE-70 PER MIL-T-9046 TYPE 1, COMP B ANNEALED SEE DETAIL VI	

LIST OF MATERIALS FOR DETAIL II

**Trailing Edge Flap Structure Identification
Figure 1 (Sheet 4 of 8)**

IDENTIFICATION 1
Page 4
Jan 20/2005

57-53-02

D634N201

**757-200
STRUCTURAL REPAIR MANUAL**

REF DWG
113N3003

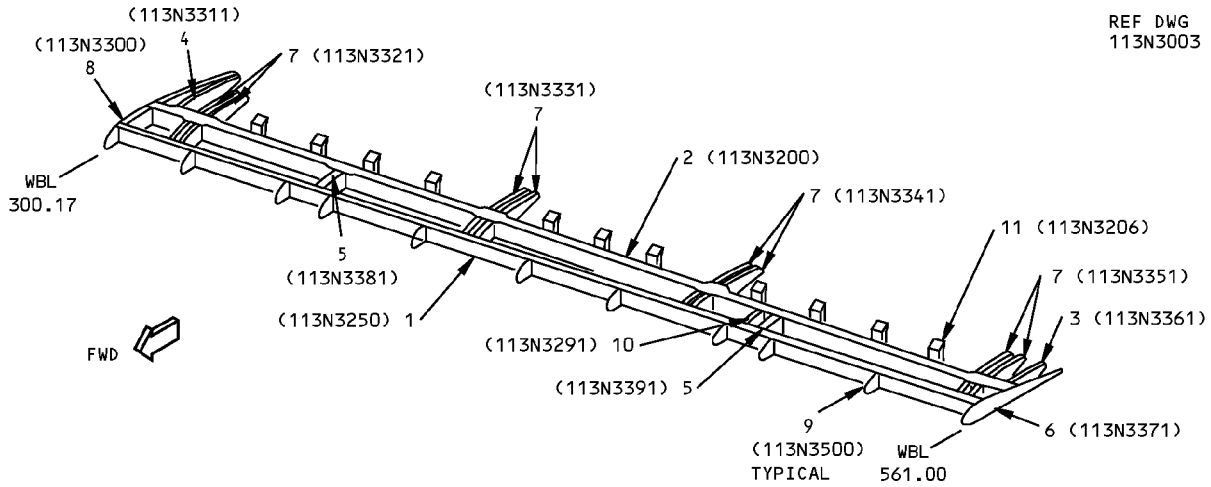

**MAIN FLAP - OUTBOARD TRAILING EDGE FLAP
DETAIL III**

ITEM	DESCRIPTION	GAGE	MATERIAL	EFFECTIVITY
1	FRONT SPAR ASSY WEB STIFFENER UPR CHORD LWR CHORD	0.032	CLAD 2024-T3 OPTIONAL: CLAD 2024-T4 AND10134 7075-T73511 BAC1514-2542 7075-T73511 BAC1514-2541 2024-T3511	
2	REAR SPAR ASSY WEB-INBD (CHEM MILLED) WEB-OUTBD (CHEM MILLED) WEB-CENTER STIFFENER UPR CHORD LWR CHORD UPR FAILSAFE STRAP LWR FAILSAFE STRAP	0.090 0.125 0.050 0.200 0.200	2024-T3 2024-T3 CLAD 2024-T3 AND10133 7075-T73511 BAC1514-2540 7075-T73511 BAC1514-2540 2024-T3511 7075-T76 7075-T76	
3	RIB		MACHINED BLOCK 7075-T7351	
4	RIB		MACHINED BLOCK 7075-T7351	
5	RIB		FORGED BLOCK 7075-T73	
6	OUTBD CLOSURE RIB		MACHINED BLOCK 7075-T7351	
7	RIB ASSY		FORGED BLOCK 7075-T73	
8	INBD CLOSURE RIB		MACHINED BLOCK 7075-T7351	
9	RIB	0.063	CLAD 2024-T42	
10	RIB		FORGED BLOCK 7075-T73	
11	STRUT		FORGED BLOCK 7075-T73 OPTIONAL: MACHINED BLOCK 7075-T7351	

LIST OF MATERIALS FOR DETAIL III

**Trailing Edge Flap Structure Identification
Figure 1 (Sheet 5 of 8)**

IDENTIFICATION 1
Page 5
Jan 20/2005

57-53-02

D634N201

**757-200
STRUCTURAL REPAIR MANUAL**

REF DWG
113N3800

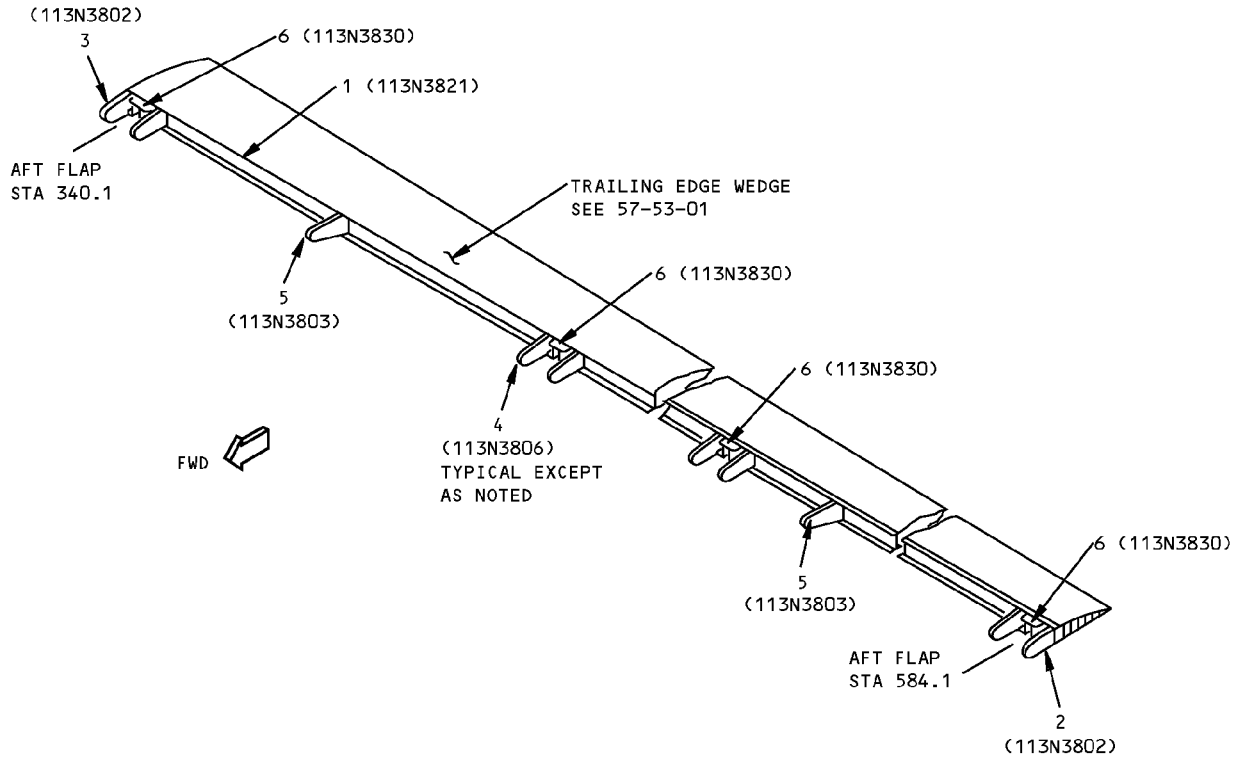

**AFT FLAP - OUTBOARD TRAILING EDGE FLAP
DETAIL IV**

ITEM	DESCRIPTION	GAGE	MATERIAL	EFFECTIVITY
1	SPAR ASSY BACKING PLATE BOND ASSY		TI-COM-PURE-70 PER MIL-T-9046, TYPE 1, COMP B, ANNEALED SEE DETAIL V	
2	RIB		FORGED BLOCK 7075-T73	
3	RIB		TI-6AL-4V HAND FORGING PER MIL-T-9047 OPTIONAL: TI-6AL-4V PER BMS 7-186	
4	TRACK SUPPORT RIB		FORGED BLOCK 7075-T73 OPTIONAL: 7075-T7351	
5	RIB		FORGING TI-6AL-4V OPTIONAL: TI-6AL-4V	
6	TRACK SUPPORT FITTING		7075-T73 FORGED BLOCK OR 7075-T7351 PLATE	

LIST OF MATERIALS FOR DETAIL IV

**Trailing Edge Flap Structure Identification
Figure 1 (Sheet 6 of 8)**

IDENTIFICATION 1
Page 6
Jan 20/2005

57-53-02

D634N201

**757-200
STRUCTURAL REPAIR MANUAL**

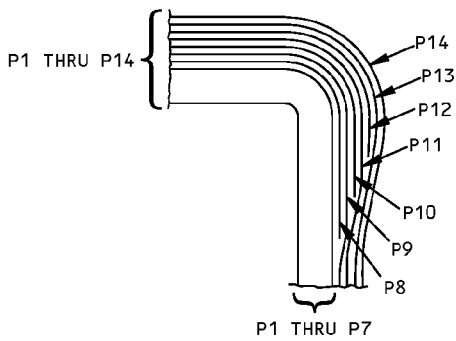
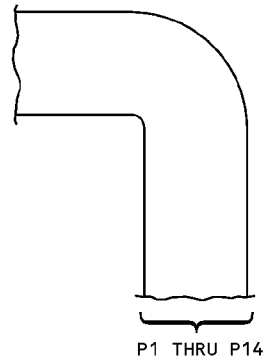
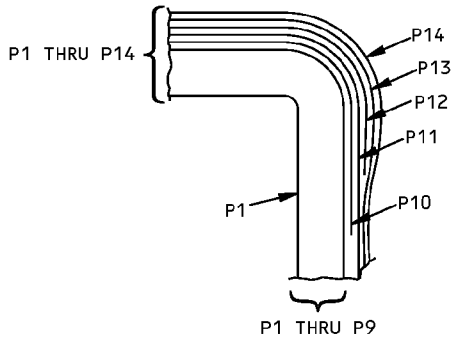
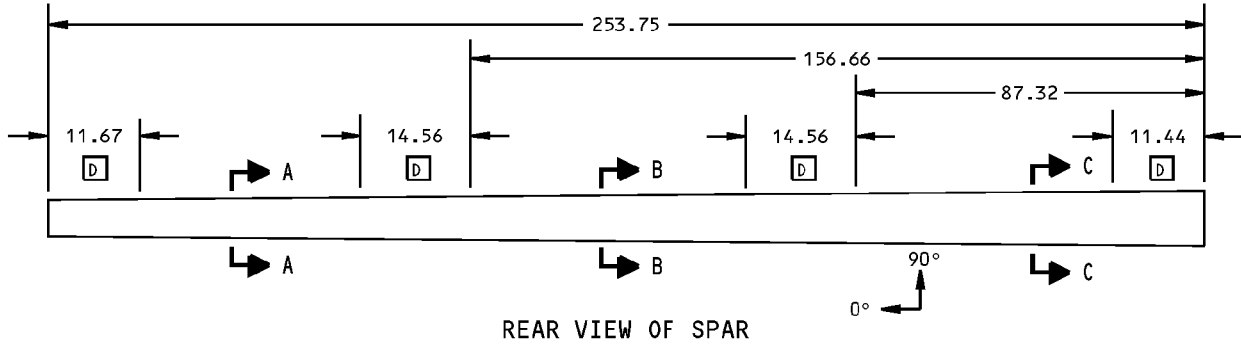

ITEM NO.	PLY NUMBER	MATERIAL	PLY [E] ORIENTATION
1	P1, P2, P4, P6, P8 P10, P11, P13, P14	[C]	0° OR 90°
	P3, P5, P7, P9 P12	[C]	45°

DETAIL V

**Trailing Edge Flap Structure Identification
Figure 1 (Sheet 7 of 8)**

**757-200
STRUCTURAL REPAIR MANUAL**

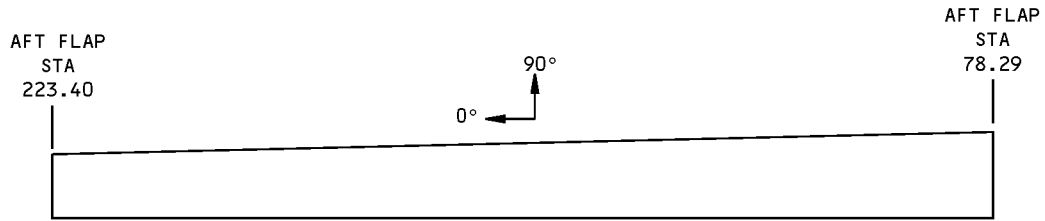

VIEW FROM REAR
PLY ORIENTATION DIAGRAM

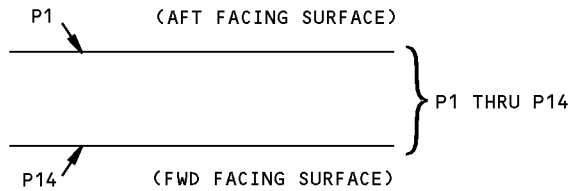

SECTION THRU SPAR

ITEM NO.	PLY NO.	MATERIAL	PLY ORIENTATION ^E
4 (DETAIL II)	P1,P2,P4,P6, P8,P10,P11,P13	C	0° OR 90°
	P3,P5,P7,P9,P12	C	45°
	P14	F	OPTIONAL

PLY TABLE

PLY ORIENTATION DIAGRAM AND TABLE FOR
AFT FLAP - INBD TRAILING EDGE FLAP
DETAIL VI

**Trailing Edge Flap Structure Identification
Figure 1 (Sheet 8 of 8)**

IDENTIFICATION 1
Page 8
Jan 20/2005

57-53-02

D634N201

IDENTIFICATION 2 - TRAILING EDGE FLAP SUPPORT STRUCTURE IDENTIFICATION

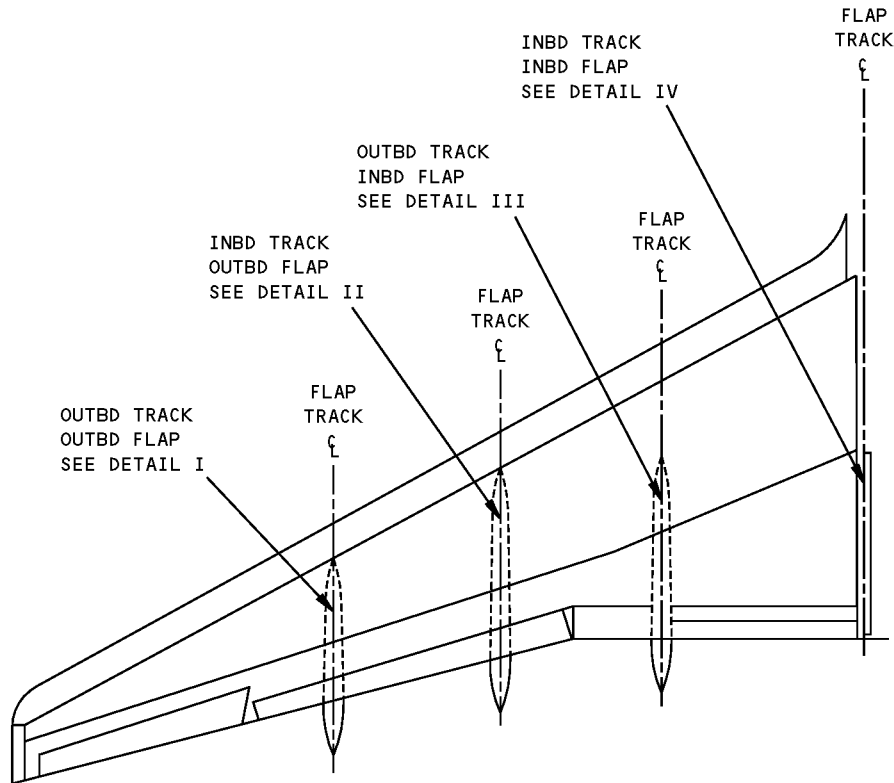

**Trailing Edge Flap Support Structure Identification
Figure 1 (Sheet 1 of 4)**

**757-200
STRUCTURAL REPAIR MANUAL**

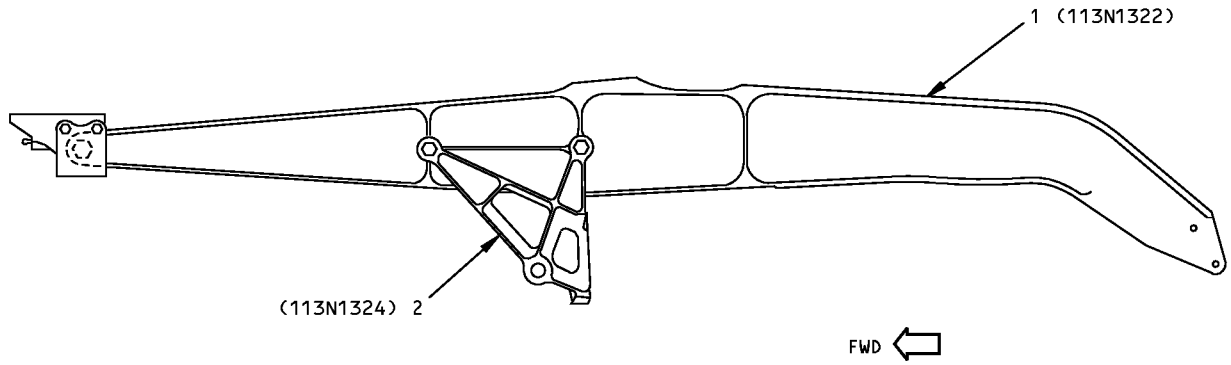

**OUTBD TRACK - OUTBD FLAP
DETAIL I**

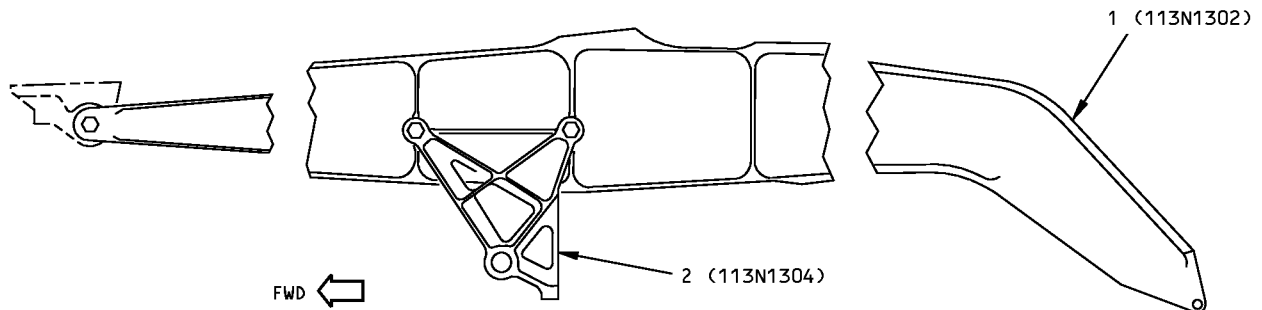

**INBD TRACK - OUTBD FLAP
DETAIL II**

**Trailing Edge Flap Support Structure Identification
Figure 1 (Sheet 2 of 4)**

**757-200
STRUCTURAL REPAIR MANUAL**

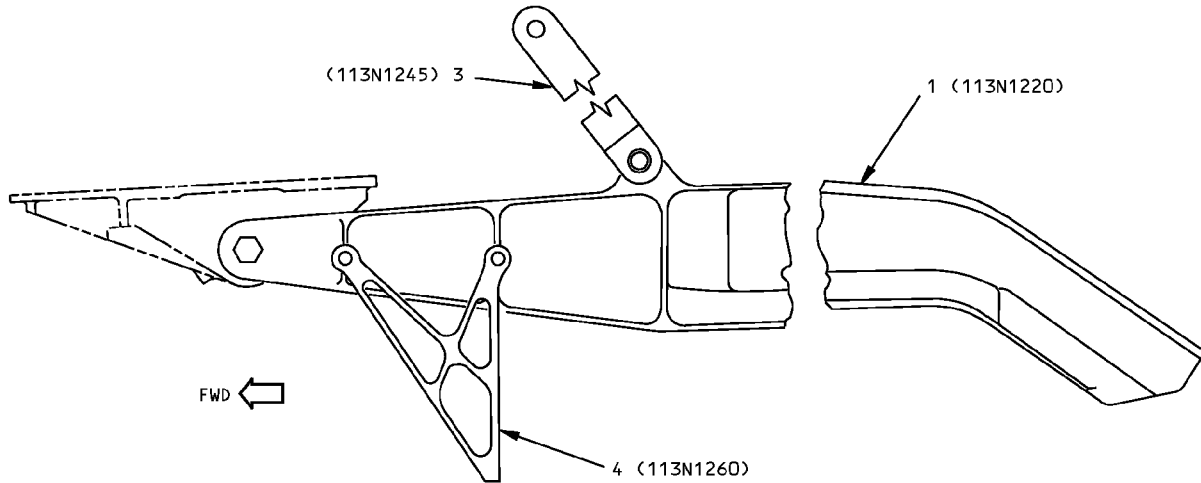

OUTBD TRACK - INBD FLAP
DETAIL III

ITEM	DESCRIPTION	GAGE	MATERIAL	EFFECTIVITY
1	TRACK		4330M STEEL FORGING HT TR 220-240 KSI	
2	GEARBOX SUPPORT FITTING		7075-T73 FORGED BLOCK	
3	LINK		7175-T736 FORGING	
4	SUPPORT FITTING		FORGING 7075-T73	
5	FITTING		7075-T73 FORGED BLOCK	

LIST OF MATERIALS FOR DETAILS I,II, AND III

**Trailing Edge Flap Support Structure Identification
Figure 1 (Sheet 3 of 4)**

**757-200
STRUCTURAL REPAIR MANUAL**

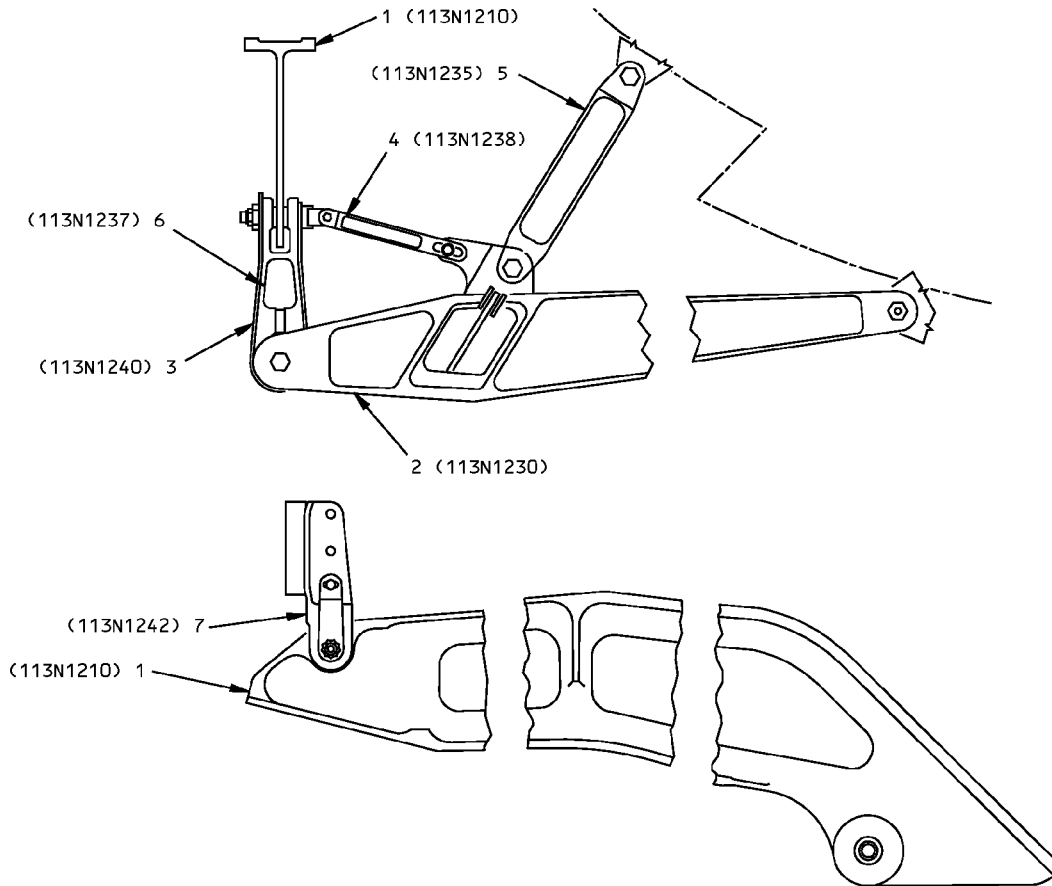

**INBD TRACK - INBD FLAP
DETAIL IV**

ITEM	DESCRIPTION	GAGE	MATERIAL	EFFECTIVITY
1	TRACK		4330M STEEL FORGING HT TR 275-300 KSI	
2	BEAM ASSY		7075-T73 OR FORGED BLOCK 7075-T7352	
3	FAILSAFE STRAP		15-5 PH CRES HT TR 180-200 KSI	
4	FLOATING LINK		7075-T7351 BAR	
5	VERTICAL SUPPORT STRUT		FORGED BLOCK 7075-T73 OR 7075-T7351 BAR	
6	AFT LINK ASSY		FORGED BLOCK 7075-T73 OR 7075-T7351 BAR	
7	FWD SUPPORT FITTING		FORGED BLOCK 7075-T73	

LIST OF MATERIALS FOR DETAIL IV

**Trailing Edge Flap Support Structure Identification
Figure 1 (Sheet 4 of 4)**

**757-200
STRUCTURAL REPAIR MANUAL**

ALLOWABLE DAMAGE 1 - TRAILING EDGE FLAP STRUCTURE

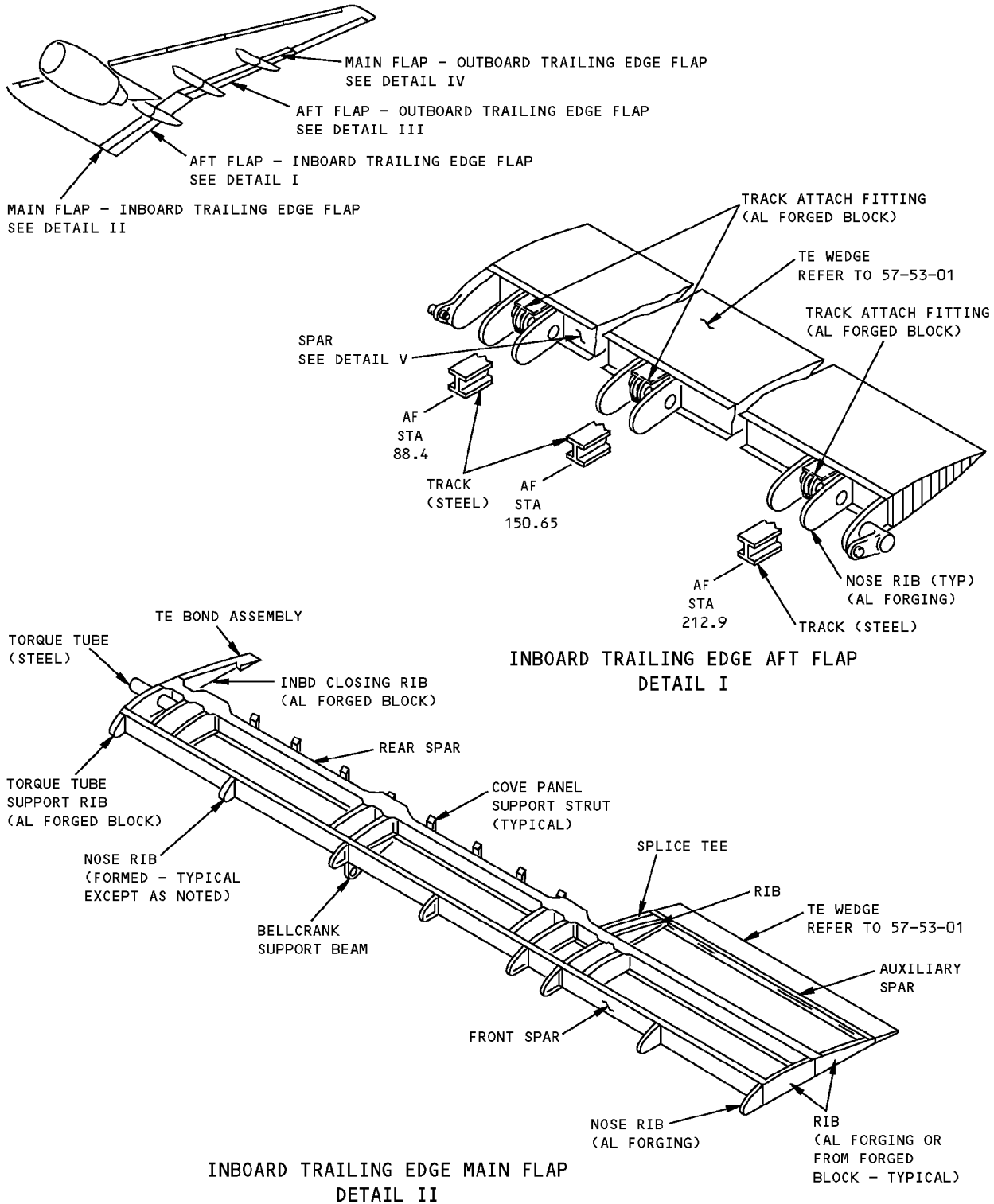

**Trailing Edge Flap Structure Allowable Damage
Figure 101 (Sheet 1 of 8)**

**757-200
STRUCTURAL REPAIR MANUAL**

	DESCRIPTION	CRACKS	NICKS, GOUGES AND CORROSION	DENTS	HOLES AND PUNCTURES	
MAIN FLAP	FRONT SPAR ASSY					
	UPR/LWR CHORD	A	B	C	NOT ALLOWED	NOT ALLOWED
	WEB		B	C	SEE DETAIL XI	D
	STIFFENER		B	C	NOT ALLOWED	SEE DETAIL XII
	REAR SPAR ASSY					
	UPR/LWR CHORD	A	B	C	NOT ALLOWED	NOT ALLOWED
	WEB		B	C	SEE DETAIL XI	D
	STIFFENER		B	C	NOT ALLOWED	SEE DETAIL XII
	FAILSAFE STRAP	A	B	C	NOT ALLOWED	NOT ALLOWED
	AUXILIARY SPAR		B	C	SEE DETAIL XI	D FOR WEB ONLY
	RIB	A	B	C	NOT ALLOWED	NOT ALLOWED
	NOSE RIB -					
	FORGING	A	B	C	NOT ALLOWED	NOT ALLOWED
	FORMED		B	C	SEE DETAIL XI	D FOR WEB ONLY
	SPLICE TEE	A	B	C	NOT ALLOWED	NOT ALLOWED
	COVE PANEL SUPPORT STRUT	A	B	C	NOT ALLOWED	D
	BELL CRANK SUPPORT BEAM	A	B	E	NOT ALLOWED	NOT ALLOWED
TE BOND ASSY						
CHANNEL		B	E	NOT ALLOWED	D FOR WEB ONLY	
AL HONEYCOMB WEDGE ASSY		F	G	SEE DETAIL XI	J	
TORQUE TUBE SUPPORT RIB	A	B	C	NOT ALLOWED	NOT ALLOWED	
TORQUE TUBE	A H	F	G	NOT ALLOWED	NOT ALLOWED	
AFT FLAP	NOSE RIB	A	B	C	NOT ALLOWED	NOT ALLOWED
	TRACK ATTACH FITTING	A	B	C	NOT ALLOWED	NOT ALLOWED
	TRACK	K L	B	E	NOT ALLOWED	NOT ALLOWED

ALLOWABLE DAMAGE FOR INBOARD
TRAILING EDGE FLAP

**Trailing Edge Flap Structure Allowable Damage
Figure 101 (Sheet 2 of 8)**

**757-200
STRUCTURAL REPAIR MANUAL**

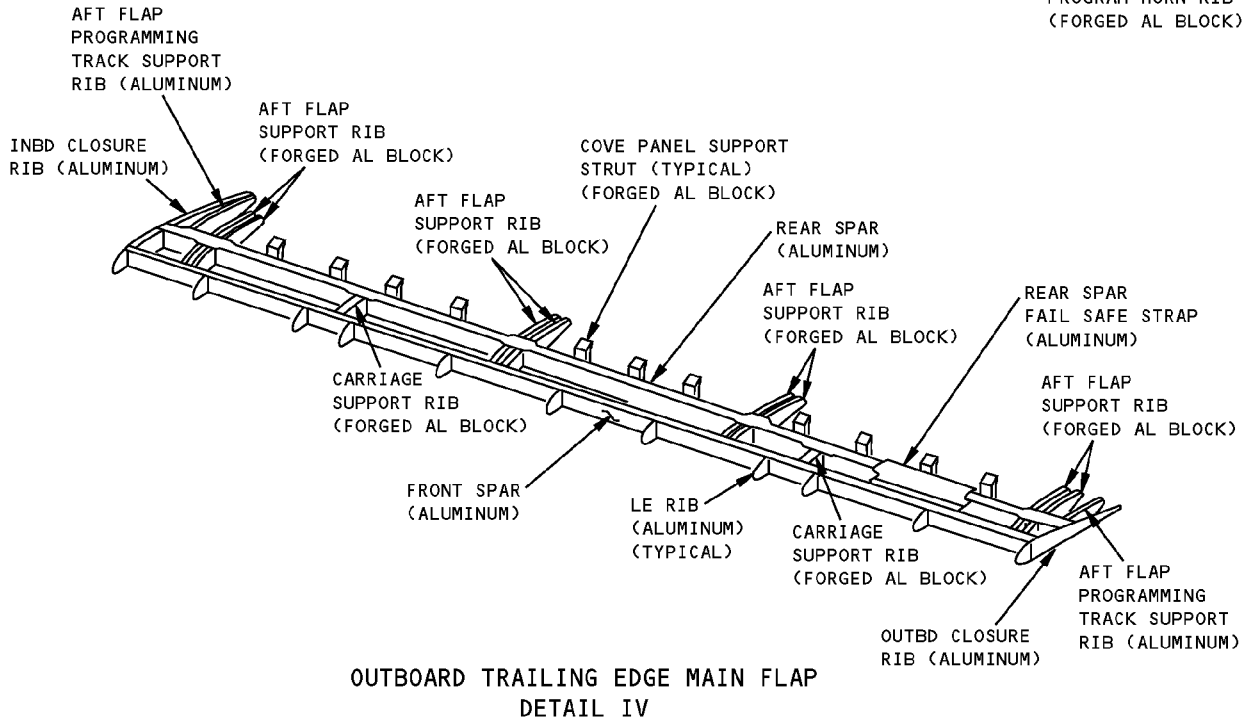
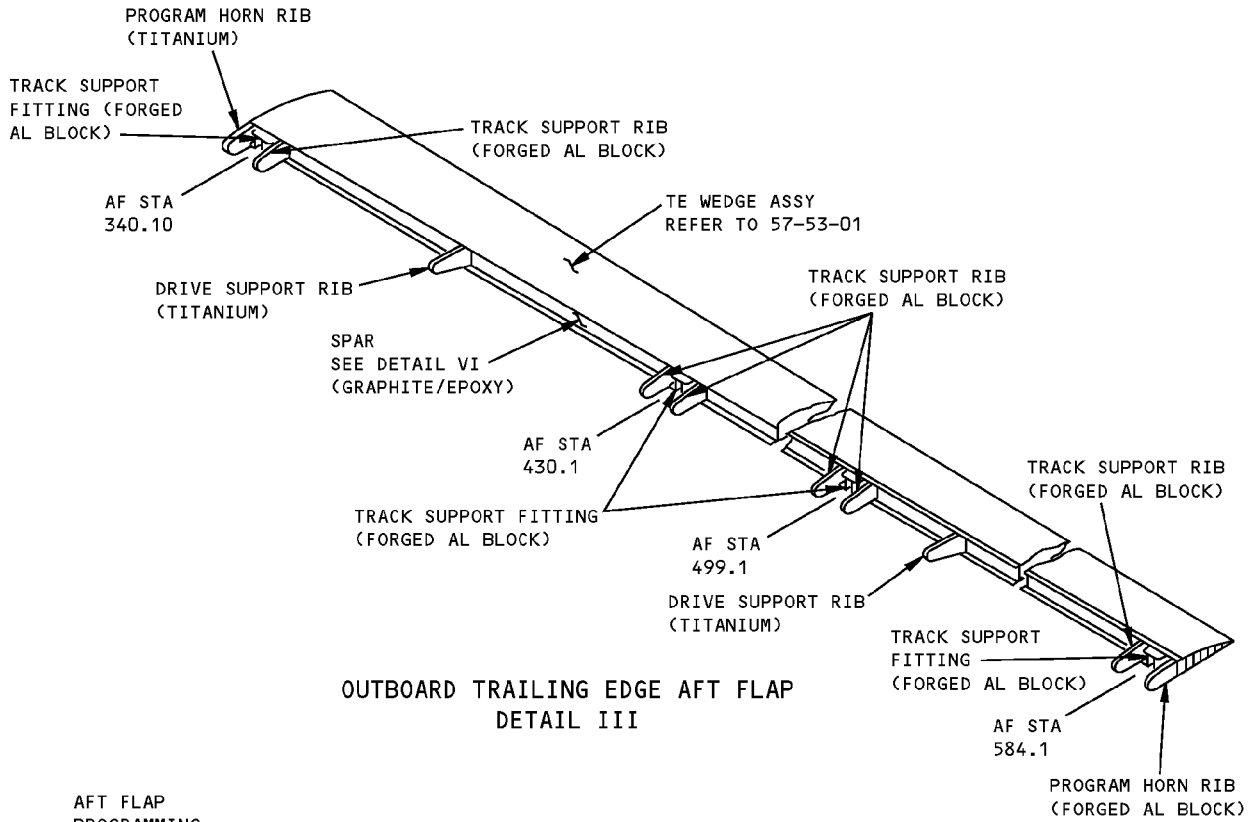

**Trailing Edge Flap Structure Allowable Damage
Figure 101 (Sheet 3 of 8)**



**757-200
STRUCTURAL REPAIR MANUAL**

	DESCRIPTION	CRACKS	NICKS, GOUGES AND CORROSION	DENTS	HOLES AND PUNCTURES	
MAIN FLAP	FRONT SPAR ASSY					
	UPR/LWR CHORD	A	B	C	NOT ALLOWED	NOT ALLOWED
	WEB		B	C	SEE DETAIL XI	D
	STIFFENER		B	C	NOT ALLOWED	SEE DETAIL XII
	REAR SPAR ASSY					
	UPR/LWR CHORD	A	B	C	NOT ALLOWED	NOT ALLOWED
	WEB		B	C	SEE DETAIL XI	D
	STIFFENER		B	C	NOT ALLOWED	SEE DETAIL XII
	R/S FAILSAFE STRAP	A	B	C	NOT ALLOWED	NOT ALLOWED
	CLOSURE RIB					
	INBD/OUTBD	A	B	C	NOT ALLOWED	NOT ALLOWED
	LE RIB		I	C	SEE DETAIL XI	D FOR WEB ONLY
AFT FLAP PROGRAMMING TRACK SUPPORT RIB	A	B	C	NOT ALLOWED	NOT ALLOWED	
AFT FLAP SUPPORT RIB	A	B	C	NOT ALLOWED	NOT ALLOWED	
CARRIAGE SUPPORT RIB	A	B	C	NOT ALLOWED	NOT ALLOWED	
COVE PANEL SUPPORT STRUT	A	B	C	NOT ALLOWED	D	
AFT FLAP	PROGRAM HORN RIB	A	B	C	NOT ALLOWED	NOT ALLOWED
	TRACK SUPPORT RIB	A	B	C	NOT ALLOWED	NOT ALLOWED
	TRACK SUPPORT FTG	A	B	C	NOT ALLOWED	NOT ALLOWED
	DRIVE SUPPORT RIB	A	B	C	NOT ALLOWED	NOT ALLOWED

**ALLOWABLE DAMAGE FOR OUTBOARD
TRAILING EDGE FLAP**

**Trailing Edge Flap Structure Allowable Damage
Figure 101 (Sheet 4 of 8)**

STRUCTURAL REPAIR MANUAL

DESCRIPTION	CRACKS	NICKS, GOUGES, SCRATCHES AND CORROSION	DENTS	HOLES AND PUNCTURES	DELAMINATION
AFT FLAP SPAR OUTBOARD TRAILING EDGE FLAP	M	O	P	Q	R
AFT FLAP SPAR INBOARD TRAILING EDGE FLAP	M	O	P	Q	R

ALLOWABLE DAMAGE FOR AFT FLAP SPARS

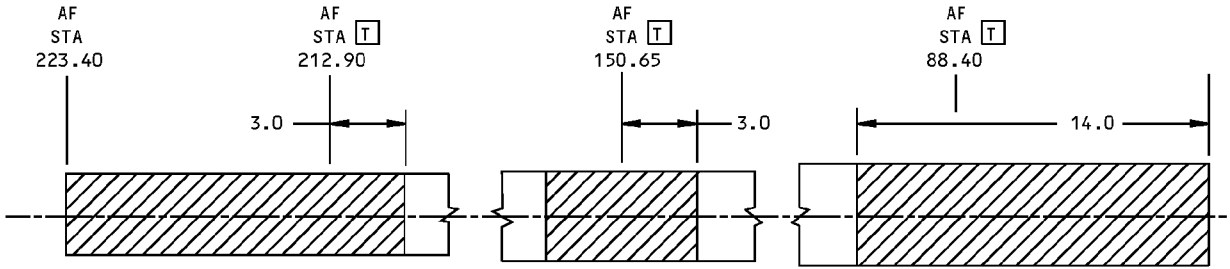

AFT FLAP SPAR INBOARD TRAILING EDGE FLAP
DETAIL V

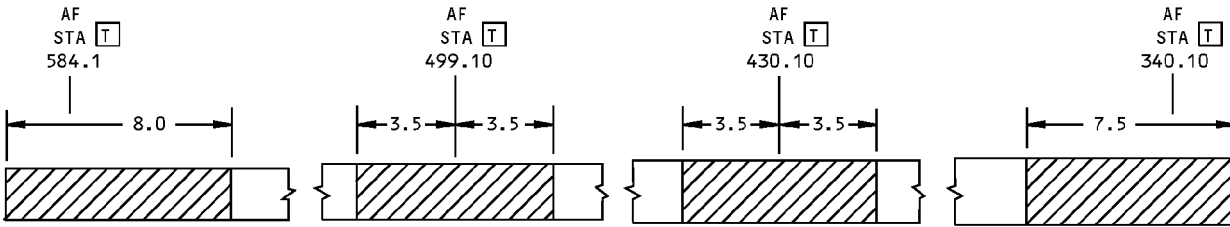

AFT FLAP SPAR OUTBOARD TRAILING EDGE FLAP
DETAIL VI

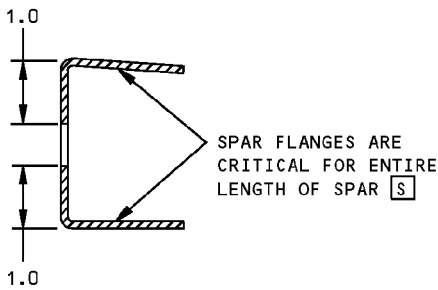

SECTION THRU SPAR - OUTBOARD FLAP

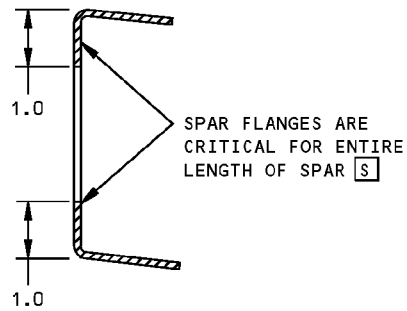

SECTION THRU SPAR - INBOARD FLAP

CRITICAL AREAS [S]

Trailing Edge Flap Structure Allowable Damage
Figure 101 (Sheet 5 of 8)

STRUCTURAL REPAIR MANUAL

NOTES

- REFER TO SRM 51-10-02 FOR INSPECTION AND REMOVAL OF DAMAGE.
 - COMPONENTS ARE IN HIGH SONIC ENVIRONMENT. SHARP EDGES AND BURRS MUST BE REMOVED.
 - REFINISH REWORKED AREAS PER 51-20 OF THE MAINTENANCE MANUAL.
- A** SHOT PEEN REWORKED SURFACES PER SRM 51-20-06.
- B** CRACKS NOT ALLOWED EXCEPT FOR EDGE CRACKS WHICH MUST BE REMOVED PER DETAILS VII, VIII, AND IX.
- C** REMOVE DAMAGE PER DETAILS VII, VIII AND X.
- D** CLEAN OUT DAMAGE UP TO 0.25 INCH (6 mm) MAX DIA AND NOT CLOSER THAN 1.0 INCH (25 mm) TO FASTENER HOLE OR OTHER DAMAGE. FILL HOLE WITH 2117-T3 OR T4 ALUMINUM RIVET INSTALLED WET WITH BMS 5-95 SEALANT.
- E** FOR EDGE DAMAGE SEE DETAIL VII. FOR LUG DAMAGE SEE DETAIL VII. FOR OTHER DAMAGE, SEE DETAIL XIII. DAMAGE NOT ALLOWED IN VICINITY OF BUSHINGS.
- F** REMOVE EDGE DAMAGE PER DETAIL IX. OTHER CRACKS NOT ALLOWED.
- G** REMOVE DAMAGE PER DETAIL VIII.
- H** REMOVE DAMAGE USING HAND TOOLS ONLY. MACHINE TOOLS MAY CAUSE OVERHEATING AND LOSS OF HEAT TREAT.
- I** CRACKS NOT ALLOWED EXCEPT FOR EDGE CRACKS WHICH MUST BE REMOVED PER DETAILS VII, VIII, IX AND XIV.
- J** 0.25 INCH (6 mm) MAX DIA ALLOWED PROVIDED DAMAGE IS 1.0 INCH (25 mm) MIN FROM OTHER DAMAGE, NEAREST HOLE, OR MATERIAL EDGE.
- K** CLEAN UP NOT ALLOWED IN AREAS OF ROLLER CONTACT.
- L** CRITICAL, HEAT-TREATED PART. USE HAND TOOLS ONLY DURING REWORK TO PREVENT OVERHEATING OF PART.
- M** REMOVE EDGE CRACKS PER DETAILS XI AND XIII. 0.5 INCH (12.7 mm) MAX LENGTH ALLOWED PER LINEAR FOOT OF SPAR. MINIMUM OF 6.0 INCHES (150 mm) FROM ANY OTHER DAMAGE. **N S**
- N** REMOVE MOISTURE FROM DAMAGE AREA. USE OF VACUUM AND HEAT (MAX OF 125°F (52°C)) TO REMOVE MOISTURE FROM HONEYCOMB CELLS IS RECOMMENDED. PROTECT DAMAGE FROM ENTRANCE OF WATER, SUNLIGHT OR OTHER FOREIGN MATTER BY SEALING WITH ALUMINUM FOIL TAPE (SPEED TAPE). RECORD THE LOCATION AND INSPECT EVERY AIRPLANE "A" CHECK. REPLACE THE ALUMINUM FOIL TAPE IF ANY PEELING OR DETERIORATION EVIDENT. REPAIR NO LATER THAN NEXT AIRPLANE "C" CHECK. **V**
- O** REMOVE EDGE DAMAGE PER DETAILS XI AND XII. 0.5 INCH (12.7 mm) MAX LENGTH ALLOWED PER LINEAR FOOT OF SPAR. MINIMUM OF 6.0 INCHES (150 mm) FROM ANY OTHER DAMAGE. **N S**
- P** DENTS GENERALLY RESULT IN FIBER DAMAGE OR DELAMINATION. HOWEVER, IF THERE IS NO FIBER DAMAGE OR DELAMINATION, DENTS UP TO 1.0 INCH (25 mm) MAX DIA ARE ALLOWED. ONE DENT PER LINEAR FOOT OF SPAR. MINIMUM OF 3.0 INCHES (75 mm) FROM ANY OTHER DAMAGE OR FASTENER HOLE. SEE **Q** OR **R** IF FIBER DAMAGE OR DELAMINATION IS PRESENT.
- Q** 0.5 INCH (12.7 mm) MAX DIA ALLOWED. ONE DENT PER LINEAR FOOT OF SPAR. MINIMUM OF 3.0 INCHES (75 mm) FROM ANY OTHER DAMAGE, HOLE, OR MATERIAL EDGE. DO NOT CLEAN UP DAMAGE EXCEPT TO REMOVE RESIN BURRS. **N**
- R** 1.0 INCH (25 mm) MAX DIMENSION ALLOWED WITHOUT REWORK.
- S** CONTACT THE BOEING COMPANY FOR ALLOWABLE DAMAGE IN CRITICAL AREAS.
- T** CENTER OF FITTING
- U** THESE ALLOWABLE DAMAGE LIMITS HAVE FAA APPROVAL CONTINGENT ON ACCOMPLISHMENT OF THE INSPECTIONS CONTAINED HEREIN.

Trailing Edge Flap Structure Allowable Damage
Figure 101 (Sheet 6 of 8)

ALLOWABLE DAMAGE 1

57-53-02Page 106
Jan 20/2005

D634N201

STRUCTURAL REPAIR MANUAL

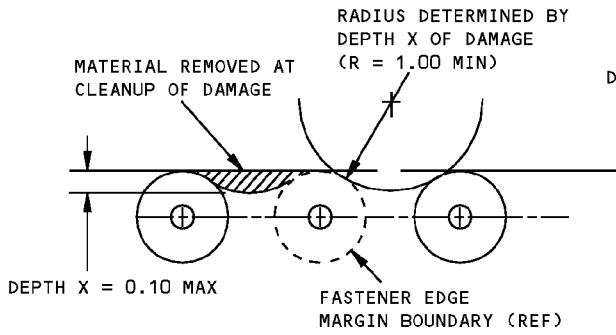

DAMAGE CLEANUP OF EDGES WHERE FASTENER EDGE MARGINS DO NOT OVERLAP

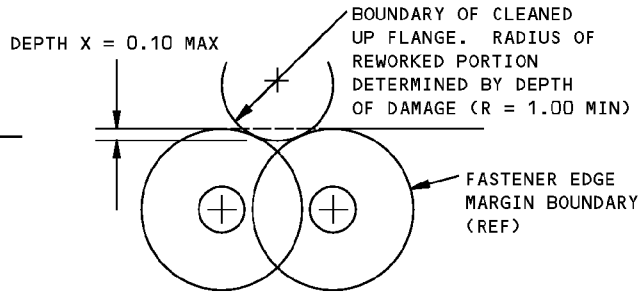

DAMAGE CLEANUP OF EDGES WHERE FASTENER EDGE MARGINS OVERLAP

DETAIL VII

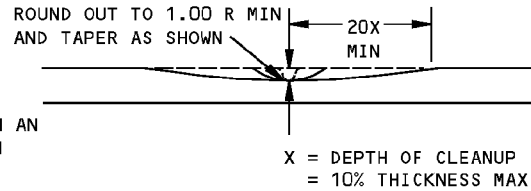
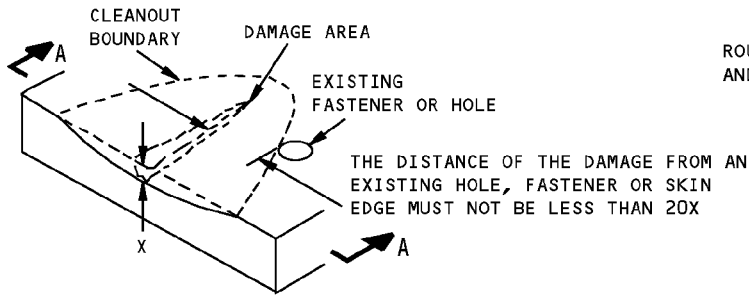

SECTION A-A

REMOVAL OF NICK, GOUGE AND SCRATCH DAMAGE ON A SURFACE
DETAIL VIII

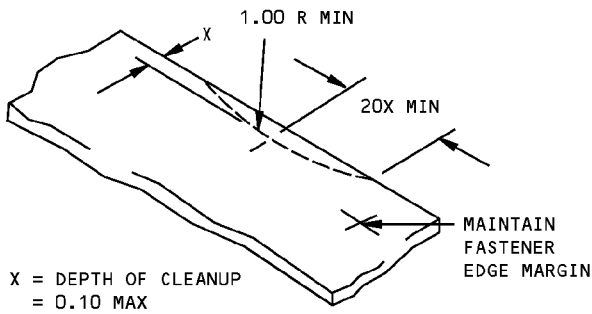

REMOVAL OF NICK OR CRACK DAMAGE ON AN EDGE
DETAIL IX

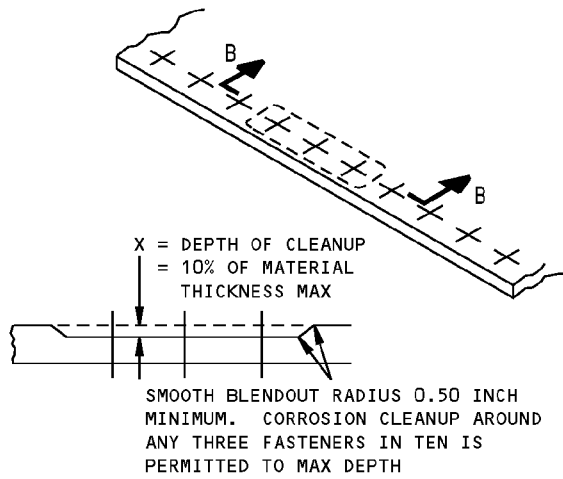

SECTION B-B

CORROSION CLEANUP
DETAIL X

Trailing Edge Flap Structure Allowable Damage
Figure 101 (Sheet 7 of 8)

**757-200
STRUCTURAL REPAIR MANUAL**

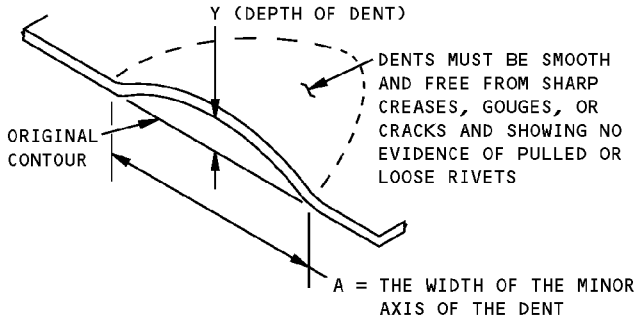

$\frac{A}{Y}$ MUST NOT BE LESS THAN 30

Y = 0.125 MAX FOR WEBS

**ALLOWABLE DAMAGE FOR DENT
DETAIL XI**

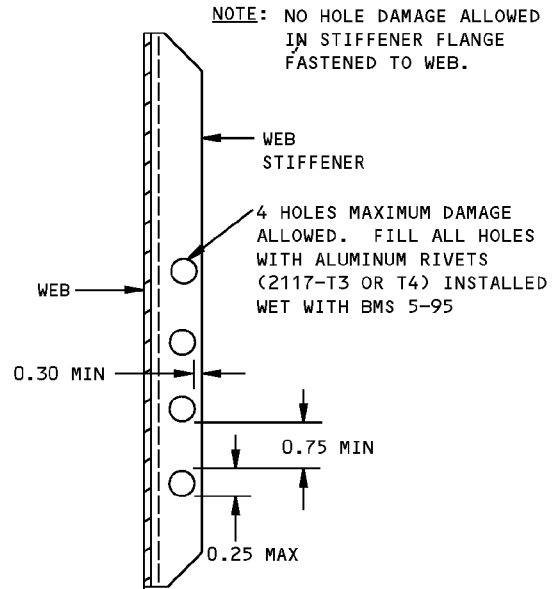

**ALLOWABLE DAMAGE LIMITS FOR
HOLES IN WEB STIFFENERS
DETAIL XII**

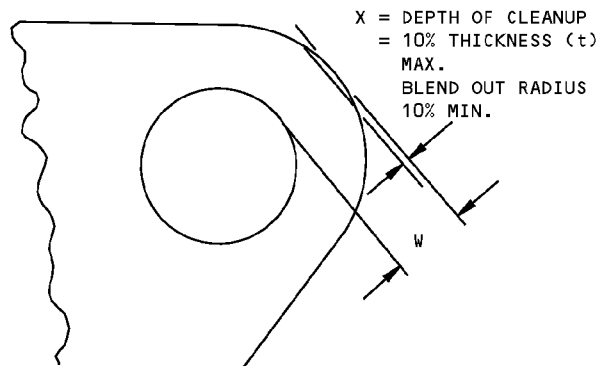

**DAMAGE CLEANUP FOR EDGES OF LUG
DETAIL XIII**

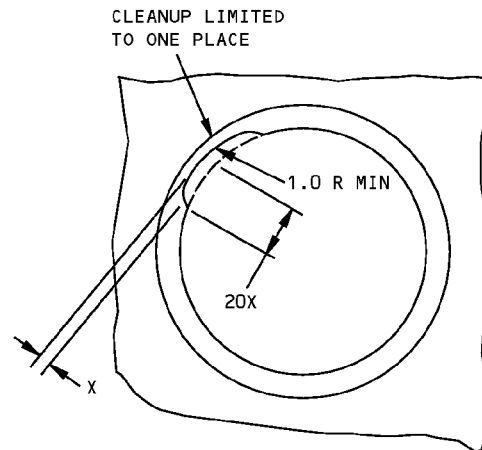

X = DEPTH OF CLEANUP = 0.10 MAX OR 1/2 FLANGE WIDTH WHICHEVER IS LESS

**FLANGED HOLE EDGE DAMAGE CLEANUP
DETAIL XIV**

**Trailing Edge Flap Structure Allowable Damage
Figure 101 (Sheet 8 of 8)**

**757-200
STRUCTURAL REPAIR MANUAL**

ALLOWABLE DAMAGE 2 - TRAILING EDGE FLAP SUPPORT STRUCTURE

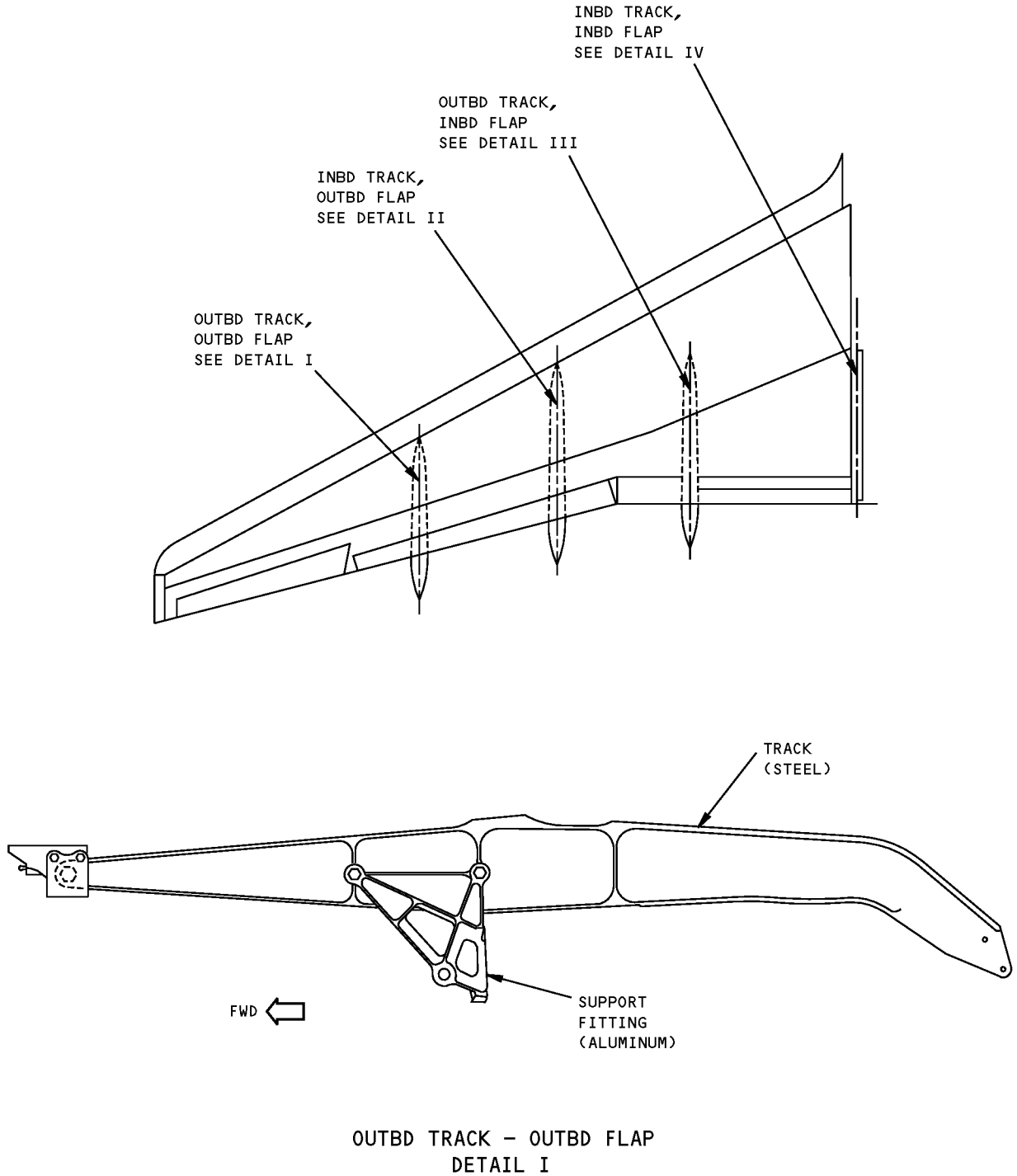

**Trailing Edge Flap Support Structure Allowable Damage
Figure 101 (Sheet 1 of 5)**

**757-200
STRUCTURAL REPAIR MANUAL**

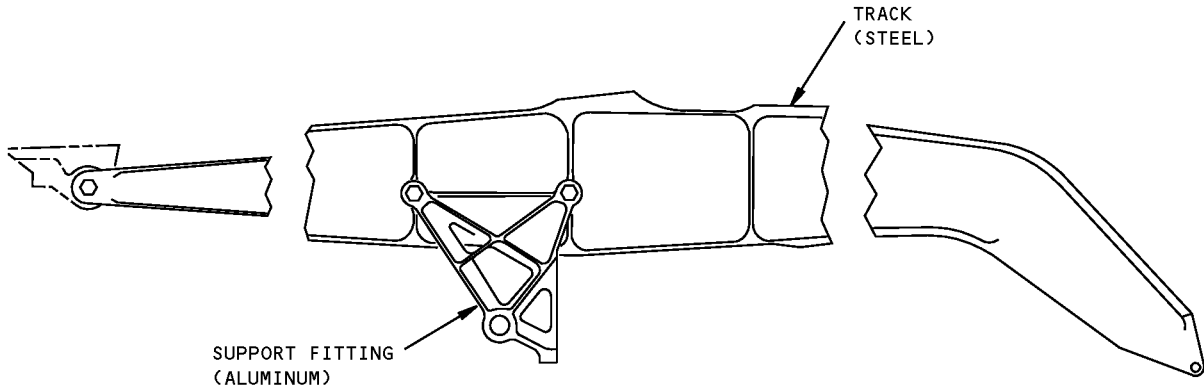

**INBD TRACK - OUTBD FLAP
DETAIL II**

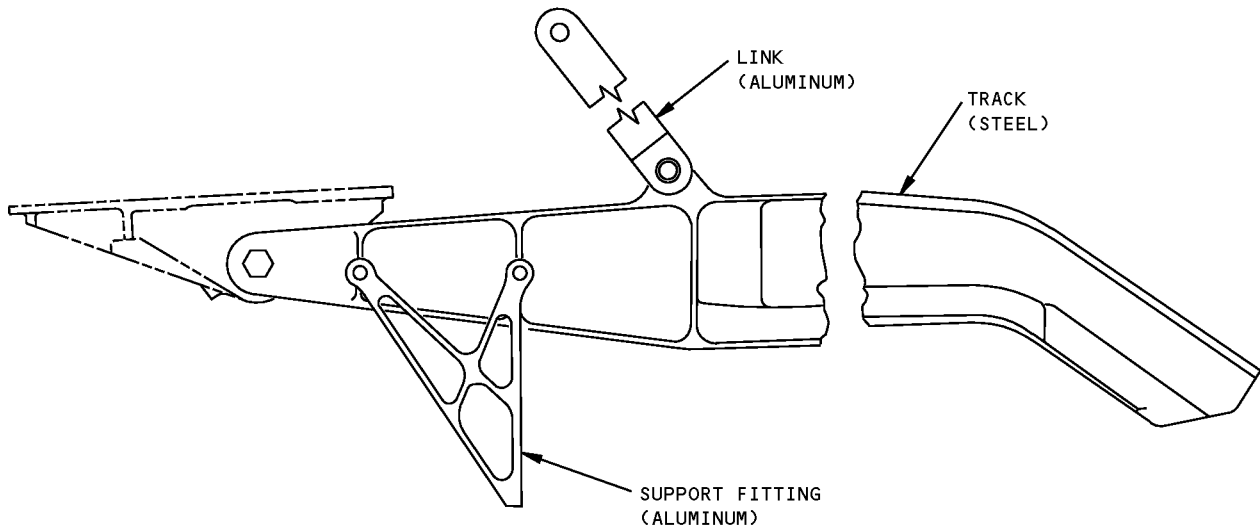

**OUTBD TRACK - INBD FLAP
DETAIL III**

**Trailing Edge Flap Support Structure Allowable Damage
Figure 101 (Sheet 2 of 5)**

**757-200
STRUCTURAL REPAIR MANUAL**

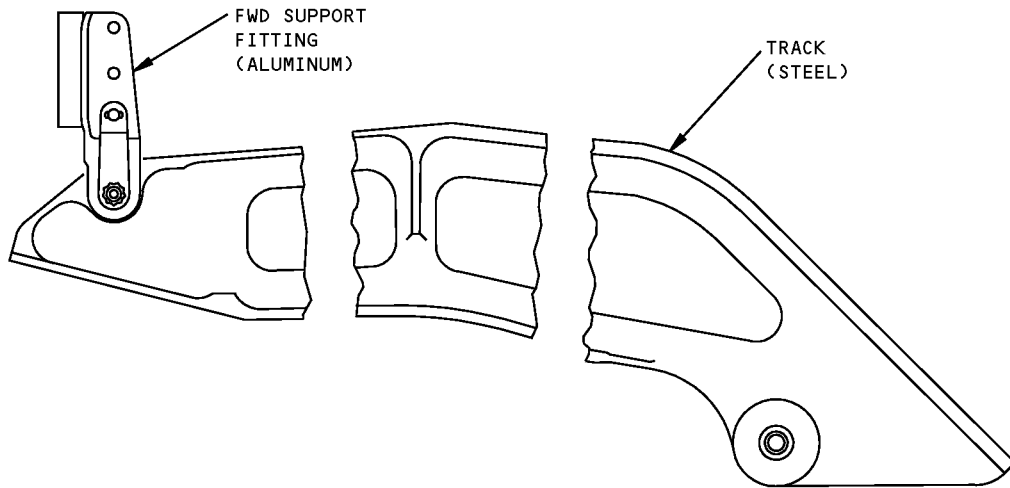
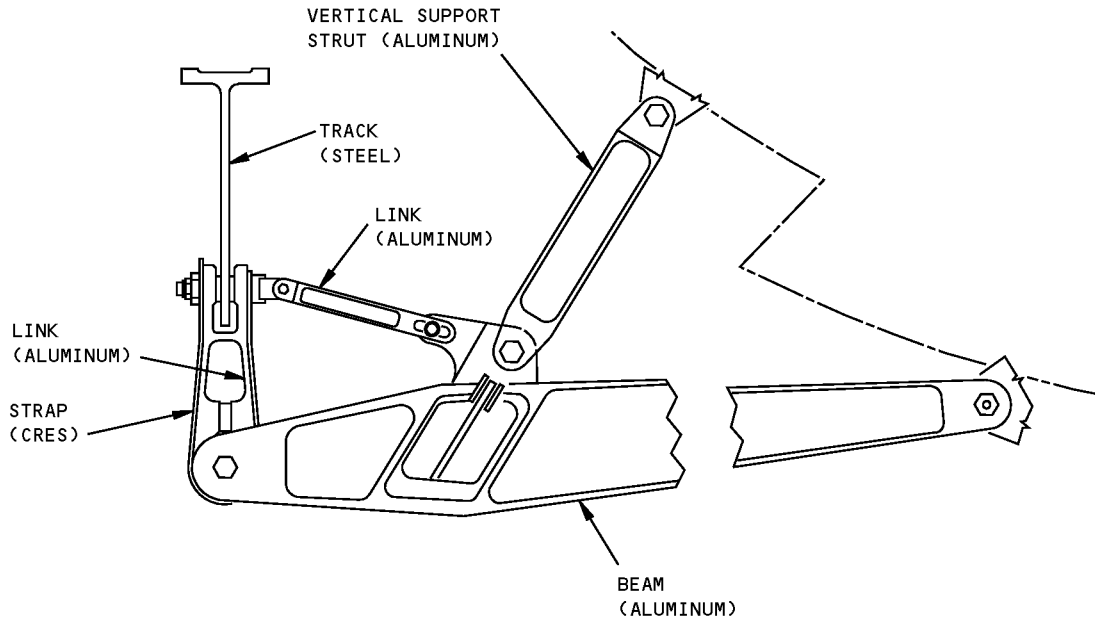

**INBD TRACK - INBD FLAP
DETAIL IV**

**Trailing Edge Flap Support Structure Allowable Damage
Figure 101 (Sheet 3 of 5)**



**757-200
STRUCTURAL REPAIR MANUAL**

DESCRIPTION	CRACKS	NICKS, GOUGES AND CORROSION	DENTS	HOLES AND PUNCTURES
TRACK	E A C	B C	NOT ALLOWED	NOT ALLOWED
SUPPORT FITTING	E A	B	NOT ALLOWED	NOT ALLOWED
BEAM	E A	B	NOT ALLOWED	NOT ALLOWED
VERTICAL STRUT	E A	B	NOT ALLOWED	NOT ALLOWED
LINK	E A	B	NOT ALLOWED	NOT ALLOWED
FAILSAFE STRAP	A F	D F	NOT ALLOWED	NOT ALLOWED

CAUTION: THE USE OF POWER MACHINERY FOR DAMAGE REMOVAL IS PROHIBITED. LOSS OF HEAT TREAT WILL OCCUR

NOTES

- REFINISH REWORKED AREAS PER 51-20 OF THE MAINTENANCE MANUAL
- REFER TO SRM 51-10-02 FOR INSPECTION AND REMOVAL OF DAMAGE.
- BREAK SHARP EDGES 0.02 TO 0.04 (0.5 to 1.0 mm)

- A** CRACKS NOT ALLOWED EXCEPT FOR EDGE CRACKS WHICH MUST BE REMOVED PER DETAIL V
- B** FOR LUG DAMAGE SEE DETAIL VI FOR OTHER SEE DETAIL V. DAMAGE NOT ALLOWED IN VICINITY OF BUSHINGS. REFER TO 27-51 OF THE 757 COMPONENT MAINTENANCE MANUAL

- C** CLEANUP NOT ALLOWED IN AREAS OF ROLLER CONTACT
- D** FOR EDGE DAMAGE SEE DETAIL VIII FOR OTHER DAMAGE SEE DETAIL VII
- E** SHOT PEEN REWORKED AREAS PER 51-20-06. SHOT PEEN INTENSITIES MAY VARY WITH THE THICKNESS REMAINING AFTER REWORK
- F** DAMAGE NOT ALLOWED IN VICINITY OF BUSHINGS OR WHERE LOCKWIRE ATTACHES TO STRAP
- G** CRACKS NOT ALLOWED EXCEPT FOR EDGE CRACKS WHICH MUST BE REMOVED PER DETAIL VIII

**Trailing Edge Flap Support Structure Allowable Damage
Figure 101 (Sheet 4 of 5)**

**757-200
STRUCTURAL REPAIR MANUAL**

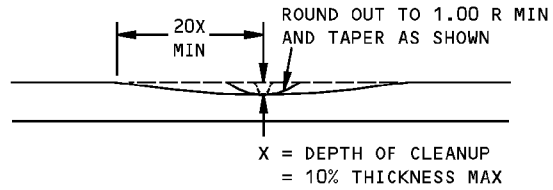
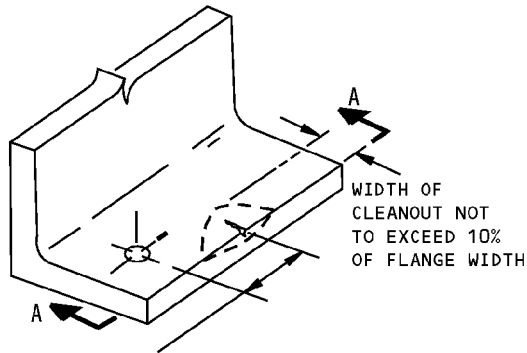

SECTION A-A

THE DISTANCE OF THE DAMAGE FROM AN EXISTING HOLE, FASTENERS OR EDGE MUST NOT BE LESS THAN 20X

REMOVAL OF NICK OR CRACK DAMAGE ON AN EDGE
DETAIL V

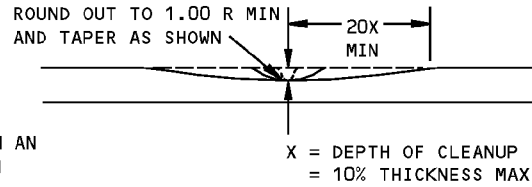
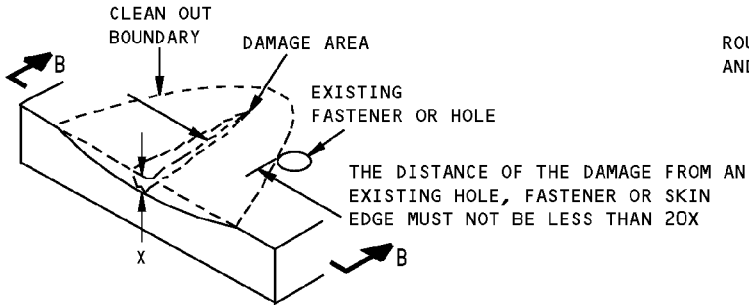

SECTION B-B

REMOVAL OF NICK, GOUGE AND SCRATCH DAMAGE ON A SURFACE
DETAIL VI

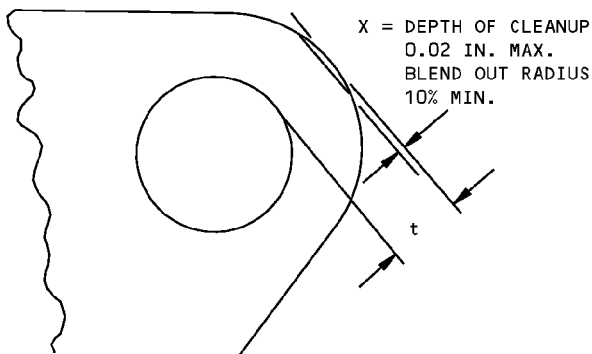

DAMAGE CLEANUP FOR EDGES OF LUG
DETAIL VII

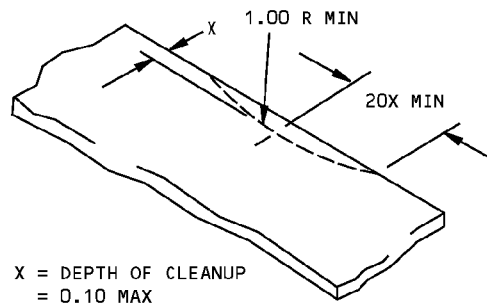

REMOVAL OF NICK OR CRACK
DAMAGE ON AN EDGE
DETAIL VIII

**Trailing Edge Flap Support Structure Allowable Damage
Figure 101 (Sheet 5 of 5)**

**757-200
STRUCTURAL REPAIR MANUAL**

REPAIR 1 - TRAILING EDGE FLAP STRUCTURE - AFT FLAP SPAR REPAIRS

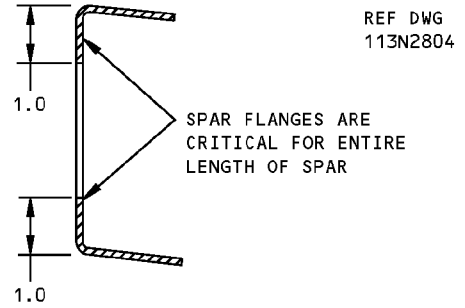
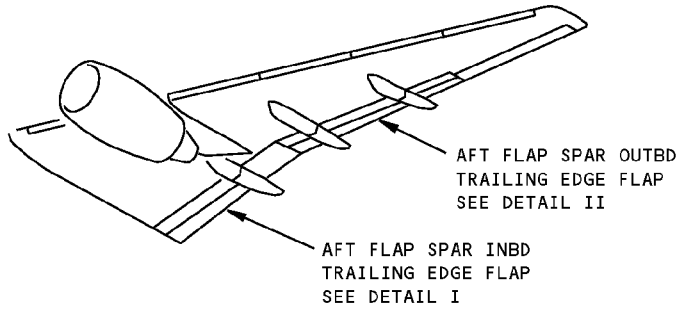

SECTION THRU SPAR

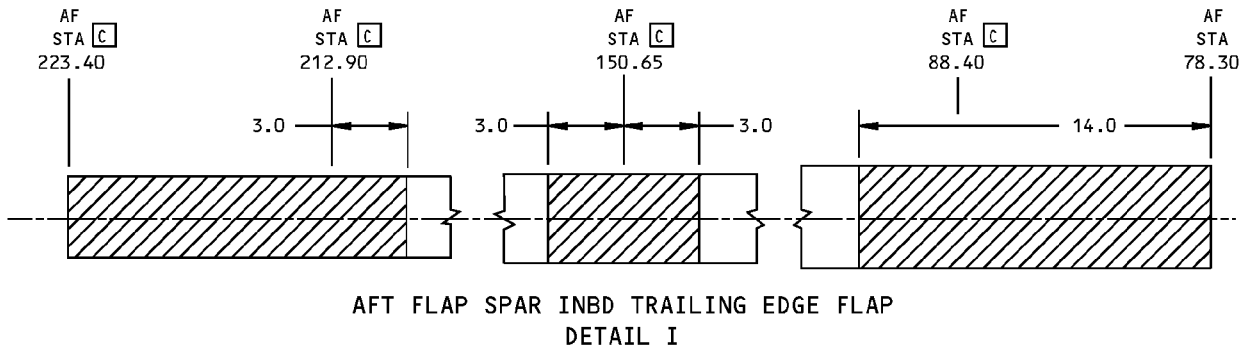

REF DWG 113N3821

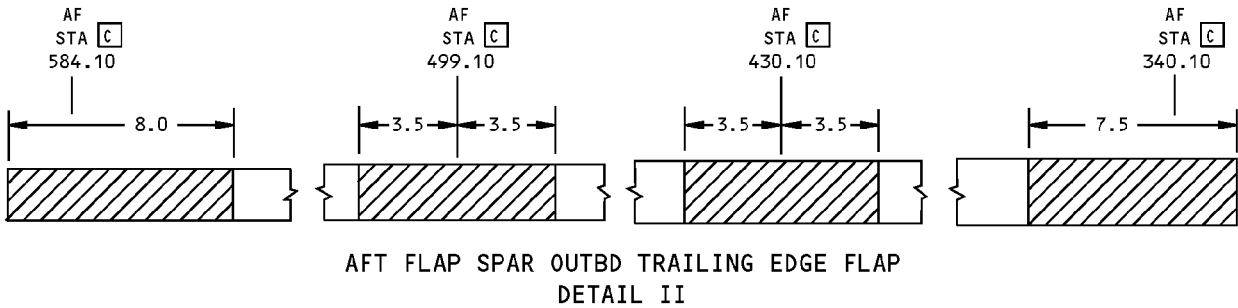

REPAIR UNSHADED AREAS PER TABLE I

CRITICAL AREAS. CONTACT THE BOEING COMPANY FOR REPAIRS TO DAMAGE IN CRITICAL AREAS

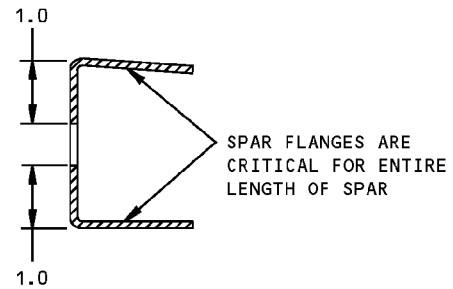

SECTION THRU SPAR

**Trailing Edge Flap Structure - Aft Flap Spar Repairs
Figure 201 (Sheet 1 of 2)**

**757-200
STRUCTURAL REPAIR MANUAL**

DAMAGE	INTERIM REPAIRS B	PERMANENT REPAIRS		
	WET LAYUP 150°F (66°C) CURE (51-70-03)	WET LAYUP 200°F (93°C) CURE (51-70-17)	250°F (121°C) CURE (51-70-05)	350°F (177°C) CURE (51-70-04)
CRACKS	UP TO 2.0 INCHES (50 mm) LONG, REPAIR WITH PATCH PER 51-70-03, PAR. 5.N. A	CLEAN UP DAMAGE AND REPAIR AS HOLE.	CLEAN UP DAMAGE AND REPAIR AS HOLE.	CLEAN UP DAMAGE AND REPAIR AS HOLE.
HOLES AND PUNCTURES	2.0 INCHES (50 mm) MAX DIA NOT TO EXCEED 30% OF SMALLEST DIMENSION ACROSS LAMINATE PANEL AT THE DAMAGE LOCATION. FILL WITH BMS 5-28, TYPE 7 POTTING COMPOUND AND PATCH PER 51-70-03, PAR. 5.N. A	5.0 MAX INCHES (125 mm) DIA NOT TO EXCEED 50% OF SMALLEST DIMENSION ACROSS LAMINATE PANEL AT THE DAMAGE LOCATION. USE TWO EXTRA PLIES PER FACESHEET REPAIRED. A	5.0 MAX INCHES (125 mm) DIA NOT TO EXCEED 50% OF SMALLEST DIMENSION ACROSS LAMINATE PANEL AT THE DAMAGE LOCATION. USE TWO EXTRA PLIES PER FACESHEET REPAIRED. A	NO SIZE LIMIT
DELAMINATION	CUT OUT AND REPAIR AS HOLE.			
NICKS AND GOUGES	IF THERE IS NO FIBER DAMAGE OR DELAMINATION, FILL NICKS OR GOUGES PER 51-70-03. IF FIBER DAMAGE OR DELAMINATION EXISTS, REPAIR AS A HOLE.			
DENTS	UP TO 2.0 INCHES (50 mm) DIA WITH NO FIBER DAMAGE OR DELAMINATION, FILL WITH BMS 5-28, TYPE 7 POTTING COMPOUND AND PATCH PER 51-70-03, PAR. 5.L. C OVER 2.0 INCHES (50 mm) DIA OR WITH FIBER DAMAGE OR DELAMINATION, REPAIR AS HOLE.			

TABLE I

NOTES

- REFINISH REWORKED AREAS AS GIVEN IN AMM 51-20
- REFER TO SRM 51-10-01 FOR AERODYNAMIC SMOOTHNESS REQUIREMENTS. WHERE THE DAMAGE EXCEEDS THE LIMITS SHOWN IN SRM 51-10-01, CONSIDERATION SHOULD BE GIVEN TO THE LOSS OF PERFORMANCE INVOLVED.
- REFER TO SRM 51-10-02 FOR INSPECTION AND REMOVAL OF DAMAGE

A ONE REPAIR PER 12.0 INCHES (300 mm) OF SPAR AND A MINIMUM OF 6.0 INCHES (150 mm) (EDGE TO EDGE) FROM ANY OTHER DAMAGE, FASTENER HOLE, OR EDGE OR PANEL.

B INSPECT INTERIM REPAIR USING INSTRUMENTED NDI METHODS OR "TAP" TEST EVERY AIRPLANE "2A" CHECK. FOR "TAP" TEST, USE A SOLID METAL DISK AND TAP THE REPAIR AREA LIGHTLY BUT FIRMLY. VOID AREAS WILL PRODUCE A DULL SOUND AS OPPOSED TO A SHARP RING ON A SOLID BONDED AREA. PERMANENT REPAIR IS REQUIRED IF ANY DETERIORATION IS EVIDENT. REFER TO 51-70-03, PAR. 4.I. AND THE NONDESTRUCTIVE TEST MANUAL. **D**

C CENTER OF FITTING

D THIS REPAIR HAS FAA APPROVAL CONTINGENT ON ACCOMPLISHMENT OF THE INSPECTIONS CONTAINED HEREIN.

**Trailing Edge Flap Structure - Aft Flap Spar Repairs
Figure 201 (Sheet 2 of 2)**

STRUCTURAL REPAIR MANUAL

REPAIR 2 - TRAILING EDGE FLAP SUPPORT STRUCTURE REPAIR

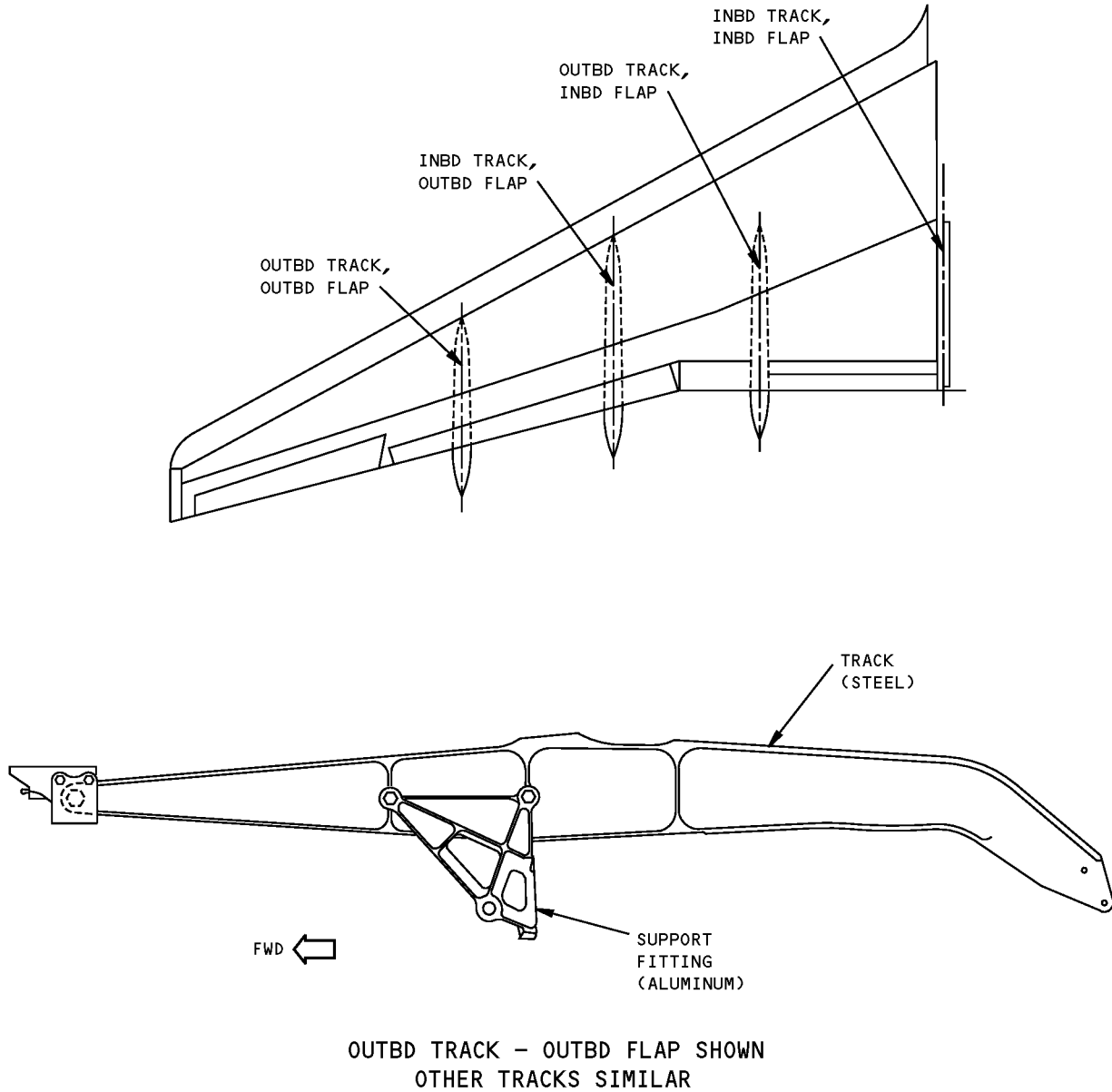

NOTES

- NO TYPICAL REPAIR TO FITTINGS AND TRACKS APPLICABLE. SPECIFIC REPAIRS MAY BE PROVIDED BASED ON SERVICE EXPERIENCE
- SEE 27-51 OF THE 757 COMPONENT MAINTENANCE MANUAL FOR REPAIR OF BUSHING HOLE

**Trailing Edge Flap Support Structure Repair
Figure 201**

**757-200
STRUCTURAL REPAIR MANUAL**

IDENTIFICATION 1 - FLAP TRACK FAIRING SKIN

REF DWG
113N1710
113N1730
113N1750

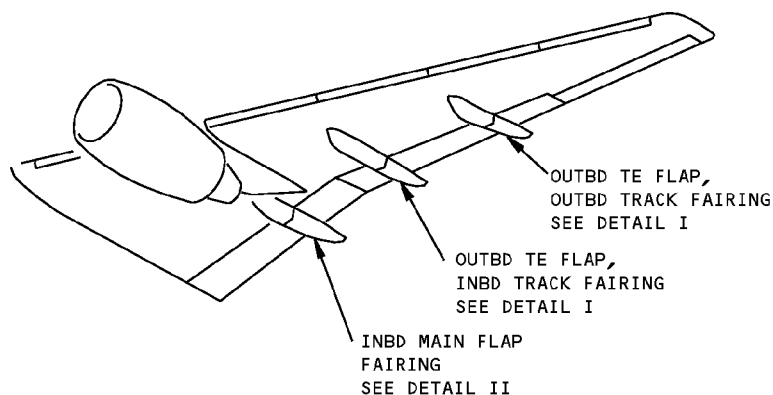

NOTES

- | | |
|---|---|
| <p>A PLY ORIENTATION CONVENTION, DEGREES INDICATED, IS PARALLEL TO THE FABRIC WARP DIRECTION</p> <p>B MATERIAL AND PLY ORIENTATION SHOWN FOR FIELD AREAS ONLY. SEE BOEING DRAWINGS FOR EDGE BANDS AND AREAS WITH DOUBLERS</p> <p>C DIAGRAM OF PLY ORIENTATION, SEE PLY TABLE FOR PLY ORIENTATION AND MATERIAL</p> <p>D ARAMID/EPOXY PREPREG FABRIC PER BMS 8-219, STYLE 285, 250°F (121°C) CURE</p> <p>E GRAPHITE EPOXY PREPREG FABRIC PER BMS 8-168, TYPE II, CLASS II, STYLE 3K-70-PW, 250°F (121°C) CURE</p> <p>F FIBERGLASS/EPOXY PREPREG FABRIC PER BMS 8-139, STYLE 120, 350°F (177°C) CURE</p> | <p>G ARAMID/EPOXY PREPREG FABRIC PER BMS 8-218, STYLE 285, 350°F (177°C) CURE</p> <p>H GRAPHITE/EPOXY PREPREG FABRIC PER BMS 8-212, CLASS II, STYLE 3K-70-PW, 350°F (177°C) CURE</p> <p>I FIBERGLASS/EPOXY PREPREG FABRIC PER BMS 8-79, CLASS III, GRADE I, TYPE 1581, 250°F (121°C) CURE</p> <p>J FOR CUM LINE NUMBERS: 138, 141, 143 THRU 148, 150 AND ON</p> <p>K FIBERGLASS/EPOXY PREPREG FABRIC PER BMS 8-139, TYPE 1581, CLASS I, 350°F (177°C) CURE</p> <p>L FOR ALL AIRPLANES NOT IN J</p> |
|---|---|

**Flap Track Fairing Skin Identification
Figure 1 (Sheet 1 of 7)**

**757-200
STRUCTURAL REPAIR MANUAL**

REF DWGS
113N1710
113N1730

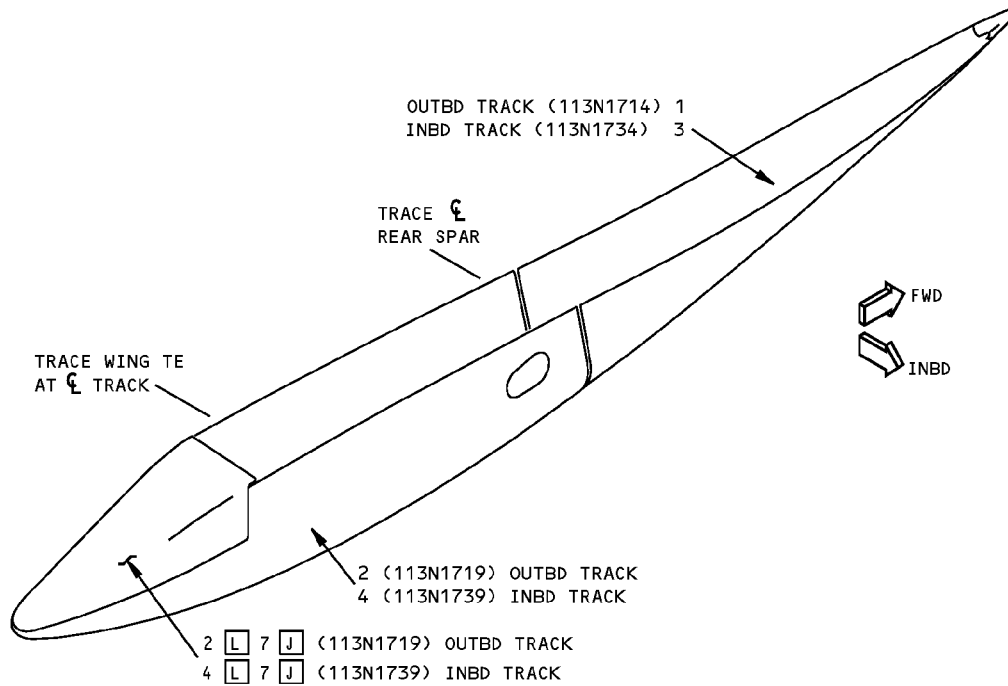

**OUTBOARD FLAP TRACK FAIRINGS
DETAIL I**

REF DWG
113N1750

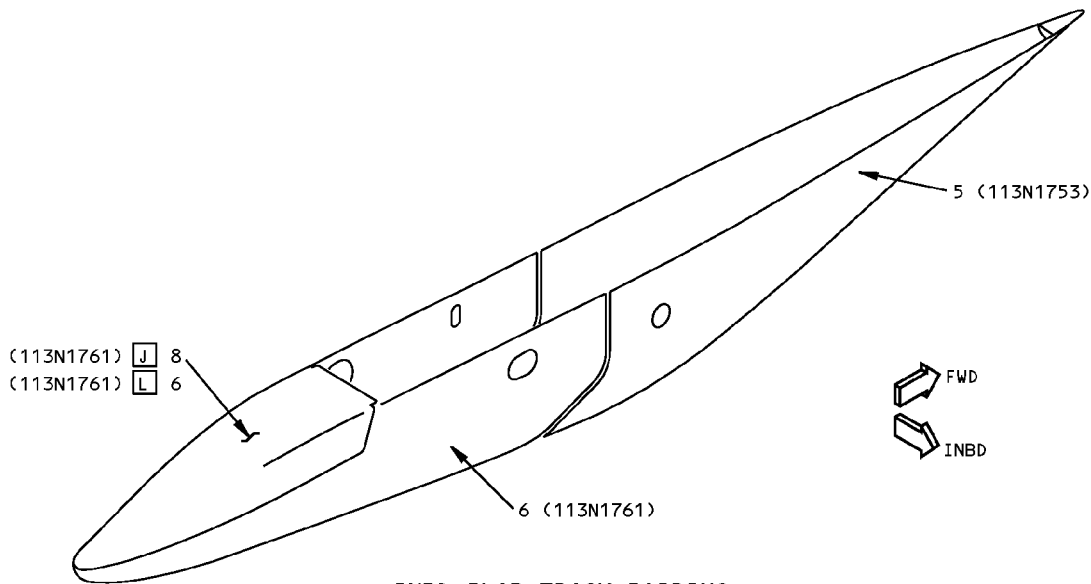

**INBD FLAP TRACK FAIRING
DETAIL II**

LIST OF
MATERIAL

**Flap Track Fairing Skin Identification
Figure 1 (Sheet 2 of 7)**

IDENTIFICATION 1
Page 2
Jan 20/2005

57-53-70

D634N201



**757-200
STRUCTURAL REPAIR MANUAL**

ITEM	DESCRIPTION	GAGE	MATERIAL	EFFECTIVITY
1	SKIN PANEL SKIN CORE		ARAMID/GRAPHITE/EPOXY HONEYCOMB SANDWICH SEE DETAIL III NOMEX HONEYCOMB PER BMS 8-124, CLASS IV, TYPE VI, GRADE 3.0	
2	SKIN PANEL SKIN CORE		ARAMID/GRAPHITE/EPOXY HONEYCOMB SANDWICH SEE DETAIL IV NOMEX HONEYCOMB PER BMS 8-124, CLASS IV, TYPE VI, GRADE 3.0	
3	SKIN PANEL SKIN CORE		ARAMID/GRAPHITE/EPOXY HONEYCOMB SANDWICH SEE DETAIL III NOMEX HONEYCOMB PER BMS 8-124, CLASS IV, TYPE VI, GRADE 3.0	
4	SKIN PANEL SKIN CORE		ARAMID/GRAPHITE/EPOXY HONEYCOMB SANDWICH SEE DETAIL V NOMEX HONEYCOMB PER BMS 8-124, CLASS IV, TYPE VI, GRADE 3.0	
5	SKIN PANEL SKIN CORE		ARAMID/GRAPHITE/EPOXY HONEYCOMB SANDWICH SEE DETAIL VI NOMEX HONEYCOMB PER BMS 8-124, CLASS IV, TYPE VI, GRADE 3.0	
6	SKIN PANEL SKIN CORE		ARAMID/GRAPHITE/FIBERGLASS/EPOXY HONEYCOMB SANDWICH SEE DETAIL VII NOMEX HONEYCOMB PER BMS 8-124, CLASS IV, TYPE VI, GRADE 3.0	
7	SKIN PANEL SKIN CORE		FIBERGLASS/EPOXY HONEYCOMB SANDWICH SEE DETAIL VIII NOMEX HONEYCOMB PER BMS 8-124, CLASS IV, TYPE VI, GRADE 3.0	J
8	SKIN PANEL SKIN CORE		FIBERGLASS/EPOXY HONEYCOMB SANDWICH SEE DETAIL IX NOMEX HONEYCOMB PER BMS 8-124, CLASS IV, TYPE VI, GRADE 3.0	J

LIST OF MATERIALS FOR DETAILS I AND II

**Flap Track Fairing Skin Identification
Figure 1 (Sheet 3 of 7)**

D634N201

57-53-70

IDENTIFICATION 1
Page 3
May 20/2008

**757-200
STRUCTURAL REPAIR MANUAL**

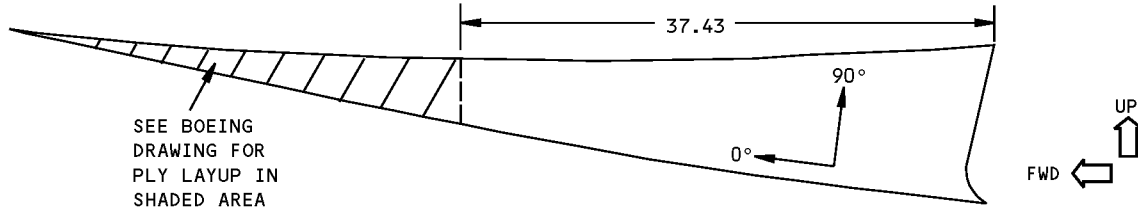

SIDE VIEW
ITEM 1

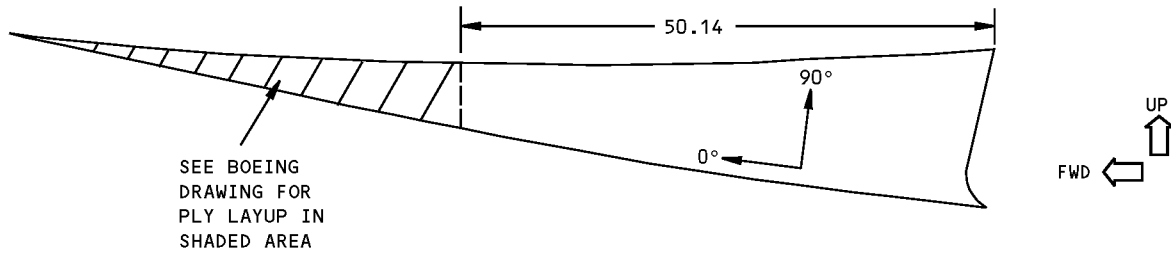

SIDE VIEW
ITEM 3

VIEW ON PANELS [C]

ITEM NO.	PLY NO.	MATERIAL	PLY ORIENTATION [A]
1,3	P1,P10	[D]	0° OR 90°
	P3,P4,P5, P6,P7,P8	[E]	0° OR 90°

PLY TABLE [B]

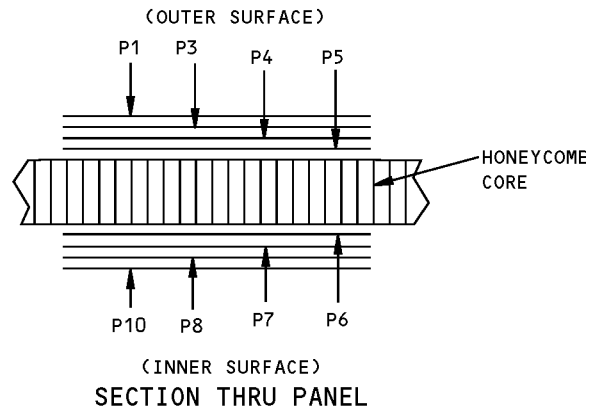

DETAIL III

**Flap Track Fairing Skin Identification
Figure 1 (Sheet 4 of 7)**

757-200 STRUCTURAL REPAIR MANUAL

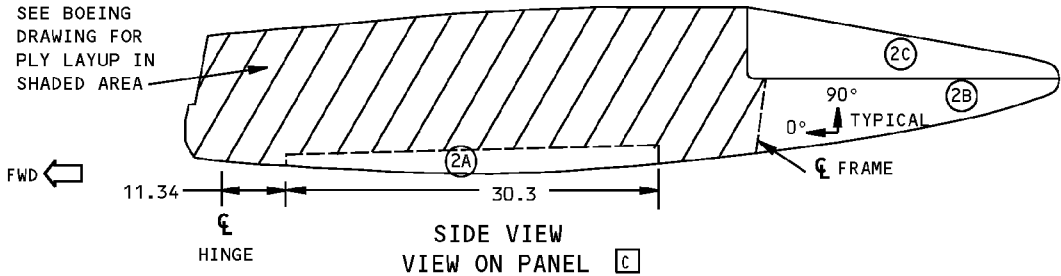

ITEM NO.	PLY NO.	MATERIAL	PLY ORIENTATION [A]
2	(2A)	P1,P6	[D] 0° OR 90°
		P4,P6,P7,P8,P9,P10,P11,P12	[E] 0° OR 90°
	(2B)	P1,P6	[D] 0° OR 90°
		P19,P20	[E] 0° OR 90°
	(2C)	P22,P27	[D] 0° OR 90°
		[L]	P24,P25

PLY TABLE [B]

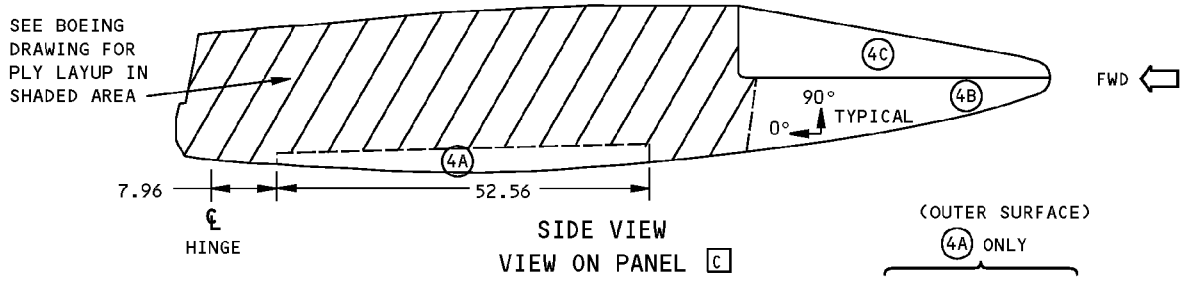
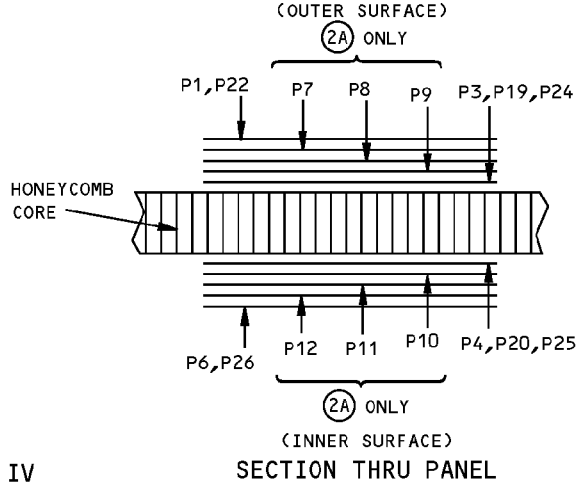

ITEM NO.	PLY NO.	MATERIAL	PLY ORIENTATION [A]
4	(4A)	P1,P6	[D] 0° OR 90°
		P3,P4,P7,P8,P9,P10,P11,P12,P13,P14	[E] 0° OR 90°
	(4B)	P1,P6	[D] 0° OR 90°
		P21,P22	[E] 0° OR 90°
	(4C)	P24,P29	[D] 0° OR 90°
		[L]	P26,P27

PLY TABLE [B]

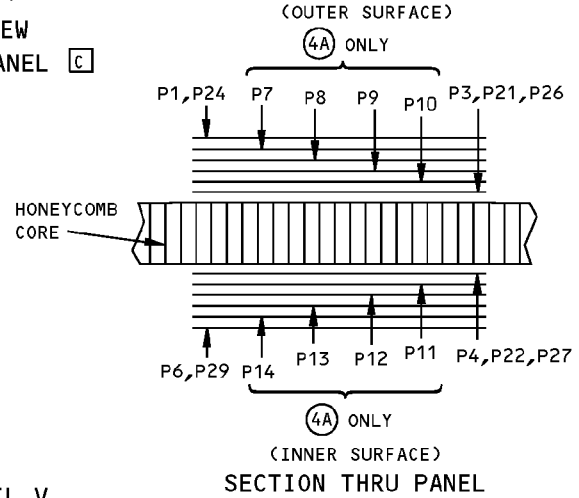

**Flap Track Fairing Skin Identification
Figure 1 (Sheet 5 of 7)**

**757-200
STRUCTURAL REPAIR MANUAL**

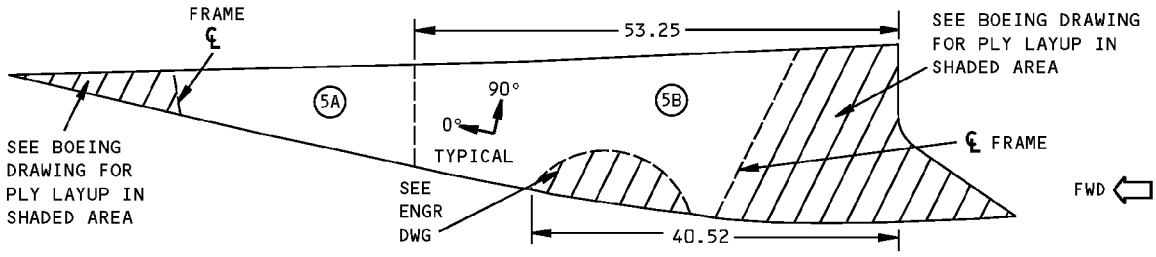

**SIDE VIEW
VIEW ON PANEL C**

ITEM NO.	PLY NO.	MATERIAL	PLY ORIENTATION ^[A]
5	5A	P2, P13	D
		P7, P8	E
	5B	P2, P13	D
		P6, P7, P8, P9	E

PLY TABLE B

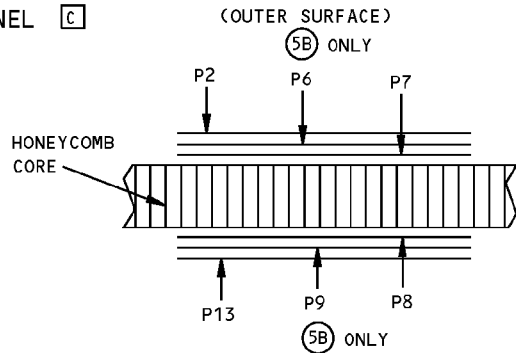

DETAIL VI

**(INNER SURFACE)
SECTION THRU PANEL**

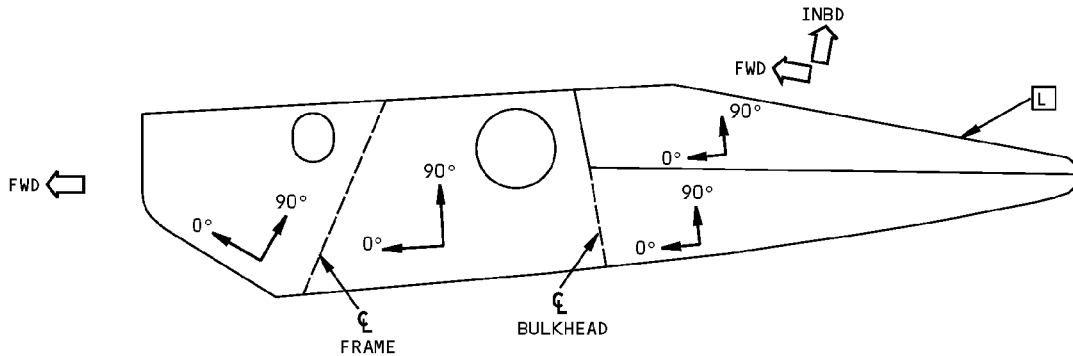

**SIDE VIEW
VIEW ON PANEL C**

ITEM NO.	PLY NO.	MATERIAL	PLY ORIENTATION ^[A]
6	P1, P8	F	0° OR 90°
	P2, P7	G	0° OR 90°
	P4, P5	H	90°

PLY TABLE B

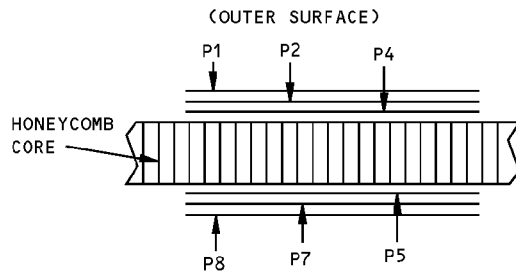

DETAIL VII

**(INNER SURFACE)
SECTION THRU PANEL**

**Flap Track Fairing Skin Identification
Figure 1 (Sheet 6 of 7)**

**757-200
STRUCTURAL REPAIR MANUAL**

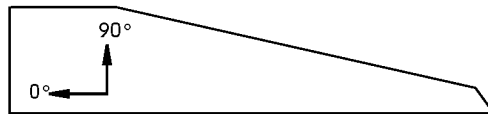

SIDE VIEW ON PANEL **C**

ITEM NO.	PLY NO.	MATERIAL	PLY ORIENTATION A
7 J	P1,P3,P4,P5,P8	I	0 OR 90°
	P2,P9	I	±45°

PLY TABLE **B**

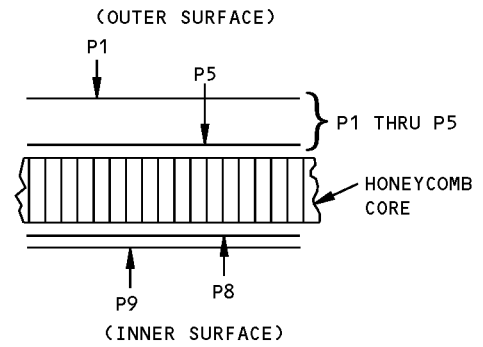

DETAIL VIII

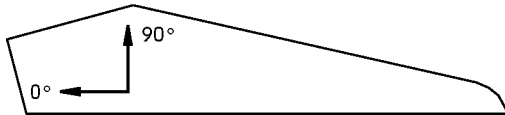

SIDE VIEW ON PANEL **C**

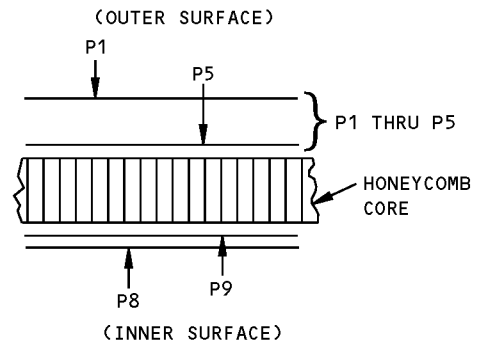

ITEM NO.	PLY NO.	MATERIAL	PLY ORIENTATION A
8 J	P1,P3,P4,P5,P8	K	0 OR 90°
	P2,P9	K	±45°

PLY TABLE **B**

DETAIL IX

**Flap Track Fairing Skin Identification
Figure 1 (Sheet 7 of 7)**

**757-200
STRUCTURAL REPAIR MANUAL**

ALLOWABLE DAMAGE 1 - FLAP TRACK FAIRING SKIN

REF DWGS
113N1710
113N1730
113N1750

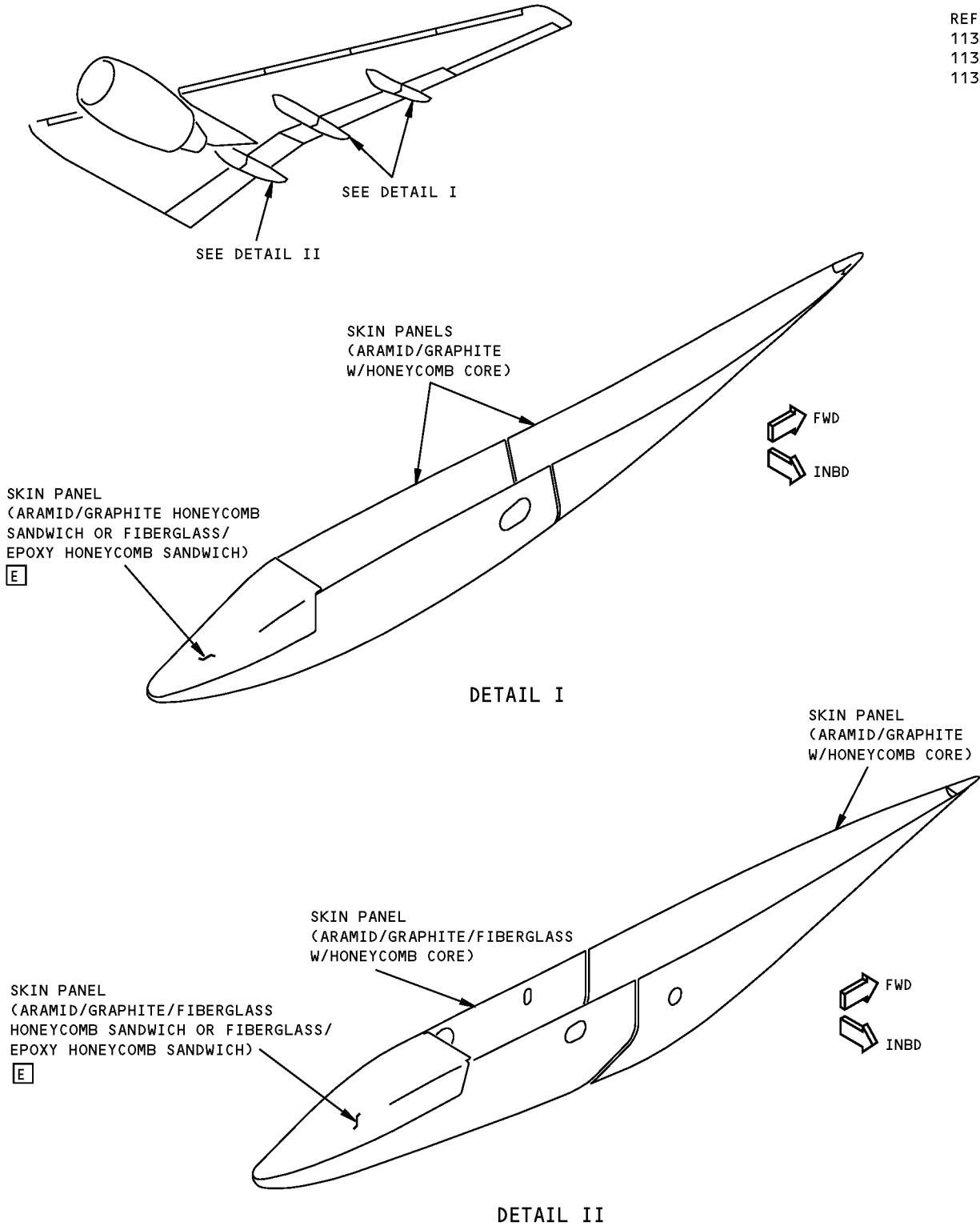

**Flap Track Fairing Skin Allowable Damage
Figure 101 (Sheet 1 of 4)**

**757-200
STRUCTURAL REPAIR MANUAL**

DESCRIPTION	CRACKS	NICKS, GOUGES AND CORROSION	DENTS	HOLES AND PUNCTURES	DELAMINATION	EDGE EROSION
SKIN PANELS	A	B	C	A	A	SEE DETAIL V

**ALLOWABLE DAMAGE DATA
TABLE I**

NOTES

- REFINISH REWORKED AREAS AS GIVEN IN AMM 51-20
- REFER TO SRM 51-10-01 FOR AERODYNAMIC SMOOTHNESS REQUIREMENTS. WHERE DAMAGE EXCEEDS THE LIMITS SHOWN IN SRM 51-10-01. CONSIDERATION SHOULD BE GIVEN TO LOSS OF PERFORMANCE INVOLVED.
- REFER TO SRM 51-10-02 FOR INSPECTION AND REMOVAL OF DAMAGE

A DAMAGE TO SKIN PANEL EDGES MAY BE A COMBINATION OF EDGE DELAMINATION AND/OR CRACKS, GOUGES, ETC. WHICH CAN RESULT IN FIBER DAMAGE AND A LOSS OF CROSS-SECTIONAL AREA. REMOVE EDGE DAMAGE PER DETAILS III AND IV. NOT MORE THAN 1 FASTENER HOLE IN SIX MAY BE CRACKED OR DAMAGED. DAMAGE MUST NOT EXCEED 10% OF THE EDGE BAND LENGTH PER SIDE. 2.00 INCHES (50 mm) MAX DIA ALLOWED FOR SINGLE DAMAGE SITE IN HONEYCOMB AREA. MULTIPLE DAMAGE SITES MUST NOT BE CLOSER THAN A MINIMUM OF $a/D = 3.0$ SEE DETAIL VI FOR DAMAGE CRITERIA. DAMAGE ALLOWED TO ONE SURFACE AND HONEYCOMB CORE ONLY. PROTECT DAMAGE NOT REWORKED PER **D**.

B DAMAGE ALLOWED ON SURFACE RESIN ONLY WITH NO FIBER DAMAGE. CLEAN UP EDGE DAMAGE PER DETAILS III AND IV. REFER TO **A** FOR FIBER DAMAGE IN OTHER AREAS.

C DENTS RESULT IN DELAMINATION AND FIBER DAMAGE AND MUST BE TREATED AS A HOLE OR PUNCTURE DAMAGE.

D REMOVE MOISTURE FROM DAMAGE AREA. USE OF VACUUM AND HEAT (MAX OF 125°F (52°C)) TO REMOVE MOISTURE FROM HONEYCOMB CELLS IS RECOMMENDED. PROTECT DAMAGE FROM ENTRANCE OF WATER, SUNLIGHT OR OTHER FOREIGN MATTER BY SEALING WITH ALUMINUM FOIL TAPE (SPEED TAPE). RECORD THE LOCATION AND INSPECT EVERY AIRPLANE "A" CHECK. REPLACE THE ALUMINUM FOIL TAPE IF ANY PEELING OR DETERIORATION EVIDENT. REPAIR NO LATER THAN NEXT AIRPLANE "C" CHECK. **F**

E REFER TO IDENTIFICATION 1 FOR MATERIAL EFFECTIVITY.

F THESE ALLOWABLE DAMAGE LIMITS HAVE APPROVAL CONTINGENT ON ACCOMPLISHMENT OF THE INSPECTIONS CONTAINED HEREIN.

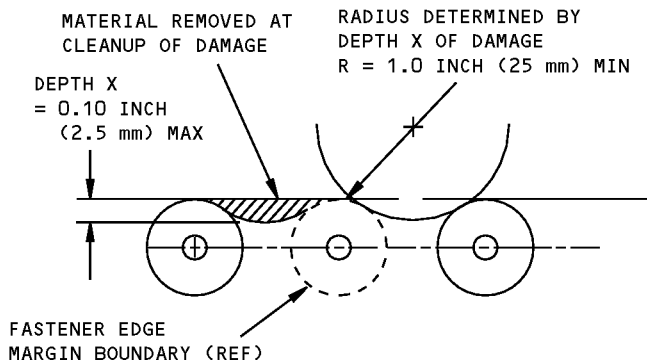

**DAMAGE CLEANUP OF EDGES WHERE
FASTENER EDGE MARGINS DO NOT OVERLAP**

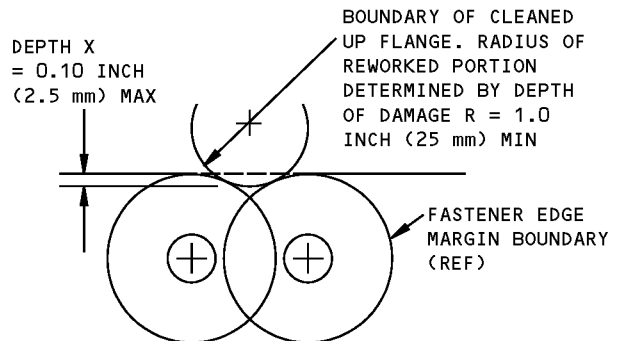

**DAMAGE CLEANUP OF EDGES WHERE
FASTENER EDGE MARGINS OVERLAP**

DETAIL III

**Flap Track Fairing Skin Allowable Damage
Figure 101 (Sheet 2 of 4)**

**757-200
STRUCTURAL REPAIR MANUAL**

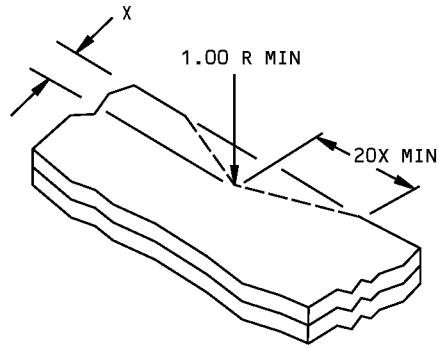

X = DEPTH OF CLEANUP = 0.10 MAX

**REMOVAL OF NICK OR CRACK
DAMAGE OF AN EDGE
DETAIL IV**

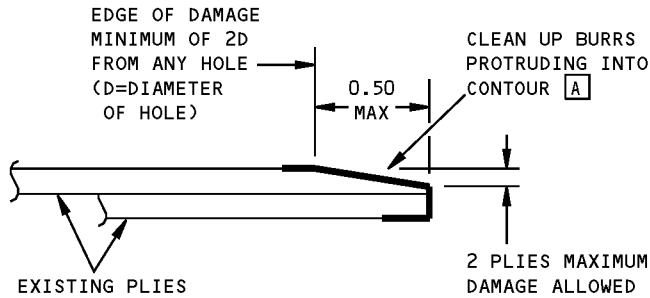

**DAMAGE CLEANUP AND SEALING
OF EDGE EROSION
DETAIL V**

**Flap Track Fairing Skin Allowable Damage
Figure 101 (Sheet 3 of 4)**

**757-200
STRUCTURAL REPAIR MANUAL**

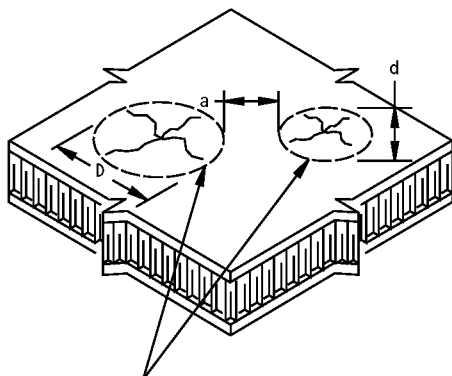

ADJACENT DAMAGE SITES ON SURFACE OF COMPOSITE PANEL

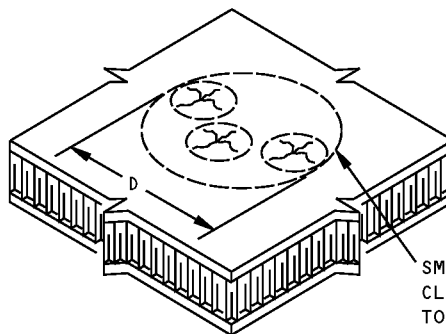

SMALL DAMAGE SITES THAT ARE CLOSELY SPACED MAY BE GROUPED TOGETHER AND CONSIDERED AS ONE DAMAGE SITE

- DAMAGE TO COMPOSITE PANELS EXPOSED TO MULTIPLE IMPACTS, I.E., HAIL DAMAGE, CAN BE DETECTED BY USING INSTRUMENTED NON-DESTRUCTIVE INSPECTION METHODS OR BY TAPPING THE SUSPECTED DAMAGE AREA WITH A SMALL METALLIC DISK OBJECT. INSPECTION SHOULD COVER THE AREA WITHIN 3 DIAMETERS AROUND THE EDGE OF THE VISIBLE DAMAGE SITE. FOR TAP TEST, USE A SOLID METAL DISK AND TAP THE DAMAGE AREA LIGHTLY BUT FIRMLY. VOID AREAS SHOULD PRODUCE A DULL SOUND AS OPPOSED TO A SHARP RING ON A SOLID BONDED AREA
- DAMAGE SITE IS ANY SINGLE AREA OF A PANEL WHERE A DENT, CRACK, DELAMINATION, PUNCTURE OR ANY COMBINATION OF THESE EXIST. SMALL DAMAGE SITES THAT ARE CLOSELY SPACED MAY BE GROUPED TOGETHER AND CONSIDERED AS ONE DAMAGE SITE
- "D" IS DETERMINED BY MEASURING THE MAX DIMENSION OF A DENT, CRACK, OR OTHER DAMAGE, WHICHEVER IS GREATER
- "a" IS THE DISTANCE BETWEEN TWO ADJACENT DAMAGE SITES
- "d" IS THE MAX DIMENSION OF THE SMALLER OF TWO ADJACENT DAMAGE SITES
- CALCULATE a/D BY DIVIDING DISTANCE "a" BY DIAMETER "D"
- DAMAGE IS ALLOWED WHEN "D" IS EQUAL TO OR LESS THAN THE MAXIMUM ALLOWABLE "D" FROM TABLE I AND WHEN a/D IS EQUAL TO OR GREATER THAN THE MINIMUM a/D GIVEN IN TABLE I

**DAMAGE SIZING AND SPACING DATA
FOR COMPOSITE PANELS
DETAIL VI**

**Flap Track Fairing Skin Allowable Damage
Figure 101 (Sheet 4 of 4)**



757-200
STRUCTURAL REPAIR MANUAL

REPAIR GENERAL - SERVICE BULLETIN REPAIR CHART

SERVICE BULLETIN REPAIRS

The following Service Bulletins contain repairs which are available for use where specific damage has been encountered. Usually, the Service Bulletin also covers preventive modification data which operators are encouraged to use to eliminate the need for repair.

DAMAGED AREA	CUM LINE NUMBER EFFECTIVITY	SB NUMBER
OUTER SURFACE, FWD FLAP TRACK FAIRING PANELS	1 THRU 36, 38 THRU 52	51-0003

Service Bulletin Repair Chart
Figure 201

D634N201

57-53-70

REPAIR GENERAL
Page 201
Jan 20/2005

**757-200
STRUCTURAL REPAIR MANUAL**

REPAIR 1 - FLAP TRACK FAIRING SKIN REPAIRS

REF DWGS
113N1710
113N1730
113N1750

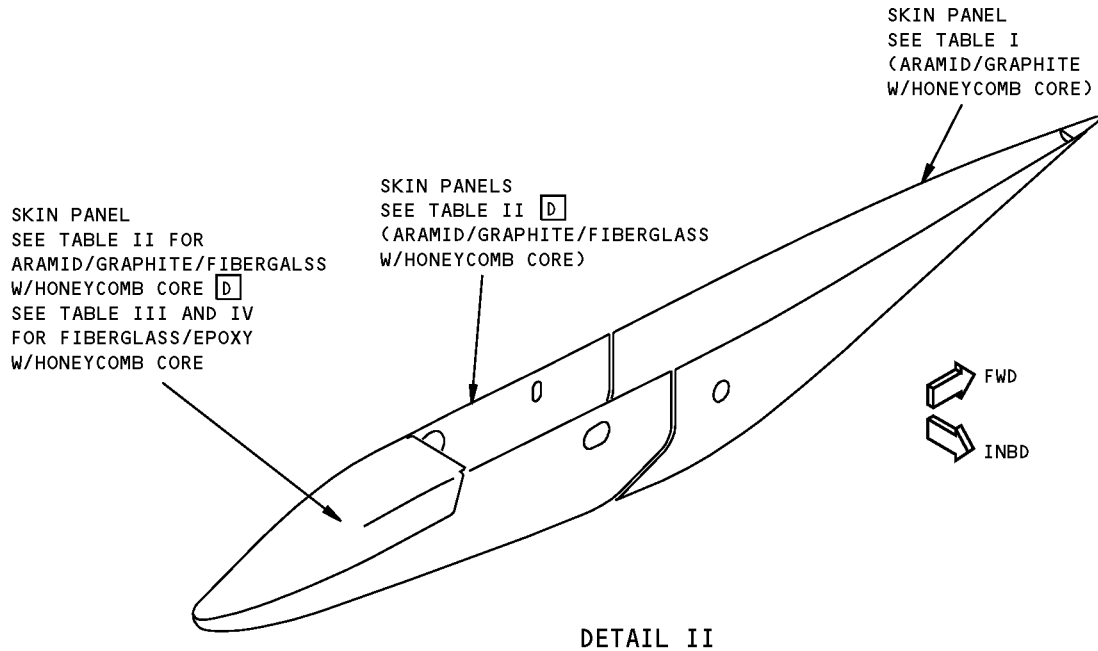
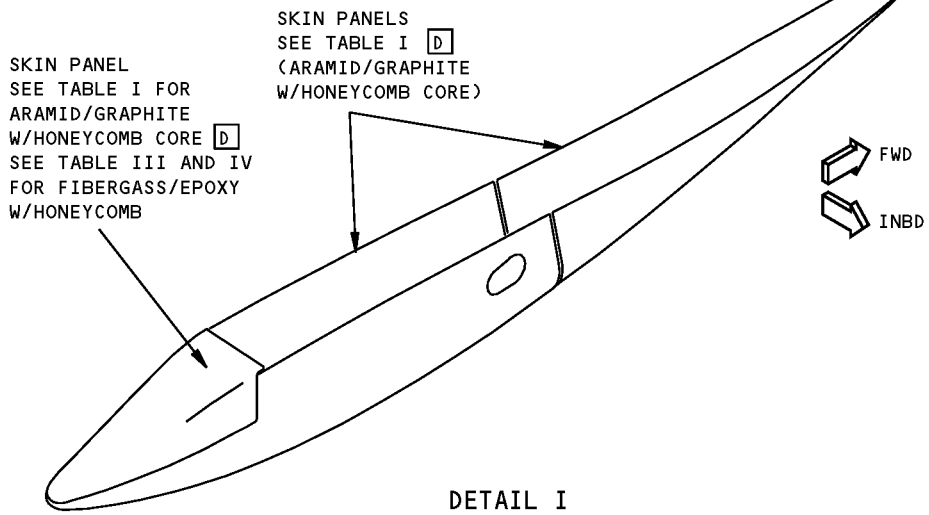
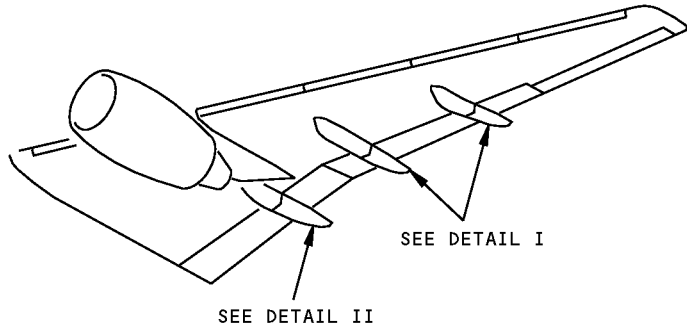

**Flap Track Fairing Skin Repairs
Figure 201 (Sheet 1 of 6)**

STRUCTURAL REPAIR MANUAL

NOTES

- REFINISH REWORKED AREAS AS GIVEN IN AMM 51-20
 - REFER TO 51-10-01 FOR AERODYNAMIC SMOOTHNESS REQUIREMENTS. WHERE THE DAMAGE EXCEEDS THE LIMITS SHOWN IN 51-10-01, CONSIDERATION SHOULD BE GIVEN TO THE LOSS OF PERFORMANCE INVOLVED
- A** LIMITED TO REPAIR OF DAMAGE TO ONE FACESHEET SKIN AND HONEYCOMB CORE. ONE REPAIR PER SQUARE FOOT (930 SQUARE cm) OF AREA AND MINIMUM OF 6.0 INCHES (150 mm) (EDGE TO EDGE) FROM ANY OTHER DAMAGE, FASTENER HOLE, OR EDGE OF PANEL
- B** INSPECT INTERIM REPAIR USING INSTRUMENTED NDI METHODS OR "TAP" TEST EVERY AIRPLANE "2A" CHECK. FOR "TAP" TEST, USE A SOLID METAL DISK AND TAP THE REPAIR AREA LIGHTLY BUT FIRMLY. VOID AREAS WILL PRODUCE A DULL SOUND AS OPPOSED TO A SHARP RING ON A SOLID BONDED AREA. PERMANENT REPAIR IS REQUIRED IF ANY DETERIORATION IS EVIDENT. REFER TO 51-70-03 OR 51-70-06 FOR FIBERGLASS, PAR. 4.I. AND THE NONDESTRUCTIVE TEST MANUAL **E**
- C** ONE REPAIR PER SQUARE FOOT (930 SQUARE cm) OF AREA AND A MINIMUM OF 6.0 INCHES (150 mm) (EDGE TO EDGE) FROM ANY OTHER DAMAGE, FASTENER HOLE, OR EDGE OR PANEL
- D** FOR ADDED PROTECTION AGAINST MOISTURE INGESTION, INCORPORATION OF SB 757-51-0003 FOR AIRPLANES 1 THRU 36 AND 38 THRU 52 IS RECOMMENDED. FOR PANELS WITH EXISTING MOISTURE BARRIER COATING, REAPPLY BMS 5-95 SEALANT ON REWORKED AREAS PRIOR TO THE APPLICATION OF ENAMEL FINISH. REFER TO AMM 51-21-12
- E** THIS REPAIR HAS FAA APPROVAL CONTINGENT ON ACCOMPLISHMENT OF THE INSPECTIONS CONTAINED HEREIN
- F** FOR EDGE BAND, CUT OUT DAMAGE AND REPAIR AS A HOLE
- G** FOR LAMINATE, UP TO 2.0 INCHES (50 mm) LONG REPAIR WITH PATCH PER 51-70-03 PAR. 5.H. ONE REPAIR PER SQUARE FOOT (930 SQUARE cm) OF AREA AND A MINIMUM OF 3.0 INCHES (75 mm) (EDGE-TO-EDGE) FROM ANY OTHER DAMAGE, FASTENER HOLE, OR EDGE OF PANEL

Flap Track Fairing Skin Repairs
Figure 201 (Sheet 2 of 6)



**757-200
STRUCTURAL REPAIR MANUAL**

DAMAGE	INTERIM REPAIRS B	PERMANENT REPAIRS		
	WET LAYUP ROOM TEMP (SRM 51-70-03)	WET LAYUP 150°F (66°C) CURE (SRM 51-70-03)	WET LAYUP 200°F TO 230°F (93°C TO 110°C) CURE (SRM 51-70-17)	250°F (121°C) CURE (SRM 51-70-05)
CRACKS	UP TO 4.0 INCHES (100 mm) INCHES LONG, REPAIR WITH PATCH AS GIVEN IN SRM 51-70-03, PAR. 5.N. A	CLEAN UP DAMAGE AND REPAIR AS A HOLE	CLEAN UP DAMAGE AND REPAIR AS A HOLE	CLEAN UP DAMAGE AND REPAIR AS A HOLE
HOLES	4.0 INCHES (100 mm) MAXIMUM DIA NOT TO EXCEED 30% OF SMALLEST DIMENSION ACROSS HONEYCOMB PANEL AT THE DAMAGE LOCATION. FILL WITH BMS 5-28, TYPE 7 POTTING COMPOUND AND PATCH AS GIVEN IN SRM 51-70-03, PAR. 5.N. A	8.0 INCHES (200 mm) MAXIMUM DIA NOT TO EXCEED 50% OF SMALLEST DIMENSION ACROSS HONEYCOMB PANEL AT THE DAMAGE LOCATION. USE TWO EXTRA PLIES FOR EACH FACESHEET REPAIRED C	12.0 INCHES (300 mm) MAXIMUM DIA NOT TO EXCEED 50% OF SMALLEST DIMENSION ACROSS HONEYCOMB PANEL AT THE DAMAGE LOCATION. USE TWO EXTRA PLIES FOR EACH FACESHEET REPAIRED C	NO SIZE LIMIT
DELAMINATION	CUT OUT AND REPAIR AS A HOLE			
NICKS AND GOUGES	IF THERE IS NO FIBER DAMAGE OR DELAMINATION, FILL NICKS OR GOUGES AS GIVEN IN SRM 51-70-03 IF YOU FIND FIBER DAMAGE OR DELAMINATION, THEN REPAIR AS A HOLE			
DENTS	UP TO 2.0 INCHES (50 mm) DIA WITH NO FIBER DAMAGE OR DELAMINATION, FILL WITH BMS 5-28, TYPE 7 POTTING COMPOUND AND PATCH AS GIVEN IN SRM 51-70-03, PAR. 5.L. C OVER 2.0 INCHES (50 mm) DIA OR WITH FIBER DAMAGE OR DELAMINATION, REPAIR AS A HOLE			

REPAIR DATA FOR 250°F CURE HONEYCOMB PANELS (ARAMID/GRAPHITE)
TABLE I

**Flap Track Fairing Skin Repairs
Figure 201 (Sheet 3 of 6)**



**757-200
STRUCTURAL REPAIR MANUAL**

DAMAGE	INTERIM REPAIRS B	PERMANENT REPAIRS		
	WET LAYUP 150°F (66°C) CURE (SRM 51-70-03)	WET LAYUP 200°F TO 230°F (93°C TO 110°C) CURE (SRM 51-70-17)	250°F (121°C) CURE (SRM 51-70-05)	350°F (177°C) CURE (SRM 51-70-04)
CRACKS	UP TO 3.0 INCHES (75 mm) LONG, REPAIR WITH PATCH AS GIVEN IN SRM 51-70-03, PAR. 5.N. A	CLEAN UP DAMAGE AND REPAIR AS A HOLE	CLEAN UP DAMAGE AND REPAIR AS A HOLE	CLEAN UP DAMAGE AND REPAIR AS A HOLE
HOLES	3.0 INCHES (75 mm) MAXIMUM DIA NOT TO EXCEED 30% OF SMALLEST DIMENSION ACROSS HONEYCOMB PANEL AT THE DAMAGE LOCATION. FILL WITH BMS 5-28, TYPE 7 POTTING COMPOUND AND PATCH AS GIVEN IN SRM 51-70-03, PAR. 5.N. A	12.0 INCHES (300 mm) MAXIMUM DIA NOT TO EXCEED 50% OF SMALLEST DIMENSION ACROSS HONEYCOMB PANEL AT THE DAMAGE LOCATION. USE TWO EXTRA PLIES FOR EACH FACESHEET REPAIRED C	6.0 INCHES (150 mm) MAXIMUM DIA NOT TO EXCEED 50% OF SMALLEST DIMENSION ACROSS HONEYCOMB PANEL AT THE DAMAGE LOCATION. USE TWO EXTRA PLIES FOR EACH FACESHEET REPAIRED C	NO SIZE LIMIT
DELAMINATION	CUT OUT AND REPAIR AS A HOLE			
NICKS AND GOUGES	IF THERE IS NO FIBER DAMAGE OR DELAMINATION, FILL NICKS OR GOUGES AS GIVEN IN SRM 51-70-03 IF YOU FIND FIBER DAMAGE OR DELAMINATION, THEN REPAIR AS A HOLE			
DENTS	UP TO 2.0 INCHES (50 mm) DIA WITH NO FIBER DAMAGE OR DELAMINATION, FILL WITH BMS 5-28, TYPE 7 POTTING COMPOUND AND PATCH AS GIVEN IN SRM 51-70-03, PAR. 5.L. C OVER 2.0 INCHES (50 mm) DIA OR WITH FIBER DAMAGE OR DELAMINATION, REPAIR AS A HOLE			

REPAIR DATA FOR 350°F CURE HONEYCOMB PANELS **D** (ARAMID/GRAPHITE/FIBERGLASS)
TABLE II

**Flap Track Fairing Skin Repairs
Figure 201 (Sheet 4 of 6)**

D634N201

57-53-70

REPAIR 1
Page 204
Jan 20/2005



757-200

STRUCTURAL REPAIR MANUAL

DAMAGE	INTERIM REPAIRS B	PERMANENT REPAIRS		
	WET LAYUP ROOM TEMP (SRM 51-70-06)	WET LAYUP 150°F (66°C) CURE (SRM 51-70-06)	WET LAYUP 200°F TO 230°F (93°C TO 110°C) CURE (SRM 51-70-17)	250°F (121°C) CURE (SRM 51-70-07)
CRACKS	UP TO 2.0 INCHES (50 mm) LONG, REPAIR WITH PATCH SRM 51-70-06, PAR. 5.N. A	CLEAN UP DAMAGE AND REPAIR AS A HOLE	CLEAN UP DAMAGE AND REPAIR AS A HOLE	CLEAN UP DAMAGE AND REPAIR AS A HOLE
HOLES AND PUNCTURES	4.0 INCHES (100 mm) MAXIMUM DIA NOT TO EXCEED 30% OF SMALLEST DIMENSION ACROSS HONEYCOMB PANEL AT THE DAMAGE LOCATION. FILL WITH BMS 5-28, TYPE 7 POTTING COMPOUND AND PATCH AS GIVEN IN SRM 51-70-06, PAR. 5.N. A	8.0 INCHES (200 mm) MAXIMUM DIA NOT TO EXCEED 50% OF SMALLEST DIMENSION ACROSS HONEYCOMB PANEL AT THE DAMAGE LOCATION. USE TWO EXTRA PLYS FOR EACH SIDE C	12.0 INCHES (300 mm) MAXIMUM DIA NOT TO EXCEED 50% OF SMALLEST DIMENSION ACROSS HONEYCOMB PANEL AT THE DAMAGE LOCATION. USE TWO EXTRA PLYS FOR EACH SIDE C	NO SIZE LIMIT
DELAMINATION	CUT OUT AND REPAIR AS A HOLE			
NICKS AND GOUGES	IF THERE IS NO FIBER DAMAGE OR DELAMINATION, FILL NICKS OR GOUGES AS GIVEN IN SRM 51-70-06 IF YOU FIND FIBER DAMAGE OR DELAMINATION, THEN REPAIR AS A HOLE			
DENTS	UP TO 2.0 (50 mm) INCHES DIA WITH NO FIBER DAMAGE OR DELAMINATION, FILL WITH BMS 5-28, TYPE 7 POTTING COMPOUND AND PATCH AS GIVEN IN SRM 51-70-06, PAR. 5.L. C OVER 2.0 (50 mm) INCHES DIA OR WITH FIBER DAMAGE OR DELAMINATION, REPAIR AS A HOLE			

REPAIR DATA FOR 250°F CURE HONEYCOMB PANELS (FIBERGLASS)
TABLE III

Flap Track Fairing Skin Repairs
Figure 201 (Sheet 5 of 6)

D634N201

57-53-70

REPAIR 1
Page 205
Jan 20/2005

**757-200
STRUCTURAL REPAIR MANUAL**

DAMAGE	INTERIM REPAIRS B	PERMANENT REPAIRS		
	WET LAYUP ROOM TEMP (SRM 51-70-06)	WET LAYUP 150°F (66°C) CURE (SRM 51-70-06)	WET LAYUP 200°F TO 230°F (93°C TO 110°C) CURE (SRM 51-70-17)	250°F (121°C) CURE (SRM 51-70-07)
CRACKS	FOR EDGE BAND, REFER TO F FOR LAMINATE, REFER TO G	CLEAN UP DAMAGE AND REPAIR AS A HOLE	CLEAN UP DAMAGE AND REPAIR AS A HOLE	CLEAN UP DAMAGE AND REPAIR AS A HOLE
HOLES AND PUNCTURES	2.0 INCHES (50 mm) MAXIMUM DIA NOT TO EXCEED 15% OF CROSS-SECTIONAL AREA OF LAMINATE OR EDGE BAND OR 10% OF THE EDGE BAND LENGTH FOR EACH SIDE. REPAIR AS GIVEN IN SRM 51-70-03 PAR. 5.G., 5.H., 5.I., OR 5.K. AS APPLICABLE A	5.0 INCHES (125 mm) MAXIMUM DIA NOT TO EXCEED 50% OF CROSS-SECTIONAL AREA OF LAMINATE OR EDGE BAND OR 25% OF THE EDGE BAND LENGTH FOR EACH SIDE. USE TWO EXTRA PLIES FOR EACH FACESHEET C	10.0 INCHES (250 mm) MAXIMUM DIA NOT TO EXCEED 50% OF CROSS-SECTIONAL AREA OF LAMINATE OR EDGE BAND OR 25% OF THE EDGE BAND LENGTH FOR EACH SIDE. USE TWO EXTRA PLIES FOR EACH FACESHEET	NO SIZE LIMIT
EDGE EROSION	_____	FOR DAMAGE THAT IS NOT LARGER THAN 35% OF THE EDGE BAND THICKNESS, REPAIR AS GIVEN IN SRM 51-70-06 PAR. 5.O. FOR LARGER DAMAGE, REPAIR AS GIVEN IN: SRM 51-70-06 PAR. 5.G. SRM 51-70-17 PAR. 4.G. SRM 51-70-07 PAR. 5.G.		
DELAMINATION	CUT OUT AND REPAIR AS A HOLE			
NICKS AND GOUGES	IF THERE IS NO FIBER DAMAGE OR DELAMINATION, FILL NICKS OR GOUGES AS GIVEN IN SRM 51-70-06 IF YOU FIND FIBER DAMAGE OR DELAMINATION EXISTS, REPAIR AS A HOLE			
DENTS	UP TO 2.0 INCHES (50 mm) DIA WITH NO FIBER DAMAGE OR DELAMINATION, FILL WITH BMS 5-28, TYPE 7 POTTING COMPOUND AND PATCH AS GIVEN IN SRM 51-70-06, PAR. 5.L. OVER 2.0 INCHES (50 mm) DIA OR WITH FIBER DAMAGE OR DELAMINATION, REPAIR AS A HOLE			

REPAIR DATA FOR 250°F CURE LAMINATES AND EDGE BANDS (FIBERGLASS)

TABLE IV

**Flap Track Fairing Skin Repairs
Figure 201 (Sheet 6 of 6)**



757-200
STRUCTURAL REPAIR MANUAL

IDENTIFICATION 1 - FLAP TRACK FAIRING STRUCTURE

REF DWG
113N1710
113N1730
113N1750

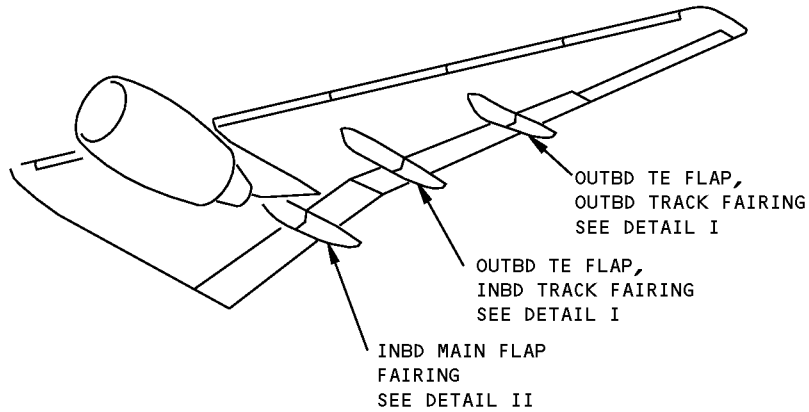

NOTES

A OPTIONAL FOR CUM LINE NUMBERS:
1 THRU 36

B OPTIONAL FOR CUM LINE NUMBERS:
1 THRU 16

C FOR CUM LINE NUMBERS:
1 THRU 52

D FOR CUM LINE NUMBERS:
53 AND ON

Flap Track Fairing Structure Identification
Figure 1 (Sheet 1 of 3)

**757-200
STRUCTURAL REPAIR MANUAL**

REF DWG
113N1710
113N1730

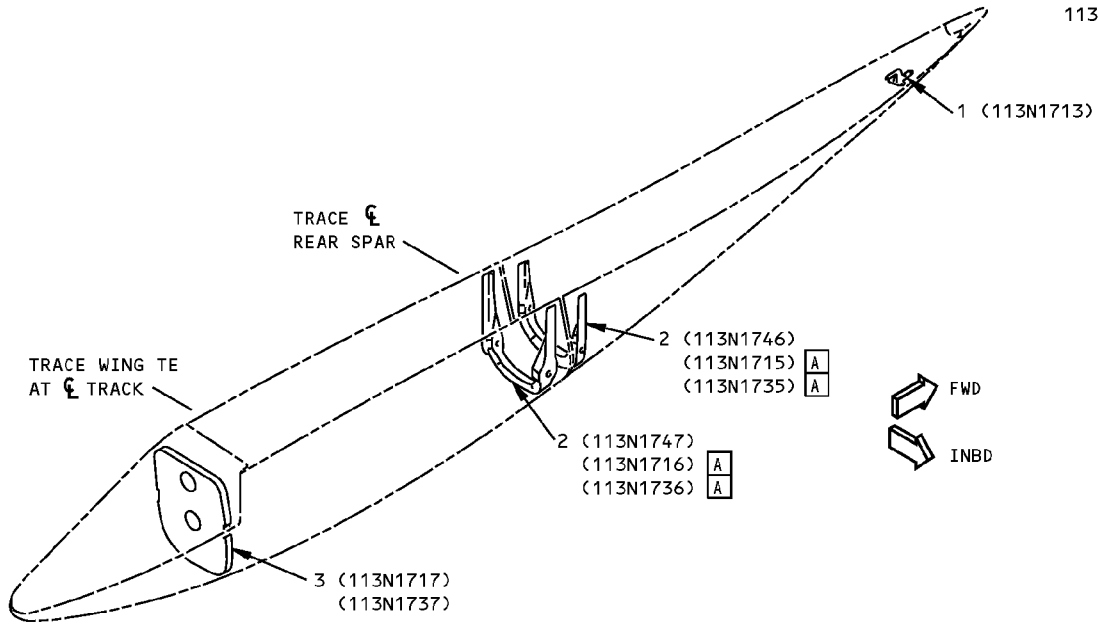

DETAIL I

REF DWG
113N1750

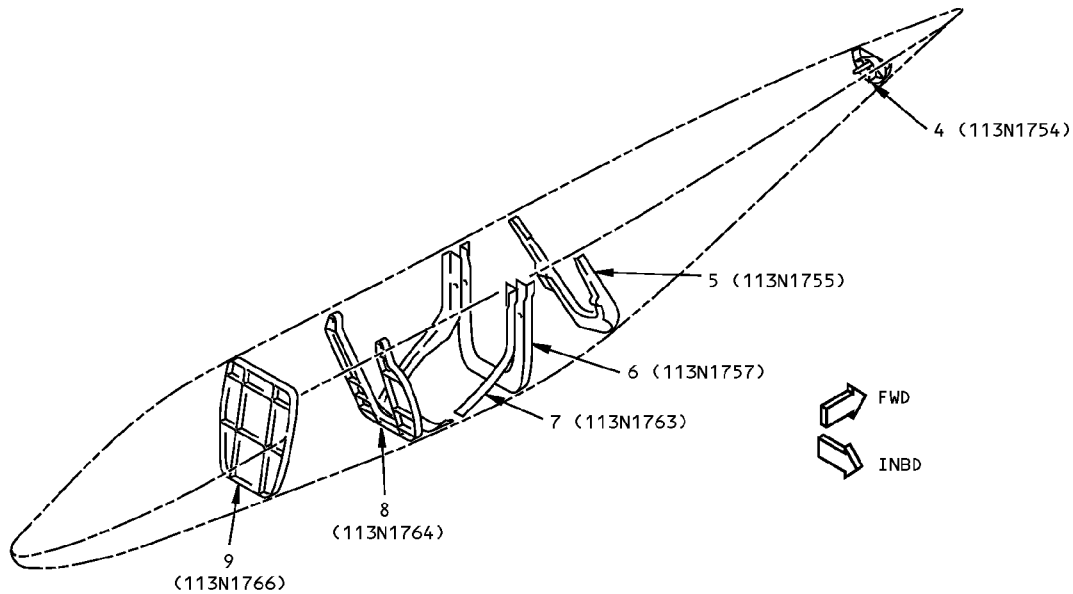

DETAIL II

LIST OF
MATERIAL

**Flap Track Fairing Structure Identification
Figure 1 (Sheet 2 of 3)**

IDENTIFICATION 1
Page 2
Jan 20/2005

57-53-71

D634N201



757-200
STRUCTURAL REPAIR MANUAL

ITEM	DESCRIPTION	GAGE	MATERIAL	EFFECTIVITY
1	FITTING		15-5 PH CRES HT TR TO 180-200 KSI	
2	FRAME		7075-T73 DIE FORGING 7075-T73 FORGED BLOCK	A
3	BULKHEAD		7075-T73 FORGED BLOCK	
4	FRAME		7075-T7351 MACHINED PLATE 7075-T73 DIE FORGING	C D
5	FRAME		7075-T7351 MACHINED PLATE 7075-T73 DIE FORGING	C D
6	FRAME		7075-T7351 MACHINED PLATE 7075-T73 DIE FORGING	C D
7	FRAME	0.063	CLAD 2024-T42	
8	FRAME		7075-T73 DIE FORGING 7075-T7351 MACHINED PLATE	B
9	BULKHEAD		7075-T7351 MACHINED PLATE	

LIST OF MATERIALS FOR DETAILS I AND II

Flap Track Fairing Structure Identification
Figure 1 (Sheet 3 of 3)

D634N201

57-53-71

IDENTIFICATION 1
Page 3
Jan 20/2005

**757-200
STRUCTURAL REPAIR MANUAL**

ALLOWABLE DAMAGE 1 - FLAP TRACK FAIRING STRUCTURE

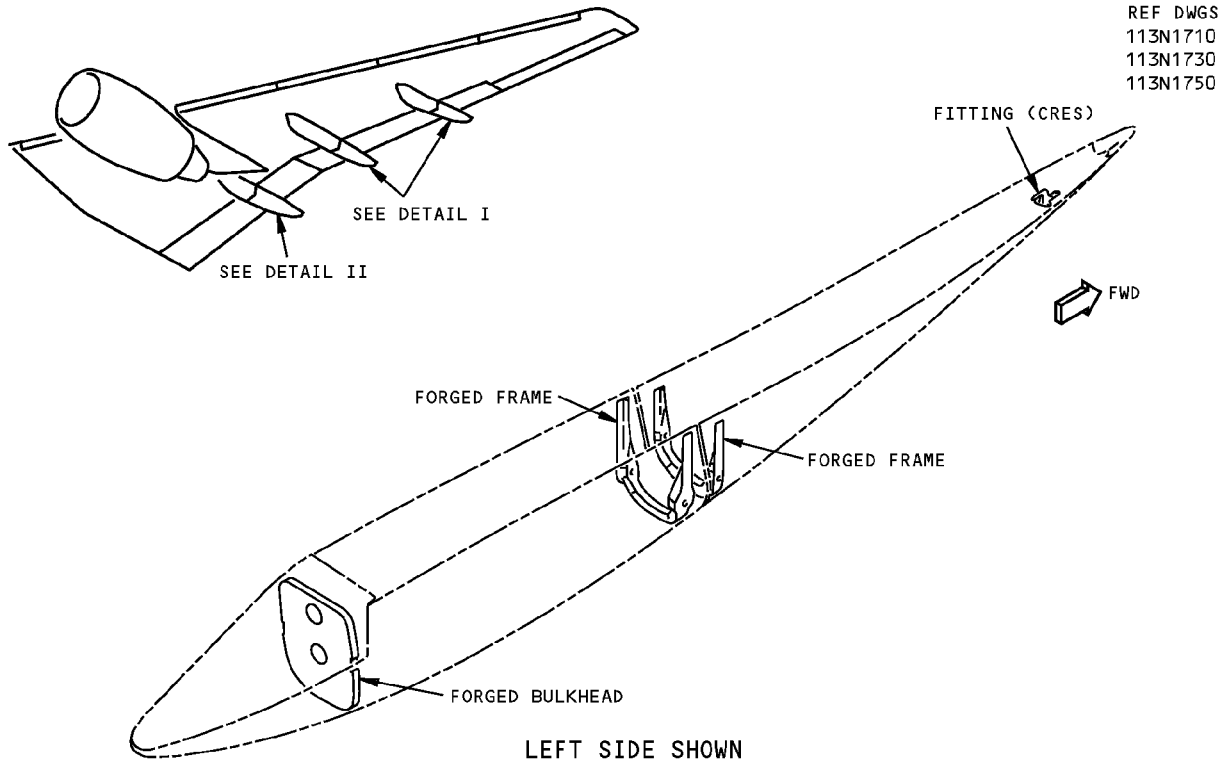

LEFT SIDE SHOWN
RIGHT SIDE OPPOSITE
DETAIL I

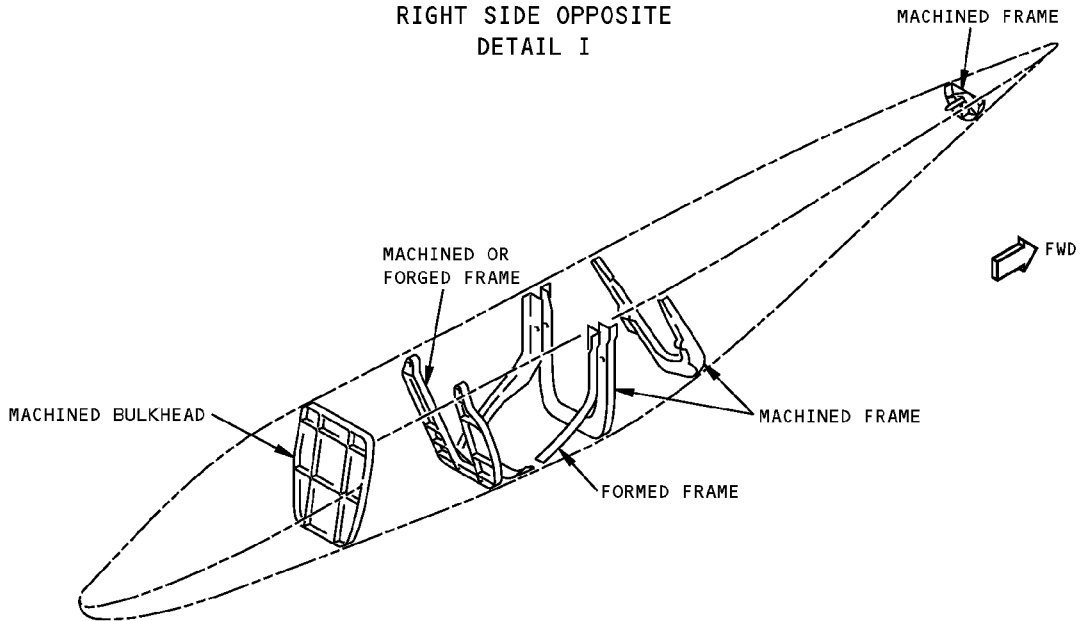

MATERIAL: ALUMINUM, EXCEPT AS NOTED

LEFT SIDE SHOWN
RIGHT SIDE OPPOSITE
DETAIL II

**Flap Track Fairing Structure Allowable Damage
Figure 101 (Sheet 1 of 4)**



**757-200
STRUCTURAL REPAIR MANUAL**

DESCRIPTION	CRACKS	NICKS, GOUGES AND CORROSION	DENTS	HOLES AND PUNCTURES
FRAMES				
FORMED	A	C	SEE DETAIL V	NOT ALLOWED
MACHINED E	B	D	NOT ALLOWED	NOT ALLOWED
FORGED E	B	D	NOT ALLOWED	NOT ALLOWED
BULKHEADS				
MACHINED E	B	D	NOT ALLOWED	NOT ALLOWED
FORGED E	B	D	NOT ALLOWED	NOT ALLOWED
FITTING E	B	D	NOT ALLOWED	NOT ALLOWED

NOTES

- REFINISH REWORKED AREAS AS GIVEN IN AMM 51-20
- REFER TO SRM 51-10-02 FOR INSPECTION AND REMOVAL OF DAMAGE

- A CRACKS NOT ALLOWED EXCEPT FOR EDGE CRACKS WHICH MUST BE REMOVED PER DETAILS III AND VII.
- B CRACKS NOT ALLOWED EXCEPT FOR EDGE CRACKS WHICH MUST BE REMOVED PER DETAILS III AND VIII.
- C REMOVE DAMAGE PER DETAILS III, IV, VI AND VII.
- D REMOVE DAMAGE PER DETAILS III, IV, VI AND VIII.
- E SHOT PEEN REWORKED AREAS PER SRM 51-20-06.

**Flap Track Fairing Structure Allowable Damage
Figure 101 (Sheet 2 of 4)**

**757-200
STRUCTURAL REPAIR MANUAL**

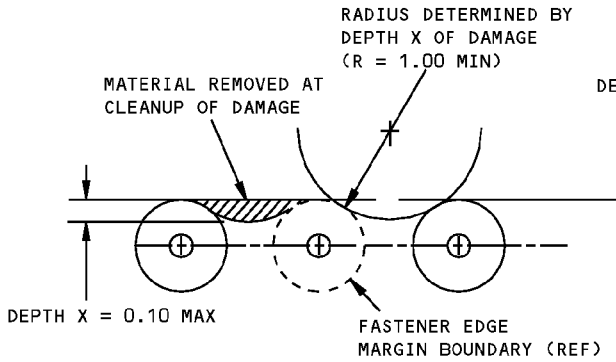

DAMAGE CLEANUP OF EDGES WHERE FASTENER EDGE MARGINS DO NOT OVERLAP

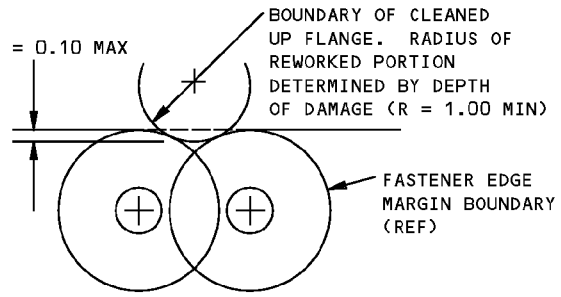

DAMAGE CLEANUP OF EDGES WHERE FASTENER EDGE MARGINS OVERLAP

DETAIL III

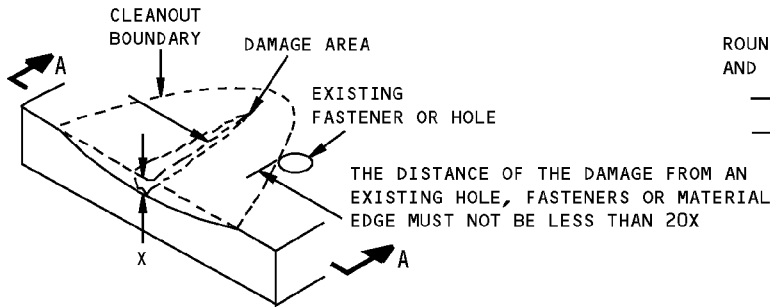

**REMOVAL OF NICK, GOUGE AND SCRATCH DAMAGE ON A SURFACE
DETAIL IV**

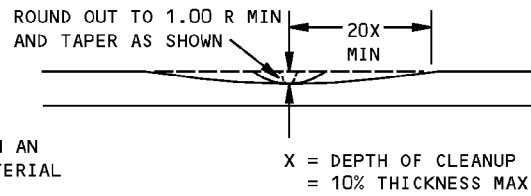

SECTION A-A

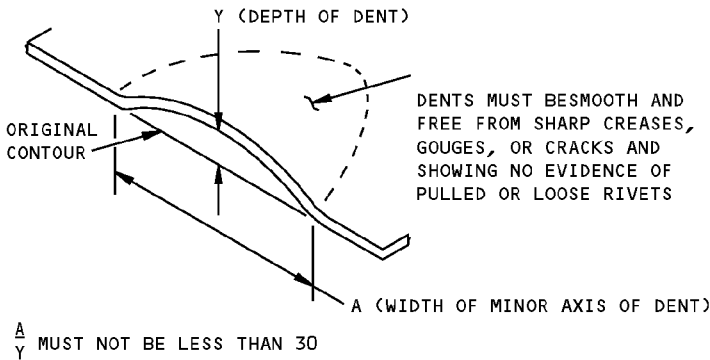

**ALLOWABLE DAMAGE FOR DENT
DETAIL V**

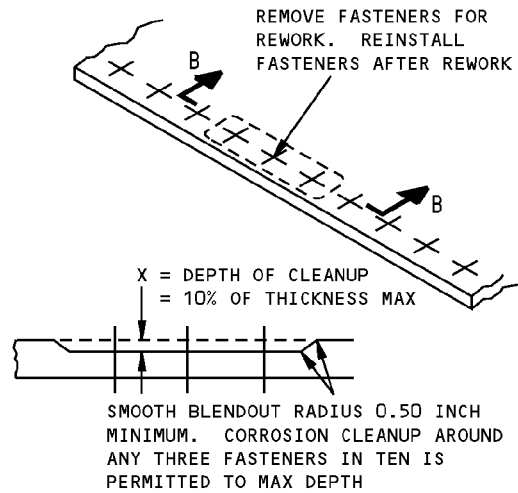

SECTION B-B

**CORROSION CLEANUP
DETAIL VI**

**Flap Track Fairing Structure Allowable Damage
Figure 101 (Sheet 3 of 4)**

**757-200
STRUCTURAL REPAIR MANUAL**

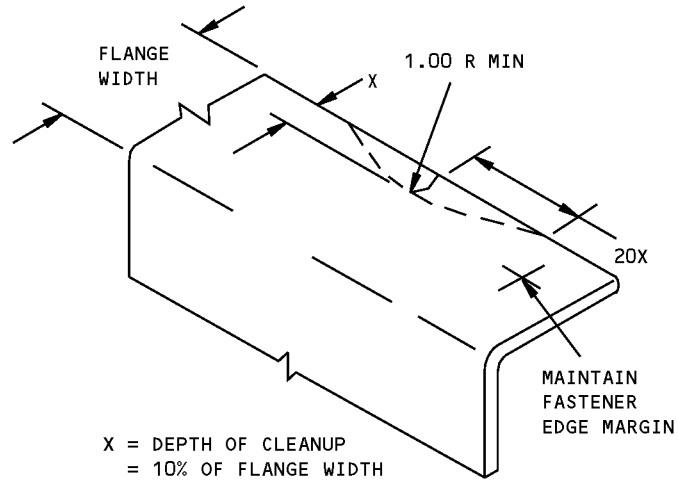

**REMOVAL OF NICK OR CRACK
DAMAGE ON AN EDGE
DETAIL VII**

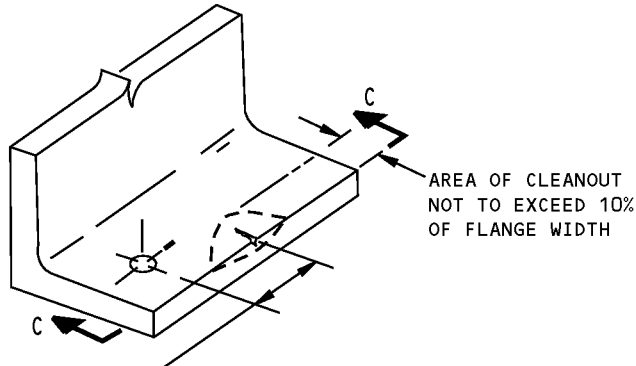

THE DISTANCE OF THE DAMAGE FROM AN EXISTING HOLE, FASTENERS OR MATERIAL EDGE MUST NOT BE LESS THAN 20X

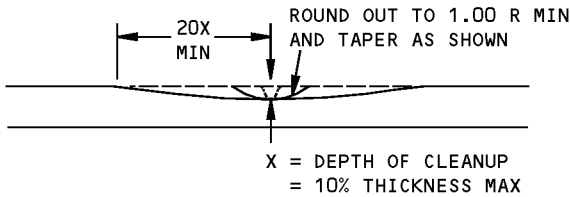

**SECTION C-C
REMOVAL OF NICK OR CRACK
DAMAGE ON AN EDGE
DETAIL VIII**

**Flap Track Fairing Structure Allowable Damage
Figure 101 (Sheet 4 of 4)**

**757-200
STRUCTURAL REPAIR MANUAL**

IDENTIFICATION GENERAL - FLAP TRACK FAIRING FITTING

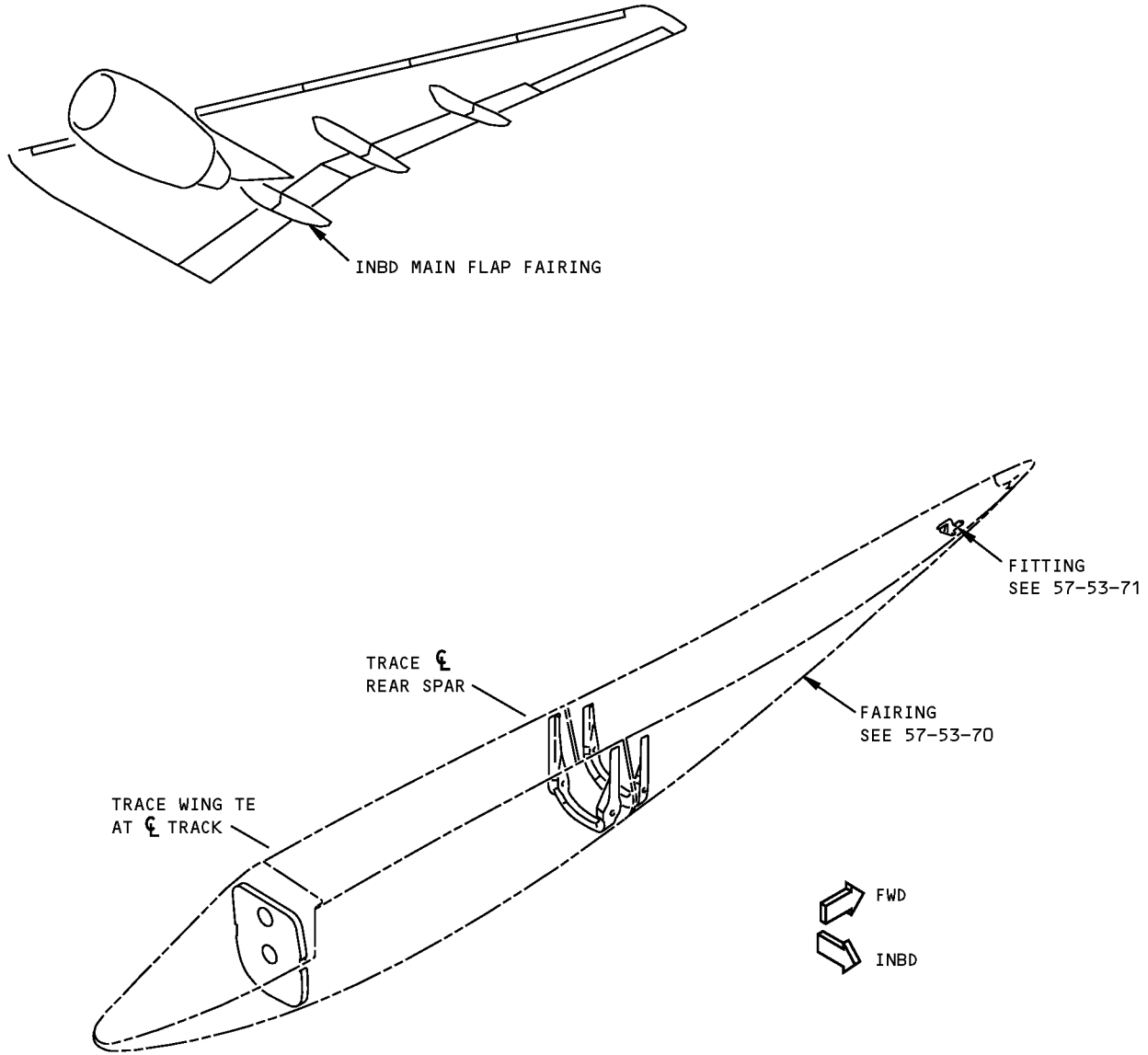

**Flap Track Fairing Fitting Identification
Figure 1**

**757-200
STRUCTURAL REPAIR MANUAL**

ALLOWABLE DAMAGE 1 - FLAP TRACK FAIRING FITTING

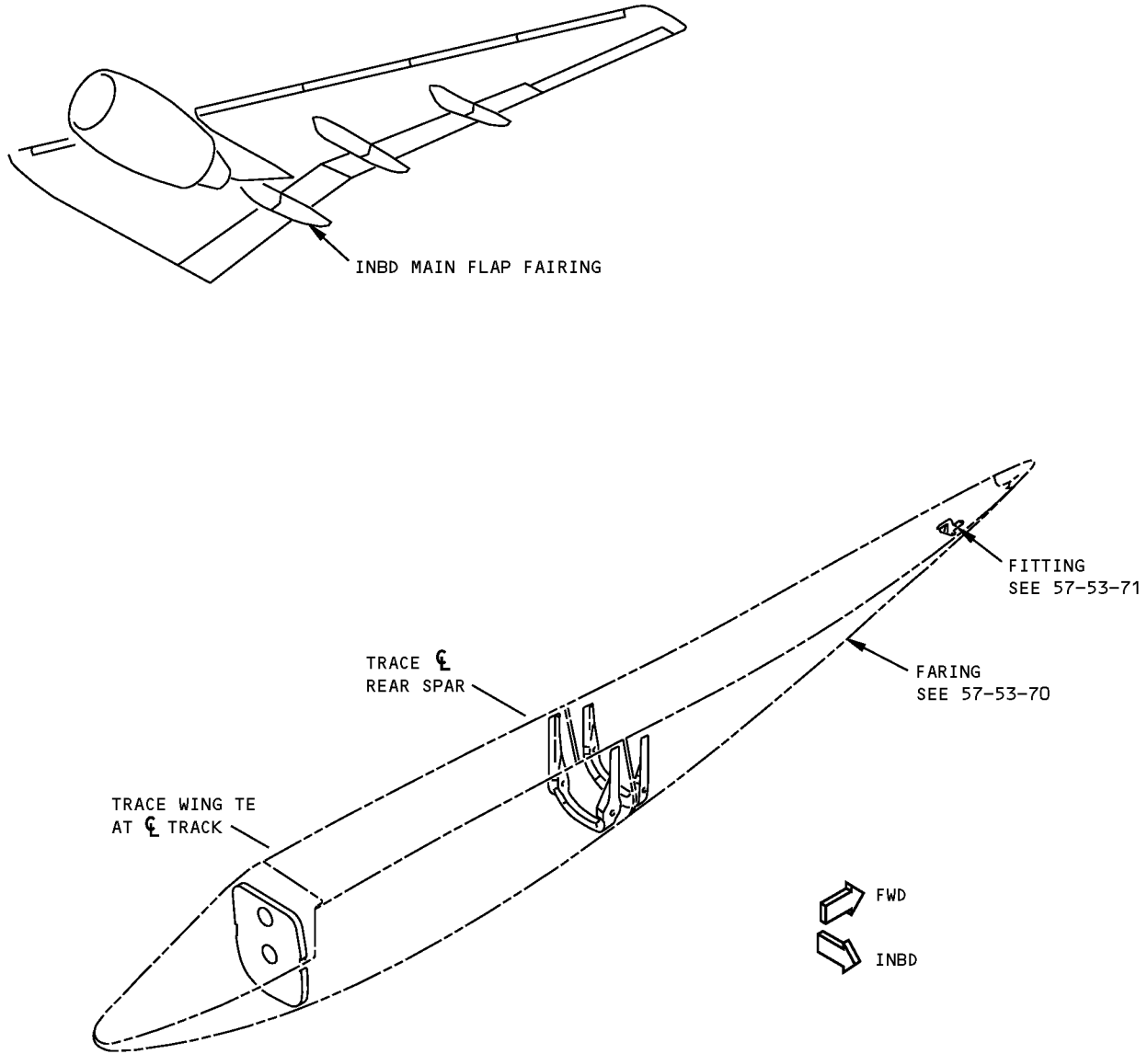

**Flap Track Fairing Fitting Allowable Damage
Figure 101**

D634N201

57-53-90
ALLOWABLE DAMAGE 1
Page 101
Jan 20/2005

757-200
STRUCTURAL REPAIR MANUAL

REPAIR GENERAL - FLAP TRACK FAIRING ATTACHMENT FITTINGS REPAIR

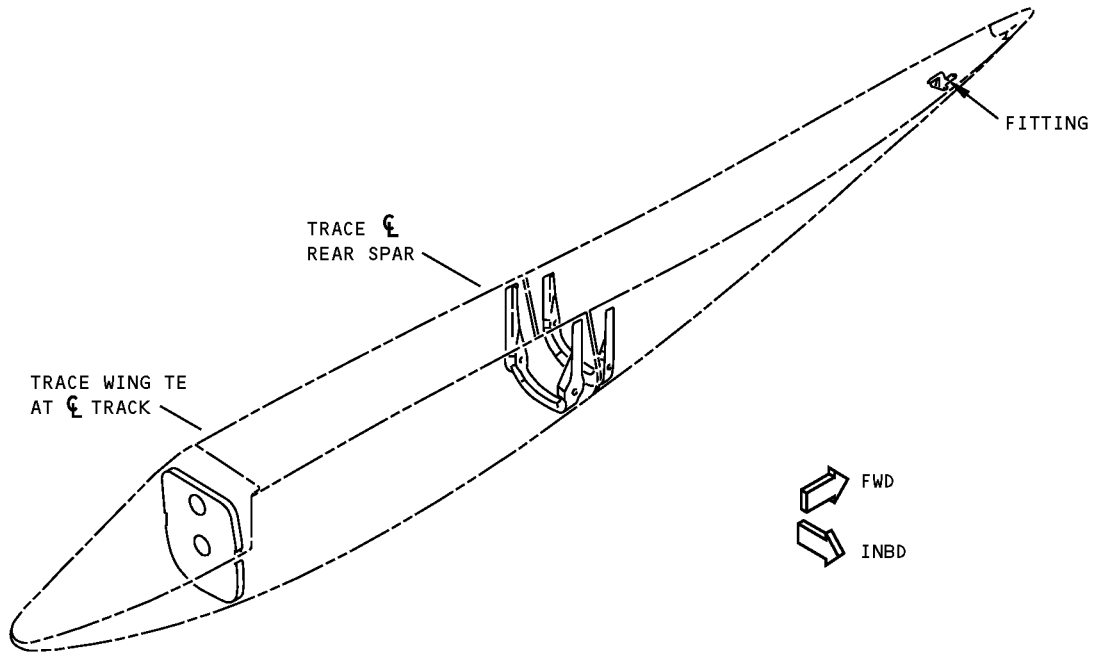
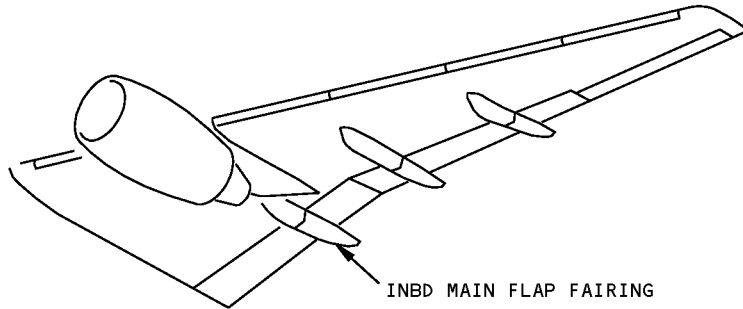

NOTES

- SEE 57-53-71 FOR STRUCTURE IDENTIFICATION AND ALLOWABLE DAMAGE INFORMATION
- NO TYPICAL REPAIR TO FITTINGS APPLICABLE. SPECIFIC REPAIRS TO FITTINGS WILL BE PROVIDED BASED ON SERVICE EXPERIENCE

Flap Track Fairing Attachment Fittings Repair
Figure 201

D634N201

57-53-90

REPAIR GENERAL
Page 201
Jan 20/2005

757-200
STRUCTURAL REPAIR MANUAL

IDENTIFICATION 1 - AILERON SKIN

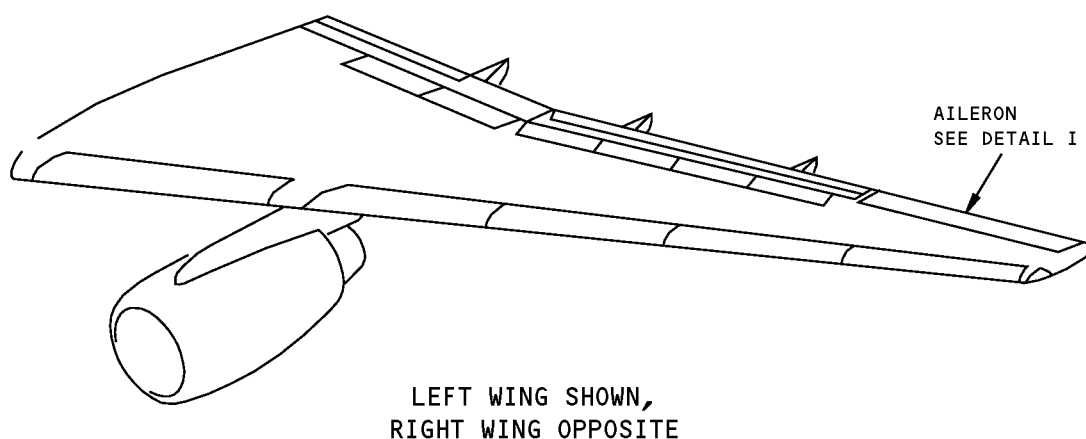

NOTES

- A** PLY ORIENTATION CONVENTION, DEGREES INDICATED, IS PARALLEL TO THE FABRIC WARP DIRECTION
- B** GRAPHITE/EPOXY FABRIC PER BMS 8-212, TYPE IV, CLASS 2, STYLE 3K-70-PW, 350°F (177°C) CURE
- C** MATERIAL AND PLY ORIENTATION SHOWN FOR FIELD AREAS ONLY. SEE BOEING DRAWINGS FOR EDGE BANDS AND AREAS WITH DOUBLERS
- D** FOR AIRPLANES WITH CUM LINE NUMBERS 169 AND ON OR AIRPLANES WITH SB 51-0006 INCORPORATED

**Aileron Skin Identification
Figure 1 (Sheet 1 of 3)**

**757-200
STRUCTURAL REPAIR MANUAL**

REF DWG
113N7100

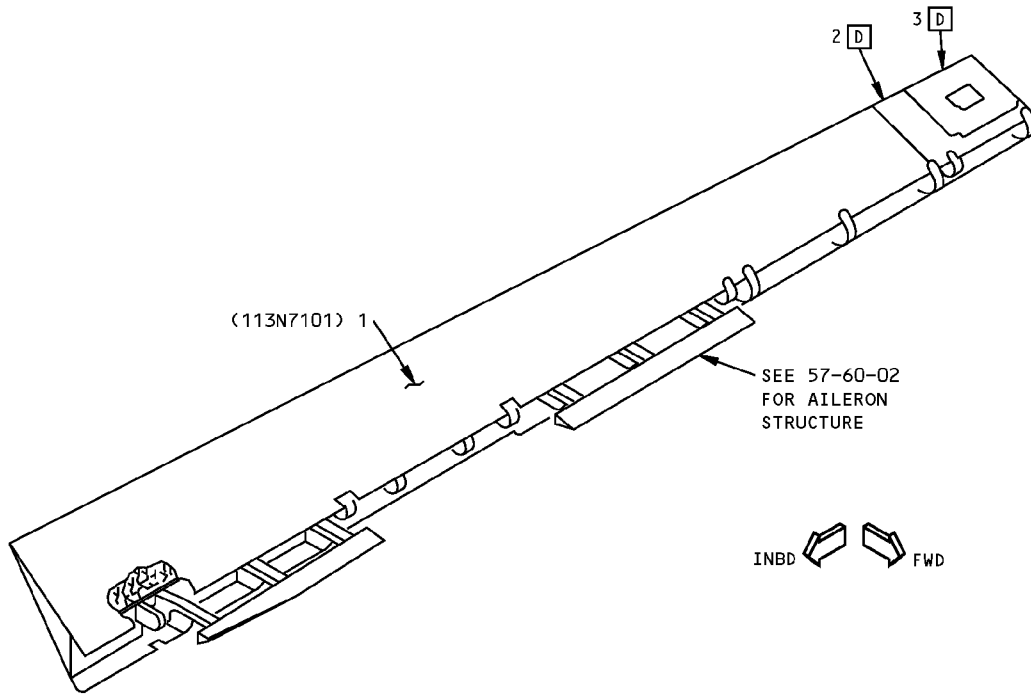

DETAIL I

ITEM	DESCRIPTION	GAGE	MATERIAL	EFFECTIVITY
1	SKIN PANELS SKIN CORE	5.0	GRAPHITE/EPOXY HONEYCOMB SANDWICH SEE DETAIL II NONMETALLIC HONEYCOMB PER BMS 8-124 CLASS 4, TYPE V, GRADE 3.0	
2	FIBERGLASS ISOLATION PLY		FIBERGLASS WOVEN CLOTH STYLE 120 PER BMS 9-3, TYPE 0	D
3	CONDUCTIVE FRAME	0.020	6061-T4	D

LIST OF MATERIALS FOR DETAIL I

**Aileron Skin Identification
Figure 1 (Sheet 2 of 3)**

IDENTIFICATION 1
Page 2
Jan 20/2005

57-60-01

D634N201

**757-200
STRUCTURAL REPAIR MANUAL**

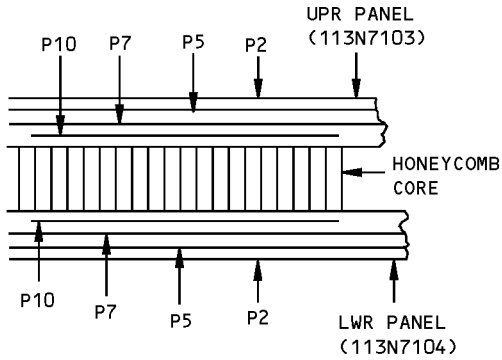

ITEM NO.	PLY NO.	MATERIAL	PLY ORIENTATION A
1	P2	B	±45°
	P5	B	±45°
	P7	B	±45°
	P10	B	±45°

PLY TABLE C

SECTION THRU HONEYCOMB PANEL

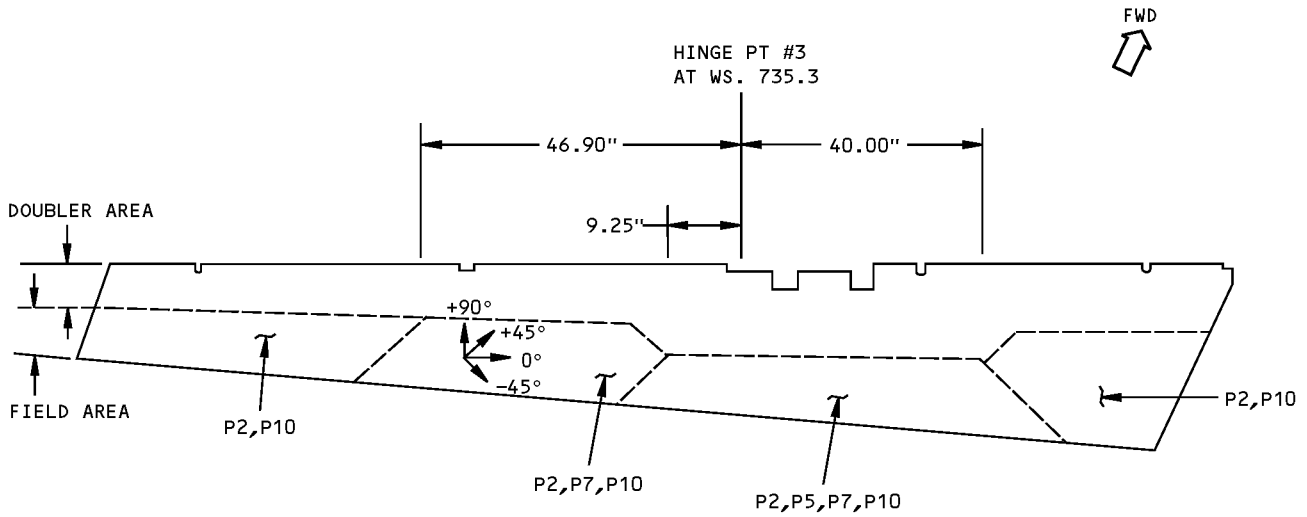

PLY LAYUP DIAGRAM
SEE PLY TABLE FOR MATERIAL AND ORIENTATION

DETAIL II

**Aileron Skin Identification
Figure 1 (Sheet 3 of 3)**

IDENTIFICATION 1
Page 3
Jan 20/2005

57-60-01

D634N201

**757-200
STRUCTURAL REPAIR MANUAL**

ALLOWABLE DAMAGE 1 - AILERON SKIN

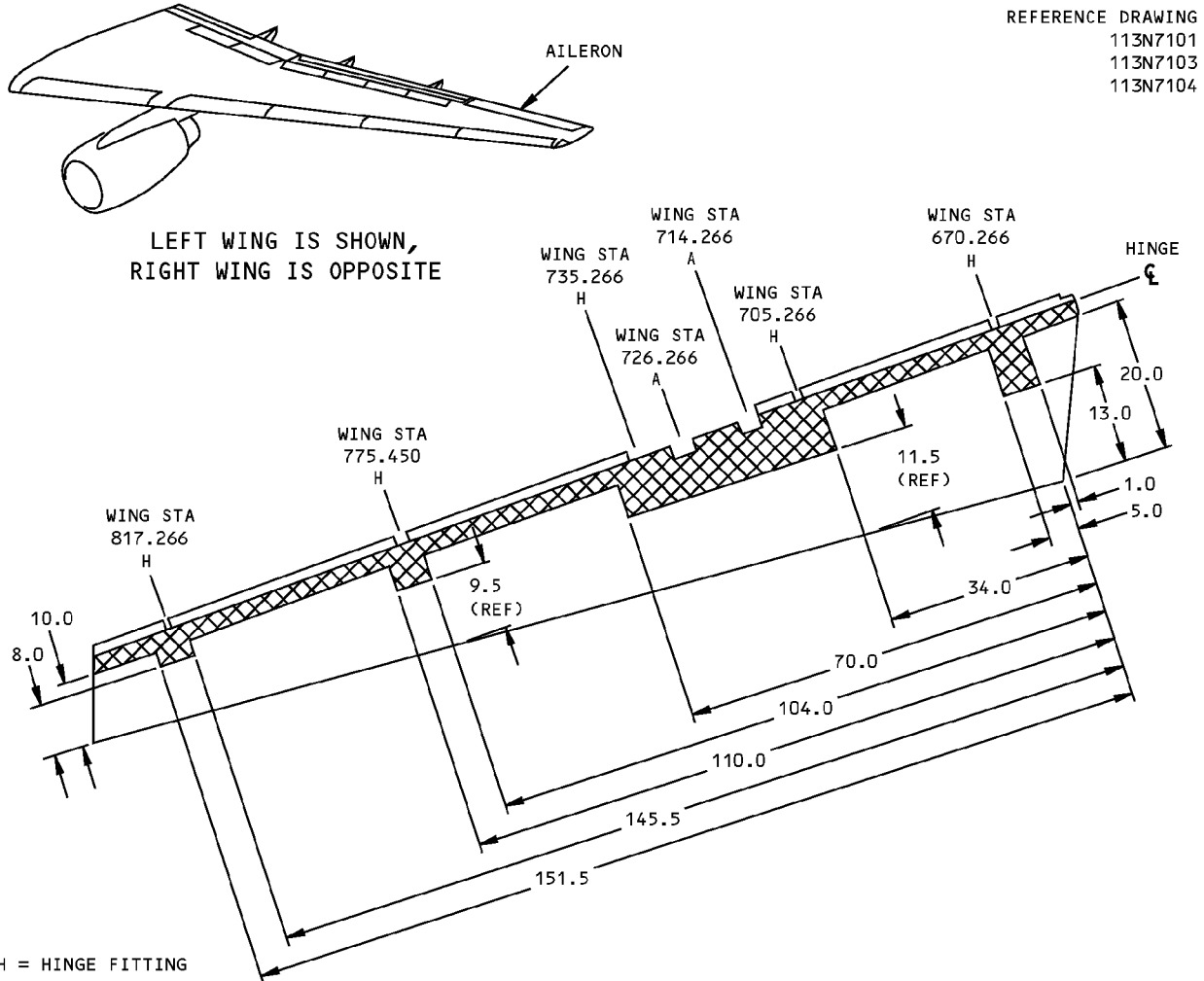

H = HINGE FITTING
A = ACTUATOR FITTING

NON-CRITICAL AREA
SEE TABLE I FOR THE REPAIR DATA.

CRITICAL AREA
SEE TABLE II FOR THE REPAIR DATA.

MATERIAL:
GRAPHITE/EPOXY SKIN WITH
NONMETALLIC HONEYCOMB CORE

UPPER PANEL IS SHOWN
(LOWER PANEL IS ALMOST THE SAME)

DESCRIPTION	CRACKS	NICKS, GOUGES AND CORROSION	DENTS	HOLES AND PUNCTURES	DELAMINA- TION	EDGE EROSION
SKIN PANEL NON-CRITICAL AREA	A	B	C	A	A	SEE DETAIL III
CRITICAL AREA	F	B F	C	F	F	SEE DETAIL III

TABLE I

**Aileron Skin Allowable Damage
Figure 101 (Sheet 1 of 4)**

STRUCTURAL REPAIR MANUAL

NOTES

- REFINISH REWORKED AREAS AS GIVEN IN AMM 51-20.
- REFER TO SRM 51-10-01 FOR AERODYNAMIC SMOOTHNESS REQUIREMENTS. WHERE DAMAGE EXCEEDS THE LIMITS SHOWN IN SRM 51-10-01, CONSIDERATION SHOULD BE GIVEN TO LOSS OF PERFORMANCE INVOLVED.
- REFER TO SRM 51-10-02 FOR INSPECTION AND REMOVAL OF DAMAGE **E**
- THE AILERON IS A BALANCED CATEGORY I CONTROL SURFACE. REFER TO SRM 51-60-01 FOR AILERON BALANCING PROCEDURES.

A DAMAGE TO THE EDGES OF THE SKIN PANEL CAN CAUSE FIBER DAMAGE AND A DECREASE IN CROSS-SECTIONAL AREA. REMOVE EDGE DAMAGE AS SHOWN IN DETAILS I AND II.

DAMAGE IS PERMITTED ONLY ON ONE SURFACE OF HONEYCOMB CORE TO A TOTAL MAXIMUM DIMENSION (D) OF 2.0 INCHES (50 mm) FOR EACH SQUARE FOOT OF AREA.

A DAMAGE SITE MUST BE:

- A MINIMUM OF 3D (EDGE TO EDGE) FROM ANOTHER DAMAGE SITE. SEE DETAIL IV FOR DAMAGE SITE SPECIFICATIONS
- A MINIMUM OF 3D (EDGE TO EDGE) FROM A HOLE OR THE EDGE OF THE MATERIAL.

DAMAGE IS NOT PERMITTED:

- FOR MORE THAN ONE FASTENER HOLE IN SIX ON MORE THAN ONE 10% OF THE LENGTH OF THE EDGE BAND ON A SIDE.

PROTECT DAMAGE THAT IS NOT REWORKED AS GIVEN IN NOTE **D**.

B DAMAGE IS ALLOWED ON THE SURFACE RESIN ONLY WITH NO FIBER DAMAGE. CLEAN UP EDGE DAMAGE AS SHOWN IN DETAILS I AND II. FIBER DAMAGE MUST BE TREATED AS A HOLE OR PUNCTURE DAMAGE.

C DENTS RESULT IN DELAMINATION AND FIBER DAMAGE AND MUST BE TREATED AS A HOLE OR PUNCTURE DAMAGE.

D REMOVE MOISTURE FROM DAMAGE AREA. USE OF VACUUM AND HEAT (MAX OF 125°F) (52°C) TO REMOVE MOISTURE FROM HONEYCOMB CELLS IS RECOMMENDED. PROTECT DAMAGE FROM ENTRANCE OF WATER, SUNLIGHT OR OTHER FOREIGN MATTER BY SEALING WITH ALUMINUM FOIL TAPE (SPEED TAPE). RECORD THE LOCATION AND INSPECT EVERY AIRPLANE "A" CHECK. REPLACE THE ALUMINUM FOIL TAPE IF ANY PEELING OR DETE-RIORATION IS EVIDENT. REPAIR NO LATER THAN NEXT AIRPLANE "C" CHECK. **E**

E THESE ALLOWABLE DAMAGE LIMITS HAVE FAA APPROVAL CONTINGENT ON ACCOMPLISHMENT OF THE INSPECTIONS CONTAINED HEREIN.

F DAMAGE TO THE EDGES OF THE SKIN PANEL CAN CAUSE FIBER DAMAGE AND A DECREASE IN CROSS-SECTIONAL AREA. REMOVE EDGE DAMAGE AS SHOWN IN DETAILS I AND II.

DAMAGE IS PERMITTED ONLY ON ONE SURFACE OF HONEYCOMB CORE TO A TOTAL MAXIMUM DIMENSION (D) OF 0.25 INCH (6 mm) FOR EACH SQUARE FOOT OF AREA.

A DAMAGE SITE MUST BE:

- A MINIMUM OF 3D (EDGE TO EDGE) FROM ANOTHER DAMAGE SITE. SEE DETAIL IV FOR DAMAGE SITE SPECIFICATIONS
- A MINIMUM OF 3D (EDGE TO EDGE) FROM A HOLE OR THE EDGE OF THE MATERIAL.

DAMAGE IS NOT PERMITTED:

- FOR MORE THAN ONE FASTENER HOLE IN TEN
- ON MORE THAN 10% OF THE LENGTH OF THE EDGE BAND ON A SIDE
- FOR MORE THAN ONE ATTACHMENT BOLT ON AN ACTUATOR HINGE OR A BALANCE WEIGHT FITTING. THERE MUST BE NO DAMAGE TO ADJACENT FITTINGS OR ATTACHMENTS.

REPAIR THE AREA BY 300 FLIGHT HOURS.

PROTECT DAMAGE THAT IS NOT REWORKED AS GIVEN IN NOTE **D**.

**Aileron Skin Allowable Damage
Figure 101 (Sheet 2 of 4)**

**757-200
STRUCTURAL REPAIR MANUAL**

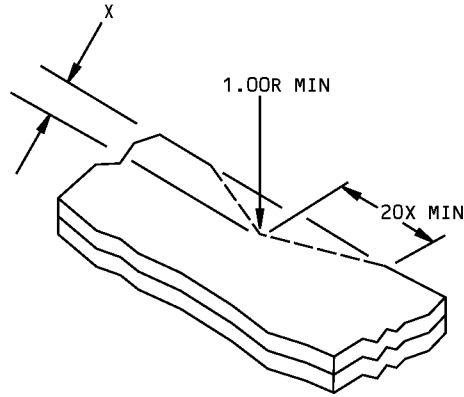

X = DEPTH OF CLEANUP = 0.10 MAX

DETAIL I

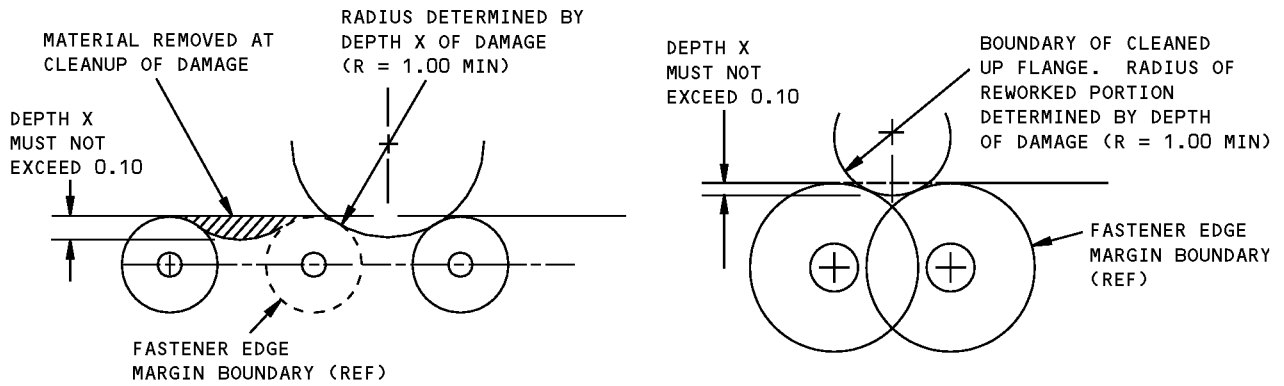

DAMAGE CLEANUP OF EDGES WHERE FASTENER EDGE MARGINS DO NOT OVERLAP

DAMAGE CLEANUP OF EDGES WHERE FASTENER EDGE MARGINS OVERLAP

DETAIL II

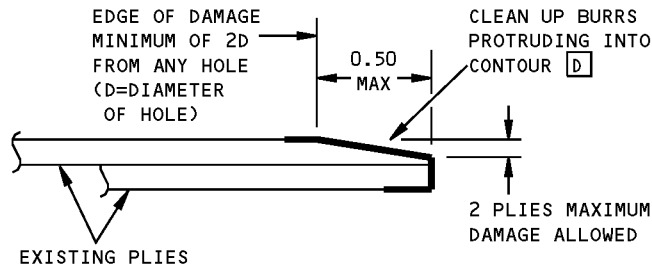

**DAMAGE CLEANUP AND SEALING
OF EDGE EROSION
DETAIL III**

**Aileron Skin Allowable Damage
Figure 101 (Sheet 3 of 4)**

**757-200
STRUCTURAL REPAIR MANUAL**

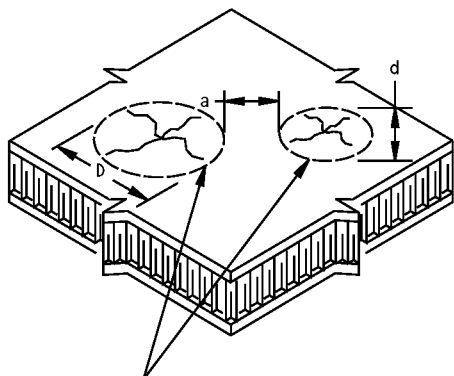

ADJACENT DAMAGE SITES ON SURFACE OF COMPOSITE PANEL

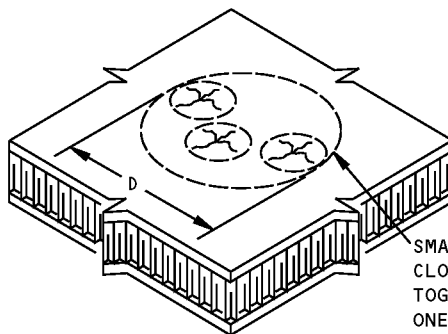

SMALL DAMAGE SITES THAT ARE CLOSELY SPACED MAY BE GROUPED TOGETHER AND CONSIDERED AS ONE DAMAGE SITE

- DAMAGE TO COMPOSITE PANELS EXPOSED TO MULTIPLE IMPACTS, I.E., HAIL DAMAGE, CAN BE DETECTED BY USING INSTRUMENTED NON-DESTRUCTIVE INSPECTION METHODS OR BY TAPPING THE SUSPECTED DAMAGE AREA WITH A SMALL METALLIC DISK OBJECT. INSPECTION SHOULD COVER THE AREA WITHIN 3 DIAMETERS AROUND THE EDGE OF THE VISIBLE DAMAGE SITE. FOR TAP TEST, USE A SOLID METAL DISK AND TAP THE DAMAGE AREA LIGHTLY BUT FIRMLY. VOID AREAS SHOULD PRODUCE A DULL SOUND AS OPPOSED TO A SHARP RING ON A SOLID BONDED AREA.
- DAMAGE SITE IS ANY SINGLE AREA OF A PANEL WHERE A DENT, CRACK, DELAMINATION, PUNCTURE OR ANY COMBINATION OF THESE EXIST. SMALL DAMAGE SITES THAT ARE CLOSELY SPACED MAY BE GROUPED TOGETHER AND CONSIDERED AS ONE DAMAGE SITE.
- "D" IS DETERMINED BY MEASURING THE MAXIMUM DIMENSION OF A DENT, CRACK, OR OTHER DAMAGE, WHICHEVER IS GREATER.
- "a" IS THE DISTANCE BETWEEN TWO ADJACENT DAMAGE SITES.
- "d" IS THE DIAMETER OF THE SMALLER OF TWO ADJACENT DAMAGE SITES.
- CALCULATE a/D BY DIVIDING DISTANCE "a" BY DIAMETER "D".
- DAMAGE IS ALLOWED WHEN "D" IS EQUAL TO OR LESS THAN THE MAXIMUM ALLOWABLE "D" FROM TABLE I.

**DAMAGE SIZING AND SPACING DATA
FOR COMPOSITE PANELS
DETAIL IV**

**Aileron Skin Allowable Damage
Figure 101 (Sheet 4 of 4)**

**757-200
STRUCTURAL REPAIR MANUAL**

REPAIR 1 - AILERON SKIN REPAIRS

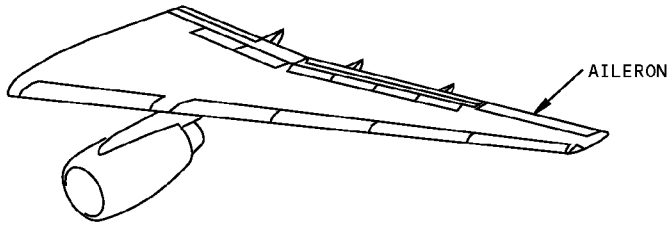

REFERENCE DRAWING
113N7101
113N7103
113N7104

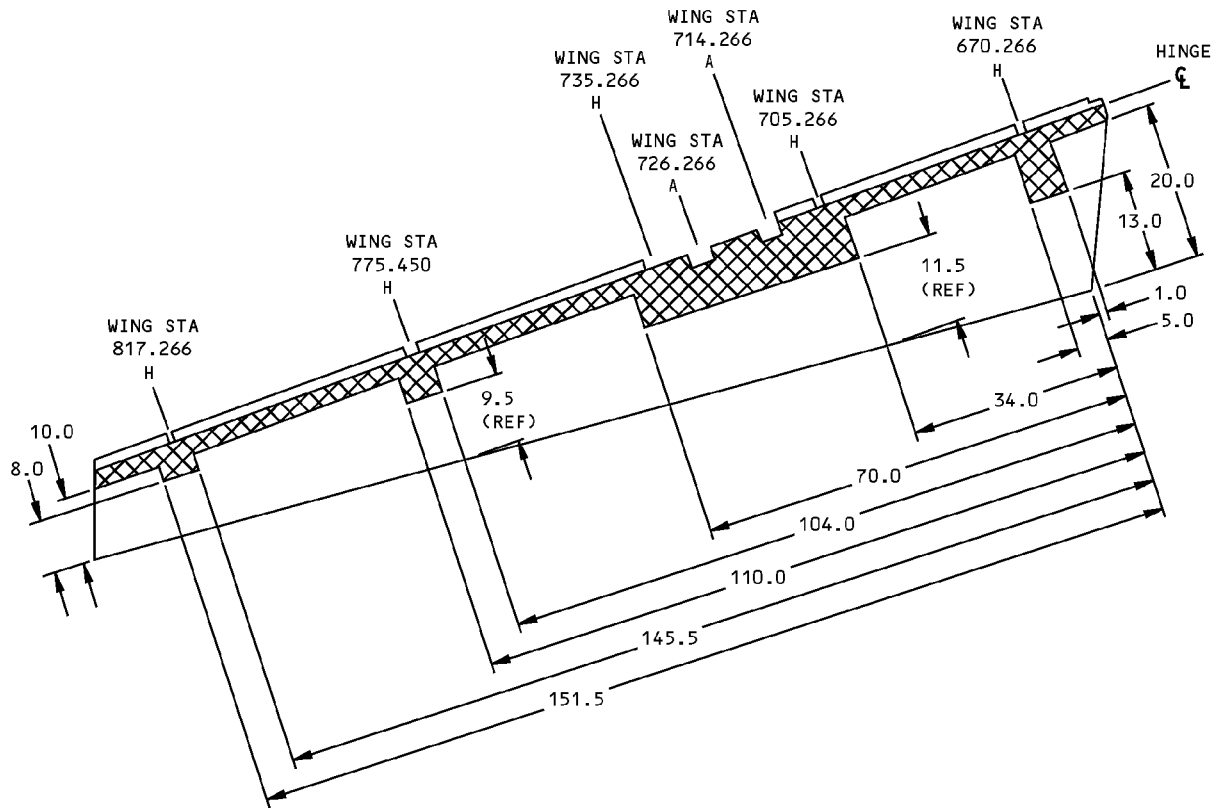

LEFT WING IS SHOWN,
RIGHT WING IS OPPOSITE



H = HINGE FITTING
A = ACTUATOR FITTING

 NON-CRITICAL AREA
SEE TABLE I FOR THE REPAIR DATA.
 CRITICAL AREA
SEE TABLE II FOR THE REPAIR DATA.

MATERIAL:
GRAPHITE/EPOXY SKIN WITH
NONMETALLIC HONEYCOMB CORE

UPPER PANEL IS SHOWN
(LOWER PANEL IS ALMOST THE SAME)

**Aileron Skin Repairs
Figure 201 (Sheet 1 of 3)**

STRUCTURAL REPAIR MANUAL

NOTES

- WHEN YOU USE THIS REPAIR, REFER TO:
 - AMM 51-21-01 FOR APPLICATION OF FINISHES
 - SRM 51-10-01, FOR AERODYNAMIC SMOOTHNESS REQUIREMENTS. WHERE THE DAMAGE IS MORE THAN THE LIMITS GIVEN IN SRM 51-10-01, THOUGHT SHOULD BE GIVEN TO THE LOSS OF PERFORMANCE THAT MAY OCCUR
 - SRM 51-10-02 FOR INSPECTION AND REMOVAL OF DAMAGE.
- THE ALILERON IS A BALANCED CATEGORY I CONTROL SURFACE. REFER TO SRM 51-60-01 FORAILERON BALANCING PROCEDURES.

A LIMITED TO REPAIR OF DAMAGE TO ONE FACESHEET SKIN AND HONEYCOMB CORE. ONE REPAIR FOR EACH SQUARE FOOT OF AREA AND MINIMUM OF 6.0 INCHES (150 mm) (EDGE TO EDGE) FROM ANY OTHER DAMAGE, FASTENER HOLE, OR EDGE OF PANEL.

B INSPECT INTERIM REPAIR USING INSTRUMENTED NDT METHODS OR "TAP" TEST EVERY AIRPLANE "2A" CHECK. FOR "TAP" TEST, USE A SOLID METAL DISK AND TAP THE REPAIR AREA LIGHTLY BUT FIRMLY. VOID AREAS WILL PRODUCE A DULL SOUND AS OPPOSED TO A SHARP RING ON A SOLID BONDED AREA. PERMANENT REPAIR IS REQUIRED IF ANY DETERIORATION IS EVIDENT. REFER TO SRM 51-70-03, PARAGRAPH 4.I. AND NDT MANUAL. **D**

C ONE REPAIR FOR EACH SQUARE FOOT OF AREA AND A MINIMUM OF 6.0 INCHES (150 mm) (EDGE TO EDGE) FROM ANY OTHER DAMAGE, FASTENER HOLE, OR EDGE OR PANEL.

D THIS REPAIR HAS FAA APPROVAL CONTINGENT ON ACCOMPLISHMENT OF THE INSPECTIONS CONTAINED HEREIN.

DAMAGE	INTERIM REPAIRS B		PERMANENT REPAIRS	
	WET LAYUP 150°F (66°C) CURE (SRM 51-70-03)	WET LAYUP 200°F (93°C) CURE (SRM 51-70-17)	250°F (121°C) CURE (SRM 51-70-05)	350°F (177°C) CURE (SRM 51-70-04)
CRACKS	UP TO 2.0 INCHES (50 mm) LONG, REPAIR WITH PATCH AS GIVEN IN SRM 51-70-03, PARAGRAPH 5.N. A	CLEAN UP DAMAGE AND REPAIR AS A HOLE.	CLEAN UP DAMAGE AND REPAIR AS A HOLE.	CLEAN UP DAMAGE AND REPAIR AS A HOLE.
HOLES	2.0 INCHES (50 mm) MAXIMUM DIAMETER NOT TO EXCEED 30% OF SMALLEST DIMENSION ACROSS THE HONEYCOMB PANEL AT THE DAMAGE LOCATION. FILL WITH BMS 5-28, TYPE 7 POTTING COMPOUND AND PATCH AS GIVEN IN SRM 51-70-03, PARAGRAPH 5.N. A	10.0 INCHES (250 mm) MAXIMUM DIAMETER NOT TO EXCEED 50% OF SMALLEST DIMENSION ACROSS THE HONEYCOMB PANEL AT THE DAMAGE LOCATION. USE TWO EXTRA PLIES PER FACESHEET REPAIRED. C	5.0 INCHES (125 mm) MAXIMUM DIAMETER NOT TO EXCEED 50% OF SMALLEST DIMENSION ACROSS THE HONEYCOMB PANEL AT THE DAMAGE LOCATION. USE TWO EXTRA PLIES FOR EACH FACESHEET REPAIRED. C	NO SIZE LIMIT
EDGE EROSION	_____	FOR DAMAGE NOT EXCEEDING 35% OF EDGE BAND THICKNESS, REPAIR AS GIVEN IN SRM 51-70-03, PARAGRAPH 5.O. FOR LARGER DAMAGE, REPAIR AS GIVEN IN: SRM 51-70-17, PARAGRAPH 4.G. SRM 51-70-05, PARAGRAPH 5.G. SRM 51-70-04, PARAGRAPH 5.G.		
DELAMINATION	CUT OUT AND REPAIR AS A HOLE.			
NICKS AND GOUGES	IF THERE IS NO FIBER DAMAGE OR DELAMINATION, FILL NICKS OR GOUGES AS GIVEN IN SRM 51-70-03. IF FIBER DAMAGE OR DELAMINATION EXISTS, REPAIR AS A HOLE.			
DENTS	UP TO 2.0 INCHES (50 mm) DIAMETER WITH NO FIBER DAMAGE OR DELAMINATION IN THE HONEYCOMB WEDGE AREA, FILL WITH BMS 5-28, TYPE 7 POTTING COMPOUND AND PATCH AS GIVEN IN SRM 51-70-03, PARAGRAPH 5.L. C OVER 2.0 INCHES (50 mm) DIAMETER OR WITH FIBER DAMAGE OR DELAMINATION, REPAIR AS HOLE.			

REPAIR DATA FOR 350°F CURE GRAPHITE/EPOXY HONEYCOMB PANELS IN NON-CRITICAL AREAS

TABLE I

**Aileron Skin Repairs
Figure 201 (Sheet 2 of 3)**

**757-200
STRUCTURAL REPAIR MANUAL**

DAMAGE	INTERIM REPAIRS A	PERMANENT REPAIRS		
	WET LAYUP 150°F (66°C) CURE (SRM 51-70-03)	WET LAYUP 200°F (93°C) CURE (SRM 51-70-17)	250°F (121°C) CURE (SRM 51-70-05)	350°F (177°C) CURE (SRM 51-70-04)
CRACKS	UP TO 0.25 INCH (6 mm) LONG, REPAIR WITH PATCH AS GIVEN IN SRM 51-70-03, PAR. 5.N. B	CLEAN UP DAMAGE AND REPAIR AS A HOLE.	CLEAN UP DAMAGE AND REPAIR AS A HOLE.	CLEAN UP DAMAGE AND REPAIR AS A HOLE.
HOLES	0.25 INCH (6 mm) MAXIMUM DIA. FILL WITH BMS 5-28, TYPE 7 POTTING COMPOUND AND PATCH AS GIVEN IN SRM 51-70-03, PAR. 5.N. B	5.0 INCHES (125 mm) MAXIMUM DIA. USE TWO EXTRA PLYS FOR EACH FACESHEET REPAIRED. 0.5 INCH (13 mm) MAXIMUM DIA IN SOLID LAMINATE AREAS. C	2.0 INCHES (50 mm) MAXIMUM DIA. USE TWO EXTRA PLYS FOR EACH FACESHEET REPAIRED. NOT PERMITTED IN SOLID LAMINATE AREAS. C	NO SIZE LIMIT
EDGE EROSION	_____	FOR DAMAGE THAT IS NOT LARGER THAN 10% OF EDGE BAND THICKNESS, REPAIR AS GIVEN IN SRM 51-70-03, PAR. 5.O. FOR LARGER DAMAGE, REPAIR AS GIVEN IN: SRM 51-70-17, PAR. 4.G. SRM 51-70-05, PAR. 5.G. SRM 51-70-04, PAR. 5.G.		
DELAMINATION	CUT OUT AND REPAIR AS HOLE.			
NICKS AND GOUGES	IF THERE IS NO FIBER DAMAGE OR DELAMINATION, FILL NICKS OR GOUGES AS GIVEN IN SRM 51-70-03. IF YOU FIND FIBER DAMAGE OR DELAMINATION, THEN REPAIR AS A HOLE.			
DENTS	UP TO 2.0 INCHES (50 mm) DIA WITH NO FIBER DAMAGE OR DELAMINATION IN THE HONEYCOMB WEDGE AREA, FILL WITH BMS 5-28, TYPE 7 POTTING COMPOUND AND PATCH AS GIVEN IN SRM 51-70-03, PAR. 5.L. C OVER 2.0 INCHES (50 mm) DIA OR WITH FIBER DAMAGE OR DELAMINATION, REPAIR AS A HOLE.			

REPAIR DATA FOR 350°F CURE GRAPHITE/EPOXY HONEYCOMB PANELS IN CRITICAL AREAS

TABLE II

**Aileron Skin Repairs
Figure 201 (Sheet 3 of 3)**

757-200
STRUCTURAL REPAIR MANUAL

IDENTIFICATION 1 - AILERON STRUCTURE

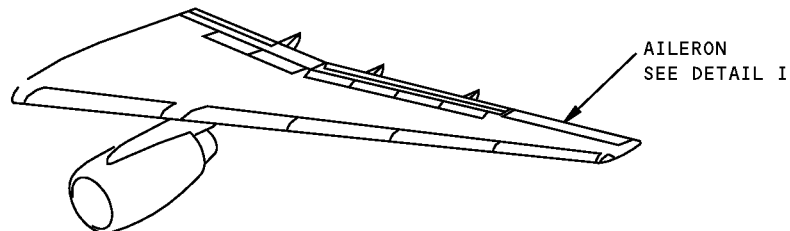

NOTES

- A** PLY ORIENTATION CONVENTION, DEGREES INDICATED, IS PARALLEL TO THE FABRIC WARP DIRECTION
- B** FIBERGLASS PREPREG FABRIC PER BMS 8-139, TYPE 120, 350°F (177°C) CURE
- C** GRAPHITE/EPOXY PREPREG FABRIC PER BMS 8-212, TYPE IV, CLASS 2, STYLE 3K-70-PW, 350°F (177°C) CURE
- D** GRAPHITE/EPOXY PREPREG UNIDIRECTIONAL TAPE PER BMS 8-212, CLASS I, TYPE III, GRADE 145, 350°F (177°C) CURE
- E** MATERIAL AND PLY ORIENTATION SHOWN FOR FIELD AREAS ONLY. SEE BOEING DRAWINGS FOR EDGE BANDS AND AREAS WITH DOUBLERS
- F** DIAGRAM OF PLY ORIENTATION. SEE APPLICABLE TABLE I FOR INDIVIDUAL PLY ORIENTATION AND MATERIAL

**Aileron Structure Identification
Figure 1 (Sheet 1 of 3)**

**757-200
STRUCTURAL REPAIR MANUAL**

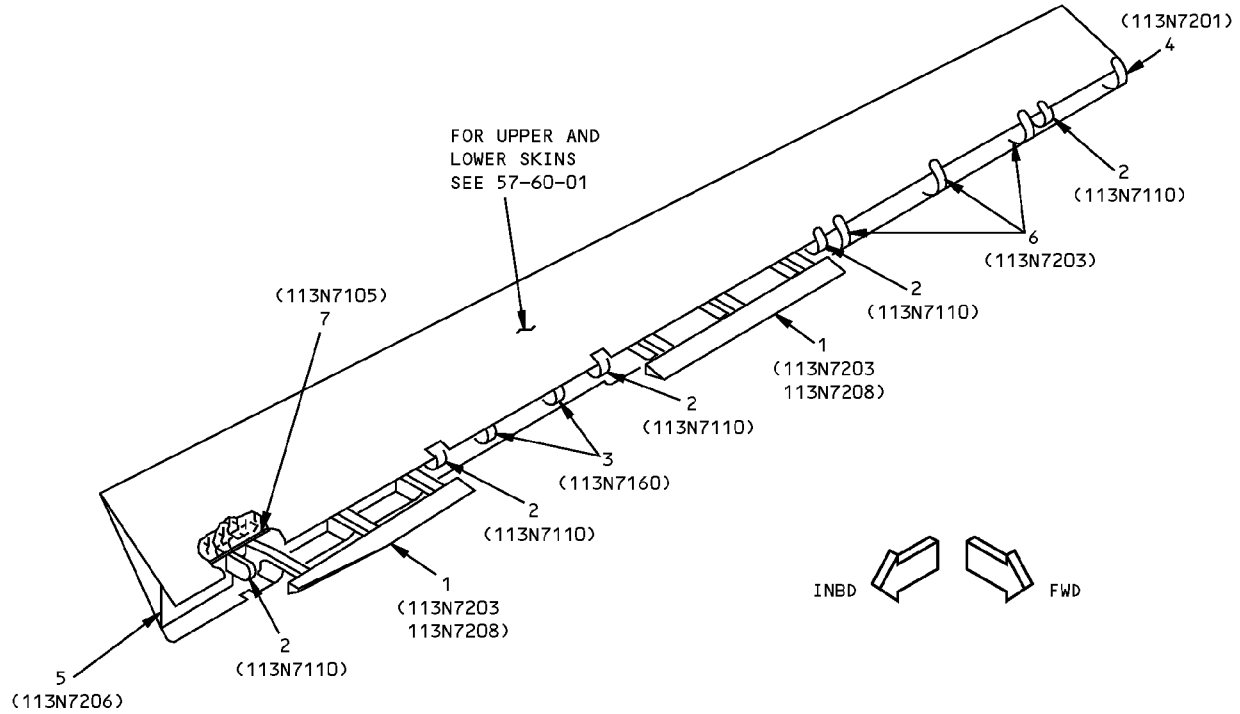

DETAIL I

ITEM	DESCRIPTION	GAGE	MATERIAL	EFFECTIVITY
1	BALANCE ARM ASSEMBLY BALANCE WEIGHT SUPPORT RIB BALANCE WEIGHT	2.20	PLATE 7075-T7351 TUNGSTEN ALLOY PER MIL-T-21014, TYPE II, CLASS 3	
2	HINGE FITTING		FORGING 7075-T73	
3	ACTUATOR FITTING		FORGING 7075-T73	
4	OUTBOARD CLOSURE RIB		FIBERGLASS/EPOXY PER BMS 8-79, TYPE 1581	
5	INBOARD CLOSURE RIB		PLATE 7075-T7351	
6	BALANCE WEIGHT SUPPORT RIB	2.20	PLATE 7075-T7351	
7	SPAR ASSEMBLY		SEE DETAIL II	

LIST OF MATERIALS FOR DETAIL I

**Aileron Structure Identification
Figure 1 (Sheet 2 of 3)**

**757-200
STRUCTURAL REPAIR MANUAL**

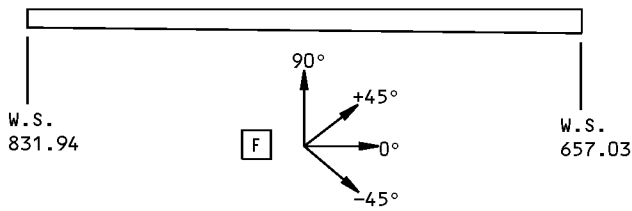

REAR VIEW OF SPAR

ITEM NO.	PLY NUMBER	MATERIAL	PLY ORIENTATION A
7	1	B	NONE
	2, 3, 5, 10, 14, 19, 21, 22	C	$\pm 45^\circ$
	7, 12, 17	C	0°
	4, 6, 8, 9, 11, 13, 15, 16, 18, 20	D	0°

TABLE I E

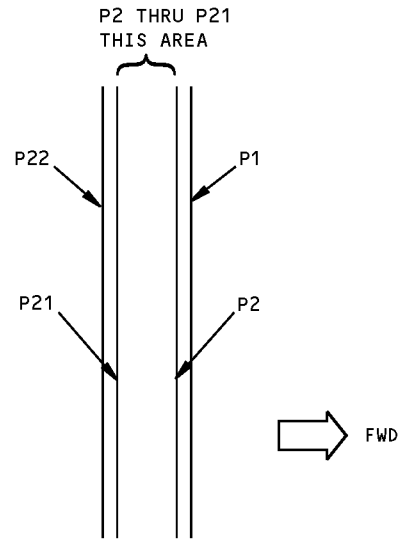

TYPICAL SECTION THROUGH SPAR

DETAIL II

**Aileron Structure Identification
Figure 1 (Sheet 3 of 3)**

**757-200
STRUCTURAL REPAIR MANUAL**

ALLOWABLE DAMAGE 1 - AILERON STRUCTURE

REF DWG
113N7100

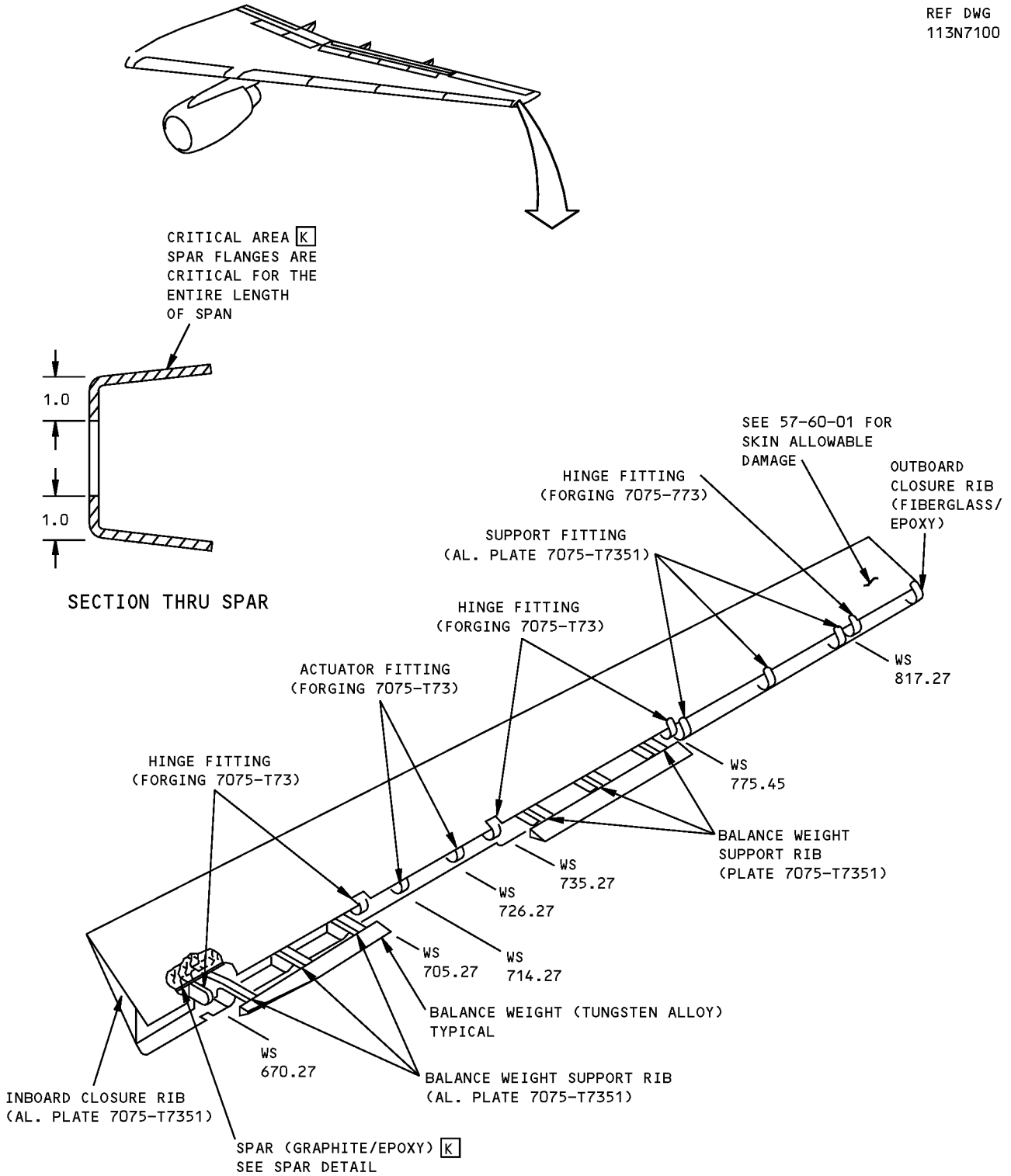

**Aileron Structure Allowable Damage
Figure 101 (Sheet 1 of 5)**

ALLOWABLE DAMAGE 1

57-60-02

Page 101
Jan 20/2005

D634N201

**757-200
STRUCTURAL REPAIR MANUAL**

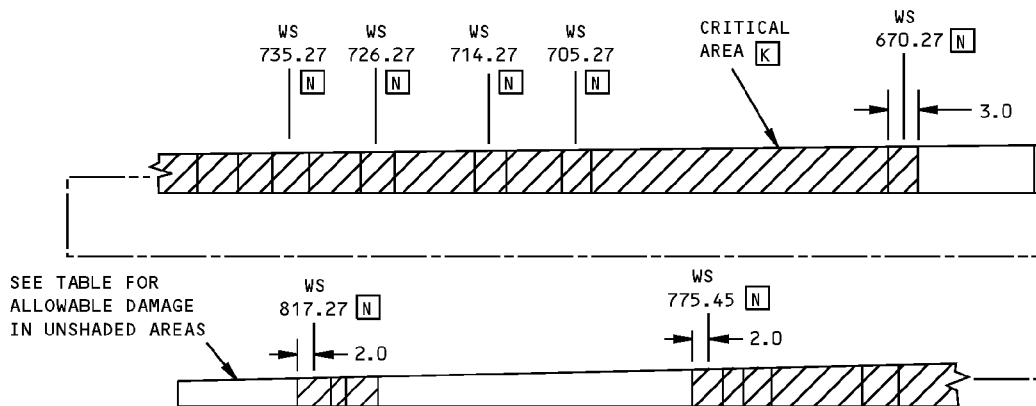

AILERON SPAR - REAR VIEW

SPAR DETAIL

DESCRIPTION	CRACKS	NICKS, GOUGES AND CORROSION	DENTS	HOLES AND PUNCTURES	DELAMINATION
OUTBD CLOSURE RIB	B	C	D	E	F
ACTUATOR FITTING J	M	G	NOT ALLOWED	NOT ALLOWED	----
HINGE FITTING J	M	G	NOT ALLOWED	NOT ALLOWED	----
INBOARD CLOSURE RIB J	B	H	SEE DETAIL III	I	----
SUPPORT FITTING AND RIBS	B	H	NOT ALLOWED	I	----
BALANCE WEIGHT	B	H	NOT ALLOWED	NOT ALLOWED	----
SPAR (UNSHADED AREAS)	L	L	D	E	F

**Aileron Structure Allowable Damage
Figure 101 (Sheet 2 of 5)**

STRUCTURAL REPAIR MANUAL

NOTES

- REFINISH REWORKED AREAS PER AMM 51-20.
 - TYPICAL DAMAGE TO A PANEL EDGE BAND MAY CONSIST OF EDGE CRUSHING, CRACKS OR DELAMINATION. DAMAGE AROUND HOLES MAY CONSIST OF OVALIZATION, FASTENER PULL-THROUGH OR CRACKS OUT OF HOLE. DAMAGE MAY REDUCE THE EFFECTIVE CROSS SECTIONAL AREA OF AN EDGE BAND. DAMAGE TO EDGES SHOULD BE BLENDED OUT TO LIMITATIONS GIVEN FOR COMPONENT.
 - THE AILERON IS A BALANCED CATEGORY I CONTROL SURFACE. REFER TO SRM 51-60-01 FOR AILERON BALANCING PROCEDURES.
- A** REMOVE MOISTURE FROM DAMAGE AREA. USE OF VACUUM AND HEAT (MAX OF 125°F (52°C)) TO REMOVE MOISTURE FROM HONEYCOMB CELLS IS RECOMMENDED. PROTECT DAMAGE FROM ENTRANCE OF WATER, SUNLIGHT OR OTHER FOREIGN MATTER BY SEALING WITH ALUMINUM FOIL TAPE (SPEED TAPE). RECORD THE LOCATION AND INSPECT EVERY AIRPLANE "A" CHECK. REPLACE THE ALUMINUM FOIL TAPE IF ANY PEELING OR DETE-
RIORATION EVIDENT. REPAIR NO LATER THAN NEXT AIRPLANE "C" CHECK. **O**
 - B** CRACKS NOT ALLOWED EXCEPT FOR EDGE CRACKS WHICH MUST BE REMOVED PER DETAIL I. MAIN-TAIN EDGE MARGIN SHOWN. REFINISH OR **A**.
 - C** DAMAGE ALLOWED ON SURFACE RESIN ONLY. DAMAGE TO FIBERS NOT ALLOWED. CLEAN UP EDGE DAMAGE PER DETAIL IV. **A**
 - D** DENTS GENERALLY RESULT IN FIBER DAMAGE OR DELAMINATION. HOWEVER, IF THERE IS NO FIBER DAMAGE OR DELAMINATION, DENTS UP TO 1.0 INCH DIAMETER MAXIMUM ARE ALLOWED. ONE DENT PER LINEAR FOOT ALLOWED WHICH MUST BE A MINIMUM OF 3.0 INCHES (EDGE TO EDGE) FROM ANY OTHER DAMAGE, FASTENER HOLE, OR PANEL EDGE. SEE **E** OR **F** IF FIBER DAMAGE OR DELAMINATION IS PRESENT.
 - E** 0.50 INCH MAXIMUM DIAMETER ALLOWED PROVIDED DAMAGE IS MINIMUM OF 3.0 INCHES FROM OTHER DAMAGE, NEAREST HOLE, OR PANEL EDGE. DO NOT CLEAN UP DAMAGE EXCEPT TO REMOVE RESIN BURRS EXTENDING INTO SURFACE CONTOUR **A**.
 - F** 1.00 INCH MAXIMUM DIAMETER ALLOWED WITHOUT REWORK. PROTECT EDGE DAMAGE PER **A**.
 - G** FOR EDGE DAMAGE SEE DETAIL I. FOR LUG DAMAGE SEE DETAIL V. FOR OTHER DAMAGE SEE DETAIL II. DAMAGE NOT ALLOWED IN VICINITY OF BUSHINGS.
 - H** REMOVE DAMAGE PER DETAILS I AND II.
 - I** CLEAN OUT DAMAGE UP TO 0.25 INCH MAXIMUM DIAMETER AND NOT CLOSER THAN 1.0 INCH TO FASTENER HOLE OR OTHER DAMAGE. FILL HOLE WITH A 2117-T3 OR T4 ALUMINUM RIVET INSTALLED WET WITH BMS 5-95 SEALANT. ALL OTHER HOLES TO BE REPAIRED.
 - J** SHOT PEEN REWORKED AREAS PER SRM 51-20-06. SHOT PEEN INTENSITIES MAY VARY WITH THICKNESS REMAINING AFTER REWORK.
 - K** CRITICAL AREA - CONSULT THE BOEING COMPANY FOR ALLOWABLE DAMAGE.
 - L** EDGE CRACKS MUST BE REMOVED PER DETAILS I AND II. 0.50 INCH MAXIMUM LENGTH IS ALLOWED PER LINEAR FOOT. MINIMUM OF 3.0 INCHES FORM ANY OTHER DAMAGE.
 - M** CRACKS NOT ALLOWED EXCEPT FOR EDGE CRACKS WHICH MUST BE REMOVED PER DETAIL I.
 - N** CENTER OF FITTING.
 - O** THESE ALLOWABLE DAMAGE LIMITS HAVE FAA APPROVAL CONTINGENT ON ACCOMPLISHMENT OF THE INSPECTIONS CONTAINED HEREIN.

**Aileron Structure Allowable Damage
Figure 101 (Sheet 3 of 5)**

**757-200
STRUCTURAL REPAIR MANUAL**

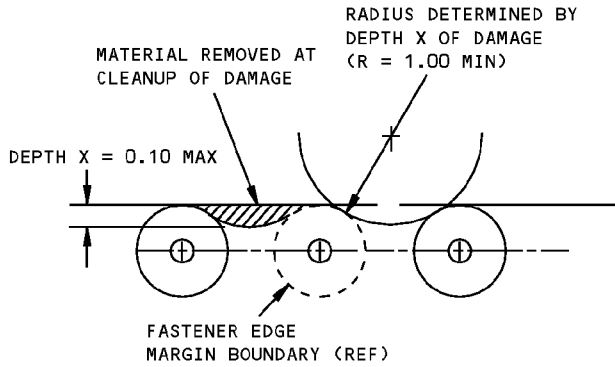

DAMAGE CLEANUP OF EDGES WHERE FASTENER EDGE MARGINS DO NOT OVERLAP

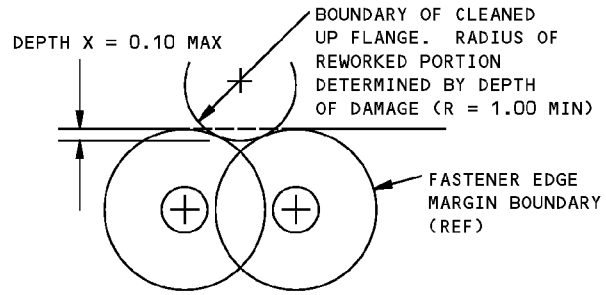

DAMAGE CLEANUP OF EDGES WHERE FASTENER EDGE MARGINS OVERLAP

DETAIL I

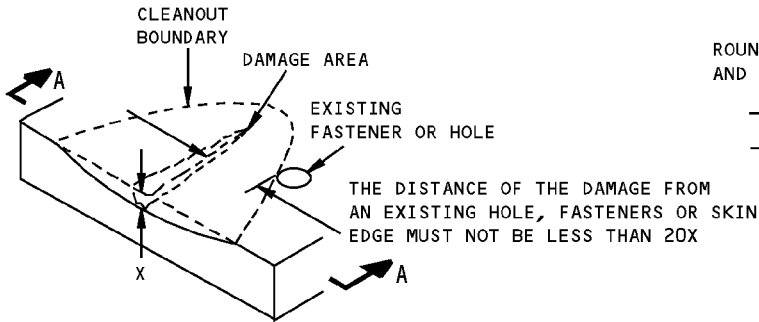

**REMOVAL OF NICK, GOUGE AND SCRATCH DAMAGE ON A SURFACE
DETAIL II**

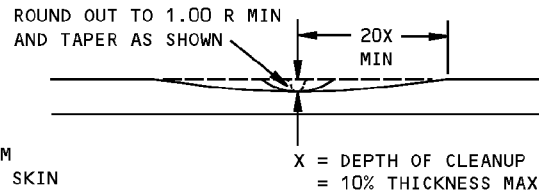

SECTION A-A

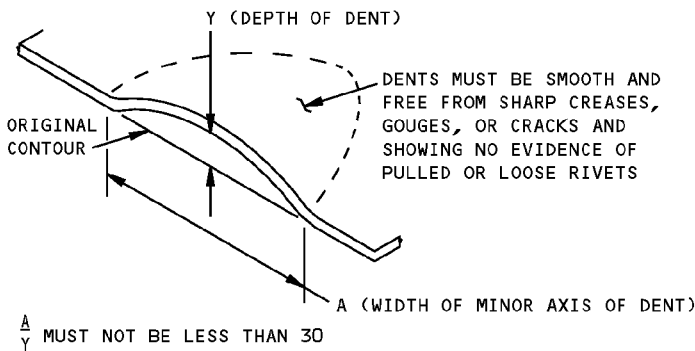

**ALLOWABLE DAMAGE FOR DENT
DETAIL III**

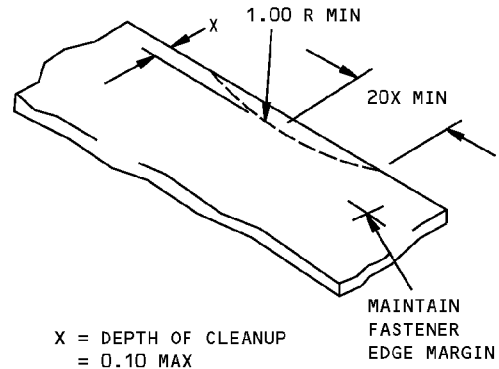

**REMOVAL OF NICK OR CRACK DAMAGE ON AN EDGE
DETAIL IV**

**Aileron Structure Allowable Damage
Figure 101 (Sheet 4 of 5)**

757-200
STRUCTURAL REPAIR MANUAL

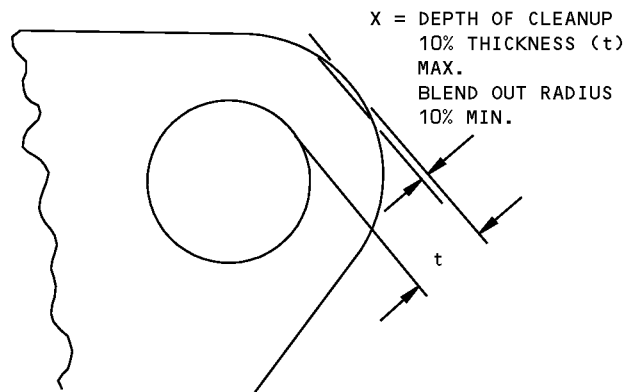

**DAMAGE CLEANUP FOR EDGES OF LUG
DETAIL V**

**Aileron Structure Allowable Damage
Figure 101 (Sheet 5 of 5)**

**757-200
STRUCTURAL REPAIR MANUAL**

REPAIR 1 - AILERON SPAR AND OUTBOARD CLOSURE RIB REPAIR

REF DWG
113N7100

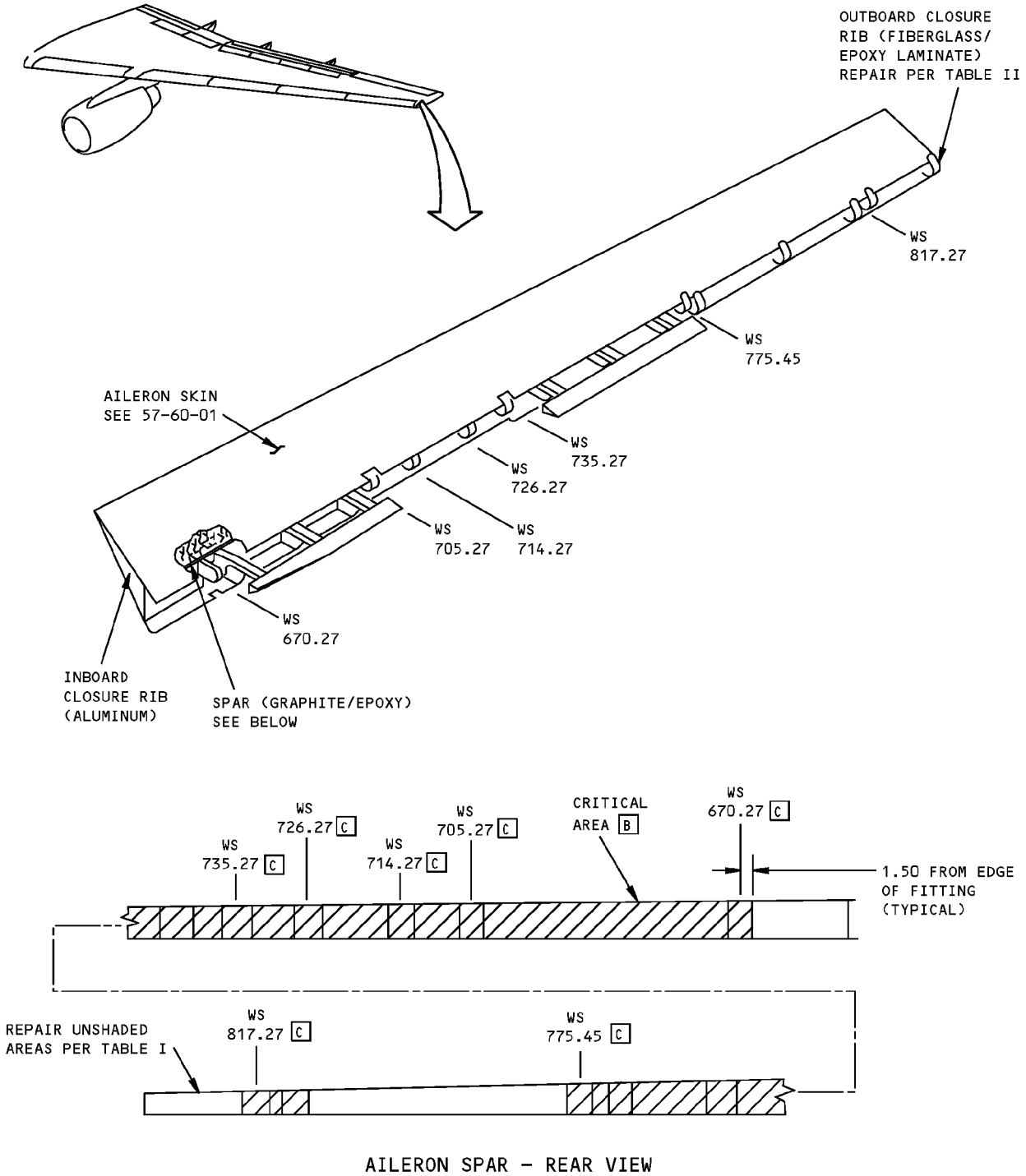

**Aileron Spar and Outboard Closure Rib Repair
Figure 201 (Sheet 1 of 3)**

**757-200
STRUCTURAL REPAIR MANUAL**

DAMAGE	INTERIM REPAIRS D	PERMANENT REPAIRS		
	WET LAYUP 150°F (66°C) CURE (SRM 51-70-03)	WET LAYUP 200°F (93°C) CURE (SRM 51-70-17)	250°F (121°C) CURE (SRM 51-70-05)	350°F (177°C) CURE (SRM 51-70-04)
CRACKS	UP TO 2.0 INCHES (50 mm) LONG, REPAIR WITH PATCH AS GIVEN IN SRM 51-70-03, PARAGRAPH 5.N. A	CLEAN UP DAMAGE AND REPAIR AS A HOLE.	CLEAN UP DAMAGE AND REPAIR AS A HOLE.	CLEAN UP DAMAGE AND REPAIR AS A HOLE.
HOLES	2.0 INCHES (50 mm) MAXIMUM DIAMETER NOT TO EXCEED 30% OF SMALLEST DIMENSION ACROSS LAMINATE PANEL AT THE DAMAGE LOCATION. FILL WITH BMS 5-28, TYPE 7 POTTING COMPOUND AND PATCH AS GIVEN IN SRM 51-70-03, PARAGRAPH 5.N. A	5.0 INCHES (125 mm) MAXIMUM DIAMETER NOT TO EXCEED 50% OF SMALLEST DIMENSION ACROSS LAMINATE PANEL AT THE DAMAGE LOCATION. USE TWO EXTRA PLYS FOR EACH FACESHEET REPAIRED. E	5.0 INCHES (125 mm) MAXIMUM DIAMETER NOT TO EXCEED 50% OF SMALLEST DIMENSION ACROSS LAMINATE PANEL AT THE DAMAGE LOCATION. USE TWO EXTRA PLYS FOR EACH FACESHEET REPAIRED. E	NO SIZE LIMIT
DELAMI-NATION	CUT OUT AND REPAIR AS A HOLE.			
NICKS AND GOUGES	IF THERE IS NO FIBER DAMAGE OR DELAMINATION, FILL NICKS OR GOUGES AS GIVEN IN SRM 51-70-03. IF YOU FIND FIBER DAMAGE OR DELAMINATION, THEN REPAIR AS A HOLE.			
DENTS	UP TO 2.0 INCHES (50 mm) DIAMETER WITH NO FIBER DAMAGE OR DELAMINATION, FILL WITH BMS 5-28, TYPE 7 POTTING COMPOUND AND PATCH AS GIVEN IN SRM 51-70-03, PARAGRAPH 5.L. OVER 2.0 INCHES (50 mm) DIAMETER OR WITH FIBER DAMAGE OR DELAMINATION, REPAIR AS A HOLE. E			

**REPAIR DATA FOR 350°F (177°C) CURE LAMINATES (GRAPHITE)
TABLE I**

NOTES

- WHEN YOU USE THIS REPAIR, REFER TO:
 - AMM 51-21-01 FOR APPLICATION OF FINISHES
 - SRM 51-10-01, FOR AERODYNAMIC SMOOTHNESS REQUIREMENTS. WHERE THE DAMAGE IS MORE THAN THE LIMITS GIVEN IN SRM 51-10-01, THOUGHT SHOULD BE GIVEN TO THE LOSS OF PERFORMANCE THAT MAY OCCUR
 - SRM 51-10-02 FOR INSPECTION AND REMOVAL OF DAMAGE.

- A** LIMITED TO REPAIR OF DAMAGE TO ONE FACE-SHEET SKIN AND HONEYCOMB CORE. ONE REPAIR PER 12.0 INCHES (300 mm) OF SPAR AND A MINIMUM OF 3.0 INCHES (75 mm) (EDGE TO EDGE) FROM ANY OTHER DAMAGE, FASTENER HOLE, OR EDGE OF PANEL.
- B** CONTACT THE BOEING COMPANY FOR REPAIRS TO DAMAGE IN CRITICAL AREAS.
- C** CENTER OF FITTING

- D** INSPECT INTERIM REPAIR USING INSTRUMENTED NDT METHODS OR "TAP" TEST EVERY AIRPLANE "2A" CHECK. FOR "TAP" TEST, USE A SOLID METAL DISK AND TAP THE REPAIR AREA LIGHTLY BUT FIRMLY. VOID AREAS WILL GIVE A DULL SOUND INSTEAD OF A SHARP RING THAT YOU WILL HEAR ON A SOLID BONDED AREA. PERMANENT REPAIR IS REQUIRED IF ANY DETERIORATION IS FOUND. REFER TO SRM 51-70-03, PARAGRAPH 4.I. OR SRM 51-70-06, PARAGRAPH 4.I. AND THE NDT MANUAL. **F**

- E** ONE REPAIR FOR EACH 12.0 INCHES (300 mm) OF SPAN AND A MINIMUM OF 3.0 INCHES (75 mm) (EDGE TO EDGE) FROM ANY OTHER DAMAGE, FASTENER HOLE, OR EDGE OF PANEL.

- F** THIS REPAIR HAS FAA APPROVAL ONLY IF YOU DO THE INSPECTIONS GIVEN IN THIS REPAIR.

**Aileron Spar and Outboard Closure Rib Repair
Figure 201 (Sheet 2 of 3)**

STRUCTURAL REPAIR MANUAL

DAMAGE	INTERIM REPAIRS D	PERMANENT REPAIRS		
	WET LAYUP ROOM TEMP (SRM 51-70-06)	WET LAYUP 150°F (66°C) CURE (SRM 51-70-06)	WET LAYUP 200°F (93°C) CURE (51-70-17)	250°F (121°C) CURE (51-70-07)
CRACKS	UP TO 2.0 INCHES (50 mm) , REPAIR WITH PATCH AS GIVEN IN SRM 51-70-06, PAR. 5.N. E	CLEAN UP DAMAGE AND REPAIR AS A HOLE	CLEAN UP DAMAGE AND REPAIR AS A HOLE	CLEAN UP DAMAGE AND REPAIR AS A HOLE
HOLES AND PUNCTURES	2.0 INCHES (50 mm) MAXIMUM DIA NOT TO EXCEED 15% OF CROSS-SECTIONAL AREA OF LAMINATE OR EDGE BAND OR 10% OF THE EDGE BAND LENGTH FOR EACH SIDE. REPAIR AS GIVEN IN SRM 51-70-03 PAR. 5.G., 5.H., 5.I., OR 5.K. AS APPLICABLE E	5.0 INCHES (125 mm) MAXIMUM DIA NOT TO EXCEED 50% OF CROSS-SECTIONAL AREA OF LAMINATE OR EDGE BAND OR 25% OF THE EDGE BAND LENGTH FOR EACH SIDE. USE TWO EXTRA PLIES FOR EACH SIDE E	5.0 INCHES (125 mm) MAXIMUM DIA NOT TO EXCEED 50% OF CROSS-SECTIONAL AREA OF LAMINATE OR EDGE BAND OR 25% OF THE EDGE BAND LENGTH FOR EACH SIDE. USE TWO EXTRA PLIES FOR EACH SIDE	NO SIZE LIMIT
DELAMINATION	CUT OUT AND REPAIR AS A HOLE			
NICKS AND GOUGES	IF THERE IS NO FIBER DAMAGE OR DELAMINATION, FILL NICKS OR GOUGES AS GIVEN SRM 51-70-03 IF YOU FIND FIBER DAMAGE OR DELAMINATION, THEN REPAIR AS A HOLE			
DENTS	UP TO 2.0 INCHES (50 mm) DIA WITH NO FIBER DAMAGE OR DELAMINATION, FILL WITH BMS 5-28, TYPE 7 POTTING COMPOUND AND PATCH AS GIVEN IN SRM 51-70-06, PAR. 5.L. OVER 2.0 INCHES (50 mm) DIA OR WITH FIBER DAMAGE OR DELAMINATION, REPAIR AS A HOLE			

REPAIR DATA FOR 250°F CURE LAMINATES (FIBERGLASS)
TABLE II

Aileron Spar and Outboard Closure Rib Repair
Figure 201 (Sheet 3 of 3)

**757-200
STRUCTURAL REPAIR MANUAL**

IDENTIFICATION 1 - AILERON ATTACHMENT FITTINGS

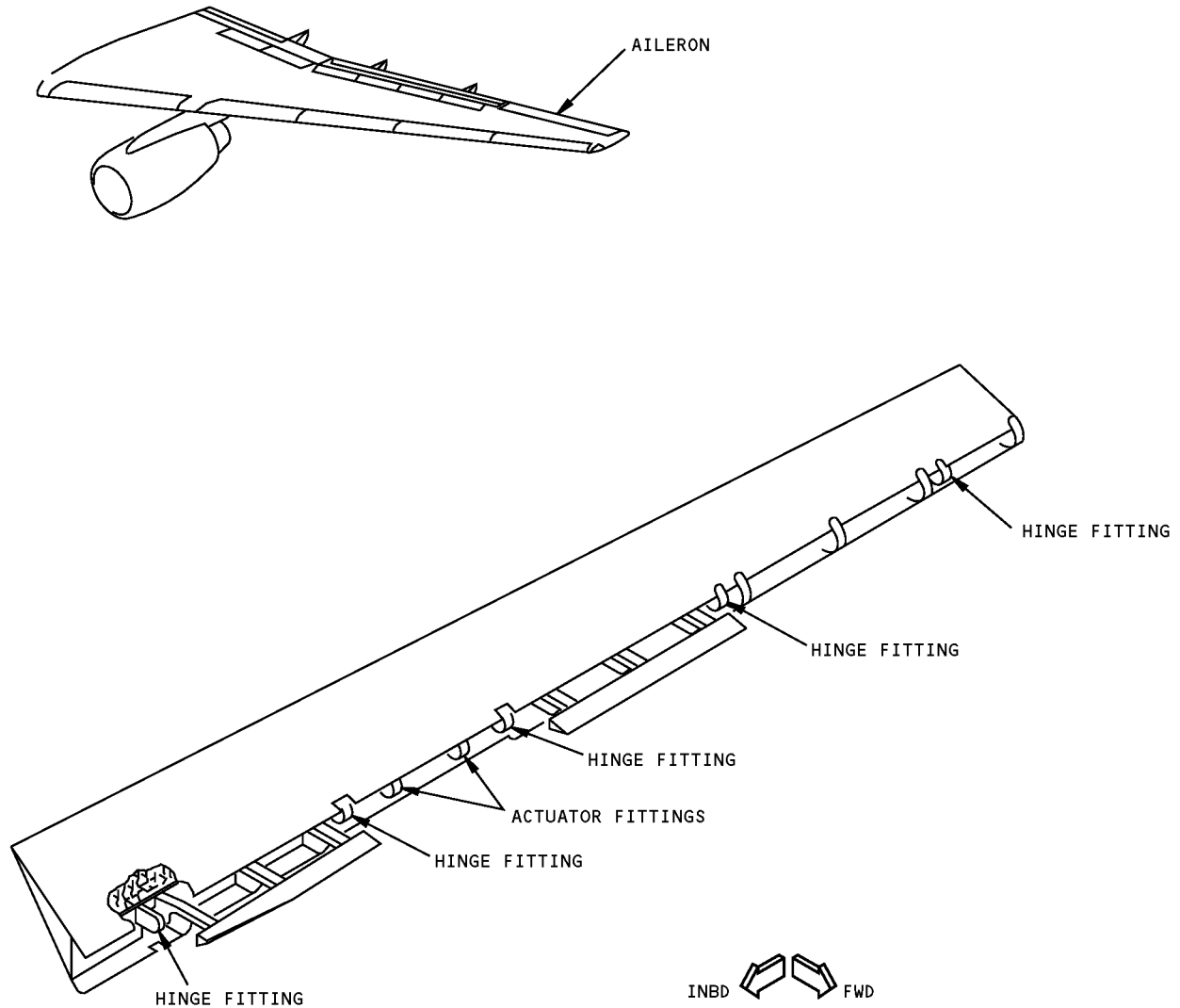

NOTES

- SEE 57-60-02 FOR STRUCTURE IDENTIFICATION

**Aileron Attachment Fittings Identification
Figure 1**

**757-200
STRUCTURAL REPAIR MANUAL**

ALLOWABLE DAMAGE 1 - AILERON ATTACHMENT FITTINGS

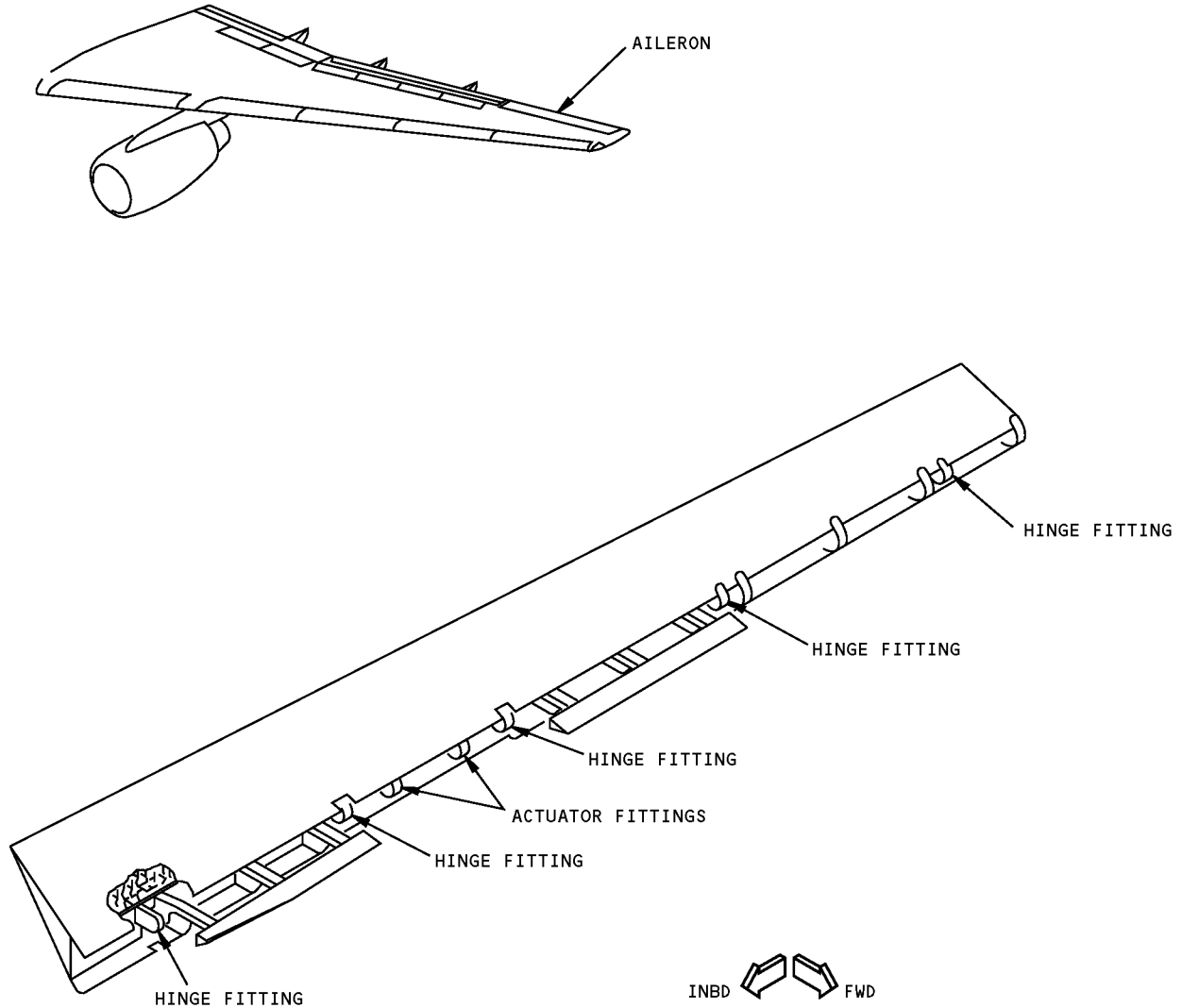

NOTES

- SEE 57-60-02 FOR FITTING ALLOWABLE DAMAGE

**Aileron Attachment Fittings Allowable Damage
Figure 101**

D634N201

ALLOWABLE DAMAGE 1
Page 101
57-60-90
Jan 20/2005

**757-200
STRUCTURAL REPAIR MANUAL**

REPAIR GENERAL - AILERON ATTACHMENT FITTINGS

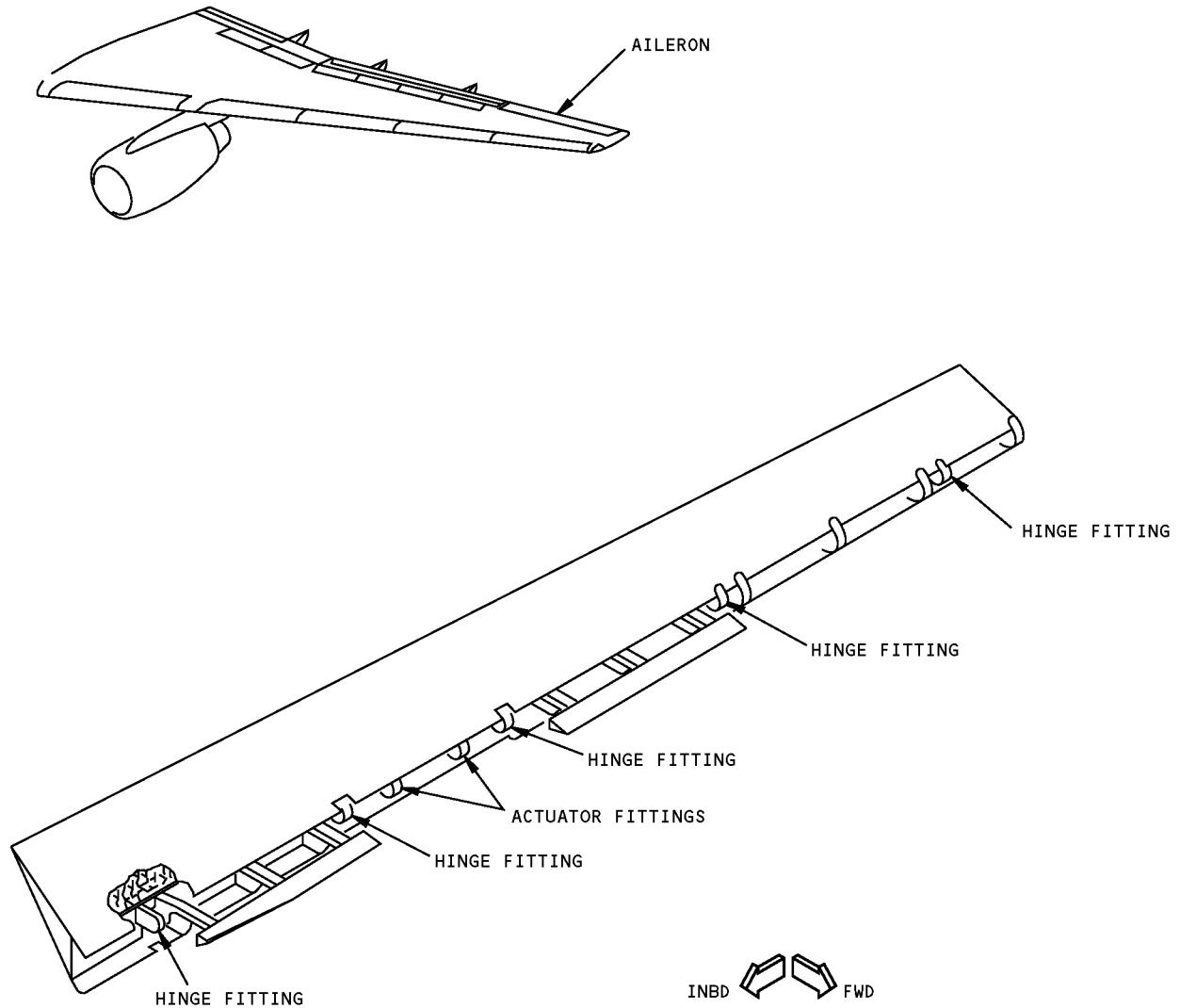

NOTES

- SEE 57-60-02 FOR STRUCTURE IDENTIFICATION AND ALLOWABLE DAMAGE INFORMATION
- NO TYPICAL REPAIR TO FITTINGS APPLICABLE. SPECIFIC REPAIRS TO FITTINGS WILL BE PROVIDED BASED ON SERVICE EXPERIENCE

**Aileron Attachment Fittings Repair
Figure 201**

D634N201

57-60-90

REPAIR GENERAL
Page 201
Jan 20/2005



757-200
STRUCTURAL REPAIR MANUAL

IDENTIFICATION 1 - SPOILER SKIN

REF DWG
113N5000
113N4000

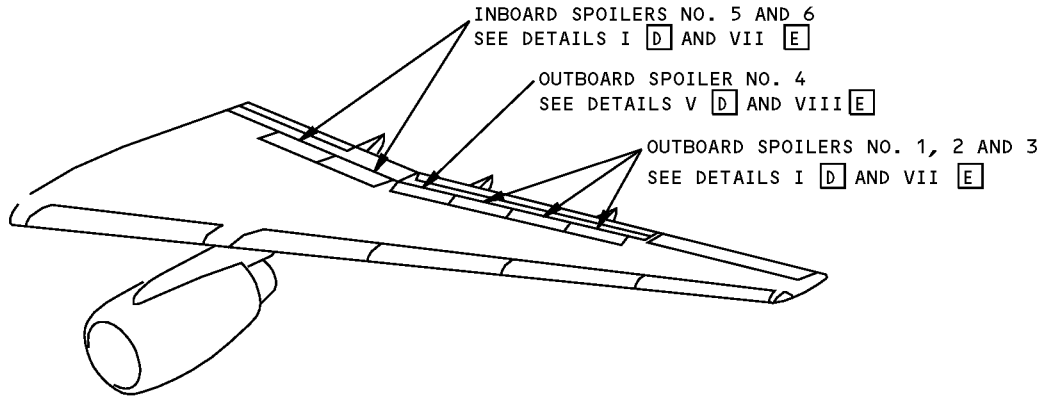

NOTES

- A** PLY ORIENTATION CONVENTION, DEGREES INDICATED, IS PARALLEL TO THE FABRIC WARP DIRECTION
- B** GRAPHITE/EPOXY PREPREG FABRIC PER BMS 8-256, TYPE I, CLASS 2, STYLE 3K-70-PW, 350°F (177°C) CURE
- C** MATERIAL AND PLY ORIENTATION SHOWN FOR FIELD AREAS ONLY. SEE BOEING DRAWINGS FOR EDGE BANDS AND AREAS WITH DOUBLERS
- D** FOR CUM LINE NUMBERS:
1 THRU 31
- E** FOR CUM LINE NUMBERS:
32 AND ON

Spoiler Skin Identification
Figure 1 (Sheet 1 of 9)

D634N201

57-70-01

IDENTIFICATION 1
Page 1
Jan 20/2005

**757-200
STRUCTURAL REPAIR MANUAL**

REF DWG
113N5100
113N5400
113N4100
113N4200

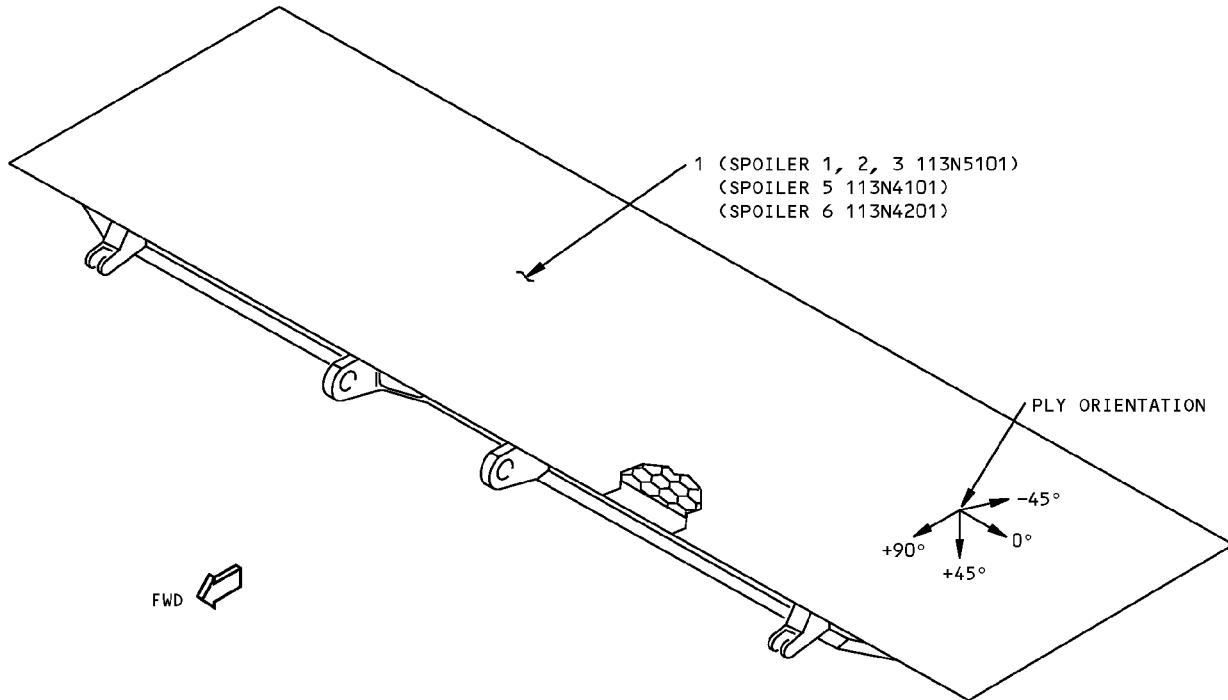

SPOILERS NO. 1, 2, AND 3 SHOWN,
SPOILERS NO. 5 AND 6 SIMILAR

DETAIL I D

ITEM	DESCRIPTION	GAGE	MATERIAL	EFFECTIVITY
1	PANEL ASSY SKIN		GRAPHITE/EPOXY HONEYCOMB SANDWICH SEE DETAIL II FOR SPOILERS 1, 2, 3 SEE DETAIL III FOR SPOILER 5 SEE DETAIL IV FOR SPOILER 6	
	CORE		HONEYCOMB PER BMS 8-124, CLASS 4, TYPE V, GRADE 3.0	

LIST OF MATERIALS FOR DETAIL I

**Spoiler Skin Identification
Figure 1 (Sheet 2 of 9)**

IDENTIFICATION 1
Page 2
Jan 20/2005

57-70-01

D634N201

**757-200
STRUCTURAL REPAIR MANUAL**

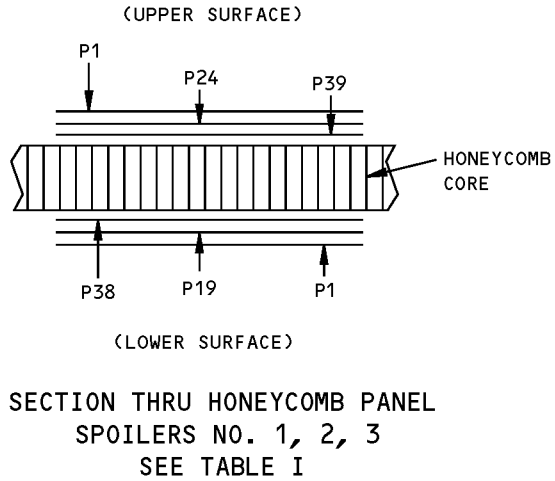

ITEM NO.	PLY NO.	MATERIAL	PLY ORIENTATION A
1 UPR SURFACE	P1	B	+45°
	P24	B	+45°
	P39	B	0°
1 LWR SURFACE	P38	B	+45°
	P19	B	+45°
	P1	B	0°

TABLE I C

DETAIL II

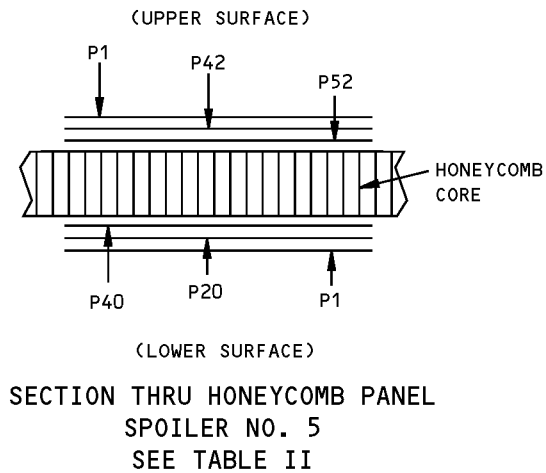

ITEM NO.	PLY NO.	MATERIAL	PLY ORIENTATION A
1 UPR SURFACE	P1	B	+45°
	P42	B	-45°
	P52	B	0°
1 LWR SURFACE	P40	B	+45°
	P20	B	+45°
	P1	B	0°

TABLE II C

DETAIL III

**Spoiler Skin Identification
Figure 1 (Sheet 3 of 9)**

**757-200
STRUCTURAL REPAIR MANUAL**

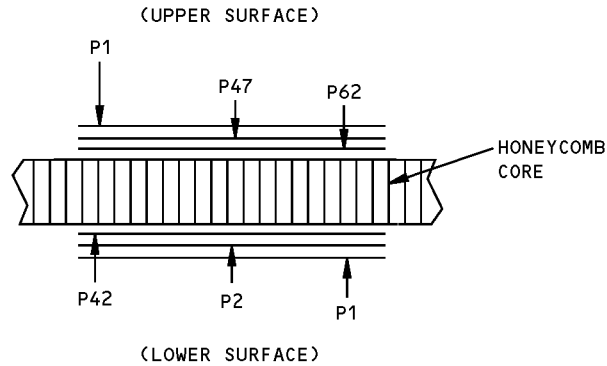

SECTION THRU HONEYCOMB PANEL
SPOILER NO. 6
SEE TABLE III

ITEM NO.	PLY NO.	MATERIAL	PLY ORIENTATION A
1 UPR SURFACE	P1	B	+45°
	P47	B	0°
	P62	B	0°
1 LWR SURFACE	P42	B	+45°
	P2	B	+45°
	P1	B	0°

TABLE III C

DETAIL IV

**Spoiler Skin Identification
Figure 1 (Sheet 4 of 9)**

IDENTIFICATION 1
Page 4
Jan 20/2005

57-70-01

D634N201

**757-200
STRUCTURAL REPAIR MANUAL**

REF DWG
113N5400

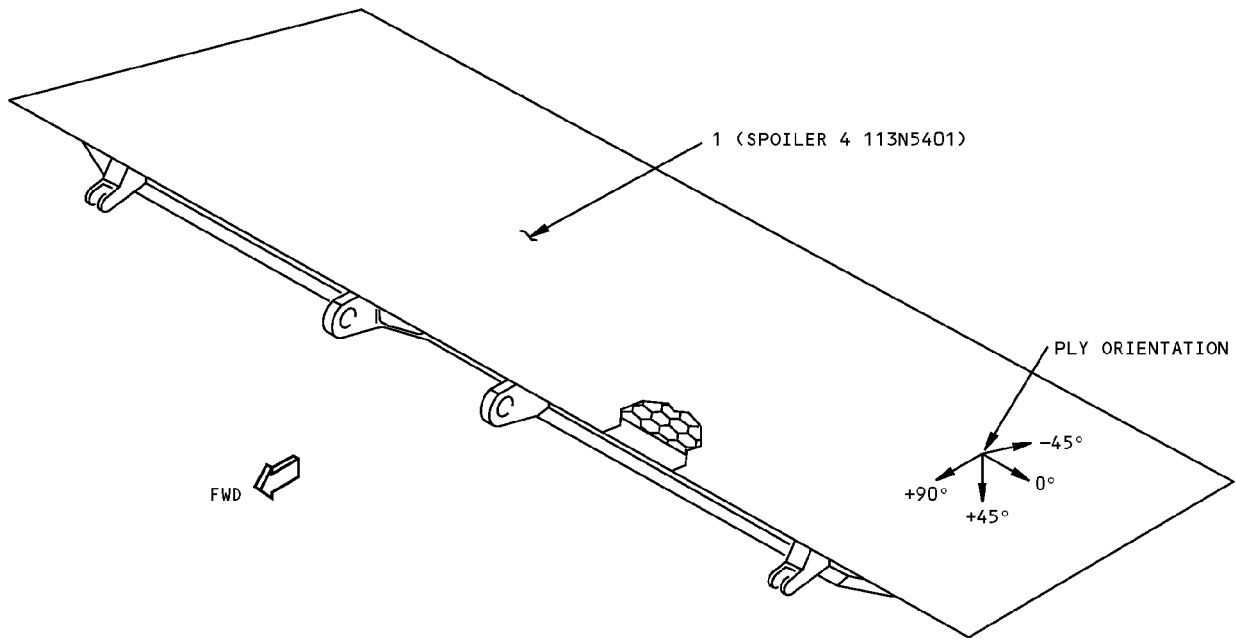

DETAIL V D

ITEM	DESCRIPTION	GAGE	MATERIAL	EFFECTIVITY
1	PANEL ASSY SKIN CORE		GRAPHITE/EPOXY HONEYCOMB SANDWICH SEE DETAIL VI FOR SPOILER NO. 4 HONEYCOMB PER BMS 8-124, CLASS 4, TYPE V, GRADE 3.0	

LIST OF MATERIALS FOR DETAIL V

**Spoiler Skin Identification
Figure 1 (Sheet 5 of 9)**

IDENTIFICATION 1
Page 5
Jan 20/2005

57-70-01

D634N201

**757-200
STRUCTURAL REPAIR MANUAL**

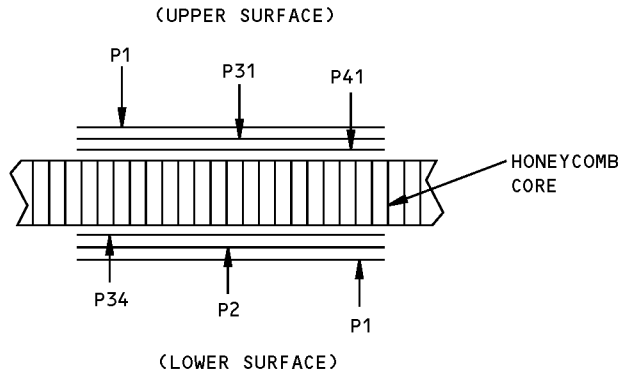

SECTION THRU HONEYCOMB PANEL
SPOILER NO. 4
SEE TABLE IV

ITEM NO.	PLY NO.	MATERIAL	PLY ORIENTATION A
1 UPR SURFACE	P1	B	+45°
	P31	B	-45°
	P41	B	0°
1 LWR SURFACE	P34	B	+45°
	P2	B	+45°
	P1	B	0°

TABLE IV C

DETAIL VI

**Spoiler Skin Identification
Figure 1 (Sheet 6 of 9)**

**757-200
STRUCTURAL REPAIR MANUAL**

REF DWG
113N5501
113N4501
113N4601

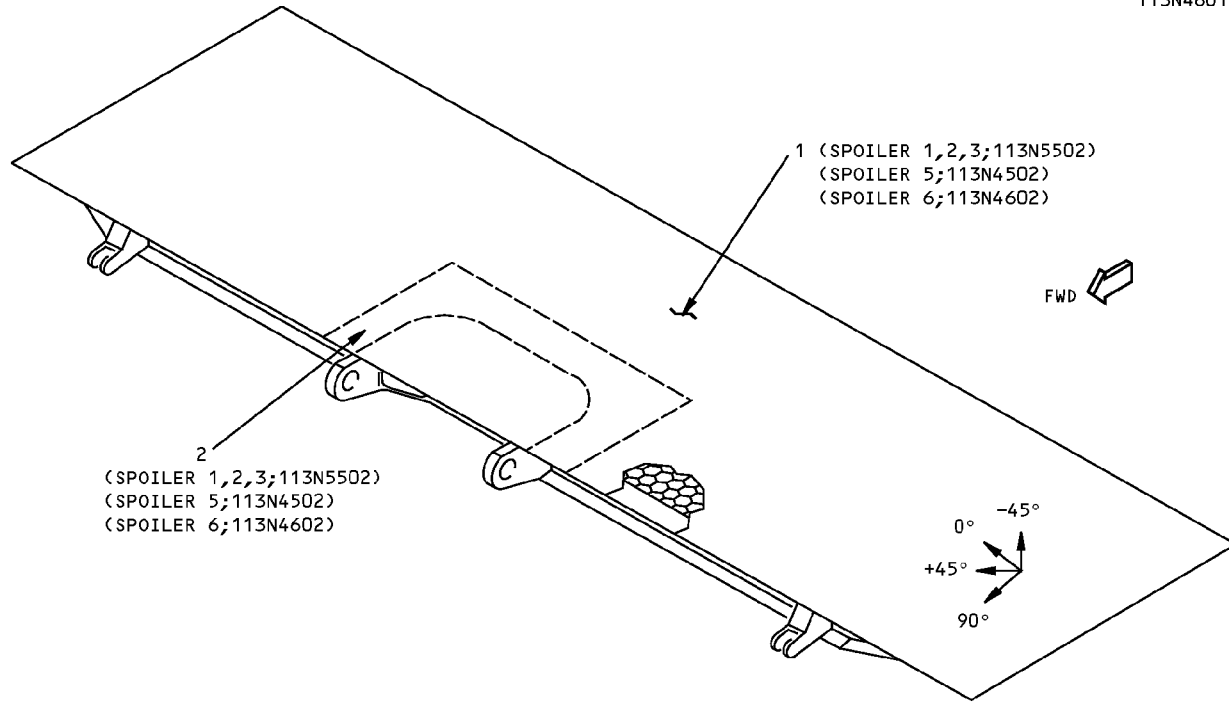

SPOILERS NO. 1,2,3 SHOWN
SPOILERS NO. 5,6 SIMILAR
DETAIL VII E

ITEM	DESCRIPTION	GAGE	MATERIAL	EFFECTIVITY
1	PANEL ASSY SKIN CORE		GRAPHITE/EPOXY HONEYCOMB SANDWICH SEE DETAIL IX NONMETALLIC HONEYCOMB PER BMS 8-124, CLASS IV, TYPE V, GRADE 3.0	
2	PANEL ASSY SKIN CORE		GRAPHITE/EPOXY HONEYCOMB SANDWICH SEE DETAIL X NONMETALLIC HONEYCOMB PER BMS 8-124, CLASS I, TYPE I, GRADE 5.5	

LIST OF MATERIALS FOR DETAIL VII

**Spoiler Skin Identification
Figure 1 (Sheet 7 of 9)**

D634N201

57-70-01

IDENTIFICATION 1
Page 7
Jan 20/2005

**757-200
STRUCTURAL REPAIR MANUAL**

REF DWG
113N5601

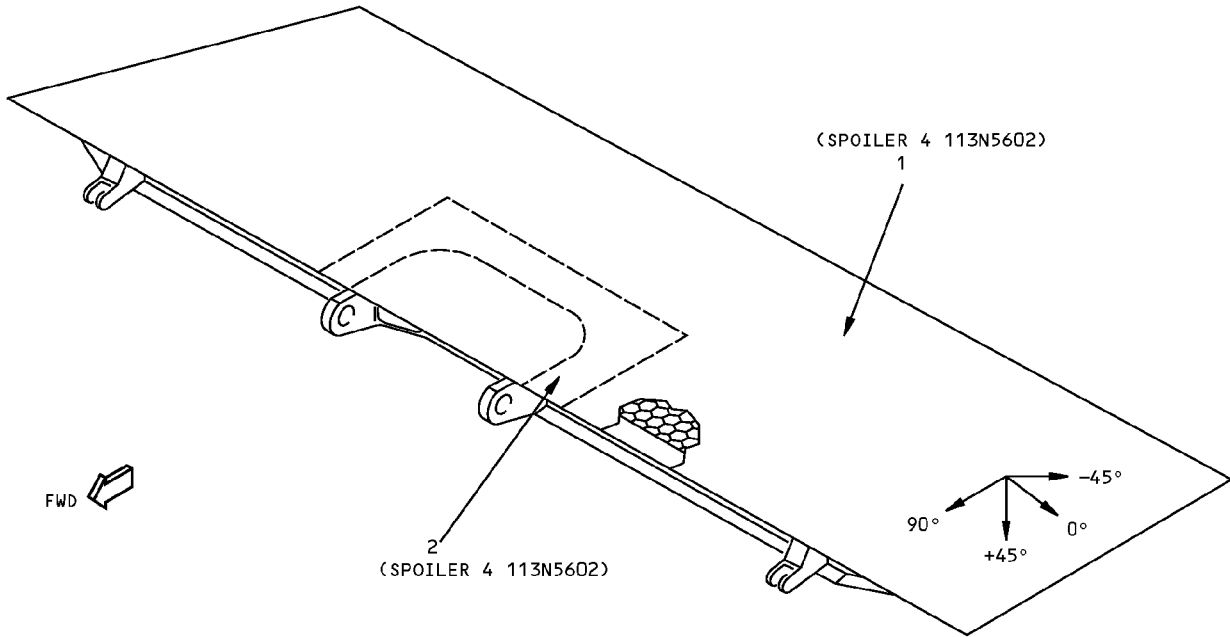

**SPOILER 4
DETAIL VIII E**

ITEM	DESCRIPTION	GAGE	MATERIAL	EFFECTIVITY
1	PANEL ASSY SKIN CORE		GRAPHITE/EPOXY HONEYCOMB SANDWICH SEE DETAIL IX NONMETALLIC HONEYCOMB PER BMS 8-124, CLASS IV, TYPE V, GRADE 3.0	
2	PANEL ASSY SKIN CORE		GRAPHITE/EPOXY HONEYCOMB SANDWICH SEE DETAIL XI NONMETALLIC HONEYCOMB PER BMS 8-124, CLASS I, TYPE I, GRADE 4.0	

LIST OF MATERIALS FOR DETAIL VIII

**Spoiler Skin Identification
Figure 1 (Sheet 8 of 9)**

IDENTIFICATION 1
Page 8
Jan 20/2005

57-70-01

D634N201

**757-200
STRUCTURAL REPAIR MANUAL**

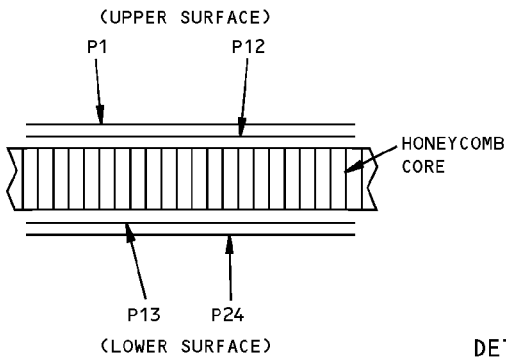

SECTION THRU HONEYCOMB
PANEL ALL SPOILERS

ITEM NO.	PLY NO.	MATERIAL	PLY ORIENTATION ^A
1	P1,P24	B	± 45°
	P12,P13	B	0° OR 90°

PLY TABLE ^C

DETAIL IX

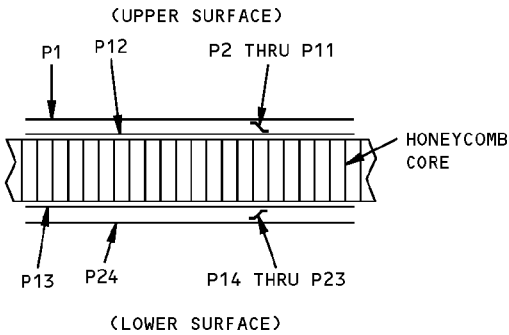

SECTION THRU HONEYCOMB
PANEL SPOILERS 1,2,3,5,6

ITEM NO.	PLY NO.	MATERIAL	PLY ORIENTATION ^A
2 (DETAIL VII)	P1,P5, P7,P9, P11,P14, P16,P18, P22,P24	B	± 45°
	P2,P3, P4,P6, P8,P10, P12,P13, P15,P17, P19,P20, P21,P23	B	0° OR 90°

PLY TABLE ^C

DETAIL X

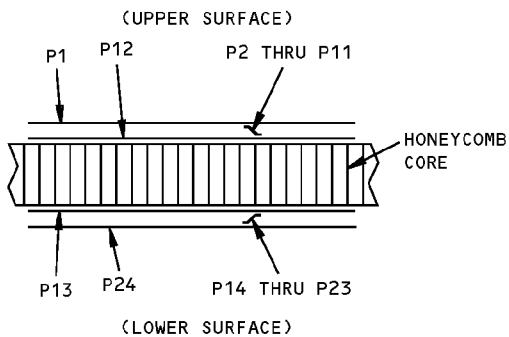

SECTION THRU HONEYCOMB
PANEL SPOILER NO. 4

ITEM NO.	PLY NO.	MATERIAL	PLY ORIENTATION ^A
2 (DETAIL VIII)	P1,P5, P7,P9, P11,P14, P17,P19, P23,P24	B	± 45°
	P2,P3, P4,P6, P8,P10, P12,P13, P15,P16, P18,P20, P21,P22	B	0° OR 90°

PLY TABLE ^C

DETAIL XI

**Spoiler Skin Identification
Figure 1 (Sheet 9 of 9)**

**757-200
STRUCTURAL REPAIR MANUAL**

ALLOWABLE DAMAGE 1 - SPOILER SKIN

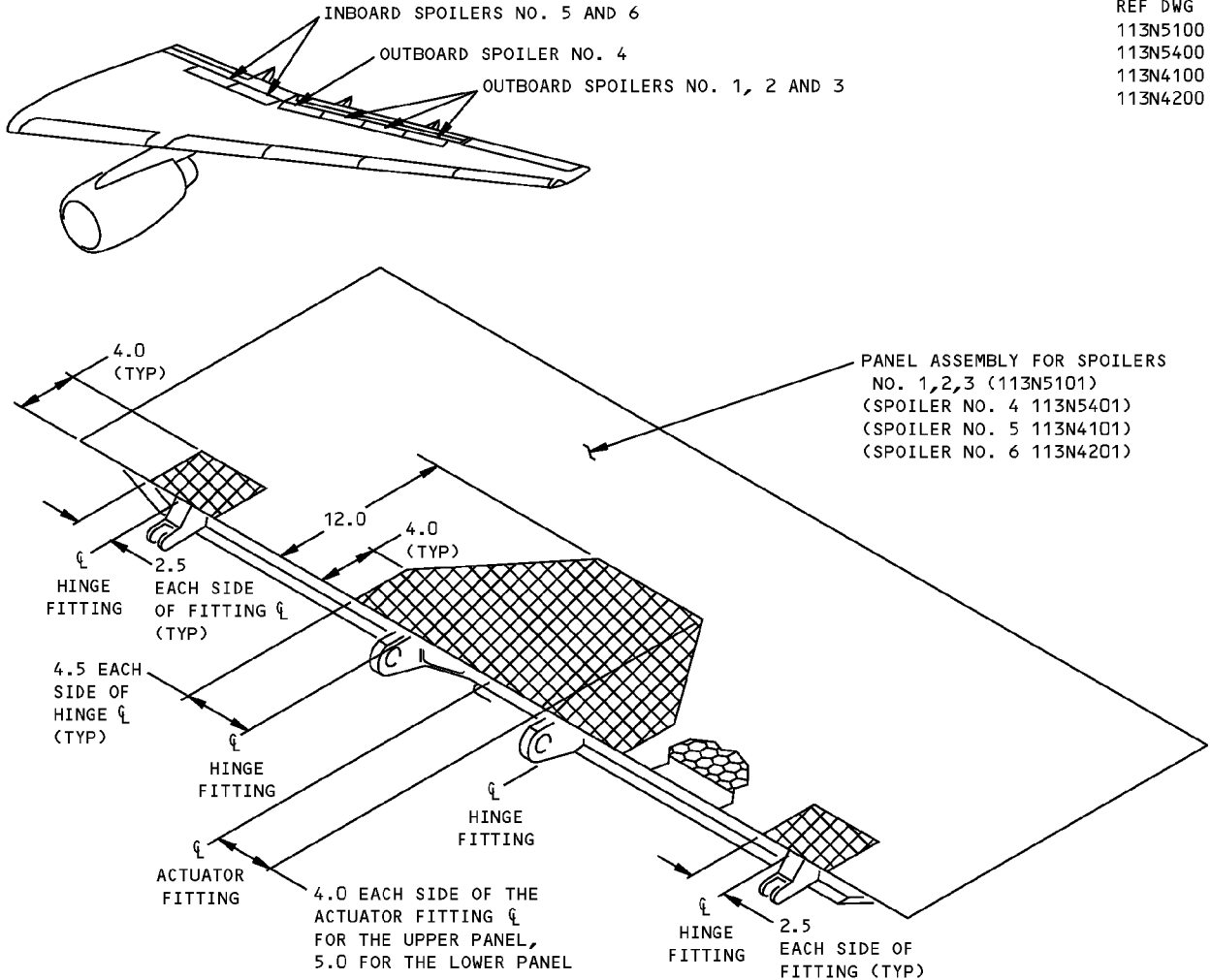

REF DWG
113N5100
113N5400
113N4100
113N4200

NON-CRITICAL AREA
 CRITICAL AREA

NOTE: DIMENSIONS ARE IN INCHES.
MATERIAL: GRAPHITE/EPOXY SKIN WITH NON-METALLIC HONEYCOMB CORE

THE UPPER PANEL OF SPOILER NO. 1 IS SHOWN,
SPOILERS 2 THRU 12 ARE ALMOST THE SAME

DESCRIPTION	CRACKS	NICKS, GOUGES AND CORROSION	DENTS	HOLES AND PUNCTURES	PANEL DELAMINA- TION	EDGE EROSION
SKIN PANEL NON-CRITICAL AREA CRITICAL AREA	A F	B F	C C	A F	A F	SEE DETAIL III SEE DETAIL III

**Spoiler Skin Allowable Damage
Figure 101 (Sheet 1 of 4)**

STRUCTURAL REPAIR MANUAL

NOTES

- REFINISH REWORKED AREAS AS GIVEN IN AMM 51-20.
- REFER TO SRM 51-10-01 FOR AERODYNAMIC SMOOTHNESS REQUIREMENTS. WHERE DAMAGE EXCEEDS THE LIMITS SHOWN IN SRM 51-10-01, CONSIDERATION SHOULD BE GIVEN TO LOSS OF PERFORMANCE INVOLVED.
- REFER TO SRM 51-10-02 FOR INSPECTION AND REMOVAL OF DAMAGE

A DAMAGE TO THE EDGES OF THE SKIN PANEL CAN CAUSE FIBER DAMAGE AND A DECREASE IN CROSS-SECTIONAL AREA. REMOVE EDGE DAMAGE AS SHOWN IN DETAILS I AND II.

DAMAGE IS PERMITTED ONLY ON ONE SURFACE OF HONEYCOMB CORE TO A TOTAL MAXIMUM DIMENSION (D) OF 2.0 INCHES (50 mm) FOR EACH SQUARE FOOT OF AREA.

A DAMAGE SITE MUST BE:

- A MINIMUM OF 3D (EDGE TO EDGE) FROM ANOTHER DAMAGE SITE. SEE DETAIL IV FOR DAMAGE SITE SPECIFICATIONS
- A MINIMUM OF 3D (EDGE TO EDGE) FROM A HOLE OR THE EDGE OF THE MATERIAL.

DAMAGE IS NOT PERMITTED:

- FOR MORE THAN ONE FASTENER HOLE IN SIX
- ON MORE THAN ONE 10% OF THE LENGTH OF THE EDGE BAND ON A SIDE.

PROTECT DAMAGE THAT IS NOT REWORKED AS GIVEN IN NOTE **D**.

B DAMAGE IS ALLOWED ON THE SURFACE RESIN ONLY WITH NO FIBER DAMAGE. CLEAN UP EDGE DAMAGE AS SHOWN IN DETAILS I AND II. FIBER DAMAGE MUST BE TREATED AS A HOLE OR PUNCTURE DAMAGE.

C DENTS RESULT IN DELAMINATION AND FIBER DAMAGE AND MUST BE TREATED AS A HOLE OR PUNCTURE DAMAGE.

D REMOVE MOISTURE FROM DAMAGE AREA. USE OF VACUUM AND HEAT (MAX OF 125°F (52°C)) TO REMOVE MOISTURE FROM HONEYCOMB CELLS IS RECOMMENDED. PROTECT DAMAGE FROM ENTRANCE OF WATER, SUNLIGHT OR OTHER FOREIGN MATTER BY SEALING WITH ALUMINUM FOIL TAPE (SPEED TAPE). RECORD THE LOCATION AND INSPECT EVERY AIRPLANE "A" CHECK. REPLACE THE ALUMINUM FOIL TAPE IF ANY PEELING OR DETE-RIORATION IS EVIDENT. REPAIR NO LATER THAN NEXT AIRPLANE "C" CHECK. **E**

E THESE ALLOWABLE DAMAGE LIMITS HAVE FAA APPROVAL CONTINGENT ON ACCOMPLISHMENT OF THE INSPECTIONS CONTAINED HEREIN.

F DAMAGE TO THE EDGES OF THE SKIN PANEL CAN CAUSE FIBER DAMAGE AND A DECREASE IN CROSS-SECTIONAL AREA. REMOVE EDGE DAMAGE AS SHOWN IN DETAILS I AND II.

DAMAGE IS PERMITTED ONLY ON ONE SURFACE OF HONEYCOMB CORE TO A TOTAL MAXIMUM DIMENSION (D) OF 0.25 INCH (6.35 mm) FOR EACH SQUARE FOOT OF AREA.

A DAMAGE SITE MUST BE:

- A MINIMUM OF 3D (EDGE TO EDGE) FROM ANOTHER DAMAGE SITE. SEE DETAIL IV FOR DAMAGE SITE SPECIFICATIONS
- A MINIMUM OF 3D (EDGE TO EDGE) FROM A HOLE OR THE EDGE OF THE MATERIAL.

DAMAGE IS NOT PERMITTED:

- FOR MORE THAN ONE FASTENER HOLE IN TEN IN THE ACTUATOR FITTING
- FOR MORE THAN ONE ATTACHMENT BOLT IN A HINGE FITTING
- ON MORE THAN 5% OF THE LENGTH OF THE EDGE BAND ON A SIDE.

REPAIR THE AREA BY 300 FLIGHT HOURS.

PROTECT DAMAGE THAT IS NOT REWORKED AS GIVEN IN NOTE **D**.

**Spoiler Skin Allowable Damage
Figure 101 (Sheet 2 of 4)**

**757-200
STRUCTURAL REPAIR MANUAL**

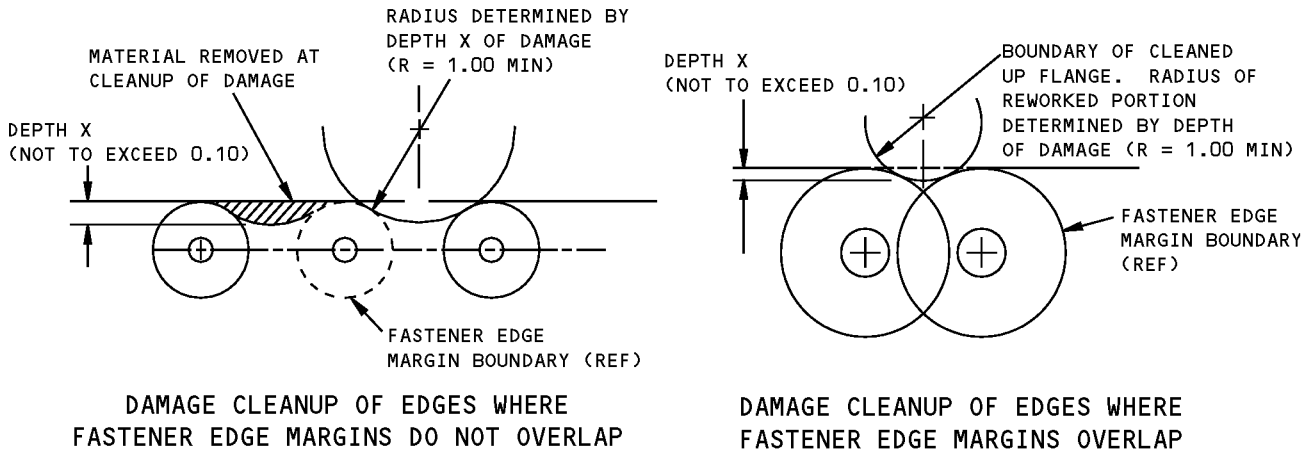

DETAIL I

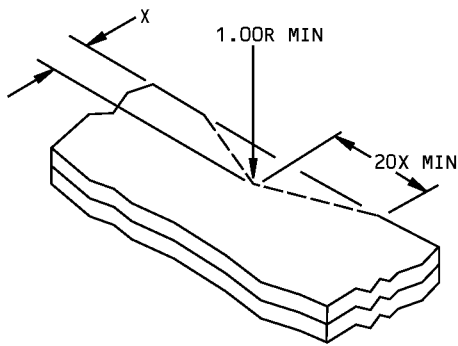

X = DEPTH OF CLEANUP = 0.10 MAX

DETAIL II

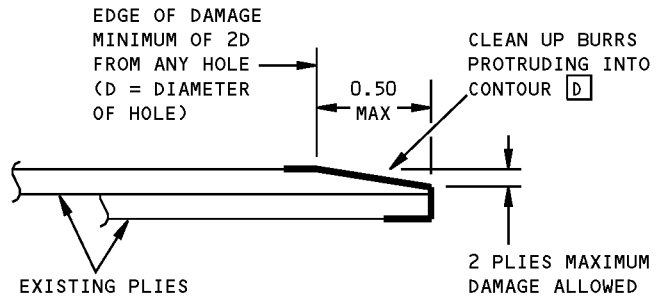

DAMAGE CLEANUP AND SEALING OF EDGE EROSION

DETAIL III

**Spoiler Skin Allowable Damage
Figure 101 (Sheet 3 of 4)**

**757-200
STRUCTURAL REPAIR MANUAL**

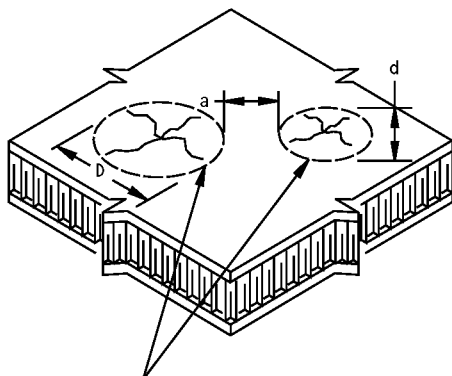

ADJACENT DAMAGE SITES ON SURFACE OF COMPOSITE PANEL

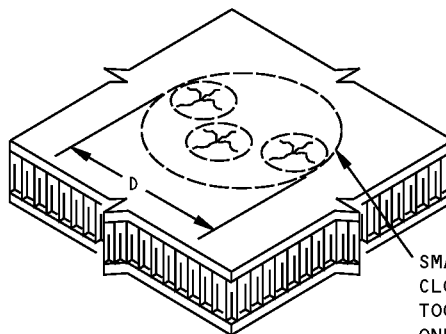

SMALL DAMAGE SITES THAT ARE CLOSELY SPACED MAY BE GROUPED TOGETHER AND CONSIDERED AS ONE DAMAGE SITE

- DAMAGE TO COMPOSITE PANELS EXPOSED TO MULTIPLE IMPACTS, I.E., HAIL DAMAGE, CAN BE DETECTED BY USING INSTRUMENTED NON-DESTRUCTIVE INSPECTION METHODS OR BY TAPPING THE SUSPECTED DAMAGE AREA WITH A SMALL METALLIC DISK OBJECT. INSPECTION SHOULD COVER THE AREA WITHIN 3 DIAMETERS AROUND THE EDGE OF THE VISIBLE DAMAGE SITE. FOR TAP TEST, USE A SOLID METAL DISK AND TAP THE DAMAGE AREA LIGHTLY BUT FIRMLY. VOID AREAS SHOULD PRODUCE A DULL SOUND AS OPPOSED TO A SHARP RING ON A SOLID BONDED AREA.
- DAMAGE SITE IS ANY SINGLE AREA OF A PANEL WHERE A DENT, CRACK, DELAMINATION, PUNCTURE OR ANY COMBINATION OF THESE EXIST. SMALL DAMAGE SITES THAT ARE CLOSELY SPACED MAY BE GROUPED TOGETHER AND CONSIDERED AS ONE DAMAGE SITE.
- "D" IS DETERMINED BY MEASURING THE MAX DIMENSION OF A DENT, CRACK, OR OTHER DAMAGE, WHICHEVER IS GREATER.
- "a" IS THE DISTANCE BETWEEN TWO ADJACENT DAMAGE SITES.
- "d" IS THE MAX DIMENSION OF THE SMALLER OF TWO ADJACENT DAMAGE SITES.
- CALCULATE a/D BY DIVIDING DISTANCE "a" BY DIMENSION "D".
- DAMAGE IS ALLOWED WHEN "D" IS EQUAL TO OR LESS THAN THE MAXIMUM ALLOWABLE "D" FROM TABLE I.

**DAMAGE SIZING AND SPACING DATA
FOR COMPOSITE PANELS**

DETAIL IV

**Spoiler Skin Allowable Damage
Figure 101 (Sheet 4 of 4)**

757-200 STRUCTURAL REPAIR MANUAL

REPAIR 1 - SPOILER SKIN

REFERENCE DRAWINGS
113N5100
113N5400
113N4100
113N4200

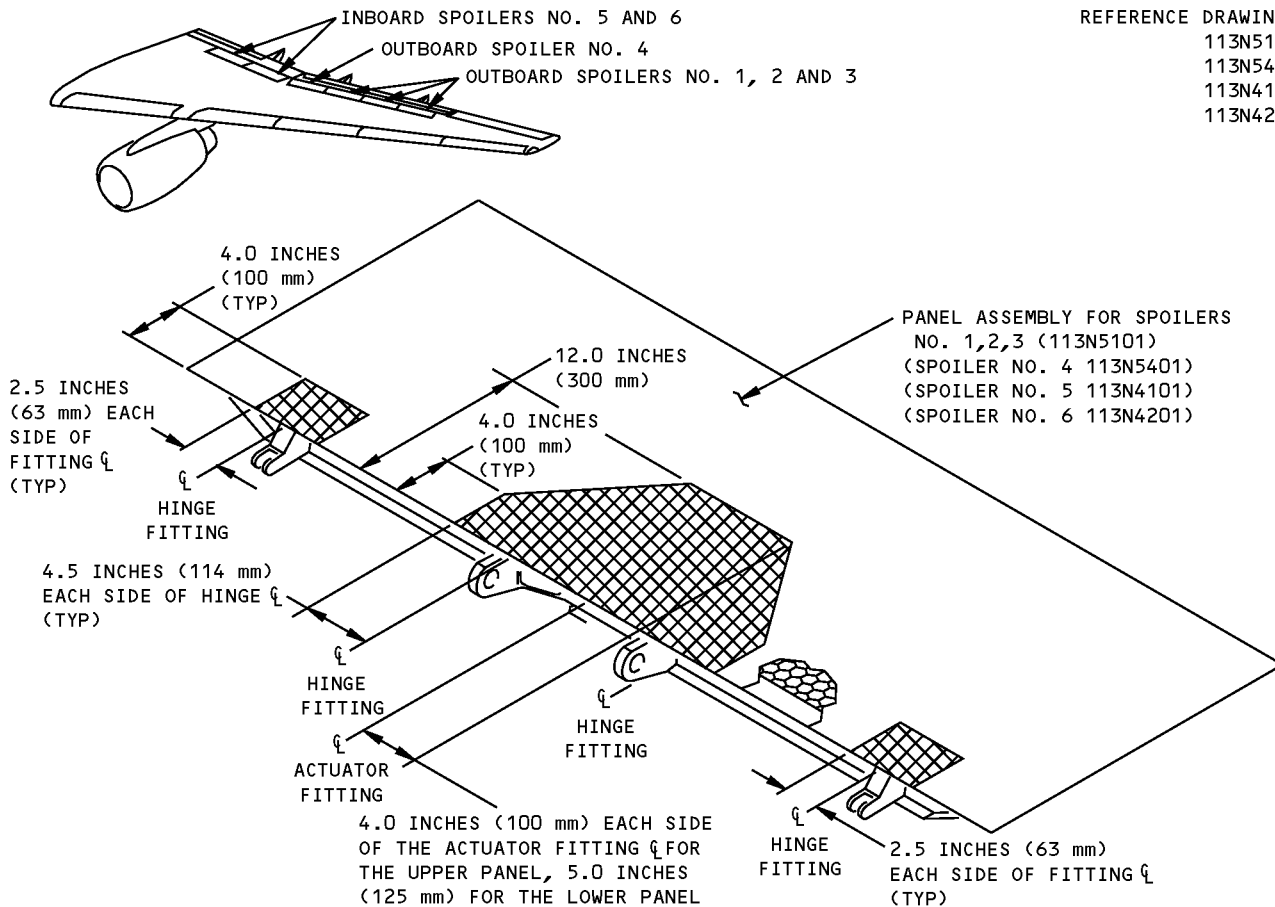

- NON-CRITICAL AREA
SEE TABLE I FOR THE REPAIR DATA.
- CRITICAL AREA
SEE TABLE II FOR THE REPAIR DATA.

NOTE: DIMENSIONS ARE IN INCHES.
MATERIAL: GRAPHITE/EPOXY SKIN WITH
NON-METALLIC HONEYCOMB CORE

**THE UPPER PANEL OF SPOILER NO. 1 IS SHOWN,
SPOILERS 2 THRU 12 ARE ALMOST THE SAME**

NOTES

- REFINISH REWORKED AREAS PER AMM 51-20.
- REFER TO SRM 51-10-01 FOR AERODYNAMIC SMOOTHNESS REQUIREMENTS. WHERE THE DAMAGE EXCEEDS THE LIMITS SHOWN IN SRM 51-10-01, CONSIDERATION SHOULD BE GIVEN TO THE LOSS OF PERFORMANCE INVOLVED.
- A** INSPECT INTERIM REPAIR USING INSTRUMENTED NDI METHODS OR "TAP" TEST EVERY AIRPLANE "2A" CHECK. FOR "TAP" TEST, USE A SOLID METAL DISK AND TAP THE REPAIR AREA LIGHTLY BUT FIRMLY. VOID AREAS WILL PRODUCE A DULL SOUND AS OPPOSED TO A SHARP RING ON A SOLID BONDED AREA. PERMANENT REPAIR IS REQUIRED IF ANY DETEIORATION IS EVIDENT. REFER TO SRM 51-70-03, PAR. 4.I. AND THE NONDESTRUCTIVE TEST MANUAL **D**
- B** LIMITED TO REPAIR OF DAMAGE TO ONE FACESHEET SKIN AND HONEYCOMB CORE. ONE REPAIR PER SQUARE FOOT OF AREA AND MINIMUM OF 6.0 INCHES (150 mm) (EDGE TO EDGE) FROM ANY OTHER DAMAGE, FASTENER HOLE, OR EDGE OF PANEL.
- C** ONE REPAIR PER SQUARE FOOT OF AREA AND A MINIMUM OF 6.0 INCHES (150 mm) (EDGE TO EDGE) FROM ANY OTHER DAMAGE, FASTENER HOLE, OR EDGE OR PANEL.
- D** THIS REPAIR HAS FAA APPROVAL CONTINGENT ON ACCOMPLISHMENT OF THE INSPECTIONS CONTAINED HEREIN.

**Spoiler Skin Repair
Figure 201 (Sheet 1 of 3)**

**757-200
STRUCTURAL REPAIR MANUAL**

DAMAGE	INTERIM REPAIRS A	PERMANENT REPAIRS		
	WET LAYUP 150°F (66°C) CURE (SRM 51-70-03)	WET LAYUP 200°F (121°C) CURE (SRM 51-70-17)	250°F (121°C) CURE (SRM 51-70-05)	350°F (177°C) CURE (SRM 51-70-04)
CRACKS	UP TO 3.0 INCHES (75 mm) LONG, REPAIR WITH PATCH AS GIVEN IN SRM 51-70-03, PAR. 5.N. B	CLEAN UP DAMAGE AND REPAIR AS A HOLE.	CLEAN UP DAMAGE AND REPAIR AS A HOLE.	CLEAN UP DAMAGE AND REPAIR AS A HOLE.
HOLES	3.0 INCHES (75 mm) MAXIMUM DIA NOT TO EXCEED 30% OF SMALLEST DIMENSION ACROSS THE HONEYCOMB PANEL AT THE DAMAGE LOCATION. FILL WITH BMS 5-28, TYPE 7 POTTING COMPOUND AND PATCH AS GIVEN IN SRM 51-70-03, PAR. 5.N. B	12.0 INCHES (300 mm) MAXIMUM DIA NOT TO EXCEED 50% OF SMALLEST DIMENSION ACROSS THE HONEYCOMB PANEL AT THE DAMAGE LOCATION. USE TWO EXTRA PLIES FOR EACH FACESHEET REPAIRED. C	6.0 INCHES (150 mm) MAXIMUM DIA NOT TO EXCEED 50% OF SMALLEST DIMENSION ACROSS THE HONEYCOMB PANEL AT THE DAMAGE LOCATION. USE TWO EXTRA PLIES FOR EACH FACESHEET REPAIRED. C	NO SIZE LIMIT
EDGE EROSION	_____	FOR DAMAGE THAT IS NOT LARGER THAN 10% OF EDGE BAND THICKNESS, REPAIR AS GIVEN IN SRM 51-70-03, PAR. 5.O. FOR LARGER DAMAGE, REPAIR AS GIVEN IN: SRM 51-70-17, PAR. 4.G. SRM 51-70-05, PAR. 5.G. SRM 51-70-04, PAR. 5.G.		
DELAMINATION	CUT OUT AND REPAIR AS A HOLE.			
NICKS AND GOUGES	IF THERE IS NO FIBER DAMAGE OR DELAMINATION, FILL NICKS OR GOUGES AS GIVEN IN SRM 51-70-03. IF YOU FIND FIBER DAMAGE OR DELAMINATION, THEN REPAIR AS A HOLE.			
DENTS	UP TO 2.0 INCHES (50 mm) DIA WITH NO FIBER DAMAGE OR DELAMINATION IN HONEYCOMB PANEL AREAS, FILL WITH BMS 5-28, TYPE 7 POTTING COMPOUND AND PATCH AS GIVEN IN SRM 51-70-03, PAR. 5.L. C OVER 2.0 INCHES (50 mm) DIA OR WITH FIBER DAMAGE OR DELAMINATION, REPAIR AS A HOLE.			

REPAIR DATA FOR 350°F CURE GRAPHITE/EPOXY HONEYCOMB PANELS IN NON-CRITICAL AREAS

TABLE I

**Spoiler Skin Repair
Figure 201 (Sheet 2 of 3)**

**757-200
STRUCTURAL REPAIR MANUAL**

DAMAGE	INTERIM REPAIRS A	PERMANENT REPAIRS		
	WET LAYUP 150°F (66°C) CURE (SRM 51-70-03)	WET LAYUP 200°F (93°C) CURE (SRM 51-70-17)	250°F (121°C) CURE (SRM 51-70-05)	350°F (177°C) CURE (SRM 51-70-04)
CRACKS	UP TO 0.25 INCH (6 mm) INCHES LONG, REPAIR WITH PATCH AS GIVEN IN SRM 51-70-03, PAR. 5.N. B	CLEAN UP DAMAGE AND REPAIR AS A HOLE.	CLEAN UP DAMAGE AND REPAIR AS A HOLE.	CLEAN UP DAMAGE AND REPAIR AS A HOLE.
HOLES	0.25 INCH (6 mm) MAXIMUM DIA. FILL WITH BMS 5-28, TYPE 7 POTTING COMPOUND AND PATCH AS GIVEN IN SRM 51-70-03, PAR. 5.N. B	5.0 INCHES (125 mm) MAXIMUM DIA. USE TWO EXTRA PLIES FOR EACH FACESHEET REPAIRED. C	2.0 INCHES (50 mm) MAXIMUM DIA. USE TWO EXTRA PLIES FOR EACH FACESHEET REPAIRED. C	NO SIZE LIMIT
EDGE EROSION	_____	FOR DAMAGE THAT IS NOT LARGER THAN 10% OF EDGE BAND THICKNESS, REPAIR AS GIVEN IN SRM 51-70-03, PAR. 5.O. FOR LARGER DAMAGE, REPAIR AS GIVEN IN: SRM 51-70-17, PAR. 4.G. SRM 51-70-05, PAR. 5.G. SRM 51-70-04, PAR. 5.G.		
DELAMINATION	CUT OUT AND REPAIR AS A HOLE.			
NICKS AND GOUGES	IF THERE IS NO FIBER DAMAGE OR DELAMINATION, FILL NICKS OR GOUGES AS GIVEN IN SRM 51-70-03. IF YOU FIND FIBER DAMAGE OR DELAMINATION THEN, REPAIR AS A HOLE			
DENTS	UP TO 2.0 INCHES (50 mm) DIA WITH NO FIBER DAMAGE OR DELAMINATION IN THE HONEYCOMB PANEL AREAS, FILL WITH BMS 5-28, TYPE 7 POTTING COMPOUND AND PATCH AS GIVEN IN SRM 51-70-03, PAR. 5.L. C OVER 2.0 INCHES (50 mm) DIA OR WITH FIBER DAMAGE OR DELAMINATION, REPAIR AS A HOLE.			

REPAIR DATA FOR 350°F CURE GRAPHITE/EPOXY HONEYCOMB PANELS IN CRITICAL AREAS

TABLE II

**Spoiler Skin Repair
Figure 201 (Sheet 3 of 3)**

**757-200
STRUCTURAL REPAIR MANUAL**

IDENTIFICATION 1 - SPOILER STRUCTURE

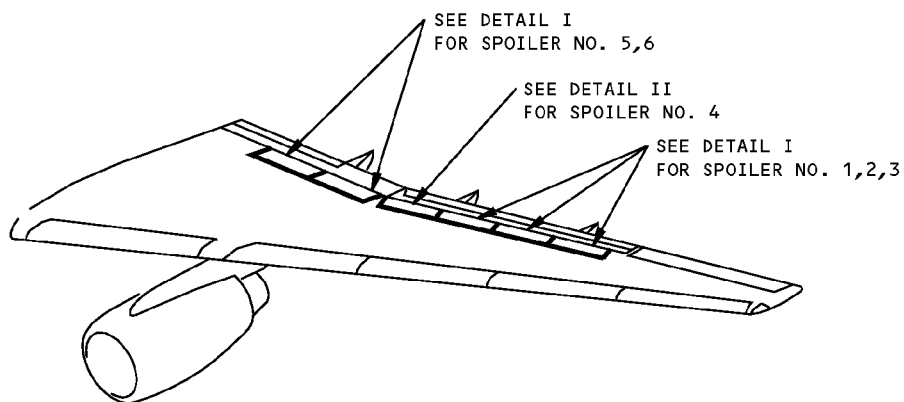

LEFT SIDE SHOWN,
RIGHT SIDE OPPOSITE

NOTES

- | | |
|---|--|
| <p>A 7075-T73 PLATE OPTIONAL FOR CUM LINE NUMBERS: 1 THRU 29,33,37</p> <p>B PLY ORIENTATION CONVENTION - DEGREES INDICATED IS PARALLEL TO THE FABRIC WARP DIRECTION</p> <p>C GRAPHITE/EPOXY PRE-PREG FABRIC PER BMS 8-212, TYPE IV, CLASS 2, STYLE 3K-70-PW, 350°F (177°C) CURE</p> <p>D DIAGRAM OF PLY ORIENTATION. SEE APPLICABLE TABLE FOR INDIVIDUAL PLY ORIENTATION AND MATERIAL</p> <p>E MATERIAL AND PLY ORIENTATION SHOWN FOR FIELD AREAS ONLY. SEE BOEING DRAWINGS FOR EDGE BANDS AND AREAS WITH DOUBLERS</p> | <p>F FOR SPOILER NO. 6 ONLY</p> <p>G FOR SPOILERS 1,2,3,5</p> <p>H GRAPHITE/EPOXY PREPREG FABRIC PER BMS 8-256, TYPE I, CLASS 2, STYLE 3K-70-PW, 350°F (177°C) CURE</p> <p>J FOR CUM LINE NUMBERS: 1 THRU 31</p> <p>K FOR CUM LINE NUMBERS: 32 AND ON</p> <p>L 7075-T73651 PLATE OPTIONAL FOR CUM LINE NUMBERS: 1 THRU 100</p> |
|---|--|

**Spoiler Structure Identification
Figure 1 (Sheet 1 of 5)**

**757-200
STRUCTURAL REPAIR MANUAL**

(SPOILER NO. 1,2,3,5; 113N5104
OPTIONAL 113N4120)
(SPOILER NO. 6; 113N4104
OPTIONAL 113N4120)

(SPOILER NO. 1,2,3; 113N5103
OPTIONAL 113N5140)
(SPOILER NO. 5, 113N5107
OPTIONAL 113N5140)
(SPOILER NO. 6; 113N4103
OPTIONAL 113N4140)

REF DWG
113N5100
113N5400
113N4100
113N4200

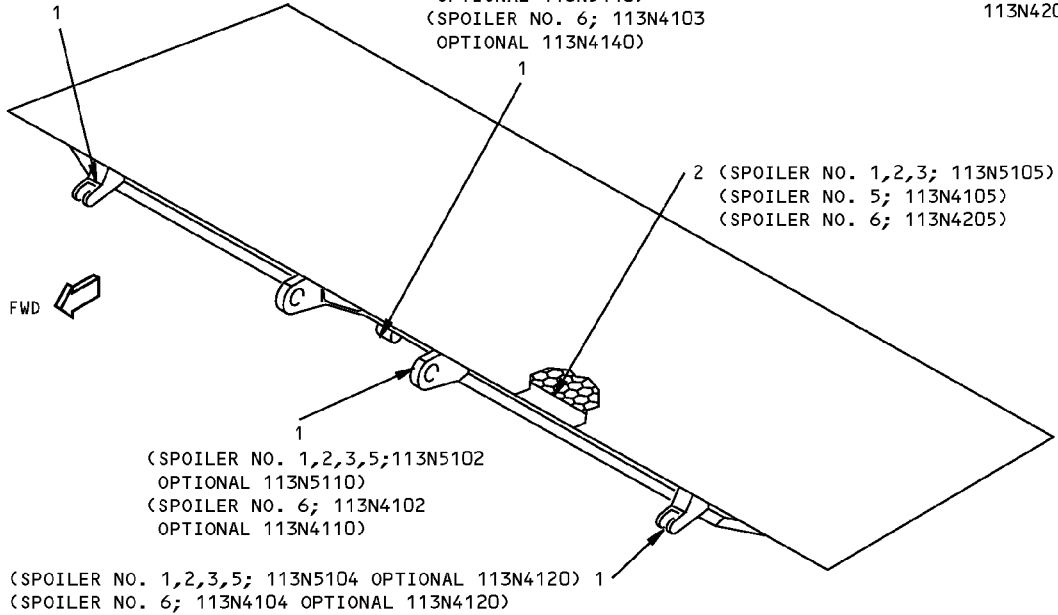

**SPOILER NO. 1,2,3,5,6
DETAIL I J**

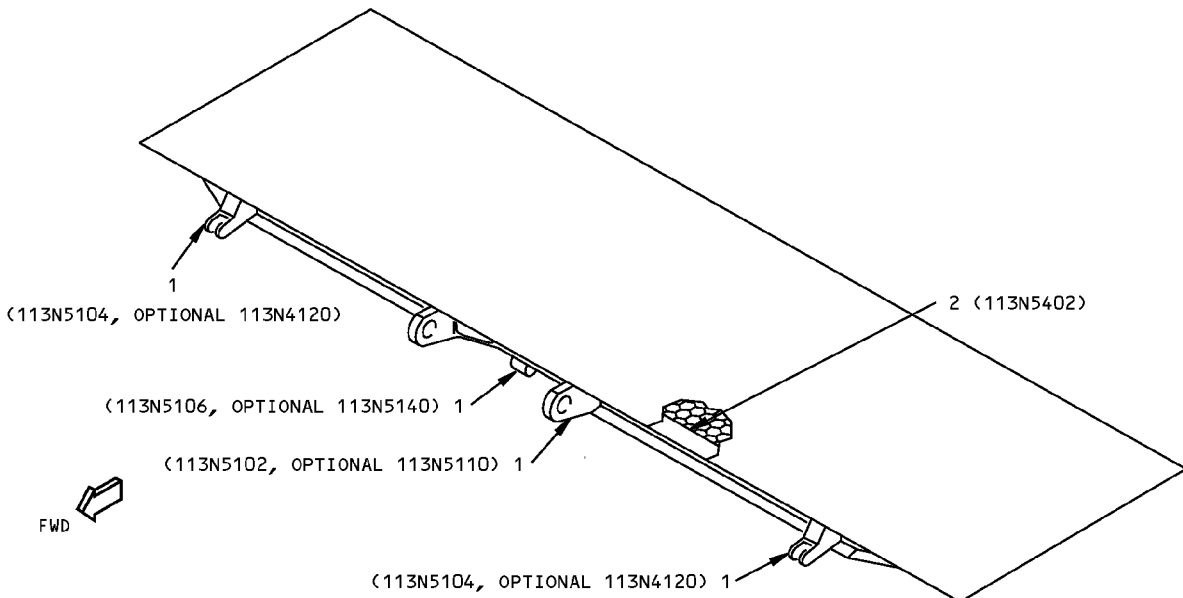

**SPOILER NO. 4
DETAIL II J**



**Spoiler Structure Identification
Figure 1 (Sheet 2 of 5)**

IDENTIFICATION 1
Page 2
Jan 20/2005

57-70-02

D634N201

**757-200
STRUCTURAL REPAIR MANUAL**

ITEM	DESCRIPTION	GAGE	MATERIAL	EFFECTIVITY
1	HINGE AND ACTUATOR FITTINGS		FORGING 7075-T73	A
2	SPAR		GRAPHITE/FIBERGLASS/EPOXY LAMINATE SEE DETAIL III	

LIST OF MATERIALS FOR DETAIL I AND II

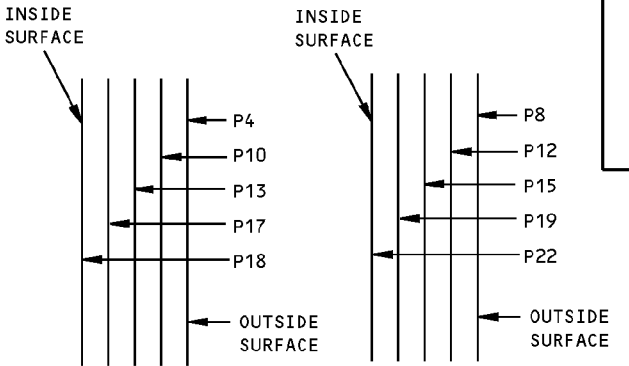

SECTION THRU SPAR
SPOILER NO. 4

SECTION THRU
SPOILER NO. 1,2,3,5

ITEM NO.	PLY NO.	MATERIAL	PLY ORIENTATION
2	P4,P8,P10, P12,P17,P18	C	$\pm 45^\circ$
	P13,P15	C	0°
	P19	C	0° F $\pm 45^\circ$ G
	P22,P25,P30	C	$\pm 45^\circ$

PLY TABLE E

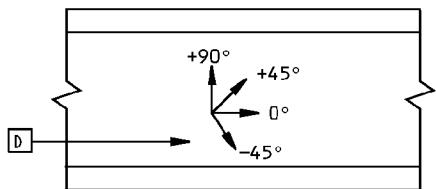

VIEW ON SPAR LOOKING AFT

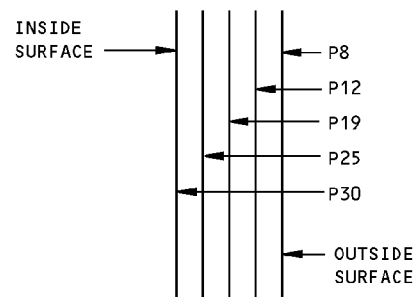

SECTION THRU
SPOILER NO. 6

DETAIL III

**Spoiler Structure Identification
Figure 1 (Sheet 3 of 5)**

**757-200
STRUCTURAL REPAIR MANUAL**

REF DWG
113N5501
113N4501
113N5601
113N4601

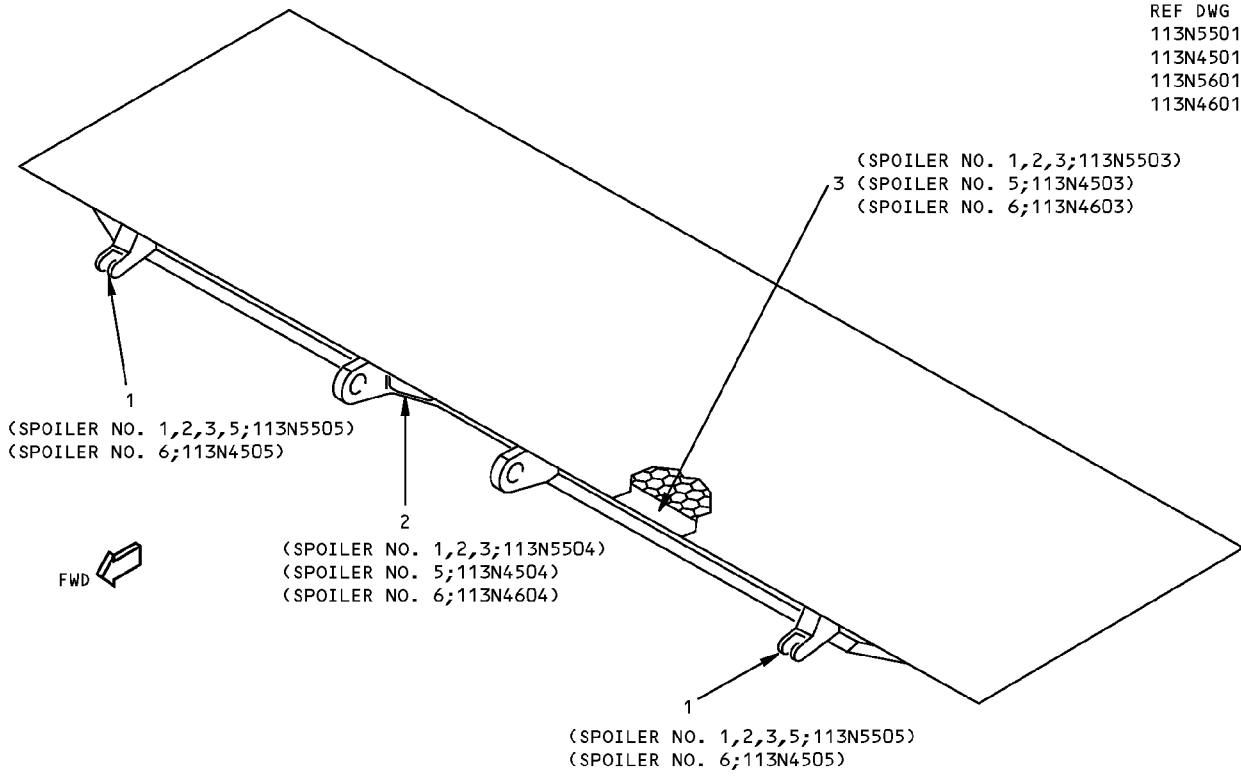

**SPOILER NO. 1, 2, 3, 5, 6
DETAIL IV [K]**

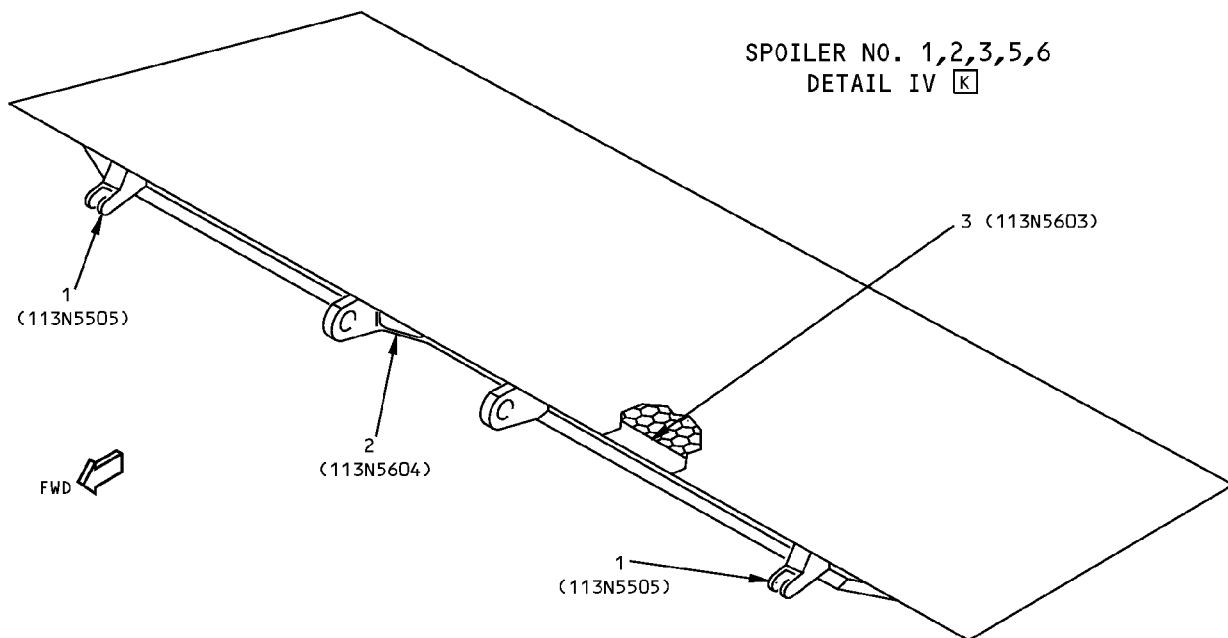

**SPOILER NO. 4
DETAIL V [K]**



**Spoiler Structure Identification
Figure 1 (Sheet 4 of 5)**

**757-200
STRUCTURAL REPAIR MANUAL**

ITEM	DESCRIPTION	GAGE	MATERIAL	EFFECTIVITY
1	OUTER HINGE FITTINGS		FORGING 7075-T73	
2	HINGE/ACTUATOR FITTING		FORGING 7075-T73 OPTIONAL: MACHINED PLATE 7075-T73651	L
3	SPAR		GRAPHITE/EPOXY LAMINATE. SEE DETAIL VI	

LIST OF MATERIALS FOR DETAILS IV AND V

ITEM NO.	PLY NO.	MATERIAL	PLY ORIENTATION B
3	P6	H	0° OR 90°
	P4,P5,P7,P8	H	± 45°

PLY TABLE E

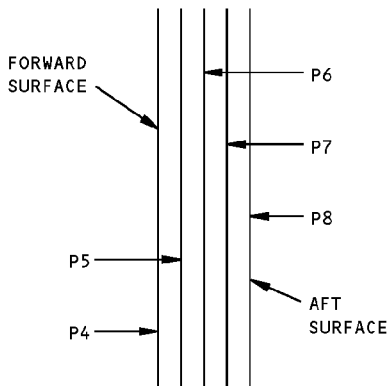

SECTION THRU SPAR
ALL SPOILERS

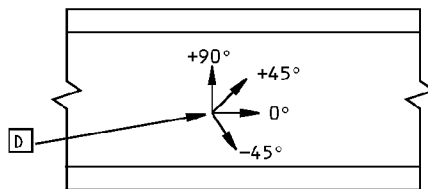

VIEW ON SPAR LOOKING AFT

DETAIL VI

**Spoiler Structure Identification
Figure 1 (Sheet 5 of 5)**

**757-200
STRUCTURAL REPAIR MANUAL**

ALLOWABLE DAMAGE 1 - SPOILER STRUCTURE

REF DWG
113N5100
113N5400
113N4100
113N4200

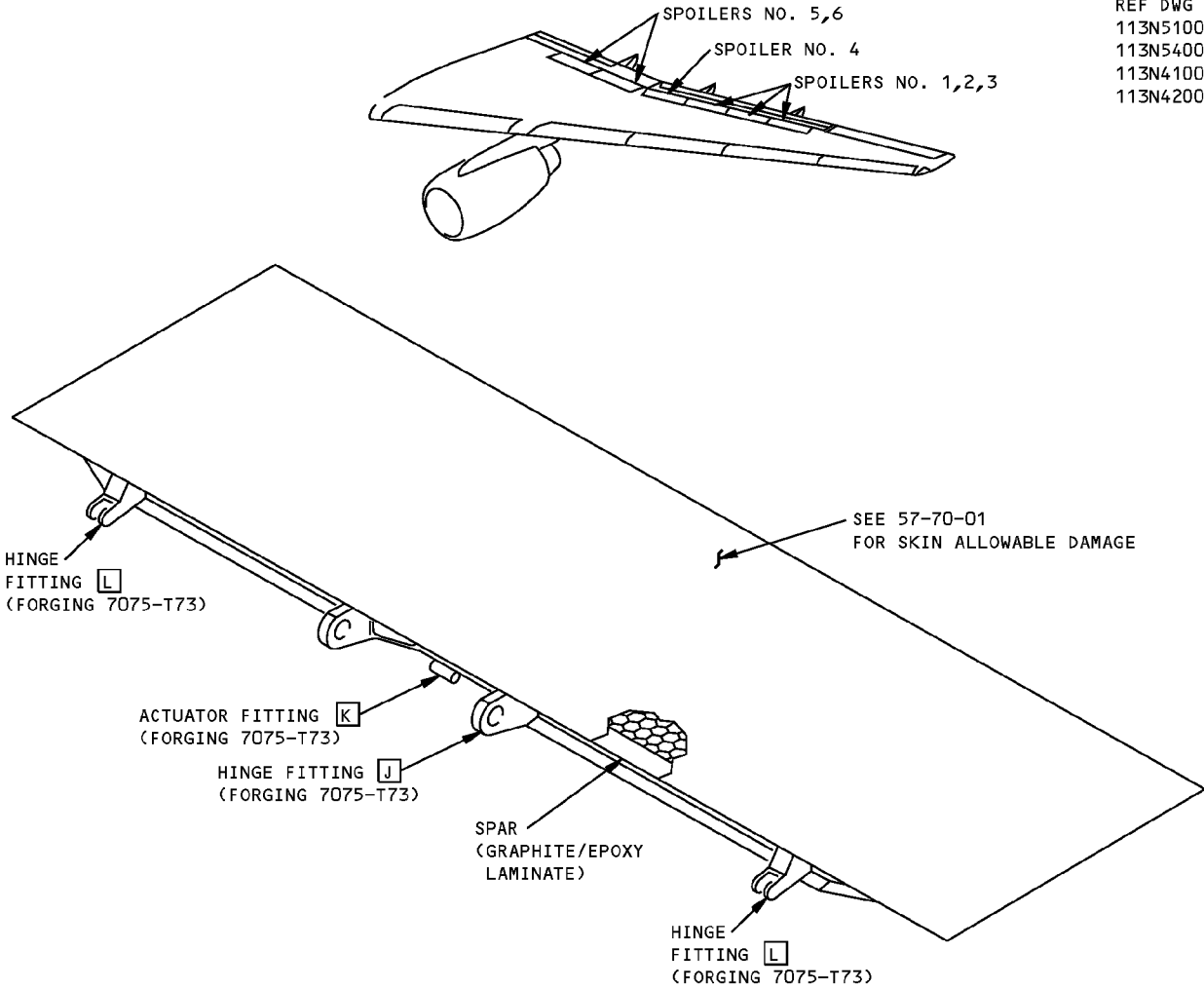

SPOILER NO. 1 SHOWN
SPOILERS 2 THRU 6 SIMILAR
DETAIL I

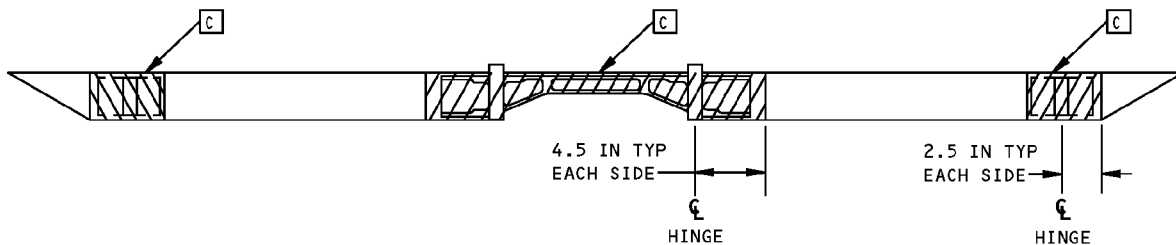

VIEW ON SPAR

**Spoiler Structure Allowable Damage
Figure 101 (Sheet 1 of 4)**

STRUCTURAL REPAIR MANUAL

DESCRIPTION	CRACKS	NICKS, GOUGES AND CORROSION	DENTS	HOLES AND PUNCTURES	DELAMINATION
HINGE AND ACTUATOR FITTINGS	[A]	[B]	NOT PERMITTED	NOT PERMITTED	—
SPAR	[D]	[F]	[G]	[H]	[I]

NOTES

- REFINISH REWORKED AREAS AS GIVEN IN AMM 51-20.
 - TYPICAL DAMAGE TO A PANEL EDGE BAND MAY CONSIST OF EDGE CRUSHING, CRACKS OR DELAMINATION. DAMAGE AROUND HOLES MAY CONSIST OF OVALIZATION, FASTENER PULL-THROUGH OR CRACKS OUT OF HOLE. DAMAGE MAY REDUCE THE EFFECTIVE CROSS SECTIONAL AREA OF AN EDGE BAND. DAMAGE TO EDGES SHOULD BE BLENDED OUT TO LIMITATIONS GIVEN FOR COMPONENT.
- [A] CRACKS ARE NOT PERMITTED EXCEPT FOR EDGE CRACKS WHICH MUST BE REMOVED AS SHOWN IN DETAIL II. SEE DETAIL I FOR APPLICABLE SHOT PEEN REQUIREMENTS.
- [B] FOR EDGE DAMAGE SEE DETAIL II. FOR LUG DAMAGE SEE DETAIL IV. FOR OTHER DAMAGE SEE DETAIL V. DAMAGE IS NOT PERMITTED IN VICINITY OF BUSHINGS. SEE DETAIL I FOR APPLICABLE SHOT PEEN REQUIREMENTS.
- [C] CRITICAL AREA - CONSULT THE BOEING COMPANY FOR ALLOWABLE DAMAGE.
- [D] CRACKS ARE NOT PERMITTED EXCEPT FOR EDGE CRACKS WHICH MUST BE REMOVED AS SHOWN IN DETAILS III AND VI. MAINTAIN EDGE MARGIN SHOWN. REFINISH OR [E].
- [E] REMOVE MOISTURE FROM DAMAGE AREA. USE OF VACUUM AND HEAT (MAXIMUM OF 125°F [52°C]) TO REMOVE MOISTURE FROM HONEYCOMB CELLS IS RECOMMENDED. PROTECT DAMAGE FROM ENTRANCE OF WATER, SUNLIGHT OR OTHER FOREIGN MATTER BY SEALING WITH ALUMINUM FOIL TAPE (SPEED TAPE). RECORD THE LOCATION AND INSPECT EVERY AIRPLANE "A" CHECK. REPLACE THE ALUMINUM FOIL TAPE IF ANY PEELING OR DETERIORATION EVIDENT. REPAIR NO LATER THAN NEXT AIRPLANE "C" CHECK. [N]
- [F] DAMAGE IS PERMITTED ON SURFACE RESIN ONLY. DAMAGE TO FIBERS IS NOT PERMITTED. CLEAN UP EDGE DAMAGE AS SHOWN IN DETAIL VI [E].
- [G] DENTS GENERALLY RESULT IN FIBER DAMAGE OR DELAMINATION. HOWEVER, IF THERE IS NO FIBER DAMAGE OR DELAMINATION, DENTS UP TO 1.0 INCH DIAMETER MAXIMUM ARE PERMITTED. ONE DENT ON EACH SQUARE FOOT OF AREA IS PERMITTED WHICH MUST BE A MINIMUM OF 6 INCHES FROM ANY OTHER DAMAGE, FASTENER HOLE, OR PANEL EDGE. SEE [H] OR [I] IF FIBER DAMAGE OR DELAMINATION IS PRESENT.
- [H] 0.50 INCH MAXIMUM DIAMETER PERMITTED PROVIDED DAMAGE IS A MINIMUM OF 3 D FROM OTHER DAMAGE, NEAREST HOLE, OR MATERIAL EDGE. [E]
- [I] 1.0 INCH MAXIMUM DIAMETER IS PERMITTED, AND A MAXIMUM OF 0.03 INCH DELAMINATION FROM EDGE IS PERMITTED. REPAIR DELAMINATION AS GIVEN IN AMM 51-70 NO LATER THAN THE NEXT "C" CHECK. PROTECT EDGE DAMAGE AS GIVEN IN. [E]
- [J] SHOT PEEN REWORKED AREA AS GIVEN IN SOPM 20-10-03 WITH SHOT NO. 230-550, INTENSITY 0.006A-0.008A. [M]
- [K] SHOT PEEN REWORKED AREA AS GIVEN IN SOPM 20-10-03 WITH SHOT NO. 230-550, INTENSITY 0.004A-0.007A. [M]
- [L] SHOT PEEN REWORKED AREA AS GIVEN IN SOPM 20-10-03 WITH SHOT NO. 230-550, INTENSITY 0.008A. [M]
- [M] SHOT PEEN INTENSITIES SHOWN FOR MANUFACTURED COMPONENTS. REFER TO SRM 51-20-06 FOR SHOT PEEN INTENSITIES REQUIRED DUE TO THICKNESS REDUCTION RESULTING FROM REWORK.
- [N] THESE ALLOWABLE DAMAGE LIMITS HAVE FAA APPROVAL CONTINGENT ON ACCOMPLISHMENT OF THE INSPECTIONS CONTAINED HEREIN.

Spoiler Structure Allowable Damage
Figure 101 (Sheet 2 of 4)

**757-200
STRUCTURAL REPAIR MANUAL**

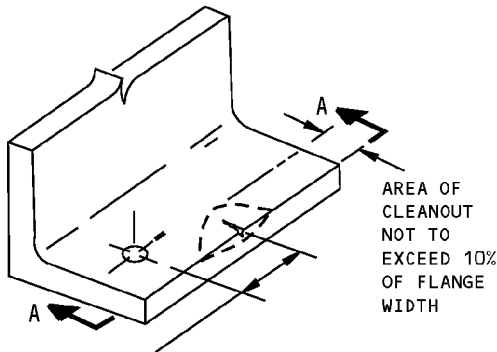

THE DISTANCE OF THE DAMAGE FROM AN EXISTING HOLE, FASTENERS OR EDGE MUST NOT BE LESS THAN 20X

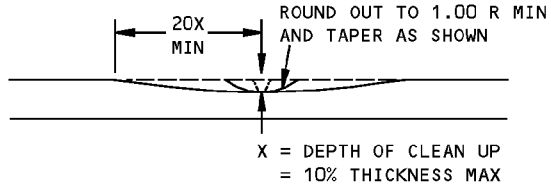

A-A

**REMOVAL OF NICK OR CRACK DAMAGE ON AN EDGE
DETAIL II**

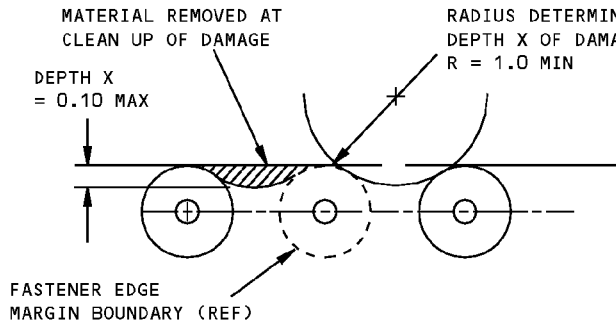

DAMAGE CLEAN UP OF EDGES WHERE FASTENER EDGE MARGINS DO NOT OVERLAP

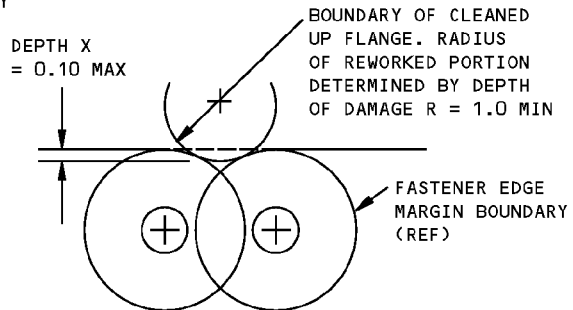

DAMAGE CLEAN UP OF EDGES WHERE FASTENER EDGE MARGINS OVERLAP

DETAIL III

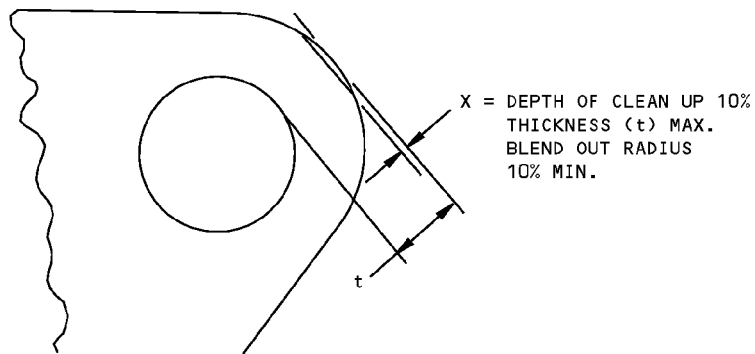

DAMAGE CLEAN UP FOR EDGES OF LUG
DETAIL IV

**Spoiler Structure Allowable Damage
Figure 101 (Sheet 3 of 4)**

**757-200
STRUCTURAL REPAIR MANUAL**

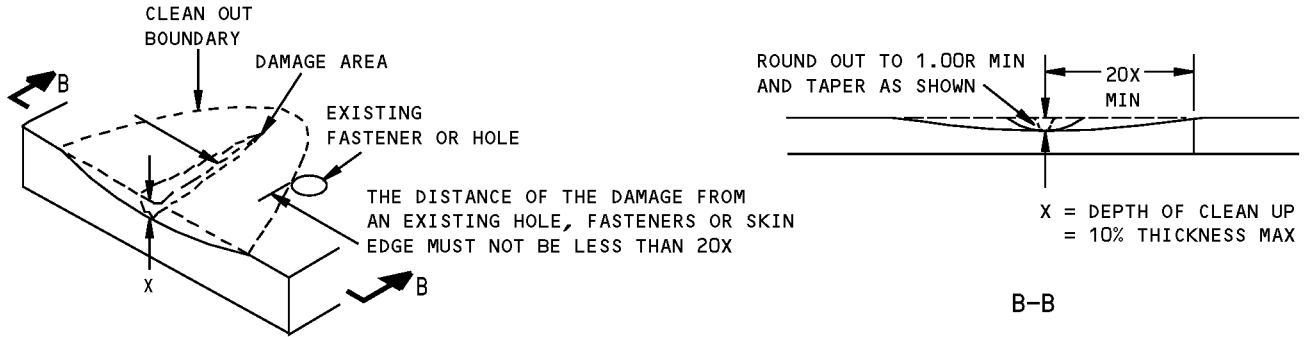

**REMOVAL OF NICK, GOUGE AND SCRATCH DAMAGE ON A SURFACE
DETAIL V**

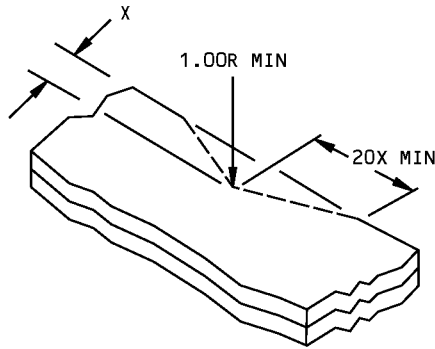

X = DEPTH OF CLEANUP = 0.10 MAX

**REMOVAL OF NICK OR CRACK
DAMAGE OF AN EDGE**

DETAIL VI

**Spoiler Structure Allowable Damage
Figure 101 (Sheet 4 of 4)**

**757-200
STRUCTURAL REPAIR MANUAL**

REPAIR 1 - SPOILER SPAR

REF DWG
113N5100
113N5400
113N4100
113N4200

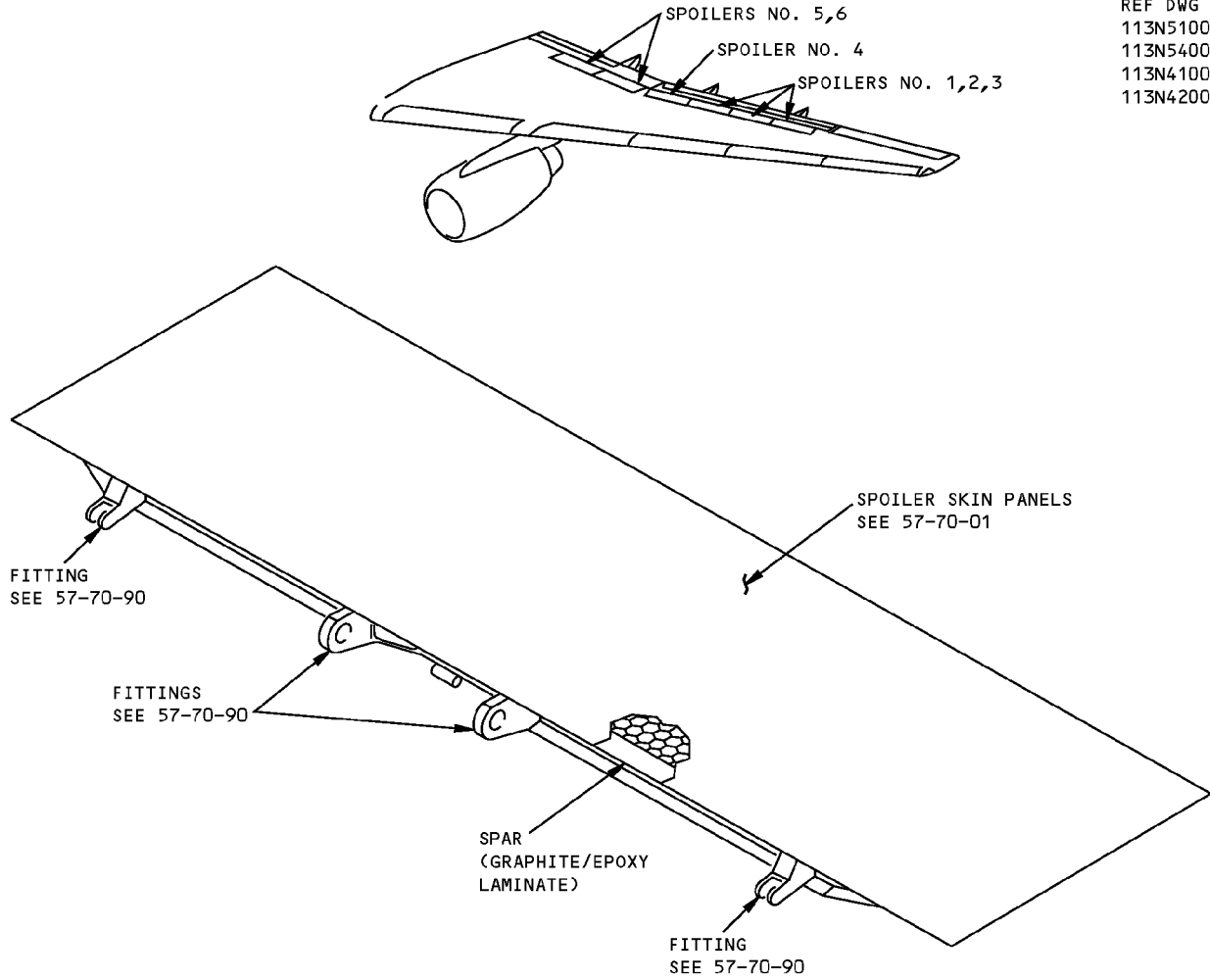

SPOILER NO. 1 SHOWN
SPOILERS 2 THRU 6 SIMILAR
DETAIL I

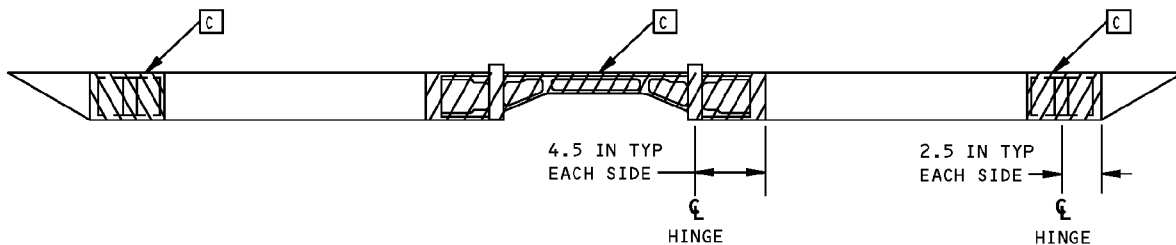

VIEW ON SPAR

**Spoiler Spar Repairs
Figure 201 (Sheet 1 of 2)**

STRUCTURAL REPAIR MANUAL

DAMAGE	INTERIM REPAIRS B	PERMANENT REPAIRS		
	WET LAYUP 150°F (66°C) CURE (51-70-03)	WET LAYUP 200°F (95°C) CURE (51-70-17)	250°F (121°C) CURE (51-70-05)	350°F (177°C) CURE (51-70-04)
CRACKS	UP TO 2.0 INCHES (50 mm) LONG, REPAIR WITH PATCH PER 51-70-03, PAR. 5.N. A	CLEAN UP DAMAGE AND REPAIR AS HOLE.	CLEAN UP DAMAGE AND REPAIR AS HOLE.	CLEAN UP DAMAGE AND REPAIR AS HOLE.
HOLES	2.0 INCHES (50 mm) MAX DIA NOT TO EXCEED 30% OF SMALLEST DIMENSION ACROSS LAMINATE PANEL AT THE DAMAGE LOCATION. FILL WITH BMS 5-28, TYPE 7 POTTING COMPOUND AND PATCH PER 51-70-03, PAR. 5.N. A	5.0 INCHES (125 mm) MAX DIA NOT TO EXCEED 50% OF SMALLEST DIMENSION ACROSS LAMINATE PANEL AT THE DAMAGE LOCATION. USE TWO EXTRA PLYS PER FACESHEET REPAIRED.	5.0 INCHES (125 mm) MAX DIA NOT TO EXCEED 50% OF SMALLEST DIMENSION ACROSS LAMINATE PANEL AT THE DAMAGE LOCATION. USE TWO EXTRA PLYS PER FACESHEET REPAIRED.	NO SIZE LIMIT
DELAMINATION	CUT OUT AND REPAIR AS HOLE.			
NICKS AND GOUGES	IF THERE IS NO FIBER DAMAGE OR DELAMINATION, FILL NICKS OR GOUGES PER 51-70-03. IF FIBER DAMAGE OR DELAMINATION EXISTS, REPAIR AS A HOLE.			
DENTS	UP TO 2.0 INCHES (50 mm) DIA WITH NO FIBER DAMAGE OR DELAMINATION, FILL WITH BMS 5-28, TYPE 7 POTTING COMPOUND AND PATCH PER 51-70-03, PAR. 5.M. OVER 2.0 INCHES (50 mm) DIA OR WITH FIBER DAMAGE OR DELAMINATION, REPAIR AS HOLE.			

TABLE I

NOTES

- REFINISH REWORKED AREAS AS GIVEN IN AMM 51-20.
- REFER TO SRM 51-10-01 FOR AERODYNAMIC SMOOTHNESS REQUIREMENTS. WHERE THE DAMAGE EXCEEDS THE LIMITS SHOWN IN 51-10-01, CONSIDERATION SHOULD BE GIVEN TO THE LOSS OF PERFORMANCE INVOLVED.
- REFER TO SRM 51-10-02 FOR INSPECTION AND REMOVAL OF DAMAGE.

A ONE REPAIR PER 12.0 INCHES (300 mm) OF SPAR AND A MINIMUM OF 6.0 INCHES (150 mm) (EDGE TO EDGE) FROM ANY OTHER DAMAGE, FASTENER HOLE, OR EDGE OR PANEL.

B INSPECT INTERIM REPAIR USING INSTRUMENTED NDI METHODS OR "TAP" TEST EVERY AIRPLANE "2A" CHECK. FOR "TAP" TEST, USE A SOLID METAL DISK AND TAP THE REPAIR AREA LIGHTLY BUT FIRMLY. VOID AREAS WILL PRODUCE A DULL SOUND AS OPPOSED TO A SHARP RING ON A SOLID BONDED AREA. PERMANENT REPAIR IS REQUIRED IF ANY DETERIORATION IS EVIDENT. REFER TO SRM 51-70-03, PAR. 4.I. AND THE NONDESTRUCTIVE TEST MANUAL **D**

C CRITICAL AREA - CONTACT THE BOEING COMPANY FOR REPAIRS IN THIS AREA.

D THIS REPAIR HAS FAA APPROVAL CONTINGENT ON ACCOMPLISHMENT OF INSPECTIONS CONTAINED HEREIN.

**Spoiler Spar Repairs
Figure 201 (Sheet 2 of 2)**

757-200
STRUCTURAL REPAIR MANUAL

IDENTIFICATION 1 - SPOILER ATTACHMENT FITTINGS

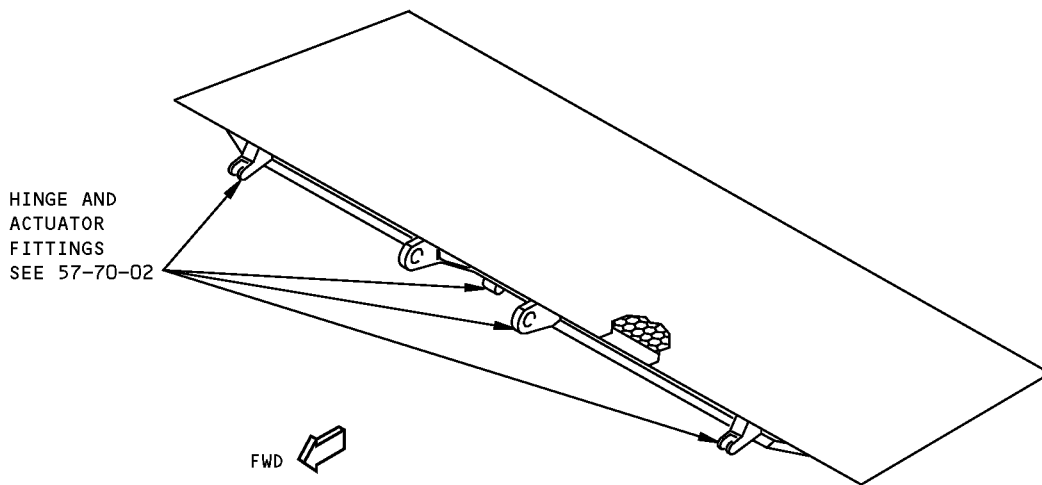
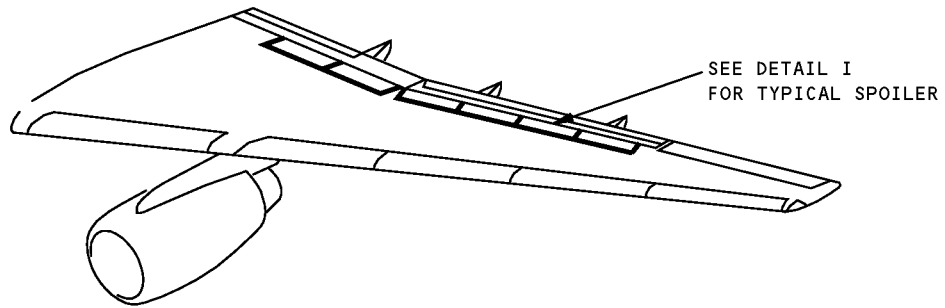

**TYPICAL SPOILER
DETAIL I**

**Spoiler Attachment Fittings Identification
Figure 1**

**757-200
STRUCTURAL REPAIR MANUAL**

ALLOWABLE DAMAGE 1 - SPOILER ATTACHMENT FITTINGS

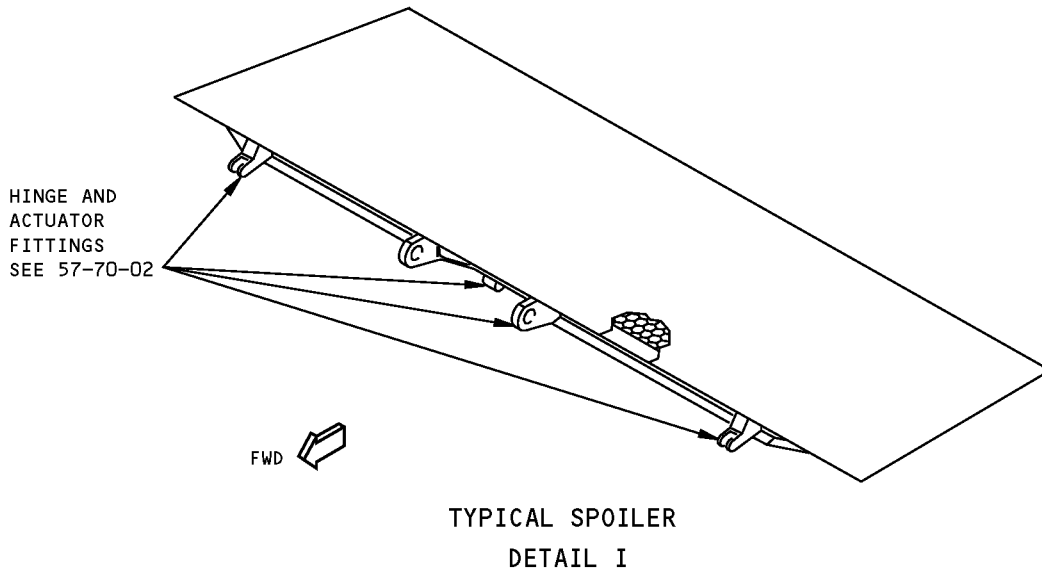
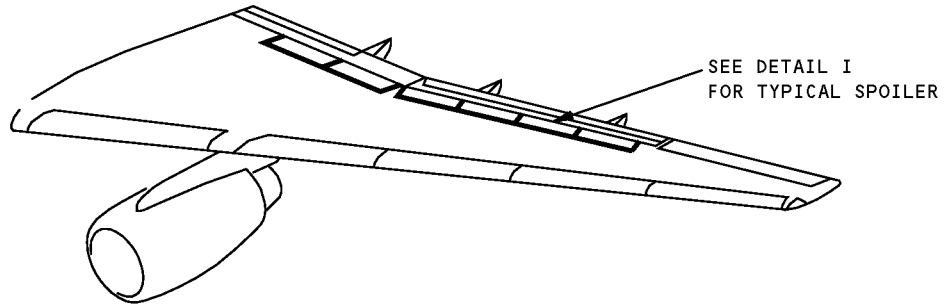

**Spoiler Attachment Fittings Allowable Damage
Figure 101**

757-200
STRUCTURAL REPAIR MANUAL

REPAIR GENERAL - SPOILER ATTACHMENT FITTINGS

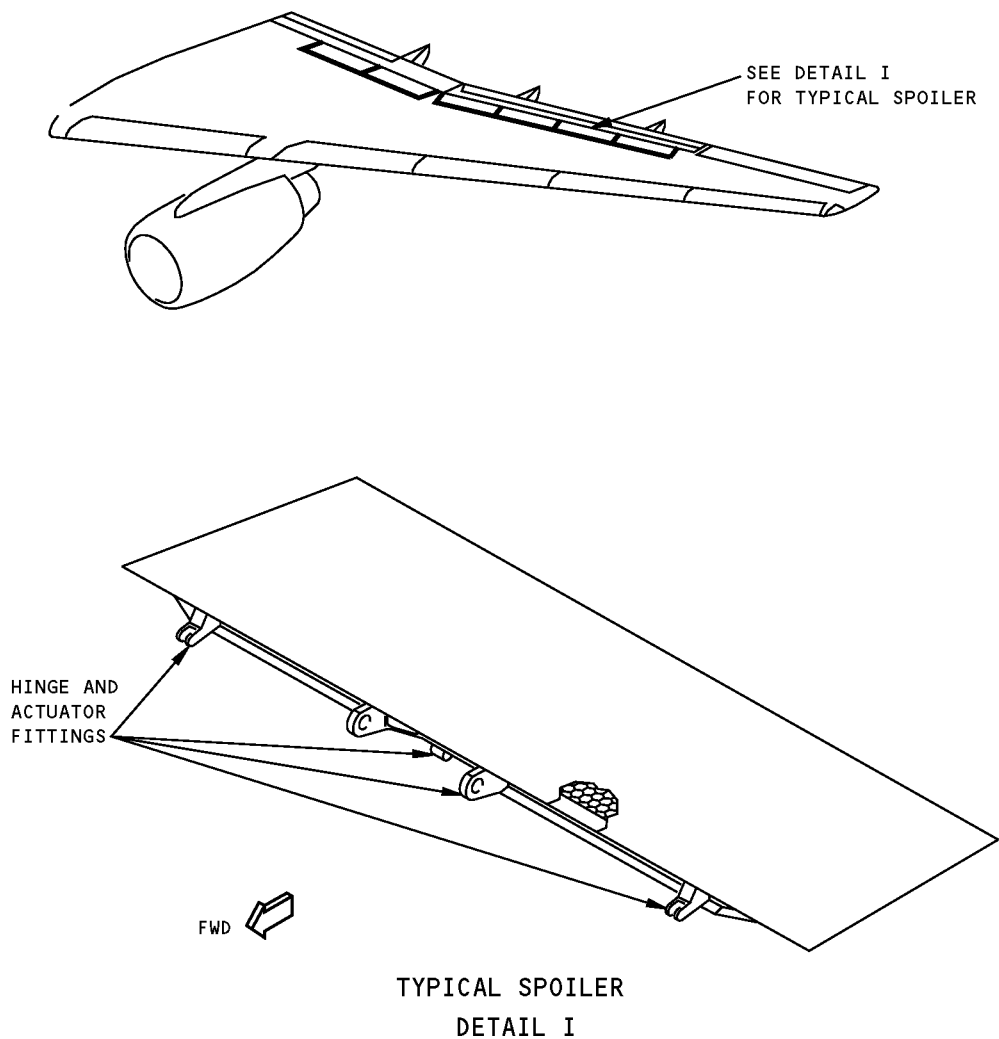

NOTES

- SEE 57-70-02 FOR STRUCTURE IDENTIFICATION AND ALLOWABLE DAMAGE INFORMATION
- NO TYPICAL REPAIR TO FITTINGS APPLICABLE. SPECIFIC REPAIRS TO FITTINGS WILL BE PROVIDED BASED ON SERVICE EXPERIENCE

Spoiler Attachment Fittings Repair
Figure 201

D634N201

REPAIR GENERAL
Page 201
57-70-90
Jan 20/2005