

CHAPTER

09

TOWING AND TAXIING



757
ILLUSTRATED TOOL AND EQUIPMENT MANUAL

CHAPTER 09
TOWING AND TAXIING

Subject/Page	Date	Subject/Page	Date	Subject/Page	Date
EFFECTIVE PAGES					
1	Sep 20/2008				
2	BLANK				
09-CONTENTS					
1	Sep 20/2006				
2	BLANK				
09-00-01					
1	Sep 20/2006				
2	BLANK				
09-00-02					
1	Sep 20/2006				
2	Sep 20/2006				

A = Added, R = Revised, O = Overflow, D = Deleted

09-EFFECTIVE PAGES



757
ILLUSTRATED TOOL AND EQUIPMENT MANUAL

TABLE OF CONTENTS

<u>Subject</u>	<u>Title</u>	<u>Part No.</u>
09-	TOWING AND TAXIING	
09-00-01	DATA SHEET - 757 TOWBAR	B09001
09-00-02	LOCKPIN - NOSE GEAR TOWING LEVER	A09003-1

09-CONTENTS



757
ILLUSTRATED TOOL AND EQUIPMENT MANUAL

PART NUMBER: B09001

NAME: DATA SHEET - 757 TOWBAR

AIRPLANE MAINTENANCE: YES

COMPONENT MAINTENANCE: NO

USAGE & DESCRIPTION: The B09001 data sheet provides design load data and tow fitting dimensions required for 757 airplane towbar design.

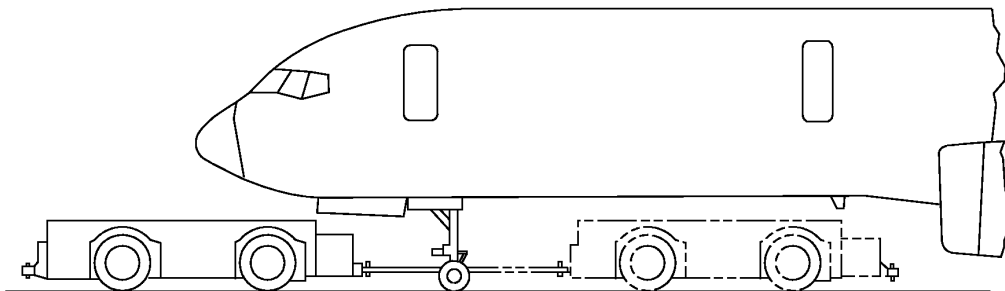

757 Towbar Data Sheet
Figure 1



757

ILLUSTRATED TOOL AND EQUIPMENT MANUAL

PART NUMBER: A09003-1

NAME: LOCKPIN - NOSE GEAR TOWING LEVER

AIRPLANE MAINTENANCE: YES

COMPONENT MAINTENANCE: NO

USAGE & DESCRIPTION: This tool is used to lock the nose landing gear steering towing lever during towing procedures. The tool is a basic quick-release pin with an attached warning streamer.

DIMENSIONS: 1 x 1 x 5 inches (25 x 25 x 127 mm)

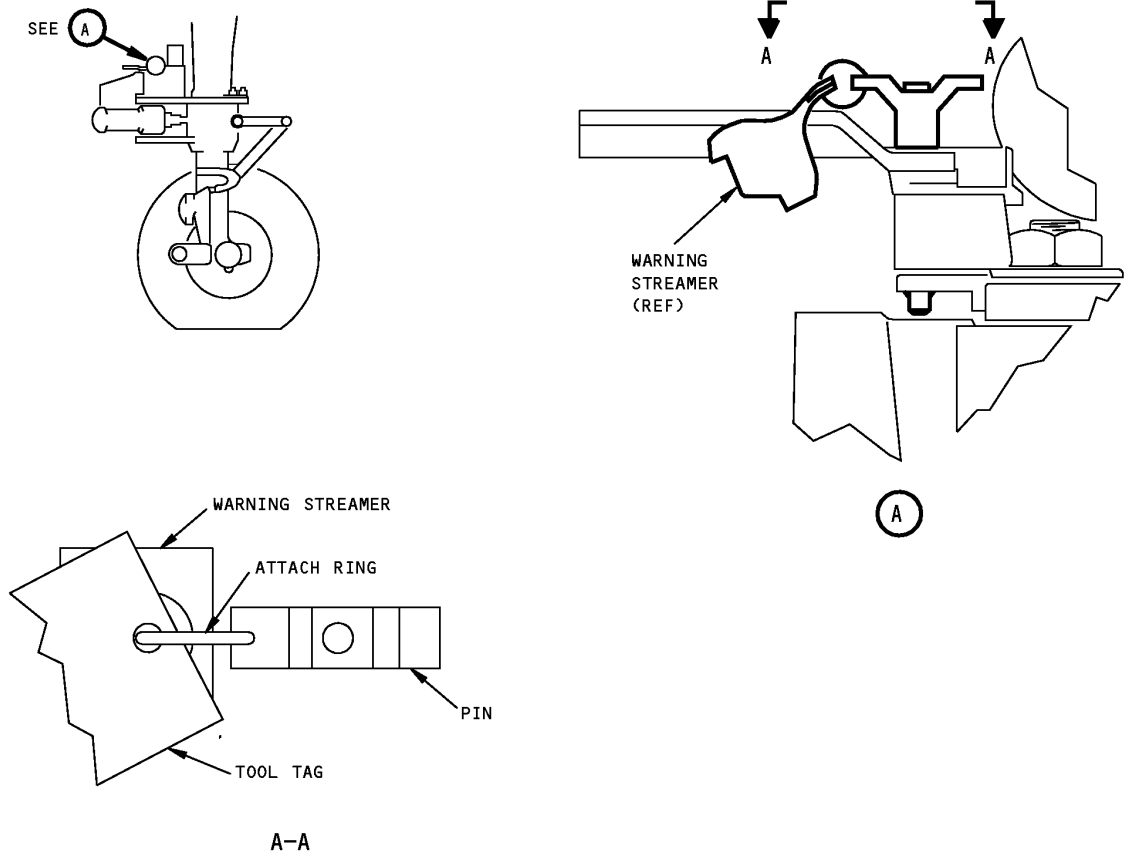

**Nose Gear Towing Lever Lockpin
Figure 1**