

**CHAPTER**

**35**

**OXYGEN**



757  
ILLUSTRATED TOOL AND EQUIPMENT MANUAL

CHAPTER 35  
OXYGEN

Subject/Page	Date	Subject/Page	Date	Subject/Page	Date
EFFECTIVE PAGES					
1	Sep 20/2008				
2	BLANK				
35-CONTENTS					
1	Sep 20/2006				
2	BLANK				
35-00-01					
1	Sep 20/2006				
2	Sep 20/2006				
35-20-01					
1	Sep 20/2006				
2	Sep 20/2006				

A = Added, R = Revised, O = Overflow, D = Deleted

# 35-EFFECTIVE PAGES



757

## ILLUSTRATED TOOL AND EQUIPMENT MANUAL

### TABLE OF CONTENTS

<u>Subject</u>	<u>Title</u>	<u>Part No.</u>
<b>35-</b>	<b>OXYGEN</b>	
35-00-01	RETRACTION EQUIPMENT - FIRING PIN, OXYGEN SYSTEM	A35001-10
35-20-01	RETRACTION EQUIPMENT - FIRING PIN, OXYGEN SYSTEM	C35003-1

# 35-CONTENTS

Page 1  
Sep 20/2006

D634N501



757

## ILLUSTRATED TOOL AND EQUIPMENT MANUAL

**PART NUMBER: A35001-10**

**NAME:** RETRACTION EQUIPMENT - FIRING PIN, OXYGEN SYSTEM

**AIRPLANE MAINTENANCE:** YES

**COMPONENT MAINTENANCE:** YES

**USAGE & DESCRIPTION:** The A35001-10 retraction equipment is used on all 757 airplanes that are not equipped with Draeger Aerospace oxygen generators. Draeger Aerospace oxygen generators use Draeger's own unique equipment. A35001 is used to arm or disarm the oxygen system generator during removal or installation. An A35001-2 pliers assembly is used to retract the firing pin of the oxygen generator, allowing an A35001-8 safety pin assembly to be placed between the release pin and firing pin spring case to prevent activation of the oxygen canister. Refer to AMM 35-21-04, CMM 36-21-04, CMM 36-21-05, CMM 36-21-34 and CMM 36-21-35 for complete usage instructions. A35001 consists of twelve A35001-8 safety pin assemblies and one A35001-2 pliers assembly contained in a storage box.

**WEIGHT:** 2 lbs (0.9 kg)

**DIMENSIONS:** 3 x 10 x 10 inches (76 x 254 x 254 mm)

**NOTE:** A35001-10 supersedes A35001-1.  
C35003 replaces A35001 for future procurement.

**ILLUSTRATED TOOL AND EQUIPMENT MANUAL**

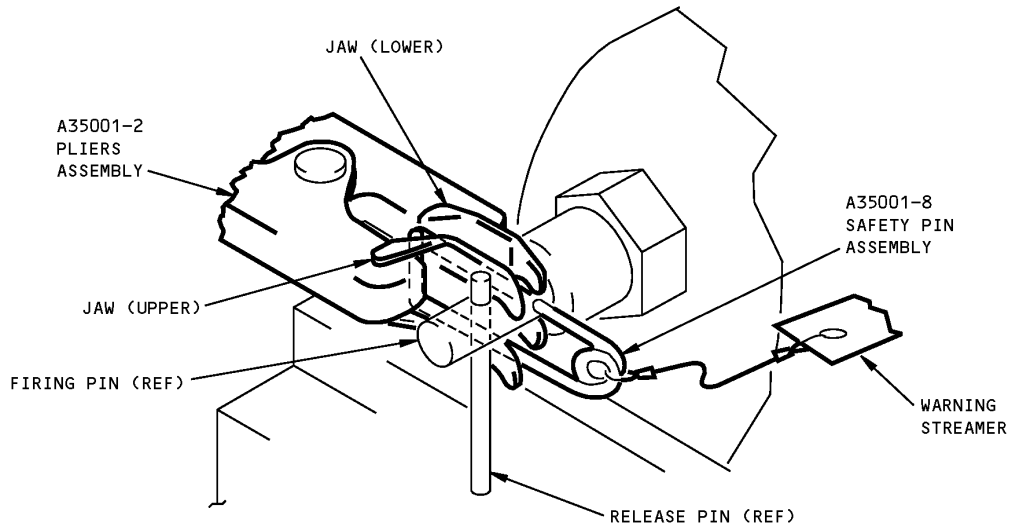

**Oxygen System Firing Pin Retraction Equipment  
Figure 1**



757

## ILLUSTRATED TOOL AND EQUIPMENT MANUAL

**PART NUMBER: C35003-1**

**NAME:** RETRACTION EQUIPMENT - FIRING PIN, OXYGEN SYSTEM

**AIRPLANE MAINTENANCE:** YES

**COMPONENT MAINTENANCE:** NO

**USAGE & DESCRIPTION:** The C35003-1 retraction equipment has a limited effectivity. The C35003 is used on airplanes that are equipped with chemical oxygen generators manufactured by B/E Aerospace and Avox Systems/Scott Aviation. The C35003 retraction equipment is used to disarm the B/E Aerospace and Avox Systems/Scott Aviation chemical oxygen generators during removal or installation. Refer to the current C35003 drawing and AMM 35-21-00 for complete usage information.

The C35003-1 consists of:

C35003-1		
QUANTITY	NOMENCLATURE	PART NUMBER
1	PLIERS ASSEMBLY	C35003-2
12	SAFETY PIN	C35003-3
1	STORAGE BOX	

**WEIGHT:** 2 lbs (0.9 kg)

**DIMENSIONS:** 3 x 10 x 10 inches (76 x 254 x 254 mm)

ILLUSTRATED TOOL AND EQUIPMENT MANUAL

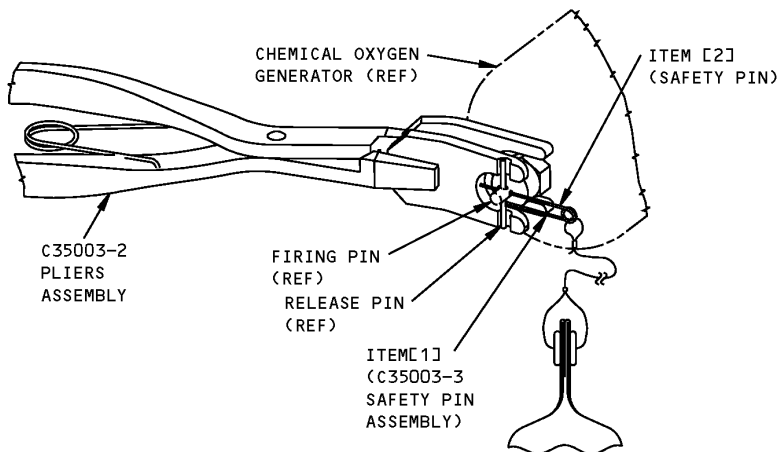

Oxygen System Firing Pin Retraction Equipment  
Figure 1

C35003-1			
ITEM NO.	PART NO.	NOMENCLATURE	VENDOR CODE
1	C35003-3	SAFETY PIN ASSEMBLY	
2	C35003-8	SAFETY PIN	