

BOEING
 757
 FAULT ISOLATION/MAINT MANUAL

GPA Group plc

PAGE	DATE	CODE	PAGE	DATE	CODE	PAGE	DATE	CODE
CHAPTER 21 TAB			21-FAULT CODE INDEX			21-30-00		
AIR CONDITIONING			1	JUN 20/96	04	105	JAN 28/01	CONT.
EFFECTIVE PAGES			2	JUN 20/96	06	106	JAN 28/01	01
SEE LAST PAGE OF LIST FOR			3	JAN 20/08	05	107	JAN 28/01	01
NUMBER OF PAGES			4	JUN 20/96	05	108	JAN 28/01	01
21-CONTENTS			5	JUN 20/96	03	109	JAN 28/01	01
1	MAY 28/06	GUI	6	DEC 20/96	13	110	JAN 28/01	01
2	SEP 28/05	GUI	7	JUN 20/96	08	111	SEP 28/05	01
3	JAN 28/00	GUI	8	JUN 20/96	07	112	SEP 28/05	01
4	JAN 28/00	GUI	9	JUN 20/97	09	113	SEP 28/05	02
5	JAN 28/00	GUI	10	SEP 28/01	16	114	SEP 28/05	01
6	JAN 28/00	GUI	11	JUN 20/96	16	115	SEP 28/05	01
7	JAN 20/09	GUI	12	JUN 20/96	16	116	SEP 28/05	01
8	JAN 28/00	GUI	13	JUN 20/96	16	117	SEP 28/05	01
9	JAN 20/09	GUI	14	JUN 20/96	15	118	SEP 28/05	01
10	BLANK		15	JUN 20/96	16	119	SEP 28/05	01
21-HOW TO USE THE FIM			16	MAY 28/02	15	120	SEP 28/05	06
1	SEP 20/98	01	17	JAN 20/98	12	121	SEP 28/05	10
2	SEP 20/98	01	18	BLANK		122	SEP 28/05	09
3	SEP 28/99	01	21-BITE INDEX			21-40-00		
4	SEP 20/98	01	1	SEP 28/99	01	101	DEC 20/96	11
5	SEP 20/98	01	2	SEP 28/99	01	102	MAR 20/94	03
6	SEP 20/98	01	3	SEP 28/99	01	103	MAY 28/05	03
21-INDEX			4	BLANK		104	MAY 28/05	03
1	SEP 20/94	04	21-00-01			105	SEP 20/95	01
2	SEP 28/99	16	101	MAY 28/07	01	106	DEC 20/96	15
21-EICAS MESSAGES			102	MAY 28/07	01	107	DEC 20/96	05
1	DEC 20/90	01	103	MAY 28/07	01	108	DEC 20/96	05
2	DEC 20/90	01	R 104	MAY 20/09	01.1	109	DEC 20/96	06
3	MAR 20/96	13	105	MAY 28/07	01	110	JAN 20/98	03
4	MAR 20/96	12	106	MAY 28/07	01	111	SEP 20/94	01
5	MAR 20/96	11	R 107	MAY 20/09	01.1	112	BLANK	
6	MAR 20/96	07	108	MAY 28/07	01	21-51-00		
21-FAULT CODE DIAGRAM			109	MAY 28/07	01	101	DEC 20/87	11
1	SEP 28/99	01	110	MAY 28/07	01	102	MAR 20/94	10
2	SEP 28/99	01	111	JAN 28/01	01	103	MAR 20/94	01
3	SEP 28/99	02	112	BLANK		104	SEP 20/96	01
4	JUN 20/97	03	21-20-00			105	MAR 20/94	01
5	JUN 20/97	05	101	JUN 15/86	09	106	MAR 20/94	01
6	JUN 20/97	05	102	MAR 20/89	18	107	MAY 28/01	01
7	SEP 28/99	02	103	JUN 15/86	02	108	JAN 28/00	01
8	SEP 28/99	01	104	JUN 15/87	05	109	MAY 28/99	01
9	SEP 28/99	05	105	MAR 20/89	14	110	SEP 28/02	01
10	SEP 28/99	05	106	MAR 15/85	04	111	SEP 28/02	01
11	SEP 28/99	02	107	MAY 28/99	02	112	JUN 20/95	01
12	SEP 28/99	04	108	SEP 20/87	03	113	JUN 20/95	07
13	SEP 28/99	06	109	MAR 20/96	06	114	MAY 28/01	01
14	SEP 20/89	09	110	MAR 20/95	05	115	MAY 28/01	06
15	SEP 28/00	04	111	MAR 20/95	03	116	MAY 28/01	01
16	BLANK		112	MAR 20/95	03	117	MAY 28/01	01
			21-30-00			118	DEC 20/95	01
			101	JUN 20/92	09	119	SEP 28/02	01
			102	MAY 20/98	01	120	MAR 20/96	01
			103	JUN 20/92	06	121	MAR 20/96	01
			104	SEP 20/91	01	122	JUN 20/97	01
						123	DEC 20/95	01
						124	DEC 20/95	01

R = REVISED, A = ADDED OR D = DELETED

F = FOLDOUT PAGE

32

MAY 20/09

D633N632

CHAPTER 21

EFFECTIVE PAGES

PAGE 1

CONTINUED



BOEING
757
FAULT ISOLATION/MAINT MANUAL

GPA Group plc

PAGE	DATE	CODE	PAGE	DATE	CODE	PAGE	DATE	CODE
21-51-00		CONT.	21-58-00	CONFIG 3	CONT.	21-60-00		CONT.
125	DEC 20/95	01	131	MAR 20/94	07	105	SEP 20/90	02
126	SEP 20/96	01	132	SEP 20/98	11	106	JAN 20/98	02
127	DEC 20/95	07	133	MAY 28/07	06	107	SEP 20/90	03
R 128	MAY 20/09	01.1	134	JAN 28/00	06	108	SEP 20/98	08
129	DEC 20/95	08	135	JUN 20/95	07	109	SEP 20/90	13
130	DEC 20/95	08	136	JAN 28/05	06	110	SEP 28/02	05
131	MAY 28/99	01	137	JAN 20/98	07	111	SEP 28/02	03
132	MAY 28/99	01	138	JUN 20/95	07	112	JUN 20/95	03
133	DEC 20/95	01	139	JUN 20/95	07	113	JUN 20/95	04
134	DEC 20/95	01	140	JUN 20/95	07	114	SEP 28/00	05
135	MAY 28/99	01	141	SEP 20/98	06	115	JUN 20/95	05
136	DEC 20/95	01	142	BLANK		116	JAN 20/98	03
137	JUN 20/96	02				117	JUN 20/95	03
138	BLANK		21-58-00	CONFIG 4		118	JUN 20/95	03
21-52-00			101	SEP 20/98	12	119	JUN 20/95	03
101	SEP 20/93	08	102	JAN 28/02	10	120	JUN 20/95	03
102	SEP 20/93	06	103	SEP 20/92	10	121	SEP 20/95	03
103	JUN 15/86	04	104	JAN 28/00	10	122	JUN 20/95	03
104	JUN 15/86	01	105	SEP 20/92	10	123	JUN 20/95	03
21-53-00			106	SEP 20/92	09	124	JUN 20/95	03
101	MAR 20/94	01	107	SEP 20/92	10	125	JUN 20/95	03
102	MAR 20/94	01	108	MAR 20/93	11	126	JUN 20/95	03
103	MAY 20/98	01	109	JAN 20/98	11	127	MAY 20/98	06
104	BLANK		110	MAR 20/93	09	128	DEC 20/95	03
21-58-00	CONFIG 3		111	MAY 28/99	10	129	DEC 20/95	03
101	JAN 28/00	05	112	MAY 28/07	08	130	SEP 28/01	03
102	JAN 28/00	05	113	MAY 28/07	08	131	JUN 20/95	03
103	SEP 20/92	07	114	DEC 20/96	11	132	SEP 28/01	03
104	JAN 28/00	06	115	JAN 28/00	09	133	JUN 20/95	03
105	SEP 20/92	07	116	MAR 20/94	09	134	JUN 20/95	03
106	SEP 20/92	07	117	MAR 20/94	09	135	JUN 20/95	03
107	SEP 20/92	07	118	JUN 20/97	10	136	JAN 28/01	03
108	JAN 20/98	07	119	JUN 20/97	10	137	MAY 20/08	03
109	JUN 20/95	07	120	JUN 20/97	10	138	MAY 20/08	03
110	SEP 20/92	07	121	JAN 28/00	10	139	JUN 20/95	03
111	JUN 20/95	07	122	JAN 28/00	10	140	JUN 20/95	03
112	SEP 20/98	11	123	JUN 20/97	10	141	JUN 20/95	03
113	SEP 20/95	07	124	JUN 20/97	10	142	JUN 20/95	03
114	JUN 20/95	07	125	JUN 20/97	10	143	JUN 20/95	03
115	JUN 20/95	07	126	SEP 20/98	12	144	JUN 20/95	03
116	SEP 20/94	07	127	JUN 20/97	10	145	JUN 20/95	03
117	DEC 20/93	07	128	JUN 20/97	10	146	JUN 20/95	03
118	JAN 28/00	04	129	MAY 28/07	09	147	JUN 20/95	02
119	JAN 28/00	05	130	JAN 28/00	10	148	BLANK	
120	MAR 20/94	07	131	MAY 28/07	09			
121	JUN 20/95	07	132	JAN 28/05	10			
122	JUN 20/94	07	133	JUN 20/97	10			
123	JUN 20/95	07	134	JUN 20/97	10			
124	JAN 28/01	06	135	JUN 20/97	10			
125	JAN 28/00	06	136	JUN 20/97	10			
126	JAN 28/00	06	137	JAN 28/00	09			
127	JUN 20/95	07	138	JAN 28/00	06			
128	MAR 20/94	07						
129	JUN 20/94	07	21-60-00					
130	JUN 20/94	07	101	SEP 20/90	13			
			102	SEP 20/90	09			
			103	SEP 20/90	02			
			104	MAR 20/93	05			

R = REVISED, A = ADDED OR D = DELETED

F = FOLDOUT PAGE

32

MAY 20/09

D633N632

CHAPTER 21

EFFECTIVE PAGES

PAGE 2

LAST PAGE



BOEING
757
FAULT ISOLATION/MAINT MANUAL

CHAPTER 21 - AIR CONDITIONING

TABLE OF CONTENTS

<u>Subject</u>	Chapter Section <u>Subject</u>	<u>Page</u>	<u>Effectivity</u>
HOW TO USE THE FIM	21-HOW TO USE THE FIM	1	ALL
INDEX ISOLATION	21-INDEX	1	ALL
EICAS MESSAGES	21-EICAS MESSAGES	1	ALL
FAULT CODE DIAGRAMS	21-FAULT CODE DIAGRAM	1	ALL
FAULT CODE INDEX	21-FAULT CODE INDEX	1	ALL
BITE INDEX	21-BITE INDEX	1	ALL
<u>AIR CONDITIONING</u>	21-00-00		
CONTAMINATION - AIR CONDITIONING SYSTEM	21-00-01		
Fault Isolation		101	ALL
<u>DISTRIBUTION</u>	21-20-00		
Component Location		101	ALL
Component Index			
Component Location			
Fault Isolation			
EICAS Msg AFT EQ EXH FAN 1 Displayed (Fig. 105)		112	
EICAS Msg AFT EQ EXH FAN 2 Displayed (Fig. 103)		108	
Recirc Fan INOP Light On, L(R) RECIR FAN EICAS Msg Displayed With L (R) Recirc Fan Switch/Light ON (Fig. 104)		109	



BOEING
757
FAULT ISOLATION/MAINT MANUAL

CHAPTER 21 - AIR CONDITIONING

TABLE OF CONTENTS

<u>Subject</u>	Chapter Section <u>Subject</u>	<u>Page</u>	<u>Effectivity</u>
<u>PRESSURIZATION CONTROL</u>	21-30-00		
Component Location		101	ALL
Component Index			
Component Location			
Fault Isolation			
Cabin Altitude Indications On in Auto. Manual Operation Abnormal (Fig. 109)		117	
Cabin Differential Pressure Indicator Inaccurate/ Fluctuates (Fig. 110)		118	
Cabin Pressure Controller BITE Procedure (Fig. 103)		105	
Cabin Rate Off Schedule In AUTO. System Not Normal In Other Auto Mode (Fig. 105)		113	
CABIN ALT AUTO EICAS Messages Illum, CABIN AUTO INOP EICAS Message And AUTO INOP Light On In Auto, Manual Not Normal (Fig. 108)		116	
EICAS Message CABIN ALT AUTO 1 or 2 Displayed (Fig. 104)		111	
Figure Not Used		114	
High Alt Ldg Sw Selected ON. High Alt Ldg Inop Light Extin. Cabin Alt Did Not Climb To Selected Altitude. (Fig. 111B)		121	
High Alt Sw Selected ON. Cabin Diff Press Gauge Was Not Zero When Landing at High Altitude Field. (Fig. 111A)		120	
High Altitude Landing Switch Selected ON. High Altitude Landing INOP Light Illuminated. (Fig. 111C)		122	
Outflow Valve Did Not Begin To Close At Liftoff (Fig. 111)		119	
Pressure Bump During Takeoff (Fig. 107)		115	

21-CONTENTS

GUI

Page 2
Sep 28/05



BOEING
757
FAULT ISOLATION/MAINT MANUAL

CHAPTER 21 - AIR CONDITIONING

TABLE OF CONTENTS

<u>Subject</u>	Chapter Section <u>Subject</u>	<u>Page</u>	<u>Effectivity</u>
<u>HEATING</u>	21-40-00		
Component Location		101	ALL
Component Index			
Component Location			
Fault Isolation			
EICAS Msg FWD (AFT) CARGO FAN		106	
Displayed (Fig. 104)			
Figure Not Used		105	
Foot and Shoulder Heaters Inop		111	
in Low and Hi (Fig. 106)			
Shoulder Heater Inop in Low and		110	
Hi (Fig. 105)			



BOEING
757
FAULT ISOLATION/MAINT MANUAL

CHAPTER 21 - AIR CONDITIONING

TABLE OF CONTENTS

<u>Subject</u>	Chapter Section <u>Subject</u>	<u>Page</u>	<u>Effectivity</u>
<u>COOLING</u>	21-50-00		
COOLING PACK SYSTEM	21-51-00		
Component Location		101	ALL
Component Index			
Component Location			
Fault Isolation			
Figure Not Used		112	
INOP and PACK OFF Lights Illum in Auto; Could Not Reset. Pack Did Not Operate Normal in STBY (Fig. 107)		130	
INOP and PACK OFF Lights Illum in Auto, and Air Cycle Machine (ACM) Will Not Operate With APU ON. (Fig. 107B)		134	
INOP and PACK OFF Lights Illum in AUTO, and Air Cycle Machine (ACM) Will Not Operate With Engines ON (Fig. 107A)		131	
L (R) Pack BITE Continues to Find Altitude Switch Fault (Fig. 104A)		124	
Pack INOP Light Illum In Auto; Could Not Reset (Fig. 106)		129	
Pack Standby Controller BITE Procedure (Ground) (Fig. 105)		127	
Pack Temperature Controller BITE Procedure (Fig. 104)		113	
PACK OFF Light Extin. & PACK OFF EICAS Msg Not Displayed with PACK Sw in OFF (Fig. 108)		137	
COOLING PACK TEMPERATURE INDICATION SYSTEM	21-52-00		
Component Location		101	ALL
Component Index			
Component Location			

 **BOEING**
757
FAULT ISOLATION/MAINT MANUAL

CHAPTER 21 - AIR CONDITIONING

TABLE OF CONTENTS

<u>Subject</u>	Chapter Section <u>Subject</u>	<u>Page</u>	<u>Effectivity</u>
RAM AIR SYSTEM	21-53-00		
Component Location		101	ALL
Component Index			
Component Location			



BOEING
757
FAULT ISOLATION/MAINT MANUAL

CHAPTER 21 - AIR CONDITIONING

TABLE OF CONTENTS

<u>Subject</u>	Chapter Section <u>Subject</u>	<u>Page</u>	<u>Effectivity</u>
EQUIPMENT COOLING SYSTEM	21-58-00		
Component Location		101	CONFIG 3 [*]
Component Index			
Component Location			
Fault Isolation			
EICAS Msg AFT EQ FLOW Displayed (Fig. 107)		112	
EICAS Msg AFT EQ SNSR Displayed (Fig. 106)		111	
EICAS Msg AFT EQ SUP FAN 1 Displayed (Fig. 108)		114	
EICAS Msg AFT EQ SUP FAN 2 Displayed (Fig. 109)		115	
EICAS Msg EQPT CLG FAN Displayed (Fig. 105)		110	
EICAS Msg EQPT CLG FLOW Displayed (Fig. 117)		126	
EICAS Msg EQPT CLG SENSOR Displayed (Fig. 116)		125	
EICAS Msg EQPT CLG TEST Displayed (Fig. 125)		138	
EICAS Msg EQPT OVHT Displayed. OVHT Lgt Illum. EICAS Msg EQPT CLG FAN Displayed. OVHT Lgt Remained Illum When ALTN Was Selected (Fig. 123)		135	
EICAS Msg EQPT OVHT Displayed. OVHT Lgt Illum. L RECIRC INOP Lgt Illum. OVHT Lgt Extin When ALTN Was Selected. EICAS Msgs EQPT CLG FAN and OVBD EX VAL OPEN Not Displayed. (Fig. 121)		132	
EICAS Msg EQPT OVHT Displayed. OVHT Lgt Illum. OVHT Lgt Remained Illum When ALTN Selected. EICAS Msgs EQPT CLG FAN and OVBD EX VAL OPEN Not Displayed. (Fig. 111)		118	
EICAS Msg EQPT SMOKE TEST Displayed (Fig. 128)		141	
EICAS Msg FWD EQ EXH FLOW Displayed (Fig. 112)		119	

21-CONTENTS

GUI

Page 6
Jan 28/00



BOEING
757
FAULT ISOLATION/MAINT MANUAL

CHAPTER 21 - AIR CONDITIONING

TABLE OF CONTENTS

<u>Subject</u>	Chapter Section <u>Subject</u>	<u>Page</u>	<u>Effectivity</u>
EICAS Msg FWD EQ EXH SNSR Displayed (Fig. 115)		124	
EICAS Msg FWD EQ SUP FAN 1 Displayed (Fig. 113)		121	
EICAS Msg FWD EQ SUP FAN 2 Displayed (Fig. 114)		123	
EICAS Msg FWD EQ SUP FLOW Displayed (Fig. 110)		116	
EICAS Msg FWD EQ SUP SNSR Displayed (Fig. 104)		109	
EICAS Msg FWD EQPT DET 1 Displayed (Fig. 126)		139	
EICAS Msg FWD EQPT DET 2 Displayed (Fig. 127)		140	
EICAS Msg FWD EQPT EXH DET Displayed (Fig. 103)		108	
EICAS Msg FWD EQPT SMOKE Displayed. SMOKE Lgt Illum. OVBD EX VAL OPEN Displayed. (Fig. 119)		129	
EICAS Msg FWD EQPT SMOKE Displayed. SMOKE Lgt Illum. OVBD EX VAL OPEN Displayed. (Fig. 120)		130	
EICAS Msg OVBD EX VAL OPEN Displayed (Fig. 118)		127	
EICAS Msg OVBD EX VAL TEST Displayed (Fig. 124)		136	
Ground Crew Call Horn Sounds Continuously. C IRS, L IRS, or R IRS Not Selected ON. (Fig. 122)		134	
[*] GUI 115			
Component Location		101	CONFIG 4 [*]
Component Index			
Component Location			
Fault Isolation			
EICAS Msg EQPT CLG FAN Displayed (Fig. 105)		111	
EICAS Msg EQPT CLG FLOW Displayed (Fig. 113)		123	

21-CONTENTS

GUI Page 7
Jan 20/09



BOEING
757
FAULT ISOLATION/MAINT MANUAL

CHAPTER 21 - AIR CONDITIONING

TABLE OF CONTENTS

<u>Subject</u>	Chapter Section <u>Subject</u>	<u>Page</u>	<u>Effectivity</u>
EICAS Msg EQPT CLG SENSOR Displayed (Fig. 112)		122	
EICAS Msg EQPT CLG TEST Displayed (Fig. 121)		134	
EICAS Msg EQPT OVHT Displayed. OVHT Lgt Illum. EICAS Msg EQPT CLG FAN Displayed. OVHT Lgt Remained Illum When ALTN Was Selected (Fig. 119)		131	
EICAS Msg EQPT OVHT Displayed. OVHT Lgt Illum. L RECIRC INOP Lgt Illum. OVHT Lgt Extin When ALTN Was Selected. EICAS Msgs EQPT CLG FAN and OVBD EX VAL OPEN Not Displayed (Fig. 117)		129	
EICAS Msg EQPT OVHT Displayed. OVHT Lgt Illum. OVHT Lgt Remained Illum When ALTN Selected. EICAS Msgs EQPT CLG FAN and OVBD EX VAL OPEN Not Displayed (Fig. 107)		114	
EICAS Msg EQPT SMOKE TEST Shown (Fig. 124)		137	
EICAS Msg FWD EQ EXH FLOW Displayed (Fig. 108)		115	
EICAS Msg FWD EQ EXH SNSR Displayed (Fig. 111)		121	
EICAS Msg FWD EQ SUP FAN 1 Displayed (Fig 109)		117	
EICAS Msg FWD EQ SUP FAN 2 Displayed (Fig. 110)		120	
EICAS Msg FWD EQ SUP FLOW Displayed (Fig. 106)		112	
EICAS Msg FWD EQ SUP SNSR Displayed (Fig. 104)		110	
EICAS Msg FWD EQPT DET 1 Displayed (Fig. 122)		135	
EICAS Msg FWD EQPT DET 2 Displayed (Fig. 123)		136	
EICAS Msg FWD EQPT EXH DET Displayed (Fig. 103)		109	

21-CONTENTS

GUI

Page 8
Jan 28/00

CHAPTER 21 - AIR CONDITIONING

TABLE OF CONTENTS

<u>Subject</u>	<u>Chapter Section Subject</u>	<u>Page</u>	<u>Effectivity</u>
EICAS Msg FWD EQPT SMOKE Displayed. SMOKE Lgt Illum. OVBD EX VAL OPEN Displayed (Fig. 116)		127	
EICAS Msg FWD EQPT SMOKE Displayed. SMOKE Lgt Illum. OVBD EX VAL OPEN Displayed (Fig. 115)		126	
EICAS Msg OVBD EX VAL OPEN Displayed (Fig. 114)		124	
EICAS Msg OVBD EX VAL TEST Displayed (Fig. 120)		132	
Ground Crew Call Horn Sounds Continuously. C IRS, L IRS, or R IRS Not Selected ON (Fig. 118)		130	
[*] GUI 001-099			
<u>TEMPERATURE CONTROL</u>	21-60-00		
Component Location		101	ALL
Component Index			
Component Location			
Fault Isolation			
(FLT DECK TEMP, FWD CABIN TEMP, AFT CABIN TEMP) EICAS Message Displayed and Zone Temperature INOP Light Illuminated (Fig. 105)		121	
Flt Deck/Fwd Cabin/Aft Cabin Fails To Maintain Desired Temp With Trim Air Switch Selected ON and Temp Control in AUTO. INOP Lgt Extin (Fig. 106)		130	
Flt Deck, Fwd Cabin, and Aft Cabin Temp does not Respond with Trim Air Switch ON and all Zone Temperature Selectors in AUTO (Fig. 103)		113	
Temperature Sensor Calibration Problems (Fig. 107)		139	
Zone Temperature Controller BITE Procedure (Fig. 104)		114	

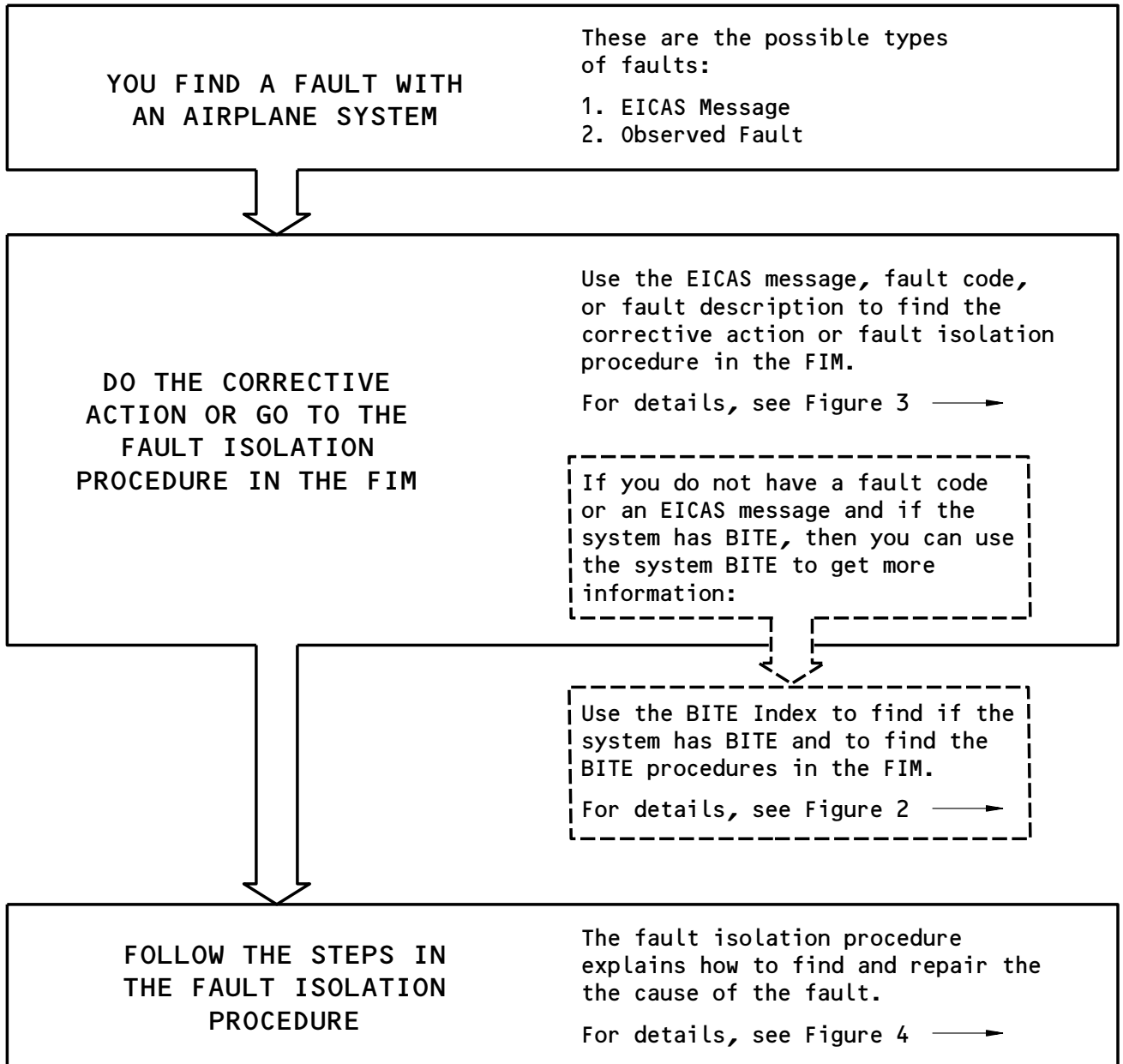

Basic Fault Isolation Process
Figure 1

EFFECTIVITY

ALL

21-HOW TO USE THE FIM

01

Page 1
Sep 20/98

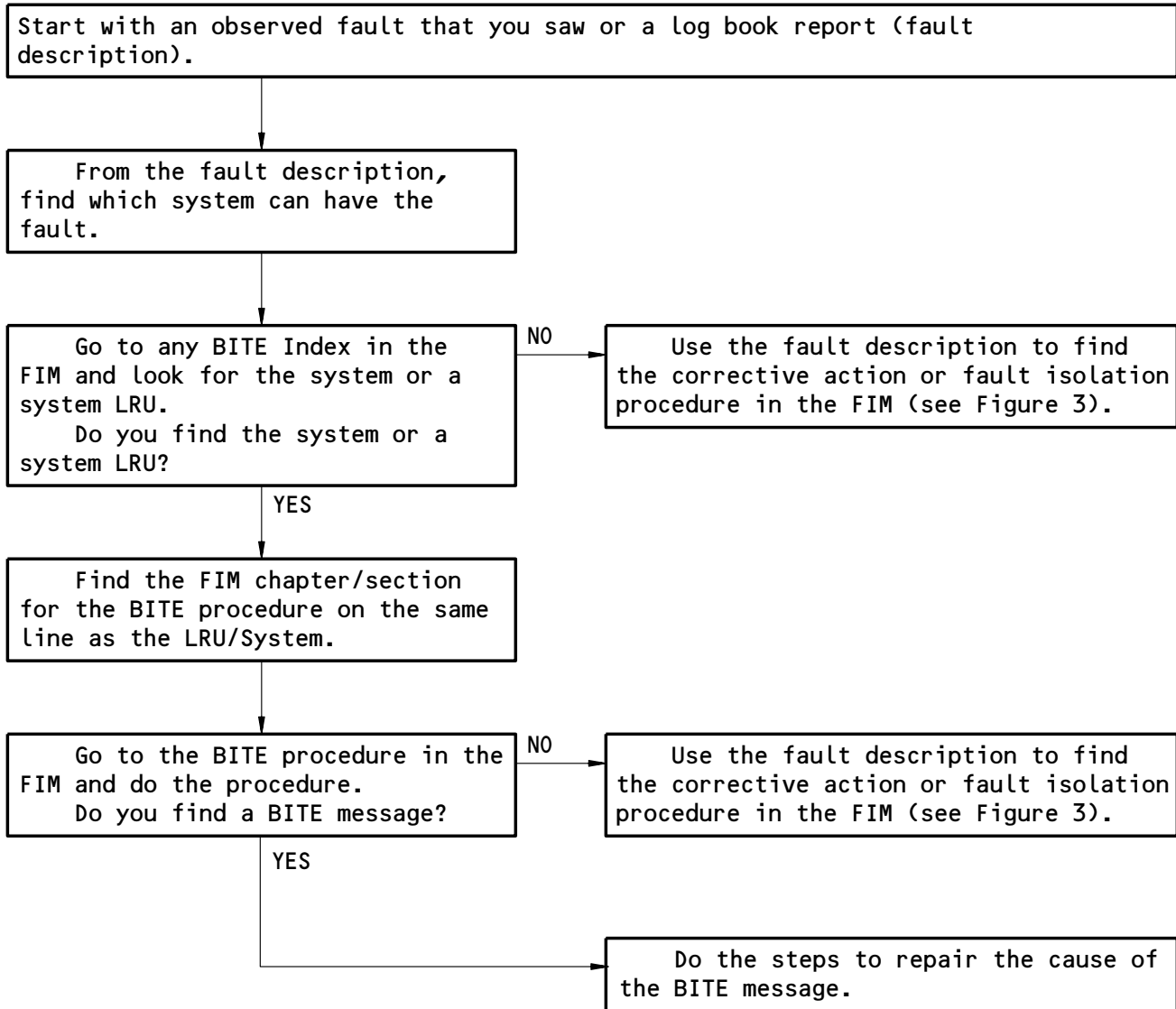

How to Get Fault Information from BITE
Figure 2

EFFECTIVITY

ALL

21-HOW TO USE THE FIM

01

Page 2
Sep 20/98

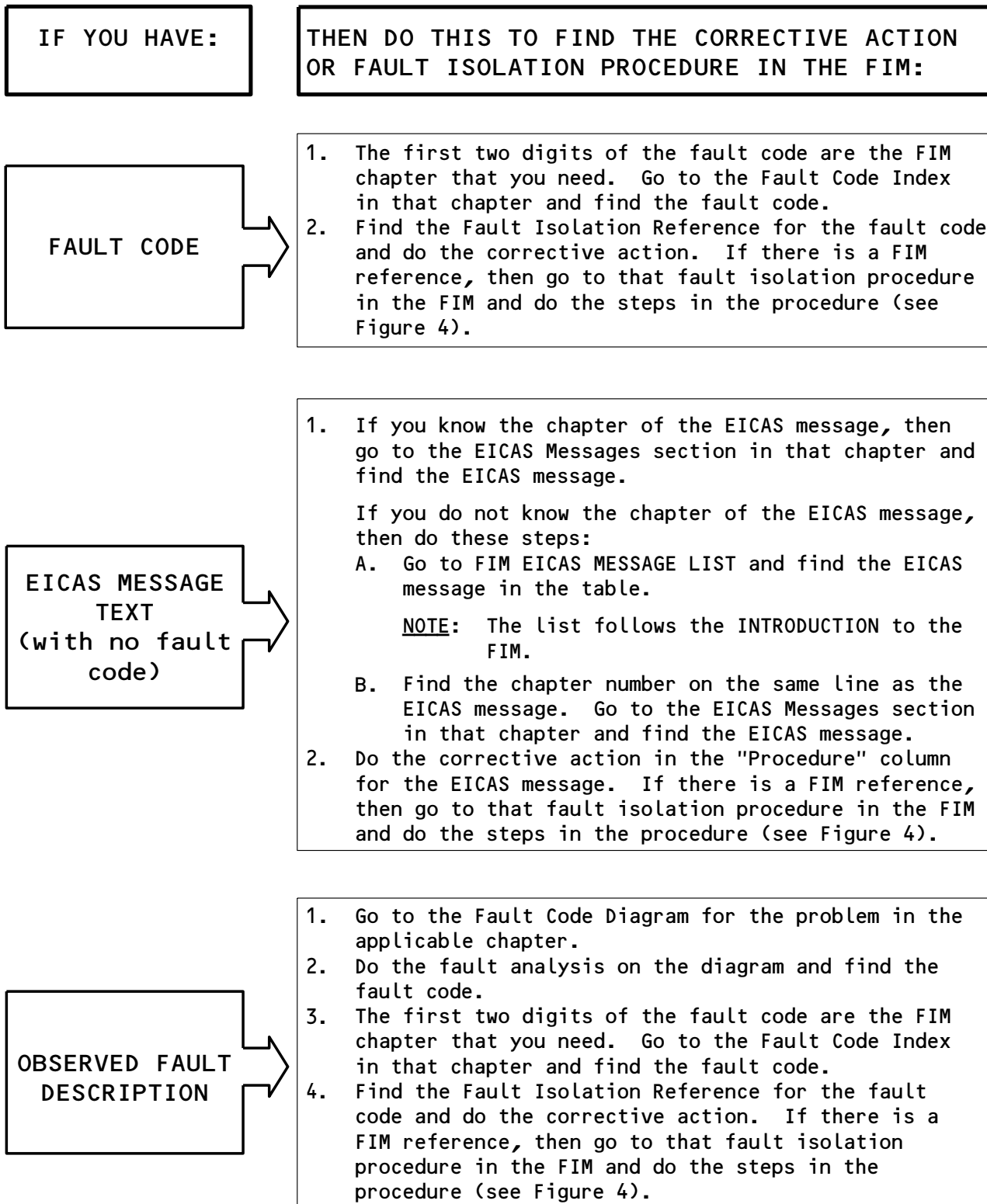

How to Find the Corrective Action or Fault Isolation Procedure in the FIM

Figure 3

EFFECTIVITY

ALL

21-HOW TO USE THE FIM

01

Page 3
Sep 28/99

ASSUMED CONDITIONS AT START OF TASK

- External electrical power is OFF
- Hydraulic power and pneumatic power are OFF
- Engines are shut down
- Circuit breakers for the system are closed
- No equipment in the system is deactivated

PREREQUISITES

- This box gives the steps to get the airplane from the normal shutdown condition to the configuration necessary to do the fault isolation procedure.
- The Prerequisites give procedure references, circuit breakers, and special tools and equipment requirements.

FAULT ISOLATION BLOCKS

- Start the fault isolation procedure at block 1 unless specified differently.
- Do the check to get an answer to the question in the box. Follow the arrow that applies to your answer. This will go to the next check.
- When you get to a box in the column at the right of the page, you have isolated that fault. Do the steps in that box to repair the cause of the fault.
- Make sure that fault is corrected to complete the procedure.

Do the Fault Isolation Procedure
Figure 4

EFFECTIVITY

ALL

21-HOW TO USE THE FIM

01

Page 4
Sep 20/98

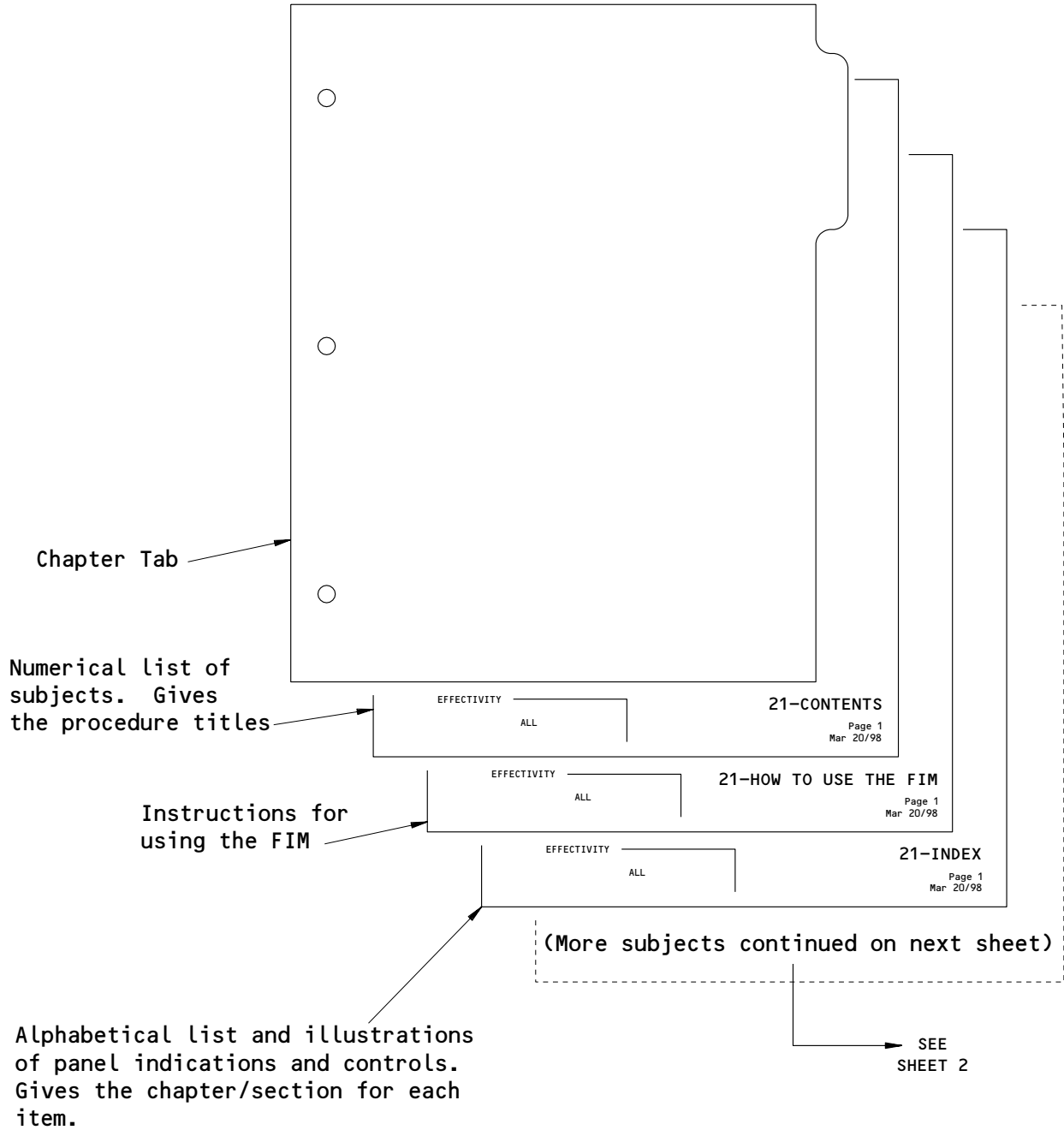

Subjects in Each FIM Chapter
Figure 5 (Sheet 1)

EFFECTIVITY	ALL	21-HOW TO USE THE FIM	01	Page 5 Sep 20/98
-------------	-----	------------------------------	----	---------------------

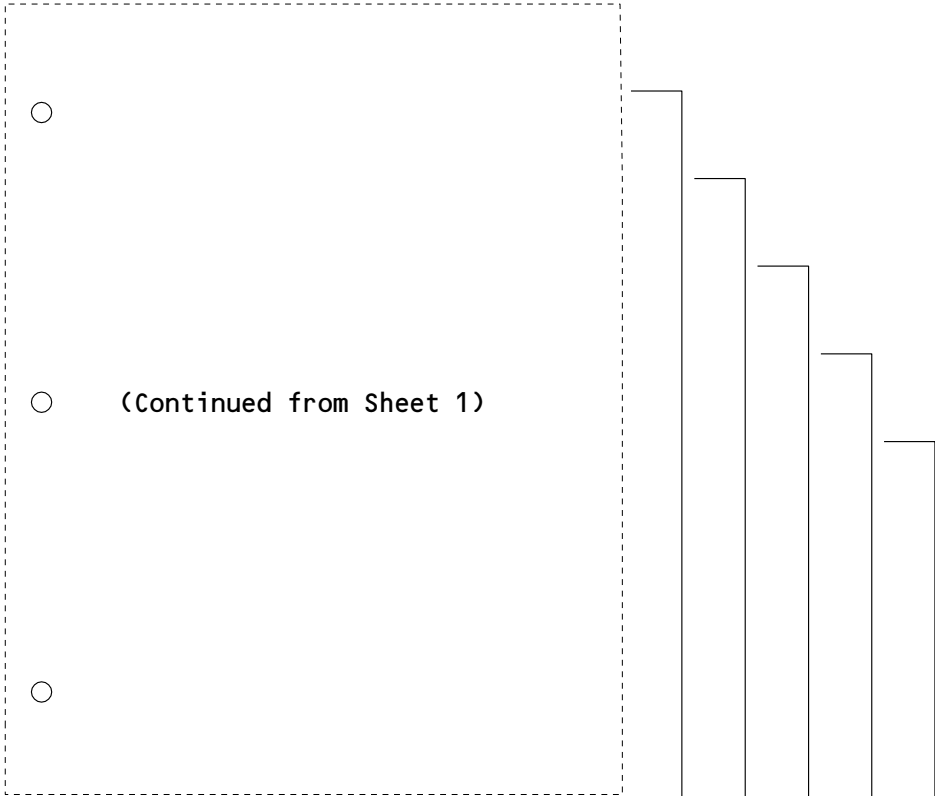

Alphabetical list of the EICAS messages. Gives the procedure to repair the cause of the message or a reference to a fault isolation procedure.

Failure analysis diagrams for the airplane systems to find the correct fault code for the fault.

Numerical list of fault codes. Gives the procedure to repair the cause of the fault or a reference to a fault isolation procedure.

EFFECTIVITY	ALL	21-EICAS MESSAGES	Page 1 Mar 20/98
-------------	-----	-------------------	---------------------

EFFECTIVITY	ALL	21-FAULT CODE DIAGRAMS	Page 1 Mar 20/98
-------------	-----	------------------------	---------------------

EFFECTIVITY	ALL	21-FAULT CODE INDEX	Page 1 Mar 20/98
-------------	-----	---------------------	---------------------

EFFECTIVITY	ALL	21-BITE INDEX	Page 1 Mar 20/98
-------------	-----	---------------	---------------------

EFFECTIVITY	ALL	21-11-00	Page 101 Mar 20/98
-------------	-----	----------	-----------------------

Alphabetical list of all the LRUs/systems that have BITE. Gives the chapter/section for the BITE procedure.

Component index, component location, and fault isolation procedures for the systems in the chapter.

Subjects in Each FIM Chapter
Figure 5 (Sheet 2)

EFFECTIVITY	ALL
-------------	-----

21-HOW TO USE THE FIM

<u>TITLE</u>	<u>CHAP/SEC</u>
CARGO HEAT.....	2140
AFT CARGO FAN.....	2140
FWD CARGO FAN.....	2140
EQUIPMENT COOLING.....	2158
ALTN.....	2158
FAN INOP.....	2158
OVERHEAT LIGHT.....	2158
SMOKE LIGHT.....	2158
TEST.....	2158
FLIGHT DECK SUPPLEMENTARY HEATERS.....	2140
FOOT HEATER.....	2140
SHOULDER HEATER.....	2140
PACK CONTROL.....	2151
PACK INOP LIGHT.....	2151
PACK OFF LIGHT.....	2151
PRESSURIZATION.....	2130
AUTO CONTROL.....	2130
CABIN ALT AUTO.....	2130
CABIN ALTITUDE.....	2130
CABIN AUTO INOP.....	2130
TEMPERATURE CONTROL AND AIR DISTRIBUTION	
AIR CONDITIONING NOISE AND VIBRATION.....	2120
COLD AREAS.....	2120
COMPT TEMP INOP LIGHT.....	2160
COMPT TEMP CONTROL.....	2160
RECIRCULATION FAN.....	2120
SMOKE, ELECTRICAL.....	CHAPTER 24
SMOKE, FUMES FROM APU.....	CHAPTER 49
TEMPERATURE CONTROL.....	2160
TRIM AIR.....	2160

AIR CONDITIONING - INDEX
Figure 1 (Sheet 1)

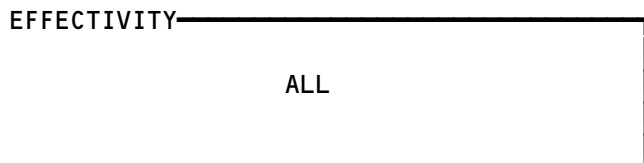

21-INDEX

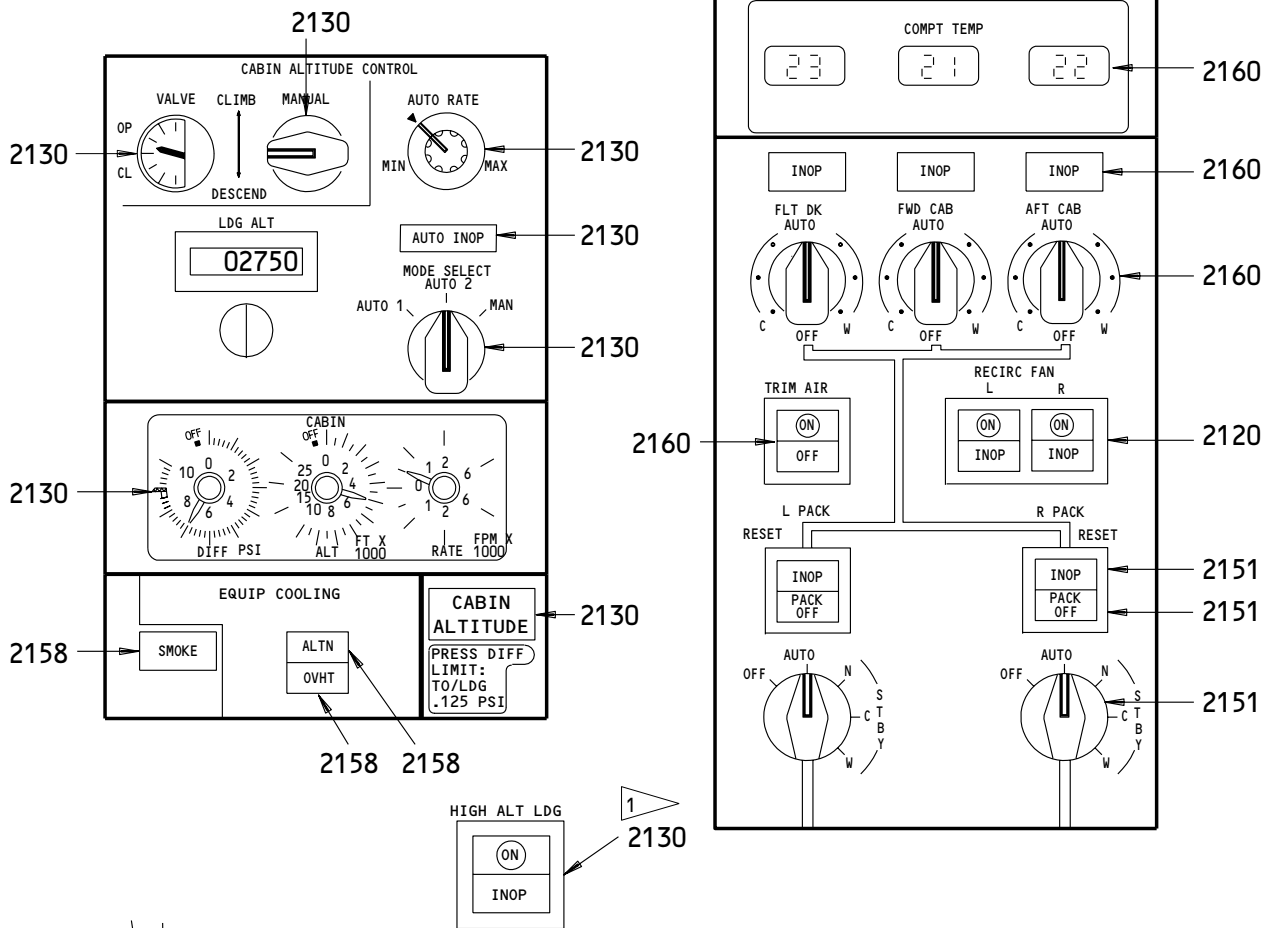

OVERHEAD PANEL

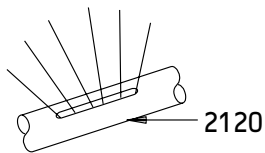

DUCT RUPTURE
OR VIBRATION

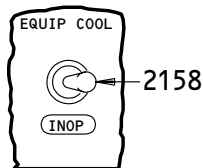

ACCESSORY PANEL

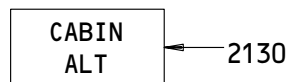

PILOTS' CTR PANEL

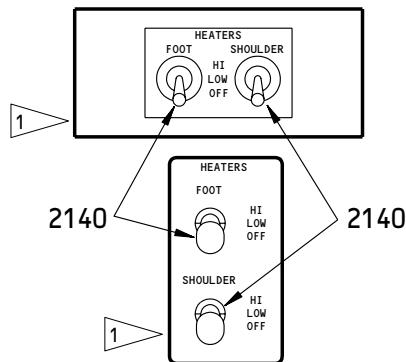

CAPT & F/O SIDE CONSOLES

1 AS INSTALLED

AIR CONDITIONING - INDEX
Figure 1 (Sheet 2)

EFFECTIVITY	ALL
-------------	-----

21-INDEX

AIR CONDITIONING – EICAS MESSAGE LIST

1. General

- A. This procedure shows the EICAS message locations and gives a list of procedures to find the solution for each message.
 - (1) EICAS Message Locations (Fig. 1)
 - (a) Figure 1 shows the location of the EICAS display units and the area where the messages show on the display units.
 - (b) Each message level has a different location. The location and color of each message level is also shown.
 - (2) The EICAS MESSAGE LIST gives the message, level, and procedure for each message.
 - (a) The EICAS MESSAGE column lists the messages alphabetically. Messages which start with L, R, or C are put together and alphabetized at L.
 - (b) The LEVEL column gives all levels for each message as follows:
 - A – Warning messages
 - B – Caution messages
 - C – Advisory messages
 - S – Status messages
 - M – Maintenance messages
 - (c) The PROCEDURE column gives the steps that are necessary to remove the message and includes one or more of the procedures that follow:
 - 1) A Fault Isolation Manual procedure reference
 - 2) A Maintenance Manual procedure and reference
 - 3) Wiring checks and a Wiring Diagram Manual reference
 - 4) A reference to an EICAS message list in a different chapter.
 - 5) A reference to a FAULT CODE INDEX and specified fault codes
 - 6) A step to change the airplane configuration

EFFECTIVITY

ALL

21-EICAS MESSAGES

01

Page 1
Dec 20/90

BOEING
757
FAULT ISOLATION/MAINT MANUAL

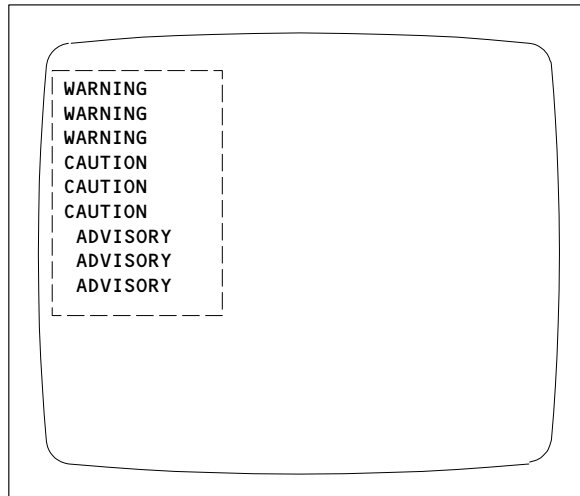
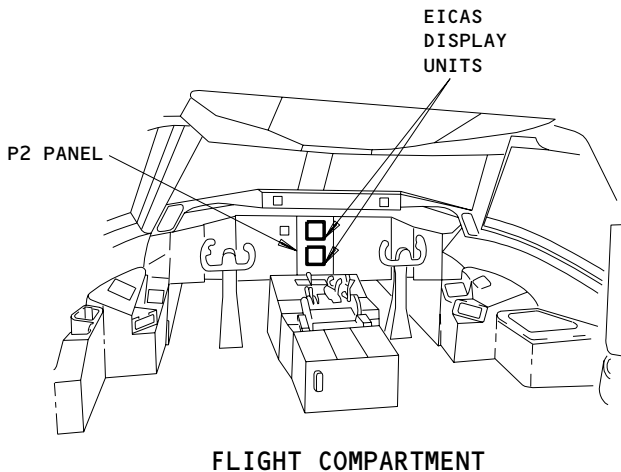

ENGINE PRIMARY PAGE OR COMPACTED PAGE
(TOP DISPLAY UNIT)

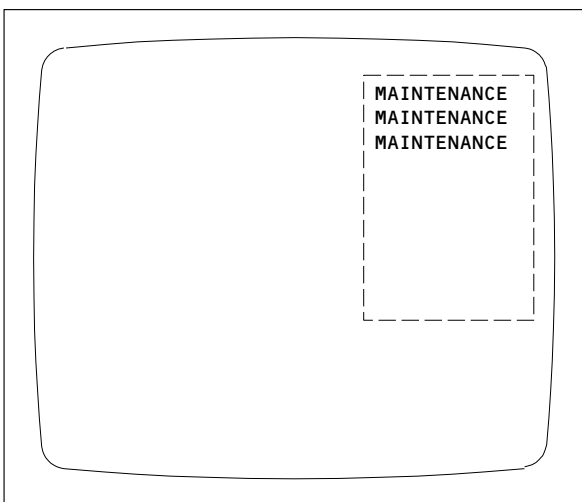

ECS/MSG PAGE
(BOTTOM DISPLAY UNIT)

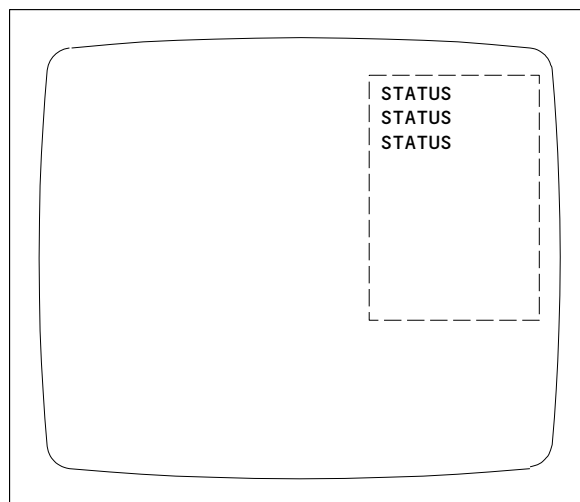

STATUS PAGE
(BOTTOM DISPLAY UNIT)

LEVEL	COLOR
A-WARNING	RED
B-CAUTION	YELLOW
C-ADVISORY	YELLOW
S-STATUS	WHITE
M-MAINTENANCE	WHITE

EICAS Message Locations
Figure 1

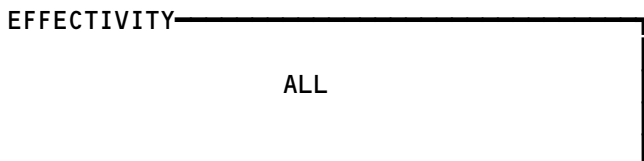

21-EICAS MESSAGES

BOEING
 757
 FAULT ISOLATION/MAINT MANUAL

EICAS MESSAGE LIST		
EICAS MESSAGE	LEVEL	PROCEDURE
AFT CABIN TEMP	C	FIM 21-60-00/101, Fig. 105
AFT CARGO FAN	S,M	FIM 21-40-00/101, Fig. 104
AFT EQ EXH FAN 1	M	FIM 21-20-00/101, Fig. 105
AFT EQ EXH FAN 2	M	FIM 21-20-00/101, Fig. 103
AFT EQ FLOW	M	FIM 21-58-00/101, CONFIG 1, Not Used FIM 21-58-00/101, CONFIG 2, Not Used FIM 21-58-00/101, CONFIG 3, Fig. 107 FIM 21-58-00/101, CONFIG 4, Fig. 103 FIM 21-58-00/101, CONFIG 4, Fig. 105 FIM 21-20-00/101, Fig. 103 FIM 21-20-00/101, Fig. 105
CABIN ALTITUDE	A	FIM 21-30-00/101, Fig. 103
CABIN ALT AUTO (1,2)	S,M	FIM 21-30-00/101, Fig. 104
CABIN AUTO INOP	B	FIM 21-30-00/101, Fig. 108
EQPT CLG FAN	S	FIM 21-58-00/101, Fig. 105
EQPT CLG FLOW	S	FIM 21-58-00/101, Fig. 113
EQPT CLG SENSOR	S	FIM 21-58-00/101, Fig. 112

EFFECTIVITY

ALL

21-EICAS MESSAGES

BOEING
 757
 FAULT ISOLATION/MAINT MANUAL

EICAS MESSAGE LIST		
EICAS MESSAGE	LEVEL	PROCEDURE
EQPT CLG TEST	S,M	FIM 21-58-00/101, Fig. 121
EQPT OVHT	C	FIM 21-58-00/101, Fig. 117
EQPT SMOKE TEST	S	FIM 21-58-00/101, Fig. 124
FLT DK TEMP	C	FIM 21-60-00/101, Fig. 105
FWD CABIN TEMP	C	FIM 21-60-00/101, Fig. 105
FWD CARGO FAN	S,M	FIM 21-40-00/101, Fig. 104
FWD EQ EXH FLOW	M	FIM 21-58-00/101, Fig. 108
FWD EQ EXH SNSR	M	FIM 21-58-00/101, Fig. 111
FWD EQ SUP FAN 1	M	FIM 21-58-00/101, Fig. 109
FWD EQ SUP FAN 2	M	FIM 21-58-00/101, Fig. 110
FWD EQ SUP FLOW	M	FIM 21-58-00/101, Fig. 106

EFFECTIVITY

ALL

21-EICAS MESSAGES



BOEING
757
FAULT ISOLATION/MAINT MANUAL

EICAS MESSAGE LIST		
EICAS MESSAGE	LEVEL	PROCEDURE
FWD EQ SUP SNSR	M	FIM 21-58-00/101, Fig. 104
FWD EQPT DET 1	M	FIM 21-58-00/101, Fig. 122
FWD EQPT DET 2	M	FIM 21-58-00/101, Fig. 123
FWD EQPT EXH DET	M	FIM 21-58-00/101, Fig. 103
FWD EQPT SMOKE	C	FIM 21-58-00/101, Fig. 115 FIM 21-58-00/101, Fig. 116
(L,R) PACK BITE	M	FIM 21-51-00/101, Fig. 104
(L,R) PACK TEMP	C	FIM 21-51-00/101, Fig. 104 FIM 21-51-00/101, Fig. 106 FIM 21-51-00/101, Fig. 107 FIM 21-51-00/101, Fig. 107A FIM 21-51-00/101, Fig. 107B
(L,R) PACK OFF	C	This message does not indicate a failure if pack is selected off. FIM 21-51-00/101, Fig. 107A FIM 21-51-00/101, Fig. 107B
(L,R) RECIR FAN	C	FIM 21-20-00/101, Fig. 104
OVBD EX VAL OPEN	S	FIM 21-58-00/101, Fig. 114
OVBD EX VAL TEST	S	FIM 21-58-00/101, Fig. 120

EFFECTIVITY

ALL

21-EICAS MESSAGES

BOEING
 757
 FAULT ISOLATION/MAINT MANUAL

EICAS MESSAGE LIST		
EICAS MESSAGE	LEVEL	PROCEDURE
TRIM AIR	C	This message does not indicate a failure.
ZONE TEMP BITE	M	FIM 21-60-00/101, Fig. 104

EFFECTIVITY

ALL

21-EICAS MESSAGES

07

Page 6
Mar 20/96

BOEING

757

FAULT ISOLATION/MAINT MANUAL

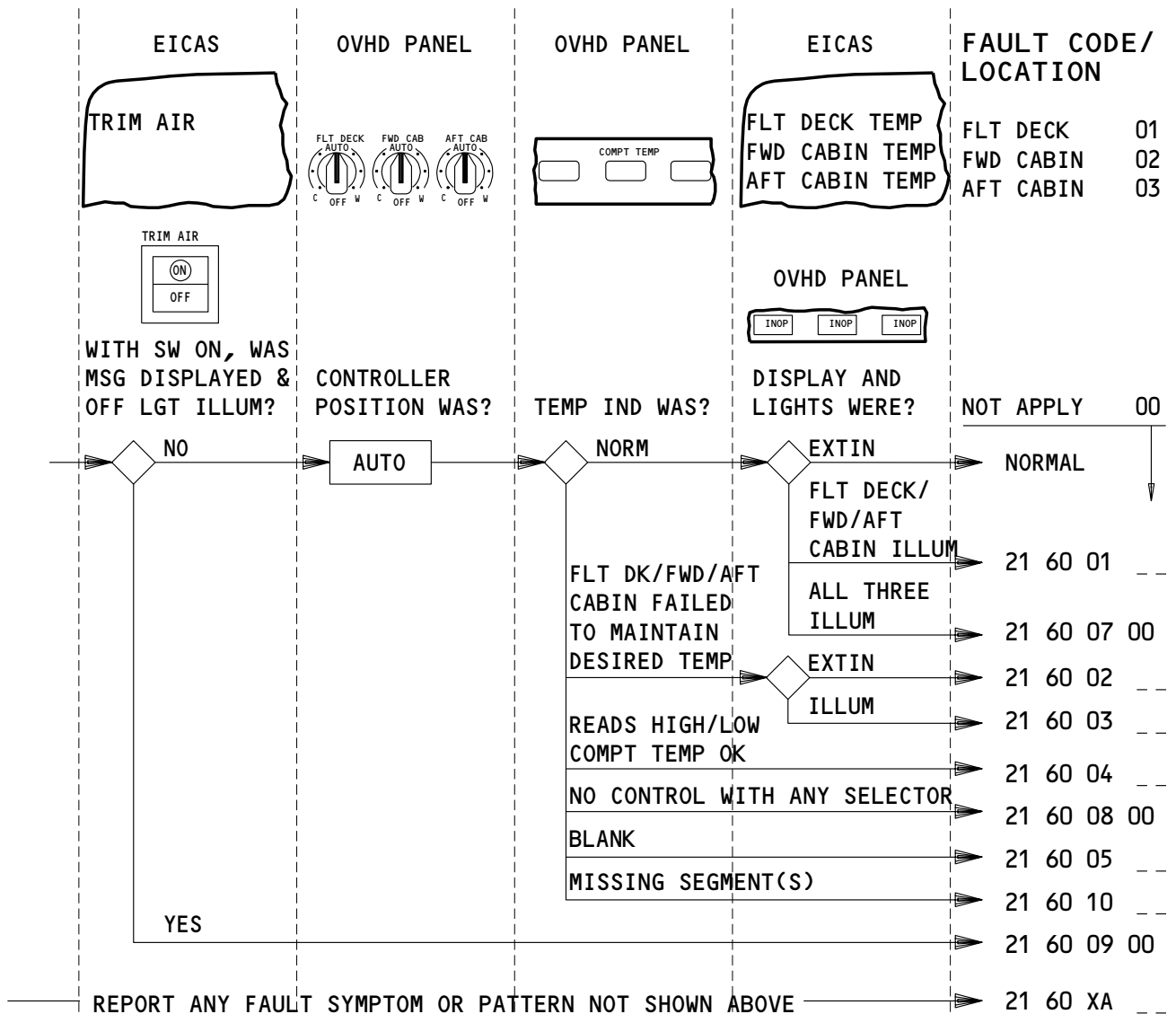

APPLICABLE CIRCUIT BREAKERS AS INSTALLED

11N25	ZONE TRIM VLV CLOSE F/D	11P17	CABIN ZONE TEMP IND
11N26	ZONE TRIM VLV CLOSE FWD	11P20	FLT DECK FAN CONT
11N27	ZONE TRIM VLV CLOSE AFT	11P21	ZONE FAN FWD CONT
11N25	ZONE TEMP CONT VLV (CL,CLOSE) (FLT DK, F/D)	11P22	ZONE FAN AFT CONT
11N26	ZONE TEMP CONT VLV (CL,CLOSE) FWD	11P25	ZONE DUCT OVHT (INOP) (FLT DK, F/D)
11N27	ZONE TEMP CONT VLV (CL,CLOSE) AFT	11P26	ZONE DUCT OVHT (INOP) FWD
11P15	CABIN TRIM AIR	11P27	ZONE DUCT OVHT (INOP) AFT
11P16	CABIN ZONE (CONT,CNTRL)		

TEMPERATURE CONTROL - FAULT CODES

EFFECTIVITY

ALL

21-FAULT CODE DIAGRAM

01

Page 1
Sep 28/99

EICAS STATUS

FAULT CODE/
LOCATION

FWD CARGO FAN
AFT CARGO FAN

FWD 01
AFT 02

MESSAGE DISPLAYED?

NOT APPLY 00

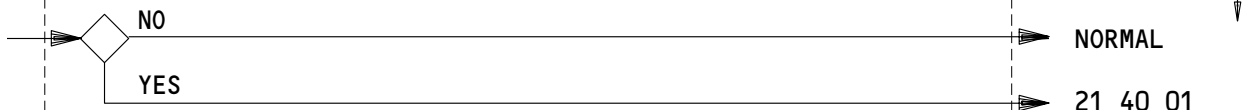

REPORT ANY FAULT SYMPTOM OR PATTERN NOT SHOWN ABOVE → 21 40 XA _ _

APPLICABLE CIRCUIT BREAKERS AS INSTALLED

11N12	FAN CONTROL FWD CARGO	11N21	FAN CONT AFT CARGO
11N17	CARGO HEAT FAN FWD	11N22	CARGO HEAT FAN AFT
11N18	CARGO HEATER AFT	11N22	FAN CONT AFT CARGO
11N18	AFT CARGO HEAT (CONT)		

CARGO HEAT – FAULT CODES

EFFECTIVITY
ALL

21-FAULT CODE DIAGRAM

SIDEWALL PANELS

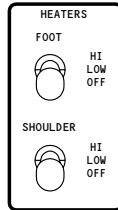
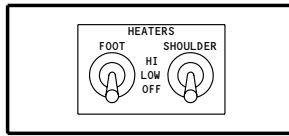

FAULT CODE/
LOCATION

CAPT 01
F/O 02

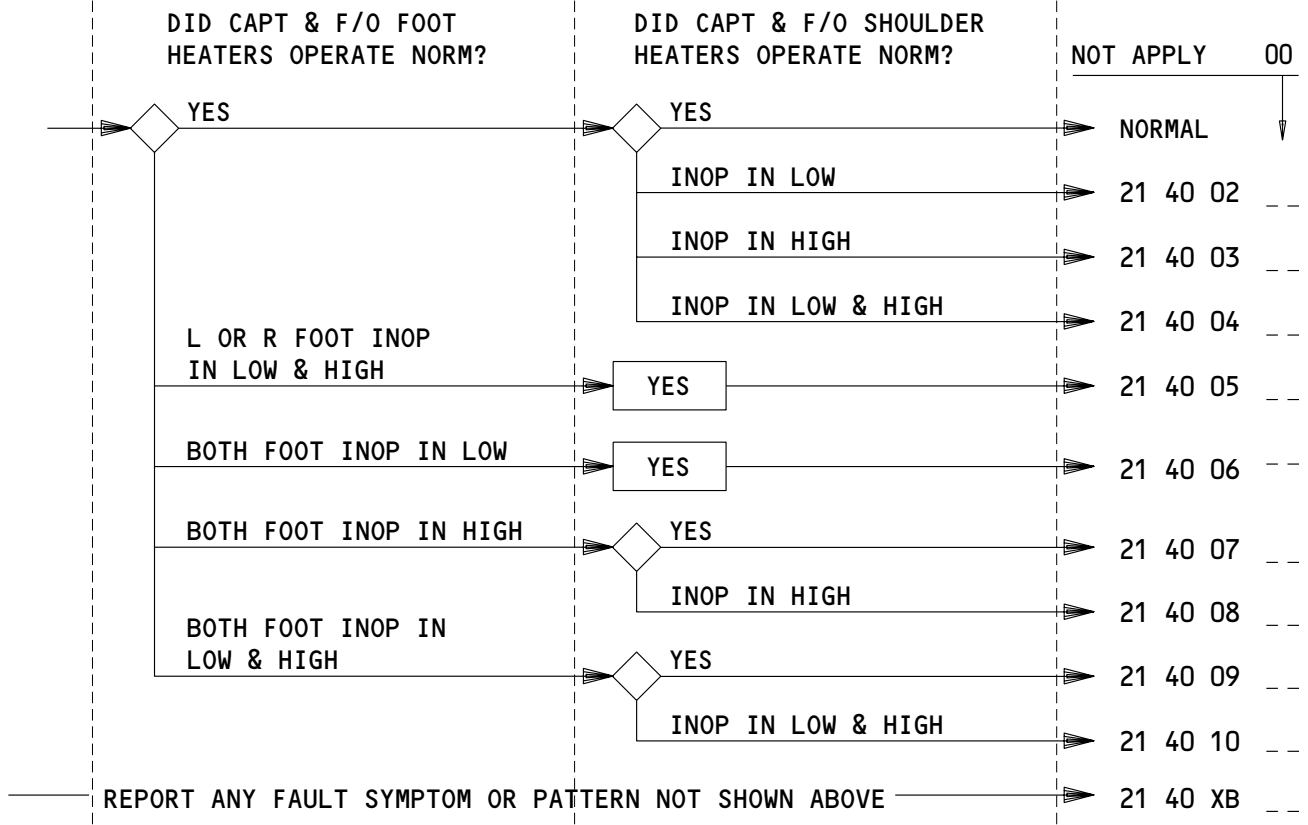

APPLICABLE CIRCUIT BREAKERS
NONE

FLIGHT DECK SUPPLEMENTARY HEATERS - FAULT CODES

EFFECTIVITY

ALL

21-FAULT CODE DIAGRAM

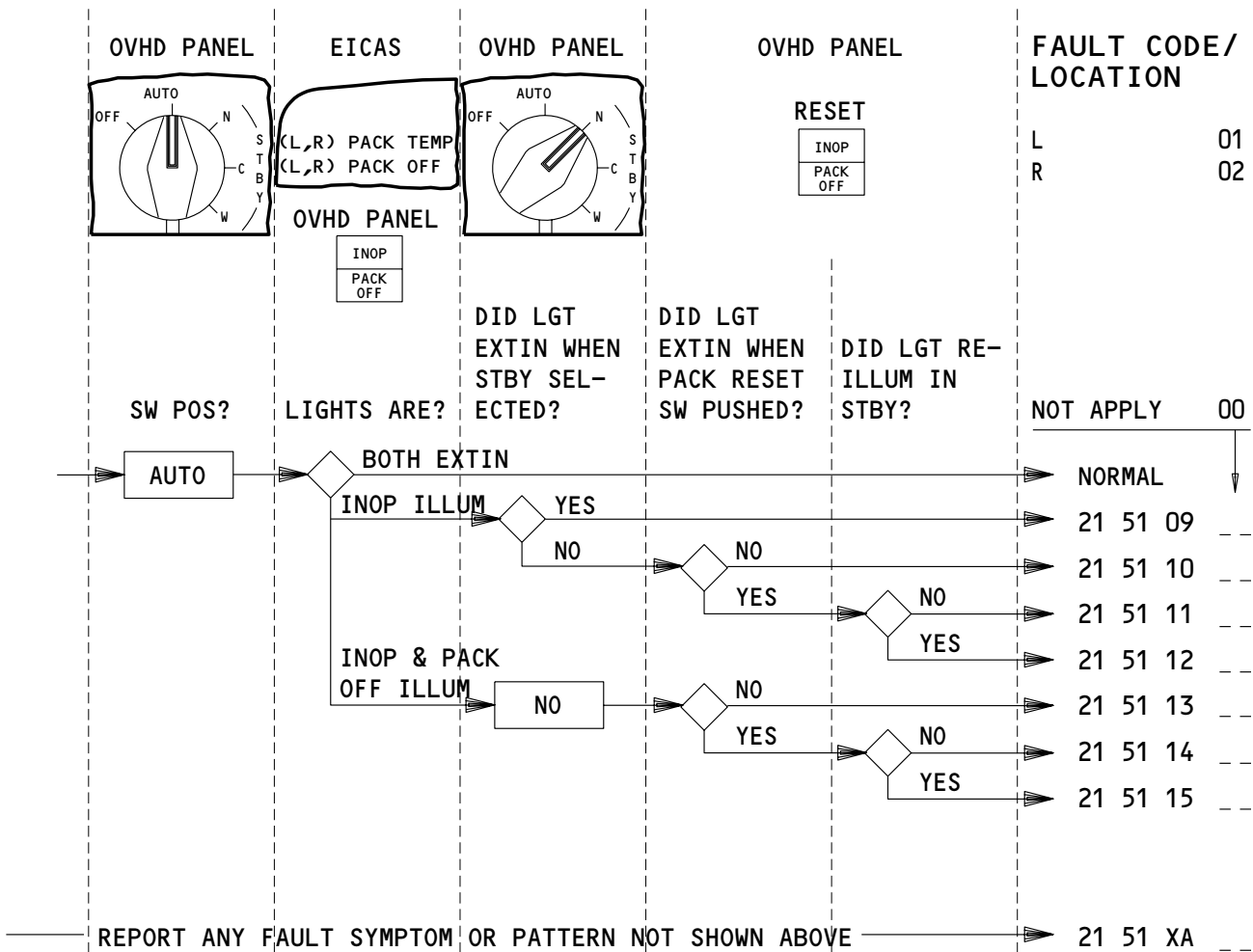

APPLICABLE CIRCUIT BREAKERS AS INSTALLED

11A13	(AIR COND PACK) LEFT AUTO CONT	11M11	LEFT PACK AUTO (PWR, POWER)
11A14	(AIR COND PACK) LEFT FLOW CONT	11M13	LEFT PACK FLOW CONT
11A14	LEFT PACK AUTO CONT	11M15	RIGHT PACK STANDBY (PWR, POWER)
11A15	LEFT PACK FLOW CONT	11M16	RIGHT PACK STANDBY CONT
11A15	(AIR COND PACK) RIGHT STBY CONT	11M17	PACK FLOW IND
11A26	(AIR COND PACK) LEFT STBY CONT	11M19	RIGHT PACK AUTO (PWR, POWER)
11A28	(AIR COND PACK) RIGHT AUTO CONT	11M20	RIGHT PACK AUTO CONT
11A29	(AIR COND PACK) RIGHT FLOW CONT	11M22	RIGHT PACK FLOW CONT
11M10	LEFT PACK AUTO PWR	11M24	(LEFT, L) PACK STANDBY (PWR, POWER)
11M11	LEFT PACK AUTO CONT	11M25	(LEFT, L) PACK STANDBY CONT

PACK CONTROL – FAULT CODES

EFFECTIVITY

ALL

21-FAULT CODE DIAGRAM

BOEING
757
FAULT ISOLATION/MAINT MANUAL

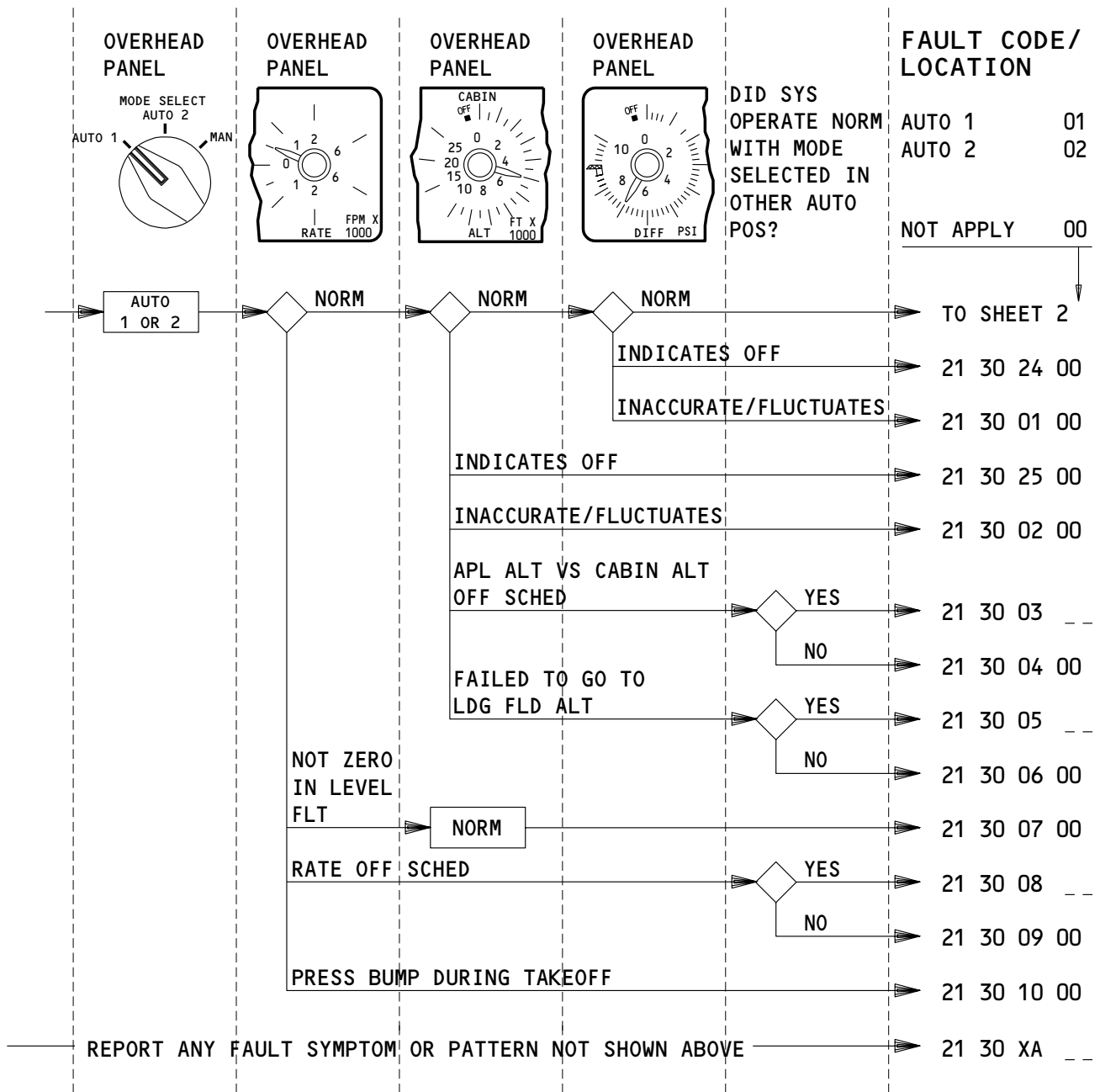

APPLICABLE CIRCUIT BREAKERS AS INSTALLED

11B12	CABIN DIFF PRESS IND	11B15	CABIN ALT/PRESS SEL
11B13	CABIN ALTM	11N15	CABIN ALTITUDE CONTROL AUTO 1
11B14	CABIN ALTITUDE CONTROL (MAN, MANUAL)	11N15	CABIN ALT/PRESS AUTO 1
11B14	CABIN ALT/PRESS MAN	11N24	CABIN ALTITUDE CONTROL AUTO 2
11B15	CABIN ALTITUDE CONTROL (SEL, SELECT)	11N24	CABIN ALT/PRESS AUTO 2

AUTO CONTROL (SHEET 1) - FAULT CODES

EFFECTIVITY

ALL

21-FAULT CODE DIAGRAM

05

Page 5
Jun 20/97

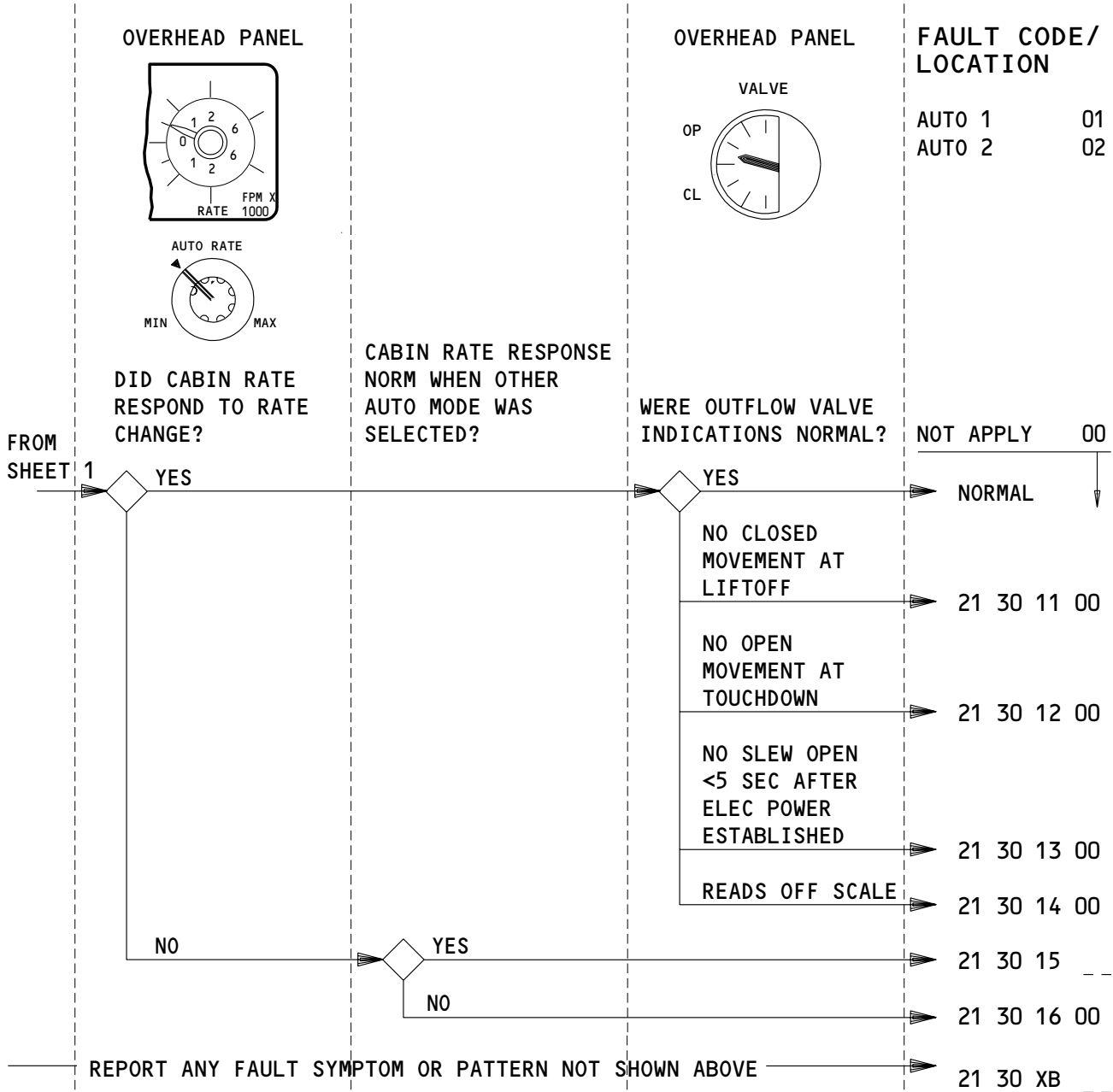

APPLICABLE CIRCUIT BREAKERS AS INSTALLED

11B12	CABIN DIFF PRESS IND
11B13	CABIN ALTM
11B14	CABIN ALTITUDE CONTROL (MAN, MANUAL)
11B14	CABIN ALT/PRESS MAN
11B15	CABIN ALTITUDE CONTROL (SEL, SELECT)

11B15	CABIN ALT/PRESS SEL
11N15	CABIN ALTITUDE CONTROL AUTO 1
11N15	CABIN ALT/PRESS AUTO 1
11N24	CABIN ALTITUDE CONTROL AUTO 2
11N24	CABIN ALT/PRESS AUTO 2

AUTO CONTROL (SHEET 2) - FAULT CODES

EFFECTIVITY

ALL

21-FAULT CODE DIAGRAM

BOEING

757 FAULT ISOLATION/MAINT MANUAL

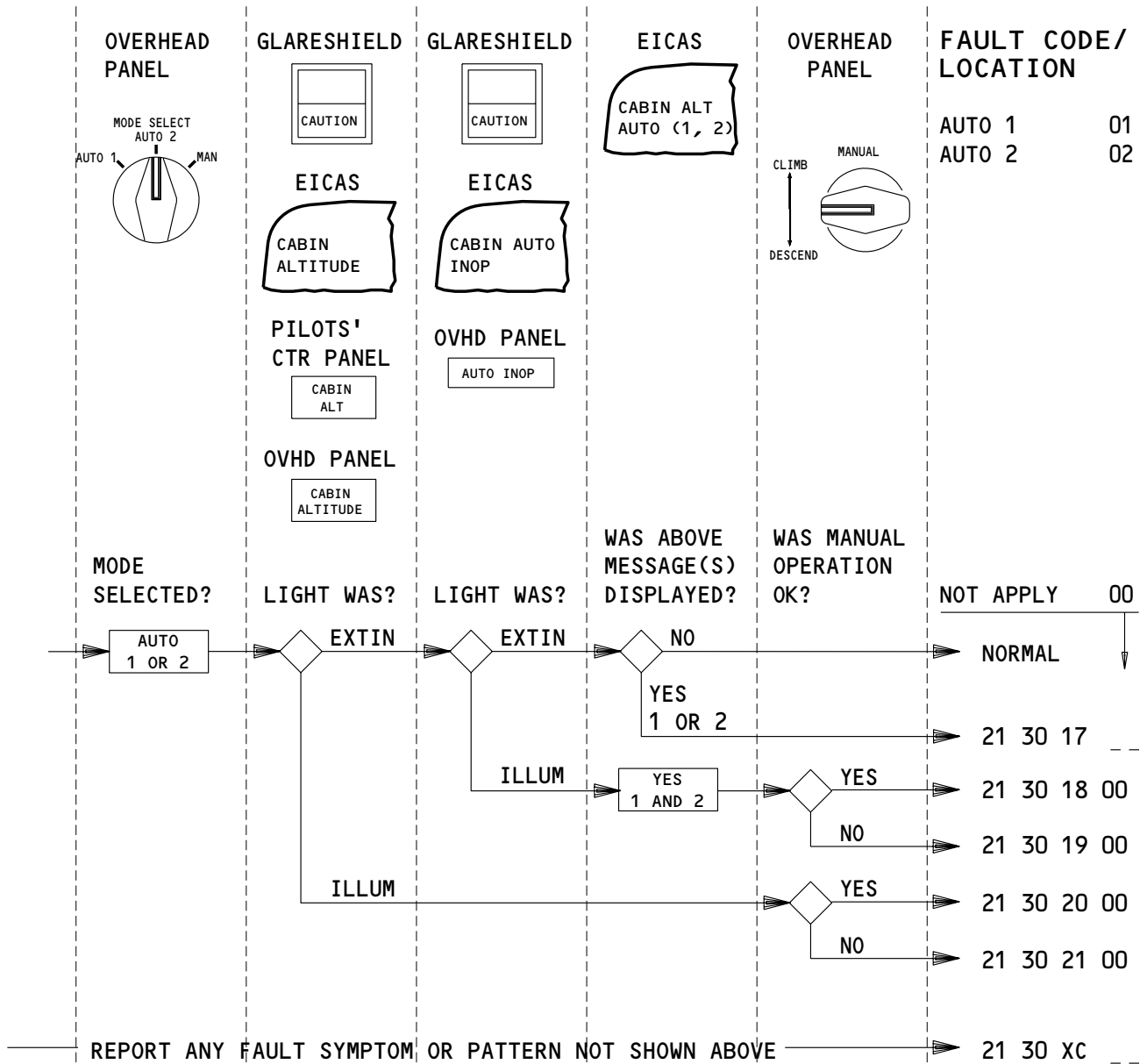

APPLICABLE CIRCUIT BREAKERS AS INSTALLED

11B12	CABIN DIFF PRESS IND	11B15	CABIN ALT/PRESS SEL
11B13	CABIN ALTM	11N15	CABIN ALTITUDE CONTROL AUTO 1
11B14	CABIN ALTITUDE CONTROL (MAN, MANUAL)	11N15	CABIN ALT/PRESS AUTO 1
11B14	CABIN ALT/PRESS MAN	11N24	CABIN ALTITUDE CONTROL AUTO 2
11B15	CABIN ALTITUDE CONTROL (SEL, SELECT)	11N24	CABIN ALT/PRESS AUTO 2

CABIN ALTITUDE/AUTO INOP/CABIN ALT AUTO - FAULT CODES

EFFECTIVITY

ALL

21-FAULT CODE DIAGRAM

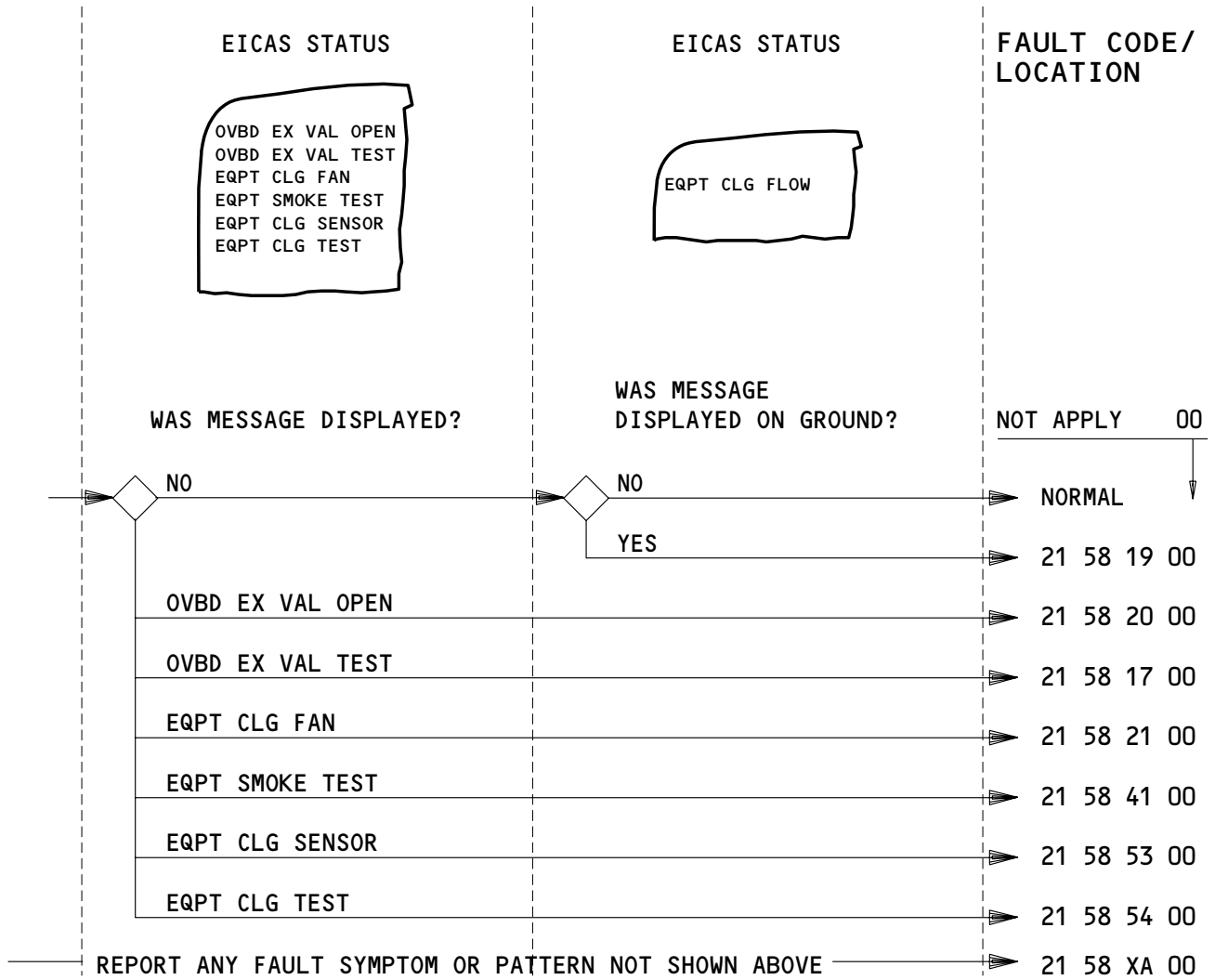

APPLICABLE CIRCUIT BREAKERS AS INSTALLED

6D6 EQUIP COOL GND WARN	11N11 EQUIP COOLING FAN CONT AFT EXH XFR
6D6 EQUIP COOL GND WARN AND TEST	11N11 FAN CONT AFT SUPPLY 1
6F17 EQUIP COOL SUPPLY FAN 1	11N12 FAN CONT FWD SUPPLY 1
6F17 EQUIP COOL AUX FAN	11N14 FAN CONTROL AFT EQPT SUPPLY 1
6F17 FWD EQUIP COOL SUPPLY FAN 1	11N13/17 EQUIP COOLING LO FLOW DET
6F23 EQUIP COOL SUPPLY FAN 2	11N19 FAN CONT AFT EQUIP (EXH) 2
6F23 FWD EQUIP COOL SUPPLY FAN 2	11N20 FAN CONT FWD EQPT (E/E) COOL SPLY 2
11C19 SMOKE CLEAR EQUIP COOL	11N20 FAN CONT AFT SUPPLY 2
11C20 SMOKE CLEAR INOP	11N21 FAN CONT FWD SUPPLY 2
11C20 EQUIP COOL SMOKE DET (CONT)	11N22 FAN CONT AFT EQPT SPLY 2
11C21 EQUIP COOL TEST	11P14 RECIRC CARGO FIRE CONT (LEFT, L)
11N10 FAN CONTROL AFT EQPT (EXH) 1	11P23 RECIRC CARGO FIRE CONT (RIGHT, R)
11N11 FAN CONTROL FWD (E/E) EQPT COOL SPLY 1	

EQUIPMENT COOLING - FAULT CODES

EFFECTIVITY

ALL

21-FAULT CODE DIAGRAM

05

Page 9
Sep 28/99

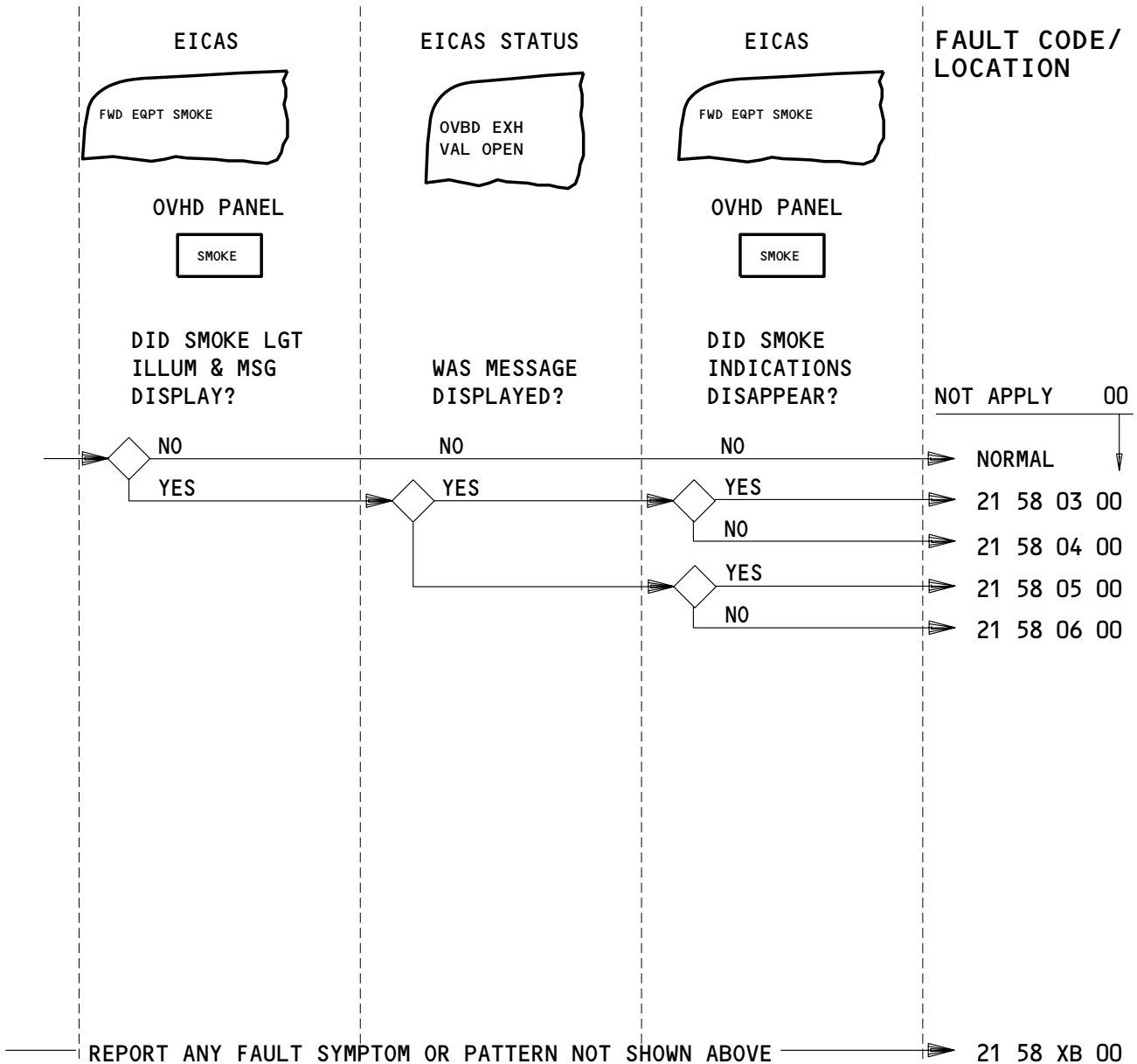

APPLICABLE CIRCUIT BREAKERS AS INSTALLED

6D6	EQUIP COOL GND WARN	11N11	EQUIP COOLING FAN CONT AFT EXH XFR
6D6	EQUIP COOL GND WARN AND TEST	11N13/17	EQUIP COOLING LOW FLOW DET
6D17	EQUIP COOL AUX FAN	11P14	RECIRC CARGO FIRE CONT (LEFT, L)
6F17	FWD EQUIP COOL SUPPLY FAN 1	11P23	RECIRC CARGO FIRE CONT (RIGHT, R)
6F23	FWD EQUIP COOL SUPPLY FAN 2		
11C20	EQUIP COOL SMOKE DET CONT		

EQUIPMENT COOLING SMOKE – FAULT CODES

EFFECTIVITY

ALL

21-FAULT CODE DIAGRAM

05

Page 10
Sep 28/99

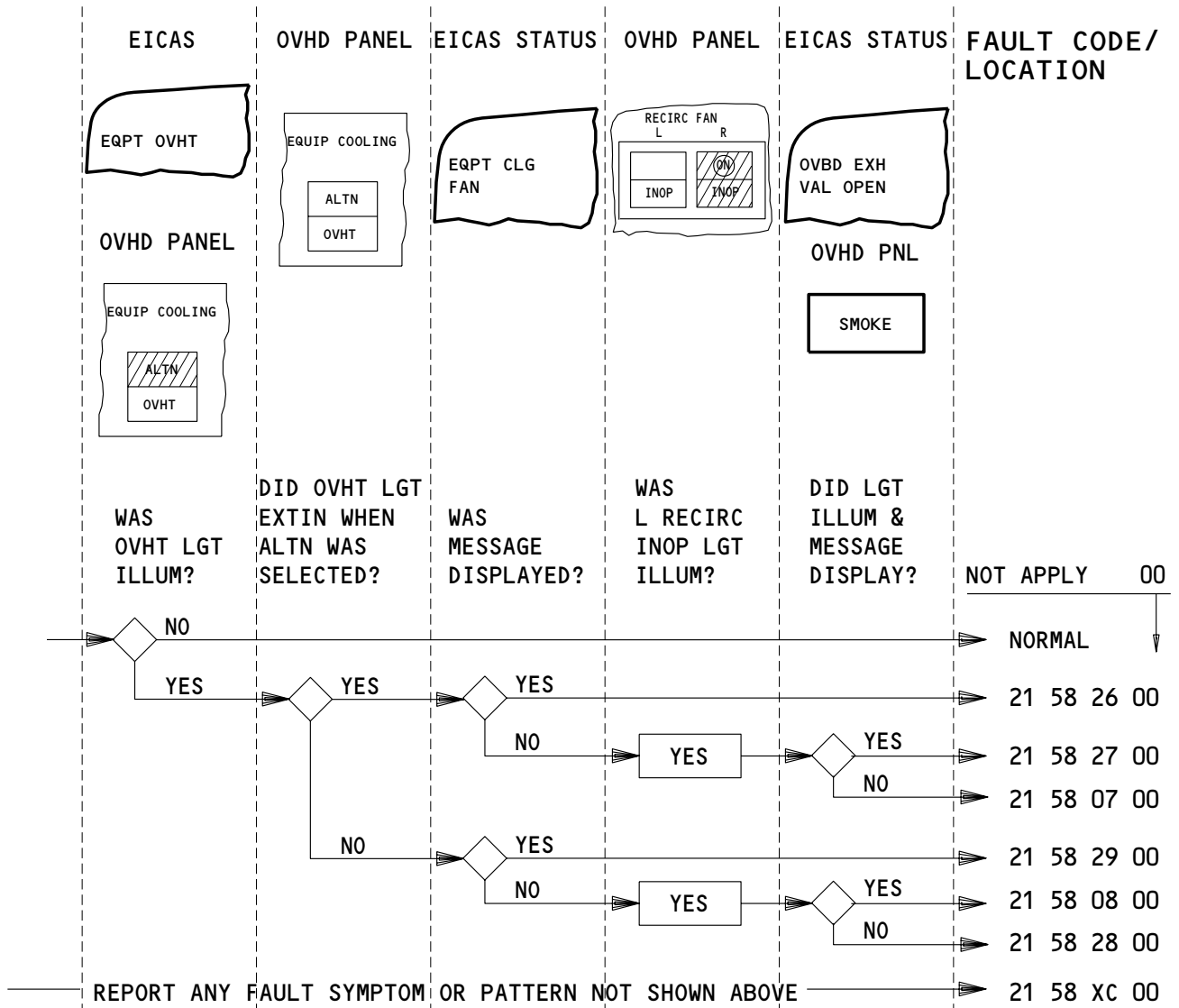

APPLICABLE CIRCUIT BREAKERS AS INSTALLED

6D6	EQUIP COOL (GRD WARN, GRD WARN AND TEST)	11N12	EQUIP COOLING FAN CONT FWD SUPPLY 1
6D17	EQUIP COOL AUX FAN	11N13/17	EQUIP COOLING (LO, LOW) FLOW DET
6F17	(FWD) EQUIP COOL SUPPLY FAN 1	11N14	FAN CONTROL AFT EQUIP SUPPLY
6F23	(FWD) EQUIP COOL SUPPLY FAN 2	11N19	EQUIP COOLING FAN CONT AFT (EXH, EQUIP) 2
11C19	EQUIP COOL SMOKE CLEAR	11N20	FAN CONT FWD EQPT COOL SUPPLY 2
11C20	EQUIP COOLING SMOKE DET CONT	11N20	EQUIP COOLING FAN CONT AFT SUPPLY 2
11C20	EQUIP COOLING SMOKE DET CONT	11N21	EQUIP COOLING FAN CONT FWD SUPPLY 2
11N10	EQUIP COOLING FAN CONT AFT EXH 1	11N22	FAN CONT AFT EQPT SUPPLY 2
11N10	FAN CONTROL AFT EQUIP	11P14	RECIRC (CARGO FIRE CONT LEFT, FAN L)
11N11	FAN CONTROL FWD EQPT COOL SUPPLY 1	11P23	RECIRC (CARGO FIRE CONT RIGHT, FAN R)
11N11	EQUIP COOLING FAN CONT AFT (SUPPLY 1, EXH XFER)		

EQUIPMENT COOLING OVERHEAT – FAULT CODES

EFFECTIVITY

ALL

21-FAULT CODE DIAGRAM

02

Page 11
Sep 28/99

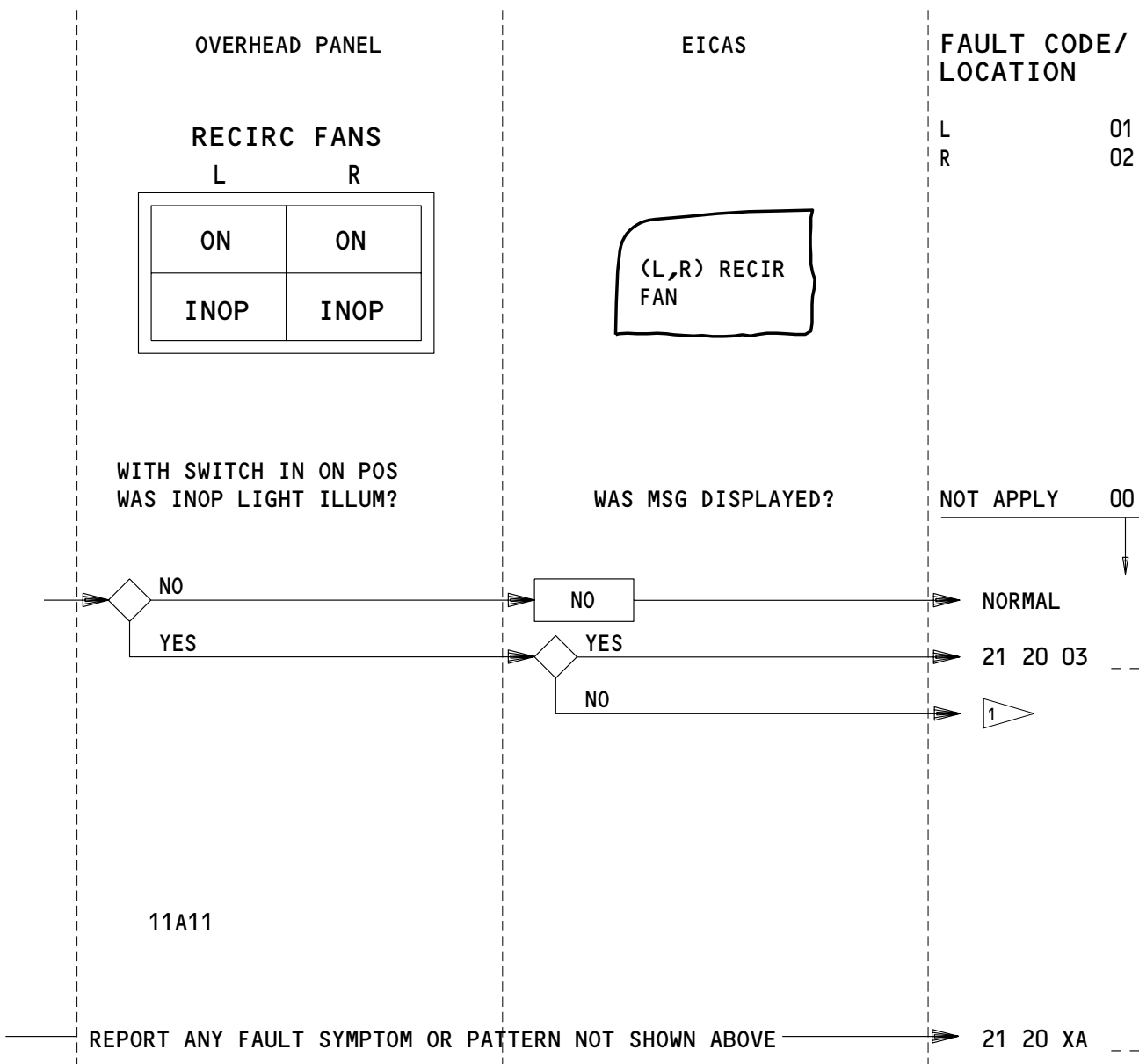

1 SEE "EQUIP COOLING SMOKE" FAULT CODES. EICAS MSG INHIBITED WHEN SMOKE IS DETECTED.

APPLICABLE CIRCUIT BREAKERS AS INSTALLED

11P14 RECIRC FAN L	11P23 RECIRC FAN R
11P14 RECIRC CARGO FIRE CONT LEFT	11P23 RECIRC CARGO FIRE CONT RIGHT

RECIRCULATION FAN - FAULT CODES

EFFECTIVITY

ALL

21-FAULT CODE DIAGRAM

BOEING
757
FAULT ISOLATION/MAINT MANUAL

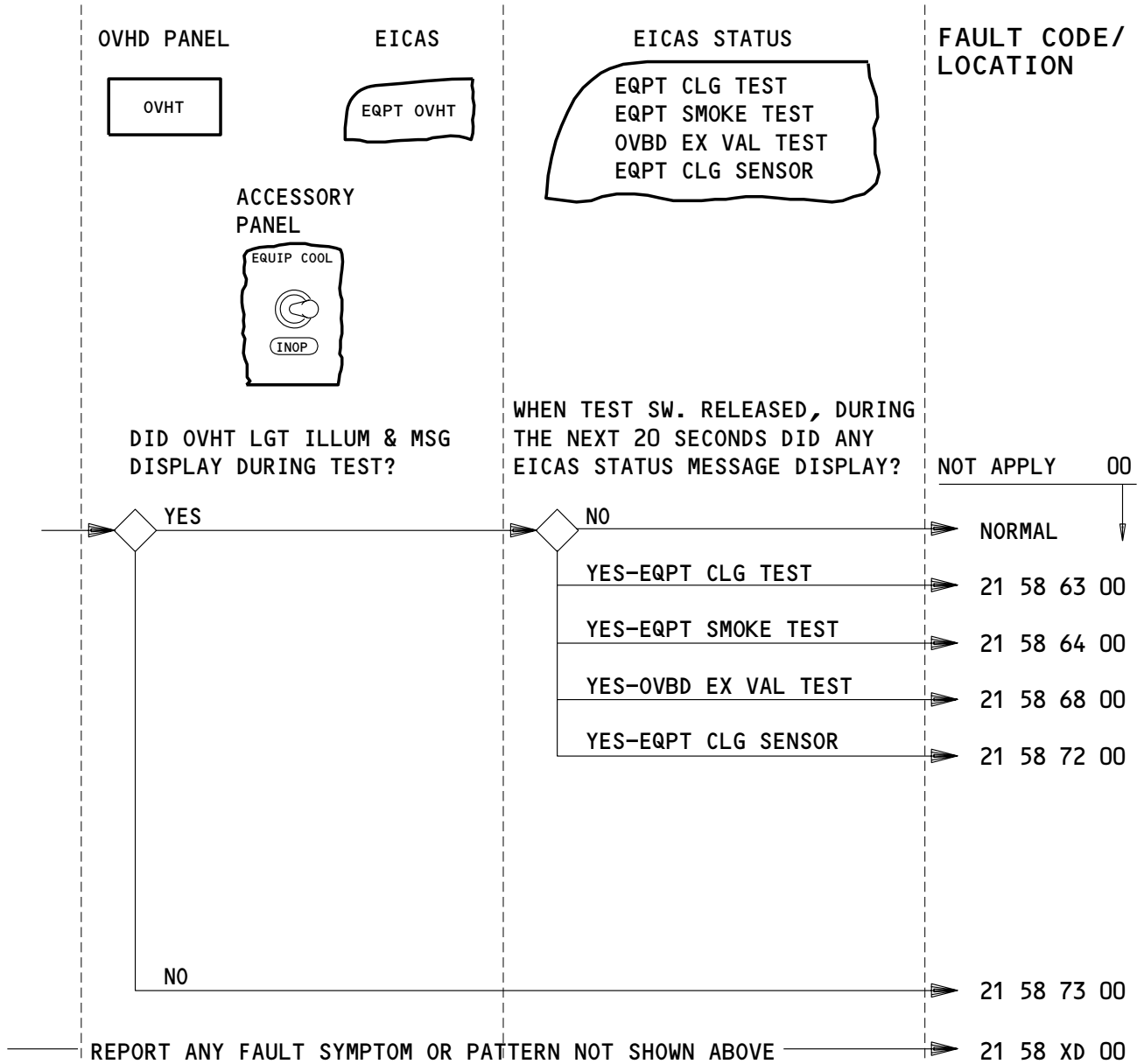

APPLICABLE CIRCUIT BREAKERS AS INSTALLED

6D6	EQUIP COOL GRD WARN AND TEST	11N11	EQUIP COOLING FAN CONT AFT EXH XFR
6D17	EQUIP COOL AUX FAN	11N13	EQUIP COOLING LOW FLOW DET
6F17	FWD EQUIP COOL SUPPLY FAN 1	11P14	RECIRC CARGO FIRE CONT (LEFT, L)
6F23	FWD EQUIP COOL SUPPLY FAN 2	11P23	RECIRC CARGO FIRE CONT (RIGHT, R)
11C20	EQUIP COOLING SMOKE DET CONT		

EQUIPMENT COOLING TEST - FAULT CODES

EFFECTIVITY

ALL

21-FAULT CODE DIAGRAM

06

Page 13
Sep 28/99

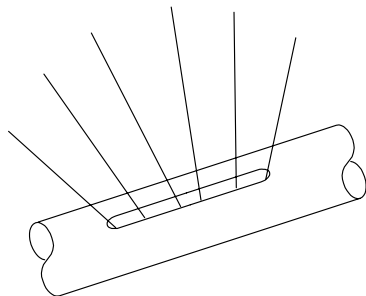

FAULT CODE/
LOCATION

L 01
R 02
C 03

WAS THERE ABNORMAL NOISE OR VIBRATION IN

FLIGHT DECK?

MAIN CABIN? ¹

NOT APPLY 00

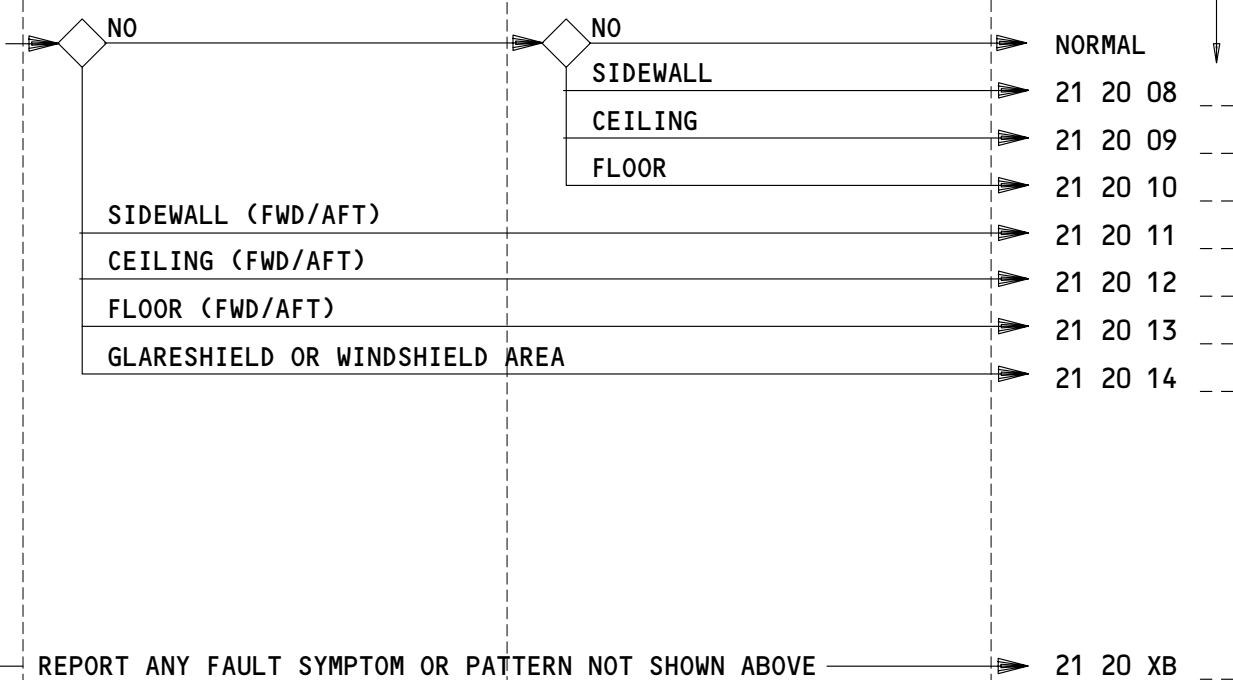

¹ IDENTIFY BY NEAREST SEAT ROW, GALLEY OR LAVATORY

APPLICABLE CIRCUIT BREAKERS
NONE

AIR CONDITIONING NOISE AND VIBRATION – FAULT CODES

EFFECTIVITY

ALL

21-FAULT CODE DIAGRAM

09

Page 14
Sep 20/89

GALLEY (TYPICAL)

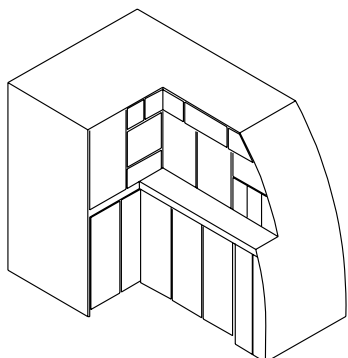

MAIN CABIN AREA

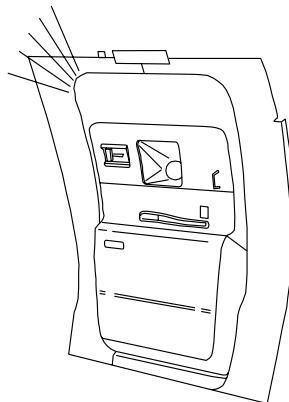

FAULT CODE/
LOCATION

GALLEYS

FWD 01
MID 02
AFT 03

DOORS

1L 04
2L 05
3L EMER 06
4L 07
1R 08
2R 09
3R EMER 10
4R 11

WAS THERE A COLD AREA IN

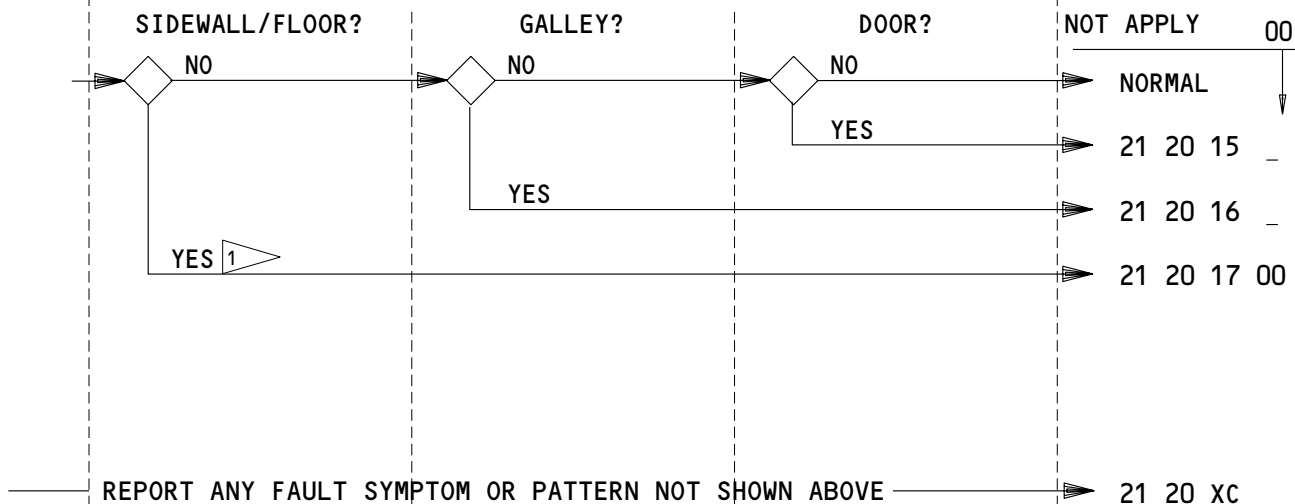

¹ LOCATE BY NEAREST SEAT OR ROW.

APPLICABLE CIRCUIT BREAKERS

NONE

AIR CONDITIONING COLD AREAS - FAULT CODES

EFFECTIVITY

ALL

21-FAULT CODE DIAGRAM

04

Page 15
Sep 28/00

BOEING
 757
 FAULT ISOLATION/MAINT MANUAL

FAULT CODE	1. LOG BOOK REPORT 2. FAULT ISOLATION REFERENCE
21 20 XA --	1. A (O1=L, O2=R,) recirculation system failure occurred that did not show in the fault code diagrams. (Refer to the fault code diagrams for flight crew action). 2. Right: SSM 21-25-01 Left: SSM 21-25-02.
21 20 XB --	1. A (O1=L, O2=R, O3=C) duct noise or vibration problem occurred that did not show in the fault code diagrams. (Refer to the fault code diagrams for flight crew action). 2. Replace or repair the duct (AMM 21-23-01).
21 20 XC --	1. Local cold areas occurred that did not show in the fault code diagrams. (Refer to the fault code diagrams for flight crew action). 2. Make sure the seals and the insulation in the area are in good condition.
21 30 XA --	1. A (O1=AUTO 1, O2=AUTO 2) control failure occurred that did not show in the fault code diagrams. (Refer to the fault code diagrams for flight crew action). 2. FIM 21-30-00/101, Fig. 103, Block 1.
21 30 XB --	1. A (O1=AUTO 1, O2=AUTO 2) control failure occurred that did not show in the fault code diagrams. (Refer to the fault code diagrams for flight crew action). 2. FIM 21-30-00/101, Fig. 103, Block 1.
21 30 XC --	1. A (O1=AUTO 1, O2= AUTO 2) control failure occurred that did not show in the fault code diagrams. (Refer to the fault code diagrams for flight crew action). 2. FIM 21-30-00/101, Fig. 103, Block 1.

EFFECTIVITY

ALL

21-FAULT CODE INDEX

04

Page 1
Jun 20/96

BOEING
 757
 FAULT ISOLATION/MAINT MANUAL

FAULT CODE	1. LOG BOOK REPORT 2. FAULT ISOLATION REFERENCE
21 40 XA --	1. A (01=FWD, 02=AFT) cargo heat failure occurred that did not show in the fault code diagrams. (Refer to the fault code diagrams for flight crew action). 2. FWD: SSM 21-43-01 AFT: SSM 21-44-01.
21 40 XB --	1. A (01=Capt, 02=F/O) flight deck supplementary heater failure occurred that did not show in the fault code diagrams. (Refer to the fault code diagrams for flight crew action). 2. SSM 21-45-01.
21 51 XA --	1. A (01=L, 02=R) pack control failure occurred that did not show in the fault code diagrams. (Refer to the fault code diagrams for flight crew actions). 2. FIM 21-51-00/101, Fig. 104, Block 1.
21 58 XA 00	1. An equipment cooling failure occurred that did not show in the fault code diagrams. (Refer to the fault code diagrams for flight crew action). 2. SSM 21-58-07.
21 58 XB 00	1. An equipment cooling smoke failure occurred that did not show in the fault code diagrams. (Refer to the fault code diagrams for flight crew action). 2. SSM 21-58-02.
21 58 XC 00	1. An equipment cooling overheat failure occurred that did not show in the fault code diagrams. (Refer to the fault code diagrams for flight crew action). 2. SSM 21-58-01.

EFFECTIVITY

ALL

21-FAULT CODE INDEX

06

Page 2
Jun 20/96



BOEING
757
FAULT ISOLATION/MAINT MANUAL

FAULT CODE	1. LOG BOOK REPORT 2. FAULT ISOLATION REFERENCE
21 58 XD 00	1. An equipment cooling test failure occurred that did not show in the fault code diagrams (Refer to the fault code diagrams for maintenance crew action). 2. SSM 21-58-06.
21 60 XA --	1. An (01=FLT DECK, 02=FWD CABIN, 03=AFT CABIN) temperature control system failure occurred that did not show in the fault code diagrams. (Refer to the fault code diagrams for flight crew action). 2. FIM 21-60-00/101, Fig. 104, Block 1.
21 20 01 00	1. Smoke from air conditioning outlets. Stopped with both utility buses off. (Ref Chapter 24 for Fault Code Diagram). 2. Replace inoperative recirculation air fan (AMM 21-25-01/401).
21 20 02 00	1. Smoke from air conditioning outlets. Continued with both utility buses off. (Ref Chapter 24 for Fault Code Diagram). 2. Isolate the APU or the Engine as the source of smoke: If the APU is the source of smoke, see the APU chapter 49 for Fault Code Diagram. If the engine is the source of smoke, see the engine chapter 71 for Fault Code Diagram. Once the source of smoke is determined and repaired, do the smoke and oil contamination removal procedure (AMM 21-00-21/201).
21 20 03 --	1. EICAS msg (L=01, R=02) RECIRC FAN shown. (L, R) RECIRC FAN INOP light on. 2. FIM 21-20-00/101, Fig. 104, Block 1.
21 20 04 00	1. EICAS msg AFT EQ EXH FAN 1 shown (Refer to Chapter 31 for the code diagram). 2. FIM 21-20-00/101, Fig. 105, Block 1.
21 20 05 00	1. EICAS msg AFT EQ EXH FAN 2 shown (Refer to Chapter 31 for the fault code diagram). 2. FIM 21-20-00/101, Fig. 103, Block 1.
21 20 06 00	Not Used
21 20 07 00	Not Used
21 20 08 --	1. Too much noise or vibration in the (01=L, 02=R) main cabin sidewall, near the (seat row, galley, or lavatory). 2. Replace or repair the applicable duct (AMM 21-23-01).

EFFECTIVITY

ALL

21-FAULT CODE INDEX

05

Page 3
Jan 20/08

BOEING
 757
 FAULT ISOLATION/MAINT MANUAL

FAULT CODE	1. LOG BOOK REPORT 2. FAULT ISOLATION REFERENCE
21 20 09 --	1. Too much noise or vibration in the (01=L, 02=R, 03=C) main cabin ceiling, near the (seat row, galley, or lavatory). 2. Replace or repair the applicable duct (AMM 21-23-01).
21 20 10 --	1. Too much noise or vibration in the (01=L, 02=R, 03=C) main cabin floor, near the (seat row, galley, or lavatory). 2. Replace or repair the applicable duct (AMM 21-23-01).
21 20 11 --	1. Too much noise or vibration in the (01=L, 02=R) sidewall of the (fwd, aft) flight deck area. 2. Replace or repair the applicable duct (AMM 21-23-01).
21 20 12 --	1. Too much noise or vibration in the (01=L, 02=R, 03=C) ceiling of the (fwd, aft) flight deck area. 2. Replace or repair the applicable duct (AMM 21-23-01).
21 20 13 --	1. Too much noise or vibration in the (01=L, 02=R, 03=C) floor of the (fwd, aft) flight deck area. 2. Replace or repair the applicable duct (AMM 21-23-01).
21 20 14 --	1. Too much noise or vibration around the (01=L, 02=R) (glare shield, windshield) area. 2. Remove the unwanted material from the windshield diffuser.
21 20 15 --	1. Cold area near the (04=1L, 05=2L, 06=3L Emer, 07=4L, 08=1R, 09=2R, 10=3R Emer, 11=4R) door. 2. Make sure the seals and the insulation in the door area are in good condition.
21 20 16 --	1. Cold area around the (01=Fwd, 02=Mid, 03=Aft) galley in the (floor, ceiling, etc) area. 2. Make sure the seals in the refrigeration unit are in good condition.
21 20 17 --	1. Cold area around the (nearest seat or row) in the (sidewall, floor, sidewall/floor) area. 2. Make sure the insulation in the sidewall is in good condition.
21 30 01 00	1. The DIFF pressure gauge is (inaccurate, fluctuates). The CABIN ALT pressure gauge and the RATE pressure gauge are correct. 2. FIM 21-30-00/101, Fig. 110, Block 1.

EFFECTIVITY

ALL

21-FAULT CODE INDEX

05

Page 4
Jun 20/96



BOEING
757
FAULT ISOLATION/MAINT MANUAL

FAULT CODE	1. LOG BOOK REPORT 2. FAULT ISOLATION REFERENCE
21 30 02 00	1. The CABIN ALT pressure gauge is (inaccurate, fluctuates). The RATE pressure gauge is correct. 2. Replace the cabin pressure indication and warning module, M19 (AMM 21-33-01).
21 30 03 --	1. The DIFF pressure was off schedule in the (01=AUTO 1, 02=AUTO 2) mode. Operated correctly when the other mode was selected. 2. FIM 21-30-00/101, Fig. 103, Block 1.
21 30 04 00	1. The DIFF pressure was off schedule in both modes. 2. Replace the cabin pressure indication and warning module, M19 (AMM 21-33-01).
21 30 05 --	1. The CABIN ALT did not go to the landing altitude in the (01=AUTO 1, 02=AUTO 2) mode. Operated correctly when the other mode was selected. 2. FIM 21-30-00/101, Fig. 103, Block 1.
21 30 06 00	1. The CABIN ALT did not go to the landing altitude in both modes. 2. Replace the cabin pressure indication and warning module, M19 (AMM 21-33-01).
21 30 07 00	1. The CABIN RATE not zero in level flight. The CABIN ALT operated correctly. 2. Replace the cabin pressure indication and warning module, M19 (AMM 21-33-01).
21 30 08 --	1. The CABIN RATE is not the same as the selected rate in the (01=AUTO 1, 02=AUTO 2) mode. Operated correctly when the other mode was selected. 2. FIM 21-30-00/101, Fig. 103, Block 1.
21 30 09 00	1. The CABIN RATE is not the same as the selected rate in both modes. 2. FIM 21-30-00/101, Fig. 105, Block 1.
21 30 10 00	1. A pressure bump was felt during the takeoff and seen on the CABIN RATE pressure gauge. 2. FIM 21-30-00/101, Fig. 107, Block 1.
21 30 11 00	1. Outflow valve did not move after the liftoff. 2. FIM 21-30-00/101, Fig. 111, Block 1.

EFFECTIVITY

ALL

21-FAULT CODE INDEX

03

Page 5
Jun 20/96

BOEING
 757
 FAULT ISOLATION/MAINT MANUAL

FAULT CODE	1. LOG BOOK REPORT 2. FAULT ISOLATION REFERENCE
21 30 12 00	1. Outflow valve did not fully open after the touchdown. 2. FIM 21-30-00/101, Fig. 111, Block 1.
21 30 13 00	1. Outflow valve did not open within five seconds after the electrical power was supplied. 2. FIM 21-30-00/101, Fig. 111, Block 1.
21 30 14 00	1. Outflow valve indicator reads off scale. 2. Replace the valve position indicator, M13 (AMM 21-31-01).
21 30 15 --	1. When the AUTO RATE selector was moved, there was no change in the RATE gauge when in the (O1=AUTO 1, O2=AUTO 2) mode. Operation was OK when the other mode was selected. 2. FIM 21-30-00/101, Fig. 103, Block 1.
21 30 16 00	1. When the AUTO RATE selector was moved, there was no change in the RATE gauge, in both AUTO modes. 2. Replace the cabin pressure indicating and warning module, M19 (AMM 21-33-01).
21 30 17 --	1. EICAS msg CABIN ALT AUTO (O1=1, O2=2) shown. Cabin pressure was O.K. 2. FIM 21-30-00/101, Fig. 103, Block 1.
21 30 18 00	1. EICAS msgs CABIN AUTO INOP & CABIN ALT AUTO 1 & 2 shown. AUTO INOP light on. Operation in MANUAL mode was OK. 2. FIM 21-30-00/101, Fig. 103, Block 1. If the problem continues and the airplane is QFE configured, replace the standby altimeter, N23 (AMM 34-13-06/401).
21 30 19 00	1. EICAS msgs CABIN AUTO INOP & CABIN ALT AUTO 1 & 2 shown. AUTO INOP light on. Could not control outflow valve in the MANUAL mode. 2. FIM 21-30-00/101, Fig. 108, Block 1.
21 30 20 00	1. EICAS msg CABIN ALTITUDE shown. CABIN ALT & CABIN ALTITUDE lights on. Operation in the MANUAL mode O.K. 2. FIM 21-30-00/101, Fig. 103, Block 1.

EFFECTIVITY

ALL

21-FAULT CODE INDEX

BOEING
 757
 FAULT ISOLATION/MAINT MANUAL

FAULT CODE	1. LOG BOOK REPORT 2. FAULT ISOLATION REFERENCE
21 30 21 00	1. EICAS msg CABIN ALTITUDE shown. CABIN ALT & CABIN ALTITUDE lights on. Could not control the cabin pressure in the MANUAL mode. (describe cause of depressurization, if known). 2. FIM 21-30-00/101, Fig. 109, Block 1.
21 30 22 00	1. EICAS msg CABIN ALT AUTO 1 shown. (Ref Chapter 31 for the fault code diagram). 2. FIM 21-30-00/101, Fig. 104, Block 1.
21 30 23 00	1. EICAS msg CABIN ALT AUTO 2 shown. (Ref Chapter 31 for the fault code diagram). 2. FIM 21-30-00/101, Fig. 104, Block 1.
21 30 24 00	1. DIFF gauge in off position. Other indications were OK. 2. Replace the differential pressure sensor, TS5072 (AMM 21-33-04). If the problem continues, replace the cabin pressurization indicating and warning module, M19 (AMM 21-33-01).
21 30 25 00	1. CABIN ALT gauge in the off position. Other indications were OK. 2. Replace the cabin pressurization indicating and warning module, M19 (AMM 21-33-01).
21 40 01 --	1. EICAS status msg (FWD=01, AFT=02) CARGO FAN displayed. 2. FIM 21-40-00/101, Fig. 104, Block 1.
21 40 02 --	1. (01=Capt, 02=F/O) shoulder heater inop in LOW pos. Operation in HI norm. 2. Replace the Capt (F/O) foot heater switch, S1, M901 (M902), on the Capt (F/O) auxiliary instrument panel, P13 (P14) (WDM 21-45-11).
21 40 03 --	1. (01=Capt, 02=F/O) shoulder heater inop in HI pos. Operation in LOW norm. 2. Replace the Capt (F/O) foot heater switch, S1, M901 (M902), on the Capt (F/O) auxiliary instrument panel, P13 (P14) (WDM 21-45-11).

EFFECTIVITY

ALL

21-FAULT CODE INDEX

08

Page 7
Jun 20/96

BOEING
 757
 FAULT ISOLATION/MAINT MANUAL

FAULT CODE	1. LOG BOOK REPORT 2. FAULT ISOLATION REFERENCE
21 40 04 --	1. (01=Capt, 02=F/O) shoulder heater inop in LOW & HI pos. 2. FIM 21-40-00/101, Fig. 105, Block 1.
21 40 05 --	1. (01=Capt, 02=F/O) (L, R) foot heater inop in LOW & HI pos. 2. Replace the Capt (F/O) L (R) foot heater B10044, (B10045), (B10046, (B10047)) (AMM 21-45-01).
21 40 06 --	1. (01=Capt, 02=F/O) L & R foot heater inop in LOW pos. Operation in HI norm. Shoulder heater operates norm. 2. Replace the Capt (F/O) foot heater switch, S2, M901 (M902), on the Capt (F/O) auxiliary instrument panel, P13 (P14) (WDM 21-45-11).
21 40 07 --	1. (01=Capt, 02=F/O) L & R foot heater inop in HI pos. Operation in LOW norm. Shoulder heater operates norm. 2. Replace the Capt (F/O) foot heater switch S2, M901 (M902), on the Capt (F/O) auxiliary instrument panel, P13 (P14) (WDM 21-45-11).
21 40 08 --	1. (01=Capt, 02=F/O) foot and shoulder heaters inop in HI pos. Operation in LOW norm. 2. Replace the Capt (F/O) heater control module, M901 (M902), on the Capt (F/O) auxiliary instrument panel, P13 (P14) (WDM 21-45-11).
21 40 09 --	1. (01=Capt, 02=F/O) foot heaters inop in LOW & HI pos. Shoulder heater operates norm. 2. Replace the Capt (F/O) foot heater switch, S2, M901 (M902), on the Capt (F/O) auxiliary instrument panel, P13 (P14) (WDM 21-45-11).
21 40 10 --	1. (01=Capt, 02=F/O) foot and shoulder heaters inop in LOW & HI pos. 2. FIM 21-40-00/101, Fig. 106, Block 1.
21 40 11 00	1. EICAS msg AFT CARGO FAN shown (Ref Chapter 31 for the fault code diagram). 2. FIM 21-40-00/101, Fig. 104, Block 1.

EFFECTIVITY

ALL

21-FAULT CODE INDEX

07

Page 8
Jun 20/96

BOEING
 757
 FAULT ISOLATION/MAINT MANUAL

FAULT CODE	1. LOG BOOK REPORT 2. FAULT ISOLATION REFERENCE
21 40 12 00	1. EICAS msg FWD CARGO FAN shown (Ref Chapter 31 for the fault code diagram). 2. FIM 21-40-00/101, Fig. 104, Block 1.
21 51 01 -- thru 21 51 06 --	Not Used
21 51 07 00	1. EICAS msg L PACK BITE shown. (Ref Chapter 31 for the fault code diagram). 2. FIM 21-51-00/101, Fig. 104, Block 1.
21 51 08 00	1. EICAS msg R PACK BITE shown (Ref Chapter 31 for the fault code diagram). 2. FIM 21-51-00/101, Fig. 104, Block 1.
21 51 09 --	1. EICAS msg (L, R) PACK TEMP displayed. (01=L, 02=R) pack INOP lgt illum. Lgt extin when STBY selected. Operated norm in STBY. 2. FIM 21-51-00/101, Fig. 104, Block 1 If the problem continues, replace the L(R) pack outlet overheat switch, S48 (S49) (AMM 21-51-18).
21 51 10 --	1. EICAS msg (L, R) PACK TEMP displayed. (01=L, 02=R) pack INOP lgt illum. Lgt failed to extin when pack reset sw pushed. 2. Replace the L(R) flow control card, M863 (M864)(AMM 21-51-09). If the problem continues, replace the L(R) PACK RESET switch-light, YNRS04 (YNRS05) (WDM 21-51-15, WDM 21-51-25).
21 51 11 --	1. EICAS msg (L, R) PACK TEMP displayed. (01=L, 02=R) pack INOP lgt illum. Lgt extin when pack reset in STBY. Operated norm in STBY. 2. FIM 21-51-00/101, Fig. 104, Block 1.
21 51 12 --	1. EICAS msg (L, R) PACK TEMP displayed. (01=L, 02=R) pack INOP lgt illum. Lgt re-illum after pack reset in STBY. 2. FIM 21-51-00/101, Fig. 106, Block 1.

EFFECTIVITY

ALL

21-FAULT CODE INDEX

09

Page 9
Jun 20/97

BOEING
 757
 FAULT ISOLATION/MAINT MANUAL

FAULT CODE	1. LOG BOOK REPORT 2. FAULT ISOLATION REFERENCE
21 51 13 --	1. EICAS msg (L, R) PACK OFF & PACK TEMP displayed. (O1=L, O2=R) INOP & PACK off lgts illum. Lgts failed to extin when pack reset sw pushed. 2. Replace the L(R) flow control card, M863, (M864) (AMM 21-51-09). If the problem continues, replace the L(R) PACK RESET switch-light, YNRS04 (YNRS05) (WDM 21-51-15, WDM 21-51-25).
21 51 14 --	1. EICAS msg (L, R) PACK OFF & PACK TEMP displayed. (O1=L, O2=R) INOP & PACK off lgts illum. Lgts extin when pack reset sw in STBY. Operation norm in STBY. 2. FIM 21-51-00/101, Fig. 104, Block 1 If the problem continues, do FIM 21-51-00/101, Fig. 107, Block 1.
21 51 15 --	1. EICAS msg (L, R) PACK OFF & PACK TEMP displayed. (O1=L, O2=R) INOP & PACK off lgts illum. Lgt re-illum after pack reset in STBY. 2. 21-51-00/101, Fig. 107, Block 1 If Air Cycle Machine will not operate, do FIM 21-51-00/101, Fig. 107A, Block 1 or FIM 21-51-00/101, Fig. 107B, Block 1.
21 58 01 00 thru 21 58 02 00	Not Used
21 58 03 00	1. EICAS msg FWD EQPT SMOKE displayed. SMOKE lgt illum. OVBD EXH VAL OPEN displayed. Smoke indications disappeared after _____ minutes. 2. FIM 21-58-00/101, Fig. 115, Block 1.
21 58 04 00	1. EICAS msg FWD EQPT SMOKE displayed. SMOKE lgt illum. OVBD EXH VAL OPEN displayed. Smoke indications remained. 2. FIM 21-58-00/101, Fig. 115, Block 1.
21 58 05 00	1. EICAS msg FWD EQPT SMOKE displayed. SMOKE lgt illum. OVBD EXH VAL OPEN not displayed. Smoke indications disappeared after _____ minutes. 2. FIM 21-58-00/101, Fig. 116, Block 1.

EFFECTIVITY

ALL

21-FAULT CODE INDEX

BOEING
 757
 FAULT ISOLATION/MAINT MANUAL

FAULT CODE	1. LOG BOOK REPORT 2. FAULT ISOLATION REFERENCE
21 58 06 00	1. EICAS msg FWD EQPT SMOKE displayed. SMOKE lgt illum. OVBD EXH VAL OPEN not displayed. Smoke indications remained. 2. FIM 21-58-00/101, Fig. 116, Block 1.
21 58 07 00	1. EICAS msg EQPT OVHT displayed. OVHT lgt illum. L RECIRC FAN INOP lgt illum. OVHT lgt extin when ALTN was selected. 2. FIM 21-58-00/101, Fig. 117, Block 1
21 58 08 00	1. EICAS msg EQPT OVHT displayed. OVHT lgt illum. L RECIRC FAN INOP lgt illum. SMOKE lgt and OVBD EXH VAL OPEN message appeared. OVHT lgt remained illum when ALTN was selected. 2. Find and remove the source of smoke. Do the equipment cooling manual test.
21 58 09 00 thru 21 58 11 00	Not Used
21 58 12 00	1. EICAS msg FWD EQ SUP FLOW shown. (Ref Chapter 31 for the fault code diagram). 2. FIM 21-58-00/101, Fig. 106, Block 1.
21 58 13 00	Not Used
21 58 14 00	1. EICAS msg FWD EQ EXH FLOW shown. (Ref Chapter 31 for the fault code diagram). 2. FIM 21-58-00/101, Fig. 108, Block 1
21 58 15 00	1. EICAS msg FWD EQ SUP FAN 1 shown. (Ref Chapter 31 for the fault code diagram). 2. FIM 21-58-00/101, Fig. 109, Block 1.

EFFECTIVITY

ALL

21-FAULT CODE INDEX

BOEING
 757
 FAULT ISOLATION/MAINT MANUAL

FAULT CODE	1. LOG BOOK REPORT 2. FAULT ISOLATION REFERENCE
21 58 16 00	1. EICAS msg FWD EQ SUP FAN 2 shown. (Ref Chapter 31 for the fault code diagram). 2. FIM 21-58-00/101, Fig. 110, Block 1.
21 58 17 00	1. EICAS msg OVDB EX VAL TEST displayed. 2. FIM 21-58-00/101, Fig. 120, Block 1.
21 58 18 00	1. EICAS msg FWD EQPT EXH DET shown (Ref Chapter 31 for the fault code diagram). 2. FIM 21-58-00/101, Fig. 103, Block 1
21 58 19 00	1. EICAS msg EQPT CLG FLOW displayed on ground. 2. FIM 21-58-00/101, Fig. 113, Block 1.
21 58 20 00	1. EICAS msg OVBD EX VAL OPEN displayed. 2. FIM 21-58-00/101, Fig. 114, Block 1.
21 58 21 00	1. EICAS msg EQPT CLG FAN displayed. 2. FIM 21-58-00/101, Fig. 105, Block 1.
21 58 22 00 thru 21 58 25 00	Not Used
21 58 26 00	1. EICAS msg EQPT OVHT displayed. OVHT lgt illum. EICAS msg EQPT CLG FAN displayed. OVHT lgt extin when ALTN was selected. 2. FIM 21-58-00/101, Fig. 105, Block 1.
21 58 27 00	1. EICAS msg EQPT OVHT displayed. OVHT lgt illum. L RECIRC FAN INOP lgt illum. SMOKE lgt and OVBD EXH VAL OPEN message appeared. OVHT lgt extin when ALTN was selected.

EFFECTIVITY

ALL

21-FAULT CODE INDEX

BOEING
 757
 FAULT ISOLATION/MAINT MANUAL

FAULT CODE	1. LOG BOOK REPORT 2. FAULT ISOLATION REFERENCE
21 58 28 00	2. Find and remove the source of the smoke. 1. EICAS msg EQPT OVHT displayed. OVHT lgt illum. L RECIRC FAN INOP lgt illum. OVHT lgt remained illum when ALTN was selected. 2. FIM 21-58-00/101, Fig. 114, Block 1.
21 58 29 00	1. EICAS msg EQPT OVHT displayed. OVHT lgt illum. EICAS msg EQPT CLG FAN displayed. OVHT lgt remained illum when ALTN was selected. 2. FIM 21-58-00/101, Fig. 119, Block 1.
21 58 30 00	1. EICAS msg OVBD EX VAL TEST shown. (Ref Chapter 31 for the fault code diagram). 2. FIM 21-58-00/101, Fig. 120, Block 1.
21 58 31 00	1. EICAS msg OVBD EX VAL OPEN shown. (Ref Chapter 31 for the fault code diagram). 2. FIM 21-58-00/101, Fig. 114, Block 1.
21 58 32 00	1. EICAS msg FWD EQ SUP SNSR shown. (Ref Chapter 31 for the fault code diagram). 2. FIM 21-58-00/101, Fig. 104, Block 1.
21 58 33 00	1. EICAS msg FWD EQ EXH SNSR shown. (Ref Chapter 31 for the fault code diagram). 2. FIM 21-58-00/101, Fig. 111, Block 1.
21 58 34 00	1. EICAS msg EQPT CLG TEST shown. (Ref Chapter 31 for the fault code diagram). 2. FIM 21-58-00/101, Fig. 121, Block 1.
21 58 35 00 thru 21 58 38 00	Not Used
21 58 39 00	1. EICAS msg FWD EQPT DET 1 shown (Ref Chapter 31 for the fault code diagrams). 2. FIM 21-58-00/101, Fig. 122, Block 1.

EFFECTIVITY

ALL

21-FAULT CODE INDEX

BOEING
 757
 FAULT ISOLATION/MAINT MANUAL

FAULT CODE	1. LOG BOOK REPORT 2. FAULT ISOLATION REFERENCE
21 58 40 00	1. EICAS msg FWD EQPT DET 2 shown (Ref Chapter 31 for the fault code diagrams). 2. FIM 21-58-00/101, Fig. 123, Block 1.
21 58 41 00	1. EICAS msg EQPT SMOKE TEST displayed. 2. FIM 21-58-00/101, Fig. 124, Block 1.
21 58 42 00	1. Ground crew call horn sounds continuously. L, R, and C IRS in the OFF position (Ref Chapter 23 for the fault code diagrams). 2. FIM 21-58-00/101, Fig. 118, Block 1.
21 58 43 00 thru 21 58 51 00	Not Used
21 58 52 00	1. EICAS msg EQPT SMOKE TEST shown (Ref Chapter 31 for the fault code diagrams). 2. FIM 21-58-00/101, Fig. 124, Block 1.
21 58 53 00	1. EICAS msg EQPT CLG SENSOR displayed. 2. FIM 21-58-00/101, Fig. 112, Block 1.
21 58 54 00	1. EICAS msg EQPT CLG TEST displayed. 2. FIM 21-58-00/101, Fig. 121, Block 1.
21 58 55 00 thru 21 58 62 00	Not Used
21 58 63 00	1. When EQUIP COOL TEST sw was placed in TEST then released, during the next 20 seconds EICAS msg EQPT CLG TEST displayed. Other indications normal. 2. FIM 21-58-00/101, Fig. 121, Block 1.
21 58 64 00	1. When EQUIP COOL TEST sw was placed in TEST then released, during the next 20 seconds EICAS msg EQPT SMOKE TEST displayed. Other indications normal. 2. FIM 21-58-00/101, Fig. 124, Block 1.
21 58 65 00	1. EQUIP COOL TEST switch was in the TEST position and then released. During the next 20 seconds, the EICAS msg FWD EQ SUP SNSR showed. Other indications were normal. 2. FIM 21-58-00/101, Fig. 104, Block 1.

EFFECTIVITY

ALL

21-FAULT CODE INDEX



BOEING
757
FAULT ISOLATION/MAINT MANUAL

FAULT CODE	1. LOG BOOK REPORT 2. FAULT ISOLATION REFERENCE
21 58 66 00	1. EQUIP COOL TEST switch was in the TEST position and then released. During the next 20 seconds, the EICAS msg FWD EQ EXH SNSR showed. Other indications were normal. 2. FIM 21-58-00/101, Fig. 111, Block 1.
21 58 67 00	Not Used
21 58 68 00	1. When EQUIP COOL TEST sw was placed in TEST then released, during the next 20 seconds EICAS msg OVBD EX VAL TEST displayed. Other indications normal. 2. FIM 21-58-00/101, Fig. 120, Block 1.
21 58 69 00	1. EQUIP COOL TEST switch was in the TEST position and then released. During the next 20 seconds, the EICAS msg FWD EQPT DET 1 showed. Other indications were normal. 2. FIM 21-58-00/101, Fig. 122, Block 1.
21 58 70 00	1. EQUIP COOL TEST switch was in the TEST position and then released. During the next 20 seconds, the EICAS msg FWD EQPT DET 2 showed. Other indications were normal. 2. FIM 21-58-00/101, Fig. 123, Block 1.
21 58 71 00	1. EQUIP COOL TEST switch was in the TEST position and then released. During the next 20 seconds, the EICAS msg FWD EQPT EXH DET showed. Other indications were normal. 2. FIM 21-58-00/101, Fig. 103, Block 1.
21 58 72 00	1. When EQUIP COOL TEST sw was placed in TEST then released, during the next 20 seconds EICAS msg EQPT CLG SENSOR displayed. Other indications normal. 2. FIM 21-58-00/101, Fig. 112, Block 1.
21 58 73 00	1. When EQUIP COOL TEST sw was placed in TEST pos EICAS msg EQPT OVHT and OVHT lgt did not display. 2. Replace the miscellaneous test panel, on the P61 panel (WDM 21-58-11).
21 60 01 --	1. EICAS msg (01=FLT DECK, 02=FWD CABIN, 03=AFT CABIN) TEMP displayed & compt temp INOP light illum with trim air switch selected ON and temp control selectors in AUTO. 2. FIM 21-60-00/101, Fig. 105, Block 1.

EFFECTIVITY

ALL

21-FAULT CODE INDEX

BOEING
 757
 FAULT ISOLATION/MAINT MANUAL

FAULT CODE	1. LOG BOOK REPORT 2. FAULT ISOLATION REFERENCE
21 60 02 --	1. (01=FLT DECK, 02=FWD CABIN, 03=AFT CABIN) fails to maintain desired temp with trim air switch selected ON and temp control selector in AUTO. INOP lgt extin. 2. FIM 21-60-00/101, Fig. 106, Block 1.
21 60 03 --	1. (01=FLT DECK, 02=FWD CABIN, 03=AFT CABIN) fails to maintain desired temp with trim air switch selected ON and temp control selector in AUTO. INOP lgt illum. 2. FIM 21-60-00/101, Fig. 105, Block 1.
21 60 04 --	1. (01=FLT DECK, 02=FWD CABIN, 03=AFT CABIN) indicates high/low with compartment temperature ok. Trim air switch selected ON and temp control selector in AUTO. 2. Replace the applicable zone temperature bulb (YRUTS02, YRWTS02, YRVTS02) (AMM 21-65-02). If the problem continues, replace the temperature indicator, M10078 (AMM 21-65-01).
21 60 05 --	1. (01=FLT DECK, 02=FWD CABIN, 03=AFT CABIN) compartment temp indicator blank. 2. Replace the applicable zone temperature bulb (YRUTS02, YRWTS02, YRVTS02) (AMM 21-65-02).
21 60 06 00	1. EICAS msg ZONE TEMP BITE shown. (Ref Chapter 31 for the fault code diagram). 2. FIM 21-60-00/101, Fig. 104, Block 1.
21 60 07 00	1. EICAS msgs: FLT DECK TEMP, AFT CABIN TEMP, FWD CABIN TEMP displayed and all three compt temp INOP lgts illum with trim air switch selected ON and temp cont selectors in AUTO. 2. FIM 21-60-00/101, Fig. 105, Block 1.
21 60 08 00	1. With trim air switch selected ON and temp control selectors in AUTO compt temp did not respond with any selector. 2. FIM 21-60-00/101, Fig. 103, Block 1.
21 60 09 00	1. EICAS msg TRIM AIR displayed and OFF light illum with trim air switch selected ON. 2. Replace the TRIM AIR switch-light, YNRS03, M10193, on the P5 panel (AMM 33-13-00).

EFFECTIVITY

ALL

21-FAULT CODE INDEX

 **BOEING**
757
FAULT ISOLATION/MAINT MANUAL

FAULT CODE	1. LOG BOOK REPORT 2. FAULT ISOLATION REFERENCE
---------------	--

21 60 10 --	1. (01=FLT DECK, 02=FWD CABIN, 03=AFT CABIN) compartment temp indicator has missing segment(s). 2. Replace the temperature indicator, M10078 (AMM 21-65-01).
-------------	---

EFFECTIVITY

ALL

21-FAULT CODE INDEX

12

Page 17
Jan 20/98

BITE Index

1. General

- A. Use this index to find the BITE procedure for the applicable LRU/System.
- B. The BITE procedure will provide the fault isolation instructions for the fault indications/LRU maintenance messages.

<u>LRU/System Name</u>	<u>Acronym</u>	<u>FIM Reference</u>
Air Data Computer	ADC	34-12
Air Data Inertial Reference Unit	ADIRU	34-26
Air Traffic Control Transponder	ATC	34-53
Airborne Vibration Monitor Signal Conditioner	AVM	77-31
Antiskid/Autobrake Control Unit		32-42
APU Fire Detection System		26-15
Automatic Direction Finder Receiver	ADF	34-57
APU Control Unit	ECU	49-11
Brake Temperature Monitor Unit		32-46
Bus Power Control Unit	BPCU	24-20
Cabin Pressure Controller		21-30
Digital Flight Data Acquisition Unit	DFDAU	31-31
Distance Measuring Equipment Interrogator	DME	34-55
Duct Leak (Wing and Body)		26-18
E/E Cooling Control Card (If cards installed)		21-58
ECS Bleed Configuration Card		36-10
Electronic Engine Control (RR Engines)	EEC	73-21
Electronic Engine Control Monitor Unit (PW Engines)	EECM	71-EPCS Message Index
Electronic Flight Instrument System	EFIS	34-22
Electronic Propulsion Control System (PW Engines)	EPCS	71-EPCS Message Index
Engine Fire/Overheat Detection System		26-11
Engine Indication and Crew Alerting System Computer	EICAS	31-41

Bite Index
Figure 1 (Sheet 1)

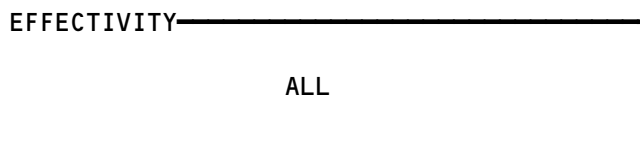

21-BITE INDEX

BOEING
 757
 FAULT ISOLATION/MAINT MANUAL

<u>LRU/System Name</u>	<u>Acronym</u>	<u>FIM Reference</u>
Engine Turbine Cooling Overheat Detection System (RR Engines)		26-13
Enhanced Ground Proximity Warning Computer	EGPWC	34-46
Flap/Slat Accessory Module	FSAM	27-51
Flap/Slat Electronic Unit	FSEU	27-51
Flight Management Computer	FMC	34-61
Fuel Quantity Indicating System Processor	FQIS	28-41
Ground Proximity Warning Computer	GPWC	34-46
HF (High Frequency) Communication		23-11
Inertial Reference Unit	IRU	34-21
Instrument Comparator Unit	ICU	34-25
Instrument Landing System Receiver	ILS	34-31
Lower Cargo Compartment Smoke Detection System		26-16
Maintenance Control Display Panel	MCDP	22-00
PA (Passenger Address) Amplifier		23-31
Pack Standby Temperature Controller		21-51
Pack Temperature Controller		21-51
Passenger Entertainment System	PES	23-34
Power Supply Module (Control System Electronics Units)	PSM	27-09
Propulsion Discrete Interface Unit (PW Engines)	PDIU	73-21
Proximity Switch Electronics Unit	PSEU	32-09
Radio Altimeter Transmitter/Receiver	RA	34-33
Rudder Ratio Changer Module	RRCM	27-09
Spoiler Control Module	SCM	27-09
Stabilizer Position Module	SPM	27-48
Stabilizer Trim/Elevator Asymmetry Limit Module	SAM	27-09
Stall Warning Computer/Module (in Warning Electronic Unit)	SWC	27-32
Strut Overheat Detection System (RR Engines)		26-12

Bite Index
Figure 1 (Sheet 2)

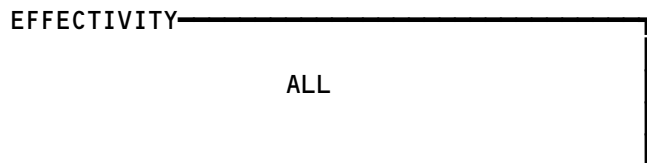

21-BITE INDEX

BOEING
 757
 FAULT ISOLATION/MAINT MANUAL

<u>LRU/System Name</u>	<u>Acronym</u>	<u>FIM Reference</u>
Thrust Management Computer/Autothrottle	TMC	22-00
Traffic Alert and Collision Avoidance Computer	TCAS	34-45
VHF (Very High Frequency) Communication		23-12
VOR/Marker Beacon Receiver	VOR/MKR	34-51
Warning Electronic Unit BITE Module (Stall Warning)	WEU	27-32
Weather Radar Transceiver	WXR	34-43
Wheel Well Fire Detection		26-17
Window Heat Control Unit	WHCU	30-41
Yaw Damper Module	YDM	22-21
Yaw Damper/Stabilizer Trim Module	YSM	27-09
Zone Temperature Controller		21-60

Bite Index
Figure 1 (Sheet 3)

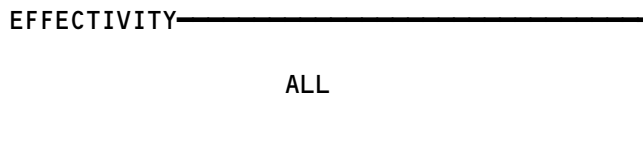

21-BITE INDEX

01

Page 3
Sep 28/99

SMOKE OR FUMES REMOVAL FROM THE AIR CONDITIONING SYSTEM – TROUBLESHOOTING

1. General

- A. This procedure has the steps to identify the cause of smoke or fumes in the flight compartment or in the main deck compartment.
- B. Smoke or fumes can go into the flight compartment or the main deck compartment through the air distribution system during flight. This problem is usually caused by contamination of the air by oil, glycol, fuel, or hydraulic fluid.
- C. Smoke or fumes that enter the air conditioning system can be caused by contamination from the engines, the APU, or the hydraulic system.
- (1) Smoke and fumes from engine contamination can be caused by:
- (a) An oil leak in the engine compressor or compressor bearing area.
- NOTE: Oil leaks are not easily detected by monitoring oil consumption trends because the oil consumption may be within acceptable limits.
- (b) An over-filled engine oil system.
 - (c) Anti-icing fluid ingested by the engines during cold weather operations.
- (2) Smoke and fumes from APU contamination can be caused by:
- (a) Oil leaks in the inlet plenum and load compressor areas.
 - (b) Contaminants puddled in the inlet plenum. This includes oil, anti-icing fluid, or hydraulic fluid.
- (3) Smoke and fumes from hydraulic system contamination can be caused by:
- (a) An over-serviced hydraulic system.
- NOTE: Hydraulic fluid can go into the pneumatic ducts through the hydraulic system pressurization line when over-serviced.
- (b) Petroleum jelly that is used during maintenance of the pneumatic ducts or air distribution ducts.
- D. After the source of the contamination has been identified and eliminated, smoke or fumes may continue because of contamination in the ducts. If this is the case, then do the procedure to remove oil contamination from the air conditioning system (AMM 21-00-01/201).
- E. If the source of the smoke or fumes is in an engine, then the heat exchanger or the precooler may also be contaminated. Do the procedures to inspect these components and clean or replace them if necessary.
- F. Also make sure you examine the ventilation and recirculation filters for contamination and replace them if necessary.
- G. References
- (1) AMM 21-00-00/201, Air Conditioning – General
 - (2) AMM 21-00-01/201, Air Conditioning System Oil Contamination (Removal)

EFFECTIVITY

ALL

21-00-01

01

Page 101
May 28/07

 **BOEING**
757
FAULT ISOLATION/MAINT MANUAL

- (3) AMM 21-25-00/501, Recirculation System
- (4) AMM 21-25-01/401, Cabin Air Recirculation Fan
- (5) AMM 21-25-02/401, Recirculation Air Filter
- (6) AMM 29-00-00/601, Hydraulic Power
- (7) AMM 36-11-00/501, Air Supply Distribution System
- (8) AMM 36-11-01/601, Pneumatic Duct
- (9) AMM 49-11-00/201, Auxiliary Power Unit
- (10) AMM 71-00-00/201, Power Plant (Operation Procedures)
- (11) AMM 71-00-00/601, Power Plant
- (12) AMM 71-71-00/601, Engine Vents and Drains
- (13) AMM 79-00-00/601, Oil

H. Fault isolation is given for the faults that follow:

- (1) PROCEDURE 1
 - (a) Smoke or Fumes in the Flight Compartment or Main Deck Compartment Reported During Flight. Smoke Stops With the Isolation Valve Closed and the Right Pack Switch Off.
- (2) PROCEDURE 2
 - (a) Smoke or Fumes in the Flight Compartment or Main Deck Compartment Reported During Flight. Smoke Stops With the Isolation Valve Closed and the Left Pack Switch Off.
- (3) PROCEDURE 3
 - (a) Smoke or Fumes in the Flight Compartment or Main Deck Compartment Reported During Flight. Smoke Does Not Stop With the Isolation Valve Closed and the Two Pack Switches Off (In Turn).
- (4) PROCEDURE 4
 - (a) Smoke or Fumes in the Flight Compartment or Main Deck Compartment. Smoke Stops with Left/Right Recirculation Fans Off.

2. Prepare for the Test

- A. Prepare the left and the right engines for usual operation (AMM 71-00-00/201).
- B. Start the left and the right engine (AMM 71-00-00/201).
- C. Start the APU (AMM 49-11-00/201).
- D. Make sure all of the doors and windows are closed.

NOTE: Do not do these procedures with the people on the airplane, except authorized personnel, because these procedures can cause a high concentration of smoke or fumes in the airplane.

EFFECTIVITY

ALL

21-00-01

01

Page 102
May 28/07

3. PROCEDURE 1 – Smoke or Fumes in the Flight Compartment or Main Deck Compartment Reported During Flight. Smoke Stops With the Isolation Valve Closed and the Right Pack Switch Off.

A. General

- (1) Make sure the fault report shows that the smoke or fumes stopped with the isolation valve closed, the right pack selector switch off, and the left/right recirculation fan switch/lights off. This means that the left engine, the pneumatic air supply from the left engine, the APU air supply, the left air conditioning pack, and the related air distribution ducts were not the source of the smoke or fumes.
- (2) The fault isolation procedure that follows tells you how to find the cause of smoke or fumes in the right engine, the pneumatic air supply from the right engine, the right air conditioning pack, the left/right recirculation system, and the related air distribution ducts.

B. Possible Causes

- (1) Contamination in the right engine pneumatic system.
- (2) Hydraulic fluid leak.
- (3) Contamination in the air distribution system.
- (4) Overheating of the left/right recirculation fans.

C. Fault Isolation Procedure

- (1) Do a check of the air recirculation system:
 - (a) Remove the recirculation fan filters (AMM 21-25-02/401).
 - (b) Examine the air recirculation filters to see if it is necessary to replace them. Replace the recirculation fan filters if necessary (AMM 21-25-02/401).
 - (c) Do an operational test of the left/right recirculation system (AMM 21-25-00/501) to see if the left/right recirculation fans or the related wiring are the source of the smoke or fumes.
 - (d) If there is smoke from the left/right air recirculation fans or the related wiring, then do the steps that follow:
 - 1) Repair the defective wiring.
 - 2) Replace the defective recirculation fan (AMM 21-25-01/401).
 - 3) Replace the defective left/right recirculation fan (AMM 21-25-01/401).
 - 4) Do the repair confirmation at the end of this task.
 - (e) If there is no smoke or fumes, then continue.
- (2) Do a check of the right engine and the right engine pneumatic system:
 - (a) Do the external oil system inspection (AMM 79-00-00/601) and look for indications of oil leaks on the right engine.
 - (b) Do the inspection of the engine vents and drains (AMM 71-71-00/601) and look for indications of oil, hydraulic fluid, or fuel fluid, or fuel leaks on the right engine.
 - (c) If you find indications of leaks on the right engine, then do the steps that follow:
 - 1) Do the corrective action shown in the inspection procedures or repair the problems that you find.
 - 2) Do the repair confirmation at the end of this task.

EFFECTIVITY

ALL

21-00-01

01

Page 103
May 28/07

- (d) RR RB211 ENGINES;
If there are no indications of external leaks, then do the power plant fault isolation procedure (FIM 71-05-00 Fig. 125) for the right engine.
- (e) If you find indications of leaks in the right engine, then do the steps that follow:
 - 1) Do the corrective action shown in the inspection procedure or repair the problems that you find.
 - 2) Do the repair confirmation at the end of this task.
- (f) If there are no indications of leaks in the right engine, then continue.
- (g) Do a test of the air supply distribution system (AMM 36-11-00/501) and look for smoke or fumes in the flight compartment or main deck compartment.
- (h) If there is smoke or fumes, then do the steps that follow:
 - 1) Do the corrective action in the test procedure or repair the problems that you find.
 - 2) Do the repair confirmation at the end of this task.
- (3) Do the steps that follow to do a check for hydraulic fluid leaks:
 - (a) Do the hydraulic power inspection check (AMM 29-00-00/601).
 - (b) If you find indications of hydraulic fluid leaks, then do the steps that follow:
 - 1) Do the corrective action shown in the inspection procedure or repair the problems that you find.
 - 2) Do the repair confirmation at the end of this task.
 - (c) If there are no indications of hydraulic fluid leaks, then continue.
- (4) Do a check for contamination in the air distribution system.
 - (a) Do the task to remove oil contamination from the air conditioning and pneumatic systems (AMM 21-00-01/201) with the right engine and the right air conditioning pack on.
 - (b) If there is smoke or fumes, then do a check of the air distribution system for the source of the contamination. Examine the components that follow:
 - 1) Examine each of the components of the right air conditioning pack.
 - 2) Examine the components of the main distribution manifold.
 - 3) Examine the air distribution ducts where the smoke or fumes first appeared.
 - 4) Replace the component or clean the duct that is the source of the smoke or fumes.
 - 5) Do the repair confirmation at the end of this task.
 - (c) If there is no smoke or fumes, then do all of the task to remove of oil contamination from the air conditioning and pneumatic systems (AMM 21-00-01/201), with the two engines, the APU, and the two air conditioning packs on.

EFFECTIVITY

ALL

21-00-01

01.1

Page 104
May 20/09

- (d) If there is smoke or fumes, then do the steps that follow to do a check of the air distribution system for the source of the contamination:
 - 1) Examine each of the components of the two air conditioning packs.
 - 2) Examine the components of the main distribution manifold.
 - 3) Examine the air distribution ducts where the smoke or fumes first appeared.
 - 4) Replace the component or clean the duct that is the source of the smoke or fumes.
 - 5) Do the repair confirmation at the end of this task.
- (e) If there is no smoke or fumes, and if the problem does not occur on the subsequent flight, then there was an intermittent fault.

D. Repair Confirmation

- (1) Check that smoke and fumes do not appear in the flight compartment or in the main deck compartment when the air conditioning system operates (AMM 21-00-01/201).
 - (a) If the procedure to remove oil contamination from the air conditioning system is run until there is no smoke or fumes, and if the problem does not occur on the next flight, then you corrected the problem.
 - (b) If there is smoke and fumes, then go to PROCEDURE 2 and do the task to remove contamination from the left engine and the left air conditioning pack.

4. PROCEDURE 2 – Smoke or Fumes in the Flight Compartment or Main Deck Compartment Reported During Flight. Smoke Stops With the Isolation Valve Closed and the Left Pack Switch Off.

A. General

- (1) Make sure the fault report shows that the smoke or fumes stopped with the isolation valve closed, the left pack selector switch off, and the left/right recirculation fan switch/lights off. This means that the right engine, the pneumatic air supply from the right engine, the right air conditioning pack, and the related air distribution ducts were not the source of the smoke and fumes.
- (2) The fault isolation procedure that follows tells you how to find the cause of smoke or fumes in the APU pneumatic air supply, the left engine, the pneumatic air supply from the left engine, the left air conditioning pack, the left/right recirculation system, and the related air distribution ducts.

NOTE: If the smoke and fumes are only in the flight compartment, then the left engine and left air conditioning pack should be inspected first as possible sources of contamination. If the problem continues, the right engine and right air conditioning pack should be inspected as well.

EFFECTIVITY

ALL

21-00-01

01

Page 105
May 28/07

B. Possible Causes

- (1) Contamination in the left engine pneumatic system.
- (2) Contamination in the APU pneumatic system.
- (3) Hydraulic fluid leak.
- (4) Contamination in the air distribution system.
- (5) Overheating of the left/right recirculation fans.

C. Fault Isolation Procedure

- (1) Do this check of the left/right air recirculation system.
 - (a) Remove the recirculation fan filters (AMM 21-25-02/401).
 - (b) Examine the air recirculation filters to see if it is necessary to replace them. Replace the recirculation fan filters if necessary (AMM 21-25-02/401).
 - (c) Do an operational test of the left/right recirculation system (AMM 21-25-00/501) to see if the left/right air recirculation fans or the related wiring are the source of the smoke or fumes.
 - (d) If there is smoke from the left/right air recirculation fans or the related wiring, then do the steps that follow:
 - 1) Repair the defective wiring.
 - 2) Replace the defective left/right recirculation fan (AMM 21-25-01/401).
 - 3) Do the repair confirmation at the end of this task.
 - (e) If there is no smoke or fumes, then continue.
- (2) Do a checks for contamination in the APU pneumatic system.

NOTE: If smoke or fumes appear in the flight compartment or main deck compartment when the APU is running but the engines are shut down, go directly to the APU and bleed air inspection tasks that follow.

- (a) Start the APU (AMM 49-11-00/201).
- (b) When the APU has stabilized, supply conditioned air to the airplane from the APU through the left air conditioning pack (AMM 21-00-00/201).
- (c) If there is smoke or fumes from the APU bleed air supply, then do the steps that follow:
 - 1) Inspect the APU for leaks and oil contamination.
 - a) If you find indications of leaks, repair the leaks.
 - 2) Do the inspection and check of the APU pneumatic ducts (AMM 36-11-01/601).
 - 3) If you find indications of leaks, then do the steps that follow:
 - a) Do the corrective action indicated in the procedure.
 - b) Do the repair confirmation at the end of this task.
- (d) If no smoke or fumes come from the APU bleed air supply, and the operational test is satisfactory, then do the APU usual shutdown (AMM 49-11-00/201) and continue.

EFFECTIVITY

ALL

21-00-01

01

Page 106
May 28/07

- (3) Do this check of the left engine pneumatic system:
 - (a) Do the external oil system inspection (AMM 79-00-00/601) and look for indication of oil leaks in the left engine.
 - (b) Do the inspection of the engine vents and drains (AMM 71-71-00/601) and look for indications of oil, hydraulic fluid, or fuel leaks in the left engine.
 - (c) If you find indications of leakage on the left engine, then do the steps that follow:
 - 1) Do the corrective action shown in the inspection procedures or repair the problems that you find.
 - 2) Do the repair confirmation at the end of this task.
 - (d) RR RB211 ENGINES;
If there are no indications of external leaks, then do the power plant fault isolation procedure (FIM 71-05-00 Fig. 125) for the left engine.
 - (e) If you find indications of leaks in the left engine, then do the steps that follow:
 - 1) Do the corrective action shown in the inspection procedure or repair the problems that you find.
 - 2) Do the repair confirmation at the end of this task.
 - (f) If you there are no indications of leaks in the left engine, then continue.
- (4) Do the steps that follow to do a check for hydraulic fluid leaks:
 - (a) Do the hydraulic power inspection check (AMM 29-00-00/601).
 - (b) If you find indications of hydraulic fluid leaks, then do the steps that follow:
 - 1) Do the corrective action shown in the inspection/check procedure or repair the problems that you find.
 - 2) Do the repair confirmation at the end of this task.
 - (c) If there are no indications of hydraulic fluid leaks, then continue.
- (5) Do a check for contamination in the air distribution system.
 - (a) Do the task to remove oil contamination from the air conditioning and pneumatic systems (AMM 21-00-01/201) with left engine and the left air conditioning pack on.
 - (b) If there is smoke or fumes, then do a check of the air distribution system for the source of the contamination. Examine the components that follow:
 - 1) Examine each of the components of the left air conditioning pack.
 - 2) Examine the components of the main distribution manifold.
 - 3) Examine the air distribution ducts where the smoke first appeared.
 - 4) Replace the component or clean the duct that is the source of the smoke or fumes.
 - 5) Do the repair confirmation at the end of this task.

EFFECTIVITY

ALL

21-00-01

01.1

Page 107
May 20/09

- (c) If there is no smoke or fumes, then do all of the task to remove oil contamination from the air conditioning and pneumatic systems (AMM 21-00-01/201), with the two engines, the APU, and the two air conditioning packs on.
- (d) If there is smoke or fumes, then do the steps that follow to do a check of the air distribution system for the source of the contamination:
 - 1) Examine each of the components of the two air conditioning packs.
 - 2) Examine the components of the main distribution manifold.
 - 3) Examine the air distribution ducts where the smoke or fumes first appeared.
 - 4) Replace the component or clean the duct that is the source of the smoke or fumes.
 - 5) Do the repair confirmation at the end of this task.
- (e) If there is no smoke or fumes, and if the problem does not occur on the subsequent flight, then there was an intermittent fault.

D. Repair Confirmation

- (1) Make sure that smoke and fumes do not appear in the flight compartment or in the main deck compartment when the air conditioning system is operates (AMM 21-00-01/201).
 - (a) If the procedure to remove oil contamination from the air conditioning system is run until there is no smoke or fumes, and if the problem does not occur on the next flight, then you corrected the problem.
 - (b) If there is smoke or fumes, then go to PROCEDURE 1 and do the task to remove contamination from the right engine, the right air conditioning pack, and the hydraulic system.

5. PROCEDURE 3 – Smoke or Fumes in the Flight Compartment or Main Deck Compartment Reported During Flight. Smoke Does Not Stop With Isolation Valve Closed, Each of the Two Pack Switches Off (In Turn).

A. Possible Causes

- (1) Hydraulic fluid leak.
- (2) Contamination in the air distribution system.

B. Fault Isolation Procedure

- (1) Do the steps that follow to do a check for hydraulic fluid leaks:
 - (a) Do the hydraulic power inspection check (AMM 29-00-00/601).
 - (b) If you find indications of hydraulic fluid leaks, then do the steps that follow:
 - 1) Do the corrective action shown in the inspection procedure or repair the problems that you find.
 - 2) Do the repair confirmation at the end of this task.
- (c) If there are no indications of hydraulic fluid leaks, then continue.

EFFECTIVITY

ALL

21-00-01

01

Page 108
May 28/07

- (2) Do a check for contamination in the air distribution system.
 - (a) Do the task to removal oil contamination from the air conditioning and pneumatic systems (AMM 21-00-01/201).
 - (b) If there is smoke or fumes, then do a check of the areas in the air distribution system for the source of the contamination. Examine the components that follow:
 - 1) Examine the components of main distribution manifold.
 - 2) Examine the air distribution ducts where the smoke first appeared.
 - (c) Replace the component or clean the duct that is the source of the smoke or fumes.
 - (d) Do the repair confirmation at the end of this task.
 - (3) If there is no smoke or fumes, then there was an intermittent fault.
- C. Repair Confirmation
- (1) Make sure that smoke and fumes do not appear in the flight compartment or in the main deck compartment when the air conditioning system operates (AMM 21-00-01/201).
 - (a) If the procedure to removal oil contamination from the air conditioning and pneumatic systems (AMM 21-00-01/201) is run until there is no smoke or fumes, and if the problem does not occur on the next flight, then you corrected the problem.
 - (b) If there is smoke or fumes, then go to PROCEDURE 4 and do a check of the recirculation system.
6. PROCEDURE 4 – Smoke or Fumes in the Flight Compartment or Main Deck Compartment. Smoke Stops with Left/Right Recirculation Fans Off.
- A. Possible Causes
- (1) Overheating of the left/right recirculation fans or the related wiring.
- B. Fault Isolation Procedure
- (1) Do this check of the left/right air recirculation system:
 - (a) Remove the left and right air recirculation fan filters (AMM 21-25-02/401).
 - (b) Examine the left and right air recirculation fan filters to see if it is necessary to replace them.
 - 1) If a filter needs replacement, install a new air recirculation fan filter (AMM 21-25-02/401).
 - (c) Do an operational test of the left/right recirculation fan system (AMM 21-25-00/501) to see if the left/right air recirculation fan or the related wiring generates smoke while it operates.
 - (d) If there is smoke or fumes from the left/right air recirculation fan or the related wiring, then do the steps that follow:
 - 1) Repair the applicable wiring.
 - 2) If necessary, replace the left/right air recirculation fan (AMM 21-25-01/401).

EFFECTIVITY

ALL

21-00-01

01

Page 109
May 28/07

 **BOEING**
757
FAULT ISOLATION/MAINT MANUAL

- 3) Do an operational test of the left/right recirculation fan system (AMM 21-25-00/501).
 - 4) If the operational test is satisfactory and the problem does not occur on the next flight, then you corrected the problem.
 - (e) If there is no smoke or fumes from the left/right air recirculation fans or the related wiring, and the operational test is satisfactory, then there was an intermittent fault.
7. Put the Airplane Back to its Usual Condition
- A. Shut down the APU if it is no longer needed (AMM 49-11-00/201).
 - B. Do the procedure to shut down the left and the right engine (AMM 71-00-00/201).

EFFECTIVITY

ALL

21-00-01

01

Page 110
May 28/07

INTENTIONALLY LEFT BLANK

Not Used
Figure 101

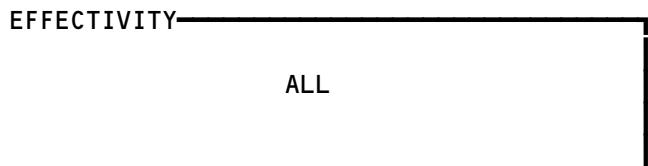

21-00-01

01

Page 111
Jan 28/01

L77796

 **BOEING**
757
FAULT ISOLATION/MAINT MANUAL

DISTRIBUTION

COMPONENT	FIG. 102 SHT	QTY	ACCESS/AREA	REFERENCE
CIRCUIT BREAKERS	1		FLT COMPT, P11	
EQUIP COOLING FAN CONT AFT EXH XFER, C705		1	11N11	*
RECIRC CARGO FIRE CONT LEFT, C660		1	11P14	*
RECIRC CARGO FIRE CONT RIGHT, C661		1	11P23	*
CIRCUIT BREAKERS	5		119BL, MAIN EQUIP CTR, P37	
AFT EQPT COOLING FAN EXH NO. 1, C333		1	37D5	*
R RECIRC FAN CONT, C4374		1	37D7	*
RECIRC FAN R, C337		1	37J5	*
CIRCUIT BREAKERS	5		119BL, MAIN EQUIP CTR, P70	
AFT EQPT COOLING FAN EXH NO. 2, C334		1	70B2	*
L RECIRC FAN CONT, C4373		1	70B16	*
RECIRC FAN LEFT, C336		1	70C10	*
COMPUTER - (REF 31-41-00, FIG. 101)				
EICAS L, M10181				
EICAS R, M10181				
CONNECTOR - GROUND AIR SERVICE	3	1	821, FWD CARGO COMPT	21-21-02
DIFFUSER - WINDSHIELD	1	1	FLT COMPT	21-22-00
FAN - AFT EQUIPMENT/LAVATORY/GALLEY VENTILATION, B15,B16	2	2	822, AFT CARGO COMPT, AFT BULKHEAD LINING	21-26-01
FAN - L RECIRCULATION AIR, B13	3	1	821, FWD CARGO COMPT	21-25-01
FAN - R RECIRCULATION AIR, B14	3	1	821, FWD CARGO COMPT	21-25-01
FILTER - GALLEY VENTILATION	3	5	GALLEY	21-26-03
FILTER - RECIRCULATION AIR	3	4	821, FWD CARGO COMPT	21-25-02
GASPERS - FLIGHT DECK	1	4	FLT COMPT	21-22-00
GRILLES - RETURN AIR	5		PASSENGER COMPT	21-23-05
MANIFOLD - MAIN DISTRIBUTION	3	1	821, FWD CARGO COMPT	21-21-00
MODULE - (REF 27-58-00)				
FSEU 3, M10333				
OUTLETS - AIR CONDITONING SYSTEM	2	65	PASSENGER CABIN	21-23-02
OUTLETS - FLOOR	1	4	FLT COMPT	21-22-01
OUTLETS - OVERHEAD	1	1	FLT DOMPT	21-22-03
PANEL - AIR CONDITIONING CONTROL, M10193	1	1	P5, FLT DECK	*
PANEL - (REF 26-22-00, FIG. 101)				
APU/CARGO FIRE CONTROL, M10444				
RELAYS - (REF 31-01-36, FIG. 101)				
AFT CARGO FIRE, K10443				
AFT EQUIP EXH FAN 2, K347				
AIR/GND SYS 1, K124				
AUTO TEST RELAY, K10511				
EXH SMOKE SENSING, K10509				
RECIRC OVERRIDE, K10497				
SUPPLY SMOKE SENSING, K369				

* SEE WM EQUIPMENT LIST

Component Index
Figure 101 (Sheet 1)

EFFECTIVITY

ALL

21-20-00

09

Page 101
Jun 15/86

217826

BOEING
 757
 FAULT ISOLATION/MAINT MANUAL

COMPONENT	FIG. 102 SHT	QTY	ACCESS/AREA	REFERENCE
RELAYS - (REF 31-01-37, FIG. 101) AFT EQUIP EXH FAN 1, K346 AFT EQUIP EXH FAN 1 FAIL, K10322 AIR/GND SYS 2, K201 FWD CARGO FIRE, K10432 R RECIRC FAN, K416				
RELAYS - (REF 31-01-70, FIG. 101) L RECIRC FAN, K415				
SWITCH/LIGHT - AFT CARGO FIRE, YQPS2		1	FLT COMPT, P8, APU/CARGO FIRE CONTROL PANEL M10444	*
SWITCH/LIGHT - FWD CARGO FIRE, YQPS1		1	FLT COMPT, P8, APU/CARGO FIRE CONTROL PANEL M10444	*
SWITCH/LIGHT - L RECIRC FAN, YNRS1	1	1	FLT COMPT, P5 AIR COND CONTROL PANEL, M10193	*
SWITCH/LIGHT - R RECIRC FAN, YNRS2	1	1	FLT COMPT, P5 AIR COND CONTROL PANEL, M10193	*
VALVE - AFT EQUIP/LAV/GALLEY VENTILATION CHECK	2	2	822, AFT CARGO COMPT, AFT BULKHEAD LINING	21-26-02
VALVE - CONDITIONED AIR CHECK	3	2	821, FWD CARGO COMPT MIX BAY	21-21-01
VALVE - L RECIRCULATION AIR CHECK	3	1	821, FWD CARGO COMPT	21-25-03
VALVE - R RECIRCULATION AIR CHECK	3	1	821, FWD CARGO COMPT	21-25-03

* SEE WM EQUIPMENT LIST

Component Index
Figure 101 (Sheet 2)

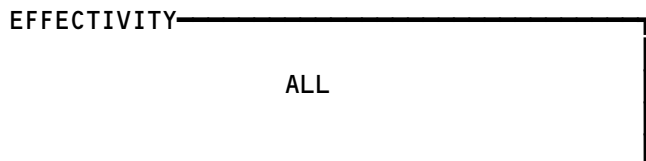

21-20-00

BOEING

757

FAULT ISOLATION/MAINT MANUAL

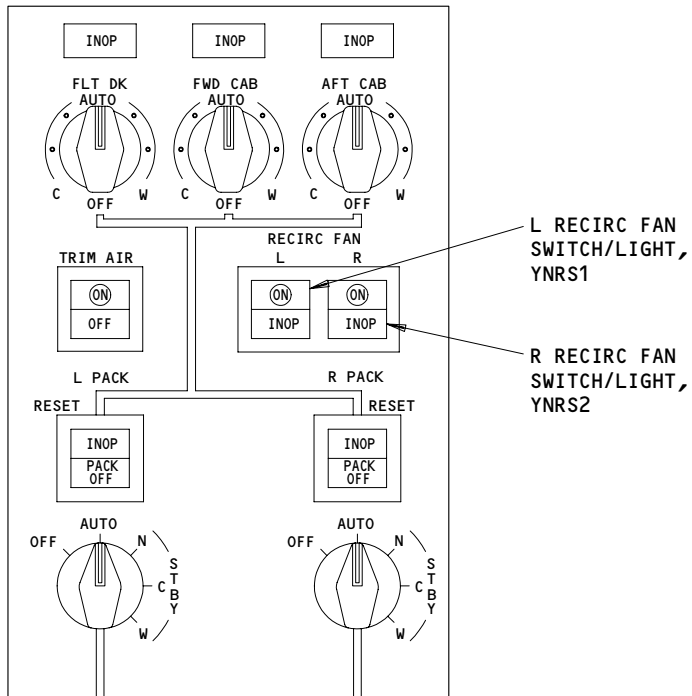
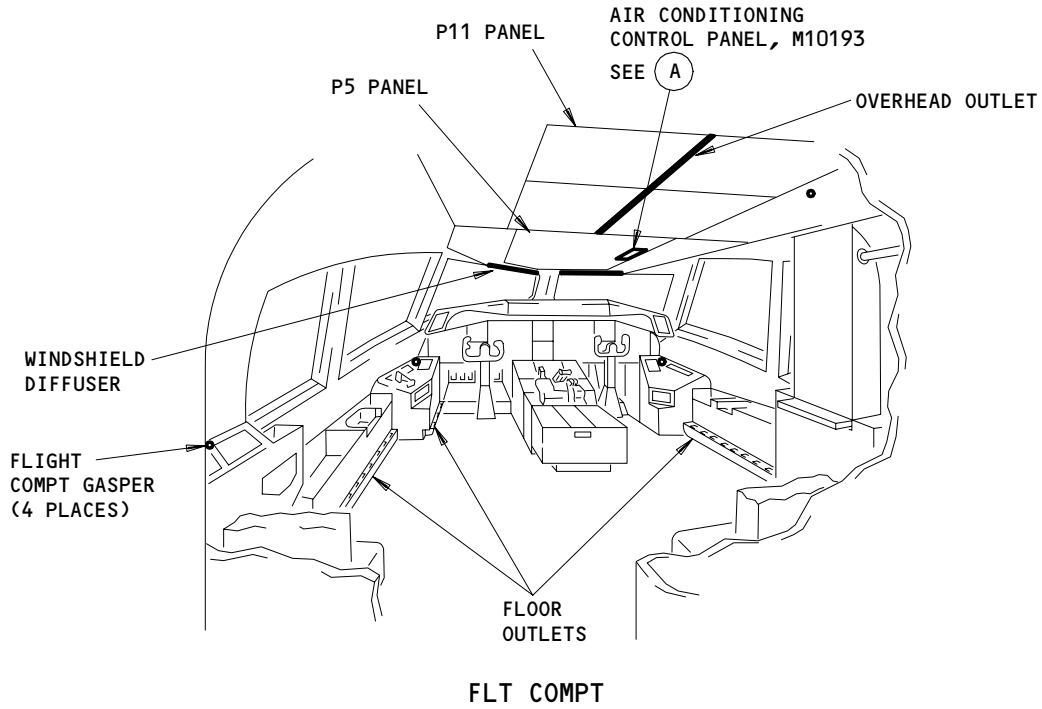

AIR CONDITIONING CONTROL PANEL, M10193

(A)

Component Location
Figure 102 (Sheet 1)

EFFECTIVITY	
	ALL

21-20-00

BOEING
757
FAULT ISOLATION/MAINT MANUAL

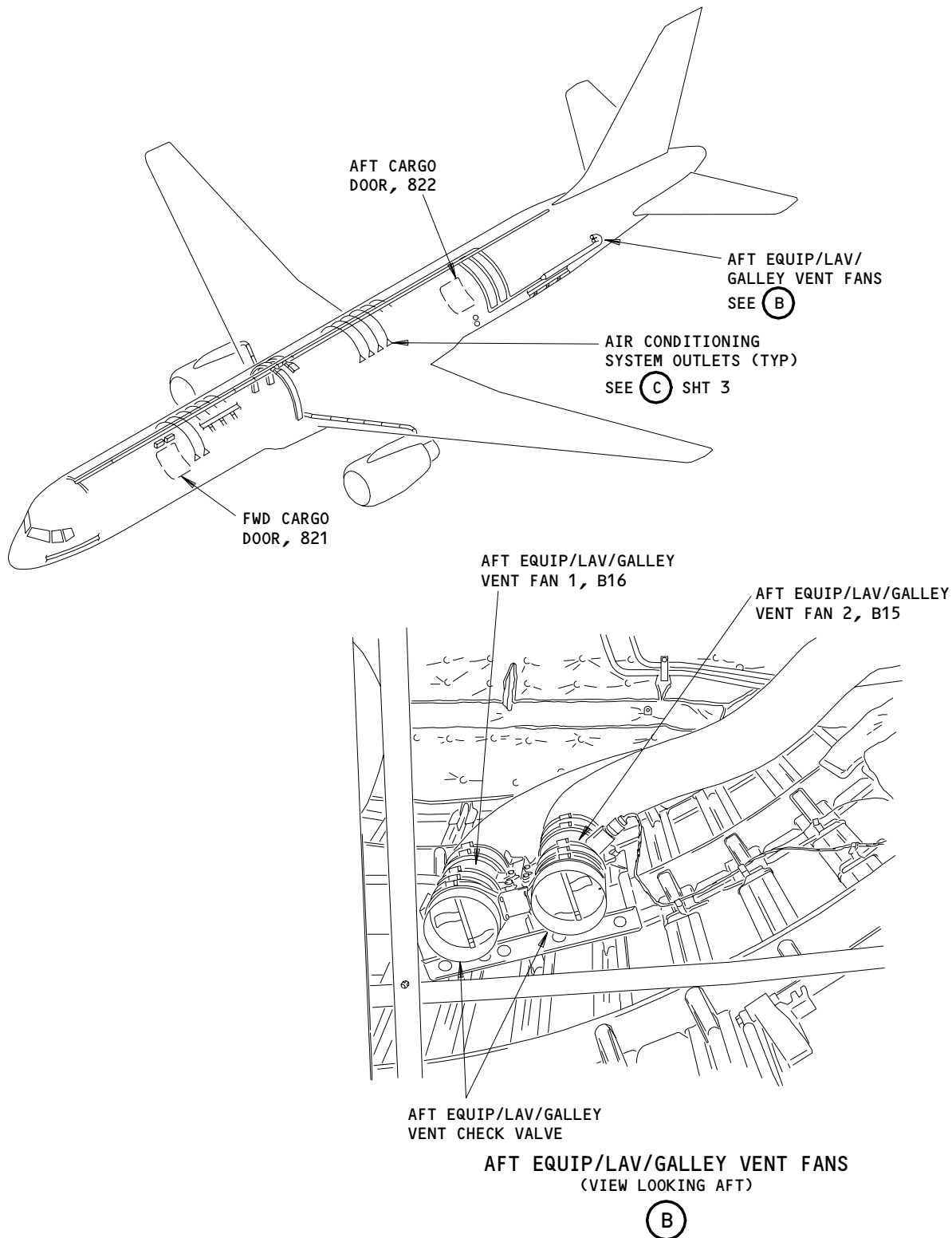

Component Location
Figure 102 (Sheet 2)

EFFECTIVITY	
	ALL

21-20-00

05

Page 104
Jun 15/87

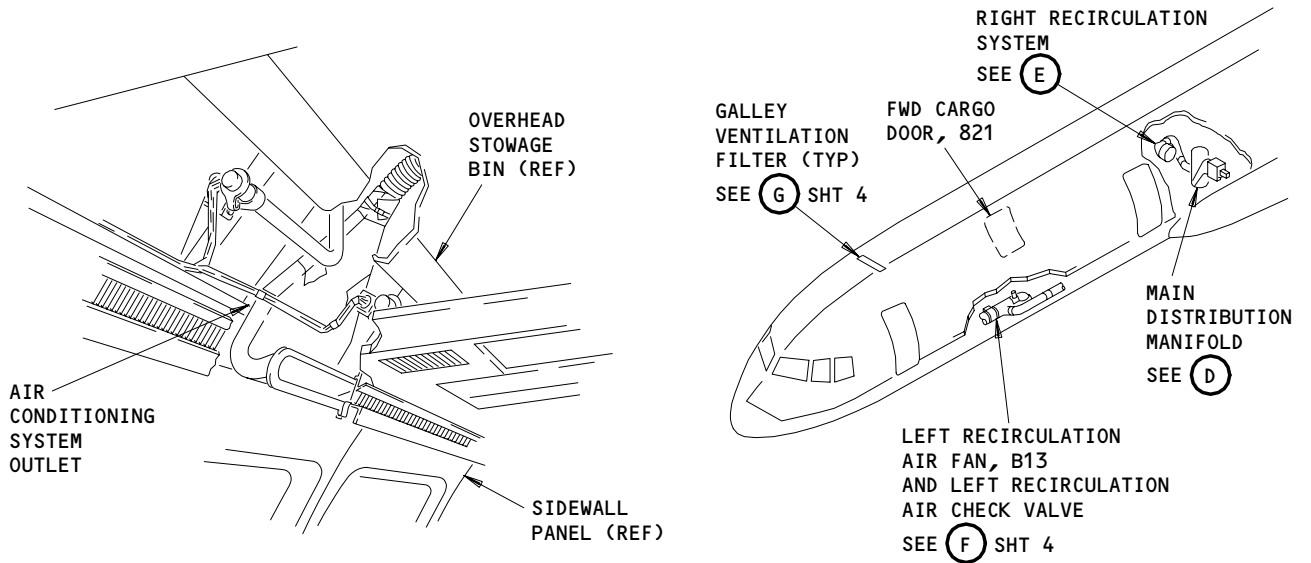

AIR CONDITIONING SYSTEM OUTLETS (TYP)

(C) FROM SHT 2

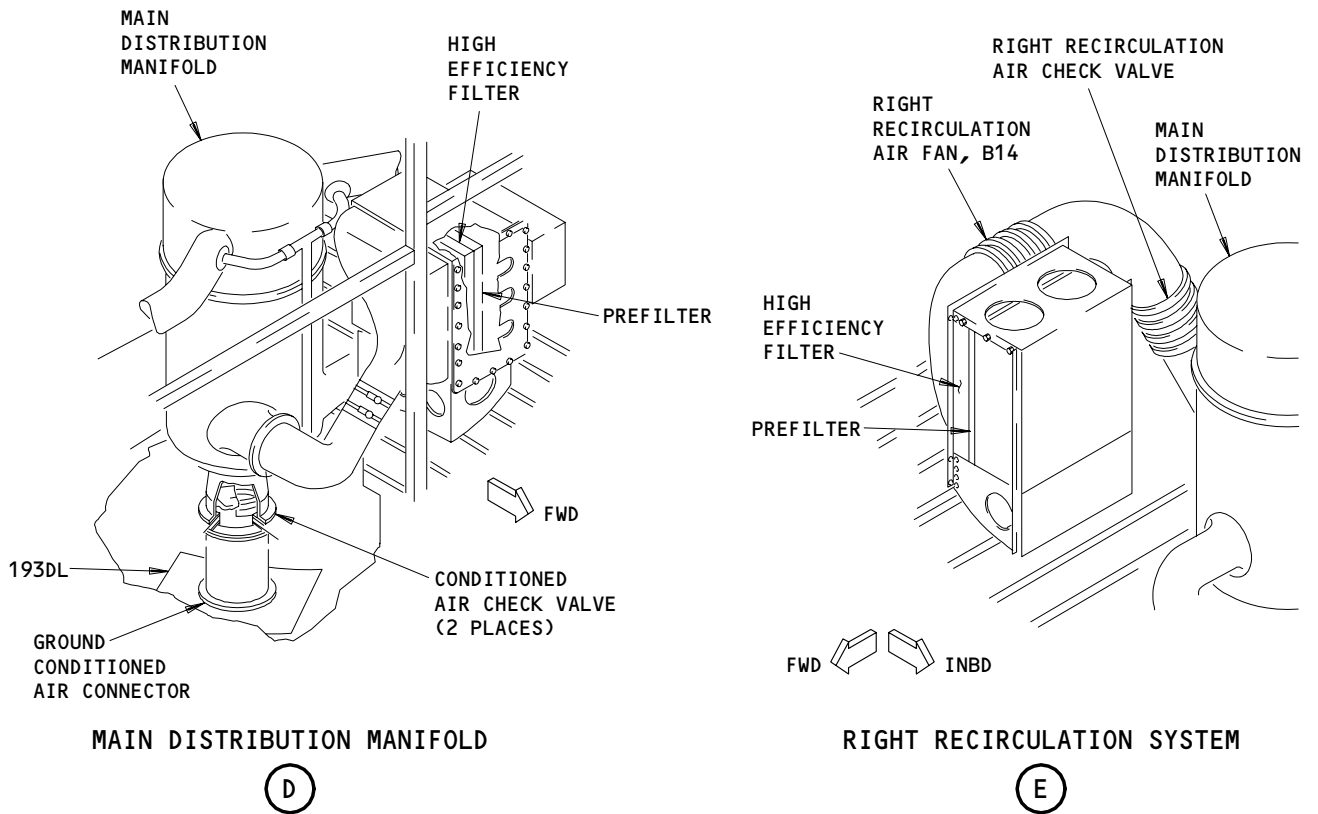

Component Location
Figure 102 (Sheet 3)

EFFECTIVITY	ALL
-------------	-----

21-20-00

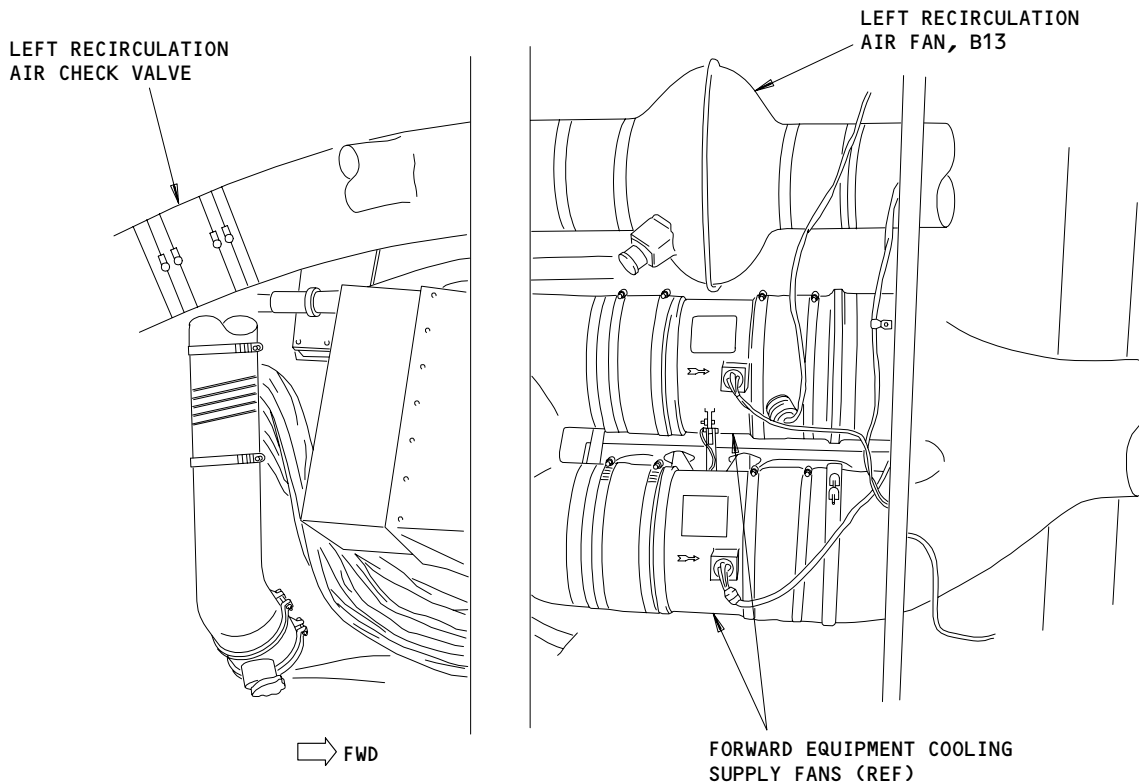

LEFT RECIRCULATION AIR FAN

F

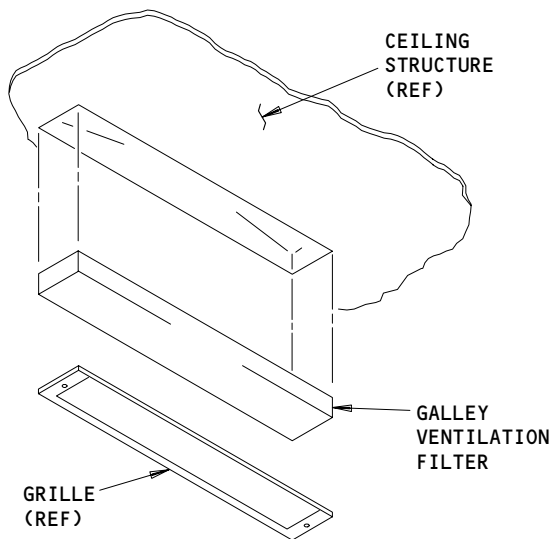

GALLEY VENTILATION FILTER (TYP)

G

Component Location (Details from Sht 3)
Figure 102 (Sheet 4)

EFFECTIVITY	ALL

21-20-00

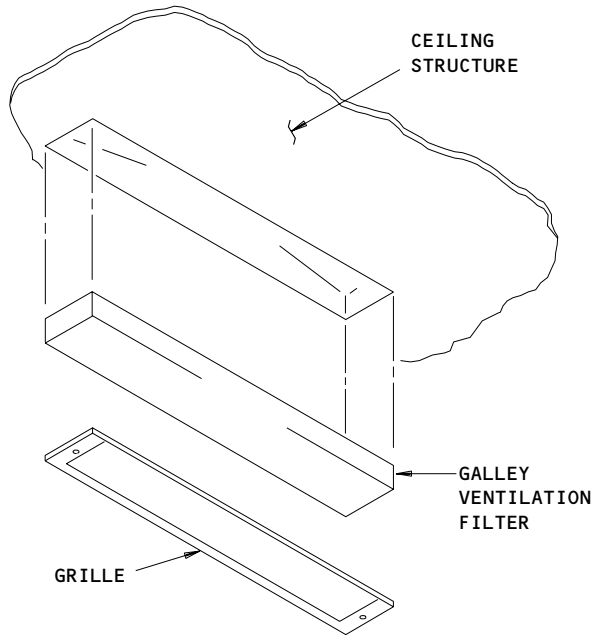
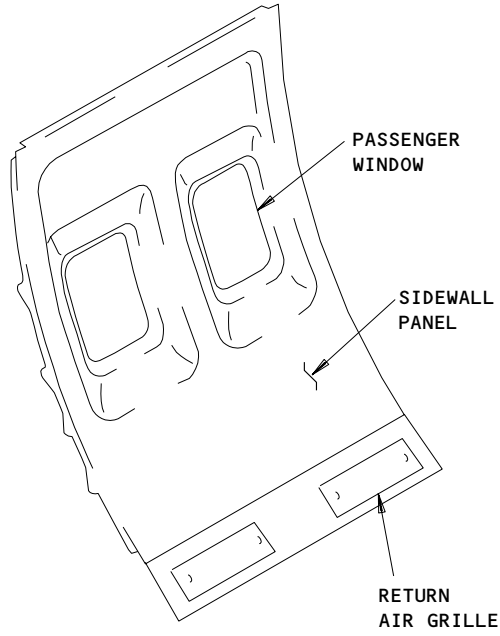

GALLEY VENTILATION FILTER
(EXAMPLE)

(G) FROM SHT 3

Component Location
Figure 102 (Sheet 5)

EFFECTIVITY	ALL
-------------	-----

21-20-00

02

Page 107
May 28/99

217672

EICAS MSG "AFT EQ
EXH FAN 2" DISPLAYED

PREREQUISITES

ELECTRICAL POWER (MM 24-22-00)
CB'S: 11N11,32A8,70B2

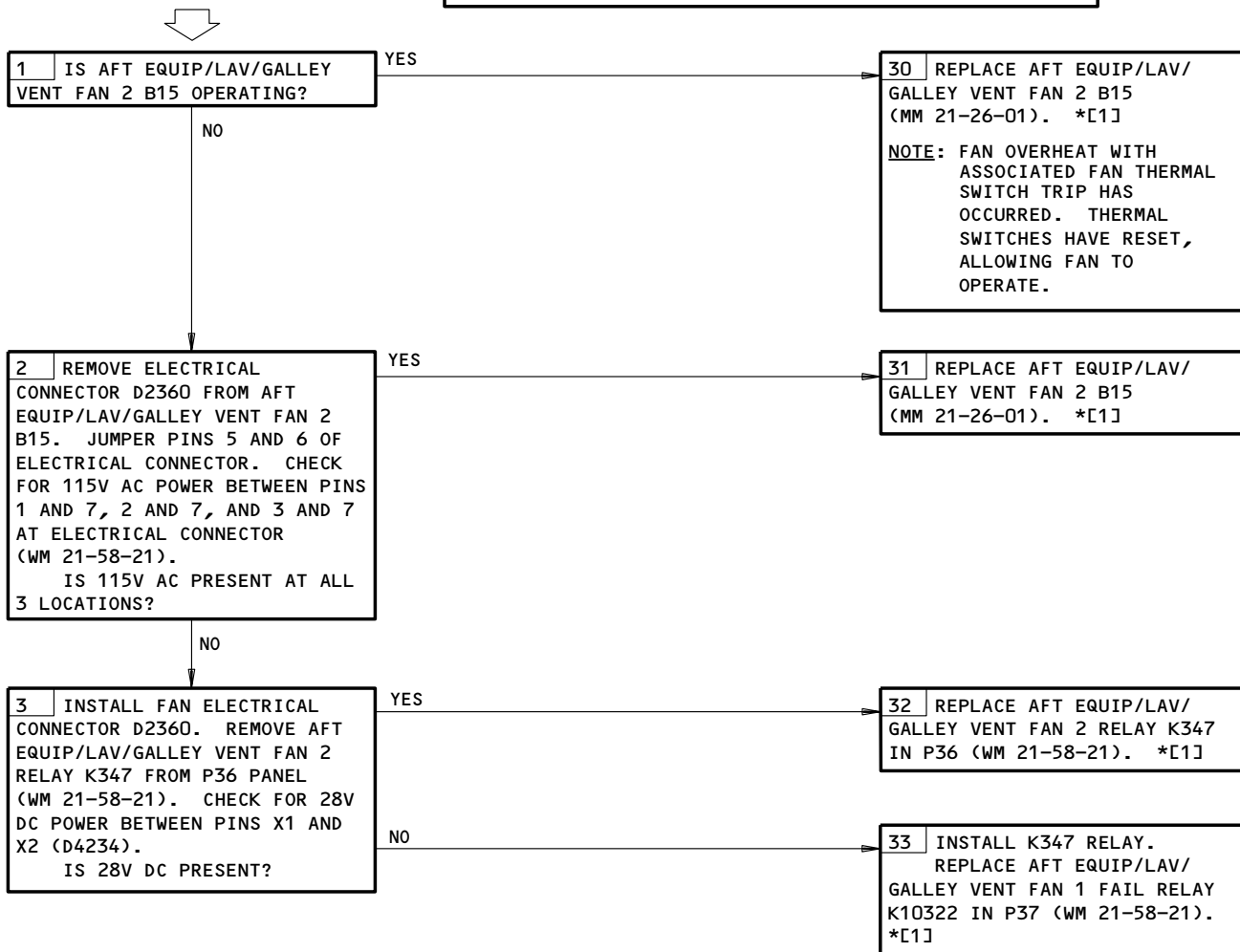

*[1] PERFORM EICAS MAINTENANCE MESSAGE ERASE PROCEDURE (31-41-00, FIG. 109)

EICAS Msg AFT EQ EXH FAN 2 Displayed
Figure 103

EFFECTIVITY

ALL

21-20-00

03

Page 108
Sep 20/87

217302

RECIRC FAN "INOP"
LIGHT ON, "L (R)
RECIR FAN" EICAS
MESSAGE DISPLAYED
WITH L (R) RECIRC
FAN SWITCH/LIGHT
"ON"

PREREQUISITES

MAKE SURE THESE CIRCUIT BREAKERS ARE CLOSED:
11P14,11P23,37D7,37J5,70B16,70C10

MAKE SURE THE AIRPLANE IS IN THIS CONFIGURATION:
ELECTRICAL POWER IS ON (AMM 24-22-00/201)
FWD AND AFT CARGO FIRE SWITCH/LIGHT ON P8 PANEL IN
UNARMED POSITION
SLATS RETRACTED

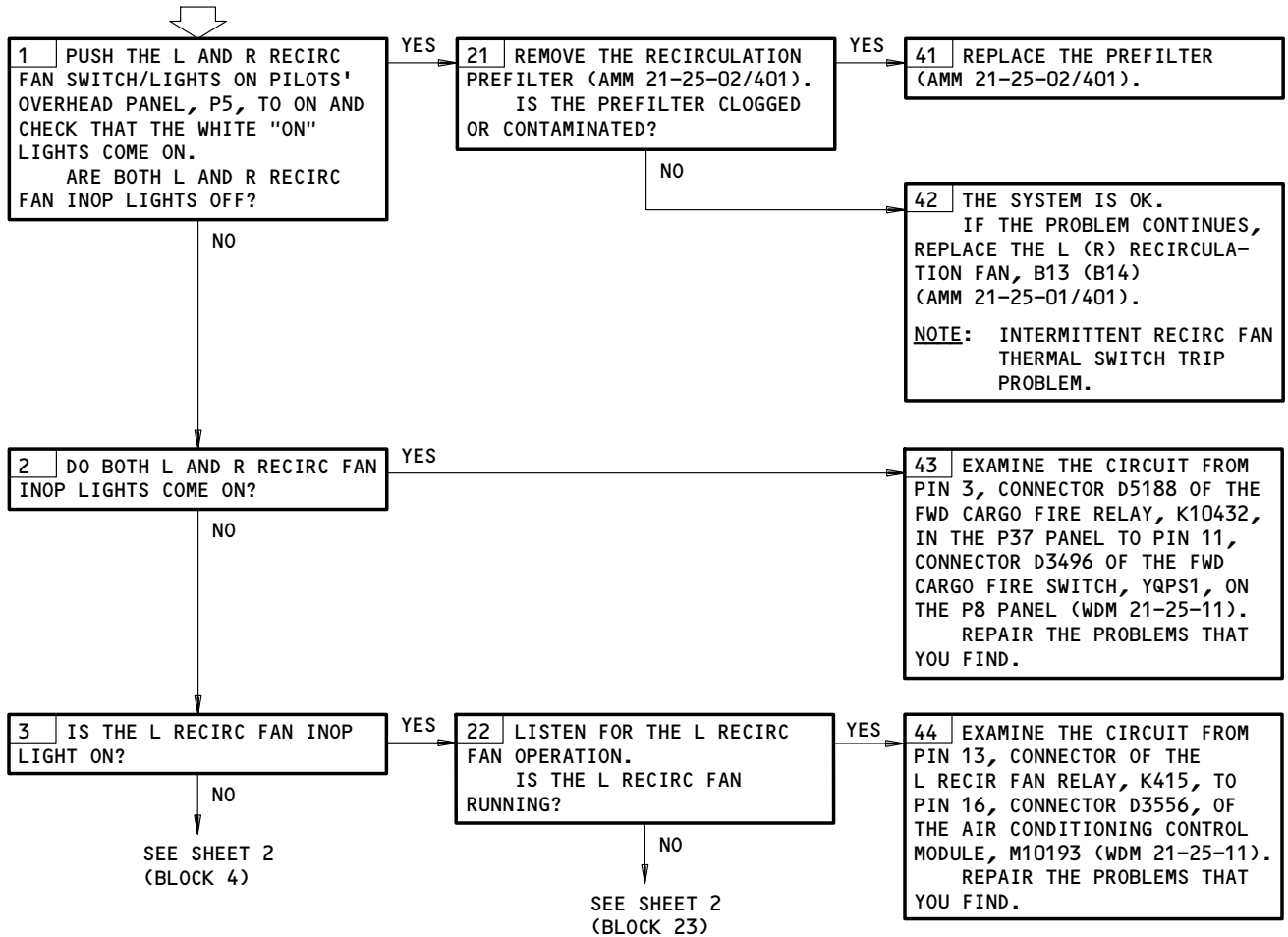

Recirc Fan INOP Light On, L (R) RECIR FAN EICAS Msg Displayed
With L (R) Recirc Fan Switch/Light ON
Figure 104 (Sheet 1)

EFFECTIVITY

ALL

21-20-00

06

Page 109
Mar 20/96

BOEING
757
FAULT ISOLATION/MAINT MANUAL

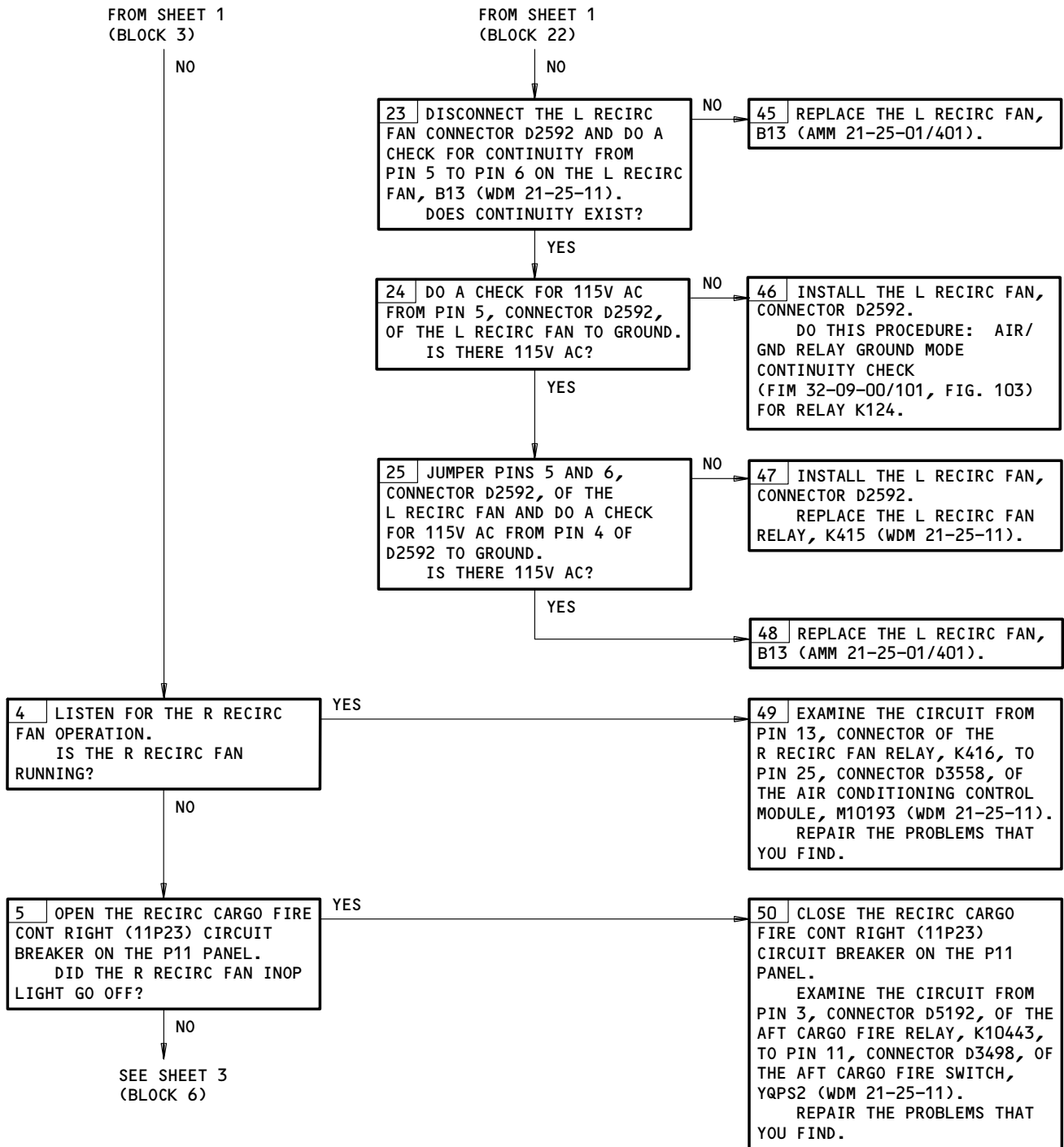

Recirc Fan INOP Light On, L (R) RECIRC FAN EICAS Msg Displayed
With L (R) Recirc Fan Switch/Light ON
Figure 104 (Sheet 2)

EFFECTIVITY

ALL

21-20-00

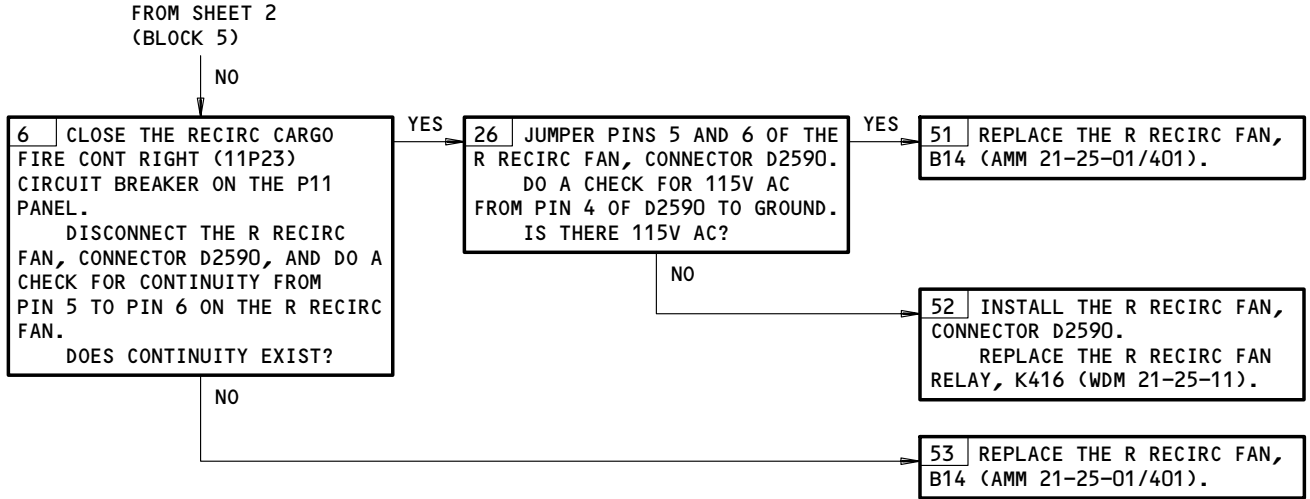

Recirc Fan INOP Light On, L (R) RECIR FAN EICAS Msg Displayed
 With L (R) Recirc Fan Switch/Light ON
 Figure 104 (Sheet 3)

EFFECTIVITY	ALL
-------------	-----

21-20-00

EICAS MSG "AFT EQ
EXH FAN 1" DISPLAYED

PREREQUISITES
 ELECTRICAL POWER (MM 24-22-00)
 CB'S: 11N11,32A8,37D5

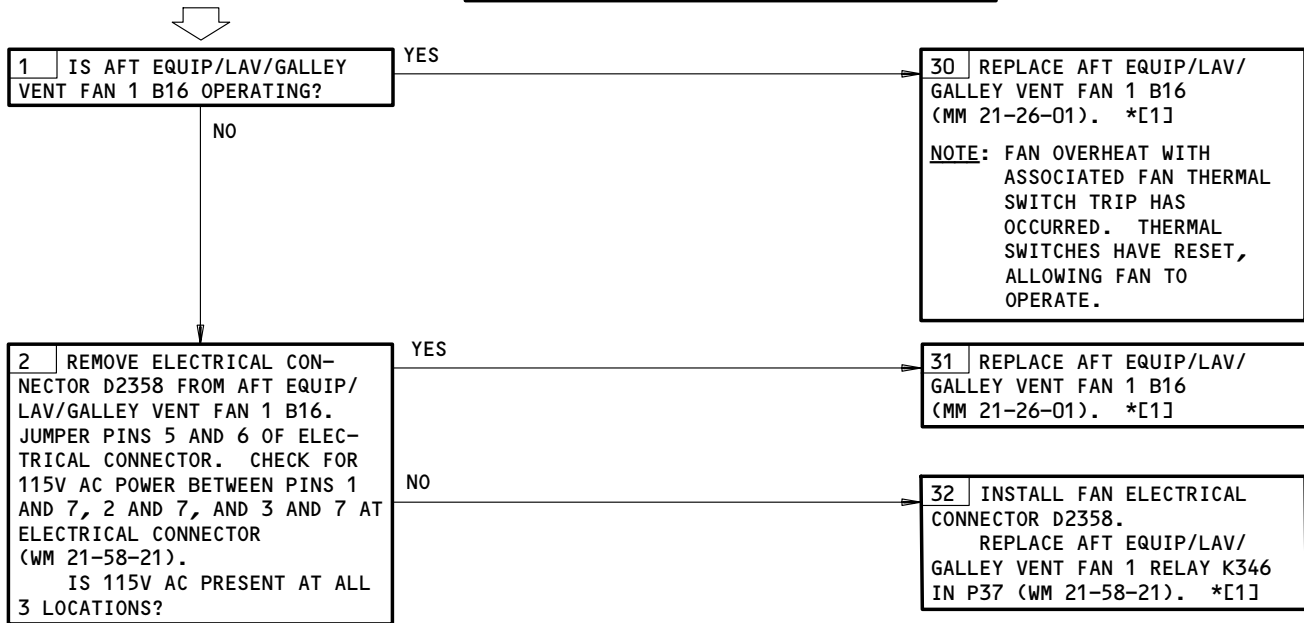

*[1] PERFORM EICAS MAINTENANCE MESSAGE ERASE PROCEDURE (31-41-00, FIG. 109)

EICAS Msg AFT EQ EXH FAN 1 Displayed
Figure 105

EFFECTIVITY	ALL
-------------	-----

21-20-00

217474

BOEING

757
FAULT ISOLATION/MAINT MANUAL

PRESSURIZATION

COMPONENT	FIG. 102 SHT	QTY	ACCESS/AREA	REFERENCE
ACTUATOR - CABIN PRESSURE OUTFLOW VALVE, YBWM1	3	1	822, AFT CARGO COMPT, CABIN PRESS OUTFLOW VALVE, V15	21-31-04
CIRCUIT BREAKERS -	2		FLT COMPT, P11	
CABIN ALTITUDE CONTROL AUTO 1, C686		1	11N15	*
CABIN ALTITUDE CONTROL AUTO 2, C701		1	11N24	*
CABIN ALTITUDE CONTROL MANUAL, C683		1	11B14	*
CABIN ALTM, C4205		1	11B13	*
CABIN ALT/PRESS SELECT, C658		1	11B15	*
CABIN DIFF PRESS IND, C4206		1	11B12	*
COMPUTERS - (31-41-00/101)				
EICAS L, M10181				
EICAS R, M10182				
COMPUTERS - (34-12-00/601)				
AIR DATA L, M100				
AIR DATA R, M101				
CONTROLLERS - CABIN PRESSURE			821, FWD CARGO COMPT, E5 RACK	21-31-02
NO. 1, M118	2	1		
NO. 2, M119	2	1		
DIODE - R10315 1			119BL, MAIN EQPT CTR, P36	*
MICROSWITCH PACK - (22-32-00/101)				
AUTO THROTTLE, M966				
MODULE - HIGH ALTITUDE WARNING, M10756 1	2	1	FLT COMPT, P5	*
MODULE - PRESSURIZATION AND INDICATING WARNING, M19	2	1	FLT COMPT, P5	21-33-01
MOTOR - OUTFLOW VALVE ACTUATOR AC, YBWM2	3	2	822, AFT CARGO COMPT, CABIN PRESS OUTFLOW VALVE, V15	21-31-03
MOTOR - OUTFLOW VALVE ACTUATOR DC	3	1	822, AFT CARGO COMPT, CABIN PRESS OUTFLOW VALVE, V15	21-31-03
PANEL - DISCRETE WARNING DISPLAY, M779	2	1	FLT COMPT, P1	21-33-00
RELAYS - (31-01-36/101)				
HIGH ALT SEL/ENABLE, K10610 1				
HIGH ALT SEL/INOP, K10611 1				
SYS 1 AIR/GND, K10238				
RELAY - (31-01-37/101)				
SYS 2 AIR/GND, K207				
SELECTOR - CABIN PRESSURE, M13	2	1	FLT COMPT, P5	21-31-01
SENSOR - DIFFERENTIAL PRESSURE, TS5072	3	1	113AL, FWD EQUIP CTR	21-33-04
SWITCH - CABIN ALT WARNING, S431		1	119BL, MAIN EQUIP CTR, P36	*
SWITCH - CABIN HIGH ALT WARNING, S10553 1		1	119BL, MAIN EQUIP CTR, P36	*
SWITCH - THROTTLE POSITION, S17	2	1	113AL, FWD EQUIP CTR, MICRO-SWITCH PACK, M966	22-32-04
SWITCH - THROTTLE POSITION, S18	2	1	113AL, FWD EQUIP CTR, MICRO-SWITCH PACK, M966	22-32-04
SWITCH/LIGHT - HIGH ALT LANDING, YTLS1 1	2	1	FLT COMPT, P5, HIGH ALTITUDE WARNING MODULE, M10756	*
VALVE - CABIN PRESSURE OUTFLOW, V15	3	1	822, AFT CARGO COMPT	21-31-03
VALVE - POSITIVE PRESSURE RELIEF	1	2	822, AFT CARGO COMPT	21-32-01
VALVE - VACUUM PRESSURE RELIEF	1	2	119BL, MAIN EQUIP CTR	21-32-02

* SEE THE WDM EQUIPMENT LIST

1 AIRPLANES WITH "HIGH ALT LDG" SWITCH ON THE P5 PANEL

Pressurization - Component Index
Figure 101

EFFECTIVITY

ALL

21-30-00

09

Page 101
Jun 20/92

A52832

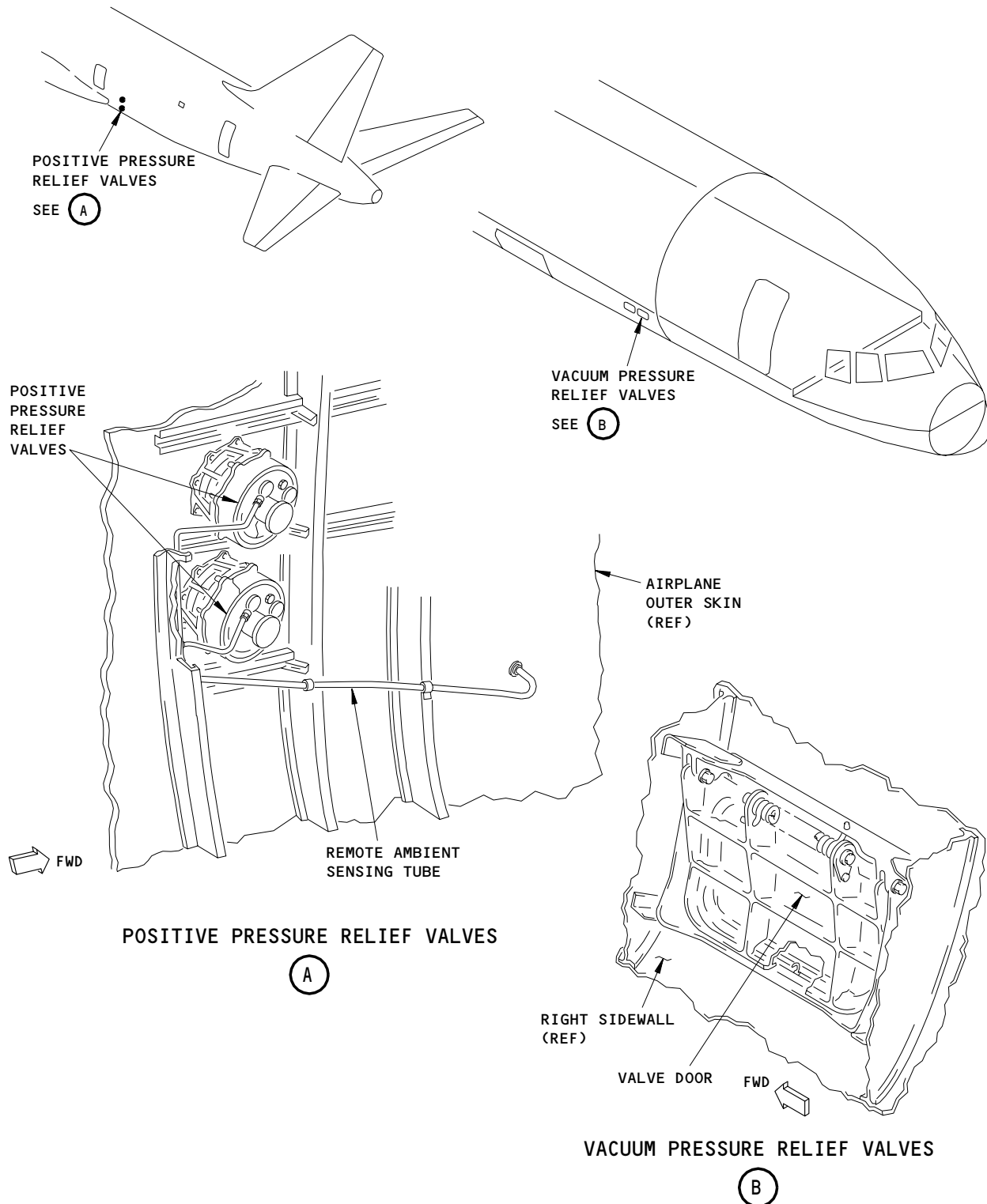

Pressurization - Component Location
Figure 102 (Sheet 1)

EFFECTIVITY	
	ALL

21-30-00

BOEING

757

FAULT ISOLATION/MAINT MANUAL

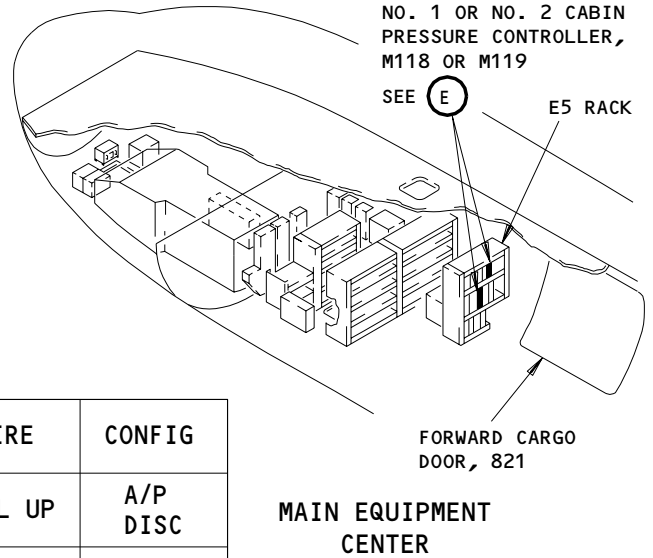
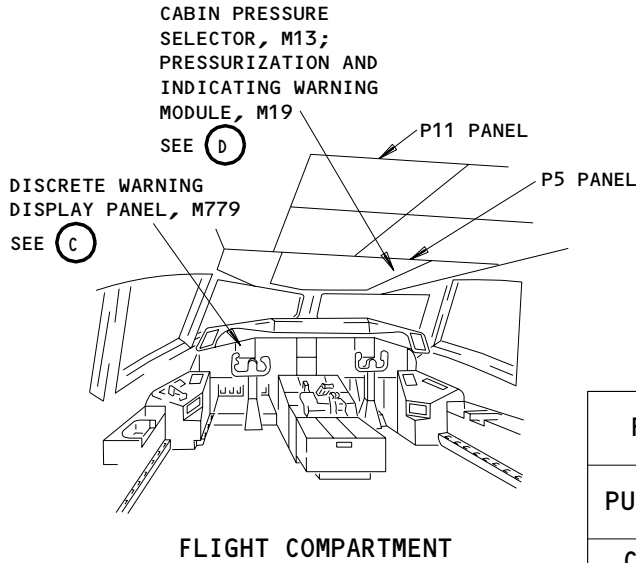

FIRE	CONFIG
PULL UP	A/P DISC
CABIN ALT	OVSPD

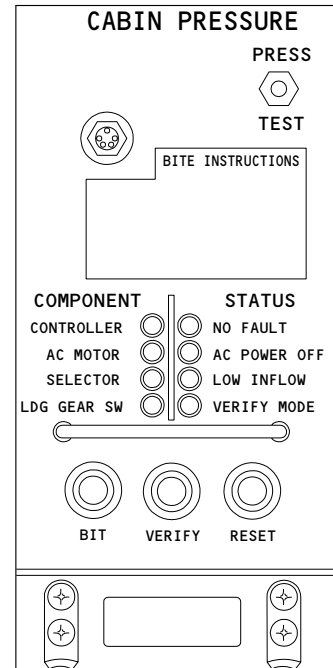
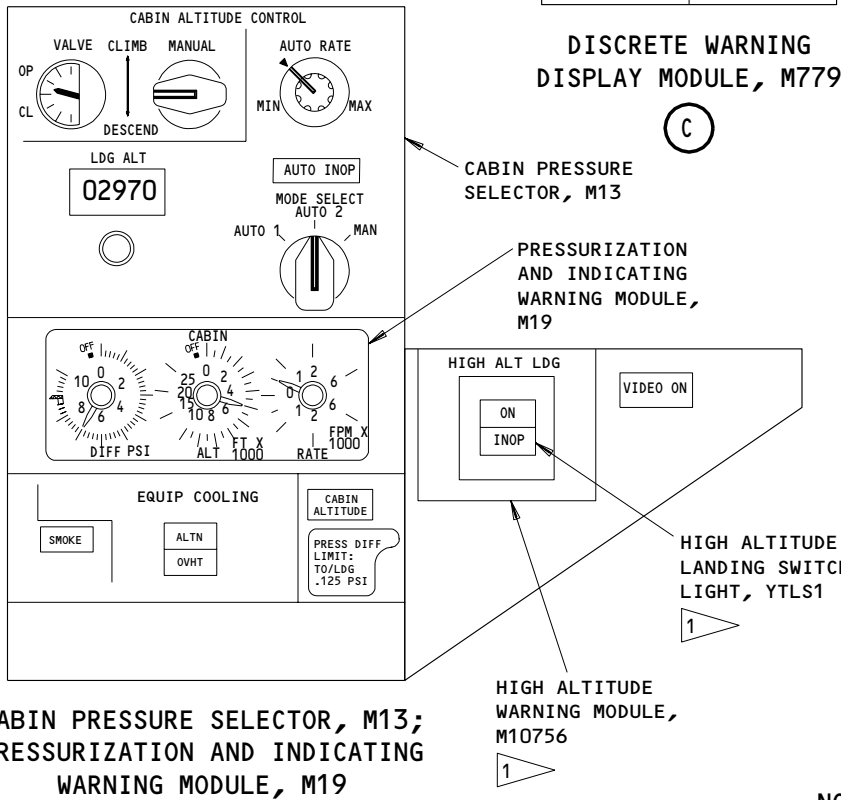

CABIN PRESSURE SELECTOR, M13;
PRESSURIZATION AND INDICATING WARNING MODULE, M19

(D)

1 AIRPLANES WITH "HIGH ALT LDG" SWITCH ON THE P5 PANEL

NO. 1 OR NO. 2 CABIN PRESSURE CONTROLLER, M118 OR M119

Pressurization - Component Location
Figure 102 (Sheet 2)

EFFECTIVITY

ALL

21-30-00

06

Page 103
Jun 20/92

A52867

BOEING
757
FAULT ISOLATION/MAINT MANUAL

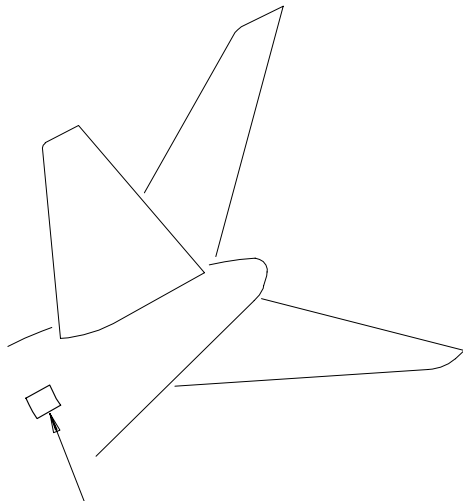

CABIN PRESSURE
OUTFLOW VALVE, V15
SEE (F)

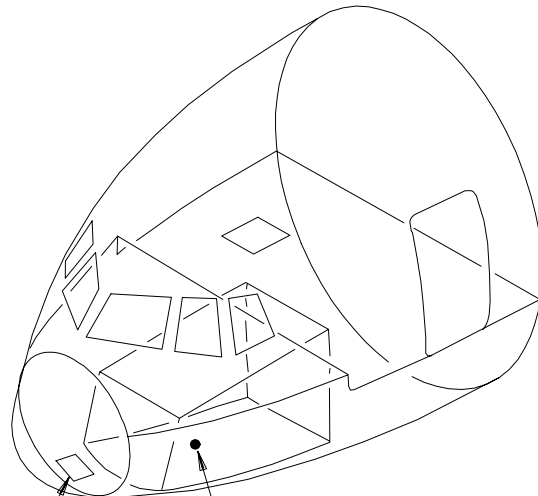

FORWARD EQUIPMENT
CENTER ACCESS
PANEL, 113AL

DIFFERENTIAL
PRESSURE SENSOR,
TS5072
SEE (G)

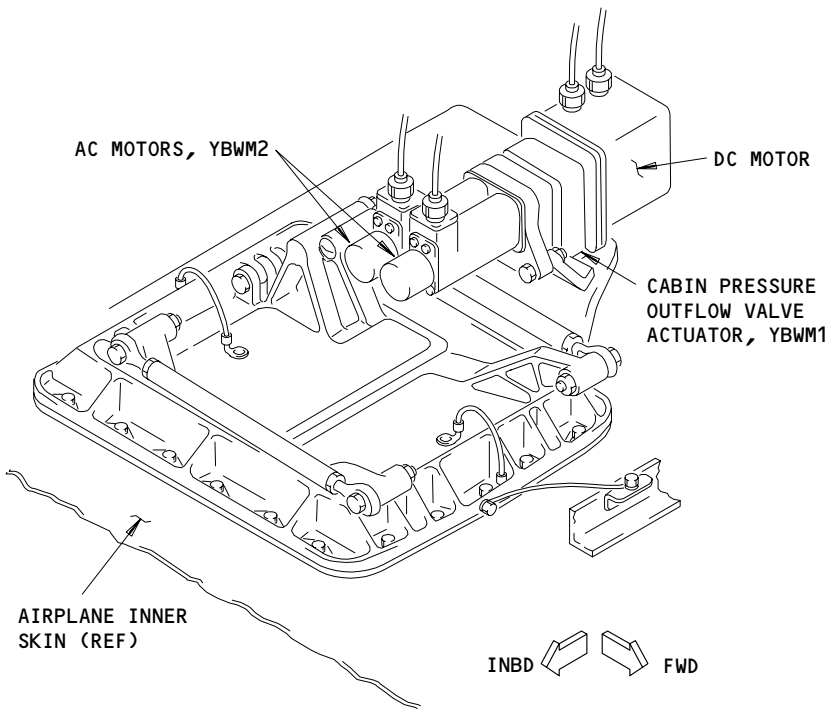

CABIN PRESSURE OUTFLOW VALVE, V15

(F)

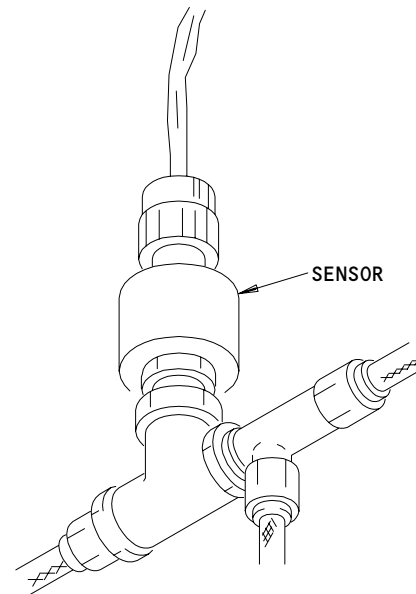

DIFFERENTIAL PRESSURE SENSOR, TS5072

(G)

Pressurization - Component Location
Figure 102 (Sheet 3)

EFFECTIVITY	
ALL	

21-30-00

01

Page 104
Sep 20/91

**CABIN PRESSURE
CONTROLLER BITE
PROCEDURE**

PREREQUISITES

MAKE SURE THESE CIRCUIT BREAKERS ARE CLOSED:
11B12, 11B13, 11B14, 11N15, 11N24

MAKE SURE THE AIRPLANE IS IN THIS CONFIGURATION:
ELECTRICAL POWER IS ON (AMM 24-22-00/201)

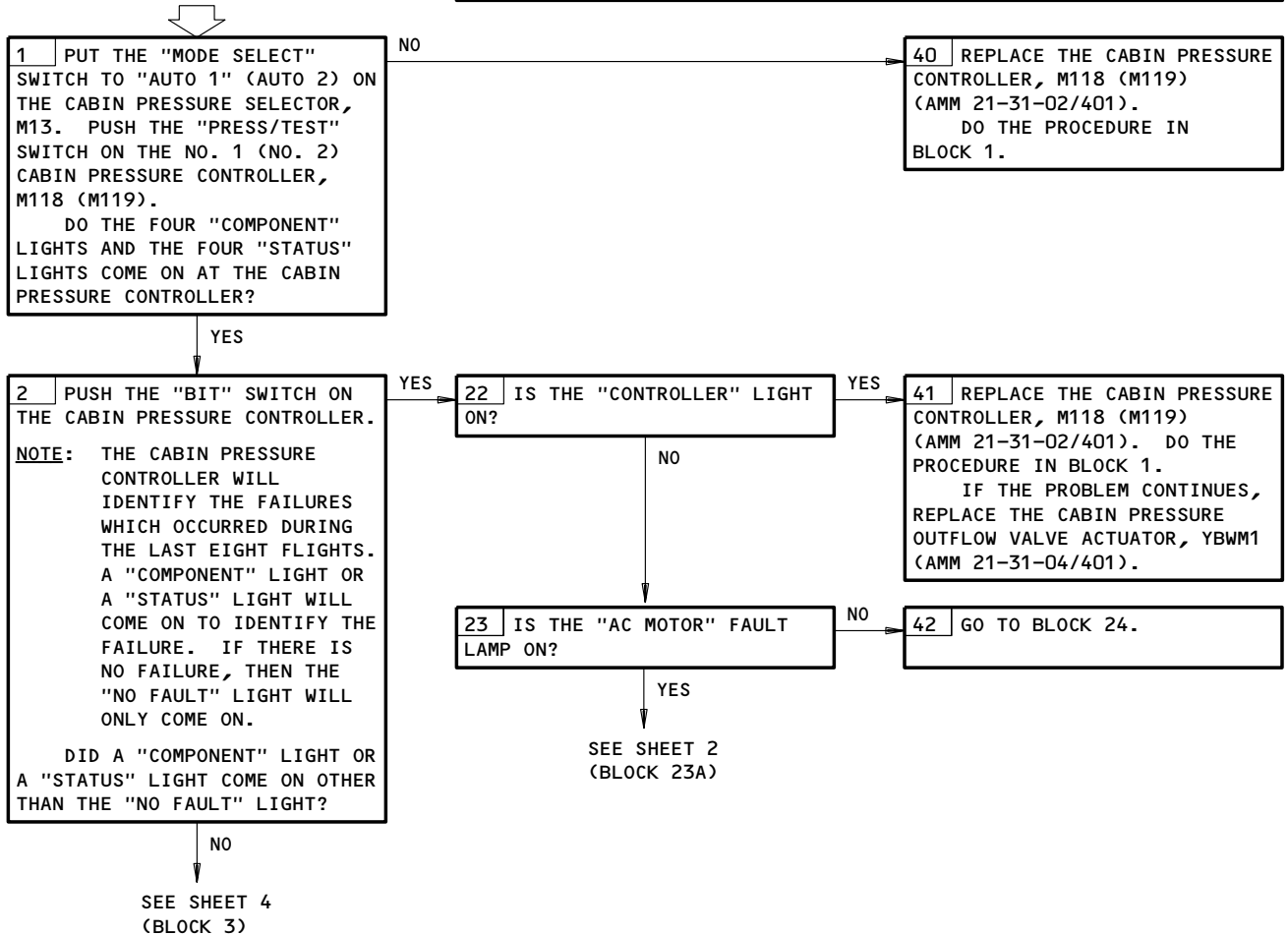

Cabin Pressure Controller BITE Procedure
Figure 103 (Sheet 1)

EFFECTIVITY	ALL
-------------	-----

21-30-00

BOEING
757
FAULT ISOLATION/MAINT MANUAL

FROM SHEET 1
(BLOCK 23)

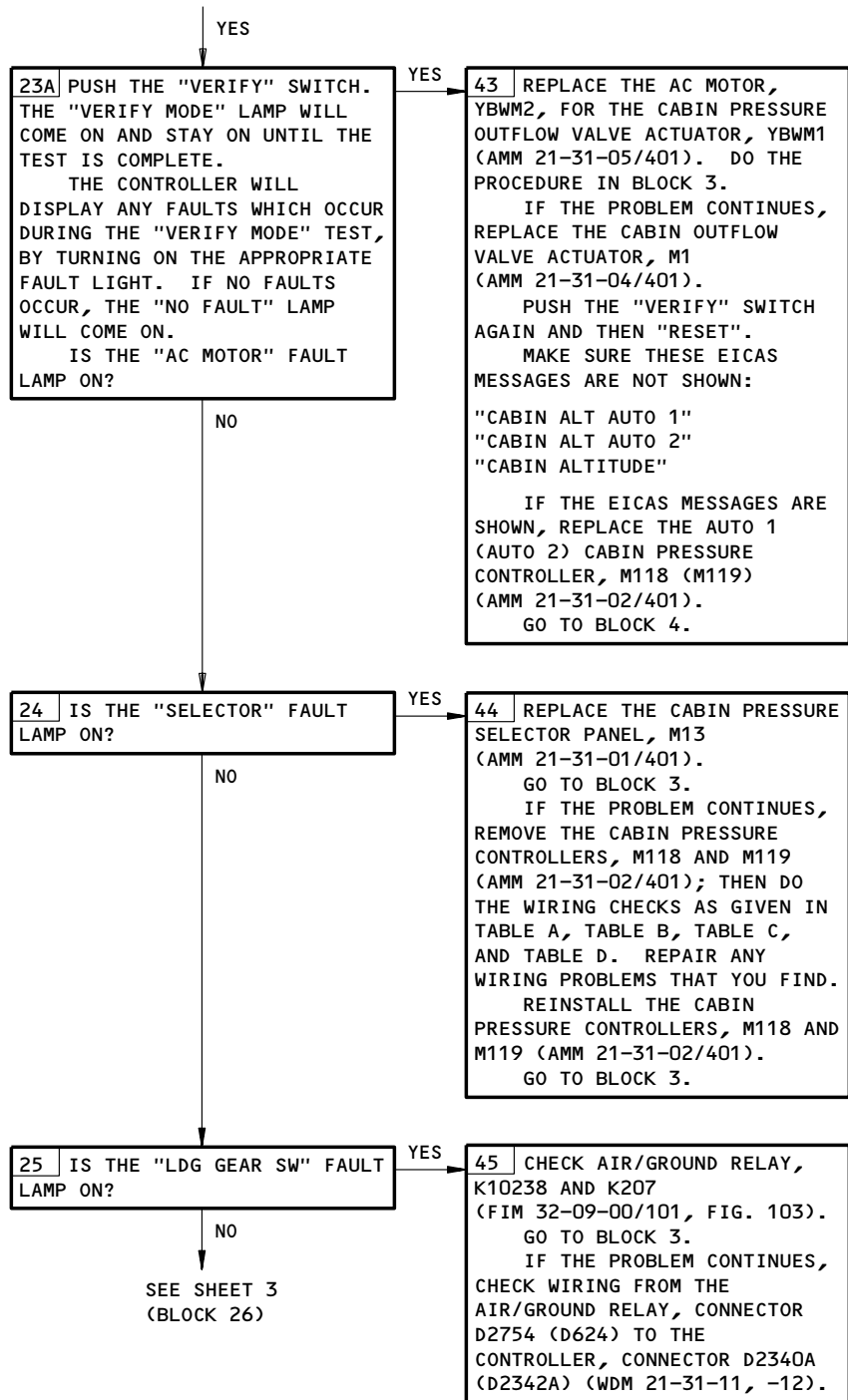

Cabin Pressure Controller BITE Procedure
Figure 103 (Sheet 2)

EFFECTIVITY	ALL
-------------	-----

21-30-00

BOEING
757
FAULT ISOLATION/MAINT MANUAL

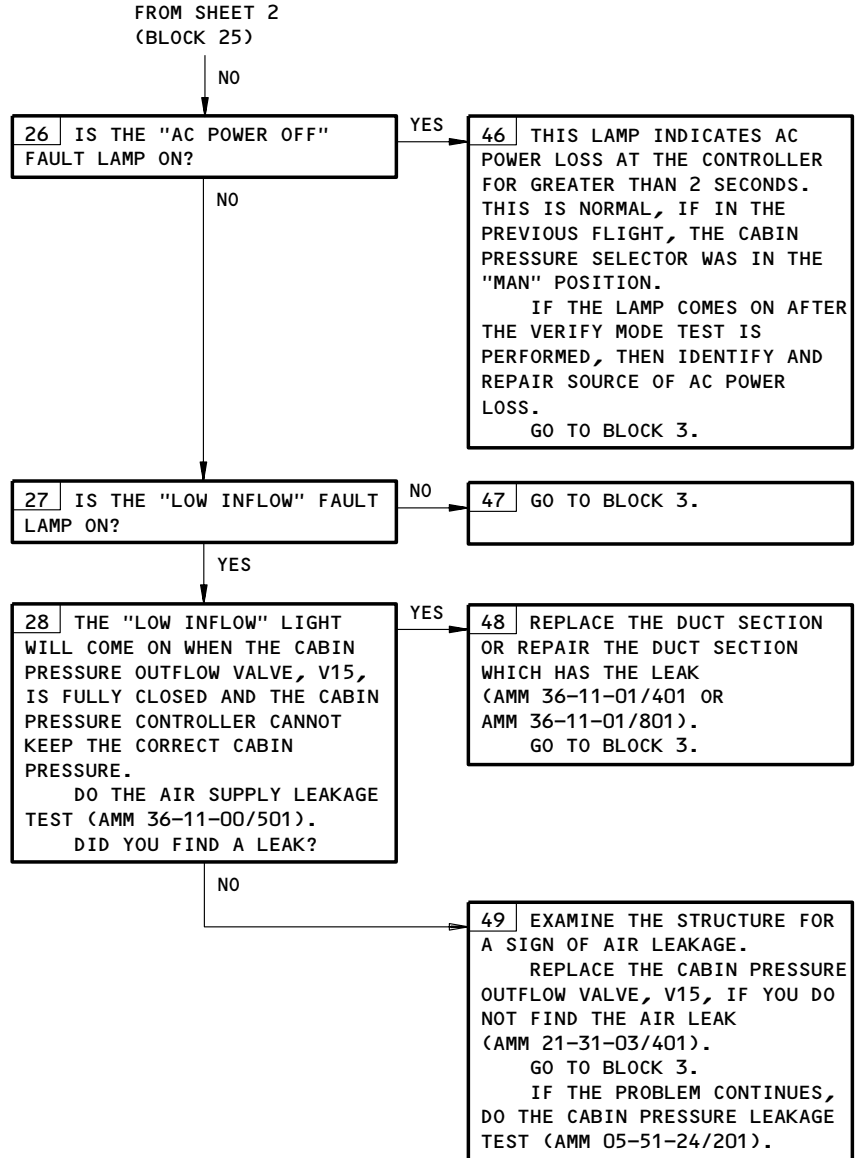

Cabin Pressure Controller BITE Procedure
Figure 103 (Sheet 3)

EFFECTIVITY	ALL
-------------	-----

21-30-00

01

Page 107
Jan 28/01

966456

FROM SHEET 1
(BLOCK 2)

NO

3 PUSH THE "VERIFY" SWITCH ON THE CABIN PRESSURE CONTROLLER. DO THE PROCEDURE IN BLOCK 1 IF THE "VERIFY MODE" LIGHT FLASHES ON THE CABIN PRESSURE CONTROLLER.

NOTE: THE "VERIFY MODE" LIGHT WILL COME ON AND STAY ON UNTIL YOU COMPLETE THE VERIFY MODE TEST. THE CABIN PRESSURE CONTROLLER WILL IDENTIFY THE FAILURES WHICH OCCUR DURING THE VERIFY MODE TEST. A "COMPONENT" LIGHT OR A "STATUS" LIGHT WILL COME ON TO IDENTIFY THE FAILURE. IF THERE IS NO FAILURE, THEN THE "NO FAULT" LIGHT WILL COME ON.

DID A "COMPONENT" LIGHT OR A "STATUS" LIGHT COME ON OTHER THAN THE "VERIFY MODE" LIGHT AND THE "NO FAULT" LIGHT?

YES

50 DO THE PROCEDURE IN BLOCK 22.

NO

4 PUSH THE "VERIFY" SWITCH AND THE "RESET" SWITCH ON THE CABIN PRESSURE CONTROLLER. THE SYSTEM IS OK.

Cabin Pressure Controller BITE Procedure
Figure 103 (Sheet 4)

EFFECTIVITY

ALL

21-30-00

01

Page 108
Jan 28/01

L77212

BOEING
 757
 FAULT ISOLATION/MAINT MANUAL

CABIN PRESSURE CONTROLLER		CABIN PRESSURE SELECTOR	WIRING CHECK ACCEPTANCE
UNIT	CONNECTOR	MODE	
M118 (AUTO 1)	D2340A, PIN A2	AUTO 1	GROUND (DC)
		AUTO 2	OPEN CIRCUIT
		MANUAL	OPEN CIRCUIT
M119 (AUTO 2)	D2342A, PIN A2	AUTO 1	OPEN CIRCUIT
		AUTO 2	GROUND (DC)
		MANUAL	OPEN CIRCUIT

CPC - SELECTOR PANEL WIRING CHECK
TABLE A

CABIN PRESSURE CONTROLLER		WIRING CHECK ACCEPTANCE
M118 (AUTO 1)	M119 (AUTO 2)	
FROM CONNECTOR D2340A	TO CONNECTOR D2342A	
PIN C3	PIN D3	CONTINUITY
PIN C4	PIN D4	CONTINUITY
PIN D3	PIN C3	CONTINUITY
PIN D4	PIN C4	CONTINUITY

CPC-BUS CROSS-TALK WIRING CHECK
TABLE B

Cabin Pressure Controller BITE Procedure
Figure 103 (Sheet 5)

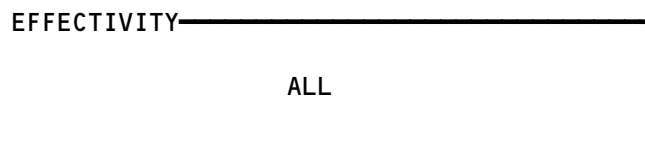

21-30-00

01

Page 109
Jan 28/01

L77631

BOEING
 757
 FAULT ISOLATION/MAINT MANUAL

CABIN PRESSURE CONTROLLER	FROM CONNECTOR	TO CONNECTOR	WIRING CHECK ACCEPTANCE
M118 (AUTO 1)	D2340A, PIN B9	D2340A, PIN B10	OPEN CIRCUIT
M119 (AUTO 2)	D2342A, PIN B9	D2342A, PIN B10	CONTINUITY

CPC TIE-BREAKER WIRING CHECK
TABLE C

CABIN PRESSURE CONTROLLER		CABIN PRESSURE SELECTOR	WIRING CHECK ACCEPTANCE
UNIT	FROM CONNECTOR	TO CONNECTOR	
M118 (AUTO 1)	D2340A, PIN A1	D2344, PIN 21	CONTINUITY
	D2340A, PIN B1	D2344, PIN 9	CONTINUITY
	D2340A, PIN C1	D2344, PIN 20	CONTINUITY
	D2340A, PIN D1	D2344, PIN 8	CONTINUITY
M119 (AUTO 2)	D2342A, PIN A1	D2344, PIN 23	CONTINUITY
	D2342A, PIN B1	D2344, PIN 11	CONTINUITY
	D2342A, PIN C1	D2344, PIN 22	CONTINUITY
	D2342A, PIN D1	D2344, PIN 10	CONTINUITY

CPC - SELECTOR PANEL POTENTIOMETER WIRING CHECK
TABLE D

Cabin Pressure Controller BITE Procedure
Figure 103 (Sheet 6)

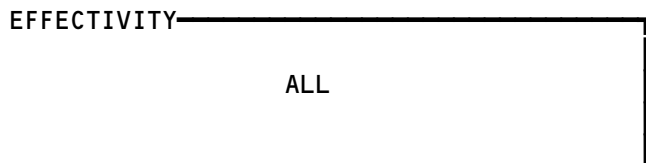

21-30-00

01

Page 110
Jan 28/01

L77632

EICAS MESSAGE "CABIN ALT AUTO 1" OR "2" DISPLAYED

PREREQUISITES

MAKE SURE THESE CIRCUIT BREAKERS ARE CLOSED:
11B12, 11B13, 11B14, 11N15, 11N24

MAKE SURE THE AIRPLANE IS IN THIS CONFIGURATION:
ELECTRICAL POWER IS ON (AMM 24-22-00/201)

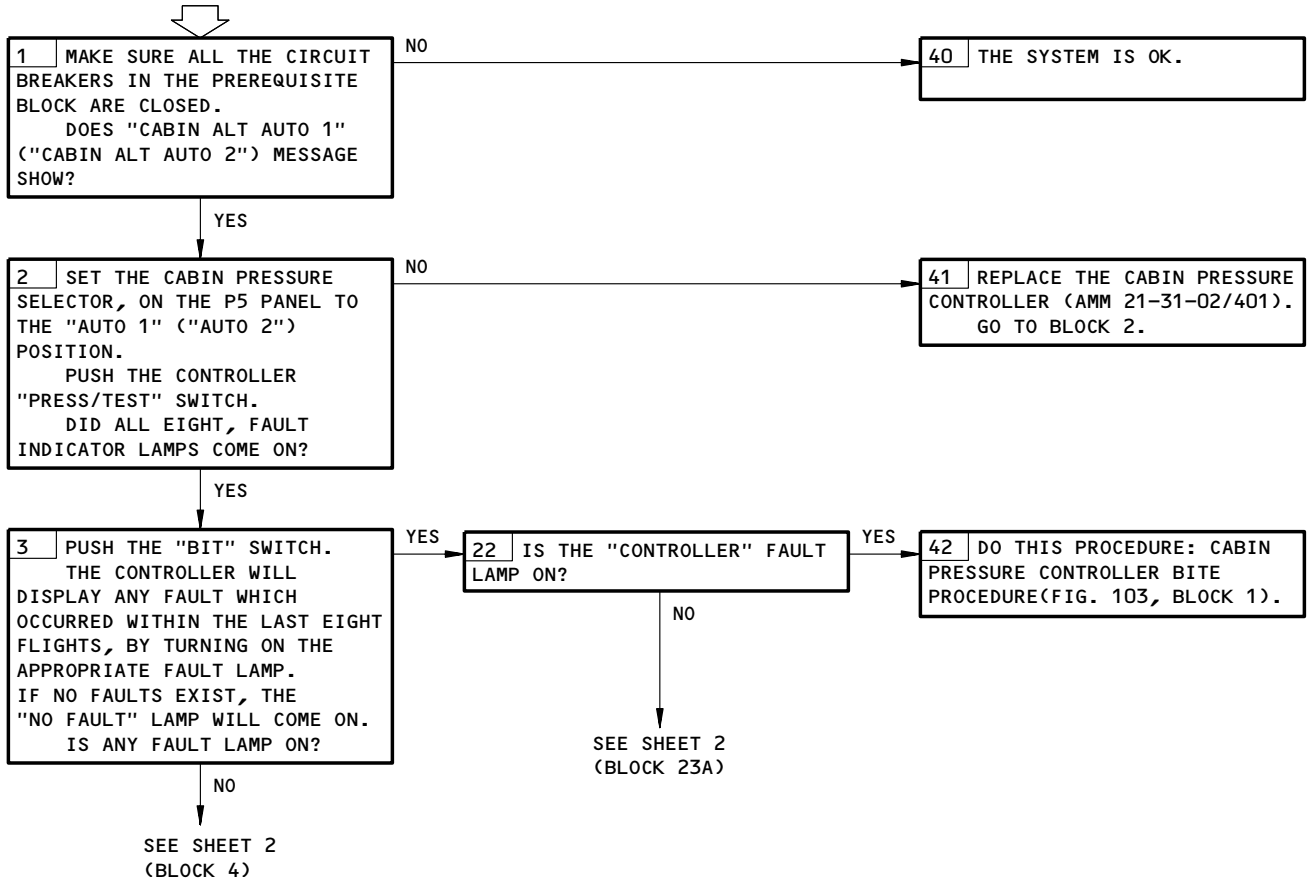

EICAS Message CABIN ALT AUTO 1 or 2 Displayed
Figure 104 (Sheet 1)

EFFECTIVITY	ALL
--------------------	-----

21-30-00

BOEING
757
FAULT ISOLATION/MAINT MANUAL

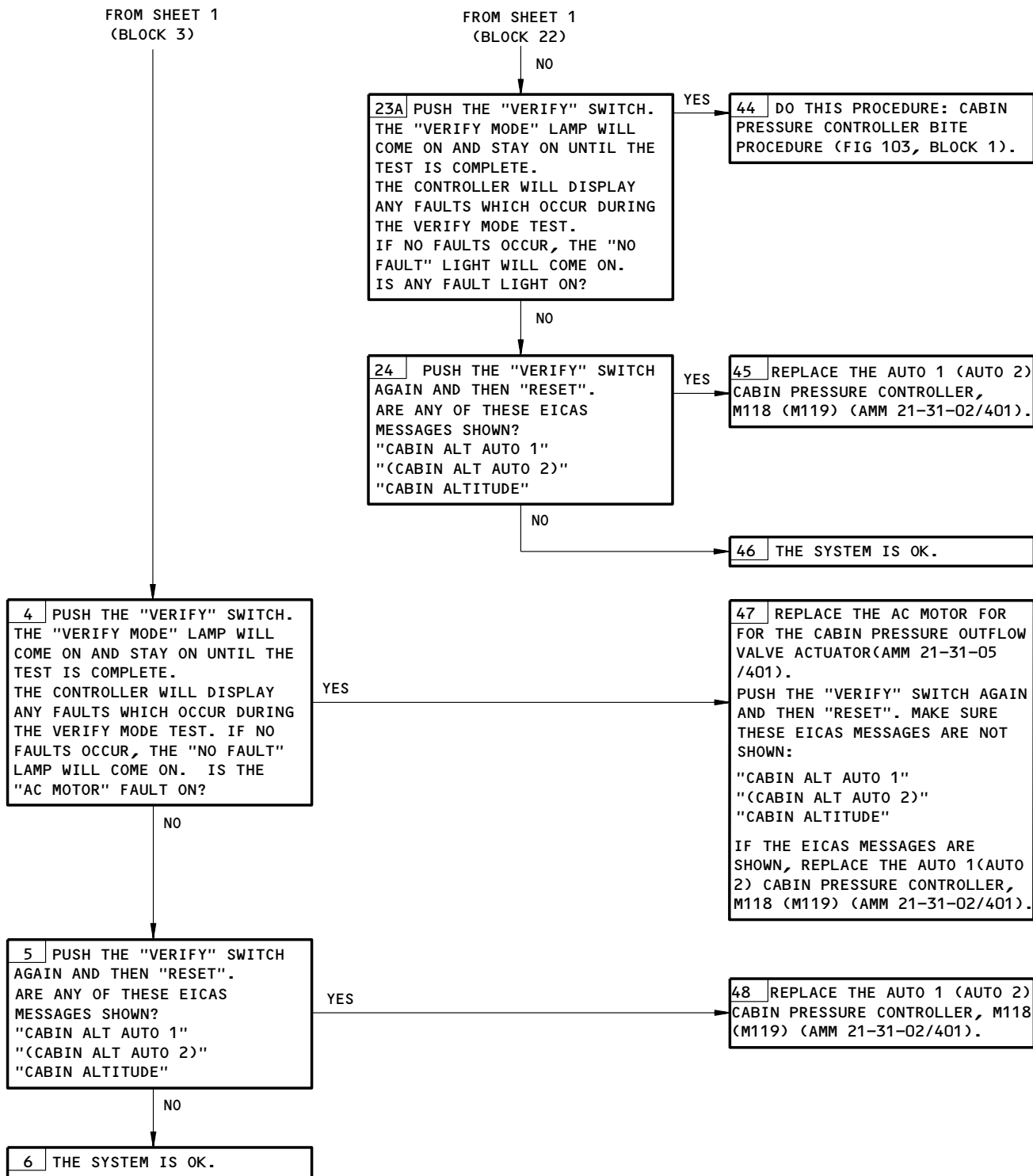

EICAS Message CABIN ALT AUTO 1 or 2 Displayed
Figure 104 (Sheet 2)

EFFECTIVITY

ALL

21-30-00

01

Page 112
Sep 28/05

FD9115

CABIN RATE OFF
SCHEDULE IN AUTO.
SYSTEM NOT NORMAL
IN OTHER AUTO MODE

PREREQUISITES

MAKE SURE THESE CIRCUIT BREAKERS ARE CLOSED:
11B12,11B13,11B14,11B15,11N15,11N24

MAKE SURE THE AIRPLANE IS IN THE CONFIGURATION THAT
FOLLOWS:
ELECTRICAL POWER IS ON (MM 24-22-00/201)

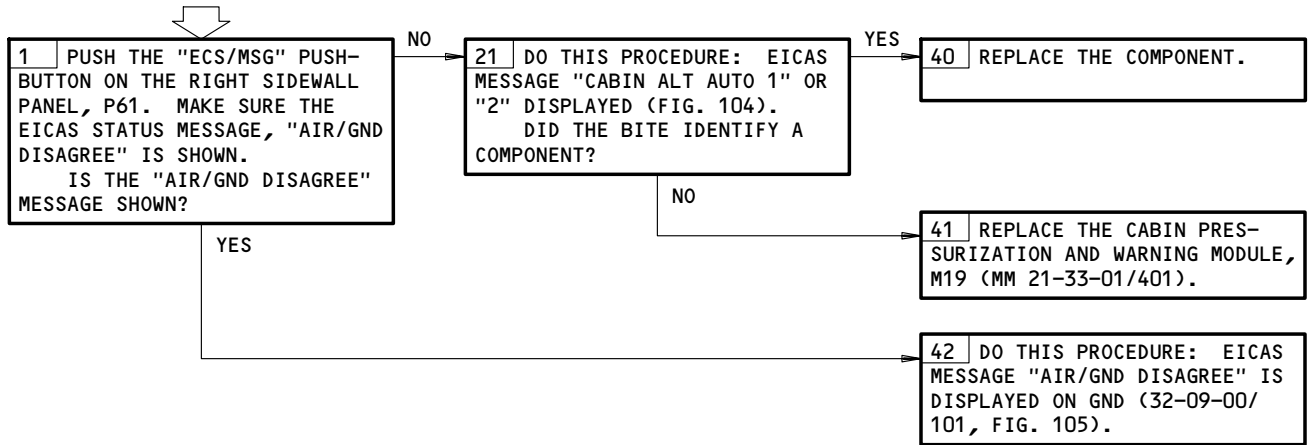

Cabin Rate Off Schedule In Auto. System Not Normal In Other Auto Mode
Figure 105

EFFECTIVITY	ALL
-------------	-----

21-30-00

Not Used
Figure 106

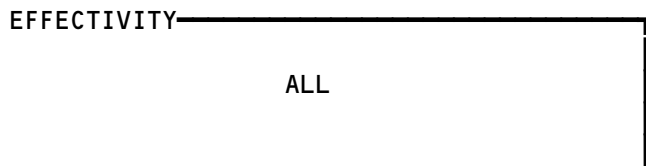

21-30-00

01

Page 114
Sep 28/05

E50236

PREREQUISITES

MAKE SURE THESE CIRCUIT BREAKERS ARE CLOSED:
 11B12,11B13,11B14,11B15,11N15,11N24

MAKE SURE THE AIRPLANE IS IN THIS CONFIGURATION:
 ELECTRICAL POWER IS ON (AMM 24-22-00/201)

**PRESSURE BUMP
 DURING TAKEOFF**

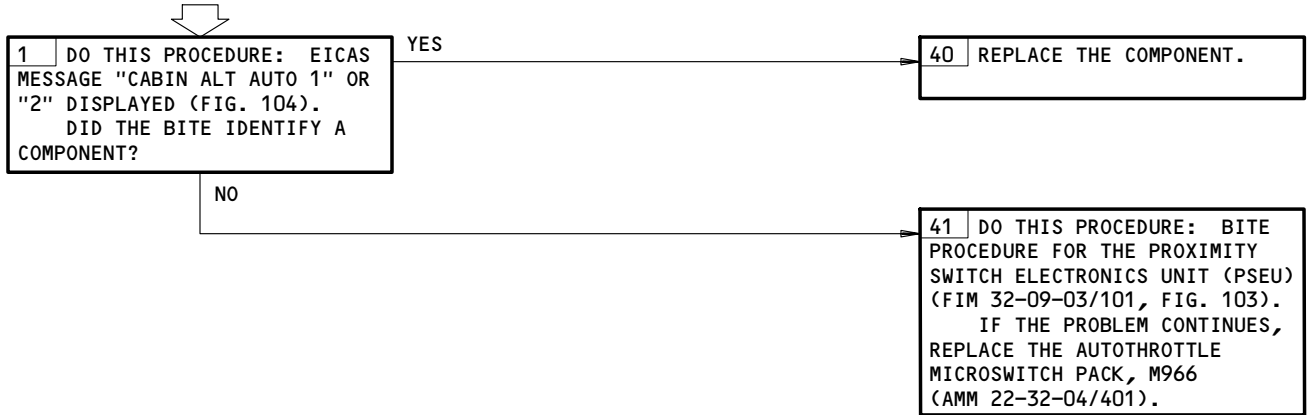

Pressure Bump During Takeoff
 Figure 107

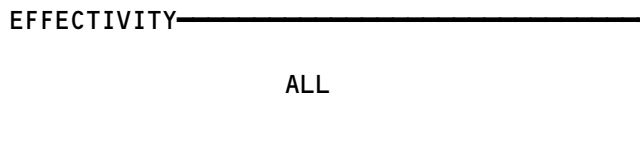

21-30-00

BOTH "CABIN ALT AUTO" EICAS MESSAGES ILLUM, "CABIN AUTO INOP" EICAS MESSAGE AND "AUTO INOP" LIGHT ON IN AUTO, MANUAL MODE NOT NORMAL

PREREQUISITES

MAKE SURE THESE CIRCUIT BREAKERS ARE CLOSED:
11B12,11B13,11B14,11B15,11N15,11N24

MAKE SURE THE AIRPLANE IS IN THE CONFIGURATION THAT FOLLOWS:
ELECTRICAL POWER IS ON (MM 24-22-00/201)

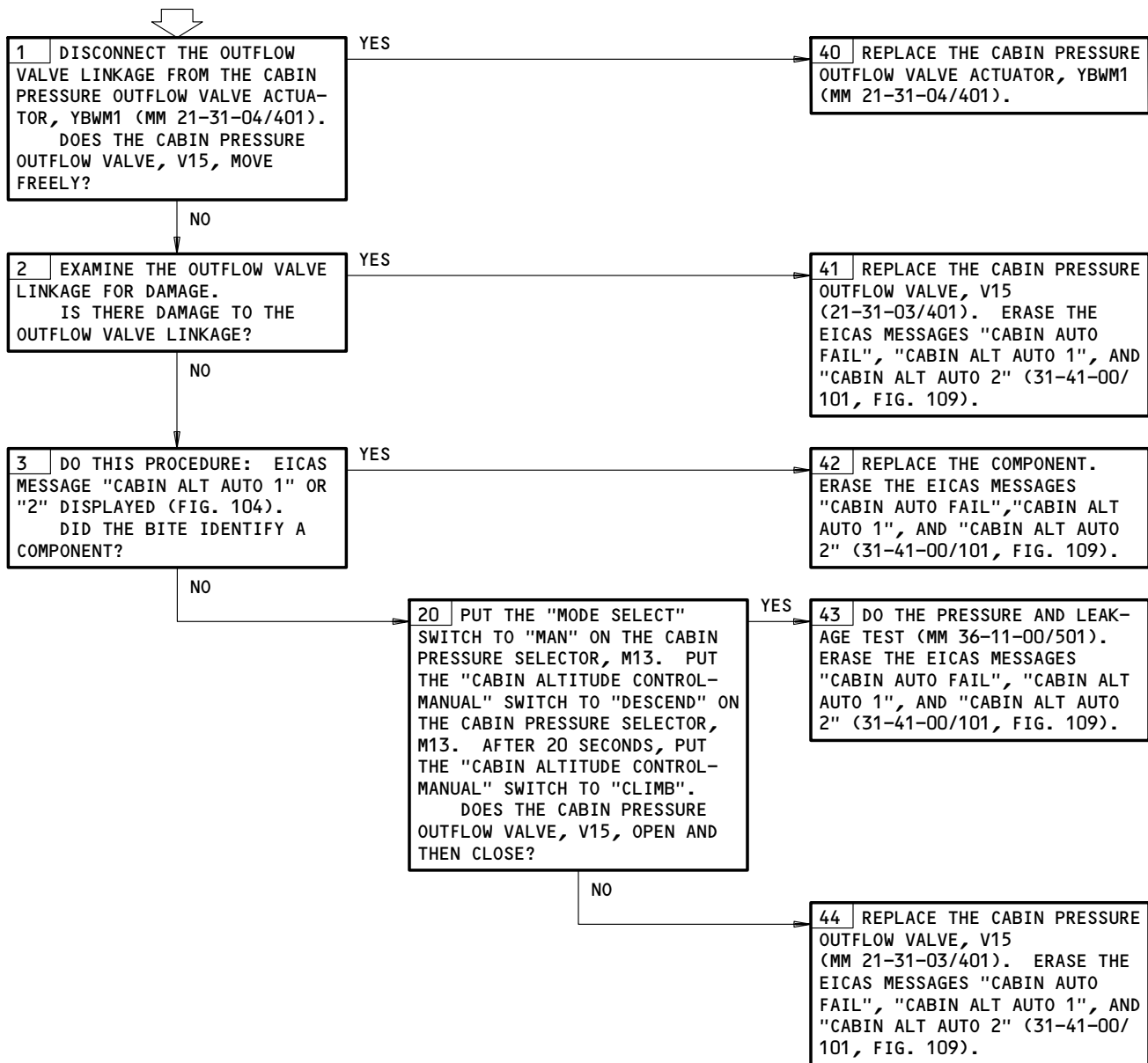

Both CABIN ALT AUTO EICAS Messages Illum, CABIN AUTO INOP EICAS Message and AUTO INOP Light On In Auto, Manual Mode Not Normal
Figure 108

EFFECTIVITY	ALL
-------------	-----

21-30-00

PREREQUISITES

MAKE SURE THESE CIRCUIT BREAKERS ARE CLOSED:
11B12,11B13,11B14,11B15,11N15,11N24

MAKE SURE THE AIRPLANE IS IN THIS CONFIGURATION:
ELECTRICAL POWER IS ON (AMM 24-22-00/201)

NOTE: IF PNEUMATIC DUCT PRESSURE IS LOW WITH THE ENGINES ON, DO THIS PROCEDURE: "LOW DUCT PRESSURE" PROCEDURE (AMM 36-10-00/101, FIG. 106).

CABIN ALTITUDE INDICATIONS ON IN AUTO. MANUAL OPERATION ABNORMAL

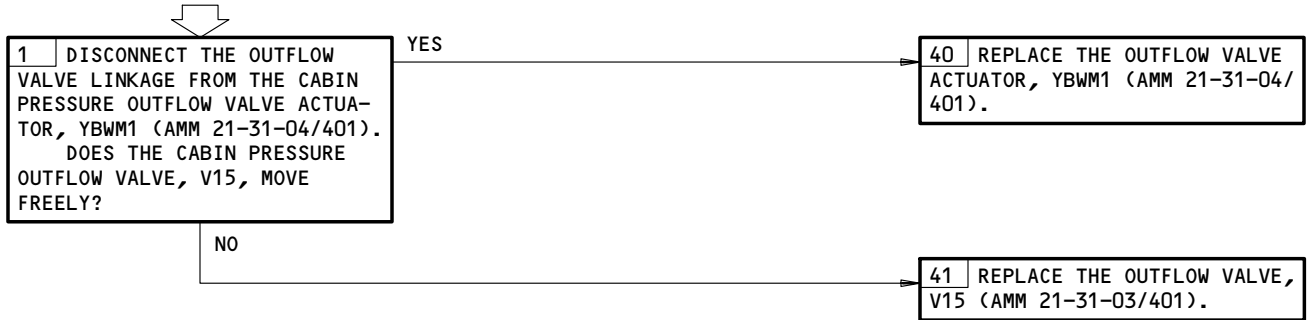

Cabin Altitude Indications On in Auto. Manual Operation Abnormal
Figure 109

EFFECTIVITY	ALL
-------------	-----

21-30-00

CABIN DIFFERENTIAL
PRESSURE INDICATOR
INACCURATE/
FLUCTUATES

PREREQUISITES

MAKE SURE THESE CIRCUIT BREAKERS ARE CLOSED:
11B12,11B13

MAKE SURE THE AIRPLANE IS IN THIS CONFIGURATION:
ELECTRICAL POWER IS ON (AMM 24-22-00/201)



1. REPLACE THE DIFFERENTIAL PRESSURE SENSOR, TS5072 (AMM 21-33-04/401) . IF THE PROBLEM CONTINUES, REPLACE THE CABIN PRESSURIZATION AND WARNING MODULE, M19 (AMM 21-33-01/401) . IF THE PROBLEM CONTINUES, DO THIS PROCEDURE: STATIC SYSTEM PROBLEM (FIM 34-11-00/101, FIG. 103).

THE DIFFERENTIAL PRESSURE SENSOR AND THE PRESSURIZATION INDICATION AND WARNING MODULE OPERATE TOGETHER AS A SET. AN INCORRECT COMBINATION WILL CAUSE AN INCORRECT INDICATION. MAKE SURE THE IPC HAS THE CORRECT PART NUMBER EFFECTIVITY FOR EACH OF THE COMPONENTS.

Cabin Differential Pressure Indicator Inaccurate/Fluctuates
Figure 110

EFFECTIVITY	ALL
-------------	-----

21-30-00



757
FAULT ISOLATION/MAINT MANUAL

OUTFLOW VALVE DID
NOT BEGIN TO CLOSE
AT LIFTOFF

PREREQUISITES
NONE



1 REPLACE THE VALVE POSITION INDICATOR ON THE CABIN PRESSURE SELECTOR, M13 (AMM 21-31-01/401). IF THE PROBLEM CONTINUES, REPLACE THE CABIN PRESSURE OUTFLOW VALVE, V15 (AMM 21-31-03/401).

Outflow Valve Did Not Begin To Close At Liftoff
Figure 111

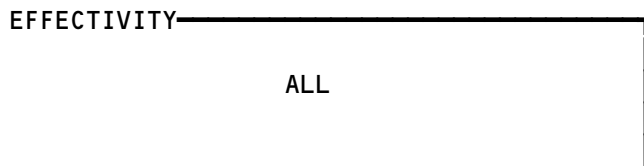

21-30-00

01

Page 119
Sep 28/05

70276

HIGH ALT SW SELECTED "ON". CABIN DIFF PRESS GAUGE WAS NOT ZERO WHEN LANDING AT HIGH ALTITUDE FIELD.

PREREQUISITES

MAKE SURE THIS SYSTEM WILL OPERATE:
EICAS (MM 31-41-00/201)

MAKE SURE THESE CIRCUIT BREAKERS ARE CLOSED:
11B15,11N15,11N24

MAKE SURE THE AIRPLANE IS IN THE CONFIGURATION THAT FOLLOWS:
ELECTRICAL POWER IS ON (MM 24-22-00/201)

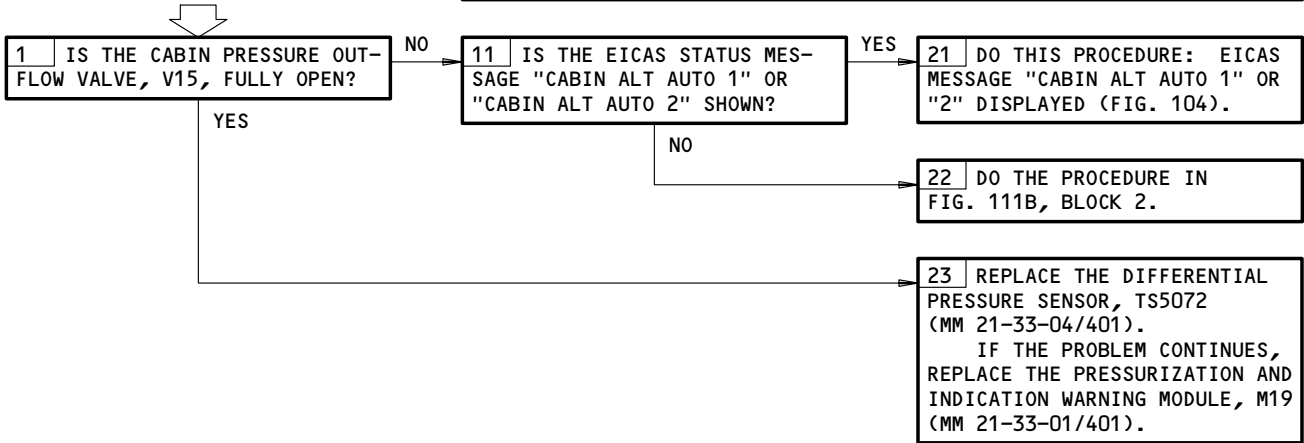

High Alt Sw Selected ON. Cabin Diff Press Gauge Was Not Zero When Landing at High Altitude Field.
Figure 111A

EFFECTIVITY
GUI 004, 006

21-30-00

HIGH ALT LDG SW
SELECTED "ON". HIGH
ALT LDG INOP LIGHT
EXTIN. CABIN ALT DID
NOT CLIMB TO SELECTED
ALTITUDE.

PREREQUISITES

MAKE SURE THIS SYSTEM WILL OPERATE:
EICAS (AMM 31-41-00/201)

MAKE SURE THESE CIRCUIT BREAKERS ARE CLOSED:
11B12,11B13,11B14,11B15,11N15,11N24

MAKE SURE THE AIRPLANE IS IN THIS CONFIGURATION:
ELECTRICAL POWER IS ON (AMM 24-22-00/201)

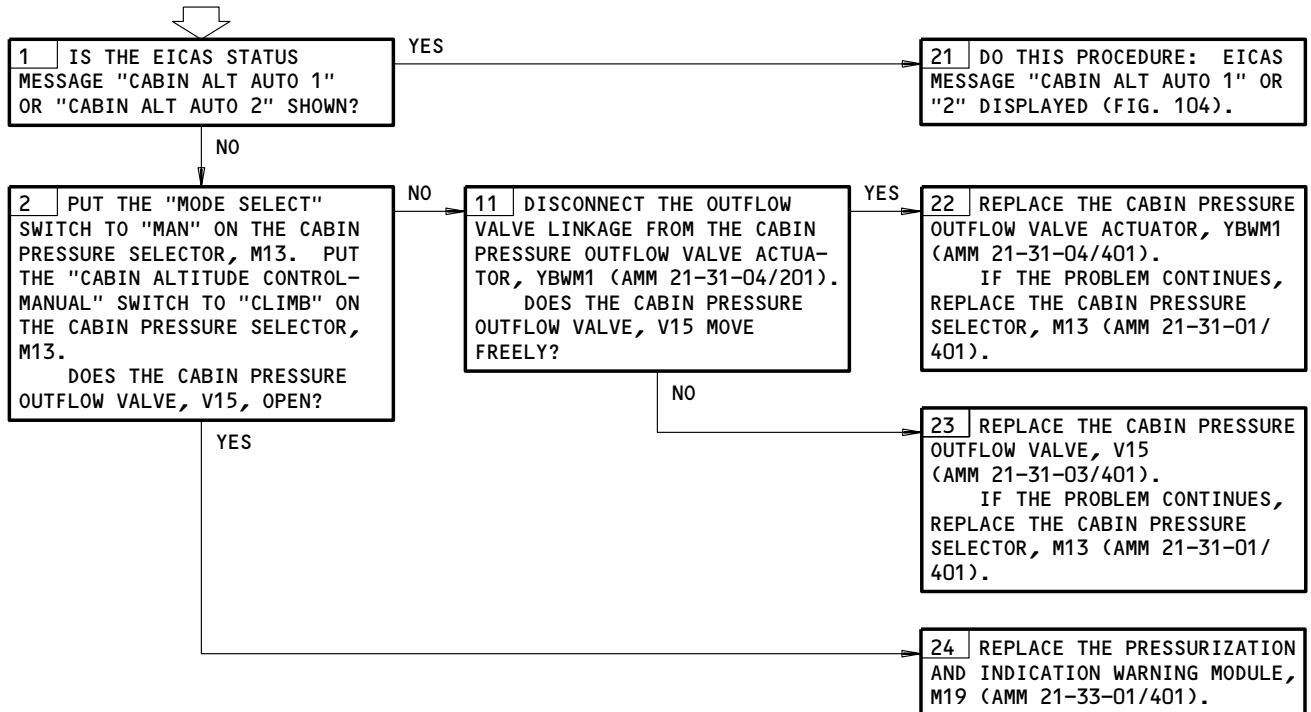

High Alt Ldg Sw Selected ON. High Alt Ldg Inop Light Extin.
Cabin Alt Did Not Climb To Selected Altitude.
Figure 111B

EFFECTIVITY
GUI 004, 006

21-30-00

HIGH ALTITUDE
 LANDING SWITCH
 SELECTED "ON".
 HIGH ALTITUDE
 LANDING "INOP"
 LIGHT ILLUMINATED.

PREREQUISITES

MAKE SURE THIS CIRCUIT BREAKER IS CLOSED:
 11B15
 MAKE SURE THE AIRPLANE IS IN THE CONFIGURATION THAT
 FOLLOWS:
 ELECTRICAL POWER IS ON (MM 24-22-00/201)
 "HIGH ALT LDG" SWITCH IS SET TO "ON" AT THE HIGH
 ALTITUDE WARNING MODULE, M10756, ON THE P5 PANEL

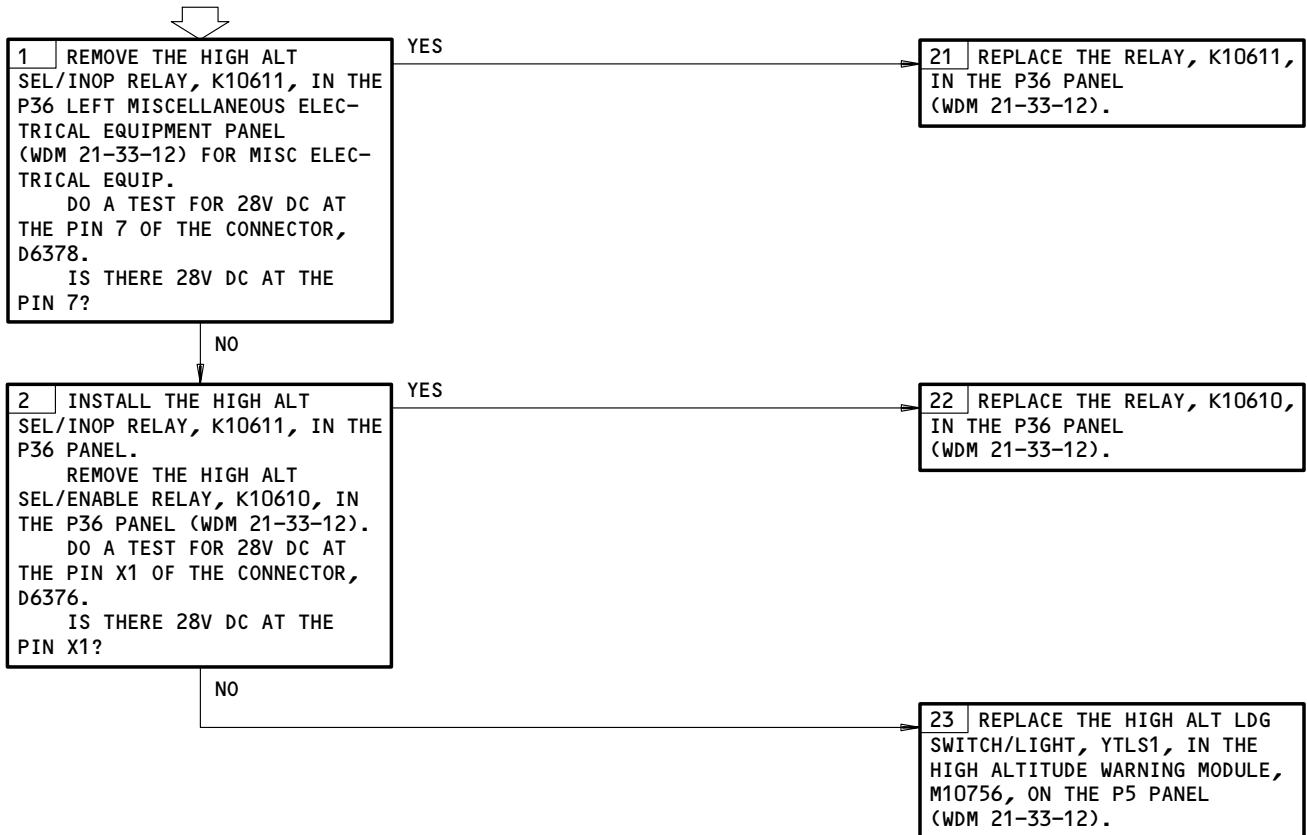

High Altitude Landing Switch Selected ON. High Altitude
 Landing INOP Light Illuminated.
 Figure 111C

EFFECTIVITY
 GUI 004, 006

21-30-00

 **BOEING**
757
FAULT ISOLATION/MAINT MANUAL

HEATING

COMPONENT	FIG. 102 SHT	QTY	ACCESS/AREA	AMM REFERENCE
CIRCUIT BREAKER -			FLT COMPT, P11	
CARGO HEATER AFT, C4071		1	11N18	*
CARGO HEATER FAN FWD, C4059		1	11N17	*
FAN CONT AFT CARGO, C4072		1	11N22	*
CIRCUIT BREAKER -			119BL, MAIN EQUIP CTR, P37	
AFT CARGO FAN, C3010		1	37C2	*
HEATERS F/O AUX HI, C699		1	37F4	*
HEATERS F/O AUX LO, C700		1	37F3	*
CIRCUIT BREAKER -			P70	
AFT CARGO HTR, C3009		1	70C8	*
CAPT AUX HTR HI, C662		1	70A6	*
CAPT AUX HTR LO, C663		1	70A5	*
FWD CARGO FAN, C3002		1	70B8	*
FAN - AFT CARGO HEATING FLOW		1	822, AFT CARGO COMPT	21-44-06
FAN - FWD CARGO HEATING FLOW		1	821, FWD CARGO COMPT	21-43-04
FILTER - AFT CARGO HEAT INLET GRILL		2	822, AFT CARGO COMPT	21-44-06
FILTER - FWD CARGO HEAT INLET GRILL		2	821, FWD CARGO COMPT	21-43-04
HEATER - AFT CARGO		1	822, AFT CARGO COMPT	21-44-05
HEATER - FOOT ELECTRIC SURFACE		4	FLT COMPT	21-45-01
HEATER - SHOULDER AIR SUPPLY		2	FLT COMPT	21-45-02
MODULE - APU/CARGO FIRE CONTROL, M10444		1	FLT COMPT, P8	*
RELAY - (FIM 21-40-00/101				
AFT CARGO FAN CURRENT SENSE, K10598	1	1	119BL, MAIN EQUIP CTR, P37	
FWD CARGO FAN CURRENT SENSE, K10597	1	1	119BL, MAIN EQUIP CTR, P70	
RELAY - (FIM 31-01-36/101)				
AIR/GND SYS 1, K145				
RELAY - (FIM 31-01-37/101)				
AFT CARGO FAN, K10084				
AIR/GND SYS 2, K205				
ON DROP OUT T/D, K10164				
RELAY - (FIM 31-01-70/101)				
AFT CARGO HTR, K10083				
FWD CARGO FAN, K10057				
SENSOR - (FIM 21-40-00/101				
AFT CARGO FAN CURRENT, TS5044	2	1	119BL, MAIN EQUIP CTR, P37	21-44-09
FWD CARGO FAN CURRENT, TS5018	2	1	119BL, MAIN EQUIP CTR, P70	21-43-07
SWITCH - AFT CARGO TEMPERATURE THERMAL		1	822, AFT CARGO COMPT	21-44-07
SWITCH - FWD CARGO TEMPERATURE THERMAL		1	821, FWD CARGO COMPT	21-43-05
SWITCH/LIGHT - AFT CARGO, YQPS2		1	FLT COMPT, P8, APU/CARGO FIRE M10444	*
SWITCH/LIGHT - FWD CARGO, YQPS1		1	FLT COMPT, P8, APU/CARGO FIRE M10444	*

* SEE THE WDM EQUIPMENT LIST

- 1 NOT ON ALL AIRPLANES - ALTERNATE TO CARGO FAN CURRENT SENSOR
- 2 NOT ON ALL AIRPLANES - ALTERNATE TO CARGO FAN CURRENT SENSE RELAY

Heating - Component Index
Figure 101

EFFECTIVITY

ALL

21-40-00

BOEING
757
FAULT ISOLATION/MAINT MANUAL

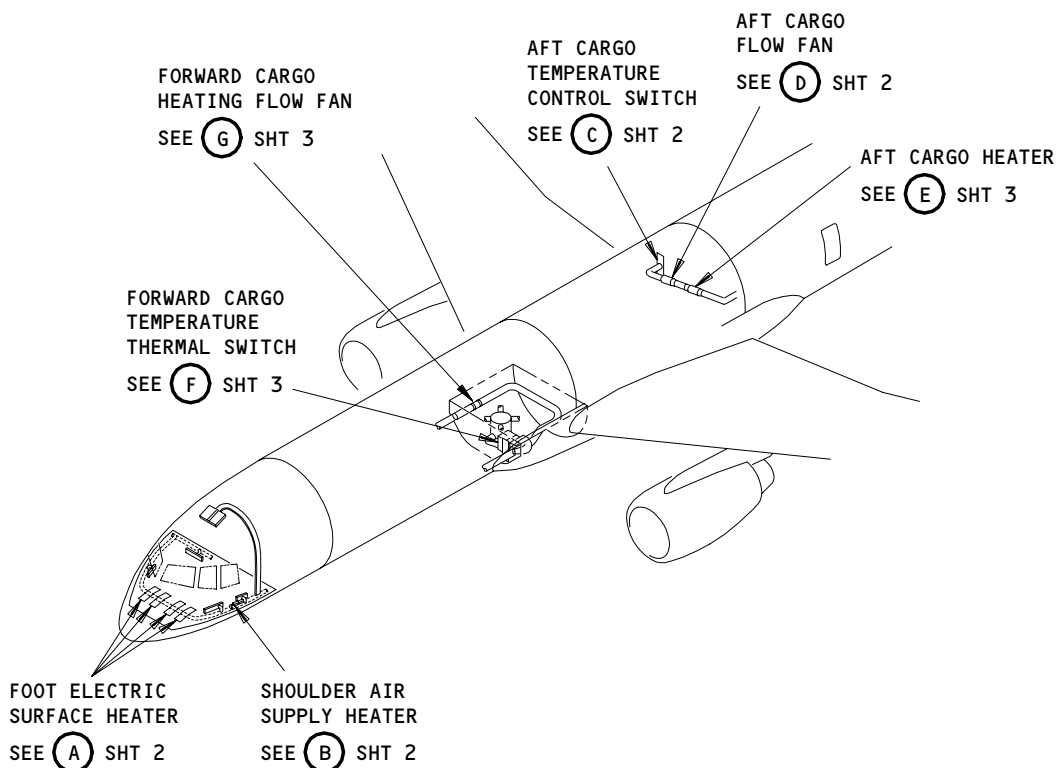
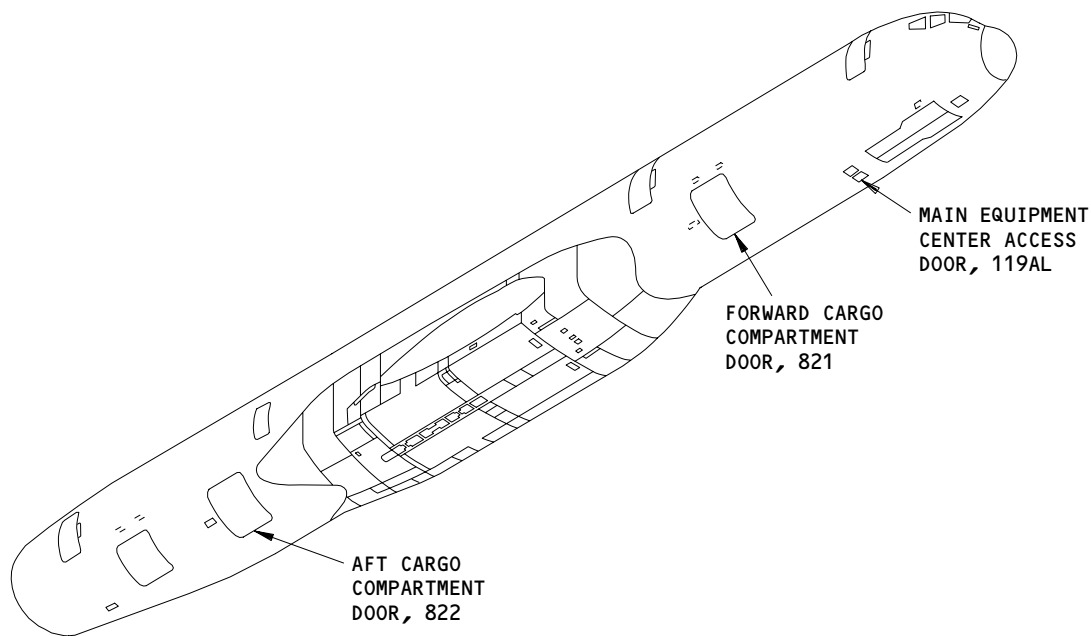

Heating - Component Location
Figure 102 (Sheet 1)

EFFECTIVITY	ALL
-------------	-----

21-40-00

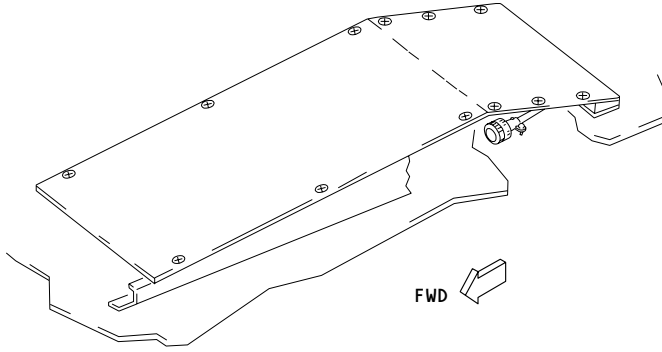

FOOT ELECTRIC SURFACE HEATER

(A)

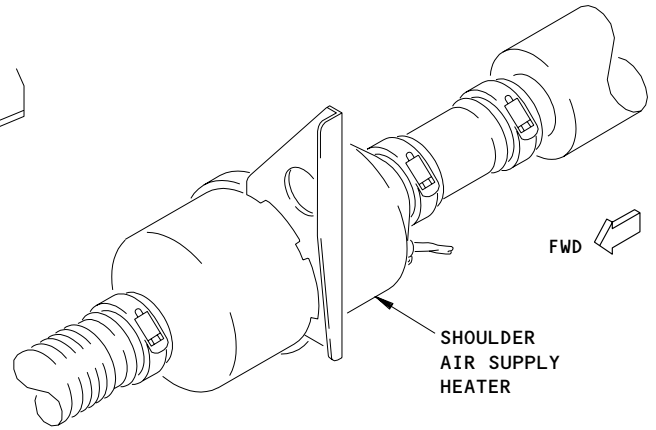

SHOULDER AIR SUPPLY HEATER

(B)

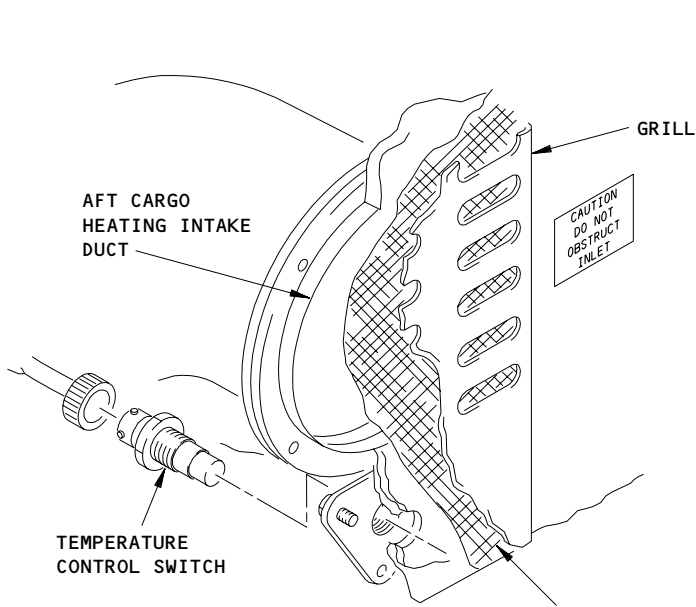

AFT CARGO TEMPERATURE CONTROL SWITCH

(C)

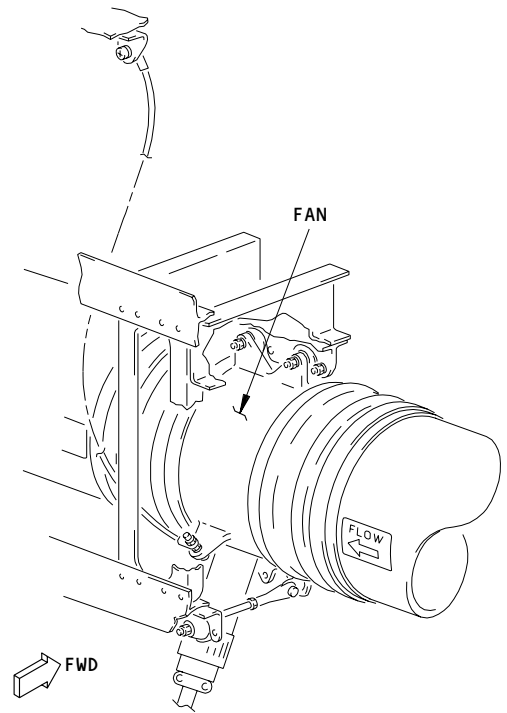

AFT CARGO FLOW FAN

(D)

Heating - Component Location (Details from Sht 1)
Figure 102 (Sheet 2)

EFFECTIVITY	ALL
-------------	-----

21-40-00

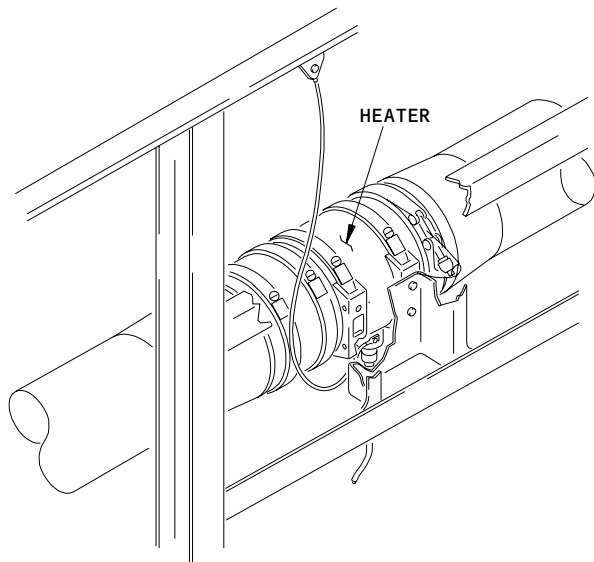

AFT CARGO HEATER

(E)

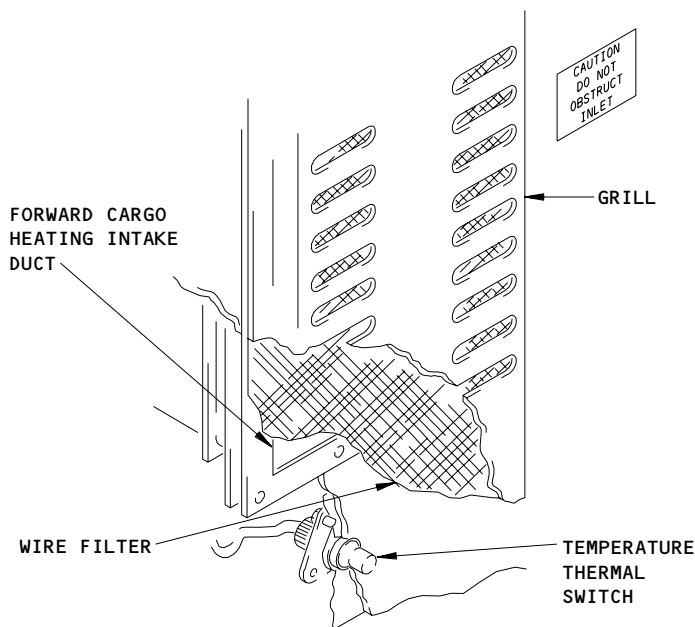

FORWARD CARGO TEMPERATURE THERMAL SWITCH

(F)

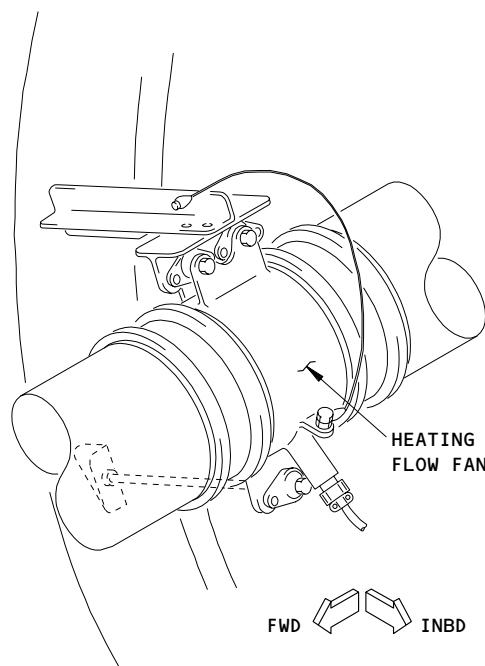

FORWARD CARGO HEATING FLOW FAN

(G)

Heating - Component Location (Details from Sht 1)
Figure 102 (Sheet 3)

EFFECTIVITY	ALL
-------------	-----

21-40-00

Not Used
Figure 103

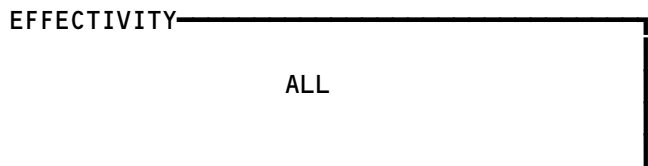

21-40-00

01

Page 105
Sep 20/95

264475

EICAS MSG "FWD (AFT)
CARGO FAN" DISPLAYED



PREREQUISITES

MAKE SURE THIS SYSTEM WILL OPERATE:
EICAS (AMM 31-41-00/201)

MAKE SURE THESE CIRCUIT BREAKERS ARE CLOSED:
11N17,70B8 (11N22,37C2)

MAKE SURE THE AIRPLANE IS IN THIS CONFIGURATION:
ELECTRICAL POWER IS ON (AMM 24-22-00/201)

DESCRIPTION:

THE FORWARD (AFT) CARGO HEAT FAN OVERHEATED, OR THERE IS A PROBLEM WITH THE CIRCUIT.

POSSIBLE CAUSES:

1. FWD (AFT) CARGO HEAT FAN, B10003 (B10030)
2. THE APPLICABLE CARGO FAN RELAY IS FAILED:
 - FWD RELAY, K10057 (WDM 21-43-11)
 - AFT RELAY, K10084 (WDM 21-44-11).
3. THE APPLICABLE CARGO FAN CURRENT SENSE RELAY IS FAILED:
 - FWD RELAY, K10597 (WDM 21-43-11)
 - AFT RELAY, K10598 (WDM 21-44-11).
4. THE APPLICABLE CARGO FAN CURRENT SENSOR IS FAILED:
 - FWD CURRENT SENSOR, TS5018 (AMM 21-43-07/401)
 - AFT CURRENT SENSOR, TS5044 (AMM 21-44-09/401).
5. THE AFT CARGO FAN/FAILURE TIME DELAY RELAY IS FAILED:
 - FWD RELAY, K10597 (WDM 21-43-11)
 - AFT RELAY, K10598 (WDM 21-44-11).

FAULT ISOLATION:



BOEING
757
FAULT ISOLATION/MAINT MANUAL

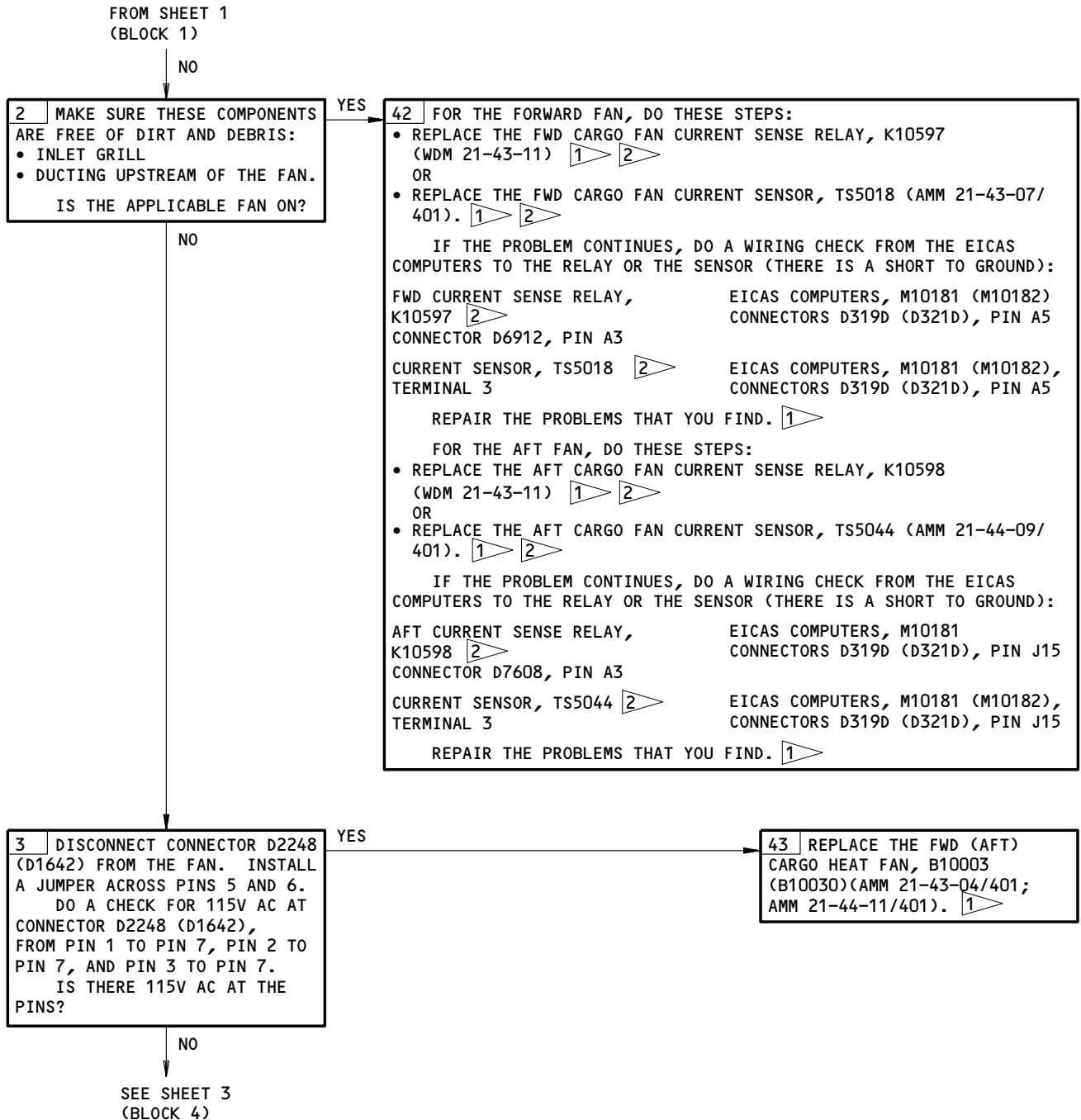

EICAS Msg FWD (AFT) CARGO FAN Displayed
Figure 104 (Sheet 2)

EFFECTIVITY

ALL

21-40-00

05

Page 107
Dec 20/96

BOEING
757
FAULT ISOLATION/MAINT MANUAL

FROM SHEET 2
(BLOCK 3)

NO

4 REPLACE THE FWD (AFT) CARGO FAN RELAY, K10057 (K10084)(WDM 21-43-11; WDM 21-44-11).
DO A CHECK FOR 115V AC AT CONNECTOR D2248 (D1642), FROM PIN 1 (+) TO PIN 7 (-), AND PIN 2 (+) TO PIN 7 (-), AND PIN 3 (+) TO PIN 7 (-) AGAIN.
IS THERE 115V AC AT THE PINS?

YES

44 YOU FIXED THE PROBLEM, THE CARGO FAN RELAY WAS FAILED.
CONNECT CONNECTOR D2248 (D1642), TO THE FAN. **1**

NO

5 FOR THE FORWARD CARGO HEAT FAN, DO THE APPLICABLE STEP:
• REPLACE THE FWD CARGO FAN SENSE RELAY, K10597 (WDM 21-43-11) **2**
OR
• REPLACE THE FWD CARGO FAN CURRENT SENSOR, TS5018 (AMM 21-43-07/401). **2**
FOR THE AFT CARGO HEAT FAN, DO THE APPLICABLE STEP:
• REPLACE THE AFT CARGO FAN SENSE RELAY, K10598 (WDM 21-43-11) **2**
OR
• REPLACE THE FWD CARGO FAN CURRENT SENSOR, TS5044 (AMM 21-43-07/401). **2**
DO A CHECK FOR 115V AC AT CONNECTOR D2248 (D1642), FROM PIN 1 (+) TO PIN 7 (-), AND PIN 2 (+) TO PIN 7 (-), AND PIN 3 (+) TO PIN 7 (-) AGAIN.
IS THERE 115V AC AT THE PINS?

YES

45 YOU FIXED THE PROBLEM, THE RELAY OR THE SENSOR WAS FAILED.
CONNECT CONNECTOR D2248 (D1642), TO THE FAN. **1**

NO

SEE SHEET 4
(BLOCK 6)

EICAS Msg FWD (AFT) CARGO FAN Displayed
Figure 104 (Sheet 3)

EFFECTIVITY

ALL

21-40-00

05

Page 108
Dec 20/96

G21620

BOEING
757
FAULT ISOLATION/MAINT MANUAL

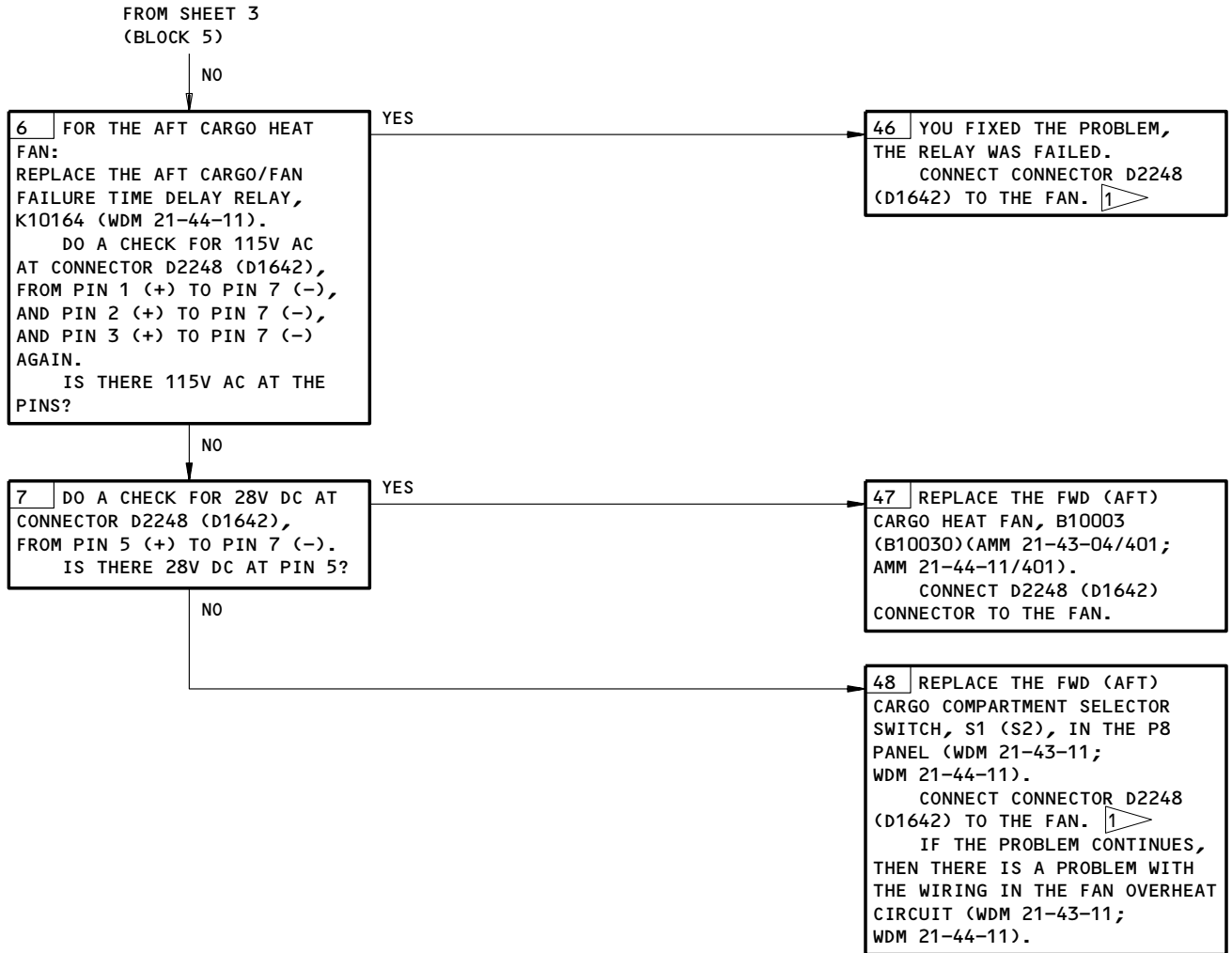

- 1 **CAUTION:** MAKE A RECORD OF ALL THE EICAS MESSAGES ON ALL THE ECS/MSG MAINTENANCE PAGES BEFORE YOU ERASE THE "FWD (AFT) CARGO FAN" MESSAGE. IF YOU DO NOT MAKE A RECORD OF THE EICAS MESSAGES, YOU WILL LOSE THE DATA.
- DO THIS PROCEDURE: EICAS STATUS/MAINTENANCE MESSAGE ERASE PROCEDURE (FIM 31-41-00/101, FIG. 109).
- 2 NOT INSTALLED IN ALL AIRPLANES

EICAS Msg FWD (AFT) CARGO FAN Displayed
Figure 104 (Sheet 4)

EFFECTIVITY	ALL
-------------	-----

21-40-00

SHOULDER HTR INOP
IN LOW AND HI

PREREQUISITES

MAKE SURE THESE CIRCUIT BREAKERS ARE CLOSED:
37F3, 37F4, 70A5, 70A6

MAKE SURE THE AIRPLANE IS IN THIS CONFIGURATION:
ELECTRICAL POWER IS ON (AMM 24-22-00/201)

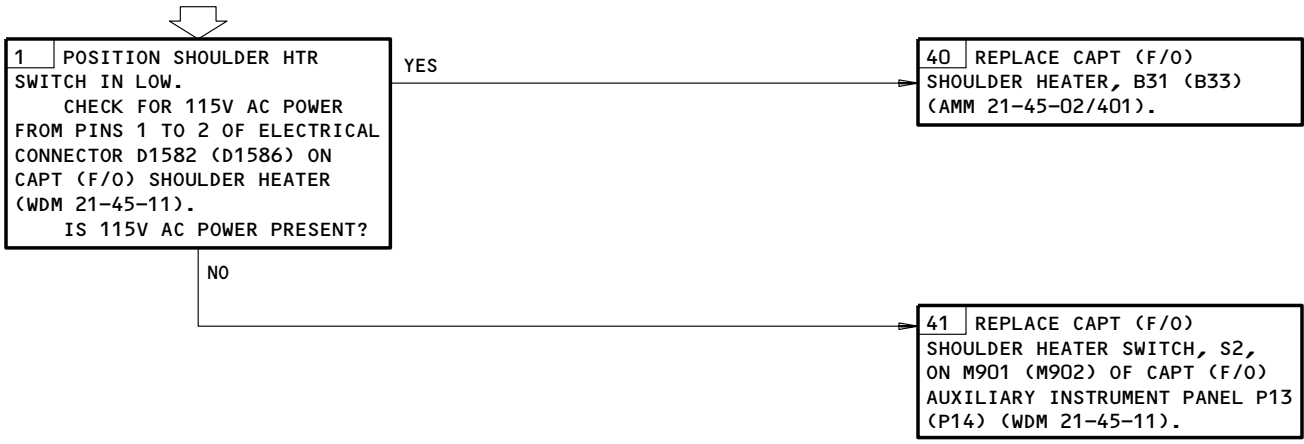

Shoulder Heater Inop in Low and Hi
Figure 105

EFFECTIVITY	ALL
-------------	-----

21-40-00

E50247

**FOOT AND SHOULDER
HEATERS INOP IN LOW
AND HI**

PREREQUISITES

MAKE SURE THESE SYSTEMS WILL OPERATE:
SIMULATE SYSTEM NO. 1 (NO. 2) AIR/GROUND RELAYS
IN FLIGHT MODE (AMM 32-09-02/201)

MAKE SURE THESE CIRCUIT BREAKERS ARE CLOSED:
37F3, 37F4, 70A5, 70A6

MAKE SURE THE AIRPLANE IS IN THIS CONFIGURATION:
ELECTRICAL POWER IS ON (AMM 24-22-00/201)

1 CHECK FOR 115V AC POWER AT
PINS 1 AND 2 OF EACH HEATER
CONNECTOR D1580, D1582, D2720,
D1584, D1586, D2722.
IS 115V AC POWER PRESENT
AT ALL HEATERS?

NO

40 REPLACE FOOT AND SHOULDER
HEATER SWITCHES, S1 AND S2, ON
MODULE M901 (M902) OF P13
(P14) PANEL.

YES

41 REPLACE CAPT (F/O)
SHOULDER HEATER, B31, (B33)
(AMM 21-45-02/401) AND BOTH
CAPT (F/O) FOOT HEATERS,
B10044, B10045 (B10046, B10047)
(AMM 21-45-01/401).

Foot and Shoulder Heaters Inop in Low and Hi
Figure 106

EFFECTIVITY

ALL

21-40-00

01

Page 111
Sep 20/94

 **BOEING**
757
FAULT ISOLATION/MAINT MANUAL

COOLING PACK

COMPONENT	QTY	ACCESS/AREA	REFERENCE
CARD - FLOW CONTROL	2	119BL, MAIN EQUIP CTR, P50	21-51-09
CIRCUIT BREAKERS	1	FLT COMPT, P11	
CONT - AIR COND PACK LEFT STBY, C4037	1	11A26	*
CONT - AIR COND PACK LEFT AUTO, C702	1	11A13	*
CONT - AIR COND PACK LEFT FLOW, C653	1	11A14	*
CONT - AIR COND PACK RIGHT AUTO, C703	1	11A28	*
CONT - AIR COND PACK RIGHT FLOW, C704	1	11A29	*
CONT - AIR COND PACK RIGHT STBY, C4039	1	11A15	*
PWR - LEFT PACK AUTO, C673	1	11M11	*
PWR - LEFT PACK STANDBY, C4036	1	11M24	*
PWR - RIGHT PACK AUTO, C674	1	11M19	*
PWR - RIGHT PACK STANDBY, C4038	1	11M15	*
CONDENSER	2	193HL, 194ER	21-51-10
CONTROLLER - PACK STANDBY	1	119BL, MAIN EQUIP CTR, E3	21-51-14
CONTROLLER - PACK TEMPERATURE	2	119BL, MAIN EQUIP CTR, E3	21-51-14
EXCHANGER - HEAT	4	193HL, 194ER	21-51-02
EXTRACTOR - WATER	2	193HL, 194ER	21-51-04
FAN/AIR PLENUM/DIFFUSER	2	193HL, 194ER	21-51-16
MACHINE - AIR CYCLE	2	193HL, 194ER	21-51-03
REHEATER - PACK	2	193HL, 194ER	21-51-07
RELAYS - (REF 31-01-36, FIG. 101)			
L PACK AUTO/MAN 3, K10315	1		*
L PACK AUTO/MAN 2, K58	1		*
L PACK AUTO/MAN 1, K57	1		*
L PACK EXIT DOOR OPEN MAN, K59	1		*
L PACK EXIT DOOR CLOSE MAN, K60	1		*
L PACK INLET DOOR OPEN MAN, K61	1		*
L PACK INLET DOOR CLOSE MAN, K62	1		*
L PACK TEMP CONT VALVE OPEN MAN, K63	1		*
L PACK TEMP CONT VALVE OPEN MAN, K64	1		*
L PACK LOW LIMIT VALVE, K10317	1		*
RELAYS - (REF 31-01-37, FIG. 101)			
R PACK AUTO/MAN 3, K10316	1		*
R PACK AUTO/MAN 2, K50	1		*
R PACK AUTO/MAN 1, K49	1		*
R PACK EXIT DOOR OPEN MAN, K51	1		*
R PACK EXIT DOOR CLOSE MAN, K52	1		*
R PACK INLET DOOR OPEN MAN, K53	1		*
R PACK INLET DOOR CLOSE MAN, K54	1		*
R PACK TEMP CONT VALVE OPEN MAN, K55	1		*
R PACK TEMP CONT VALVE CLOSE MAN, K56	1		*
R PACK LOW LIMIT VALVE, K10318	1		*
SENSOR - COMPRESSOR OUTLET	2	193HL, 194ER	25-51-06
SENSOR - PACK TEMPERATURE	2	193HL, 194ER	21-51-08
SWITCH - ALTITUDE	1	193HL	21-51-17
SWITCH - COMPRESSOR OUTLET OVERHEAT	2	193HL, 194ER	21-51-05
SWITCH - PACK OVERHEAT	2	193HL, 194ER	21-51-18
VALVE - CABIN AIR SUPPLY CHECK	2	193HL, 194ER	21-51-15
VALVE - FLOW CONTROL AND SHUTOFF	2	193HL, 194ER	21-51-01
VALVE - PACK LOW LIMIT CONTROL	2	193HL, 194ER	21-51-11
VALVE - PACK TEMPERATURE CONTROL	2	193HL, 194ER	21-51-12

* SEE WM EQUIPMENT LIST

Component Index
Figure 101

EFFECTIVITY

ALL

21-51-00

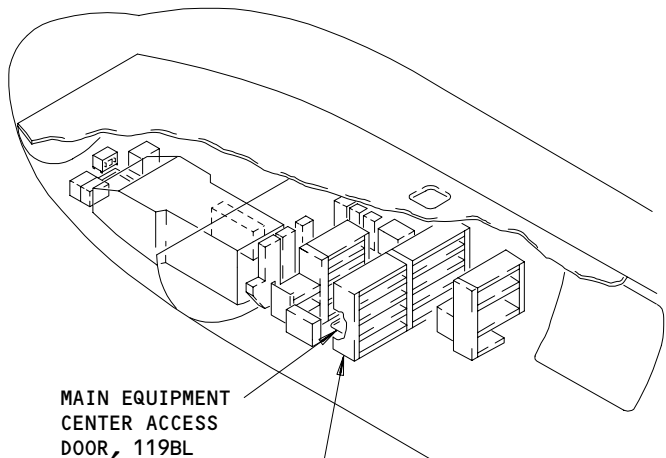

MAIN EQUIPMENT
CENTER ACCESS
DOOR, 119BL

ELECTRONIC
EQUIPMENT
RACK, E3
SEE (A)

PACK STANDBY
TEMPERATURE
CONTROLLER
SEE (B) SHT 2

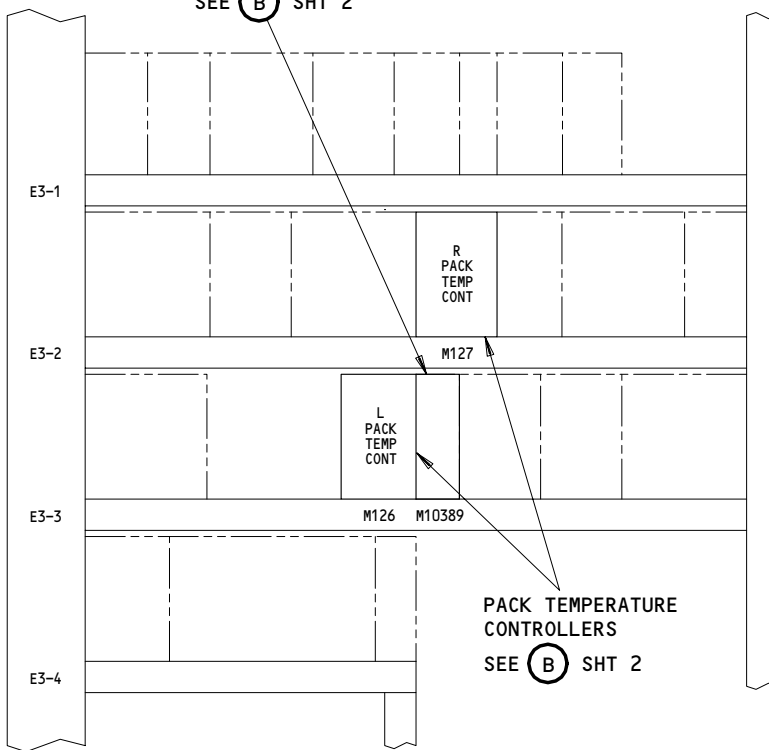

ELECTRONIC EQUIPMENT RACK, E3
(VIEW IN THE AFT DIRECTION)

(A)

Cooling Pack - Component Location
Figure 102 (Sheet 1)

EFFECTIVITY

ALL

21-51-00

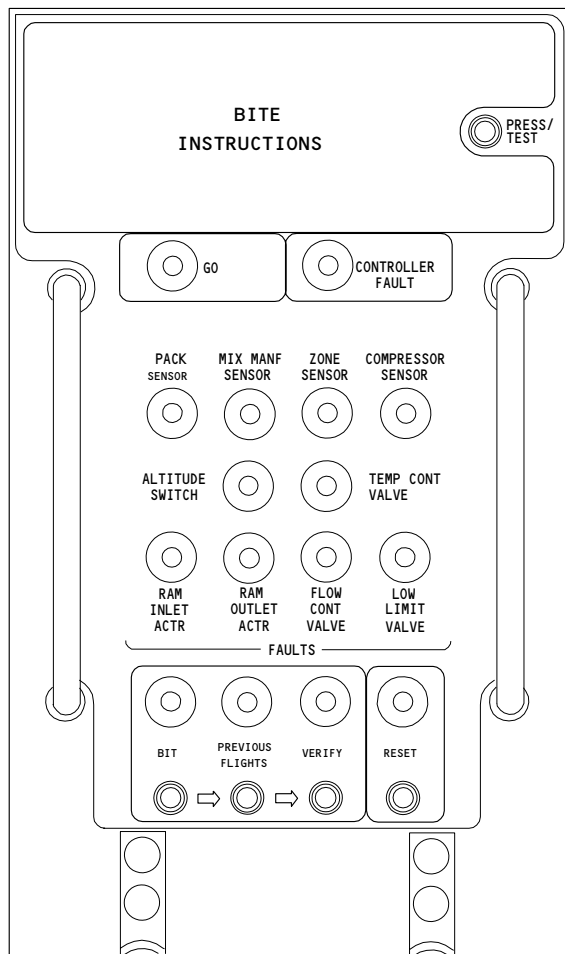

PACK TEMPERATURE CONTROLLER

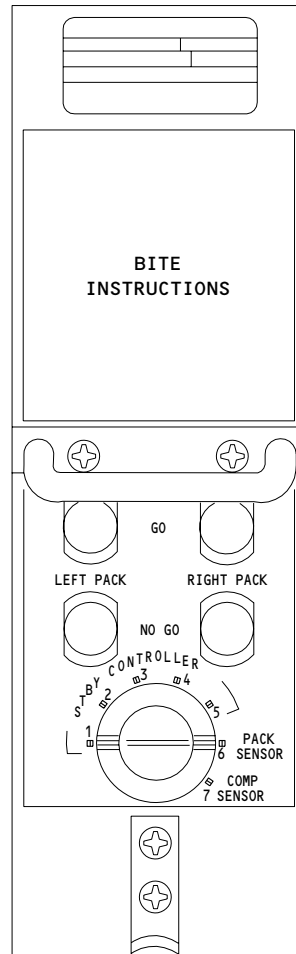

PACK STANDBY TEMPERATURE CONTROLLER

B

Cooling Pack - Component Location
Figure 102 (Sheet 2)

EFFECTIVITY	ALL
-------------	-----

21-51-00

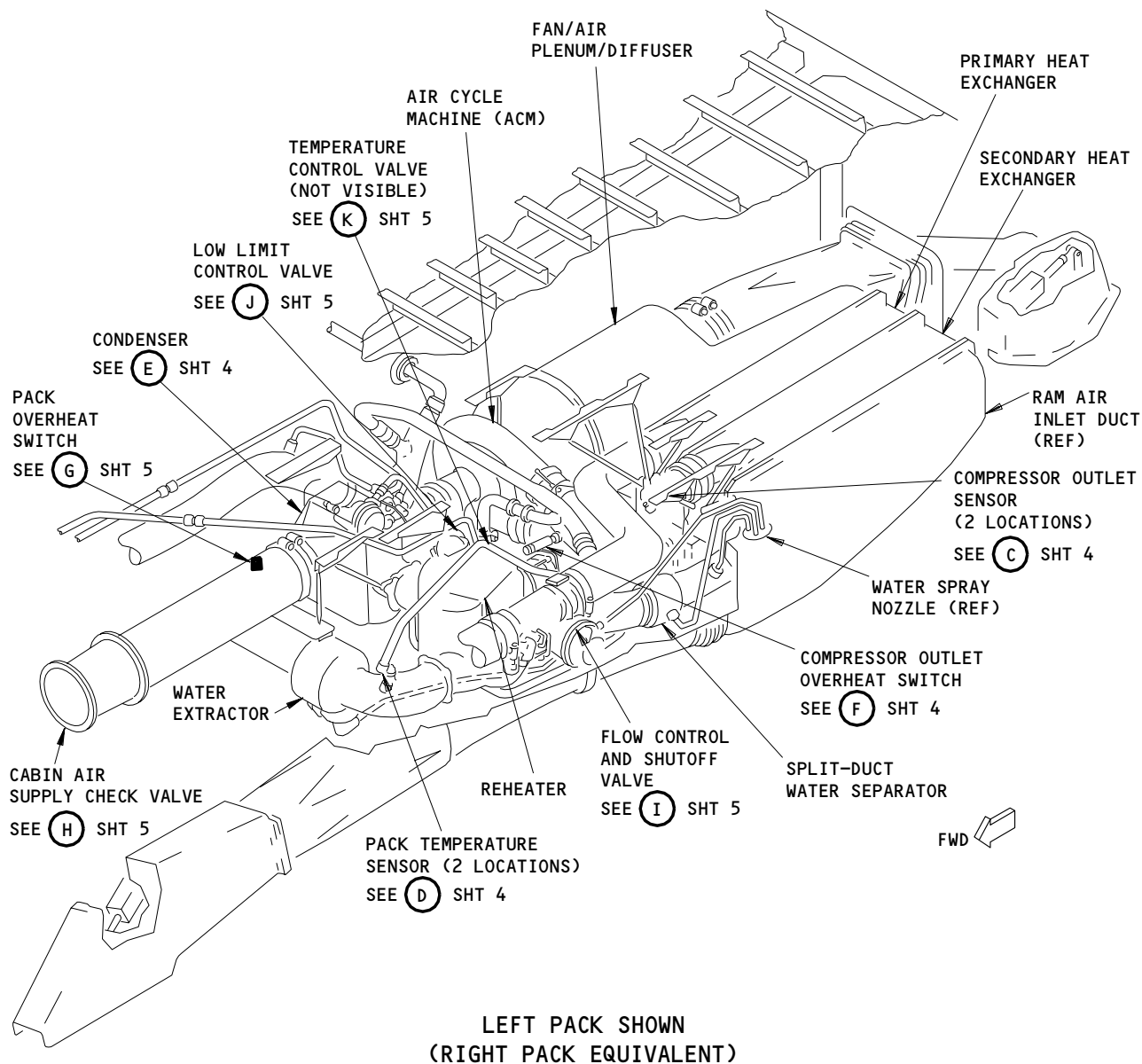

Cooling Pack - Component Location
Figure 102 (Sheet 3)

EFFECTIVITY	
ALL	

21-51-00

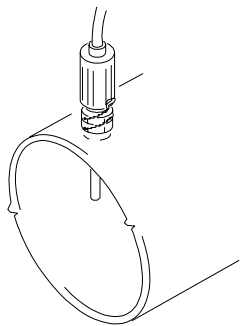

COMPRESSOR OUTLET SENSOR

(C)

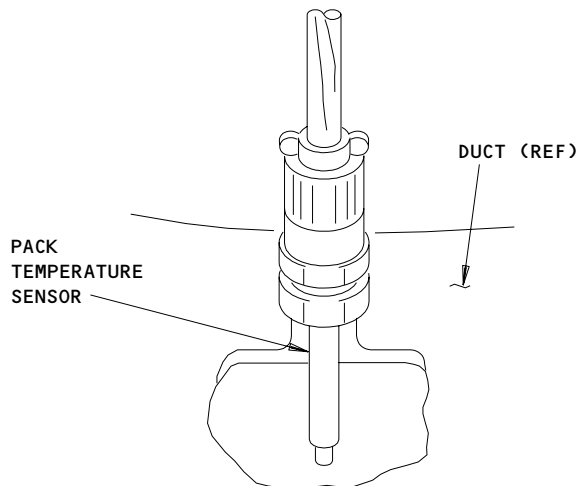

PACK
TEMPERATURE
SENSOR

DUCT (REF)

(D)

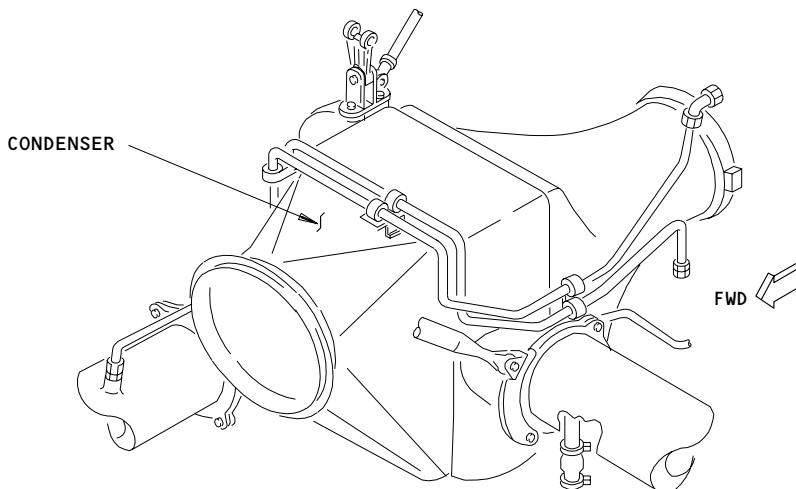

CONDENSER

FWD

(E)

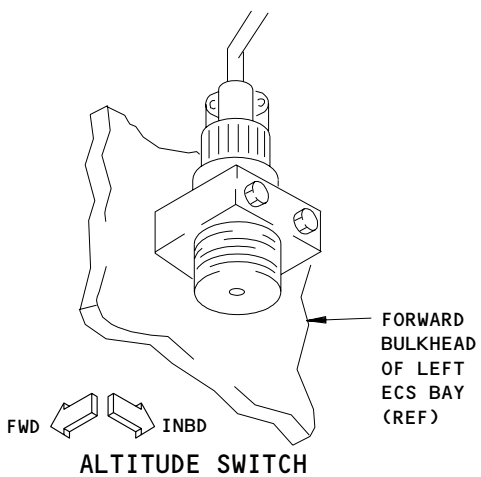

FWD INBD

ALTITUDE SWITCH

FORWARD
BULKHEAD
OF LEFT
ECS BAY
(REF)

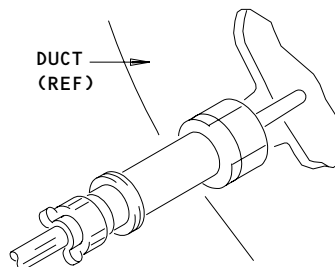

DUCT
(REF)

COMPRESSOR OUTLET OVERHEAT SWITCH

(F)

Cooling pack - Component Location (Details from Sht 3)
Figure 102 (Sheet 4)

EFFECTIVITY

ALL

21-51-00

01

Page 105
Mar 20/94

68257

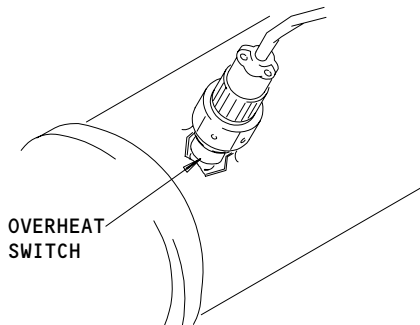

OVERHEAT SWITCH

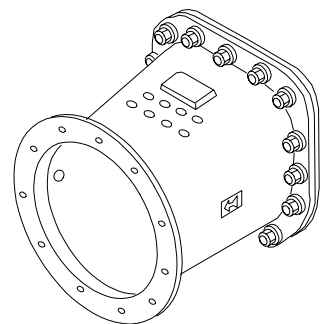

CABIN AIR SUPPLY CHECK VALVE

PACK OVERHEAT SWITCH

(G)

(H)

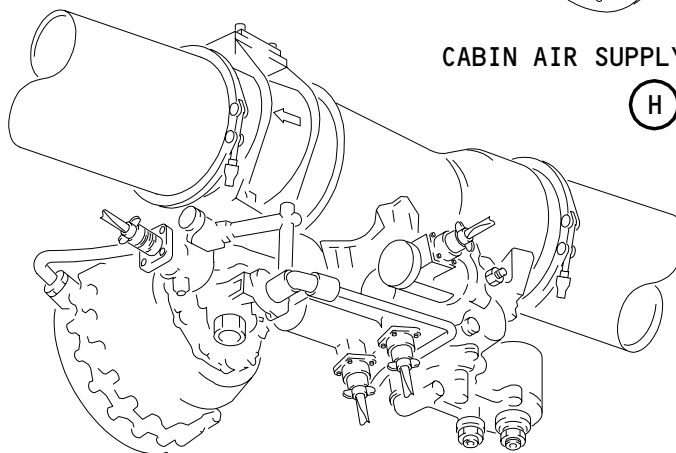

FLOW CONTROL AND SHUTOFF VALVE

(I)

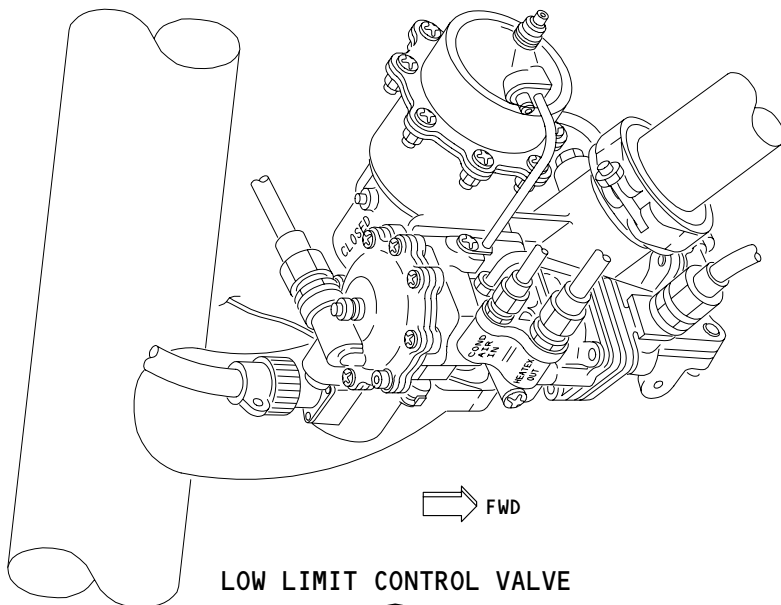

LOW LIMIT CONTROL VALVE

(J)

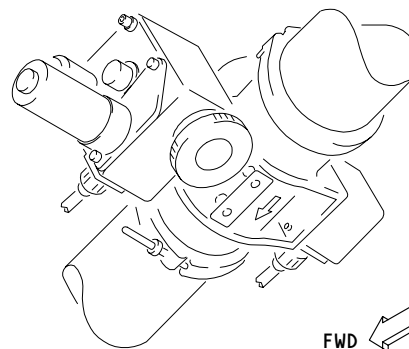

TEMPERATURE CONTROL VALVE

(K)

Cooling Pack - Component Location (Details from Sht 3)
Figure 102 (Sheet 5)

EFFECTIVITY

ALL

21-51-00

01

Page 106
Mar 20/94

68260

COOLING PACK SYSTEM – FAULT ISOLATION

1. General

- A. This procedure has the steps to troubleshoot cooling pack problems.
- B. To do these Fault Isolation procedures, electrical power and EICAS must be available.

2. Fault Isolation Procedures

Fig. 103 – NOT USED

Fig. 104 – PACK TEMPERATURE CONTROLLER BITE PROCEDURE

Fig. 104A – L (R) PACK BITE CONTINUES TO FIND AN ALTITUDE SWITCH FAULT

Fig. 105 – PACK STANDBY CONTROLLER BITE PROCEDURE (GROUND)

Fig. 106 – PACK "INOP" LIGHT ILLUM IN AUTO; COULD NOT RESET

Fig. 107 – "INOP" AND "PACK OFF" LIGHTS ILLUM IN AUTO; COULD NOT RESET.
PACK DID NOT OPERATE NORMAL IN STBY

Fig. 107A – "INOP" AND "PACK OFF" LIGHTS ILLUM IN AUTO, AND AIR CYCLE
MACHINE (ACM) WILL NOT OPERATE WITH ENGINES ON.

Fig. 107B – "INOP" AND "PACK OFF" LIGHTS ILLUM IN AUTO, AND AIR CYCLE
MACHINE (ACM) WILL NOT OPERATE WITH APU ON.

Fig. 108 – "PACK OFF" LIGHT EXTN. & "PACK OFF" EICAS MSG NOT DISPLAYED
WITH PACK SW IN "OFF"

3. Pack Temperature Controller Bite Description (Fig. 104)

A. General

- (1) The purpose of the pack temperature controller (PTC) is to control the pack outlet temperature. The PTC controls the ram air doors, and the temperature control valve to keep the pack out temperature at the desired level. The PTC monitors the pack demand signal from the zone temperature controller and monitors various temperature sensors.
- (2) The PTC BITE test is done on the front of the controller.
- (3) The PTC does a BITE test of these components:
 - (a) Pack Temperature Controller (self test)
 - (b) Pack Temperature Sensor
 - (c) Mix Manifold Temperature Sensor
 - (d) Zone Temperature Sensor
 - (e) Compressor Discharge Temperature Sensor
 - (f) Altitude Switch
 - (g) Temperature Control Valve
 - (h) Ram Inlet Door Actuator
 - (i) Ram Outlet Door Actuator
 - (j) Low Limit Valve

EFFECTIVITY

ALL

21-51-00

01

Page 107
May 28/01

B. Pack Temperature Controller BITE Description:

- (1) Controller Fault:
 - (a) There are two types of pack temperature controller faults, critical and non critical.
 - (b) Critical Faults:
 - 1) Critical faults are internal PTC faults. Critical faults affect the ability of the PTC to control the pack outlet temperature. These faults include power supply problems, A/D converter problems, memory problems, and processor problems.
 - 2) When the PTC has a critical fault, the pack will default to these parameters:
 - a) The temperature control valve will hold its position.
 - b) The ram air doors will hold their positions.
 - c) The flow control valve will move to the normal flow position.
 - d) The low limit valve will close.
 - 3) Critical faults have these flight deck effects:
 - a) The left (right) pack "INOP" light on the P5 overhead panel comes on.
 - b) The L (R) PACK TEMP EICAS Advisory Message shows.
 - c) The L (R) PACK BITE EICAS Maintenance Message will show on the EICAS maintenance page.
 - (c) Non-Critical Faults:
 - 1) Non-critical faults are internal PTC faults. Non-critical faults affect the performance of the pack. These faults include signal conditioner problems and driver circuit faults.
 - 2) If the signal conditioner circuit for the compressor outlet temperature sensor has a problem, the pack will default to these parameters:
 - a) The torque motor driver circuit for the flow control valve is disabled.
 - b) The low limit valve moves to 30% open.
 - 3) Non-critical faults have this flight deck effect:
 - a) The L (R) PACK BITE EICAS Maintenance Message will show on the EICAS maintenance page.
- (2) PACK SENSOR
 - (a) The PTC detects that the input signal from the sensor is out of range (less than 0.15V or more than 1.60V).
 - (b) The L (R) PACK BITE EICAS Maintenance Message will show on the EICAS maintenance page.
- (3) MIX MANF SENSOR
 - (a) The PTC detects that the input signal from the sensor is out of range (less than 0.15V or more than 1.60V).
 - (b) The L (R) PACK BITE EICAS Maintenance Message will show on the EICAS maintenance page.
- (4) ZONE SENSOR
 - (a) The PTC detects that the input signal from the sensor is out of range (less than 0.67V or more than 3.51V).

EFFECTIVITY

ALL

21-51-00

01

Page 108
Jan 28/00

- (b) The L (R) PACK BITE EICAS Maintenance Message will show on the EICAS maintenance page.
- (5) COMPRESSOR SENSOR
 - (a) The PTC detects that the input signal from the sensor is out of range (less than 1.63V or more than 3.38V).
 - (b) The L (R) PACK BITE EICAS Maintenance Message will show on the EICAS maintenance page.
- (6) ALTITUDE SWITCH
 - (a) The PTC can detect two different altitude switch faults.
 - 1) The PTC detects an open circuit in both of the switch contacts in the altitude switch.
 - 2) The PTC compares the weight on wheels switch to the low altituded switch contact. If the altitude switch indicates high altitude and there is weight on wheels, then the fault is set.
 - (b) The L (R) PACK BITE EICAS Maintenance Message will show on the EICAS maintenance page.
- (7) TEMP CONTROL VALVE
 - (a) The PTC can detect three different temperature control valve faults.
 - 1) The PTC detects an open circuit in the potentiometer for the valve.
 - 2) The PTC detects an open circuit in both limit switches.

NOTE: In normal operation, one of the limit switches is always closed.
 - 3) The valve position does not follow the command.

NOTE: The position test is only done when the BIT VERIFY switch on the PTC is pushed.
 - (b) The L (R) PACK BITE EICAS Maintenance Message will show on the EICAS maintenance page.
- (8) RAM INLET ACTR
 - (a) The PTC can detect three different ram air inlet door actuator faults.
 - 1) The PTC detects an open circuit in the potentiometer for the actuator.
 - 2) The PTC detects an open circuit in both limit switches.

NOTE: In normal operation, one of the limit switches is always closed.
 - 3) The actuator position does not follow the command.

NOTE: The position test is only done when the BIT VERIFY switch on the PTC is pushed.
 - (b) The L (R) PACK BITE EICAS Maintenance Message will show on the EICAS maintenance page.

EFFECTIVITY

ALL

21-51-00

01

Page 109
May 28/99

- (9) RAM OUTLET ACTR
- (a) The PTC can detect three different ram air outlet door actuator faults.
 - 1) The PTC detects an open circuit in the potentiometer for the actuator.
 - 2) The PTC detects an open circuit in both limit switches.

NOTE: In normal operation, one of the limit switches is always closed.

 - 3) The actuator position does not follow the command.
- NOTE: The position test is only done when the BIT VERIFY switch on the PCT is pushed.
- (b) The L (R) PACK BITE EICAS Maintenance Message will show on the EICAS maintenance page.
- (10) FLOW CONTROL VALVE
- (a) The PTC detects an open or a short circuit in the flow control valve.
 - (b) The L (R) PACK BITE EICAS Maintenance Message will show on the EICAS maintenance page.
- (11) LOW LIMIT VALVE
- (a) The PTC detects two different low limit valve faults; one without pneumatic power applied and one with pneumatic power applied.
 - 1) With pneumatic power off, the PTC detects an open or a short in the torque motor circuit of the low limit valve when the VERIFY button is pressed.
 - 2) With pneumatic power applied, the PTC performs a dynamic test of the low limit valve when the VERIFY button is pressed.
 - (b) The PTC does this dynamic test on the low limit valve when pneumatic power is applied:
- NOTE: To do the low limit valve dynamic test, there must be pneumatic power (APU bleed valve open), and the other pack must be off.
- The dynamic test can take up to three minutes to complete.
- 1) When the VERIFY switch is pushed, the temperature control valve moves to the 50% open position.
 - 2) After 10 seconds, the PTC does a BITE check.
 - 3) The PTC makes a record of the pack outlet temperature.
 - 4) The PTC commands the low limit valve to the 33% open position.
 - 5) After 10 seconds the PTC makes a record of the pack outlet temperature and compares it to the first temperature.

EFFECTIVITY

ALL

21-51-00

01

Page 110
Sep 28/02



- 6) If the new pack out temperature is more than 10 deg. F above the first pack out temperature, then the low limit valve passes the test.
- 7) If the temperature difference is less than 10 deg. F, the PTC commands the low limit valve to 78% open.
- 8) The PTC makes another record the the pack out temperature and compares it to the first record.
- 9) If the temperature difference is more than 10 deg. F, the low limit valve passes the test.
- 10) If the temperature difference is less than 10 deg. F, the PTC commands the valve to 100% open and does the temperature comparison test again.
- 11) If the temperature difference is less than 10 deg. F, the PTC determines that the low limit valve has a problem.

4. Standby-Pack-Temperature Controller BITE Description (Fig. 105)

A. General:

- (1) The purpose of the standby-pack-temperature controller is to control the pack outlet temperature when the pack temperature controller (PTC) has a critical failure.
- (2) When the pack selector is in the STBY N position, the PTC is disconnected from the ram air doors and the pack valves. The temperature control valve moves to the closed position and the ram air doors move to the open position. The standby-pack-temperature controller controls the torque motor for the low limit valve to maintain a 40 deg. F pack out temperature. If the compressor discharge temperature exceeds 450 deg. F, then the low limit valve opens to keep the compressor discharge temperature at 450 deg. F.
- (3) The controller monitors the pack temperature sensor and the compressor discharge temperature sensor.
- (4) The BITE test for the standby-pack-temperature controller is done on the front of the controller with the airplane in ground mode.
- (5) The standby-pack-temperature controller does a BITE test of these components:
 - (a) Standby-Pack-Temperature Controller (self test)
 - (b) Pack Temperature Sensor
 - (c) Compressor Discharge Temperature Sensor

B. Standby-Pack-Temperature Contrllr BITE description:

- (1) STBY CONTROLLER (position 1 through position 5):
 - (a) The standby-pack-temperature controller detects an internal fault in the controller. These faults include power supply problems and current output problems.
- (2) PACK SENSOR (position 6):
 - (a) The standby-pack-temperature controller detects that the resistance of the pack temperature sensor is out of range.
- (3) COMP SENSOR (position 7):
 - (a) The standby-pack-temperature controller detects that the resistance of the compressor discharge temperature sensor is out of range.

EFFECTIVITY

ALL

21-51-00

Not Used
Figure 103

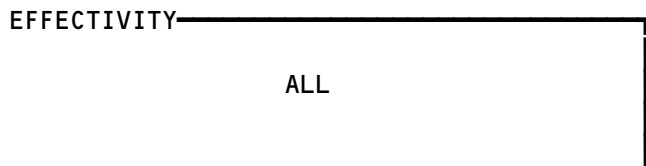

21-51-00

01

Page 112
Jun 20/95

ED4111

PREREQUISITES

MAKE SURE THESE CIRCUIT BREAKERS ARE CLOSED:
11A13,11A14,11A28,11M11,11M19

MAKE SURE THE AIRPLANE IS IN THIS CONFIGURATION:
ELECTRICAL POWER IS ON (AMM 24-22-00/201)
PNEUMATIC SYSTEM IS OFF (AMM 36-00-00/201)
"L PACK" AND "R PACK" SELECTORS, ON THE P5 PANEL,
ARE IN THE "AUTO" POSITION
"TRIM AIR" SWITCH-LIGHT, ON THE P5 PANEL, IS ON
ZONE TEMPERATURE SELECTORS, ON THE P5 PANEL, ARE IN
THE AUTO (12 O'CLOCK) POSITION
RECIRC FANS ARE ON

NOTE: THE BUILT-IN-TEST EQUIPMENT (BITE) DOES AN ELECTRICAL CHECK OF THE PACK TEMPERATURE CONTROLLER, THE AUTO PACK TEMPERATURE SENSOR, THE AUTO COMPRESSOR OUTLET SENSOR, THE MIX MANIFOLD TEMP SENSOR, THE ZONE TEMP SENSOR, THE ALTITUDE SWITCH, AND THE TORQUE MOTOR OF THE FLOW CONTROL AND SHUTOFF VALVE. THE BITE DOES AN OPERATIONAL CHECK OF THE TEMPERATURE CONTROL VALVE, THE RAM AIR INLET ACTUATOR, THE RAM EXHAUST ACTUATOR, AND THE LOW LIMIT VALVE.

NOTE: BITE DOES NOT KNOW THE DIFFERENCE BETWEEN A COMPONENT FAULT AND AN AIRPLANE WIRING FAULT. MAKE SURE THE CIRCUIT IS CORRECT AND THE CONNECTOR IS IN GOOD CONDITION BEFORE YOU REPLACE A COMPONENT.

Pack Temperature Controller BITE Procedure
Figure 104 (Sheet 1)

EFFECTIVITY	ALL
-------------	-----

21-51-00

**PACK TEMPERATURE
CONTROLLER BITE
PROCEDURE**

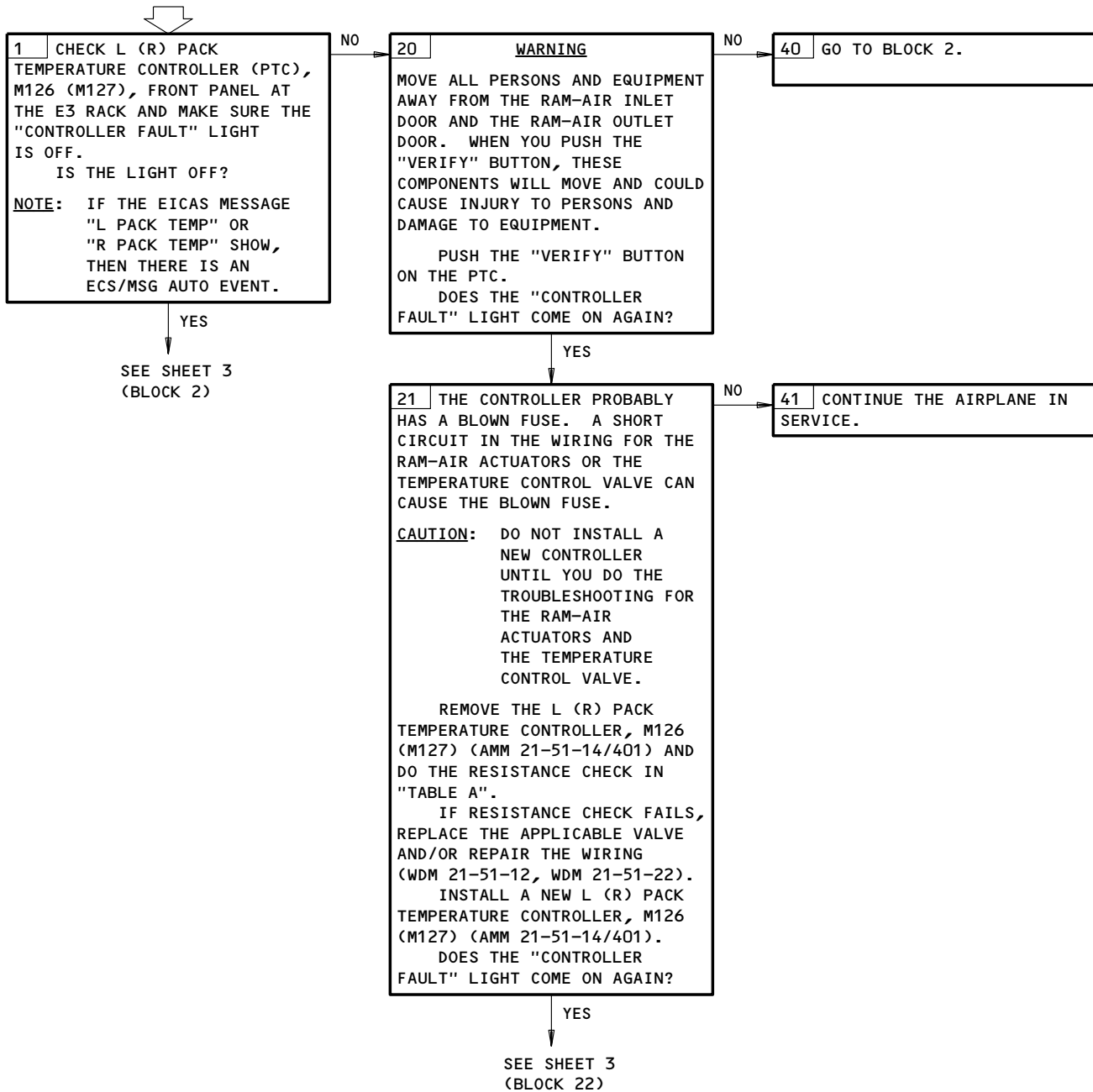

Pack Temperature Controller BITE Procedure
Figure 104 (Sheet 2)

EFFECTIVITY	ALL
-------------	-----

21-51-00

BOEING
757
FAULT ISOLATION/MAINT MANUAL

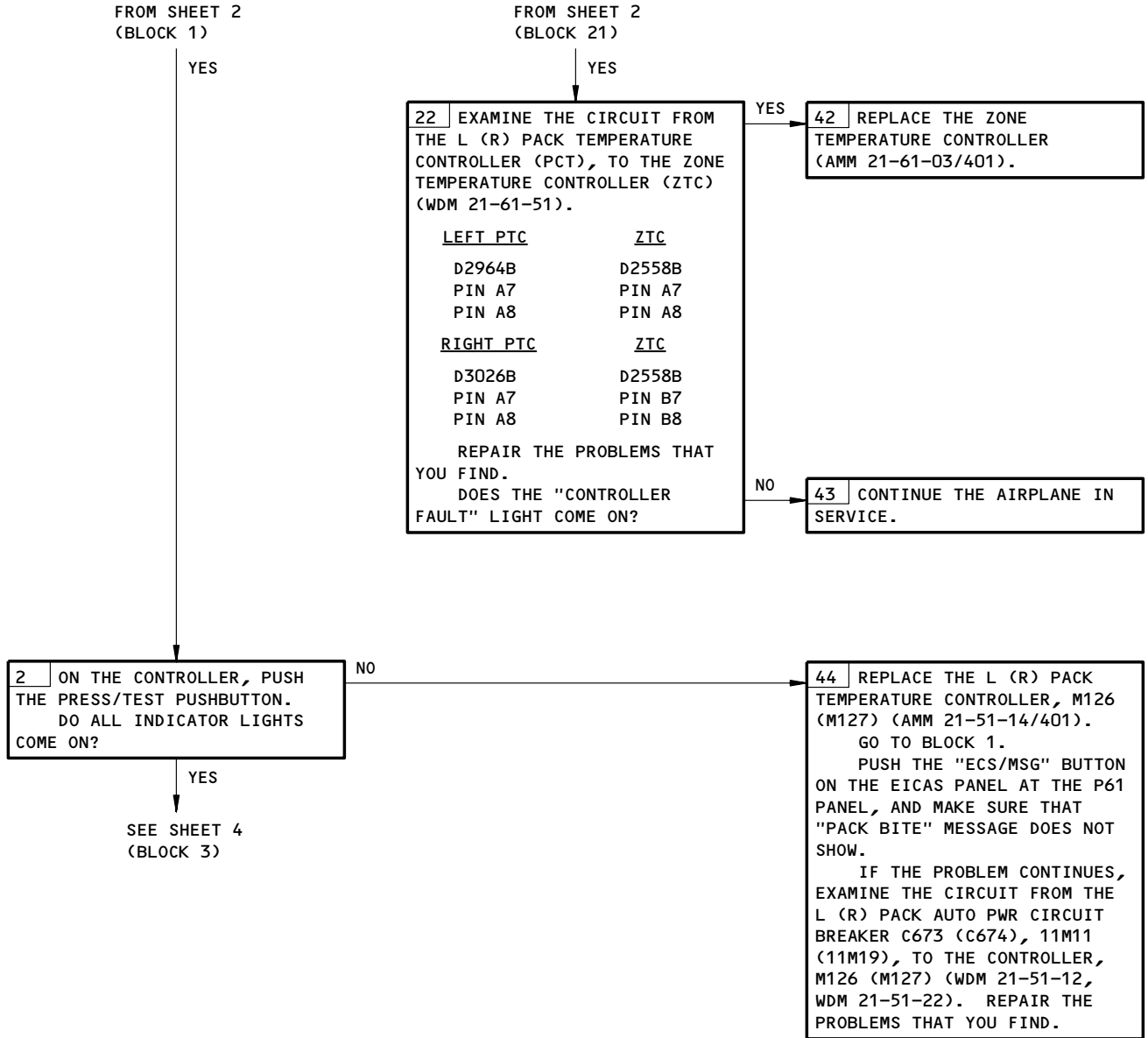

Pack Temperature Controller BITE Procedure
Figure 104 (Sheet 3)

EFFECTIVITY

ALL

21-51-00

06

Page 115
May 28/01

A70725

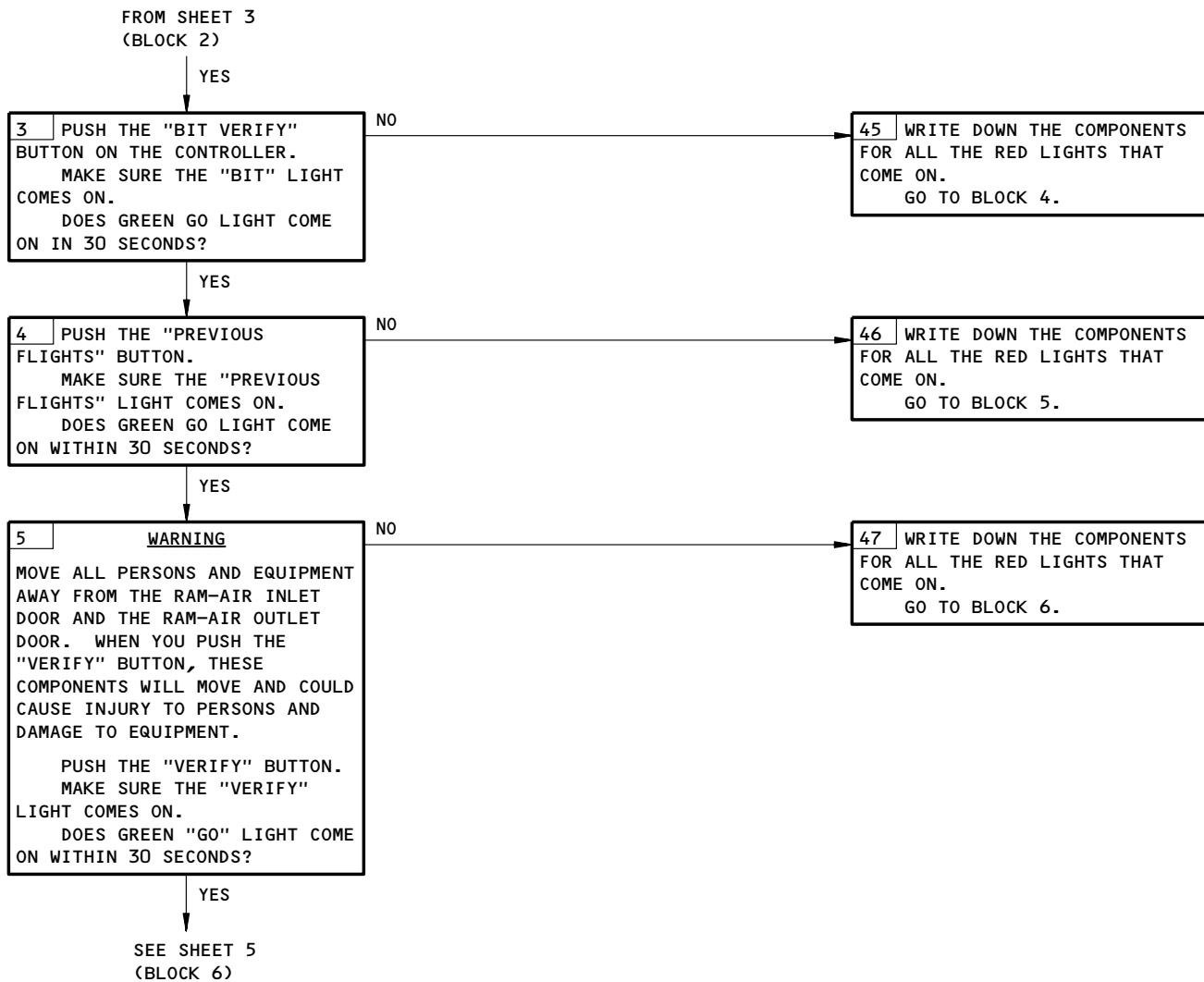

Pack Temperature Controller BITE Procedure
Figure 104 (Sheet 4)

EFFECTIVITY	ALL
-------------	-----

21-51-00

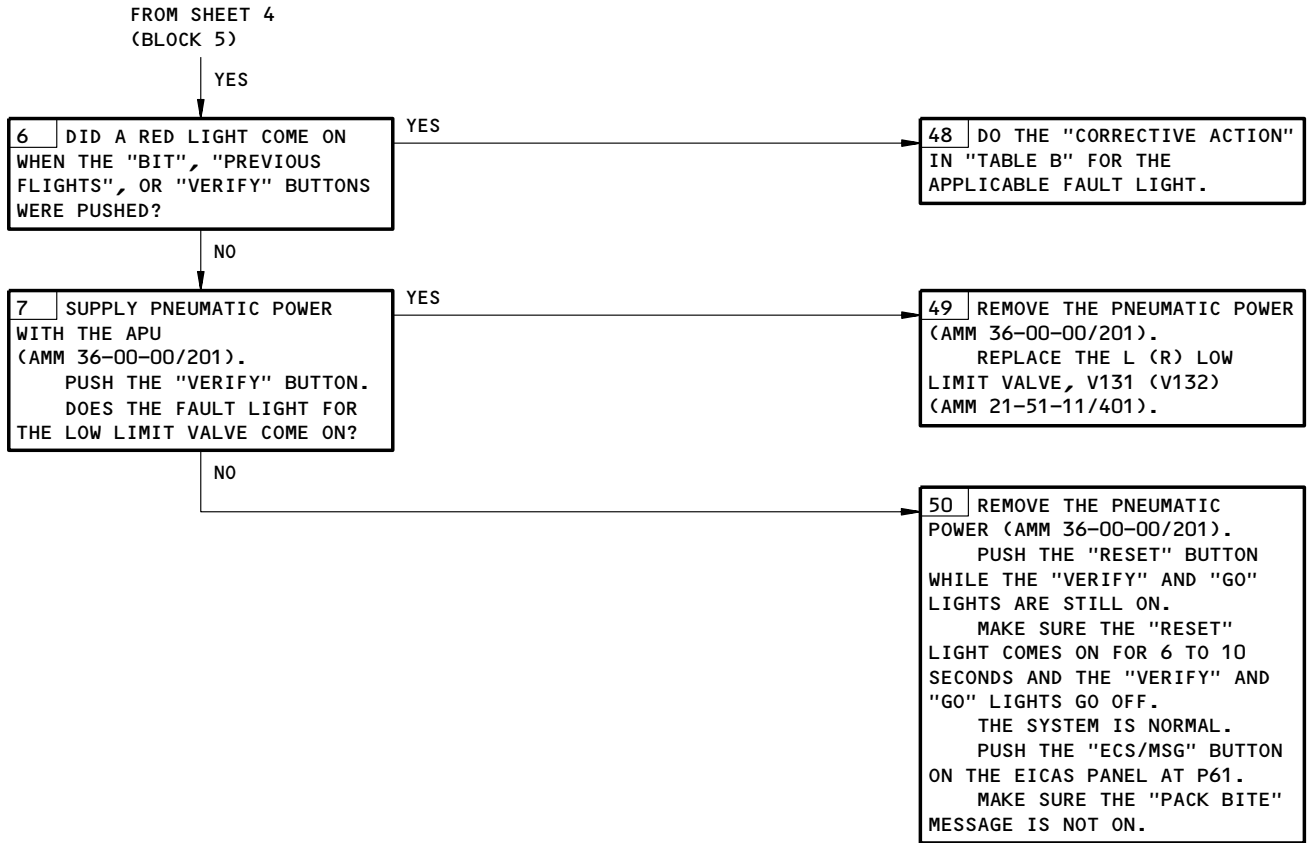

Pack Temperature Controller BITE Procedure
Figure 104 (Sheet 5)

EFFECTIVITY	ALL
-------------	-----

21-51-00

BOEING
 757
 FAULT ISOLATION/MAINT MANUAL

COMPONENT CHECKED	FROM CONNECTOR D2964B (D3026B)	TO CONNECTOR D2964C (D3026C)	ACCEPTABLE RESISTANCE (OHMS)
TEMPERATURE CONTROL VALVE, V18 (V19) (WDM 21-51-12,-22) (AMM 21-51-12/401)	PIN A13	PIN 4	70-105
	PIN A15	PIN 4	70-105
RAM AIR INLET ACTUATOR, M322 (M323) (WDM 21-51-12,-22) (AMM 21-53-03/401)	PIN B13	PIN 4	15-30
	PIN B15	PIN 4	15-30
RAM AIR EXHAUST ACTUATOR, M320 (M321) (WDM 21-51-12,-22) (AMM 21-53-04/401)	PIN C13	PIN 4	15-30
	PIN C15	PIN 4	15-30

LEFT (RIGHT) PACK TEMPERATURE CONTROLLER RESISTANCE CHECK
TABLE A

Pack Temperature Controller BITE Procedure
Figure 104 (Sheet 6)

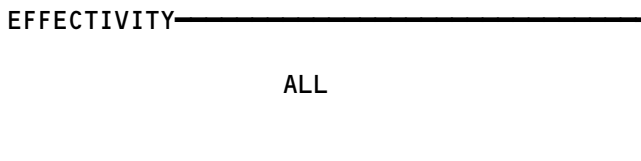

21-51-00

01

Page 118
Dec 20/95

E49802

BOEING
 757
 FAULT ISOLATION/MAINT MANUAL

BITE MESSAGE	CORRECTIVE ACTION
CONTROLLER FAULT	1. DO THE RESISTANCE CHECK IN "TABLE A". 2. IF THE WIRING IS OK, REPLACE THE PACK TEMPERATURE CONTROLLER, M126 (M127) (AMM 21-51-14/401).
PACK SENSOR	1. MAKE SURE THE AIR CYCLE MACHINE IS NOT SEIZED. 2. REPLACE THE LEFT (RIGHT) PACK TEMPERATURE SENSOR, TS198 (TS199) (AMM 21-51-08/401). 3. IF THE PROBLEM CONTINUES, DO A CHECK OF THE WIRING: <ul style="list-style-type: none"> • FOR THE LEFT PACK TEMPERATURE CONTROLLER: <ul style="list-style-type: none"> - EXAMINE THE CIRCUIT FROM THE PACK TEMPERATURE CONTROLLER, M126, CONNECTOR D2964A, PINS A4 AND A5, TO THE LEFT PACK TEMPERATURE SENSOR, TS198, CONNECTOR D2952, PINS 1 AND 2 (WDM 21-51-12). • FOR THE RIGHT PACK TEMPERATURE CONTROLLER: <ul style="list-style-type: none"> - EXAMINE THE CIRCUIT FROM THE PACK TEMPERATURE CONTROLLER, M127, CONNECTOR D3026A, PINS A4 AND A5, TO THE RIGHT PACK TEMPERATURE SENSOR, TS199, CONNECTOR D2952, PINS 1 AND 2 (WDM 21-51-22).
MIX MANF SENSOR	1. REPLACE THE SENSOR: <ul style="list-style-type: none"> • FOR THE LEFT PACK TEMPERATURE CONTROLLER: <ul style="list-style-type: none"> - REPLACE THE LEFT MIX MANIFOLD TEMPERATURE SENSOR (TS200) (AMM 21-61-02/401). • FOR THE RIGHT PACK TEMPERATURE CONTROLLER: <ul style="list-style-type: none"> - REPLACE THE RIGHT MIX MANIFOLD TEMPERATURE SENSOR (TS201) (AMM 21-61-02/401). 2. IF THE PROBLEM CONTINUES, DO A CHECK OF THE WIRING: <ul style="list-style-type: none"> • FOR THE LEFT PACK TEMPERATURE CONTROLLER: <ul style="list-style-type: none"> - EXAMINE THE CIRCUIT FROM THE PACK TEMPERATURE CONTROLLER, M126, CONNECTOR D2964A, PINS B4 AND B5, TO THE MIX MANIFOLD TEMPERATURE SENSOR 1, TS200, CONNECTOR D2954, PINS 1 AND 2 (WDM 21-51-12). • FOR THE RIGHT PACK TEMPERATURE CONTROLLER: <ul style="list-style-type: none"> - EXAMINE THE CIRCUIT FROM THE PACK TEMPERATURE CONTROLLER, M127, CONNECTOR D3026A, PINS B4 AND B5, TO THE MIX MANIFOLD TEMPERATURE SENSOR 2, TS201, CONNECTOR D3012, PINS 1 AND 2 (WDM 21-51-22).
ZONE SENSOR	1. REPLACE THE SENSOR: <ul style="list-style-type: none"> • FOR THE LEFT PACK TEMPERATURE CONTROLLER: <ul style="list-style-type: none"> - REPLACE THE FLIGHT DECK ZONE TEMPERATURE SENSOR, YRUTS01 (AMM 21-61-08/401). • FOR THE RIGHT PACK TEMPERATURE CONTROLLER: <ul style="list-style-type: none"> - REPLACE THE FORWARD CABIN TEMPERATURE SENSOR, YRWTS01 (AMM 21-61-08/401). 2. IF THE PROBLEM CONTINUES, DO A CHECK OF THE WIRING: <ul style="list-style-type: none"> • FOR THE LEFT PACK TEMPERATURE CONTROLLER: <ul style="list-style-type: none"> - EXAMINE THE CIRCUIT FROM THE PACK TEMPERATURE CONTROLLER, M126, CONNECTOR D2964A, PINS C4 AND C5, TO THE FLIGHT DECK TEMP SENSOR MODULE, M10452 (YRU), CONNECTOR D2554, PINS 4 AND 3 (WDM 21-61-11). • FOR THE RIGHT PACK TEMPERATURE CONTROLLER: <ul style="list-style-type: none"> - EXAMINE THE CIRCUIT FROM THE PACK TEMPERATURE CONTROLLER, M127, CONNECTOR D3026A, PINS C4 AND C5, TO THE FWD CABIN TEMP SENSOR MODULE, M10025 (YRW), CONNECTOR D2568, PINS 3 AND 4 (WDM 21-61-21).

PACK TEMPERATURE CONTROLLER – FAULT LIGHT TROUBLESHOOTING
TABLE B

Pack Temperature Controller BITE Procedure
Figure 104 (Sheet 7)

EFFECTIVITY

ALL

21-51-00

01

Page 119
Sep 28/02

F49342

 **BOEING**
757
FAULT ISOLATION/MAINT MANUAL

BITE MESSAGE	CORRECTIVE ACTION
COMPRESSOR SENSOR	<ol style="list-style-type: none"> 1. REPLACE THE LEFT (RIGHT) PACK COMPRESSOR OUTLET TEMPERATURE SENSOR, TS41 (TS42)(AMM 21-51-06/401). 2. IF THE PROBLEM CONTINUES, DO A CHECK OF THE WIRING: <ul style="list-style-type: none"> • FOR THE LEFT PACK TEMPERATURE CONTROLLER: <ul style="list-style-type: none"> - EXAMINE THE CIRCUIT FROM THE PACK TEMPERATURE CONTROLLER, M126, CONNECTOR D2964A, PINS D4 AND D5, TO THE LEFT PACK COMPRESSOR OUTLET TEMPERATURE SENSOR, TS41, CONNECTOR D2966, PINS 1 AND 2 (WDM 21-51-15). • FOR THE RIGHT PACK TEMPERATURE CONTROLLER: <ul style="list-style-type: none"> - EXAMINE THE CIRCUIT FROM THE RIGHT PACK COMPRESSOR OUTLET TEMPERATURE CONTROLLER, M127, CONNECTOR D3026A, PINS D4 AND D5, TO THE RIGHT PACK COMPRESSOR OUTLET TEMPERATURE SENSOR, TS42, CONNECTOR D3028, PINS 1 AND 2 (WDM 21-51-25).
ALTITUDE SWITCH	<ol style="list-style-type: none"> 1. REPLACE THE LEFT (RIGHT) PACK ALTITUDE SWITCH, S10305 (S397) (AMM 21-51-17/401). 2. IF THE PROBLEM CONTINUES, DO THIS PROCEDURE: "L (R) PACK BITE CONTINUES TO FIND AN ALTITUDE SWITCH FAULT" (FIG. 104A).
TEMP CONT VALVE	<ol style="list-style-type: none"> 1. DO THE STEPS THAT FOLLOW: <ol style="list-style-type: none"> A. MOVE THE L (R) PACK SELECTOR TO "STBY N" AND WAIT 30 SECONDS. B. MOVE THE L (R) PACK SELECTOR TO "STBY W". C. REPEAT THE ABOVE STEPS 3 TIMES. <p style="margin-left: 40px;"><u>NOTE:</u> A NOT EQUAL DISTRIBUTION OF THE LUBRICATION IN THE TCV POTENTIOMETER CAN CAUSE AN INTERMITTENT OPEN CIRCUIT.</p> <ol style="list-style-type: none"> D. MOVE THE L (R) PACK SELECTOR TO "AUTO". E. PUSH THE "VERIFY" SWITCH ON THE PACK TEMP CONTROLLER. IF THE "TEMP CONT VALVE" FAULT LIGHT DOES NOT SHOW, THEN THE TEMPERATURE CONTROL VALVE IS OK. 2. IF THE STEPS ABOVE DID NOT FIX THE PROBLEM, THEN REPLACE THE LEFT (RIGHT) PACK TEMPERATURE CONTROL VALVE, V18 (V19)(AMM 21-51-12/401). 3. REPLACE THE LEFT (RIGHT) PACK AUTO/MANUAL RELAY 1, K57 (K49)(WDM 21-51-12, -22). 4. IF THE PROBLEM CONTINUES, DO A CHECK OF THE WIRING FOR THE LIMIT SWITCHES: <ul style="list-style-type: none"> • FOR THE LEFT PACK TEMPERATURE CONTROLLER: <ul style="list-style-type: none"> - EXAMINE THE CIRCUIT FROM THE PACK TEMPERATURE CONTROLLER, M126, CONNECTOR D2964A, PINS A10, A11, AND A12, TO THE LEFT PACK TEMPERATURE CONTROL VALVE, V18, CONNECTOR D2962, PINS 4, 5, AND 12 (WDM 21-51-12). • FOR THE RIGHT PACK TEMPERATURE CONTROLLER: <ul style="list-style-type: none"> - EXAMINE THE CIRCUIT FROM THE PACK TEMPERATURE CONTROLLER, M127, CONNECTOR D3026A, PINS A10, A11, AND A12, TO THE RIGHT PACK TEMPERATURE CONTROL VALVE, V19, CONNECTOR D3014, PINS 4, 5, AND 12 (WDM 21-51-22). 5. DO A CHECK OF THE WIRING FOR THE POTENTIOMETER: <ul style="list-style-type: none"> • FOR THE LEFT PACK TEMPERATURE CONTROLLER: <ul style="list-style-type: none"> - EXAMINE THE CIRCUIT FROM THE PACK TEMPERATURE CONTROLLER, M126, CONNECTOR D2964A, PINS A1, A2, AND A3, TO THE LEFT PACK TEMPERATURE CONTROL VALVE, V18, CONNECTOR D2946, PINS 2, 4, AND 6 (WDM 21-51-12). • FOR THE RIGHT PACK TEMPERATURE CONTROLLER: <ul style="list-style-type: none"> - EXAMINE THE CIRCUIT FROM THE PACK TEMPERATURE CONTROLLER, M127, CONNECTOR D3026A, PINS A1, A2, AND A3, TO THE RIGHT PACK TEMPERATURE CONTROL VALVE, V19, CONNECTOR D3004, PINS 2, 4, AND 6 (WDM 21-51-22).

PACK TEMPERATURE CONTROLLER - FAULT LIGHT TROUBLESHOOTING
TABLE B

Pack Temperature Controller BITE Procedure
Figure 104 (Sheet 8)

EFFECTIVITY

ALL

21-51-00

01

Page 120
Mar 20/96

F49372

 **BOEING**
757
FAULT ISOLATION/MAINT MANUAL

BITE MESSAGE	CORRECTIVE ACTION
TEMP CONT VALVE (CONTINUED)	<p>6. DO A CHECK OF THE WIRING FOR THE VALVE DRIVER CIRCUIT:</p> <ul style="list-style-type: none"> • FOR THE LEFT PACK TEMPERATURE CONTROLLER: <ul style="list-style-type: none"> - EXAMINE THE CIRCUIT FROM THE PACK TEMPERATURE CONTROLLER, M126, CONNECTOR D2964B, PINS A13 AND A15, TO THE LEFT PACK TEMPERATURE CONTROL VALVE, V18, CONNECTOR D2962, PINS 1,2, AND 3 (WDM 21-51-12). • FOR THE RIGHT PACK TEMPERATURE CONTROLLER: <ul style="list-style-type: none"> - EXAMINE THE CIRCUIT FROM THE PACK TEMPERATURE CONTROLLER, M127, CONNECTOR D3026B, PINS A13 AND A15, TO THE RIGHT PACK TEMPERATURE CONTROL VALVE, V19, CONNECTOR D3014, PINS 1,2, AND 3 (WDM 21-51-22).
RAM INLET ACTR	<p>1. REPLACE THE LEFT (RIGHT) RAM AIR INLET DOOR ACTUATOR, M322 (M323) (AMM 21-53-03/401).</p> <p>2. REPLACE THE LEFT (RIGHT) PACK AUTO/MANUAL RELAY 1 AND 2, K57 AND K58 (K49 AND K50)(WDM 21-51-12,-22).</p> <p>3. IF THE PROBLEM CONTINUES, DO A CHECK OF THE WIRING FOR THE LIMIT SWITCHES:</p> <ul style="list-style-type: none"> • FOR THE LEFT PACK TEMPERATURE CONTROLLER: <ul style="list-style-type: none"> - EXAMINE THE CIRCUIT FROM THE PACK TEMPERATURE CONTROLLER, M126, CONNECTOR D2964A, PINS B10,B11, AND B12, TO THE LEFT RAM AIR INLET ACTUATOR, M322, CONNECTOR D2944, PINS 11,10, AND 12 (WDM 21-51-12). • FOR THE RIGHT PACK TEMPERATURE CONTROLLER: <ul style="list-style-type: none"> - EXAMINE THE CIRCUIT FROM THE PACK TEMPERATURE CONTROLLER, M127, CONNECTOR D3026A, PINS B10,B11, AND B12, TO THE RIGHT RAM AIR INLET ACTUATOR, M323, CONNECTOR D3002, PINS 11,10, AND 12 (WDM 21-51-22). <p>4. DO A CHECK OF THE WIRING FOR THE POTENTIOMETER:</p> <ul style="list-style-type: none"> • FOR THE LEFT PACK TEMPERATURE CONTROLLER: <ul style="list-style-type: none"> - EXAMINE THE CIRCUIT FROM THE PACK TEMPERATURE CONTROLLER, M126, CONNECTOR D2964A, PINS B1,B2, AND B3, TO THE LEFT RAM AIR INLET ACTUATOR, M322, CONNECTOR D2944, PINS 6,5, AND 4 (WDM 21-51-12). • FOR THE RIGHT PACK TEMPERATURE CONTROLLER: <ul style="list-style-type: none"> - EXAMINE THE CIRCUIT FROM THE PACK TEMPERATURE CONTROLLER, M127, CONNECTOR D3026A, PINS B1,B2, AND B3, TO THE RIGHT RAM AIR INLET ACTUATOR, M323, CONNECTOR D3002, PINS 6,5, AND 4 (WDM 21-51-22). <p>5. DO A CHECK OF THE WIRING FOR THE VALVE DRIVER CIRCUIT:</p> <ul style="list-style-type: none"> • FOR THE LEFT PACK TEMPERATURE CONTROLLER: <ul style="list-style-type: none"> - EXAMINE THE CIRCUIT FROM THE PACK TEMPERATURE CONTROLLER, M126, CONNECTOR D2964B, PINS B13 AND B15, TO THE LEFT RAM AIR INLET ACTUATOR, M322, CONNECTOR D2944, PINS 2 AND 3 (WDM 21-51-12). • FOR THE RIGHT PACK TEMPERATURE CONTROLLER: <ul style="list-style-type: none"> - EXAMINE THE CIRCUIT FROM THE PACK TEMPERATURE CONTROLLER, M127, CONNECTOR D3026B, PINS B13 AND B15, TO THE RIGHT RAM AIR INLET ACTUATOR, M323, CONNECTOR D3002, PINS 2 AND 3 (WDM 21-51-22).
RAM OUTLET ACTR	<p>1. REPLACE THE LEFT (RIGHT) RAM AIR OUTLET DOOR ACTUATOR, M320 (M321) (AMM 21-53-04/401).</p> <p>2. REPLACE THE LEFT (RIGHT) PACK AUTO/MANUAL RELAY 2, K58 (K50)(WDM 21-51-12,-22).</p> <p>3. IF THE PROBLEM CONTINUES, DO A CHECK OF THE WIRING FOR THE LIMIT SWITCHES:</p> <ul style="list-style-type: none"> • FOR THE LEFT PACK TEMPERATURE CONTROLLER: <ul style="list-style-type: none"> - EXAMINE THE CIRCUIT FROM THE PACK TEMPERATURE CONTROLLER, M126, CONNECTOR D2964A, PINS C10,C11, AND C12, TO THE LEFT RAM AIR OUTLET ACTUATOR, M320, CONNECTOR D2942, PINS 11,10, AND 12 (WDM 21-51-12). • FOR THE RIGHT PACK TEMPERATURE CONTROLLER: <ul style="list-style-type: none"> - EXAMINE THE CIRCUIT FROM THE PACK TEMPERATURE CONTROLLER, M127, CONNECTOR D3026A, PINS C10,C11, AND C12, TO THE RIGHT RAM AIR OUTLET ACTUATOR, M321, CONNECTOR D3000, PINS 11,10, AND 12 (WDM 21-51-22).

**PACK TEMPERATURE CONTROLLER – FAULT LIGHT TROUBLESHOOTING
TABLE B**

Pack Temperature Controller BITE Procedure
Figure 104 (Sheet 9)

EFFECTIVITY

ALL

21-51-00

01

Page 121
Mar 20/96

F49382

BOEING
 757
 FAULT ISOLATION/MAINT MANUAL

BITE MESSAGE	CORRECTIVE ACTION
RAM OUTLET ACTR (CONTINUED)	4. DO A CHECK OF THE WIRING FOR THE POTENTIOMETER: <ul style="list-style-type: none"> • FOR THE LEFT PACK TEMPERATURE CONTROLLER: <ul style="list-style-type: none"> - EXAMINE THE CIRCUIT FROM THE PACK TEMPERATURE CONTROLLER, M126, CONNECTOR D2964A, PINS C1,C2, AND C3, TO THE LEFT RAM AIR OUTLET ACTUATOR, M320, CONNECTOR D2942, PINS 6,5, AND 4 (WDM 21-51-12). • FOR THE RIGHT PACK TEMPERATURE CONTROLLER: <ul style="list-style-type: none"> - EXAMINE THE CIRCUIT FROM THE PACK TEMPERATURE CONTROLLER, M127, CONNECTOR D3026A, PINS B1,B2, AND B3, TO THE RIGHT RAM AIR OUTLET ACTUATOR, M321, CONNECTOR D3000, PINS 6,5, AND 4 (WDM 21-51-22). 5. DO A CHECK OF THE WIRING FOR THE VALVE DRIVER CIRCUIT: <ul style="list-style-type: none"> • FOR THE LEFT PACK TEMPERATURE CONTROLLER: <ul style="list-style-type: none"> - EXAMINE THE CIRCUIT FROM THE PACK TEMPERATURE CONTROLLER, M126, CONNECTOR D2964B, PINS C13 AND C15, TO THE LEFT RAM AIR OUTLET ACTUATOR, M320, CONNECTOR D2942, PINS 2 AND 3 (WDM 21-51-12). • FOR THE RIGHT PACK TEMPERATURE CONTROLLER: <ul style="list-style-type: none"> - EXAMINE THE CIRCUIT FROM THE PACK TEMPERATURE CONTROLLER, M127, CONNECTOR D3026B, PINS C13 AND C15, TO THE RIGHT RAM AIR OUTLET ACTUATOR, M321, CONNECTOR D3000, PINS 2 AND 3 (WDM 21-51-22).
FLOW CONT VALVE	1. REPLACE THE LEFT (RIGHT) PACK AUTO/MANUAL RELAY 3, K10315 (K10316) (WDM 21-51-12,-22). 2. IF THE PROBLEM CONTINUES, REPLACE THE L (R) FLOW CONTROL AND SHUTOFF VALVE, V16 (V17)(AMM 21-51-01/201). 3. IF THE PROBLEM CONTINUES, DO A CHECK OF THE WIRING: <ul style="list-style-type: none"> • FOR THE LEFT PACK TEMPERATURE CONTROLLER: <ul style="list-style-type: none"> - EXAMINE THE CIRCUIT FROM THE PACK TEMPERATURE CONTROLLER, M126, CONNECTOR D2964B, PINS B1 AND B2, TO THE LEFT PACK FLOW CONTROL AND SHUTOFF VALVE, V16, CONNECTOR D4128, PINS 3 AND 1 (WDM 21-51-12). • FOR THE RIGHT PACK TEMPERATURE CONTROLLER: <ul style="list-style-type: none"> - EXAMINE THE CIRCUIT FROM THE PACK TEMPERATURE CONTROLLER, M127, CONNECTOR D3026B, PINS B1 AND B2, TO THE RIGHT PACK FLOW CONTROL AND SHUTOFF VALVE, V17, CONNECTOR D4236, PINS 3 AND 1 (WDM 21-51-22).
LOW LIMIT VALVE	1. REPLACE THE LEFT (RIGHT) PACK LOW LIMIT VALVE RELAY, K10317 (K10318) (WDM 21-51-14,-24). 2. IF THE PROBLEM CONTINUES, REPLACE THE L (R) LOW LIMIT VALVE, V16 (V17) (AMM 21-51-11/201). 3. IF THE PROBLEM CONTINUES, DO A CHECK OF THE WIRING: <ul style="list-style-type: none"> • FOR THE LEFT PACK TEMPERATURE CONTROLLER: <ul style="list-style-type: none"> - EXAMINE THE CIRCUIT FROM THE PACK TEMPERATURE CONTROLLER, M126, CONNECTOR D2964B, PINS C1 AND C2, TO THE LEFT PACK LOW LIMIT VALVE, V10077, CONNECTOR D4136, PINS 3 AND 1 (WDM 21-51-14). • FOR THE RIGHT PACK TEMPERATURE CONTROLLER: <ul style="list-style-type: none"> - EXAMINE THE CIRCUIT FROM THE PACK TEMPERATURE CONTROLLER, M127, CONNECTOR D3026B, PINS C1 AND C2, TO THE RIGHT PACK LOW LIMIT VALVE, V10076, CONNECTOR D4058, PINS 3 AND 1 (WDM 21-51-24).

PACK TEMPERATURE CONTROLLER – FAULT LIGHT TROUBLESHOOTING
TABLE B

Pack Temperature Controller BITE Procedure
Figure 104 (Sheet 10)

EFFECTIVITY

ALL

21-51-00

01

Page 122
Jun 20/97

F49387

BOEING
757
FAULT ISOLATION/MAINT MANUAL

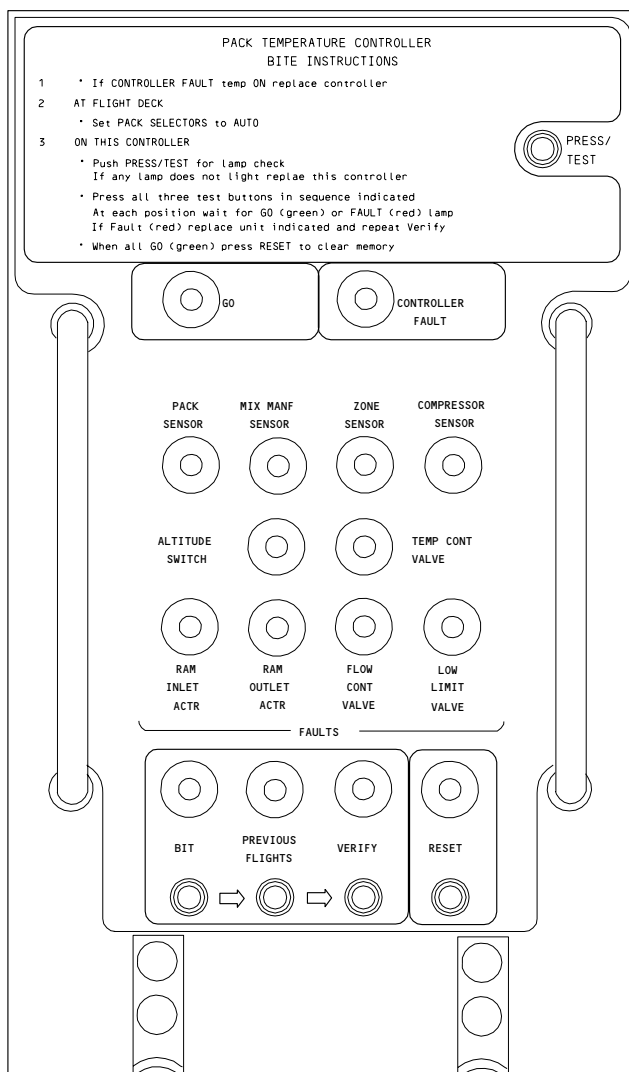

**PACK TEMPERATURE
CONTROLLER**

Pack Temperature Controller BITE Procedure
Figure 104 (Sheet 11)

EFFECTIVITY

ALL

21-51-00

01

Page 123
Dec 20/95

FD09639

**L (R) PACK BITE
CONTINUES TO FIND
AN ALTITUDE SWITCH
FAULT**

PREREQUISITES

MAKE SURE THESE CIRCUIT BREAKERS ARE CLOSED:
11C30,11S15

MAKE SURE THE AIRPLANE IS IN THIS CONFIGURATION:
L (R) PACK CONTROLLER IS REMOVED (AMM 21-51-14/401)

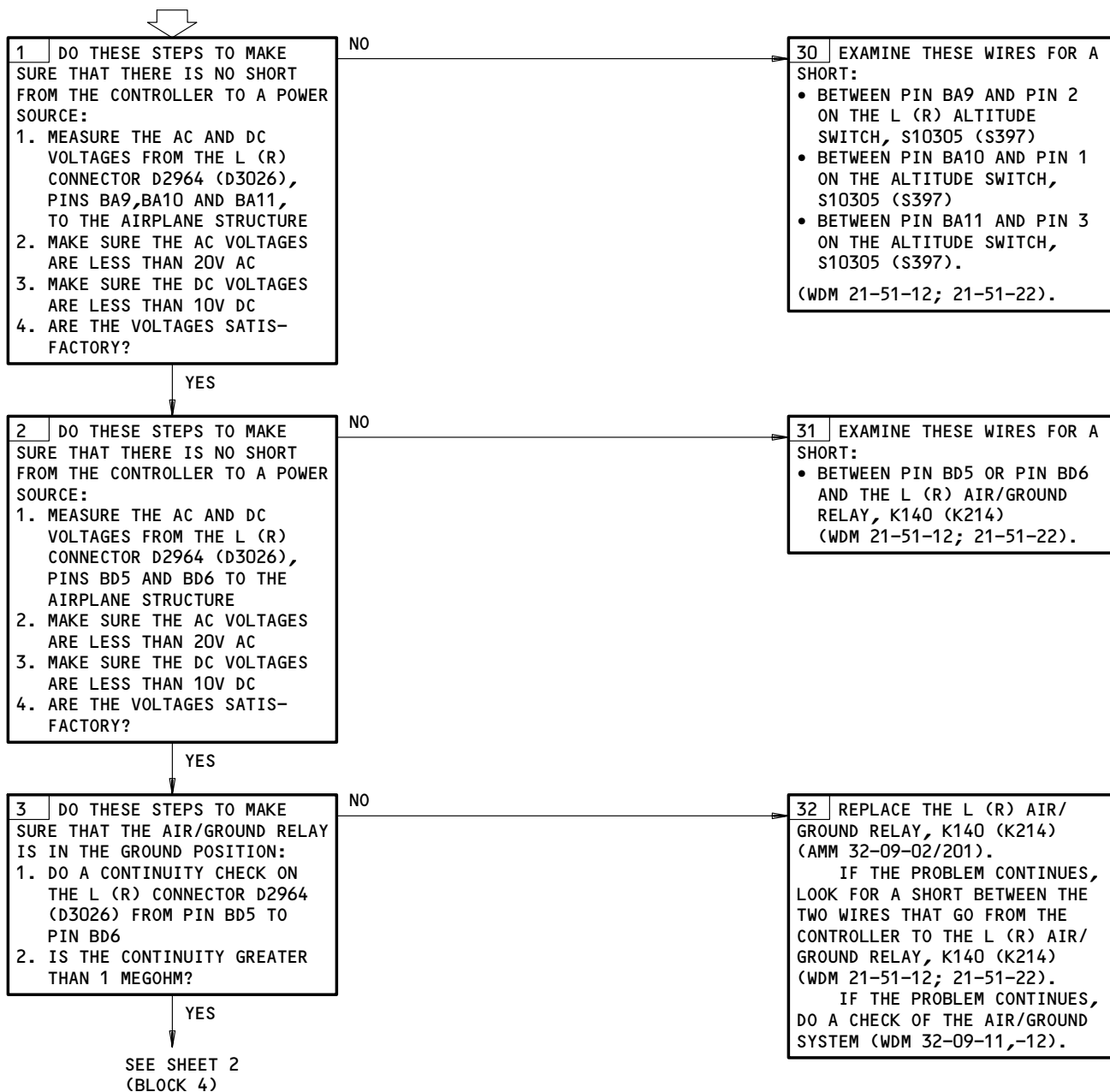

L (R) Pack Bite Continues to Find an Altitude Switch Fault
Figure 104A (Sheet 1)

EFFECTIVITY

ALL

21-51-00

01

Page 124
Dec 20/95

ED08816

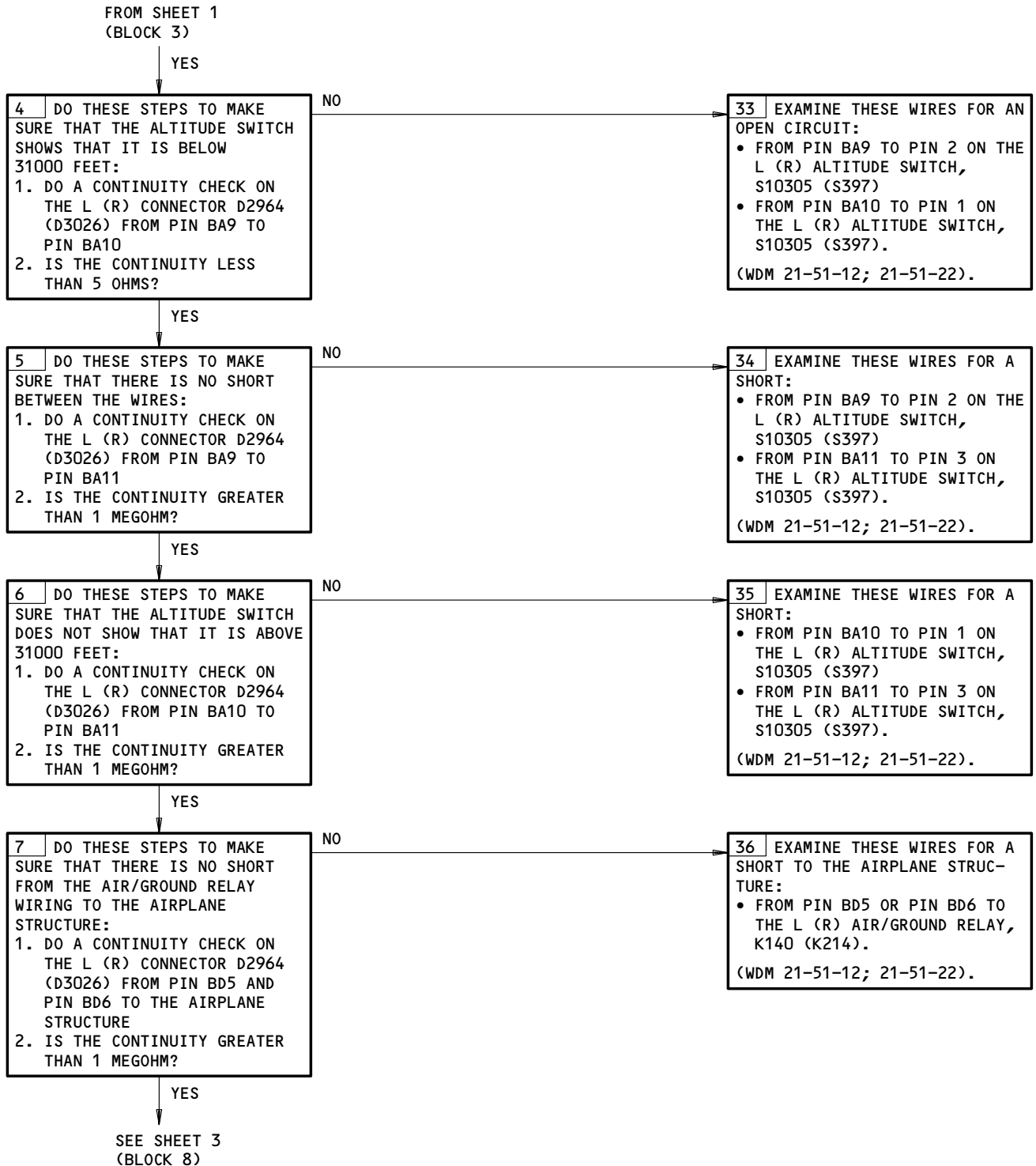

L (R) Pack Bite Continues to Find an Altitude Switch Fault
Figure 104A (Sheet 2)

EFFECTIVITY

ALL

21-51-00

01

Page 125
Dec 20/95

FROM SHEET 2
(BLOCK 7)

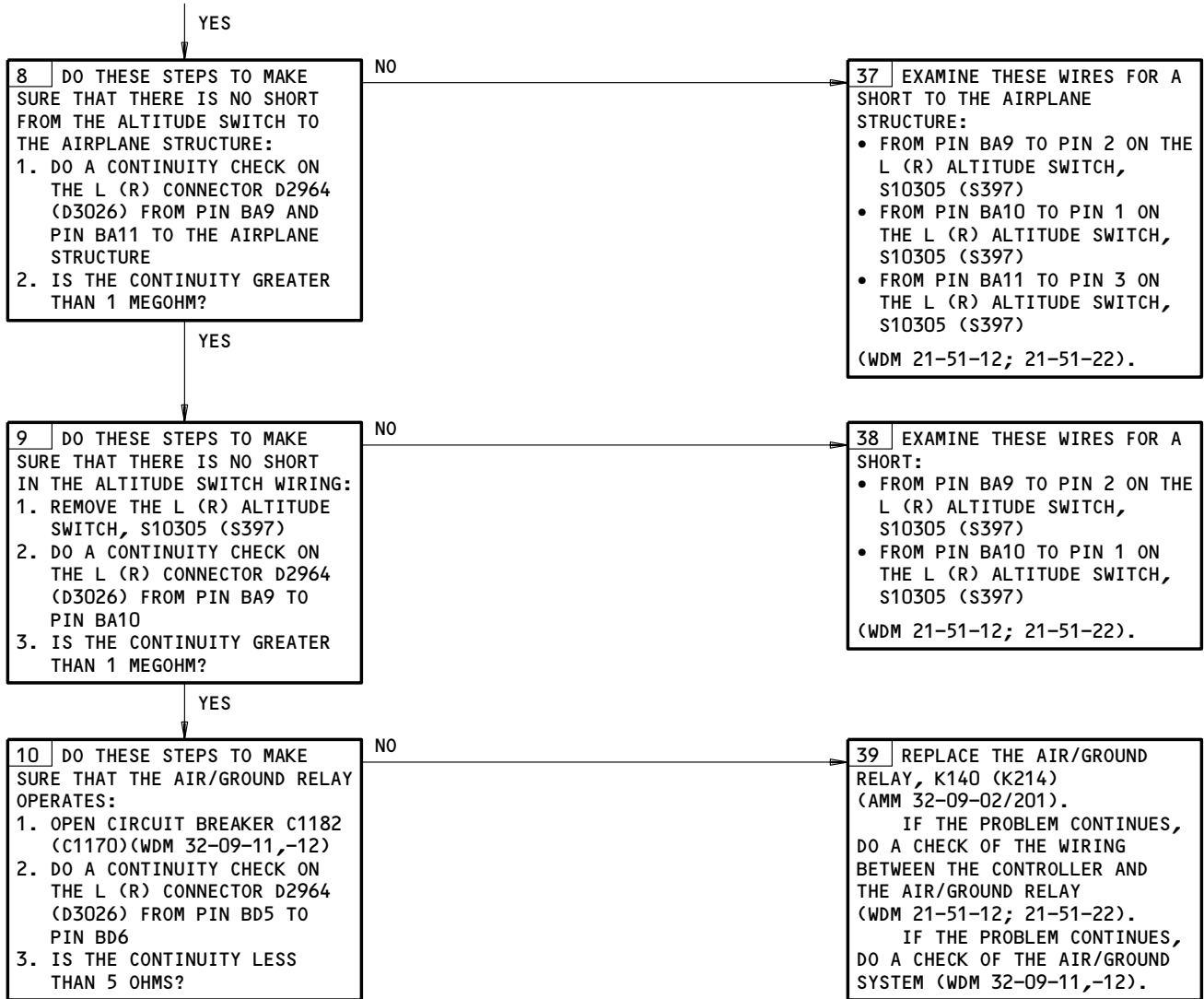

L (R) Pack Bite Continues to Find an Altitude Switch Fault
Figure 104A (Sheet 3)

EFFECTIVITY

ALL

21-51-00

01

Page 126
Sep 20/96

ED08903

**PACK STANDBY
CONTROLLER BITE
PROCEDURE**

PREREQUISITES

MAKE SURE THESE CIRCUIT BREAKERS ARE CLOSED:
11A15,11A26,11M15,11M24

MAKE SURE THE AIRPLANE IS IN THIS CONFIGURATION:
ELECTRICAL POWER IS ON (AMM 24-22-00/201)
BOTH PACK SELECTORS IN STBY-N

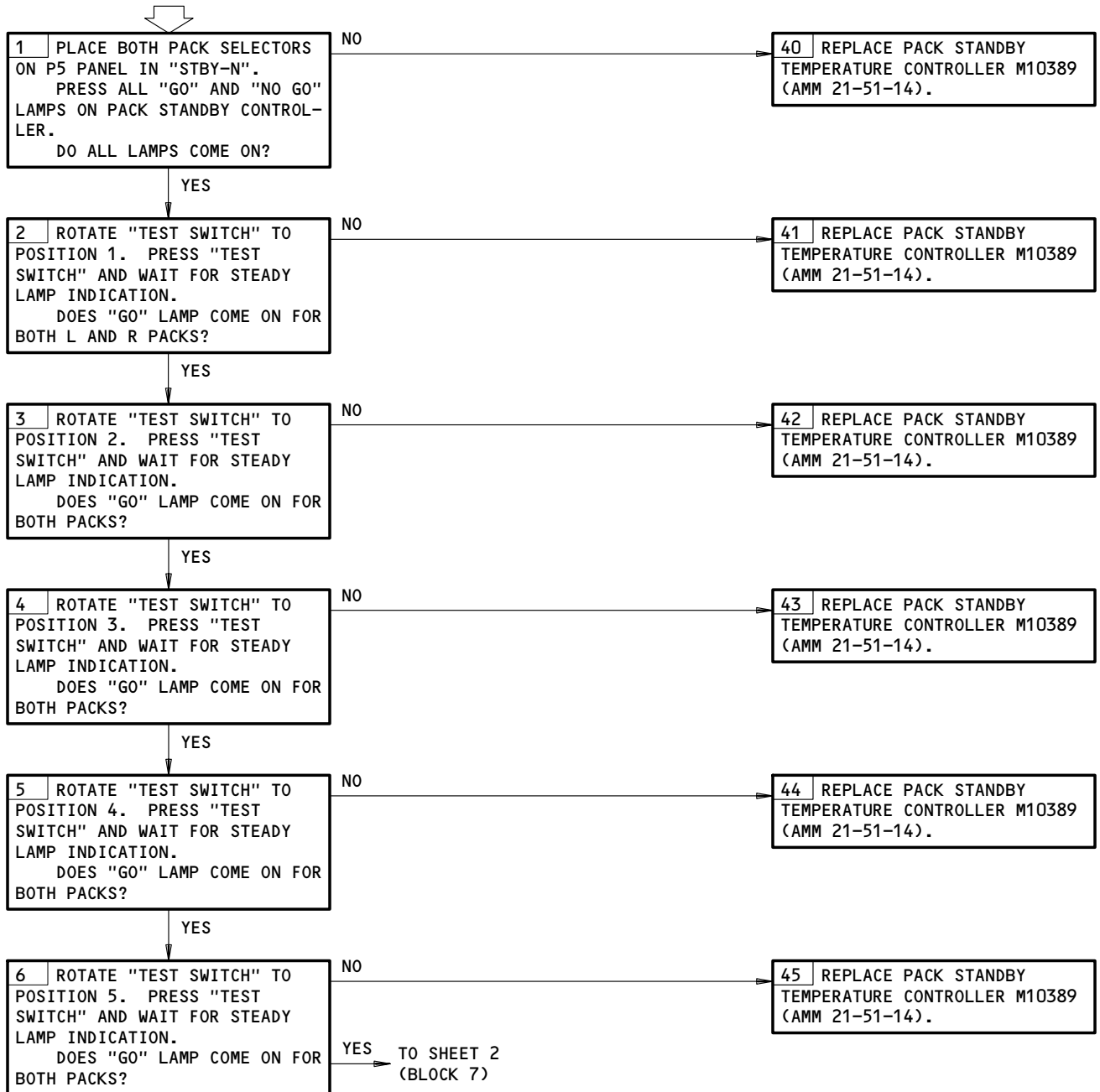

Pack Standby Controller BITE Procedure (Ground)
Figure 105 (Sheet 1)

EFFECTIVITY

ALL

21-51-00

07

Page 127
Dec 20/95

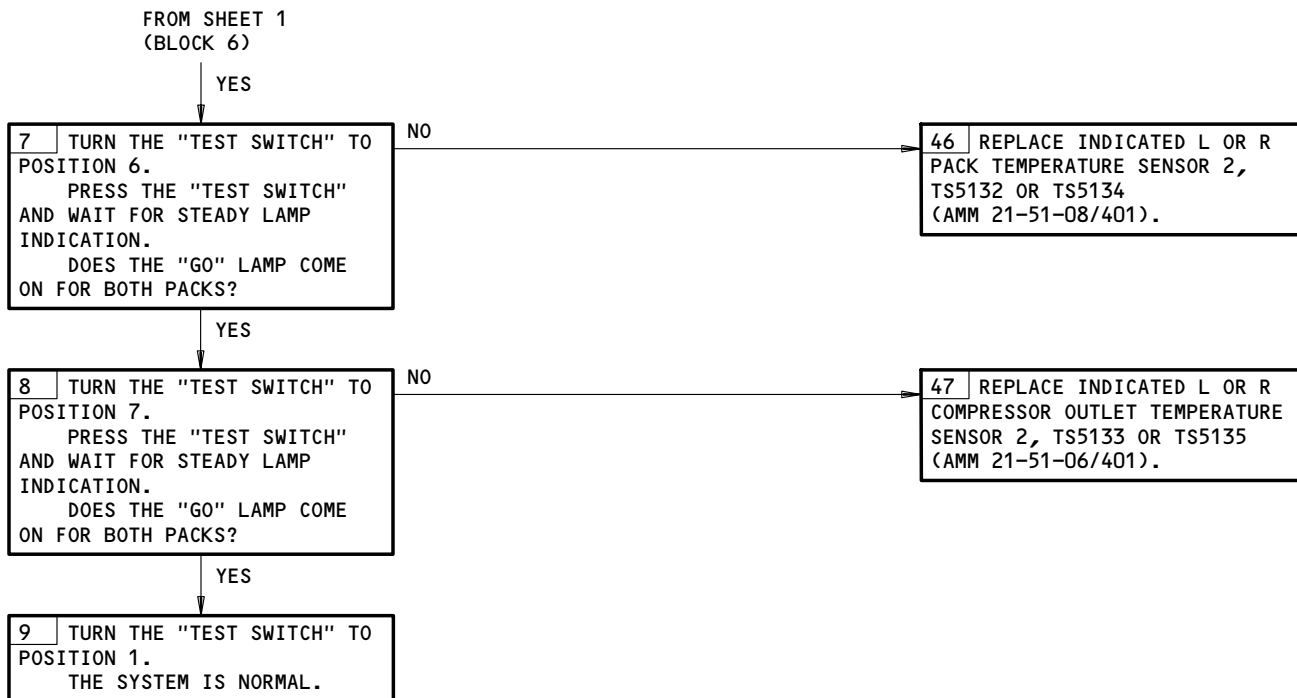

Pack Standby Controller BITE Procedure (Ground)
Figure 105 (Sheet 2)

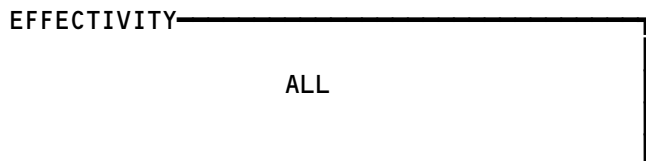

21-51-00

**PACK "INOP" LIGHT
ILLUM IN AUTO;
COULD NOT RESET**

PREREQUISITES

MAKE SURE THESE CIRCUIT BREAKERS ARE CLOSED:
11A13,11A14,11A15,11A26,11A28,11M11,11M15,11M19,
11M24

MAKE SURE THE AIRPLANE IS IN THIS CONFIGURATION:
ELECTRICAL POWER IS ON (AMM 24-22-00/201)

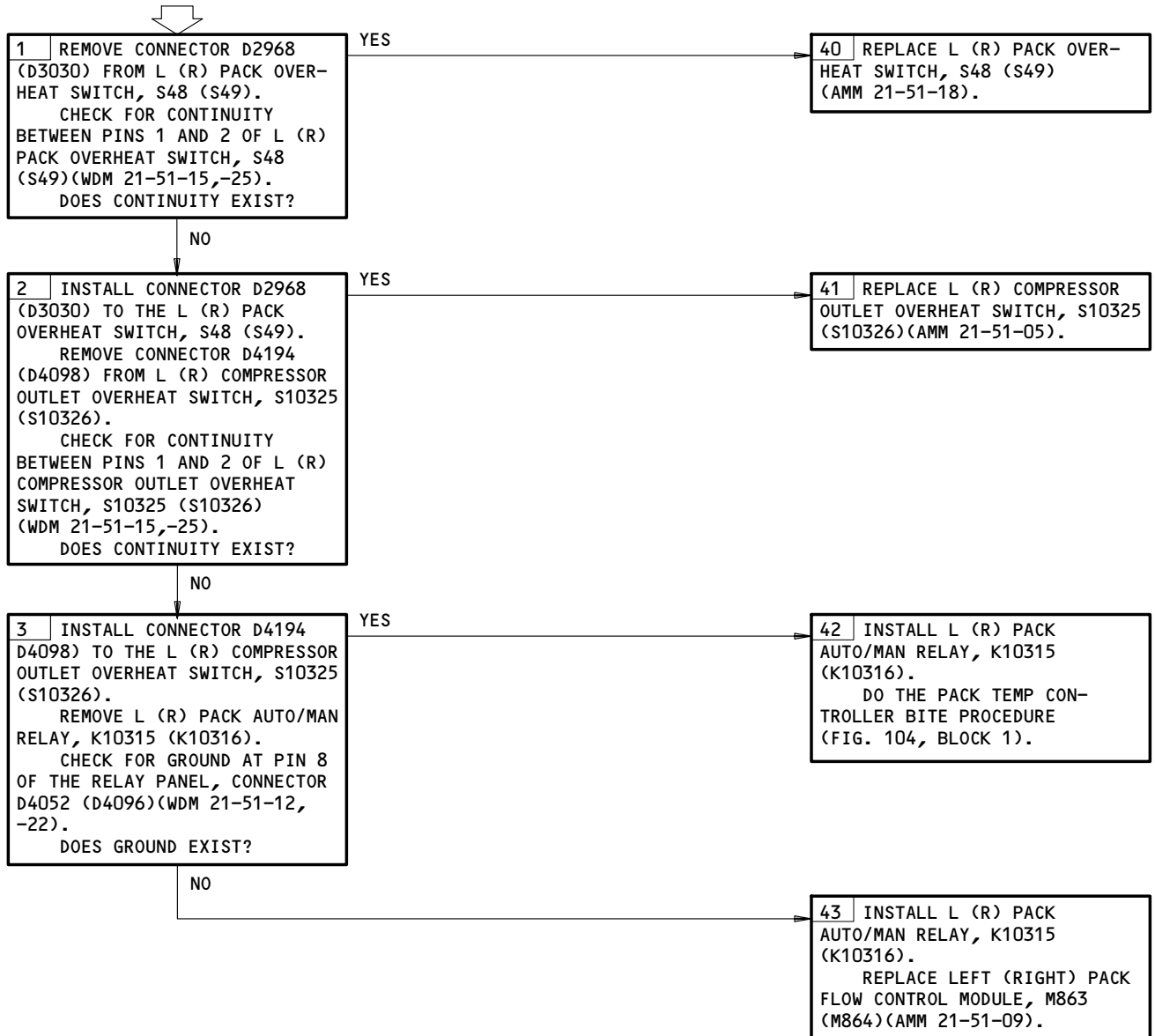

Pack INOP Light Illum In Auto; Could Not Reset
Figure 106

EFFECTIVITY

ALL

21-51-00

08

Page 129
Dec 20/95

"INOP" AND "PACK OFF" LIGHTS ILLUM IN AUTO; COULD NOT RESET. PACK DID NOT OPERATE NORMAL IN STBY

PREREQUISITES
MAKE SURE THESE CIRCUIT BREAKERS ARE CLOSED:
11A13,11A14,11A15,11A26,11A28,11A29,11M11,11M15,11M19,11M24
MAKE SURE THE AIRPLANE IS IN THIS CONFIGURATION:
ELECTRICAL POWER IS ON (AMM 24-22-00/201)

NOTE: IF PNEUMATIC DUCT PRESSURE IS LOW WITH THE ENGINES ON, DO THIS PROCEDURE: "LOW DUCT PRESSURE" PROCEDURE (AMM 36-10-00/101, FIG. 106).

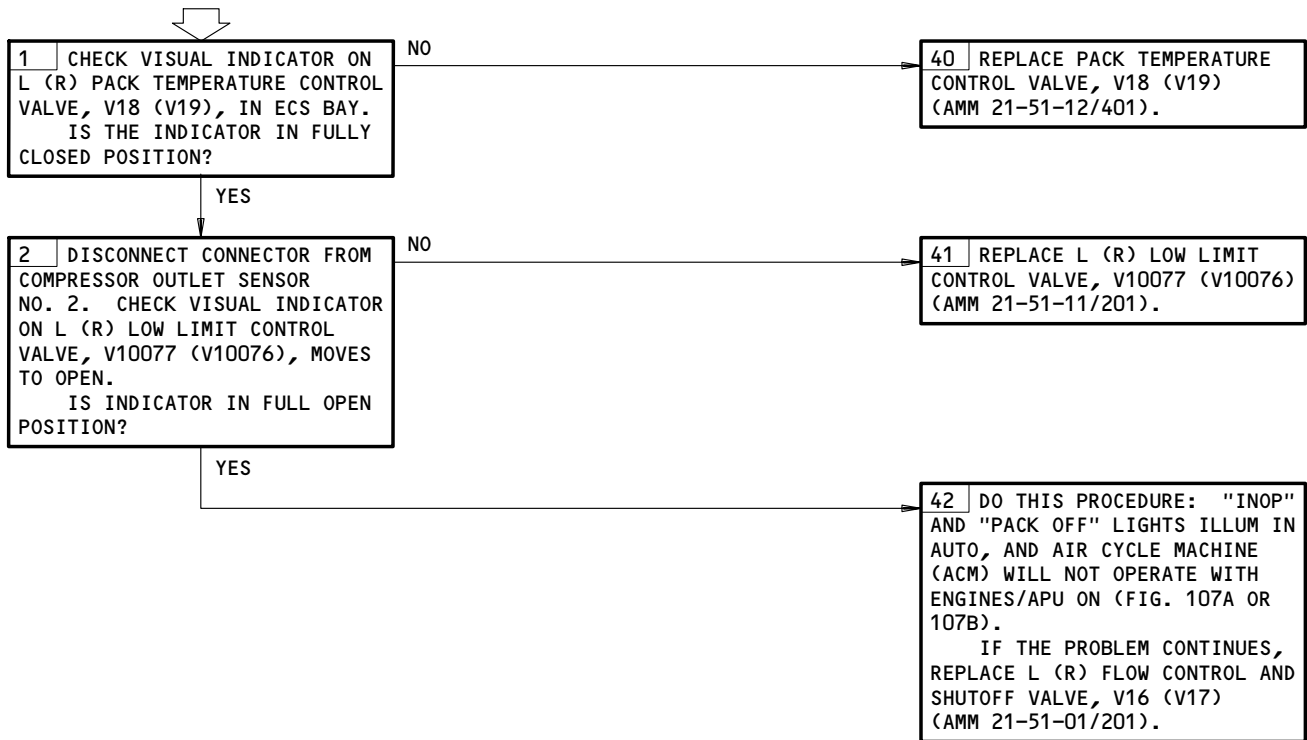

INOP and PACK OFF Lights Illum in Auto; Could Not Reset.
Pack Did Not Operate Normal in STBY
Figure 107

EFFECTIVITY	ALL
-------------	-----

21-51-00

206464

"INOP" AND "PACK OFF" LIGHTS ILLUM IN AUTO, AND AIR CYCLE MACHINE (ACM) WILL NOT OPERATE WITH ENGINES ON.

PREREQUISITES

MAKE SURE THIS SYSTEM WILL OPERATE:
EICAS (AMM 31-41-00/201)

MAKE SURE THE AIRPLANE IS IN THIS CONFIGURATION:
ELECTRICAL POWER IS ON (AMM 24-22-00/201)
ENGINES ARE ON
ENGINE BLEED AIR SWITCHES ARE IN THE "ON" POSITION

NOTE: CONTAMINATION OF THE ACM TURBINE THRUST BEARING CAN CAUSE THE ACM IMPELLER SHAFT NOT TO TURN. THIS PROCEDURE CAN HELP YOU START THE ACM IF IT HAS CONTAMINATION.

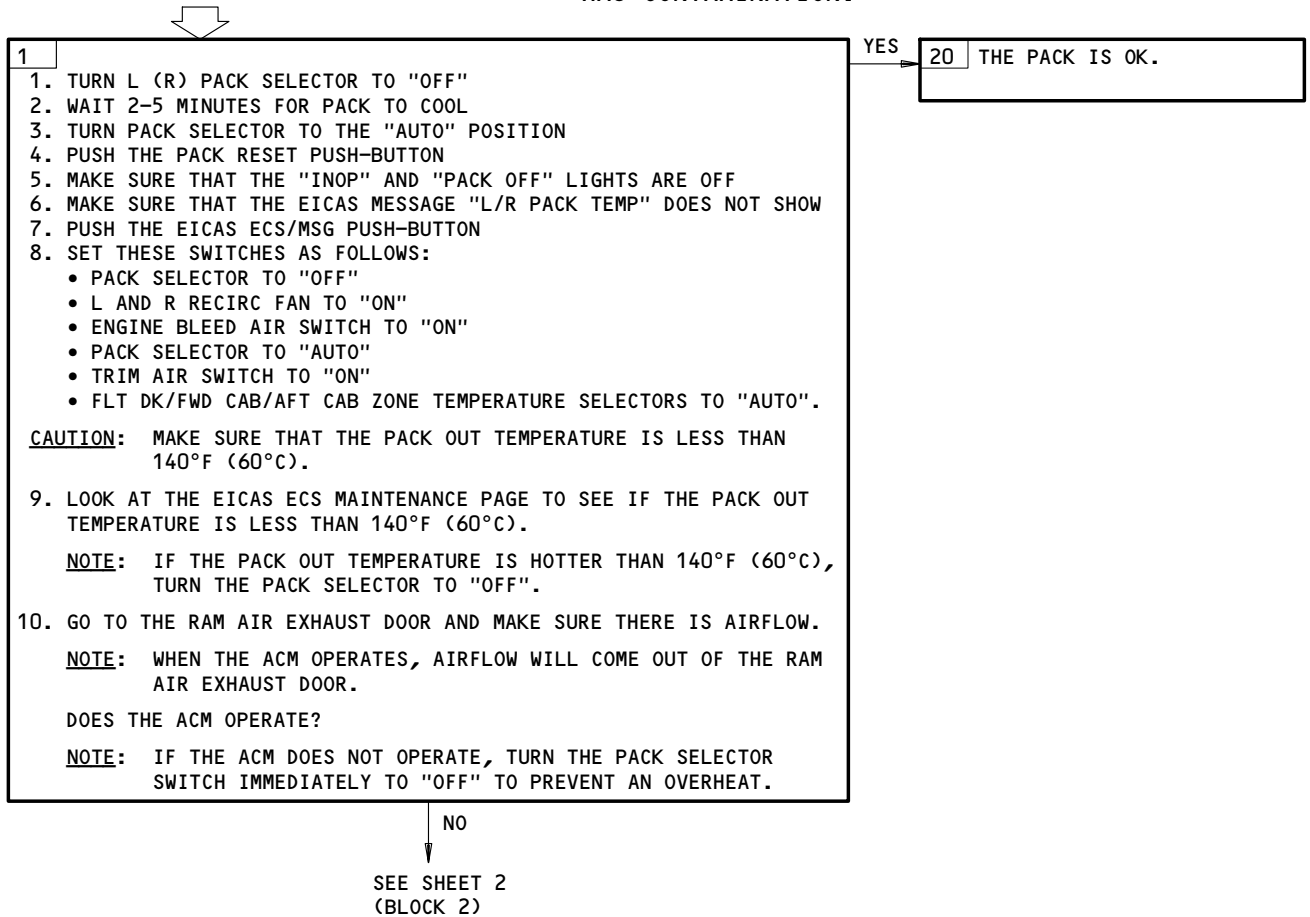

INOP and PACK OFF Lights Illum in Auto, and Air Cycle Machine (ACM) Will Not Operate With Engines On.
Figure 107A (Sheet 1)

EFFECTIVITY	ALL
-------------	-----

21-51-00

BOEING

757

FAULT ISOLATION/MAINT MANUAL

FROM SHEET 1
(BLOCK 1)

NO

2

1. TURN THE TRIM AIR SWITCH TO "OFF"
2. ADVANCE THE THROTTLES UNTIL THE BLEED AIR DUCT PRESSURE IS APPROXIMATELY 45 PSIG
3. TURN THE PACK SELECTOR TO "STBY C"

NOTE: HIGHER BLEED AIR PRESSURE IS DIRECTED TO THE ACM WHEN THE TRIM AIR IS OFF AND THE PACK SELECTOR IS SET TO "STBY C".

4. GO TO THE RAM AIR EXHAUST DOOR AND MAKE SURE THERE IS AIRFLOW.

NOTE: WHEN THE ACM OPERATES, AIRFLOW WILL COME OUT OF THE RAM AIR EXHAUST DOOR.

DOES THE ACM OPERATE?

NOTE: IF THE ACM DOES NOT OPERATE, TURN THE PACK SELECTOR SWITCH IMMEDIATELY TO "OFF" TO PREVENT AN OVERHEAT.

YES

21 SET THE PACK SELECTOR TO THE "AUTO" POSITION. THE PACK IS OK.

NO

3

1. GET ACCESS TO THE ENVIRONMENTAL CONTROL SYSTEMS PACK
2. TURN THE PACK SELECTOR TO THE "AUTO" POSITION.

CAUTION: DO NOT HIT THE ACM WITH A METAL OBJECT. DAMAGE CAN OCCUR.

3. LIGHTLY HIT THE TURBINE ANTI-ICE MUFF WITH A PLASTIC HAMMER OR RUBBER MALLET.
4. GO TO THE RAM AIR EXHAUST DOOR AND MAKE SURE THERE IS AIRFLOW.

NOTE: WHEN THE ACM OPERATES, AIRFLOW WILL COME OUT OF THE RAM AIR EXHAUST DOOR.

DOES THE ACM OPERATE?

NOTE: IF THE ACM DOES NOT OPERATE, TURN THE PACK SELECTOR SWITCH IMMEDIATELY TO "OFF" TO PREVENT AN OVERHEAT.

YES

22 THE PACK IS OK.

NO

4

1. REMOVE THE ACM (AMM 21-51-03/401)
2. PUT THE ACM IN A HORIZONTAL POSITION
3. TORQUE THE IMPELLER SHAFT AT THE TURBINE END OF THE ACM IN THE CLOCKWISE DIRECTION
4. MAKE SURE THE BREAKAWAY TORQUE IS LESS THAN 90 INCH-POUNDS.

CAUTION: DO NOT TURN THE IMPELLER SHAFT MORE THAN TWO ROTATIONS, OR YOU CAN DAMAGE THE BEARINGS.

5. MAKE SURE YOU CAN CONTINUE TO TURN THE IMPELLER SHAFT WITH LESS THAN 35 INCH-POUNDS OF TORQUE.

WAS THE BREAKAWAY TORQUE LESS THAN 90 INCH-POUNDS AND THE RUN-ON TORQUE LESS THAN 35 INCH-POUNDS?

NOTE: CHECK THE ACM ROTOR FOR ICE IMPINGEMENT DAMAGE AND REPLACE THE ACM IF NECESSARY. DO THE TEST OF THE WATER EXTRACTION SYSTEM AND THE TURBINE ANTI-ICE SYSTEM.

YES

23 REINSTALL THE ACM (AMM 21-51-03/401).

NO

24 REPLACE THE ACM (AMM 21-51-03/401).

INOP and PACK OFF Lights Illum in Auto, and Air Cycle Machine (ACM)
Will Not Operate with Engines On.
Figure 107A (Sheet 2)

EFFECTIVITY

ALL

21-51-00

01

Page 132
May 28/99

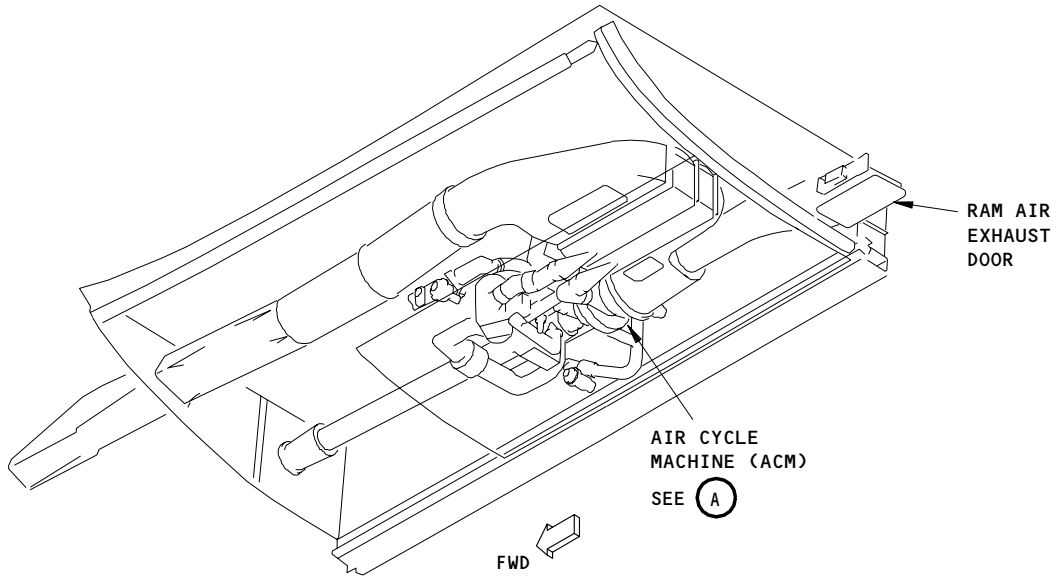

AIR CONDITIONING PACK

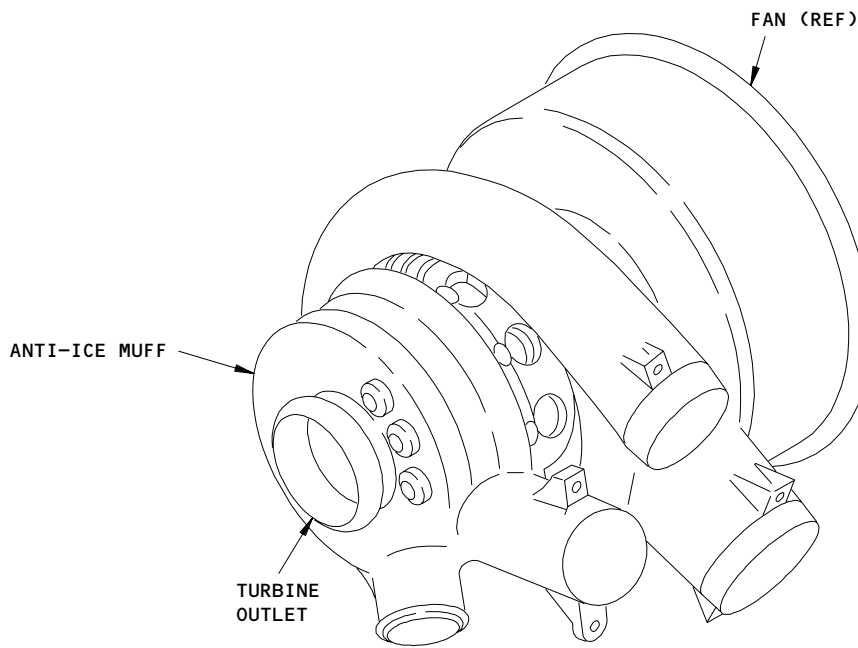

AIR CYCLE MACHINE (ACM)

(A)

INOP and PACK OFF Lights Illum in Auto, and Air Cycle Machine (ACM)
Will Not Turn with Engines On.
Figure 107A (Sheet 3)

EFFECTIVITY	
	ALL

21-51-00

01

Page 133
Dec 20/95

023393

"INOP" AND "PACK OFF" LIGHTS ILLUM IN AUTO, AND AIR CYCLE MACHINE (ACM) WILL NOT OPERATE WITH APU ON.

PREREQUISITES

MAKE SURE THIS SYSTEM WILL OPERATE:
EICAS (AMM 31-41-00/201)

MAKE SURE THE AIRPLANE IS IN THIS CONFIGURATION:
ELECTRICAL POWER IS ON (AMM 24-22-00/201)
APU IS ON
APU BLEED AIR SWITCH IS IN THE "ON" POSITION

NOTE: CONTAMINATION OF THE ACM TURBINE THRUST BEARING CAN CAUSE THE ACM IMPELLER SHAFT NOT TO TURN. THIS PROCEDURE CAN HELP YOU START THE ACM IF IT HAS CONTAMINATION.

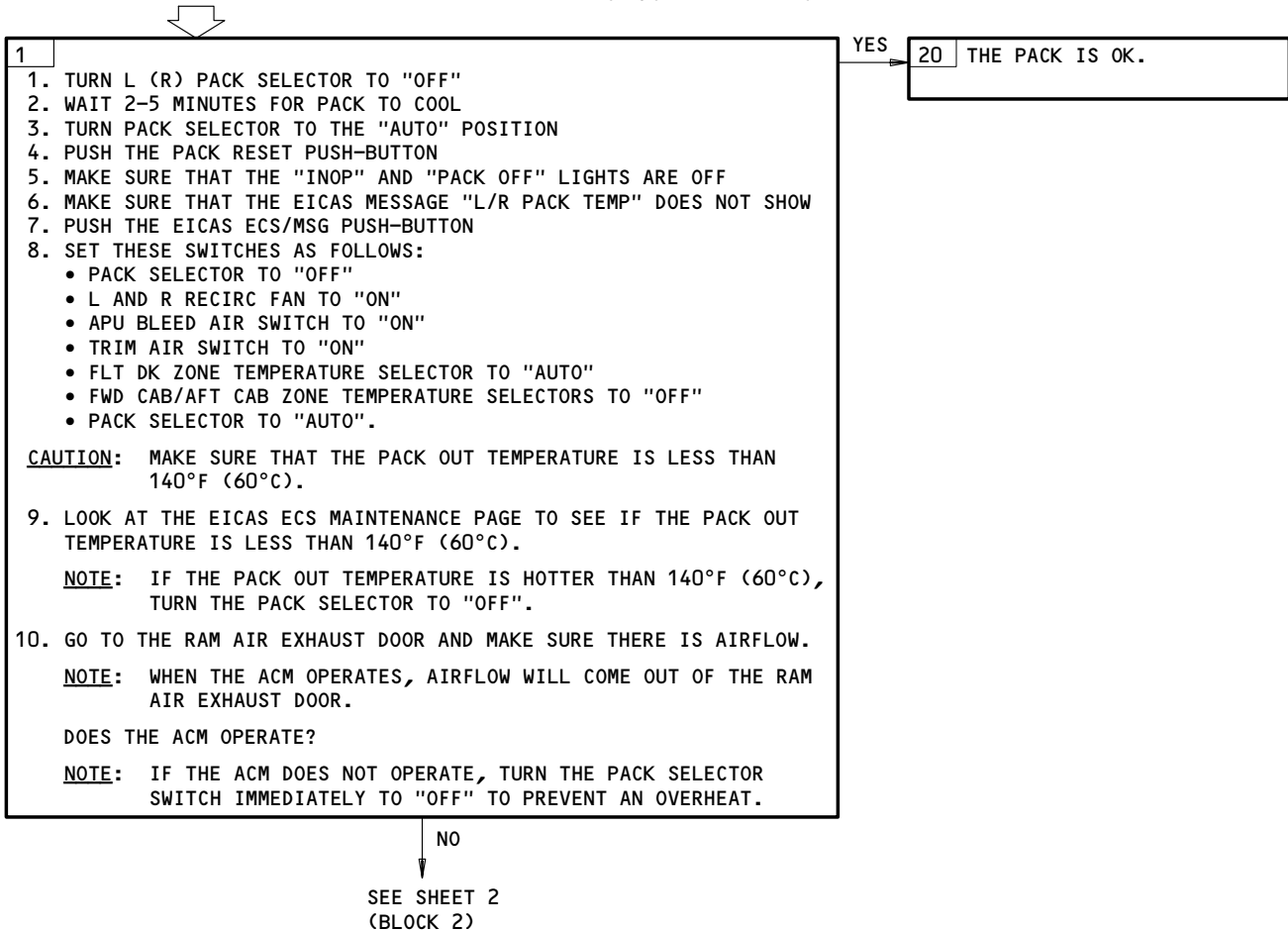

INOP and PACK OFF Lights Illum in Auto, and Air Cycle Machine (ACM)
Will Not Operate With APU On.
Figure 107B (Sheet 1)

EFFECTIVITY	ALL
-------------	-----

21-51-00

BOEING
757
FAULT ISOLATION/MAINT MANUAL

FROM SHEET 1
(BLOCK 1)

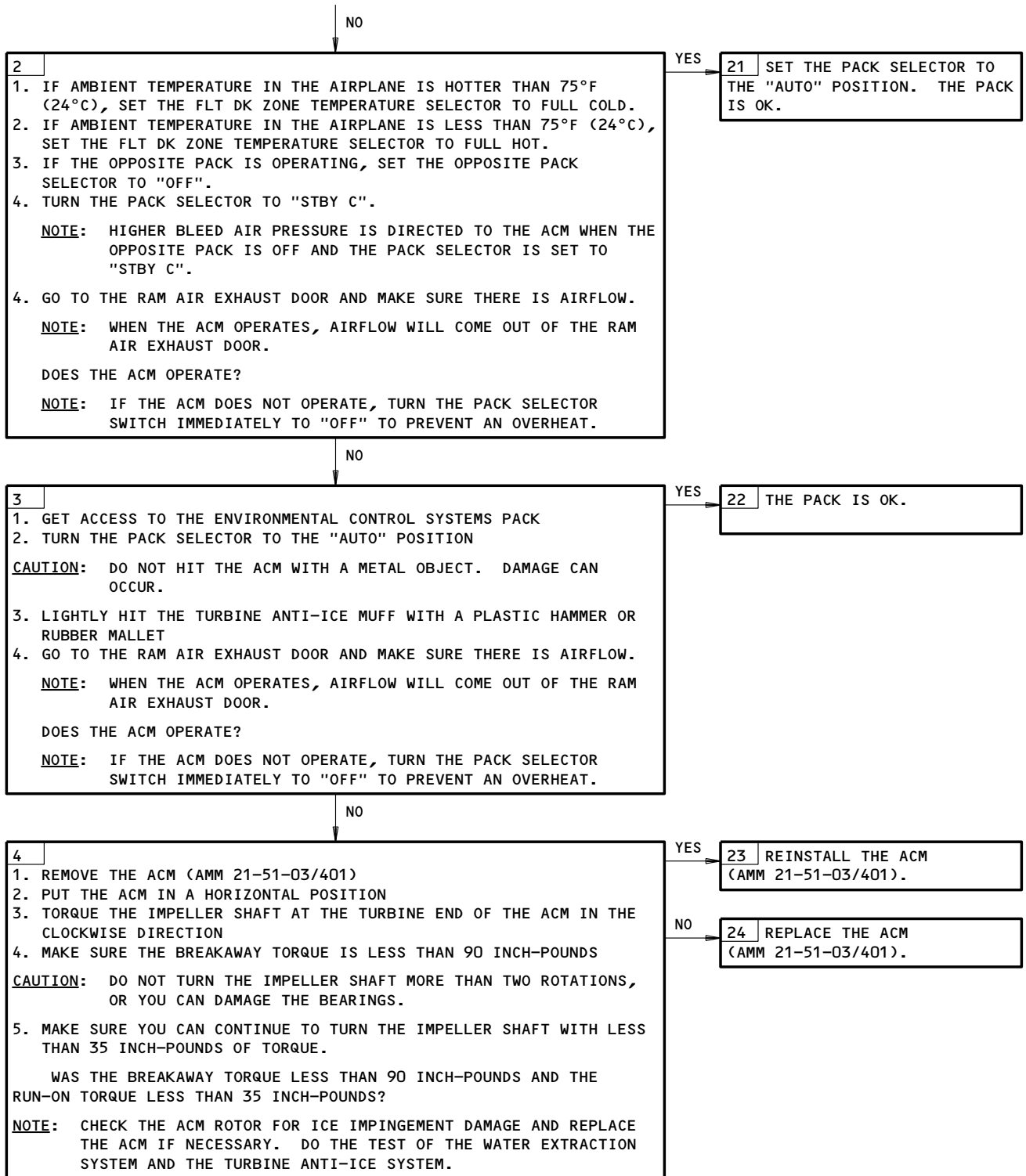

INOP and PACK OFF Lights Illum in Auto, and Air Cycle Machine (ACM)
Will Not Operate With APU On.
Figure 107B (Sheet 2)

EFFECTIVITY	ALL
-------------	-----

21-51-00

01

Page 135
May 28/99

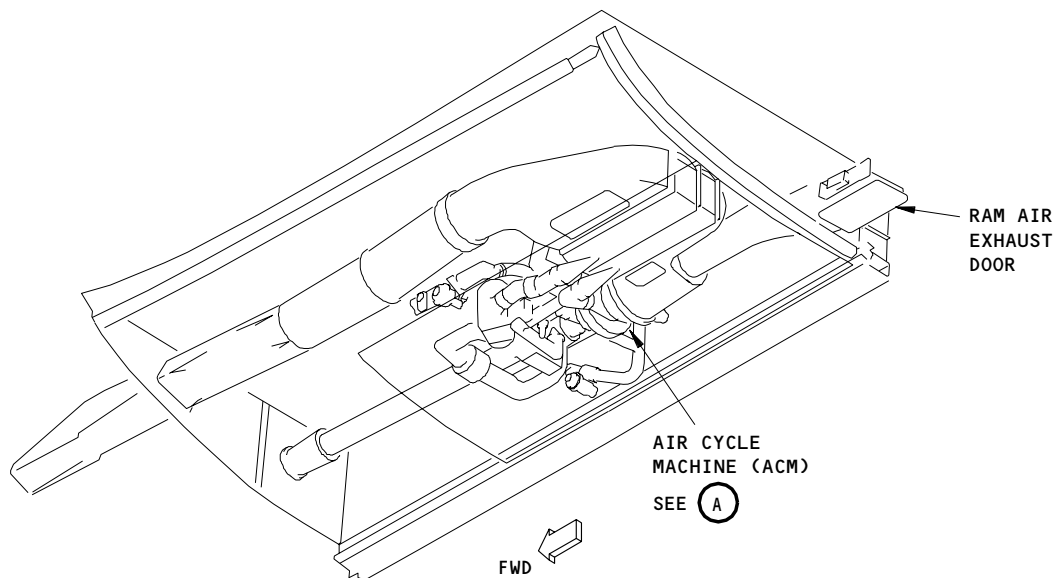

AIR CONDITIONING PACK

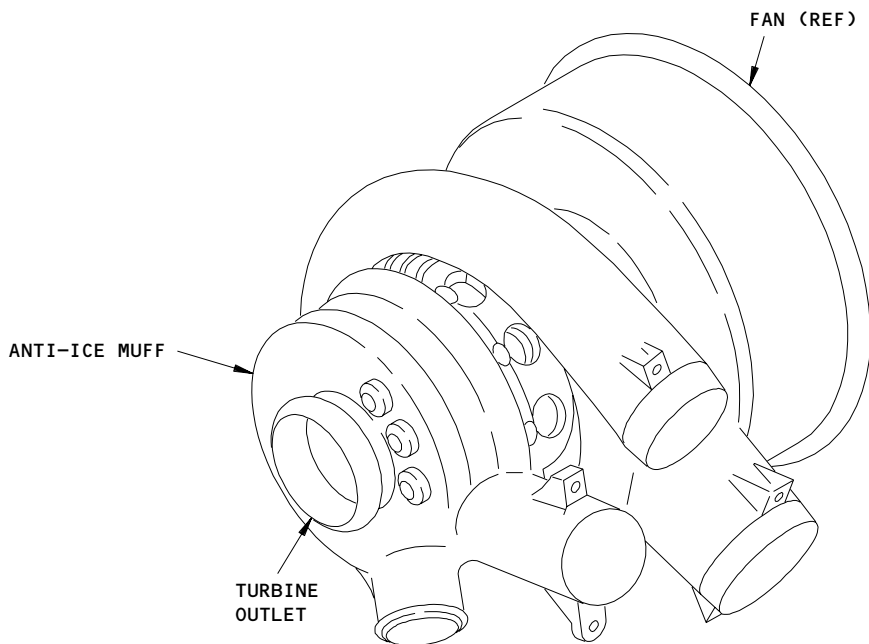

AIR CYCLE MACHINE (ACM)

(A)

INOP and PACK OFF Lights Illum in Auto, and Air Cycle Machine (ACM)
Will Not Turn with APU On.
Figure 107B (Sheet 3)

EFFECTIVITY	ALL
-------------	-----

21-51-00

01

Page 136
Dec 20/95

"PACK OFF" LIGHT
EXTIN. & "PACK OFF"
EICAS MSG NOT DIS-
PLAYED WITH PACK
SW IN "OFF"

PREREQUISITES

MAKE SURE THESE CIRCUIT BREAKERS ARE CLOSED:
11A14,11A29

MAKE SURE THE AIRPLANE IS IN THIS CONFIGURATION:
ELECTRICAL POWER IS ON (AMM 24-22-00/201)
PNEUMATIC POWER (AMM 36-00-00/201)

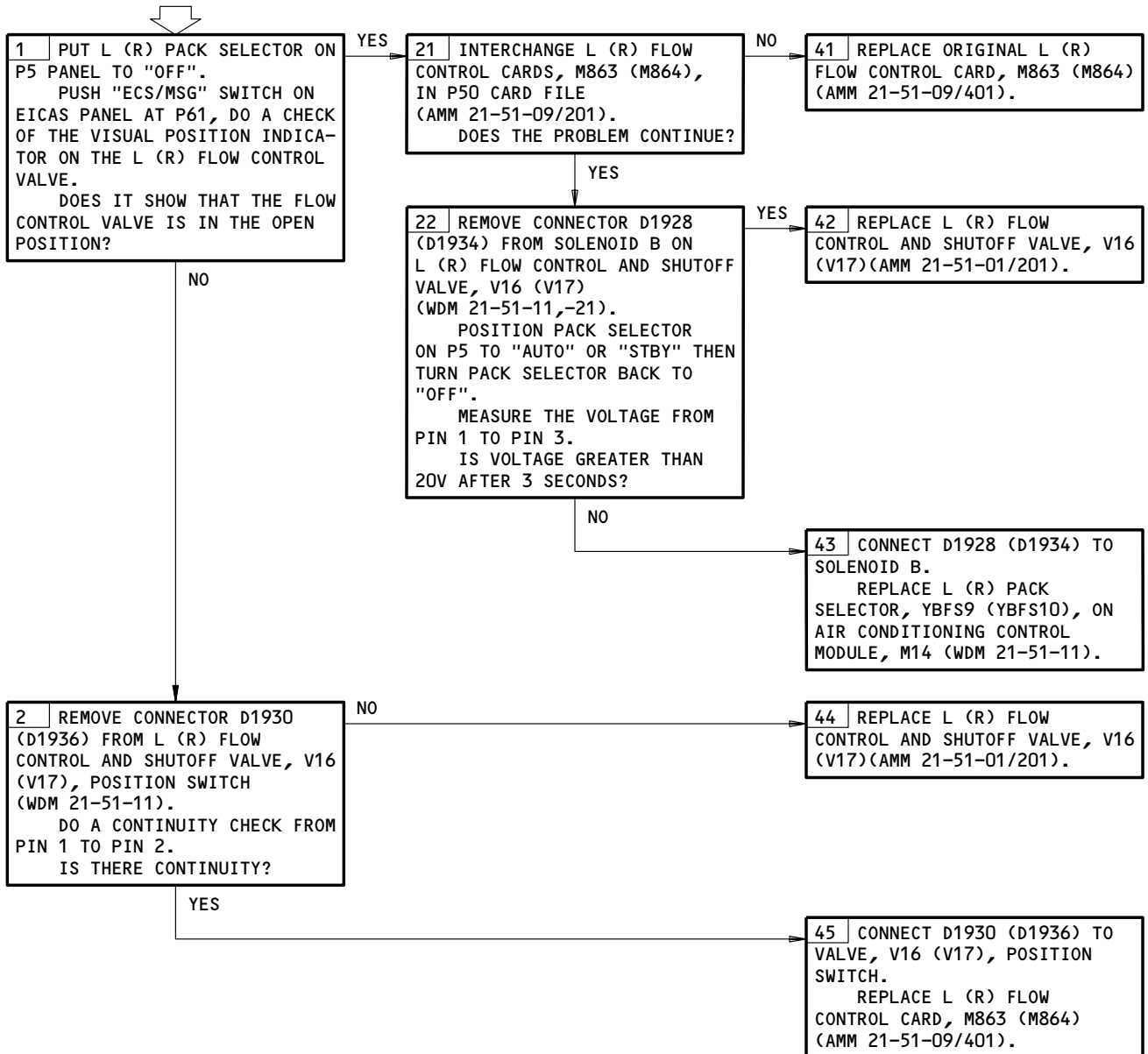

PACK OFF Light Extin. & PACK OFF EICAS Msg Not Displayed with PACK Sw in OFF
Figure 108

EFFECTIVITY

ALL

21-51-00





02

Page 137
Jun 20/96

F80733

BOEING
757
FAULT ISOLATION/MAINT MANUAL

PACK TEMPERATURE INDICATION

COMPONENT	FIG. 102 SHT	QTY	ACCESS/AREA	AMM REFERENCE
BULB - COMPRESSOR OUTLET TEMPERATURE  LEFT PACK, TS5089 RIGHT PACK, TS5090	1	1 1	193HL 194ER	21-52-01
BULB - PACK OUTLET TEMPERATURE LEFT PACK, TS5002 RIGHT PACK, TS5003	1	1 1	193HL 194ER	21-52-06
BULB - PRIMARY HEAT EXCHANGER INLET (PACK INLET) TEMPERATURE 	1	1 1	193HL 194ER	21-52-10
BULB - PRIMARY HEAT EXCHANGER OUTLET  LEFT PACK, TS5087 RIGHT PACK, TS5088	1	1 1	193HL 194ER	21-52-09
BULB - SECONDARY HEAT EXCHANGER OUTLET  LEFT PACK, TS5091 RIGHT PACK, TS5092	1	1 1	193HL 194ER	21-52-05
BULB - TURBINE INLET TEMPERATURE  LEFT PACK, TS5263 RIGHT PACK, TS5264	1	1 1	193HL 194ER	21-52-07
CIRCUIT BREAKERS PACK FLOW IND, C709	3	1	FLT COMPT, P11 PANEL 11M17	*
PROCESSOR - PACK FLOW SENSOR SIGNAL, M916 SENSOR - PACK FLOW LEFT PACK, TS285 RIGHT PACK, TS286	3 2 2	1 1 1	119BL, MAIN EQUIP CTR, E4-2 193HL 194ER	21-52-04 21-52-03

* SEE THE WDM EQUIPMENT LIST

 GUI 001-099

Pack Temperature Indication - Component Index
Figure 101

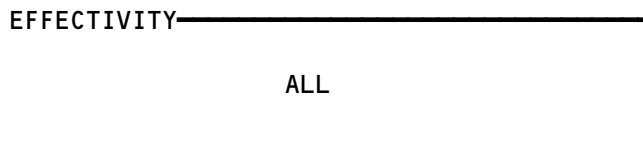

21-52-00

08

Page 101
Sep 20/93

C72131

BOEING
757
FAULT ISOLATION/MAINT MANUAL

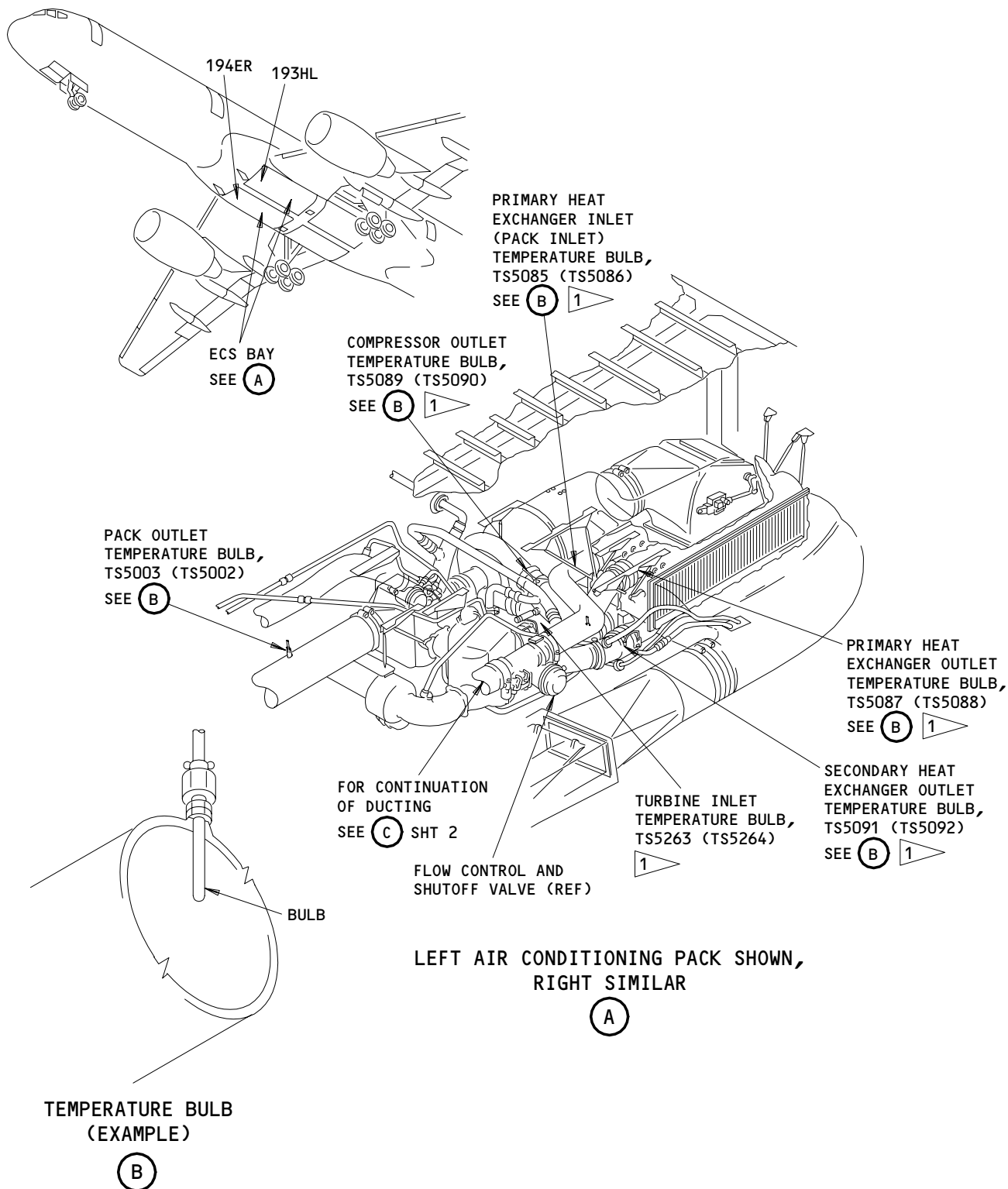

1 GUI 001-099

Pack Temperature Indication - Component Location
Figure 102 (Sheet 1)

EFFECTIVITY	
	ALL

21-52-00

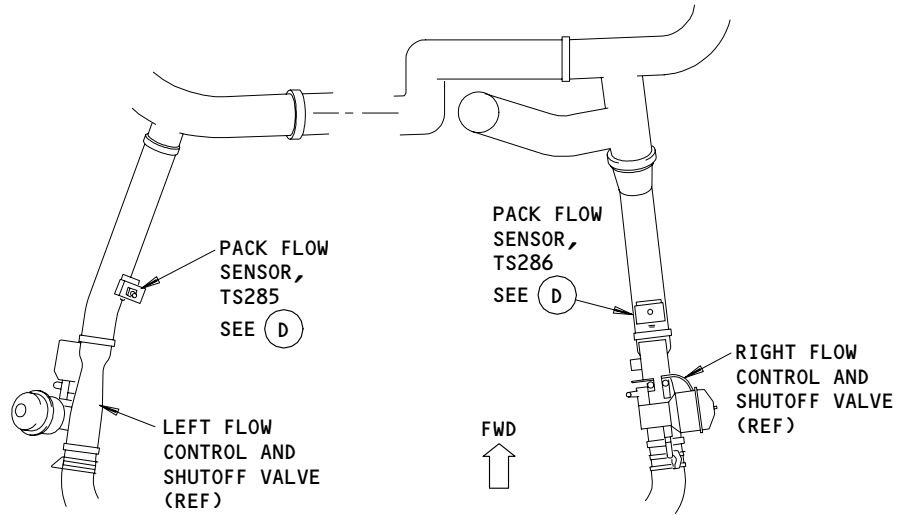

(C)

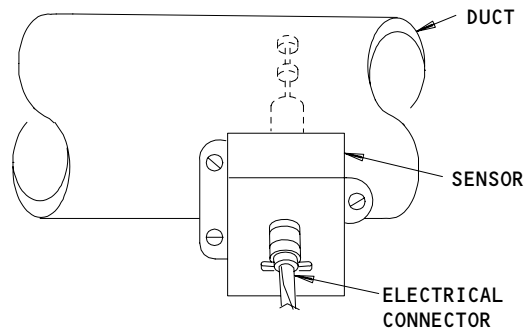

PACK FLOW SENSOR, TS285 (TS286)

(D)

Component Location
Figure 102 (Sheet 2)

EFFECTIVITY	
	ALL

218057

21-52-00

04

Page 103
Jun 15/86

BOEING
757
FAULT ISOLATION/MAINT MANUAL

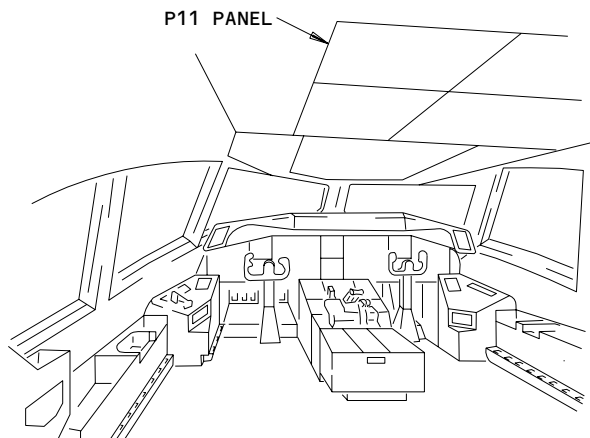

FLIGHT COMPARTMENT

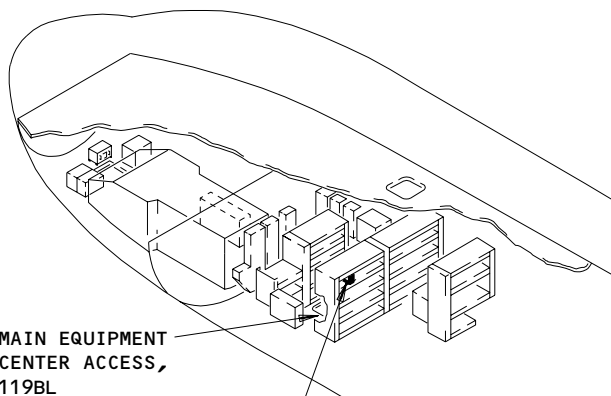

MAIN EQUIPMENT CENTER
SEE (E)

FLOW SENSOR SIGNAL PROCESSOR, M916

SEE (F)

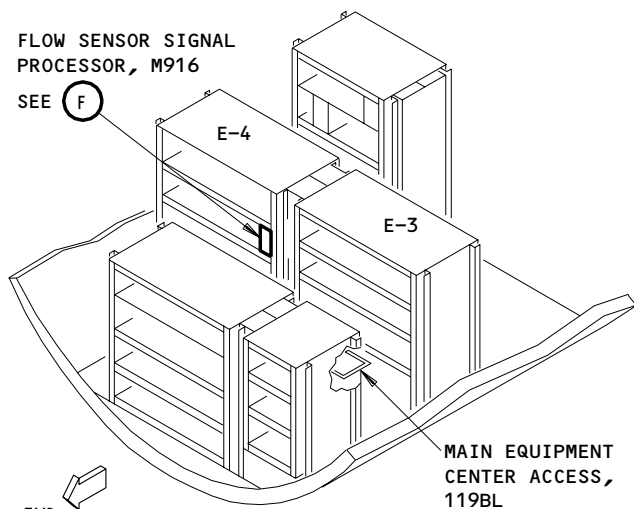

MAIN EQUIPMENT CENTER

(E)

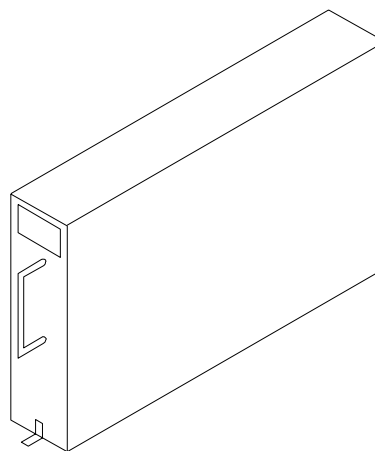

FLOW SENSOR SIGNAL PROCESSOR, M916

(F)

Component Location
Figure 102 (Sheet 3)

EFFECTIVITY

ALL

21-52-00

01

Page 104
Jun 15/86

68281

BOEING
 757
 FAULT ISOLATION/MAINT MANUAL

RAM AIR SYSTEM

COMPONENT	FIG. 102 SHT	QTY	ACCESS/AREA	AMM REFERENCE
ACTUATOR - RAM AIR EXHAUST DOOR	2	2	193HL,194ER	21-53-04
ACTUATOR - RAM AIR INLET DOOR	2	2	193BL,194BR	21-53-03
CARD - TEMPERATURE CONTROL, M10403,M10404	2	2	119BL,P50	21-53-06
DOOR - RAM AIR EXHAUST	1	2	193HL,194ER	21-53-02
DOOR - RAM AIR INLET	1	2	193HL,194ER	21-53-01
NOZZLE - WATER SPRAY	2	2	193HL,194ER	21-53-05

Ram Air System - Component Index
Figure 101

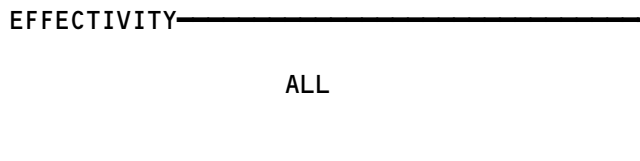

21-53-00

01

Page 101
Mar 20/94

E07069

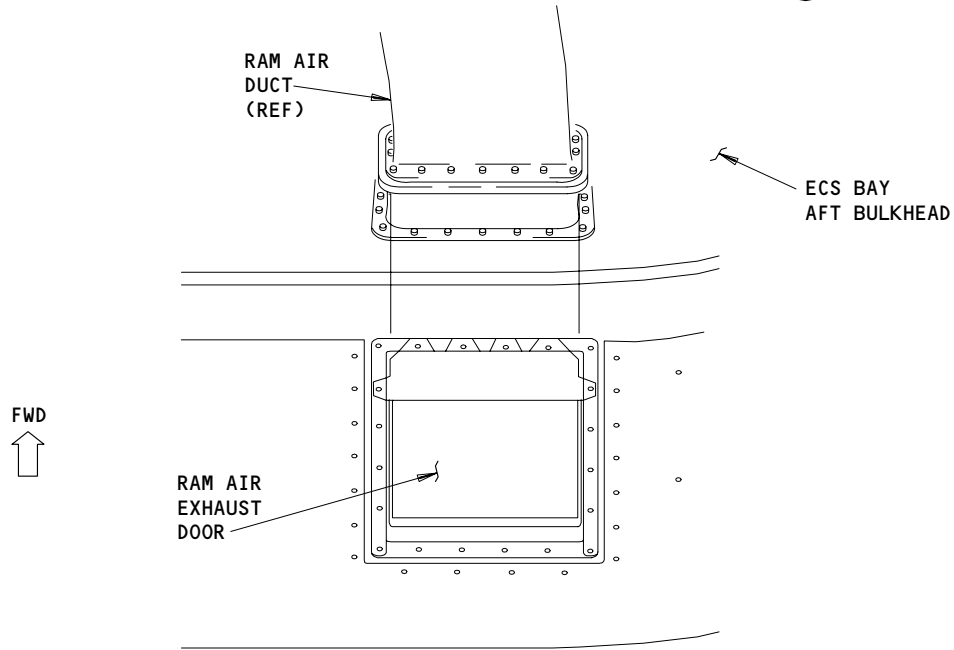
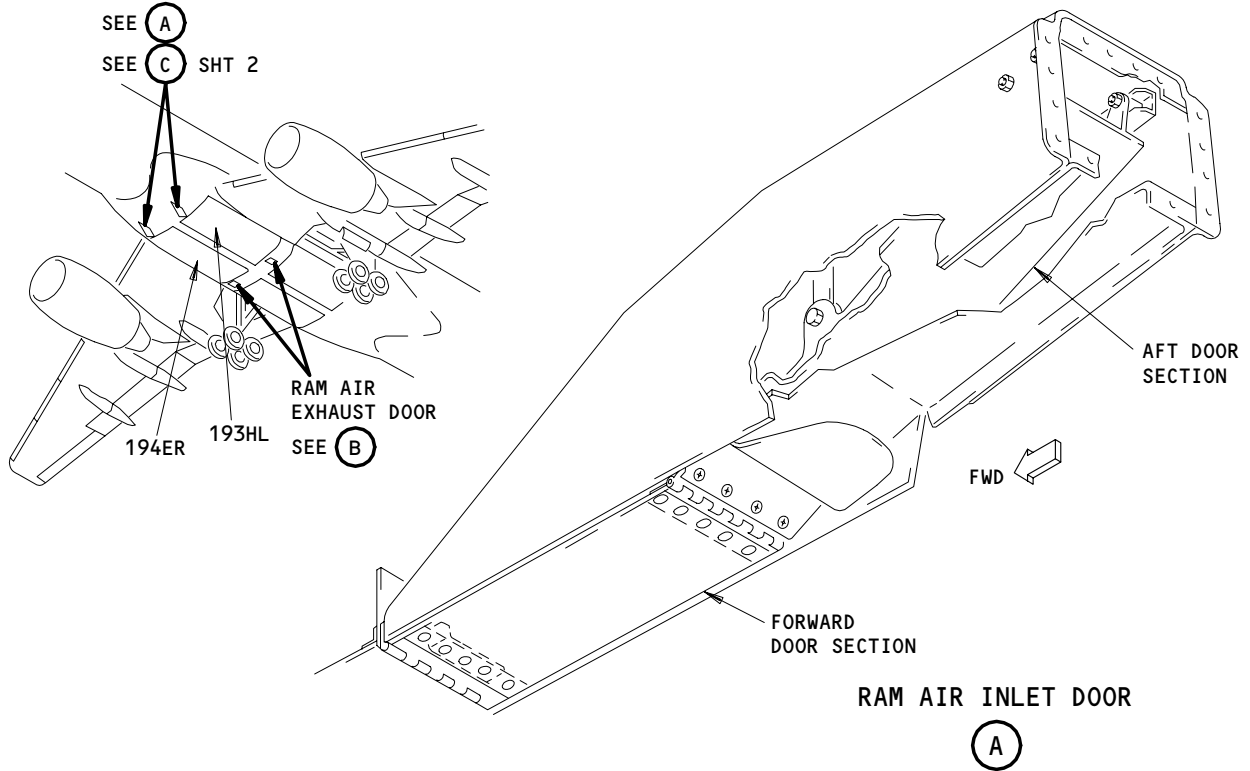

RAM AIR EXHAUST DOOR

(B)

Ram Air System - Component Location
Figure 102 (Sheet 1)

EFFECTIVITY	
ALL	

21-53-00

01

Page 102
Mar 20/94

BOEING
757
FAULT ISOLATION/MAINT MANUAL

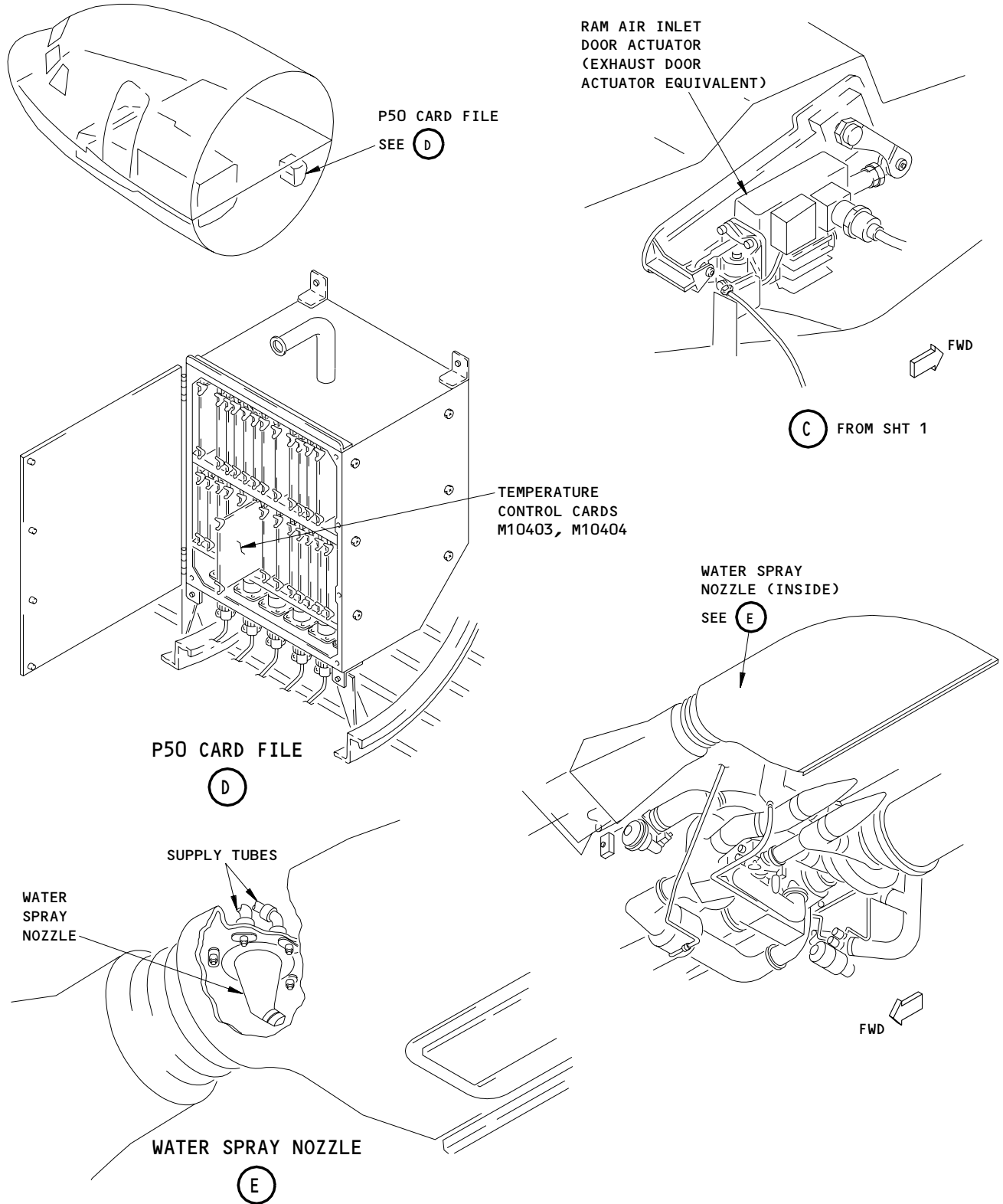

Ram Air System - Component Location
Figure 102 (Sheet 2)

EFFECTIVITY	
	ALL

21-53-00

01

Page 103
May 20/98

68762

 **BOEING**
757
FAULT ISOLATION/MAINT MANUAL

EQUIPMENT COOLING

COMPONENT	FIG. 102 SHT	QTY	ACCESS/AREA	AMM REFERENCE
CIRCUIT BREAKER - EQPT COOL GND WARN AND TEST, C4070	1	1	FLT COMPT, P6 6D6	*
EQUIP COOL SUPPLY FAN 1, C331		1	6F17	*
EQUIP COOL SUPPLY FAN 2, C332		1	6F23	*
EQUIP COOLING AUX FAN, C3044		1	6D17	*
CIRCUIT BREAKER - EQUIP COOLING FAN CONT AFT EXH XFER, C705	1	1	FLT COMPT, P11 11N11	*
EQUIP COOLING LOW FLOW DET, C4069		1	11N13	*
EQUIP COOLING SMOKE DET CONT, C4085		1	11C20	*
RECIRC CARGO FIRE CONT LEFT, C660		1	11P14	*
CIRCUIT BREAKER - AFT EQPT COOLING FAN EXH NO. 1, C333		1	119BL, MAIN EQUIP CTR, P37 37D5	*
AFT EQPT COOLING FAN SPLY NO. 1, C3029		1	37D2	*
CIRCUIT BREAKER - AFT EQPT COOLING FAN EXH NO. 2, C334		1	119BL, MAIN EQUIP CTR, P70 70B2	*
AFT EQPT COOLING FAN SPLY NO. 2, C3028		1	70B5	*
RECIRC FAN LEFT, C336		1	70C10	*
LEFT RECIRC FAN CONT, C4373		1	70B16	*
CLEANER - EQUIPMENT COOLING AIR, AFT	4	1	822, AFT CARGO COMPT	21-58-21
CLEANER - EQUIPMENT COOLING AIR, FWD	3	1	821, FWD CARGO COMPT	21-58-21
COMPUTER - (FIM 31-41-00/101) EICAS LEFT, M10181 EICAS RIGHT, M10182				
DIODE - (FIM 31-01-36/101) R10044,R10096,R10171,R10172,R10173,R10174, R10180,R10181,R10204,R10218,R10221,R10223, R10227,R10230,R10235				
DIODE - (FIM 31-01-37/101) R10074,R10179,R10224,R10225,R10226				
FAN - AFT EQUIP COOLING SUPPLY 1, B10061	4	1	822, AFT CARGO COMPT	21-58-21
FAN - AFT EQUIP COOLING SUPPLY 2, B10062	4	1	822, AFT CARGO COMPT	21-58-10
FAN - AFT EQUIP/LAV/GALLEY VENT 1, B16	5	1	822, AFT CARGO COMPT	21-26-01
FAN - AFT EQUIP/LAV/GALLEY VENT 2, B15	5	1	822, AFT CARGO COMPT	21-26-01
FAN - EQUIP COOLING AUXILIARY, B10133	5	1	119BL, MAIN EQUIP CTR	21-58-22
FAN - FWD EQUIP COOLING SUPPLY 1, B10	3	1	821, FWD CARGO COMPT	21-58-06
FAN - FWD EQUIP COOLING SUPPLY 2, B11	3	1	821, FWD CARGO COMPT	21-58-06
FAN - LEFT RECIRCULATION AIR, B13	3	1	821, FWD CARGO COMPT	21-25-01
FILTER - LEFT RECIRCULATION AIR	4	2	821, FWD CARGO COMPT	21-25-02
LIGHT - SMOKE, YNML1	1	1	FLT COMPT, P5 EQUIP COOLING PANEL, M10067	*
MODULE - (FIM 27-51-00/101) FSEU3, M10333				
PANEL - AIR CONDITIONING CONTROL, M10193	1	1	FLT COMPT, P5	
PANEL - (FIM 26-22-00/101) APU/CARGO FIRE CONTROL, M10444				
PANEL - EQUIP COOLING, M10067	1	1	FLT COMPT, P5	
PANEL - (FIM 34-21-00/101) IRS MODE SEL, M59				
PANEL - MISC TEST, M10399	1	1	FLT COMPT, P61	
PANEL - (FIM 23-42-00/101) PILOT CALL, M51				

* SEE THE WDM EQUIPMENT LIST

Equipment Cooling - Component Index
Figure 101 (Sheet 1)

EFFECTIVITY
GUI 115

21-58-00

CONFIG 3

05

Page 101

Jan 28/00

293027

 **BOEING**
757
FAULT ISOLATION/MAINT MANUAL

COMPONENT	FIG. 102 SHT	QTY	ACCESS/AREA	AMM REFERENCE
RELAYS - (FIM 31-01-36/101) AFT EQUIP COOL SUPPLY FAN 1, K10323 AFT EQUIP/LAV/GALLEY VENT FAN 1, K347 AIR/GND SYS NO. 1, K124 AIR/GND SYS NO. 1, K148 ALTN MODE, K10506 AUTO TEST, K10511 EXHAUST SMOKE SENSING, K10509 FWD EQUIP SUPPLY FAN 1, K343 HORN, K10080 OEV INHIBIT, K10167 OVBD EXH VLV, K10442 OVHT LT INHIBIT, K10507 PWR XFR, K10079 RECIRC OVERRIDE, K10497 SUPPLY SMOKE SENSING, K369 SUPPLY SMOKE SHUT DOWN, K10360				
RELAYS - (FIM 31-01-37/101) AFT EQUIP COOLING SUPPLY FAN 2, K10324 AFT EQUIP EXH FAN 1, FAIL, K10322 AFT EQUIP/LAV/GALLEY VENT FAN 2, K346 AIR/GND SYS NO. 2, K201 EQUIP COOL AUX FAN, K10569 FWD CARGO FIRE, K10432 FWD EQUIP COOLING SUPPLY FAN 2, K344 LEFT ENG OUT NO. 3, K10339 OEV OPEN IND, K10086 RIGHT ENG OUT NO. 3, K10342				
RELAYS - (FIM 31-01-70/101) LEFT RECIRC FAN, K415				
SENSOR - AFT EQUIP COOLING LOW FLOW, TS5138	4	1	822, AFT CARGO COMPT	21-58-17
SENSOR - FWD EQUIP EXH LOW FLOW, TS5156 1	2	1	113AL, FWD ACCESS DOOR	21-58-17
SENSOR - FWD EQUIP EXH SMOKE, TS164	3	1	821, FWD CARGO COMPT	21-58-19
SENSOR - FWD EQUIP SUPPLY LOW FLOW, TS5155	2	1	113AL, FWD ACCESS DOOR	21-58-17
SENSOR - FWD EQUIP SUPPLY SMOKE 1, TS5267	3	1	821, FWD CARGO COMPT	21-58-19
SENSOR - FWD EQUIP SUPPLY SMOKE 2, TS5268	3	1	821, FWD CARGO COMPT	21-58-19
SWITCH - SMOKE/LOW FLOW TEST, YPHS9	1	1	FLT COMPT, P61, MISC TEST PNL, M10398	*
SWITCH/LIGHT - ALTERNATE COOLING/OVHT, YNMS1	1	1	FLT COMPT, P5, EQUIP COOLING PANEL, M10067	*
SWITCH/LIGHT - LEFT RECIRC FAN, YNRS1	1	1	FLT COMPT, P5, AIR CONDITIONING CONT PANEL, M10193	*
TIME DELAY - (FIM 31-01-36/101) OEV POWER RESET, M10689 SMOKE AUTO TEST RESET, M10691 SMOKE LIGHT, M10690				
TIME DELAY - (FIM 31-01-37/101) OEV DRIVE, M10688				
VALVE - (FIM 21-20-00/101) AFT EQUIP/LAV/GALLEY VENT CHECK				
VALVE - AFT SUPPLY FAN CHECK	4	2	822, AFT CARGO COMPT	21-58-02
VALVE - AUXILIARY FAN CHECK	5	1	119BL, MAIN EQUIP CTR	21-58-02
VALVE - FORWARD SUPPLY FAN CHECK	3	2	821, FWD CARGO COMPT	21-58-02
VALVE - (FIM 21-20-00/101) LEFT RECIRCULATION AIR CHECK				
VALVE - OVERBOARD EXHAUST, V95	3	1	821, FWD CARGO COMPT	21-58-05

* SEE THE WDM EQUIPMENT LIST

1 NOT INSTALLED ON ALL AIRPLANES

Equipment Cooling - Component Index
Figure 101 (Sheet 2)

EFFECTIVITY
GUI 115

21-58-00

CONFIG 3

Page 102

Jan 28/00

05

BOEING

757

FAULT ISOLATION/MAINT MANUAL

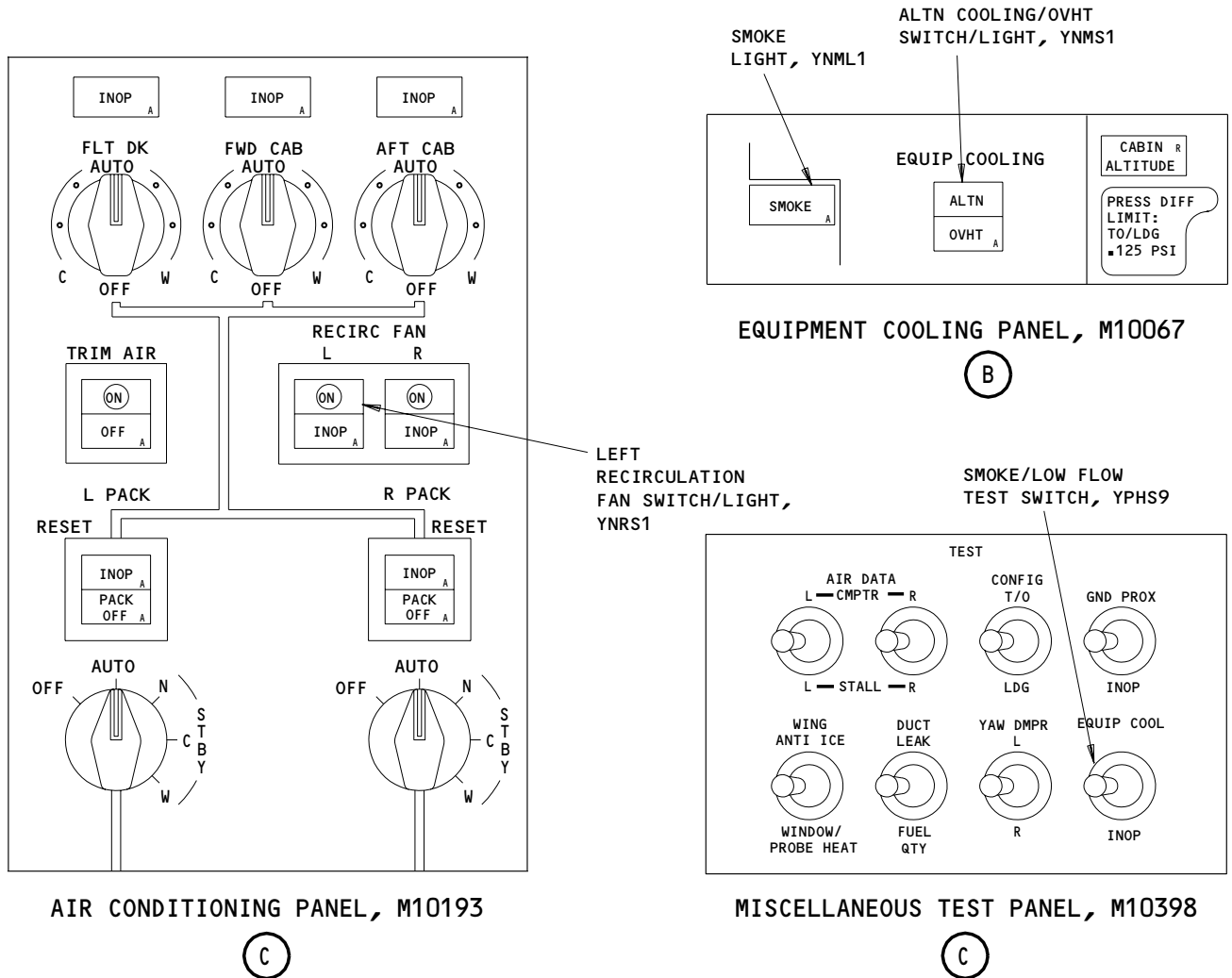
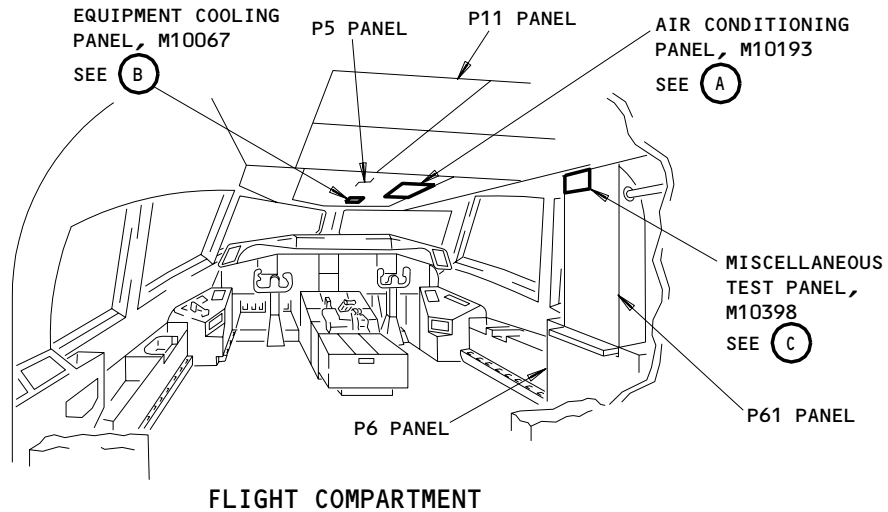

Equipment Cooling - Component Location
Figure 102 (Sheet 1)

EFFECTIVITY
GUI 115

21-58-00

CONFIG 3

07

Page 103

Sep 20/92

BOEING
757
FAULT ISOLATION/MAINT MANUAL

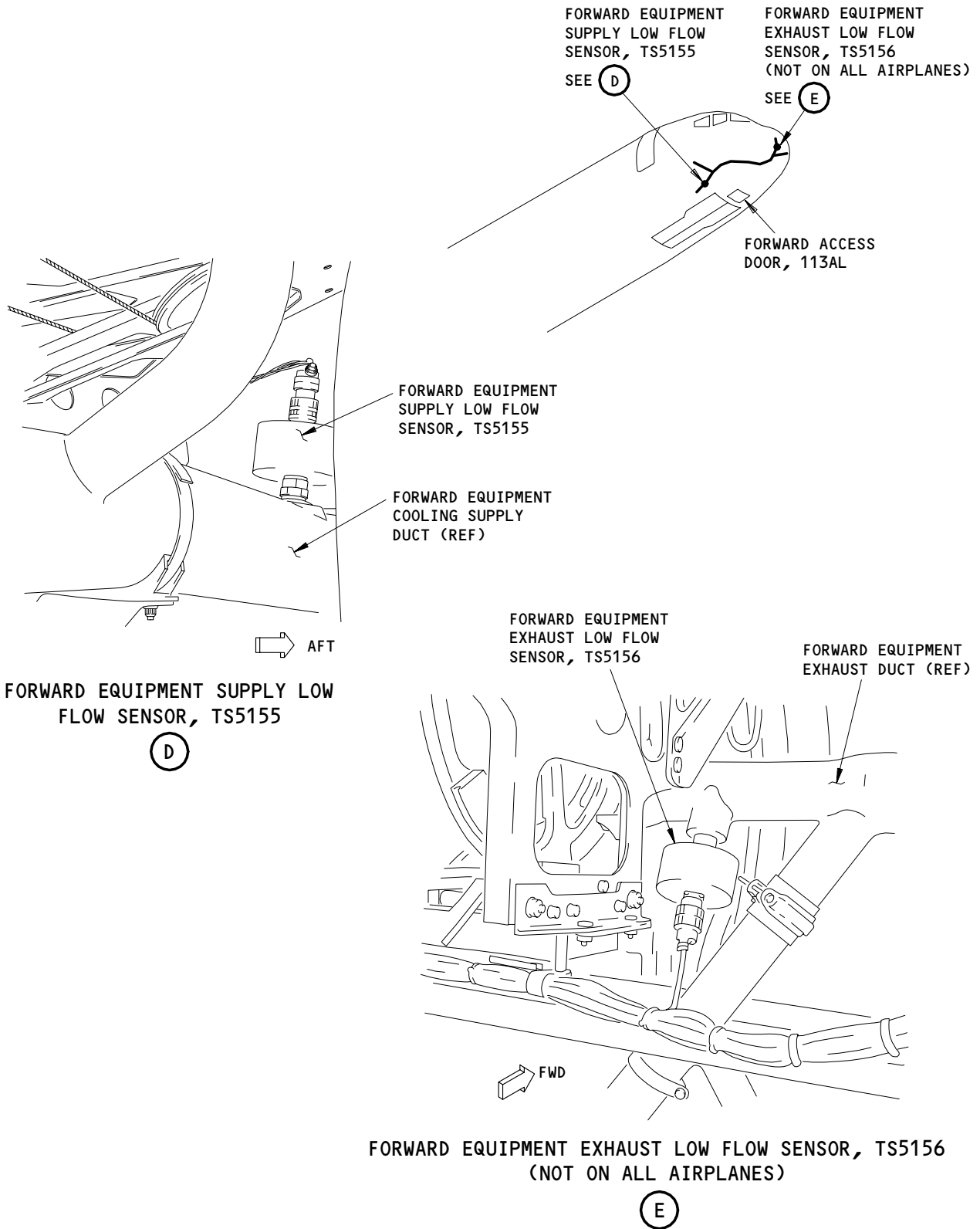

Equipment Cooling - Component Location
Figure 102 (Sheet 2)

EFFECTIVITY
GUI 115

21-58-00

CONFIG 3
Page 104
Jan 28/00

06

BOEING
757
FAULT ISOLATION/MAINT MANUAL

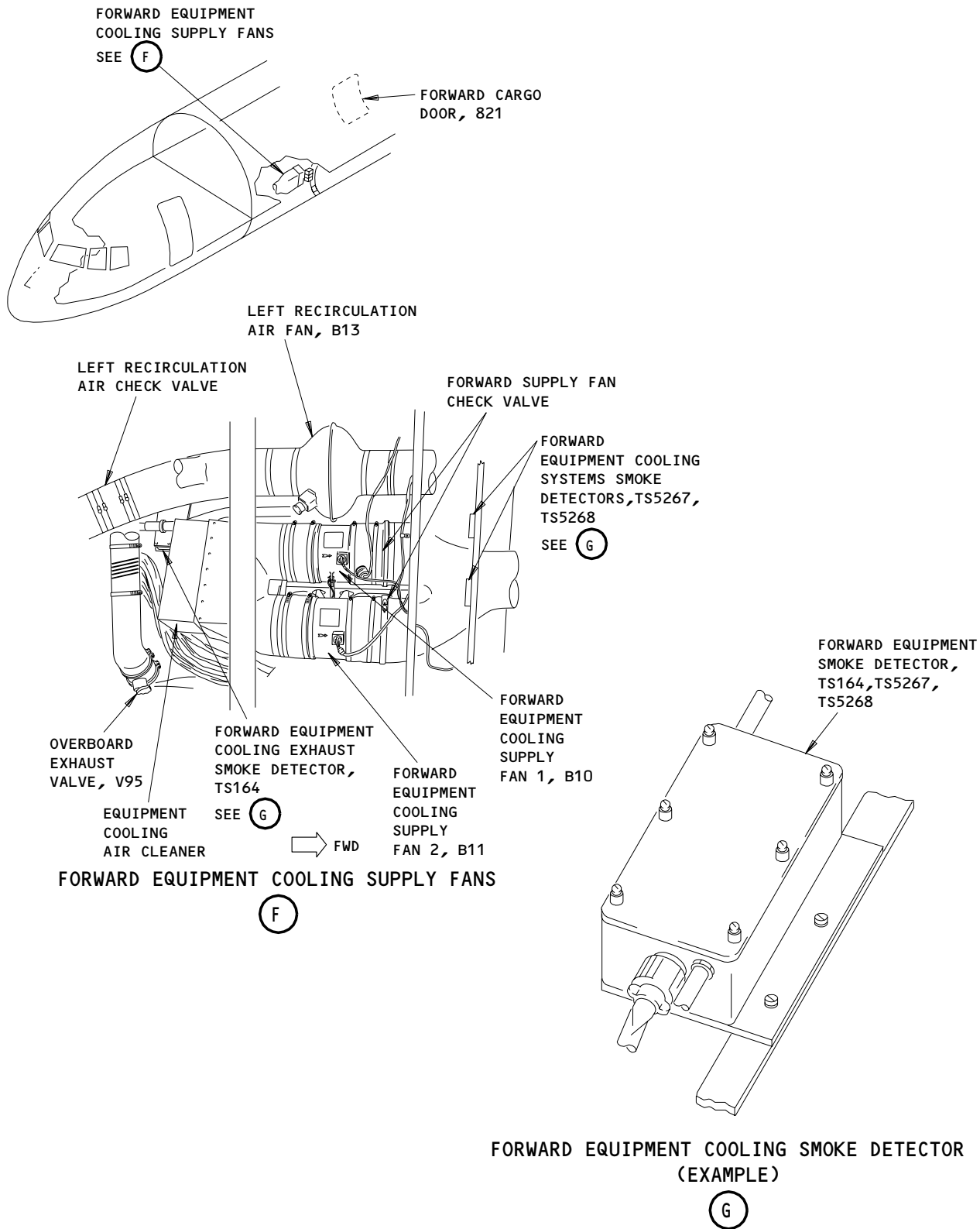

Equipment Cooling - Component Location
Figure 102 (Sheet 3)

EFFECTIVITY
GUI 115

21-58-00

CONFIG 3
Page 105
Sep 20/92

07

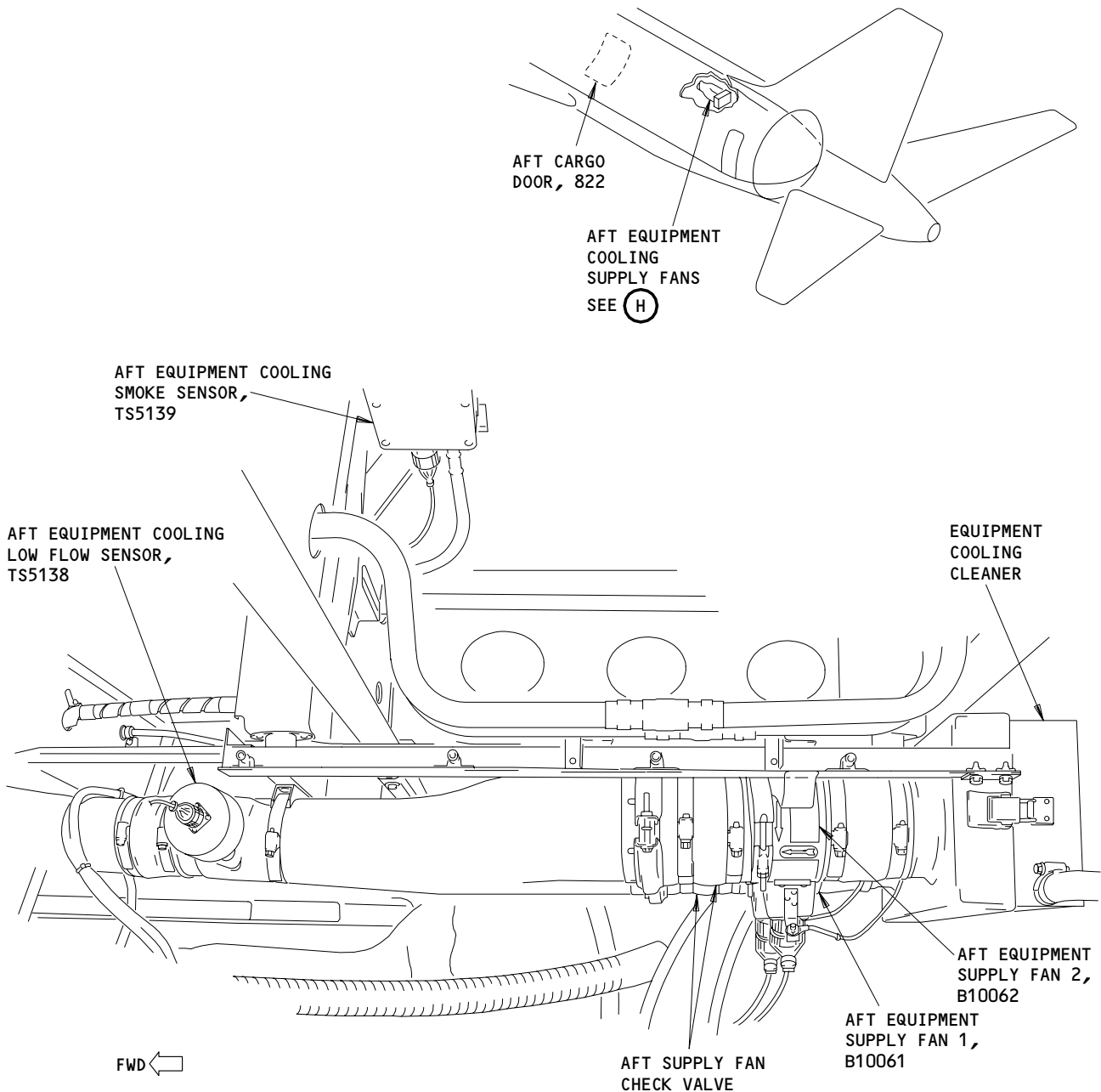

AFT EQUIPMENT COOLING SUPPLY FANS

(H)

Equipment Cooling - Component Location
Figure 102 (Sheet 4)

EFFECTIVITY
GUI 115

21-58-00

CONFIG 3
Page 106
Sep 20/92

07

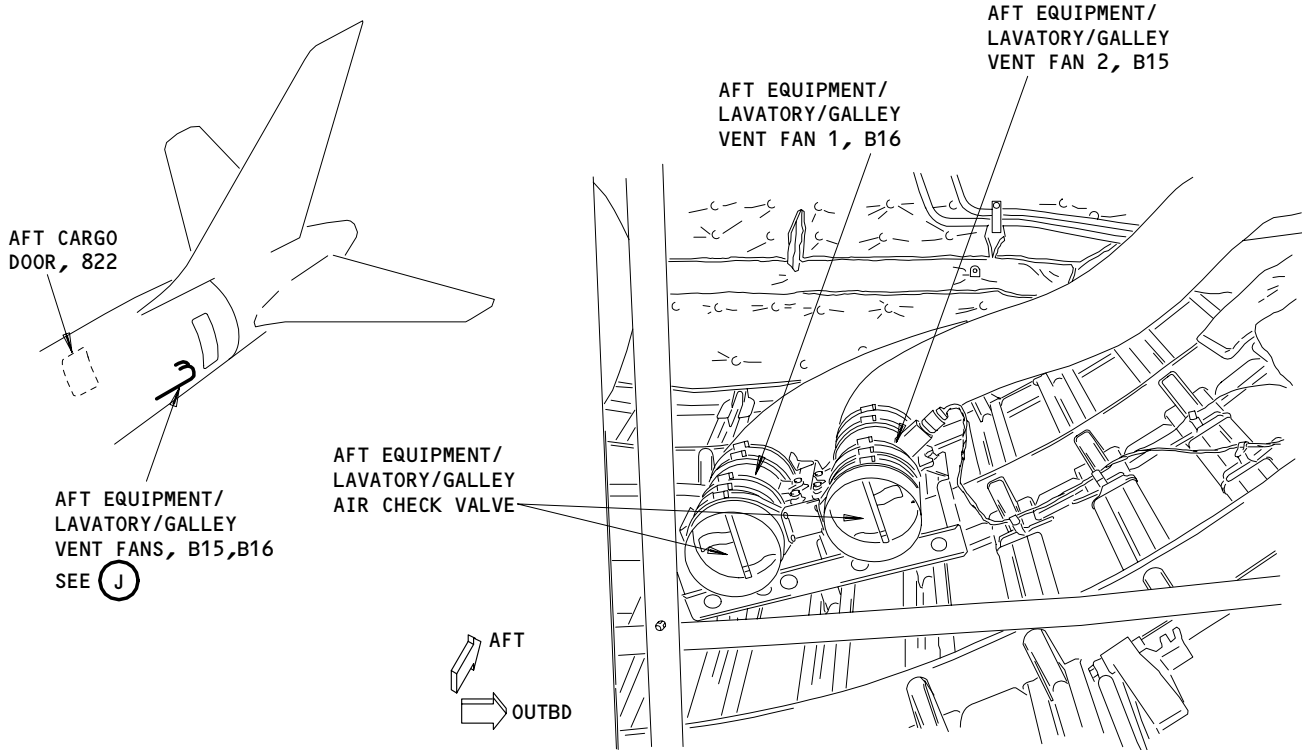

AFT EQUIPMENT/LAVATORY/GALLEY VENT FANS

(J)

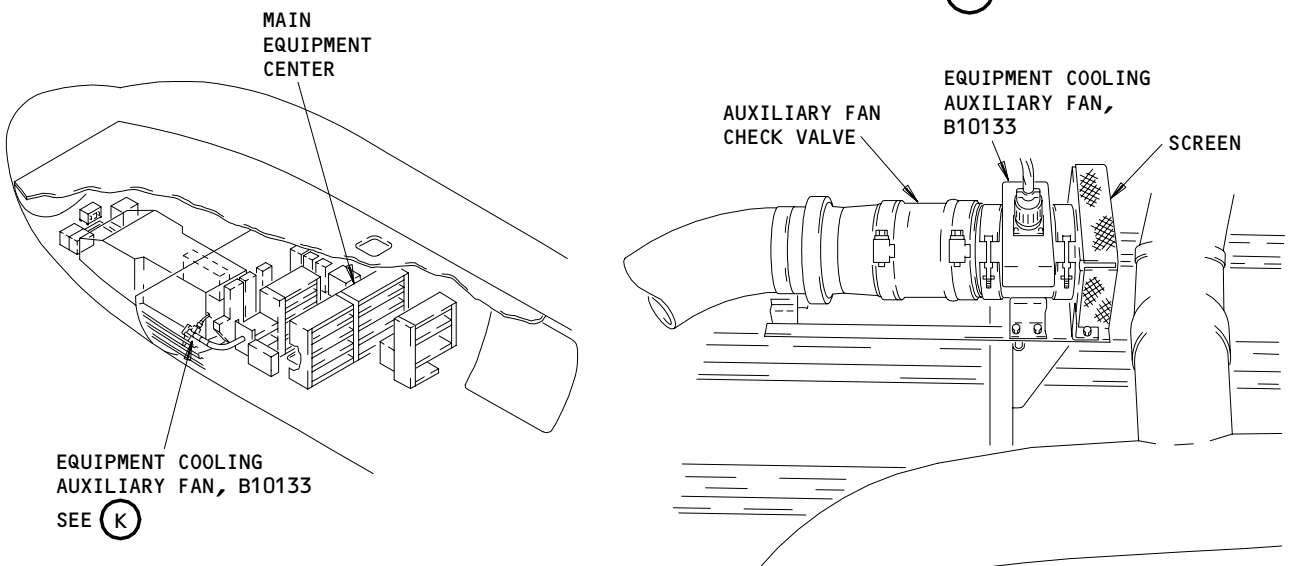

EQUIPMENT COOLING AUXILIARY FAN

(K)

Equipment Cooling - Component Location
Figure 102 (Sheet 5)

EFFECTIVITY
GUI 115

21-58-00

CONFIG 3

Page 107

Sep 20/92

07

EICAS MSG "FWD EQPT EXH DET" DISPLAYED

PREREQUISITES

MAKE SURE THIS SYSTEM WILL OPERATE:
EICAS (AMM 31-41-00/201)

MAKE SURE THESE CIRCUIT BREAKERS ARE CLOSED:
6D6,6F17,6F23,11C20,11N11,11N13

MAKE SURE THE AIRPLANE IS IN THIS CONFIGURATION:
ELECTRICAL POWER IS ON (AMM 24-22-00/201)

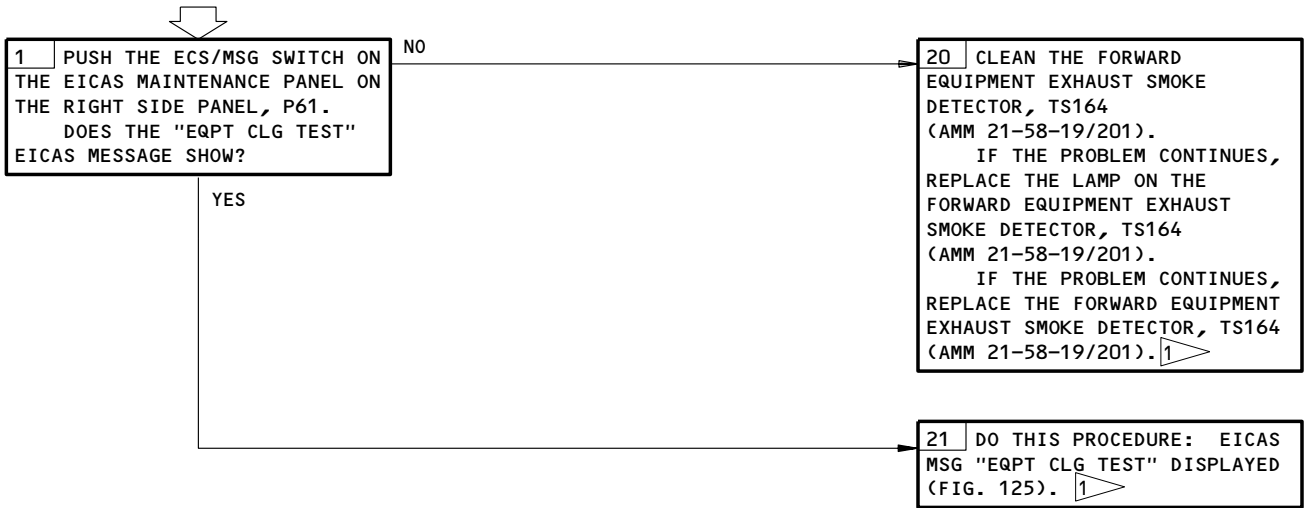

CAUTION: IF OTHER MESSAGES SHOW ON THE ECS/MSG PAGES, MAKE A RECORD OF THESE MESSAGES FOR TROUBLESHOOTING REFERENCE. ALL OF THE MESSAGES WHICH SHOW ON THE ECS/MSG PAGES WILL BE ERASED WHEN YOU DO THE ERASE PROCEDURE.

DO THIS PROCEDURE: MAINTENANCE MESSAGE ERASE PROCEDURE (FIM 31-41-00/101, FIG. 109). HOLD THE EQUIPMENT COOLING TEST SWITCH ON THE P61 PANEL TO THE "EQUIP COOL" POSITION FOR 5 SECONDS, THEN RELEASE IT. WAIT 20 SECONDS. MAKE SURE THAT THE EICAS MESSAGE "FWD EQPT EXH DET" DOES NOT SHOW.

EICAS Msg FWD EQPT EXH DET Displayed
Figure 103

EFFECTIVITY
GUI 115

21-58-00
CONFIG 3
Page 108
Jan 20/98

07

EICAS MSG "FWD EQ
SUP SNSR" DISPLAYED

PREREQUISITES

MAKE SURE THIS SYSTEM WILL OPERATE:
EICAS (AMM 31-41-00/201)

MAKE SURE THESE CIRCUIT BREAKERS ARE CLOSED:
6D6,6F17,6F23,11C20,11N11,11N13

MAKE SURE THE AIRPLANE IS IN THIS CONFIGURATION:
ELECTRICAL POWER IS ON (AMM 24-22-00/201)

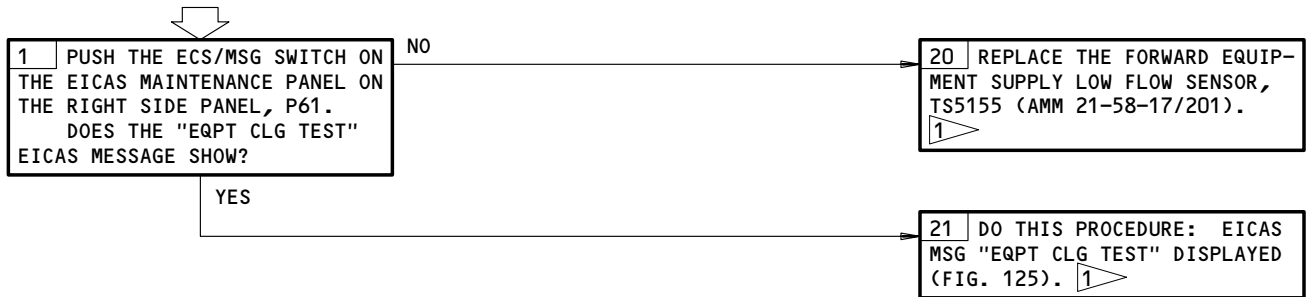

1 CAUTION: IF OTHER MESSAGES SHOW ON THE ECS/MSG PAGES, MAKE A RECORD OF THESE MESSAGES FOR TROUBLESHOOTING REFERENCE. ALL OF THE MESSAGES WHICH SHOW ON THE ECS/MSG PAGES WILL BE ERASED WHEN YOU DO THE ERASE PROCEDURE.

DO THIS PROCEDURE: MAINTENANCE MESSAGE ERASE PROCEDURE (FIM 31-41-00/101, FIG. 109). HOLD THE EQUIPMENT COOLING TEST SWITCH ON THE P61 PANEL TO THE "EQUIP COOL" POSITION FOR 5 SECONDS, THEN RELEASE IT. WAIT 20 SECONDS. MAKE SURE THAT THE EICAS MESSAGE "FWD EQ SUP SNSR" DOES NOT SHOW.

EICAS Msg FWD EQ SUP SNSR Displayed
Figure 104

EFFECTIVITY
GUI 115

21-58-00
CONFIG 3
Page 109
Jun 20/95

07

PREREQUISITES

MAKE SURE THIS SYSTEM WILL OPERATE:
 EICAS (MM 31-41-00/201)

MAKE SURE THESE CIRCUIT BREAKERS ARE CLOSED:
 6F17,6F23,37D2,70B5

MAKE SURE THE AIRPLANE IS IN THE CONFIGURATION THAT FOLLOWS:
 ELECTRICAL POWER IS ON (MM 24-22-00/201)

EICAS MSG "EQPT CLG FAN" DISPLAYED

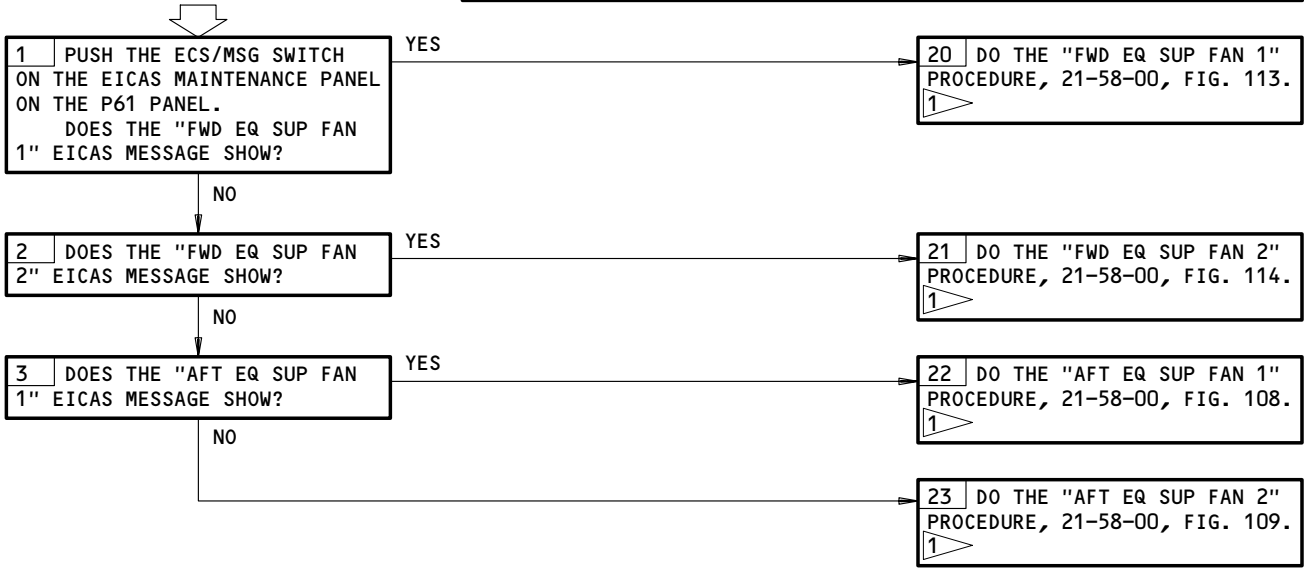

1 ▷ MAKE SURE THAT THE EICAS MESSAGE "EQPT CLG FAN" DOES NOT SHOW.

EICAS Msg EQPT CLG FAN Displayed
 Figure 105

EFFECTIVITY
 GUI 115

21-58-00
 CONFIG 3
 Page 110
 Sep 20/92

07

PREREQUISITES

MAKE SURE THIS SYSTEM WILL OPERATE:
EICAS (AMM 31-41-00/201)

MAKE SURE THESE CIRCUIT BREAKERS ARE CLOSED:
6D6,6F17,6F23,11C20,11N11,11N13

MAKE SURE THE AIRPLANE IS IN THIS CONFIGURATION:
ELECTRICAL POWER IS ON (AMM 24-22-00/201)

**EICAS MSG "AFT EQ
SNSR" DISPLAYED**

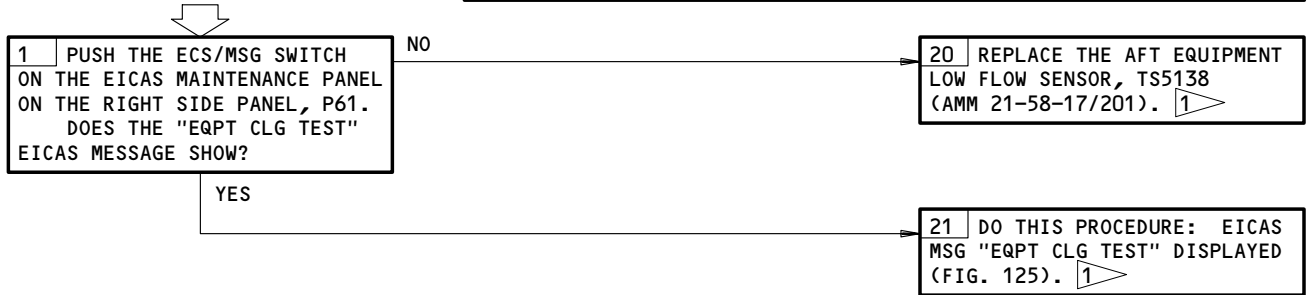

1 CAUTION: IF OTHER MESSAGES SHOW ON THE ECS/MSG PAGES, MAKE A RECORD OF THESE MESSAGES FOR TROUBLESHOOTING REFERENCE. ALL OF THE MESSAGES WHICH SHOW ON THE ECS/MSG PAGES WILL BE ERASED WHEN YOU DO THE ERASE PROCEDURE.

DO THIS PROCEDURE: MAINTENANCE MESSAGE ERASE PROCEDURE (FIM 31-41-00/101, FIG. 109). HOLD THE EQUIPMENT COOLING TEST SWITCH ON THE P61 PANEL TO THE "EQUIP COOL." POSITION FOR 5 SECONDS, THEN RELEASE IT. WAIT 20 SECONDS. MAKE SURE THAT THE EICAS MESSAGE "AFT EQ SNSR" DOES NOT SHOW.

EICAS Msg AFT EQ SNSR Displayed
Figure 106

EFFECTIVITY
GUI 115

21-58-00

CONFIG 3

07

Page 111

Jun 20/95

218101

PREREQUISITES

MAKE SURE THIS SYSTEM WILL OPERATE:
EICAS (AMM 31-41-00/201)

MAKE SURE THESE CIRCUIT BREAKERS ARE CLOSED:
11N13,37D2,70B5

MAKE SURE THE AIRPLANE IS IN THIS CONFIGURATION:
ELECTRICAL POWER IS ON (AMM 24-22-00/201)

EICAS MSG "AFT EQ FLOW" DISPLAYED

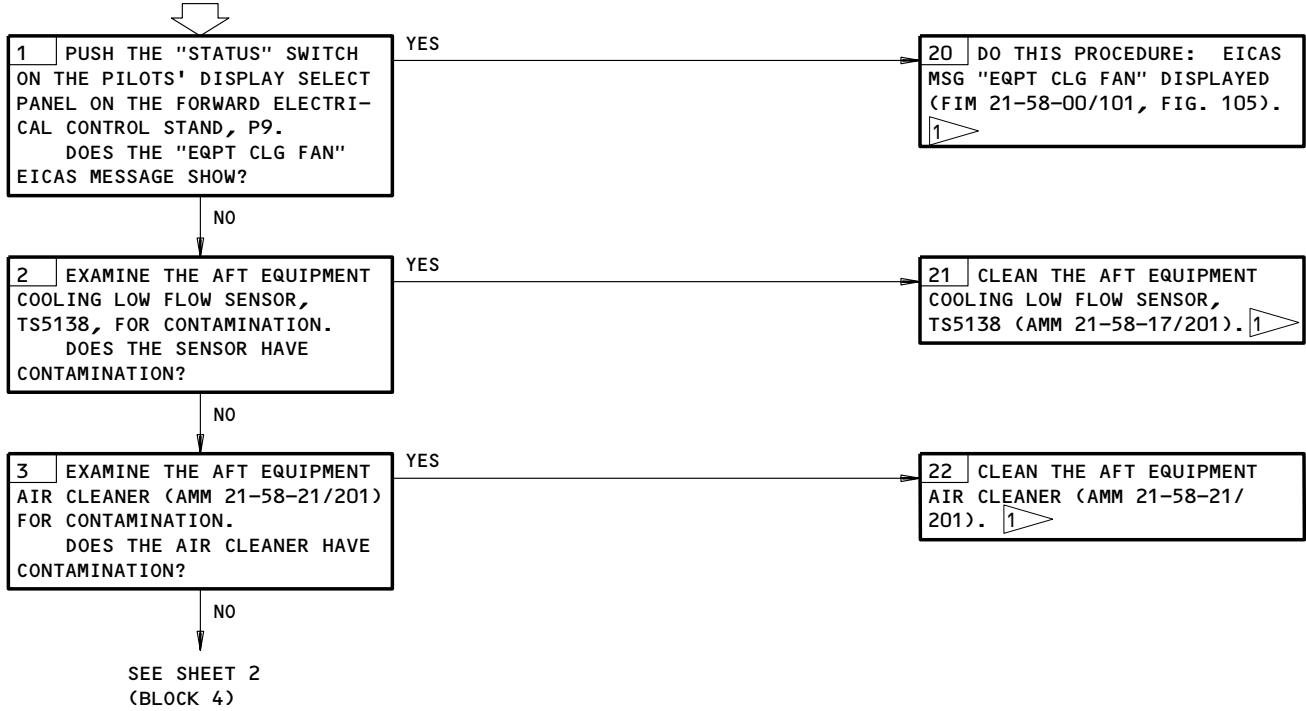

1 MAKE SURE THAT THE EICAS MESSAGE "AFT EQ FLOW" DOES NOT SHOW.

EICAS Msg AFT EQ FLOW Displayed
Figure 107 (Sheet 1)

EFFECTIVITY
AIRPLANES WITH GARRETT
SB 645055-21-2453

21-58-00
CONFIG 3
Page 112
Sep 20/98

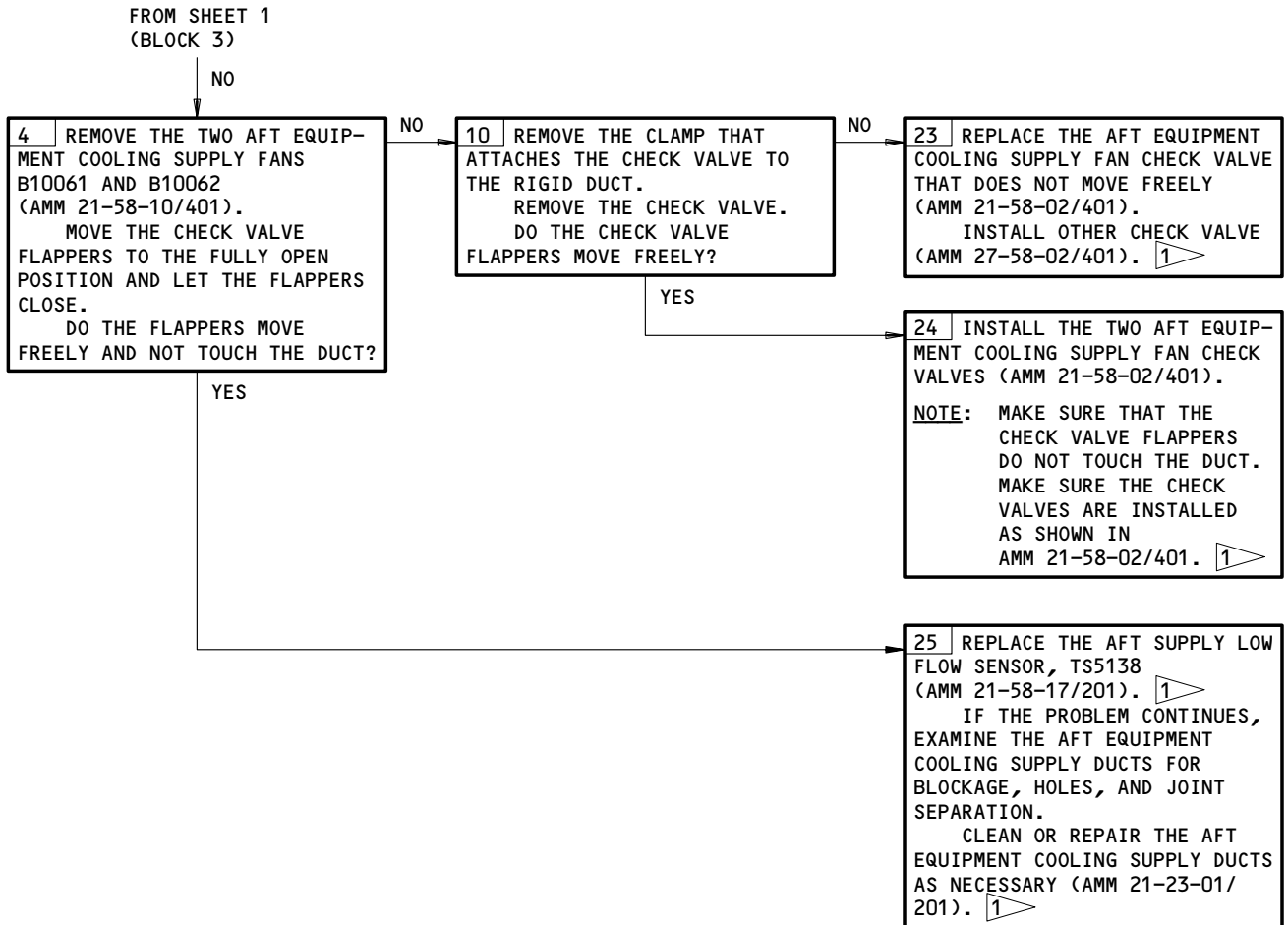

EICAS Msg AFT EQ FLOW Displayed
Figure 107 (Sheet 2)

EFFECTIVITY
AIRPLANES WITH GARRETT
SB 645055-21-2453

21-58-00
 CONFIG 3
 Page 113
 Sep 20/95

07

EICAS MSG "AFT EQ
SUP FAN 1"
DISPLAYED

PREREQUISITES

MAKE SURE THIS SYSTEM WILL OPERATE:
EICAS (AMM 31-41-00/201)

MAKE SURE THESE CIRCUIT BREAKERS ARE CLOSED:
11C20,37D2,70B5

MAKE SURE THE AIRPLANE IS IN THIS CONFIGURATION:
ELECTRICAL POWER IS ON (AMM 24-22-00/201)

1 MAKE SURE THAT THE "EQUIP COOLING ALTN" SWITCH/LIGHT ON THE P5 PANEL IS IN THE OUT POSITION.
DISCONNECT CONNECTOR D4216 FROM THE AFT SUPPLY FAN 1, B10061.
INSTALL A JUMPER BETWEEN PIN 5 AND PIN 6 ON CONNECTOR D4216.
IS THERE 115V AC BETWEEN PINS 1,2,3 AND PIN 7 OF CONNECTOR D4216 (WDM 21-58-24)?

YES

20 REPLACE THE AFT SUPPLY FAN 1, B10061 (AMM 21-58-10/401).
DO THIS PROCEDURE: MAINTENANCE MESSAGE ERASE PROCEDURE (FIM 31-41-00/101, FIG. 109). 1

NO

21 REMOVE THE JUMPER FROM PINS 5 AND 6 OF CONNECTOR D4216.
INSTALL CONNECTOR D4216 TO THE FAN 1, B10061.
REPLACE THE AFT EQUIPMENT SUPPLY FAN 1 RELAY, K10324, IN THE P37 PANEL (WDM 21-58-24).
DO THIS PROCEDURE: MAINTENANCE MESSAGE ERASE PROCEDURE (FIM 31-41-00/101, FIG. 109). 1

1 CAUTION: IF OTHER MESSAGES SHOW ON THE ECS/MSG PAGES, MAKE A RECORD OF THESE MESSAGES FOR TROUBLESHOOTING REFERENCE. ALL OF THE MESSAGES WHICH SHOW ON THE ECS/MSG PAGES WILL BE ERASED WHEN YOU DO THE ERASE PROCEDURE.

DO THIS PROCEDURE: MAINTENANCE MESSAGE ERASE PROCEDURE (FIM 31-41-00/101, FIG. 109). WITH THE "EQUIPMENT COOLING ALTN" SWITCH/LIGHT ON THE P5 PANEL IN THE OUT POSITION ("ALTN" LIGHT OFF), MAKE SURE THAT THE EICAS MESSAGE "AFT EQ SUP FAN 1" DOES NOT SHOW.

EICAS Msg AFT EQ SUP FAN 1 Displayed
Figure 108

EFFECTIVITY
GUI 115

21-58-00
CONFIG 3
Page 114
Jun 20/95

07

EICAS MSG "AFT EQ SUP FAN 2" DISPLAYED

PREREQUISITES

MAKE SURE THIS SYSTEM WILL OPERATE:
EICAS (AMM 31-41-00/201)

MAKE SURE THESE CIRCUIT BREAKERS ARE CLOSED:
6F17,6F23,11C20

MAKE SURE THE AIRPLANE IS IN THIS CONFIGURATION:
ELECTRICAL POWER IS ON (AMM 24-22-00/201)

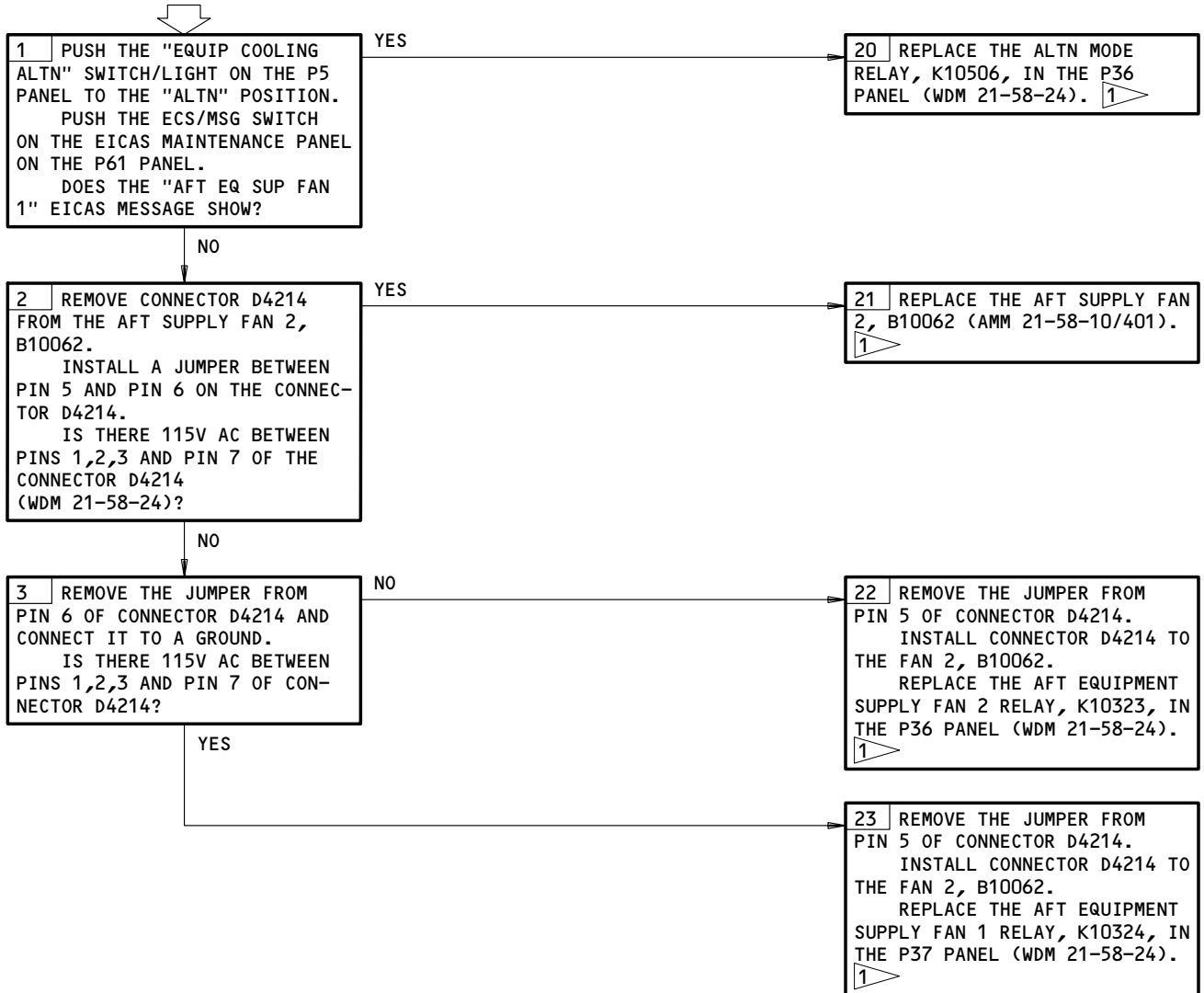

1 **CAUTION:** IF OTHER MESSAGES SHOW ON THE ECS/MSG PAGES, MAKE A RECORD OF THESE MESSAGES FOR TROUBLESHOOTING REFERENCE. ALL OF THE MESSAGES WHICH SHOW ON THE ECS/MSG PAGES WILL BE ERASED WHEN YOU DO THE ERASE PROCEDURE.

DO THIS PROCEDURE: MAINTENANCE MESSAGE ERASE PROCEDURE (FIM 31-41-00/101, FIG. 109). WITH THE "EQUIPMENT COOLING ALTN" SWITCH/LIGHT ON THE P5 PANEL IN THE "ALTN" POSITION, MAKE SURE THAT THE EICAS MESSAGE "AFT EQ SUP FAN 2" DOES NOT SHOW.

EICAS Msg AFT EQ SUP FAN 2 Displayed
Figure 109

EFFECTIVITY
GUI 115

21-58-00
CONFIG 3
Page 115
Jun 20/95

07

EICAS MSG "FWD EQ
SUP FLOW"
DISPLAYED



PREREQUISITES

MAKE SURE THIS SYSTEM WILL OPERATE:
EICAS (AMM 31-41-00/201)

MAKE SURE THESE CIRCUIT BREAKERS ARE CLOSED:
6F17,6F23,11N13

MAKE SURE THE AIRPLANE IS IN THIS CONFIGURATION:
ELECTRICAL POWER IS ON (AMM 24-22-00/201)

DESCRIPTION:

THE LOW FLOW SENSOR FOUND A LOW FLOW CONDITION IN THE FORWARD EQUIPMENT COOLING SUPPLY SYSTEM.

POSSIBLE CAUSES:

1. THE SMOKE DETECTORS IN THE FORWARD EQUIPMENT COOLING SUPPLY SYSTEM FOUND SMOKE, AND STOPPED THE EQUIPMENT COOLING SUPPLY FAN.
2. THE SUPPLY FAN HAS A PROBLEM
3. THE LOW FLOW SENSOR HAS CONTAMINATION OR HAS A PROBLEM
4. THE SUPPLY AIR CLEANER HAS CONTAMINATION
5. A FORWARD EQUIPMENT COOLING SUPPLY DUCT IS BROKEN OR BLOCKED.

FAULT ISOLATION:

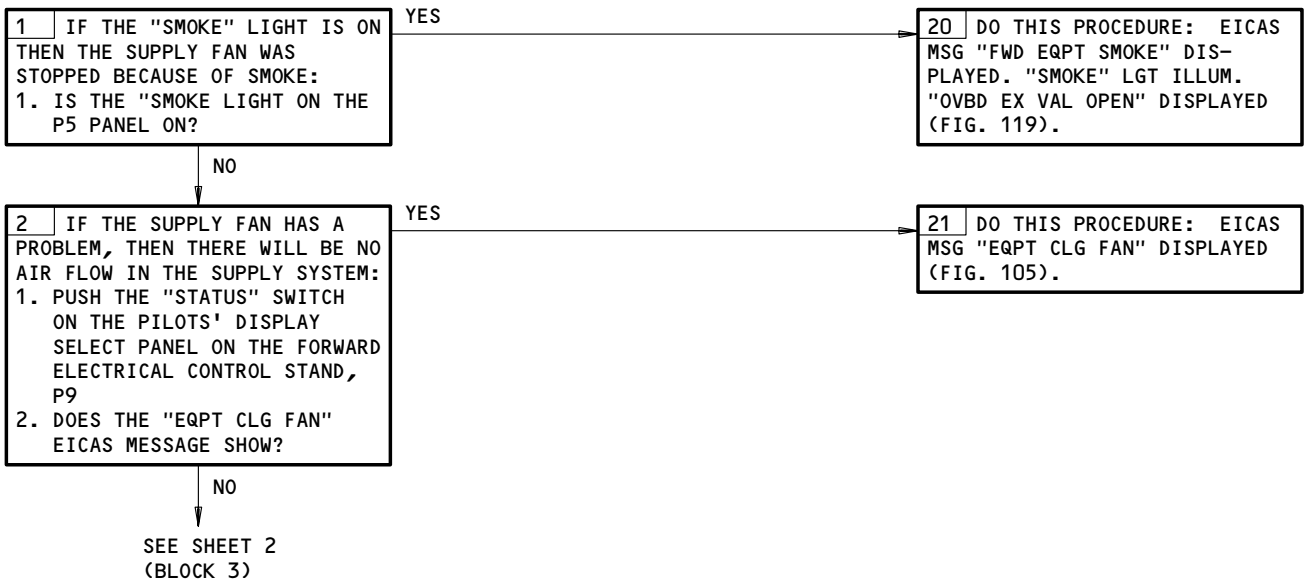

1 MAKE SURE THAT THE EICAS MESSAGE "FWD EQ SUP FLOW" DOES NOT SHOW.

EICAS Msg FWD EQ SUP FLOW Displayed
Figure 110 (Sheet 1)

EFFECTIVITY
GUI 115

21-58-00
CONFIG 3
Page 116
Sep 20/94

07

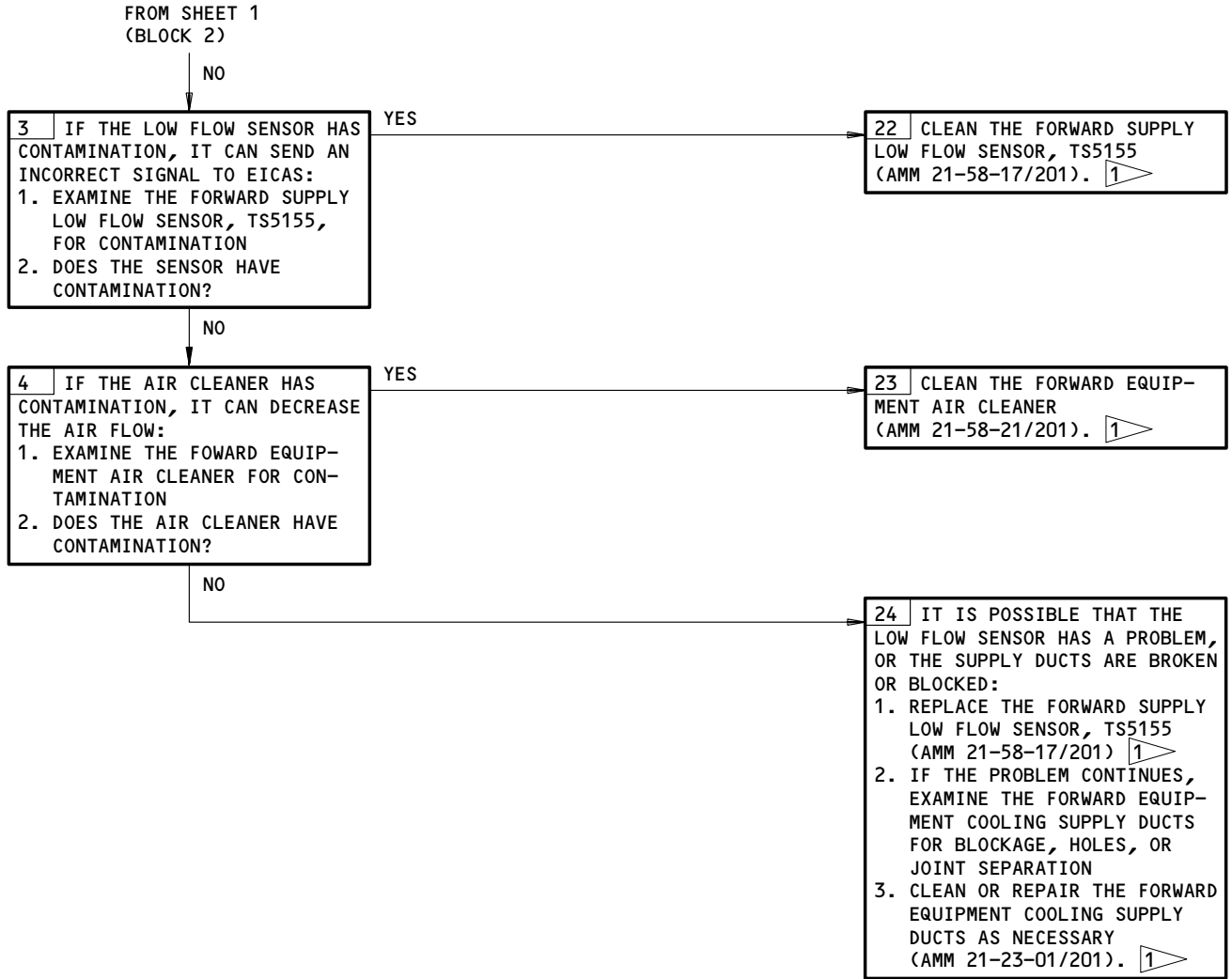

EICAS Msg FWD EQ SUP FLOW Displayed
Figure 110 (Sheet 2)

EFFECTIVITY
GUI 115

21-58-00

CONFIG 3

07

Page 117

Dec 20/93

EICAS MSG "EQPT OVHT" DISPLAYED.
"OVHT" LGT ILLUM.
"OVHT" LGT REMAINED ILLUM WHEN "ALTN" SELECTED. EICAS MSGS "EQPT CLG FAN" AND "OVBD EX VAL OPEN" NOT DISPLAYED.

PREREQUISITES

MAKE SURE THIS SYSTEM WILL OPERATE:
EICAS (AMM 31-41-00/201)

MAKE SURE THESE CIRCUIT BREAKERS ARE CLOSED:
6D6, 6F17, 6F23, 11C20, 11N11, 11N13, 11P14, 37D2, 70B5, 70C10

MAKE SURE THE AIRPLANE IS IN THIS CONFIGURATION:
ELECTRICAL POWER IS ON (AMM 24-22-00/201)

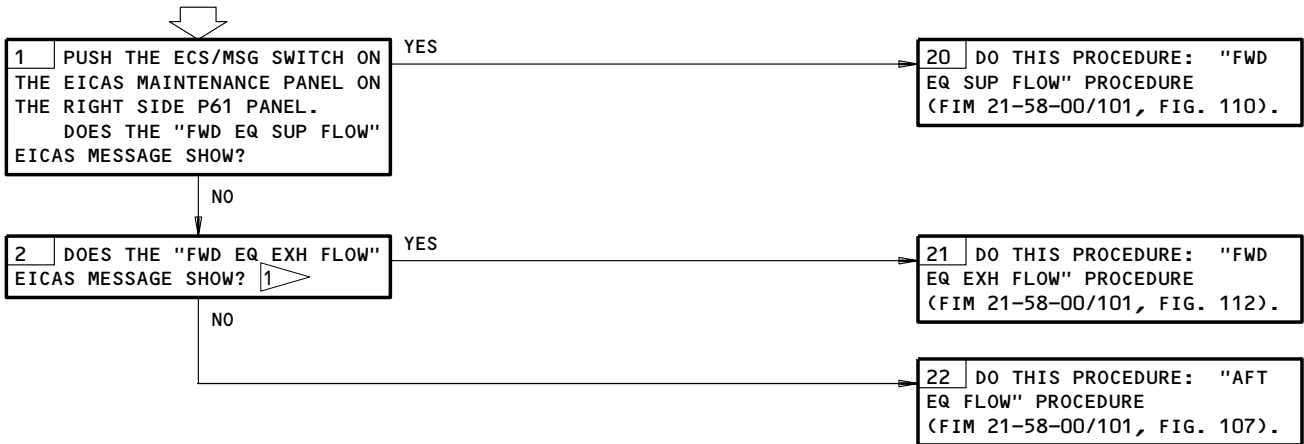

1 AIRPLANES PRE-SB 21-64

EICAS Msg EQPT OVHT Displayed. OVHT Lgt Illum. OVHT Lgt Retained Illum
When ALTN Selected. EICAS Msgs EQPT CLG FAN and
OVBD EX VAL OPEN Not Displayed.

Figure 111

EFFECTIVITY
GUI 115

21-58-00
CONFIG 3
Page 118
Jan 28/00

04

EICAS MSG
"FWD EQ EXH FLOW"
DISPLAYED 

PREREQUISITES

MAKE SURE THIS SYSTEM WILL OPERATE:
EICAS (AMM 31-41-00/201)

MAKE SURE THESE CIRCUIT BREAKERS ARE CLOSED:
11N13, 11P14, 70C10

MAKE SURE THE AIRPLANE IS IN THIS CONFIGURATION:
ELECTRICAL POWER IS ON (AMM 24-22-00/201)



DESCRIPTION:

THE LOW FLOW SENSOR FOUND UNSATISFACTORY AIR FLOW IN THE FORWARD EQUIPMENT COOLING EXHAUST SYSTEM.

POSSIBLE CAUSES:

1. THE LEFT RECIRCULATION FAN IS SET TO THE "OFF" POSITION
2. THE LEFT RECIRCULATION FAN HAS A PROBLEM
3. THE LOW FLOW SENSOR HAS CONTAMINATION OR HAS A PROBLEM
4. THE LEFT RECIRCULATION FILTER HAS CONTAMINATION
5. A FORWARD EQUIPMENT COOLING EXHAUST DUCT IS BROKEN OR BLOCKED.

FAULT ISOLATION:



-  MAKE SURE THAT THE EICAS MESSAGE "FWD EQ EXH FLOW" DOES NOT SHOW.
-  AIRPLANES PRE-SB 21-61

EICAS Msg FWD EQ EXH FLOW Displayed
Figure 112 (Sheet 1)

EFFECTIVITY
GUI 115

21-58-00
CONFIG 3
Page 119
Jan 28/00

05

BOEING
757
FAULT ISOLATION/MAINT MANUAL

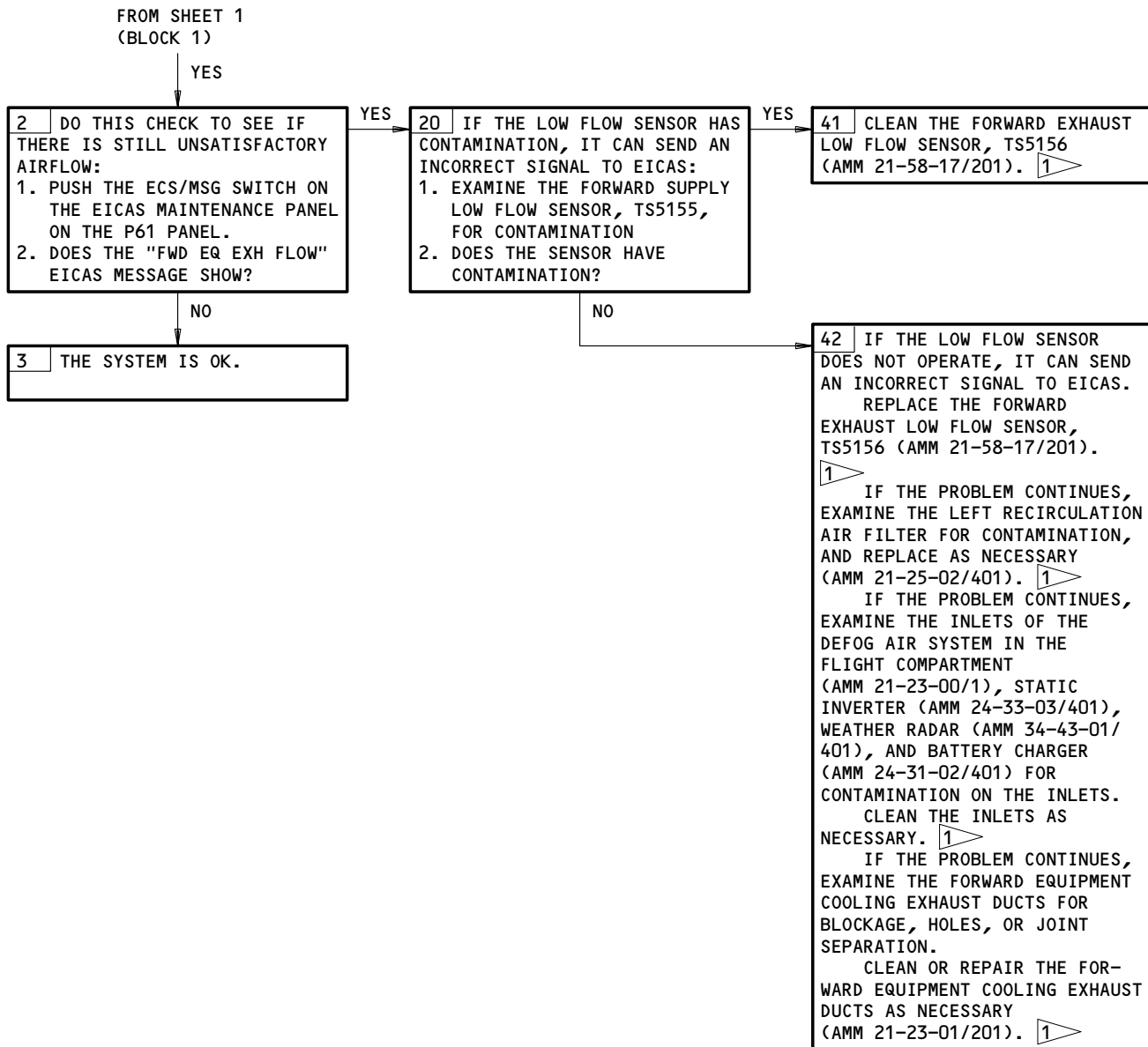

EICAS Msg FWD EQ EXH FLOW Displayed
Figure 112 (Sheet 2)

EFFECTIVITY
GUI 115

21-58-00
CONFIG 3
Page 120
Mar 20/94

07

EICAS MSG "FWD EQ
SUP FAN 1"
DISPLAYED

PREREQUISITES

MAKE SURE THIS SYSTEM WILL OPERATE:

EICAS (AMM 31-41-00/201)

MAKE SURE THESE CIRCUIT BREAKERS ARE CLOSED:

6F17,6F23,11C20

MAKE SURE THE AIRPLANE IS IN THIS CONFIGURATION:

ELECTRICAL POWER IS ON (AMM 24-22-00/201)

DESCRIPTION:

THE FORWARD EQUIPMENT SUPPLY FAN 1 WILL NOT OPERATE AND SMOKE IS NOT PRESENT.

POSSIBLE CAUSES:

1. THE SUPPLY FAN HAS A PROBLEM
2. THERE IS A PROBLEM IN THE FAN CONTROL SYSTEM
3. THERE IS A PROBLEM IN THE SMOKE DETECTION SYSTEM.

FAULT ISOLATION:



CAUTION: IF OTHER MESSAGES SHOW ON THE ECS/MSG PAGES, MAKE A RECORD OF THESE MESSAGES FOR TROUBLESHOOTING REFERENCE. ALL OF THE MESSAGES WHICH SHOW ON THE ECS/MSG PAGES WILL BE ERASED WHEN YOU DO THE ERASE PROCEDURE.

DO THIS PROCEDURE: MAINTENANCE MESSAGE ERASE PROCEDURE (FIM 31-41-00/101, FIG. 109). WITH THE "EQUIPMENT COOLING ALTN" SWITCH/LIGHT ON THE P5 PANEL IN THE USUAL POSITION, MAKE SURE THAT THE EICAS MESSAGE "FWD EQ SUP FAN 1" DOES NOT SHOW.

EICAS Msg FWD EQ SUP FAN 1 Displayed
Figure 113 (Sheet 1)

EFFECTIVITY
GUI 115

21-58-00
CONFIG 3
Page 121
Jun 20/95

07

FROM SHEET 1
(BLOCK 1)

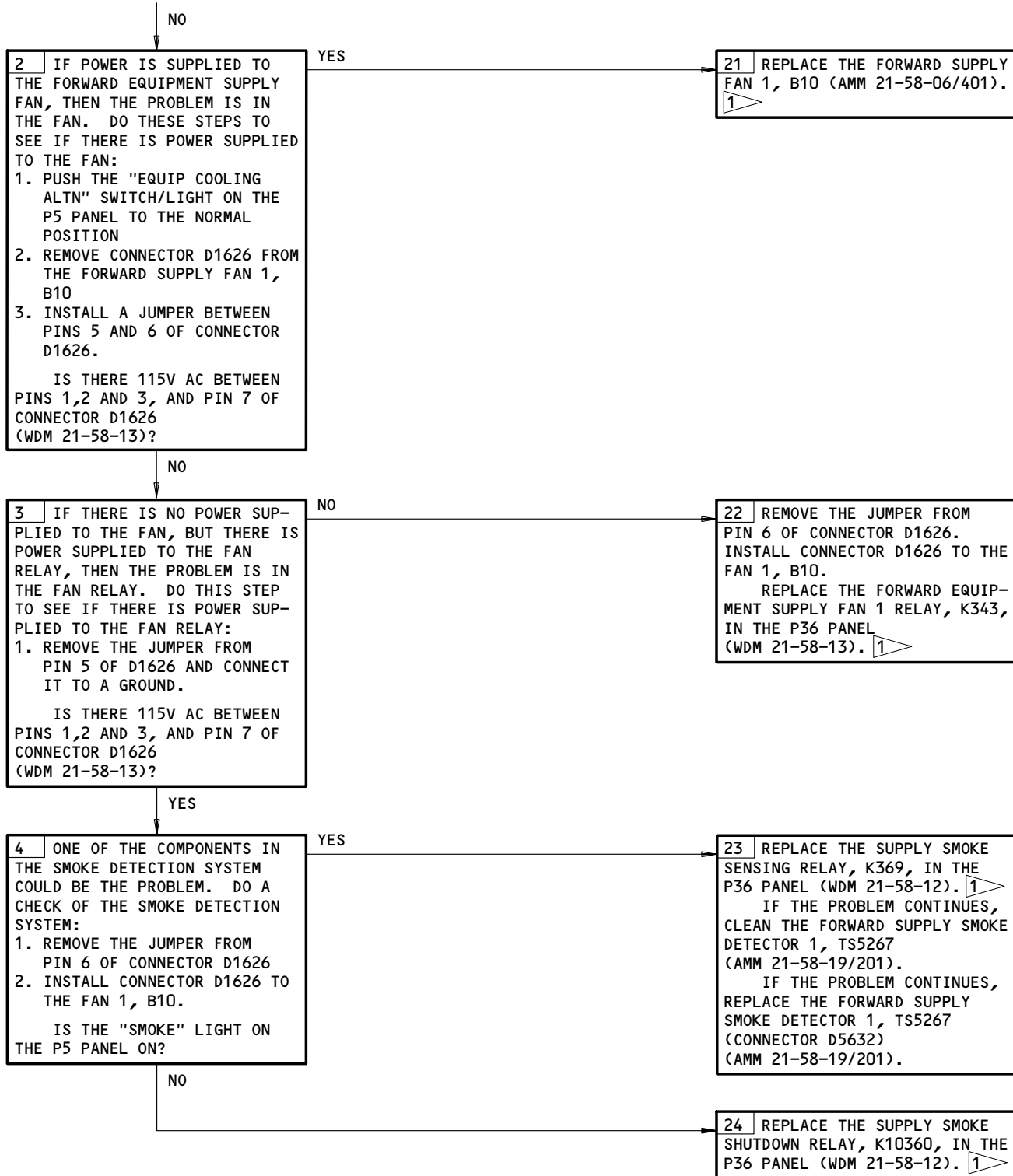

EICAS Msg FWD EQ SUP FAN 1 Displayed
Figure 113 (Sheet 2)

EFFECTIVITY
GUI 115

21-58-00

CONFIG 3

07

Page 122

Jun 20/94

831238

EICAS MSG "FWD EQ
SUP FAN 2"
DISPLAYED

PREREQUISITES

MAKE SURE THIS SYSTEM WILL OPERATE:
EICAS (AMM 31-41-00/201)

MAKE SURE THESE CIRCUIT BREAKERS ARE CLOSED:
6F23,11C20

MAKE SURE THE AIRPLANE IS IN THIS CONFIGURATION:
ELECTRICAL POWER IS ON (AMM 24-22-00/201)

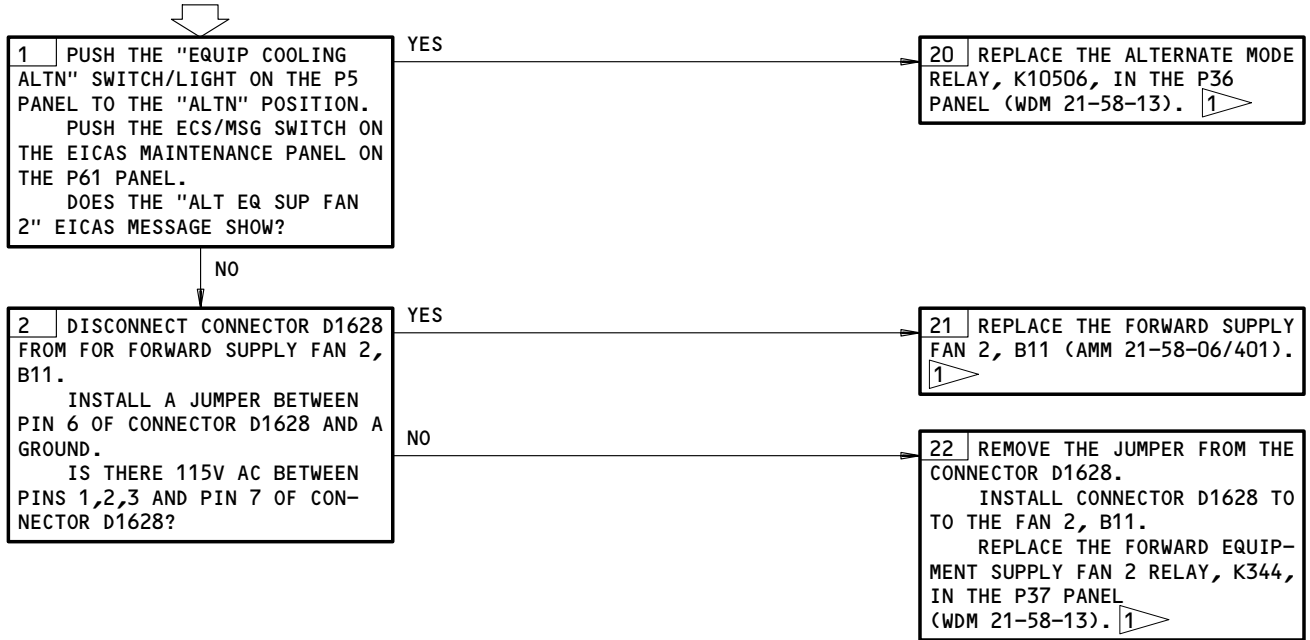

1 CAUTION: IF OTHER MESSAGES SHOW ON THE ECS/MSG PAGES, MAKE A RECORD OF THESE MESSAGES FOR TROUBLESHOOTING REFERENCE. ALL OF THE MESSAGES WHICH SHOW ON THE ECS/MSG PAGES WILL BE ERASED WHEN YOU DO THE ERASE PROCEDURE.

DO THIS PROCEDURE: MAINTENANCE MESSAGE ERASE PROCEDURE (FIM 31-41-00/101, FIG. 109). WITH THE "EQUIP COOLING ALTN" SWITCH/LIGHT ON THE P5 PANEL IN THE "ALTN" POSITION, MAKE SURE THAT THE EICAS MESSAGE "FWD EQ SUP FAN 2" DOES NOT SHOW.

EICAS Msg FWD EQ SUP FAN 2 Displayed
Figure 114

EFFECTIVITY
GUI 115

21-58-00
CONFIG 3
Page 123
Jun 20/95

07

EICAS MSG
 "FWD EQ EXH SNSR"
 DISPLAYED 

PREREQUISITES

MAKE SURE THIS SYSTEM WILL OPERATE:
 EICAS (AMM 31-41-00/201)

MAKE SURE THESE CIRCUIT BREAKERS ARE CLOSED:
 6D6, 6F17, 6F23, 11C20, 11N11, 11N13

MAKE SURE THE AIRPLANE IS IN THIS CONFIGURATION:
 ELECTRICAL POWER IS ON (AMM 24-22-00/201)

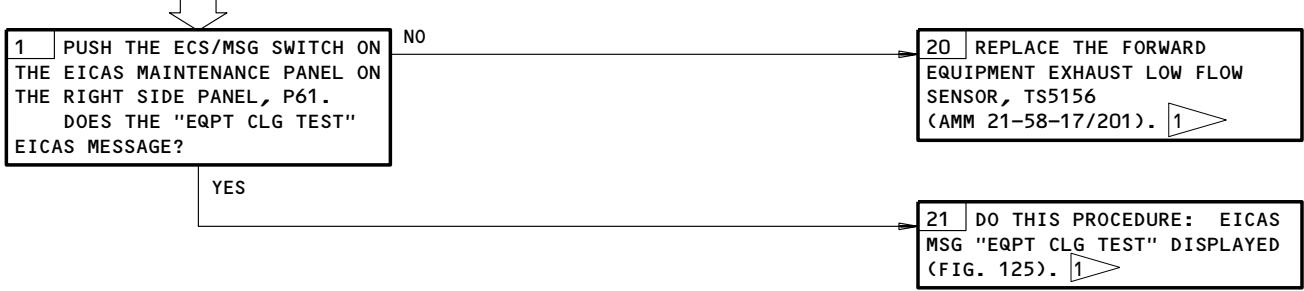

 **CAUTION:** IF OTHER MESSAGES SHOW ON THE ECS/MSG PAGES, MAKE A RECORD OF THESE MESSAGES FOR TROUBLESHOOTING REFERENCE. ALL OF THE MESSAGES WHICH SHOW ON THE ECS/MSG PAGES WILL BE ERASED WHEN YOU DO THE ERASE PROCEDURE.

DO THIS PROCEDURE: MAINTENANCE MESSAGE ERASE PROCEDURE (FIM 31-41-00/101, FIG. 109). HOLD THE EQUIPMENT COOLING TEST SWITCH ON THE P61 PANEL TO THE "EQUIP COOL" POSITION FOR 5 SECONDS, THEN RELEASE IT. WAIT 20 SECONDS. MAKE SURE THAT THE EICAS MESSAGE "FWD EQ SUP SNSR" DOES NOT SHOW.

 AIRPLANES PRE-SB 21-61

EICAS Msg FWD EQ EXH SNSR Displayed
 Figure 115

EFFECTIVITY
 GUI 115

21-58-00
 CONFIG 3
 Page 124
 Jan 28/01

06

PREREQUISITES

MAKE SURE THIS SYSTEM WILL OPERATE:
EICAS (AMM 31-41-00/201)

MAKE SURE THESE CIRCUIT BREAKERS ARE CLOSED:
6D6, 11N13

MAKE SURE THE AIRPLANE IS IN THE CONFIGURATION THAT
ELECTRICAL POWER IS ON (AMM 24-22-00/201)

EICAS MSG "EQPT CLG SENSOR" DISPLAYED

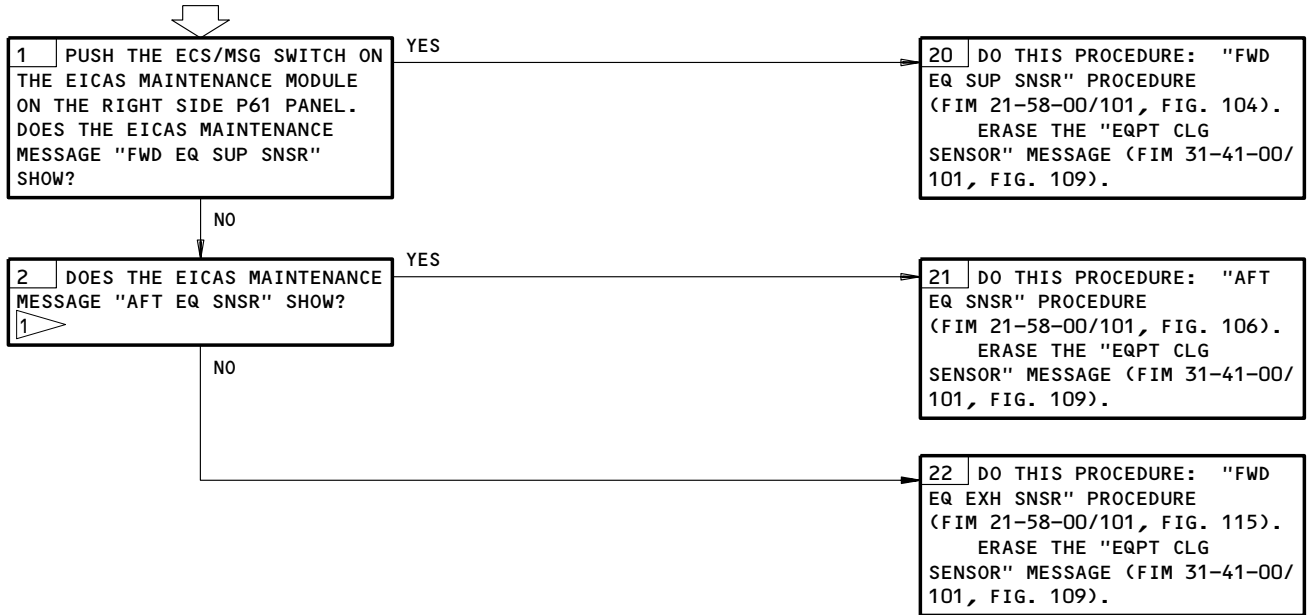

1 AIRPLANES PRE-SB 21-61

EICAS Msg EQPT CLG SENSOR Displayed
Figure 116

EFFECTIVITY
GUI 115

21-58-00
CONFIG 3
Page 125
Jan 28/00

06

PREREQUISITES

MAKE SURE THIS SYSTEM WILL OPERATE:
EICAS (AMM 31-41-00/201)

MAKE SURE THESE CIRCUIT BREAKERS ARE CLOSED:
6D6, 6F2, 6F17, 11N11, 11N13, 11P14, 37D2, 70B5,
70C10

MAKE SURE THE AIRPLANE IS IN THIS CONFIGURATION:
ELECTRICAL POWER IS ON (AMM 24-22-00/201)

EICAS MSG "EQPT CLG FLOW" DISPLAYED

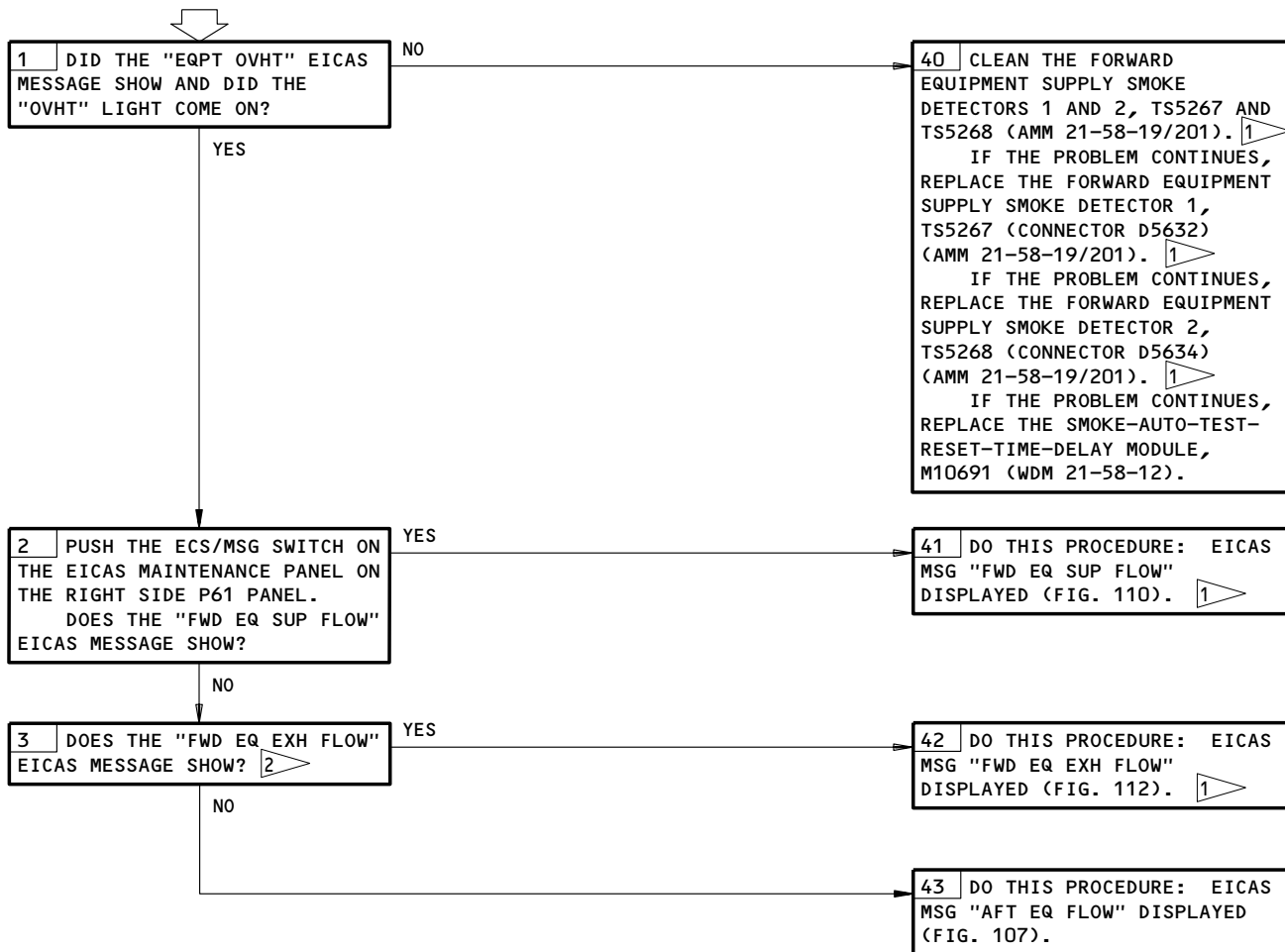

1 MAKE SURE THAT THE EICAS MESSAGE "EQPT CLG FLOW" DOES NOT SHOW.

2 AIRPLANES PRE-SB 21-61

EICAS Msg EQPT CLG FLOW Displayed
Figure 117

EFFECTIVITY
GUI 115

21-58-00

CONFIG 3

Page 126

Jan 28/00

06

EICAS MSG "OVBD EX VAL OPEN" DISPLAYED



PREREQUISITES

MAKE SURE THIS SYSTEM WILL OPERATE:
EICAS (AMM 31-41-00/201)

MAKE SURE THESE CIRCUIT BREAKERS ARE CLOSED:
11C20,11P14,70C10

MAKE SURE THE AIRPLANE IS IN THIS CONFIGURATION:
ELECTRICAL POWER IS ON (AMM 24-22-00/201)

DESCRIPTION:

THE OVERBOARD EXHAUST VALVE (OEV) WAS COMMANDED OPEN.

NOTE: THE OVERBOARD EXHAUST VALVE WILL BE COMMANDED OPEN IF THE LEFT RECIRCULATION FAN WAS OFF OR DID NOT OPERATE DURING FLIGHT.

POSSIBLE CAUSES:

1. THERE WAS SMOKE IN THE FORWARD EQUIPMENT COOLING SYSTEM.
2. THE LEFT RECIRCULATION FAN DID NOT OPERATE.
3. THERE IS A PROBLEM WITH THE "EQUIP COOLING ALTN" SWITCH/LIGHT, YNMS1.
4. THERE IS A PROBLEM WITH THE OEV COMMAND RELAY, K10442.
5. THERE IS A PROBLEM WITH THE OVERBOARD EXHAUST VALVE, V95.
6. THERE IS A PROBLEM WITH THE OEV OPEN INDICATION RELAY, K10086.

FAULT ISOLATION:

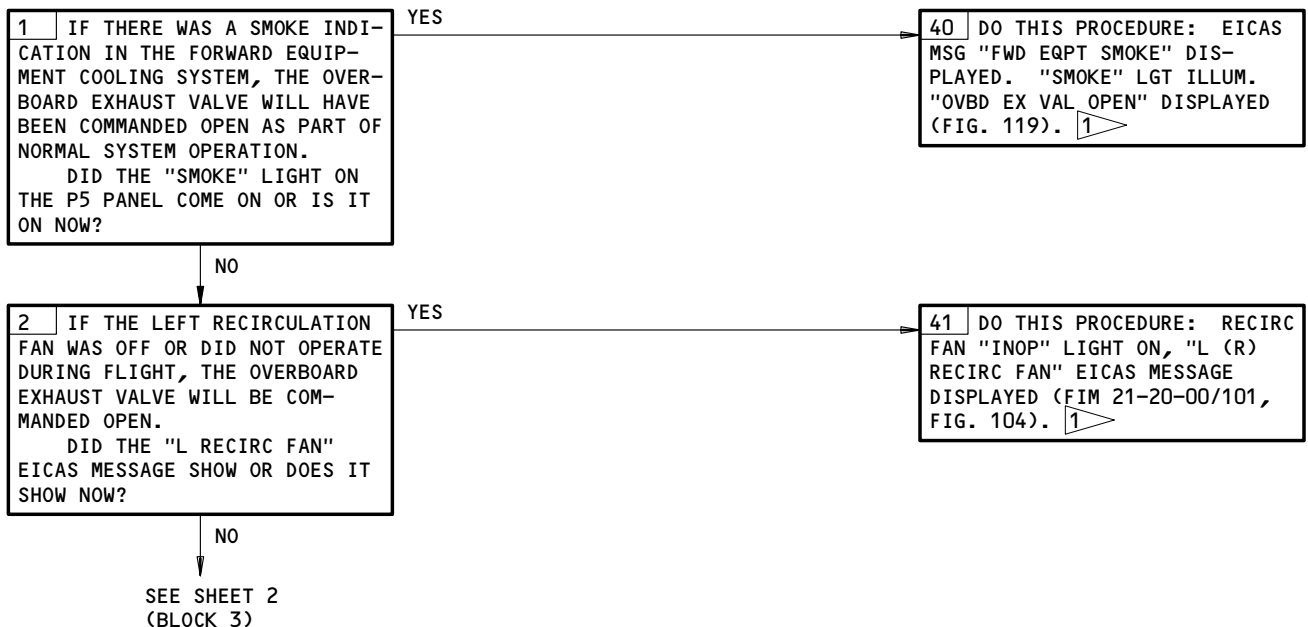

1 CAUTION: IF OTHER MESSAGES SHOW ON THE ECS/MSG PAGES, MAKE A RECORD OF THESE MESSAGES FOR TROUBLESHOOTING REFERENCE. ALL OF THE MESSAGES WHICH SHOW ON THE ECS/MSG PAGES WILL BE ERASED WHEN YOU DO THE ERASE PROCEDURE.

DO THIS PROCEDURE: MAINTENANCE MESSAGE ERASE PROCEDURE (FIM 31-41-00/101, FIG. 109). HOLD THE EQUIPMENT COOLING TEST SWITCH ON THE P61 PANEL TO THE "EQUIP COOL POSITION" FOR 5 SECONDS AND THEN RELEASE. WAIT 20 SECONDS. MAKE SURE THAT THE EICAS MESSAGE "OVBD EX VAL OPEN" DOES NOT SHOW.

**EICAS Msg OVBD EX VAL OPEN Displayed
Figure 118 (Sheet 1)**

EFFECTIVITY
GUI 115

21-58-00
CONFIG 3
Page 127
Jun 20/95

07

BOEING
757
FAULT ISOLATION/MAINT MANUAL

FROM SHEET 1
(BLOCK 2)

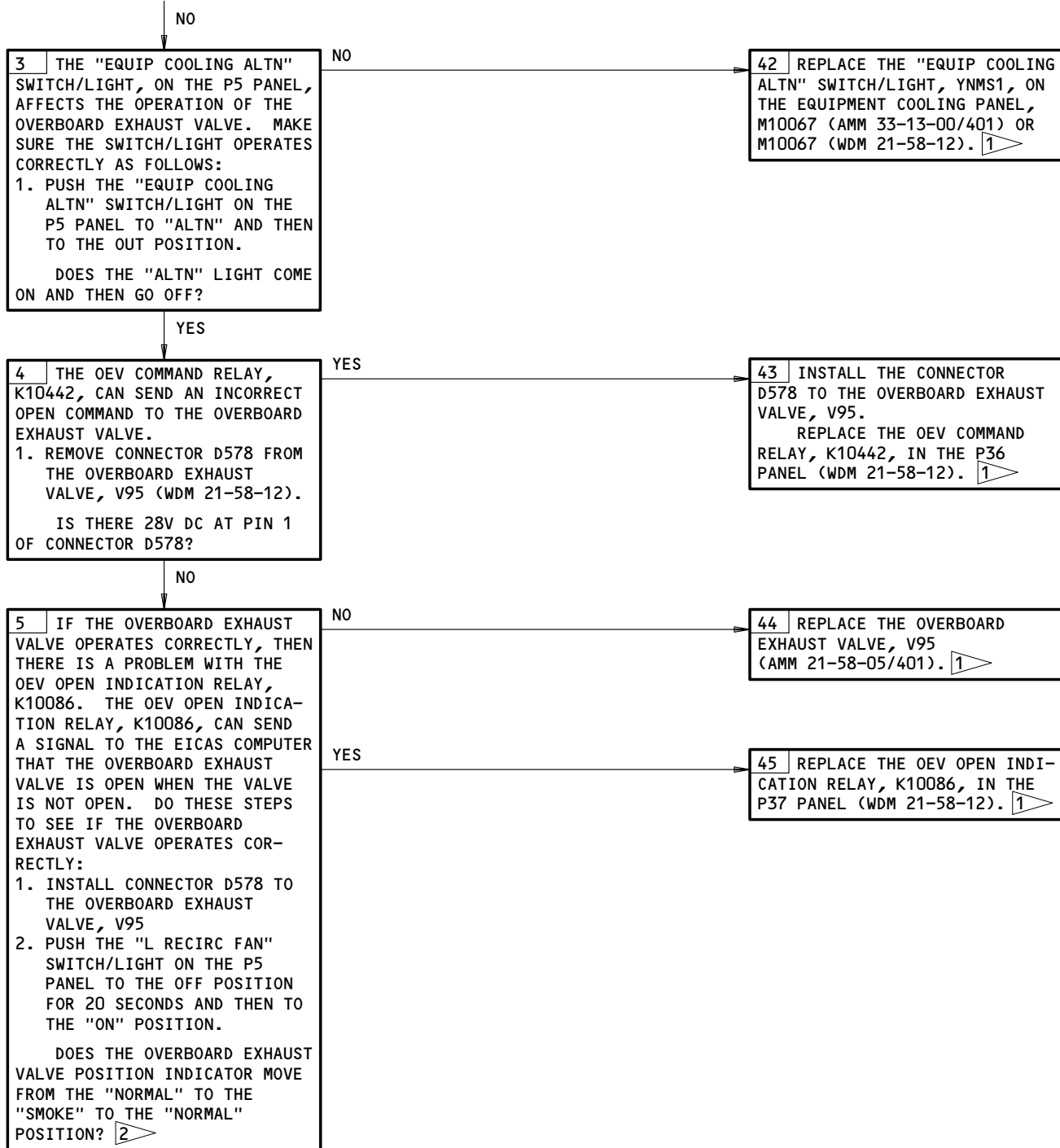

2 THE OVERBOARD EXHAUST VALVE IS SPRING-LOADED OPEN ON THE GROUND. THE VALVE ACTUATOR ONLY WILL MOVE, THE VALVE FLAPPER WILL NOT MOVE.

EICAS Msg OVBD EX VAL OPEN Displayed
Figure 118 (Sheet 2)

EFFECTIVITY
GUI 115

21-58-00
CONFIG 3
Page 128
Mar 20/94

07

EICAS MSG "FWD EQPT SMOKE" DISPLAYED.
"SMOKE" LGT ILLUM.
"OVBD EX VAL OPEN" DISPLAYED.

PREREQUISITES

MAKE SURE THIS SYSTEM WILL OPERATE:
EICAS (AMM 31-41-00/201)

MAKE SURE THESE CIRCUIT BREAKERS ARE CLOSED:
6D6,6F17,6F23,11C20,11N11,11N13,11P14,70C10

MAKE SURE THE AIRPLANE IS IN THIS CONFIGURATION:
ELECTRICAL POWER IS ON (AMM 24-22-00/201)

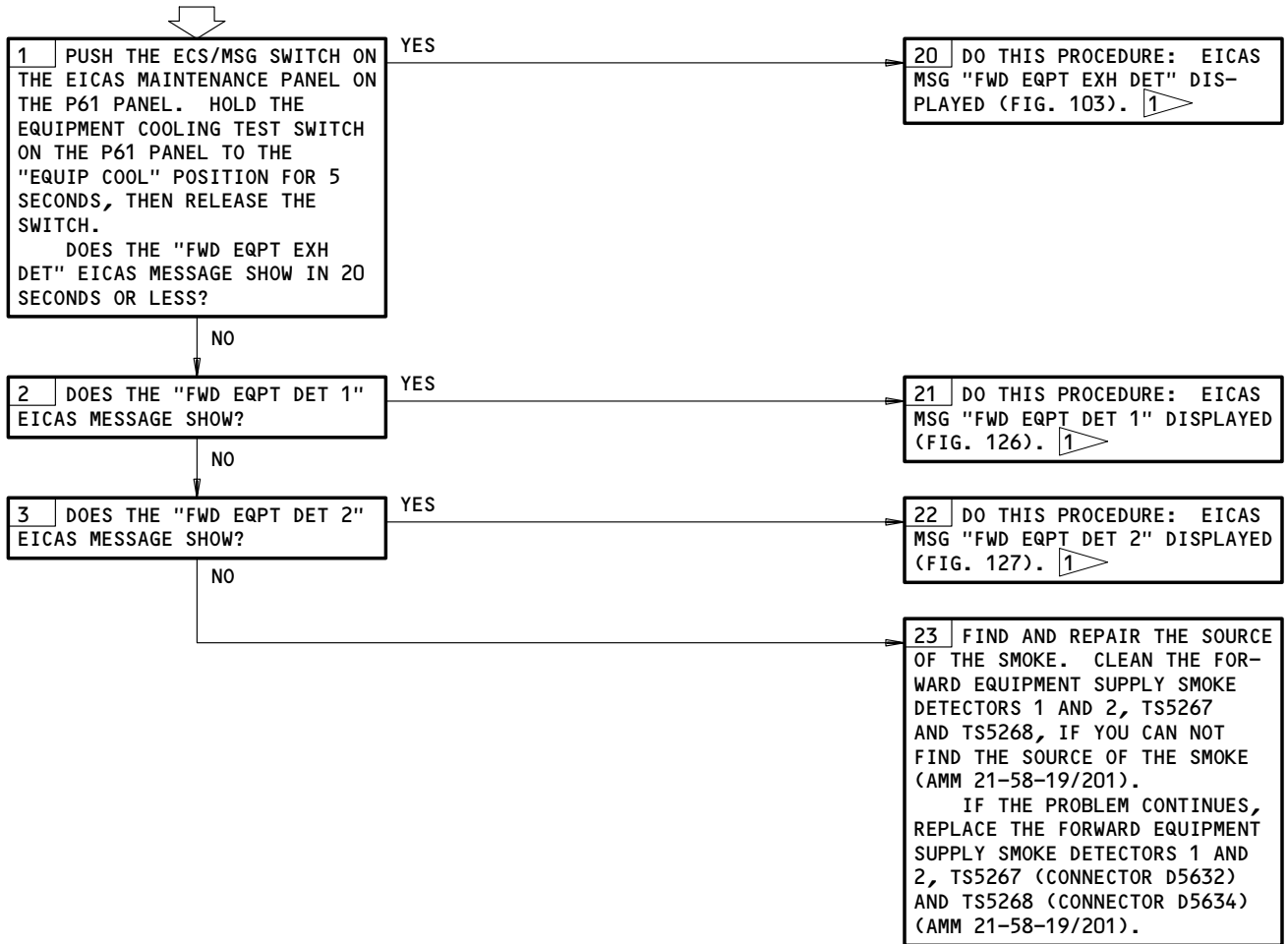

1 MAKE SURE THAT THE EICAS MESSAGE "FWD EQPT SMOKE" DOES NOT SHOW.

EICAS Msg FWD EQPT SMOKE Displayed. SMOKE Lgt Illum.
OVBD EX VAL OPEN Displayed.
Figure 119

EFFECTIVITY
GUI 115

21-58-00
CONFIG 3
Page 129
Jun 20/94

07

EICAS MSG "FWD EQPT SMOKE" DISPLAYED.
"SMOKE" LGT ILLUM.
"OVBD EX VAL OPEN" NOT DISPLAYED.

PREREQUISITES

MAKE SURE THIS SYSTEM WILL OPERATE:
EICAS (AMM 31-41-00/201)

MAKE SURE THESE CIRCUIT BREAKERS ARE CLOSED:
6D6,6F17,6F23,11C20,11N11,11N13,11P14,70C10

MAKE SURE THE AIRPLANE IS IN THIS CONFIGURATION:
ELECTRICAL POWER IS ON (AMM 24-22-00/201)

NOTE: THERE MAY BE A SMOKE CONDITION. FIND AND REPAIR THE SOURCE OF THE SMOKE. DO THE BLOCK 1 ACTION. IF YOU CAN NOT FIND THE SOURCE OF THE SMOKE.

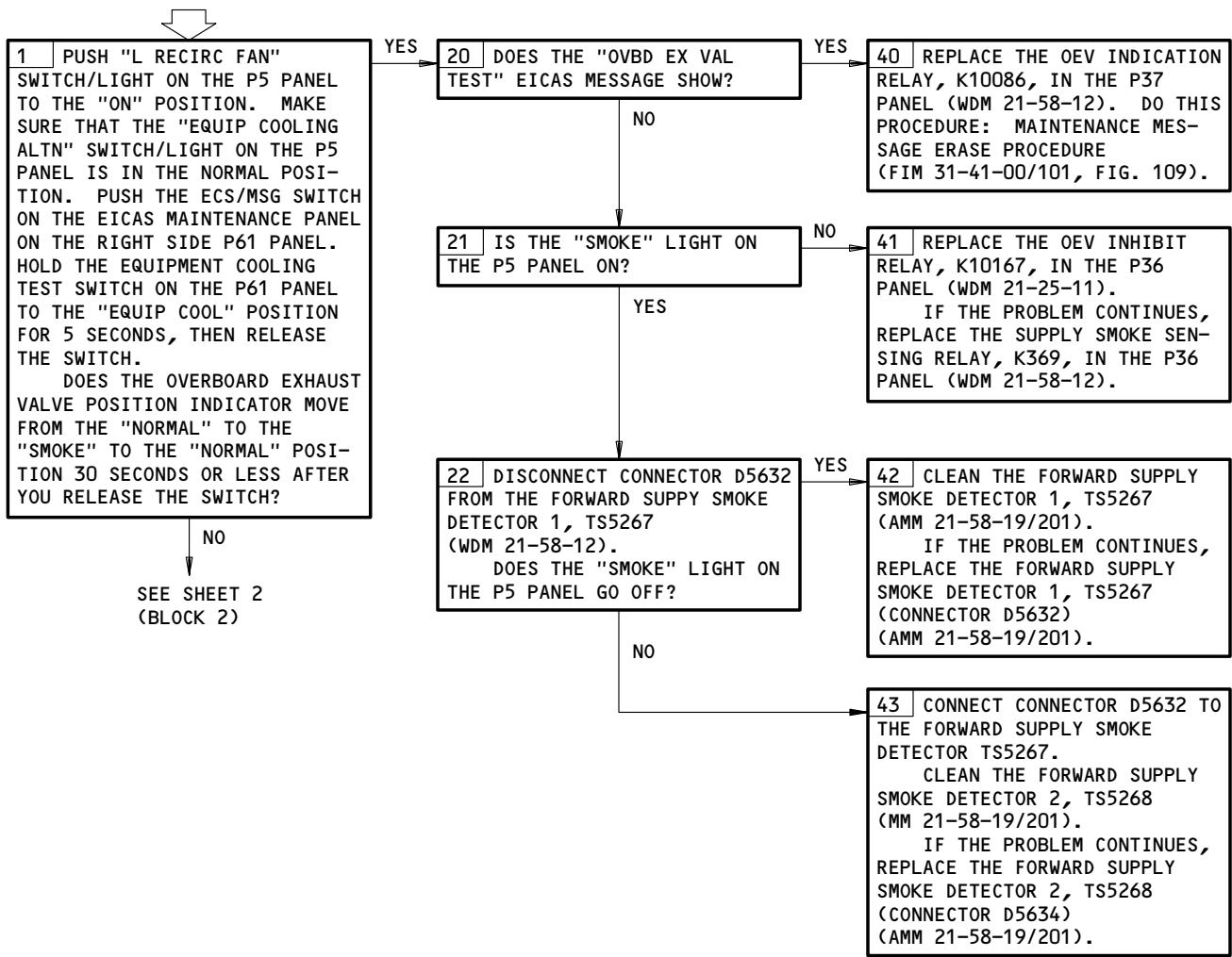

EICAS Msg FWD EQPT SMOKE Displayed. SMOKE Lgt Illum.
OVBD EX VAL OPEN Not Displayed.
Figure 120 (Sheet 1)

EFFECTIVITY
GUI 115

21-58-00
CONFIG 3
Page 130
Jun 20/94

07

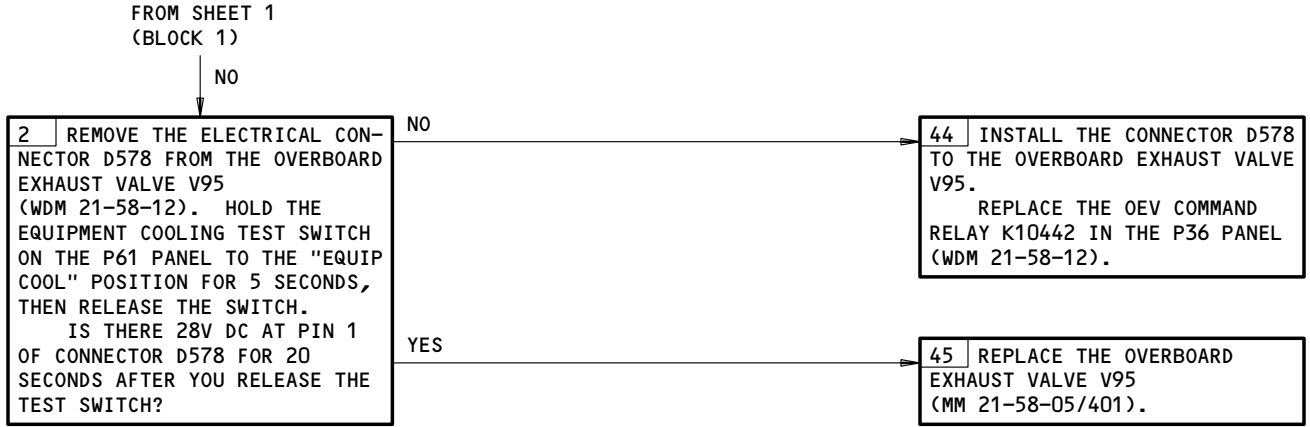

EICAS Msg FWD EQPT SMOKE Displayed. SMOKE Lgt Illum.
 OVBD EX VAL OPEN Not Displayed.
 Figure 120 (Sheet 2)

EFFECTIVITY
GUI 115

21-58-00

CONFIG 3

07

Page 131

Mar 20/94

EICAS MSG "EQPT OVHT" DISPLAYED.
"OVHT" LGT ILLUM.
"L RECIRC FAN INOP" LGT ILLUM. "OVHT" LGT EX TIN WHEN "ALTN" WAS SELECTED. EICAS MSGS "EQPT CLG FAN" AND "OVBD EX VAL OPEN" NOT DISPLAYED.

PREREQUISITES

MAKE SURE THIS SYSTEM WILL OPERATE:
EICAS (AMM 31-41-00/201)

MAKE SURE THESE CIRCUIT BREAKERS ARE CLOSED:
6D6,6F17,6F23,11C20,11N11,11N13,11P14,70C10

MAKE SURE THE AIRPLANE IS IN THIS CONFIGURATION:
ELECTRICAL POWER IS ON (AMM 24-22-00/201)

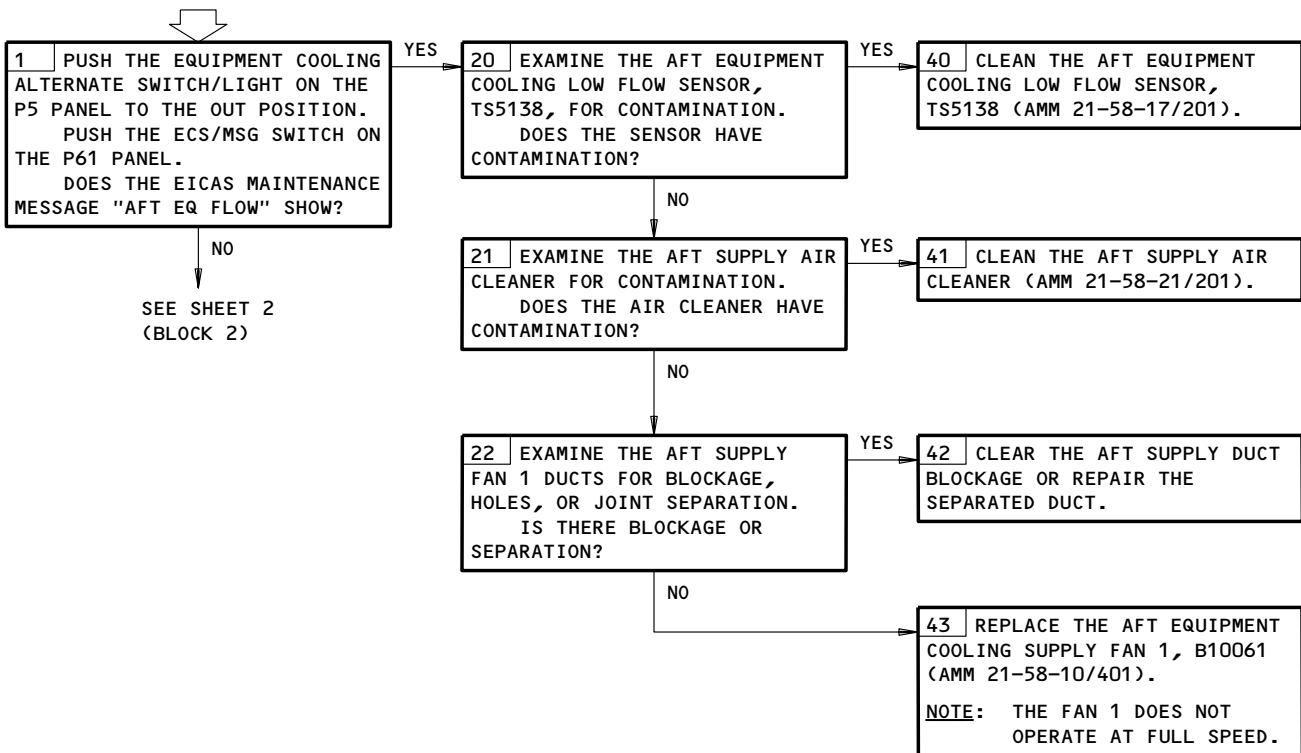

EICAS Msg EQPT OVHT Displayed. OVHT Lgt Illum. L RECIRC INOP Lgt Illum.
OVHT Lgt Ex tin When ALTN Was Selected. EICAS Msgs EQPT CLG FAN and
OVBD EX VAL OPEN Not Displayed.
Figure 121 (Sheet 1)

EFFECTIVITY
GUI 115

21-58-00
CONFIG 3
Page 132
Sep 20/98

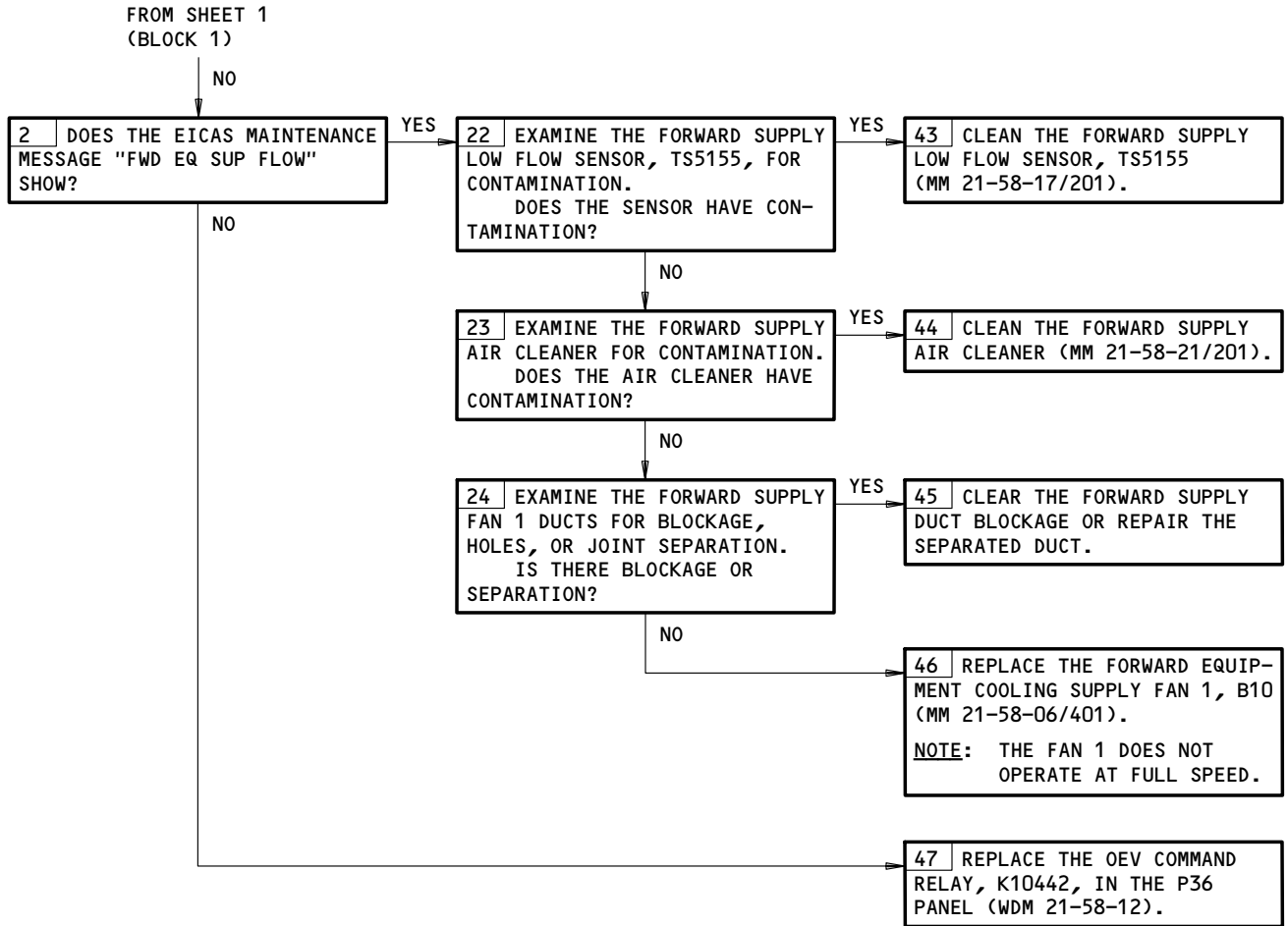

EICAS Msg EQPT OVHT Displayed. OVHT Lgt Illum. L RECIRC INOP Lgt Illum.
 OVHT Lgt Extin When ALTN Was Selected. EICAS Msgs EQPT CLG FAN and
 OVBD EX VAL OPEN Not Displayed.
 Figure 121 (Sheet 2)

EFFECTIVITY
GUI 115

21-58-00
 CONFIG 3
 Page 133
 May 28/07

06

GROUND CREW CALL
HORN SOUNDS
CONTINUOUSLY.
C IRS, L IRS,
OR R IRS NOT
SELECTED ON.

PREREQUISITES

MAKE SURE THIS SYSTEM WILL OPERATE:
EICAS (AMM 31-41-00/201)

MAKE SURE THESE CIRCUIT BREAKERS ARE CLOSED:
6D6, 11N13

MAKE SURE THE AIRPLANE IS IN THIS CONFIGURATION:
ELECTRICAL POWER IS ON (AMM 24-22-00/201)

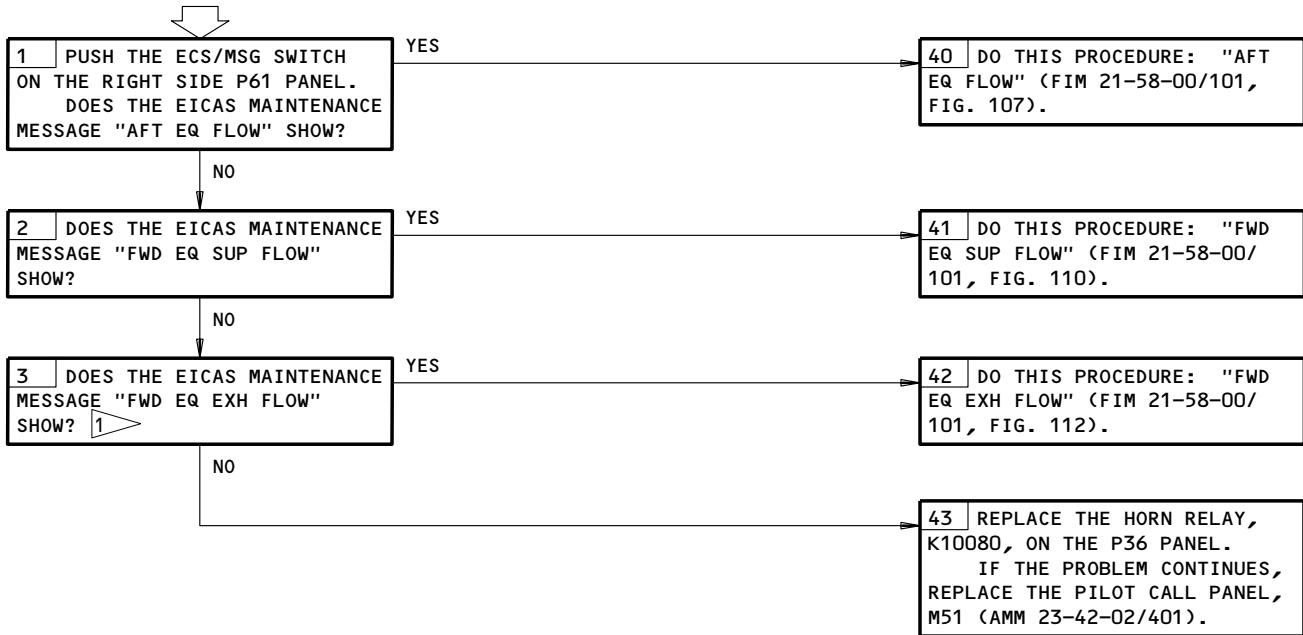

1 AIRPLANES PRE-SB 21-61

Ground Crew Call Horn Sounds Continuously. C IRS, L IRS, or R IRS Not Selected ON.
Figure 122

EFFECTIVITY
GUI 115

21-58-00
CONFIG 3
Page 134
Jan 28/00

06

EICAS MSG "EQPT
OVHT" DISPLAYED.
"OVHT" LGT ILLUM.
EICAS MSG "EQPT CLG
FAN" DISPLAYED.
"OVHT" LIGHT
REMAINED ILLUM WHEN
"ALTN" WAS SELECTED.

PREREQUISITES

MAKE SURE THIS SYSTEM WILL OPERATE:
EICAS (AMM 31-41-00/201)

MAKE SURE THESE CIRCUIT BREAKERS ARE CLOSED:
6D6,6F17,6F23,11C20,11N11,11N13,11P14,37D2,70B5,
70C10

MAKE SURE THE AIRPLANE IS IN THIS CONFIGURATION:
ELECTRICAL POWER IS ON (AMM 24-22-00/201)

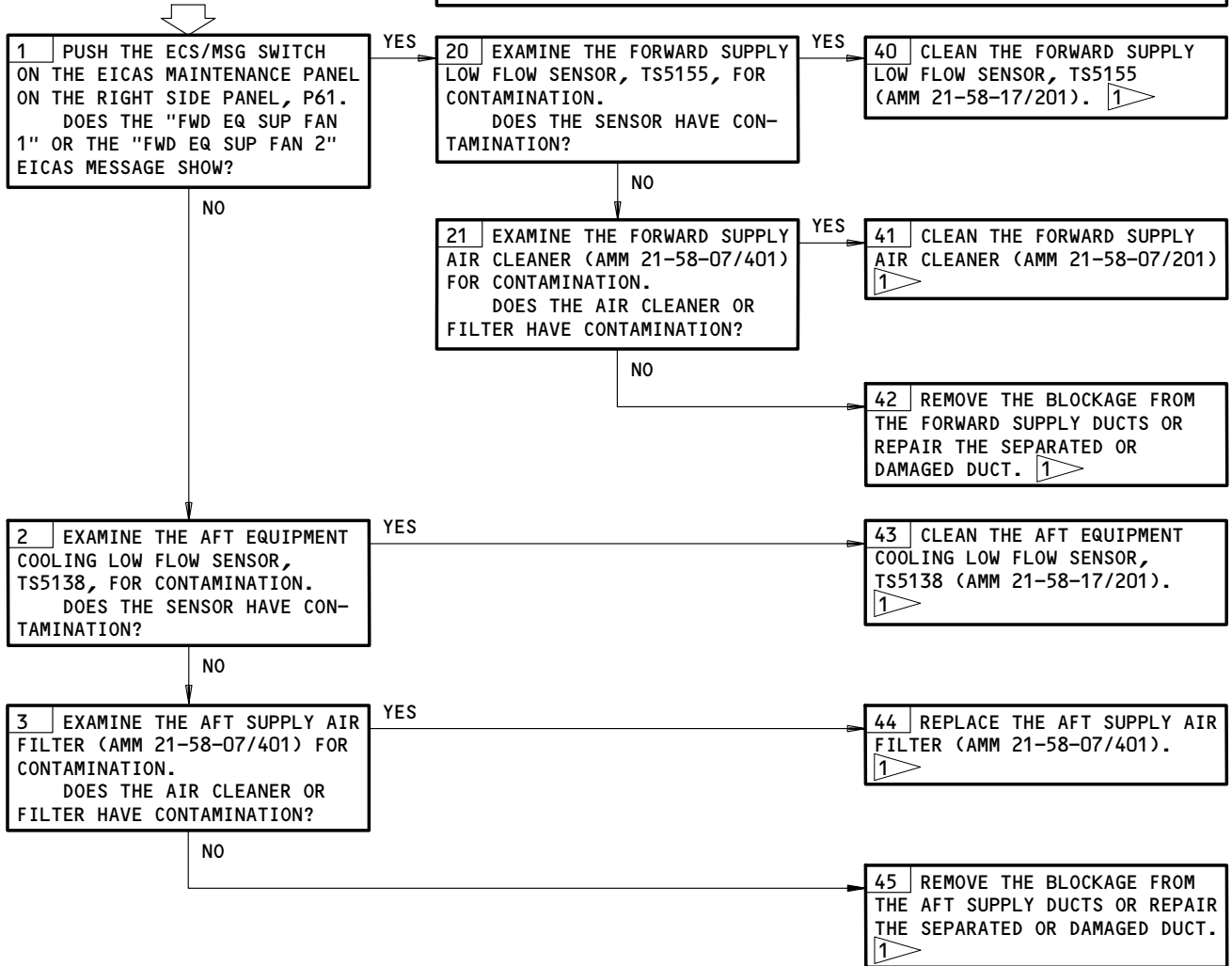

1 CAUTION: IF OTHER MESSAGES SHOW ON THE ECS/MSG PAGES, MAKE A RECORD OF THESE MESSAGES FOR TROUBLESHOOTING REFERENCE. ALL OF THE MESSAGES WHICH SHOW ON THE ECS/MSG PAGES WILL BE ERASED WHEN YOU DO THE ERASE PROCEDURE.

DO THIS PROCEDURE: MAINTENANCE MESSAGE ERASE PROCEDURE (FIM 31-41-00/101, FIG. 109).

EICAS Msg EQPT OVHT Displayed. OVHT Lgt Illum. EICAS Msg EQPT CLG FAN Displayed.
OVHT Lgt Remained Illum When ALTN Was Selected.

Figure 123

EFFECTIVITY
GUI 115

21-58-00

CONFIG 3

07

Page 135

Jun 20/95

PREREQUISITES
 MAKE SURE THIS SYSTEM WILL OPERATE:
 EICAS (AMM 31-41-00/501)
 MAKE SURE THESE CIRCUIT BREAKERS ARE CLOSED:
 6D6, 6F17, 6F23, 11C20, 11N11, 11N13 OR 11N17,
 11P23, 37D7, 37J5
 MAKE SURE THE AIRPLANE IS IN THIS CONFIGURATION:
 ELECTRICAL POWER IS ON (AMM 24-22-00/201)

EICAS MSG "OVBD EX VAL TEST" DISPLAYED

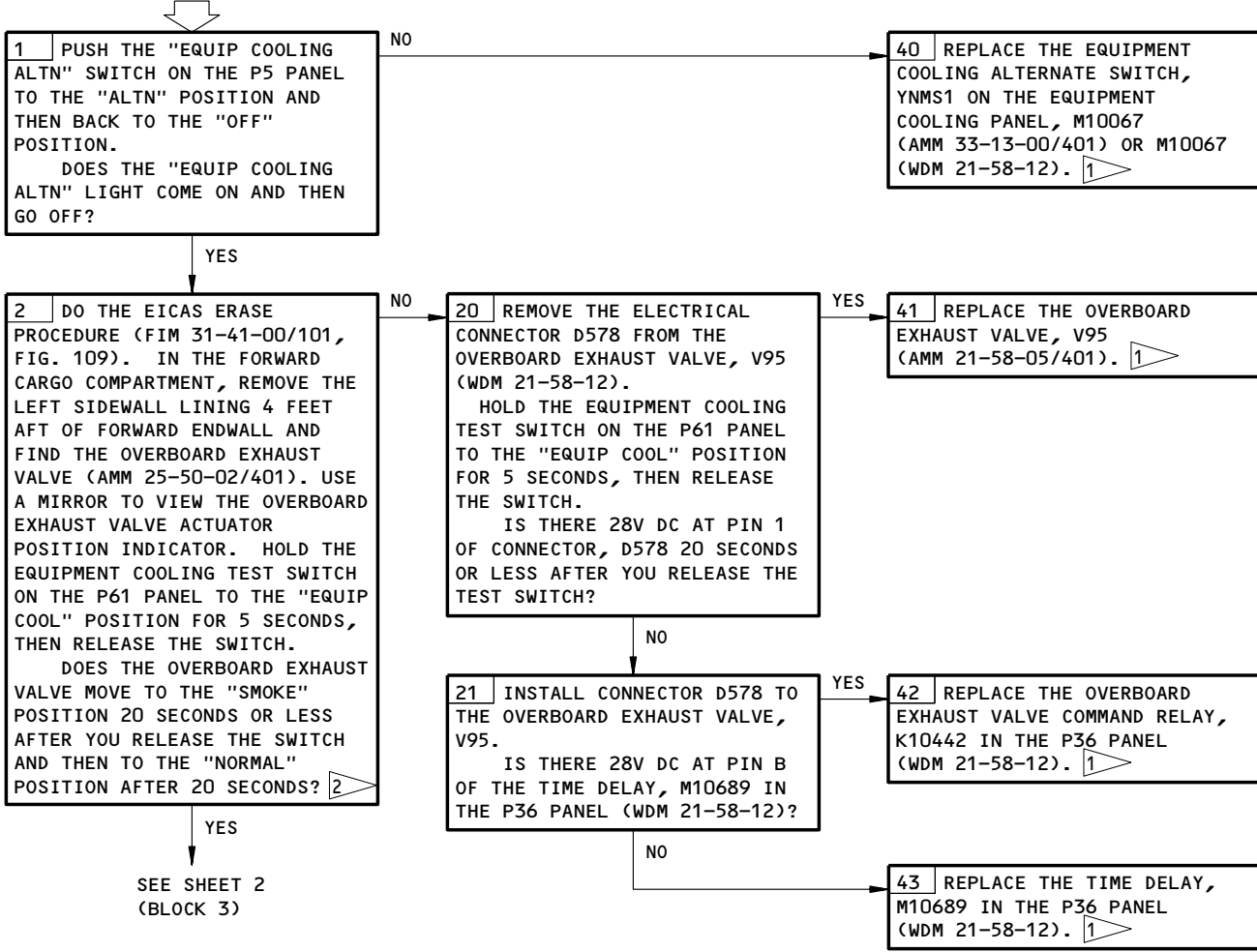

- 1 DO THE EICAS "ERASE PROCEDURE" (FIM 31-41-00/101, FIG. 109). HOLD THE EQUIPMENT COOLING TEST SWITCH ON THE P61 PANEL TO THE "EQUIP COOL" POSITION FOR 5 SECONDS AND THEN RELEASE THE SWITCH. WAIT 20 SECONDS. MAKE SURE THAT THE EICAS MESSAGE "OVBD EX VAL TEST" DOES NOT SHOW.
- 2 ONLY THE OVERBOARD EXHAUST VALVE ACTUATOR WILL MOVE. THE VALVE FLAPPERS WILL NOT MOVE. THEY ARE SPRING-LOADED OPEN ON THE GROUND.

EICAS Msg OVBD EX VAL TEST Displayed
Figure 124 (Sheet 1)

EFFECTIVITY
GUI 115

21-58-00
CONFIG 3
Page 136
Jan 28/05

06

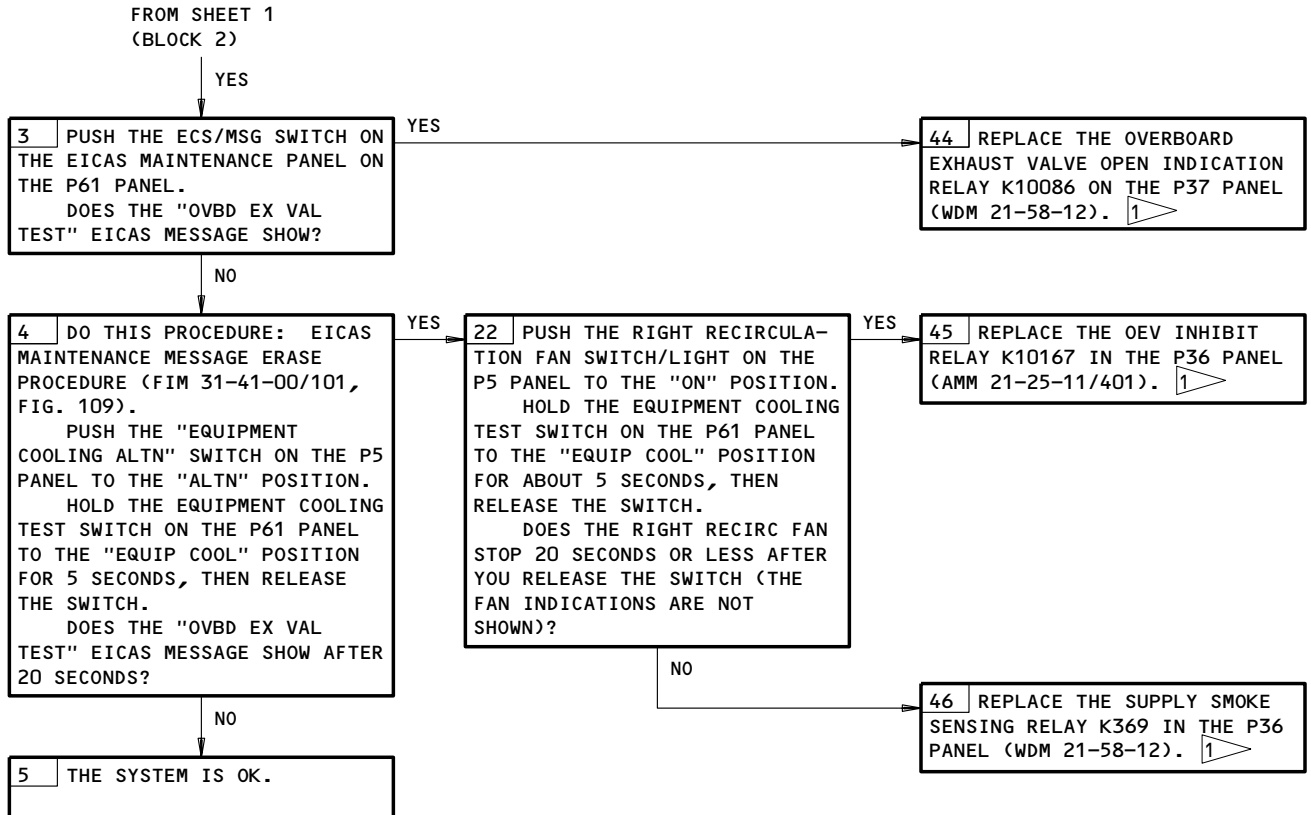

EICAS Msg OVBD EX VAL TEST Displayed
Figure 124 (Sheet 2)

EFFECTIVITY
GUI 115

21-58-00

CONFIG 3

07

Page 137

Jan 20/98

PREREQUISITES

MAKE SURE THIS SYSTEM WILL OPERATE:
EICAS (AMM 31-41-00/201)

MAKE SURE THIS CIRCUIT BREAKER IS CLOSED:
6D6

MAKE SURE THE AIRPLANE IS IN THIS CONFIGURATION:
ELECTRICAL POWER IS ON (AMM 24-22-00/201)

NOTE: THIS IS USUALLY A NUISANCE MESSAGE. IT IS USUALLY CAUSED BY OSCILLATIONS FROM THE ENGINE SPEED CARD.

EICAS MSG "EQPT CLG TEST" DISPLAYED

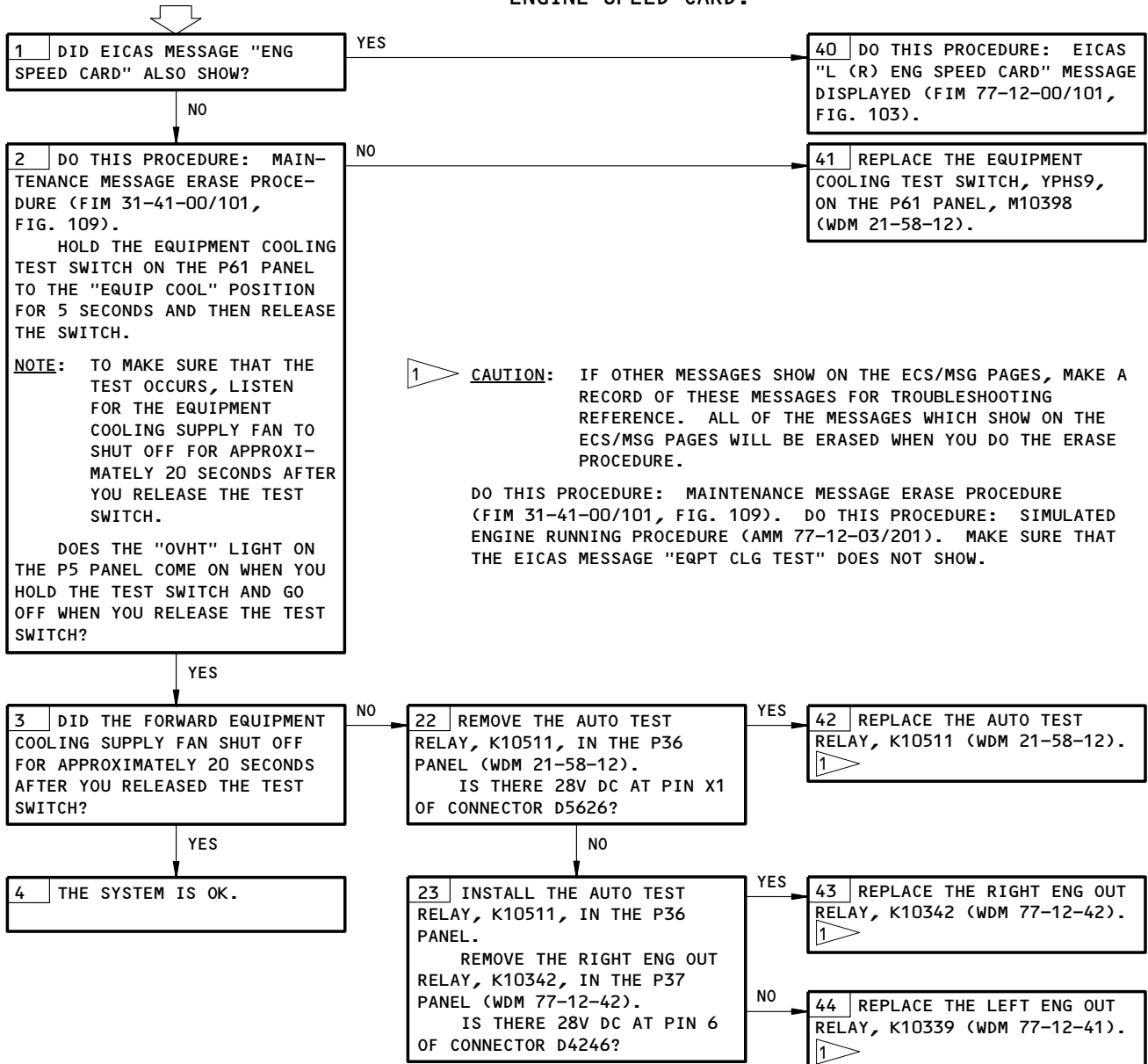

EICAS Msg EQPT CLG TEST Displayed
Figure 125

EFFECTIVITY
GUI 115

21-58-00
CONFIG 3
Page 138
Jun 20/95

07

EICAS MSG "FWD EQPT
DET 1" DISPLAYED

PREREQUISITES

MAKE SURE THIS SYSTEM WILL OPERATE:
EICAS (AMM 31-41-00/201)

MAKE SURE THESE CIRCUIT BREAKERS ARE CLOSED:
6D6,6F17,6F23,11C20,11N11,11N13

MAKE SURE THE AIRPLANE IS IN THIS CONFIGURATION:
ELECTRICAL POWER IS ON (AMM 24-22-00/201)

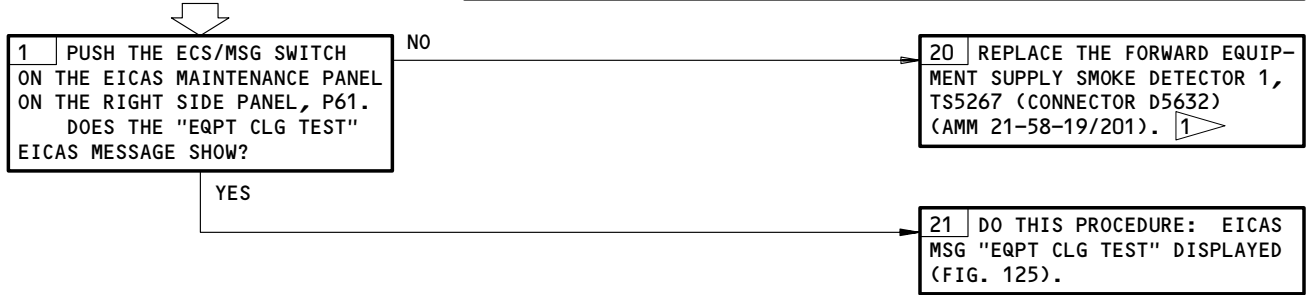

CAUTION: IF OTHER MESSAGES SHOW ON THE ECS/MSG PAGES, MAKE A RECORD OF THESE MESSAGES FOR TROUBLESHOOTING REFERENCE. ALL OF THE MESSAGES WHICH SHOW ON THE ECS/MSG PAGES WILL BE ERASED WHEN YOU DO THE ERASE PROCEDURE.

DO THIS PROCEDURE: MAINTENANCE MESSAGE ERASE PROCEDURE (FIM 31-41-00/101, FIG. 109). HOLD THE EQUIPMENT COOLING TEST SWITCH ON THE P61 PANEL TO "EQUIP COOL" POSITION FOR 5 SECONDS AND THEN RELEASE THE SWITCH. WAIT 20 SECONDS. MAKE SURE THAT EICAS MESSAGE "FWD EQPT DET 1" DOES NOT SHOW.

EICAS Msg FWD EQPT DET 1 Displayed
Figure 126

EFFECTIVITY
GUI 115

21-58-00

CONFIG 3

07

Page 139

Jun 20/95

PREREQUISITES

MAKE SURE THIS SYSTEM WILL OPERATE:
 EICAS (AMM 31-41-00/201)

MAKE SURE THESE CIRCUIT BREAKERS ARE CLOSED:
 6D6,6F17,6F23,11C20,11N11,11N13

MAKE SURE THE AIRPLANE IS IN THIS CONFIGURATION:
 ELECTRICAL POWER IS ON (AMM 24-22-00/201)

EICAS MSG "FWD EQPT
 DET 2" DISPLAYED

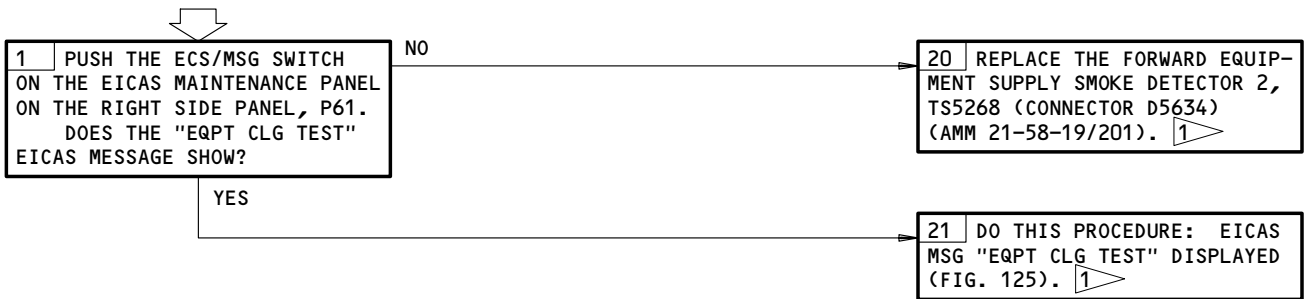

CAUTION: IF OTHER MESSAGES SHOW ON THE ECS/MSG PAGES, MAKE A RECORD OF THESE MESSAGES FOR TROUBLESHOOTING REFERENCE. ALL OF THE MESSAGES WHICH SHOW ON THE ECS/MSG PAGES WILL BE ERASED WHEN YOU DO THE ERASE PROCEDURE.

DO THIS PROCEDURE: MAINTENANCE MESSAGE ERASE PROCEDURE (FIM 31-41-00/101, FIG. 109). HOLD THE EQUIPMENT COOLING TEST SWITCH ON THE P61 PANEL TO THE "EQUIP COOL" POSITION FOR 5 SECONDS, THEN RELEASE IT. WAIT 20 SECONDS. MAKE SURE THAT THE EICAS MESSAGE "FWD EQPT DET 2" DOES NOT SHOW.

EICAS Msg FWD EQPT DET 2 Displayed
 Figure 127

EFFECTIVITY
 GUI 115

21-58-00
 CONFIG 3
 Page 140
 Jun 20/95

07

218123

EICAS MSG "EQPT
SMOKE TEST"
DISPLAYED

PREREQUISITES

MAKE SURE THIS SYSTEM WILL OPERATE:
EICAS (AMM 31-41-00/201)

MAKE SURE THIS CIRCUIT BREAKER IS CLOSED:
6D6

MAKE SURE THE AIRPLANE IS IN THIS CONFIGURATION:
ELECTRICAL POWER IS ON (AMM 24-22-00/201)

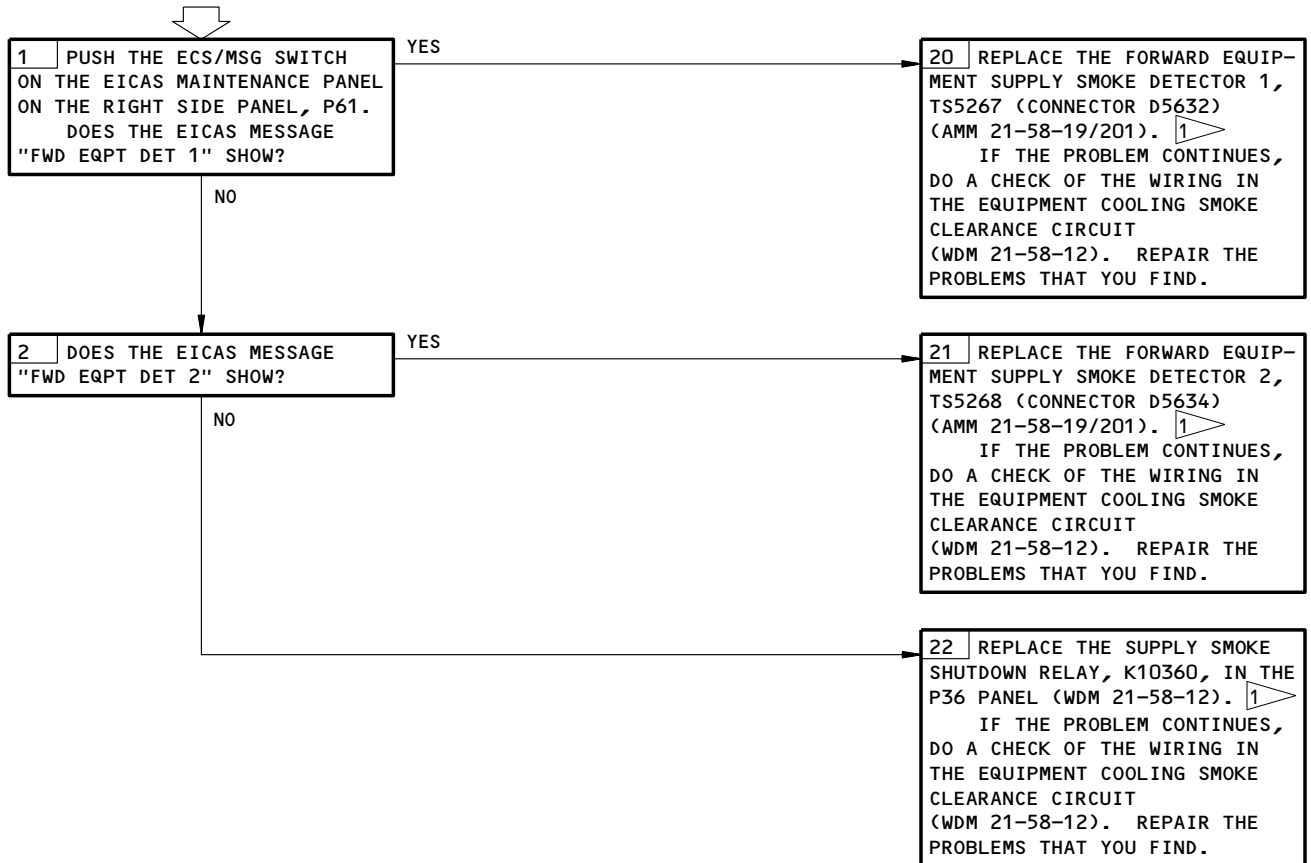

1 CAUTION: IF OTHER MESSAGES SHOW ON THE ECS/MSG PAGES, MAKE A RECORD OF THESE MESSAGES FOR TROUBLESHOOTING REFERENCE. ALL OF THE MESSAGES WHICH SHOW ON THE ECS/MSG PAGES WILL BE ERASED WHEN YOU DO THE ERASE PROCEDURE.

DO THIS PROCEDURE: MAINTENANCE MESSAGE ERASE PROCEDURE (FIM 31-41-00/101, FIG. 109). HOLD THE EQUIPMENT COOLING TEST SWITCH ON THE P61 PANEL TO THE "EQUIP COOL" POSITION FOR 5 SECONDS, THEN RELEASE IT. WAIT 20 SECONDS. MAKE SURE THAT THE EICAS MESSAGE "EQPT SMOKE TEST" DOES NOT SHOW.

EICAS Msg EQPT SMOKE TEST Displayed
Figure 128

EFFECTIVITY
GUI 115

21-58-00
CONFIG 3
Page 141
Sep 20/98

06

 **BOEING**
757
FAULT ISOLATION/MAINT MANUAL

EQUIPMENT COOLING

COMPONENT	FIG. 102 SHT	QTY	ACCESS/AREA	AMM REFERENCE
CIRCUIT BREAKER - EQPT COOL GND WARN AND TEST, C4070	1	1	FLT COMPT, P6 6D6	*
EQUIP COOLING AUX FAN, C3044		1	6D17	*
EQUIP COOL SUPPLY FAN 1, C331		1	6F17	*
EQUIP COOL SUPPLY FAN 2, C332		1	6F23	*
CIRCUIT BREAKER -	1		FLT COMPT, P11	
EQUIP COOLING FAN CONT AFT EXH XFER, C705		1	11N11	*
EQUIP COOLING LOW FLOW DET, C4069		1	11N13	*
EQUIP COOLING SMOKE DET CONT, C4085		1	11C20	*
RECIRC CARGO FIRE CONT LEFT, C660		1	11P14	*
CIRCUIT BREAKER -			119BL, MAIN EQUIP CTR, P37	
AFT EQPT COOLING FAN EXH NO. 1, C333		1	37D5	*
CIRCUIT BREAKER -			119BL, MAIN EQUIP CTR, P70	
AFT EQPT COOLING FAN EXH NO. 2, C334		1	70B2	*
RECIRC FAN LEFT, C336		1	70C10	*
LEFT RECIRC FAN CONT, C4373		1	70B16	*
CLEANER - EQUIPMENT COOLING AIR, FWD	3	1	821, FWD CARGO COMPT	21-58-21
COMPUTER - (FIM 31-41-00/101)				
EICAS LEFT, M10181				
EICAS RIGHT, M10182				
DIODE - (FIM 31-01-36/101)				
R10044,R10096,R10171,R10172,R10173,R10174, R10180,R10181,R10204,R10218,R10221,R10223, R10230				
DIODE - (FIM 31-01-37/101)				
R10074,R10179,R10224,R10225,R10226				
FAN - AFT EQUIP/LAV/GALLEY VENT 1, B16	4	1	822, AFT CARGO COMPT	21-26-01
FAN - AFT EQUIP/LAV/GALLEY VENT 2, B15	4	1	822, AFT CARGO COMPT	21-26-01
FAN - EQUIP COOLING AUXILIARY FAN, B10133	5	1	119BL, MAIN EQUIP CTR	21-58-22
FAN - FWD EQUIP COOLING SUPPLY 1, B10	3	1	821, FWD CARGO COMPT	21-58-06
FAN - FWD EQUIP COOLING SUPPLY 2, B11	3	1	821, FWD CARGO COMPT	21-58-06
FAN - LEFT RECIRCULATION AIR, B13	3	1	821, FWD CARGO COMPT	21-25-01
FILTER - LEFT RECIRCULATION AIR	4	2	821, FWD CARGO COMPT	21-25-02
LIGHT - SMOKE, YNML1	1	1	FLT COMPT, P5 EQUIP COOLING PANEL, M10067	
MODULE - (FIM 27-51-00/101)				
FSEU3, M10333				
PANEL - AIR CONDITIONING CONTROL, M10193	1	1	FLT COMPT, P5	*
PANEL - (FIM 26-22-00/101)				
APU/CARGO FIRE CONTROL, M10444				
PANEL - EQUIP COOLING, M10067	1	1	FLT COMPT, P5	
PANEL - (FIM 34-21-00/101)				
IRS MODE SELECT, M59				
PANEL - MISC TEST, M10399	1	1	FLT COMPT, P61	

* SEE THE WDM EQUIPMENT LIST

Equipment Cooling - Component Index
Figure 101 (Sheet 1)

EFFECTIVITY
GUI 001-099

21-58-00

CONFIG 4

12

Page 101

Sep 20/98

596056

BOEING
757
FAULT ISOLATION/MAINT MANUAL

COMPONENT	FIG. 102 SHT	QTY	ACCESS/AREA	AMM REFERENCE
PANEL - (23-42-00/101) PILOT CALL, M51				
RELAY - (31-01-36/101) AFT EQUIP/LAV/GALLEY VENT FAN 1, K347 AIR/GND SYS NO. 1, K124 AIR/GND SYS NO. 1, K148 ALTN MODE, K10506 AUTO TEST, K10511 EXHAUST SMOKE SENSING, K10509 FWD EQUIP SUPPLY FAN 1, K343 HORN, K10080 OEV INHIBIT, K10167 OVBD EXH VLV, K10442 OVHT LT INHIBIT, K10507 PWR XFR, K10079 RECIRC OVERRIDE, K10497 SUPPLY SMOKE SENSING, K369 SUPPLY SMOKE SHUT DOWN, K10360				
RELAY - (31-01-37/101) AFT EQUIP EXH FAN 1, FAIL, K10322 AFT EQUIP/LAV/GALLEY VENT FAN 2, K346 AIR/GND SYS NO. 2, K201 EQUIP COOL AUX FAN, K10569 1 FWD CARGO FIRE, K10432 FWD EQUIP COOLING SUPPLY FAN 2, K344 LEFT ENG OUT NO. 3, K10339 OEV OPEN IND, K10086 RIGHT ENG OUT NO. 3, K10342				
RELAY - (31-01-70/101) LEFT RECIRC FAN, K415				
SENSOR - FWD EQUIP EXH LOW FLOW, TS5156 2	2	1	113AL, FWD ACCESS DOOR	21-58-17
SENSOR - FWD EQUIP EXH SMOKE, TS164	3	1	821, FWD CARGO COMPT	21-58-19
SENSOR - FWD EQUIP SUPPLY LOW FLOW, TS5155	2	1	113AL, FWD ACCESS DOOR	21-58-17
SENSOR - FWD EQUIP SUPPLY SMOKE 1, TS5267	3	1	821, FWD CARGO COMPT	21-58-19
SENSOR - FWD EQUIP SUPPLY SMOKE 2, TS5268	3	1	821, FWD CARGO COMPT	21-58-19
SWITCH - SMOKE/LOW FLOW TEST, YPHS9	1	1	FLT COMPT, P61, MISC TEST PNL, M10398	*
SWITCH/LIGHT - ALTERNATE COOLING/OVHT, YNMS1	1	1	FLT COMPT, P5, EQUIP COOLING PANEL, M10067	*
SWITCH/LIGHT - LEFT RECIRC FAN, YNRS1	1	1	FLT COMPT, P5, AIR CONDITIONING CONT PANEL, M10193	*
TIME DELAY - (31-01-36/101) OEV POWER RESET, M10689 SMOKE AUTO TEST RESET, M10691 SMOKE LIGHT, M10690				
TIME DELAY - (FIM 31-01-37/101) OEV DRIVE, M10688				
VALVE - (21-20-00/101) AFT EQUIP/LAV/GALLEY VENT CHECK LEFT RECIRCULATION AIR CHECK				
VALVE - AUXILIARY FAN CHECK 1	5	1	119BL, MAIN EQUIP CTR	
VALVE - ETOPS ISOLATION CHECK 1	6	1	119BL, MAIN EQUIP CTR	
VALVE - FORWARD SUPPLY FAN CHECK	3	2	821, FWD CARGO COMPT	21-58-02
VALVE - OVERBOARD EXHAUST, V95	3	1	821, FWD CARGO COMPT	21-58-05

* SEE THE WDM EQUIPMENT LIST

2 NOT INSTALLED ON ALL AIRPLANES

Equipment Cooling - Component Index
Figure 101 (Sheet 2)

EFFECTIVITY
GUI 001-099

21-58-00

CONFIG 4

Page 102

Jan 28/02

10

BOEING

757

FAULT ISOLATION/MAINT MANUAL

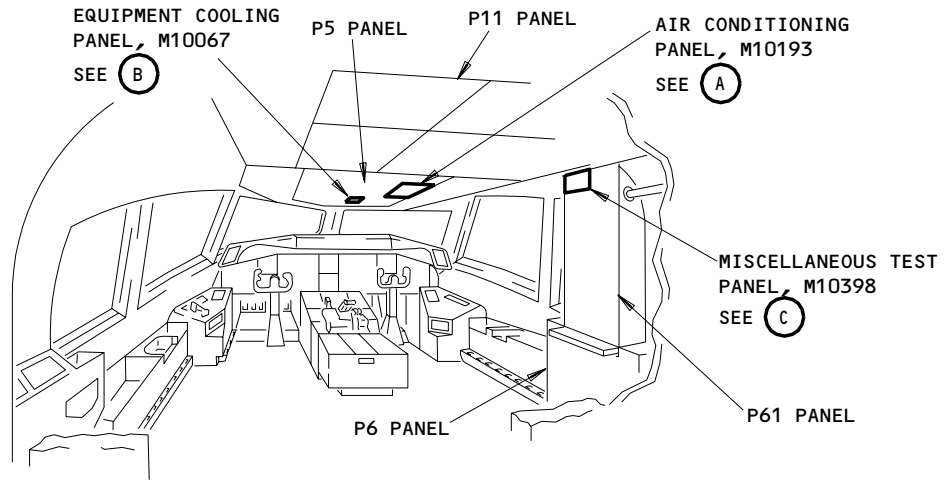

FLIGHT COMPARTMENT

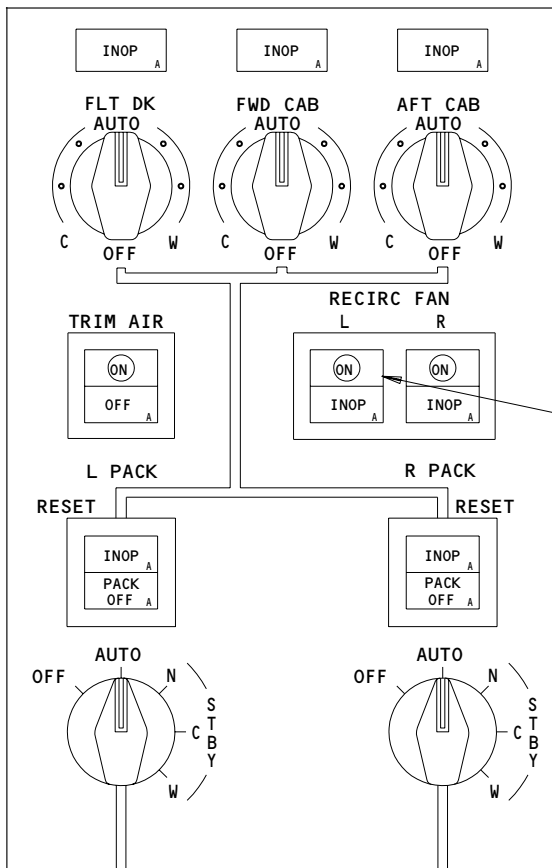

AIR CONDITIONING PANEL, M10193

(A)

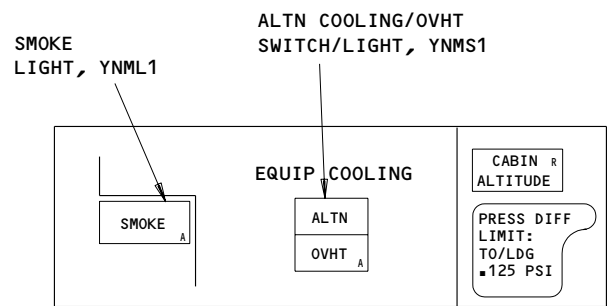

EQUIPMENT COOLING PANEL, M10067

(B)

LEFT RECIRCULATION FAN SWITCH/LIGHT, YNRS1

SMOKE/LOW FLOW TEST SWITCH, YPHS9

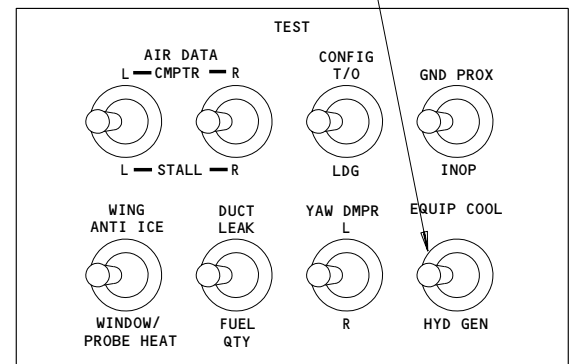

MISCELLANEOUS TEST PANEL, M10398

(C)

**Equipment Cooling - Component Location
Figure 102 (Sheet 1)**

EFFECTIVITY
GUI 001-099

21-58-00

CONFIG 4

10

Page 103

Sep 20/92

BOEING
757
FAULT ISOLATION/MAINT MANUAL

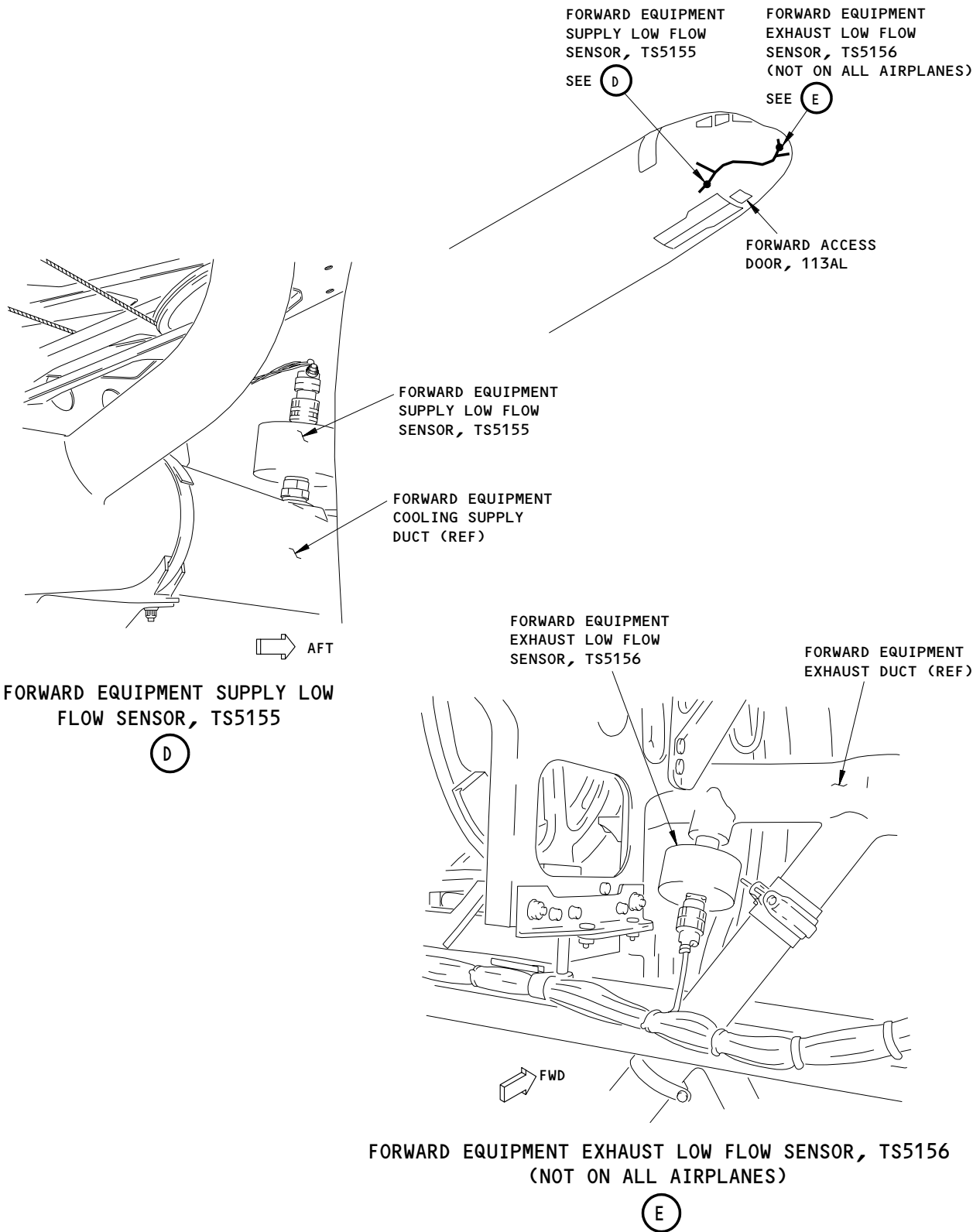

Equipment Cooling - Component Location
Figure 102 (Sheet 2)

EFFECTIVITY
GUI 001-099

21-58-00

CONFIG 4
Page 104
Jan 28/00

BOEING
757
FAULT ISOLATION/MAINT MANUAL

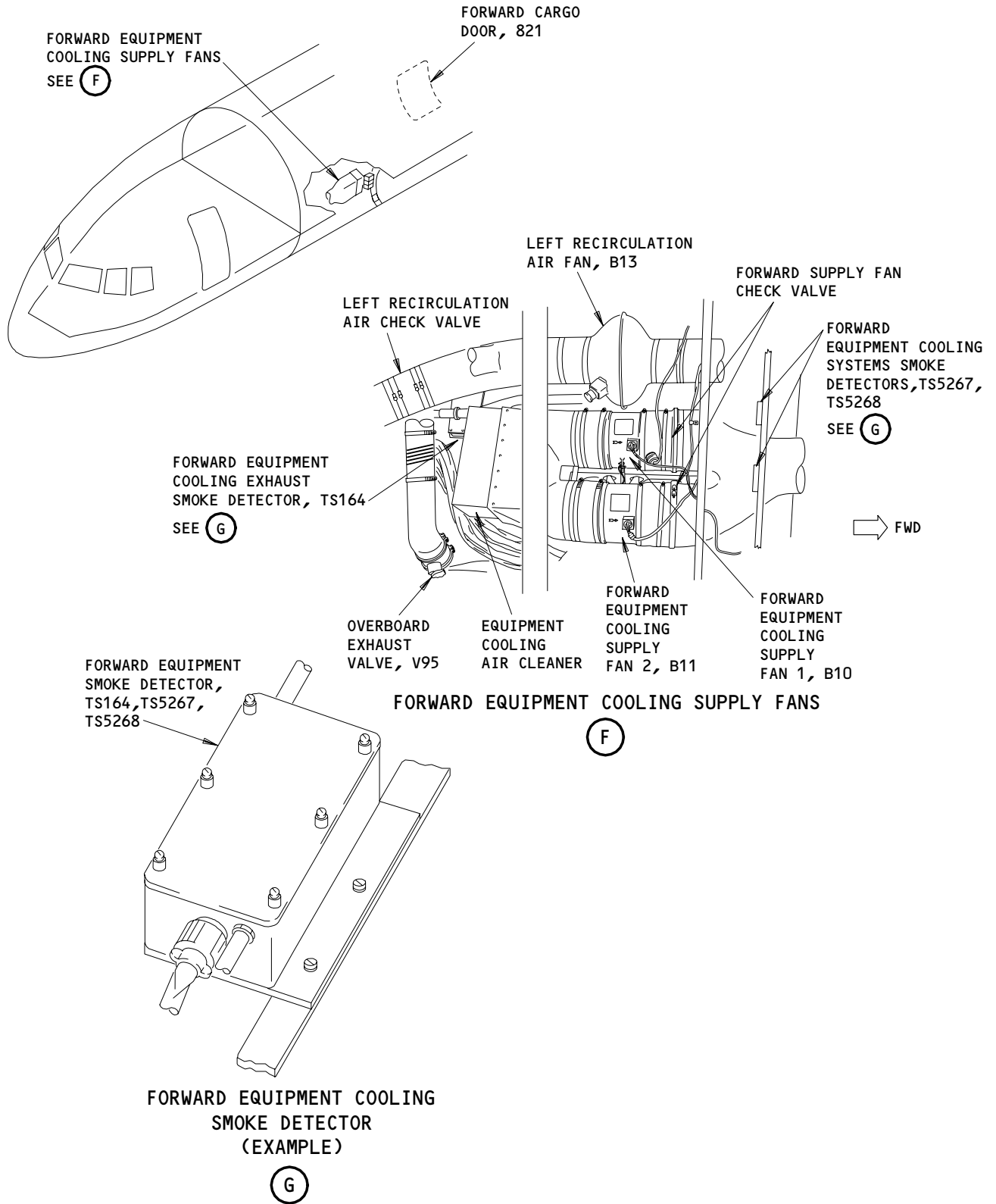

Equipment Cooling - Component Location
Figure 102 (Sheet 3)

EFFECTIVITY
GUI 001-099

290786

21-58-00

CONFIG 4
Page 105
Sep 20/92

BOEING
757
FAULT ISOLATION/MAINT MANUAL

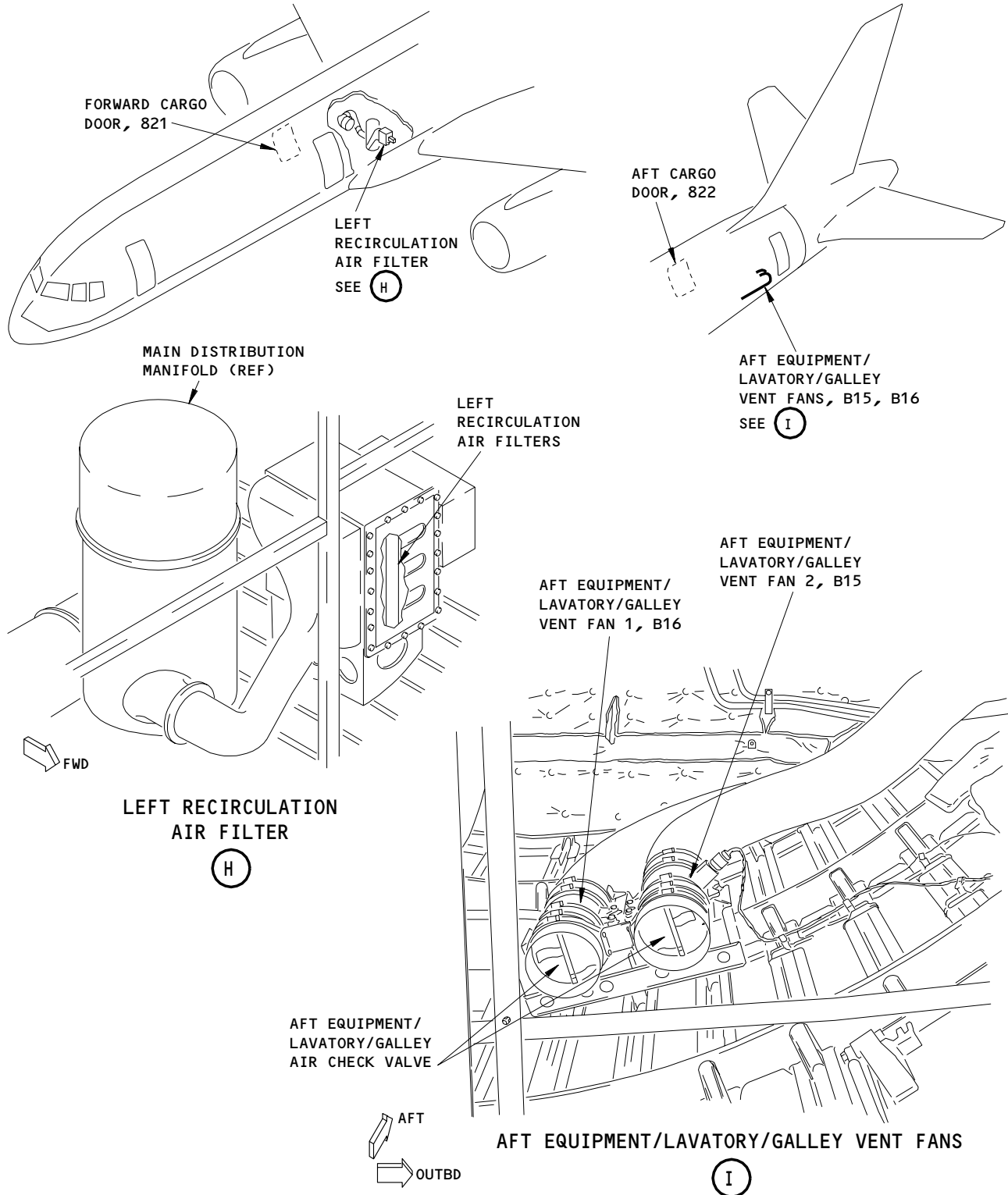

Equipment Cooling - Component Location
Figure 102 (Sheet 4)

EFFECTIVITY
GUI 001-099

21-58-00

CONFIG 4

Page 106

Sep 20/92

09

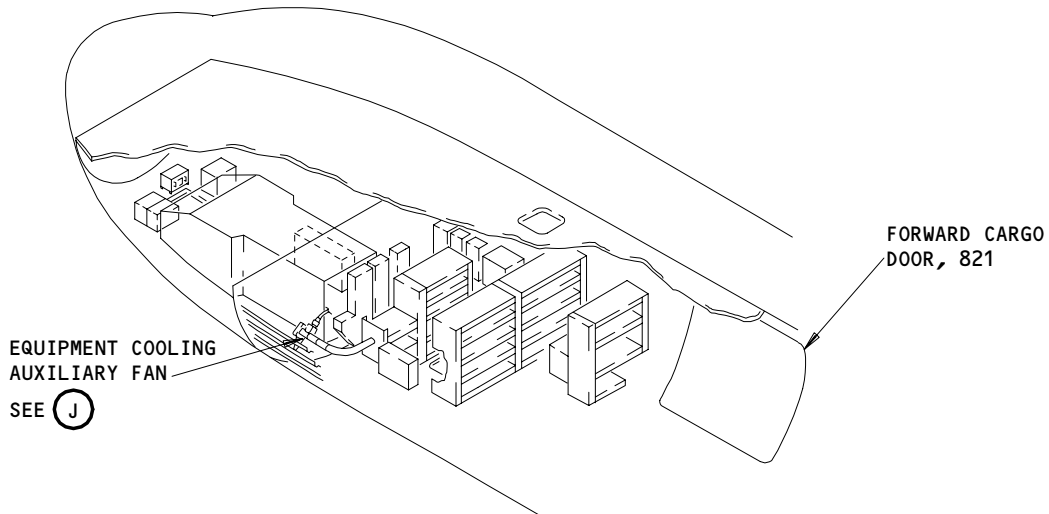

MAIN EQUIPMENT CENTER

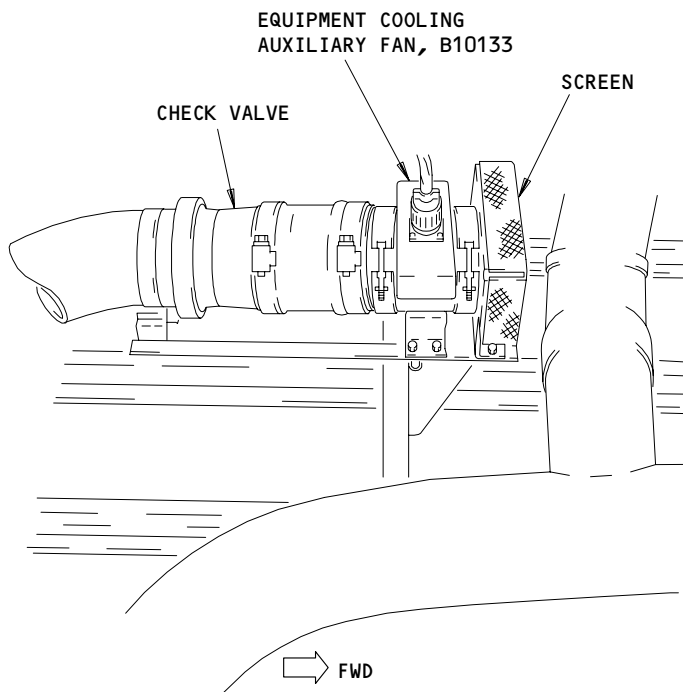

EQUIPMENT COOLING AUXILIARY FAN

(J)

Equipment Cooling - Component Location
Figure 102 (Sheet 5)

EFFECTIVITY
GUI 001-099

21-58-00

CONFIG 4
Page 107
Sep 20/92

BOEING
757
FAULT ISOLATION/MAINT MANUAL

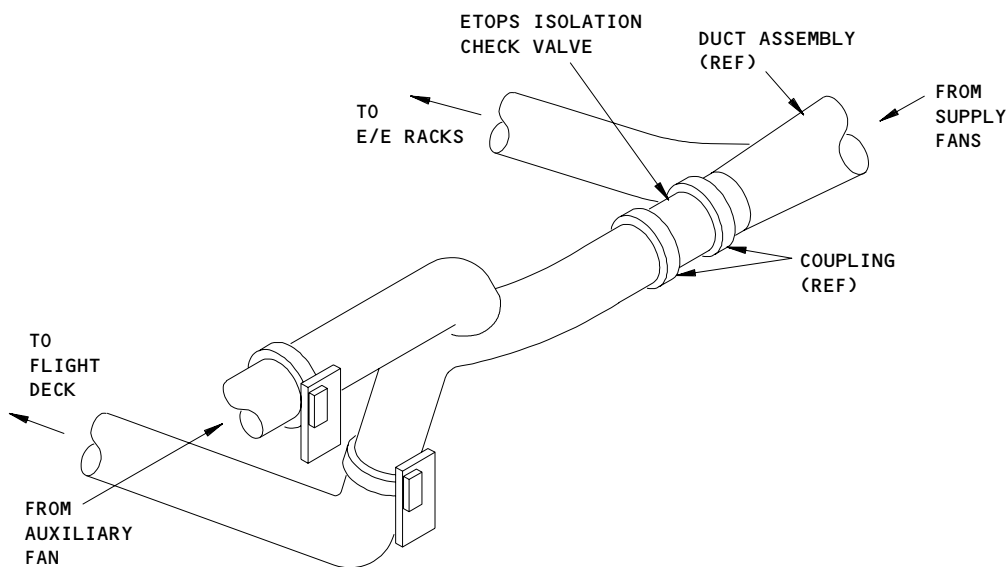
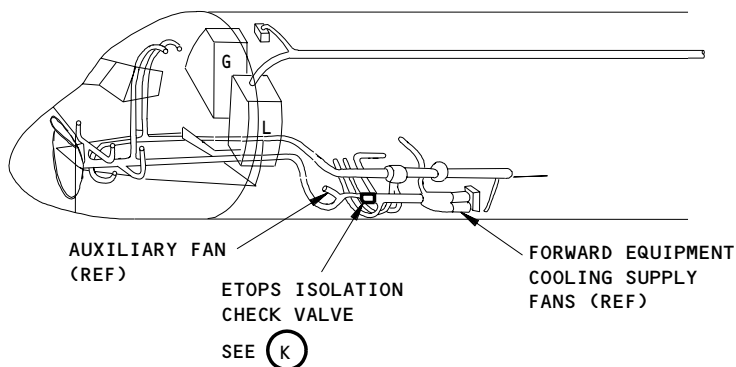

ETOPS ISOLATION CHECK VALVE

(K)

Equipment Cooling - Component Location
Figure 102 (Sheet 6)

EFFECTIVITY
GUI 001-099

21-58-00

CONFIG 4
Page 108
Mar 20/93

EICAS MSG "FWD EQPT EXH DET" DISPLAYED

PREREQUISITES

MAKE SURE THIS SYSTEM WILL OPERATE:
EICAS (AMM 31-41-00/201)

MAKE SURE THESE CIRCUIT BREAKERS ARE CLOSED:
6D6,6F17,6F23,11C20,11N11,11N13

MAKE SURE THE AIRPLANE IS IN THIS CONFIGURATION:
ELECTRICAL POWER IS ON (AMM 24-22-00/201)

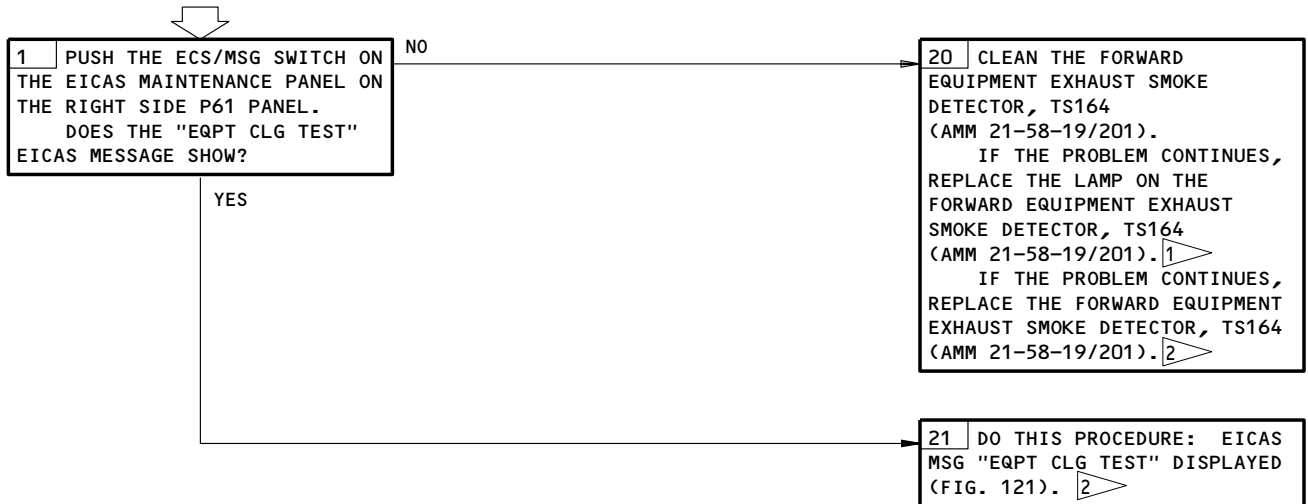

1 YOU CAN REPLACE THE LAMP ON THE SMOKE DETECTOR WITH PART NUMBER 2156-204A.

2 DO THIS PROCEDURE: MAINTENANCE MESSAGE ERASE PROCEDURE (FIM 31-41-00/101, FIG. 109). HOLD THE EQUIPMENT COOLING TEST SWITCH ON THE P61 PANEL TO THE "EQUIP COOL" POSITION FOR 5 SECONDS, THEN RELEASE IT. WAIT 20 SECONDS. MAKE SURE THAT THE EICAS MESSAGE "FWD EQPT EXH DET" DOES NOT SHOW.

EICAS Msg FWD EQPT EXH DET Displayed
Figure 103

EFFECTIVITY
GUI 001-099

21-58-00
CONFIG 4
Page 109
Jan 20/98

EICAS MSG "FWD EQ
SUP SNSR" DISPLAYED

PREREQUISITES

MAKE SURE THIS SYSTEM WILL OPERATE:
EICAS (MM 31-41-00/201)

MAKE SURE THESE CIRCUIT BREAKERS ARE CLOSED:
6D6,6F17,6F23,11C20,11N11,11N13

MAKE SURE THE AIRPLANE IS IN THIS CONFIGURATION:
ELECTRICAL POWER IS ON (MM 24-22-00/201)

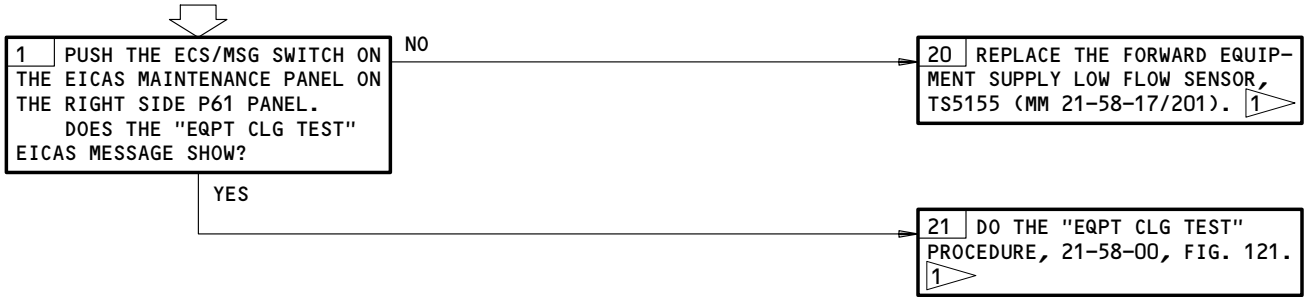

1 DO THE EICAS ERASE PROCEDURE (31-41-00, FIG. 109). HOLD THE EQUIPMENT COOLING TEST SWITCH ON THE P61 PANEL TO THE "EQUIP COOL" FOR 5 SECONDS, THEN RELEASE. WAIT 20 SECONDS. CHECK THAT THE EICAS MESSAGE "FWD EQPT EXH DET" DOES NOT SHOW.

EICAS Msg FWD EQ SUP SNSR Displayed
Figure 104

EFFECTIVITY
GUI 001-099

21-58-00
CONFIG 4
Page 110
Mar 20/93

09

PREREQUISITES

MAKE SURE THIS SYSTEM WILL OPERATE:
EICAS (AMM 31-41-00/201)

MAKE SURE THESE CIRCUIT BREAKERS ARE CLOSED:
6F17, 6F23, 37D2, 70B5

MAKE SURE THE AIRPLANE IS IN THIS CONFIGURATION:
ELECTRICAL POWER IS ON (AMM 24-22-00/201)

**EICAS MSG "EQPT
CLG FAN" DISPLAYED**

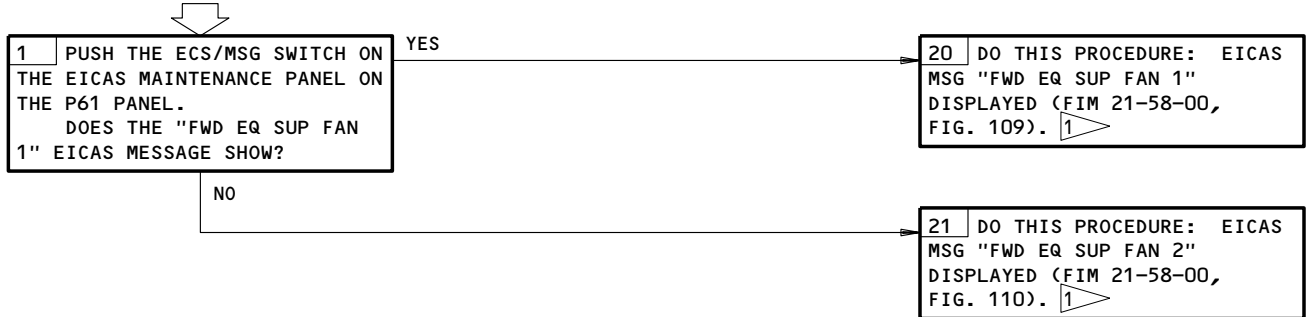

1 MAKE SURE THAT THE EICAS MESSAGE "EQPT CLG FAN" DOES NOT SHOW.

EICAS Msg EQPT CLG FAN Displayed
Figure 105

EFFECTIVITY
GUI 001-099

21-58-00
CONFIG 4
Page 111
May 28/99

**EICAS MSG "FWD EQ
SUP FLOW"
DISPLAYED**

PREREQUISITES

MAKE SURE THIS SYSTEM WILL OPERATE:
EICAS (AMM 31-41-00/201)

MAKE SURE THESE CIRCUIT BREAKERS ARE CLOSED:
6F17,6F23,11N13

MAKE SURE THE AIRPLANE IS IN THIS CONFIGURATION:
ELECTRICAL POWER IS ON (AMM 24-22-00/201)

DESCRIPTION:

THE LOW FLOW SENSOR FOUND A LOW FLOW CONDITION IN THE FORWARD EQUIPMENT COOLING SUPPLY SYSTEM.

POSSIBLE CAUSES:

1. THE SMOKE DETECTORS IN THE FORWARD EQUIPMENT COOLING SUPPLY SYSTEM FOUND SMOKE, AND STOPPED THE EQUIPMENT COOLING SUPPLY FAN.
2. THE SUPPLY FAN HAS A PROBLEM
3. THE LOW FLOW SENSOR HAS CONTAMINATION OR HAS A PROBLEM
4. THE EQUIPMENT COOLING AIR CLEANER HAS CONTAMINATION
5. A FORWARD EQUIPMENT COOLING SUPPLY DUCT IS BROKEN OR BLOCKED.

FAULT ISOLATION:

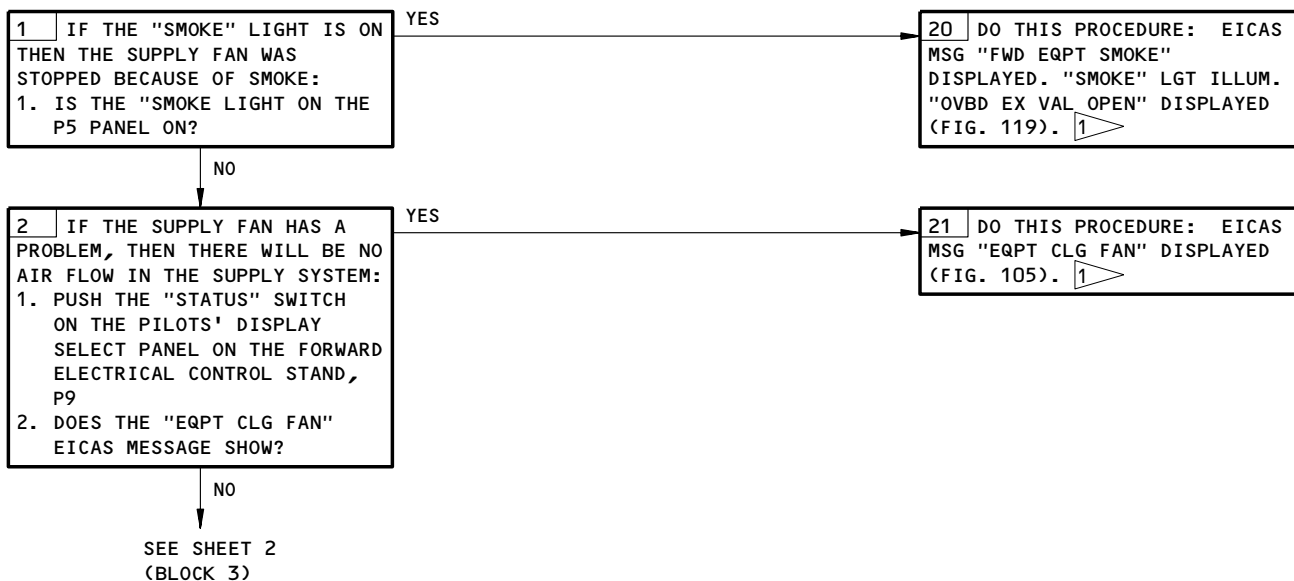

1 MAKE SURE THAT THE EICAS MESSAGE "FWD EQ SUP FLOW" DOES NOT SHOW.

EICAS Msg FWD EQ SUP FLOW Displayed
Figure 106 (Sheet 1)

EFFECTIVITY
GUI 001-099

21-58-00
CONFIG 4
Page 112
May 28/07

08

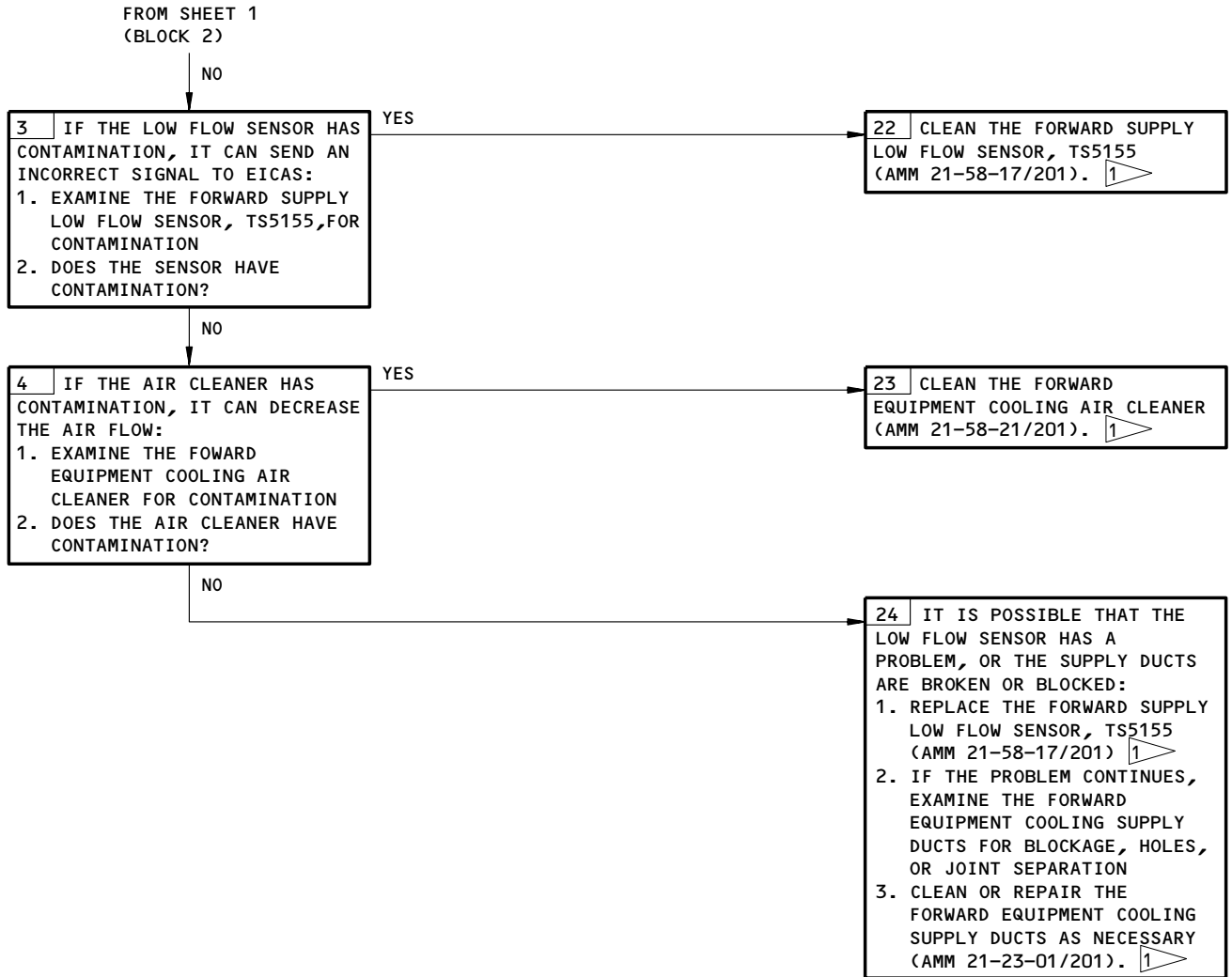

EICAS Msg FWD EQ SUP FLOW Displayed
Figure 106 (Sheet 2)

EFFECTIVITY
GUI 001-099

21-58-00

CONFIG 4

08

Page 113

May 28/07

C99480

EICAS MSG "EQPT OVHT" DISPLAYED.
"OVHT" LGT ILLUM.
"OVHT" LGT REMAINED ILLUM WHEN "ALTN" SELECTED. EICAS MSGS "EQPT CLG FAN" AND "OVBD EX VAL OPEN" NOT DISPLAYED.

PREREQUISITES

MAKE SURE THIS SYSTEM WILL OPERATE:
EICAS (AMM 31-41-00/201)

MAKE SURE THESE CIRCUIT BREAKERS ARE CLOSED:
6D6,6F17,6F23,11C20,11N11,11N13,11P14,37D2,70B5,70C10

MAKE SURE THE AIRPLANE IS IN THIS CONFIGURATION:
ELECTRICAL POWER IS ON (AMM 24-22-00/201)

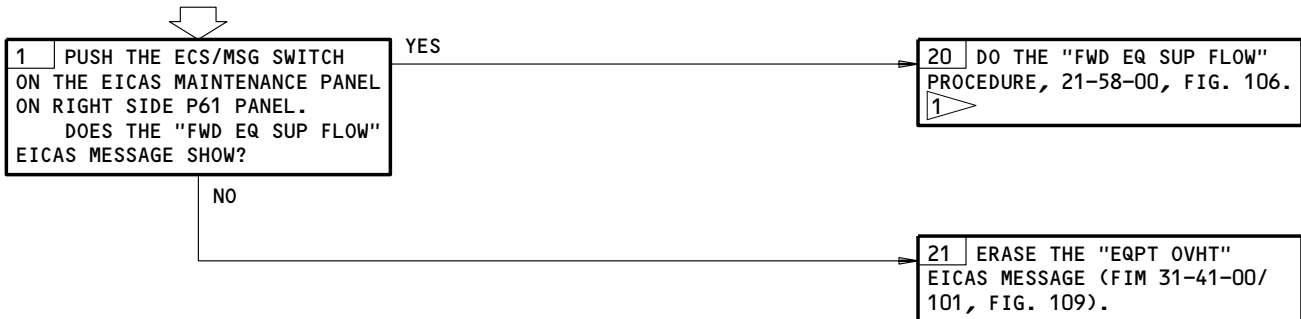

1 MAKE SURE THAT THE EICAS MESSAGE "EQPT OVHT" DOES NOT SHOW.

EICAS Msg EQPT OVHT Displayed. OVHT Lgt Illum. OVHT Lgt Remained Illum When ALTN Selected. EICAS Msgs EQPT CLG FAN and OVBD EX VAL OPEN Not Displayed.
Figure 107

EFFECTIVITY
GUI 001-099

21-58-00
CONFIG 4
Page 114
Dec 20/96

EICAS MSG
"FWD EQ EXH FLOW"
DISPLAYED 



DESCRIPTION:

THE LOW FLOW SENSOR FOUND UNSATISFACTORY AIR FLOW IN THE FORWARD EQUIPMENT COOLING EXHAUST SYSTEM.

POSSIBLE CAUSES:

1. THE LEFT RECIRCULATION FAN IS SET TO THE "OFF" POSITION
2. THE LEFT RECIRCULATION FAN HAS A PROBLEM
3. THE LOW FLOW SENSOR HAS CONTAMINATION OR HAS A PROBLEM
4. THE LEFT RECIRCULATION FILTER HAS CONTAMINATION
5. A FORWARD EQUIPMENT COOLING EXHAUST DUCT IS BROKEN OR BLOCKED.

FAULT ISOLATION:



-  1 MAKE SURE THAT THE EICAS MESSAGE "FWD EQ EXH FLOW" DOES NOT SHOW.
-  2 AIRPLANES PRE-SB 21-61

EICAS Msg FWD EQ EXH FLOW Displayed
Figure 108 (Sheet 1)

EFFECTIVITY
GUI 001-099

21-58-00
CONFIG 4
Page 115
Jan 28/00

09

BOEING
757
FAULT ISOLATION/MAINT MANUAL

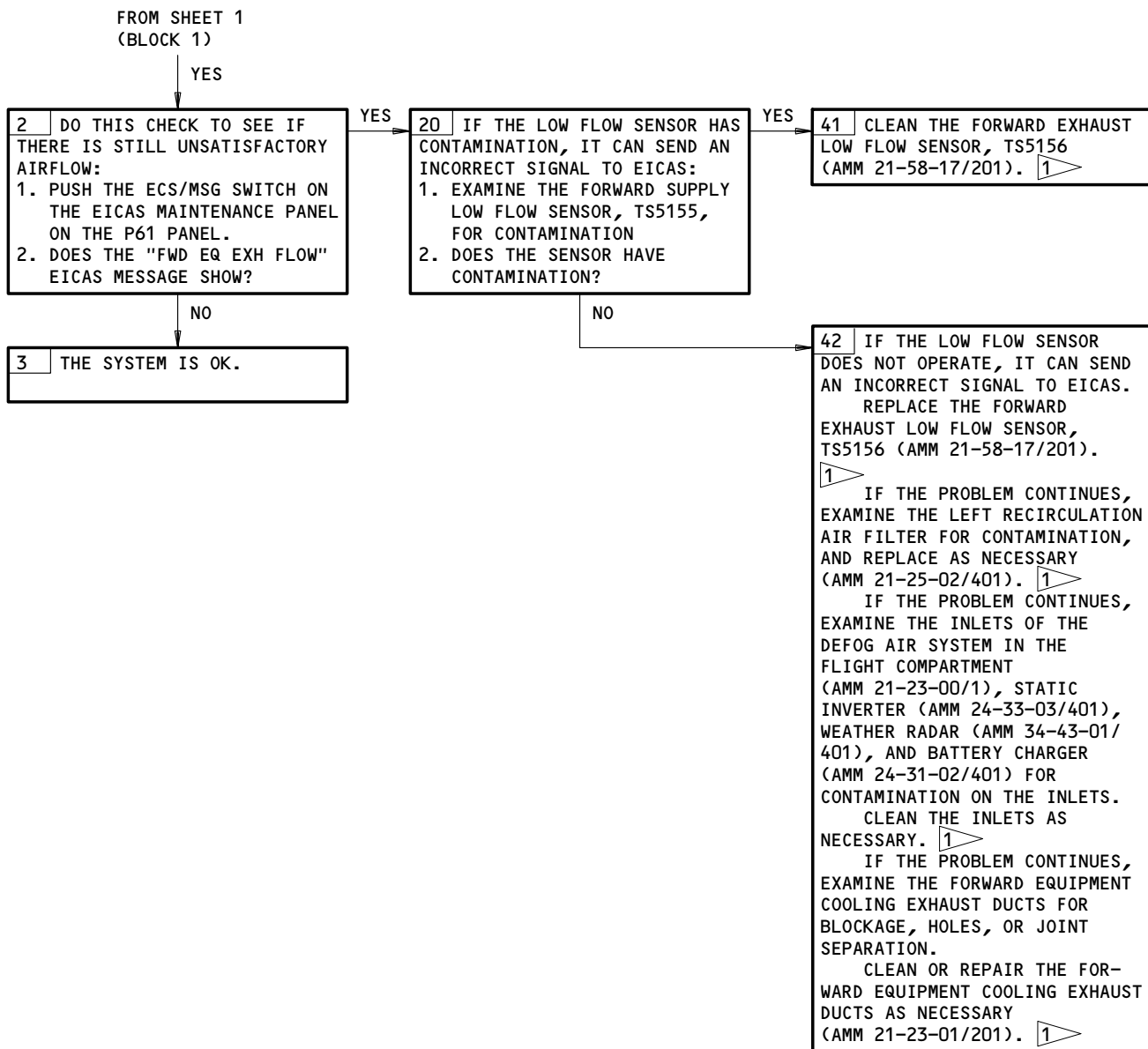

EICAS Msg FWD EQ EXH FLOW Displayed
Figure 108 (Sheet 2)

EFFECTIVITY
GUI 001-099

21-58-00
CONFIG 4
Page 116
Mar 20/94

09

EICAS MSG "FWD EQ
SUP FAN 1"
DISPLAYED

PREREQUISITES

MAKE SURE THIS SYSTEM WILL OPERATE:
EICAS (MM 31-41-00/201)

MAKE SURE THESE CIRCUIT BREAKERS ARE CLOSED:
6F17,6F23,11C20

MAKE SURE THE AIRPLANE IS IN THIS CONFIGURATION:
ELECTRICAL POWER IS ON (MM 24-22-00/201)

DESCRIPTION:

THE FORWARD EQUIPMENT SUPPLY FAN 1 WILL NOT OPERATE AND SMOKE IS NOT PRESENT.

POSSIBLE CAUSES:

1. THE SUPPLY FAN HAS A PROBLEM
2. THERE IS A PROBLEM IN THE FAN CONTROL SYSTEM
3. THERE IS A PROBLEM IN THE SMOKE DETECTION SYSTEM.

FAULT ISOLATION:



1 DO THIS PROCEDURE: MAINTENANCE MESSAGE ERASE PROCEDURE (31-41-00/101, FIG. 109). WITH THE "EQUIP COOLING ALTN" SWITCH/LIGHT ON THE P5 PANEL IN THE USUAL POSITION, MAKE SURE THAT THE EICAS MESSAGE "FWD EQ SUP FAN 1" DOES NOT SHOW.

EICAS Msg FWD EQ SUP FAN 1 Displayed
Figure 109 (Sheet 1)

EFFECTIVITY
GUI 001-099

21-58-00
CONFIG 4
Page 117
Mar 20/94

09

BOEING
757
FAULT ISOLATION/MAINT MANUAL

FROM SHEET 1
(BLOCK 1)

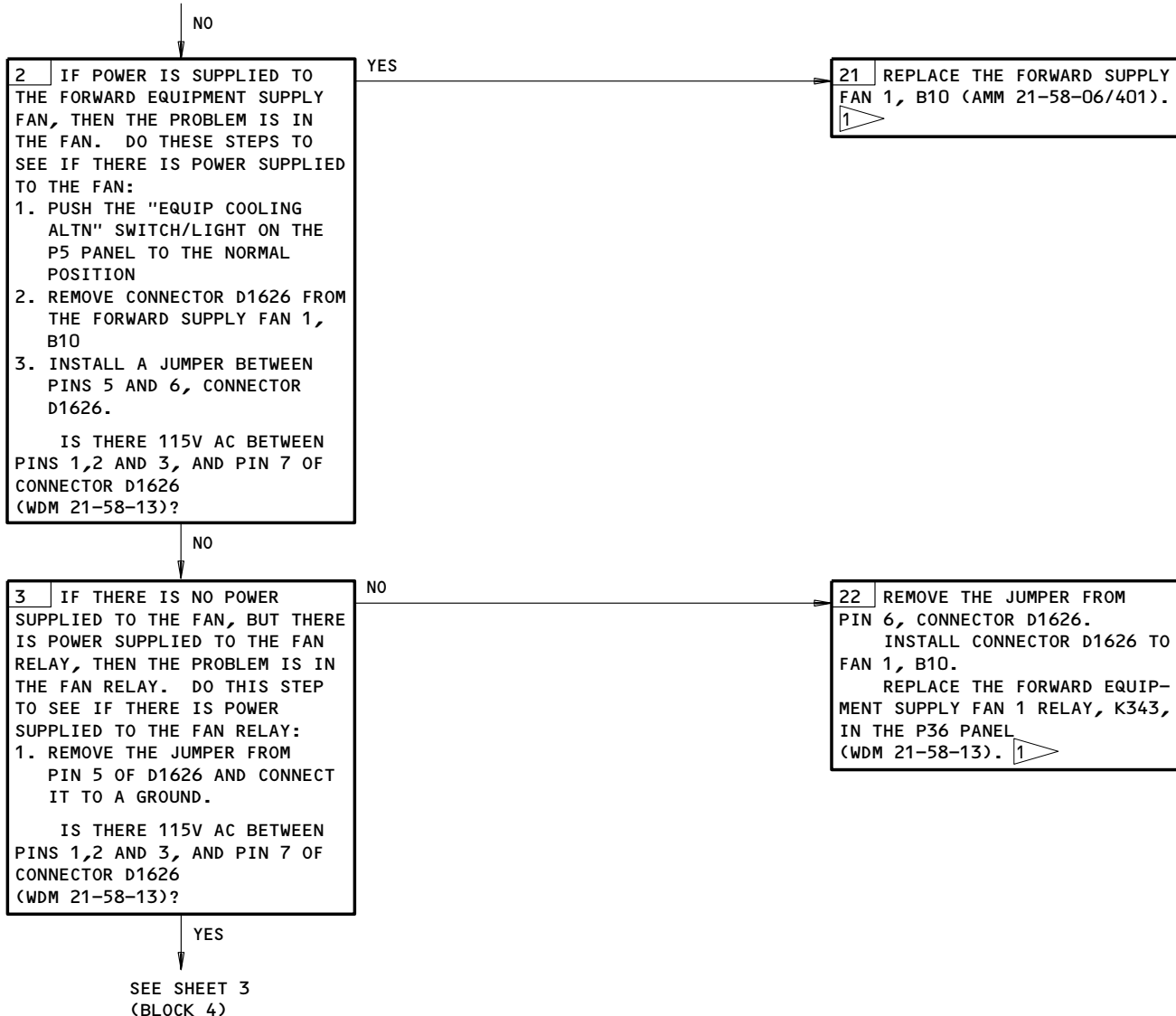

EICAS Msg FWD EQ SUP FAN 1 Displayed
Figure 109 (Sheet 2)

EFFECTIVITY
GUI 001-099

21-58-00
CONFIG 4
Page 118
Jun 20/97

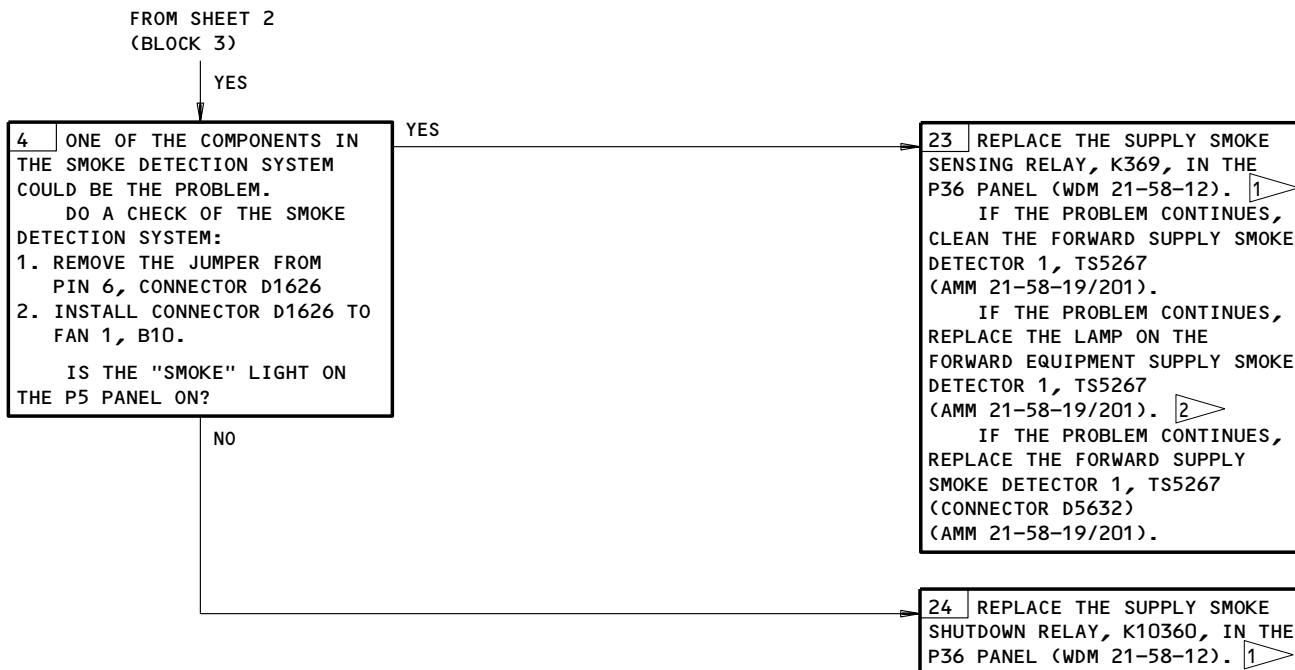

2 YOU CAN REPLACE THE LAMPS ON THE SMOKE
DETECTOR WITH PART NUMBER 2156-204A.

EICAS Msg FWD EQ SUP FAN 1 Displayed
Figure 109 (Sheet 3)

EFFECTIVITY
GUI 001-099

659207

21-58-00
 CONFIG 4
 Page 119
 Jun 20/97

EICAS MSG "FWD EQ SUP FAN 2" DISPLAYED

PREREQUISITES

MAKE SURE THIS SYSTEM WILL OPERATE:
EICAS (MM 31-41-00/201)

MAKE SURE THESE CIRCUIT BREAKERS ARE CLOSED:
6F23,11C20

MAKE SURE THE AIRPLANE IS IN THE CONFIGURATION THAT FOLLOWS:
ELECTRICAL POWER IS ON (MM 24-22-00/201)

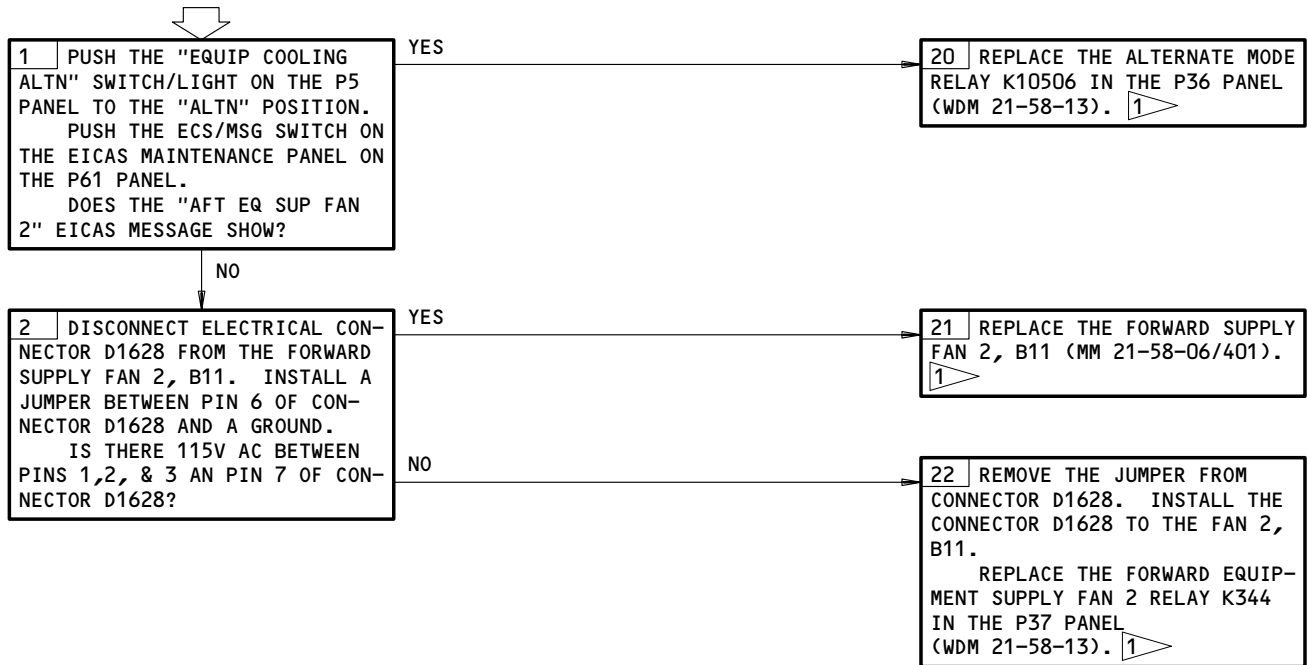

1 DO THE EICAS ERASE PROCEDURE (31-41-00, FIG. 109). WITH THE "EQUIP COOLING ALTN" SWITCH/LIGHT ON THE P5 PANEL IN THE "ALTN" POSITION, MAKE SURE THAT THE EICAS MESSAGE "FWD EQ SUP FAN 2" DOES NOT SHOW.

EICAS Msg FWD EQ SUP FAN 2 Displayed
Figure 110

EFFECTIVITY
GUI 001-099

21-58-00
CONFIG 4
Page 120
Jun 20/97

EICAS MSG
"FWD EQ EXH SNSR"
DISPLAYED 

PREREQUISITES

MAKE SURE THIS SYSTEM WILL OPERATE:
EICAS (AMM 31-41-00/201)

MAKE SURE THESE CIRCUIT BREAKERS ARE CLOSED:
6D6, 6F17, 6F23, 11C20, 11N11, 11N13

MAKE SURE THE AIRPLANE IS IN THE CONFIGURATION THAT
ELECTRICAL POWER IS ON (AMM 24-22-00/201)

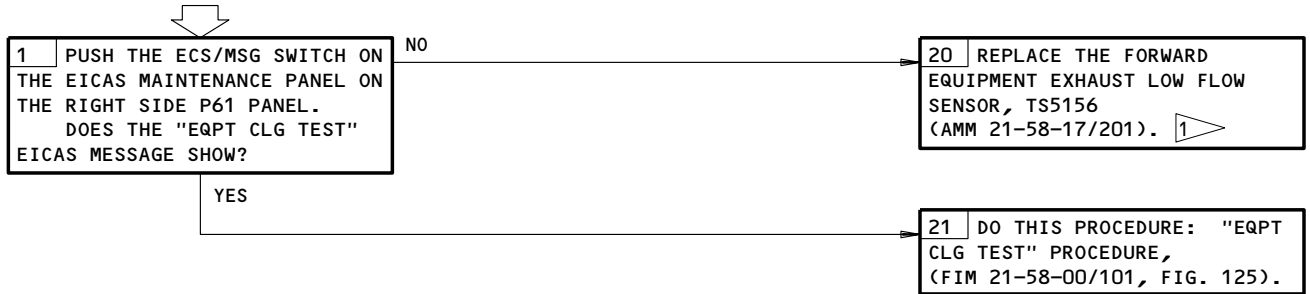

 DO THE EICAS ERASE PROCEDURE (FIM 31-41-00/101, FIG. 109). HOLD THE EQUIPMENT COOLING TEST SWITCH ON THE P61 PANEL TO THE "EQUIP COOL" POSITION FOR 5 SECONDS, THEN RELEASE IT. WAIT 20 SECONDS. MAKE SURE THAT THE EICAS MESSAGE "FWD EQ EXH SNSR" DOES NOT SHOW.

 AIRPLANES PRE-SB 21-61

EICAS Msg FWD EQ EXH SNSR Displayed
Figure 111

EFFECTIVITY
GUI 001-099

21-58-00
CONFIG 4
Page 121
Jan 28/00

PREREQUISITES

MAKE SURE THIS SYSTEM WILL OPERATE:
EICAS (AMM 31-41-00/201)

MAKE SURE THESE CIRCUIT BREAKERS ARE CLOSED:
6D6, 11N13

MAKE SURE THE AIRPLANE IS IN THE CONFIGURATION THAT
ELECTRICAL POWER IS ON (AMM 24-22-00/201)

**EICAS MSG "EQPT CLG
SENSOR" DISPLAYED**

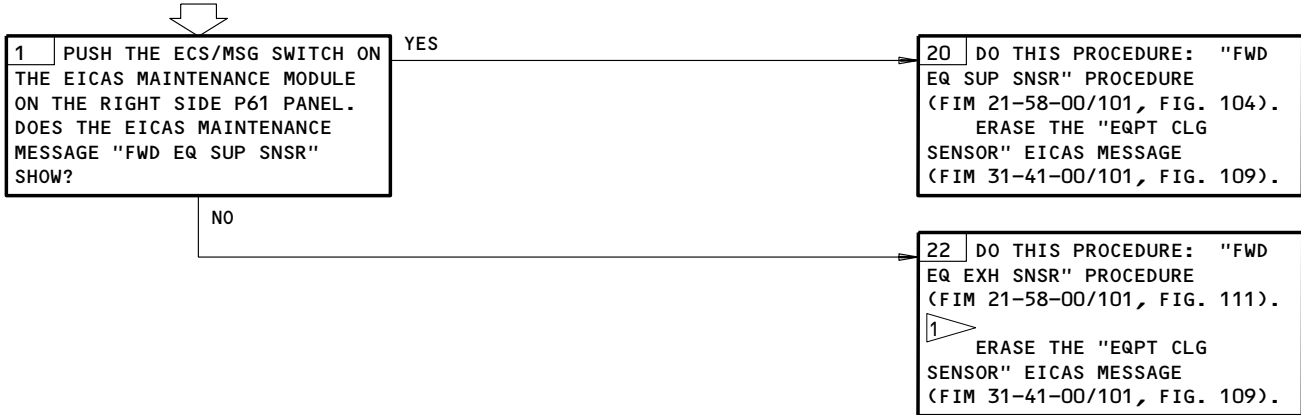

1 AIRPLANES PRE-SB 21-61

EICAS Msg EQPT CLG SENSOR Displayed
Figure 112

EFFECTIVITY
GUI 001-099

21-58-00
CONFIG 4
Page 122
Jan 28/00

PREREQUISITES

MAKE SURE THIS SYSTEM WILL OPERATE:
EICAS (AMM 31-41-00/201)

MAKE SURE THESE CIRCUIT BREAKERS ARE CLOSED:
6D6,6F2,6F17,11N11,11N13,11P14,37D2,70B5,70C10

MAKE SURE THE AIRPLANE IS IN THIS CONFIGURATION:
ELECTRICAL POWER IS ON (AMM 24-22-00/201)

EICAS MSG "EQPT CLG FLOW" DISPLAYED

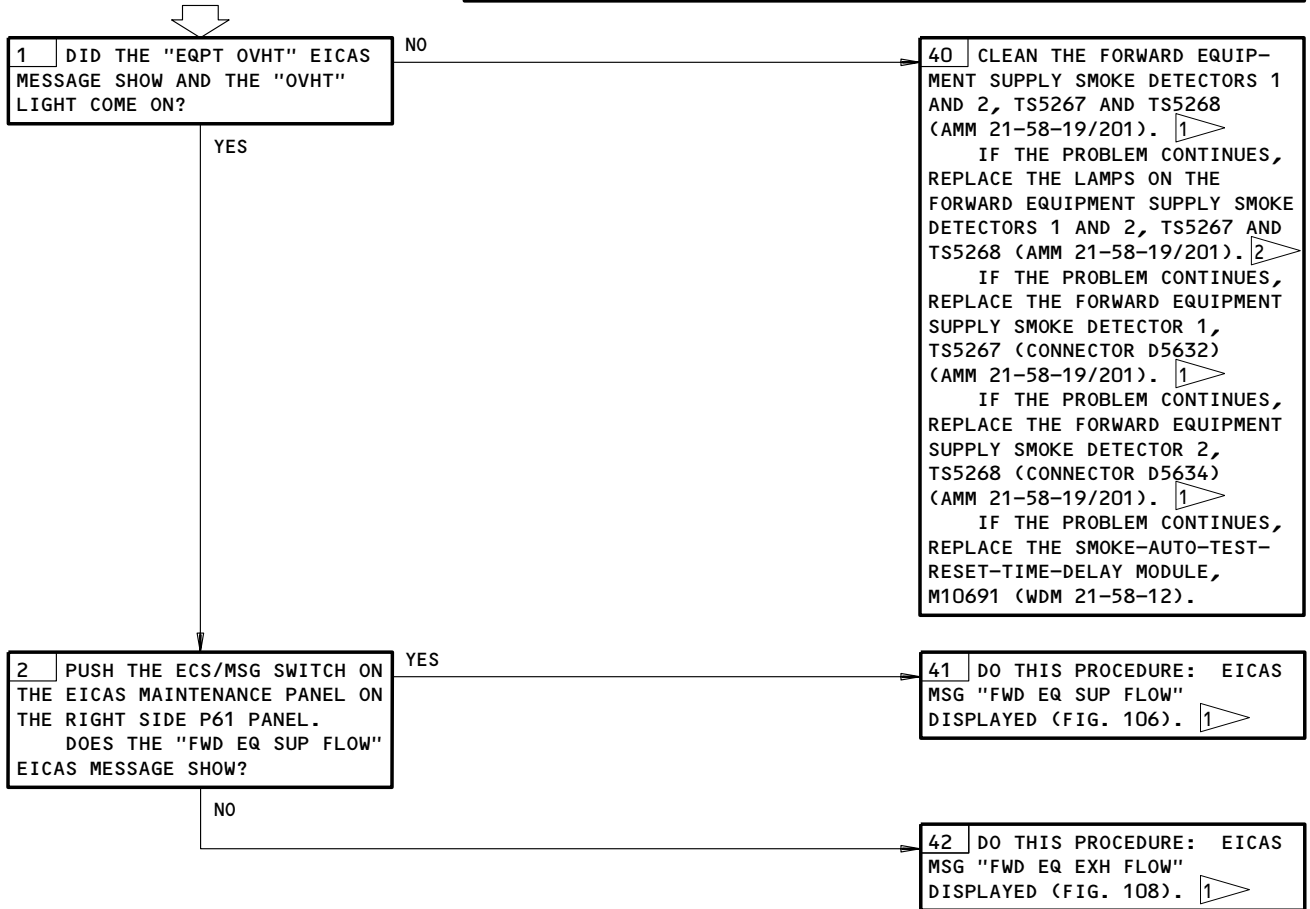

- 1 MAKE SURE THAT THE EICAS MESSAGE "EQPT CLG FLOW" DOES NOT SHOW.
- 2 YOU CAN REPLACE THE LAMPS ON THE SMOKE DETECTORS WITH PART NUMBER 2156-204A.

EICAS Msg EQPT CLG FLOW Displayed
Figure 113

EFFECTIVITY
GUI 001-099

21-58-00
CONFIG 4
Page 123
Jun 20/97

EICAS MSG "OVBD EX VAL OPEN" DISPLAYED



PREREQUISITES

MAKE SURE THIS SYSTEM WILL OPERATE:
EICAS (AMM 31-41-00/201)

MAKE SURE THESE CIRCUIT BREAKERS ARE CLOSED:
11C20,11P14,70C10

MAKE SURE THE AIRPLANE IS IN THIS CONFIGURATION:
ELECTRICAL POWER IS ON (AMM 24-22-00/201)

DESCRIPTION:

THE OVERBOARD EXHAUST VALVE (OEV) WAS COMMANDED OPEN.

NOTE: THE OVERBOARD EXHAUST VALVE WILL BE COMMANDED OPEN IF THE LEFT RECIRCULATION FAN WAS OFF OR DID NOT OPERATE DURING FLIGHT.

POSSIBLE CAUSES:

1. THERE WAS SMOKE IN THE FORWARD EQUIPMENT COOLING SYSTEM.
2. THE LEFT RECIRCULATION FAN DID NOT OPERATE.
3. THERE IS A PROBLEM WITH THE "EQUIP COOLING ALTN" SWITCH/LIGHT, YNMS1.
4. THERE IS A PROBLEM WITH THE OEV COMMAND RELAY, K10442.
5. THERE IS A PROBLEM WITH THE OVERBOARD EXHAUST VALVE, V95.
6. THERE IS A PROBLEM WITH THE OEV OPEN INDICATION RELAY, K10086.

FAULT ISOLATION:

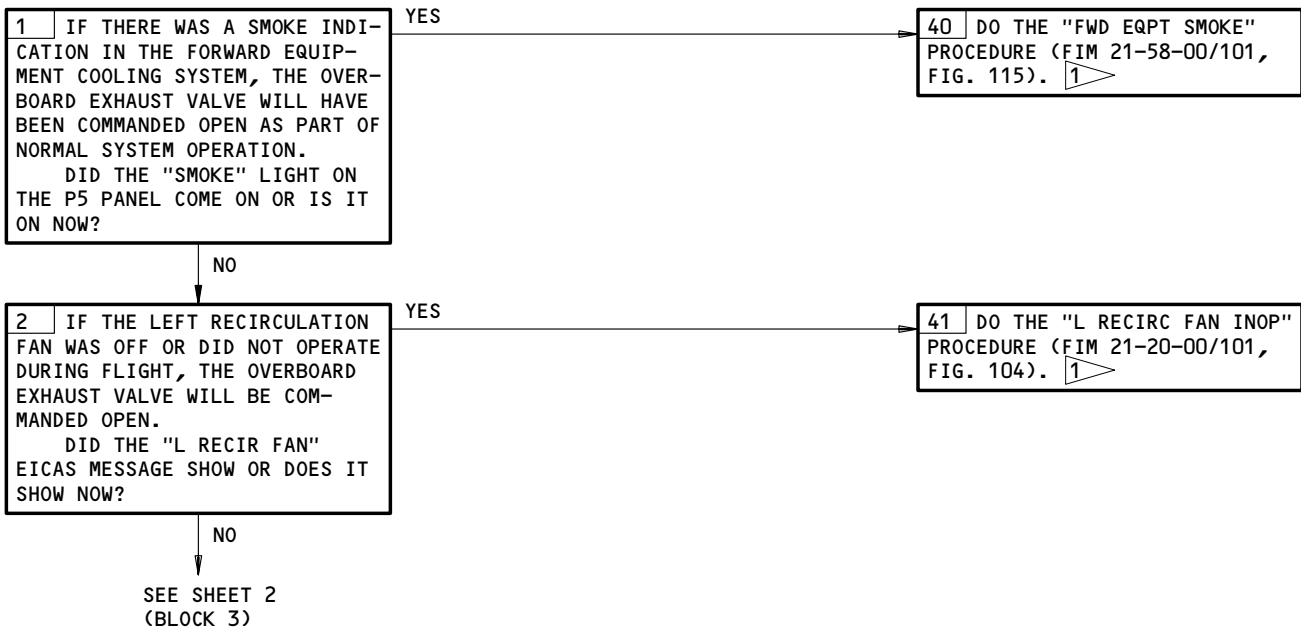

1 DO THIS PROCEDURE: MAINTENANCE MESSAGE ERASE PROCEDURE (FIM 31-41-00/101, FIG. 109). HOLD THE EQUIPMENT COOLING TEST SWITCH ON THE P61 PANEL TO THE "EQUIP COOL POSITION" FOR 5 SECONDS AND THEN RELEASE. WAIT 20 SECONDS. MAKE SURE THAT THE EICAS MESSAGE "OVBD EX VAL TEST" DOES NOT SHOW.

EICAS Msg OVBD EX VAL OPEN Displayed
Figure 114 (Sheet 1)

EFFECTIVITY
GUI 001-099

21-58-00
 CONFIG 4
 Page 124
 Jun 20/97

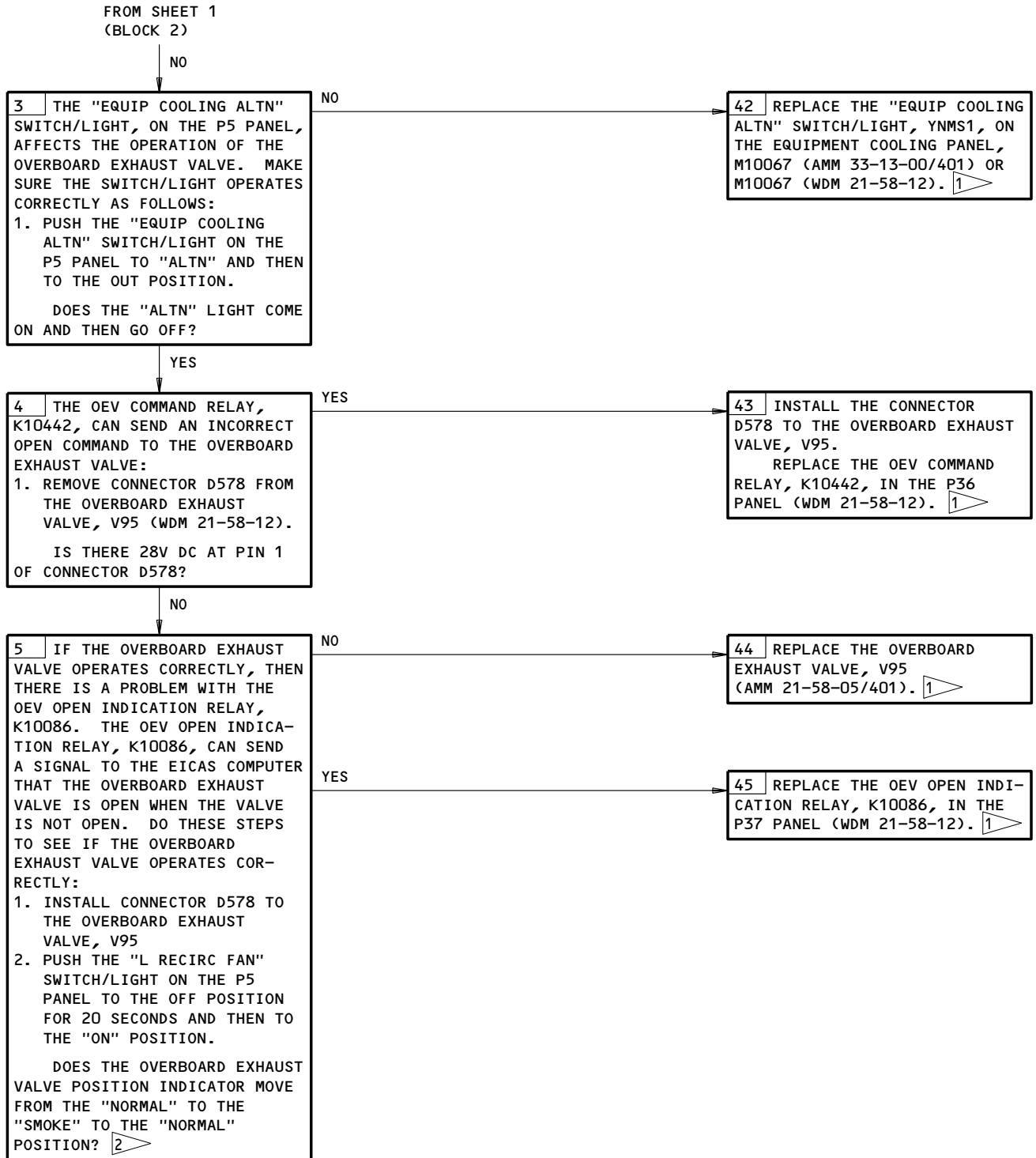

▶ 2 THE OVERBOARD EXHAUST VALVE IS SPRING-LOADED OPEN ON THE GROUND. THE VALVE ACTUATOR ONLY WILL MOVE, THE VALVE FLAPPER WILL NOT MOVE.

EICAS Msg OVBD EX VAL OPEN Displayed
Figure 114 (Sheet 2)

EFFECTIVITY
GUI 001-099

21-58-00

CONFIG 4

10

Page 125

Jun 20/97

EICAS MSG "FWD EQPT SMOKE" DISPLAYED.
"SMOKE" LGT ILLUM.
"OVBD EX VAL OPEN" DISPLAYED.

PREREQUISITES

MAKE SURE THIS SYSTEM WILL OPERATE:
EICAS (AMM 31-41-00/201)

MAKE SURE THESE CIRCUIT BREAKERS ARE CLOSED:
6D6,6F17,6F23,11C20,11N11,11N13,11P14,70C10

MAKE SURE THE AIRPLANE IS IN THIS CONFIGURATION:
ELECTRICAL POWER IS ON (AMM 24-22-00/201)

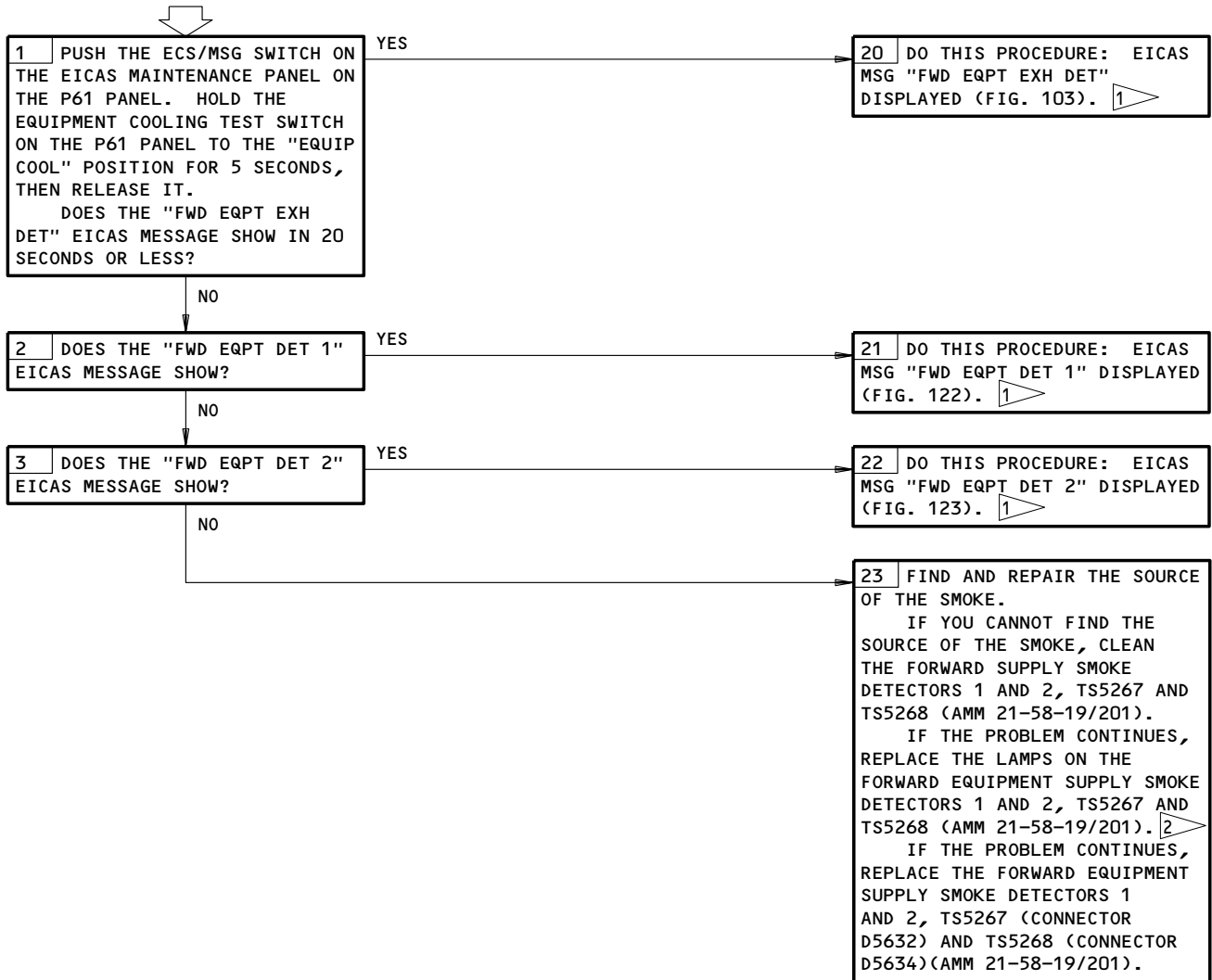

1 MAKE SURE THAT THE EICAS MESSAGE "FWD EQPT SMOKE" DOES NOT SHOW.

2 YOU CAN REPLACE THE LAMPS ON THE SMOKE DETECTORS WITH PART NUMBER 2156-204A.

EICAS Msg FWD EQPT SMOKE Displayed. SMOKE Lgt Illum.
OVBD EX VAL OPEN Displayed.

Figure 115

EFFECTIVITY
GUI 001-099

21-58-00

CONFIG 4

12

Page 126

Sep 20/98

EICAS MSG "FWD EQPT SMOKE" DISPLAYED.
"SMOKE" LGT ILLUM.
"OVBD EX VAL OPEN" NOT DISPLAYED.

PREREQUISITES

MAKE SURE THIS SYSTEM WILL OPERATE:
EICAS (AMM 31-41-00/201)

MAKE SURE THESE CIRCUIT BREAKERS ARE CLOSED:
6D6,6F17,6F23,11C20,11N11,11N13,11P14,70C10

MAKE SURE THE AIRPLANE IS IN THIS CONFIGURATION:
ELECTRICAL POWER IS ON (AMM 24-22-00/201)

NOTE: THERE MAY BE A SMOKE CONDITION. FIND AND REPAIR THE SOURCE OF THE SMOKE. IF YOU CANNOT FIND THE SOURCE OF THE SMOKE DO THE BLOCK 1 ACTION.

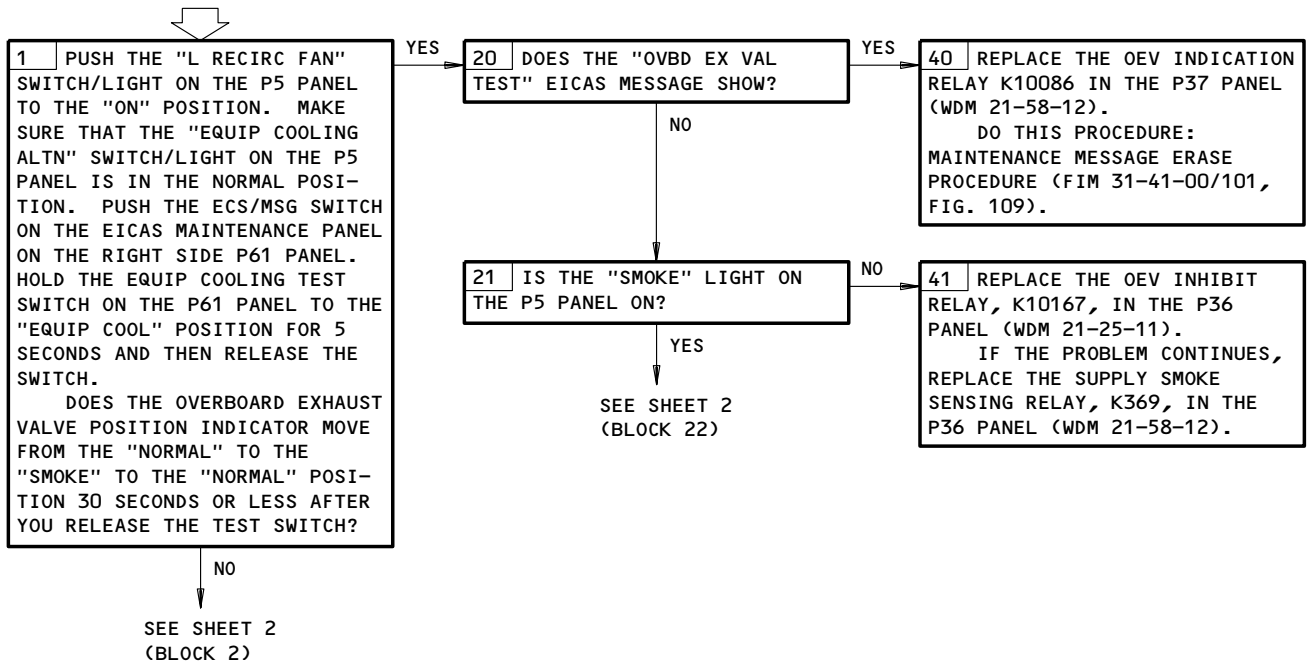

EICAS Msg FWD EQPT SMOKE Displayed. SMOKE Lgt Illum.
OVBD EX VAL OPEN Not Displayed.
Figure 116 (Sheet 1)

EFFECTIVITY
GUI 001-099

21-58-00
CONFIG 4
Page 127
Jun 20/97

BOEING
757
FAULT ISOLATION/MAINT MANUAL

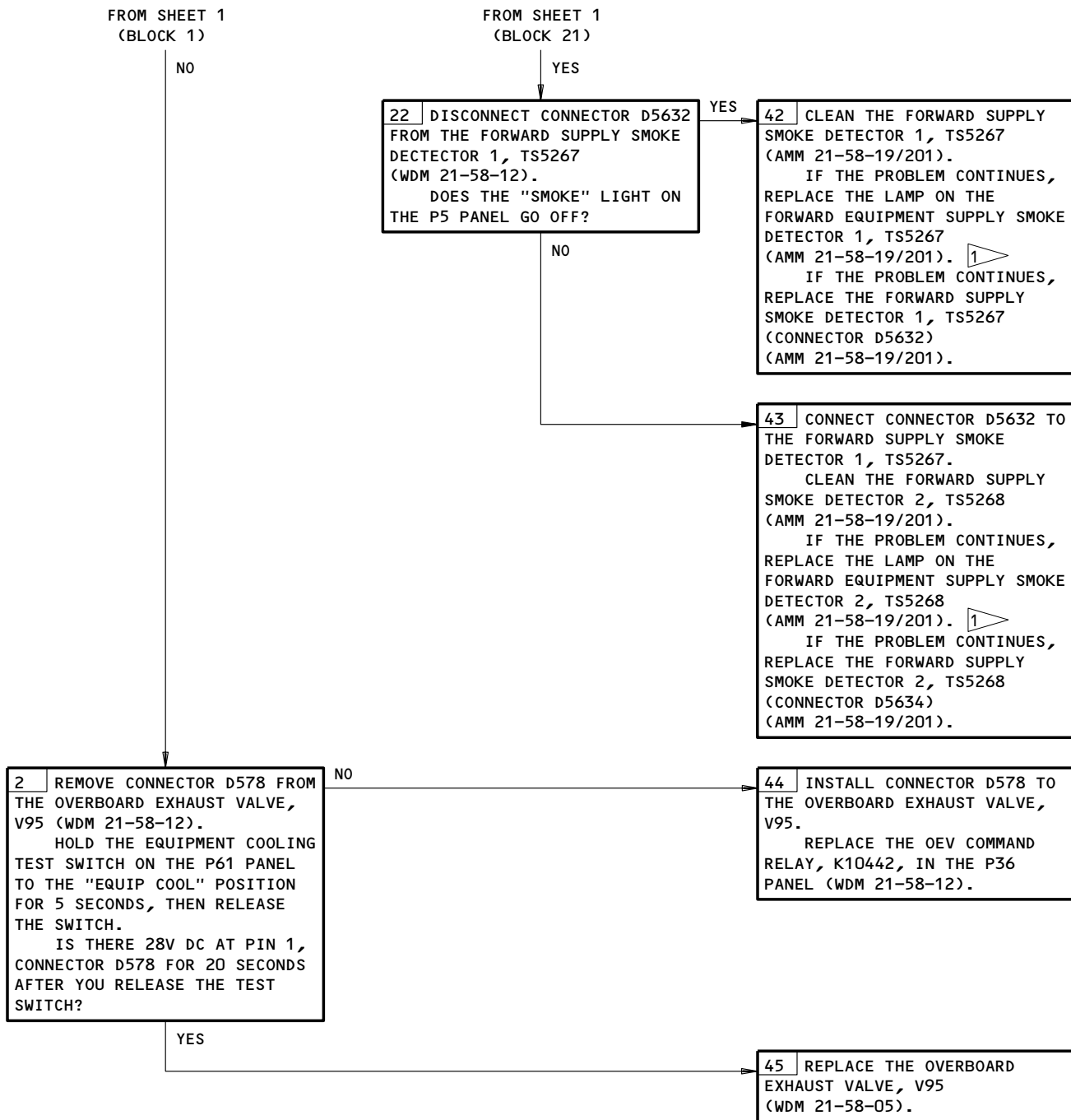

1 YOU CAN REPLACE THE LAMPS ON THE SMOKE DETECTOR WITH PART NUMBER 2156-204A.

EICAS Msg FWD EQPT SMOKE Displayed. SMOKE Lgt Illum.
OVBD EX VAL OPEN Not Displayed.
Figure 116 (Sheet 2)

EFFECTIVITY
GUI 001-099

21-58-00
CONFIG 4
Page 128
Jun 20/97

EICAS MSG "EQPT OVHT" DISPLAYED.
"OVHT" LGT ILLUM.
"L RECIRC FAN INOP" LGT ILLUM. "OVHT" LGT EXTIN WHEN "ALTN" WAS SELECTED.
EICAS MSGS "EQPT CLG FAN" AND "OVBD EX VAL OPEN" NOT DISPLAYED.

PREREQUISITES

MAKE SURE THIS SYSTEM WILL OPERATE:
EICAS (AMM 31-41-00/201)

MAKE SURE THESE CIRCUIT BREAKERS ARE CLOSED:
6D6 ,6F17 ,6F23 ,11C20, 11N11, 11N13, 11P14, 37D2, 70B5, 70C10

MAKE SURE THE AIRPLANE IS IN THIS CONFIGURATION:
ELECTRICAL POWER IS ON (AMM 24-22-00/201)

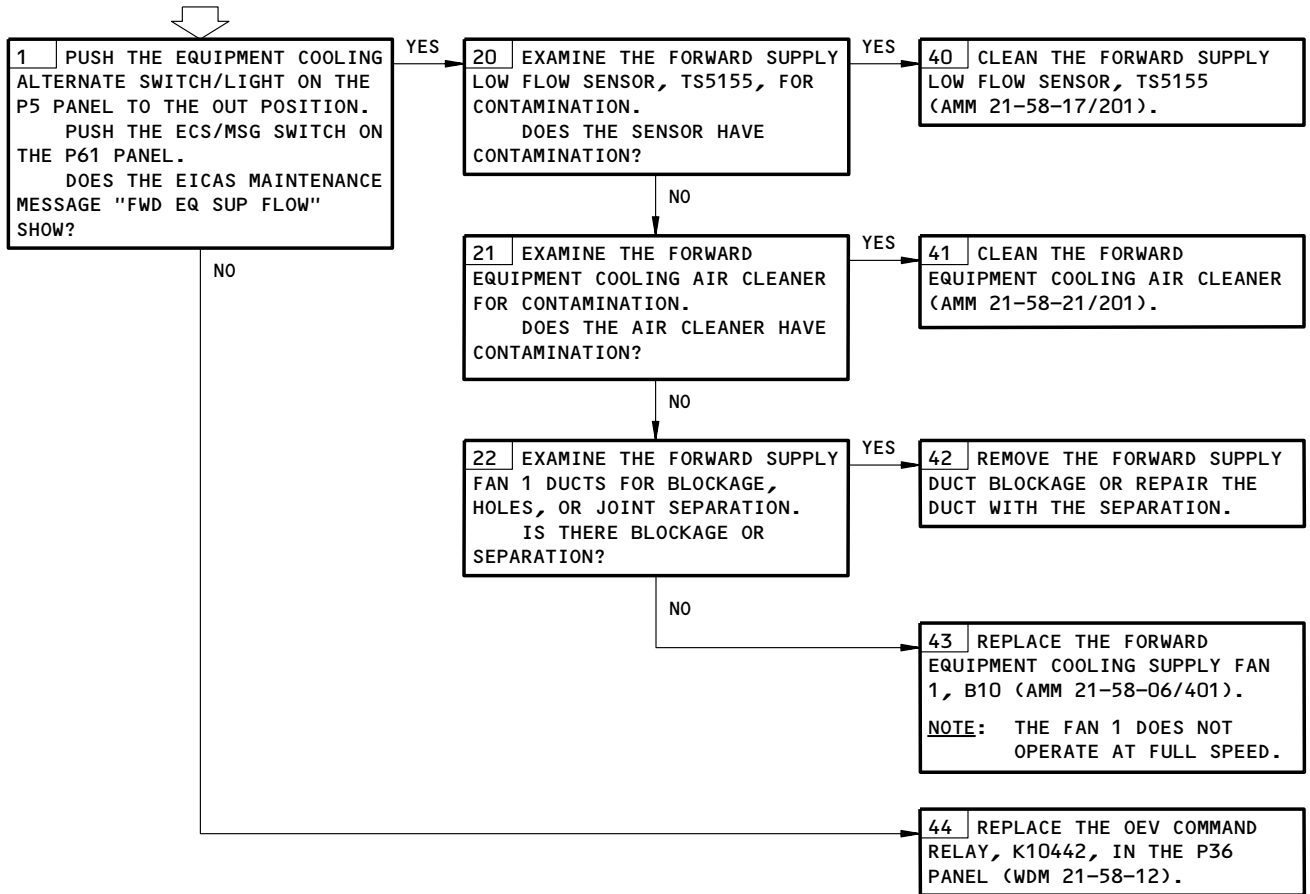

EICAS Msg EQPT OVHT Displayed. OVHT Lgt Illum. L RECIRC INOP Lgt Illum.
OVHT Lgt Extin When ALTN Was Selected. EICAS Msgs EQPT CLG FAN and
OVBD EX VAL OPEN Not Displayed.

Figure 117

EFFECTIVITY
GUI 001-099

21-58-00

CONFIG 4

09

Page 129

May 28/07

GROUND CREW CALL
HORN SOUNDS CON-
TINUOUSLY. C IRS,
L IRS, OR R IRS NOT
SELECTED ON.

PREREQUISITES

MAKE SURE THIS SYSTEM WILL OPERATE:
EICAS (AMM 31-41-00/201)

MAKE SURE THESE CIRCUIT BREAKERS ARE CLOSED:
6D6, 11N13

MAKE SURE THE AIRPLANE IS IN THE CONFIGURATION THAT
ELECTRICAL POWER IS ON (AMM 24-22-00/201)

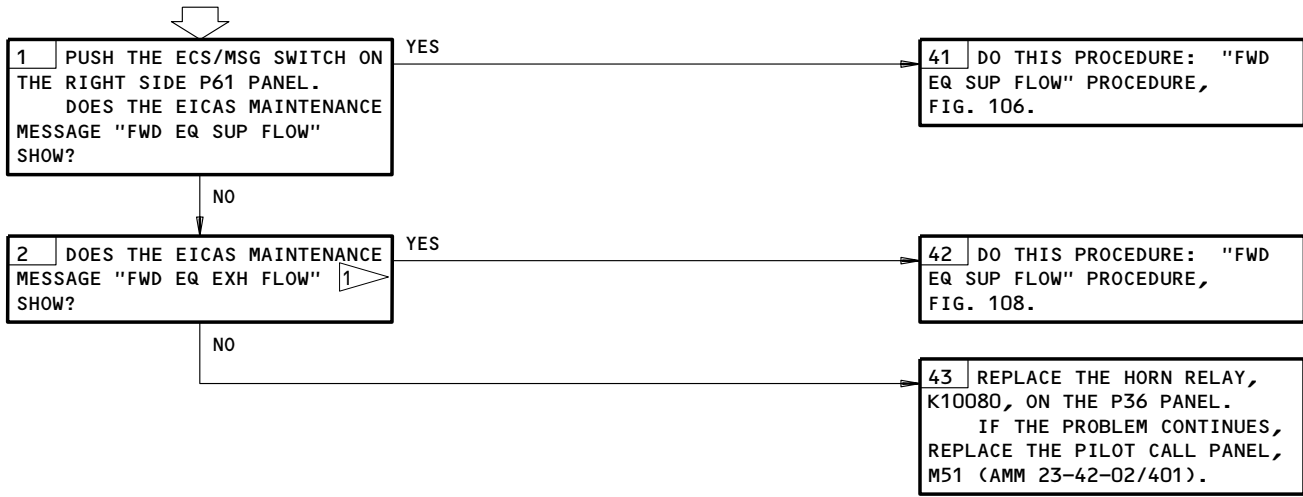

1 AIRPLANES PRE-SB 21-61

Ground Crew Call Horn Sounds Continuously. C IRS, L IRS, or R IRS Not Selected ON.
Figure 118

EFFECTIVITY
GUI 001-099

21-58-00

CONFIG 4
Page 130
Jan 28/00

EICAS MSG "EQPT
OVHT" DISPLAYED.
"OVHT" LGT ILLUM.
EICAS MSG "EQPT CLG
FAN" DISPLAYED.
"OVHT" LIGHT
REMAINED ILLUM WHEN
"ALTN" WAS SELECTED.

PREREQUISITES

MAKE SURE THIS SYSTEM WILL OPERATE:
EICAS (AMM 31-41-00/201)

MAKE SURE THESE CIRCUIT BREAKERS ARE CLOSED:
6D6 ,6F17, 6F23, 11C20, 11N11, 11N13, 11P14, 37D2,
70B5, 70C10

MAKE SURE THE AIRPLANE IS IN THIS CONFIGURATION:
ELECTRICAL POWER IS ON (AMM 24-22-00/201)

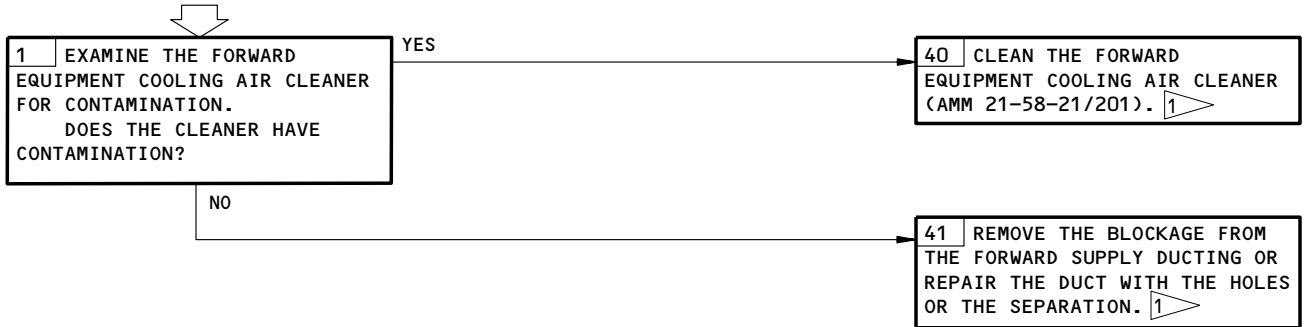

1 DO THIS PROCEDURE: MAINTENANCE MESSAGE ERASE PROCEDURE (FIM 31-41-00/101, FIG. 109).

EICAS Msg EQPT OVHT Displayed. OVHT Lgt Illum. EICAS Msg EQPT CLG FAN Displayed.
OVHT Lgt Remained Illum When ALTN Was Selected.

Figure 119

EFFECTIVITY
GUI 001-099

21-58-00

CONFIG 4

09

Page 131

May 28/07

PREREQUISITES

MAKE SURE THIS SYSTEM WILL OPERATE:
EICAS (AMM 31-41-00/501)

MAKE SURE THESE CIRCUIT BREAKERS ARE CLOSED:
6D6, 6F17, 6F23, 11C20, 11N11, 11N13 OR 11N17,
11P23, 37D7, 37J5

MAKE SURE THE AIRPLANE IS IN THIS CONFIGURATION:
ELECTRICAL POWER IS ON (AMM 24-22-00/201)

EICAS MSG "OVBD EX VAL TEST" DISPLAYED

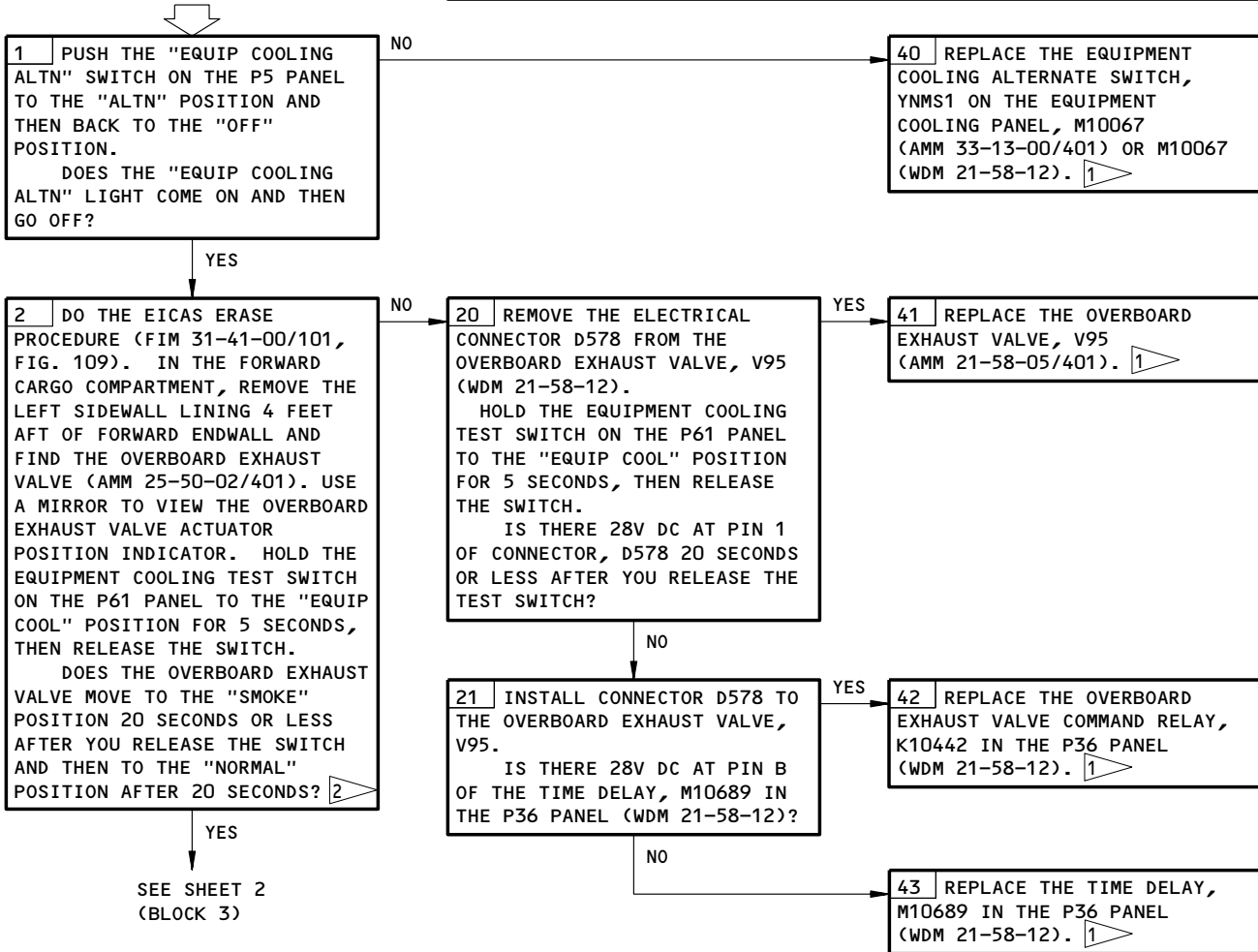

1 DO THE EICAS "ERASE PROCEDURE" (FIM 31-41-00/101, FIG. 109). HOLD THE EQUIPMENT COOLING TEST SWITCH ON THE P61 PANEL TO THE "EQUIP COOL" POSITION FOR 5 SECONDS AND THEN RELEASE THE SWITCH. WAIT 20 SECONDS. MAKE SURE THAT THE EICAS MESSAGE "OVBD EX VAL TEST" DOES NOT SHOW.

2 ONLY THE OVERBOARD EXHAUST VALVE ACTUATOR WILL MOVE. THE VALVE FLAPPERS WILL NOT MOVE. THEY ARE SPRING-LOADED OPEN ON THE GROUND.

EICAS Msg OVBD EX VAL TEST Displayed
Figure 120 (Sheet 1)

EFFECTIVITY
GUI 001-099

21-58-00

CONFIG 4

Page 132

Jan 28/05

10

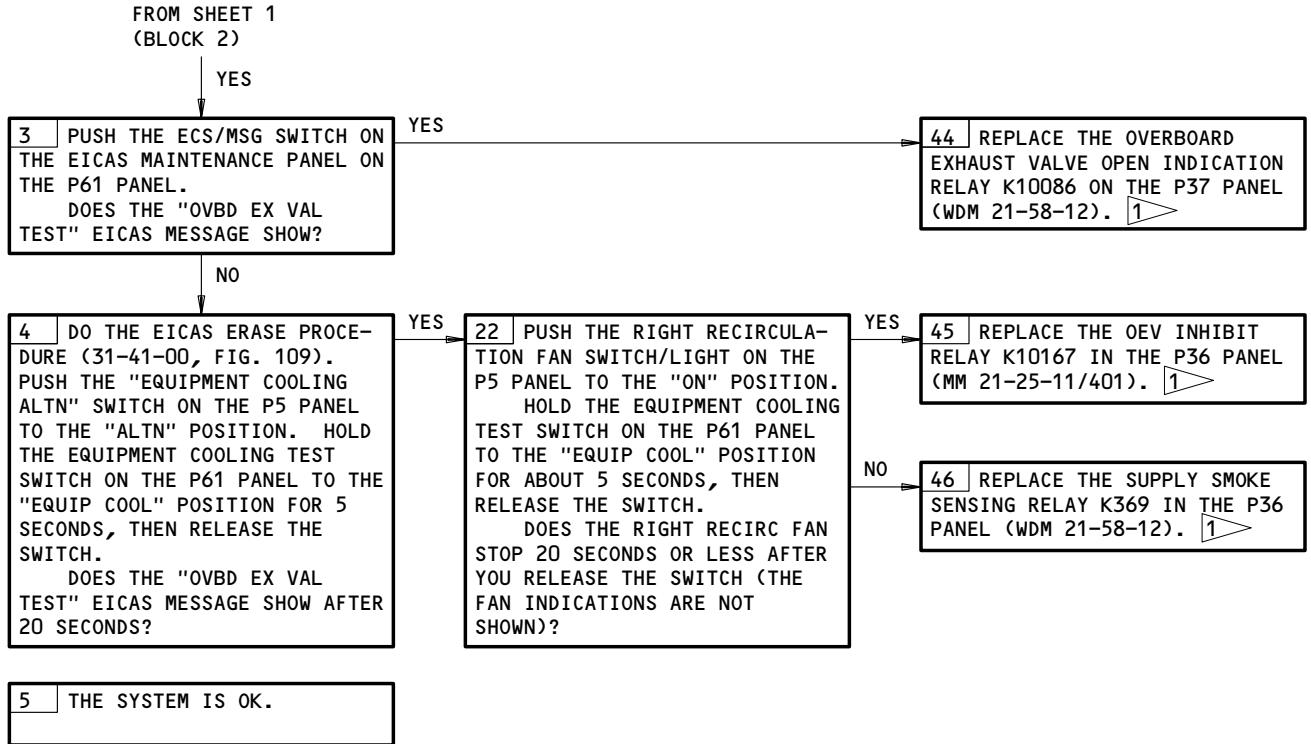

EICAS Msg OVBD EX VAL TEST Displayed
Figure 120 (Sheet 2)

EFFECTIVITY
GUI 001-099

21-58-00
 CONFIG 4
 Page 133
 Jun 20/97

PREREQUISITES

MAKE SURE THIS SYSTEM WILL OPERATE:
EICAS (MM 31-41-00/201)

MAKE SURE THIS CIRCUIT BREAKER IS CLOSED:
6D6

MAKE SURE THE AIRPLANE IS IN THIS CONFIGURATION:
ELECTRICAL POWER IS ON (MM 24-22-00/201)

EICAS MSG "EQPT CLG TEST" DISPLAYED

NOTE: THIS IS USUALLY A NUISANCE MESSAGE. IT IS USUALLY CAUSED BY OSCILLATIONS FROM THE ENGINE SPEED CARD.

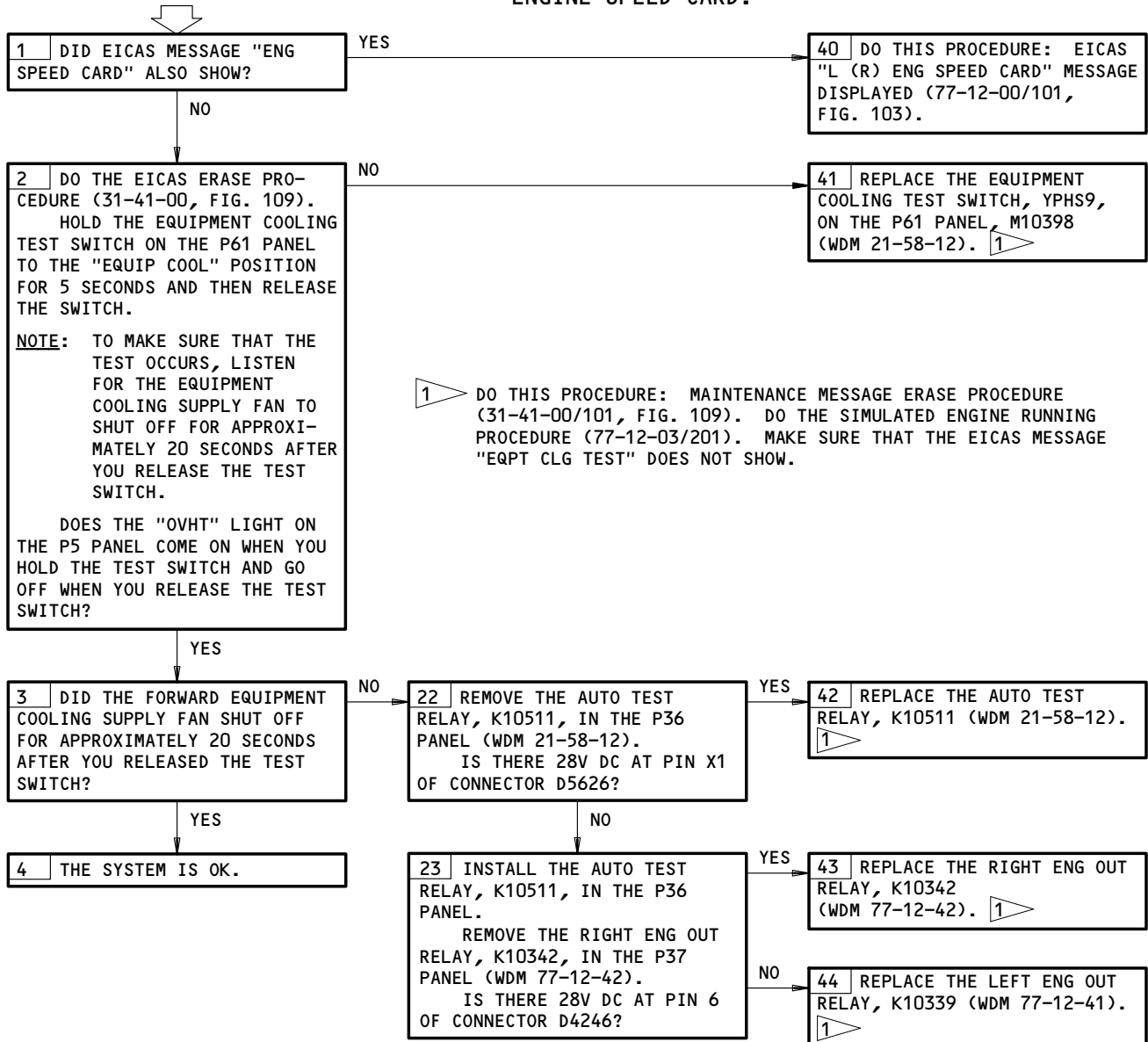

EICAS Msg EQPT CLG TEST Displayed
Figure 121

EFFECTIVITY
GUI 001-099

21-58-00
CONFIG 4
Page 134
Jun 20/97

**EICAS MSG "FWD EQPT
DET 1" DISPLAYED**

PREREQUISITES

MAKE SURE THIS SYSTEM WILL OPERATE:
EICAS (AMM 31-41-00/201)

MAKE SURE THESE CIRCUIT BREAKERS ARE CLOSED:
6D6,6F17,6F23,11C20,11N11,11N13

MAKE SURE THE AIRPLANE IS IN THIS CONFIGURATION:
ELECTRICAL POWER IS ON (AMM 24-22-00/201)

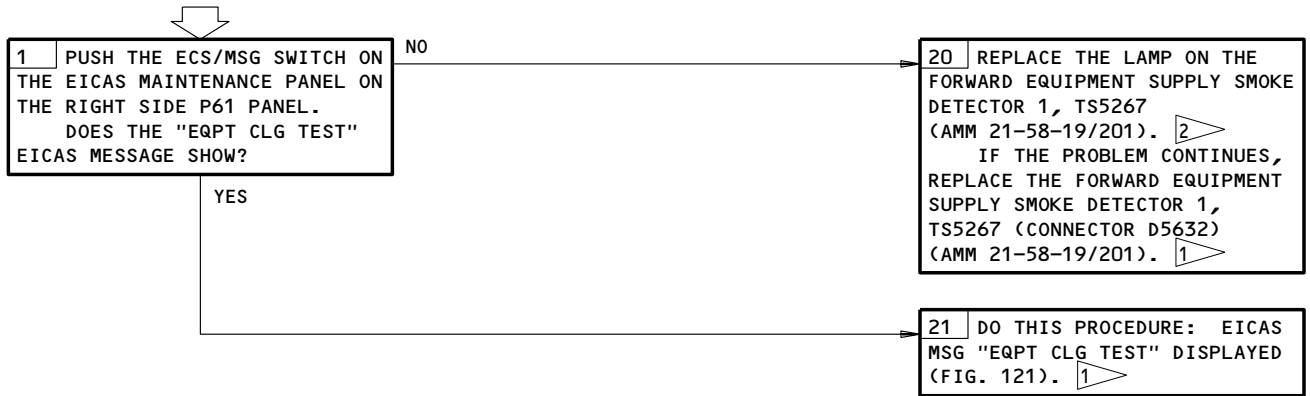

- 1 DO THIS PROCEDURE: MAINTENANCE MESSAGE ERASE PROCEDURE (FIM 31-41-00/101, FIG. 109). HOLD THE EQUIPMENT COOLING TEST SWITCH ON THE P61 PANEL TO THE "EQUIP COOL" POSITION FOR 5 SECONDS, THEN RELEASE IT. WAIT 20 SECONDS. MAKE SURE THAT THE EICAS MESSAGE "FWD EQPT DET 1" DOES NOT SHOW.
- 2 YOU CAN REPLACE THE LAMPS ON THE SMOKE DETECTOR WITH PART NUMBER 2156-204A.

EICAS Msg FWD EQPT DET 1 Displayed
Figure 122

EFFECTIVITY
GUI 001-099

21-58-00
CONFIG 4
Page 135
Jun 20/97

**EICAS MSG "FWD EQPT
DET 2" DISPLAYED**

PREREQUISITES

MAKE SURE THIS SYSTEM WILL OPERATE:
EICAS (MM 31-41-00/201)

MAKE SURE THESE CIRCUIT BREAKERS ARE CLOSED:
6D6,6F17,6F23,11C20,11N11,11N13

MAKE SURE THE AIRPLANE IS IN THIS CONFIGURATION:
ELECTRICAL POWER IS ON (AMM 24-22-00/201)



- 1 ▷ DO THIS PROCEDURE: MAINTENANCE MESSAGE ERASE PROCEDURE (FIM 31-41-00/101, FIG. 109). HOLD THE EQUIPMENT COOLING TEST SWITCH ON THE P61 PANEL TO THE "EQUIP COOL" POSITION FOR 5 SECONDS, THEN RELEASE IT. WAIT 20 SECONDS. MAKE SURE THAT THE EICAS MESSAGE "FWD EQPT DET 1" DOES NOT SHOW.
- 2 ▷ YOU CAN REPLACE THE LAMPS ON THE SMOKE DETECTOR WITH PART NUMBER 2156-204A.

EICAS Msg FWD EQPT DET 2 Displayed
Figure 123

EFFECTIVITY
GUI 001-099

21-58-00
 CONFIG 4
 Page 136
 Jun 20/97

EICAS MSG "EQPT SMOKE TEST" SHOWN



PREREQUISITES

MAKE SURE THIS SYSTEM WILL OPERATE:
EICAS (AMM 31-41-00/201)

MAKE SURE THIS CIRCUIT BREAKER IS CLOSED:
6D6

MAKE SURE THE AIRPLANE IS IN THIS CONFIGURATION:
ELECTRICAL POWER IS ON (AMM 24-22-00/201)

DESCRIPTION:

THE EQUIPMENT COOLING SELF-TEST FOUND A PROBLEM WITH A COMPONENT OF THE SMOKE DETECTION SYSTEM.

POSSIBLE CAUSES:

1. THERE IS A PROBLEM WITH THE FORWARD EQUIPMENT SUPPLY SMOKE DETECTOR 1, TS5267.
2. THERE IS A PROBLEM WITH THE FORWARD EQUIPMENT SUPPLY SMOKE DETECTOR 2, TS5268.
3. THERE IS A PROBLEM WITH THE FORWARD EQUIPMENT EXHAUST SMOKE DETECTOR, TS164.
4. THE SMOKE SHUTDOWN RELAY, K10360, DOES NOT OPERATE.

FAULT ISOLATION:



1 DO THIS PROCEDURE: MAINTENANCE MESSAGE ERASE PROCEDURE (FIM 31-41-00/101, FIG. 109). HOLD THE EQUIPMENT COOLING TEST SWITCH ON THE P61 PANEL TO THE "EQUIP COOL" POSITION FOR 5 SECONDS THEN RELEASE IT. WAIT 20 SECONDS. MAKE SURE THAT THE EICAS MESSAGE "EQUIP SMOKE TEST" DOES NOT SHOW.

2 YOU CAN REPLACE THE LAMP ON SMOKE DETECTORS WITH PART NUMBER 2156-204A.

EICAS Msg EQPT SMOKE TEST Shown
Figure 124 (Sheet 1)

EFFECTIVITY
GUI 001-099

21-58-00

CONFIG 4

09

Page 137

Jan 28/00

FROM SHEET 1
(BLOCK 1)

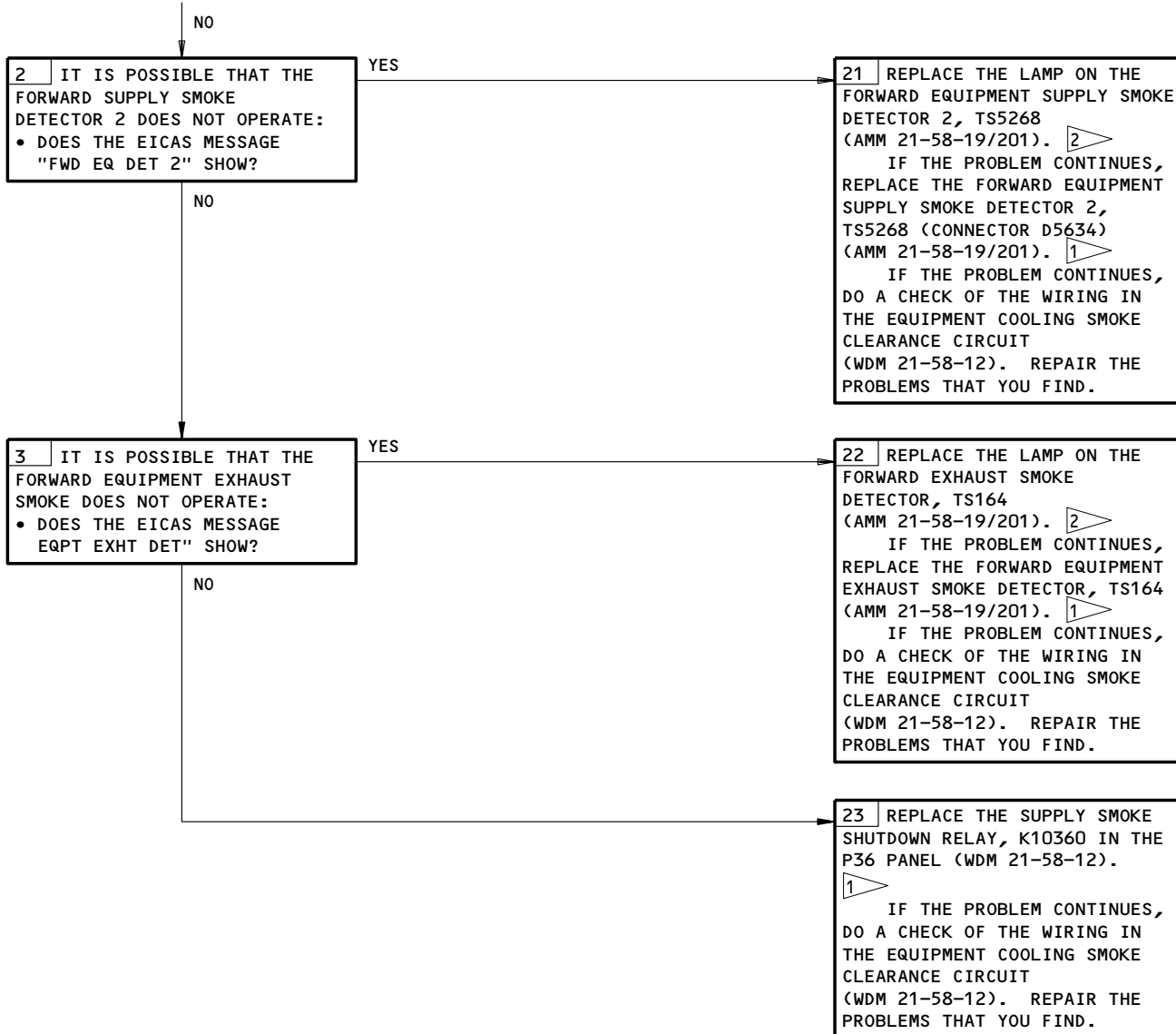

EICAS Msg EQPT SMOKE TEST Shown
Figure 124 (Sheet 2)

EFFECTIVITY
GUI 001-099

21-58-00
CONFIG 4
Page 138
Jan 28/00

06

 **BOEING**
757
FAULT ISOLATION/MAINT MANUAL

TEMPERATURE CONTROL

COMPONENT	FIG. 102 SHT	QTY	ACCESS/AREA	REFERENCE
BULB - ZONE DUCT TEMPERATURE FLIGHT COMPARTMENT ZONE, TS184	4	1	119BL, MAIN EQUIP CTR, LEFT SIDEWALL	21-65-04
FORWARD ZONE, TS185	4	1	SCULPTURED CEILING PANEL	21-65-04
AFT ZONE, TS186	4	1	SCULPTURED CEILING PANEL	21-65-04
BULB - ZONE TEMPERATURE FLIGHT COMPARTMENT ZONE, YRUTS02	5	1	CEILING PANEL, FLIGHT COMPARTMENT ZONE TEMPERATURE SENSOR MODULE, M10452	21-65-02
FORWARD ZONE, YRWTS02	5	1	STOWAGE BIN BULLNOSE, FORWARD ZONE TEMPERATURE SENSOR MODULE, M10025	21-65-02
AFT ZONE, YRVTS02	5	1	STOWAGE BIN BULLNOSE, AFT ZONE TEMPERATURE SENSOR MODULE, M10024	21-65-02
CIRCUIT BREAKERS - CABIN TRIM AIR, C670	1		FLT COMPT, P11	
CABIN ZONE CNTLR, C667		1	11P15	*
ZONE DUCT OVHT/INOP AFT, C4031		1	11P16	*
ZONE DUCT OVHT/INOP FLT DK, C4029		1	11P27	*
ZONE DUCT OVHT/INOP FWD, C4030		1	11P25	*
ZONE TEMP CONT VLV CL AFT, C4186		1	11P26	*
ZONE TEMP CONT VLV CL FLT DK, C4184		1	11N27	*
ZONE TEMP CONT VLV CL FWD, C4185		1	11N25	*
ZONE TEMP IND, C4019		1	11N26	*
COMPUTER - (REF 31-41-00, FIG. 101)		1	11P17	*
EICAS LEFT, M10181				
EICAS RIGHT, M10182				
CONTROLLER - (REF 21-51-00, FIG. 101)				
LEFT PACK TEMP, M126				
RIGHT PACK TEMP, M127				
CONTROLLER - ZONE TEMPERATURE, M195	1	1	119BL, MAIN EQUIP CTR, E3-3	21-61-03
FAN - ZONE TEMPERATURE SENSOR FLIGHT COMPARTMENT ZONE, YRUM001	5	1	CEILING PANEL, FLIGHT COMPARTMENT ZONE TEMPERATURE SENSOR MODULE, M10452	21-61-09
FORWARD ZONE, YRWMO01	5	1	STOWAGE BIN BULLNOSE, FORWARD ZONE TEMPERATURE SENSOR MODULE, M10025	21-61-09
AFT ZONE, YRVMO01	5	1	STOWAGE BIN BULLNOSE, AFT ZONE TEMPERATURE SENSOR MODULE, M10024	21-61-09
INDICATOR - COMPARTMENT TEMPERATURE, M10078	1		FLT COMPT, P5	21-65-01
LIGHTS - AFT ZONE INOP, YNRL3	1	1	FLT COMPT, P5, AIR COND MODULE, M10193	*
LIGHTS - FLIGHT COMPARTMENT ZONE INOP, YNRL1	1	1	FLT COMPT, P5, AIR COND MODULE, M10193	*
LIGHTS - FORWARD ZONE INOP, YNRL2	1	1	FLT COMPT, P5, AIR COND MODULE, M10193	*

* SEE THE WDM EQUIPMENT LIST

Temperature Control - Component Index
Figure 101 (Sheet 1)

EFFECTIVITY

ALL

21-60-00

BOEING
757
FAULT ISOLATION/MAINT MANUAL

COMPONENT	FIG. 102 SHT	QTY	ACCESS/AREA	REFERENCE
MODULE - AIR CONDITIONING CONTROL, M10193	1	1	FLT COMPT P5	*
MODULE - ZONE TEMPERATURE SENSOR				
FLIGHT COMPARTMENT ZONE, M10452	4	1	FLT COMPT, CEILING PANEL	*
FORWARD ZONE, M10025	4	1	PASS COMPT, STOWAGE BIN BULLNOSE	*
AFT ZONE, M10024	4	1	PASS COMPT, STOWAGE BIN BULLNOSE	*
MUFFLER - TRIM AIR	6	2	821, FWD CARGO COMPT, AFT LINING, MIX BAY	21-61-12
PANEL - (REF 31-41-00, FIG. 101)				
EICAS MAINTENANCE, M10372				
RELAY - (REF 31-01-36, FIG. 101)				
AIR/GND SYS 1, K141				
RELAYS - (REF 31-01-37, FIG. 101)				
AFT ZONE AUTO/OFF, K10313				
AFT ZONE DUCT OVHT, K240				
AFT ZONE INOP, K10364				
FLT DK ZONE AUTO/OFF, K10311				
FLT DK ZONE DUCT OVHT, K238				
FLT DK ZONE INOP, K10362				
FWD ZONE AUTO/OFF, K10312				
FWD ZONE DUCT OVHT, K239				
FWD ZONE INOP, K10363				
SELECTOR - ZONE TEMPERATURE			FLT COMPT P5, AIR COND MODULE, M10193	
FLIGHT COMPARTMENT ZONE, YNRS6	1	1		21-61-04
FORWARD ZONE, YNRS7	1	1		21-61-04
AFT ZONE, YNRS8	1	1		21-61-04
SENSOR - DUCT AIR TEMPERATURE				
FLIGHT COMPARTMENT ZONE, TS175	4	1	119BL, MAIN EQUIP CTR, LEFT SIDEWALL	21-61-02
FORWARD ZONE, TS177	4	1	SCULPTURED CEILING PANEL	21-61-02
AFT ZONE, TS179	4	1	SCULPTURED CEILING PANEL	21-61-02
MIX MANIFOLD 1, TS200	4	1	821, FWD CARGO COMPT, AFT LINING, MIX MANIFOLD	21-61-02
MIX MANIFOLD 2, TS201	4	1	821, FWD CARGO COMPT, AFT LINING, MIX MANIFOLD	21-61-02
SENSOR - ZONE TEMPERATURE				
FLIGHT COMPARTMENT ZONE, YRUTS01	5	1	CEILING PANEL, FLIGHT COMPARTMENT ZONE TEMPERATURE SENSOR MODULE, M10452	21-61-08
FORWARD ZONE, YRWTS01	5	1	STOWAGE BIN BULLNOSE, FORWARD ZONE TEMPERATURE SENSOR MODULE, M10025	21-61-08
AFT ZONE, YRVTS01	5	1	STOWAGE BIN BULLNOSE, AFT ZONE TEMPERATURE SENSOR MODULE, M10024	21-61-08
SWITCH - ZONE DUCT OVHT				
FLIGHT COMPARTMENT ZONE, S21	4	1	119BL, LEFT SIDEWALL	21-61-01
FORWARD ZONE, S22	4	1	SCULPTURED CEILING PANEL	21-61-01
AFT ZONE, S23	4	1	SCULPTURED CEILING PANEL	21-61-01

* SEE THE WDM EQUIPMENT LIST

Temperature Control - Component Index
Figure 101 (Sheet 2)

EFFECTIVITY

ALL

21-60-00

09

Page 102
Sep 20/90

319890

BOEING
 757
 FAULT ISOLATION/MAINT MANUAL

COMPONENT	FIG. 102 SHT	QTY	ACCESS/AREA	REFERENCE
SWITCH-LIGHT - TRIM AIR, YNRS3	1	1	FLT COMPT, P5, AIR COND MODULE M10193	21-61-01
UNIT - (REF 49-61-00, FIG. 101) APU CONTROL, M206				
VALVE - TRIM AIR MODULATING FLIGHT COMPARTMENT ZONE, V1	3	1	821, FWD CARGO COMPT, AFT LINING	21-61-07
FORWARD ZONE, V2	3	1	821, FWD CARGO COMPT, AFT LINING	21-61-07
AFT ZONE, V3	3	1	821, FWD CARGO COMPT, AFT LINING	21-61-07
VALVE - TRIM AIR PRESSURE REGULATING, V4	2	1	193HL, LEFT ECS BAY	21-61-06
VALVE - LEFT TRIM AIR SUPPLY CHECK	2	1	193HL, LEFT ECS BAY	21-61-05
VALVE - RIGHT TRIM AIR SUPPLY CHECK	2	1	194ER, RIGHT ECS BAY	21-61-05

* SEE THE WDM EQUIPMENT LIST

Temperature Control - Component Index
 Figure 101 (Sheet 3)

EFFECTIVITY

ALL

21-60-00

02

Page 103
Sep 20/90

319892

BOEING

757 FAULT ISOLATION/MAINT MANUAL

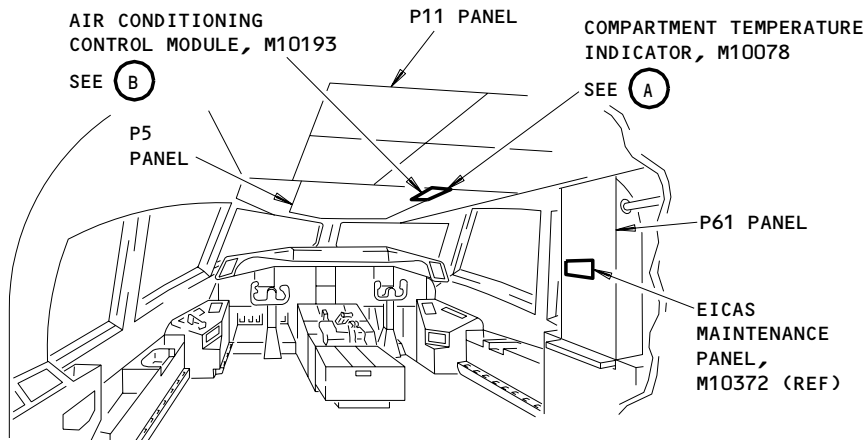

FLIGHT COMPARTMENT

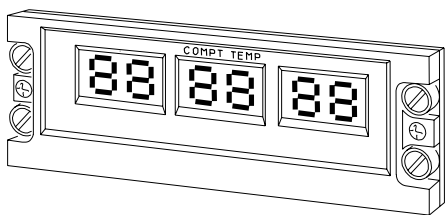

COMPARTMENT TEMPERATURE INDICATOR, M10078

(A)

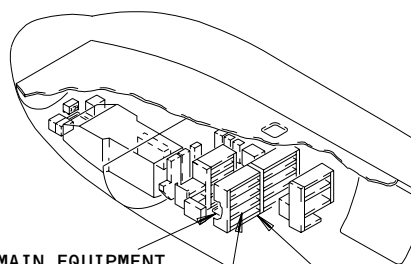

MAIN EQUIPMENT CENTER ACCESS, 119BL

ELECTRONIC EQUIPMENT RACK, E3

ZONE TEMPERATURE CONTROLLER, M195

SEE (C)

ZONE INOP LIGHTS, YNRL1, YNRL2, YNRL3

ZONE TEMPERATURE SELECTOR SWITCHES, YNRS6, YNRS7, YNRS8

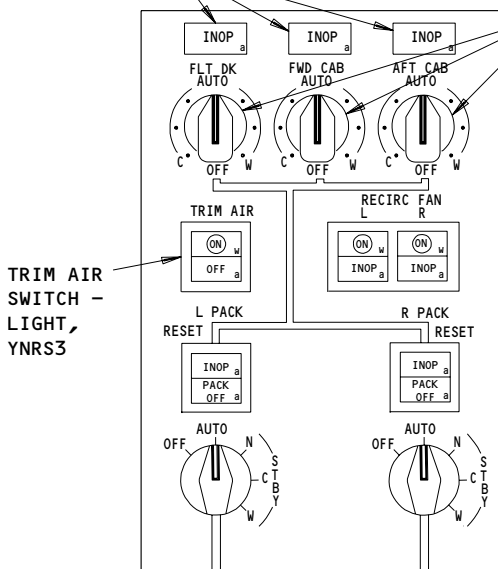

AIR CONDITIONING CONTROL MODULE, M10193

(B)

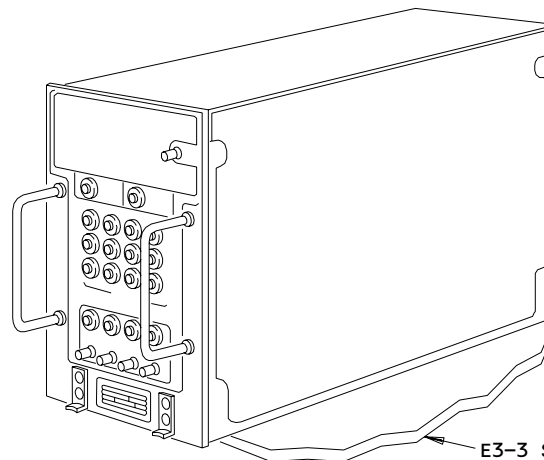

ZONE TEMPERATURE CONTROLLER, M195

(C)

**Temperature Indication - Component Location
Figure 102 (Sheet 1)**

EFFECTIVITY

ALL

21-60-00

05

Page 104
Mar 20/93

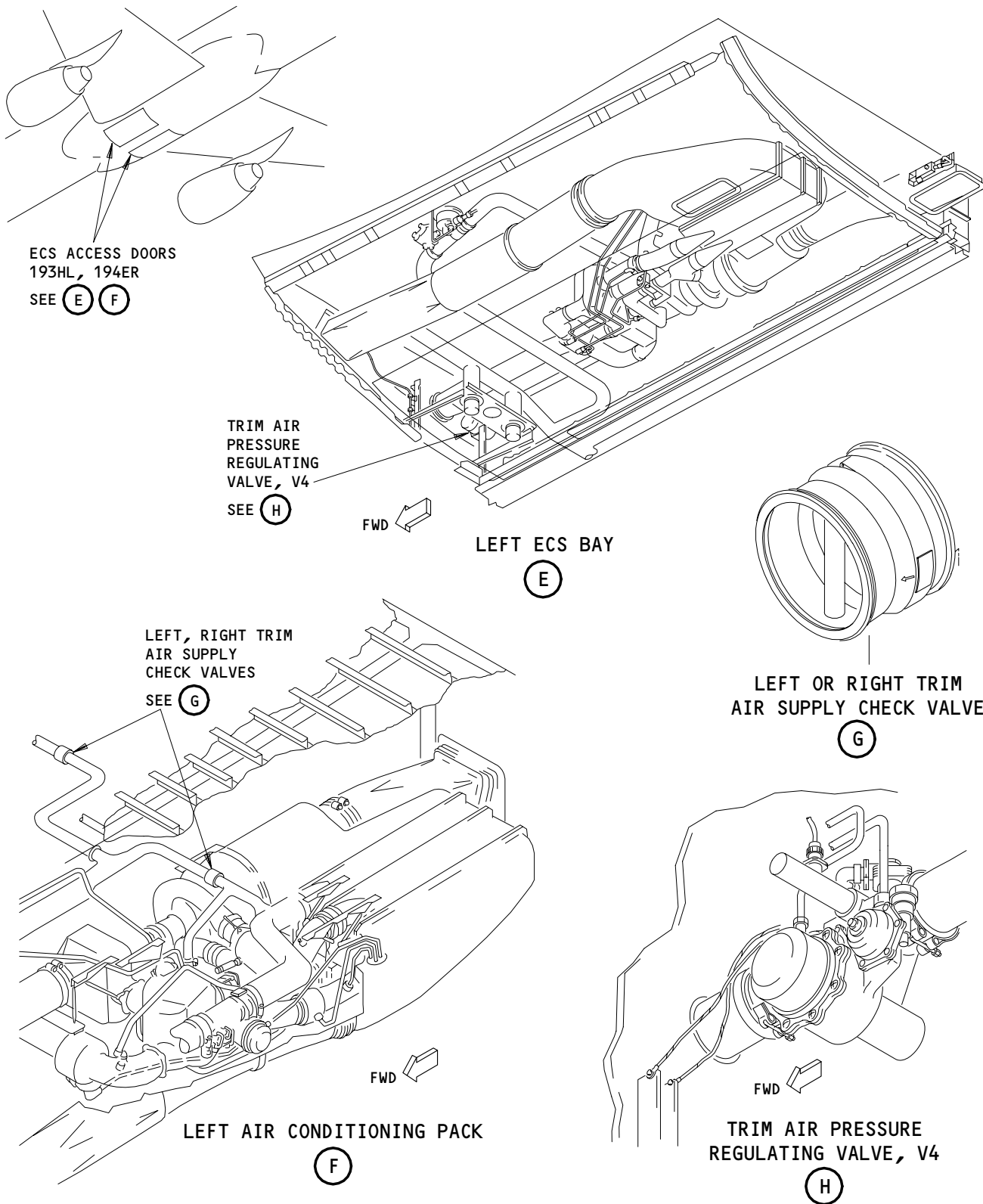

Temperature Indication - Component Location
Figure 102 (Sheet 2)

EFFECTIVITY

ALL

21-60-00

02

Page 105
Sep 20/90

168079

BOEING
757
FAULT ISOLATION/MAINT MANUAL

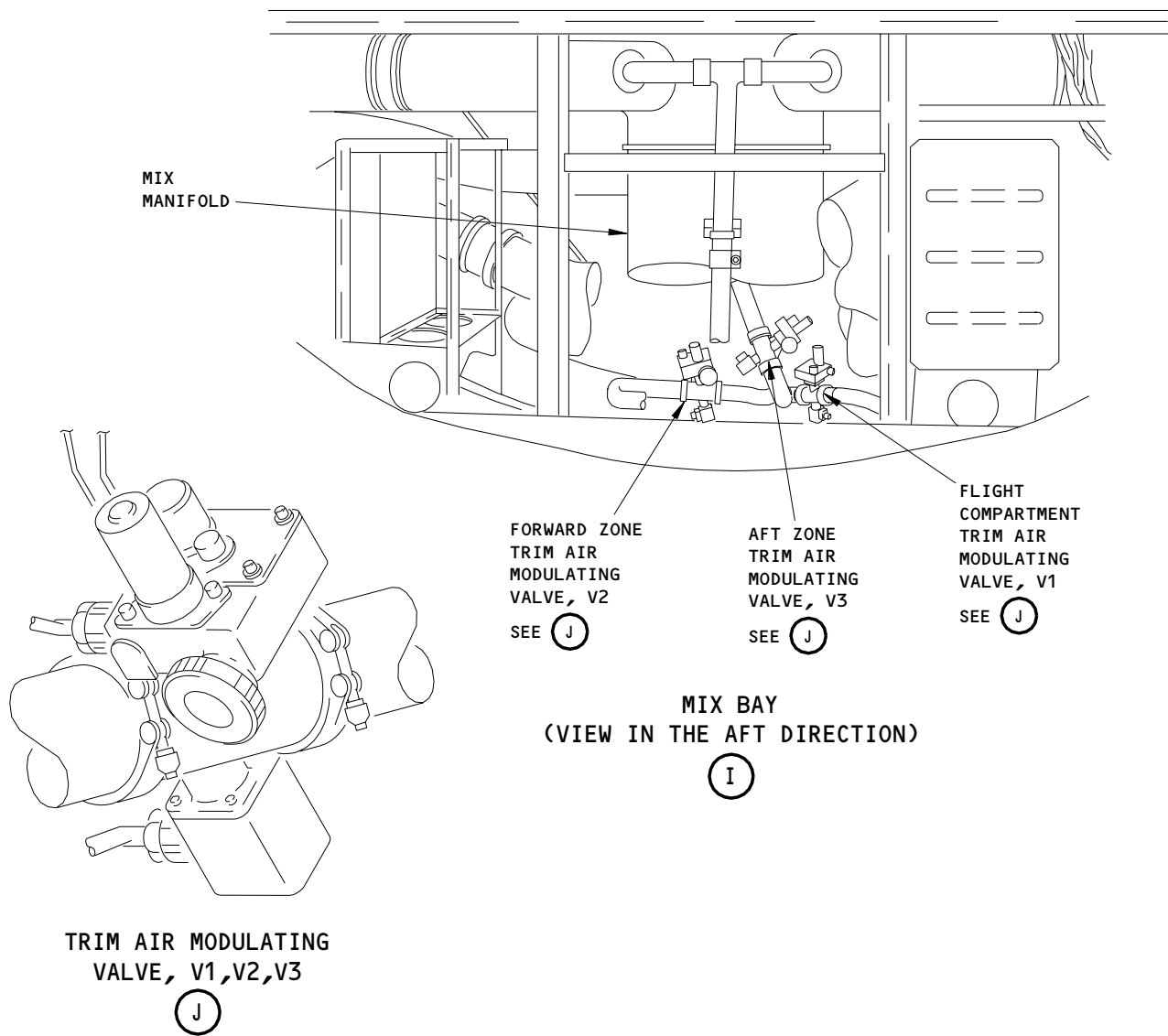
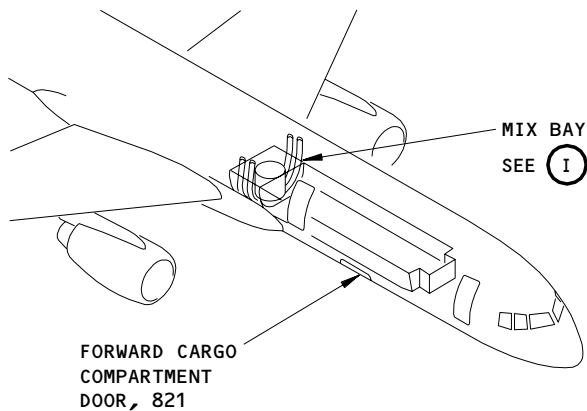

Temperature Indication - Component Location
Figure 102 (Sheet 3)

EFFECTIVITY	
	ALL

21-60-00

BOEING

757

FAULT ISOLATION/MAINT MANUAL

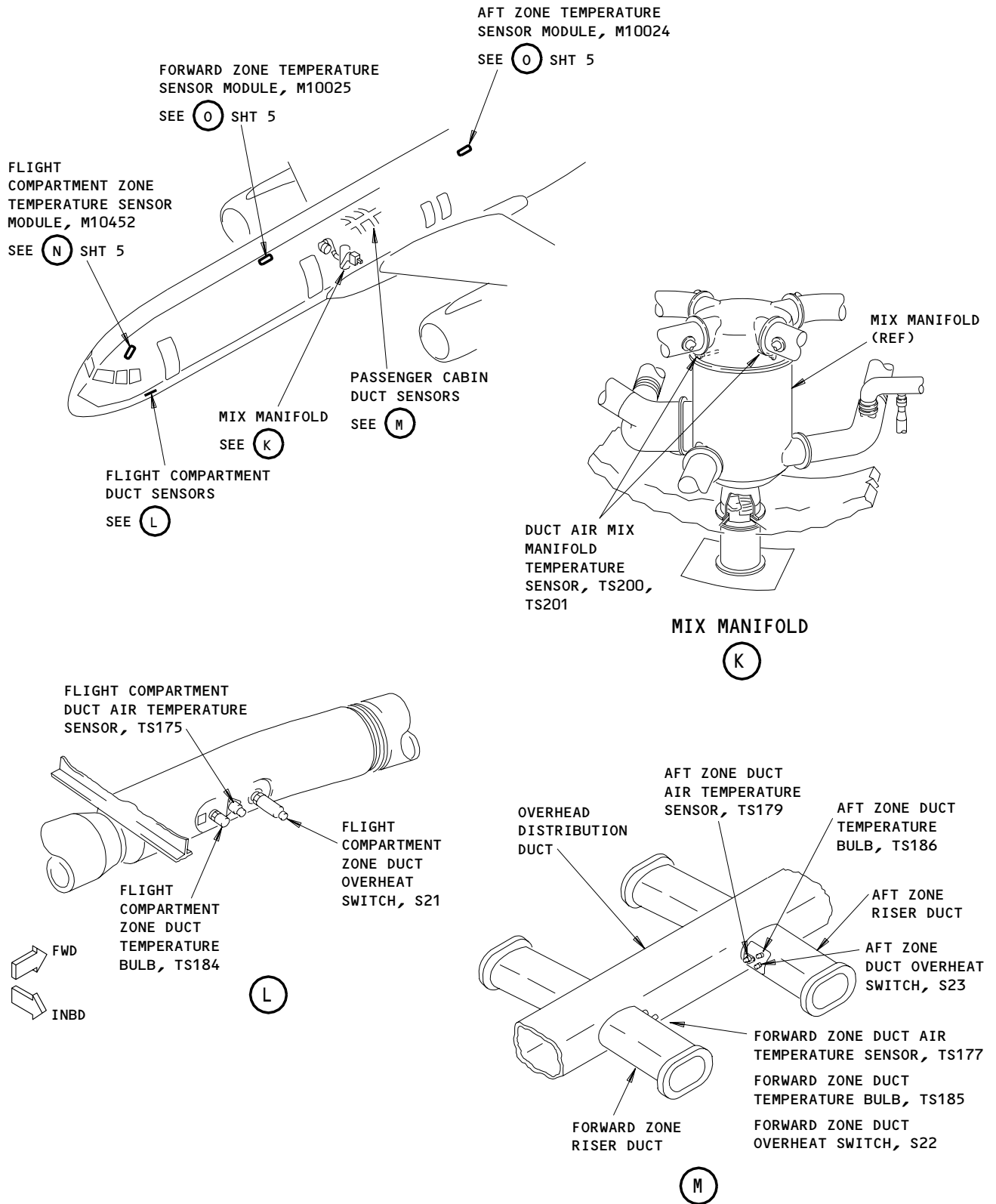

Temperature Indication - Component Location
Figure 102 (Sheet 4)

EFFECTIVITY	
	ALL

187443

21-60-00

03

Page 107
Sep 20/90

BOEING

757

FAULT ISOLATION/MAINT MANUAL

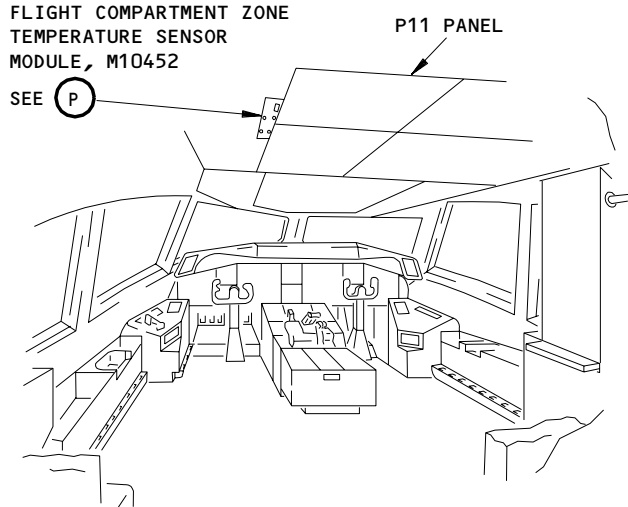

FLIGHT COMPARTMENT

(N) FROM SHT 4

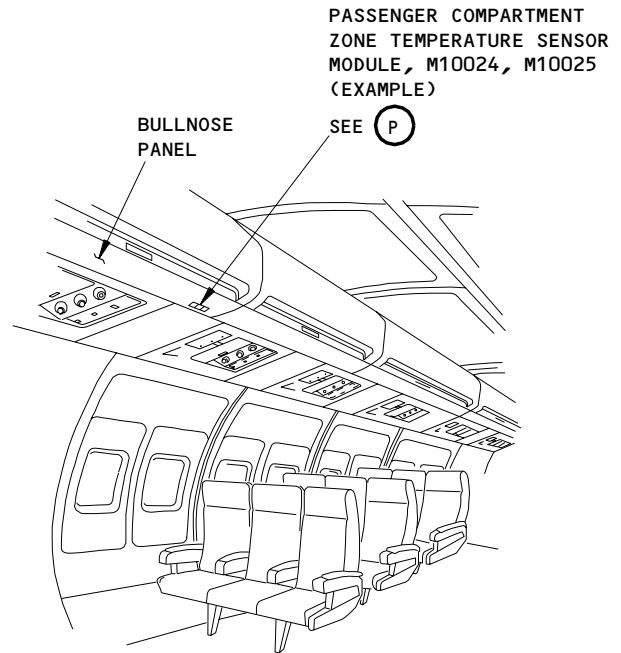

PASSENGER COMPARTMENT

(O) FROM SHT 4

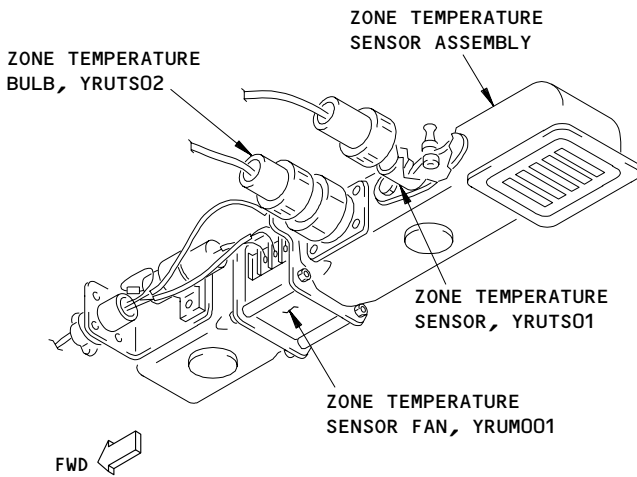

FLIGHT COMPARTMENT ZONE TEMPERATURE SENSOR MODULE M10452

(P)

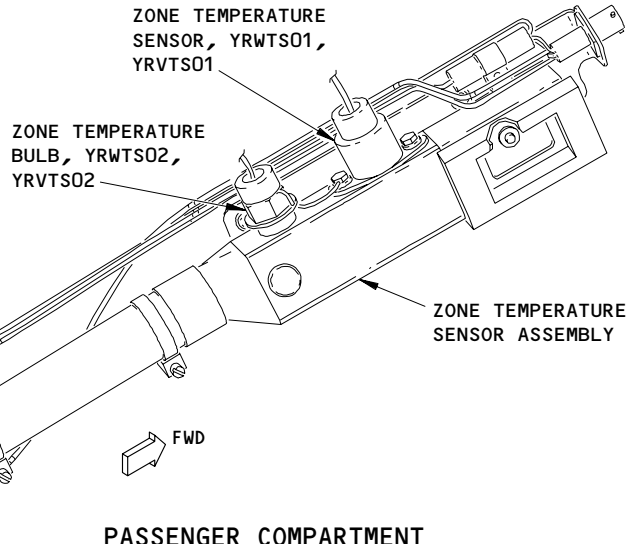

PASSENGER COMPARTMENT ZONE TEMPERATURE SENSOR MODULE, M10024, M10025 (EXAMPLE)

(P)

Temperature Indication - Component Location
Figure 102 (Sheet 5)

EFFECTIVITY	
	ALL

21-60-00

BOEING
757
FAULT ISOLATION/MAINT MANUAL

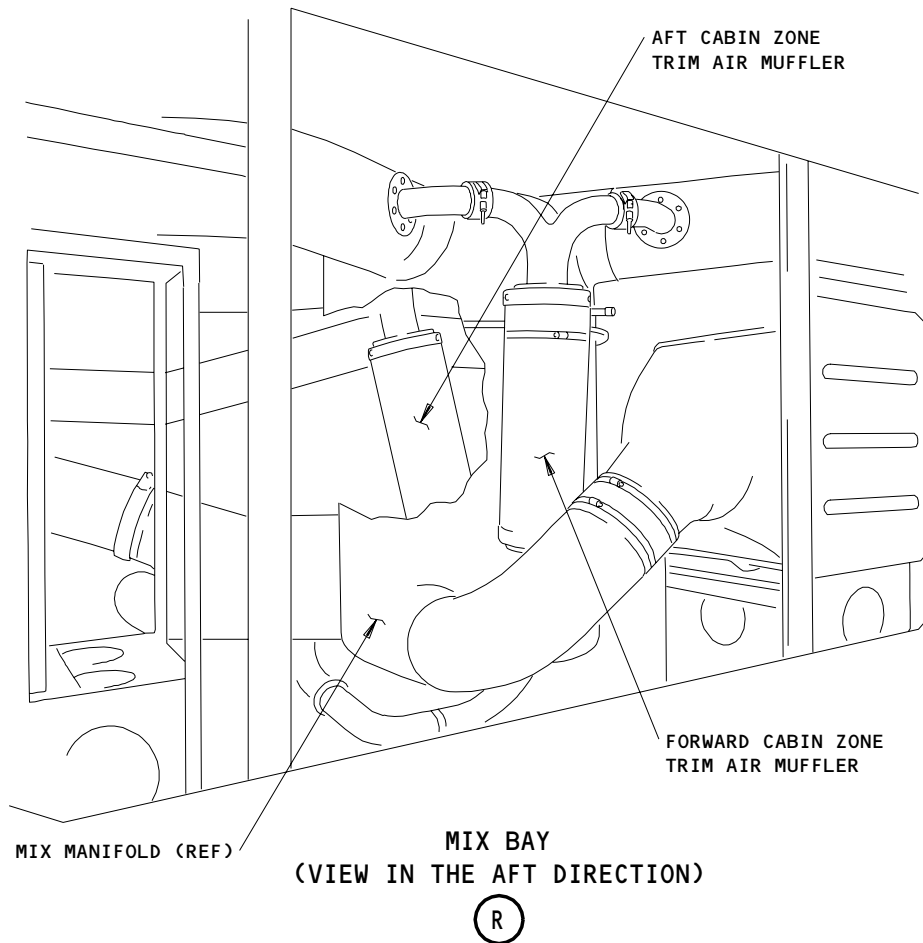
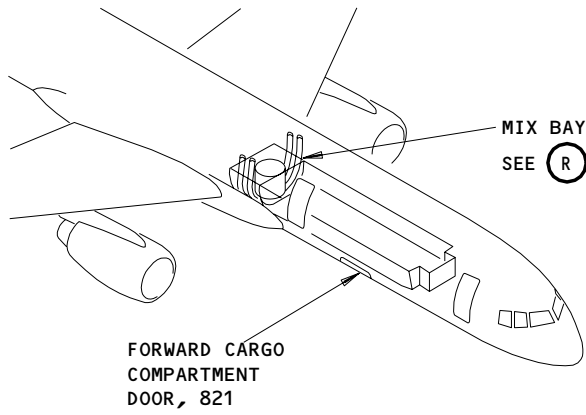

Temperature Indication - Component Location
Figure 102 (Sheet 6)

EFFECTIVITY	
	ALL

21-60-00

TEMPERATURE CONTROL – FAULT ISOLATION

1. General

- A. This procedure has the steps to troubleshoot temperature control problems in the cabin.
- B. To do these Fault Isolation procedures, electrical power and EICAS must be available.
- C. Inspect and replace all clogged or dirty zone temperature sensor filters before performing fault isolation procedures.

2. Fault Isolation Procedures

Fig. 103 – FLT DECK, FWD CABIN, AND AFT CABIN TEMP DOES NOT RESPOND WITH TRIM AIR SWITCH "ON" AND ALL ZONE TEMPERATURE SELECTORS IN "AUTO"

Fig. 104 – ZONE TEMPERATURE CONTROLLER BITE PROCEDURE

Fig. 105 – ("FLT DECK TEMP", "FWD CABIN TEMP", "AFT CABIN TEMP" EICAS MESSAGES DISPLAYED AND ZONE TEMPERATURE "INOP" LIGHT ILLUMINATED

Fig. 106 – FLT DECK / FWD CABIN / AFT CABIN FAILS TO MAINTAIN DESIRED TEMP WITH TRIM AIR SWITCH SELECTED "ON" AND TEMP CONTROL IN "AUTO". "INOP" LGT EXTN.

Fig. 107 – TEMPERATURE SENSOR CALIBRATION PROBLEMS

3. Zone Temperature Controller BITE Procedure (Fig. 104)

A. General

- (1) The purpose of the zone temperature controller (ZTC) is to regulate the temperature of the three cabin zones.
- (2) The ZTC controls the trim air system and the demand signals to the APU and the pack temperature controller.
- (3) The ZTC determines the zone that has the largest cooling requirement. The requirement is sent to the pack temperature controller as a demand signal to adjust the pack outlet temperature. The ZTC commands the trim air system to heat the other two zones.
- (4) The ZTC sends a demand signal to the APU electronic control unit (ECU) to control the pneumatic output of the APU. If the temperature of the zone with the most heating or cooling cannot be maintained, then the ZTC will increase the demand signal to the APU ECU.
- (5) The ZTC BITE procedure is done on the front of the controller.
- (6) The ZTC does a BITE test of these components:
 - (a) Zone temperature controller (self test)
 - (b) Temperature Selector (flight deck, forward zone, aft zone)
 - (c) Zone Temperature Sensor (flight deck, forward zone, aft zone)
 - (d) Duct Temperature Sensor (flight deck, forward zone, aft zone)
 - (e) Trim Air Modulating Valve (flight deck, forward zone, aft zone)

EFFECTIVITY

ALL

21-60-00

05

Page 110
Sep 28/02

B. Zone Temperature Controller BITE Description:

- (1) Controller Fault:
 - (a) There are two types of zone temperature controller faults, critical and non-critical.
 - (b) Critical Faults:
 - 1) Critical faults are internal ZTC faults that affect the temperature control of all three zones. These faults include power supply problems, A/D converter problems, memory problems, and processor problems.
 - 2) Critical faults have these flight deck effects:
 - a) All three zone INOP lights on the P5 overhead panel will come on.
 - b) AFT CABIN TEMP, FWD CABIN TEMP, and FLT DECK TEMP EICAS Advisory messages will show.
 - 3) ZONE TEMP BITE EICAS Maintenance Message will show on the EICAS maintenance page.
 - (c) Non-Critical Faults:
 - 1) Non-critical faults are internal ZTC faults that affect the temperature control of one zone. These faults include signal conditioner problems and valve driver problems.
 - 2) Non-critical faults have these flight deck effects:
 - a) The applicable INOP light on the P5 overhead panel will come on.
 - b) The applicable EICAS Advisory message will show (AFT CABIN TEMP, FWD CABIN TEMP, FLT DECK TEMP)
 - 3) The ZONE TEMP BITE EICAS Maintenance Message will show on the EICAS maintenance page.
- (2) SELECTOR (Flight Deck, FWD Zone, AFT Zone)
 - (a) The ZTC detects that the input signal from the selector is out of range (less than 2.5V or more than 7.5V).
 - (b) The ZONE TEMP BITE EICAS Maintenance Message will show on the EICAS maintenance page.
- (3) ZONE SENSOR (FLT DECK, FWD ZONE, AFT ZONE)
 - (a) The ZTC detects that the input signal from the zone temperature sensor is out of range (less than 0.67V or more than 3.51V).
 - (b) The ZONE TEMP BITE EICAS Maintenance Message will show on the EICAS maintenance page.
- (4) DUCT SENSOR (FLT DECK, FWD ZONE, AFT ZONE)
 - (a) The ZTC detects that the input signal from the duct temperature sensor is out of range (less than 0.15V or more than 1.60V).
 - (b) The ZONE TEMP BITE EICAS Maintenance Message will show on the EICAS maintenance page.
- (5) TRIM VALVE (FLT DECK, FWD ZONE, AFT ZONE)
 - (a) The ZTC can detect two different trim air modulating valve faults:
 - 1) The ZTC detects an open circuit in both of the limit switches in the trim air modulating valve.

NOTE: In normal operation, one of limit switches is always closed.

EFFECTIVITY

ALL

21-60-00

03

Page 111
Sep 28/02

 **BOEING**
757
FAULT ISOLATION/MAINT MANUAL

- 2) The trim air modulating valve takes more than 60 seconds to open or close. The valve is electrically or mechanically inoperative.

NOTE: This test for the trim air modulating valve is done when the VERIFY switch on the ZTC is pushed or when the valve is commanded full open or full closed.

EFFECTIVITY

ALL

21-60-00

03

Page 112
Jun 20/95

FLT DECK, FWD CABIN,
AND AFT CABIN TEMP
DOES NOT RESPOND
WITH TRIM AIR
SWITCH "ON" AND ALL
ZONE TEMPERATURE
SELECTORS IN "AUTO"

PREREQUISITES
ELECTRICAL POWER (AMM 24-22-00)
CB'S: 11N25,11N26,11N27,11P15,11P16,11P17,11P25,11P26,
11P27



Flt Deck, Fwd Cabin, and Aft Cabin Temp does not Respond with Trim Air
Switch ON and all Zone Temperature Selectors in AUTO
Figure 103

EFFECTIVITY	
	ALL

21-60-00

PREREQUISITES

MAKE SURE THESE CIRCUIT BREAKERS ARE CLOSED:
11N25, 11N26, 11N27, 11P15, 11P16, 11P17, 11P25,
11P26, 11P27

MAKE SURE THE AIRPLANE IS IN THIS CONFIGURATION:
ELECTRICAL POWER IS ON (AMM 24-22-00/201)
PNEUMATIC PRESSURE IS ZERO

NOTE: THE BUILT-IN-TEST EQUIPMENT (BITE) DOES AN ELECTRICAL CHECK OF THE ZONE TEMPERATURE CONTROLLER, TEMPERATURE SELECTORS, ZONE TEMPERATURE SENSORS, AND DUCT TEMPERATURE SENSORS. THE BITE DOES AN OPERATIONAL CHECK OF THE TRIM AIR MODULATING VALVES.

NOTE: BITE DOES NOT KNOW THE DIFFERENCE BETWEEN A COMPONENT FAULT AND AN AIRPLANE WIRING FAULT. MAKE SURE THE CIRCUIT IS CORRECT AND THE CONNECTOR IS IN GOOD CONDITION BEFORE YOU REPLACE A COMPONENT.

ZONE TEMPERATURE CONTROLLER BITE PROCEDURE

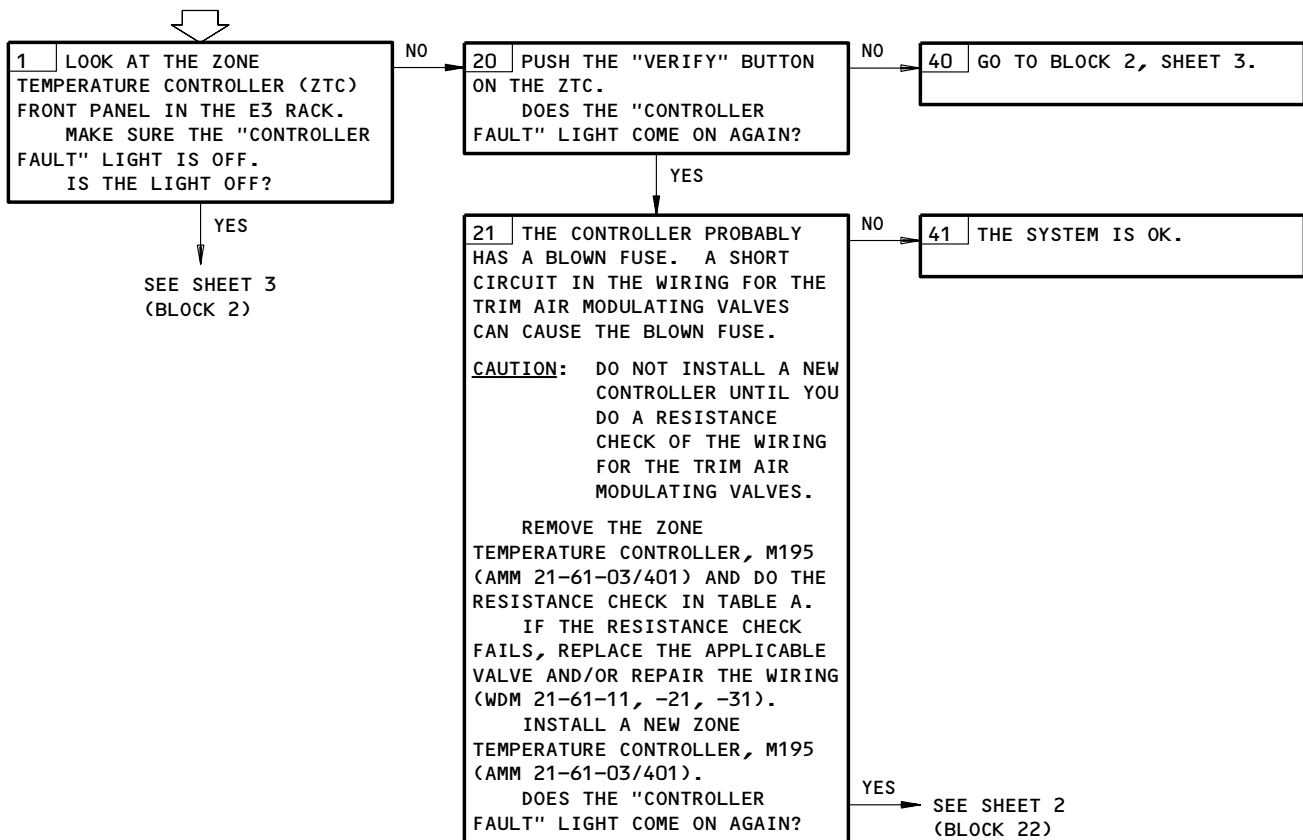

Zone Temperature Controller BITE Procedure
Figure 104 (Sheet 1)

EFFECTIVITY	ALL
-------------	-----

21-60-00

BOEING
757
FAULT ISOLATION/MAINT MANUAL

FROM SHEET 1
(BLOCK 21)

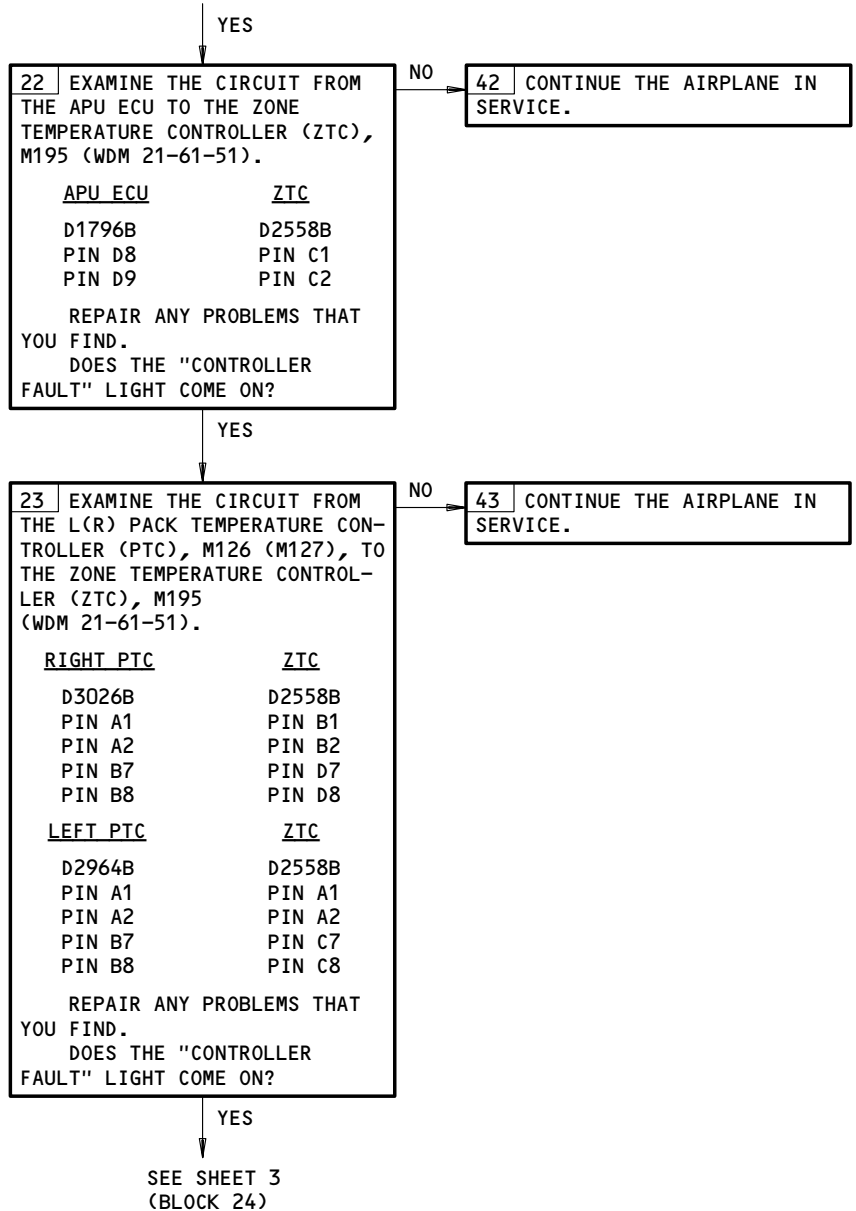

Zone Temperature Controller BITE Procedure
Figure 104 (Sheet 2)

EFFECTIVITY	ALL
-------------	-----

21-60-00

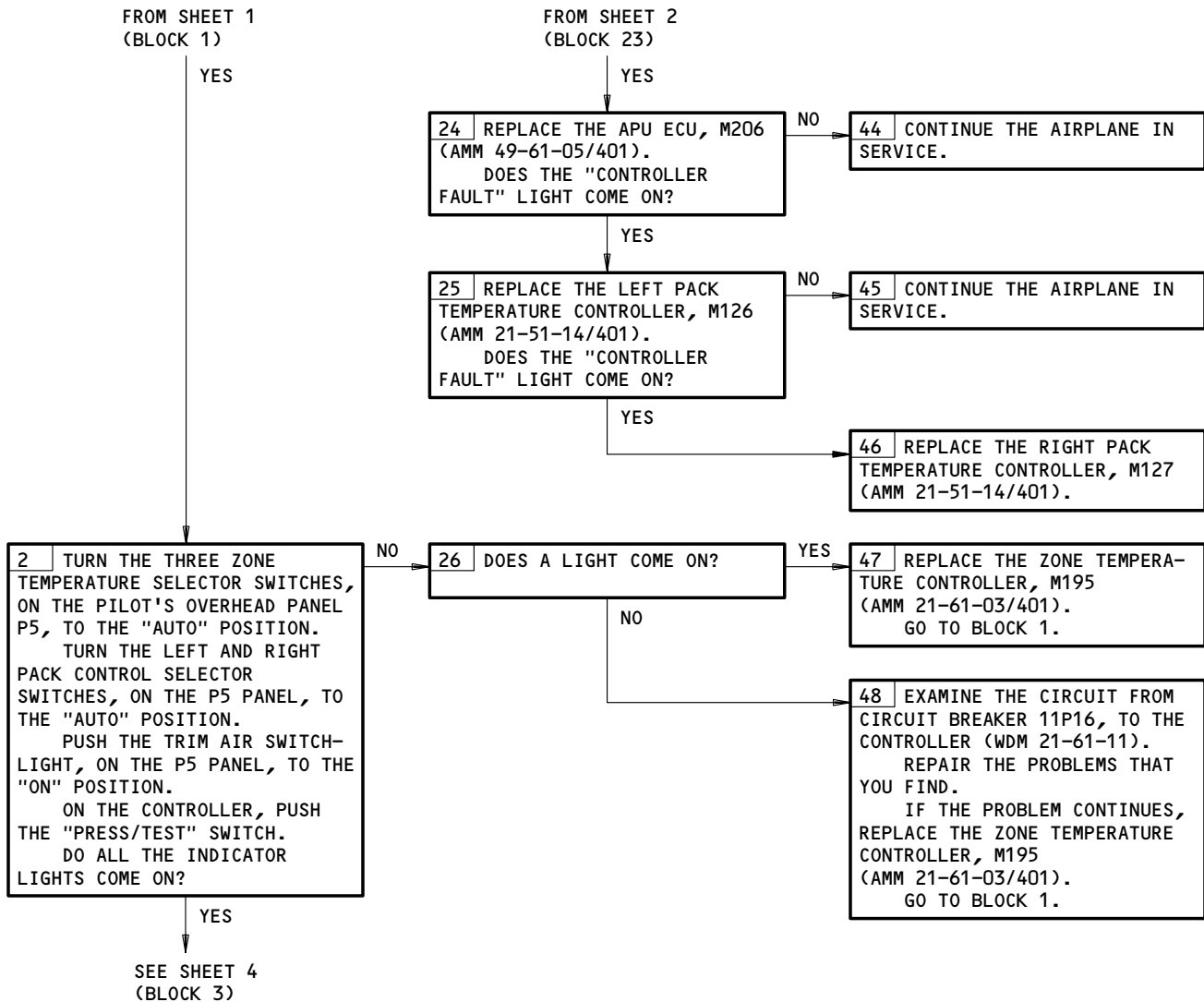

Zone Temperature Controller BITE Procedure
Figure 104 (Sheet 3)

EFFECTIVITY

ALL

21-60-00

03

Page 116
Jan 20/98

F00790

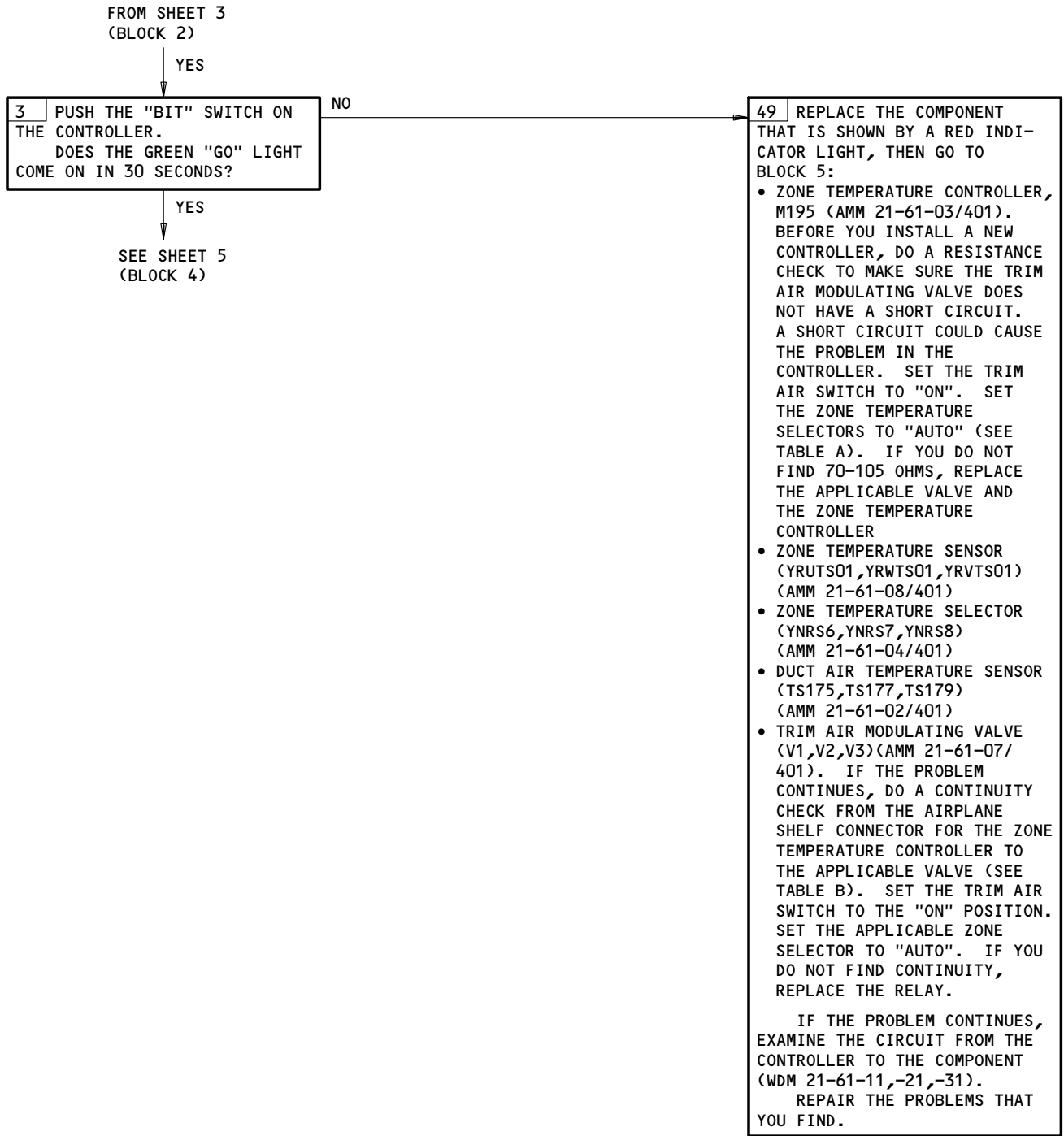

Zone Temperature Controller BITE Procedure
Figure 104 (Sheet 4)

EFFECTIVITY	ALL
-------------	-----

21-60-00

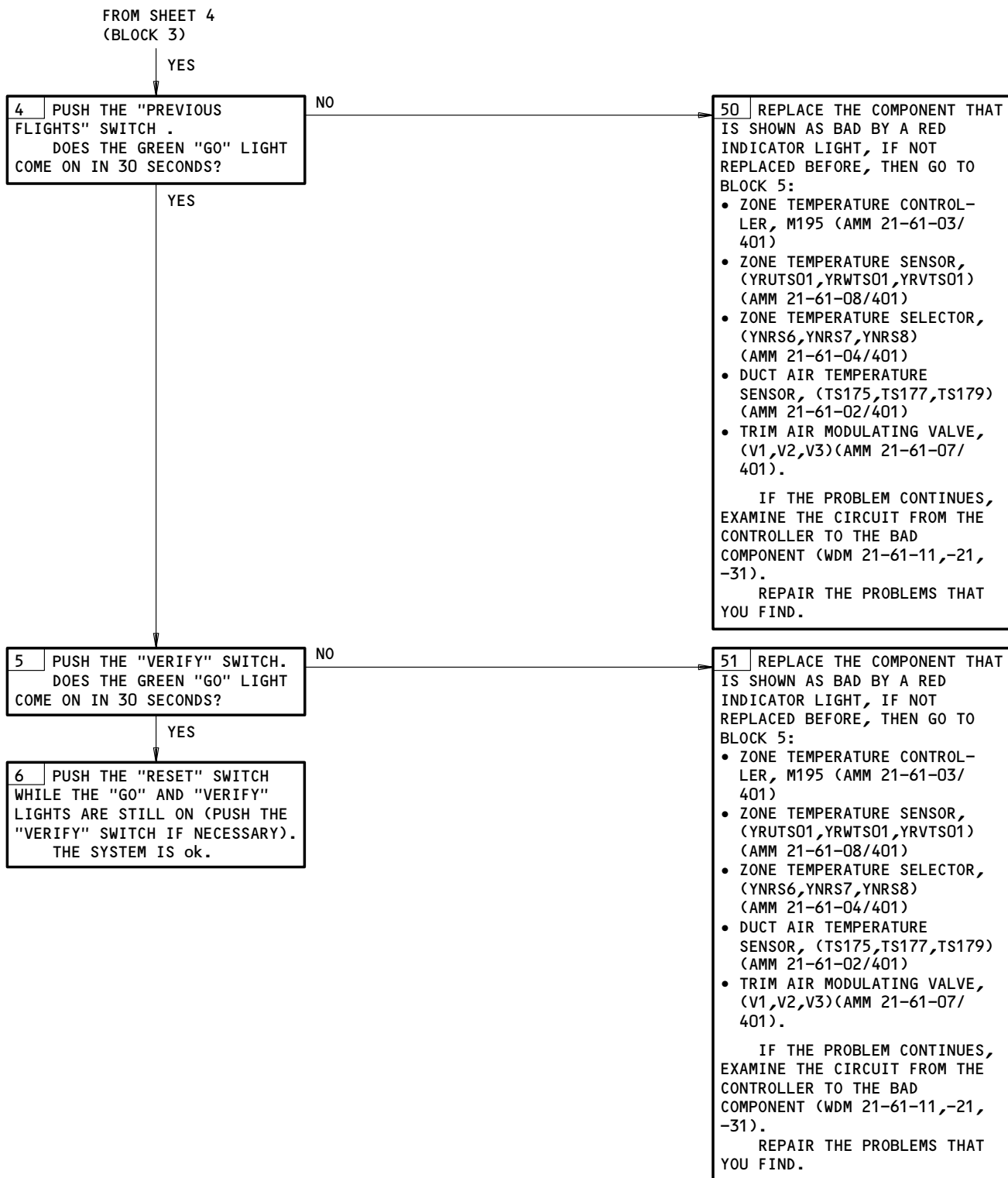

Zone Temperature Controller BITE Procedure
Figure 104 (Sheet 5)

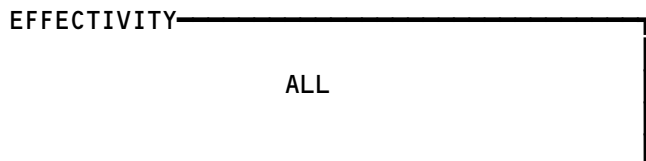

21-60-00



757

FAULT ISOLATION/MAINT MANUAL

VALVE CHECKED	FROM CONNECTOR D2558B	TO CONNECTOR D2558C	ACCEPTABLE RESISTANCE (OHMS)
FLIGHT DECK TRIM AIR MODULATING VALVE, V1 (WDM 21-61-11)	PIN A13 PIN A15	PIN 4 PIN 4	70-105 70-105
FORWARD ZONE TRIM AIR MODULATING VALVE, V2 (WDM 21-61-21)	PIN B13 PIN B15	PIN 4 PIN 4	70-105 70-105
AFT ZONE TRIM AIR MODULATING VALVE, V3 (WDM 21-61-31)	PIN C13 PIN C15	PIN 4 PIN 4	70-105 70-105

ZONE TEMPERATURE CONTROLLER RESISTANCE CHECK
TABLE A

ZONE	AIRPLANE SHELF CONNECTOR	PIN	VALVE	CONNECTOR	PIN	RELAY TO REPLACE
FLIGHT DECK	D2558B	A13 A15	V1	D2546	1 2	K238
FORWARD	D2558B	B13 B15	V2	D2560	1 2	K239
AFT	D2558B	C13 C15	V3	D2574	1 2	K240

TRIM AIR MODULATING VALVE RELAY CONTINUITY CHECK
TABLE B

Zone Temperature Controller BITE Procedure
Figure 104 (Sheet 6)

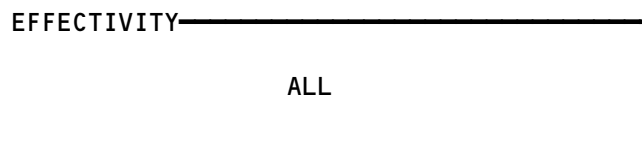

21-60-00

03

Page 119
Jun 20/95

E47599

BOEING
757
FAULT ISOLATION/MAINT MANUAL

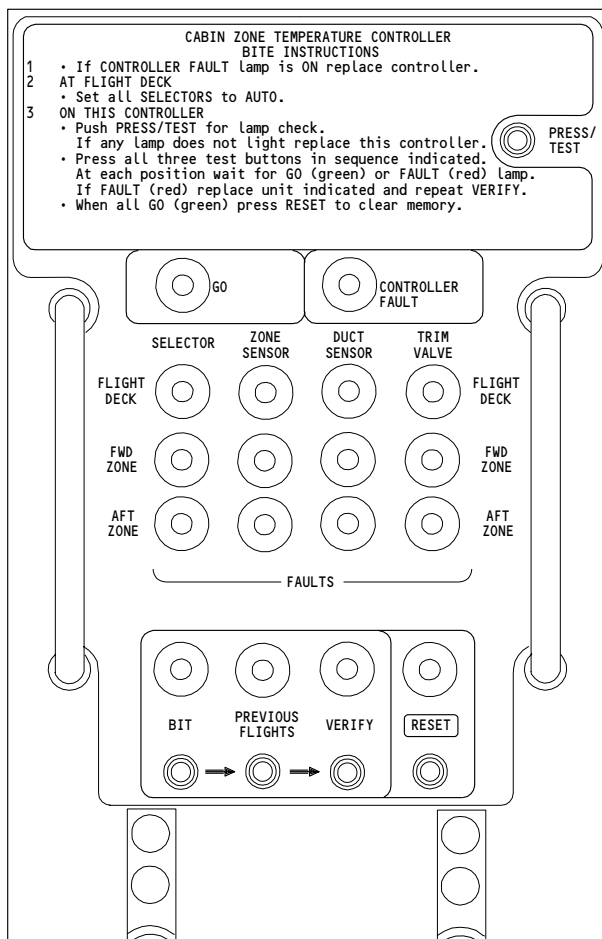

ZONE TEMPERATURE CONTROLLER, M195

Zone Temperature Controller BITE Procedure
Figure 104 (Sheet 7)

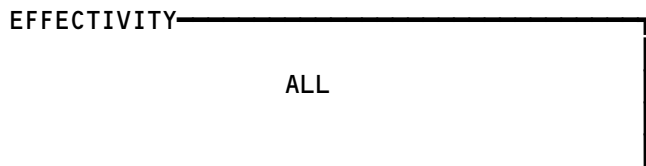

21-60-00

("FLT DECK TEMP",
"FWD CABIN TEMP",
"AFT CABIN TEMP")
EICAS MESSAGE
DISPLAYED AND ZONE
TEMPERATURE "INOP"
LIGHT ILLUMINATED



PREREQUISITES

MAKE SURE THIS SYSTEM WILL OPERATE:
EICAS (AMM 31-41-00/201)

MAKE SURE THE AIRPLANE IS IN THIS CONFIGURATION:
ELECTRICAL POWER IS ON (AMM 24-22-00/201)

NOTE: "FLT DECK TEMP", "FWD CABIN TEMP", AND
"AFT CABIN TEMP" EICAS MESSAGES WILL CAUSE
AN ECS/MSG AUTO EVENT.

DESCRIPTION:

THE DUCT TEMPERATURE FOR THE FLIGHT DECK, THE FORWARD ZONE, OR THE AFT ZONE, IS MORE THAN 190°F (88°C). THE "INOP" LIGHT ON THE P5 PANEL AND THE EICAS ADVISORY MESSAGE "FLT DECK TEMP", "FWD CABIN TEMP", OR "AFT CABIN TEMP" SHOWS.

POSSIBLE CAUSES:

1. THE "TRIM AIR" SWITCH, ON THE P5 PANEL, IS IN THE OFF POSITION
2. THE TEMPERATURE SELECTOR, ON THE P5 PANEL, FOR THE APPLICABLE ZONE IS IN THE "OFF" POSITION
3. THE APPLICABLE DUCT OVERHEAT SWITCH IS FAILED (AMM 21-61-01/401):
 - FLIGHT DECK OVHT SWITCH, S21
 - FWD OVHT SWITCH, S22
 - AFT OVHT SWITCH, S23
4. THE APPLICABLE DUCT OVERHEAT RELAY IS FAILED (WDM 21-61-11,-21,-31):
 - FLIGHT DECK OVHT RELAY, K238
 - FWD ZONE OVHT RELAY, K239
 - AFT OVHT RELAY, K240
5. THE APPLICABLE ZONE AUTO/OFF RELAY IS FAILED (WDM 21-61-11,-21,-31):
 - FLIGHT DECK ZONE AUTO/OFF RELAY, K10311
 - FWD ZONE AUTO/OFF RELAY, K10312
 - AFT ZONE AUTO/OFF RELAY, K10313
6. THE APPLICABLE ZONE INOP RELAY IS FAILED (WDM 21-61-11,-21,-31):
 - FLIGHT DECK ZONE INOP RELAY, K10362
 - FWD ZONE INOP RELAY, K10363
 - AFT ZONE INOP RELAY, K10364
7. THERE IS AN OVERHEAT CONDITION FOR THE TRIM AIR DUCT:
 - A. TRIM AIR MODULATING VALVE FAILS TO CLOSE (AMM 21-61-07/401)
 - B. THE ZONE TEMPERATURE CONTROLLER HAS A PROBLEM, M195 (AMM 21-61-03/401)
8. THE TEMPERATURE SENSOR FOR THE APPLICABLE ZONE OR DUCT IS OUT OF CALIBRATION
9. THE APPLICABLE ZONE TEMPERATURE SELECTOR IS FAILED
10. WIRING:
 - FLIGHT DECK (WDM 21-61-11)
 - FWD ZONE (WDM 21-61-21)
 - AFT ZONE (WDM 21-61-31)
11. ZONE TEMPERATURE CONTROLLER, M195 (AMM 21-61-03/401).

(FLT DECK TEMP, FWD CABIN TEMP, AFT CABIN TEMP) EICAS Message
Displayed and Zone Temperature INOP Light Illuminated
Figure 105 (Sheet 1)

EFFECTIVITY

ALL

21-60-00

03

Page 121
Sep 20/95

FAULT ISOLATION:

1 MAKE SURE THE "TRIM AIR" LIGHT SWITCH ON THE P5 PANEL IS ON.
MAKE SURE THESE TEMPERATURE SELECTORS ARE IN THE "AUTO" POSITION:

- FLT DK
- FWD CAB
- AFT CAB.

NOTE: THE EICAS MESSAGE WILL SHOW WHEN THE "TRIM AIR" SWITCH IS "OFF" OR THE TEMPERATURE SELECTORS ARE "OFF".

2 DO THIS PROCEDURE: ZONE TEMPERATURE CONTROLLER BITE PROCEDURE (FIG. 104).
DID THE BITE FIND A PROBLEM?

YES

42 DO THE CORRECTIVE ACTION (FIG. 104).

NO

3 FOR THE LEFT AND THE RIGHT PACK TEMPERATURE CONTROLLERS: DO THIS PROCEDURE: PACK TEMPERATURE CONTROLLER BITE PROCEDURE (FIM 21-51-00/101, FIG. 104).
DID THE BITE FIND A PROBLEM?

YES

43 DO THE CORRECTIVE ACTION (FIM 21-51-00/101, FIG. 104).

NO

4 DO THIS PROCEDURE: STANDBY PACK CONTROLLER BITE PROCEDURE (FIM 21-51-00/101, FIG. 105).
DID THE BITE FIND A PROBLEM?

YES

44 DO THE CORRECTIVE ACTION (FIM 21-51-00/101, FIG. 105).

NO

SEE SHEET 3
(BLOCK 5)

(FLT DECK TEMP, FWD CABIN TEMP, AFT CABIN TEMP) EICAS Message
Displayed and Zone Temperature INOP Light Illuminated
Figure 105 (Sheet 2)

EFFECTIVITY

ALL

21-60-00

03

Page 122
Jun 20/95

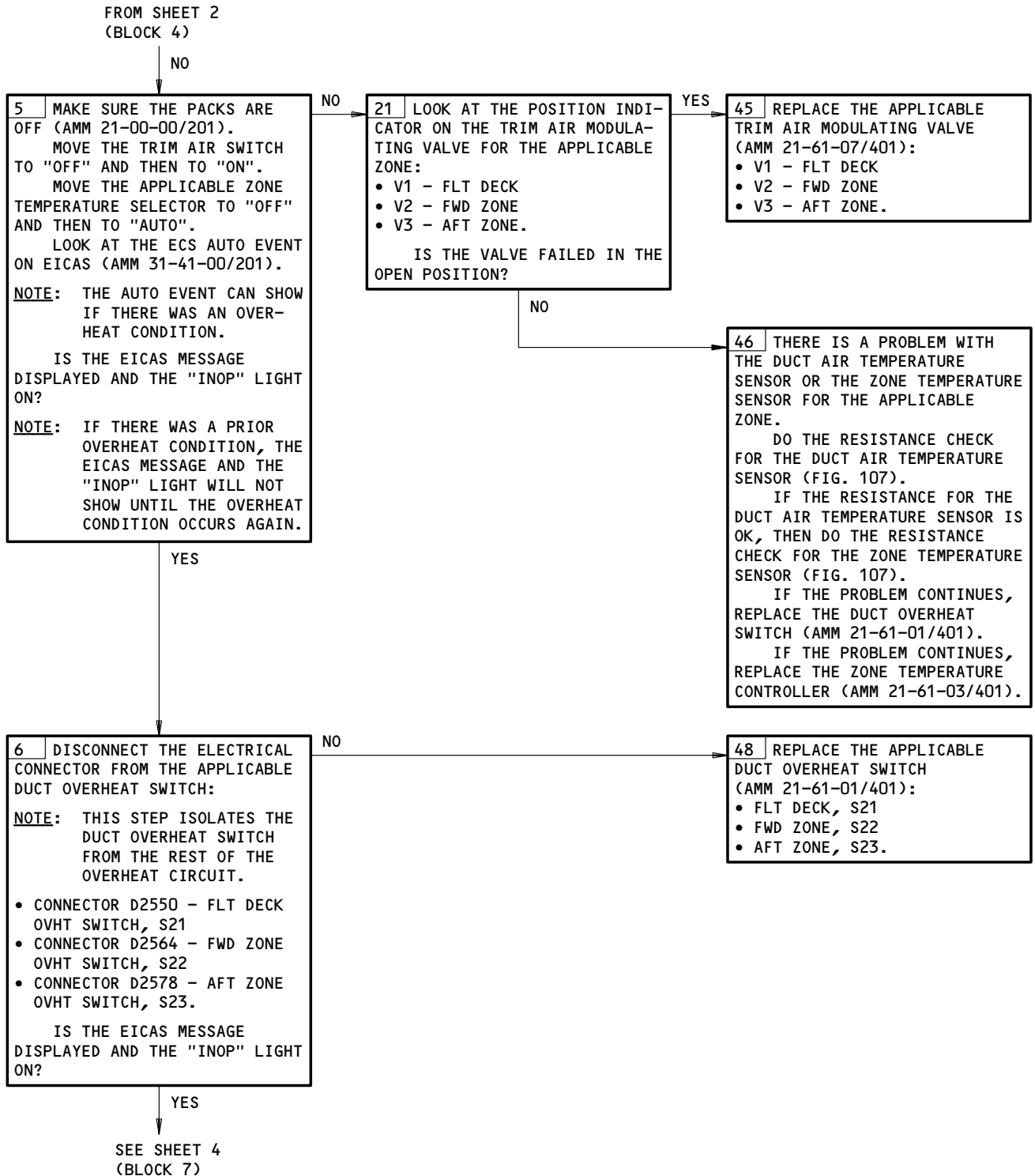

(FLT DECK TEMP, FWD CABIN TEMP, AFT CABIN TEMP) EICAS Message
Displayed and Zone Temperature INOP Light Illuminated
Figure 105 (Sheet 3)

EFFECTIVITY

ALL

21-60-00

03

Page 123
Jun 20/95

FROM SHEET 3
(BLOCK 4)

NO

7 RECONNECT THE ELECTRICAL CONNECTOR TO THE APPLICABLE DUCT OVERHEAT SWITCH:

- CONNECTOR D2550 - FLT DECK OVHT SWITCH, S21
- CONNECTOR D2564 - FWD ZONE OVHT SWITCH, S22
- CONNECTOR D2578 - AFT ZONE OVHT SWITCH, S23.

OPEN THE APPLICABLE ZONE DUCT OVHT/INOP CIRCUIT BREAKER:

- FLT DECK, 11P25
- FWD CABIN, 11P26
- AFT CABIN, 11P27

NOTE: THIS STEP ISOLATES THE DUCT OVERHEAT RELAY COIL FROM THE CIRCUIT.

IS THE EICAS MESSAGE DISPLAYED AND THE "INOP" LIGHT ON?

YES

49 REPLACE THE APPLICABLE ZONE DUCT OVHT RELAY AND CLOSE THE APPLICABLE ZONE DUCT OVHT/INOP CIRCUIT BREAKER:

- FLT DECK, K238
- FWD ZONE, D239
- AFT ZONE, K240

IF THE PROBLEM CONTINUES, EXAMINE THE CIRCUIT FROM THE APPLICABLE ZONE DUCT OVHT RELAY TO THE "INOP" LIGHT IN THE P5 PANEL (WDM 21-61-11, -21,-31):

- FLT DECK AIR COND RELAY, K238, PANEL, CONNECTOR M10193, CON-D2548, PIN A1 NECTOR D3558, PIN 38
- FWD ZONE AIR COND RELAY, K239, PANEL, CONNECTOR M10193, CON-D2562, PIN A1 NECTOR D3558, PIN 45
- AFT ZONE AIR COND RELAY, K240, PANEL, CONNECTOR M10193, CON-D2576, PIN A1 NECTOR D3558, PIN 21.

DO A CHECK FOR A SHORT CIRCUIT FROM THE APPLICABLE ZONE DUCT OVHT RELAY TO THE LEFT AND RIGHT EICAS COMPUTERS IN THE E4-2 SHELF (WDM 21-61-11,-21,-31):

- FLT DECK EICAS COMPUTERS, CONNECTOR D319D (D321D), PIN A14
- FWD ZONE EICAS COMPUTERS, CONNECTOR D319F (D321F), PIN K9
- AFT ZONE EICAS COMPUTERS, CONNECTOR D319E (D321E), PIN J10.

REPAIR ANY PROBLEMS THAT YOU FIND.

NO

SEE SHEET 5
(BLOCK 8)

(FLT DECK TEMP, FWD CABIN TEMP, AFT CABIN TEMP) EICAS Message
Displayed and Zone Temperature INOP Light Illuminated
Figure 105 (Sheet 4)

EFFECTIVITY

ALL

21-60-00

03

Page 124
Jun 20/95

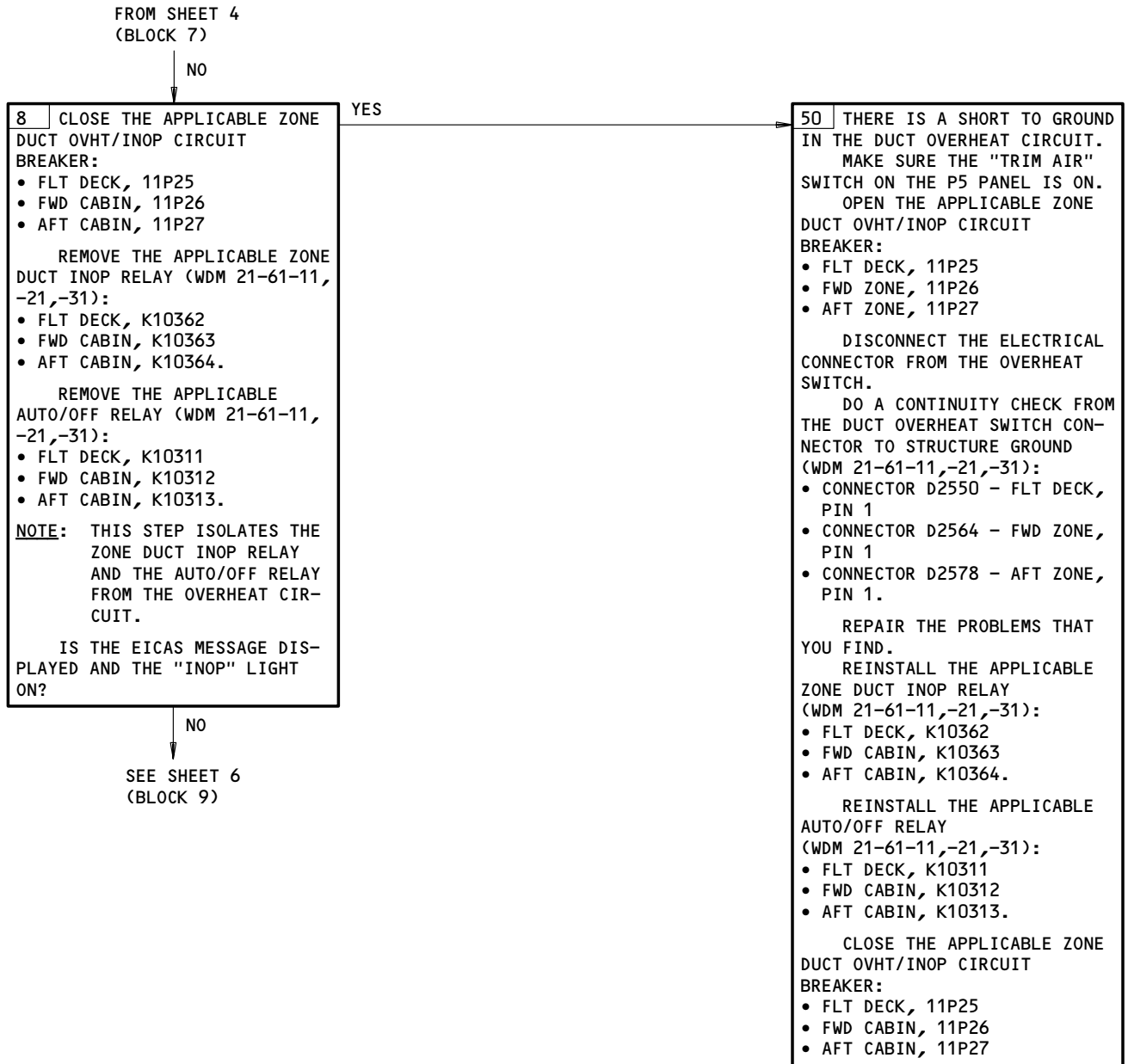

(FLT DECK TEMP, FWD CABIN TEMP, AFT CABIN TEMP) EICAS Message
Displayed and Zone Temperature INOP Light Illuminated
Figure 105 (Sheet 5)

EFFECTIVITY	ALL
-------------	-----

21-60-00

FROM SHEET 5
(BLOCK 7)

NO

9 REINSTALL THE APPLICABLE ZONE DUCT INOP RELAY (WDM 21-61-11,-21,-31):

- FLT DECK, K10362
- FWD CABIN, K10363
- AFT CABIN, K10364.

NOTE: THIS STEP ISOLATES THE ZONE DUCT INOP RELAY FROM THE AUTO/OFF RELAY.

IS THE EICAS MESSAGE DISPLAYED AND THE "INOP" LIGHT ON?

YES

51 REPLACE THE APPLICABLE ZONE DUCT INOP RELAY (WDM 21-61-11,-21,-31).

- FLT DECK, K10362
- FWD CABIN, K10363
- AFT CABIN, K10364.

REINSTALL THE APPLICABLE AUTO/OFF RELAY (WDM 21-61-11,-21,-31).

- FLT DECK, K10311
- FWD CABIN, K10312
- AFT CABIN, K10313.

NO

52 REPLACE THE APPLICABLE AUTO/OFF RELAY (WDM 21-61-11,-21,-31).

- FLT DECK, K10311
- FWD CABIN, K10312
- AFT CABIN, K10313.

(FLT DECK TEMP, FWD CABIN TEMP, AFT CABIN TEMP) EICAS Message
 Displayed and Zone Temperature INOP Light Illuminated
 Figure 105 (Sheet 6)

EFFECTIVITY

ALL

21-60-00

03

Page 126
Jun 20/95

F01217

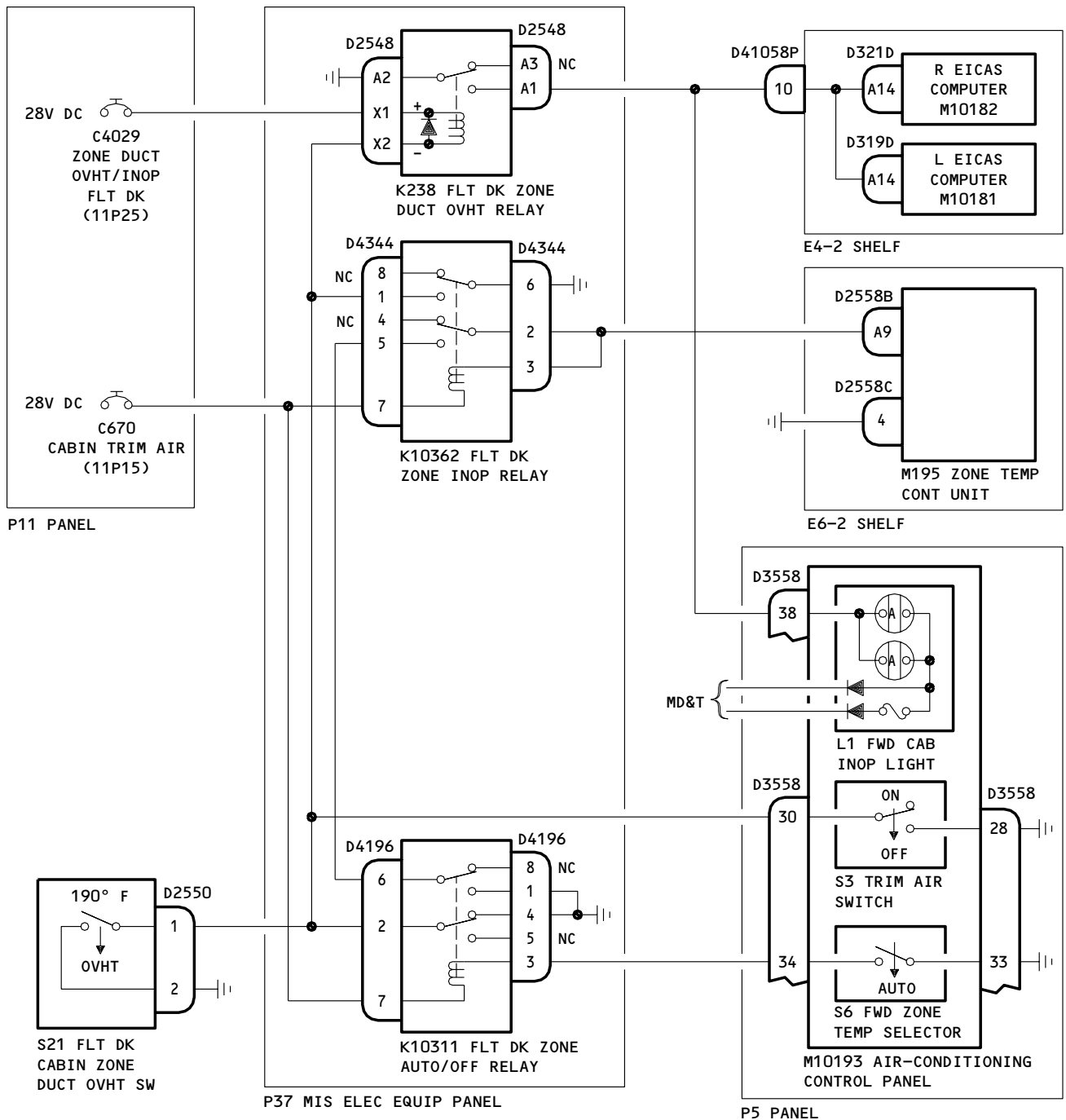

"INOP" LIGHT CIRCUIT FOR THE FIGHT DECK ZONE
(WDM 21-61-11, 21-51-61)

(FLT DECK TEMP, FWD CABIN TEMP, AFT CABIN TEMP) EICAS Message
Displayed and Zone Temperature INOP Light Illuminated
Figure 105 (Sheet 7)

EFFECTIVITY	ALL
-------------	-----

21-60-00

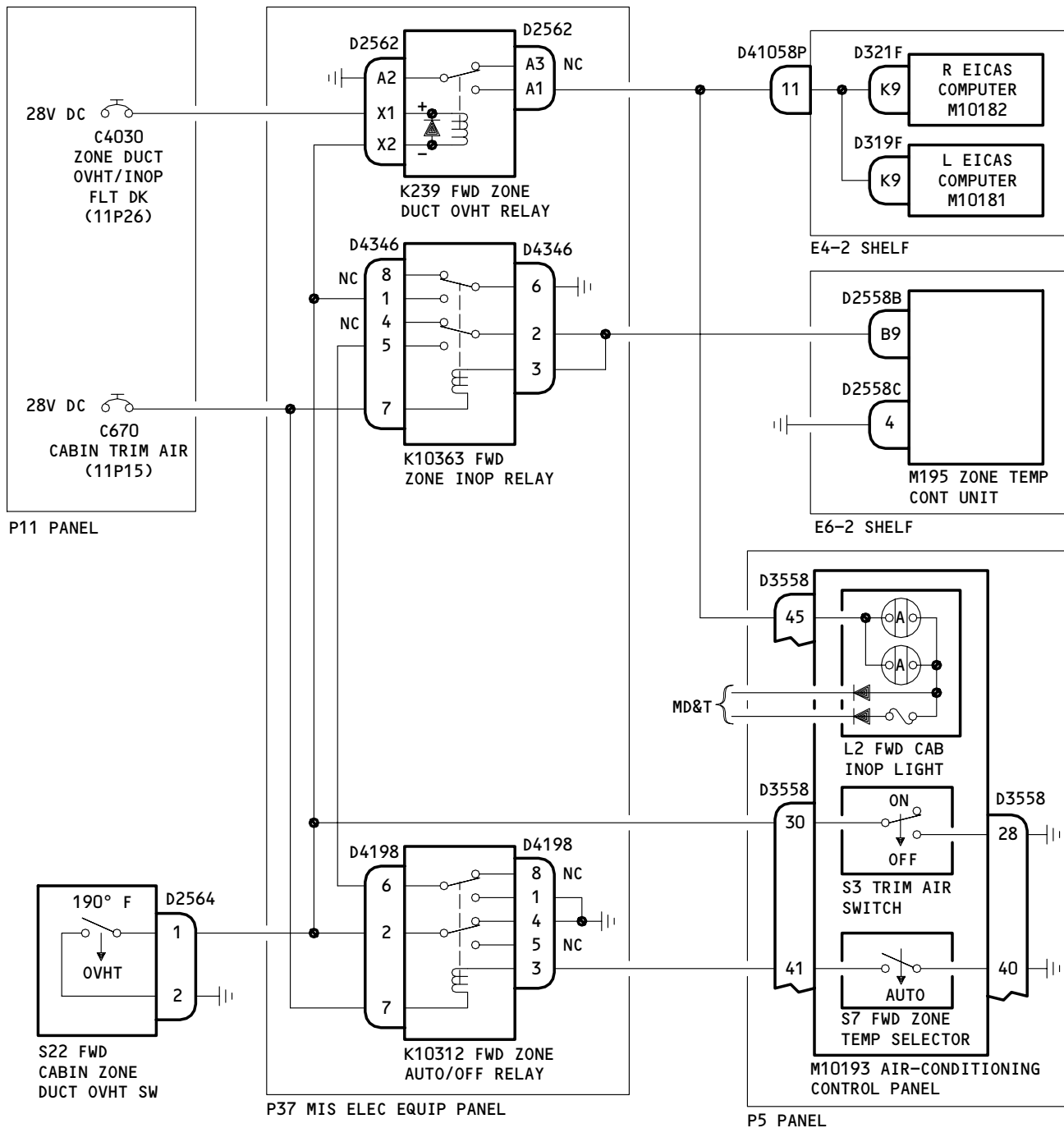

"INOP" LIGHT CIRCUIT FOR THE FORWARD ZONE
(WDM 21-61-21)

(FLT DECK TEMP, FWD CABIN TEMP, AFT CABIN TEMP) EICAS Message
Displayed and Zone Temperature INOP Light Illuminated
Figure 105 (Sheet 8)

EFFECTIVITY	ALL
-------------	-----

21-60-00

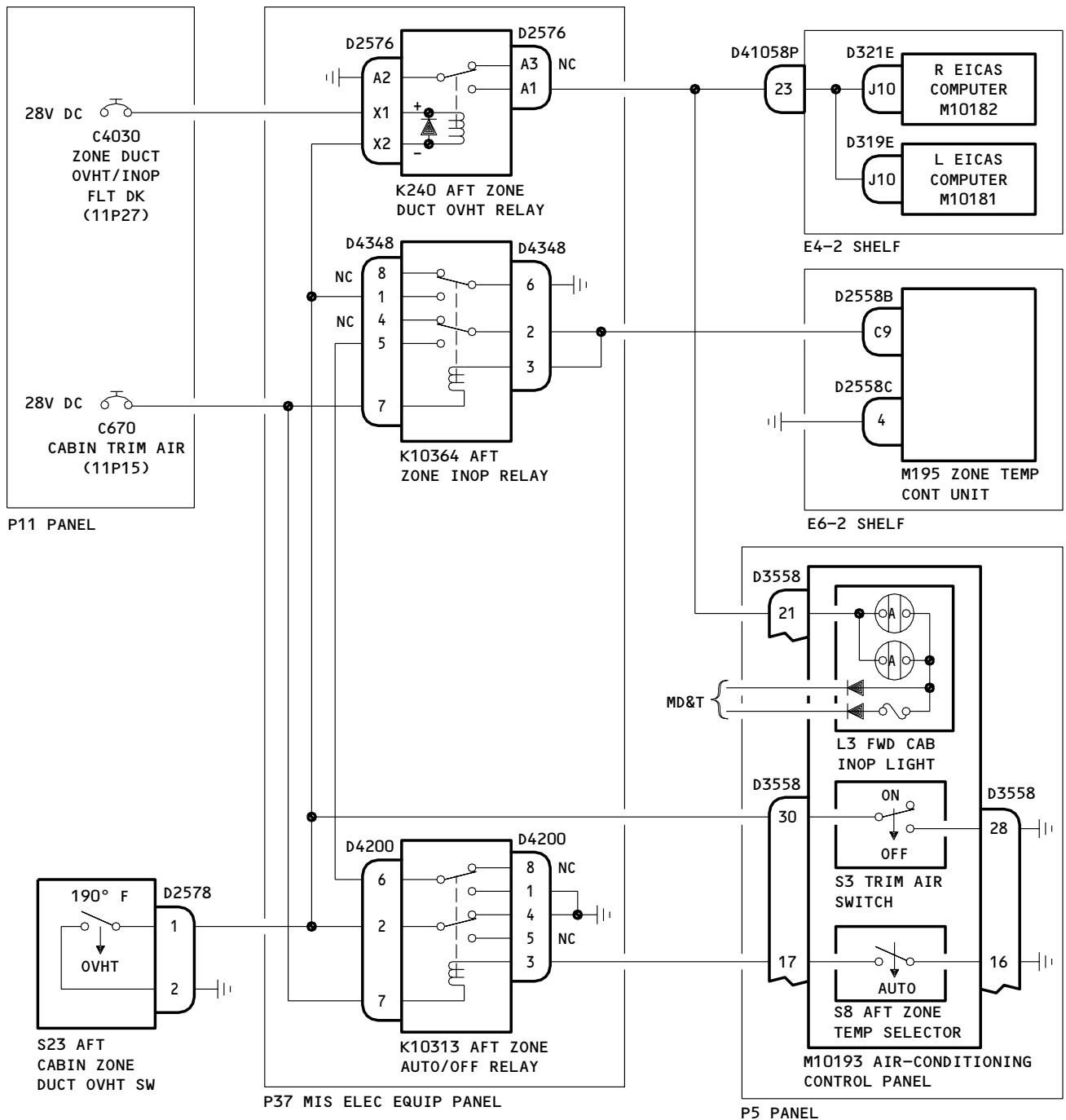

"INOP" LIGHT CIRCUIT FOR THE AFT ZONE
(WDM 21-61-31)

(FLT DECK TEMP, FWD CABIN TEMP, AFT CABIN TEMP) EICAS Message
Displayed and Zone Temperature INOP Light Illuminated
Figure 105 (Sheet 9)

EFFECTIVITY	ALL
-------------	-----

F01952

21-60-00

03

Page 129
Dec 20/95

PREREQUISITES

MAKE SURE THIS SYSTEM WILL OPERATE:
EICAS (AMM 31-41-00/201)

MAKE SURE THE AIRPLANE IS IN THIS CONFIGURATION:
ELECTRICAL POWER IS ON (AMM 24-22-00/201)

FLT DECK/FWD CABIN/AFT CABIN FAILS TO MAINTAIN DESIRED TEMP WITH TRIM AIR SWITCH SELECTED "ON" AND TEMP CONTROL IN "AUTO". "INOP" LGT EXTN.

NOTE: IF THE REPORT IN THE LOG BOOK SHOWS THE FLIGHT DECK AS THE ZONE THAT HAS THE PROBLEM, THEN DO THE STEPS FOR THE LEFT PACK. IF THE REPORT IN THE LOG BOOK SHOWS THE FORWARD OR AFT ZONE AS THE ZONE THAT HAS THE PROBLEM, DO THE STEPS FOR THE RIGHT PACK FIRST, THEN DO THE STEPS FOR THE LEFT PACK, IF NECESSARY.



DESCRIPTION:

THE TEMPERATURE IN THE APPLICABLE ZONE DOES NOT AGREE WITH THE SELECTED TEMPERATURE.

POSSIBLE CAUSES:

1. THE TRIM AIR PRESSURE REGULATING VALVE, V4 (AMM 21-61-06/401)(IF THE TEMPERATURE CONTROL PROBLEM EXISTS FOR ALL THREE ZONES)
2. THE TRIM AIR MODULATING VALVE (AMM 21-61-07/401):
 - FLIGHT DECK, V1
 - FWD ZONE, V2
 - AFT ZONE, V3.
3. THE AIR CYCLE MACHINE IS SEIZED (FIM 21-51-00/101, FIG. 107A OR 107B)
4. THE ZONE TEMPERATURE SENSOR MODULE:
 - FLIGHT DECK MODULE, M10452
 - FWD ZONE MODULE, M10025
 - AFT ZONE MODULE, M10024
 - THE TEMPERATURE SENSOR IS OUT OF CALIBRATION (AMM 21-61-08/601)
 - THE FAN IS FAILED (AMM 21-61-09/401)
 - THE FILTER AND PLENUM ARE CLOGGED (AMM 21-61-11/701).
5. THE DUCT TEMPERATURE SENSOR IS OUT OF CALIBRATION (AMM 21-61-02/601)
 - FLIGHT DECK DUCT, TS175
 - FWD ZONE DUCT, TS177
 - AFT ZONE DUCT, TS179.
6. THE PACK TEMPERATURE SENSOR IS OUT OF CALIBRATION (AMM 21-51-08/601)
 - LEFT PACK, TS198
 - RIGHT PACK, TS199.
7. FWD OR AFT ZONE:
 - MIX MANIFOLD TEMPERATURE SENSOR, TS200 (TS201)(AMM 21-61-02/401).
8. THE ZONE TEMPERATURE CONTROLLER, M195 (AMM 21-61-03/401)
9. THE ZONE TEMPERATURE SELECTOR, S7 (AMM 21-61-04/401)
10. FLIGHT DECK ZONE:
 - LEFT PACK TEMPERATURE CONTROLLER, M126 (AMM 21-51-14/401).
 FWD OR AFT ZONES:
 - RIGHT PACK TEMPERATURE CONTROLLER, M127 (AMM 21-51-14/401).
11. THE PACK FLOW CONTROL AND SHUTOFF VALVE (AMM 21-51-01/201).
 - LEFT PACK FLOW CONTROL AND SHUTOFF VALVE, V16
 - RIGHT PACK FLOW CONTROL AND SHUTOFF VALVE, V17.
12. WIRING.

Flt Deck/Fwd Cabin/Aft Cabin Fails to Maintain Desired Temp with Trim Air Switch Selected ON and Temp Control in AUTO. INOP Lgt Extn.
Figure 106 (Sheet 1)

EFFECTIVITY

ALL

21-60-00

03

Page 130
Sep 28/01

F01235

FAULT ISOLATION:

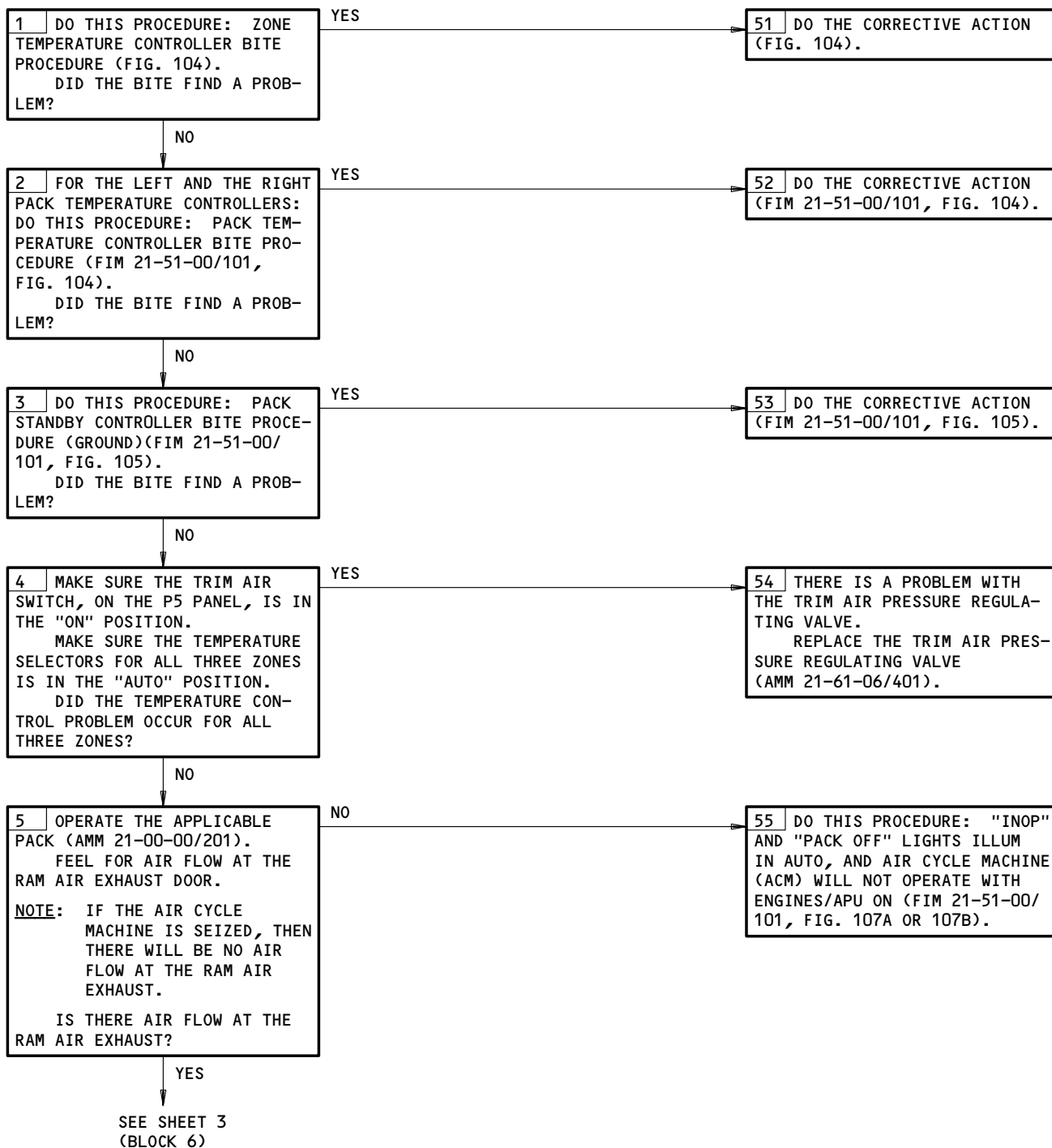

Flt Deck/Fwd Cabin/Aft Cabin Fails to Maintain Desired Temp with Trim Air Switch Selected ON and Temp Control in AUTO. INOP Lgt Extin.
Figure 106 (Sheet 2)

EFFECTIVITY

ALL

21-60-00

03

Page 131
Jun 20/95

FD1248

FROM SHEET 2
(BLOCK 5)

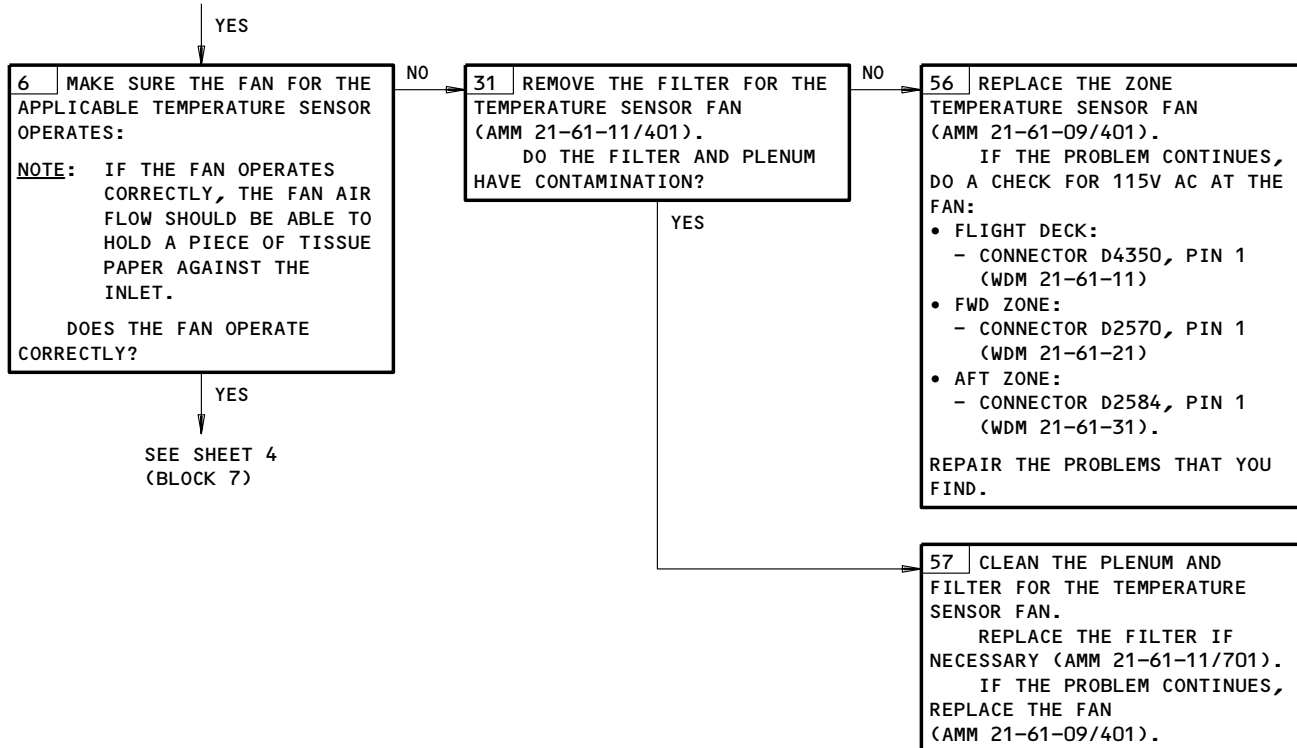

Flt Deck/Fwd Cabin/Aft Cabin Fails to Maintain Desired Temp with Trim Air Switch Selected ON and Temp Control in AUTO. INOP Lgt Extin.
Figure 106 (Sheet 3)

EFFECTIVITY	ALL
-------------	-----

21-60-00

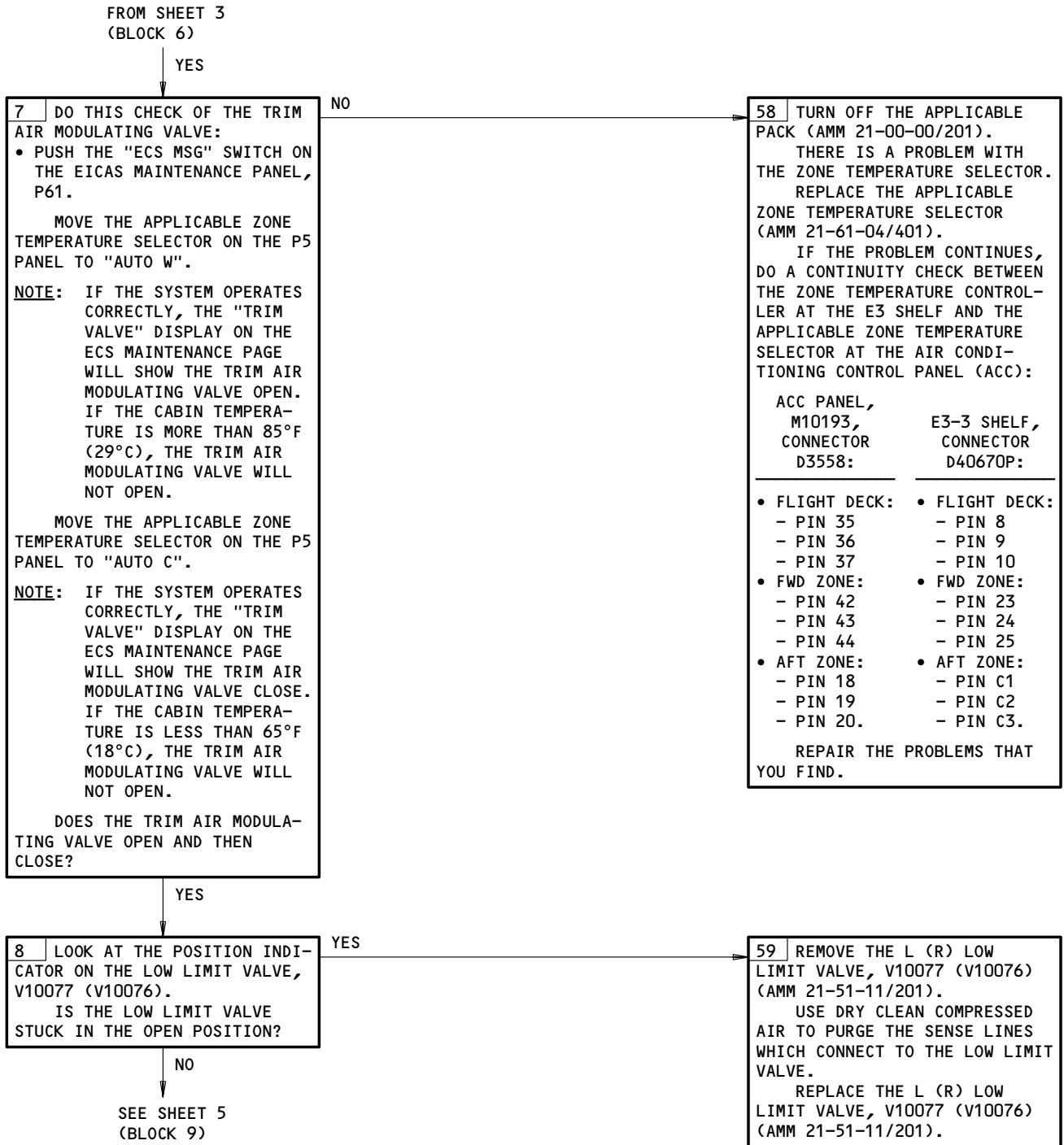

Flt Deck/Fwd Cabin/Aft Cabin Fails to Maintain Desired Temp with Trim Air Switch Selected ON and Temp Control in AUTO. INOP Lgt Extin.
 Figure 106 (Sheet 4)

EFFECTIVITY	ALL
-------------	-----

21-60-00

BOEING
757
FAULT ISOLATION/MAINT MANUAL

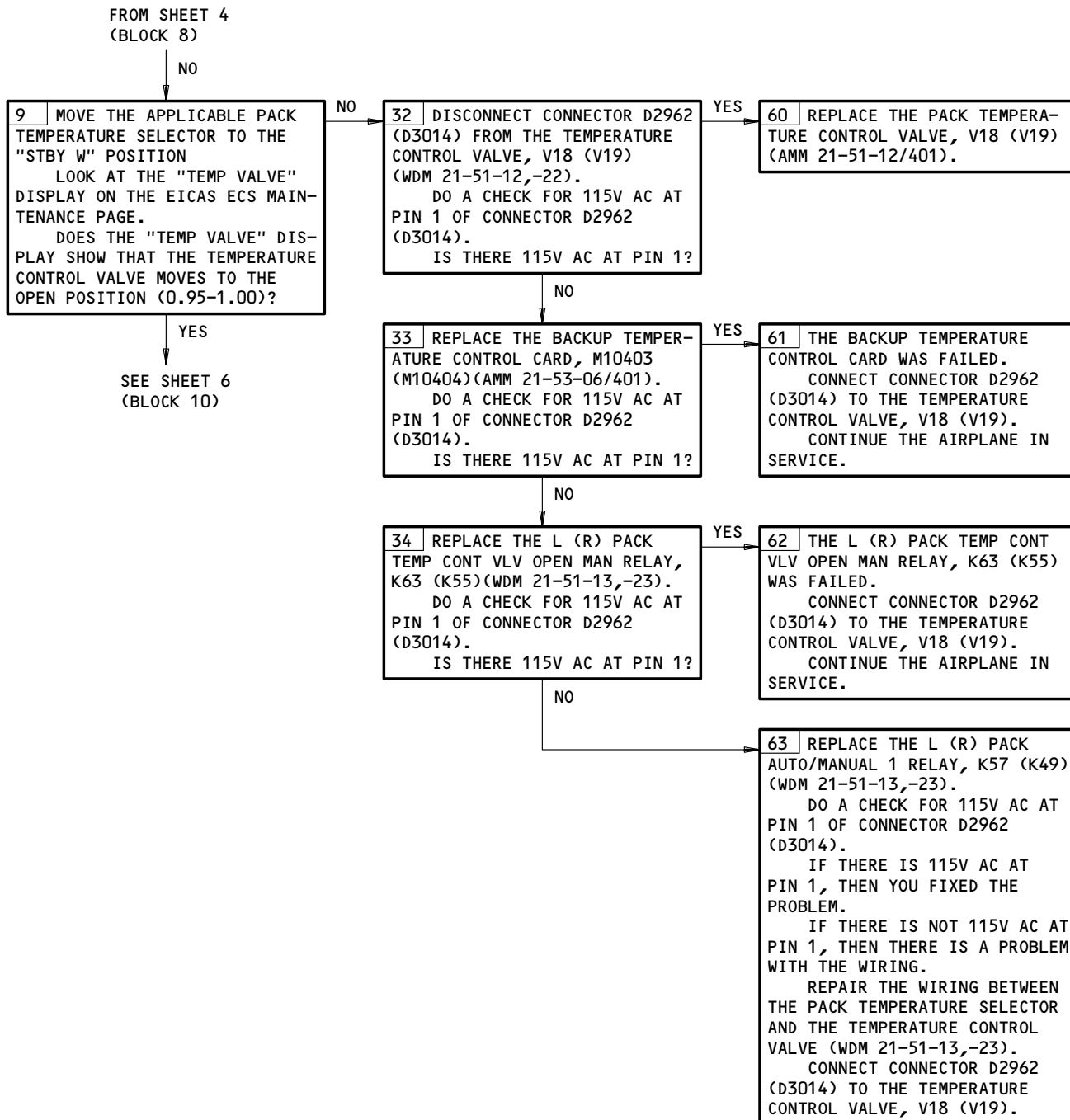

Flt Deck/Fwd Cabin/Aft Cabin Fails to Maintain Desired Temp with Trim Air Switch
Selected ON and Temp Control in AUTO. INOP Lgt Extn.
Figure 106 (Sheet 5)

EFFECTIVITY	ALL
-------------	-----

21-60-00

BOEING
757
FAULT ISOLATION/MAINT MANUAL

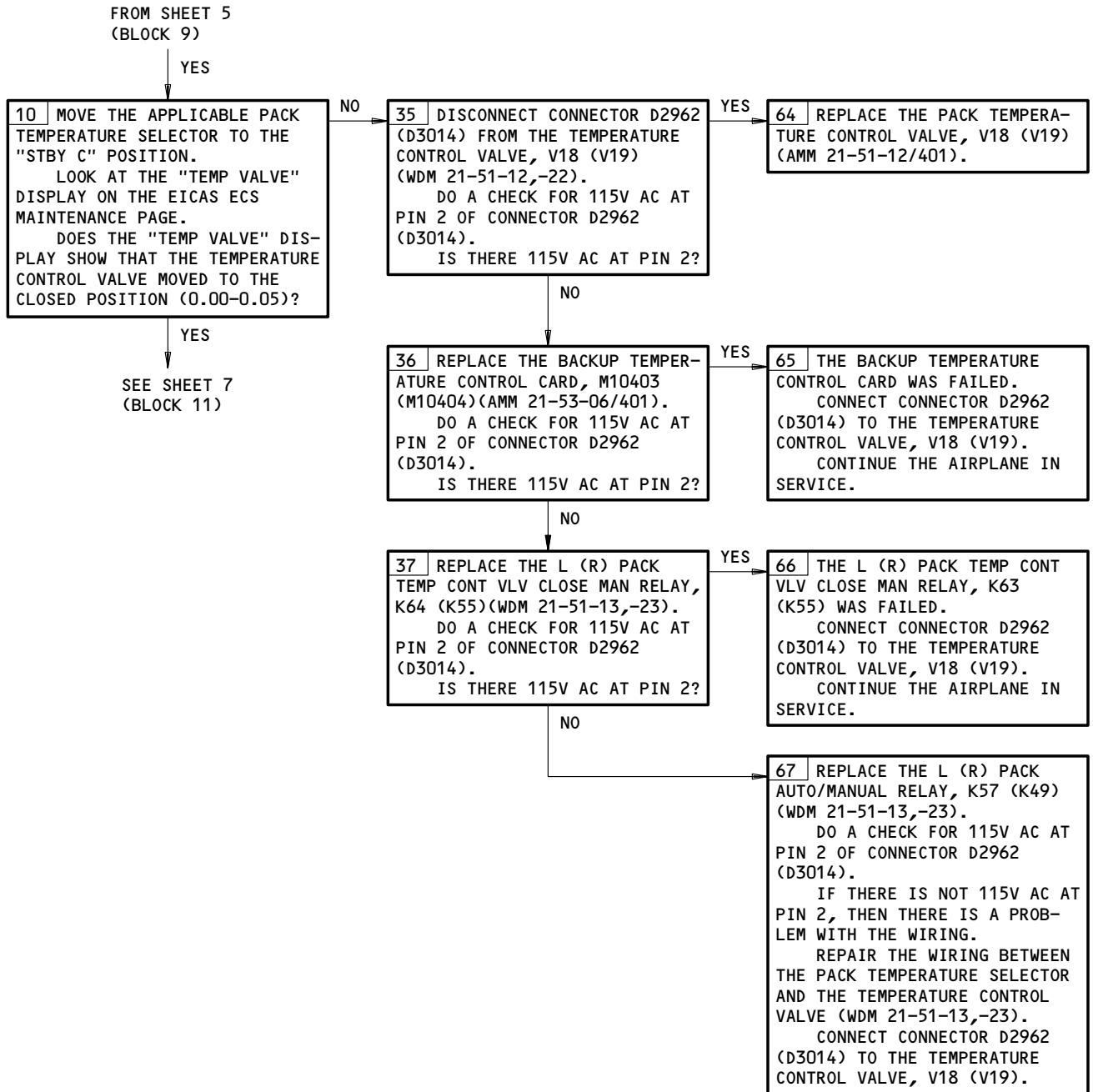

Flt Deck/Fwd Cabin/Aft Cabin Fails to Maintain Desired Temp with Trim Air Switch
Selected ON and Temp Control in AUTO. INOP Lgt Extin.
Figure 106 (Sheet 6)

EFFECTIVITY

ALL

21-60-00

03

Page 135
Jun 20/95

F01303

FROM SHEET 6
(BLOCK 10)

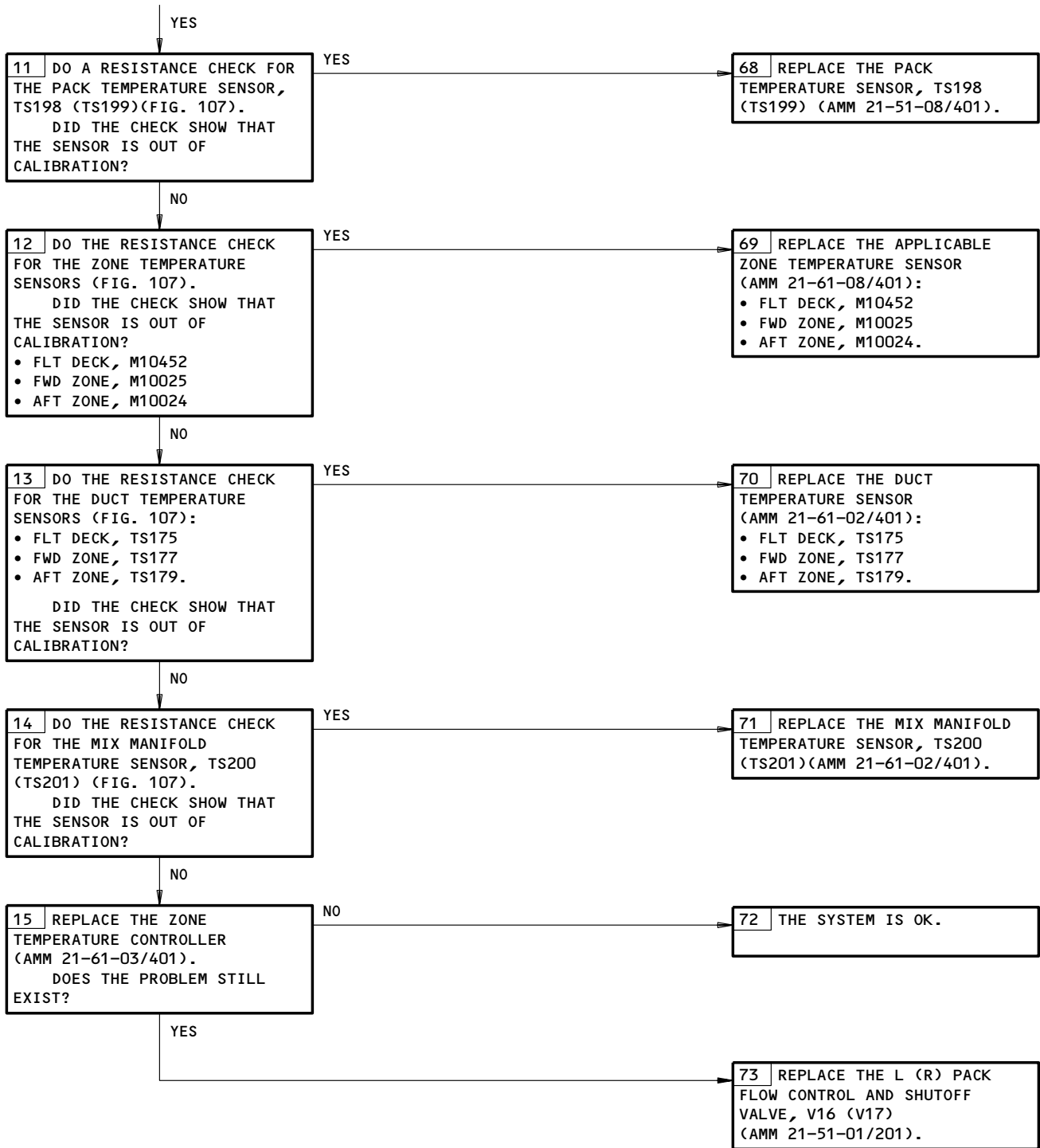

Flt Deck/Fwd Cabin/Aft Cabin Fails to Maintain Desired Temp with Trim Air Switch Selected ON and Temp Control in AUTO. INOP Lgt Extn.
 Figure 106 (Sheet 7)

EFFECTIVITY	ALL
-------------	-----

21-60-00

BOEING

757

FAULT ISOLATION/MAINT MANUAL

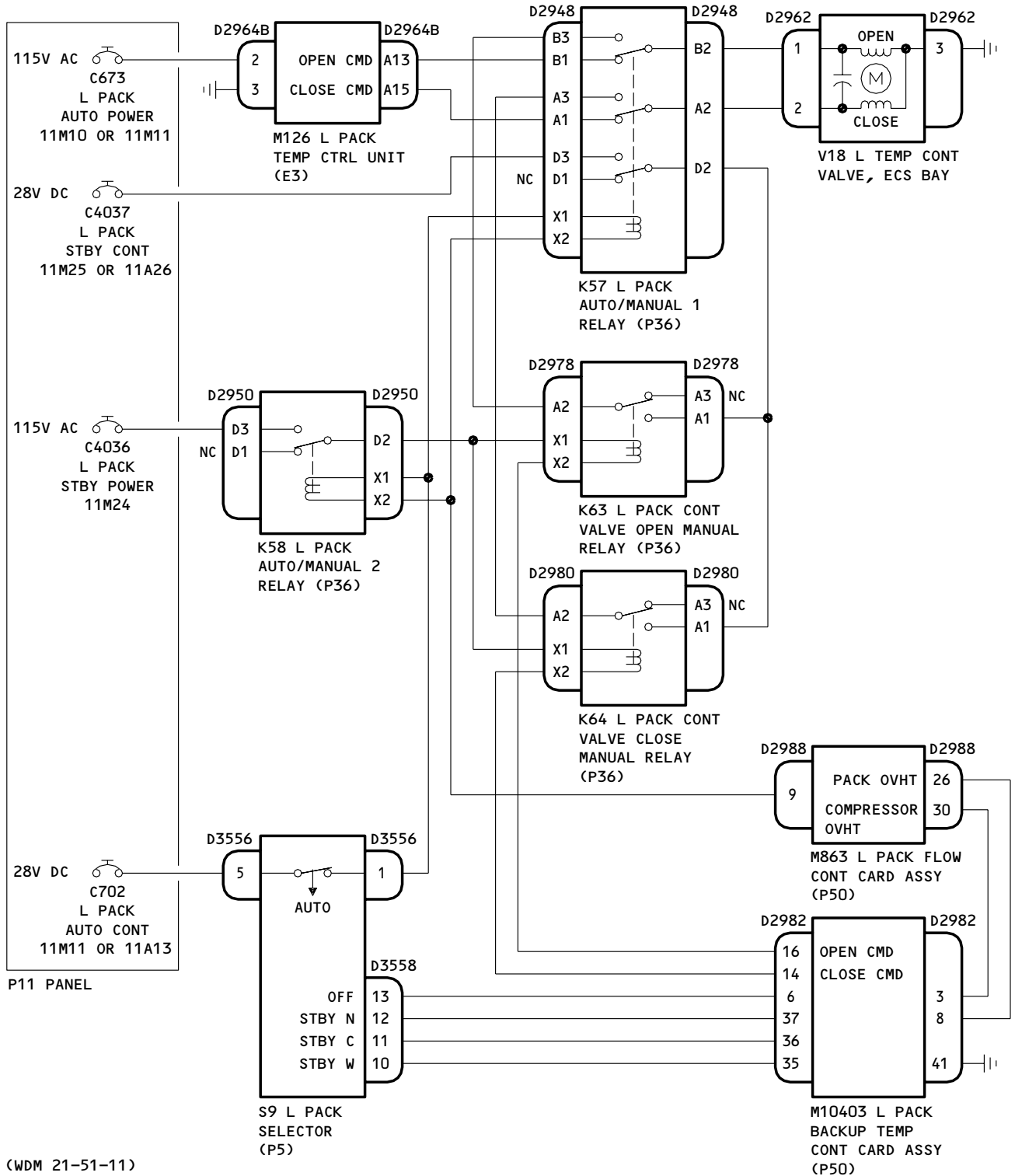

(WDM 21-51-11)
(WDM 21-51-12)
(WDM 21-51-13)

LEFT PACK TEMPERATURE CONTROL VALVE CIRCUIT

Flt Deck/Fwd Cabin/Aft Cabin Fails To Maintain Desired Temp with Trim Air Switch Selected "ON" and Temp Control in "AUTO". "INOP" Lgt Extn.

Figure 106 (Sheet 8)

EFFECTIVITY	
	ALL

21-60-00

03

Page 137
May 20/08

FD1583

BOEING

757

FAULT ISOLATION/MAINT MANUAL

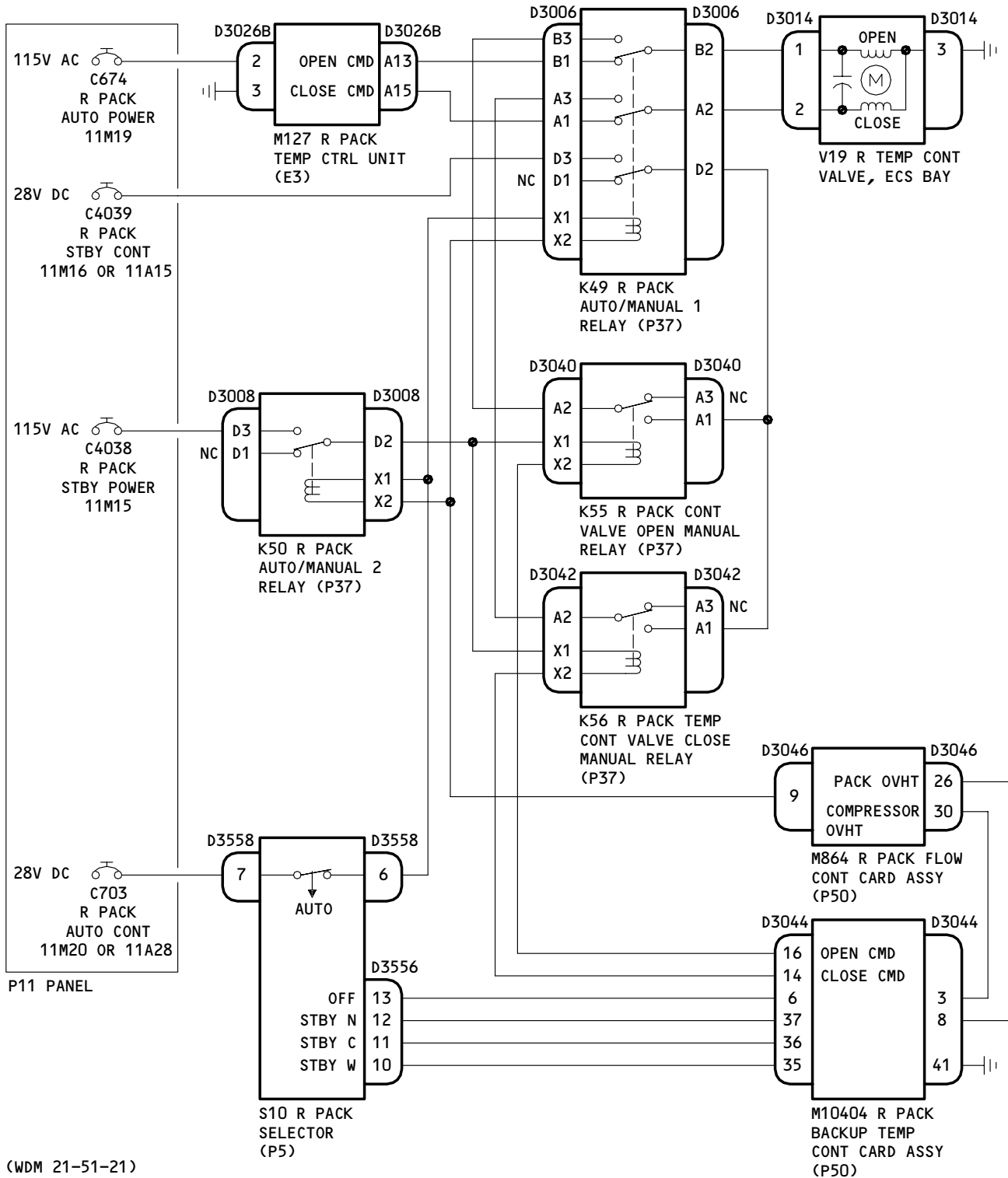

(WDM 21-51-21)
(WDM 21-51-22)
(WDM 21-51-23)

RIGHT PACK TEMPERATURE CONTROL VALVE CIRCUIT

Flt Deck/Fwd Cabin/Aft Cabin Fails To Maintain Desired Temp with Trim Air Switch Selected "ON" and Temp Control in "AUTO". "INOP" Lgt Extin.

Figure 106 (Sheet 9)

EFFECTIVITY

ALL

21-60-00

03

Page 138
May 20/08

PREREQUISITES

MAKE SURE THIS SYSTEM WILL OPERATE:
EICAS (AMM 31-41-00/201)

MAKE SURE THE AIRPLANE IS IN THIS CONFIGURATION:
ELECTRICAL POWER IS ON (AMM 24-22-00/201)

EQUIPMENT: DIGITAL MULTIMETER, HEWLETT PACKARD MODEL,
3465A

DIGITAL MULTIMETER, HIGH IMPEDANCE (ALTERNATIVE)

THERMOMETER (CAPABLE OF MEASURING TEMPERATURES TO
AN ACCURACY OF ± 1 DEG. F FROM -40 TO 140°F)

NOTE: THE DIGITAL MULTIMETER MUST LIMIT THE CURRENT THROUGH THE SENSOR TO LESS THAN 100 MICROAMPERES. IF THE CURRENT IS MORE THAN 100 MICROAMPERES, THE SENSOR TIP WILL HEAT UP AND YOU WILL GET AN ERROR IN THE RESISTANCE MEASUREMENT.

**TEMPERATURE SENSOR
CALIBRATION PROBLEMS**



DESCRIPTION:

THIS PROCEDURE DOES A CALIBRATION CHECK OF THESE TEMPERATURE SENSORS:

- FLIGHT DECK ZONE TEMPERATURE SENSOR, M10452
- FORWARD ZONE TEMPERATURE SENSOR, M10025
- AFT ZONE TEMPERATURE SENSOR, M10024
- FLIGHT DECK DUCT TEMPERATURE SENSOR, TS175
- FORWARD ZONE DUCT TEMPERATURE SENSOR, TS177
- AFT ZONE DUCT TEMPERATURE SENSOR, TS179
- FORWARD ZONE MIX MANIFOLD TEMPERATURE SENSOR, TS200
- AFT ZONE MIX MANIFOLD TEMPERATURE SENSOR, TS201
- COMPRESSOR OUTLET TEMPERATURE SENSOR, TS41 (TS42)
- STANDBY COMPRESSOR OUTLET TEMPERATURE SENSOR, TS5133 (TS5135)
- PACK TEMPERATURE SENSOR, TS1198 (TS199)
- STANDBY PACK TEMPERATURE SENSOR, TS5132 (TS5134).

BECAUSE YOU CAN NOT ACCURATELY FIND THE AMBIENT TEMPERATURE OF THE SENSOR, THIS CHECK IS FOR TROUBLESHOOTING ONLY.

Temperature Sensor Calibration Problems
Figure 107 (Sheet 1)

EFFECTIVITY

ALL

21-60-00

03

Page 139
Jun 20/95

FAULT ISOLATION:

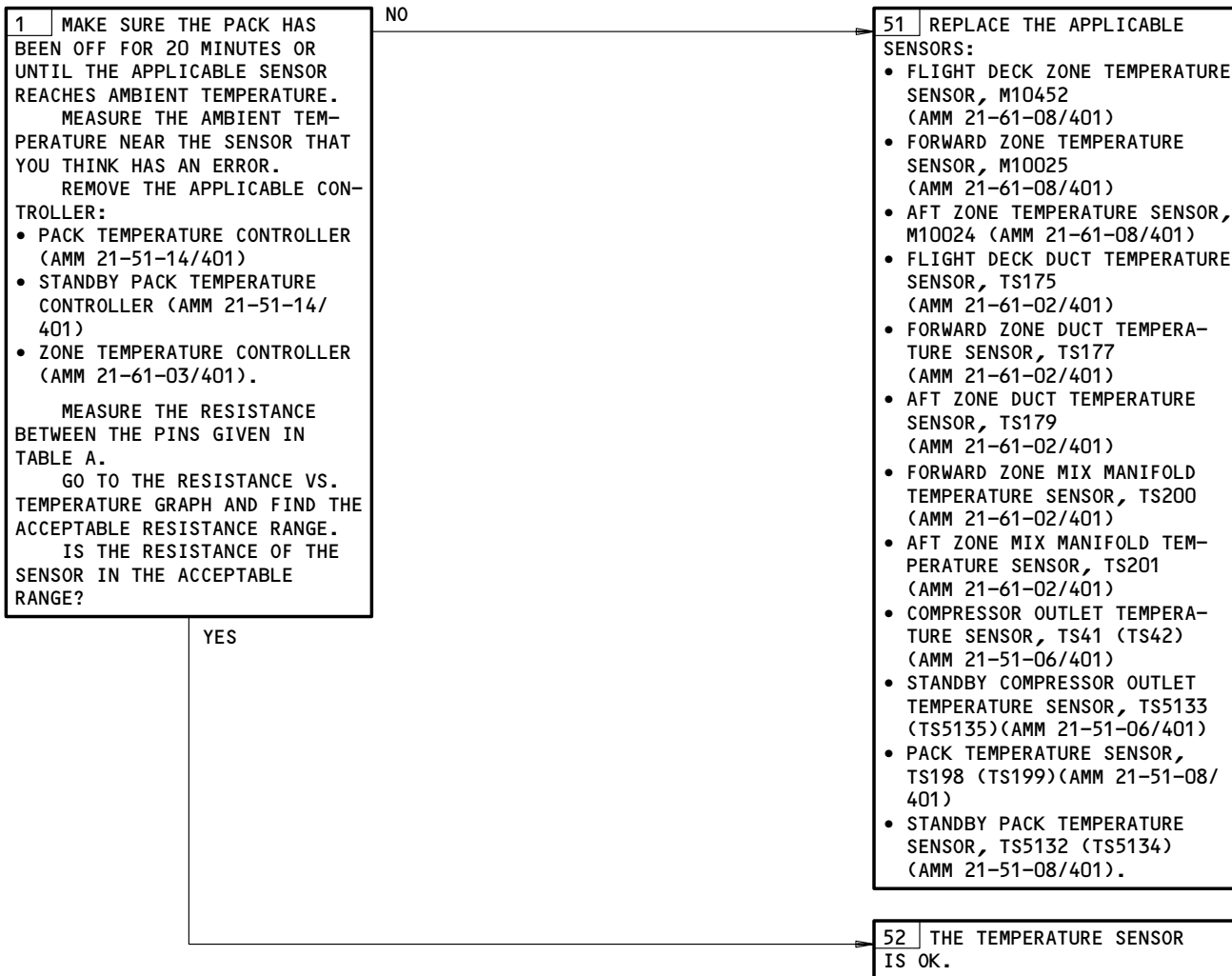

Temperature Sensor Calibration Problems
Figure 107 (Sheet 2)

EFFECTIVITY	ALL
-------------	-----

21-60-00

BOEING
 757
 FAULT ISOLATION/MAINT MANUAL

SENSOR	AMBIENT TEMPERATURE MEASUREMENT	APPLICABLE CONTROLLER	CONNECTOR	PINS	TEMPERATURE VS. RESISTANCE GRAPH
FLIGHT DECK DUCT TEMPERATURE SENSOR, TS175 (WDM 21-61-11)	FLIGHT DECK	ZONE TEMPERATURE CONTROLLER, M195	D2558A	A6 TO A7	A
FORWARD ZONE DUCT TEMPERATURE SENSOR, TS177 (WDM 21-61-21)	NEXT TO THE OVERHEAD DISTRIBUTION DUCT	ZONE TEMPERATURE CONTROLLER, M195	D2558A	B6 TO B7	A
AFT ZONE DUCT TEMPERATURE SENSOR, TS179 (WDM 21-61-31)	NEXT TO THE OVERHEAD DISTRIBUTION DUCT	ZONE TEMPERATURE CONTROLLER, M195	D2558A	C6 TO C7	A
FORWARD ZONE MIX MANIFOLD TEMPERATURE SENSOR, TS200 (WDM 21-51-12)	NEXT TO THE MIX MANIFOLD	LEFT PACK TEMPERATURE CONTROLLER, M126	D2964A	B4 TO B5	A
AFT ZONE MIX MANIFOLD TEMPERATURE SENSOR, TS201 (WDM 21-51-22)	NEXT TO THE MIX MANIFOLD	RIGHT PACK TEMPERATURE CONTROLLER, M127	D3026A	B4 TO B5	A
FLIGHT DECK ZONE TEMPERATURE SENSOR (PRIMARY ELEMENT), M10452 (WDM 21-61-11)	FLIGHT DECK	ZONE TEMPERATURE CONTROLLER, M195	D2558A	A4 TO A5	B
FORWARD ZONE TEMPERATURE SENSOR (PRIMARY ELEMENT), M10025 (WDM 21-61-21)	FORWARD ZONE	ZONE TEMPERATURE CONTROLLER, M195	D2558A	B4 TO B5	B
AFT ZONE TEMPERATURE SENSOR (PRIMARY ELEMENT), M10024 (WDM 21-61-31)	AFT ZONE	ZONE TEMPERATURE CONTROLLER, M195	D2558A	C4 TO C5	B

TEMPERATURE SENSOR CALIBRATION CHECK
(TABLE A)

Temperature Sensor Calibration Problems
Figure 107 (Sheet 3)

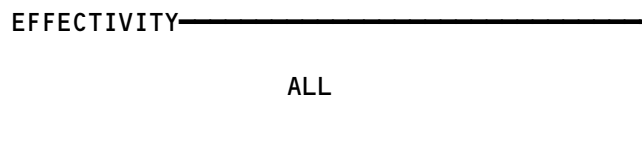

21-60-00

03

Page 141
Jun 20/95

F01623

BOEING
757
FAULT ISOLATION/MAINT MANUAL

SENSOR	AMBIENT TEMPERATURE MEASUREMENT	APPLICABLE CONTROLLER	CONNECTOR	PINS	TEMPERATURE VS. RESISTANCE GRAPH
FLIGHT DECK ZONE TEMPERATURE SENSOR (BACKUP ELEMENT), M10452 (WDM 21-61-11)	FLIGHT DECK	LEFT PACK TEMPERATURE CONTROLLER, M126	D2964A	C4 TO C5	C
FORWARD ZONE TEMPERATURE SENSOR (BACKUP ELEMENT), M10025 (WDM 21-61-21)	FORWARD ZONE	RIGHT PACK TEMPERATURE CONTROLLER, M127	D3026A	C4 TO C5	C
COMPRESSOR OUTLET TEMPERATURE SENSOR, TS41 (TS42) (WDM 21-51-15,-25)	LEFT (RIGHT) PACK BAY NEXT TO THE SENSOR	LEFT (RIGHT) PACK TEMPERATURE CONTROLLER, M126 (M127)	D2964A (D3026A)	D4 TO D5	D
STANDBY COMPRESSOR OUTLET TEMPERATURE, TS5133 (TS5135) (WDM 21-51-14,-24)	LEFT (RIGHT) PACK BAY NEXT TO THE SENSOR	STANDBY PACK TEMPERATURE CONTROLLER, M10389	D4130A (D4130B)	A10 TO B10	D
PACK TEMPERATURE SENSOR, TS198 (TS199) (WDM 21-51-12,-22)	LEFT (RIGHT) PACK BAY NEXT TO THE SENSOR	LEFT (RIGHT) PACK TEMPERATURE CONTROLLER, M126 (M127)	D2964A (D3026A)	A4 TO A5	E
STANDBY PACK TEMPERATURE SENSOR, TS5132 (TS5134) (WDM 21-51-14,-24)	LEFT (RIGHT) PACK BAY NEXT TO THE SENSOR	STANDBY PACK TEMPERATURE CONTROLLER, M10389	D4130A (D4130B)	A9 TO B9	E

TEMPERATURE SENSOR CALIBRATION CHECK
(TABLE A)

TEMPERATURE SENSOR CALIBRATION CHECK (TABLE A)
Temperature Sensor Calibration Problems
Figure 107 (Sheet 4)

EFFECTIVITY

ALL

21-60-00

BOEING
 757
 FAULT ISOLATION/MAINT MANUAL

°F	OHMS
-40	43030-45210
-35	36690-38550
-30	31360-32960
-25	26930-28230
-20	23140-24260
-15	19940-20900
-10	17220-18050
-5	14890-15580
0	12950-13550
5	11310-11780
10	9870-10290
15	8640-9000
20	7520-7900
25	6660-6940
30	5870-6120
35	5180-5400
40	4580-4770
45	4060-4230
50	3600-3750

°F	OHMS
55	3200-3340
60	2850-2980
65	2550-2660
70	2290-2390
75	2040-2130
80	1830-1920
85	1650-1730
90	1480-1560
95	1340-1400
100	1210-1270
105	1100-1150
110	990-1040
115	900-950
120	820-860
125	740-790
130	680-720
135	620-660
140	560-600

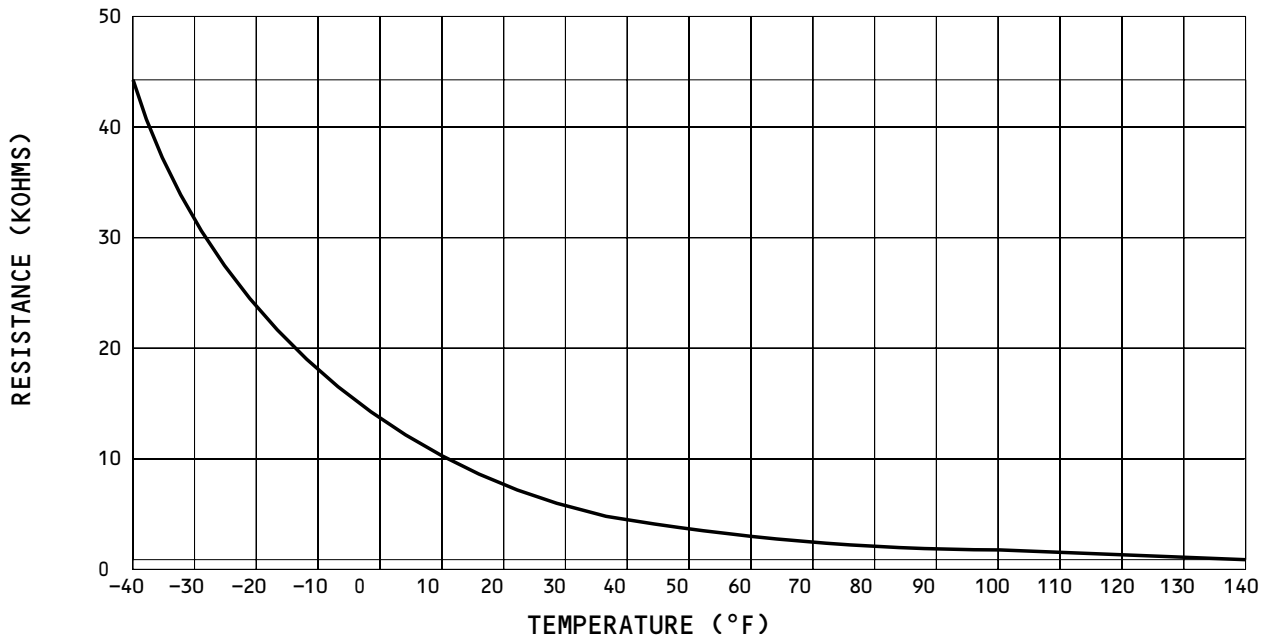

DUCT TEMPERATURE SENSOR
 RESISTANCE VS TEMPERATURE GRAPH A

Temperature Sensor Calibration Problems
 Figure 107 (Sheet 5)

EFFECTIVITY

ALL

21-60-00

03

Page 143
Jun 20/95

FD1628

BOEING
 757
 FAULT ISOLATION/MAINT MANUAL

°F	OHMS
-40	87350-89130
-35	74480-76000
-30	63670-64970
-25	54600-55720
-20	46920-47880
-15	40430-41250
-10	34910-35630
-5	30160-30780
0	26240-26780
5	22850-23320
10	19950-20370
15	17460-17820
20	15310-15630
25	13460-13750
30	11860-12110
35	10470-10690
40	9250-9450
45	8200-8380
50	7270-7430

°F	OHMS
55	6470-6610
60	5770-5900
65	5150-5270
70	4610-4710
75	4130-4220
80	3710-3790
85	3330-3410
90	3000-3070
95	2710-2780
100	2450-2510
105	2220-2270
110	2010-2060
115	1830-1870
120	1660-1700
125	1510-1550
130	1380-1410
135	1260-1290
140	1150-1180
145	1050-1080

MAIN ELEMENT

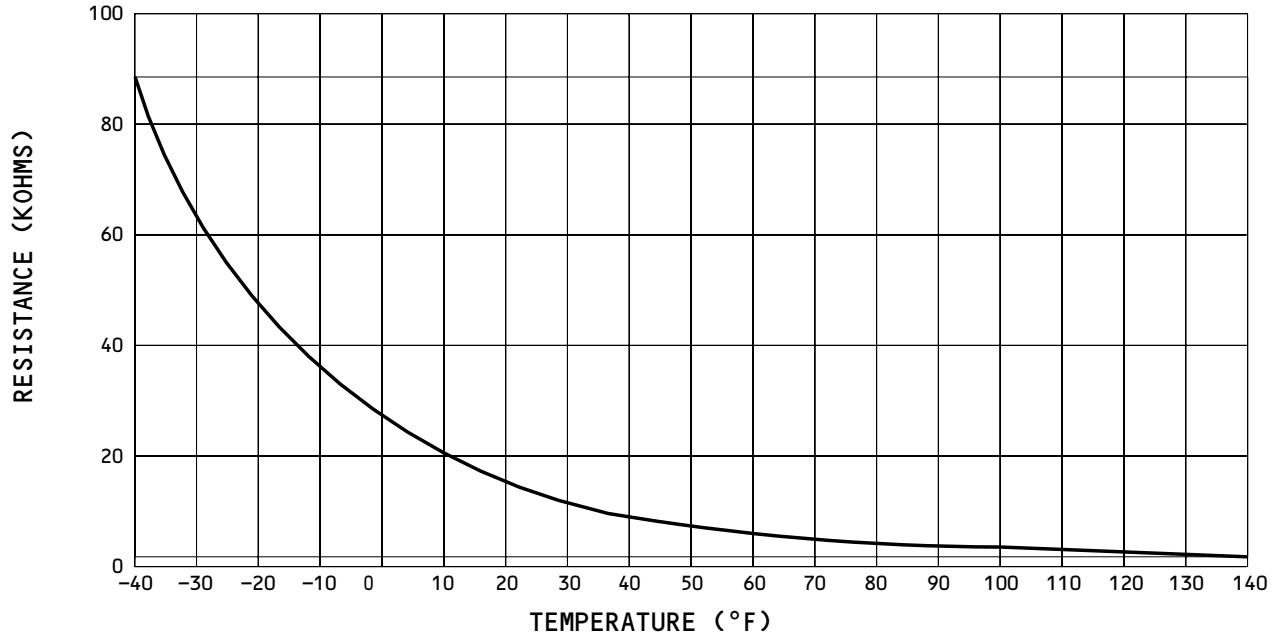

ZONE TEMPERATURE SENSOR
 RESISTANCE VS TEMPERATURE GRAPH B
 Temperature Sensor Calibration Problems
 Figure 107 (Sheet 6)

EFFECTIVITY

ALL

21-60-00

03

Page 144
Jun 20/95

BOEING
757
FAULT ISOLATION/MAINT MANUAL

°F	OHMS
-40	85850-90630
-35	73200-77280
-30	62580-66060
-25	53670-56650
-20	46120-48680
-15	39730-41950
-10	34310-36230
-5	29640-31300
0	25790-27230
5	22460-23720
10	19610-20710
15	17160-18120
20	15050-15890
25	13230-13980
30	11660-12310
35	10290-10870
40	9090-9610
45	8060-8520
50	7150-7560

°F	OHMS
55	6360-6720
60	5670-5990
65	5060-5350
70	4530-4790
75	4060-4290
80	3640-3860
85	3280-3470
90	2950-3130
95	2660-2820
100	2410-2550
105	2180-2310
110	1980-2100
115	1790-1900
120	1630-1730
125	1480-1580
130	1350-1440
135	1240-1310
140	1130-1200
145	1030-1100

BACKUP ELEMENT

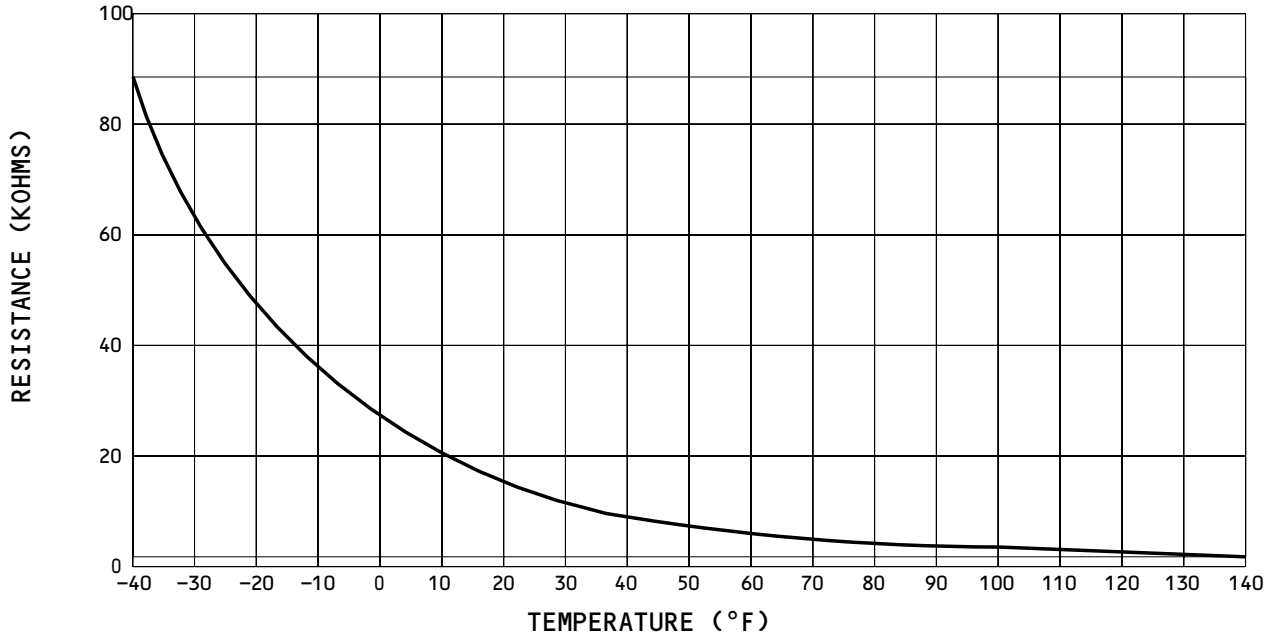

ZONE TEMPERATURE SENSOR
RESISTANCE VS TEMPERATURE GRAPH C
Temperature Sensor Calibration Problems
Figure 107 (Sheet 7)

EFFECTIVITY _____
ALL

21-60-00

03

Page 145
Jun 20/95

FD2447



757
 FAULT ISOLATION/MAINT MANUAL

°F	OHMS
-40	418-424
-20	440-446
0	462-468
20	484-490
40	506-511
60	528-533
80	549-555
100	571-576
120	592-598
140	614-619
160	635-640
180	657-662
200	678-683
220	699-704
240	720-725
260	741-746
280	762-767
300	783-788
320	803-809
340	824-829

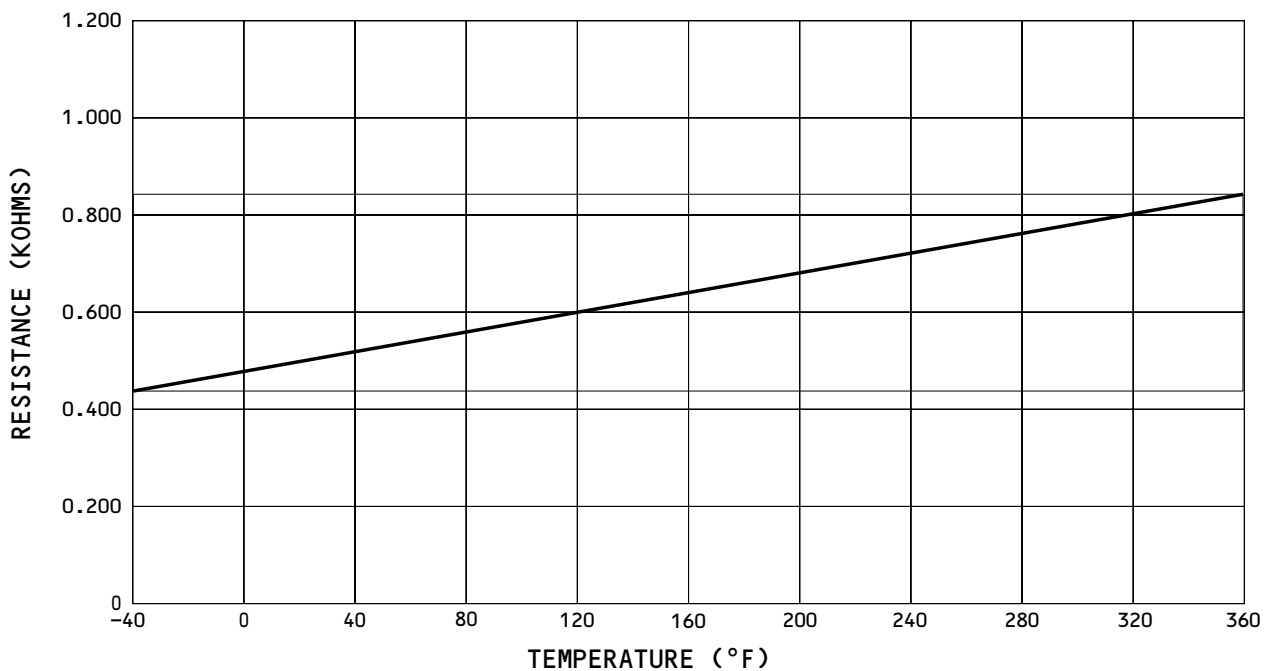

COMPRESSOR OUTLET TEMPERATURE SENSOR
 RESISTANCE VS TEMPERATURE GRAPH D
 Temperature Sensor Calibration Problems
 Figure 107 (Sheet 8)

EFFECTIVITY ————
 ALL

21-60-00

03

Page 146
 Jun 20/95

FD2449

BOEING
 757
 FAULT ISOLATION/MAINT MANUAL

°F	OHMS
-40	43030-45210
-35	36690-38550
-30	31360-32960
-25	26930-28230
-20	23140-24260
-15	19940-20900
-10	17220-18050
-5	14890-15580
0	12950-13550
5	11310-11780
10	9870-10290
15	8640-9000
20	7520-7900
25	6660-6940
30	5870-6120
35	5180-5400
40	4580-4770
45	4060-4230
50	3600-3750

°F	OHMS
55	3200-3340
60	2850-2980
65	2550-2660
70	2290-2390
75	2040-2130
80	1830-1920
85	1650-1730
90	1480-1560
95	1340-1400
100	1210-1270
105	1100-1150
110	990-1040
115	900-950
120	820-860
125	740-790
130	680-720
135	620-660
140	560-600

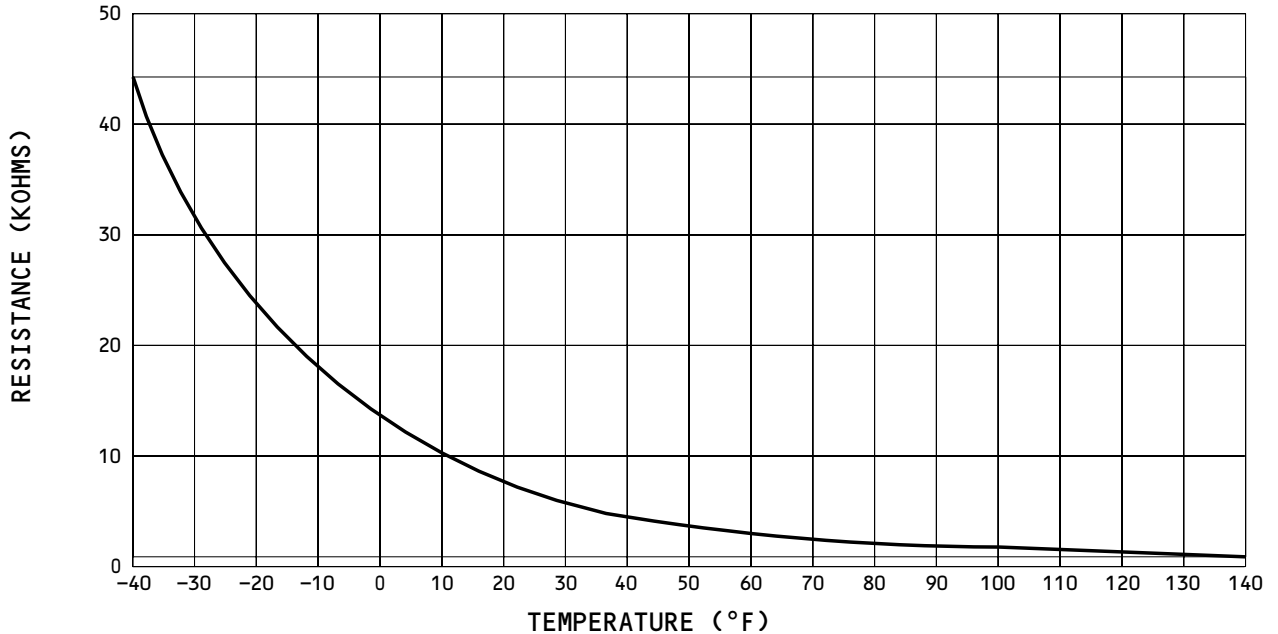

PACK TEMPERATURE SENSOR
 RESISTANCE VS TEMPERATURE GRAPH E
 Temperature Sensor Calibration Problems
 Figure 107 (Sheet 9)

EFFECTIVITY

ALL

21-60-00

02

Page 147
Jun 20/95

FD2450