

**BOEING**  
 757  
 FAULT ISOLATION/MAINT MANUAL

GPA Group plc

PAGE	DATE	CODE	PAGE	DATE	CODE	PAGE	DATE	CODE
CHAPTER 33 TAB			33-FAULT CODE DIAGRAM			33-13-00		
LIGHTS			CONT.			101 MAY 28/01 01		
EFFECTIVE PAGES			21 MAR 20/97 02			102 MAY 28/01 01		
SEE LAST PAGE OF LIST FOR			22 MAR 20/97 02			103 MAY 28/00 01		
NUMBER OF PAGES			23 MAR 20/97 08			104 MAY 28/01 01		
33-CONTENTS			24 MAR 20/97 12			105 MAY 28/00 01		
1	SEP 28/99	GUI	25 MAR 20/97 01			106 JUN 20/95 02		
2	SEP 28/00	GUI	26 JUN 20/97 02			107 MAY 28/00 01		
3	SEP 28/06	GUI	27 JUN 20/97 04			108 MAY 28/00 01		
4	MAY 28/00	GUI	28 JUN 20/97 04			109 JUN 20/95 01		
5	JAN 28/00	GUI	29 JUN 20/97 06			110 MAY 28/00 01		
6	SEP 28/06	GUI	30 BLANK			111 JUN 20/95 02		
33-HOW TO USE THE FIM			33-FAULT CODE INDEX			112 JUN 20/95 01		
1	SEP 20/98	01	1 SEP 20/08 06			33-14-00		
2	SEP 20/98	01	2 SEP 20/08 25			101 JUN 20/94 01		
3	SEP 28/99	01	3 SEP 20/08 12			102 JUN 20/94 01		
4	SEP 20/98	01	4 SEP 20/08 10			103 JUN 20/94 01		
5	SEP 20/98	01	5 SEP 20/08 01			104 DEC 20/96 01		
6	SEP 20/98	01	6 SEP 20/08 01			105 MAR 20/94 01		
33-INDEX			7 SEP 20/08 01			106 MAR 20/94 01		
1	MAR 20/92	15	8 SEP 20/08 01			107 MAR 20/94 01		
2	MAR 20/92	01	9 SEP 20/08 01			108 BLANK		
3	MAR 20/92	06	10 SEP 20/08 06			33-16-00		
4	DEC 20/92	21	11 SEP 20/08 01			101 SEP 20/93 01		
33-EICAS MESSAGES			12 SEP 20/08 01			102 SEP 20/93 01		
1	DEC 20/90	01	13 SEP 20/08 05			103 SEP 20/93 01		
2	DEC 20/90	01	14 SEP 20/08 06			104 SEP 28/01 01		
3	DEC 20/95	01	15 SEP 20/08 21			105 SEP 28/01 01		
4	BLANK		16 SEP 20/08 25			106 JUN 20/96 01		
33-FAULT CODE DIAGRAM			17 SEP 20/08 24			107 JUN 20/96 01		
1	SEP 20/96	03	18 SEP 20/08 01			108 BLANK		
2	SEP 20/96	01	19 SEP 20/08 13			33-21-00		
3	SEP 20/96	03	20 SEP 20/08 16			101 MAR 20/95 01		
4	SEP 20/96	03	21 SEP 20/08 12			102 JUN 20/95 01		
5	SEP 20/96	02	22 SEP 20/08 17			103 JAN 20/98 01		
6	JAN 20/99	01	23 SEP 20/08 17			104 JAN 28/02 01		
7	MAR 20/97	02	24 SEP 20/08 16			105 SEP 20/94 01		
8	MAR 20/97	02	33-BITE INDEX			106 BLANK		
9	MAR 20/97	02	1 SEP 28/99 01			33-22-00		
10	MAR 20/97	01	2 SEP 28/99 01			101 SEP 20/94 01		
11	MAR 20/97	02	3 SEP 28/99 01			102 SEP 20/94 01		
12	MAR 20/97	06	4 BLANK			103 SEP 20/94 01		
13	MAR 20/97	02	33-11-00			104 SEP 20/94 01		
14	MAR 20/97	02	101 SEP 20/93 01			105 SEP 20/94 01		
15	MAR 20/97	02	102 SEP 20/93 01			106 SEP 20/94 01		
16	MAR 20/97	17	103 SEP 20/93 01			107 SEP 20/94 01		
17	MAR 20/97	23	104 SEP 20/93 01			108 SEP 20/94 01		
18	MAR 20/97	02	105 SEP 20/93 01			33-23-00		
19	MAR 20/97	02	106 MAR 20/94 02			101 MAR 20/95 01		
20	MAR 20/97	02	107 MAR 20/94 01			102 DEC 20/93 01		
			108 MAR 20/94 01					
			109 MAR 20/94 01					
			110 SEP 20/98 01					

R = REVISED, A = ADDED OR D = DELETED

F = FOLDOUT PAGE

32

MAY 20/09

# D633N632

CHAPTER 33

EFFECTIVE PAGES

PAGE 1

CONTINUED



**BOEING**  
757  
FAULT ISOLATION/MAINT MANUAL

GPA Group plc

PAGE	DATE	CODE	PAGE	DATE	CODE	PAGE	DATE	CODE
33-24-00			33-42-00					
101	SEP 20/93	01	101	DEC 20/94	01			
102	DEC 20/93	01	102	DEC 20/94	01			
103	MAR 20/96	01	103	DEC 20/96	01			
104	MAR 20/91	01	104	MAR 20/94	01			
105	JUN 20/95	03	105	MAR 20/94	01			
106	MAR 20/91	02	106	MAR 20/94	01			
107	JUN 20/95	03	107	MAR 20/95	01			
108	MAR 20/91	01	108	MAR 20/95	01			
33-25-00			33-43-00					
101	SEP 20/94	01	101	JAN 28/05	01			
102	SEP 20/93	01	102	JAN 28/05	01			
103	SEP 20/94	01	103	MAR 20/94	01			
104	DEC 20/96	01	104	BLANK				
33-26-00			33-44-00					
101	MAY 28/00	01	101	MAR 20/94	01			
102	MAY 28/00	01	102	MAR 20/94	01			
103	MAY 28/00	01	103	MAR 20/94	01			
104	MAY 28/00	01	104	MAY 28/06	01			
105	MAY 28/00	01	105	MAY 28/06	01			
106	BLANK		106	BLANK				
33-27-00			33-45-00					
101	SEP 20/93	01	101	JUN 20/94	01			
102	DEC 20/92	01	102	JUN 20/94	01			
103	DEC 20/96	01	103	JUN 20/94	01			
104	BLANK		104	BLANK				
33-31-00			33-51-00					
101	DEC 20/94	01	101	MAR 20/94	09			
102	DEC 20/94	01	102	MAR 20/94	01			
103	DEC 20/94	01	103	MAR 20/94	01			
104	DEC 20/94	01	104	MAR 20/94	01			
105	DEC 20/94	01	105	MAR 20/94	01			
106	BLANK		106	MAR 20/94	03			
33-37-00			107	MAR 20/95	02			
101	JAN 20/99	02	108	MAR 20/95	01			
102	MAY 28/01	01						
103	DEC 20/94	01						
104	DEC 20/94	06						
105	SEP 28/05	07						
106	DEC 20/94	05						
107	SEP 28/05	06						
108	DEC 20/94	03						
109	DEC 20/94	03						
110	BLANK							
33-41-00								
101	MAR 20/94	01						
102	MAR 20/94	01						
103	MAR 20/94	01						
104	BLANK							

R = REVISED, A = ADDED OR D = DELETED  
F = FOLDOUT PAGE  
32  
MAY 20/09

**D633N632**

CHAPTER 33  
EFFECTIVE PAGES  
PAGE 2  
LAST PAGE



**BOEING**  
757  
FAULT ISOLATION/MAINT MANUAL

CHAPTER 33 - LIGHTS

TABLE OF CONTENTS

<u>Subject</u>	Chapter Section <u>Subject</u>	<u>Page</u>	<u>Effectivity</u>
HOW TO USE THE FIM	33-HOW TO USE THE FIM	1	ALL
INDEX	33-INDEX	1	ALL
EICAS MESSAGES	33-EICAS MESSAGES	1	ALL
FAULT CODE DIAGRAMS	33-FAULT CODE DIAGRAM	1	ALL
FAULT CODE INDEX	33-FAULT CODE INDEX	1	ALL
BITE INDEX	33-BITE INDEX	1	ALL
<u>LIGHTS - GENERAL</u>	33-00-00		
<u>FLIGHT COMPARTMENT LIGHTS</u>	33-10-00		
FLIGHT COMPARTMENT ILLUMINATION	33-11-00		
Component Location		101	ALL
Component Index			
Component Location			
Fault Isolation			
Aisle Stand Floodlight Problems (Fig. 105)		108	
Dome Light Problems (Fig. 106)		109	
Flight Compartment Main Power Distribution Panel (P6) Floodlight Problems (Fig. 107)		110	
Flight Compartment Panel Floodlight Problems (Fig. 103)		105	
Glareshield Floodlight Problems (Fig. 104)		106	

## 33-CONTENTS



**BOEING**  
757  
FAULT ISOLATION/MAINT MANUAL

CHAPTER 33 - LIGHTS

TABLE OF CONTENTS

<u>Subject</u>	Chapter Section <u>Subject</u>	<u>Page</u>	<u>Effectivity</u>
INTEGRAL PANEL LIGHTS	33-13-00		
Component Location		101	ALL
Component Index			
Component Location			
Fault Isolation			
Aisle Stand Panel Light Problems (Fig. 107)		111	
Flight Compartment - Captain's and Center Panel Light Problems (Fig. 103)		105	
Flight Compartment - First Officer's Panel Light Problems (Fig. 104)		107	
Flight Compartment - Glareshield Panel Light Problems (Fig. 106)		110	
Flight Compartment - Overhead CB Panel Light Problems (Fig. 107A)		112	
Flight Compartment - Overhead Panel (P5) Light Problems (Fig. 105)		109	
FLIGHT COMPARTMENT MISCELLANEOUS LIGHTS	33-14-00		
Component Location		101	ALL
Component Index			
Component Location			
Fault Isolation			
Flight Compartment Chart Light Problems (Fig. 104)		105	
Flight Compartment Flt Kit/Utility Light Problems (Fig. 105)		106	
Flight Compartment Map Light Problems (Fig. 103)		104	
Flight Compartment Threshold Step Light Problems (Fig. 106)		107	

**33-CONTENTS**



**BOEING**  
757  
FAULT ISOLATION/MAINT MANUAL

CHAPTER 33 - LIGHTS

TABLE OF CONTENTS

<u>Subject</u>	<u>Chapter Section Subject</u>	<u>Page</u>	<u>Effectivity</u>
MASTER DIM AND TEST	33-16-00		
Component Location		101	ALL
Component Index			
Component Location			
Fault Isolation			
Flight Compartment Master Dim and Test Problems (Fig. 103)		104	
<u>PASSENGER COMPARTMENT LIGHTS</u>	33-20-00		
<u>PASSENGER COMPARTMENT ILLUMINATION</u>	33-21-00		
Component Location		101	ALL
Component Index			
Component Location			
Fault Isolation			
Indirect Ceiling Lights Problems (Fig. 103)		103	
Problems with the Sidewall Lights (Fig. 104)		105	
<u>PASSENGER LOADING LIGHTS</u>	33-22-00		
Component Location		101	ALL
Component Index			
Component Location			
Fault Isolation			
Attendant's Work Lights Problems (Fig. 105)		107	
Left Forward Entry Lights Problems (Fig. 103)		104	
Threshold Lights and Entry Spot Lights Problems (Fig. 104)		105	
<u>PASSENGER READING LIGHTS</u>	33-23-00		
Component Location		101	ALL
Component Index			
Component Location			

## 33-CONTENTS



**BOEING**  
757  
FAULT ISOLATION/MAINT MANUAL

CHAPTER 33 - LIGHTS

TABLE OF CONTENTS

<u>Subject</u>	Chapter Section <u>Subject</u>	<u>Page</u>	<u>Effectivity</u>
PASSENGER SIGNS	33-24-00		
Component Location		101	ALL
Component Index			
Component Location			
Fault Isolation			
Figure Not Used		103	
No Smoking Lights Problems (Fig. 104)		104	
Seatbelt And Return To Seat Signs Problems (Fig. 105)		106	
CALL LIGHTS	33-25-00		
Component Location		101	ALL
Component Index			
Component Location			
Fault Isolation			
Passenger Call System Problems (Fig. 103)		104	
LAVATORY LIGHTS	33-26-00		
Component Location		101	ALL
Component Index			
Component Location			
Fault Isolation			
Lavatory Lights Problems (Fig. 103)		104	
GALLEY LIGHTS	33-27-00		
Component Location		101	ALL
Component Index			
Component Location			
Fault Isolation			
Galley Lights Problems (Fig. 103)		103	

## 33-CONTENTS



**BOEING**  
757  
FAULT ISOLATION/MAINT MANUAL

CHAPTER 33 - LIGHTS

TABLE OF CONTENTS

<u>Subject</u>	<u>Chapter Section Subject</u>	<u>Page</u>	<u>Effectivity</u>
<u>CARGO AND SERVICE COMPARTMENT LIGHTS</u>	33-30-00		
SERVICE LIGHTS	33-31-00		
Component Location		101	ALL
Component Index			
Component Location			
Fault Isolation			
APU Compartment Lights		104	
Problems (Fig. 104)			
Main Gear Wheel Well Service		103	
Light Problems (Fig. 103)			
Tailcone Compartment Light		105	
Problems (Fig. 105)			
LOWER LOBE CARGO COMPARTMENT	33-37-00		
LIGHTS			
Component Location		101	ALL
Component Index			
Component Location			
Fault Isolation			
Aft Cargo Compartment Light		106	
Problems (Fig. 104)			
Forward Cargo Compartment		104	
Light Problems (Fig. 103)			
<u>EXTERIOR LIGHTS</u>	33-40-00		
WING ILLUMINATION LIGHTS	33-41-00		
Component Location		101	ALL
Component Index			
Component Location			
LANDING, RUNWAY TURNOFF AND TAXI	33-42-00		
LIGHTS			
Component Location		101	ALL
Component Index			
Component Location			
Fault Isolation			
Nose Gear Landing Light		105	
Problems (Fig. 104)			
Runway Turnoff Light Problems		104	
(Fig. 103)			
Taxi Light Problems (Fig. 106)		107	
Wing Landing Light Problems		106	
(Fig. 105)			

## 33-CONTENTS



**BOEING**  
757  
FAULT ISOLATION/MAINT MANUAL

CHAPTER 33 - LIGHTS

TABLE OF CONTENTS

<u>Subject</u>	Chapter Section <u>Subject</u>	<u>Page</u>	<u>Effectivity</u>
POSITION LIGHTS	33-43-00		
Component Location		101	ALL
Component Index			
Component Location			
ANTI-COLLISION LIGHTS	33-44-00		
Component Location		101	ALL
Component Index			
Component Location			
Fault Isolation			
Body Anti-Collision Lights Problems (Fig. 103)		104	
Wing Anti-Collision Lights Problem (Fig. 104)		105	
LOGO LIGHTS	33-45-00		
Component Location		101	ALL
Component Index			
Component Location			
Fault Isolation			
Logo Lights Problems (Fig. 103)		103	
<u>EMERGENCY LIGHTING</u>	33-50-00		
EMERGENCY LIGHTS	33-51-00		
Component Location		101	ALL
Component Index			
Component Location			
Fault Isolation			
Exterior Emergency Lights Problems (Fig. 104)		108	
Interior Emergency Lights Problems (Fig. 103)		107	

## 33-CONTENTS



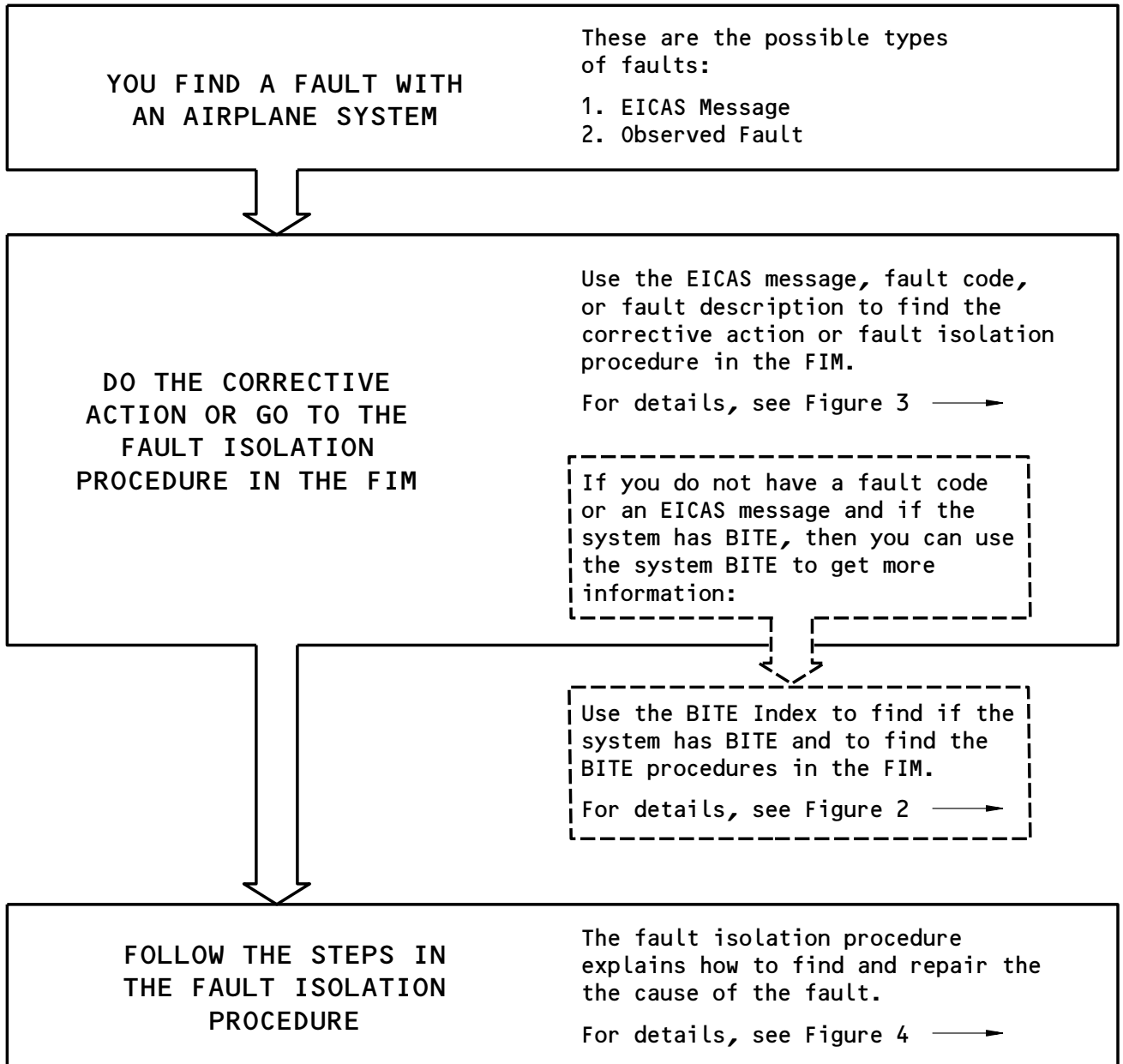

Basic Fault Isolation Process  
Figure 1

EFFECTIVITY

ALL

## 33-HOW TO USE THE FIM

01

Page 1  
Sep 20/98

H54399

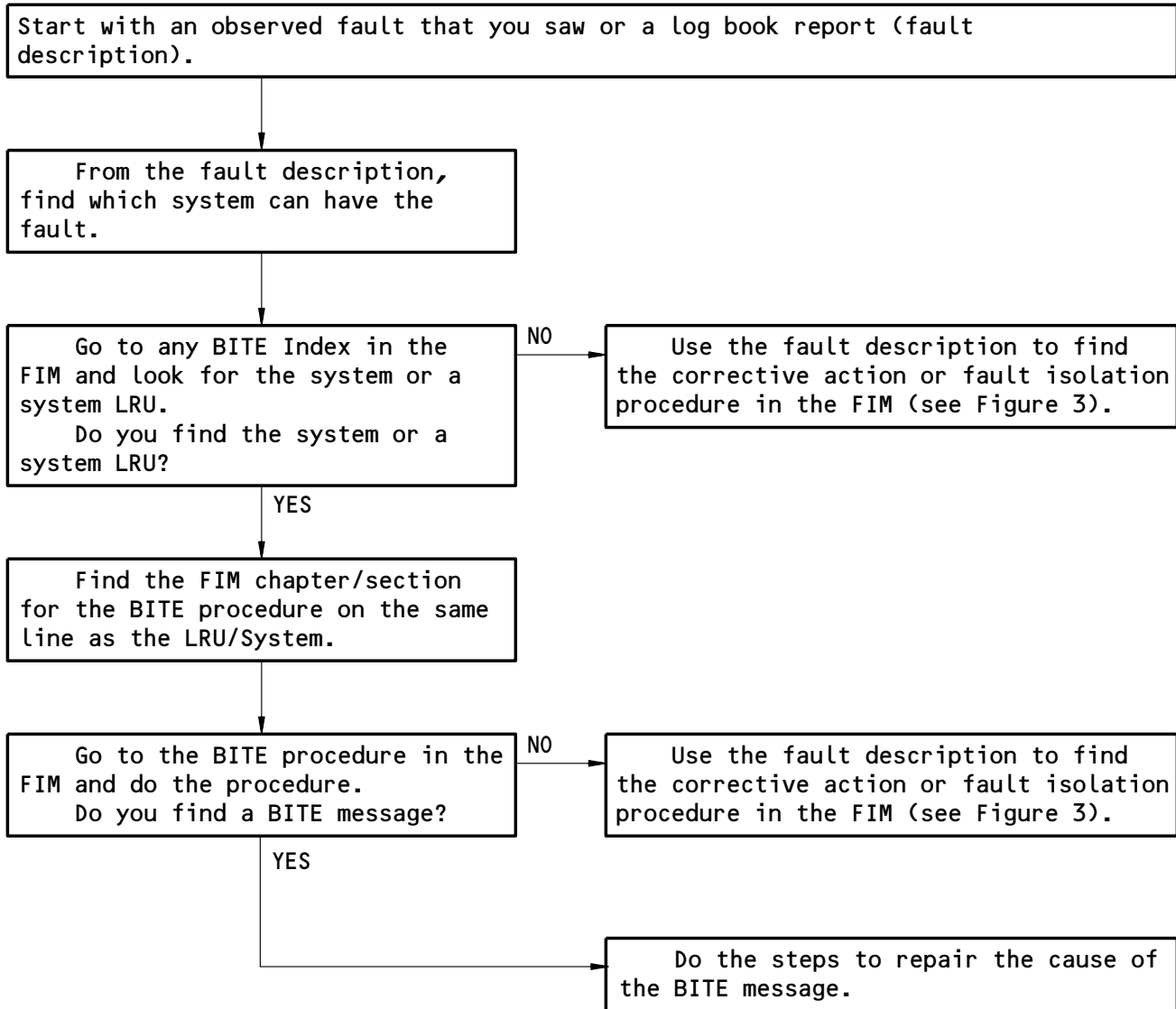

How to Get Fault Information from BITE  
Figure 2

EFFECTIVITY

ALL

## 33-HOW TO USE THE FIM

01

Page 2  
Sep 20/98

IF YOU HAVE:

THEN DO THIS TO FIND THE CORRECTIVE ACTION OR FAULT ISOLATION PROCEDURE IN THE FIM:

FAULT CODE

1. The first two digits of the fault code are the FIM chapter that you need. Go to the Fault Code Index in that chapter and find the fault code.
2. Find the Fault Isolation Reference for the fault code and do the corrective action. If there is a FIM reference, then go to that fault isolation procedure in the FIM and do the steps in the procedure (see Figure 4).

EICAS MESSAGE TEXT  
(with no fault code)

1. If you know the chapter of the EICAS message, then go to the EICAS Messages section in that chapter and find the EICAS message.  
  
If you do not know the chapter of the EICAS message, then do these steps:
  - A. Go to FIM EICAS MESSAGE LIST and find the EICAS message in the table.  
  
**NOTE:** The list follows the INTRODUCTION to the FIM.
  - B. Find the chapter number on the same line as the EICAS message. Go to the EICAS Messages section in that chapter and find the EICAS message.
2. Do the corrective action in the "Procedure" column for the EICAS message. If there is a FIM reference, then go to that fault isolation procedure in the FIM and do the steps in the procedure (see Figure 4).

OBSERVED FAULT DESCRIPTION

1. Go to the Fault Code Diagram for the problem in the applicable chapter.
2. Do the fault analysis on the diagram and find the fault code.
3. The first two digits of the fault code are the FIM chapter that you need. Go to the Fault Code Index in that chapter and find the fault code.
4. Find the Fault Isolation Reference for the fault code and do the corrective action. If there is a FIM reference, then go to that fault isolation procedure in the FIM and do the steps in the procedure (see Figure 4).

How to Find the Corrective Action or Fault Isolation Procedure in the FIM

Figure 3

EFFECTIVITY

ALL

## 33-HOW TO USE THE FIM

ASSUMED CONDITIONS AT START OF TASK

- External electrical power is OFF
- Hydraulic power and pneumatic power are OFF
- Engines are shut down
- Circuit breakers for the system are closed
- No equipment in the system is deactivated

PREREQUISITES

- This box gives the steps to get the airplane from the normal shutdown condition to the configuration necessary to do the fault isolation procedure.
- The Prerequisites give procedure references, circuit breakers, and special tools and equipment requirements.

FAULT ISOLATION BLOCKS

- Start the fault isolation procedure at block 1 unless specified differently.
- Do the check to get an answer to the question in the box. Follow the arrow that applies to your answer. This will go to the next check.
- When you get to a box in the column at the right of the page, you have isolated that fault. Do the steps in that box to repair the cause of the fault.
- Make sure that fault is corrected to complete the procedure.

Do the Fault Isolation Procedure  
Figure 4

EFFECTIVITY

ALL

**33-HOW TO USE THE FIM**

01

Page 4  
Sep 20/98

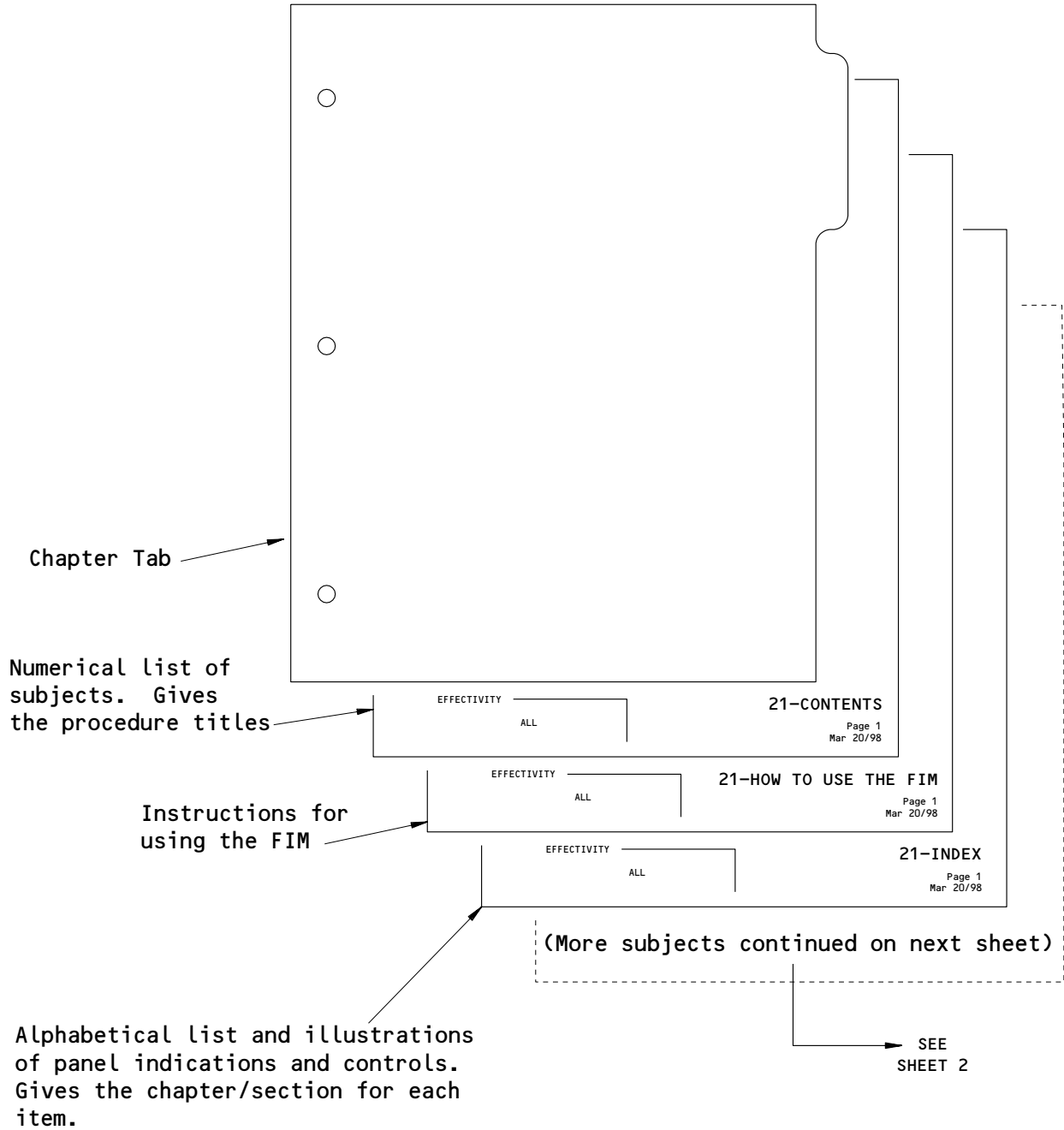

Subjects in Each FIM Chapter  
Figure 5 (Sheet 1)

EFFECTIVITY	ALL	<b>33-HOW TO USE THE FIM</b>	01	Page 5 Sep 20/98
-------------	-----	------------------------------	----	---------------------

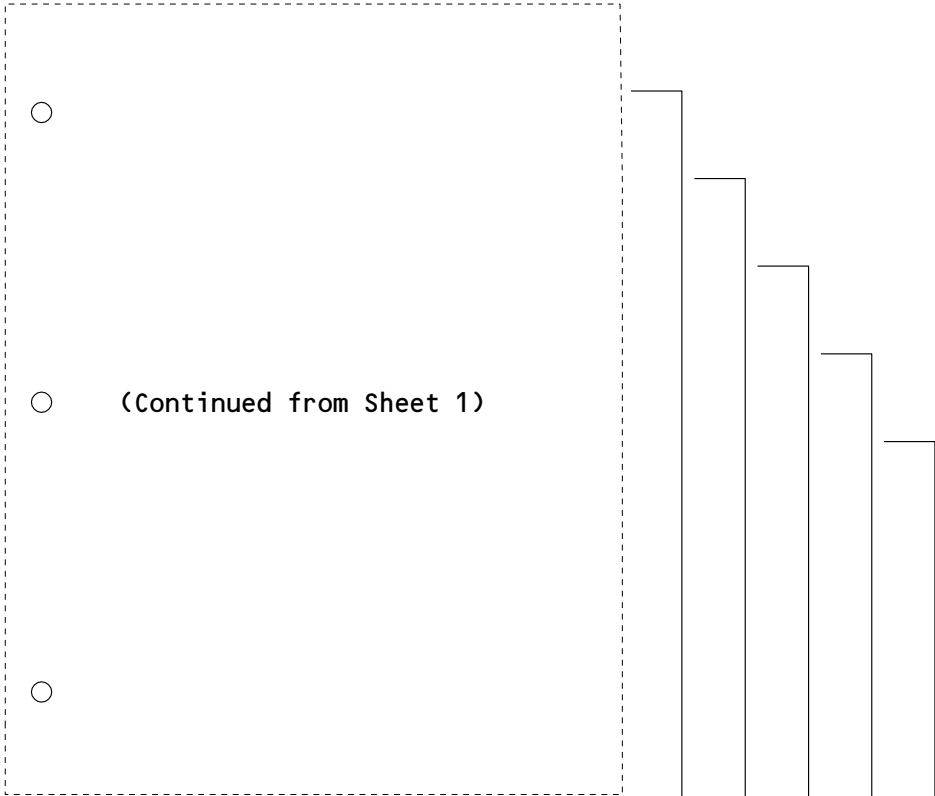

Alphabetical list of the EICAS messages. Gives the procedure to repair the cause of the message or a reference to a fault isolation procedure.

Failure analysis diagrams for the airplane systems to find the correct fault code for the fault.

Numerical list of fault codes. Gives the procedure to repair the cause of the fault or a reference to a fault isolation procedure.

EFFECTIVITY	ALL	21-EICAS MESSAGES	Page 1 Mar 20/98
-------------	-----	-------------------	---------------------

EFFECTIVITY	ALL	21-FAULT CODE DIAGRAMS	Page 1 Mar 20/98
-------------	-----	------------------------	---------------------

EFFECTIVITY	ALL	21-FAULT CODE INDEX	Page 1 Mar 20/98
-------------	-----	---------------------	---------------------

EFFECTIVITY	ALL	21-BITE INDEX	Page 1 Mar 20/98
-------------	-----	---------------	---------------------

EFFECTIVITY	ALL	21-11-00	Page 101 Mar 20/98
-------------	-----	----------	-----------------------

Alphabetical list of all the LRUs/systems that have BITE. Gives the chapter/section for the BITE procedure.

Component index, component location, and fault isolation procedures for the systems in the chapter.

Subjects in Each FIM Chapter  
Figure 5 (Sheet 2)

EFFECTIVITY	ALL
-------------	-----

# 33-HOW TO USE THE FIM

EXTERIOR LIGHTS

COCKPIT LIGHTS

<u>TITLE</u>	<u>CHAP/SEC</u>
ANTICOLLISION.....	3344
LANDING (NOSE).....	3342
LANDING (WING).....	3342
LOGO.....	3345
POSITION.....	3343
RUNWAY TURNOFF.....	3342
TAXI.....	3342
WHEEL WELL.....	3331
WING.....	3341

<u>TITLE</u>	<u>CHAP/SEC</u>
CHART.....	3314
COMPASS.....	3313
DOME.....	3311
FLOODLIGHTS	
AISLE STAND.....	3311
GLARESHIELD.....	3311
INSTRUMENT PANEL.....	3311
LIGHT OVERRIDE.....	3311
MAP.....	3314
MASTER DIM & TEST SW.....	3316
MISCELLANEOUS BULBS/LAMPS,	
SPARE BULB KIT.....	3316
PANELS	
ACCESSORY.....	3313
AISLE STAND.....	3313
GLARESHIELD.....	3313
INSTRUMENT.....	3313
MISCELLANEOUS.....	3313
OVERHEAD.....	3313
OVERHEAD CB.....	3313
UTILITY.....	3314
THRESHOLD.....	3314

CABIN LIGHTS

CEILING.....	3321
EMERGENCY (INTERIOR)	
(ATTND PNL SW).....	3351
EMERGENCY (INTERIOR)	
(OVHD PNL SW).....	3351
ENTRY.....	3322
GALLEY.....	3327
LAVATORY	
DOME.....	3326
FLUORESCENT.....	3326
SIGNS.....	3326
THRESHOLD.....	3326
NIGHT.....	3321
NO SMOKING SIGNS.....	3324
PASSENGER CALL.....	3325
READING.....	3323
SEAT BELT SIGNS.....	3324
THRESHOLD.....	3322
TRACK MOUNTED EXIT.....	3351
WINDOW (SIDEWALL).....	3321
WORK.....	3322

LIGHTS - INDEX

EFFECTIVITY

ALL

**33-INDEX**

<u>TITLE</u>	<u>CHAP/SEC</u>
AIR CONDITIONING COMPARTMENT AND HYDRAULIC SERVICE	
CENTER LIGHTS .....	3331
APU & TAILCONE COMPARTMENT LIGHTS .....	3331
CARGO COMPARTMENT LIGHTS - AFT .....	3337
CARGO COMPARTMENT LIGHTS - FWD .....	3337
ELECTRICAL EQUIPMENT CENTER LIGHTS .....	3331
EXTERIOR EMERGENCY LIGHTS TEST .....	3351

LIGHTS - INDEX (GROUND)

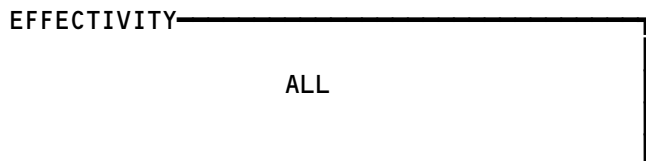

33-INDEX



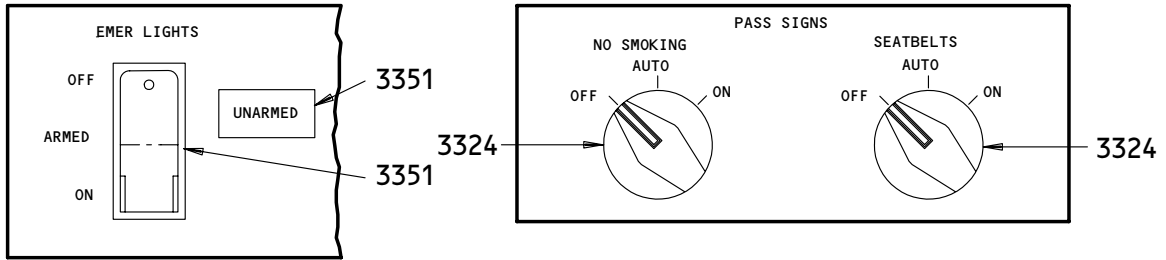

OVERHEAD PANEL

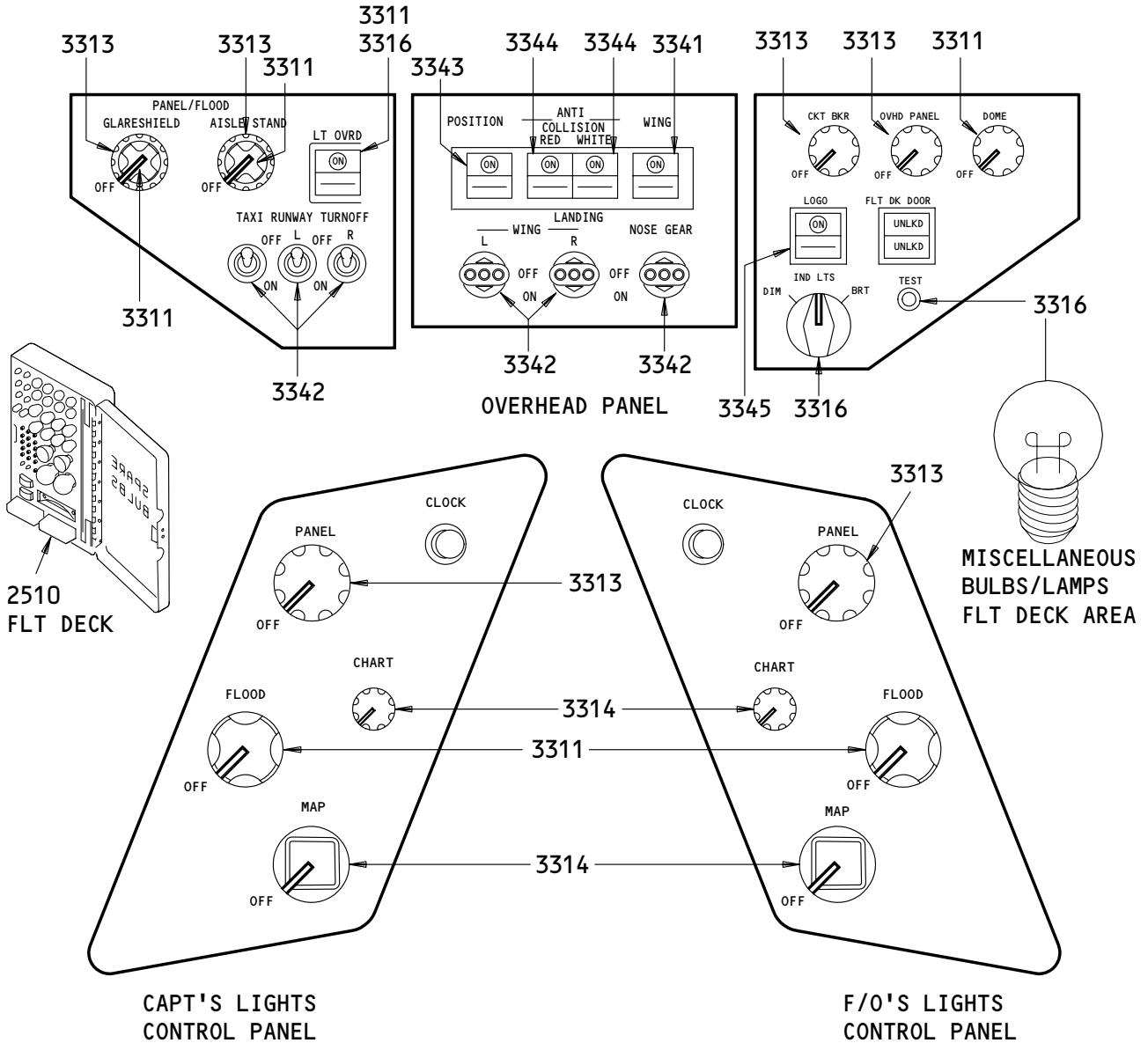

LIGHTS - INDEX

EFFECTIVITY	ALL
-------------	-----

**33-INDEX**

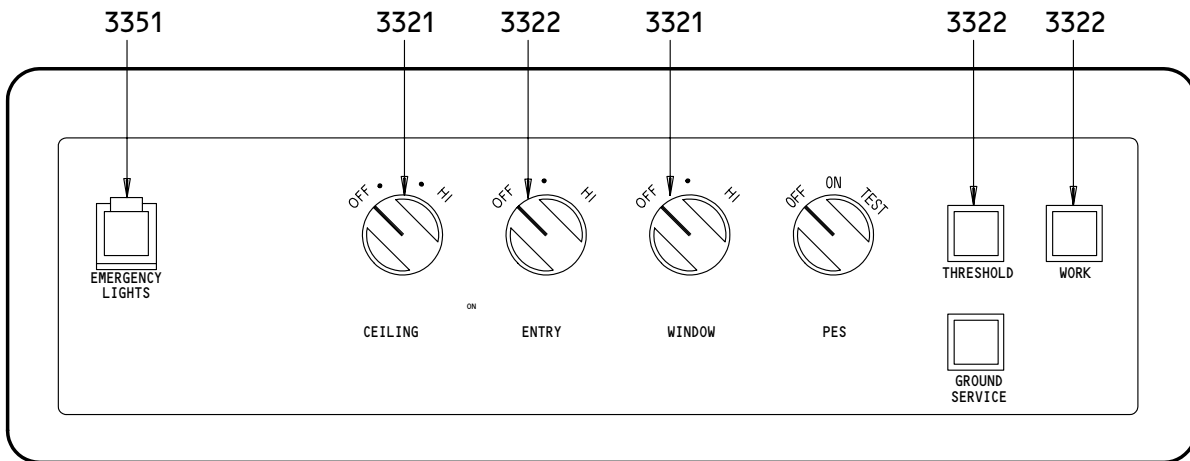

**FORWARD ATTENDANT'S PANEL**

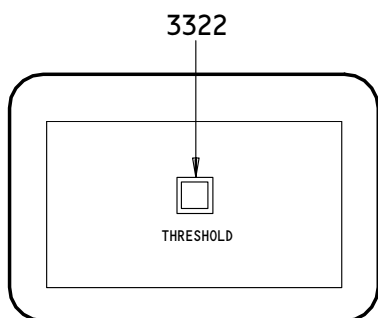

**CENTER ATTENDANTS PANEL**

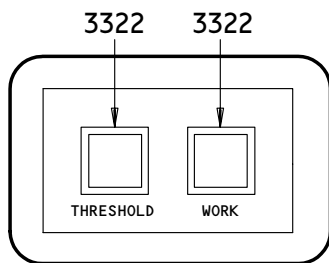

**AFT ATTENDANT'S PANEL**

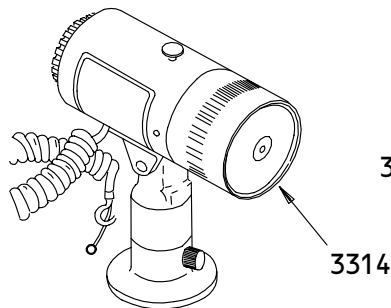

**EACH CREWMEMBER'S STATION**

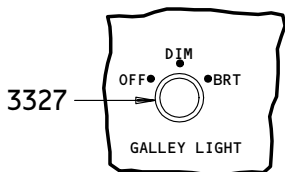

**EACH GALLEY**

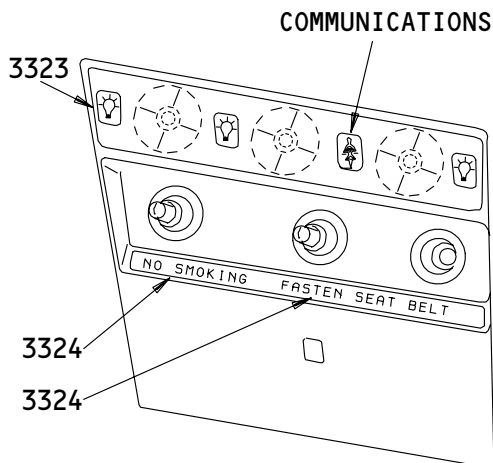

**PASSENGER SERVICE UNIT**

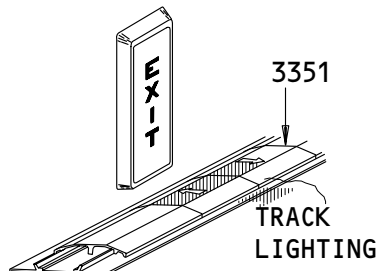
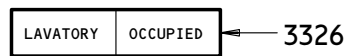

**MAIN CABIN AREA**

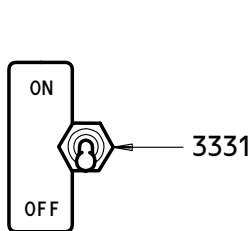

**NOSE WHEEL WELL**

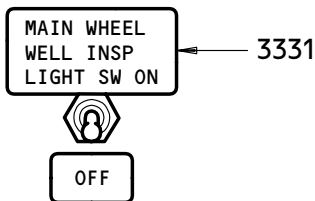

**RIGHT MAIN WHEEL WELL**

### LIGHTS - INDEX

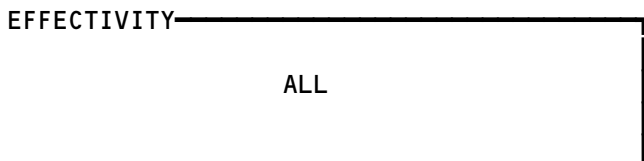

## 33-INDEX

LIGHTS - EICAS MESSAGE LIST

1. General

- A. This procedure shows the EICAS message locations and gives a list of procedures to find the solution for each message.
  - (1) EICAS Message Locations (Fig. 1)
    - (a) Figure 1 shows the location of the EICAS display units and the area where the messages show on the display units.
    - (b) Each message level has a different location. The location and color of each message level is also shown.
  - (2) The EICAS MESSAGE LIST gives the message, level, and procedure for each message.
    - (a) The EICAS MESSAGE column lists the messages alphabetically. Messages which start with L, R, or C are put together and alphabetized at L.
    - (b) The LEVEL column gives all levels for each message as follows:
      - A - Warning messages
      - B - Caution messages
      - C - Advisory messages
      - S - Status messages
      - M - Maintenance messages
    - (c) The PROCEDURE column gives the steps that are necessary to remove the message and includes one or more of the procedures that follow:
      - 1) A Fault Isolation Manual procedure reference
      - 2) A Maintenance Manual procedure and reference
      - 3) Wiring checks and a Wiring Diagram Manual reference
      - 4) A reference to an EICAS message list in a different chapter.
      - 5) A reference to a FAULT CODE INDEX and specified fault codes
      - 6) A step to change the airplane configuration

EFFECTIVITY

ALL

## 33-EICAS MESSAGES

01

Page 1  
Dec 20/90

**BOEING**  
757  
FAULT ISOLATION/MAINT MANUAL

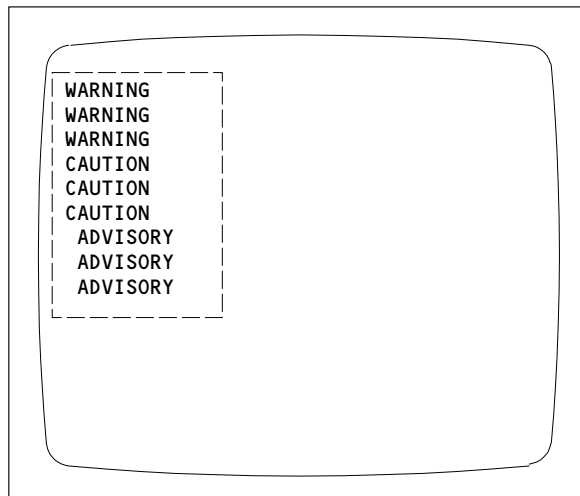
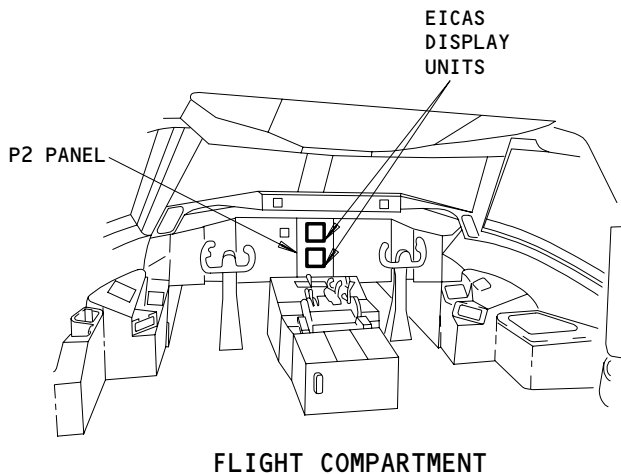

ENGINE PRIMARY PAGE OR COMPACTED PAGE  
(TOP DISPLAY UNIT)

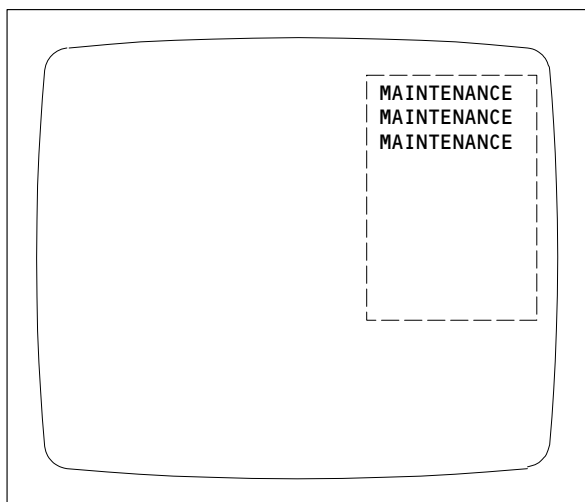

ECS/MSG PAGE  
(BOTTOM DISPLAY UNIT)

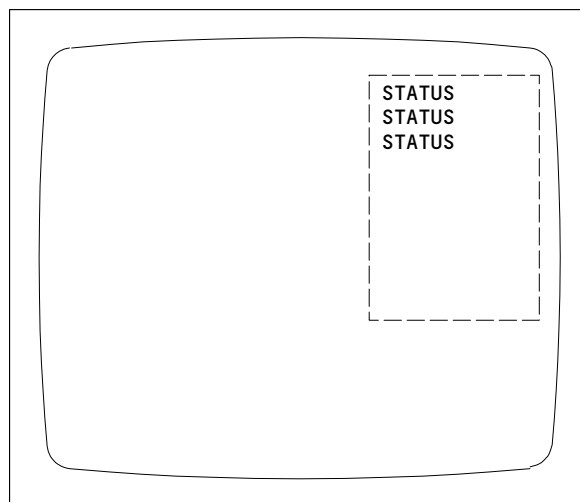

STATUS PAGE  
(BOTTOM DISPLAY UNIT)

LEVEL	COLOR
A-WARNING	RED
B-CAUTION	YELLOW
C-ADVISORY	YELLOW
S-STATUS	WHITE
M-MAINTENANCE	WHITE

EICAS Message Locations  
Figure 1

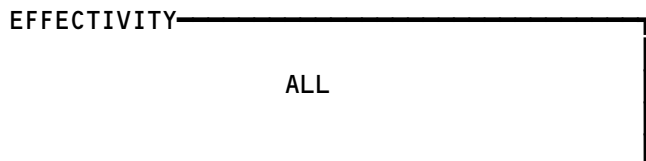

# 33-EICAS MESSAGES

**BOEING**  
 757  
 FAULT ISOLATION/MAINT MANUAL

EICAS MESSAGE LIST		
EICAS MESSAGE	LEVEL	PROCEDURE
EMER LIGHTS	C	Place EMER LIGHTS switch on P5 to ARMED position. If fault persists, replace EMER LIGHTS switch YBIS1 (WDM 33-51-11).

EFFECTIVITY

ALL

## 33-EICAS MESSAGES

01

Page 3  
Dec 20/95

# BOEING

## 757

### FAULT ISOLATION/MAINT MANUAL

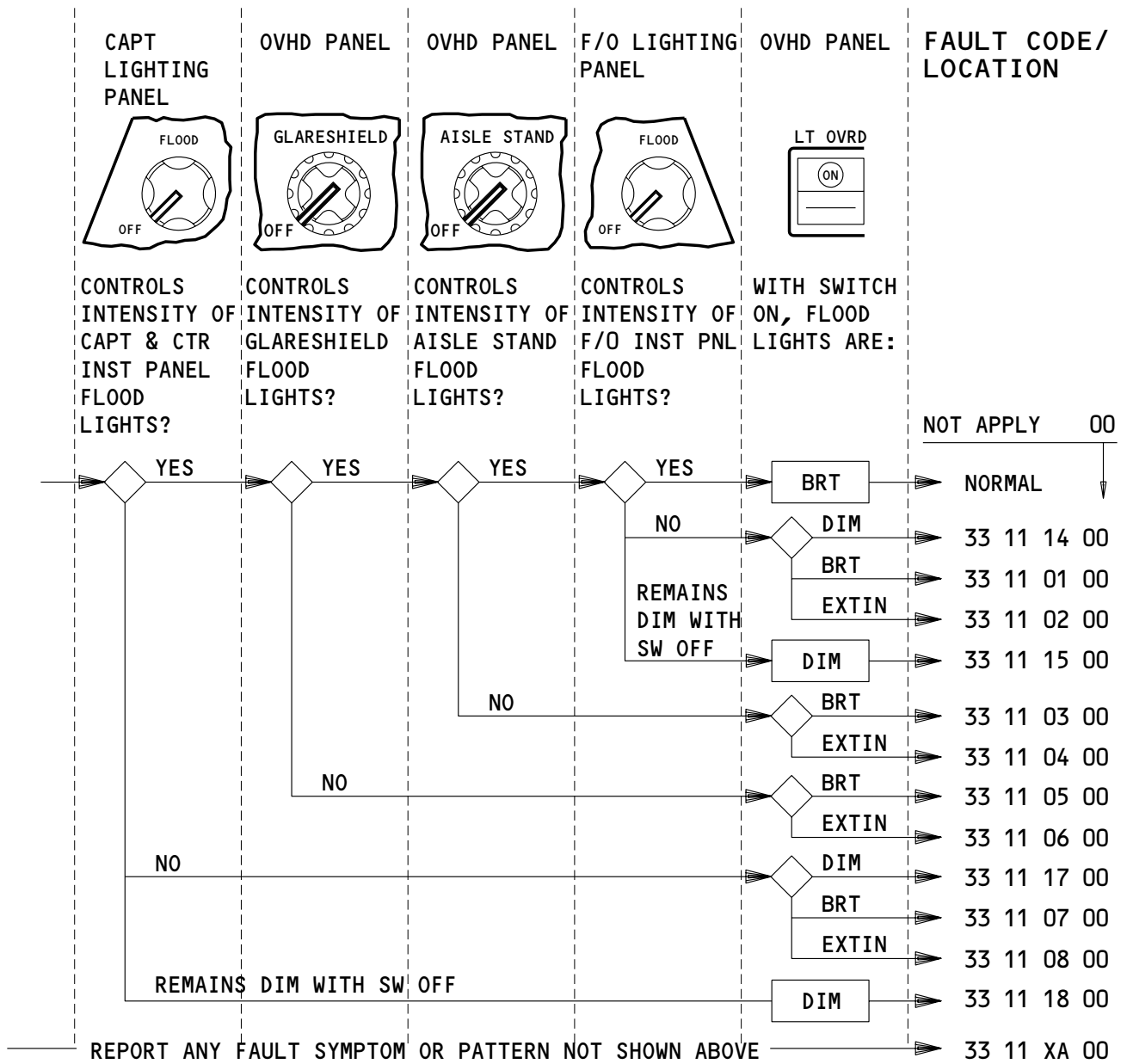

**APPLICABLE CIRCUIT BREAKERS AS INSTALLED**

11B6	FLOOD MAIN PANEL	11N33	PNL FLOOD CAPT	11P7	GLARESHIELD FLOOD
11N6	PNL FLOOD F/O	11N33	FLOOD CAPT PANEL	11P7	FLOOD GLARESHIELD
11N6	FLOOD F/O (PANEL, PNL)	11N34	FLOOD ISLE STAND	11Q32	FLOOD AISLE STAND
11N6	F/O PNL FLOOD				

**FLOODLIGHTS - FAULT CODES**

EFFECTIVITY

ALL

## 33-FAULT CODE DIAGRAM

03

Page 1  
Sep 20/96

**BOEING**  
757  
FAULT ISOLATION/MAINT MANUAL

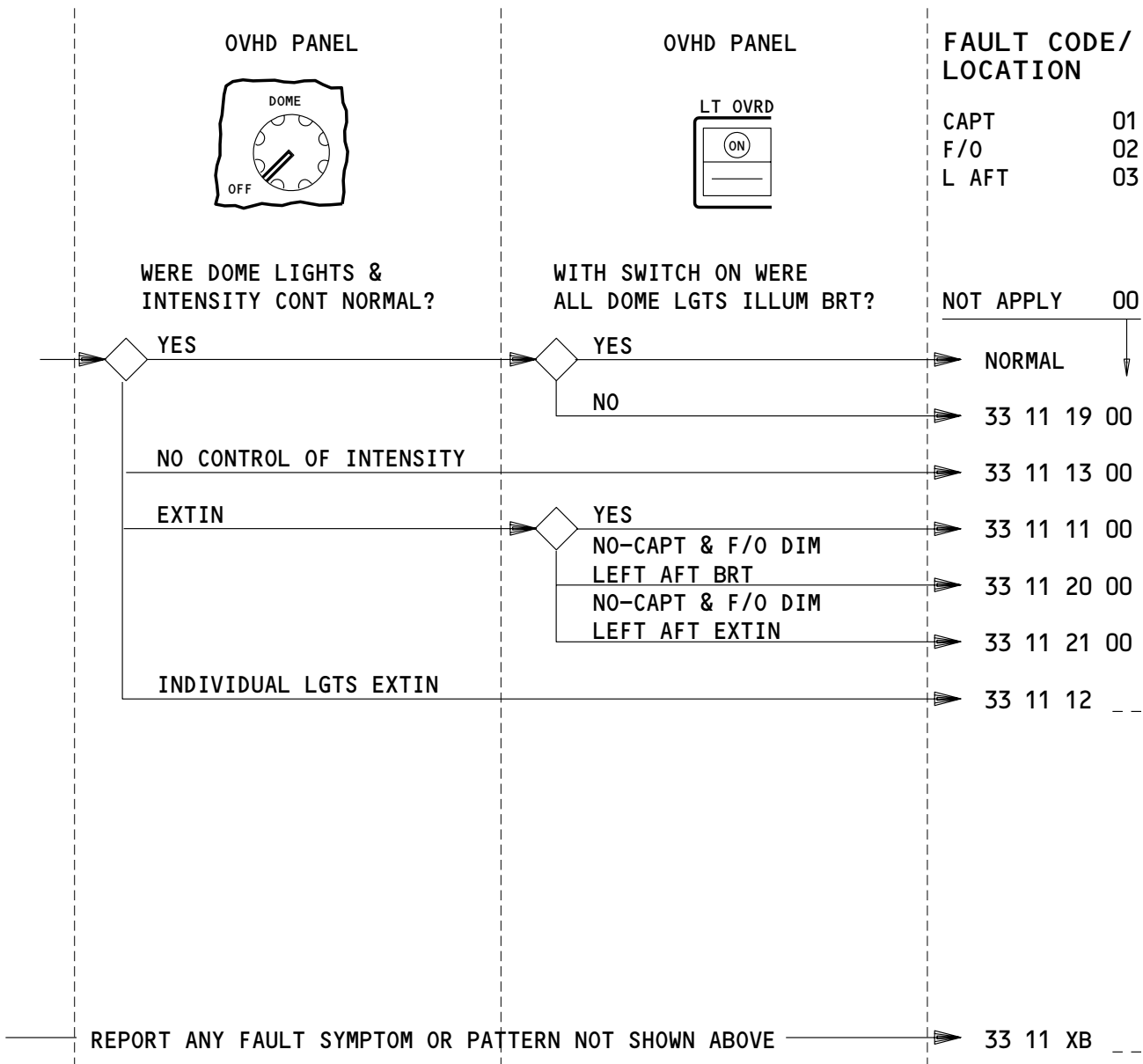

APPLICABLE CIRCUIT BREAKERS

11A30 F/D DOME LTS DC

DOME LIGHTS - FAULT CODES

EFFECTIVITY

ALL

# 33-FAULT CODE DIAGRAM

01

Page 2  
Sep 20/96

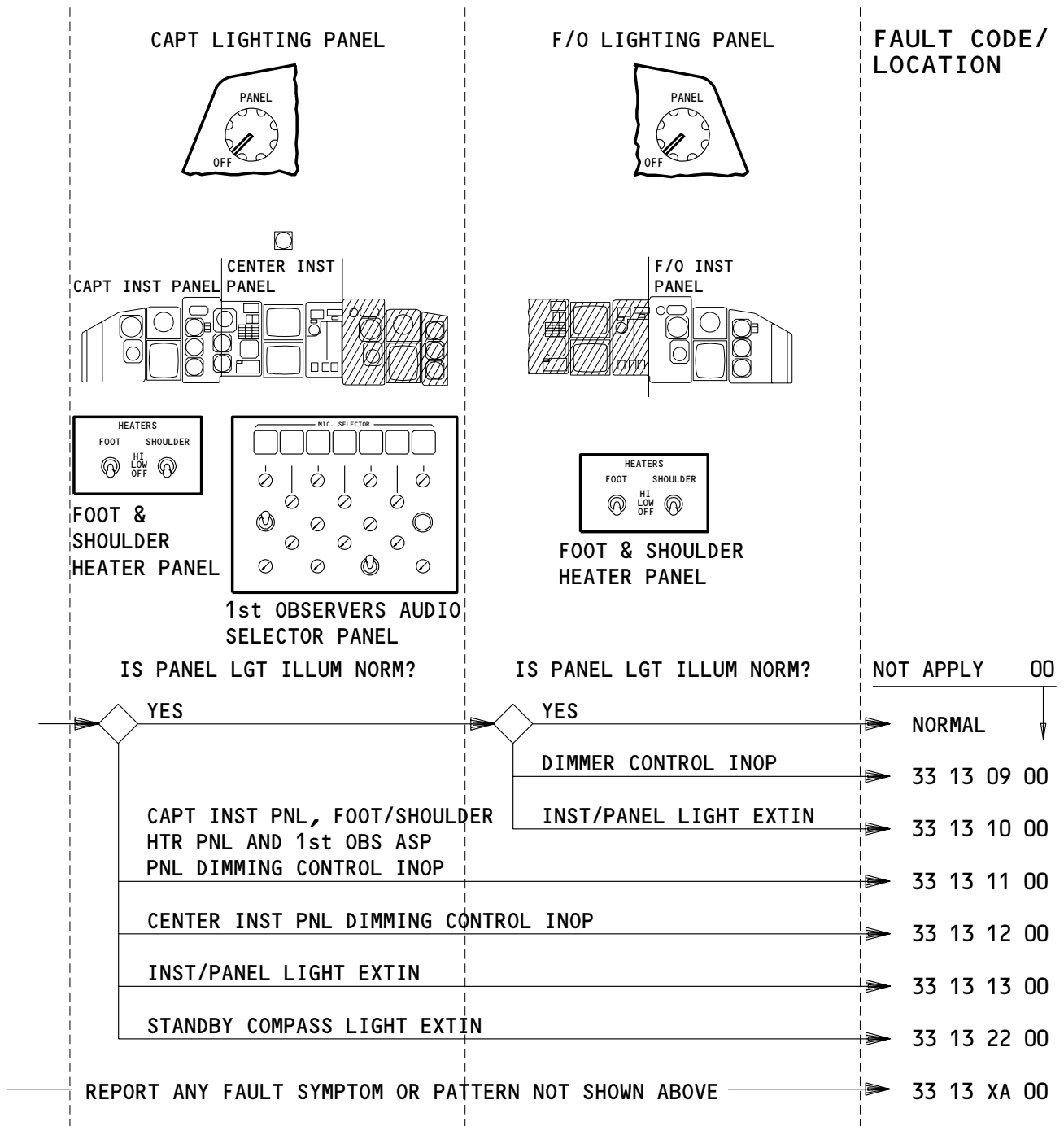

APPLICABLE CIRCUIT BREAKERS AS INSTALLED

11N2	INSTRUMENT (AND, &) PANEL CAPT
11N28	(INSTRUMENT, INST) & PANEL F/O

**PILOTS' INSTRUMENT/MISC PANEL LIGHTING - FAULT CODES**

EFFECTIVITY

ALL

**33-FAULT CODE DIAGRAM**

03

Page 3  
Sep 20/96



# BOEING

## 757

### FAULT ISOLATION/MAINT MANUAL

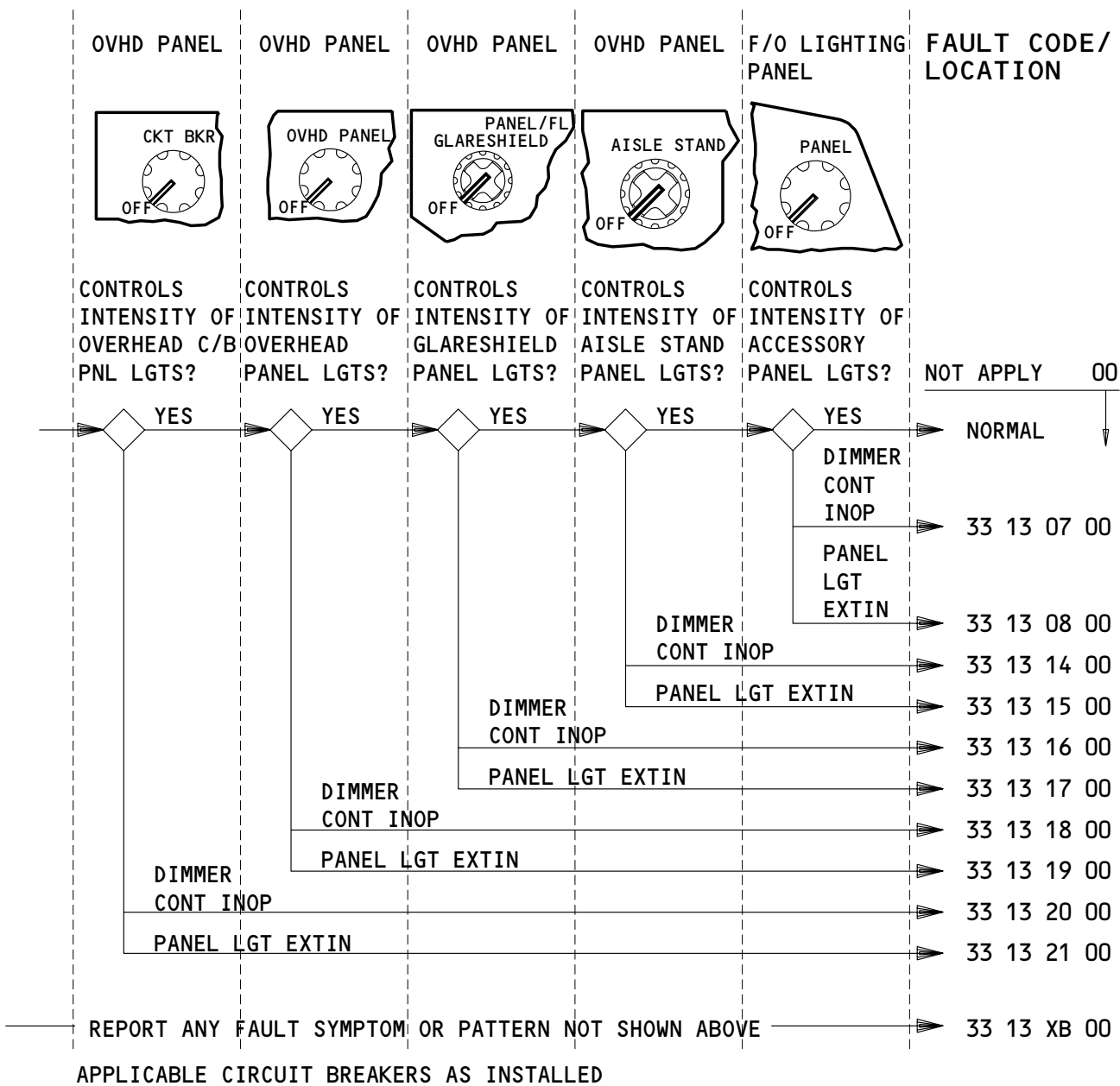

- APPLICABLE CIRCUIT BREAKERS AS INSTALLED
- |      |                                       |  |                                      |
|------|---------------------------------------|--|--------------------------------------|
| 11B7 | (LIGHTS, STBY) INSTR                  |  |                                      |
| 11N1 | INSTRUMENT (AND, &) PANEL AISLE STAND |  |                                      |
| 11N2 | INSTRUMENT (AND, &) PANEL CAPT        |  |                                      |
| 11N4 | INSTRUMENT (AND, &) PANEL OVHD        |  | 11N28 (INSTRUMENT, INST) & PANEL F/O |
| 11N5 | INSTRUMENT (AND, &) PANEL OVHD CB     | 11N30 (INSTRUMENT, INST) & PANEL GLARESHIELD |                                      |
| 11N5 | OVHD C/B PNL                          | 11P6 SIDEWALL                                |                                      |

### OVERHEAD, GLARESHIELD, AISLE STAND AND ACCESSORY PANEL LIGHTS - FAULT CODES

EFFECTIVITY

ALL

## 33-FAULT CODE DIAGRAM

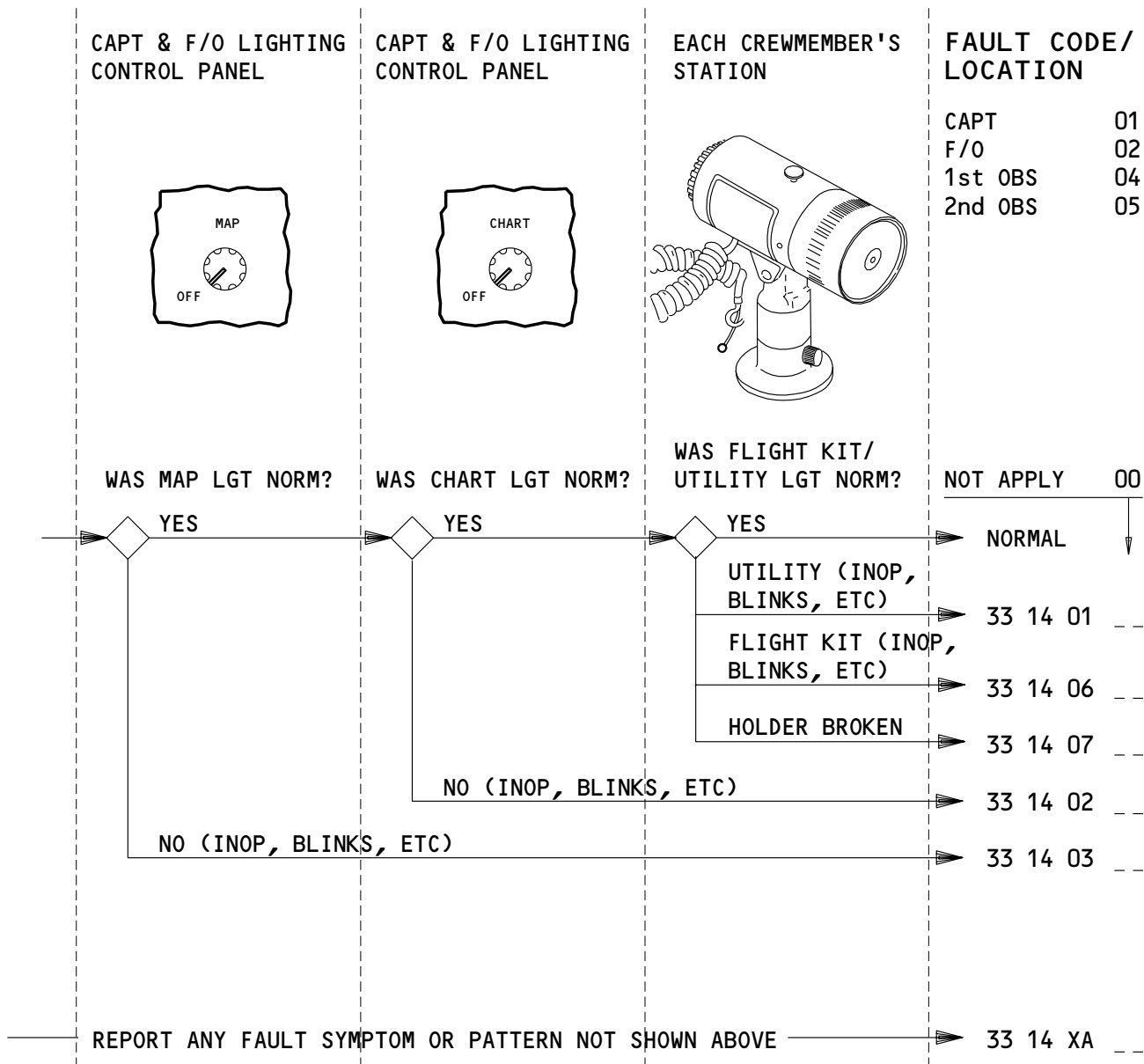

**APPLICABLE CIRCUIT BREAKERS**

11N7	CHART
11N31	MAP
11N32	UTILITY

**MAP, CHART, FLIGHT KIT/UTILITY LIGHTS – FAULT CODES**

EFFECTIVITY	ALL
-------------	-----

## 33-FAULT CODE DIAGRAM

# BOEING

## 757 FAULT ISOLATION/MAINT MANUAL

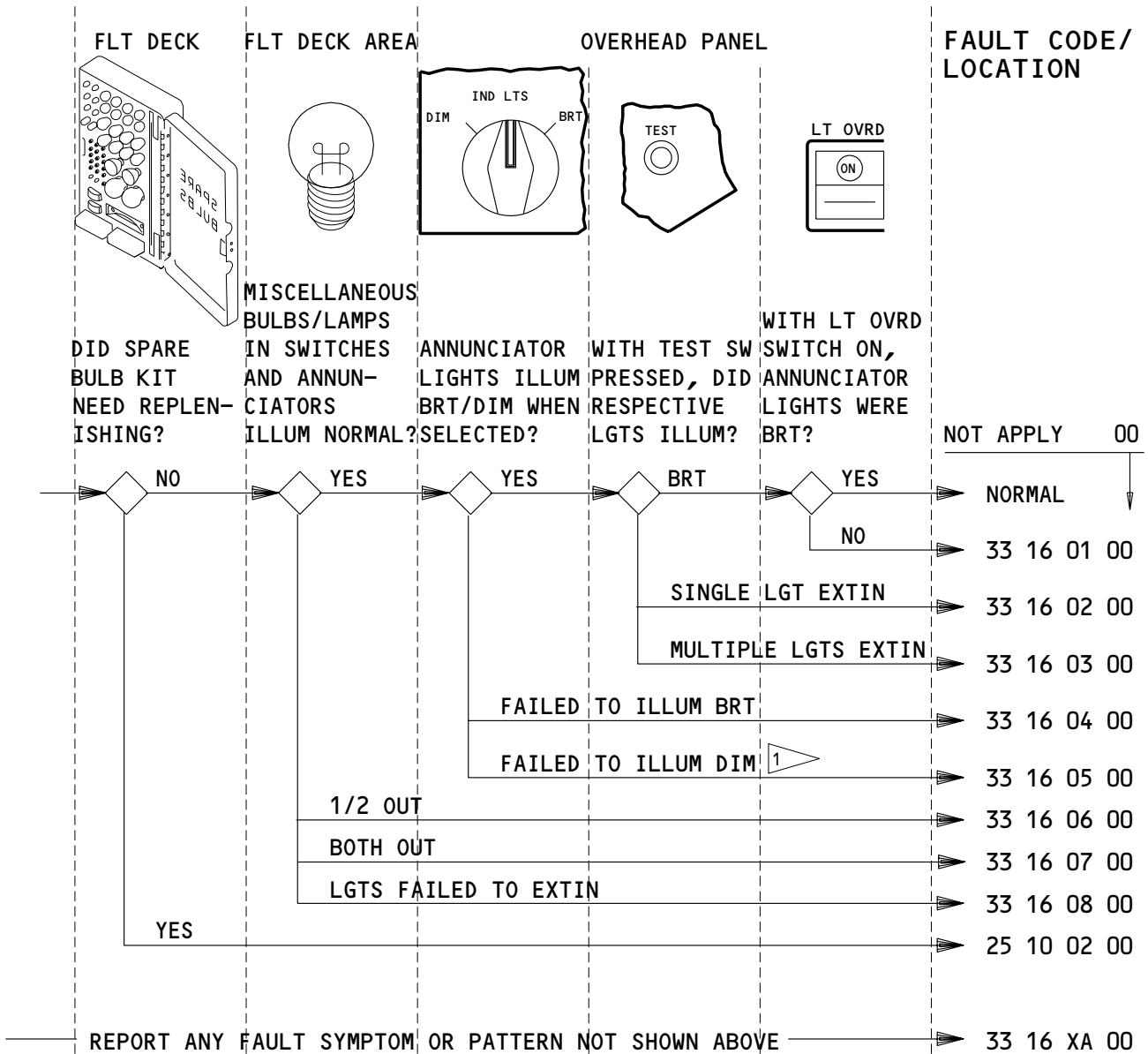

<sup>1</sup> ENSURE RECIRCULATION FAN IS ON.

APPLICABLE CIRCUIT BREAKERS AS INSTALLED

11A31	(INDICATOR, IND) LIGHTS TEST	11P1	L IND LTS 1
11A32	(INDICATOR, IND) LIGHTS 1	11P2	L IND LTS 2
11A33	(INDICATOR, IND) LIGHTS 2	11P5	IND LTS DIM CONT
11A34	(INDICATOR, IND) LIGHTS 3	11P28	R IND LTS 1
11A35	(INDICATOR, IND) LIGHTS 4	11P29	R IND LTS 2

### MISCELLANEOUS BULBS/MASTER DIM AND TEST - FAULT CODES

EFFECTIVITY

ALL

## 33-FAULT CODE DIAGRAM

01

Page 6  
Jan 20/99

PASSENGER SERVICE UNIT

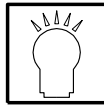

FAULT CODE/  
LOCATION

- R FWD 01
- L FWD 02
- R MID FWD 03
- L MID FWD 04
- R MID AFT 05
- L MID AFT 06
- R AFT 07
- L AFT 08

DO READING LIGHTS ILLUM WHEN CORRESPONDING SWITCH IS PRESSED?



REPORT ANY FAULT SYMPTOM OR PATTERN NOT SHOWN ABOVE → 33 23 XA --

APPLICABLE CIRCUIT BREAKERS

RIGHT MISC ELEC EQPT PNL

READING LIGHTS - FAULT CODES

EFFECTIVITY

ALL

# 33-FAULT CODE DIAGRAM

02

Page 7  
Mar 20/97

E71265

**BOEING**  
757  
FAULT ISOLATION/MAINT MANUAL

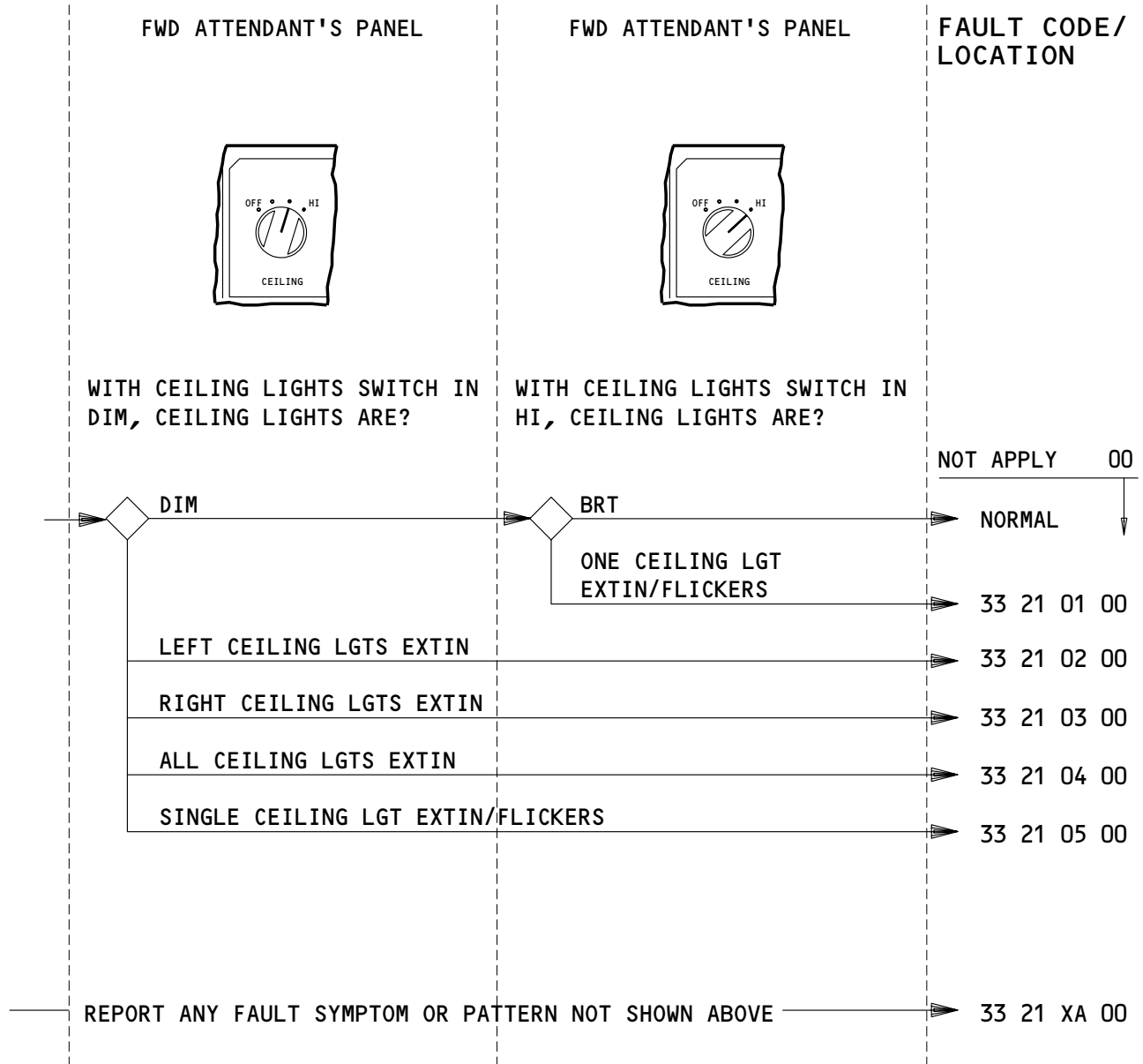

APPLICABLE CIRCUIT BREAKERS  
RIGHT MISC RELAY PNL

CEILING LIGHTS - FAULT CODES

EFFECTIVITY

ALL

# 33-FAULT CODE DIAGRAM

02

Page 8  
Mar 20/97

FWD ATTENDANT'S PANEL

FAULT CODE/  
LOCATION

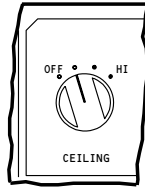

WITH CEILING LIGHTS SWITCH IN  
POSITION SHOWN, NIGHT LIGHTS  
ARE?

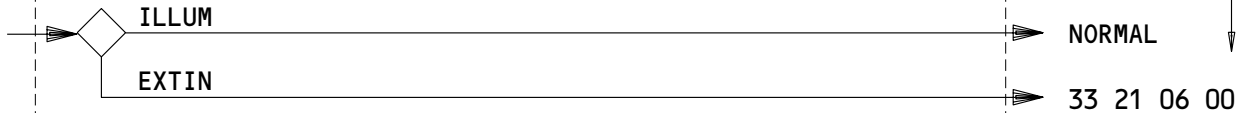

REPORT ANY FAULT SYMPTOM OR PATTERN NOT SHOWN ABOVE → 33 21 XB 00

APPLICABLE CIRCUIT BREAKERS

APU/EXT PWR PNL

NIGHT LIGHTS – FAULT CODES

EFFECTIVITY

ALL

## 33-FAULT CODE DIAGRAM

02

Page 9  
Mar 20/97

**BOEING**  
757  
FAULT ISOLATION/MAINT MANUAL

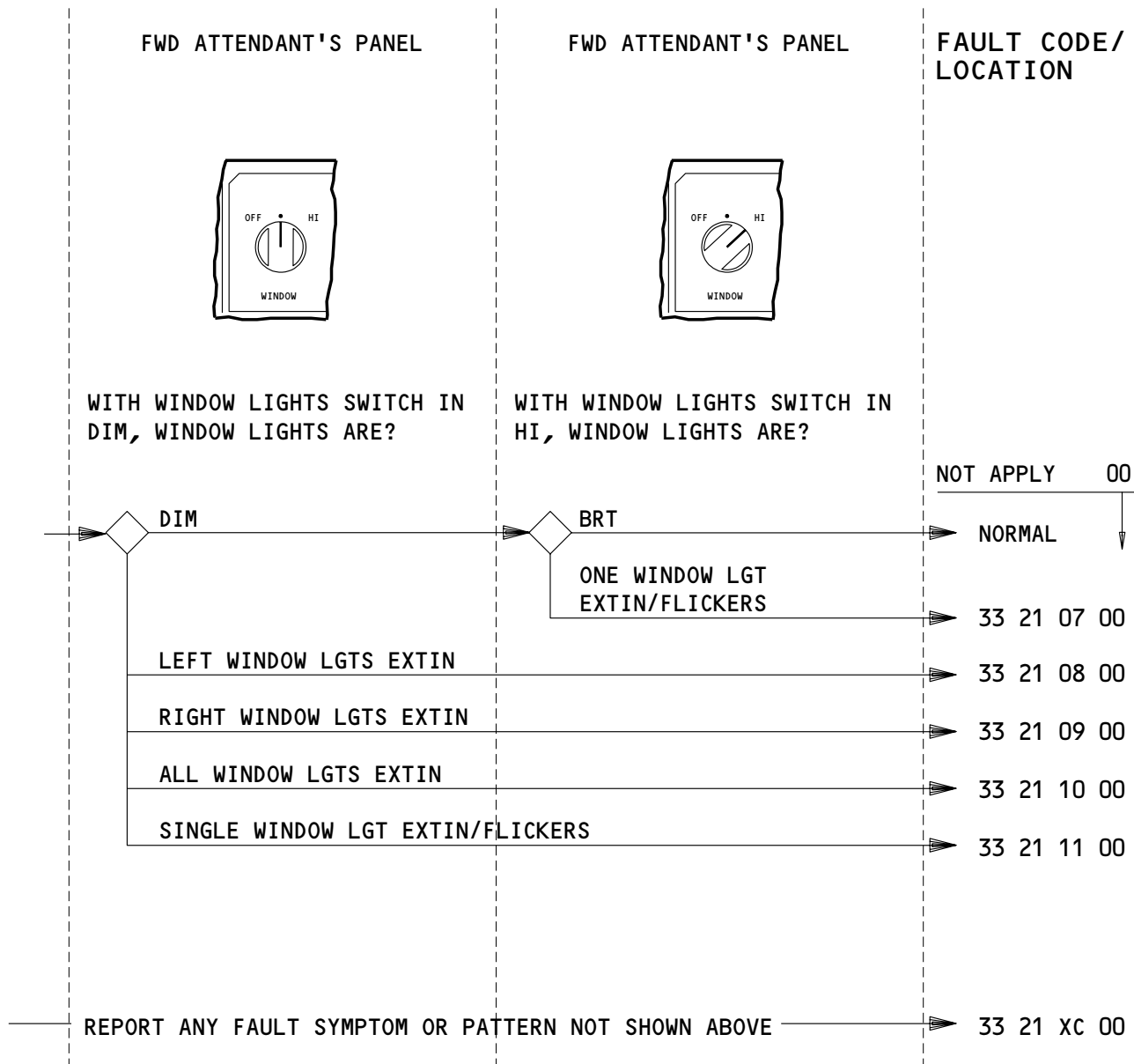

APPLICABLE CIRCUIT BREAKERS  
RIGHT MISC RELAY PNL

WINDOW (SIDEWALL) LIGHTS - FAULT CODES

EFFECTIVITY

ALL

# 33-FAULT CODE DIAGRAM

01

Page 10  
Mar 20/97

# BOEING

## 757

### FAULT ISOLATION/MAINT MANUAL

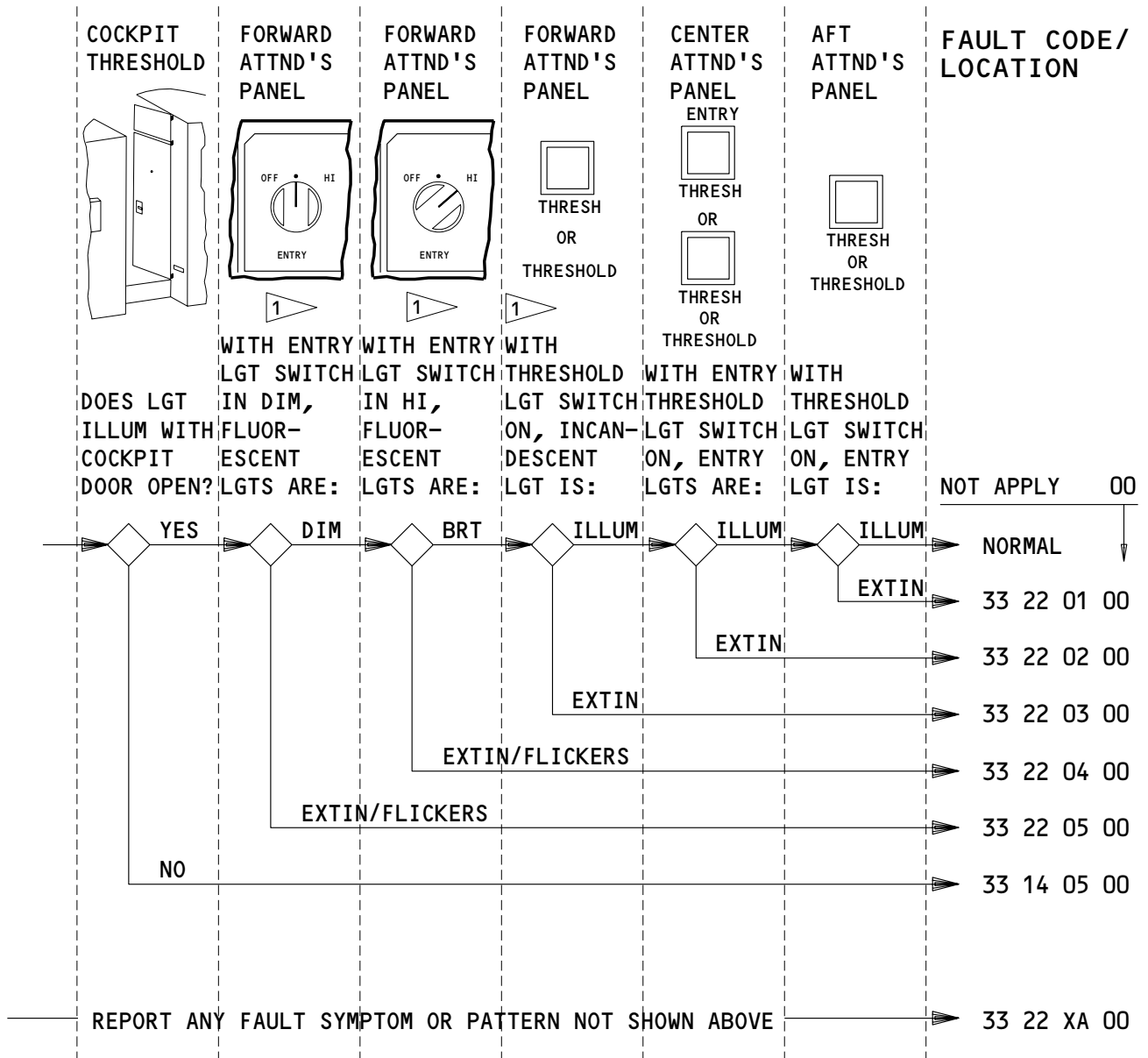

1 LEFT FWD THRESHOLD, WORK, LAV AND FLUORESCENT ENTRY LIGHTS CANNOT BE TURNED ON IF L FWD ENTRY DOOR IS CLOSED AND THE FLIGHT DECK DOOR IS OPEN.

APPLICABLE CIRCUIT BREAKERS AS INSTALLED

11R34 DOOR GIRT BAR

11R34 DOOR GIRT BAR ENT DIM

APU/EXT PWR PNL  
RIGHT MISC RELAY PNL

### ENTRY/THRESHOLD LIGHTS - FAULT CODES

EFFECTIVITY

ALL

## 33-FAULT CODE DIAGRAM

02

Page 11  
Mar 20/97



**BOEING**  
757  
FAULT ISOLATION/MAINT MANUAL

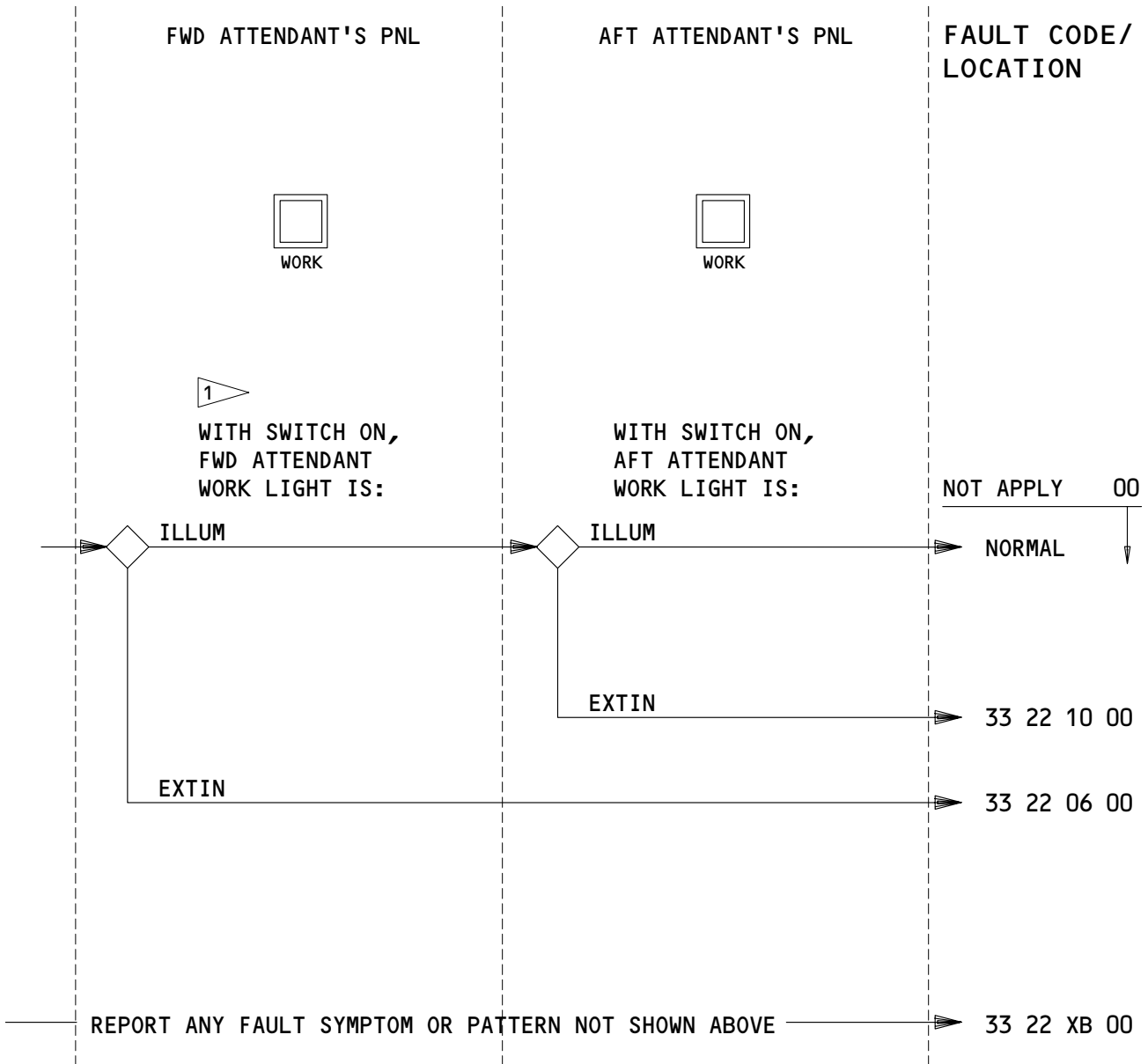

1 WORK LGT CANNOT BE TURNED ON IF L FWD ENTRY DOOR IS CLOSED AND THE FLIGHT DECK DOOR IS OPEN.

APPLICABLE CIRCUIT BREAKERS

11R34 DOOR GIRT BAR ENT DIM

ATTENDANT'S WORK LIGHTS – FAULT CODES

EFFECTIVITY

ALL

# 33-FAULT CODE DIAGRAM

06

Page 12  
Mar 20/97



757  
FAULT ISOLATION/MAINT MANUAL

PASSENGER SERVICE UNIT



FAULT CODE/  
LOCATION

- R FWD 01
- L FWD 02
- R MID FWD 03
- L MID FWD 04
- R MID AFT 05
- L MID AFT 06
- R AFT 07
- L AFT 08

DO READING LIGHTS ILLUM WHEN CORRESPONDING SWITCH IS PRESSED?

NOT APPLY 00



REPORT ANY FAULT SYMPTOM OR PATTERN NOT SHOWN ABOVE → 33 23 XA --

APPLICABLE CIRCUIT BREAKERS

RIGHT MISC ELEC EQPT PNL

READING LIGHTS - FAULT CODES

EFFECTIVITY

ALL

# 33-FAULT CODE DIAGRAM

02

Page 13  
Mar 20/97

**BOEING**  
757  
FAULT ISOLATION/MAINT MANUAL

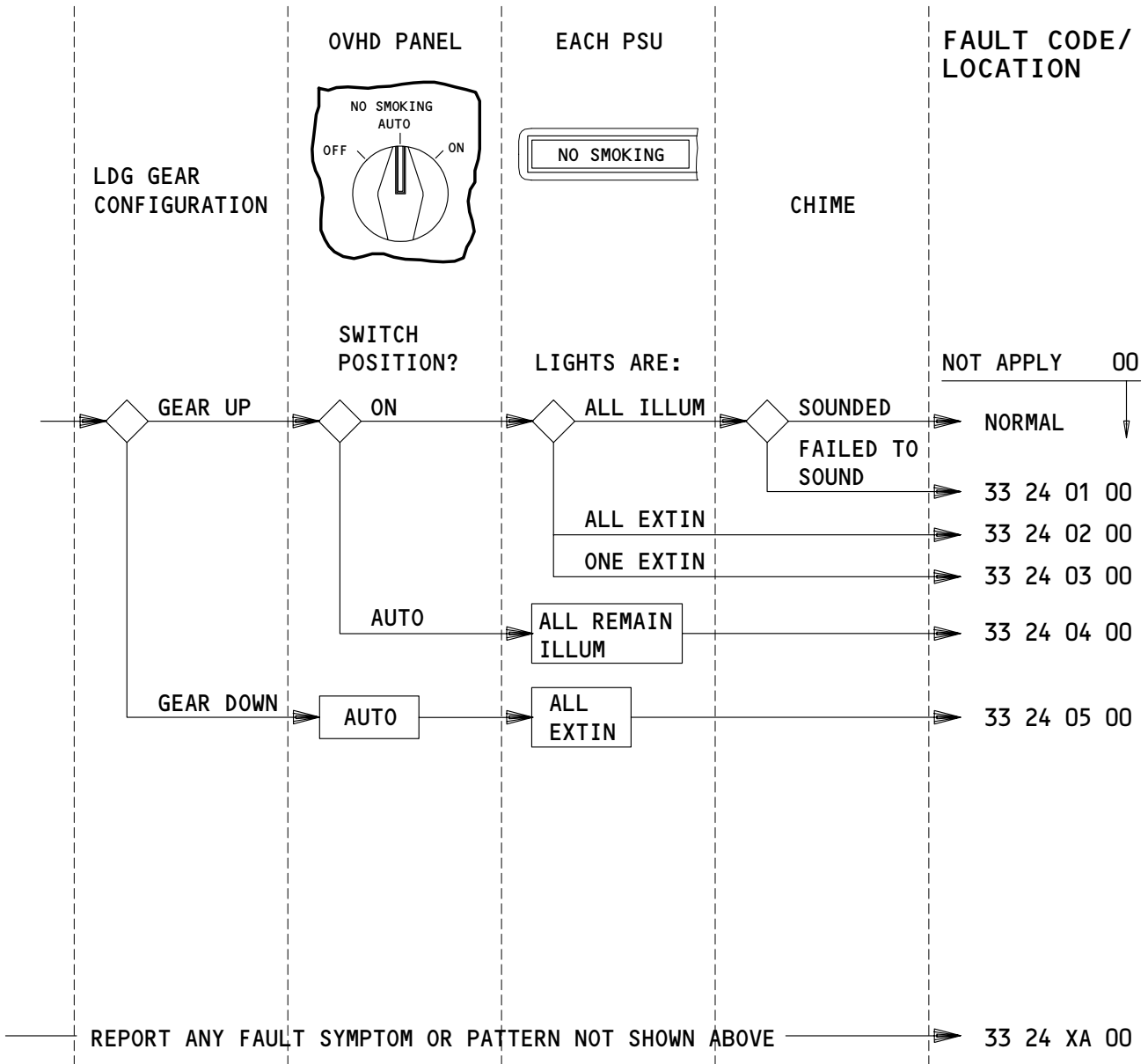

APPLICABLE CIRCUIT BREAKERS

11P9 PASS SIGN CONT

APU/EXT PWR PNL

NO SMOKING LIGHTS - FAULT CODES

EFFECTIVITY

ALL

# 33-FAULT CODE DIAGRAM

02

Page 14  
Mar 20/97

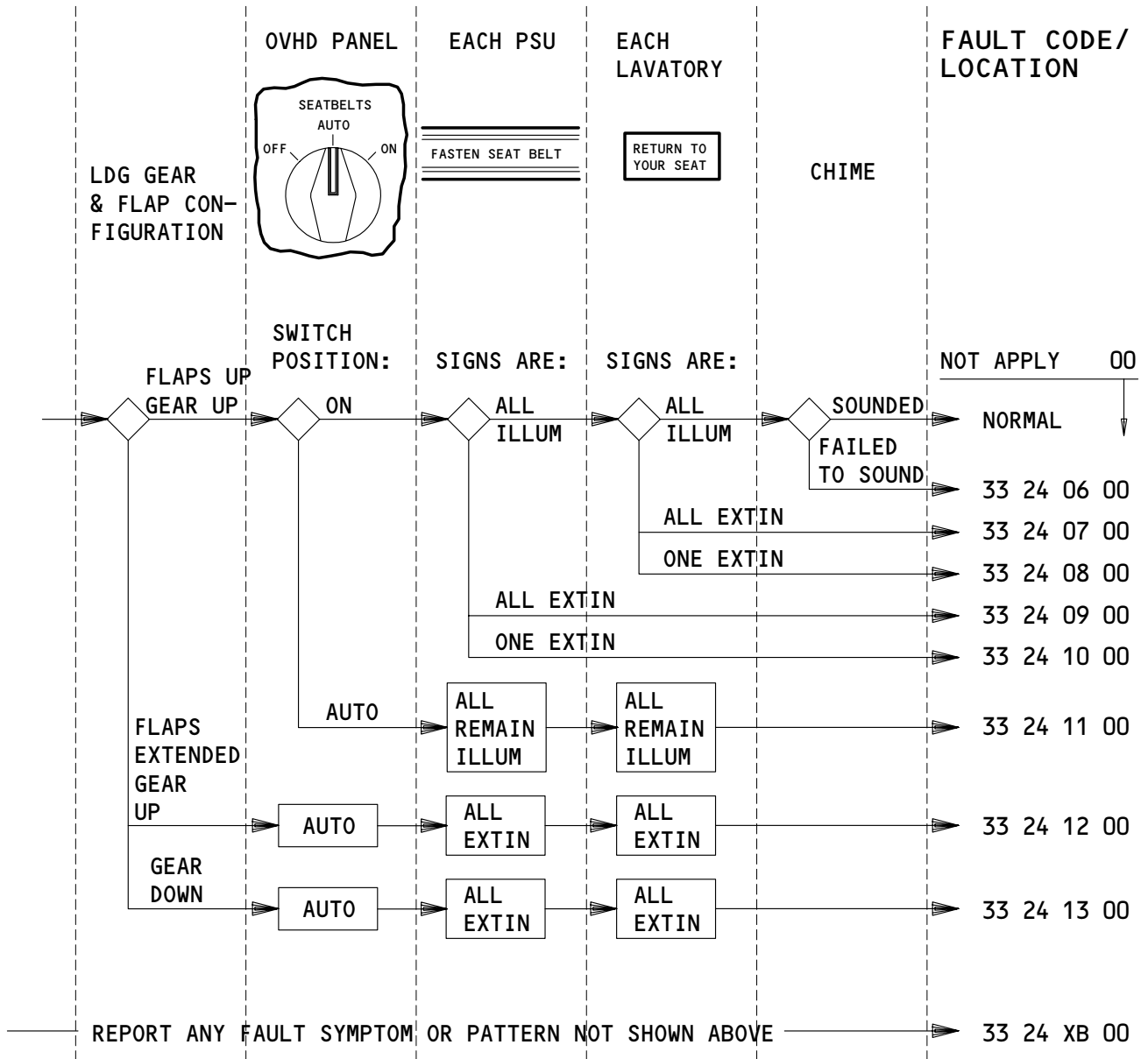

APPLICABLE CIRCUIT BREAKERS

11P9 PASS SIGN CONT

APU/EXT PWR PNL

SEAT BELT AND RETURN TO SEAT SIGNS – FAULT CODES

EFFECTIVITY  
ALL

# 33-FAULT CODE DIAGRAM

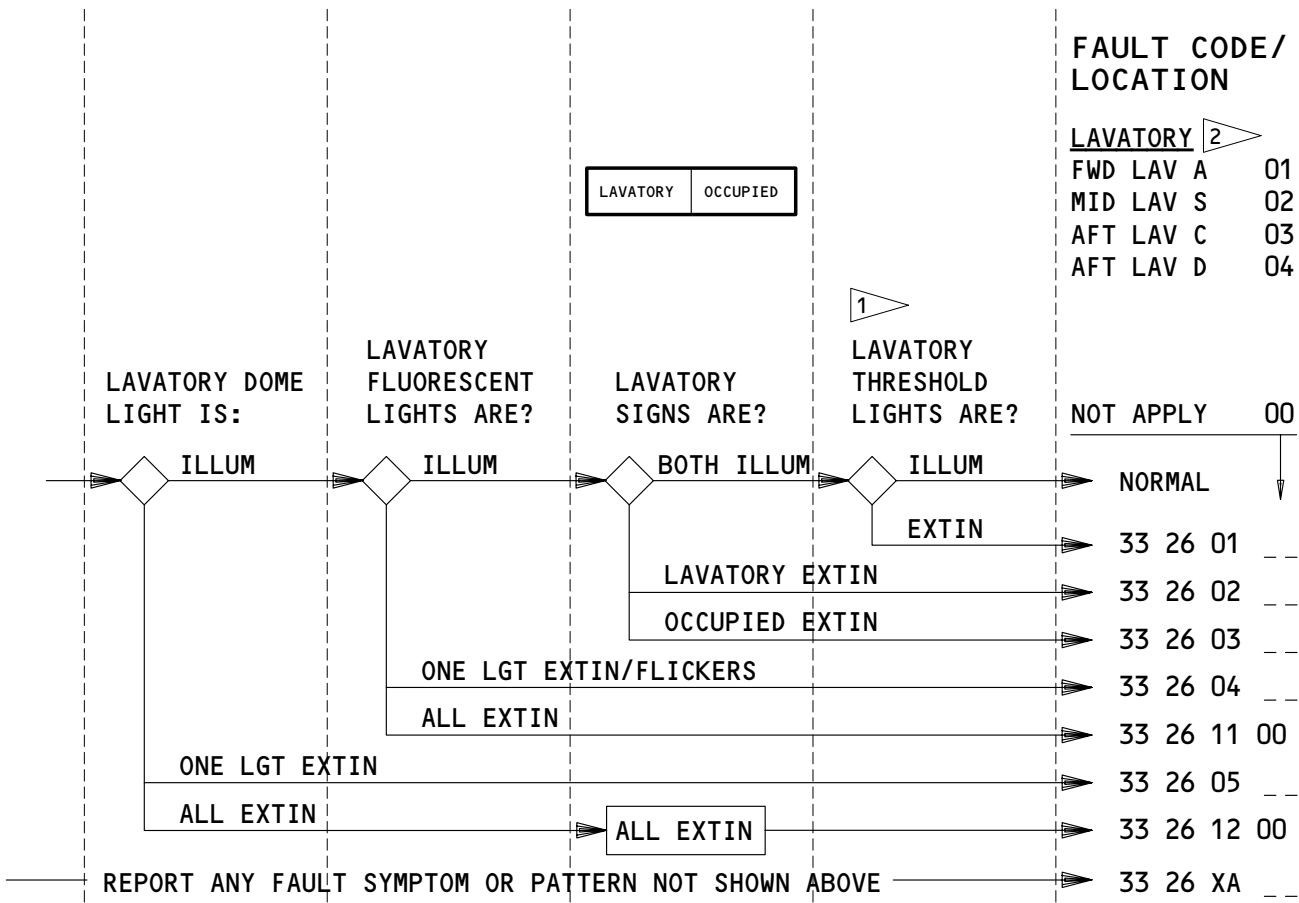

<sup>1</sup> LAV A THRESHOLD LGT CANNOT BE TURNED ON IF L FWD ENTRY DOOR IS CLOSED (SLIDE LGT ILLUM) AND THE FLIGHT DECK DOOR IS OPEN.

<sup>2</sup> LAVATORY LOCATIONS

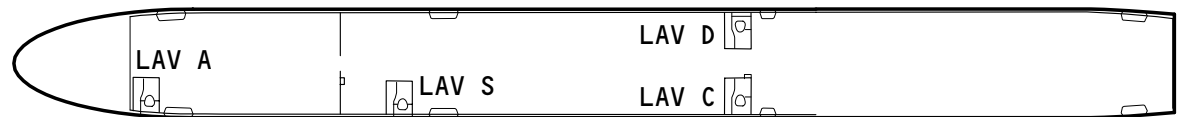

APPLICABLE CIRCUIT BREAKERS

11R34 DOOR GIRT BAR ENT DIM

APU/EXT PWR PNL

LAVATORY LIGHTS - FAULT CODES

EFFECTIVITY  
ALL

**33-FAULT CODE DIAGRAM**

156609

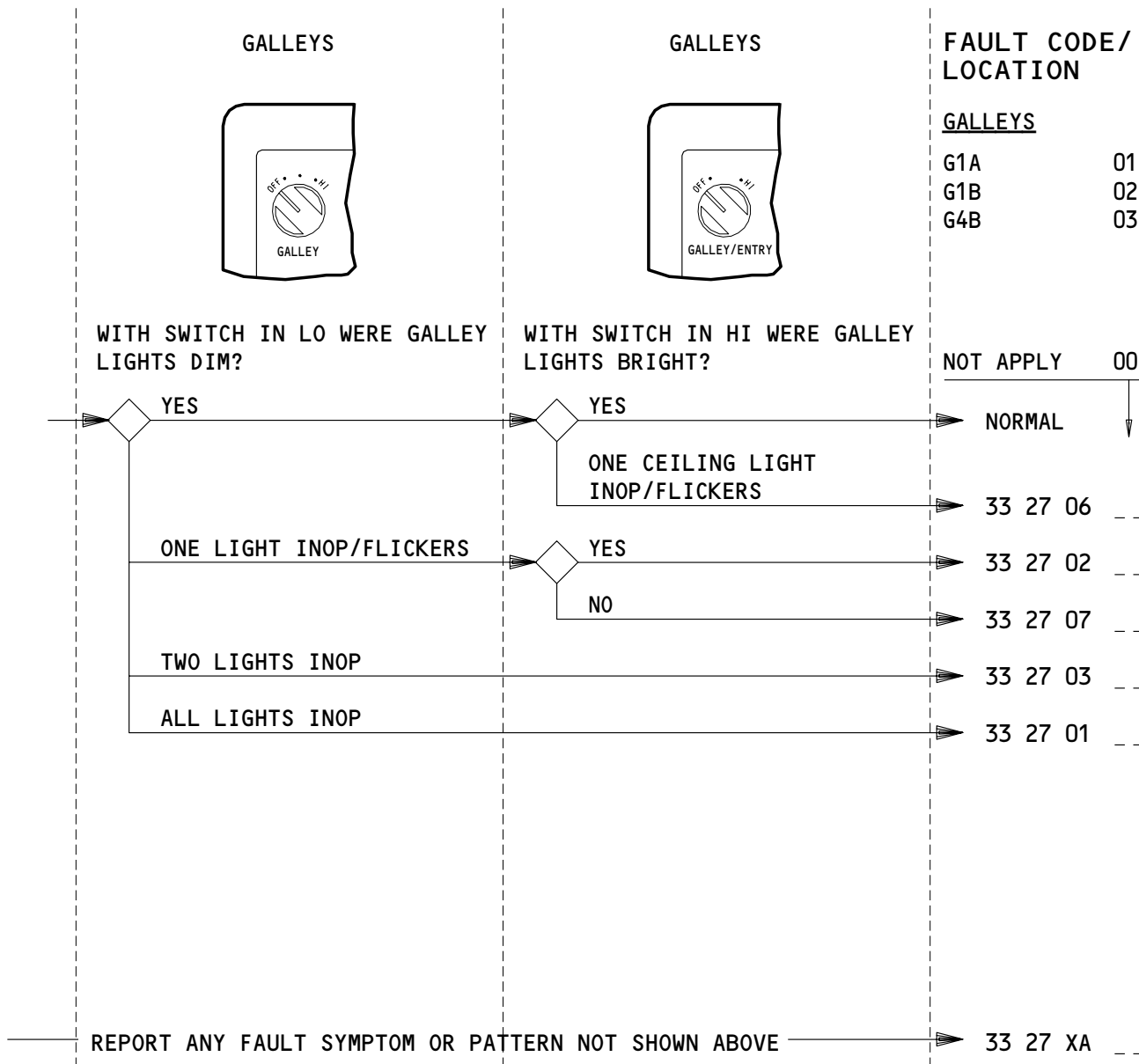

APPLICABLE CIRCUIT BREAKERS  
RIGHT MISC RELAY PNL

**GALLEY LIGHTS - FAULT CODES**

EFFECTIVITY

ALL

## 33-FAULT CODE DIAGRAM

**BOEING**  
757  
FAULT ISOLATION/MAINT MANUAL

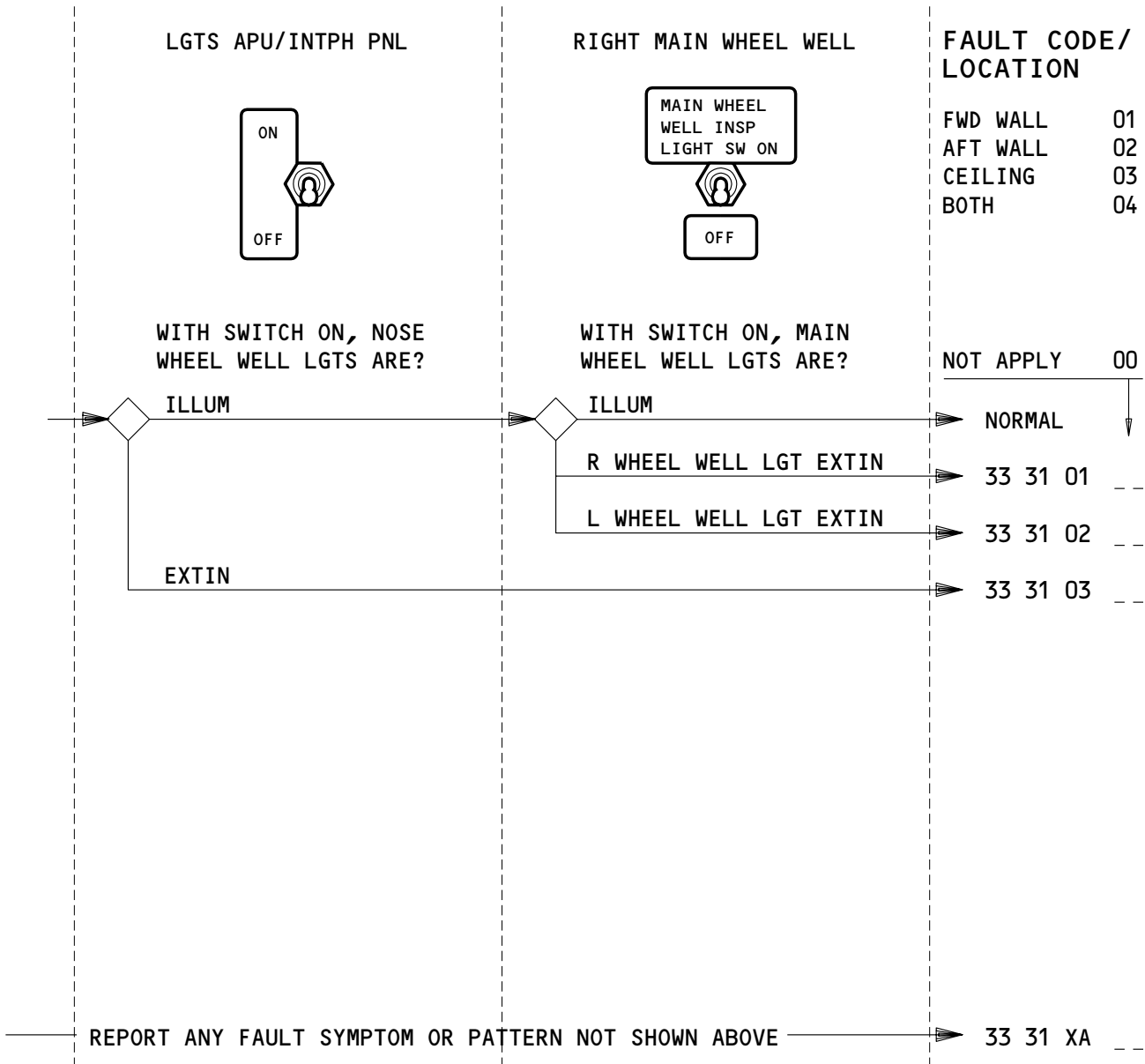

APPLICABLE CIRCUIT BREAKERS

APU/EXT PWR PNL

WHEEL WELL LIGHTS - FAULT CODES

EFFECTIVITY

ALL

# 33-FAULT CODE DIAGRAM

02

Page 18  
Mar 20/97



757

FAULT ISOLATION/MAINT MANUAL

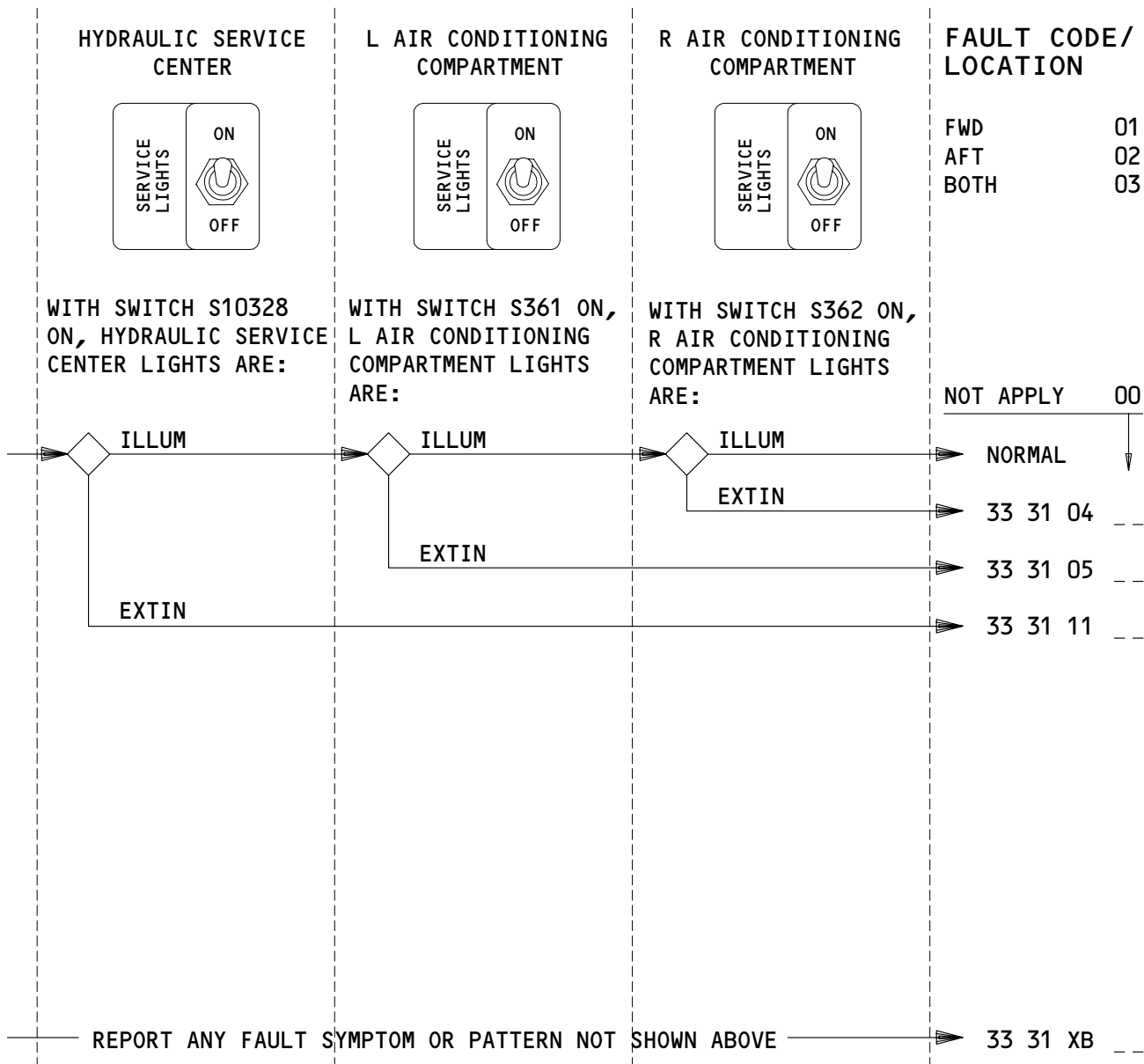

APPLICABLE CIRCUIT BREAKERS

34B10(A) LIGHTS AIR COND COMPT HYD SVCE

AIR CONDITIONING COMPARTMENT AND HYDRAULIC SERVICE CENTER LIGHTS - FAULT CODES (GROUND)

EFFECTIVITY  
ALL

33-FAULT CODE DIAGRAM



**BOEING**  
757  
FAULT ISOLATION/MAINT MANUAL

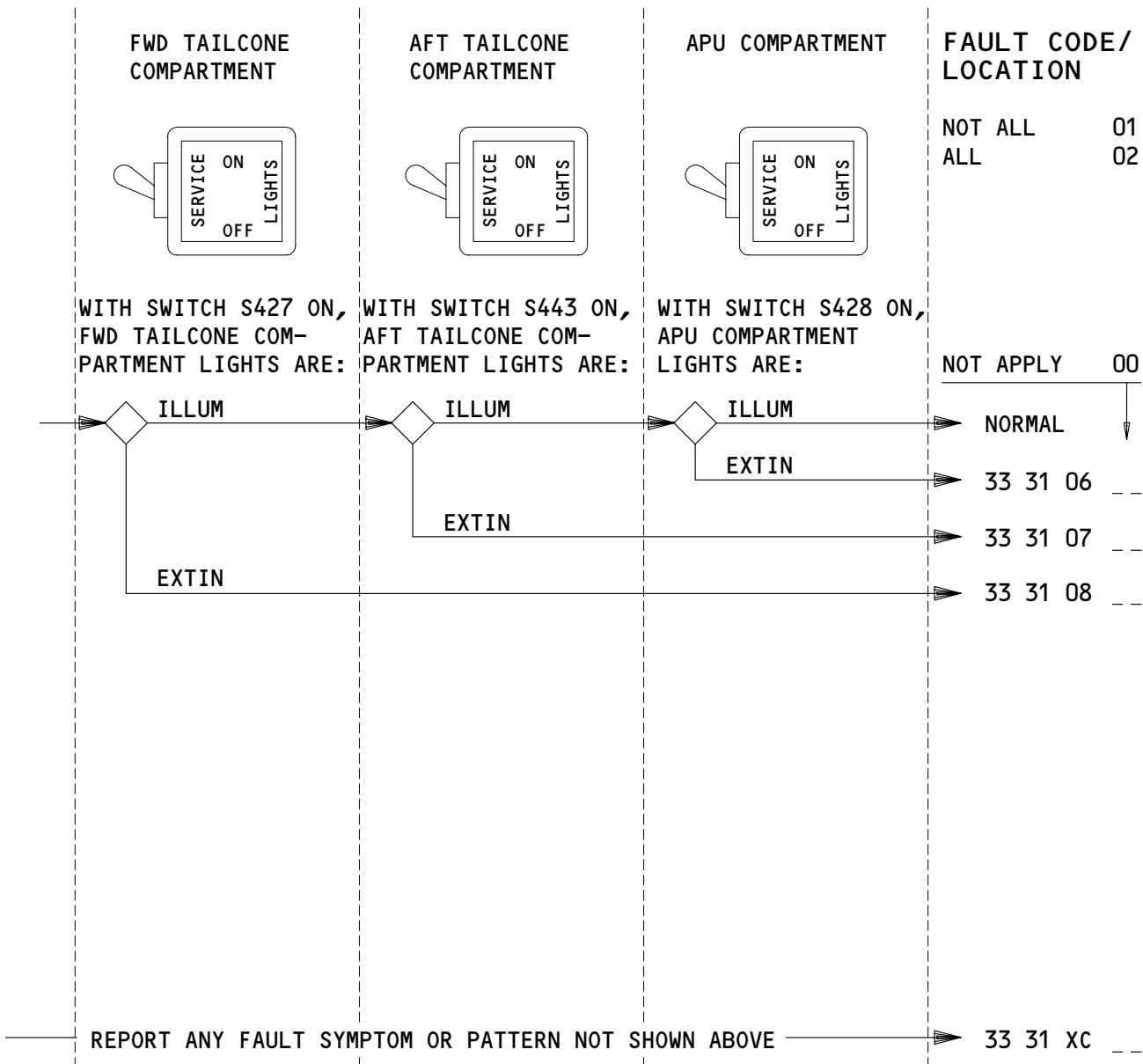

APPLICABLE CIRCUIT BREAKERS

34B7(A) LIGHTS COMPARTMENT APU & TAIL CONE

APU & TAILCONE COMPARTMENT LIGHTS - FAULT CODES (GROUND)

EFFECTIVITY  
ALL

33-FAULT CODE DIAGRAM

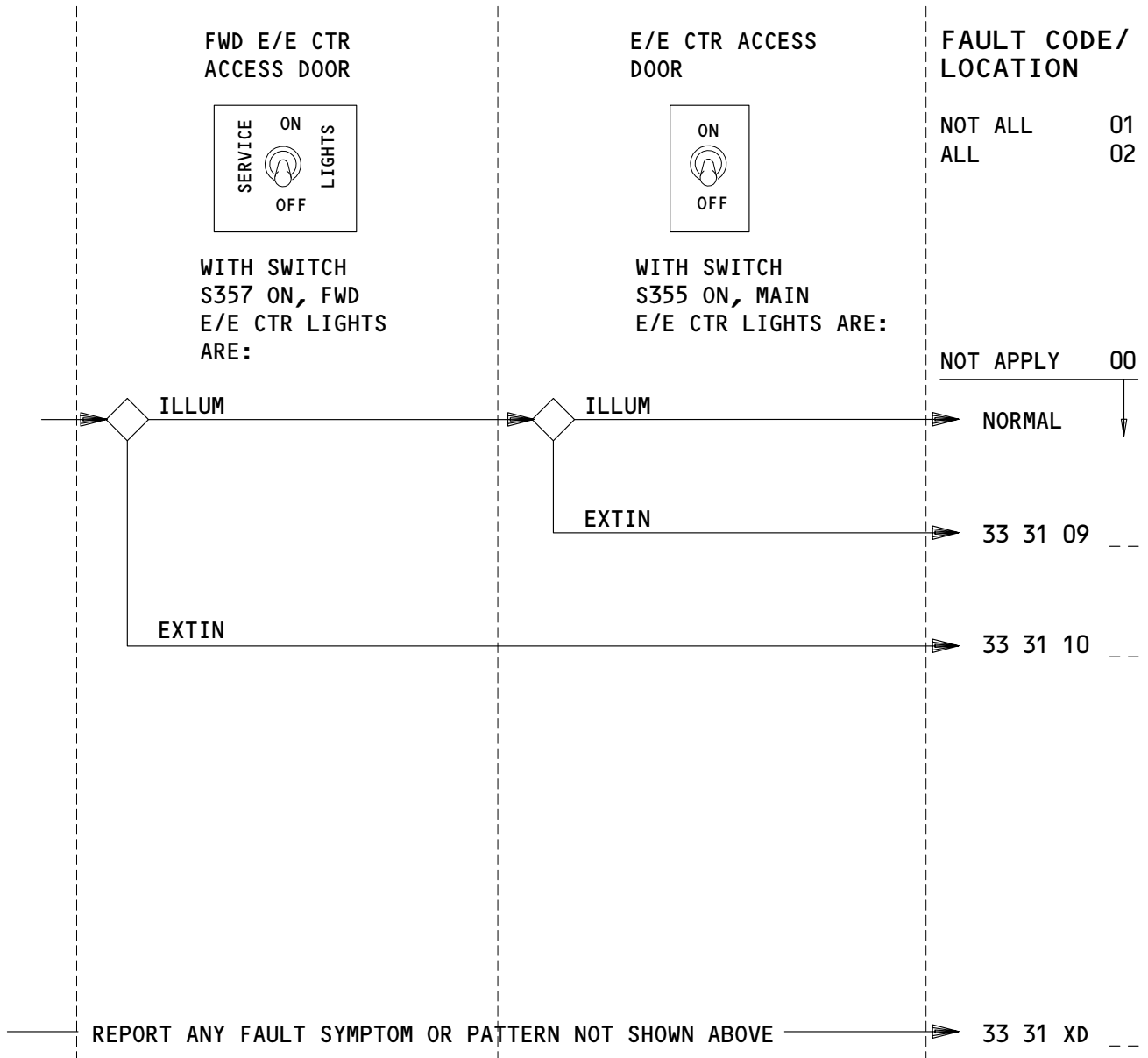

APPLICABLE CIRCUIT BREAKERS

34C1(B)	ELEC EQUIP CTR LIGHTS FWD
34C2(B)	ELEC EQUIP CTR LIGHTS MAIN

ELECTRICAL EQUIPMENT CENTER LIGHTS – FAULT CODES (GROUND)

EFFECTIVITY

---

ALL

## 33-FAULT CODE DIAGRAM

P43 PANEL

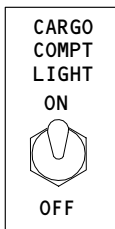

FAULT CODE/  
LOCATION

NOT ALL 01  
ALL 02

WITH SWITCH S10128 ON, FWD CARGO DOOR AND OVERHEAD LIGHTS  
ARE:

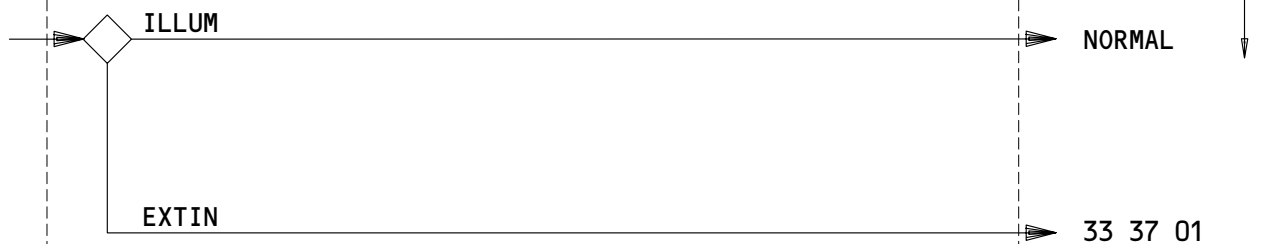

NOT APPLY 00

NORMAL

33 37 01

REPORT ANY FAULT SYMPTOM OR PATTERN NOT SHOWN ABOVE

33 37 XA

APPLICABLE CIRCUIT BREAKERS

34A5(A)	CARGO DOOR CONT
34B8(A)	LIGHTS COMPARTMENT FWD CARGO
P65	LIGHTS CARGO COMPT FWD
P65	LIGHTS CARGO DOOR FWD

FWD CARGO COMPARTMENT LIGHTS - FAULT CODES (GROUND)

EFFECTIVITY

ALL

# 33-FAULT CODE DIAGRAM

02

Page 22  
Mar 20/97

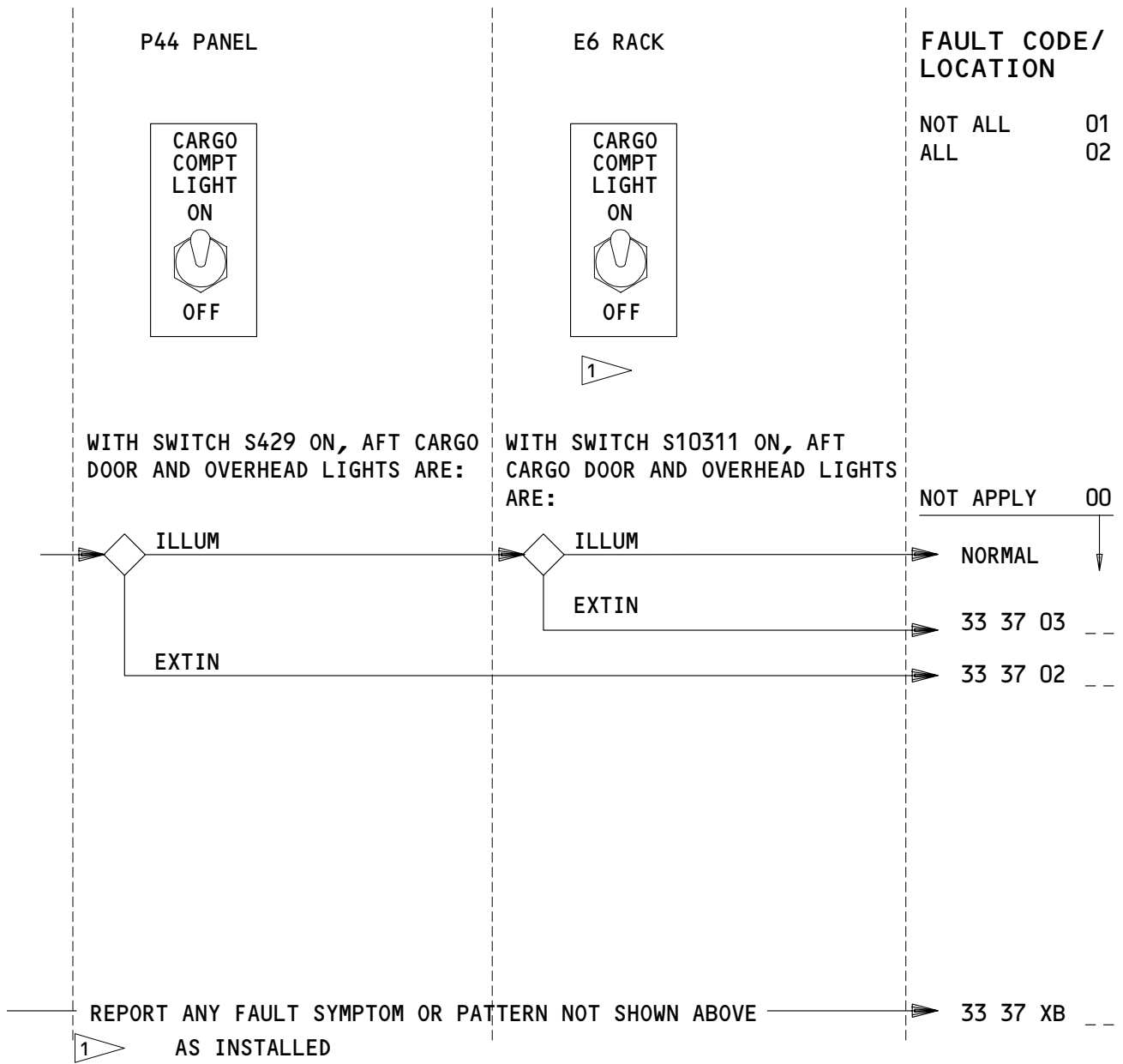

- APPLICABLE CIRCUIT BREAKERS
- |          |                              |
|----------|------------------------------|
| 34A5(A)  | CARGO DOOR CONT              |
| 34B9(A)  | LIGHTS COMPARTMENT AFT CARGO |
| E6 (TOP) | CARGO LIGHTS L               |
| E6 (TOP) | CARGO LIGHTS R               |
| E6 (TOP) | CARGO LIGHTS NO. 2 DOOR      |

**AFT CARGO COMPARTMENT LIGHTS – FAULT CODES (GROUND)**

EFFECTIVITY

ALL
-----

## 33-FAULT CODE DIAGRAM

# BOEING

## 757

### FAULT ISOLATION/MAINT MANUAL

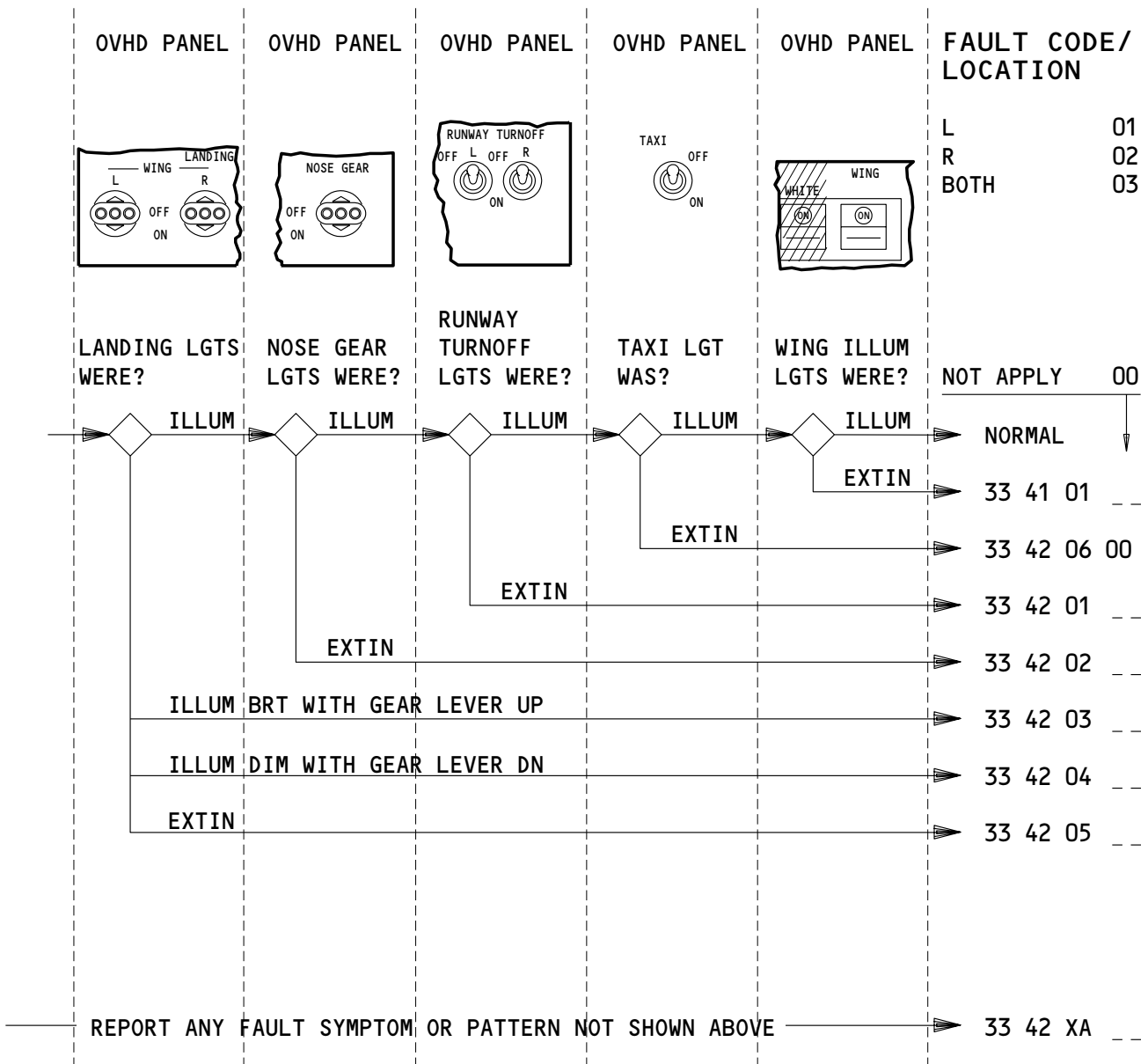

**APPLICABLE CIRCUIT BREAKERS AS INSTALLED**

11M3	LANDING NOSE GEAR LEFT	11M8	TAXI LTS LEFT
11M4	LANDING NOSE GEAR RIGHT	11M9	TAXI LTS RIGHT
11M5	LANDING WING LEFT	11M31	LANDING & TAXI CONT
11M6	RUNWAY TURNOFF LEFT	11M32	LANDING WING RIGHT
11M8	TAXI	11M33	RUNWAY TURNOFF RIGHT
11M8	TAXI LIGHT	11M35	WING ILLUM

### LANDING, RUNWAY TURNOFF, TAXI AND WING LIGHTS - FAULT CODES

EFFECTIVITY

ALL

## 33-FAULT CODE DIAGRAM

12

Page 24  
Mar 20/97

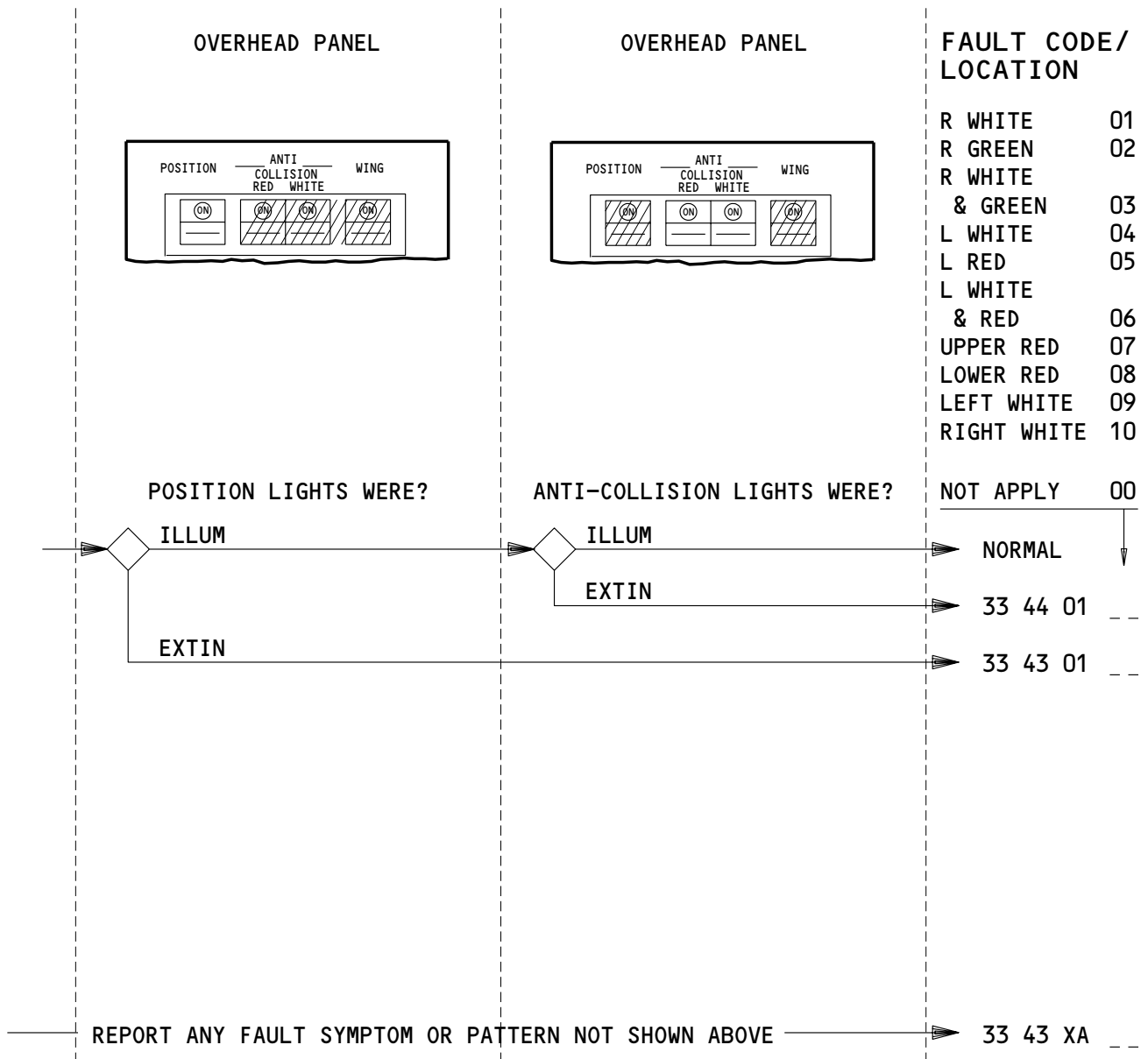

APPLICABLE CIRCUIT BREAKERS AS INSTALLED

11M7	ANTI-COLL WHITE	11Q29	POSITION LEFT B
11M34	ANTI-COLL RED	11Q30	POSITION RIGHT (A)
11Q28	POSITION LEFT (A)	11Q31	POSITION RIGHT B

POSITION AND ANTI-COLLISION LIGHTS - FAULT CODES

EFFECTIVITY

ALL

## 33-FAULT CODE DIAGRAM

01

Page 25  
Mar 20/97

OVERHEAD PANEL

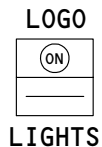

FAULT CODE/  
LOCATION

R INBD 01  
 R OUTBD 02  
 L INBD 03  
 L OUTBD 04  
 ALL 05

LOGO LIGHTS ARE:

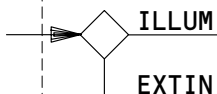

NOT APPLY 00

NORMAL

33 45 01

REPORT ANY FAULT SYMPTOM OR PATTERN NOT SHOWN ABOVE

33 45 XA

APPLICABLE CIRCUIT BREAKERS

MISC RELAY PNL

LOGO LIGHTS - FAULT CODES

EFFECTIVITY

ALL

# 33-FAULT CODE DIAGRAM

02

Page 26  
 Jun 20/97

# BOEING

## 757

### FAULT ISOLATION/MAINT MANUAL

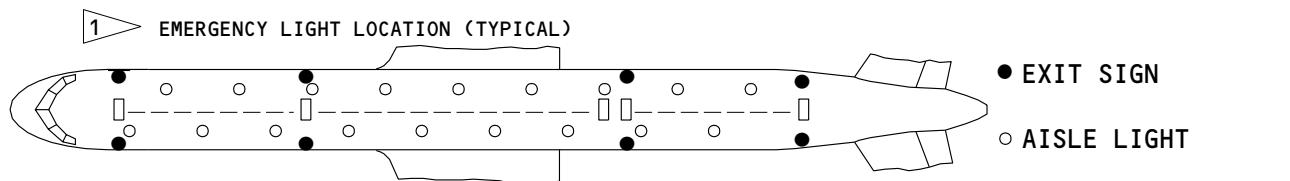
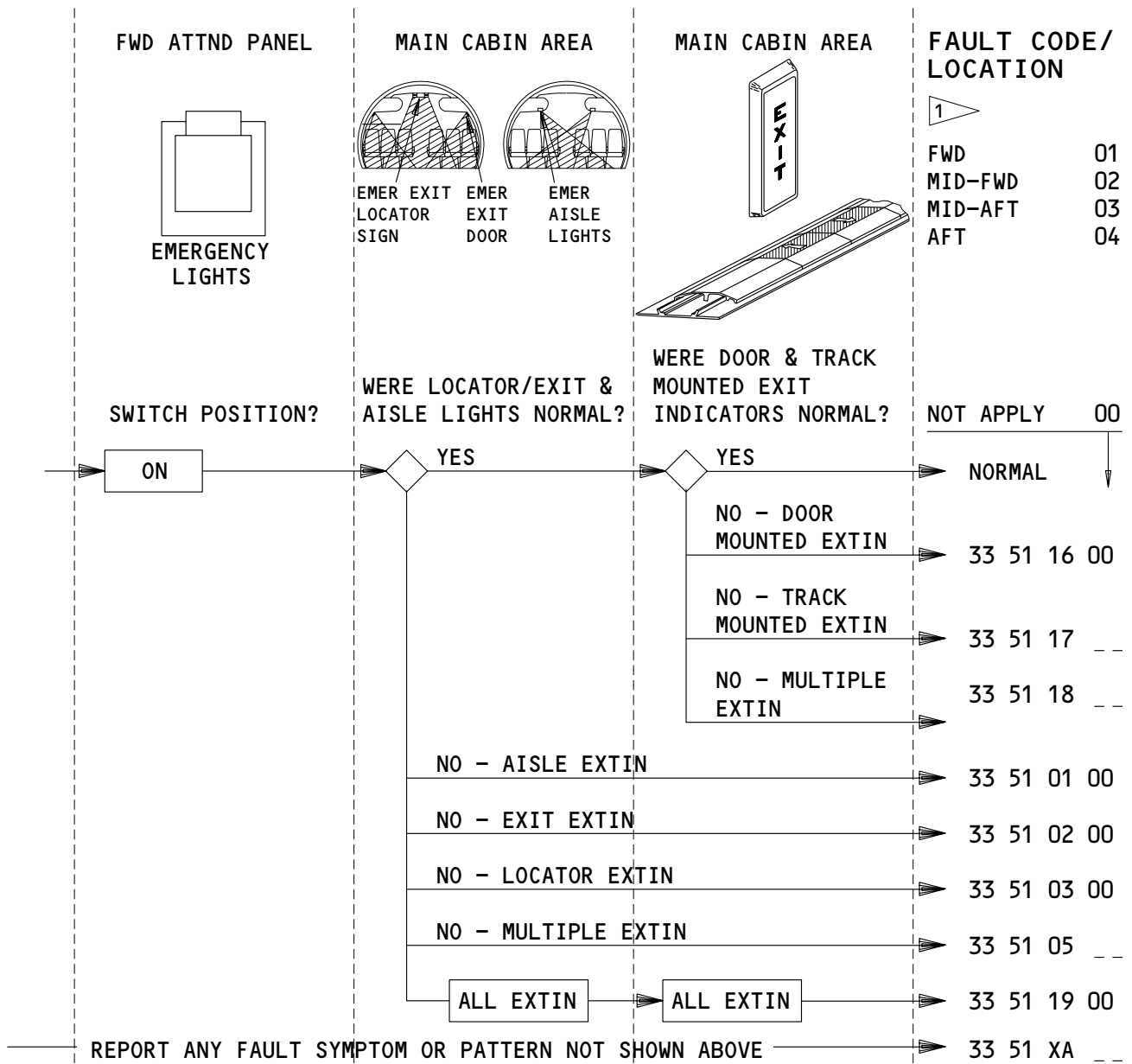

APPLICABLE CIRCUIT BREAKERS AS INSTALLED

11C35	EMER CHGR ALTN (LEFT, L)	11N35	EMERGENCY CHARGER L
11C36	EMER CHGR ALTN (RIGHT, R)	11N36	EMERGENCY CHARGER R
11N35	EMER CHGR L	11N36	EMER CHGR R

--- TRACK MOUNTED EXIT INDICATORS

#### EMERGENCY LIGHTS INTERIOR (ATTND PNL SW) - FAULT CODES

EFFECTIVITY

ALL

## 33-FAULT CODE DIAGRAM

262022



# BOEING

## 757

### FAULT ISOLATION/MAINT MANUAL

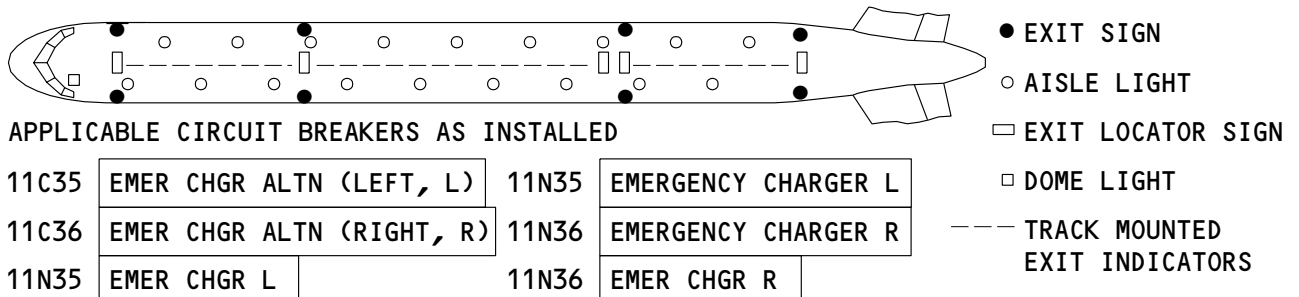
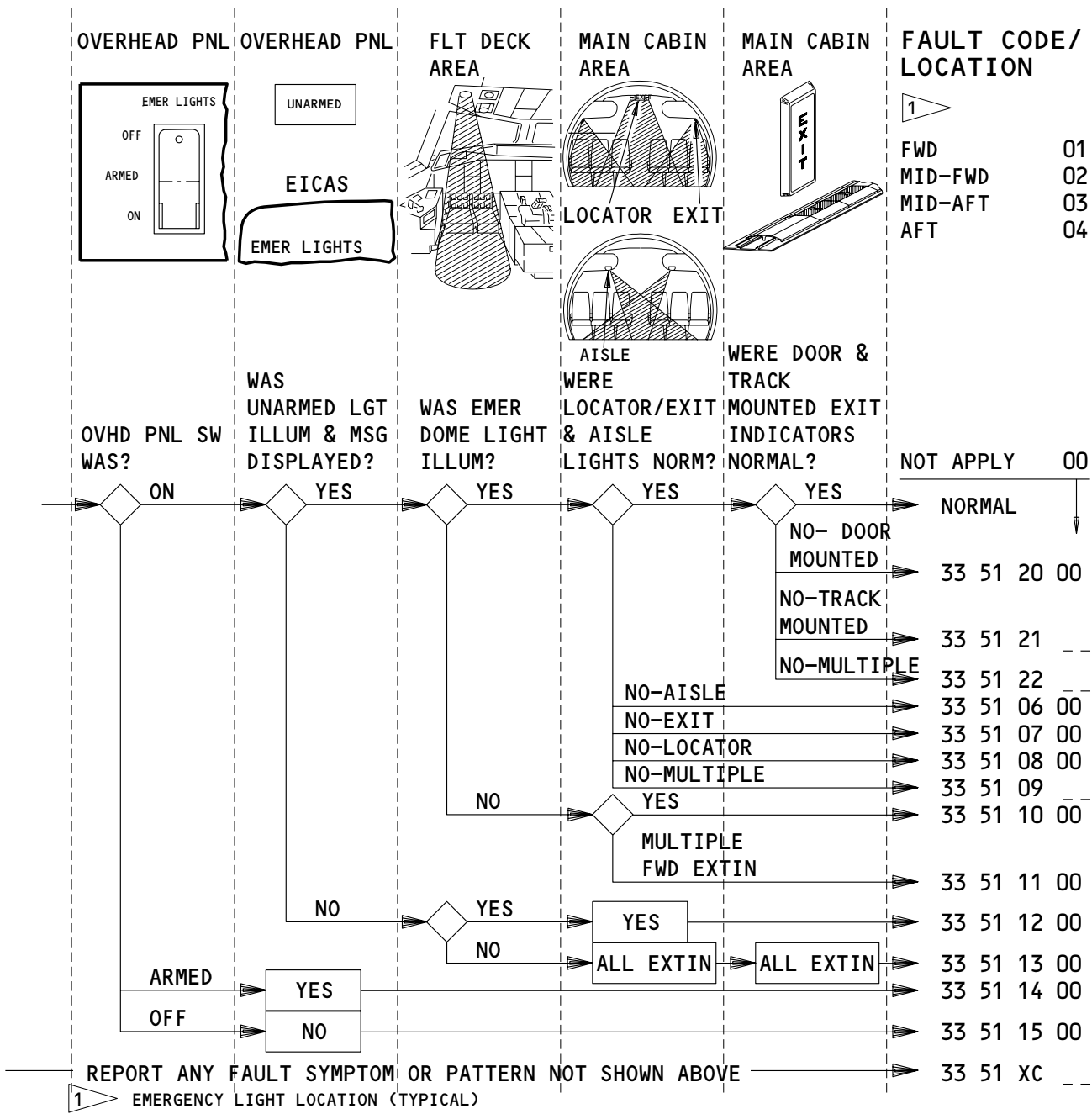

### EMERGENCY LIGHTS INTERIOR (OVHD PNL SW) - FAULT CODES

EFFECTIVITY

ALL

## 33-FAULT CODE DIAGRAM

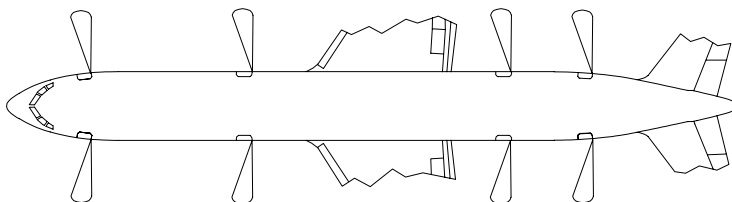

**FAULT CODE/  
LOCATION**

DOOR 1L	01
DOOR 1R	02
DOOR 2L	03
DOOR 2R	04
DOOR 3L	05
DOOR 3R	06
DOOR 4L	07
DOOR 4R	08
ALL	09

LIGHTS INTERPHONE  
PANEL  
EMER  
LT TEST SW

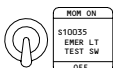

EXTERIOR EMER  
SLIDE LTS ARE:

NOT APPLY 00

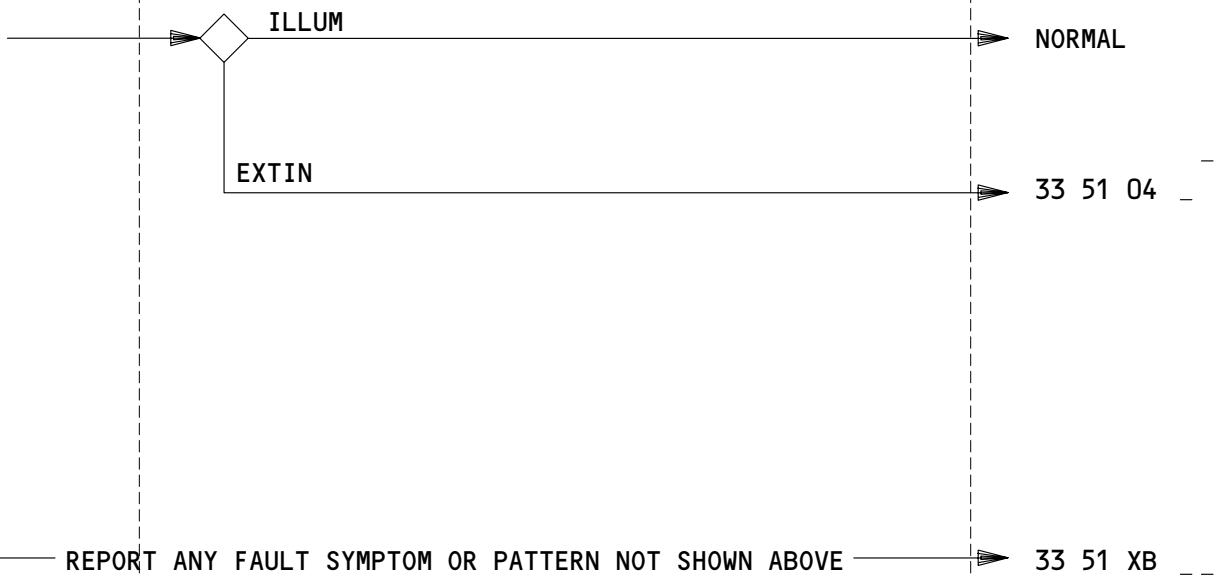

**APPLICABLE CIRCUIT BREAKERS**

11C35	EMER CHGR ALTN LEFT
11C36	EMER CHGR ALTN RIGHT
11N35	EMERGENCY CHARGER LEFT
11N36	EMERGENCY CHARGER RIGHT

**EXTERIOR EMERGENCY LIGHTS TEST - FAULT CODES (GROUND)**

EFFECTIVITY

ALL

**33-FAULT CODE DIAGRAM**

06

Page 29  
Jun 20/97



**BOEING**  
757  
FAULT ISOLATION/MAINT MANUAL

FAULT CODE	LOG BOOK REPORT	FAULT ISOLATION REFERENCE
33 11 XA 00	Report floodlights symptoms or patterns along with fault code.	SSM 33-11-01 thru SSM 33-11-04
33 11 XB --	(01=CAPT, 02=F/O, 03=L AFT) A dome light problem was encountered by the flight crew which is not covered in the fault code diagram.	SSM 33-11-03
33 13 XA 00	Report pilots instrument/misc panel lighting symptoms or patterns along with fault code.	SSM 33-13-01 thru SSM 33-13-03
33 13 XB 00	An overhead, glareshield, aisle stand, or accessory panel light problem was encountered by the flight crew which is not covered in the fault code diagram.	SSM 33-13-03 thru SSM 33-13-07
33 14 XA --	Report map, chart, flight kit/utility lights symptoms or patterns along with fault code.	SSM 33-14-01, SSM 33-14-02
33 16 XA 00	Report miscellaneous bulbs/master dim and test symptoms or patterns along with fault code.	SSM 33-16-00 thru SSM 33-16-05
33 21 XA 00	Report ceiling lights symptoms or patterns along with fault code.	SSM 33-21-01, SSM 33-21-02
33 21 XB 00	Report night lights symptoms or patterns along with fault code.	SSM 33-21-05
33 21 XC 00	Report window (sidewall) lights symptoms or patterns along with fault code.	SSM 33-21-03, SSM 33-21-04
33 22 XA 00	Report entry/threshold lights symptoms or patterns along with fault code.	SSM 33-22-01
33 22 XB 00	Report attendant's work lights symptoms or patterns along with fault code.	SSM 33-22-01

EFFECTIVITY

ALL

## 33-FAULT CODE INDEX

06

Page 1  
Sep 20/08



**BOEING**  
757  
FAULT ISOLATION/MAINT MANUAL

FAULT CODE	LOG BOOK REPORT	FAULT ISOLATION REFERENCE
33 23 XA --	Report reading lights symptoms or patterns along with fault code.	SSM 33-23-01, SSM 33-23-02
33 24 XA 00	A no smoking light problem was encountered by the flight crew which is not covered in the fault code diagram.	SSM 33-24-00, SSM 33-24-01
33 24 XB 00	A seat belt and return to seat signs problem was encountered by the flight crew which is not covered in the fault code diagram.	SSM 33-24-00, SSM 33-24-01
33 25 XB --	(01=L, 02=R, 03=FWD, 04=MID FWD, 05=MID AFT, 06=AFT) An attendant's call from seat problem was encountered by the flight crew which is not covered in the fault code diagram.	SSM 33-25-01, SSM 33-25-02
33 25 XC --	(01=FWD LAV A, 02=FWD LAV F, 03=MID LAV S, 04=MID LAV C, 05=MID LAV D, 06=FWD, 07=MID FWD, 08=MID AFT, 09=AFT) An attendant's call from lavatory problem was encountered by the flight crew which is not covered in the fault code diagram.	SSM 33-25-01, SSM 33-25-02
33 26 XA --	(01=FWD LAV A, 02=MID LAV S, 03=AFT LAV C, 04=AFT LAV D) A lavatory light problem was encountered by the flight crew which is not covered in the fault code diagram.	SSM 33-26-01, SSM 33-26-02
33 27 XA --	(01=G1A, 02=G1B, 03=G4B) A galley light problem was encountered by the flight crew which is not covered in the fault code diagram.	SSM 33-27-01, SSM 33-27-03
33 31 XA --	Report wheel well lights symptoms or patterns along with fault code.	SSM 33-31-01

EFFECTIVITY

ALL

## 33-FAULT CODE INDEX



**BOEING**  
757  
FAULT ISOLATION/MAINT MANUAL

FAULT CODE	LOG BOOK REPORT	FAULT ISOLATION REFERENCE
33 31 XB --	(01=FWD, 02=AFT, 03=BOTH) An air conditioning compartment and hydraulic service center lights problem was encountered on ground which is not covered in the fault code diagram.	SSM 33-31-04
33 31 XC --	(01=NOT ALL, 02=ALL) An APU and tailcone compartment lights problem was encountered on ground which is not covered in the fault code diagram.	SSM 33-31-04
33 31 XD --	(01=NOT ALL, 02=ALL) An electrical equipment center lights problem was encountered on ground which is not covered in the fault code diagram.	SSM 33-31-03
33 37 XA --	(01=NOT ALL, 02=ALL) A fwd cargo compartment lights problem was encountered on ground which is not covered in the fault code diagram.	SSM 33-37-01
33 37 XB --	(01=NOT ALL, 02=ALL) An aft cargo compartment lights problem was encountered on ground which is not covered in the fault code diagram.	SSM 33-37-02
33 42 XA --	(01=L, 02=R, 03=BOTH) A landing, runway turnoff, taxi, or wing lights problem was encountered by the flight crew which is not covered in the fault code diagram.	SSM 33-41-01, SSM 33-42-01, SSM 33-42-02
33 43 XA --	Report position and anticollision lights symptoms and patterns along with fault code.	For position lights, refer to SSM 33-43-01. For anticollision lights, refer to SSM 33-44-01.
33 45 XA --	Report logo lights symptoms or patterns along with fault code.	SSM 33-45-01

EFFECTIVITY

ALL

## 33-FAULT CODE INDEX

12

Page 3  
Sep 20/08

**BOEING**  
 757  
 FAULT ISOLATION/MAINT MANUAL

FAULT CODE	LOG BOOK REPORT	FAULT ISOLATION REFERENCE
33 51 XA --	Report emergency lights interior (attn pnl sw) symptoms or patterns along with fault code.	SSM 33-51-01
33 51 XB --	(01=D00R 1L, 02=D00R 1R, 03=D00R 2L, 04=D00R 2R, 05=D00R 3L, 06=D00R 3R, 07=D00R 4L, 08=D00R 4R, 09=ALL) An exterior emergency lights test problem was encountered on ground which is not covered in the fault code diagram.	SSM 33-51-01
33 51 XC --	Report emergency lights interior (ovhd pnl sw) symptoms or patterns along with fault code.	SSM 33-51-01
33 11 01 00	First Officer's instrument panel floodlight control will not control intensity of lights. Lights come on bright with LT OVRD switch ON.	Replace F/O panel floodlight control potentiometer R508 (WDM 33-11-11). If fault persists, replace F/O panel floodlight dimmer control unit M506 (AMM 33-11-03).
33 11 02 00	First Officer's instrument panel floodlight control will not control intensity of lights. Lights do not come on bright with LT OVRD switch ON.	Relamp F/O instrument panel floodlight L274 (AMM 33-11-00). If fault persists, replace F/O panel floodlight dimmer control unit M506 (AMM 33-11-03).
33 11 03 00	Aisle stand floodlight control will not control intensity of lights. Lights come on bright with LT OVRD switch ON.	Replace left lighting control panel M10056 (PANEL/FLOOD AISLE STAND control YSNR2 is faulty) (WDM 33-11-21).
33 11 04 00	Aisle stand floodlight control will not control intensity of lights. Lights do not come on bright with LT OVRD switch ON.	Relamp left and right aisle stand floodlights L443 and L444 (AMM 33-11-00).

EFFECTIVITY

ALL

## 33-FAULT CODE INDEX



**BOEING**  
757  
FAULT ISOLATION/MAINT MANUAL

FAULT CODE	LOG BOOK REPORT	FAULT ISOLATION REFERENCE
33 11 05 00	Glareshield floodlight control will not control intensity of lights. Lights come on bright with LT OVRD switch ON.	Replace left lighting control panel M10056 (PANEL/FLOOD GLARESHIELD control YSNR1 is faulty) (WDM 33-11-21). If fault persists, replace glareshield floodlight dimmer control unit M843 (AMM 33-11-03).
33 11 06 00	Glareshield floodlight control will not control intensity of lights. Lights do not come on bright with LT OVRD switch ON.	Replace glareshield floodlight dimmer control unit M843 (AMM 33-11-03).
33 11 07 00	Captain's instrument panel floodlight control will not control intensity of (captain's instrument panel, center instrument panel) lights. Lights come on bright with LT OVRD switch ON.	Replace capt and ctr panel floodlight control potentiometer R507 (WDM 33-11-11). If fault persists, replace capt and ctr panel floodlights dimmer control unit M505 (AMM 33-11-03).
33 11 08 00	Captain's instrument panel floodlight control will not control intensity of (captain's instrument panel, center instrument panel) lights. Lights do not come on bright with LT OVRD switch ON.	Replace capt and ctr panel floodlights dimmer control unit M505 (AMM 33-11-03).
33 11 11 00	Dome lgts would not come on using dome lgt switch but come on brt with lgt override switch ON.	Replace right lighting control panel M10057 (DOME control YSPT1 is faulty) (WDM 33-11-31).
33 11 12 --	(01=Capt, 02=F/O, 03=L AFT) Dome lgt would not come on using dome lgt switch or with lgt override switch ON.	Relamp capt (F/O, L AFT) dome light L275 (L276, M10549 [L1]) (AMM 33-11-00).
33 11 13 00	Dome lgts intensity could not be controlled with dome lgt switch.	Replace right lighting control panel M10057 (DOME control YSPT1 is faulty) (WDM 33-11-31). If fault persists, perform FIM 33-11-00/101, Fig. 106.

EFFECTIVITY

ALL

## 33-FAULT CODE INDEX

01

Page 5  
Sep 20/08



**757**  
FAULT ISOLATION/MAINT MANUAL

FAULT CODE	LOG BOOK REPORT	FAULT ISOLATION REFERENCE
33 11 14 00	First Officer's instrument panel floodlight control will not control intensity of lights. Lights remain dim with LT OVRD switch ON.	Replace F/O panel floodlight dimmer control unit M506 (AMM 33-11-03). If fault persists, replace F/O standby relay K10273 (WDM 33-11-11).
33 11 15 00	First Officer's instrument panel floodlight control will not control intensity of lights. Lights remain dim with light control OFF, and LT OVRD switch ON or off.	Replace F/O standby relay K10273 (WDM 33-11-11). If fault persists, replace F/O panel floodlight dimmer control unit M506 (AMM 33-11-03).
33 11 17 00	Captain's instrument panel floodlight control will not control intensity of lights. Lights remain dim with LT OVRD switch ON.	Replace capt and ctr panel floodlights dimmer control unit M505 (AMM 33-11-03). If fault persists, replace capt standby relay K10271 (WDM 33-11-11).
33 11 18 00	Captain's instrument panel floodlight control will not control intensity of lights. Lights remain dim with control OFF, and LT OVRD switch ON or OFF.	Replace capt standby relay K10271 (WDM 33-11-11). If fault persists, replace capt and ctr panel floodlights dimmer control unit M505 (AMM 33-11-03).
33 11 19 00	With LT OVRD sw ON, dome lgts did not come on brt. Other dome lgt control normal.	FIM 33-11-00/101, Fig. 106
33 11 20 00	Dome lgts would not come on using dome lgt cont sw. Capt & F/O dome lgts on dim and left aft dome lgt on brt with LT OVRD sw ON.	Replace dome light relay K10155 (WDM 33-11-31). If fault persists, perform FIM 33-11-00/101, Fig. 106.
33 11 21 00	Dome lgts would not come on using dome lgt cont sw. Capt & F/O dome lgts on dim and left aft dome lgt remained off with LT OVRD sw ON.	FIM 33-11-00/101, Fig. 106
33 13 07 00	Accessory panel lgts dimmer control inop from F/O lighting panel.	Replace right side panel instrument and panel lights dimmer control unit M10198 (AMM 33-13-02).

EFFECTIVITY

ALL

## 33-FAULT CODE INDEX

01

Page 6  
Sep 20/08





**BOEING**  
757  
FAULT ISOLATION/MAINT MANUAL

FAULT CODE	LOG BOOK REPORT	FAULT ISOLATION REFERENCE
33 13 08 00	Accessory panel lgt (state location) off.	<p>For Pushbutton Switch/Lights: Relamp switch/light (AMM 33-13-00). If fault persists, replace diode/fuse card (AMM 33-13-00). If fault persists, replace switch/light (AMM 33-13-00).</p> <p>For Lightplates: Replace lightplate (AMM 33-13-01).</p> <p>For Instrument Lights: Relamp instrument light (AMM 33-13-03).</p> <p>For Lights Not Specifically Covered Above: Relamp or replace light as necessary (WDM 33-13-71).</p>
33 13 09 00	F/O inst and pnl lgt dimmer control inop.	FIM 33-13-00/101, Fig. 104
33 13 10 00	Instrument/panel (state location) lgt off.	<p>For Pushbutton Switch/Lights: Relamp switch/light (AMM 33-13-00). If fault persists, replace diode/fuse card (AMM 33-13-00). If fault persists, replace switch/light (AMM 33-13-00).</p> <p>For Lightplates: Replace lightplate (AMM 33-13-01).</p> <p>For Instrument Lights: Relamp instrument light (AMM 33-13-03).</p> <p>For Lights Not Specifically Covered Above: Relamp or replace light as necessary (WDM 33-13-21).</p>
33 13 11 00	Captain's inst pnl, foot and shoulder heater panel, and 1st Observer's audio selector panel dimmer control inop.	Replace capt instrument and panel lights dimmer control unit M788 (AMM 33-13-02).
33 13 12 00	Center inst pnl dimmer control inop.	Replace pilots' ctr instrument panel dimmer control unit M790 (AMM 33-13-02).

EFFECTIVITY

ALL

## 33-FAULT CODE INDEX

01

Page 7  
Sep 20/08

**BOEING**  
 757  
 FAULT ISOLATION/MAINT MANUAL

FAULT CODE	LOG BOOK REPORT	FAULT ISOLATION REFERENCE
33 13 10 00	Instrument/panel (state location) lgt off.	For Pushbutton Switch/Lights: Relamp switch/light (AMM 33-13-00). If fault persists, replace diode/fuse card (AMM 33-13-00). If fault persists, replace switch/light (AMM 33-13-00). For Lightplates: Replace lightplate (AMM 33-13-01). For Instrument Lights: Relamp instrument light (AMM 33-13-03). For Lights Not Specifically Covered Above: Relamp or replace light as necessary (WDM 33-13-11, WDM 33-13-12).
33 13 14 00	Aisle stand panel lgts dimmer control inop.	FIM 33-13-00/101, Fig. 107
33 13 15 00	Aisle stand panel lgt (state location) off.	For Pushbutton Switch/Lights: Relamp switch/light (AMM 33-13-00). If fault persists, replace diode/fuse card (AMM 33-13-00). If fault persists, replace switch/light (AMM 33-13-00). For Lightplates: Replace lightplate (AMM 33-13-01). For Instrument Lights: Relamp instrument light (AMM 33-13-03). For Lights Not Specifically Covered Above: Relamp or replace light as necessary (WDM 33-13-51, WDM 33-13-52).
33 13 16 00	Glareshield panel lgts dimmer control inop.	FIM 33-13-00/101, Fig. 106

EFFECTIVITY

ALL

## 33-FAULT CODE INDEX

01

Page 8  
Sep 20/08



**BOEING**  
757  
FAULT ISOLATION/MAINT MANUAL

FAULT CODE	LOG BOOK REPORT	FAULT ISOLATION REFERENCE
33 13 17 00	Glareshield panel lgt (state location) off.	For Pushbutton Switch/Lights: Relamp switch/light (AMM 33-13-00). If fault persists, replace diode/fuse card (AMM 33-13-00). If fault persists, replace switch/light (AMM 33-13-00). For Lightplates: Replace lightplate (AMM 33-13-01). For Instrument Lights: Relamp instrument light (AMM 33-13-03). For Lights Not Specifically Covered Above: Relamp or replace light as necessary (WDM 33-13-41).
33 13 18 00	Overhead panel lgts dimmer control inop.	FIM 33-13-00/101, Fig. 105
33 13 19 00	Overhead panel light (state location) off.	For Pushbutton Switch/Lights: Relamp switch/light (AMM 33-13-00). If fault persists, replace diode/fuse card (AMM 33-13-00). If fault persists, replace switch/light (AMM 33-13-00). For Lightplates: Replace lightplate (AMM 33-13-01). For Instrument Lights: Relamp instrument light (AMM 33-13-03). For Lights Not Specifically Covered Above: Relamp or replace light as necessary (WDM 33-13-31, WDM 33-13-32).
33 13 20 00	Overhead CB panel lgts dimmer control inop.	FIM 33-13-00/101, Fig. 107A
33 13 21 00	Overhead CB panel lgt (state location) off.	Replace lightplate (WDM 33-13-61).
33 13 22 00	Standby compass lgt off.	Relamp pilots' standby magnetic compass N99 (WDM 33-13-11).

EFFECTIVITY

ALL

## 33-FAULT CODE INDEX

01

Page 9  
Sep 20/08



**757**  
**FAULT ISOLATION/MAINT MANUAL**

FAULT CODE	LOG BOOK REPORT	FAULT ISOLATION REFERENCE
33 14 01 --	(04=1st OBS, 05=2nd OBS) Utility lgt (inop, blinks, etc).	FIM 33-14-00/101, Fig. 105
33 14 02 --	(01=CAPT, 02=F/O) Chart lgt (inop, blinks, etc).	FIM 33-14-00/101, Fig. 104
33 14 03 --	(01=CAPT, 02=F/O) Map lgt (inop, blinks, etc).	FIM 33-14-00/101, Fig. 103
33 14 05 00	Cockpit threshold step lgt does not come on with cockpit door open.	FIM 33-14-00/101, Fig. 106
33 14 06 --	(01=CAPT, 02=F/O) Flight kit lgt (inop, blinks, etc).	FIM 33-14-00/101, Fig. 105
33 14 07 --	(01=CAPT, 02=F/O) Flight kit lgt holder broken.	Replace Capt (F/O) flight kit light L375 (L376)(WDM 33-14-31).
33 16 01 00	Annunciator lgts on dim with LT OVHD switch ON.	FIM 33-16-00/101, Fig. 103
33 16 02 00	Single lgt off with IND LTS test switch pushed (specify lgt).	Relamp annunciator (AMM 33-13-00 for switch/light annunciator, AMM 33-16-02 for annunciator). If fault persists, replace annunciator diode/fuse card (AMM 33-13-00 for switch/light annunciator, AMM 33-16-02 for annunciator). If fault persists, replace annunciator (AMM 33-13-00 for switch/light annunciator, AMM 33-16-02 for annunciator).
33 16 03 00	Multiple lgts off with IND LTS test switch pushed (specify inop lgts).	FIM 33-16-00/101, Fig. 103
33 16 04 00	Annunciator lgts failed to come on brt with IND LTS selector switch in BRT.	FIM 33-16-00/101, Fig. 103
33 16 05 00	With IND LTS selector switch in DIM annunciator lgts failed to come on dim.	FIM 33-16-00/101, Fig. 103

EFFECTIVITY

ALL

## 33-FAULT CODE INDEX

06

Page 10  
Sep 20/08



**BOEING**  
757  
FAULT ISOLATION/MAINT MANUAL

FAULT CODE	LOG BOOK REPORT	FAULT ISOLATION REFERENCE
33 16 06 00	Single bulb inop in _____ (identify switch, annunciator or other).	Relamp annunciator (AMM 33-13-00 for switch/light annunciator, AMM 33-16-02 for annunciator). If fault persists, replace annunciator diode/fuse card (AMM 33-13-00 for switch/light annunciator, AMM 33-16-02 for annunciator). If fault persists, replace annunciator (AMM 33-13-00 for switch/light annunciator, AMM 33-16-02 for annunciator).
33 16 07 00	Both bulbs inop in _____ (identify switch, annunciator or other).	Relamp annunciator (AMM 33-13-00 for switch/light annunciator, AMM 33-16-02 for annunciator). If fault persists, replace annunciator diode/fuse card (AMM 33-13-00 for switch/light annunciator, AMM 33-16-02 for annunciator). If fault persists, replace annunciator (AMM 33-13-00 for switch/light annunciator, AMM 33-16-02 for annunciator).
33 16 08 00	Several lgts (identify) failed to go off.	FIM 33-16-00/101, Fig. 103
33 21 01 00	Ceiling lgt at _____ (give nearest seat number) (extin/flickers) with ceiling lgt switch in HI.	Relamp extinguished light (AMM 33-21-00). If fault persists, replace associated ballast (WDM 33-21-12, WDM 33-21-13, WDM 33-21-14, WDM 33-21-21, WDM 33-21-22, WDM 33-21-23).
33 21 02 00	Left ceiling lgts go off with ceiling lgt switch in dim.	FIM 33-21-00/101, Fig. 103
33 21 03 00	Right ceiling lgts go off with ceiling lgt switch in dim.	FIM 33-21-00/101, Fig. 103
33 21 04 00	All ceiling lgts go off with ceiling lgt switch in dim.	FIM 33-21-00/101, Fig. 103

EFFECTIVITY

ALL

## 33-FAULT CODE INDEX

01

Page 11  
Sep 20/08

**BOEING**  
 757  
 FAULT ISOLATION/MAINT MANUAL

FAULT CODE	LOG BOOK REPORT	FAULT ISOLATION REFERENCE
33 21 05 00	Ceiling lgt at _____ (give nearest seat number) (extin/flickers) with ceiling lgt switch in dim.	Relamp extinguished light (AMM 33-21-00). If fault persists, replace associated ballast (WDM 33-21-12, WDM 33-21-13, WDM 33-21-14, WDM 33-21-21, WDM 33-21-22, WDM 33-21-23).
33 21 06 00	With ceiling lgt switch in first position, night light at _____ (give nearest seat number) is off.	Relamp extinguished light (AMM 33-21-00). If all night lights are extinguished, replace forward attendant's panel P21 (CEILING switch S10298 is faulty) (AMM 33-22-05).
33 21 07 00	Window lgt at _____ (give nearest seat number) (extin/flickers) with window lgt switch in HI.	Relamp extinguished light (AMM 33-21-00). If fault persists, replace associated ballast (WDM 33-21-32, WDM 33-21-33, WDM 33-21-34, WDM 33-21-41, WDM 33-21-42, WDM 33-21-43).
33 21 08 00	Left window lgts go off with window lgt switch in dim.	FIM 33-21-00/101, Fig. 104
33 21 09 00	Right window lights go off with WINDOW light switch in dim.	FIM 33-21-00/101, Fig. 104
33 21 10 00	All window lgts go off with window lgt switch in dim.	FIM 33-21-00/101, Fig. 104
33 21 11 00	Window lgt _____ (give nearest seat number) (extin/flickers) with window lgt switch in dim.	Relamp extinguished light (AMM 33-21-00). If fault persists, replace associated ballast (WDM 33-21-32, WDM 33-21-33, WDM 33-21-34, WDM 33-21-41, WDM 33-21-42, WDM 33-21-43).
33 22 01 00	Aft left entry door threshold light goes off.	FIM 33-22-00/101, Fig. 104
33 22 02 00	Center left entry door threshold light goes off.	FIM 33-22-00/101, Fig. 104

EFFECTIVITY

ALL

## 33-FAULT CODE INDEX

01

Page 12  
Sep 20/08



**BOEING**  
757  
FAULT ISOLATION/MAINT MANUAL

FAULT CODE	LOG BOOK REPORT	FAULT ISOLATION REFERENCE
33 22 03 00	Forward left entry door incandescent threshold light off.	FIM 33-22-00/101, Fig. 104
33 22 04 00	Forward left entry door fluorescent light (extin/flickers) with entry light switch in HI.	FIM 33-22-00/101, Fig. 103
33 22 05 00	Forward left entry door fluorescent light (exting/flickers) with entry light switch in dim.	FIM 33-22-00/101, Fig. 103
33 22 06 00	Forward attendant work light will not go off.	FIM 33-22-00/101, Fig. 105
33 22 10 00	Aft attendant work lgt will not come on.	FIM 33-22-00/101, Fig. 105
33 23 01 00	Reading lgt off at seat number _____.	Relamp turned off reading light (AMM 33-23-00).
33 23 02 01	Reading lgts in R fwd section off.	Replace right zone A passenger reading lights transformer T10015 (WDM 33-23-21).
33 23 02 02	Reading lgts in L fwd section off.	Replace left zone A passenger reading lights transformer T10011 (WDM 33-23-11).
33 23 02 03	Reading lgts in R mid fwd section off.	Replace right zone B passenger reading lights transformer T10016 (WDM 33-23-22).
33 23 02 04	Reading lgts in L mid fwd section off.	Replace left zone B passenger reading lights transformer T10012 (WDM 33-23-12).
33 23 02 05	Reading lgts in R mid aft section off.	Replace right zone C passenger reading lights transformer T10017 (WDM 33-23-23).
33 23 02 06	Reading lgts in L mid aft section off.	Replace left zone C passenger reading lights transformer T10013 (WDM 33-23-13).

EFFECTIVITY

ALL

## 33-FAULT CODE INDEX

05

Page 13  
Sep 20/08

**BOEING**  
 757  
 FAULT ISOLATION/MAINT MANUAL

FAULT CODE	LOG BOOK REPORT	FAULT ISOLATION REFERENCE
33 23 02 07	Reading lgts in R aft section off.	Replace right zone D passenger reading lights transformer T10018 (WDM 33-23-24).
33 23 02 08	Reading lgts in L aft section off.	Replace left zone D passenger reading lights transformer T10014 (WDM 33-23-14).
33 24 01 00	Chime failed to sound when no smoking lgts come on.	Replace passenger address amplifier M177 on E4-3 shelf (AMM 23-31-01).
33 24 02 00	With no smoking light switch ON, all lights remain off.	Replace passenger signs control panel M52 on panel P5 (WDM 33-24-11). If fault persists, replace no smoking relay K10029 on panel P34 (WDM 33-24-11).
33 24 03 00	With no smoking lgt switch ON, lgt at (give nearest seat number) failed to come on.	Relamp turned off light (AMM 33-24-00).
33 24 04 00	With no smoking lgt switch in AUTO and ldg gear retracted, all lgts remain on.	FIM 33-24-00/101, Fig. 104
33 24 05 00	With no smoking lgt switch in AUTO and ldg gear extended, all lgts remain off.	FIM 33-24-00/101, Fig. 104
33 24 06 00	Chime failed to sound when fasten seat belt signs came on.	Replace passenger address amplifier M177 on E4-3 shelf (AMM 23-31-01).
33 24 07 00	With seat belts switch ON, return to seat signs in all lavatories fail to come on.	FIM 33-24-00/101, Fig. 105
33 24 08 00	With seat belts switch ON, return to seat sign in (state lavatory) fails to come on.	Relamp turned off light (AMM 33-24-00).

EFFECTIVITY

ALL

## 33-FAULT CODE INDEX

06

Page 14  
Sep 20/08





**BOEING**  
757  
FAULT ISOLATION/MAINT MANUAL

FAULT CODE	LOG BOOK REPORT	FAULT ISOLATION REFERENCE
33 24 09 00	With seat belts switch ON, all fasten seat belt signs fail to come on.	Replace passenger signs control panel M52 on panel P5 (WDM 33-24-11). If fault persists, replace fasten seat belt relay K10028 on panel P34 (WDM 33-24-11).
33 24 10 00	With seat belts switch ON, fasten seat belt sign at (state seat number) failed to come on.	Relamp turned off light (AMM 33-24-00).
33 24 11 00	With seat belts switch in AUTO and gear and flaps up, all fasten seat belt and lavatory return to seat signs remain on.	FIM 33-24-00/101, Fig. 105
33 24 12 00	With seat belts switch in AUTO, gear up and flaps extended, all fasten seat belt and lavatory return to seat signs go off.	FIM 33-24-00/101, Fig. 105
33 24 13 00	With seat belts switch in AUTO, and gear down, all fasten seat belt and lavatory return to seat signs go off.	FIM 33-24-00/101, Fig. 105
33 24 14 00	No smoking switch fails to sound chime.	FIM 33-24-00/101, Fig. 104
33 24 15 00	Fasten seat belt switch fails to sound chime.	FIM 33-24-00/101, Fig. 105
33 25 01 --	(01=FWD LAV A, 02=FWD LAV F, 03=MID LAV S, 04=MID LAV C, 05=AFT LAV D) Lavatory call reset lgt sw will not reset light.	SSM 33-25-01
33 25 09 00	Attendant call lgt in PSU, ROW _____ inop.	FIM 33-25-00/101, Fig. 103
33 25 10 --	(03=FWD, 04=MID FWD, 05=MID AFT, 06=AFT) Blue call lgt inop. Chime is normal.	FIM 33-25-00/101, Fig. 103

EFFECTIVITY

ALL

## 33-FAULT CODE INDEX

21

Page 15  
Sep 20/08



**BOEING**  
757  
FAULT ISOLATION/MAINT MANUAL

FAULT CODE	LOG BOOK REPORT	FAULT ISOLATION REFERENCE
33 25 12 00	Cabin call chime inop when calling from PSU. Seat belt chime is OK.	SSM 33-25-01
33 25 13 00	Chime fails to sound and blue call lgt fails to come on when called from _____ seat row.	FIM 33-25-00/101, Fig. 103
33 25 14 --	(01=L, 02=R) Chime fails to sound and blue call lgt fails to come on when calls attempted from side of cabin.	FIM 33-25-00/101, Fig. 103
33 25 15 --	(01=FWD LAV A, 02=MID LAV F, 03=MID LAV S, 04=MID LAV C, 05=AFT LAV D) Lavatory call reset sw lgt inop.	Replace attendant call switch S1 (WDM 33-25-11).
33 25 16 --	(06=FWD, 07=MID FWD, 08=MID AFT, 09=AFT) Amber lav call light inop. Chime does not sound.	SSM 33-25-01
33 25 17 00	Lavatory call chime inop. Seat belt sw will sound chime.	SSM 33-25-01
33 25 18 00	Lavatory call chime inop. Seat belt sw will not sound chime.	SSM 33-25-01
33 25 19 --	(01=FWD LAV A, 02=FWD LAV F, 03=MID LAV S, 04=MID LAV C, 05=AFT LAV D) Lavatory call sw will not turn on amber lav call lgt or sound chime.	Replace attendant call switch S1 (WDM 33-25-11). If fault persists, replace call relay K1 (WDM 33-25-11).
33 26 01 --	(01=FWD LAV A, 02=MID LAV S, 03=AFT LAV C, 04=AFT LAV D) Lavatory threshold light will not come on.	FIM 33-26-00/101, Fig. 103
33 26 02 --	(01=FWD LAV A, 02=MID LAV S, 03=AFT LAV C, 04=AFT LAV D) LAVATORY sign will not come on.	FIM 33-26-00/101, Fig. 103

EFFECTIVITY

ALL

## 33-FAULT CODE INDEX



**BOEING**  
757  
FAULT ISOLATION/MAINT MANUAL

FAULT CODE	LOG BOOK REPORT	FAULT ISOLATION REFERENCE
33 26 03 --	(01=FWD LAV A, 02=MID LAV S, 03=AFT LAV C, 04=AFT LAV D) Lavatory OCCUPIED sign will not come on.	FIM 33-26-00/101, Fig. 103
33 26 04 --	(01=FWD LAV A, 02=MID LAV S, 03=AFT LAV C, 04=AFT LAV D) Lavatory fluorescent lgt (will not come on, flickers).	FIM 33-26-00/101, Fig. 103
33 26 05 --	(01=FWD LAV A, 02=MID LAV S, 03=AFT LAV C, 04=AFT LAV D) Lavatory dome light goes off.	FIM 33-26-00/101, Fig. 103
33 26 11 00	All lavatory fluorescent lgts will not come on.	FIM 33-26-00/101, Fig. 103
33 26 12 00	All lavatory dome lgts and sign lgts will not come on.	FIM 33-26-00/101, Fig. 103
33 27 01 --	(01=G1A, 02=G1B, 03=G4B) All overhead fluor lgts inop in galley.	FIM 33-27-00/101, Fig. 103
33 27 02 --	(01=G1A, 02=G1B, 03=G4B) One overhead fluor lgt (inop, flickers) in DIM pos in galley. Light is normal in BRT pos.	FIM 33-27-00/101, Fig. 103
33 27 03 --	(01=G1A, 02=G1B, 03=G4B) Two overhead fluor lgts inop in galley.	FIM 33-27-00/101, Fig. 103
33 27 06 --	(01=G1A, 02=G1B, 03=G4B) One overhead fluor lgt (inop, flickers) in BRT pos in galley.	FIM 33-27-00/101, Fig. 103
33 27 07 --	(01=G1A, 02=G1B, 03=G4B) One overhead fluor lgt (inop, flickers) in both DIM & BRT positions in galley.	FIM 33-27-00/101, Fig. 103
33 31 01 --	(02=AFT WALL, 03=CEILING, 04=BOTH) Light(s) in R main wheel well will not come on.	(02=AFT WALL, 03=CEILING) Relamp corresponding light (AMM 33-31-00). (04=BOTH) FIM 33-31-00/101, Fig. 103

EFFECTIVITY

ALL

## 33-FAULT CODE INDEX

24

Page 17  
Sep 20/08



**BOEING**  
757  
FAULT ISOLATION/MAINT MANUAL

FAULT CODE	LOG BOOK REPORT	FAULT ISOLATION REFERENCE
33 31 02 --	(02=AFT WALL, 03=CEILING, 04=BOTH) Light(s) in L main wheel well will not come on.	(02=AFT WALL, 03=CEILING) Relamp corresponding light (AMM 33-31-00). (04=BOTH) FIM 33-31-00/101, Fig. 103
33 31 03 --	(01=FWD WALL, 03=CEILING, 04=BOTH) Light(s) in nose wheel well will not come on.	(01=FWD WALL, 03=CEILING) Relamp corresponding light (AMM 33-31-00). (04=BOTH) Replace nose gear wheel well lgt switch S324 (WDM 33-31-11).
33 31 04 --	(01=FWD, 02=AFT, 03=BOTH) The right air conditioning compartment light(s) is(are) turned off with switch S362 ON.	(01=FWD, 02=AFT) Relamp turned off light (WDM 33-31-21). (03=BOTH) Replace right air conditioning compartment lights switch S362 (WDM 33-31-21).
33 31 05 --	(01=FWD, 02=AFT, 03=BOTH) The left air conditioning compartment light(s) is(are) turned off with switch S361 ON.	(01=FWD, 02=AFT) Relamp turned off light (WDM 33-31-21). (03=BOTH) Replace left air conditioning compartment lights switch S361 (WDM 33-31-21).
33 31 06 01	At least one but not all APU compartment lights are turned off with switch S428 ON.	Relamp turned off light(s) (WDM 33-31-31).
33 31 06 02	All APU compartment lights are turned off with switch S428 ON.	FIM 33-31-00/101, Fig. 104
33 31 07 01	At least one but not all aft tail cone compartment lights are turned off with switch S443 ON.	Relamp turned off light(s) (WDM 33-31-31).
33 31 07 02	All aft tail cone compartment lights are turned off with switch S443 ON.	FIM 33-31-00/101, Fig. 105
33 31 08 01	At least one but not all fwd tail cone compartment lights are turned off with switch S427 ON.	Relamp turned off light(s) (WDM 33-31-31).

EFFECTIVITY

ALL

## 33-FAULT CODE INDEX

01

Page 18  
Sep 20/08



**BOEING**  
757  
FAULT ISOLATION/MAINT MANUAL

FAULT CODE	LOG BOOK REPORT	FAULT ISOLATION REFERENCE
33 31 08 02	All fwd tail cone compartment lights are turned off with switch S427 ON.	FIM 33-31-00/101, Fig. 105
33 31 09 01	At least one but not all main E/E ctr lights are turned off with switch S355 ON.	Relamp turned off light(s) (WDM 33-31-41).
33 31 09 02	All main E/E ctr lights are turned off with switch S355 ON.	Replace main E/E ctr lights switch S355 (WDM 33-31-41).
33 31 10 01	At least one but not all fwd E/E ctr lights are turned off with switch S357 ON.	Relamp turned off light(s) (WDM 33-31-41).
33 31 10 02	All fwd E/E ctr lights are turned off with switch S357 ON.	Replace fwd E/E ctr lights switch S357 (WDM 33-31-41).
33 31 11 --	(01=FWD, 02=AFT, 03=BOTH) The hydraulic service center light(s) is(are) turned off with switch S10328 ON.	(01=FWD, 02=AFT) Relamp turned off light (WDM 33-31-21). (03=BOTH) Replace hydraulic service center lights switch S10328 (WDM 33-31-21).
33 37 01 01	At least one but not all fwd cargo compartment lights are turned off with switch S10128 ON.	Relamp turned off light(s) (WDM 33-37-11). If fault persists, perform FIM 33-37-00/101, Fig. 103, Block 1 action.
33 37 01 02	All fwd cargo compartment lights are turned off with switch S10128 ON.	FIM 33-37-00/101, Fig. 103
33 37 02 01	At least one but not all aft cargo compartment lights are turned off with switch S429 ON.	Relamp turned off light(s) (WDM 33-37-21). If fault persists, perform FIM 33-37-00/101, Fig. 104, Block 1 action.
33 37 02 02	All aft cargo compartment lights are turned off with switch S429 ON.	FIM 33-37-00/101, Fig. 104

EFFECTIVITY

ALL

## 33-FAULT CODE INDEX

13

Page 19  
Sep 20/08



**757**  
FAULT ISOLATION/MAINT MANUAL

FAULT CODE	LOG BOOK REPORT	FAULT ISOLATION REFERENCE
33 37 03 01	At least one but not all aft cargo compartment lights are turned off with switch S10311 ON.	Relamp turned off light(s) (WDM 33-37-21). If fault persists, perform FIM 33-37-00/101, Fig. 104, Block 1 action.
33 37 03 02	All aft cargo compartment lights are turned off with switch S10311 ON.	FIM 33-37-00/101, Fig. 104
33 41 01 01	Left wing illumination lgt off.	Relamp L wing illumination light L70 (AMM 33-41-00). If fault persists, replace L wing illumination light transformer on L70 (AMM 33-41-00).
33 41 01 02	Right wing illumination lgt off.	Relamp R wing illumination light L69 (AMM 33-41-00). If fault persists, replace R wing illumination light transformer on L69 (AMM 33-41-00).
33 41 01 03	Both wing illumination lgts off.	Replace anticollision and landing lights control panel M56 (WDM 33-41-11).
33 42 01 --	(01=L, 02=R, 03=BOTH) Runway turnoff lgts off.	(01=L, 02=R) FIM 33-42-00 Fig. 103 (03=BOTH) Perform proximity switch electronics unit sensor target test BITE procedure for nose gear up/down locked sensors S10065 and S10078 (FIM 32-09-03/101, Fig. 104).
33 42 02 --	(01=L, 02=R, 03=BOTH) Nose gear ldg lgts off.	FIM 33-42-00/101, Fig. 104
33 42 03 --	(01=L, 02=R, 03=BOTH) Wing ldg lgts on brt with gear lever up.	(01=L, 02=R) Replace landing light dimming relay K161 (left) or K162 (right) (WDM 33-42-11, WDM 33-42-12). (03=BOTH) Replace landing gear lever module M937 (AMM 32-31-01).

EFFECTIVITY

ALL

## 33-FAULT CODE INDEX

16

Page 20  
Sep 20/08



**BOEING**  
757  
FAULT ISOLATION/MAINT MANUAL

FAULT CODE	LOG BOOK REPORT	FAULT ISOLATION REFERENCE
33 42 04 --	(01=L, 02=R, 03=BOTH) Wing ldg lgts on dim with gear lever down.	(01=L, 02=R) Replace landing light dimming relay K161 (left) or K162 (right) (WDM 33-42-11, WDM 33-42-12). (03=BOTH) Replace landing gear lever module M937 (AMM 32-31-01).
33 42 05 --	(01=L, 02=R, 03=BOTH) Wing ldg lgts off.	FIM 33-42-00/101, Fig. 105
33 42 06 00	Taxi lgt off.	FIM 33-42-00/101, Fig. 106
33 43 01 --	(01=R WHITE, 02=R GREEN, 03=R WHITE AND GREEN, 04=L WHITE, 05=L RED, 06=L WHITE AND RED) Position lgt off.	(01=R WHITE, 02=R GREEN, 04=L WHITE, 05=L RED) Relamp L(R) white position light L16 (L19) (AMM 33-43-02); or L red (R green) position light L17 (L18)(AMM 33-43-01). (03=R WHITE AND GREEN, 06=L WHITE AND RED) Replace L(R) wing A position lights transformer T131 (T132), or L(R) wing B position lights transformer T133 (T134) (AMM 33-43-03).
33 44 01 --	(07=UPPER RED, 08=LOWER RED, 09=LEFT WHITE, 10=RIGHT WHITE) Anticollision light off.	Replace the anticollision light assembly. If the problem continues, replace the power supply: - Left wingtip L20 (AMM 33-44-01) or M588 (AMM 33-44-03). - Right wingtip L21 (AMM 33-44-01) or M589 (AMM 33-44-03). - Upper fuselage L22 (AMM 33-44-02) or M570 (AMM 33-44-04). - Lower fuselage L23 (AMM 33-44-02) or M571 (AMM 33-44-04). If the problem continues, check for electrical continuity at the switch and along the wiring. Do the repairs that are necessary.

EFFECTIVITY

ALL

## 33-FAULT CODE INDEX

12

Page 21  
Sep 20/08



**BOEING**  
757  
FAULT ISOLATION/MAINT MANUAL

FAULT CODE	LOG BOOK REPORT	FAULT ISOLATION REFERENCE
33 45 01 --	(01=R INBD, 02=R OUTBD, 03=L INBD, 04=L OUTBD, 05=ALL) Logo lgts off.	FIM 33-45-00/101, Fig. 103
33 51 01 00	With attnd pnl sw ON, emer aisle lgt at seat No. ____ off. All other lights normal.	Relamp aisle light (AMM 33-51-05).
33 51 02 00	With attnd pnl sw ON, emer exit door lgt at door No. ____ off. All other lights normal.	Relamp exit light (AMM 33-51-01).
33 51 03 00	With attnd pnl sw ON, emer exit locator sign lgt at door No. ____ off. All other lights normal.	Relamp exit locator sign (AMM 33-51-01).
33 51 04 --	(01=D00R 1L, 02=D00R 1R, 03=D00R 2L, 04=D00R 2R, 05=D00R 3L, 06=D00R 3R, 07=D00R 4L, 08=D00R 4R, 09=ALL) Exterior emer slide lights off on ground.	FIM 33-51-00/101, Fig. 104
33 51 05 --	(01=FWD, 02=MID FWD, 03=MID AFT, 04=AFT) With attnd pnl sw ON, multiple emer lights off in main cabin area. All other lights normal.	FIM 33-51-00/101, Fig. 103
33 51 06 00	With ovhd pnl sw ON, emer aisle light at seat No. ____ off. All other lights and indications normal.	Relamp aisle light (AMM 33-51-05).
33 51 07 00	With ovhd pnl sw ON, emer exit light at door No. ____ off. All other lights and indications normal.	Relamp exit light (AMM 33-51-01).
33 51 08 00	With ovhd pnl sw ON, emer exit locator at door No. ____ off. All other lights and indications normal.	Relamp exit locator sign (AMM 33-51-01).

EFFECTIVITY

ALL

## 33-FAULT CODE INDEX





**BOEING**  
757  
FAULT ISOLATION/MAINT MANUAL

FAULT CODE	LOG BOOK REPORT	FAULT ISOLATION REFERENCE
33 51 09 --	(01=FWD, 02=MID FWD, 03=MID AFT, 04=AFT) With ovhd pnl sw ON, multiple emer lights off in area. All other lights and indications normal.	FIM 33-51-00/101, Fig. 103
33 51 10 00	With ovhd pnl sw ON, emer dome light off. All other lights and indications normal.	Relamp emer dome light (AMM 33-51-09).
33 51 11 00	With ovhd pnl sw ON, emer dome light off. Multiple emer lights in fwd main cabin off. All other lights and indications normal.	Replace emer lights power supply M731 (AMM 33-51-07).
33 51 12 00	With ovhd pnl sw ON, UNARMED light off and msg not displayed. All emer lights (flt deck and main cabin) on.	Remove Emergency Lights/Pass. Oxy Panel M43 (AMM 33-51-08) and replace Emer Lights switch YBIS1 (WDM 33-51-11).
33 51 13 00	With ovhd pnl sw ON, UNARMED light off and msg not displayed. All emer lights (flt deck and main cabin) off.	Remove Emergency Lights/Pass. Oxy Panel M43 (AMM 33-51-08) and replace Emer Lights switch YBIS1 (WDM 33-51-11).
33 51 14 00	With ovhd pnl sw in ARMED pos, UNARMED light on and msg displayed.	Remove Emergency Lights/Pass. Oxy Panel M43 (AMM 33-51-08) and replace Emer Lights switch YBIS1 (WDM 33-51-11).
33 51 15 00	With ovhd pnl sw in OFF pos, UNARMED light off and msg not displayed.	Remove Emergency Lights/Pass. Oxy Panel M43 (AMM 33-51-08) and replace Emer Lights switch YBIS1 (WDM 33-51-11).
33 51 16 00	With atnd pnl sw ON, door-mounted exit indicators at door ___ off. All other lights normal.	FIM 33-51-00/101, Fig. 103
33 51 17 --	(01=FWD, 02=MID FWD, 03=MID AFT, 04=AFT) With atnd pnl sw ON, track-mounted exit indicators at main cabin area off. All other lights normal.	FIM 33-51-00/101, Fig. 103

EFFECTIVITY

ALL

## 33-FAULT CODE INDEX



**BOEING**  
757  
FAULT ISOLATION/MAINT MANUAL

FAULT CODE	LOG BOOK REPORT	FAULT ISOLATION REFERENCE
33 51 18 --	(01=FWD, 02=MID FWD, 03=MID AFT, 04=AFT) With attnd pnl sw ON, door and track-mounted exit indicators at main cabin area off. All other lights normal.	FIM 33-51-00/101, Fig. 103
33 51 19 00	With attnd pnl sw ON, all emer exit lights remained off.	FIM 33-51-00/101, Fig. 103
33 51 20 00	With ovhd pnl sw ON, door-mounted exit indicators at door ___ off. All other lights normal.	FIM 33-51-00/101, Fig. 103
33 51 21 --	(01=FWD, 02=MID FWD, 03=MID AFT, 04=AFT) With ovhd pnl sw ON, track-mounted exit indicators at main cabin area off. All other lights normal.	FIM 33-51-00/101, Fig. 103
33 51 22 --	(01=FWD, 02=MID FWD, 03=MID AFT, 04=AFT) With ovhd pnl sw ON, door and track-mounted exit indicators at main cabin area off. All other lights normal.	FIM 33-51-00/101, Fig. 103

EFFECTIVITY

ALL

## 33-FAULT CODE INDEX

**BITE Index**

**1. General**

- A. Use this index to find the BITE procedure for the applicable LRU/System.
- B. The BITE procedure will provide the fault isolation instructions for the fault indications/LRU maintenance messages.

<u>LRU/System Name</u>	<u>Acronym</u>	<u>FIM Reference</u>
Air Data Computer	ADC	34-12
Air Data Inertial Reference Unit	ADIRU	34-26
Air Traffic Control Transponder	ATC	34-53
Airborne Vibration Monitor Signal Conditioner	AVM	77-31
Antiskid/Autobrake Control Unit		32-42
APU Fire Detection System		26-15
Automatic Direction Finder Receiver	ADF	34-57
APU Control Unit	ECU	49-11
Brake Temperature Monitor Unit		32-46
Bus Power Control Unit	BPCU	24-20
Cabin Pressure Controller		21-30
Digital Flight Data Acquisition Unit	DFDAU	31-31
Distance Measuring Equipment Interrogator	DME	34-55
Duct Leak (Wing and Body)		26-18
E/E Cooling Control Card (If cards installed)		21-58
ECS Bleed Configuration Card		36-10
Electronic Engine Control (RR Engines)	EEC	73-21
Electronic Engine Control Monitor Unit (PW Engines)	EECM	71-EPCS Message Index
Electronic Flight Instrument System	EFIS	34-22
Electronic Propulsion Control System (PW Engines)	EPCS	71-EPCS Message Index
Engine Fire/Overheat Detection System		26-11
Engine Indication and Crew Alerting System Computer	EICAS	31-41

Bite Index  
Figure 1 (Sheet 1)

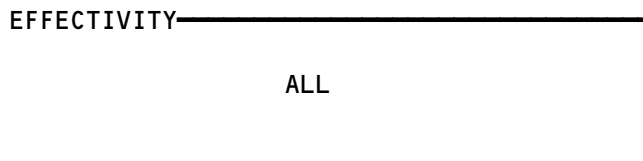

# 33-BITE INDEX

**BOEING**  
 757  
 FAULT ISOLATION/MAINT MANUAL

<u>LRU/System Name</u>	<u>Acronym</u>	<u>FIM Reference</u>
Engine Turbine Cooling Overheat Detection System (RR Engines)		26-13
Enhanced Ground Proximity Warning Computer	EGPWC	34-46
Flap/Slat Accessory Module	FSAM	27-51
Flap/Slat Electronic Unit	FSEU	27-51
Flight Management Computer	FMC	34-61
Fuel Quantity Indicating System Processor	FQIS	28-41
Ground Proximity Warning Computer	GPWC	34-46
HF (High Frequency) Communication		23-11
Inertial Reference Unit	IRU	34-21
Instrument Comparator Unit	ICU	34-25
Instrument Landing System Receiver	ILS	34-31
Lower Cargo Compartment Smoke Detection System		26-16
Maintenance Control Display Panel	MCDP	22-00
PA (Passenger Address) Amplifier		23-31
Pack Standby Temperature Controller		21-51
Pack Temperature Controller		21-51
Passenger Entertainment System	PES	23-34
Power Supply Module (Control System Electronics Units)	PSM	27-09
Propulsion Discrete Interface Unit (PW Engines)	PDIU	73-21
Proximity Switch Electronics Unit	PSEU	32-09
Radio Altimeter Transmitter/Receiver	RA	34-33
Rudder Ratio Changer Module	RRCM	27-09
Spoiler Control Module	SCM	27-09
Stabilizer Position Module	SPM	27-48
Stabilizer Trim/Elevator Asymmetry Limit Module	SAM	27-09
Stall Warning Computer/Module (in Warning Electronic Unit)	SWC	27-32
Strut Overheat Detection System (RR Engines)		26-12

Bite Index  
Figure 1 (Sheet 2)

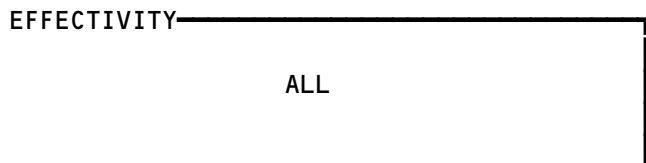

## 33-BITE INDEX

**BOEING**  
 757  
 FAULT ISOLATION/MAINT MANUAL

<u>LRU/System Name</u>	<u>Acronym</u>	<u>FIM Reference</u>
Thrust Management Computer/Autothrottle	TMC	22-00
Traffic Alert and Collision Avoidance Computer	TCAS	34-45
VHF (Very High Frequency) Communication		23-12
VOR/Marker Beacon Receiver	VOR/MKR	34-51
Warning Electronic Unit BITE Module (Stall Warning)	WEU	27-32
Weather Radar Transceiver	WXR	34-43
Wheel Well Fire Detection		26-17
Window Heat Control Unit	WHCU	30-41
Yaw Damper Module	YDM	22-21
Yaw Damper/Stabilizer Trim Module	YSM	27-09
Zone Temperature Controller		21-60

Bite Index  
Figure 1 (Sheet 3)

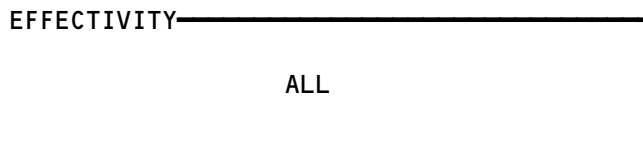

## 33-BITE INDEX

01

Page 3  
Sep 28/99



757  
 FAULT ISOLATION/MAINT MANUAL

FLIGHT COMPARTMENT ILLUMINATION

COMPONENT*	FIG. 102 SHT	QTY *	ACCESS/AREA	AMM REFERENCE
CIRCUIT BREAKER -			FLT COMPT, OVHD CB PNL, P11	*
CIRCUIT BREAKER -			119BL, MAIN EQUIP CTR, P34	*
DIMMER CONTROL UNIT -				
GLRSHLD FLOOD LT	3		FLT COMPT, ACCESS PANEL	33-11-03
INST PANEL FLOODLIGHTS	3		FLT COMPT, ACCESS PANEL	33-11-03
LIGHT - DOME AND FLOOD	1		FLT COMPT	33-11-00
RELAY -			FLT COMPT	*
SWITCH -			FLT COMPT	*
DOME LIGHT AND FLOODLIGHT	2		FLT COMPT	*

\* SEE THE WDM OR SSM FOR THE EQUIPMENT NUMBER, QUANTITY, AND LOCATION OF EACH COMPONENT IN THE LIGHTING CIRCUIT

Flight Compartment Illumination - Component Index  
 Figure 101

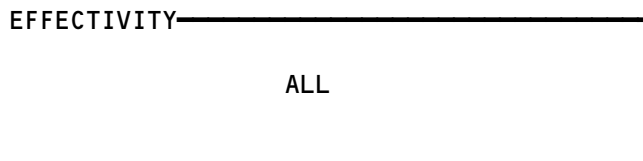

33-11-00

01

Page 101  
 Sep 20/93

263802

# BOEING

## 757

### FAULT ISOLATION/MAINT MANUAL

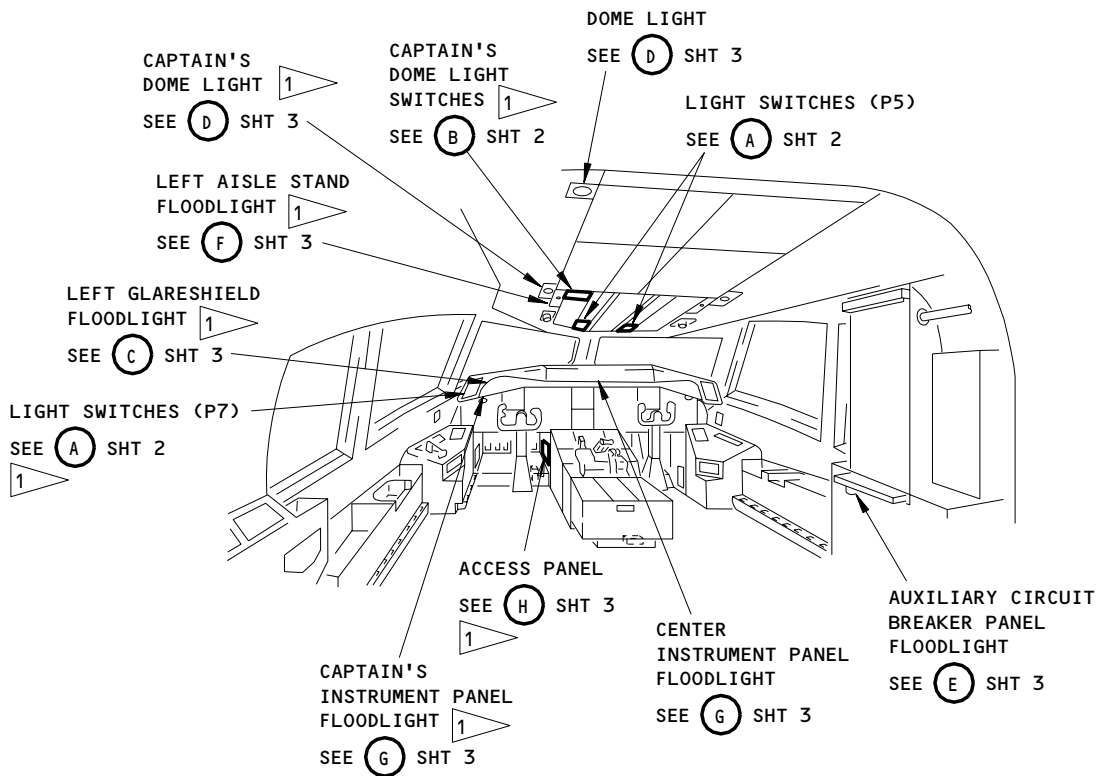

#### FLIGHT COMPARTMENT

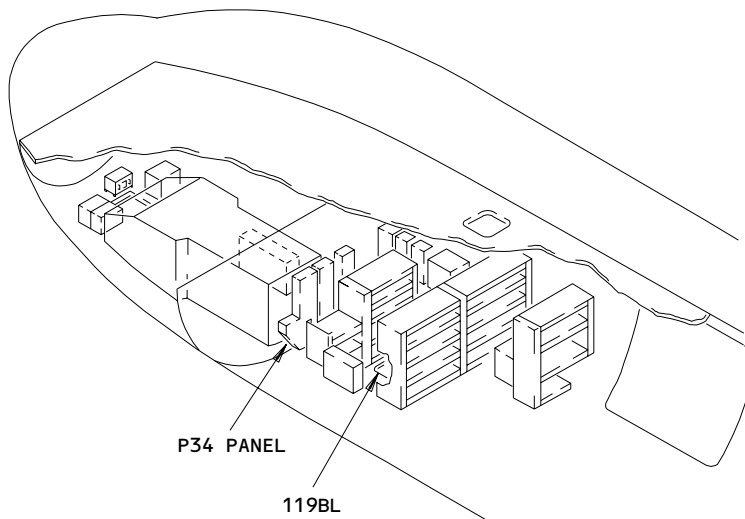

#### MAIN EQUIPMENT CENTER

1 CAPTAIN AND LEFT SIDE SHOWN,  
FIRST OFFICER AND RIGHT SIDE EQUIVALENT

Flight Compartment Illumination - Component Location  
Figure 102 (Sheet 1)

EFFECTIVITY	
	ALL

33-11-00

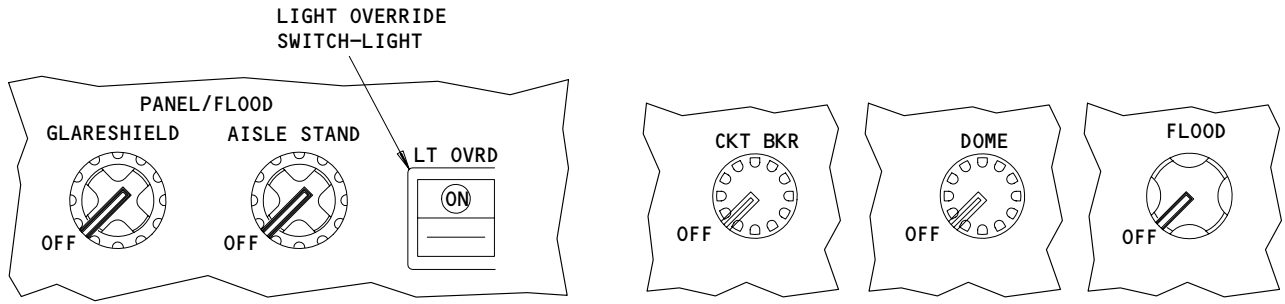

LIGHT SWITCHES  
(EXAMPLE)

(A)

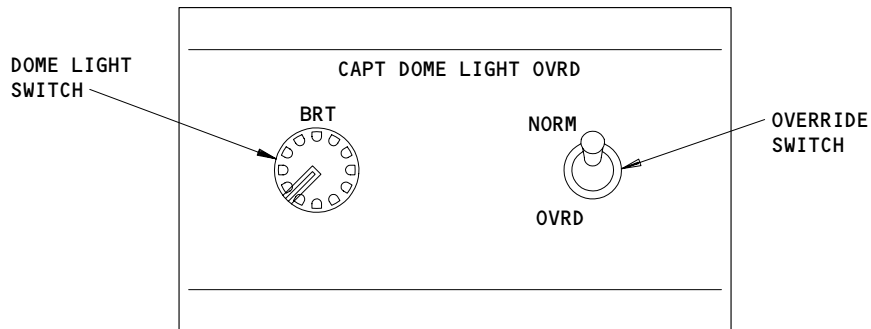

DOME LIGHT SWITCHES  
(EXAMPLE)

(B)

Flight Compartment Illumination - Component Location (Details from Sht 1)  
Figure 102 (Sheet 2)

EFFECTIVITY	ALL
-------------	-----

**33-11-00**



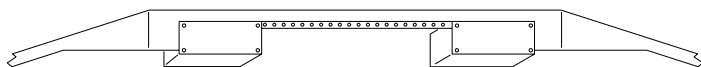

GLARESHIELD FLOODLIGHTS

(C) FROM SHT 1

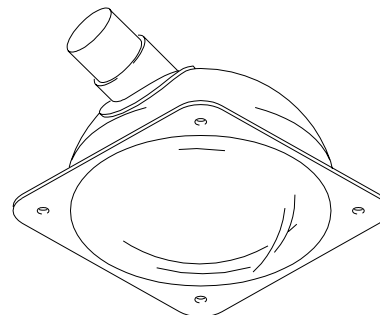

DOME LIGHT  
(EXAMPLE)

(D) FROM SHTS 1 AND 4

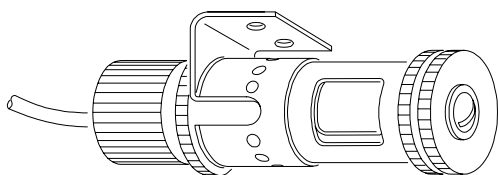

AUXILIARY CIRCUIT BREAKER  
PANEL FLOODLIGHT

(E) FROM SHT 1

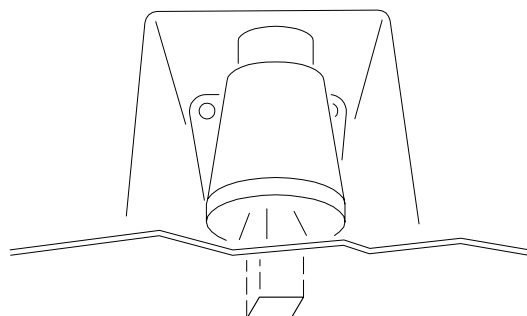

AISLE STAND FLOODLIGHT  
(EXAMPLE)

(F) FROM SHT 1

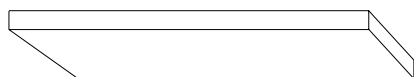

INSTRUMENT PANEL FLOODLIGHT  
(EXAMPLE)

(G) FROM SHT 1

DIMMER CONTROL UNIT FOR  
THE GLARESHIELD FLOODLIGHT  
(EXAMPLE)

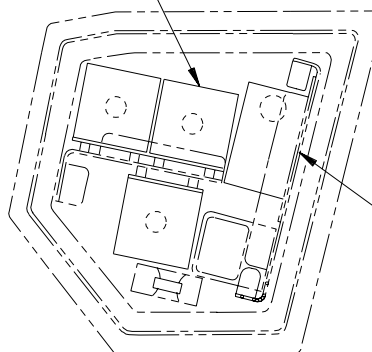

DIMMER CONTROL UNIT FOR  
THE INSTRUMENT PANEL  
FLOODLIGHT  
(EXAMPLE)

ACCESS PANEL  
(EXAMPLE)

(H) FROM SHT 1

FWD ←

Flight Compartment Illumination - Component Location  
Figure 102 (Sheet 3)

EFFECTIVITY	ALL
-------------	-----

**33-11-00**

**FLIGHT COMPARTMENT  
PANEL FLOODLIGHT  
PROBLEMS**

**PREREQUISITES**

ELECTRICAL POWER (MM 24-22-00/201)

CB'S: 11B6,11N6,11N33

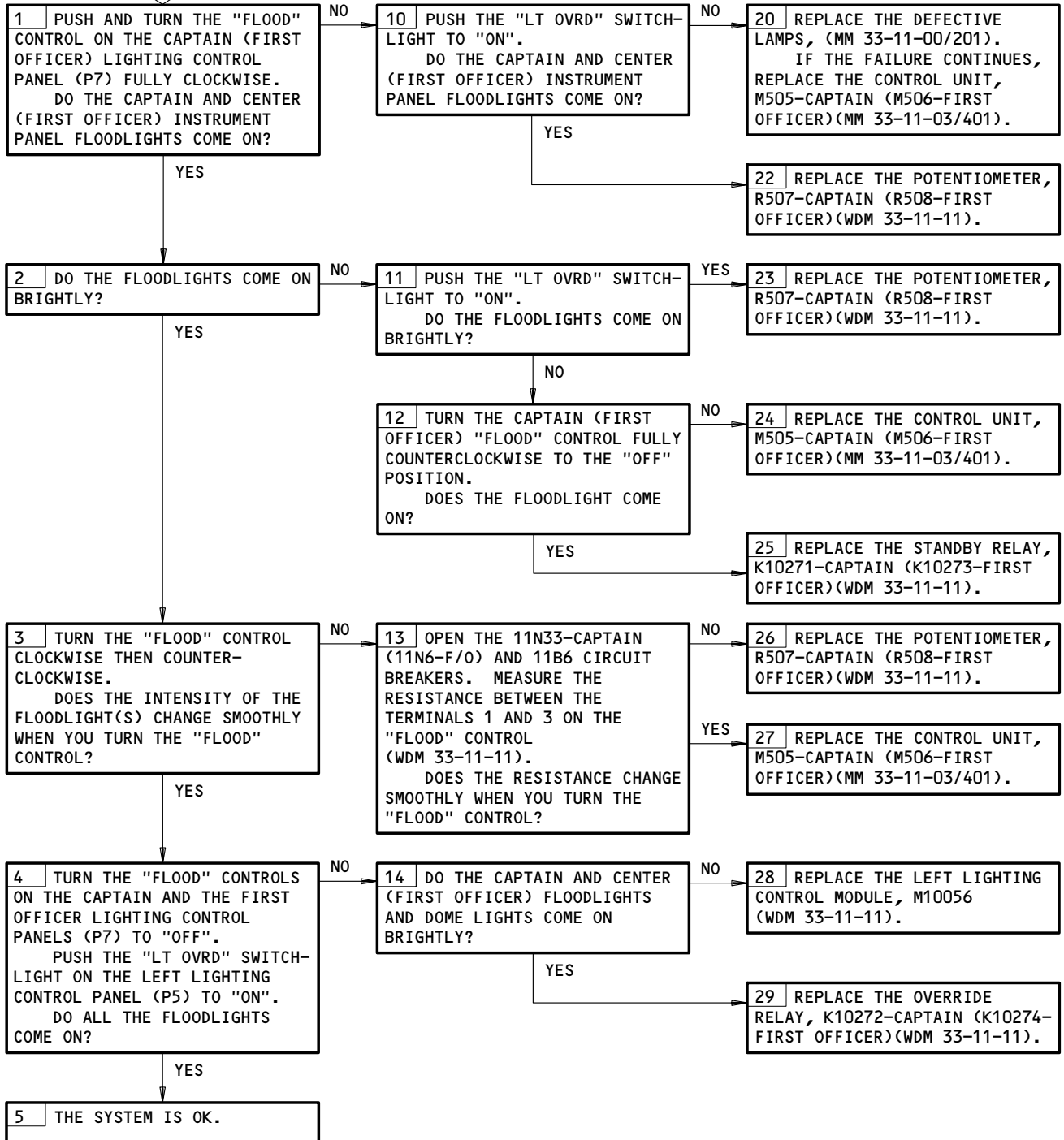

Flight Compartment Panel Floodlight Problems  
Figure 103

EFFECTIVITY

ALL

**33-11-00**

01

Page 105  
Sep 20/93

56361

**GLARESHIELD FLOOD-  
LIGHT PROBLEMS**

**PREREQUISITES**

MAKE SURE THE APPLICABLE CIRCUIT BREAKERS ARE CLOSED:  
(WDM 33-11-21 OR SSM 33-11-02)

MAKE SURE THE AIRPLANE IS IN THIS CONFIGURATION:  
ELECTRICAL POWER IS ON (AMM 24-22-00/201)

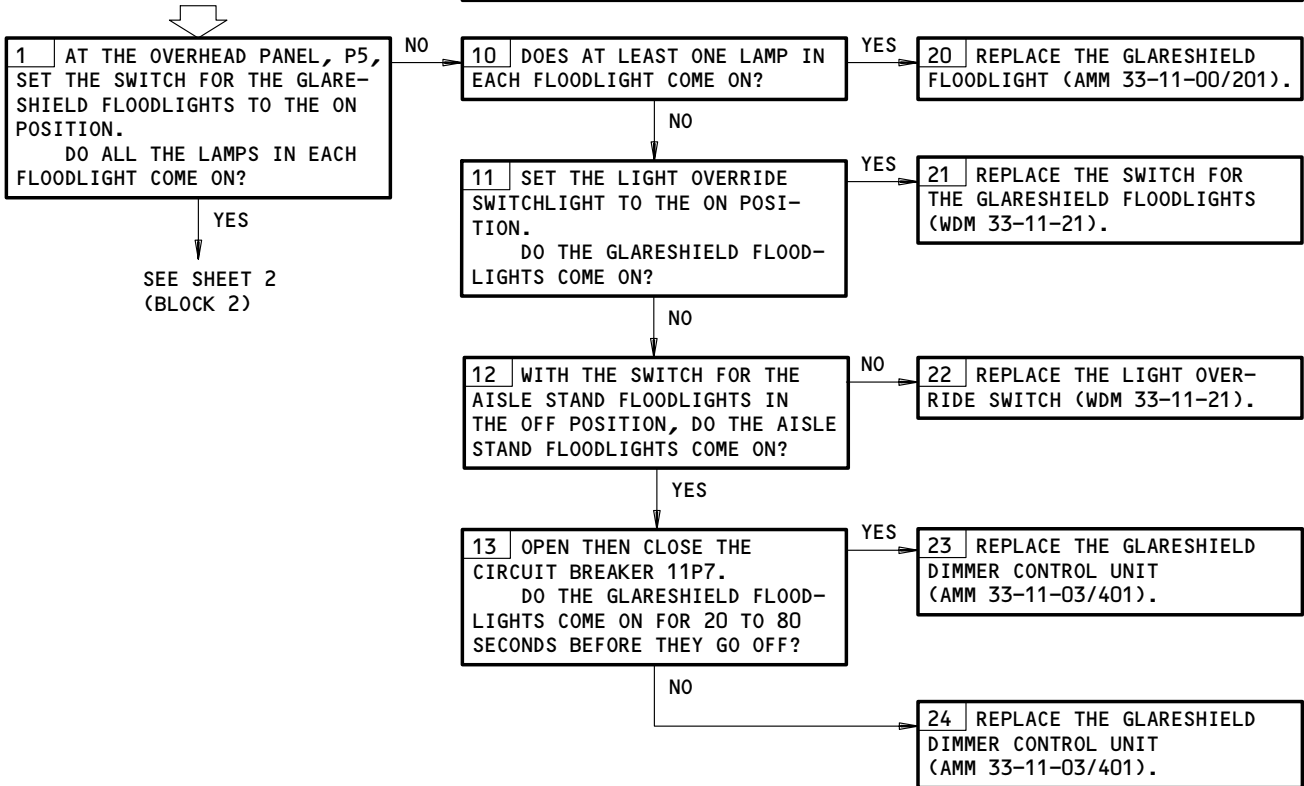

Glareshield Floodlight Problems  
Figure 104 (Sheet 1)

EFFECTIVITY	ALL
-------------	-----

**33-11-00**

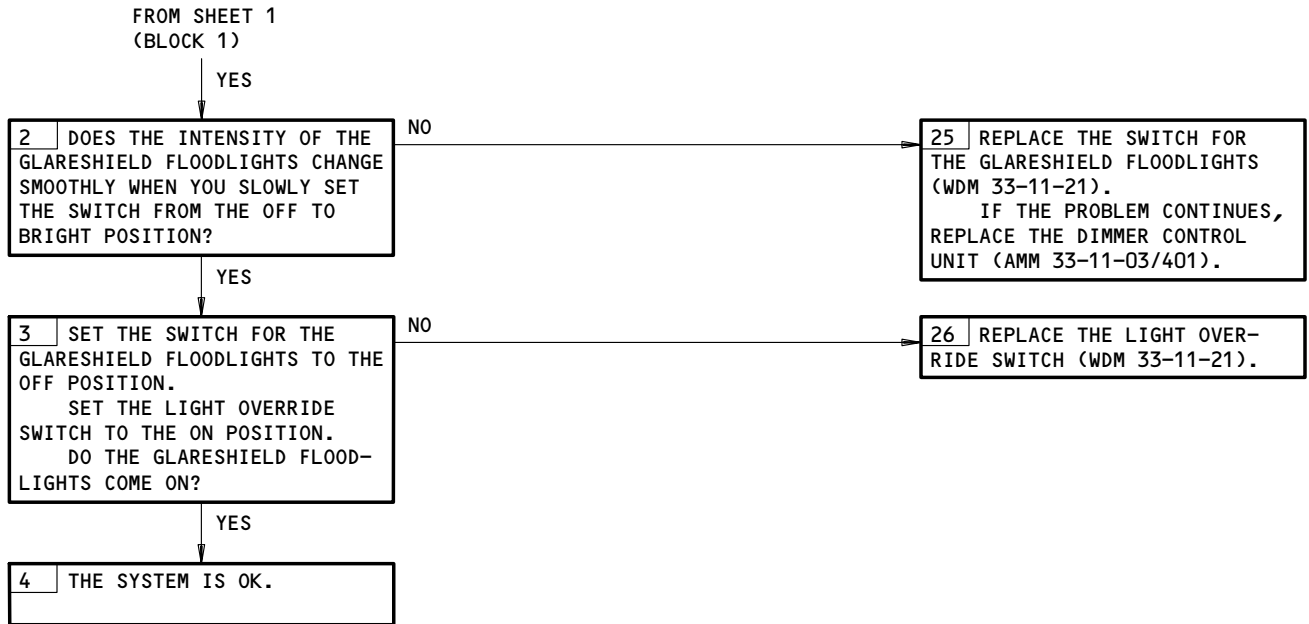

Glareshield Floodlight Problems  
Figure 104 (Sheet 2)

EFFECTIVITY

---

ALL

33-11-00

01

Page 107  
Mar 20/94

**AISLE STAND FLOOD-  
LIGHT PROBLEMS**

**PREREQUISITES**  
MAKE SURE THE APPLICABLE CIRCUIT BREAKERS ARE CLOSED:  
(WDM 33-11-21 OR SSM 33-11-02)  
MAKE SURE THE AIRPLANE IS IN THIS CONFIGURATION:  
ELECTRICAL POWER IS ON (AMM 24-22-00/201)

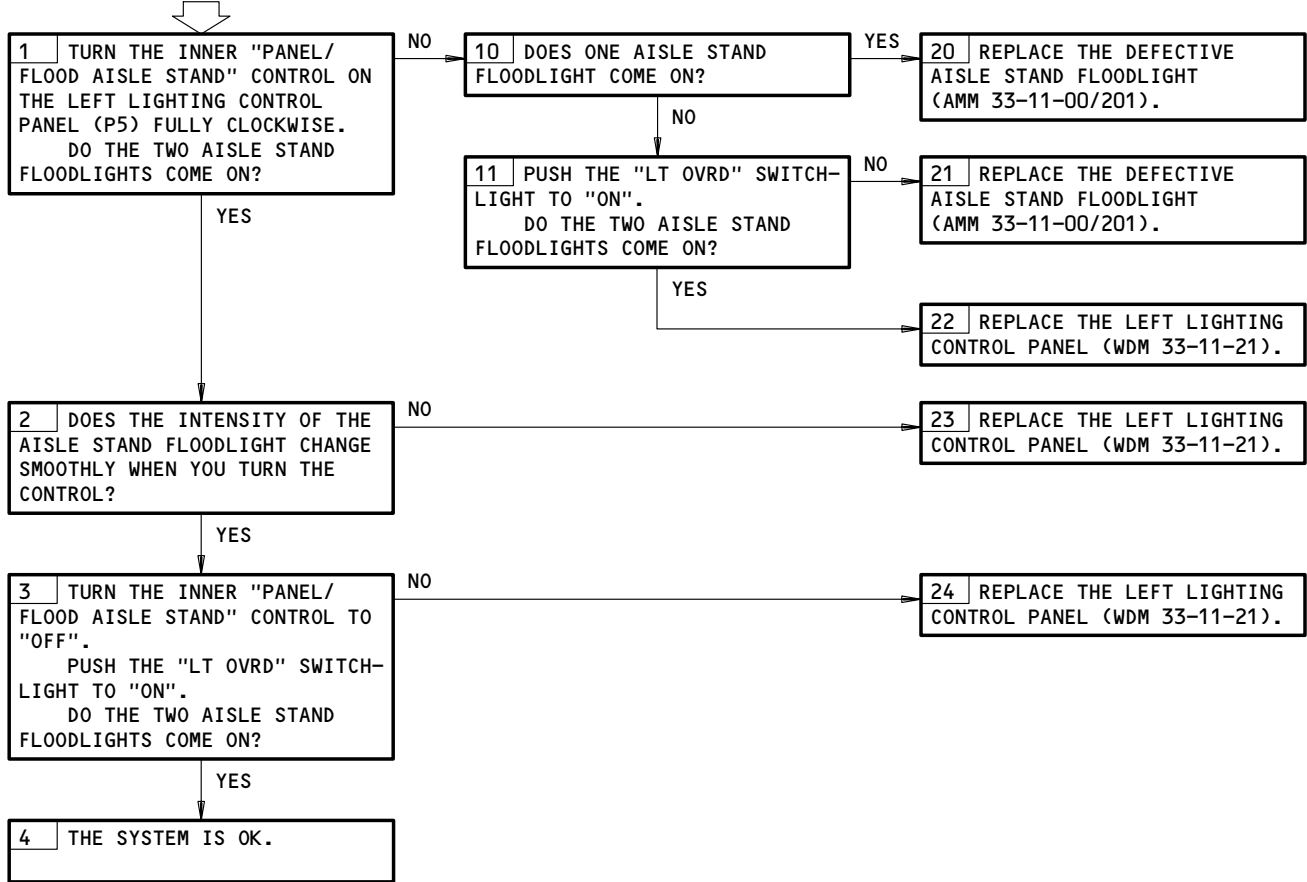

Aisle Stand Floodlight Problems  
Figure 105

EFFECTIVITY

ALL

**33-11-00**

01

Page 108  
Mar 20/94

A73215

**DOME LIGHT PROBLEMS**

**PREREQUISITES**

MAKE SURE THE APPLICABLE CIRCUIT BREAKERS ARE CLOSED:  
(WDM 33-11-31 OR SSM 33-11-03)

MAKE SURE THE AIRPLANE IS IN THIS CONFIGURATION:  
ELECTRICAL POWER IS ON (AMM 24-22-00/201)

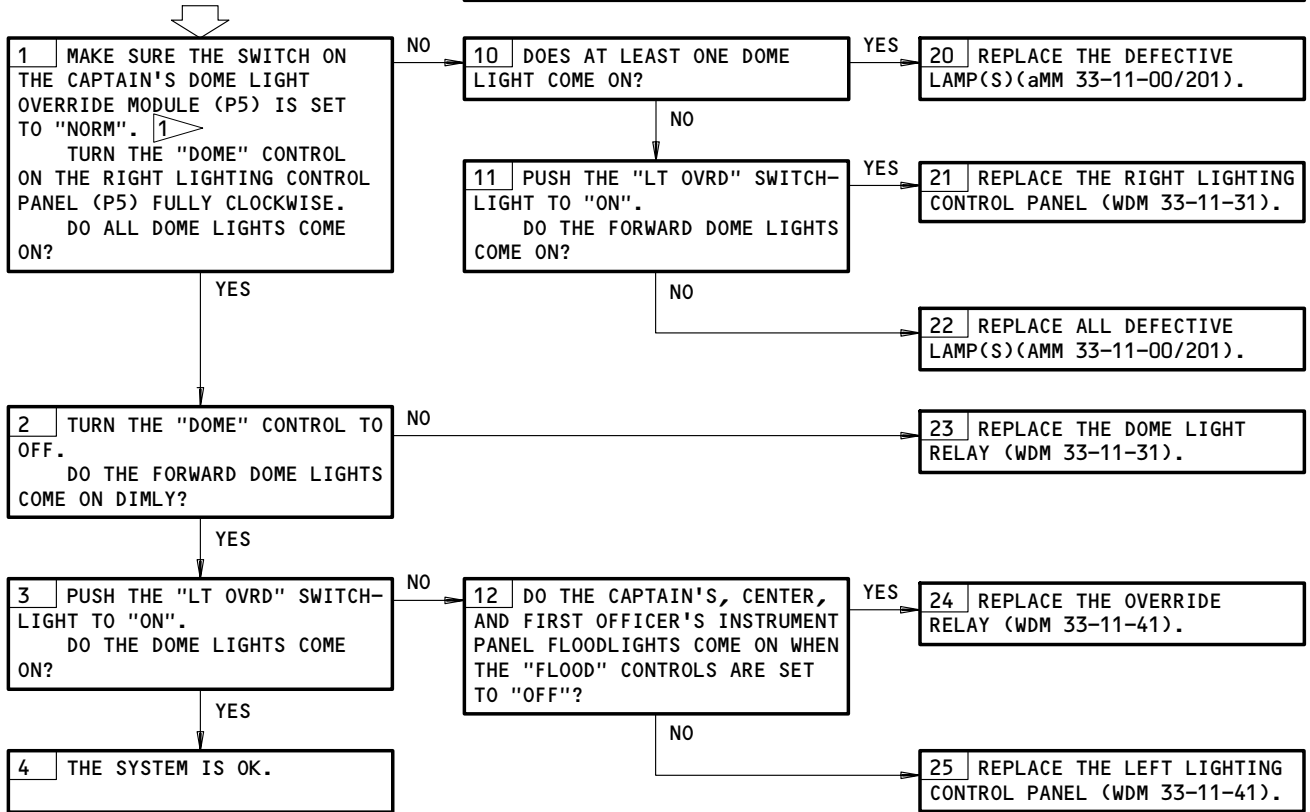

1 NOT INSTALLED ON ALL AIRPLANES

Dome Light Problems  
Figure 106

EFFECTIVITY	ALL
-------------	-----

**33-11-00**

**FLIGHT COMPARTMENT  
MAIN POWER DISTRI-  
BUTION PANEL (P6)  
FLOODLIGHT PROBLEMS**

**PREREQUISITES**

MAKE SURE THIS CIRCUIT BREAKER IS CLOSED:  
11N31

MAKE SURE THE AIRPLANE IS IN THIS CONFIGURATION:  
ELECTRICAL POWER IS ON (AMM 24-22-00/201)

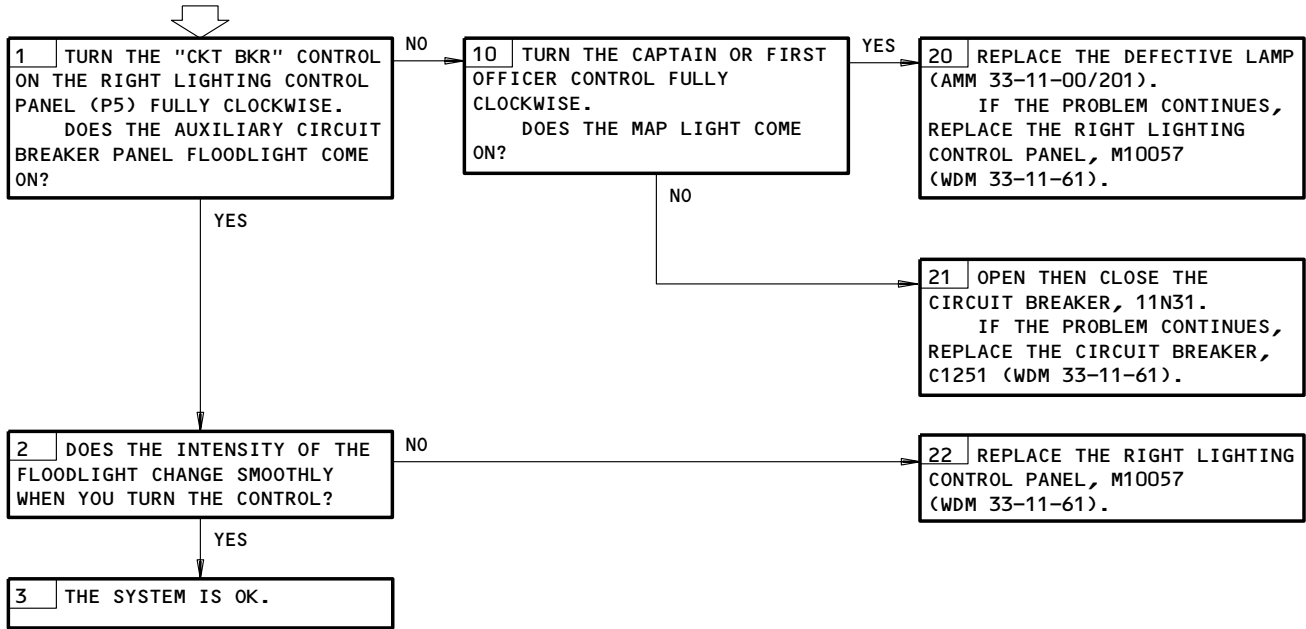

Flight Compartment Main Power Distribution Panel (P6) Floodlight Problems  
Figure 107

EFFECTIVITY

ALL
-----

33-11-00

**BOEING**  
757  
FAULT ISOLATION/MAINT MANUAL

INTEGRAL PANEL LIGHTS

COMPONENT*	FIG. 102 SHT	QTY *	ACCESS/AREA	AMM REFERENCE
CIRCUIT BREAKER -	1		FLT COMPT, P11	*
DIMMER CONTROL UNIT -				
AISLE STAND PNL LIGHTS			FLT COMPT	33-13-02
AISLE STAND PNL LIGHTS	1		FLT COMPT	33-13-02
CENTER INST AND GLARESHIELD PNL LIGHTS			FLT COMPT	33-13-02
OVERHEAD AND CIRCUIT BREAKER PNL LIGHTS			FLT COMPT/NLG WHEEL WELL, P12 <span style="font-size: small;">▶</span>	33-13-02
PILOTS' INST PNL LIGHTS			FLT COMPT	33-13-02
RIGHT SIDE PNL INST LIGHTS <span style="font-size: small;">▶</span>			FLT COMPT, ABOVE P61	33-13-02
LIGHT - INSTRUMENT AND PANEL	*		FLT COMPT	*
SWITCH - INST AND PNL LIGHTS	1		FLT COMPT	*
RELAY -	1		FLT COMPT	*

\* SEE THE SSM OR WDM FOR THE EQUIPMENT NUMBER, QUANTITY, AND LOCATION OF EACH COMPONENT IN THE LIGHTING CIRCUIT

- ▶ 1 NOT INSTALLED ON ALL AIRPLANES
- ▶ 2 AIRPLANES WITH A P12 PANEL (POST PRR 54360), THE P12 PANEL IS BEHIND ACCESS PANEL 115AL IN THE FORWARD LEFT SECTION OF THE NLG WHEEL WELL.

**NOTE:** AIRPLANES WITH ONE AISLE STAND FLOOD LIGHT HAVE DIMMER CONTROL UNITS INSTALLED ON P12 PANEL. AIRPLANES WITH TWO AISLE STAND FLOOD LIGHTS HAVE DIMMER CONTROL UNITS INSTALLED BEHIND CEILING PANELS. (WDM 33-13-31, 33-13-32)

Integral Panel Lights - Component Index  
Figure 101

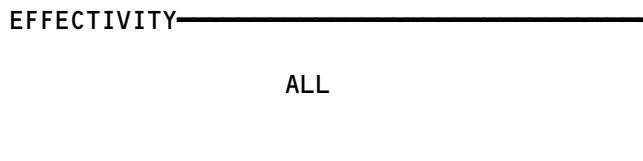

33-13-00

01

Page 101  
May 28/01

FD9143



# BOEING

## 757 FAULT ISOLATION/MAINT MANUAL

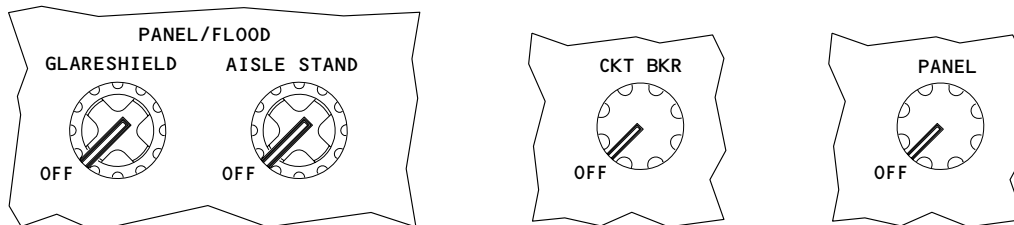
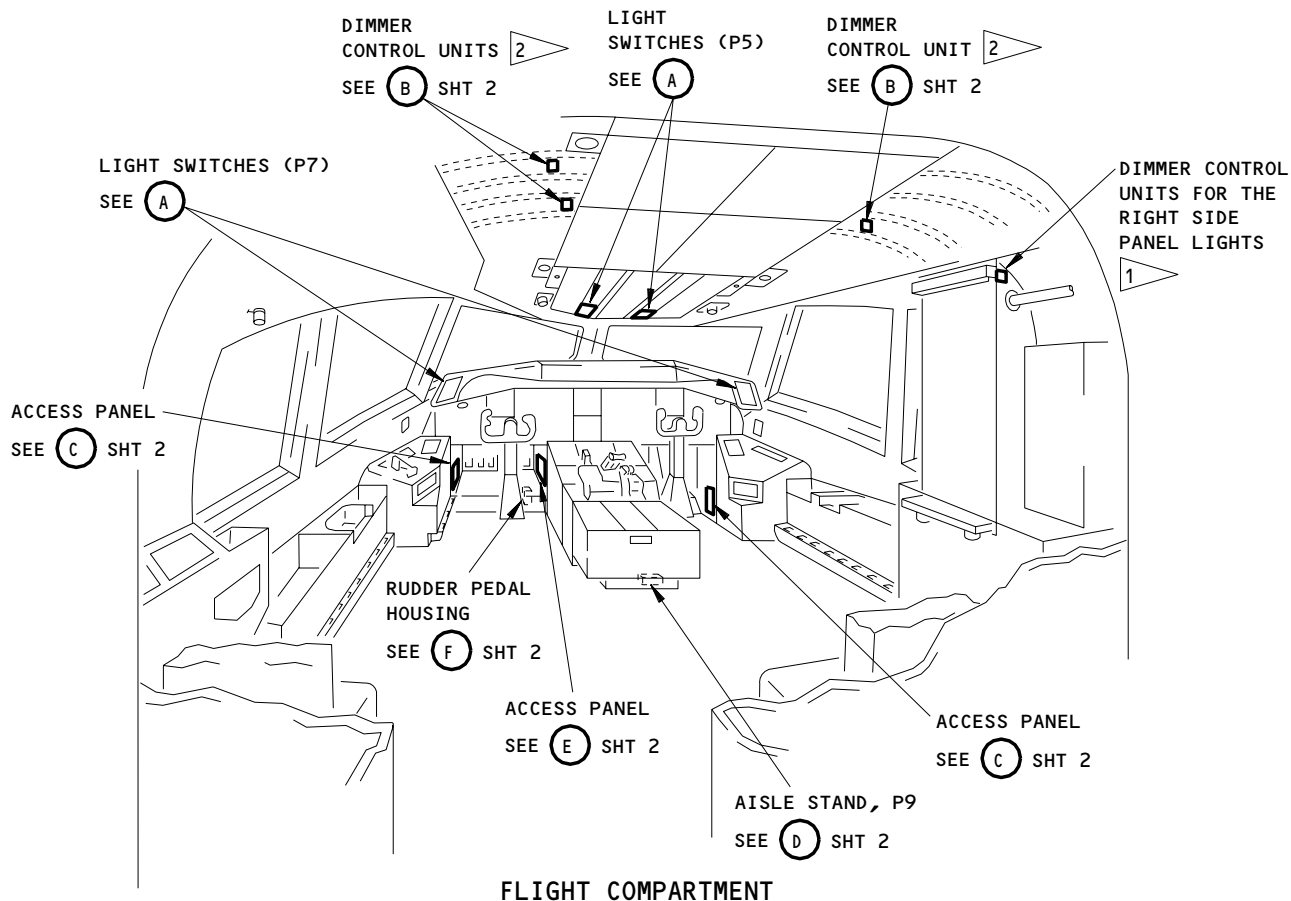

### LIGHT SWITCHES (EXAMPLE)

- 1 NOT INSTALLED ON ALL AIRPLANES
- 2 AIRPLANES WITH A P12 PANEL (POST PRR 54360), THE P12 PANEL IS BEHIND ACCESS PANEL 115AL IN THE FORWARD LEFT SECTION OF THE NLG WHEEL WELL.

**NOTE:** AIRPLANES WITH ONE AISLE STAND FLOOD LIGHT HAVE DIMMER CONTROL UNITS INSTALLED ON P12 PANEL. AIRPLANES WITH TWO AISLE STAND FLOOD LIGHTS HAVE DIMMER CONTROL UNITS INSTALLED BEHIND CEILING PANELS.  
(WDM 33-13-31, 33-13-32)

Integral Panel Lights - Component Location  
Figure 102 (Sheet 1)

EFFECTIVITY

ALL

# 33-13-00

01

Page 102  
May 28/01

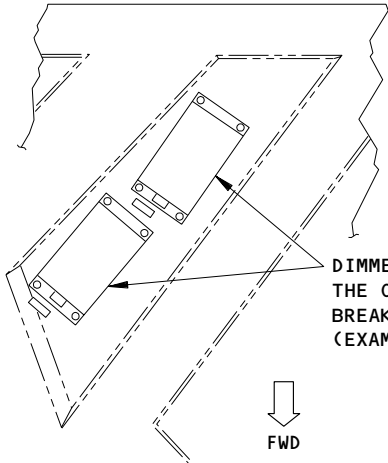

DIMMER CONTROL UNITS

(B)

DIMMER CONTROL UNIT FOR THE PILOT'S INSTRUMENT PANEL LIGHTS (EXAMPLE)

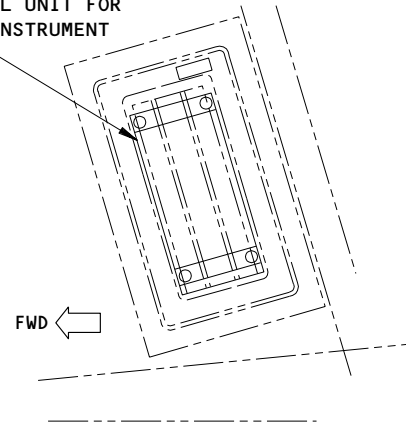

ACCESS PANEL

(LEFT SIDE IS SHOWN, RIGHT SIDE IS OPPOSITE)

(C)

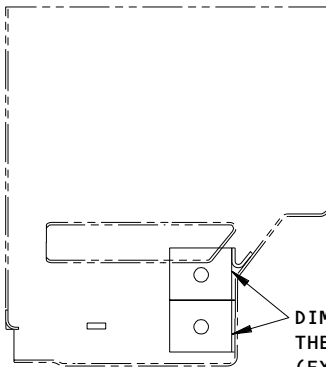

AISLE STAND, P9

(D)

DIMMER CONTROL UNITS FOR THE CENTER INSTRUMENT AND GLARESHIELD PANEL LIGHTS (EXAMPLE)

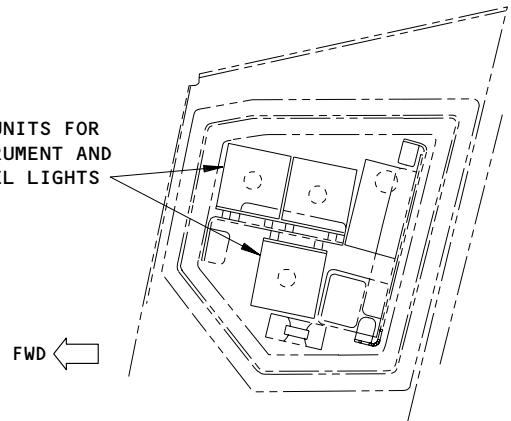

ACCESS PANEL

(E)

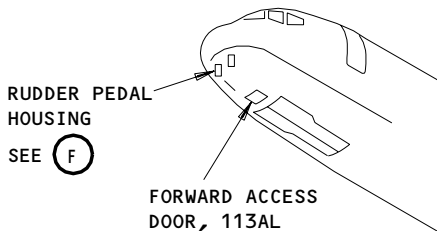

RUDDER PEDAL HOUSING  
SEE (F)

FORWARD ACCESS DOOR, 113AL

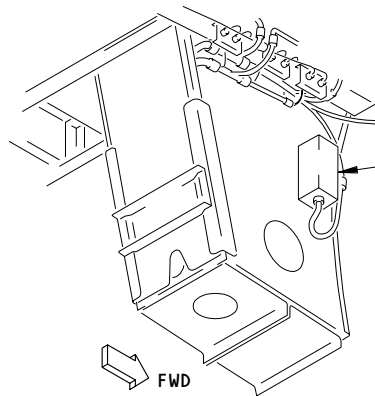

DIMMER CONTROL UNIT FOR THE AISLE STAND PANEL LIGHTS (LEFT SIDE IS SHOWN, RIGHT SIDE IS OPPOSITE)

RUDDER PEDAL HOUSING

(F)

Integral Panel Lights - Component Location  
Figure 102 (Sheet 2)

EFFECTIVITY

ALL

33-13-00

01

Page 103  
May 28/00

**BOEING**  
757  
FAULT ISOLATION/MAINT MANUAL

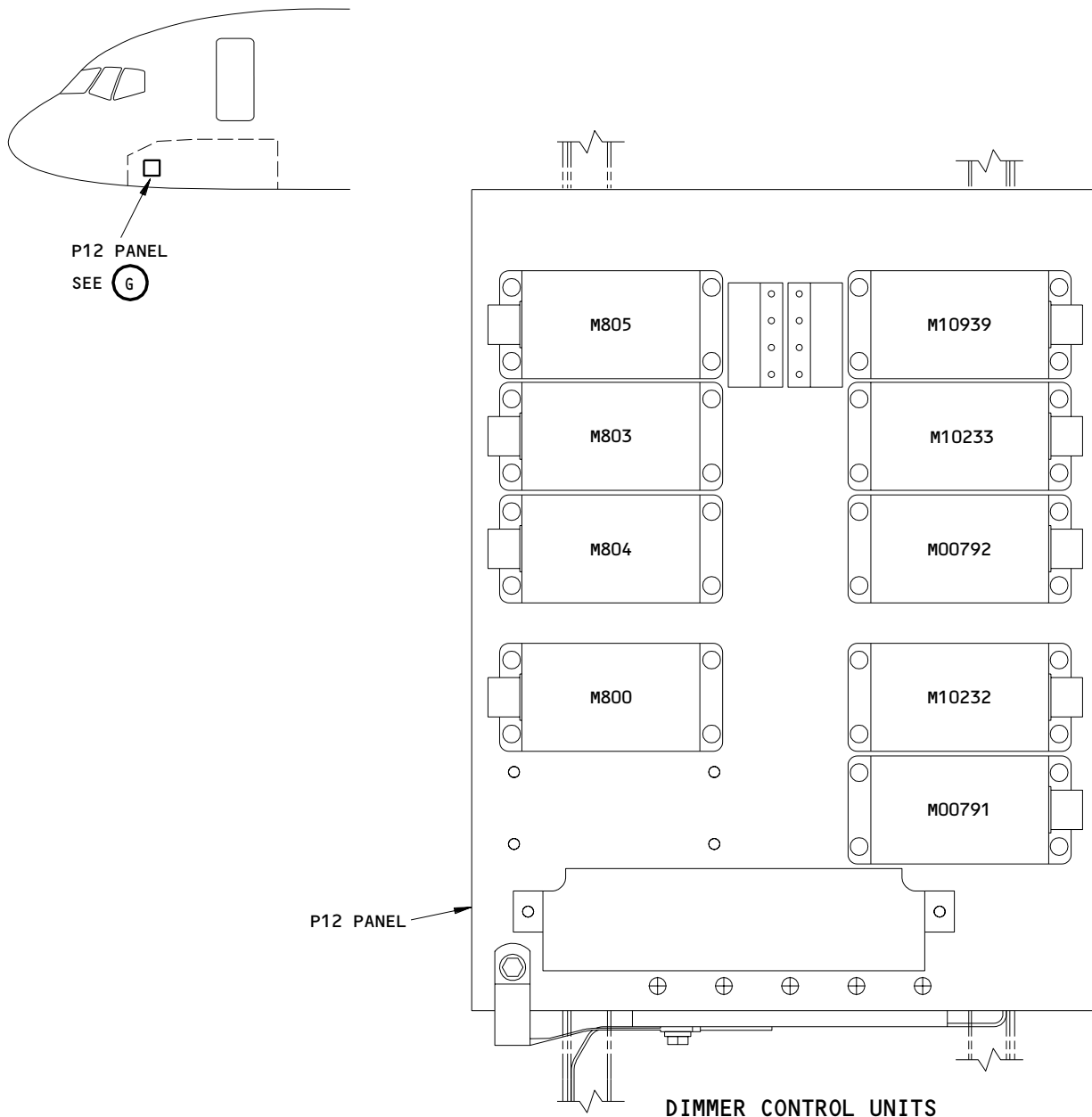

2 AIRPLANES WITH A P12 PANEL (POST PRR 54360), THE P12 PANEL IS BEHIND ACCESS PANEL 115AL IN THE FORWARD LEFT SECTION OF THE NLG WHEEL WELL.

G 2

**NOTE:** AIRPLANES WITH ONE AISLE STAND FLOOD LIGHT HAVE DIMMER CONTROL UNITS INSTALLED ON P12 PANEL. AIRPLANES WITH TWO AISLE STAND FLOOD LIGHTS HAVE DIMMER CONTROL UNITS INSTALLED BEHIND CEILING PANELS.  
(WDM 33-13-31, 33-13-32)

Integral Panel Lights - Component Location  
Figure 102 (Sheet 3)

EFFECTIVITY	ALL
-------------	-----

**33-13-00**

**FLIGHT COMPARTMENT -  
CAPTAIN'S AND  
CENTER PANEL LIGHT  
PROBLEMS**

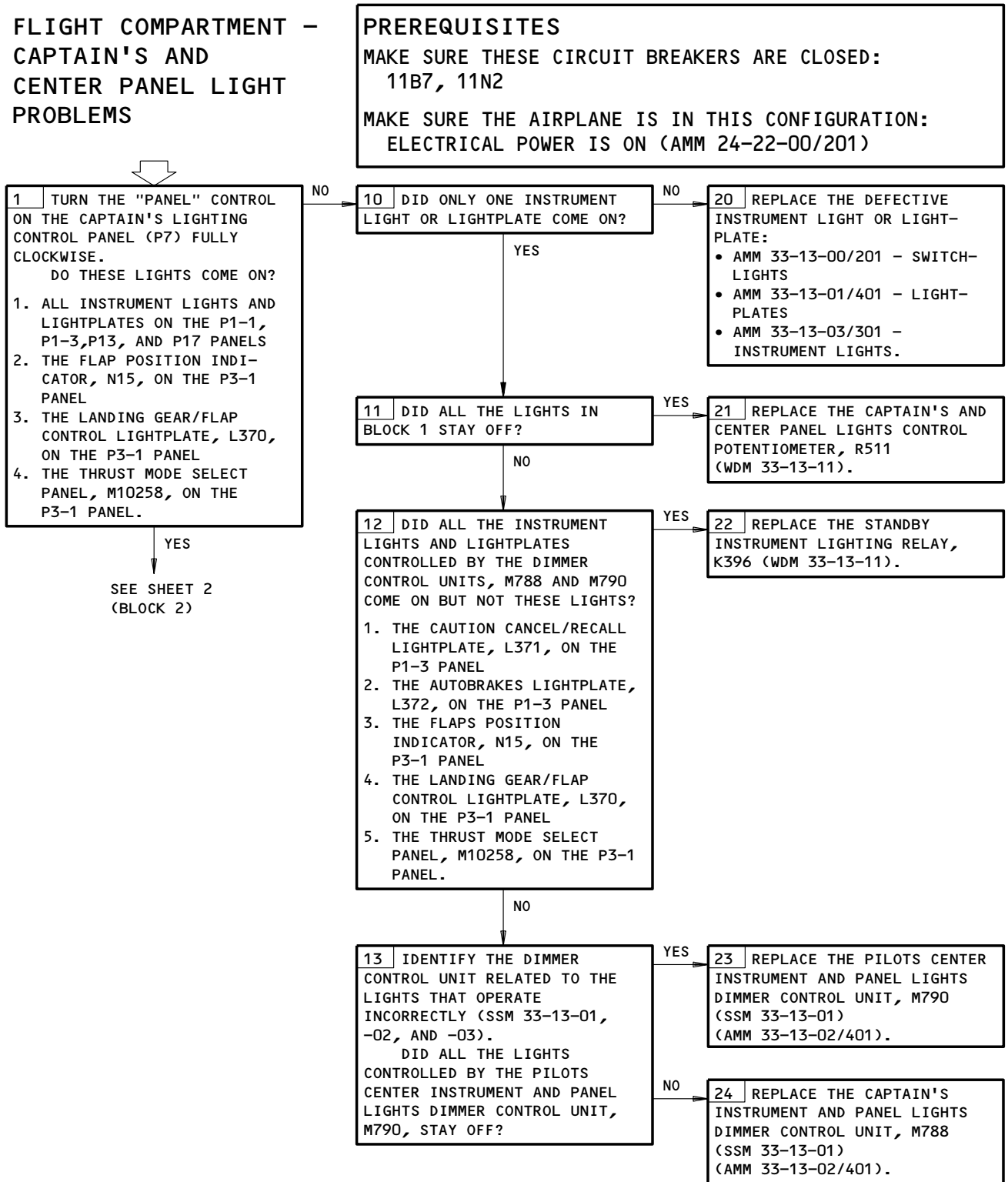

Flight Compartment - Captain's and Center Panel Light Problems  
Figure 103 (Sheet 1)

EFFECTIVITY

ALL

**33-13-00**

01

Page 105  
May 28/00

57117

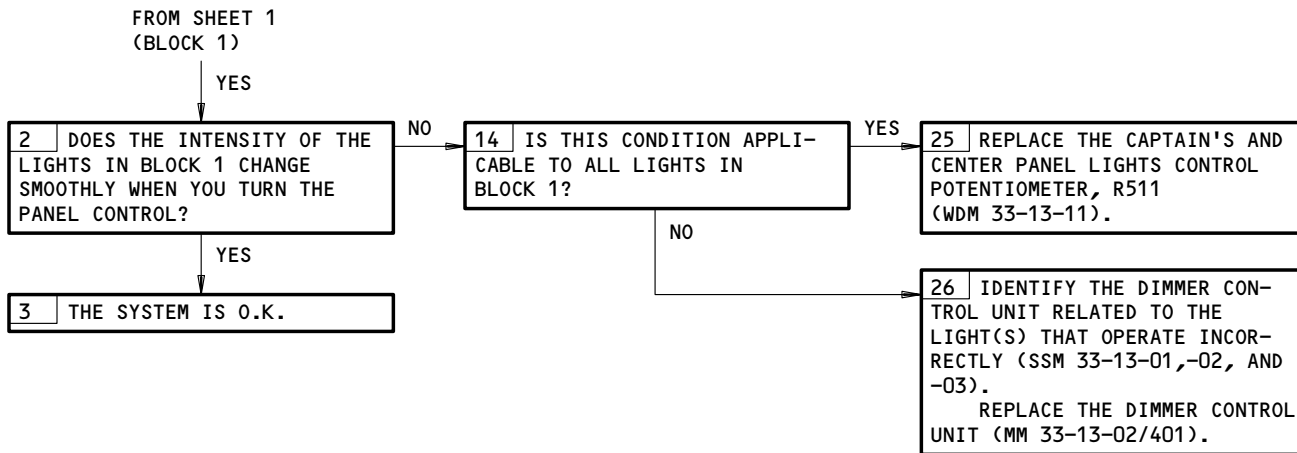

Flight Compartment - Captain's and Center Panel Light Problems  
Figure 103 (Sheet 2)

EFFECTIVITY	ALL
-------------	-----

33-13-00

**FLIGHT COMPARTMENT –  
FIRST OFFICER'S  
PANEL LIGHT  
PROBLEMS**

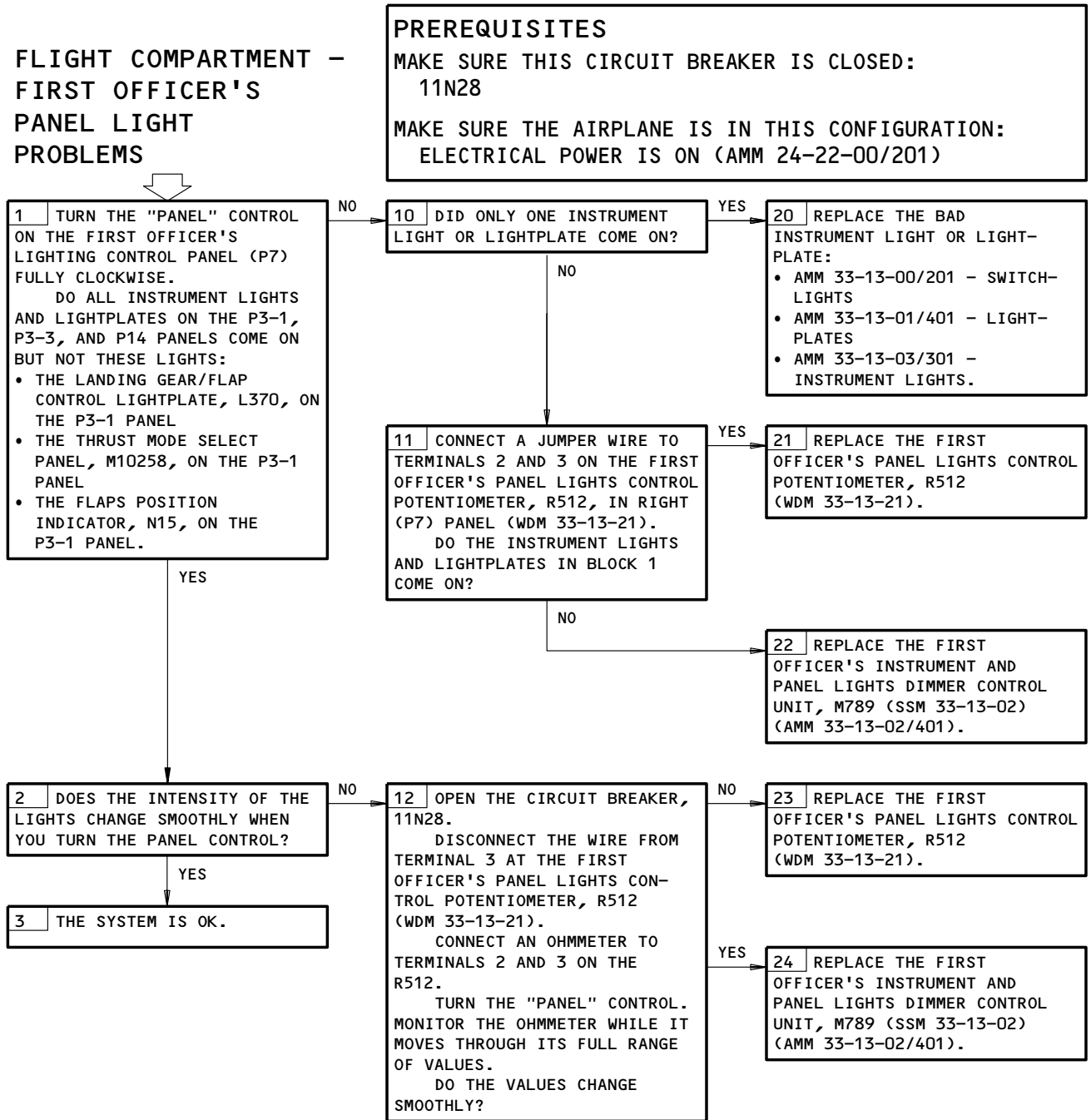

Flight Compartment – First Officer's Panel Light Problems  
Figure 104 (Sheet 1)

EFFECTIVITY  
AIRPLANES WITHOUT PANEL LIGHTS  
ON THE RIGHT SIDE PANEL

**33-13-00**

**FLIGHT COMPARTMENT -  
FIRST OFFICER'S  
PANEL AND RIGHT  
SIDE PANEL LIGHT  
PROBLEMS**

**PREREQUISITES**  
MAKE SURE THESE CIRCUIT BREAKERS ARE CLOSED:  
11N28, 11P6  
MAKE SURE THE AIRPLANE IS IN THIS CONFIGURATION:  
ELECTRICAL POWER IS ON (AMM 24-22-00/201)

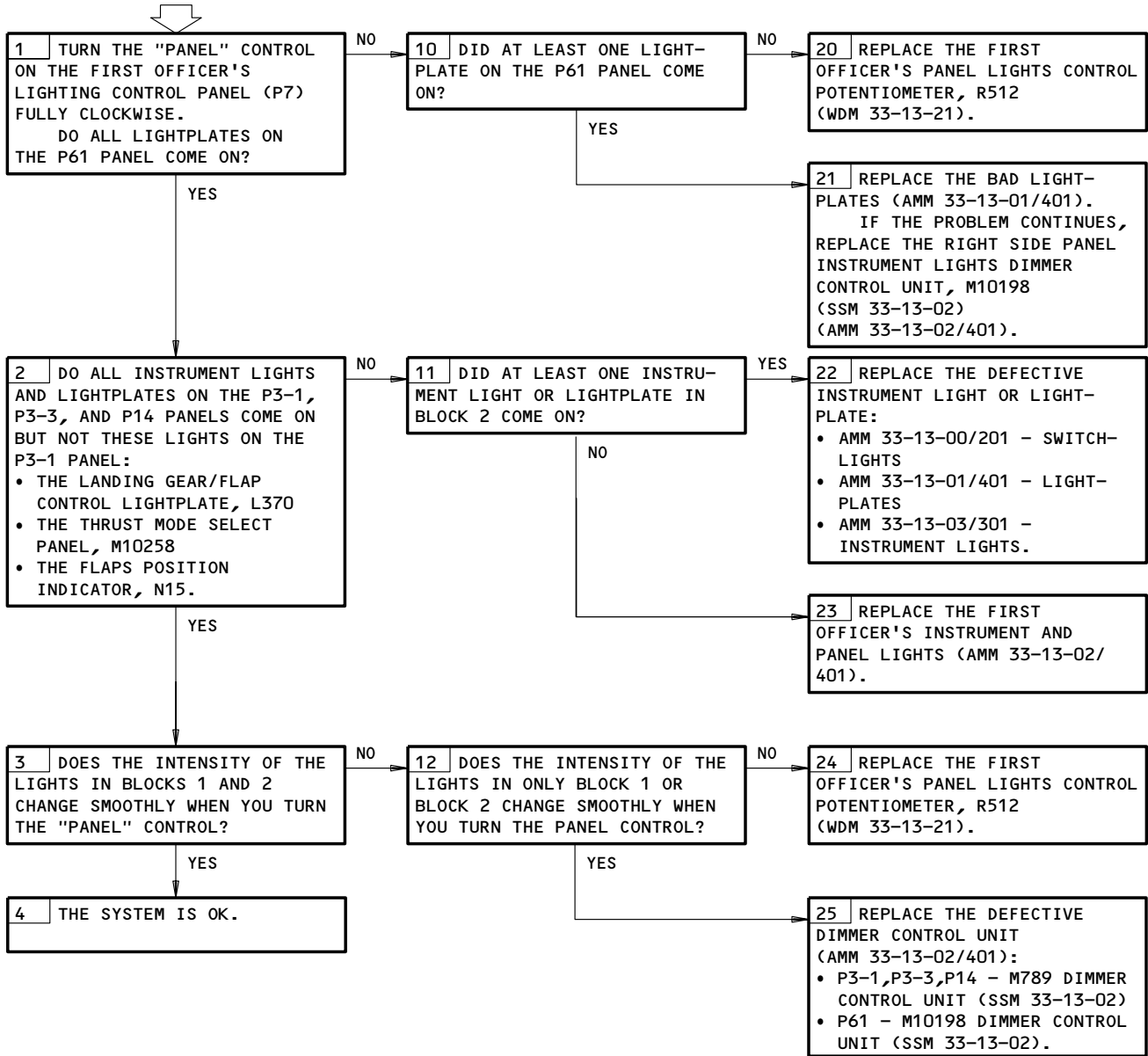

Flight Compartment - First Officer's Panel and Right Side Panel Light Problems  
Figure 104 (Sheet 2)

EFFECTIVITY  
AIRPLANES WITH PANEL LIGHTS  
ON THE RIGHT SIDE PANEL

**33-13-00**

A49820

**FLIGHT COMPARTMENT –  
OVERHEAD PANEL (P5)  
LIGHT PROBLEMS**

**PREREQUISITES**

MAKE SURE THESE CIRCUIT BREAKERS ARE CLOSED:  
11B7, 11N4

MAKE SURE THE AIRPLANE IS IN THIS CONFIGURATION:  
ELECTRICAL POWER IS ON (MM 24-22-00/201)

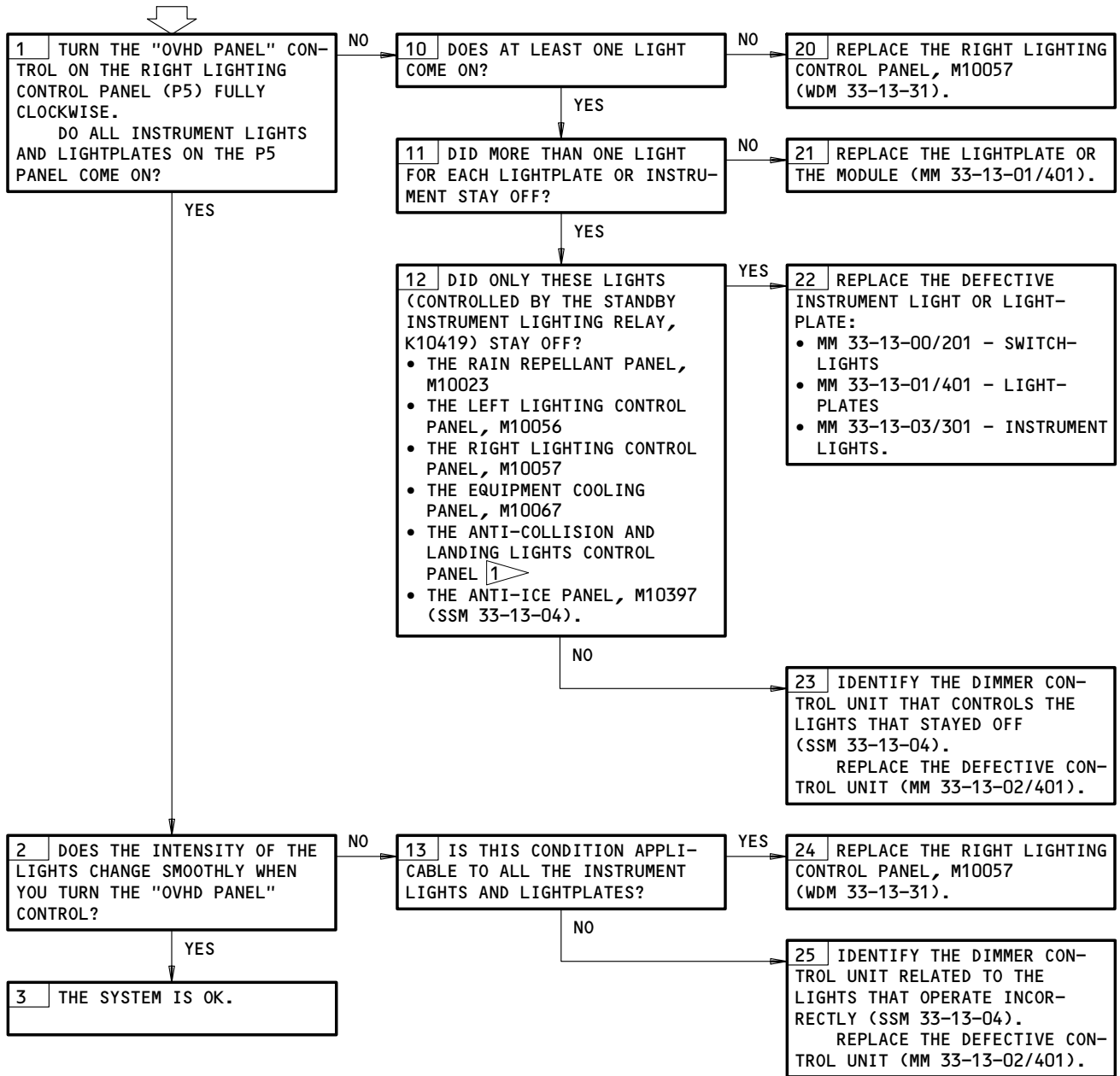

1 ▽ FOR THE EQUIPMENT NUMBER, REFER TO THE SSM OR WDM.

Flight Compartment - Overhead Panel (P5) Light Problems  
Figure 105

EFFECTIVITY

ALL

**33-13-00**

01

Page 109  
Jun 20/95



**FLIGHT COMPARTMENT –  
GLARESHIELD PANEL  
LIGHT PROBLEMS**

**PREREQUISITES**  
 MAKE SURE THESE CIRCUIT BREAKERS ARE CLOSED:  
 11B7, 11N2, 11N30  
 MAKE SURE THE AIRPLANE IS IN THIS CONFIGURATION:  
 ELECTRICAL POWER IS ON (AMM 24-22-00/201)

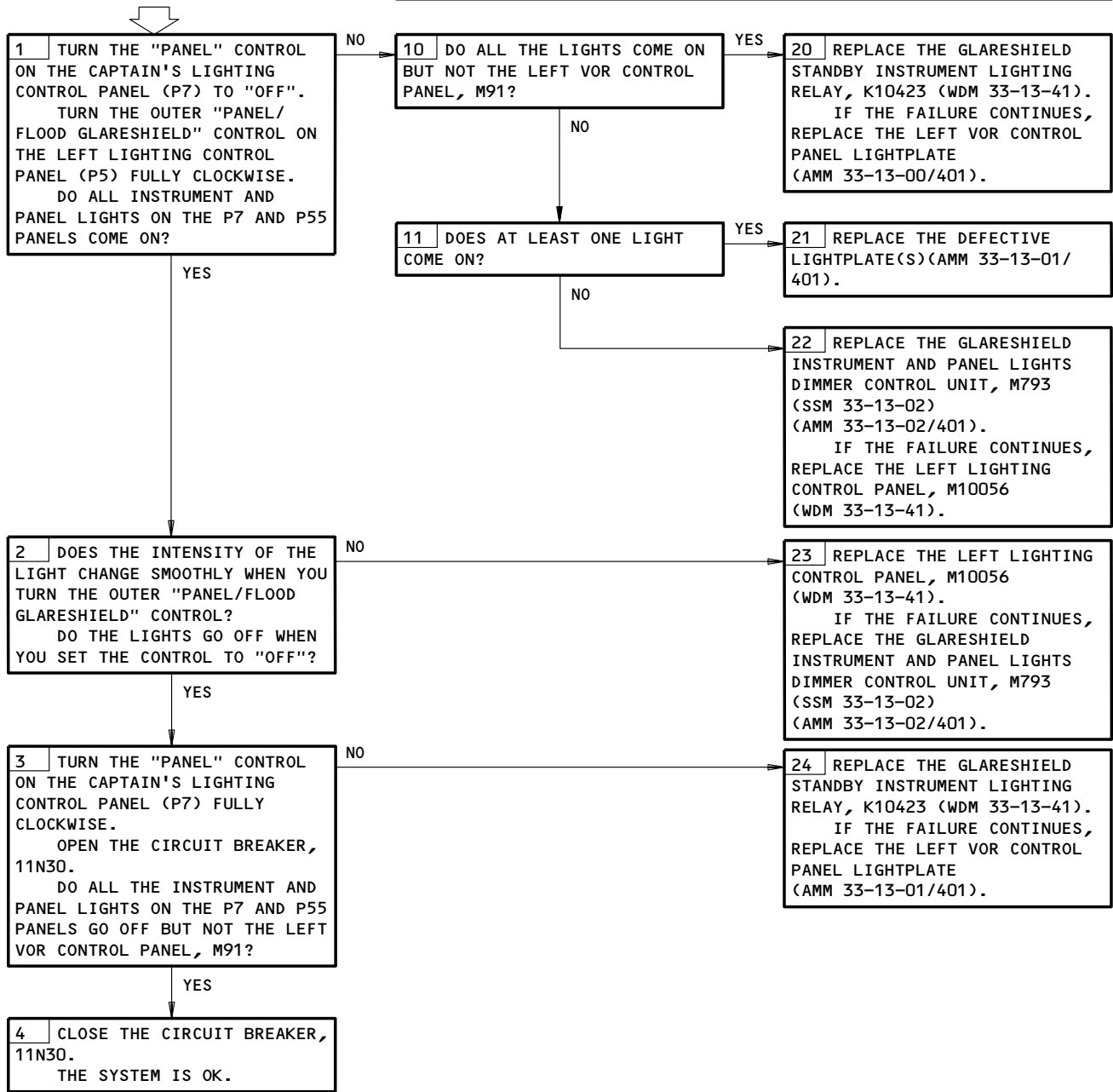

Flight Compartment – Glareshield Panel Light Problems  
Figure 106

EFFECTIVITY ————  
 ALL

**33-13-00**

**AISLE STAND PANEL LIGHT PROBLEMS**

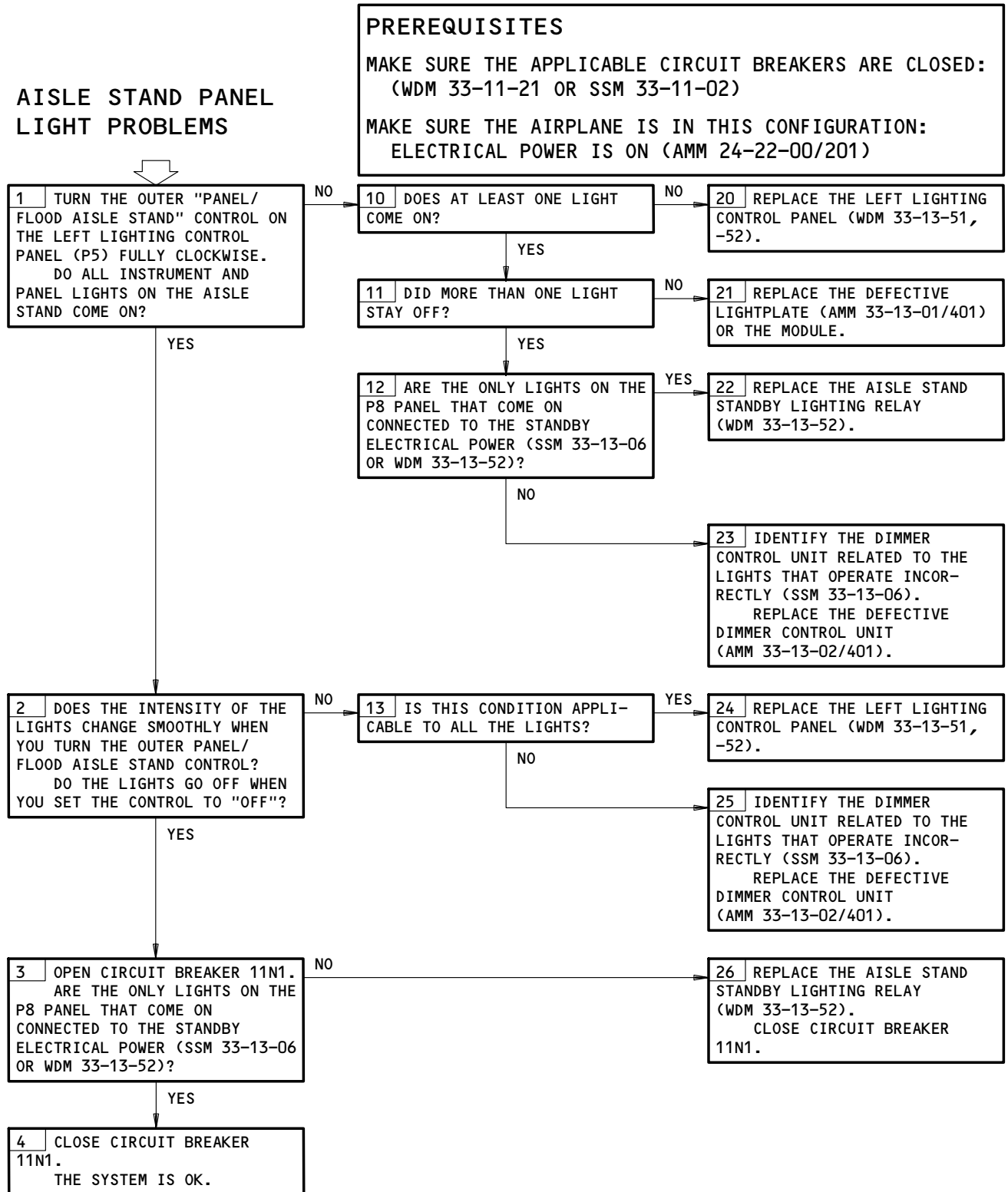

Aisle Stand Panel Light Problems  
Figure 107

EFFECTIVITY

ALL

33-13-00

02

Page 111  
Jun 20/95

**FLIGHT COMPARTMENT -  
 OVERHEAD CB PANEL  
 LIGHT PROBLEMS**

**PREREQUISITES**  
 ELECTRICAL POWER (MM 24-22-00/201)  
 CB'S: 11N5

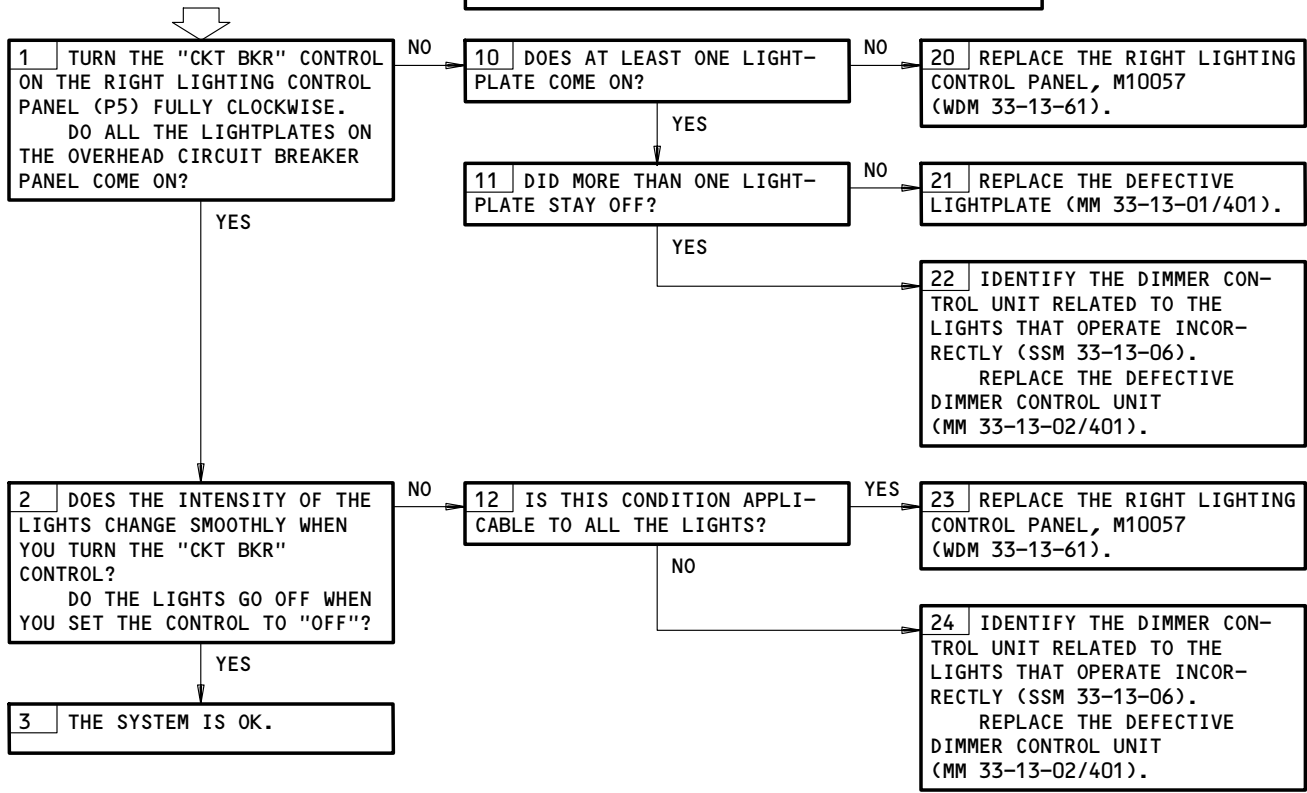

Flight Compartment - Overhead CB Panel Light Problems  
 Figure 107A

EFFECTIVITY \_\_\_\_\_  
 ALL

**33-13-00**

147410



757  
 FAULT ISOLATION/MAINT MANUAL

FLIGHT COMPARTMENT MISCELLANEOUS LIGHTS

COMPONENT*	FIG. 102 SHT	QTY *	ACCESS/AREA	AMM REFERENCE
BOX - SPARE LAMP <span style="border: 1px solid black; padding: 0 2px;">1</span>	2		FLT COMPT	*
CIRCUIT BREAKER -	1		FLT COMPT, OVHD CB PNL, P11	*
CIRCUIT BREAKER - LIGHT -	1		119BL, MAIN EQUIP CTR PNL, P34	*
CHART	1		FLT COMPT	33-14-00
FLIGHT KIT	1		FLT COMPT	33-14-00
MAP	1		FLT COMPT	33-14-00
UTILITY	1		FLT COMPT	33-14-00
THRESHOLD STEP	2		FLT COMPT	33-14-00
SWITCH -	1		FLT COMPT	*

\* SEE THE SSM OR WDM FOR THE EQUIPMENT NUMBER, QUANTITY, AND LOCATION OF EACH COMPONENT IN THE LIGHTING CIRCUIT.

1 NOT INSTALLED ON ALL AIRPLANES

Flight Compartment Miscellaneous Lights - Component Index  
 Figure 101

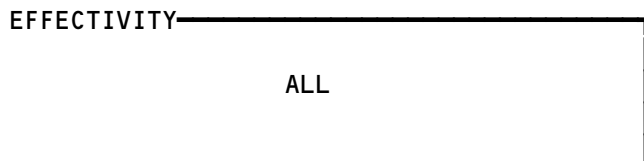

**33-14-00**

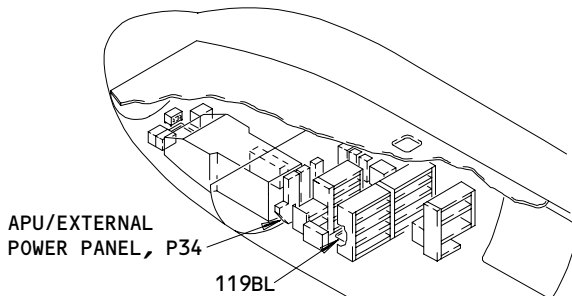

**MAIN EQUIPMENT CENTER**

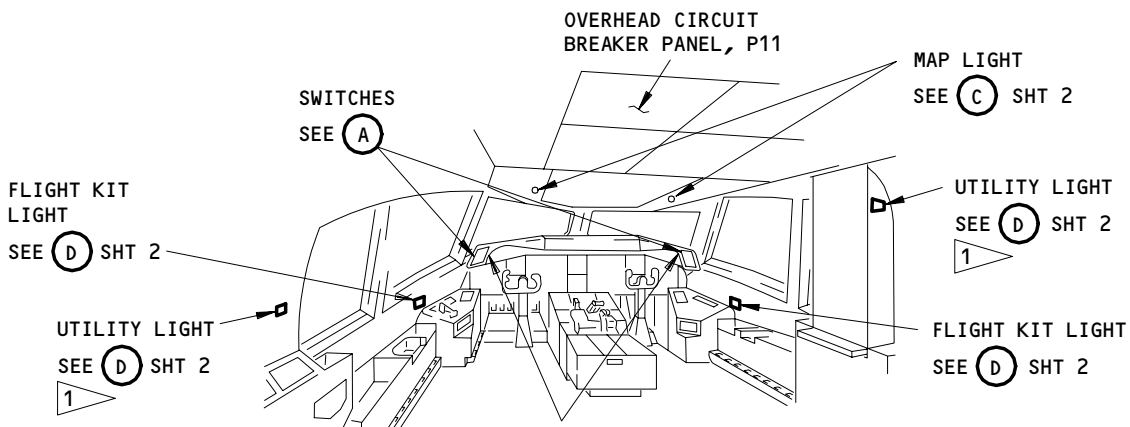

**FLIGHT COMPARTMENT**

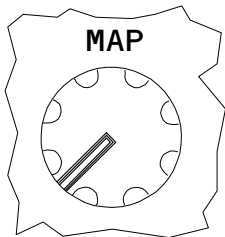
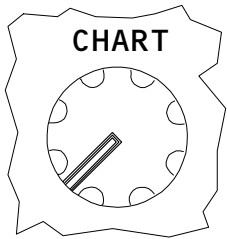

SWITCHES (EXAMPLES)

(A)

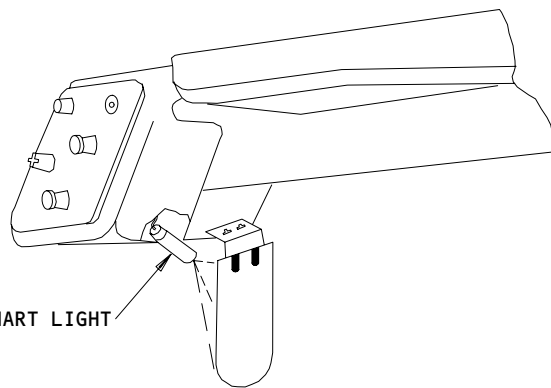

CHART LIGHT (EXAMPLE)

(B)

1 NOT INSTALLED ON ALL AIRPLANES

**Flight Compartment Miscellaneous Lights - Component Location**  
Figure 102 (Sheet 1)

EFFECTIVITY	ALL
-------------	-----

**33-14-00**

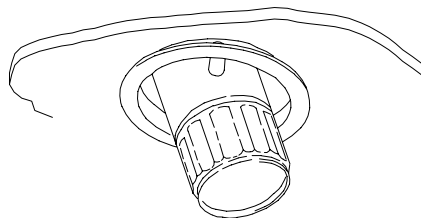

MAP LIGHT  
(EXAMPLE)  
SEE (C) FROM SHT 1

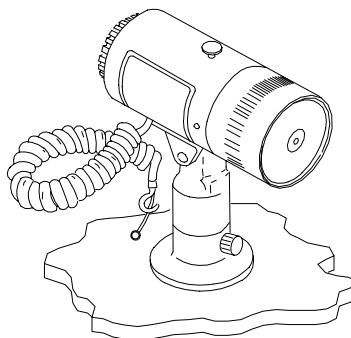

FLIGHT KIT/UTILITY LIGHT  
(EXAMPLE)  
(D) FROM SHT 1

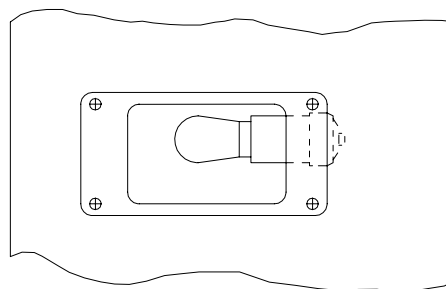
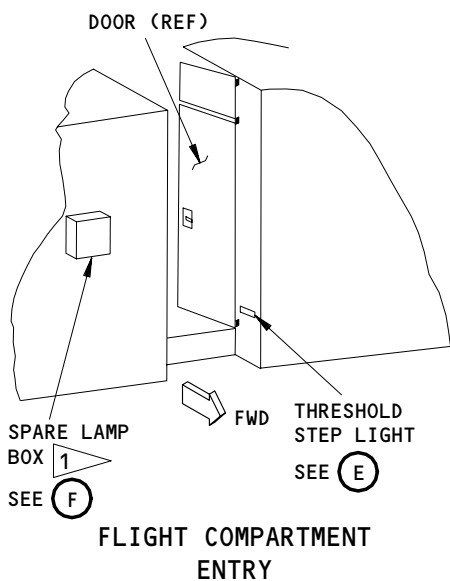

FWD

THRESHOLD STEP LIGHT  
(EXAMPLE)  
(E)

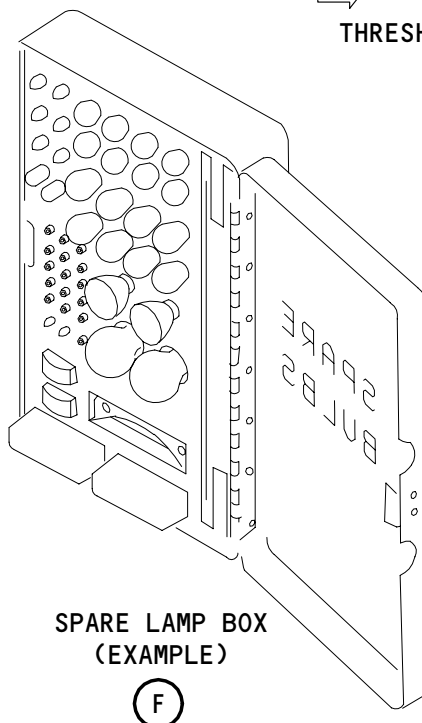

1 NOT INSTALLED ON ALL AIRPLANES

Flight Compartment Miscellaneous Lights - Component Location  
Figure 102 (Sheet 2)

EFFECTIVITY	ALL
-------------	-----

33-14-00

**FLIGHT COMPARTMENT  
MAP LIGHT PROBLEMS**

**PREREQUISITES**

MAKE SURE THIS CIRCUIT BREAKER IS CLOSED:  
11N31

MAKE SURE THE AIRPLANE IS IN THIS CONFIGURATION:  
ELECTRICAL POWER IS ON (AMM 24-22-00/201)

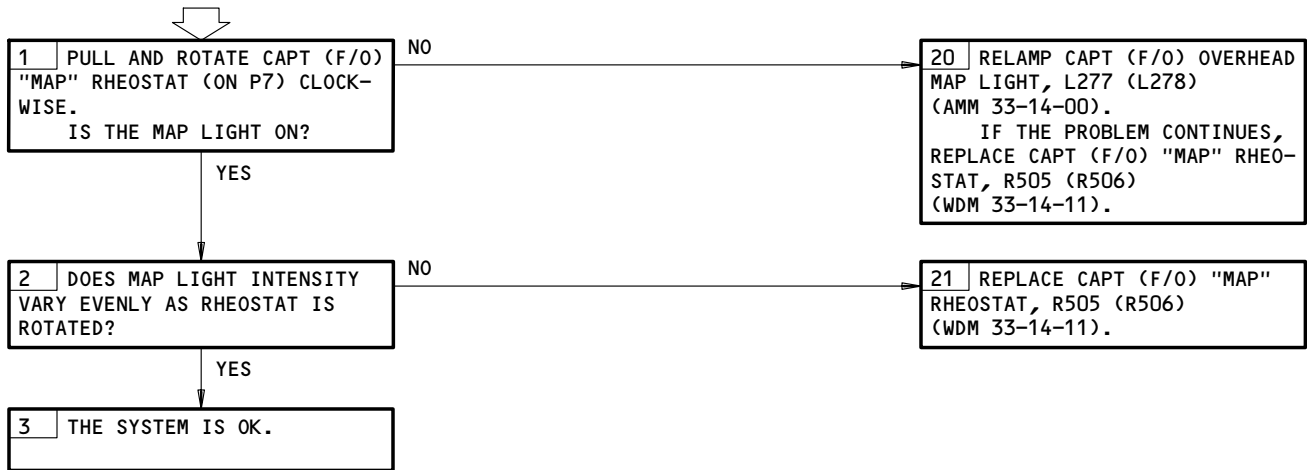

Flight Compartment Map Light Problems  
Figure 103

EFFECTIVITY

ALL
-----

**33-14-00**

ED7645

**FLIGHT COMPARTMENT  
CHART LIGHT PROBLEMS**

**PREREQUISITES**

MAKE SURE THIS CIRCUIT BREAKER IS CLOSED:  
11N7

MAKE SURE THE AIRPLANE IS IN THIS CONFIGURATION:  
ELECTRICAL POWER IS ON (AMM 24-22-00/201)

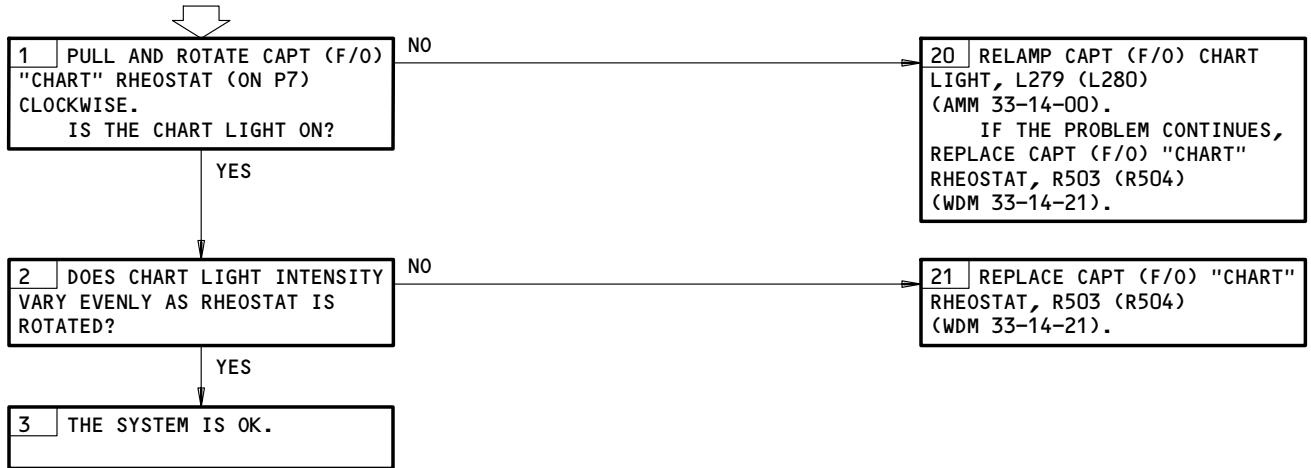

Flight Compartment Chart Light Problems  
Figure 104

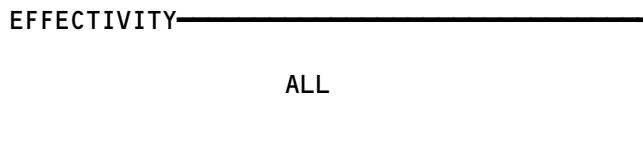

**33-14-00**



**FLIGHT COMPARTMENT  
 FLT KIT/UTILITY  
 LIGHT PROBLEMS**

**PREREQUISITES**

MAKE SURE THIS CIRCUIT BREAKER IS CLOSED:  
11N32

MAKE SURE THE AIRPLANE IS IN THIS CONFIGURATION:  
ELECTRICAL POWER IS ON (AMM 24-22-00/201)



Flight Compartment Flt Kit/Utility Light Problems  
Figure 105

EFFECTIVITY	ALL
-------------	-----

**33-14-00**

**FLIGHT COMPARTMENT  
THRESHOLD STEP  
LIGHT PROBLEMS**

**PREREQUISITES**

MAKE SURE THIS CIRCUIT BREAKER IS CLOSED:  
11R34,34G3(B)

MAKE SURE THE AIRPLANE IS IN THIS CONFIGURATION:  
ELECTRICAL POWER IS ON (AMM 24-22-00/201)

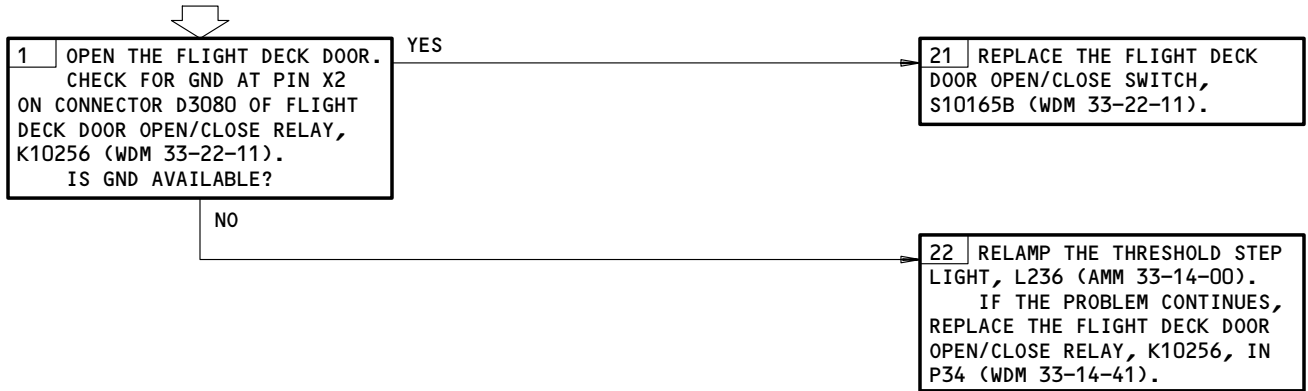

Flight Compartment Threshold Step Light Problems  
Figure 106

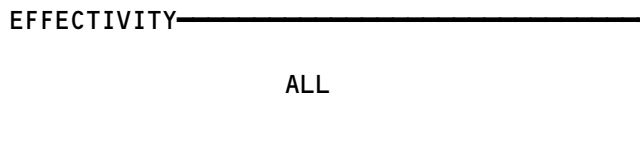

**33-14-00**



**BOEING**  
 757  
 FAULT ISOLATION/MAINT MANUAL

MASTER DIM AND TEST

COMPONENT	FIG. 102 SHT	QTY	ACCESS/AREA	AMM REFERENCE
CARD -	2	*	FLT COMPT, P26	33-16-01
CIRCUIT BREAKER -	1	*	FLT COMPT, P11 AND P26	33-16-01
PANEL -				
LIGHTING CONTROL			FLT COMPT, P5	
LIGHTING EQUIPMENT			FLT COMPT, P26	
RELAY -		*	119BL, MAIN EQUIP. CTR, P36	
RELAY -	2	*	FLT COMPT, P26	
SENSOR -	1		FLT COMPT, P1-3	
SWITCH -	1		FLT COMPT, LIGHTING CONTROL PANEL, P5	

\* SEE THE WDM OR SSM FOR THE EQUIPMENT NUMBER, QUANTITY, AND LOCATION OF EACH COMPONENT IN THE LIGHTING CIRCUIT

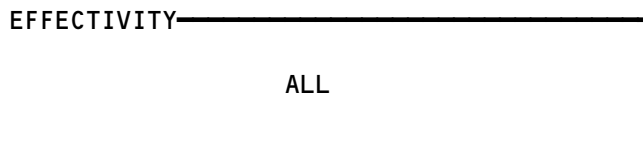
Master Dim and Test - Component Index  
Figure 101



**33-16-00**

01

Page 101  
Sep 20/93

B115722

# BOEING

## 757

### FAULT ISOLATION/MAINT MANUAL

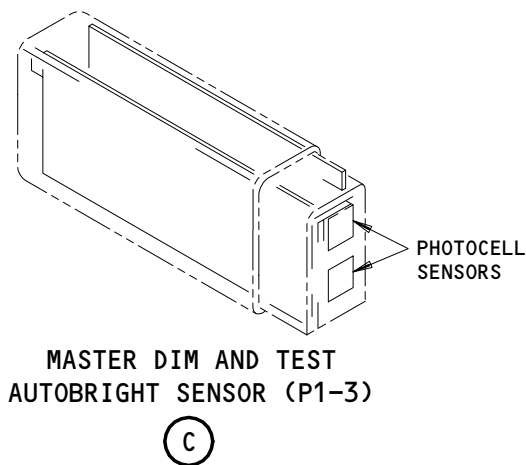
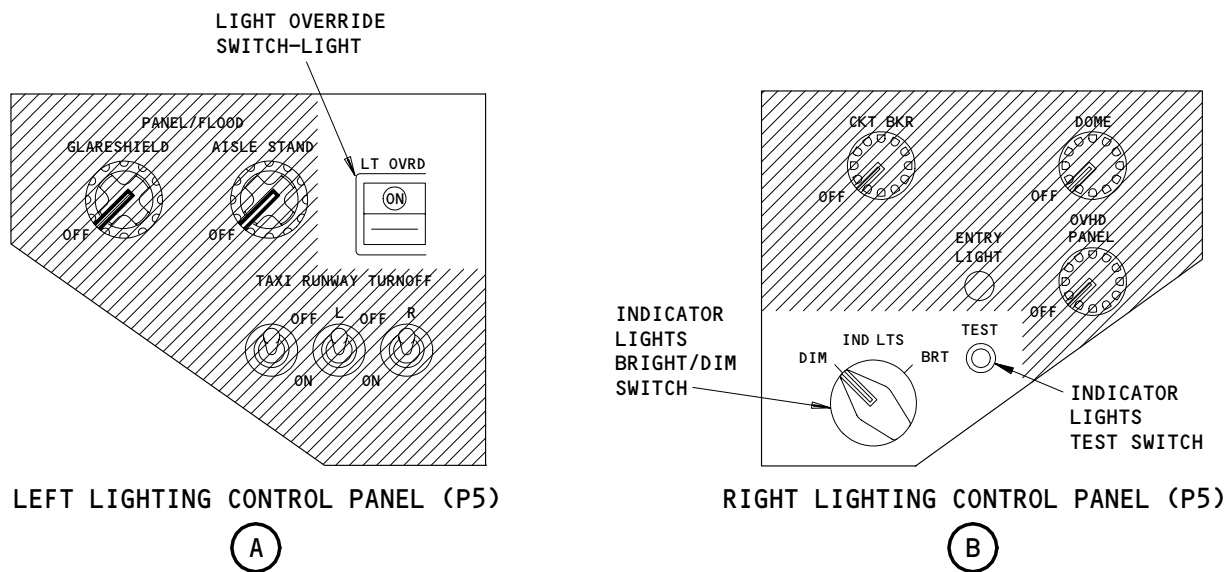
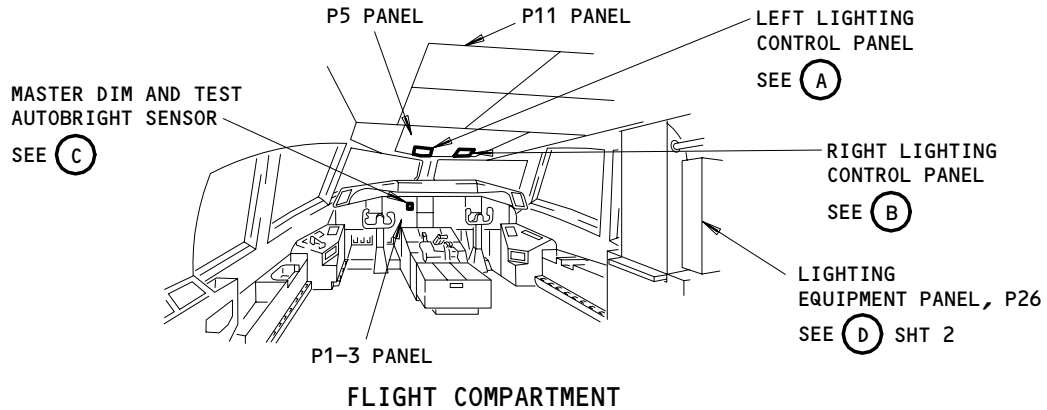

Master Dim and Test - Component Location  
Figure 102 (Sheet 1)

EFFECTIVITY	
	ALL

33-16-00

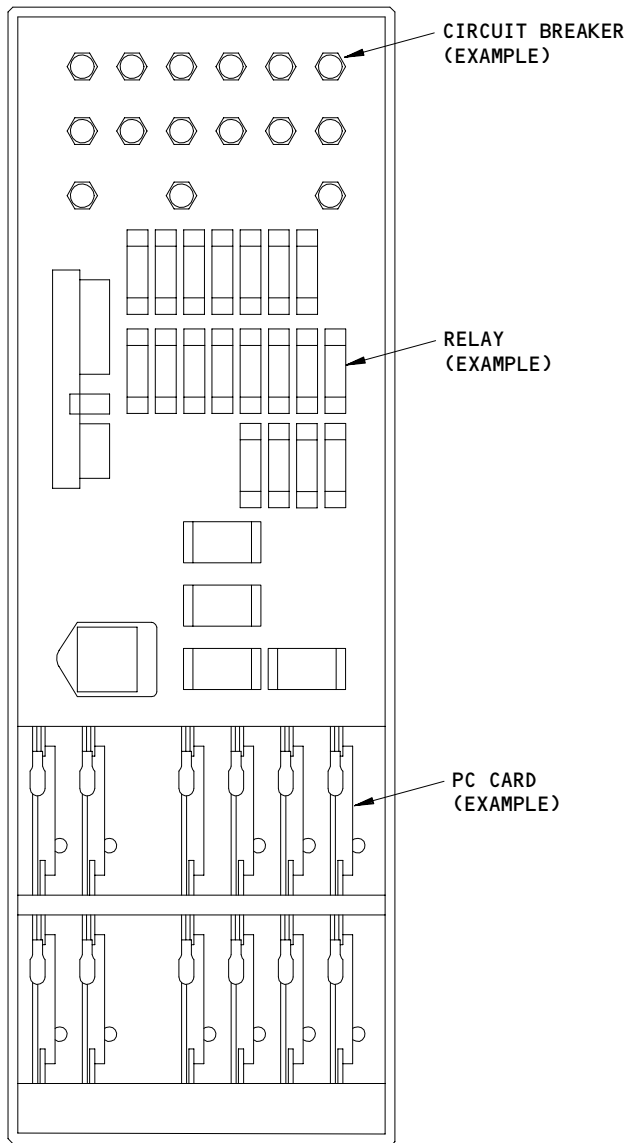

LIGHTING EQUIPMENT PANEL, P26

(D)

Master Dim and Test - Component Location (Detail from Sht 1)  
Figure 102 (Sheet 2)

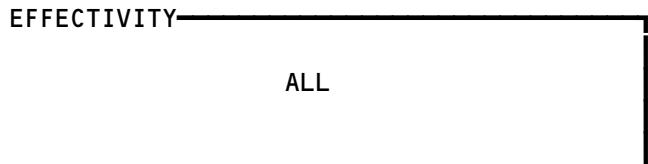

305570

**33-16-00**

01

Page 103  
Sep 20/93

**FLIGHT COMPARTMENT  
MASTER DIM AND TEST  
PROBLEMS**

**PREREQUISITES**

MAKE SURE THESE SYSTEMS WILL OPERATE:  
 EICAS SYSTEM (AMM 31-41-00/501)  
 IRU SYSTEM (AMM 34-21-00/501)  
 EFIS SYSTEM (AMM 34-22-00/501)

MAKE SURE THESE CIRCUIT BREAKERS ARE CLOSED:  
 11A31, 11A32, 11A33, 11A34, 11A35, 11P1, 11P2,  
 11P5, 11P28, 11P29  
 P26 PANEL - ALL CIRCUIT BREAKERS

MAKE SURE THE AIRPLANE IS IN THIS CONFIGURATION:  
 ELECTRICAL POWER IS ON (AMM 24-22-00/201)

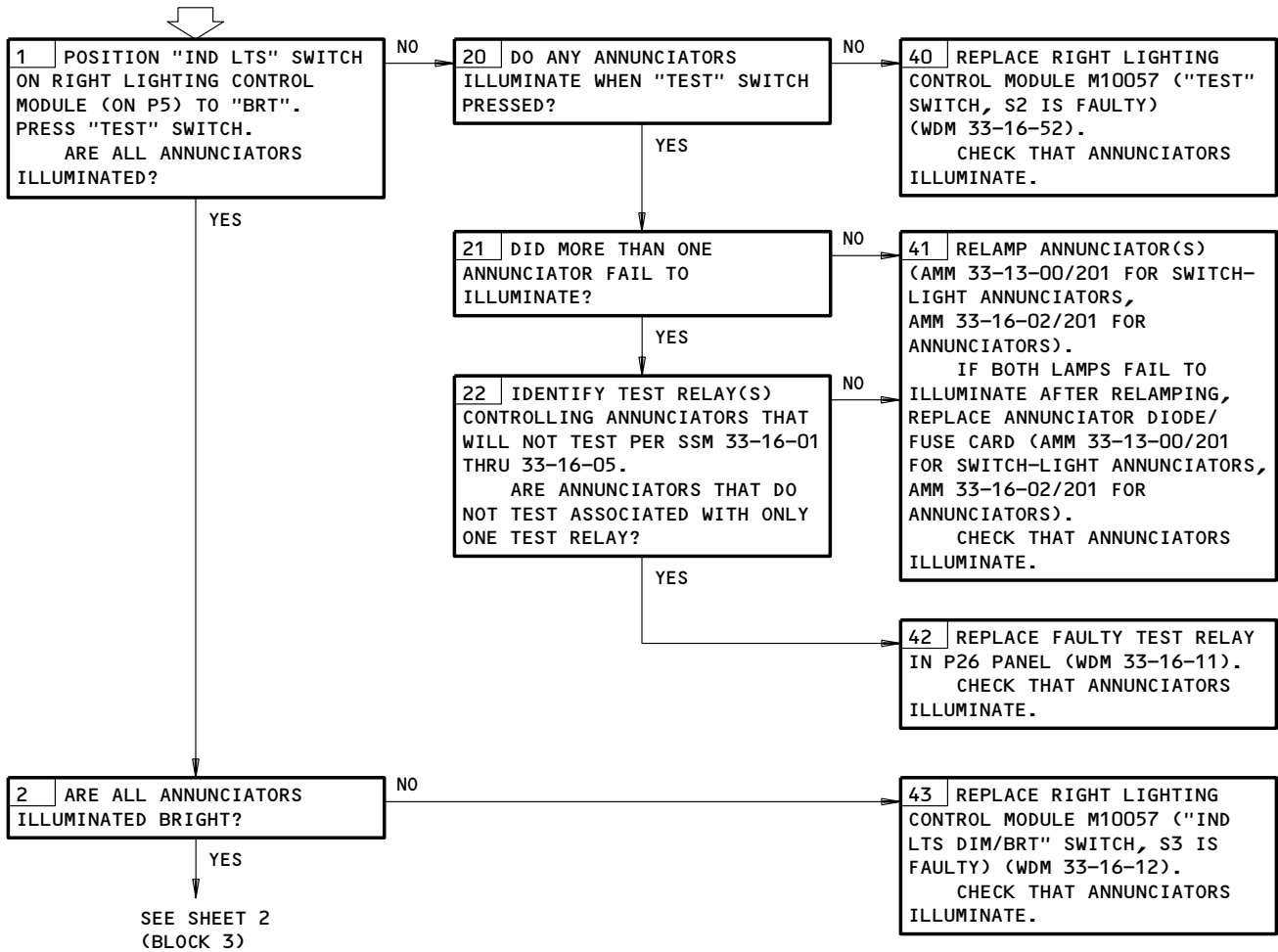

Flight Compartment Master Dim and Test Problems  
Figure 103 (Sheet 1)

EFFECTIVITY	ALL
-------------	-----

**33-16-00**

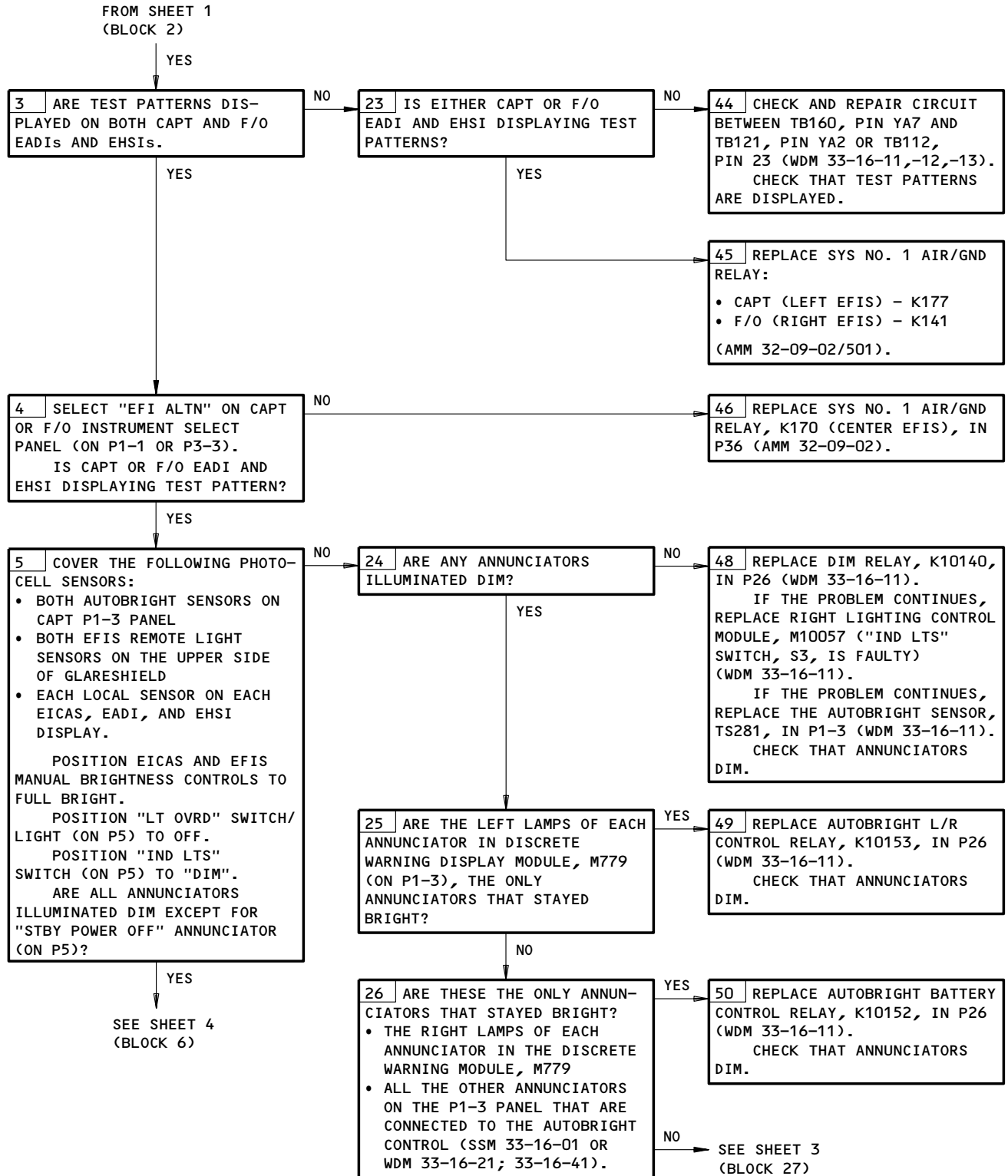

Master Dim and Test Problems  
Figure 103 (Sheet 2)

EFFECTIVITY

ALL

33-16-00

01

Page 105  
Sep 28/01

A13950

**BOEING**  
757  
FAULT ISOLATION/MAINT MANUAL

FROM SHEET 2  
(BLOCK 26)

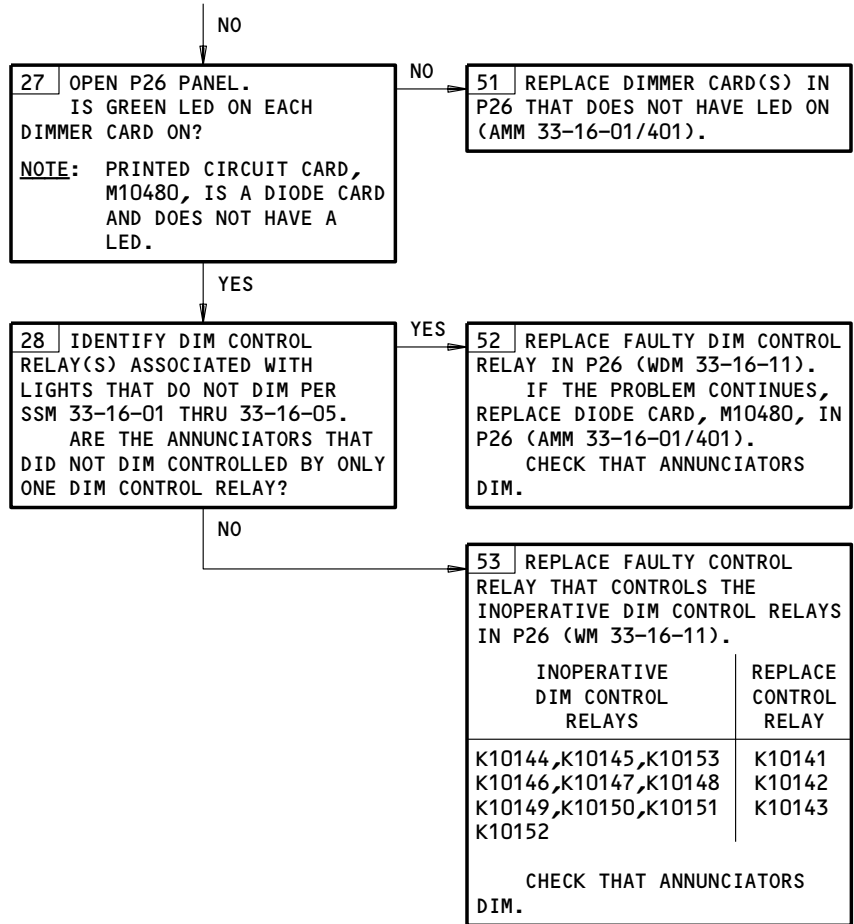

Master Dim and Test Problems  
Figure 103 (Sheet 3)

EFFECTIVITY	ALL
-------------	-----

33-16-00



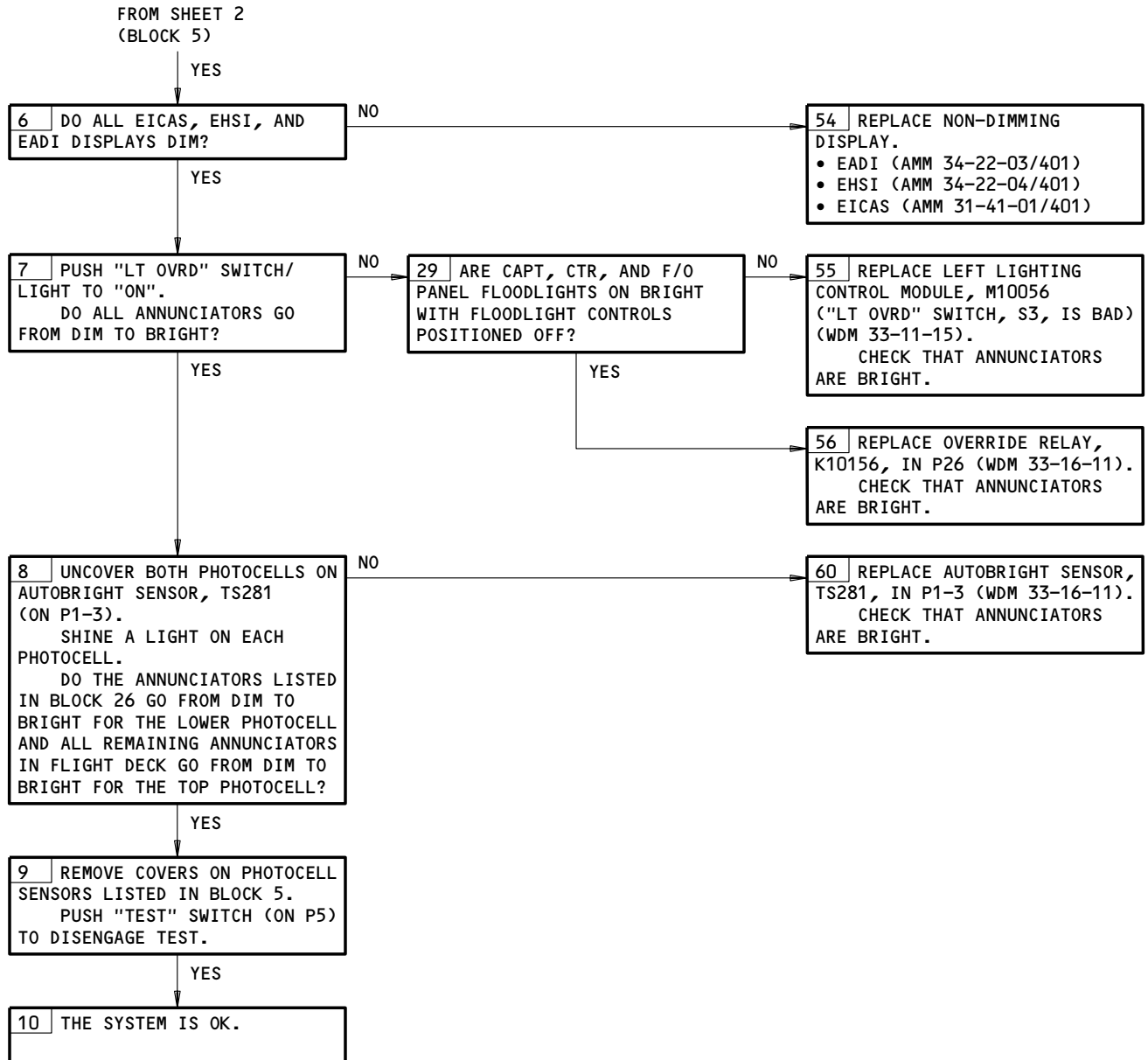

Flight Compartment Master Dim and Test Problems  
Figure 103 (Sheet 4)

EFFECTIVITY

ALL
-----

33-16-00



757  
 FAULT ISOLATION/MAINT MANUAL

PASSENGER COMPARTMENT ILLUMINATION

COMPONENT*	FIG. 102 SHT	QTY *	ACCESS/AREA	AMM REFERENCE
BALLAST - INDIRECT CEILING LIGHT SIDEWALL LIGHT CIRCUIT BREAKER -			PASS. COMPT PASS. COMPT 119BL, MAIN EQUIP CTR, P34 AND P37	33-21-10 33-21-30 *
LIGHT - INDIRECT CEILING NIGHT SIDEWALL RELAY -			PASS. COMPT PASS. COMPT PASS. COMPT 119BL, MAIN EQUIP CTR, P34 AND P37	33-21-10 33-21-20 33-21-30 *
SWITCH - TRANSFORMER -			PASS. COMPT 119BL, MAIN EQUIP CTR, P34	* *

\* SEE THE SSM OR WDM FOR THE EQUIPMENT NUMBER, QUANTITY AND LOCATION OF EACH COMPONENT IN THE LIGHTING CIRCUIT.

Passenger Compartment Illumination - Component Index  
 Figure 101

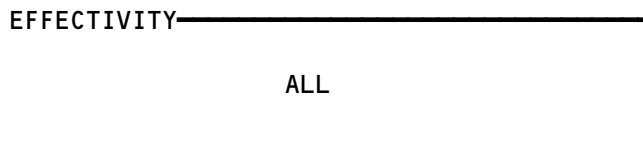

33-21-00

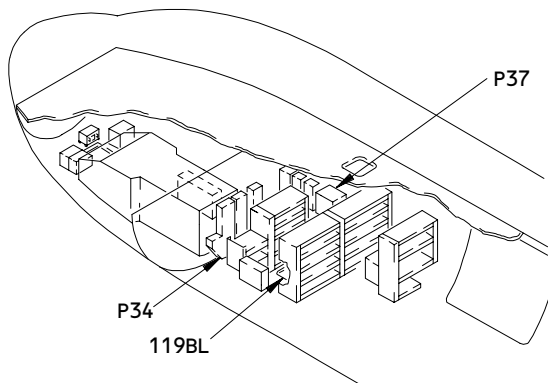

MAIN EQUIPMENT CENTER

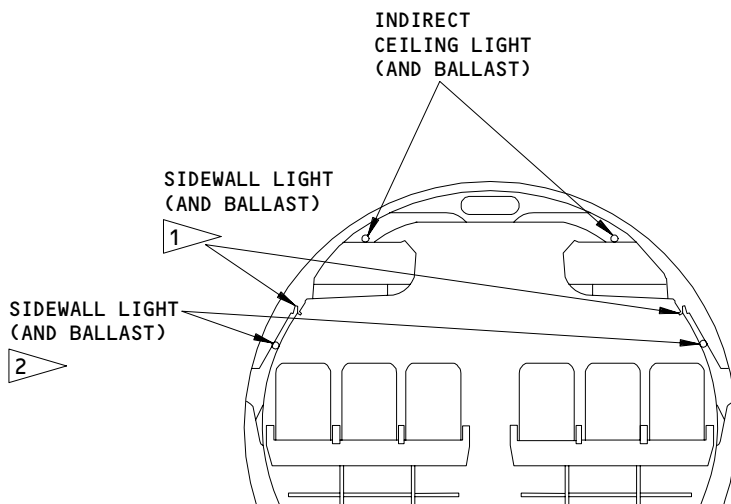

- 1 AIRPLANES WITH THE SIDEWALL LIGHTS INSTALLED ABOVE THE SIDEWALL
- 2 AIRPLANES WITH THE SIDEWALL LIGHTS INSTALLED IN THE SIDEWALL

Passenger Compartment Illumination - Component Location  
Figure 102

EFFECTIVITY	ALL
-------------	-----

33-21-00

**INDIRECT CEILING LIGHTS PROBLEMS**

**PREREQUISITES**

MAKE SURE THESE CIRCUIT BREAKERS ARE CLOSED:  
34H1 (B), 37G6, 37G7, 37G8

MAKE SURE THE AIRPLANE IS IN THIS CONFIGURATION:  
ELECTRICAL POWER IS ON (AMM 24-22-00/201)

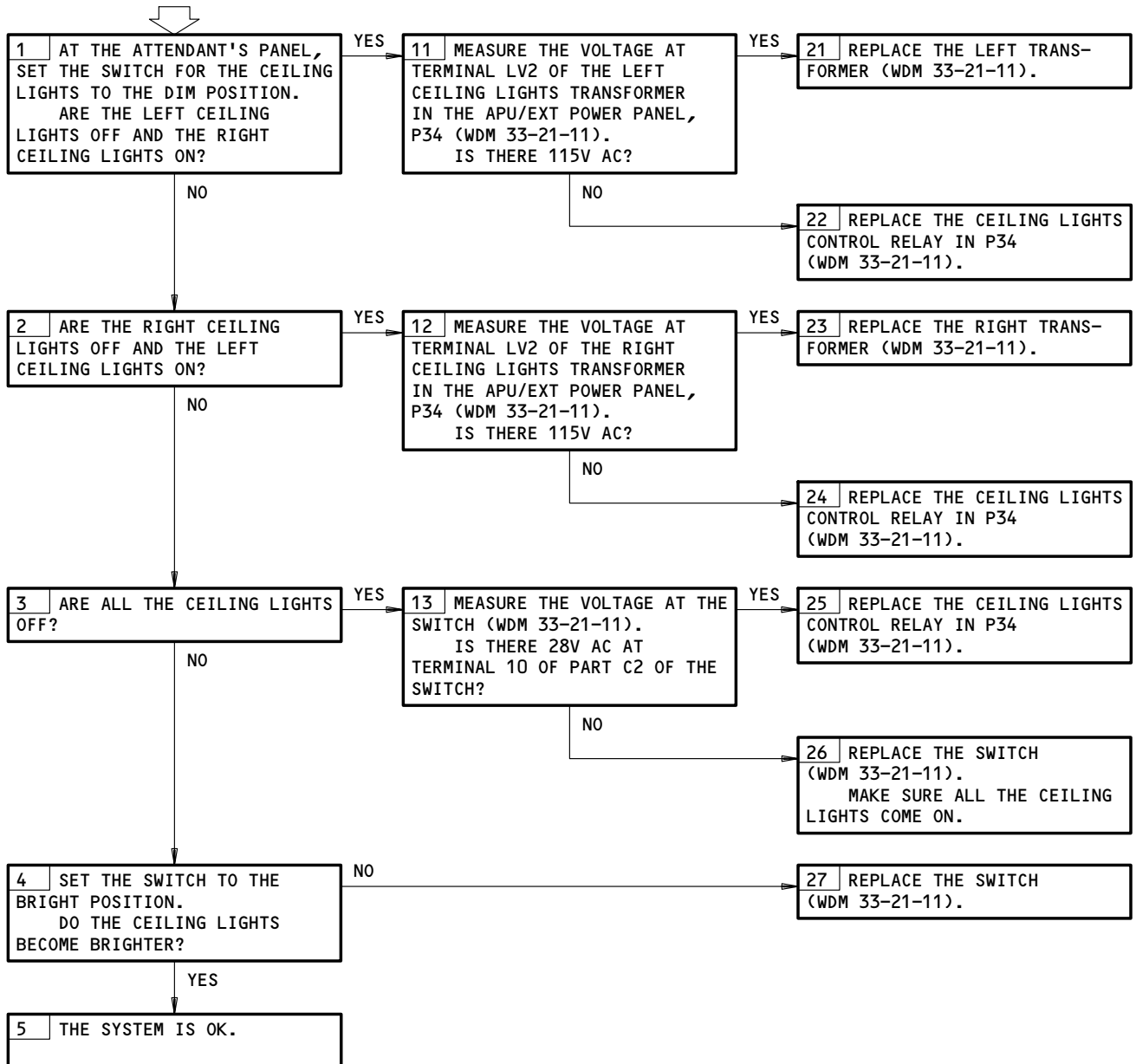

Indirect Ceiling Lights Problems  
Figure 103 (Sheet 1)

EFFECTIVITY  
AIRPLANES WITH ONE SWITCH  
FOR ALL THE CEILING LIGHTS

**33-21-00**

**INDIRECT CEILING LIGHTS PROBLEMS**

**PREREQUISITES**  
 MAKE SURE THESE CIRCUIT BREAKERS ARE CLOSED:  
 34H1 (B), 37G6, 37G7, 37G8  
 MAKE SURE THE AIRPLANE IS IN THIS CONFIGURATION:  
 ELECTRICAL POWER IS ON (AMM 24-22-00/201)

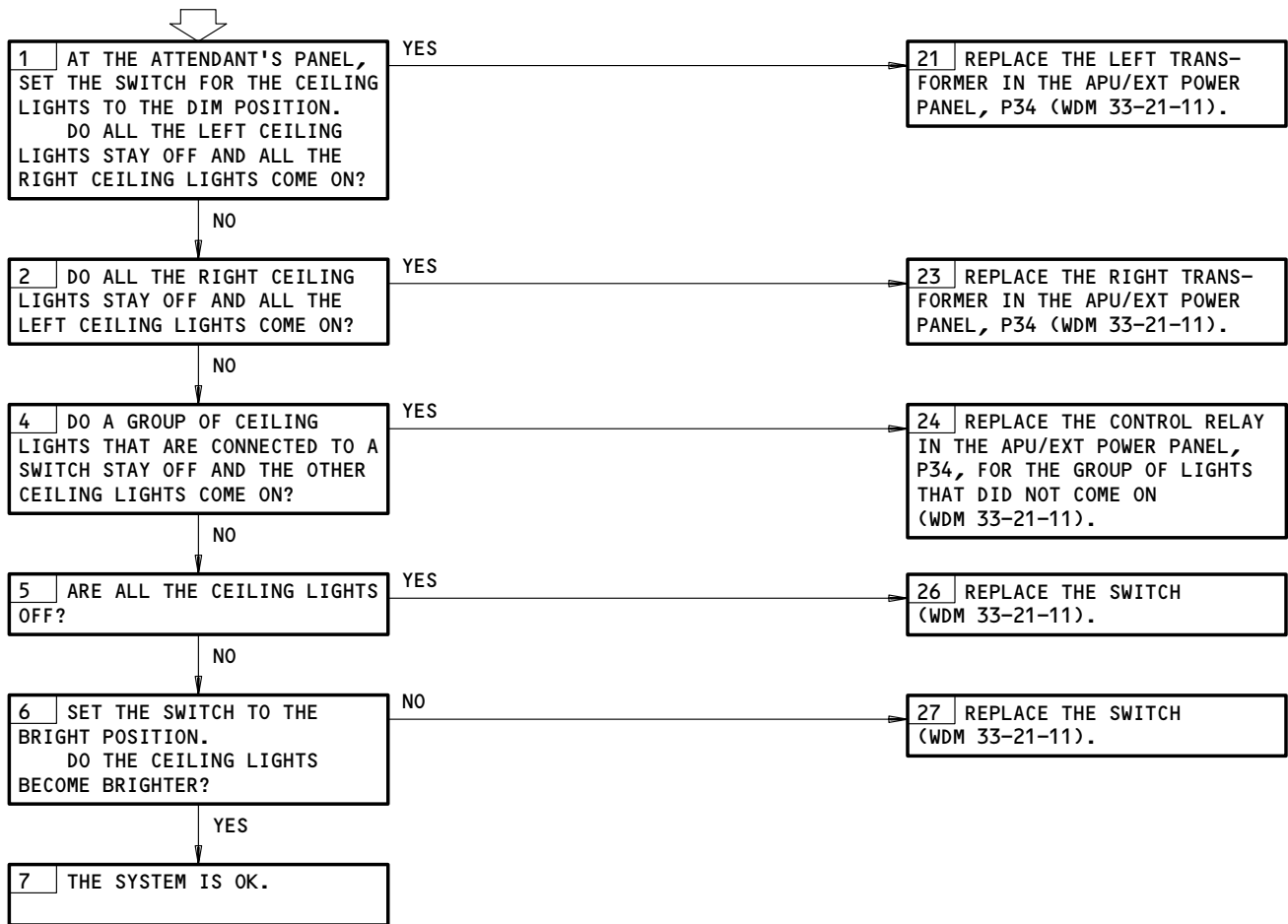

Indirect Ceiling Lights Problems  
Figure 103 (Sheet 2)

EFFECTIVITY  
 AIRPLANES WITH A SWITCH  
 FOR EACH GROUP OF LIGHTS

**33-21-00**

**PROBLEMS WITH THE  
SIDEWALL LIGHTS**

**PREREQUISITES**  
MAKE SURE THE APPLICABLE CIRCUIT BREAKERS ARE CLOSED:  
(SSM 33-21-03 THRU 33-21-04 OR WDM 33-21-31)  
MAKE SURE THE AIRPLANE IS IN THIS CONFIGURATION:  
ELECTRICAL POWER IS ON (AMM 24-22-00/201)

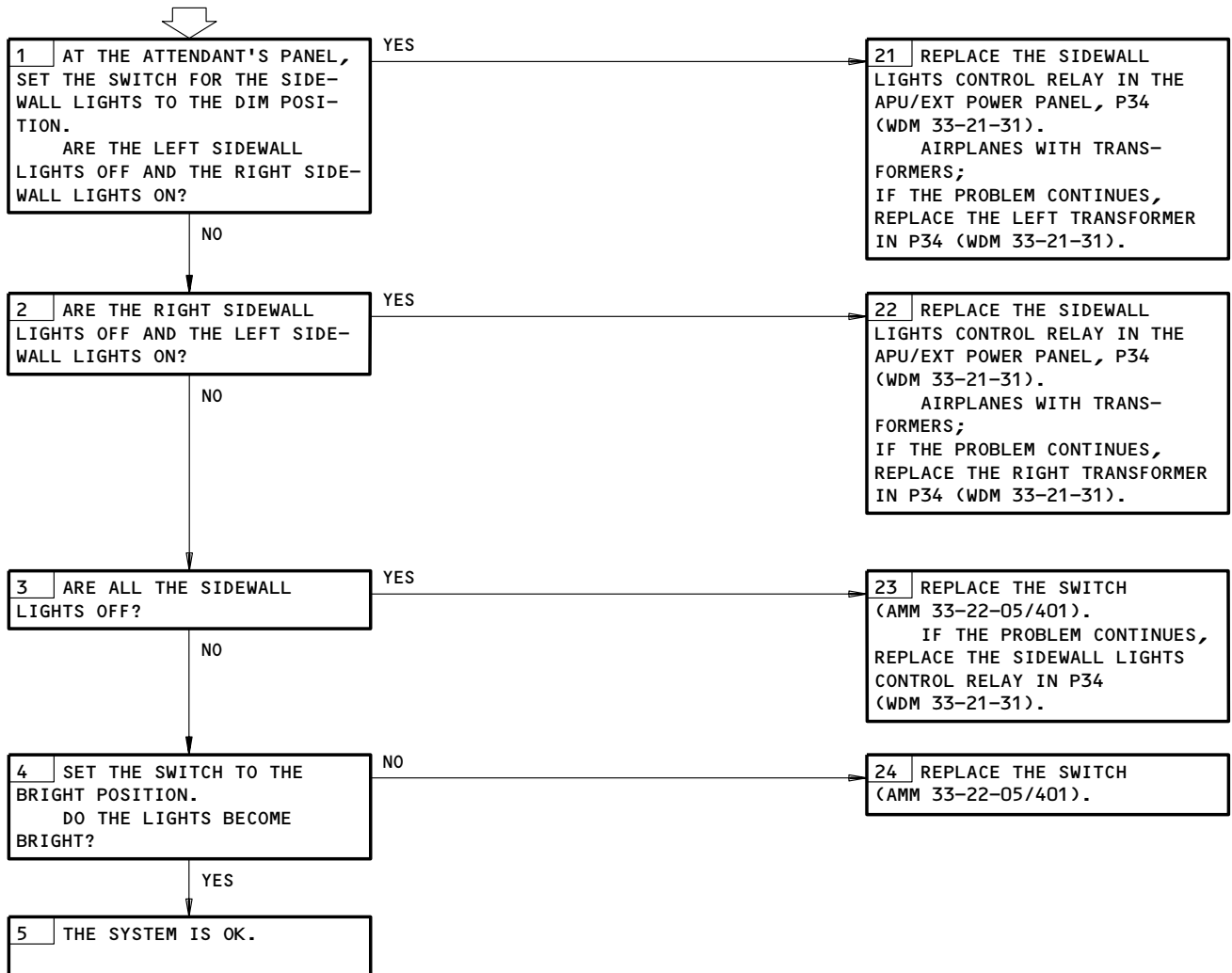

Problems with the Sidewall Lights  
Figure 104

EFFECTIVITY

ALL
-----

33-21-00

**BOEING**  
757  
FAULT ISOLATION/MAINT MANUAL

PASSENGER LOADING LIGHTS

COMPONENT*	FIG. 102 SHT	QTY *	ACCESS/AREA	AMM REFERENCE
BALLAST -	2		PASS. COMPT	*
ENTRY FLUORESCENT LIGHT			ENTRY FLUORESCENT LIGHT	33-22-00
CIRCUIT BREAKER -	1		FLT COMPT, OVHD PNL, P11	*
CIRCUIT BREAKER -	1		119BL, MAIN EQUIP CTR, P34 AND P37	*
LIGHT -				
ATTENDANT'S WORK	2		PASS. COMPT	33-22-00
CLOSET 	2		PASS. COMPT	33-22-00
ENTRY FLUORESCENT	2		PASS. COMPT	33-22-00
ENTRY SPOT	2		PASS. COMPT	33-22-00
THRESHOLD	2		PASS. COMPT	33-22-00
PANEL -				
AFT ATTENDANT'S	2		PASS. COMPT	33-22-07
FORWARD ATTENDANT'S	2		PASS. COMPT	33-22-05
MID ATTENDANT'S	2		PASS. COMPT	33-22-06
RELAY -			119BL, MAIN EQUIP CTR, P34	*
SENSOR - (FIM 25-66-01/101)				*
NO. 1 PASS. DOOR PROXIMITY				*
SWITCH - (FIM 52-51-01/101)				*
FLT COMPT DOOR PROXIMITY				*
SWITCH-	2		PASS. COMPT, ATTENDANT PANELS	*
TRANSFORMER -			119BL, MAIN EQUIP CTR, P34	*

\* SEE THE WDM OR SSM FOR THE EQUIPMENT NUMBER, QUANTITY, AND LOCATION OF EACH COMPONENT IN THE LIGHTING CIRCUIT

 NOT INSTALLED ON ALL AIRPLANES

Passenger Loading Lights - Component Index  
Figure 101

EFFECTIVITY

ALL

**33-22-00**

01

Page 101  
Sep 20/94

654979

**BOEING**  
 757  
 FAULT ISOLATION/MAINT MANUAL

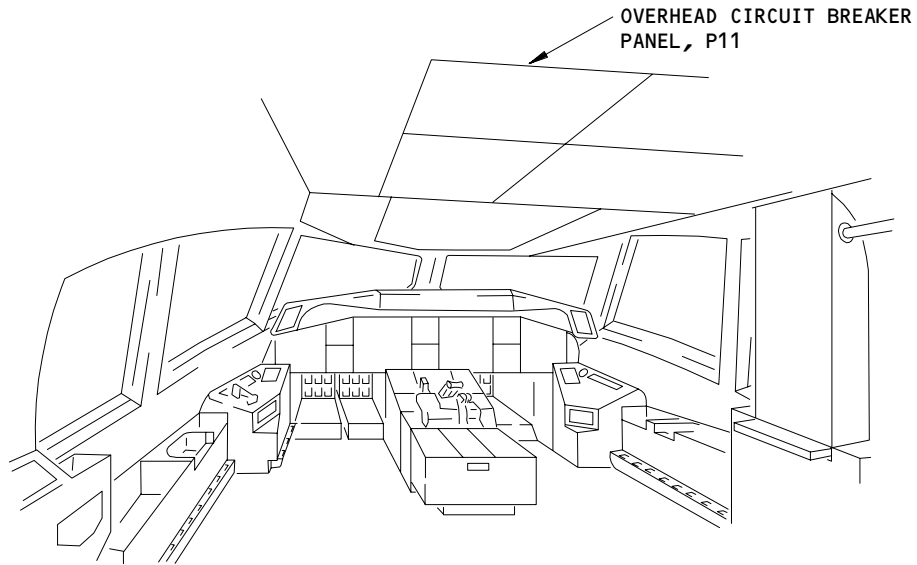

FLIGHT COMPARTMENT

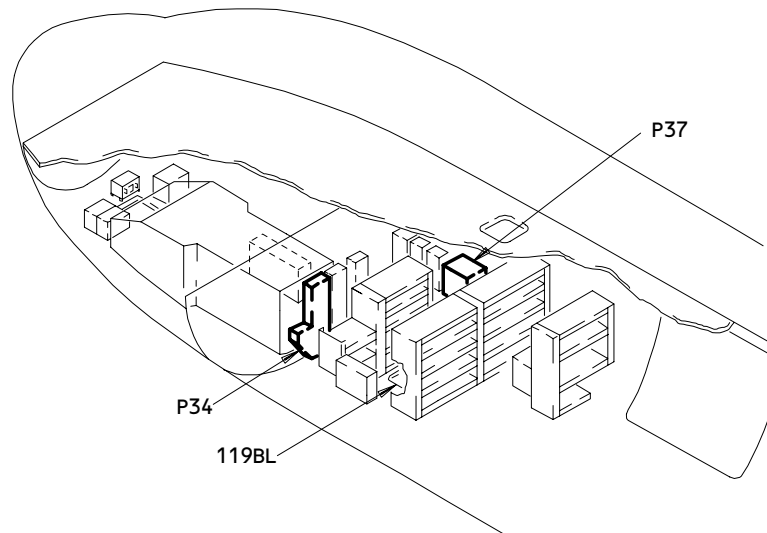

MAIN EQUIPMENT CENTER

Passenger Loading Lights - Component Location  
 Figure 102 (Sheet 1)

EFFECTIVITY	
	ALL

33-22-00

01

Page 102  
 Sep 20/94

78431



**BOEING**  
757  
FAULT ISOLATION/MAINT MANUAL

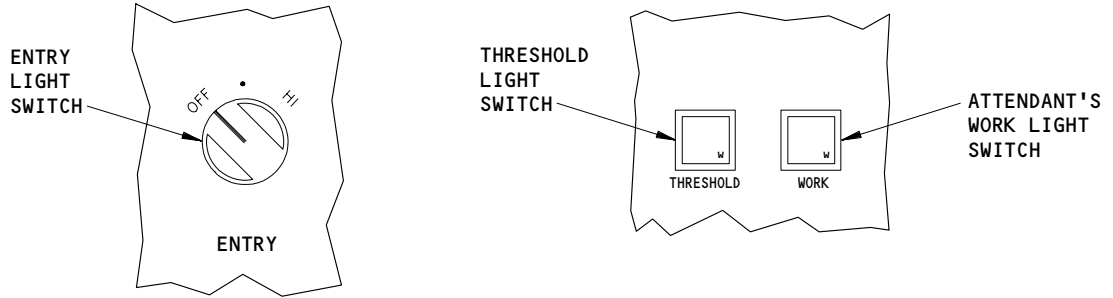

ATTENDANT'S PANEL CONTROL SWITCH

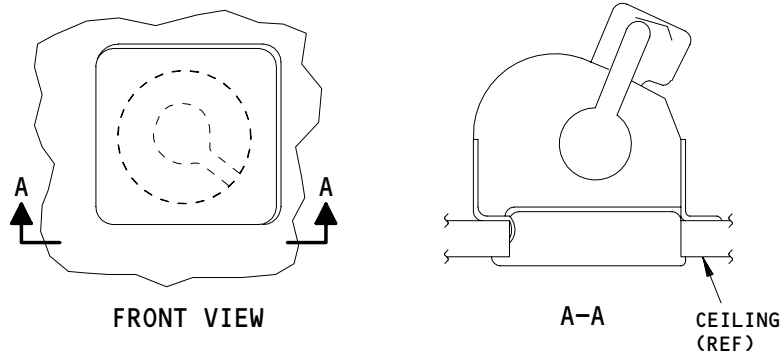

ATTENDANT'S WORK LIGHT/THRESHOLD LIGHT/ENTRY SPOT LIGHT  
(EXAMPLE)

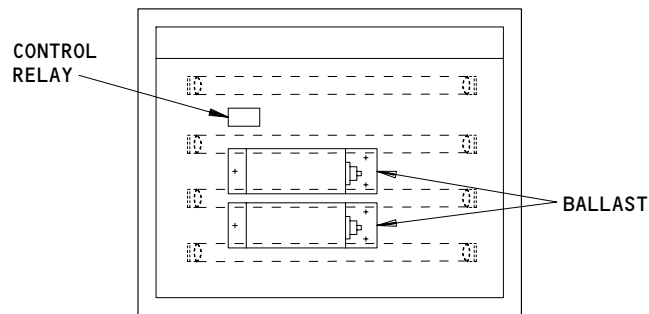

FORWARD ENTRY LIGHT

Passenger Loading Lights - Component Location  
Figure 102 (Sheet 2)

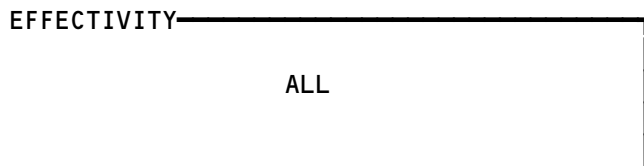

A73757

**33-22-00**

01

Page 103  
Sep 20/94

**LEFT FORWARD ENTRY LIGHTS PROBLEMS**

**PREREQUISITES**  
 MAKE SURE EACH APPLICABLE CIRCUIT BREAKER IS CLOSED:  
 (SSM 33-22-01 OR WDM 33-22-11)  
 MAKE SURE THE AIRPLANE IS IN THIS CONFIGURATION:  
 ELECTRICAL POWER IS ON (AMM 24-22-00/201)

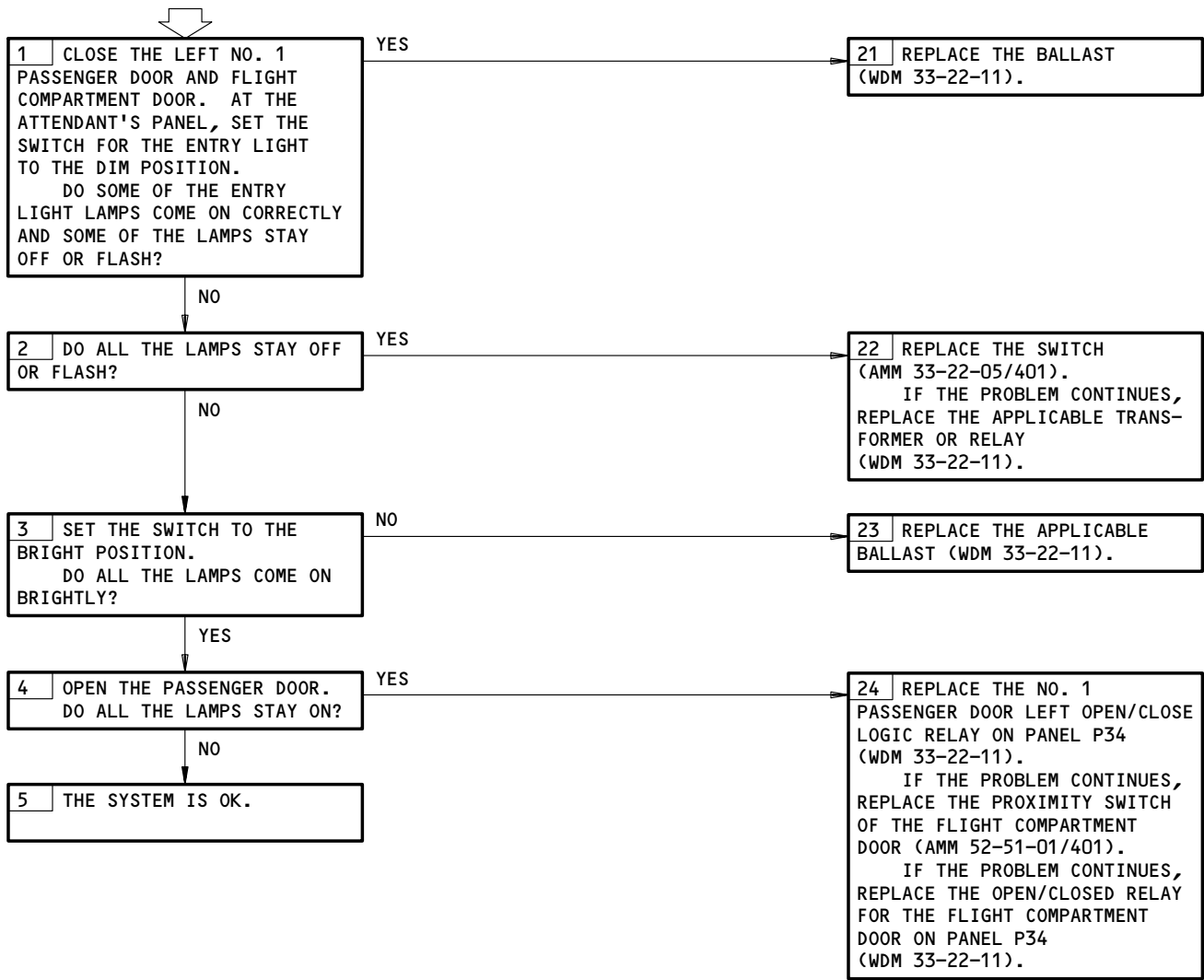

Left Forward Entry Lights Problems  
Figure 103

EFFECTIVITY	ALL
-------------	-----

**33-22-00**

55238

**THRESHOLD LIGHTS  
AND ENTRY SPOT  
LIGHTS PROBLEMS**

**PREREQUISITES**

MAKE SURE THE APPLICABLE CIRCUIT BREAKERS ARE CLOSED:  
(WDM 33-22-11 OR SSM 33-22-01)

MAKE SURE THE AIRPLANE IS IN THIS CONFIGURATION:  
ELECTRICAL POWER IS ON (AMM 24-22-00/201)

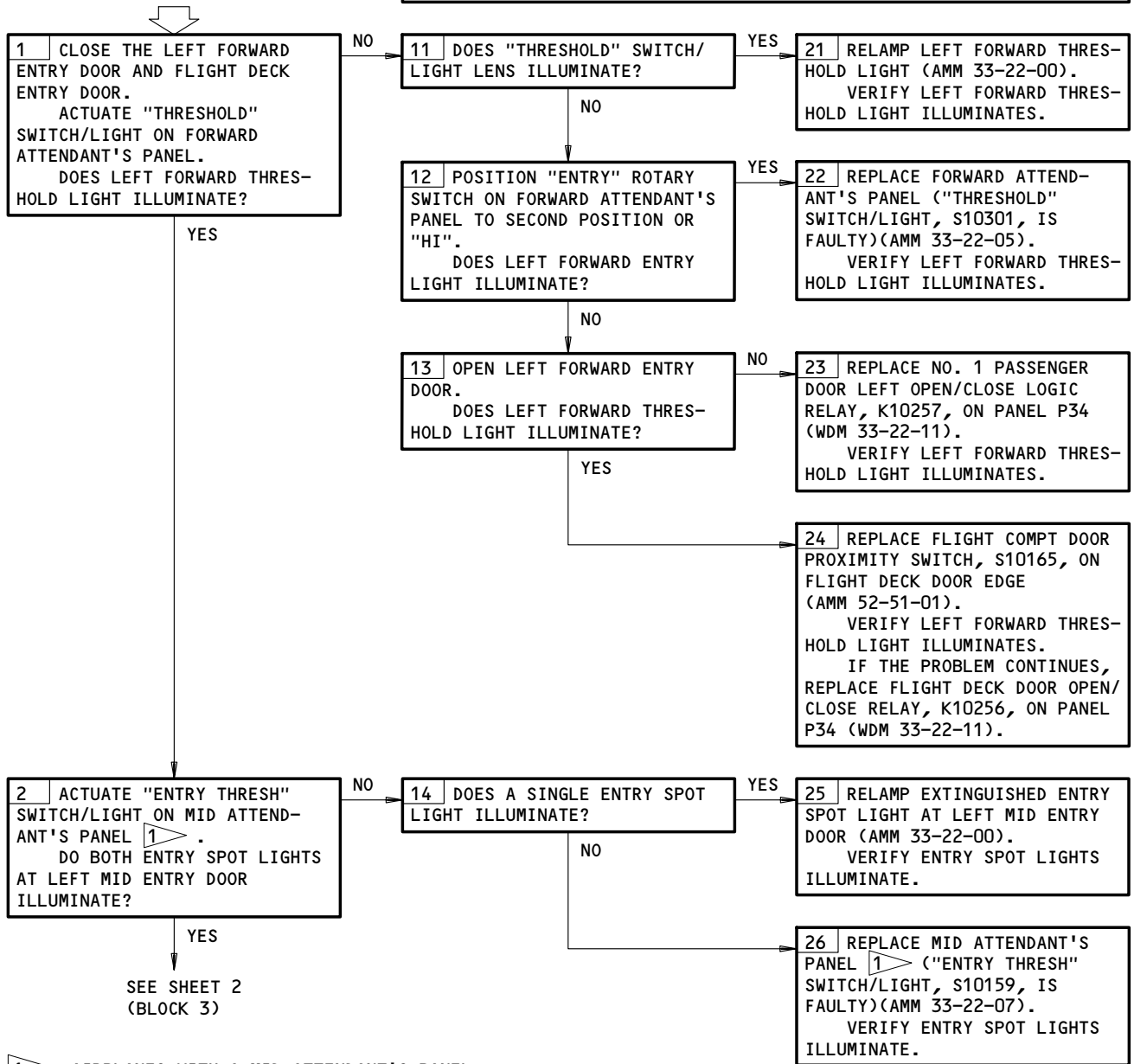

Threshold Lights and Entry Spot Lights Problems  
Figure 104 (Sheet 1)

EFFECTIVITY

ALL

**33-22-00**

01

Page 105  
Sep 20/94

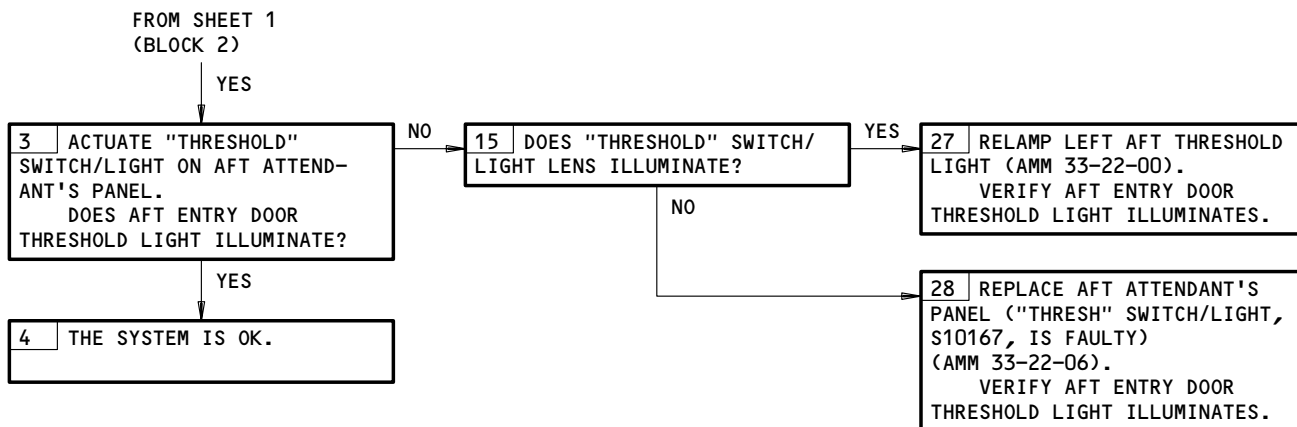

Threshold Lights and Entry Spot Lights Problems  
Figure 104 (Sheet 2)

EFFECTIVITY

ALL
-----

33-22-00

**ATTENDANT'S WORK LIGHTS PROBLEMS**

**PREREQUISITES**

MAKE SURE THESE CIRCUIT BREAKERS ARE CLOSED:  
11R34,34G3 (SECTION B)

MAKE SURE THE AIRPLANE IS IN THIS CONFIGURATION:  
ELECTRICAL POWER IS ON (AMM 24-22-00/201)

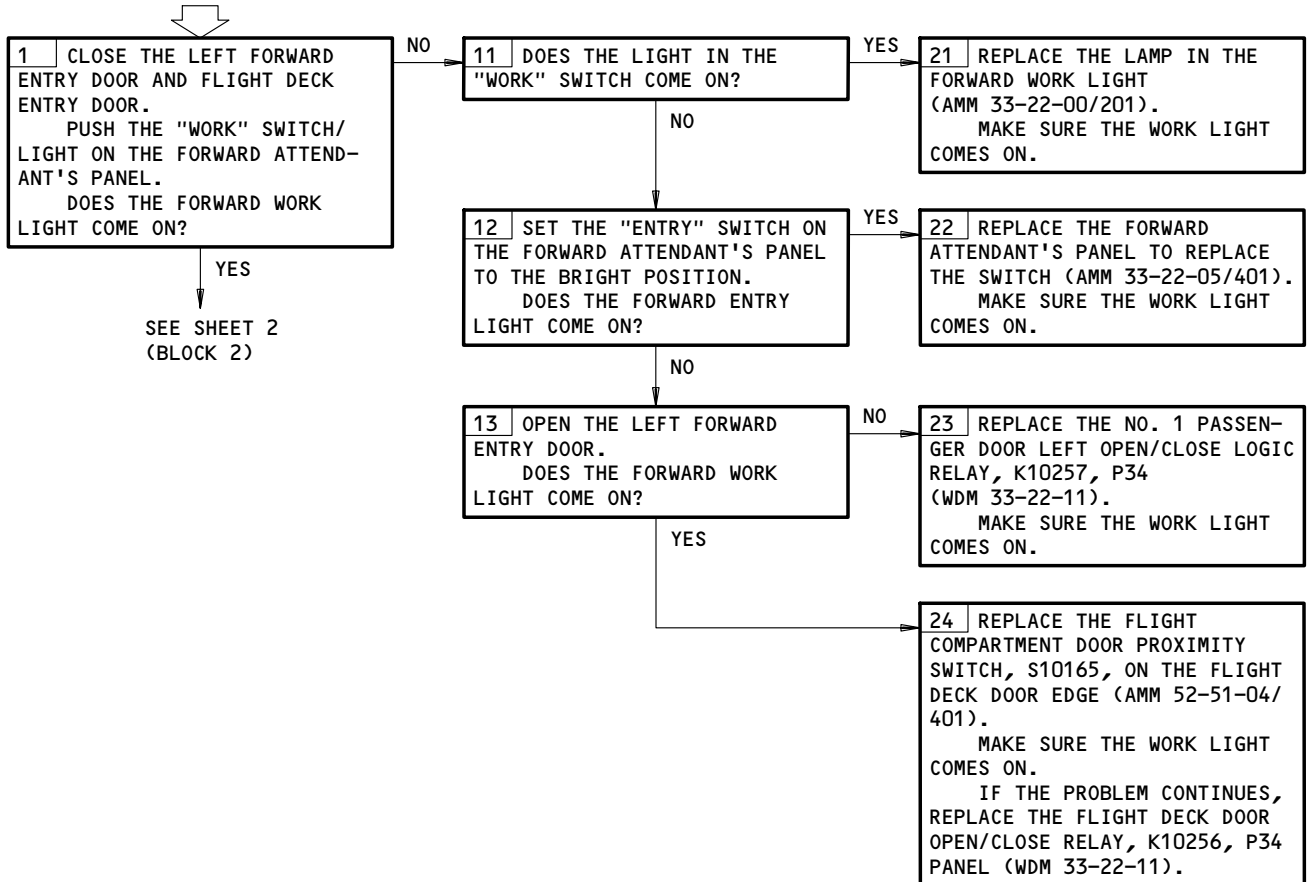

Attendant's Work Lights Problems  
Figure 105 (Sheet 1)

EFFECTIVITY	ALL
-------------	-----

**33-22-00**

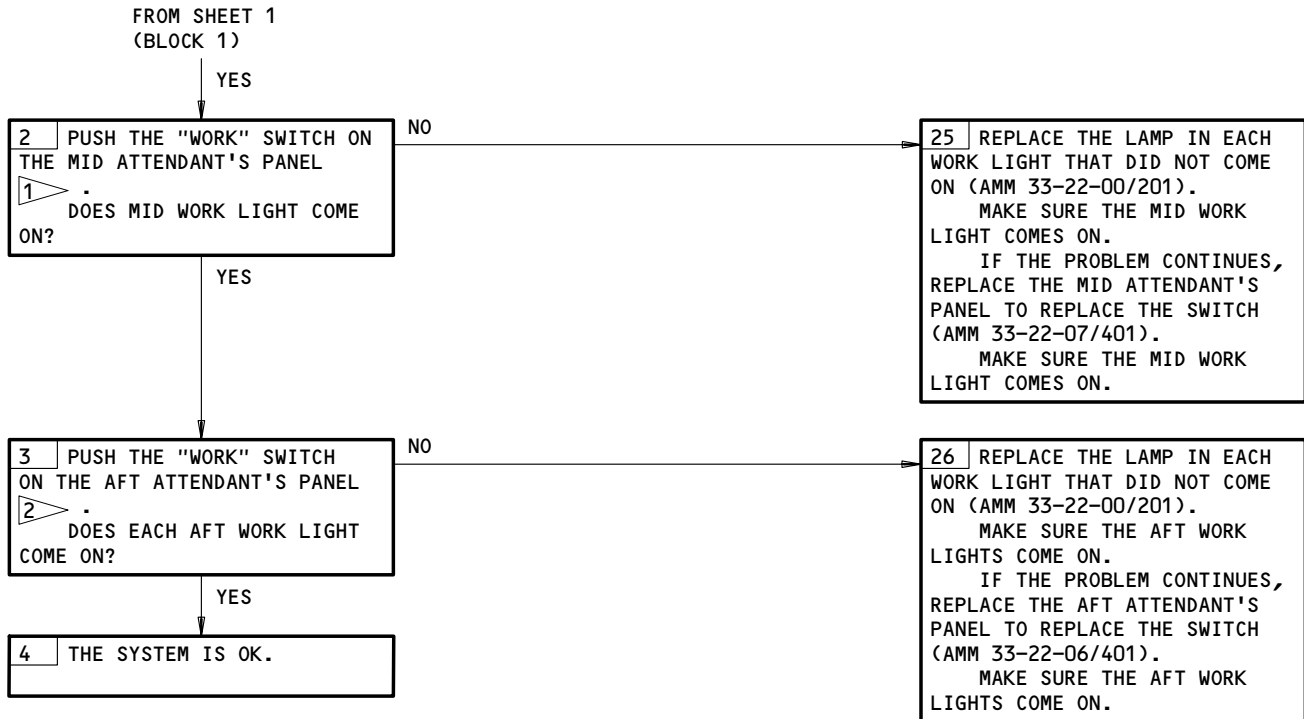

- 1 ▷ AIRPLANES WITH A SWITCH FOR THE WORK LIGHTS ON THE MID ATTENDANT'S PANEL.
- 2 ▷ AIRPLANES WITH A SWITCH FOR THE WORK LIGHTS ON THE AFT ATTENDANT'S PANEL.

Attendant's Work Lights Problems  
Figure 105 (Sheet 2)

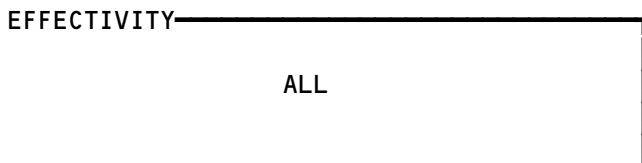

33-22-00

**BOEING**  
757  
FAULT ISOLATION/MAINT MANUAL

PASSENGER READING LIGHTS

COMPONENT*	FIG. 102 SHT	QTY *	ACCESS/AREA	AMM REFERENCE
CIRCUIT BREAKER -			119BL, MAIN EQUIP CTR, P37	*
CIRCUIT BREAKER -			119BL, MAIN EQUIP CTR, P70	*
LIGHT -				
ATTENDANT WORK	--		PASS. COMPT, ATTND SERV UNITS	33-23-00
PASSENGER READING			PASS. COMPT, PASSENGER SERV UNITS	33-23-00
SWITCH -				
ATTENDANT WORK LIGHT	--		PASS. COMPT, ATTND SERV UNITS	*
PASSENGER READING LIGHT			PASS. COMPT, PASSENGER SERV UNITS	*
TRANSFORMER -				
READING LIGHTS				*

\* SEE THE SSM OR WDM FOR THE EQUIPMENT NUMBER, QUANTITY AND LOCATION OF EACH COMPONENT IN THE LIGHTING CIRCUIT.

Passenger Reading Lights - Component Index  
Figure 101

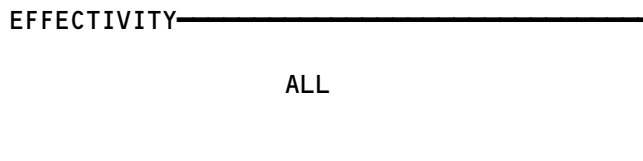

**33-23-00**

01

Page 101  
Mar 20/95

# BOEING

## 757 FAULT ISOLATION/MAINT MANUAL

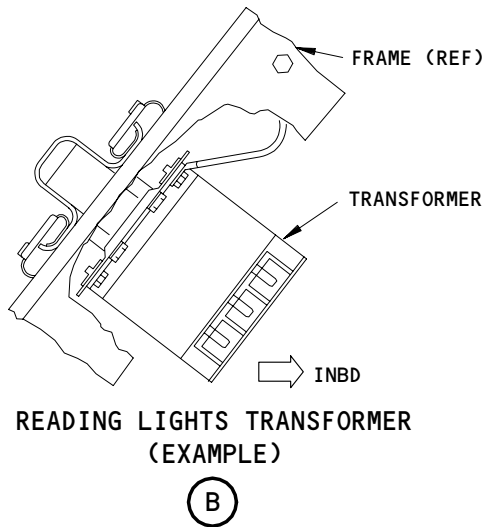
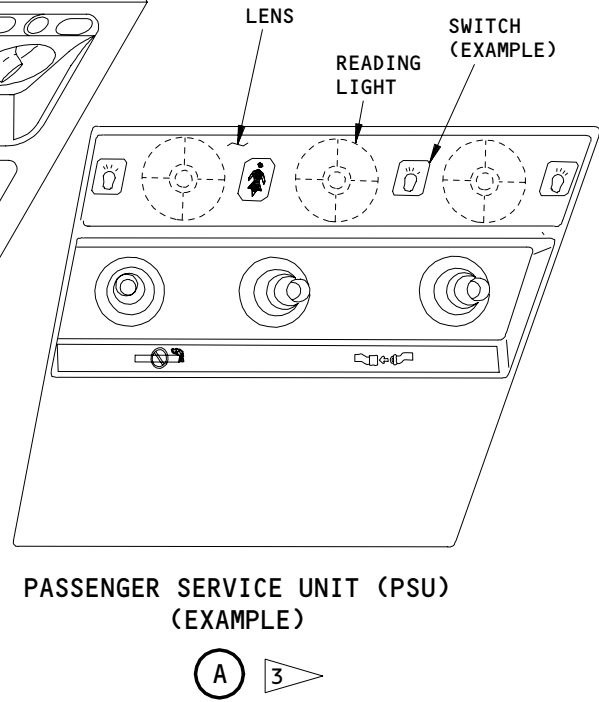
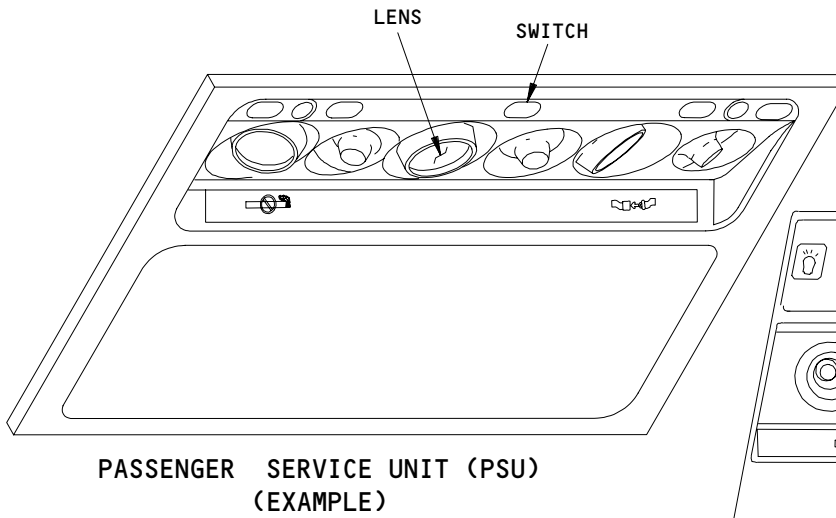
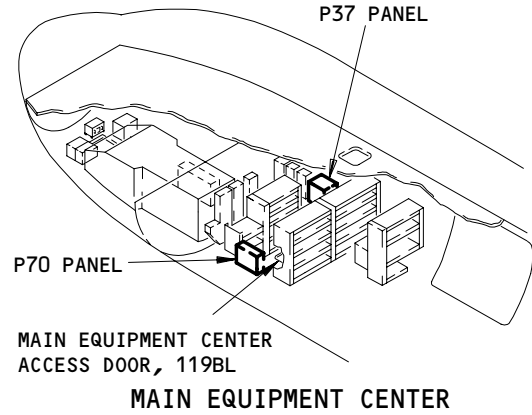
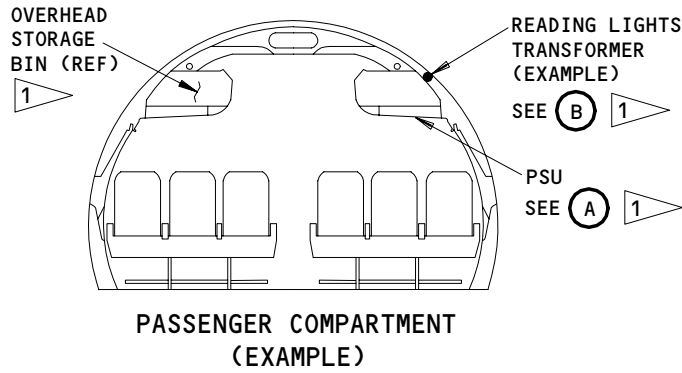

- 1 THE LEFT AND RIGHT SIDES ARE EQUIVALENT
- 2 READING LIGHT WITH A CIRCULAR LENS
- 3 READING LIGHT WITH A RECTANGULAR LENS

Reading Lights - Component Location  
Figure 102

EFFECTIVITY	
	ALL

# 33-23-00





**BOEING**  
 757  
 FAULT ISOLATION/MAINT MANUAL

PASSENGER SIGNS

COMPONENT*	FIG. 102 SHT	QTY *	ACCESS/AREA	AMM REFERENCE
CIRCUIT BREAKER - CIRCUIT BREAKER - MODULE - (FIM 25-23-00/101) PSU UNDER BIN MODULE - (FIM 27-51-00/101) FLAP/SLAT ELECTRONICS UNIT (FSEU) MODULE - (FIM 32-09-03/101) PROXIMITY SWITCH ELECTRONICS UNIT (PSEU) RELAY -			FLT COMPT, P11 119BL, MAIN EQUIP CTR, P34	
SIGN - NO SMOKING/FASTEN SEAT BELT SWITCH - CABIN PRESSURE SWITCH - PASS. SIGNS	--		119BL, MAIN EQUIP CTR, P34 AND P37 PASS. COMPT 119BL, MAIN EQUIP CTR, P34 FLT COMPT, P5	*  33-24-00  *

\* SEE THE WDM OR SSM FOR THE EQUIPMENT NUMBER, QUANTITY, AND LOCATION OF EACH COMPONENT IN THE LIGHTING CIRCUIT

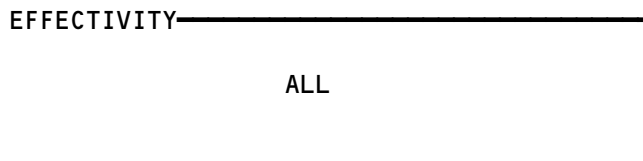
Passenger Signs - Component Index  
Figure 101



33-24-00

01

Page 101  
Sep 20/93

851268

# BOEING

## 757

### FAULT ISOLATION/MAINT MANUAL

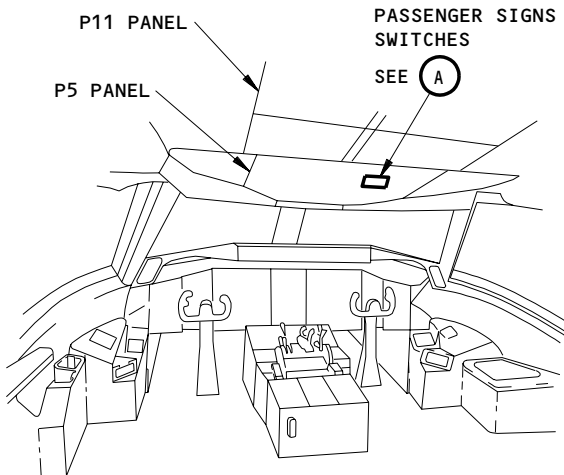

**FLIGHT COMPARTMENT**

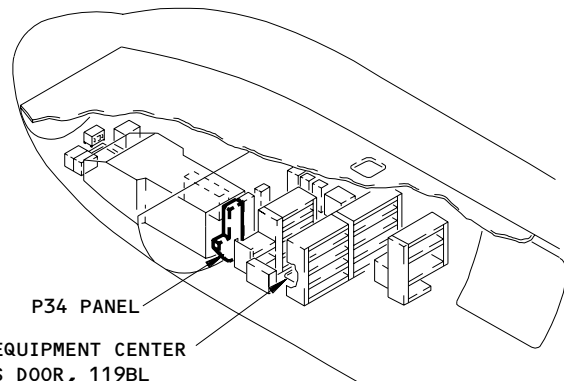

**MAIN EQUIPMENT CENTER**

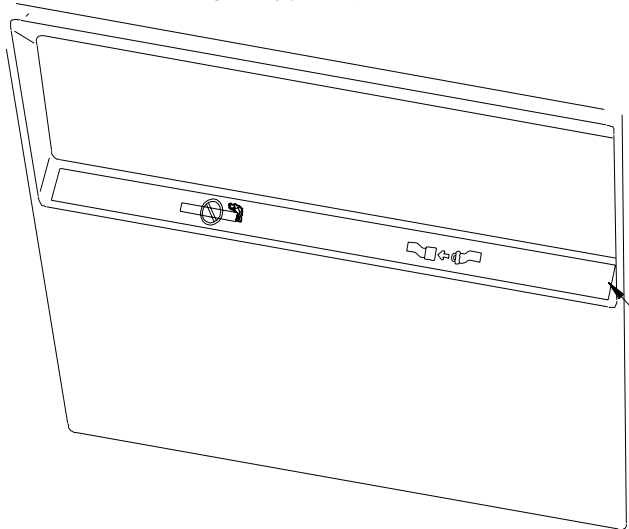

**PASSENGER SERVICE UNIT (EXAMPLE)**

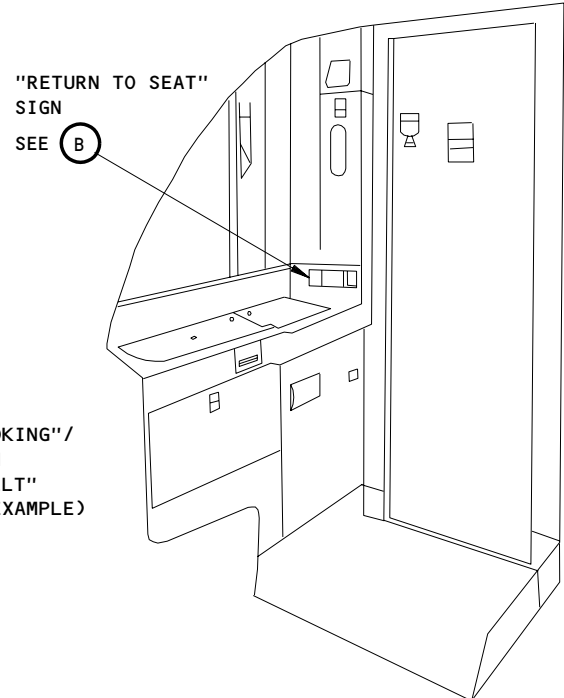

**LAVATORY (EXAMPLE)**

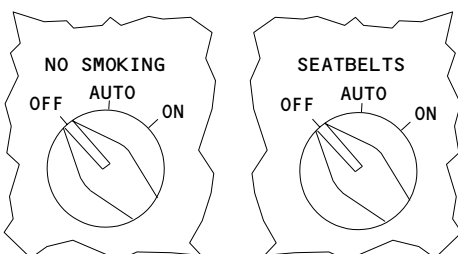

**PASSENGER SIGNS SWITCHES (EXAMPLE)**

(A)

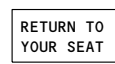

**"RETURN TO SEAT" SIGN (EXAMPLE)**

(B)

**Passenger Signs - Component Location**  
Figure 102

EFFECTIVITY	ALL
-------------	-----

**33-24-00**

851404

Not Used  
Figure 103

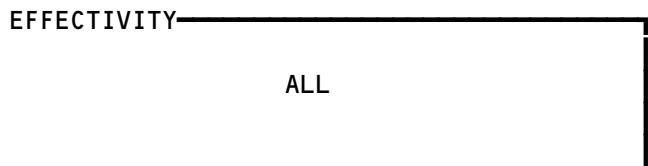

**33-24-00**

01

Page 103  
Mar 20/96

166914

**PREREQUISITES**

MAKE SURE THESE CIRCUIT BREAKERS ARE CLOSED:  
 11P9,34E1,34E2,34F1,34F2

MAKE SURE THE AIRPLANE IS IN THE CONFIGURATION THAT FOLLOWS:  
 ELECTRICAL POWER IS ON (MM 24-22-00/201)

**NO SMOKING LIGHTS PROBLEMS**

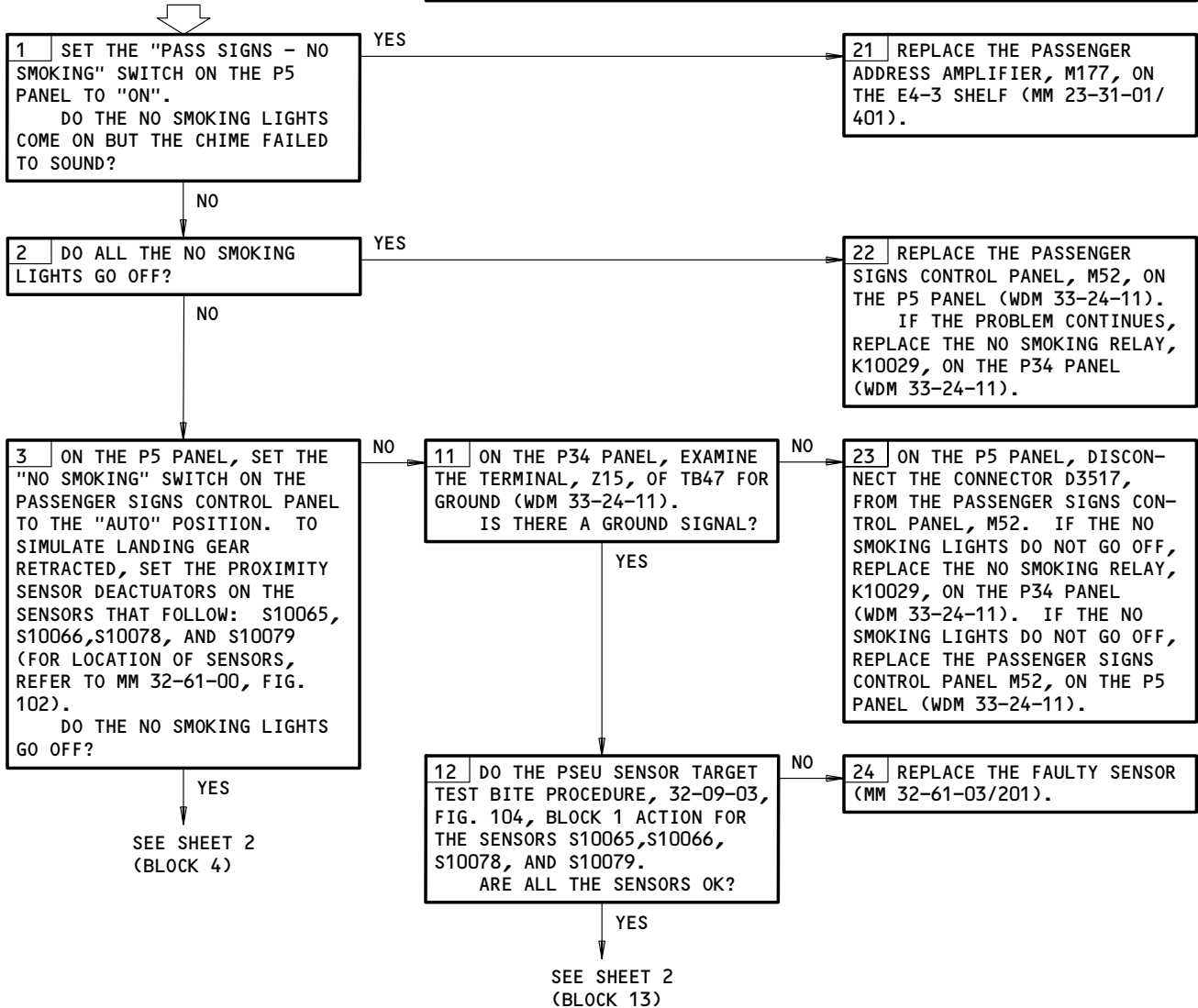

No Smoking Lights Problems  
 Figure 104 (Sheet 1)

EFFECTIVITY	ALL
-------------	-----

**33-24-00**

**BOEING**  
757  
FAULT ISOLATION/MAINT MANUAL

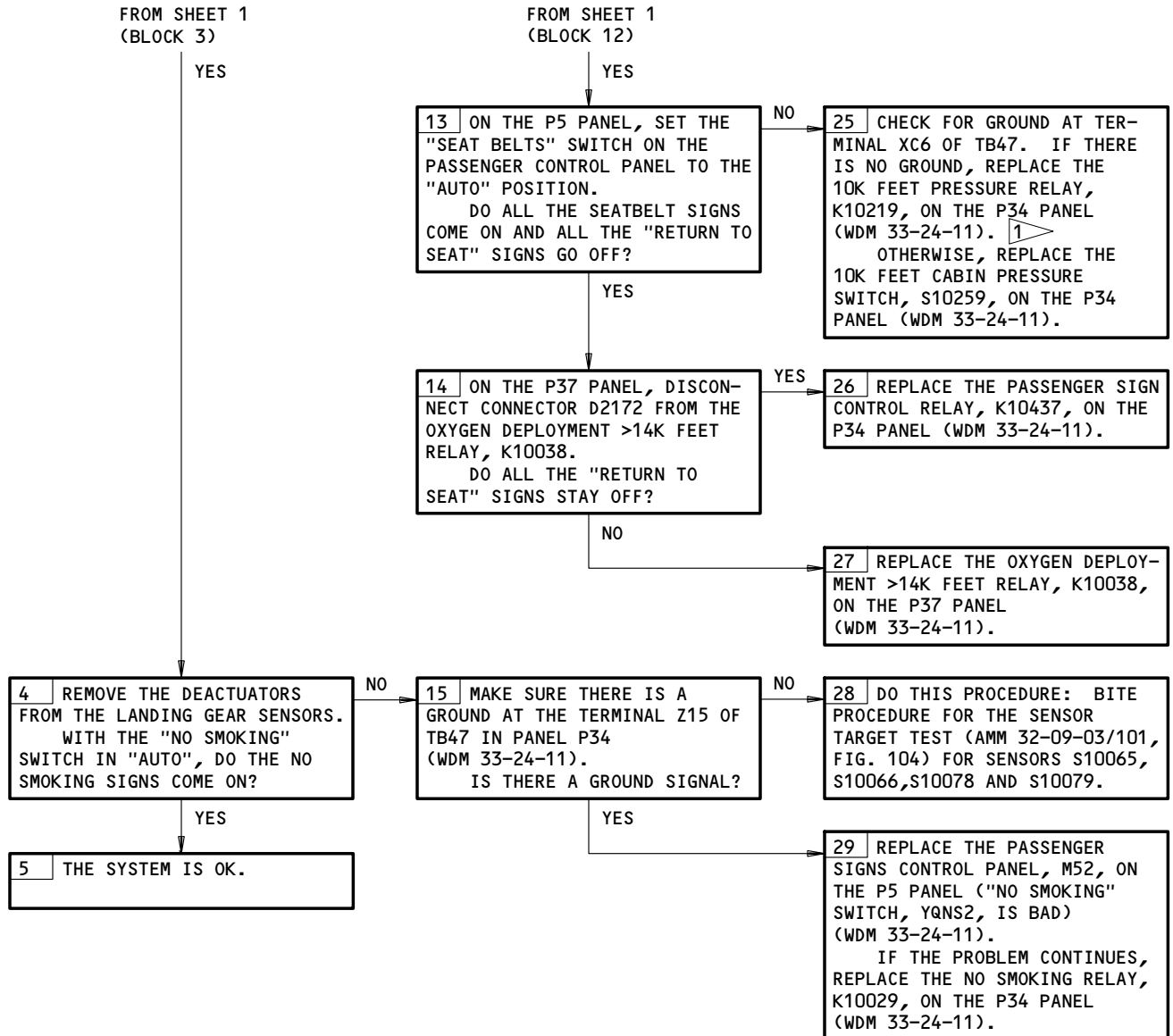

1 AIRPLANES WITH RELAY K10219 INSTALLED

No Smoking Signs Problems  
Figure 104 (Sheet 2)

EFFECTIVITY	ALL
-------------	-----

**33-24-00**

**PREREQUISITES**

MAKE SURE THESE CIRCUIT BREAKERS ARE CLOSED:  
 11P9,34E1,34E2,34F1,34F2

MAKE SURE THE AIRPLANE IS IN THE CONFIGURATION THAT FOLLOWS:  
 ELECTRICAL POWER IS ON (MM 24-22-00/201)

**SEATBELT AND RETURN TO SEAT SIGNS PROBLEMS**

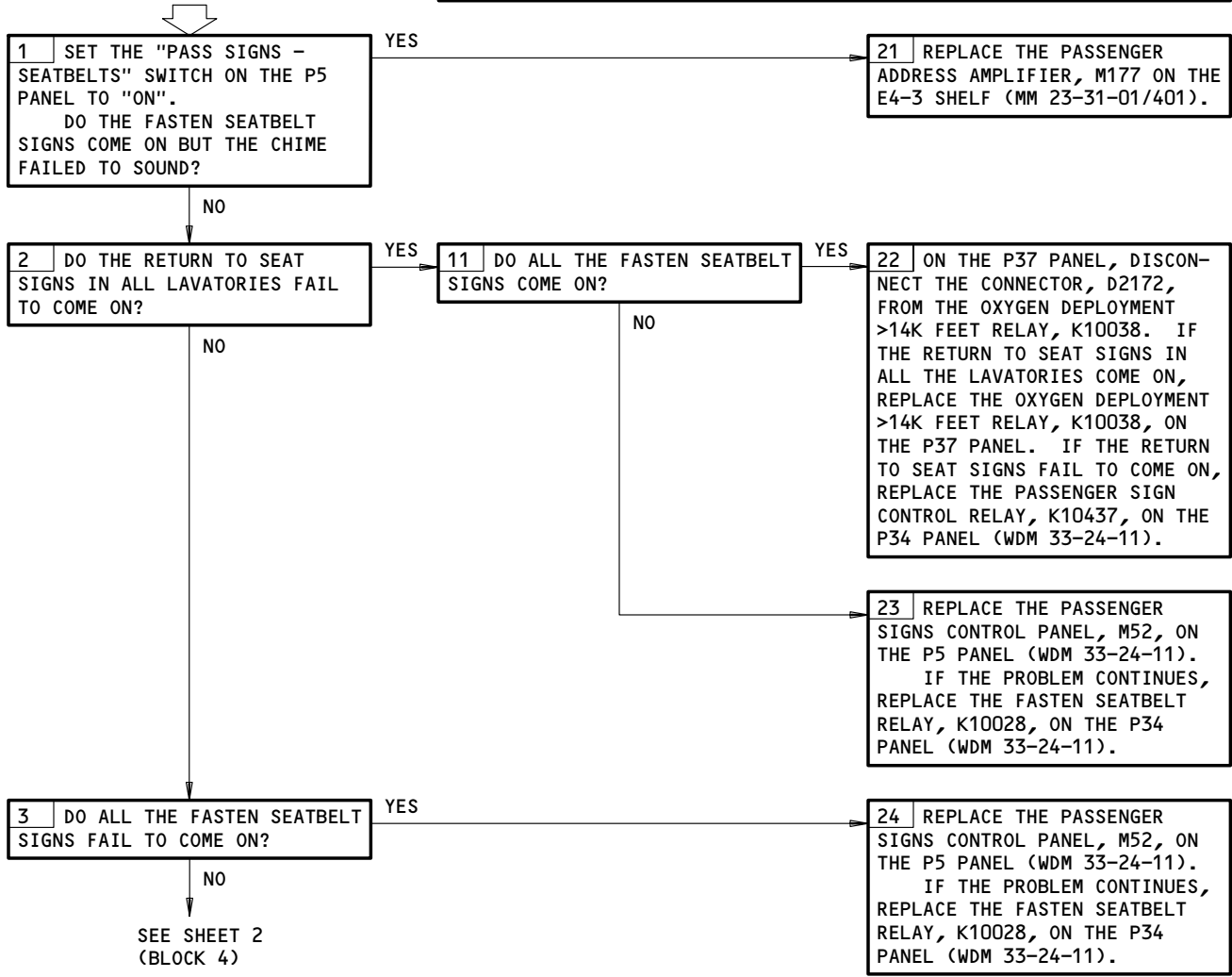

Seatbelt And Return To Seat Signs Problems  
 Figure 105 (Sheet 1)

EFFECTIVITY	ALL
-------------	-----

**33-24-00**

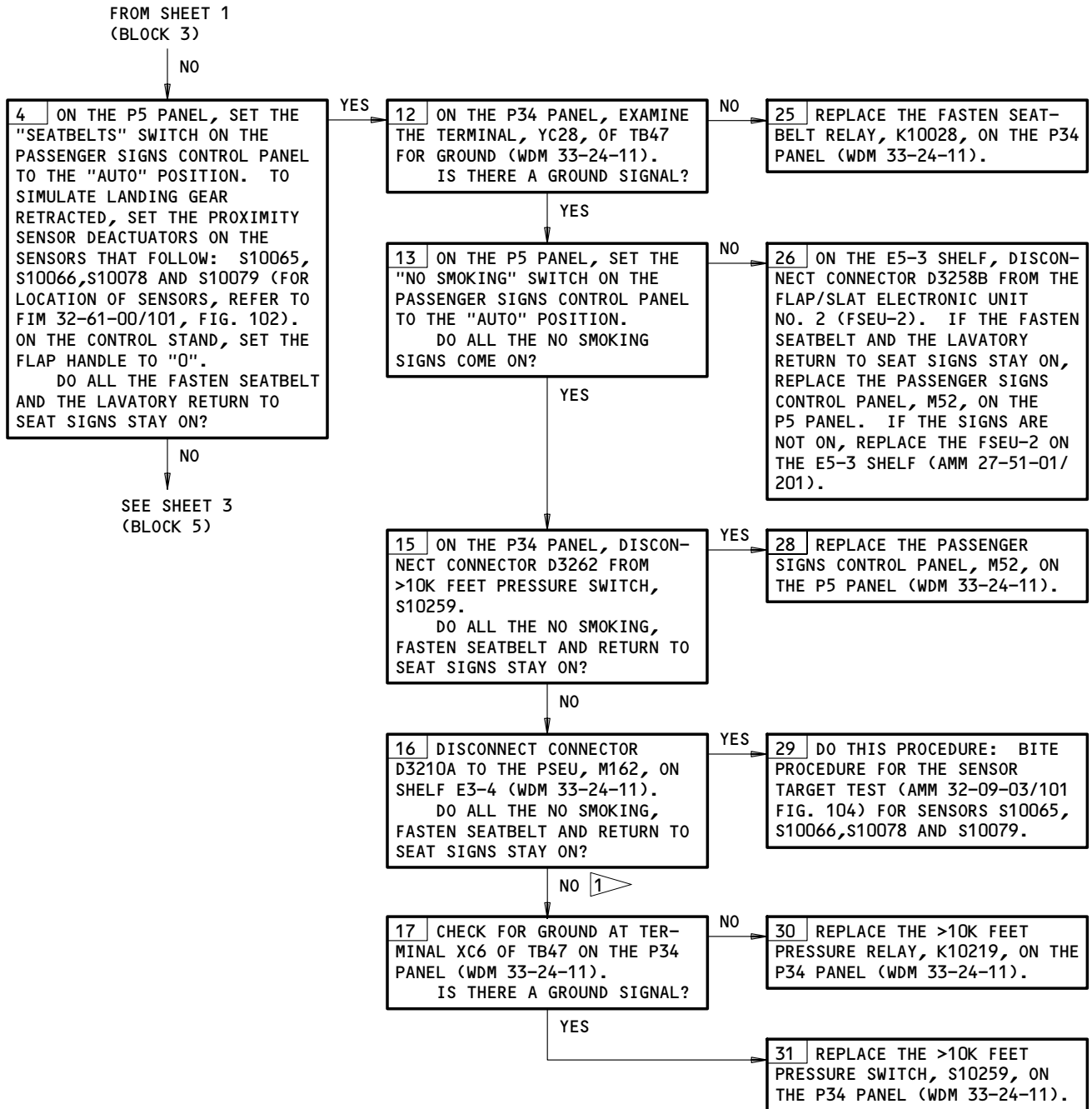

1 ON AIRPLANES WITHOUT RELAY K10219 INSTALLED, GO TO BLOCK 31

Seatbelt And Return To Seat Signs Problems  
Figure 105 (Sheet 2)

EFFECTIVITY

ALL

**33-24-00**

03

Page 107  
Jun 20/95

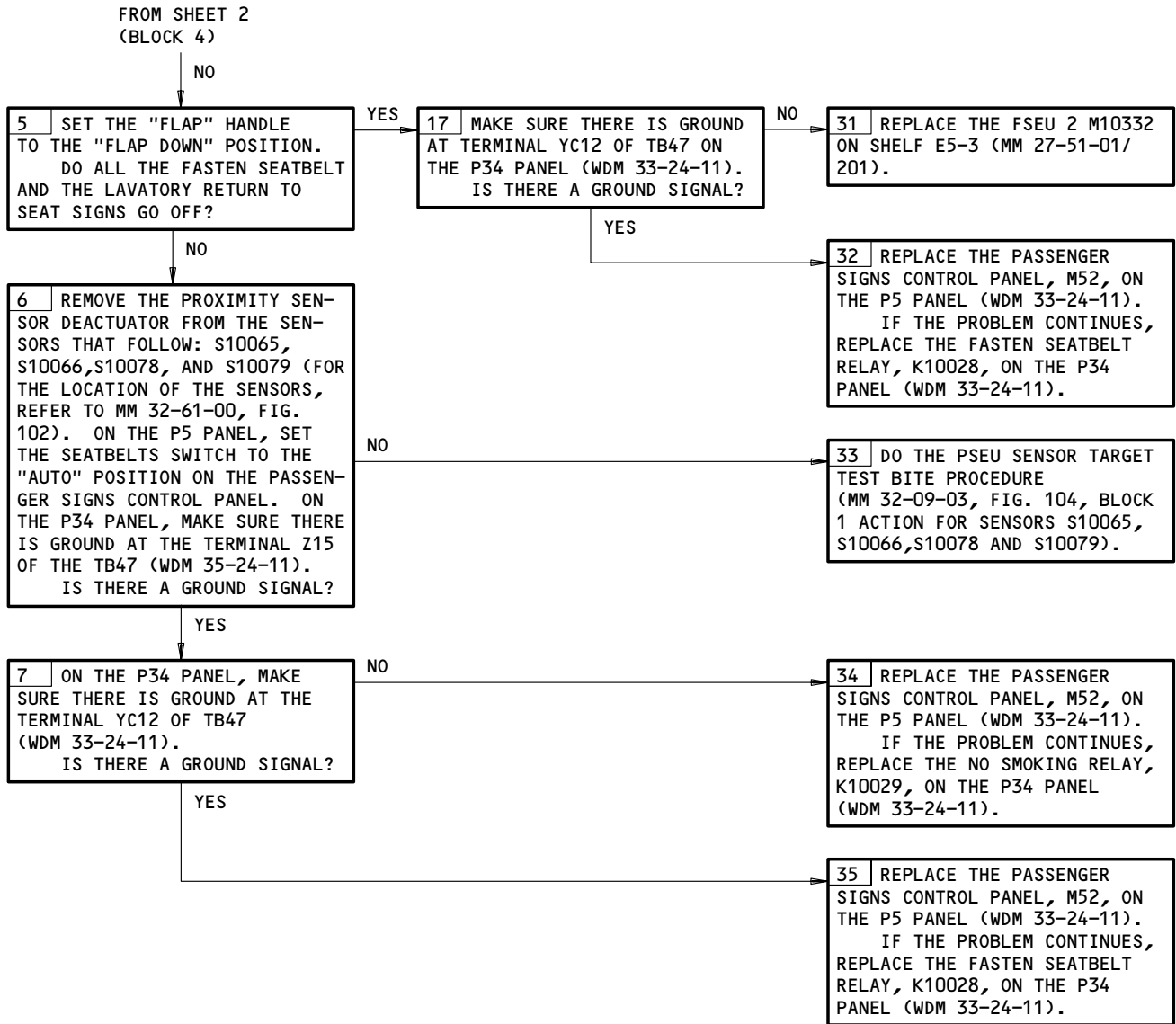

Seatbelt And Return To Seat Signs Problems  
Figure 105 (Sheet 3)

EFFECTIVITY

ALL
-----

33-24-00





**BOEING**  
 757  
 FAULT ISOLATION/MAINT MANUAL

CALL LIGHTS

COMPONENT*	FIG. 102 SHT	QTY *	ACCESS/AREA	AMM REFERENCE
CIRCUIT BREAKER -	1		FLT COMPT, P11	*
LIGHT -				
ATTENDANT CALL	2		PASS. COMPT	33-25-00
LAVATORY CALL	2		PASS. COMPT	33-25-00
PASSENGER CALL	2		PASS. COMPT	33-25-00
RELAY -				
ATTENDANT CALL			PASS. COMPT, LAVATORIES	*
SWITCH -				
LAVATORY CALL	1		PASS. COMPT, LAVATORIES	*
LAVATORY CALL RESET	1		PASS. COMPT, LAVATORIES	*
PASS. CALL	2		PASS. COMPT, PASS. SERV UNITS	*
PASS. CALL LIGHTS CONTROL			PASS. COMPT, EXIT LOCATOR SIGN	*
PASS. CALL SELECT	2		PASS. COMPT, PASS. SERV UNITS	*

\* SEE THE WDM OR SSM FOR THE EQUIPMENT NUMBER, QUANTITY, AND LOCATION OF EACH COMPONENT IN THE LIGHTING CIRCUIT

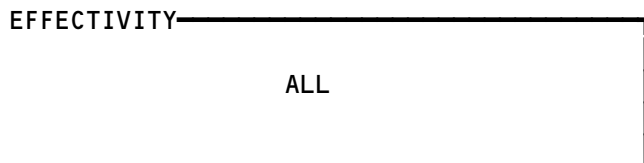
Call Lights - Component Index  
Figure 101



33-25-00

**BOEING**  
757  
FAULT ISOLATION/MAINT MANUAL

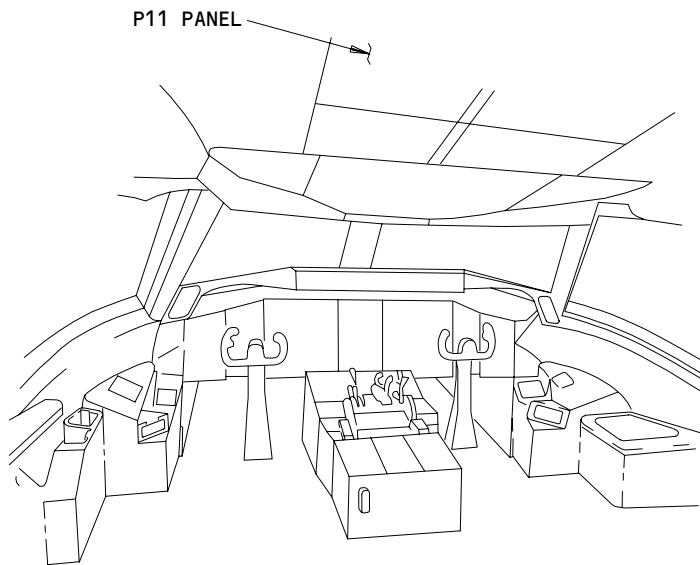

FLIGHT COMPARTMENT

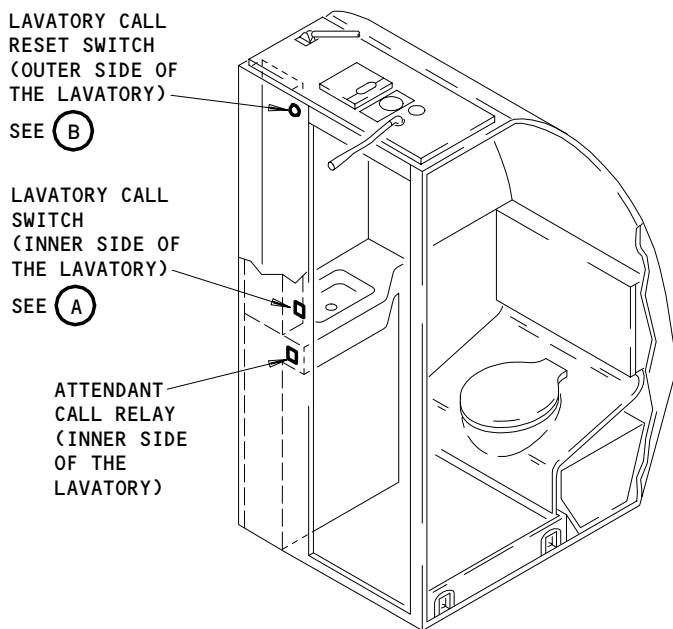

LAVATORY (EXAMPLE)

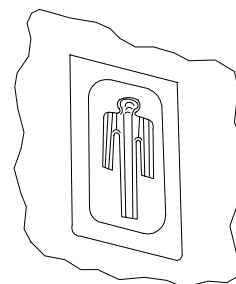

LAVATORY CALL SWITCH

(A)



LAVATORY CALL RESET SWITCH

(B)

Call Lights - Component Location  
Figure 102 (Sheet 1)

EFFECTIVITY	ALL
-------------	-----

33-25-00

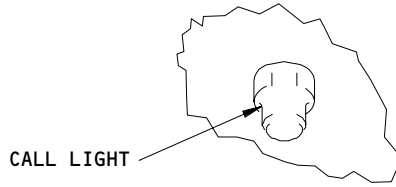

CALL LIGHT  
(EXAMPLE)

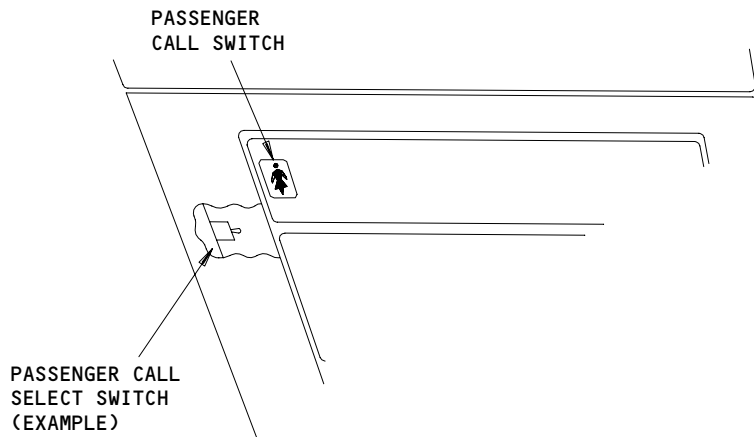

PASSENGER SERVICE UNIT  
(EXAMPLE)

Call Lights - Component Location  
Figure 102 (Sheet 2)

EFFECTIVITY	ALL
-------------	-----

33-25-00

01

Page 103  
Sep 20/94

78386

**PREREQUISITES**  
 ELECTRICAL POWER (MM 24-22-00)  
 CB'S: 11N8,11N9

**PASSENGER CALL SYSTEM PROBLEMS**

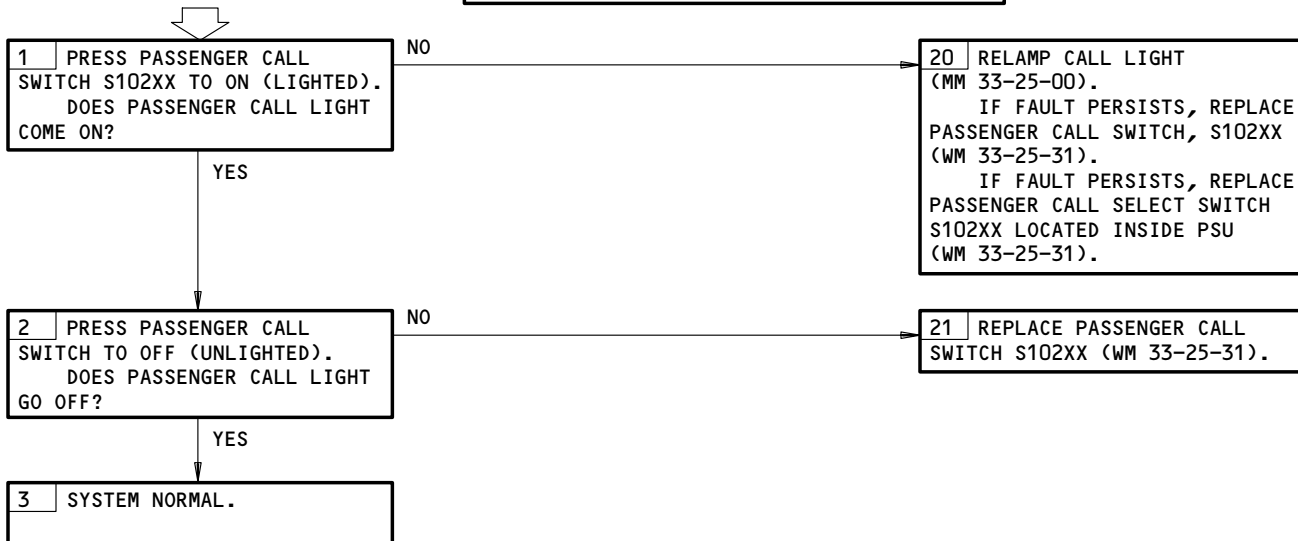

Passenger Call System Problems  
Figure 103



EFFECTIVITY

ALL
-----



**33-25-00**

**BOEING**  
757  
FAULT ISOLATION/MAINT MANUAL

LAVATORY LIGHTS

COMPONENT*	FIG. 102 SHT	QTY *	ACCESS/AREA	AMM REFERENCE
BALLAST -	--		EACH LAVATORY	*
CIRCUIT BREAKER -	--		119BL, MAIN EQUIP CTR, P34	*
CIRCUIT BREAKER -	--		119BL, MAIN EQUIP CTR, P37	*
LIGHT -				
DOME	--		EACH LAVATORY	33-26-00
MIRROR	--		EACH LAVATORY	33-26-00
THRESHOLD	--		PASS. COMPT	33-26-00
RELAY -			119BL, MAIN EQUIP CTR, P34 AND P37	*
SIGN -				
LAVATORY/OCCUPIED	--		PASS. COMPT	33-26-00
FORWARD LAVATORY OCCUPIED LIGHT 	--		FLIGHT COMPT	33-26-00
SWITCH -				
DOOR LATCH	--		EACH LAVATORY	*
EXTERNAL (HANDICAPPED) 			EACH LAVATORY	
HOLD-OPEN DEVICE 			EACH LAVATORY	

\* SEE THE SSM OR WDM FOR THE EQUIPMENT NUMBER, QUANTITY, AND LOCATION OF EACH COMPONENT IN THE LIGHTING CIRCUIT

-  NOT INSTALLED ON ALL LAVATORIES
-  NOT ON ALL AIRPLANES

Lavatory Lights - Component Index  
Figure 101

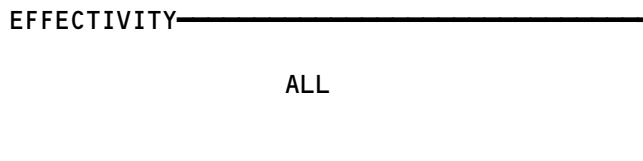

**33-26-00**

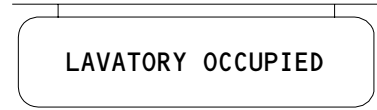
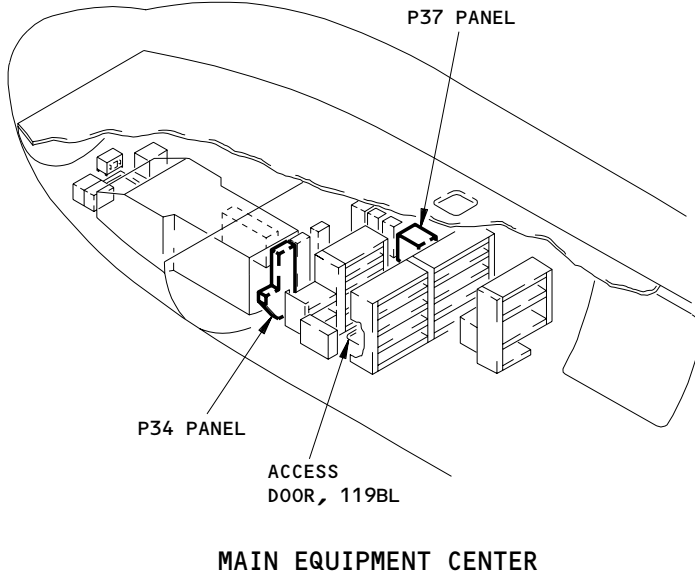

LAVATORY OCCUPIED SIGN  
(EXAMPLE)



EXTERNAL (HANDICAPPED) SWITCH

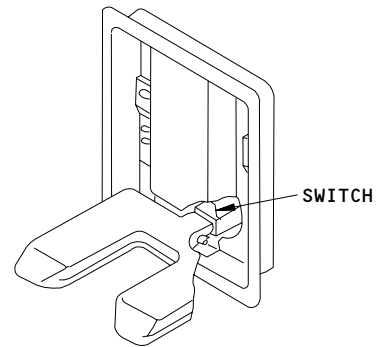
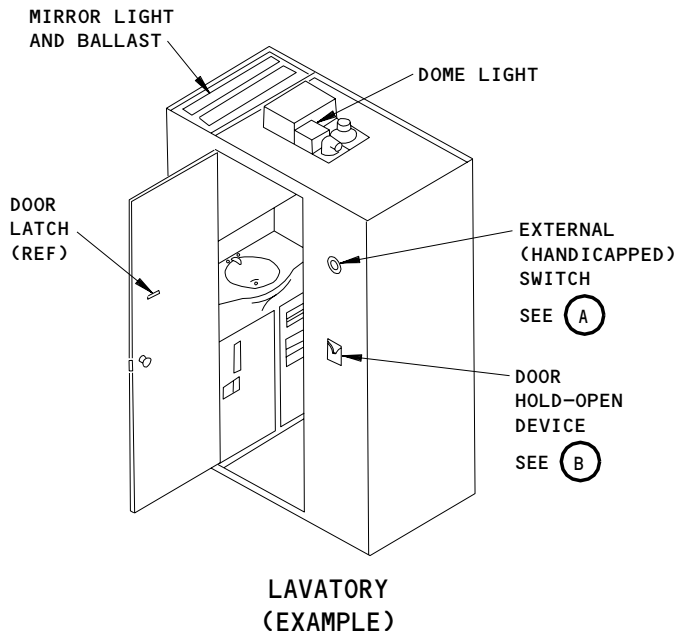

DOOR HOLD-OPEN DEVICE  
(EXAMPLE)

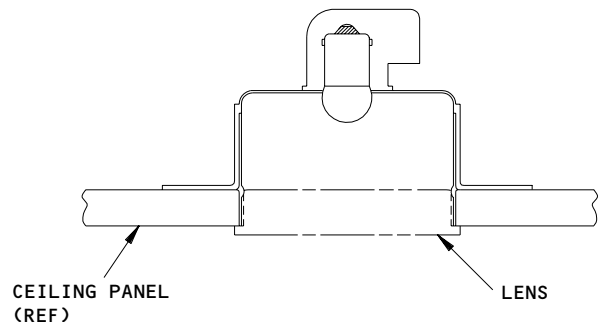
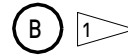

LAVATORY THRESHOLD LIGHT  
(EXAMPLE)

1 NOT INSTALLED ON ALL LAVATORIES

Lavatory Lights - Component Location  
Figure 102 (Sheet 1)

EFFECTIVITY	ALL
-------------	-----

33-26-00

**BOEING**  
757  
FAULT ISOLATION/MAINT MANUAL

MISCELLANEOUS  
ANNUNCIATOR  
PANEL, M10394

SEE (C)

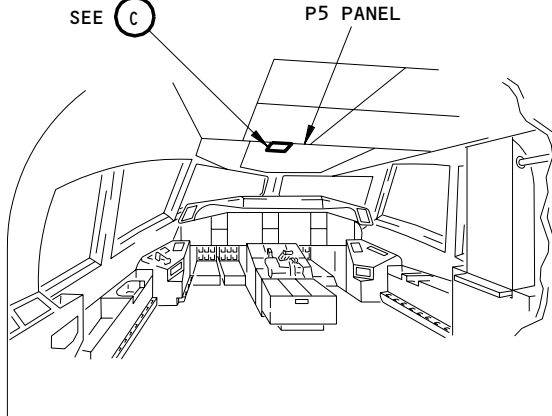

FLIGHT COMPARTMENT

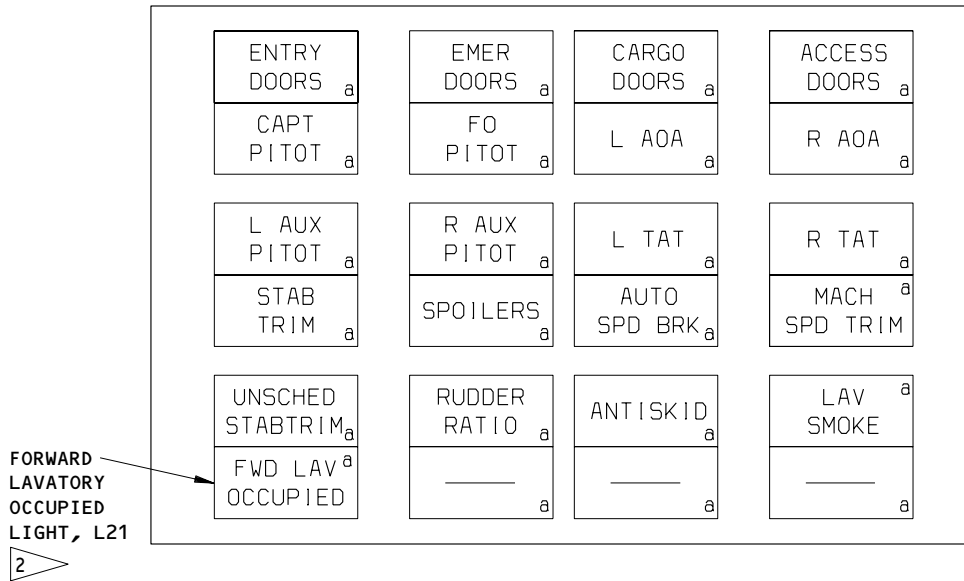

MISCELLANEOUS ANNUNCIATOR PANEL, M10394

(C)

2 NOT ON ALL AIRPLANES

Lavatory Lights - Component Location  
Figure 102 (Sheet 2)

EFFECTIVITY	ALL
-------------	-----

**33-26-00**

01

Page 103  
May 28/00

L16794

**PREREQUISITES**

MAKE SURE EACH APPLICABLE CIRCUIT BREAKER IS CLOSED:  
 (SSM 33-26-01 THRU 33-26-02 OR WDM 33-26-11 THRU 33-26-21)

MAKE SURE THE AIRPLANE IS IN THIS CONFIGURATION:  
 ELECTRICAL POWER IS ON (AMM 24-22-00/201)

**LAVATORY LIGHTS PROBLEMS**

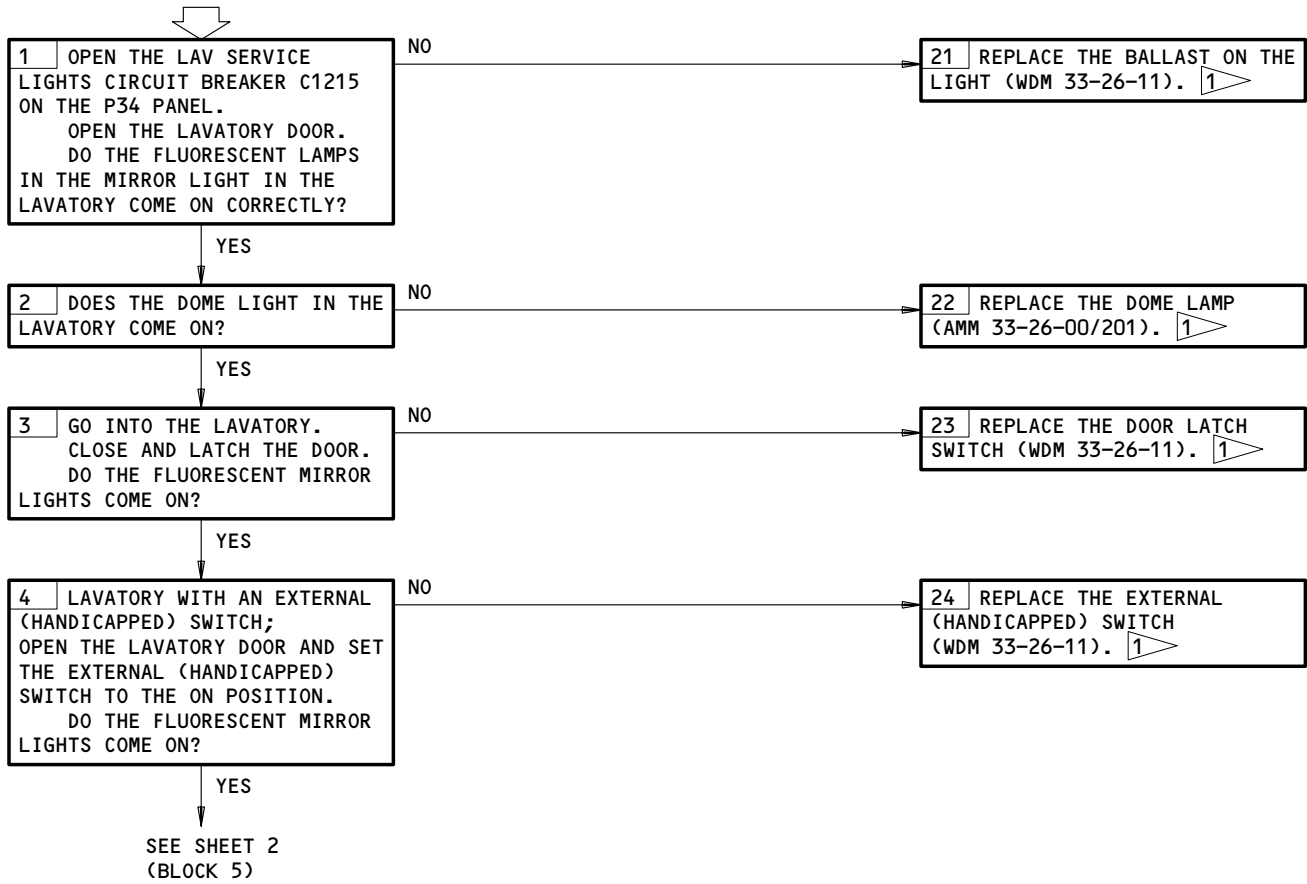

1 CLOSE THE LAV SERVICE LIGHTS CIRCUIT BREAKER WHEN FINISHED.

Lavatory Lights Problems  
Figure 103 (Sheet 1)

EFFECTIVITY	
	ALL

**33-26-00**



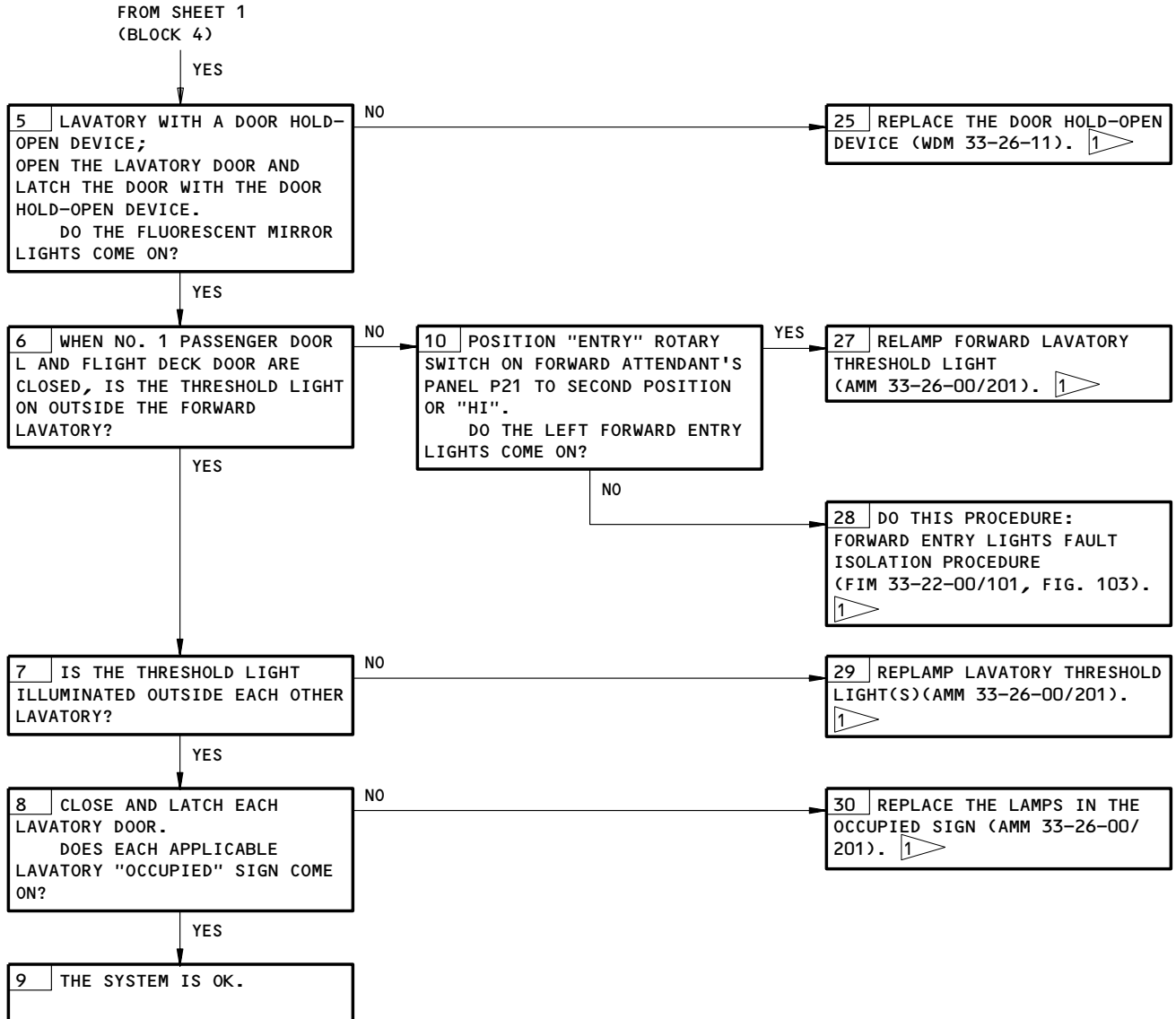

Lavatory Lights Problems  
Figure 103 (Sheet 2)

EFFECTIVITY

ALL
-----

33-26-00



**BOEING**  
 757  
 FAULT ISOLATION/MAINT MANUAL

GALLEY LIGHTS

COMPONENT*	FIG. 102 SHT	QTY *	ACCESS/AREA	AMM REFERENCE
BALLAST -	2		PASS. COMPT, EACH GALLEY LIGHT	33-27-00
CIRCUIT BREAKER -			FLT COMPT, P11	
CIRCUIT BREAKER -			119BL, MAIN EQUIP CTR, P37	
LIGHT -	1		PASS. COMPT, GALLEY	33-27-00
RELAY -	2		PASS. COMPT, EACH GALLEY LIGHT	33-27-00
RELAY -			119BL, MAIN EQUIP CTR, P34	*
SWITCH -			PASS. COMPT, EACH GALLEY	*
TRANSFORMER -			119BL, MAIN EQUIP CTR, P34	*

\* SEE THE WDM OR SSM FOR THE EQUIPMENT NUMBER, QUANTITY, AND LOCATION OF EACH COMPONENT IN THE LIGHTING CIRCUIT

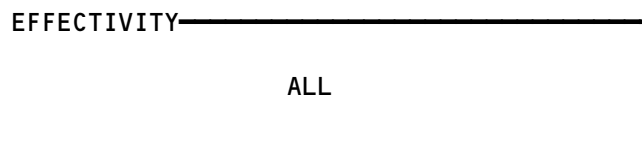
Galley Lights - Component Index  
Figure 101



**33-27-00**

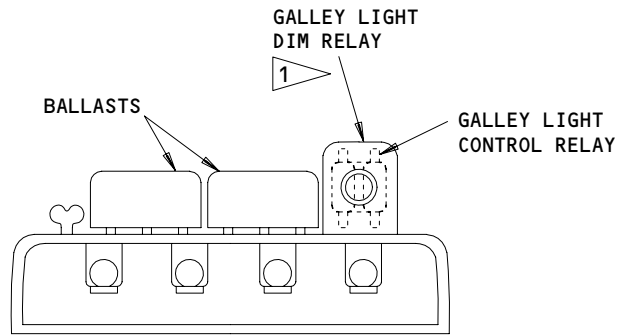

**GALLEY LIGHT  
 (EXAMPLE)**

**1** ONLY INSTALLED ON THE FORWARD GALLEY LIGHT

**Galley Lights - Component Location  
 Figure 102**

EFFECTIVITY	ALL
-------------	-----

**33-27-00**

**GALLEY LIGHTS PROBLEMS**

**PREREQUISITES**

MAKE SURE THE APPLICABLE CIRCUIT BREAKERS ARE CLOSED:  
(WDM 33-27-11 OR SSM 33-27-01)

MAKE SURE THE AIRPLANE IS IN THIS CONFIGURATION:  
ELECTRICAL POWER IS ON (AMM 24-22-00/201)

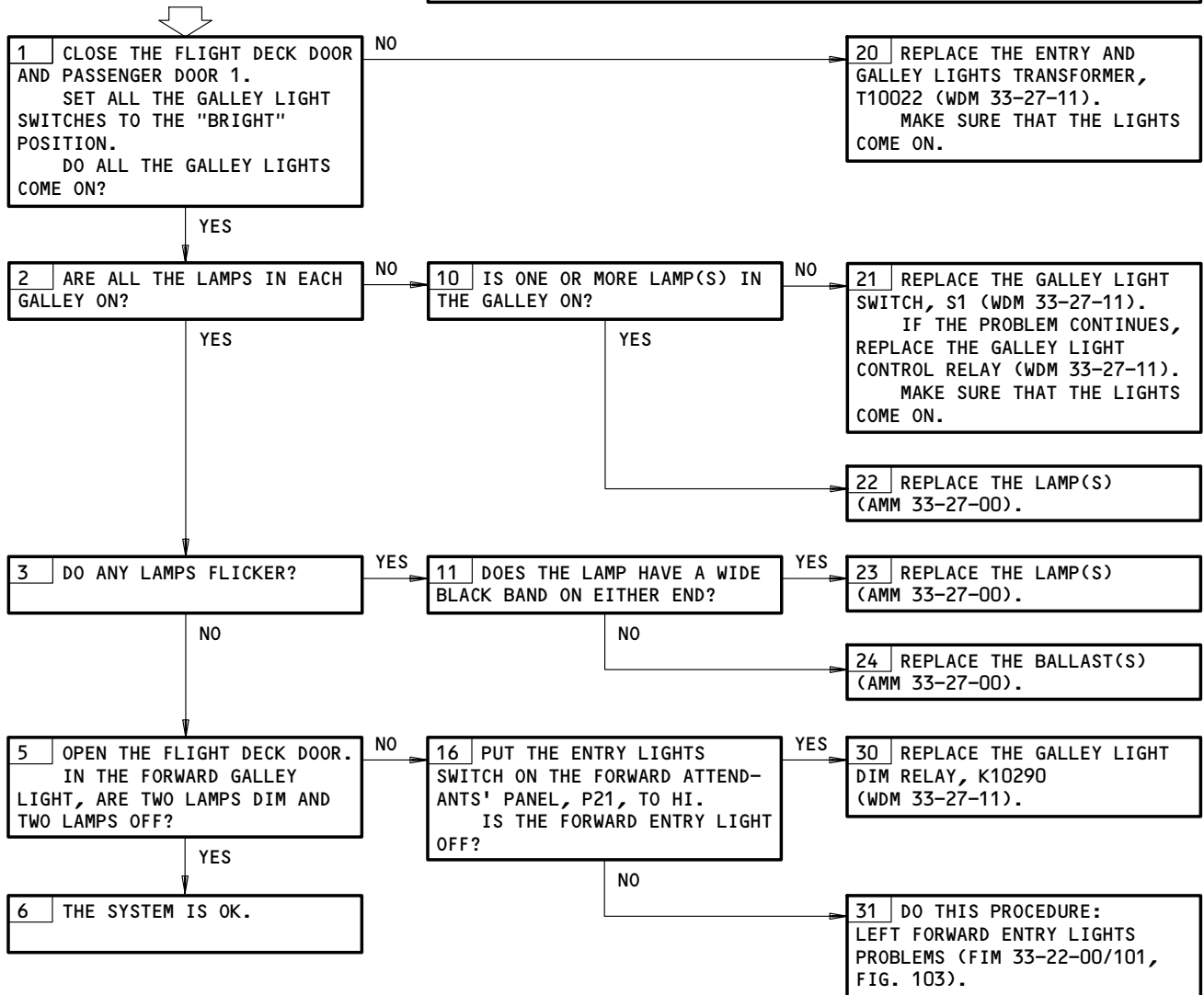

Galley Lights Problems  
Figure 103

EFFECTIVITY

ALL

**33-27-00**

01

Page 103  
Dec 20/96

654282

**BOEING**  
757  
FAULT ISOLATION/MAINT MANUAL

SERVICE LIGHTS

COMPONENT*	FIG. 102 SHT	QTY *	ACCESS/AREA	AMM REFERENCE
CIRCUIT BREAKER -			119BL, MAIN EQUIP CTR, P34	*
LIGHT -				
AIR COND COMPT			193HL,194ER, ECS BAY	33-31-00
APU COMPT			315AL,316AR, APU COMPT	*
FWD EQUIP CTR			113AL, FWD OF NLG WHEEL WELL	*
HYDRAULIC SERVICE			197KL, HYD SERV CTR	*
MAIN EQUIP CTR			119BL, MAIN EQUIP CTR	*
TAILCONE COMPT			311AL, AFT OF PRESSURE BULKHEAD	*
WHEEL WELL			WHEEL WELLS	*
SWITCH -				
AIR COND COMPT LIGHT			193HL,194ER, ECS BAY	*
APU COMPT LIGHT			315AL,316AR, APU COMPT	*
FWD EQUIP CTR LIGHT			113AL, FWD OF NLG WHEEL WELL	*
HYDRAULIC SERV LIGHT			197KL, HYD SERV CTR	*
MAIN EQUIP CTR LIGHT			119BL, MAIN EQUIP CTR	*
MAIN AND NOSE GEAR WHEEL WELL LIGHT			MLG WHEEL WELL	*
TRANSFORMER -				
APU AND TAILCONE			311AL, AFT OF PRESS. BULKHEAD	*
WHEEL WELL			R MLG WHEEL WELL	*

\* SEE THE SSM OR WDM FOR THE EQUIPMENT NUMBER, QUANTITY, AND LOCATION OF EACH COMPONENT IN THE LIGHTING CIRCUIT.

Service Lights - Component Index  
Figure 101

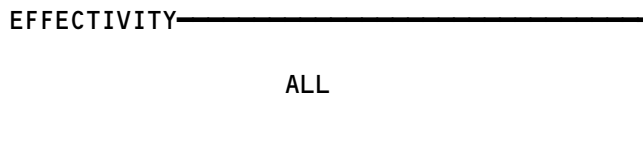

**33-31-00**

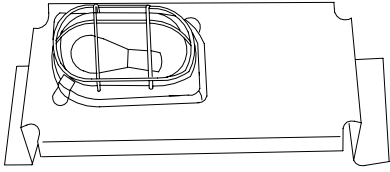

APU, AIR CONDITIONING AND  
TAILCONE COMPARTMENT LIGHT  
(EXAMPLE)

(G)

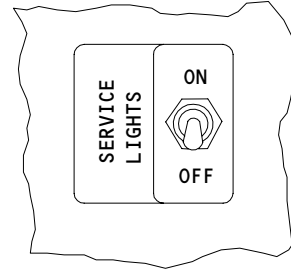

APU, AIR CONDITIONING AND  
TAILCONE COMPARTMENT LIGHT SWITCH  
(EXAMPLE)

(H)

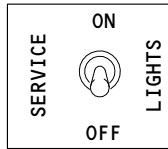

EQUIPMENT CENTER  
LIGHTS SWITCH  
(EXAMPLE)

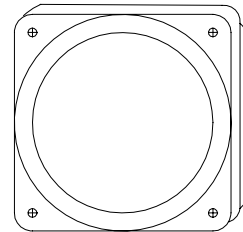

EQUIPMENT CENTER LIGHTS  
(EXAMPLE)

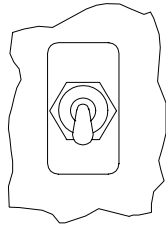

HYDRAULIC SERVICE CENTER  
LIGHTS SWITCH

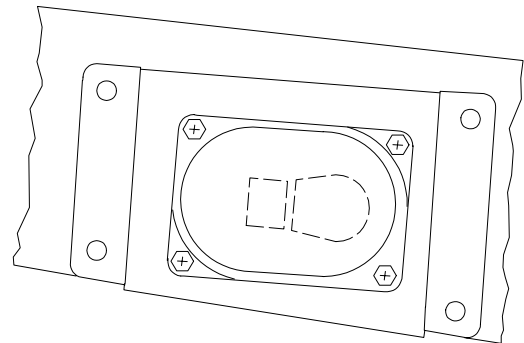

HYDRAULIC SERVICE CENTER LIGHT

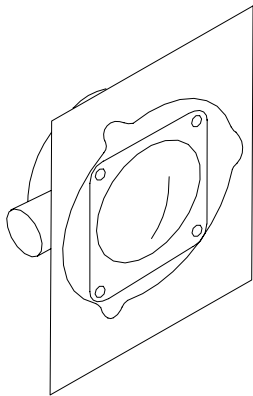

WHEEL WELL LIGHT  
(EXAMPLE)

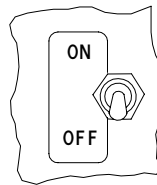

WHEEL WELL LIGHTS SWITCH  
(EXAMPLE)

Service Lights - Component Location  
Figure 102

EFFECTIVITY	ALL
-------------	-----

33-31-00

**MAIN GEAR WHEEL WELL SERVICE LIGHT PROBLEMS**

**PREREQUISITES**

MAKE SURE THIS CIRCUIT BREAKER IS CLOSED:  
34B5

MAKE SURE THE AIRPLANE IS IN THE CONFIGURATION THAT FOLLOWS:  
ELECTRICAL POWER IS ON (MM 24-22-00/201)

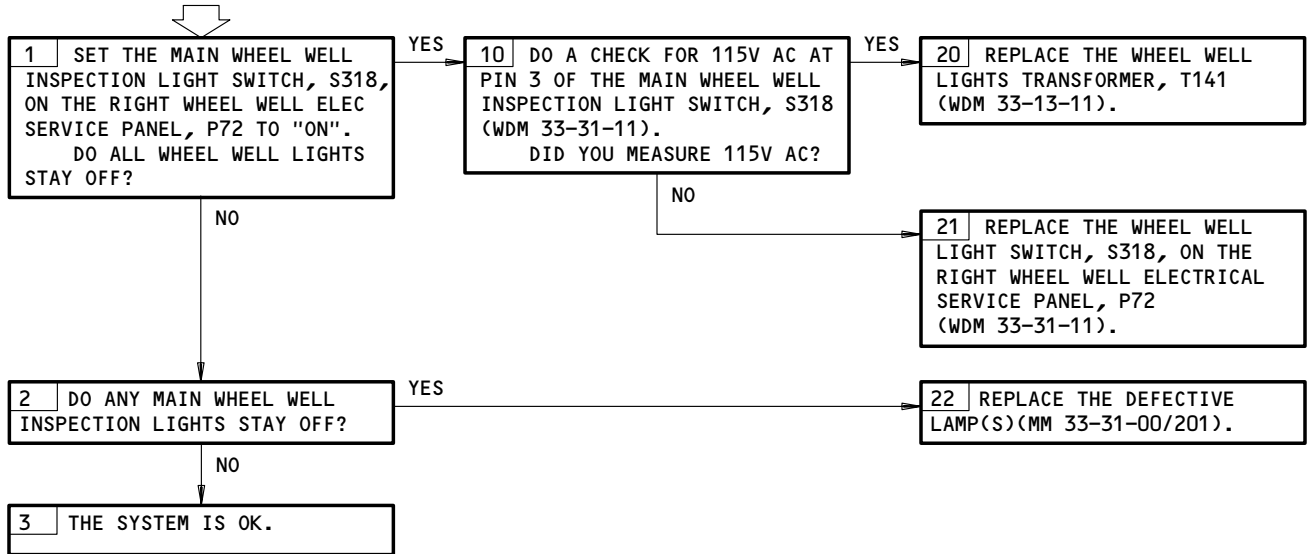

Main Gear Wheel Well Service Light Problems  
Figure 103

EFFECTIVITY	ALL
-------------	-----

**33-31-00**

01

Page 103  
Dec 20/94

55963

**APU COMPARTMENT LIGHTS PROBLEMS**

**PREREQUISITES**

MAKE SURE THIS CIRCUIT BREAKER IS CLOSED:  
34B7

MAKE SURE THE AIRPLANE IS IN THE CONFIGURATION THAT FOLLOWS:  
ELECTRICAL POWER IS ON (MM 24-22-00/201)

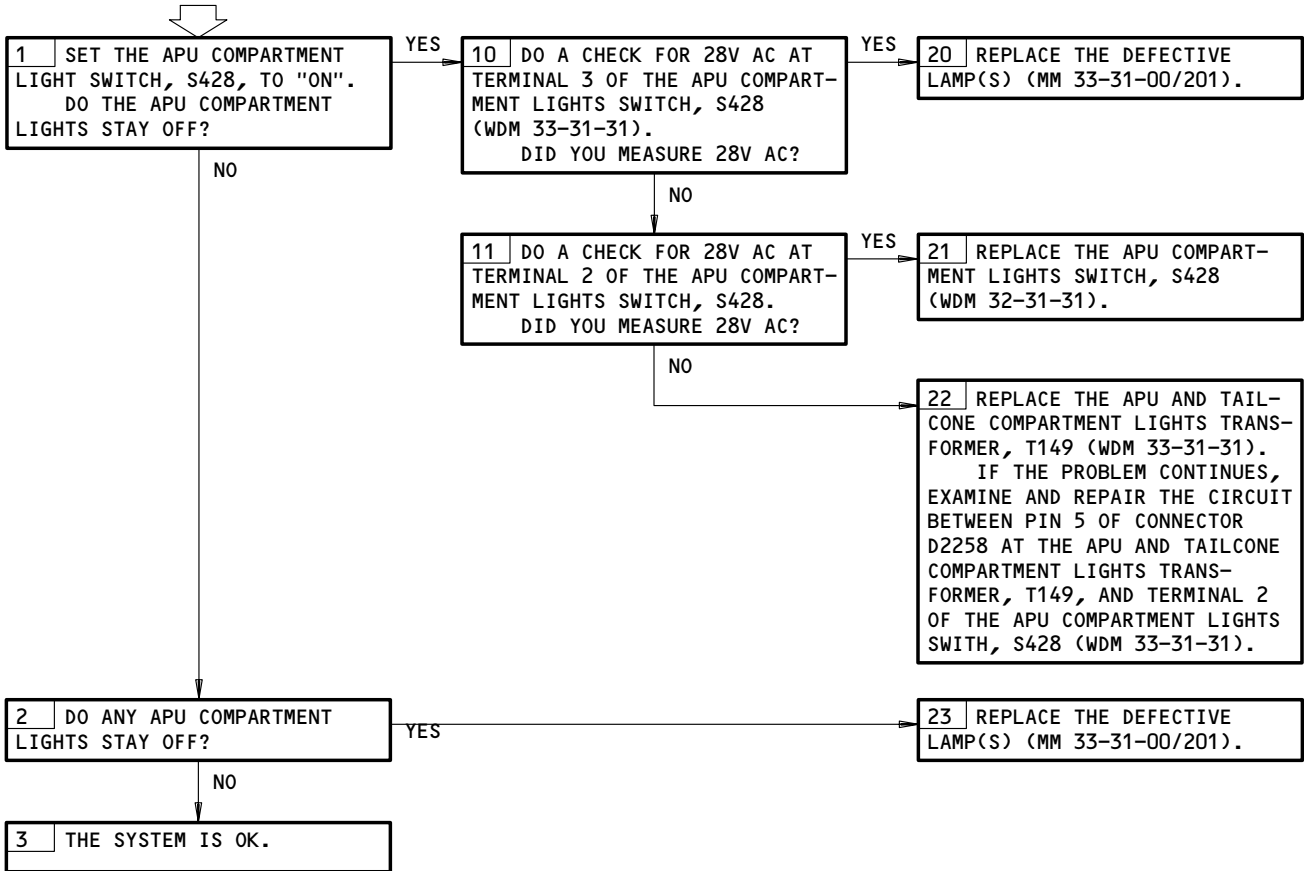

APU Compartment Lights Problems  
Figure 104

EFFECTIVITY

ALL
-----

**33-31-00**



**TAILCONE COMPARTMENT LIGHT PROBLEMS**

**PREREQUISITES**

MAKE SURE THIS CIRCUIT BREAKER IS CLOSED:  
34B7

MAKE SURE THE AIRPLANE IS IN THE CONFIGURATION THAT FOLLOWS:  
ELECTRICAL POWER IS ON (MM 24-22-00/201)

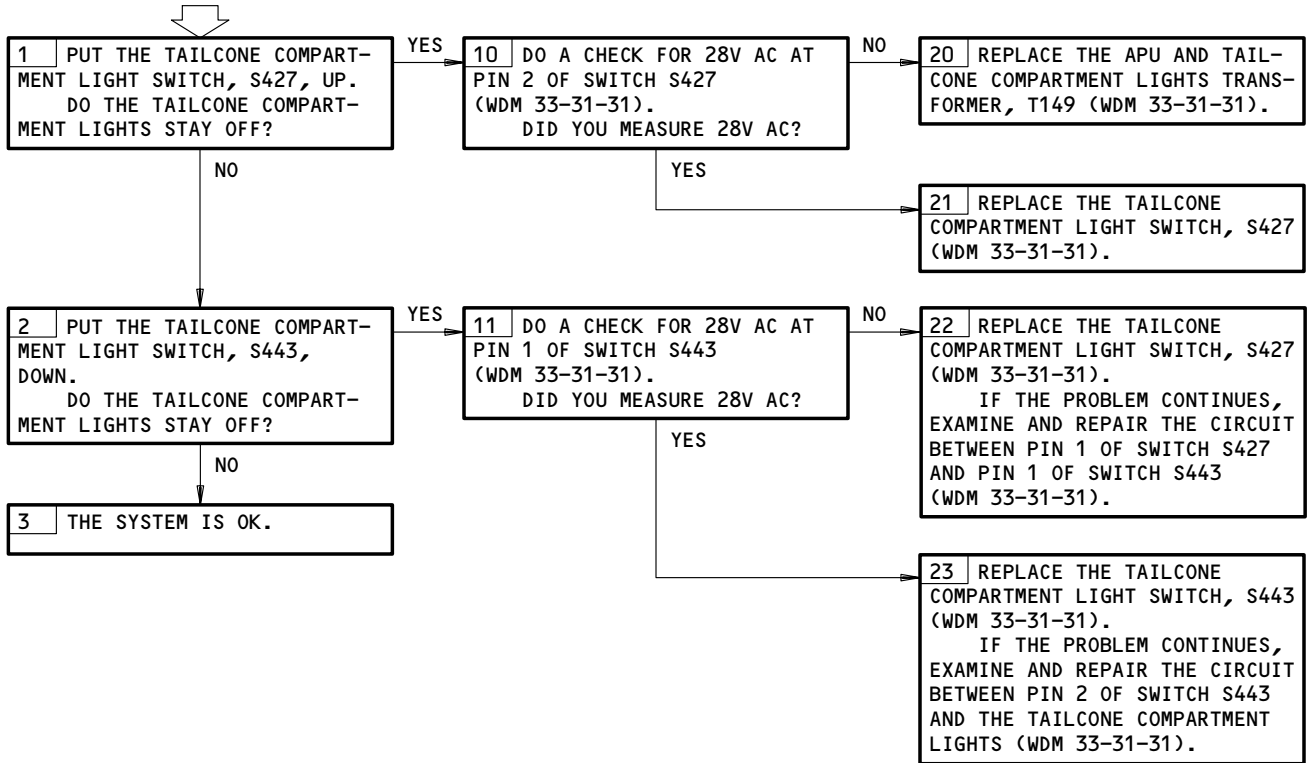



Tailcone Compartment Light Problems  
Figure 105

EFFECTIVITY	ALL
-------------	-----

**33-31-00**

**BOEING**  
757  
FAULT ISOLATION/MAINT MANUAL

LOWER LOBE CARGO COMPARTMENT LIGHTS

COMPONENT*	FIG. 102 SHT	QTY *	ACCESS/AREA	AMM REFERENCE
CIRCUIT BREAKER -	1		119BL, MAIN EQUIP CTR, P34,P65	*
CIRCUIT BREAKER -	1		AFT CARGO COMPT, E6	*
LIGHT -				
CARGO COMPT	2		CARGO COMPT	33-37-00
CARGO DOOR	2		CARGO DOOR	33-37-00
MAIN EQUIP CENTER	2		119BL, MAIN EQUIP CTR	33-37-00
RELAY -				
AFT CARGO COMPT CONT 	1		AFT CARGO COMPT, E6	*
AFT CARGO COMPT LIGHTS ENABLE	1		AFT CARGO COMPT, E6	*
FWD CARGO COMPT CONT 	1		119BL, MAIN EQUIP CTR, P65	*
FWD CARGO COMPT LIGHTS ENABLE	1		119BL, MAIN EQUIP CTR, P65	*
SWITCH -				
AFT CARGO COMPT LIGHTS	1		AFT CARGO COMPT, P44	*
FWD CARGO COMPT LIGHTS	1		FWD CARGO COMPT, P43	*
TRANSFORMER -				
AFT CARGO COMPT LIGHTS	1		AFT CARGO COMPT, E6	*
FWD CARGO COMPT LIGHTS	1		119BL, MAIN EQUIP CTR, P65	*

\* SEE THE SSM OR WDM FOR THE EQUIPMENT NUMBER, QUANTITY, AND LOCATION OF EACH COMPONENT IN THE LIGHTING CIRCUIT.

 AIRPLANES WITH THE AFT AND FWD CARGO COMPARTMENT CONTROL RELAYS

Lower Lobe Cargo Compartment Lights - Component Index  
Figure 101

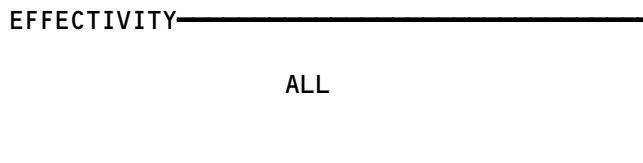

**33-37-00**

**BOEING**  
757  
FAULT ISOLATION/MAINT MANUAL

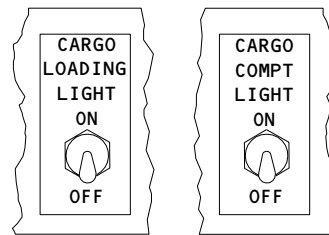
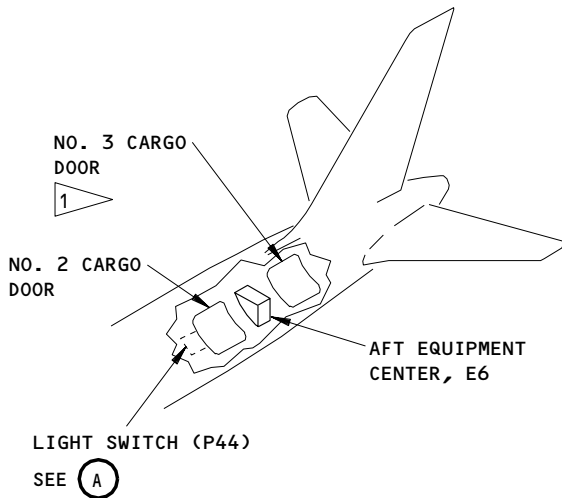
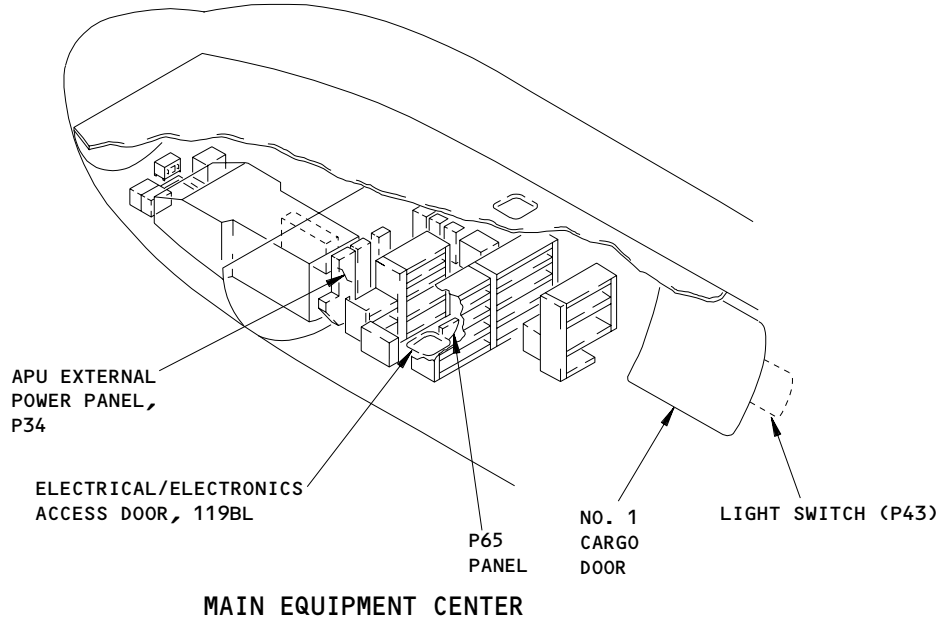

**LIGHT SWITCH (EXAMPLES)**

(A)

1 NOT INSTALLED ON ALL AIRPLANES

**Lower Lobe Cargo Compartment Lights - Component Location**  
Figure 102 (Sheet 1)

EFFECTIVITY	ALL
-------------	-----

**33-37-00**

01

Page 102  
May 28/01

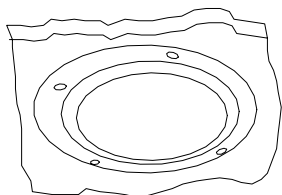

CARGO COMPARTMENT LIGHT  
(EXAMPLE)

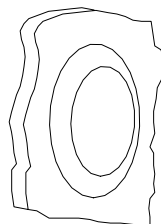

CARGO DOOR LIGHT  
(EXAMPLE)

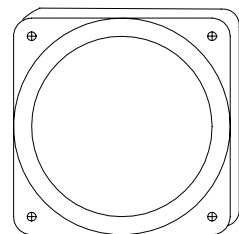

MAIN EQUIPMENT  
CENTER LIGHT, L381

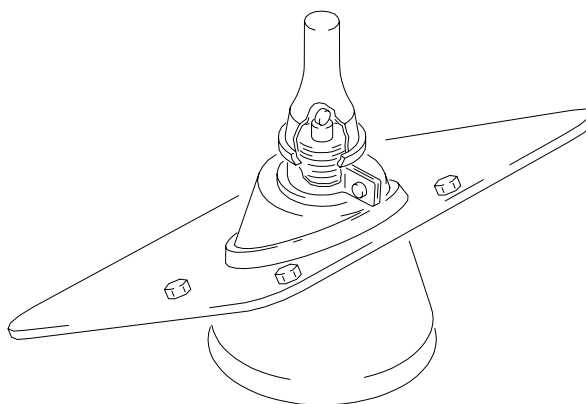

NO. 3 CARGO DOOR LIGHT  
(EXAMPLE) 1

Lower Lobe Cargo Compartment Lights - Component Location  
Figure 102 (Sheet 2)

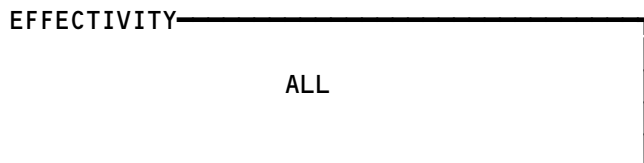

33-37-00

01

Page 103  
Dec 20/94

**FORWARD CARGO  
COMPARTMENT LIGHT  
PROBLEMS**

**PREREQUISITES**

MAKE SURE THESE CIRCUIT BREAKERS ARE CLOSED:  
34A1,34A5,34B8, FWD DOOR CARGO LIGHTS (P65), FWD  
COMPT CARGO LIGHTS (P65)

MAKE SURE THE AIRPLANE IS IN THIS CONFIGURATION:  
ELECTRICAL POWER IS ON (MM 24-22-00/201)

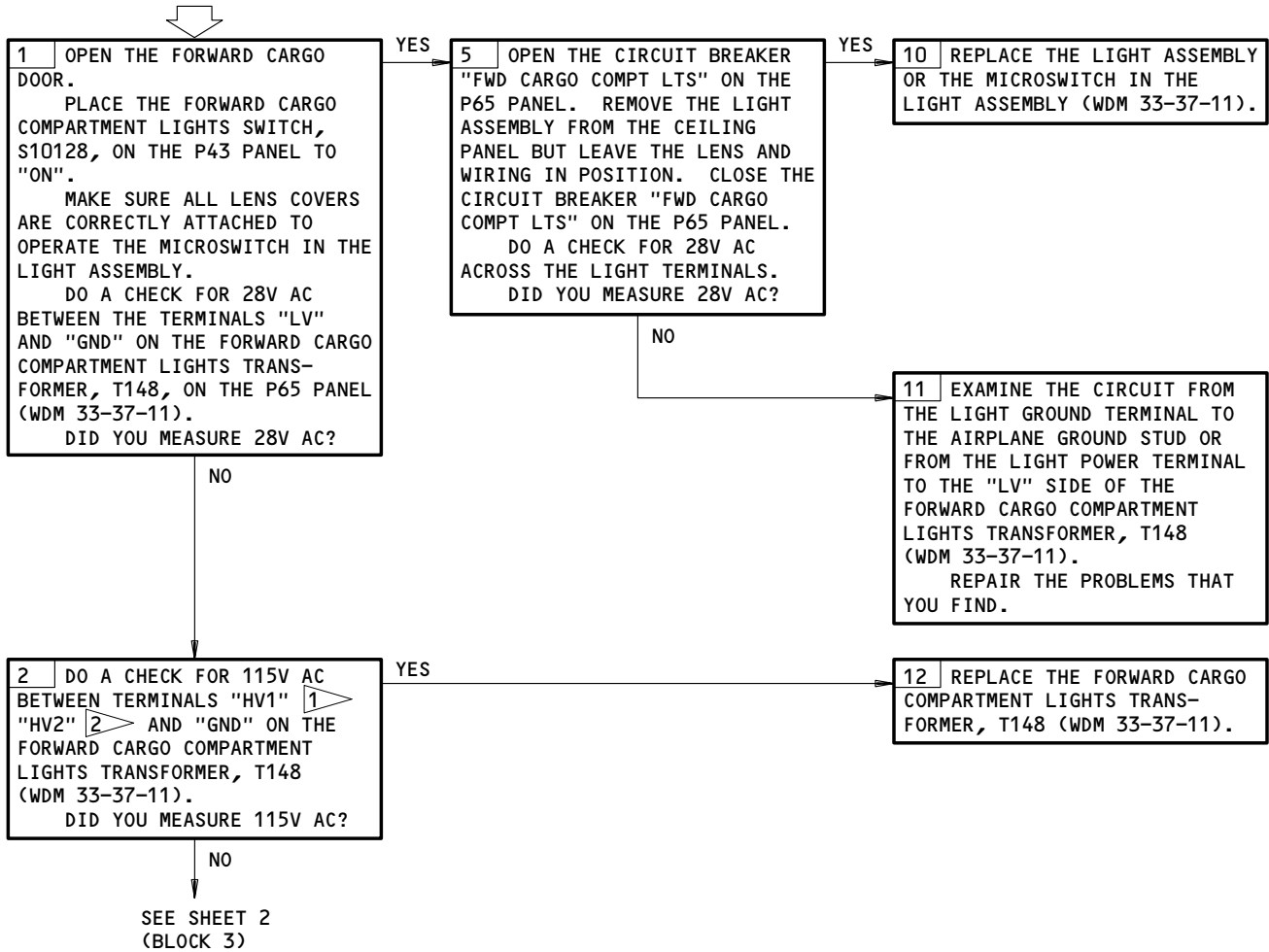

- 1 GUI 001-114,116-999
- 2 GUI 115

Forward Cargo Compartment Light Problems  
Figure 103 (Sheet 1)

EFFECTIVITY

ALL
-----

33-37-00

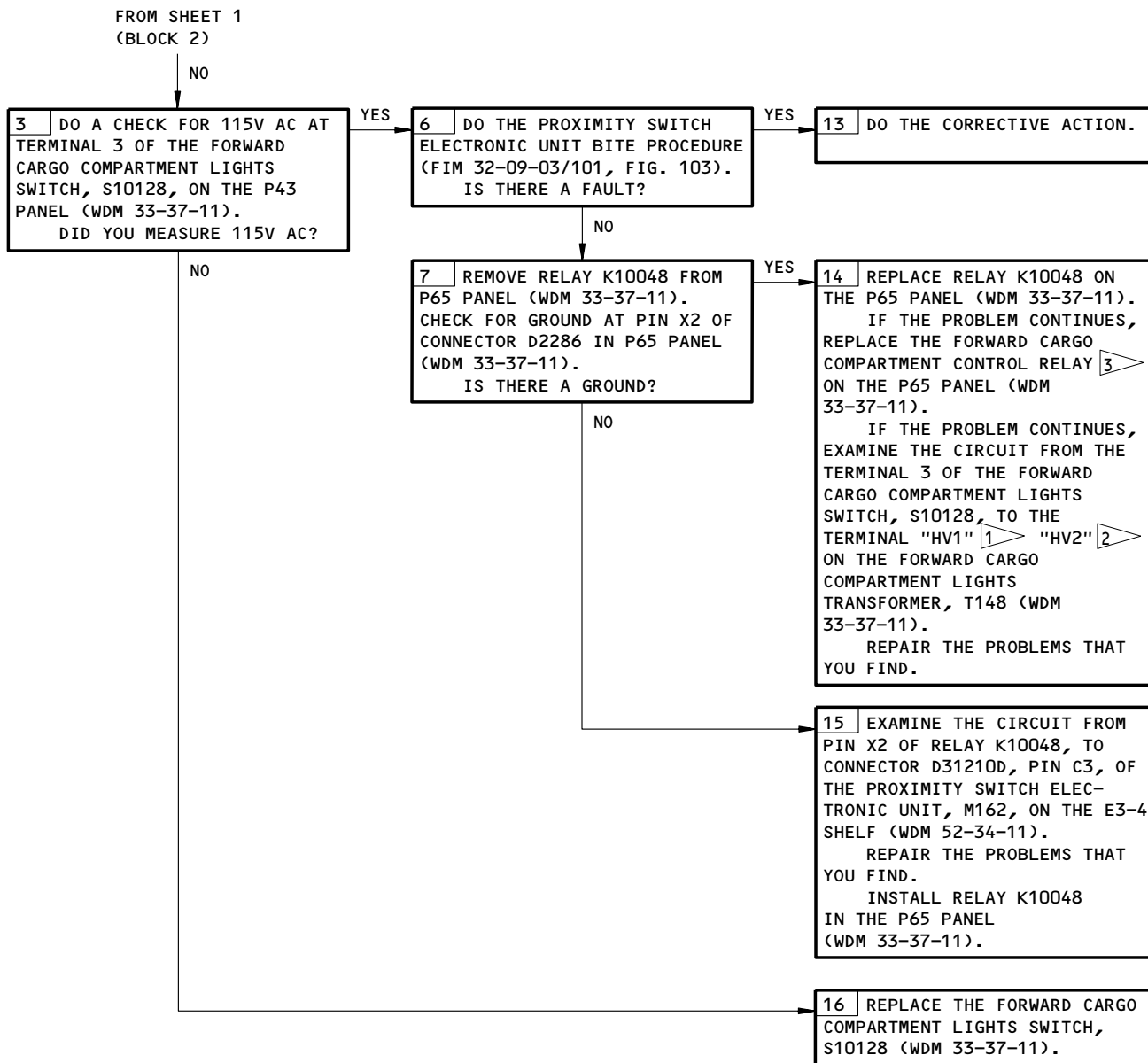

- 1 GUI 001-114, 116-999
- 2 GUI 115
- 3 AIRPLANES WITH THE FORWARD CARGO COMPARTMENT CONTROL RELAY

Forward Cargo Compartment Light Problems  
Figure 103 (Sheet 2)

EFFECTIVITY ————  
ALL

33-37-00

**AFT CARGO  
COMPARTMENT LIGHT  
PROBLEMS**

**PREREQUISITES**

MAKE SURE THESE CIRCUIT BREAKERS ARE CLOSED:  
34A2, 34A5, 34B9, CARGO LIGHTS NO. 2 DOOR (E6), CARGO LIGHTS L (E6), CARGO LIGHTS R (E6)

MAKE SURE THE AIRPLANE IS IN THE CONFIGURATION THAT FOLLOWS:  
ELECTRICAL POWER IS ON (MM 24-22-00/201)

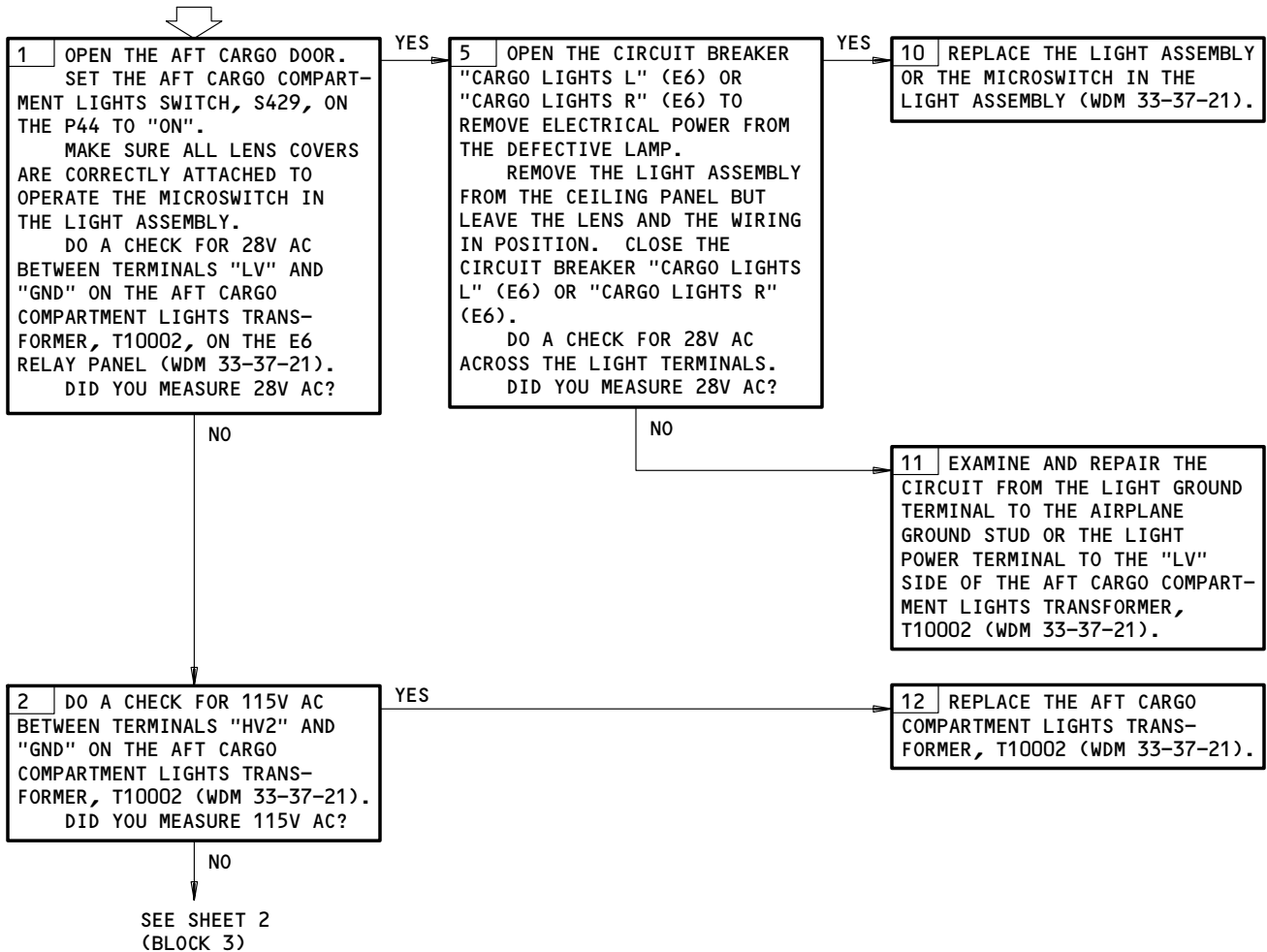

Aft Cargo Compartment Light Problems  
Figure 104 (Sheet 1)

EFFECTIVITY  
GUI 001-114, 116-999

**33-37-00**

**BOEING**  
757  
FAULT ISOLATION/MAINT MANUAL

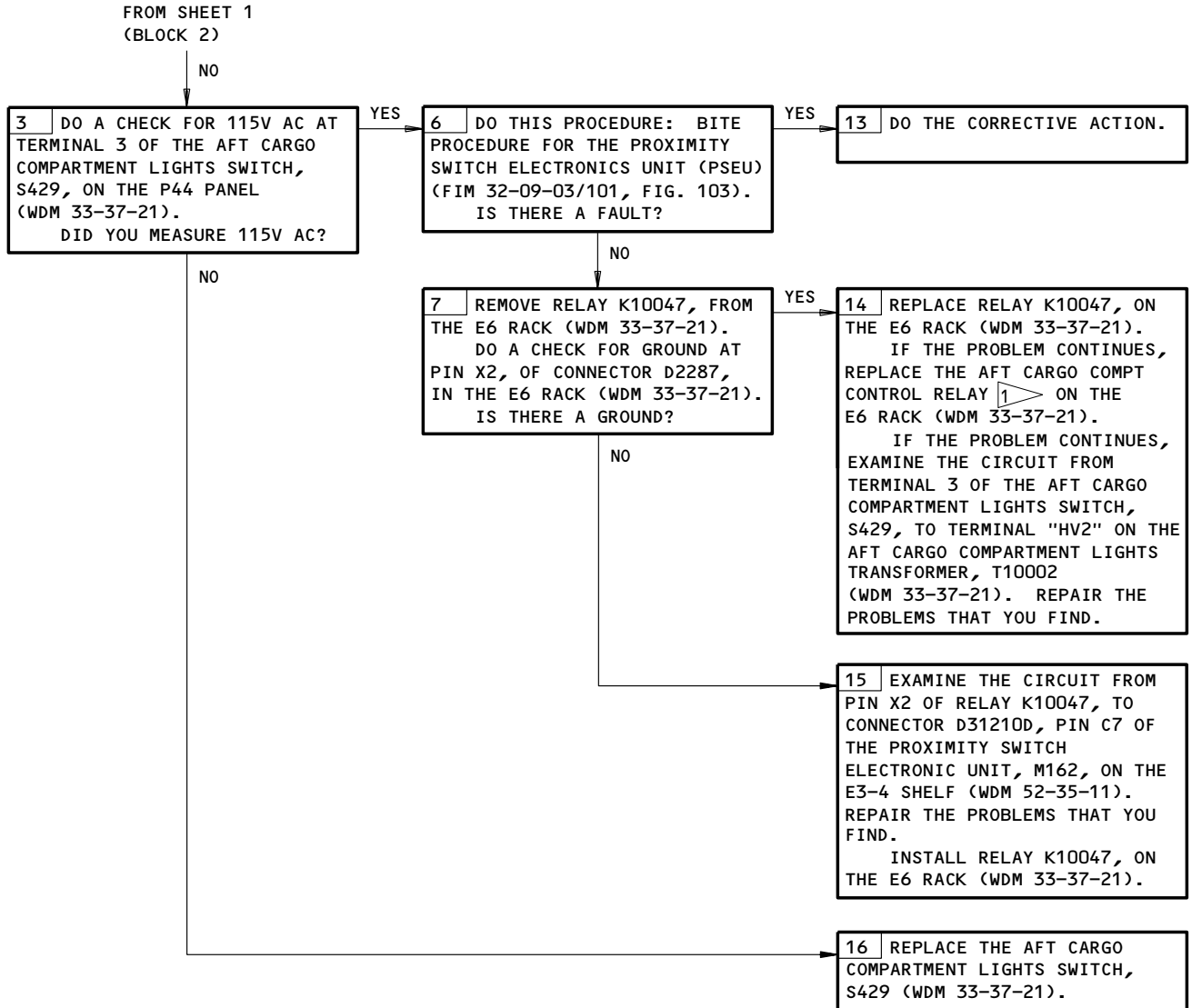

1 AIRPLANES WITH THE AFT CARGO COMPARTMENT CONTROL RELAY

Aft Cargo Compartment Light Problems  
Figure 104 (Sheet 2)

EFFECTIVITY  
GUI 001-114, 116-999

**33-37-00**

06

Page 107  
Sep 28/05



**AFT CARGO COMPARTMENT LIGHT PROBLEMS**

**PREREQUISITES**

MAKE SURE THESE CIRCUIT BREAKERS ARE CLOSED:  
34A5, 34B9, CARGO LIGHTS NO. 2 DOOR (E6), CARGO LIGHTS L (E6), CARGO LIGHTS R (E6)

MAKE SURE THE AIRPLANE IS IN THE CONFIGURATION THAT FOLLOWS:  
ELECTRICAL POWER IS ON (MM 24-22-00/201)

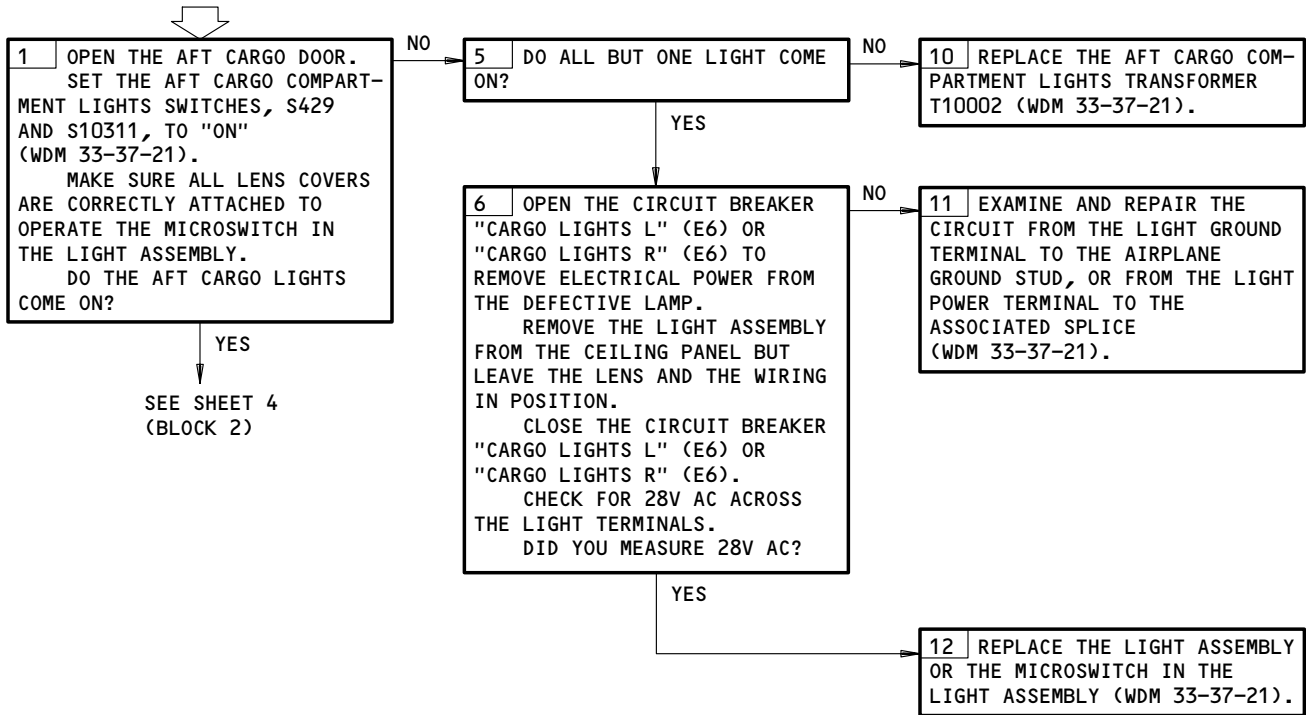

Aft Cargo Compartment Light Problems  
Figure 104 (Sheet 3)

EFFECTIVITY  
GUI 115

**33-37-00**

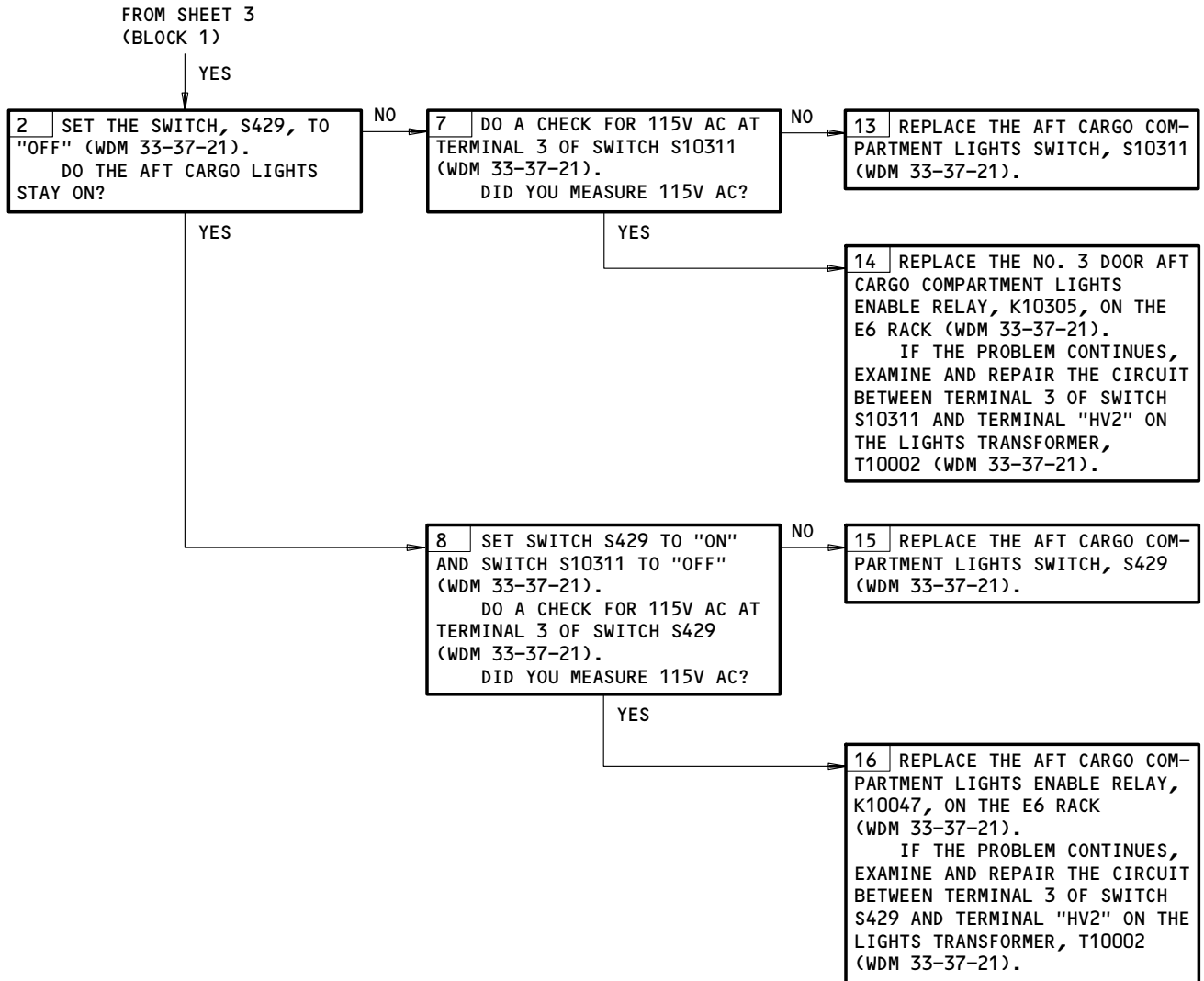

Aft Cargo Compartment Light Problems  
Figure 104 (Sheet 4)

EFFECTIVITY  
GUI 115

33-37-00

03

Page 109  
Dec 20/94



**BOEING**  
 757  
 FAULT ISOLATION/MAINT MANUAL

WING ILLUMINATION LIGHTS

COMPONENT	FIG. 102 SHT	QTY	ACCESS/AREA	AMM REFERENCE
CIRCUIT BREAKER - WING ILLUM, C1227	2	1	FLT COMPT, P11 11M35	*
LIGHT - WING ILLUMINATION, L69,L70	1	2	FWD FUSELAGE SIDE	33-41-00
PANEL - (FIM 33-44-00/101) ANTI-COLLISION AND LANDING LIGHT CONTROL PANEL	2	1		
SWITCH - WING ILLUMINATION, S7	2	1	FLT COMPT, P5, ANTI-COLLISION AND LANDING LIGHT CONTROL PANEL	*

\* SEE THE WDM EQUIPMENT LIST

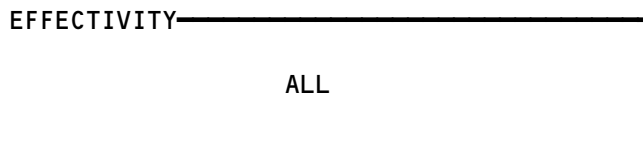
Wing Illumination Lights - Component Location  
Figure 101



**33-41-00**

01

Page 101  
Mar 20/94

E07717

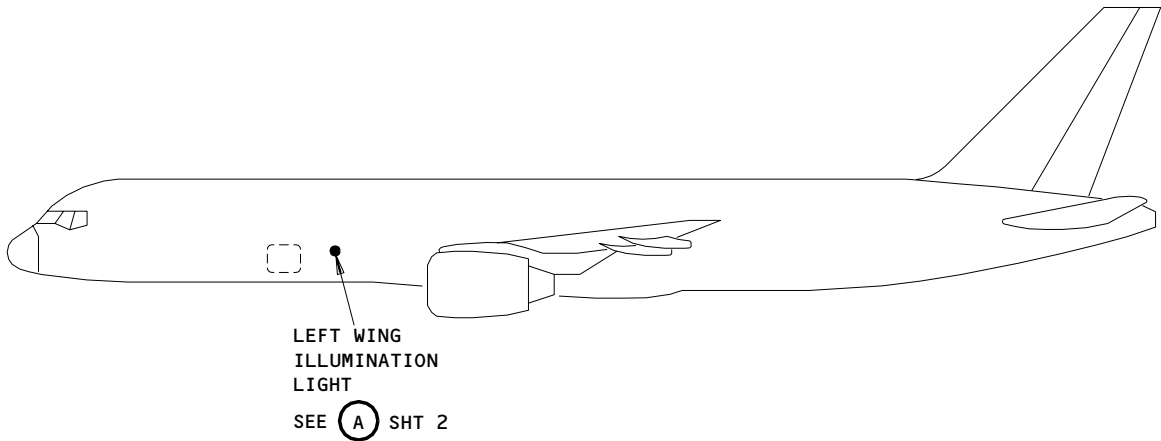
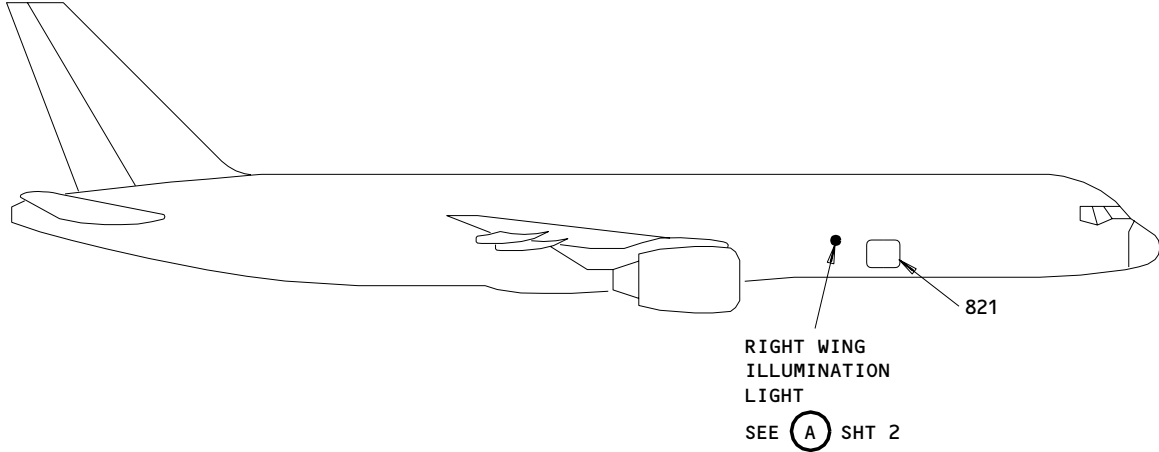

Wing Illumination Lights - Component Location  
 Figure 102 (Sheet 1)

EFFECTIVITY	ALL
-------------	-----

**33-41-00**

01

Page 102  
 Mar 20/94

**BOEING**  
757  
FAULT ISOLATION/MAINT MANUAL

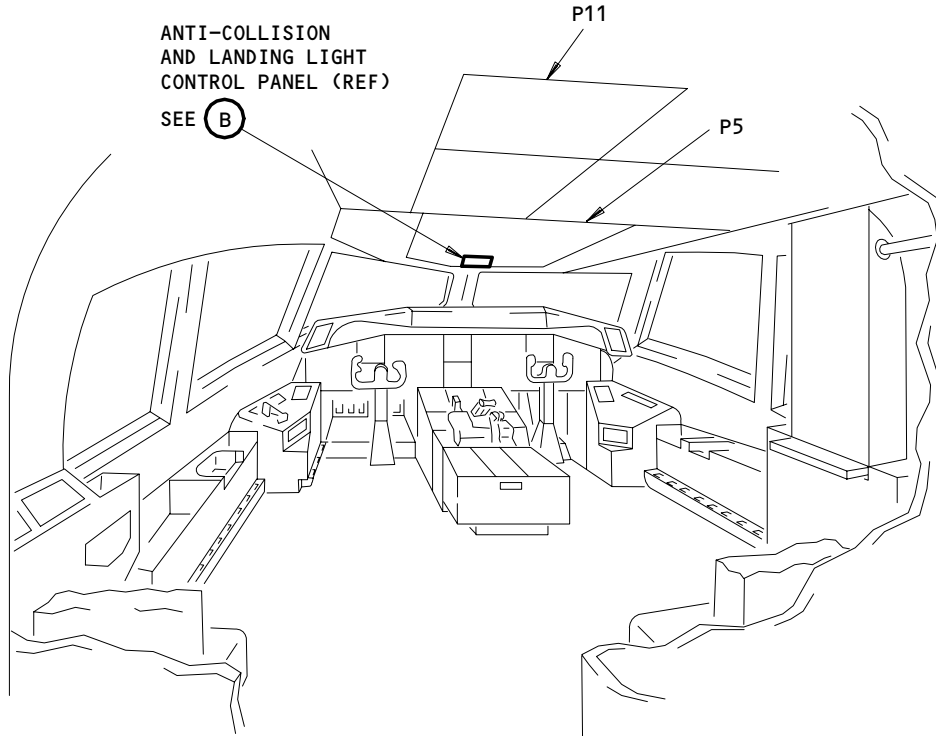

FLIGHT COMPARTMENT

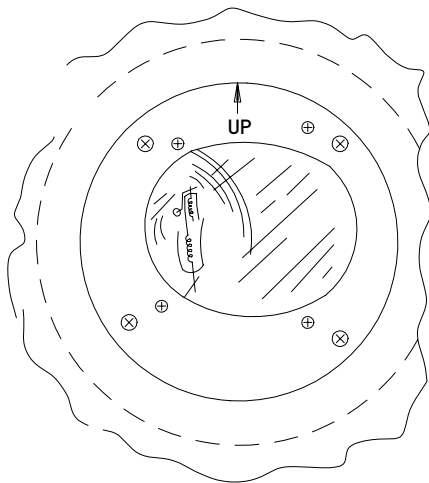

WING ILLUMINATION LIGHT  
(EXAMPLE)

(A) FROM SHT 1

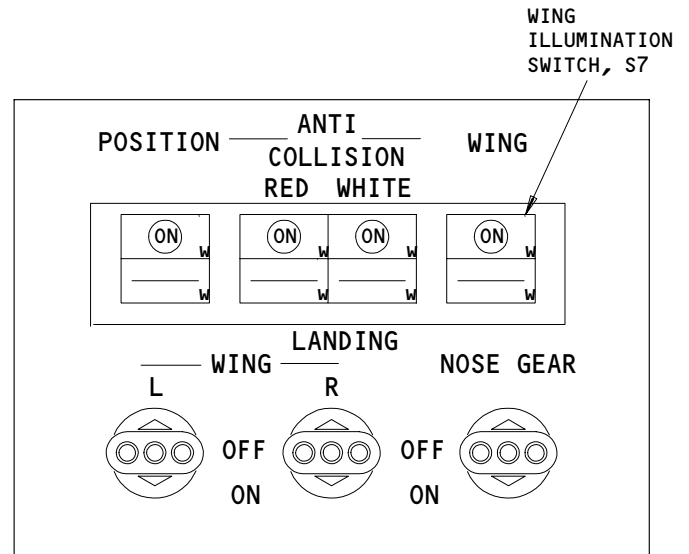

ANTI-COLLISION AND LANDING LIGHT  
CONTROL PANEL (REF)

(B)

Wing Illumination Lights - Component Location  
Figure 102 (Sheet 2)

EFFECTIVITY

ALL

33-41-00



01

Page 103  
Mar 20/94



757  
 FAULT ISOLATION/MAINT MANUAL

LANDING, RUNWAY TURNOFF, AND TAXI LIGHTS

COMPONENT*	FIG. 102 SHT	QTY *	ACCESS/AREA	AMM REFERENCE
CIRCUIT BREAKER -	1		FLT COMPT, P11	
LIGHT -				
NOSE GEAR LANDING	2		NOSE GEAR STRUT	33-42-01
RUNWAY TURNOFF	2		NOSE GEAR STRUT	*
TAXI 	2		NOSE LANDING GEAR	33-42-02
WING LANDING	2		EACH WING	33-42-03
RELAY -			MAIN EQUIPMENT CETNER, P33,P34	*
SWITCH -				
ELEX UNIT 1 - PROX	1		MAIN EQUIPMENT CENTER, E5-3	*
NOSE GEAR LANDING LT	1		FLT COMPT, P5	*
RUNWAY TURNOFF LT	1		FLT COMPT, P5	*
TAXI LIGHT 	1		FLT COMPT, P5	*
WING LANDING LT	1		FLT COMPT, P5	*
TRANSFORMER -	2		NOSE LANDING GEAR, P62,P63	

\* SEE THE SSM OR WDM FOR THE EQUIPMENT NUMBER, QUANTITY, AND LOCATION OF EACH COMPONENT IN THE LIGHTING CIRCUIT.

 NOT INSTALLED ON ALL AIRPLANES

Landing, Runway Turnoff, and Taxi Lights - Component Index  
 Figure 101

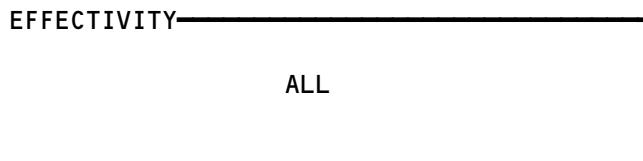

33-42-00

**BOEING**  
757  
FAULT ISOLATION/MAINT MANUAL

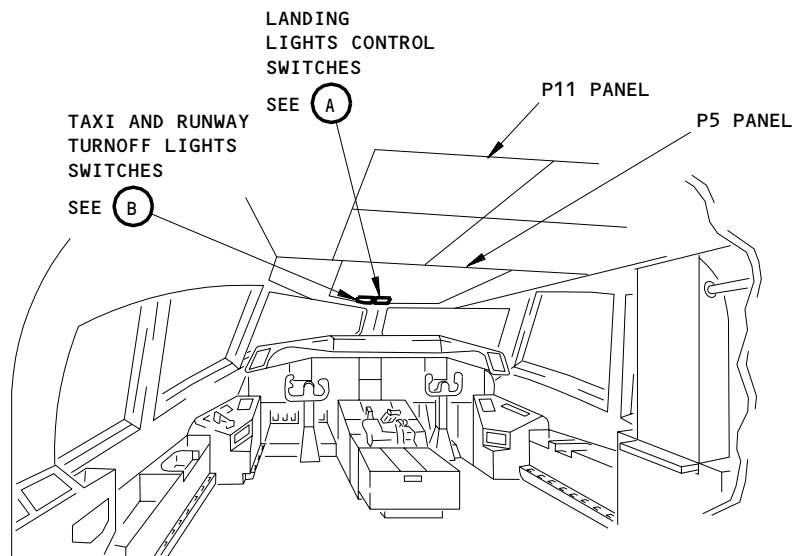
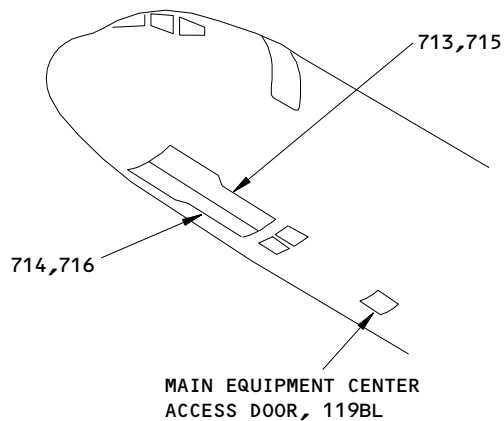

**FLIGHT COMPARTMENT**

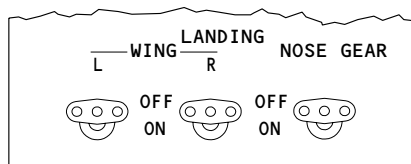

**LANDING LIGHTS SWITCHES  
(EXAMPLE)**

(A)

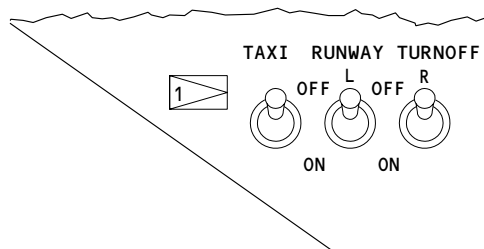

**TAXI AND RUNWAY TURNOFF LIGHTS SWITCHES  
(EXAMPLE)**

(B)

1 NOT INSTALLED ON ALL AIRPLANES

**Landing, Runway Turnoff, and Taxi Lights - Component Location  
Figure 102 (Sheet 1)**

EFFECTIVITY	ALL
-------------	-----

**33-42-00**

**BOEING**  
757  
FAULT ISOLATION/MAINT MANUAL

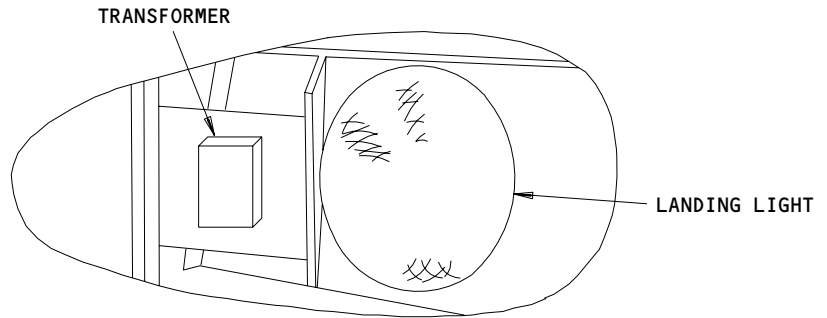
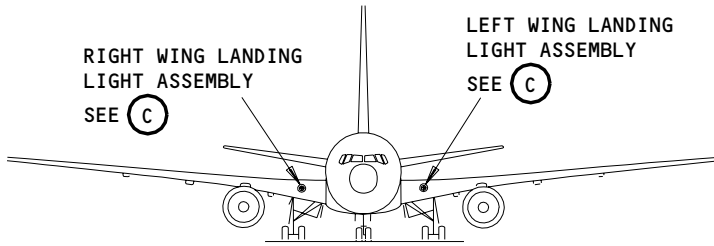

WING LANDING LIGHT ASSEMBLY (EXAMPLE)

(C)

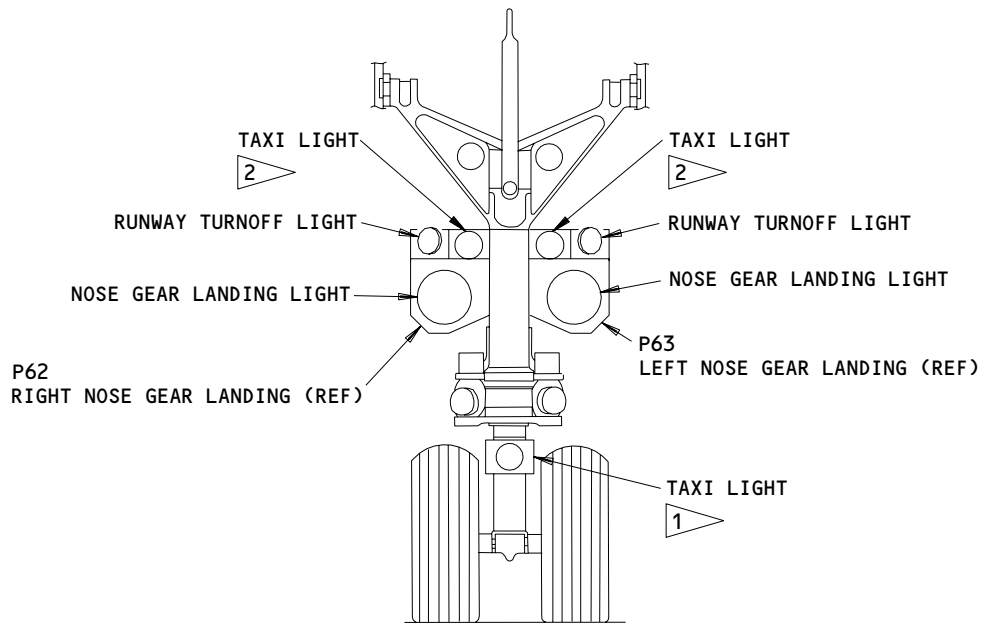

NOSE LANDING GEAR

- 1 AIRPLANES WITH ONE TAXI LIGHT
- 2 AIRPLANES WITH TWO TAXI LIGHTS

Landing, Runway Turnoff, and Taxi Lights - Component Location  
Figure 102 (Sheet 2)

EFFECTIVITY	ALL
-------------	-----

**33-42-00**



**RUNWAY TURNOFF LIGHT PROBLEMS**

**PREREQUISITES**  
MAKE SURE THE APPLICABLE CIRCUIT BREAKERS ARE CLOSED:  
(WDM 33-42-21 OR SSM 33-42-02)  
MAKE SURE THE AIRPLANE IS IN THIS CONFIGURATION:  
ELECTRICAL POWER IS ON (AMM 24-22-00/201)

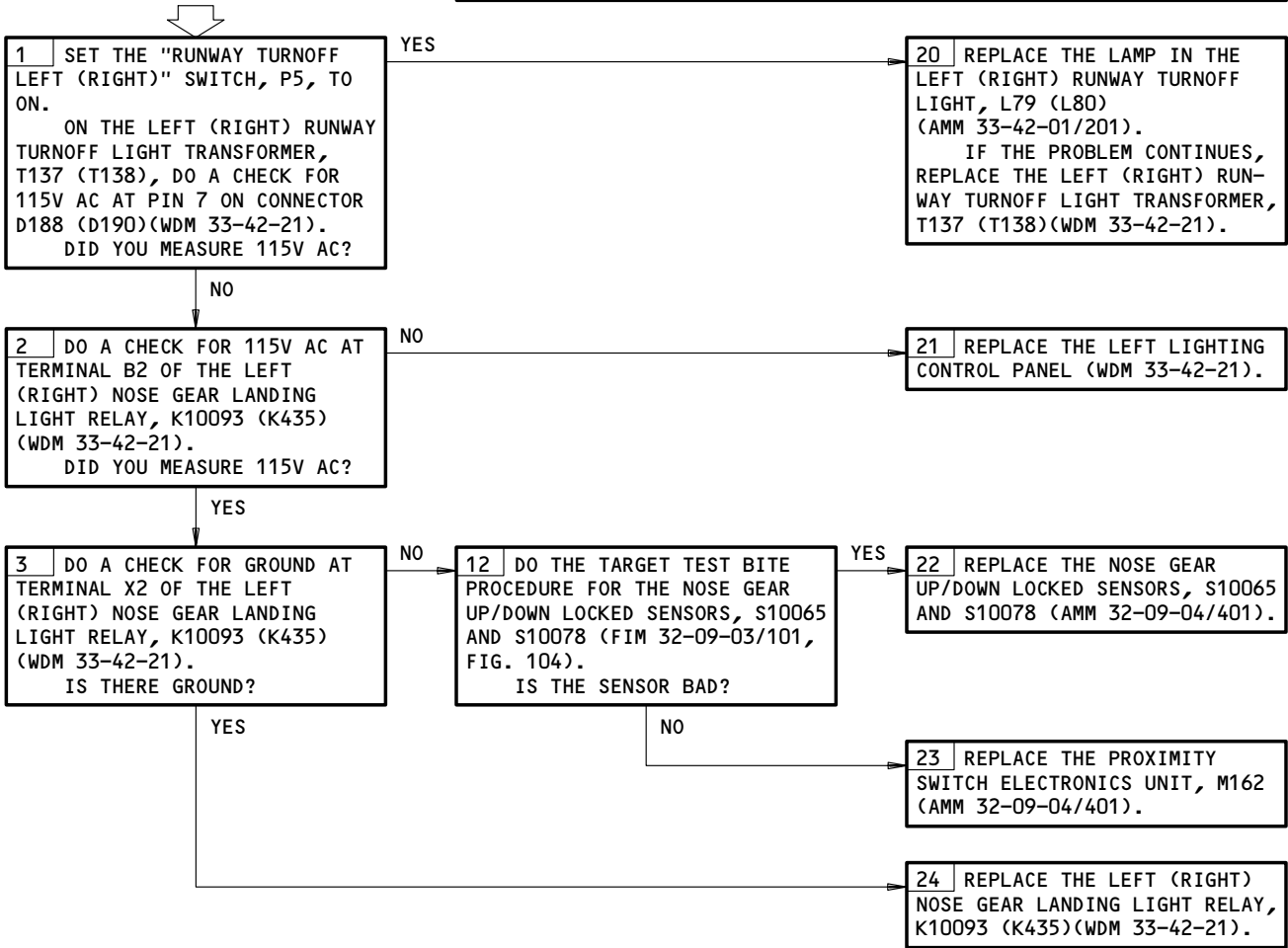

Runway Turnoff Light Problems  
Figure 103

EFFECTIVITY	ALL
-------------	-----

**33-42-00**

B64234

**NOSE GEAR LANDING LIGHT PROBLEMS**

**PREREQUISITES**

MAKE SURE THE APPLICABLE CIRCUIT BREAKERS ARE CLOSED:  
(WDM 33-42-11 OR SSM 33-42-01)

MAKE SURE THE AIRPLANE IS IN THIS CONFIGURATION:  
ELECTRICAL POWER IS ON (AMM 24-22-00/201)

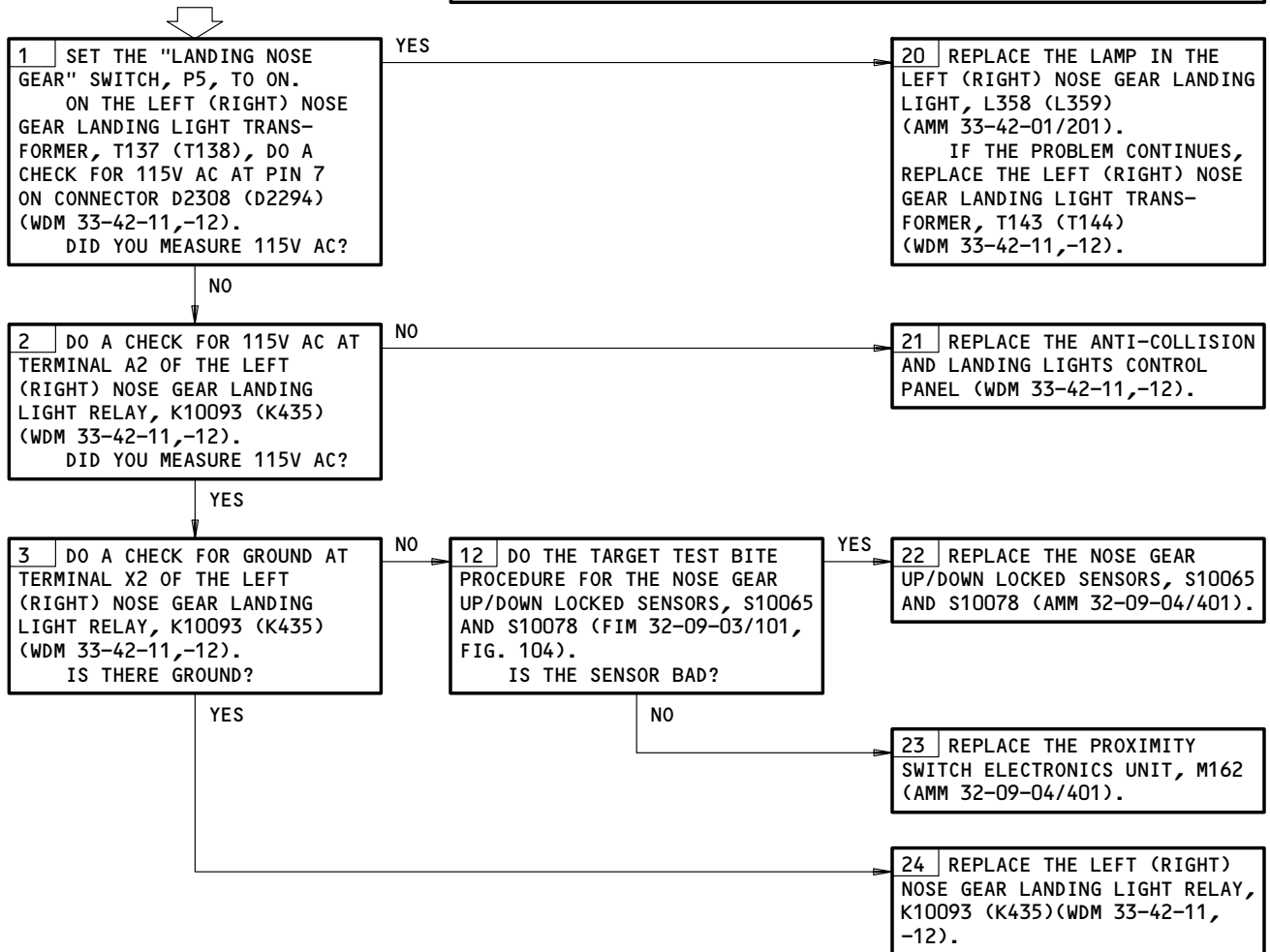

Nose Gear Landing Light Problems  
Figure 104

EFFECTIVITY	ALL
-------------	-----

**33-42-00**

B64267

**WING LANDING  
LIGHT PROBLEMS**

**PREREQUISITES**  
MAKE SURE THE APPLICABLE CIRCUIT BREAKERS ARE CLOSED:  
(WDM 33-42-11 OR SSM 33-42-01)  
MAKE SURE THE AIRPLANE IS IN THIS CONFIGURATION:  
ELECTRICAL POWER IS ON (AMM 24-22-00/201)

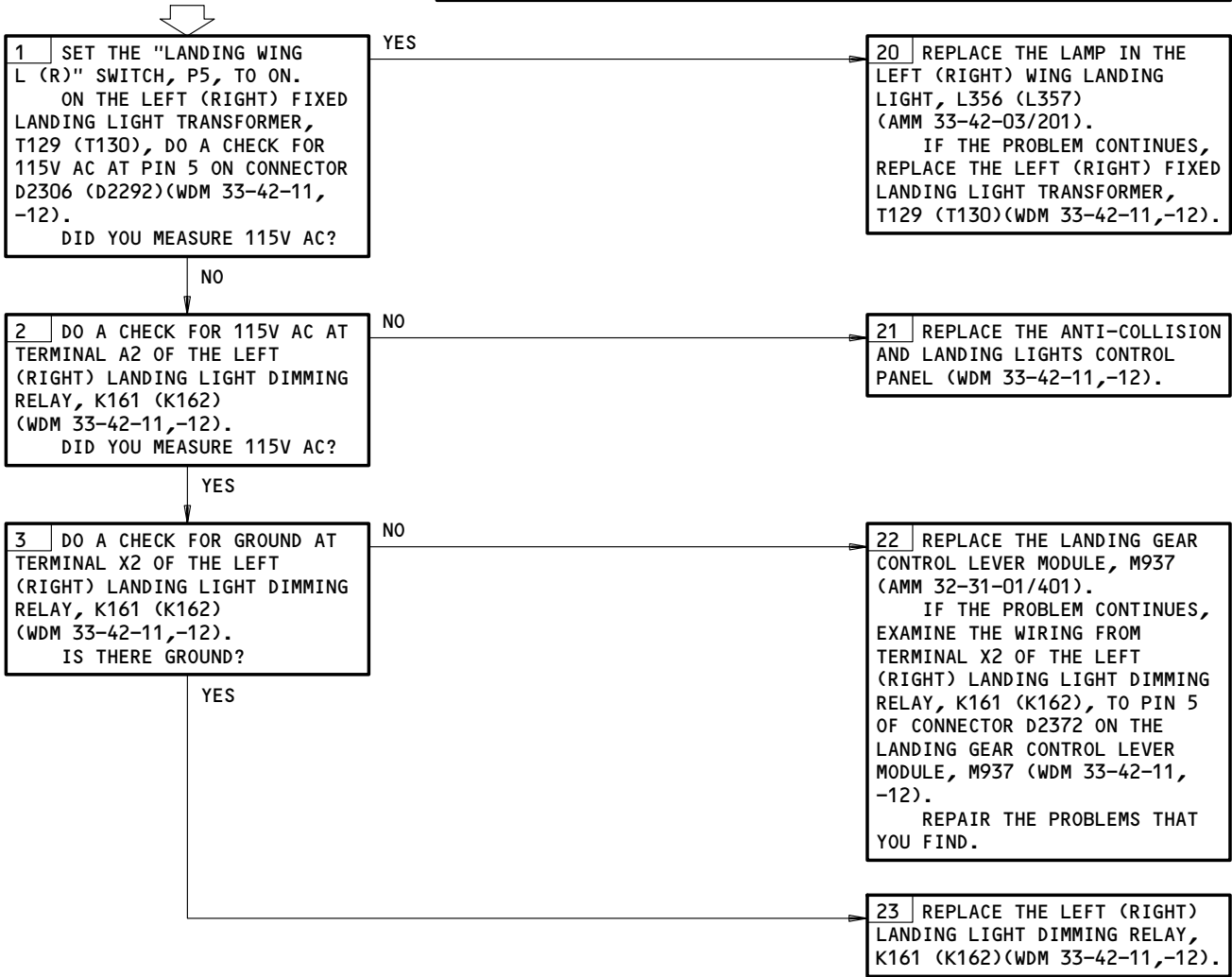

Wing Landing Light Problems  
Figure 105

EFFECTIVITY

ALL

**33-42-00**

01

Page 106  
Mar 20/94

B64279

**TAXI LIGHT PROBLEMS**

**PREREQUISITES**

MAKE SURE THESE CIRCUIT BREAKERS ARE CLOSED:  
11M8, 11M31

MAKE SURE THE AIRPLANE IS IN THIS CONFIGURATION:  
ELECTRICAL POWER IS ON (AMM 24-22-00/201)

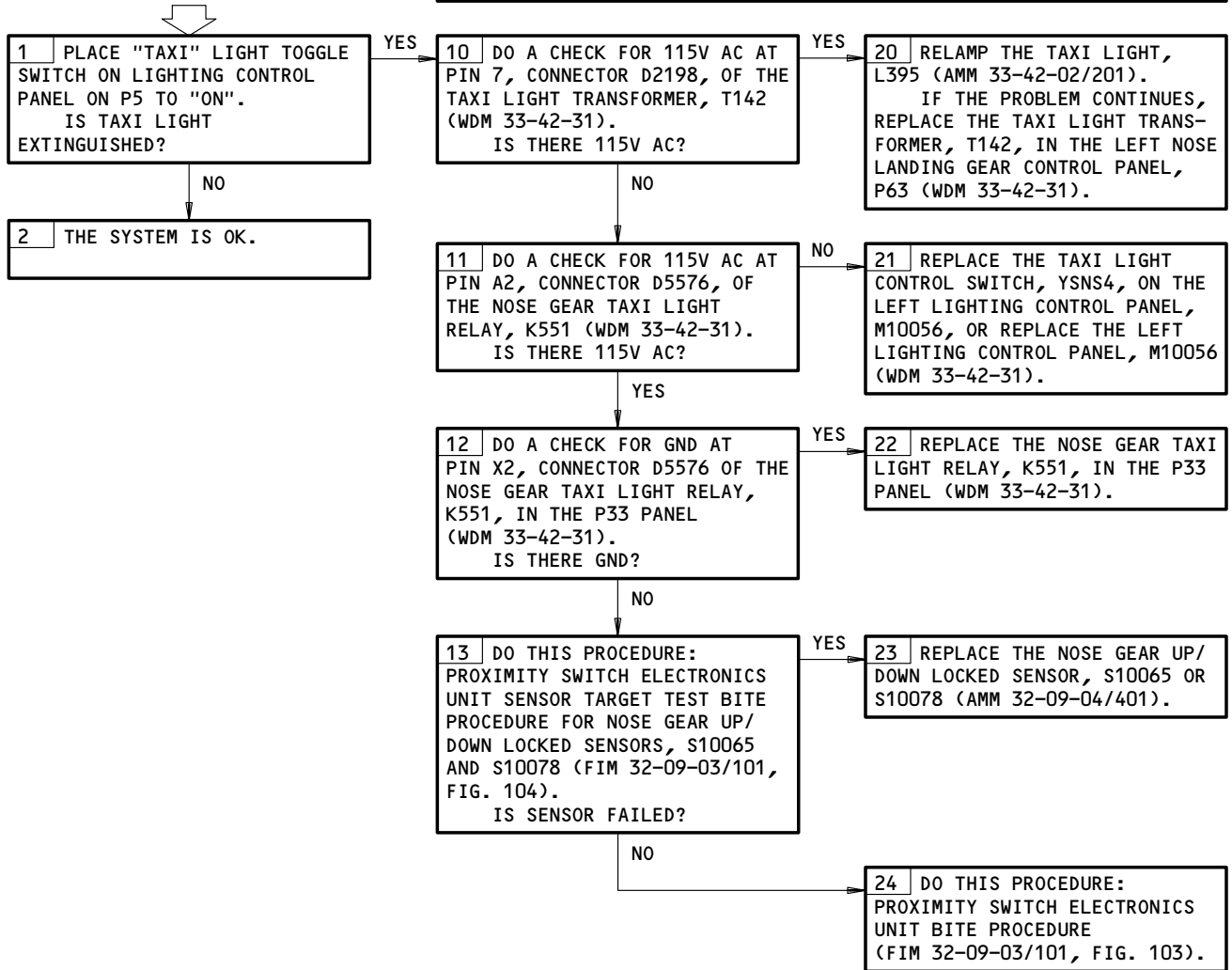

Taxi Light Problems  
Figure 106 (Sheet 1)

EFFECTIVITY  
AIRPLANES WITH ONE TAXI LIGHT

**33-42-00**

**PREREQUISITES**

MAKE SURE THESE CIRCUIT BREAKERS ARE CLOSED:  
11M8,11M9,11M31

MAKE SURE THE AIRPLANE IS IN THIS CONFIGURATION:  
ELECTRICAL POWER IS ON (AMM 24-22-00/201)

**TAXI LIGHT PROBLEMS**

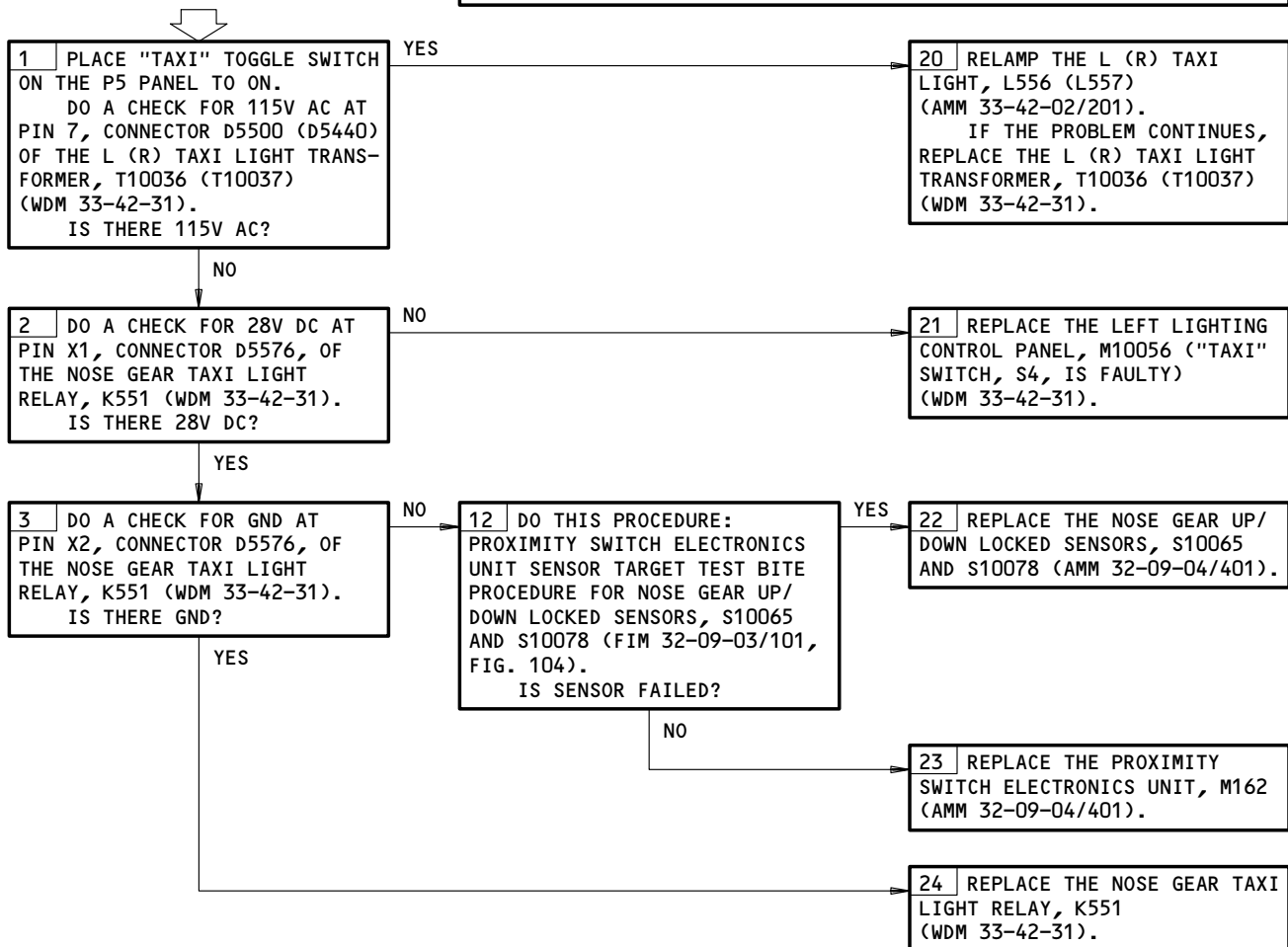

Taxi Light Problems  
Figure 106 (Sheet 2)

EFFECTIVITY  
AIRPLANES WITH TWO TAXI LIGHTS

**33-42-00**



**BOEING**  
 757  
 FAULT ISOLATION/MAINT MANUAL

POSITION LIGHTS

COMPONENT*	FIG. 102 SHT	QTY *	ACCESS/AREA	AMM REFERENCE
CIRCUIT BREAKER - LIGHT -			FLT COMPT, P11	*
WING FWD POSITION	1		WINGTIP	33-43-01
WING REAR POSITION	1		WINGTIP	33-43-02
SWITCH -	1		FLT COMPT	*
TRANSFORMER -	2		521TBX, WING POSITION LIGHT	33-43-03
			TRANSFORMER ACCESS - LEFT WING	
TRANSFORMER -	2		621TBX, WING POSITION LIGHT	33-43-03
			TRANSFORMER ACCESS - RIGHT WING	

\* SEE THE WDM OR SSM FOR THE EQUIPMENT NUMBER, QUANTITY, AND LOCATION OF EACH COMPONENT IN THE LIGHTING CIRCUIT.

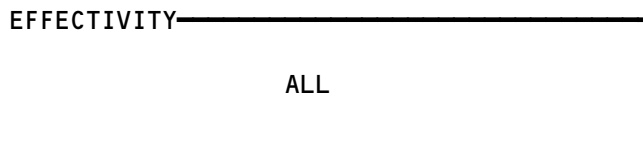
Position Lights - Component Location  
Figure 101



**33-43-00**

**BOEING**  
757  
FAULT ISOLATION/MAINT MANUAL

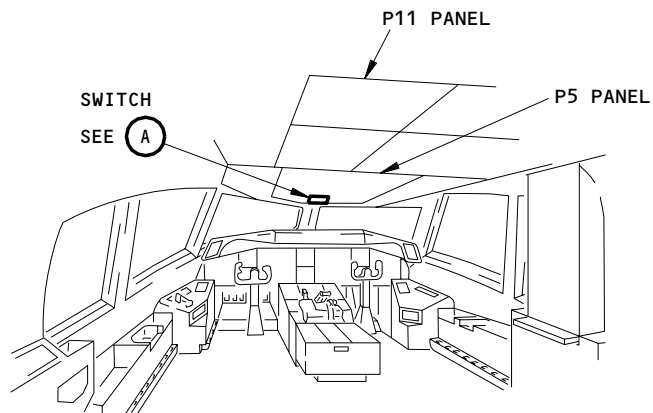

FLIGHT COMPARTMENT

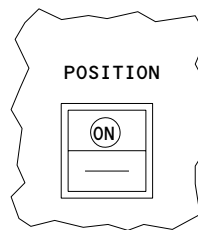

SWITCH  
(EXAMPLE)

(A)

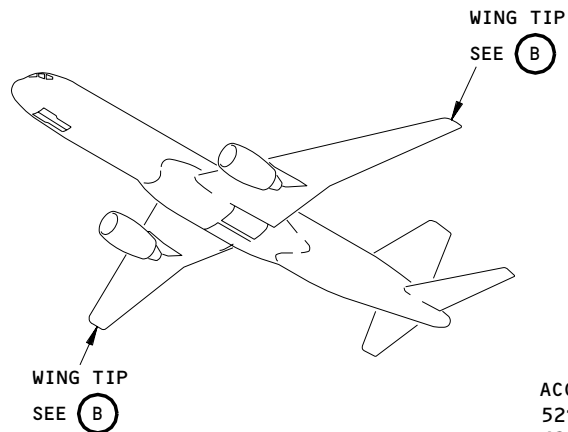

ACCESS PANEL,  
521TBX (LEFT WING)  
621TBX (RIGHT WING)

TRANSFORMERS  
SEE (E)

WING  
FORWARD  
POSITION  
LIGHT  
SEE (C)

WING REAR  
POSITION  
LIGHT  
SEE (D)

FWD  
↑

WINGTIP  
(EXAMPLE)

(B)

Position Lights - Component Location  
Figure 102 (Sheet 1)

EFFECTIVITY

ALL

33-43-00

01

Page 102  
Jan 28/05

986204

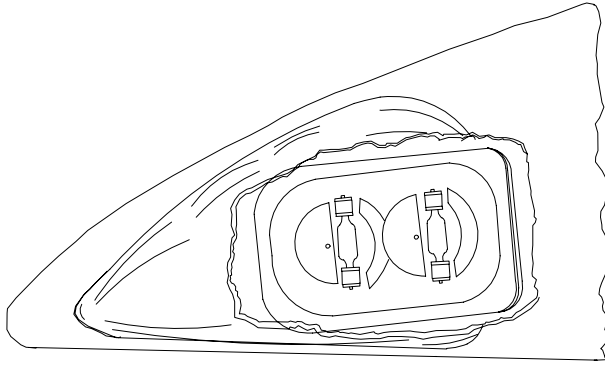

WING FORWARD POSITION LIGHT (EXAMPLE)

(C)

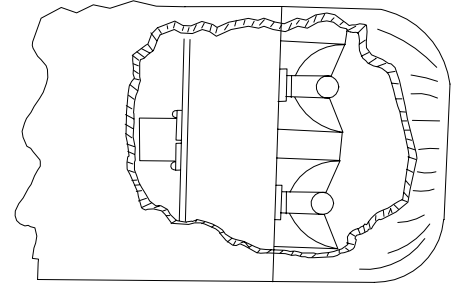

WING REAR POSITION LIGHT (EXAMPLE)

(D)

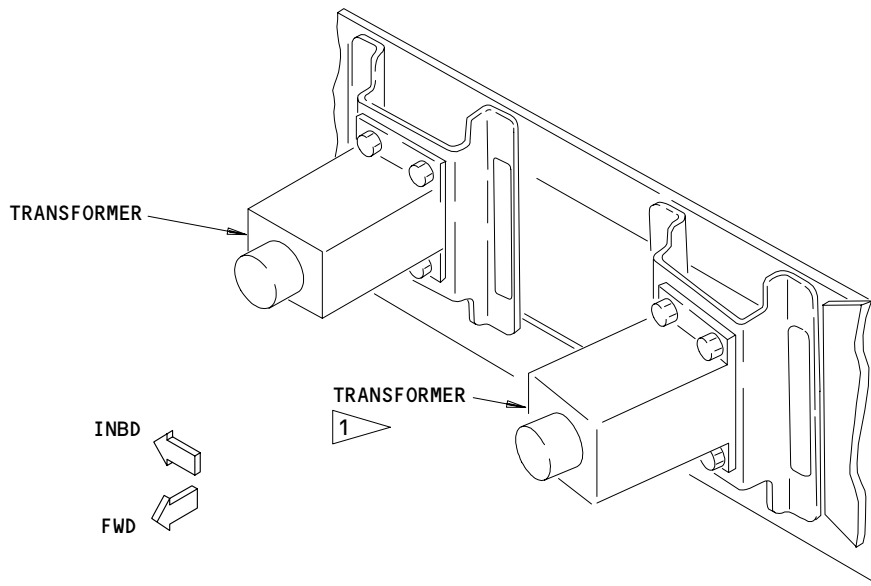

WING POSITION LIGHTS TRANSFORMERS (EXAMPLE)

(E)

1 AIRPLANES WITH TWO TRANSFORMERS IN EACH WINGTIP

Position Lights - Component Location  
Figure 102 (Sheet 2)

EFFECTIVITY	ALL
-------------	-----

33-43-00

01

Page 103  
Mar 20/94

986210





**BOEING**  
 757  
 FAULT ISOLATION/MAINT MANUAL

ANTI-COLLISION LIGHTS

COMPONENT*	FIG. 102 SHT	QTY *	ACCESS/AREA	AMM REFERENCE
CIRCUIT BREAKER - LIGHT -	1		FLT COMPT, P11	
BODY ANTI-COLLISION	1	1	FUSELAGE	33-44-02
WING ANTI-COLLISION	2	1	WINGTIP	33-44-01
SUPPLY - POWER	2	1	FUSELAGE	33-44-04
SUPPLY - POWER	2	1	WINGTIP	33-44-03
SWITCH -		1	FLT COMPT, P5	*

\* SEE THE WDM OR SSM FOR THE EQUIPMENT NUMBER, QUANTITY, AND LOCATION OF EACH COMPONENT IN THE LIGHTING CIRCUIT

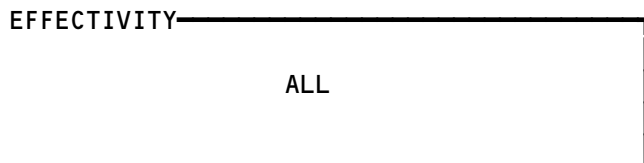
Anti-Collision Lights - Component Index  
Figure 101



33-44-00

# BOEING

## 757 FAULT ISOLATION/MAINT MANUAL

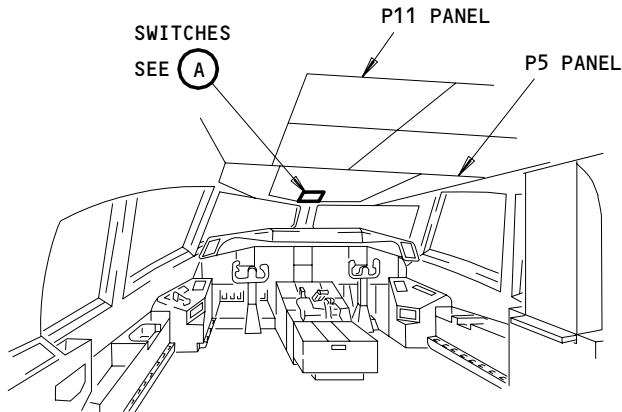

FLIGHT COMPARTMENT

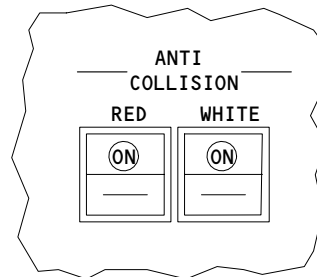

SWITCHES (EXAMPLE)

(A)

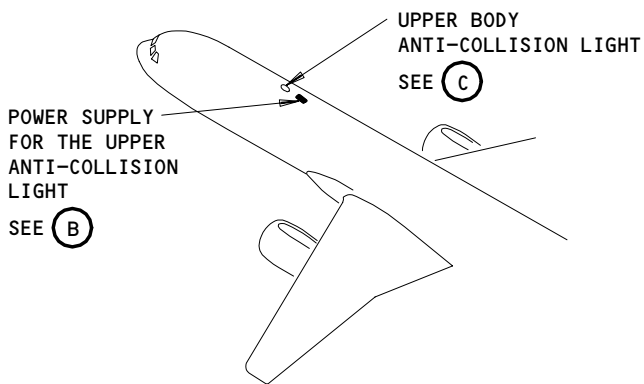

POWER SUPPLY FOR THE  
LOWER ANTI-COLLISION LIGHT

SEE (B)

LOWER BODY  
ANTI-COLLISION  
LIGHT

SEE (C)

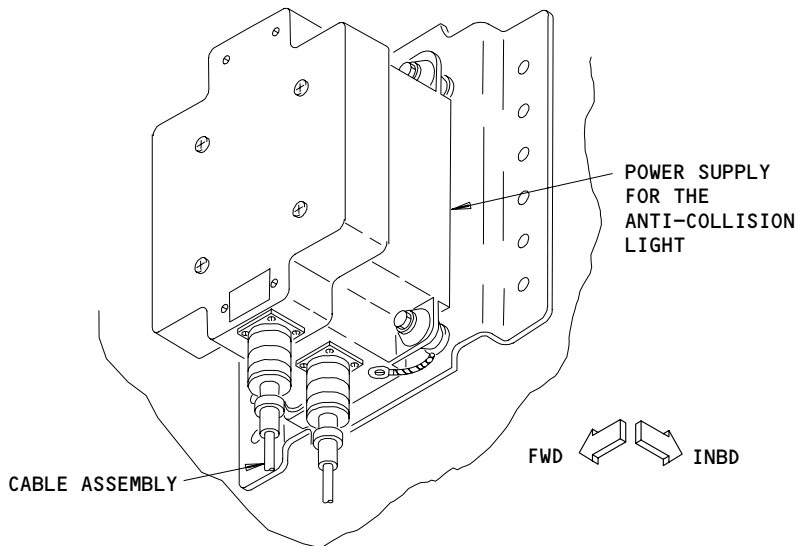

ANTI-COLLISION LIGHT POWER SUPPLY  
(EXAMPLE)

(B)

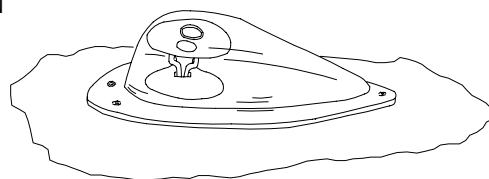

UPPER OR LOWER BODY  
ANTI-COLLISION LIGHT  
(EXAMPLE)

(C)

Anti-Collision Lights - Component Location  
Figure 102 (Sheet 1)

EFFECTIVITY

ALL

33-44-00

01

Page 102  
Mar 20/94

811528

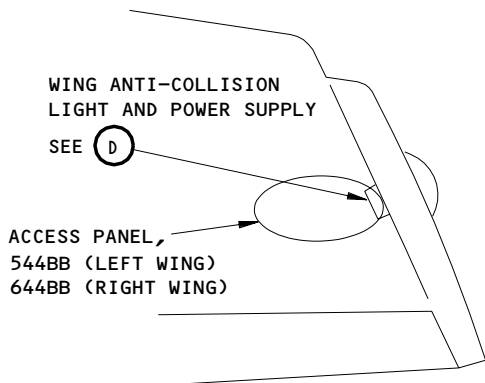

BOTTOM OF WINGTIP  
(EXAMPLE)

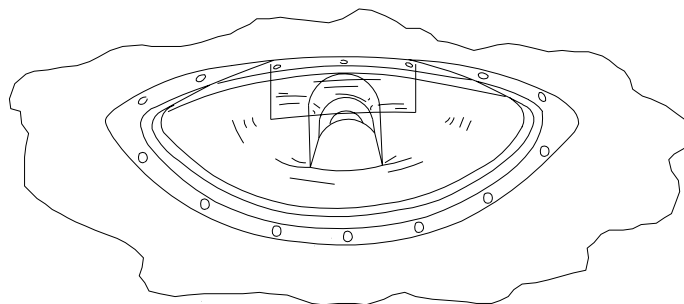

WING ANTI-COLLISION LIGHT  
(EXAMPLE)

(E)

POWER SUPPLY FOR THE  
WING ANTI-COLLISION LIGHT

CABLE ASSEMBLY, B66

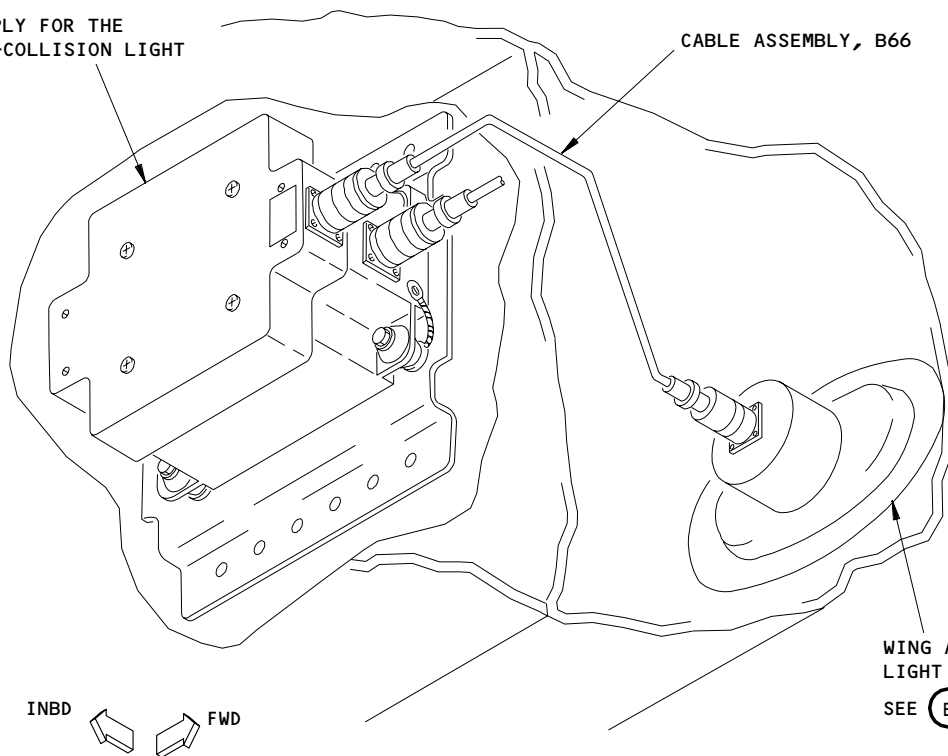

WING ANTI-COLLISION LIGHT  
SEE (E)

INBD      FWD

WING ANTI-COLLISION LIGHT AND POWER SUPPLY  
(EXAMPLE)

(D)

Anti-Collision Lights - Component Location  
Figure 102 (Sheet 2)

EFFECTIVITY

ALL

**33-44-00**

01

Page 103  
Mar 20/94

167524

**BODY ANTI-COLLISION LIGHTS PROBLEMS**

**PREREQUISITES**

MAKE SURE THIS CIRCUIT BREAKER IS CLOSED:  
11M7

MAKE SURE THE AIRPLANE IS IN THIS CONFIGURATION:  
ELECTRICAL POWER IS ON (AMM 24-22-00/201)

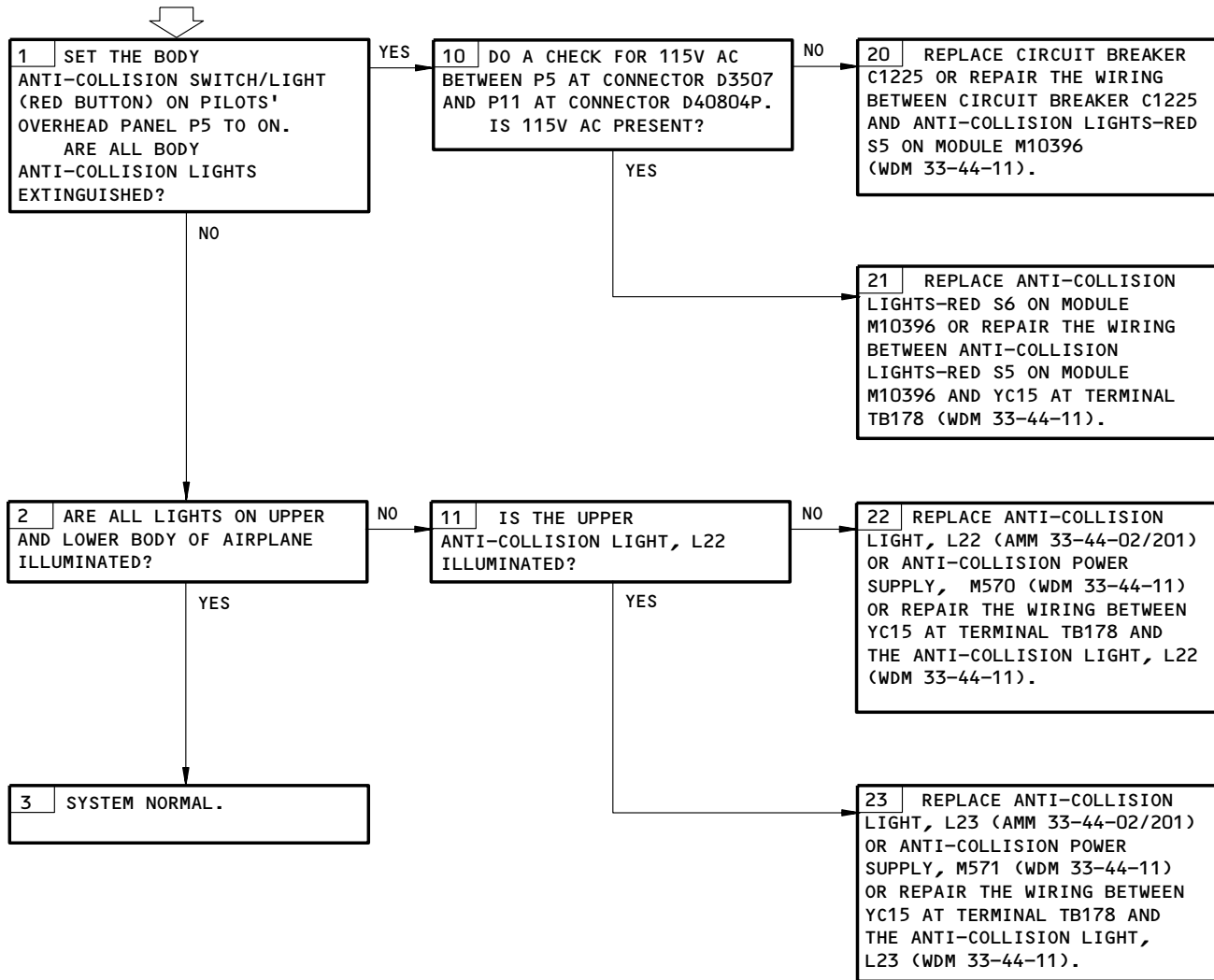

Body Anti-Collision Lights Problems  
Figure 103

EFFECTIVITY	ALL
-------------	-----

33-44-00

**WING ANTI-COLLISION LIGHTS PROBLEMS**

**PREREQUISITES**

MAKE SURE THIS CIRCUIT BREAKER IS CLOSED:  
11M7

MAKE SURE THE AIRPLANE IS IN THIS CONFIGURATION:  
ELECTRICAL POWER IS ON (AMM 24-22-00/201)

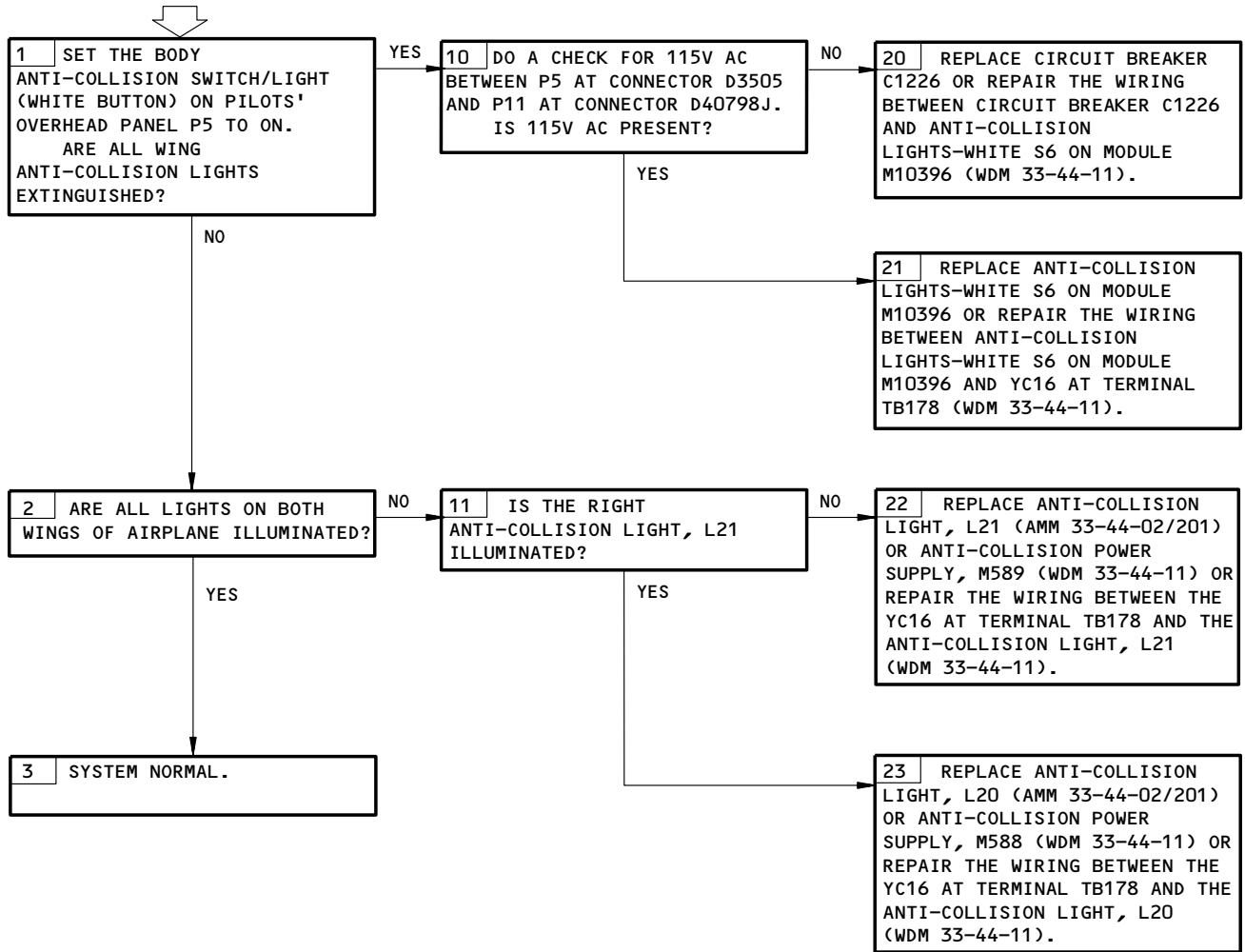

Wing Anti-Collision Lights Problems  
Figure 104

EFFECTIVITY

ALL

**33-44-00**

01

Page 105  
May 28/06

U66624



**BOEING**  
 757  
 FAULT ISOLATION/MAINT MANUAL

LOGO LIGHTS

COMPONENT*	FIG. 102 SHT	QTY *	ACCESS/AREA	AMM REFERENCE
CIRCUIT BREAKER -	1		119BL, MAIN EQUIP CTR, P70	*
LIGHT - LOGO	2		HORIZONTAL STABILIZER	33-45-00
RELAY -			119BL, MAIN EQUIP CTR	*
SWITCH -	2		FLT COMPT	*

\* SEE THE SSM OR WDM FOR THE EQUIPMENT NUMBER, QUANTITY AND LOCATION OF EACH COMPONENT IN THE LIGHTING CIRCUIT.

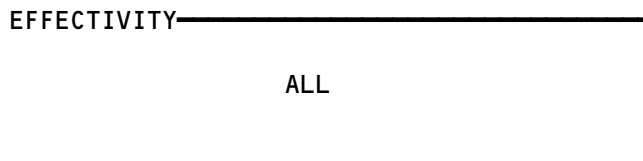
Logo Lights - Component Index  
Figure 101



**33-45-00**

01

Page 101  
Jun 20/94

E31490

**BOEING**  
757  
FAULT ISOLATION/MAINT MANUAL

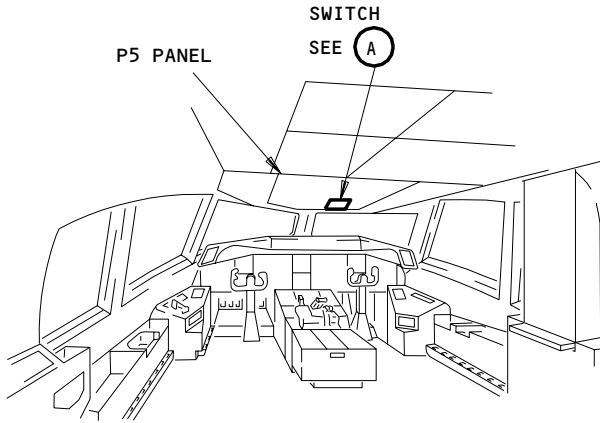

FLIGHT COMPARTMENT

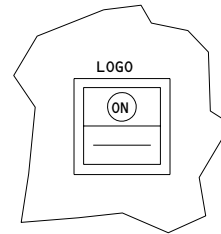

SWITCH  
(EXAMPLE)

(A)

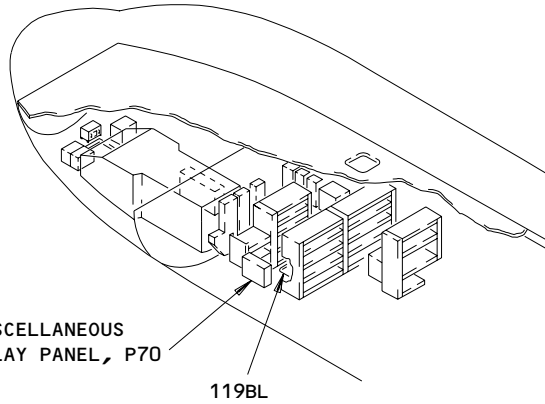

MAIN EQUIPMENT CENTER

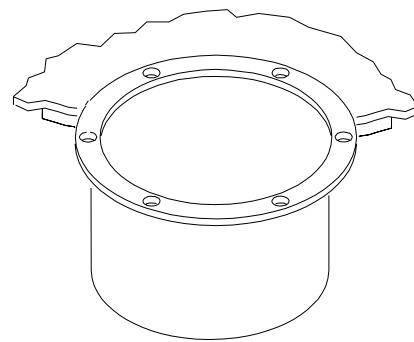
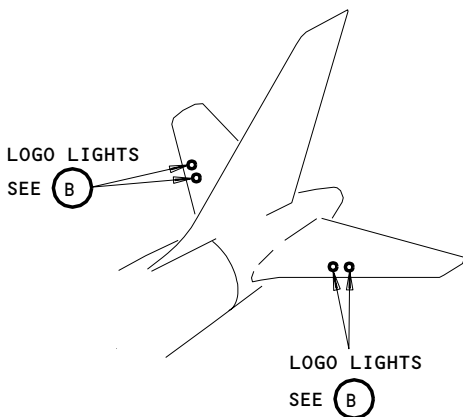

LOGO LIGHT  
(EXAMPLE)

(B)

Logo Lights - Component Location  
Figure 102

EFFECTIVITY	ALL
-------------	-----

**33-45-00**

**PREREQUISITES**

ELECTRICAL POWER (MM 24-22-00)  
CB'S: 70B22,70B23

**LOGO LIGHTS  
PROBLEMS**

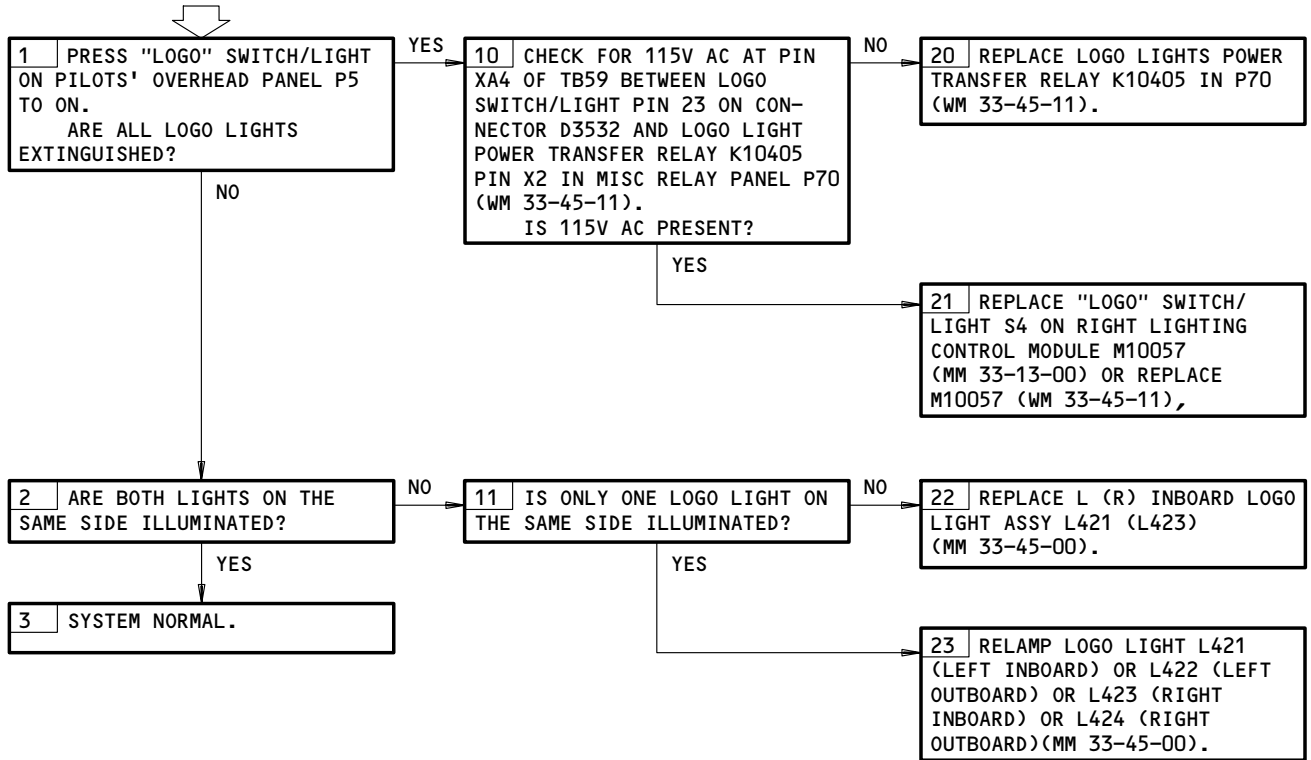

Logo Lights Problems  
Figure 103

EFFECTIVITY

ALL

**33-45-00**

01

Page 103  
Jun 20/94



**BOEING**  
757  
FAULT ISOLATION/MAINT MANUAL

EMERGENCY LIGHTS

COMPONENT*	FIG. 102 SHT	QTY *	ACCESS/AREA	AMM REFERENCE
CIRCUIT BREAKER -			FLT COMPT, P11	*
COMPUTER - EICAS (FIM 31-41-00/101)			MAIN EQUIP CTR	*
LIGHT -				
AISLE	4		PASS. COMPT	33-51-05
DOME	4		FLT COMPT	33-51-09
FLOOR PROXIMITY				
EMERGENCY ESCAPE PATH LIGHT	5		PASS. COMPT	33-51-11
EXIT INDICATOR SIGN	5		PASS. COMPT	33-51-10
INDICATOR	1		FLT COMPT, P5	*
SLIDE	3		FUSELAGE	33-51-06
RELAY -				
SIGN - EXIT			MAIN EQUIP CTR	*
ELECTRICALLY ILLUMINATED	4		PASS. COMPT	33-51-01
SELF-ILLUMINATED 	4		PASS. COMPT	33-51-02
SUPPLY - POWER	3		PASS. COMPT	33-51-10
SWITCH -				
ATTENDANT'S	2		PASS. COMPT	*
PILOTS'	1		FLT COMPT	*
TEST	2		NOSE LANDING GEAR, P62	*
TEST	2		PASS. COMPT	*

\* SEE THE WDM OR SSM FOR THE EQUIPMENT NUMBER, QUANTITY, AND LOCATION OF EACH COMPONENT IN THE LIGHTING CIRCUIT.

 NOT INSTALLED ON ALL AIRPLANES

Emergency Lights - Component Index  
Figure 101

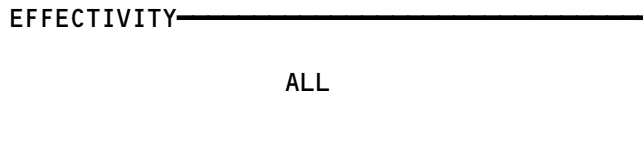

33-51-00

**BOEING**  
 757  
 FAULT ISOLATION/MAINT MANUAL

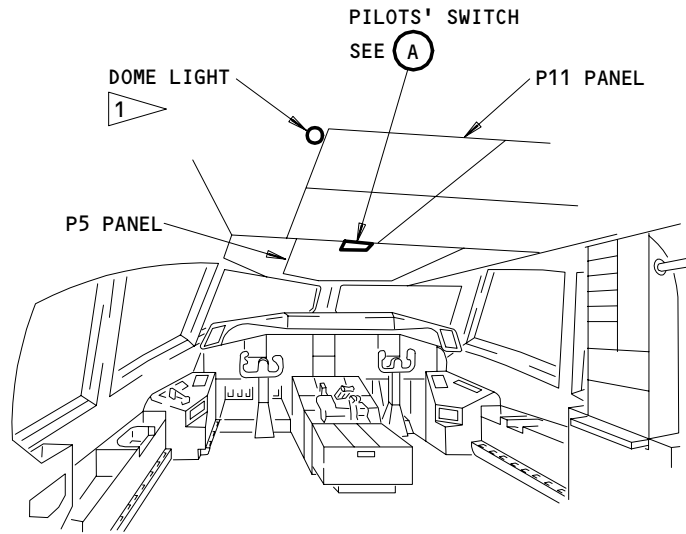

FLIGHT COMPARTMENT

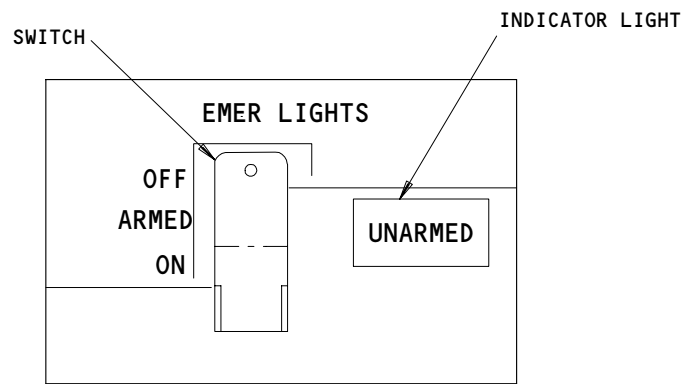

PILOTS' SWITCH  
(EXAMPLE)

(A)

1 PASSENGER AIRPLANES

Emergency Lights - Component Location  
Figure 102 (Sheet 1)

EFFECTIVITY	ALL
-------------	-----

**33-51-00**

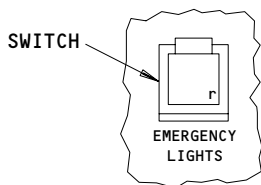

ATTENDANT'S SWITCH IN THE  
PASSENGER COMPARTMENT  
(EXAMPLE)

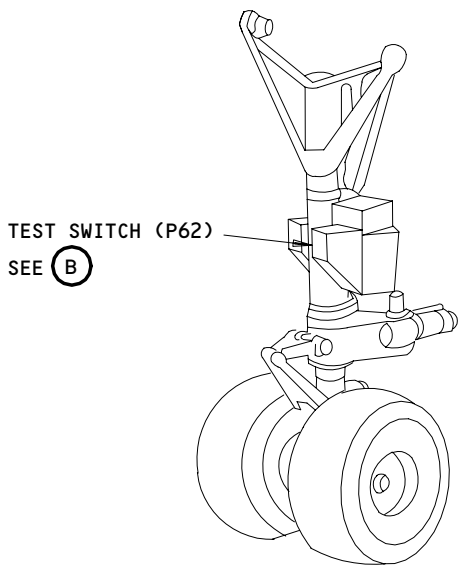

NOSE LANDING GEAR

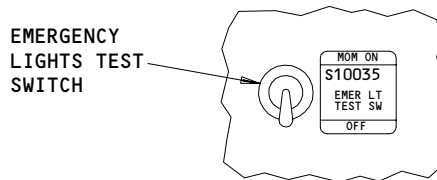

TEST SWITCH  
(EXAMPLE)

(B)

Emergency Lights - Component Location  
Figure 102 (Sheet 2)

EFFECTIVITY	ALL
-------------	-----

**33-51-00**

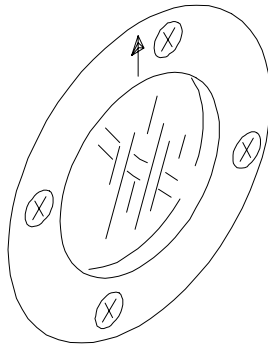

SLIDE LIGHT  
(EXAMPLE)

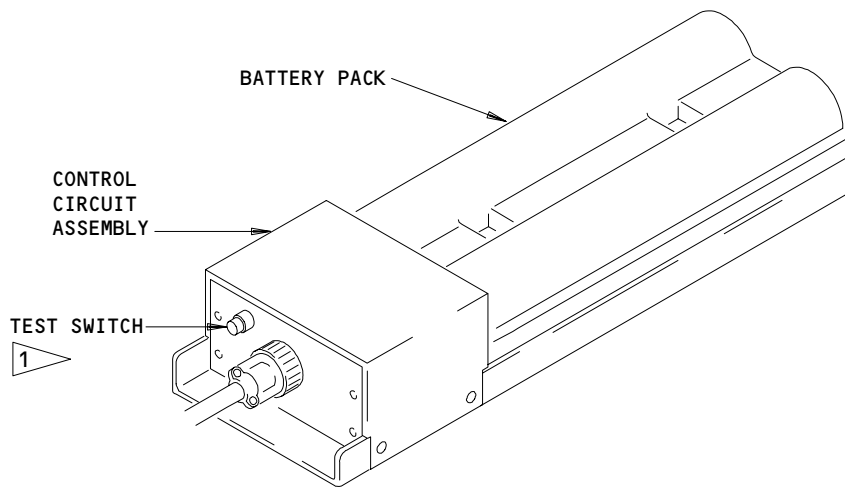

POWER SUPPLY  
(EXAMPLE)

1 POWER SUPPLIES WITH A TEST SWITCH

Emergency Light - Component Location  
Figure 102 (Sheet 3)

EFFECTIVITY	
	ALL

33-51-00

01

Page 104  
Mar 20/94

A13146

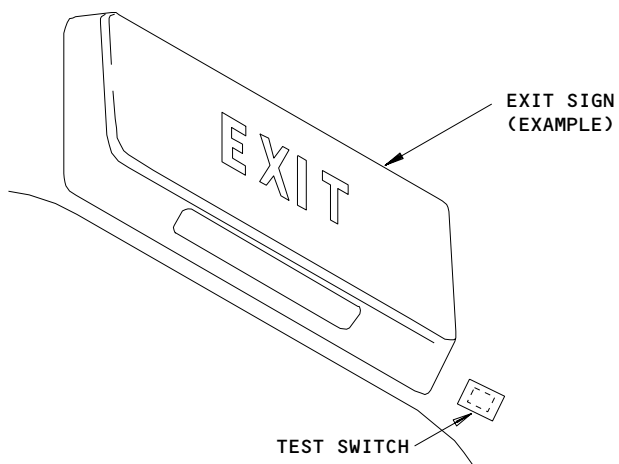

EXIT SIGN  
(EXAMPLE)

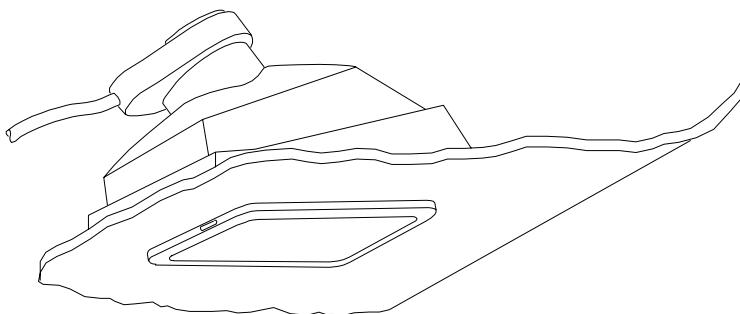

AISLE LIGHT  
(EXAMPLE)

EMERGENCY LIGHTS IN THE  
PASSENGER COMPARTMENT

Emergency Lights - Component Location  
Figure 102 (Sheet 4)

EFFECTIVITY	
	ALL

33-51-00

01

Page 105  
Mar 20/94

851342

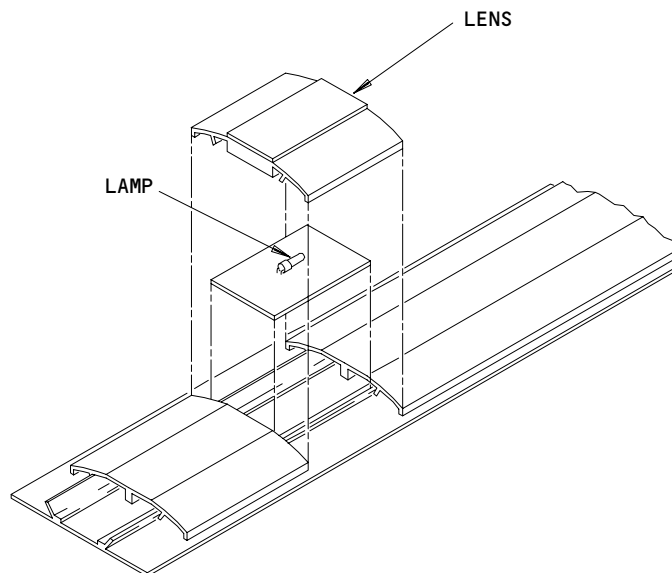

EMERGENCY ESCAPE PATH LIGHT  
(EXAMPLE)

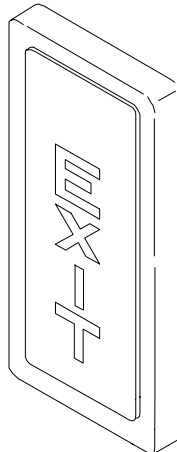

EXIT INDICATOR SIGN  
(EXAMPLE)

EMERGENCY LIGHTS IN THE  
PASSENGER COMPARTMENT

Emergency Lights - Component Location  
Figure 102 (Sheet 5)

EFFECTIVITY	
	ALL

**33-51-00**

**INTERIOR EMERGENCY LIGHTS PROBLEMS**

**PREREQUISITES**

MAKE SURE THE AIRPLANE IS IN THIS CONFIGURATION:  
EMERGENCY LIGHTS SWITCHES ON THE PILOTS' AND ATTENDANT'S PANELS ARE IN THE OFF POSITION

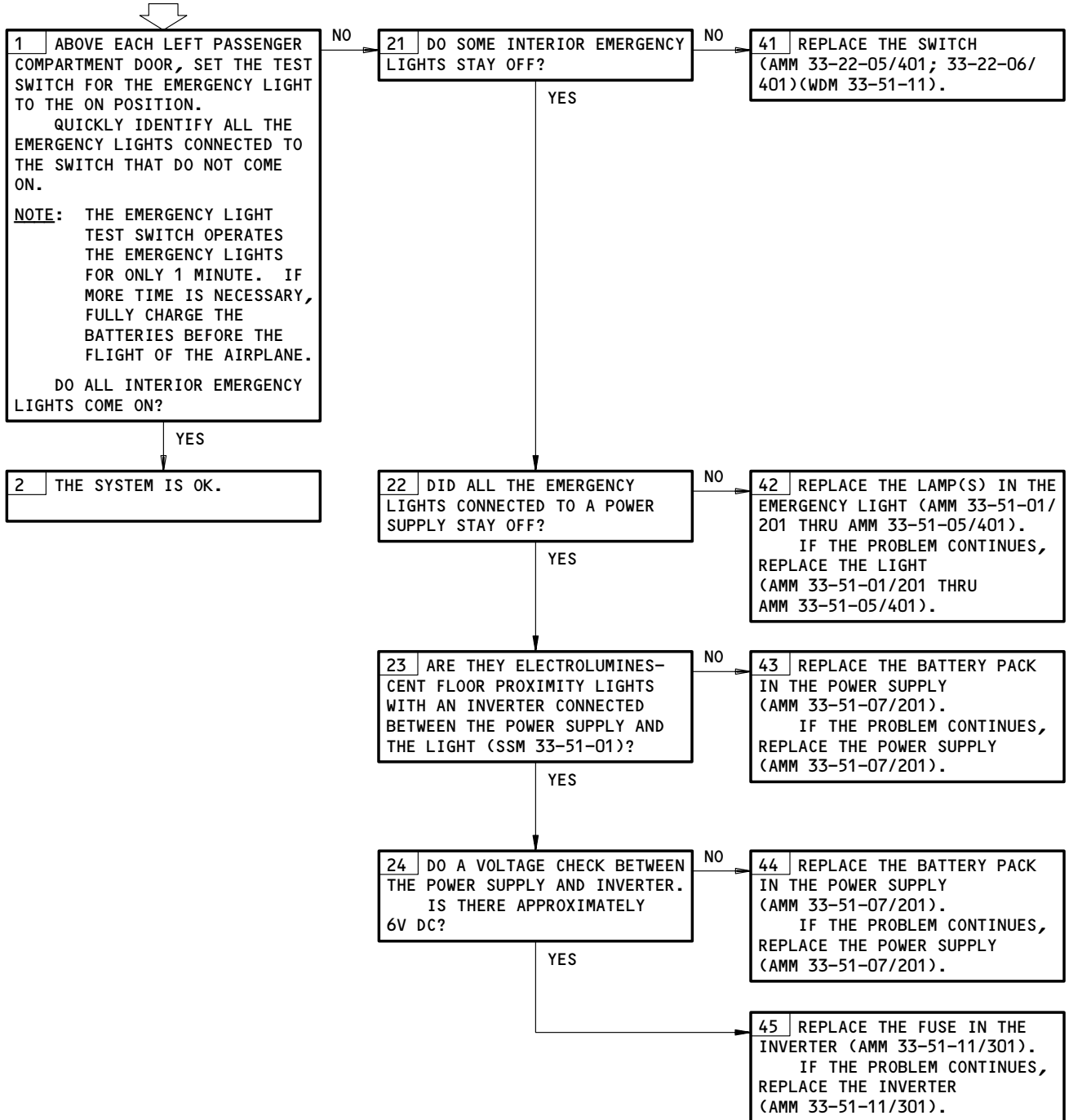

Interior Emergency Lights Problems  
Figure 103

EFFECTIVITY

ALL

**33-51-00**

02

Page 107  
Mar 20/95

262730

**EXTERIOR EMERGENCY LIGHTS PROBLEMS**

**PREREQUISITES**  
 MAKE SURE THE AIRPLANE IS IN THIS CONFIGURATION:  
 EMERGENCY LIGHTS SWITCHES ON THE PILOT'S AND ATTENDANT'S PANELS ARE IN THE "OFF" POSITION

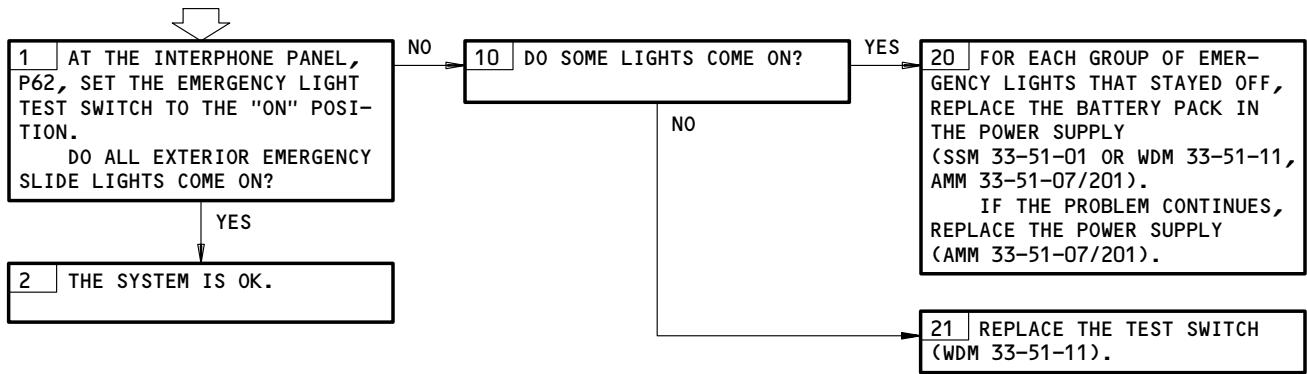

Exterior Emergency Lights Problems  
 Figure 104

EFFECTIVITY

ALL
-----

**33-51-00**