

BOEING
 757
 FAULT ISOLATION/MAINT MANUAL

GPA Group plc

PAGE	DATE	CODE	PAGE	DATE	CODE	PAGE	DATE	CODE
CHAPTER 34 TAB			34--FAULT CODE DIAGRAM			34--FAULT CODE DIAGRAM		
NAVIGATION			CONT.			CONT.		
EFFECTIVE PAGES			5	MAY 28/01	08	63	MAY 28/03	04
SEE LAST PAGE OF LIST FOR			6	MAY 28/01	09	64	MAY 28/01	04
NUMBER OF PAGES			7	MAY 28/01	05	65	MAY 28/01	02
34--CONTENTS			8	MAY 28/01	01	66	BLANK	
1	MAY 28/03	GUI	9	MAY 28/01	08	34--FAULT CODE INDEX		
2	MAY 28/07	GUI	10	MAY 28/01	09	1	DEC 20/96	01
3	JAN 28/07	GUI	11	MAY 28/01	02	2	JAN 20/99	07
4	SEP 28/06	GUI	12	MAY 28/01	02	3	MAY 28/01	07
5	SEP 28/06	GUI	13	MAY 28/01	02	4	JAN 28/03	11
6	SEP 28/06	GUI	14	MAY 28/01	05	5	MAY 20/98	22
R 7	JAN 20/09	GUI.1	15	MAY 28/01	01	6	MAY 20/98	11
8	SEP 28/06	GUI	16	MAY 28/01	01	7	MAY 28/01	05
9	SEP 28/06	GUI	17	MAY 28/01	01	8	MAY 28/01	04
10	SEP 28/06	GUI	18	JAN 28/03	01	9	MAY 20/98	10
R 11	JAN 20/09	GUI.1	19	SEP 28/00	05	10	MAY 20/98	10
12	SEP 20/08	GUI	20	MAY 28/01	02	11	MAY 20/98	08
34--HOW TO USE THE FIM			21	MAY 20/98	02	12	DEC 20/96	06
1	SEP 20/98	01	22	MAY 20/98	04	13	MAR 20/96	05
2	SEP 20/98	01	23	MAY 20/98	05	14	MAY 28/01	06
3	SEP 28/99	01	24	MAY 20/98	05	15	MAY 28/01	07
4	SEP 20/98	01	25	MAY 28/01	07	16	JAN 20/98	06
5	SEP 20/98	01	26	MAY 20/98	04	17	MAY 20/08	08
6	SEP 20/98	01	27	MAY 20/98	05	18	JAN 20/98	09
34--INDEX			28	MAY 28/01	16	19	SEP 20/98	11
1	JAN 28/00	03	29	MAY 28/01	16	20	JAN 20/98	05
2	JUN 20/95	20	30	MAY 28/01	20	21	MAY 20/98	12
3	MAR 20/93	25	31	MAY 28/01	16	22	MAR 20/96	14
4	MAR 20/93	25	32	MAY 28/01	16	23	MAY 20/98	18
5	DEC 20/92	01	33	MAY 28/01	14	24	SEP 28/03	23
6	MAY 20/98	01	34	MAY 28/01	09	25	SEP 28/03	18
7	MAY 20/98	01	35	MAY 28/01	03	26	SEP 20/98	15
8	BLANK		36	MAY 28/01	03	27	MAY 20/08	11
34--EICAS MESSAGES			37	MAY 28/01	03	28	MAR 20/96	14
1	MAY 28/00	01	38	MAY 28/01	21	29	MAR 20/96	10
2	MAR 20/91	01	39	MAY 28/01	19	30	MAR 20/96	11
3	SEP 28/03	02	40	MAY 28/01	22	31	JAN 20/98	11
4	JAN 28/06	15	41	MAY 28/01	18	32	SEP 28/02	16
5	SEP 28/03	12	42	MAY 28/01	13	33	JAN 28/03	19
6	JAN 28/06	21	43	MAY 28/01	10	34	MAY 28/01	17
7	SEP 28/03	11	44	MAY 28/01	08	35	SEP 28/02	21
8	SEP 28/03	17	45	JAN 28/03	12	36	JAN 28/03	18
9	JAN 28/06	15	46	MAY 28/01	08	37	JAN 28/03	23
10	JAN 28/06	08	47	MAY 28/01	08	38	JAN 28/00	17
34--FAULT CODE DIAGRAM			48	MAY 28/01	08	39	MAY 20/98	17
1	MAY 20/98	02	49	JAN 28/03	07	40	MAR 20/96	20
2	JAN 28/03	02	50	MAY 28/01	09	41	DEC 20/96	22
3	MAY 28/01	04	51	MAY 28/01	09	42	SEP 28/02	25
4	MAY 28/01	07	52	MAY 28/01	12	43	SEP 28/02	23
			53	MAY 28/01	14	44	MAY 28/01	24
			54	MAY 28/01	14	45	SEP 28/02	25
			55	MAY 28/01	12	46	MAY 28/01	29
			56	MAY 28/01	11	47	JAN 28/02	40
			57	JAN 28/03	12	48	MAY 28/02	23
			58	MAY 28/01	08	49	MAY 28/02	25
			59	JAN 28/03	09	50	SEP 28/02	38
			60	JAN 28/03	09	51	MAY 28/02	20
			61	MAY 28/01	06	52	MAY 28/02	26
			62	MAY 28/06	04			

R = REVISED, A = ADDED OR D = DELETED

F = FOLDOUT PAGE

32

JAN 20/09

D633N632

CHAPTER 34

EFFECTIVE PAGES

PAGE 1

CONTINUED



757
FAULT ISOLATION/MAINT MANUAL

GPA Group plc

PAGE	DATE	CODE	PAGE	DATE	CODE	PAGE	DATE	CODE
34-FAULT CODE INDEX			34-12-00			34-21-00		
53	JAN 28/03	24	127	MAY 28/07	06	129	SEP 28/00	01
54	MAY 28/02	22	128	MAY 28/07	06	130	JAN 28/03	01
R 55	JAN 20/09	21.101	129	MAY 28/07	05	34-22-00		
R 56	JAN 20/09	23.1	130	MAY 28/07	05	101	DEC 20/93	14
57	SEP 28/02	22	131	MAY 28/07	05	102	SEP 20/08	19
58	MAY 28/01	21	132	MAY 28/07	05	103	DEC 20/93	09
59	MAY 28/07	23	133	MAY 28/07	04	104	SEP 20/08	21
60	SEP 28/02	20	134	MAY 28/07	02	105	DEC 20/93	02
61	MAR 20/96	20	34-13-00			106	DEC 20/93	15
62	MAY 28/01	19	101	JAN 20/98	10	107	SEP 20/08	05
63	MAY 28/01	18	102	JAN 20/98	07	108	DEC 20/93	10
64	SEP 28/02	19	103	JUN 20/96	09	109	MAR 20/96	08
65	JAN 28/03	21	104	BLANK		110	JAN 28/03	05
66	JAN 28/03	19	34-16-00			111	JAN 28/03	10
67	JAN 20/98	10	101	JUN 20/90	02	112	DEC 20/96	15
68	DEC 20/96	03	102	JUN 20/90	01	113	SEP 28/03	03
69	DEC 20/96	09	103	SEP 20/98	14	114	SEP 28/03	09
70	MAY 28/01	11	104	SEP 20/97	05	115	DEC 20/96	03
34-BITE INDEX			105	SEP 20/97	05	116	SEP 28/06	05
1	SEP 28/99	01	106	SEP 20/97	03	117	SEP 28/06	03
2	SEP 28/99	01	107	JAN 20/98	03	118	SEP 28/06	07
3	SEP 28/99	01	108	SEP 20/97	03	119	SEP 28/06	07
4	BLANK		109	SEP 20/97	01	120	SEP 28/06	04
34-11-00			110	SEP 20/97	01	121	SEP 28/06	05
101	SEP 20/94	01	111	SEP 20/97	01	122	SEP 28/06	04
102	SEP 20/94	01	112	BLANK		123	SEP 28/06	06
103	SEP 20/94	01	34-21-00			124	SEP 28/06	06
104	SEP 20/94	01	101	DEC 20/96	05	125	SEP 28/06	09
34-12-00			102	JAN 20/98	01	126	DEC 20/96	05
101	MAY 28/05	04	103	DEC 20/96	04	127	DEC 20/96	06
102	MAR 20/97	01	104	DEC 20/96	04	128	DEC 20/96	06
103	MAR 20/90	01	105	SEP 28/00	01	129	DEC 20/96	06
104	MAY 28/02	01	106	DEC 20/96	01	130	DEC 20/96	06
105	MAY 28/07	17	107	DEC 20/96	09	131	DEC 20/96	06
106	MAY 28/07	17	108	JAN 28/07	17	132	DEC 20/96	05
107	MAY 28/07	07	109	JAN 28/07	06	133	DEC 20/96	05
108	MAY 28/07	07	110	DEC 20/96	01	134	DEC 20/96	04
109	MAY 28/07	03	111	DEC 20/96	01	135	DEC 20/96	03
110	MAY 28/07	04	112	DEC 20/96	01	136	DEC 20/96	02
111	MAY 28/07	14	113	DEC 20/96	01	137	DEC 20/96	01
112	MAY 28/07	15	114	DEC 20/96	02	138	DEC 20/96	01
113	MAY 28/07	13	115	JAN 28/07	15	34-23-00		
114	MAY 28/07	20	116	JAN 28/07	13	101	SEP 28/03	01
115	MAY 28/07	17	117	MAR 20/96	03	102	SEP 28/03	01
116	MAY 28/07	14	118	SEP 28/00	04	103	SEP 28/03	01
117	MAY 28/07	13	119	MAR 20/96	04	104	BLANK	
118	MAY 28/07	13	120	SEP 20/96	03	34-24-00		
119	MAY 28/07	13	121	SEP 20/96	03	101	SEP 20/94	01
120	MAY 28/07	13	122	SEP 20/96	04	102	SEP 20/94	02
121	MAY 28/07	13	123	JAN 28/07	09	103	MAY 20/08	01
122	MAY 28/07	13	124	SEP 20/96	03	104	BLANK	
123	MAY 28/07	12	125	JAN 28/07	09			
124	MAY 28/07	10	126	JAN 28/07	11			
125	MAY 28/07	08	127	JAN 28/07	10			
126	MAY 28/07	06	128	SEP 28/00	01			

R = REVISED, A = ADDED OR D = DELETED

F = FOLDOUT PAGE

32

JAN 20/09

D633N632

CHAPTER 34
EFFECTIVE PAGES
PAGE 2
CONTINUED



BOEING
757
FAULT ISOLATION/MAINT MANUAL

GPA Group plc

PAGE	DATE	CODE	PAGE	DATE	CODE	PAGE	DATE	CODE
34-25-00			34-33-00		CONT.	34-46-00	CONFIG 1	CONT.
101	SEP 20/94	02	111	SEP 20/96	07	115	MAY 28/01	02
102	DEC 20/93	01	112	BLANK		116	MAY 28/99	02
103	SEP 20/94	08				117	MAY 28/99	03
104	DEC 20/96	01	34-43-00			118	MAY 28/02	05
105	DEC 20/96	01	101	JAN 20/99	01	119	MAY 28/99	03
106	DEC 20/96	01	102	DEC 20/96	01	120	JAN 28/03	04
107	DEC 20/96	01	103	MAY 20/08	26	121	JAN 28/03	05
108	DEC 20/96	01	104	MAY 28/99	20	122	JAN 28/03	03
			105	SEP 20/94	01	123	MAY 28/99	03
34-31-00			106	MAY 28/99	21	124	JAN 28/03	02
101	MAY 20/98	15	107	SEP 20/94	01	125	JAN 28/03	05
102	JUN 20/91	08	108	SEP 20/94	01	126	JAN 28/03	04
103	MAY 20/08	36	109	SEP 28/03	01	127	JAN 28/03	03
104	MAR 20/97	09	110	SEP 20/96	01	128	JAN 28/03	02
105	MAY 28/01	11				129	JAN 28/03	03
106	DEC 20/92	11	34-45-00	CONFIG 1		130	JAN 28/03	03
107	JAN 28/02	11	101	SEP 20/95	01	131	MAY 28/01	02
108	DEC 20/92	08	102	SEP 20/95	01	132	MAY 28/99	02
109	JUN 20/92	03	103	JUN 20/96	01	133	MAY 28/99	02
110	MAR 20/97	10	104	SEP 20/95	01	134	MAY 28/02	03
111	JUN 20/92	03	105	SEP 20/95	01	135	JAN 28/03	04
112	JUN 20/92	07	106	SEP 20/95	01	136	MAY 28/02	02
113	JUN 20/92	08	107	SEP 20/95	01	137	MAY 28/02	02
114	JUN 20/92	04	108	SEP 20/95	01	138	MAY 28/99	02
115	JUN 20/92	04	109	SEP 20/95	01	139	MAY 28/99	02
116	JUN 20/92	03	110	DEC 20/96	01	140	MAY 28/99	01
117	JUN 20/92	02	111	DEC 20/96	01	141	MAY 28/99	01
118	JUN 20/92	02	112	BLANK		142	BLANK	
119	SEP 20/94	04						
120	JUN 20/95	04	34-45-00	CONFIG 2		34-46-00	CONFIG 3	
121	MAY 28/01	05	101	JAN 28/02	01	101	JAN 28/00	01
122	JUN 20/95	03	102	JAN 28/02	01	102	MAY 28/99	01
123	MAY 28/01	02	103	JAN 28/02	04	103	JAN 28/00	02
124	JUN 20/95	01	104	JAN 28/02	01	104	MAY 28/99	01
125	SEP 20/96	03	105	JAN 28/02	02	105	JAN 28/00	01
126	SEP 20/96	02	106	JAN 28/02	01	106	JAN 28/00	01
127	SEP 20/96	02	107	JAN 28/02	01	107	JAN 28/00	01
128	BLANK		108	JAN 28/02	01	108	MAY 28/99	01
			109	JAN 28/02	01	109	JAN 28/00	01
34-32-00			110	JAN 28/02	01	110	BLANK	
101	JAN 20/98	09	111	JAN 28/02	01			
102	JAN 20/98	01	112	JAN 28/02	01	34-51-00		
103	JAN 20/98	05				101	DEC 20/96	12
104	JAN 28/00	03	34-46-00	CONFIG 1		102	JUN 20/91	07
105	JAN 28/00	02	101	MAY 28/99	02	103	DEC 20/96	20
106	BLANK		102	MAY 28/99	01	104	JUN 20/92	08
			103	MAY 28/99	02	105	JUN 20/92	11
34-33-00			104	JAN 28/03	07	106	JUN 20/92	14
101	DEC 20/90	01	105	JAN 28/03	07	107	JUN 20/92	12
102	DEC 20/96	13	106	JAN 28/03	02	108	SEP 20/92	13
103	JUN 20/93	02	107	MAY 28/99	02	109	JUN 20/92	09
104	JUN 20/93	01	108	MAY 28/99	02	110	JUN 20/92	09
105	JUN 20/95	14	109	JAN 28/03	03	111	JUN 20/92	06
106	SEP 20/92	15	110	JAN 28/03	02	112	JUN 20/92	05
107	SEP 20/92	15	111	JAN 28/03	02	113	DEC 20/95	06
108	JUN 20/95	04	112	JAN 28/03	02	114	SEP 20/92	04
109	SEP 20/92	04	113	JAN 28/03	02	115	SEP 20/92	03
110	SEP 20/96	08	114	JAN 28/03	02	116	DEC 20/93	04

R = REVISED, A = ADDED OR D = DELETED

F = FOLDOUT PAGE

32

JAN 20/09

D633N632

CHAPTER 34

EFFECTIVE PAGES

PAGE 3

CONTINUED



BOEING
757
FAULT ISOLATION/MAINT MANUAL

GPA Group plc

PAGE	DATE	CODE	PAGE	DATE	CODE	PAGE	DATE	CODE
34-51-00		CONT.	34-57-00			34-61-00		CONT.
117	DEC 20/93	03	101	SEP 20/94	23	133	JAN 28/03	13
118	DEC 20/93	03	102	DEC 20/93	28	134	JAN 28/03	12
119	DEC 20/93	02	103	SEP 20/94	24	135	JAN 28/03	12
120	DEC 20/93	01	104	SEP 20/94	23	136	JAN 28/03	12
121	MAY 20/98	03	105	SEP 20/94	10	137	JAN 28/03	11
122	MAY 20/98	01	106	JUN 20/95	22	138	BLANK	
123	SEP 20/96	02	107	SEP 20/94	05			
124	SEP 20/96	02	108	SEP 20/95	08			
125	SEP 20/96	01	109	SEP 20/94	06			
126	BLANK		110	DEC 20/96	10			
			111	SEP 20/94	03			
34-53-00	CONFIG 3		112	DEC 20/96	07			
101	SEP 20/94	05	113	SEP 20/96	02			
102	SEP 20/94	05	114	SEP 20/96	02			
103	SEP 20/94	05	115	MAR 20/97	03			
104	JAN 28/02	08	116	MAR 20/97	01			
105	SEP 20/94	05	117	MAR 20/97	05			
106	SEP 20/94	05	118	BLANK				
107	SEP 20/94	05						
108	SEP 20/94	05	34-58-00					
109	SEP 20/94	05	101	JAN 28/02	02			
110	SEP 20/94	05	102	JAN 28/07	02			
111	SEP 20/94	05	103	JAN 28/03	01			
112	DEC 20/96	08	104	SEP 28/04	01			
34-53-00	CONFIG 4		34-61-00					
101	SEP 20/94	09	101	MAR 20/93	12			
102	SEP 20/94	09	102	SEP 20/90	01			
103	SEP 20/94	09	103	MAY 20/08	35			
104	SEP 20/94	09	104	MAY 20/08	27			
105	SEP 20/94	09	105	MAY 28/99	07			
106	SEP 20/94	09	106	JAN 20/98	02			
107	SEP 20/94	09	107	JAN 20/98	08			
108	SEP 20/94	09	108	MAY 28/05	11			
109	SEP 20/94	09	109	JAN 20/98	02			
110	SEP 20/94	09	110	JAN 20/98	08			
111	SEP 20/94	09	111	MAY 20/08	09			
112	DEC 20/96	10	112	JAN 28/05	02			
			113	MAY 20/08	04			
34-55-00			114	DEC 20/96	02			
101	SEP 20/98	04	115	SEP 28/99	02			
102	MAY 20/98	07	116	SEP 28/00	03			
103	SEP 20/98	03	117	JAN 28/03	03			
104	SEP 28/03	08	118	MAY 20/08	10			
105	SEP 20/98	07	119	MAY 20/08	11			
106	SEP 28/03	08	120	JAN 28/03	18			
107	SEP 28/03	04	121	MAY 20/08	27			
108	SEP 28/03	04	122	JAN 28/03	18			
109	MAY 28/01	01	123	JAN 28/03	18			
110	MAY 20/98	12	124	JAN 28/03	18			
111	SEP 20/98	04	125	JAN 28/03	20			
112	SEP 20/98	04	126	JAN 28/03	20			
113	SEP 28/03	03	127	JAN 28/03	19			
114	MAY 20/98	05	128	JAN 28/03	17			
115	MAY 20/98	06	129	JAN 28/03	14			
116	BLANK		130	JAN 28/03	15			
			131	JAN 28/03	13			
			132	JAN 28/03	14			

R = REVISED, A = ADDED OR D = DELETED

F = FOLDOUT PAGE

32

JAN 20/09

D633N632

CHAPTER 34
EFFECTIVE PAGES
PAGE 4
LAST PAGE

CHAPTER 34 - NAVIGATION

TABLE OF CONTENTS

<u>Subject</u>	Chapter Section <u>Subject</u>	<u>Page</u>	<u>Effectivity</u>
HOW TO USE THE FIM	34-HOW TO USE THE FIM	1	ALL
INDEX	34-INDEX	1	ALL
EICAS MESSAGES	34-EICAS MESSAGES	1	ALL
FAULT CODE DIAGRAMS	34-FAULT CODE DIAGRAM	1	ALL
FAULT CODE INDEX	34-FAULT CODE INDEX	1	ALL
BITE INDEX	34-BITE INDEX	1	ALL
<u>NAVIGATION - GENERAL</u>	34-00-00		
<u>FLIGHT ENVIRONMENT DATA</u>	34-10-00		
PITOT-STATIC SYSTEM	34-11-00		
Component Location		101	ALL
Component Index			
Component Location			
Fault Isolation			
Pitot System Problem (Fig. 104)		104	
Static System Problem (Fig. 103)		103	

34-CONTENTS



BOEING
757
FAULT ISOLATION/MAINT MANUAL

CHAPTER 34 - NAVIGATION

TABLE OF CONTENTS

<u>Subject</u>	Chapter Section <u>Subject</u>	<u>Page</u>	<u>Effectivity</u>
AIR DATA COMPUTING SYSTEM	34-12-00		
Component Location		101	ALL
Component Index			
Component Location			
Fault Isolation			
ADC BITE Procedure (Fig. 109)		117	
ADC BITE Procedure (Fig. 109A)		122	
ARINC Data Bus Charts		127	
Capt (F/O) Airspeed and/or Mach Indications in Error. Selecting Altn Air Data Corrects Fault (Fig. 107B)		114	
Capt (F/O) Altimeter is Corrected with ALTN Air Data Selected (Fig. 103)		104	
Capt (F/O) MASI in Error. Selecting Altn Air Data Corrects Fault (Fig. 107)		112	
Not Used (Fig. 105)		109	
Off Flag in View on Capt's (F/O's) Altimeter (Fig. 104)		105	
Off Flag in View on Capt's (F/O's) Altimeter (Fig. 104)		106	
Off Flag in View on Capt's Metric Altimeter (Fig. 106A)		111	
SPD Flag in View on L (R) EADI (Fig. 107A)		113	
TAS/SAT and Mach Are In Error (Fig. 106)		110	
VMO, Mach, and AS Flags in View on Capt (F/O) Mach/ Airspeed Indicator (Fig. 108)		115	
AIR DATA INSTRUMENTS	34-13-00		
Component Location		101	ALL
Component Index			
Component Location			
Fault Isolation			
Standby Airspeed Indicator Error (Fig. 103)		103	

34-CONTENTS



757
FAULT ISOLATION/MAINT MANUAL

CHAPTER 34 - NAVIGATION

TABLE OF CONTENTS

<u>Subject</u>	<u>Chapter Section Subject</u>	<u>Page</u>	<u>Effectivity</u>
ALTITUDE ALERT SYSTEM	34-16-00		
Component Location		101	ALL
Component Index			
Component Location			
Fault Isolation			
Altitude Alert System Fault Isolation (Fig. 103)		103	
<u>ATTITUDE AND DIRECTION</u>	34-20-00		
INERTIAL REFERENCE SYSTEM	34-21-00		
Component Location		101	ALL
Component Index			
Component Location			
Fault Isolation			
Align Failed to Extin After 10 Min (Nav Sel) (Fig. 106D)		114	
ARINC Data Bus Charts		120	
Capt (F/O) RDMI VOR and HDG Flags In View (Fig. 103)		103	
Capt (F/O) VSI Off Flag In View (Fig. 104)		105	
Entry Inop to ALL IRS'S (ALIGN Flashes after Second Entry). (Fig. 106C)		113	
Entry Inop to Single IRS (Align Flashes after Second Entry). Position Entry from FMC-CDU Unsuccessful (Fig. 106A)		111	
Entry Inop to Single IRS (Align Flashes after Second Entry). Position Entry from FMC-CDU Successful (Fig. 106B)		112	
IRS BITE Procedure (Fig. 107)		115	
IRS Indicates IRS on DC (Fig. 106)		110	
IRS Indicates IRS DC Fail (Fig. 105)		108	
IRS Removal Checks (Fig. 107A)		117	
IRU Radial Position Error (Fig 107B)		119	

34-CONTENTS



BOEING
757
FAULT ISOLATION/MAINT MANUAL

CHAPTER 34 - NAVIGATION

TABLE OF CONTENTS

<u>Subject</u>	Chapter Section <u>Subject</u>	<u>Page</u>	<u>Effectivity</u>
ELECTRONIC FLIGHT INSTRUMENT SYSTEM	34-22-00		
Component Location		101	ALL
Component Index			
Component Location			
Fault Isolation			
ARINC Data Bus Charts		122	
Brightness Control Problem on Capt (F/O) EADI (Fig. 105)		112	
Brightness Control Problem on Capt (F/O) EHSI (Fig. 107)		115	
Display Problems on Capt (F/O) EADI (Fig. 104)		110	
Display Problems on Capt (F/O) EHSI (Fig. 106)		113	
EFIS BITE Procedure (Fig. 108) Not Used (Fig. 103)		116 109	
STANDBY MAGNETIC COMPASS	34-23-00		
Component Location		101	ALL
Component Index			
Component Location			
STANDBY ATTITUDE REFERENCE SYSTEM	34-24-00		
Component Location		101	ALL
Component Index			
Component Location			
Fault Isolation			
Standby Attitude Indication Problems (Fig. 103)		103	
INSTRUMENT COMPARISON SYSTEM	34-25-00		
Component Location		101	ALL
Component Index			
Component Location			
Fault Isolation			
Instrument Comparison System BITE Procedure (Fig. 103)		103	

34-CONTENTS

CHAPTER 34 - NAVIGATION

TABLE OF CONTENTS

<u>Subject</u>	<u>Chapter Section Subject</u>	<u>Page</u>	<u>Effectivity</u>
<u>LANDING AND TAXIING AIDS</u>	34-30-00		
INSTRUMENT LANDING SYSTEM	34-31-00		
Component Location		101	ALL
Component Index			
Component Location			
Fault Isolation			
Abnormal ILS Test Response on Capt (F/O) EADI & EHSI (Fig. 104)		110	
ARINC Data Bus Charts		125	
Capt (F/O) EHSI & EADI - Both G/S and LOC Dev Pointers Missing (NCD) (Fig. 106)		116	
Faulty Standby Attitude Indicator Operation (Fig. 107)		117	
G/S and LOC Flags in View on Capt (F/O) EHSI & EADI (Fig. 105)		114	
G/S Dev Pointer Not Displayed (Fig. 111)		123	
ILS BITE Procedure (Fig. 103)		104	
Loc (G/S) Dev Pointer Missing on Stby Att Ind (Fig. 109)		120	
LOC Dev Pointer Not Displayed (Fig. 110)		121	
Stby Att - Both Dev Pointers Missing (NCD) (Fig. 108)		119	
MARKER BEACON SYSTEM	34-32-00		
Component Location		101	ALL
Component Index			
Component Location			
Fault Isolation			
Marker Beacon Lights and/or Audio Problems (Fig. 103)		104	

34-CONTENTS



BOEING
757
FAULT ISOLATION/MAINT MANUAL

CHAPTER 34 - NAVIGATION

TABLE OF CONTENTS

<u>Subject</u>	Chapter Section <u>Subject</u>	<u>Page</u>	<u>Effectivity</u>
RADIO ALTIMETER SYSTEM	34-33-00		
Component Location		101	ALL
Component Index			
Component Location			
Fault Isolation			
ARINC Data Bus Charts		110	
DH Flag Displayed on Capt (F/O) EADI (Fig. 105)		107	
Radio Altitude Height on the Capt (F/O) EADI Is Inaccurate, Intermittent (Fig. 103)		103	
RA BITE Procedure (Fig. 105A)		108	
RA Flag Displayed on Capt (F/O) EADI (Fig. 104)		105	
<u>INDEPENDENT POSITION DETERMINING</u>	34-40-00		
WEATHER RADAR SYSTEM	34-43-00		
Component Location		101	ALL
Component Index			
Component Location			
Fault Isolation			
ARINC Data Bus Charts		109	
Visual Check		109	
WXR BITE Procedure (Fig. 103)		104	
WXR Range Disagree Problems (Fig. 103A)		107	

34-CONTENTS

CHAPTER 34 - NAVIGATION

TABLE OF CONTENTS

<u>Subject</u>	<u>Chapter Section Subject</u>	<u>Page</u>	<u>Effectivity</u>
TRAFFIC ALERT AND COLLISION	34-45-00		
AVOIDANCE SYSTEM			
Component Location		101	CONFIG 1 [*]
Component Index			
Component Location			
Fault Isolation			
TCAS BITE Procedure (Fig. 103)		104	
TCAS Voice Advisory Alert		109	
Failure (Fig. 104)			
[*] AIRPLANES WITH COLLINS TCAS			
Component Location		101	CONFIG 2 [*]
Component Index			
Component Location			
Fault Isolation			
TCAS BITE Procedure (Fig. 103)		104	
TCAS Voice Advisory Alert		110	
Failure (Fig. 104)			
[*] AIRPLANES WITH RT-950 TCAS			

34-CONTENTS

CHAPTER 34 - NAVIGATION

TABLE OF CONTENTS

<u>Subject</u>	<u>Chapter Section Subject</u>	<u>Page</u>	<u>Effectivity</u>
GROUND PROXIMITY WARNING SYSTEM	34-46-00		
Component Location		101	CONFIG 1 [*]
Component Index			
Component Location			
Fault Isolation			
ARINC Data Bus Charts		140	
Ground Proximity Warning		120	
Computer BITE Procedure (Fig. 103B)			
Ground Proximity Warning		104	
Computer BITE Procedure (Fig. 103)			
Ground Proximity Warning		135	
System Self-Test (Fig. 104)			
Not Used (Fig. 103A)		119	
[*] AIRPLANES WITHOUT ENHANCED GPWC			
Component Location		101	CONFIG 3 [*]
Component Index			
Component Location			
Fault Isolation			
Ground Proximity Warning		104	
Computer BITE Procedure (Fig. 103)			
[*] AIRPLANES WITH THE ENHANCED GPWC			

34-CONTENTS

CHAPTER 34 - NAVIGATION

TABLE OF CONTENTS

<u>Subject</u>	<u>Chapter Section Subject</u>	<u>Page</u>	<u>Effectivity</u>
<u>DEPENDENT POSITION DETERMINING</u>	34-50-00		
VOR NAVIGATION SYSTEM	34-51-00		
Component Location		101	ALL
Component Index			
Component Location			
Fault Isolation			
Autotune - VOR Flag in View on RDMIs, Manual Operation Normal (Fig. 105)		113	
ARINC Data Bus Charts		123	
Brq Flag on RDMIs, No VOR Flag on EHSI, VORCP Freq Select Ok (Fig. 109)		121	
VOR BITE Procedure (Fig. 103)		104	
VOR Display Problems on Left (Right) RDMI and EHSI (Fig. 107)		117	
VOR Flag on EHSI, RDMI/RMI Displays are Normal (Fig. 106)		116	
VOR Flags in View, VORCP Display Problems (Fig. 104)		110	
VOR Indications Normal, Freq Display on VORCP Abnormal (Fig. 108)		120	

34-CONTENTS

CHAPTER 34 - NAVIGATION

TABLE OF CONTENTS

<u>Subject</u>	<u>Chapter Section Subject</u>	<u>Page</u>	<u>Effectivity</u>
AIR TRAFFIC CONTROL (ATC) SYSTEM	34-53-00		
Component Location		101	CONFIG 3 [*]
Component Index			
Component Location			
Fault Isolation			
Alt Rptg Inop (Fig. 104)		108	
ATC System BITE Procedure (Fig. 103)		104	
ATC Transmission Problems (Fig. 105)		110	
[*] GUI 115			
Component Location		101	CONFIG 4 [*]
Component Index			
Component Location			
Fault Isolation			
Alt Rptg Inop (Fig. 104)		108	
ARINC Data Bus Charts		112	
ATC System BITE Procedure (Fig. 103)		104	
ATC Transmission Problems (Fig. 105)		110	
[*] GUI 001-114, 116-999			

34-CONTENTS

CHAPTER 34 - NAVIGATION

TABLE OF CONTENTS

<u>Subject</u>	<u>Chapter Section Subject</u>	<u>Page</u>	<u>Effectivity</u>
DME SYSTEM	34-55-00		
Component Location		101	ALL
Component Index			
Component Location			
Fault Isolation			
Autotune Mode - DME Displays		112	
Show Dashes (Fig. 108)			
ARINC Data Bus Charts		114	
Blank DME Display on EHSI -		110	
Otherwise Normal (Fig. 106)			
DME EHSI and RDMI Displays		111	
Blank (Fig. 107)			
DME Ident Signal Missing -		113	
Displays Normal (Fig. 109)			
DME System BITE Procedure		104	
(Fig. 103)			
ILS Mode - DME Displays		108	
Dashes, ILS Ident Normal			
(Fig. 105)			
VOR Mode - DME Displays		107	
Dashes, VOR Ident Normal			
(Fig. 104)			
AUTOMATIC DIRECTION FINDER SYSTEM	34-57-00		
Component Location		101	ALL
Component Index			
Component Location			
Fault Isolation			
ADF problems on Both RDMIs		107	
(Fig. 104)			
ADF Audio Problems (Fig. 103)		105	
ARINC Data Bus Charts		113	
GLOBAL POSITIONING SYSTEM	34-58-00		
Component Location		101	[*]
Component Index			
Component Location			
Fault Isolation			
GPS BITE Procedure		103	
[*] AIRPLANES WITH GPS			

34-CONTENTS



BOEING
757
FAULT ISOLATION/MAINT MANUAL

CHAPTER 34 - NAVIGATION

TABLE OF CONTENTS

<u>Subject</u>	Chapter Section <u>Subject</u>	<u>Page</u>	<u>Effectivity</u>
<u>FLIGHT MANAGEMENT COMPUTING</u>	34-60-00		
FLIGHT MANAGEMENT COMPUTER SYSTEM	34-61-00		
Component Location		101	ALL
Component Index			
Component Location			
Fault Isolation			
Action Performed on Left (Right) CDU Keyboard is Not Effective (Fig. 103)		107	
ARINC Data Bus Charts		126	
Data Incorrect on Left (Right) CDU Display (Fig. 104)		109	
Erroneous Display of ".ATC" and ".FMC" Message on EICAS (Fig. 108A)		116	
Flight Management Computer System BITE Procedure (Fig. 109)		118	
Fuel Error on CDU Display (Fig. 105)		111	
FMC Failure Caused by VOR/DME Data Error (Fig. 110A)		124	
FMC Flight Faults BITE Procedure (Fig. 102A) See Autoflight BITE Fault Isolation (FIM 22-00-02/101).		106	
FMC Light Fails To Illuminate With CDU Alert (Fig. 107)		114	
FMC Nav Data Loading Problems (Fig. 111)		125	
FMC Navigation Data Base or Program Wrong (Fig. 106)		113	
L(R) FMC FAIL message shows on EICAS (Fig. 108B)		117	
MAP RANGE DISAGREE Message Displayed on Left (Right) EHSI (Fig. 108)		115	
VNAV Path, Altitude, Transition, LNAV Path, Heading, Transition Error (Fig. 110)		123	

34-CONTENTS

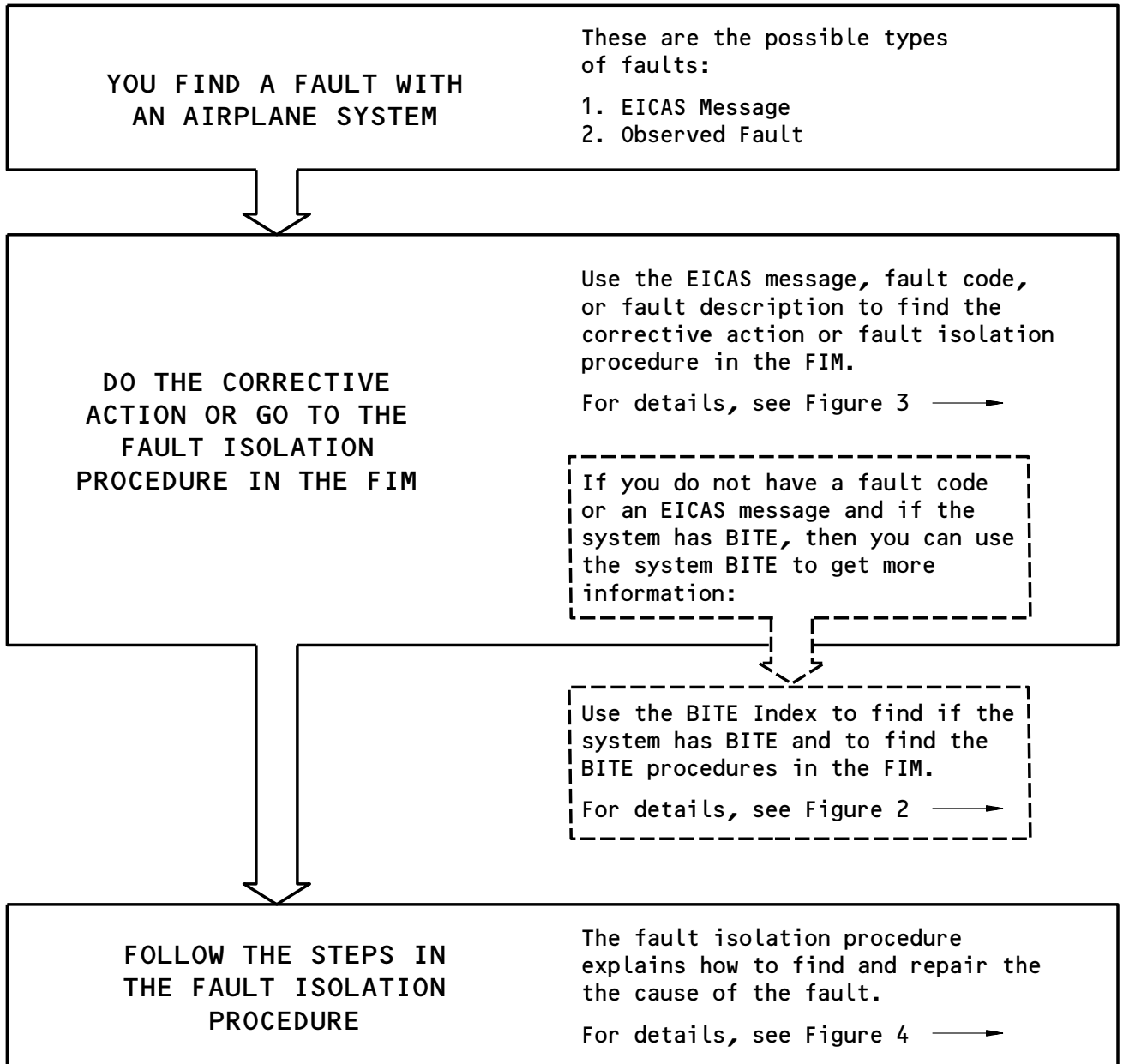

Basic Fault Isolation Process
Figure 1

EFFECTIVITY

ALL

34-HOW TO USE THE FIM

01

Page 1
Sep 20/98

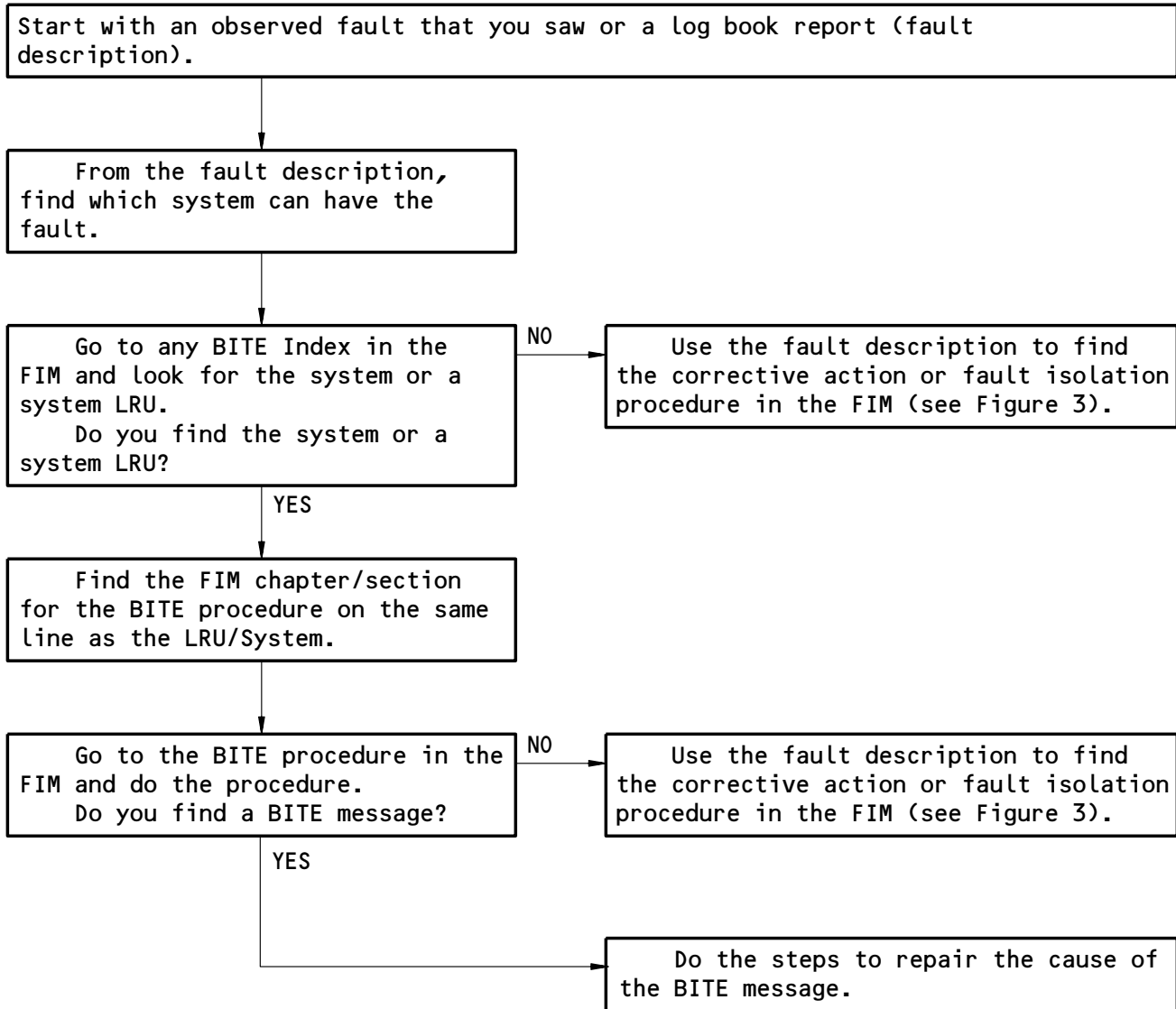

How to Get Fault Information from BITE
Figure 2

EFFECTIVITY

ALL

34-HOW TO USE THE FIM

01

Page 2
Sep 20/98

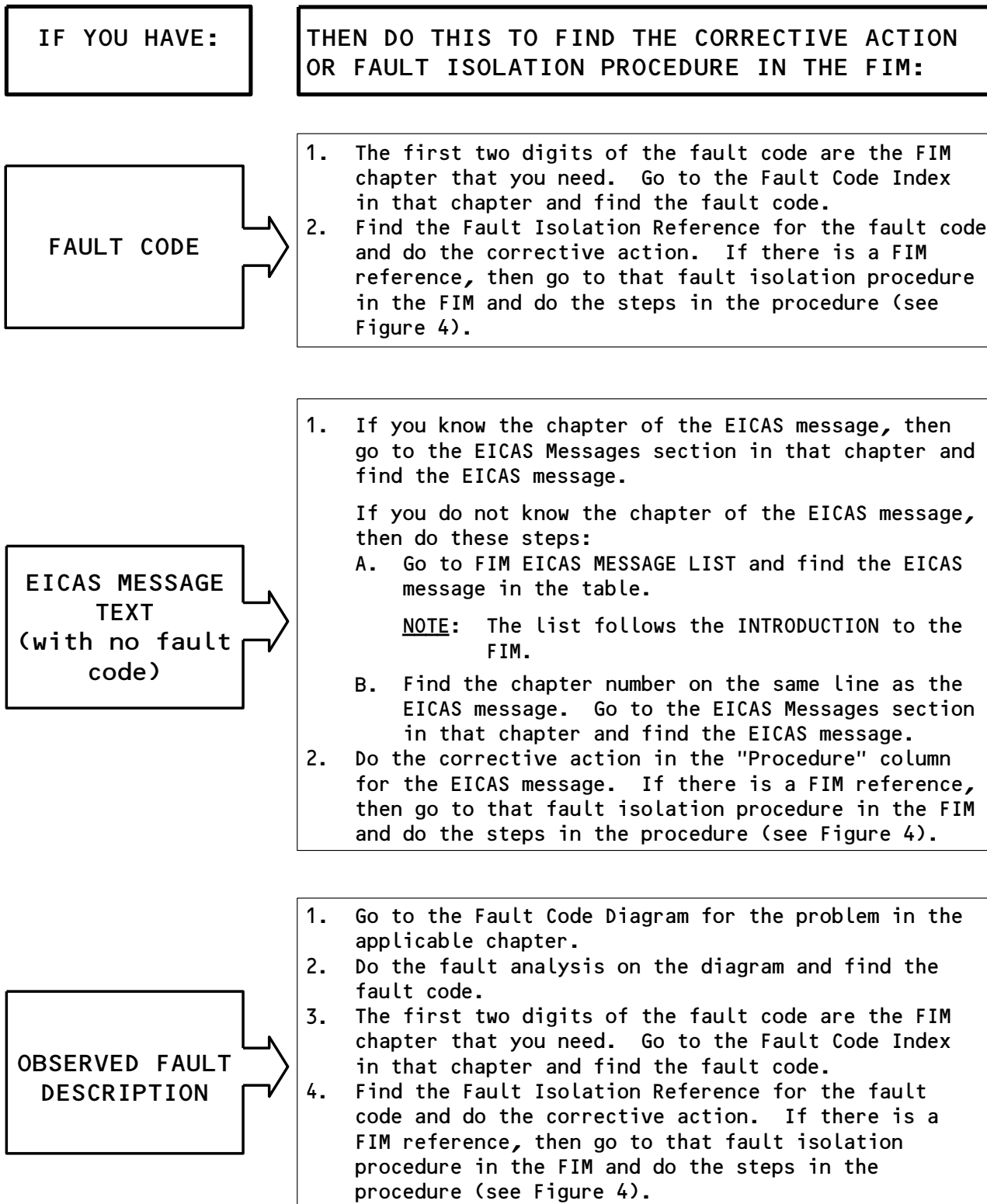

How to Find the Corrective Action or Fault Isolation Procedure in the FIM

Figure 3

EFFECTIVITY

ALL

34-HOW TO USE THE FIM

01

Page 3
Sep 28/99

ASSUMED CONDITIONS AT START OF TASK

- External electrical power is OFF
- Hydraulic power and pneumatic power are OFF
- Engines are shut down
- Circuit breakers for the system are closed
- No equipment in the system is deactivated

PREREQUISITES

- This box gives the steps to get the airplane from the normal shutdown condition to the configuration necessary to do the fault isolation procedure.
- The Prerequisites give procedure references, circuit breakers, and special tools and equipment requirements.

FAULT ISOLATION BLOCKS

- Start the fault isolation procedure at block 1 unless specified differently.
- Do the check to get an answer to the question in the box. Follow the arrow that applies to your answer. This will go to the next check.
- When you get to a box in the column at the right of the page, you have isolated that fault. Do the steps in that box to repair the cause of the fault.
- Make sure that fault is corrected to complete the procedure.

Do the Fault Isolation Procedure
Figure 4

EFFECTIVITY

ALL

34-HOW TO USE THE FIM

01

Page 4
Sep 20/98

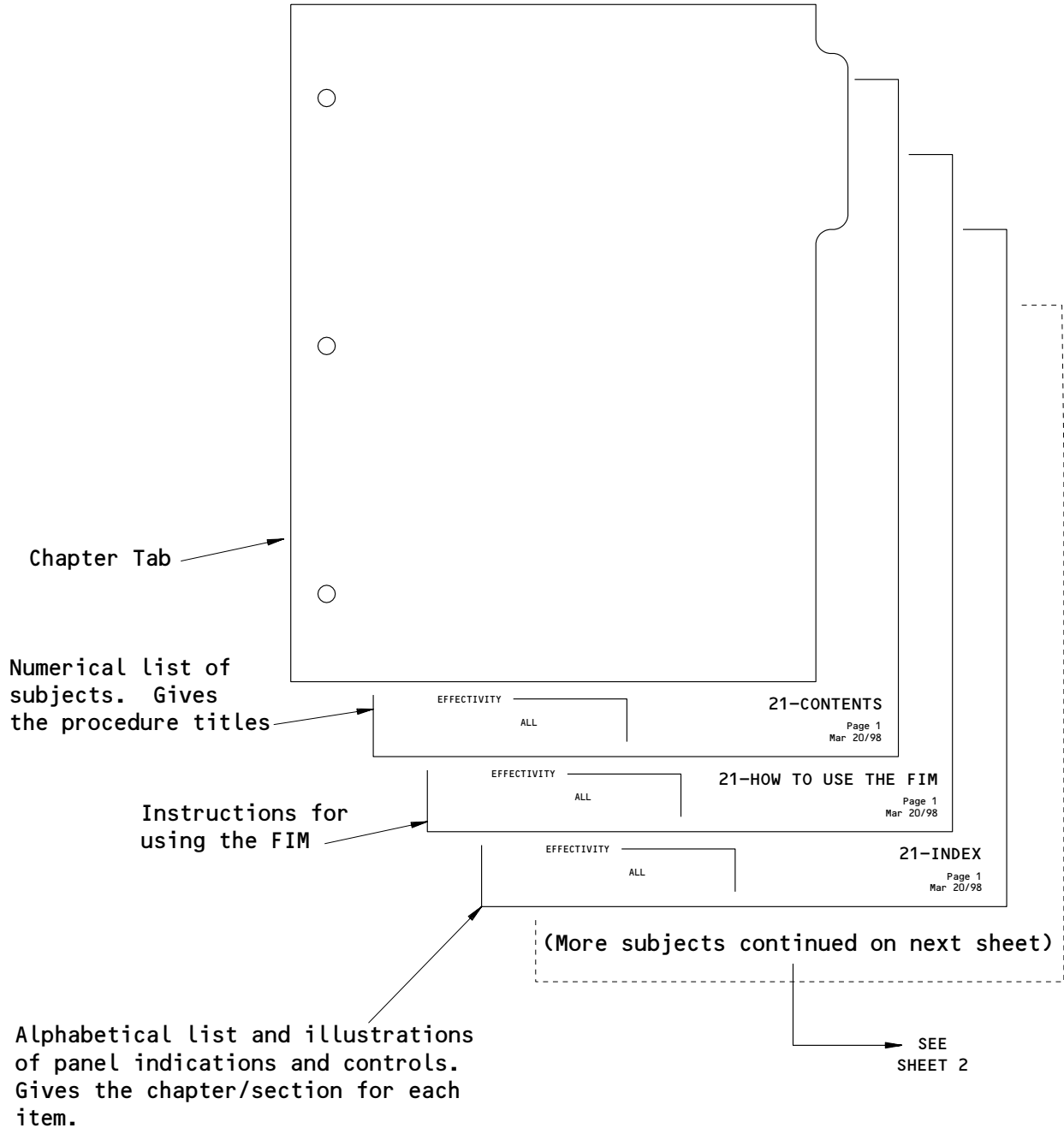

Subjects in Each FIM Chapter
Figure 5 (Sheet 1)

EFFECTIVITY	ALL
-------------	-----

34-HOW TO USE THE FIM

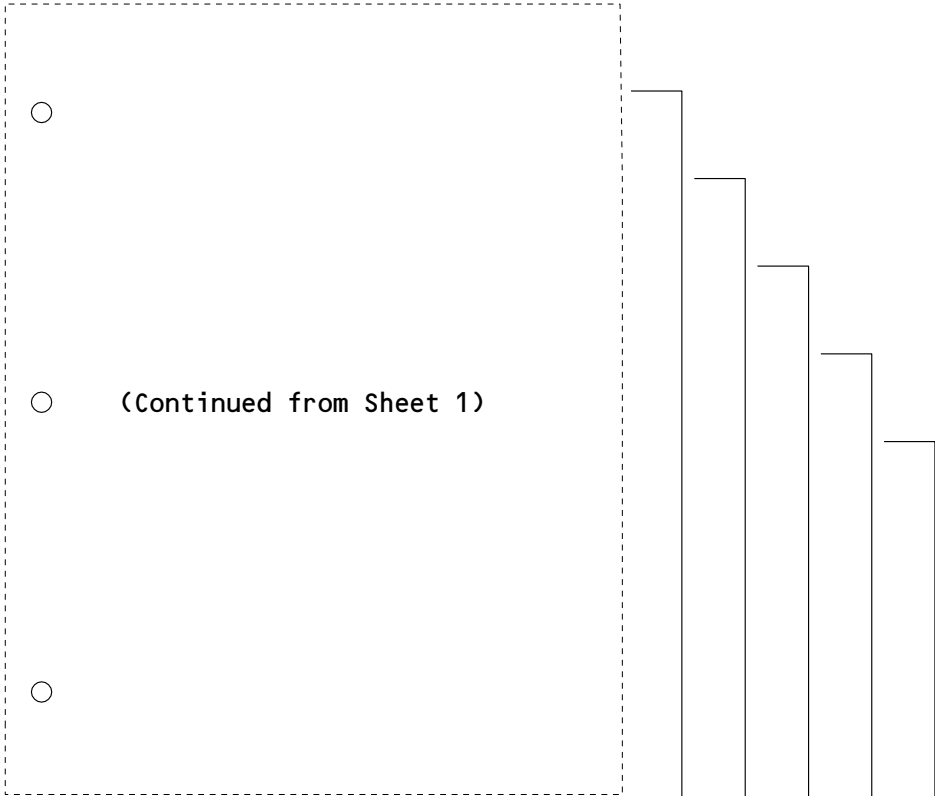

Alphabetical list of the EICAS messages. Gives the procedure to repair the cause of the message or a reference to a fault isolation procedure.

Failure analysis diagrams for the airplane systems to find the correct fault code for the fault.

Numerical list of fault codes. Gives the procedure to repair the cause of the fault or a reference to a fault isolation procedure.

EFFECTIVITY	ALL	21-EICAS MESSAGES	Page 1 Mar 20/98
-------------	-----	-------------------	---------------------

EFFECTIVITY	ALL	21-FAULT CODE DIAGRAMS	Page 1 Mar 20/98
-------------	-----	------------------------	---------------------

EFFECTIVITY	ALL	21-FAULT CODE INDEX	Page 1 Mar 20/98
-------------	-----	---------------------	---------------------

EFFECTIVITY	ALL	21-BITE INDEX	Page 1 Mar 20/98
-------------	-----	---------------	---------------------

EFFECTIVITY	ALL	21-11-00	Page 101 Mar 20/98
-------------	-----	----------	-----------------------

Alphabetical list of all the LRUs/systems that have BITE. Gives the chapter/section for the BITE procedure.

Component index, component location, and fault isolation procedures for the systems in the chapter.

Subjects in Each FIM Chapter
Figure 5 (Sheet 2)

EFFECTIVITY	ALL
-------------	-----

34-HOW TO USE THE FIM

NAVIGATION

TABLE OF CONTENTS ON PAGES 2 THRU 3

<u>FMC MESSAGES</u>	<u>PAGE</u>
FUEL (QTY ERROR, DISAGREE) - PROG 2/2	3461
IRS NAV ONLY	3461
PERF/VNAV UNAVAILABLE	3461
RESYNC FAIL - SINGLE FMC	3461
REENTER IRS POS	3461
RESYNCING OTHER FMC	3461
SINGLE FMC OPERATION	3461

MISCELLANEOUS MESSAGES

SG FAIL	3422
MAP FAIL	3461

NAVIGATION - INDEX

EFFECTIVITY

ALL

34-INDEX

03

Page 1
Jan 28/00

L03678

BOEING

757

FAULT ISOLATION/MAINT MANUAL

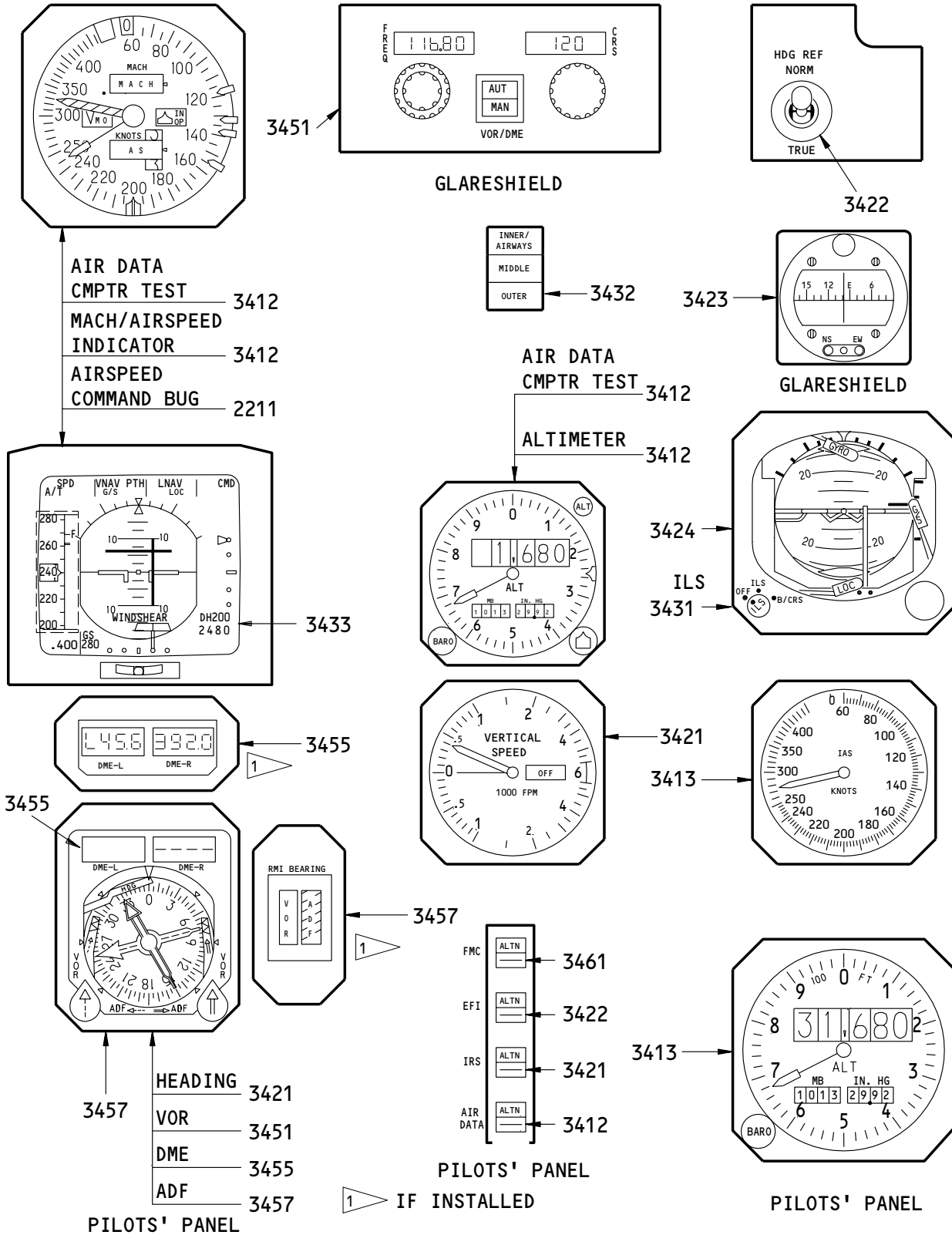

IF INSTALLED

NAVIGATION - INDEX

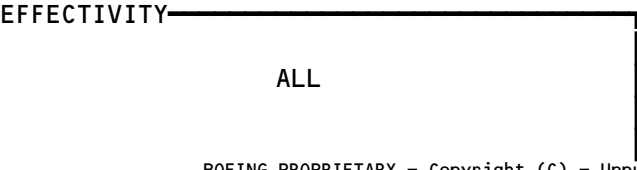

34-INDEX

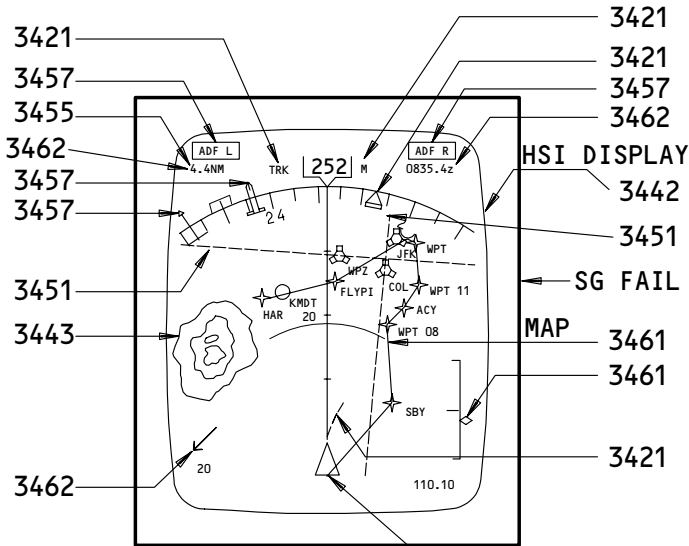
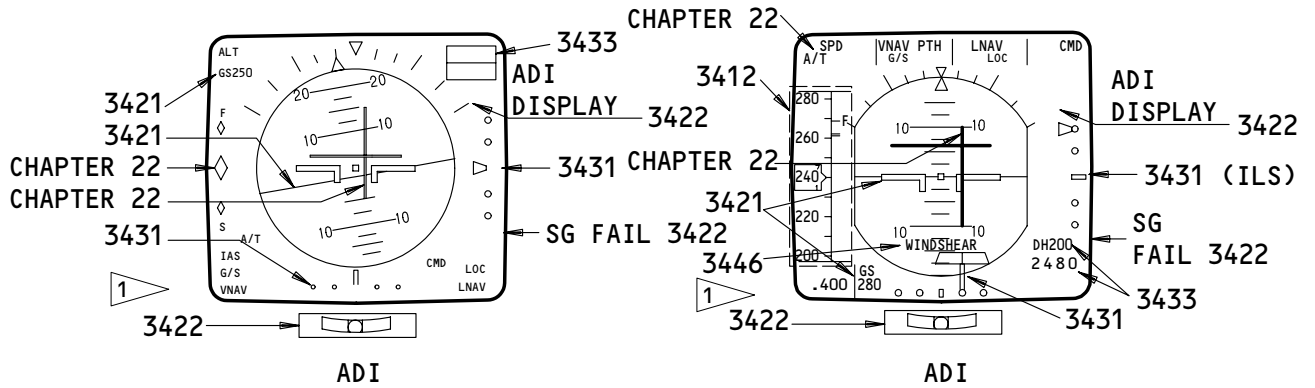

HSI (MAP MODE)
PILOTS' PNL

ILS MODE 3431
VOR MODE 3451

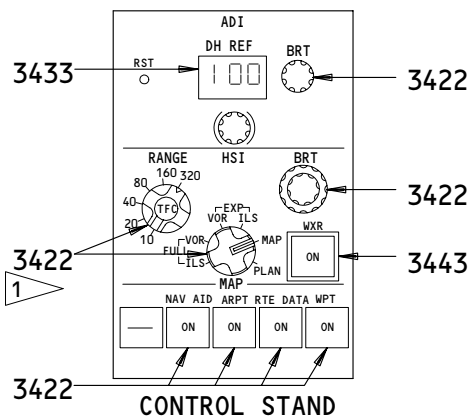

1 AS INSTALLED

ADI FLAGS

ATT	3421
DH	3433
FD	CHAPTER 22
GS	3431
LOC	3431
RA	3433
SPD	CHAPTER 22 /3412

HSI (PLAN MODE, MAP MODE AND WXR) FLAGS, MSGS

ADF L	3457
ADF R	3457
HDG	3421
MAP	3462
MAP RANGE DISAGREE	3462
TRK	3421
VTK	3462
WXR ATT	3443
WXR DSPY	3443
WXR FAIL	3443
WXR FAIL ANT	3443
WXR FAIL ATT	3443
WXR FAIL CONT	3443
WXR FAIL RT	3443
WXR FAIL WEAK	3443
WXR RANGE DISAGREE	3443
WXR/MAP RANGE DISAGREE	3443

HSI (VOR MODE) FLAGS

VOR	3451
-----	-------	------

HSI (ILS MODE) FLAGS

GS	3431
LOC	3431

NAVIGATION - INDEX

EFFECTIVITY

ALL

34-INDEX

BOEING

757 FAULT ISOLATION/MAINT MANUAL

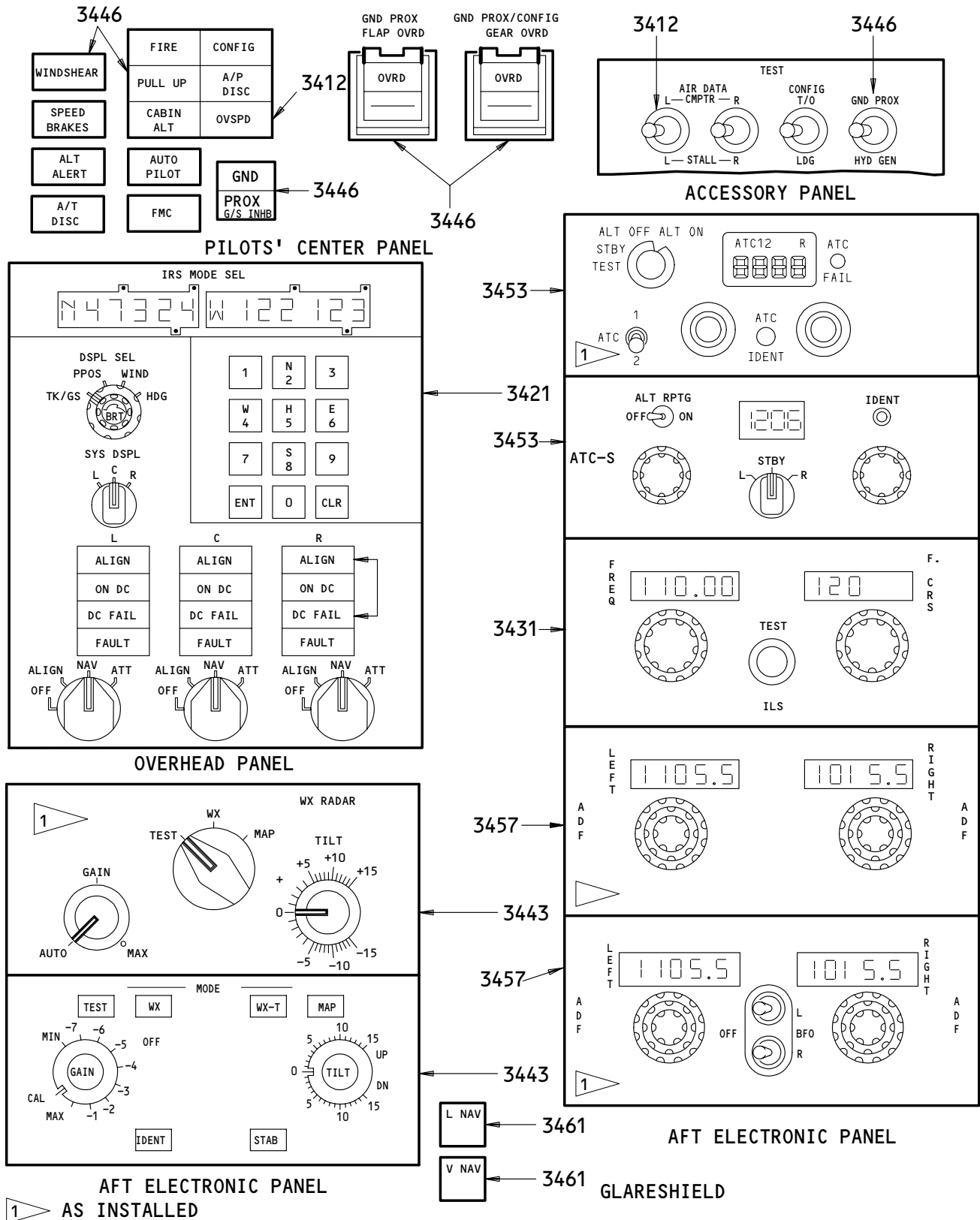

NAVIGATION - INDEX

EFFECTIVITY

ALL

34-INDEX

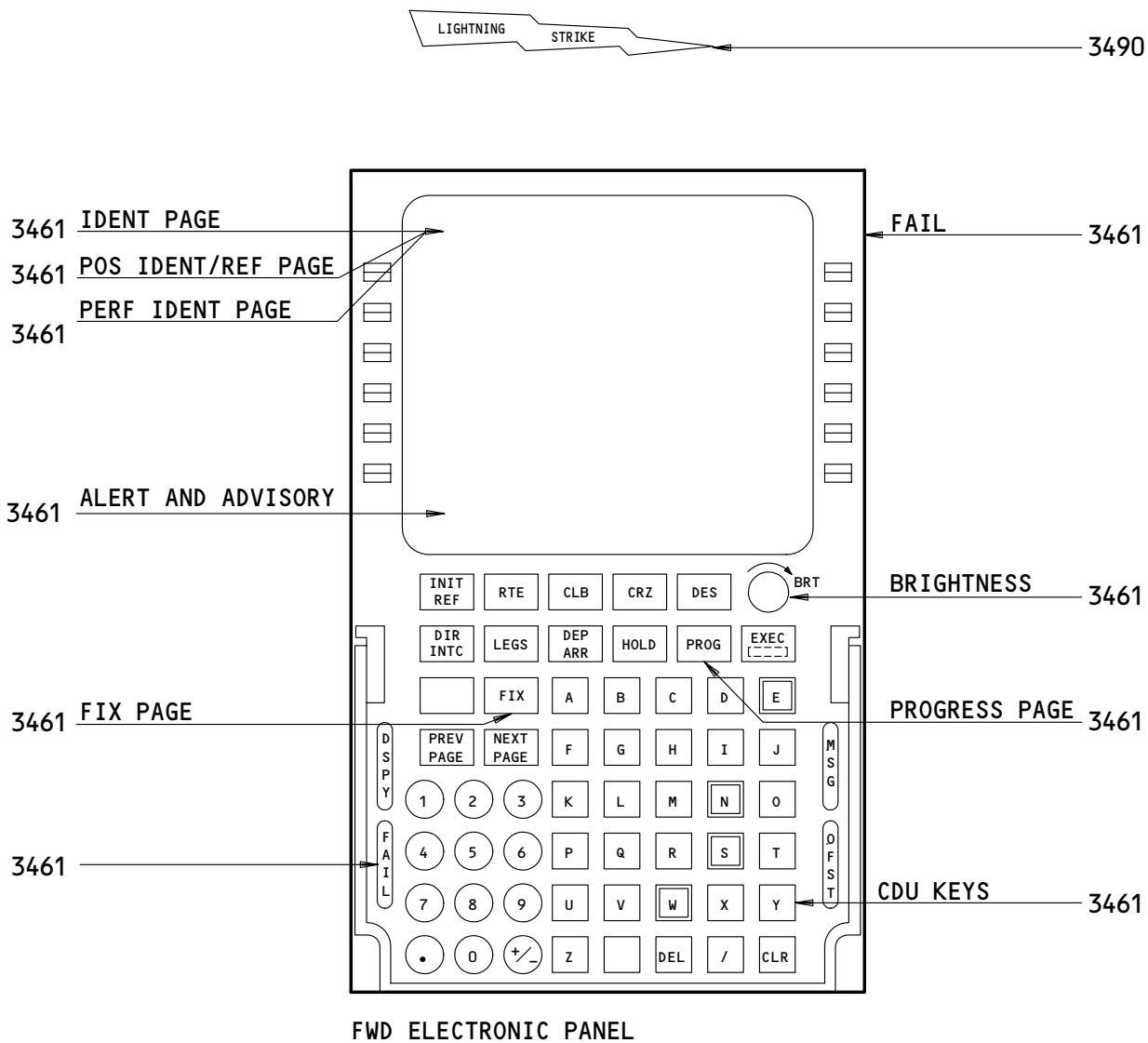

NAVIGATION - INDEX

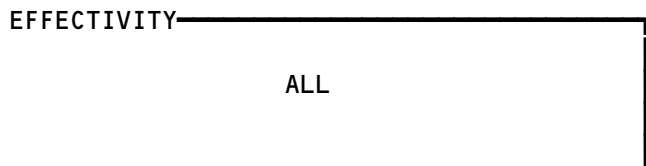

34-INDEX

 **BOEING**
757
FAULT ISOLATION/MAINT MANUAL

<u>TITLE</u>	<u>CHAP/SEC</u>	<u>TITLE</u>	<u>CHAP/SEC</u>
CHART		DH	3433
AIRSPEED TOLERANCES		DME	3455
(CHART 2)	3412,3413	EFI SW (ALTN)	3422
ALTIMETER TOLERANCES		FLIGHT DIRECTOR	CHAPTER 22
(CHART 1)	3412,3413	FMC SW (ALTN).....	3422
CHECK		FMCS	
IRS ACCURACY CHECK.....	3421	AIRSPEED BUG (VNAV MODE) ..	3461
ADF		ALERT/ADVISORY.....	3461
ADF MODE (AUDIO & FLAGS) ..	3457	MESSAGES.....	3461
ANT MODE (AUDIO & FLAGS) ..	3457	CDU BRIGHTNESS.....	3461
CONTROL	3457	CDU FAIL	3461
RMI/RDMI	3457	CDU KEYS	3461
ADI		DISPLAY.....	3461
ATTITUDE	3421	EPR BUG (VNAV MODE).....	3461
DISPLAY	3422	FIX PAGE	3461
STANDBY.....	3424	FMC FAIL	3461
AIR DATA COMPUTER		HSI RANGE, MAP AND	
TEST, SW (ALTN).....	3412	MODE SEL.....	3461
AIRSPEED (ELECTRIC, METRIC) .	3412	IDENT PAGE.....	3461
AIRSPEED (STANDBY).....	3413	LNAV GUIDANCE.....	3461
ALTIMETER (ELECTRIC).....	3413	MAP DATA	3461
ALTIMETER STANDBY	3413	MAP GENERAL.....	3461
ALTITUDE ALERT.....	CHAPTER 22	PERFORMANCE INIT.....	3461
ATC TRANSPONDER.....	3453	POSITION INIT.....	3461
AUTOPILOT.....	CHAPTER 22	POSITION REF	3461
AUTOTHROTTLE	CHAPTER 22	PROGRESS PAGE.....	3461
COMPASS (STANDBY).....	3423	RESYNC	3461
CDU	SEE FMC	VNAV GUIDANCE.....	3461

NAVIGATION – INDEX

EFFECTIVITY

ALL

34-INDEX

01

Page 6
May 20/98



757

FAULT ISOLATION/MAINT MANUAL

<u>TITLE</u>	<u>CHAP/SEC</u>	<u>TITLE</u>	<u>CHAP/SEC</u>
GLIDESLOPE	3431	IRS DATA ENTRY AND DISPLAY	3421
GROUND PROXIMITY WARN		IRS SW (ALTN).....	3422
INHIBIT	3446	LIGHTNING STRIKE	3490
OPERATION	3446	MACH (ELEC).....	3412
OVERRIDE	3446	MARKER BEACON	3432
TEST	3446	RADIO ALTIMETER.....	3433
GROUND SPEED (ADI).....	3421	RMI/RDMI HEADING.....	3421
GROUND SPEED (IRS).....	3421	STANDBY	
HEADING REF.....	3422	AIRSPEED	3413
HSI		ALTIMETER	3413
DISPLAY	3421	ATTITUDE INDICATOR.....	3424
HEADING	3421	COMPASS	3423
TRACK	3421	TCAS	3445
TREND VECTOR.....	3421	TEMPERATURE (SAT, TAT).....	3412
ILS		TRUE AIRSPEED (TAS).....	3412
ADI DISPLAY.....	3431	VERTICAL SPEED INDICATOR.....	3421
CONTROLS	3431	VOR	
HSI DISPLAY.....	3431	BRG FLAG MAP MODE	3443
HSI FAULTS.....	3431	CONT & DISPLAY.....	3443
IDENT.....	3431	IDENT	3443
STANDBY ATTITUDE DISPLAY	3431	WEATHER RADAR	
TEST	3431	CONTROLS	3443
INSTRUMENT COMPARATOR BITE	3425	DISPLAY	3443
IRS ACCURACY FAULTS.....	3421	FAULT	3443
IRS ALIGN FAULTS.....	3421	TEST	3443
		WINDSHEAR	3446

NAVIGATION - INDEX

EFFECTIVITY

ALL

34-INDEX

01

Page 7
May 20/98

NAVIGATION - EICAS MESSAGE LIST

1. General

- A. This procedure shows the EICAS message locations and gives a list of procedures to find the solution for each message.
- (1) EICAS Message Locations (Fig. 1)
 - (a) Figure 1 shows the location of the EICAS display units and the area where the messages show on the display units.
 - (b) Each message level has a different location. The location and color of each message level is also shown.
 - (2) The EICAS MESSAGE LIST gives the message, level, and procedure for each message.
 - (a) The EICAS MESSAGE column lists the messages alphabetically. Messages which start with L, R, or C are put together and alphabetized at L.
 - (b) The LEVEL column gives all levels for each message as follows:
 - A - Warning messages
 - B - Caution messages
 - C - Advisory messages
 - E - Communications messages (with aural chime)
 - F - Communications messages
 - S - Status messages
 - M - Maintenance messages
 - (c) The PROCEDURE column gives the steps that are necessary to remove the message and includes one or more of the procedures that follow:
 - 1) A Fault Isolation Manual procedure reference
 - 2) A Maintenance Manual procedure and reference
 - 3) Wiring checks and a Wiring Diagram Manual reference
 - 4) A reference to an EICAS message list in a different chapter.
 - 5) A reference to a FAULT CODE INDEX and specified fault codes
 - 6) A step to change the airplane configuration

EFFECTIVITY

ALL

34-EICAS MESSAGES

01

Page 1
May 28/00

BOEING
757
FAULT ISOLATION/MAINT MANUAL

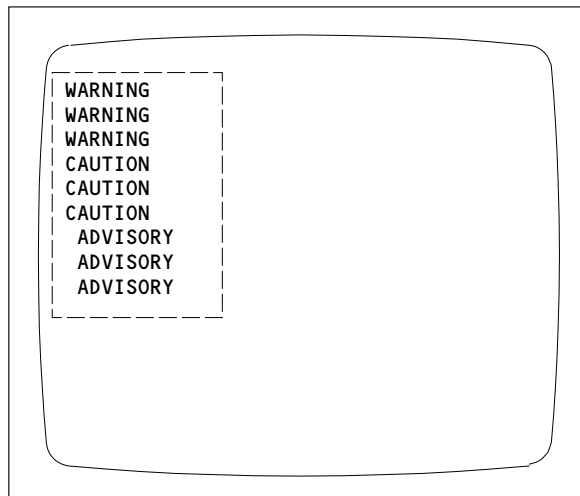
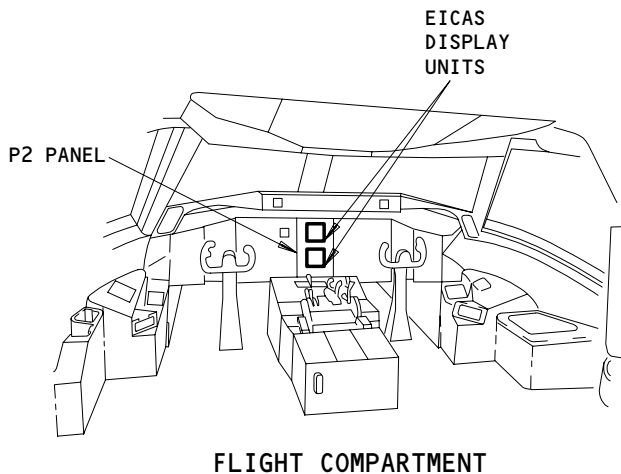

ENGINE PRIMARY PAGE OR COMPACTED PAGE
(TOP DISPLAY UNIT)

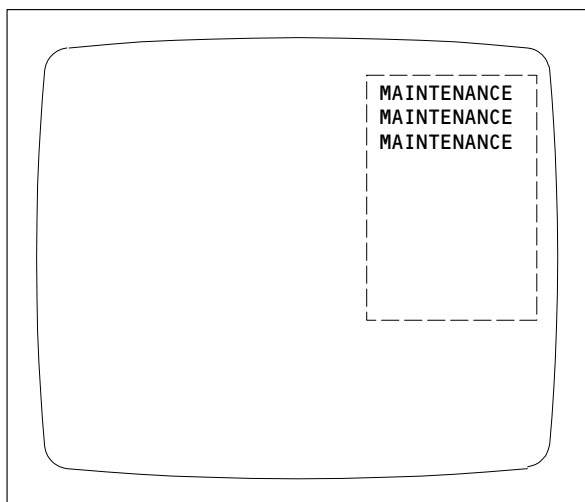

ECS/MSG PAGE
(BOTTOM DISPLAY UNIT)

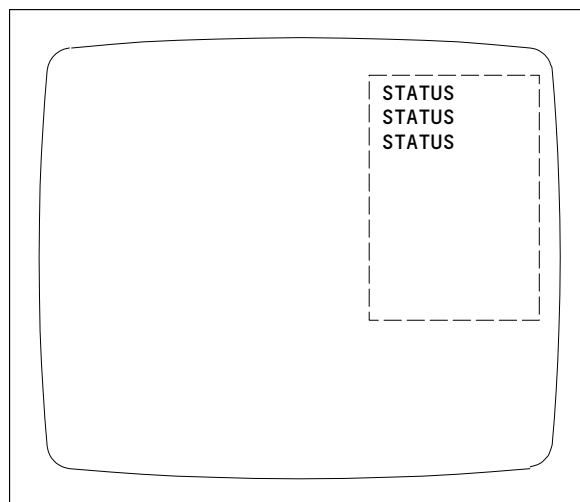

STATUS PAGE
(BOTTOM DISPLAY UNIT)

LEVEL	COLOR
A-WARNING	RED
B-CAUTION	YELLOW
C-ADVISORY	YELLOW
S-STATUS	WHITE
M-MAINTENANCE	WHITE

EICAS Message Locations
Figure 1

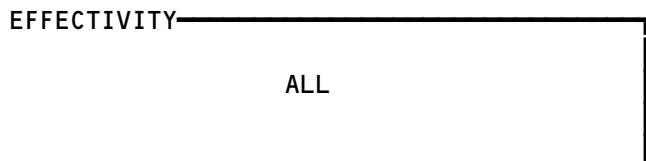

34-EICAS MESSAGES



BOEING
757
FAULT ISOLATION/MAINT MANUAL

EICAS MESSAGE LIST		
EICAS MESSAGE	LEVEL	PROCEDURE
ALT CALLOUTS	C	This message shows when there is a problem with the EGPWC altitude callout function. The most likely cause is a problem with the radio altitude data. Refer to FIM 34-46-00/101, Fig. 103.
ALTITUDE ALERT	B	Replace the altitude alert module, M617 (AMM 34-16-01/401).
ALT DISAGREE	B	FIM 34-12-00/101, Fig. 104.
ATC FAULT	C	FIM 34-53-00/101, Fig. 103
ATT DISAGREE	B	FIM 34-21-00/101, Fig. 107
ATT FAIL	C	Do a check for a nuisance EICAS message: Put the EICAS computer select switch to an alternative position. If the message does not show, open and then close the circuit breaker for the EICAS computer that shows the nuisance message. If the problem continues, replace the EICAS computer that shows the nuisance message. This message is used only during self-test. If this message is not a nuisance message and shows during usual operation, replace the instrument comparator unit (AMM 34-25-01/401).
COMPARATOR BITE	S,M NVM	FIM 34-25-00/101, Fig. 103
F/O PVD	C	EICAS OPS S/W -01 THRU -03; Do a check for a nuisance EICAS message: Put the EICAS computer select switch to an alternative position. If the message does not show, open and then close the circuit breaker for the EICAS computer that shows the nuisance message. If the problem continues, replace the EICAS computer that shows the nuisance message.

EFFECTIVITY

ALL

34-EICAS MESSAGES

02

Page 3
Sep 28/03

BOEING
 757
 FAULT ISOLATION/MAINT MANUAL

EICAS MESSAGE LIST		
EICAS MESSAGE	LEVEL	PROCEDURE
FAST/SLOW FAIL	C	Do a check for a nuisance EICAS message: Put the EICAS computer select switch to an alternative position. If the message does not show, open and then close the circuit breaker for the EICAS computer that shows the nuisance message. If the problem continues, replace the EICAS computer that shows the nuisance message. Used only during self-test. If this message shows during usual operation, replace the instrument comparator unit (AMM 34-25-01/401).
FD COMMAND FAIL	C	Used only during self-test. If this message shows during usual operation, replace the instrument comparator unit (AMM 34-25-01/401).
FMC MESSAGE	C	FIM 34-61-00/101, Fig. 109
GND PROX BITE	S,M	FIM 34-46-00/101, Fig. 103
GND PROX SYS	C	FIM 34-46-00/101, Fig. 103
GND PROX SYS	S,M	FIM 34-46-00/101, Fig. 103
GPS	C	Replace the left and right multimode receivers (AMM 34-31-01/401).
G/S DISAGREE	C	Do a check for a nuisance EICAS message: Put the EICAS computer select switch to an alternative position. If the message does not show, open and then close the circuit breaker for the EICAS computer that shows the nuisance message. If the problem continues, replace the EICAS computer that shows the nuisance message. Used only during self-test. If this message shows during usual operation, replace the instrument comparator unit (AMM 34-25-01/401).

EFFECTIVITY

ALL

34-EICAS MESSAGES



BOEING
757
FAULT ISOLATION/MAINT MANUAL

EICAS MESSAGE LIST		
EICAS MESSAGE	LEVEL	PROCEDURE
G/S FAIL	C	Do a check for a nuisance EICAS message: Put the EICAS computer select switch to an alternative position. If the message does not show, open and then close the circuit breaker for the EICAS computer that shows the nuisance message. If the problem continues, replace the EICAS computer that shows the nuisance message. Used only during self-test. If this message shows during usual operation, replace the instrument comparator unit (AMM 34-25-01/401).
HDG DISAGREE	C	Do a check for a nuisance EICAS message: Put the EICAS computer select switch to an alternative position. If the message does not show, open and then close the circuit breaker for the EICAS computer that shows the nuisance message. If the problem continues, replace the EICAS computer that shows the nuisance message. GUI 115; If the message is not a nuisance message, see FIM 34-24-00/101, Fig. 107. GUI 001-114, 116-999; Used only during self-test. If this message shows during usual operation, replace the instrument comparator unit (AMM 34-25-01/401).
HDG FAIL	C	Do a check for a nuisance EICAS message: Put the EICAS computer select switch to an alternative position. If the message does not show, open and then close the circuit breaker for the EICAS computer that shows the nuisance message. If the problem continues, replace the EICAS computer that shows the nuisance message. Used only during self-test. If this message shows during usual operation, replace the instrument comparator unit (AMM 34-25-01/401).
IAS DISAGREE	B	FIM 34-12-00/101, Fig. 107.

EFFECTIVITY

ALL

34-EICAS MESSAGES

12

Page 5
Sep 28/03

BOEING
 757
 FAULT ISOLATION/MAINT MANUAL

EICAS MESSAGE LIST		
EICAS MESSAGE	LEVEL	PROCEDURE
INSTR SWITCH	B	If "INSTR SWITCH" shows when only one of the two EFI switches are in the ALTN position, replace the L (R) EFI source select switch, S3 (S11) (AMM 33-13-00/201). If the problem continues, examine and repair the applicable circuits (WDM 34-22-17, WDM 34-22-27).
L(R) FMC FAIL	C	FIM 34-61-00/101, Fig. 108B
L(R) GPS	C	Replace the left (right) multimode receiver (AMM 34-31-01/401).
L(R,C) IRS DC FAIL	C	Restore DC power (AMM 24-22-00/201). If the problem continues, refer to FIM 34-21-00/101, Fig. 105
L(R,C) IRS FAULT	C	FIM 34-21-00/101, Fig. 107
L(R,C) IRS ON DC	C	Restore AC power (AMM 24-22-00/201). If the problem continues, refer to FIM 34-21-00/101, Fig. 106
LOC DISAGREE	C	Do a check for a nuisance EICAS message: Put the EICAS computer select switch to an alternative position. If the message does not show, open and then close the circuit breaker for the EICAS computer that shows the nuisance message. If the problem continues, replace the EICAS computer that shows the nuisance message. Used only during self-test. If this message shows during usual operation, replace the instrument comparator unit (AMM 34-25-01/401).

EFFECTIVITY

ALL

34-EICAS MESSAGES

EICAS MESSAGE LIST		
EICAS MESSAGE	LEVEL	PROCEDURE
LOC FAIL	C	Do a check for a nuisance EICAS message: Put the EICAS computer select switch to an alternative position. If the message does not show, open and then close the circuit breaker for the EICAS computer that shows the nuisance message. If the problem continues, replace the EICAS computer that shows the nuisance message. This message is used only during self-test. If this message is not a nuisance message and shows during usual operation, replace the instrument comparator unit (AMM 34-25-01/401).
OVERSPEED	A	<ul style="list-style-type: none"> - Visually examine the airplane structure (AMM 05-51-04/201). - Do the Air Data System - Operational Test (AMM 34-12-00/501). - If an air data computer fails, replace the applicable air data computer (AMM 34-12-01/401).
PILOT RESPONSE	A,B,C	No activity has been detected on the MCP, EFIS/EICAS, Radio Control Panel, MCDU, or HF/VHF radios. Do a check for a nuisance EICAS message: Put the EICAS computer select switch to an alternative position. If the message does not show, open and then close the circuit breaker for the EICAS computer that shows the nuisance message. If the problem continues, replace the EICAS computer that shows the nuisance message.

EFFECTIVITY

ALL

34-EICAS MESSAGES

BOEING
 757
 FAULT ISOLATION/MAINT MANUAL

EICAS MESSAGE LIST		
EICAS MESSAGE	LEVEL	PROCEDURE
RA DISAGREE	C	Do a check for a nuisance EICAS message: Put the EICAS computer select switch to an alternative position. If the message does not show, open and then close the circuit breaker for the EICAS computer that shows the nuisance message. If the problem continues, replace the EICAS computer that shows the nuisance message. Used only during self-test. If this message shows during usual operation, replace the instrument comparator unit (AMM 34-25-01/401).
TCAS	C	FIM 34-45-00/101, Fig. 103
TCAS FAIL	C	FIM 34-45-00/101, Fig. 103
TCAS OFF	C	TCAS is in TA or TA/RA mode. No maintenance action is necessary.
TERR OVRD	C	This message shows when the TERR OVRD switch is in the OVRD position. If the message shows when the switch is not in the OVRD position, do the Ground Proximity Warning Computer BITE Procedure (FIM 34-46-00/101, Fig. 103).
TERR POS	C	This message shows when there is not enough accuracy in the horizontal position data or if the horizontal position data is not available. This message will stop showing when the accuracy returns or when the data becomes available. If the message continues to show, do the Ground Proximity Warning Computer Bite Procedure (FIM 34-46-00/101, Fig. 103).
TERR SYS	S	This message shows if there is a problem with the EGPWS terrain clearance floor or terrain awareness and display functions. Do the Ground Proximity Warning Computer BITE Procedure (FIM 34-46-00/101, Fig. 103).

EFFECTIVITY

ALL

34-EICAS MESSAGES

EICAS MESSAGE LIST		
EICAS MESSAGE	LEVEL	PROCEDURE
TRACK DISAGREE	C	GUI 115; FIM 34-21-00/101, Fig. 107 GUI 001-114, 116-999; Used only during self-test. If this message shows during usual operation, replace the instrument comparator unit (AMM 34-25-01/401).
TRACK FAIL	C	Do a check for a nuisance EICAS message: Put the EICAS computer select switch to an alternative position. If the message does not show, open and then close the circuit breaker for the EICAS computer that shows the nuisance message. If the problem continues, replace the EICAS computer that shows the nuisance message. Used only during self-test. If this message shows during usual operation, replace the instrument comparator unit (AMM 34-25-01/401).
UNABLE RNP	B,C	Required navigation performance accuracy has not been met. Message is for flight crew awareness only. No maintenance action is necessary.
WINDSHEAR PRED	S	Open then close this circuit breaker on the P11 panel: 11F2, WXR L / 11F27 WXR R (if installed). If the problem continues, do this task: Replace the weather radar transceiver (AMM 34-43-01/401). If the problem continues, refer to FIM 34-43-00/101, Fig. 103.

EFFECTIVITY _____
 ALL

34-EICAS MESSAGES

BOEING
 757
 FAULT ISOLATION/MAINT MANUAL

EICAS MESSAGE LIST		
EICAS MESSAGE	LEVEL	PROCEDURE
WINDSHEAR SYS	C	If this message shows and the "WINDSHEAR PRED" message shows, do the procedure for the "WINDSHEAR PRED" message. If this message shows and the "WINDSHEAR REAC" message shows, do the procedure for the "WINDSHEAR REAC" message.
WXR SYS	S,M (NVM)	Open and then close this circuit breaker on the P11 panel: 11F2, WXR L/ 11F27 WXR R (if installed). If the problem continues, do this task: FIM 34-43-00/101, Fig. 103.

EFFECTIVITY

ALL

34-EICAS MESSAGES

BOEING

757 FAULT ISOLATION/MAINT MANUAL

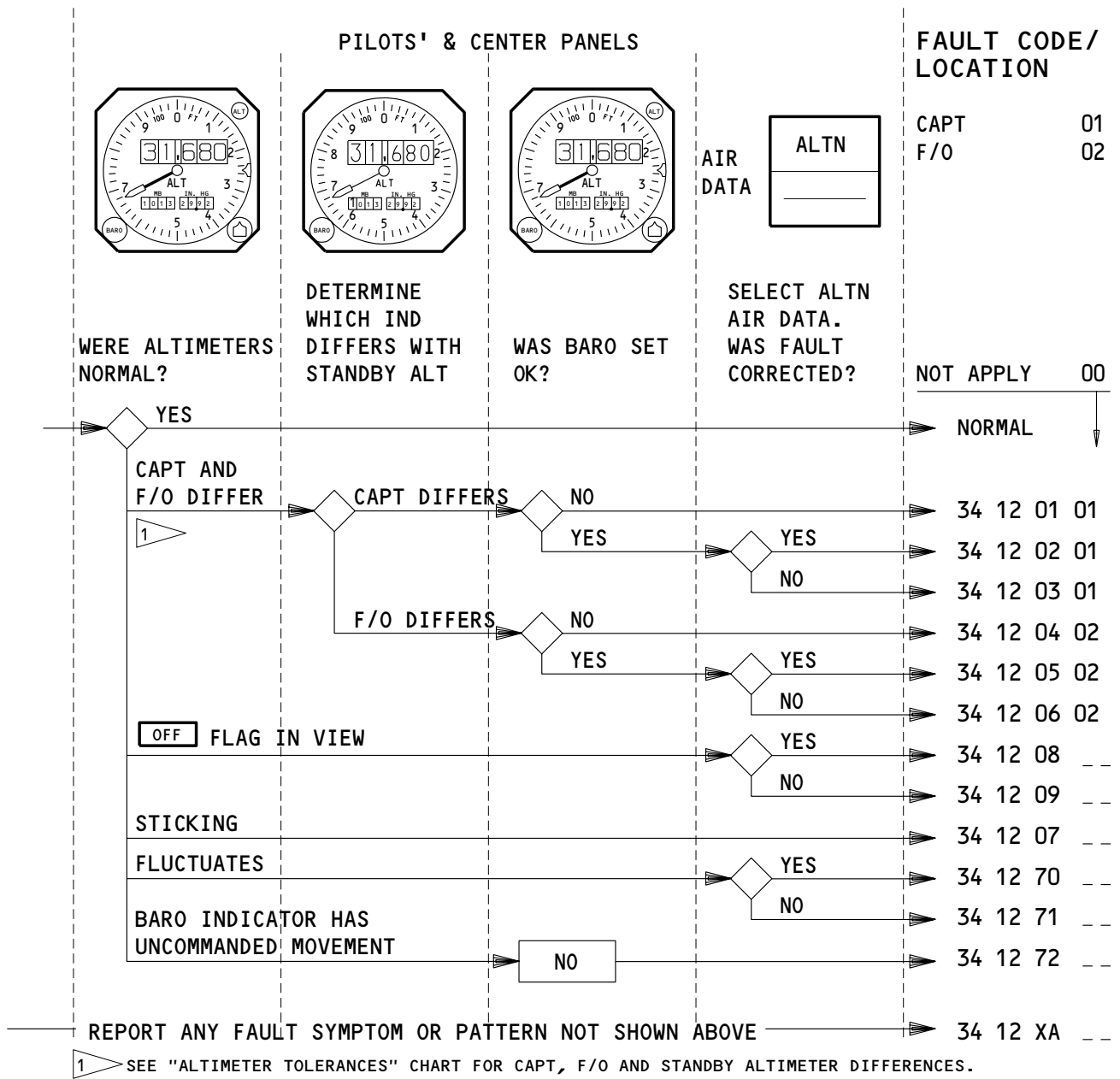

APPLICABLE CIRCUIT BREAKERS AS INSTALLED

11A10	AIR DATA CMPTR (L, LEFT)	11E23	ALTM (R, RIGHT)
11A11	AIR DATA AOA SENSOR (L, LEFT)	11F30	AIR DATA CMPTR (R, RIGHT)
11A12	AIR DATA BARO CORRECT (L, LEFT)	11F31	AIR DATA AOA SENSOR (R, RIGHT)
11E2	ALTM (L, LEFT)	11F32	AIR DATA BARO CORRECT (R, RIGHT)

ELECTRIC ALTIMETER – FAULT CODES

EFFECTIVITY

ALL

34-FAULT CODE DIAGRAM

02

Page 1
May 20/98

PILOTS' CENTER PANEL

FAULT CODE/
LOCATION

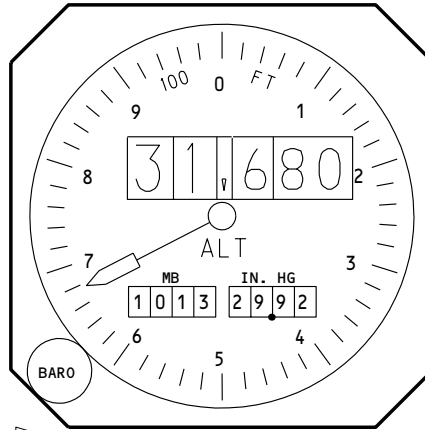
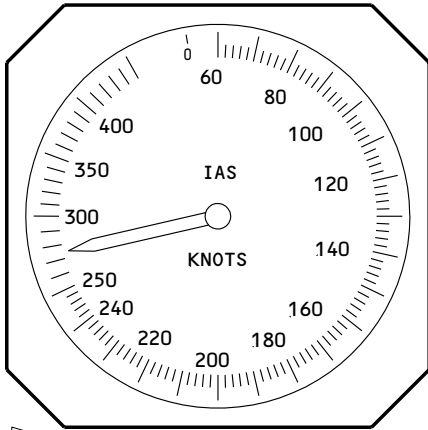

1 WAS STANDBY AIRSPEED INDICATOR NORMAL?

1 WAS STANDBY ALTIMETER NORMAL?

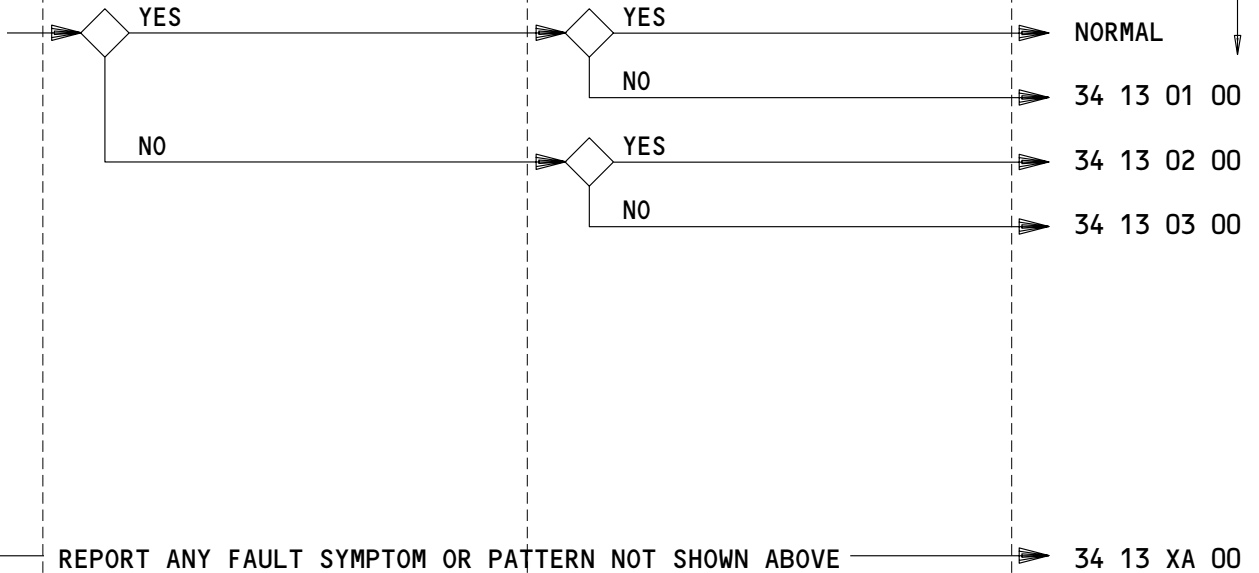

1 FOR ADDITIONAL AIRSPEED/ALTIMETER INFORMATION, REFER TO AIRSPEED/ALTIMETER TOLERANCE CHART.

APPLICABLE CIRCUIT BREAKERS

11A8 STBY ALTM VIB

STANDBY AIRSPEED AND ALTIMETER - FAULT CODES

EFFECTIVITY

ALL

34-FAULT CODE DIAGRAM

BOEING
757
FAULT ISOLATION/MAINT MANUAL

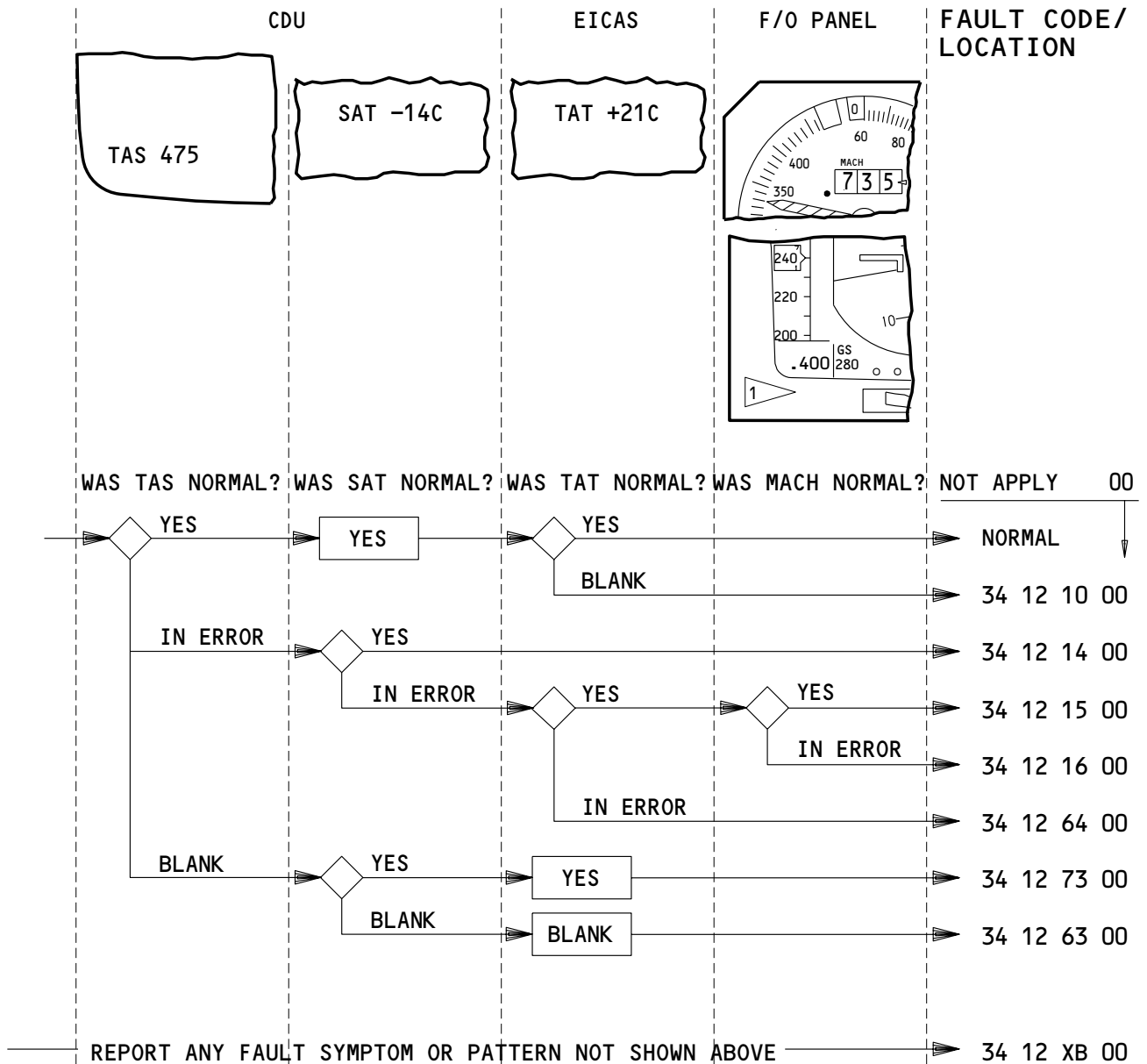

1 AS INSTALLED

APPLICABLE CIRCUIT BREAKERS AS INSTALLED

11A10	AIR DATA CMPTR (L, LEFT)
11E22	IAS MACH (R, RIGHT)
11F14	TMC AC
11F15	TMC DC

11F30	AIR DATA CMPTR (R, RIGHT)
11F31	AIR DATA AOA SENSOR (R, RIGHT)
11F32	AIR DATA BARO CORRECT (R, RIGHT)

TAS, SAT AND TAT - FAULT CODES

EFFECTIVITY

ALL

34-FAULT CODE DIAGRAM

04

Page 3
May 28/01

BOEING

757

FAULT ISOLATION/MAINT MANUAL

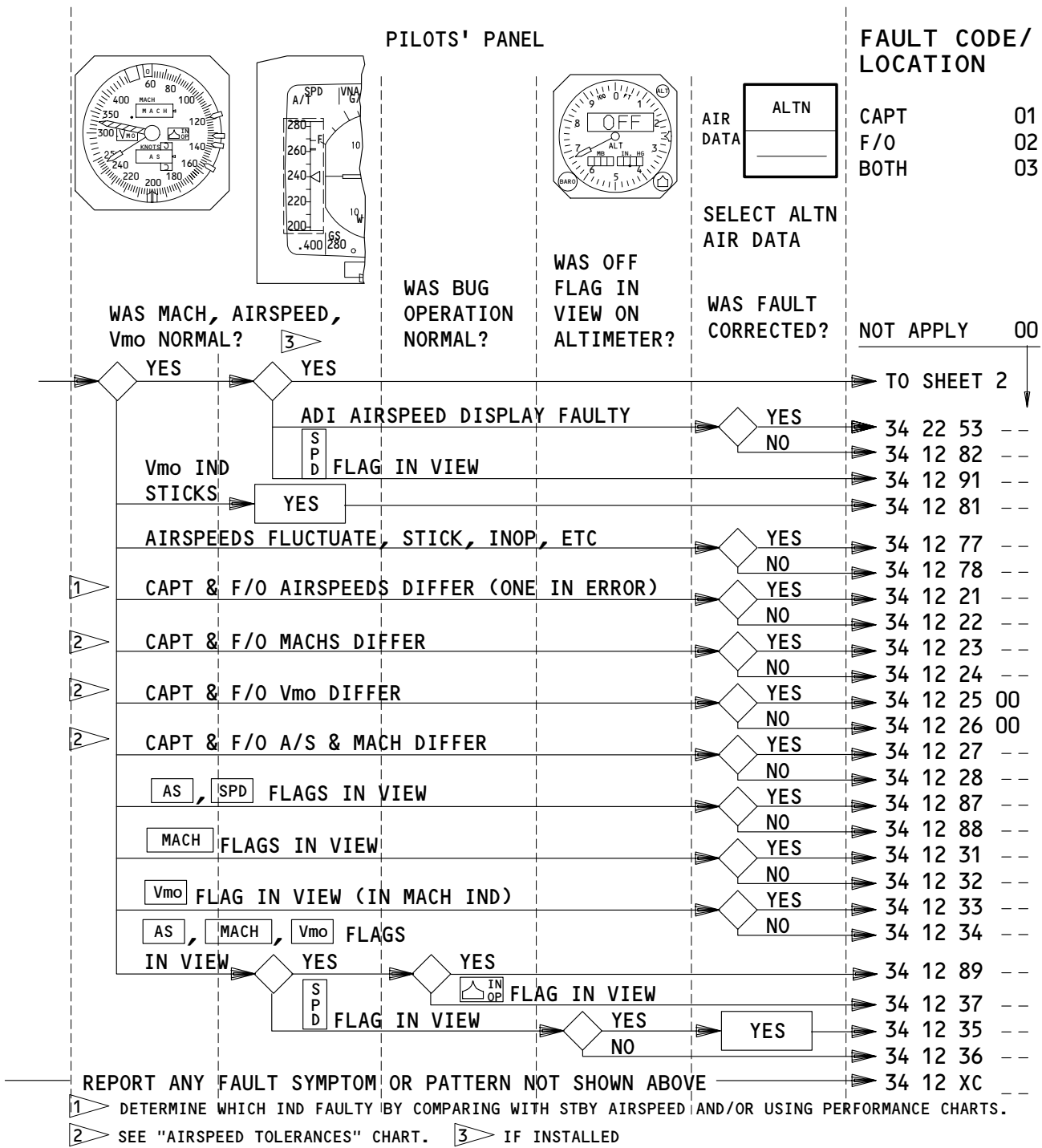

APPLICABLE CIRCUIT BREAKERS

11A10 AIR DATA CMPTR (LEFT, L)	11A12 AIR DATA BARO CORRECT (LEFT, L)	11F30 AIR DATA CMPTR (RIGHT, R)
11A11 AIR DATA AOA SENSOR (LEFT, L)	11F8 EFIS SYM GEN (LEFT, L)	11F31 AIR DATA AOA SENSOR (RIGHT, R)
11E1 IAS MACH (LEFT, L)	11F9 EFIS SYM GEN (CENTER, C)	11F32 AIR DATA BARO CORRECT (RIGHT, R)
11E22 IAS MACH (RIGHT, R)	11F29 EFIS SYM GEN (RIGHT, R)	

ELECTRIC MACH, AIRSPEED & ALTN AIR DATA (SHEET 1) - FAULT CODES

EFFECTIVITY

ALL

34-FAULT CODE DIAGRAM

BOEING

757

FAULT ISOLATION/MAINT MANUAL

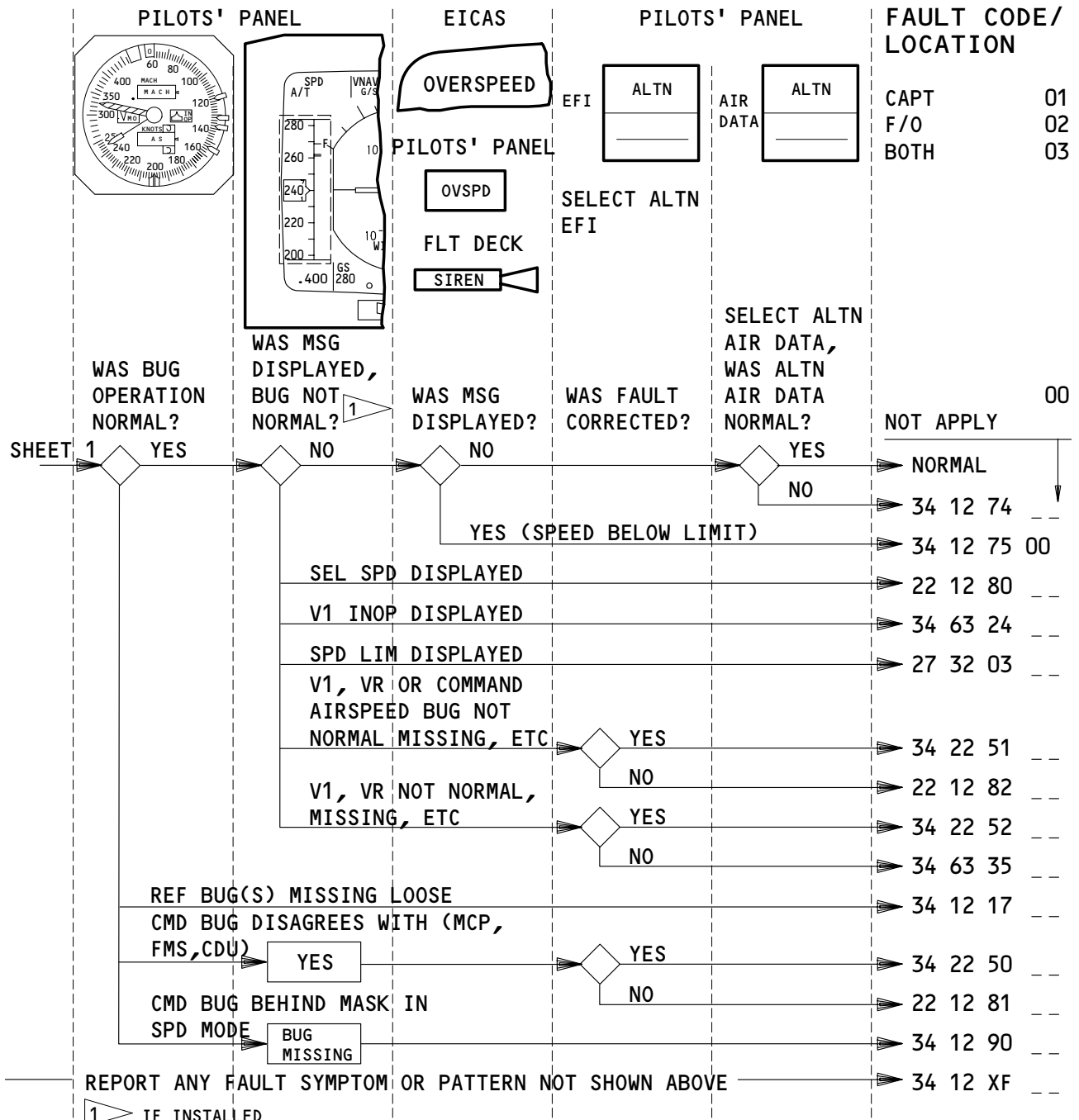

APPLICABLE CIRCUIT BREAKERS

11A10	AIR DATA CMPTR (LEFT, L)	11E22	IAS MACH (RIGHT, R)
11A11	AIR DATA AOA SENSOR (LEFT, L)	11F30	AIR DATA CMPTR (RIGHT, R)
11A12	AIR DATA BARO CORRECT (LEFT, L)	11F31	AIR DATA AOA SENSOR (RIGHT, R)
11E1	IAS MACH (LEFT, L)	11F32	AIR DATA BARO CORRECT (RIGHT, R)

ELECTRIC MACH, AIRSPEED & ALTN AIR DATA (SHEET 2) - FAULT CODES

EFFECTIVITY

ALL

34-FAULT CODE DIAGRAM

08

Page 5
May 28/01

BOEING

757 FAULT ISOLATION/MAINT MANUAL

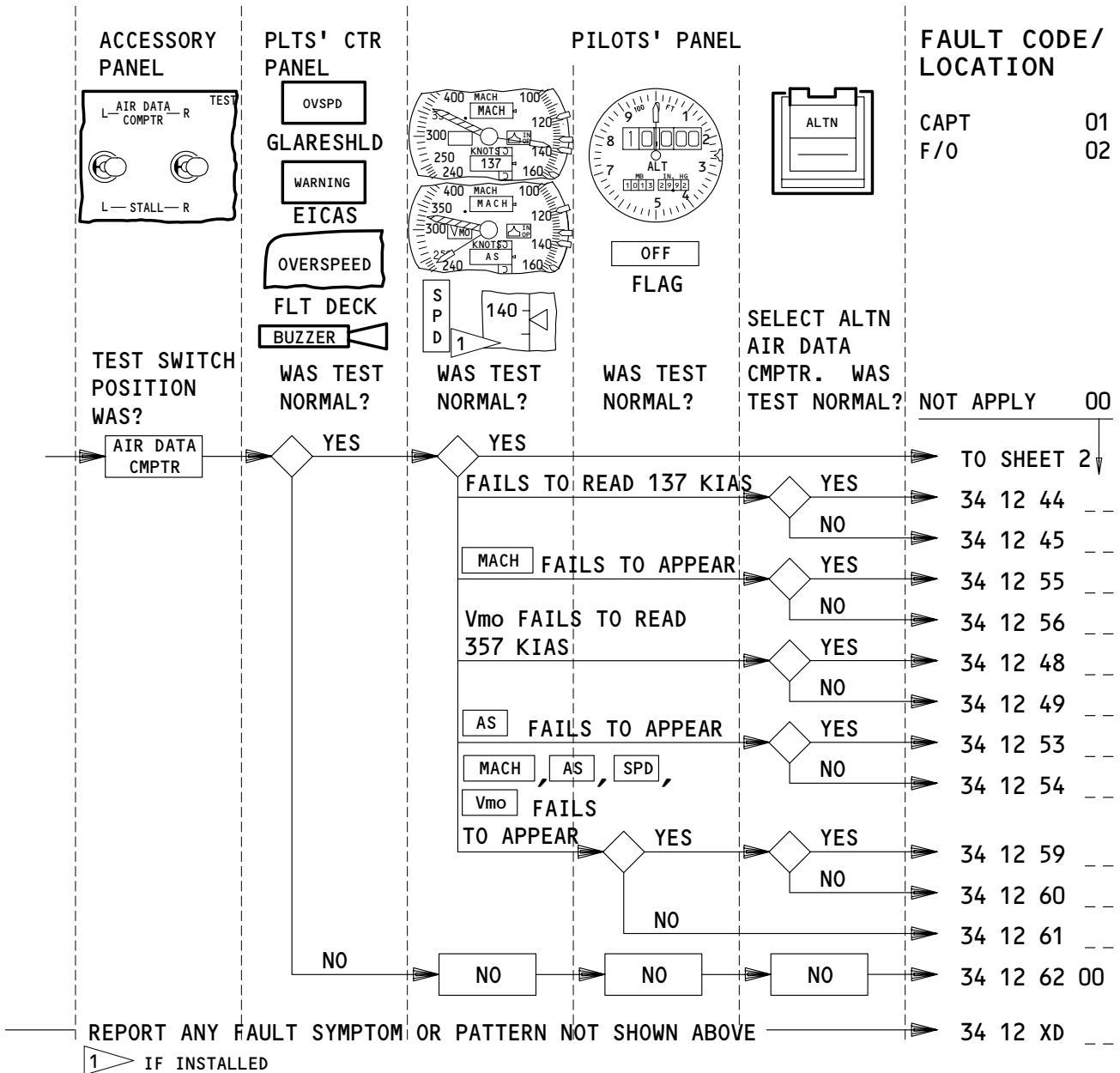

APPLICABLE CIRCUIT BREAKERS

11A10 AIR DATA CMPTR (LEFT, L)	11E22 IAS MACH (RIGHT, R)
11A11 AIR DATA AOA SENSOR (LEFT, L)	11E23 ALTM (RIGHT, R)
11A12 AIR DATA BARO CORRECT (LEFT, L)	11F30 AIR DATA CMPTR (RIGHT, R)
11E1 IAS MACH (LEFT, L)	11F31 AIR DATA AOA SENSOR (RIGHT, R)
11E2 ALTM (LEFT, L)	11F32 AIR DATA BARO CORRECT (RIGHT, R)

AIR DATA COMPUTER TEST (SHEET 1) - FAULT CODES

EFFECTIVITY

ALL

34-FAULT CODE DIAGRAM

09

Page 6
May 28/01

BOEING

757 FAULT ISOLATION/MAINT MANUAL

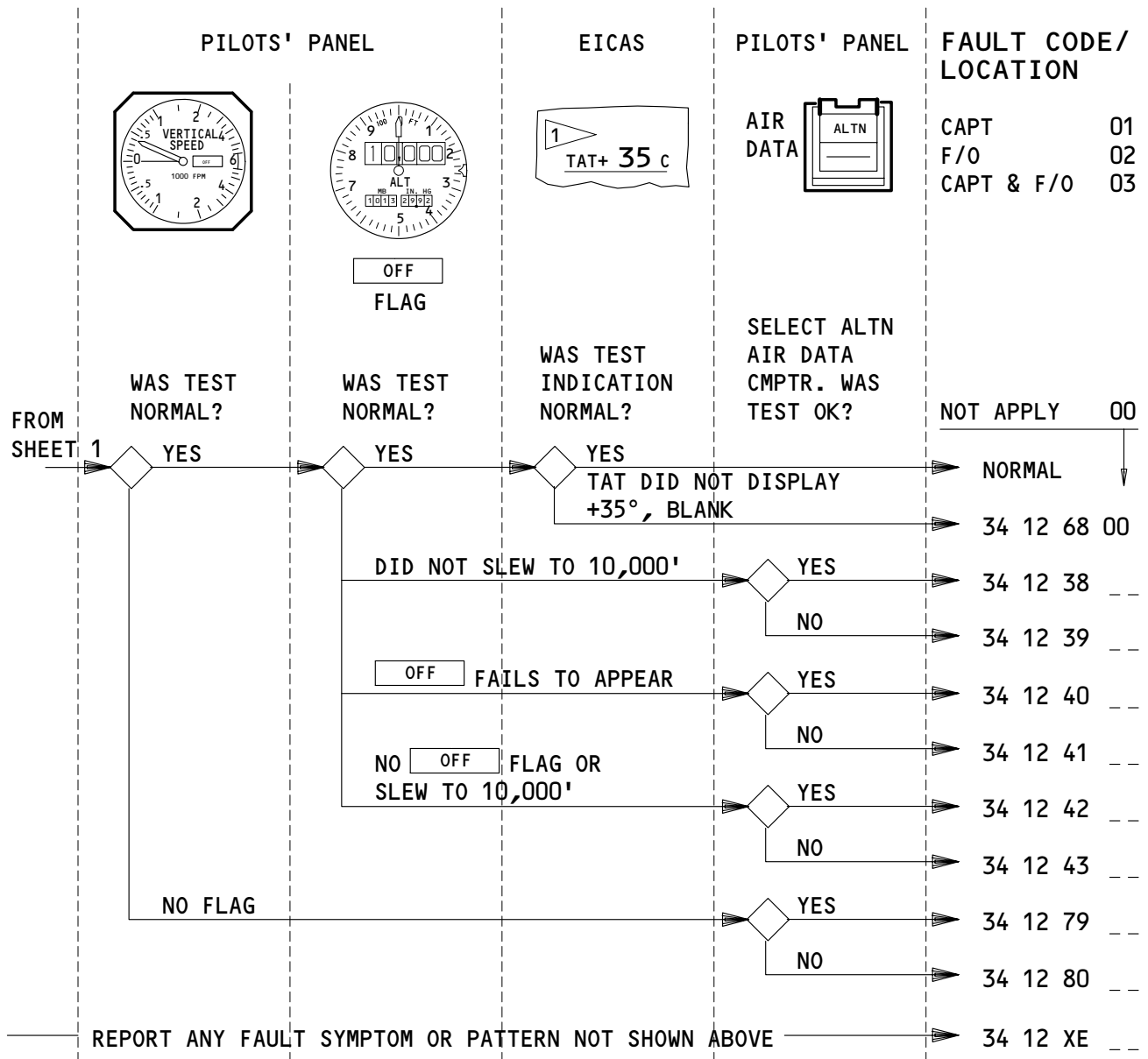

1 TMC MUST BE OFF AND EICAS COMPUTER SELECTED MUST CORRESPOND TO ADC BEING TESTED FOR TAT DISPLAY.

APPLICABLE CIRCUIT BREAKERS

- | | | | |
|-------|---------------------------------|-------|----------------------------------|
| 11A10 | AIR DATA CMPTR (LEFT, L) | 11E22 | IAS MACH (RIGHT, R) |
| 11A11 | AIR DATA AOA SENSOR (LEFT, L) | 11E23 | ALTM (RIGHT, R) |
| 11A12 | AIR DATA BARO CORRECT (LEFT, L) | 11F30 | AIR DATA CMPTR (RIGHT, R) |
| 11E1 | IAS MACH (LEFT, L) | 11F31 | AIR DATA AOA SENSOR (RIGHT, R) |
| 11E2 | ALTM (LEFT, L) | 11F32 | AIR DATA BARO CORRECT (RIGHT, R) |

AIR DATA COMPUTER TEST (SHEET 2) - FAULT CODES

EFFECTIVITY
ALL

34-FAULT CODE DIAGRAM

A52191

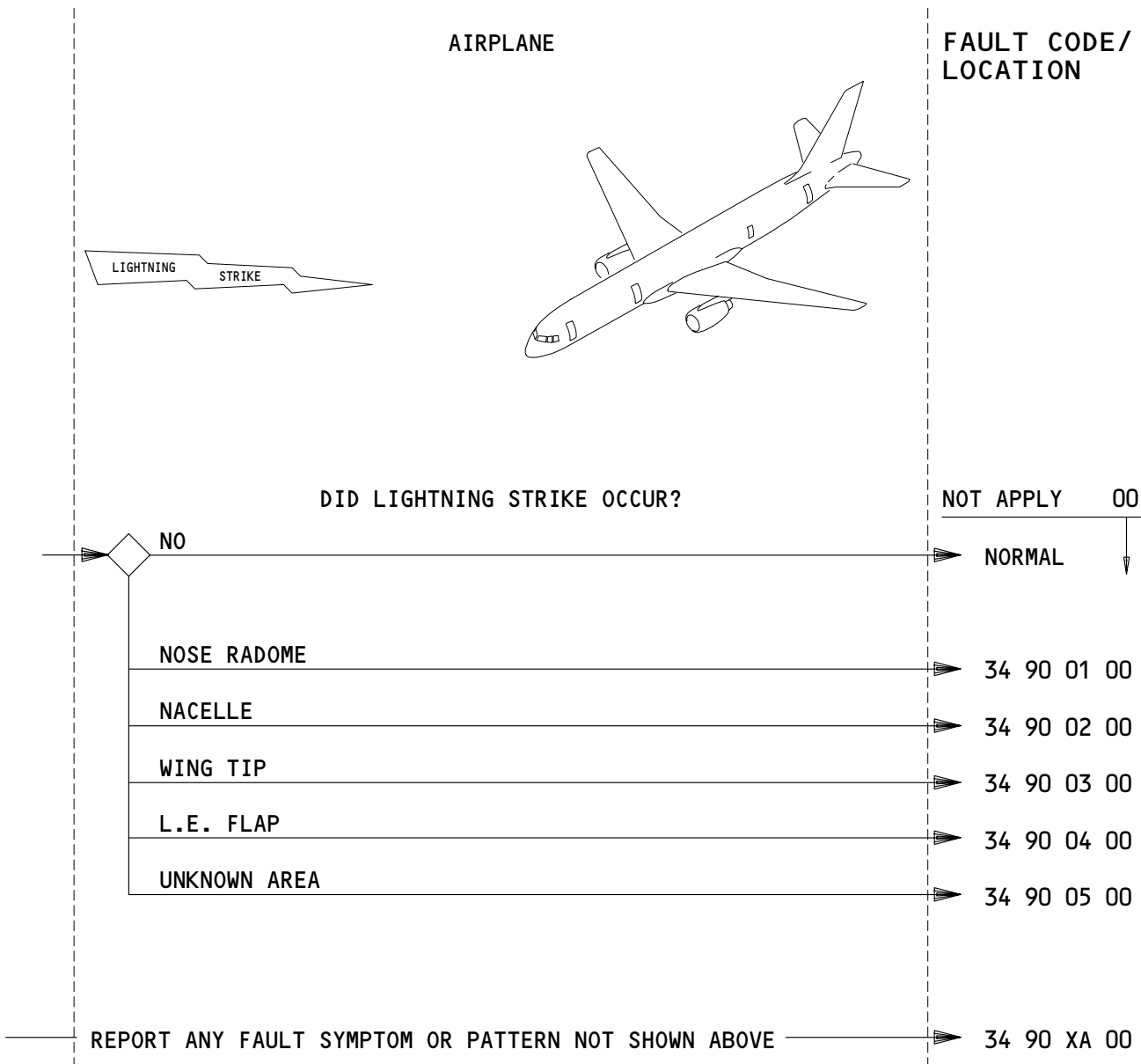

APPLICABLE CIRCUIT BREAKERS

NONE

LIGHTNING STRIKE - FAULT CODES

EFFECTIVITY

ALL

34-FAULT CODE DIAGRAM

01

Page 8
May 28/01

BOEING

757 FAULT ISOLATION/MAINT MANUAL

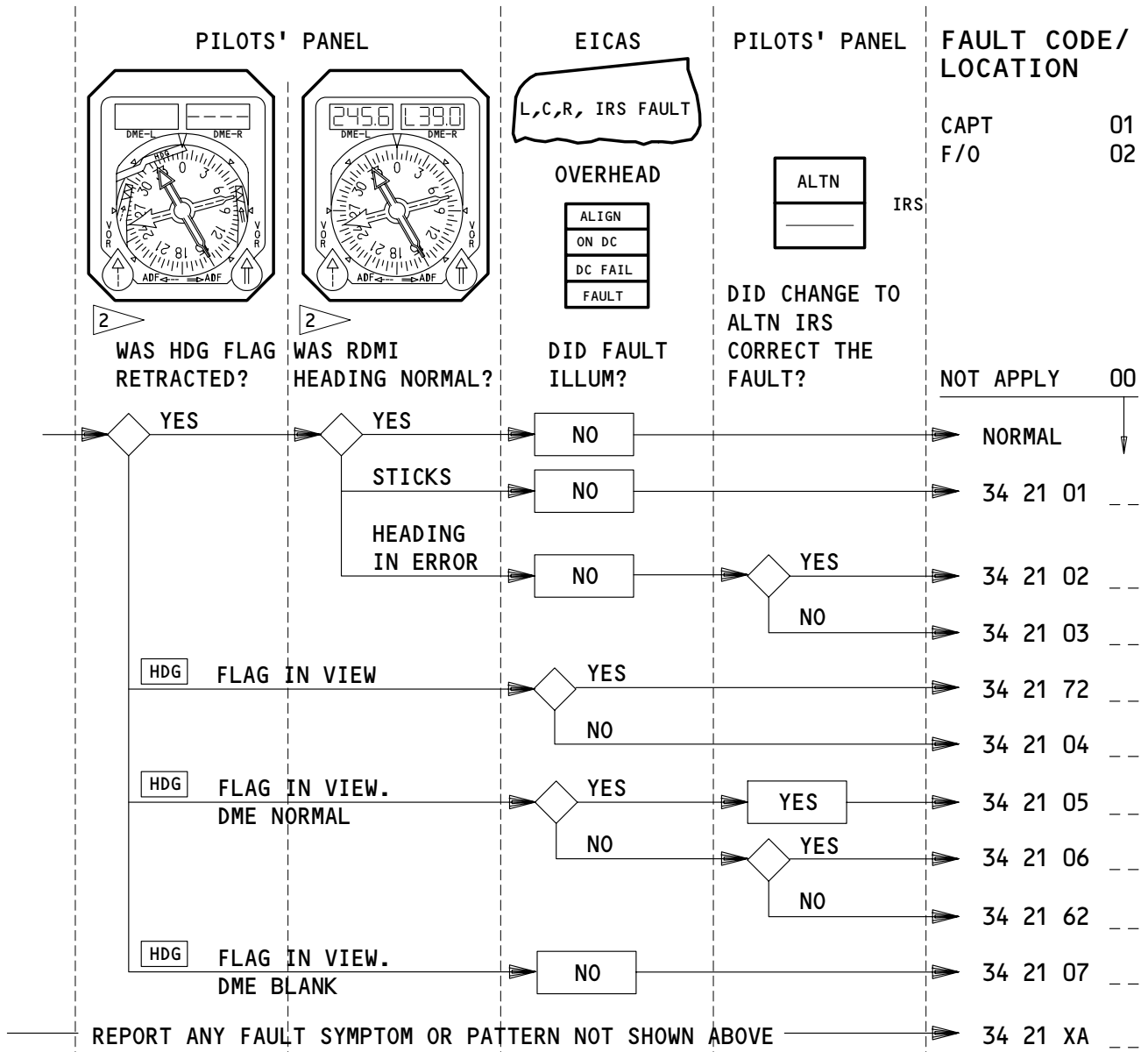

1 AS INSTALLED

2 ON SOME AIRPLANES DME INDICATOR MAY BE SEPERATE FROM RMI INDICATOR

APPLICABLE CIRCUIT BREAKERS

6D3	L IRS	11F1	IRS (LEFT, L)
6D4	C IRS	11F21	IRS (CENTER, C)
6D5	R IRS	11F22	IRS (RIGHT, R)
1 11A6	RDMI LEFT	1 11F23	RMI R
1 11A7	RMI L	1 11F25	RDMI RIGHT

RDMI HEADING - FAULT CODES

EFFECTIVITY

ALL

34-FAULT CODE DIAGRAM

08

Page 9
May 28/01

BOEING

757 FAULT ISOLATION/MAINT MANUAL

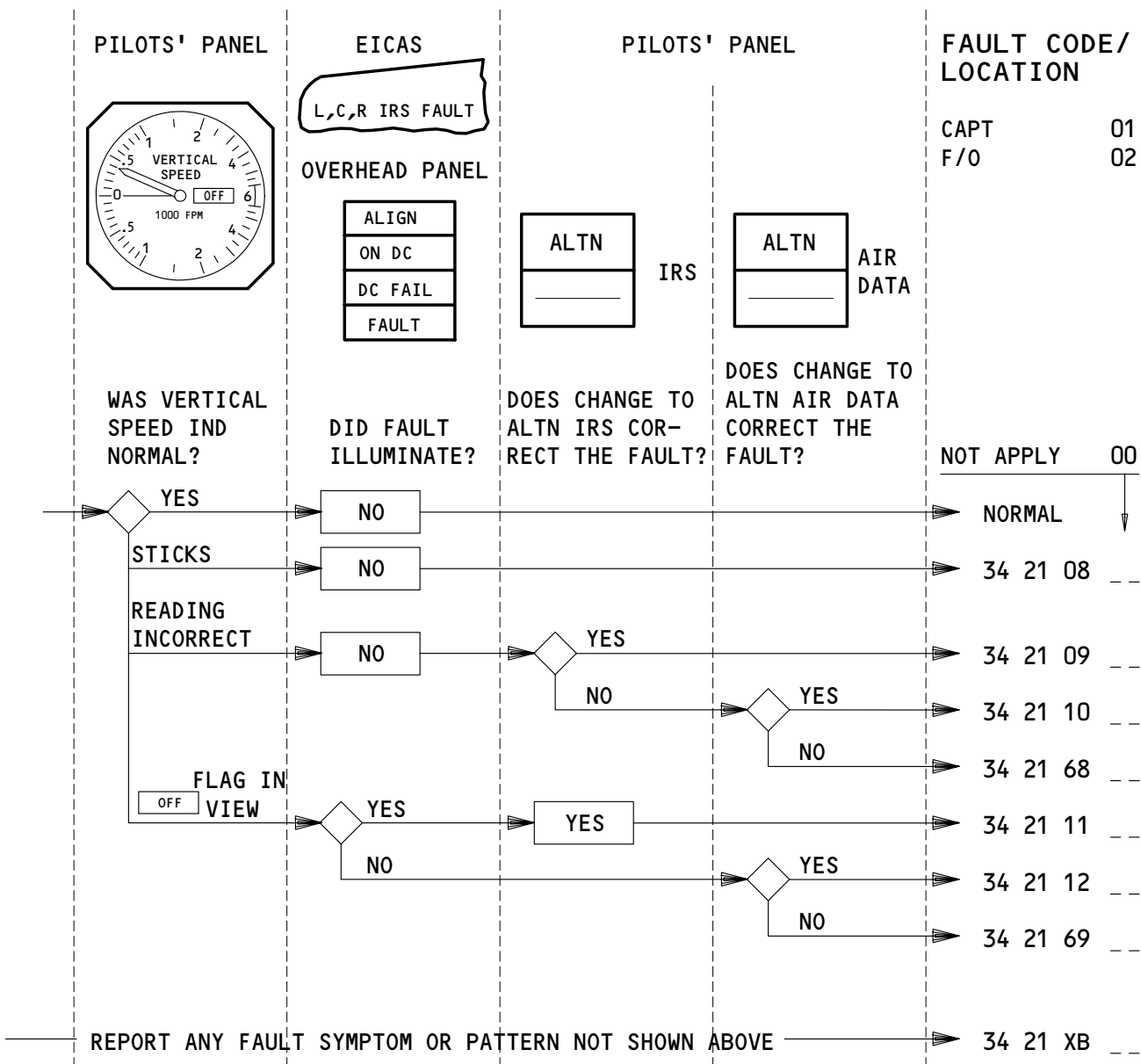

APPLICABLE CIRCUIT BREAKERS

6D3	IRS L	11E26	VSI (RIGHT, R)
6D4	IRS C	11F1	IRS (LEFT, L)
6D5	IRS R	11F21	IRS (CENTER, C)
11E5	VSI (LEFT, L)	11F22	IRS (RIGHT, R)

VERTICAL SPEED INDICATOR - FAULT CODES

EFFECTIVITY

ALL

34-FAULT CODE DIAGRAM

09

Page 10
May 28/01

BOEING

757

FAULT ISOLATION/MAINT MANUAL

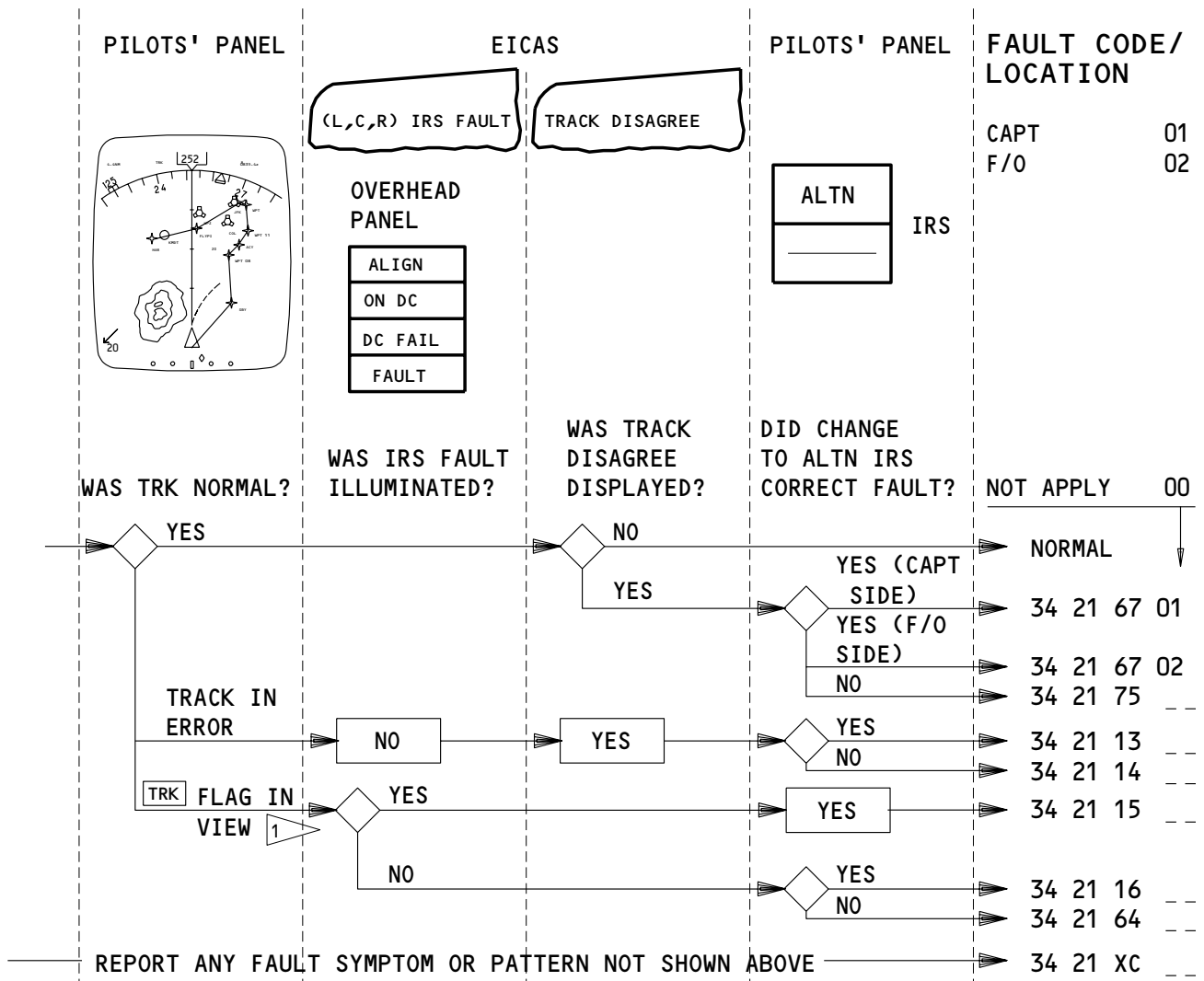

NOTE: MAP MODE SHOWN. FAULTS RECOGNIZED IN VOR/ILS MODES CAN USE THE SAME FAULT CODES. IN VOR/ILS MODES **TRK** FLAG WILL BE REPLACED BY REMOVAL OF TRACK BUG.

APPLICABLE CIRCUIT BREAKERS

6D3	IRS L	11F1	IRS (L, LEFT)
6D4	IRS C	11F8	EFIS SYM GEN (L, LEFT)
6D5	IRS R	11F9	EFIS SYM GEN (C, CENTER)
11A7	EFIS DSPL SW (L, LEFT)	11F21	IRS (C, CENTER)
11E4	EFIS CONT PNL (L, LEFT)	11F22	IRS (R, RIGHT)
11E6	HSI (L, LEFT)	11F24	EFIS DSPL SW (R, RIGHT)
11E25	EFIS CONT PNL (R, RIGHT)	11F29	EFIS SYM GEN (R, RIGHT)
11E27	HSI (R, RIGHT)		

HSI TRACK - FAULT CODES

EFFECTIVITY

ALL

34-FAULT CODE DIAGRAM

02

Page 11
May 28/01

BOEING
757
FAULT ISOLATION/MAINT MANUAL

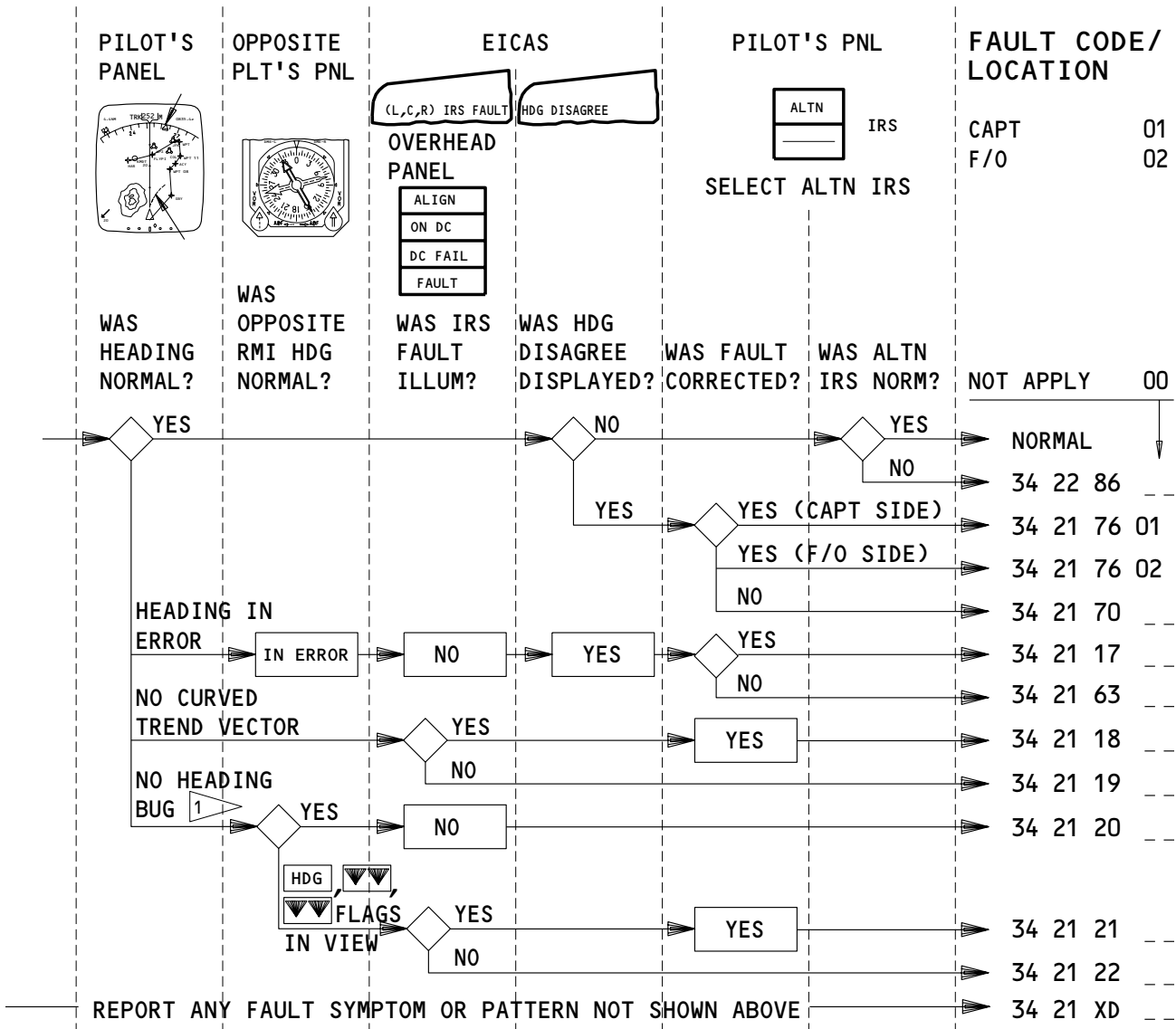

¹ NOTE: MAP MODE SHOWN. FAULTS RECOGNIZED IN VOR/ILS MODES CAN USE THE SAME FAULT CODES. IN VOR/ILS MODES "NO HEADING BUG" WILL BE REPLACED BY HDG FLAGS.

APPLICABLE CIRCUIT BREAKERS AS INSTALLED

6D3	L IRS	11E4	EFIS CONT PNL L	11F21	IRS (CENTER, C)
6D4	C IRS	11E6	HSI (LEFT, L)	11F22	IRS (RIGHT, R)
6D5	R IRS	11E25	EFIS CONT PNL (RIGHT, R)	11F23	RMI R
11A6	RDMI LEFT	11E27	HSI R	11F24	EFIS DSPL SW (RIGHT, R)
11A7	RMI L	11F1	IRS (LEFT, L)	11F25	RDMI RIGHT
11A7	EFIS DSPL SW LEFT	11F8	EFIS SYM GEN (LEFT, L)	11F29	EFIS SYM GEN (RIGHT, R)
11C4	EFIS DSPL SW L	11F9	EFIS SYM GEN (CENTER, C)		

HSI HEADING, TREND VECTOR & ALTN IRS - FAULT CODES

EFFECTIVITY

ALL

34-FAULT CODE DIAGRAM

02

Page 12
May 28/01

PILOT'S PANEL

FAULT CODE/
LOCATION

CAPT 01
F/O 02
CAPT & F/O 03

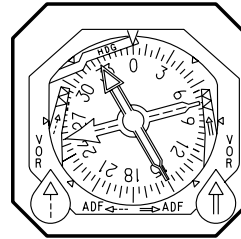
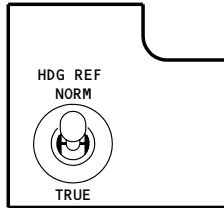
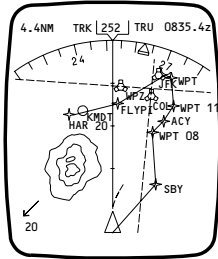

WITH SW PLACED IN TRUE, WERE INSTRUMENT CHANGES NORM?

WITH AIRPLANE ABOVE 73°N OR BELOW 60°S WERE INSTRUMENT CHANGES NORM?

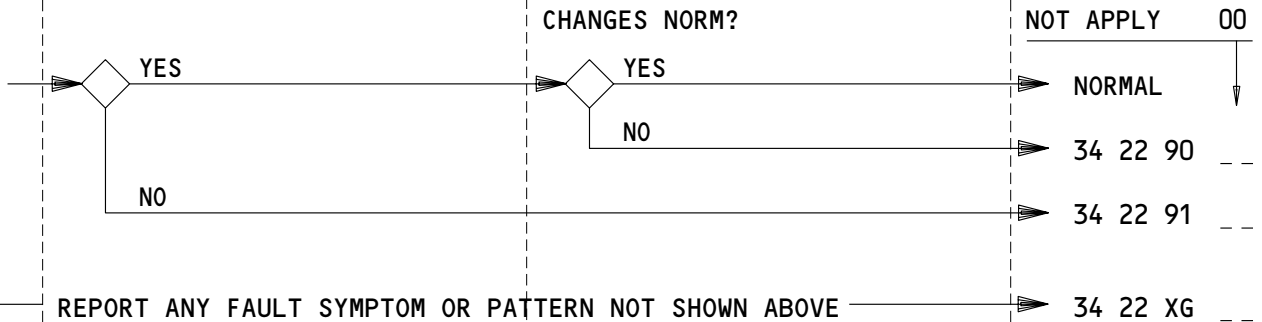

REPORT ANY FAULT SYMPTOM OR PATTERN NOT SHOWN ABOVE

APPLICABLE CIRCUIT BREAKERS AS INSTALLED

6D3	IRS L	11E33	VOR (R, RIGHT)
6D4	IRS C	11F1	IRS (L, LEFT)
6D5	IRS R	11F8	EFIS SYM GEN (L, LEFT)
11A2	VOR MKR (L, LEFT)	11F9	EFIS SYM GEN (C, CENTER)
11A6	RDMI (L, LEFT)	11F21	IRS (C, CENTER)
11A7	EFIS DSPL SW (L, LEFT)	11F22	IRS (R, RIGHT)
11E4	EFIS CONT PNL (L, LEFT)	11F24	EFIS DSPL SW (R, RIGHT)
11E6	HSI (L, LEFT)	11F25	RDMI (R, RIGHT)
11E25	EFIS CONT PNL (R, RIGHT)	11F29	EFIS SYM GEN (R, RIGHT)
11E27	HSI R		

HEADING REFERENCE - FAULT CODES

EFFECTIVITY

ALL

34-FAULT CODE DIAGRAM

02

Page 13
May 28/01

BOEING

757 FAULT ISOLATION/MAINT MANUAL

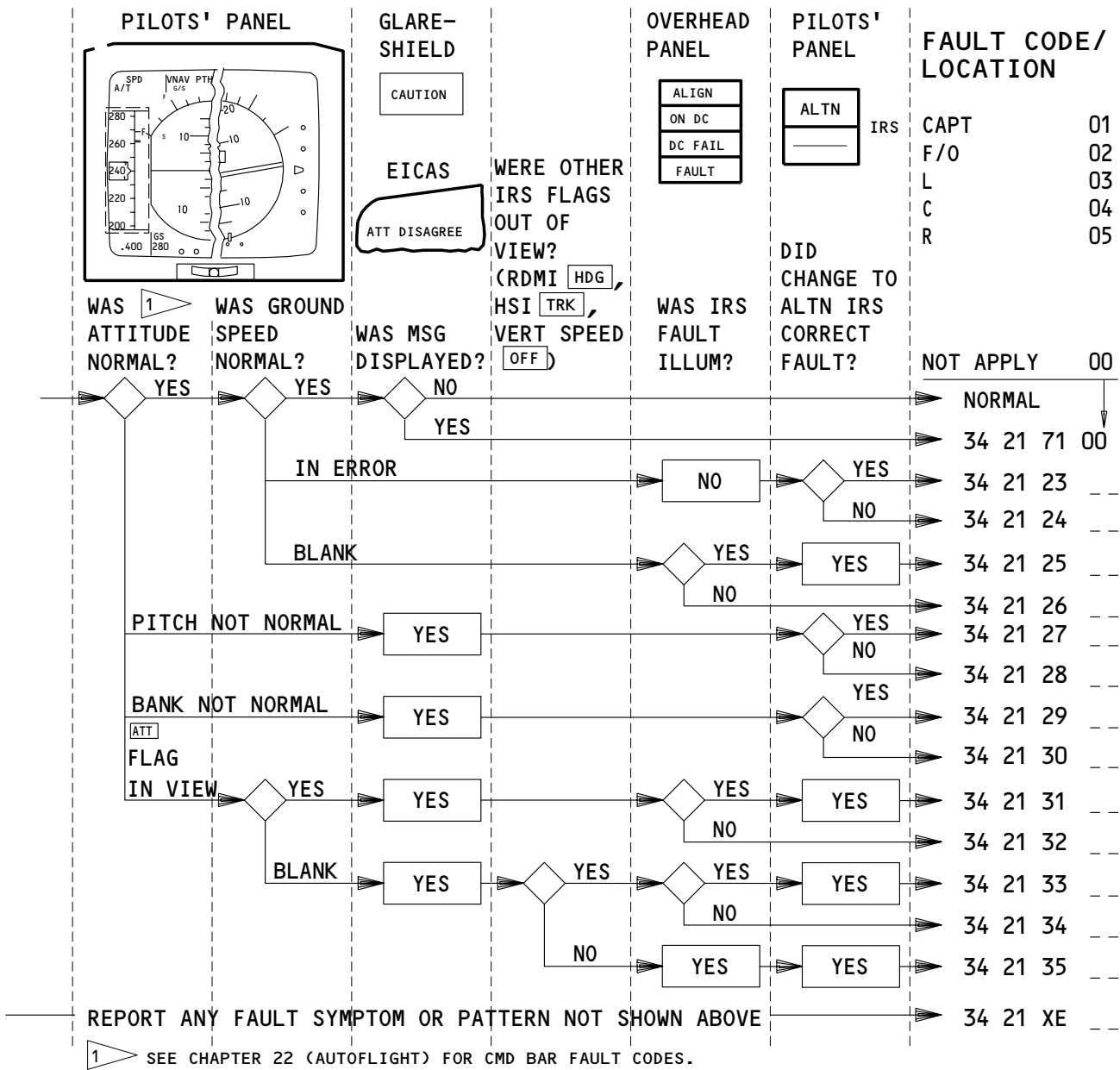

APPLICABLE CIRCUIT BREAKERS AS INSTALLED

6D3	L IRS	11E4	EFIS CONT PNL (L, LEFT)	11F10	INSTR COMPTR
6D4	C IRS	11E24	ADI (R, RIGHT)	11F21	IRS (C, CENTER)
6D5	R IRS	11E25	EFIS CONT PNL (R, RIGHT)	11F22	IRS (R, RIGHT)
11A6	RDMI (L, LEFT)	11F1	IRS (L, LEFT)	11F24	EFIS DSPL SW (R, RIGHT)
11A7	EFIS DSPL SW (L, LEFT)	11F8	EFIS SYM GEN (L, LEFT)	11F25	RDMI (R, RIGHT)
11E3	ADI (L, LEFT)	11F9	EFIS SYM GEN (C, CENTER)	11F29	EFIS SYM GEN (R, RIGHT)

ADI ATTITUDE AND GROUND SPEED - FAULT CODES

EFFECTIVITY

ALL

34-FAULT CODE DIAGRAM

05

Page 14
May 28/01

BOEING
757
FAULT ISOLATION/MAINT MANUAL

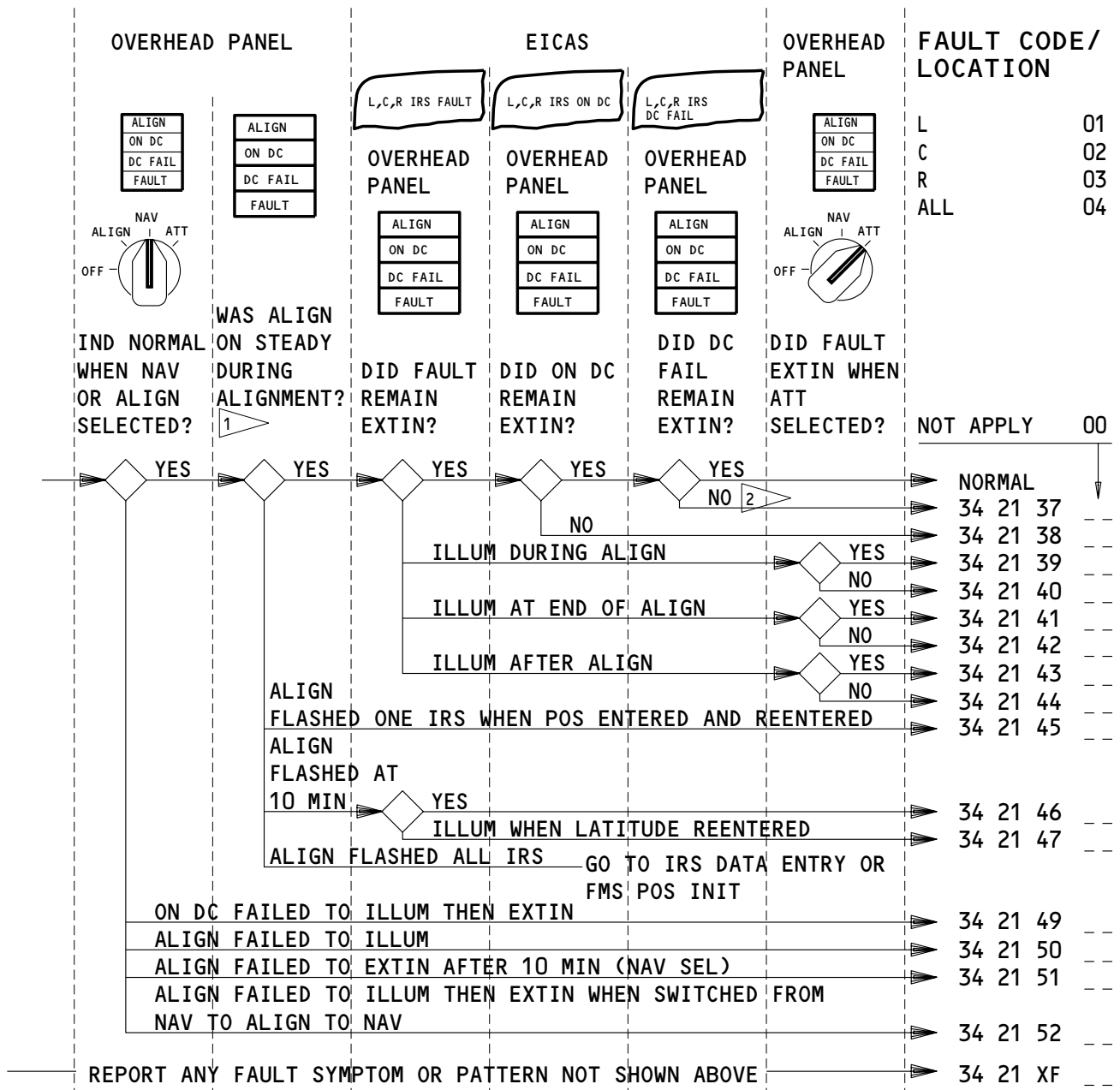

NOTE: THE FOLLOWING OPERATION ERRORS WILL CAUSE ALIGN TO FLASH:

- EXCESSIVE A/C MOTION DURING ALIGN.
- ENTERED LONG FAILS TO MATCH LAST POS OF IRS.
- ENTERED LAT FAILS TO MATCH IRS CALCULATED LAT.

APPLICABLE CIRCUIT BREAKERS AS INSTALLED

6D3 L IRS	6D5 R IRS	11F21 IRS (C, CENTER)	
6D4 C IRS	11F1 IRS (L, LEFT)	11F22 IRS (R, RIGHT)	

IRS MODE SEL PANEL – FAULT CODES

EFFECTIVITY ALL **34-FAULT CODE DIAGRAM**

594590

BOEING
757
FAULT ISOLATION/MAINT MANUAL

PILOTS' PANEL

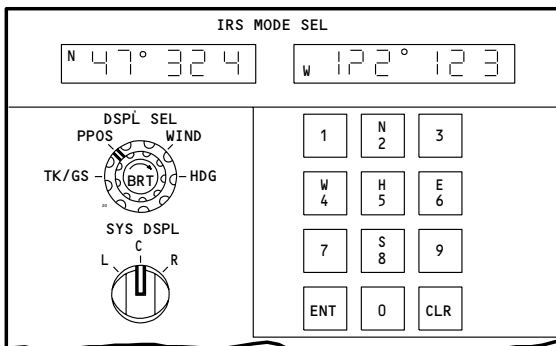

FMC CDU

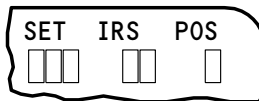

FAULT CODE/ LOCATION

L 01
C 02
R 03
ALL 04

IRS MANUAL KEYBOARD OPERATION WAS?

DATA DISPLAY WAS?

COULD IRS POS BE SET USING FMC POS INIT?

NOT APPLY 00

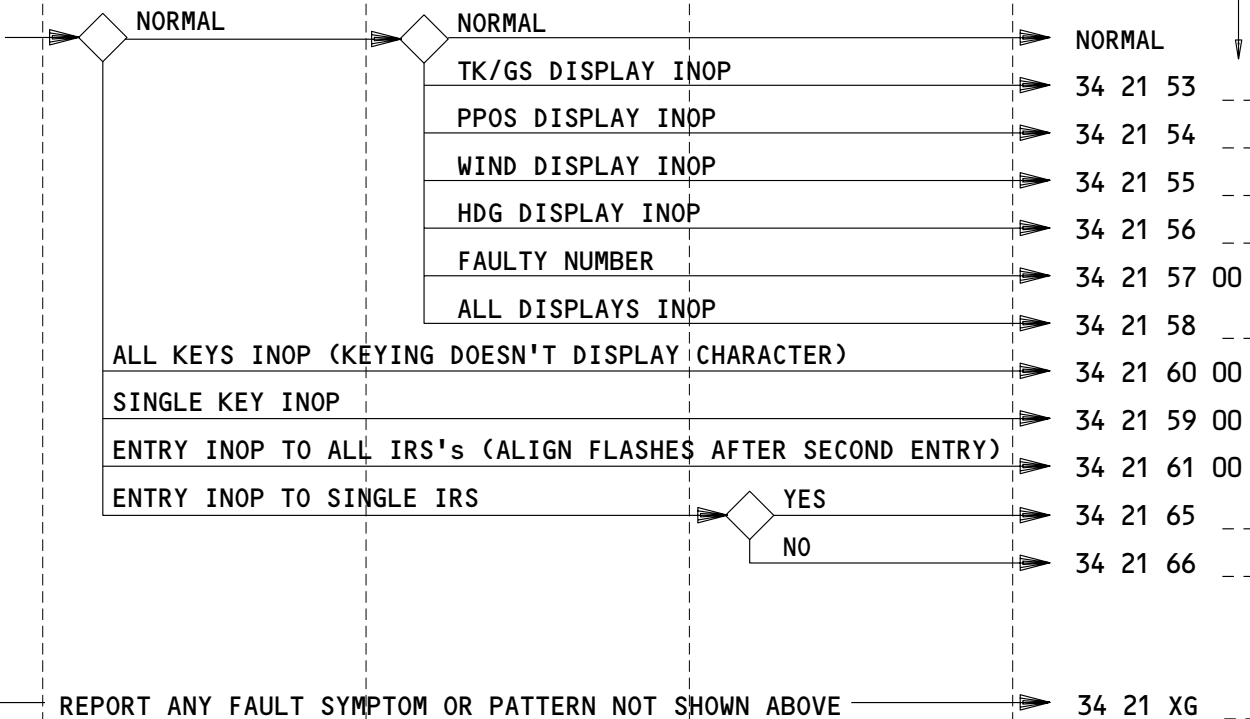

APPLICABLE CIRCUIT BREAKERS AS INSTALLED

6D3	IRS L	11F1	IRS (L, LEFT)
6D4	IRS C	11F21	IRS (C, CENTER)
6D5	IRS R	11F22	IRS (R, RIGHT)

IRS DATA ENTRY AND DISPLAY - FAULT CODES

EFFECTIVITY

ALL

34-FAULT CODE DIAGRAM

01

Page 16
May 28/01

BOEING

757 FAULT ISOLATION/MAINT MANUAL

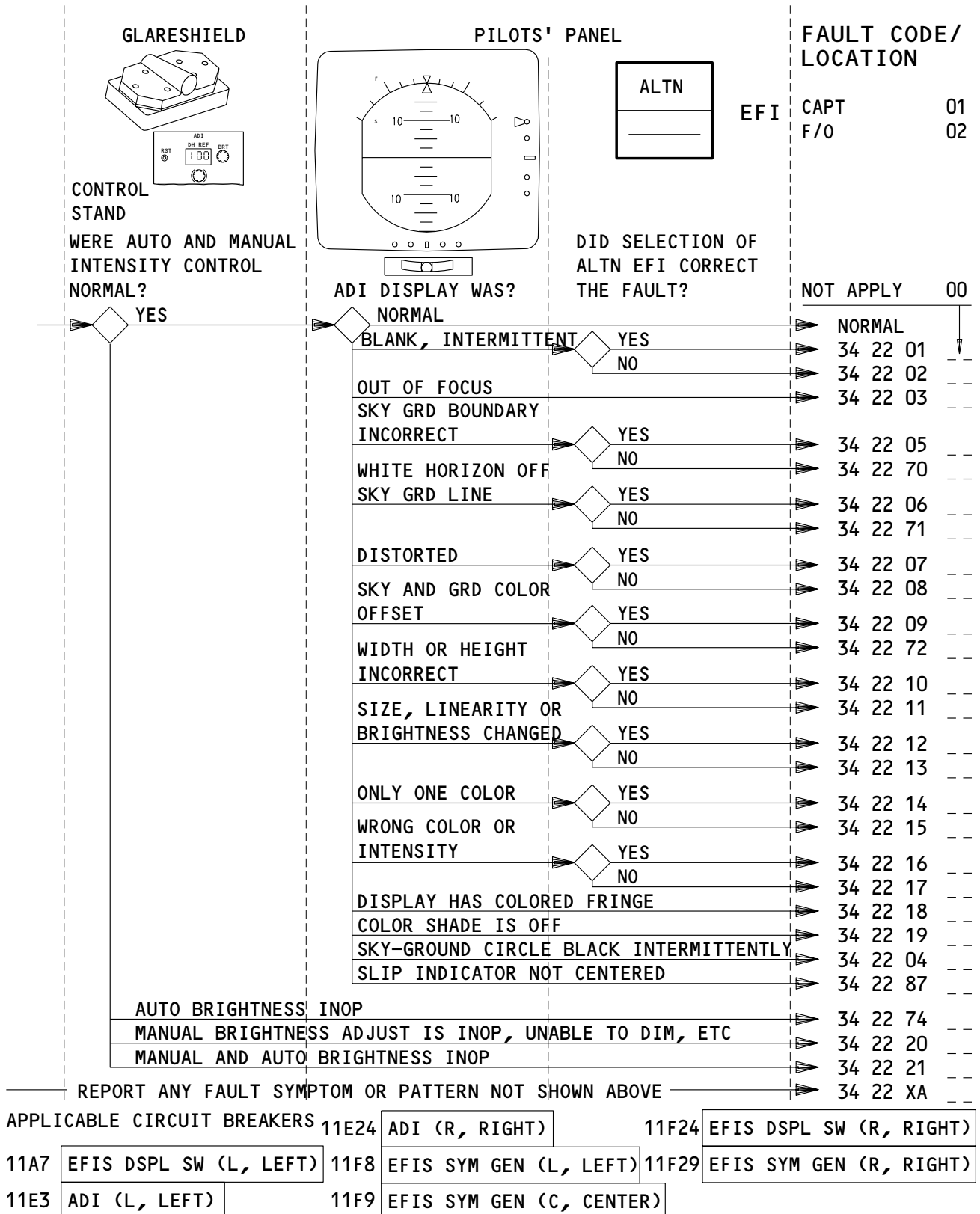

ADI DISPLAY - FAULT CODES

EFFECTIVITY

ALL

34-FAULT CODE DIAGRAM

01

Page 17
May 28/01

FMC-CDU

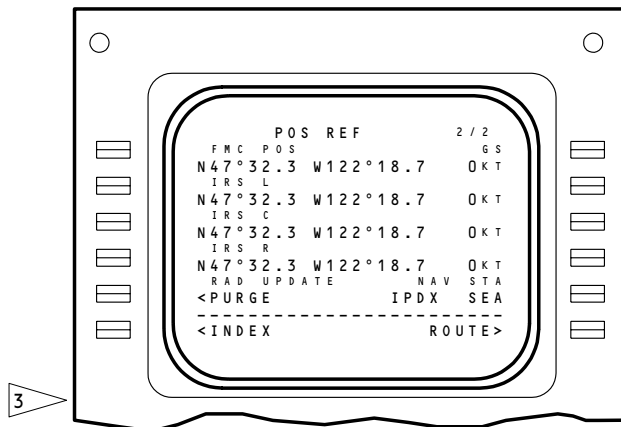

FAULT CODE/
LOCATION

L 01
C 02
R 03

WAS IRS RESIDUAL GROUND SPEED ERROR OR
RADIAL POSITION ERROR EXCESSIVE? 1

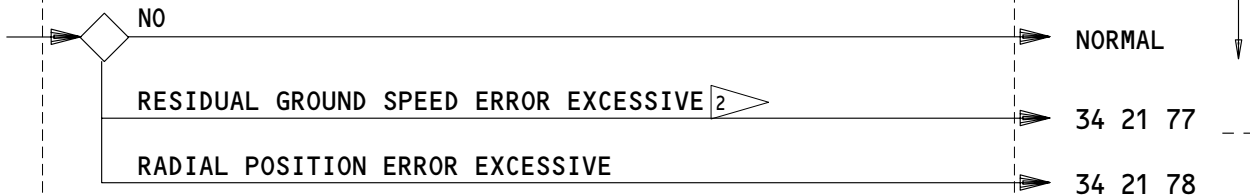

NOT APPLY 00

NORMAL

34 21 77

34 21 78

REPORT ANY FAULT SYMPTOM OR PATTERN NOT SHOWN ABOVE ▶ 34 21 XF

1 SEE IRS ACCURACY CHECKS FOR RESIDUAL GROUND SPEED/RADIAL POSITION ERROR LIMITS.

2 FMC "FREEZE" CAN CAUSE FMC-CDU TO DISPLAY EXCESSIVE GROUND SPEED. VERIFY RESIDUAL GROUND SPEED USING IRMP.

3 AS INSTALLED

APPLICABLE CIRCUIT BREAKERS

NONE

IRS ACCURACY - FAULT CODES

EFFECTIVITY

ALL

34-FAULT CODE DIAGRAM

01

Page 18
Jan 28/03

BOEING
757
FAULT ISOLATION/MAINT MANUAL

PILOTS PNL

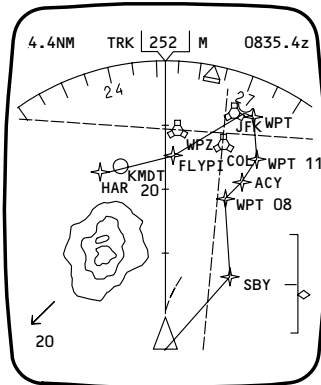

PILOTS PNL

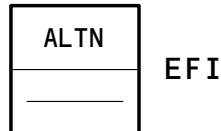

FAULT CODE/
LOCATION

CAPT 01
F/O 02

WAS HSI DISPLAY NORMAL?

DID SELECTION OF ALTN EFI
CORRECT THE FAULT?

NOT APPLY 00

<input type="checkbox"/>	YES						NORMAL	
<input type="checkbox"/>	BLANK, INTERMITTENT	<input type="checkbox"/>	YES	<input type="checkbox"/>	34 22 22			
		<input type="checkbox"/>	NO	<input type="checkbox"/>	34 22 23			
<input type="checkbox"/>	OUT OF FOCUS				34 22 24			
	DISTORTED	<input type="checkbox"/>	YES	<input type="checkbox"/>	34 22 26			
		<input type="checkbox"/>	NO	<input type="checkbox"/>	34 22 27			
	WIDTH OR HEIGHT INCORRECT	<input type="checkbox"/>	YES	<input type="checkbox"/>	34 22 28			
	SIZE CHANGED, LINEARITY	<input type="checkbox"/>	NO	<input type="checkbox"/>	34 22 29			
	OR BRIGHTNESS ALSO CHANGED	<input type="checkbox"/>	YES	<input type="checkbox"/>	34 22 30			
		<input type="checkbox"/>	NO	<input type="checkbox"/>	34 22 31			
	DISPLAY IS ONLY ONE COLOR	<input type="checkbox"/>	YES	<input type="checkbox"/>	34 22 32			
	DISPLAY IS WRONG COLOR OR	<input type="checkbox"/>	NO	<input type="checkbox"/>	34 22 33			
	INTENSITY	<input type="checkbox"/>	YES	<input type="checkbox"/>	34 22 34			
		<input type="checkbox"/>	NO	<input type="checkbox"/>	34 22 35			
	DISPLAY HAS COLORED FRINGE			<input type="checkbox"/>	34 22 36			
	COLOR SHADE IS OFF			<input type="checkbox"/>	34 22 37			
	AUTO BRIGHTNESS INOP			<input type="checkbox"/>	34 22 77			
	MANUAL BRIGHTNESS ADJUST IS INOP			<input type="checkbox"/>	34 22 38			
	MANUAL AND AUTO BRIGHTNESS INOP			<input type="checkbox"/>	34 22 39			

REPORT ANY FAULT SYMPTOM OR PATTERN NOT SHOWN ABOVE 34 22 XB

APPLICABLE CIRCUIT BREAKERS

11A7 EFIS DSPL SW (L, LEFT)

11E6 HSI (L, LEFT)

11E27 HSI R

11F8 EFIS SYM GEN (L, LEFT)

11F9 EFIS SYM GEN (C, CENTER)

11F24 EFIS DSPL SW (R, RIGHT)

11F29 EFIS SYM GEN (R, RIGHT)

HSI DISPLAY - FAULT CODES

EFFECTIVITY

ALL

34-FAULT CODE DIAGRAM

05

Page 19
Sep 28/00

594599

BOEING

757 FAULT ISOLATION/MAINT MANUAL

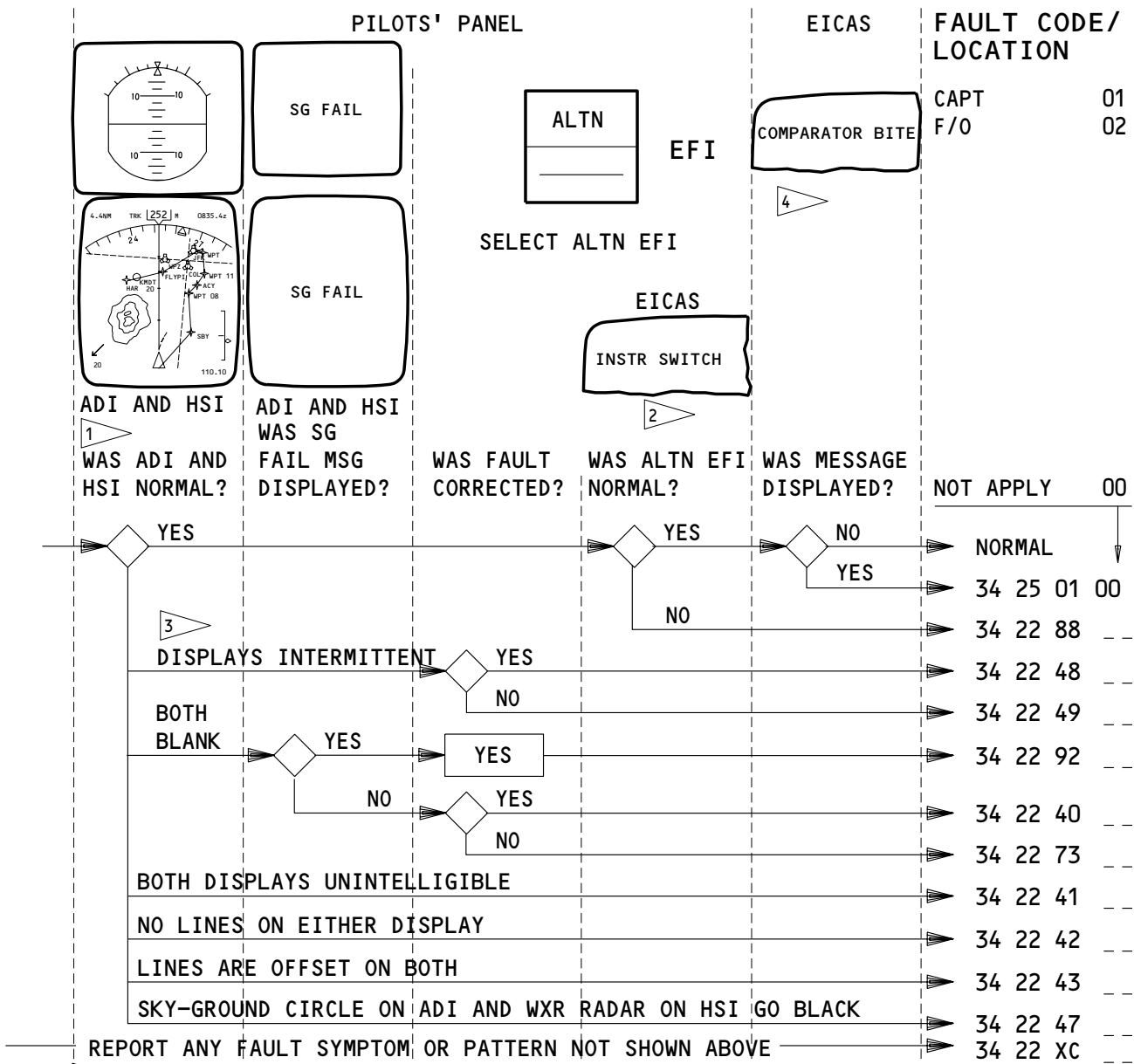

- 1 LOSS OF ADI & HSI DISPLAYS MAY BE CAUSED BY MOVING AIRPLANE DURING IRS ALIGNMENT.
- 2 EICAS MSG DISPLAYS IF BOTH CAPT & F/O EFI SELECTED TO ALTN.
- 3 IF GEN OFF LGT IS INTERMITTENT, SEE ELECTRICAL CHAPTER "GENERATOR AND BUS TIE CONTROL" FAULT CODES.
- 4 FAILURE OF THE INSTRUMENT COMPARATOR UNIT (IF INSTALLED) MAY PRODUCE ASSOCIATED EICAS MESSAGE DISPLAYS. REFER TO NAVIGATION CHAPTER, "COMPARATOR BITE EICAS MESSAGE."

APPLICABLE CIRCUIT BREAKERS AS INSTALLED

11E3	ADI (L, LEFT)	11E27	HSI R	11F20	RADIO ALTM (C, CENTER)
11E6	HSI (L, LEFT)	11F8	EFIS SYM GEN (L, LEFT)	11F29	EFIS SYM GEN (R, RIGHT)
11E24	ADI (R, RIGHT)	11F9	EFIS SYM GEN (C, CENTER)		

ALTN EFI, ADI AND HSI - FAULT CODES

EFFECTIVITY

ALL

34-FAULT CODE DIAGRAM

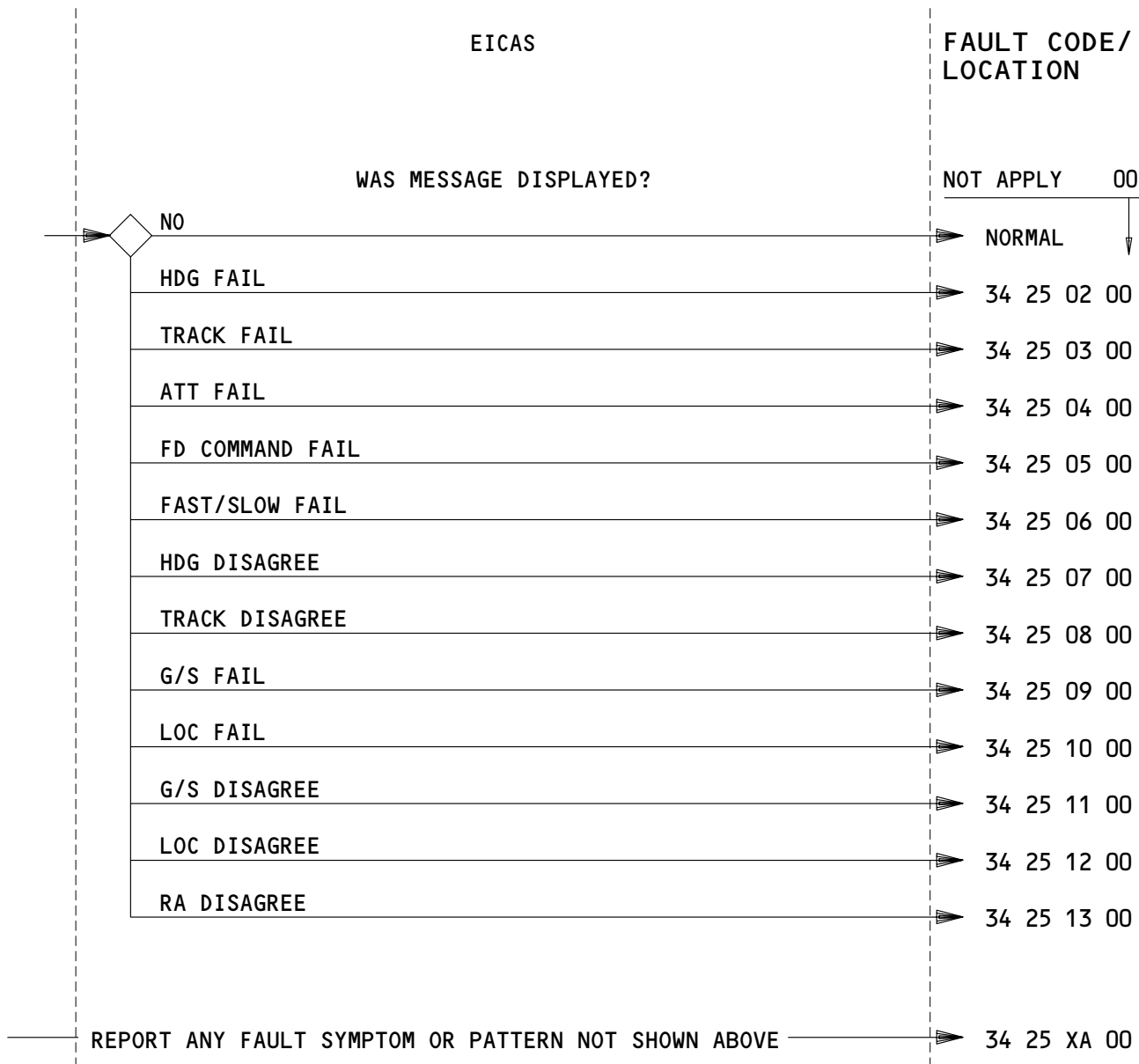

APPLICABLE CIRCUIT BREAKERS

NONE

COMPARATOR BITE EICAS MESSAGE – FAULT CODES

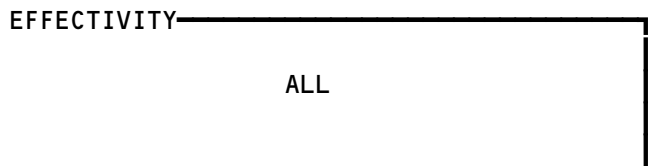

34-FAULT CODE DIAGRAM

GLARESHIELD PANEL

FAULT CODE/
LOCATION

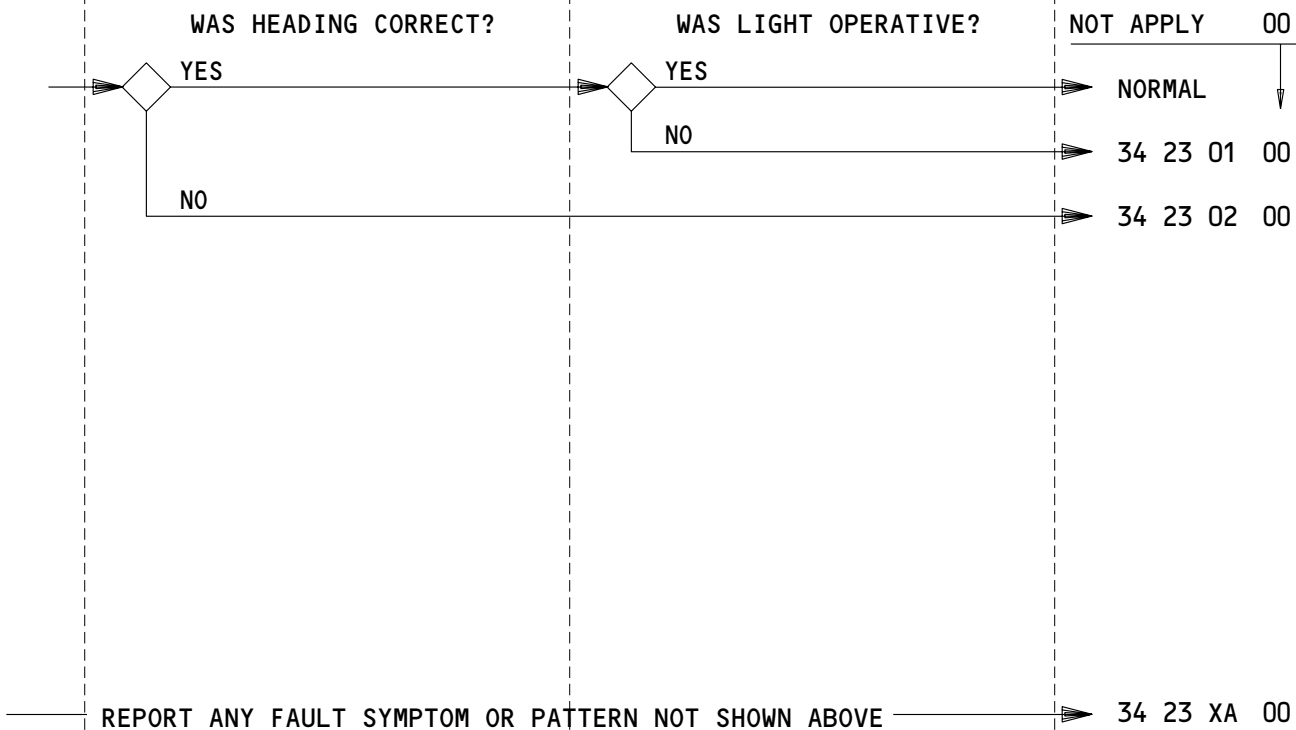
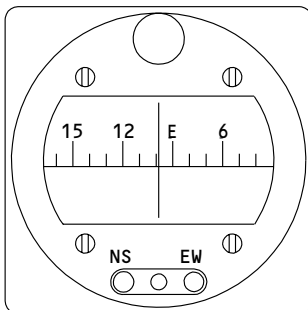

APPLICABLE CIRCUIT BREAKERS AS INSTALLED

11B7 LIGHTS (STBY) INSTR

STANDBY COMPASS – FAULT CODES

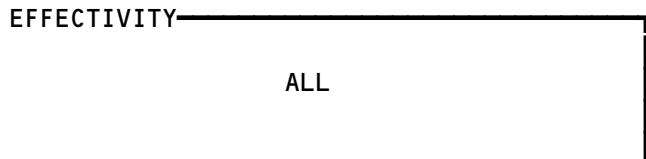

34-FAULT CODE DIAGRAM

PILOTS' CENTER PANEL

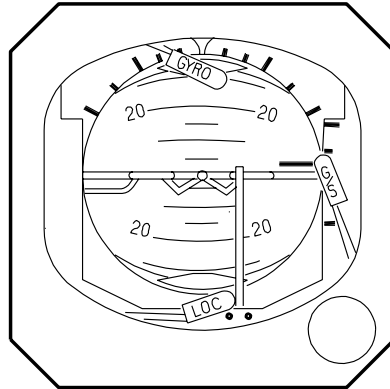

FAULT CODE/
LOCATION

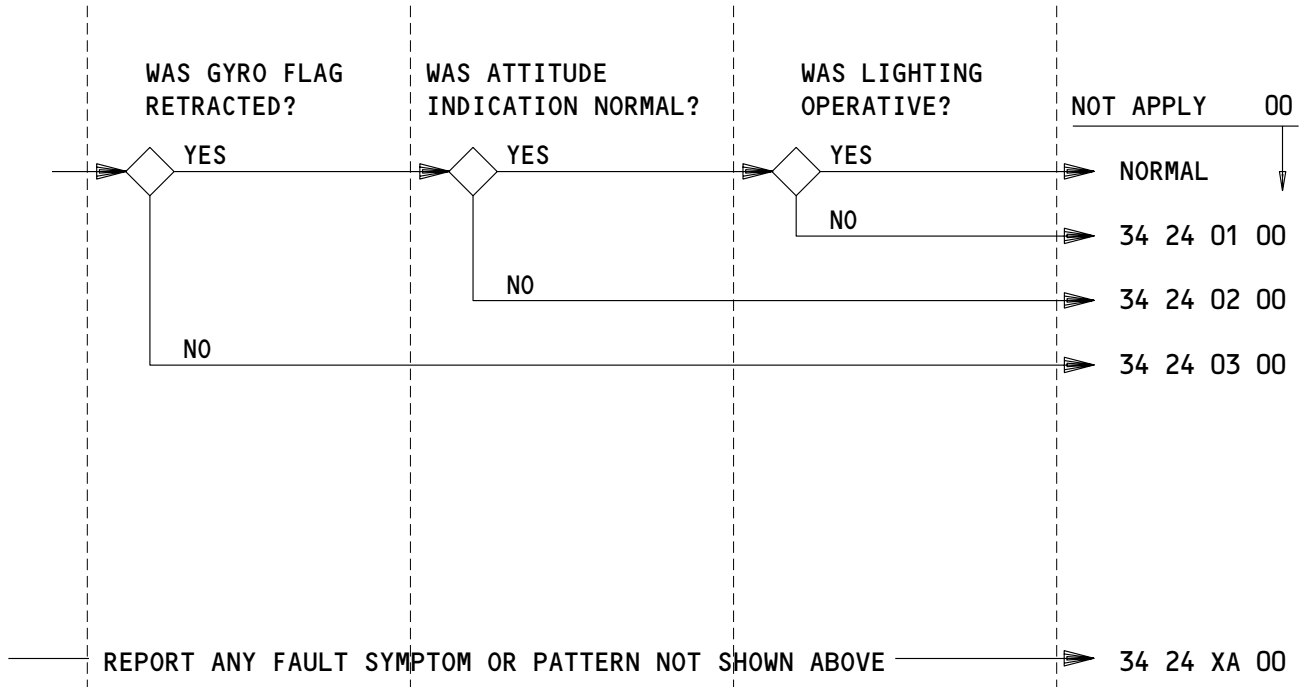

APPLICABLE CIRCUIT BREAKERS AS INSTALLED

- 11A5 STBY ATT IND
- 11B7 LIGHTS (STBY) INSTR

STANDBY ATTITUDE INDICATOR – FAULT CODES

EFFECTIVITY

ALL

34-FAULT CODE DIAGRAM

AFT ELECTRONIC PANEL

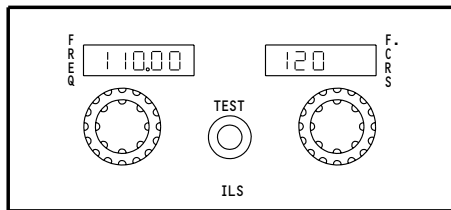

(TYPICAL)

WAS TEST OK?

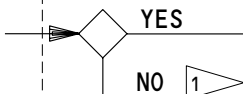

FAULT CODE/
LOCATION

CAPT ADI & HSI 01
F/O ADI & HSI 02
STBY ATT IND 03

NOT APPLY 00

NORMAL

34 31 01

REPORT ANY FAULT SYMPTOM OR PATTERN NOT SHOWN ABOVE

34 31 XA

1 BEFORE REPORTING MISSING GLIDESLOPE POINTER, ENSURE ILS FRONT CRS AND AIRPLANE HDG ARE SAME DURING TEST.

APPLICABLE CIRCUIT BREAKERS AS INSTALLED

11A3 ILS (C, CENTER)

11A9 STBY ILS IND

11E10 ILS L

11E31 ILS (R, RIGHT)

ILS TEST - FAULT CODES

EFFECTIVITY

ALL

34-FAULT CODE DIAGRAM

05

Page 24
May 20/98

BOEING

757

FAULT ISOLATION/MAINT MANUAL

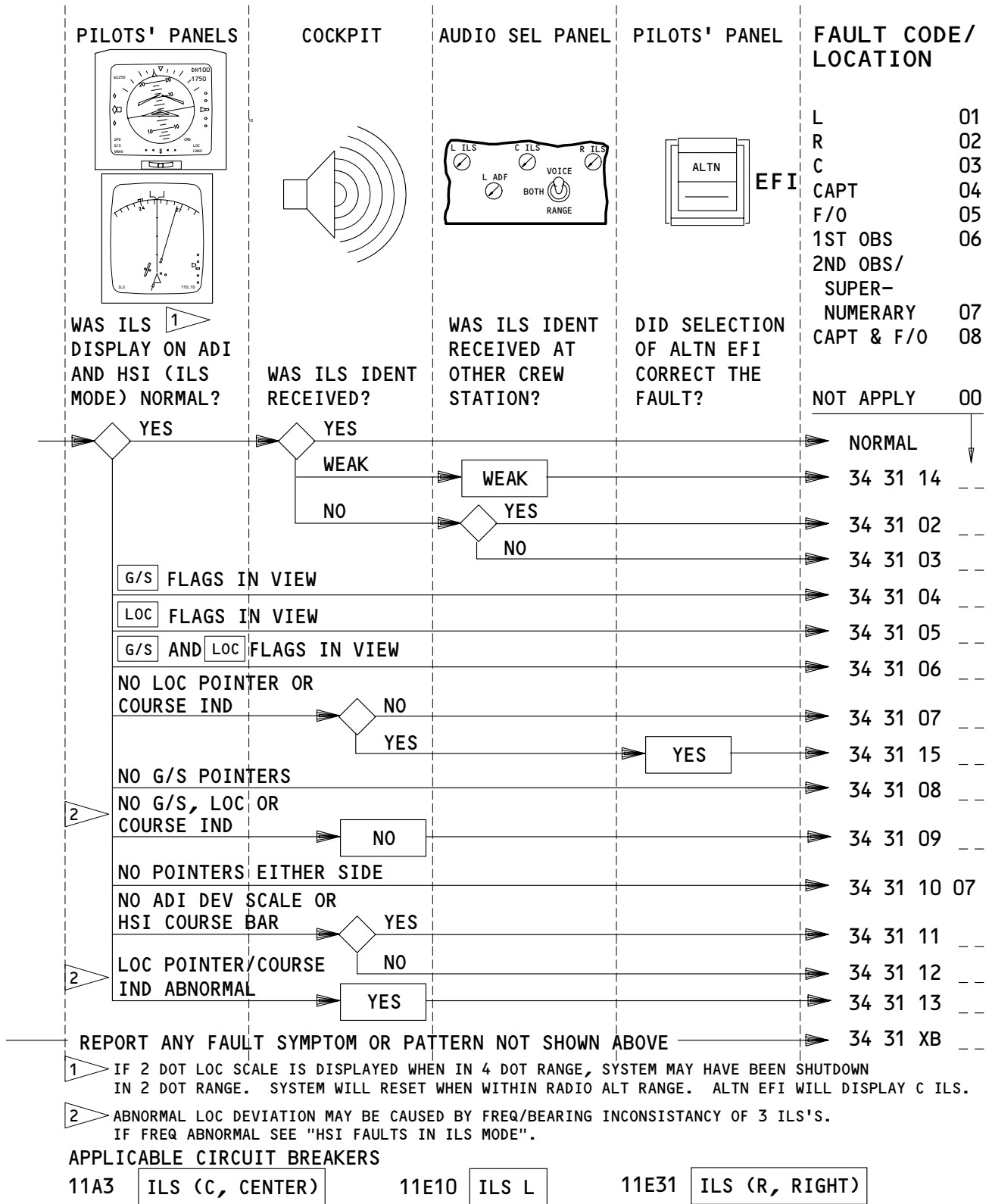

ILS ADI/HSI DISPLAYS AND IDENT - FAULT CODES

EFFECTIVITY

ALL

34-FAULT CODE DIAGRAM

07

Page 25
May 28/01

PILOTS' PANELS

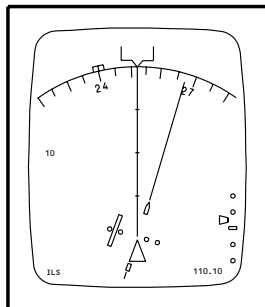

ILS MODE HSI DISPLAY NORMAL?

FAULT CODE/
LOCATION

CAPT 01
F/O 02

NOT APPLY 00

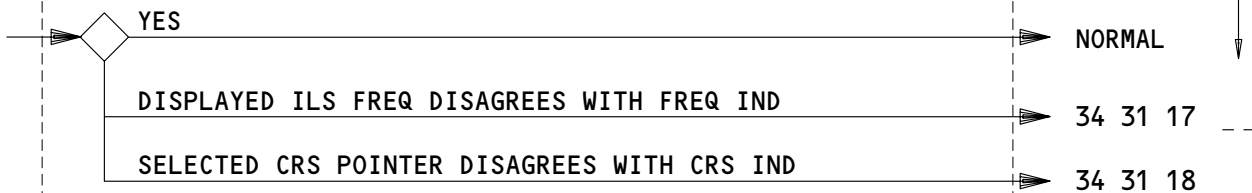

REPORT ANY FAULT SYMPTOM OR PATTERN NOT SHOWN ABOVE → 34 31 XC --

APPLICABLE CIRCUIT BREAKERS AS INSTALLED

- 11E10 ILS L
- 11E31 ILS (R, RIGHT)

HSI FAULTS IN ILS MODE - FAULT CODES

EFFECTIVITY

ALL

34-FAULT CODE DIAGRAM

156676

PLTS' CENTER PANEL

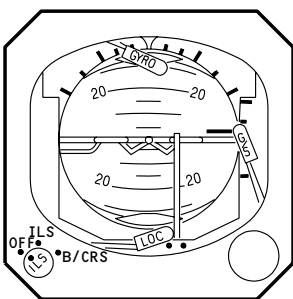

AFT ELECTRONIC PANEL

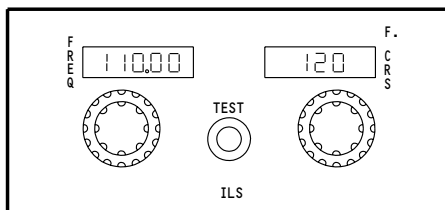

(TYPICAL)

FAULT CODE/
LOCATION

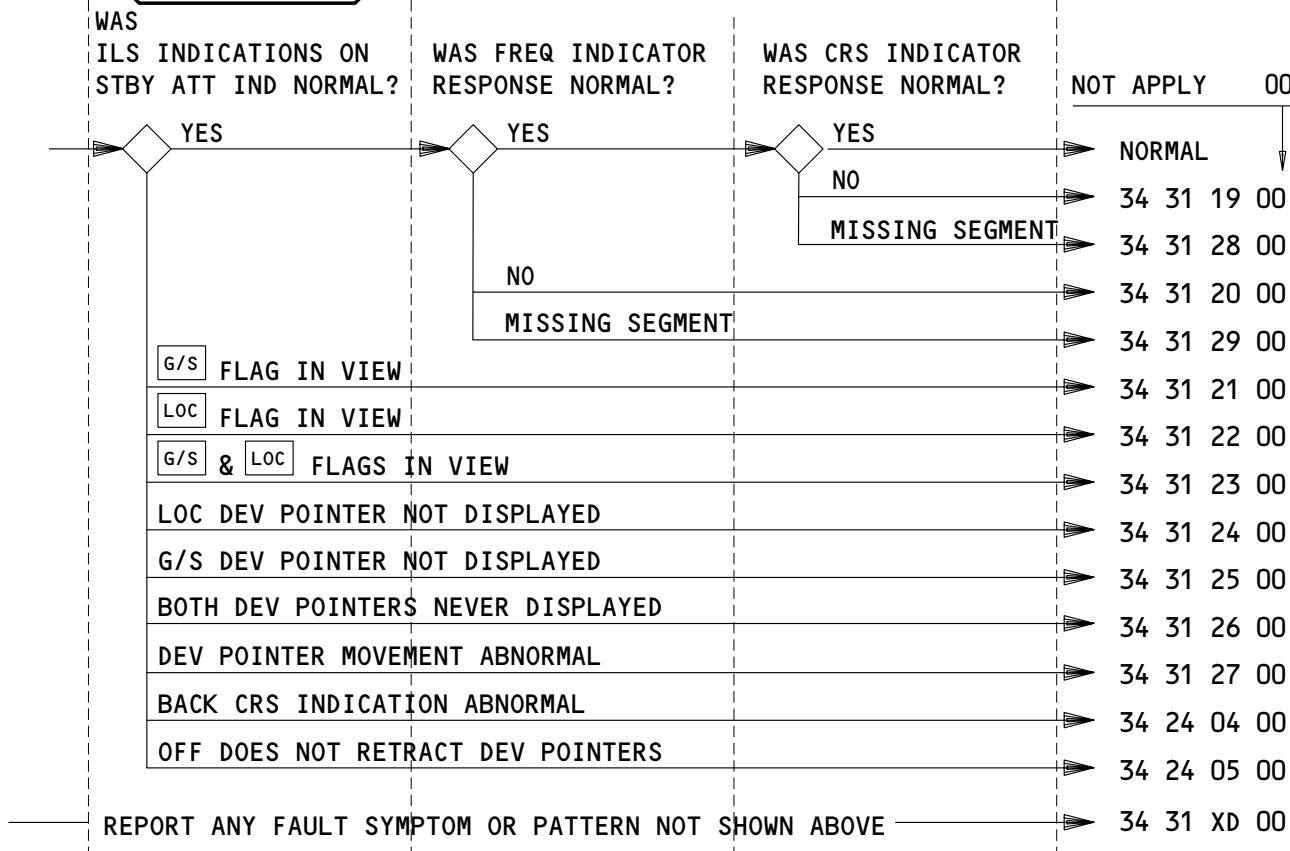

APPLICABLE CIRCUIT BREAKERS AS INSTALLED

11A3 ILS (C, CENTER)

11A9 STBY ILS IND

ILS STANDBY ATTITUDE DISPLAY AND ILS CONTROLS – FAULT CODES

EFFECTIVITY

ALL

34-FAULT CODE DIAGRAM

05

Page 27
May 20/98

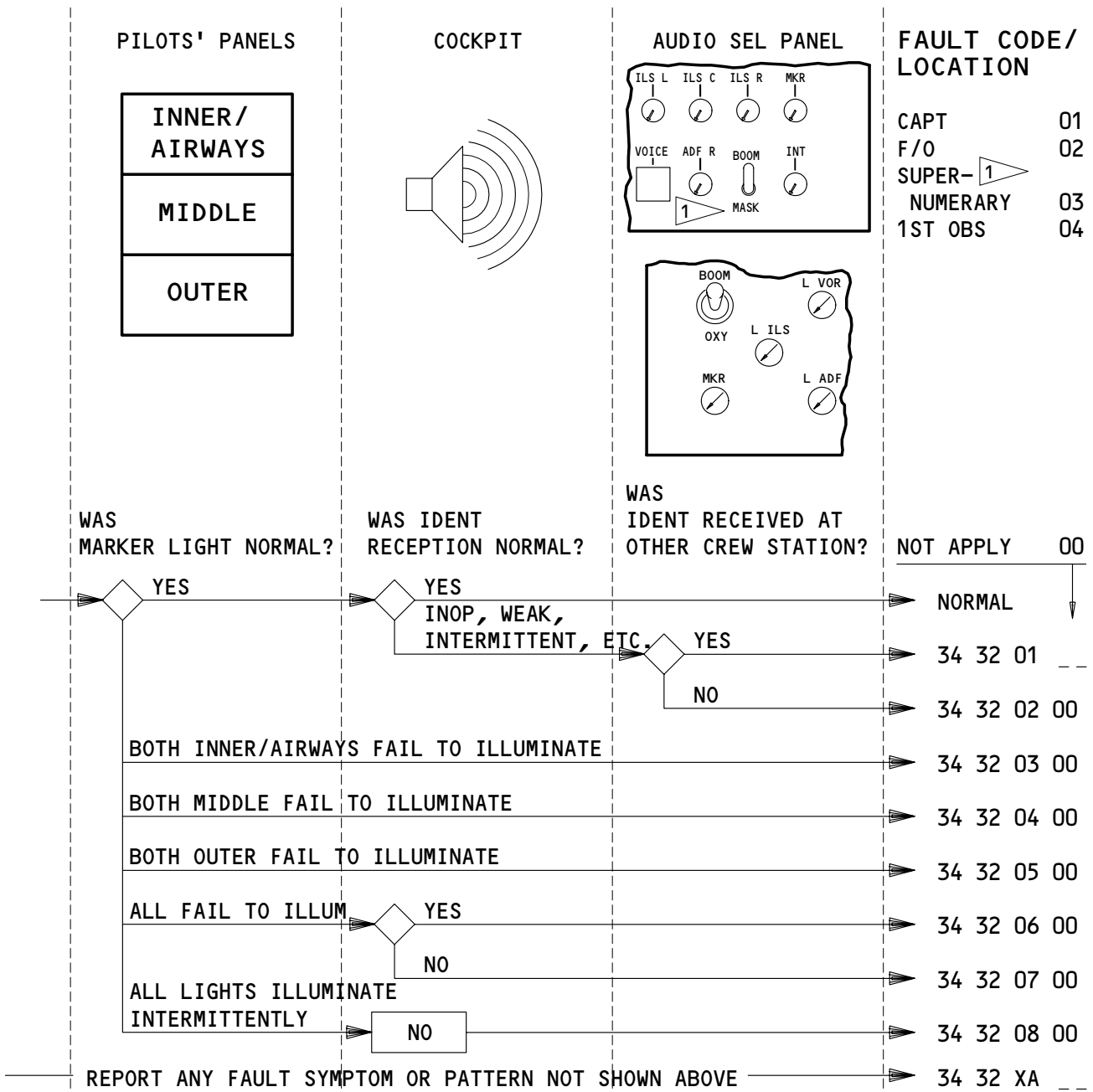

 IF INSTALLED

APPLICABLE CIRCUIT BREAKERS

11A2 VOR MKR (LEFT, L)

MARKER BEACON - FAULT CODES

EFFECTIVITY

ALL

34-FAULT CODE DIAGRAM

BOEING

757

FAULT ISOLATION/MAINT MANUAL

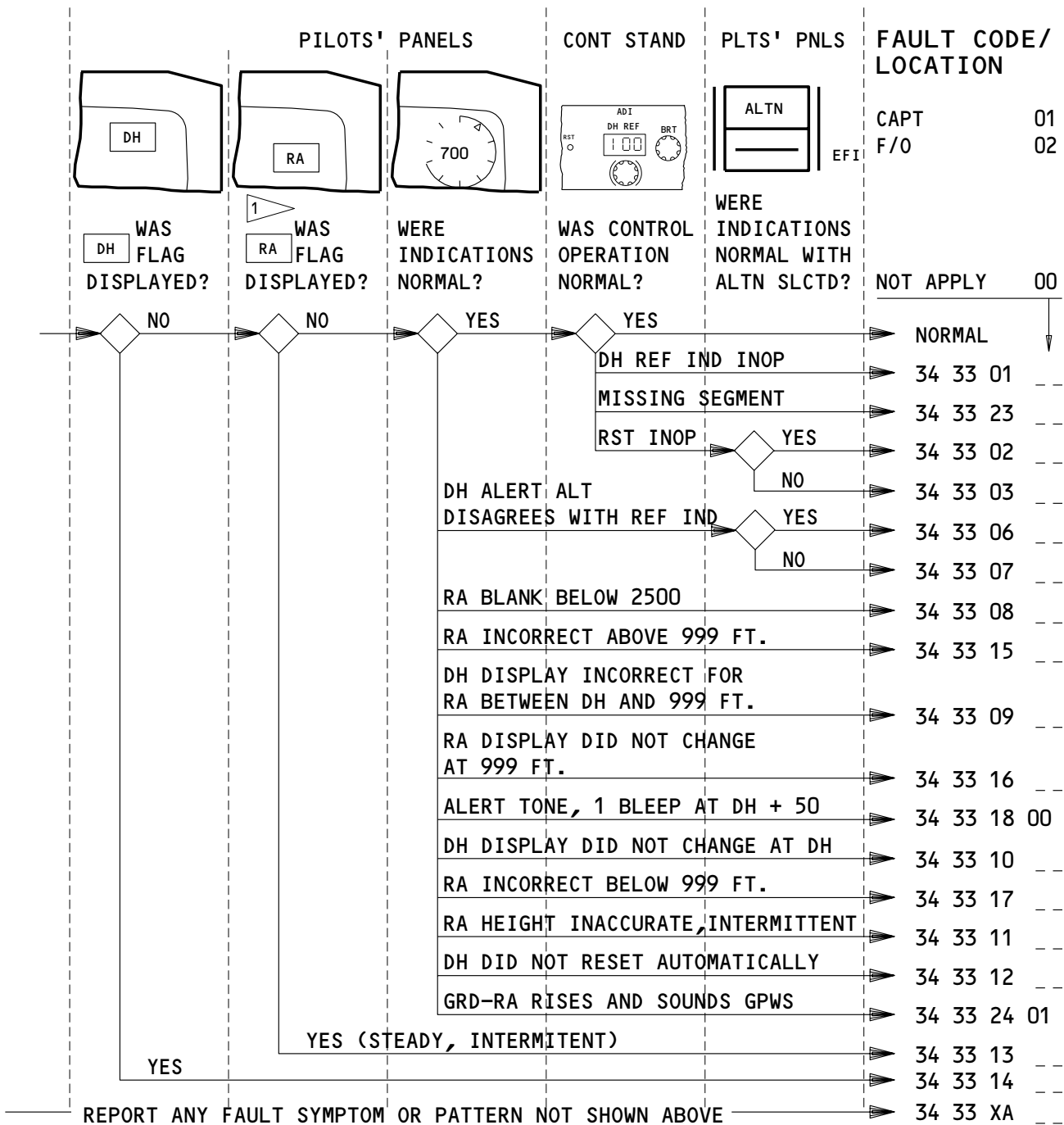

¹ AN INOP L RADIO ALTIMETER WILL CAUSE THE CONFIG LGT TO ILLUM AND GEAR NOT DOWN MSG TO APPEAR ABOVE 800' RA WITH A THRUST LEVER RETARDED.

APPLICABLE CIRCUIT BREAKERS

- | | | | | | |
|-------|-----------------|-------|------------|-------|------------|
| 11E4 | EFIS CONT PNL L | 11F5 | RAD ALTM L | 11F26 | RAD ALTM R |
| 11E25 | EFIS CONT PNL R | 11F20 | RAD ALTM C | | |

RADIO ALTIMETER & DH (ADI) - FAULT CODES

EFFECTIVITY AIRPLANES WITH DIAL RA > 1000'

34-FAULT CODE DIAGRAM

BOEING

757

FAULT ISOLATION/MAINT MANUAL

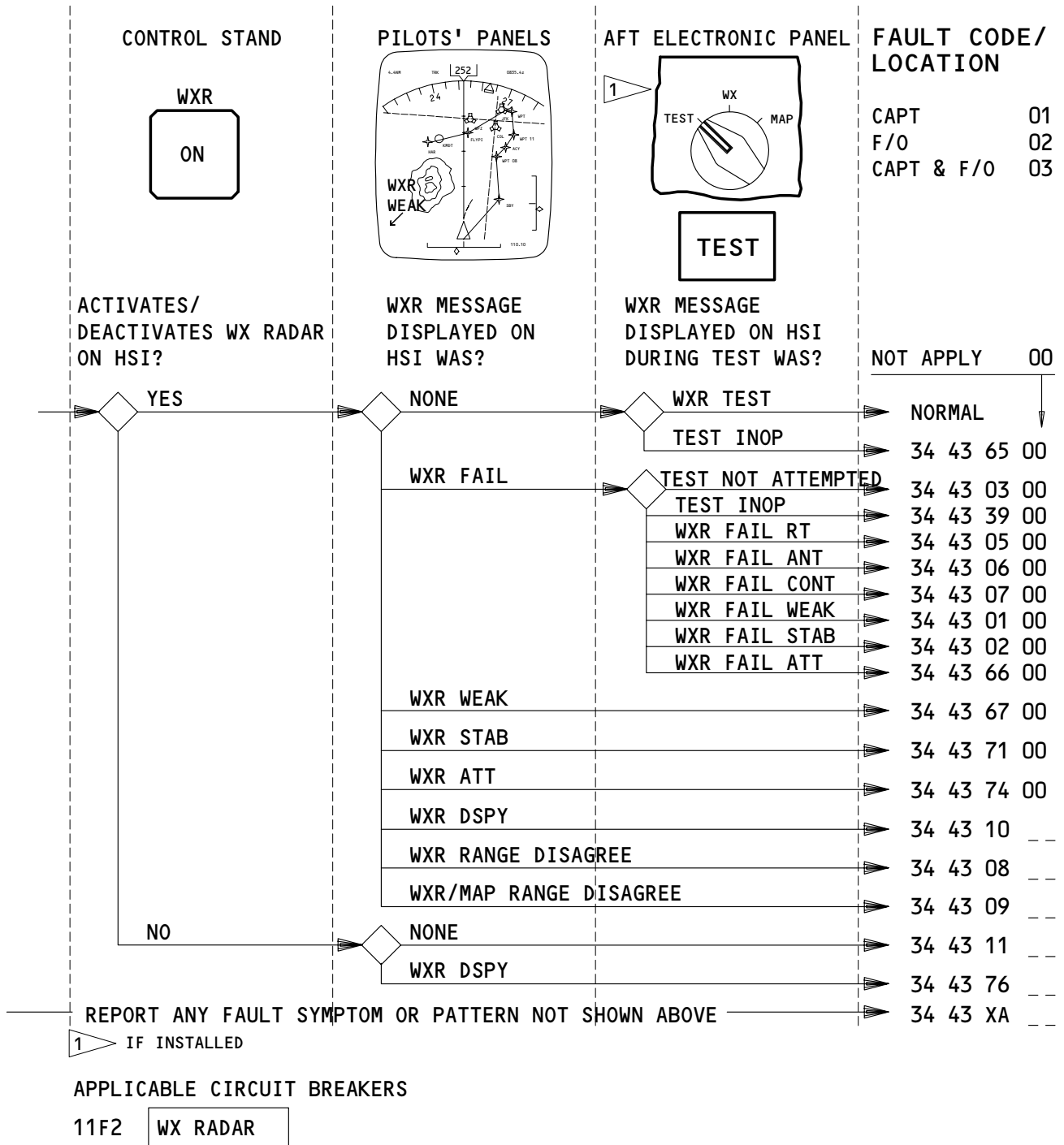

WEATHER RADAR FAULTS (HSI) – FAULT CODES

EFFECTIVITY

ALL

34-FAULT CODE DIAGRAM

AFT ELECTRONIC PANEL

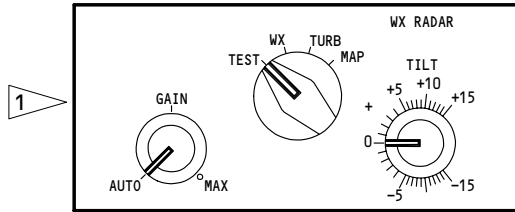

FAULT CODE/
LOCATION

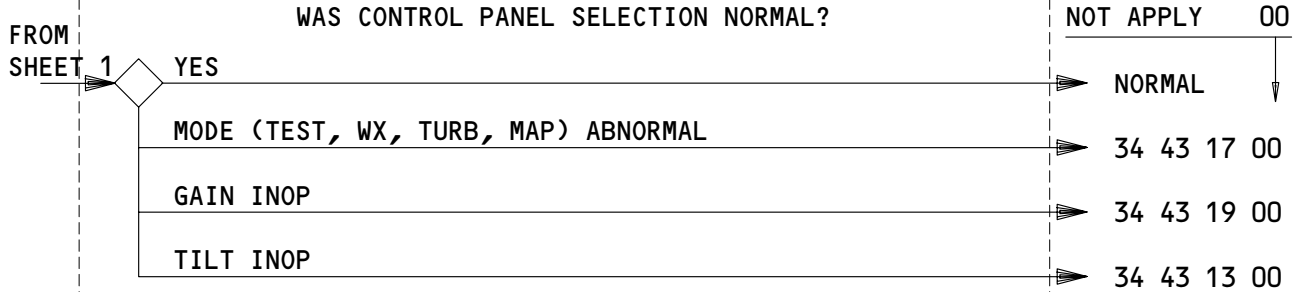

REPORT ANY FAULT SYMPTOM OR PATTERN NOT SHOWN ABOVE → 34 43 XB 00

1 AS INSTALLED

APPLICABLE CIRCUIT BREAKERS

11F2 WX RADAR

WEATHER RADAR CONTROLS – FAULT CODES

EFFECTIVITY

ALL

34-FAULT CODE DIAGRAM

PILOTS' PANELS

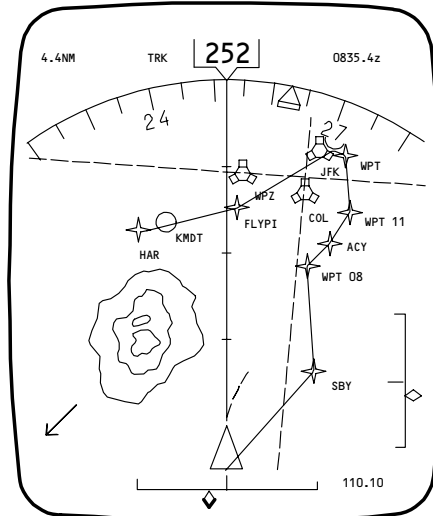

WAS HSI WXR DISPLAY NORMAL?

FAULT CODE/
LOCATION

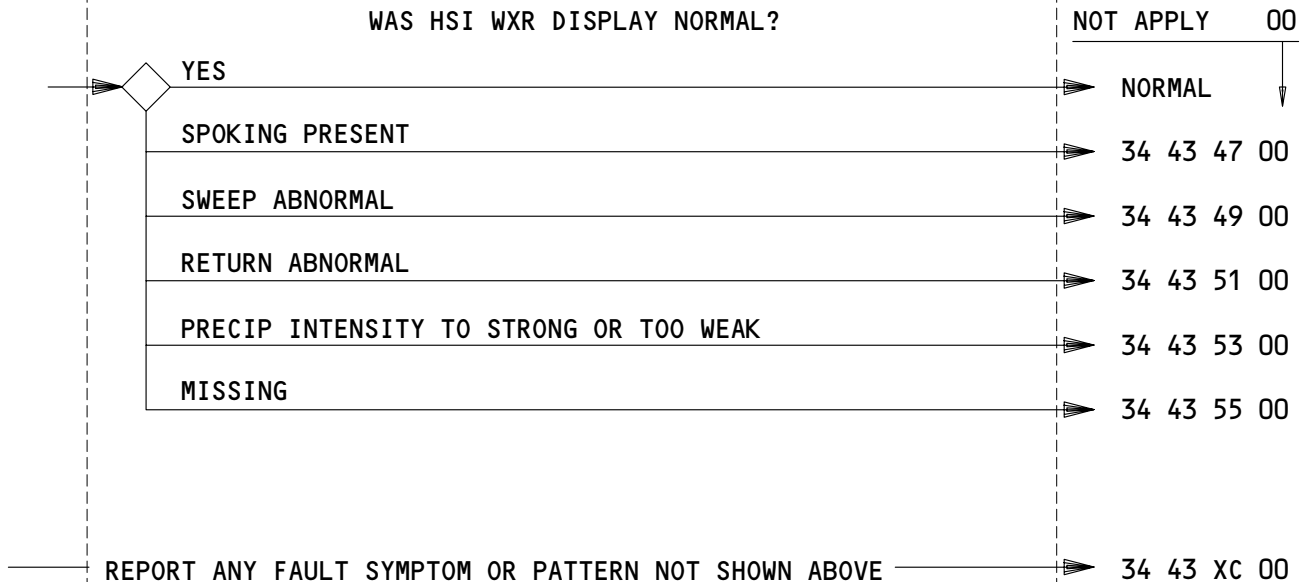

APPLICABLE CIRCUIT BREAKERS

11F2 WX RADAR

WEATHER RADAR DISPLAY QUALITY – FAULT CODES

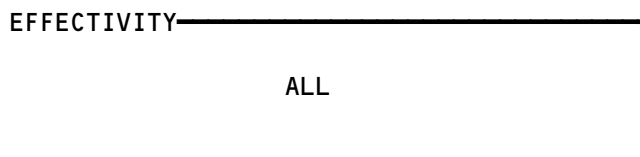

34-FAULT CODE DIAGRAM

BOEING

757 FAULT ISOLATION/MAINT MANUAL

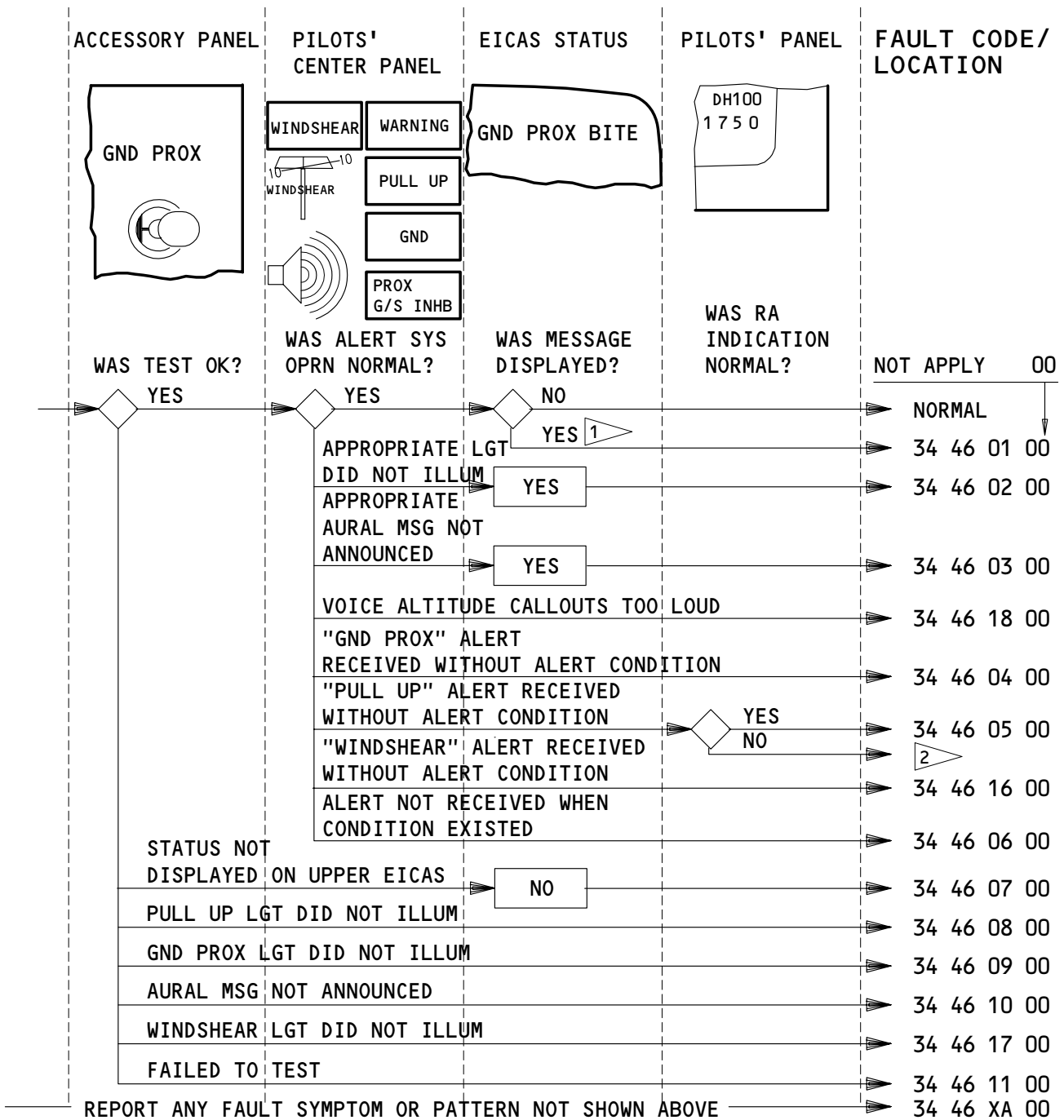

¹ GND PROX BITE WILL NOT DISPLAY WITH L-IRS OFF.

² SEE "RADIO ALTIMETER & DH (ADI)" FAULT CODES.

APPLICABLE CIRCUIT BREAKERS

11F4 GND PROX (CMPTR)

GROUND PROXIMITY & WINDSHEAR WARNING TEST AND OPERATION – FAULT CODES

EFFECTIVITY

ALL

34-FAULT CODE DIAGRAM

09

Page 34
May 28/01

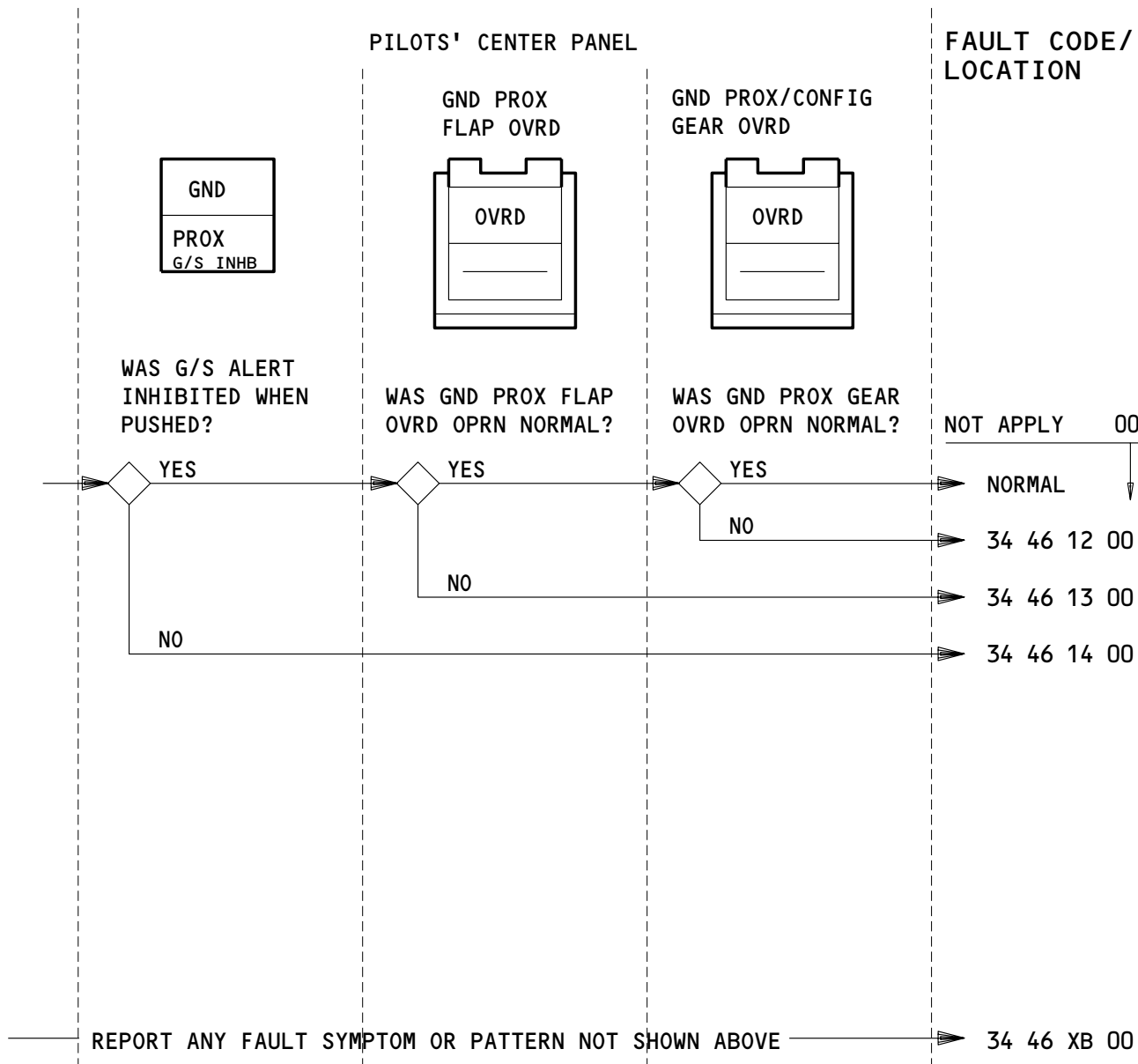

APPLICABLE CIRCUIT BREAKERS AS INSTALLED

11F4 GND PROX (CMPTR)

GROUND PROXIMITY WARNING, INHB & OVRD – FAULT CODES

EFFECTIVITY

ALL

34-FAULT CODE DIAGRAM

03

Page 35
May 28/01

BOEING

757

FAULT ISOLATION/MAINT MANUAL

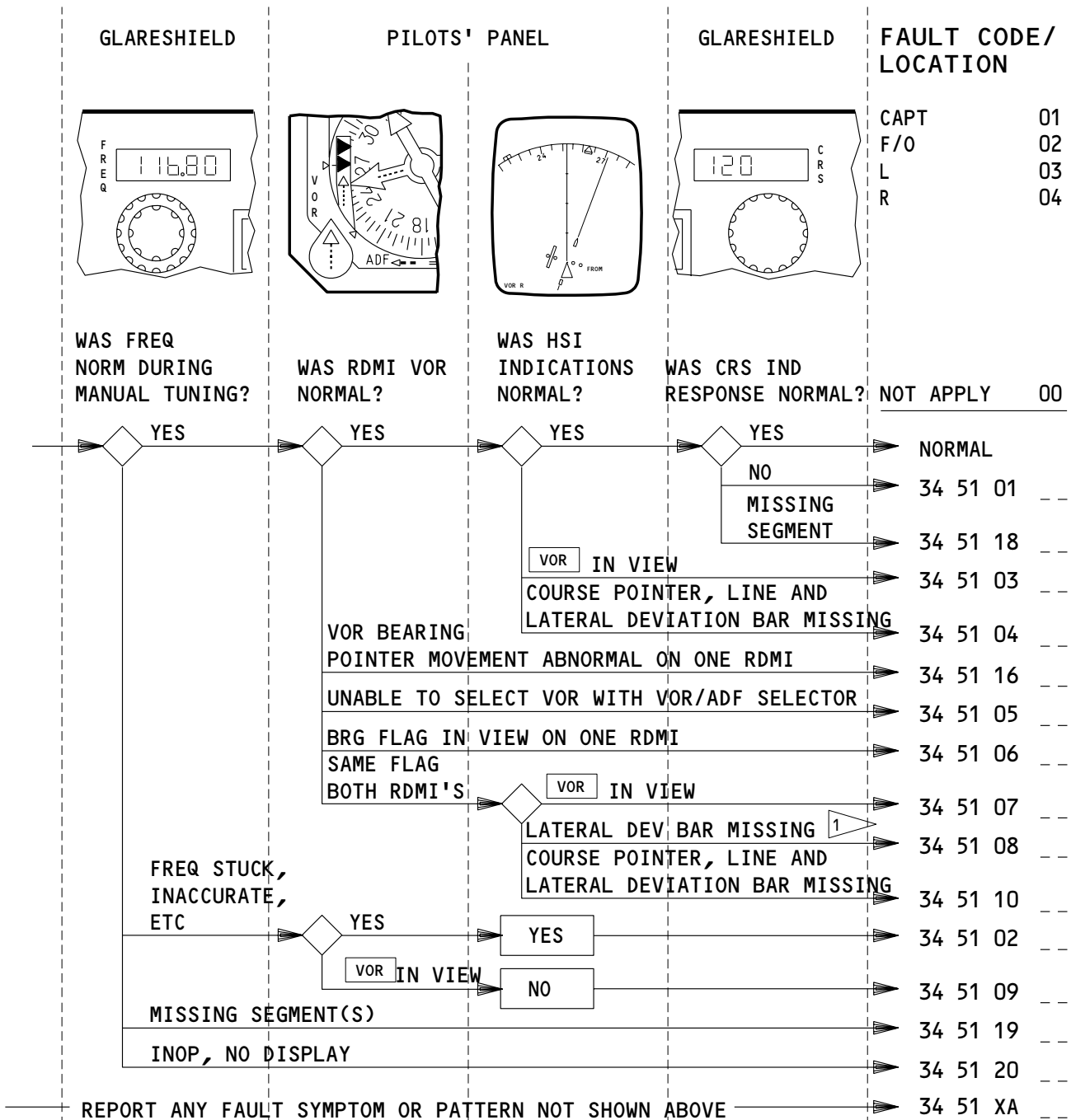

1 VOR FLAG ON THE RDMI AND MISSING LATERAL DEVIATION BAR ARE NORMAL WHEN NO VOR SIGNAL IS AVAILABLE. USE THIS CODE ONLY WHEN YOU KNOW VOR SIGNAL IS AVAILABLE.

APPLICABLE CIRCUIT BREAKERS AS INSTALLED

11A2 VOR MKR (L, LEFT)	11E33 VOR (R, RIGHT)
11A6 RDMI (L, LEFT)	11F25 RDMI (R, RIGHT)

VOR - CONTROL AND DISPLAY - FAULT CODES

EFFECTIVITY

ALL

34-FAULT CODE DIAGRAM

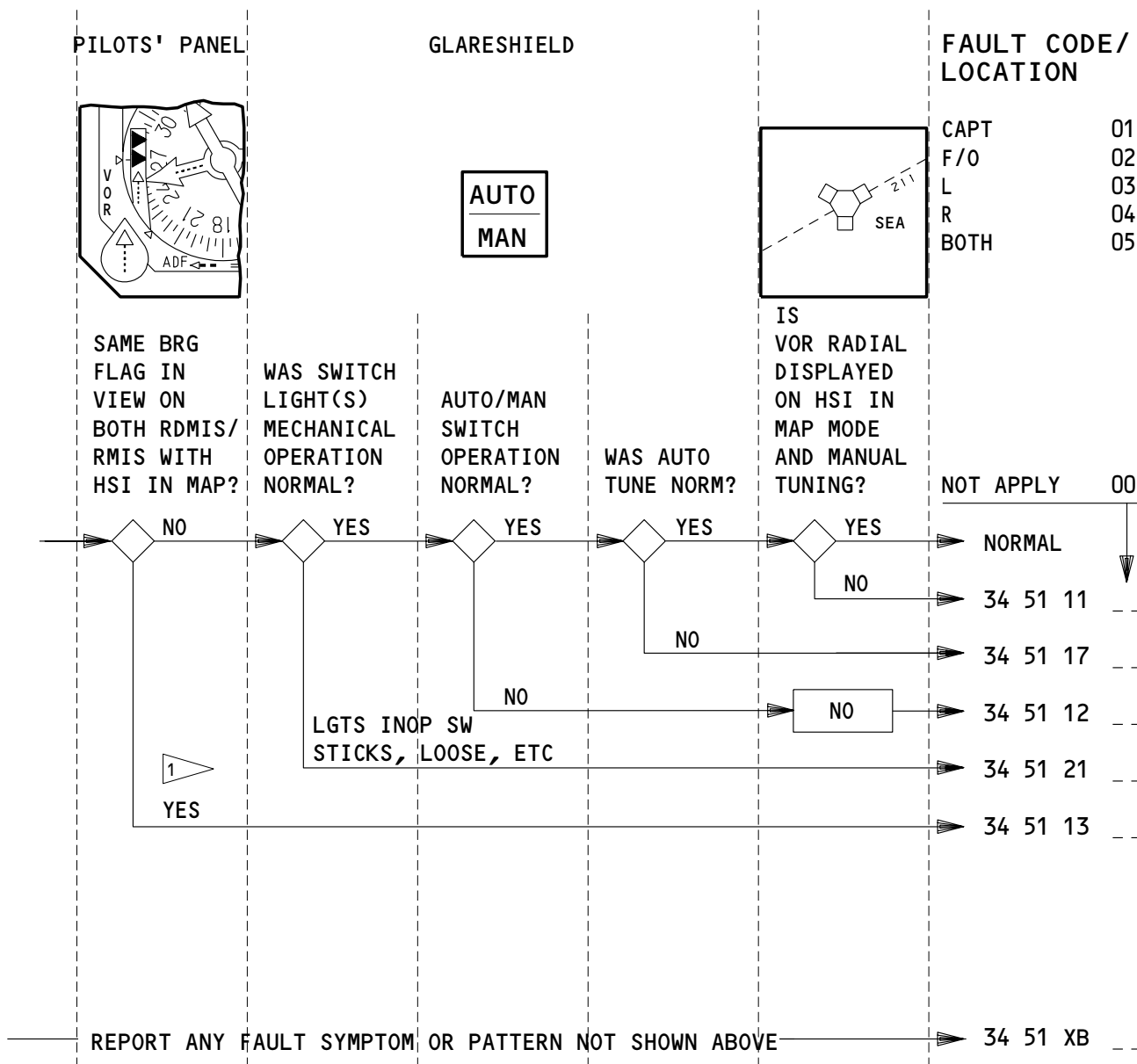

1 VERIFY VOR IS OK WITH HSI IN VOR MODE BEFORE SELECTING THIS CODE. IF NOT SELECT CODE FROM "VOR - CONTROL AND DISPLAY" PAGE.

APPLICABLE CIRCUIT BREAKERS AS INSTALLED

- 11A2 VOR MKR (L, LEFT)
- 11A6 RDMI (L, LEFT)
- 11E33 VOR (R, RIGHT)
- 11F25 RDMI (R, RIGHT)

VOR - HSI IN MAP MODE - FAULT CODES

EFFECTIVITY

ALL

34-FAULT CODE DIAGRAM

03

Page 37
May 28/01

BOEING

757 FAULT ISOLATION/MAINT MANUAL

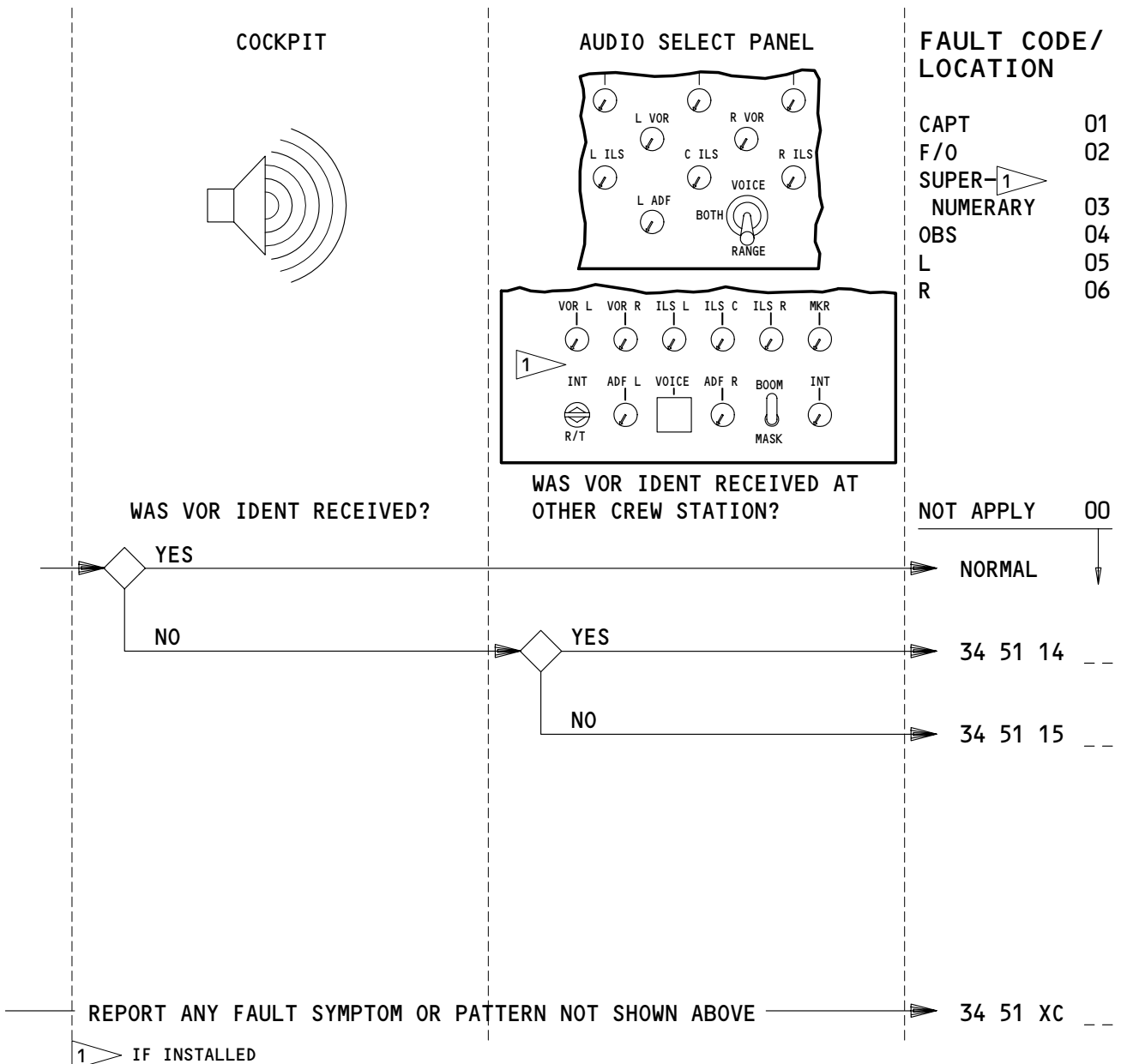

APPLICABLE CIRCUIT BREAKERS

- 11A2 VOR MKR (LEFT, L)
- 11E33 VOR (RIGHT, R)

VOR IDENT - FAULT CODES

EFFECTIVITY

ALL

34-FAULT CODE DIAGRAM

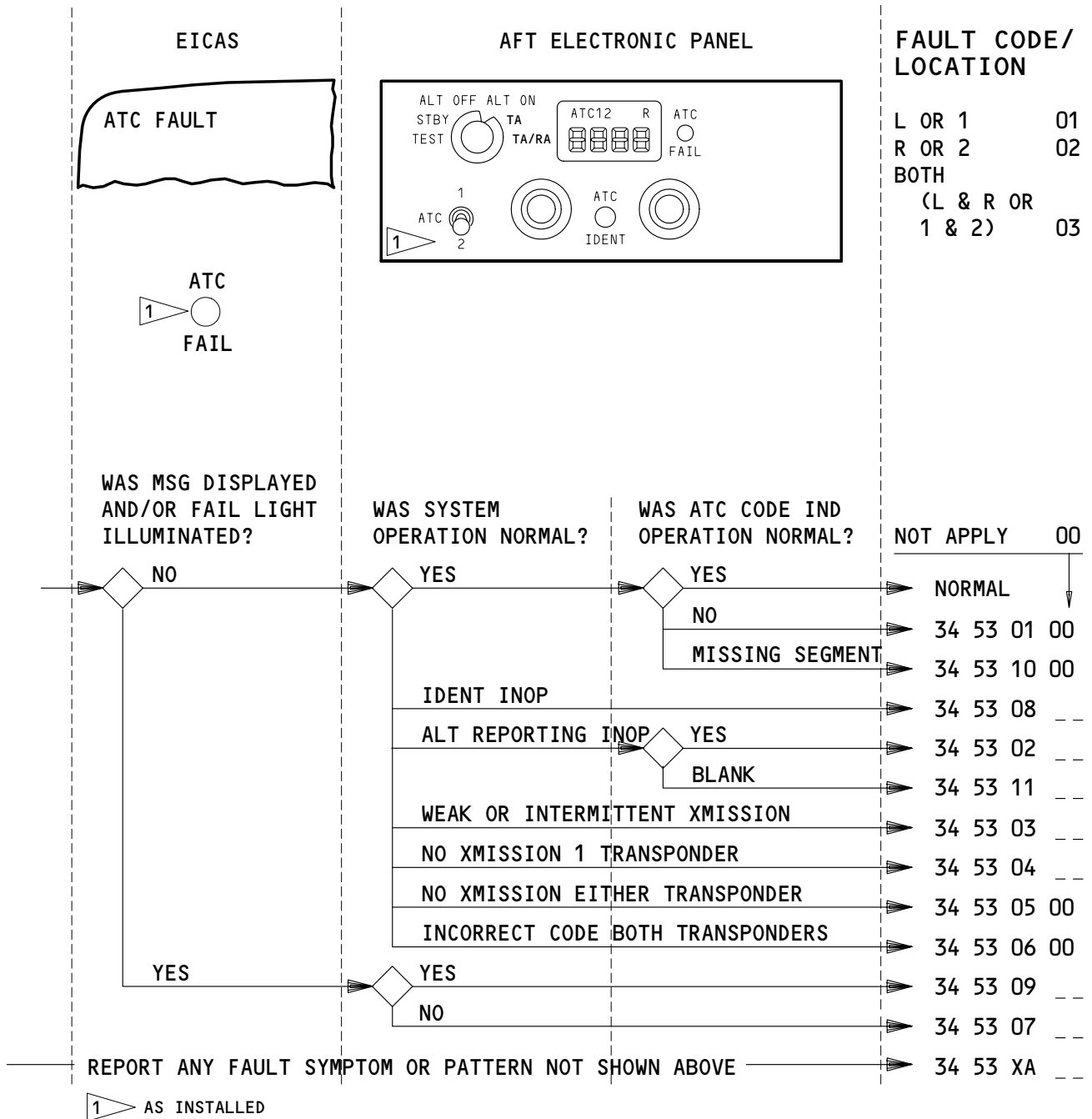

APPLICABLE CIRCUIT BREAKERS

- 11F7 ATC (L, LEFT)
- 11F28 ATC (R, RIGHT)

ATC TRANSPONDER – FAULT CODES

EFFECTIVITY

ALL

34-FAULT CODE DIAGRAM

BOEING
757
FAULT ISOLATION/MAINT MANUAL

PILOTS' PANEL

FAULT CODE/
LOCATION

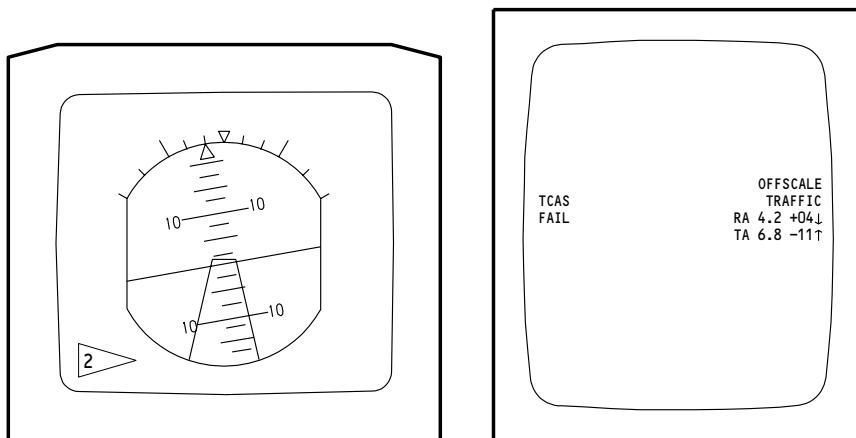

CAPT 01
F/O 02

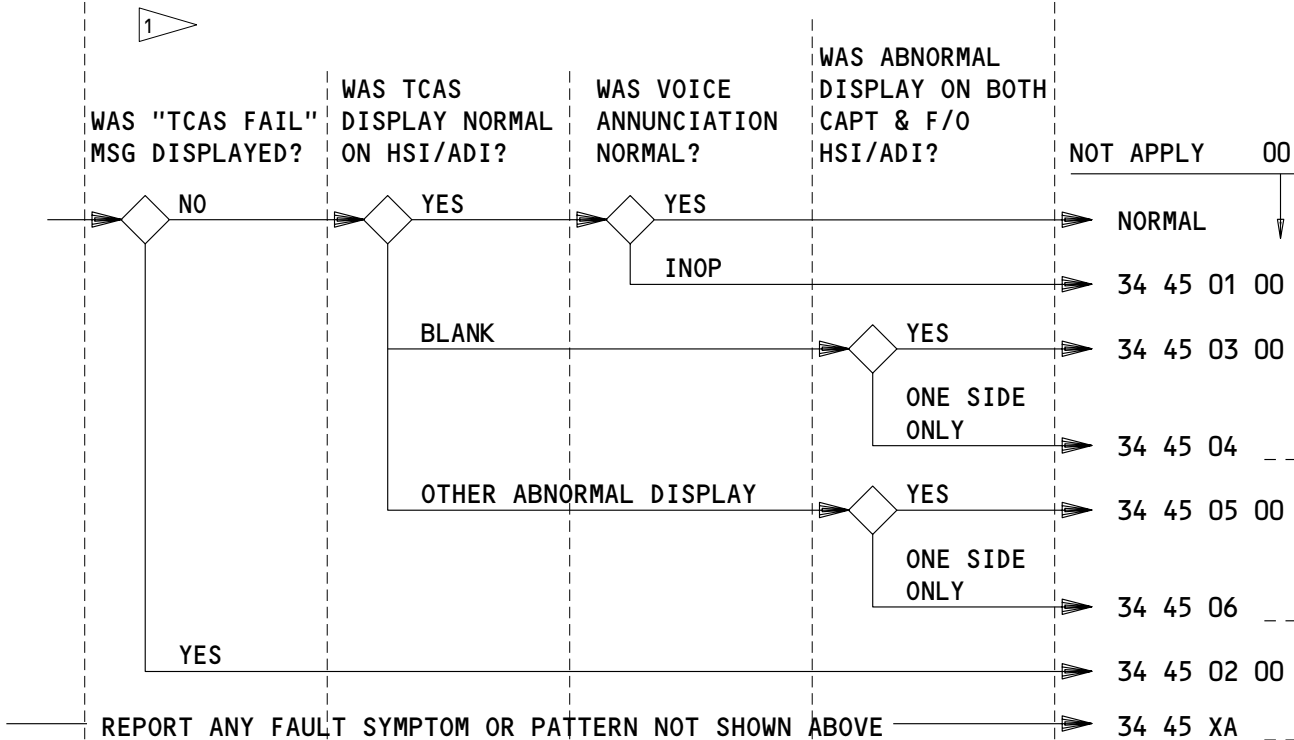

1 TCAS RA PITCH COMMAND (DOWN ADVISORY) NOT SHOWN.

2 TCAS DISPLAYS AS INSTALLED.

APPLICABLE CIRCUIT BREAKERS AS INSTALLED

11F3	TCAS
11F7	ATC (L, LEFT)
11F28	ATC (R, RIGHT)

TCAS - FAULT CODES

EFFECTIVITY

ALL

34-FAULT CODE DIAGRAM

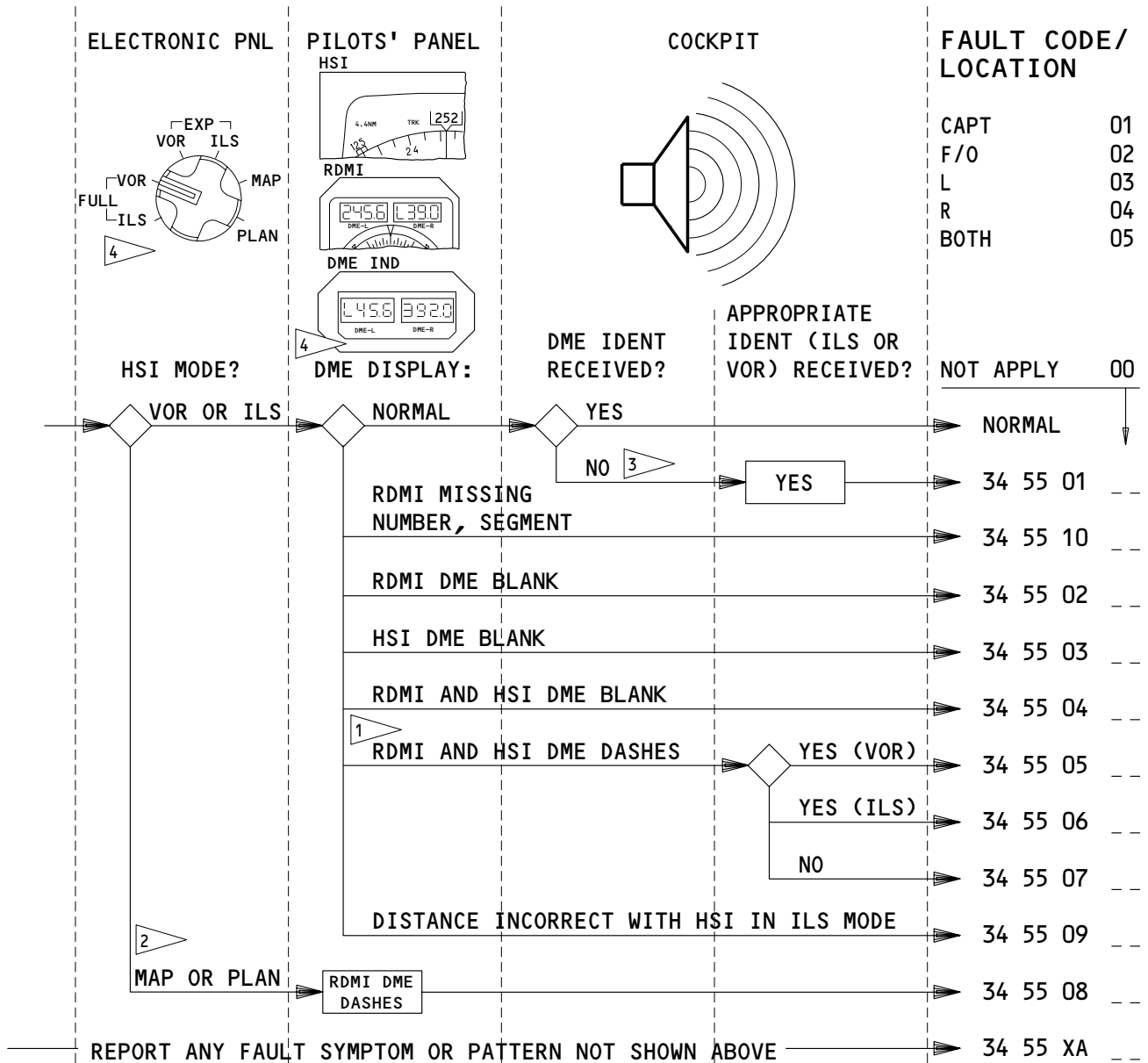

- 1 DASHES ON THE RDMI AND HSI DME ARE NORMAL WHEN NO DME SIGNAL IS AVAILABLE. USE THESE CODES ONLY WHEN YOU KNOW DME SIGNAL IS AVAILABLE.
- 2 VERIFY DME IS OK WITH HSI IN VOR OR ILS MODE BEFORE SELECTING THESE CODES. IF NOT OK IN VOR OR ILS SELECT CODE FROM VOR OR ILS BRANCH.
- 3 FILTER SW ON ASP MUST BE IN BOTH OR RANGE FOR AUDIO RECEPTION.
- 4 AS INSTALLED

APPLICABLE CIRCUIT BREAKERS

11A2	VOR MKR (L, LEFT)	11E32	DME (R, RIGHT)
11E11	DME (L, LEFT)	11E33	VOR (R, RIGHT)

DME - FAULT CODES

EFFECTIVITY

ALL

34-FAULT CODE DIAGRAM

BOEING

757

FAULT ISOLATION/MAINT MANUAL

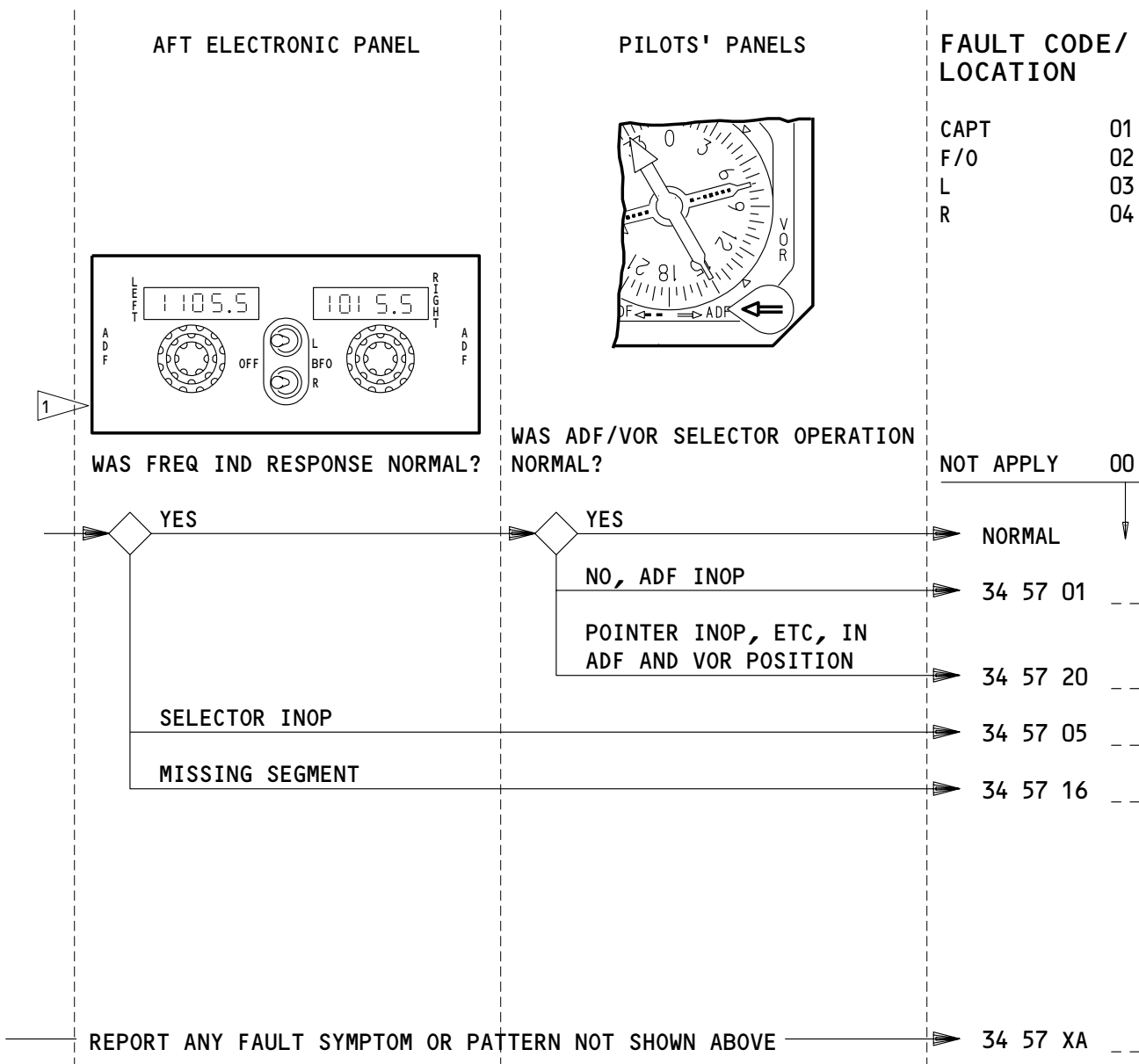

1 AS INSTALLED

APPLICABLE CIRCUIT BREAKERS AS INSTALLED

11A4	ADF R
11A6	RDMI (L, LEFT)
11F6	ADF (L, LEFT)
11F25	RDMI (R, RIGHT)
11F27	ADF (R, RIGHT)

ADF CONTROL PANEL/RDMI/RMI - FAULT CODES

EFFECTIVITY

ALL

34-FAULT CODE DIAGRAM

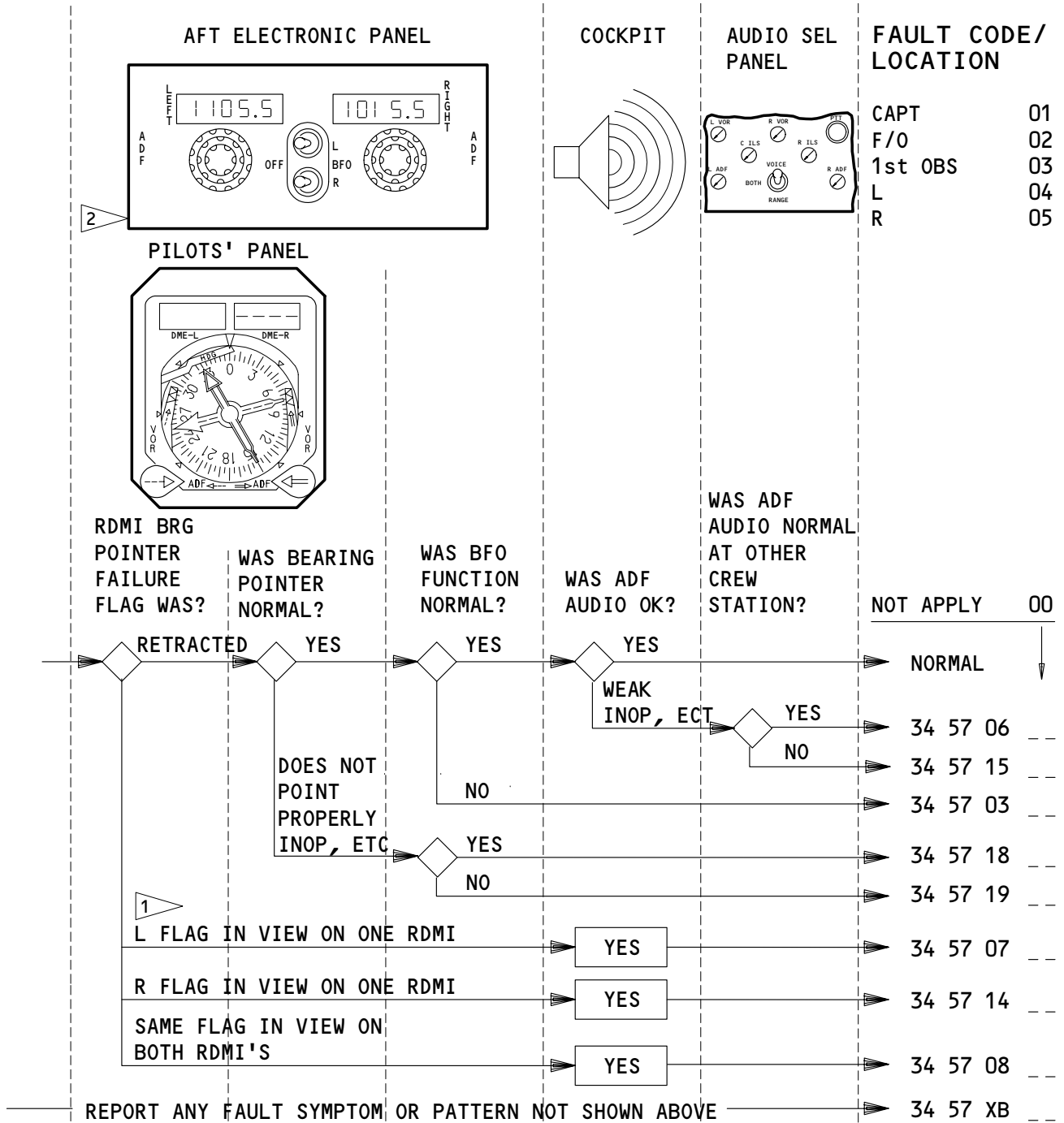

1 ADF RECEIVER MAY LOCK UP DURING ELEC POWER TRANSFER. BRG POINTER FLAG WILL DISPLAY ON RDMI. ADF MAY BE RETORED BY CYCLING ADF CIRCUIT BREAKER.

2 AS INSTALLED

APPLICABLE CIRCUIT BREAKERS

11A4	ADF RIGHT	11F6	ADF LEFT
11A6	RDMI LEFT	11F25	RDMI RIGHT

ADF (ADF, ANT MODE) - FAULT CODES

EFFECTIVITY AIRPLANES WITH RDMI

34-FAULT CODE DIAGRAM

872202

BOEING

757 FAULT ISOLATION/MAINT MANUAL

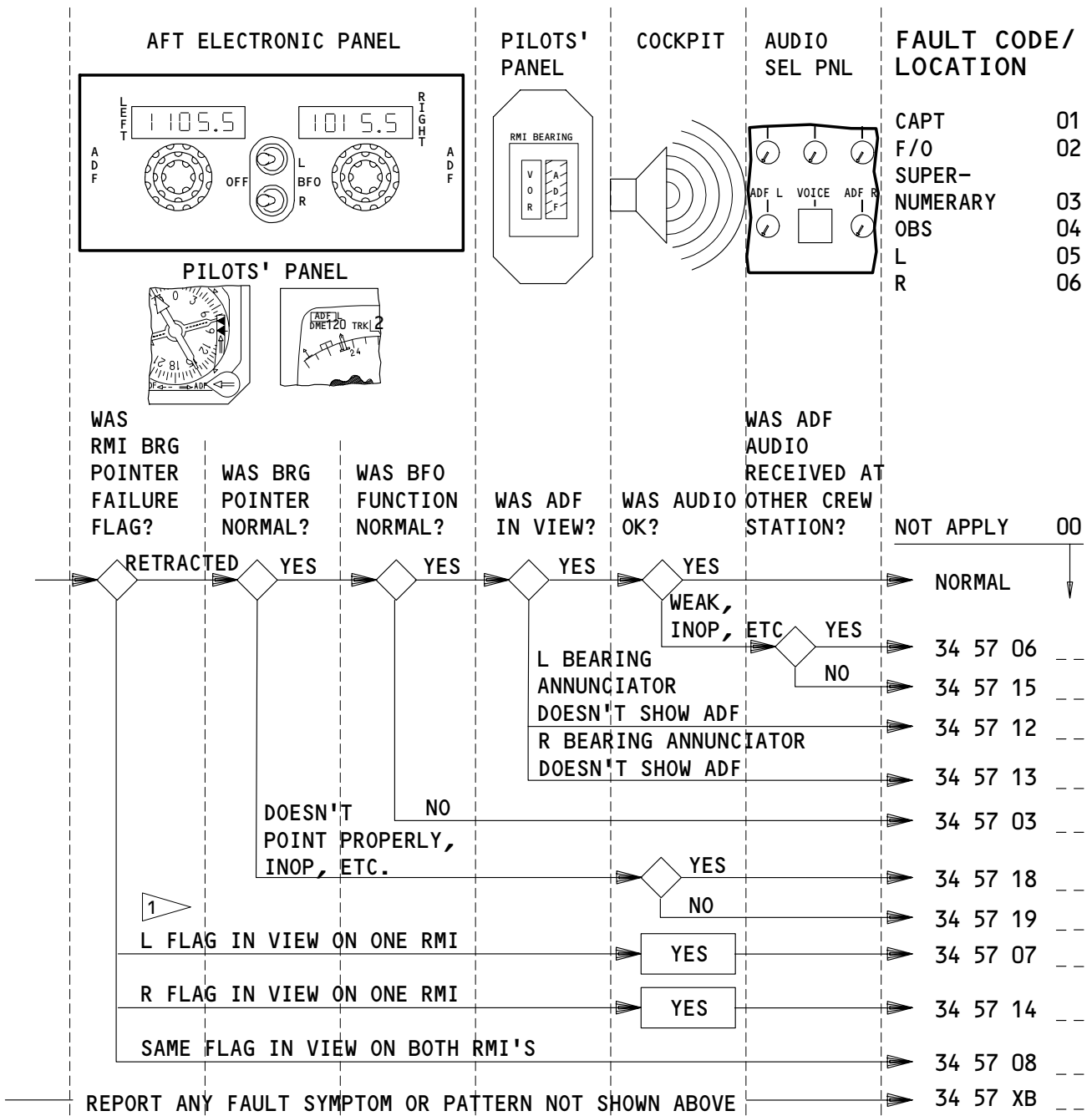

1 ADF RECEIVER MAY LOCK UP DURING ELEC POWER TRANSFER. BRG POINTER FLAG WILL DISPLAY ON RMI. ADF MAY BE RESTORED BY CYCLING ADF CIRCUIT BREAKER.

2 AS INSTALLED

APPLICABLE CIRCUIT BREAKERS

2 11A4	ADF R	11A7	RMI L	2 11A14	ADF L	11F25	RBA R
11A6	RBA L	2 11A13	ADF L	11F23	RMI R	2 11F27	ADF R

ADF - FAULT CODES

EFFECTIVITY AIRPLANES WITH RMI

34-FAULT CODE DIAGRAM

BOEING

757

FAULT ISOLATION/MAINT MANUAL

FWD ELECTRONICS PANEL

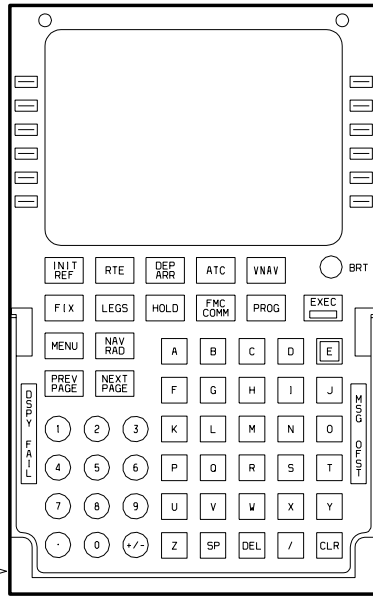

1

PILOTS' PANEL

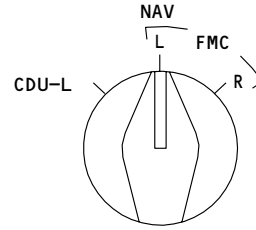

OR

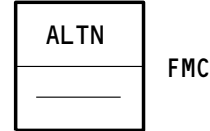

SELECT ALTN FMC

FAULT CODE/ LOCATION

CAPT	01
F/O	02
BOTH	03

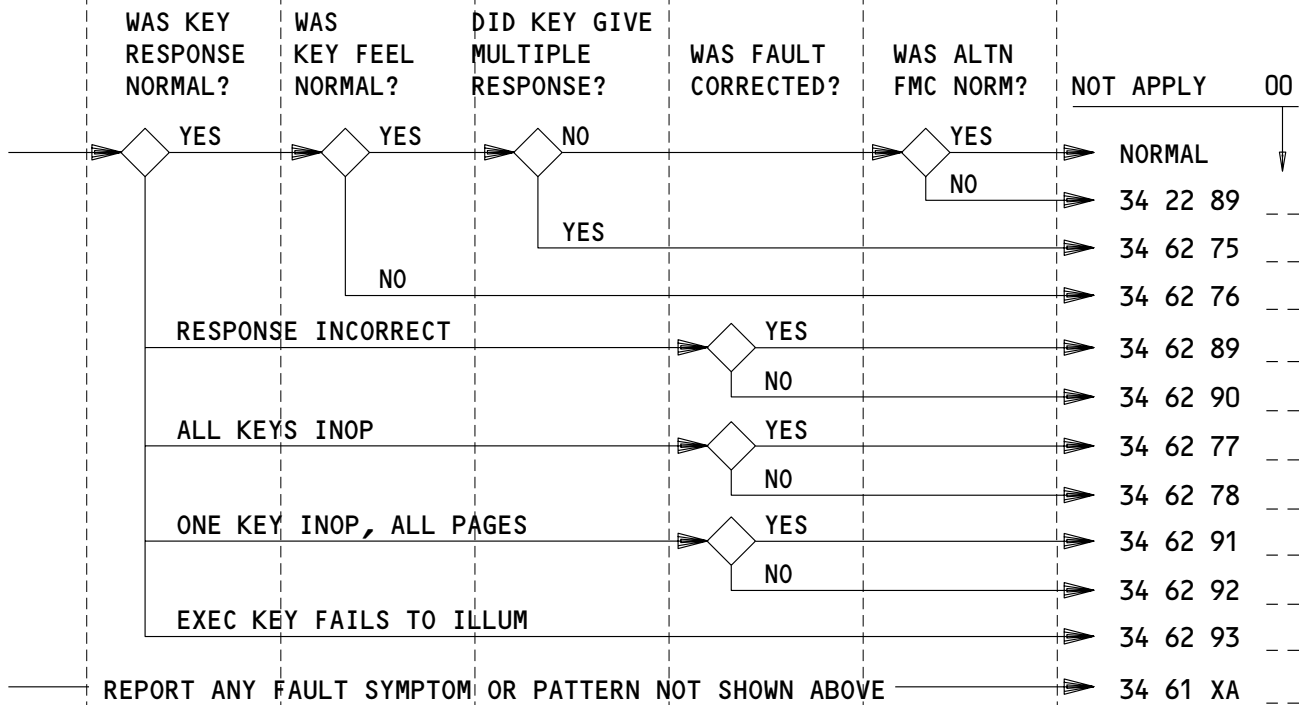

1 AS INSTALLED

APPLICABLE CIRCUIT BREAKERS AS INSTALLED

11E8	FMCS CDU (L, LEFT)	11E29	FMCS CDU (R, RIGHT)
11E9	FMCS CMPTR (L, LEFT)	11E30	FMCS CMPTR (R, RIGHT)

FMC-CDU KEYS & ALTN FMC - FAULT CODES

EFFECTIVITY

ALL

34-FAULT CODE DIAGRAM

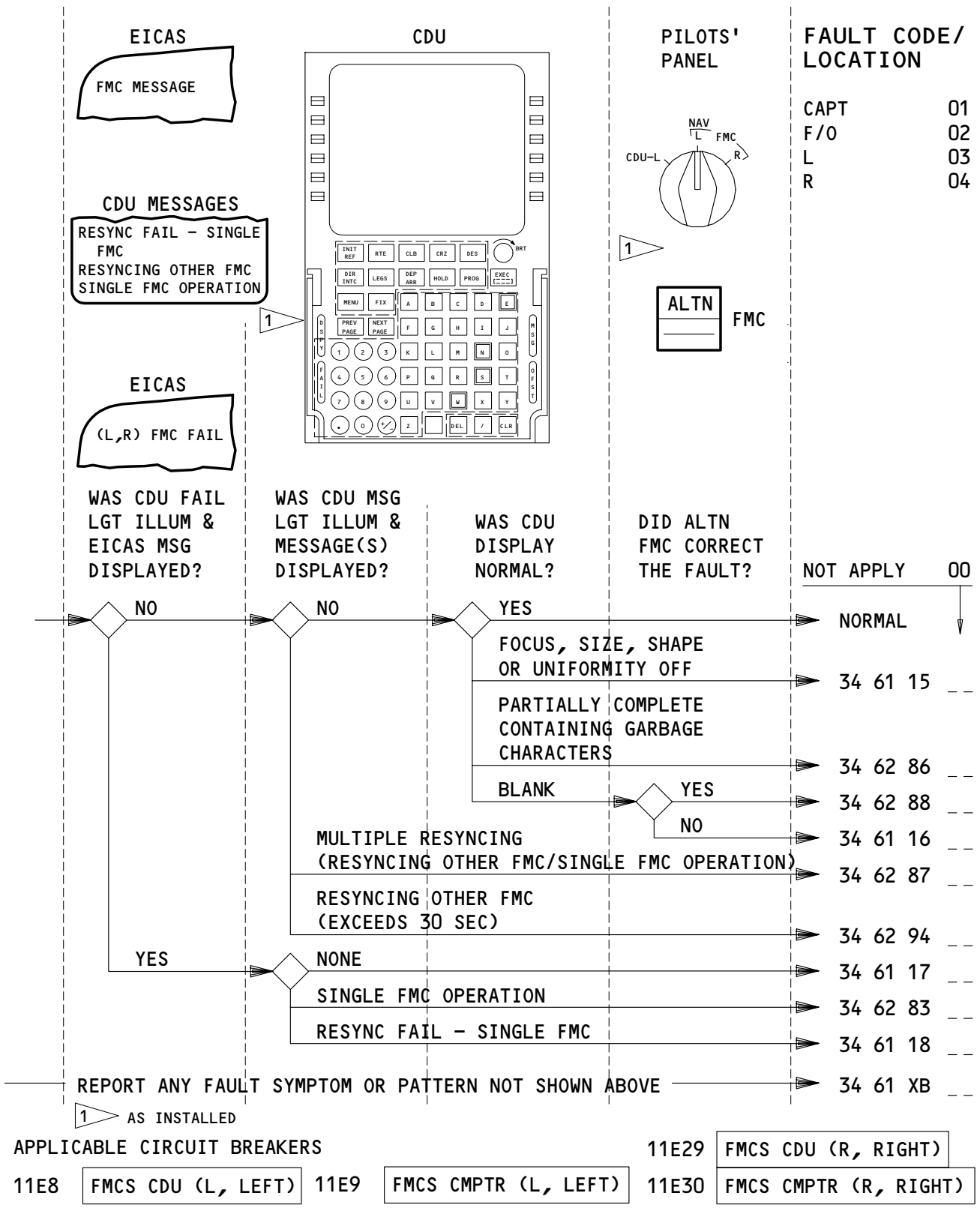

CDU FAIL, FMC FAIL AND RESYNC - FAULT CODES

EFFECTIVITY

ALL

34-FAULT CODE DIAGRAM

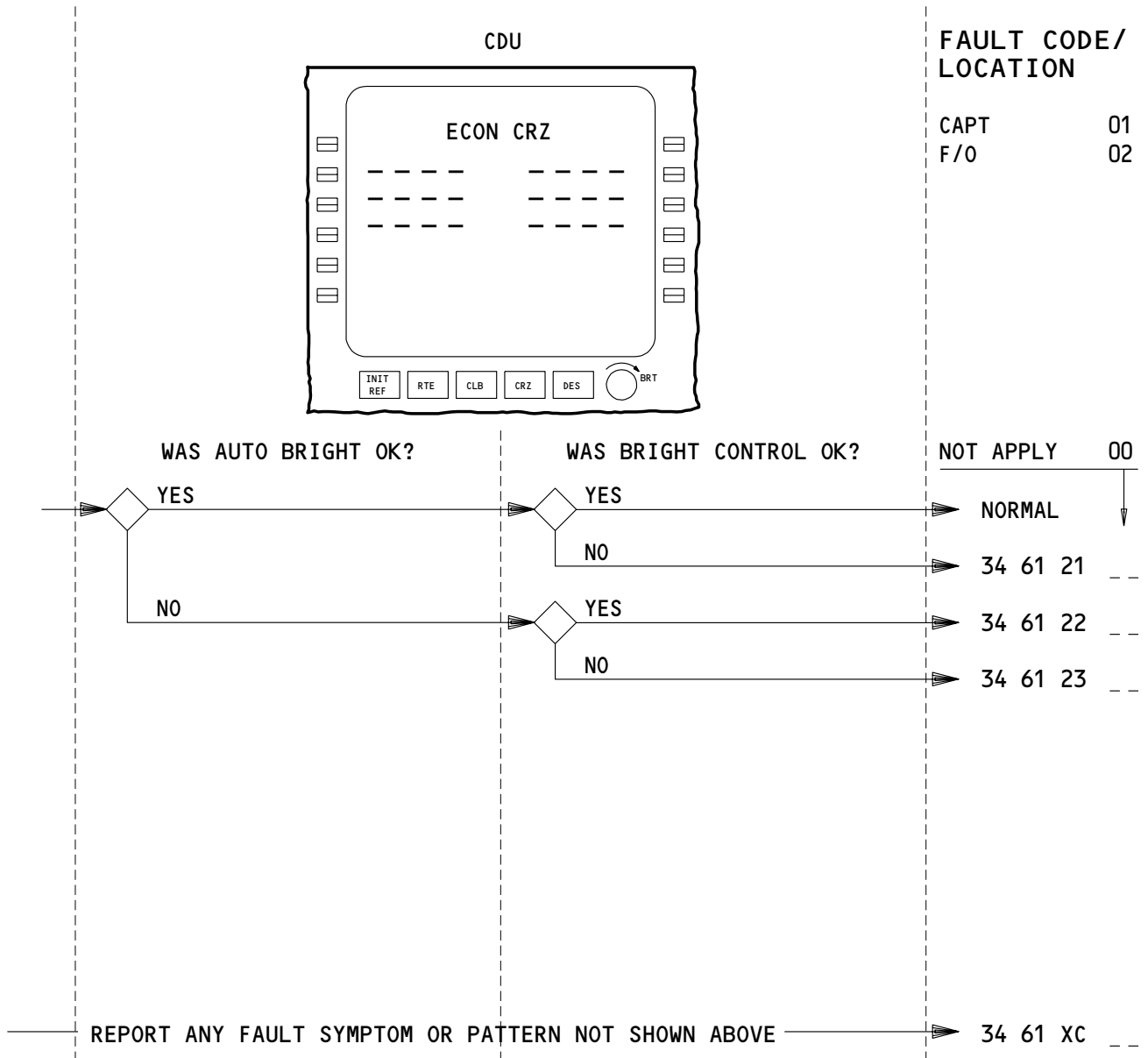

APPLICABLE CIRCUIT BREAKERS AS INSTALLED AS INSTALLED

- | | |
|------------------------------|--------------------------------|
| 11E8 FMCS CDU (L, LEFT) | 11E29 FMCS CDU (R, RIGHT) |
| 11E9 FMCS CMPTR (L, LEFT) | 11E30 FMCS CMPTR (R, RIGHT) |

FMC-CDU BRIGHTNESS - FAULT CODES

EFFECTIVITY

ALL

34-FAULT CODE DIAGRAM

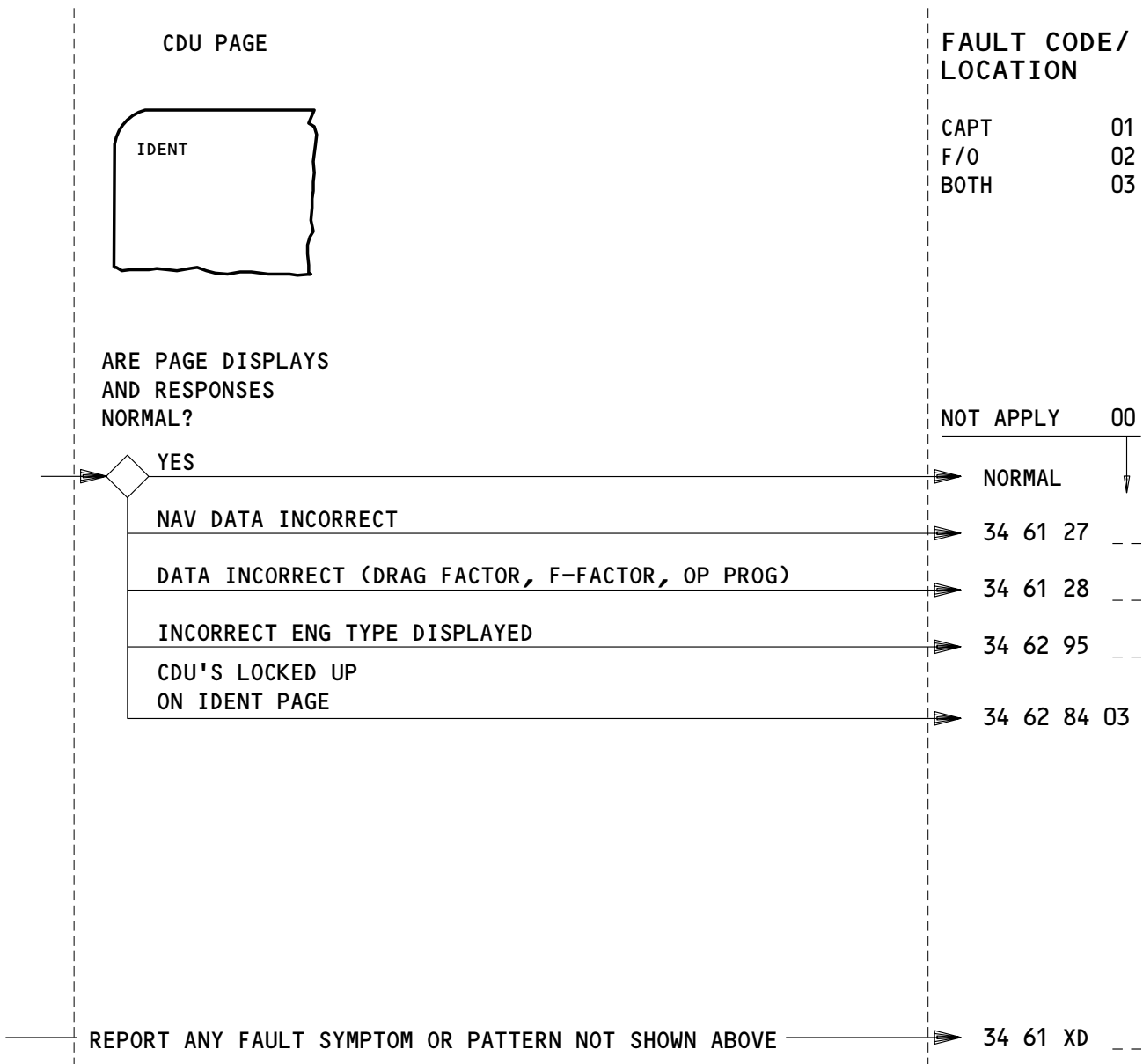

APPLICABLE CIRCUIT BREAKERS AS INSTALLED

11E8	FMCS CDU (L, LEFT)	11E29	FMCS CDU (R, RIGHT)
11E9	FMCS CMPTR (L, LEFT)	11E30	FMCS CMPTR (R, RIGHT)

FMC-CDU IDENT PAGE - FAULT CODES

EFFECTIVITY	ALL
-------------	-----

34-FAULT CODE DIAGRAM

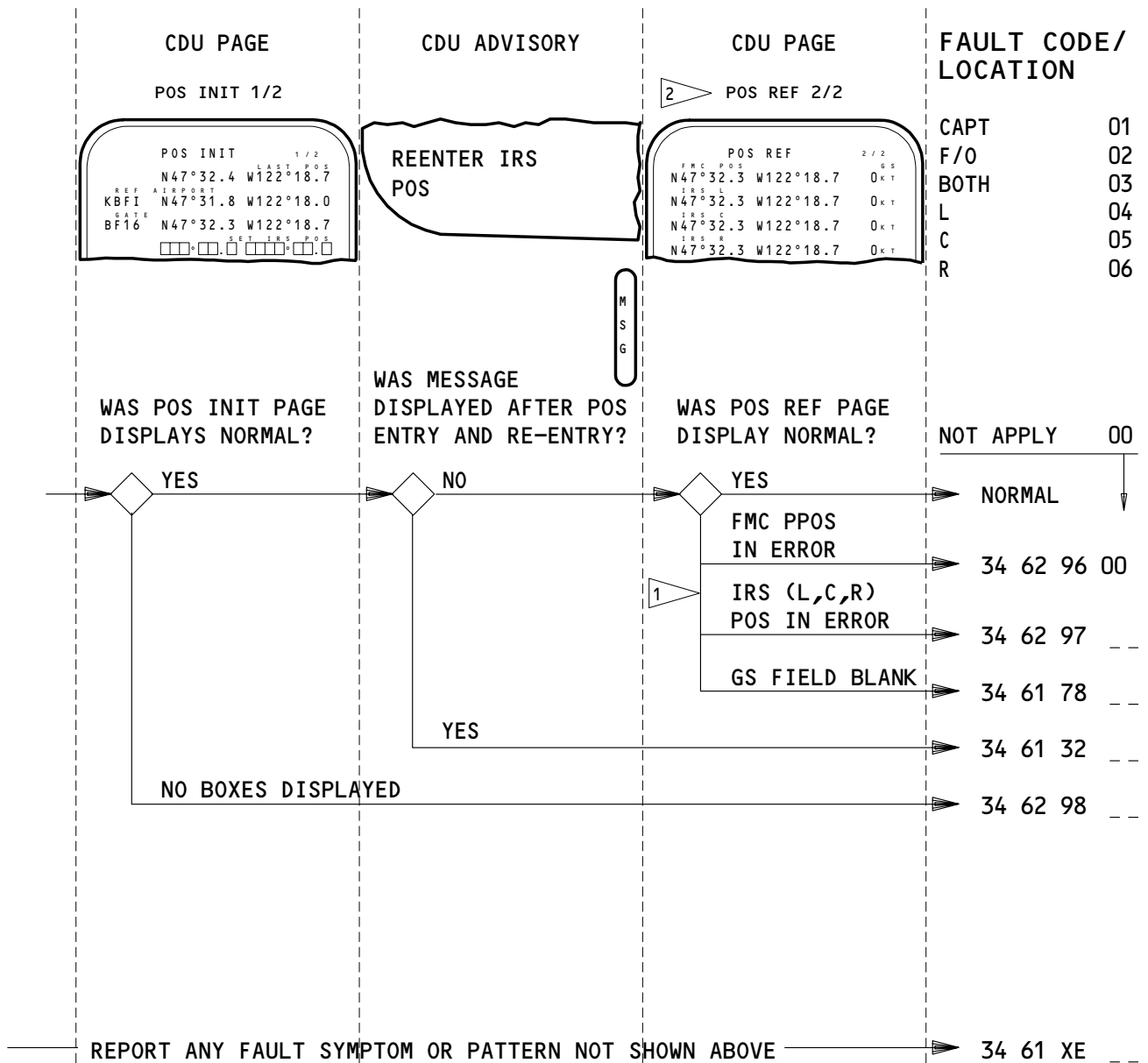

1 RECORD TIME IRS WAS IN OPERATION, ACTUAL AND INDICATED LATITUDE AND LONGITUDE. ADD ADDITIONAL NOTE TO LOG BOOK REPORT IF ERROR IS EXCESSIVE FOR 2 CONSECUTIVE FLIGHTS. (SEE RADIAL POSITION ERROR CHECK)

2 AS INSTALLED

APPLICABLE CIRCUIT BREAKERS AS INSTALLED

6D3	L IRS	11E8	FMCS CDU (L, LEFT)	11F1	IRS (L, LEFT)
6D4	C IRS	11E9	FMCS CMPTR (L, LEFT)	11F21	IRS (C, CENTER)
6D5	R IRS	11E29	FMCS CDU (R, RIGHT)	11F22	IRS (R, RIGHT)
		11E30	FMCS CMPTR (R, RIGHT)		

FMC-CDU POS INIT/REF PAGE - FAULT CODES

EFFECTIVITY
ALL

34-FAULT CODE DIAGRAM

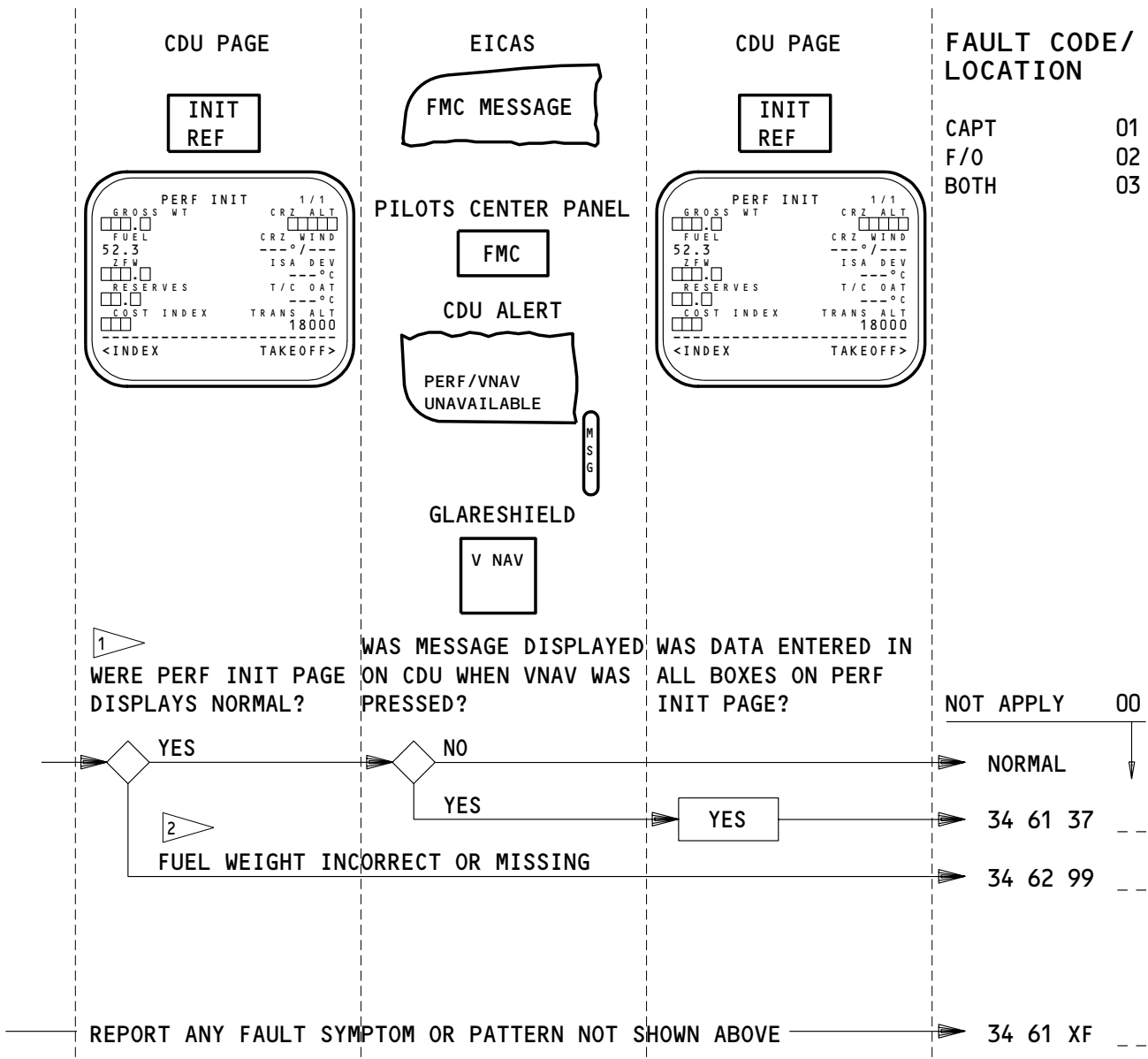

1 ALL FUEL INFORMATION, EXCEPT TOTAL FUEL, WILL BE BLANK IF ENG SHUTDOWN OR EICAS TEST BUTTON IS PRESSED.

2 TO CORRECT DIFFERENCE BETWEEN FMC FUEL & TOTALIZER FUEL, MANUALLY ENTER ANY AMOUNT OF FUEL, THEN DELETE FUEL WITH DELETE KEY. FMC SHOULD THEN DISPLAY TOTALIZER FUEL.

APPLICABLE CIRCUIT BREAKERS AS INSTALLED

11E8	FMCS CDU (L, LEFT)
11E9	FMCS CMPTR (L, LEFT)
11E29	FMCS CDU (R, RIGHT)
11E30	FMCS CMPTR (R, RIGHT)

FMC-CDU PERFORMANCE INITIALIZATION PAGE - FAULT CODES

EFFECTIVITY

ALL

34-FAULT CODE DIAGRAM

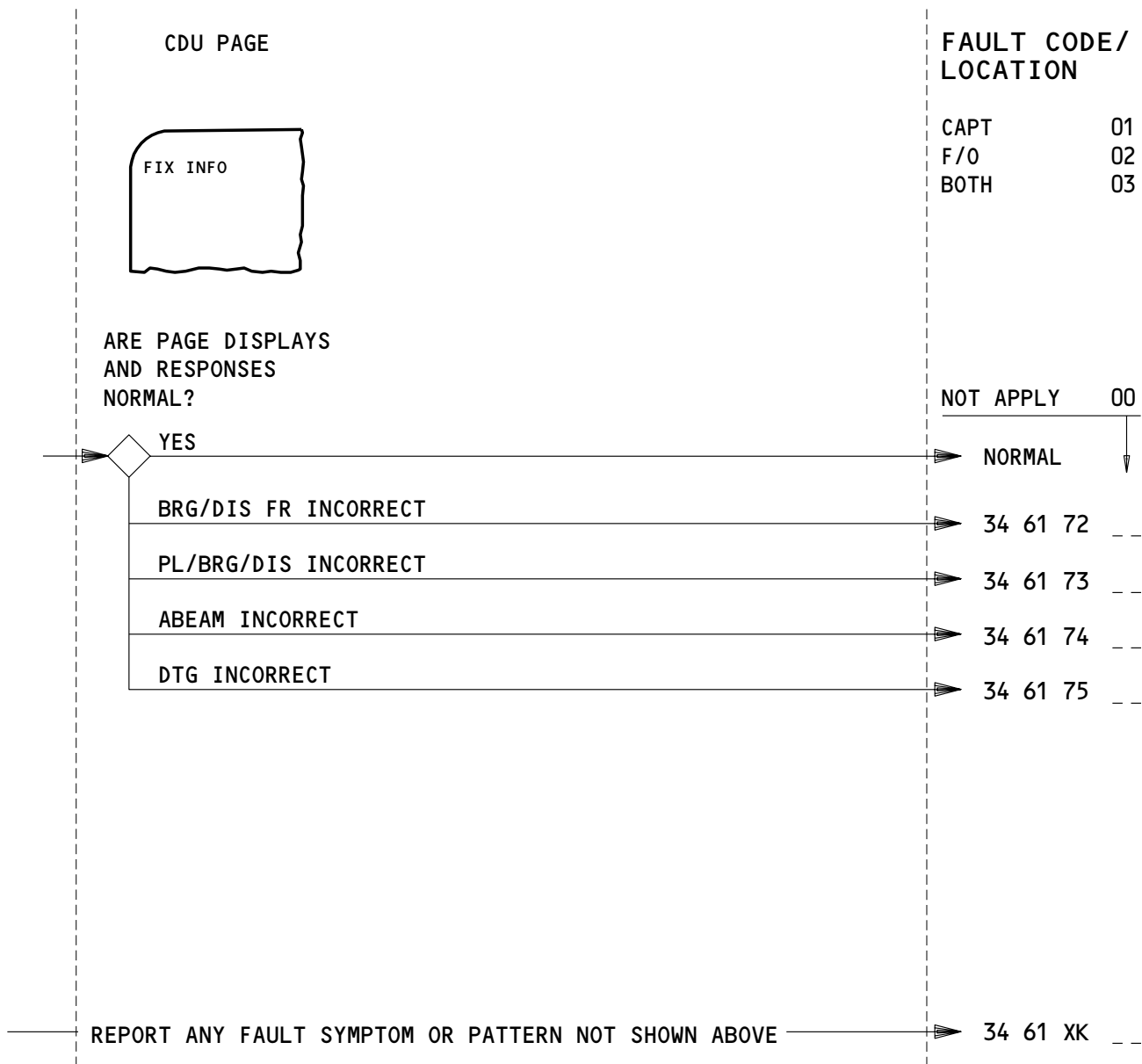

APPLICABLE CIRCUIT BREAKERS AS INSTALLED

11E8	FMCS CDU (L, LEFT)
11E9	FMCS CMPTR (L, LEFT)
11E29	FMCS CDU (R, RIGHT)
11E30	FMCS CMPTR (R, RIGHT)

FMC - CDU FIX PAGE - FAULT CODES

EFFECTIVITY

ALL

34-FAULT CODE DIAGRAM

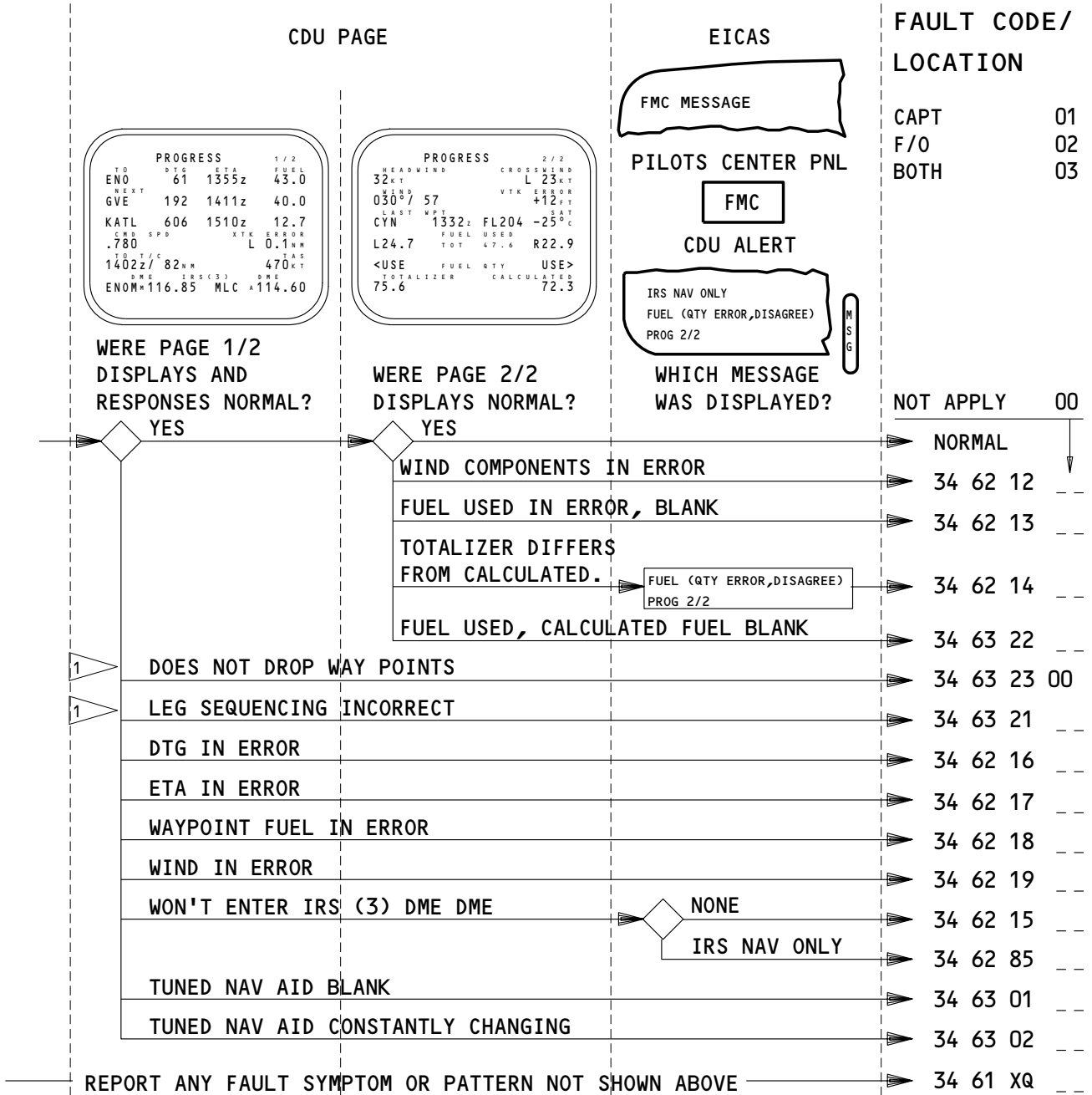

1 SEQUENCE PROBLEMS MAY BE RESTORED AFTER LANDING BY CYCLING NAV DATA BASE DATES ON IDENT PAGE.

APPLICABLE CIRCUIT BREAKERS AS INSTALLED

11A2	VOR MKR (L, LEFT)	11E11	DME (L, LEFT)	11E32	DME (R, RIGHT)
11E8	FMCS CDU (L, LEFT)	11E29	FMCS CDU (R, RIGHT)	11E33	VOR (R, RIGHT)
11E9	FMCS CMPTR (L, LEFT)	11E30	FMCS CMPTR (R, RIGHT)		

FMC-CDU PROGRESS PAGE - FAULT CODES

EFFECTIVITY

ALL

34-FAULT CODE DIAGRAM

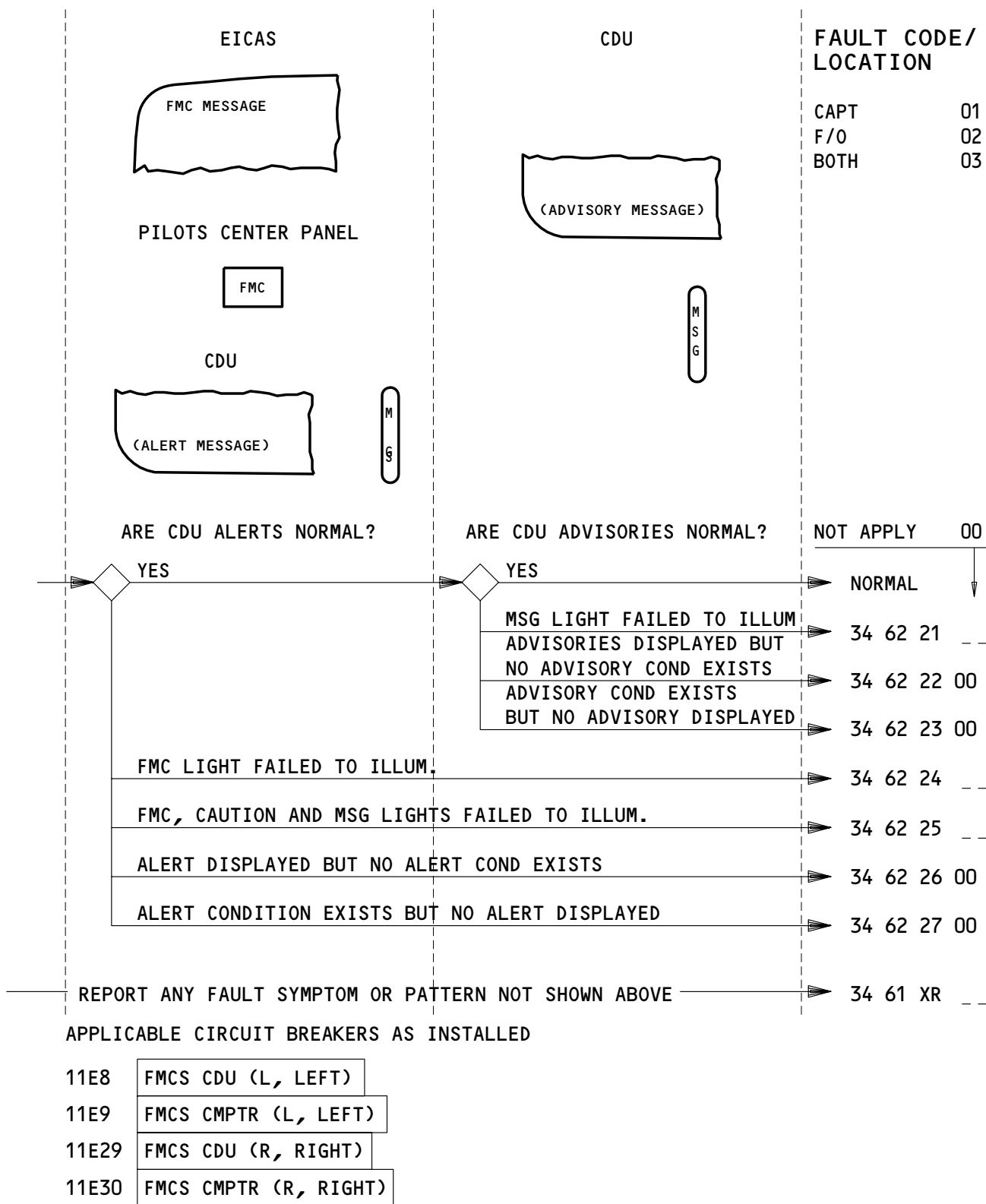

FMC-CDU ALERT AND ADVISORY MESSAGES - FAULT CODES

EFFECTIVITY

ALL

34-FAULT CODE DIAGRAM

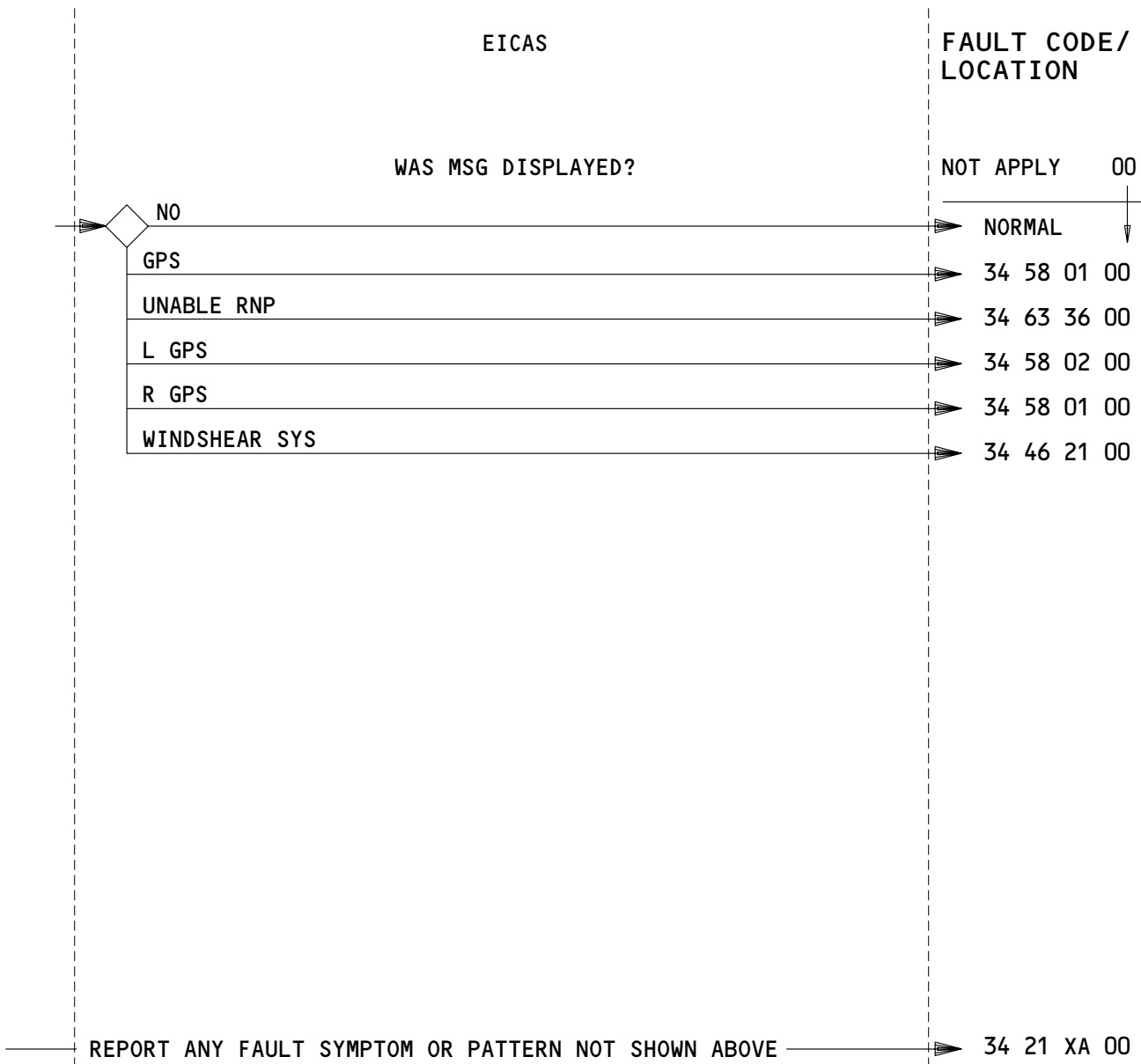

EICAS MESSAGE – FAULT CODES

EFFECTIVITY
AIRPLANES WITH PEGASUS FMC

34-FAULT CODE DIAGRAM

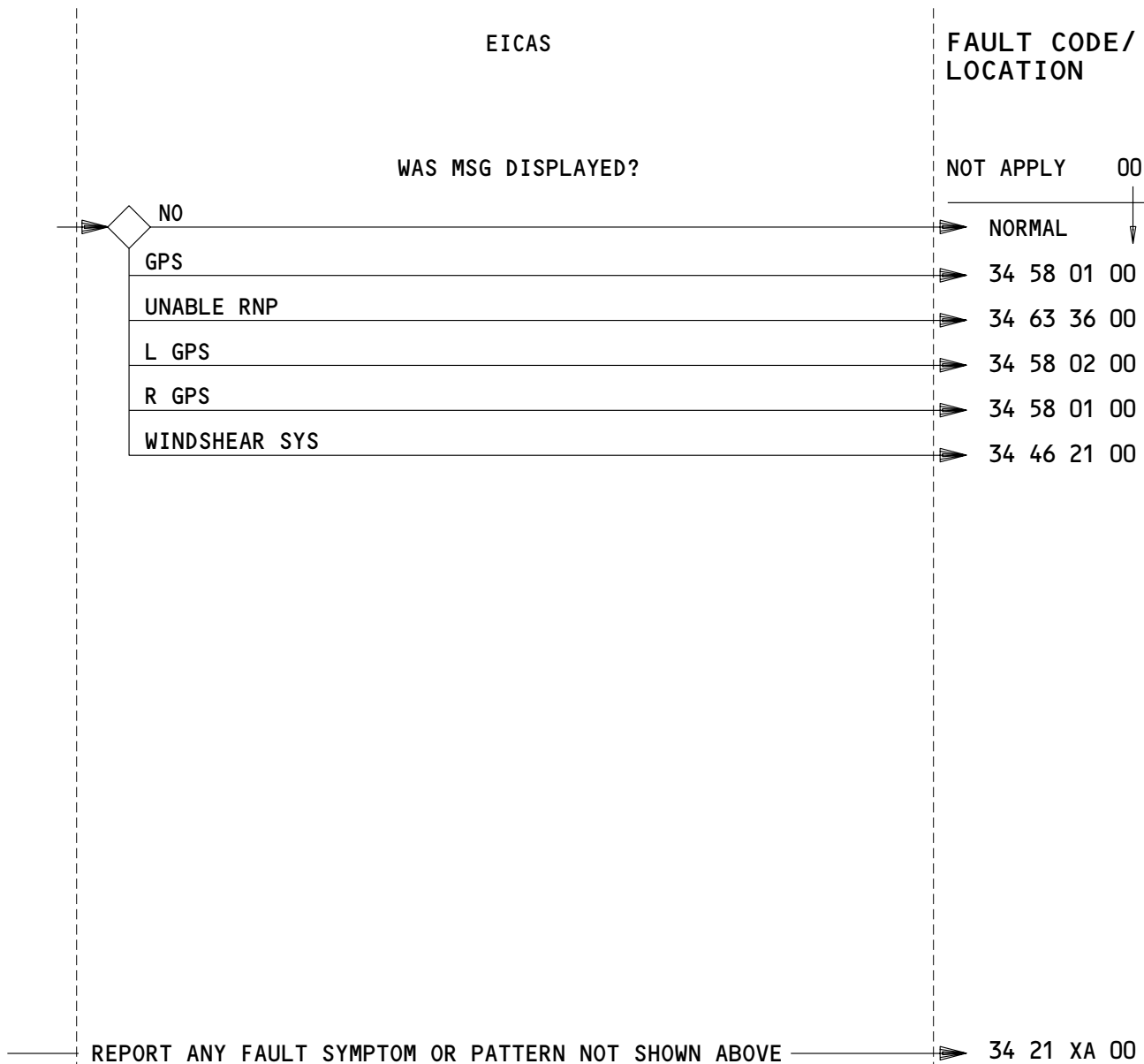

EICAS MESSAGE – FAULT CODES

EFFECTIVITY

ALL

34-FAULT CODE DIAGRAM

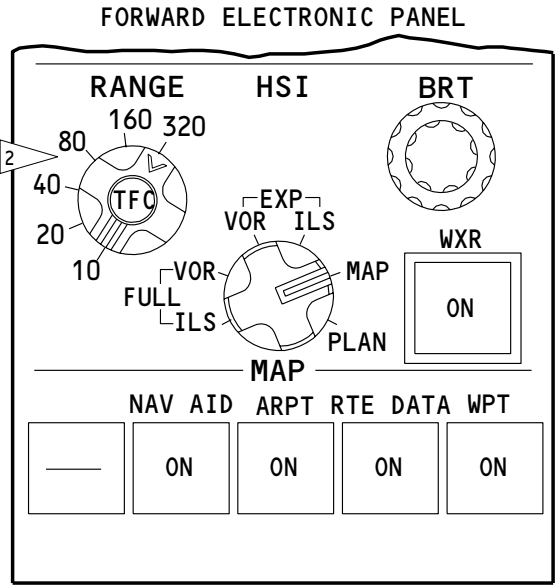

FAULT CODE/
LOCATION

CAPT 01
F/O 02

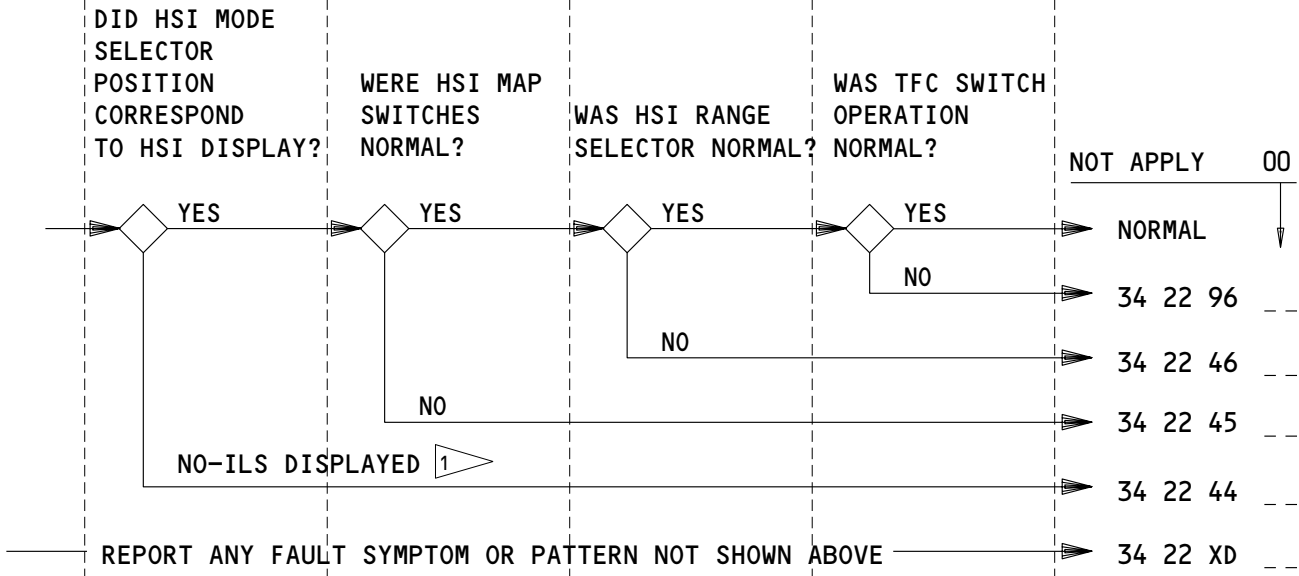

¹ DH AND WX RADAR FAIL FLAGS DISPLAYED.

² AS INSTALLED

APPLICABLE CIRCUIT BREAKERS

- 11E4 EFIS CONT PANEL (L, LEFT)
- 11E8 FMCS CDU (L, LEFT)
- 11E9 FMCS CMPTR (L, LEFT)
- 11E25 EFIS CONT PANEL (R, RIGHT)

- 11E29 FMCS CDU (R, RIGHT)
- 11E30 FMCS CMPTR (R, RIGHT)

FMC – HSI TRAFFIC RANGE, MAP AND MODE SELECT – FAULT CODES

EFFECTIVITY

ALL

34-FAULT CODE DIAGRAM

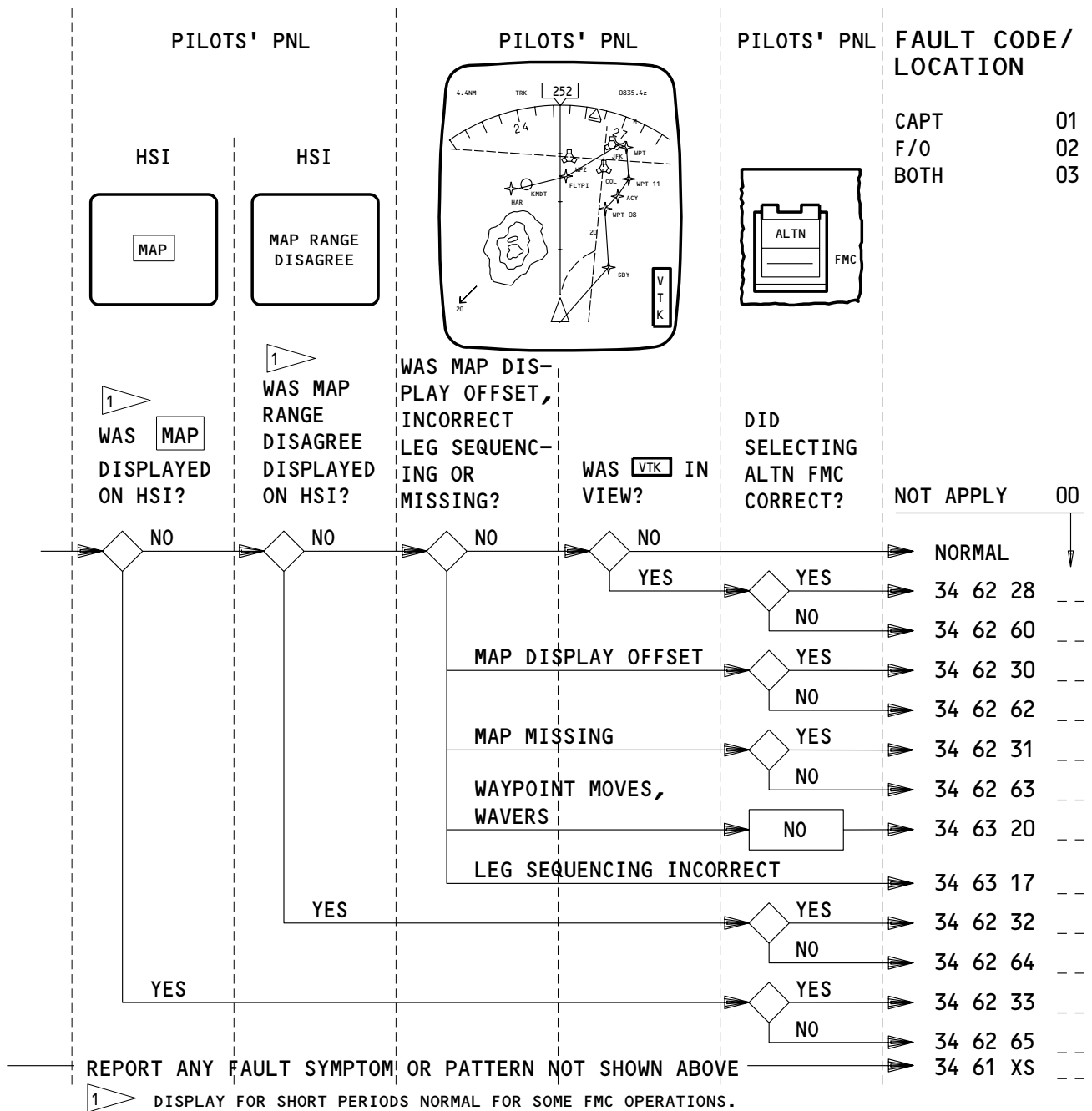

APPLICABLE CIRCUIT BREAKERS AS INSTALLED

11E4	EFIS CONT PANEL (L, LEFT)	11E25	EFIS CONT PANEL (R, RIGHT)	11F8	EFIS SYM GEN (L, LEFT)
11E6	HSI (L, LEFT)	11E27	HSI (R, RIGHT)	11F9	EFIS SYM GEN (C, CENTER)
11E8	FMCS CDU (L, LEFT)	11E29	FMCS CDU (R, RIGHT)	11F29	EFIS SYM GEN (R, RIGHT)
11E9	FMCS CMPTR (L, LEFT)	11E30	FMCS CMPTR (R, RIGHT)		

FMC-HSI MAP GENERAL - FAULT CODES

EFFECTIVITY

ALL

34-FAULT CODE DIAGRAM

PILOTS' PNL

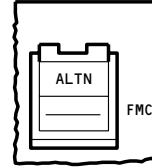
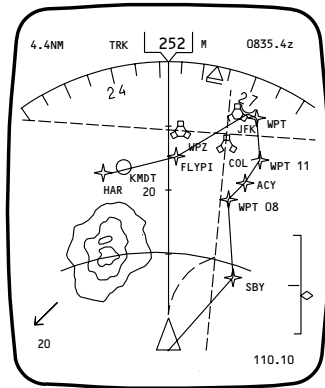

FAULT CODE/
LOCATION

CAPT 01
F/O 02
BOTH 03

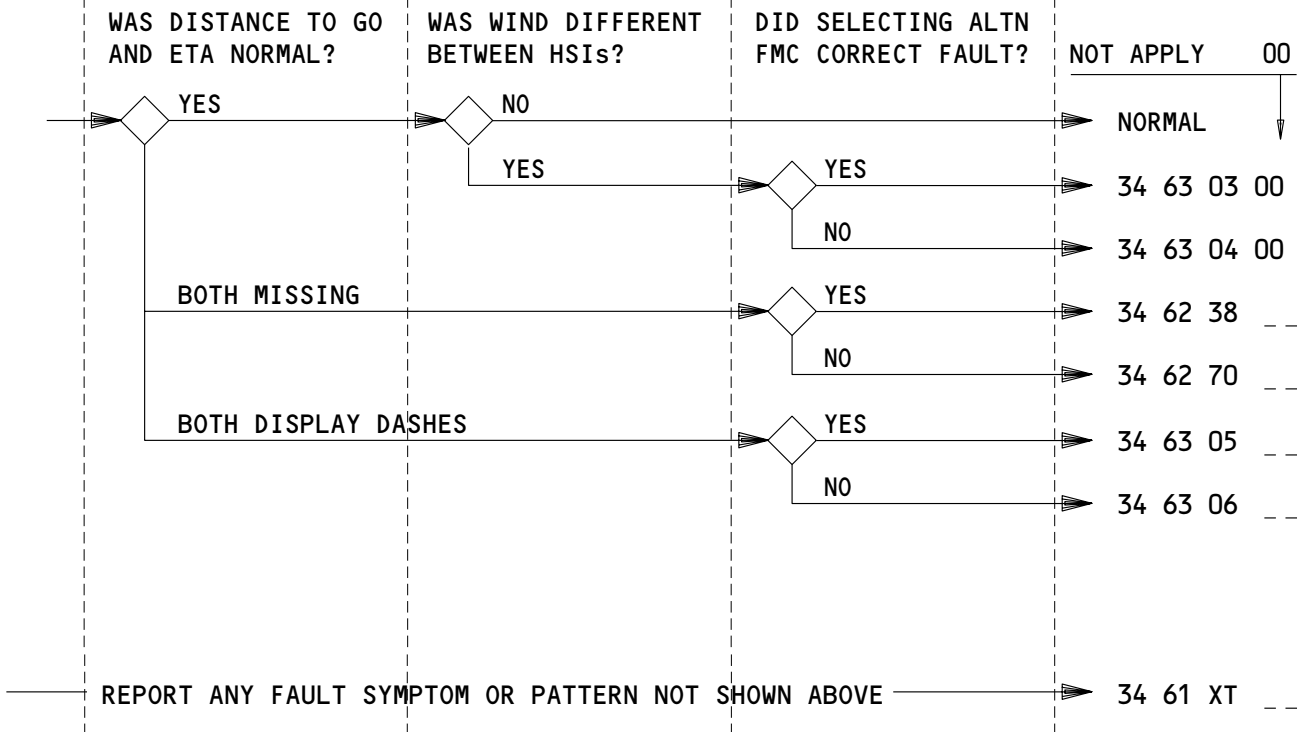

APPLICABLE CIRCUIT BREAKERS AS INSTALLED

11E4	EFIS CONT PANEL (L, LEFT)	11E25	EFIS CONT PANEL (R, RIGHT)	11F8	EFIS SYM GEN (L, LEFT)
11E6	HSI (L, LEFT)	11E27	HSI (R, RIGHT)	11F9	EFIS SYM GEN (C, CENTER)
11E8	FMCS CDU (L, LEFT)	11E29	FMCS CDU (R, RIGHT)	11F29	EFIS SYM GEN (R, RIGHT)
11E9	FMCS CMPTR (L, LEFT)	11E30	FMCS CMPTR (R, RIGHT)		

FMC-HSI MAP DATA - FAULT CODES

EFFECTIVITY

ALL

34-FAULT CODE DIAGRAM

BOEING
757
FAULT ISOLATION/MAINT MANUAL

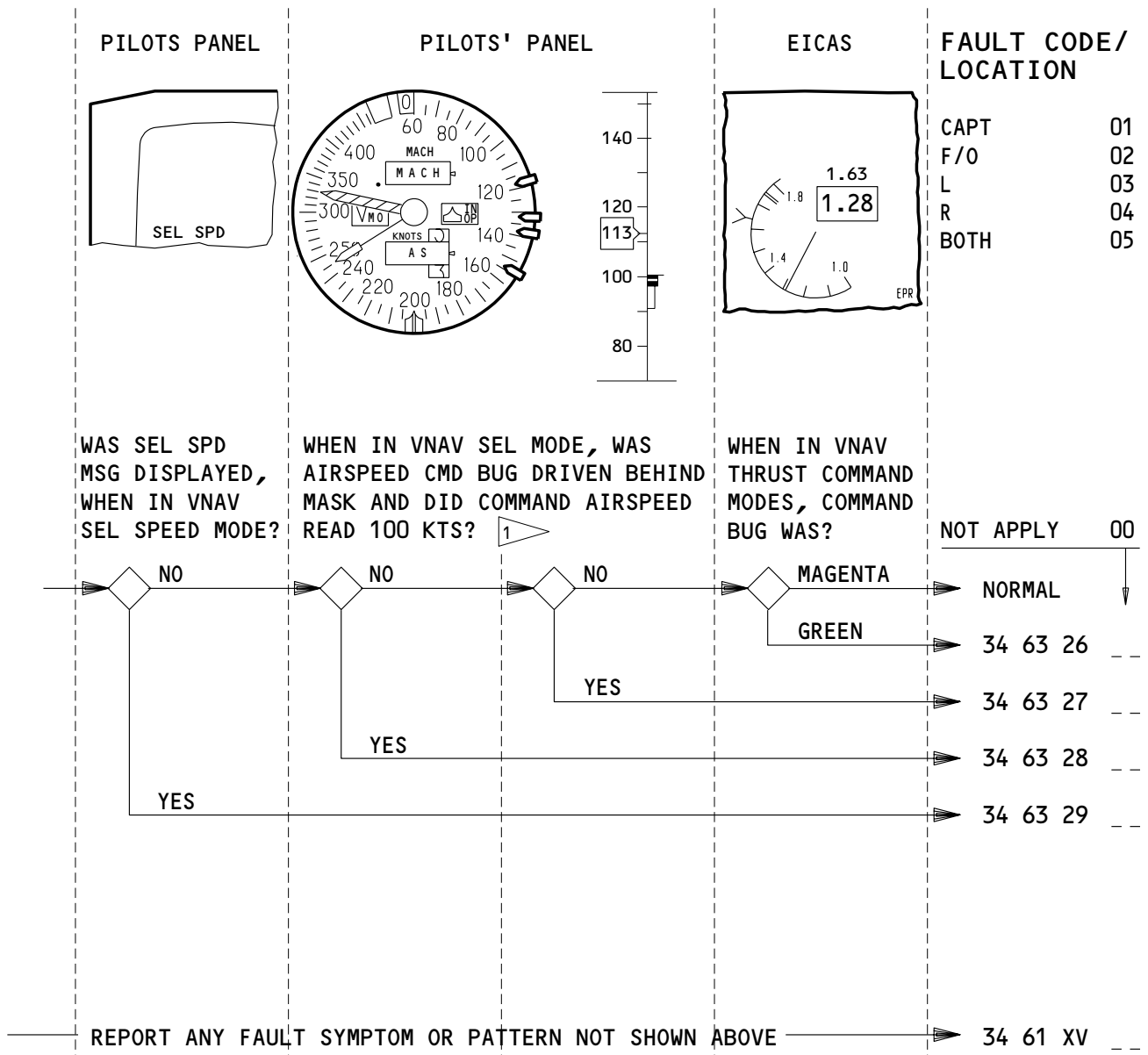

¹ THIS IS A NORMAL INDICATION WHEN RESYNCRING FMC.

APPLICABLE CIRCUIT BREAKERS AS INSTALLED

11E1	IAS MACH (L, LEFT)	11E22	IAS MACH (R, RIGHT)
11E8	FMCS CDU (L, LEFT)	11E29	FMCS CDU (R, RIGHT)
11E9	FMCS CMPTR (L, LEFT)	11E30	FMCS CMPTR (R, RIGHT)

FMC-VNAV MODE EPR AND AIRSPEED BUGS - FAULT CODES

EFFECTIVITY
AIRPLANES WITH EADI SPEED TAPE

34-FAULT CODE DIAGRAM

PILOTS PANEL

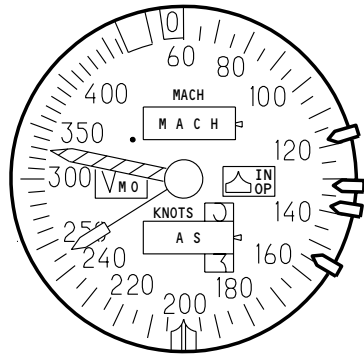

EICAS

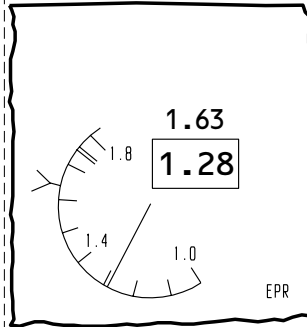

FAULT CODE/
LOCATION

CAPT	01
F/O	02
L	03
R	04
BOTH	05

IS AIRSPEED CMD BUG
DRIVEN BEHIND MASK
WHEN IN VNAV SEL
SPEED MODE?

IS AIRSPEED CMD BUG
DRIVEN TO 100 KTS
WHEN IN VNAV SEL
SPEED MODE? ¹

WHEN IN VNAV THRUST
COMMAND MODES,
COMMAND BUG IS:

NOT APPLY 00

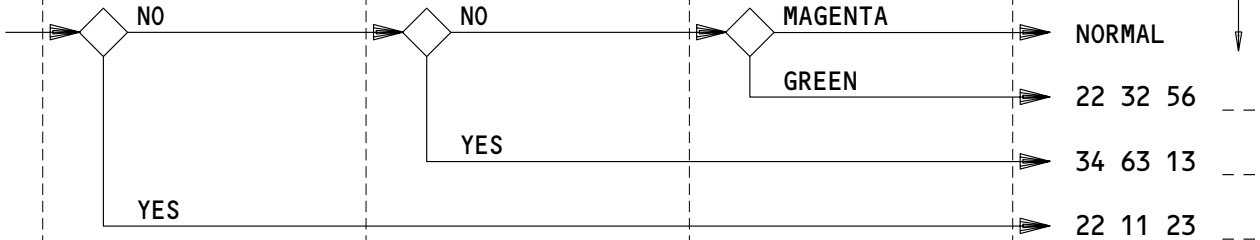

REPORT ANY FAULT SYMPTOM OR PATTERN NOT SHOWN ABOVE → 34 61 XV

¹ THIS IS A NORMAL INDICATION WHEN RESYNCING FMC.

APPLICABLE CIRCUIT BREAKERS

11E1	IAS MACH L	11E22	IAS MACH R
11E8	FMCS CDU L	11E29	FMCS CDU R
11E9	FMCS CMPTR L	11E30	FMCS CMPTR R

FMC-VNAV MODE EPR AND AIRSPEED BUGS - FAULT CODES

EFFECTIVITY
AIRPLANES WITHOUT EADI SPEED TAPE

34-FAULT CODE DIAGRAM

BOEING
757
FAULT ISOLATION/MAINT MANUAL

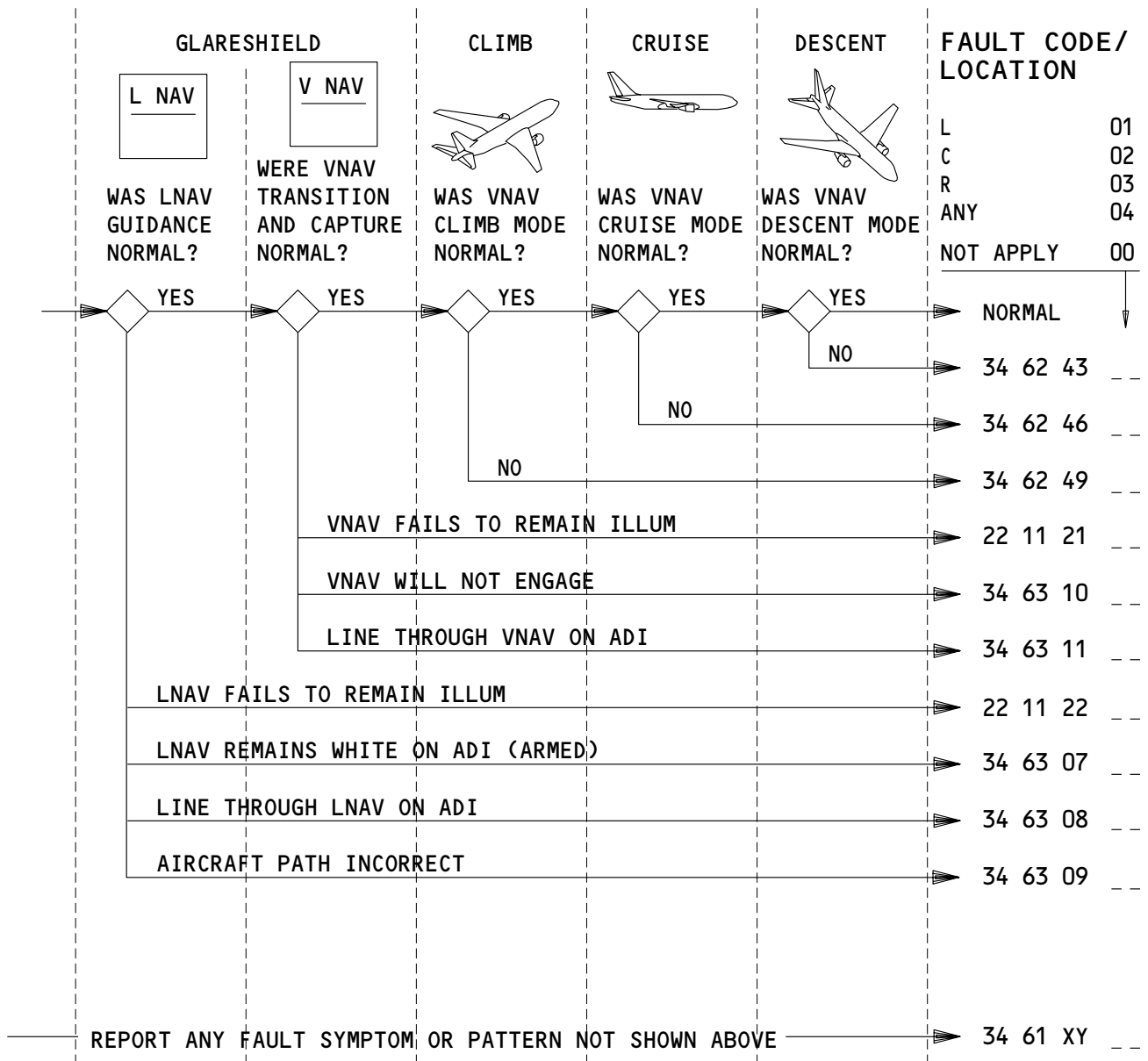

APPLICABLE CIRCUIT BREAKERS AS INSTALLED

<table style="width: 100%; border-collapse: collapse;"> <tr><td style="border: 1px solid black; padding: 2px;">11E8 FMCS CDU (L, LEFT)</td></tr> <tr><td style="border: 1px solid black; padding: 2px;">11E9 FMCS CMPTR (L, LEFT)</td></tr> <tr><td style="border: 1px solid black; padding: 2px;">11E16 MODE CONT PNL (L, LEFT)</td></tr> <tr><td style="border: 1px solid black; padding: 2px;">11E17 FLT CONT (CMPTR PWR L, COMPUTER POWER LEFT)</td></tr> <tr><td style="border: 1px solid black; padding: 2px;">11E18 FLT CONT (CMPTR, COMPUTER) SERVO (L, LEFT)</td></tr> <tr><td style="border: 1px solid black; padding: 2px;">11E20 FLT CONT CMPTR PWR (C, CTR)</td></tr> </table>	11E8 FMCS CDU (L, LEFT)	11E9 FMCS CMPTR (L, LEFT)	11E16 MODE CONT PNL (L, LEFT)	11E17 FLT CONT (CMPTR PWR L, COMPUTER POWER LEFT)	11E18 FLT CONT (CMPTR, COMPUTER) SERVO (L, LEFT)	11E20 FLT CONT CMPTR PWR (C, CTR)	<table style="width: 100%; border-collapse: collapse;"> <tr><td style="border: 1px solid black; padding: 2px;">11E21 FLT CONT CMPTR SERVO (C, CTR)</td></tr> <tr><td style="border: 1px solid black; padding: 2px;">11E29 FMCS CDU (R, RIGHT)</td></tr> <tr><td style="border: 1px solid black; padding: 2px;">11E30 FMCS CMPTR (R, RIGHT)</td></tr> <tr><td style="border: 1px solid black; padding: 2px;">11E34 MODE CONT PNL (R, RIGHT)</td></tr> <tr><td style="border: 1px solid black; padding: 2px;">11E35 FLT CONT CMPTR PWR (R, RIGHT)</td></tr> <tr><td style="border: 1px solid black; padding: 2px;">11E36 FLT CONT CMPTR SERVO (R, RIGHT)</td></tr> </table>	11E21 FLT CONT CMPTR SERVO (C, CTR)	11E29 FMCS CDU (R, RIGHT)	11E30 FMCS CMPTR (R, RIGHT)	11E34 MODE CONT PNL (R, RIGHT)	11E35 FLT CONT CMPTR PWR (R, RIGHT)	11E36 FLT CONT CMPTR SERVO (R, RIGHT)
11E8 FMCS CDU (L, LEFT)													
11E9 FMCS CMPTR (L, LEFT)													
11E16 MODE CONT PNL (L, LEFT)													
11E17 FLT CONT (CMPTR PWR L, COMPUTER POWER LEFT)													
11E18 FLT CONT (CMPTR, COMPUTER) SERVO (L, LEFT)													
11E20 FLT CONT CMPTR PWR (C, CTR)													
11E21 FLT CONT CMPTR SERVO (C, CTR)													
11E29 FMCS CDU (R, RIGHT)													
11E30 FMCS CMPTR (R, RIGHT)													
11E34 MODE CONT PNL (R, RIGHT)													
11E35 FLT CONT CMPTR PWR (R, RIGHT)													
11E36 FLT CONT CMPTR SERVO (R, RIGHT)													

FMC-LNAV AND VNAV GUIDANCE - FAULT CODES

EFFECTIVITY

ALL

34-FAULT CODE DIAGRAM

06

Page 61
May 28/01

CHART 1

ALTIMETER TOLERANCES - GROUND

ALTITUDE FEET	MAX DIFFERENCE	
	CAPT & F/O	CAPT & F/O AND STANDBY
SEA LEVEL	40	35
5,000'	40	50
10,000'	45	60

ALTIMETER TOLERANCES - FLIGHT

ALTITUDE FEET	IAS/MACH	MAX. DIFFERENCE	
		CAPT & F/O	CAPT OR F/O & STANDBY
10,000'	250 KTS	60	100
20,000'	300 KTS	115	20,010 ± 180
30,000'	M.80	135	30,085 ± 250
35,000'	M.80	145	35,080 ± 265
40,000'	M.80	160	40,080 ± 280

CHART 2

AIRSPEED TOLERANCES

AIRSPEED KNOTS	MAX. DIFFERENCE	
	CAPT & F/O	STANDBY
100	± 3 KTS	99 - 105
140	± 3 KTS	139.5 - 145.5
200	± 3 KTS	200.5 - 207.5
250	± 3 KTS	251 - 258 (35,000 & BELOW)
300	± 3 KTS	300 - 308 (35,000') 301 - 309 (30,000 & BELOW)
MACH		
.40 - .50	± .010M	---
.60 - .70	± .009M	---
.80 & ABOVE	± .008M	---

CHARTS

EFFECTIVITY

ALL

34-FAULT CODE DIAGRAM

RESIDUAL GOUNDSPEED ERROR CHECK

THE FMC-CDU POS REF PAGE 2/2 DISPLAYS RESIDUAL GOUNDSPEED FOR FMC AND EACH IRS AT THE END OF THE FLIGHT. USE THE FOLLOWING PROCEDURE TO DETERMINE EXCESSIVE RESIDUAL GOUNDSPEED ERROR.

NOTE: THE IRS'S AND FMC'S MUST NOT BE SHUTOFF PRIOR TO COMPLETING THIS PROCEDURE. FMC "FREEZE" CAN CAUSE FMC-CDU TO DISPLAY EXCESSIVE GROUND SPEED. VERIFY RESIDUAL GROUND SPEED USING IRMP.

- 1 - SELECT POS REF PAGE 2/2 (4/4 PEGASUS EQUIPPED AIRPLANES) AND CHECK EACH IRS RESIDUAL GOUNDSPEED ERROR.
- 2 - IF THE IRS RESIDUAL GOUNDSPEED ERROR IS 21 KNOTS OR GREATER AFTER COMPLETION OF ANY ONE CHECK (FLIGHT) OR 15 KNOTS OR GREATER AFTER EACH OF TWO CONSECUTIVE CHECKS (FLIGHTS), MAINTENANCE ACTION IS REQUIRED.

RADIAL POSITION ERROR CHECK

THE FMC-CDU POS REF PAGE 2/2 (4/4 PEGASUS EQUIPPED AIRPLANES) DISPLAYS CURRENT POSITION FOR EACH IRS AND AN ACTUAL POSITION ERROR CHECK IS PERFORMED USING THE RTE 1 OR RTE 2 LEGS PAGE. THIS IS DONE BY ENTERING THE ACTUAL (PARKING) AND IRS POSITIONS AS WAYPOINTS AND COMPARING THEIR DIFFERENCE IN NAUTICAL MILES TO A DEVIATION CRITERIA. USE THE FOLLOWING PROCEDURE TO DETERMINE EXCESSIVE RADIAL POSITION ERROR.

NOTE: THE IRS'S AND FMC'S MUST NOT BE SHUTOFF PRIOR TO COMPLETING THIS PROCEDURE.

- 1 - SELECT THE POS REF 2/2 (4/4 PEGASUS EQUIPPED AIRPLANES) PAGE AND RECORD THE DISPLAYED LATITUDE AND LONGITUDE FOR EACH IRS.
- 2 - SELECT THE RTE 1 OR RTE 2 LEGS PAGE AND ENTER ACTUAL LATITUDE AND LONGITUDE (GATE, RAMP, ETC) AS A WAYPOINT.
- 3 - ENTER DISPLAYED LATITUDE AND LONGITUDE OF IRS AS NEXT WAYPOINT ON RTE 1 OR RTE 2 LEGS PAGE. ENTER MANUALLY RECORDED DATA FROM (1) OR LINE SELECT FROM POS REF PAGE.
- 4 - RADIAL POSITION ERROR IS THE DISTANCE BETWEEN THE TWO ENTERED WAYPOINTS OR THE COMPUTED LEG LENGTH.
- 5 - COMPARE THE DISTANCE ALONG WITH THE TIME IN NAV MODE TO THE ACCEPT/REJECT LIMITS ON THE FOLLOWING IRS PERFORMANCE CRITERIA CHART.
- 6 - IF THE IRS RADIAL POSITION ERROR FALLS UPON THE SHADED AREA FOR TWO CONSECUTIVE FLIGHTS OR ABOVE THE SHADED AREA FOR ONE FLIGHT, MAINTENANCE ACTION IS REQUIRED.

IRS ACCURACY CHECKS

EFFECTIVITY

ALL

34-FAULT CODE DIAGRAM

04

Page 63
May 28/03

IRS PERFORMANCE CRITERIA CHART

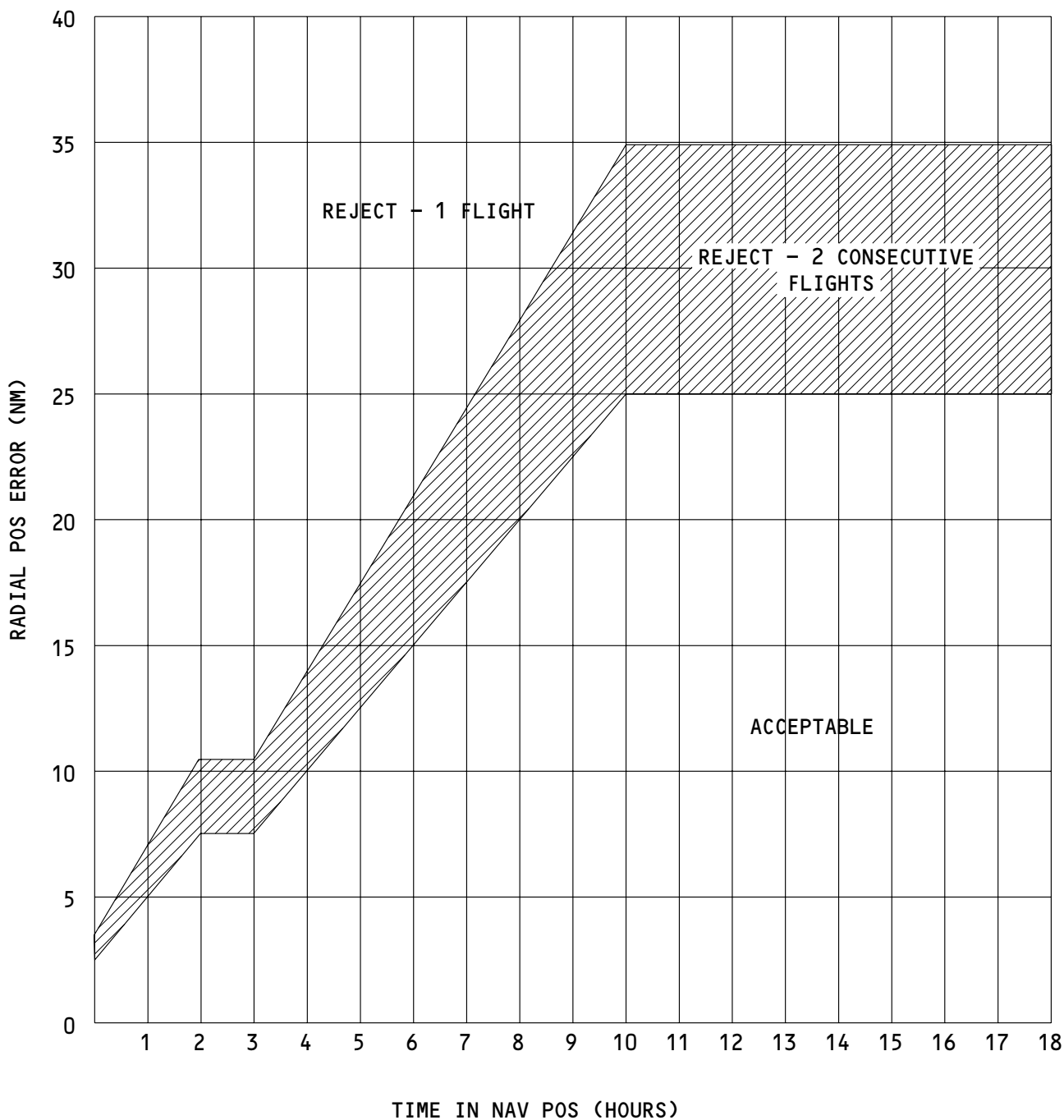

IRS ACCURACY CHECKS

EFFECTIVITY
WITHOUT RNP

34-FAULT CODE DIAGRAM

IRS PERFORMANCE CRITERIA CHART

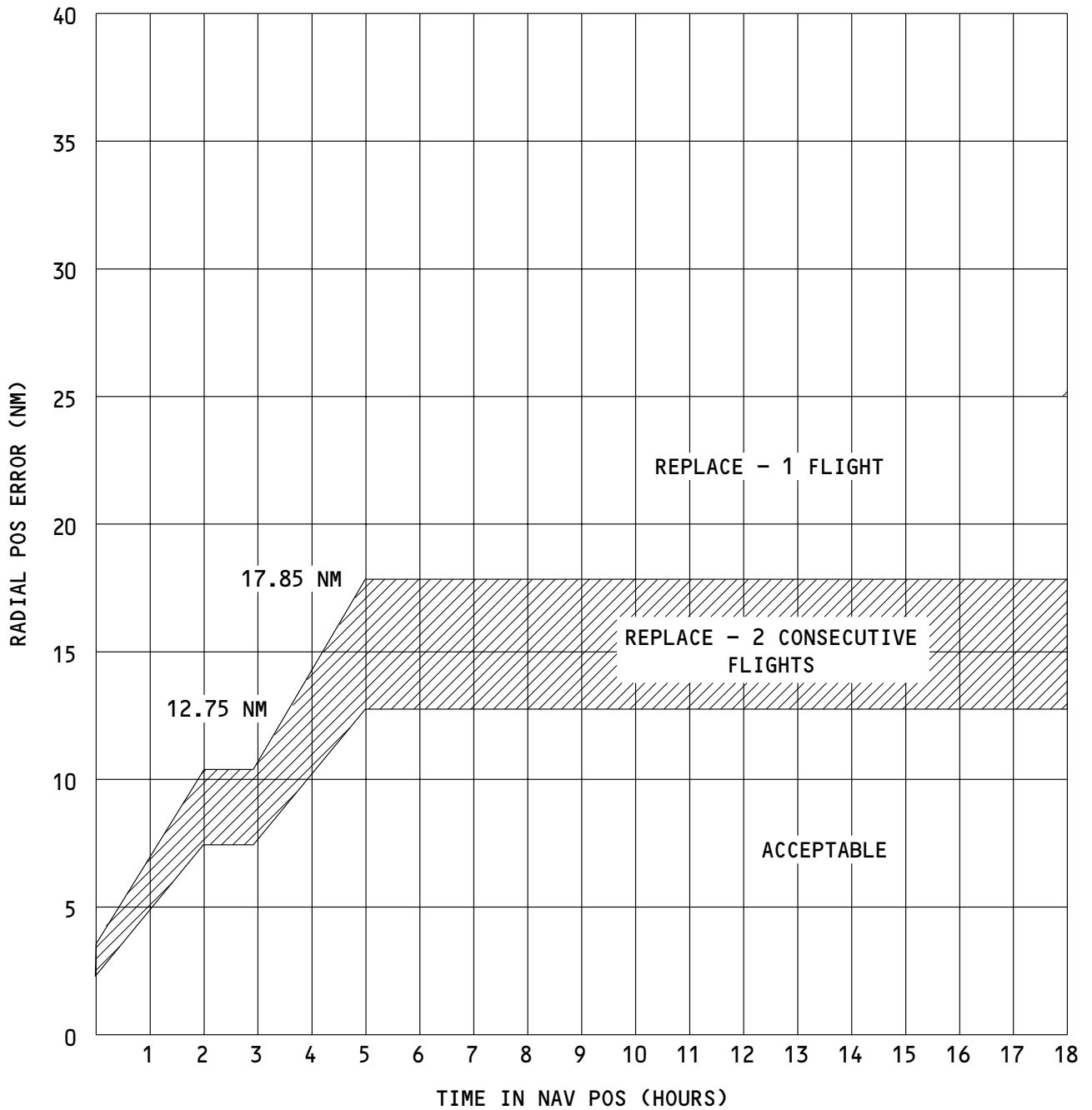

IRS ACCURACY CHECKS

EFFECTIVITY
WITH RNP

34-FAULT CODE DIAGRAM



BOEING
757
FAULT ISOLATION/MAINT MANUAL

FAULT CODE	1. LOG BOOK REPORT 2. FAULT ISOLATION REFERENCE
34 12 XA --	1. A (01=Capt, 02=F/O) electric altimeter problem was encountered by the flight crew which is not covered in the fault code diagrams. (Ref fault code diagram for flight crew actions.) 2. SSM 34-12-01, SSM 34-12-02, SSM 34-13-01
34 12 XB 00	1. Report TAS, SAT and TAT symptoms or pattering along with fault code. (Ref fault code diagram for flight crew actions.) 2. SSM 34-12-01, SSM 34-12-02
34 12 XC --	1. A (01=Capt, 02=F/O) electric mach, airspeed, and ALTN AIR DATA problem was encountered by the flight crew which is not covered in the fault code diagrams. (Ref fault code diagram sheet one for flight crew actions.) 2. SSM 34-12-01, SSM 34-12-02, SSM 34-13-01
34 12 XD --	1. A (01=Capt, 02=F/O) air data computer test problem was encountered by the flight crew which is not covered in the fault code diagrams (Ref fault code diagram for flight crew actions.) 2. SSM 34-12-01, SSM 34-12-02
34 12 XE --	1. An air data computer test problem was encountered by the flight crew which is not covered in the fault code diagrams. (Ref fault code diagram sheet two for flight crew actions.) 2. SSM 34-12-01, SSM 34-12-02
34 12 XF --	1. A (01=Capt, 02=F/O) electric mach, airspeed, and ALTN AIR DATA problem was encountered by the flight crew which is not covered in the fault code diagrams. (Ref fault code diagram sheet two for flight crew actions.) 2. SSM 34-12-01, SSM 34-12-02, SSM 34-13-01
34 13 XA 00	1. A standby airspeed and altimeter problem was encountered by the flight crew which is not covered in the fault code diagrams. (Ref fault code diagram for flight crew actions.) 2. SSM 34-13-01.

EFFECTIVITY

ALL

34-FAULT CODE INDEX

01

Page 1
Dec 20/96

BOEING
 757
 FAULT ISOLATION/MAINT MANUAL

FAULT CODE	1. LOG BOOK REPORT 2. FAULT ISOLATION REFERENCE
34 16 XA --	1. A (01=Capt, 02=F/O, 03=Both) altitude alert problem was encountered by the flight crew which is not covered in the fault code diagrams. (Ref Chapter 22 fault code diagram for flight crew actions.) 2. SSM 34-16-01
34 21 XA --	1. A (01=Capt, 02=F/O) RDMI heading problem was encountered by the flight crew which is not covered in the fault code diagrams. (Ref fault code diagram for flight crew actions.)
34 21 XB --	1. A (01=Capt, 02=F/O) vertical speed indicator problem was encountered by the flight crew which is not covered in the fault code diagrams. (Ref fault code diagram for flight crew actions.) 2. SSM 34-21-01, SSM 34-21-02, SSM 34-21-03, SSM 34-22-03
34 21 XC --	1. A (01=Capt, 02=F/O) EHSI track problem was encountered by the flight crew which is not covered in the fault code diagrams. (Ref fault code diagram for flight crew actions.) 2. SSM 34-21-01, SSM 34-21-02, SSM 34-21-03, SSM 34-22-12, SSM 34-22-22
34 21 XD --	1. A (01=Capt, 02=F/O) EHSI heading and trend vector problem was encountered by the flight crew which is not covered in the fault code diagrams. (Ref fault code diagram for flight crew actions.) 2. SSM 34-21-01, SSM 34-21-02, SSM 34-21-03, SSM 34-22-12, SSM 34-22-22
34 21 XE --	1. A (01=Capt, 02=F/O, 03=L, 04=C, 05=R) EADI attitude and ground speed problem was encountered by the flight crew which is not covered in the fault code diagrams. (Ref fault code diagram for flight crew actions.)
34 21 XF --	1. A (01=L, 02=C, 03=R, 04=ALL) IRS mode control panel problem was encountered by the flight crew which is not covered in the fault code diagrams. (Ref fault code diagram for flight crew actions.) 2. SSM 34-21-01, SSM 34-21-02, SSM 34-21-03

EFFECTIVITY

ALL

34-FAULT CODE INDEX

07

Page 2
Jan 20/99



757
FAULT ISOLATION/MAINT MANUAL

FAULT CODE	1. LOG BOOK REPORT 2. FAULT ISOLATION REFERENCE
34 21 XF 00	1. A (01=L, 02=C, 03=R, 04=ALL) IRS accuracy problem was encountered by the flight crew which is not covered in the fault code diagrams. (Ref fault code diagram for flight crew actions.) 2. SSM 34-21-01, SSM 34-21-02, SSM 34-21-03
34 21 XG --	1. A (01=L, 02=C, 03=R, 04=ALL) IRS data entry and display problem was encountered by the flight crew which is not covered in the fault code diagrams. (Ref fault code diagram for flight crew actions.) 2. SSM 34-21-01 through SSM 34-21-03
34 22 XA --	1. A (01=Capt, 02=F/O) EADI problem was encountered by the flight crew which is not covered in the fault code diagrams. (Ref fault code diagram for flight crew actions.) 2. SSM 34-22-12
34 22 XB --	1. A (01=Capt, 02=F/O) EHSI problem was encountered by the flight crew which is not covered in the fault code diagrams. (Ref fault code diagram for flight crew actions.) 2. SSM 34-22-12
34 22 XC --	1. A (01=Capt, 02=F/O) EHSI and EADI problem was encountered by the flight crew which is not covered in the fault code diagrams. (Ref fault code diagram for flight crew actions.) 2. SSM 34-22-11, SSM 34-22-12
34 22 XD --	1. A (01=Capt, 02=F/O) EHSI mode, map, or range select problem was encountered by the flight crew which is not covered in the fault code diagrams. (Ref fault code diagram for flight crew actions.) 2. SSM 34-22-12
34 22 XE --	34 22 XE -- thru 34 22 XF -- Not Used
34 22 XG --	1. An EFIS (heading reference) problem was encountered by the flight crew which is not covered in the fault code diagrams. (Ref fault code diagram for flight crew actions.) 2. SSM 34-22-12

EFFECTIVITY

ALL

34-FAULT CODE INDEX

07

Page 3
May 28/01



BOEING
757
FAULT ISOLATION/MAINT MANUAL

FAULT CODE	1. LOG BOOK REPORT 2. FAULT ISOLATION REFERENCE
34 23 XA 00	1. A standby magnetic compass problem was encountered by the flight crew which is not covered in the fault code diagrams. (Ref fault code diagram for flight crew actions.) 2. Perform standby compass swing operation (AMM 34-23-00/201).
34 24 XA 00	1. A standby attitude reference system problem was encountered by the flight crew which is not covered in the fault code diagrams. (Ref fault code diagram for flight crew actions.) 2. SSM 34-24-01
34 31 XA --	1. A (01=Capt EHSI and EADI, 02=F/O EADI and EHSI, 03=STBY ATT IND) ILS TEST problem was encountered by the flight crew which is not covered in the fault code diagrams. (Ref fault code diagram for flight crew actions.)
34 31 XB --	1. A (01=L, 02=C, 03=R, 04=Capt, 04=F/O) ILS-EADI/EHSI and Ident problem was encountered by the flight crew which is not covered in the fault code diagrams. (Ref fault code diagram for flight crew actions.) 2. SSM 34-31-01, SSM 34-31-02, SSM 34-31-03
34 31 XC --	1. A (01=Capt, 02=F/O) ILS/EHSI problem was encountered by the flight crew which is not covered in the fault code diagrams. (Ref fault code diagram for flight crew actions.) 2. SSM 34-31-01, SSM 34-31-02, SSM 34-31-03
34 31 XD 00	1. An ILS controls and STBY ATT IND problem was encountered by the flight crew which is not covered in the fault code diagrams. (Ref fault code diagram for flight crew actions.) 2. SSM 34-31-01, SSM 34-31-02, SSM 34-31-03

EFFECTIVITY

ALL

34-FAULT CODE INDEX

FAULT CODE	1. LOG BOOK REPORT 2. FAULT ISOLATION REFERENCE
34 32 XA --	1. A (01=Capt, 02=F/O, 03=Sup Num, 04=1st Obs) marker beacon problem was encountered by the flight crew which is not covered in the fault code diagrams. (Ref fault code diagram for flight crew actions.) 2. SSM 34-32-01.
34 33 XA --	1. A (01=Capt, 02=F/O) radio altimeter and DH (ADI) problem was encountered by the flight crew which is not covered in the fault code diagrams. (Ref fault code diagram for flight crew actions.) 2. SSM 34-33-01, SSM 34-33-02, SSM 34-33-03, SSM 34-22-11, SSM 34-22-21
34 43 XA --	1. A (01=Capt, 02=F/O, 03=Capt and F/O) WXR display (EHSI) problem was encountered by the flight crew which is not covered in the fault code diagrams. (Ref fault code diagram for flight crew actions.) 2. SSM 34-43-01
34 43 XB 00	1. A WXR control problem was encountered by the flight crew which is not covered in the fault code diagrams. (Ref fault code diagram for flight crew actions.) 2. SSM 34-43-01
34 43 XC 00	1. A WXR display quality problem was encountered by the flight crew which was not covered in the fault code diagrams (Ref fault code diagrams for flight crew actions). 2. SSM 34-43-01
34 45 XA --	1. A (01=Capt, 02=F/O) TCAS problem was encountered by the flight crew which is not covered in the fault code diagrams. (Ref fault code diagram for flight crew actions.) 2. SSM 34-45-01
34 46 XA 00	1. A ground proximity and wind shear warning problem was encountered by the flight crew which is not covered in the fault code diagrams. (Ref fault code diagram for flight crew actions.) 2. SSM 34-46-01
34 46 XB 00	1. A ground proximity warning control problem was encountered by the flight crew which is not covered in the fault code diagrams. (Ref fault code diagram for flight crew actions.) 2. SSM 34-46-01

EFFECTIVITY

ALL

34-FAULT CODE INDEX

BOEING
 757
 FAULT ISOLATION/MAINT MANUAL

FAULT CODE	1. LOG BOOK REPORT 2. FAULT ISOLATION REFERENCE
34 51 XA --	1. A (01=Capt, 02=F/O) VOR-Control and display - problem was encountered by the flight crew which is not covered in the fault code diagrams. (Ref fault code diagram for flight crew actions.) 2. SSM 34-51-01, SSM 34-51-02
34 51 XB --	1. A (01=Capt, 02=F/O, 03=L, 04=R) VOR-EHSI in MAP mode - display problem was encountered by the flight crew which is not covered in the fault code diagrams. (Ref fault code diagram for flight crew actions.) 2. SSM 34-51-01, SSM 34-51-02
34 51 XC --	1. A (01=Capt, 02=F/O) VOR Ident problem was encountered by the flight crew which is not covered in the fault code diagrams. (Ref fault code diagram for flight crew actions.)
34 53 XA --	1. A (01=L, 02=R) ATC transponder problem was encountered by the flight crew which is not covered in the fault code diagrams. (Ref fault code diagram for flight crew actions.) 2. SSM 34-53-01, SSM 34-53-02
34 55 XA --	1. A (01=Capt, 02=F/O, 03=L, 04=R) DME problem was encountered by the flight crew which is not covered in the fault code diagrams. (Ref fault code diagram for flight crew actions.) 2. SSM 34-55-01, SSM 34-55-02
34 57 XA --	1. A (01=CAPT, 02=F/O) ADF control panel/RDMI problem was encountered by the flight crew which is not covered in the fault code diagrams. (Ref Fault Code diagram for flight crew actions.) 2. SSM 34-57-01
34 57 XB --	1. A (01=Capt, 02=F/O, 03=OBS) ADF/RDMI problem was encountered by the flight crew which is not covered in the fault code diagrams. (Ref fault code diagram for flight crew actions.) 2. SSM 34-57-01
34 61 XA --	1. A (01=Capt, 02=F/O, 03=Both) FMC CDU keys problem was encountered by the flight crew which is not covered in the fault code diagrams. (Ref fault code diagram for flight crew actions.) 2. SSM 34-60-01, SSM 34-61-01, SSM 34-61-02, SSM 34-61-03, SSM 34-61-04

EFFECTIVITY

ALL

34-FAULT CODE INDEX

FAULT CODE	1. LOG BOOK REPORT 2. FAULT ISOLATION REFERENCE
34 61 XB --	1. A (01=Capt, 02=F/O) CDU fail, FMC fail, or resync problem was encountered by the flight crew which is not covered in the fault code diagrams. (Ref fault code diagram for flight crew actions.) 2. SSM 34-60-01, SSM 34-61-01, SSM 34-61-02, SSM 34-61-03, SSM 34-61-04
34 61 XC --	1. A (01=Capt, 02=F/O) FMC-CDU brightness and paging problem was encountered by the flight crew which is not covered in the fault code diagrams. (Ref fault code diagram for flight crew actions.) 2. SSM 34-60-01, SSM 34-61-01, SSM 34-61-02, SSM 34-61-03, SSM 34-61-04
34 61 XD --	1. A (01=Capt, 02=F/O, 03=Both) FMC-CDU IDENT page problem was encountered by the flight crew which is not covered in the fault code diagrams. (Ref fault code diagram for flight crew actions.) 2. SSM 34-60-01, SSM 34-61-01, SSM 34-61-02, SSM 34-61-03, SSM 34-61-04
34 61 XE --	1. A (01=Capt, 02=F/O, 03=Both) FMC-CDU POS INIT/REF page problem was encountered by the flight crew which is not covered in the fault code diagrams. (Ref fault code diagram for flight crew actions.) 2. SSM 34-60-01, SSM 34-61-01, SSM 34-61-02, SSM 34-61-03, SSM 34-61-04
34 61 XF --	1. A (01=Capt, 02=F/O, 03=Both) FMC-CDU PERFORMANCE INITIALIZATION PAGE Problem was encountered by the flight crew which is not covered in the fault code diagrams. (Ref fault code diagram for flight crew actions.) 2. SSM 34-60-01, SSM 34-61-01, SSM 34-61-02, SSM 34-61-03, SSM 34-61-04
34 61 XG --	34 61 XG -- thru 34 61 XJ -- Not Used.
34 61 XK --	1. A (01=Capt, 02=F/O, 03=Both) FMC-CDU FIX INFO page problem was encountered by the flight crew which is not covered in the fault code diagrams. (Ref fault code diagram for flight crew actions.) 2. SSM 34-60-01, SSM 34-61-01, SSM 34-61-02, SSM 34-61-03, SSM 34-61-04

EFFECTIVITY

ALL

34-FAULT CODE INDEX

05

Page 7
May 28/01

BOEING
 757
 FAULT ISOLATION/MAINT MANUAL

FAULT CODE	1. LOG BOOK REPORT 2. FAULT ISOLATION REFERENCE
34 61 XL --	34 61 XL -- thru 34 61 XP -- Not Used
34 61 XQ --	1. A (01=Capt, 02=F/O, 03=Both) FMC-CDU PROGRESS page problem was encountered by the flight crew which is not covered in the fault code diagrams. (Ref fault code diagram for flight crew actions.) 2. SSM 34-60-01, SSM 34-61-01, SSM 34-61-02, SSM 34-61-03, SSM 34-61-04
34 61 XR --	1. A (01=Capt, 02=F/O, 03=Both) FMC-CDU alert and advisory problem was encountered by the flight crew which is not covered in the fault code diagrams. (Ref fault code diagram for flight crew actions.) 2. SSM 34-60-01, SSM 34-61-01, SSM 34-61-02, SSM 34-61-03, SSM 34-61-04
34 61 XS --	1. A (01=Capt, 02=F/O, 03=Both) FMC-EHSI MAP general problem was encountered by the flight crew which is not covered in the fault code diagrams. (Ref fault code diagram for flight crew actions.) 2. SSM 34-61-02, SSM 34-61-04
34 61 XT --	1. A (01=Capt, 02=F/O, 03=Both) FMC-EHSI MAP data problem was encountered by the flight crew which is not covered in the fault code diagrams. (Ref fault code diagram for flight crew actions.) 2. SSM 34-61-02, SSM 34-61-04
34 61 XU --	Not Used
34 61 XV --	1. A (01=Capt, 02=F/O, 03=L, 04=R, 05=Both) FMC-VNAV mode EPR and airspeed bug problem was encountered by the flight crew which is not covered in the fault code diagrams. (Ref fault code diagram for flight crew actions.) 2. SSM 34-60-01, SSM 34-61-01, SSM 34-61-02, SSM 34-61-03, SSM 34-61-04
34 61 XW --	Not used.
34 61 XX --	Not used.

EFFECTIVITY

ALL

34-FAULT CODE INDEX

04

Page 8
May 28/01

BOEING
 757
 FAULT ISOLATION/MAINT MANUAL

FAULT CODE	1. LOG BOOK REPORT 2. FAULT ISOLATION REFERENCE
34 61 XY --	1. A (01=Capt, 02=F/O, 03=Both) FMC-LNAV and VNAV guidance problem was encountered by the flight crew which is not covered in the fault code diagrams. (Ref fault code diagram for flight crew actions.) 2. SSM 34-60-01, SSM 34-61-01, SSM 34-61-02, SSM 34-61-03, SSM 34-61-04
34 90 XA 00	1. A lightning strike occurred which was not covered in the fault code diagrams (Ref fault code diagrams for flight crew action). 2. Examine the airplane for a lightning strike or a severe static discharge (AMM 05-51-19).
34 12 01 01	1. BARO SET INOP on captain's altimeter. 2. Replace the captain's altimeter, N8 (AMM 34-13-01/401)
34 12 02 01	1. Capt altimeter in error. It reads _____. F/O altimeter reads _____. Stby altimeter reads _____. Capt altimeter norm with ALTN AIR DATA selected. 2. FIM 34-12-00/101, Fig. 103, Block 1
34 12 03 01	1. Capt altimeter in error with both normal and ALTN AIR DATA selected. It reads _____. F/O altimeter reads _____. Stby altimeter reads _____. 2. Replace the captain's altimeter, N8 (AMM 34-13-01/401)
34 12 04 02	1. BARO SET INOP on F/O's altimeter. 2. Replace the F/O's altimeter, N48 (AMM 34-13-01/401)
34 12 05 02	1. F/O altimeter in error. It reads _____. Capt altimeter reads _____. Stby altimeter reads _____. F/O altimeter norm with ALTN AIR DATA selected. 2. FIM 34-12-00/101, Fig. 103, Block 1
34 12 06 02	1. F/O altimeter in error with both normal and ALTN AIR DATA selected. It reads _____. Capt altimeter reads _____. Stby altimeter reads _____. 2. Replace the F/O's altimeter, N48 (AMM 34-13-01/401).
34 12 07 --	1. (01=Capt, 02=F/O) Altimeter sticking. 2. Replace the applicable altimeter, N8 (captain) or N48 (F/O) (AMM 34-13-01/401).

EFFECTIVITY

ALL

34-FAULT CODE INDEX

BOEING
 757
 FAULT ISOLATION/MAINT MANUAL

FAULT CODE	1. LOG BOOK REPORT 2. FAULT ISOLATION REFERENCE
34 12 08 --	1. OFF flag in view on (01 = Capt, 02 = F/O) altimeter. OFF flag out of view with ALTN AIR DATA selected. 2. FIM 34-12-00/101, Fig. 104, Block 1
34 12 09 --	1. Off flag in view on (01 = Capt, 02 = F/O) altimeter with NORMAL or ALTN AIR DATA selected. 2. Replace the applicable altimeter, N8 (captain) or N48 (F/O) (AMM 34-13-01/401).
34 12 10 00	1. TAT indication blank. TAS and SAT normal. 2. FIM 34-12-00/101, Fig. 109, Block 1
34 12 11 00	Not used.
34 12 12 00	Not used.
34 12 13 00	Not used.
34 12 14 00	1. TAS in error. Reads _____, should be _____. SAT normal. 2. Replace the applicable ADC, M100 (left) of M101 (right) (AMM 34-12-01/401).
34 12 15 00	1. TAS and SAT in error. TAS reads _____, should be _____. SAT reads _____, should be _____. TAT and Mach normal. 2. Replace the applicable ADC, M100 (left) or M101 (right) (AMM 34-12-01/401).
34 12 16 00	1. TAS and SAT and Mach in error. TAS reads _____, SAT reads _____, Mach reads _____. 2. FIM 34-12-00/101, Fig. 106, Block 1
34 12 17 --	1. Ref bug(s) (missing, loose) from (01 = Capt, 02 = F/O, 03 = Both) Mach/IAS indicators. 2. Replace the applicable Mach/airspeed indicator, N1 (captain) or N41 (F/O) (AMM 34-13-02/401).
34 12 18 -- thru 34 12 20 --	Not Used.

EFFECTIVITY

ALL

34-FAULT CODE INDEX

BOEING
 757
 FAULT ISOLATION/MAINT MANUAL

FAULT CODE	1. LOG BOOK REPORT 2. FAULT ISOLATION REFERENCE
34 12 21 --	1. (01=Capt, 02=F/O) A/S in error. Capt's A/S reads _____. F/O A/S reads _____. Stby A/S reads _____. ALTN AIR DATA selection corrects the fault. 2. Replace the applicable ADC, M100 (left) or M101 (right) (AMM 34-12-01/401).
34 12 22 --	1. (01=Capt, 02=F/O) A/S in error. Capt's A/S reads _____. F/O's A/S reads _____. Stby A/S reads _____. ALTN AIR DATA selection fails to correct fault. 2. MASI in error: replace the applicable Mach/airspeed indicator, N1 (captain) or N41 (F/O) (AMM 34-13-02/401). EADI in error: (FIM 34-22-00/101)
34 12 23 --	1. (01=Capt, 02=F/O) Mach indication in error. Capt's Mach reads _____. F/O Mach reads _____. ALTN AIR DATA selection corrects the fault. 2. Replace the applicable ADC, M100 (left) or M101 (right) (AMM 34-12-01/401).
34 12 24 --	1. (01=Capt, 02=F/O) Mach indication in error. Capt's Mach reads _____. F/O Mach reads _____. ALTN AIR DATA selection fails to correct fault. 2. MASI in error: replace the applicable Mach/airspeed indicator, N1 (captain) or N41 (F/O) (AMM 34-13-02/401). EADI in error: (FIM 34-22-00/101)
34 12 25 00	1. Capt and F/O Vmo differ. Capt's Vmo reads _____. F/O Vmo reads _____. Selecting (Capt, F/O) ALTN AIR DATA corrects the fault. 2. Replace the applicable ADC, M100 (left) or M101 (right) (AMM 34-12-01/401).
34 12 26 00	1. Capt and F/O Vmo differ. Capt's Vmo reads _____. F/O Vmo reads _____. ALTN AIR DATA selection fails to correct fault. 2. Replace the applicable Mach/airspeed indicator, N1 (captain) or N41 (F/O) (AMM 34-13-02/401).
34 12 27 --	1. (01=Capt, 02=F/O) A/S and Mach in error. Readings are: Capt A/S _____, F/O A/S _____, Stby A/S _____, Capt Mach _____, F/O Mach _____. Selecting ALTN AIR DATA corrects the fault. 2. FIM 34-12-00/101, Fig. 107, Block 1

EFFECTIVITY

ALL

34-FAULT CODE INDEX

08

Page 11
May 20/98

BOEING
 757
 FAULT ISOLATION/MAINT MANUAL

FAULT CODE	1. LOG BOOK REPORT 2. FAULT ISOLATION REFERENCE
34 12 28 --	1. (01=Capt, 02=F/O) A/S and Mach in error. Readings are: Capt A/S _____, F/O A/S _____, Stby A/S _____, Capt Mach _____, F/O Mach _____. Selecting ALTN AIR DATA fails to correct the fault. 2. MASI error: replace the applicable mach/airspeed indicator, N1 (captain) or N41 (F/O) (AMM 34-13-02/401). EADI error: (FIM 34-22-00/101)
34 12 29 -- and 34 12 30 --	Not Used
34 12 31 --	1. (01=Capt, 02=F/O) MACH flag in view. ALTN AIR DATA selection corrects the fault. 2. Replace the applicable ADC, M100 (left) or M101 (right) (AMM 34-12-01/401).
34 12 32 --	1. (01=Capt, 02=F/O) MACH flag in view. ALTN AIR DATA selection fails to correct fault. 2. Replace the applicable mach/airspeed indicator, N1 (captain) or N41 (F/O) (AMM 34-13-02/401).
34 12 33 --	1. (01=Capt, 02=F/O) Vmo flag in view. ALTN AIR DATA selection corrects the fault. 2. Replace the applicable ADC M100 (left) or M101 (right) (AMM 34-12-01/401).
34 12 34 --	1. (01=Capt, 02=F/O) Vmo flag in view. ALTN AIR DATA selection fails to correct fault. 2. Replace the applicable mach/airspeed indicator, N1 (captain) or N41 (F/O) (AMM 34-13-02/401).
34 12 35 --	1. (01=Capt, 02=F/O) AS, MACH, Vmo, and SPD flags in view. Command bug operation normal. Altimeter OFF flag in view. ALTN AIR DATA selection corrects the fault. 2. FIM 34-12-00/101, Fig. 108, Block 2
34 12 36 --	1. (01=Capt, 02=F/O) AS, MACH, Vmo, and SPD flags in view. Altimeter OFF flag not in view. 2. Replace the applicable ADC, M100 (left) or M101 (right) (AMM 34-12-01/401).
34 12 37 --	1. (01=Capt, 02=F/O) AS, MACH, Vmo and command bug INOP flags in view. EADI airspeed tape was normal. 2. FIM 34-12-00/101, Fig. 108, Block 1

EFFECTIVITY

ALL

34-FAULT CODE INDEX

06

Page 12
Dec 20/96



BOEING
757
FAULT ISOLATION/MAINT MANUAL

FAULT CODE	1. LOG BOOK REPORT 2. FAULT ISOLATION REFERENCE
34 12 38 --	1. (01=Capt, 02=F/O) Altm fails to read 10,000 ft during ADC test. Test OK with ALTN AIR DATA selected. 2. Replace the applicable ADC, M100 (left) or M101 (right) (AMM 34-12-01/401).
34 12 39 --	1. (01=Capt, 02=F/O) Altm fails to read 10,000 ft during ADC, test with normal or ALTN AIR DATA selected. 2. Replace the applicable altimeter, N8 (captain) or N48 (F/O) (AMM 34-13-01/401).
34 12 40 --	1. (01=Capt, 02=F/O) Altm OFF flag fails to appear during ADC test. Test OK with ALTN AIR DATA selected. 2. Replace the applicable ADC, M100 (left) or M101 (right) (AMM 34-12-01/401).
34 12 41 --	1. (01=Capt, 02=F/O) Altm OFF flag fails to appear during ADC computer test with normal or ALTN AIR DATA selected. 2. Replace the applicable ADC, M100 (left) or M101 (right) (AMM 34-12-01/401).
34 12 42 --	1. (01=Capt, 02=F/O) Altm OFF flag fails to appear and altm fails to read 10,000 ft during ADC test. Test OK with ALTN AIR DATA selected. 2. Replace the applicable ADC, M100 (left) or M101 (right) (AMM 34-12-01/401).
34 12 43 --	1. (01=Capt, 02=F/O) Altm OFF flag fails to appear and altm fails to read 10,000 ft during ADC test with normal or ALTN AIR DATA selected. 2. Replace the applicable altimeter, N8 (captain) or N48 (F/O) (AMM 34-13-01/401).
34 12 44 --	1. (01=Capt, 02=F/O) Airspeed fails to read 137 KIAS during ADC test. Test OK with ALTN AIR DATA selected. 2. Replace the applicable ADC, M100 (left) or M101 (right) (AMM 34-12-01/401).

EFFECTIVITY

ALL

34-FAULT CODE INDEX

05

Page 13
Mar 20/96

BOEING
 757
 FAULT ISOLATION/MAINT MANUAL

FAULT CODE	1. LOG BOOK REPORT 2. FAULT ISOLATION REFERENCE
34 12 45 --	1. (01=Capt, 02=F/O) Airspeed fails to read 137 KIAS during ADC test. With normal or ALTN AIR DATA selected. 2. Replace the applicable MACH/AIRSPEED indicator, N1 (captain) or N41 (F/O) (AMM 34-13-02/401).
34 12 46 --	Not Used
34 12 47 --	Not Used
34 12 48 --	1. (01=Capt, 02=F/O) Vmo fails to read 357 KIAS during ADC test. Test OK with ALTN AIR DATA selected. 2. Replace the applicable ADC, M100 (left) or M101 (right) (AMM 34-12-01/401).
34 12 49 --	1. (01=Capt, 02=F/O) Vmo fails to read 357 KIAS during ADC test with normal or ALTN AIR. 2. Replace the applicable MACH/AIRSPEED indicator, N1 (captain) or N41 (F/O) (AMM 34-13-02/401).
34 12 50 --	34 12 50 -- thru 34 12 52 -- Not Used
34 12 53 --	1. (01=Capt, 02=F/O) A/S flag fails to appear during ADC test. Test OK with ALTN AIR DATA selected. 2. Replace the applicable ADC, M100 (left) or M101 (right) (AMM 34-12-01/401).
34 12 54 --	1. (01=Capt, 02=F/O) A/S flag fails to appear during ADC test with normal or ALTN AIR DATA selected. 2. Replace the applicable MACH/AIRSPEED indicator, N1 (captain) or N41 (F/O) (AMM 34-13-02/401).
34 12 55 --	1. (01=Capt, 02=F/O) MACH flag fails to appear during ADC test. Test OK with ALTN AIR DATA selected. 2. Replace the applicable ADC, M100 (left) or M101 (right) (AMM 34-12-01/401).

EFFECTIVITY

ALL

34-FAULT CODE INDEX

06

Page 14
May 28/01

BOEING
 757
 FAULT ISOLATION/MAINT MANUAL

FAULT CODE	1. LOG BOOK REPORT 2. FAULT ISOLATION REFERENCE
34 12 56 --	1. (01=Capt, 02=F/O) MACH flag fails to appear during ADC test with normal or ALTN AIR DATA selected. 2. Replace the applicable MACH/AIRSPEED indicator, N1 (captain) or N41 (F/O) (AMM 34-13-02/401).
34 12 57 --	Not Used
34 12 58 --	Not Used
34 12 59 --	1. (01=Capt, 02=F/O) Mach/AS and Vmo flags fail to appear during ADC test. Test OK with ALTN AIR DATA selected. 2. Replace the applicable ADC, M100 (left) or M101 (right) (AMM 34-12-01/401).
34 12 60 --	1. All (01=Capt, 02=F/O) Mach/IAS, SPD, and VMO failure flags fail to appear during ADC test with normal or ALTN AIR DATA selected. 2. FIM 34-12-00/101, Fig. 109, Block 1.
34 12 61 --	1. All (01=Capt, 02=F/O) Mach/IAS, VMO, SPD and altm failure flags fail to appear during ADC test. 2. Replace the applicable ADC, M100 (left) or M101 (right) (AMM 34-12-01/401).
34 12 62 00	1. ADC test is inop. 2. Replace the applicable ADC, M100 (left) or M101 (right) (AMM 34-12-01/401).
34 12 63 00	1. TAS, SAT and TAT indications are blank. 2. FIM 34-12-00/101, Fig. 109, Block 1
34 12 64 00	1. TAS, SAT and TAT in error. TAS reads _____, SAT reads _____, TAT reads _____. 2. FIM 34-12-00/101, Fig. 109, Block 1
34 12 65 --	34 12 65 -- thru 34 12 67 -- Not Used

EFFECTIVITY

ALL

34-FAULT CODE INDEX

07

Page 15
May 28/01

BOEING
 757
 FAULT ISOLATION/MAINT MANUAL

FAULT CODE	1. LOG BOOK REPORT 2. FAULT ISOLATION REFERENCE
34 12 68 00	1. ADC test of TAT +35°C on EICAS (did not display, was blank, etc). 2. FIM 34-12-00/101, Fig. 109, Block 1
34 12 69 00	Not Used
34 12 70 --	1. (01=Capt, 02=F/O) Altimeter fluctuates. Altimeter normal with ALTN AIR DATA selected. 2. FIM 34-12-00/101, Fig. 103, Block 1
34 12 71 --	1. (01=Capt, 02=F/O) Altimeter fluctuates with normal or ALTN AIR DATA selected. 2. Replace the applicable altimeter, N8 (captain) or N48 (F/O) (N48) (AMM 34-13-01/401).
34 12 72 --	1. (01=Capt, 02=F/O) Altimeter baro indicator has uncommanded movement. 2. Replace the applicable altimeter, N8 (captain) or N48 (F/O) (AMM 34-13-01/401).
34 12 73 00	1. TAS indication blank. SAT and TAT normal. 2. Replace the applicable ADC, M100 (left) or M101 (right) (AMM 34-12-01/401).
34 12 74 --	1. Selecting (01=Capt, 02=F/O) ALTN AIR DATA not norm. (Describe) 2. Replace the applicable ADC, M100 (left) or M101 (right) (AMM 34-12-01/401).
34 12 75 00	1. EICAS msg OVERSPEED displayed and OVSP lgt illum. Airspeed below limit. 2. Replace the applicable ADC, M100 (left) or M101 (right) (AMM 34-12-01/401).
34 12 77 --	1. (01=Capt, 02=F/O) A/S indicator (fluctuates, sticks, inop, etc.) ALTN AIR DATA selection corrects the fault. 2. FIM 34-12-00/101, Fig. 107, Block 1
34 12 78 --	1. (01=Capt, 02=F/O) A/S indicator (fluctuates, sticks, inop, etc.) ALTN AIR DATA selection fails to correct the fault. 2. Replace the applicable MASI, N1 (captain) or N41 (F/O) (AMM 34-13-02/401).

EFFECTIVITY

ALL

34-FAULT CODE INDEX

06

Page 16
Jan 20/98

FAULT CODE	1. LOG BOOK REPORT 2. FAULT ISOLATION REFERENCE
34 12 79 --	1. (01=Capt, 02=F/O, 03=Capt & F/O) VSI did not display flag(s) during ADC test. Test OK with ALTN AIR DATA selected. 2. Replace the applicable ADC, M100 (left) or M101 (right) (AMM 34-13-02/401).
34 12 80 --	1. (01=Capt, 02=F/O, 03=Capt & F/O) VSI did not display flag(s) during ADC test with norm or ALTN AIR DATA selected. 2. Replace the applicable VSI, N9 (captain) or N49 (F/O) (AMM 34-22-06/401).
34 12 81 --	1. (01=Capt, 02=F/O) VM0 indicator sticks. 2. Replace the applicable ADC, M100 (left) or M101 (right) (AMM 34-13-02/401).
34 12 82 --	1. (01=Capt, 02=F/O) EADI speed tape faulty (describe) with normal or ALTN AIR DATA selected. 2. FIM 34-22-00/101, Fig. 108, Block 1. If the problem continues FIM 34-12-00/101, Fig. 109, Block 1.
34 12 83 --	1. (01=Capt, 02=F/O) SPD flag and Altn OFF flag in view. ALTN AIR DATA selection corrects fault. 2. FIM 34-12-00/101, Fig. 104, Block 1
34 12 84 --	1. (01=Capt, 02=F/O) SPD and MACH flag fails to appear during ADC test. Test ok with ALTN AIR DATA selected. 2. Replace the applicable ADC, M100 (left) or M101 (right) (AMM 34-12-01/401).
34 12 85 --	1. (01=Capt, 02=F/O) SPD and MACH flag fails to appear during ADC test with normal or ALTN AIR DATA selected. 2. FIM 34-12-00/101, Fig. 109, Block 1.
34 12 86 --	1. (01=Capt, 02=F/O) SPD, MACH and ALTM OFF flags fail to appear during ADC test. 2. FIM 34-12-00/101, Fig. 109, Block 1.
34 12 87 --	1. (01=Capt, 02=F/O) AS and SPD flags in view. ALTN AIR DATA selection corrected the fault. 2. FIM 34-12-00/101, Fig. 107A, Block 1.
34 12 88 --	1. (01=Capt, 02=F/O) AS and SPD flags in view. ALTN AIR DATA selection fails to correct the fault. 2. FIM 34-12-00/101, Fig. 109, Block 1.

EFFECTIVITY

ALL

34-FAULT CODE INDEX

08

Page 17
May 20/08

BOEING
 757
 FAULT ISOLATION/MAINT MANUAL

FAULT CODE	1. LOG BOOK REPORT 2. FAULT ISOLATION REFERENCE
34 12 89 --	1. (01=Capt, 02=F/O) AS, MACH, VMO flags in view in Mach/Airspeed Ind. Command Bug and EADI airspeed are norm. 2. FIM 34-12-00/101, Fig. 108, Block 1.
34 12 90 --	1. Command bug(s) on (01=Capt, 02=F/O, 03=Both) AS/MACH indicator(s) behind mask(s) and disappear from EADI speed tape during SPD mode. 2. Replace the AFDS mode control panel (AMM 22-11-02).
34 12 91 --	1. (01=Capt, 02=F/O) EADI SPD flag in view. MACH ind is normal. 2. FIM 34-12-00/101, Fig. 107A, Block 1.
34 13 01 00	1. Standby Altimeter (Describe the problem: low, high, sticks, fluctuates, vibrates, INOP, etc.). 2. Replace the standby altimeter, N23 (AMM 34-13-06/401).
34 13 02 00	1. Standby airspeed (Describe the problem: low, high, sticks, fluctuates, etc.). 2. FIM 34-13-00/101, Fig. 103, Block 1
34 13 03 00	1. Standby altimeter and standby airspeed (Describe the problem: low, high, fluctuates, Etc.) 2. FIM 34-11-00/101, Fig. 104, Block 1.
34 21 01 --	1. (01=Capt, 02=F/O) RDMI heading card sticks. 2. Replace the applicable RDMI, N43 (Capt) or N3 (F/O) (AMM 34-22-05/401).
34 21 02 --	1. (01=Capt, 02=F/O) RDMI and opposite EHSI heading in error. Capt's RDMI reads _____, F/O's RDMI reads _____, standby compass reads _____. OK on ALTN IRS. 2. Replace the applicable IRU, M159 (left) or M161 (right) (AMM 34-21-01/401).
34 21 03 --	1. (01=Capt, 02=F/O) RDMI heading in error. Capt reads _____, F/O reads _____, standby compass reads _____. ALTN IRS doesn't correct. 2. Replace the applicable RDMI, N43 (capt) or N3 (F/O) (AMM 34-22-05/401).

EFFECTIVITY

ALL

34-FAULT CODE INDEX

09

Page 18
Jan 20/98

BOEING
 757
 FAULT ISOLATION/MAINT MANUAL

FAULT CODE	1. LOG BOOK REPORT 2. FAULT ISOLATION REFERENCE
34 21 04 --	1. (01=Capt, 02=F/O) RDMI heading flag in view. IRS FAULT not illuminated. 2. Open, and then close, the applicable RDMI circuit breaker, L RDMI 11A6 (C635), or R RDMI 11F25 (C636). If the problem continues replace the applicable RDMI, N43 (captain) or N3 (F/O) (AMM 34-22-05/401).
34 21 05 --	1. (01=Capt, 02=F/O) RDMI HDG flag in view. DME normal. (L, R) IRS fault is indicated. Ok on ALTN IRS. 2. Replace the applicable IRU, M159 (left) or M161 (right) (AMM 34-21-01/401).
34 21 06 --	1. (01=Capt, 02=F/O) RDMI HDG flag in view. DME normal. ALTN IRS corrects fault. 2. FIM 34-21-00/101, Fig. 103, Block 1
34 21 07 --	1. (01=Capt, 02=F/O) RDMI HDG flag in view. DME is blank. 2. Replace the applicable RDMI, N43 (Capt) or N3 (F/O) (AMM 34-22-05/401)
34 21 08 --	1. (01=Capt, 02=F/O) Vertical speed sticks. 2. Replace the applicable VSI N9 (left) or N49 (Right) (AMM 34-22-06).
34 21 09 --	1. (01=Capt, 02=F/O) Vertical speed incorrect. Ok on ALTN IRS. 2. Replace the applicable IRU, M159 (left) or M161 (right) (AMM 34-21-01/401).
34 21 10 --	1. (01=Capt, 02=F/O) Vertical speed incorrect. ALTN IRS doesn't correct. ALTN AIR DATA corrects. 2. FIM 34-12-00/101, Fig. 109, Block 1
34 21 11 --	1. (01=Capt, 02=F/O) VSI flag in view. (L, R) IRS fault indicated. Ok on ALTN IRS. 2. Replace the applicable IRU, M159 (left) or M161 (right) (AMM 34-21-01/401).
34 21 12 --	1. (01=Capt, 02=F/O) VSI flag in view. ALT AIR DATA corrects. 2. FIM 34-12-00/101, Fig. 109, Block 1

EFFECTIVITY

ALL

34-FAULT CODE INDEX

BOEING
 757
 FAULT ISOLATION/MAINT MANUAL

FAULT CODE	1. LOG BOOK REPORT 2. FAULT ISOLATION REFERENCE
34 21 13 --	1. (01=Capt, 02=F/O) EHSI track in error. Capt track _____, F/O track _____. Ok on ALTN IRS. 2. Replace the applicable IRU, M159 (left) or M161 (right) (AMM 34-21-01/401).
34 21 14 --	1. (01=Capt, 02=F/O) EHSI track in error. Capt track _____, F/O track _____. ALTN IRS doesn't correct. 2. Replace the applicable symbol generator, M148 (left) or M150 (right) (AMM 34-22-01/401).
34 21 15 --	1. (01=Capt, 02=F/O) EHSI track flag in view. IRS fault light illuminates and EICAS message (L, C, R) IRS FAULT displayed. Ok on ALTN IRS. 2. Replace the applicable IRU, M159 (left) or M161 (right) (AMM 34-21-01/401).
34 21 16 --	1. (01=Capt, 02=F/O) EHSI track flag in view. Ok on ALTN IRS. 2. Replace the applicable IRU, M159 (left) or M161 (right) (AMM 34-21-01/401).
34 21 17 --	1. (01=Capt, 02=F/O) EHSI heading bug in error. Capt EHSI heading _____, F/O RDMI heading _____, standby compass heading _____. OK on ALTN IRS. 2. Replace the applicable IRU, M159 (left) or M161 (right) (AMM 34-21-01/401).
34 21 18 --	1. (01=Capt, 02=F/O) HSI curved trend vector missing. IRS fault light illuminates. EICAS message (L, C, R) IRS FAULT displayed. OK on ALTN IRS. 2. Replace the applicable IRU, M159 (left) or M161 (right) (AMM 34-21-01/401).
34 21 19 --	1. (01=Capt, 02=F/O) EHSI curved trend vector missing. 2. Replace the applicable symbol generator, M148 (left) or M150 (right) (AMM 34-22-01/401).
34 21 20 --	1. (01=Capt, 02=F/O) EHSI heading bug missing. Opposite RDMI HDG normal. 2. Replace the applicable symbol generator, (M148) (left) or M150 (right) (AMM 34-22-01/401).

EFFECTIVITY

ALL

34-FAULT CODE INDEX

05

Page 20
Jan 20/98



BOEING
757
FAULT ISOLATION/MAINT MANUAL

FAULT CODE	1. LOG BOOK REPORT 2. FAULT ISOLATION REFERENCE
34 21 21 --	1. (01=Capt, 02=F/0) EHSI heading bug missing. HDG and VOR flags in view on opposite RDMI. IRS fault light illuminates, EICAS message (L,C,R,) IRS FAULT displayed. Ok on ALTN IRS. 2. Replace the applicable IRU, M159 (left) or M161 (right) (AMM 34-21-01/401).
34 21 22 --	1. (01=Capt, 02=F/0) EHSI heading bug missing. HDG and VOR flags in view on opposite RDMI. 2. Replace the applicable IRU, M159 (left) or M161 (right) (AMM 34-21-01/401).
34 21 23 --	1. (01=Capt, 02=F/0) EADI ground speed in error. Capt ground speed reads _____, F/0 ground speed reads _____. Ok on ALTN IRS. 2. Replace the applicable IRU, M159 (left) or M161 (right) (AMM 34-21-01/401).
34 21 24 --	1. (01=Capt, 02=F/0) ADI ground speed in error. ALTN IRS doesn't correct. 2. Replace the applicable symbol generator, M148 (left) or M150 (right) (AMM 34-22-01/401).
34 21 25 --	1. (01=Capt, 02=F/0) EADI ground speed blank. (L,R) IRS fault indicated. Ok on ALTN IRS. 2. Replace the applicable IRU, M159 (left) or M161 (right) (AMM 34-21-01/401).
34 21 26 --	1. (01=Capt, 02=F/0) EADI ground speed blank. 2. Replace the applicable symbol generator, M148 (left) or M150 right (AMM 34-22-01/401).
34 21 27 --	1. (01=Capt, 02=F/0) EADI pitch (describe problem: indicates excessive pitch, oscillates, drifts, etc). ATT DISAGREE message displayed on EICAS. Ok on ALTN IRS. 2. Replace the applicable IRU, M159 (left) or M161 (right) (AMM 34-21-01/401).
34 21 28 --	1. (01=Capt, 02=F/0) EADI pitch (describe problem: indicates excessive pitch, oscillates, drifts, etc). ALTN IRS doesn't correct. 2. Replace the applicable symbol generator M148 (left) or M150 (right) (AMM 34-22-01/401).

EFFECTIVITY

ALL

34-FAULT CODE INDEX

12

Page 21
May 20/98

BOEING
 757
 FAULT ISOLATION/MAINT MANUAL

FAULT CODE	1. LOG BOOK REPORT 2. FAULT ISOLATION REFERENCE
34 21 29 --	1. (01=Capt, 02=F/0) EADI bank (describe problem: indicates excessive bank, oscillates, drifts, etc). ATT DISAGREE message displayed on EICAS. Ok on ALTN IRS. 2. Replace the applicable IRU, M159 (left) or M161 (right) (AMM 34-21-01/401).
34 21 30 --	1. (01=Capt, 02=F/0) EADI bank (describe problem: indicates excessive bank, oscillates, drifts, etc). ATT DISAGREE message display on EICAS. ALTN IRS doesn't correct. 2. Replace the symbol generator, M148 (left) or M150 (right) (AMM 34-22-01/401).
34 21 31 --	1. (01=Capt, 02=F/0) EADI ATT flag in view. (L, R) IRS fault indicated. ATT DISAGREE message displayed on EICAS. Ok on ALTN IRS. 2. Replace the applicable IRU, M159 (left) or M161 (right) (AMM 34-21-01/401).
34 21 32 --	1. (01=Capt, 02=F/0) EADI ATT flag in view. ATT DISAGREE message displayed on EICAS. 2. Replace the applicable symbol generator, M148 (left) or M150 (right) (AMM 34-22-01/401).
34 21 33 --	1. (01=Capt, 02=F/0) EADI ATT flag in view and ground speed blank. ATT DISAGREE message displayed on EICAS. (L, R) IRS fault indicated. OK on ALTN IRS. 2. Replace the applicable IRU, M159 (left) or M161 (right) (AMM 34-21-01/401).
34 21 34 --	1. (01=Capt, 02=F/0) EADI ATT flag in view and ground speed blank. ATT DISAGREE message displayed on EICAS. 2. Replace the symbol generator, M148 (left) or M150 (right) (AMM 34-22-01/401).
34 21 35 --	1. (01=Capt, 02=F/0) EADI ATT flag in view and ground speed blank. ATT DISAGREE message displayed on EICAS. RDMI HDG flag, EHSI TRK flag, and vert speed OFF flag also in view. (L, R) IRS fault indicated. Ok on ALTN IRS.

EFFECTIVITY

ALL

34-FAULT CODE INDEX

BOEING
 757
 FAULT ISOLATION/MAINT MANUAL

FAULT CODE	1. LOG BOOK REPORT 2. FAULT ISOLATION REFERENCE
	2. Replace the applicable IRU, M159 (left) or M161 (right) (AMM 34-21-01/401).
34 21 36 --	Not used
34 21 37 --	1. (01=L, 02=C, 03=R, 04=All) IRS indicate(s) IRS DC FAIL. 2. FIM 34-21-00/101, Fig. 105, Block 1
34 21 38 --	1. (01=L, 02=C, 03=R, 04=ALL) IRS indicate(s) IRS ON DC. 2. FIM 34-21-00/101, Fig. 106, Block 1
34 21 39 --	1. During alignment (01=L, 02=C, 03=R) IRS indicated IRS FAULT. Selecting ATT extinguished FAULT. 2. Replace the applicable IRU, M159 (left), M160 (center), or M161 (right) (AMM 34-21-01/401).
34 21 40 --	1. During alignment (01=L, 02=C, 03=R) IRS indicated IRS FAULT. FAULT remained illum with ATT selected. 2. Replace the applicable IRU, M159 (left), M160 (center), or M161 (right) (AMM 34-21-01/401).
34 21 41 --	1. At end of alignment (01=L, 02=C, 03=R) IRS indicated IRS FAULT. Selecting ATT extinguished FAULT. 2. Replace the applicable IRU, M159 (left), M160 (center), or M161 (right) (AMM 34-21-01/401).
34 21 42 --	1. At end of alignment (01=L, 02=C, 03=R) IRS indicated IRS FAULT. FAULT remained illum with ATT selected. 2. Replace the applicable IRU, M159 (left), M160 (center), or M161 (right) (AMM 34-21-01/401).
34 21 43 --	1. After alignment (01=L, 02=C, 03=R) IRS indicated IRS FAULT. Selecting ATT extinguished FAULT. 2. Replace the applicable IRU, M159 (left), M160 (center), or M161 (right) (AMM 34-21-01/401).
34 21 44 --	1. After alignment (01=L, 02=C, 03=R) IRS indicated IRS FAULT. FAULT remained illum with ATT selected. 2. Replace the applicable IRU, M159 (left), M160 (center), or M161 (right) (AMM 34-21-01/401).

EFFECTIVITY

ALL

34-FAULT CODE INDEX

BOEING
 757
 FAULT ISOLATION/MAINT MANUAL

FAULT CODE	1. LOG BOOK REPORT 2. FAULT ISOLATION REFERENCE
34 21 45 --	1. (01=L, 02=C, 03=R) ALIGN flashed when pos entered and re-entered. 2. Replace the applicable IRU, M159 (left), M160 (center), or M161 (right) (AMM 34-21-01/401).
34 21 46 --	1. (01=L, 02=C, 03=R, 04=ALL) ALIGN flashed approx 10 min after align mode entered. IRS FAULT remained extin. 2. Replace the applicable IRU, M159 (left), M160 (center), or M161 (right) (AMM 34-21-01/401). 3. If all flashed, replace the IRS panel, M59 (AMM 34-21-02/201).
34 21 47 --	1. (01=L, 02=C, 03=R, 04=ALL) ALIGN flashed approx 10 min after align entered. IRS FAULT illuminated when latitude was re-entered. 2. Replace the applicable IRU, M159 (left), M160 (center), or M161 (right) (AMM 34-21-01/401). For (04), replace the IRS panel, M59 (AMM 34-21-02/201).
34 21 48 --	Not used.
34 21 49 --	1. ON DC failed to illum and then exting on (01=L, 02=C, 03=R) IRS(s) when align initiated. 2. Replace the applicable IRU, M159 (left), M160 (center), or M161 (right) (AMM 34-21-01/401).
34 21 50 --	1. ALIGN failed to illum on (01=L, 02=C, 03=R) IRS(s) when align initiated. 2. Replace the applicable IRU, M159 (left), M160 (center), or M161 (right) (AMM 34-21-01/401).
34 21 51 --	1. ALIGN failed to exting on (01=L, 02=C, 03=R) IRS when NAV entered. NAV selected when turned on. 2. FIM 34-21-00/101, Fig. 106D, Block 1
34 21 52 --	1. ALIGN failed to illum and then exting on (01=L, 02=C, 03=R) IRS when switched from NAV to ALIGN to NAV. 2. Replace the applicable IRU, M159 (left), M160 (center), or M161 (right) (AMM 34-21-01/401).

EFFECTIVITY

ALL

34-FAULT CODE INDEX



BOEING
757
FAULT ISOLATION/MAINT MANUAL

FAULT CODE	1. LOG BOOK REPORT 2. FAULT ISOLATION REFERENCE
34 21 53 --	1. TK/GS display on IRS panel is inop from (01=L, 02=C, 03=R), 04=ALL) IRS system(s). 2. Replace the IRS panel, (M59) (AMM 34-21-02/201).
34 21 54 --	1. PPOS display on IRS panel is inop from (01=L, 02=C, 03=R, 04=ALL) IRS system(s). 2. Replace the IRS panel, M59 (AMM 34-21-02/201).
34 21 55 --	1. WIND display on IRS panel is inop from (01=L, 02=C, 03=R, 04=ALL) IRS system(s). 2. Replace the IRS panel, M59 (AMM 34-21-02/201).
34 21 56 --	1. HDG display on IRS panel is inop from (01=L, 02=C, 03=R, 04=ALL) IRS system(s). 2. Replace the IRS panel, M59 (AMM 34-21-02/201).
34 21 57 --	1. (01=L, 02=C, 03=R) IRS residual position error excessive, (indicate NM error, time in nav & No. of flights). 2. Replace the IRU M159 (left) (M160 (center), M161 (right)) (AMM 34-21-01/401).
34 21 57 00	1. The number in (describe position) is (describe problem: segment missing, blank, cycling, etc) on IRS panel. 2. Replace the IRS panel, M59 (AMM 34-21-02/201).
34 21 58 --	1. All displays on IRS panel are inop from (01=L, 02=C, 03=R, 04=ALL) IRS system(s). 2. Replace the applicable IRU, M159 (left), M160 (center), or M161 (right) (AMM 34-21-01/401). If the problem continues, replace the IRS panel, M59 (AMM 34-21-02/201).
34 21 59 --	1. (01=L, 02=C, 03=R) IRS residual groundspeed error excessive, (indicate G.S. error, No. of flights). 2. Do the residual groundspeed error check (FIM 34-21-00/101). 3. Replace the IRU M159 (left) (M160 (center), M161 (right)) (AMM 34-21-01/401).
34 21 59 00	1. (describe key: 1, 2, 3, etc) key is inop on IRS panel. 2. Replace the IRS panel, M59 (AMM 34-21-02/201).
34 21 60 00	1. All keys are inop on IRS panel. 2. Replace the IRS panel, M59 (AMM 34-21-02/201).

EFFECTIVITY

ALL

34-FAULT CODE INDEX

BOEING
 757
 FAULT ISOLATION/MAINT MANUAL

FAULT CODE	1. LOG BOOK REPORT 2. FAULT ISOLATION REFERENCE
34 21 61 00	1. Align light flashes on all IRU annunciators, after second position was entered on IRS panel. 2. FIM 34-21-00/101, Fig. 106C, Block 1
34 21 62 --	1. (01=Capt, 02=F/O) RDMI HDG flag in view. DME normal. ALTN IRS doesn't correct. 2. Replace the applicable RDMI, N43 (captain) or N3 (F/O) (AMM 34-22-05/401).
34 21 63 --	1. (01=Capt, 02=F/O) EHSI heading bug in error. Capt HSI heading _____, F/O RDMI heading _____. Standby compass heading _____. ALTN IRS doesn't correct. 2. FIM 34-22-00/101, Fig. 108, Block 1
34 21 64 --	1. (01=Capt, 02=F/O) EHSI track flag in view. ALTN IRS doesn't correct. 2. Replace the applicable symbol generator, M148 (left) or M150 (right) (AMM 34-22-01/401).
34 21 65 --	1. Align light flashes on (01=L, 02=C, 03=R) IRS panel after second position entry from IRS panel. IRS pos entry from FMC-CDU ok. 2. FIM 34-21-00/101, Fig. 106B, Block 1
34 21 66 --	1. Align light flashes on (01=L, 02=C, 03=R) IRS panel after second position entry from IRS panel. IRS pos entry from FMC unsuccessful. 2. FIM 34-21-00/101, Fig. 106A, Block 1
34 21 67 01	1. TRACK DISAGREE displayed on EICAS. Changing to ALTN IRS on Capt side corrects the fault. 2. Replace the left IRU, M159 (AMM 34-21-01/401).
34 21 67 02	1. TRACK DISAGREE displayed on EICAS. Changing to ALTN IRS on F/O side corrects the fault. 2. Replace the right IRU, M161 (AMM 34-21-01/401).
34 21 68 --	1. (01=Capt, 02=F/O) vertical speed incorrect. ALTN IRS doesn't correct. ALTN AIR DATA doesn't correct. 2. Replace the applicable VSI, N9 (captain) or N49 (F/O) (AMM 34-22-06/401).
34 21 69 --	1. (01=Capt, 02=F/O) VSI flag in view. ALTN AIR DATA doesn't correct. 2. FIM 34-21-00/101, Fig. 104, Block 1.

EFFECTIVITY

ALL

34-FAULT CODE INDEX

BOEING
 757
 FAULT ISOLATION/MAINT MANUAL

FAULT CODE	1. LOG BOOK REPORT 2. FAULT ISOLATION REFERENCE
34 21 70 00	1. HDG DISAGREE displayed on EICAS. Changing to ALTN IRS doesn't correct the fault. 2. FIM 34-25-00/101, Fig. 103, Block 1 FIM 34-22-00/101, Fig. 108, Block 1
34 21 70 00	Not used
34 21 71 00	1. ATT DISAGREE message displayed on EICAS. 2. FIM 34-21-00/101, Fig. 107, Block 1
34 21 72 --	1. (01=CAPT, 02=F/O) RDMI heading flag in view. IRS FAULT illuminated. 2. Replace the applicable IRU, M159 (left) or M160 (right) (AMM 34-21-01/401).
34 21 73 --	1. After flight residual GS on (01=L, 02=C, 03=R) IRU is too high for two consecutive flights (Record GS error per flight). 2. Replace the applicable IRU, M159 (left), M160 (center), or M161 (right) (AMM 34-21-01/401).
34 21 74 --	1. After flight P POS is in error on (01=L, 02=C, 03=R, IRU). (Record time IRS was in operation, actual and indicated latitude and longitude. Add note if IRS error was excessive for 2 consecutive flights. 2. FIM 34-21-00/101, Fig. 107A, Block 1
34 21 75 --	1. TRACK DISAGREE displayed on EICAS. Changing to ALTN IRS does not correct the fault. 2. FIM 34-25-00/101, Fig. 103, Block 1 FIM 34-22-00/101, Fig. 108, Block 1
34 21 76 01	1. HDG DISAGREE displayed on EICAS. Changing to ALTN IRS on Capt side corrects the fault. 2. Replace the left IRU, M159 (AMM 34-21-01/401).
34 21 76 02	1. HDG DISAGREE displayed on EICAS changing to ALTN IRS on F/O side corrects the fault. 2. Replace the right IRU, M161 (AMM 34-21-01/401).

EFFECTIVITY

ALL

34-FAULT CODE INDEX

BOEING
 757
 FAULT ISOLATION/MAINT MANUAL

FAULT CODE	1. LOG BOOK REPORT 2. FAULT ISOLATION REFERENCE
34 21 77 ___	1. (01=L, 02=C, 03=R) IRS residual groundspeed error excessive, (indicate G.S. error, No. of flights). 2. Replace the L (C, R) IRU, B7161 (B7163, B7162) (AMM 34-21-01/401).
34 21 78 ___	1. (01=L, 02=C, 03=R) IRS residual position error excessive, (indicate NM error, time in nav & No. of flights). 2. Replace the L (C, R) IRU, B7161 (B7163, B7162) (AMM 34-21-01/401).
34 22 01 --	1. (01=Capt, 02=F/O) EADI is (blank, intermittent). Selecting ALT EFI corrects the fault. 2. Replace the applicable EFIS symbol generator, M148 (left) or M150 (right) (AMM 34-22-01/401).
34 22 02 --	1. (01=Capt, 02=F/O) EADI is (blank, intermittent). Selecting ALT EFI does not correct fault. 2. FIM 34-22-00/101, Fig. 104, Block 2
34 22 03 --	1. (01=Capt, 02=F/O) EADI is out of focus. 2. FIM 34-22-00/101, Fig. 104, Block 1
34 22 04 --	1. (01=Capt, 02=F/O) EADI SKY-GND display goes black intermittently. 2. FIM 34-22-00/101, Fig. 104, Block 1
34 22 05 --	1. (01=Capt, 02=F/O) EADI sky/ground boundary is incorrect. Selecting ALTN EFI corrects fault. 2. Replace the applicable EFIS symbol generator, M148 (left) or M150 (right) (AMM 34-22-01/401).
34 22 06 --	1. (01=Capt, 02=F/O) EADI white horizon line is not aligned with the sky/ground line. Selecting ALTN EFI corrects fault. 2. Replace the applicable EFIS symbol generator, M148 (left) or M150 (right) (AMM 34-22-01/401).
34 22 07 --	1. (01=Capt, 02=F/O) EADI is distorted. Selecting ALT EFI corrects the fault. 2. Replace the applicable EFIS symbol generator, M148 (left) or M150 (right) (AMM 34-22-01/401).
34 22 08 --	1. (01=Capt, 02=F/O) EADI is distorted. Selecting ALT EFI does not correct the fault. 2. FIM 34-22-00/101, Fig. 104, Block 2

EFFECTIVITY

ALL

34-FAULT CODE INDEX

BOEING
 757
 FAULT ISOLATION/MAINT MANUAL

FAULT CODE	1. LOG BOOK REPORT 2. FAULT ISOLATION REFERENCE
34 22 09 --	1. (01=Capt, 02=F/0) EADI sky and ground colors are offset. Selecting ALTN EFI corrects fault. 2. Replace the applicable EFIS symbol generator, M148 (left) or M150 (right) (AMM 34-22-01/401).
34 22 10 --	1. (01=Capt, 02=F/0) EADI (width, height) is incorrect. Selecting ALT EFI corrects fault. 2. Replace the applicable EFIS symbol generator, M148 (left) or M150 (right) (AMM 34-22-01/401).
34 22 11 --	1. (01=Capt, 02=F/0) EADI (width, height) is incorrect. Selecting ALT EFI does not correct fault. 2. FIM 34-22-00/101, Fig. 104, Block 2
34 22 12 --	1. (01=Capt, 02=F/0) EADI size and (linearity, brightness) changed. Selecting ALT EFI corrects the fault. 2. Replace the applicable EFIS symbol generator, M148 (left) or M150 (right) (AMM 34-22-01/401).
34 22 13 --	1. (01=Capt, 02=F/0) EADI size and (linearity, brightness) changed. Selecting ALT EFI does not correct the fault. 2. FIM 34-22-00/101, Fig. 104, Block 2
34 22 14 --	1. (01=Capt, 02=F/0) EADI is only one color. Selecting ALT EFI corrects fault. 2. Replace the applicable EFIS symbol generator, M148 (left) or M150 (right) (AMM 34-22-01/401).
34 22 15 --	1. (01=Capt, 02=F/0) EADI is only one color. Selecting ALT EFI does not correct fault. 2. FIM 34-22-00/101, Fig. 104, Block 2
34 22 16 --	1. (01=Capt, 02=F/0) EADI is wrong (color, intensity). Selecting ALT EFI corrects the fault. 2. Replace the applicable EFIS symbol generator, M148 (left) or M150 (right) (AMM 34-22-01/401).
34 22 17 --	1. (01=Capt, 02=F/0) EADI is wrong (color, intensity). Selecting ALT EFI does not correct fault. 2. FIM 34-22-00/101, Fig. 104, Block 2
34 22 18 --	1. (01=Capt, 02=F/0) EADI has a colored fringe on the display. 2. Replace the applicable EADI, N4 (captain) or N44 (F/0) as necessary (AMM 34-22-03/401).

EFFECTIVITY

ALL

34-FAULT CODE INDEX

BOEING
 757
 FAULT ISOLATION/MAINT MANUAL

FAULT CODE	1. LOG BOOK REPORT 2. FAULT ISOLATION REFERENCE
34 22 19 --	1. (01=Capt, 02=F/O) EADI color shade is off. 2. FIM 34-22-00/101, Fig. 104, Block 1
34 22 20 --	1. (01=Capt, 02=F/O) EADI manual brightness adjust is (inop, unable to dim, etc). 2. FIM 34-22-00/101, Fig. 105, Block 1
34 22 21 --	1. (01=Capt, 02=F/O) EADI manual and auto brightness adjust are inop. 2. FIM 34-22-00/101, Fig. 105, Block 1
34 22 22 --	1. (01=Capt, 02=F/O) EHSI is (blank, intermittent). Selecting ALT EFI corrects the fault. 2. Replace the applicable EFIS symbol generator, M148 (left) or M150 (right) (AMM 34-22-01/401).
34 22 23 --	1. (01=Capt, 02=F/O) EHSI is (blank, intermittent). Selecting ALT EFI does not correct fault. 2. FIM 34-22-00/101, Fig. 106, Block 1
34 22 24 --	1. (01=Capt, 02=F/O) EHSI is out of focus. 2. FIM 34-22-00/101, Fig. 105, Block 1
34 22 25 --	Not Used
34 22 26 --	1. (01=Capt, 02=F/O) EHSI is distorted. Selecting ALT EFI corrects the fault. 2. Replace the applicable EFIS symbol generator, M148 (left) or M150 (right) (AMM 34-22-01/401).
34 22 27 --	1. (01=Capt, 02=F/O) EHSI is distorted. Selecting ALT EFI does not correct the fault. 2. FIM 34-22-00/101, Fig. 106, Block 1
34 22 28 --	1. (01=Capt, 02=F/O) EHSI (width, height) is incorrect. Selecting ALT EFI corrects the fault. 2. Replace the applicable EFIS symbol generator, M148 (left) or M150 (right) (AMM 34-22-01/401).
34 22 29 --	1. (01=Capt, 02=F/O) EHSI (width, height) is incorrect. Selecting ALT EFI does not correct fault. 2. FIM 34-22-00/101, Fig. 106, Block 1

EFFECTIVITY

ALL

34-FAULT CODE INDEX



757
FAULT ISOLATION/MAINT MANUAL

FAULT CODE	1. LOG BOOK REPORT 2. FAULT ISOLATION REFERENCE
34 22 30 --	<ol style="list-style-type: none"> 1. (01=Capt, 02=F/0) EHSI size and (linearity, brightness) changed. Selecting ALT EFI corrects the fault. 2. Replace the applicable EFIS symbol generator, M148 (left) or M150 (right) (AMM 34-22-01/401).
34 22 31 --	<ol style="list-style-type: none"> 1. (01=Capt, 02=F/0) EHSI size and (linearity, brightness) changed. Selecting ALT EFI does not correct the fault. 2. FIM 34-22-00/101, Fig. 106, Block 1
34 22 32 --	<ol style="list-style-type: none"> 1. (01=Capt, 02=F/0) EHSI is only one color. Selecting ALT EFI corrects fault. 2. Replace the applicable EFIS symbol generator, M148 (left) or M150 (right) (AMM 34-22-01/401).
34 22 33 --	<ol style="list-style-type: none"> 1. (01=Capt, 02=F/0) EHSI is only one color. Selecting ALT EFI does not correct fault. 2. FIM 34-22-00/101, Fig. 106, Block 1
34 22 34 --	<ol style="list-style-type: none"> 1. (01=Capt, 02=F/0) EHSI is wrong (color, intensity). Selecting ALT EFI corrects the faults. 2. Replace the applicable EFIS symbol generator, M148 (left) or M150 (right) (AMM 34-22-01/401).
34 22 35 --	<ol style="list-style-type: none"> 1. (01=Capt, 02=F/0) EHSI is wrong (color, intensity). Selecting ALT EFI does not correct the fault. 2. FIM 34-22-00/101, Fig. 106, Block 1
34 22 36 --	<ol style="list-style-type: none"> 1. (01=Capt, 02=F/0) EHSI has a colored fringe on the display. 2. Replace the applicable EHSI, N5 (captain) or N45 (F/0) as necessary (AMM 34-22-04/401).
34 22 37 --	<ol style="list-style-type: none"> 1. (01=Capt, 02=F/0) EHSI color shade is off. 2. FIM 34-22-00/101, Fig. 107, Block 1
34 22 38 --	<ol style="list-style-type: none"> 1. (01=Capt, 02=F/0) EHSI manual brightness adjust is inop. 2. FIM 34-22-00/101, Fig. 107, Block 1
34 22 39 --	<ol style="list-style-type: none"> 1. (01=Capt, 02=F/0) EHSI manual and auto brightness adjust is inop. 2. FIM 34-22-00/101, Fig. 107, Block 1

EFFECTIVITY

ALL

34-FAULT CODE INDEX

BOEING
 757
 FAULT ISOLATION/MAINT MANUAL

FAULT CODE	1. LOG BOOK REPORT 2. FAULT ISOLATION REFERENCE
34 22 40 --	1. (01=Capt, 02=F/0) EADI and EHSI are blank. Selecting ALTN EFI corrects the fault. 2. FIM 34-22-00/101, Fig. 108, Block 1
34 22 41 --	1. (01=Capt, 02=F/0) EADI and EHSI displays are unintelligible. 2. Replace the applicable EFIS symbol generator, M148 (left) or M150 (right) (AMM 34-22-01/401).
34 22 42 --	1. (01=Capt, 02=F/0) EADI and EHSI have no lines on the displays. 2. Replace the applicable EFIS symbol generator, M148 (left) or M150 (right) (AMM 34-22-01/401).
34 22 43 --	1. (01=Capt, 02=F/0) EADI and EHSI lines are offset. 2. Replace the applicable EFIS symbol generator, M148 (left) or M150 (right) (AMM 34-22-01/401).
34 22 44 --	1. (01=Capt, 02=F/0) HSI mode selector position does not correspond to HSI display. ILS mode displayed. DH and WX RADAR FAIL displayed. 2. Replace the applicable EFIS control panel, M94 (left) or M95 (right) as necessary (AMM 34-22-02/201).
34 22 45 --	1. (01=Capt, 02=F/0) HSI (NAV AID, ARPT, RTE DATA, WPT) MAP feature switch(es) (describe fault). 2. Replace the applicable EFIS control panel, M94 (left) or M95 (right) as necessary (AMM 34-22-02/201).
34 22 46 --	1. (01=Capt, 02=F/0) HSI RANGE selector (describe fault). 2. Replace the applicable EFIS control panel, M94 (left) or M95 (right) as necessary (AMM 34-22-02/201).
34 22 47 --	1. (01=CAPT, 02=F/0) sky-gnd circle on EADI and WXR radar on HSI go black. 2. FIM 34-22-00/101, Fig. 108, Block 1
34 22 48 --	1. (01=Capt, 02=F/0) EADI and EHSI displays intermittent. Displays normal on ALTN EFI. 2. Replace the applicable EFIS symbol generator, M148 (left) or M150 (right) (AMM 34-22-01/401).
34 22 49 --	1. (01=Capt, 02=F/0) EADI and EHSI displays intermittent. Condition same on ALTN EFI. 2. FIM 34-22-00/101, Fig. 108, Block 1

EFFECTIVITY

ALL

34-FAULT CODE INDEX

BOEING
 757
 FAULT ISOLATION/MAINT MANUAL

FAULT CODE	1. LOG BOOK REPORT 2. FAULT ISOLATION REFERENCE
34 22 50 --	1. Command bug(s) on (01=Capt, 02=F/O, 03=both) EADI speed Tape(s) and MACH/AS Indicator(s) disagree(s) with (MCP FMS CDU). Bugs normal using ALTN EFI. 2. Replace the applicable EFIS symbol generator, M148 (left) or M150 (right) (AMM 34-22-01/401).
34 22 51 --	1. (V1, Vr, Command) Airspeed Command Bug(s) (not normal, missing, etc) on (01=Capt, 02=F/O) EADI speed tape(s). ALTN EFI selection corrects fault. 2. Replace the applicable EFIS symbol generator, M148 (left) or M150 (right) (AMM 34-22-01/401).
34 22 52 --	1. V1, Vr Bug(s) (not normal, missing etc) on (01=Capt, 02=F/O, 03=both) EADI speed tape(s). ALTN EFI selection corrects fault. 2. Replace the applicable EFIS symbol generator, M148 (left) or M150 (right) (AMM 34-22-01/401).
34 22 53 --	1. (01=Capt, 02=F/O) ADI speed Tape faulty (describe). ALTN AIR DATA selection corrects fault. 2. FIM 34-12-00/101, Fig. 109, Block 1. IF fault persists, perform FIM 34-22-00/101, Fig. 104, Block 1.
34 22 54 --	34 22 54 -- thru 34 22 69 -- Not Used
34 22 70 --	1. (01=CAPT, 02=F/O) EADI sky/gnd boundry is incorrect. Selecting ALTN EFI does not correct fault. 2. FIM 34-22-00/101, Fig. 104, Block 1
34 22 71 --	1. (01=CAPT, 02=F/O) EADI white horizon line is offset from sky/gnd boundry. Selecting ALTN EFI does not correct fault. 2. FIM 34-22-00/101, Fig. 104, Block 1
34 22 72 --	1. (01=CAPT, 02=F/O) EADI sky and gnd color are offset. Selecting ALTN EFI does not correct fault. 2. FIM 34-22-00/101, Fig. 104, Block 1
34 22 73 --	1. (01=CAPT, 02=F/O) EADI and EHSI are both blank. Selecting ALTN EFI does not correct fault. 2. FIM 34-22-00/101, Fig. 108, Block 1
34 22 74 --	1. (01=CAPT, 02=F/O) EADI auto brightness inop. 2. FIM 34-22-00/101, Fig. 105, Block 1

EFFECTIVITY

ALL

34-FAULT CODE INDEX

BOEING
 757
 FAULT ISOLATION/MAINT MANUAL

FAULT CODE	1. LOG BOOK REPORT 2. FAULT ISOLATION REFERENCE
34 22 75 00	Not Used
34 22 76 00	Not Used
34 22 77 --	1. (01=CAPT, 02=F/O) EHSI auto brightness inop. 2. FIM 34-22-00/101, Fig. 107, Block 1
34 22 78 --	34 22 78 -- thru 34 22 85 -- Not used
34 22 86 --	1. Selecting (01=Capt, 02=F/O) ALTN IRS not norm. (Describe). 2. Replace the applicable IRU, M159 (left), M160 (center), or M161 (right) (AMM 34-21-01/401).
34 22 87 --	1. (01=Capt, 02=F/O) slip indicator not centered. 2. Adjust the EADI inclinometer (AMM 34-22-00/501)
34 22 88 --	1. Selecting (01=Capt, 02=F/O) ALTN EFI not norm. (Describe). 2. Examine and repair the applicable ALTN EFI switch and the related circuits (WDM 34-22-17, WDM 34-22-27)
34 22 89 --	1. Selecting (01=Capt, 02=F/O) ALTN FMC not norm. (Describe). 2. Examine and repair the applicable ALTN FMC switch and the related circuits (WDM 34-22-17, WDM 34-22-27)
34 22 90 --	1. (01=Capt, 02=F/O, 03=Capt & F/O) HSI and (opposite side, both) RDMI/RMI failed to indicate change to true heading when (above 73 degrees N, below 60 degrees S). System normal with HDG REF sw in TRUE. 2. Replace the applicable EFIS symbol generator, M148 (left) or M150 (right) (AMM 34-22-01/401).

EFFECTIVITY

ALL

34-FAULT CODE INDEX

BOEING
 757
 FAULT ISOLATION/MAINT MANUAL

FAULT CODE	1. LOG BOOK REPORT 2. FAULT ISOLATION REFERENCE
34 22 91 --	1. (01=Capt, 02=F/O, 03=Capt & F/O) HSI and (opposite side, both) RDMI RMI failed to indicate change to true heading with HDG REF sw in TRUE. 2. Examine and repair or replace the HDG REF SW and the related circuits (WDM 34-22-26).
34 22 92 --	1. (01=Capt., 02=F/O) EADI and EHSI are blank with SG FAIL message displayed in both indicators. Selecting ALTN EFI corrects fault. 2. FIM 34-22-00/101, Fig. 108, Block 1. If the problem continues replace the EFIS symbol generator, M148 (left) or M150 (right) as necessary (AMM 34-22-01/401).
34 22 96 --	1. (01=Capt, 02=F/O) TFC switch (describe fault). 2. Replace the EFIS control panel.
34 23 01 00	1. Standby compass light inoperative. 2. Replace the bulb.
34 23 02 00	1. Standby compass heading incorrect. Reads _____, should read _____. 2. Do a standby compass calibration (AMM 34-23-00/201)
34 24 01 00	1. Standby attitude indicator lights inoperative. 2. Replace the standby attitude indicator (AMM 34-23-00).
34 24 02 00	1. Standby attitude indicator attitude display abnormal (pitch, roll, etc.) and GYRO flag is out of view. 2. FIM 34-24-00/101, Fig. 103, Block 1

EFFECTIVITY

ALL

34-FAULT CODE INDEX

BOEING
 757
 FAULT ISOLATION/MAINT MANUAL

FAULT CODE	1. LOG BOOK REPORT 2. FAULT ISOLATION REFERENCE
34 24 03 00	1. Standby attitude indicator GYRO flag is in view. 2. FIM 34-24-00/101, Fig. 103, Block 1
34 24 04 00	1. With the back course mode selected, the localizer deviation pointer of the standby indicator did not reverse. 2. FIM 34-24-00/101, Fig. 103, Block 1
34 24 05 00	1. The deviation pointers of the standby attitude indicator do not retract with the ILS selector in the OFF position. 2. FIM 34-24-00/101, Fig. 103, Block 1
34 25 01 00	1. COMPARATOR BITE message displayed on EICAS status page. (Ref Chapter 31 for fault code diagram). 2. FIM 34-25-00/101, Fig. 103, Block 1
34 25 02 00	1. EICAS msg HDG FAIL displayed. 2. Used only during self-test. If this message shows during usual operation, replace the instrument comparator unit (AMM 34-25-01/401).
34 25 03 00	1. EICAS msg TRACK FAIL displayed. 2. Used only during self-test. If this message shows during usual operation, replace the instrument comparator unit (AMM 34-25-01/401).
34 25 04 00	1. EICAS msg ATT FAIL displayed. 2. Do a check for a nuisance EICAS message: Put the EICAS computer select switch to an alternative position. If the message does not show, open and then close the circuit breaker for the EICAS computer that shows the nuisance message. If the problem continues, replace the EICAS computer that shows the nuisance message. 3. This message is used only during self-test. If this message is not a nuisance message and shows during usual operation, replace the instrument comparator unit (AMM 34-25-01/401).

EFFECTIVITY

ALL

34-FAULT CODE INDEX

BOEING
 757
 FAULT ISOLATION/MAINT MANUAL

FAULT CODE	1. LOG BOOK REPORT 2. FAULT ISOLATION REFERENCE
34 25 05 00	1. EICAS msg FD COMMAND FAIL displayed. 2. Used only during self-test. If this message shows during usual operation, replace the instrument comparator unit (AMM 34-25-01/401).
34 25 06 00	1. EICAS msg FAST/SLOW FAIL displayed. 2. Used only during self-test. If this message shows during usual operation, replace the instrument comparator unit (AMM 34-25-01/401).
34 25 07 00	1. EICAS msg HDG DISAGREE displayed. 2. GUI 001-114, 116-999; Used only during self-test. If this message shows during usual operation, replace the instrument comparator unit (AMM 34-25-01/401). 3. GUI 115; FIM 34-21-00/101, Fig. 107, Block 1.
34 25 08 00	1. EICAS msg TRACK DISAGREE displayed. 2. GUI 001-114, 116-999; Used only during self-test. If this message shows during usual operation, replace the instrument comparator unit (AMM 34-25-01/401). 3. GUI 115; FIM 34-21-00/101, Fig. 107, Block 1.
34 25 09 00	1. EICAS msg G/S FAIL displayed. 2. Used only during self-test. If this message shows during usual operation, replace the instrument comparator unit (AMM 34-25-01/401).
34 25 10 00	1. EICAS msg LOC FAIL displayed. 2. Do a check for a nuisance EICAS message: Put the EICAS computer select switch to an alternative position. If the message does not show, open and then close the circuit breaker for the EICAS computer that shows the nuisance message. If the problem continues, replace the EICAS computer that shows the nuisance message. 3. This message is used only during self-test. If this message is not a nuisance message and shows during usual operation, replace the instrument comparator unit (AMM 34-25-01/401).

EFFECTIVITY

ALL

34-FAULT CODE INDEX

BOEING
 757
 FAULT ISOLATION/MAINT MANUAL

FAULT CODE	1. LOG BOOK REPORT 2. FAULT ISOLATION REFERENCE
34 25 11 00	1. EICAS msg G/S DISAGREE displayed. 2. Used only during self-test. If this message shows during usual operation, replace the instrument comparator unit (AMM 34-25-01/401).
34 25 12 00	1. EICAS msg LOC DISAGREE displayed. 2. Used only during self-test. If this message shows during usual operation, replace the instrument comparator unit (AMM 34-25-01/401).
34 25 13 00	1. EICAS msg RA DISAGREE displayed. 2. Used only during self-test. If this message shows during usual operation, replace the instrument comparator unit (AMM 34-25-01/401).
34 31 01 --	1. ILS test response abnormal on (01=Capt EADI & EHSI, 02=F/O EADI & EHSI, 03=STBY ATT IND). Identify those test indications which were abnormal. 2. (01=Capt EADI & EHSI, 02=F/O EADI & EHSI) FIM 34-31-00/101, Fig. 104, Block 1 (03=STBY ATT IND) FIM 34-31-00/101, Fig. 107, Block 1
34 31 02 --	1. (L, R, C) ILS ident not received at (04=Capt, 05=F/O, 06=1st Obs, 07= 2nd OBS/Supernumerary) crew position. Deviation pointer display normal. 2. Replace the applicable audio select panel, M70 (captain), M71 (F/O), or M98 (1st Obs) (AMM 23-51-01/401).
34 31 03 --	1. (01=L, 02=R, 03=C) ILS ident not received at any crew position. Deviation pointer normal. 2. Replace the applicable ILS receiver, M156 (left), M158 (right), or M157 (center) (AMM 34-31-01/401).

EFFECTIVITY

ALL

34-FAULT CODE INDEX

BOEING
 757
 FAULT ISOLATION/MAINT MANUAL

FAULT CODE	1. LOG BOOK REPORT 2. FAULT ISOLATION REFERENCE
34 31 04 --	1. G/S flag in view in the (04=Capt, 05=F/O) EADI & EHSI. 2. Replace the applicable ILS receiver, M156 (left) or M158 (right) (AMM 34-31-01/401).
34 31 05 --	1. LOC flag in view on the (04=Capt, 05=F/O) EADI and EHSI. 2. Replace (left-M156, right-M158) the ILS receiver (AMM 34-31-01).
34 31 06 --	1. G/S and LOC flags in view on the (04=Capt, 05=F/O) EADI and EHSI. 2. FIM 34-31-00/101, Fig. 105, Block 1
34 31 07 --	1. Loc pointer or COURSE indicator not displayed on the (04=Capt, 05=F/O) EADI & EHSI. ILS ident not received. 2. FIM 34-31-00/101, Fig. 110, Block 1
34 31 08 --	1. G/S pointer not displayed on the (04=Capt, 05=F/O) EADI & EHSI. 2. FIM 34-31-00/101, Fig. 111, Block 1
34 31 09 --	1. G/S and LOC pointers or COURSE indicator not displayed on the (04=Capt, 05=F/O) EADI and EHSI. ILS ident not received. 2. Replace the ILS control panel, M87 (AMM 34-31-02/401).
34 31 10 07	1. G/S and LOC pointers not displayed on Capt's or F/O's EADI and EHSI. 2. Replace the ILS control panel, M87 (AMM 34-31-02/401).
34 31 11 --	1. The deviation scales and COURSE bar(s) are missing on (04=Capt's, 05=F/O's, 08=Capt & F/O) EADI's. The pointers are not displayed on the corresponding EHSI. ILS ident received. 2. Replace the applicable EFIS symbol generator, M148 (left) or M150 (right) (AMM 34-22-01/401).

EFFECTIVITY

ALL

34-FAULT CODE INDEX

BOEING
 757
 FAULT ISOLATION/MAINT MANUAL

FAULT CODE	1. LOG BOOK REPORT 2. FAULT ISOLATION REFERENCE
34 31 12 --	1. The deviation scales and COURSE bar(s) are missing on (04=Capt, 05=F/O, 08=Capt & F/O) EADI. The pointers are not displayed on the corresponding EHSI. ILS ident not received. 2. Replace the ILS control panel, M87 (AMM 34-31-02/401).
34 31 13 --	1. (04=Capt, 05=F/O) EADI and EHSI LOC pointer and COURSE indicator (intermittent, has reverse heading, etc). 2. Replace the ILS control panel, M87 (AMM 34-31-02/401).
34 31 14 --	1. (01=L, 02=R, 03=C) ILS reception is weak. 2. Replace the dual localizer antenna, M248 (left) or M249 (right) (AMM 34-31-04/401).
34 31 15 --	1. LOC pointer or COURSE ind not displayed on the (04=Capt, 05=F/O) EADI and EHSI. Displays were norm with ALTN EFI selected. 2. Replace the ILS receiver, M156 (left) or M158 (right) (AMM 34-31-01/401).
34 31 16 --	Not Used
34 31 17 --	1. ILS frequency displayed on the (01=Capt, 02=F/O) EHSI disagrees with the frequency indicator. HSI reads _____. Control reads _____. 2. Replace the ILS control panel, M87 (AMM 34-31-02/401)
34 31 18 --	1. Selected course pointer display on the (01=Capt, 02=F/O) EHSI disagrees with the course indicator. 2. Replace the ILS control panel, M87 (AMM 34-31-02/401)
34 31 19 00	1. ILS F. CRS indicator does not respond to selector movement. 2. Replace the ILS control panel, M87 (AMM 34-31-02/401)

EFFECTIVITY

ALL

34-FAULT CODE INDEX

BOEING
 757
 FAULT ISOLATION/MAINT MANUAL

FAULT CODE	1. LOG BOOK REPORT 2. FAULT ISOLATION REFERENCE
34 31 20 00	1. Frequency indicator does not respond to selector movement. 2. Replace the ILS control panel, M87 (AMM 34-31-02/401)
34 31 21 00	1. G/S flag in view in the standby attitude indicator. 2. FIM 34-31-00/101, Fig. 107, Block 1
34 31 22 00	1. LOC flag in view in the standby attitude indicator. 2. FIM 34-31-00/101, Fig. 107, Block 1
34 31 23 00	1. G/S & LOC flags in view in the standby attitude indicator. 2. FIM 34-31-00/101, Fig. 107, Block 1
34 31 24 00	1. Localizer deviation pointer not displayed in the standby attitude indicator. 2. Replace the dual localizer antenna, M249 (right/center) (AMM 34-31-04/401)
34 31 25 00	1. Glideslope deviation pointer never displayed in the standby attitude indicator. 2. FIM 34-31-00/101, Fig. 109, Block 1
34 31 26 00	1. G/S and LOC pointers not displayed in the standby attitude indicator. 2. FIM 34-31-00/101, Fig. 108, Block 1
34 31 27 00	1. The (glideslope, localizer) deviation pointer of the standby attitude indicator (fluctuates, sticks, etc). 2. Replace the standby attitude indicator, M20 (AMM 34-24-01/401).
34 31 28 00	1. ILS F. CRS indicator has missing segment. . 2. Replace the ILS control panel, M87 (AMM 34-31-02/401).
34 31 29 00	1. ILS FREQ indicator has missing segment. . 2. Replace the ILS control panel, M87 (AMM 34-31-02/401).

EFFECTIVITY

ALL

34-FAULT CODE INDEX

BOEING
 757
 FAULT ISOLATION/MAINT MANUAL

FAULT CODE	1. LOG BOOK REPORT 2. FAULT ISOLATION REFERENCE
34 32 01 --	1. Marker beacon ident (inop, weak, intermittent, etc) at (01=Capt, 02=F/O, 03=Supernumerary, 04=1st Obs) station. All other crew stations OK. Marker lgts OK. 2. Replace the applicable audio selector panel (AMM 23-51-01/401).
34 32 02 00	1. Marker beacon ident (inop, weak, intermittent, etc) at any crew station. Marker lights are OK. 2. Replace the left VOR receiver, M186 (AMM 34-51-01/401).
34 32 03 00	1. Both INNER/AIRWAYS marker lights fail to illuminate. 2. Replace the left VOR receiver, M186 (AMM 34-51-01/401).
34 32 04 00	1. Both MIDDLE marker lights fail to illuminate. 2. Replace the left VOR receiver, M186 (AMM 34-51-01/401).
34 32 05 00	1. Both OUTER marker lights fail to illuminate. 2. Replace the left VOR receiver, M186 (AMM 34-51-01/401).
34 32 06 00	1. All marker beacon lights fail to illuminate ident received. 2. Replace the left VOR receiver, M186 (AMM 34-51-01/401).
34 32 07 00	1. All marker beacon lights fail to illuminate. Ident not received. 2. FIM 34-32-00/101, Fig. 103, Block 1
34 32 08 00	1. All marker beacon lights illuminate intermittently. No ident received. 2. FIM 34-32-00/101, Fig. 103, Block 1
34 33 01 --	1. (01=Capt, 02=F/O) Decision height reference indicator does not respond to selector movement. 2. Replace the applicable EFIS control panel, M94 (left) or M93 (right) (AMM 34-22-02/201)
34 33 02 --	1. (01=Capt, 02=F/O) DH reset SW does not reset decision height display on EADI. Operation normal with ALTN EFI selected. 2. Replace the applicable Symbol Generator M148 (left) or M150 (right) (AMM 34-22-01/401).
34 33 03 --	1. (01=Capt, 02=F/O) DH reset SW does not reset decision height display on EADI. Condition remains the same with ALTN EFI selected. 2. Replace the L (R) EFIS control panel M94 (M93) (AMM 34-22-02)

EFFECTIVITY

ALL

34-FAULT CODE INDEX



BOEING
757
FAULT ISOLATION/MAINT MANUAL

FAULT CODE	1. LOG BOOK REPORT 2. FAULT ISOLATION REFERENCE
34 33 04 --	Not Used
34 33 05 --	Not Used
34 33 06 --	<ol style="list-style-type: none"> 1. Decision height alert altitude on (01=Capt, 02=F/O) EADI disagrees with decision height reference indicator. Operation normal with alternate EFI selected. 2. Replace the applicable Symbol Generator, M148 (left) or M150 (right) (AMM 34-22-01/401)
34 33 07 --	<ol style="list-style-type: none"> 1. Decision height alert altitude on (01=Capt, 02=F/O) EADI disagrees with decision height reference indicator. Condition remains the same with alternate EFI selected. 2. Replace the applicable EFIS control panel, M94 (left) or M93 (right) (AMM 34-22-02/201)
34 33 08 --	<ol style="list-style-type: none"> 1. Rad alt display on (01=Capt, 02=F/O) EADI blank below 2500 feet AGL. 2. Replace the applicable Symbol Generator, M148 (left) or M150 (right) (AMM 34-22-01/401).
34 33 09 --	<ol style="list-style-type: none"> 1. (Selected decision height not displayed, "DH" not displayed, display color incorrect, etc) on (01=Capt, 02=F/O) EADI for rad alt above decision height.
34 33 10 --	<ol style="list-style-type: none"> 1. Selected decision height not removed from display, "DH" did not enlarge/flash/change color, etc on (01=Capt, 02=F/O) EADI at decision height. 2. Replace the applicable Symbol Generator, M148 (left) or M150 (right) (AMM 34-22-01/401).
34 33 11 --	<ol style="list-style-type: none"> 1. Radio altitude height on the (01=Capt, 02=F/O) EADI is (inaccurate, intermittent). (State amount of inaccuracy, if known.) 2. FIM 34-33-00/101, Fig. 103, Block 1
34 33 12 --	<ol style="list-style-type: none"> 1. Decision height display on the (01=Capt, 02=F/O) EADI did not reset (automatically, etc). 2. Replace the applicable Symbol Generator, M148 (left) or M150 (right) (AMM 34-22-01/401).
34 33 13 --	<ol style="list-style-type: none"> 1. RA flag displayed (steady, intermittent) on the (01=Capt, 02=F/O) EADI. 2. FIM 34-33-00/101, Fig. 104, Block 1

EFFECTIVITY

ALL

34-FAULT CODE INDEX

BOEING
 757
 FAULT ISOLATION/MAINT MANUAL

FAULT CODE	1. LOG BOOK REPORT 2. FAULT ISOLATION REFERENCE
34 33 14 --	1. DH flag displayed on the (01=Capt, 02=F/O) EADI. 2. FIM 34-33-00/101, Fig. 105, Block 1
34 33 15 --	Not Used
34 33 16 --	Not Used
34 33 17 --	Not Used
34 33 18 --	34 33 18 -- thru 34 33 22 -- Not Used
34 33 23 --	1. (01=Capt, 02=F/O) Decision height reference indicator has missing segment(s). 2. Replace the L (R) EFIS control panel M94 (M93) (AMM 34-22-02).
34 33 24 01	1. On ground, Capt Radio alt rides to _____ and sounds GPWS. 2. Replace the applicable Radio Altimeter, M202 (left) or M203 (right) (AMM 34-33-01/401).
34 43 01 00	1. WXR FAIL displayed on EHSIs and WXR test displays WXR FAIL WEAK. 2. FIM 34-43-00/101, Fig. 103, Block 1
34 43 02 00	1. WXR FAIL displayed on EHSI and WXR test displays WXR FAIL STAB. 2. FIM 34-43-00/101, Fig. 103, Block 1
34 43 03 00	1. WXR FAIL displayed on HSI WXR SELF TEST not attempted. 2. FIM 34-43-00/101, Fig. 103, Block 1
34 43 04 00	Not used.
34 43 05 00	1. WXR FAIL displayed on EHSI. WXR SELF TEST displays WXR FAIL RT. 2. FIM 34-43-00/101, Fig. 103, Block 1
34 43 06 00	1. WXR FAIL displayed on EHSI. WXR SELF TEST displays WXR FAIL ANT. 2. FIM 34-43-00/101, Fig. 103, Block 1
34 43 07 00	1. WXR FAIL displayed on EHSI. WXR SELF TEST displays WXR FAIL CONT. 2. FIM 34-43-00/101, Fig. 103, Block 1

EFFECTIVITY

ALL

34-FAULT CODE INDEX

BOEING
 757
 FAULT ISOLATION/MAINT MANUAL

FAULT CODE	1. LOG BOOK REPORT 2. FAULT ISOLATION REFERENCE
34 43 08 --	1. WXR RANGE DISAGREE displayed on (01=CAPT, 02=F/O, 03=BOTH) EHSI(s). 2. FIM 34-43-00/101, Fig. 103, Block 1
34 43 09 --	1. WXR/MAP RANGE DISAGREE displayed on (01=CAPT, 02=F/O, 03=BOTH) EHSI(s). 2. Replace the applicable EFIS control panel, M94 (captain) or M93 (F/O) as necessary (AMM 34-22-02/201)
34 43 10 --	1. WXR DSPY displayed on (01=Capt, 02=F/O, 03=Capt and F/O) EHSI(s). (How often and number of times did it occur.) 2. FIM 34-22-00/101, Fig. 106, Block 1
34 43 11 --	1. (01=CAPT, 02=F/O, 03=CAPT & F/O) weather radar switch does not (activate, deactivate) radar. 2. FIM 34-43-00/101, Fig. 103, Block 1
34 43 12 --	Not Used
34 43 13 00	1. Antenna tilt operation is not normal. (Describe condition.) 2. FIM 34-43-00/101, Fig. 103, Block 1
34 43 14 00	Not Used
34 43 15 --	Not Used
34 43 16 --	Not Used
34 43 17 00	1. Weather radar mode switch (Test, WX, WX/TURB, MAP) (describe fault: inop, etc). 2. FIM 34-43-00/101, Fig. 103, Block 1
34 43 18 --	Not Used
34 43 19 00	1. Gain Control (inoperative, operation not normal). (Describe condition if operation not normal). 2. FIM 34-43-00/101, Fig. 103, Block 1
34 43 20 --	Not Used
34 43 21 00	1. WXR ATT displayed on both EHSIs. WXR test displays WXR FAIL ATT on EHSI. 2. FIM 34-43-00/101, Fig. 103, Block 1

EFFECTIVITY

ALL

34-FAULT CODE INDEX

25

Page 45
Sep 28/02

BOEING
 757
 FAULT ISOLATION/MAINT MANUAL

FAULT CODE	1. LOG BOOK REPORT 2. FAULT ISOLATION REFERENCE
34 43 22 --	34 43 22 -- thru 34 43 38 -- Not Used
34 43 39 00	1. WXR FAIL displayed on EHSI. WXR TEST inop. 2. FIM 34-43-00/101, Fig. 103, Block 1
34 43 40 --	34 43 40 -- thru 34 43 46 -- Not Used
34 43 47 00	1. Spoking present on WXR display. 2. FIM 34-43-00/101, Fig. 103, Block 1
34 43 48 --	Not Used
34 43 49 00	1. Sweep (describe fault: missing, sticks, etc) on WXR display. 2. FIM 34-43-00/101, Fig. 103, Block 1
34 43 50 00	Not Used
34 43 51 00	1. Returns (describe fault: fixed, noisy, false, etc) on WXR display. 2. FIM 34-43-00/101, Fig. 103, Block 1
34 43 52 00	Not Used
34 43 53 00	1. Precip intensity too (strong, weak) on WXR display. 2. FIM 34-43-00/101, Fig. 103, Block 1
34 43 54 --	Not Used
34 43 55 00	1. WXR display missing from HSI. 2. FIM 34-43-00/101, Fig. 103, Block 1
34 43 56 --	34 43 56 -- thru 34 43 65 -- Not Used

EFFECTIVITY

ALL

34-FAULT CODE INDEX

BOEING
 757
 FAULT ISOLATION/MAINT MANUAL

FAULT CODE	1. LOG BOOK REPORT 2. FAULT ISOLATION REFERENCE
34 43 65 00	1. WXR failed to test. WXR TEST message did not display on HSI. 2. FIM 34-43-00/101, Fig. 103, Block 1
34 43 67 00	1. WXR WEAK displayed on HSI. 2. Replace the WXR XCVR, M213 (AMM 34-43-01/401)
34 43 68 00	1. WXR WEAK displayed on HSI. WXR test not attempted. 2. FIM 34-43-00/101, Fig. 103, Block 1
34 43 69 00	1. WXR WEAK displayed on HSI. WXR test displays WXR FAIL RT. 2. FIM 34-43-00/101, Fig. 103, Block 1
34 43 70 00	1. WXR WEAK displayed on HSI. WXR test displays WXR FAIL ANT. 2. FIM 34-43-00/101, Fig. 103, Block 1
34 43 71 00	1. WXR STAB displayed on HSI. 2. FIM 34-43-00/101, Fig.103, Block 1.
34 43 72 00	1. WXR STAB displayed on HSI. WXR test not attempted. 2. FIM 34-43-00/101, Fig. 103, Block 1
34 43 73 00	1. WXR STAB displayed on HSI. WXR test displays WXR FAIL RT. 2. FIM 34-43-00/101, Fig. 103, Block 1
34 43 74 00	1. WXR ATT displayed on HSI. 2. FIM 34-43-00/101, Fig. 103, Block 1
34 43 75 00	1. WXR ATT displayed on HSI. WXR test not attempted. 2. FIM 34-43-00/101, Fig. 103, Block 1

EFFECTIVITY

ALL

34-FAULT CODE INDEX

BOEING
 757
 FAULT ISOLATION/MAINT MANUAL

FAULT CODE	1. LOG BOOK REPORT 2. FAULT ISOLATION REFERENCE
34 43 76 --	1. (01=Capt, 02=F/O, 03=Capt & F/O) weather radar switch doesn't activate radar. WXR DSPY message is on HSI. 2. FIM 34-43-00/101, Fig. 103, Block 1
34 45 01 00	1. TCAS voice annunciations (inoperative, inappropriate). Display on HSI/ADI normal. 2. FIM 34-45-00/101, Fig. 104, Block 1.
34 45 02 00	1. TCAS FAIL message displayed on HSI. 2. FIM 34-45-00/101, Fig. 103, Block 1. 3. If the problem persists, perform a BITE test on the appropriate Air Data Computer (ADC) to verify a possible TAT probe element failure, (AMM 34-12-00/501).
34 45 03 00	1. TCAS display blank on both CAPT & F/O HSI/ADI when selected. 2. FIM 34-45-00/101, Fig. 103, Block 1.
34 45 04 __	1. TCAS display blank on (01=CAPT, 02=F/O) HSI/ADI when selected. 2. Replace the left EFIS symbol generator, M148 (left) or M150 (right) (AMM 34-22-01/401).
34 45 05 00	1. TCAS display (describe abnormal display) on both CAPT & F/O HSI/ADI when selected. 2. FIM 34-45-00/101, Fig. 103, Block 1.
34 45 06 __	1. TCAS display (describe abnormal display) on(01=CAPT, 02=F/O) HSI/ADI when selected. 2. Replace the left or right EFIS symbol generator, M148 (left) or M150 (right) (AMM 34-22-01/401).
34 45 15 00	1. The EICAS message, TCAS displayed. 2. FIM 34-45-00/101, Figure 103, Block 1.
34 46 01 00	1. GND PROX BITE status message displayed on EICAS. 2. FIM 34-46-00/101, Fig. 103, Block 1
34 46 02 00	1. The (PULL UP, GND PROX, WINDSHEAR) lgt did not illuminate when (specify alert condition) existed. 2. FIM 34-46-00/101, Fig. 104, Block 1
34 46 03 00	1. The aural message for (specify alert condition) was not announced. 2. FIM 34-46-00/101, Fig. 104, Block 1

EFFECTIVITY

ALL

34-FAULT CODE INDEX



BOEING
757
FAULT ISOLATION/MAINT MANUAL

FAULT CODE	1. LOG BOOK REPORT 2. FAULT ISOLATION REFERENCE
34 46 04 00	1. A Gnd Prox alert was received with no alert condition (state sink rate, radio altitude, landing or ascending, gear and flap state, if known). 2. FIM 34-46-00/101, Fig. 103, Block 1
34 46 05 00	1. A PULL UP alert was received with no alert condition (state sink rate, radio altitude, landing or ascending, gear and flap state, if known). Radio Altitude indication was normal. 2. FIM 34-46-00/101, Fig. 103, Block 1
34 46 06 00	1. A (gnd prox, PULL UP) alert was not received when (specify alert condition) existed. 2. FIM 34-46-00/101, Fig. 103, Block 1
34 46 07 00	1. EICAS msg GND PROX BITE was not displayed on STATUS page during GND PROX test. 2. FIM 34-46-00/101, Fig. 103, Block 1
34 46 08 00	1. PULL UP light did not illuminate during GND PROX test. 2. Replace the ground proximity warning computer, (M147) (AMM 34-46-01/401)
34 46 09 00	1. GND PROX light did not illuminate during GND PROX test. 2. Replace the ground proximity warning computer, M147 (AMM 34-46-01/401)
34 46 10 00	1. The (sink rate, whoop-whoop pull up, terrain, don't sink, too low gear, too low flaps, too low terrain, glideslope, windshear) aural message(s) was not announced during test. (State whether test switch was momentarily positioned to GND PROX or held there for more than 5 seconds.) 2. FIM 34-46-00/101, Fig. 104, Block 1
34 46 11 00	1. The ground proximity warning system failed to test. 2. FIM 34-46-00/101, Fig. 104, Block 1
34 46 12 00	1. GND PROX/CONFIG GEAR OVRD switch did not inhibit (T00 LOW TERRAIN, T00 LOW GEAR) ground prox alerts. 2. FIM 34-46-00/101, Fig. 103, Block 1
34 46 13 00	1. The GND PROX FLAP OVRD sw did not inhibit (T00 LOW TERRAIN, T00 LOW FLAP) ground prox alerts. 2. FIM 34-46-00/101, Fig. 103, Block 1

EFFECTIVITY

ALL

34-FAULT CODE INDEX

25

Page 49
May 28/02

BOEING
 757
 FAULT ISOLATION/MAINT MANUAL

FAULT CODE	1. LOG BOOK REPORT 2. FAULT ISOLATION REFERENCE
34 46 14 00	1. The G/S INHB sw did not inhibit the G/S alert. 2. FIM 34-46-00/101, Fig. 103, Block 1
34 46 15 00	1. EICAS msg GND PROX BITE displayed (Ref Chapter 31 for fault code diagram). 2. FIM 34-46-00/101, Fig. 103, Block 1
34 46 16 00	1. WINDSHEAR alert was received with no alert condition. 2. FIM 34-46-00/101, Fig. 104, Block 1
34 46 17 00	1. WINDSHEAR did not illum during gnd prox test. 2. FIM 34-46-00/101, Fig. 104, Block 1
34 46 18 00	1. Voice Altitude callouts too loud 2. FIM 34-46-00/101, Fig. 103, Block 1
34 46 20 00	1. The EICAS message GND PROX SYS displayed. 2. FIM 34-46-00/101, Fig. 103
34 51 01 --	1. (03=L, 04=R) VOR course indicator on glareshield does not respond properly to selector operation. 2. Replace the applicable VOR control panel, M91 (left) or M92 (right) as necessary.
34 51 02 --	1. (03=L, 04=R) VOR FREQ (stuck, inaccurate, etc) during manual tuning. HSI and RDMI indications are normal. 2. FIM 34-51-00/101, Fig. 108, Block 1
34 51 03 --	1. (01=Capt, 02=F/O) HSI has VOR flag in view. RDMI VOR bearing needles are normal. 2. FIM 34-51-00/101, Fig. 106, Block 1
34 51 04 --	1. (01=Capt, 02=F/O) HSI has course pointer, line and dev bar missing. RDMI VOR bearing needles are normal. 2. Replace the applicable VOR control panel, M91 (left) or M92 (right) as necessary.
34 51 05 --	1. Unable to select (L, R) VOR with VOR/ADF selector on (01=Capt, 02=F/O) RDMI. 2. Replace the applicable RDMI, N3 (left) or N43 (right) as necessary (AMM 34-22-05/401).
34 51 06 --	1. (L, R) VOR flag in view on (01=Capt, 02=F/O) RDMI. The associated HSI VOR indication are normal. HSI is in VOR mode. 2. Replace the applicable RDMI, N3 (left) or N43 (right) as necessary (AMM 34-22-05/401).

EFFECTIVITY

ALL

34-FAULT CODE INDEX

BOEING
 757
 FAULT ISOLATION/MAINT MANUAL

FAULT CODE	1. LOG BOOK REPORT 2. FAULT ISOLATION REFERENCE
34 51 07 --	1. (03=L, 04=R) VOR flag in view on both RDMI's. The associated HSI has VOR flag in view when the HSI is in VOR mode. 2. FIM 34-51-00/101, Fig. 107, Block 1
34 51 08 --	1. (03=L, 04=R) VOR flag in view on both RMI's. The associated HSI has the lateral dev bar missing when the HSI is in VOR mode. The freq display on the VOR is normal. 2. FIM 34-51-00/101, Fig. 109, Block 1
34 51 09 --	1. (03=L, 04=R) VOR freq (stuck, inaccurate, etc) during manual tuning, VOR flags were in view. 2. FIM 34-51-00/101, Fig. 104, Block 1
34 51 10 --	1. (03=L, 04=R) VOR flag in view on both RDMI's. The associated HSI has course pointer, line and dev bar missing. 2. Replace the applicable VOR control panel, M91 (left) or M92 (right) as necessary.
34 51 11 --	1. VOR radial not displayed on (01=Capt, 02=F/O, 05=Both) HSI's with HSI in map and manual tuning selected. 2. Replace the applicable VOR control panel, M91 (left) or M92 (right) as necessary.
34 51 12 --	1. Auto/Man switch inop on (03=L, 04=R) VOR with HSI on map mode. 2. Replace the applicable VOR control panel, M91 (left) or M92 (right) as necessary.
34 51 13 --	1. (03=L, 04=R, 05=Both) BRG flags in view on both RDMI's with HSI's in MAP. VOR's are normal with HSI's in VOR mode. 2. FIM 34-51-00/101, Fig. 105, Block 1
34 51 14 --	1. (L, R) VOR ident not received at (01=Capt, 02=F/O, 03=obs) station. Other crew stations OK. 2. Replace the applicable audio select panel, M70 (captain), M71 (F/O), or M98 (1st Obs) (AMM 23-51-01/401).
34 51 15 --	1. (04=L, 05=R) VOR ident not received at any crew station. 2. Replace the applicable VOR receiver, M186 (left) or M187 (right) as necessary (AMM 34-51-01/401).
34 51 16 --	1. (L, R) VOR bearing points on (01=CAPT, 02=F/O) RDMI (describe fault, sticks, inop, etc). 2. Replace the applicable RDMI, N3 (left) or N43 (right) as necessary (AMM 34-22-05/401).

EFFECTIVITY

ALL

34-FAULT CODE INDEX

BOEING
 757
 FAULT ISOLATION/MAINT MANUAL

FAULT CODE	1. LOG BOOK REPORT 2. FAULT ISOLATION REFERENCE
34 51 17 --	1. (03=L, 04=R, 05=Both) VOR(s) will not autotune. 2. FIM 34-51-00/101, Fig. 105, Block 1
34 51 18 --	1. (03=L, 04=R) VOR course indicator on glareshield has missing segment. 2. Replace the applicable VOR control panel, M91 (left) or M92 (right).
34 51 19 --	1. (03=L, 04=R) VOR FREQ indicator on glareshield has missing segment. 2. Replace the applicable VOR control panel, M91 (left) or M92 (right).
34 51 20 --	1. (03=L, 04=R) VOR inop, no display on VOR/DME control panel. 2. FIM 34-51-00/101, Fig. 103, Block 1
34 51 21 --	1. (03=L, 04=R) VOR auto/manual select SW (light(s) inop, sticks, loose, etc). 2. Replace the applicable VOR control panel, M91 (left) or M92 (right).
34 53 01 00	1. ATC code indicator does not respond to selector movement. 2. Replace the dual ATC control panel, M10140 (AMM 34-53-02/401).
34 53 02 --	1. ATC altitude reporting inoperative with the (01=L or 1, 02=R or 2, 03=both L & R or 1 & 2) transponder(s) selected. 2. FIM 34-53-00/101, Fig. 104, Block 1.
34 53 03 --	1. ATC transmission (weak, intermittent, etc) with the (01=L or 1 02=R or 2, 03=both L & R or 1 & 2) transponder selected. 2. FIM 34-53-00/101, Fig. 105, Block 1.
34 53 04 --	1. Reported no ATC transmission with the (01=L or 1, 02=R or 2, 03=both L & R or 1 & 2) transponder(s) selected. 2. FIM 34-53-00/101, Fig. 105, Block 1
34 53 05 00	1. Reported no ATC transmission with either transponder selected. 2. FIM 34-53-00/101, Fig. 105, Block 1
34 53 06 00	1. Reported transmitted code disagrees with the ATC code indicator with either transponder selected. 2. Replace the dual ATC control panel, M10140 (AMM 34-53-02/401).

EFFECTIVITY

ALL

34-FAULT CODE INDEX

FAULT CODE	1. LOG BOOK REPORT 2. FAULT ISOLATION REFERENCE
34 53 07 --	1. EICAS message ATC fault displayed (and ATC FAIL light illuminated) with the (01=L or 1, 02=R or 2) transponder selected. Transponder reported inop. 2. FIM 34-53-00/101, Fig. 103, Block 1.
34 53 08 --	1. ATC identification inop with (01=L or 1, 02=R or 2, 03=both L & R or 1 & 2) transponder(s) selected. 2. Replace the dual ATC control panel, M10140 (AMM 34-53-02/401).
34 53 09 --	1. EICAS message ATC fault displayed (and ATC FAULT light illuminated) with the (01=L or 1, 02=R or 2) transponder selected. Transponder reported normal. 2. FIM 34-53-00/101, Fig. 103, Block 1
34 53 10 00	1. ATC code indicator has missing segment. 2. Replace the ATC control panel, M10140 (AMM 34-53-02/401).
34 53 11 --	1. (01=L or 1, 02= R or 2) ATC code indicator blank and was reported as inop. 2. Replace the dual ATC control panel, M10140 (AMM 34-53-02/401).
34 55 01 --	1. DME identification signal not received on the (03=L, 04=R) receiver. The corresponding DME displays are normal. (VOR, ILS) ident is also normal. 2. FIM 34-55-00/101, Fig. 109, Block 1
34 55 02 --	1. (01=Capt, 02=F/O) (L, R) RDMI DME display is blank. The EHSI DME display is OK. 2. Replace the applicable RDMI, N3 (left) or N43 (right) (AMM 34-22-05/401).
34 55 03 --	1. (01=Capt, 02=F/O)(L,R) EHSI DME display is blank. The RDMI DME is OK. 2. FIM 34-55-00/101, Fig. 106, Block 1
34 55 04 --	1. The RDMI (DME indicator) and EHSI DME displays are blank for the (03=L, 04=R) DME. 2. FIM 34-55-00/101, Fig. 107, Block 1
34 55 05 --	1. The RDMI (DME indicator) and EHSI DME displays are dashes for the (03=L, 04=R) DME. VOR ident OK. 2. FIM 34-55-00/101, Fig. 104, Block 1
34 55 06 --	1. The RDMI (DME indicator) and EHSI DME displays are dashes for the (03=L, 04=R) DME. ILS Ident OK. 2. FIM 34-55-00/101, Fig. 105, Block 1

EFFECTIVITY

ALL

34-FAULT CODE INDEX

BOEING
 757
 FAULT ISOLATION/MAINT MANUAL

FAULT CODE	1. LOG BOOK REPORT 2. FAULT ISOLATION REFERENCE
34 55 07 --	1. The RDMI (DME indicator) and EHSI DME displays are dashes for the (03=L,04=R) DME. (VOR, ILS) ident not received. A usable DME signal is present. 2. FIM 34-55-00/101, Fig. 103, Block 1
34 55 08 --	1. The RDMI (DME indicator) DME display for the (03=L,04=R,05=both) DME(s) is dashes with the EHSI in MAP or PLAN mode. 2. FIM 34-55-00/101, Fig. 108, Block 1
34 55 09 --	1. The RDMI (DME indicator) and EHSI DME distance is incorrect on the (01=CAPT, 02=F/O) side with the EHSI in ILS mode. 2. FIM 34-55-00/101, Fig. 103, Block 1
34 55 10 --	1. (01=Capt, 02=F/O) (L, R) RDMI (DME indicator) DME has missing (number, segment). 2. Replace the applicable RDMI, N3 (left) or N43 (right) (AMM 34-22-05/401).
34 57 01 --	1. Unable to select ADF with the (L, R) RDMI ADF/VOR selector on the (01=Capt, 02=F/O) RDMI. Warning flags are retracted. VOR operation normal. 2. Replace the applicable RDMI, N3 (left) or N43 (right) as necessary (AMM 34-22-05/401).
34 57 02 00	Not Used
34 57 03 --	1. ADF tone inoperative in (03=L, 04=R) position. 2. FIM 34-57-00/101, Fig. 103, Block 1
34 57 04 --	Not Used
34 57 05 --	1. (03=Left, 04=Right) ADF frequency indicator does not respond properly to selector operation. (Identify digits) 2. Replace the ADF control panel, M1046 (AMM 34-57-02/401).
34 57 07 --	1. During ADF operation, (L, R) bearing pointer failure flag in view in the (01=Capt, 02=F/O) RDMI with mode selector positioned to ADF. Operation of the other RDMI is normal. Identification signal reception also normal. 2. Replace the applicable RDMI, N3 (left) or N43 (right) (AMM 34-22-05/401).

EFFECTIVITY

ALL

34-FAULT CODE INDEX

BOEING
 757
 FAULT ISOLATION/MAINT MANUAL

FAULT CODE	1. LOG BOOK REPORT 2. FAULT ISOLATION REFERENCE
34 57 08 --	1. During ADF operation both (04=L, 05=R) bearing pointer failure flags continuously in view with mode selector positioned to ADF. 2. FIM 34-57-00/101, Fig. 104, Block 1
34 57 09 --	1. ADF audio (describe fault) at either crew station using (04=L, 05=R) receiver with mode selector positioned to ANT. RDMI bearing pointer operation normal. 2. FIM 34-57-00/101, Fig. 103, Block 1
34 57 10 --	1. During ADF operation, (L, R) bearing pointer failure flag retracted in the (01=Capt, 02=F/O) RMDI with mode selector positioned to ANT. Operation of the other RDMI is normal. Identification signal reception also normal. 2. Replace the applicable RDMI, N3 (left) or (right) as necessary (AMM 34-22-05/401).
34 57 11 --	1. During ADF operation, (04=L, 05=R) both bearing pointer failure flags retracted with mode selector positioned to ANT. Identification signal reception normal. 2. Replace the ADF control panel, M1046 (AMM 34-57-02/401).
34 57 12 --	1. (L, R) ADF audio (describe fault) at (01=Capt, 02=F/O, 03=1st Obs) crew station with mode selector positioned to ADF. 2. FIM 34-57-00/101, Fig. 103, Block 1
34 57 13 --	1. (L, R) ADF audio (describe fault) at (01=Capt, 02=F/O, 03=0bs) crew station with mode selector positioned to ANT. 2. FIM 34-57-00/101, Fig. 103, Block 1
34 57 14 --	Not used.
34 57 15 00	Not Used
34 57 16 --	1. (03=L, 04=R) ADF frequency indicator has segment missing. 2. Replace the ADF control panel, M1046 (AMM 34-57-02/401).

EFFECTIVITY

ALL

34-FAULT CODE INDEX

21.101

Page 55
Jan 20/09

BOEING
 757
 FAULT ISOLATION/MAINT MANUAL

FAULT CODE	1. LOG BOOK REPORT 2. FAULT ISOLATION REFERENCE
34 57 17 --	1. (03=L, 04=R) ADF fails test. (Describe.) 2. Replace the applicable ADF receiver, M215 (left) or M216 (right) (AMM 34-57-01/401).
34 57 18 --	1. (04=L, 05=R) ADF pointer (does not point properly, INOP, etc.). Audio is normal. 2. Replace the applicable RDMI, N3 (left) or N43 (right) (AMM 34-22-05/401).
34 57 19 --	1. (04=L, 05=R) ADF pointer (does not point properly, INOP, etc.). Audio is (describe fault). 2. FIM 34-57-00/101, Fig. 104, Block 1
34 57 20 --	1. (01=Capt, 02=F/O) (wide, narrow) RDMI pointer is (inop, stuck, etc) in ADF and VOR position. 2. Replace the applicable RDMI, N3 (left) or N43 (right) as necessary (AMM 34-22-05/401).
34 57 27 --	1. (03=L, 04=R) ADF fails test. (Describe.) 2. Replace the applicable ADF receiver, M215 (left) or M216 (right) (AMM 34-57-01/401).
34 61 01 --	34 61 01 thru 34 61 14 Not Used
34 61 15 --	1. (01=Capt, 02=F/O) CDU display is (describe fault, e.g., out of focus, blinking, small, etc). 2. Replace the FMC CDU, M76 (left) or M77 (right) (AMM 34-61-02/201).
34 61 16 --	1. (01=Capt, 02=F/O) CDU display blank. Selecting ALTN FMC does not correct the fault. 2. Replace the FMC CDU, M76 (left) or M77 (right) (AMM 34-61-02).
34 61 17 --	1. EICAS msg (03=L, 04=R) FMC FAIL displayed. 2. FIM 34-61-00/101, Fig. 108B
34 61 18 --	1. EICAS msg (03=L, 04=R) FMC FAIL displayed. Other CDU displays RESYNCING SINGLE FMC msg. 2. FIM 34-61-00/101, Fig. 108B

EFFECTIVITY

ALL

34-FAULT CODE INDEX

23.1

Page 56
Jan 20/09

BOEING
 757
 FAULT ISOLATION/MAINT MANUAL

FAULT CODE	1. LOG BOOK REPORT 2. FAULT ISOLATION REFERENCE
34 61 19 --	Not Used
34 61 20 --	Not Used
34 61 21 --	1. Manual brightness control is INOP on (01=Capt, 02=F/0) CDU. 2. Replace the FMC CDU M76 (left) or M77 (right) (AMM 34-61-02/201).
34 61 22 --	1. Automatic brightness control is INOP on (01=Capt, 02=F/0) CDU. 2. Replace the FMC CDU M76 (left) or M77 (right) (AMM 34-61-02/201).
34 61 23 --	1. Manual and automatic brightness controls are INOP on (01=Capt, 02=F/0) CDU. 2. Replace the FMC CDU, M76 (left) or M77 (right) (AMM 34-61-02/201).
34 61 24 --	34 61 24 -- thru 34 61 26 -- Not Used
34 61 27 --	1. Nav data incorrect on (01=Capt, 02=F/0, 03=Both) CDU IDENT page(s). 2. FIM 34-61-00/101, Fig. 106, Block 10
34 61 28 --	1. (State data, e.g., drag factor, F-F factor, op program, etc) is incorrect on (01=Capt, 02=F/0, 03=Both) CDU IDENT page(s). 2. FIM 34-61-00/101, Fig. 106, Block 1
34 61 29 --	34 61 29 -- thru 34 61 31 -- Not Used

EFFECTIVITY

ALL

34-FAULT CODE INDEX

BOEING
 757
 FAULT ISOLATION/MAINT MANUAL

FAULT CODE	1. LOG BOOK REPORT 2. FAULT ISOLATION REFERENCE
34 61 32 --	1. IRS position entry from (01=Capt, 02=F/O) CDU results in REENTER IRS POS on scratch pad. Message would not clear after position reentered. 2. FIM 34-61-00/101, Fig. 104, Block 1
34 61 33 --	34 61 33 -- thru 34 61 36 -- Not Used
34 61 37 --	1. FMC MESSAGE on EICAS and PERF/VNAV UNAVAILABLE displayed on (01=Capt, 02=F/O, 03=Both) CDU(s) when VNAV button pressed. Data was entered in all boxes on PERF UNIT page. 2. FIM 34-61-00/101, Fig. 110, Block 1
34 61 38 --	34 61 38 -- thru 34 61 71 -- Not Used
34 61 72 --	1. BRG/DIS FR incorrect on (01=Capt, 02=F/O, 03=Both) FIX INFO page(s). 2. FIM 34-61-00/101, Fig. 104, Block 1
34 61 73 --	1. PL/BRG/DIS incorrect on (01=Capt, 02=F/O, 03=Both) FIX INFO page(s). 2. FIM 34-61-00/101, Fig. 104, Block 1
34 61 74 --	1. ABEAM incorrect on (01=Capt, 02=F/O, 03=Both) FIX INFO page(s). 2. FIM 34-61-00/101, Fig. 104, Block 1
34 61 75 --	1. DTG incorrect on (01=Capt, 02=F/O, 03=Both) FIX INFO page(s). 2. FIM 34-61-00/101, Fig. 104, Block 1

EFFECTIVITY

ALL

34-FAULT CODE INDEX

BOEING
 757
 FAULT ISOLATION/MAINT MANUAL

FAULT CODE	1. LOG BOOK REPORT 2. FAULT ISOLATION REFERENCE
34 61 77 --	Not Used
34 61 78 --	1. GS field blank on (01=Capt, 02=F/0, 03=Both) CDU POS REF page. 2. Close the applicable IRU circuit breaker. Cycle the FMC circuit breaker from the open to closed position. If the problem continues do the IRS BITE procedure when (RMM 34-03).
34 61 79 --	34 61 79 -- thru 34 61 99 -- Not Used
34 62 01 --	34 62 01 -- thru 34 62 11 -- Not Used
34 62 12 --	1. Wind components in error on PROGRESS page 2 on (01=Capt, 02=F/0, 03=both) CDU(s). 2. FIM 34-61-00/101, Fig. 104, Block 1
34 62 13 --	1. FUEL USED (in error, blank) on PROGRESS page 2 on (01=Capt, 02=F/0, 03=both) CDU(s). 2. FIM 34-61-00/101, Fig. 105, Block 1
34 62 14 --	1. FUEL (QTY ERROR, DISAGREE)-PROG 2/2 alert message is displayed on CDU. TOTALIZER differs from CALCULATED on PROGRESS page 2 of (01=Capt, 02=F/0, 03=both) CDU(s). 2. FIM 34-61-00/101, Fig. 105, Block 1
34 62 15 --	1. FMC will not enter the IRS (3) DME DME mode. PROGRESS page 1 indicates (IRS (2) DME DME, IRS (3) DME VOR, etc) on the (01=Capt, 02=F/0, 03=Both) CDU(s). 2. FIM 34-61-00/101, Fig. 104, Block 1

EFFECTIVITY

ALL

34-FAULT CODE INDEX

BOEING
 757
 FAULT ISOLATION/MAINT MANUAL

FAULT CODE	1. LOG BOOK REPORT 2. FAULT ISOLATION REFERENCE
34 62 16 --	1. DTG in error on PROGRESS page 1 of (01=Capt, 02=F/0, 03=both) CDU(s). 2. FIM 34-61-00/101, Fig. 104, Block 1
34 62 17 --	1. ETA in error on PROGRESS page 1 of (01=Capt, 02=F/0, 03=both) CDU(s). 2. FIM 34-61-00/101, Fig. 104, Block 1
34 62 18 --	1. Waypoint FUEL in error on PROGRESS page 1 of (01=Capt, 02=F/0, 03=both) CDU(s). 2. FIM 34-61-00/101, Fig. 105, Block 1
34 62 19 --	1. Wind in error on PROGRESS page 1 of (01=Capt, 02=F/0, 03=both) CDU(s). 2. FIM 34-61-00/101, Fig. 104, Block 1
34 62 20	Not Used
34 62 21 --	1. MSG light fails to illuminate with CDU advisories on (01=Capt, 02=F/0, 03=both) CDU(s). 2. Replace the applicable FMC CDU, M76 (left) or M77 (right) (AMM 34-61-02/201).
34 62 22 00	1. (NOT IN DATA BASE, REENTER IRS POSITION, MAX ALT FLXXX, etc) advisory message displayed when the advisory condition does not exist. 2. Replace the applicable FMC M134 (left) or M135 (right) (AMM 34-61-01/401).
34 62 23 00	1. The following advisory condition exists and no advisory message was received: (describe advisory condition). 2. Replace the applicable FMC, M134 (left) or M135 (right) (AMM 34-61-01/401).

EFFECTIVITY

ALL

34-FAULT CODE INDEX

20

Page 60
Sep 28/02

BOEING
 757
 FAULT ISOLATION/MAINT MANUAL

FAULT CODE	1. LOG BOOK REPORT 2. FAULT ISOLATION REFERENCE
34 62 24 --	1. The FMC light fails to illuminate with CDU alert on (01=Capt, 02=F/O, 03=Both) CDU. 2. (01=Capt, 02=F/O)FIM 34-61-00/101, Fig. 107, Block 1 (03=Both) FIM 34-61-00/101, Fig. 107, Block 11
34 62 25 --	1. The FMC light, CAUTION light, and MSG light fail to illuminate with CDU alerts on (01=Capt, 02=F/O, 03=both) CDU(s). 2. Replace the applicable FMC, M134 (left) or M135 (right) (AMM 34-61-01/401).
34 62 26 00	1. (IRS NAV ONLY, RW/ILS FREQ, END OF ROUTE, DISCONTINUITY, NO ACTIVE ROUTE, etc) alert messages displayed when the alert condition does not exist. 2. Replace the applicable FMC, M134 (left) or M135 (right) (AMM 34-61-01/401).
34 62 27 00	1. The following alert condition exists and no alert message was received: (describe alert condition). 2. Replace the applicable FMC, M134 (left) or M135 (right) (AMM 34-61-01/401).
34 62 28 --	1. VTK flag is in view on (01=Capt, 02=F/O) HSI. Selecting ALTN FMC corrects the fault. 2. Replace the applicable flight management computer, M134 (left) or M135 (right) (AMM 34-61-01/401).
34 62 29 --	Not Used
34 62 30 --	1. Map display is offset on (01=Capt, 02=F/O) HSI. Selecting ALTN FMC corrects the faults. 2. Replace the applicable flight management computer, M134 (left) or M135 (right) (AMM 34-61-01/401).

EFFECTIVITY

ALL

34-FAULT CODE INDEX

BOEING
 757
 FAULT ISOLATION/MAINT MANUAL

FAULT CODE	1. LOG BOOK REPORT 2. FAULT ISOLATION REFERENCE
34 62 31 --	1. Map is missing on (01=Capt, 02=F/0) HSI. Selecting ALTN FMC corrects the fault. 2. Replace the flight management computer M134 (left) or M135 (right) (AMM 34-61-01).
34 62 32 --	1. (01=Capt, 02=F/0) HSI displays MAP RANGE DISAGREE. Selecting ALTN FMC corrects the fault. 2. Replace the applicable flight management computer, M134 (left) or M134 (right) (AMM 34-61-01/401).
34 62 33 --	1. (01=Capt, 02=F/0) HSI displays MAP flag. Selecting ALTN FMC corrects the problem. 2. Replace the applicable flight management computer, M134 (left) or M135 (right) (AMM 34-61-01/401).
34 62 34 --	34 62 34 -- thru 34 62 37 -- Not Used
34 62 38 --	1. Distance to go and ETA are missing from (01=Capt, 02=F/0) HSI. Selecting ALTN FMC corrects the fault. 2. Replace the applicable flight management computer, M134 (left) or M135 (right) (AMM 34-61-01/401).
34 62 39 --	34 62 39 -- thru 34 62 42 -- Not Used
34 62 43 --	1. The airplane (describe problem: EPR, speed or path in error, loses fuel weight) in VNAV DESCENT mode. Fault occurs with (01=L, 02=C, 03=R, 04=any) A/P engaged. 2. FIM 34-61-00/101, Fig. 110, Block 1

EFFECTIVITY

ALL

34-FAULT CODE INDEX

BOEING
 757
 FAULT ISOLATION/MAINT MANUAL

FAULT CODE	1. LOG BOOK REPORT 2. FAULT ISOLATION REFERENCE
34 62 44 --	Not Used
34 62 45 --	Not Used
34 62 46 --	1. The airplane (describe problem: EPR, speed or path in error, loses fuel weight) in VNAV CRUISE mode. Fault occurs with (01=L, 02=C, 03=R, 04=Any) A/P engaged. 2. FIM 34-61-00/101, Fig. 110, Block 1
34 62 47 --	Not Used
34 62 48 --	Not Used
34 62 49 --	1. The airplane (describe problem: EPR, speed or path in error, loses fuel weight) in VNAV CLIMB mode. Fault occurs with (01=L, 02=C, 03=R, 04=Any) A/P engaged. 2. FIM 34-61-00/101, Fig. 110, Block 1
34 62 50 --	34 62 50 -- thru 34 62 59 -- Not Used
34 62 60 --	1. VTK flag is in view on (01=Capt, 02=F/O, 03=Both) HSI(s). Selecting ALTN FMC does not correct the fault. 2. Replace the applicable EFIS symbol generator, M148 (left), M149 (center), or M150 (right) (AMM 34-22-01/401).
34 62 61 --	Not Used
34 62 62 --	1. Map display is offset on (01=Capt, 02=F/O, 03=Both) HSI(s). Selecting ALTN FMC does not correct the fault. 2. Replace the applicable EFIS symbol generator, M148 (left), M149 (center), or M150 (right) (AMM 34-22-01/401).

EFFECTIVITY

ALL

34-FAULT CODE INDEX

BOEING
 757
 FAULT ISOLATION/MAINT MANUAL

FAULT CODE	1. LOG BOOK REPORT 2. FAULT ISOLATION REFERENCE
34 62 63 --	1. Map is missing on (01=Capt, 02=F/0, 03=Both) HSI(s). Selecting ALTN FMC does not correct the fault. 2. Replace the applicable EFIS symbol generator, M148 (left), M149 (center), or M150 (right) (AMM 34-22-01/401).
34 62 64 --	1. (01=Capt, 02=F/0, 03=Both) HSI(s) display MAP RANGE DISAGREE. Selecting ALTN FMC does not correct the fault. 2. FIM 34-61-00/101, Fig. 108, Block 1
34 62 65 --	1. (01=Capt, 02=F/0, 03=Both) HSI(s) display MAP flag. Selecting ALTN FMC does not correct the fault. 2. Replace the applicable EFIS symbol generator, M148 (left), M149 (center), or M150 (right) (AMM 34-22-01/401).
34 62 66 --	34 62 66 -- thru 34 62 69 -- Not Used
34 62 70 --	1. Distance to go and ETA are missing from (01=Capt, 02=F/0, 03=Both) HSI(s). Selecting ALTN FMC does not correct the fault. 2. Replace the applicable EFIS symbol generator, M148 (left), M149 (center), or M150 (right) (AMM 34-22-01/401).
34 62 71 --	34 62 71 -- thru 34 62 74 -- Not Used
34 62 75 --	1. (Specify key) key on (01=CAPT, 02=F/0) CDU gives multiple response. 2. Replace the applicable FMC CDU, M76 (left) or M77 (right) (AMM 34-61-02/201).

EFFECTIVITY

ALL

34-FAULT CODE INDEX

BOEING
 757
 FAULT ISOLATION/MAINT MANUAL

FAULT CODE	1. LOG BOOK REPORT 2. FAULT ISOLATION REFERENCE
34 62 76 --	1. (Specify key) key on (01=CAPT, 02=F/O) CDU feel is abnormal. 2. Replace the applicable FMC CDU, M76 (left) or M77 (right) (AMM 34-61-02/201).
34 62 77 --	1. All keys on (01=CAPT, 02=F/O) CDU inop. Selection of ALTN FMC corrects the fault. 2. Replace the applicable FMC, M134 (left) or M135 (right) (AMM 34-61-01/401).
34 62 78 --	1. All keys on (01=CAPT, 02=F/O) CDU inop with normal and ALTN FMC selected. 2. Replace the applicable FMC CDU, M76 (left) or M77 (right) (AMM 34-61-02/201).
34 62 79 --	34 62 79 -- thru 34 62 82 -- Not Used
34 62 83 --	1. EICAS msg (03=L, 04=R) FMC FAIL displayed. Other CDU displays SINGLE FMC OPERATION msg. 2. FIM 34-61-00/101, Fig. 108B
34 62 84 03	1. Both CDU's are locked up on IDENT page. 2. FIM 34-61-00/101, Fig. 109, Block 1
34 62 85 --	1. IRS NAV ONLY alert message displayed on (01=Capt, 02=F/O, 03=Both) CDU(s). 2. FIM 34-61-00/101, Fig. 104, Block 1
34 62 86 --	1. (01=CAPT, 02=F/O) CDU display is (describe fault, e.g.: partially complete or garbage). 2. Replace the applicable FMC CDU, M76 (left) or M77 (right) (AMM 34-61-02/201)
34 62 87 --	1. (Record number of resyncs) resyncs experienced in (record time period) in (01=Capt, 02=F/O) CDU. 2. FIM 34-61-00/101, Fig. 109, Block 1

EFFECTIVITY

ALL

34-FAULT CODE INDEX

BOEING
 757
 FAULT ISOLATION/MAINT MANUAL

FAULT CODE	1. LOG BOOK REPORT 2. FAULT ISOLATION REFERENCE
34 62 88 --	1. (01=Capt, 02=F/O) CDU display blank. Selecting ALTN FMC corrects the fault. 2. FIM 34-61-00/101, Fig. 109, Block 1
34 62 89 --	1. (Specify key) key on (01=CAPT, 02=F/O) CDU gives incorrect response. Selecting ALTN FMC corrects the fault. 2. Replace the applicable FMC, M134 (left) or M135 (right) (AMM 34-61-01/401)
34 62 90 --	1. (Specify key) key on (01=CAPT, 02=F/O) CDU gives incorrect response with normal and ALTN FMC selected. 2. Replace the applicable FMC CDU, M76 (left) or M77 (right) (AMM 34-61-02/201).
34 62 91 --	1. (Specify key) on (01=CAPT, 02=F/O) CDU inop on all pages. Selection of ALTN FMC corrects the fault. 2. Replace the applicable FMC, M134 (left) or M135 (right) (AMM 34-61-01/401)
34 62 92 --	1. (Specify key) on (01=CAPT, 02=F/O) CDU inop on all pages with normal and ALTN FMC selected. 2. Replace the applicable FMC CDU, M76 (left) or M77 (right) (AMM 34-61-02/201).
34 62 93 --	1. EXEC key on (01=CAPT, 02=F/O, 03=BOTH) CDU(s) fails to illum. 2. FIM 34-61-00/101, Fig. 103, Block 1
34 62 94 --	1. FMC resync takes longer than 30 secs in (01=Capt, 02=F/O) CDU. 2. FIM 34-61-00/101, Fig. 109, Block 1
34 62 95 --	1. Incorrect engine type displayed on (01=Capt, 02=F/O, 03=Both) CDU IDENT page(s). 2. Replace the applicable FMC, M134 (left) or M135 (right) (AMM 34-61-01/401).
34 62 96 00	1. FMC pos on CDU POS REF page 2/2 is in error (Record error). 2. FIM 34-61-00/101, Fig. 104, Block 1
34 62 97 --	1. (04=L, 05=C, 06=R) IRS pos on CDU POS REF page 2/2 is (4/4) in error (Record time IRS was in operation, actual and indicated latitude and longitude. Add note if IRS error was excessive for 2 consecutive flights). 2. FIM 34-21-00/101, Fig. 107A, Block 1

EFFECTIVITY

ALL

34-FAULT CODE INDEX

FAULT CODE	1. LOG BOOK REPORT 2. FAULT ISOLATION REFERENCE
34 62 98 --	1. No boxes are displayed for position initialization on (01=CAPT, 02=F/O, 03=BOTH) CDU(s). 2. FIM 34-61-00/101, Fig. 104, Block 1
34 62 99 --	1. The fuel weight is (incorrect, missing) from the performance initialization page on the (01=CAPT, 02=F/O, 03=BOTH) CDU(s). 2. FIM 34-61-00/101, Fig. 105, Block 1
34 63 01 --	1. Tuned navaid data blank on progress page of (01=CAPT, 02=F/O, 03=BOTH) CDU(s). 2. FIM 34-61-00/101, Fig. 104, Block 1
34 63 02 --	1. Tuned navaid data constantly changing on progress page of (01=CAPT, 02=F/O, 03=BOTH) CDU(s). 2. FIM 34-61-00/101, Fig. 104, Block 1
34 63 03 00	1. Wind vector on Capt HSI differs from F/O HSI. Selecting ALTN FMC corrects the fault. 2. Replace the applicable FMC, M134 (left) or M135 (right) (AMM 34-61-01/401).
34 63 04 00	1. Wind vector on Capt HSI differs from F/O HSI with both normal and ALTN FMC selected. 2. Replace the applicable EFIS symbol generator, M148 (left), M149 (center), or M150 (right) (AMM 34-22-01/401).
34 63 05 --	1. Distance to go and ETA display dashes on (01=CAPT, 02=F/O, 03=BOTH) HSI(s). Selecting ALTN FMC corrects the fault. 2. Replace the applicable FMC, M134 (left) or M135 (right) (AMM 34-61-01/401).
34 63 06 --	1. Distance to go and ETA display dashes on (01=CAPT, 02=F/O, 03=BOTH) HSI(s) with normal and ALTN FMC. 2. Replace the applicable EFIS symbol generator, M148 (left), M149 (center), or M150 (right) (AMM 34-22-01/401).
34 63 07 --	1. LNAV remains white (armed) on ADI with (01=L, 02=C, 03=R, 04=ANY) A/P engaged. 2. FIM 34-61-00/101, Fig. 110, Block 1
34 63 08 --	1. There is a line through LNAV on the AOI with (01=L, 02=C, 03=R, 04=ANY) A/P engaged. 2. FIM 34-61-00/101, Fig. 110, Block 1

EFFECTIVITY

ALL

34-FAULT CODE INDEX

BOEING
 757
 FAULT ISOLATION/MAINT MANUAL

FAULT CODE	1. LOG BOOK REPORT 2. FAULT ISOLATION REFERENCE
34 63 09 --	1. The airplane (describe problem: heading, track or transition error) in LNAV mode. Fault occurs with (01=L, 02=C, 03=R, 04=ANY) A/P engaged. 2. FIM 34-61-00/101, Fig. 110, Block 1
34 63 10 --	1. VNAV will not engage with (01=L, 02=C, 03=R, 04=any) A/P engaged. 2. FIM 34-61-00/101, Fig. 110, Block 1
34 63 11 --	1. There is a line through VNAV on the ADI with (01=L, 02=C, 03=R, 04=ANY) A/P engaged. 2. FIM 34-61-00/101, Fig. 110, Block 1
34 63 12 --	Not Used
34 63 13 --	1. Airspeed command bug on (01=CAPT, 02=F/O) Mach/AS meter(s) is driven to 100 kts with VNAV selected speed mode active. 2. FIM 34-61-00/101, Fig. 109, Block 1
34 63 14 --	1. FAIL is illum and screen displays FMC on (01=Capt, 02=F/O) CDU. Selecting ALTN FMC corrects the fault. 2. FIM 34-61-00/101, Fig. 109, Block 1
34 63 15 --	1. Fail is illum and screen displays FMC on (01=Capt, 02=F/O) CDU. Selecting ALTN FMC does not correct the fault. 2. FIM 34-61-00/101, Fig. 109, Block 1
34 63 16 --	1. Leg sequencing incorrect on (01=Capt, 02=F/O) CDU. 2. Cycle the Navigatn Data Base. Cycle the Navigation Data Base again, so that the Data Base with the current date is active. Return to service (AMM 34-61-00).
34 63 17 --	1. (01=Capt, 02=F/O) HSI displays leg sequencing incorrectly. 2. Cycle the Navigatn Data Base. Cycle the Navigation Data Base again, so that the Data Base with the current date is active. Return to service (AMM 34-61-00).
34 63 18 00	1. Total fuel differs from FMC calcutaled fuel qty. Fuel qty ERROR-PROG 2/2 alert msg on CDU and EICAS msg FMC message displayed. Fuel flow was normal. Total fuel _____, FMC calculated fuel _____. 2. FIM 34-61-00/101, Fig. 105, Block 1

EFFECTIVITY

ALL

34-FAULT CODE INDEX

03

Page 68
Dec 20/96



BOEING
757
FAULT ISOLATION/MAINT MANUAL

FAULT CODE	1. LOG BOOK REPORT 2. FAULT ISOLATION REFERENCE
34 63 19 --	1. FUEL USED and CALCULATED FUEL display blank on (01=Capt, 02=F/0, 03=both) CDU(s). 2. FIM 34-61-00/101, Fig. 105, Block 1
34 63 20 --	1. Waypoint display (moves, wavers, etc) on (01=Capt, 02=F/0, 03=both) HSI(s). Selecting ALTN FMC does not correct the fault. 2. FIM 34-61-00/101, Fig. 109, Block 1
34 63 21 --	1. (01=Capt, 02=F/0) leg sequencing is incorrect on CDU. 2. Push the line select key 3 right, and then line select key 2 right on the CDU IDENT page, to cycle the Navigation Data Base. Cycle the Navigation Data Base again, so that the Data Base with current date is active. Return to service (AMM 34-61-00).
34 63 22 --	1. FUEL USED and CALCULATED FUEL display blank on (01=Capt, 02=F/0, 03=both) CDU(s). 2. FIM 34-61-00/101, Fig. 105, Block 1
34 63 23 00	1. CDU's do not drop way points. 2. Push the line select key 3 right, and then line select key 2 right on the CDU IDENT page, to cycle the Navigation Data Base. Cycle the Navigation Data Base again, so that the Data Base with current date is active. Return to service (AMM 34-61-00).
34 63 24 --	1. V1 INOP displayed on (01=Capt, 02=F/0) EADI. 2. FIM 34-61-00/101, Fig. 109, Block 1
34 63 25 00	1. V1, V2 bug(s) (not normal, missing, etc) on (01=Capt, 02=F/0, 03=both) EADI speed tape(s) with normal or ALTN EFI selected. 2. FIM 34-61-00/101, Fig. 109, Block 1
34 63 26 --	1. EPR command bug on (03=L, 04=R, 05=both) EPR indicators is green with VNAV thrust command mode active. 2. FIM 34-61-00/101, Fig. 110, Block 1
34 63 27 --	1. Command airspeed on (01=Capt, 02=F/0, 03=both) EADI speed tape(s) read(s) 100 Kts with VNAV selected, speed mode active. 2. FIM 34-61-00/101, Fig. 109, Block 1

EFFECTIVITY

ALL

34-FAULT CODE INDEX

09

Page 69
Dec 20/96

BOEING
 757
 FAULT ISOLATION/MAINT MANUAL

FAULT CODE	1. LOG BOOK REPORT 2. FAULT ISOLATION REFERENCE
34 63 28 --	1. Airspeed command bug on (01=Capt, 02=F/O, 03=both) Mach/AS meter(s) is driven behind the mask with VNAV selected, speed mode active. 2. FIM 34-61-00/101, Fig. 109, Block 1
34 63 29 --	1. SEL SPD msg displayed on (01=Capt, 02=F/O, 03=both) EADI speed tape(s) with VNAV selected, speed mode active. 2. FIM 34-61-00/101, Fig. 110, Block 1
34 63 30 --	34 63 30 -- thru 34 63 34 -- Not Used
34 63 35 --	1. V1, Vr bug(s) (not normal, missing, etc) on (01=Capt, 02=F/O, 03=both) ADI speed tape(s) with normal or ALT EFI selected. 2. FIM 34-61-00/101, Fig. 109, Block 1
34 90 01 00	1. Lightning strike occurred on the nose radome. 2. Examine the airplane for a lightning strike or a severe static discharge (AMM 05-51-19).
34 90 02 00	1. Lightning strike occurred on the nacelle(s). 2. Examine the airplane for a lightning strike or a severe static discharge (AMM 05-51-19).
34 90 03 00	1. Lightning strike occurred on the wingtip(s). 2. Examine the airplane for a lightning strike or a severe static discharge (AMM 05-51-19).
34 90 04 00	1. Lightning strike occurred on leading edge flaps. 2. Examine the airplane for a lightning strike or a severe static discharge (AMM 05-51-19).
34 90 05 00	1. Lightning strike occurred on an unknown area. 2. Examine the airplane for a lightning strike or a severe static discharge (AMM 05-51-19).

EFFECTIVITY

ALL

34-FAULT CODE INDEX

 **BOEING**
757
FAULT ISOLATION/MAINT MANUAL

BITE Index

1. General

- A. Use this index to find the BITE procedure for the applicable LRU/System.
- B. The BITE procedure will provide the fault isolation instructions for the fault indications/LRU maintenance messages.

<u>LRU/System Name</u>	<u>Acronym</u>	<u>FIM Reference</u>
Air Data Computer	ADC	34-12
Air Data Inertial Reference Unit	ADIRU	34-26
Air Traffic Control Transponder	ATC	34-53
Airborne Vibration Monitor Signal Conditioner	AVM	77-31
Antiskid/Autobrake Control Unit		32-42
APU Fire Detection System		26-15
Automatic Direction Finder Receiver	ADF	34-57
APU Control Unit	ECU	49-11
Brake Temperature Monitor Unit		32-46
Bus Power Control Unit	BPCU	24-20
Cabin Pressure Controller		21-30
Digital Flight Data Acquisition Unit	DFDAU	31-31
Distance Measuring Equipment Interrogator	DME	34-55
Duct Leak (Wing and Body)		26-18
E/E Cooling Control Card (If cards installed)		21-58
ECS Bleed Configuration Card		36-10
Electronic Engine Control (RR Engines)	EEC	73-21
Electronic Engine Control Monitor Unit (PW Engines)	EECM	71-EPCS Message Index
Electronic Flight Instrument System	EFIS	34-22
Electronic Propulsion Control System (PW Engines)	EPCS	71-EPCS Message Index
Engine Fire/Overheat Detection System		26-11
Engine Indication and Crew Alerting System Computer	EICAS	31-41

Bite Index
Figure 1 (Sheet 1)

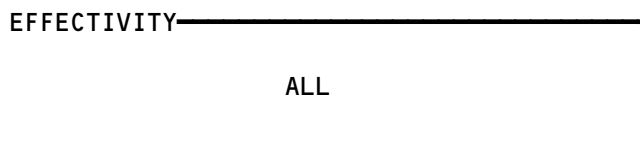

34-BITE INDEX

BOEING
 757
 FAULT ISOLATION/MAINT MANUAL

<u>LRU/System Name</u>	<u>Acronym</u>	<u>FIM Reference</u>
Engine Turbine Cooling Overheat Detection System (RR Engines)		26-13
Enhanced Ground Proximity Warning Computer	EGPWC	34-46
Flap/Slat Accessory Module	FSAM	27-51
Flap/Slat Electronic Unit	FSEU	27-51
Flight Management Computer	FMC	34-61
Fuel Quantity Indicating System Processor	FQIS	28-41
Ground Proximity Warning Computer	GPWC	34-46
HF (High Frequency) Communication		23-11
Inertial Reference Unit	IRU	34-21
Instrument Comparator Unit	ICU	34-25
Instrument Landing System Receiver	ILS	34-31
Lower Cargo Compartment Smoke Detection System		26-16
Maintenance Control Display Panel	MCDP	22-00
PA (Passenger Address) Amplifier		23-31
Pack Standby Temperature Controller		21-51
Pack Temperature Controller		21-51
Passenger Entertainment System	PES	23-34
Power Supply Module (Control System Electronics Units)	PSM	27-09
Propulsion Discrete Interface Unit (PW Engines)	PDIU	73-21
Proximity Switch Electronics Unit	PSEU	32-09
Radio Altimeter Transmitter/Receiver	RA	34-33
Rudder Ratio Changer Module	RRCM	27-09
Spoiler Control Module	SCM	27-09
Stabilizer Position Module	SPM	27-48
Stabilizer Trim/Elevator Asymmetry Limit Module	SAM	27-09
Stall Warning Computer/Module (in Warning Electronic Unit)	SWC	27-32
Strut Overheat Detection System (RR Engines)		26-12

Bite Index
Figure 1 (Sheet 2)

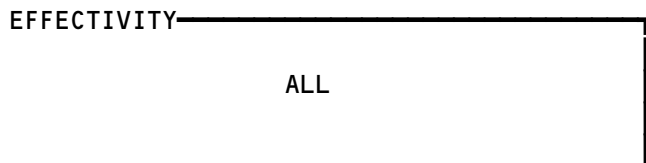

34-BITE INDEX

BOEING
 757
 FAULT ISOLATION/MAINT MANUAL

<u>LRU/System Name</u>	<u>Acronym</u>	<u>FIM Reference</u>
Thrust Management Computer/Autothrottle	TMC	22-00
Traffic Alert and Collision Avoidance Computer	TCAS	34-45
VHF (Very High Frequency) Communication		23-12
VOR/Marker Beacon Receiver	VOR/MKR	34-51
Warning Electronic Unit BITE Module (Stall Warning)	WEU	27-32
Weather Radar Transceiver	WXR	34-43
Wheel Well Fire Detection		26-17
Window Heat Control Unit	WHCU	30-41
Yaw Damper Module	YDM	22-21
Yaw Damper/Stabilizer Trim Module	YSM	27-09
Zone Temperature Controller		21-60

Bite Index
Figure 1 (Sheet 3)

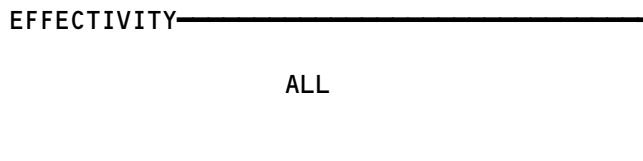

34-BITE INDEX

01

Page 3
Sep 28/99



BOEING
 757
 FAULT ISOLATION/MAINT MANUAL

PITOT-STATIC SYSTEM

COMPONENT	FIG. 102 SHT	QTY	ACCESS/AREA	AMM REFERENCE
PORT - CAPTAIN'S STATIC	--	2	FWD FUSELAGE, L UPPER AND R LOWER	34-11-03
PORT - F/O'S STATIC	--	2	FWD FUSELAGE, L LOWER AND R UPPER	34-11-03
PORT - STATIC, ALTERNATE	--	2	FWD FUSELAGE, 1 EACH SIDE	34-11-03
PROBE - AUX 1 PITOT, B27	--	1	NOSE SECTION, R SIDE - LOWER PROBE	34-11-01
PROBE - AUX 2 PITOT, B29	--	1	NOSE SECTION, L SIDE - LOWER PROBE	34-11-01
PROBE - CAPTAIN'S PITOT, B26	--	1	NOSE SECTION, L SIDE - UPPER PROBE	34-11-01
PROBE - F/O'S PITOT, B28	--	1	NOSE SECTION, R SIDE - UPPER PROBE	34-11-01
PROBE HEATER - (FIM 30-31-00/101)				

* SEE THE WDM EQUIPMENT LIST

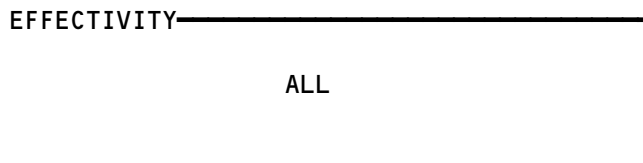
Pitot-Static System - Component Index
Figure 101



34-11-00

01

Page 101
Sep 20/94

E45491

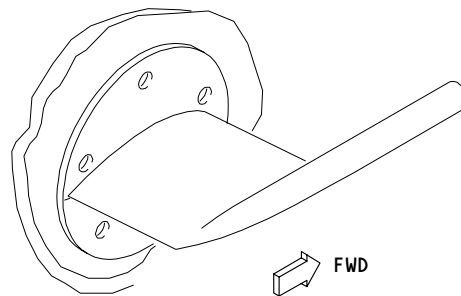
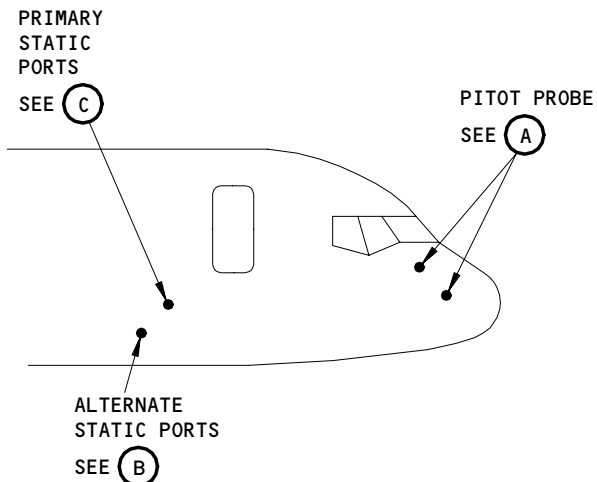

PITOT PROBE
(EXAMPLE)

(A)

STATIC PORT
DO NOT PLUG OR DEFORM HOLES
INDICATED AREAS MUST BE
SMOOTH AND CLEAN

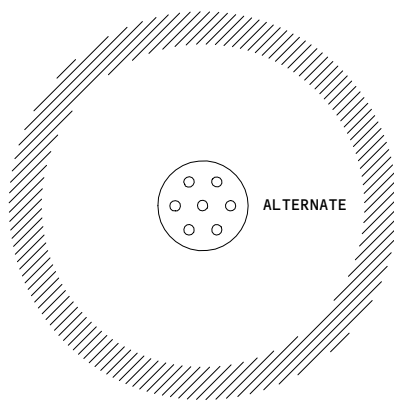

ALTERNATE STATIC PORTS

(B)

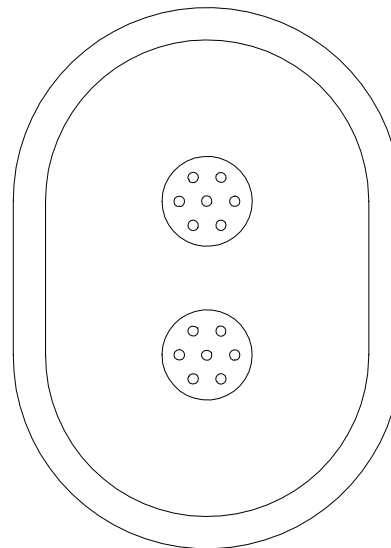

PRIMARY STATIC PORTS

(C)

Pitot-Static System - Component Location
Figure 102

EFFECTIVITY	ALL
-------------	-----

34-11-00

**STATIC SYSTEM
PROBLEM**

PREREQUISITES
NONE

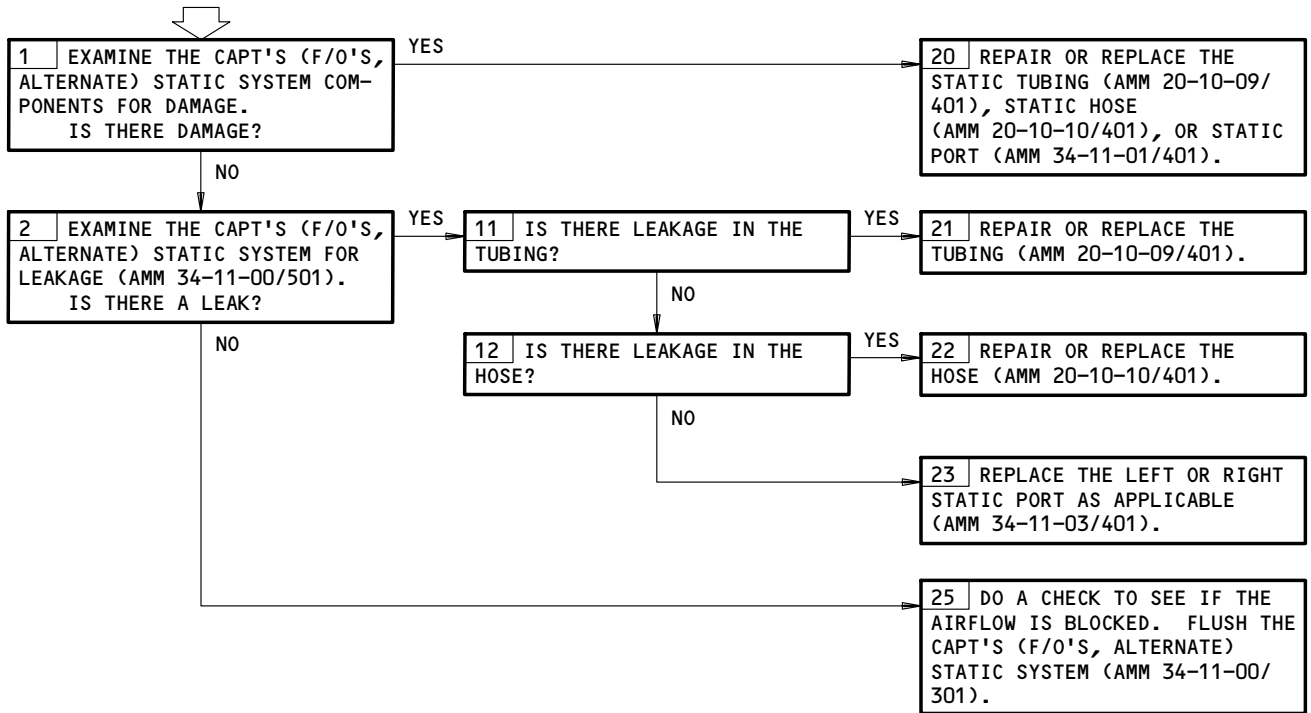

Static System Problem
Figure 103

EFFECTIVITY ————
ALL

34-11-00

**PITOT SYSTEM
PROBLEM**

PREREQUISITES
 NONE

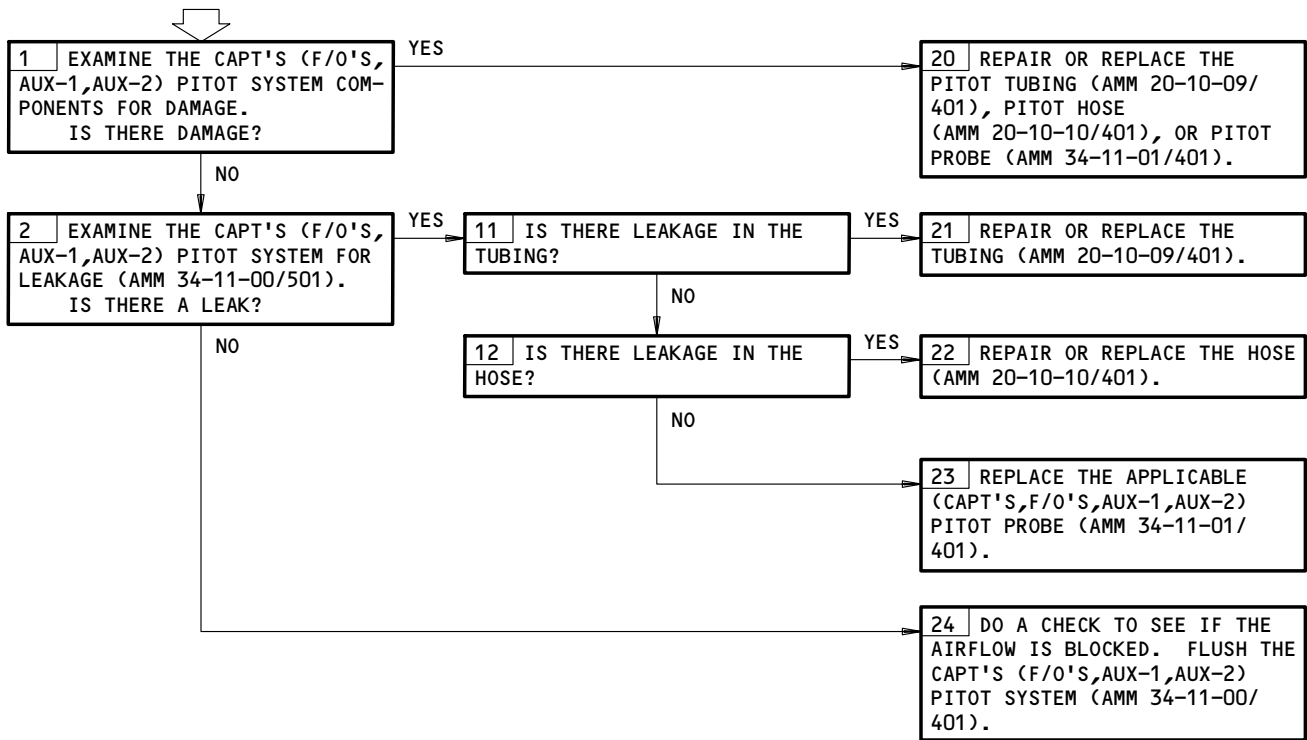

Pitot System Problem
Figure 104

EFFECTIVITY





ALL

34-11-00

54914

 **BOEING**
757
FAULT ISOLATION/MAINT MANUAL

AIR DATA COMPUTING SYSTEM

COMPONENT	FIG. 102 SHT	QTY	ACCESS/AREA	AMM REFERENCE
CIRCUIT BREAKERS	1		FLIGHT COMPARTMENT, P11	
AIR DATA AOA SENSOR LEFT, C1		1	11A11	*
AIR DATA AOA SENSOR RIGHT, C3		1	11F31	*
AIR DATA BARO CORRECT LEFT, C2		1	11A12	*
AIR DATA BARO CORRECT RIGHT, C4		1	11F32	*
AIR DATA CMPTR LEFT, C625		1	11A10	*
AIR DATA CMPTR RIGHT, C626		1	11F30	*
AIR DATA SOURCE SEL RELAY LEFT, C4664 		1	11B4	*
AIR DATA SOURCE SEL RELAY RIGHT, C4665 		1	11B5	*
COMPUTER - AIR DATA L, M100	2	1	119BL, MAIN EQUIPMENT CENTER, E2-1	34-12-01
COMPUTER - AIR DATA R, M101	2	1	119BL, MAIN EQUIPMENT CENTER, E2-2	34-12-01
MODULE - DISCRETE WARNING DISPLAY, M779	1	1	FLIGHT COMPARTMENT, P1-3	*
PANEL - (FIM 30-32-00/101)				
MISCELLANEOUS TEST, M10398				
PROBE - TOTAL AIR TEMPERATURE, TS5001	2	1	L SIDE FORWARD FUSELAGE	34-12-02
RELAY - LEFT AIR DATA SOURCE SELECT, K10802 	2	1	119BL, MAIN EQUIPMENT CENTER, E2-4	
RELAY - RIGHT AIR DATA SOURCE SELECT, K10803 	2	1	119BL, MAIN EQUIPMENT CENTER, E2-4	
RELAY - (FIM 31-01-36/101)				
SYS 1 AIR/GROUND, K148				
RELAY - (FIM 31-01-37/101)				
SYS 2 AIR/GROUND, K207				
SENSOR - ANGLE OF ATTACK L, TS12	2	1	L SIDE FUSELAGE NOSE	34-12-03
SENSOR - ANGLE OF ATTACK R, TS13	2	1	R SIDE FUSELAGE NOSE	34-12-03
SWITCH - CAPT ADC INSTR SOURCE SELECT, S482	1	1	FLIGHT COMPARTMENT, P1-1	*
SWITCH - F/O ADC INSTR SOURCE SELECT, S483	1	1	FLIGHT COMPARTMENT, P3-3	*
TRANSFORMER - (FIM 31-01-36/101)				
AIR DATA COMPUTER L, T139				
TRANSFORMER - (FIM 31-01-37/101)				
AIR DATA COMPUTER R, T140				

* SEE THE WDM EQUIPMENT LIST

 AIRPLANES POST-SB 34-0222

Air Data Computing System - Component Index
Figure 101

EFFECTIVITY

ALL

34-12-00

04

Page 101
May 28/05

D75439

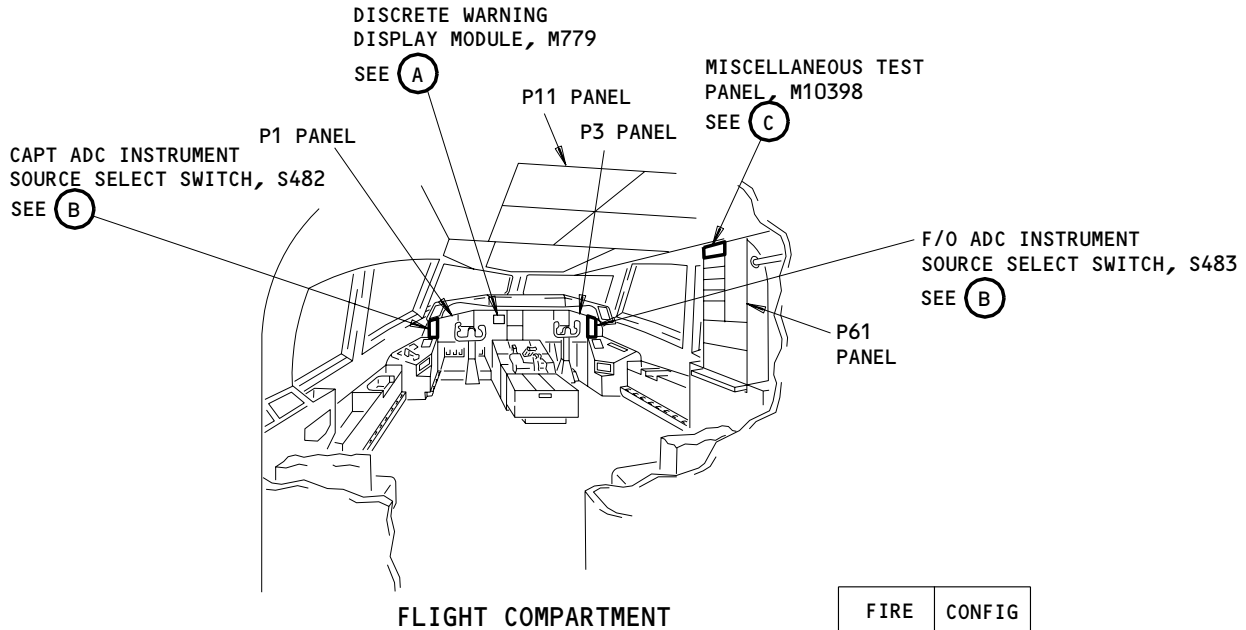

FIRE	CONFIG
PULLUP	A/P DISC
CABIN ALT	OVSPD

OVERSPEED WARNING LIGHT

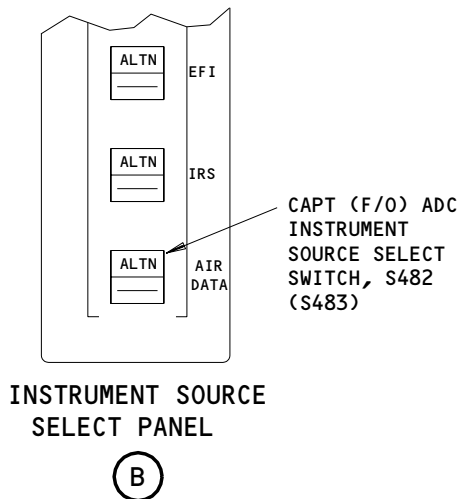

DISCRETE WARNING DISPLAY MODULE, M779

(A)

AIR DATA COMPUTER TEST SWITCHES

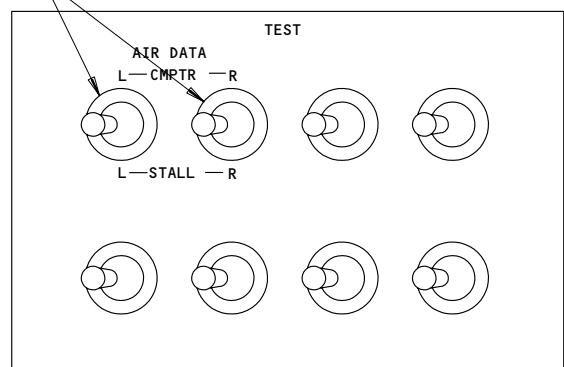

MISCELLANEOUS TEST PANEL, M10398 (REF)

(C)

Component Location
Figure 102 (Sheet 1)

EFFECTIVITY	ALL
-------------	-----

34-12-00

BOEING

757

FAULT ISOLATION/MAINT MANUAL

L (R) ANGLE OF
ATTACK SENSOR,
TS12 (TS13)
SEE (E)

TOTAL AIR TEMPERATURE
PROBE (R SIDE ONLY),
TS5001
SEE (F)

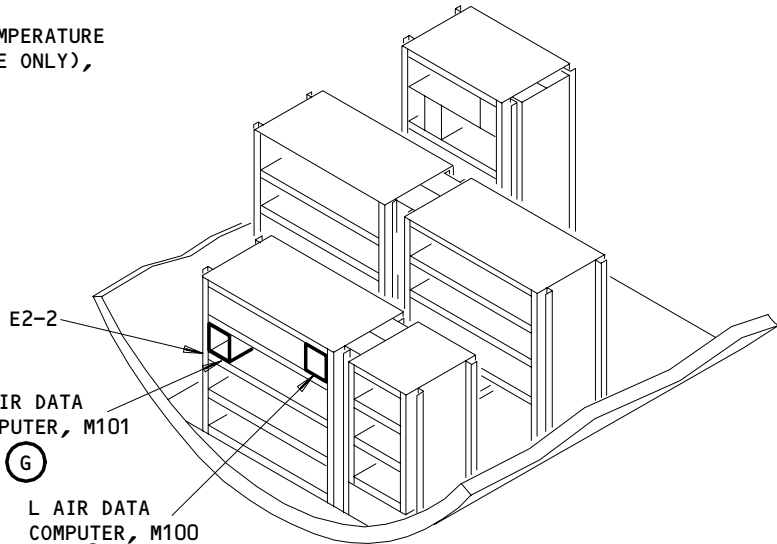
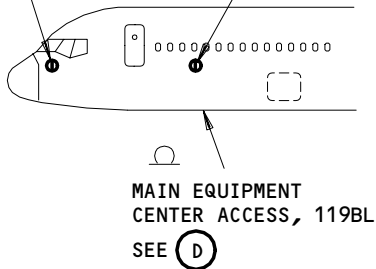

MAIN EQUIPMENT CENTER

(D)

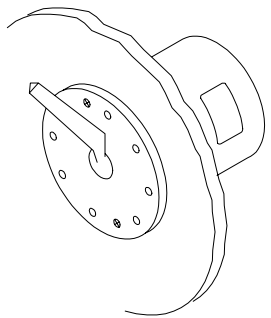

L (R) ANGLE OF ATTACK
SENSOR, TS12 (TS13)

(E)

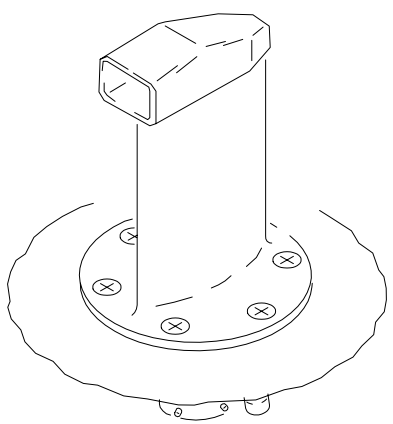

TOTAL AIR TEMPERATURE
PROBE, TS5001

(F)

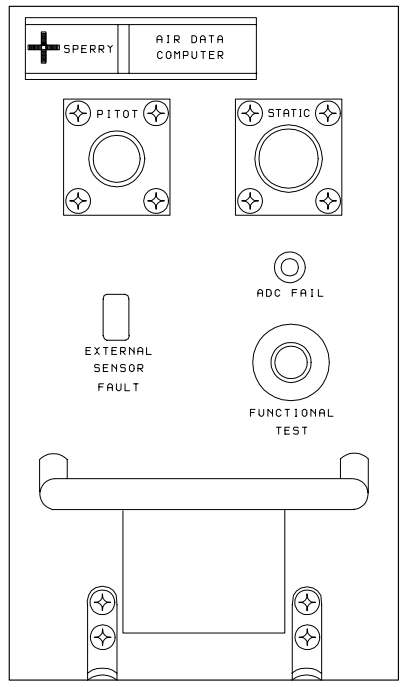

L (R) AIR DATA COMPUTER,
M100 (M101)

(G)

Component Location
Figure 102 (Sheet 2)

EFFECTIVITY	ALL
-------------	-----

34-12-00

98181

CAPT (F/O) ALTIMETER
 ERROR IS CORRECTED
 WITH ALTN AIR DATA
 SELECTED

PREREQUISITES

MAKE SURE THESE CIRCUIT BREAKERS ARE CLOSED:
 11A10, 11A11, 11A12, 11E2, 11E23, 11F30, 11F31,
 11F32
 MAKE SURE THE AIRPLANE IS IN THIS CONFIGURATION:
 ELECTRICAL POWER IS ON (AMM 24-22-00/201)
 PITOT-STATIC SYSTEM IS AT AMBIENT

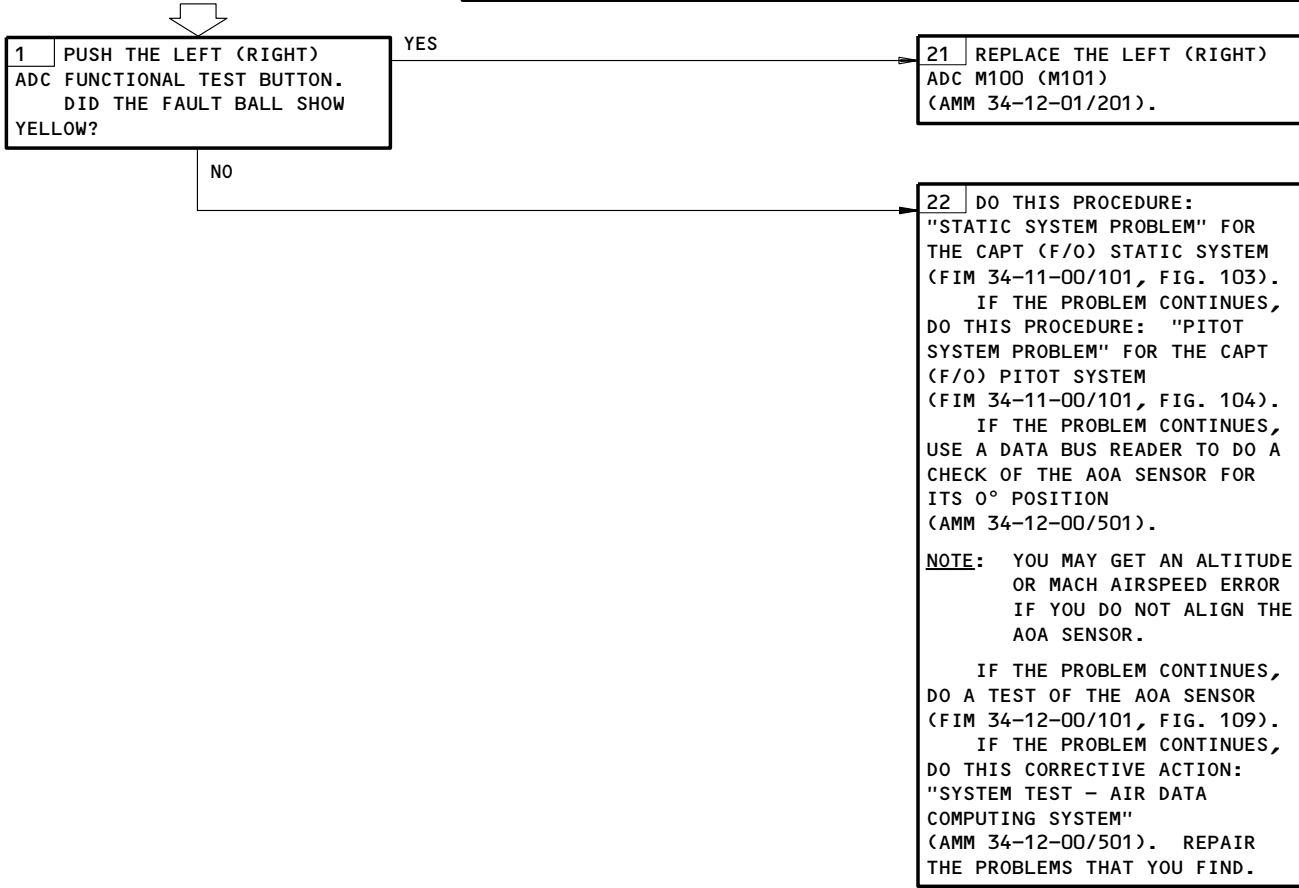

Capt (F/O) Altimeter is Corrected with ALTN Air Data Selected
 Figure 103

EFFECTIVITY	ALL
-------------	-----

34-12-00

**OFF FLAG IN VIEW
ON CAPT'S (F/O'S)
ALTIMETER**

PREREQUISITES

MAKE SURE THIS SYSTEM WILL OPERATE:
PITOT-STATIC SYSTEM AT AMBIENT (AMM 34-11-00/501)
EFIS (AMM 34-22-00-/501)

MAKE SURE THESE CIRCUIT BREAKERS ARE CLOSED:
11A10, 11A11, 11A12, 11E1, 11E2, 11E22, 11E23,
11F30, 11F31, 11F32

MAKE SURE THE AIRPLANE IS IN THIS CONFIGURATION:
ELECTRICAL POWER IS ON (AMM 24-22-00/201)

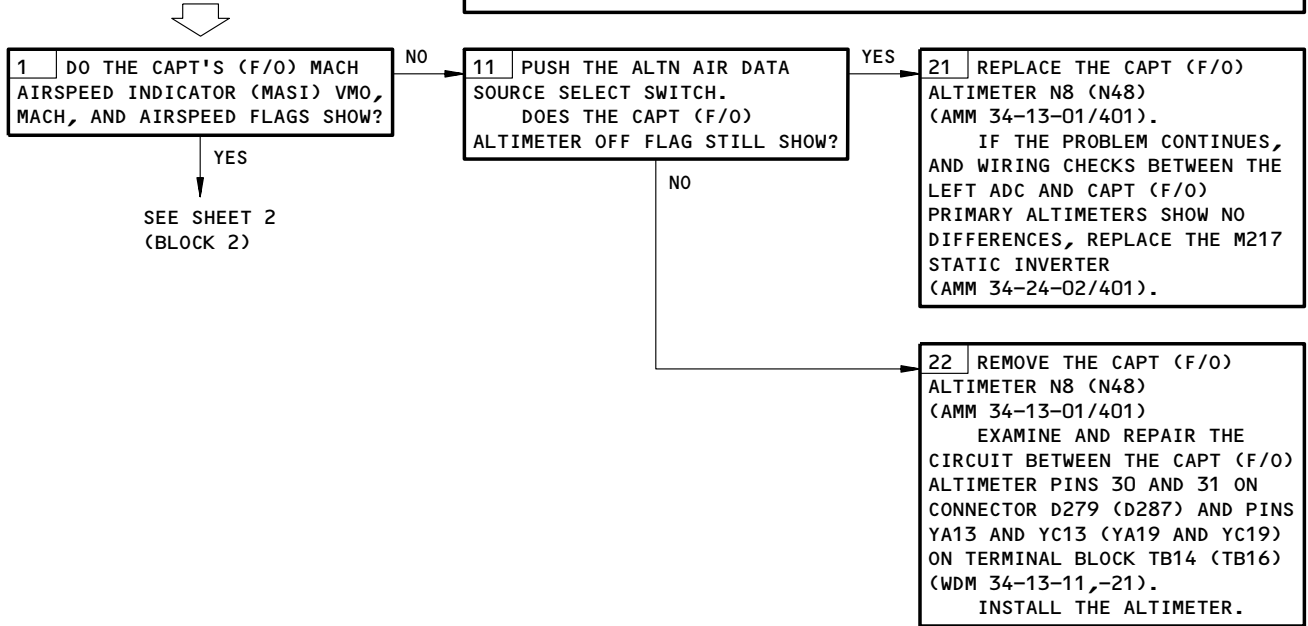

Off Flag in View on Capt's (F/O's) Altimeter
Figure 104 (Sheet 1)

EFFECTIVITY
GUI 009, 115

34-12-00

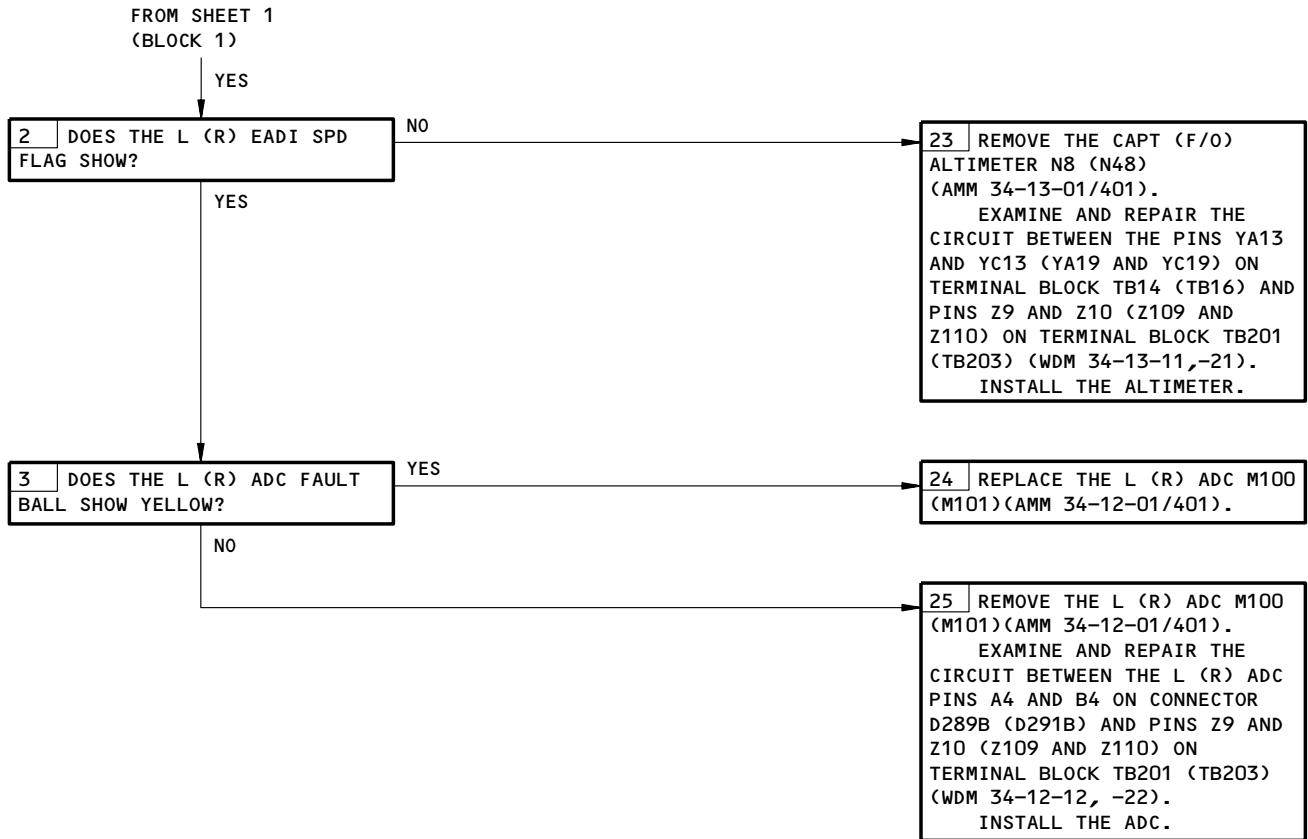

Off Flag in View on Capt's (F/O's) Altimeter
Figure 104 (Sheet 2)

EFFECTIVITY
GUI 009, 115

34-12-00

**OFF FLAG IN VIEW
ON CAPT'S (F/O'S)
ALTIMETER**

PREREQUISITES

MAKE SURE THIS SYSTEM WILL OPERATE:
PITOT-STATIC SYSTEM AT AMBIENT (AMM 34-11-00/501)
EFIS (AMM 34-22-00-/501)

MAKE SURE THESE CIRCUIT BREAKERS ARE CLOSED:
11A10, 11A11, 11A12, 11E1, 11E2, 11E22, 11E23,
11F30, 11F31, 11F32

MAKE SURE THE AIRPLANE IS IN THIS CONFIGURATION:
ELECTRICAL POWER IS ON (AMM 24-22-00/201)

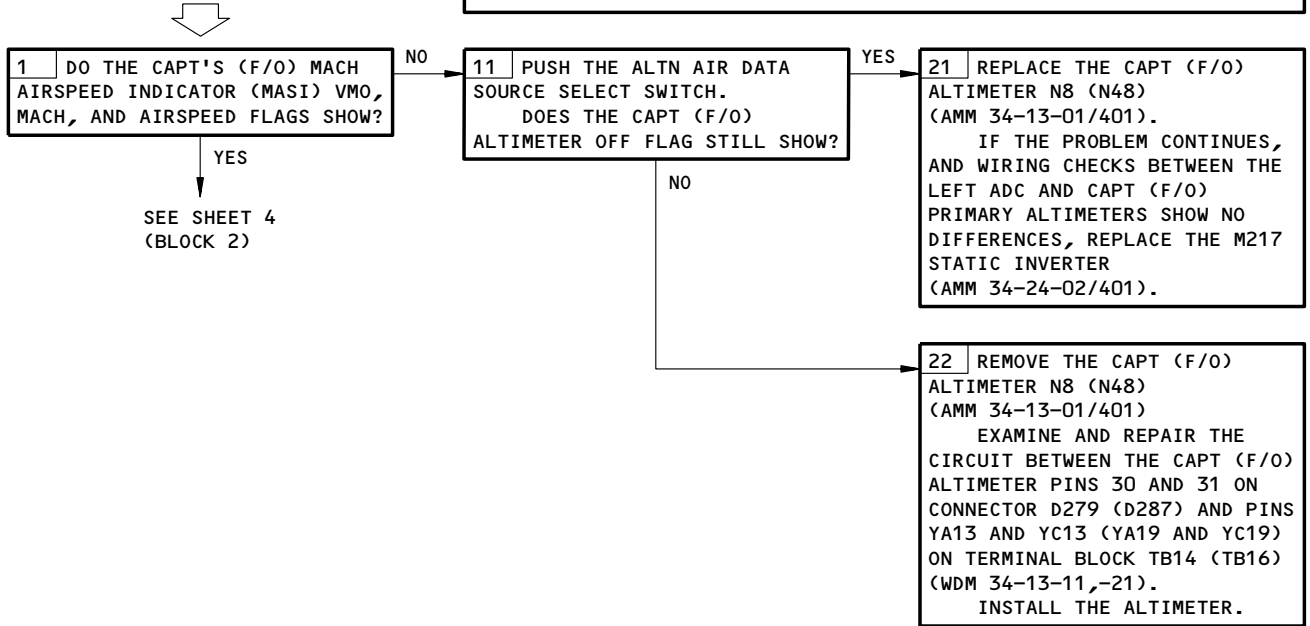

Off Flag in View on Capt's (F/O's) Altimeter
Figure 104 (Sheet 3)

EFFECTIVITY
GUI 001-008, 010-114, 116-999

34-12-00

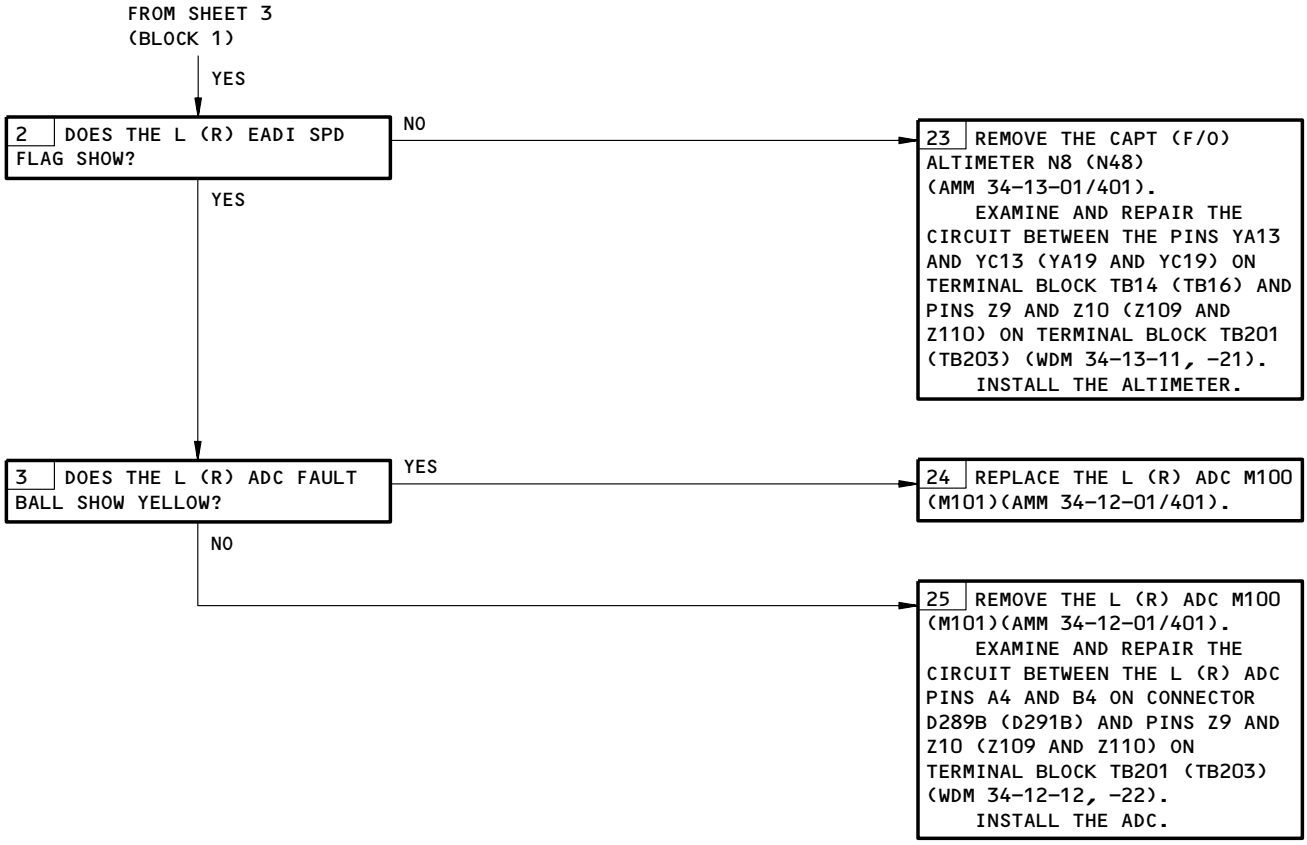

Off Flag in View on Capt's (F/O's) Altimeter
Figure 104 (Sheet 4)

EFFECTIVITY
GUI 001-008, 010-114, 116-999

34-12-00

Not Used
Figure 105

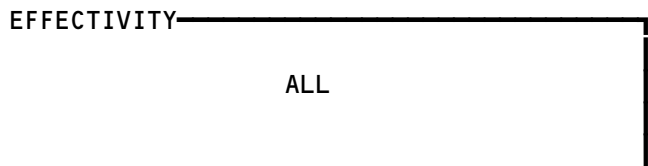

34-12-00

03

Page 109
May 28/07

E46733

**CAPT (F/O) TAS/SAT
AND MACH ARE IN
ERROR**

PREREQUISITES

MAKE SURE THESE CIRCUIT BREAKERS ARE CLOSED:
11A10,11A11,11A12,11E1,11E2,11E8,11E9,11E22,11E23,
11E29,11E30,11F30,11F31,11F32

MAKE SURE THE AIRPLANE IS IN THIS CONFIGURATION:
ELECTRICAL POWER IS ON (AMM 24-22-00/201)
PITOT-STATIC SYSTEM AT AMBIENT

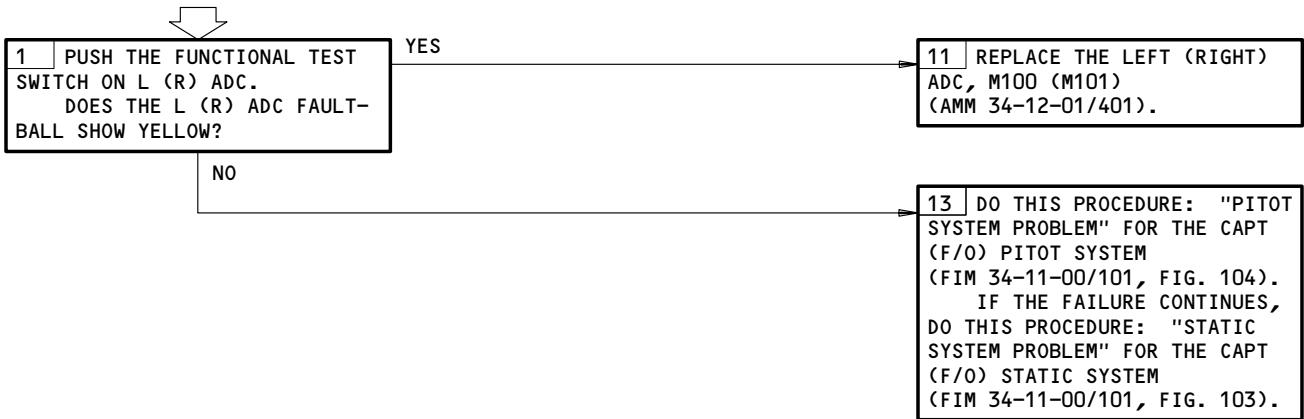

TAS/SAT and Mach Are In Error
Figure 106

EFFECTIVITY	ALL
-------------	-----

34-12-00

**OFF FLAG IN VIEW
ON CAPT'S METRIC
ALTIMETER**

PREREQUISITES

MAKE SURE THIS SYSTEM WILL OPERATE:
EFIS (AMM 34-22-00/501)

MAKE SURE THESE CIRCUIT BREAKERS ARE CLOSED:
11A10,11A11,11A12,11E1,11E2,11E3,11E4,11E7,11E22,
11E23,11F30,11F31,11F32,

MAKE SURE THE AIRPLANE IS IN THIS CONFIGURATION:
ELECTRICAL POWER IS ON (AMM 24-22-00/201)
PITOT-STATIC SYSTEM AT AMBIENT (AMM 34-11-00/501)
ALL INSTRUMENT SOURCE SELECT SWITCHES IN THE NORM
POSITION.

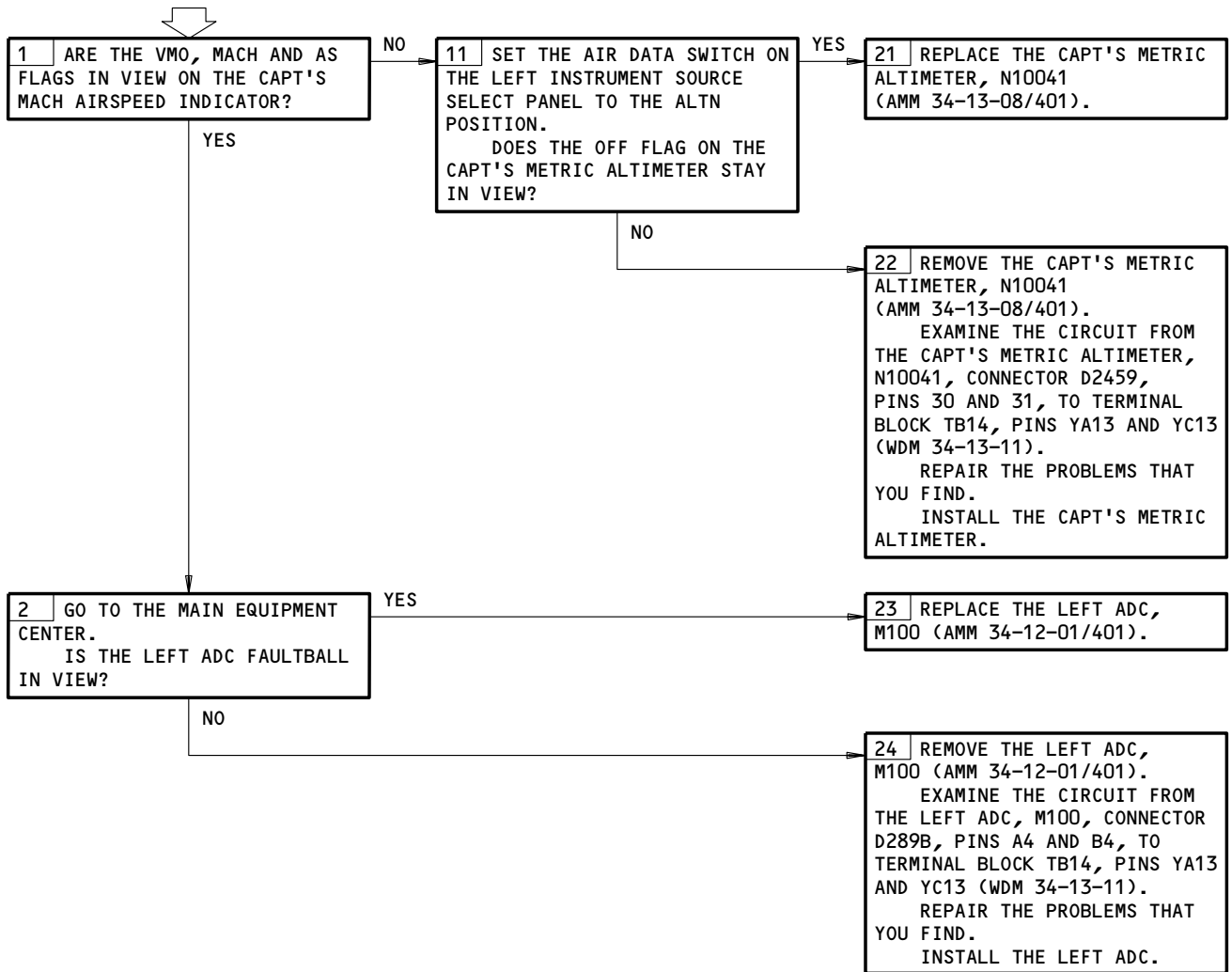

Off Flag in View on Capt's Metric Altimeter
Figure 106A

EFFECTIVITY
GUI 010, 011 WITH SB 34-166

34-12-00

**CAPT (F/O) MASI
IN ERROR. SELECT-
ING ALTN AIR DATA
CORRECTS FAULT**

PREREQUISITES
ELECTRICAL POWER (MM 24-22-00)
PITOT-STATIC SYSTEM AT AMBIENT
CB'S: (LEFT ADC) 11A10,11A11,11A12,11E1
(RIGHT ADC) 11E22,11F30,11F31,11F32

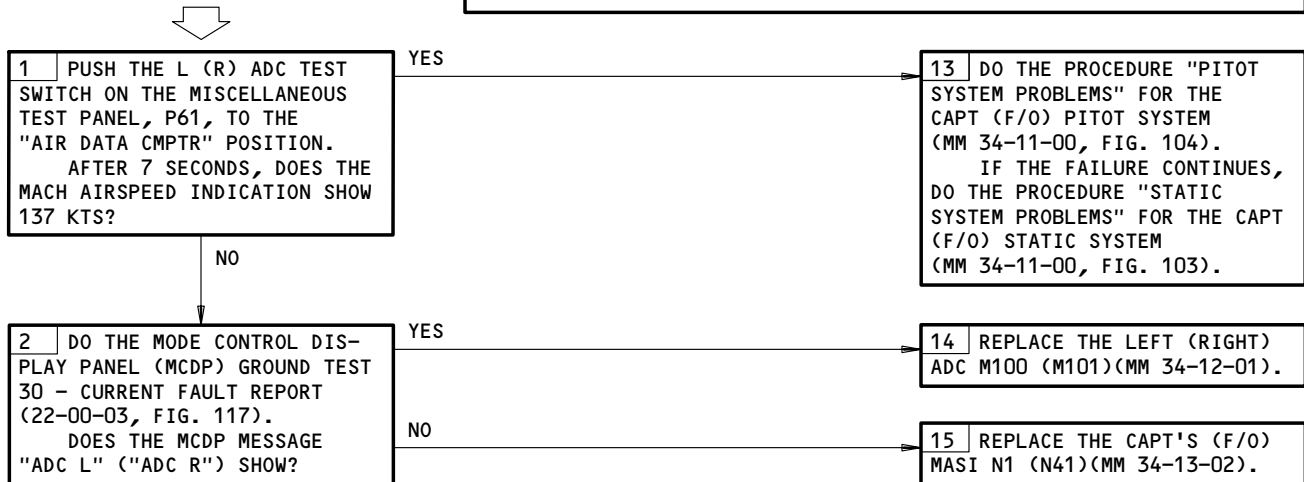

Capt (F/O) MASI in Error. Selecting Altn Air Data Corrects Fault
Figure 107

EFFECTIVITY
GUI 009, 115

34-12-00

**SPD FLAG IN VIEW
ON L (R) EADI**

PREREQUISITES

ELECTRICAL POWER (24-22-00)
PITOT STATIC SYSTEM AT AMBIENT
EFIS (34-22-00)

CB'S: 11A10,11A11,11A12,11E2,11E23,11F30,11F31,11F32

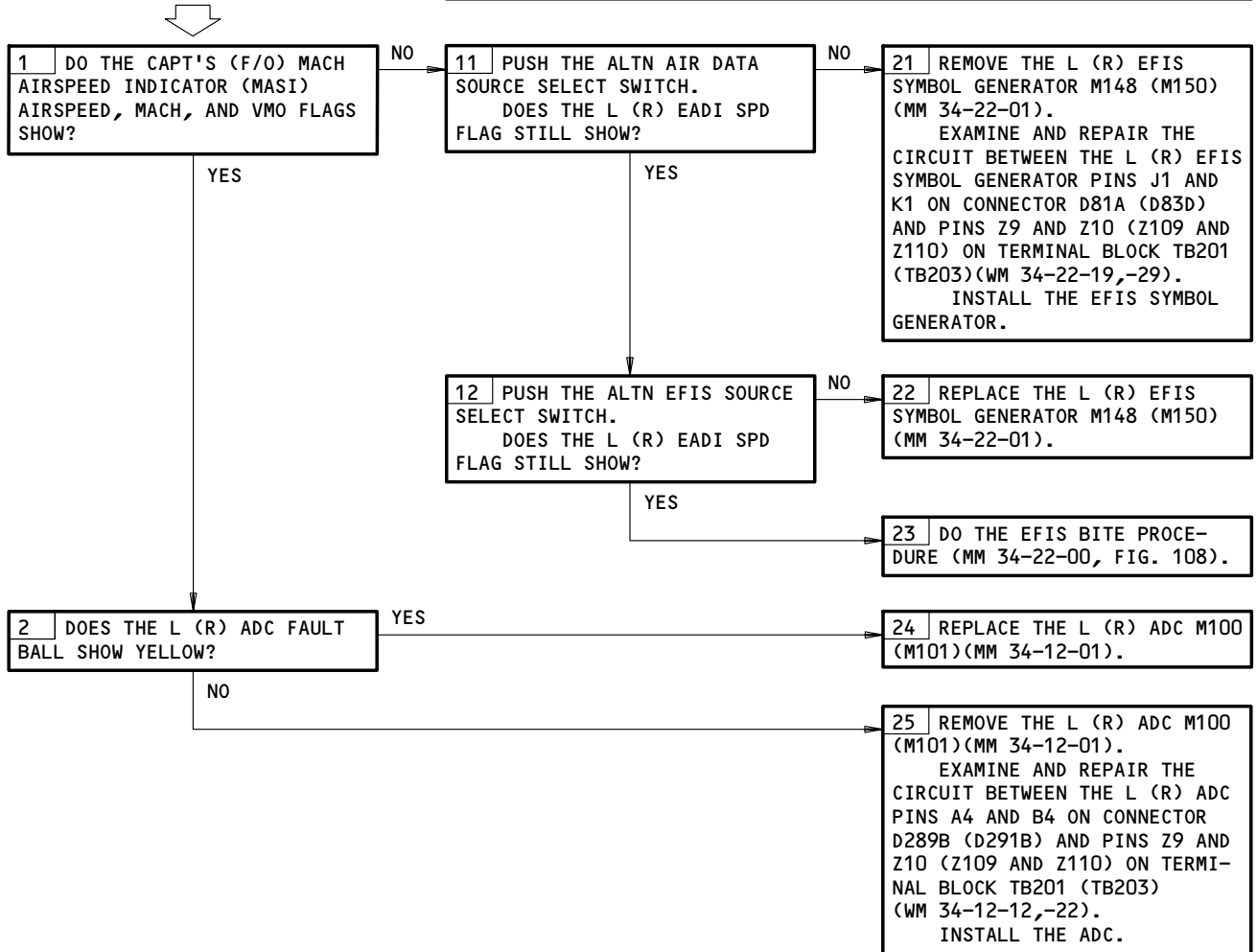

SPD Flag in View on L (R) EADI
Figure 107A

EFFECTIVITY
GUI 001-008, 010-114, 116-999

34-12-00

CAPT (F/O) AIRSPEED AND/OR MACH INDICATIONS IN ERROR. SELECTING ALTN AIR DATA CORRECTS FAULT

PREREQUISITES
ELECTRICAL POWER (MM 24-22-00)
PITOT-STATIC SYSTEM AT AMBIENT EFIS (MM 34-22-00)
CB'S: (LEFT ADC) 11A10,11A11,11A12,11E1
(RIGHT ADC) 11E22,11F30,11F31,11F32

1 PUSH THE L (R) ADC TEST SWITCH ON THE MISCELLANEOUS TEST PANEL, P61, TO THE "AIR DATA CMPTR" POSITION. AFTER 7 SECONDS, DOES THE MACH AIRSPEED INDICATION SHOW 137 KTS?

YES

13 DO THE PROCEDURE "PITOT SYSTEM PROBLEMS" FOR THE CAPT (F/O) PITOT SYSTEM (MM 34-11-00, FIG. 104). IF THE FAILURE CONTINUES, DO THE PROCEDURE "STATIC SYSTEM PROBLEMS" FOR THE CAPT (F/O) STATIC SYSTEM (MM 34-11-00, FIG. 103).

NO

14 REPLACE THE LEFT (RIGHT) ADC M100 (M101)(MM 34-12-01).

Capt (F/O) Airspeed and/or Mach Indications in Error. Selecting Altn Air Data Corrects Fault
Figure 107B

EFFECTIVITY
GUI 001-008, 010-114, 116-999

34-12-00

**VMO, MACH, AND AS
FLAGS IN VIEW ON
CAPT (F/O) MACH/
AIRSPEED INDICATOR**

PREREQUISITES
ELECTRICAL POWER (MM 24-22-00)
CB'S: 11A10,11A11,11A12,11E1,11E2,11E22,11E23,11F30,
11F31,11F32

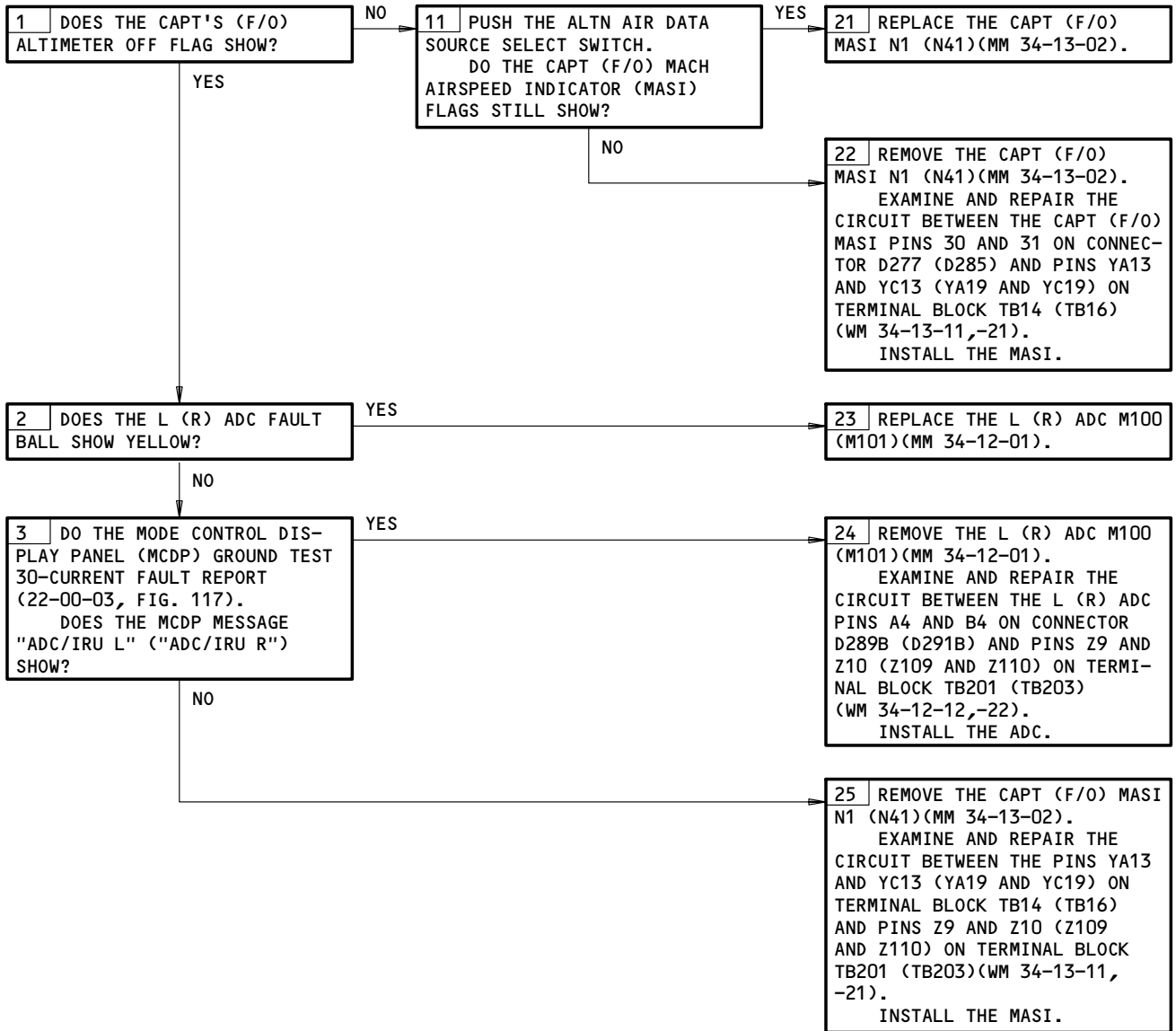

VMO, Mach, and AS Flags in View on Capt (F/O) Mach/Airspeed Indicator
Figure 108 (Sheet 1)

EFFECTIVITY
GUI 009, 115

34-12-00

VM0, MACH, AND AS
FLAGS IN VIEW ON
CAPT (F/O) MACH/
AIRSPEED INDICATOR

PREREQUISITES
ELECTRICAL POWER (MM 24-22-00)
EFIS (34-22-00)
CB'S: 11A10,11A11,11A12,11E1,11E2,11E22,11E23,11F30,
11F31,11F32

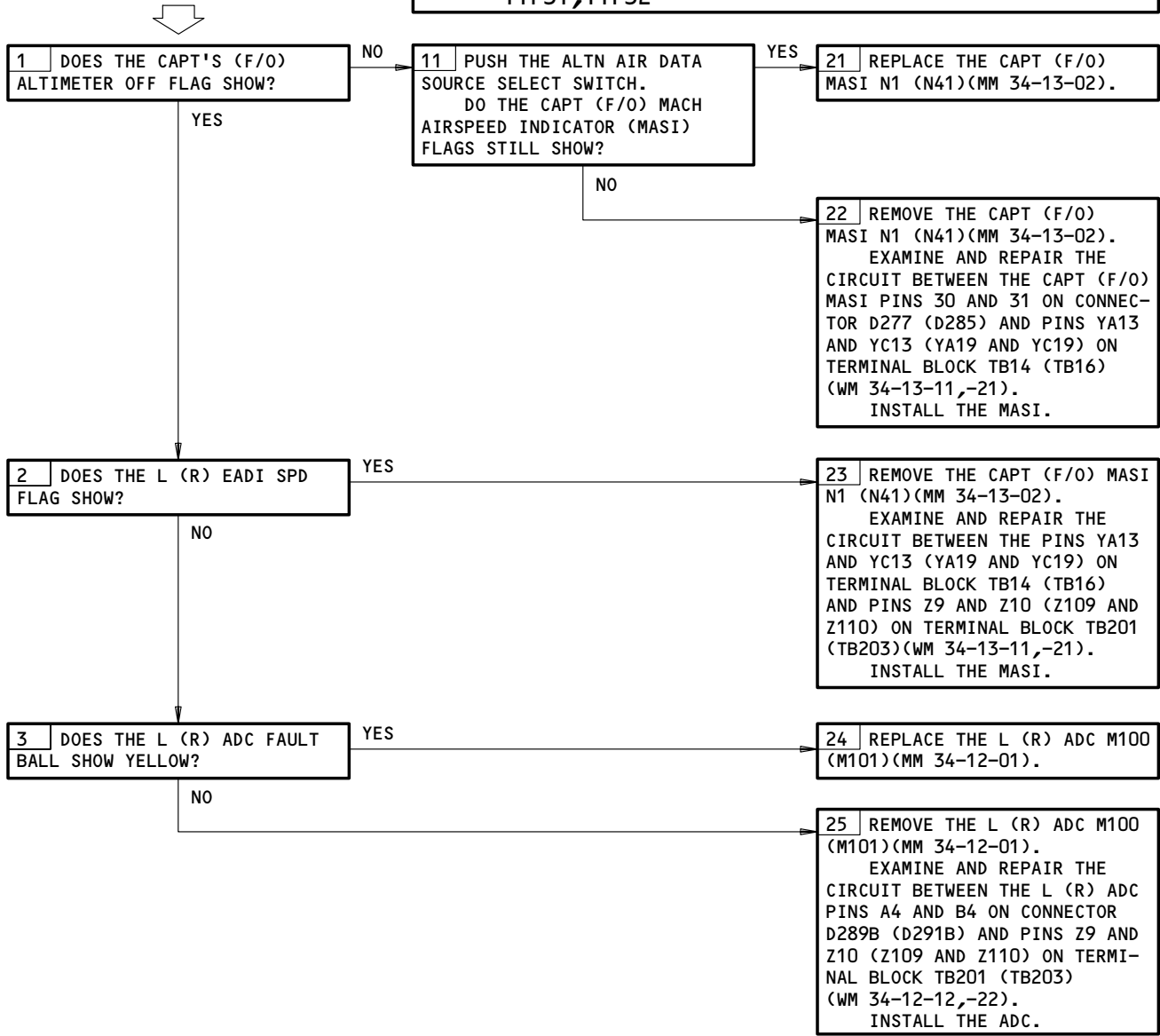

VMO, Mach, and AS Flags in View on Capt (F/O) Mach/Airspeed Indicator
Figure 108 (Sheet 2)

EFFECTIVITY
GUI 001-008, 010-114, 116-999

34-12-00

PREREQUISITES

MAKE SURE THESE SYSTEMS WILL OPERATE:

- EICAS (AMM 31-41-00/201)
- WARNING SYSTEM (AMM 31-51-00/501)

MAKE SURE THESE CIRCUIT BREAKERS ARE CLOSED:

- 11A10,11A11,11A12,11E1,11E2,11E22,11E23,11F30,11F31,11F32

MAKE SURE THESE CIRCUIT BREAKERS ARE OPEN:

- 11A17,11F14,11F15,11F16

MAKE SURE THE AIRPLANE IS IN THIS CONFIGURATION:

- ELECTRICAL POWER IS ON (AMM 24-22-00/201)
- PITOT-STATIC SYSTEM AT AMBIENT

ADC BITE PROCEDURE

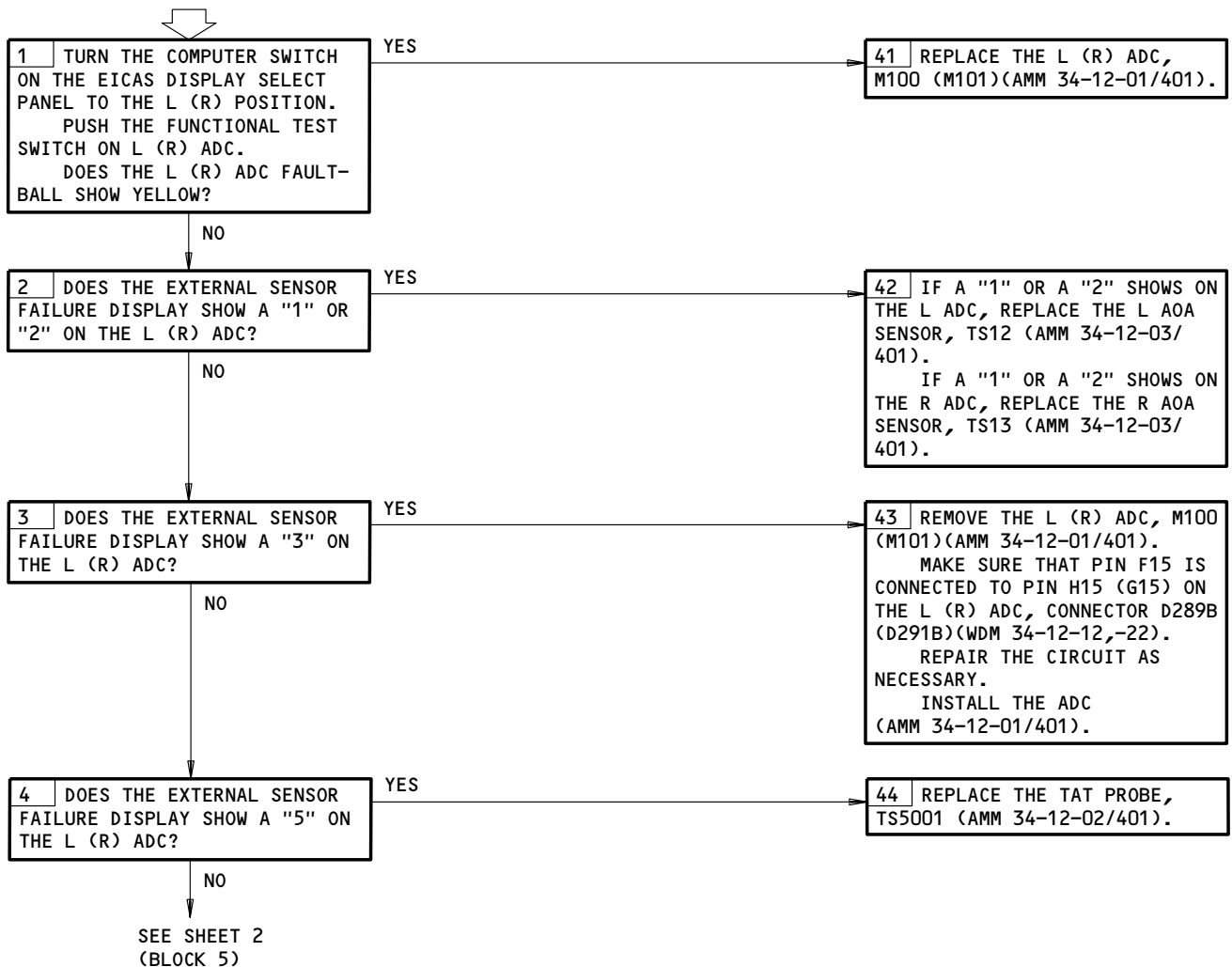

ADC BITE Procedure
Figure 109 (Sheet 1)

EFFECTIVITY
GUI 009, 115

34-12-00

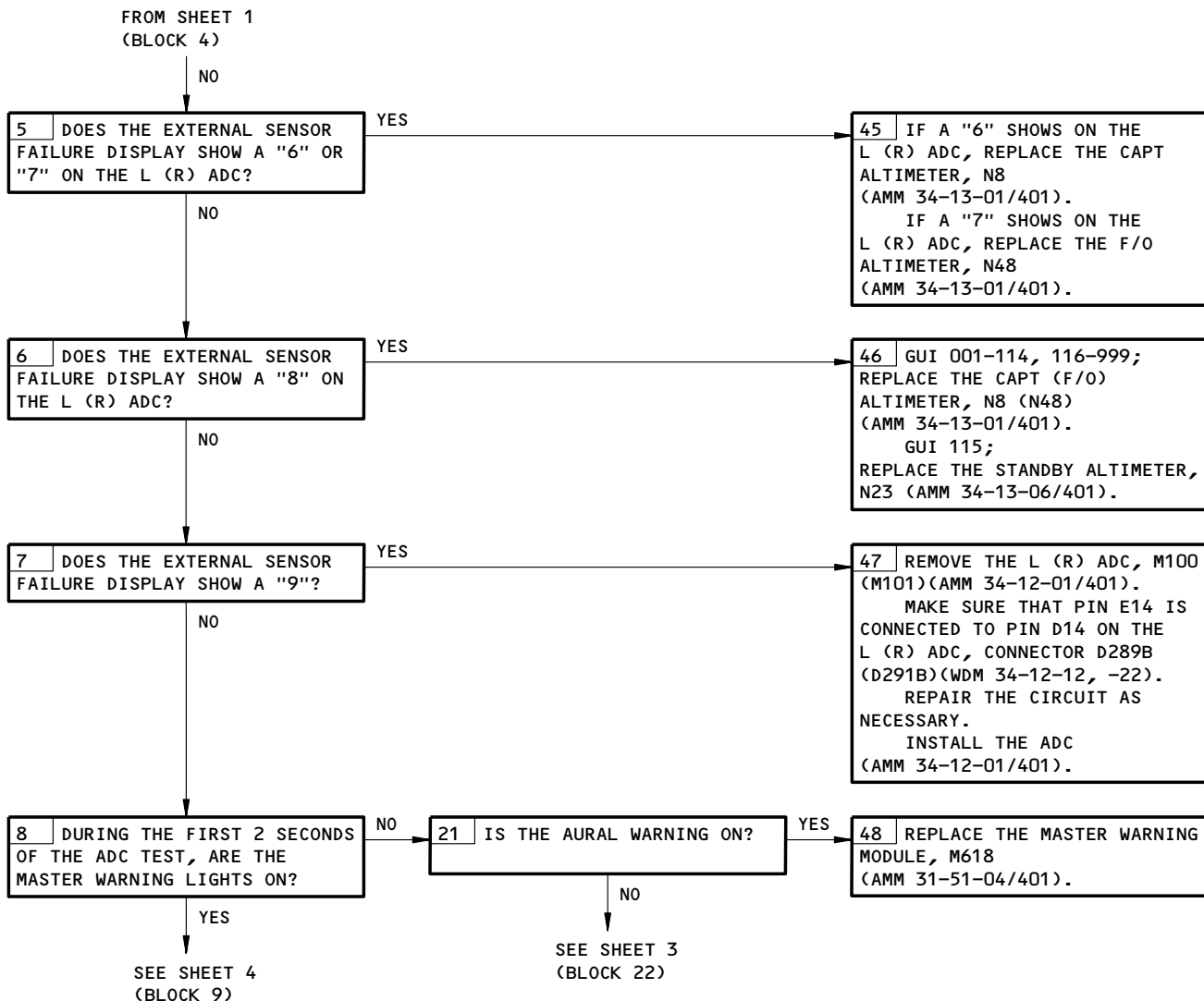

ADC BITE Procedure
Figure 109 (Sheet 2)

EFFECTIVITY
GUI 009, 115

34-12-00

BOEING
757
FAULT ISOLATION/MAINT MANUAL

FROM SHEET 2
(BLOCK 21)

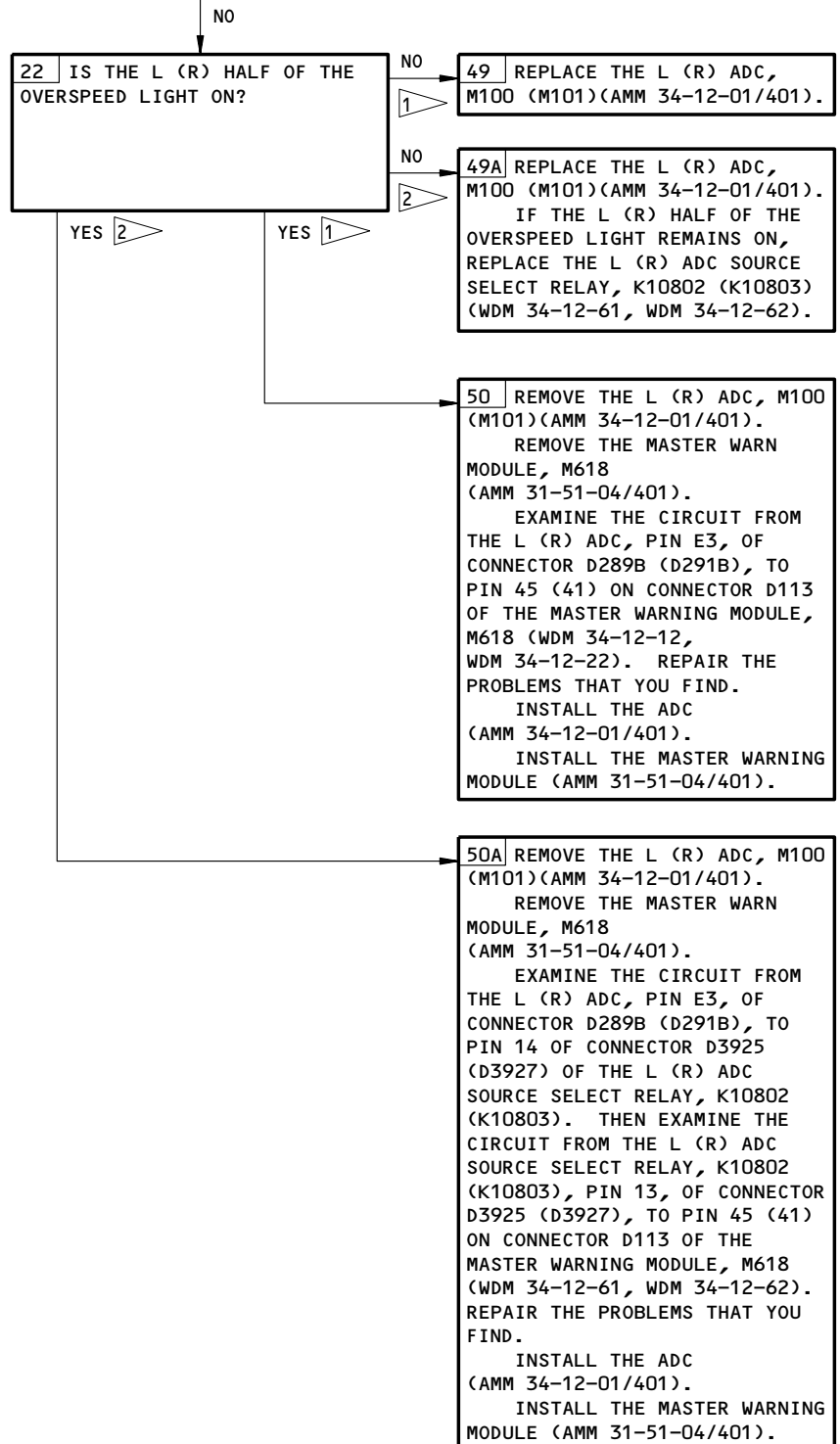

- 1 AIRPLANES PRE-SB 34-0222
- 2 AIRPLANES POST-SB 34-0222

ADC BITE Procedure
Figure 109 (Sheet 3)

EFFECTIVITY
GUI 009, 115

34-12-00

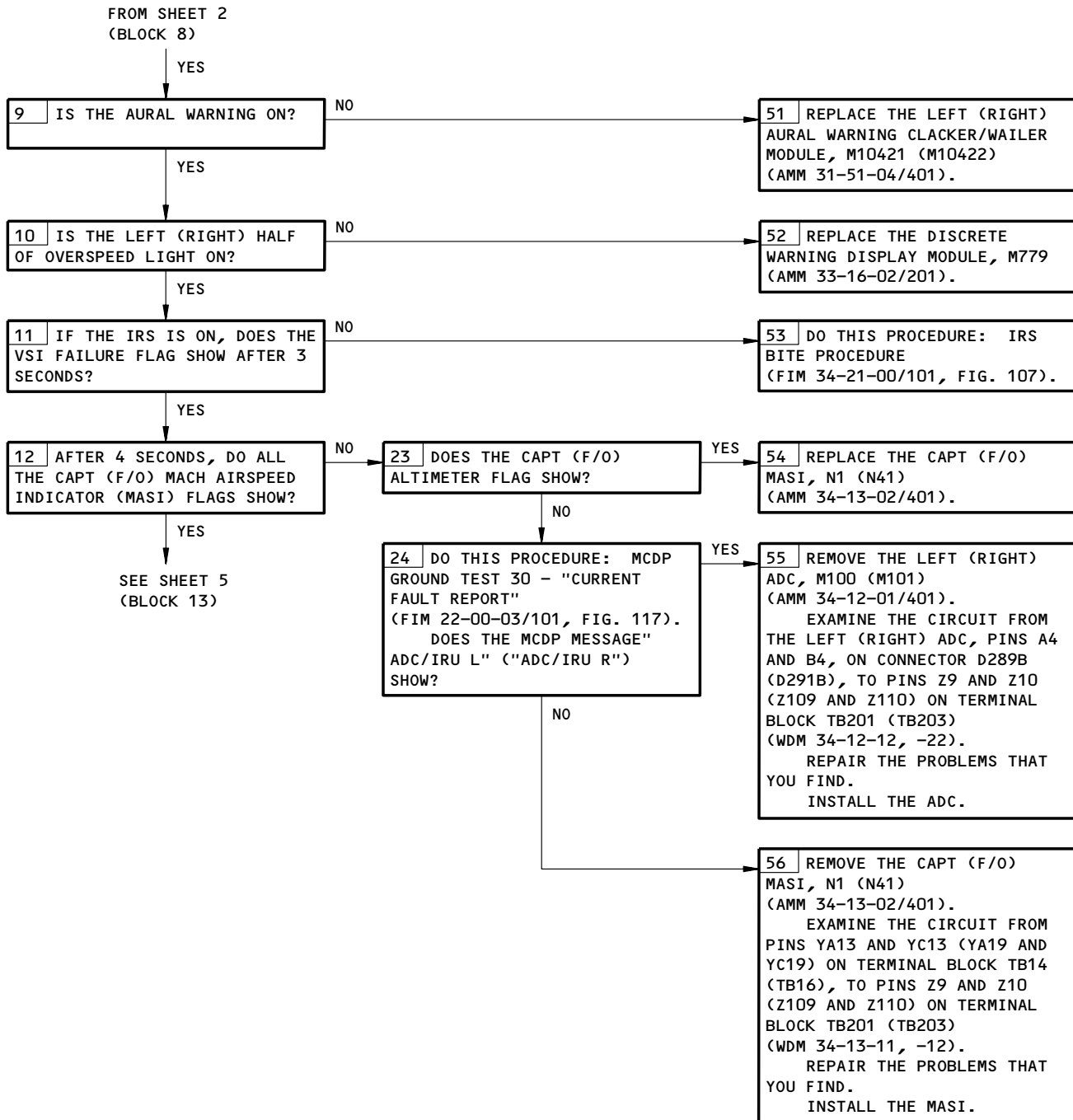

ADC BITE Procedure
Figure 109 (Sheet 4)

EFFECTIVITY

ALL

34-12-00

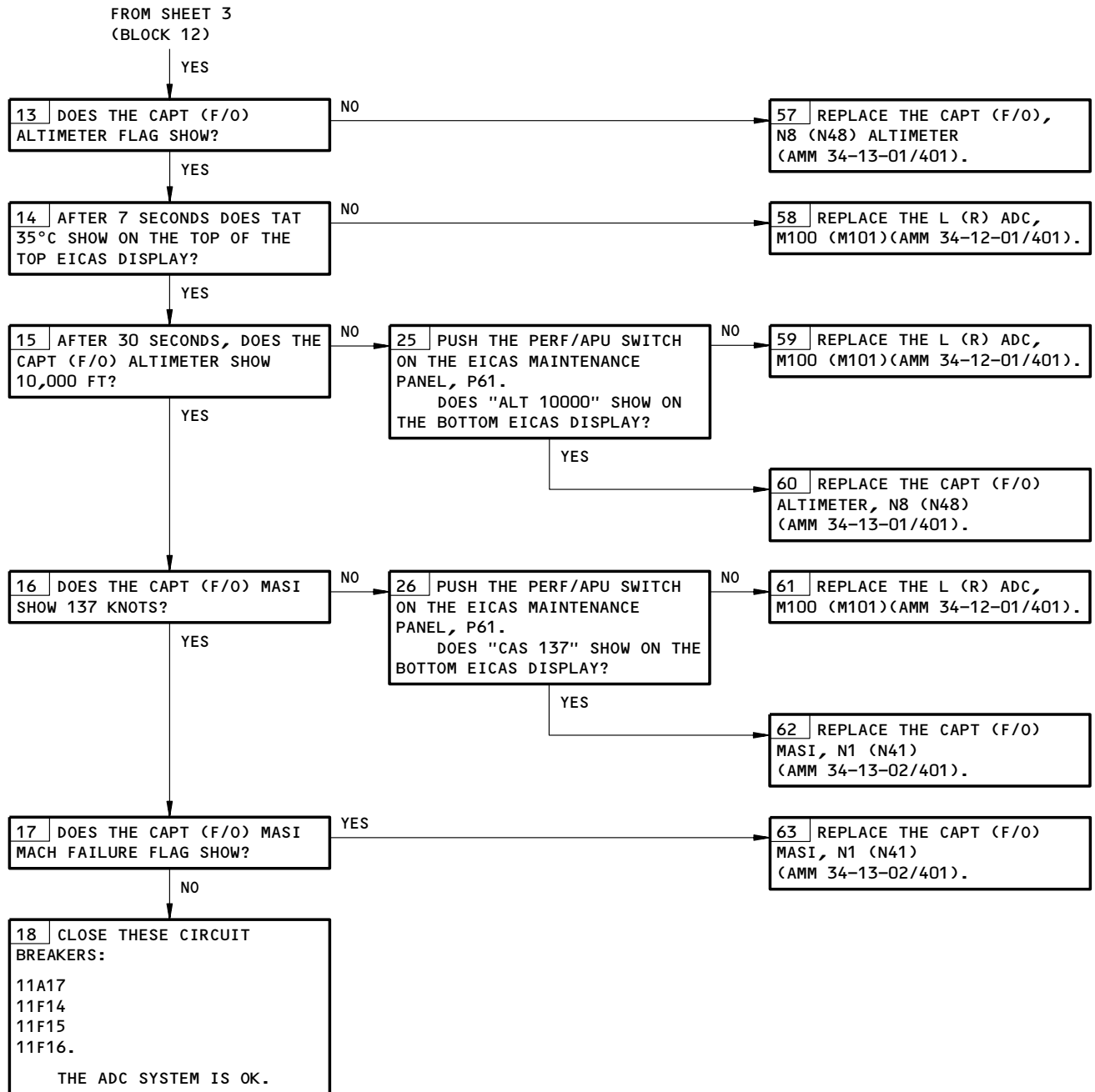

ADC BITE Procedure
Figure 109 (Sheet 5)

EFFECTIVITY

ALL

34-12-00

PREREQUISITES

MAKE SURE THESE SYSTEMS WILL OPERATE:
 EICAS (AMM 31-41-00/201)
 WARNING SYSTEM (AMM 31-51-00/501)
 EFIS (AMM 34-22-00/501)

MAKE SURE THESE CIRCUIT BREAKERS ARE CLOSED:
 11A10,11A11,11A12,11E1,11E22,11E23,11F30,11F31,
 11F32

MAKE SURE THESE CIRCUIT BREAKERS ARE OPEN:
 11A17,11F14,11F15,11F16

MAKE SURE THE AIRPLANE IS IN THIS CONFIGURATION:
 ELECTRICAL POWER IS ON (AMM 24-22-00/201)
 PITOT-STATIC SYSTEM AT AMBIENT

ADC BITE PROCEDURE

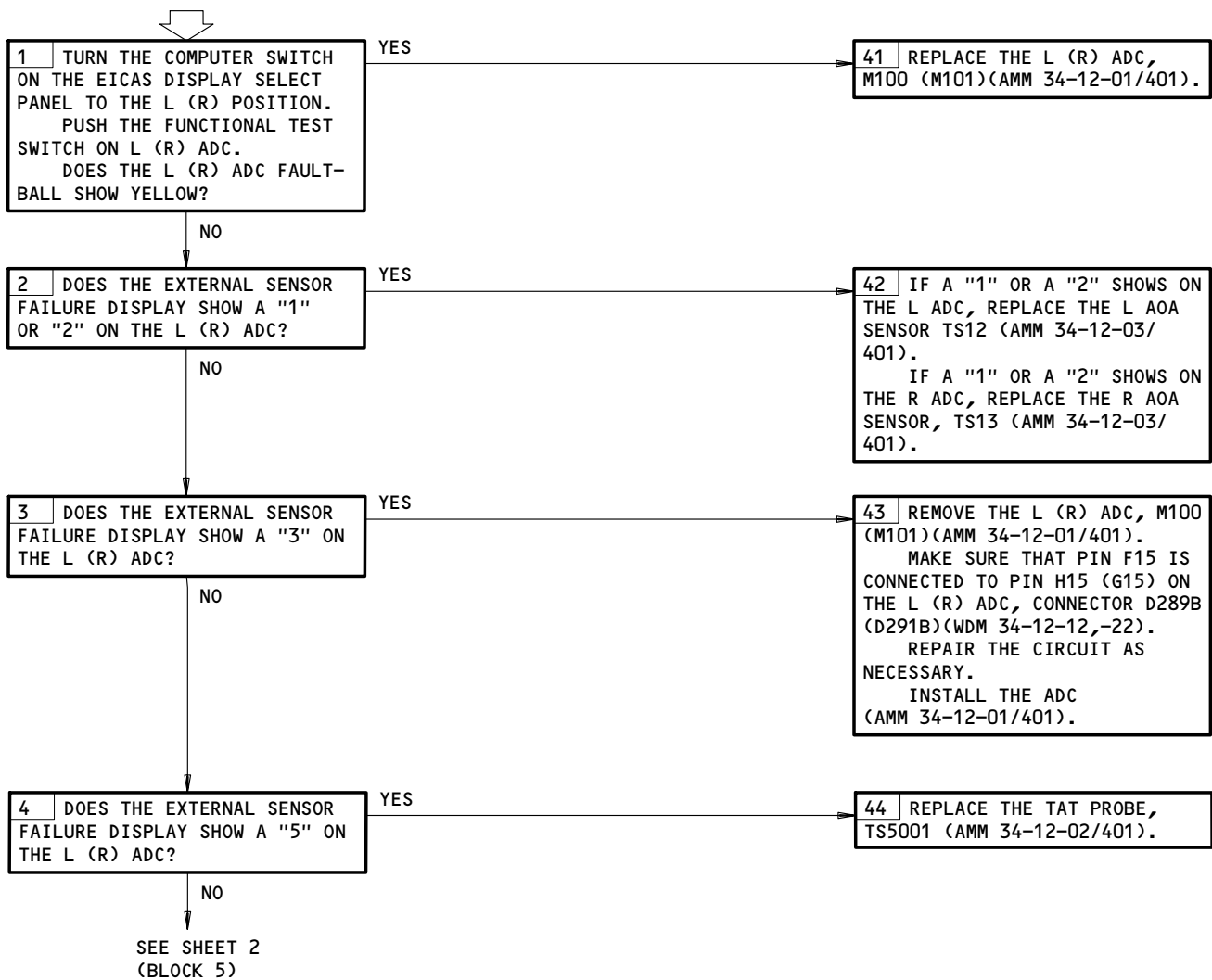

ADC BITE Procedure
 Figure 109A (Sheet 1)

EFFECTIVITY
 GUI 001-008, 010-114, 116-999

34-12-00

626107

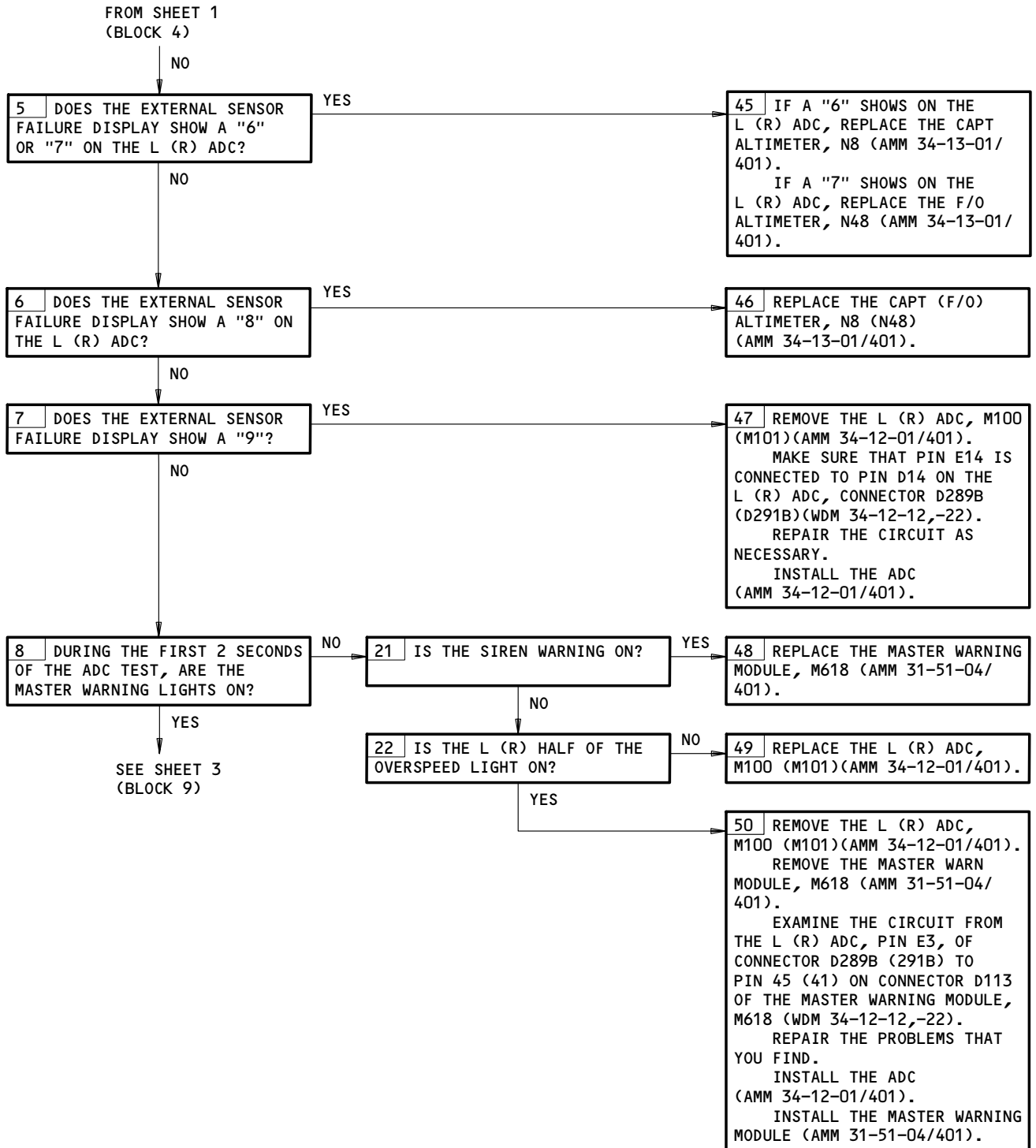

ADC BITE Procedure
Figure 109A (Sheet 2)

EFFECTIVITY
GUI 001-008, 010-114, 116-999

34-12-00

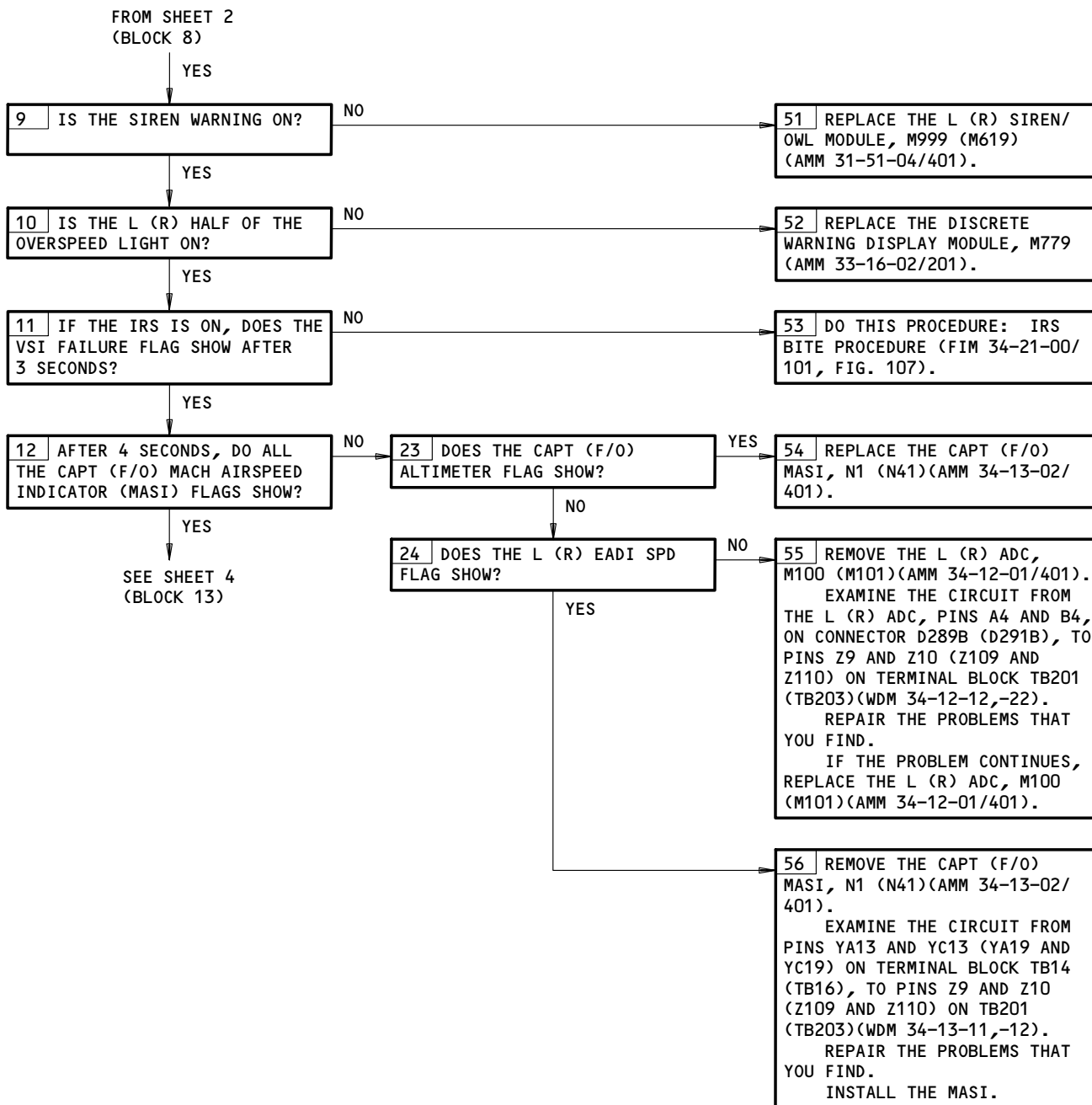

ADC BITE Procedure
Figure 109A (Sheet 3)

EFFECTIVITY
GUI 001-008, 010-114, 116-999

34-12-00

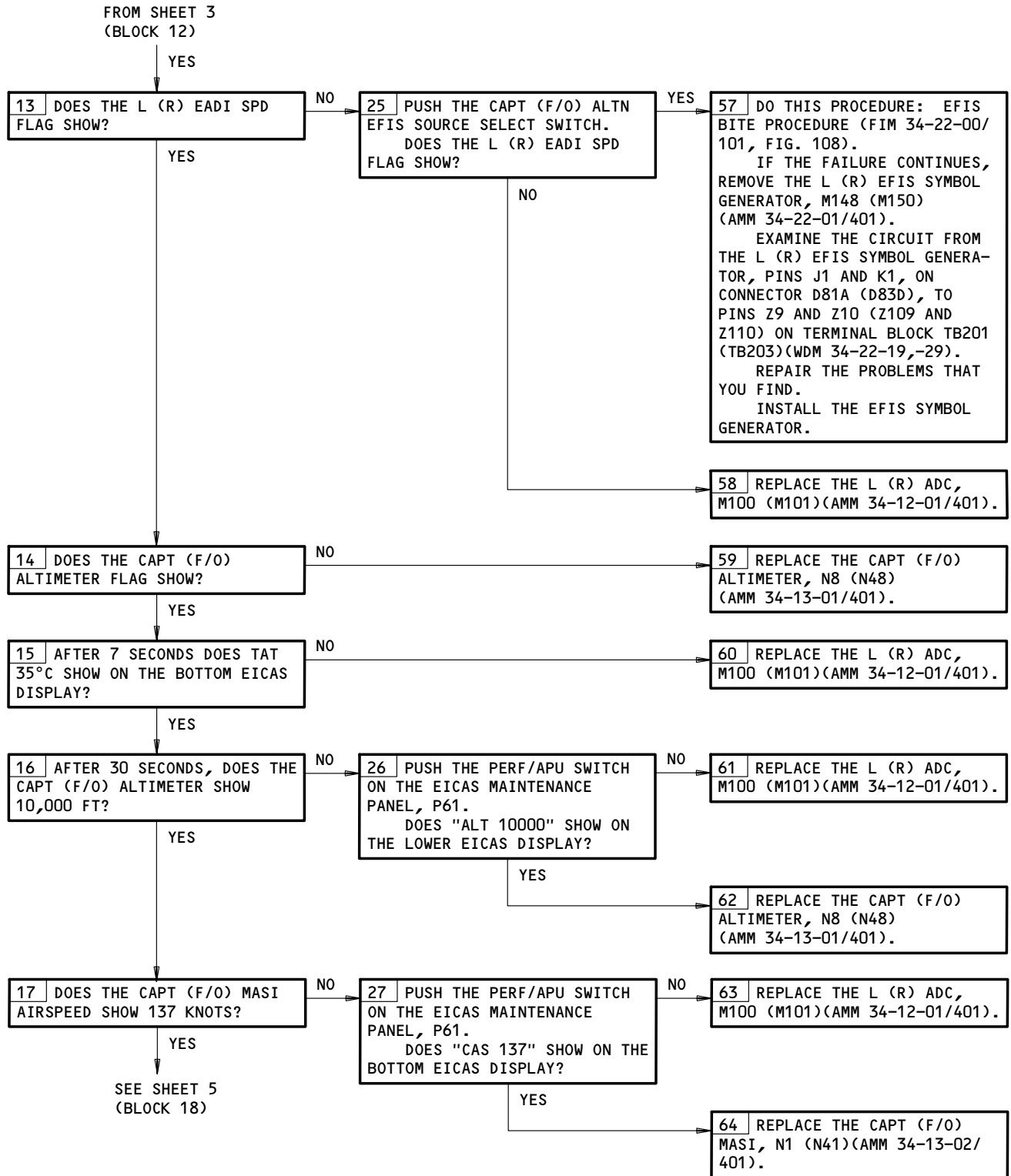

ADC BITE Procedure
Figure 109A (Sheet 4)

EFFECTIVITY
GUI 001-008, 010-114, 116-999

34-12-00

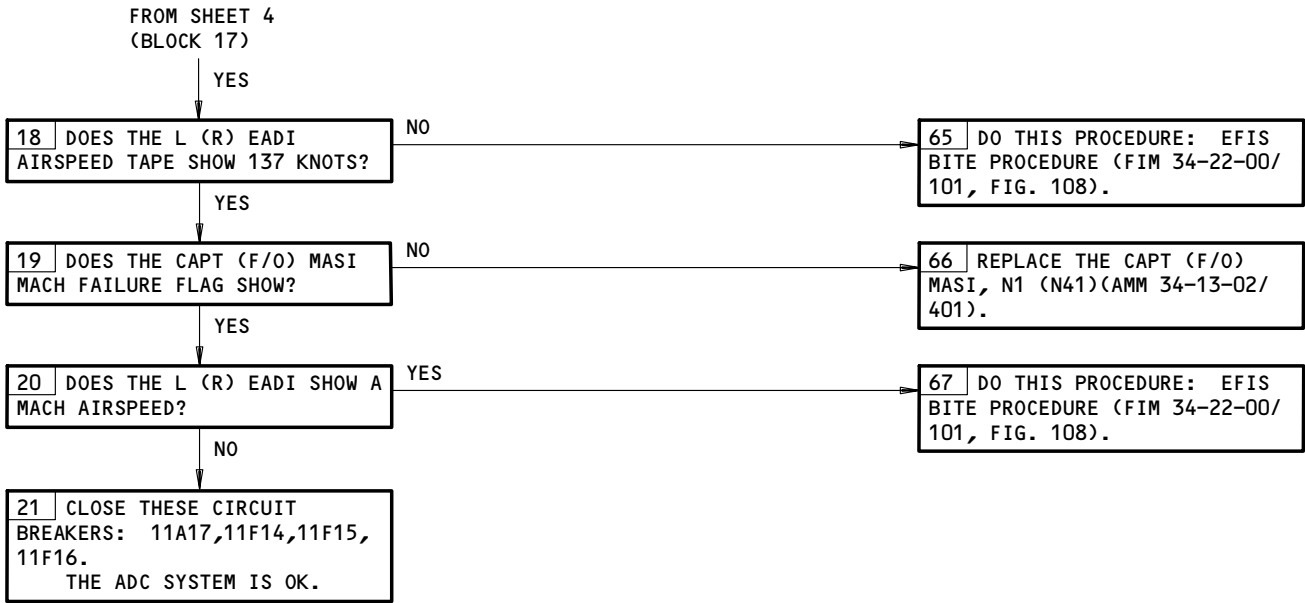

ADC BITE Procedure
Figure 109A (Sheet 5)

EFFECTIVITY
GUI 001-008, 010-114, 116-999

34-12-00

1. ARINC Data Bus Charts

A. General

CAUTION: DO NOT DIRECTLY TOUCH THE CONNECTORS. USE A BREAKOUT BOX OR YOU CAN CAUSE DAMAGE TO THE CONNECTORS.

- (1) The ARINC 429 data bus charts give data necessary to make an analysis of ARINC 429 transmitters, receivers, and data buses. For the test, use a breakout box at the available terminal or at the LRU connectors.

B. Equipment

- (1) Standard multi-meter
- (2) 429EBP Data Bus Analyzer (recommended)
 JcAIR Instrumentation
 400 Industrial Parkway
 Industrial Airport, KS 66031

429-2 Data Bus Analyzer (alternative)
 Interface Technology
 150 E. Arrow Highway
 San Dimas, CA 91773

- (3) A34011-1 Breakout Box (recommended)
 A34011-112 Breakout Box (alternative)

NOTE: Octal labels 034, 035, 251, and 252 are multiple function labels and will not show correct data in engineering units on the data bus analyzer unless you set the hex equipment identification to ID=06. If you cannot set the hex equipment identification, do the steps that follow:

- Show the label in hexadecimal format
- Make a record of the value
- Set the data bus analyzer to send a label in hex format as shown below:

RECEIVED LABEL	TRANSMIT LABEL
034	234 or 236
035	235 or 237
251	204 or 220
252	204 or 220

- Put in the hexadecimal value that you recorded for the RECEIVED LABEL.
- Use engineering format to show the correct engineering value.

EFFECTIVITY

ALL

34-12-00

06

Page 127
 May 28/07

BOEING
 757
 FAULT ISOLATION/MAINT MANUAL

ADC								
DIGITAL OUTPUT BUS CHART								
BUS NAME			CON	PINS	BUS FORMAT	BIT RATE	DATA BUS	
SOURCE	TYPE	BUS						
ADC (L R)	A	1	B	A02 B02	429	LO	ADC APFDS BUS	
ADC (L R)	A	2	B	A04 B04	429	LO	ADC INSTR BUS	
ADC (L R)	A	3	B	A06 B06	429	LO	ADC ENG CONT BUS	
ADC (L R)	A	4	B	A08 B08	429	LO	ADC GEN PRPS BUS	

EFFECTIVITY

ALL

34-12-00

06

Page 128
May 28/07



BOEING
757
FAULT ISOLATION/MAINT MANUAL

BARO COR NO.3(MB)	A	034	BCD	8	XX	± 7999.9	ALWAYS POS	MB
BARO COR NO.3(IN)	A	035	BCD	8	XX	± 79.999	ALWAYS POS	INS HG
ALTITUDE (29.92)	A	203	BNR	16	XX	± 131,072	ABOVE SEA LEV	FEET
ALTITUDE (BARO #1)	A	204	BNR	16	XX	± 131,072	ABOVE SEA LEV	FEET
MACH	A	205	BNR	8	XX	± 4.096	ALWAYS POS	MACH
COMPUTED AIRSPEED	A	206	BNR	8	XX	± 1024	ALWAYS POS	KNOTS
MAX OPRTG SCHEDULE	A	207	BNR	8	XX	± 1024	ALWAYS POS	KNOTS
TRUE AIRSPEED	A	210	BNR	8	XX	± 2048	ALWAYS POS	KNOTS
TOTAL AIR TEMP	A	211	BNR	2	XX	± 512	ABOVE FREEZIN	DEG C
ALTITUDE RATE	A	212	BNR	16	XX	± 32,768	CLIMB UP	FT/MIN
STATIC AIR TEMP	A	213	BNR	2	XX	± 512	ABOVE FREEZIN	DEG C
IMPACT PRESSURE	A	215	BNR	8	XX	± 512	ALWAYS POS	MB
ALTITUDE (BARO #2)	A	220	BNR	16	XX	± 131,072	ABOVE SEA LEV	FEET
INDICATED AOA	A	221	BNR	16	XX	± 180	NOSE UP	DEG
ANGLE OF ATTACK-#1	A	222	BNR	16	XX	± 180	NOSE UP	DEG
ANGLE OF ATTACK-#2	A	223	BNR	16	XX	± 180	NOSE UP	DEG
TRUE AIRSPEED-D	A	230	BCD	2	XX	± 799	ALWAYS POS	KNOTS
TOTAL AIR TEMP-D	A	231	BCD	2	XX	± 99	ABOVE FREEZIN	DEG C
STATIC AIR TEMP-D	A	233	BCD	2	XX	± 99	ABOVE FREEZIN	DEG C
BARO COR NO.1(MB)	A	234	BCD	8	XX	± 7999.9	ALWAYS POS	MB
BARO COR NO.1(IN)	A	235	BCD	8	XX	± 79.999	ALWAYS POS	INS HG
BARO COR NO.2(MB)	A	236	BCD	8	XX	± 7999.9	ALWAYS POS	MB
BARO COR NO.2(IN)	A	237	BCD	8	XX	± 79.999	ALWAYS POS	INS HG
CORRECTED AOA	A	241	BNR	16	XX	± 180	NOSE UP	DEG

EFFECTIVITY

ALL

34-12-00

05

Page 129
May 28/07

BOEING
 757
 FAULT ISOLATION/MAINT MANUAL

BARO COR NO.3(MB)	A	034	BCD	8	XX	± 7999.9	ALWAYS POS	MB
BARO COR NO.3(IN)	A	035	BCD	8	XX	± 79.999	ALWAYS POS	INS HG
TOTAL PRESSURE	A	242	BNR	8	XX	± 2048	ALWAYS POS	MB
ALTITUDE (BARO #3)	A	251	BNR	16	XX	± 131,072	ABOVE SEA LEV	FEET
ALTITUDE (BARO #4)	A	252	BNR	16	XX	± 131,072	ABOVE SEA LEV	FEET
ADC DISCRETES #1	A	270	DIS	2	XX	N/A	N/A	N/A
ADC DISCRETES #2	A	271	DIS	2	XX	N/A	N/A	N/A
MAINTENANCE WD 1	A	350	DIS	2	XX	N/A	N/A	N/A
MAINTENANCE WD 2	A	351	DIS	2	XX	N/A	N/A	N/A
MAINTENANCE WD 3	A	352	DIS	2	XX	N/A	N/A	N/A
MAINTENANCE WD 4	A	353	BCD	2	XX	N/A	N/A	N/A
MAINTENANCE WD 5	A	354	BNR	2	XX	± 63.999	ALWAYS POS	INS HG

EFFECTIVITY

ALL

34-12-00

05

Page 130
May 28/07



BOEING
757
FAULT ISOLATION/MAINT MANUAL

ADC				
DISCRETE OCTAL LABELS/BIT CHART				
SIGNAL	OCTAL LABEL	BIT	ONE-STATE	ZERO-STATE
SENSOR #1 HEAT ON	270	11	#1 HTR ON	#1 HTR OFF
SENSOR #2 HEAT ON	270	12	#2 HTR ON	#2 HTR OFF
ADC INVALID	270	13	ADC FAIL	ADC OK
PIT/STAT HEAT ON L	270	14	L P/S ON	L P/S OFF
PIT/STAT HEAT ON R	270	15	R P/S ON	R P/S OFF
TAT PROBE HEAT ON	270	16	TAT HTR ON	HTR OFF
#1 AOA HEAT ON	270	17	AOA #1 ON	AOA #1 OFF
#2 AOA HEAT ON	270	18	AOA #2 ON	AOA #2 OFF
OVERSPEED	270	19	OVERSPEED	NOT OVRSPD
ONSIDE AOA FAIL	270	20	ONSIDE FL	ONSIDE OK
AOA UNIQUE	270	21	UNIQUE	AVERAGE
VMO ALTERNATE #1	270	22	VMO=ALT #1	VMO NOT #1
VMO ALTERNATE #2	270	23	VMO=ALT #2	VMO NOT #2
VMO ALTERNATE #3	270	24	VMO=ALT #3	VMO NOT #3
VMO ALTERNATE #4	270	25	VMO=ALT #4	VMO NOT #4
SSEC ALTERNATE	270	26	ALTERNATE	NORMAL
AOAC ALTERNATE	270	27	ALTERNATE	NORMAL
BARO PORT "A"	270	28	BARO "A"	BARO "B"
ZERO SSEC (MACH)	270	29	NO MACH	MACH
ZERO SSEC (AOA)	271	11	NO AOA	AOA
EXT AOA MON (FAIL)	271	12	PRI AOA FL	PRI AOA OK
AOA ROT REF	271	13	#1=#2	#1=-#2

EFFECTIVITY

ALL

34-12-00

05

Page 131
May 28/07



BOEING
757
FAULT ISOLATION/MAINT MANUAL

ADC				
DISCRETE OCTAL LABELS/BIT CHART				
SIGNAL	OCTAL LABEL	BIT	ONE-STATE	ZERO-STATE
SDI PAR SET	271	14	SET	NOT SET
#4 BARO ALT=#1	271	16	#4 ALT=#1	#4 NOT #1
#4 BARO ALT=#2	271	17	#4 ALT=#2	#4 NOT #2
#4 BARO ALT=#3	271	18	#4 ALT=#3	#4 NOT #3
#1 AOA VANE TEST	350	11	#1 AOA FAIL	#1 AOA OK
#2 AOA VANE TEST	350	12	#2 AOA FAIL	#2 AOA OK
SDI PARITY	350	13	PAR FAIL	PAR OK
TAT INPUT TEST	350	15	TAT FAIL	TAT OK
BARO #1 TEST	350	16	BARO #1 FL	BARO #1 OK
BARO #2 TEST	350	17	BARO #2 FL	BARO #2 OK
BARO #3 TEST	350	18	BARO #3 FL	BARO #3 OK
A/C TYPE PROG TEST	350	19	PROG FAIL	PROG OK
A/C TYPE CONST TST	350	20	CONST FAIL	CONST OK
OSPD HDWR TEST	350	21	OSPD FAIL	OSPD OK
A TO D TEST	350	22	A TO D FL	A TO D OK
PROCESSOR TEST	350	23	PROC FAIL	PROC OK
RAM TEST	350	24	RAM FAIL	RAM OK
PROG MEM TEST	350	25	PROM FAIL	PROM OK
PS SENS PER TEST	350	26	SENSOR FL	SENSOR OK
PS SENS TEMP TEST	350	27	SENSOR FL	SENSOR OK
PS CALIB TEST	350	28	CALIB FAIL	CALIB OK
F/D CONVERSION TST	350	29	CONV FAIL	CONV OK

EFFECTIVITY

ALL

34-12-00

05

Page 132
May 28/07

BOEING
 757
 FAULT ISOLATION/MAINT MANUAL

ADC				
DISCRETE OCTAL LABELS/BIT CHART				
SIGNAL	OCTAL LABEL	BIT	ONE-STATE	ZERO-STATE
PT SENS PER TEST	351	11	SENSOR FL	SENSOR OK
PT SENS TEMP TEST	351	12	SENSOR FL	SENSOR OK
PT CALIB TEST	351	13	CALIB FAIL	CALIB OK
ARINC XMTR TEST	351	14	XMTR FAIL	XMTR OK
ARINC XMTR TEST	351	15	XMTR FAIL	XMTR OK
ARINC XMTR TEST	351	16	XMTR FAIL	XMTR OK
POWER SUPPLY TEST	351	17	PWR SUP FL	PWR SUP OK
PS=PT	351	19	PS NOT PT	PS=PT
AVERAGE AOA TEST	351	20	INVALID	AOA OK
TEMP PS=TEMP PT	351	21	PS NOT PT	PS=PT
PROG SEQ TEST	351	22	SEQ FAIL	SEQ OK
VMO TEST	351	23	>1 VMO	<2 VMO
EAROM TEST	351	24	EAROM FL	EAROM OK
BARO #4 TEST	351	26	#4=NCD	#4=PRG PIN
CKSUM CHIP1	352	11	#1 FAIL	#1 OK
CKSUM CHIP2	352	12	#2 FAIL	#2 OK
CKSUM CHIP3	352	13	#3 FAIL	#3 OK
CKSUM CHIP4	352	14	#4 FAIL	#4 OK
PS MEM CHECK	352	15	PS MEM FL	PS MEM OK
PT MEM CHECK	352	16	PT MEM FL	PT MEM OK
A/C TYPE MEM CHECK	352	17	MEM FAIL	MEM OK

EFFECTIVITY

ALL

34-12-00

04

Page 133
May 28/07

BOEING
 757
 FAULT ISOLATION/MAINT MANUAL

ADC				
DISCRETE OCTAL LABELS/BIT CHART				
SIGNAL	OCTAL LABEL	BIT	ONE-STATE	ZERO-STATE
A/C TYPE LSB	352	24	LSB=1	LSB=0
A/C TYPE LSB+1	352	25	LSB+1=1	LSB+1=0
A/C TYPE LSB+2	352	26	LSB+2=1	LSB+2=0
A/C TYPE LSB+3	352	27	LSB+3=1	LSB+3=0
A/C TYPE MSB	352	28	MSB=1	MSB=0
A/C TYPE PARITY	352	29	PRTY EVEN	PRTY ODD

EFFECTIVITY

ALL

34-12-00

BOEING
757
FAULT ISOLATION/MAINT MANUAL

AIR DATA INSTRUMENTS

COMPONENT	FIG. 102 SHT	QTY	ACCESS/AREA	AMM REFERENCE
ALTIMETER - CAPT, N8	2	1	FLIGHT COMPARTMENT, P1	34-13-01
ALTIMETER - F/O, N48	2	1	FLIGHT COMPARTMENT, P3	34-13-01
ALTIMETER - STANDBY, N23	2	1	FLIGHT COMPARTMENT, P1	34-13-06
CIRCUIT BREAKER -	1	1	FLIGHT COMPARTMENT, P11	
ALTM LEFT, C584		1	11E2	*
ALTM RIGHT, C585		1	11E23	*
IAS MACH LEFT, C580		1	11E1	*
IAS MACH RIGHT, C581		1	11E22	*
METRIC ALTM LEFT, C4499		1	11E7	*
STBY ALTM VIB, C591		1	11A8	*
INDICATOR - CAPT MACH AIRSPEED, N1	2	1	FLIGHT COMPARTMENT, P1	34-13-02
INDICATOR - F/O MACH AIRSPEED, N41	2	1	FLIGHT COMPARTMENT, P3	34-13-02
INDICATOR - STANDBY AIRSPEED, N22	2	1	FLIGHT COMPARTMENT, P1	34-13-05
METRIC ALTIMETER - CAPT, N10041		1	FLIGHT COMPARTMENT, P1	34-13-08
SWITCH - (FIM 34-12-00/101)				
CAPT ADC INSTR SOURCE SELECT, S482				
F/O ADC INSTR SOURCE SELECT, S483				

* SEE THE WDM EQUIPMENT LIST

GUI 010,011 POST SB 34-166

Air Data Instruments - Component Index
Figure 101

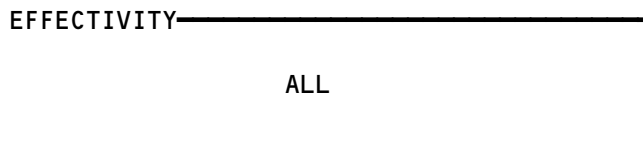

34-13-00

BOEING

757

FAULT ISOLATION/MAINT MANUAL

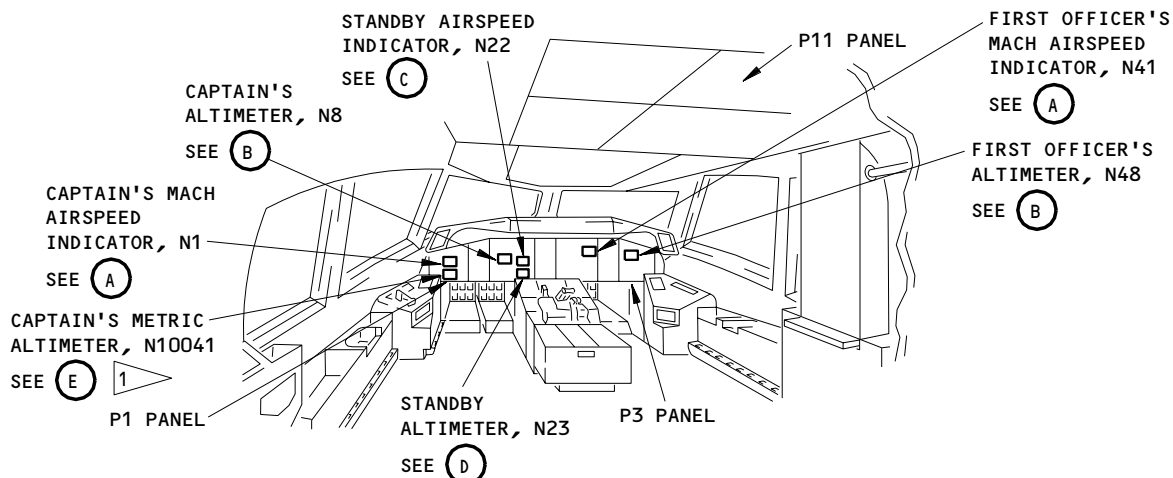

FLIGHT COMPARTMENT

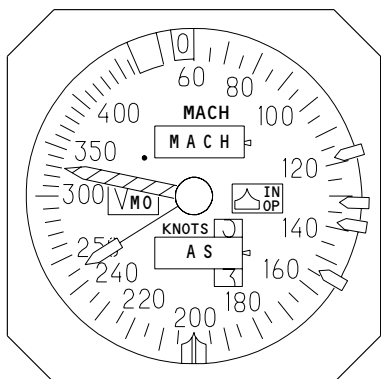

MACH AIRSPEED INDICATOR (WITH FLAGS), N1 OR N41

(A)

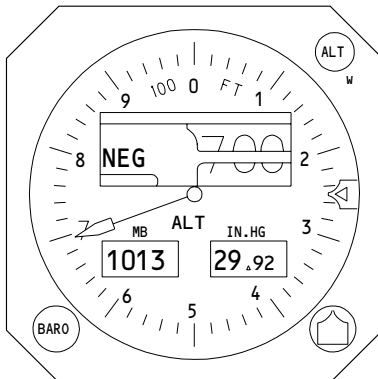

ALTIMETER (WITH OFF FLAG), N8 OR N48

(B)

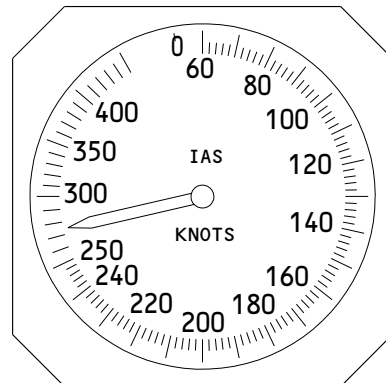

STANDBY AIRSPEED INDICATOR, N22

(C)

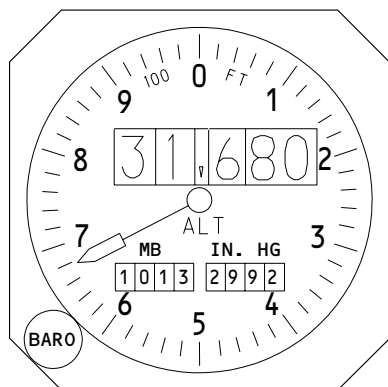

STANDBY ALTIMETER, N23

(D)

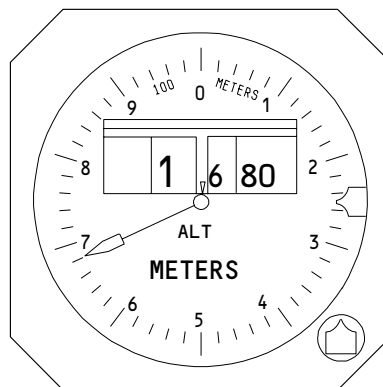

METRIC ALTIMETER, N10041

(E)

1 GUI 010,011
POST-SB 34-166

Air Data Instruments - Component Location
Figure 102

EFFECTIVITY

ALL

34-13-00

07

Page 102
Jan 20/98

H06329

**STANDBY AIRSPEED
INDICATOR ERROR**

PREREQUISITES
 ELECTRICAL POWER (MM 24-22-00/201)
 CB'S IN: 11A8,11J2,11J3,11J29,11J30,11J31,11J32

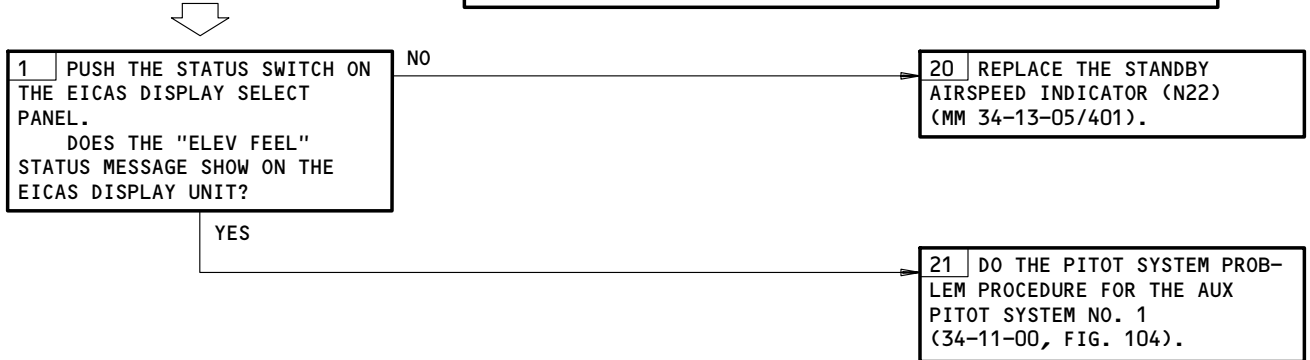

Standby Airspeed Indicator Error
Figure 103

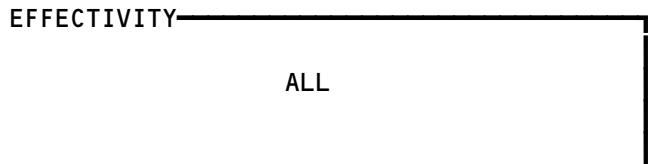

34-13-00



BOEING
 757
 FAULT ISOLATION/MAINT MANUAL

ALTITUDE ALERT SYSTEM

COMPONENT	FIG. 102 SHT	QTY	ACCESS/AREA	REFERENCE
ALTIMETER - (REF 34-13-00, FIG. 101) CAPT, N8 F/O, N48				
CIRCUIT BREAKERS			FLT COMPT, P11	
AURAL WARN SPKR LEFT, C567	--	1	11B16	*
AURAL WARN SPKR RIGHT, C568	--	1	11H35	*
WARN ELEX A, C565	--	1	11J33	*
WARN ELEX B, C566	--	1	11B18	*
LIGHT - ALTITUDE ADVISORY	--	2	FLT COMPT, P1,P3, ALTIMETER N8, N48	*
LIGHT - ALTITUDE ALERT, L485	--	1	FLT COMPT, P1	*
MODULE - ALTITUDE ALERT, M617	--	1	119BL, MAIN EQUIP CTR, P51	34-16-01
MODULE - (REF 32-09-03, FIG. 101) PSEU, M162				
SWITCH - (REF 34-12-00, FIG. 101) CAPT ADC, S482				
SWITCH - (REF 32-44-00, FIG.101) PARKING BRAKE, S459				

* SEE THE WDM EQUIPMENT LIST

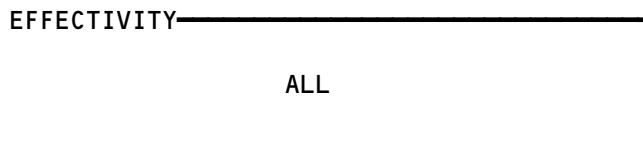
Altitude Alert System - Component Index
Figure 101



34-16-00

BOEING

757 FAULT ISOLATION/MAINT MANUAL

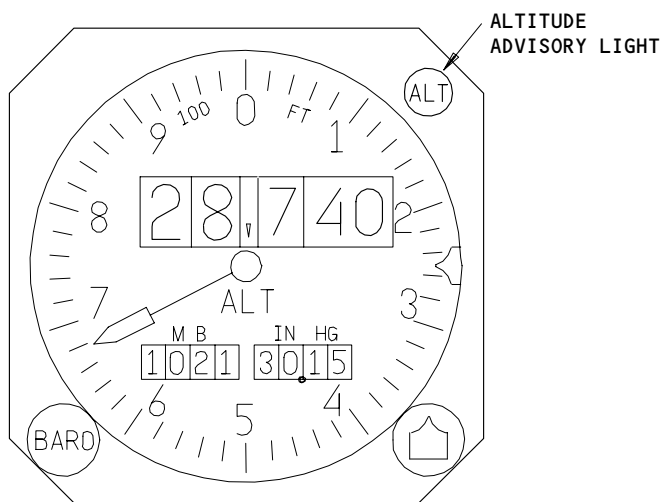
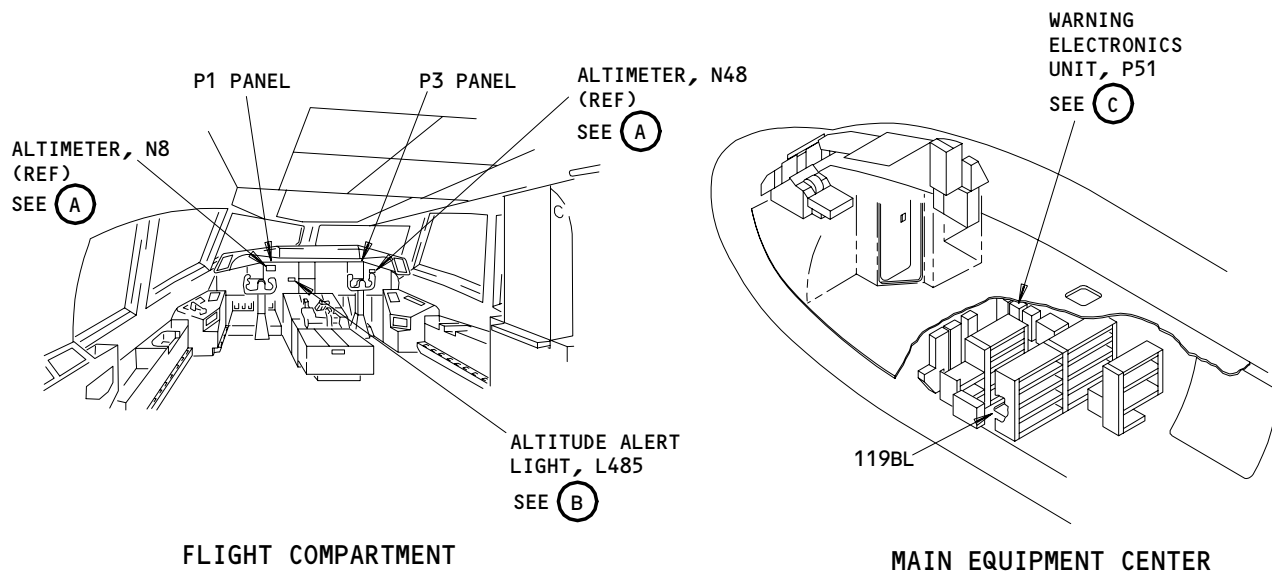

ALTIMETER, N8 OR N48 (REF)

(A)



ALTITUDE ALERT LIGHT, L485

(B)

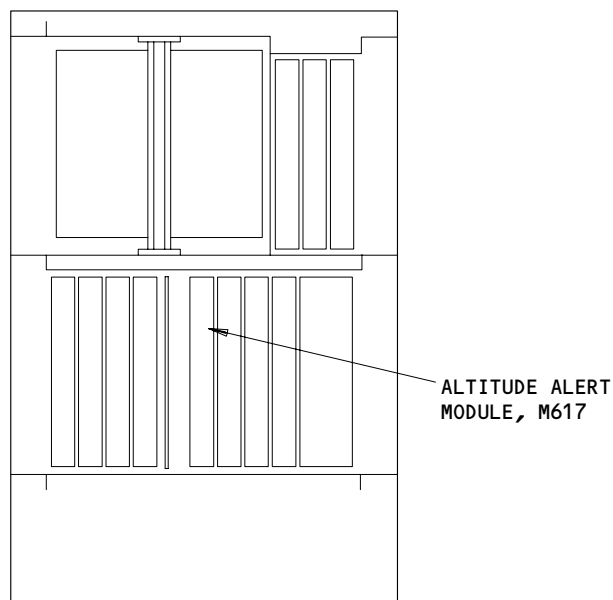

WARNING ELECTRONICS UNIT, P51

(C)

Component Location
Figure 102

EFFECTIVITY

ALL

34-16-00

01

Page 102
Jun 20/90

55241

**ALTITUDE ALERT
SYSTEM FAULT
ISOLATION**

PREREQUISITES

MAKE SURE THESE SYSTEMS WILL OPERATE:

- AUTOPILOT (AMM 22-10-00/501)
- EICAS (AMM 31-41-00/201)
- ADC (AMM 34-12-00/501)

MAKE SURE THESE CIRCUIT BREAKERS ARE CLOSED:

- 11B16,11B18,11H35,11J33

MAKE SURE THE AIRPLANE IS IN THIS CONFIGURATION:

- ELECTRICAL POWER IS ON (AMM 24-22-00/201)

EQUIPMENT:

- PROXIMITY SENSOR ACTUATOR/DEACTUATOR SET A27092-25 (AMM 27-32-00/501)

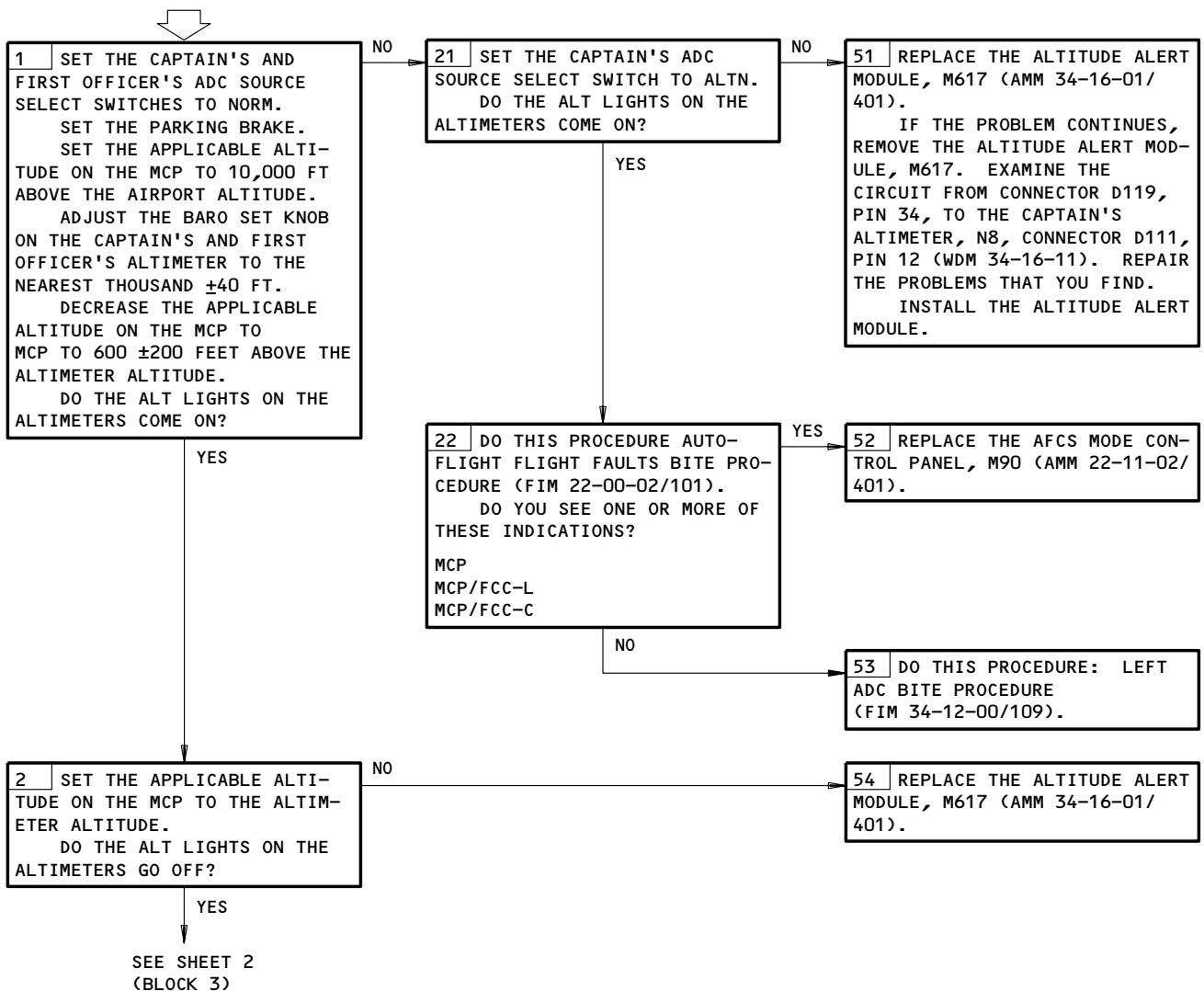

Altitude Alert System Fault Isolation
Figure 103 (Sheet 1)

EFFECTIVITY
GUI 010, 011 WITHOUT SB 34-167, AND
GUI 001-009

34-16-00

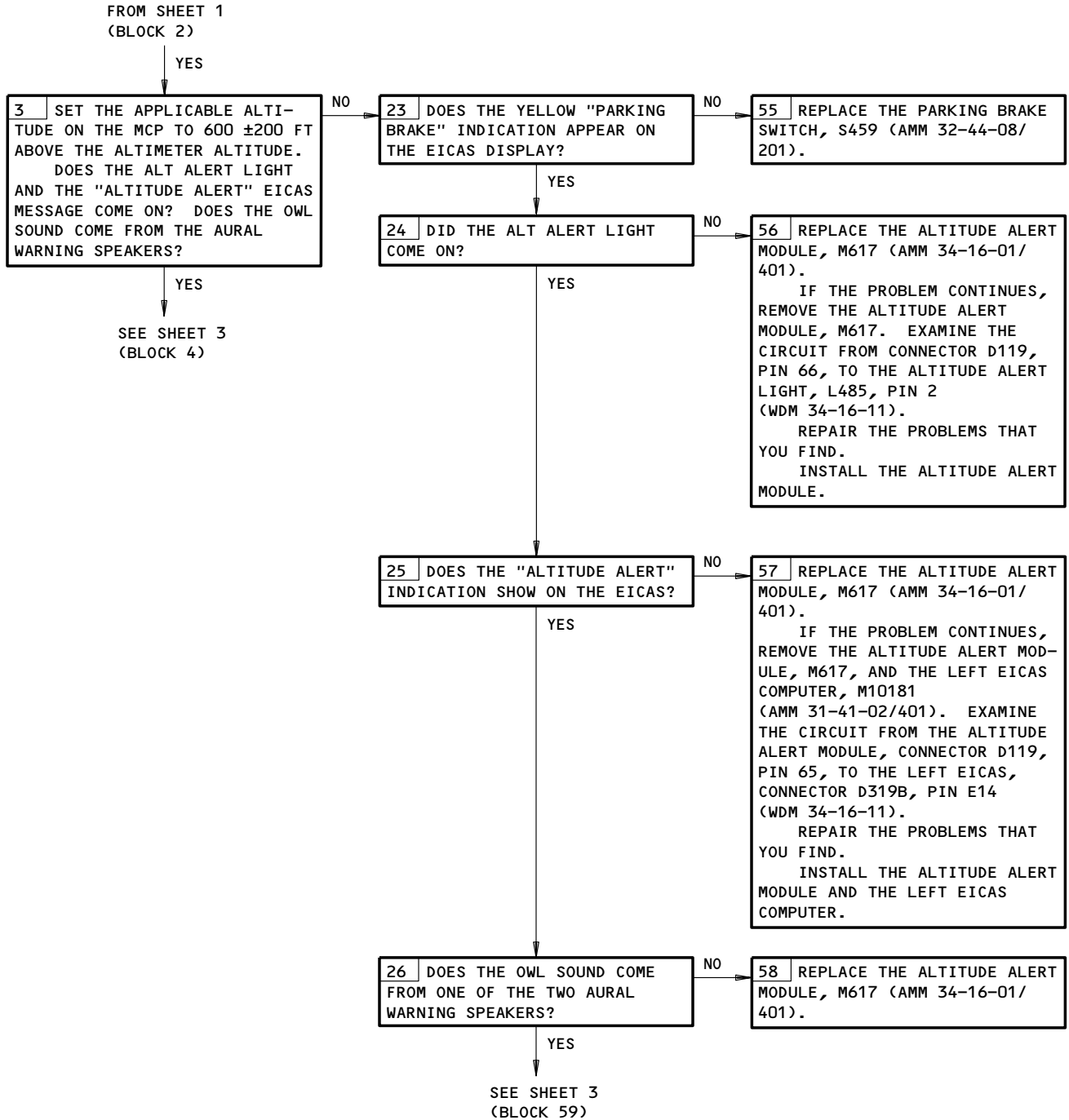

Altitude Alert System Fault Isolation
Figure 103 (Sheet 2)

EFFECTIVITY
GUI 010, 011 WITHOUT SB 34-167, AND
GUI 001-009

34-16-00

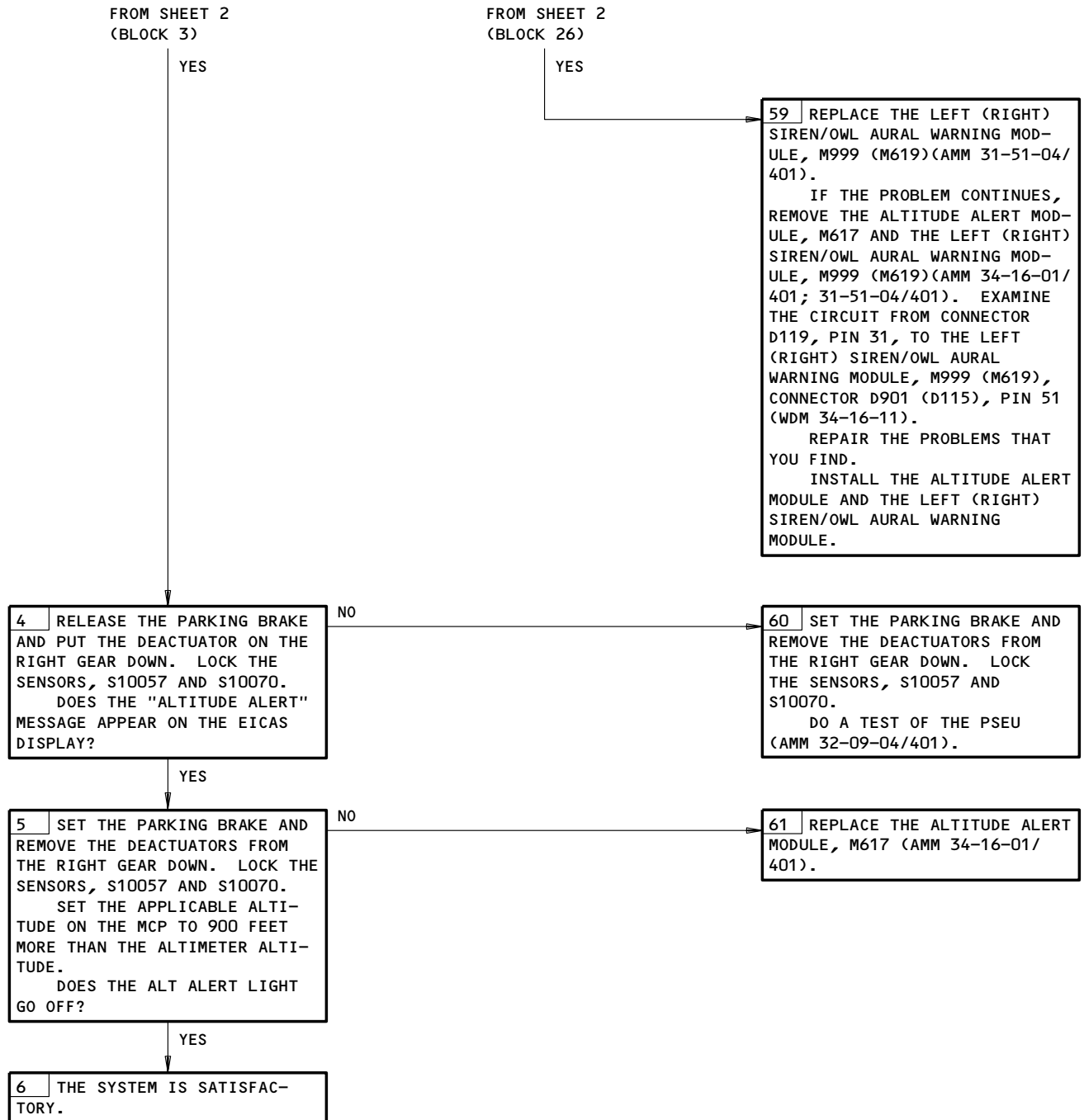

Altitude Alert System Fault Isolation
Figure 103 (Sheet 3)

EFFECTIVITY
 GUI 010, 011 WITHOUT SB 34-167, AND
 GUI 001-009

34-16-00

**ALTITUDE ALERT
SYSTEM FAULT
ISOLATION**

PREREQUISITES

MAKE SURE THESE SYSTEMS WILL OPERATE:
 AUTOPILOT (AMM 22-10-00/501)
 EICAS (AMM 31-41-00/201)
 ADC (AMM 34-12-00/501)

MAKE SURE THESE CIRCUIT BREAKERS ARE CLOSED:
 11B16,11B18,11H35,11J33

MAKE SURE THE AIRPLANE IS IN THIS CONFIGURATION:
 ELECTRICAL POWER IS ON (AMM 24-22-00/201)

EQUIPMENT:
 PROXIMITY SENSOR ACTUATOR/DEACTUATOR SET A27092-25
 (AMM 27-32-00/501)

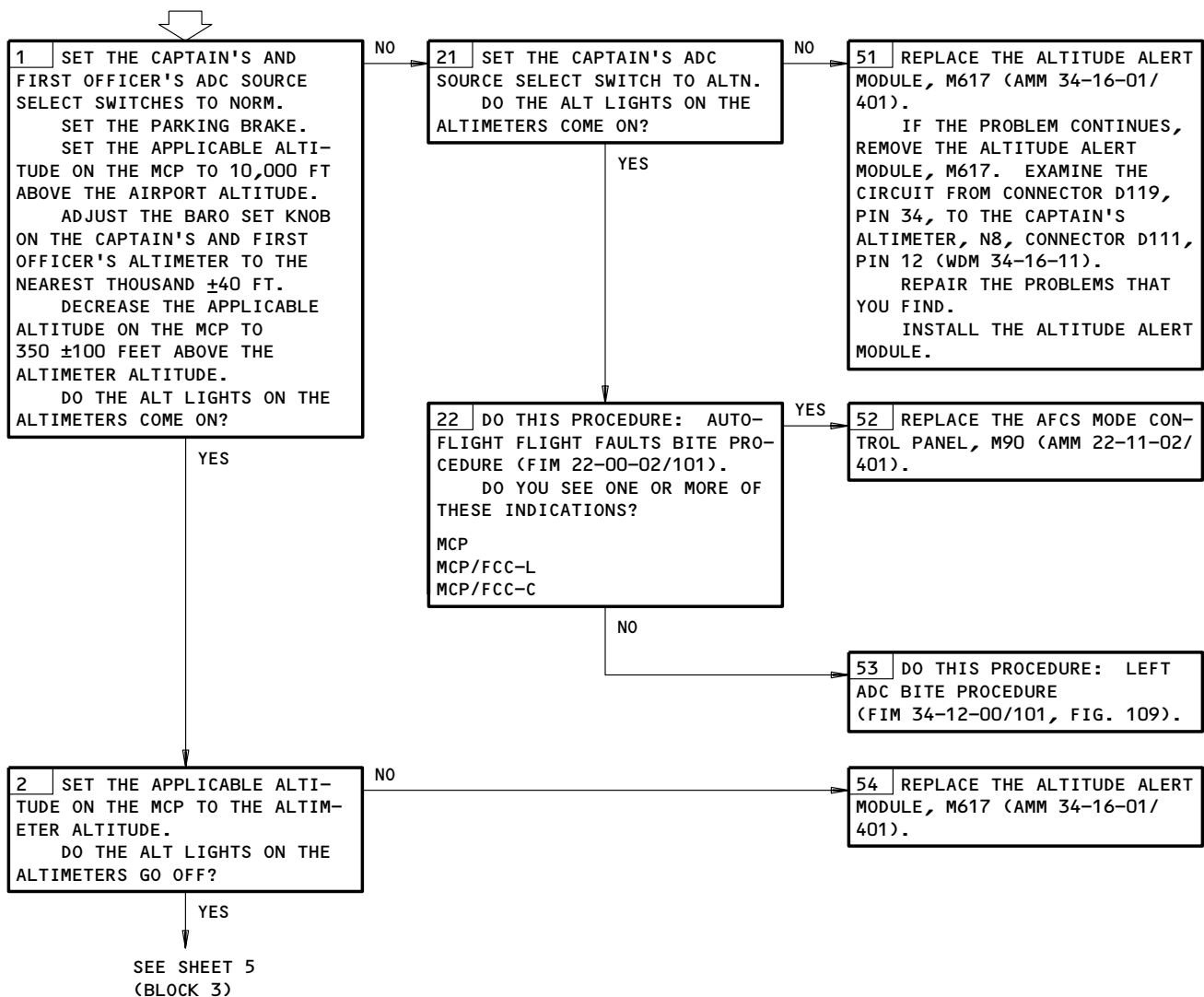

Altitude Alert System Fault Isolation
Figure 103 (Sheet 4)

EFFECTIVITY
 GUI 010, 011 WITH SB 34-167, AND
 GUI 012-114, 116-999

34-16-00

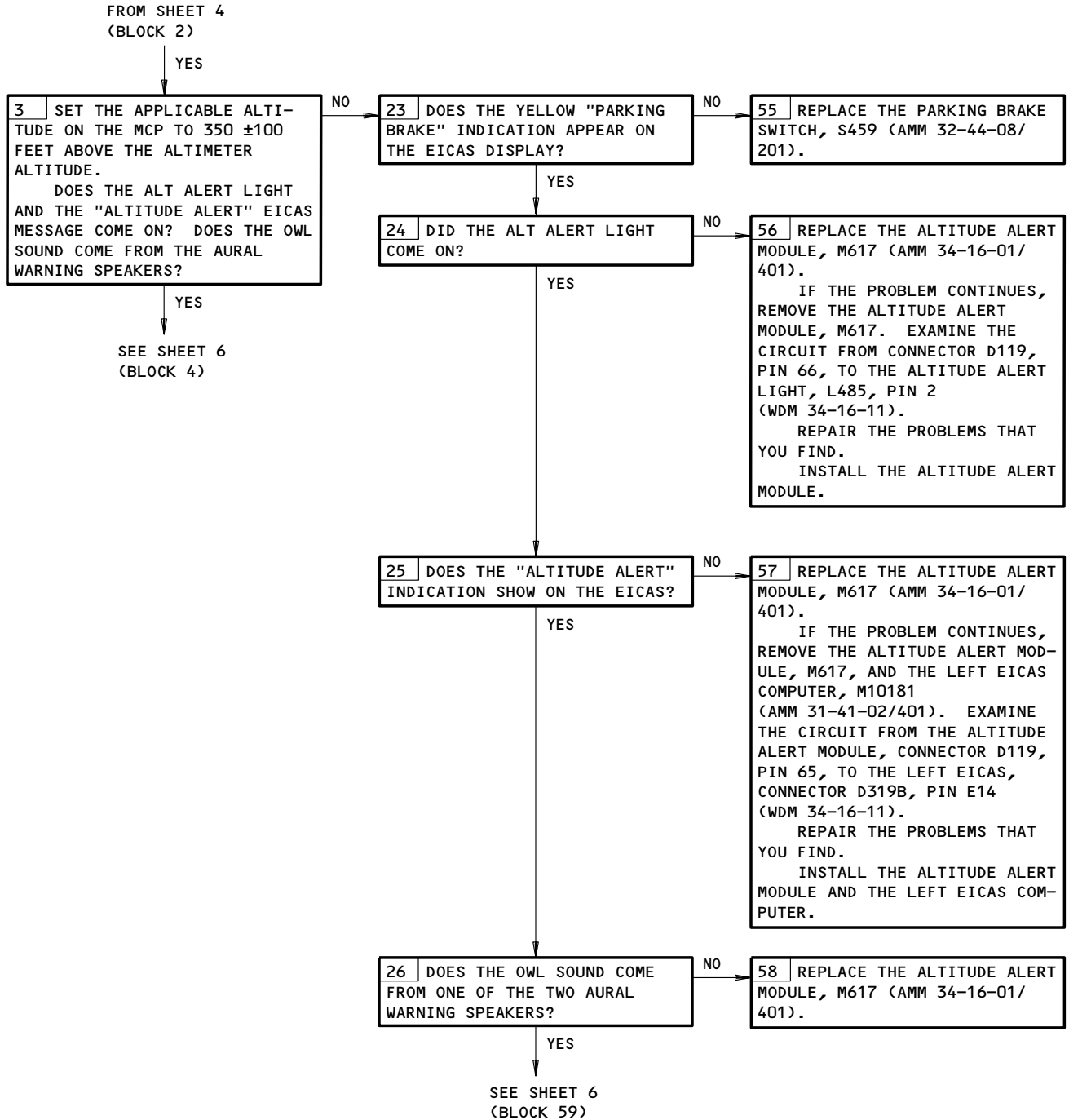

Altitude Alert System Fault Isolation
Figure 103 (Sheet 5)

EFFECTIVITY
 GUI 010, 011 WITH SB 34-167, AND
 GUI 012-114, 116-999

34-16-00

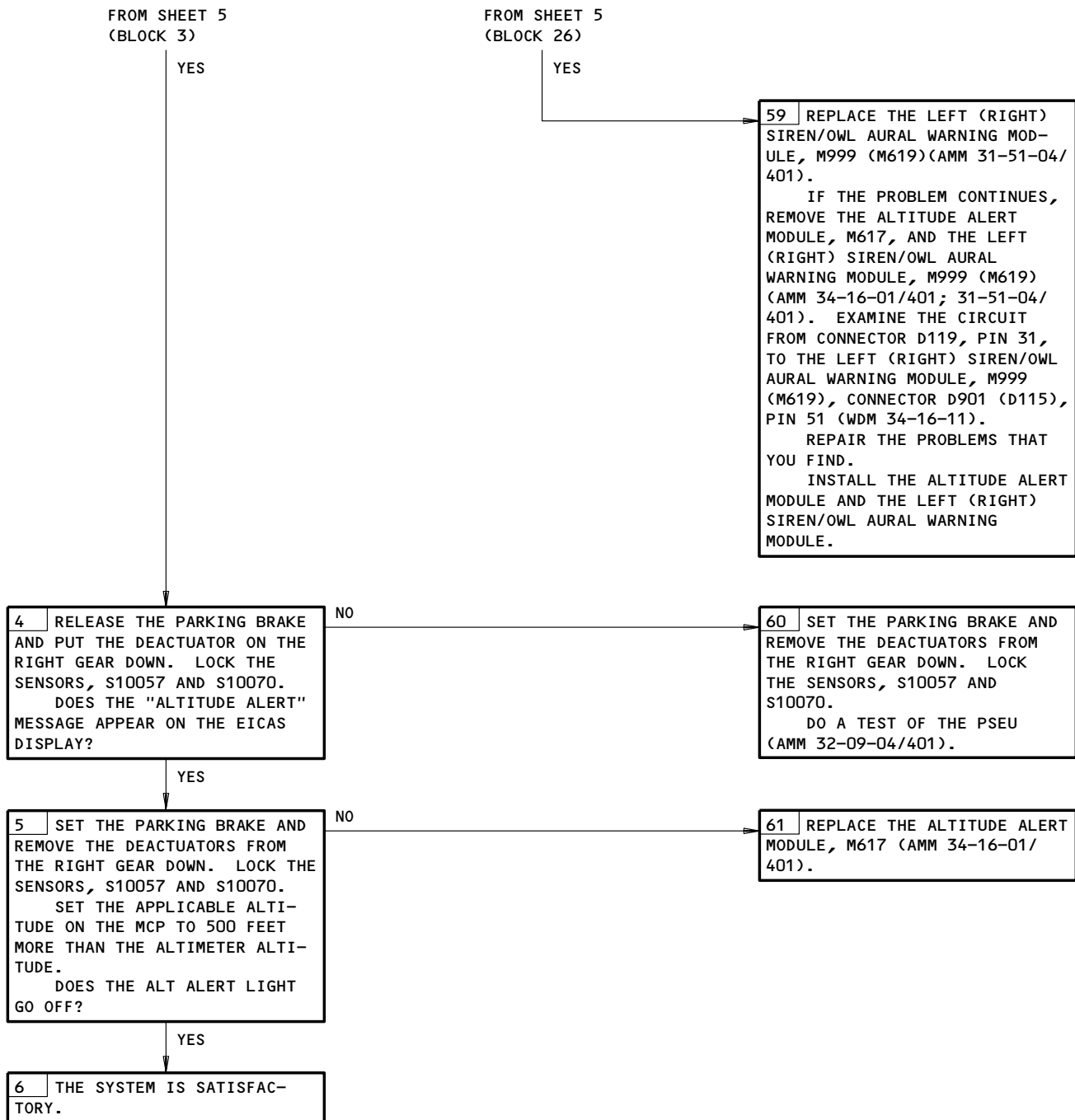

Altitude Alert System Fault Isolation
Figure 103 (Sheet 6)

EFFECTIVITY
 GUI 010, 011 WITH SB 34-167, AND
 GUI 012-114, 116-999

34-16-00

**ALTITUDE ALERT
SYSTEM FAULT
ISOLATION**

PREREQUISITES

MAKE SURE THESE SYSTEMS WILL OPERATE:

- AUTOPILOT (AMM 22-10-00/501)
- EICAS (AMM 31-41-00/201)
- ADC (AMM 34-12-00/501)

MAKE SURE THESE CIRCUIT BREAKERS ARE CLOSED:

- 11B16, 11B18, 11H35, 11J33

MAKE SURE THE AIRPLANE IS IN THIS CONFIGURATION:

- ELECTRICAL POWER IS ON (AMM 24-22-00/201)

EQUIPMENT:

- PROXIMITY SENSOR ACTUATOR/DEACTUATOR SET A27092-25 (AMM 27-32-00/501)

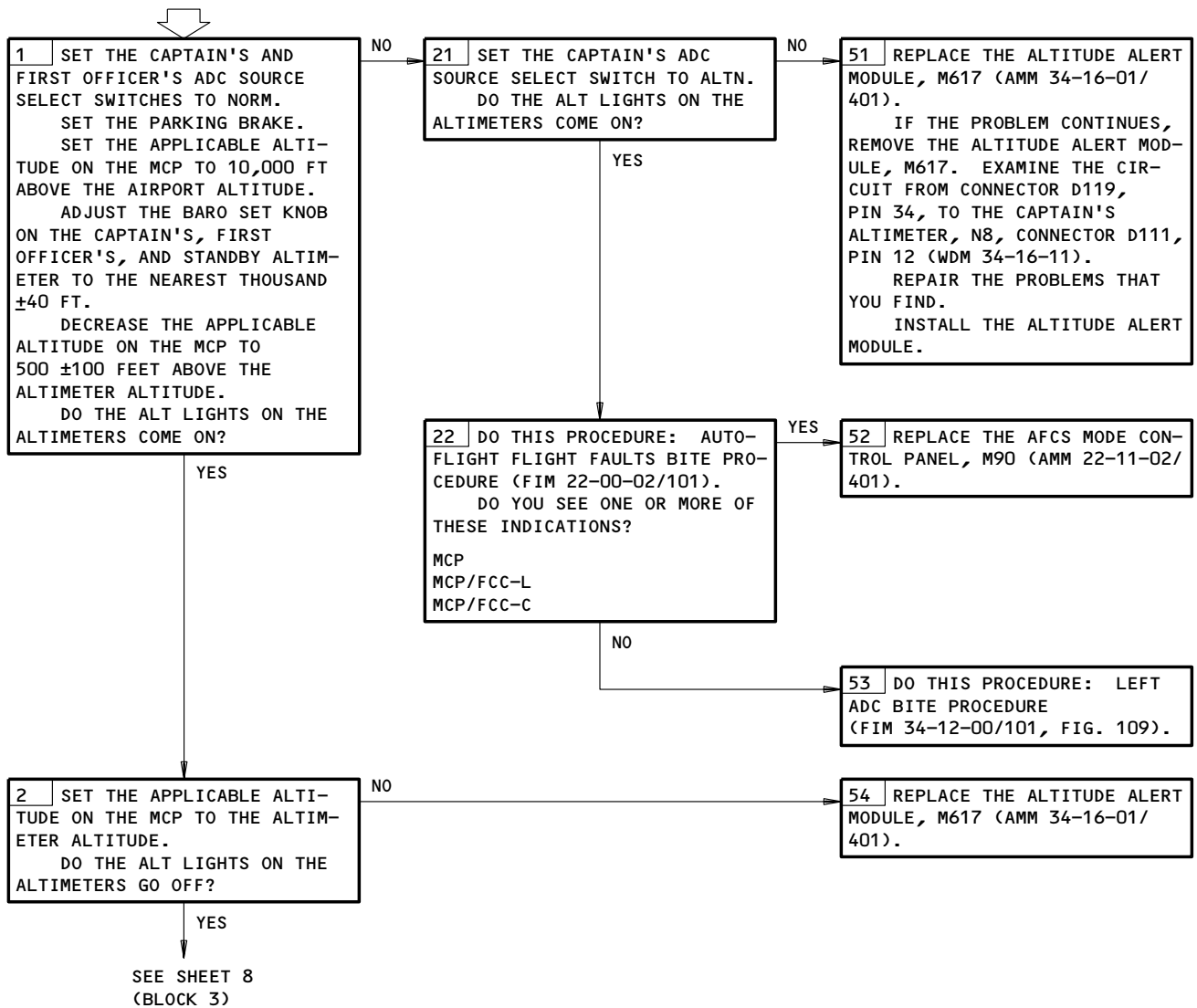

Altitude Alert System Fault Isolation
Figure 103 (Sheet 7)

EFFECTIVITY
GUI 115

34-16-00

FROM SHEET 7
(BLOCK 2)

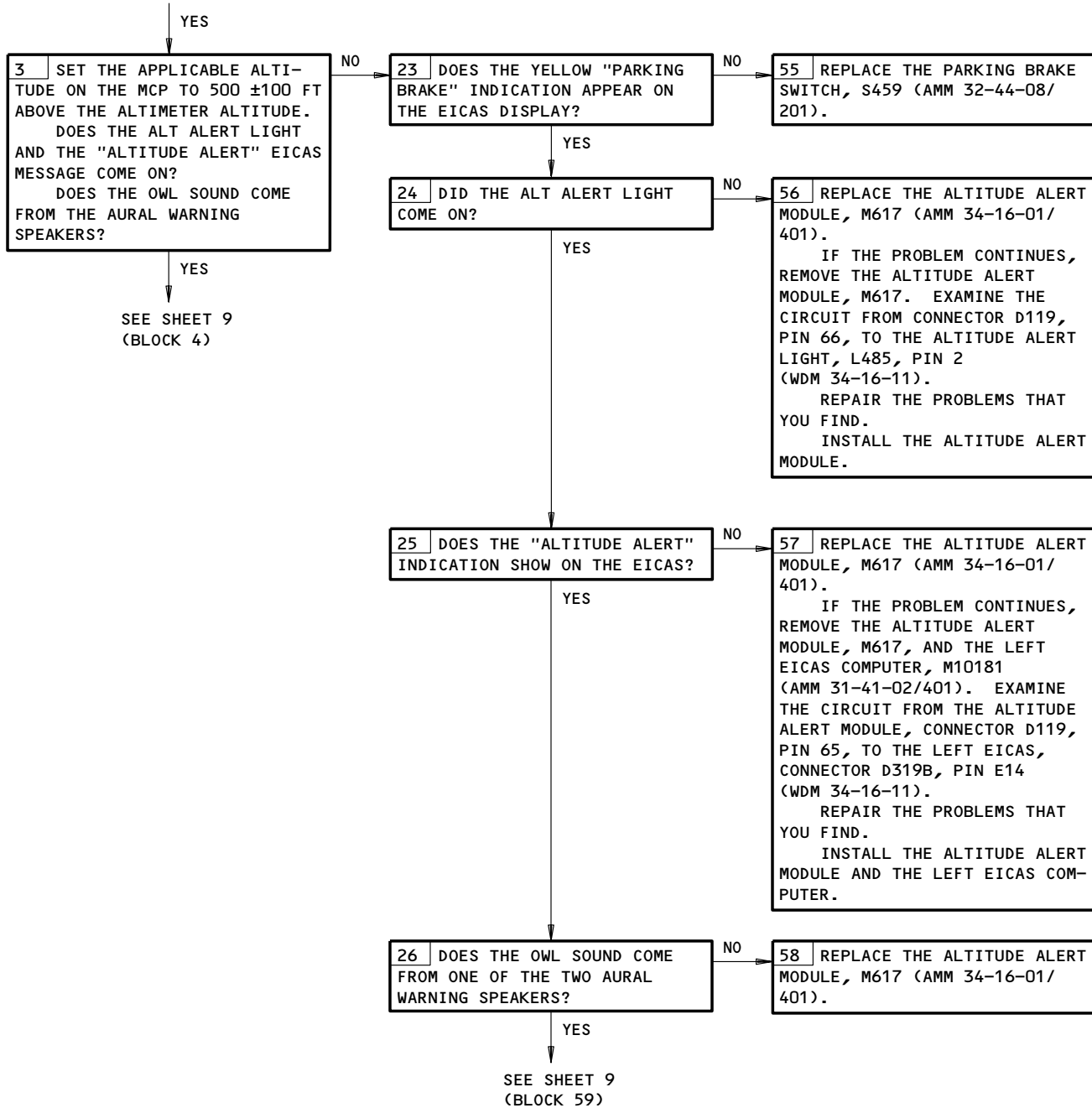

Altitude Alert System Fault Isolation
Figure 103 (Sheet 8)

EFFECTIVITY
GUI 115

34-16-00

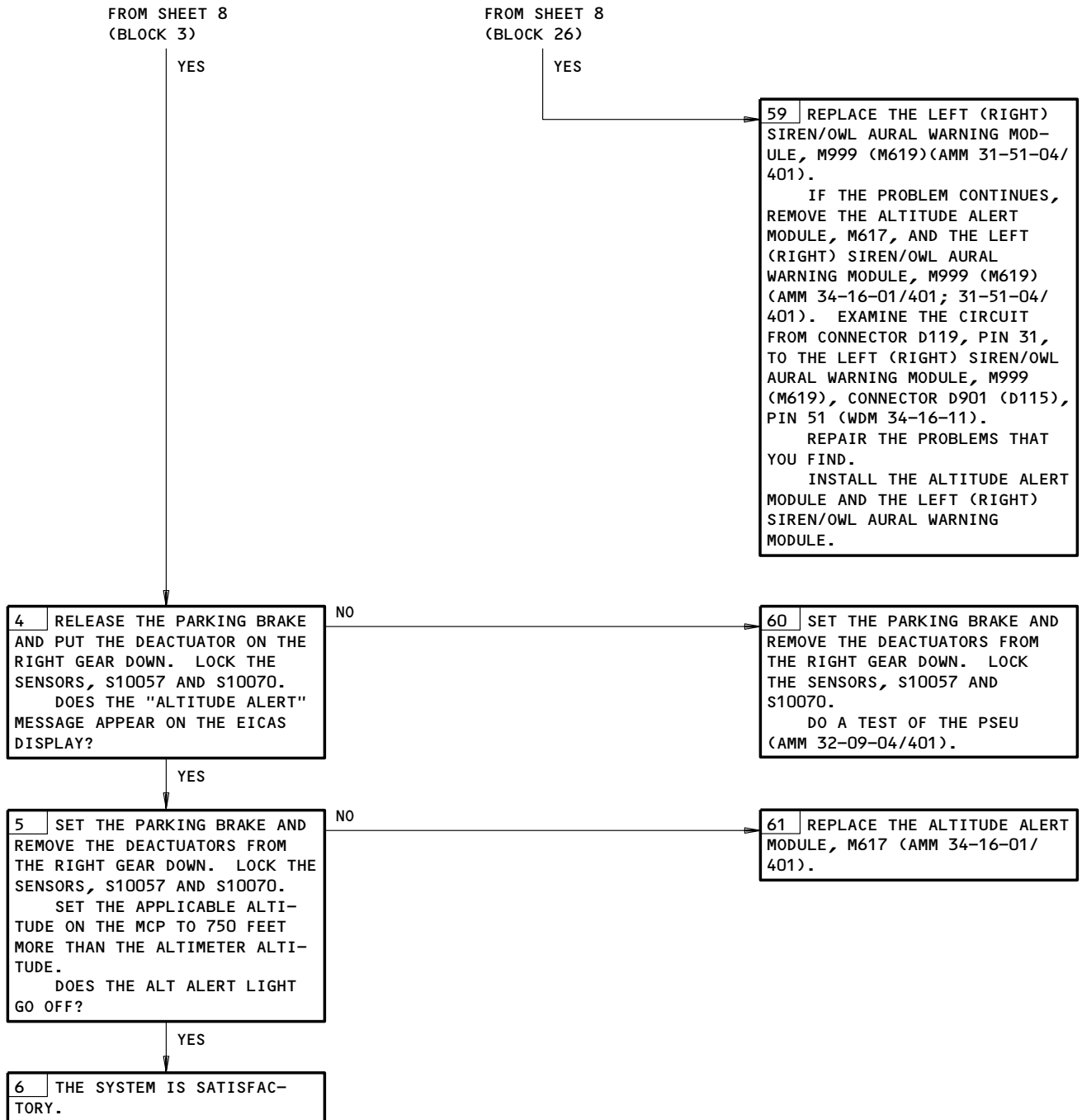

Altitude Alert System Fault Isolation
Figure 103 (Sheet 9)

EFFECTIVITY
GUI 115





34-16-00

01



Page 111
Sep 20/97

 **BOEING**
757
FAULT ISOLATION/MAINT MANUAL

INERTIAL REFERENCE SYSTEM

COMPONENT	FIG. 102 SHT	QTY	ACCESS/AREA	AMM REFERENCE
CIRCUIT BREAKER - BATTERY XFR CONT, C814 CENTER BUS CONT, C880 IRS C, C621 IRS L, C611 IRS R, C620		1 1 1 1 1	FLT COMPT, P6 6D2 6G6 6D4 6D3 6D5	* * * * *
CIRCUIT BREAKER - IRS CENTER, C613 IRS LEFT, C611 IRS RIGHT, C612		1 1 1	FLT COMPT, P11 11F21 11F1 11F22	* * *
COMPUTER - AIR DATA (FIM 34-12-00/101) ADC L, M100 ADC R, M101				
INDICATOR - (FIM 34-22-00/101) RDMI L, N3  RDMI R, N43  RMI L, N10024  RMI R, N10026  VSI L, N9 VSI R, N49				
PANEL - (FIM 24-33-00/101) STANDBY POWER CONTROL, M10062				
PANEL - INERTIAL REFERENCE MODE, M59	--	1	FLT COMPT, P5	34-21-02
RELAY - (FIM 31-01-06/101) CENTER BUS ISOLATION, K123 MAIN BATTERY, K104 MAIN BATTERY TRANSFER, K106				
RELAY - IRS DC PWR DISCONNECT, K137	--	1	FLT COMPT, P6	*
SWITCH - BATTERY, S2	--	1	FLT COMPT, P5, STANDBY POWER CONTROL PANEL, M10062	24-33-01
SWITCH - CAPT ADC INSTR SOURCE SEL, S482	--	1	FLT COMPT, P1	*
SWITCH - F/O ADC INSTR SOURCE SEL, S483	--	1	FLT COMPT, P3	*
UNIT - INERTIAL REFERENCE C, M160	--	1	119BL, MAIN EQUIP CTR, E2-4	34-21-01
UNIT - INERTIAL REFERENCE L, M159	--	1	119BL, MAIN EQUIP CTR, E2-4	34-21-01
UNIT - INERTIAL REFERENCE R, M161	--	1	119BL, MAIN EQUIP CTR, E2-4	34-21-01

* SEE THE WDM EQUIPMENT LIST

-  GUI 001-114,116-999
-  GUI 115

Inertial Reference System - Component Index
Figure 101

EFFECTIVITY

ALL

34-21-00

05

Page 101
Dec 20/96

BOEING

757 FAULT ISOLATION/MAINT MANUAL

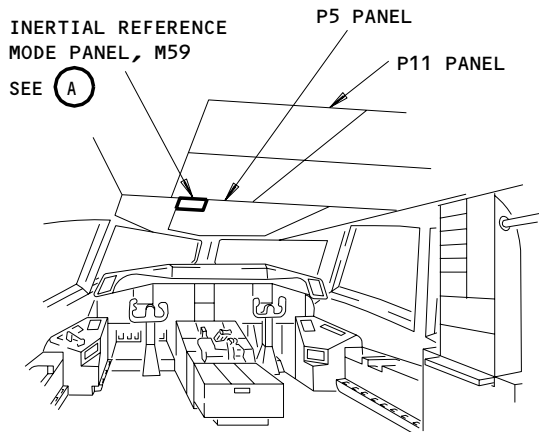

FLIGHT COMPARTMENT

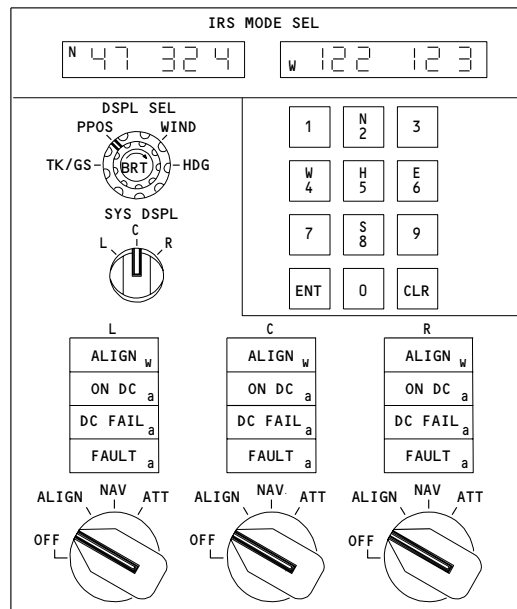
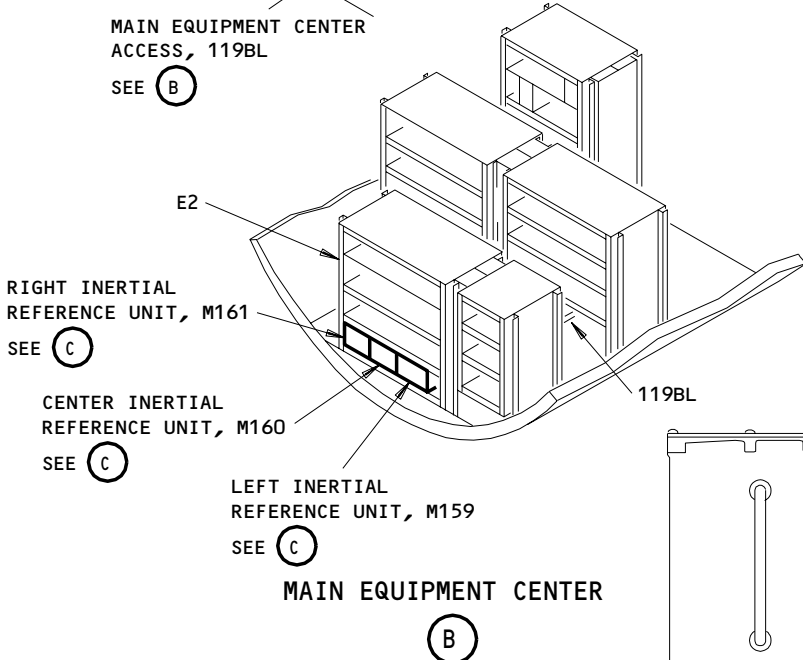
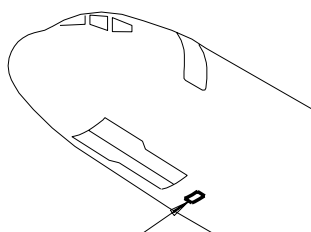

INERTIAL REFERENCE MODE PANEL (IRMP), M59

(A)

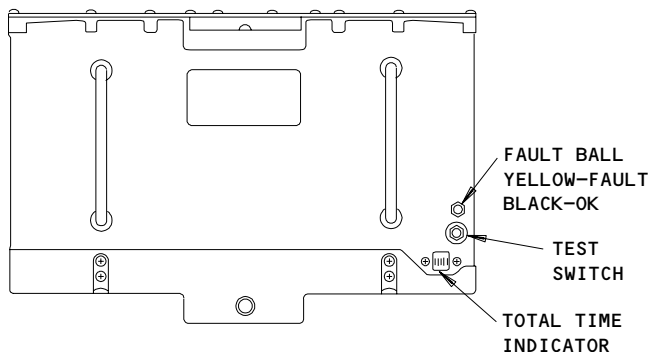

INERTIAL REFERENCE UNIT

(C)

**Inertial Reference System - Component Location
Figure 102**

EFFECTIVITY

ALL

34-21-00

01

Page 102
Jan 20/98

CAPT (F/O) RDMI
VOR AND HDG FLAGS
IN VIEW



PREREQUISITES

ELECTRICAL POWER (MM 24-22-00/201)
F/O (CAPT) IRS INSTR SOURCE SELECT SWITCH IN THE
USUAL POSITION

CB'S: 6D3,6D4,6D5,11A6,11F1,11F21,11F22,11F25

1. REPLACE THE L (R) RDMI, N3 (N43)(MM 34-22-05/401). IF THE PROBLEM CONTINUES, REMOVE THE L (R) IRU, M159 (M161)(MM 34-21-01/401). REMOVE THE L (R) RDMI, N3 (N43)(MM 34-22-05/401). REPAIR THE DATA BUS CIRCUIT FROM THE R (L) IRU PINS C10 AND C11 ON CONNECTORS D141B (D137B) TO THE L (R) RDMI PINS 41 AND 42 ON CONNECTOR D183 (D185)(WM 34-21-11,-21).
INSTALL THE IRU AND THE RDMI.

Capt (F/O) RDMI VOR and HDG Flags In View
Figure 103 (Sheet 1)

EFFECTIVITY
GUI 001-114, 116-999

34-21-00

04

Page 103
Dec 20/96

CAPT (F/O) RMI
VOR AND HDG FLAGS
IN VIEW



PREREQUISITES

ELECTRICAL POWER (MM 24-22-00/201)
F/O (CAPT) IRS SOURCE SELECT SWITCH IN THE USUAL
POSITION

CB'S: 6D3,6D4,6D5,11A7,11F1,11F21,11F22,11F23

1. REPLACE THE L (R) RMI, N10024 (N10026)(MM 34-22-05/401). IF THE PROBLEM CONTINUES, REMOVE THE L (R) IRU, M159 (M161)(MM 34-21-01/401). REMOVE THE L (R) RMI, N10024 (N10026)(MM 34-22-05/401). REPAIR THE DATA BUS CIRCUIT FROM THE R (L) IRU PINS C10 AND C11 ON CONNECTORS D141B (D137B) TO THE L (R) RMI PINS 41 AND 42 ON CONNECTOR D771 (D801)(WM 34-21-11,-21).
INSTALL THE IRU AND THE RMI.

Capt (F/O) RMI VOR and HDG Flags In View
Figure 103 (Sheet 2)

EFFECTIVITY
GUI 115

34-21-00

PREREQUISITES

MAKE SURE THESE SYSTEMS WILL OPERATE:

ADC SYSTEM (AMM 34-12-00/501)

EFIS (AMM 34-22-00/501)

MAKE SURE THESE CIRCUIT BREAKERS ARE CLOSED:

6D3,6D4,6D5,11E5,11E26,11F1,11F21,11F22

MAKE SURE THE AIRPLANE IS IN THIS CONFIGURATION:

ELECTRICAL POWER IS ON (AMM 24-22-00/201)

CAPT (F/O) IRS & ADC INSTR SOURCE SEL SWITCH IN THE USUAL POSITION

CAPT (F/O) VSI OFF FLAG IN VIEW

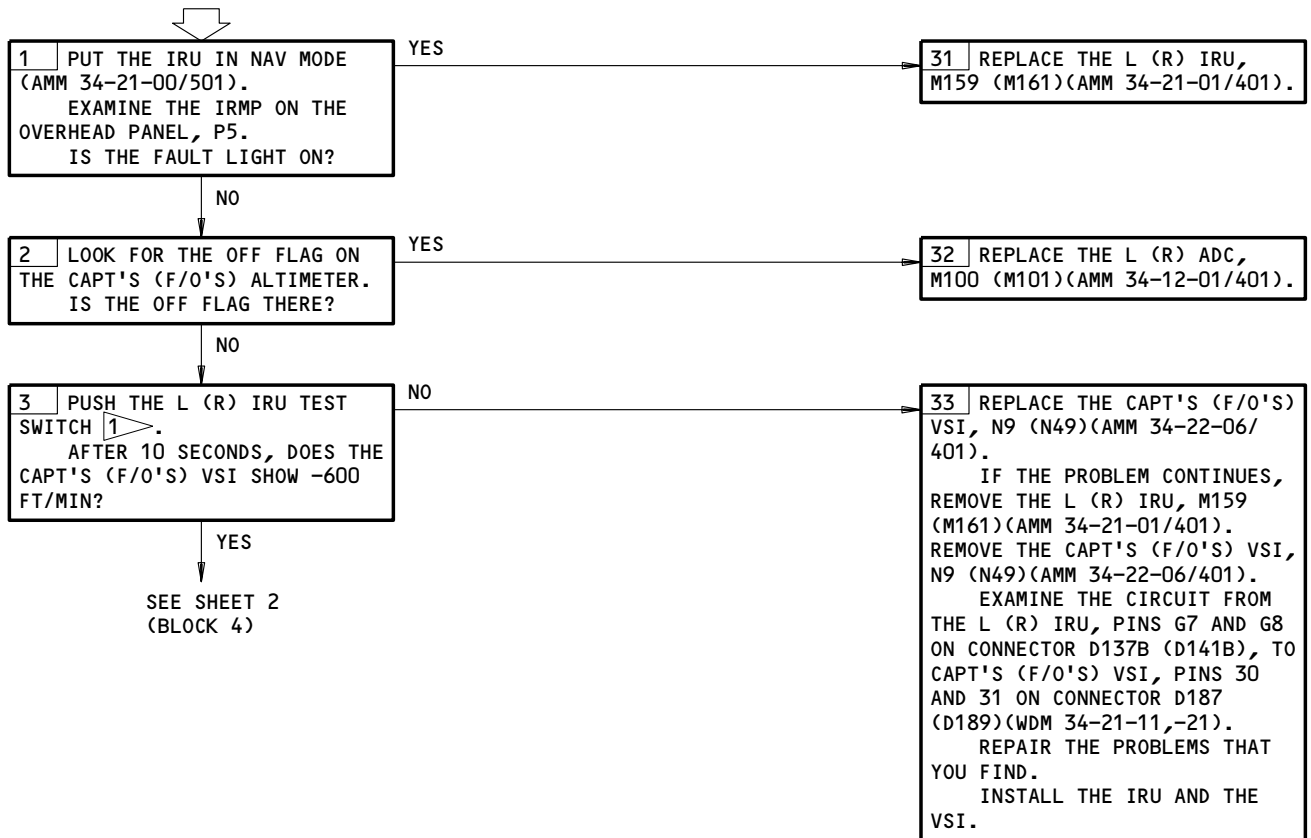

1 FOR THE LEFT AND RIGHT SYSTEM, YOU CAN USE THE YAW DAMPER TEST SWITCH TO START THE TEST. THIS IS AN ALTERNATIVE TO THE APPLICABLE IRU TEST SWITCH.

Capt (F/O) VSI Off Flag In View
Figure 104 (Sheet 1)

EFFECTIVITY

ALL

34-21-00

01

Page 105
Sep 28/00

116903

BOEING
757
FAULT ISOLATION/MAINT MANUAL

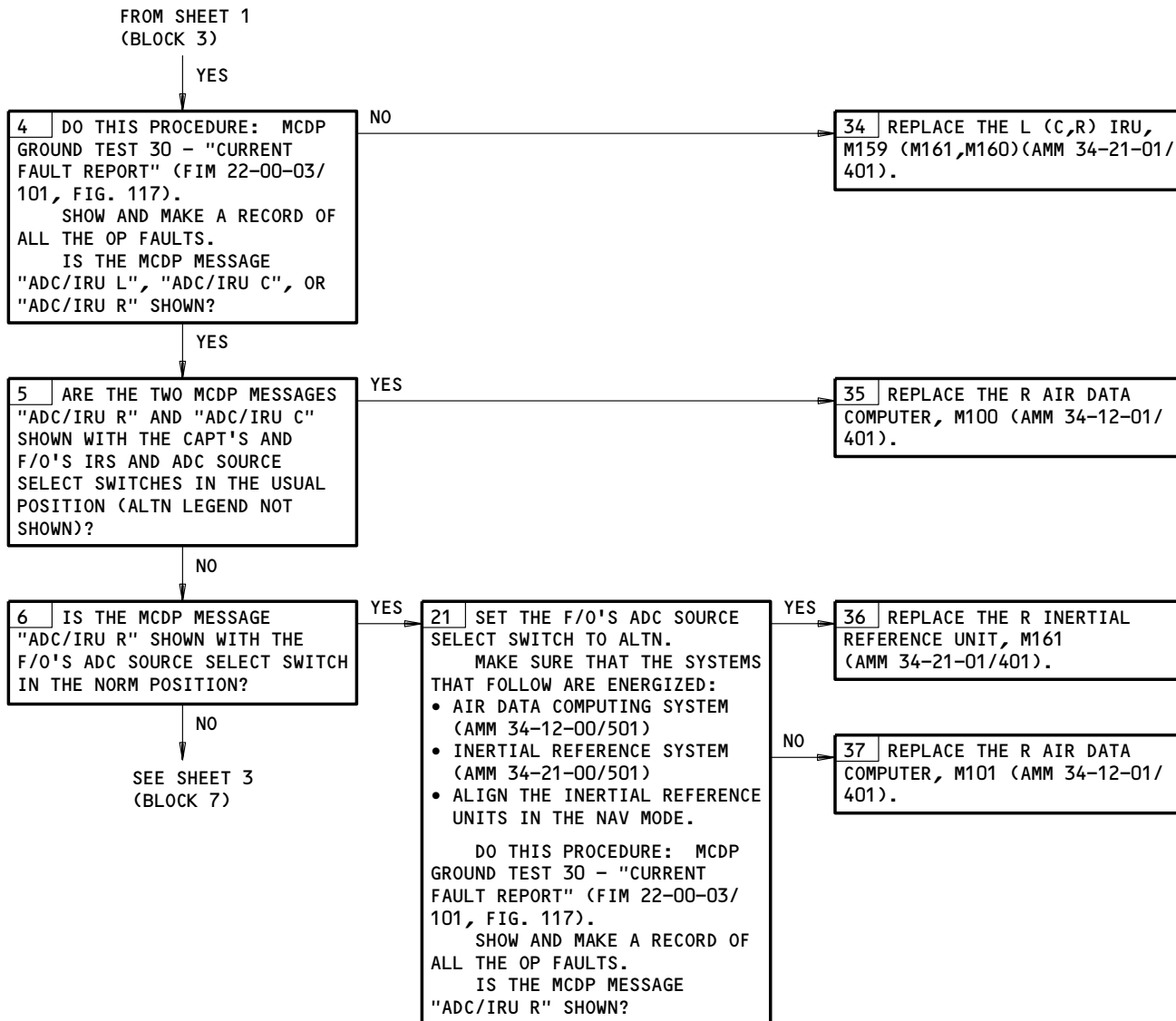

Capt (F/O) VSI Off Flag In View
Figure 104 (Sheet 2)

EFFECTIVITY

ALL

34-21-00

01

Page 106
Dec 20/96

F61353

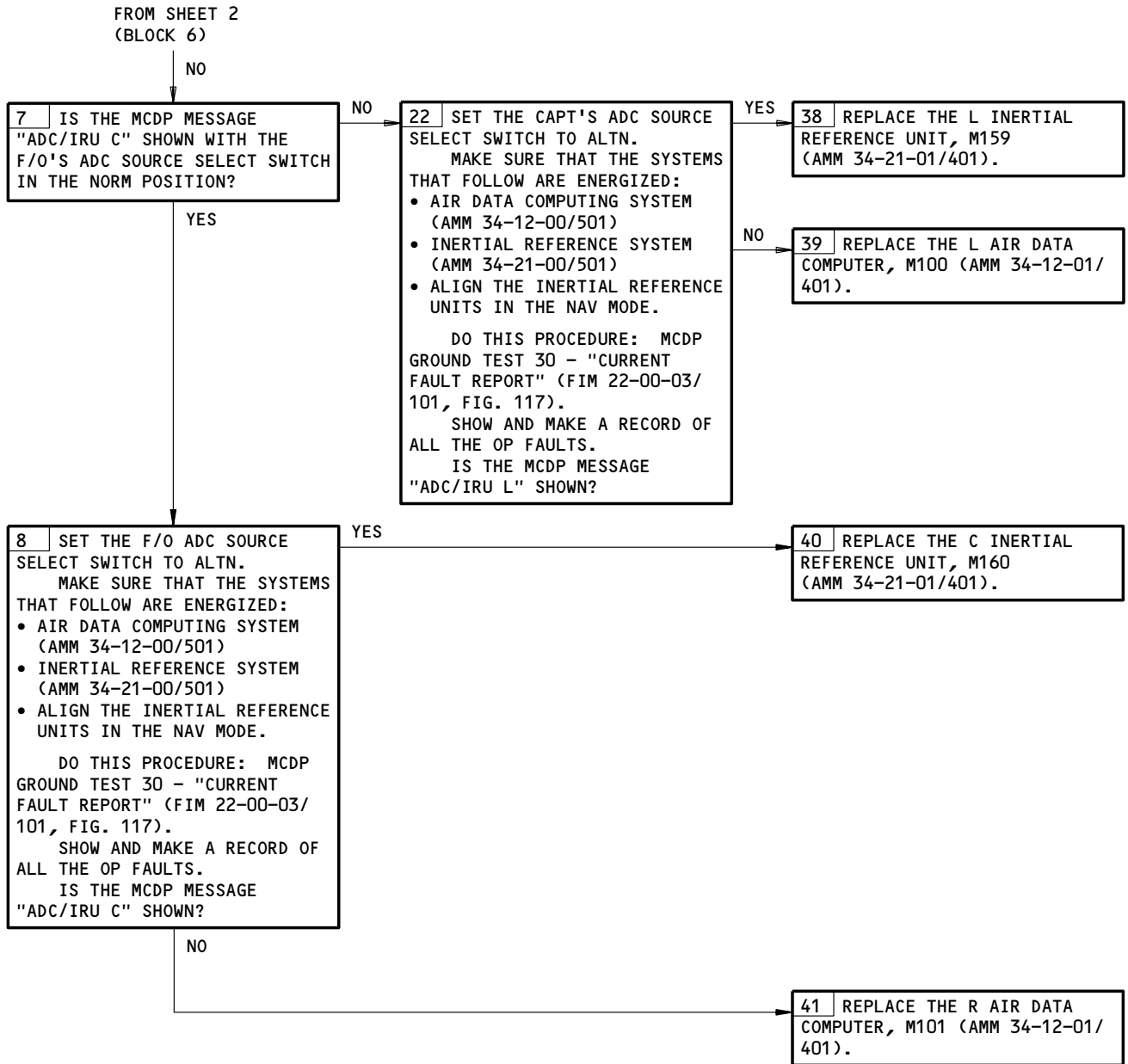

Capt (F/O) VSI OFF Flag In View
Figure 104 (Sheet 3)

EFFECTIVITY	ALL
-------------	-----

34-21-00

**IRS INDICATES IRS
DC FAIL**

PREREQUISITES

MAKE SURE THESE CIRCUIT BREAKERS ARE CLOSED:
6D3, 6D4, 6D5, 11F1, 11F21, 11F22

MAKE SURE THE AIRPLANE IS IN THIS CONFIGURATION:
ELECTRICAL POWER IS ON (AMM 24-22-00/201)

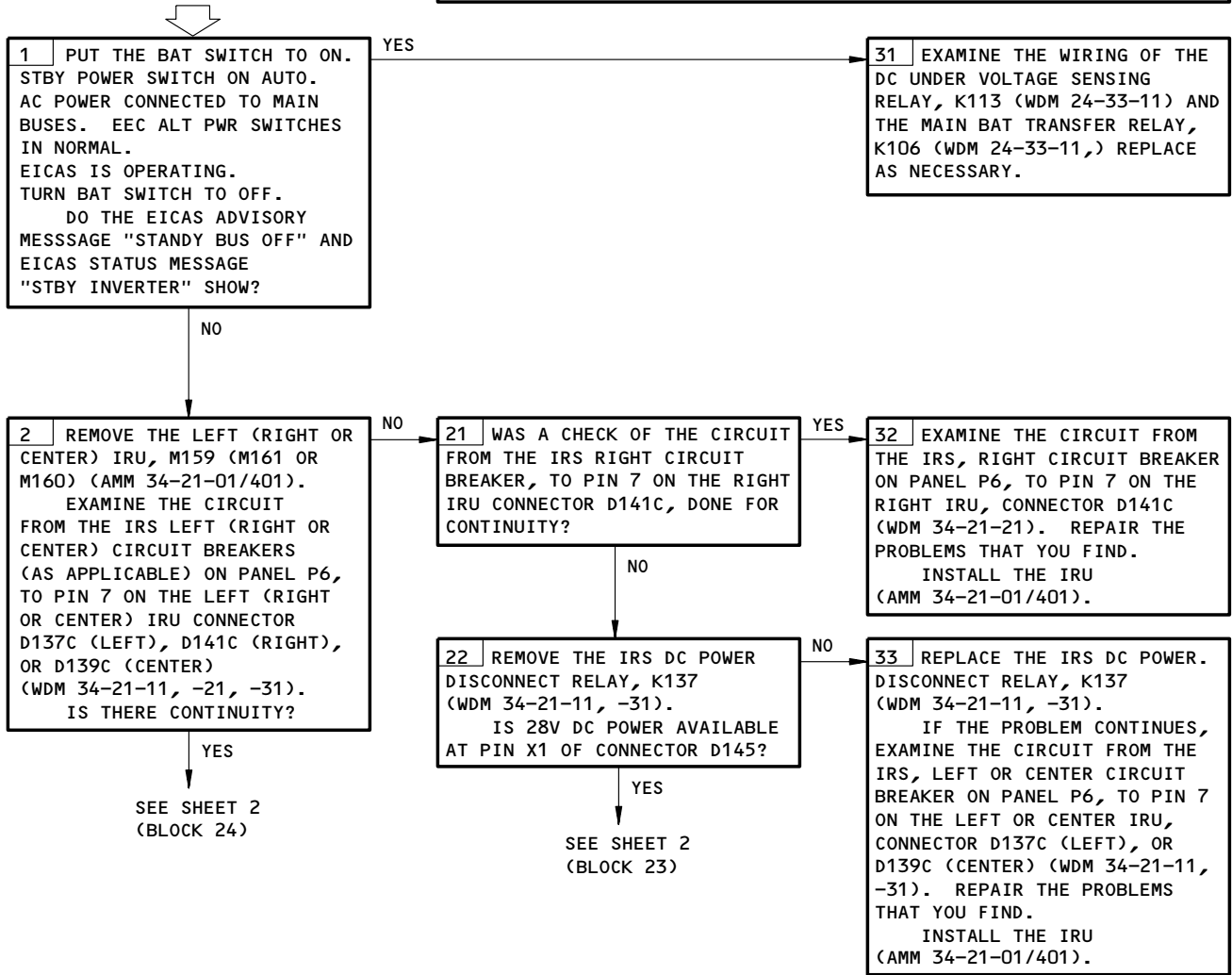

IRS Indicates IRS DC Fail
Figure 105 (Sheet 1)

EFFECTIVITY

ALL

34-21-00

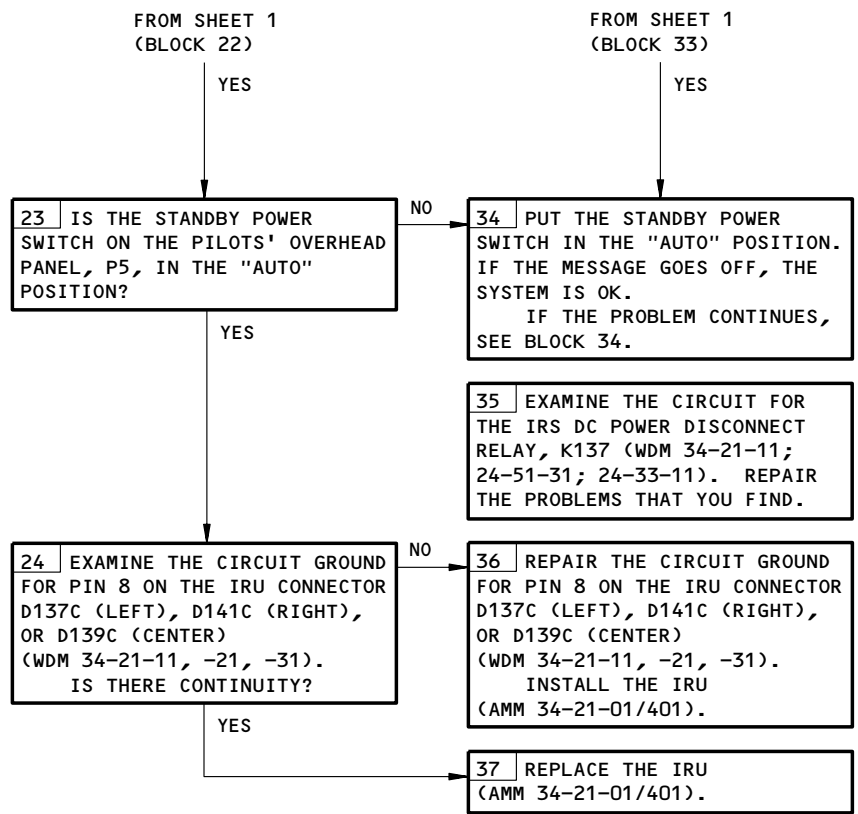

IRS Indicates IRS DC Fail
Figure 105 (Sheet 2)

EFFECTIVITY	_____
ALL	

34-21-00

1332858

IRS INDICATES IRS
ON DC



PREREQUISITES
ELECTRICAL POWER (MM 24-22-00/201)
CB'S: 6D3,6D4,6D5,11F1,11F21,11F22

1 REMOVE THE LEFT, RIGHT, OR CENTER IRU (M159,M161, OR M160) AS APPLICABLE (MM 34-21-01/401).
EXAMINE AND REPAIR THE CIRCUIT FROM THE IRS LEFT, RIGHT, OR CENTER CIRCUIT BREAKER (AS APPLICABLE)
ON PANEL P11 TO PIN 1 ON THE IRU CONNECTOR D137C (LEFT), D141C (RIGHT), OR D139C (CENTER)(WM 34-21-11,
-21,-31).
IF THE PROBLEM CONTINUES, EXAMINE PIN 5 ON THE APPLICABLE IRU CONNECTOR FOR GROUND. REPAIR THE
CIRCUIT AS NECESSARY (WM 34-21-11,-21,-31).
INSTALL THE IRU (MM 34-21-01/401).

IRS Indicates IRS on DC
Figure 106

EFFECTIVITY

ALL

34-21-00

01

Page 110
Dec 20/96

ENTRY INOP TO SINGLE IRS (ALIGN FLASHES AFTER SECOND ENTRY). POSITION ENTRY FROM FMC-CDU UNSUCCESSFUL

PREREQUISITES
ELECTRICAL POWER (MM 24-22-00/201)
CB'S: 6D3,6D4,6D5,11F1,11F21,11F22

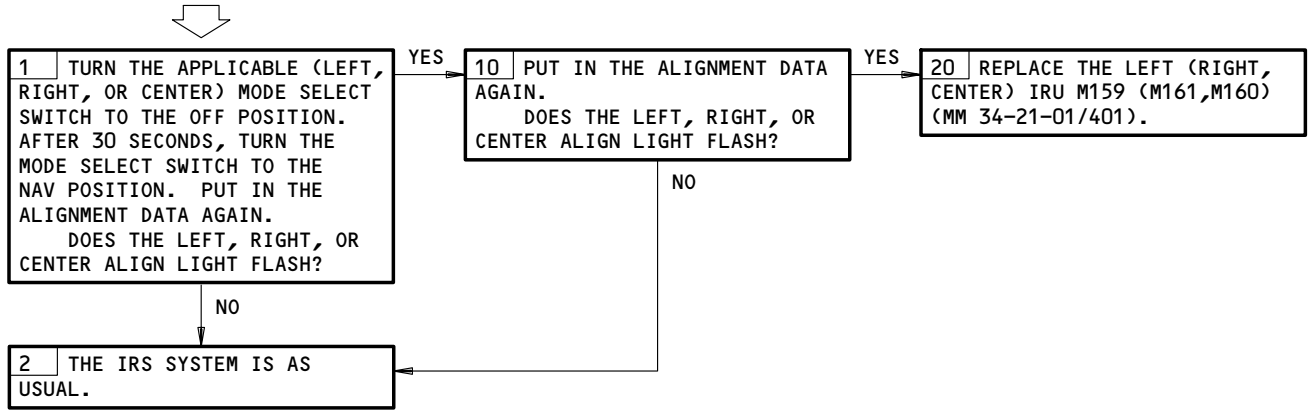

Entry Inop to Single IRS (Align Flashes after Second Entry). Position Entry from FMC-CDU Unsuccessful
Figure 106A

EFFECTIVITY	ALL
-------------	-----

34-21-00

ENTRY INOP TO SINGLE IRS (ALIGN FLASHES AFTER SECOND ENTRY). POSITION ENTRY FROM FMC-CDU SUCCESSFUL

PREREQUISITES
ELECTRICAL POWER (MM 24-22-00/201)
CB'S: 6D3,6D4,6D5,11F1,11F21,11F22

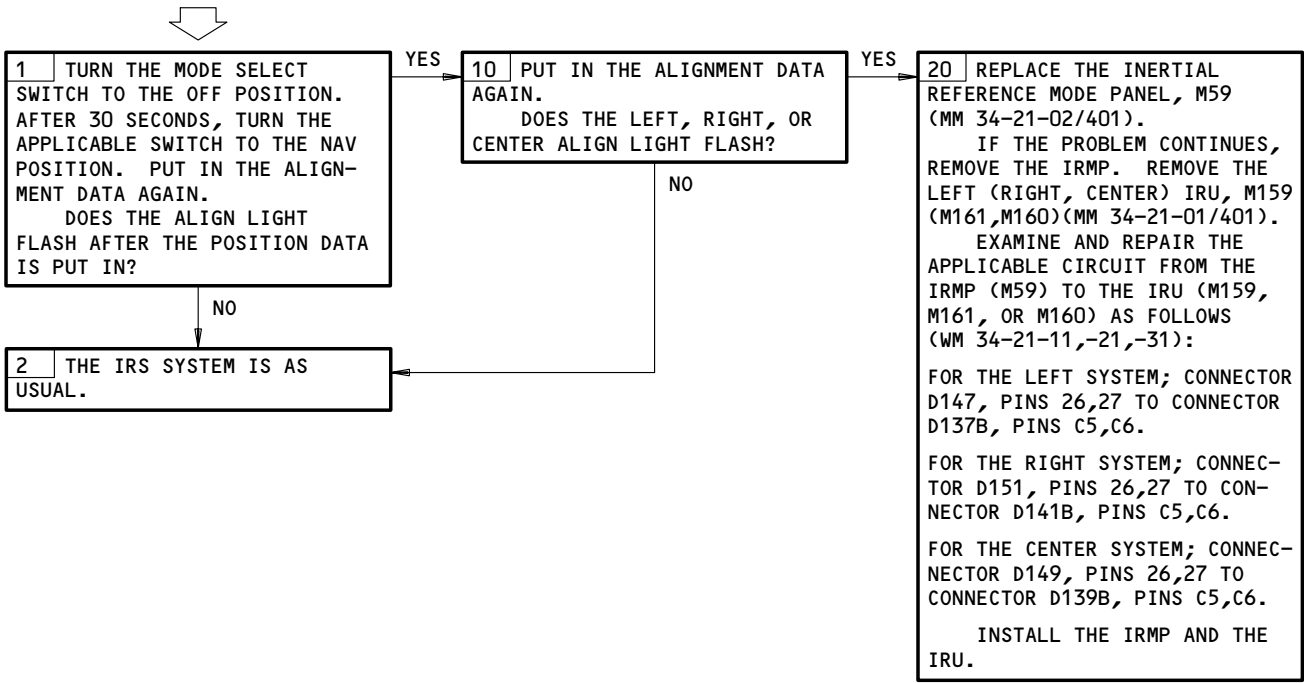

Entry Inop to Single IRS (Align Flashes after Second Entry). Position Entry from FMC-CDU Successful
Figure 106B

EFFECTIVITY	ALL
-------------	-----

34-21-00

ENTRY INOP TO ALL
IRS'S (ALIGN
FLASHES AFTER
SECOND ENTRY.)

PREREQUISITES
 ELECTRICAL POWER (MM 24-22-00/201)
 CB'S: 6D3,6D4,6D5,11F1,11F21,11F22

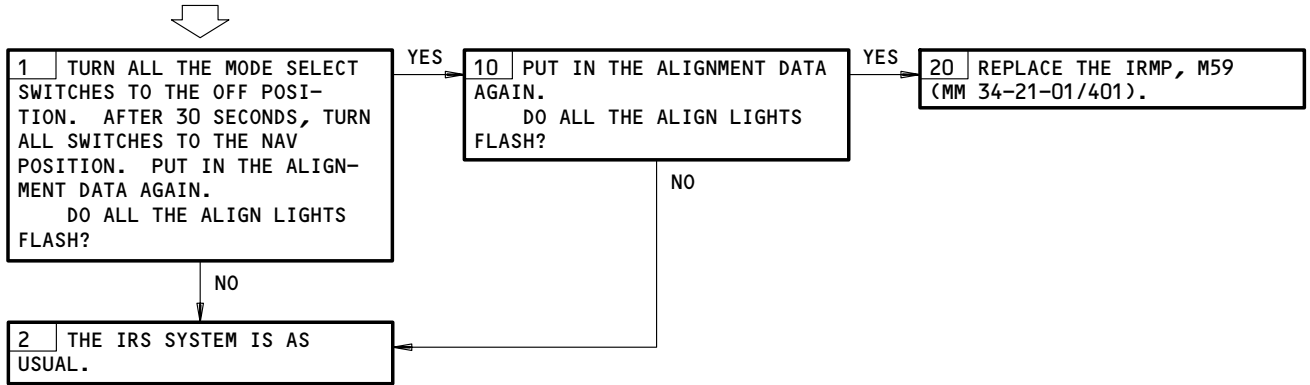

Entry Inop to ALL IRS'S (Align Flashes after Second Entry).
Figure 106C

EFFECTIVITY	ALL
-------------	-----

34-21-00

ALIGN FAILED TO
EXTIN AFTER 10 MIN
(NAV SEL)

PREREQUISITES
ELECTRICAL POWER (MM 24-22-00/201)
CB'S: 6D3,6D4,6D5,11E8,11E9,11E29,11E30,11F1,11F21,
11F22

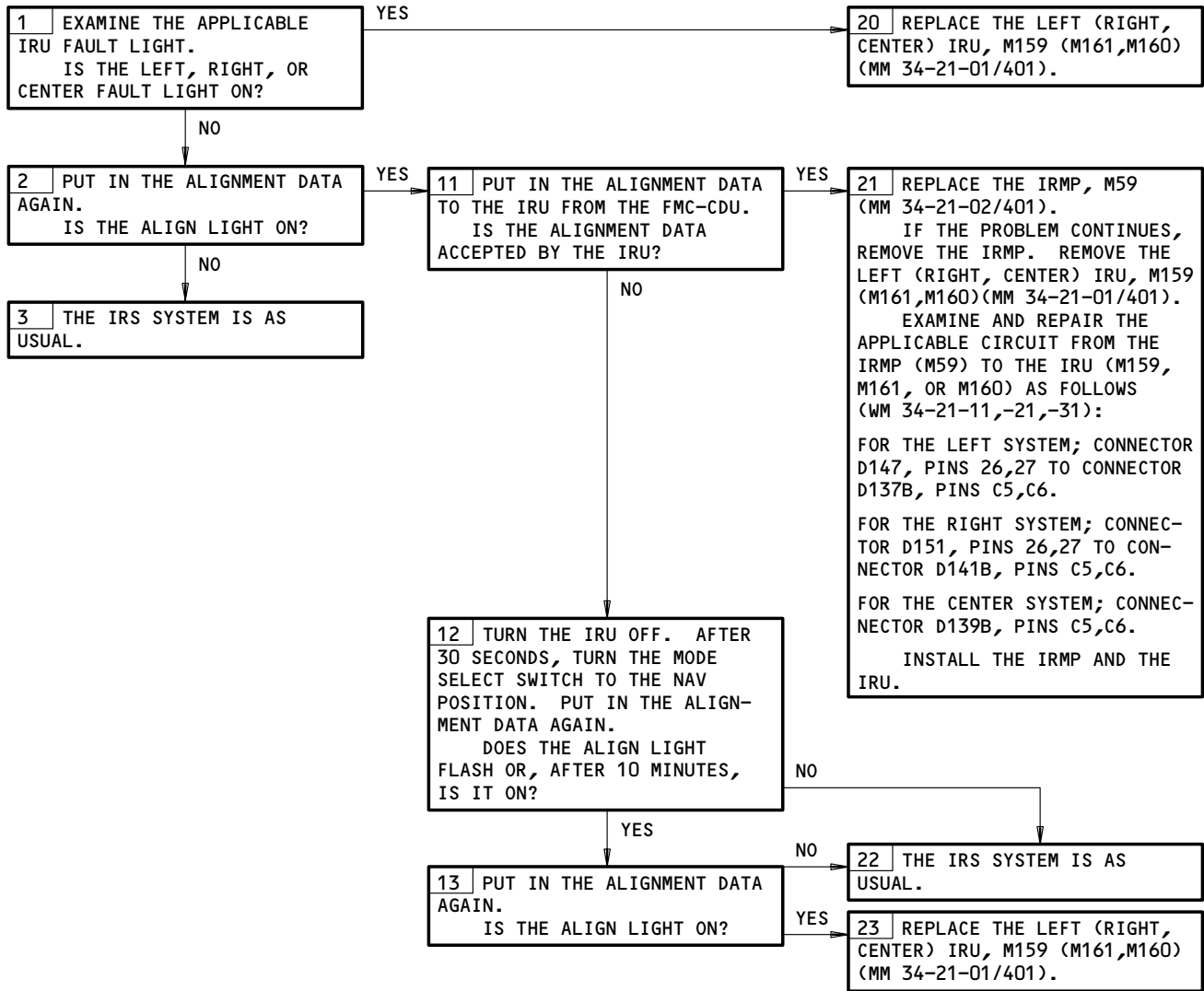

Align Failed to Extin After 10 Min (Nav Sel)
Figure 106D

EFFECTIVITY

ALL

34-21-00

IRS BITE PROCEDURE

PREREQUISITES

ELECTRICAL POWER (MM 24-22-00/201)

CB'S: 6D3,6D4,6D5,11A7,11E4,11E5,11E6,11E8,11E9,
11E25,11E26,11E27,11E29,11E30,11F1,11F8,11F9,
11F21,11F22,11F24,11F29; 3 11C4,11F23;
4 11F25

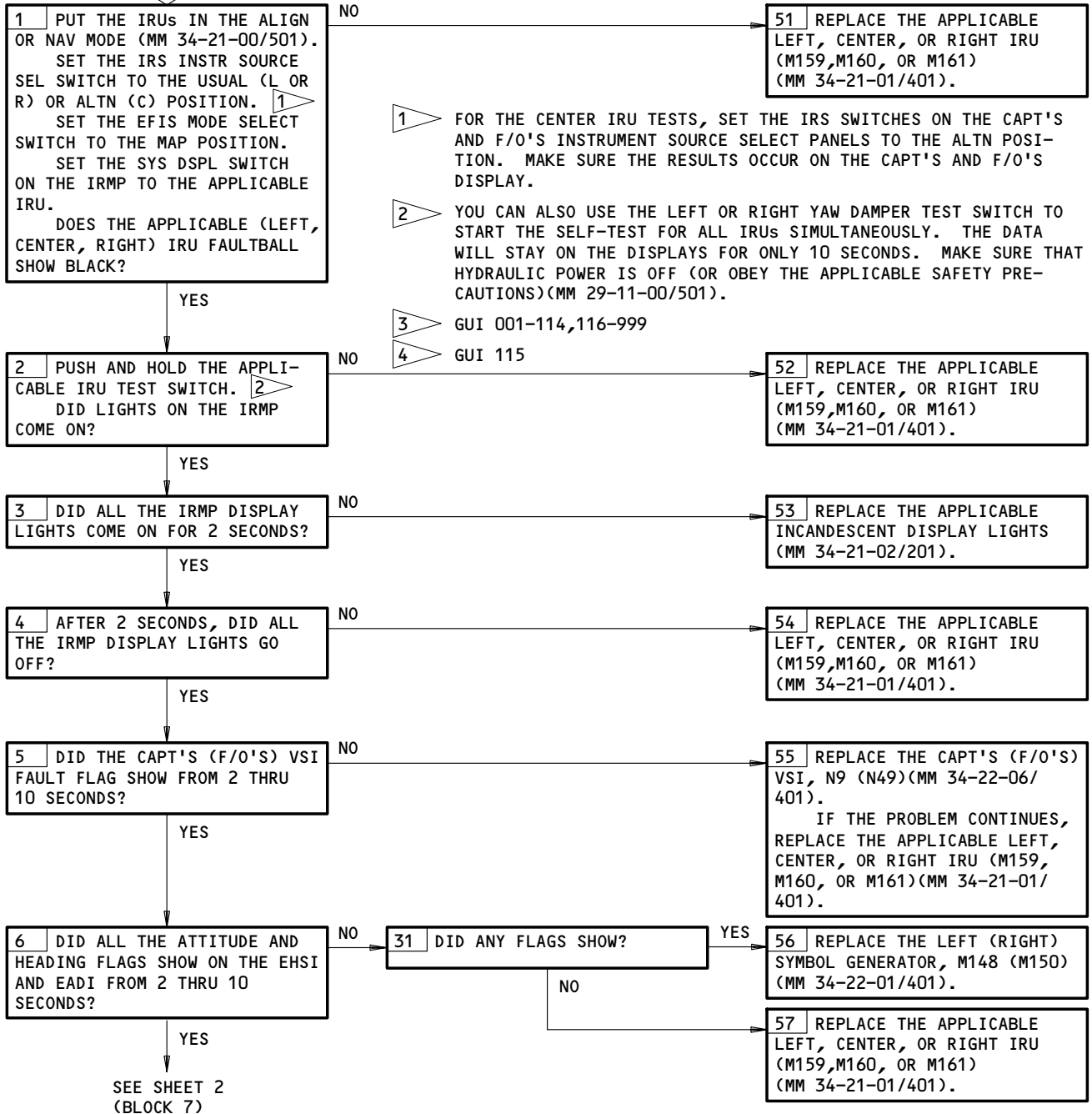

IRS BITE Procedure
Figure 107 (Sheet 1)

EFFECTIVITY

ALL

34-21-00

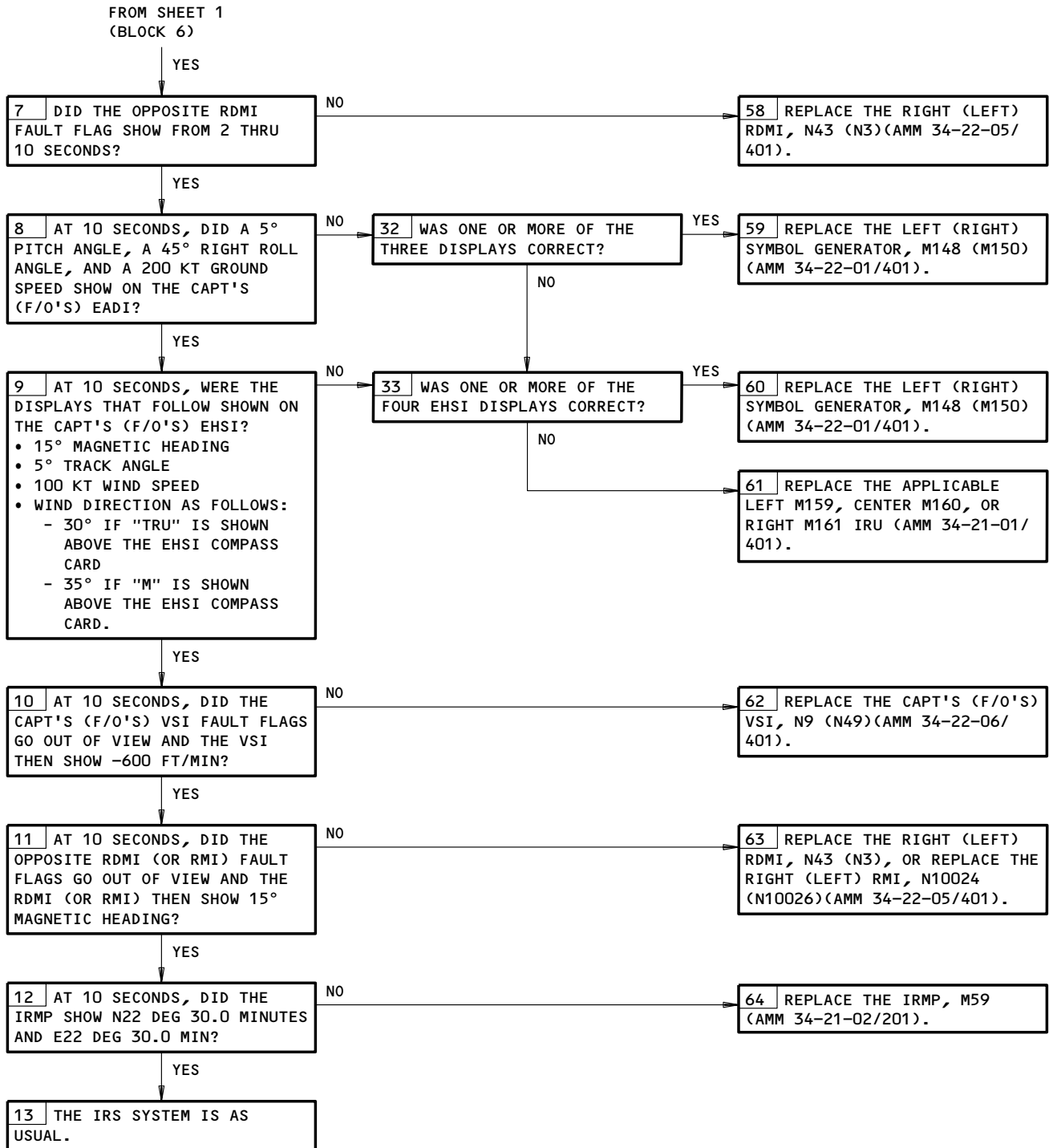

IRS BITE Procedure
Figure 107 (Sheet 2)

EFFECTIVITY

ALL

34-21-00

PREREQUISITES

NONE

NOTE: MAKE SURE THAT THE IRUs AND THE FMCs STAY ON UNTIL YOU DO THIS CHECK.

IRS REMOVAL CHECKS

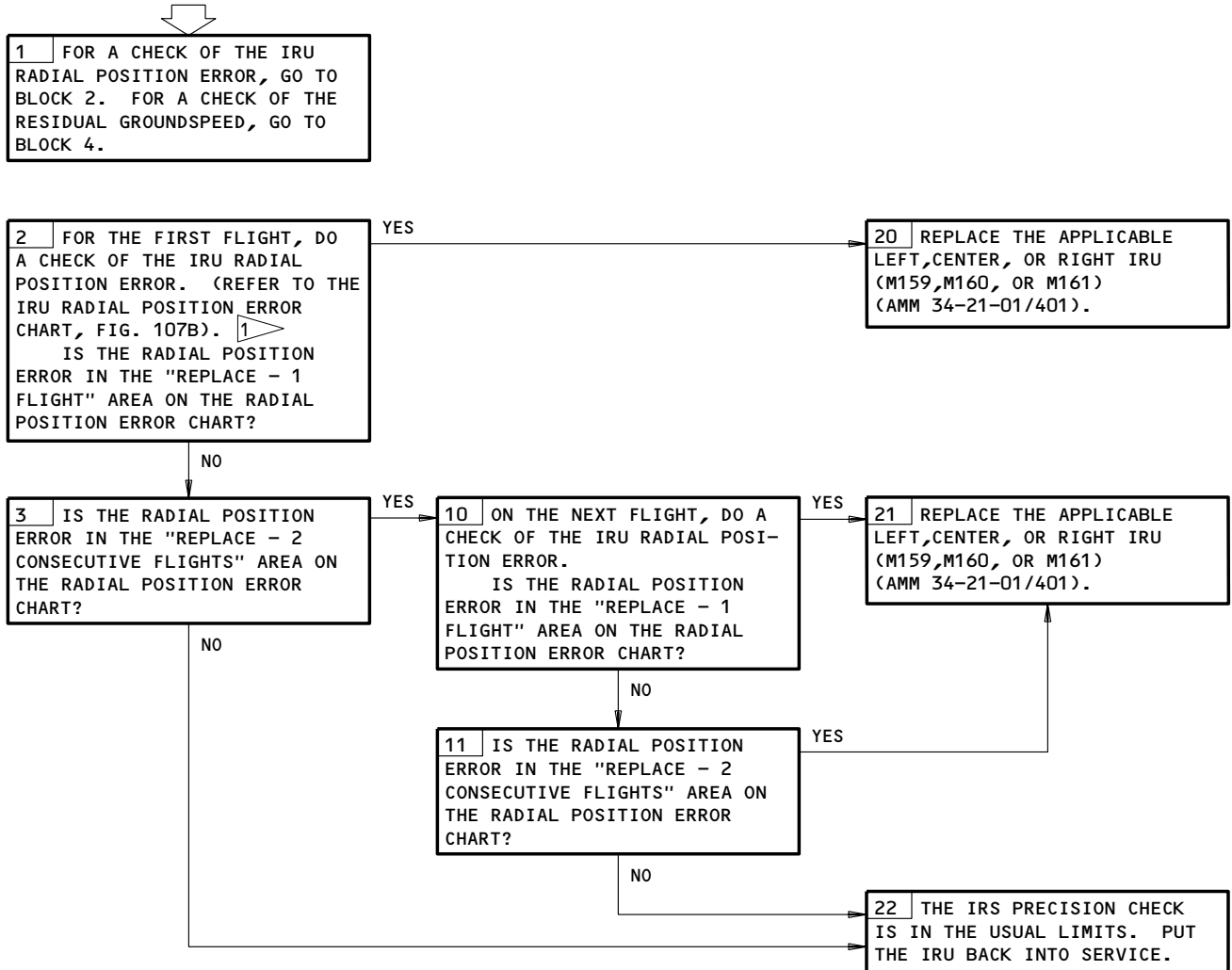

1 TO CALCULATE THIS VALUE, DO THE IRU REMOVAL CHECKS AT THE END OF THIS PROCEDURE.

IRS Removal Checks
Figure 107A (Sheet 1)

EFFECTIVITY

ALL

34-21-00

03

Page 117
Mar 20/96

218088

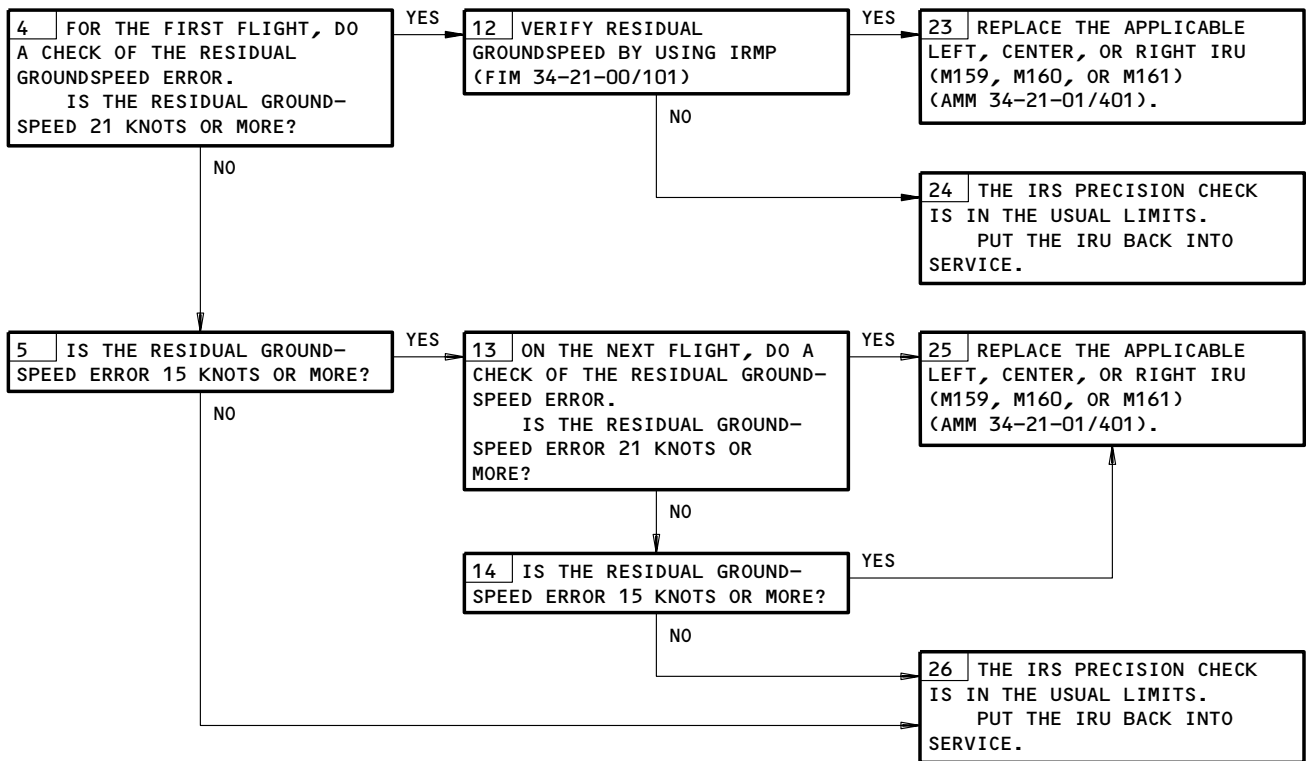

IRS Removal Checks
Figure 107A (Sheet 2)

EFFECTIVITY	ALL
-------------	-----

34-21-00

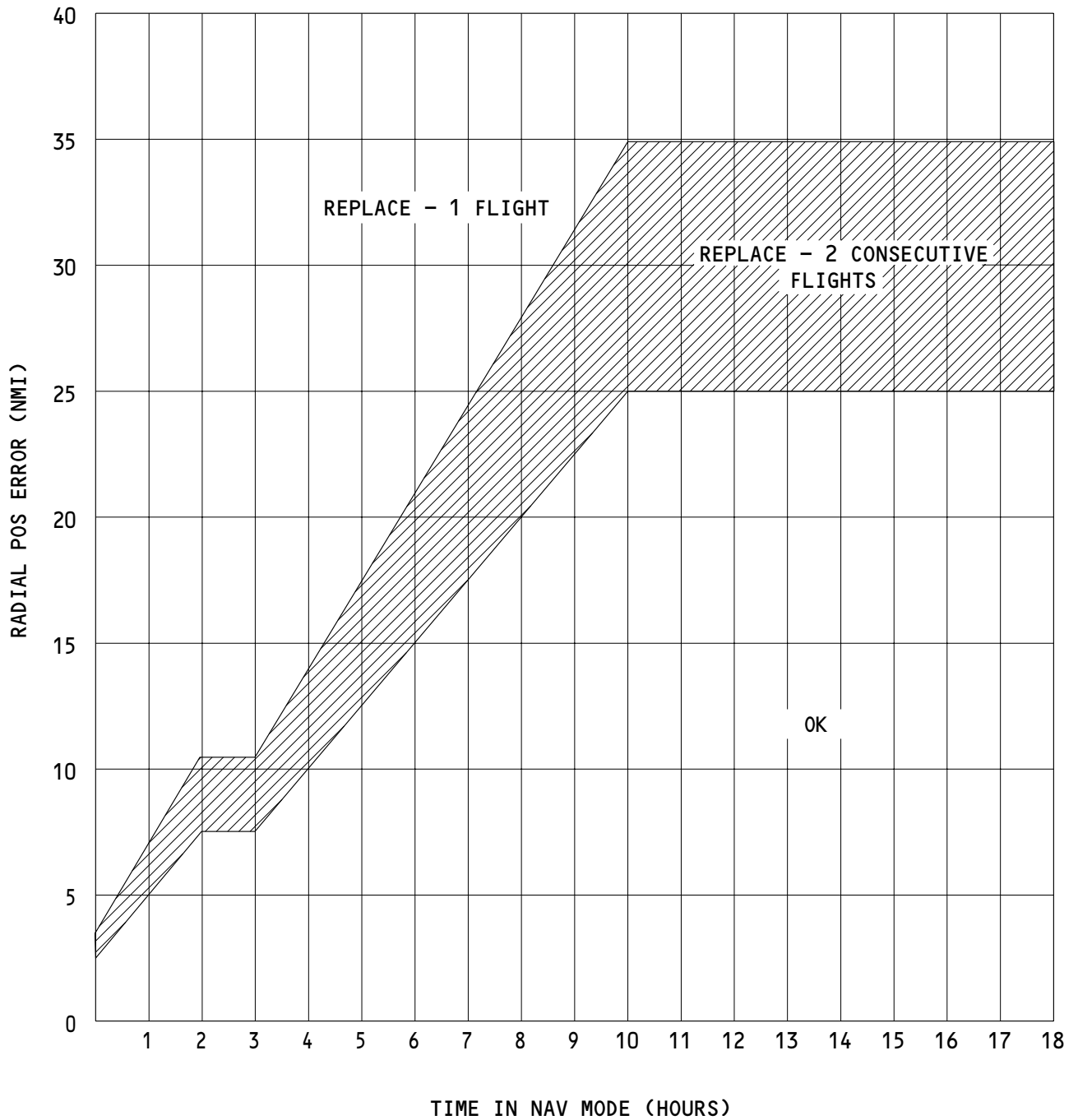

IRU Radial Position Error
Figure 107B

EFFECTIVITY ————
ALL

34-21-00

04

Page 119
Mar 20/96

218089

BOEING
 757
 FAULT ISOLATION/MAINT MANUAL

1. ARINC Data Bus Charts

A. General

CAUTION: DO NOT DIRECTLY TOUCH THE CONNECTORS. USE A BREAKOUT BOX OR YOU CAN CAUSE DAMAGE TO THE CONNECTORS.

- (1) The ARINC 429 data bus charts give data necessary to make an analysis of ARINC 429 transmitters, receivers, and data buses. For the test, use a breakout box at the available terminal or at the LRU connectors.

B. Equipment

- (1) Standard multi-meter
 (2) 429EBP Data Bus Analyzer (recommended)
 JcAIR Instrumentation
 400 Industrial Parkway
 Industrial Airport, KS 66031

429-2 Data Bus Analyzer (alternative)
 Interface Technology
 150 E. Arrow Highway
 San Dimas, CA 91773

- (3) A34011-1 Breakout Box (recommended)
 A34011-112 Breakout Box (alternative)

NOTE: Octal label 315 is a multiple function label. It does not show correctly in engineering units on the data bus analyzer unless you set the hexadecimal equipment ID = 04. For analyzers that cannot have the ID set, show the label in hexadecimal format and make a record of the value. Set the data bus analyzer to send label 015 in hex format and use the value you made a record of for label 315. Change the label 015 format to engineering to show the correct engineering units.

IRMP DIGITAL OUTPUT BUS CHART							
BUS NAME			CON	PINS	BUS FORMAT	BIT RATE	DATA BUS
SOURCE	TYPE	BUS					
IRMP	A	1	C	26 27	429	LO	IRMP BUS OUT IRU-C
IRMP	A	1	L	26 27	429	LO	IRMP BUS OUT IRU-L
IRMP	A	1	R	26 27	429	LO	IRMP BUS OUT IRU-R

EFFECTIVITY

ALL

34-21-00

03

Page 120
 Sep 20/96

BOEING
 757
 FAULT ISOLATION/MAINT MANUAL

IRMP(ID=0A4) OCTAL LABELS CHART								
SIGNAL	TYPE	LABEL	FORMAT	MIN UPDATE RATE	SDI	BINARY RANGE	POSITIVE SENSE	UNITS
SET LATITUDE	A	041	BCD	2		90S-90N	NORTH	DEG:MIN
SET LONGITUDE	A	042	BCD	2		180E-180W	EAST	DEG:MIN
SET MAGNETIC HDG	A	043	BCD	2		0-359	CW FRM NORTH	DEG

IRU DIGITAL OUTPUT BUS CHART								
BUS NAME			CON	PINS	BUS	BIT	DATA BUS	
SOURCE	TYPE	BUS			FORMAT	RATE		
IRU (L C R)	A	1	B	G07 G08	429	HI	IRU #1	
IRU (L C R)	A	2	B	E05 E06	429	HI	IRU #2	
IRU (L C R)	A	3	B	C10 C11	429	HI	IRU #3	

EFFECTIVITY

ALL

34-21-00

03

Page 121
Sep 20/96



BOEING
757
FAULT ISOLATION/MAINT MANUAL

IRU(ID=004) OCTAL LABELS CHART								
SIGNAL	TYPE	LABEL	FORMAT	MIN UPDATE RATE	SDI	BINARY RANGE	POSITIVE SENSE	UNITS
PRESENT POS LAT-D	A	010	BCD	2	00	90S-90N	NORTH FROM 0	DEG:MIN
PRESENT POS LONG-D	A	011	BCD	2	00	180E-180W	EAST FROM 0	DEG:MIN
GROUND SPEED-D	A	012	BCD	2	00	0-2000	ALWAYS POS	KNOTS
TRACK ANGLE TRUE-D	A	013	BCD	2	00	0-359.9	CW FROM NORTH	DEG
MAGNETIC HEADING-D	A	014	BCD	2	00	0-359.9	CW FROM NORTH	DEG
WIND SPEED-D	A	015	BCD	2	00	0-256	ALWAYS POS	KNOTS
WIND DIRECT TRUE-D	A	016	BCD	2	00	0-359	CW FROM NORTH	DEG
TRUE HEADING-D	A	044	BCD	2	00	0-359.9	CW FROM NORTH	DEG
IRS DISCRETES	A	270	DIS	2	00	N/A	N/A	N/A
IRS TEST	A	277	DIS	2	00	N/A	N/A	N/A
PRESENT POS-LAT	A	310	BNR	5	N/A	+180	NORTH FROM 0	DEG
PRESENT POS-LONG	A	311	BNR	5	N/A	+180	EAST FROM 0	DEG
GROUND SPEED	A	312	BNR	10	00	0-4096	ALWAYS POS	KNOTS
TRACK ANGLE TRUE	A	313	BNR	20	00	+180	CW FROM NORTH	DEG
TRUE HEADING	A	314	BNR	20	00	+180	CW FROM NORTH	DEG
WIND SPEED	A	315	BNR	10	00	0-256	ALWAYS POS	KNOTS
WIND DIRECT TRUE	A	316	BNR	10	00	+180	CW FROM NORTH	DEG
TRACK ANGLE-MAG	A	317	BNR	20	00	+180	CW FROM NORTH	DEG
MAGNETIC HEADING	A	320	BNR	20	00	+180	CW FROM NORTH	DEG
DRIFT ANGLE	A	321	BNR	20	00	+180	RIGHT	DEG

EFFECTIVITY

ALL

34-21-00

04

Page 122
Sep 20/96



757
FAULT ISOLATION/MAINT MANUAL

IRU(ID=004) OCTAL LABELS CHART								
SIGNAL	TYPE	LABEL	FORMAT	MIN UPDATE RATE	SDI	BINARY RANGE	POSITIVE SENSE	UNITS
FLIGHT PATH ANGLE	A	322	BNR	20	00	+−180	UP	DEG
FLIGHT PATH ACCEL	A	323	BNR	50	00	+−4	FORWARD	G'S
PITCH ANGLE	A	324	BNR	50	00	+−180	UP	DEG
ROLL ANGLE	A	325	BNR	50	00	+−180	RIGHT WING DO	DEG
BODY PITCH RATE	A	326	BNR	50	00	+−128	UP	DEG/SEC
BODY ROLL RATE	A	327	BNR	50	00	+−128	RIGHT WING DO	DEG/SEC
BODY YAW RATE	A	330	BNR	50	00	+−128	NOSE RIGHT	DEG/SEC
BODY LONGIT ACCEL	A	331	BNR	50	00	+−4	FORWARD	G'S
BODY LATERAL ACCEL	A	332	BNR	50	00	+−4	RIGHT	G'S
BODY NORMAL ACCEL	A	333	BNR	50	00	+−4	UP	G'S
PLATFORM HEADING	A	334	BNR	10	00	+−180	CW FROM ZERO	DEG
TRACK ANGLE RATE	A	335	BNR	50	00	+−32	CW	DEG/SEC
PITCH ATT RATE	A	336	BNR	50	00	+−128	UP	DEG/SEC
ROLL ATT RATE	A	337	BNR	50	00	+−128	RIGHT WING DO	DEG/SEC
IRS MAINT DISCRETE	A	350	DIS	2	00	N/A	N/A	N/A
IRMP BITE DSPL	A	351	DIS	2		N/A	N/A	N/A
GPS MAINT DIS	A	353	DIS	1	00	N/A	N/A	N/A
POTENTIAL VERT SPD	A	360	BNR	50	00	+−32,768	UP	FT/MIN

EFFECTIVITY

ALL

34-21-00

09

Page 123
Jan 28/07

BOEING
 757
 FAULT ISOLATION/MAINT MANUAL

IRU(ID=004) OCTAL LABELS CHART								
SIGNAL	TYPE	LABEL	FORMAT	MIN UPDATE RATE	SDI	BINARY RANGE	POSITIVE SENSE	UNITS
INERTIAL ALTITUDE	A	361	BNR	25	N/A	+−131,072	UP	FEET
ALONG TK HRZ ACCEL	A	362	BNR	50	00	+−4	FORWARD	G'S
CROSS TK HRZ ACCEL	A	363	BNR	50	00	+−4	RIGHT	G'S
VERTICAL ACCEL	A	364	BNR	50	00	+−4	UP	G'S
INERTIAL VERT SPD	A	365	BNR	50	00	+−32,768	UP	FT/MIN
N-S VELOCITY	A	366	BNR	10	00	+−4096	NORTH	KNOTS
E-W VELOCITY	A	367	BNR	10	00	+−4096	EAST	KNOTS

EFFECTIVITY

ALL

34-21-00

03

Page 124
Sep 20/96

BOEING
 757
 FAULT ISOLATION/MAINT MANUAL

IRU DISCRETE OCTAL LABELS/BIT CHART				
SIGNAL	OCTAL LABEL	BIT	ONE-STATE	ZERO-STATE
ALIGN MODE/NR	270	11	ALIGN MODE	NOT ALIGN
REV ATTITUDE MODE	270	12	REV ATT	NO REV ATT
NAV MODE	270	13	NAV	NO NAV
SET HEADING	270	14	SET HDG	NO SET HDG
ATTITUDE INVALID	270	15	ATT INVAL	ATT VALID
DC FAIL	270	16	DC FAIL	DC OK
ON DC	270	17	ON DC	OFF DC
ADC FAULT	270	18	ADC FAULT	NO FAULT
IRU FAULT	270	19	IRU FAULT	NO FAULT
DC FAIL ON DC	270	20	DC FAIL	NO FAULT
ALIGN FAULT	270	21	ALIGN FLT	NO FAULT
NO IRS INITIAL	270	22	NO INITIAL	INITAL
EXCESS MOTION ERR	270	23	EXC MOTION	NO ERROR
ADC/IRU FAULT	270	24	FAULT	NO FAULT
REENTER POS	270	25	ENTER POS	NO ACTION
ALIGN STATUS	270	26	1 MIN	0
ALIGN STATUS	270	27	2 MIN	0
ALIGN STATUS	270	28	4 MIN	0
CYCLE IRS	270	29	CYCLE IRS	NO ACTION
POWER SUPPLY	350	11	FAULT	NO FAULT
DIGITAL INPUT	350	12	FAULT	NO FAULT
SENSOR LSIC	350	13	FAULT	NO FAULT
MEMORY (RAM)	350	14	FAULT	NO FAULT

EFFECTIVITY

ALL

34-21-00

09

Page 125
Jan 28/07



757
FAULT ISOLATION/MAINT MANUAL

IRU DISCRETE OCTAL LABELS/BIT CHART				
SIGNAL	OCTAL LABEL	BIT	ONE-STATE	ZERO-STATE
MEMORY (PROM)	350	15	FAULT	NO FAULT
PITCH RATE	350	16	FAULT	NO FAULT
GYRO	350	17	FAULT	NO FAULT
TEMP SENSOR	350	19	FAULT	NO FAULT
SYSTEM TESTS	350	20	FAULT	NO FAULT
DISCRETE I/O	350	21	FAULT	NO FAULT
WDT	350	22	FAULT	NO FAULT
CPU	350	23	FAULT	NO FAULT
A/D OR MUX	350	24	FAULT	NO FAULT
GPS RESERVED *[1]	350	25	TBD	TBD
GPS RESERVED *[1]	350	26	TBD	TBD
GPS RESERVED *[1]	350	27	TBD	TBD
GPS RESERVED *[1]	350	28	TBD	TBD
PWR SUPP CRITICAL	351	11	FAULT	NO FAULT
DIG I/O WRAPROUND	351	12	FAULT	NO FAULT
RAM/NVM/PROM MMRY	351	13	FAULT	NO FAULT
LSIC	351	14	FAULT	NO FAULT
DISCRETE INPUT	351	15	FAULT	NO FAULT
PROCESSOR	351	16	FAULT	NO FAULT
GYRO	351	17	FAULT	NO FAULT
ALIGN/SYSTEM	351	18	FAULT	NO FAULT
A/D MUX DATA TRAN	351	19	FAULT	NO FAULT
POWER SUPPLY	351	20	FAULT	NO FAULT

EFFECTIVITY

ALL

34-21-00

BOEING
 757
 FAULT ISOLATION/MAINT MANUAL

IRU DISCRETE OCTAL LABELS/BIT CHART				
SIGNAL	OCTAL LABEL	BIT	ONE-STATE	ZERO-STATE
ADC/DSCRTOUT WRAP	351	21	FAULT	NO FAULT
SPARE	351	22	NOT USED	NOT USED
CALIBRATION PROM	351	23	FAULT	NO FAULT
INA/OTA	351	24	FAULT	NO FAULT
ANALOG PITCH RATE	351	25	FAULT	NO FAULT
GYRO	351	26	FAULT	NO FAULT
GYRO CONFIG	351	27	FAULT	NO FAULT
TEMP SENSOR	351	28	FAULT	NO FAULT
SPARE	351	29	NOT USED	NOT USED
GPS FAULT *[1]	351	29	FAULT	NO FAULT
NO GPS FNCTN INSTL *[2]	353	27	NOT INSTALLED	INSTALLED

*[1] -107 IRU'S AND ON (ALWAYS ZERO STATE)

*[2] -107 IRU'S AND ON (ALWAYS ONE STATE)

EFFECTIVITY

ALL

34-21-00

2. IRU Removal Checks (Fig. 107A)

- A. Two checks are used to make a decision if an IRU is recommended to be replaced. The checks are the residual groundspeed error and the radial position error measurements.
- (1) Residual groundspeed is the groundspeed of the airplane when the airplane is parked. The POS REF (position reference) page 2/2 on the FMC CDU shows the residual groundspeed for the FMC and the IRUs at the end of the flight.
 - (2) Radial position error is the distance between present position and computed IRU position. The POS REF page 2/2 on the FMC CDU shows the present position for the IRUs. The radial position error check uses the FMC CDU RTE (route) 1 or RTE 2 legs page to calculate the IRS radial position error. The actual and calculated IRS positions are input as waypoints. Their difference, in nautical miles, is compared to the deviation criteria to make a decision if the IRU is recommended to be replaced.
- B. Residual Groundspeed Error Check

NOTE: The IRUs and FMCs must not be shut down before the groundspeed error check is complete.

- (1) Push the INIT REF key on the CDU.
- (2) Push the line select key (LSK) adjacent to <INDEX.
 - (a) Make sure the INIT REF INDEX page is shown.
- (3) Push the LSK adjacent to <POS.
 - (a) Make sure the POS INIT page 1/2 is shown.
- (4) Push the NEXT PAGE or PREV PAGE key to show the POS REF page.
 - (a) Make sure the POS REF page is shown.
- (5) Record the residual groundspeed error shown on the POS REF page for each IRU.

NOTE: FMC freeze can cause FMC-CDU to display excessive groundspeed. Verify IRU residue using IRMP.

- (6) AIRPLANES WITH IRMP P/N S242T101-202 THROUGH -999;
Do these steps:

NOTE: The groundspeed will not change on the FMC when an IRU is replaced. This procedure must be performed after completion of a flight before IRU is switched out of the NAV mode. This value should be recorded before power shutdown.

- (a) Rotate IRMP "SYS DSPL" switch to L, C, or R position, as appropriate.
 - (b) Rotate IRMP "DSPL SEL" switch to TK/GS position.
 - (c) Read residual speed on the IRMP upper right display window.
 - (d) Repeat for each IRU position.
- (7) Replace the IRU (AMM 34-21-01/401) if one of these conditions occur:
 - (a) The residual groundspeed error is 15 knots or larger after each of two consecutive checks.

EFFECTIVITY

ALL

34-21-00

01

Page 128
Sep 28/00

- (b) The residual groundspeed error is 21 knots or larger at the end of one check.

C. Radial Position Error Check

NOTE: The IRUs and FMCs must not be shut down before the radial position error check is complete.

- (1) Push the INIT REF key on the CDU.
- (2) Push the line select key (LSK) adjacent to <INDEX.
 - (a) Make sure the INIT REF INDEX page is shown.
- (3) Push the LSK key adjacent to <POS.
 - (a) Make sure the POS INIT page 1/2 is shown.
- (4) Push the NEXT PAGE or PREV PAGE key to show the POS REF page.
 - (a) Make sure the POS REF page is shown.
- (5) Record the latitude and longitude shown for each IRU.
- (6) Push the LEGS mode key.
 - (a) Make sure the RTE 1 LEGS or RTE 2 LEGS page is shown.
- (7) Input the present position latitude and longitude (gate, ramp, etc.) as a waypoint.
- (8) Input the latitude and longitude of the left IRU as the next waypoint on the RTE 1 or RTE 2 LEGS page.

NOTE: This can be done manually or by line selection from the POS REF page.

- (9) Record the computed leg length between the present position waypoint and the left IRU waypoint.

NOTE: This is the radial position error of the left IRU.

- (10) Input the latitude and longitude of the center IRU after the present position waypoint, either manually or by line selection from the POS REF page.
- (11) Record the computed leg length between the present position waypoint and the center IRU waypoint.

NOTE: This is the radial position error of the center IRU.

- (12) Input the latitude and longitude of the right IRU after the present position waypoint, either manually or by line selection from the POS REF page.
- (13) Record the computed leg length between the present position waypoint and the right IRU waypoint.

NOTE: This is the radial position error of the right IRU.

EFFECTIVITY

ALL

34-21-00

01

Page 129
Sep 28/00

 **BOEING**
757
FAULT ISOLATION/MAINT MANUAL

- (14) Compare these radial position errors for a given navigation time to the accept/reject limits on Fig. 107B.

NOTE: Navigation time is the time since an IRU last entered NAV mode after a full 10 minute alignment was completed. Flight time is permitted if navigation time is not available.

- (15) Replace the IRU (AMM 34-21-01/401) if one of these conditions occur:
- (a) The radial position error of the IRU for a given navigation time falls in the "REPLACE - 1 FLIGHT" area of Fig. 107B.
 - (b) The radial position error of the IRU for a given navigation time falls in the "REPLACE - 2 CONSECUTIVE FLIGHTS" area of Fig. 107B for two consecutive flights.

EFFECTIVITY

ALL

34-21-00

01

Page 130
Jan 28/03

 **BOEING**
757
FAULT ISOLATION/MAINT MANUAL

ELECTRONIC FLIGHT INSTRUMENT SYSTEM (EFIS)

COMPONENT	FIG. 102 SHT	QTY	ACCESS/AREA	AMM REFERENCE
CIRCUIT BREAKER -	2		FLT COMPT, P11	
ADI LEFT, C593		1	11E3	*
ADI RIGHT, C594		1	11E24	*
EFIS CONT PNL LEFT, C633		1	11E4	*
EFIS CONT PNL RIGHT, C634		1	11E25	*
EFIS DSPL SW LEFT, C622		1	11A7	*
EFIS DSPL SW RIGHT, C623		1	11F24	*
EFIS SYM GEN CENTER, C639		1	11F9	*
EFIS SYM GEN LEFT, C637		1	11F8	*
EFIS SYM GEN RIGHT, C638		1	11F29	*
FLIGHT RECORDER DC, C578		1	11J8	*
HSI LEFT, C588		1	11E6	*
HSI RIGHT, C589		1	11E27	*
RDMI LEFT, C635		1	11A6	*
RDMI RIGHT, C636		1	11F25	*
VSI LEFT, C586		1	11E5	*
VSI RIGHT, C587		1	11E26	*
GENERATOR - CENTER EFIS SYMBOL, M149	1	1	119BL, MAIN EQUIP CTR, E2-3	34-22-01
GENERATOR - LEFT EFIS SYMBOL, M148	1	1	119BL, MAIN EQUIP CTR, E2-1	34-22-01
GENERATOR - RIGHT EFIS SYMBOL, M150	1	1	119BL, MAIN EQUIP CTR, E2-2	34-22-01
INDICATOR - LEFT ELECTRONIC ATTITUDE DIRECTOR, N4	2	1	FLT COMPT, P1-1	34-22-03
INDICATOR - LEFT ELECTRONIC HORIZONTAL SITUATION, N5	2	1	FLT COMPT, P1-1	34-22-04
INDICATOR - LEFT RADIO DISTANCE MAGNETIC, N3	2	1	FLT COMPT, P1-1	34-22-05
INDICATOR - LEFT VERTICAL SPEED, N9	2	1	FLT COMPT, P1-3	34-22-06
INDICATOR - RIGHT ELECTRONIC ATTITUDE DIRECTOR, N44	2	1	FLT COMPT, P3-3	34-22-03
INDICATOR - RIGHT ELECTRONIC HORIZONTAL SITUATION, N45	2	1	FLT COMPT, P3-3	34-22-04
INDICATOR - RIGHT RADIO DISTANCE MAGNETIC, N43	2	1	FLT COMPT, P3-1	34-22-05
INDICATOR - RIGHT VERTICAL SPEED, N49	2	1	FLT COMPT, P3-3	34-22-06
PANEL - (FIM 34-51-00/101)				
LEFT VOR/DME CONTROL, M91				
RIGHT VOR/DME CONTROL, M92				
PANEL - LEFT EFIS CONTROL, M94	2	1	FLT COMPT, P10	34-22-02
PANEL - RIGHT EFIS CONTROL, M93	2	1	FLT COMPT, P10	34-22-02
RELAY - (FIM 31-01-36/101)				
SYS NO. 1 AIR/GND, K141				
SYS NO. 1 AIR/GND, K167				
SYS NO. 1 AIR/GND, K170				
SYS NO. 1 AIR/GND, K177				
RELAY - (FIM 31-01-37/101)				
FLIGHT RECORDER I/P SW, K15				

* SEE THE WDM EQUIPMENT LIST

Electronic Flight Instrument System (EFIS) - Component Index
Figure 101 (Sheet 1)

EFFECTIVITY
GUI 001-114, 116-999





34-22-00



757

FAULT ISOLATION/MAINT MANUAL

ELECTRONIC FLIGHT INSTRUMENT SYSTEM (EFIS)

COMPONENT	FIG. 102 SHT	QTY	ACCESS/AREA	AMM REFERENCE
SENSOR - LEFT EFIS REMOTE LIGHT, TS187		1	FLT COMPT, P7	34-22-08
SENSOR - RIGHT EFIS REMOTE LIGHT, TS188		1	FLT COMPT, P7	34-22-08
SWITCH - HEADING REFERENCE, S616	2	1	FLT COMPT, P3-1	*
SWITCH - LEFT EFI, S3	1	1	FLT COMPT, P1-1	33-13-00
SWITCH - LEFT F/D, S1	1	1	FLT COMPT, P1-1	33-13-00
SWITCH - LEFT FMC, S2 	1	1	FLT COMPT, P1-1	33-13-00
SWITCH - LEFT IRS, S4	1	1	FLT COMPT, P1-1	33-13-00
SWITCH - LEFT NAV, S2 	1	1	FLT COMPT, P1-1	33-13-00
SWITCH - RIGHT EFI, S11	1	1	FLT COMPT, P3-3	33-13-00
SWITCH - RIGHT F/D, S9	1	1	FLT COMPT, P3-3	33-13-00
SWITCH - RIGHT FMC, S10 	1	1	FLT COMPT, P3-3	33-13-00
SWITCH - RIGHT IRS, S12	1	1	FLT COMPT, P3-3	33-13-00
SWITCH - RIGHT NAV, S10 	1	1	FLT COMPT, P3-3	33-13-00

* SEE THE WDM EQUIPMENT LIST

 ATZ 003 PRE-SB 34-414;
ATZ 001, 002, 007

 ATZ 003 POST-SB 34-414;
ATZ 101-999

Electronic Flight Instrument System (EFIS) - Component Index
Figure 101 (Sheet 2)

EFFECTIVITY
GUI 001-114, 116-999

34-22-00

1576268



757
 FAULT ISOLATION/MAINT MANUAL

ELECTRONIC FLIGHT INSTRUMENT SYSTEM (EFIS)

COMPONENT	FIG. 102 SHT	QTY	ACCESS/AREA	AMM REFERENCE
CIRCUIT BREAKER -	4		FLT COMPT, P11	
ADI LEFT, C593		1	11E3	*
ADI RIGHT, C594		1	11E24	*
EFIS CONT PNL LEFT, C633		1	11E4	*
EFIS CONT PNL RIGHT, C634		1	11E25	*
EFIS DSPL SW LEFT, C622		1	11C4	*
EFIS DSPL SW RIGHT, C623		1	11F24	*
EFIS SYM GEN LEFT, C637		1	11F8	*
EFIS SYM GEN RIGHT, C638		1	11F29	*
EFIS SYM GEN CENTER, C639		1	11F9	*
FLIGHT RECORDER DC, C578		1	11J8	*
HSI LEFT, C588		1	11E6	*
HSI RIGHT, C589		1	11E27	*
RBA L, C4239		1	11A6	*
RBA R, C4240		1	11F25	*
RMI L, C635		1	11A7	*
RMI R, C636		1	11F23	*
VSI LEFT, C586		1	11E5	*
VSI RIGHT, C587		1	11E26	*
GENERATOR - LEFT EFIS SYMBOL, M148	3	1	119BL, MAIN EQUIP CTR, E2-1	34-22-01
GENERATOR - CENTER EFIS SYMBOL, M149	3	1	119BL, MAIN EQUIP CTR, E2-3	34-22-01
GENERATOR - RIGHT EFIS SYMBOL, M150	3	1	119BL, MAIN EQUIP CTR, E2-2	34-22-01
INDICATOR - LEFT ELECTRONIC ATTITUDE DIRECTOR, N4	4	1	FLT COMPT, P1-1	34-22-03
INDICATOR - LEFT ELECTRONIC HORIZONTAL SITUATION, N5	4	1	FLT COMPT, P1-1	34-22-04
INDICATOR - LEFT RADIO MAGNETIC, N10024	4	1	FLT COMPT, P1-3	34-22-07
INDICATOR - LEFT RMI BEARING SOURCE ANNUNCIATOR, N10025	4	1	FLT COMPT, P1-3	34-22-07
INDICATOR - LEFT VERTICAL SPEED, N9	4	1	FLT COMPT, P1-3	34-22-06
INDICATOR - RIGHT ELECTRONIC ATTITUDE DIRECTOR, N44	4	1	FLT COMPT, P3-3	34-22-03
INDICATOR - RIGHT ELECTRONIC HORIZONTAL SITUATION, N45	4	1	FLT COMPT, P3-3	34-22-04
INDICATOR - RIGHT RADIO MAGNETIC, N10026	4	1	FLT COMPT, P3-3	34-22-07
INDICATOR - RIGHT RMI BEARING SOURCE ANNUNCIATOR, N10027	4	1	FLT COMPT, P3-3	34-22-07
INDICATOR - RIGHT VERTICAL SPEED, N49	4	1	FLT COMPT, P3-3	34-22-06
PANEL - (FIM 34-51-00/101)				
LEFT VOR/DME CONTROL, M91				
RIGHT VOR/DME CONTROL, M92				
PANEL - LEFT EFIS CONTROL, M94	4	1	FLT COMPT, P10	34-22-02
PANEL - RIGHT EFIS CONTROL, M93	4	1	FLT COMPT, P10	34-22-02
RELAY - (FIM 31-01-36/101)				
SYS NO. 1 AIR/GND, K141				
SYS NO. 1 AIR/GND, K170				
SYS NO. 1 AIR/GND, K177				
RELAY - (FIM 31-01-37/101)				
FLIGHT RECORDER I/P SW, K15				







* SEE THE WDM EQUIPMENT LIST

Electronic Flight Instrument System (EFIS) - Component Index
 Figure 101 (Sheet 3)

EFFECTIVITY
 GUI 115

34-22-00

BOEING
 757
 FAULT ISOLATION/MAINT MANUAL

COMPONENT	FIG. 102 SHT	QTY	ACCESS/AREA	AMM REFERENCE
SENSOR - LEFT EFIS REMOTE LIGHT, TS187		1	FLT COMPT, P7	34-22-08
SENSOR - RIGHT EFIS REMOTE LIGHT, TS188		1	FLT COMPT, P7	34-22-08
SWITCH - HEADING REFERENCE, S616	4	1	FLT COMPT, P3-1	*
SWITCH - LEFT EFI, S3	3	1	FLT COMPT, P1-1	33-13-00
SWITCH - LEFT F/D, S1	3	1	FLT COMPT, P1-1	33-13-00
SWITCH - LEFT FMC, S2 	3	1	FLT COMPT, P1-1	33-13-00
SWITCH - LEFT IRS, S4 	3	1	FLT COMPT, P1-1	33-13-00
SWITCH - LEFT NAV, S2 	3	1	FLT COMPT, P1-1	33-13-00
SWITCH - RIGHT EFI, S11	3	1	FLT COMPT, P3-3	33-13-00
SWITCH - RIGHT F/D, S9	3	1	FLT COMPT, P3-3	33-13-00
SWITCH - RIGHT FMC, S10 	3	1	FLT COMPT, P3-3	33-13-00
SWITCH - RIGHT IRS, S12 	3	1	FLT COMPT, P3-3	33-13-00
SWITCH - RIGHT NAV, S10 	3	1	FLT COMPT, P3-3	33-13-00

* SEE THE WDM EQUIPMENT LIST

 GUI 115 PRE-SB 34-414;
GUI 001-011

 GUI 115 POST-SB 34-414;

Electronic Flight Instrument System (EFIS) - Component Index
Figure 101 (Sheet 4)

EFFECTIVITY
GUI 115

34-22-00

BOEING

757

FAULT ISOLATION/MAINT MANUAL

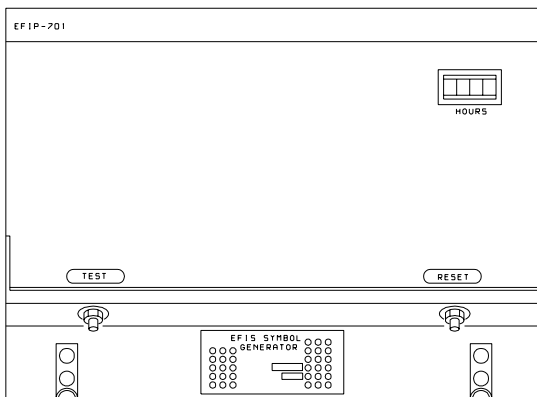
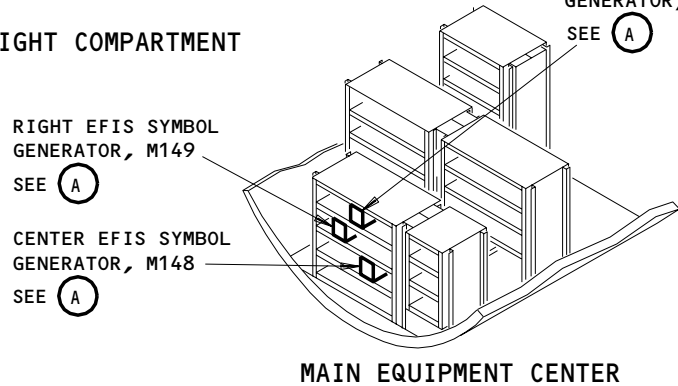
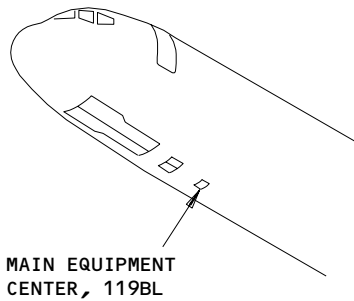
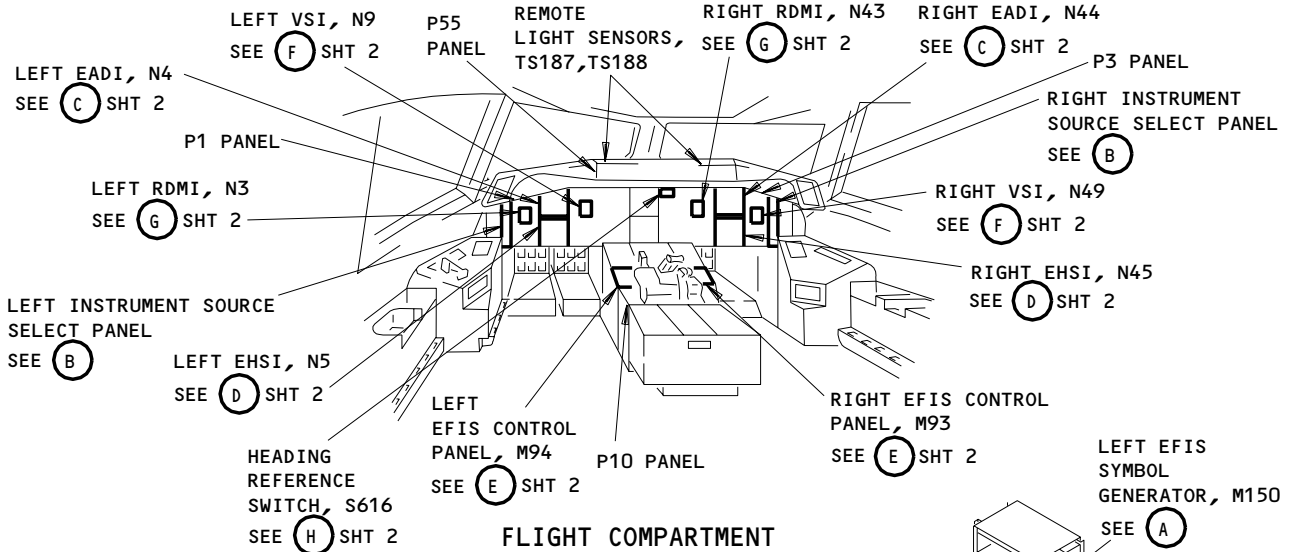

(A)

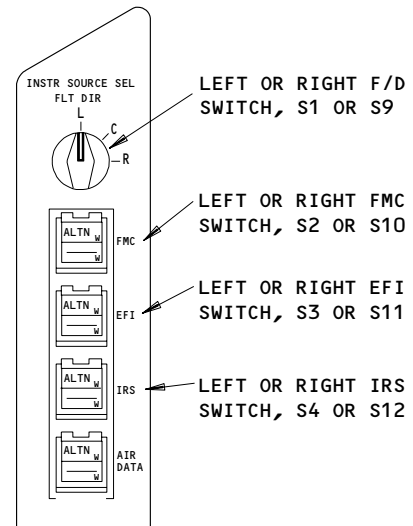

(B)

EFIS - Component Location
Figure 102 (Sheet 1)

EFFECTIVITY
GUI 001-114, 116-999

34-22-00

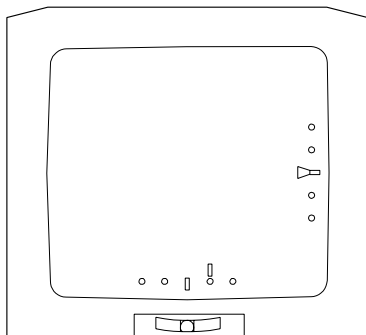

LEFT OR RIGHT EADI,
N4 OR N44

(C)

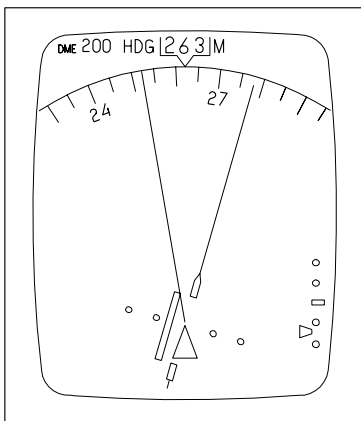

LEFT OR RIGHT EHSI,
N5 OR N45

(D)

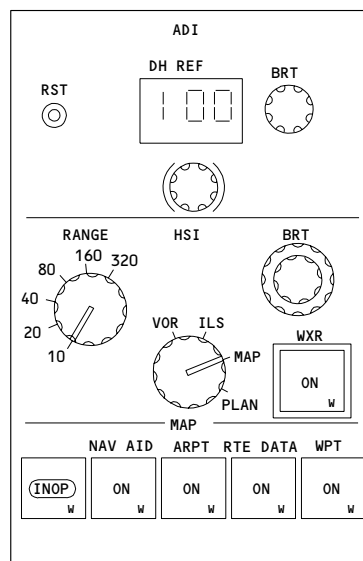

LEFT OR RIGHT EFIS CONTROL
PANEL, M94 OR M93

(E)

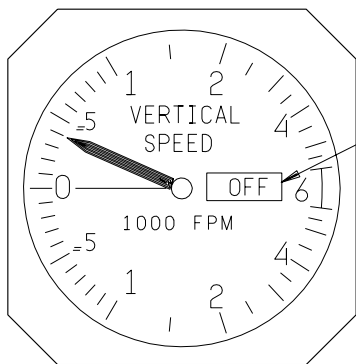

LEFT OR RIGHT VERTICAL SPEED
INDICATOR, N9 OR N49

(F)

FAULT
FLAG

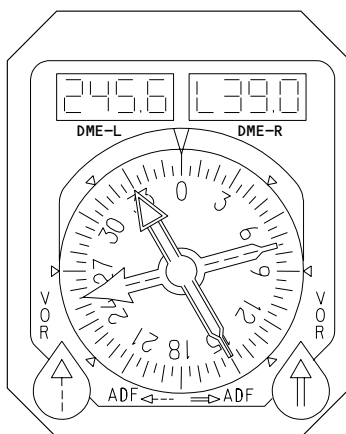

LEFT OR RIGHT RDMI, N3 OR N43

(G)

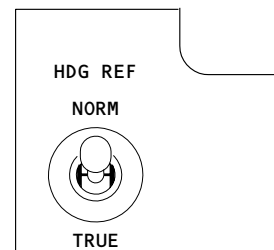

HEADING REFERENCE
SWITCH, S616

(H)

EFIS - Component Location (Details from Sht 1)
Figure 102 (Sheet 2)

EFFECTIVITY
GUI 001-114, 116-999

34-22-00

138665

BOEING

757

FAULT ISOLATION/MAINT MANUAL

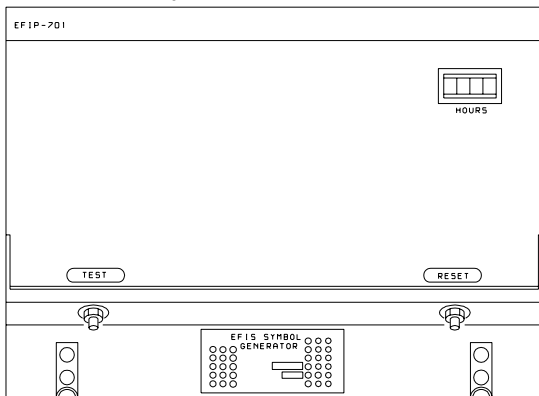
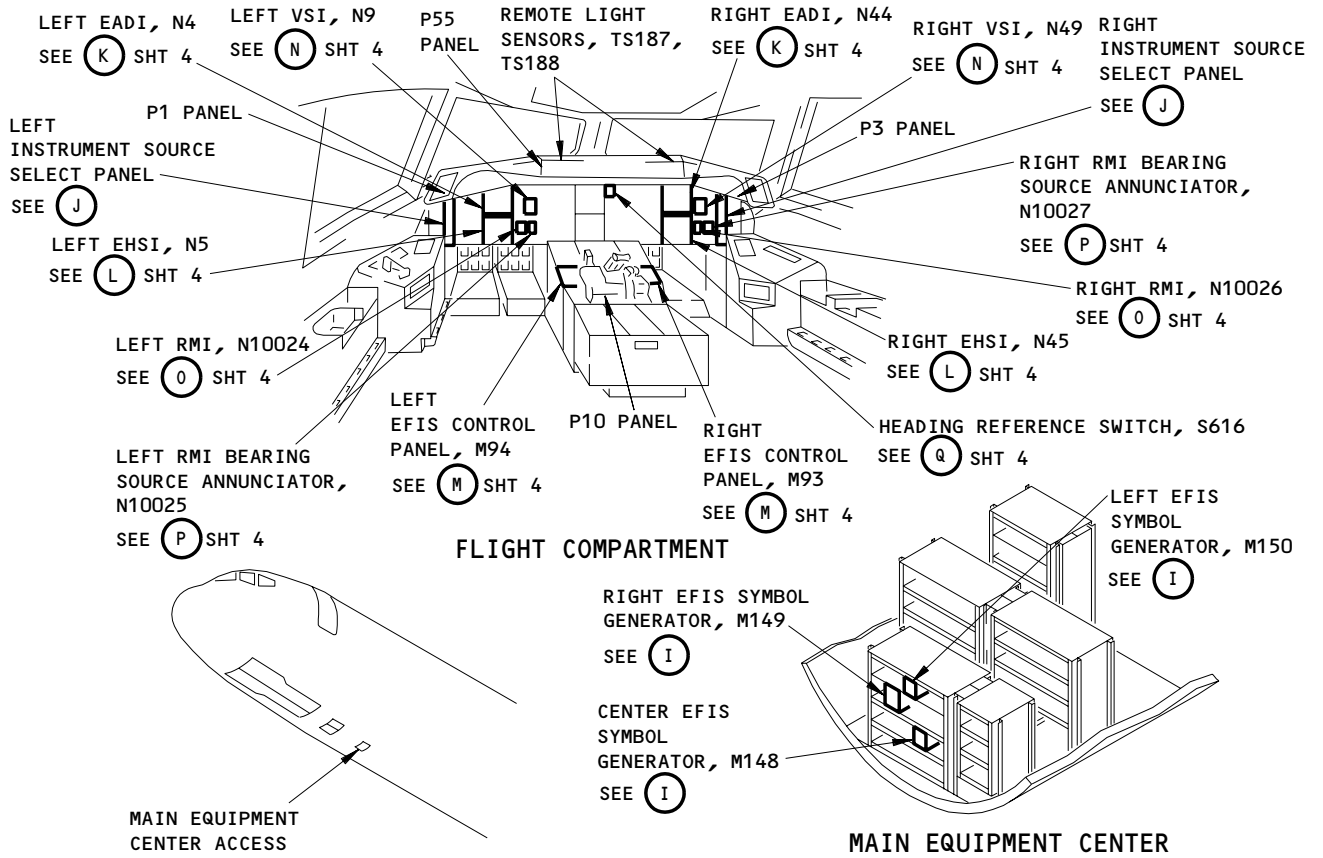

EFIS SYMBOL GENERATOR (EXAMPLE)

(I)

- 1 ▷ GUI 115 PRE SB 34-414;
GUI 001-011
- 2 ▷ GUI 115 POST SB 34-414;

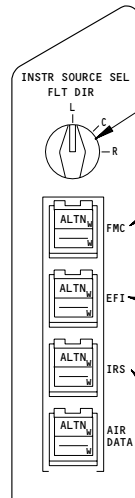

LEFT OR RIGHT INSTRUMENT SOURCE SELECT PANEL (EXAMPLE)

(J) 1 ▷

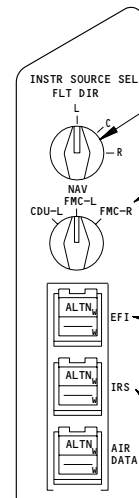

LEFT OR RIGHT INSTRUMENT SOURCE SELECT PANEL (EXAMPLE)

(J) 2 ▷

Electronic Flight Instrument System (EFIS) - Component Location
Figure 102 (Sheet 3)

EFFECTIVITY
GUI 115

34-22-00

BOEING

757

FAULT ISOLATION/MAINT MANUAL

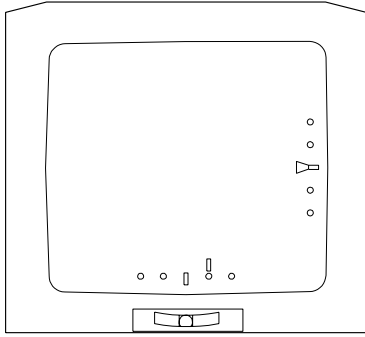

LEFT OR RIGHT EADI,
N4 OR N44

(K)

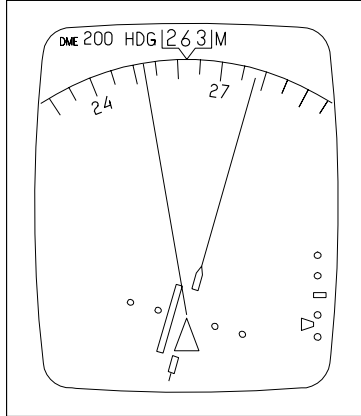

LEFT OR RIGHT EHSI,
N5 OR N45

(L)

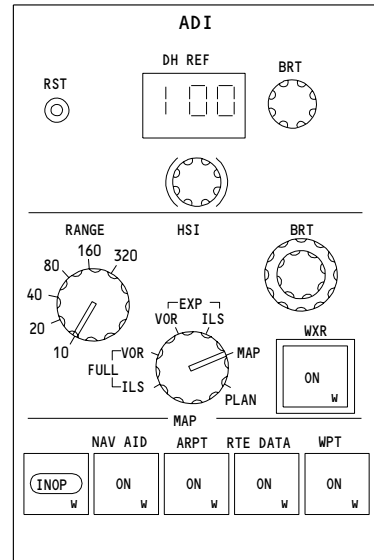

LEFT OR RIGHT EFIS CONTROL
PANEL, M94 OR M93

(M)

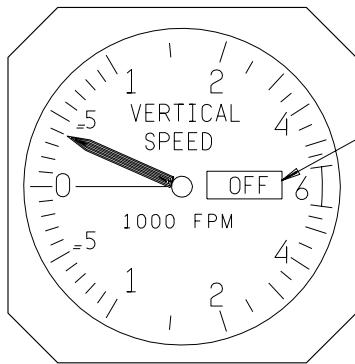

LEFT OR RIGHT VERTICAL SPEED
INDICATOR, N9 OR N49

(N)

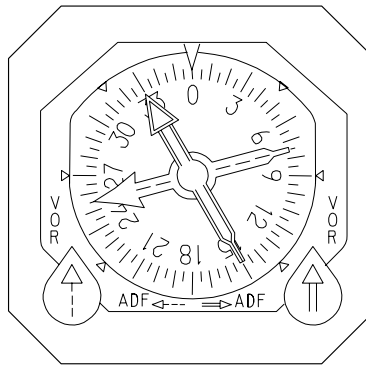

LEFT OR RIGHT RMI,
N10024 OR N10026

(O)

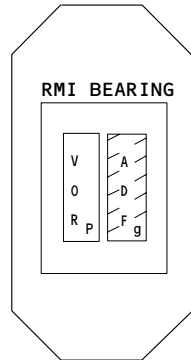

LEFT OR RIGHT RMI BEARING
SOURCE ANNUNCIATOR,
N10025 OR N10027

(P)

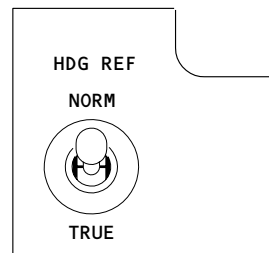

HEADING REFERENCE
SWITCH, S616

(Q)

EFIS - Component Location (Details from Sht 3)
Figure 102 (Sheet 4)

EFFECTIVITY
GUI 115

34-22-00

Not Used
Figure 103

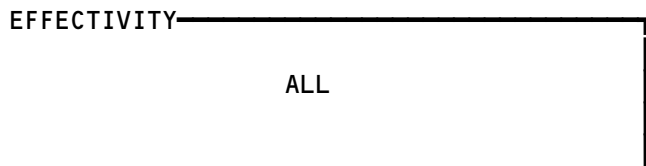

34-22-00

08

Page 109
Mar 20/96

54099

**DISPLAY PROBLEMS
ON CAPT (F/O)
EADI**

PREREQUISITES

MAKE SURE THIS SYSTEM WILL OPERATE:
EFIS (AMM 34-22-00/501)

MAKE SURE THESE CIRCUIT BREAKERS ARE CLOSED:
11E3, 11E4, 11E6, 11E24, 11E25, 11E27, 11F8, 11F9,
11F24, 11F29; 1 ▷ 11A7; 2 ▷ 11C4

MAKE SURE THE AIRPLANE IS IN THIS CONFIGURATION:
ELECTRICAL POWER IS ON (AMM 24-22-00/201)

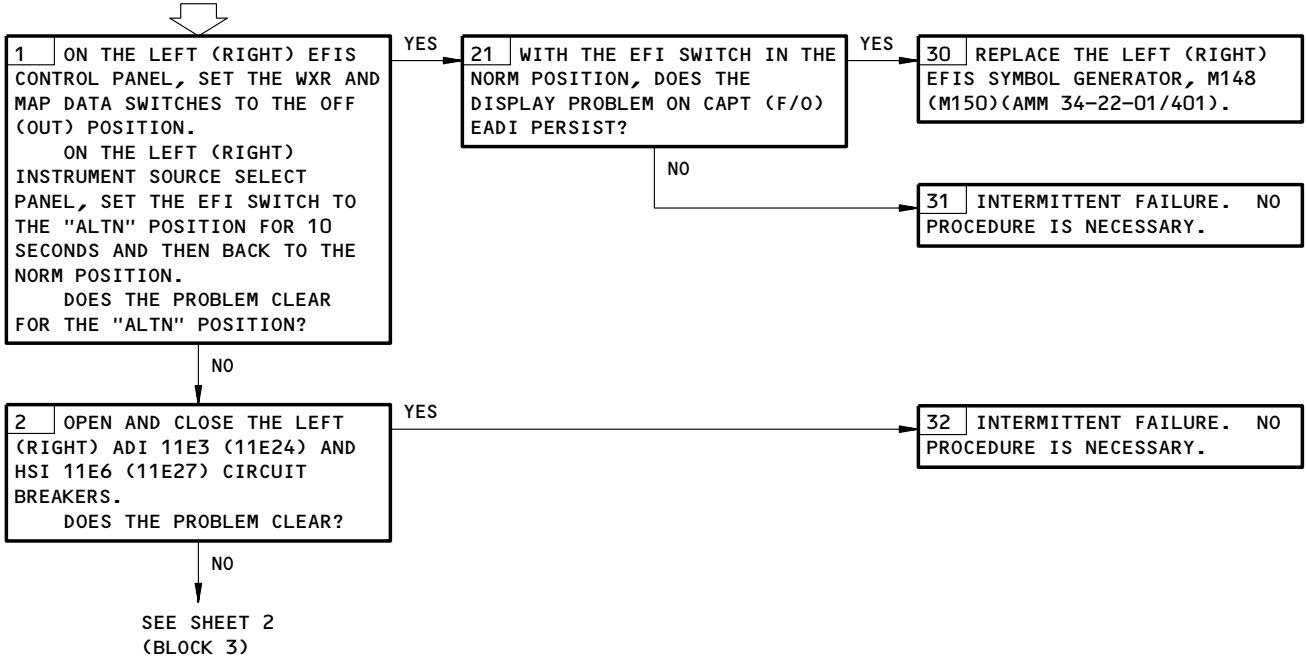

- 1 ▷ GUI 001-114, 116-999
- 2 ▷ GUI 115

Display Problems on Capt (F/O) EADI
Figure 104 (Sheet 1)

EFFECTIVITY	ALL
-------------	-----

34-22-00

A80387

BOEING
757
FAULT ISOLATION/MAINT MANUAL

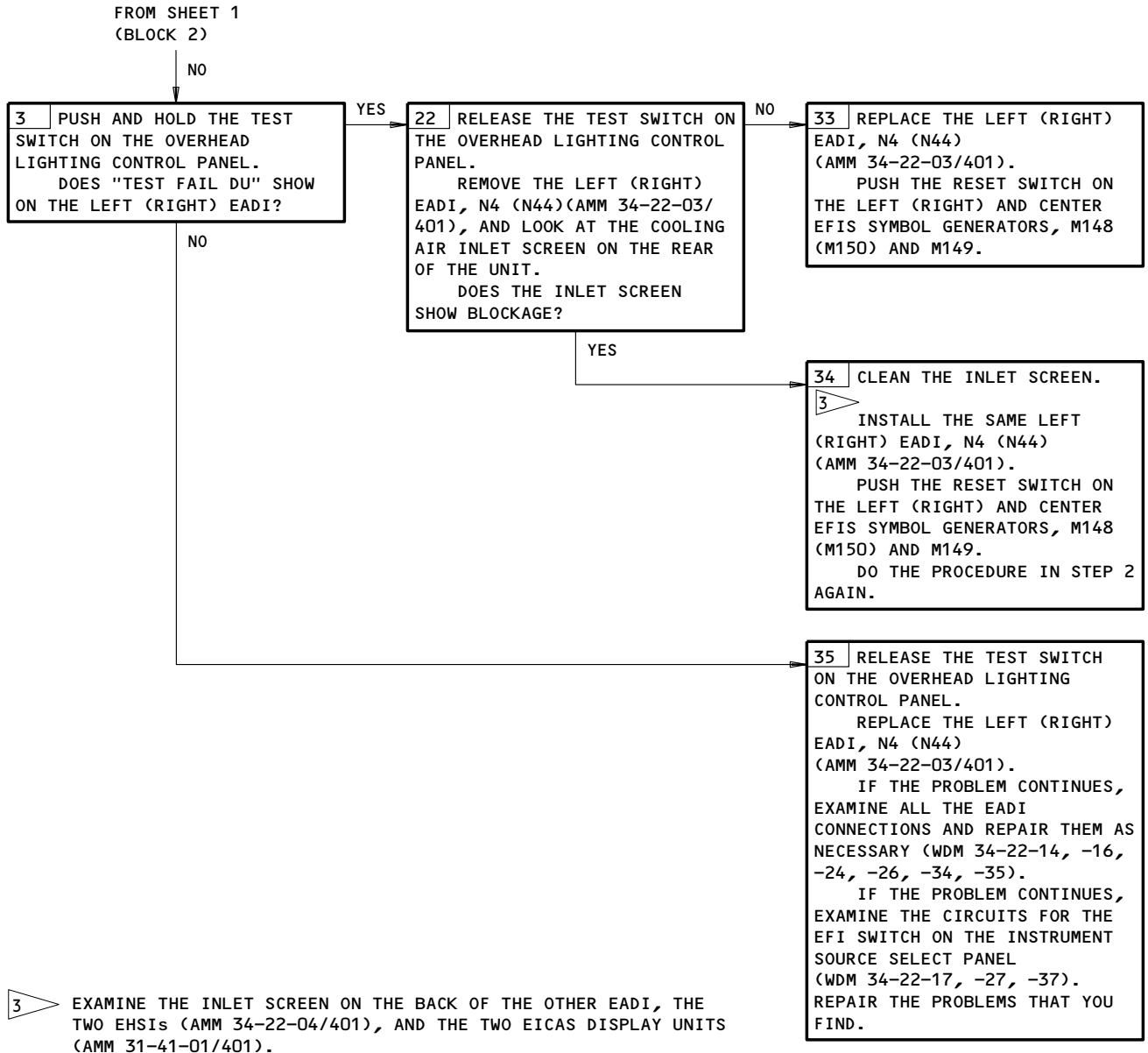

Display Problems on Capt (F/O) EADI
Figure 104 (Sheet 2)

EFFECTIVITY

ALL

34-22-00

10

Page 111
Jan 28/03

781626

**BRIGHTNESS CONTROL
PROBLEM ON CAPT
(F/O) EADI**

PREREQUISITES

MAKE SURE THIS SYSTEM WILL OPERATE:
EFIS (AMM 34-22-00/501)

MAKE SURE THESE CIRCUIT BREAKERS ARE CLOSED:
11E3,11E4,11E6,11E24,11E25,11E27,11F8,11F9,11F24,
11F29; 2 > 11A7; 3 > 11C4

MAKE SURE THE AIRPLANE IS IN THIS CONFIGURATION:
ELECTRICAL POWER IS ON (AMM 24-22-00/201)

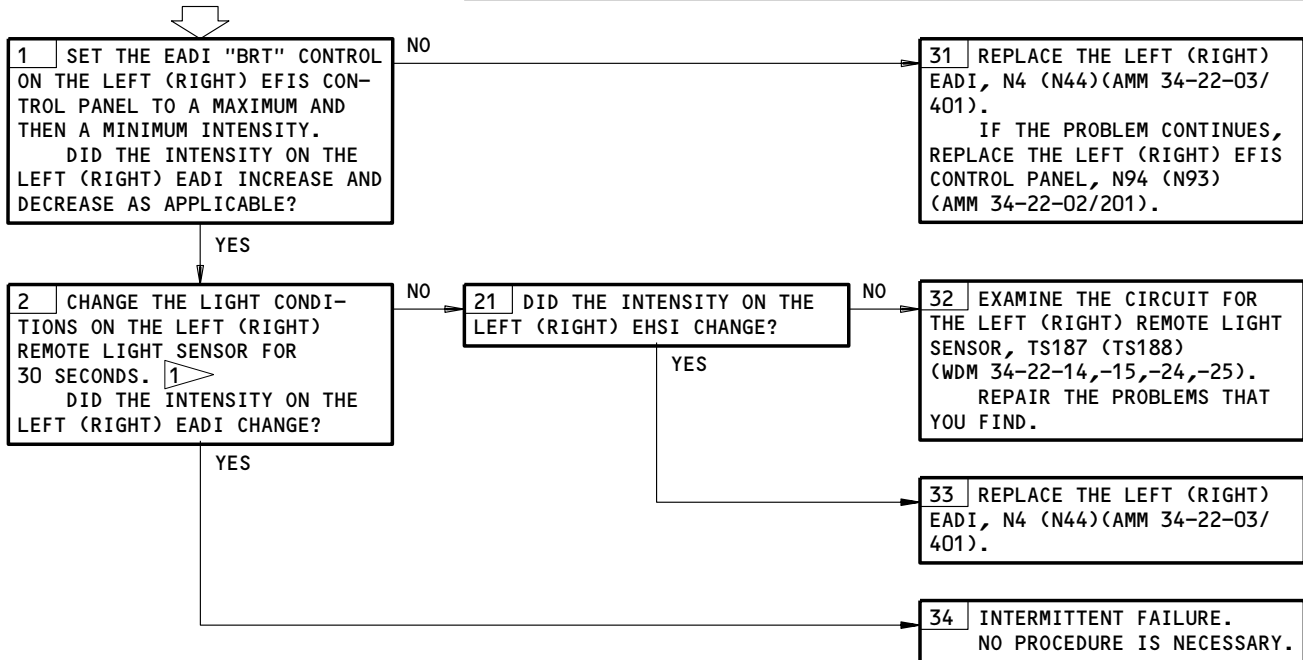

- 1 > FOR LIGHT CONDITIONS, PUT A COVER ON THE SENSOR.
FOR NO LIGHT CONDITIONS, POINT A LIGHT SOURCE AT THE SENSOR.
- 2 > GUI 001-114,116-999
- 3 > GUI 115

Brightness Control Problem on Capt (F/O) EADI
Figure 105

EFFECTIVITY	ALL
-------------	-----

34-22-00

**DISPLAY PROBLEMS
ON CAPT (F/O)
EHSI**

PREREQUISITES

MAKE SURE THIS SYSTEM WILL OPERATE:
EFIS (AMM 34-22-00/501)

MAKE SURE THESE CIRCUIT BREAKERS ARE CLOSED:
11E3,11E4,11E6,11E24,11E25,11E27,11F8,11F9,11F24,
11F29; 1 ▷ 11A7; 2 ▷ 11C4

MAKE SURE THE AIRPLANE IS IN THIS CONFIGURATION:
ELECTRICAL POWER IS ON (AMM 24-22-00/201)

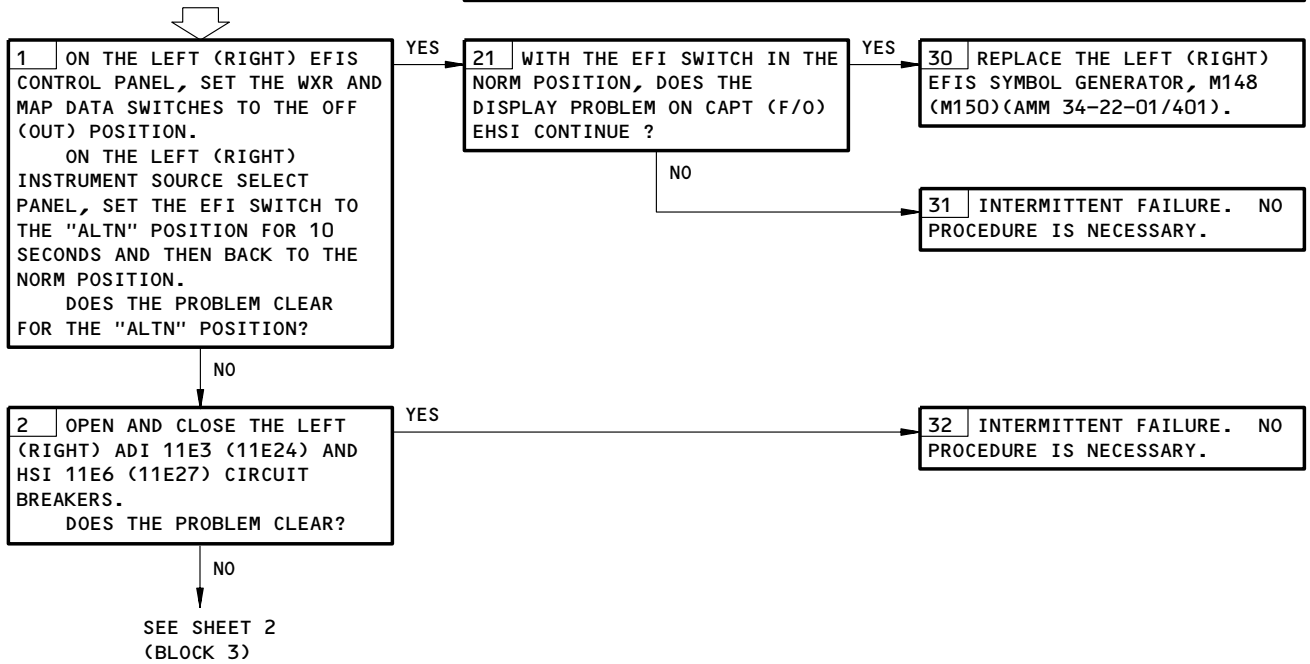

- 1 ▷ GUI 001-114,116-999
- 2 ▷ GUI 115

Display Problems on Capt (F/O) EHSI
Figure 106 (Sheet 1)

EFFECTIVITY	ALL
-------------	-----

34-22-00

BOEING
757
FAULT ISOLATION/MAINT MANUAL

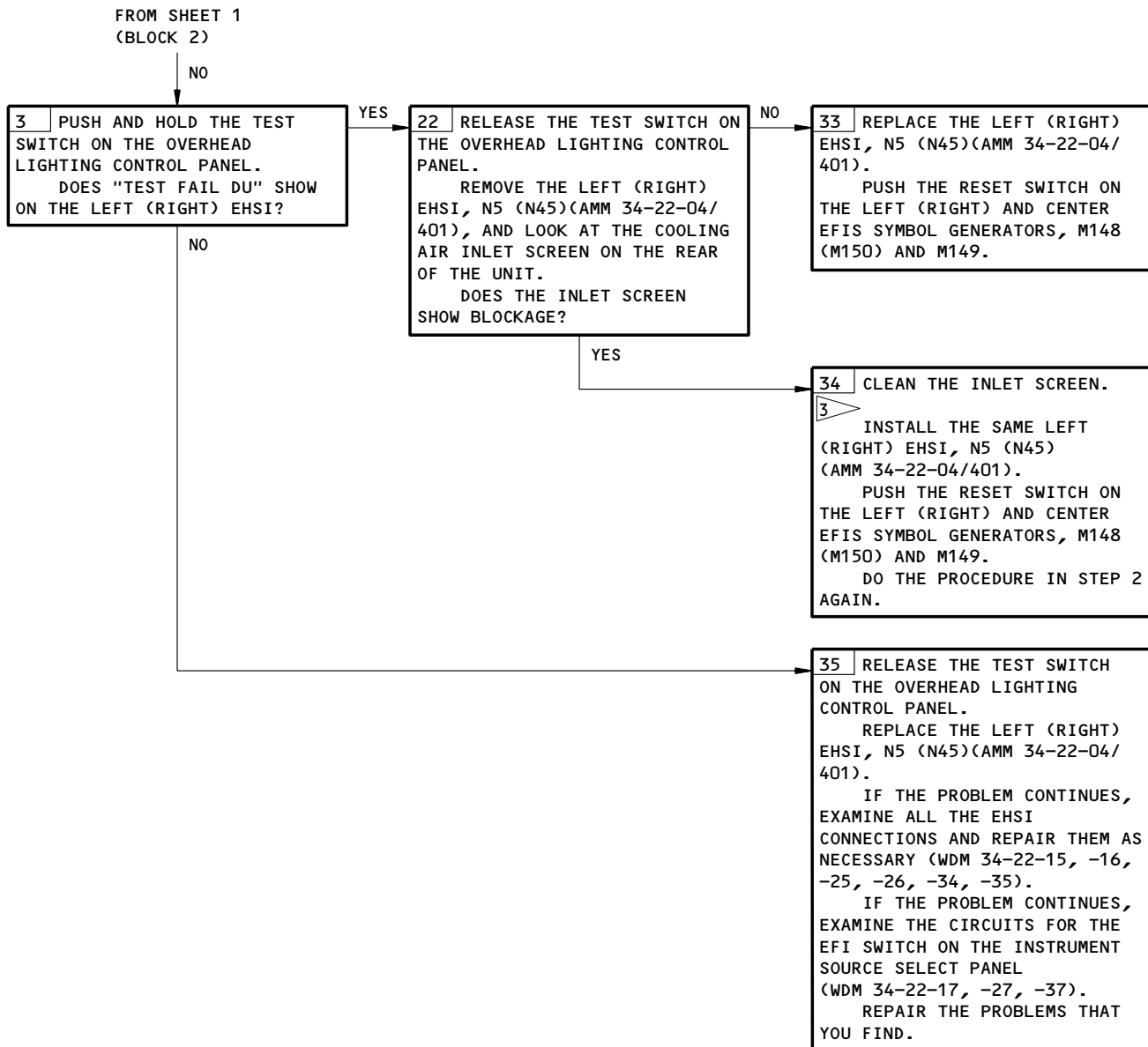

3 EXAMINE THE INLET SCREEN ON THE BACK OF THE OTHER EHSI, THE TWO EADIs (AMM 34-22-03/401), AND THE TWO EICAS DISPLAY UNITS (AMM 31-41-01/401).

Display Problems on Capt (F/O) EHSI
Figure 106 (Sheet 2)

EFFECTIVITY ————
ALL

34-22-00

**BRIGHTNESS CONTROL
PROBLEM ON CAPT
(F/O) EHSI**

PREREQUISITES

MAKE SURE THIS SYSTEM WILL OPERATE:
EFIS (AMM 34-22-00/501)

MAKE SURE THESE CIRCUIT BREAKERS ARE CLOSED:
11E3,11E4,11E6,11E24,11E25,11E27,11F8,11F9,11F24,
11F29; 2 > 11A7; 3 > 11C4

MAKE SURE THE AIRPLANE IS IN THIS CONFIGURATION:
ELECTRICAL POWER IS ON (AMM 24-22-00/201)

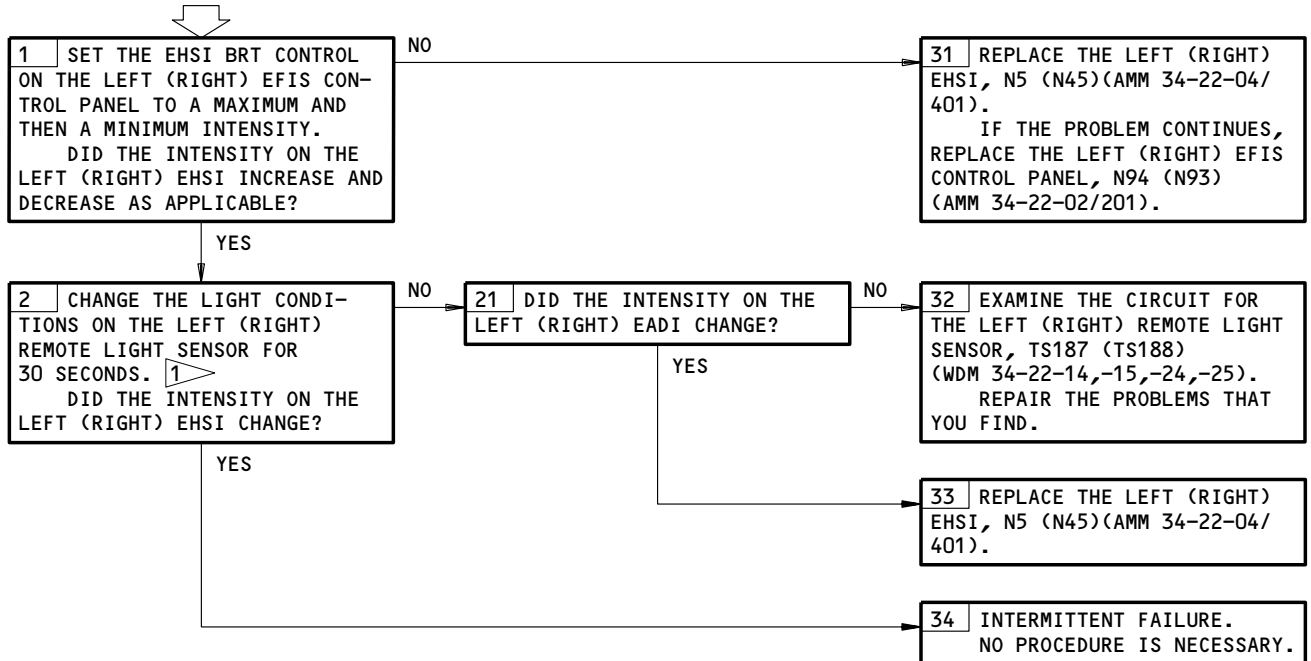

1 > FOR LIGHT CONDITIONS, PUT A COVER ON THE SENSOR.
FOR NO LIGHT CONDITIONS, POINT A LIGHT SOURCE AT THE SENSOR.

2 > GUI 001-114,116-999

3 > GUI 115

Brightness Control Problem on Capt (F/O) EHSI
Figure 107

EFFECTIVITY

ALL

34-22-00

03

Page 115
Dec 20/96

PREREQUISITES

MAKE SURE THESE SYSTEMS WILL OPERATE:
 EICAS (AMM 31-41-00/201)
 EFIS (AMM 34-22-00/501)

MAKE SURE THESE CIRCUIT BREAKERS ARE CLOSED:
 11E3, 11E4, 11E6, 11E24, 11E25, 11E27, 11F8, 11F9,
 11F24, 11F29; 2 > 11A7; 3 > 11C4

MAKE SURE THE AIRPLANE IS IN THIS CONFIGURATION:
 ELECTRICAL POWER IS ON (AMM 24-22-00/201)

EFIS BITE PROCEDURE

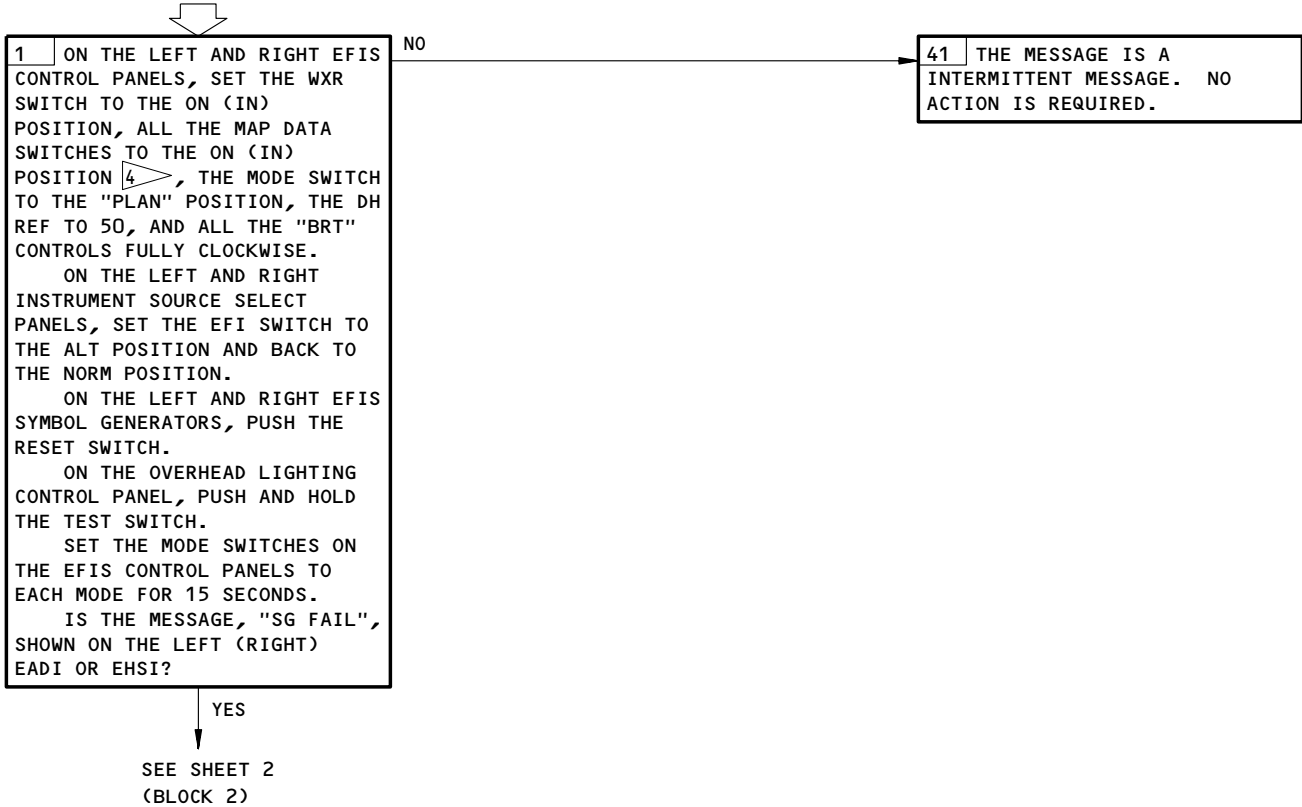

- 1 > DISENGAGE THE TEST SWITCH ON THE OVERHEAD LIGHTING CONTROL PANEL.
- 2 > GUI 001-114, 116-999
- 3 > GUI 115
- 4 > DO NOT PUSH THE INOP SWITCH ON THE EFIS CONTROL PANEL. IF YOU DO, INCORRECT DISPLAY WILL OCCUR.

EFIS BITE Procedure
Figure 108 (Sheet 1)

EFFECTIVITY	ALL
-------------	-----

34-22-00

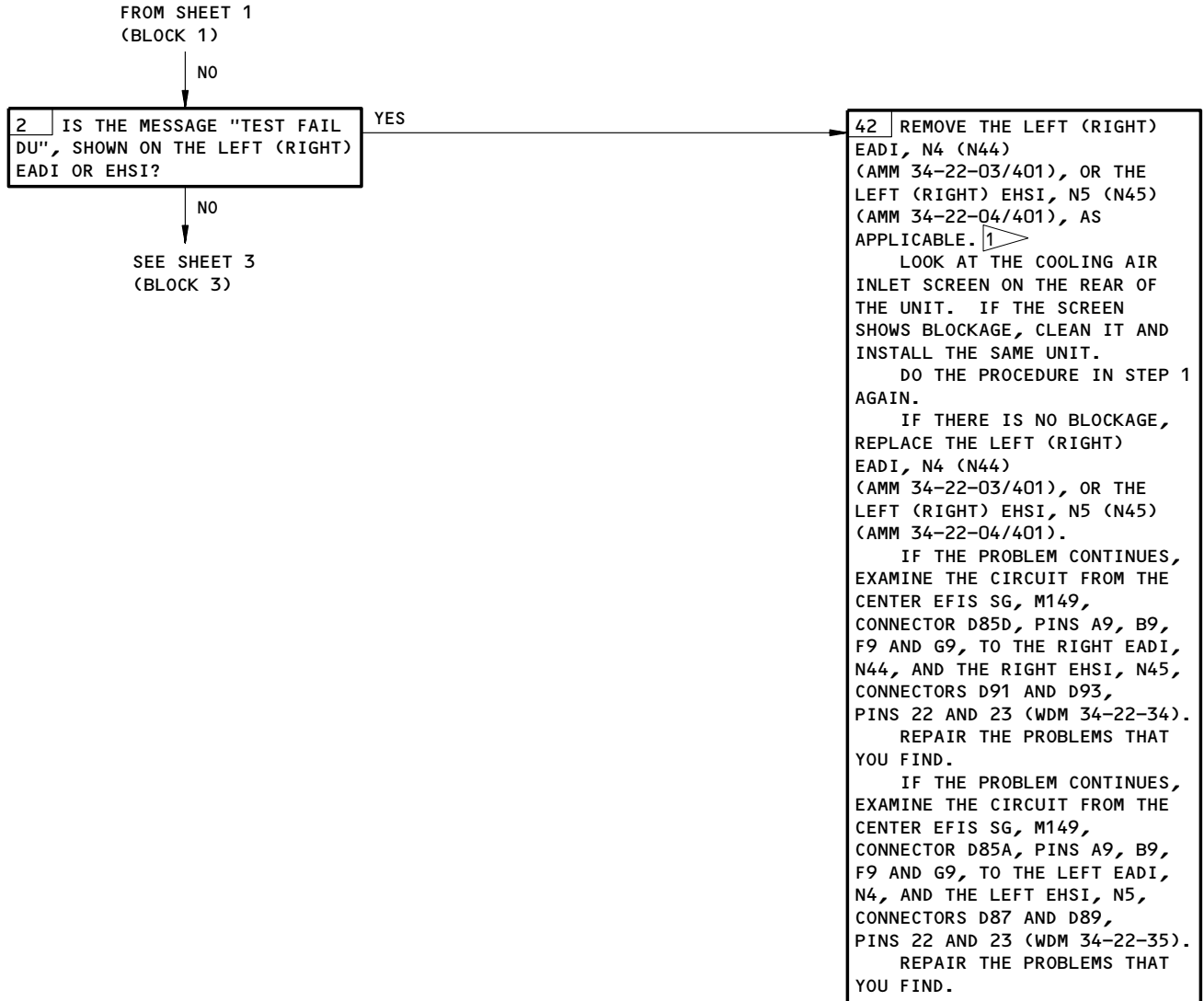

EFIS BITE Procedure
Figure 108 (Sheet 2)

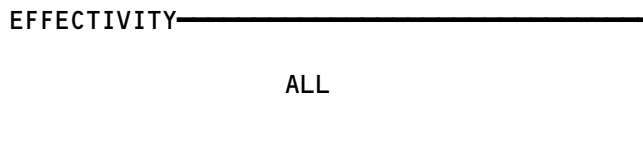

34-22-00

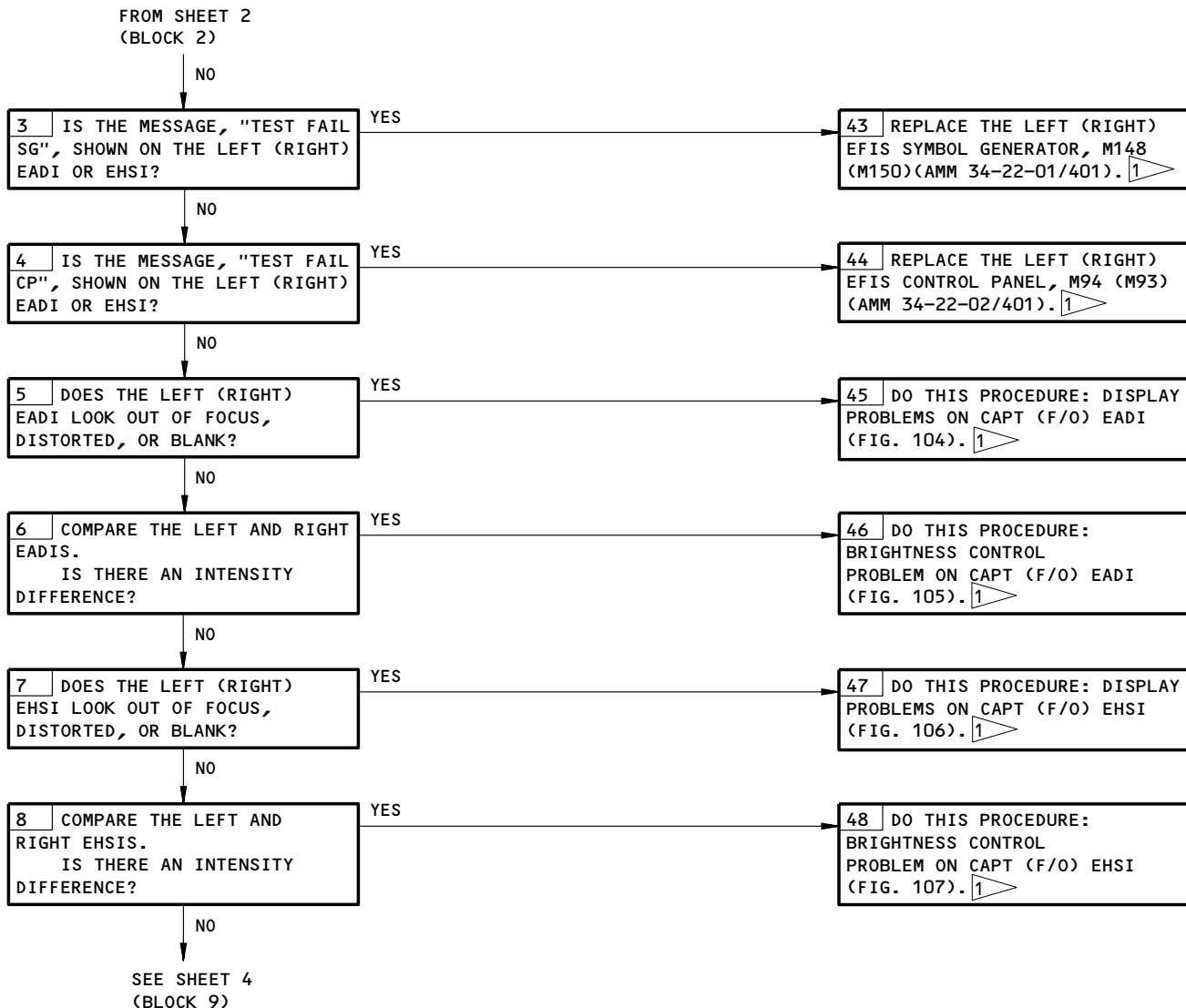

EFIS BITE Procedure
Figure 108 (Sheet 3)

EFFECTIVITY	ALL
-------------	-----

34-22-00

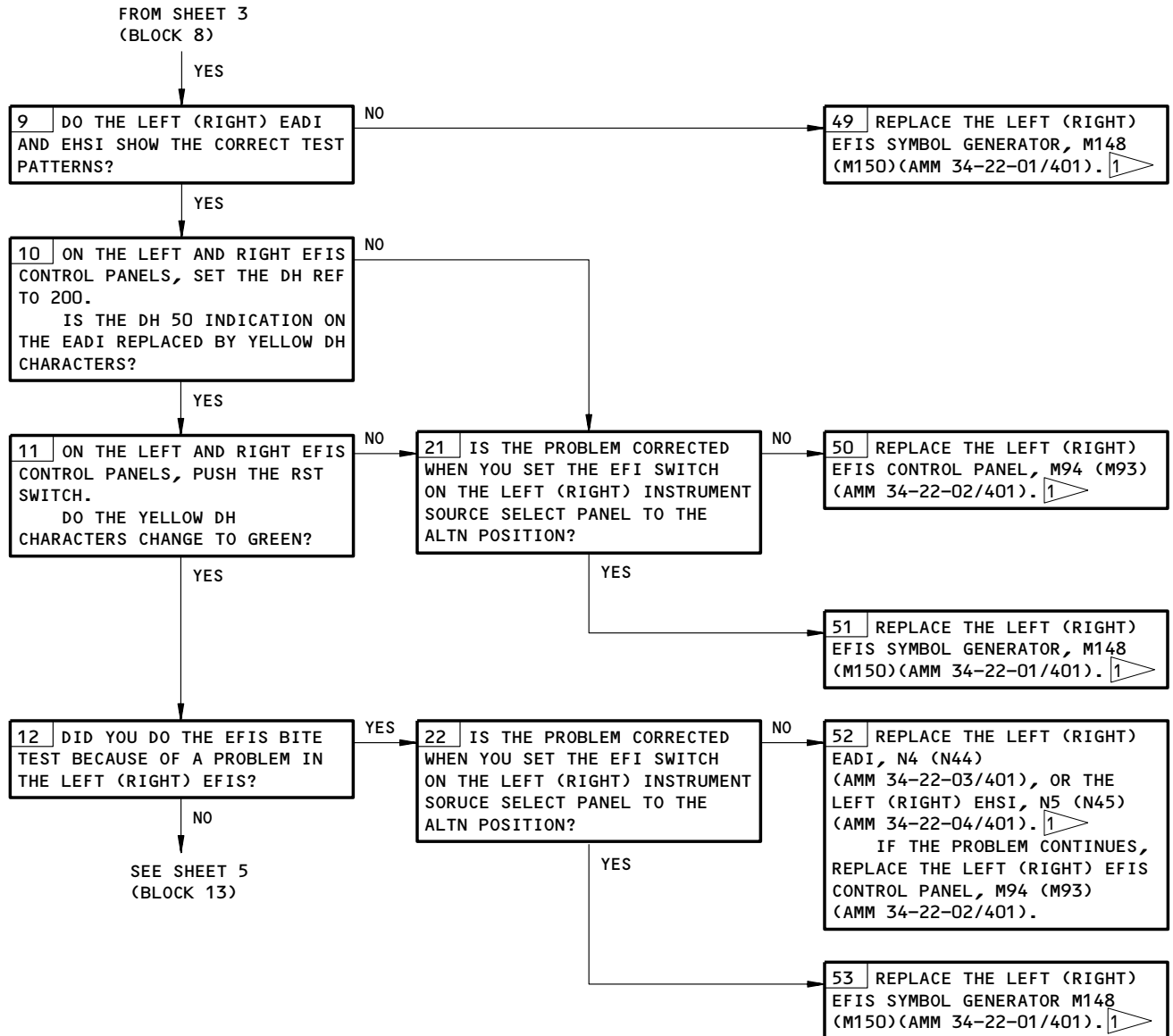

EFIS BITE Procedure
Figure 108 (Sheet 4)

EFFECTIVITY ————
ALL

34-22-00

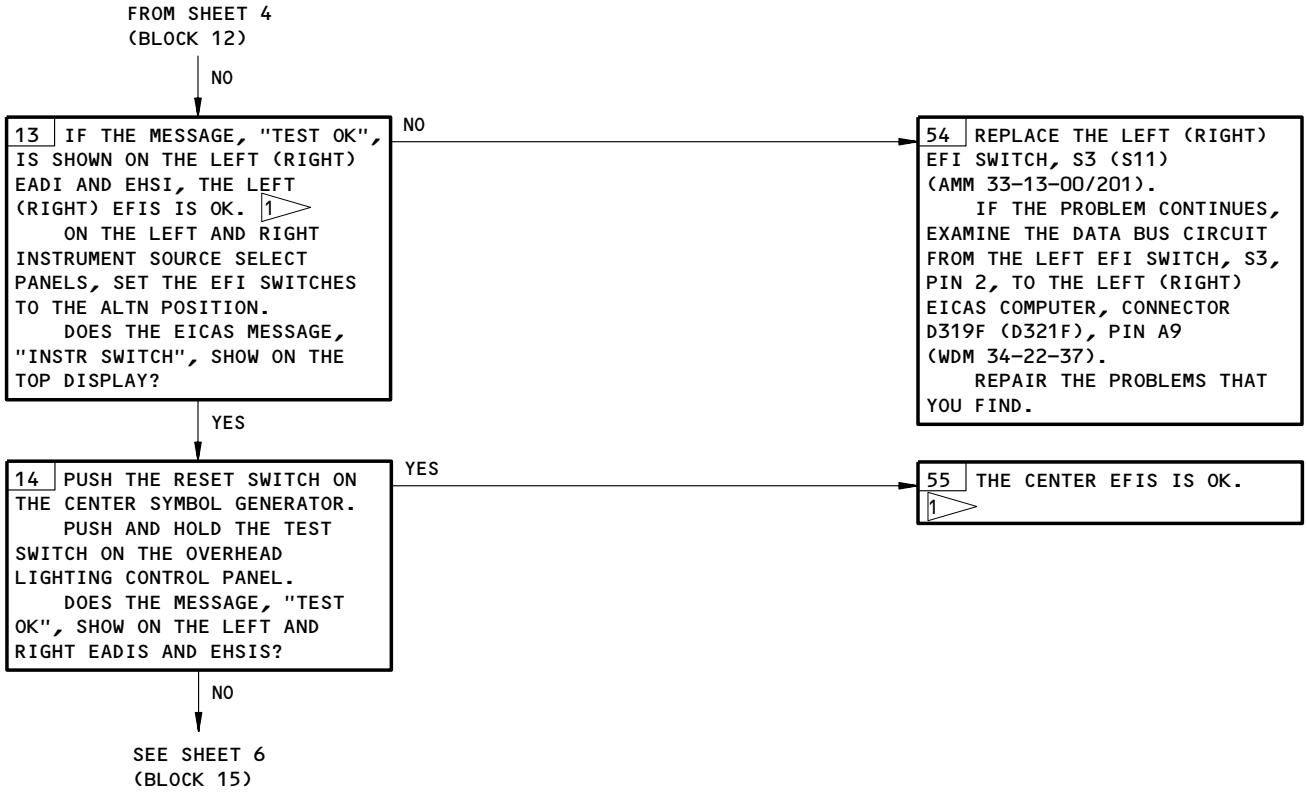

EFIS BITE Procedure
Figure 108 (Sheet 5)

EFFECTIVITY ———— ALL

34-22-00

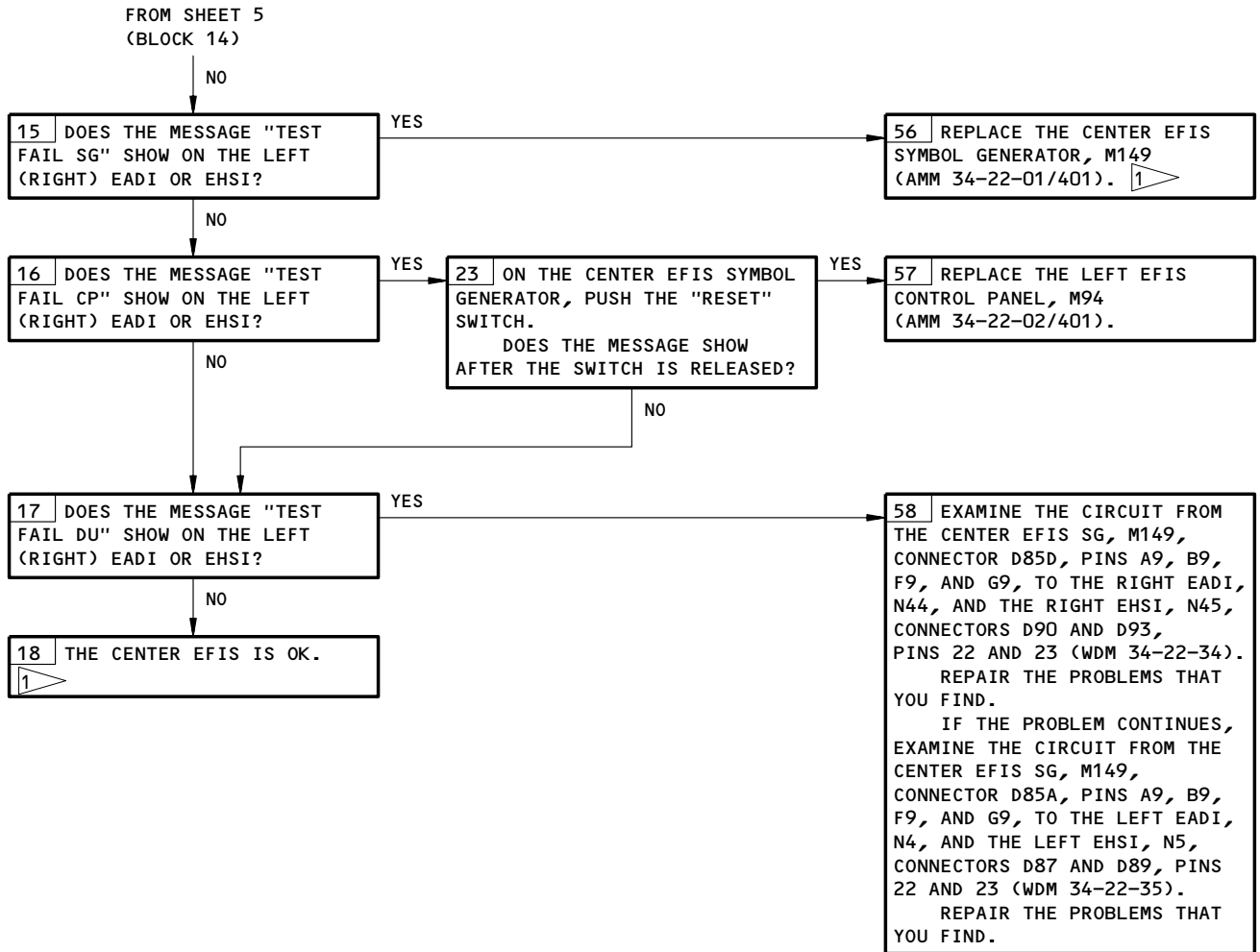

EFIS BITE Procedure
Figure 108 (Sheet 6)

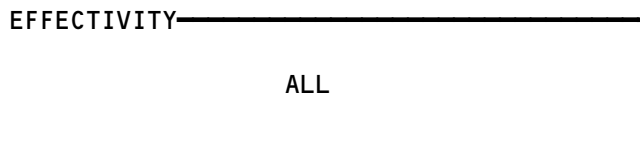

34-22-00

BOEING
 757
 FAULT ISOLATION/MAINT MANUAL

1. ARINC Data Bus Charts

A. General

CAUTION: DO NOT DIRECTLY TOUCH THE CONNECTORS. USE A BREAKOUT BOX OR YOU CAN CAUSE DAMAGE TO THE CONNECTORS.

(1) The ARINC 429 data bus charts give data necessary to make an analysis of ARINC 429 transmitters, receivers, and data buses. For the test, use a breakout box at the available terminal or at the LRU connectors.

B. Equipment

(1) Standard multi-meter
 (2) 429EBP Data Bus Analyzer (recommended)
 JcAIR Instrumentation
 400 Industrial Parkway
 Industrial Airport, KS 66031

429-2 Data Bus Analyzer (alternative)
 Interface Technology
 150 E. Arrow Highway
 San Dimas, CA 91773

(3) A34011-1 Breakout Box (recommended)
 A34011-112 Breakout Box (alternative)

EFIS CP							
DIGITAL OUTPUT BUS CHART							
BUS NAME			CON	PINS	BUS FORMAT	BIT RATE	DATA BUS
SOURCE	TYPE	BUS					
EFISCP (L R)	A	1		36 35	429	L0	OUTPUT BUS

EFFECTIVITY

ALL

34-22-00

04

Page 122
 Sep 28/06

BOEING
 757
 FAULT ISOLATION/MAINT MANUAL

EFIS CP ID = C5								
OCTAL LABELS CHART								
SIGNAL	TYPE	LABEL	FORMAT	MIN UPDATE RATE	SDI	BINARY RANGE	POSITIVE SENSE	UNITS
WXR RANGE	A	271	DIS	10	00	N/A	ALWAYS POS	N/A
EFIS DISCRETES #1	A	272	DIS	5	00	N/A	N/A	N/A
EFIS DISCRETES #2	A	273	DIS	5	00	N/A	N/A	N/A
DH SELECTED-D	A	170	BCD	5	00	-20,+2500	ABOVE GROUND	FEET
DH SELECTED	A	370	BNR	5	00	± 16,384	ABOVE GROUND	FEET

EFFECTIVITY

ALL

34-22-00

06

Page 123
Sep 28/06



BOEING
757
FAULT ISOLATION/MAINT MANUAL

EFIS CP				
DISCRETE OCTAL LABELS/BIT CHART				
SIGNAL	OCTAL LABEL	BIT	ONE-STATE	ZERO-STATE
SPARE	271	11	TBD	
SPARE	271	12	TBD	
SPARE	271	13	TBD	
SPARE	271	14	TBD	
SPARE	271	15	TBD	
SPARE	271	16	TBD	
SPARE	271	17	TBD	
SPARE	271	18	TBD	
SPARE	271	19	TBD	
SPARE	271	20	TBD	
SPARE	271	21	TBD	
SPARE	271	22	TBD	
SPARE	271	23	TBD	
10 MI RANGE SEL	271	29-24	000010	
160 MI RANGE SEL	271	29-24	100000	
20 MI RANGE SEL	271	29-24	000100	
320 MI RANGE SEL	271	29-24	000000	
40 MI RANGE SEL	271	29-24	001000	
5 MI RANGE SEL	271	29-24	000001	
80 MI RANGE SEL	271	29-24	010000	
INVALID DATA	271	31-30	01	
SLAVE	271	31-30	11	

EFFECTIVITY

ALL

34-22-00

06

Page 124
Sep 28/06



BOEING
757
FAULT ISOLATION/MAINT MANUAL

EFIS CP				
DISCRETE OCTAL LABELS/BIT CHART				
SIGNAL	OCTAL LABEL	BIT	ONE-STATE	ZERO-STATE
TEST	271	31-30	10	
VALID DATA	271	31-30	00	
ILS (MOD) MODE SEL	272	16-11	000100	
MAP MODE SELECTED	272	16-11	000001	
PLAN MODE SELECTED	272	16-11	001000	
ILS (STD) MODE SEL	272	16-11	100000	
VOR (STD) MODE SEL	272	16-11	010000	
VOR (MOD) MODE SEL	272	16-11	000010	
SUM CHECK	272	17	NOT OK	OK
SPARE	272	18	1	0
AIRPORTS	272	23-19	10000	
NAV AIDS	272	23-19	00010	
RTE DATA	272	23-19	01000	
SPARE	272	23-19	00001	
WPT	272	23-19	00100	
MAP ORIENT	272	24	TRACK	HDG
VOR/ILS ORIENT	272	25	TRACK	HDG
APPROACH MODE	272	29-27	001	
FULL COMPASS ROSE	272	29-27	010	
RSV TEST	272	29-27	100	
DEG PITCHREF S/B	273	19-11	NEG	POS

EFFECTIVITY

ALL

34-22-00

09

Page 125
Sep 28/06

BOEING
 757
 FAULT ISOLATION/MAINT MANUAL

EFIS CP				
DISCRETE OCTAL LABELS/BIT CHART				
SIGNAL	OCTAL LABEL	BIT	ONE-STATE	ZERO-STATE
0.100 DEG PITCHREF	273	19-11	00000001	
0.200 DEG PITCHREF	273	19-11	00000010	
0.400 DEG PITCHREF	273	19-11	00000100	
0.800 DEG PITCHREF	273	19-11	00001000	
RA ALERT RESET	272	26	RESET	
1.600 DEG PITCHREF	273	19-11	000010000	
12.80 DEG PITCHREF	273	19-11	010000000	
3.200 DEG PITCHREF	273	19-11	000100000	
6.400 DEG PITCHREF	273	19-11	001000000	
FLT PATH DATA	273	20	ON	OFF
SPARE	273	21	1	0
SPARE	273	22	1	0
WXR DATA	273	23	WXR SEL	NOT SEL
10 MI RANGE SEL	273	29-24	000010	
160 MI RANGE SEL	273	29-24	100000	

EFFECTIVITY

ALL

34-22-00

05

Page 126
Dec 20/96

BOEING
 757
 FAULT ISOLATION/MAINT MANUAL

EFIS CP				
DISCRETE OCTAL LABELS/BIT CHART				
SIGNAL	OCTAL LABEL	BIT	ONE-STATE	ZERO-STATE
20 MI RANGE SEL	273	29-24	000100	
320 MI RANGE SEL	273	29-24	000000	
40 MI RANGE SEL	273	29-24	001000	
5 MI RANGE SEL	273	29-24	000001	
80 MI RANGE SEL	273	29-24	010000	

EFIS CU							
DIGITAL OUTPUT BUS CHART							
BUS NAME			CON	PINS	BUS FORMAT	BIT RATE	DATA BUS
SOURCE	TYPE	BUS					
EFISCU (L)	A	1	B	A08 B08	429	L0	OUTPUT BUS 1
EFISCU (L)	A	2	B	A15 B15	429	L0	OUTPUT BUS 2

EFIS CU								
OCTAL LABELS CHART								
SIGNAL	TYPE	LABEL	FORMAT	MIN UPDATE RATE	SDI	BINARY RANGE	POSITIVE SENSE	UNITS
COMP FLAG WORD	A	270	DIS	4	00	N/A	N/A	N/A
COMP WARN WORD	A	271	DIS	4	00	N/A	N/A	N/A

EFFECTIVITY

ALL

34-22-00

BOEING
 757
 FAULT ISOLATION/MAINT MANUAL

EFIS CU				
DISCRETE OCTAL LABELS/BIT CHART				
SIGNAL	OCTAL LABEL	BIT	ONE-STATE	ZERO-STATE
CAPT G/S FLAG	270	11	FLAG	NO FLAG
F/O G/S FLAG	270	12	FLAG	NO FLAG
CAPT LOC FLAG	270	13	FLAG	NO FLAG
F/O LOC FLAG	270	14	FLAG	NO FLAG
CAPT HDG FLAG	270	15	FLAG	NO FLAG
F/O HDG FLAG	270	16	FLAG	NO FLAG
CAPT TRK FLAG	270	17	FLAG	NO FLAG
F/O TRK FLAG	270	18	FLAG	NO FLAG
CAPT ATT FLAG	270	19	FLAG	NO FLAG
F/O ATT FLAG	270	20	FLAG	NO FLAG
CAPT FD FLAG	270	21	FLAG	NO FLAG
F/O FD FLAG	270	22	FLAG	NO FLAG
CAPT SPD FLAG	270	23	FLAG	NO FLAG
F/O SPD FLAG	270	24	FLAG	NO FLAG

EFFECTIVITY

ALL

34-22-00

06

Page 128
Dec 20/96

BOEING
 757
 FAULT ISOLATION/MAINT MANUAL

EFIS CU				
DISCRETE OCTAL LABELS/BIT CHART				
SIGNAL	OCTAL LABEL	BIT	ONE-STATE	ZERO-STATE
SPARE	270	25	1	0
SPARE	270	26	1	0
SPARE	270	27	1	0
SPARE	270	28	1	0
SPARE	270	29	1	0
G/S WARN	271	11	WARN	NO WARN
LOC WARN	271	12	WARN	NO WARN
HDG WARN	271	13	WARN	NO WARN
TRK WARN	271	14	WARN	NO WARN
ATT WARN	271	15	WARN	NO WARN
RA WARN	271	16	WARN	NO WARN
SPARE	271	17	1	0
SPARE	271	18	1	0
SPARE	271	19	1	0
SPARE	271	20	1	0
SPARE	271	21	1	0

EFFECTIVITY

ALL

34-22-00

06

Page 129
Dec 20/96

BOEING
 757
 FAULT ISOLATION/MAINT MANUAL

EFIS CU				
DISCRETE OCTAL LABELS/BIT CHART				
SIGNAL	OCTAL LABEL	BIT	ONE-STATE	ZERO-STATE
SPARE	271	22	1	0
SPARE	271	23	1	0
SPARE	271	24	1	0
SPARE	271	25	1	0
SPARE	271	26	1	0
SPARE	271	27	1	0
SPARE	271	28	1	0
ICU BITE	271	29	FAULT	NO FAULT

EFIS SG							
DIGITAL OUTPUT BUS CHART							
BUS NAME			CON	PINS	BUS FORMAT	BIT RATE	DATA BUS
SOURCE	TYPE	BUS					
EFISSG (L C R)	A	1	E	A13 B13	429	LO	OUTPUT BUS

EFFECTIVITY

ALL

34-22-00

06

Page 130
Dec 20/96

BOEING
 757
 FAULT ISOLATION/MAINT MANUAL

EFIS SG ID = 25								
OCTAL LABELS CHART								
SIGNAL	TYPE	LABEL	FORMAT	MIN UPDATE RATE	SDI	BINARY RANGE	POSITIVE SENSE	UNITS
GROUND SPEED	A	012	BCD	4	00	0-2000	ALWAYS POS	KNOTS
FLT DIR-ROLL	A	140	BNR	4	00	± 180	RIGHT	DEG
FLT DIR-PITCH	A	141	BNR	4	00	± 180	UP	DEG
A/T FAST SLOW CMD	A	142	BNR	4	00	± 32	OVERSPEED	KNOTS
RADIO HEIGHT	A	164	BNR	4	00	± 8192	ABOVE TOUCHDO	FEET
LOCALIZER DEV	A	173	BNR	4	00	± .4	FLY RIGHT	DDM
GLIDESLOPE DEV	A	174	BNR	4	00	± .8	ABOVE BEAM	DDM
MODE DISCRETES #2	A	270	DIS	4	00	N/A	N/A	N/A
AFDS MODE STATUS-3	A	274	BNR	4	00	N/A	N/A	N/A
AFDS MODE STATUS-4	A	275	BNR	4	00	N/A	N/A	N/A
TRACK ANGLE TRUE	A	313	BNR	4	00	± 180	CW FROM NORTH	DEG
TRUE HEADING	A	314	BNR	4	00	± 180	CW FROM NORTH	DEG
TRACK ANGLE-MAG	A	317	BNR	4	00	± 180	CW FROM NORTH	DEG
MAGNETIC HEADING	A	320	BNR	4	00	± 180	CW FROM NORTH	DEG

EFFECTIVITY

ALL

34-22-00

06

Page 131
Dec 20/96

BOEING
 757
 FAULT ISOLATION/MAINT MANUAL

EFIS SG ID = 25								
OCTAL LABELS CHART								
SIGNAL	TYPE	LABEL	FORMAT	MIN UPDATE RATE	SDI	BINARY RANGE	POSITIVE SENSE	UNITS
PITCH ANGLE	A	324	BNR	4	00	± 180	UP	DEG
ROLL ANGLE	A	325	BNR	4	00	± 180	RIGHT WING DO	DEG
EFISSG MAINT WORD	A	350	DIS	4	00	N/A	N/A	N/A
CP & DU MAINT WORD	A	351	DIS	4	00	N/A	N/A	N/A
SENS STAT MAINT WD	A	352	DIS	4	00	N/A	N/A	N/A
MODE DISCRETES #1	A	353	DIS	4	00	N/A	N/A	N/A

EFFECTIVITY

ALL

34-22-00

05

Page 132
Dec 20/96

BOEING
 757
 FAULT ISOLATION/MAINT MANUAL

EFIS SG				
DISCRETE OCTAL LABELS/BIT CHART				
SIGNAL	OCTAL LABEL	BIT	ONE-STATE	ZERO-STATE
SPARE	270	11	1	0
SPARE	270	12	1	0
SPARE	270	13	1	0
DH ALERT	270	14	ALERT	OK
DH+DELTA (H) ALERT	270	15	ALERT	OK
H ALERT	270	16	ALERT	OK
FMC/IRS GROUND SPD	270	17	FMC	IRS
FMC/IRS TRACK DATA	270	18	FMC	IRS
MAG/TRUE DATA	270	19	TRUE	MAG
SPARE	270	20	1	0
SPARE	270	21	1	0
SPARE	270	22	1	0
SPARE	270	23	1	0
SPARE	270	24	1	0

EFFECTIVITY

ALL

34-22-00

05

Page 133
Dec 20/96

BOEING
 757
 FAULT ISOLATION/MAINT MANUAL

EFIS SG				
DISCRETE OCTAL LABELS/BIT CHART				
SIGNAL	OCTAL LABEL	BIT	ONE-STATE	ZERO-STATE
SPARE	270	25	1	0
SPARE	270	26	1	0
SPARE	270	27	1	0
SPARE	270	28	1	0
SPARE	270	29	1	0
SG OVERTEMP	350	11	FAULT	OK
SG MAIN PROCESSOR	350	12	FAULT	OK
SG MAIN MEMORY	350	13	FAULT	OK
SG DISPLAY DRIVE	350	14	FAULT	OK
SG DSPLY SEQUENCER	350	15	FAULT	OK
SG CONTROLLER	350	16	FAULT	OK
SG DIGITAL OUTPUT	350	17	FAULT	OK
SG I/O PROC NO.1	350	18	FAULT	OK
SG I/O PROC NO.2	350	19	FAULT	OK
SG I/O PROC NO.3	350	20	FAULT	OK
SPARE	350	21	1	0

EFFECTIVITY

ALL

34-22-00

04

Page 134
Dec 20/96

BOEING
 757
 FAULT ISOLATION/MAINT MANUAL

EFIS SG				
DISCRETE OCTAL LABELS/BIT CHART				
SIGNAL	OCTAL LABEL	BIT	ONE-STATE	ZERO-STATE
SPARE	350	22	1	0
SPARE	350	23	1	0
SPARE	350	24	1	0
SPARE	350	25	1	0
SPARE	350	26	1	0
SPARE	350	27	1	0
SPARE	350	28	1	0
SPARE	350	29	1	0
SPARE	351	11	1	0
L-EADI ANOMALIES	351	12	FAULT	OK
L-EADI BEAM FAIL	351	13	FAULT	OK
L-EADI OVERTEMP	351	14	FAULT	OK
R-EADI ANOMALIES	351	15	FAULT	OK
R-EADI BEAM FAIL	351	16	FAULT	OK

EFFECTIVITY

ALL

34-22-00

BOEING
 757
 FAULT ISOLATION/MAINT MANUAL

EFIS SG				
DISCRETE OCTAL LABELS/BIT CHART				
SIGNAL	OCTAL LABEL	BIT	ONE-STATE	ZERO-STATE
R-EADI OVERTEMP	351	17	FAULT	OK
L-EHSI ANOMALIES	351	18	FAULT	OK
L-EHSI BEAM FAIL	351	19	FAULT	OK
L-EHSI OVERTEMP	351	20	FAULT	OK
R-EHSI ANOMALIES	351	21	FAULT	OK
R-EHSI BEAM FAIL	351	22	FAULT	OK
R-EHSI OVERTEMP	351	23	FAULT	OK
L-CP FAULT	351	24	FAULT	OK
R-CP FAULT	351	25	FAULT	OK
SPARE	351	26	1	0
SPARE	351	27	1	0
SPARE	351	28	1	0
SPARE	351	29	1	0
L-FCC DATA FAULT	352	11	FAULT	OK

EFFECTIVITY

ALL

34-22-00

02

Page 136
Dec 20/96

BOEING
 757
 FAULT ISOLATION/MAINT MANUAL

EFIS SG				
DISCRETE OCTAL LABELS/BIT CHART				
SIGNAL	OCTAL LABEL	BIT	ONE-STATE	ZERO-STATE
C-FCC DATA FAULT	352	12	FAULT	OK
R-FCC DATA FAULT	352	13	FAULT	OK
L-FMC DATA FAULT	352	14	FAULT	OK
R-FMC DATA FAULT	352	15	FAULT	OK
TMC DATA FAULT	352	16	FAULT	OK
L-IRS DATA FAULT	352	17	FAULT	OK
C-IRS DATA FAULT	352	18	FAULT	OK
R-IRS DATA FAULT	352	19	FAULT	OK
L-ADC DATA FAULT	352	20	FAULT	OK
R-ADC DATA FAULT	352	21	FAULT	OK
L-VOR DATA FAULT	352	22	FAULT	OK
R-VOR DATA FAULT	352	23	FAULT	OK
L-DME DATA FAULT	352	24	FAULT	OK
R-DME DATA FAULT	352	25	FAULT	OK
RA DATA FAULT	352	26	FAULT	OK
ILS DATA FAULT	352	27	FAULT	OK
MLS DATA FAULT	352	28	FAULT	OK
WXR DATA FAULT	352	29	FAULT	OK
R EADI FAULT	353	12	FAULT	OK
SPARE	353	13	1	0

EFFECTIVITY

ALL

34-22-00

01

Page 137
Dec 20/96

BOEING
 757
 FAULT ISOLATION/MAINT MANUAL

EFIS SG				
DISCRETE OCTAL LABELS/BIT CHART				
SIGNAL	OCTAL LABEL	BIT	ONE-STATE	ZERO-STATE
R CP FAULT	353	15	FAULT	OK
R EHSI FAULT	353	17	FAULT	OK
SG FAULT	353	18	FAULT	OK
SPARE	353	19	1	0
SPARE	353	20	1	0
SPARE	353	21	1	0
SPARE	353	22	1	0
SPARE	353	23	1	0
SPARE	353	24	1	0
SPARE	353	25	1	0
SPARE	353	26	1	0
SPARE	353	27	1	0
SPARE	353	28	1	0
SPARE	353	29	1	0

EFFECTIVITY

ALL

34-22-00

01

Page 138
Dec 20/96

BOEING
757
FAULT ISOLATION/MAINT MANUAL

STANDBY MAGNETIC COMPASS

COMPONENT	FIG. 102 SHT	QTY	ACCESS/AREA	AMM REFERENCE
COMPASS - STANDBY MAGNETIC, N99	--	1	FLT COMPT, P5	34-23-00

* SEE THE WDM EQUIPMENT LIST

Standby Magnetic Compass - Component Index
Figure 101

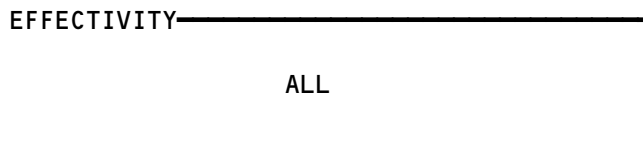

34-23-00

01

Page 101
Sep 28/03

E45850

BOEING
757
FAULT ISOLATION/MAINT MANUAL

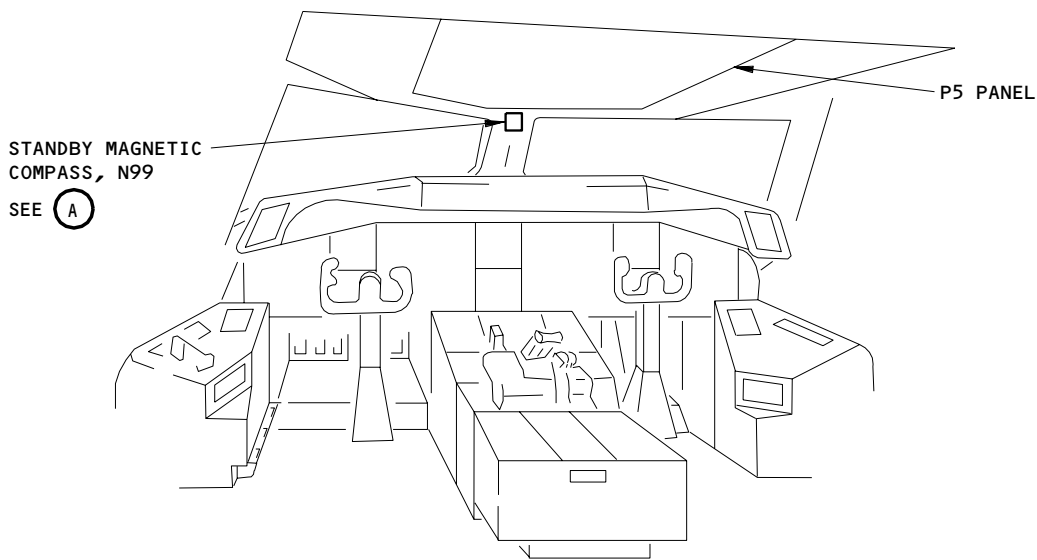

FLIGHT COMPARTMENT

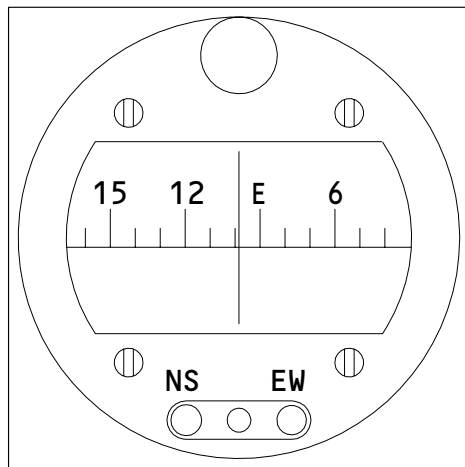

STANDBY MAGNETIC COMPASS, N99

(A)

Standby Magnetic Compass - Component Location
Figure 102 (Sheet 1)

EFFECTIVITY
AIRPLANES WITH STANDBY MAGNETIC COMPASS
P/N C-5H

34-23-00

01

Page 102
Sep 28/03

55226

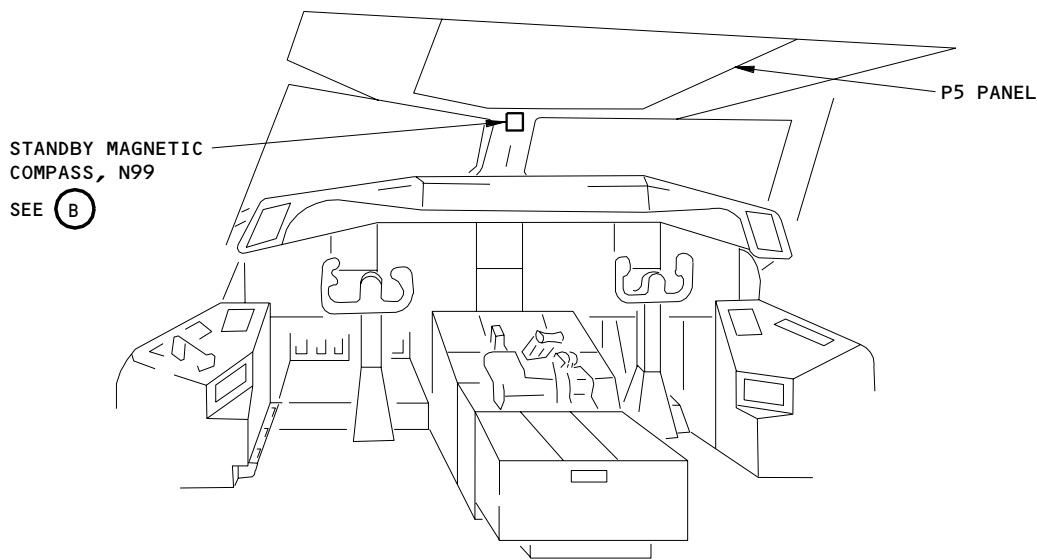

FLIGHT COMPARTMENT

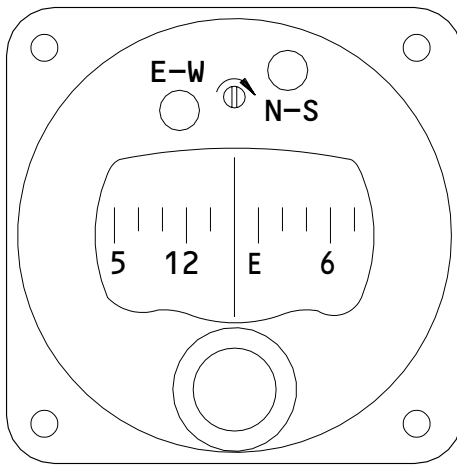

STANDBY MAGNETIC COMPASS, N99

(B)

Standby Magnetic Compass - Component Location
Figure 102 (Sheet 2)

EFFECTIVITY
AIRPLANES WITH STANDBY MAGNETIC COMPASS
P/N C-5M

34-23-00



757

FAULT ISOLATION/MAINT MANUAL

STANDBY ATTITUDE REFERENCE SYSTEM

COMPONENT	FIG. 102 SHT	QTY	ACCESS/AREA	AMM REFERENCE
CIRCUIT BREAKER -	--		FLT COMPT, P11	
STBY ATT IND, C619		1	11A5	*
STBY ILS IND, C604		1	11A9	*
INDICATOR - STANDBY ATTITUDE, N20	--	1	FLT COMPT, P1	34-24-01
UNIT - STATIC INV/ILS PRCS, M917	--	1	119BL, MAIN EQUIP CTR, E2-3	34-24-02

* SEE THE WDM EQUIPMENT LIST

Standby Attitude Reference System - Component Index
Figure 101

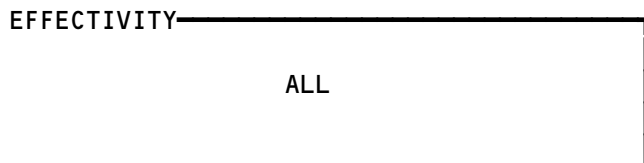

34-24-00

01

Page 101
Sep 20/94

E45848

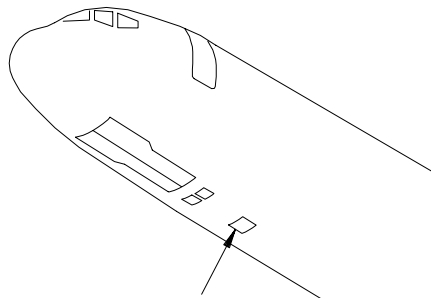

MAIN EQUIPMENT CENTER
ACCESS DOOR, 119BL

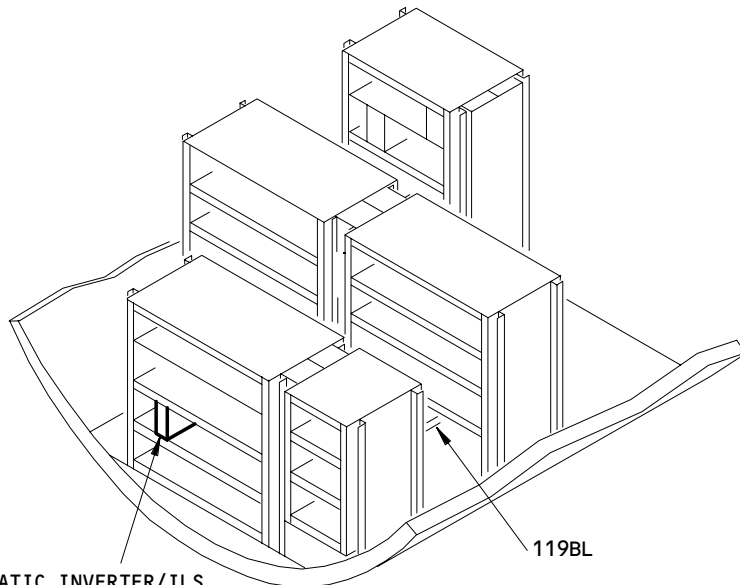

STATIC INVERTER/ILS
PROCESSOR UNIT, M917
(E2-3)

119BL

MAIN EQUIPMENT CENTER

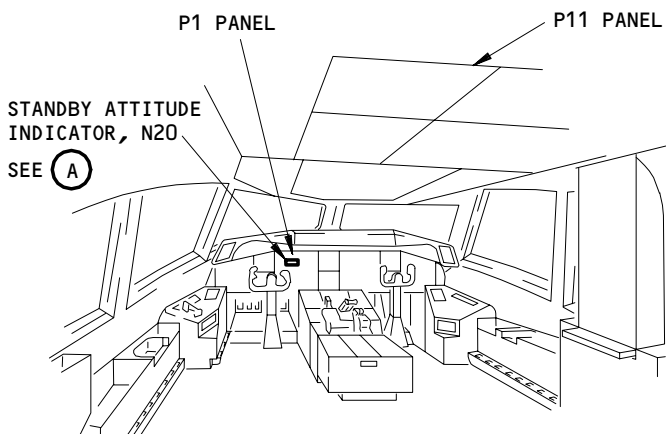

STANDBY ATTITUDE
INDICATOR, N20
SEE (A)

P1 PANEL

P11 PANEL

FLIGHT COMPARTMENT

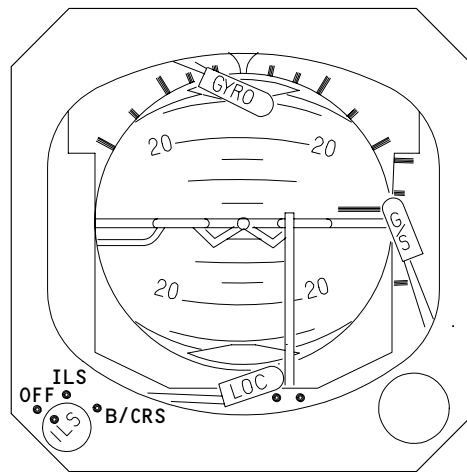

STANDBY ATTITUDE INDICATOR, N20

(A)

Standby Attitude Reference System - Component Location
Figure 102

EFFECTIVITY	
	ALL

34-24-00

**STANDBY ATTITUDE
INDICATION PROBLEMS**



1 REPLACE THE STANDBY
ATTITUDE INDICATOR, N20
(AMM 34-24-01/401).
IF THE PROBLEM CONTINUES,
REPLACE THE STATIC
INVERTER/ILS PROCESSOR, M917
(AMM 34-24-02/401).

PREREQUISITES

MAKE SURE THESE CIRCUIT BREAKERS ARE CLOSED:
11A5, 11B7

MAKE SURE THE AIRPLANE IS IN THE CONFIGURATION THAT
FOLLOWS:
ELECTRICAL POWER IS ON (AMM 24-22-00/201)

Standby Attitude Indication Problems
Figure 103

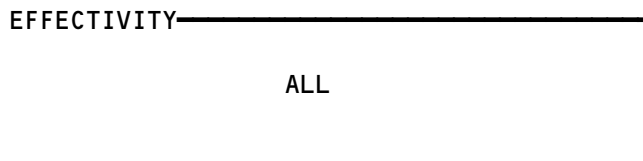

34-24-00

01

Page 103
May 20/08



BOEING
 757
 FAULT ISOLATION/MAINT MANUAL

INSTRUMENT COMPARISON SYSTEM

COMPONENT	FIG. 102 SHT	QTY	ACCESS/AREA	AMM REFERENCE
CIRCUIT BREAKER - EFIS INSTR COMPTR SWITCH - (FIM 34-22-00/101) LEFT EFIS, S3 RIGHT EFIS, S11 UNIT - INSTRUMENT COMPARATOR, M1060		1	FLIGHT COMPARTMENT, P11 11F10	*
		1	119BL, MAIN EQUIP CTR, E2-3	34-25-01

* SEE THE WDM EQUIPMENT LIST

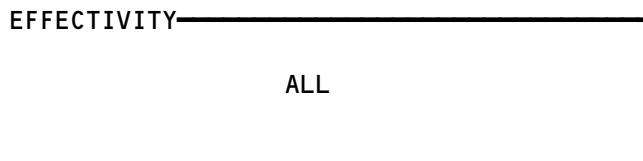
Instrument Comparison System - Component Index
Figure 101



34-25-00

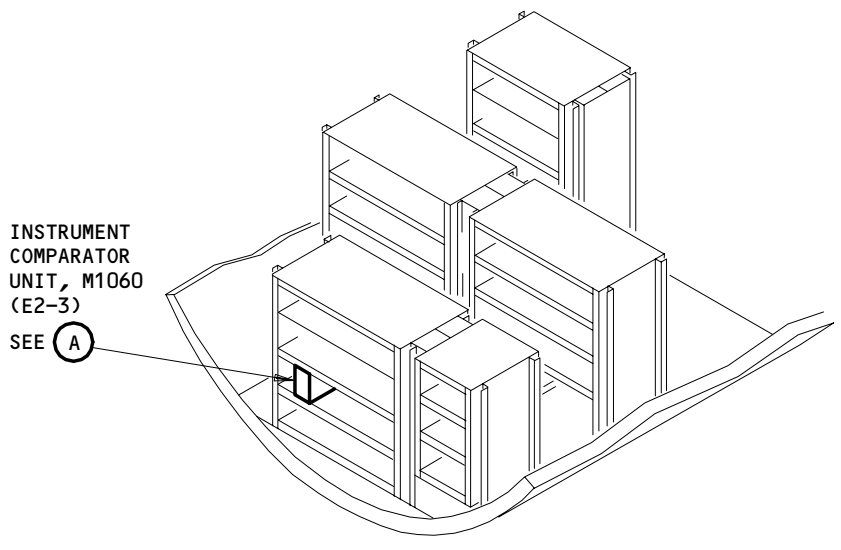
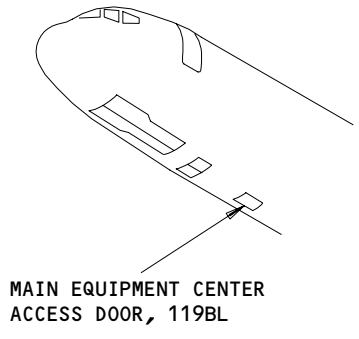

INSTRUMENT
 COMPARATOR
 UNIT, M1060
 (E2-3)
 SEE (A)

MAIN EQUIPMENT CENTER

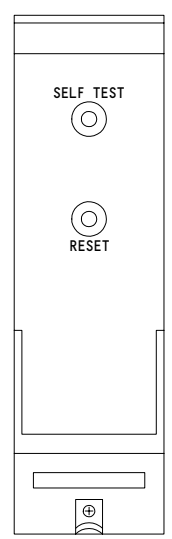

INSTRUMENT COMPARATOR
 UNIT, M1060

(A)

Instrument Comparison System - Component Location
 Figure 102

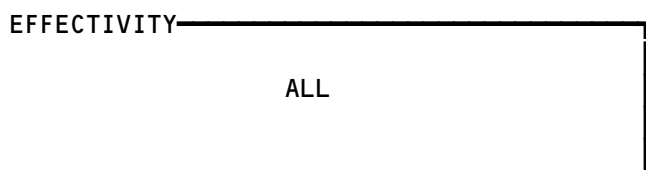

34-25-00

**INSTRUMENT COMPAR-
ISON SYSTEM BITE
PROCEDURE**

PREREQUISITES

ELECTRICAL POWER (MM 24-22-00/201)
EICAS (MM 31-41-00/201)
WARNING SYSTEM (MM 31-51-00/501)
IRS (MM 34-21-00/501)
EFIS (MM 34-22-00/501)
CB'S: 11F10

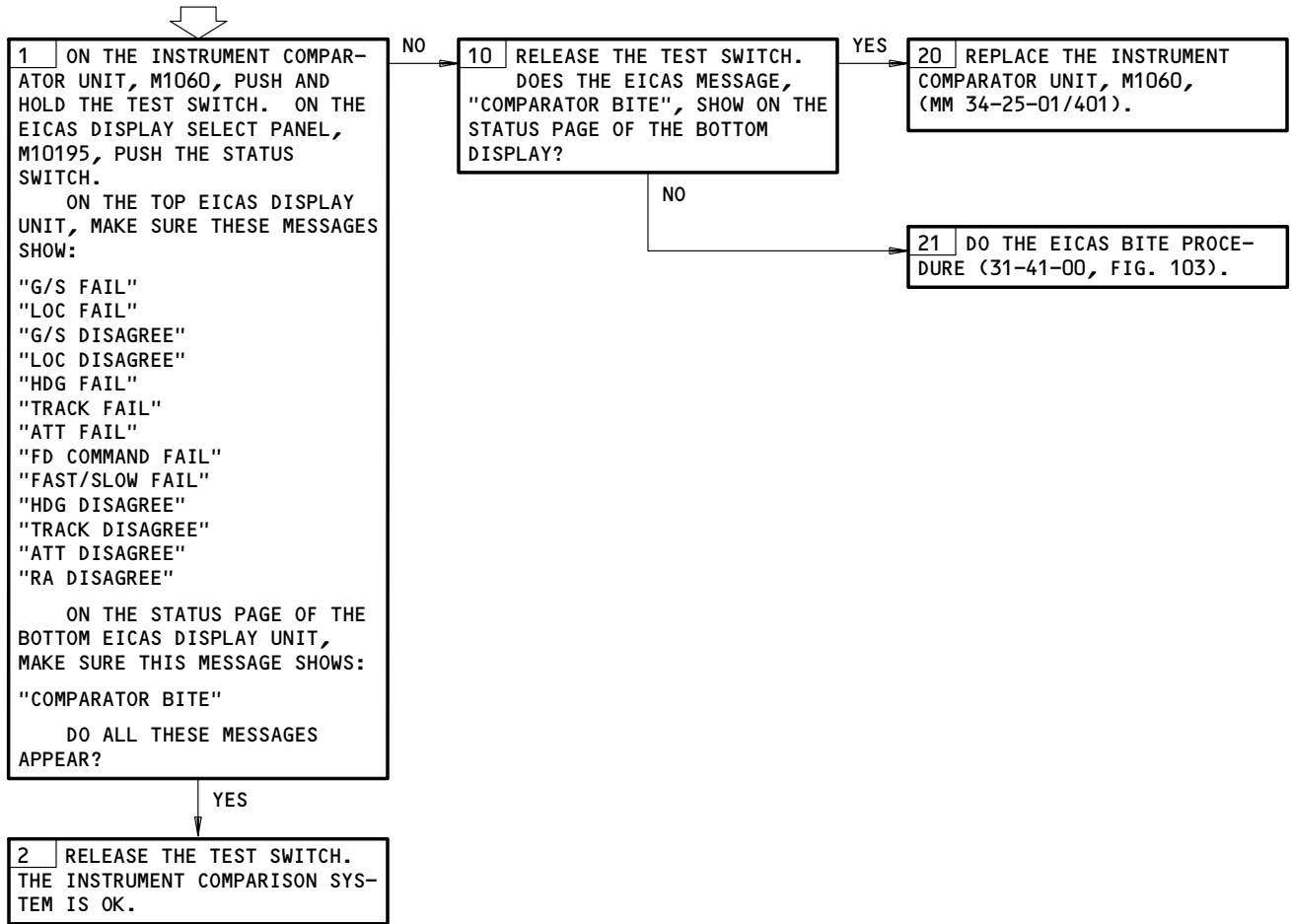

Instrument Comparison System BITE Procedure
Figure 103

EFFECTIVITY	ALL
-------------	-----

34-25-00

 **BOEING**
757
FAULT ISOLATION/MAINT MANUAL

1. ARINC Data Bus Charts

A. General

CAUTION: DO NOT DIRECTLY TOUCH THE CONNECTORS. USE A BREAKOUT BOX OR YOU CAN CAUSE DAMAGE TO THE CONNECTORS.

(1) The ARINC 429 data bus charts give data necessary to make an analysis of ARINC 429 transmitters, receivers, and data buses. For the test, use a breakout box at the available terminal or at the LRU connectors.

B. Equipment

(1) Standard multi-meter
(2) 429EBP Data Bus Analyzer (recommended)
JcAIR Instrumentation
400 Industrial Parkway
Industrial Airport, KS 66031

429-2 Data Bus Analyzer (alternative)
Interface Technology
150 E. Arrow Highway,
San Dimas, CA 91773

C. A34011-1 Breakout Box (recommended)
A34011-112 Breakout Box (alternative)

EFFECTIVITY

ALL

34-25-00

01

Page 104
Dec 20/96

BOEING
 757
 FAULT ISOLATION/MAINT MANUAL

EFIS CU							
DIGITAL OUTPUT BUS CHART							
BUS NAME			CON	PINS	BUS FORMAT	BIT RATE	DATA BUS
SOURCE	TYPE	BUS					
EFISCU-L	A	1	B	A08 B08	429	LO	OUTPUT BUS 1
EFISCU-L	A	2	B	A15 B15	429	LO	OUTPUT BUS 2

EFIS CU								
OCTAL LABELS CHART								
SIGNAL	TYPE	LABEL	FORMAT	MIN UPDATE RATE	SDI	BINARY RANGE	POSITIVE SENSE	UNITS
COMP FLAG WORD	A	270	DIS	4	00	N/A	N/A	N/A
COMP WARN WORD	A	271	DIS	4	00	N/A	N/A	N/A

EFFECTIVITY

ALL

34-25-00

01

Page 105
Dec 20/96

BOEING
 757
 FAULT ISOLATION/MAINT MANUAL

EFIS CU				
DISCRETE OCTAL LABELS/BIT CHART				
SIGNAL	OCTAL LABEL	BIT	ONE-STATE	ZERO-STATE
CAPT G/S FLAG	270	11	FLAG	NO FLAG
F/O G/S FLAG	270	12	FLAG	NO FLAG
CAPT LOC FLAG	270	13	FLAG	NO FLAG
F/O LOC FLAG	270	14	FLAG	NO FLAG
CAPT HDG FLAG	270	15	FLAG	NO FLAG
F/O HDG FLAG	270	16	FLAG	NO FLAG
CAPT TRK FLAG	270	17	FLAG	NO FLAG
F/O TRK FLAG	270	18	FLAG	NO FLAG
CAPT ATT FLAG	270	19	FLAG	NO FLAG
F/O ATT FLAG	270	20	FLAG	NO FLAG
CAPT FD FLAG	270	21	FLAG	NO FLAG
F/O FD FLAG	270	22	FLAG	NO FLAG
CAPT SPD FLAG	270	23	FLAG	NO FLAG
F/O SPD FLAG	270	24	FLAG	NO FLAG

EFFECTIVITY

ALL

34-25-00

01

Page 106
Dec 20/96

BOEING
 757
 FAULT ISOLATION/MAINT MANUAL

EFIS CU				
DISCRETE OCTAL LABELS/BIT CHART				
SIGNAL	OCTAL LABEL	BIT	ONE-STATE	ZERO-STATE
SPARE	270	25	1	0
SPARE	270	26	1	0
SPARE	270	27	1	0
SPARE	270	28	1	0
SPARE	270	29	1	0
G/S WARN	271	11	WARN	NO WARN
LOC WARN	271	12	WARN	NO WARN
HDG WARN	271	13	WARN	NO WARN
TRK WARN	271	14	WARN	NO WARN
ATT WARN	271	15	WARN	NO WARN
RA WARN	271	16	WARN	NO WARN
SPARE	271	17	1	0
SPARE	271	18	1	0
SPARE	271	19	1	0
SPARE	271	20	1	0
SPARE	271	21	1	0
SPARE	271	22	1	0
SPARE	271	23	1	0
SPARE	271	24	1	0
SPARE	271	25	1	0
SPARE	271	26	1	0
SPARE	271	27	1	0

EFFECTIVITY

ALL

34-25-00

01

Page 107
Dec 20/96

BOEING
 757
 FAULT ISOLATION/MAINT MANUAL

EFIS CU				
DISCRETE OCTAL LABELS/BIT CHART				
SIGNAL	OCTAL LABEL	BIT	ONE-STATE	ZERO-STATE
SPARE	271	28	1	0
ICU BITE	271	29	FAULT	NO FAULT

EFFECTIVITY

ALL

34-25-00

01

Page 108
Dec 20/96

BOEING

757
FAULT ISOLATION/MAINT MANUAL

INSTRUMENT LANDING SYSTEM

COMPONENT	FIG. 102 SHT	QTY	ACCESS/AREA	AMM REFERENCE
ANTENNA - CENTER DUAL GLIDE SLOPE, M251	1	1	111AL, NOSE RADOME	34-31-03
ANTENNA - CENTER DUAL LOCALIZER, M249	1	1	111AL, NOSE RADOME	34-31-04
ANTENNA - LEFT/RIGHT DUAL GLIDE SLOPE, M250	1	1	111AL, NOSE RADOME	34-31-03
ANTENNA - LEFT/RIGHT DUAL LOCALIZER, M248	1	1	111AL, NOSE RADOME	34-31-04
CIRCUIT BREAKER -	2		FLT COMPT, P11	
ILS CENTER, C606		1	11A3	*
ILS L, C603		1	11E10	*
ILS RIGHT, C605		1	11E31	*
MMR CENTER, C4602		1	11E31	*
MMR LEFT, C4600		1	11E10	*
MMR RIGHT, C4601		1	11A3	*
PANEL - ILS CONTROL, M87	2	1	FLT COMPT, P8	34-31-02
RECEIVER - CENTER ILS, M157	1	1	119BL, MAIN EQUIP CTR, E2-3	34-31-01
RECEIVER - CENTER MMR, M11251	1	1	119BL, MAIN EQUIP CTR, E2-3	34-31-02
RECEIVER - LEFT ILS, M156	1	1	119BL, MAIN EQUIP CTR, E2-3	34-31-01
RECEIVER - LEFT MMR, M11249	1	1	119BL, MAIN EQUIP CTR, E2-3	34-31-02
RECEIVER - RIGHT ILS, M158	1	1	119BL, MAIN EQUIP CTR, E2-2	34-31-01
RECEIVER - RIGHT MMR, M11250	1	1	119BL, MAIN EQUIP CTR, E2-2	34-31-02
RELAY - (FIM 31-01-36/101)				
SYS NO. 1 AIR/GND, K143				
SYS NO. 1 AIR/GND, K167				
RELAY - (FIM 31-01-37/101)				
SYS NO. 2 AIR/GND, K214				

* SEE THE WDM EQUIPMENT LIST

- AIRPLANES WITH ILS RECEIVERS
- AIRPLANES WITH MULTI-MODE RECEIVERS (MMR)

Instrument Landing System - Component Index
Figure 101

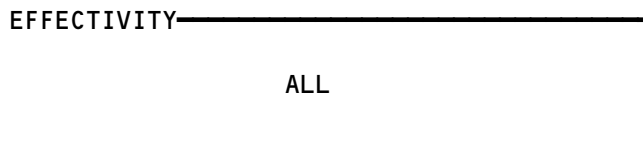

34-31-00

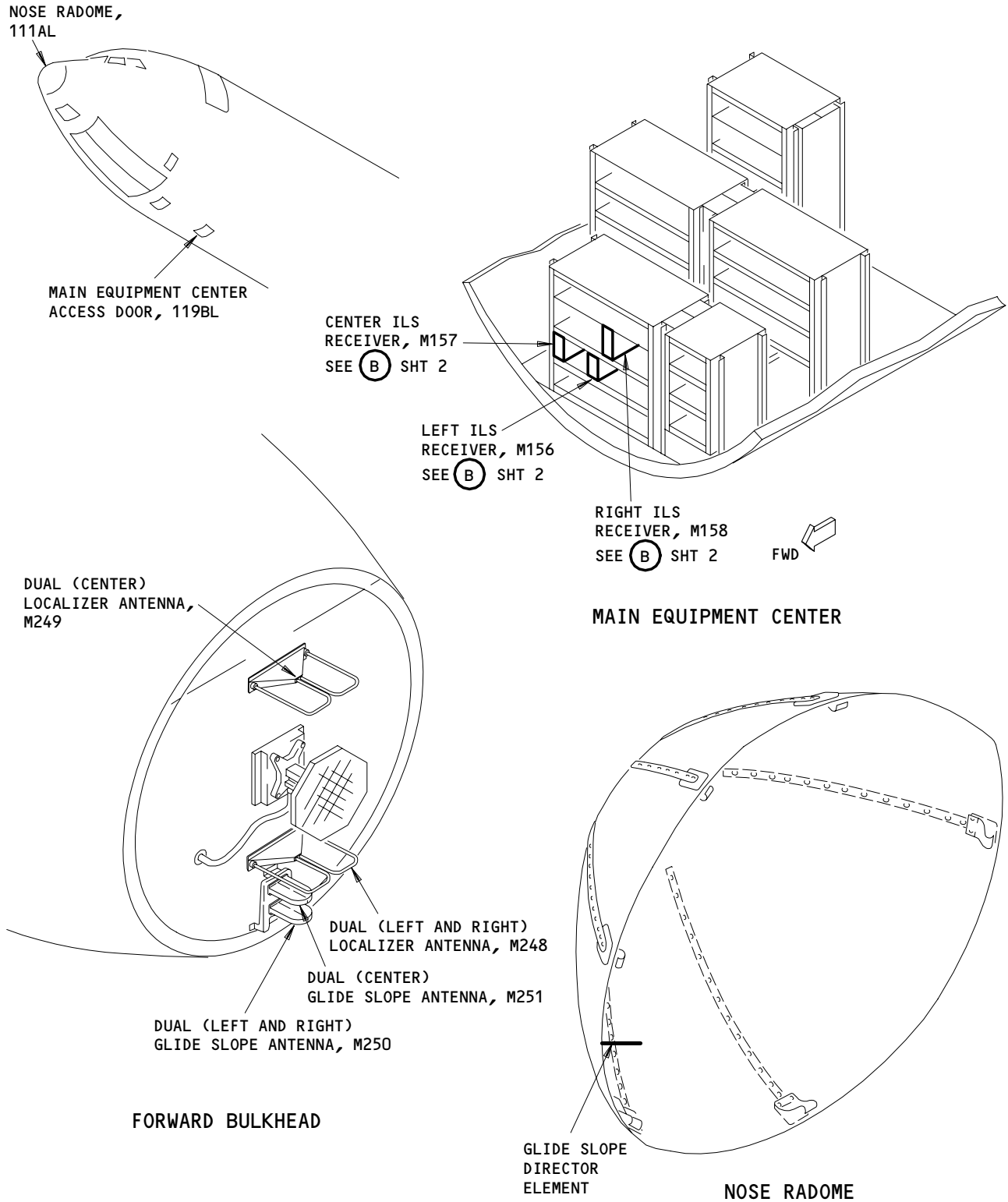

Instrument Landing System - Component Location
Figure 102 (Sheet 1)

EFFECTIVITY	
	ALL

34-31-00

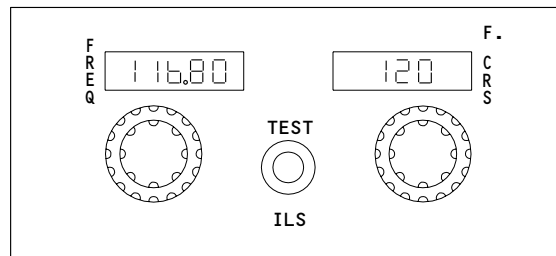
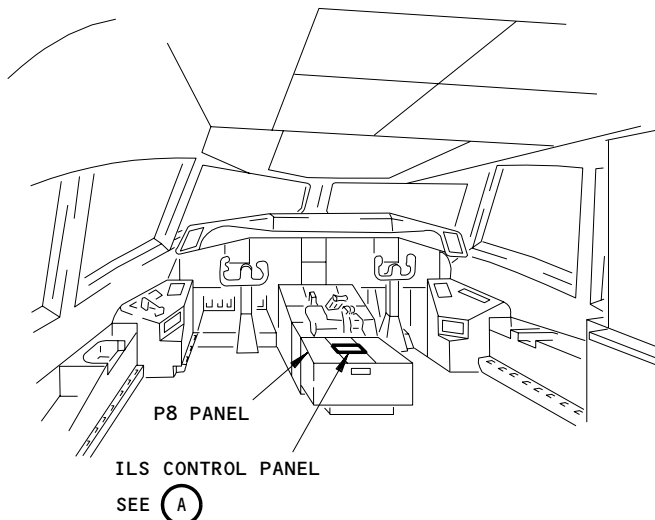

ILS CONTROL PANEL, M87

(A)

FLIGHT COMPARTMENT

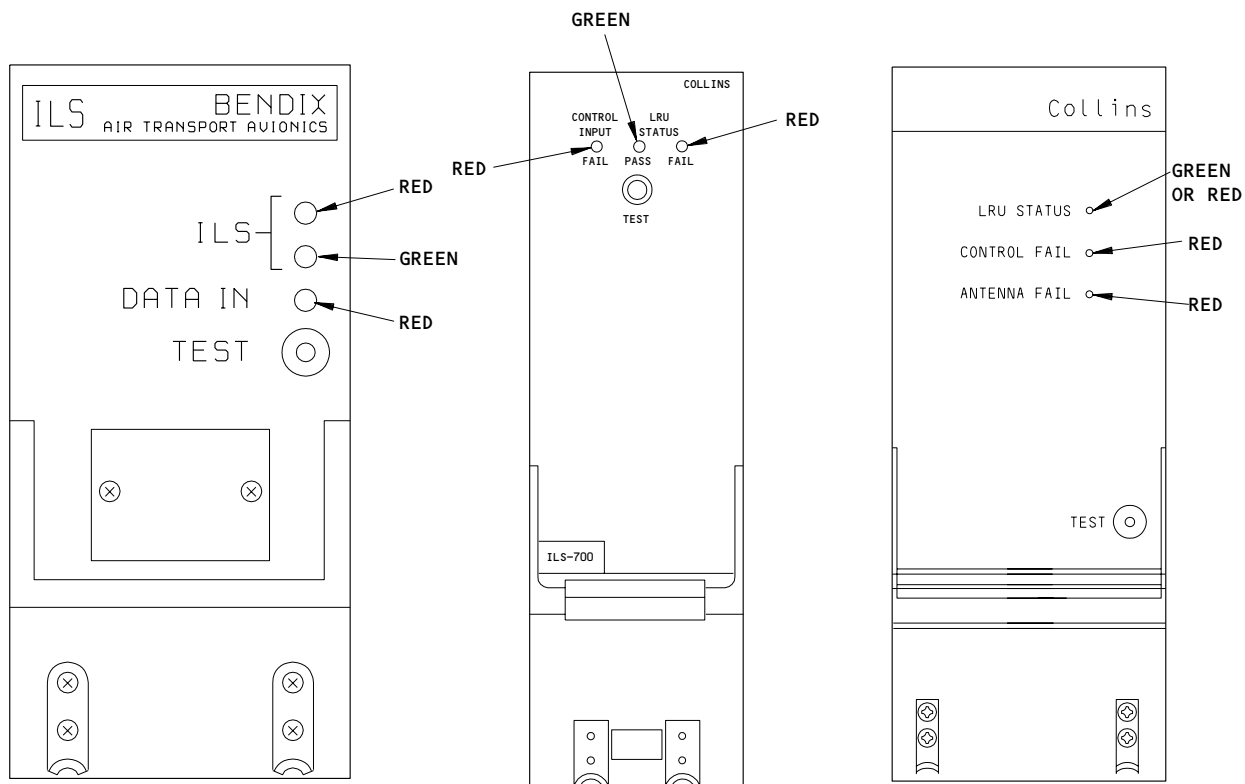

LEFT, RIGHT OR CENTER ILS RECEIVER, M156, M158 OR M157

(B) 1

LEFT, RIGHT OR CENTER ILS RECEIVER, M156, M158 OR M157

(B) 2

LEFT, RIGHT OR CENTER MULTI-MODE RECEIVER

(B) 3

1 GUI 001, 009, 115

2 GUI 002-008, 010-114, 116-999

3 GUI 115 (POST SB 34-0400)

Instrument Landing System - Component Location
Figure 102 (Sheet 2)

EFFECTIVITY

ALL

34-31-00

36

Page 103
May 20/08

PREREQUISITES

MAKE SURE THESE SYSTEMS WILL OPERATE:

IRS (AMM 34-21-00/501)

EFIS (AMM 34-22-00/501)

MAKE SURE THESE CIRCUIT BREAKERS ARE CLOSED:

11A3,11E10,11E31

MAKE SURE THE AIRPLANE IS IN THIS CONFIGURATION:

ELECTRICAL POWER IS ON (AMM 24-22-00/201)

NOTE: COLLINS ILS RECEIVERS P/N 622-5221-102 S/N 4766 AND BELOW OR P/N 822-0282-102 S/N 4764 AND BELOW WITHOUT COLLINS SERVICE BULLETIN ILS-700-34-20 DATED OCTOBER 15, 1991 AND COLLINS SERVICE BULLETIN ILS-700/700A-34-23 DATED AUGUST 22, 1995, CAN FAIL THE BITE TEST STARTED FROM THE FRONT PANEL OF THE ILS RECEIVER WHEN THERE IS NO FAULT. IF THIS OCCURS, DO THE ILS CONTROL PANEL SELF-TEST TO MAKE SURE OF THE FAULT.

ILS BITE PROCEDURE

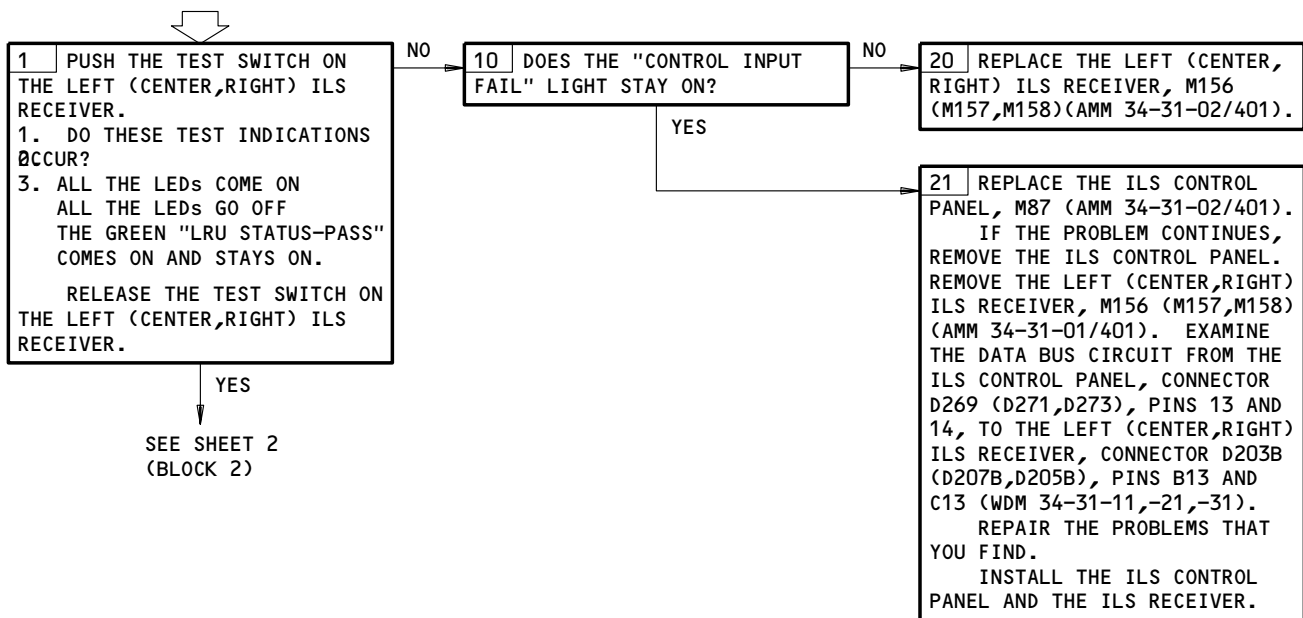

ILS BITE Procedure
Figure 103 (Sheet 1)

EFFECTIVITY
GUI 002-008, 010-114, 116-999

34-31-00

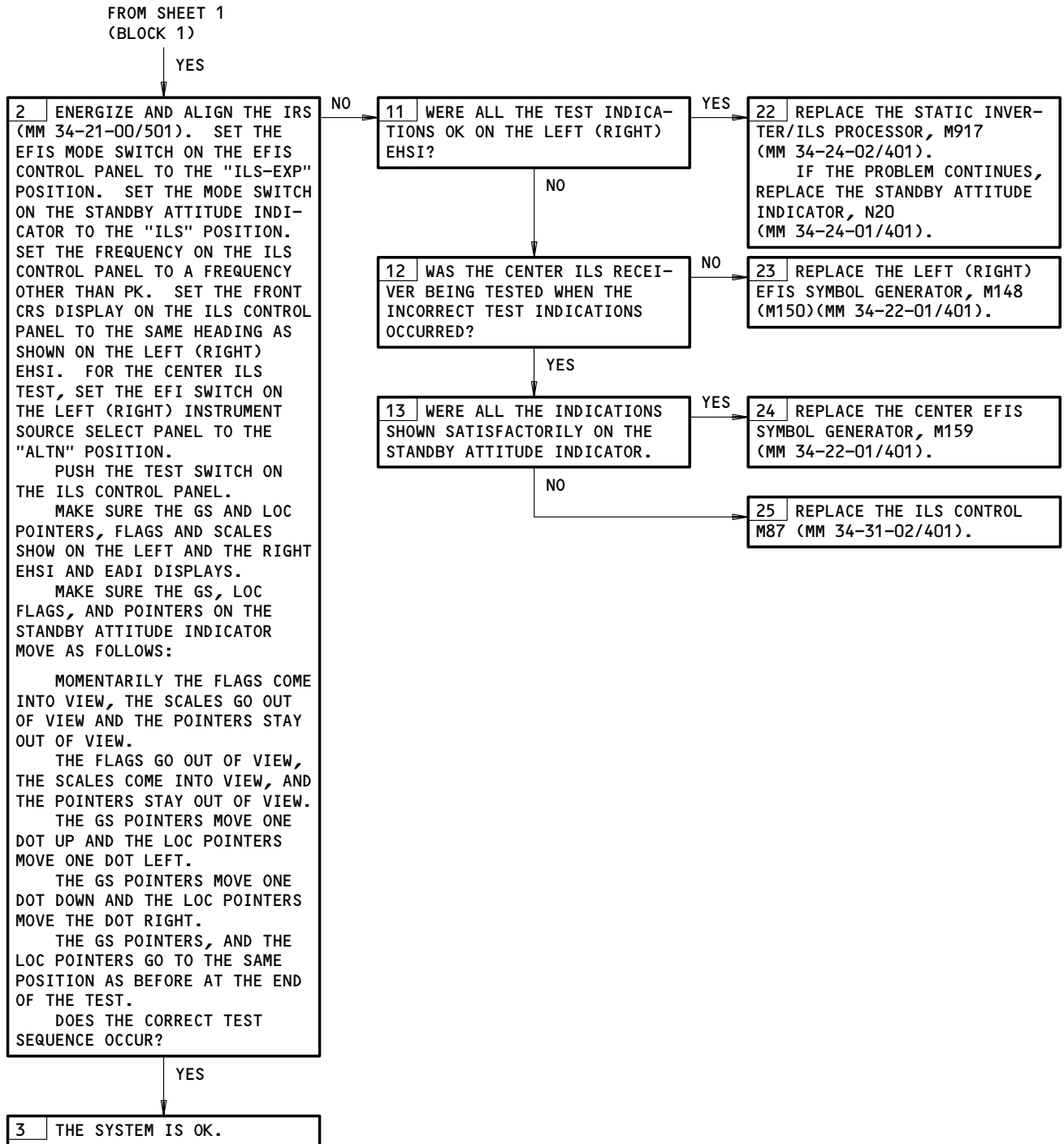

ILS BITE Procedure
Figure 103 (Sheet 2)

EFFECTIVITY
GUI 002-008, 010-114, 116-999

34-31-00

PREREQUISITES

MAKE SURE THESE SYSTEMS WILL OPERATE:
 IRS (MM 34-21-00/501)
 EFIS (MM 34-22-00/501)

MAKE SURE THESE CIRCUIT BREAKERS ARE CLOSED:
 11A3,11E10,11E31

MAKE SURE THE AIRPLANE IS IN THIS CONFIGURATION:
 ELECTRICAL POWER IS ON (MM 24-22-00/201)

ILS BITE PROCEDURE

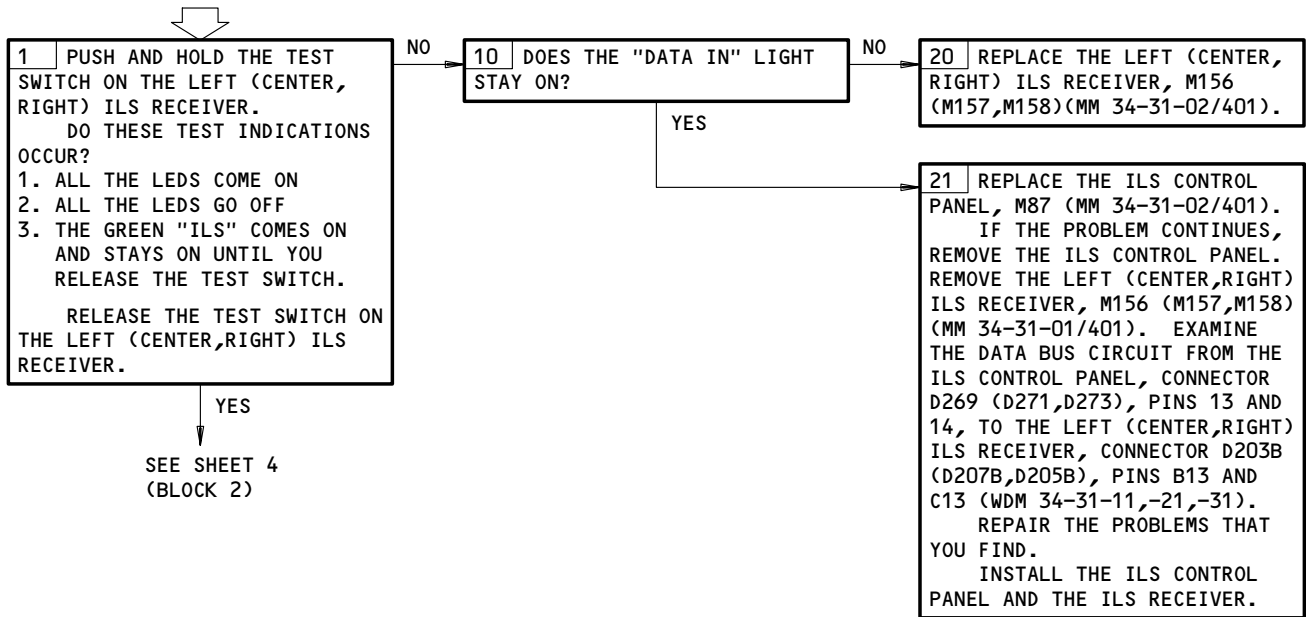

ILS BITE Procedure
Figure 103 (Sheet 3)

EFFECTIVITY
GUI 001, 009

34-31-00

FROM SHEET 3
(BLOCK 1)

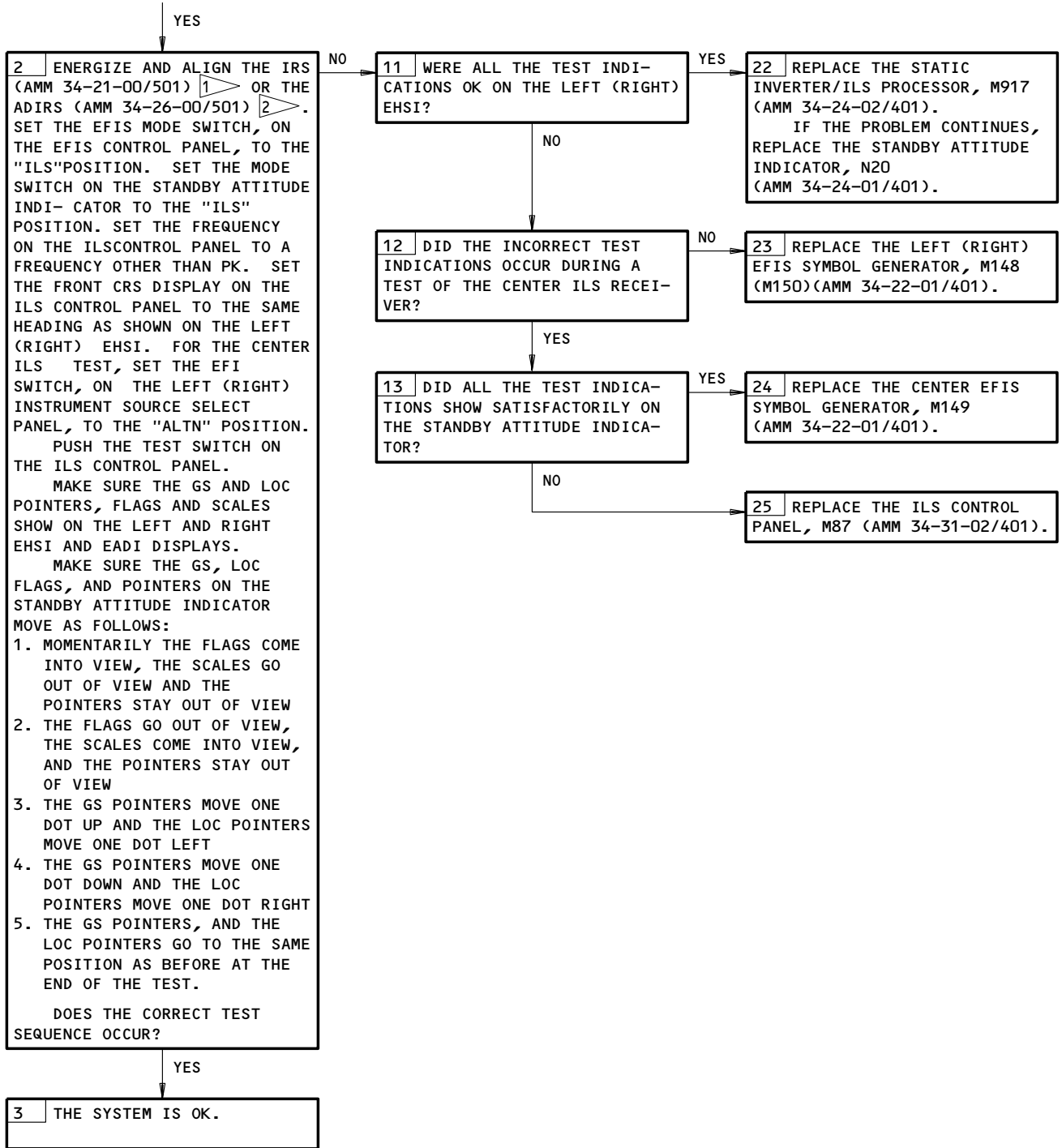

- 1 ▷ 757-200
- 2 ▷ 757-300

ILS BITE Procedure
Figure 103 (Sheet 4)

EFFECTIVITY
GUI 001, 009

34-31-00

PREREQUISITES

MAKE SURE THESE SYSTEMS WILL OPERATE:
 IRS (MM 34-21-00/501)
 EFIS (MM 34-22-00/501)

MAKE SURE THESE CIRCUIT BREAKERS ARE CLOSED:
 11A3,11E10,11E31

MAKE SURE THE AIRPLANE IS IN THIS CONFIGURATION:
 ELECTRICAL POWER IS ON (MM 24-22-00/201)

ILS BITE PROCEDURE

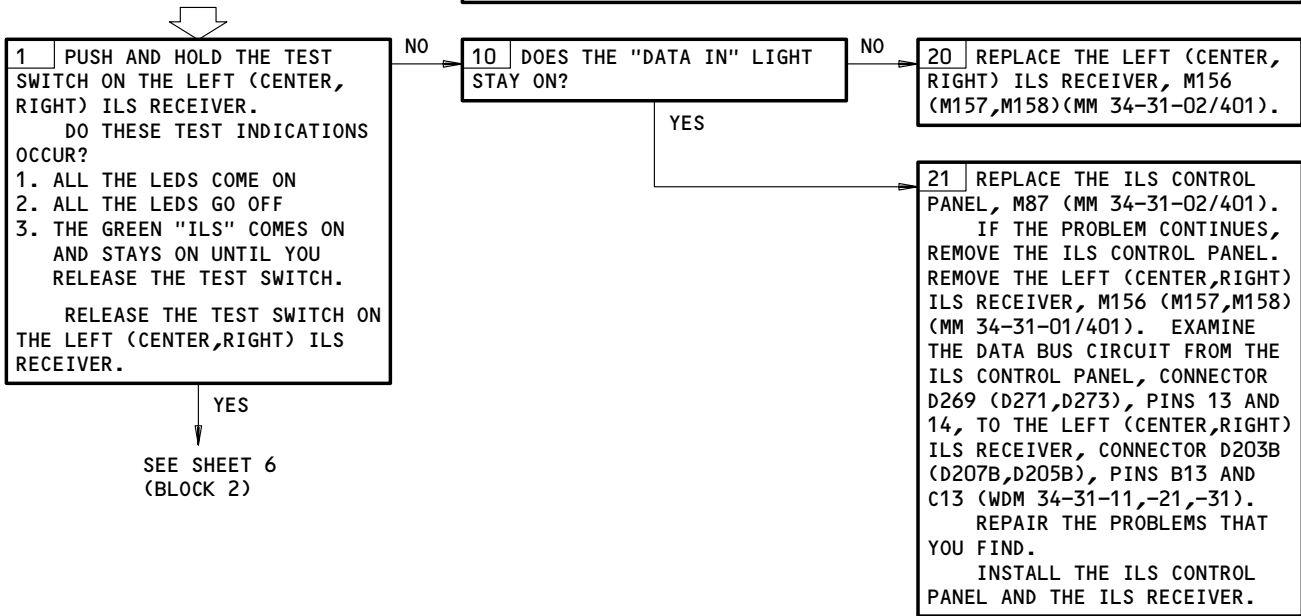

ILS BITE Procedure
Figure 103 (Sheet 5)

EFFECTIVITY
GUI 115

34-31-00

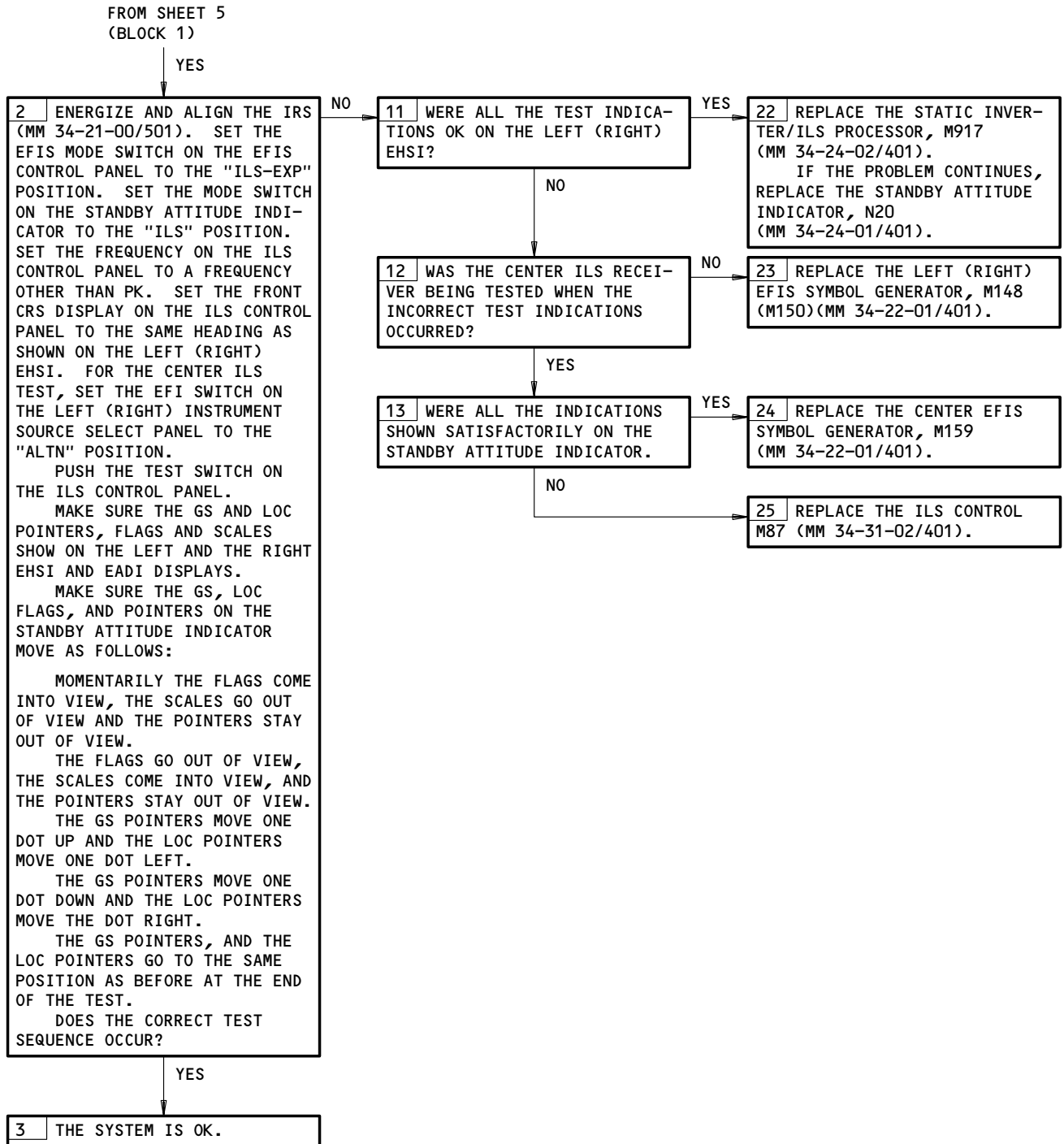

ILS BITE Procedure
Figure 103 (Sheet 6)

EFFECTIVITY
GUI 115

34-31-00

PREREQUISITES

MAKE SURE THESE SYSTEMS WILL OPERATE:

- IRS (AMM 34-21-00/501)
- EFIS (AMM 34-22-00/501)

MAKE SURE THESE CIRCUIT BREAKERS ARE CLOSED:

- 11E10, 11E31

MAKE SURE THE AIRPLANE IS IN THIS CONFIGURATION:
ELECTRICAL POWER IS ON (AMM 24-22-00/201)

NOTE: COLLINS ILS RECEIVERS P/N 622-5221-102 S/N 4766 AND BELOW OR P/N 822-0282-102 S/N 4764 AND BELOW WITHOUT COLLINS SERVICE BULLETIN ILS-700-34-20 DATED OCTOBER 15, 1991 AND COLLINS SERVICE BULLETIN ILS-700/700A-34-23 DATED AUGUST 22, 1995, CAN FAIL THE BITE TEST STARTED FROM THE FRONT PANEL OF THE ILS RECEIVER WHEN THERE IS NO FAULT. IF THIS OCCURS, DO THE ILS CONTROL PANEL SELF-TEST TO MAKE SURE OF THE FAULT.

**ABNORMAL ILS TEST
RESPONSE ON CAPT
(F/O) EADI & EHSI**

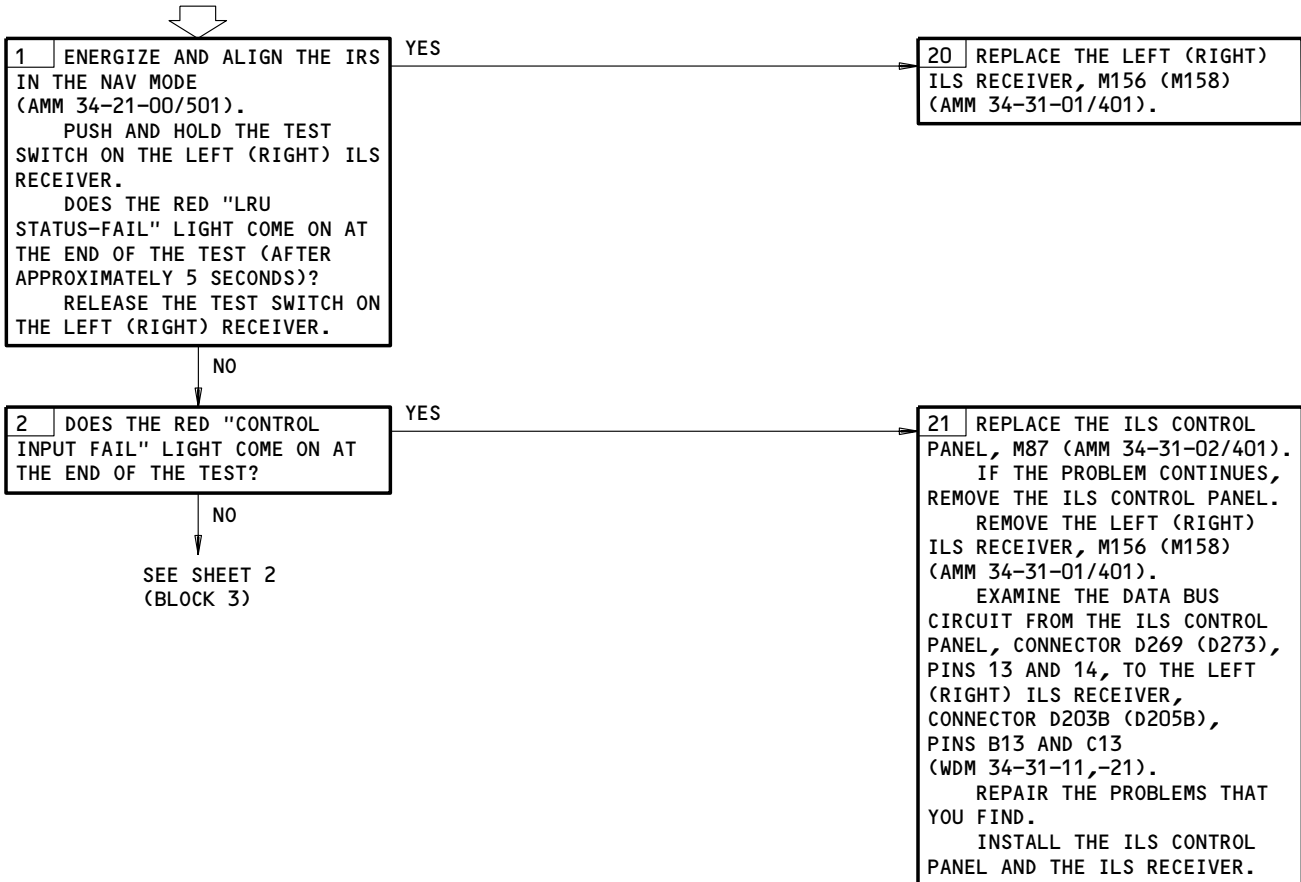

Abnormal ILS Test Response on Capt (F/O) EADI & EHSI
Figure 104 (Sheet 1)

EFFECTIVITY
GUI 002-008, 010-114, 116-999

34-31-00

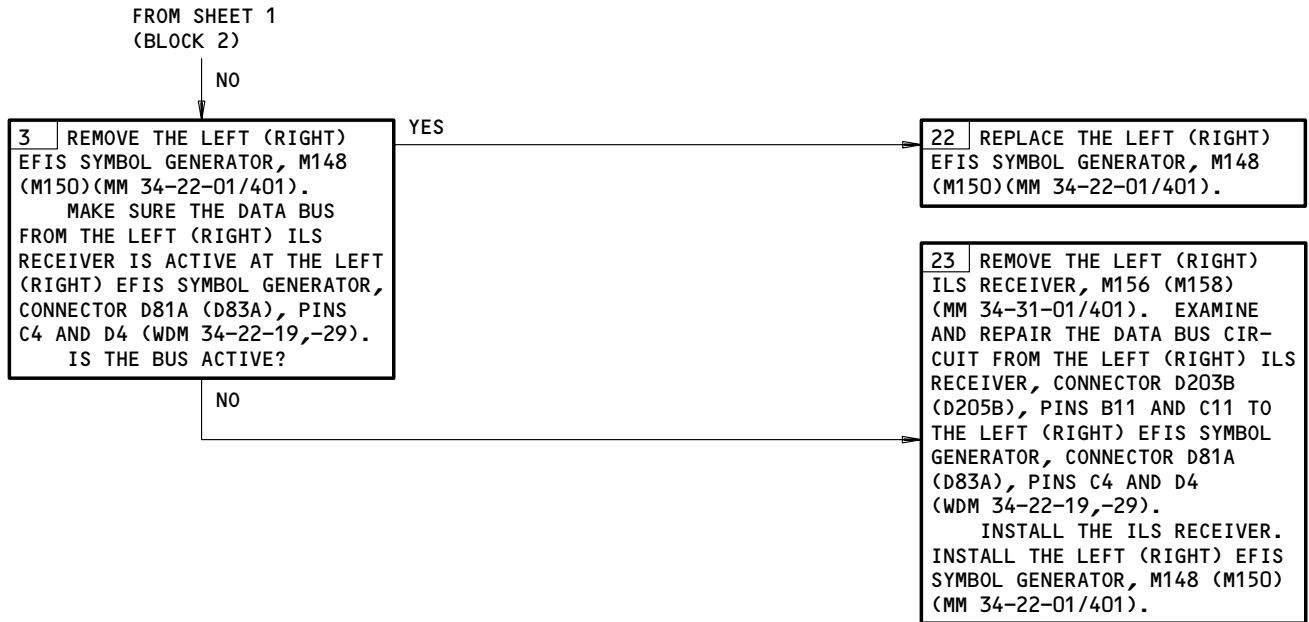

Abnormal ILS Test Response on Capt (F/O) EADI & EHSI
Figure 104 (Sheet 2)

EFFECTIVITY
GUI 002-008, 010-114, 116-999

34-31-00

PREREQUISITES

MAKE SURE THESE SYSTEMS WILL OPERATE:
 IRS (MM 34-21-00/501)
 EFIS (MM 34-22-00/501)

MAKE SURE THESE CIRCUIT BREAKERS ARE CLOSED:
 11E10,11E31

MAKE SURE THE AIRPLANE IS IN THIS CONFIGURATION:
 ELECTRICAL POWER IS ON (MM 24-22-00/201)

**ABNORMAL ILS TEST
 RESPONSE ON CAPT
 (F/O) EADI & EHSI**

1 ENERGIZE AND ALIGN THE IRS IN THE NAV MODE (MM 34-21-00/501).
 PUSH AND HOLD THE TEST SWITCH ON THE LEFT (RIGHT) ILS RECEIVER.
 DOES THE RED "ILS" LIGHT COME ON AT THE END OF THE TEST (AFTER APPROXIMATELY 5 SECONDS)?
 RELEASE THE TEST SWITCH ON THE LEFT (RIGHT) RECEIVER.

YES

20 REPLACE THE LEFT (RIGHT) ILS RECEIVER, M156 (M158) (MM 34-31-01/401).

NO

2 DOES THE RED "DATA IN" LIGHT COME ON AT THE END OF THE TEST?

YES

21 REPLACE THE ILS CONTROL PANEL, M87 (MM 34-31-02/401).
 IF THE PROBLEM CONTINUES, REMOVE THE ILS CONTROL PANEL. REMOVE THE LEFT (RIGHT) ILS RECEIVER, M156 (M158) (MM 34-31-01/401). EXAMINE AND REPAIR THE DATA BUS CIRCUIT FROM THE ILS CONTROL PANEL, CONNECTOR D269 (D273), PINS 13 AND 14 TO THE LEFT (RIGHT) ILS RECEIVER, CONNECTOR D203B (D205B), PINS B13 AND C13 (WDM 34-31-11,-21).
 INSTALL THE ILS CONTROL PANEL, AND THE ILS RECEIVER.

NO

SEE SHEET 4
 (BLOCK 3)

Abnormal ILS Test Response on Capt (F/O) EADI & EHSI
 Figure 104 (Sheet 3)

EFFECTIVITY
 GUI 001, 009, 115

34-31-00

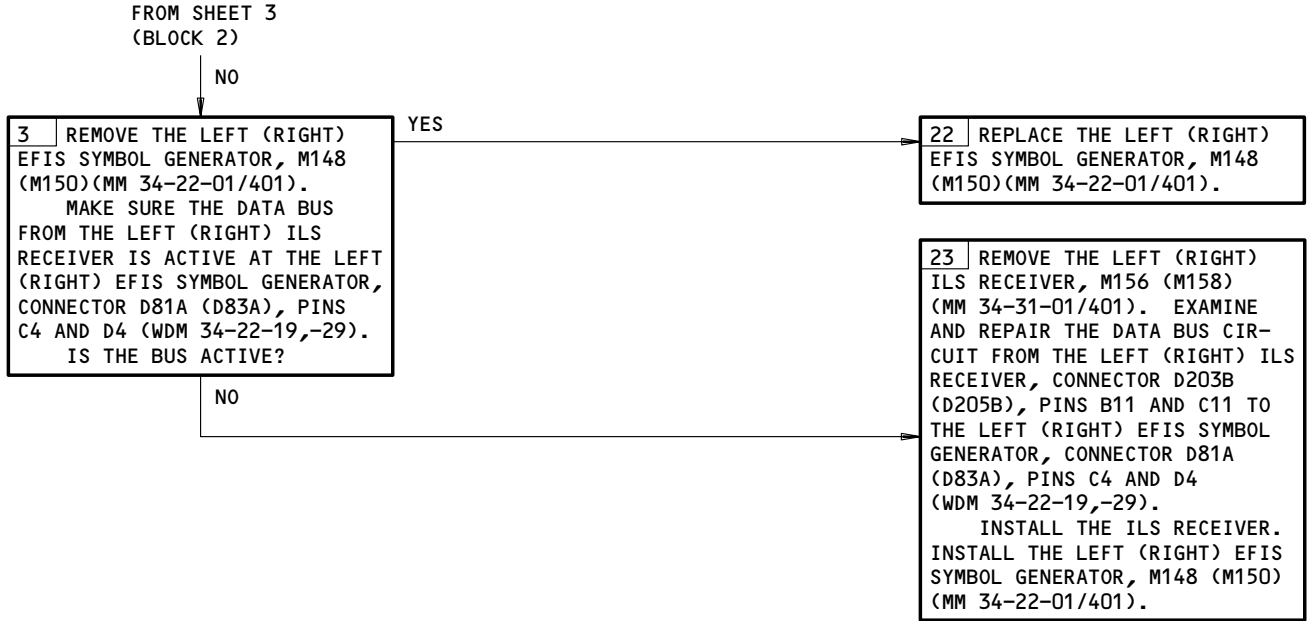

Abnormal ILS Test Response on Capt (F/O) EADI & EHSI
Figure 104 (Sheet 4)

EFFECTIVITY
GUI 001, 009, 115

34-31-00

**G/S AND LOC FLAGS
IN VIEW ON CAPT
(F/O) EHSI & EADI**

PREREQUISITES

MAKE SURE THESE SYSTEMS WILL OPERATE:
 IRS (MM 34-21-00/501)
 EFIS (MM 34-22-00/501)

MAKE SURE THESE CIRCUIT BREAKERS ARE CLOSED:
 11E10,11E31

MAKE SURE THE AIRPLANE IS IN THIS CONFIGURATION:
 ELECTRICAL POWER IS ON (MM 24-22-00/201)

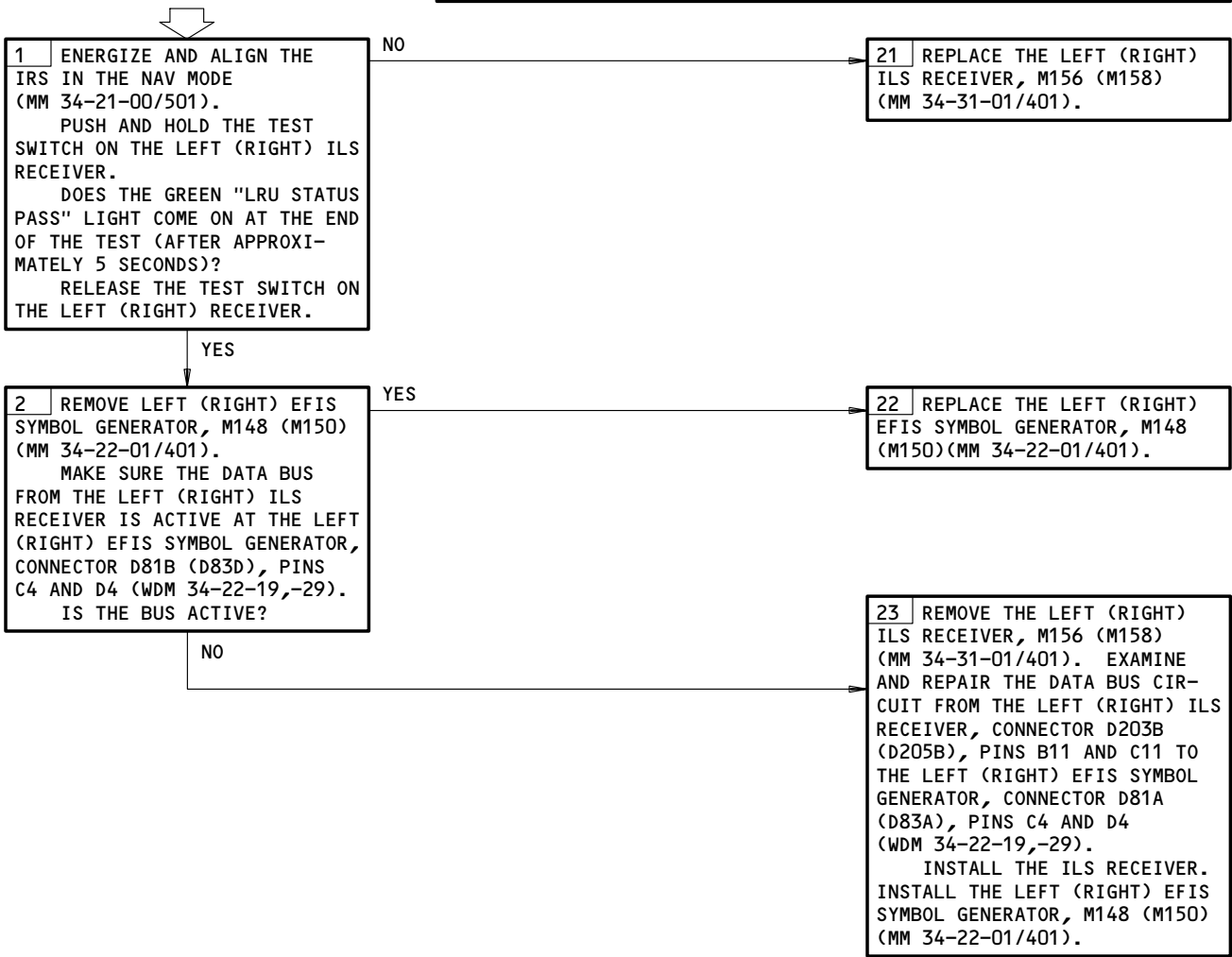

G/S and LOC Flags in View on Capt (F/O) EHSI & EADI
Figure 105 (Sheet 1)

EFFECTIVITY
 GUI 002-008, 010-114, 116-999

34-31-00

**G/S AND LOC FLAGS
IN VIEW ON CAPT
(F/O) EHSI & EADI**

PREREQUISITES

MAKE SURE THESE SYSTEMS WILL OPERATE:

- IRS (MM 34-21-00/501)
- EFIS (MM 34-22-00/501)

MAKE SURE THESE CIRCUIT BREAKERS ARE CLOSED:

- 11E10,11E31

MAKE SURE THE AIRPLANE IS IN THIS CONFIGURATION:

- ELECTRICAL POWER IS ON (MM 24-22-00/201)

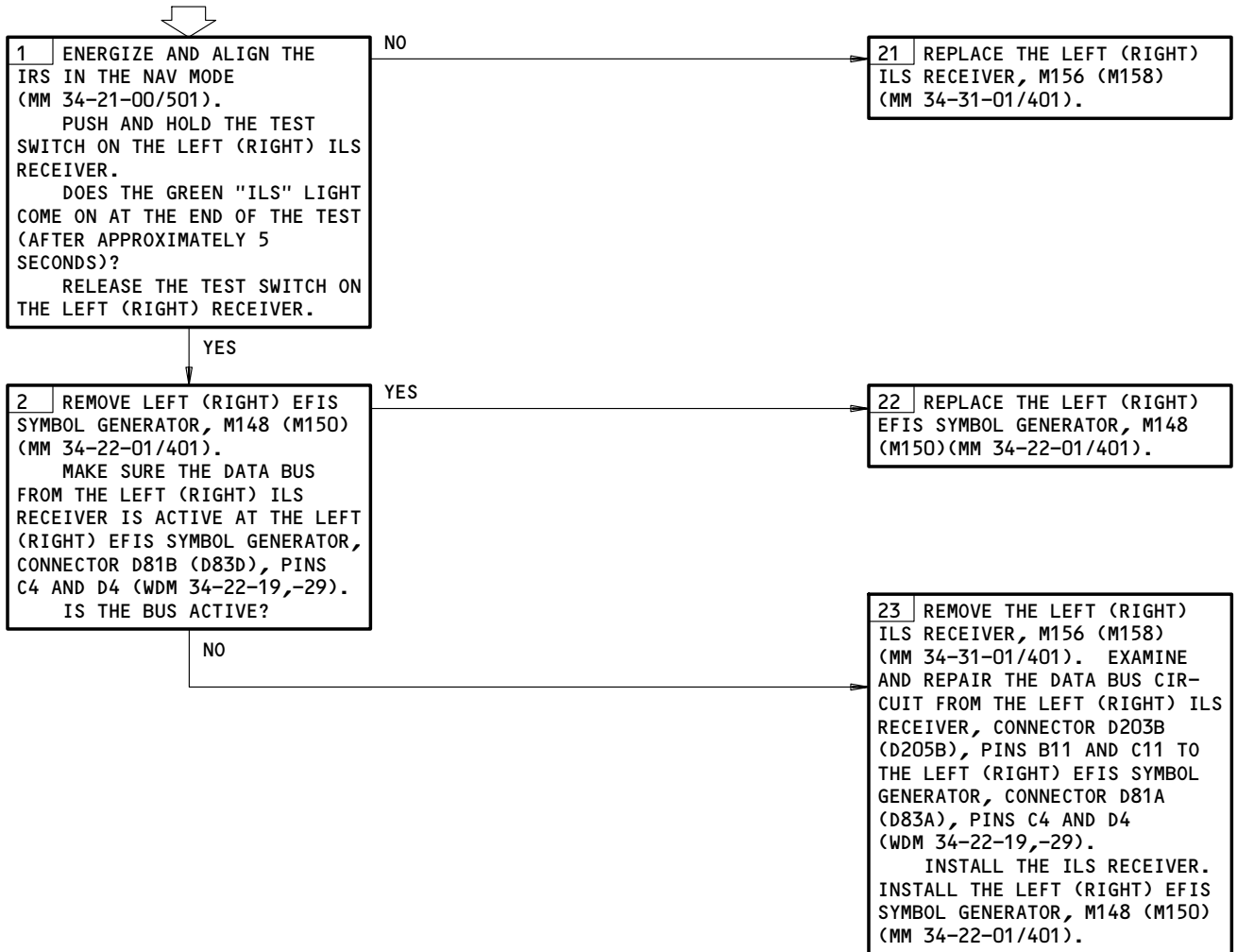

G/S and LOC Flags in View on Capt (F/O) EHSI & EADI
Figure 105 (Sheet 2)

EFFECTIVITY
GUI 001, 009, 115

34-31-00

 **BOEING**
757
FAULT ISOLATION/MAINT MANUAL

EHSI AND EADI -
BOTH G/S AND LOC
DEV POINTERS
MISSING (NCD)

PREREQUISITES

MAKE SURE THESE SYSTEMS WILL OPERATE:

- IRS (MM 34-21-00/501)
- EFIS (MM 34-22-00/501)

MAKE SURE THIS CIRCUIT BREAKER IS CLOSED:

- 11E10,11E31

MAKE SURE THE AIRPLANE IS IN THE CONFIGURATION THAT
FOLLOWS:

- ELECTRICAL POWER IS ON (MM 24-22-00/201)



- 1 ENERGIZE AND ALIGN THE IRS IN THE NAV MODE (MM 34-21-00/501).
REPLACE THE ILS CONTROL PANEL, M87 (MM 34-31-02/401).
IF THE PROBLEM CONTINUES, REMOVE THE ILS CONTROL PANEL. REMOVE THE LEFT (RIGHT) ILS RECEIVER (MM 34-31-01/401). EXAMINE AND REPAIR THE DATA BUS CIRCUIT FROM THE ILS CONTROL PANEL, CONNECTOR D269 (D273), PINS 14 AND 13 TO THE LEFT (RIGHT) ILS RECEIVER, CONNECTOR D203B(D205B), PINS B13 AND C13 (WDM 34-31-11,-21).
INSTALL THE ILS CONTROL PANEL AND THE ILS RECEIVER.

Capt (F/O) EHSI & EADI - Both G/S and LOC Dev Pointers Missing (NCD)
Figure 106

EFFECTIVITY

ALL

34-31-00

03

Page 116
Jun 20/92

**FAULTY STANDBY
ATTITUDE INDICATOR
OPERATION**

PREREQUISITES

MAKE SURE THIS SYSTEM WILL OPERATE:
STANDBY ATTITUDE REFERENCE SYSTEM (MM 34-24-00/501)

MAKE SURE THIS CIRCUIT BREAKER IS CLOSED:
11A3

MAKE SURE THE AIRPLANE IS IN THIS CONFIGURATION:
ELECTRICAL POWER IS ON (MM 24-22-00/201)

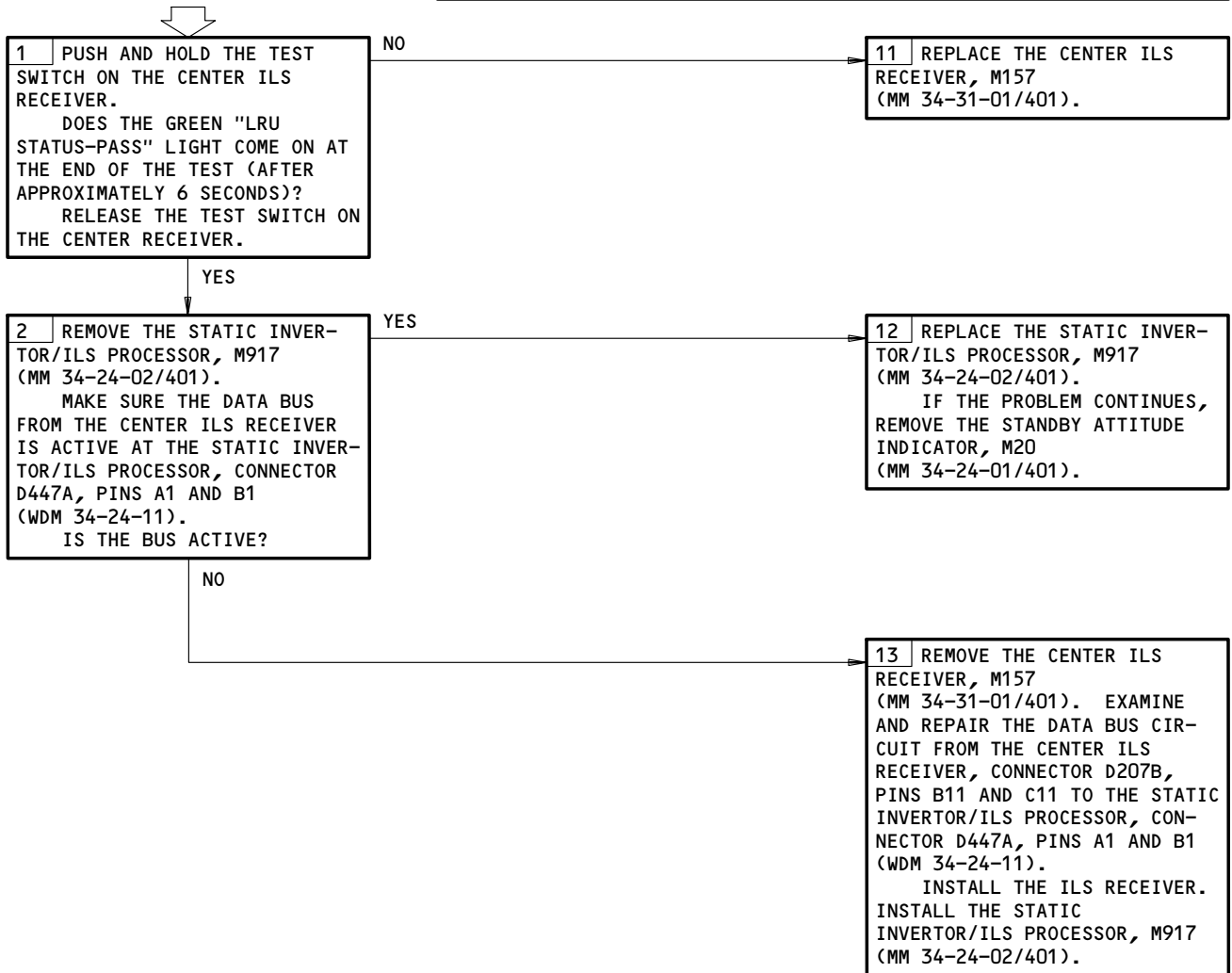

Faulty Standby Attitude Indicator Operation
Figure 107 (Sheet 1)

EFFECTIVITY
GUI 002-008, 010-114, 116-999

34-31-00

**FAULTY STANDBY
ATTITUDE INDICATOR
OPERATION**

PREREQUISITES

MAKE SURE THIS SYSTEM WILL OPERATE:
STANDBY ATTITUDE REFERENCE SYSTEM (MM 34-24-00/501)

MAKE SURE THIS CIRCUIT BREAKER IS CLOSED:
11A3

MAKE SURE THE AIRPLANE IS IN THIS CONFIGURATION:
ELECTRICAL POWER IS ON (MM 24-22-00/201)

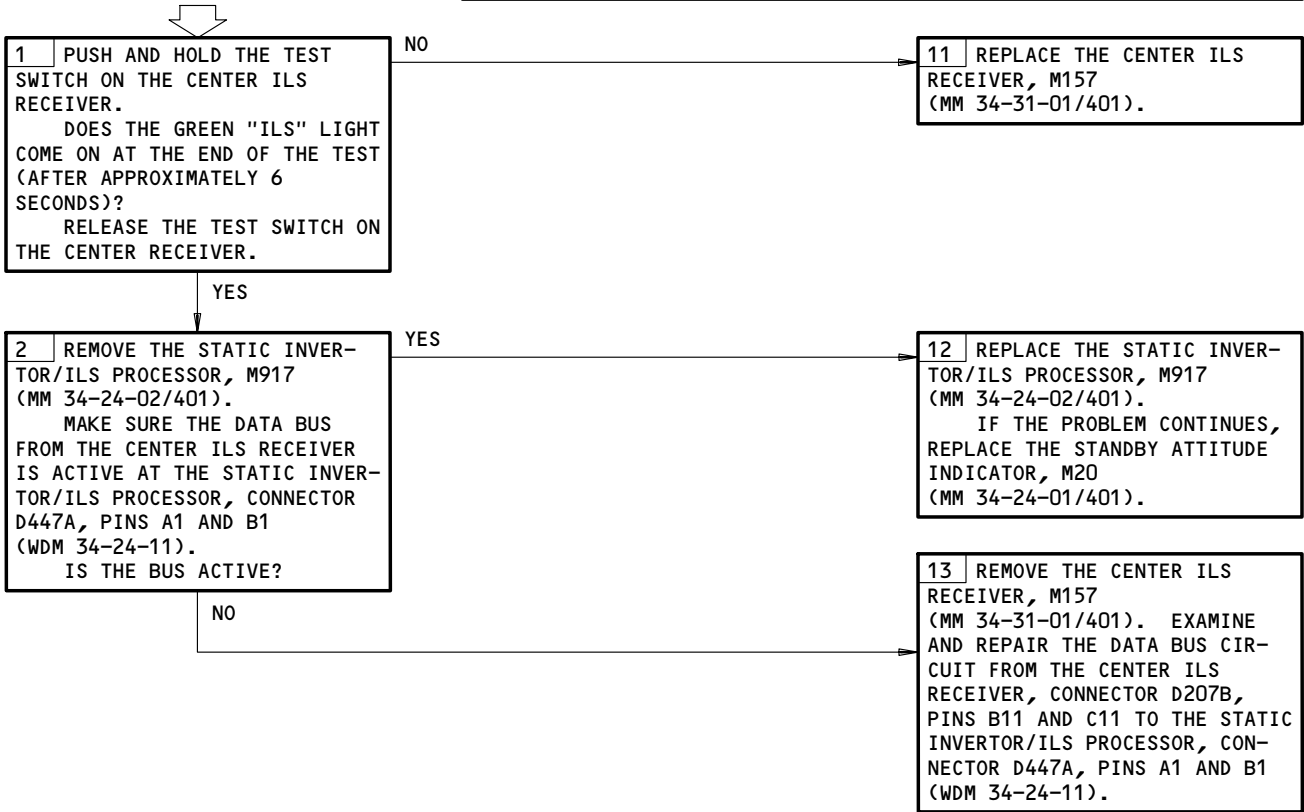

Faulty Standby Attitude Indicator Operation
Figure 107 (Sheet 2)

EFFECTIVITY
GUI 001, 009, 115

34-31-00

STBY ATT - BOTH
DEV POINTERS
MISSING (NCD)

PREREQUISITES

MAKE SURE THESE SYSTEMS WILL OPERATE:
STANDBY ATTITUDE REFERENCE SYSTEM (AMM 34-24-00/501)

MAKE SURE THIS CIRCUIT BREAKER IS CLOSED:
11A3

MAKE SURE TH AIRPLANE IS IN THIS CONFIGURATION:
ELECTRICAL POWER IS ON (AMM 24-22-00/201)



1 REPLACE THE ILS CONTROL PANEL, M87 (AMM 34-31-02/401).
IF THE PROBLEM CONTINUES, REMOVE THE ILS CONTROL PANEL. REMOVE THE CENTER ILS RECEIVER (AMM 34-31-01/401). REPAIR THE DATA BUS CIRCUIT, AS NECESSARY, FROM THE ILS CONTROL PANEL CONNECTOR D271, PINS 13 AND 14 TO THE CENTER ILS RECEIVER, CONNECTOR D207B, PINS B13 AND C13 (WDM 34-31-31).
INSTALL THE ILS CONTROL PANEL. INSTALL THE CENTER ILS RECEIVER.

Stby Att - Both Dev Pointers Missing (NCD)
Figure 108

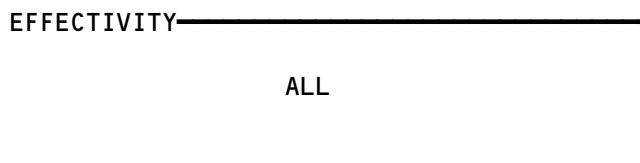

34-31-00

04

Page 119
Sep 20/94

E46430

LOC (G/S) DEV
 POINTER MISSING
 ON STBY ATT IND

PREREQUISITES

MAKE SURE THESE SYSTEMS WILL OPERATE:
 STANDBY ATTITUDE REFERENCE SYSTEM (AMM 34-24-00/501)
 MAKE SURE THIS CIRCUIT BREAKER IS CLOSED:
 11A3
 MAKE SURE THE AIRPLANE IS IN THIS CONFIGURATION:
 ELECTRICAL POWER IS ON (AMM 24-22-00/201)

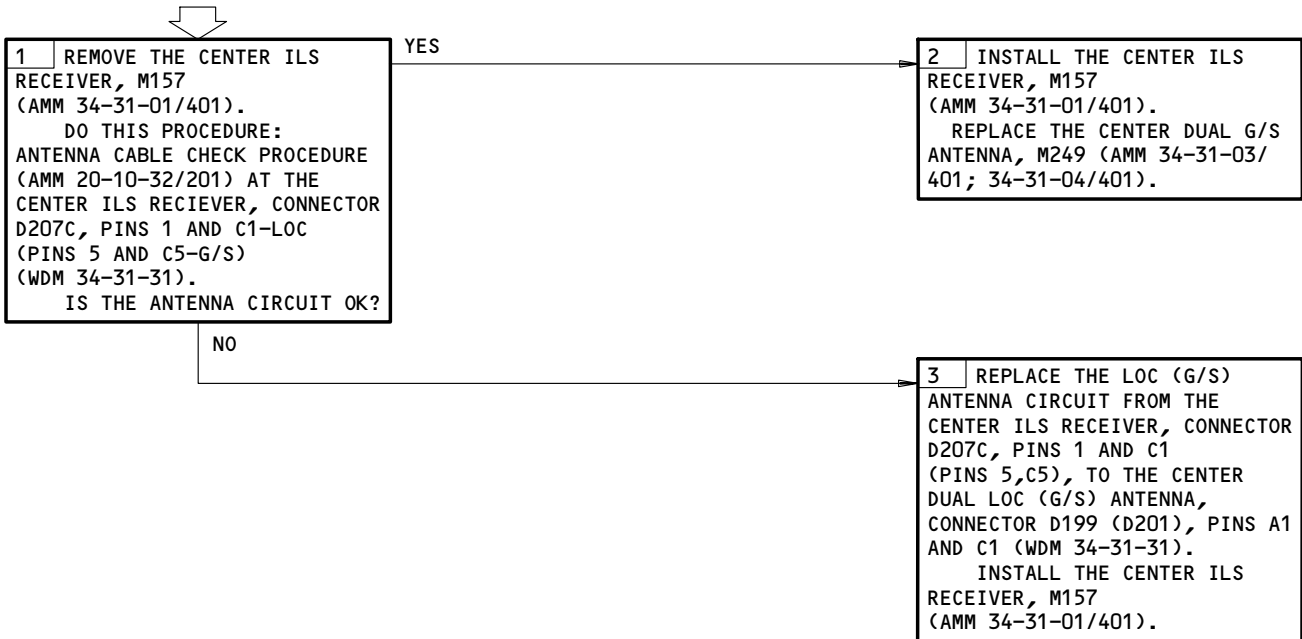

Loc (G/S) Dev Pointer Missing on Stby Att Ind
 Figure 109

EFFECTIVITY	ALL
-------------	-----

34-31-00

PREREQUISITES

MAKE SURE THESE SYSTEMS WILL OPERATE:

- IRS (AMM 34-21-00/501)
- EFIS (AMM 34-22-00/501)

MAKE SURE THESE CIRCUIT BREAKERS ARE CLOSED:

- 11E10, 11E31

MAKE SURE THE AIRPLANE IS IN THIS CONFIGURATION:

- ELECTRICAL POWER IS ON (AMM 24-22-00/201)

**LOC DEV POINTER
NOT DISPLAYED**

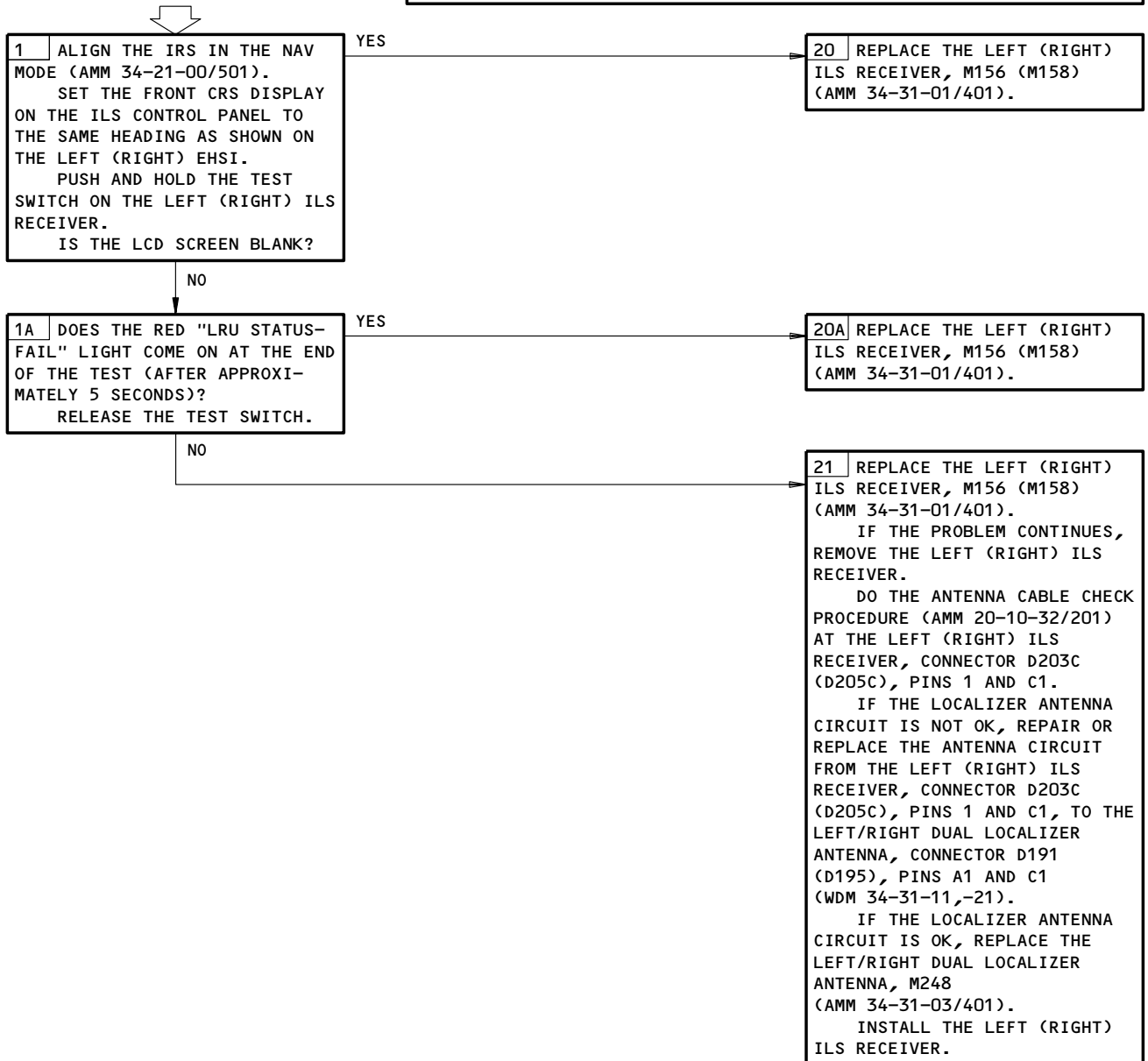

LOC Dev Pointer Not Displayed
Figure 110 (Sheet 1)

EFFECTIVITY
GUI 002-008, 010-114, 116-999

34-31-00

**LOC DEV POINTER
NOT DISPLAYED**

PREREQUISITES

MAKE SURE THESE SYSTEMS WILL OPERATE:

- IRS (AMM 34-21-00/501)
- EFIS (AMM 34-22-00/501)

MAKE SURE THESE CIRCUIT BREAKERS ARE CLOSED:

- 11E10,11E31

MAKE SURE THE AIRPLANE IS IN THE CONFIGURATION THAT ELECTRICAL POWER IS ON (AMM 24-22-00/201)

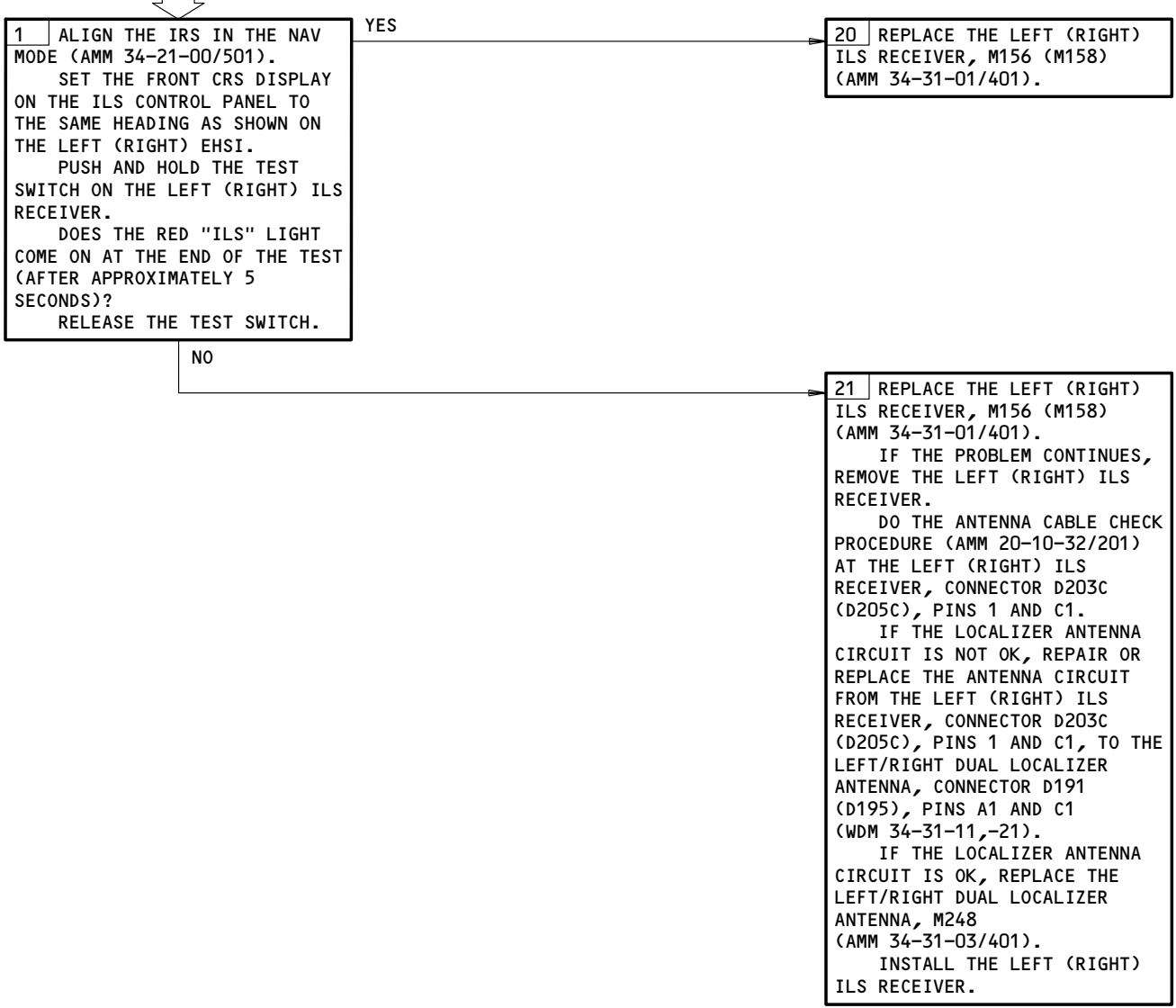

LOC Dev Pointer Not Displayed
Figure 110 (Sheet 2)

EFFECTIVITY
GUI 001, 009, 115

34-31-00

PREREQUISITES

MAKE SURE THESE SYSTEMS WILL OPERATE:

- IRS (AMM 34-21-00/501)
- EFIS (AMM 34-22-00/501)

MAKE SURE THESE CIRCUIT BREAKERS ARE CLOSED:

- 11E10,11E31

MAKE SURE THE AIRPLANE IS IN THIS CONFIGURATION:

- ELECTRICAL POWER IS ON (AMM 24-22-00/201)

NOTE: THE GLIDESLOPE DEVIATION POINTER DOES NOT SHOW ON THE EADI AND EHSI (ILS MODE), WHEN THESE CONDITIONS OCCUR:

- THE DIFFERENCE BETWEEN THE AIRPLANE TRACK ANGLE AND THE RUNWAY HEADING IS GREATER THAN 90 DEGREES
- THE BACKCOURSE IS SET.

G/S DEV POINTER NOT DISPLAYED

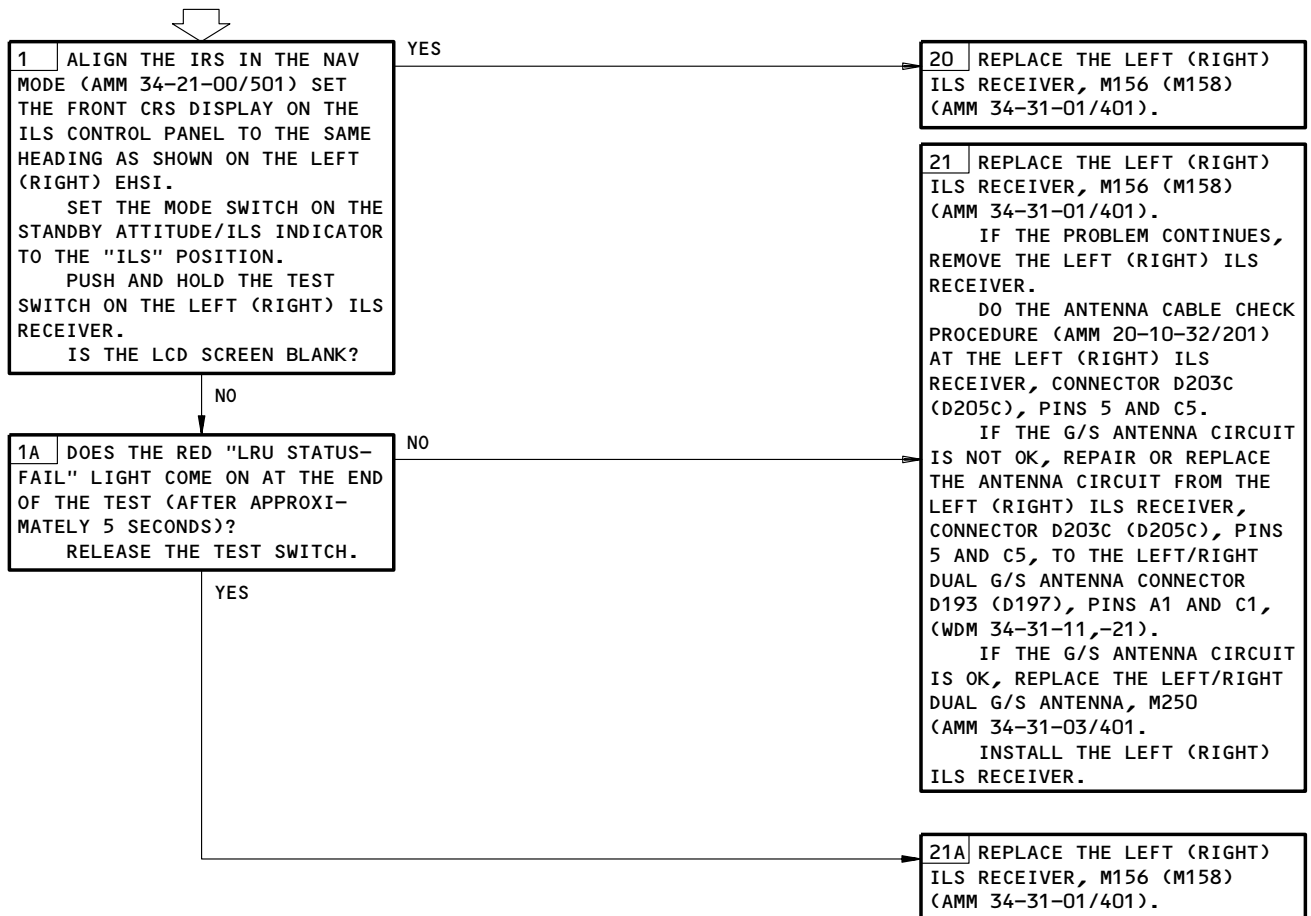

G/S Dev Pointer Not Displayed
Figure 111 (Sheet 1)

EFFECTIVITY
GUI 002-008, 010-114, 116-999

34-31-00

PREREQUISITES

MAKE SURE THESE SYSTEMS WILL OPERATE:

- IRS (AMM 34-21-00/501)
- EFIS (AMM 34-22-00/501)

MAKE SURE THESE CIRCUIT BREAKERS ARE CLOSED:

- 11E10,11E31

MAKE SURE THE AIRPLANE IS IN THIS CONFIGURATION:

- ELECTRICAL POWER IS ON (AMM 24-22-00/201)

NOTE: THE GLIDESLOPE DEVIATION POINTER DOES NOT SHOW ON THE EADI AND EHSI (ILS MODE), WHEN THESE CONDITIONS OCCUR:

- THE DIFFERENCE BETWEEN THE AIRPLANE TRACK ANGLE AND THE RUNWAY HEADING IS GREATER THAN 90 DEGREES.
- THE BACKCOURSE IS SET.

**G/S DEV POINTER
NOT DISPLAYED**

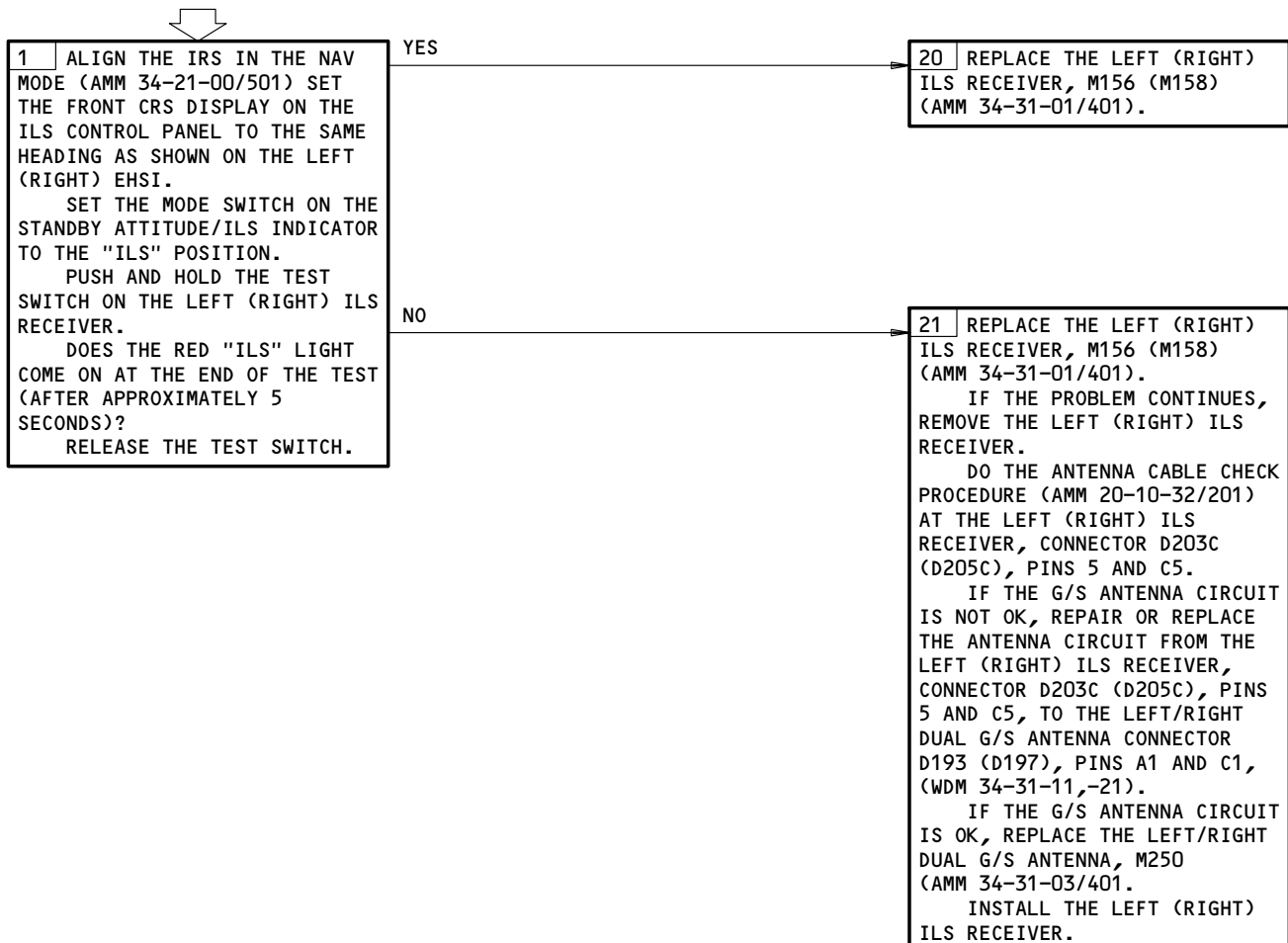

G/S Dev Pointer Not Displayed
Figure 111 (Sheet 2)

EFFECTIVITY
GUI 001, 009, 115

34-31-00

BOEING
 757
 FAULT ISOLATION/MAINT MANUAL

1. ARINC Data Bus Charts

A. General

CAUTION: DO NOT DIRECTLY TOUCH THE CONNECTORS. USE A BREAKOUT BOX OR YOU CAN CAUSE DAMAGE TO THE CONNECTORS.

- (1) The ARINC 429 data bus charts give data necessary to make an analysis of ARINC 429 transmitters, receivers, and data buses. For the test, use a breakout box at the available terminal or at the LRU connectors.

B. Equipment

- (1) Standard multi-meter
- (2) 429EBP Data Bus Analyzer (recommended)
 JcAIR Instrumentation
 400 Industrial Parkway
 Industrial Airport, KS 66031

 429-2 Data Bus Analyzer (alternative)
 Interface Technology
 150 E. Arrow Highway
 San Dimas, CA 91773
- (3) A34011-1 Breakout Box (recommended)
 A34011-112 Breakout Box (alternative)

ILS								
DIGITAL OUTPUT BUS CHART								
BUS NAME			CON	PINS	BUS	BIT	DATA	BUS
SOURCE	TYPE	BUS						
ILS	(L C R)	A	1	B	B07 C07	429	L0	ILS OUTPUT #1
ILS	(L C R)	A	2	B	B11 C11	429	L0	ILS OUTPUT #2

EFFECTIVITY

ALL

34-31-00

BOEING
 757
 FAULT ISOLATION/MAINT MANUAL

ILS ID = 010								
OCTAL LABELS CHART								
SIGNAL	TYPE	LABEL	FORMAT	MIN UPDATE RATE	SDI	BINARY RANGE	POSITIVE SENSE	UNITS
SEL RUNWAY HDG-D	A	017	BCD	5	00	0-359	ALWAYS POS	DEG
ILS FREQUENCY	A	033	BCD	5	00	108-111.95	ALWAYS POS	MHZ
LOCALIZER DEV	A	173	BNR	16	00	+-.4	FLY RIGHT	DDM
GLIDESLOPE DEV	A	174	BNR	16	00	+-.8	FLY DOWN	DDM

ILS				
DISCRETE OCTAL LABELS/BIT CHART				
SIGNAL	OCTAL LABEL	BIT	ONE-STATE	ZERO-STATE
TUNE INHIBIT	173	11	INHIBIT	NORMAL
TUNE INHIBIT	174	11	INHIBIT	NORMAL

EFFECTIVITY

ALL

34-31-00

02

Page 126
Sep 20/96

BOEING
 757
 FAULT ISOLATION/MAINT MANUAL

ILS CP							
DIGITAL OUTPUT BUS CHART							
BUS NAME			CON	PINS	BUS FORMAT	BIT RATE	DATA BUS
SOURCE	TYPE	BUS					
ILSCP (C)	A	1		14 13	429	LO	ILS FREQ-L
ILSCP (C)	A	2		14 13	429	LO	ILS FREQ-R
ILSCP (C)	A	3		14 13	429	LO	ILS FREQ-C

ILS CP ID = OBO								
OCTAL LABELS CHART								
SIGNAL	TYPE	LABEL	FORMAT	MIN UPDATE RATE	SDI	BINARY RANGE	POSITIVE SENSE	UNITS
SEL RUNWAY HDG-D	A	017	BCD	5	00	0-359	CW FROM N	DEG
ILS FREQUENCY	A	033	BCD	5	00	108-111.95	ALWAYS POS	MHZ
DME FREQUENCY	A	035	BCD	5	00	108-135.95	ALWAYS POS	MHZ

EFFECTIVITY _____

ALL

34-31-00

BOEING
757
FAULT ISOLATION/MAINT MANUAL

MARKER BEACON SYSTEM

COMPONENT	FIG. 102 SHT	QTY	ACCESS/AREA	AMM REFERENCE
ANTENNA - MARKER BEACON, M243	1	1	BOTTOM FWD FUSELAGE	34-32-01
CIRCUIT BREAKER - VOR MKR LEFT, C595	1	1	FLT COMPT, P11 11A2	*
LIGHT - CAPT INNER MKR BEACON LT ASSY, L237	1	1	FLT COMPT, P1	*
LIGHT - CAPT MIDDLE MKR BEACON LT ASSY, L238	1	1	FLT COMPT, P1	*
LIGHT - CAPT OUTER MKR BEACON LT ASSY, L239	1	1	FLT COMPT, P1	*
LIGHT - F/O INNER MKR BEACON LT ASSY, L240	1	1	FLT COMPT, P3	*
LIGHT - F/O MIDDLE MKR BEACON LT ASSY, L241	1	1	FLT COMPT, P3	*
LIGHT - F/O OUTER MKR BEACON LT ASSY, L242	1	1	FLT COMPT, P3	*
PANEL - (REF 23-51-00, FIG. 101) CAPT AUDIO SELECTOR, M70 F/O AUDIO SELECTOR, M71 OBS AUDIO SELECTOR, M98 SUPERNUMERATOR AUDIO SELECTOR, M10216 ▶	2	1	822, AFT CARGO COMPT, E6-1 ▶ ; 119BL, MAIN EQUIP CTR, E3-2 ▶	34-51-01
RECEIVER - VOR/MKR L, M186	2	1		
UNIT - (FIM 31-31-00/101) DIGITAL FLIGHT DATA ACQUISITION, M138 ▶	4			

* SEE THE WDM EQUIPMENT LIST

- ▶ 1 AIRPLANES WITH RECEIVER IN AFT EQUIPMENT CENTER
- ▶ 2 AIRPLANES WITH RECEIVER IN MAIN EQUIPMENT CENTER
- ▶ 3 AIRPLANES WITH SUPERNUMERTOR
- ▶ 4 AIRPLANES WITH DFDAU

Marker Beacon System - Component Index
Figure 101

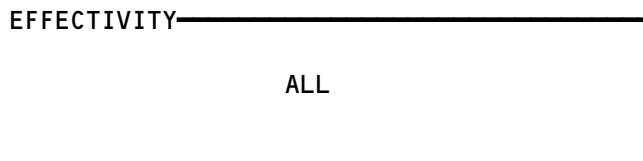

34-32-00

BOEING
757
FAULT ISOLATION/MAINT MANUAL

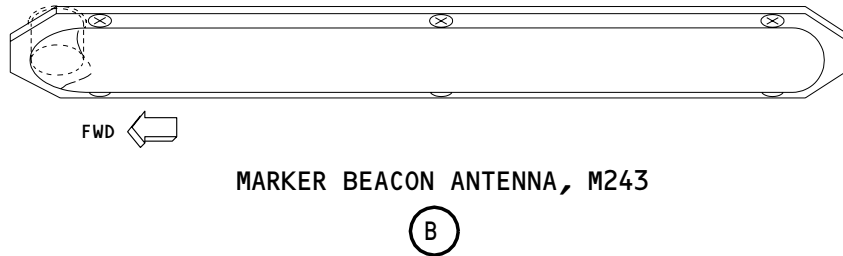
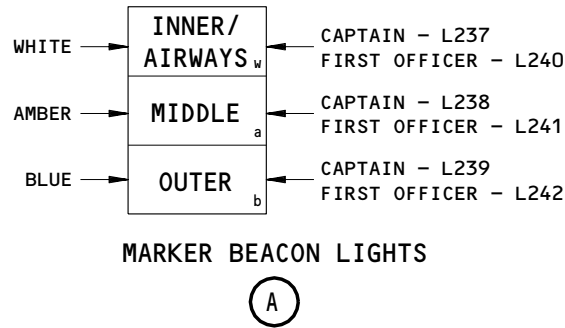
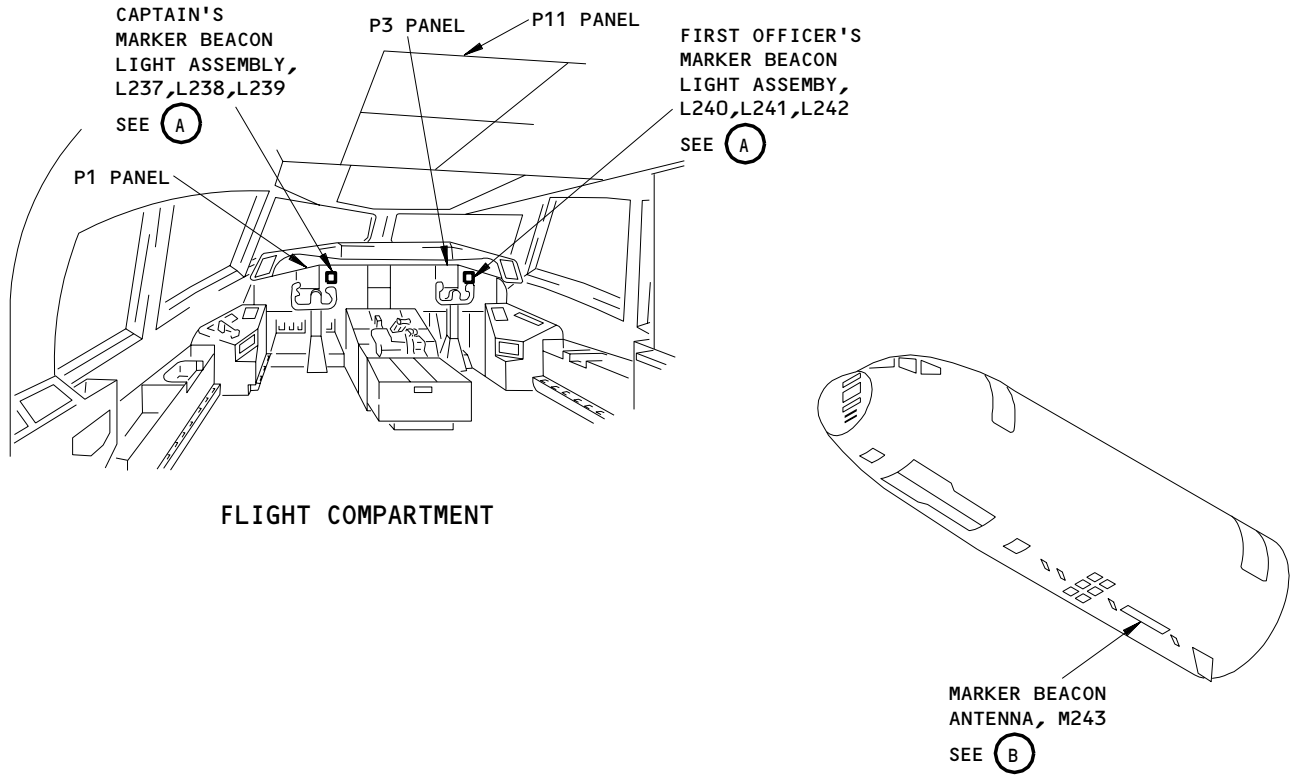

Marker Beacon System - Component Location
Figure 102 (Sheet 1)

EFFECTIVITY	ALL
-------------	-----

34-32-00

BOEING

757 FAULT ISOLATION/MAINT MANUAL

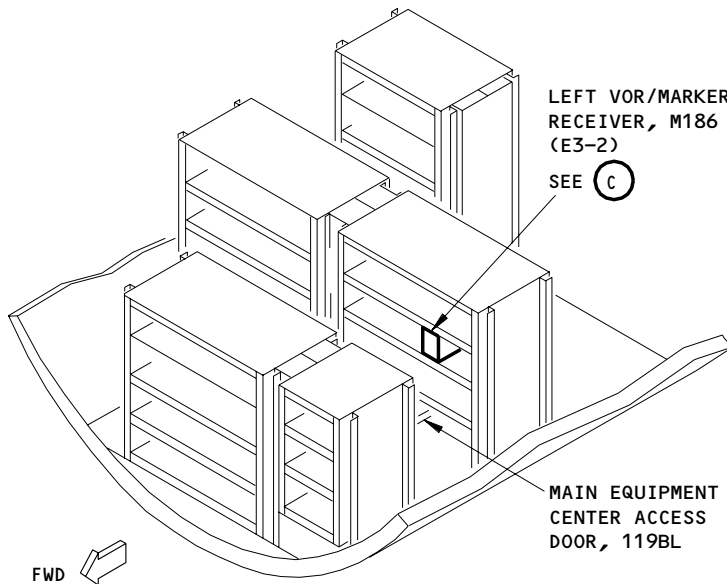

MAIN EQUIPMENT CENTER 1

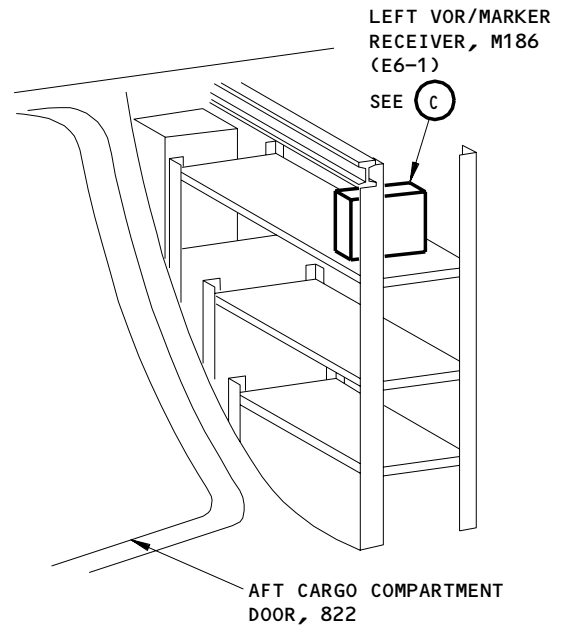

AFT EQUIPMENT CENTER 2

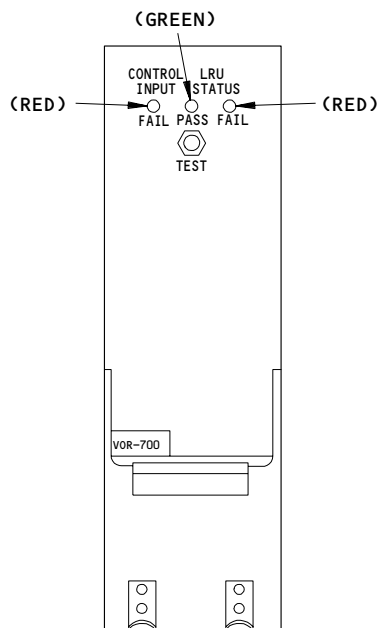

LEFT VOR/MARKER RECEIVER, M186

(C) 3

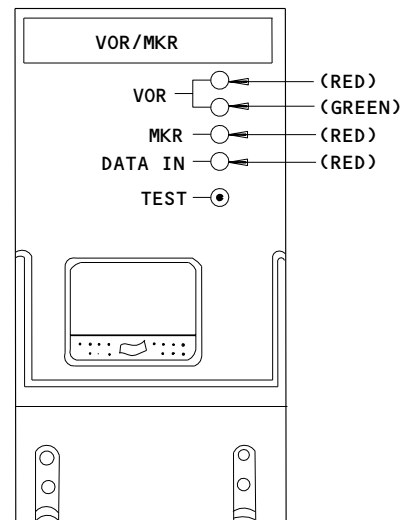

LEFT VOR/MARKER RECEIVER, M186

(C) 4

- 1 AIRPLANES WITH RECEIVER IN MAIN EQUIPMENT CENTER
- 2 AIRPLANES WITH RECEIVER IN AFT EQUIPMENT CENTER
- 3 AIRPLANES WITH COLLINS -700 SERIES RECEIVERS
- 4 AIRPLANES WITH ALLIEDSIGNAL RVA-36A SERIES RECEIVERS

Marker Beacon System - Component Location
Figure 102 (Sheet 2)

EFFECTIVITY	ALL
-------------	-----

34-32-00

**MARKER BEACON
LIGHTS AND/OR
AUDIO PROBLEMS**

PREREQUISITES

MAKE SURE THESE CIRCUIT BREAKERS ARE CLOSED:
11A2,11C25,11C26,11G29,11G30,11P2

MAKE SURE THE AIRPLANE IS IN THIS CONFIGURATION:
ELECTRICAL POWER IS ON (AMM 24-22-00/201)

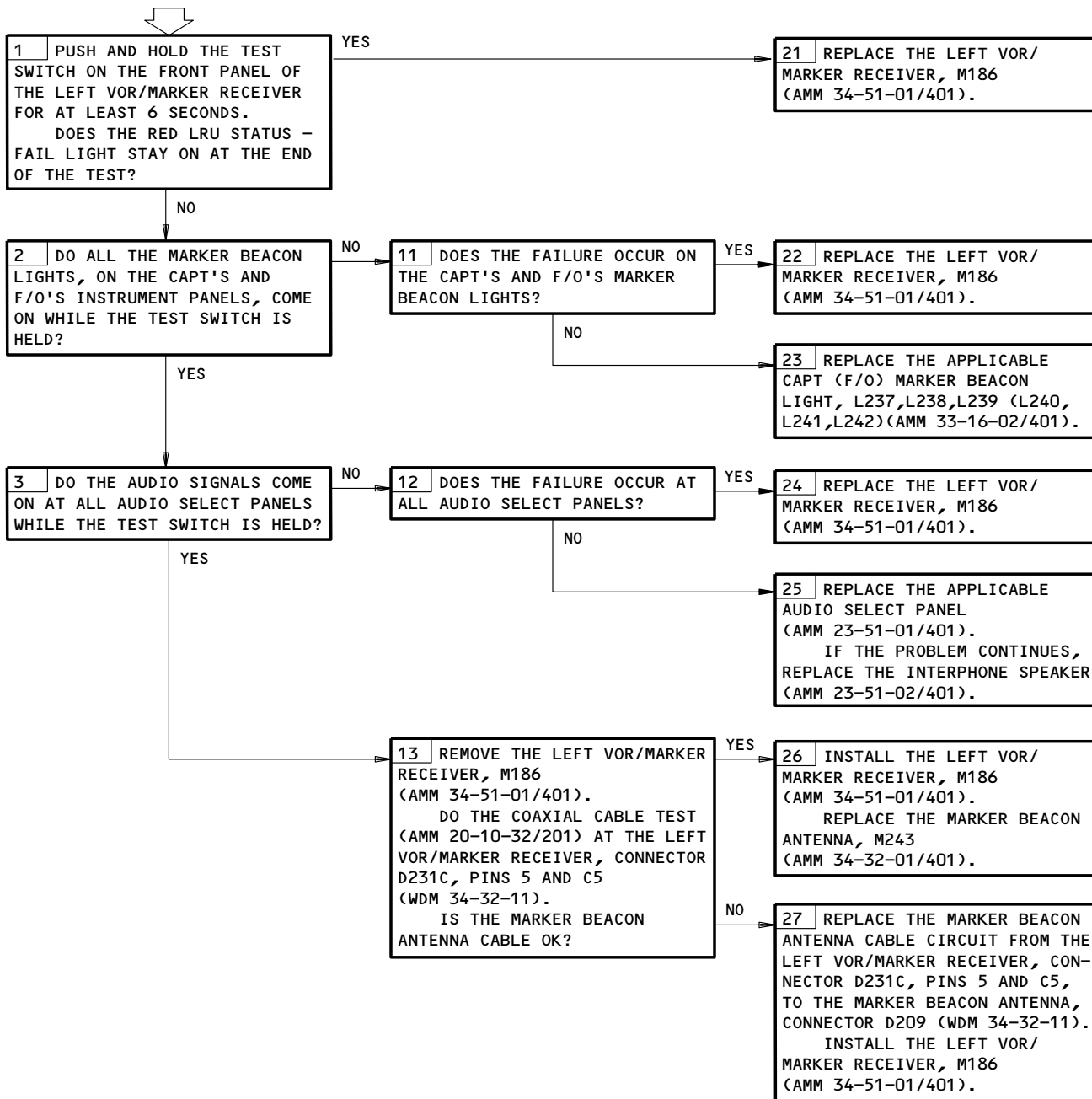

Marker Beacon Lights and/or Audio Problems
Figure 103 (Sheet 1)

EFFECTIVITY
AIRPLANES WITH VOR-700 SERIES
RECEIVERS

34-32-00

**MARKER BEACON
LIGHTS PROBLEM**

PREREQUISITES

MAKE SURE THESE CIRCUIT BREAKERS ARE CLOSED:
11A2,11C25,11C26,11G29,11G30,11P2

MAKE SURE THE AIRPLANE IS IN THIS CONFIGURATION:
ELECTRICAL POWER IS ON (AMM 24-22-00/201)

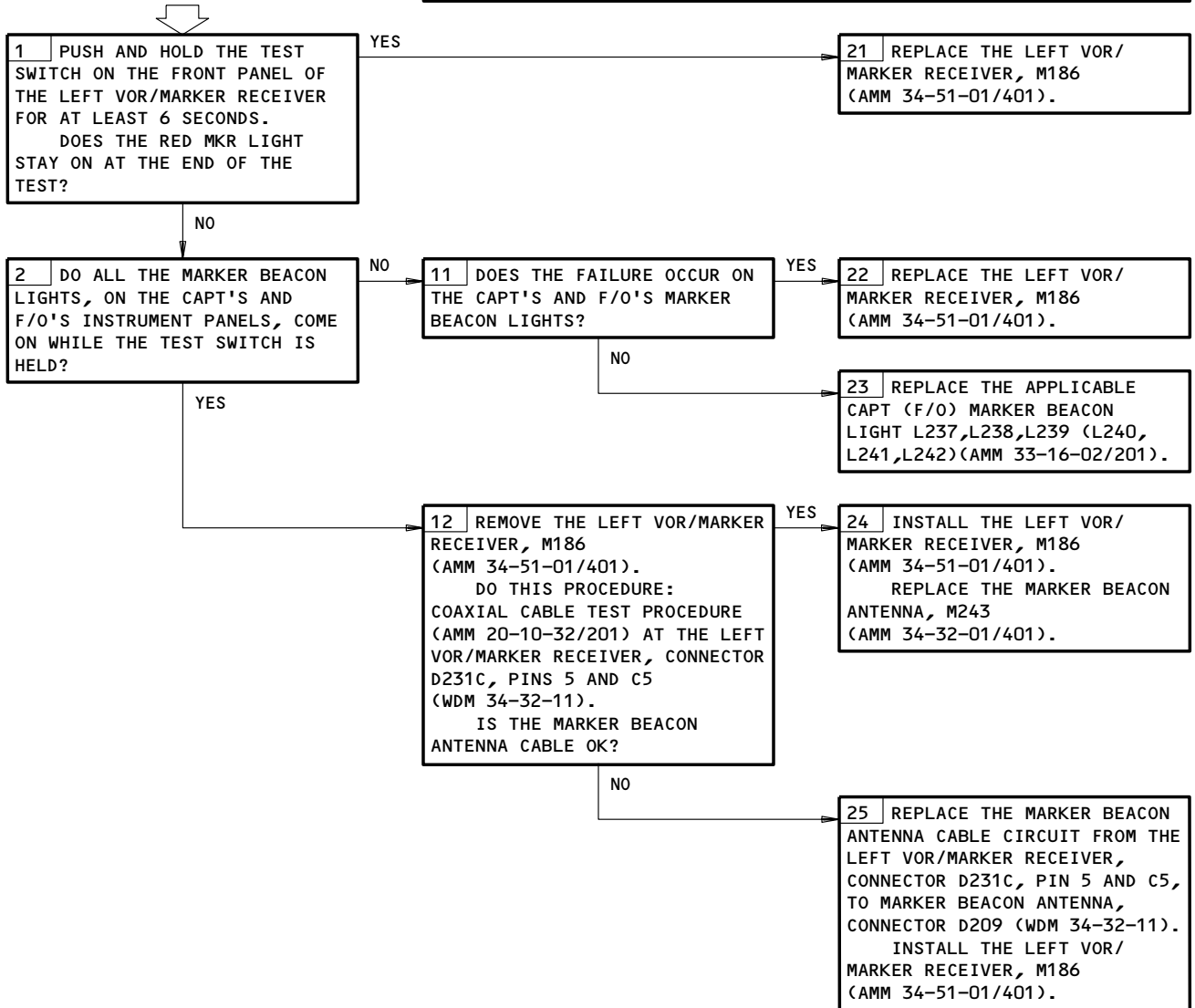

Marker Beacon Lights Problem
Figure 103 (Sheet 2)

EFFECTIVITY
AIRPLANES WITH RVA-36A
SERIES RECEIVERS

34-32-00

BOEING
757
FAULT ISOLATION/MAINT MANUAL

RADIO ALTIMETER SYSTEM

COMPONENT	FIG. 102 SHT	QTY	ACCESS/AREA	REFERENCE
ANTENNA - RADIO ALTIMETER RECEIVER, M253, M255, M257	--	3	BOTTOM FORWARD FUSELAGE	34-33-02
ANTENNA - RADIO ALTIMETER TRANSMITTER, M252, M254, M256	--	3	BOTTOM FORWARD FUSELAGE	34-33-02
CIRCUIT BREAKERS -			FLT COMPT, P11	
RAD ALTM CENTER, C602		1	11F20	*
RAD ALTM LEFT, C600		1	11F5	*
RAD ALTM RIGHT, C601		1	11F26	*
INDICATOR - (REF 34-22-00, FIG. 101)				
LEFT ELEX ATTITUDE DIRECTION, N4				
RIGHT ELEX ATTITUDE DIRECTION, N44				
PANEL - (REF 34-22-00, FIG. 101)				
LEFT EFIS CONTROL, M94				
RIGHT EFIS CONTROL, M93				
RELAY - (REF 31-01-36, FIG. 101)				
SYS NO. 1 AIR/GND, K167				
SYS NO. 2 AIR/GND, K143				
SYS NO. 2 AIR/GND, K214				
SYMBOL GENERATOR - (REF 34-22-00, FIG. 101)				
CENTER EFIS, M149				
LEFT EFIS, M148				
RIGHT EFIS, M150				
TRANSMITTER/RECEIVER - CENTER RAD ALTM, M204	--	1	821, FWD CARGO COMPARTMENT E5 RACK ACCESS PANEL, E5-3	34-33-02
TRANSMITTER/RECEIVER - LEFT RAD ALTM, M202	--	1	821, FWD CARGO COMPARTMENT E5 RACK ACCESS PANEL, E5-1	34-33-02
TRANSMITTER/RECEIVER - RIGHT RAD ALTM, M203	--	1	821, FWD CARGO COMPARTMENT E5 RACK ACCESS PANEL, E5-2	34-33-02

* SEE THE WDM EQUIPMENT LIST

Radio Altimeter System - Component Index
Figure 101

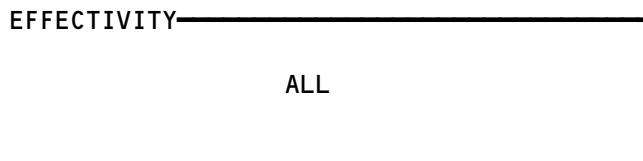

34-33-00

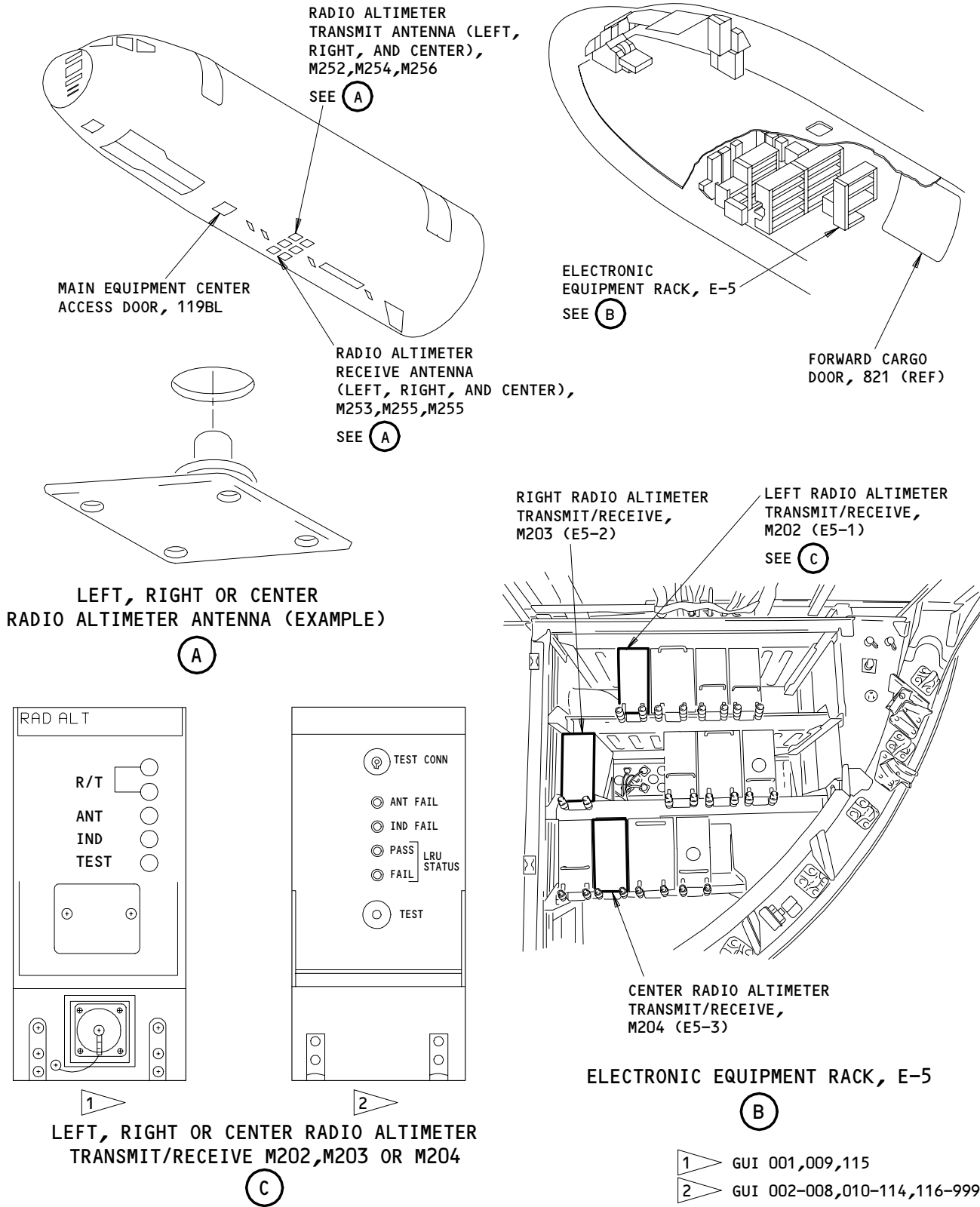

Radio Altimeter System - Component Location
Figure 102

EFFECTIVITY	
	ALL

**RADIO ALTITUDE
HEIGHT ON THE CAPT
(F/O) EADI IS
INACCURATE, INTER-
MITTENT**

PREREQUISITES

MAKE SURE THIS SYSTEM WILL OPERATE:
EFIS (AMM 34-22-00/501)

MAKE SURE THESE CIRCUIT BREAKERS ARE CLOSED:
11F5,11F20,11F26

MAKE SURE THE AIRPLANE IS IN THIS CONFIGURATION:
ELECTRICAL POWER IS ON (AMM 24-22-00/201)

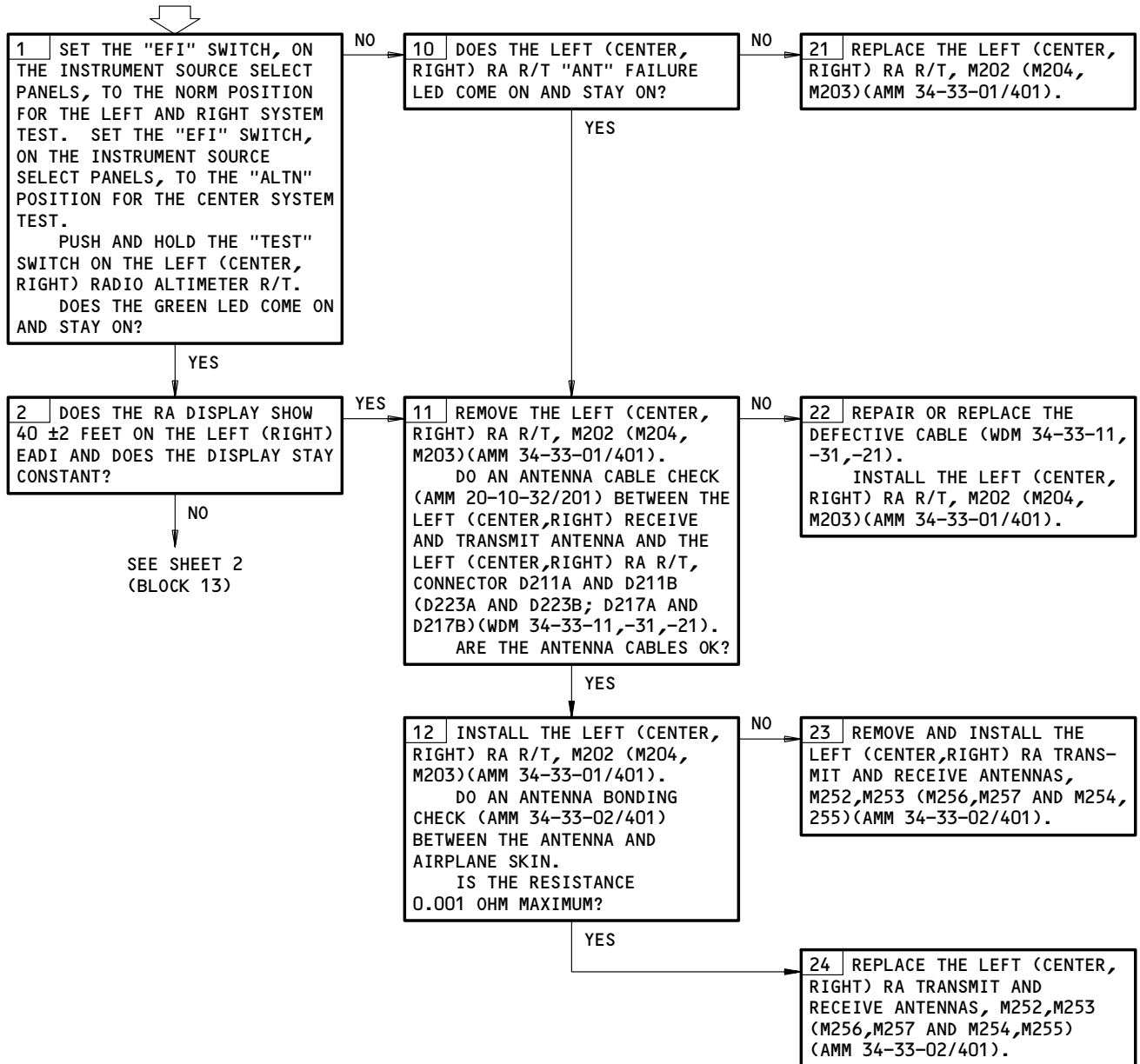

Radio Altitude Height on the Capt (F/O) EADI Is Inaccurate, Intermittent
Figure 103 (Sheet 1)

EFFECTIVITY

ALL

34-33-00

02

Page 103
Jun 20/93

BOEING
757
FAULT ISOLATION/MAINT MANUAL

FROM SHEET 1
(BLOCK 2)

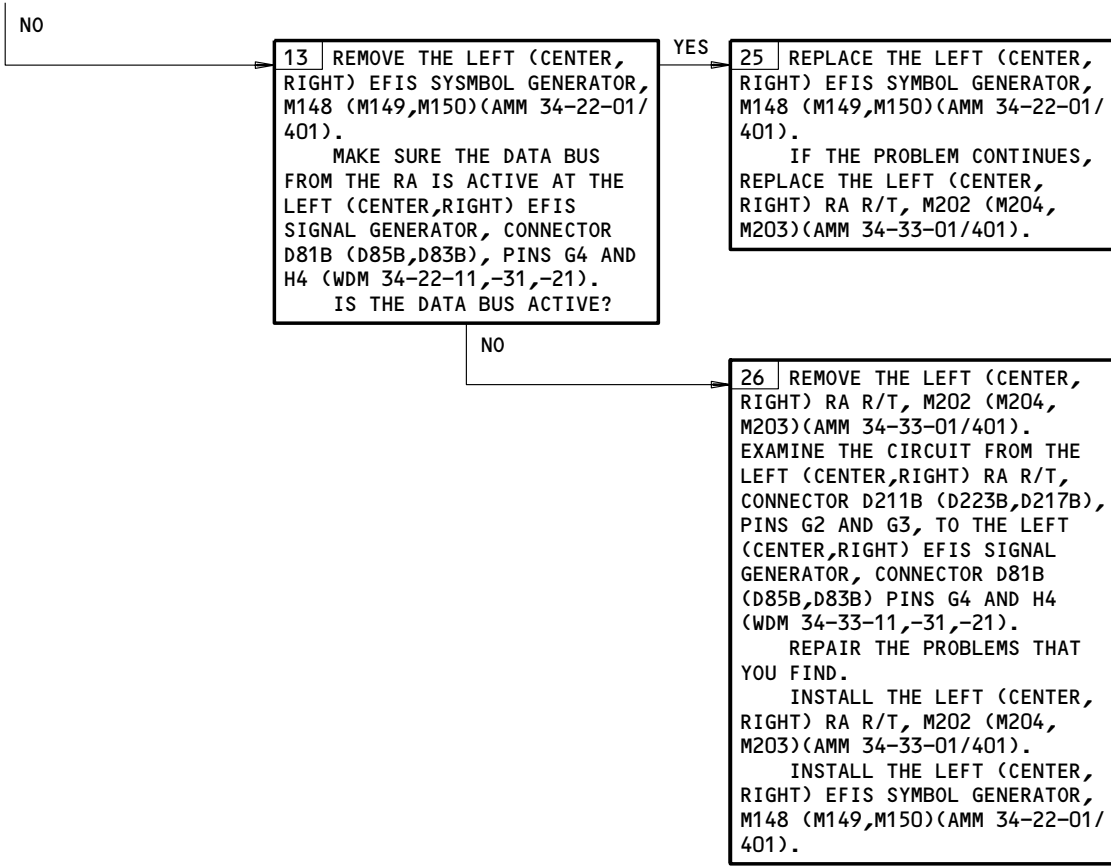

Radio Altitude Height on the Capt (F/O) EADI is Inaccurate, Intermittent
Figure 103 (Sheet 2)

EFFECTIVITY	ALL
-------------	-----

34-33-00

803355

**RA FLAG DISPLAYED
ON CAPT (F/O) EADI**

PREREQUISITES

MAKE SURE THIS SYSTEM WILL OPERATE:
EFIS (AMM 34-22-00/501)

MAKE SURE THESE CIRCUIT BREAKERS ARE CLOSED:
11F5,11F20,11F26

MAKE SURE THE AIRPLANE IS IN THIS CONFIGURATION:
ELECTRICAL POWER IS ON (AMM 24-22-00/201)

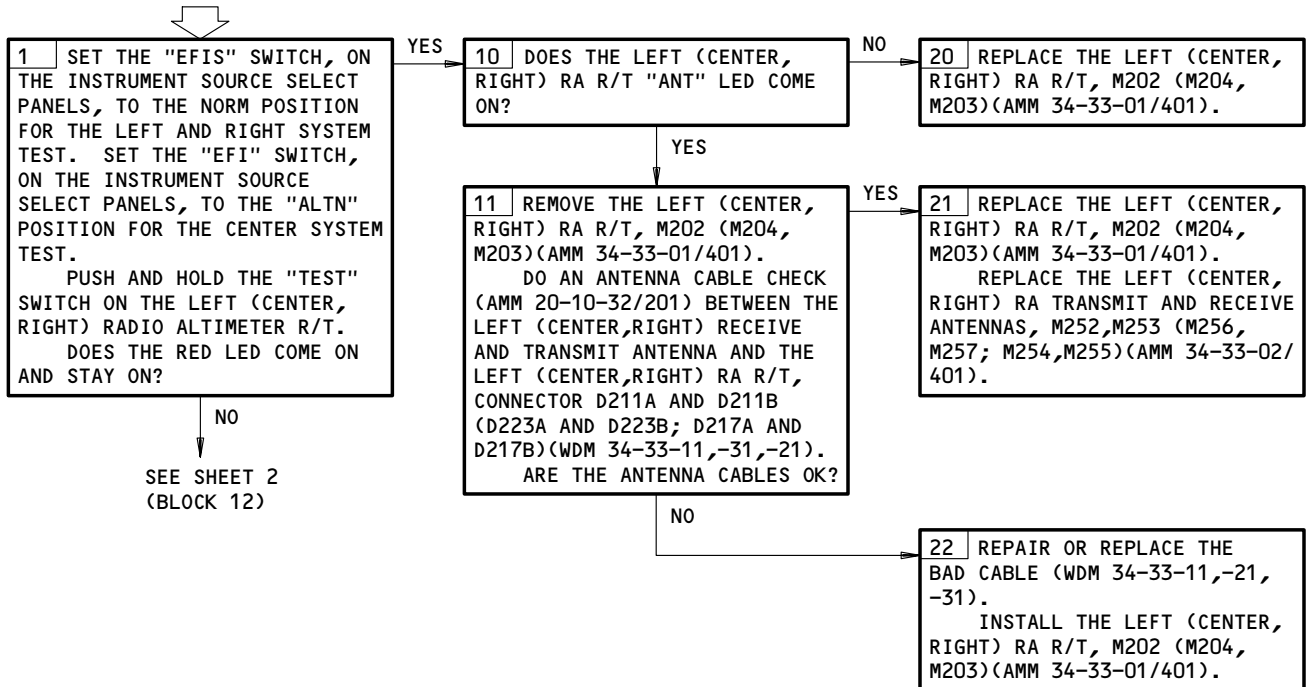

RA Flag Displayed on Capt (F/O) EADI
Figure 104 (Sheet 1)

EFFECTIVITY

ALL

34-33-00

BOEING
757
FAULT ISOLATION/MAINT MANUAL

FROM SHEET 1
(BLOCK 1)

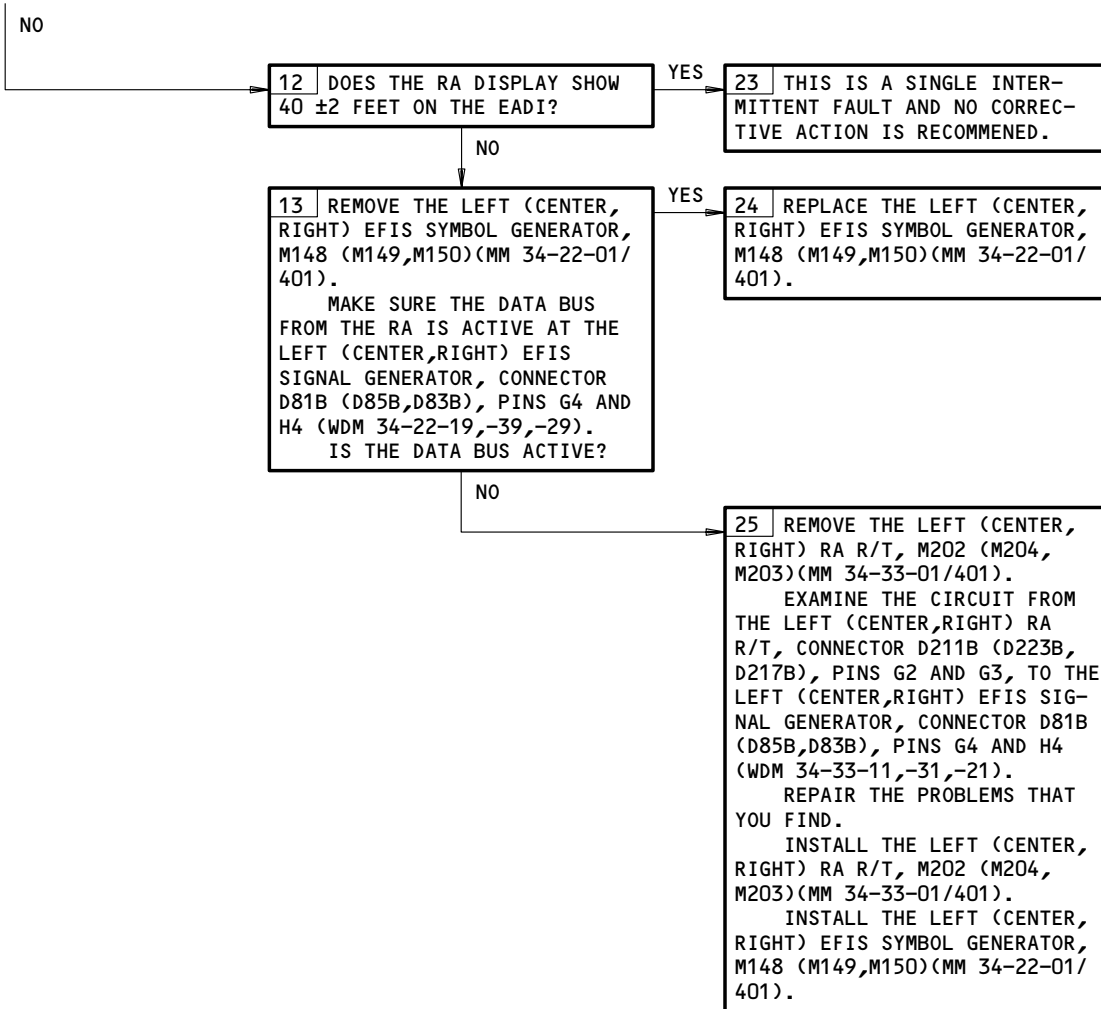

RA Flag Displayed on Capt (F/O) EADI
Figure 104 (Sheet 2)

EFFECTIVITY	ALL
-------------	-----

34-33-00

A70667

**DH FLAG DISPLAYED
ON CAPT (F/O) EADI**

PREREQUISITES

MAKE SURE THIS SYSTEM WILL OPERATE:
EFIS (MM 34-22-00/501)

MAKE SURE THESE CIRCUIT BREAKERS ARE CLOSED:
11F5,11F20,11F26

MAKE SURE THE AIRPLANE IS IN THIS CONFIGURATION:
ELECTRICAL POWER IS ON (MM 24-22-00/201)

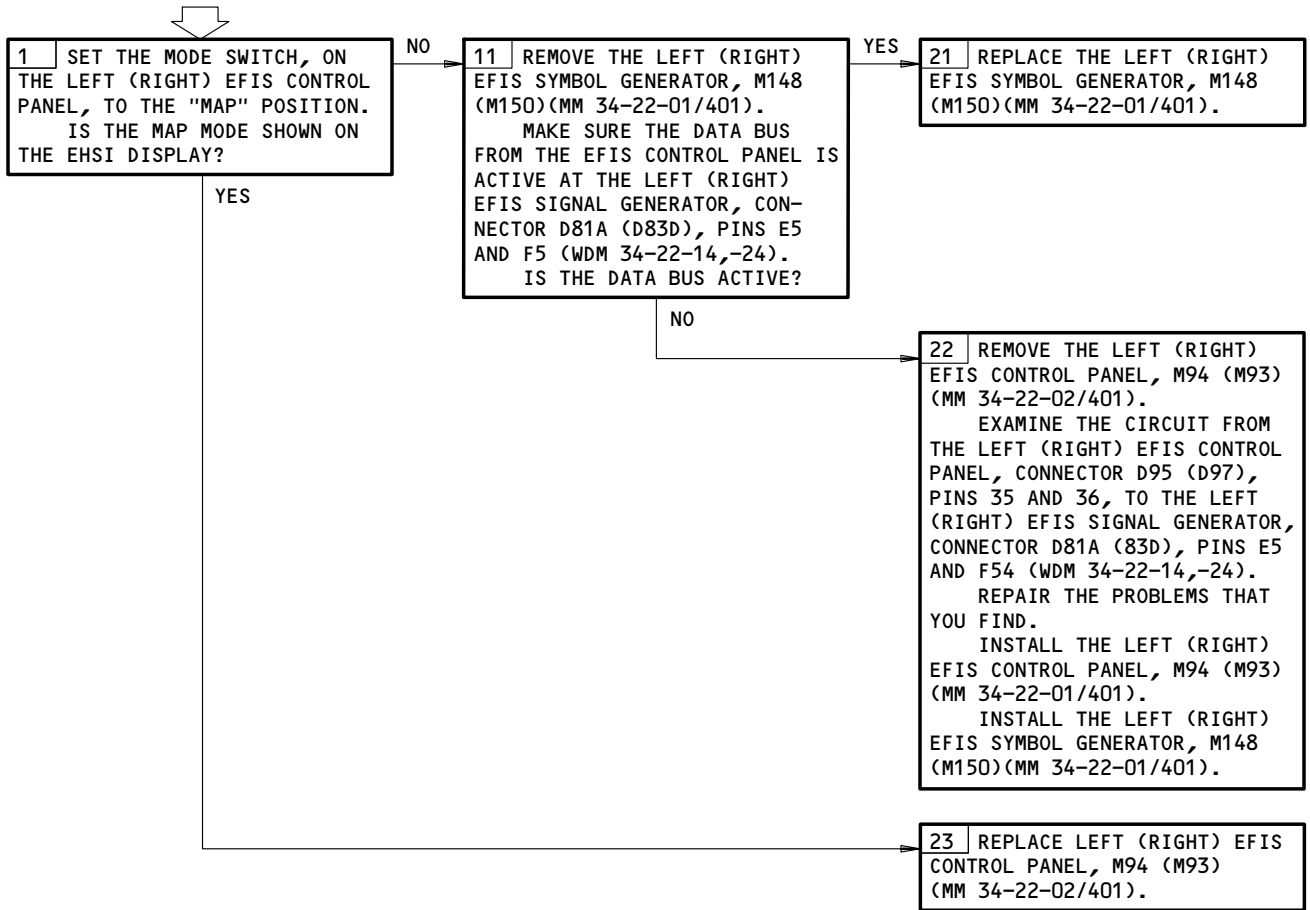

DH Flag Displayed on Capt (F/O) EADI
Figure 105

EFFECTIVITY	ALL
-------------	-----

34-33-00

PREREQUISITES

MAKE SURE THIS SYSTEM WILL OPERATE:
EFIS (AMM 34-22-00/501)

MAKE SURE THESE CIRCUIT BREAKERS ARE CLOSED:
11F5,11F20,11F26

MAKE SURE THE AIRPLANE IS IN THIS CONFIGURATION:
ELECTRICAL POWER IS ON (AMM 24-22-00/201)

RA BITE PROCEDURE

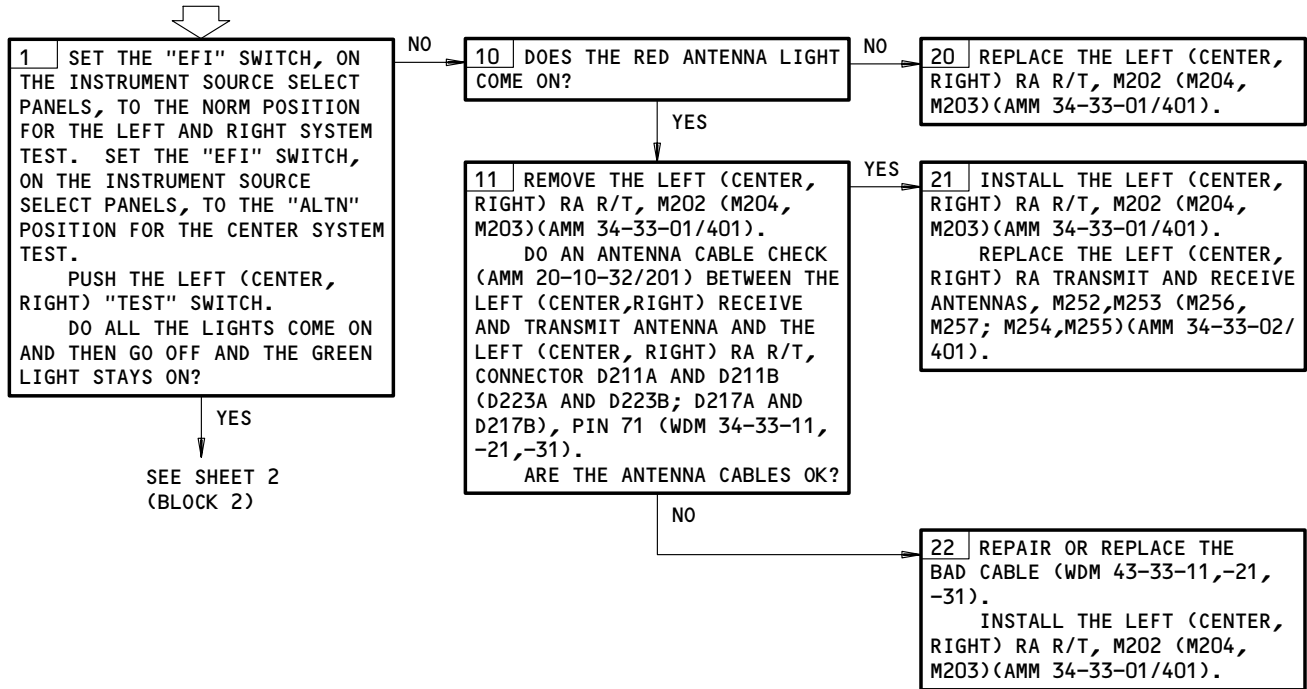

RA BITE Procedure
Figure 105A (Sheet 1)

EFFECTIVITY	ALL
-------------	-----

34-33-00

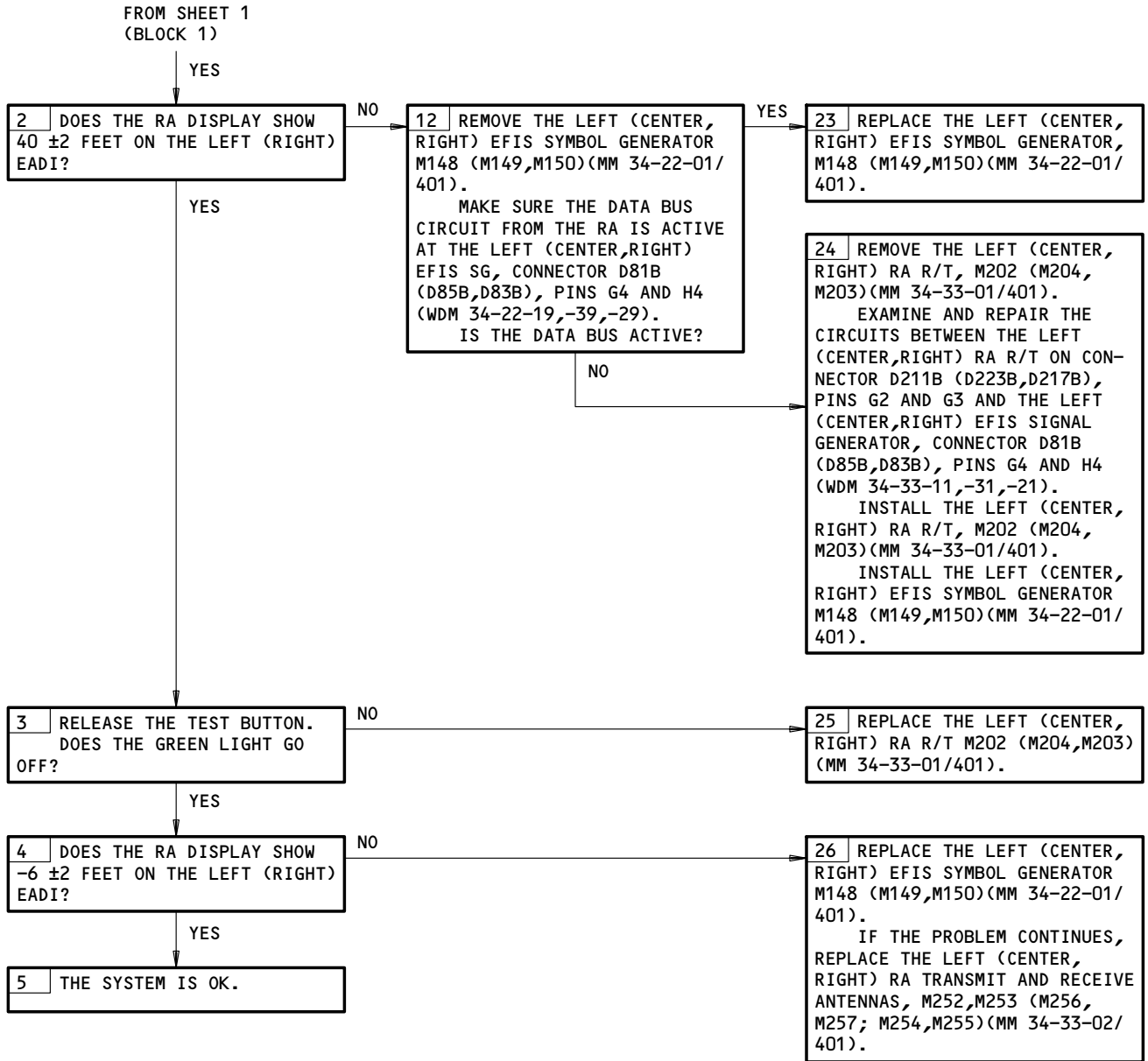

RA BITE Procedure
Figure 105A (Sheet 2)

EFFECTIVITY

ALL

34-33-00

04

Page 109
Sep 20/92

BOEING
 757
 FAULT ISOLATION/MAINT MANUAL

1. ARINC Data Bus Charts

A. General

CAUTION: DO NOT DIRECTLY TOUCH THE CONNECTORS. USE A BREAKOUT BOX OR YOU CAN CAUSE DAMAGE TO THE CONNECTORS.

- (1) The ARINC 429 data bus charts give data necessary to make an analysis of ARINC 429 transmitters, receivers, and data buses. For the test, use a breakout box at the available terminal or at the LRU connectors.

B. Equipment

- (1) Standard multi-meter
- (2) 429EBP Data Bus Analyzer (recommended)
 JcAIR Instrumentation
 400 Industrial Parkway
 Industrial Airport, KS 66031
- 429-2 Data Bus Analyzer (alternative)
 Interface Technology
 150 E. Arrow Highway
 San Dimas, CA 91773
- (3) A34011-1 Breakout Box (recommended)
 A34011-112 Breakout Box (alternative)

RA								
DIGITAL OUTPUT BUS CHART								
BUS NAME			CON	PINS	BUS FORMAT	BIT RATE	DATA	
SOURCE	TYPE	BUS					BUS	
RA	(L C R)	A	1	B	B02 B03	429	L0	ALTITUDE #1
RA	(L C R)	A	2	B	G02 G03	429	L0	ALTITUDE #2

EFFECTIVITY

ALL

34-33-00

08

Page 110
 Sep 20/96

BOEING
 757
 FAULT ISOLATION/MAINT MANUAL

RA ID=07								
OCTAL LABELS CHART								
SIGNAL	TYPE	LABEL	FORMAT	MIN UPDATE RATE	SDI	BINARY RANGE	POSITIVE SENSE	UNITS
RADIO HEIGHT	A	164	BNR	20	XX	+−8192	ABOVE TOUCHDN	FEET
RADIO HEIGHT-D	A	165	BCD	5	XX	+−7999.9	ABOVE TOUCHDN	FEET

RA				
DISCRETE OCTAL LABELS/BIT CHART				
SIGNAL	OCTAL LABEL	BIT	ONE-STATE	ZERO-STATE
TEST INHIBITED	164	11	INHIBIT	NOT INHIBIT

EFFECTIVITY

ALL

34-33-00



BOEING
 757
 FAULT ISOLATION/MAINT MANUAL

WEATHER RADAR SYSTEM

COMPONENT	FIG. 102 SHT	QTY	ACCESS/AREA	AMM REFERENCE
ANTENNA - WEATHER RADAR, M269	2	1	111AL, NOSE RADOME	34-43-05
ASSEMBLY - WAVEGUIDE	2	1	113AL, FWD BULKHEAD	34-43-04
CIRCUIT BREAKER - WX RADAR, C615	1	1	FLT COMPT, P11	*
PANEL - WEATHER RADAR CONTROL, M75	1	1	11F2	34-43-02
PANEL - (FIM 34-22-00/101) LEFT EFIS CONT PNL, M94			FLT COMPT, P8	
RIGHT EFIS CONT PNL, M93				
SWITCH - (FIM 34-22-00/101) LEFT IRS, P1				
TRANSCEIVER - WEATHER RADAR, M213	2	1	113AL, FWD EQUIP CTR	34-43-01

* SEE THE WDM EQUIPMENT LIST

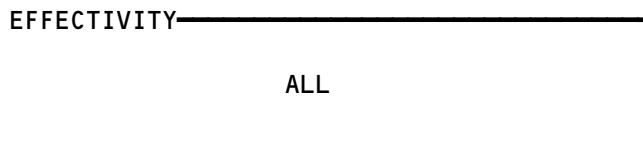
Weather Radar System - Component Index
Figure 101



34-43-00

01

Page 101
Jan 20/99

E45912

NOSE RADOME,
111AL

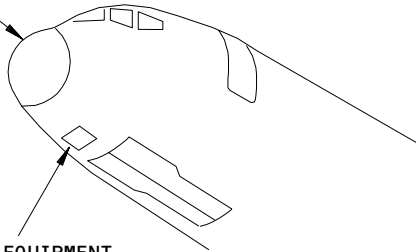

FORWARD EQUIPMENT
CENTER ACCESS
DOOR, 113AL

P11 PANEL

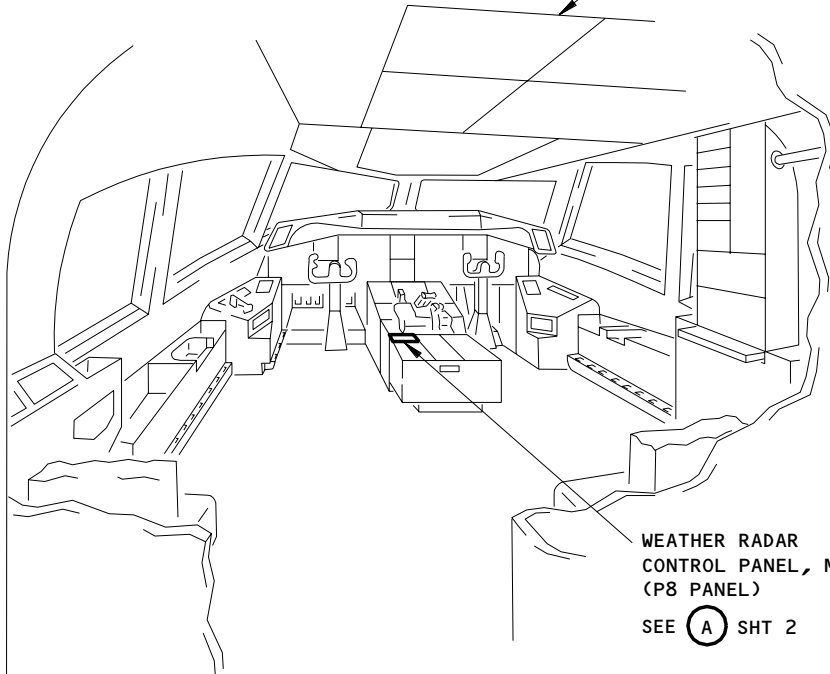

WEATHER RADAR
CONTROL PANEL, M75
(P8 PANEL)

SEE (A) SHT 2

FLIGHT COMPARTMENT

Weather Radar System - Component Location
Figure 102 (Sheet 1)

EFFECTIVITY

ALL

34-43-00

01

Page 102
Dec 20/96

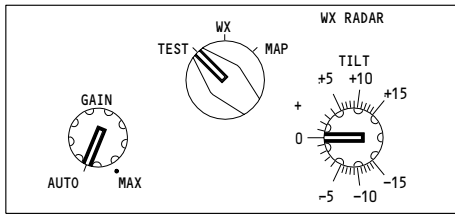

WEATHER RADAR CONTROL PANEL, M75 1

(A) FROM SHT 1

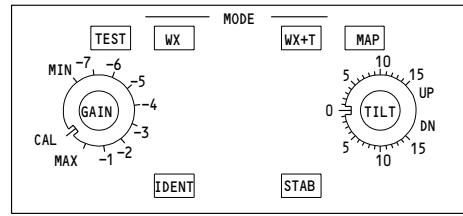

WEATHER RADAR CONTROL PANEL, M75 2

(A) FROM SHT 1

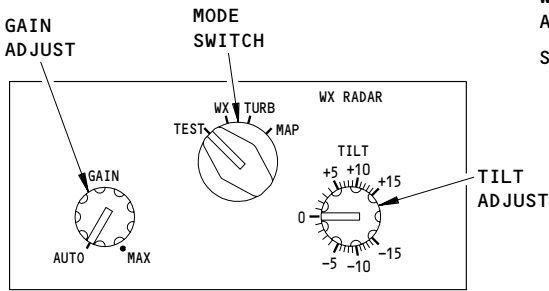

WEATHER RADAR CONTROL PANEL, M75 3

(A) FROM SHT 1

WEATHER RADAR ANTENNA, M269
SEE (B)

FORWARD EQUIPMENT CENTER ACCESS DOOR, 113AL

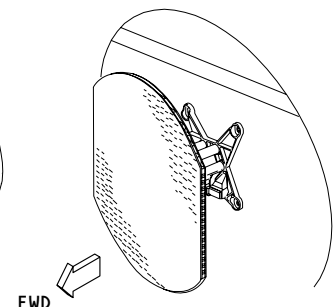
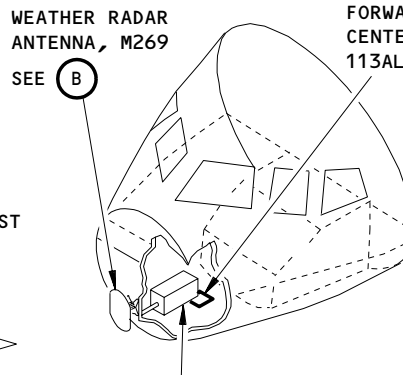

WEATHER RADAR TRANSCEIVER, M213
SEE (C)

WEATHER RADAR ANTENNA, M269

(B) 1 3

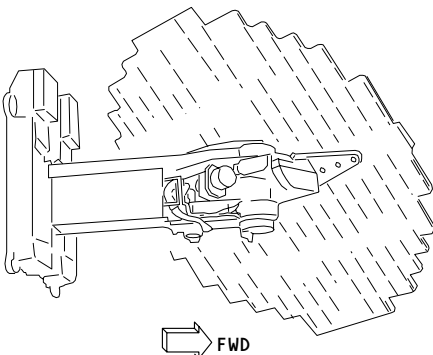

WEATHER RADAR ANTENNA, M269

(B) 2

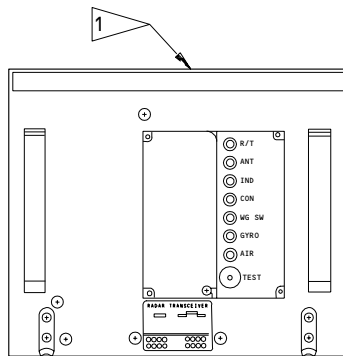

WEATHER RADAR TRANSCEIVER, M213

(C)

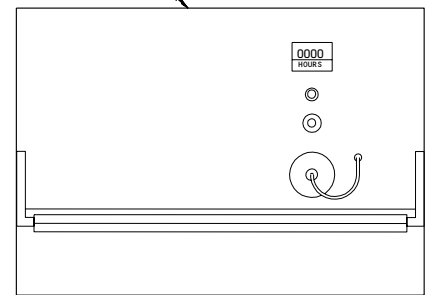

- 1 GUI 001, 009, 115 PRE-SB 34-0394
- 2 GUI 002-008, 010-114, 116-999
- 3 GUI 115 POST-SB 34-0394

Weather Radar System - Component Location
Figure 102 (Sheet 2)

EFFECTIVITY

ALL

34-43-00

PREREQUISITES

MAKE SURE THESE SYSTEMS WILL OPERATE:

- IRS (MM 34-21-00/501)
- EFIS (MM 34-22-00/501)
- WXR (MM 34-43-00/501)
- FMCS (MM 34-61-00/501)

MAKE SURE THIS CIRCUIT BREAKER IS CLOSED:
11F2

MAKE SURE THE AIRPLANE IS IN THIS CONFIGURATION:
ELECTRICAL POWER IS ON (MM 24-22-00/201)

WARNING: WHEN YOU DO THE BITE TEST, MAKE SURE YOU SET THE WXR CONTROL PANEL TO A NON-RADIATING TEST MODE OR OBEY THE PRECAUTIONS FOR WXR OPERATION IN A RADIATING MODE. IF YOU DO NOT DO ONE OF THESE ALTERNATIVES, INJURY TO PERSONS CAN OCCUR.

WXR BITE PROCEDURE

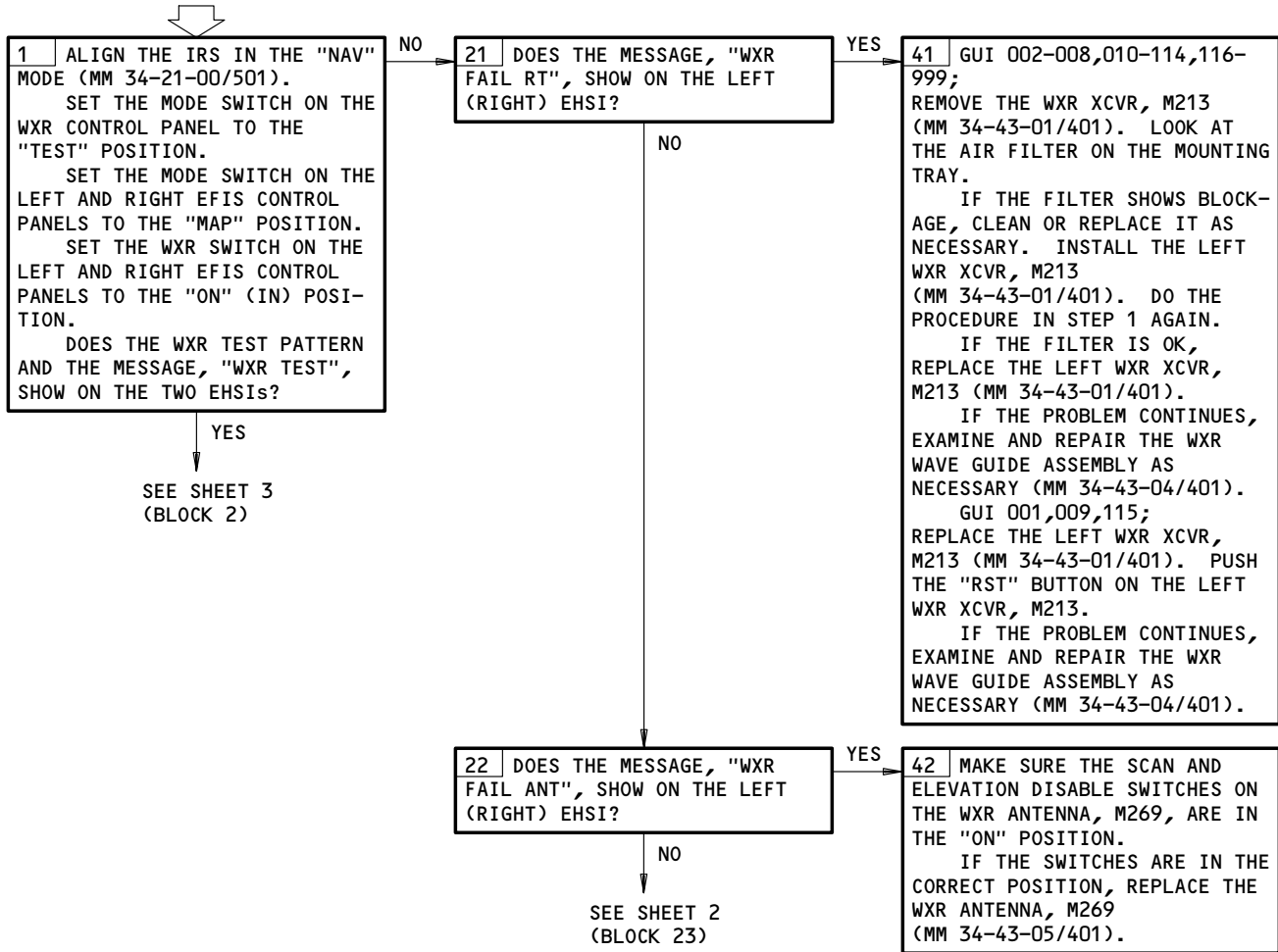

WXR BITE Procedure
Figure 103 (Sheet 1)

EFFECTIVITY

ALL

34-43-00

BOEING
757
FAULT ISOLATION/MAINT MANUAL

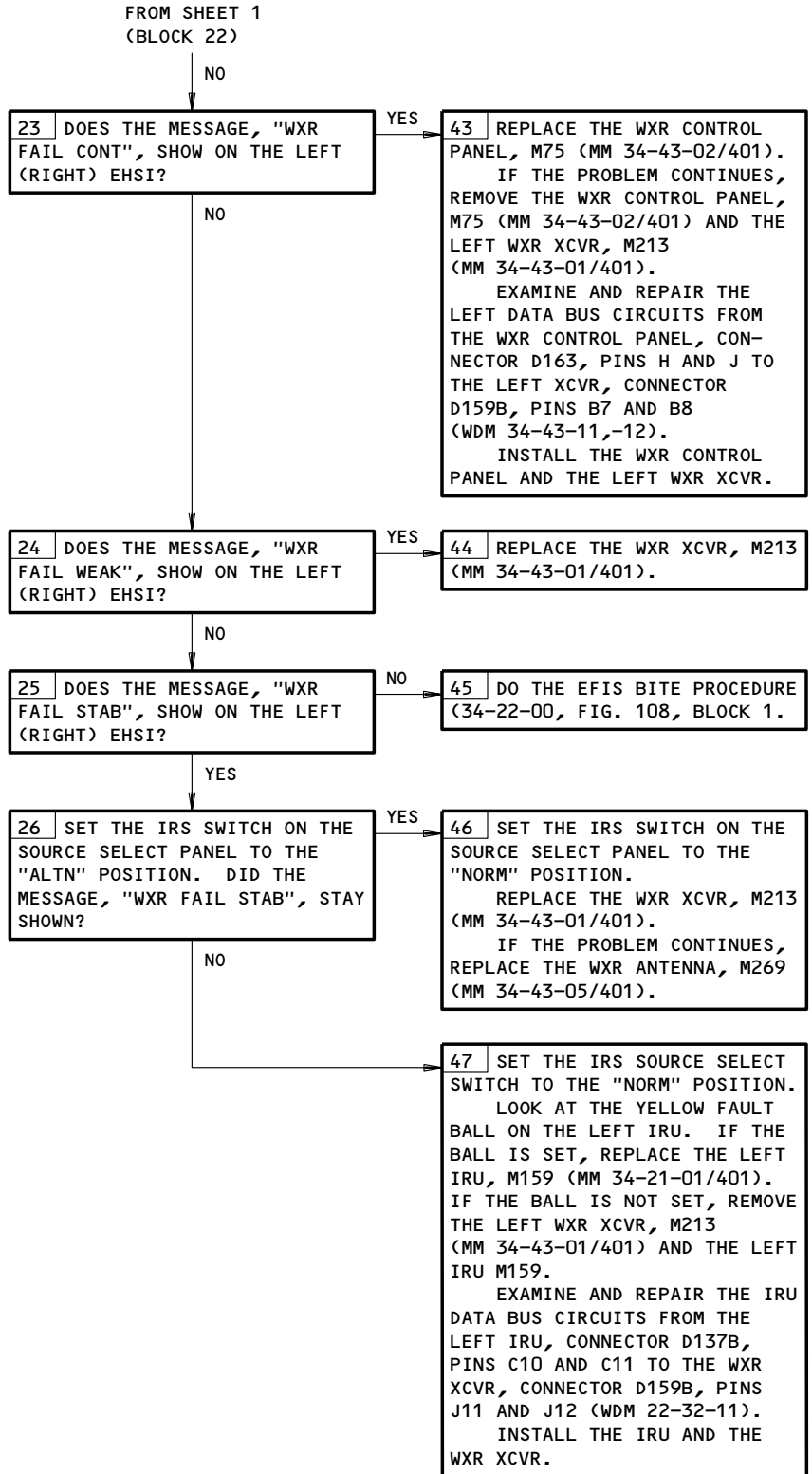

WXR BITE Procedure
Figure 103 (Sheet 2)

EFFECTIVITY	ALL
-------------	-----

34-43-00

BOEING
757
FAULT ISOLATION/MAINT MANUAL

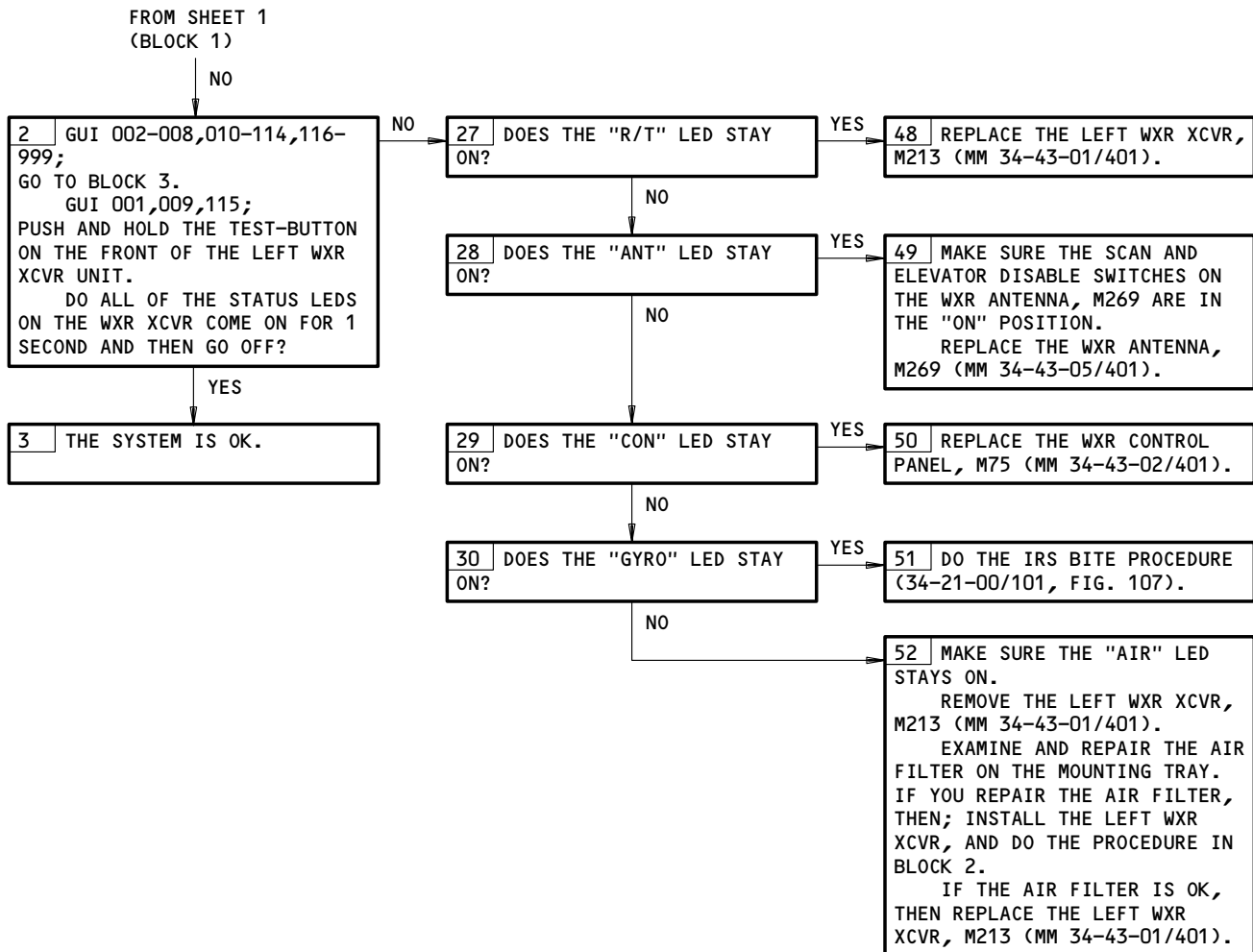

WXR BITE Procedure
Figure 103 (Sheet 3)

EFFECTIVITY

ALL

34-43-00

PREREQUISITES

MAKE SURE THESE SYSTEMS WILL OPERATE:

- IRS (AMM 34-21-00/501)
- EFIS (AMM 34-22-00/501)
- WXR (AMM 34-43-00/501)
- FMCS (AMM 34-61-00/501)

MAKE SURE THIS CIRCUIT BREAKER IS CLOSED:
11F2

MAKE SURE THE AIRPLANE IS IN THIS CONFIGURATION:
ELECTRICAL POWER IS ON (AMM 24-22-00/201)

WARNING: DO NOT OPERATE WEATHER RADAR WHILE FUEL IS PUT IN OR REMOVED FROM THE AIRPLANE. DO NOT OPERATE IN THE RADIATING MODE WHILE FUEL IS BEING HANDLED WITHIN 200 FEET OF THE ANTENNA. INCORRECT USE OF THIS SYSTEM CAN CAUSE INJURY TO PERSONS.

WARNING: WHEN THE WEATHER RADAR IS ON, YOU MUST BE AT LEAST 5 FEET IN FRONT OF THE SCANNING RADIATING ANTENNA. YOU MUST NOT BE OPEN TO THE WEATHER RADAR RADIATION. THE SYSTEMS MAXIMUM POWER OUTPUT IS 125 WATTS AT A FREQUENCY OF 9.345 GHz, IF YOU DO NOT DO THESE ALTERNATIVES INJURY TO PERSONS CAN OCCUR.

CAUTION: WHEN YOU OPERATE THE WEATHER RADAR IN THE RADIATING MODE, POINT THE NOSE OF THE AIRPLANE SO THAT THE FORWARD 180-DEGREE AREA IS FREE OF LARGE METALLIC OBJECTS (HANGERS, TRUCKS, OTHER AIRPLANES) FOR A DISTANCE OF 300 FT. IF YOU DO NOT TAKE THESE PRECAUTIONS, DAMAGE TO THE TRANSCEIVER CAN OCCUR.

WXR Range Disagree Problems
Figure 103A (Sheet 1)

EFFECTIVITY	ALL
-------------	-----

34-43-00

WXR RANGE DISAGREE PROBLEMS

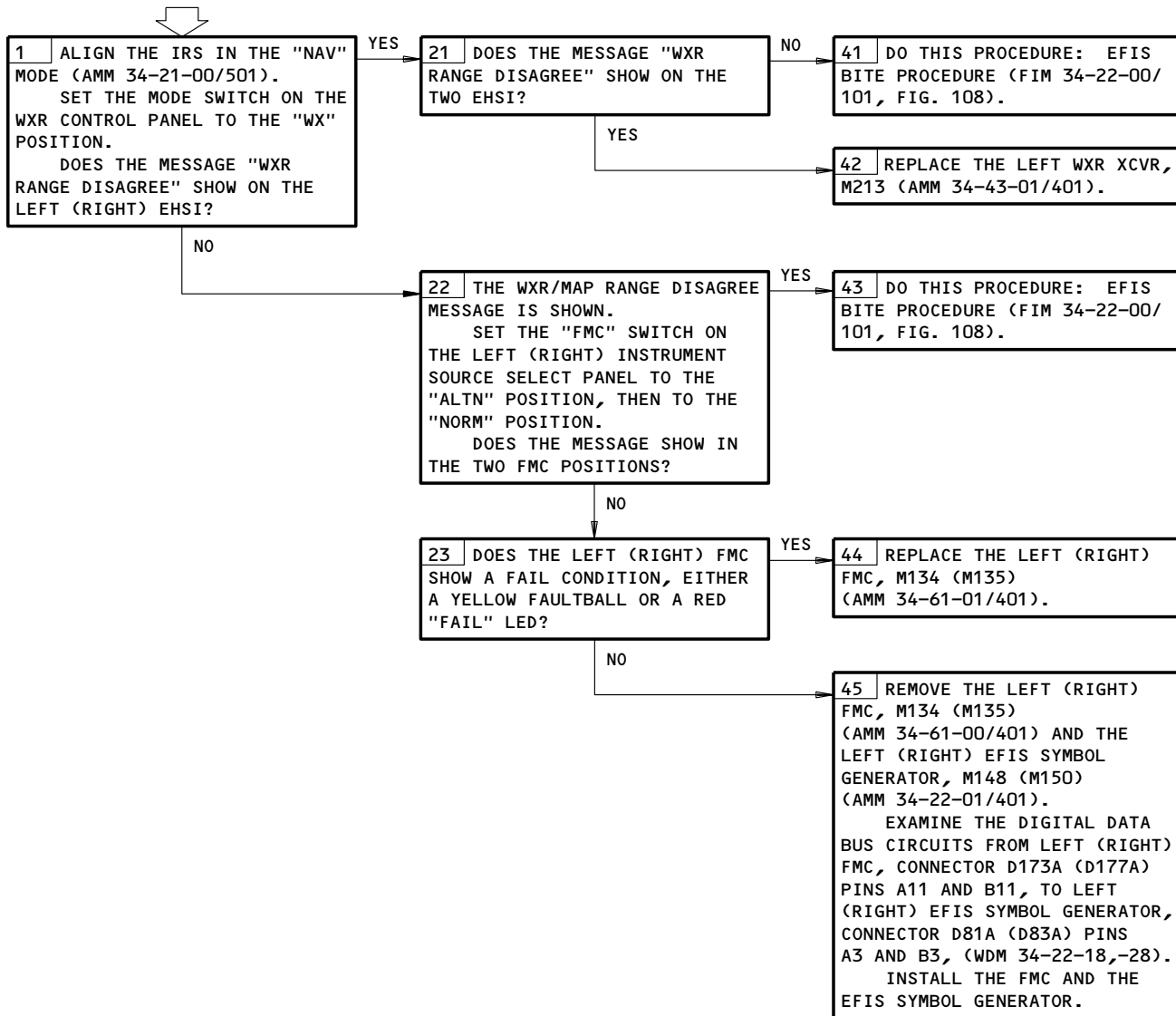

WXR Range Disagree Problems
Figure 103A (Sheet 2)

EFFECTIVITY

ALL

34-43-00

01

Page 108
Sep 20/94

1. Visual Check

A. Procedure

- (1) Do a visual check of the weather radar LRUs below and make sure that the LRUs have no damage or missing hardware and that the mount screws are tight.
 - (a) R/T mount
 - (b) Antenna drive assembly
 - (c) Antenna planar array
 - (d) Antenna
 - (e) Control Panel
- (2) Make sure the R/T hold-down screws are tight.
- (3) Make sure the system electrical connectors are connected correctly.
- (4) Make sure the waveguide connection to the antenna drive assembly is attached correctly.
- (5) Make sure there are no dirt or foreign objects in the waveguide drain hole.

NOTE: The drain hole may be checked when there is a suspected problem with R/T sensitivity or the weather radar display is blank.

2. ARINC Data Bus Charts

A. General

CAUTION: DO NOT DIRECTLY TOUCH THE CONNECTORS. USE A BREAKOUT BOX OR YOU CAN CAUSE DAMAGE TO THE CONNECTORS.

- (1) The ARINC 429 data bus charts give data necessary to make an analysis of ARINC 429 transmitters, receivers, and data buses. For the test, use a breakout box at the available terminal or at the LRU connectors.

B. Equipment

- (1) Standard multi-meter
- (2) 429EBP Data Bus Analyzer (recommended)
JcAIR Instrumentation
400 Industrial Parkway
Industrial Airport, KS 66031

429-2 Data Bus Analyzer (alternative)
Interface Technology
150 E. Arrow Highway
San Dimas, CA 91773
- (3) A34011-1 Breakout Box (recommended)
A34011-112 Breakout Box (alternative)

EFFECTIVITY

ALL

34-43-00

01

Page 109
Sep 28/03

BOEING
 757
 FAULT ISOLATION/MAINT MANUAL

WXR CP								
DIGITAL OUTPUT BUS CHART								
BUS NAME			CON	PINS	BUS FORMAT	BIT RATE	DATA	
SOURCE	TYPE	BUS					BUS	
WXR CP(L)	A	1	D395	UF	429	LO	OUTPUT BUS L	
SPARE	A	2	D395	HJ	429	LO	OUTPUT BUS R	
GAIN	A	270	BNR	10	00	N/A	N/A	dB
TILT	A	270	BNR	10	00	+-15	UP	DEG
STABILIZATION ON	270	13	CODED	1				
MAP	270	16-14	CODED	010				
TEST	270	16-14	CODED	100				
WEATHER	270	16-14	CODED	001				

EFFECTIVITY

ALL

34-43-00

01

Page 110
Sep 20/96

BOEING
757
FAULT ISOLATION/MAINT MANUAL

TRAFFIC ALERT AND COLLISION AVOIDANCE SYSTEM (TCAS)

COMPONENT	FIG. 102 SHT	QTY	ACCESS/AREA	AMM REFERENCE
ANTENNA - BOTTOM TCAS, M10821	1	1	BOTTOM OF FUSELAGE	34-45-02
ANTENNA - TOP TCAS, M10820	1	1	TOP OF FUSELAGE	34-45-02
CIRCUIT BREAKER - TCAS, C4443		1	FLIGHT COMPARTMENT, P11 11F3	*
COMPUTER - (FIM 31-41-00/101) EICAS LEFT, M10181 EICAS RIGHT, M10182				
COMPUTER - (FIM 34-46-00/101) GROUND PROXIMITY, M147				
COMPUTER - TCAS, M10819	2	1	119BL, MAIN EQUIP CENTER, E2-1	34-45-01
INDICATOR - (FIM 34-22-00/101) LEFT ELECTRONIC HORIZONTAL SITUATION, N5 RIGHT ELECTRONIC HORIZONTAL SITUATION, N45 LEFT VERTICAL SPEED, N9 RIGHT VERTICAL SPEED, N49				
INTERROGATOR - (FIM 34-55-00/101) LEFT DME, M123 RIGHT DME, M124				
MODULE - (FIM 31-51-00/101) LEFT SIREN/OWL (AURAL WARNING), M999 RIGHT SIREN/OWL (AURAL WARNING), M619				
MODULE - (FIM 32-30-00/101) LANDING GEAR LEVER, M937				
PANEL - ATC CONTROL, M10140	2	1	FLIGHT COMPARTMENT, P8	34-53-02
RELAY - (FIM 31-01-36/101) SYS NO. 1 AIR/GND, K143				
RELAY - (FIM 31-01-37/101) SYS NO. 2 AIR/GND, K201				
SWITCH - (FIM 34-12-00/101) LEFT ADC, S482 RIGHT ADC, S483				
SWITCH - (FIM 34-21-00/101) IRS SOURCE SELECT, S12				
TRANSPONDER - (FIM 34-53-00/101) LEFT ATC, M10141 RIGHT ATC, M10142				

* SEE THE WDM EQUIPMENT LIST

Traffic Alert and Collision Avoidance System (TCAS) - Component Index
Figure 101

EFFECTIVITY
AIRPLANES WITH COLLINS TCAS

34-45-00
CONFIG 1
Page 101
Sep 20/95

01

BOEING
 757
 FAULT ISOLATION/MAINT MANUAL

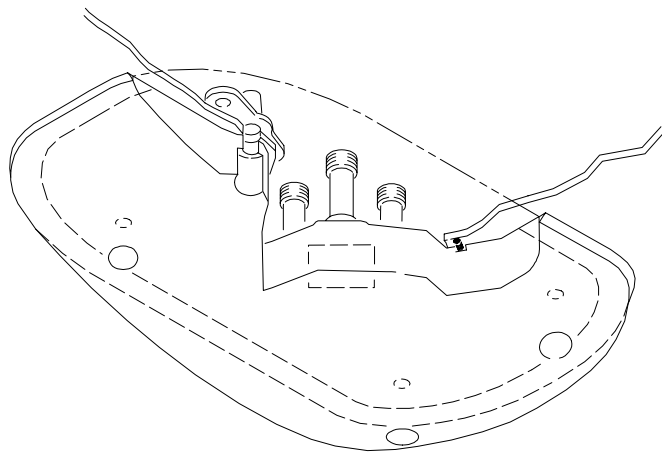
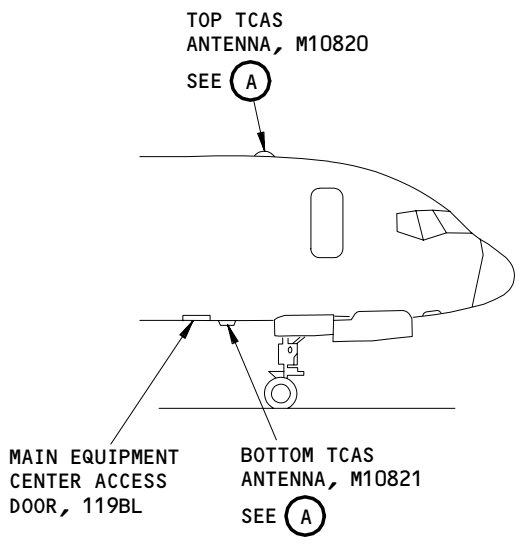

BOTTOM OR TOP TCAS ANTENNA, M10821 OR M10820
 (A)

Traffic Alert and Collision Avoidance System (TCAS) - Component Location
 Figure 102 (Sheet 1)

EFFECTIVITY
 AIRPLANES WITH COLLINS TCAS

34-45-00
 CONFIG 1
 Page 102
 Sep 20/95

01

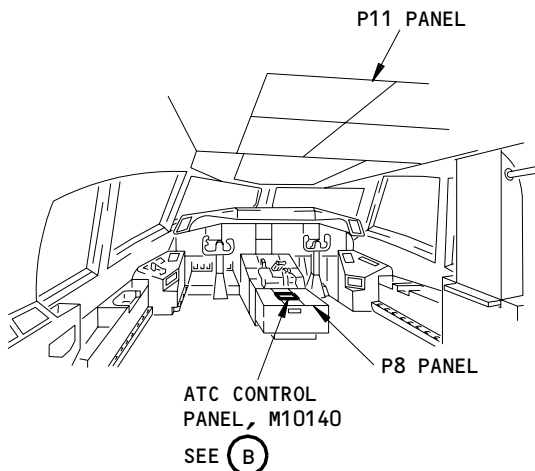

FLIGHT COMPARTMENT

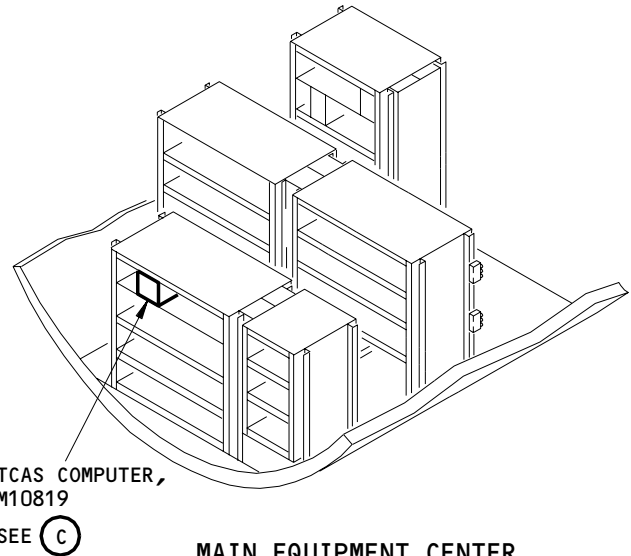

MAIN EQUIPMENT CENTER

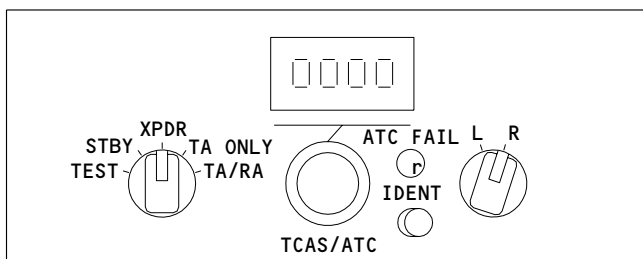

TCAS/ATC CONTROL PANEL, M10140

(B) 1

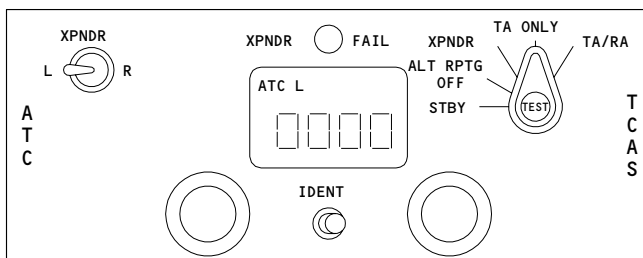

ATC CONTROL PANEL, M10140

(B) 2

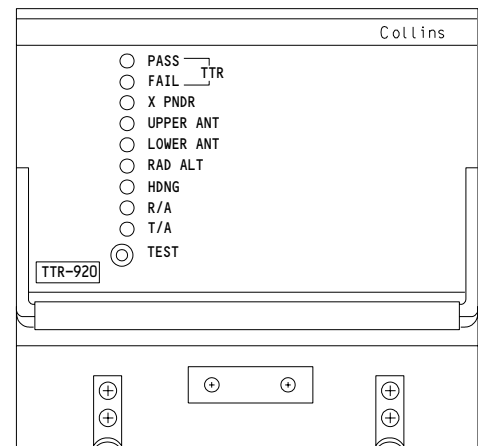

TCAS COMPUTER, M10819

(C)

- 1 ILF 224,524
- 2 ILF 523

Traffic Alert and Collision Avoidance System (TCAS) - Component Location
Figure 102 (Sheet 2)

EFFECTIVITY
AIRPLANES WITH COLLINS TCAS

34-45-00

CONFIG 1
Page 103
Jun 20/96

01

PREREQUISITES

MAKE SURE THESE SYSTEMS WILL OPERATE:

ADC SYSTEM (AMM 34-12-00/501)

ATC SYSTEM (AMM 34-53-00/501)

MAKE SURE THIS CIRCUIT BREAKER IS CLOSED:

11F3, TCAS

MAKE SURE THE AIRPLANE IS IN THIS CONFIGURATION:

ELECTRICAL POWER IS ON (AMM 24-22-00/201)

ALIGN IRS (AMM 34-21-00/201)

TCAS BITE PROCEDURE

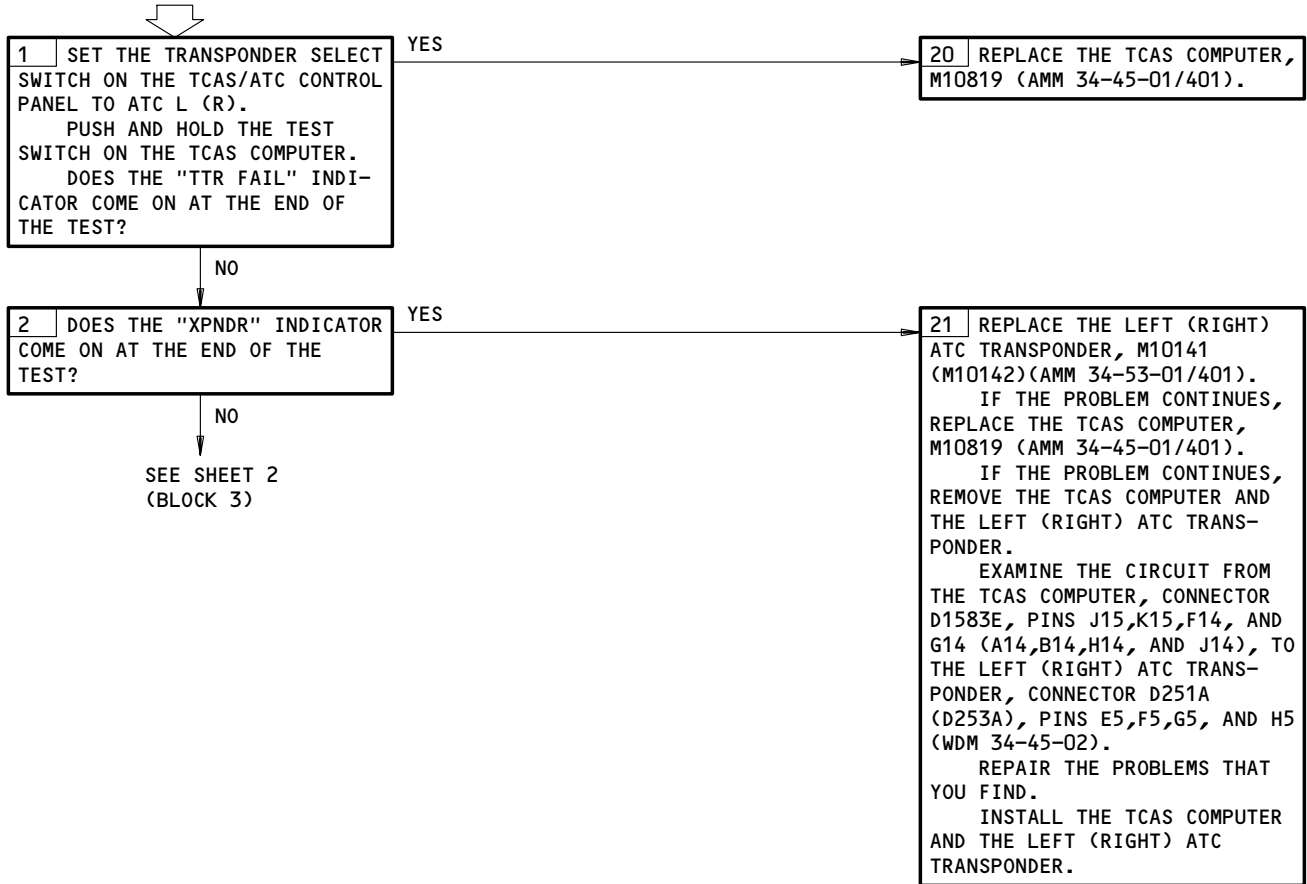

TCAS BITE Procedure
Figure 103 (Sheet 1)

EFFECTIVITY
AIRPLANES WITH COLLINS TCAS

34-45-00

CONFIG 1

Page 104

Sep 20/95

01

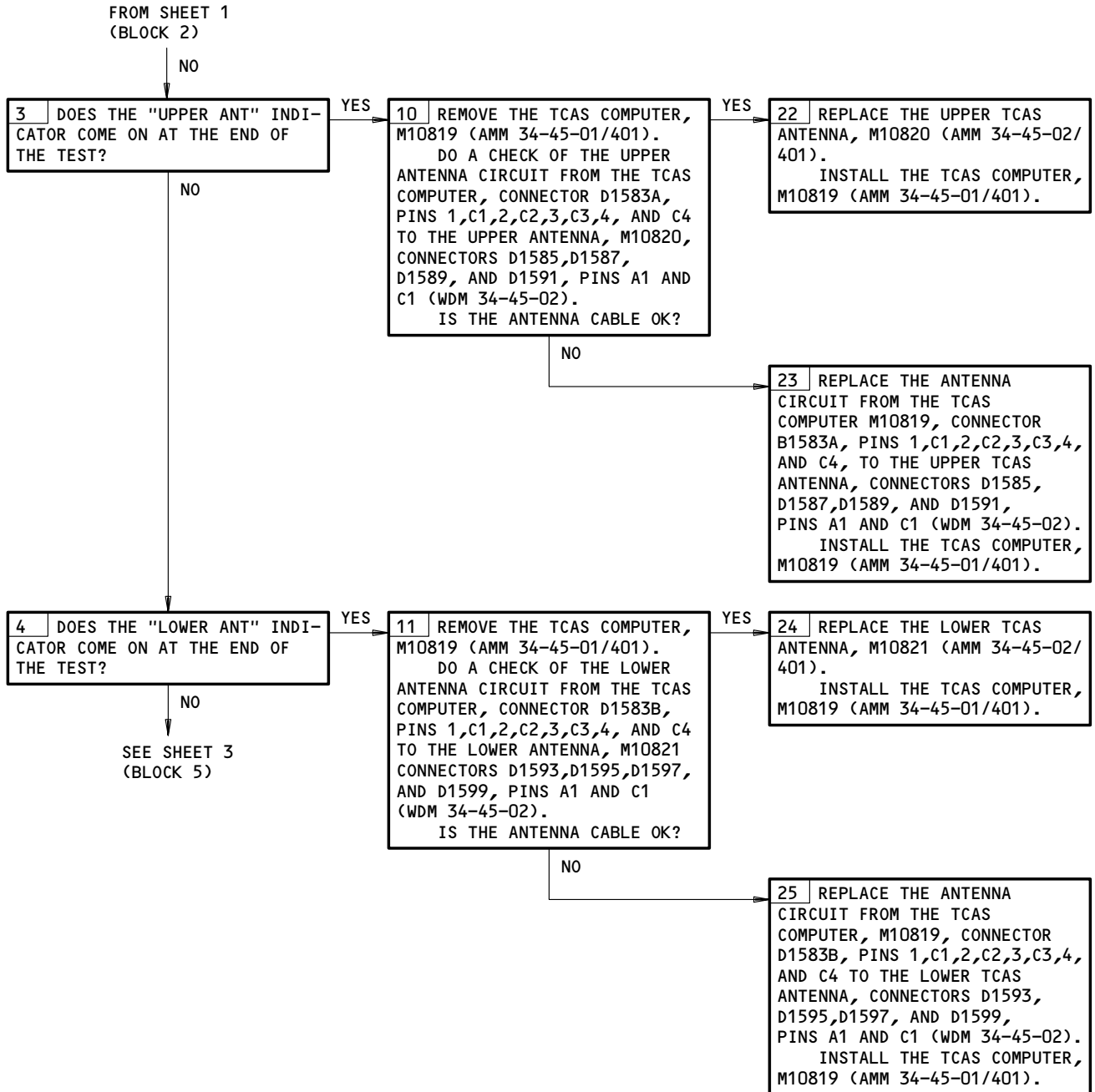

TCAS BITE Procedure
Figure 103 (Sheet 2)

EFFECTIVITY
AIRPLANES WITH COLLINS TCAS

34-45-00

CONFIG 1

01

Page 105

Sep 20/95

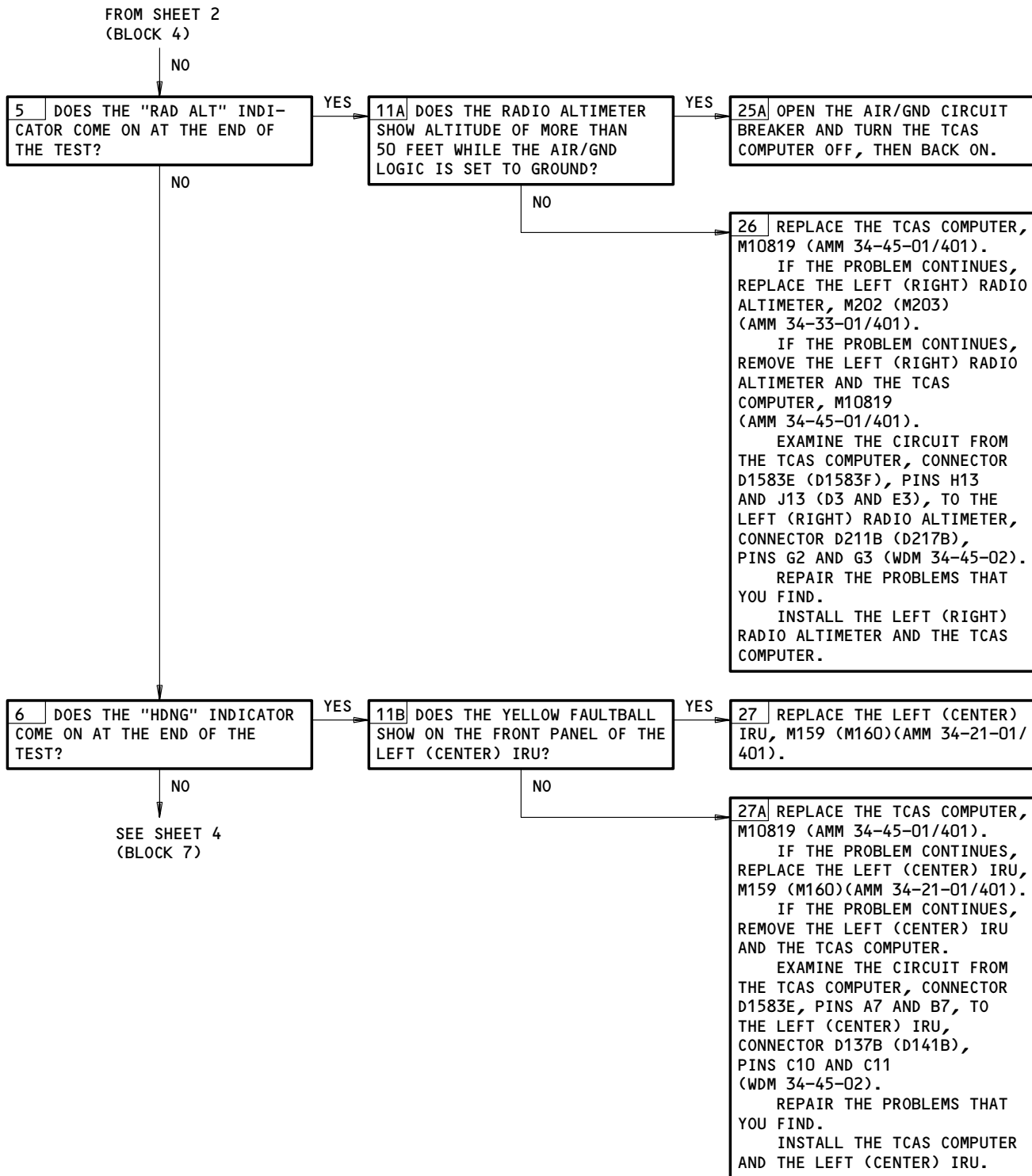

TCAS BITE Procedure
Figure 103 (Sheet 3)

EFFECTIVITY
AIRPLANES WITH COLLINS TCAS

34-45-00
CONFIG 1
Page 106
Sep 20/95

01

BOEING
 757
 FAULT ISOLATION/MAINT MANUAL

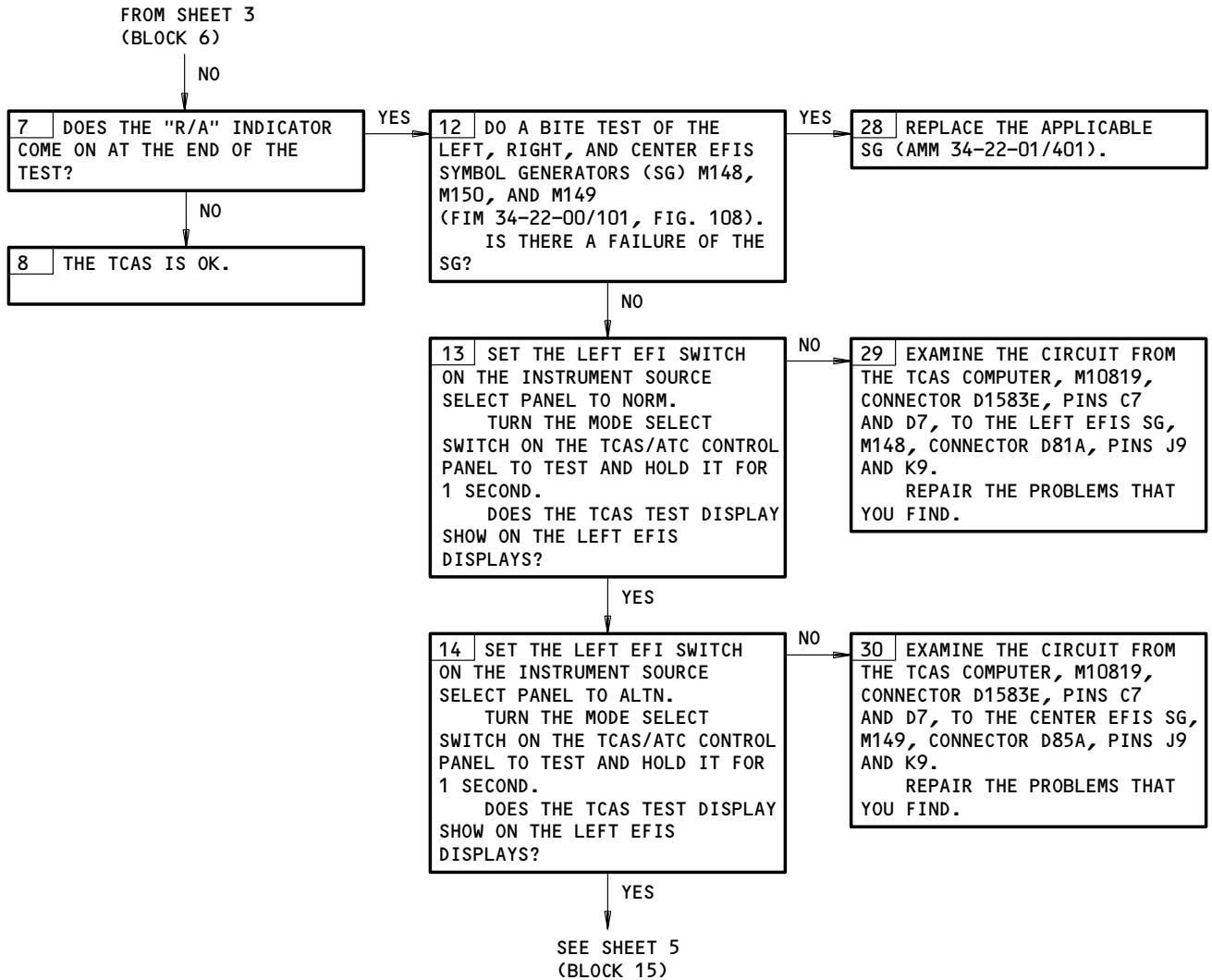

TCAS BITE Procedure
Figure 103 (Sheet 4)

EFFECTIVITY
AIRPLANES WITH COLLINS TCAS

34-45-00
 CONFIG 1
 Page 107
 Sep 20/95

01

BOEING
757
FAULT ISOLATION/MAINT MANUAL

FROM SHEET 4
(BLOCK 14)

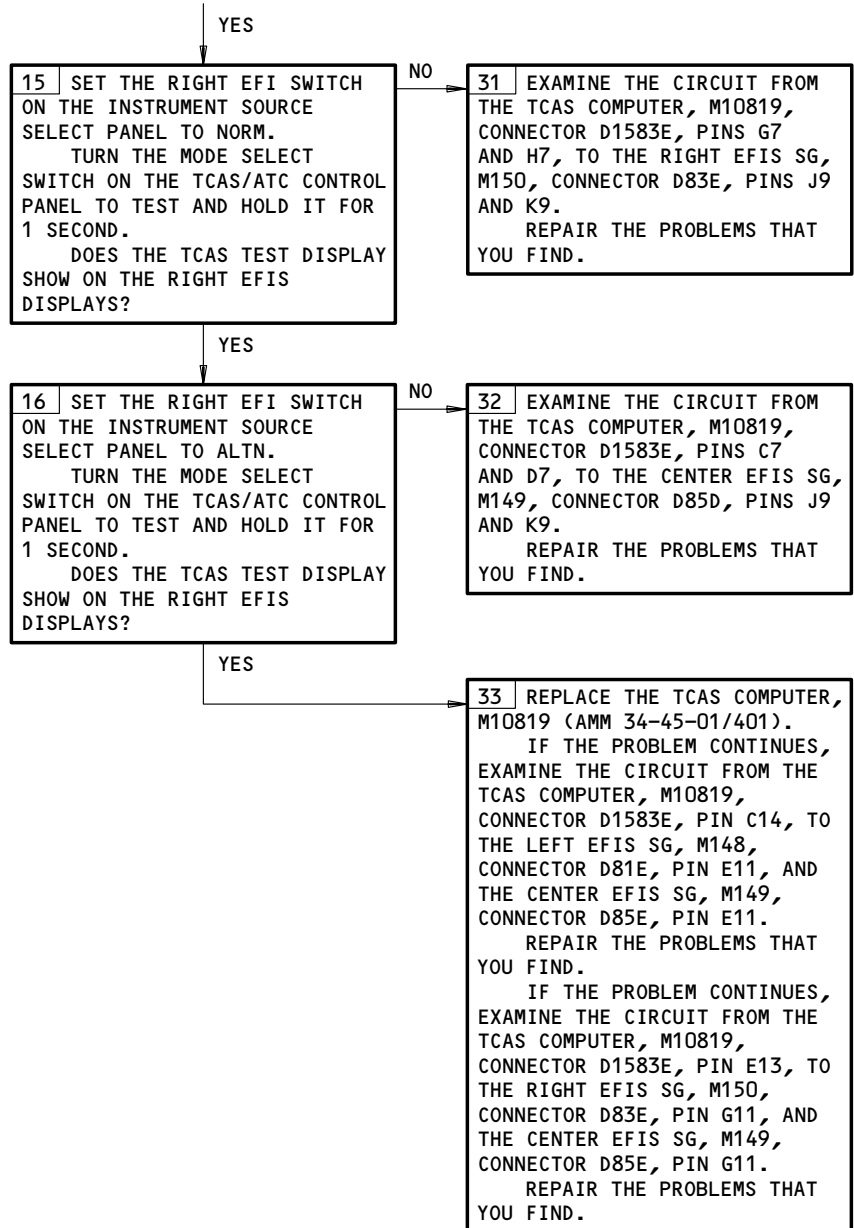

TCAS BITE Procedure
Figure 103 (Sheet 5)

EFFECTIVITY
AIRPLANES WITH COLLINS TCAS

34-45-00

CONFIG 1

01 Page 108

Sep 20/95

PREREQUISITES

MAKE SURE THESE SYSTEMS WILL OPERATE:

- ADC SYSTEM (AMM 34-12-00/501)
- ATC SYSTEM (AMM 34-53-00/501)
- WEU SYSTEM (AMM 31-51-00/501)

MAKE SURE THESE CIRCUIT BREAKERS ARE CLOSED:

- 11B16, WARN SPKR L
- 11B18, WARN ELEX B
- 11F3, TCAS
- 11H35, WARN SPKR R
- 11J33, WARN ELEX A

MAKE SURE THE AIRPLANE IS IN THIS CONFIGURATION:

- ELECTRICAL POWER IS ON (AMM 24-22-00/201)
- ALIGN IRS (AMM 34-21-00/201)

**TCAS VOICE ADVISORY
ALERT FAILURE**



TCAS Voice Advisory Alert Failure
Figure 104

EFFECTIVITY
AIRPLANES WITH COLLINS TCAS

34-45-00
 CONFIG 1
 Page 109
 Sep 20/95

01

 **BOEING**
757
FAULT ISOLATION/MAINT MANUAL

1. ARINC Data Bus Charts

A. General

CAUTION: DO NOT DIRECTLY TOUCH THE CONNECTORS. USE A BREAKOUT BOX OR YOU CAN CAUSE DAMAGE TO THE CONNECTORS.

(1) The ARINC 429 data bus charts give data necessary to make an analysis of ARINC 429 transmitters, receivers, and data buses. For the test, use a breakout box at the available terminal or at the LRU connectors.

B. Equipment

(1) Standard multi-meter
 (2) 429EBP Data Bus Analyzer (recommended)
 JcAIR Instrumentation
 400 Industrial Parkway
 Industrial Airport, KS 66031

429-2 Data Bus Analyzer (alternative)
 Interface Technology
 150 E. Arrow Highway
 San Dimas, CA 91773

(3) A34011-1 Breakout Box (recommended)
 A34011-112 Breakout Box (alternative)

TCAS COMPUTER							
DIGITAL OUTPUT BUS CHART							
BUS NAME			CON	PINS	BUS FORMAT	BIT RATE	DATA BUS
SOURCE	TYPE	BUS					
TCAS	A	1	RMP	15J 15K	429	HI	COORDINATION DATA
TCAS	A	2	RMP	14A 14B	429	HI	COORDINATION DATA
TCAS	A	1	RMP	7C 7D	429	HI	TA/RA DISPLAY #1
TCAS	A	2	RMP	7G 7H	429	HI	TA/RA DISPLAY #2

EFFECTIVITY
 AIRPLANES WITH COLLINS TCAS

34-45-00
 CONFIG 1
 Page 110
 Dec 20/96

BOEING
 757
 FAULT ISOLATION/MAINT MANUAL

TCAS COMPUTER ID=035								
OCTAL LABELS CHART								
SIGNAL	TYPE	LABEL	FORMAT	MIN UPDATE RATE	SDI	BINARY RANGE	POSITIVE SENSE	UNITS
INTRUDER ALTITUDE	A	131	BCD	2	00	± 12,700	N/A	FEET
INTRUDER BEARING	A	132	BCD	2	00	± 180	N/A	DEGREES
INTRUDER RANGE	A	130	BCD	2	00	128	N/A	NM
OWN AIRCRAFT ALT	A	203	BCD	2	00	131,072	N/A	FEET

EFFECTIVITY
 AIRPLANES WITH COLLINS TCAS

34-45-00

CONFIG 1
 Page 111
 Dec 20/96

01

BOEING
757
FAULT ISOLATION/MAINT MANUAL

TRAFFIC ALERT AND COLLISION AVOIDANCE SYSTEM (TCAS)

COMPONENT	FIG. 102 SHT	QTY	ACCESS/AREA	AMM REFERENCE
ANTENNA - BOTTOM TCAS, M10821	1	1	BOTTOM OF FUSELAGE	34-45-02
ANTENNA - TOP TCAS, M10820	1	1	TOP OF FUSELAGE	34-45-02
CIRCUIT BREAKER - TCAS, C4443		1	FLIGHT COMPARTMENT, P11 11F3	*
COMPUTER - (FIM 31-41-00/101) EICAS LEFT, M10181 EICAS RIGHT, M10182				
COMPUTER - (FIM 34-46-00/101) GROUND PROXIMITY, M147				
COMPUTER - TCAS, M10819	2	1	119BL, MAIN EQUIP CENTER, E2-1	34-45-01
INDICATOR - (FIM 34-22-00/101) LEFT ELECTRONIC HORIZONTAL SITUATION, N5 LEFT VERTICAL SPEED, N9 RIGHT ELECTRONIC HORIZONTAL SITUATION, N45 RIGHT VERTICAL SPEED, N49				
INTERROGATOR - (FIM 34-55-00/101) LEFT DME, M123 RIGHT DME, M124				
MODULE - (FIM 31-51-00/101) LEFT SIREN/OWL (AURAL WARNING), M999 RIGHT SIREN/OWL (AURAL WARNING), M619				
MODULE - (FIM 32-30-00/101) LANDING GEAR LEVER, M937				
PANEL - ATC CONTROL, M10140	2	1	FLIGHT COMPARTMENT, P8	34-53-02
RELAY - (FIM 31-01-36/101) SYS NO. 1 AIR/GND, K143				
RELAY - (FIM 31-01-37/101) SYS NO. 2 AIR/GND, K201				
SWITCH - (FIM 34-12-00/101) LEFT ADC, S482 RIGHT ADC, S483				
SWITCH - (FIM 34-21-00/101) IRS SOURCE SELECT, S12				
TRANSPONDER - (FIM 34-53-00/101) LEFT ATC, M10141 RIGHT ATC, M10142				

* SEE THE WDM EQUIPMENT LIST

Traffic Alert and Collision Avoidance System (TCAS) - Component Index
Figure 101

EFFECTIVITY
AIRPLANES WITH RT-950 TCAS

34-45-00
CONFIG 2
Page 101
Jan 28/02

01

BOEING
 757
 FAULT ISOLATION/MAINT MANUAL

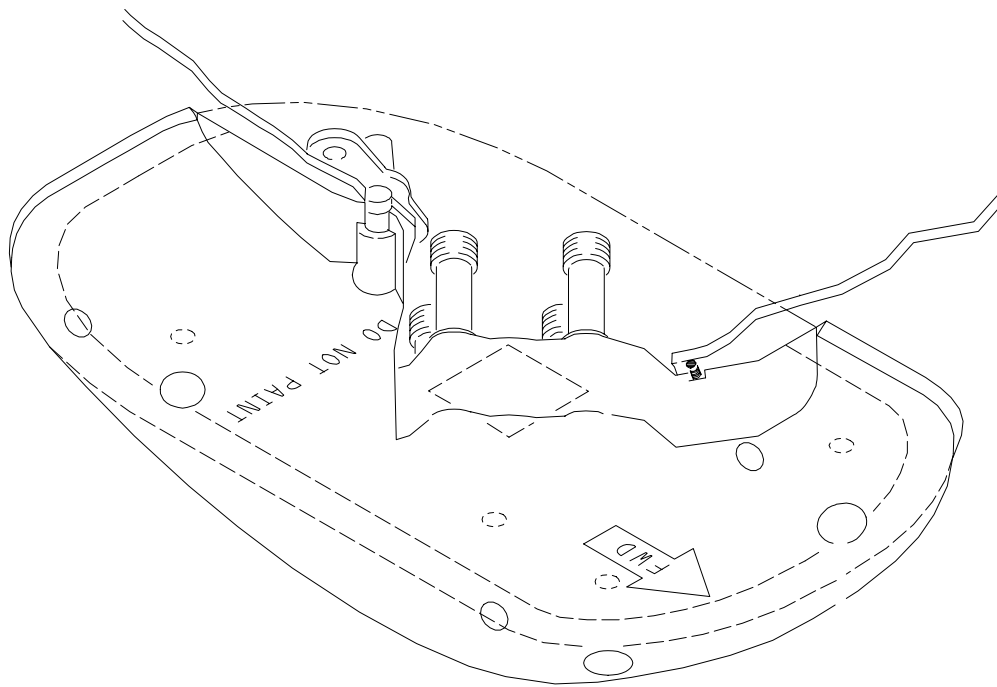
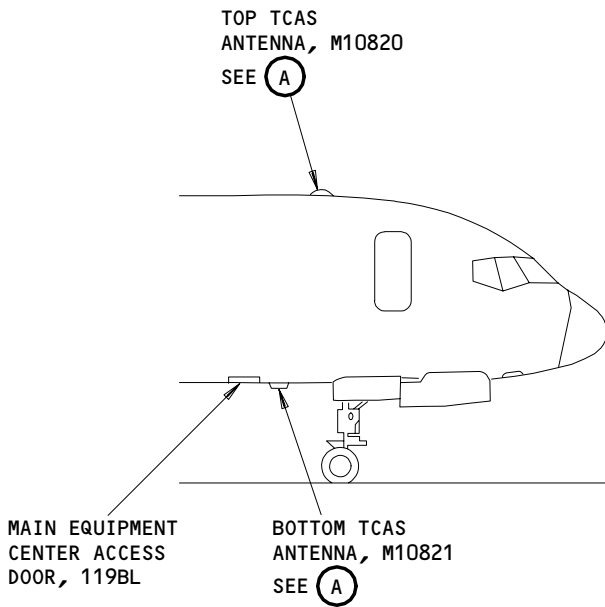

BOTTOM OR TOP TCAS ANTENNA, M10821 OR M10820

(A)

Traffic Alert and Collision Avoidance System (TCAS) - Component Location
 Figure 102 (Sheet 1)

EFFECTIVITY
 AIRPLANES WITH RT-950 TCAS

34-45-00

CONFIG 2
 Page 102
 Jan 28/02

01

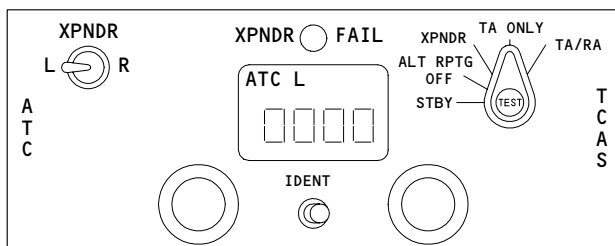
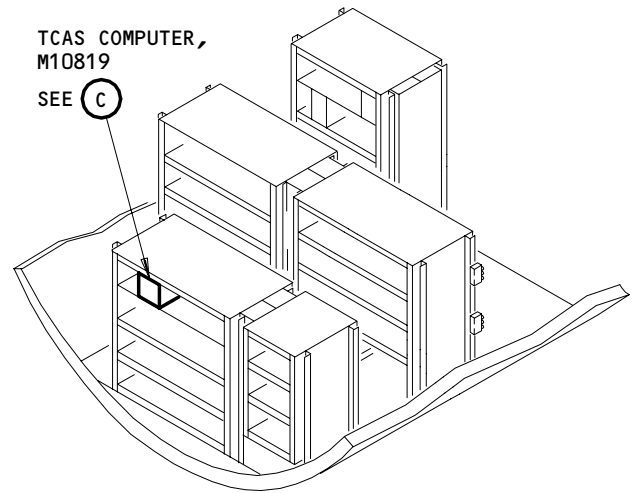
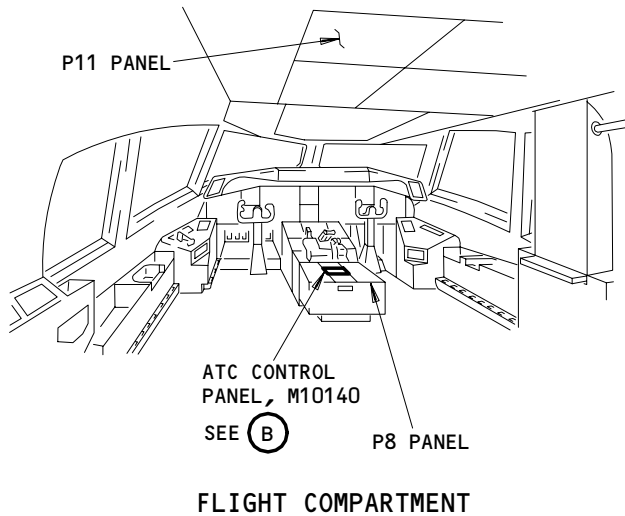

TCAS/ATC CONTROL PANEL, M10140

(B)

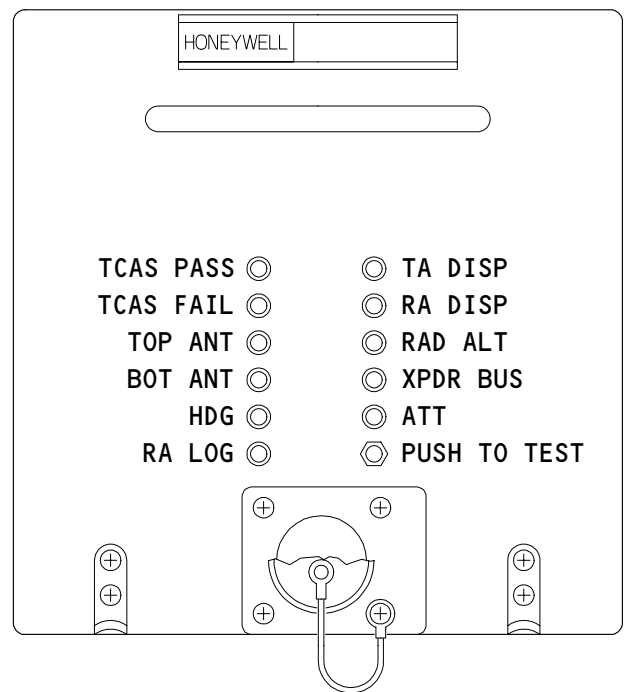

TCAS COMPUTER, M10819

(C)

Traffic Alert and Collision Avoidance System (TCAS) - Component Location
Figure 102 (Sheet 2)

EFFECTIVITY
AIRPLANES WITH RT-950 TCAS

34-45-00

CONFIG 2

04

Page 103

Jan 28/02

PREREQUISITES

MAKE SURE THESE SYSTEMS WILL OPERATE:

ADC SYSTEM (AMM 34-12-00/501)

ATC SYSTEM (AMM 34-53-00/501)

MAKE SURE THIS CIRCUIT BREAKER IS CLOSED:

11F12, TCAS

MAKE SURE THE AIRPLANE IS IN THIS CONFIGURATION:

ELECTRICAL POWER IS ON (AMM 24-22-00/201)

ALIGN IRS (AMM 34-21-00/201)

TCAS BITE PROCEDURE

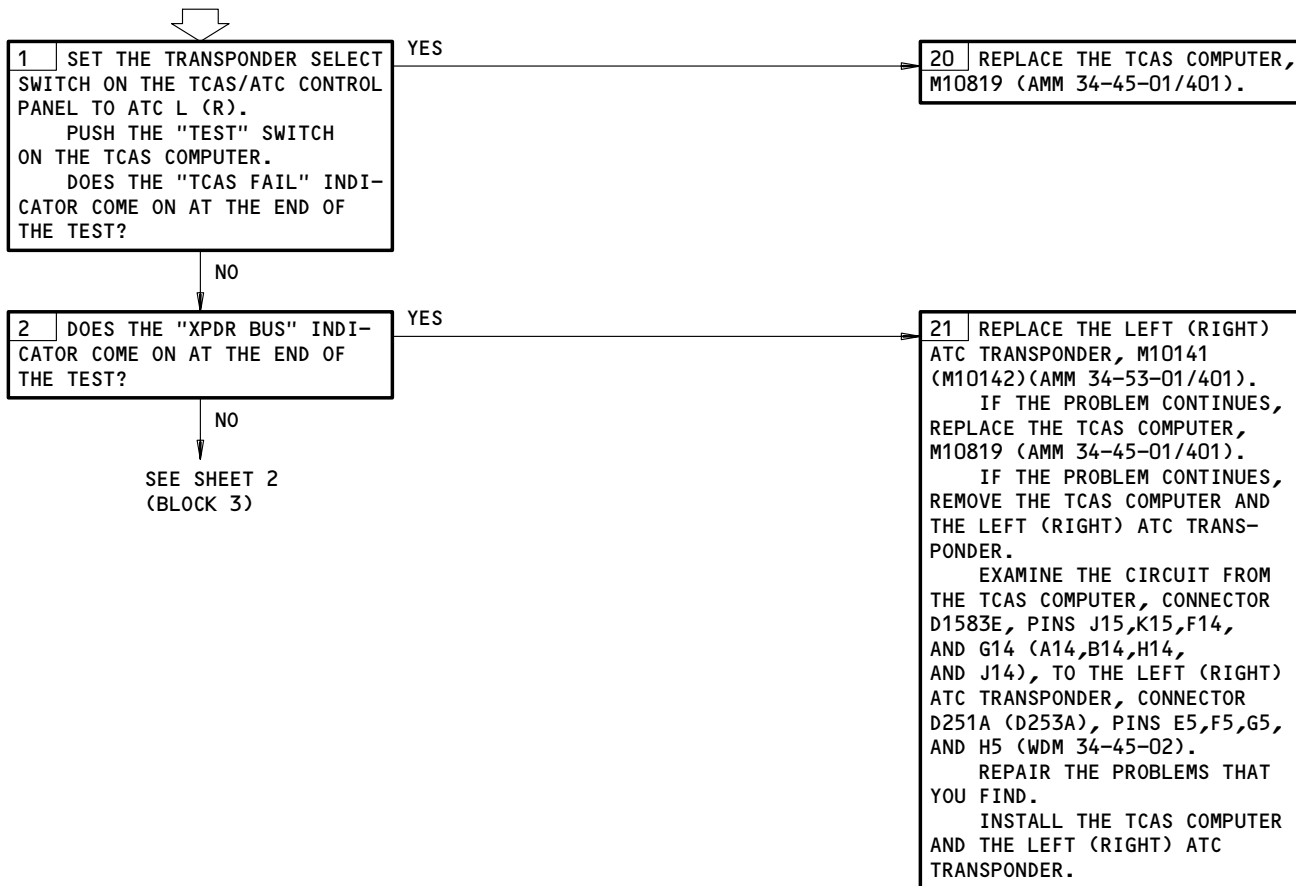

TCAS BITE Procedure
Figure 103 (Sheet 1)

EFFECTIVITY
AIRPLANES WITH RT-950 TCAS

34-45-00

CONFIG 2

Page 104

Jan 28/02

01

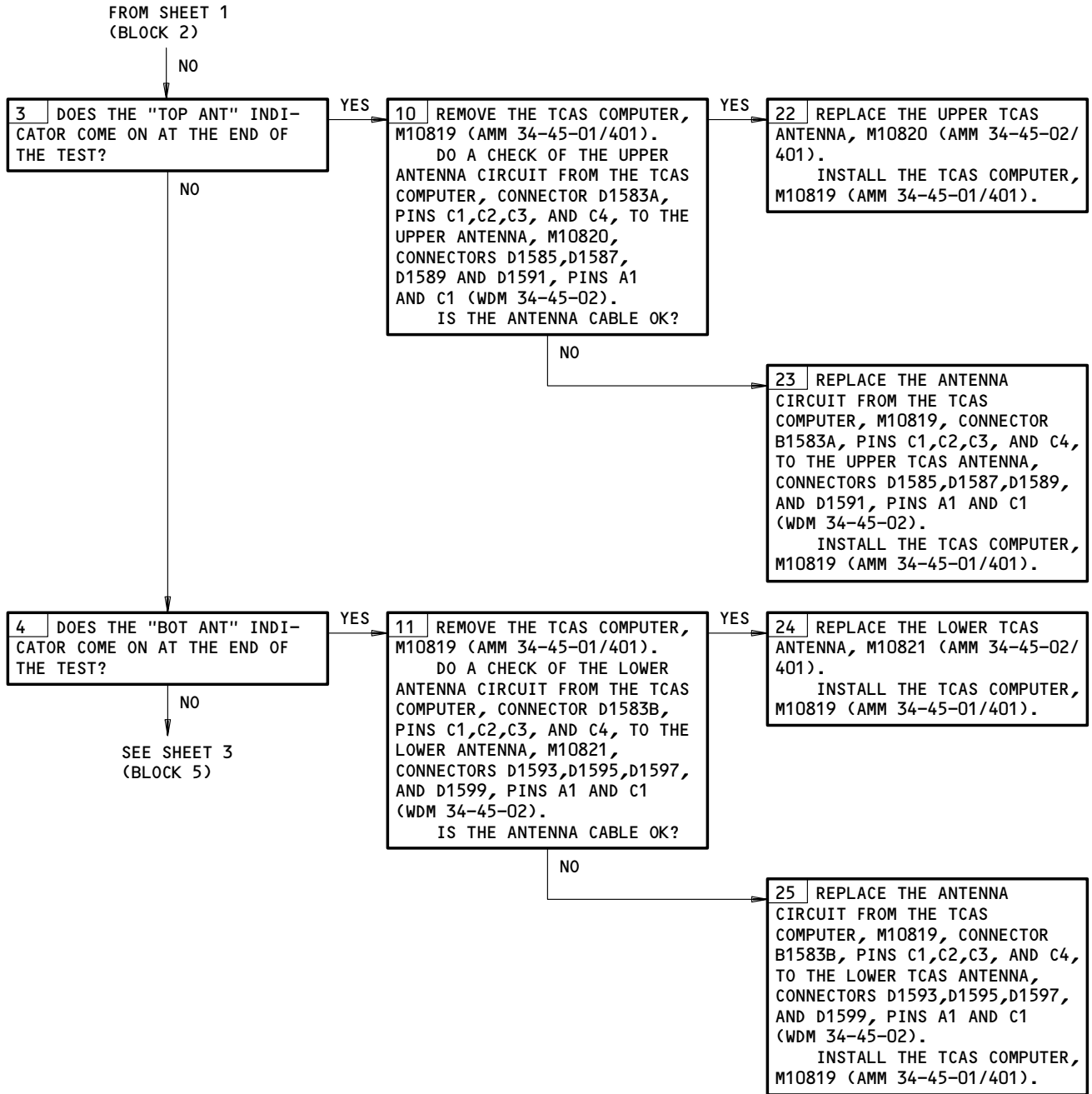

TCAS BITE Procedure
Figure 103 (Sheet 2)

EFFECTIVITY
AIRPLANES WITH RT-950 TCAS

34-45-00
 CONFIG 2
 Page 105
 Jan 28/02

02

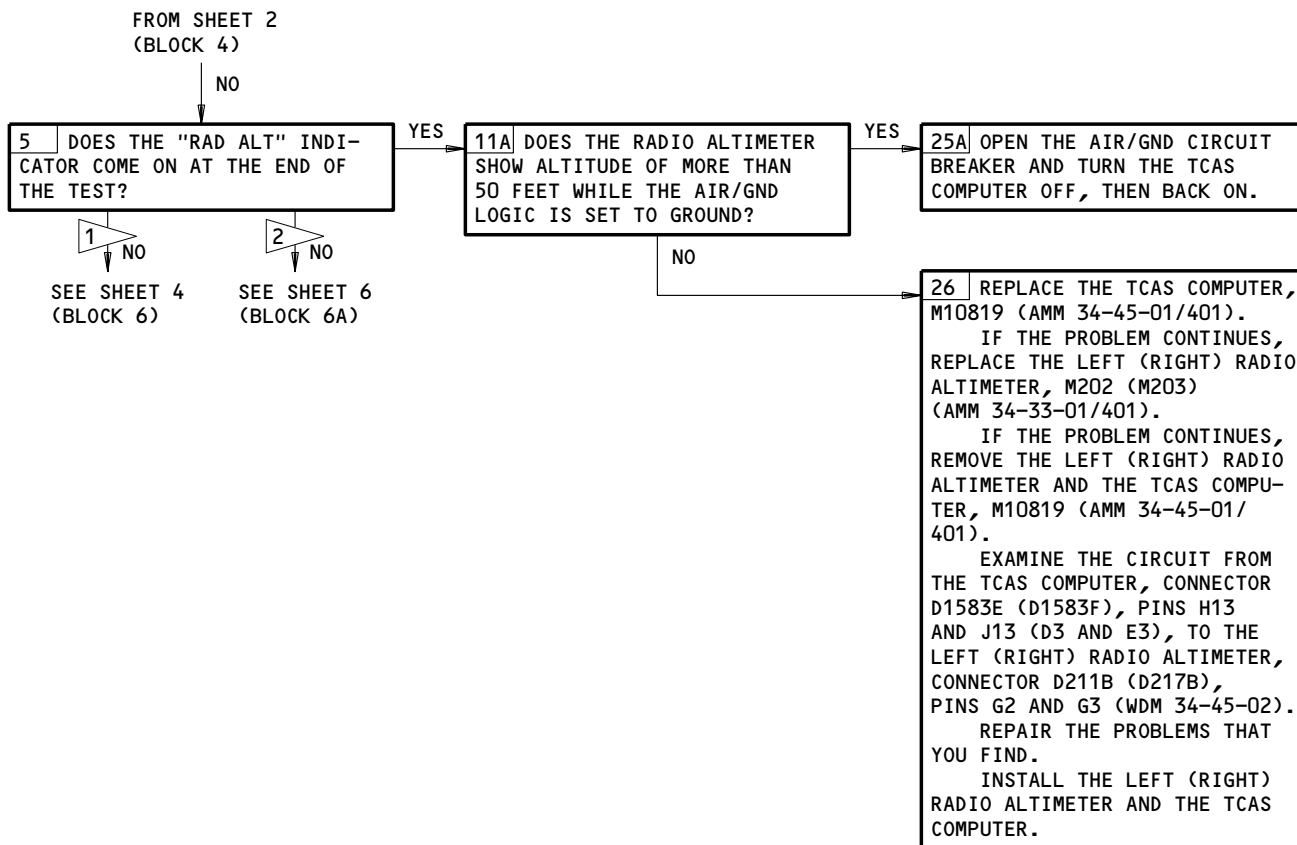

- 1 AIRPLANES WITH TCAS DISPLAYED ON THE EFIS DISPLAY
- 2 AIRPLANES WITH TCAS DISPLAYED ON THE TA/RA VSI

TCAS BITE Procedure
Figure 103 (Sheet 3)

EFFECTIVITY
AIRPLANES WITH RT-950 TCAS

34-45-00
CONFIG 2
Page 106
Jan 28/02

01

BOEING
757
FAULT ISOLATION/MAINT MANUAL

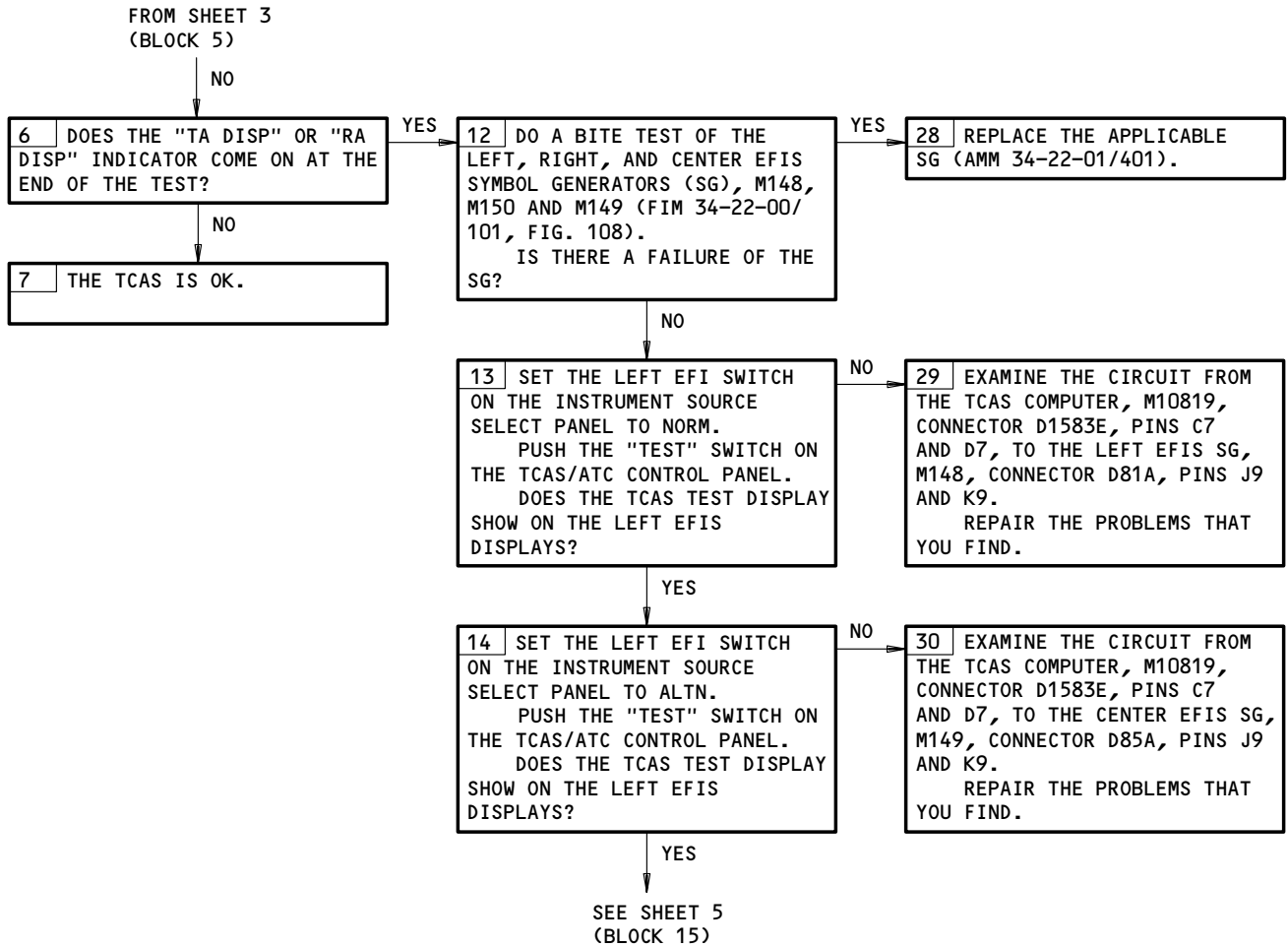

TCAS BITE Procedure
Figure 103 (Sheet 4)

EFFECTIVITY
AIRPLANES WITH RT-950 TCAS

34-45-00
CONFIG 2
Page 107
Jan 28/02

01



757

FAULT ISOLATION/MAINT MANUAL

FROM SHEET 4
(BLOCK 14)

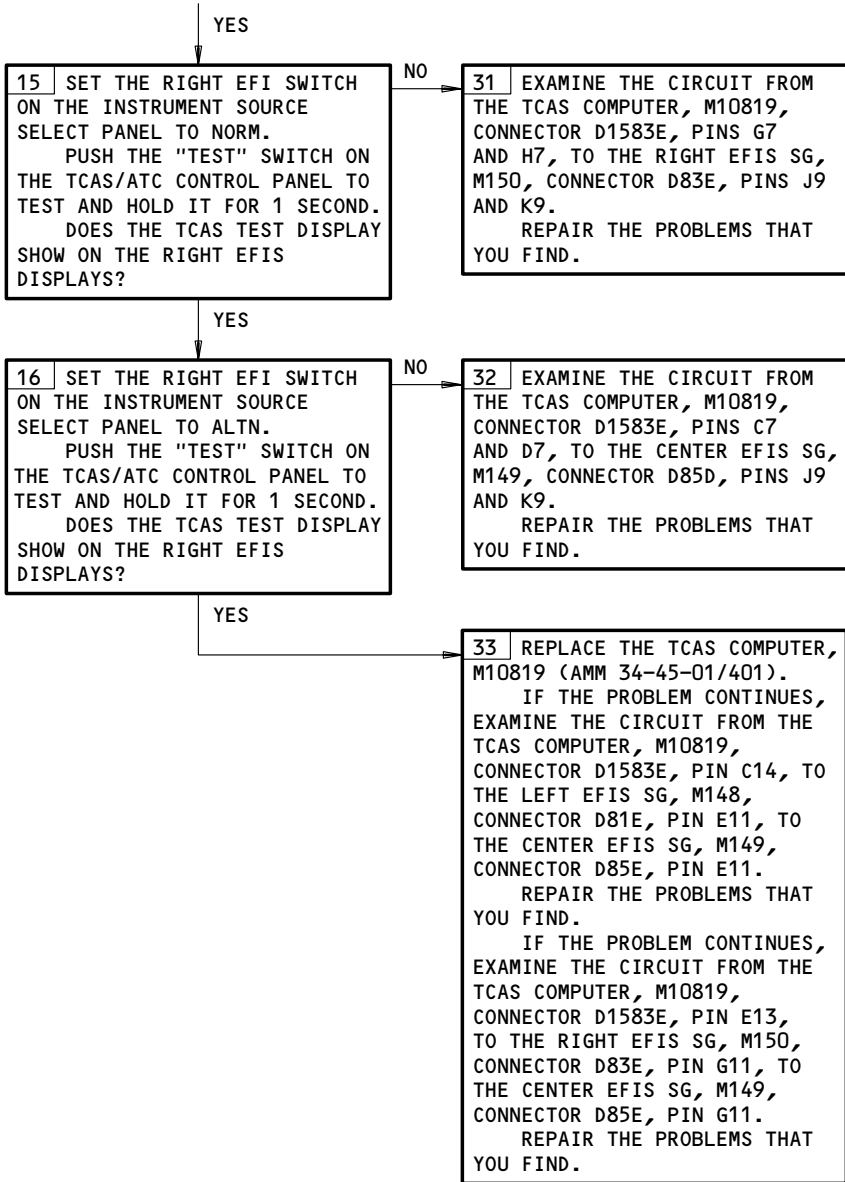

TCAS BITE Procedure
Figure 103 (Sheet 5)

EFFECTIVITY
AIRPLANES WITH RT-950 TCAS

34-45-00

CONFIG 2

Page 108

Jan 28/02

01

E86345

BOEING
757
FAULT ISOLATION/MAINT MANUAL

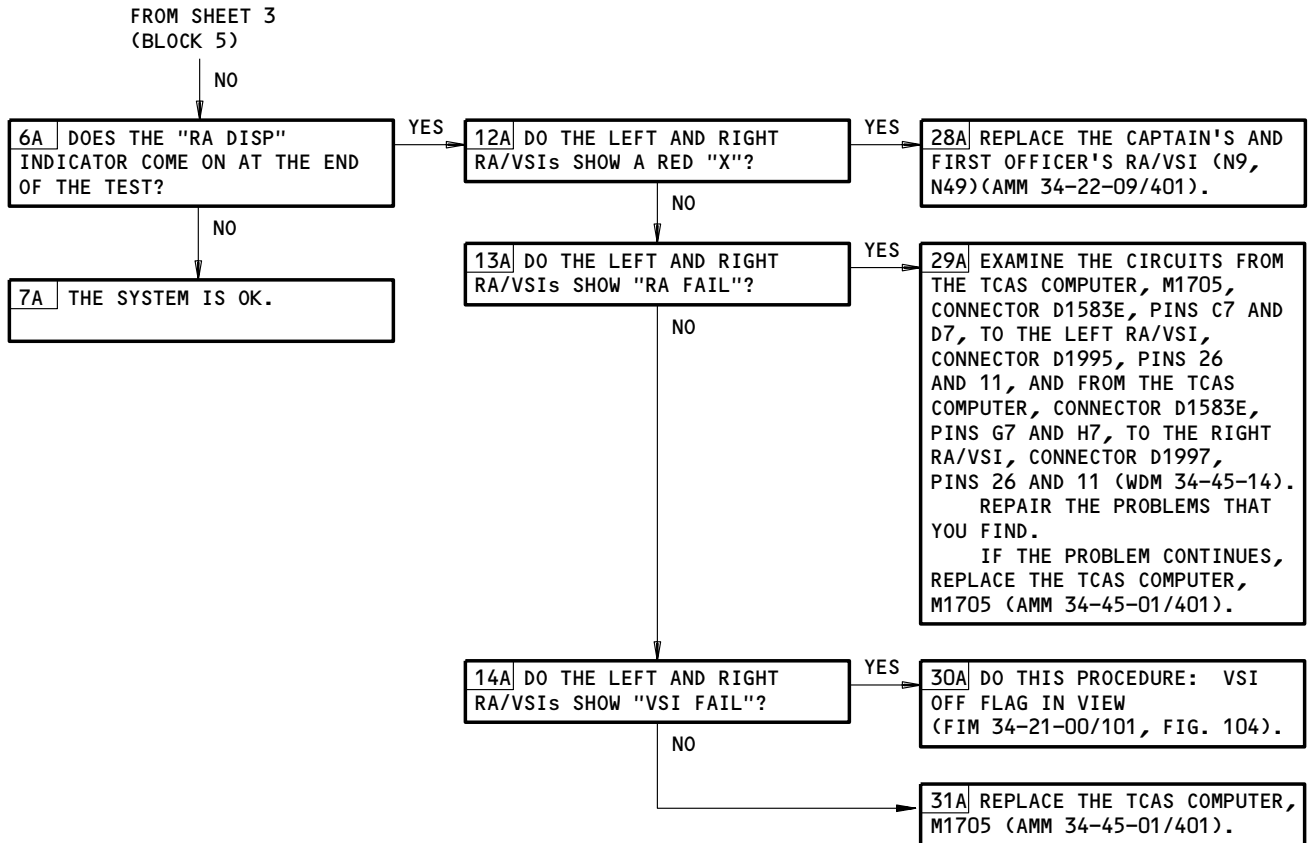

TCAS BITE Procedure
Figure 103 (Sheet 6)

EFFECTIVITY
AIRPLANES WITH RT-950 TCAS

34-45-00
CONFIG 2
Page 109
Jan 28/02

01

PREREQUISITES

MAKE SURE THESE SYSTEMS WILL OPERATE:
 WEU SYSTEM (AMM 31-51-00/501)
 ADC SYSTEM (AMM 34-12-00/501)
 ATC SYSTEM (AMM 34-53-00/501)

MAKE SURE THESE CIRCUIT BREAKERS ARE CLOSED:
 11B16, WARN SPKR L
 11B18, WARN ELEX B
 11F3, TCAS
 11H35, WARN SPKR R
 11J33, WARN ELEX A

MAKE SURE THE AIRPLANE IS IN THIS CONFIGURATION:
 ELECTRICAL POWER IS ON (AMM 24-22-00/201)
 ALIGN IRS (AMM 34-21-00/201)

**TCAS VOICE ADVISORY
ALERT FAILURE**

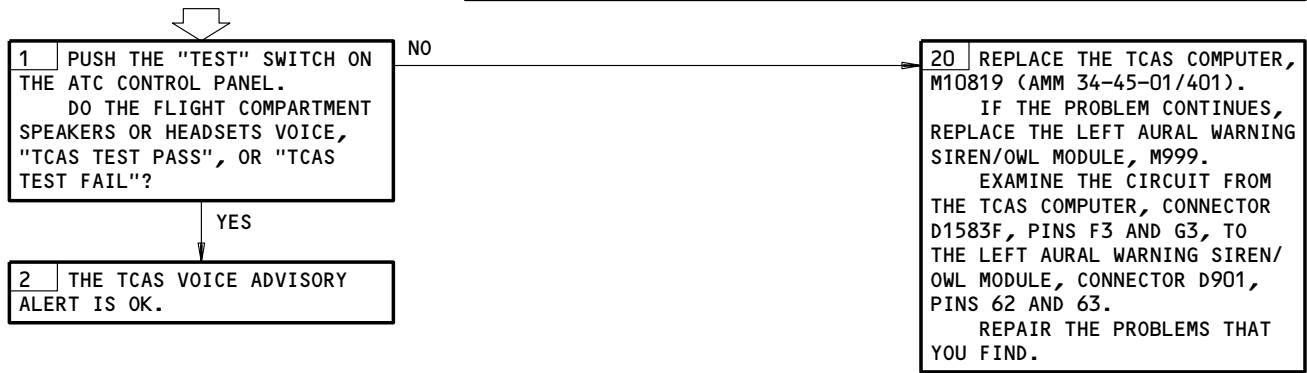

TCAS Voice Advisory Alert Failure
Figure 104

EFFECTIVITY
 AIRPLANES WITH RT-950 TCAS

34-45-00
 CONFIG 2
 Page 110
 Jan 28/02

BOEING
 757
 FAULT ISOLATION/MAINT MANUAL

1. ARINC Data Bus Charts

A. General

CAUTION: DO NOT DIRECTLY TOUCH THE CONNECTORS. USE A BREAKOUT BOX OR YOU CAN CAUSE DAMAGE TO THE CONNECTORS.

(1) The ARINC 429 data bus charts give data necessary to make an analysis of ARINC 429 transmitters, receivers, and data buses. For the test, use a breakout box at the available terminal or at the LRU connectors.

B. Equipment

(1) Standard multi-meter
 (2) 429EBP Data Bus Analyzer (recommended)
 JcAIR Instrumentation
 400 Industrial Parkway
 Industrial Airport, KS 66031

429-2 Data Bus Analyzer (alternative)
 Interface Technology
 150 E. Arrow Highway
 San Dimas, CA 91773

(3) A34011-1 Breakout Box (recommended)
 A34011-112 Breakout Box (alternative)

TCAS COMPUTER							
DIGITAL OUTPUT BUS CHART							
BUS NAME			CON	PINS	BUS FORMAT	BIT RATE	DATA BUS
SOURCE	TYPE	BUS					
TCAS	A	1	RMP	15J 15K	429	HI	COORDINATION DATA
TCAS	A	2	RMP	14A 14B	429	HI	COORDINATION DATA
TCAS	A	1	RMP	7C 7D	429	HI	TA/RA DISPLAY #1
TCAS	A	2	RMP	7G 7H	429	HI	TA/RA DISPLAY #2

EFFECTIVITY
 AIRPLANES WITH RT-950 TCAS

34-45-00

CONFIG 2

01

Page 111

Jan 28/02

BOEING
 757
 FAULT ISOLATION/MAINT MANUAL

TCAS COMPUTER ID=035								
OCTAL LABELS CHART								
SIGNAL	TYPE	LABEL	FORMAT	MIN UPDATE RATE	SDI	BINARY RANGE	POSITIVE SENSE	UNITS
INTRUDER ALTITUDE	A	131	BCD	2	00	± 12,700	N/A	FEET
INTRUDER BEARING	A	132	BCD	2	00	± 180	N/A	DEGREES
INTRUDER RANGE	A	130	BCD	2	00	± 28	N/A	NM
OWN AIRCRAFT ALT	A	203	BCD	2	00	± 31,072	N/A	FEET

EFFECTIVITY
AIRPLANES WITH RT-950 TCAS

34-45-00

CONFIG 2
Page 112
Jan 28/02

01



757
 FAULT ISOLATION/MAINT MANUAL

GROUND PROXIMITY WARNING SYSTEM

COMPONENT	FIG. 102 SHT	QTY	ACCESS/AREA	AMM REFERENCE
CIRCUIT BREAKER - GND PROX, C592		1	FLT COMPT, P11 11F4	*
COMPUTER - GROUND PROXIMITY WARNING, M147	1	1	119BL, MAIN EQUIP CTR, E2-3	34-46-01
LIGHT - GND PROX PULL UP, M779	2	1	FLT COMPT, P1	*
LIGHT - WINDSHEAR, L649	2	1	FLT COMPT, P1	*
PANEL - (FIM 30-32-00/101) MISCELLANEOUS TEST, M10398				
SWITCH - GND PROX TEST, S2	2	1	FLT COMPT, P61	*
SWITCH-LIGHT - GND PROX/CONFIG GEAR OVRD, S10231	2	1	FLT COMPT, P3	*
SWITCH-LIGHT - GND PROX FLAP OVRD, S10172	2	1	FLT COMPT, P3	*
SWITCH-LIGHT - GND PROX - G/S INHB, N10015	2	1	FLT COMPT, P1	*

* SEE THE WDM EQUIPMENT LIST

Ground Proximity Warning System - Component Index
 Figure 101

EFFECTIVITY
 AIRPLANES WITHOUT ENHANCED GPWC

34-46-00

CONFIG 1

02

Page 101

May 28/99

K23185

BOEING
757
FAULT ISOLATION/MAINT MANUAL

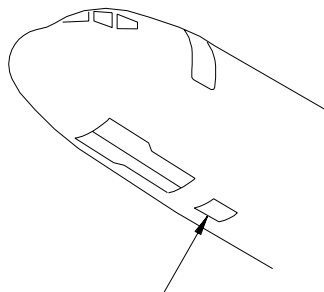

MAIN EQUIPMENT CENTER
ACCESS DOOR, 119BL

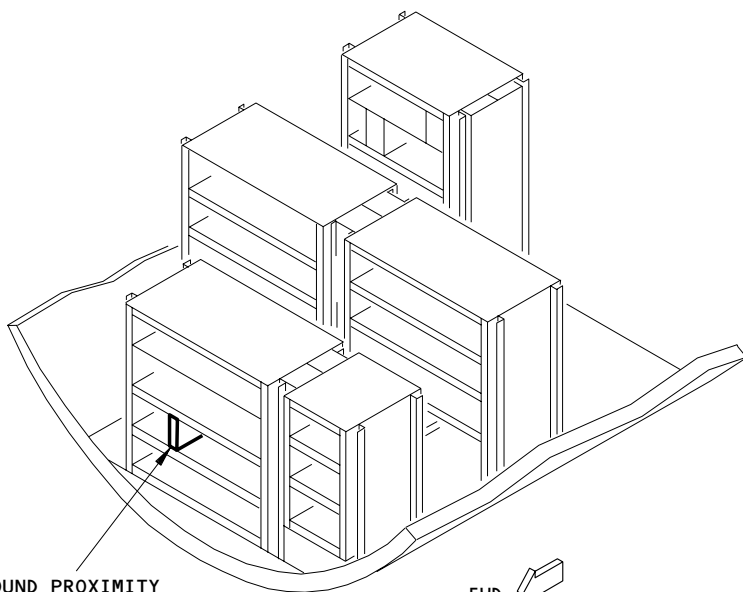

GROUND PROXIMITY
WARNING COMPUTER, M147

SEE (A)

MAIN EQUIPMENT CENTER

FWD

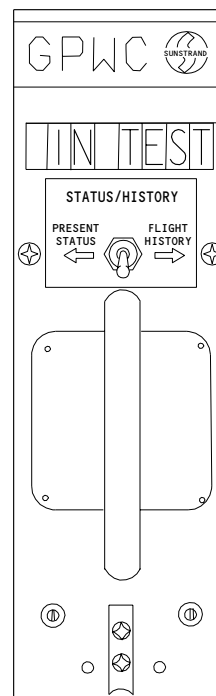

GROUND PROXIMITY
WARNING COMPUTER, M147

(A)

Ground Proximity Warning System - Component Location
Figure 102 (Sheet 1)

EFFECTIVITY
AIRPLANES WITHOUT ENHANCED GPWC

34-46-00

CONFIG 1

Page 102

May 28/99

01

BOEING
757
FAULT ISOLATION/MAINT MANUAL

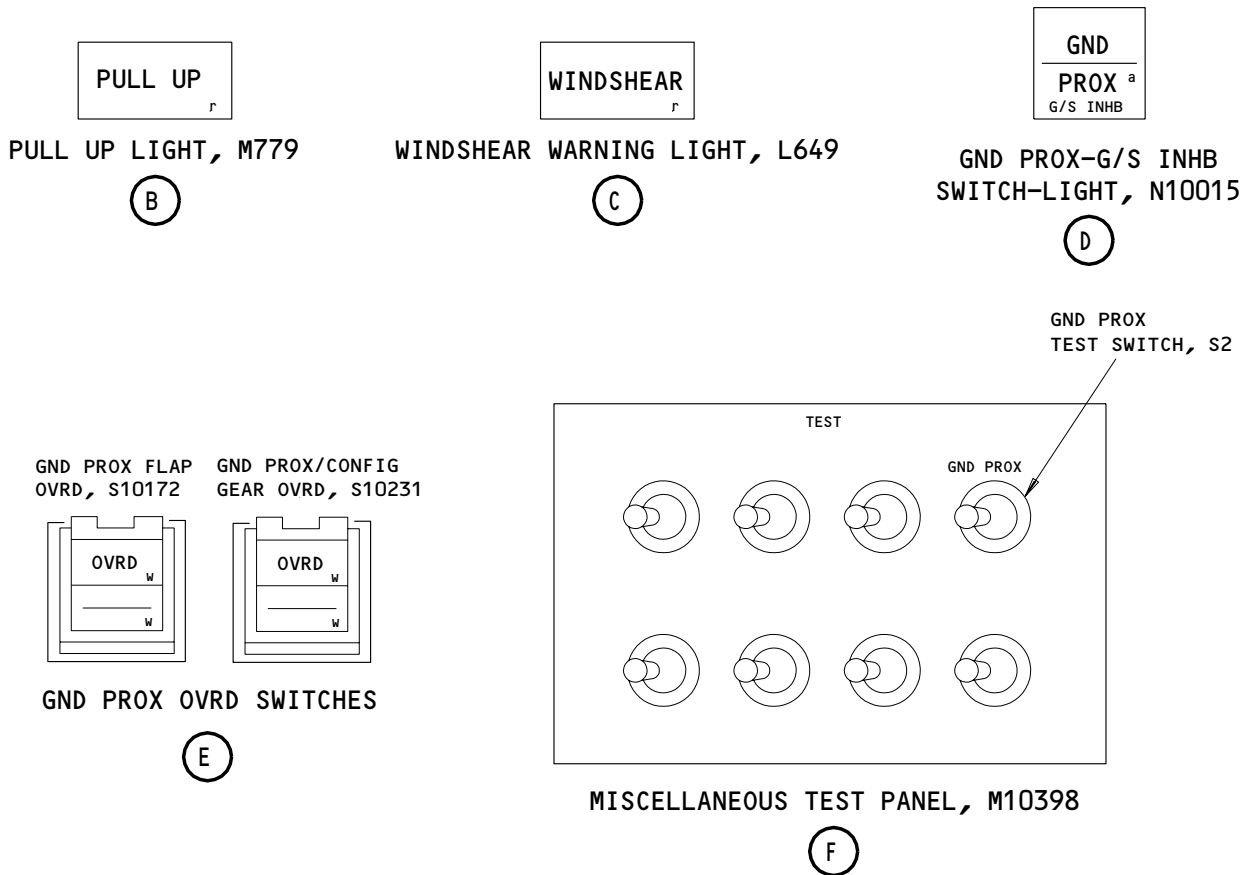
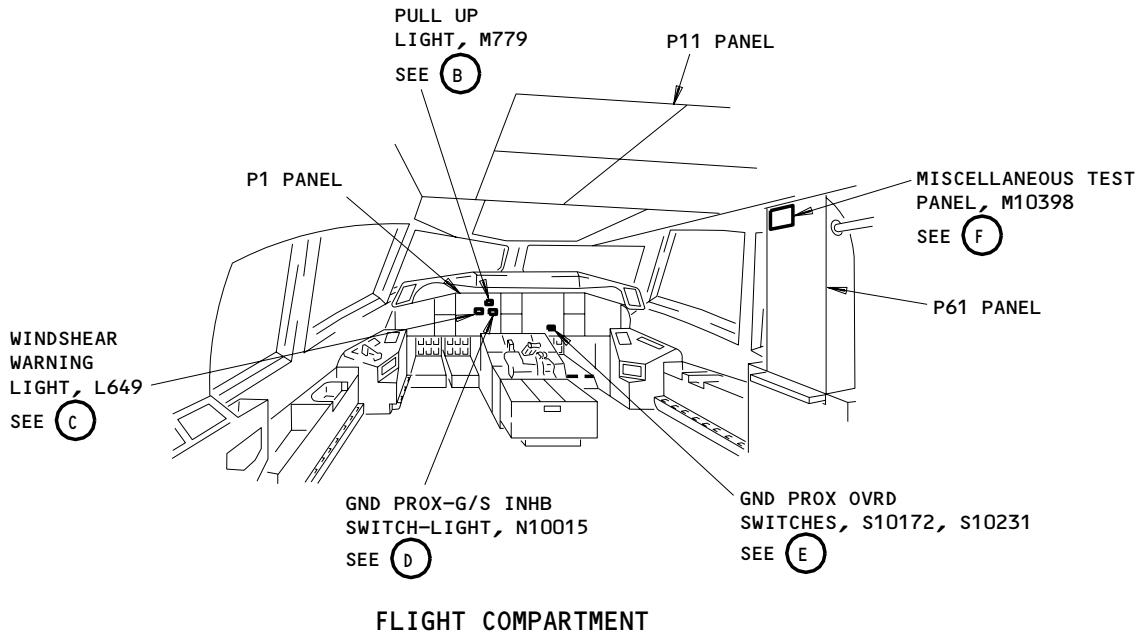

Ground Proximity Warning System - Component Location
Figure 102 (Sheet 2)

EFFECTIVITY
AIRPLANES WITHOUT ENHANCED GPWC

34-46-00
CONFIG 1
Page 103
May 28/99

**GROUND PROXIMITY
WARNING COMPUTER
BITE PROCEDURE**

PREREQUISITES

MAKE SURE THESE SYSTEMS WILL OPERATE:
 ENGINE INDICATING AND CREW ALERTING SYSTEM
 (AMM 31-41-00/501)
 WARNING SYSTEM (AMM 31-51-00/501)
 AIR DATA COMPUTING SYSTEM (AMM 34-12-00/501)
 INERTIAL REFERENCE SYSTEM (AMM 34-21-00/501)
 ELECTRONIC FLIGHT INSTRUMENT SYSTEM (EFIS)
 (AMM 34-22-00/501)
 ILS (AMM 34-31-00/501)
 RADIO ALTIMETER SYSTEM (AMM 34-33-00/501)
 FLIGHT MANAGEMENT SYSTEM (AMM 34-61-00/501)

MAKE SURE THESE CIRCUIT BREAKERS ARE CLOSED:
 11B16, 11B18, 11F4, 11H35, 11J33

MAKE SURE THE AIRPLANE IS IN THIS CONFIGURATION:
 ELECTRICAL POWER IS ON (AMM 24-22-00/201)

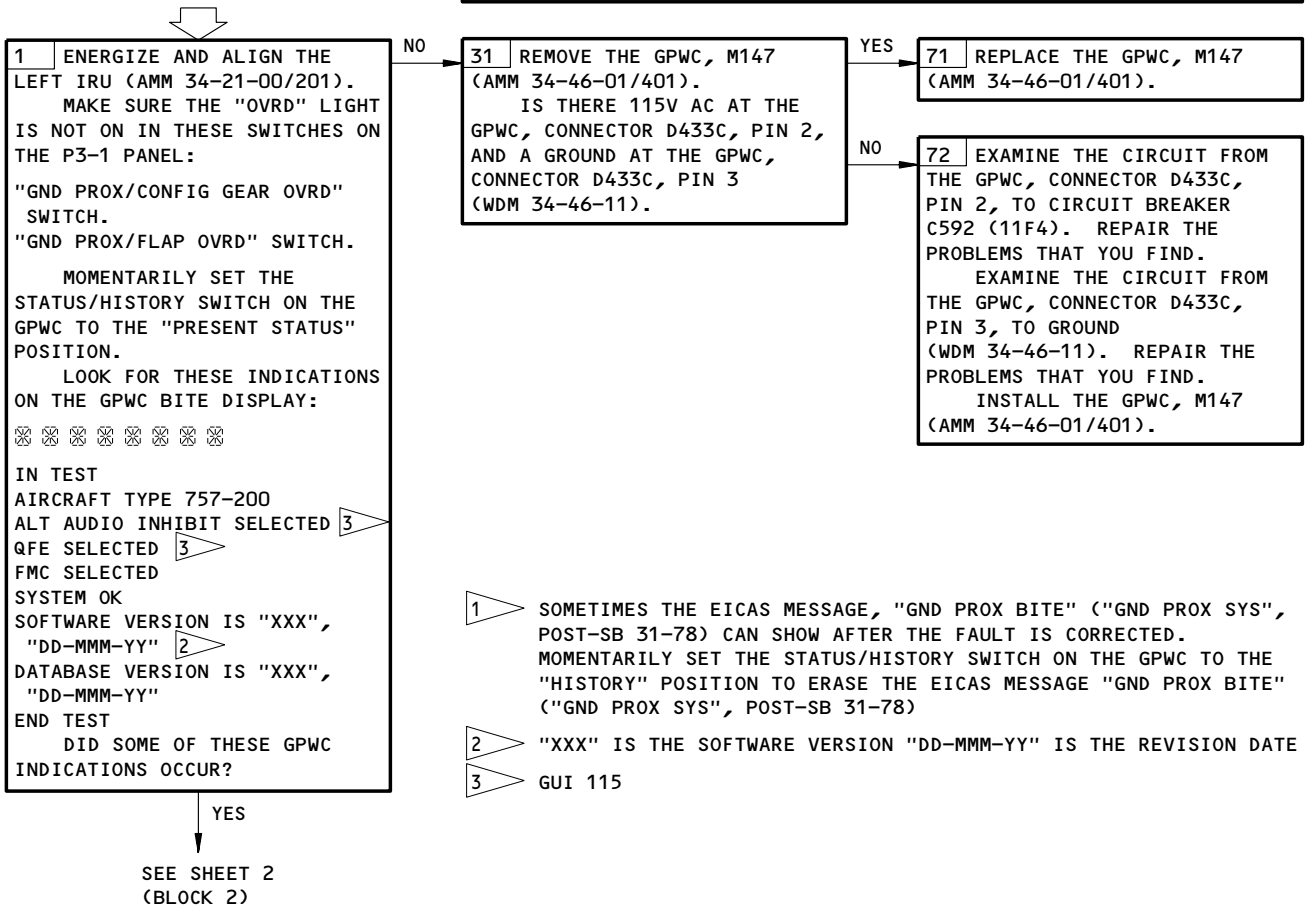

- 1 SOMETIMES THE EICAS MESSAGE, "GND PROX BITE" ("GND PROX SYS", POST-SB 31-78) CAN SHOW AFTER THE FAULT IS CORRECTED. MOMENTARILY SET THE STATUS/HISTORY SWITCH ON THE GPWC TO THE "HISTORY" POSITION TO ERASE THE EICAS MESSAGE "GND PROX BITE" ("GND PROX SYS", POST-SB 31-78)
- 2 "XXX" IS THE SOFTWARE VERSION "DD-MMM-YY" IS THE REVISION DATE
- 3 GUI 115

Ground Proximity Warning Computer BITE Procedure
Figure 103 (Sheet 1)

EFFECTIVITY
 AIRPLANES WITH -206 AND PREVIOUS GPWC

34-46-00
 CONFIG 1
 Page 104
 Jan 28/03

BOEING
757
FAULT ISOLATION/MAINT MANUAL

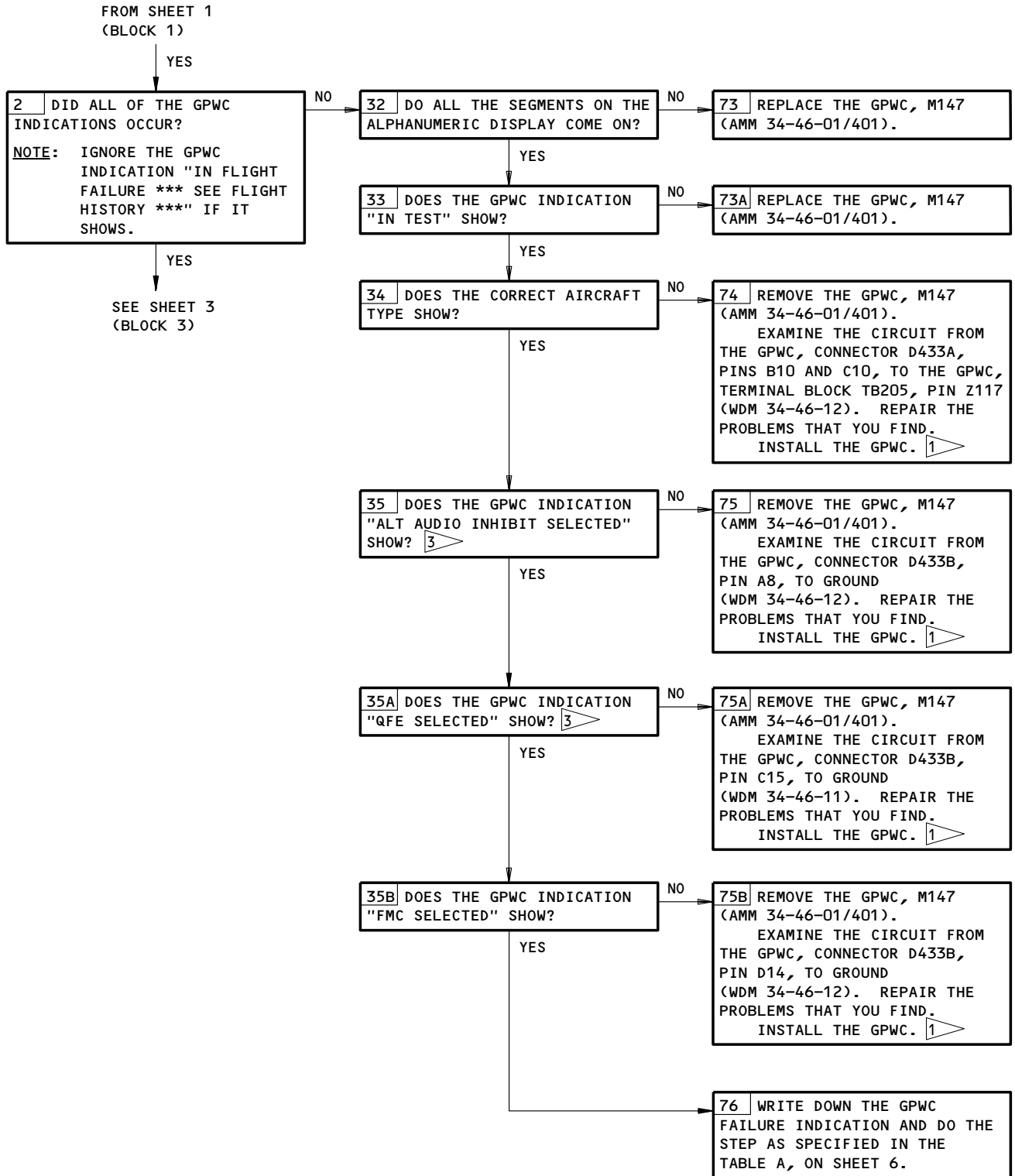

Ground Proximity Warning Computer BITE Procedure
Figure 103 (Sheet 2)

EFFECTIVITY
AIRPLANES WITH -206 AND PREVIOUS GPWC

34-46-00

CONFIG 1

07

Page 105

Jan 28/03

BOEING
 757
 FAULT ISOLATION/MAINT MANUAL

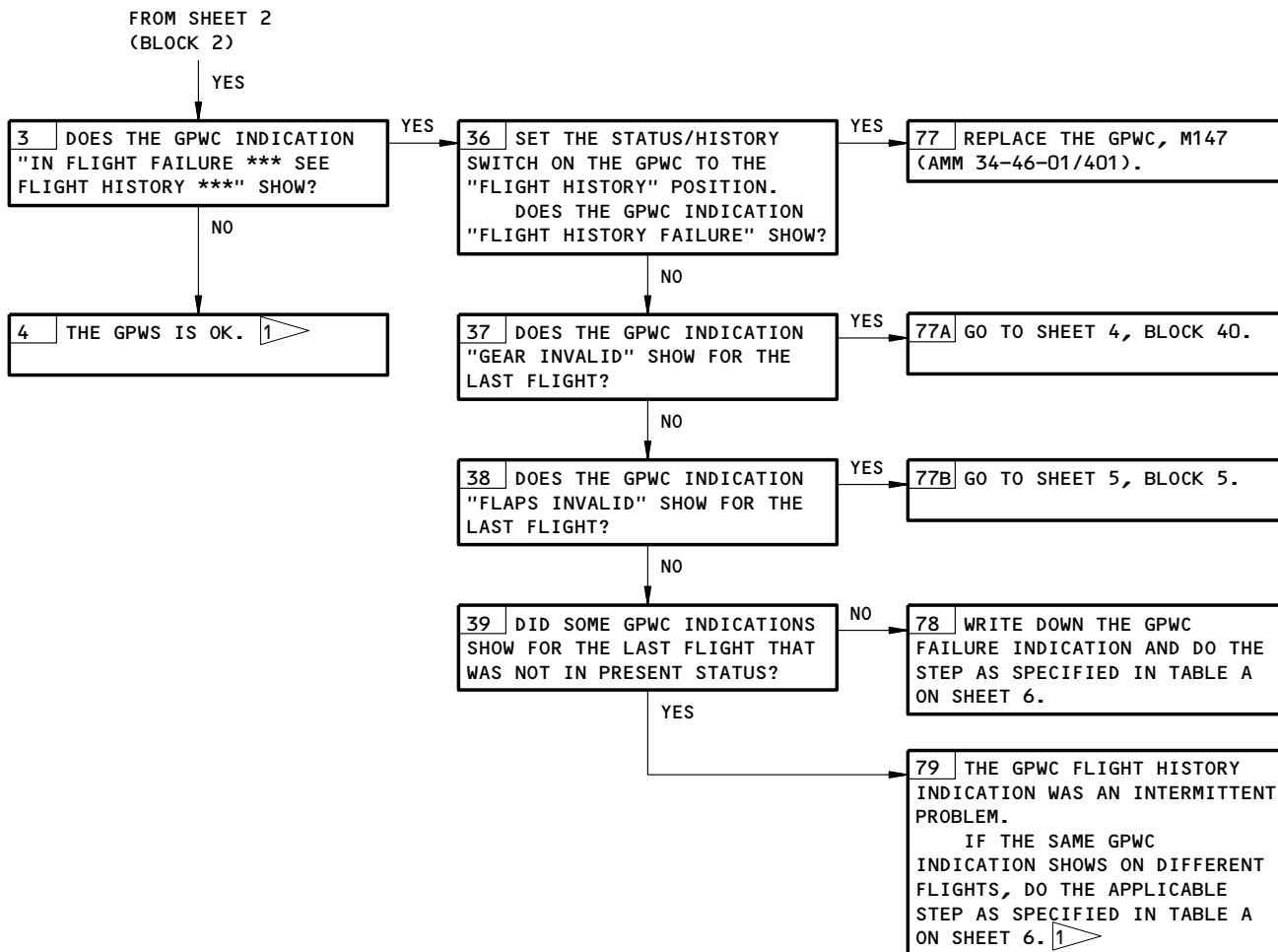

Ground Proximity Warning Computer BITE Procedure
Figure 103 (Sheet 3)

EFFECTIVITY
AIRPLANES WITH -206 AND PREVIOUS GPWC

34-46-00
 CONFIG 1
 Page 106
 Jan 28/03

02

BOEING
757
FAULT ISOLATION/MAINT MANUAL

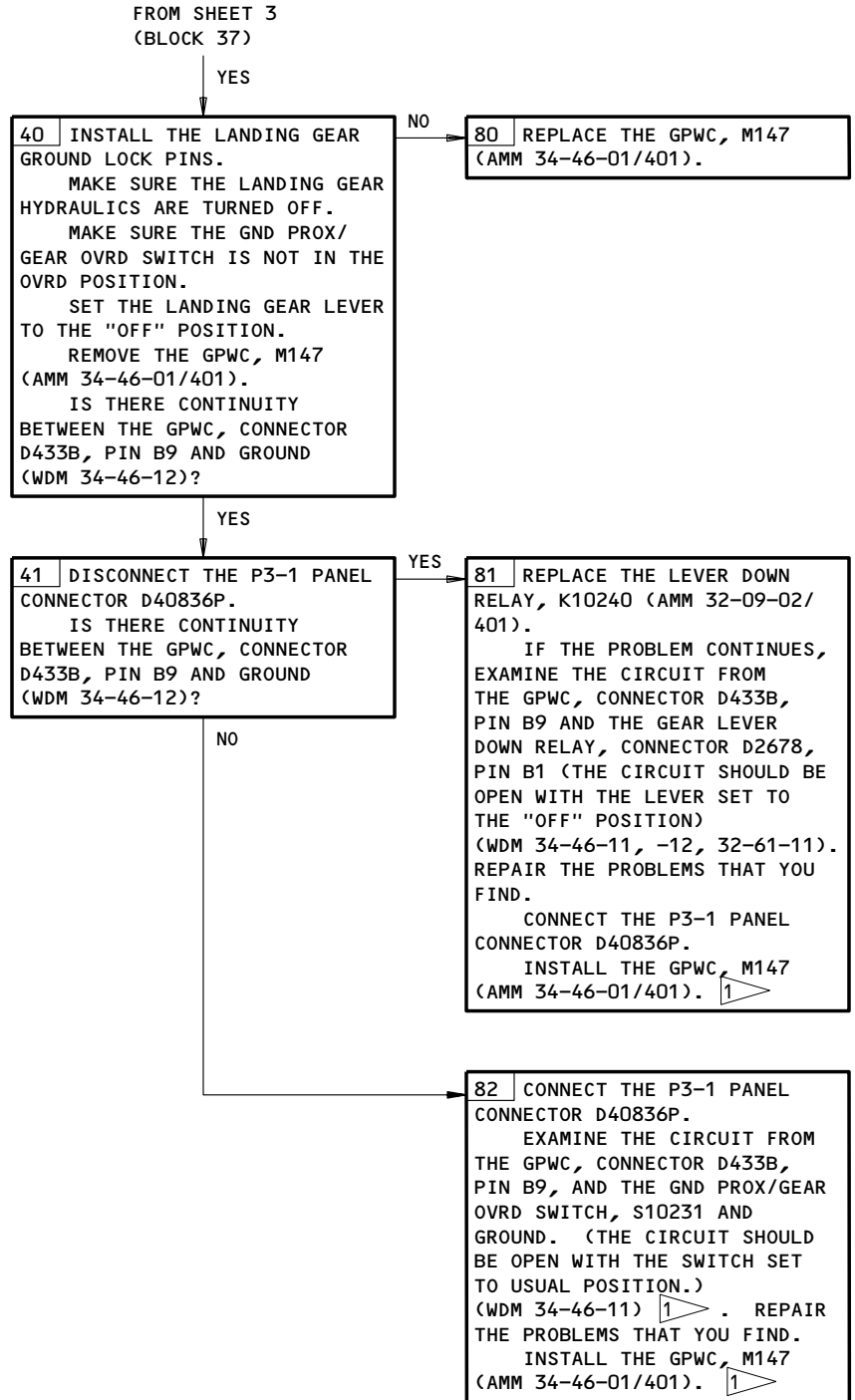

Ground Proximity Warning Computer BITE Procedure
Figure 103 (Sheet 4)

EFFECTIVITY
AIRPLANES WITH -206 AND PREVIOUS GPWC

34-46-00
CONFIG 1
Page 107
May 28/99

BOEING
757
FAULT ISOLATION/MAINT MANUAL

FROM SHEET 2
(BLOCK 38)

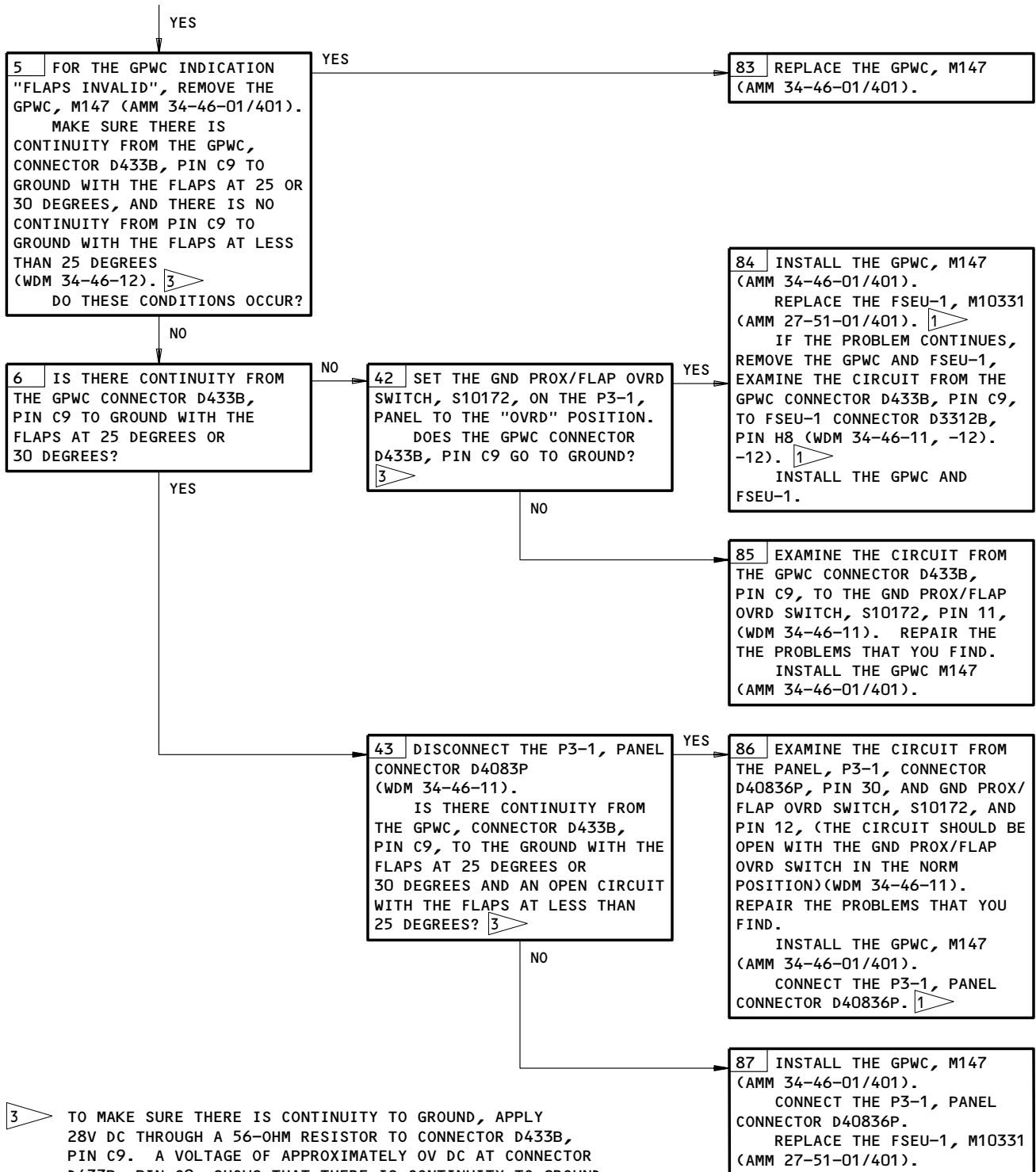

Ground Proximity Warning Computer BITE Procedure
Figure 103 (Sheet 5)

EFFECTIVITY
AIPLANES WITH -206 AND PREVIOUS GPWC

34-46-00
CONFIG 1
Page 108
May 28/99

02

BOEING
 757
 FAULT ISOLATION/MAINT MANUAL

FAILURE INDICATION	REFER TO SHT-BLOCK
AIRCRAFT TYPE INVALID	14-23
AIR DATA INACTIVE	7-8
AIR/GROUND INVALID	13-21
AUDIO SELECT INVALID	13-22
BARORATE INVALID	7-9
BARO ALTITUDE INVALID	7-9
BODY PITCH RATE INVALID	10-16
CALLOUTS OPTION INVALID	14-24
COMPUTED AIRSPEED INVALID	7-9
CORRECTED BARO ALTITUDE INVALID	7-9
CORRECTED AOA #1 INVALID	11-18
CORRECTED AOA #2 INVALID	11-18
DSW #1 DATA INACTIVE	11-17
DSW #2 DATA INACTIVE	11-17
EFS DATA INACTIVE	7-9A
FLAP ANGLE #1 INVALID	11-18
FLAP ANGLE #2 INVALID	11-18
FLAPS INVALID	3-38
FLIGHT PATH ACCEL INVALID	10-16
FMC DATA INACTIVE	8-10
FMC LATITUDE INVALID	8-11
FMC LONGITUDE INVALID	8-11
FMC MAG TRACK INVALID	8-11
GEAR INVALID	3-37
GLIDESLOPE CANCEL INVALID	9-14
GLIDESLOPE INVALID	9-13
GPWS FAILED	7-7
ILS DATA INACTIVE	9-12
INDICATED AOA #1 INVALID	11-18
INDICATED AOA #2 INVALID	11-18
INERTIAL ALTITUDE INVALID	10-16
INERTIAL VERTICAL SPEED INVALID	10-16
IRS DATA INACTIVE	10-15
IRS LATITUDE INVALID	10-16
IRS LONGITUDE INVALID	10-16
IRS MAG TRACK INVALID	10-16
IRS MODE INVALID	10-16
LOCALIZER INVALID	9-13
PITCH ANGLE INVALID	10-16
QFE SELECTED	15-25
RADIO ALTIMETER DATA INACTIVE	12-19
RADIO ALTITUDE INVALID	12-20
ROLL ANGLE INVALID	10-16
RUNWAY COURSE INVALID	9-13
STICK SHAKER AOA #1 INVALID	11-18
STICK SHAKER AOA #2 INVALID	11-18
TRUE AIRSPEED INVALID	7-9

CONNECTIONS
 TABLE A

Ground Proximity Warning Computer BITE Procedure
 Figure 103 (Sheet 6)

EFFECTIVITY
 AIRPLANES WITH -206 AND PREVIOUS GPWC

34-46-00
 CONFIG 1
 Page 109
 Jan 28/03

03

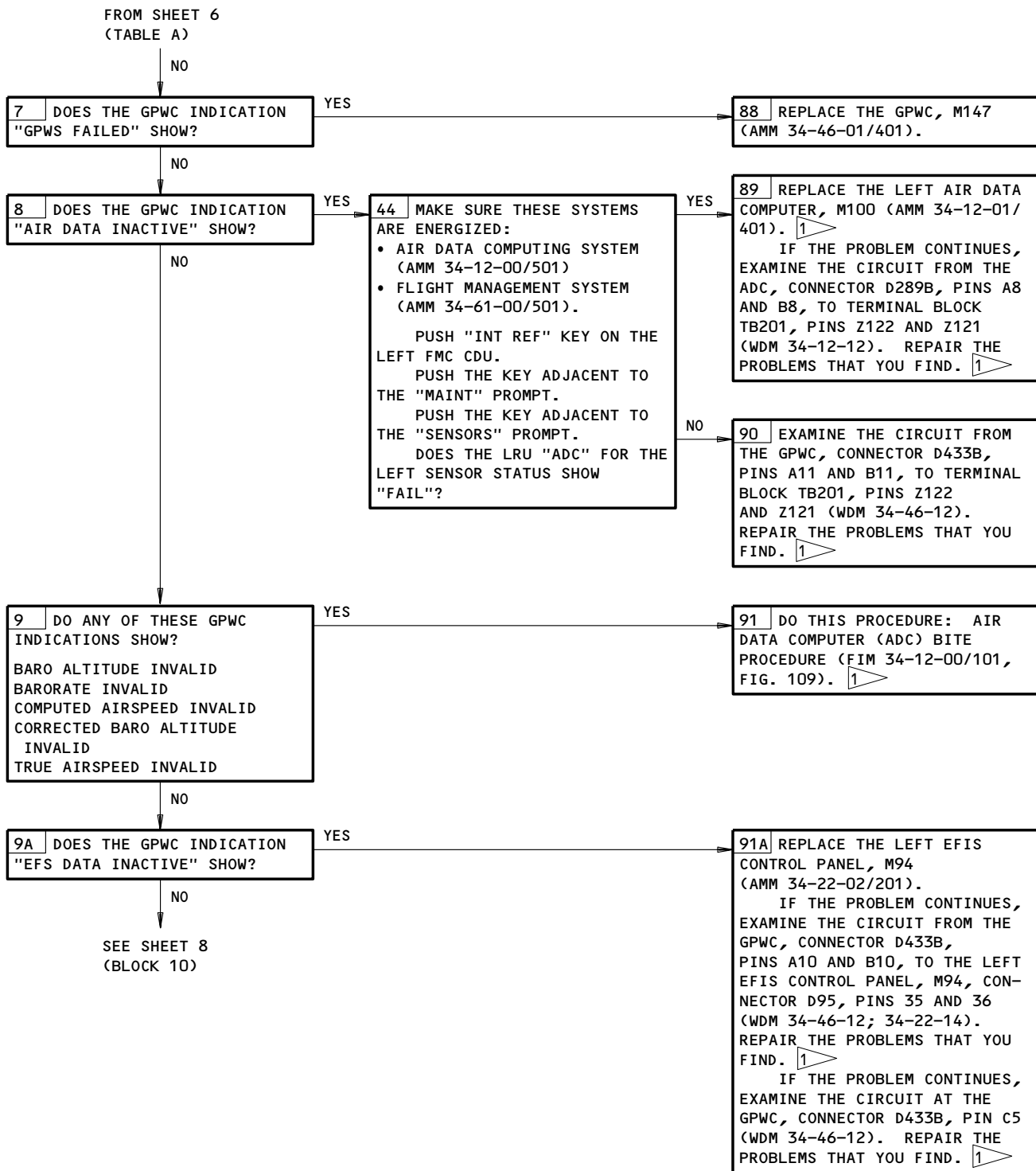

Ground Proximity Warning Computer BITE Procedure
Figure 103 (Sheet 7)

EFFECTIVITY
AIRPLANES WITH -206 AND PREVIOUS GPWC

34-46-00
 CONFIG 1
 Page 110
 Jan 28/03

02

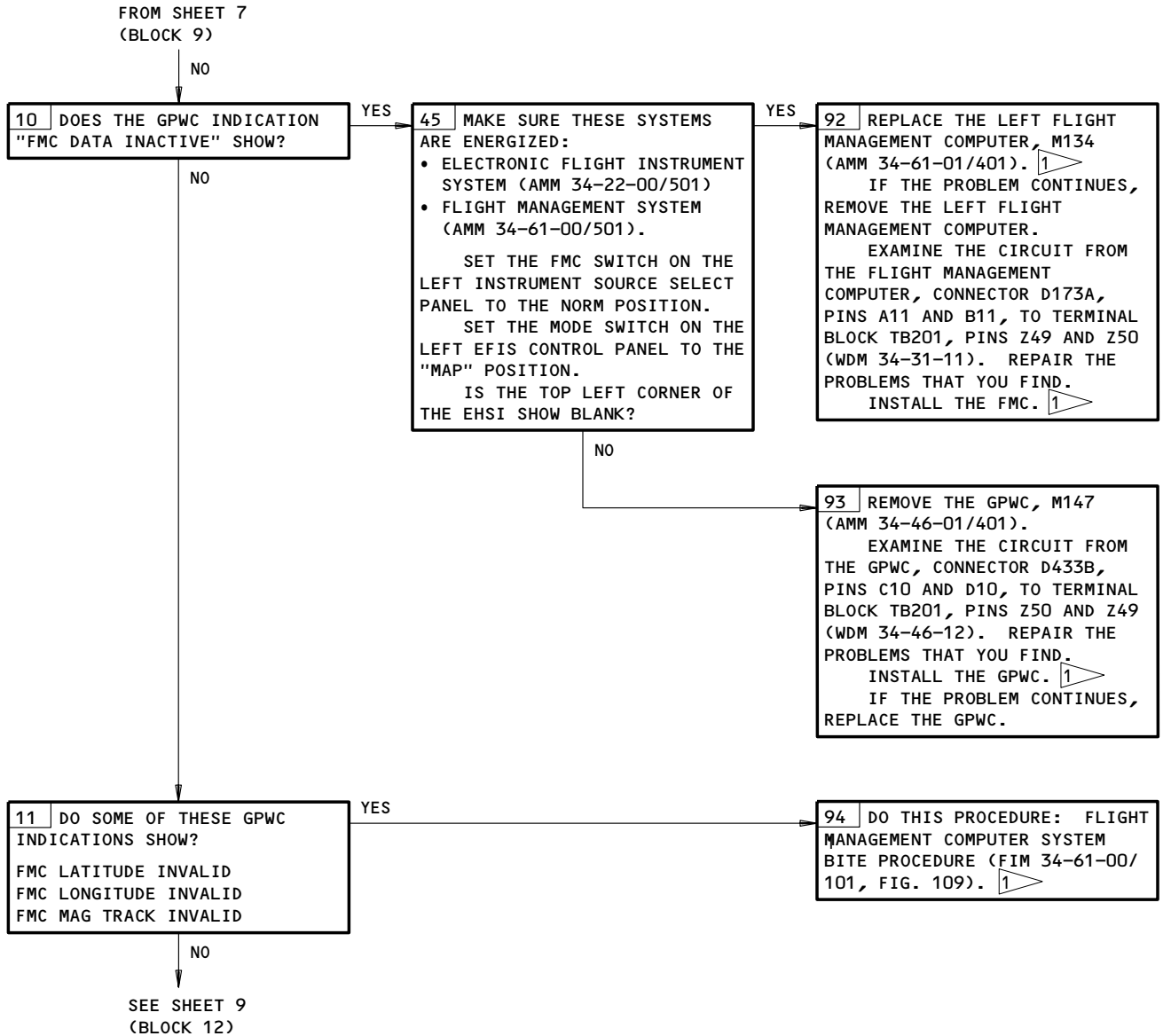

Ground Proximity Warning Computer BITE Procedure
Figure 103 (Sheet 8)

EFFECTIVITY
AIRPLANES WITH -206 AND PREVIOUS GPWC

34-46-00
 CONFIG 1
 Page 111
 Jan 28/03

02

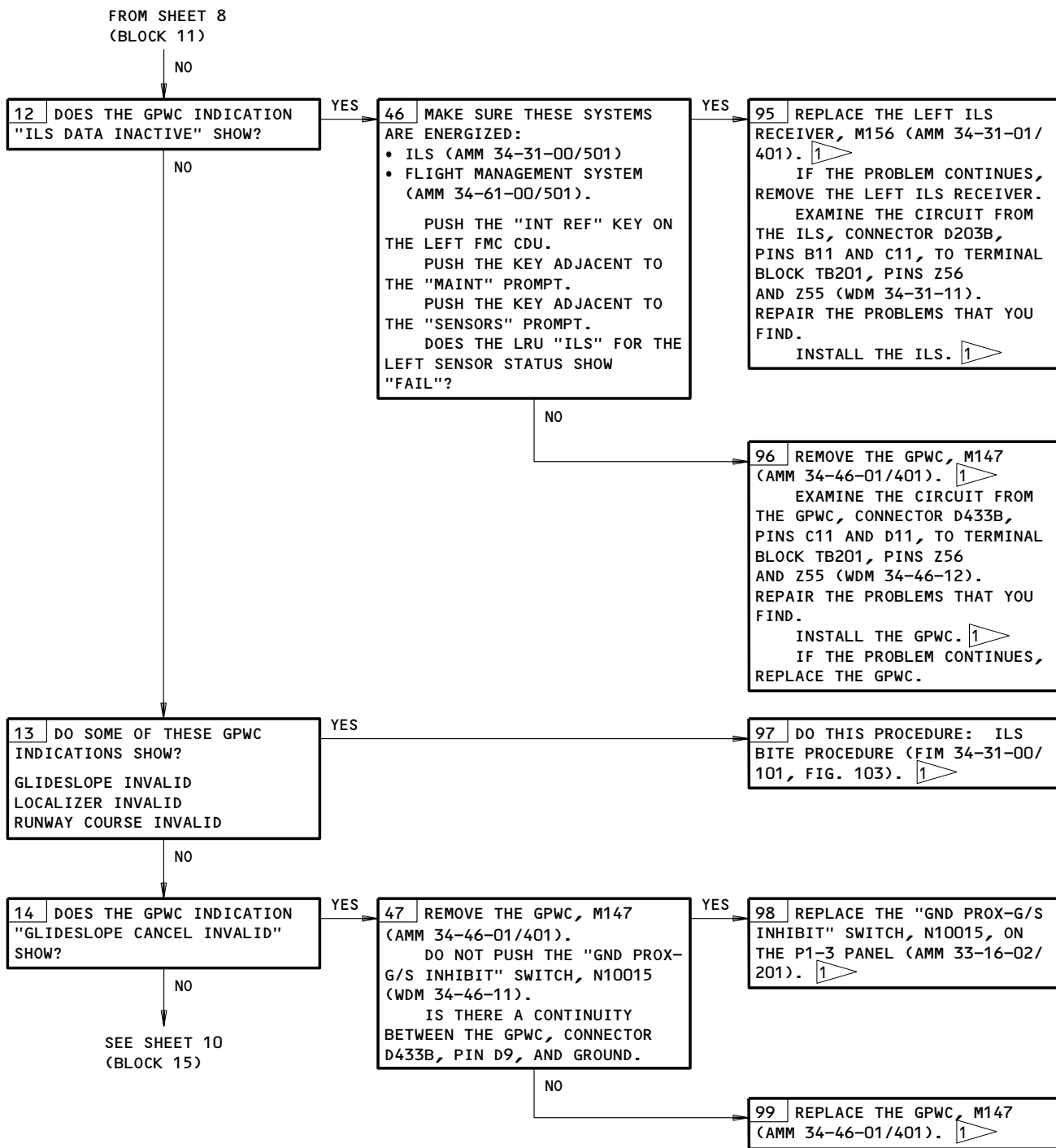

Ground Proximity Warning Computer BITE Procedure
Figure 103 (Sheet 9)

EFFECTIVITY
AIRPLANES WITH -206 AND PREVIOUS GPWC

34-46-00
 CONFIG 1
 Page 112
 Jan 28/03

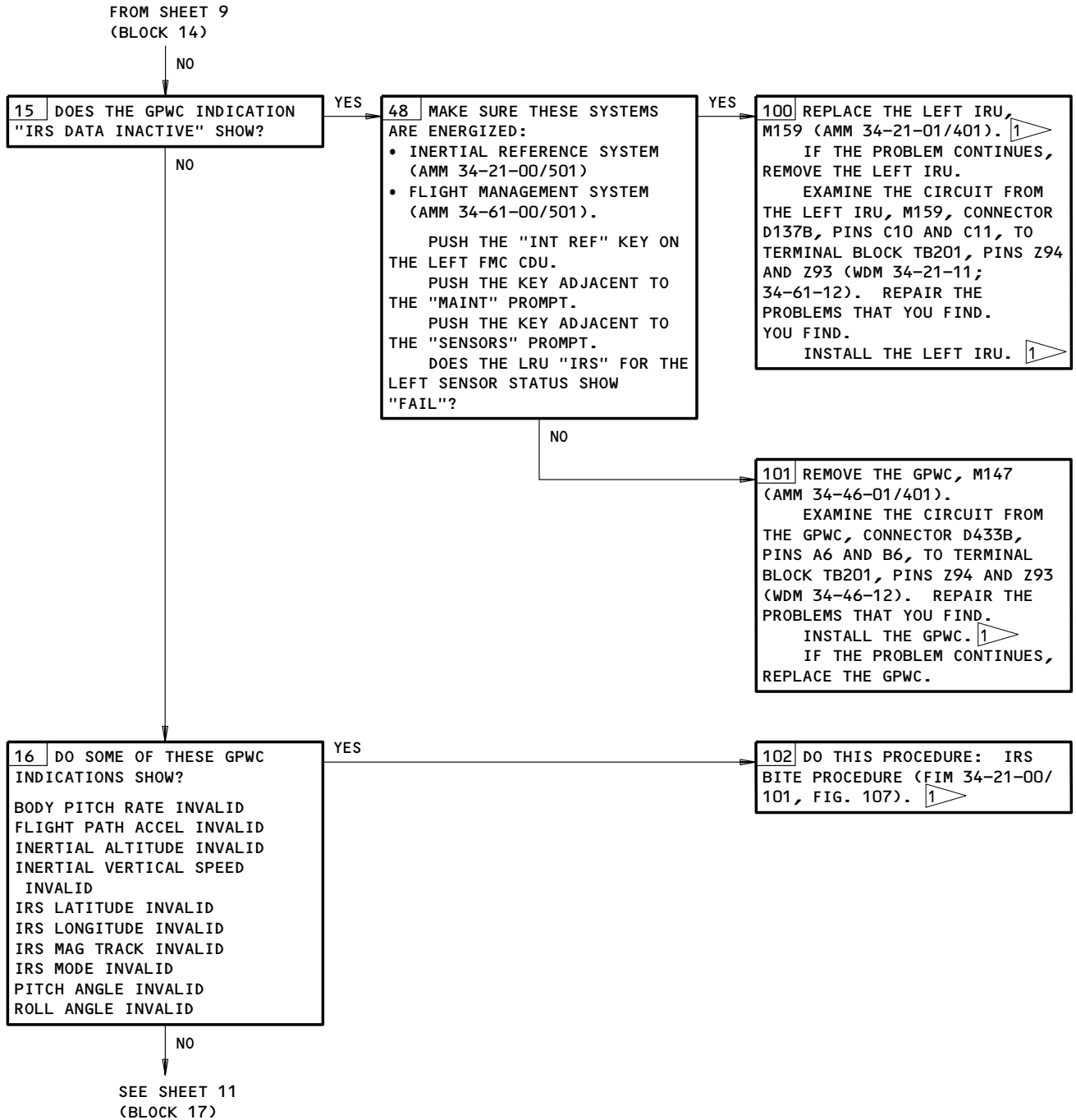

Ground Proximity Warning Computer BITE Procedure
Figure 103 (Sheet 10)

EFFECTIVITY
AIRPLANES WITH -206 AND PREVIOUS GPWC

34-46-00
CONFIG 1
Page 113
Jan 28/03

02

BOEING
757
FAULT ISOLATION/MAINT MANUAL

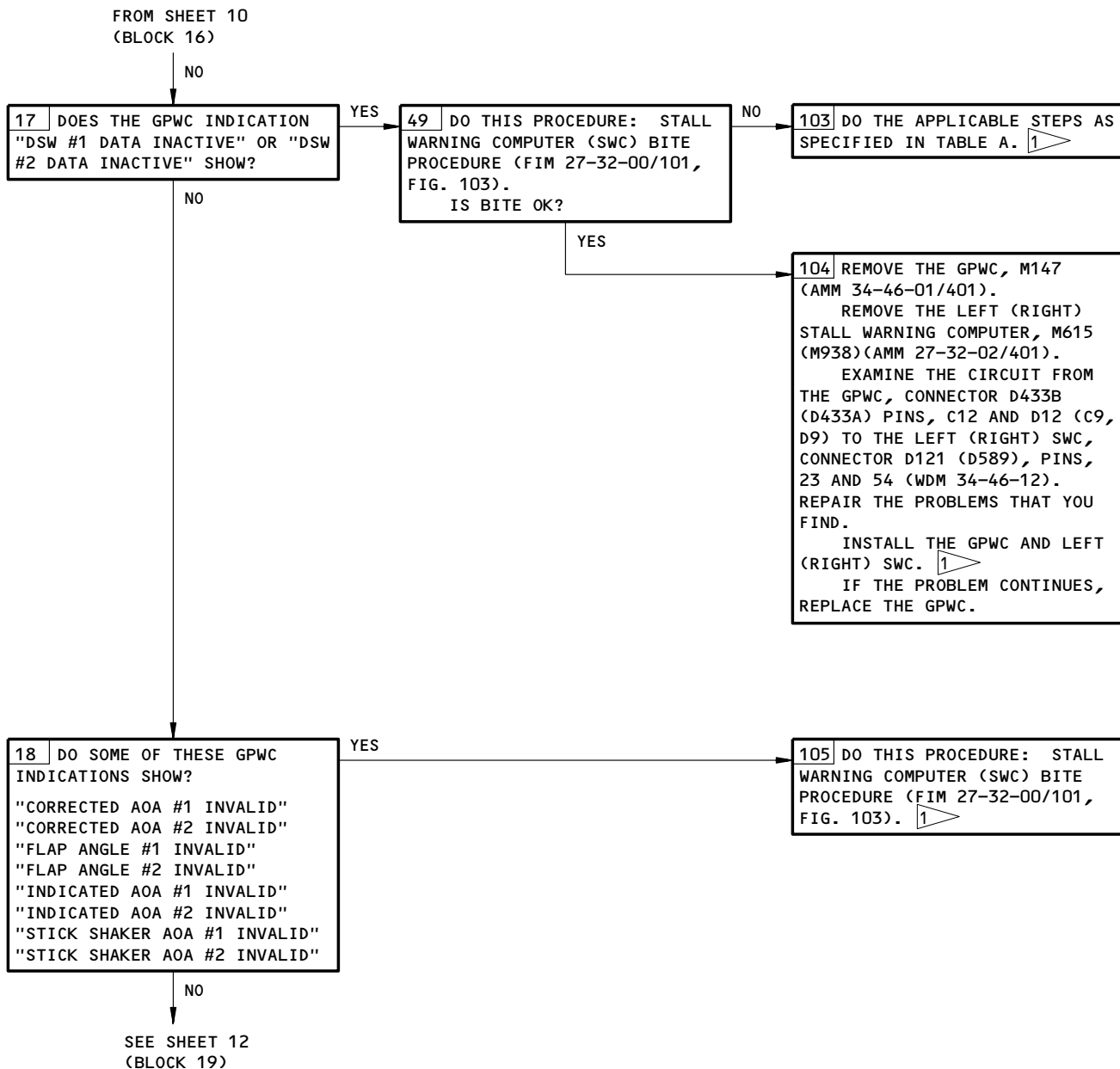

Ground Proximity Warning Computer BITE Procedure
Figure 103 (Sheet 11)

EFFECTIVITY
AIRPLANES WITH -206 AND PREVIOUS GPWC

34-46-00
CONFIG 1
Page 114
Jan 28/03

02

BOEING
757
FAULT ISOLATION/MAINT MANUAL

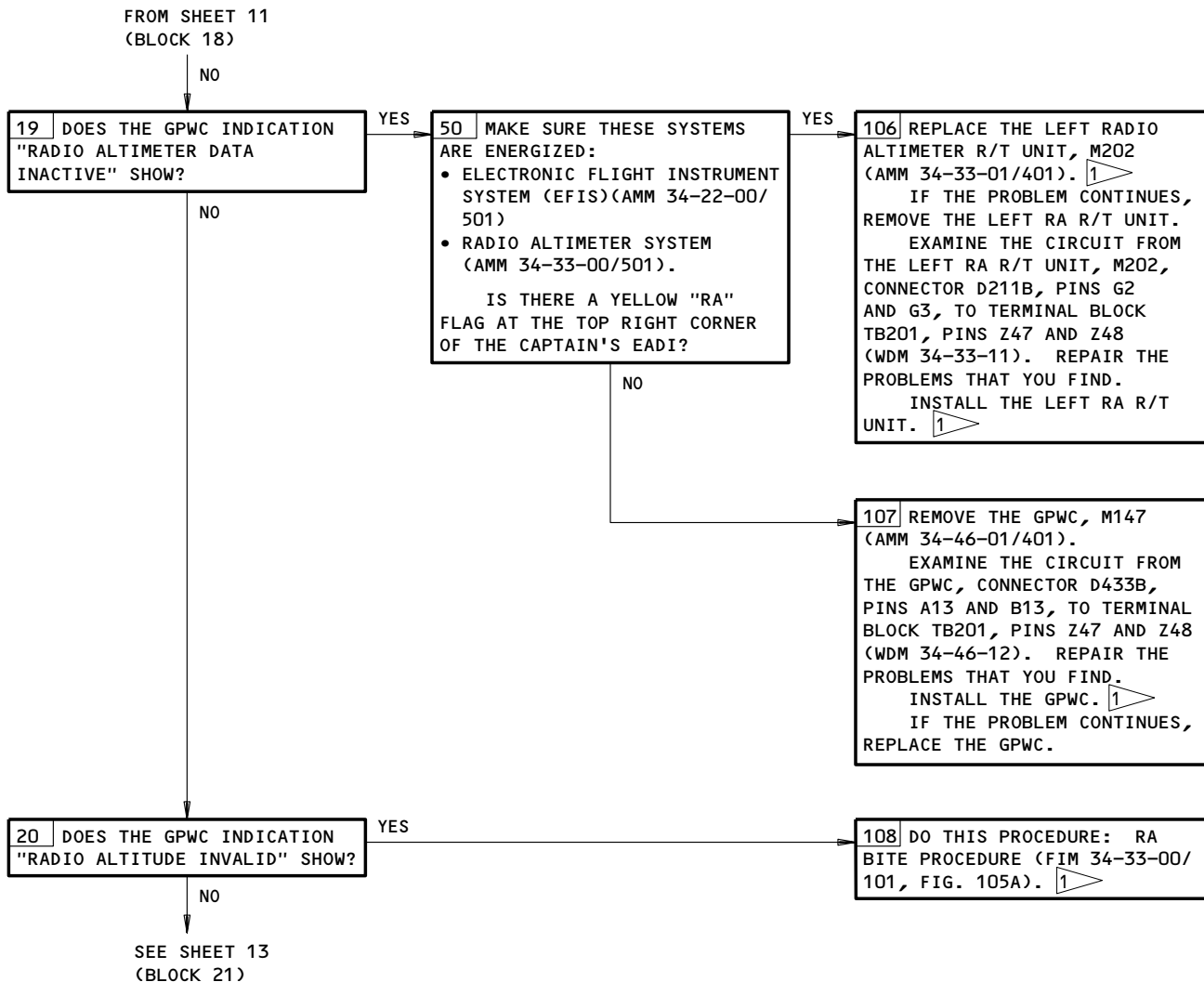

Ground Proximity Warning Computer BITE Procedure
Figure 103 (Sheet 12)

EFFECTIVITY
AIRPLANES WITH -206 AND PREVIOUS GPWC

34-46-00
CONFIG 1
Page 115
May 28/01

02

BOEING
 757
 FAULT ISOLATION/MAINT MANUAL

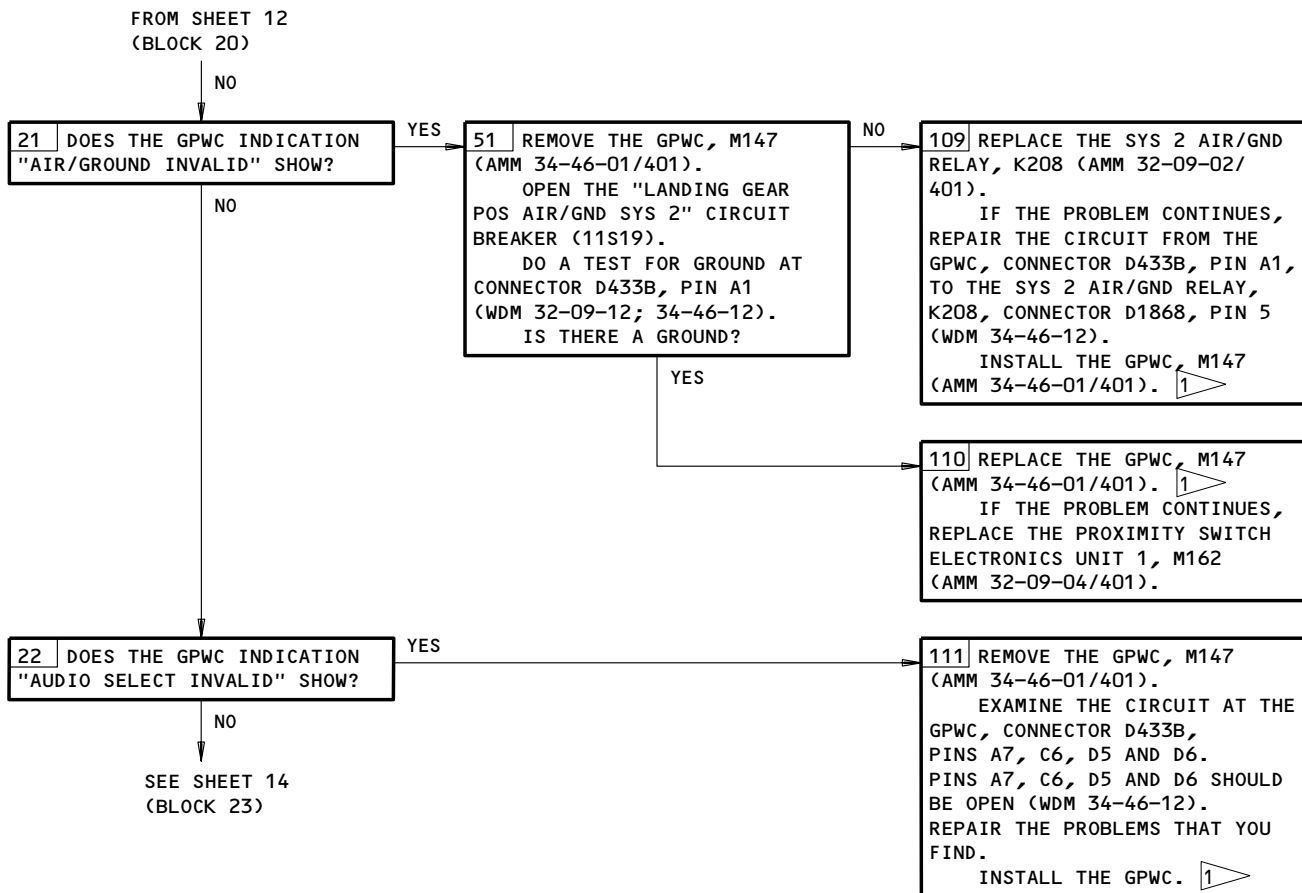

Ground Proximity Warning Computer BITE Procedure
Figure 103 (Sheet 13)

EFFECTIVITY
AIRPLANES WITH -206 AND PREVIOUS GPWC

34-46-00
 CONFIG 1
 Page 116
 May 28/99

02

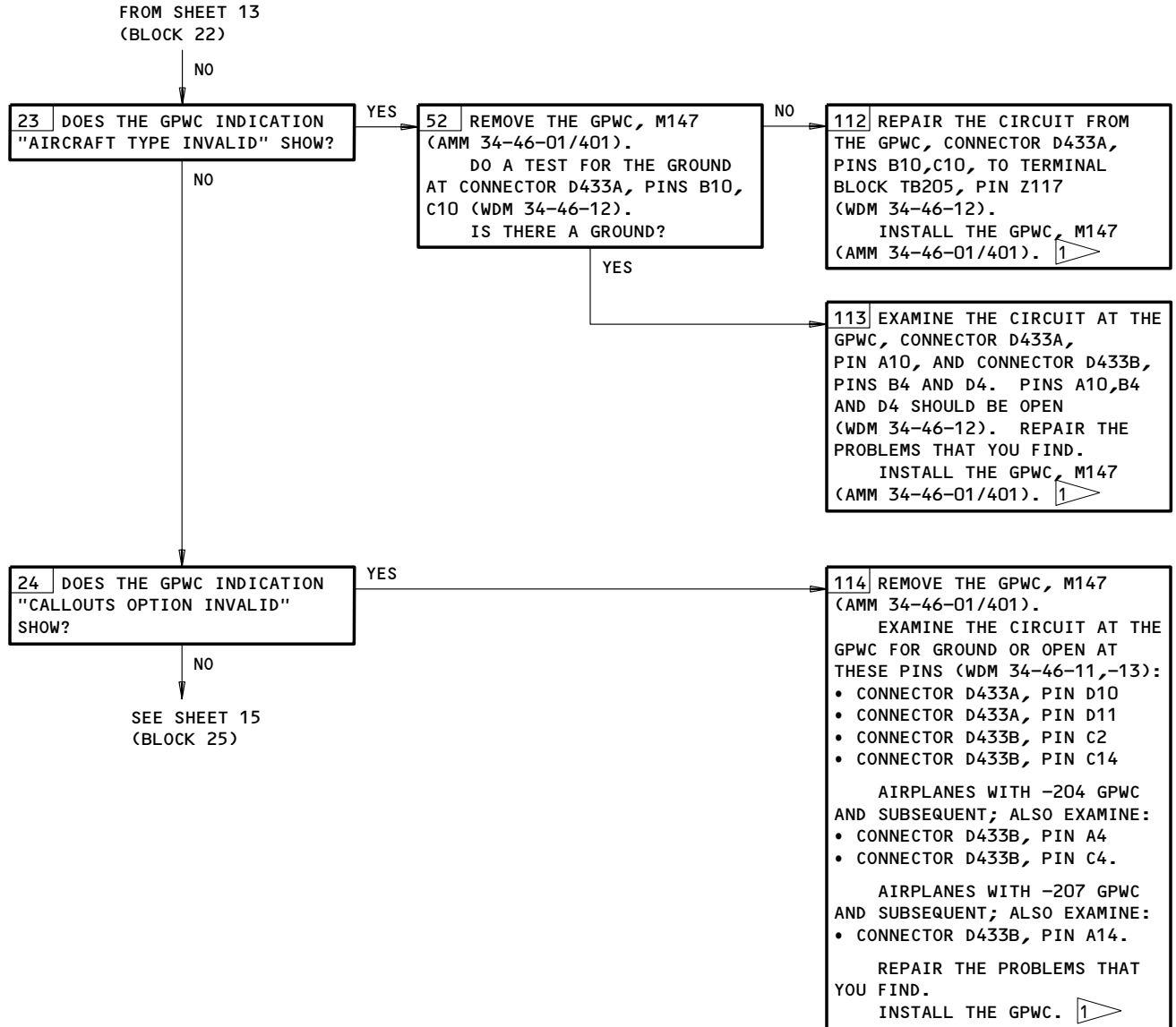

Ground Proximity Warning Computer BITE Procedure
Figure 103 (Sheet 14)

EFFECTIVITY
AIRPLANES WITH -206 AND PREVIOUS GPWC

34-46-00
CONFIG 1
Page 117
May 28/99

03

BOEING
 757
 FAULT ISOLATION/MAINT MANUAL



Ground Proximity Warning Computer BITE Procedure
Figure 103 (Sheet 15)

EFFECTIVITY
AIRPLANES WITH -206 AND PREVIOUS GPWC

34-46-00
 CONFIG 1
 Page 118
 May 28/02

05

Not Used
Figure 103A

EFFECTIVITY
AIRPLANES WITHOUT ENHANCED GPWC

34-46-00

CONFIG 1
Page 119
May 28/99

03

K23799

**GROUND PROXIMITY
WARNING COMPUTER
BITE PROCEDURE**

PREREQUISITES

MAKE SURE THESE SYSTEMS WILL OPERATE:
 ENGINE INDICATING AND CREW ALERTING SYSTEM
 (AMM 31-41-00/501)
 WARNING SYSTEM (AMM 31-51-00/501)
 AIR DATA COMPUTING SYSTEM (AMM 34-12-00/501)
 INERTIAL REFERENCE SYSTEM (AMM 34-21-00/501)
 ELECTRONIC FLIGHT INSTRUMENT SYSTEM (EFIS)
 (AMM 34-22-00/501)
 ILS (AMM 34-31-00/501)
 RADIO ALTIMETER SYSTEM (AMM 34-33-00/501)
 FLIGHT MANAGEMENT SYSTEM (AMM 34-61-00/501)

MAKE SURE THESE CIRCUIT BREAKERS ARE CLOSED:
 11B16, 11B18, 11F4, 11H35, 11J33

MAKE SURE THE AIRPLANE IS IN THIS CONFIGURATION:
 ELECTRICAL POWER IS ON (AMM 24-22-00/201)

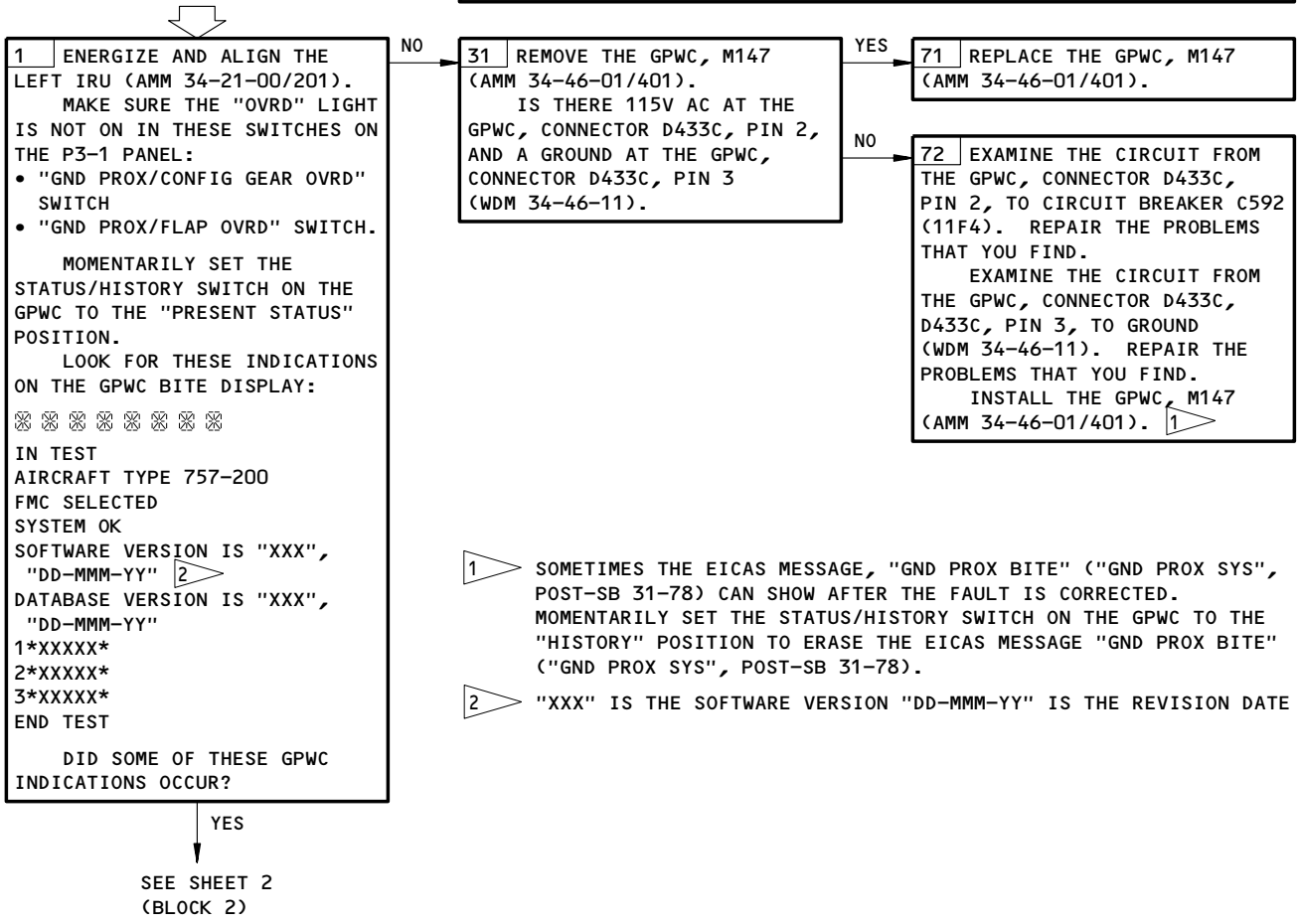

1 SOMETIMES THE EICAS MESSAGE, "GND PROX BITE" ("GND PROX SYS", POST-SB 31-78) CAN SHOW AFTER THE FAULT IS CORRECTED. MOMENTARILY SET THE STATUS/HISTORY SWITCH ON THE GPWC TO THE "HISTORY" POSITION TO ERASE THE EICAS MESSAGE "GND PROX BITE" ("GND PROX SYS", POST-SB 31-78).

2 "XXX" IS THE SOFTWARE VERSION "DD-MMM-YY" IS THE REVISION DATE

Ground Proximity Warning Computer BITE Procedure
Figure 103B (Sheet 1)

EFFECTIVITY
AIRPLANES WITH -207 AND ON GPWC

34-46-00
CONFIG 1
Page 120
Jan 28/03

BOEING
 757
 FAULT ISOLATION/MAINT MANUAL

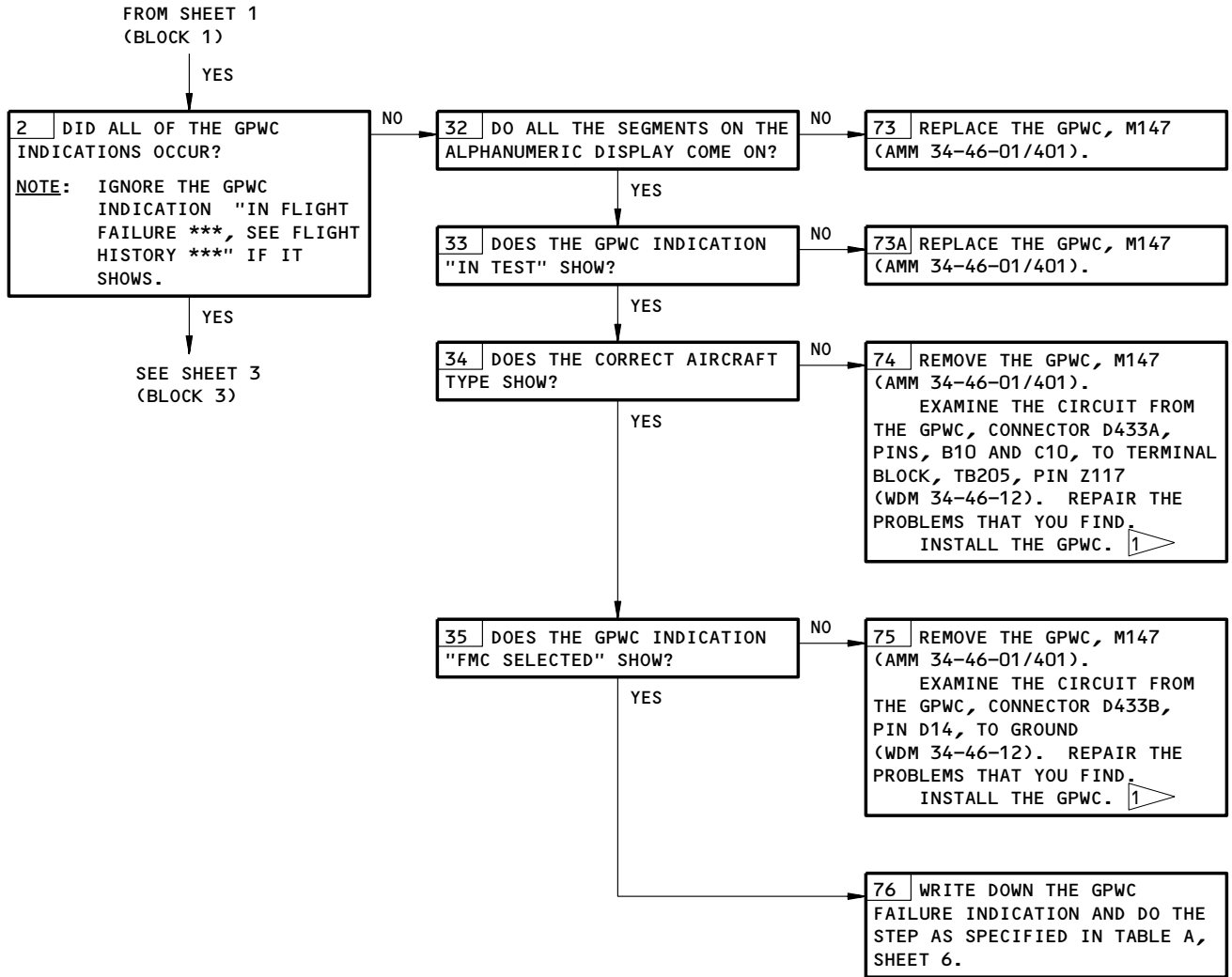

Ground Proximity Warning Computer BITE Procedure
Figure 103B (Sheet 2)

EFFECTIVITY
AIRPLANES WITH -207 AND ON GPWC

34-46-00
 CONFIG 1
 Page 121
 Jan 28/03

05

BOEING
 757
 FAULT ISOLATION/MAINT MANUAL

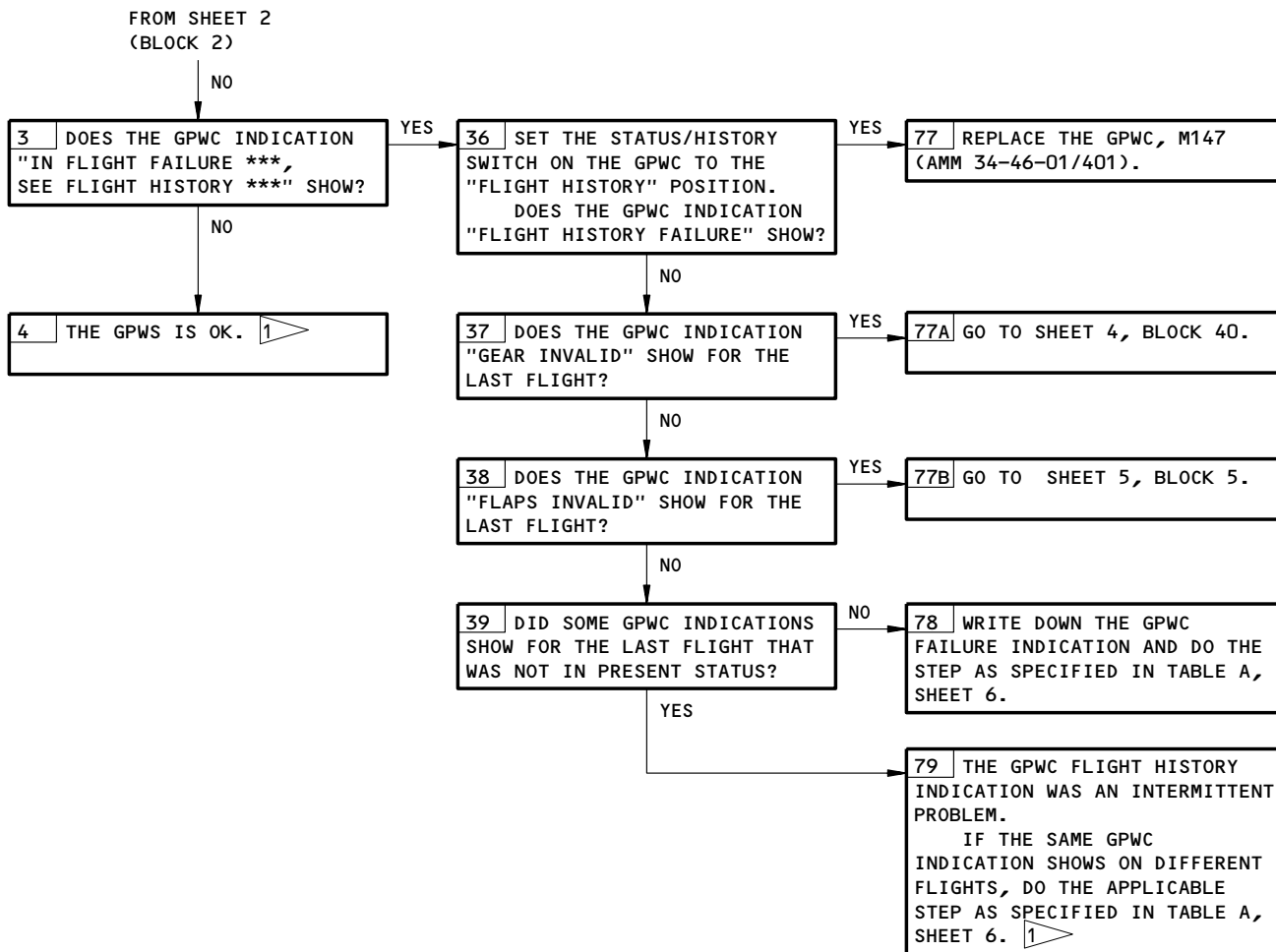

Ground Proximity Warning Computer BITE Procedure
Figure 103B (Sheet 3)

EFFECTIVITY
AIRPLANES WITH -207 AND ON GPWC

34-46-00
 CONFIG 1
 Page 122
 Jan 28/03

03

BOEING
757
FAULT ISOLATION/MAINT MANUAL

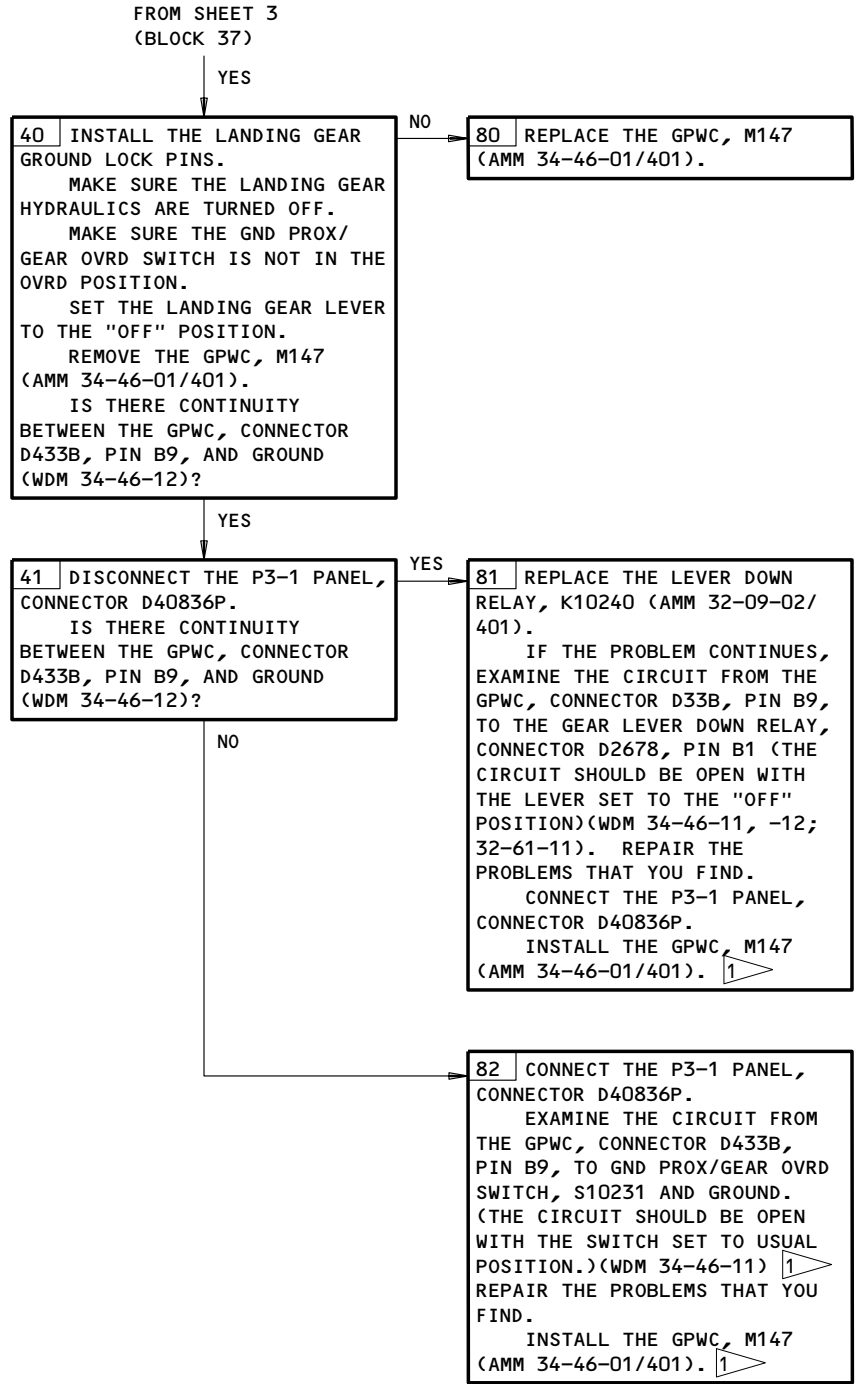

Ground Proximity Warning Computer BITE Procedure
Figure 103B (Sheet 4)

EFFECTIVITY
AIRPLANES WITH -207 AND ON GPWC

34-46-00
CONFIG 1
Page 123
May 28/99

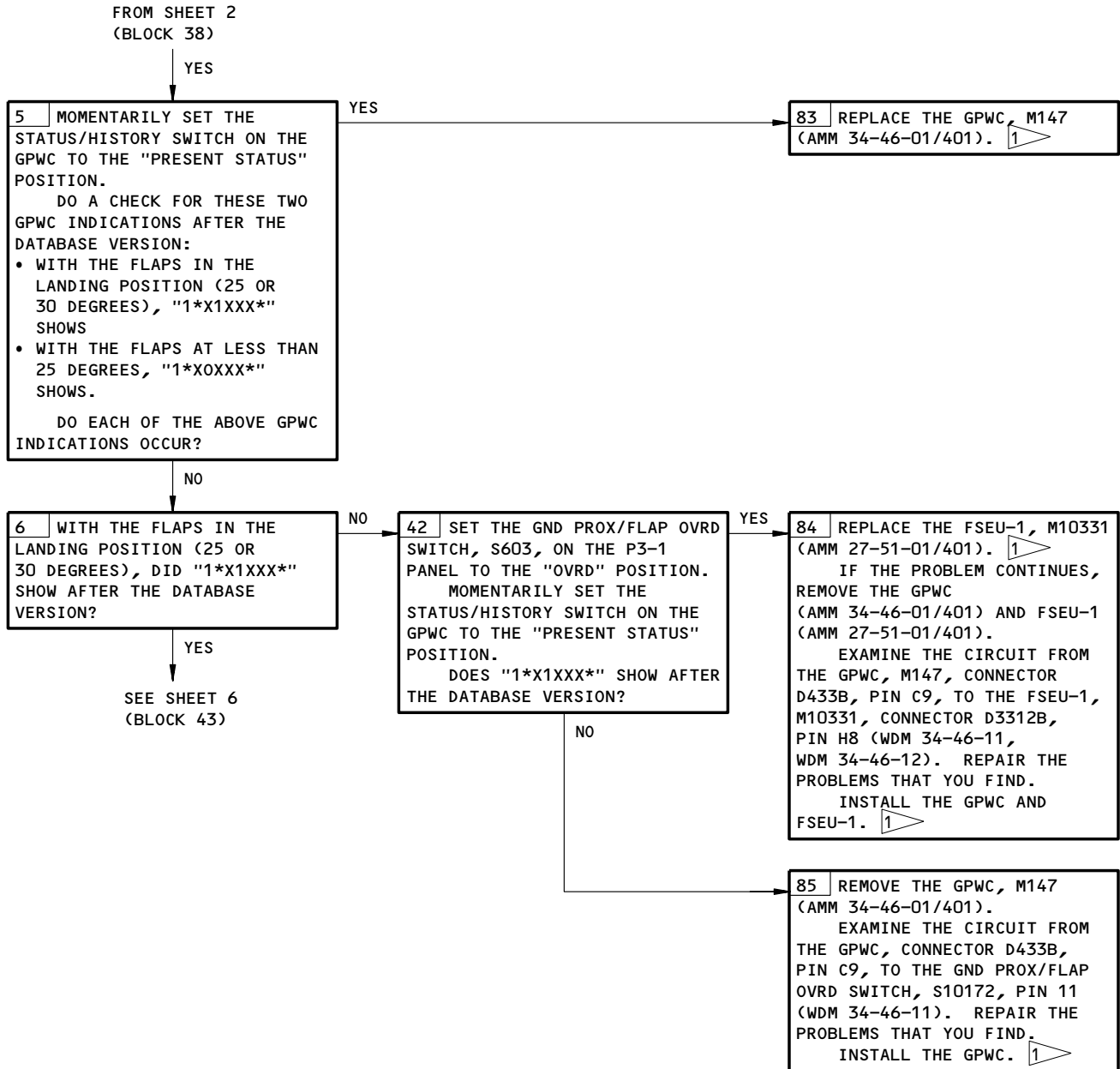

Ground Proximity Warning Computer BITE Procedure
Figure 103B (Sheet 5)

EFFECTIVITY
AIRPLANES WITH -207 AND ON GPWC

34-46-00

CONFIG 1
Page 124
Jan 28/03

BOEING

757

FAULT ISOLATION/MAINT MANUAL

FROM SHEET 5
(BLOCK 6)

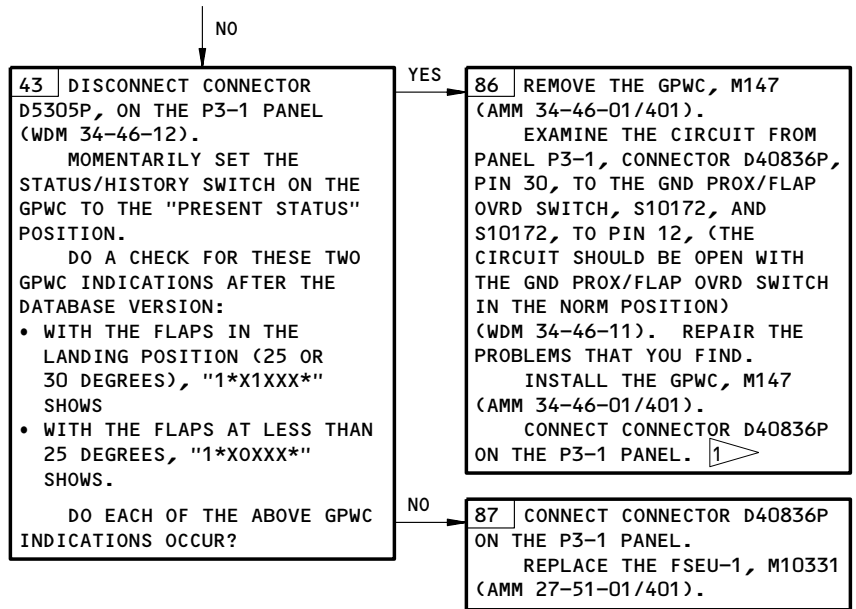

FAILURE INDICATION	REFER TO SHT-BLOCK
AIRCRAFT TYPE INVALID	14-23
AIR DATA INACTIVE	7-8
AIR/GROUND INVALID	13-21
AUDIO SELECT INVALID	13-22
BARO ALTITUDE INVALID	7-9
BARORATE INVALID	7-9
BODY PITCH RATE INVALID	10-16
CALLOUTS OPTION INVALID	14-24
COMPUTED AIRSPEED INVALID	7-9
CORRECTED BARO ALTITUDE INVALID	7-9
CORRECTED AOA #1 INVALID	11-18
CORRECTED AOA #2 INVALID	11-18
DSW #1 DATA INACTIVE	11-17
DSW #2 DATA INACTIVE	11-17
EFS DATA INACTIVE	7-9A
FLAP ANGLE #1 INVALID	11-18
FLAP ANGLE #2 INVALID	11-18
FLAPS INVALID	3-38
FLIGHT PATH ACCEL INVALID	10-16
FMC DATA INACTIVE	8-10
FMC LATITUDE INVALID	8-11
FMC LONGITUDE INVALID	8-11
FMC MAG TRACK INVALID	8-11
GEAR INVALID	3-37

FAILURE INDICATION	REFER TO SHT-BLOCK
GLIDESLOPE CANCEL INVALID	9-14
GLIDESLOPE INVALID	9-13
GPWS FAILED	7-7
ILS DATA INACTIVE	9-12
INDICATED AOA #1 INVALID	11-18
INDICATED AOA #2 INVALID	11-18
INERTIAL ALTITUDE INVALID	10-16
INERTIAL VERTICAL SPEED INVALID	10-16
IRS DATA INACTIVE	10-15
IRS LATITUDE INVALID	10-16
IRS LONGITUDE INVALID	10-16
IRS MAG TRACK INVALID	10-16
IRS MODE INVALID	10-16
LOCALIZER INVALID	9-13
PITCH ANGLE INVALID	10-16
QFE SELECTED	15-25
RADIO ALTIMETER DATA INACTIVE	12-19
RADIO ALTITUDE INVALID	12-20
ROLL ANGLE INVALID	10-16
RUNWAY COURSE INVALID	9-13
STICK SHAKER AOA #1 INVALID	11-18
STICK SHAKER AOA #2 INVALID	11-18
TRUE AIRSPEED INVALID	7-9

CONNECTIONS
TABLE A

Ground Proximity Warning Computer BITE Procedure
Figure 103B (Sheet 6)

EFFECTIVITY
AIRPLANES WITH -207 AND ON GPWC

34-46-00
CONFIG 1
Page 125
Jan 28/03

05

BOEING
757
FAULT ISOLATION/MAINT MANUAL

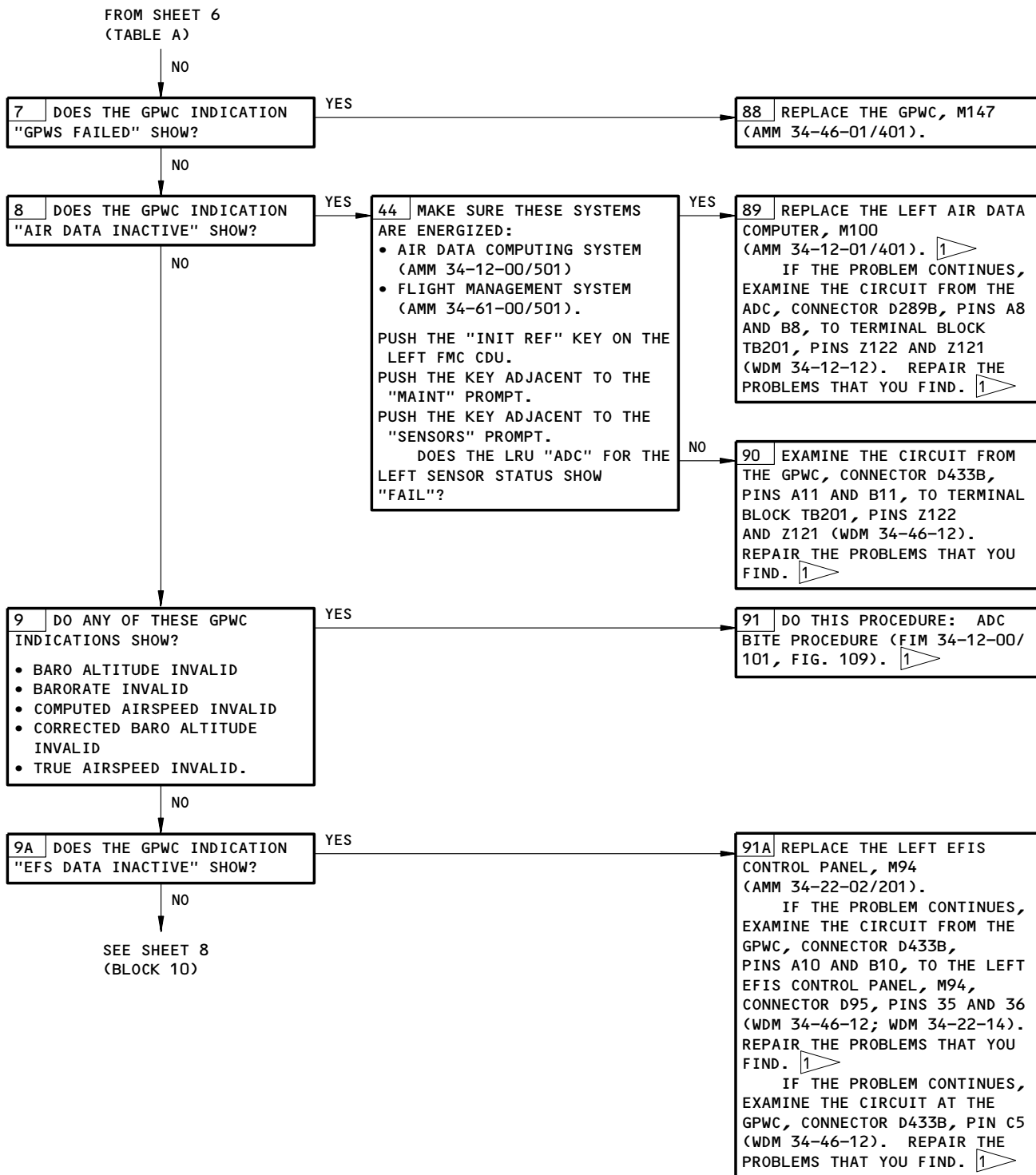

Ground Proximity Warning Computer BITE Procedure
Figure 103B (Sheet 7)

EFFECTIVITY
AIRPLANES WITH -207 AND ON GPWC

34-46-00
CONFIG 1
Page 126
Jan 28/03

04

BOEING
 757
 FAULT ISOLATION/MAINT MANUAL

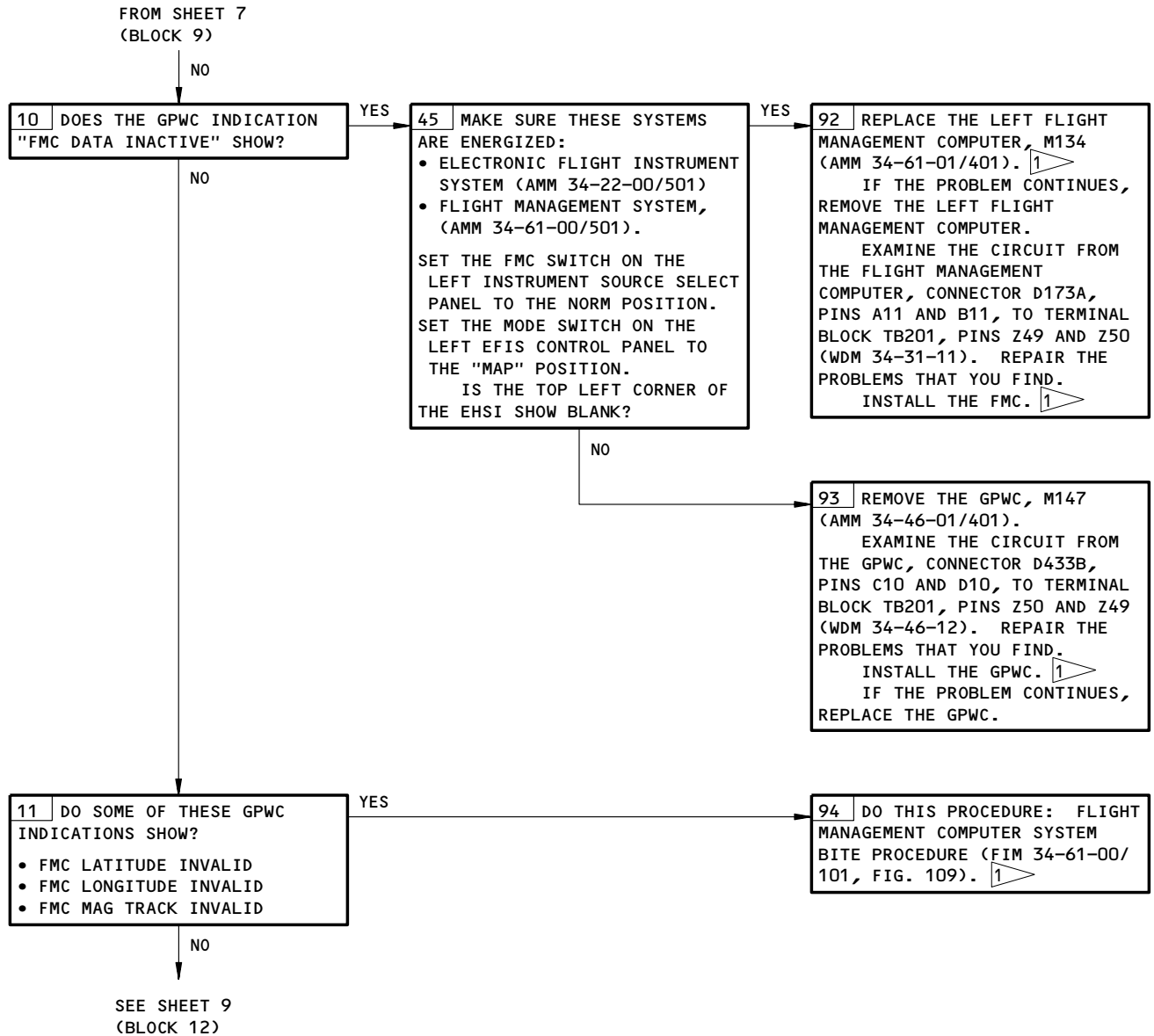

Ground Proximity Warning Computer BITE Procedure
Figure 103B (Sheet 8)

EFFECTIVITY
AIRPLANES WITH -207 AND ON GPWC

34-46-00
 CONFIG 1
 Page 127
 Jan 28/03

03

BOEING
757
FAULT ISOLATION/MAINT MANUAL

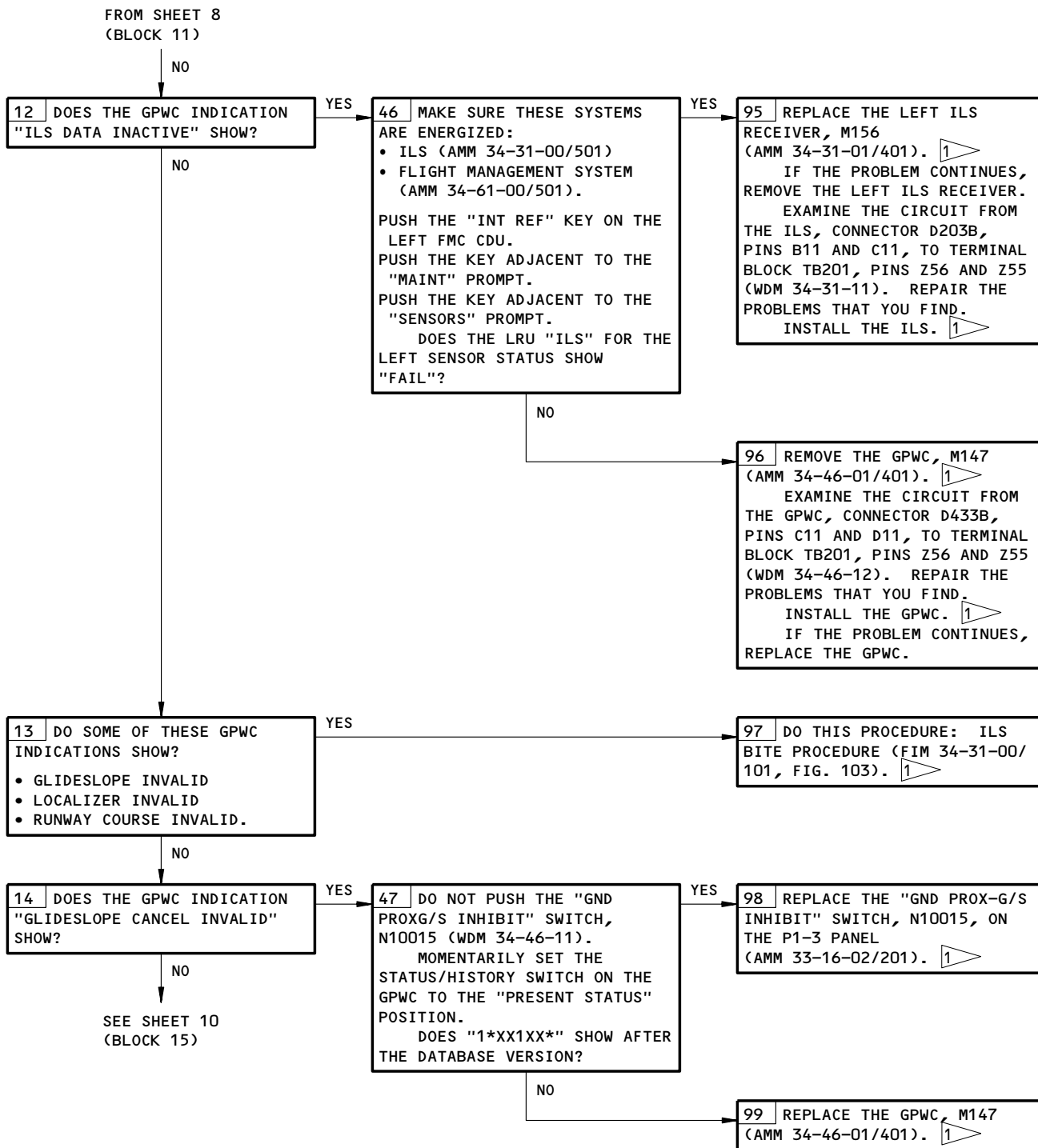

Ground Proximity Warning Computer BITE Procedure
Figure 103B (Sheet 9)

EFFECTIVITY
AIRPLANES WITH -207 AND ON GPWC

34-46-00
CONFIG 1
Page 128
Jan 28/03

02

BOEING
757
FAULT ISOLATION/MAINT MANUAL

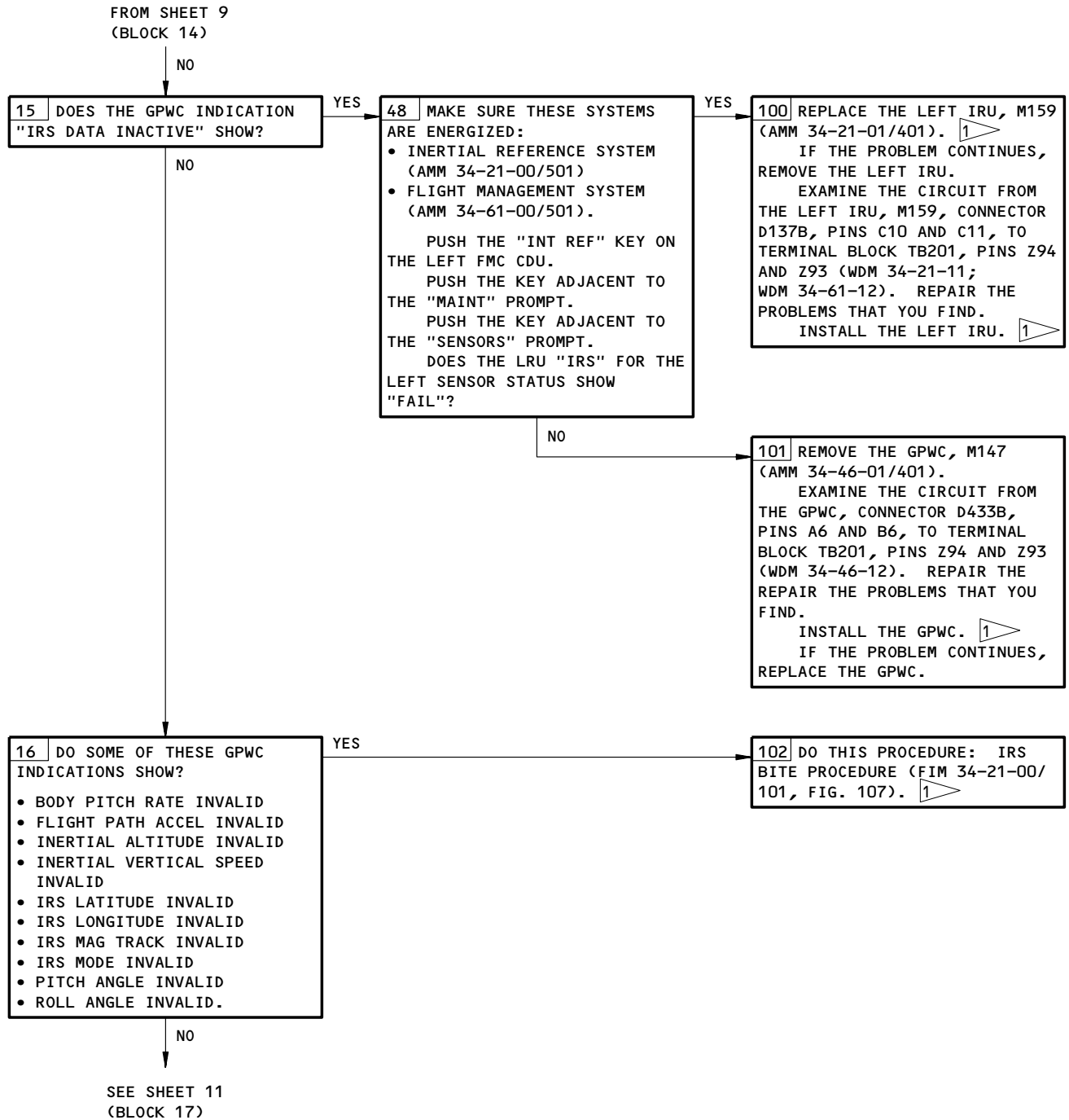

Ground Proximity Warning Computer BITE Procedure
Figure 103B (Sheet 10)

EFFECTIVITY
AIRPLANES WITH -207 AND ON GPWC

34-46-00
CONFIG 1
Page 129
Jan 28/03

03

BOEING
757
FAULT ISOLATION/MAINT MANUAL

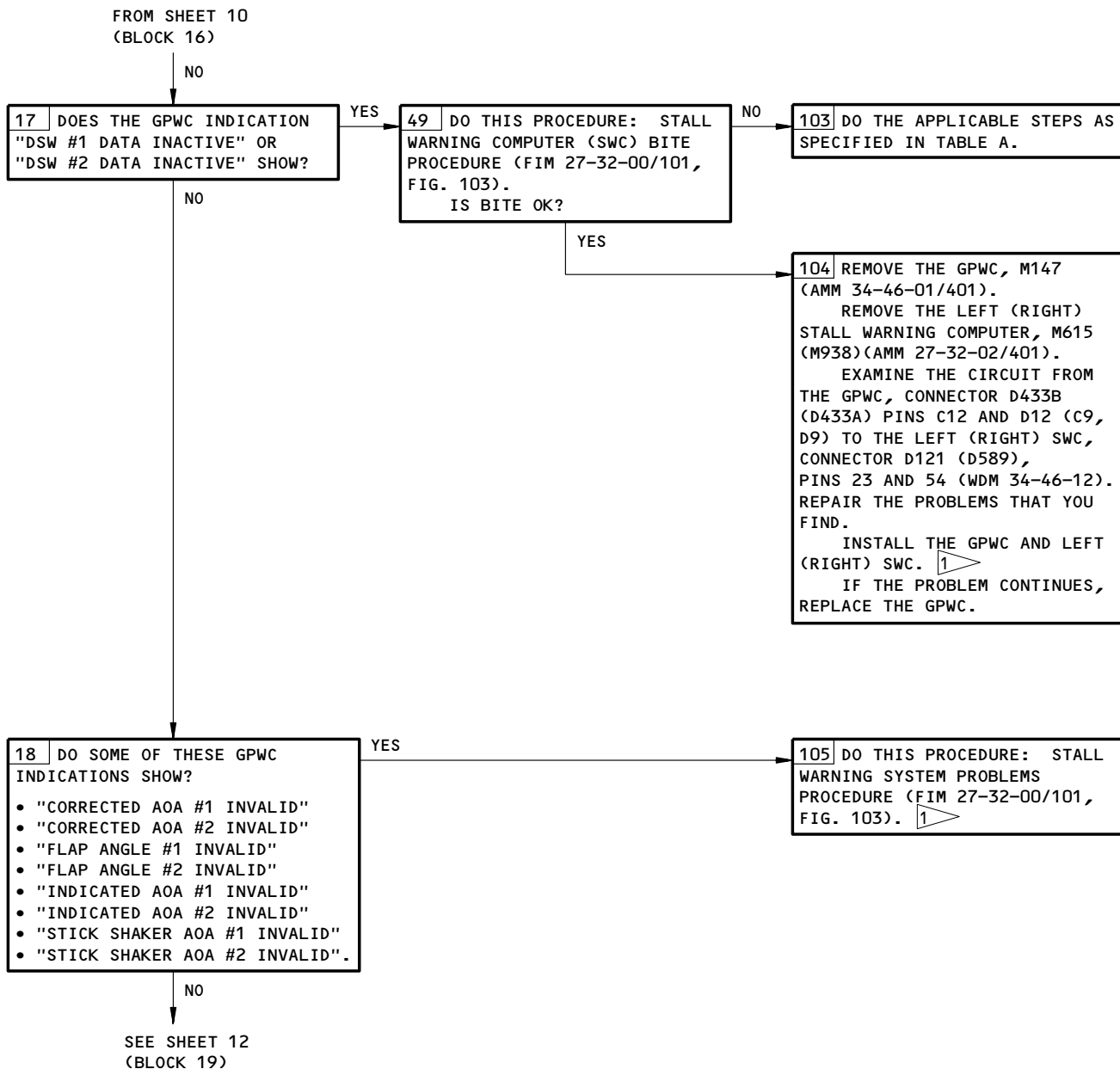

Ground Proximity Warning Computer BITE Procedure
Figure 103B (Sheet 11)

EFFECTIVITY
AIRPLANES WITH -207 AND ON GPWC

34-46-00
CONFIG 1
Page 130
Jan 28/03

03

BOEING
757
FAULT ISOLATION/MAINT MANUAL

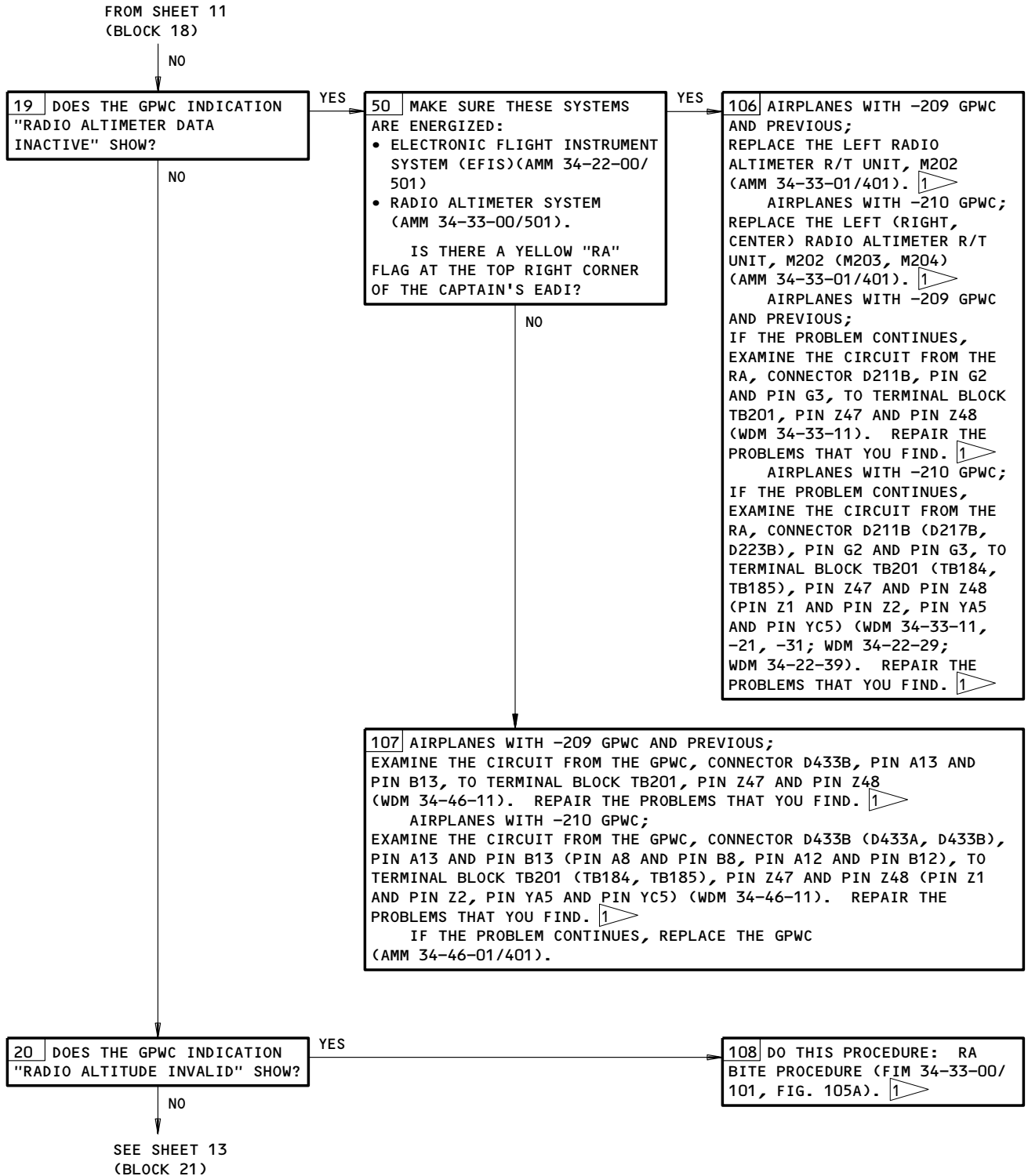

Ground Proximity Warning Computer BITE Procedure
Figure 103B (Sheet 12)

EFFECTIVITY
AIRPLANES WITH -207 AND ON GPWC

34-46-00
CONFIG 1
Page 131
May 28/01

02

BOEING
757
FAULT ISOLATION/MAINT MANUAL

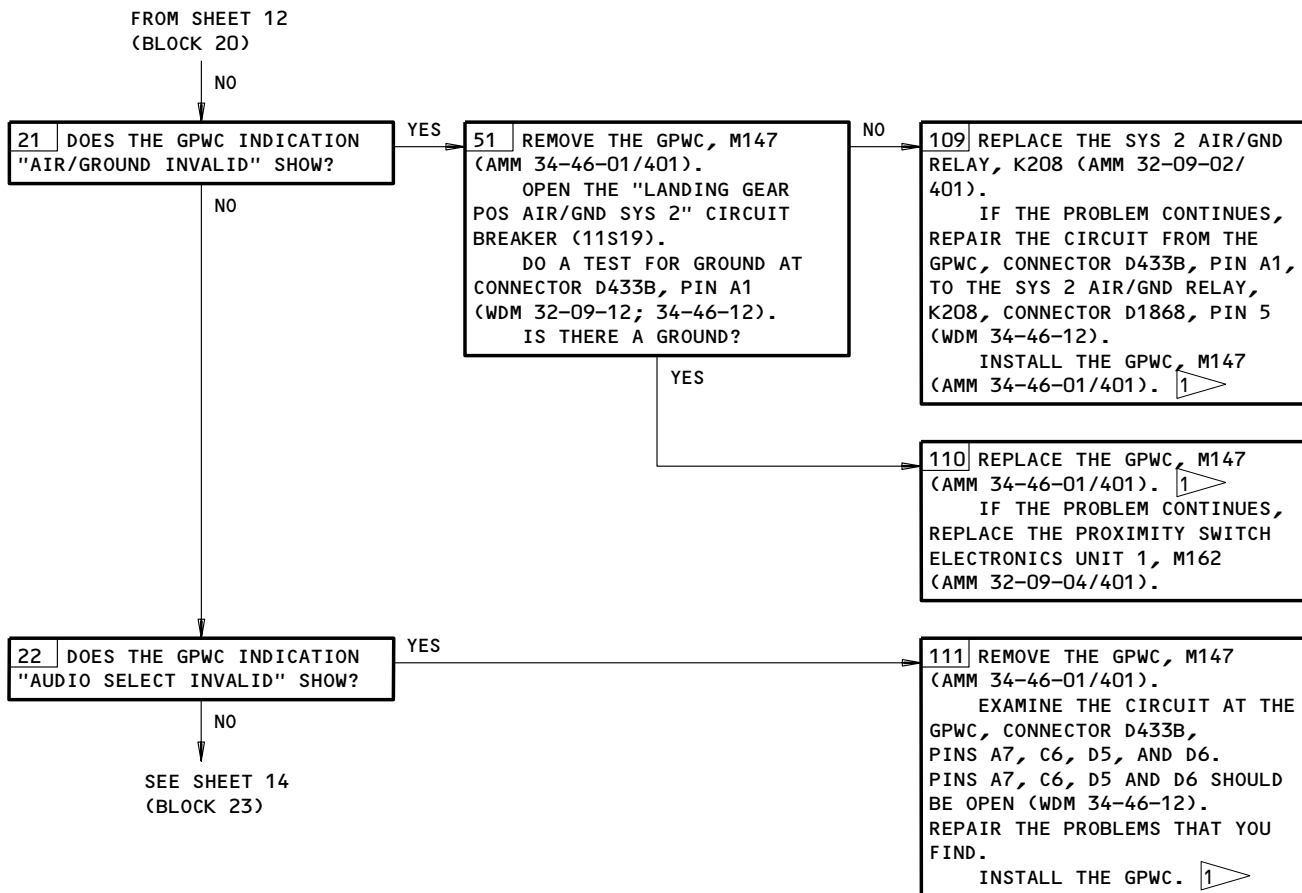

Ground Proximity Warning Computer BITE Procedure
Figure 103B (Sheet 13)

EFFECTIVITY
AIRPLANES WITH -207 AND ON GPWC

34-46-00
CONFIG 1
Page 132
May 28/99

02

BOEING
757
FAULT ISOLATION/MAINT MANUAL

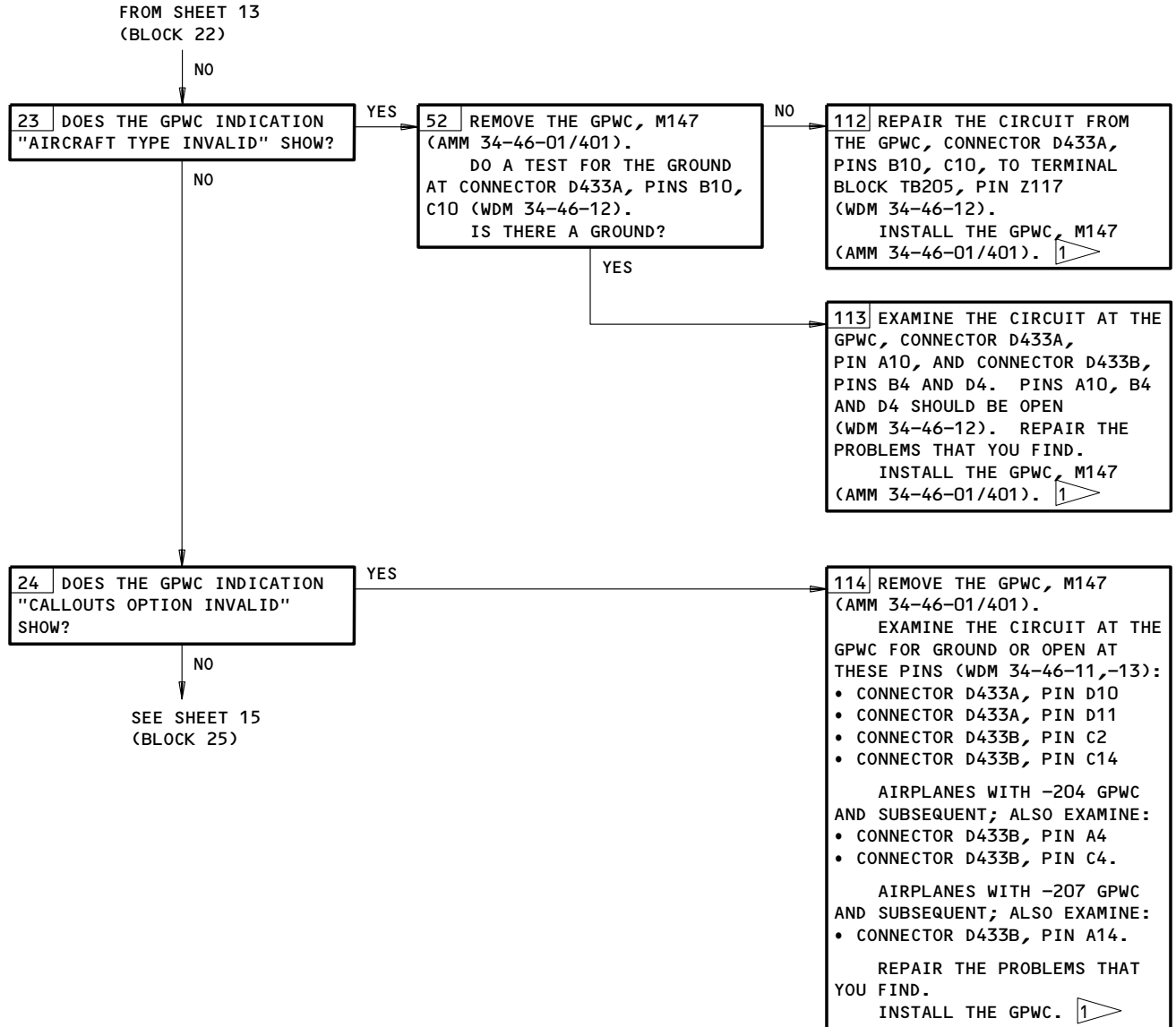

Ground Proximity Warning Computer BITE Procedure
Figure 103B (Sheet 14)

EFFECTIVITY
AIRPLANES WITH -207 AND ON GPWC

34-46-00
CONFIG 1
Page 133
May 28/99

02

BOEING
 757
 FAULT ISOLATION/MAINT MANUAL

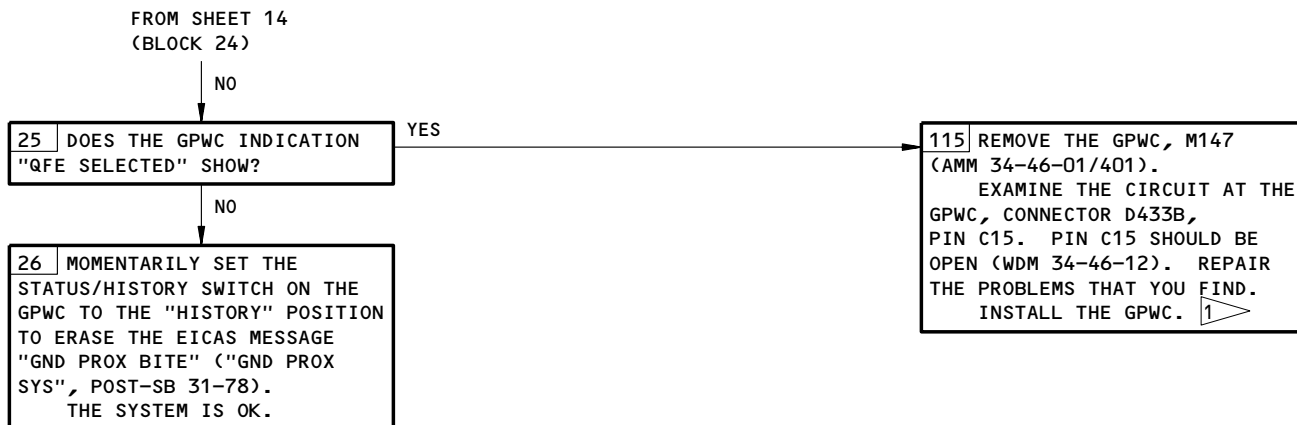

Ground Proximity Warning Computer BITE Procedure
Figure 103B (Sheet 15)

EFFECTIVITY
AIRPLANES WITH -207 AND ON GPWC

34-46-00
 CONFIG 1
 Page 134
 May 28/02

03

PREREQUISITES

MAKE SURE THESE SYSTEMS WILL OPERATE:
 STALL WARNING COMPUTER (AMM 27-32-00/501)
 ENGINE INDICATING AND CREW ALERTING SYSTEM (AMM 31-41-00/501)
 WARNING SYSTEM (AMM 31-51-00/501)
 AIR DATA COMPUTING SYSTEM (AMM 34-12-00/501)
 INERTIAL REFERENCE SYSTEM (AMM 34-21-00/501)
 ELECTRONIC FLIGHT INSTRUMENT SYSTEM (EFIS) (AMM 34-22-00/501)
 ILS (AMM 34-31-00/501), RADIO ALTIMETER SYSTEM (AMM 34-33-00/501)
 FLIGHT MANAGEMENT SYSTEM (AMM 34-61-00/501)

MAKE SURE THESE CIRCUIT BREAKERS ARE CLOSED:
 11B16, 11B18, 11F4, 11H35, 11J33

MAKE SURE THE AIRPLANE IS IN THIS CONFIGURATION:
 ELECTRICAL POWER IS ON (AMM 24-22-00/201)

GROUND PROXIMITY WARNING SYSTEM SELF-TEST

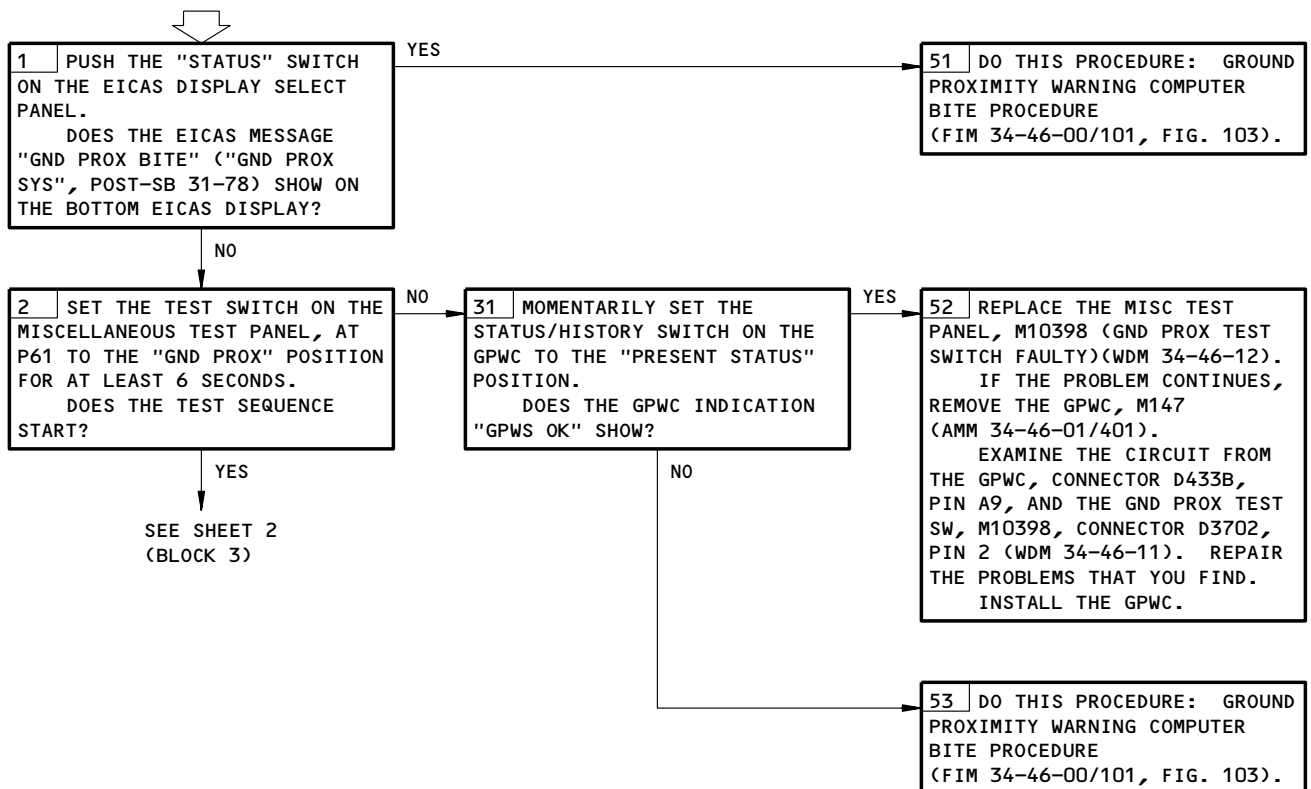

Ground Proximity Warning System Self-Test
Figure 104 (Sheet 1)

EFFECTIVITY
 AIRPLANES WITHOUT ENHANCED GPWC

34-46-00
 CONFIG 1
 Page 135
 Jan 28/03

FROM SHEET 1
(BLOCK 2)

YES

3 DO THESE TEST INDICATIONS OCCUR?

- THE "GND PROX" LIGHT COMES ON
- THE "GLIDE SLOPE" AURAL COMES ON
- THE "GND PROX" LIGHT GOES OFF
- THE "PULL UP" LIGHT COMES ON
- THE MASTER "WARNING" LIGHTS COME ON
- THE "WHOOOP-WHOOOP PULL UP" AURAL COMES ON
- THE "PULL UP" LIGHT GOES OFF
- THE "WINDSHEAR" LIGHT COMES ON
- THE RED "WINDSHEAR" MESSAGE ON
- THE CAPT AND F/O EADI COMES ON
- A SHORT SIREN AURAL COMES ON
- "WINDSHEAR" AURAL COMES ON
- THE "WINDSHEAR" LIGHT GOES OFF
- THE RED "WINDSHEAR" MESSAGE ON
- THE CAPT AND F/O EADI GOES OFF
- THE MASTER "WARNING" LIGHTS GO OFF
- THE EICAS MESSAGE "GND PROX BITE" ("GND PROX SYS", POST-SB 31-78) SHOWS ON THE STATUS PAGE.
- THE TOTAL VOCABULARY LIST IS PRONOUNCED.
- EICAS MESSAGE "GND PROX BITE" ("GND PROX SYS", POST-SB 31-78) IS NOT SHOWN.

YES

4 THE SYSTEM IS OK.

NO

32 DID THE "GND PROX" LIGHT COME ON?

NO

54 REMOVE THE GPWC, M147 (AMM 34-46-01/401).
EXAMINE THE CIRCUIT FROM THE GPWC, CONNECTOR D433B, PIN D3 AND THE TERMINAL BLOCK TB64, PIN YA11 (WDM 34-46-11). REPAIR THE PROBLEMS THAT YOU FIND.
INSTALL THE GPWC.

YES

33 DID THE "PULL UP" LIGHT COME ON?

NO

55 REMOVE THE GPWC, M147 (AMM 34-46-01/401).
EXAMINE THE CIRCUIT FROM THE GPWC, CONNECTOR D433B, PIN B7 AND THE TERMINAL BLOCK TB64, PIN YC11 (WDM 34-46-11). REPAIR THE PROBLEMS THAT YOU FIND.
INSTALL THE GPWC.

YES

SEE SHEET 3
(BLOCK 34)

Ground Proximity Warning System Self-Test
Figure 104 (Sheet 2)

EFFECTIVITY
AIRPLANES WITHOUT ENHANCED GPWC

34-46-00

CONFIG 1

Page 136

May 28/02

02

BOEING
757
FAULT ISOLATION/MAINT MANUAL

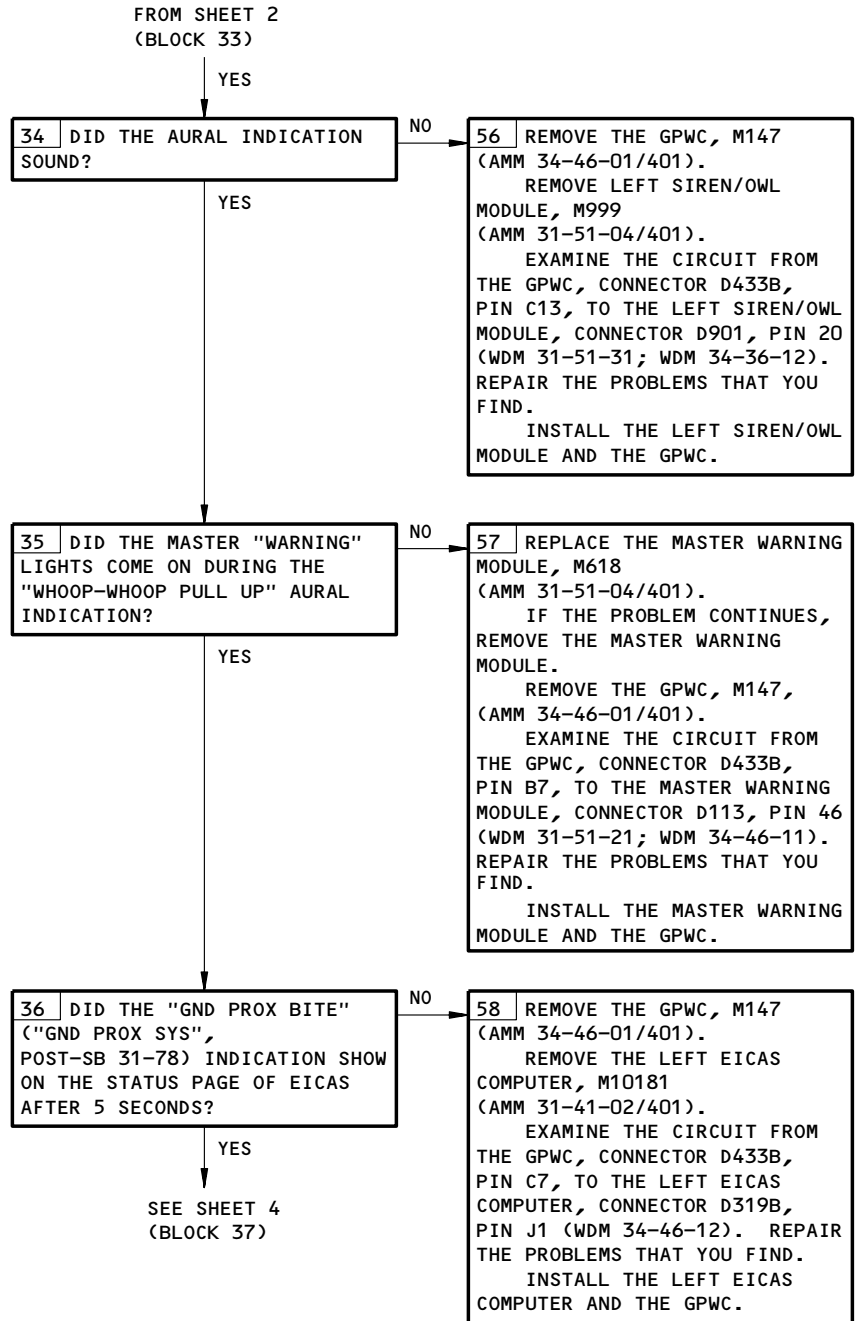

Ground Proximity Warning System Self-Test
Figure 104 (Sheet 3)

EFFECTIVITY
AIRPLANES WITHOUT ENHANCED GPWC

34-46-00
CONFIG 1
Page 137
May 28/02

02

BOEING
757
FAULT ISOLATION/MAINT MANUAL

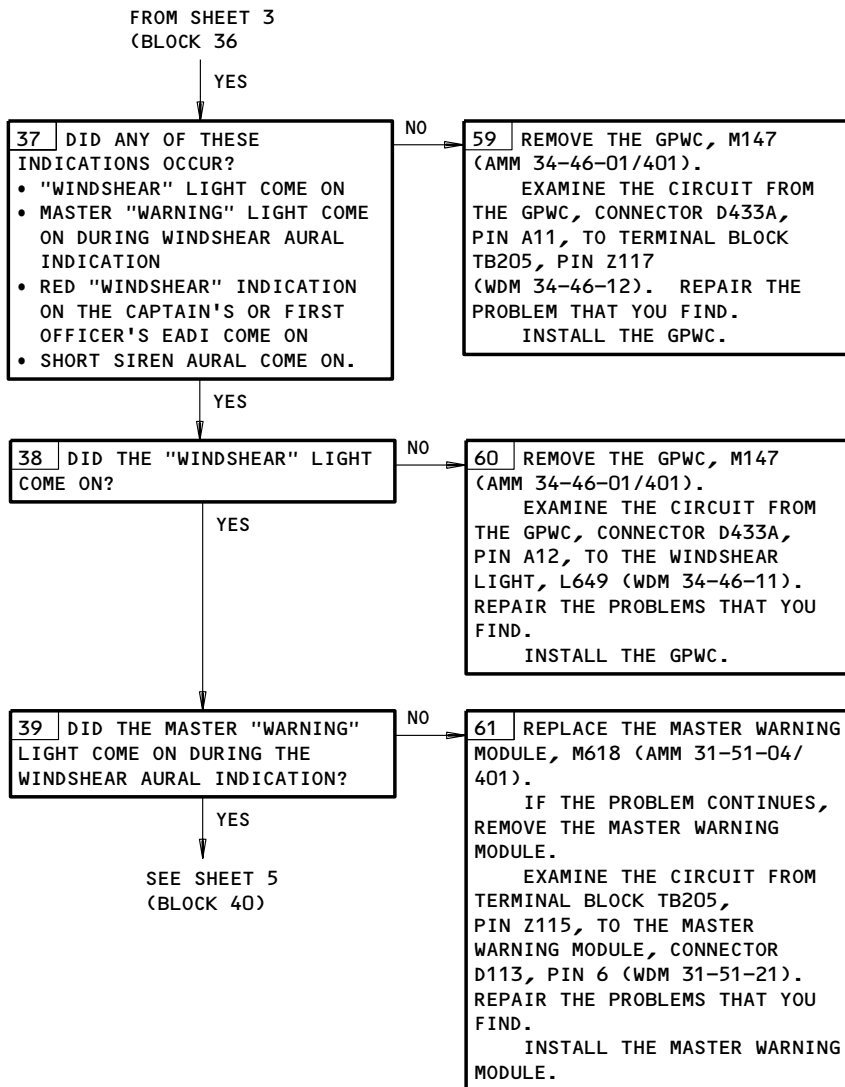

Ground Proximity Warning System Self-Test
Figure 104 (Sheet 4)

EFFECTIVITY
AIRPLANES WITHOUT ENHANCED GPWC

34-46-00
CONFIG 1
Page 138
May 28/99

02

BOEING
757
FAULT ISOLATION/MAINT MANUAL

FROM SHEET 4
(BLOCK 39)

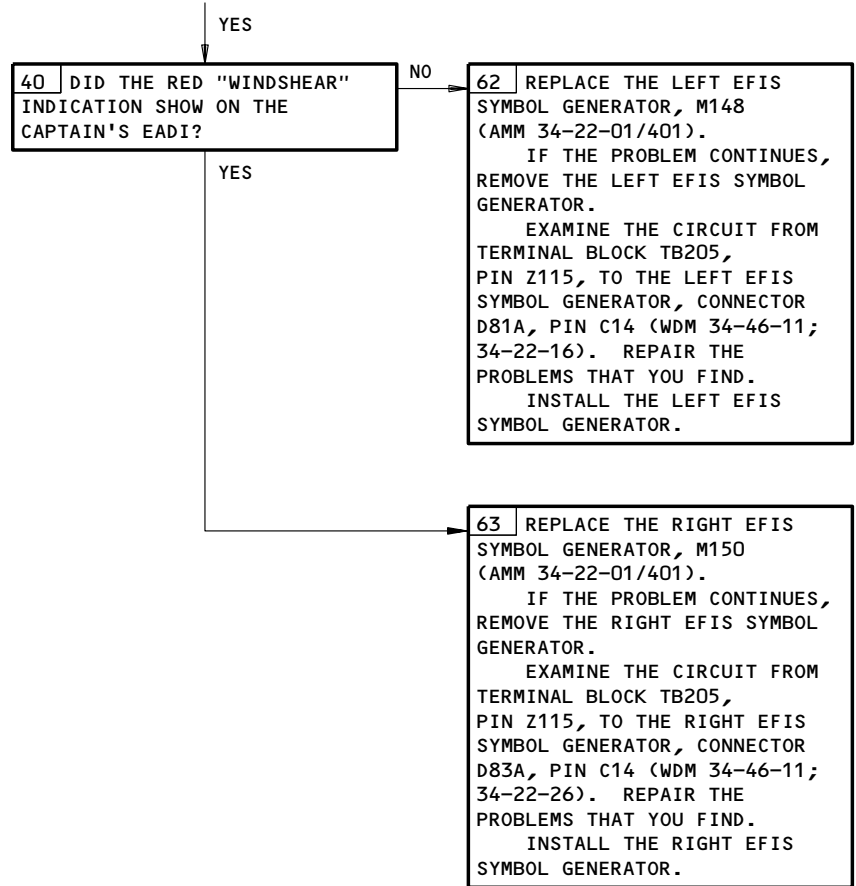

Ground Proximity Warning System Self-Test
Figure 104 (Sheet 5)

EFFECTIVITY
AIRPLANES WITHOUT ENHANCED GPWC

34-46-00
CONFIG 1
Page 139
May 28/99

02

 **BOEING**
757
FAULT ISOLATION/MAINT MANUAL

1. ARINC Data Bus Charts

A. General

CAUTION: DO NOT DIRECTLY TOUCH THE CONNECTORS. USE A BREAKOUT BOX OR YOU CAN CAUSE DAMAGE TO THE CONNECTORS.

- (1) The ARINC 429 data bus charts give data necessary to make an analysis of ARINC 429 transmitters, receivers, and data buses. For the test, use a breakout box at the available terminal or at the LRU connectors.

B. Equipment

- (1) Standard multi-meter
 (2) 429EBP Data Bus Analyzer (recommended)
 JcAIR Instrumentation
 400 Industrial Parkway
 Industrial Airport, KS 66031

429-2 Data Bus Analyzer (alternative)
 Interface Technology
 150 E. Arrow Highway
 San Dimas, CA 91773

- (3) A34011-1 Breakout Box (recommended)
 A34011-112 Breakout Box (alternative)

GPWC DIGITAL OUTPUT BUS CHART							
BUS NAME			CON	PINS	BUS FORMAT	BIT RATE	DATA BUS
SOURCE	TYPE	BUS					
GPWC	A	1	B	CO1 D01	429	LO	WARN MODE & MAINT

GPWC(ID=23) OCTAL LABELS CHART								
SIGNAL	TYPE	LABEL	FORMAT	MIN UPDATE RATE	SDI	BINARY RANGE	POSITIVE SENSE	UNITS
WARNING MODE+MAINT	A	270	DIS	12.5	00	N/A	N/A	N/A

EFFECTIVITY _____
 AIRPLANES WITHOUT ENHANCED GPWC

34-46-00

CONFIG 1
 Page 140
 May 28/99

BOEING
 757
 FAULT ISOLATION/MAINT MANUAL

GPWC DISCRETE OCTAL LABELS/BIT CHART				
SIGNAL	OCTAL LABEL	BIT	ONE-STATE	ZERO-STATE
SINK RATE	270	11	TRUE	NOT TRUE
PULL UP	270	12	TRUE	NOT TRUE
TERRAIN	270	13	TRUE	NOT TRUE
DON'T SINK	270	14	TRUE	NOT TRUE
TOO LOW GEAR	270	15	TRUE	NOT TRUE
TOO LOW FLAP	270	16	TRUE	NOT TRUE
TOO LOW TERRAIN	270	17	TRUE	NOT TRUE
GLIDESLOPE	270	18	TRUE	NOT TRUE
MINIMUMS	270	19	TRUE	NOT TRUE
TERRAIN PULL UP	270	20	TRUE	NOT TRUE
TOO LOW TERRAIN	270	22	TRUE	NOT TRUE
WIND SHEAR	270	23	TRUE	NOT TRUE

EFFECTIVITY
 AIRPLANES WITHOUT ENHANCED GPWC

34-46-00

CONFIG 1
 Page 141
 May 28/99

01



757
 FAULT ISOLATION/MAINT MANUAL

GROUND PROXIMITY WARNING SYSTEM

COMPONENT	FIG. 102 SHT	QTY	ACCESS/AREA	AMM REFERENCE
CIRCUIT BREAKER - GND PROX, C592		1	FLT COMPT, P11 11F4	*
TERRAIN DISPLAY, C4509		1	11E7	*
COMPUTER - GROUND PROXIMITY WARNING, M147	1	1	119BL, MAIN EQUIP CTR, E2-3	34-46-01
LIGHT - GND PROX PULL UP, M779	2	1	FLT COMPT, P1	*
LIGHT - WINDSHEAR, L649	2	1	FLT COMPT, P1	*
PANEL - (FIM 30-32-00/101) MISCELLANEOUS TEST, M10398				
SWITCH - GND PROX TEST, S2	2	1	FLT COMPT, P61	*
SWITCH-LIGHT - GND PROX GEAR OVRD, S10231	2	1	FLT COMPT, P3	*
SWITCH-LIGHT - GND PROX FLAP OVRD, S10172	2	1	FLT COMPT, P3	*
SWITCH-LIGHT - GND PROX - G/S INHB, N10015	2	1	FLT COMPT, P1	*
SWITCH-LIGHT - TERR OVRD, S10680	2	1	FLT COMPT, P3	*

* SEE THE WDM EQUIPMENT LIST

Ground Proximity Warning System - Component Index
 Figure 101

EFFECTIVITY
 AIRPLANES WITH THE ENHANCED GPWC

34-46-00

CONFIG 3

01

Page 101

Jan 28/00

K20972

BOEING
757
FAULT ISOLATION/MAINT MANUAL

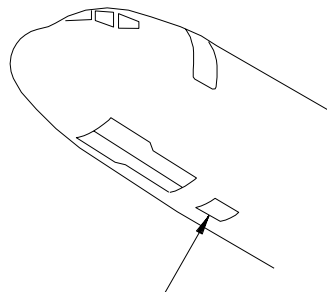

MAIN EQUIPMENT CENTER
ACCESS DOOR, 119BL

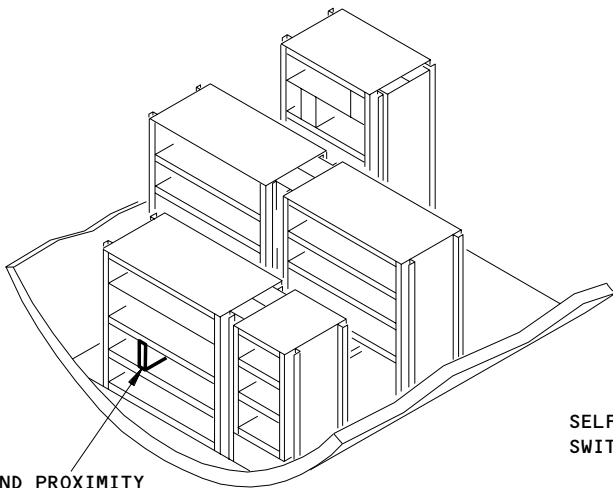

GROUND PROXIMITY
WARNING COMPUTER, M147
(E2-3)

SEE (A)

MAIN EQUIPMENT CENTER

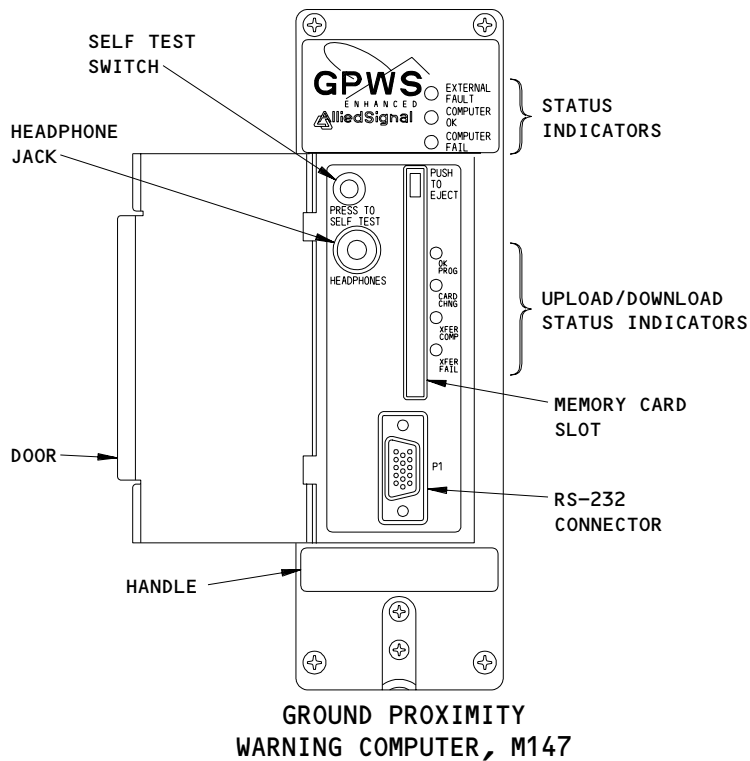

GROUND PROXIMITY
WARNING COMPUTER, M147

(A)

Ground Proximity Warning System - Component Location
Figure 102 (Sheet 1)

EFFECTIVITY
AIRPLANES WITH THE ENHANCED GPWC

34-46-00

CONFIG 3

Page 102

May 28/99

01

K21170

BOEING

757

FAULT ISOLATION/MAINT MANUAL

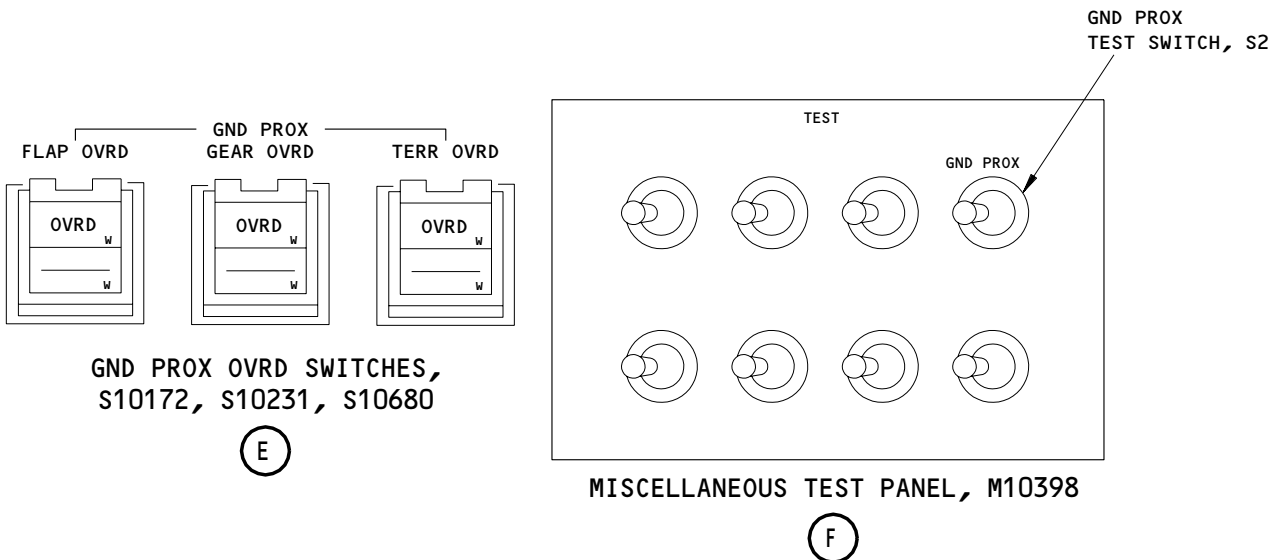
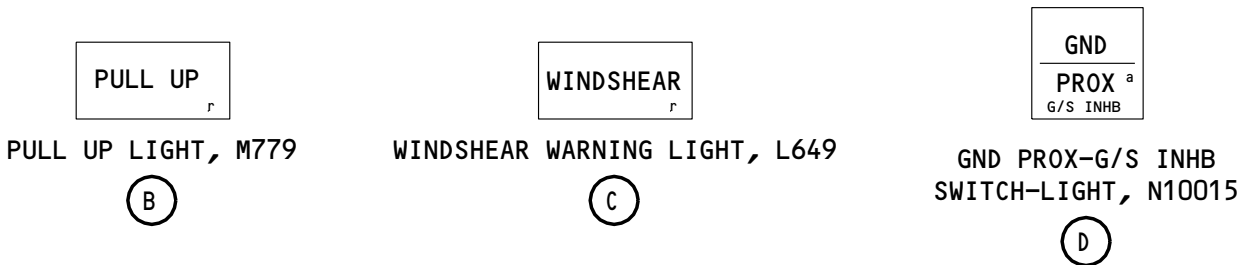
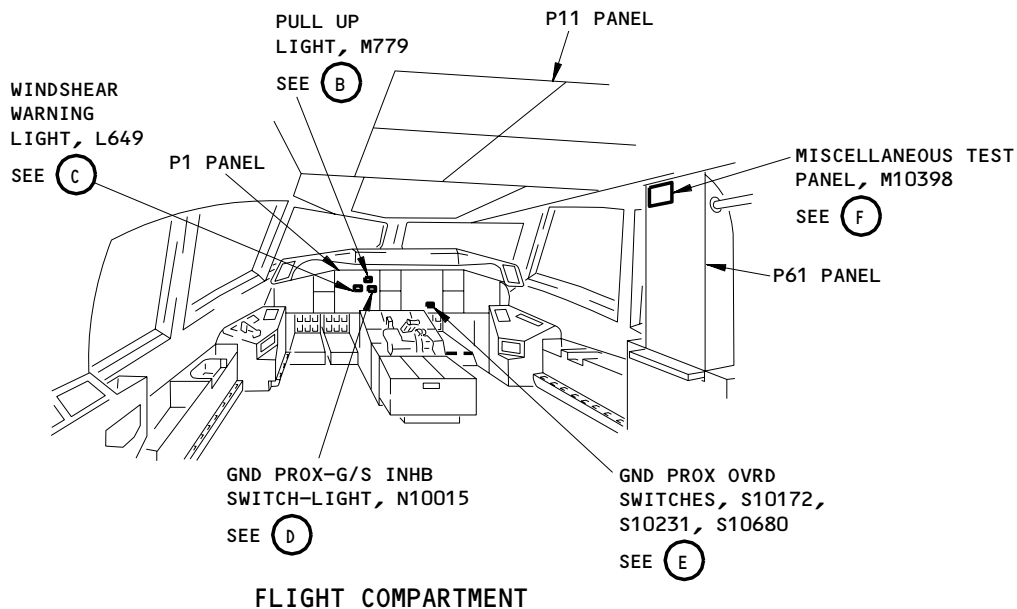

Ground Proximity Warning System - Component Location
Figure 102 (Sheet 2)

EFFECTIVITY
AIRPLANES WITH THE ENHANCED GPWC

34-46-00

CONFIG 3
Page 103
Jan 28/00

02

**GROUND PROXIMITY
WARNING COMPUTER
BITE PROCEDURE**

PREREQUISITES

MAKE SURE THESE SYSTEMS WILL OPERATE:

- ENGINE INDICATING AND CREW ALERTING SYSTEM (AMM 31-41-00/201)
- WARNING SYSTEM (AMM 31-51-00/501)
- AIR DATA COMPUTING SYSTEM (AMM 34-12-00/501)
- INERTIAL REFERENCE SYSTEM (AMM 34-21-00/501)
- ELECTRONIC FLIGHT INSTRUMENT SYSTEM (EFIS) (AMM 34-22-00/501)
- ILS (AMM 34-31-00/501)
- RADIO ALTIMETER SYSTEM (AMM 34-33-00/501)
- WEATHER RADAR SYSTEM (AMM 34-43-00/501)
- GLOBAL POSITIONING SYSTEM, IF INSTALLED (AMM 34-58-00/501)
- FLIGHT MANAGEMENT SYSTEM (AMM 34-61-00/501)

MAKE SURE THESE CIRCUIT BREAKERS ARE CLOSED:
11B16, 11B18, 11E7, 11F4, 11H35, 11J33

MAKE SURE THE AIRPLANE IS IN THIS CONFIGURATION:
ELECTRICAL POWER IS ON (AMM 24-22-00/201)

EQUIPMENT:
HEADPHONES

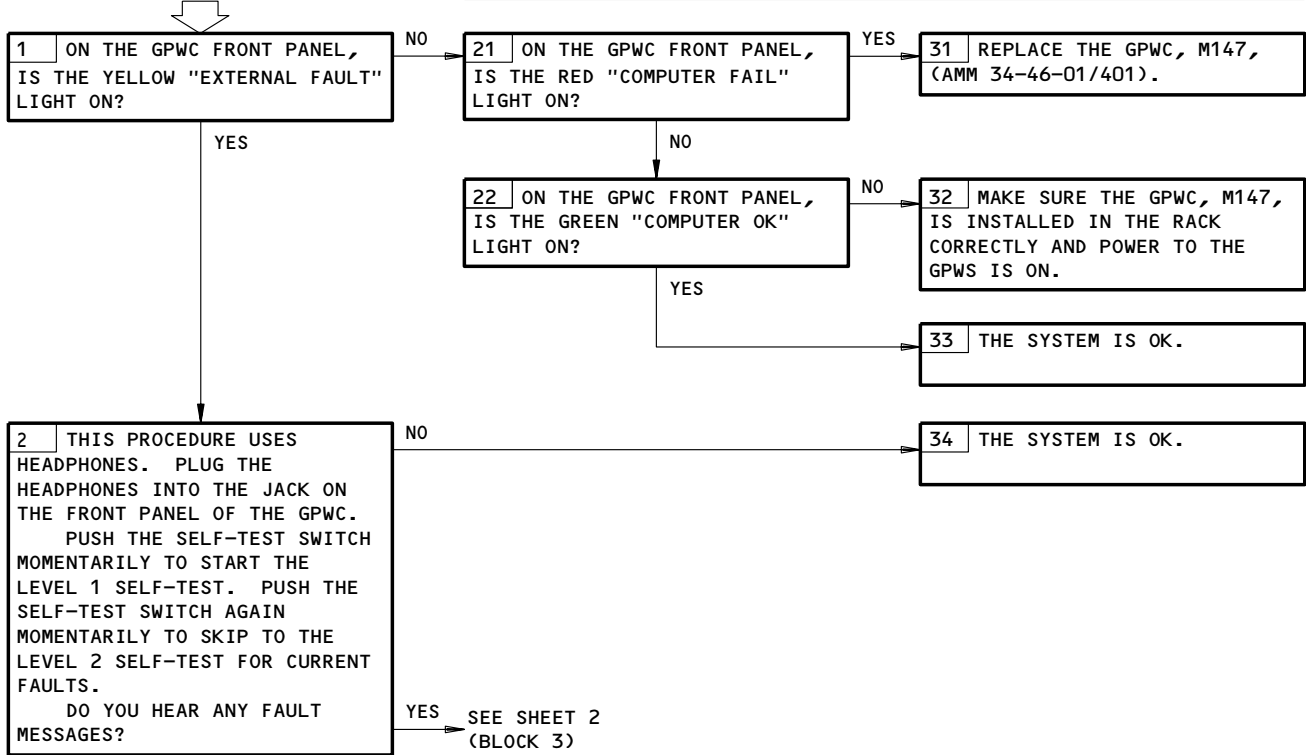

Ground Proximity Warning Computer BITE Procedure
Figure 103 (Sheet 1)

EFFECTIVITY
AIRPLANES WITH THE ENHANCED GPWC

34-46-00
CONFIG 3
Page 104
May 28/99

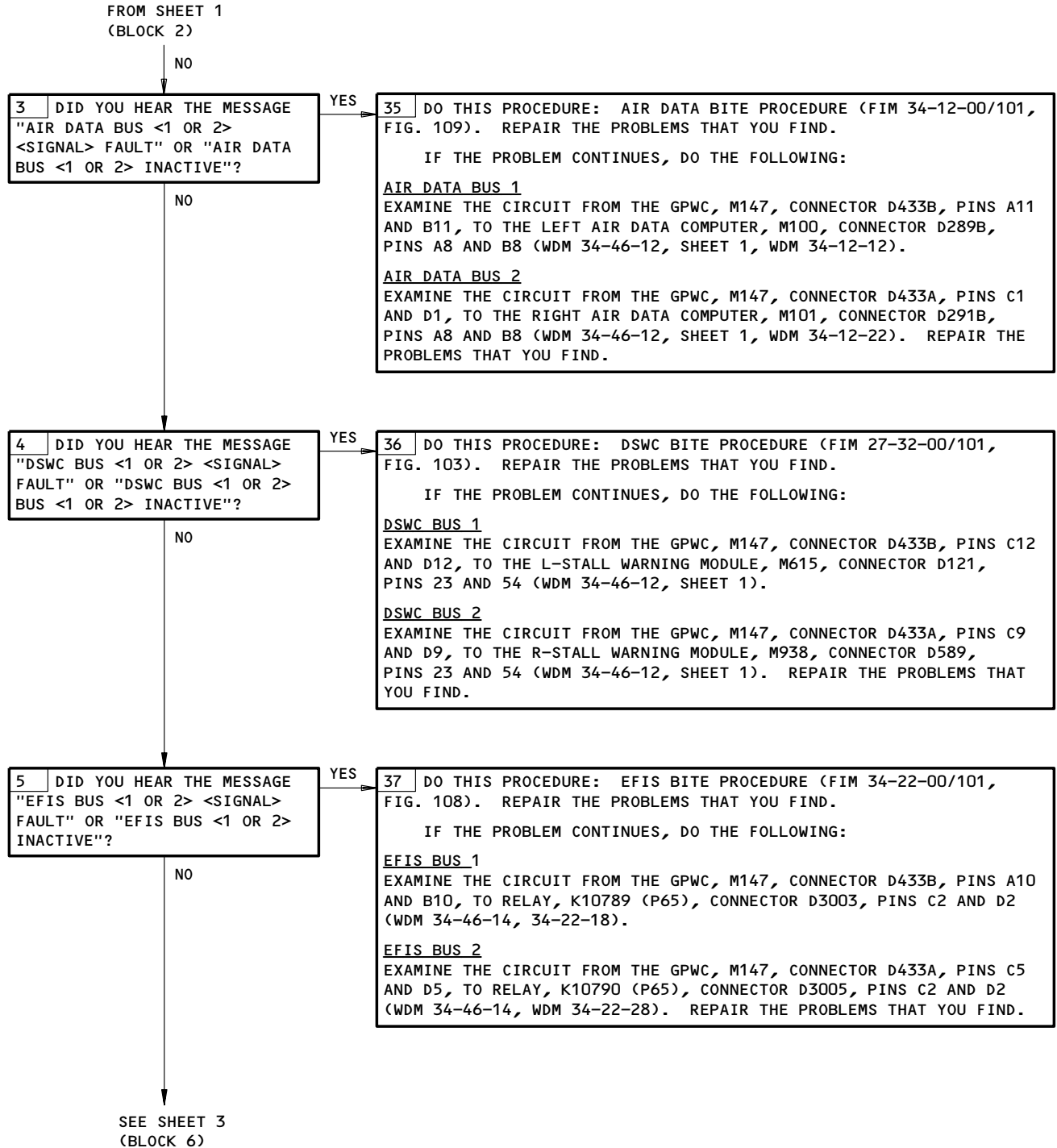

Ground Proximity Warning Computer BITE Procedure
Figure 103 (Sheet 2)

EFFECTIVITY
AIRPLANES WITH THE ENHANCED GPWC

34-46-00
 CONFIG 3
 Page 105
 Jan 28/00

01

BOEING
757
FAULT ISOLATION/MAINT MANUAL

FROM SHEET 2
(BLOCK 5)

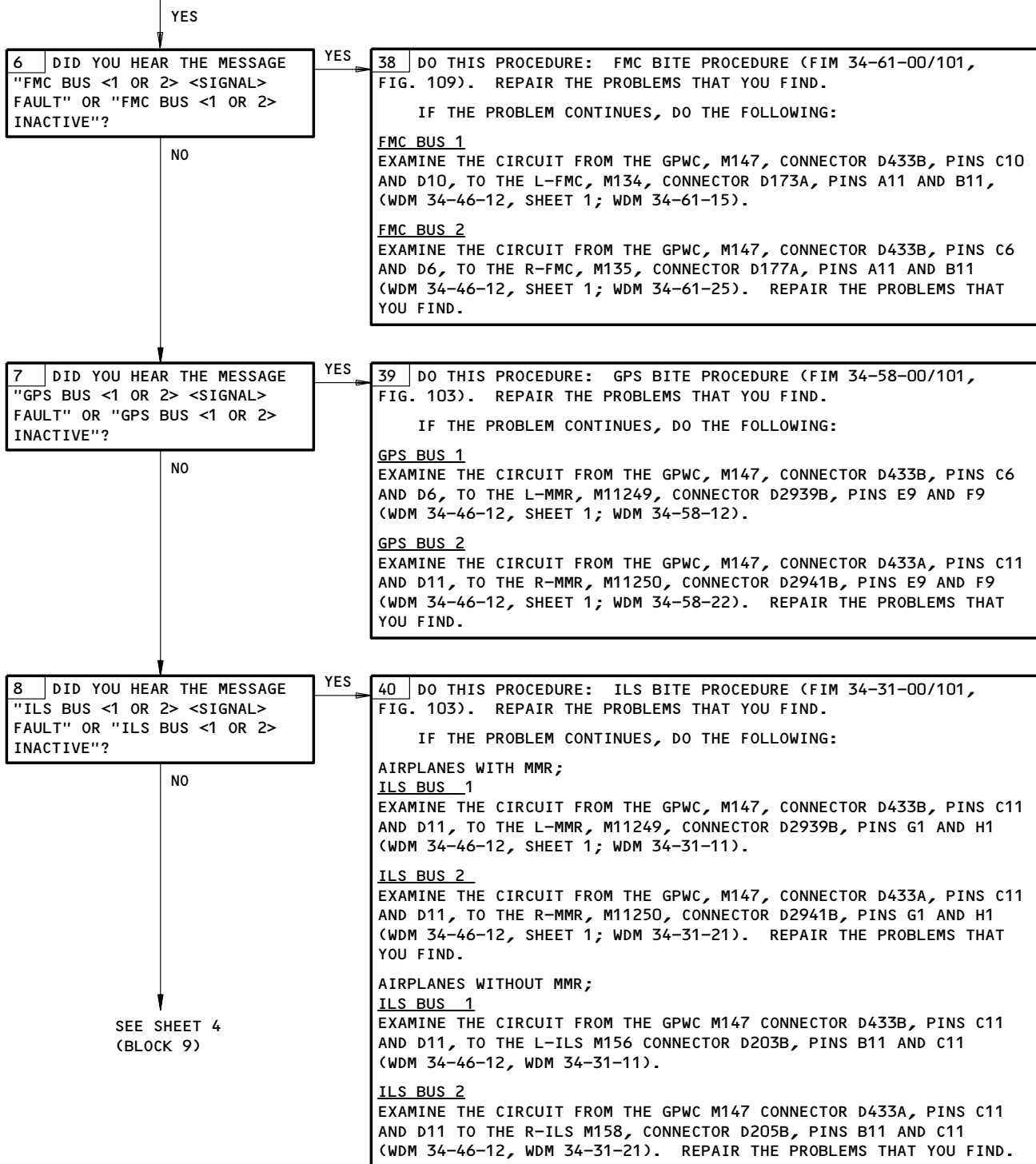

Ground Proximity Warning Computer BITE Procedure
Figure 103 (Sheet 3)

EFFECTIVITY
AIRPLANES WITH THE ENHANCED GPWC

34-46-00
CONFIG 3
Page 106
Jan 28/00

01

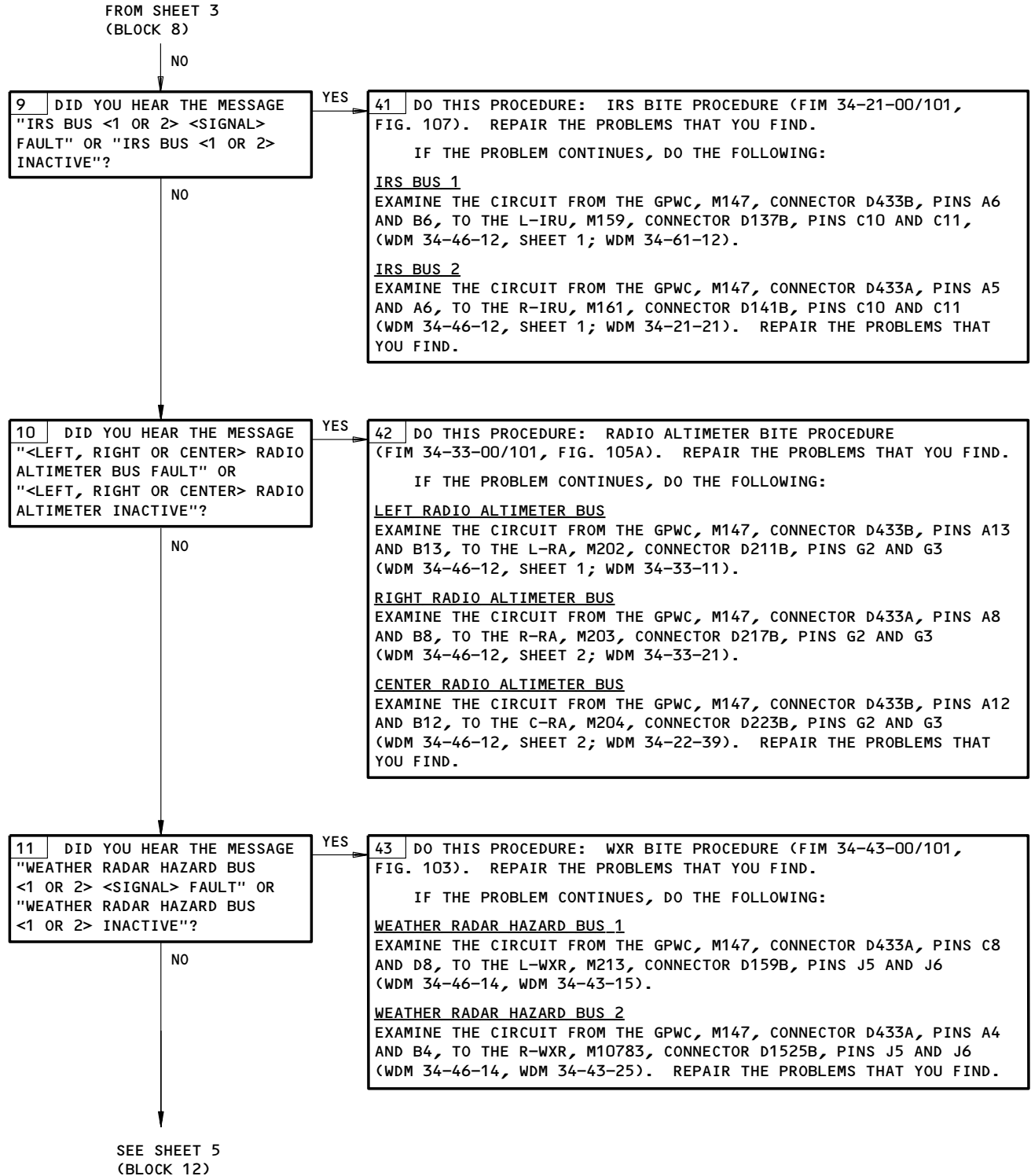

Ground Proximity Warning Computer BITE Procedure
Figure 103 (Sheet 4)

EFFECTIVITY
AIRPLANES WITH THE ENHANCED GPWC

34-46-00
 CONFIG 3
 Page 107
 Jan 28/00

01

BOEING
757
FAULT ISOLATION/MAINT MANUAL

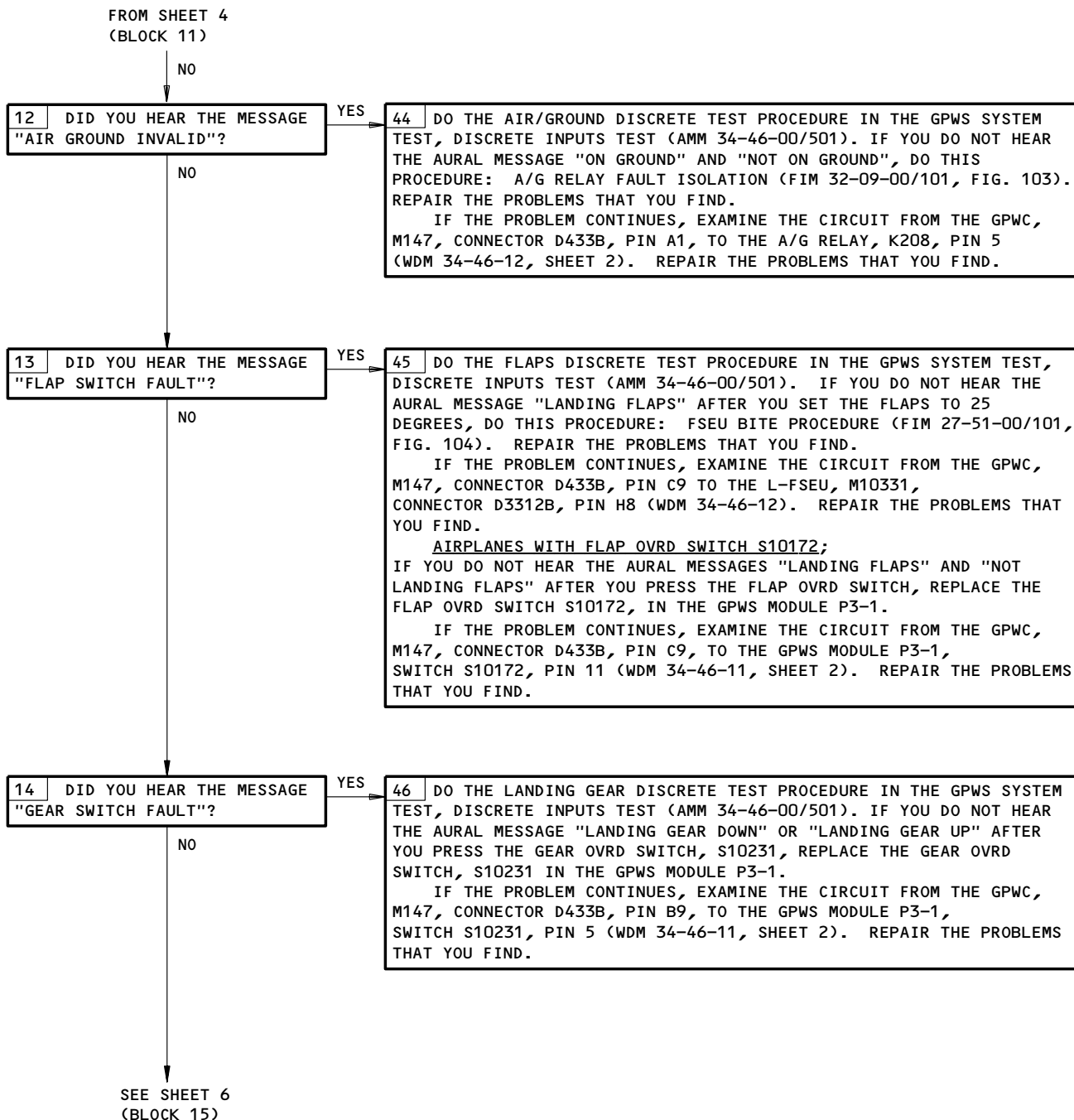

Ground Proximity Warning Computer BITE Procedure
Figure 103 (Sheet 5)

EFFECTIVITY
AIRPLANES WITH THE ENHANCED GPWC

34-46-00
CONFIG 3
Page 108
May 28/99

01

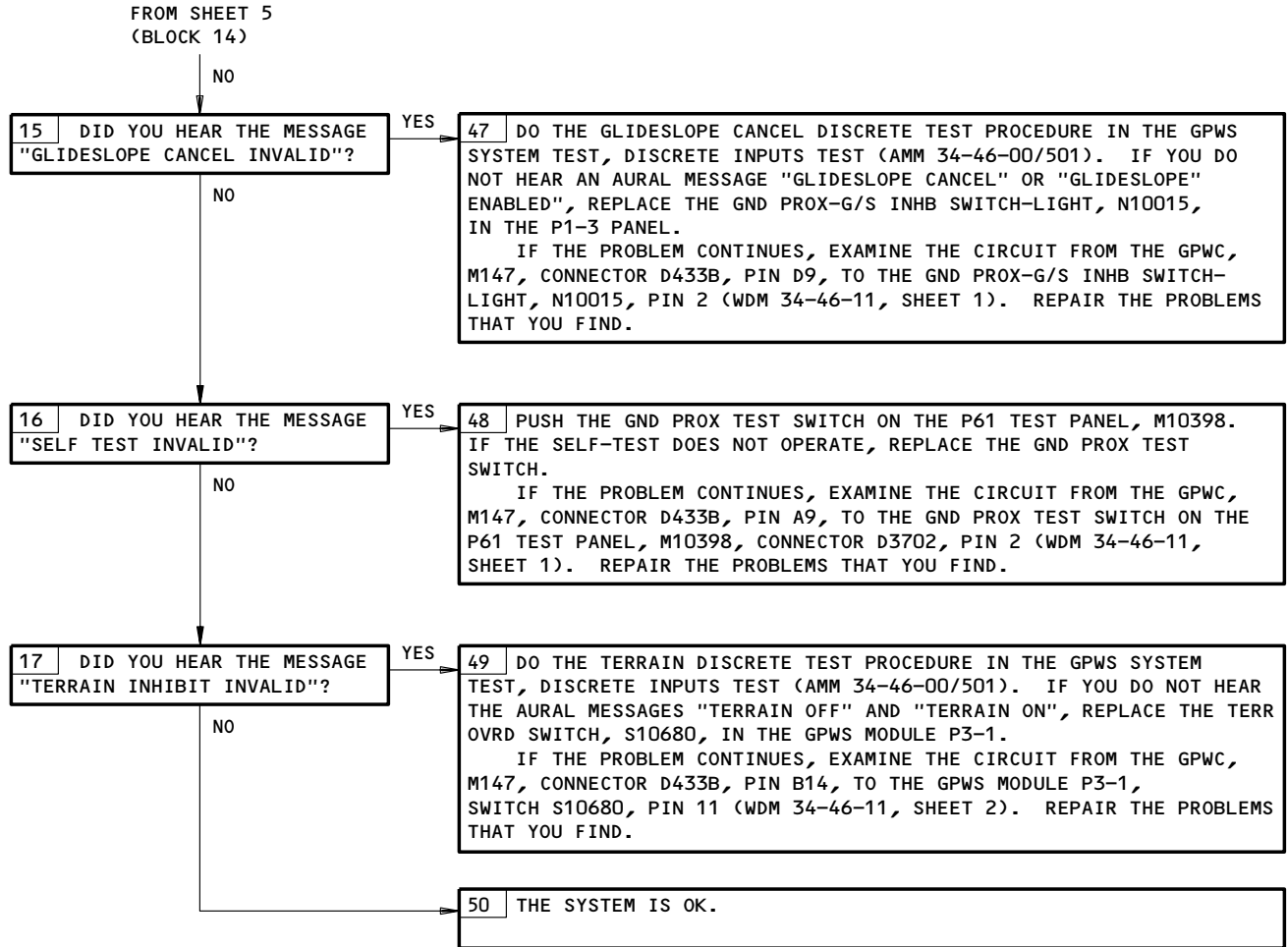

Ground Proximity Warning Computer BITE Procedure
Figure 103 (Sheet 6)

EFFECTIVITY
AIRPLANES WITH THE ENHANCED GPWC

34-46-00
 CONFIG 3
 Page 109
 Jan 28/00









01

BOEING



757

FAULT ISOLATION/MAINT MANUAL

VOR NAVIGATION SYSTEM

COMPONENT	FIG. 102 SHT	QTY	ACCESS/AREA	REFERENCE
ANTENNA - DUAL VOR, M262	1	1	326, VERTICAL STAB.	34-51-03
CIRCUIT BREAKERS -	1		FLT COMPT, P11	
VOR MKR LEFT, C595		1	11A2	*
VOR RIGHT, C596		1	11E33	*
INDICATORS - (34-22-00/101)				
LEFT RADIO MAGNETIC, M10024 				
RIGHT RADIO MAGNETIC, M10026 				
LEFT RADIO DIRECTION MAGNETIC, N3 				
RIGHT RADIO DIRECTION MAGNETIC, N43 				
PANELS - (34-22-00/101)				
LEFT EFIS CONTROL, M94				
RIGHT EFIS CONTROL, M93				
PANEL - LEFT VOR/DME CONTROL, M91	1	1	FLT COMPT, P55	34-51-02
PANEL - RIGHT VOR/DME CONTROL, M92	1	1	FLT COMPT, P55	34-51-02
RECEIVER - LEFT VOR/MARKER, M186	2	1	822, AFT CARGO COMPT, E6-1  ;	
			119BL, MAIN EQUIP CTR, E3-2 	34-51-01
RECEIVER - RIGHT VOR/MARKER, M187	2	1	822, AFT CARGO COMPT, E6-1  ;	
			119BL, MAIN EQUIP CTR, E3-2 	34-51-01
RELAY - (31-01-36/101)				
SYS NO. 1 AIR/GND, K167				
RELAY - (31-01-37/101)				
SYS NO. 2 AIR/GND, K214				

* SEE THE WDM EQUIPMENT LIST

-  GUI 115
-  GUI 001-114,116-999

VOR Navigation System - Component Index
Figure 101

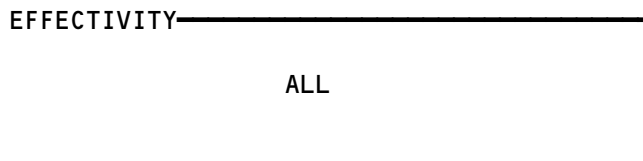

34-51-00

BOEING
757
FAULT ISOLATION/MAINT MANUAL

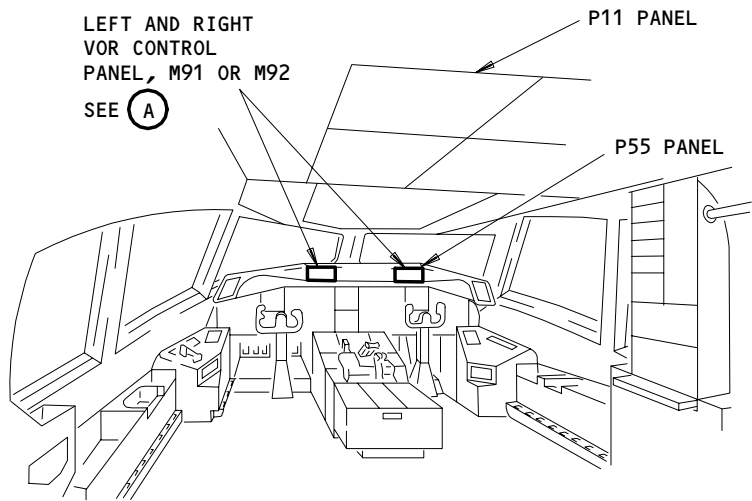

FLIGHT COMPARTMENT

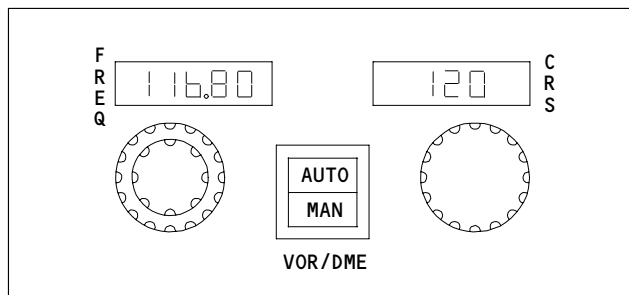
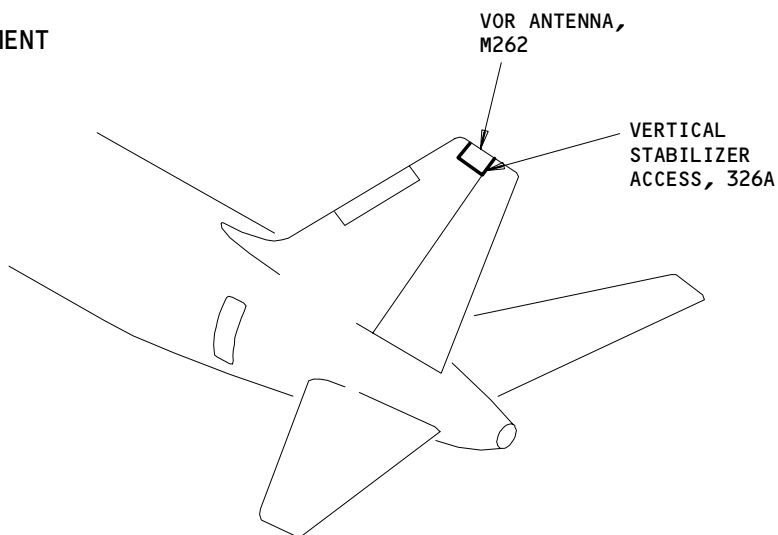

LEFT OR RIGHT VOR CONTROL PANEL, M91 OR M92

A

VOR Navigation System - Component Location
Figure 102 (Sheet 1)

EFFECTIVITY	ALL

34-51-00

BOEING

757

FAULT ISOLATION/MAINT MANUAL

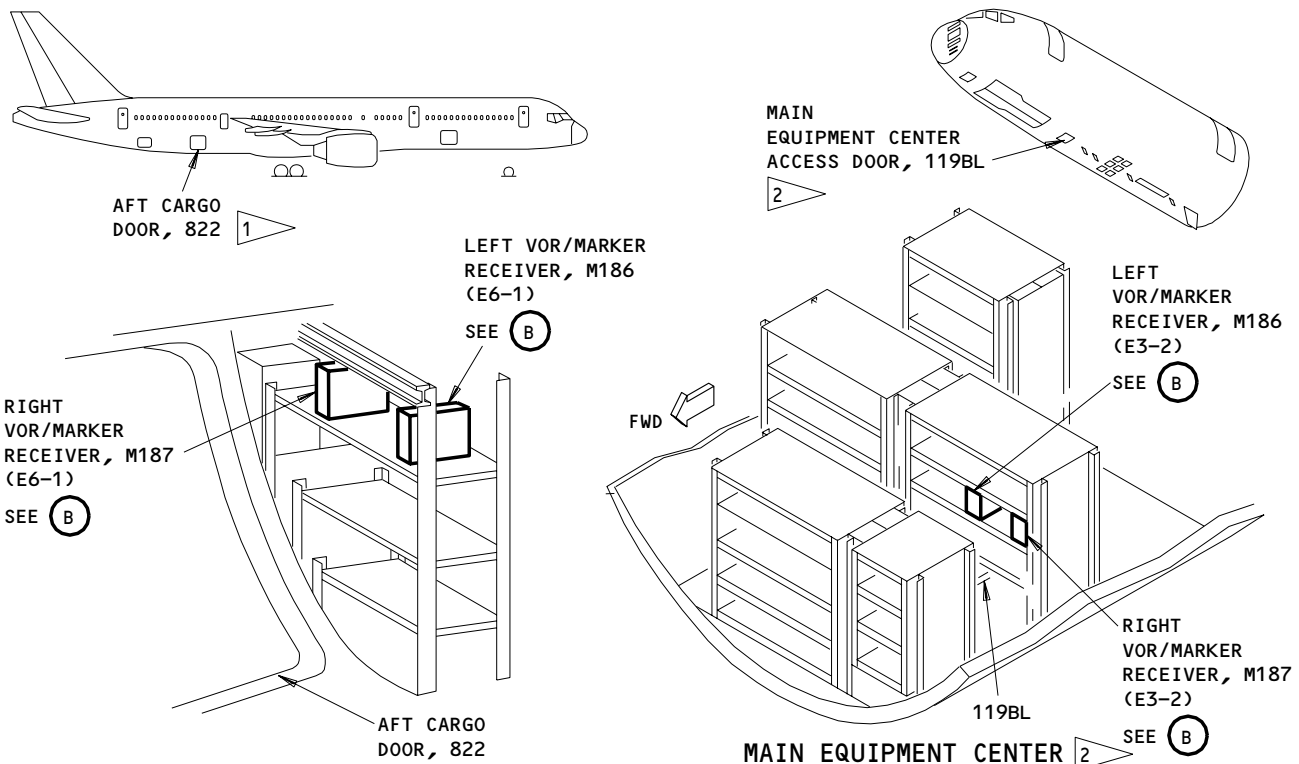

AFT EQUIPMENT CENTER 1

MAIN EQUIPMENT CENTER 2

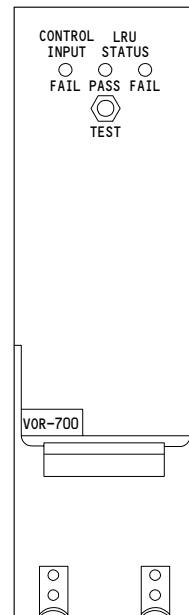
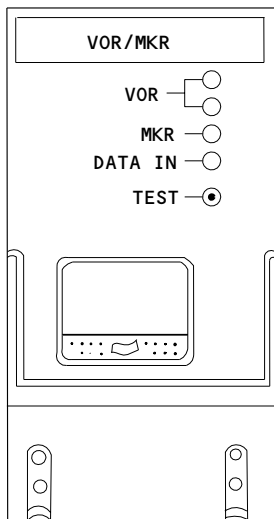

LEFT OR RIGHT VOR/MARKER RECEIVER, M186 OR M187

- 1 GUI 115
- 2 GUI 001-114, 116-999
- 3 GUI 001, 009, 115
- 4 GUI 002-008, 010-114, 116-999

(B)

VOR Navigation System - Component Location
Figure 102 (Sheet 2)

EFFECTIVITY

ALL

34-51-00

PREREQUISITES
 ELECTRICAL POWER (MM 24-22-00/201)
 IRS (MM 34-21-00/501)
 EFIS (MM 34-22-00/501)
 CB'S: 11A2,11A6,11E4,11E25,11E33,11F25

VOR BITE PROCEDURE

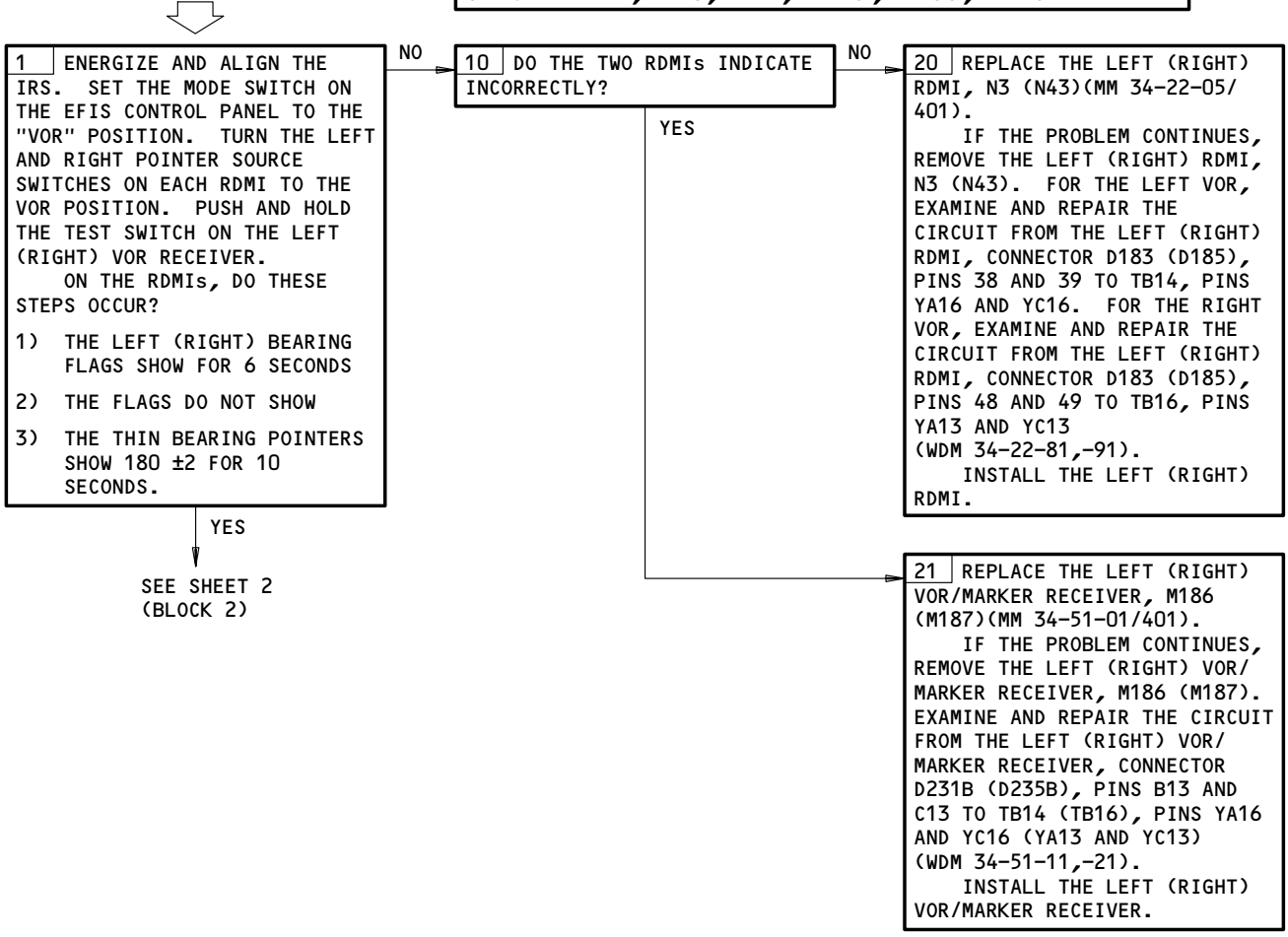

VOR BITE Procedure
Figure 103 (Sheet 1)

EFFECTIVITY
 GUI 002-008, 010-114, 116-999;

34-51-00

227771

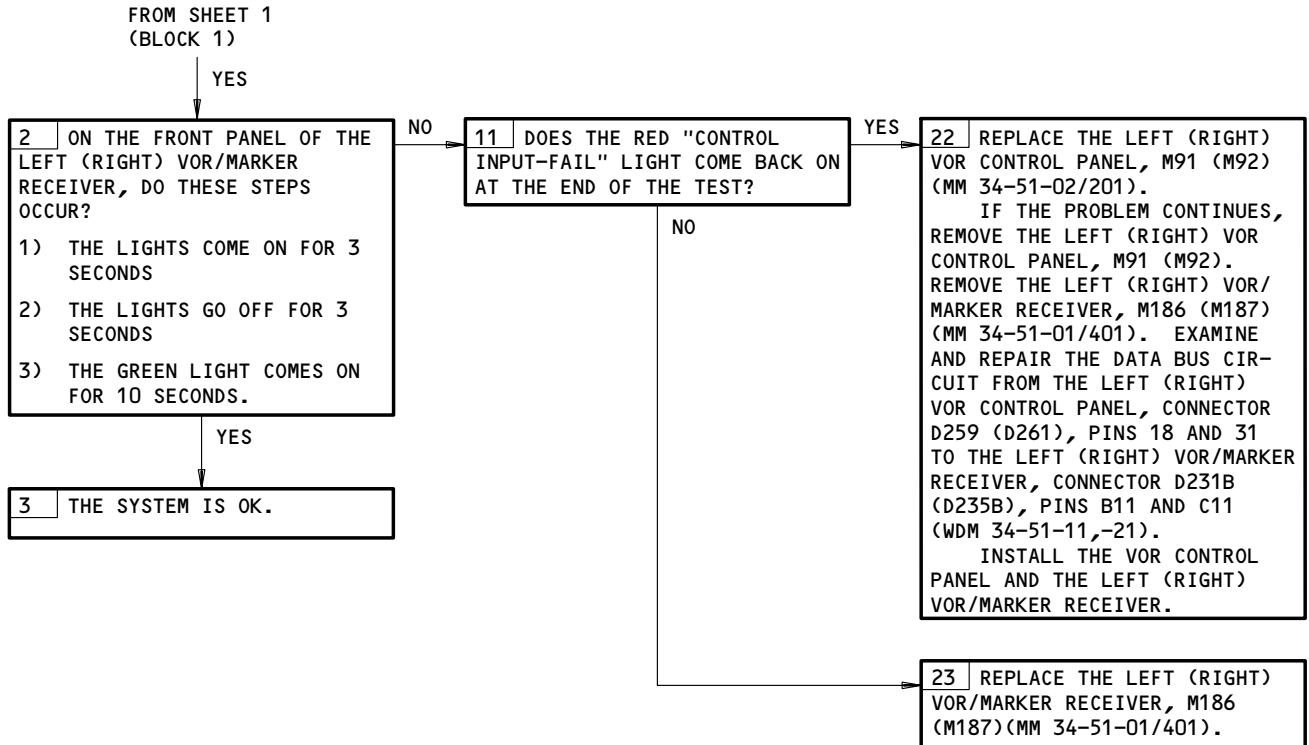

VOR BITE Procedure
Figure 103 (Sheet 2)

EFFECTIVITY
GUI 002-008, 010-114, 116-999;

34-51-00

PREREQUISITES

MAKE SURE THIS SYSTEM WILL OPERATE:
 IRS (MM 34-21-00/501)
 EFIS (MM 34-22-00/501)

MAKE SURE THESE CIRCUIT BREAKERS ARE CLOSED:
 11A2,11A6,11E4,11E25,11E33,11F25

MAKE SURE THE AIRPLANE IS IN THIS CONFIGURATION:
 ELECTRICAL POWER IS ON (MM 24-22-00/201)

VOR BITE PROCEDURE

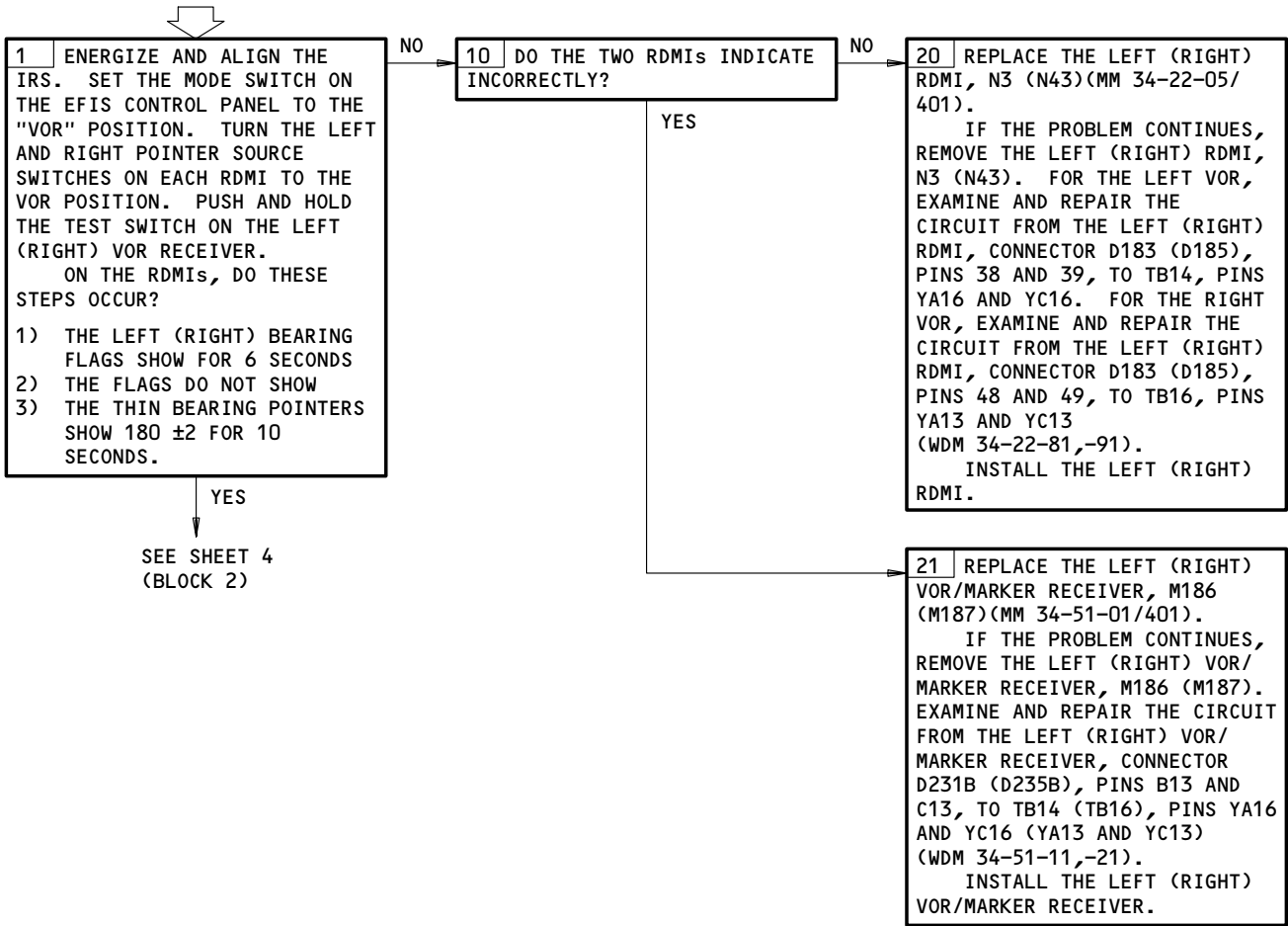

VOR BITE Procedure
 Figure 103 (Sheet 3)

EFFECTIVITY
 GUI 001, 009

34-51-00

A32116

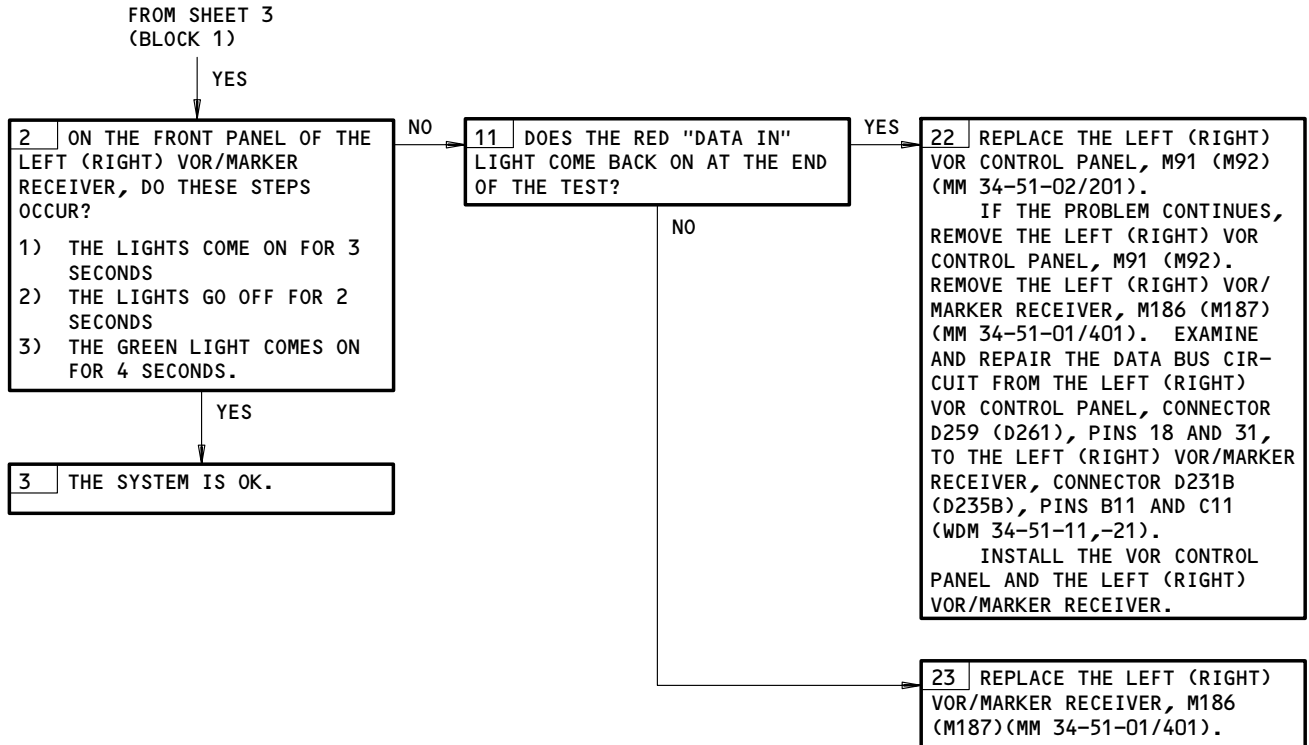

VOR BITE Procedure
Figure 103 (Sheet 4)

EFFECTIVITY
GUI 001, 009

34-51-00

PREREQUISITES

MAKE SURE THESE SYSTEMS WILL OPERATE:

- IRS (MM 34-21-00/501)
- EFIS (MM 34-22-00/501)

MAKE SURE THESE CIRCUIT BREAKERS ARE CLOSED:

- 11A2,11E33

MAKE SURE THE AIRPLANE IS IN THIS CONFIGURATION:

- ELECTRICAL POWER IS ON (MM 24-22-00/201)
- INERTIAL REFERENCE SYSTEM IS ALIGNED IN THE NAV MODE (MM 34-21-00/201)

VOR BITE PROCEDURE

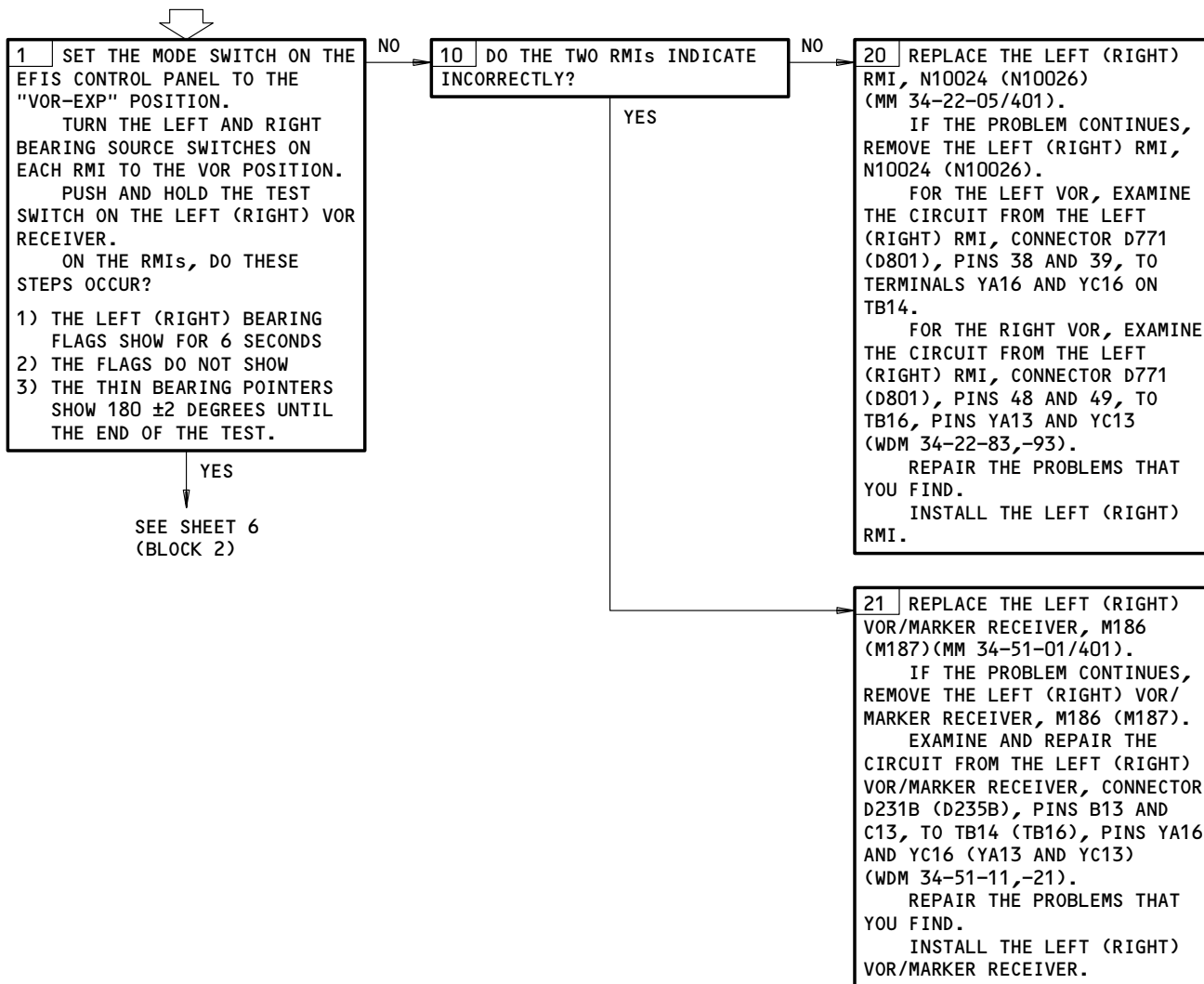

VOR BITE Procedure
 Figure 103 (Sheet 5)

EFFECTIVITY
 GUI 115

34-51-00

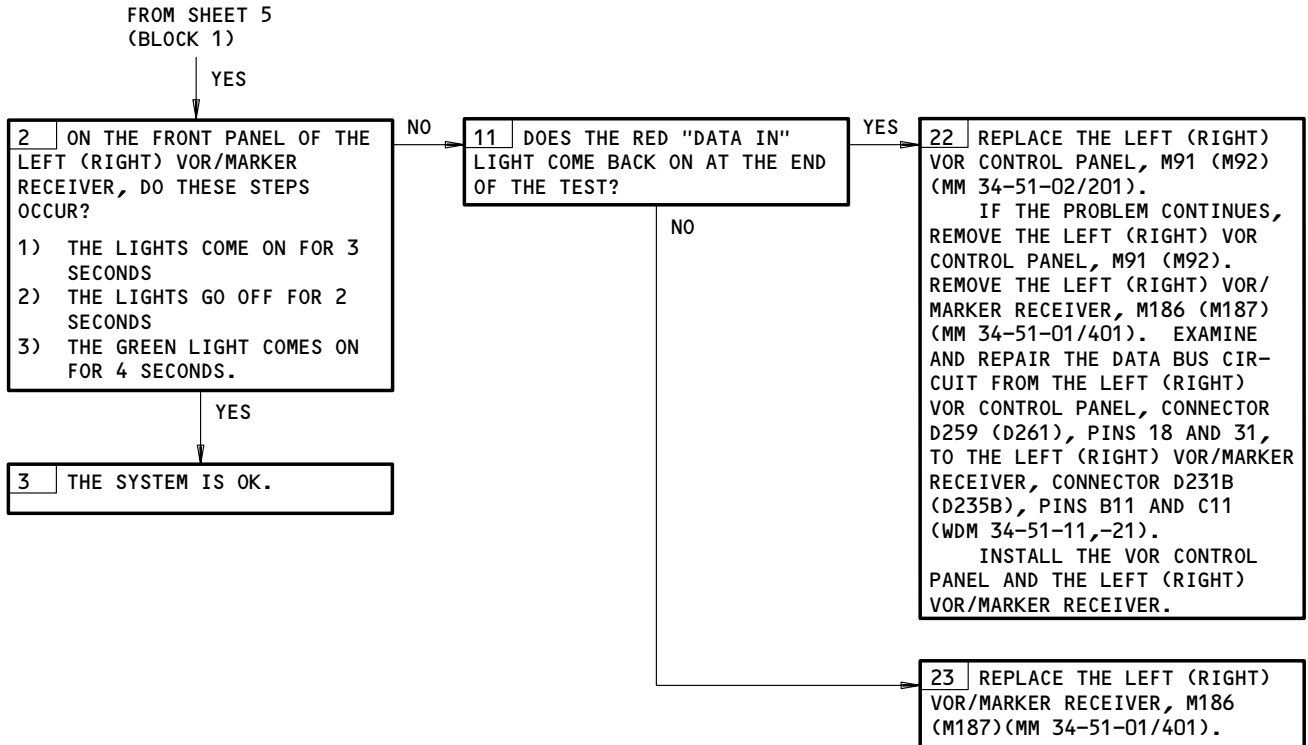

VOR BITE Procedure
Figure 103 (Sheet 6)

EFFECTIVITY
GUI 115

34-51-00

**VOR FLAGS IN VIEW,
VORCP DISPLAY
PROBLEMS**

PREREQUISITES

MAKE SURE THIS SYSTEM WILL OPERATE:
 IRS (MM 34-21-00/501)
 EFIS (MM 34-22-00/501)

MAKE SURE THESE CIRCUIT BREAKERS ARE CLOSED:
 11A2,11A6,11E33,11F25

MAKE SURE THE AIRPLANE IS IN THIS CONFIGURATION:
 ELECTRICAL POWER IS ON (MM 24-22-00/201)

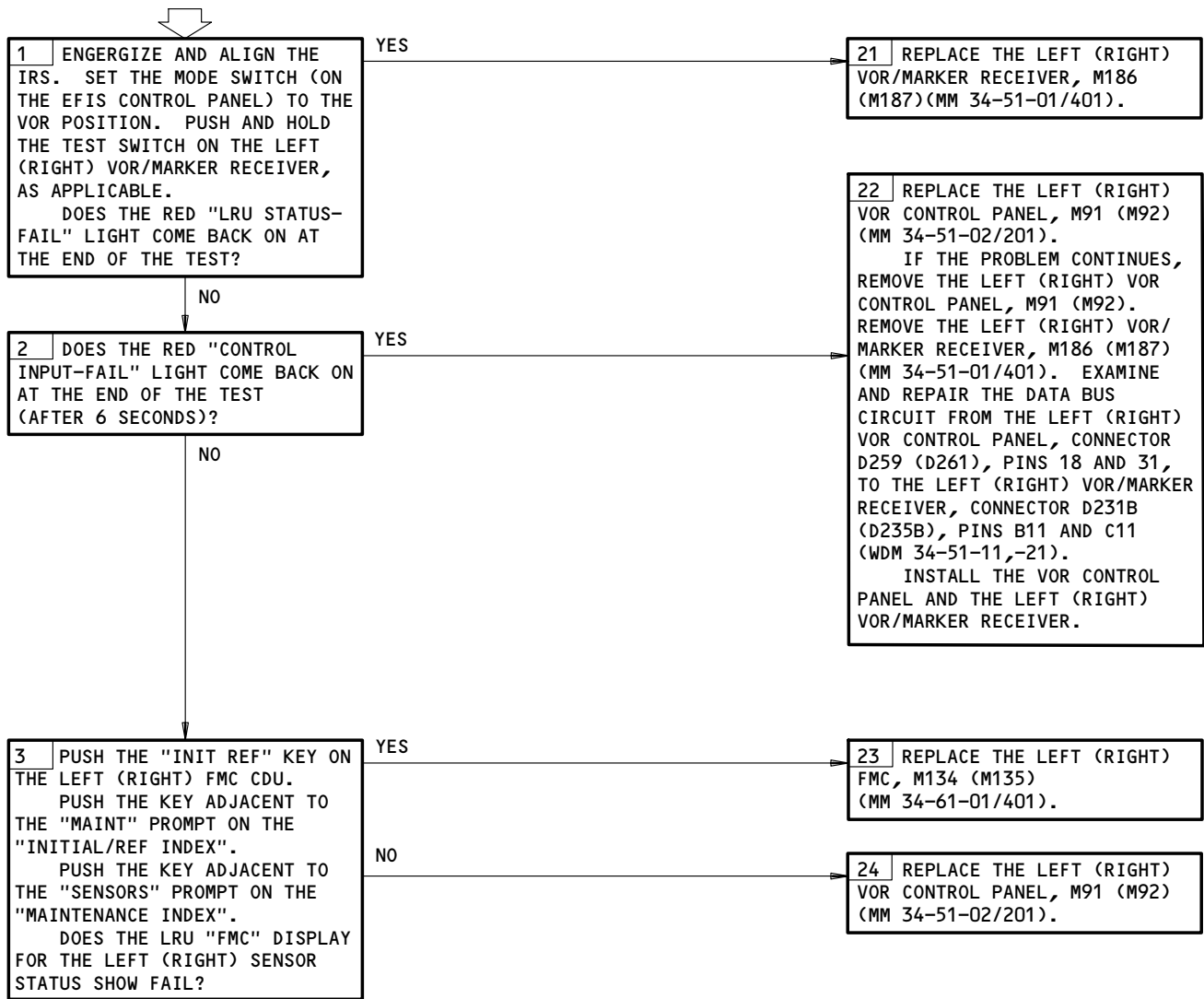

VOR Flags in View, VORCP Display Problems
Figure 104 (Sheet 1)

EFFECTIVITY
 GUI 002-008, 010-114, 116-999

34-51-00

A32122

**VOR FLAGS IN VIEW,
VORCP DISPLAY
PROBLEMS**

PREREQUISITES

MAKE SURE THIS SYSTEM WILL OPERATE:

- IRS (MM 34-21-00/501)
- EFIS (MM 34-22-00/501)

MAKE SURE THESE CIRCUIT BREAKERS ARE CLOSED:

- 11A2,11A6,11E33,11F25

MAKE SURE THE AIRPLANE IS IN THIS CONFIGURATION:

- ELECTRICAL POWER IS ON (MM 24-22-00/201)

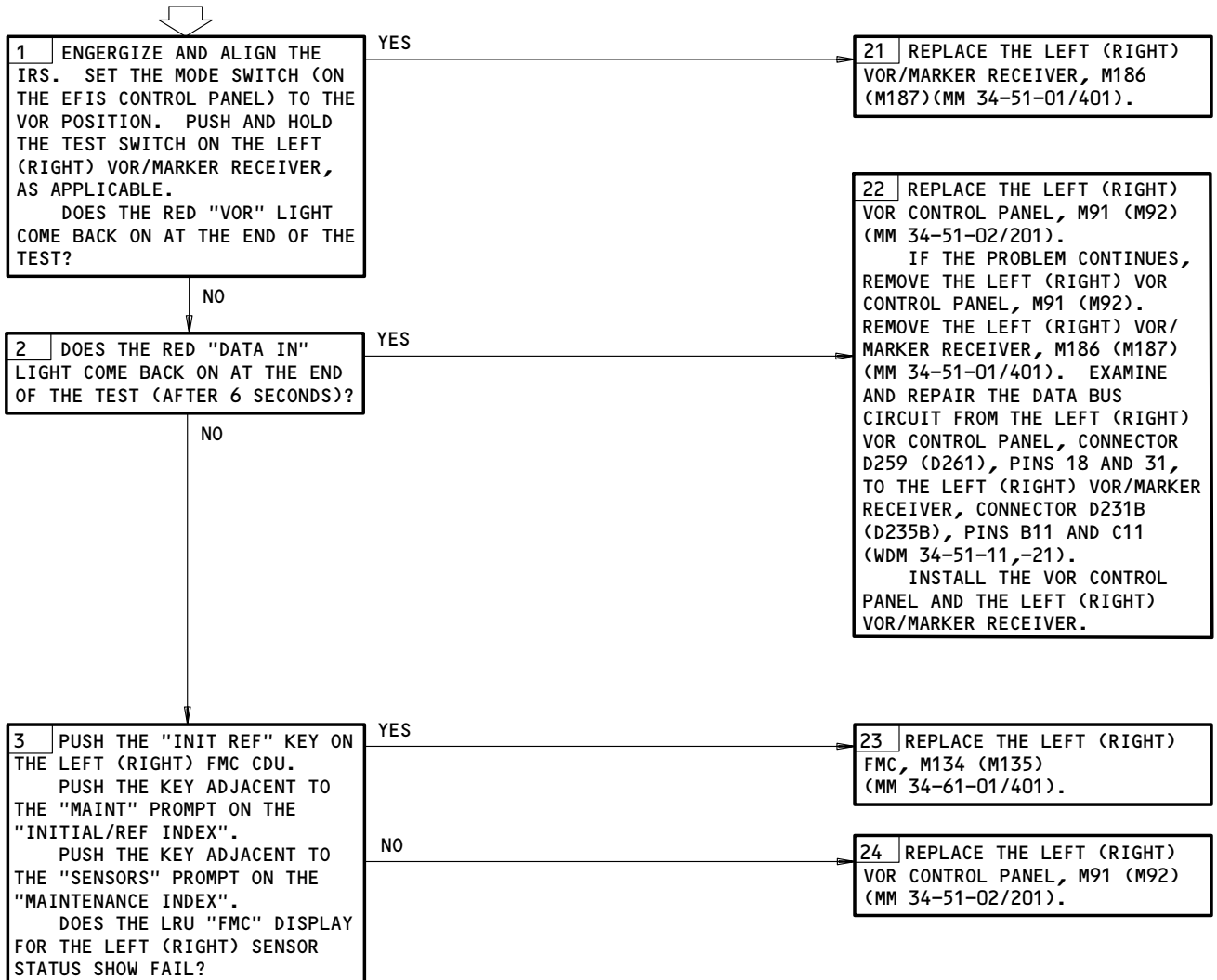

VOR Flags in View, VORCP Display Problems
Figure 104 (Sheet 2)

EFFECTIVITY
GUI 001, 009

34-51-00

**VOR FLAGS IN VIEW,
VORCP DISPLAY
PROBLEMS**

PREREQUISITES
 ELECTRICAL POWER (MM 24-22-00/201)
 IRS (MM 34-21-00/501)
 EFIS (MM 34-22-00/501)
 CB'S: 11A2,11A6,11E33,11F25

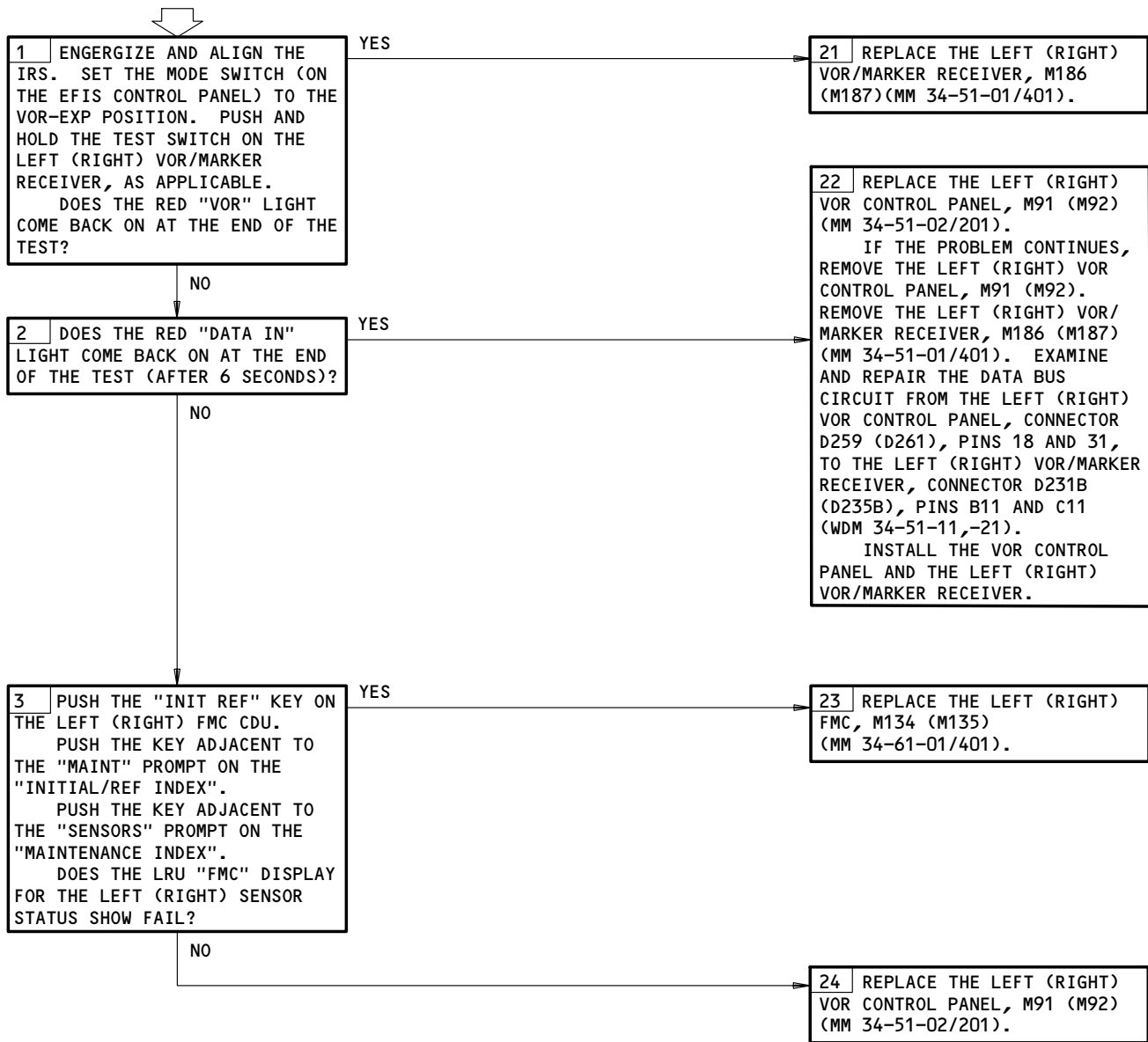

VOR Flags in View, VORCP Display Problems
Figure 104 (Sheet 3)

EFFECTIVITY
GUI 115

34-51-00

A45541

**AUTOTUNE - VOR FLAG
IN VIEW ON RDMIs,
MANUAL OPERATION
NORMAL**

PREREQUISITES

MAKE SURE THIS SYSTEM WILL OPERATE:

- IRS (AMM 34-21-00/501)
- EFIS (AMM 34-22-00/501)
- FMCS (AMM 34-61-00/501)

MAKE SURE THESE CIRCUIT BREAKERS ARE CLOSED:

- 11A2,11A6,11E9,11E30,11E33,11F25

MAKE SURE THE AIRPLANE IS IN THIS CONFIGURATION:

- ELECTRICAL POWER IS ON (AMM 24-22-00/201)

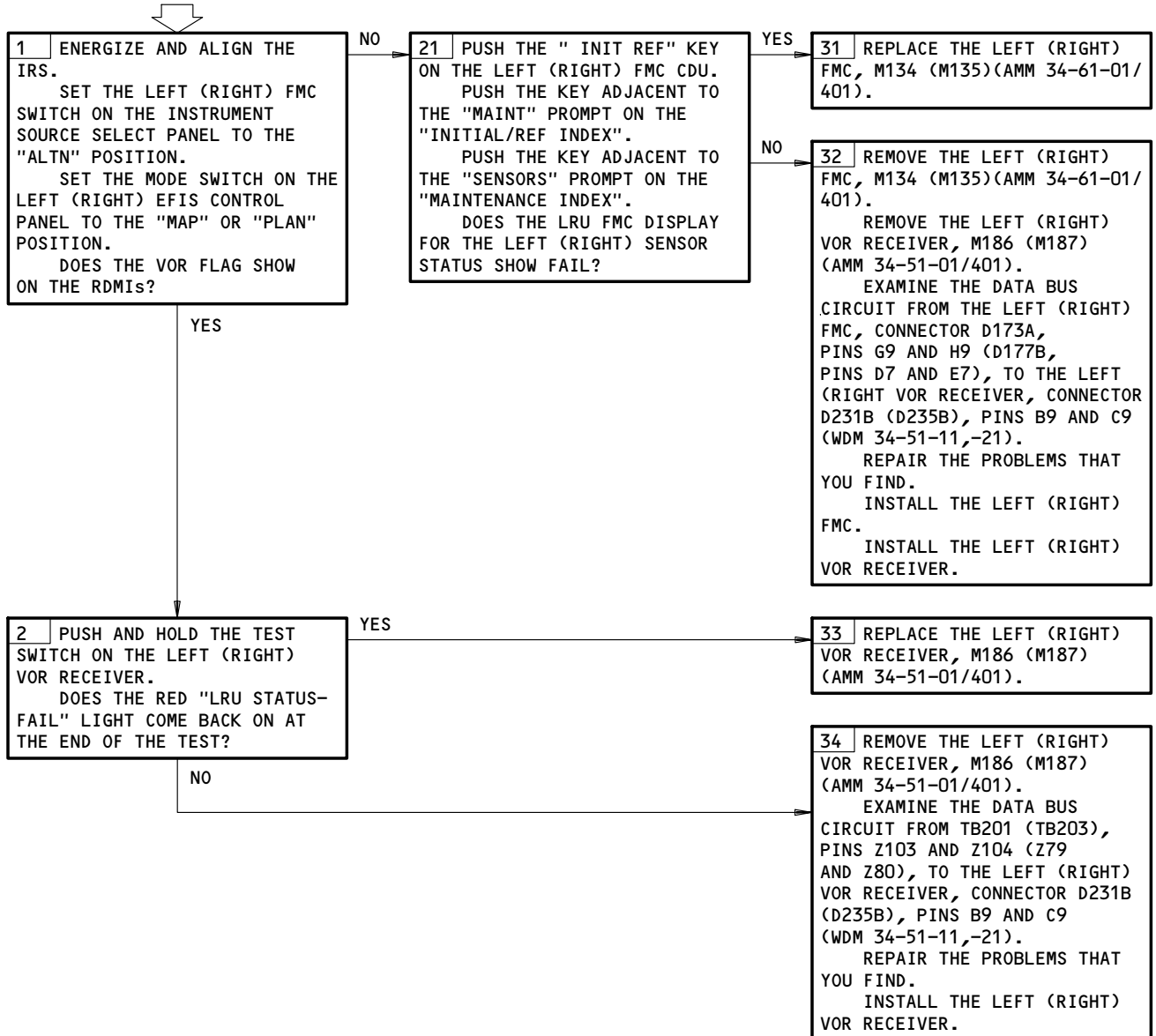

Autotune - VOR Flag in View on RDMIs, Manual Operation Normal
Figure 105 (Sheet 1)

EFFECTIVITY
GUI 002-008, 010-114, 116-999

34-51-00

**AUTOTUNE – VOR FLAG
IN VIEW ON RDMIs,
MANUAL OPERATION
NORMAL**

PREREQUISITES
 MAKE SURE THIS SYSTEM WILL OPERATE:
 IRS (MM 34-21-00/501)
 EFIS (MM 34-22-00/501)
 FMCS (MM 34-61-00/501)
 MAKE SURE THESE CIRCUIT BREAKERS ARE CLOSED:
 11A2,11A6,11E9,11E30,11E33,11F25
 MAKE SURE THE AIRPLANE IS IN THIS CONFIGURATION:
 ELECTRICAL POWER IS ON (MM 24-22-00/201)

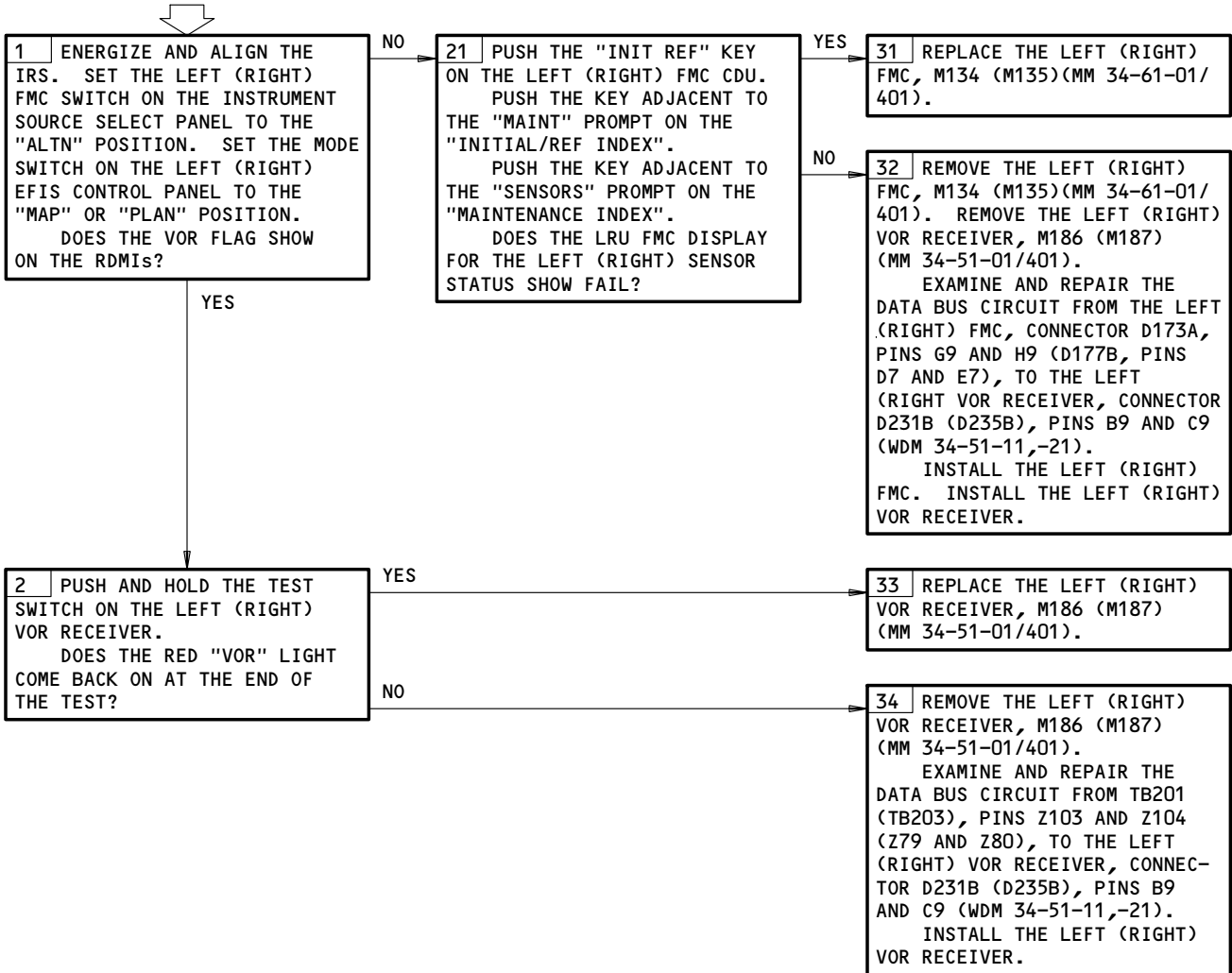

Autotune – VOR Flag in View on RDMIs, Manual Operation Normal
Figure 105 (Sheet 2)

EFFECTIVITY
GUI 001, 009

34-51-00

**AUTOTUNE - VOR FLAG
IN VIEW ON RMIs,
MANUAL OPERATION
NORMAL**

PREREQUISITES

MAKE SURE THESE SYSTEMS WILL OPERATE:

- IRS (MM 34-21-00/501)
- EFIS (MM 34-22-00/501)
- FMCS (MM 34-61-00/501)

MAKE SURE THESE CIRCUIT BREAKERS ARE CLOSED:

- 11A2,11E33

MAKE SURE THE AIRPLANE IS IN THIS CONFIGURATION:

- ELECTRICAL POWER IS ON (MM 24-22-00/201)
- INERTIAL REFERENCE SYSTEM IS ALIGNED IN THE NAV MODE (MM 34-21-00/201)

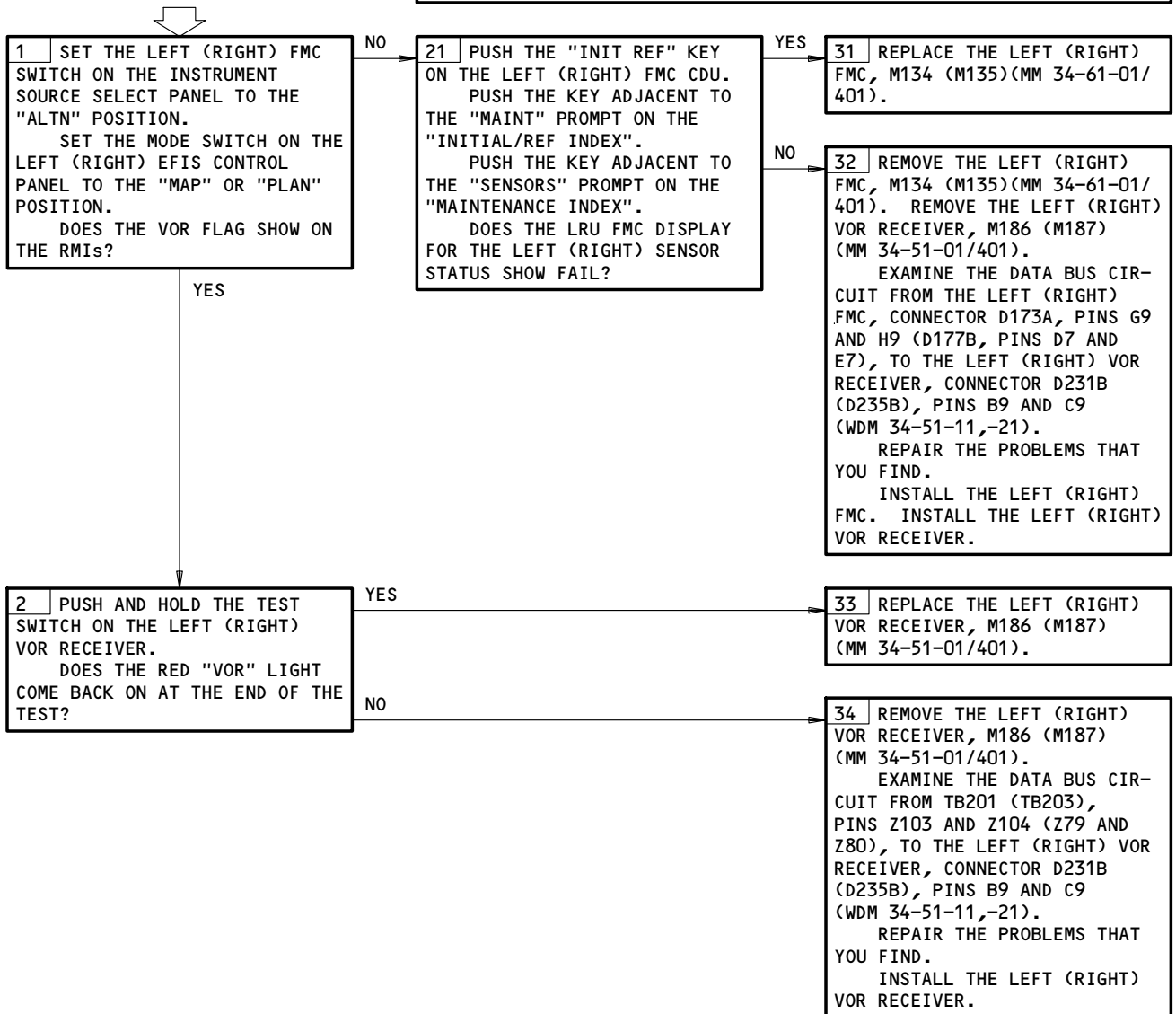

Autotune - VOR Flag in View on RMIs, Manual Operation Normal
Figure 105 (Sheet 3)

EFFECTIVITY
GUI 115

34-51-00

PREREQUISITES

MAKE SURE THESE SYSTEMS WILL OPERATE:

- IRS (AMM 34-21-00/501)
- EFIS (AMM 34-22-00/501)

MAKE SURE THESE CIRCUIT BREAKERS ARE CLOSED:

- 11A2,11E33

MAKE SURE THE AIRPLANE IS IN THIS CONFIGURATION:

- ELECTRICAL POWER IS ON (AMM 24-22-00/201)
- INERTIAL REFERENCE SYSTEM IS ALIGNED IN THE NAV MODE (AMM 34-21-00/201)

NOTE: IF YOU SET THE "INOP" SWITCH ON THE EFIS CONTROL PANEL WHEN YOU ARE IN THE MAP MODE, A VOR FLAG WILL SHOW ON THE EHSI. MAKE SURE THE "INOP" SWITCH IS NOT SET.

VOR FLAG ON EHSI,
RDMI/RMI DISPLAYS
ARE NORMAL

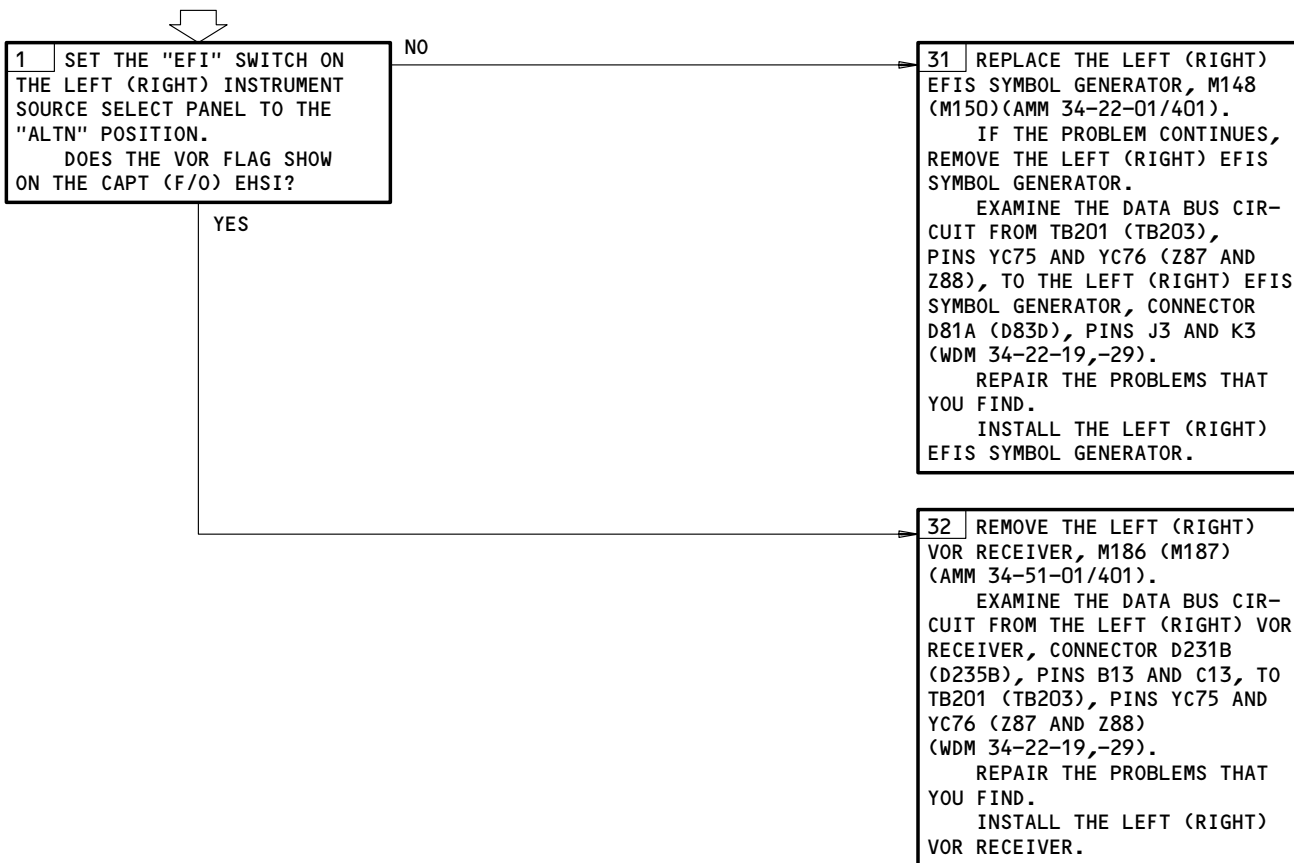

VOR Flag on EHSI, RDMI/RMI Displays are Normal
Figure 106

EFFECTIVITY
GUI 001-114, 116-999

34-51-00

**VOR DISPLAY
PROBLEMS ON LEFT
(RIGHT) RDMI AND
EHSI**

PREREQUISITES

MAKE SURE THESE SYSTEMS WILL OPERATE:

- IRS (MM 34-21-00/501)
- EFIS (MM 34-22-00/501)

MAKE SURE THESE CIRCUIT BREAKERS ARE CLOSED:

- 11A2,11E33

MAKE SURE THE AIRPLANE IS IN THIS CONFIGURATION:

- ELECTRICAL POWER IS ON (MM 24-22-00/201)
- INERTIAL REFERENCE SYSTEM IS ALIGNED IN THE NAV MODE (MM 34-21-00/201)

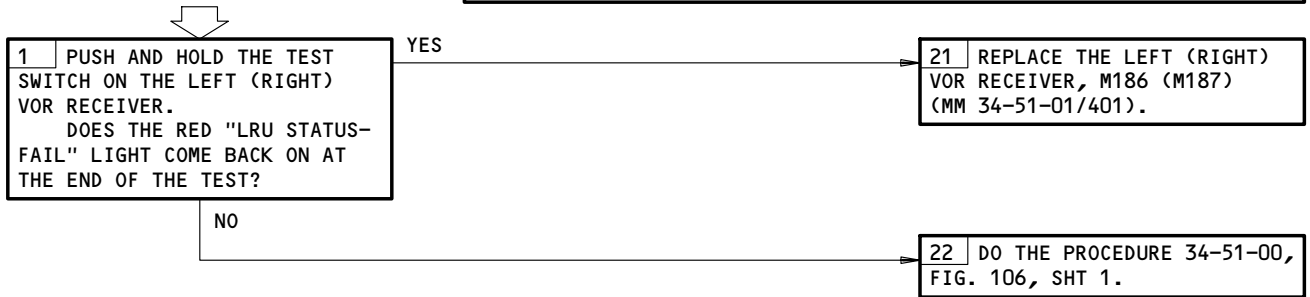

VOR Display Problems on Left (Right) RDMI and EHSI
Figure 107 (Sheet 1)

EFFECTIVITY
GUI 002-008, 010-114, 116-999

34-51-00

**VOR DISPLAY
PROBLEMS ON LEFT
(RIGHT) RDMI AND
EHSI**

PREREQUISITES

MAKE SURE THESE SYSTEMS WILL OPERATE:

- IRS (MM 34-21-00/501)
- EFIS (MM 34-22-00/501)

MAKE SURE THESE CIRCUIT BREAKERS ARE CLOSED:

- 11A2, 11E33

MAKE SURE THE AIRPLANE IS IN THIS CONFIGURATION:

- ELECTRICAL POWER IS ON (MM 24-22-00/201)
- INERTIAL REFERENCE SYSTEM IS ALIGNED IN THE NAV MODE (MM 34-21-00/201)

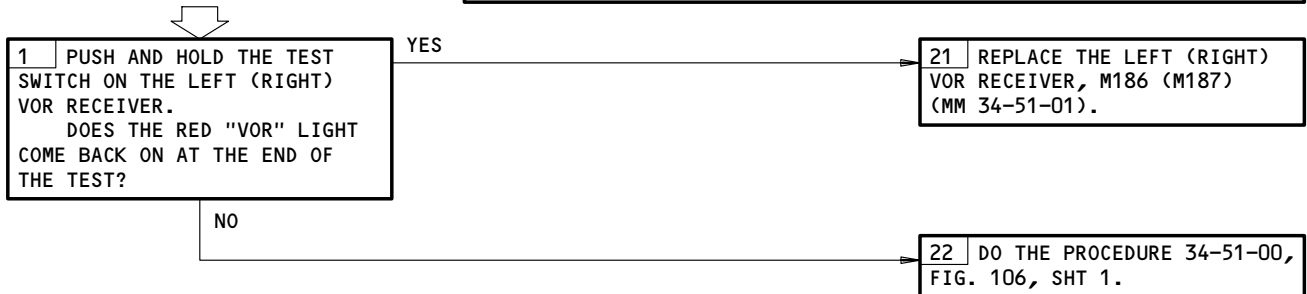

VOR Display Problems on Left (Right) RDMI and EHSI
Figure 107 (Sheet 2)

EFFECTIVITY
GUI 001, 009

34-51-00

PREREQUISITES

MAKE SURE THESE SYSTEMS WILL OPERATE:

- IRS (MM 34-21-00/501)
- EFIS (MM 34-22-00/501)

MAKE SURE THESE CIRCUIT BREAKERS ARE CLOSED:

- 11A2,11E33

MAKE SURE THE AIRPLANE IS IN THIS CONFIGURATION:

- ELECTRICAL POWER IS ON (MM 24-22-00/201)
- INERTIAL REFERENCE SYSTEM IS ALIGNED IN THE NAV MODE (MM 34-21-00/201)

**VOR DISPLAY
PROBLEMS ON LEFT
(RIGHT) RMI AND
EHSI**

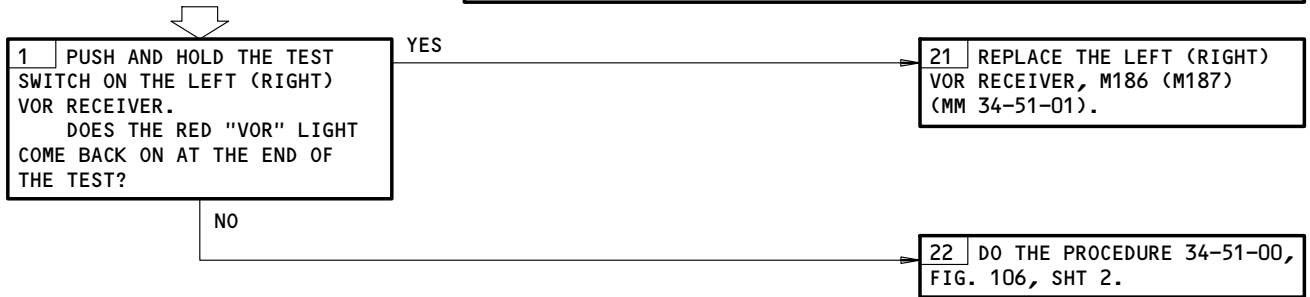

VOR Display Problems on Left (Right) RMI and EHSI
Figure 107 (Sheet 3)

EFFECTIVITY
GUI 115

34-51-00

VOR INDICATIONS
 NORMAL, FREQ DIS-
 PLAY ON VORCP
 ABNORMAL

PREREQUISITES

ELECTRICAL POWER (MM 24-22-00/201)
 IRS (MM 34-21-00/501)
 EFIS (MM 34-22-00/501)
 FMCS (MM 34-61-00/501)
 CB'S: 11A2,11A6,11E9,11E30,11E33,11F25

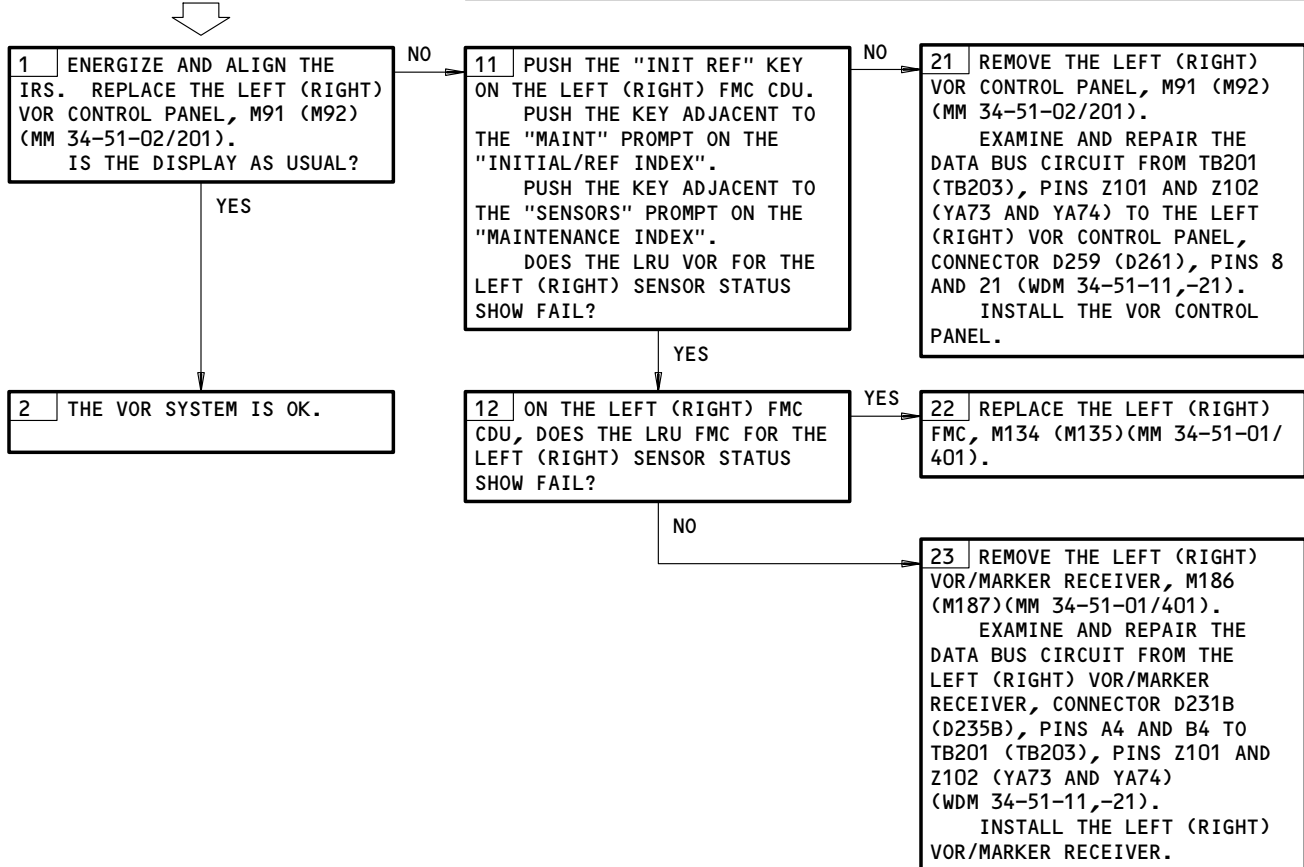

VOR Indications Normal, Freq Display on VORCP Abnormal
 Figure 108

EFFECTIVITY	ALL
-------------	-----

34-51-00

BRG FLAG ON RDMIs,
NO "VOR" FLAG ON
EHSI, VORCP FREQ
SELECT OK

PREREQUISITES

MAKE SURE THESE SYSTEMS WILL OPERATE:

- IRS (AMM 34-21-00/501)
- EFIS (AMM 34-22-00/501)

MAKE SURE THESE CIRCUIT BREAKERS ARE CLOSED:

- 11A2, 11E33

MAKE SURE THE AIRPLANE IS IN THIS CONFIGURATION:

- ELECTRICAL POWER IS ON (AMM 24-22-00/201)

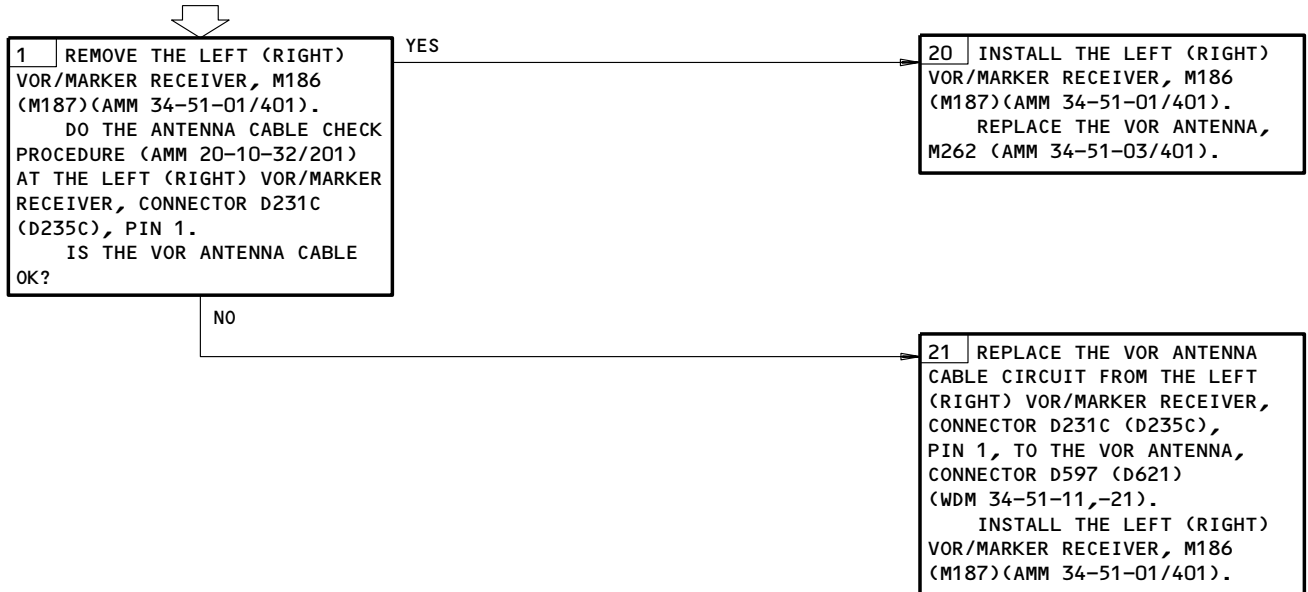

BrG Flag on RDMIs, No VOR Flag on EHSI, VORCP Freq Select OK
Figure 109 (Sheet 1)

EFFECTIVITY
GUI 001-114, 116-999

34-51-00

BRG FLAG ON RMIs,
NO "VOR" FLAG ON
EHSI, VORCP FREQ
SELECT OK

PREREQUISITES

MAKE SURE THESE SYSTEMS WILL OPERATE:
IRS (AMM 34-21-00/501)
EFIS (AMM 34-22-00/501)

MAKE SURE THESE CIRCUIT BREAKERS ARE CLOSED:
11A2,11E33

MAKE SURE THE AIRPLANE IS IN THIS CONFIGURATION:
ELECTRICAL POWER IS ON (AMM 24-22-00/201)

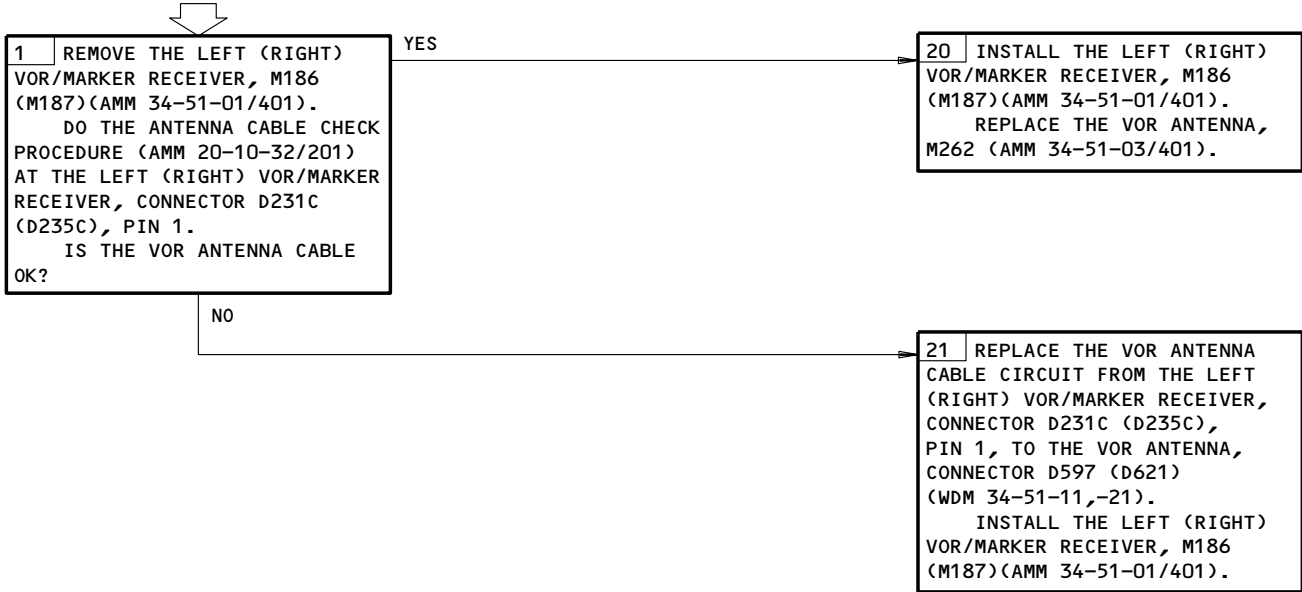

Brg Flag on RMIs, No VOR Flag on EHSI, VORCP Freq Select OK
Figure 109 (Sheet 2)

EFFECTIVITY
GUI 115

34-51-00

BOEING
 757
 FAULT ISOLATION/MAINT MANUAL

1. ARINC Data Bus Charts

A. General

CAUTION: DO NOT DIRECTLY TOUCH THE CONNECTORS. USE A BREAKOUT BOX OR YOU CAN CAUSE DAMAGE TO THE CONNECTORS.

(1) The ARINC 429 data bus charts give data necessary to make an analysis of ARINC 429 transmitters, receivers, and data buses. For the test, use a breakout box at the available terminal or at the LRU connectors.

B. Equipment

(1) Standard multi-meter
 (2) 429EBP Data Bus Analyzer (recommended)
 JcAIR Instrumentation
 400 Industrial Parkway
 Industrial Airport, KS 66031

429-2 Data Bus Analyzer (alternative)
 Interface Technology
 150 E. Arrow Highway
 San Dimas, CA 91773

(3) A34011-1 Breakout Box (recommended)
 A34011-112 Breakout Box (alternative)

VOR								
DIGITAL OUTPUT BUS CHART								
BUS NAME			CON	PINS	BUS FORMAT	BIT RATE	DATA BUS	
SOURCE	TYPE	BUS						
VOR (L R)	A	1	B	A04 B04	429	L0	OMNIBEARING #1	
VOR (L R)	A	2	B	B13 C13	429	L0	OMNIBEARING #2	

VOR ID=11								
OCTAL LABELS CHART								
SIGNAL	TYPE	LABEL	FORMAT	MIN UPDATE RATE	SDI	BINARY RANGE	POSITIVE SENSE	UNITS
SELECTED COURSE #1	A	024	BCD	5	00	0-359	CW FROM N	DEG
VOR FREQUENCY	A	034	BCD	5	00	108-117.95	ALWAYS POS	MHZ
VOR OMNIBEARING	A	222	BNR	16	00	+180	CW FROM N	DEG

EFFECTIVITY

ALL

34-51-00

02

Page 123
 Sep 20/96

BOEING
 757
 FAULT ISOLATION/MAINT MANUAL

VOR				
DISCRETE OCTAL LABELS/BIT CHART				
SIGNAL	OCTAL LABEL	BIT	ONE-STATE	ZERO-STATE
400 HZ MKR BEACON	222	11	PRESENT	NOT PRES
1300 HZ MKR BEACON	222	12	PRESENT	NOT PRES
4000 HZ MKR BEACON	222	13	PRESENT	NOT PRES

EFFECTIVITY

ALL

34-51-00

BOEING
 757
 FAULT ISOLATION/MAINT MANUAL

VOR CP								
DIGITAL OUTPUT BUS CHART								
BUS NAME			CON	PINS	BUS FORMAT	BIT RATE	A	
SOURCE	TYPE	BUS					DATA BUS	
VORCP (L R)	A	1		18 31	429	LO	VOR FREQUENCY	
VORCP (L R)	A	2		16 29	429	LO	DME FREQUENCY	

VOR CP ID=B1								
OCTAL LABELS CHART								
SIGNAL	TYPE	LABEL	FORMAT	MIN UPDATE RATE	SDI	BINARY RANGE	POSITIVE SENSE	UNITS
SEL RUNWAY HDG-D	A	017	BCD	5	00	0-359	CW FROM N	DEG
SELECTED COURSE #1	A	024	BCD	5	00	0-359	CW FROM N	DEG
ILS FREQUENCY	A	033	BCD	5	00	108-111.95	ALWAYS POS	MHZ
VOR FREQUENCY	A	034	BCD	5	00	108-117.95	ALWAYS POS	MHZ
DME FREQUENCY	A	035	BCD	5	00	108-135.95	ALWAYS POS	MHZ

VOR CP				
DISCRETE OCTAL LABELS/BIT CHART				
SIGNAL	OCTAL LABEL	BIT	ONE-STATE	ZERO-STATE
VOR/ILS FREQ	034	14	ILS	VOR
DME MODE 1	035	11	CODED	
DME MODE 2	035	12	CODED	
DME MODE 3	035	13	CODED	
VOR/ILS FREQ	035	14	ILS	VOR

EFFECTIVITY

ALL

34-51-00

01

Page 125
Sep 20/96



757
 FAULT ISOLATION/MAINT MANUAL

AIR TRAFFIC CONTROL (ATC) SYSTEM

COMPONENT	FIG. 102 SHT	QTY	ACCESS/AREA	AMM REFERENCE
ANTENNA - BOTTOM ATC, M10144	1	1	BOTTOM OF FUSELAGE	34-53-03
ANTENNA - TOP ATC, M10769	1	1	TOP OF FUSELAGE	34-53-03
CIRCUIT BREAKER -			FLIGHT COMPT, P11	
ATC ANT SWITCH, C4423		1	11C20	*
ATC LEFT, C4051		1	11F7	*
ATC RIGHT, C4052		1	11F28	*
COMPUTER - (FIM 31-41-00/101)				
EICAS LEFT, M10181				
EICAS RIGHT, M10182				
PANEL - ATC CONTROL, M10140	2	1	FLIGHT COMPT, P8	34-53-02
RELAY - (FIM 31-01-36/101)				
SYS NO. 1 AIR/GND, K143				
RELAY - (FIM 31-01-37/101)				
SYS NO. 2 AIR/GND, K201				
SWITCH - (FIM 34-12-00/101)				
LEFT ADC, S482				
RIGHT ADC, S483				
SWITCH - BOTTOM ATC ANT, S10564	2	1	119BL, MAIN EQUIP CENTER, E3-3	34-53-04
SWITCH - TOP ATC ANT, S10563	2	1	119BL, MAIN EQUIP CENTER, E3-2	34-53-04
TRANSPONDER - LEFT ATC, M10141	2	1	119BL, MAIN EQUIP CENTER, E3-3	34-53-01
TRANSPONDER - RIGHT ATC, M10142	2	1	119BL, MAIN EQUIP CENTER, E3-2	34-53-01

* SEE THE WDM EQUIPMENT LIST

Air Traffic Control (ATC) System - Component Index
 Figure 101

EFFECTIVITY
 GUI 115

34-53-00

CONFIG 3

05

Page 101

Sep 20/94

BOEING
 757
 FAULT ISOLATION/MAINT MANUAL

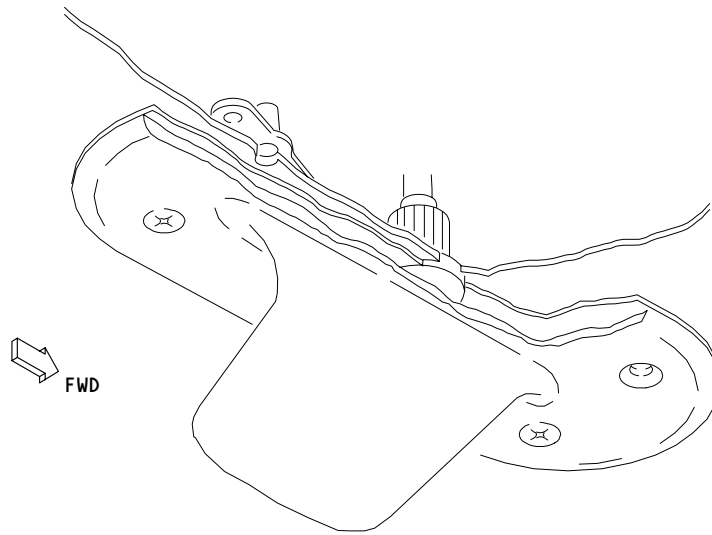
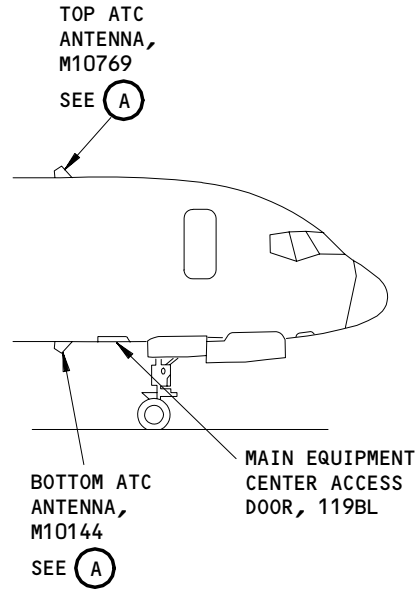

LEFT OR RIGHT ATC ANTENNA, M10144 OR M10769
 (A)

Air Traffic Control (ATC) System - Component Location
 Figure 102 (Sheet 1)

EFFECTIVITY
 GUI 115

34-53-00

CONFIG 3
 Page 102
 Sep 20/94

05

814031

BOEING

757

FAULT ISOLATION/MAINT MANUAL

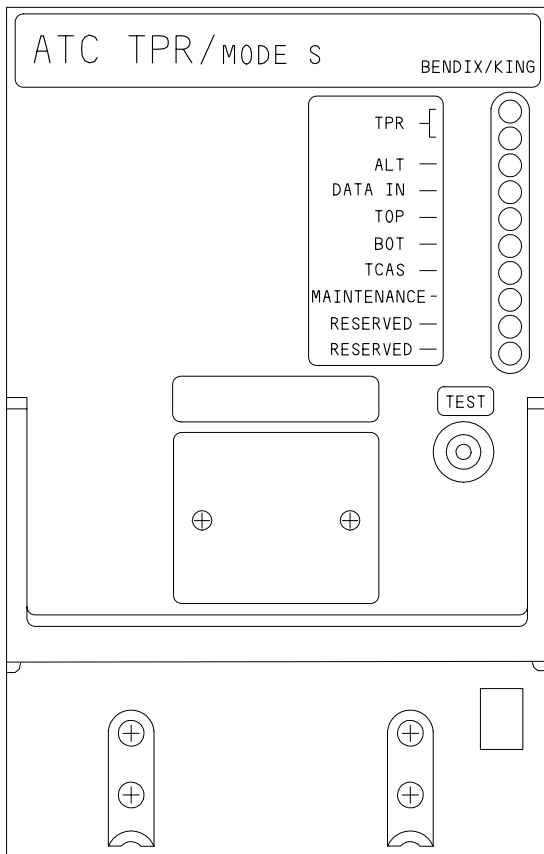
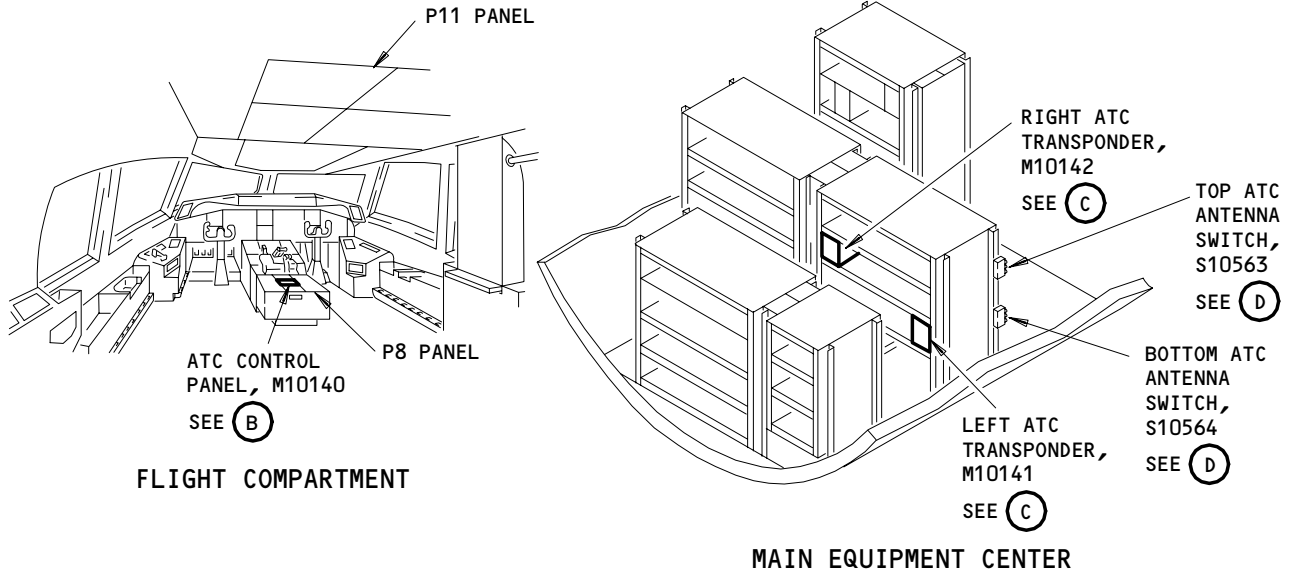

LEFT OR RIGHT ATC TRANSPONDER, M10141 OR M10142

(C)

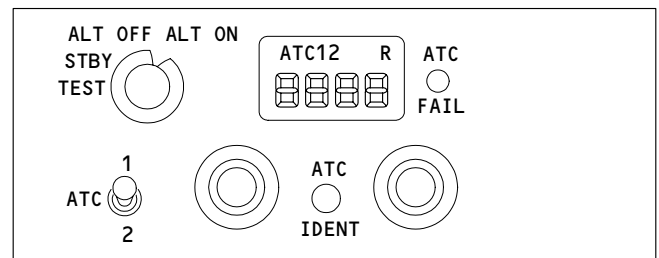

ATC CONTROL PANEL, M10140

(B)

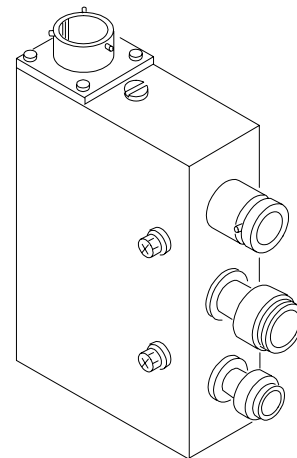

ATC ANTENNA SWITCH, S10563 OR S10564

(D)

Air Traffic Control (ATC) System - Component Location
Figure 102 (Sheet 2)

EFFECTIVITY
GUI 115

814043

34-53-00

CONFIG 3

05

Page 103

Sep 20/94

PREREQUISITES

MAKE SURE THIS SYSTEM WILL OPERATE:
ADC SYSTEM (MM 34-12-00/501)

MAKE SURE THESE CIRCUIT BREAKERS ARE CLOSED:
11C20,11F7,11F28

MAKE SURE THE AIRPLANE IS IN THE CONFIGURATION THAT FOLLOWS:
ELECTRICAL POWER IS ON (MM 24-22-00/201)

**ATC SYSTEM
BITE PROCEDURE**

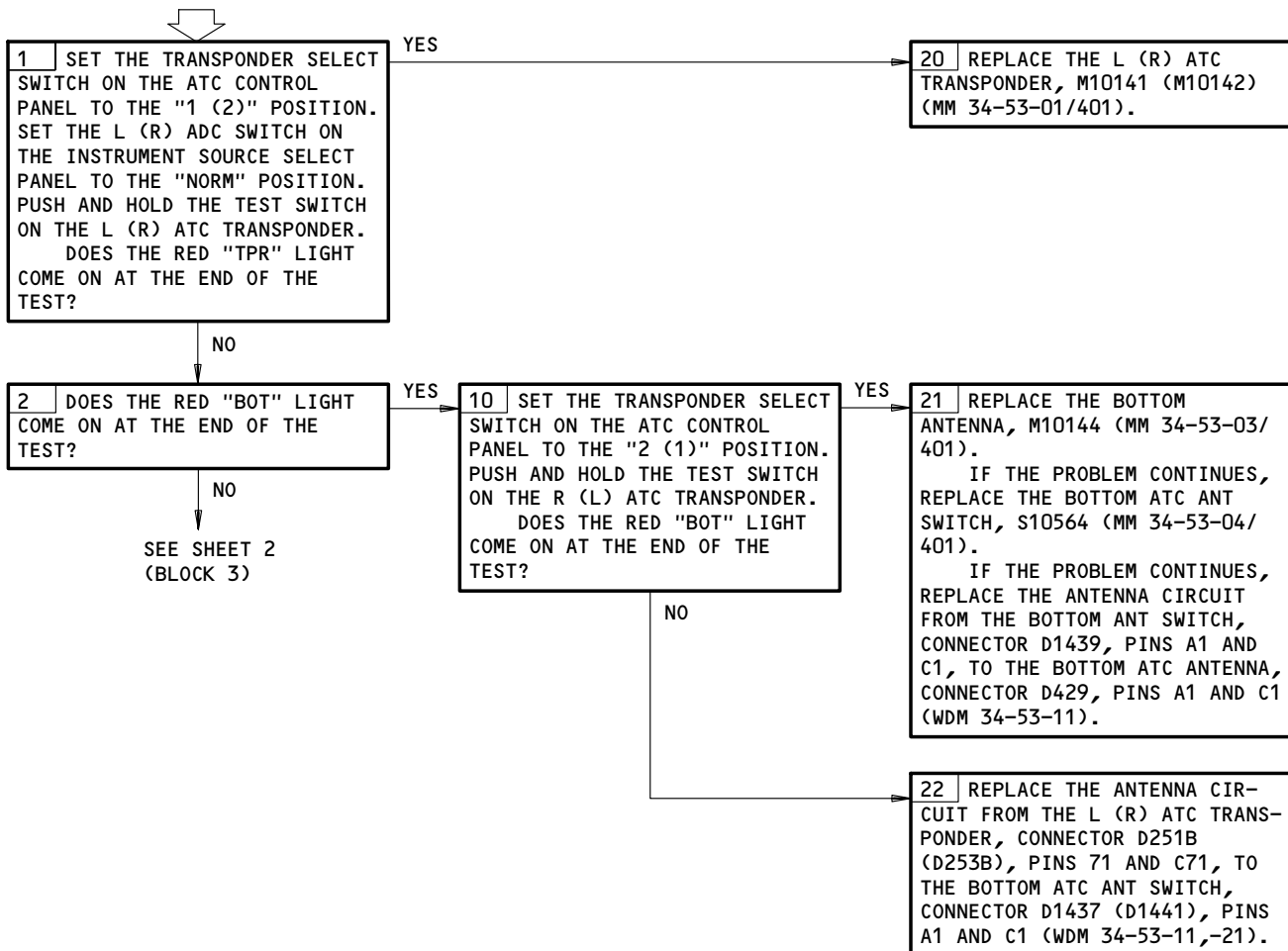

ATC System BITE Procedure
Figure 103 (Sheet 1)

EFFECTIVITY
GUI 115

34-53-00
 CONFIG 3
 Page 104
 Jan 28/02

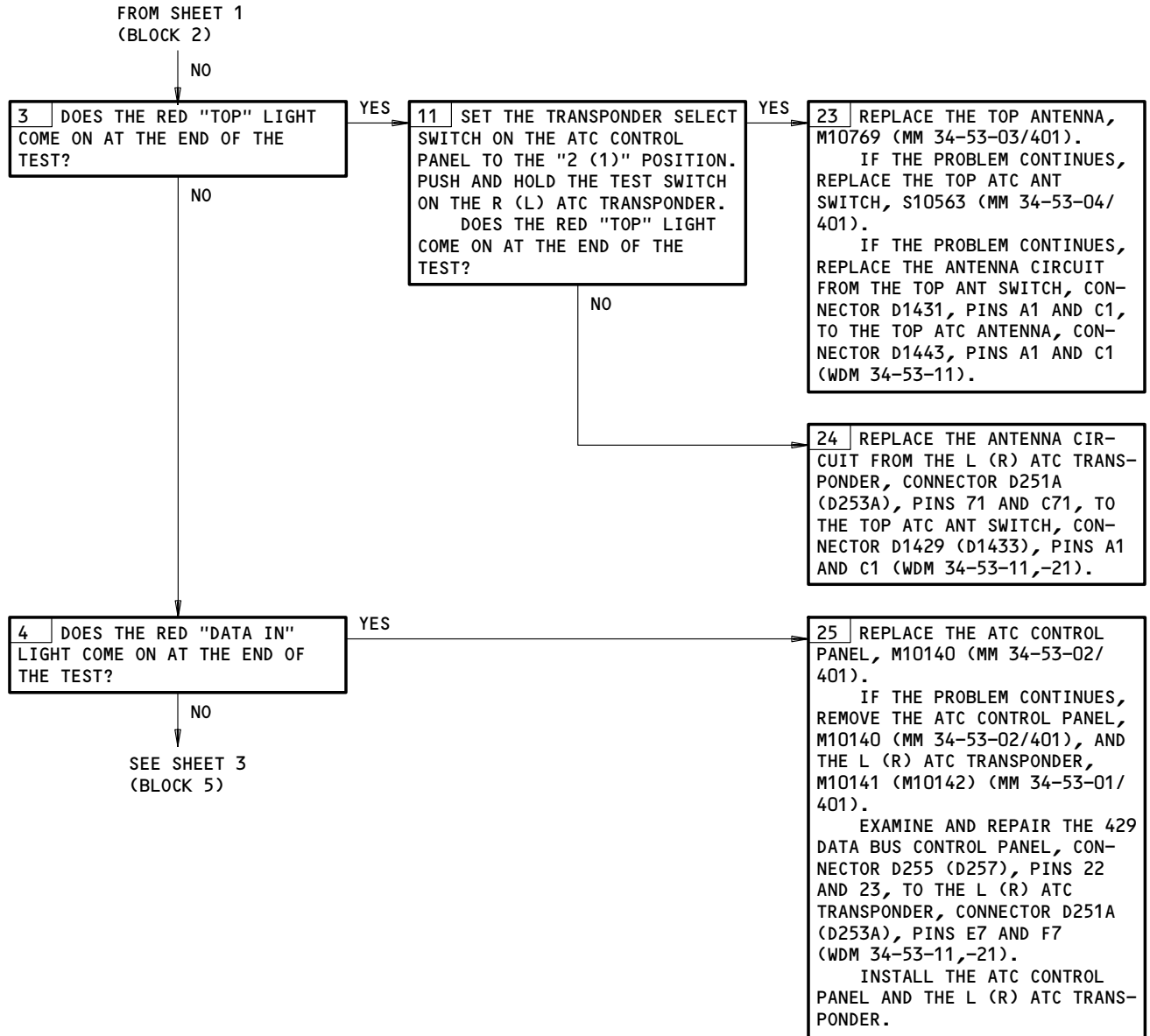

ATC System BITE Procedure
Figure 103 (Sheet 2)

EFFECTIVITY
GUI 115

34-53-00

CONFIG 3

05

Page 105

Sep 20/94

BOEING
757
FAULT ISOLATION/MAINT MANUAL

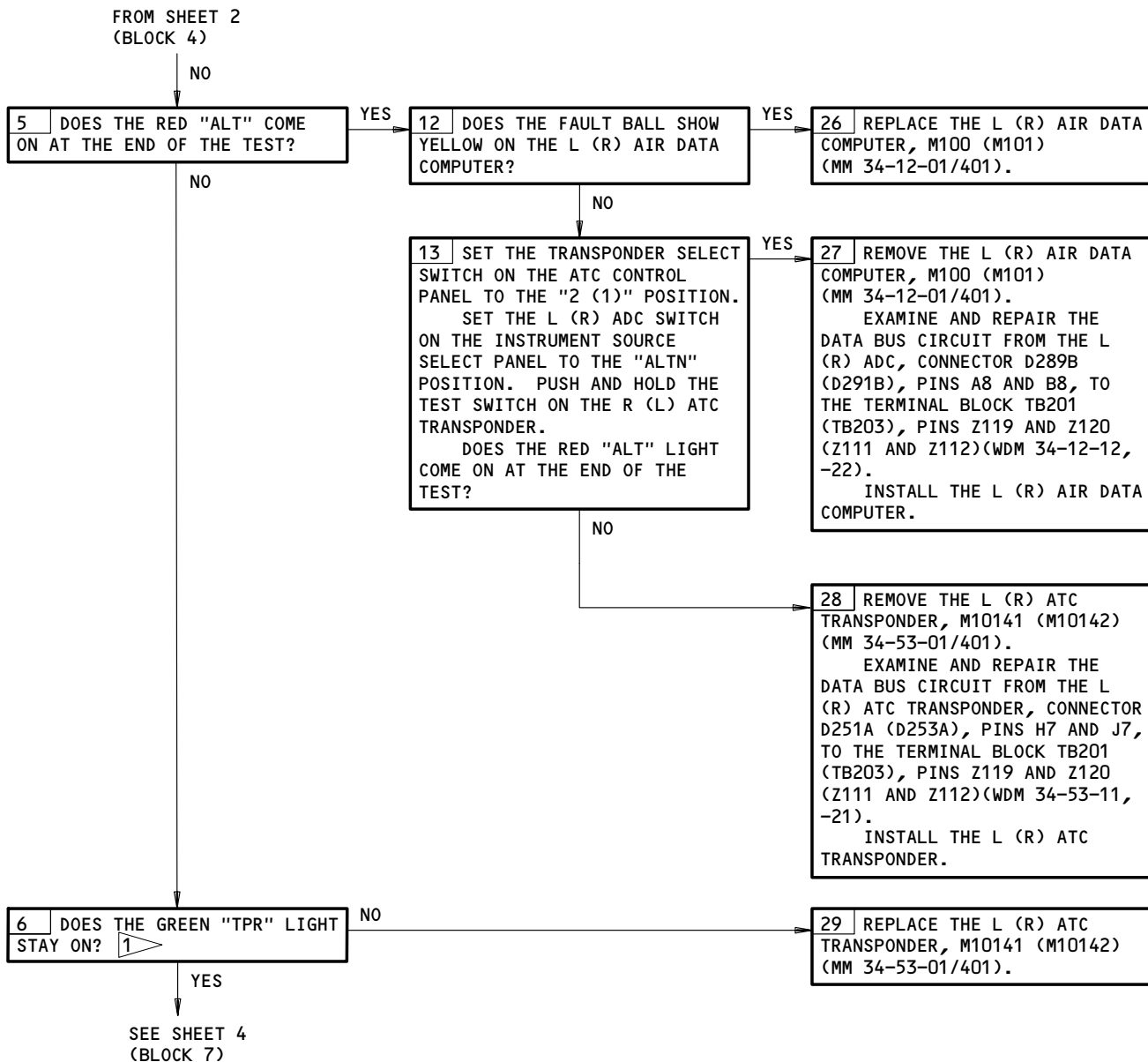

1 THE GREEN "TPR" LIGHT WILL STAY ON OR FLICKER AT THE END OF THE TEST IF THE TRANSPONDER IS REPLYING TO A SIGNAL.

ATC System BITE Procedure
Figure 103 (Sheet 3)

EFFECTIVITY
GUI 115

34-53-00
CONFIG 3
Page 106
Sep 20/94

05

BOEING
757
FAULT ISOLATION/MAINT MANUAL

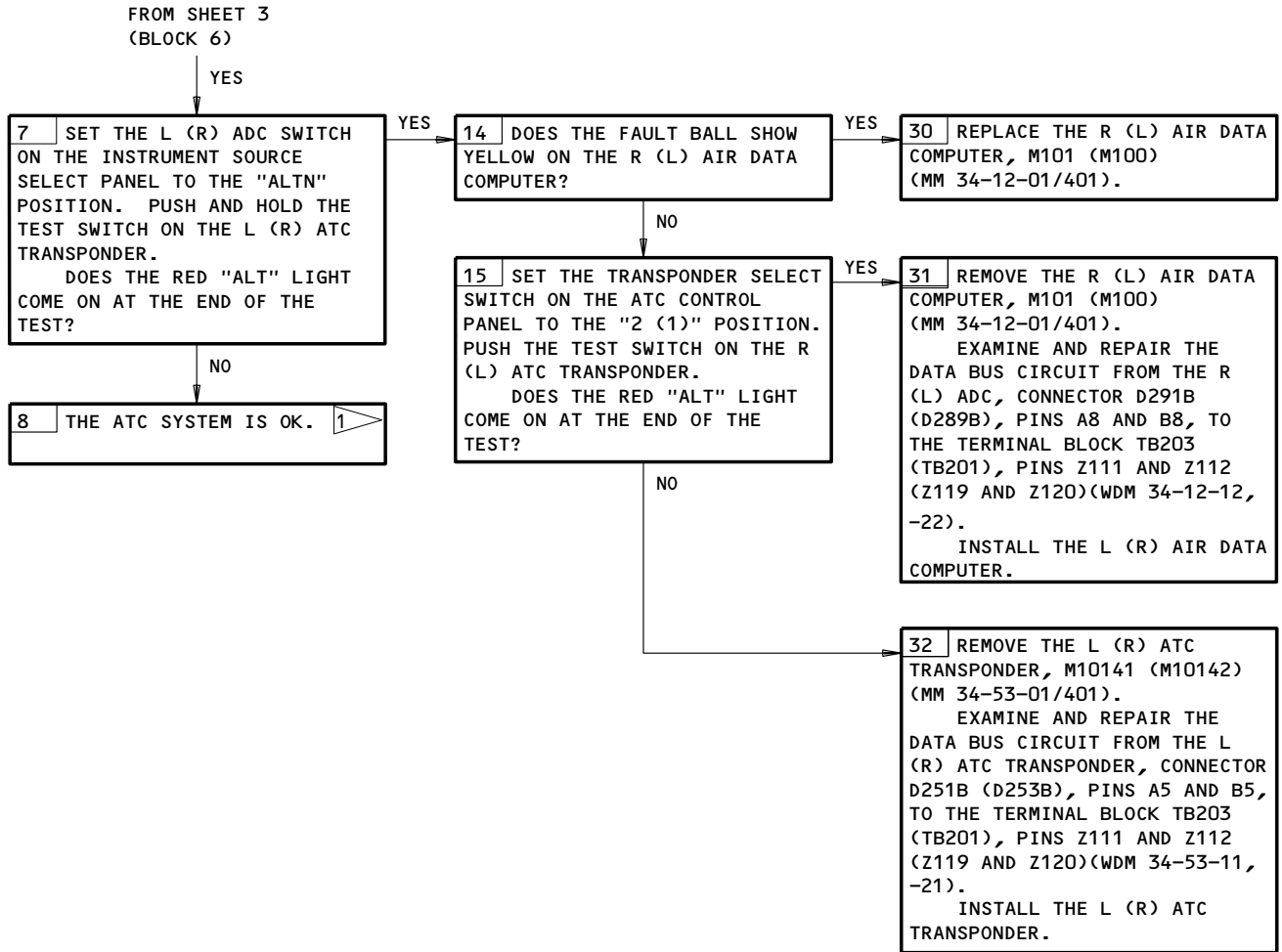

ATC System BITE Procedure
Figure 103 (Sheet 4)

EFFECTIVITY
GUI 115

34-53-00

CONFIG 3

05

Page 107

Sep 20/94

815828

PREREQUISITES

MAKE SURE THIS SYSTEM WILL OPERATE:
 ADC SYSTEM (MM 34-12-00/501)

MAKE SURE THESE CIRCUIT BREAKERS ARE CLOSED:
 11C20,11F7,11F28

MAKE SURE THE AIRPLANE IS IN THE CONFIGURATION THAT FOLLOWS:
 ELECTRICAL POWER IS ON (MM 24-22-00/201)

ALT RPTG INOP

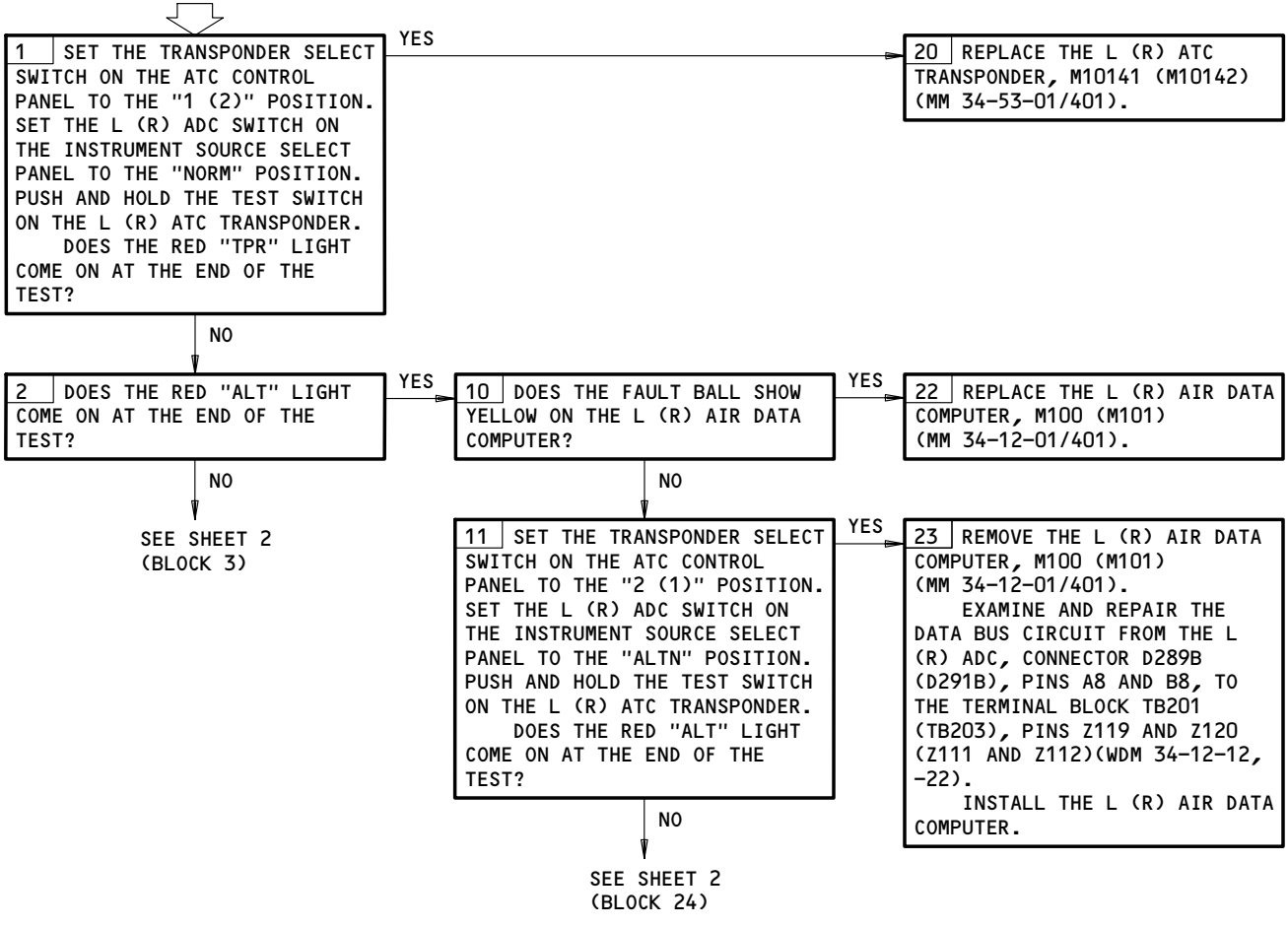

Alt Rptg Inop
 Figure 104 (Sheet 1)

EFFECTIVITY
 GUI 115

34-53-00
 CONFIG 3
 Page 108
 Sep 20/94

05

815835

BOEING
757
FAULT ISOLATION/MAINT MANUAL

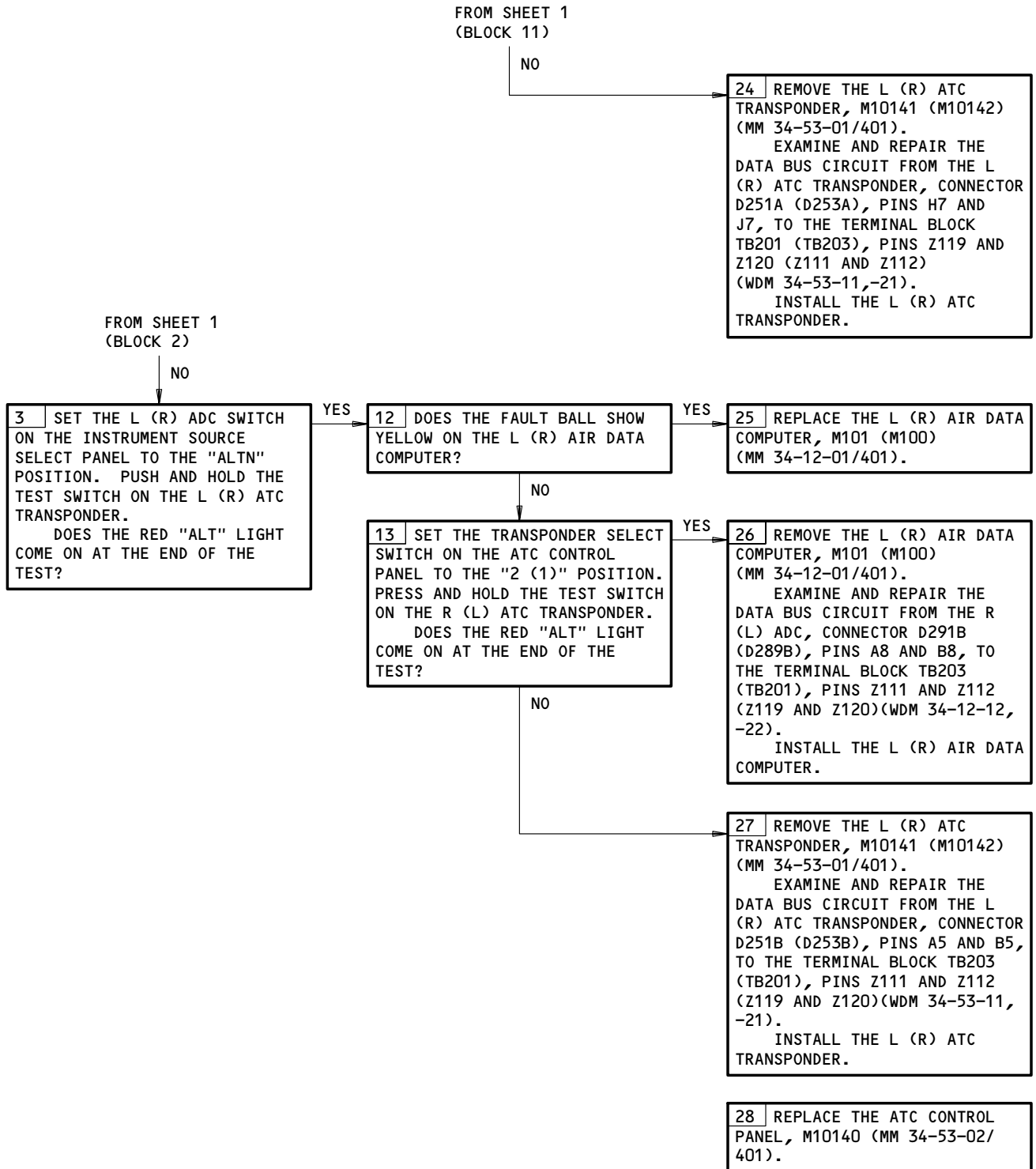

Alt Rptg Inop
Figure 104 (Sheet 2)

EFFECTIVITY
GUI 115

34-53-00

CONFIG 3

05

Page 109

Sep 20/94

PREREQUISITES

MAKE SURE THIS SYSTEM WILL OPERATE:
ADC SYSTEM (MM 34-12-00/501)

MAKE SURE THESE CIRCUIT BREAKERS ARE CLOSED:
11C20,11F7,11F28

MAKE SURE THE AIRPLANE IS IN THE CONFIGURATION THAT
FOLLOWS:
ELECTRICAL POWER IS ON (MM 24-22-00/201)

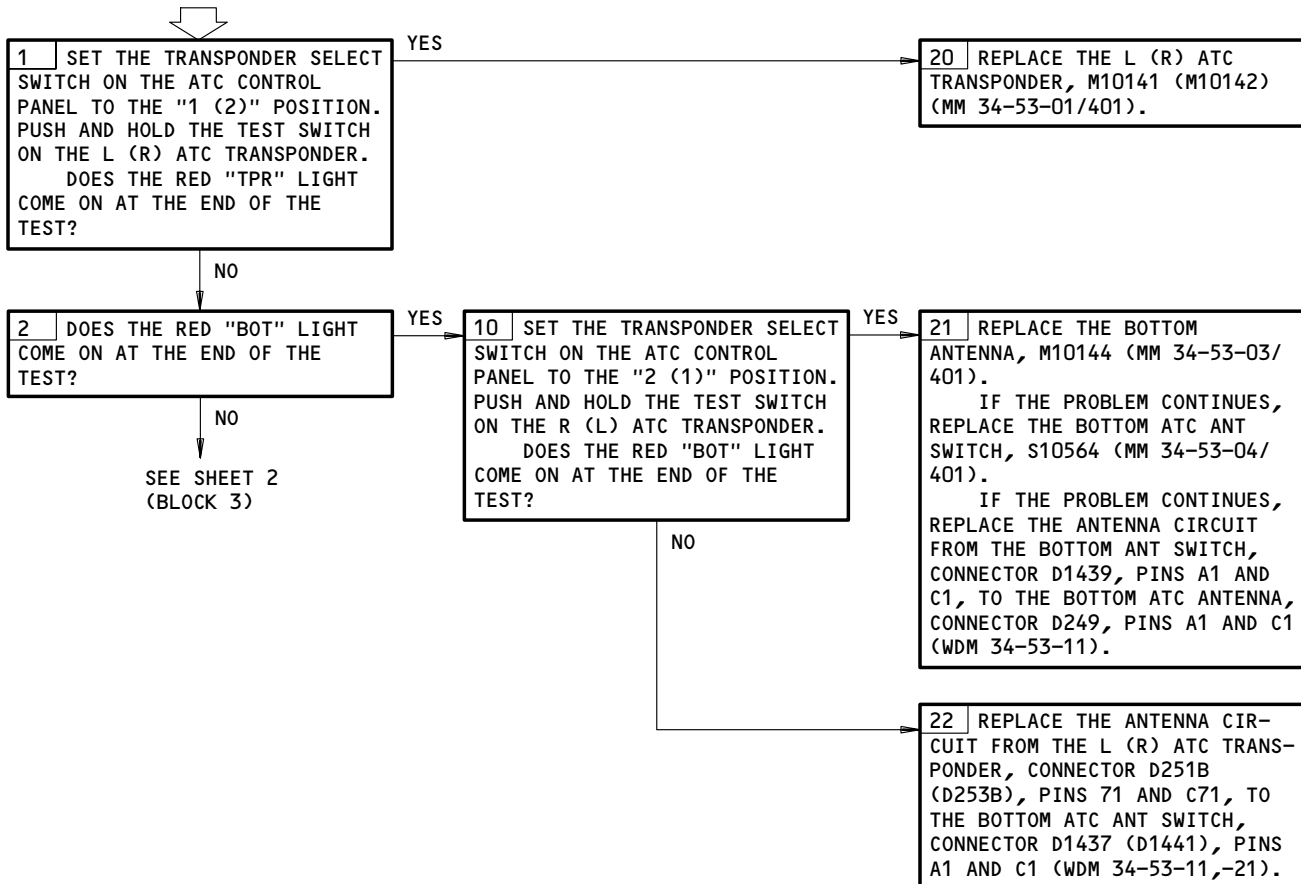
**ATC TRANSMISSION
PROBLEMS**

ATC Transmission Problems
Figure 105 (Sheet 1)

EFFECTIVITY
GUI 115

34-53-00

CONFIG 3

05

Page 110

Sep 20/94

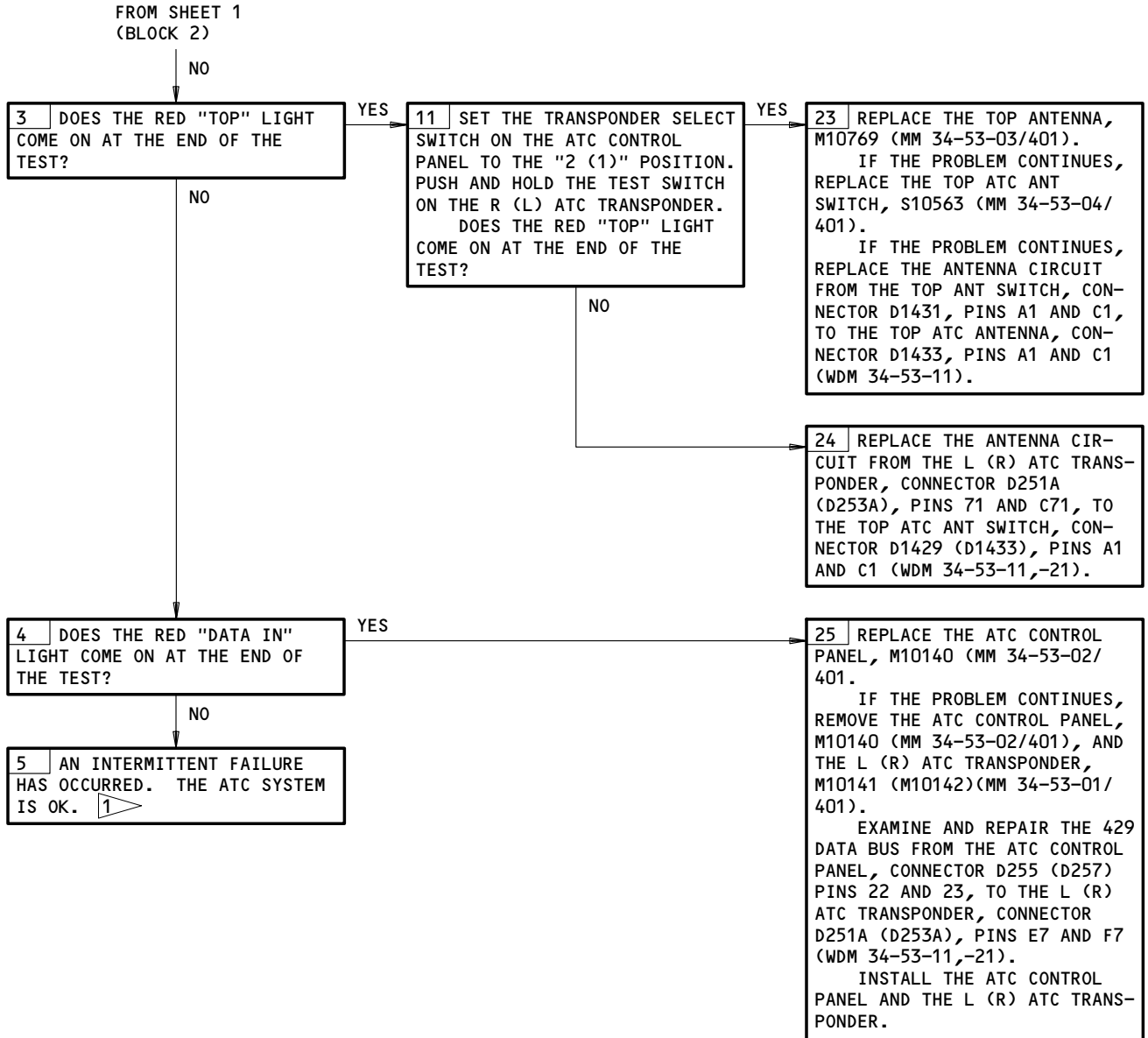

1 THE GREEN "TPR" LIGHT WILL STAY ON OR FLICKER AT THE END OF THE TEST IF THE TRANSPONDER IS REPLYING TO A SIGNAL.

ATC Transmission Problems
Figure 105 (Sheet 2)

EFFECTIVITY
GUI 115

34-53-00

CONFIG 3

05

Page 111

Sep 20/94

BOEING
 757
 FAULT ISOLATION/MAINT MANUAL

1. ARINC Data Bus Charts

A. General

CAUTION: DO NOT DIRECTLY TOUCH THE CONNECTORS. USE A BREAKOUT BOX OR YOU CAN CAUSE DAMAGE TO THE CONNECTORS.

- (1) The ARINC 429 data bus charts give data necessary to make an analysis of ARINC 429 transmitters, receivers, and data buses. For the test, use a breakout box at the available terminal or at the LRU connectors.

B. Equipment

- (1) Standard multi-meter
 (2) 429EBP Data Bus Analyzer (recommended)
 JcAIR Instrumentation
 400 Industrial Parkway
 Industrial Airport, KS 66031

429-2 Data Bus Analyzer (alternative)
 Interface Technology
 150 E. Arrow Highway
 San Dimas, CA 91773

- (3) A34011-1 Breakout Box (recommended)
 A34011-112 Breakout Box (alternative)

ATC PNL								
DIGITAL OUTPUT BUS CHART								
BUS NAME			CON	PINS	BUS FORMAT	BIT RATE	DATA BUS	
SOURCE	TYPE	BUS						
ATCPNL (L)	A	1	P1	22 23	429	LO	CONTROL DATA OUT L	
ATCPNL (R)	A	2	P2	22 23	429	LO	CONTROL DATA OUT R	

ATC PNL ID=B8								
OCTAL LABELS CHART								
SIGNAL	TYPE	LABEL	FORMAT	MIN UPDATE RATE	SDI	BINARY RANGE	POSITIVE SENSE	UNITS
XPONDER CODE	A	031	BCD	5	00	N/A	N/A	N/A

EFFECTIVITY
 GUI 115

34-53-00

CONFIG 3
 Page 112
 Dec 20/96



757
 FAULT ISOLATION/MAINT MANUAL

AIR TRAFFIC CONTROL (ATC) SYSTEM

COMPONENT	FIG. 102 SHT	QTY	ACCESS/AREA	AMM REFERENCE
ANTENNA - BOTTOM ATC, M10144	1	1	BOTTOM OF FUSELAGE	34-53-03
ANTENNA - TOP ATC, M10769	1	1	TOP OF FUSELAGE	34-53-03
CIRCUIT BREAKER -			FLIGHT COMPT, P11	
ATC ANT SWITCH, C4423		1	11C20	*
ATC LEFT, C4051		1	11F7	*
ATC RIGHT, C4052		1	11F28	*
COMPUTER - (FIM 31-41-00/101)				
EICAS LEFT, M10181				
EICAS RIGHT, M10182				
PANEL - ATC CONTROL, M10140	2	1	FLIGHT COMPT, P8	34-53-02
RELAY - (FIM 31-01-36/101)				
SYS NO. 1 AIR/GND, K143				
RELAY - (FIM 31-01-37/101)				
SYS NO. 2 AIR/GND, K201				
SWITCH - (FIM 34-12-00/101)				
LEFT ADC, S482				
RIGHT ADC, S483				
SWITCH - BOTTOM ATC ANT, S10564	2	1	119BL, MAIN EQUIP CENTER, E3-3	34-53-04
SWITCH - TOP ATC ANT, S10563	2	1	119BL, MAIN EQUIP CENTER, E3-2	34-53-04
TRANSPONDER - LEFT ATC, M10141	2	1	119BL, MAIN EQUIP CENTER, E3-3	34-53-01
TRANSPONDER - RIGHT ATC, M10142	2	1	119BL, MAIN EQUIP CENTER, E3-2	34-53-01

* SEE THE WDM EQUIPMENT LIST

Air Traffic Control (ATC) System - Component Index
 Figure 101

EFFECTIVITY
 GUI 001-114, 116-999

34-53-00

CONFIG 4
 Page 101
 Sep 20/94

09

BOEING
 757
 FAULT ISOLATION/MAINT MANUAL

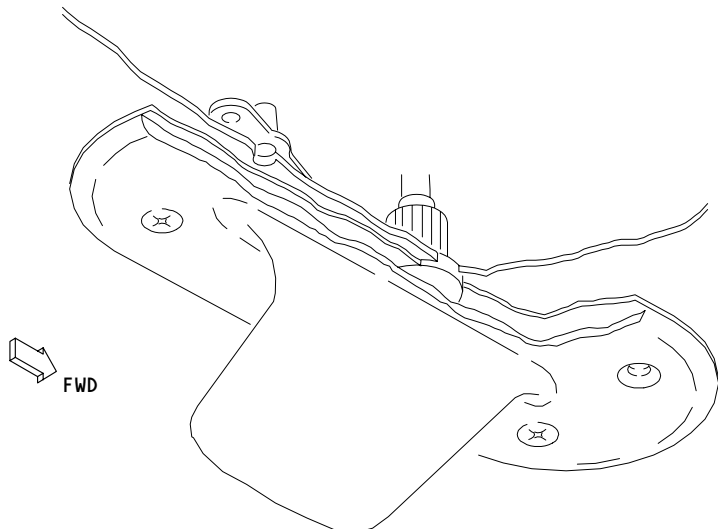
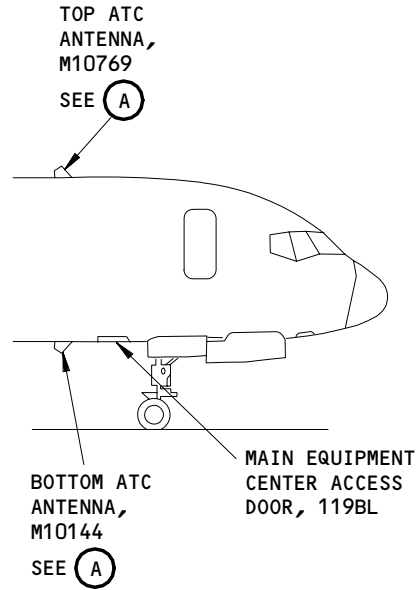

LEFT OR RIGHT ATC ANTENNA,
 M10144 OR M10769
 (A)

Air Traffic Control (ATC) System - Component Location
 Figure 102 (Sheet 1)

EFFECTIVITY
 GUI 001-114, 116-999

34-53-00
 CONFIG 4
 Page 102
 Sep 20/94

09

814010

BOEING

757 FAULT ISOLATION/MAINT MANUAL

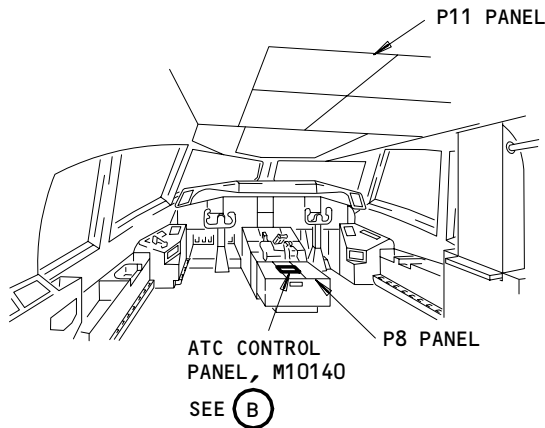

FLIGHT COMPARTMENT

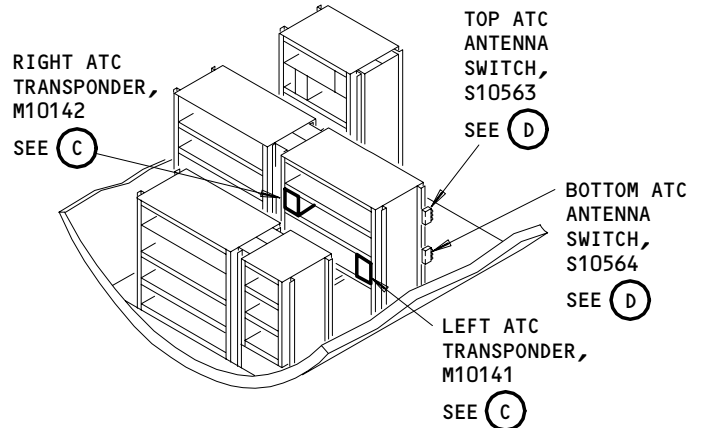

MAIN EQUIPMENT CENTER

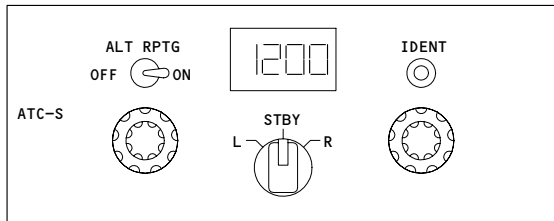

ATC CONTROL PANEL, M10140

(B) 1

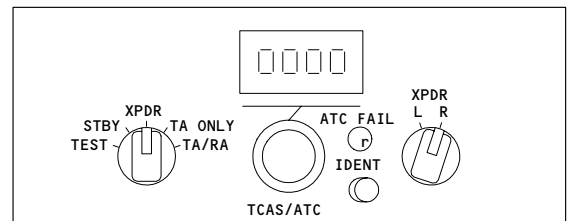

ATC CONTROL PANEL, M10140

(B) 2

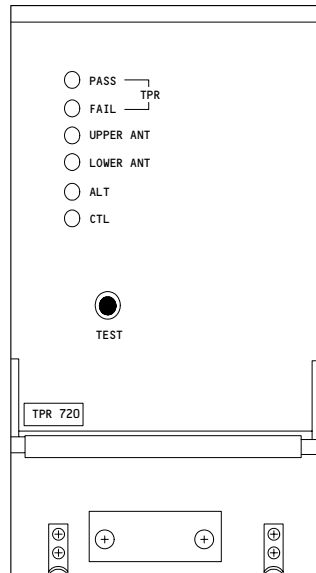

LEFT OR RIGHT ATC TRANSPONDER, M10141 OR M10142

(C)

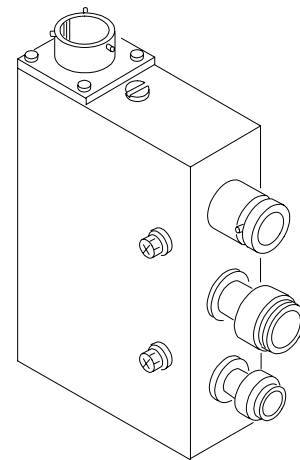

ATC ANTENNA SWITCH, S10563 OR S10564

(D)

1 GUI 001-006

2 GUI 007-114, 116-999

**Air Traffic Control (ATC) System - Component Location
Figure 102 (Sheet 2)**

EFFECTIVITY
GUI 001-114, 116-999

34-53-00

CONFIG 4

09

Page 103

Sep 20/94

**ATC SYSTEM
BITE PROCEDURE**

PREREQUISITES

MAKE SURE THIS SYSTEM WILL OPERATE:
ADC SYSTEM (MM 34-12-00/501)

MAKE SURE THESE CIRCUIT BREAKERS ARE CLOSED:
11C20,11F7,11F28

MAKE SURE THE AIRPLANE IS IN THE CONFIGURATION THAT FOLLOWS:
ELECTRICAL POWER IS ON (MM 24-22-00/201)

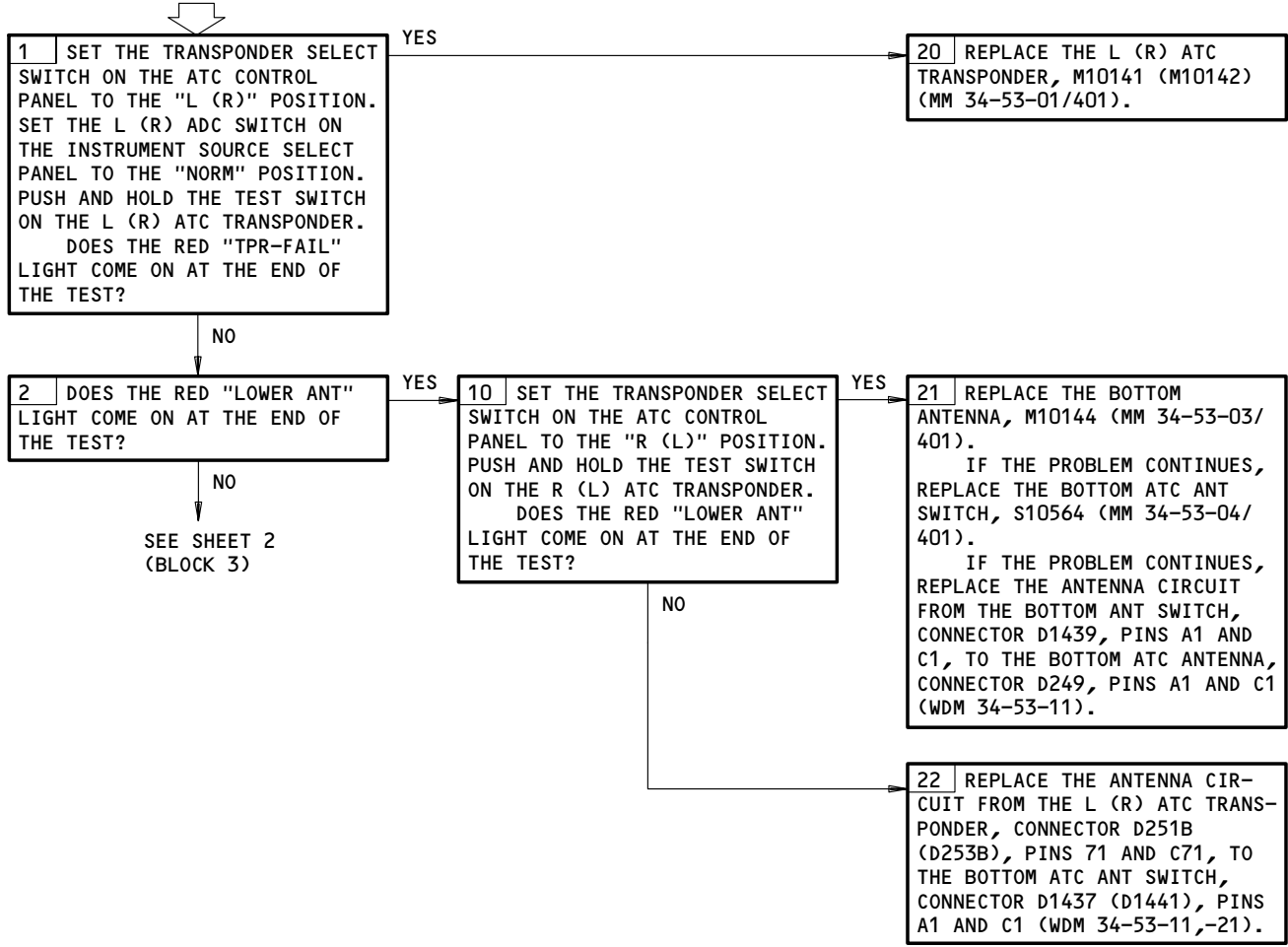

ATC System BITE Procedure
Figure 103 (Sheet 1)

EFFECTIVITY
GUI 001-114, 116-999

34-53-00
 CONFIG 4
 Page 104
 Sep 20/94

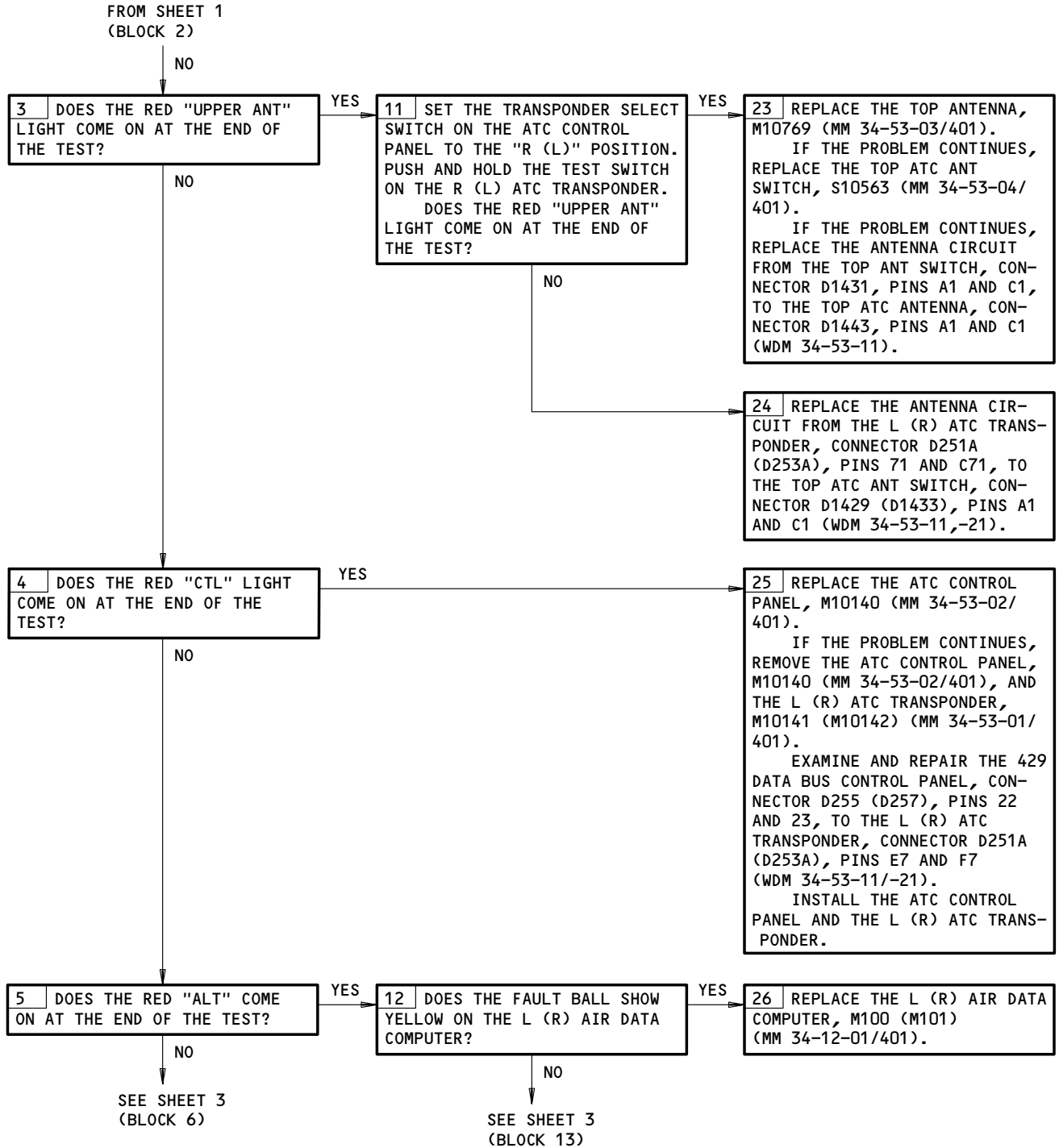

ATC System BITE Procedure
Figure 103 (Sheet 2)

EFFECTIVITY
GUI 001-114, 116-999

34-53-00

CONFIG 4

09

Page 105

Sep 20/94

BOEING
757
FAULT ISOLATION/MAINT MANUAL

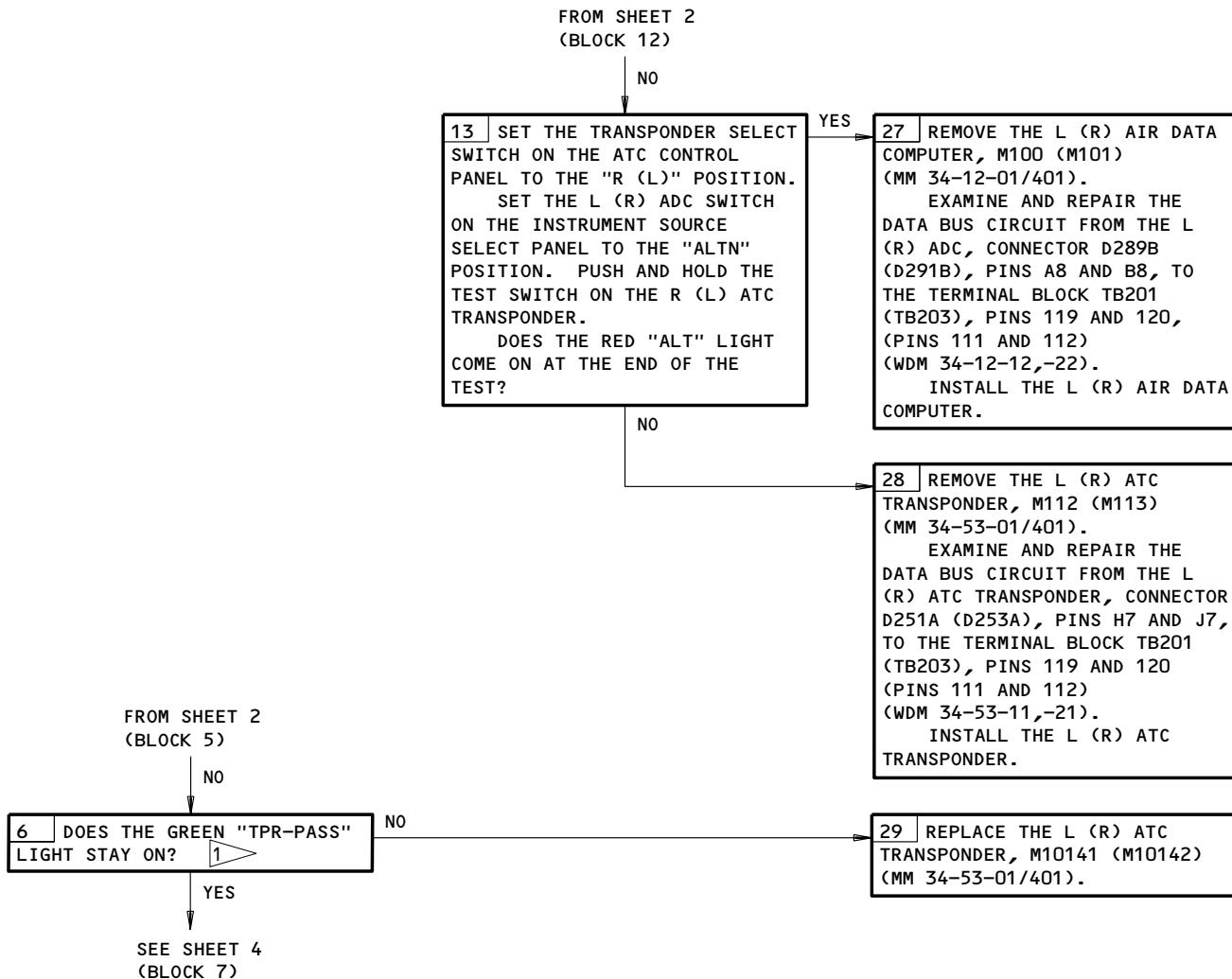

1 THE GREEN "TPR-PASS" LIGHT WILL STAY ON OR FLICKER AT THE END OF THE TEST IF THE TRANSPONDER IS REPLYING TO A SIGNAL.

ATC System BITE Procedure
Figure 103 (Sheet 3)

EFFECTIVITY
GUI 001-114, 116-999

34-53-00
CONFIG 4
Page 106
Sep 20/94

09

BOEING
757
FAULT ISOLATION/MAINT MANUAL

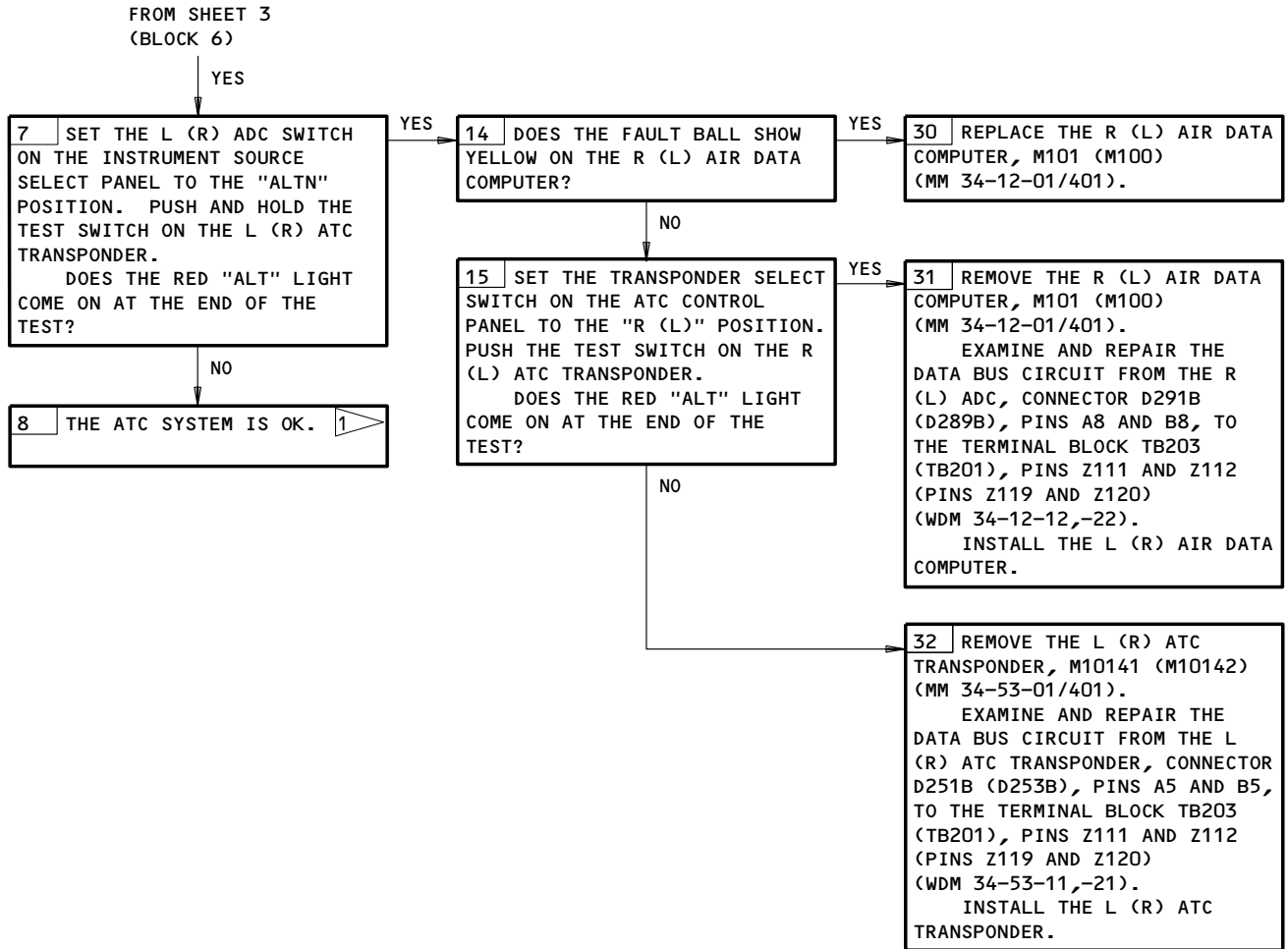

ATC System BITE Procedure
Figure 103 (Sheet 4)

EFFECTIVITY
GUI 001-114, 116-999

34-53-00
CONFIG 4
Page 107
Sep 20/94

09

PREREQUISITES

MAKE SURE THIS SYSTEM WILL OPERATE:
ADC SYSTEM (MM 34-12-00/501)

MAKE SURE THESE CIRCUIT BREAKERS ARE CLOSED:
11C20,11F7,11F28

MAKE SURE THE AIRPLANE IS IN THE CONFIGURATION THAT FOLLOWS:
ELECTRICAL POWER IS ON (MM 24-22-00/201)

ALT RPTG INOP

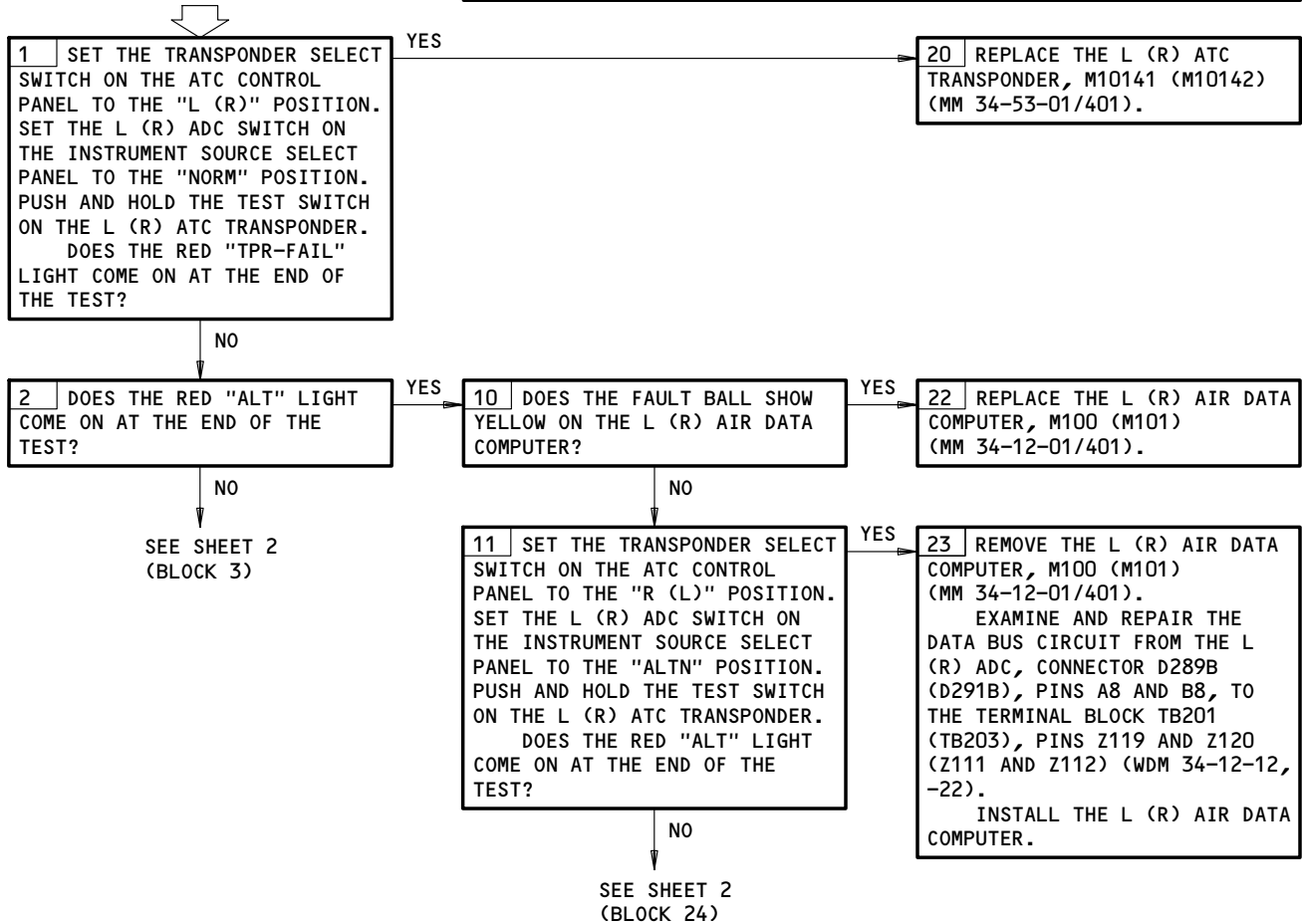

Alt Rptg Inop
Figure 104 (Sheet 1)

EFFECTIVITY
GUI 001-114, 116-999

34-53-00
 CONFIG 4
 Page 108
 Sep 20/94

09

BOEING
757
FAULT ISOLATION/MAINT MANUAL

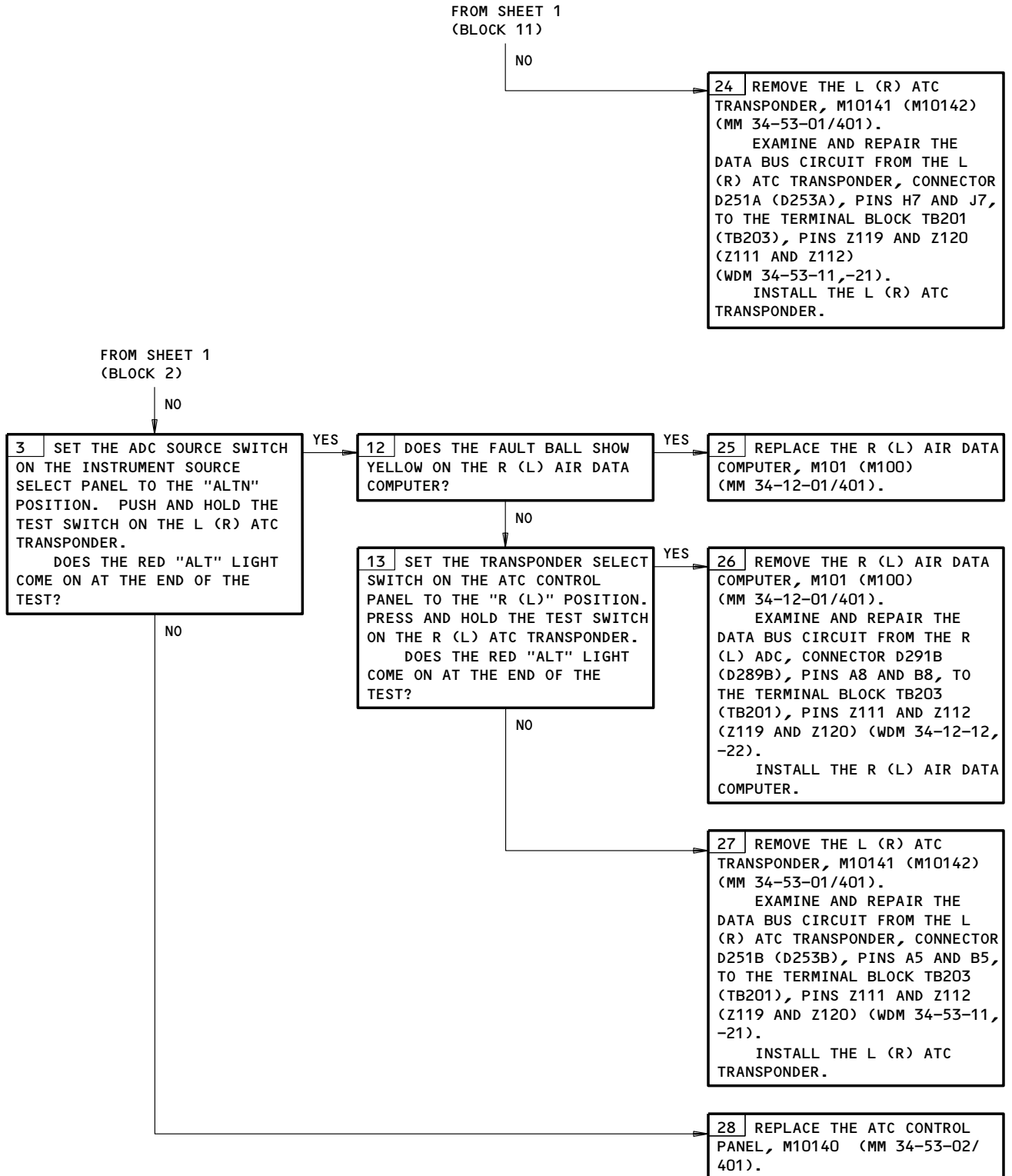

Alt Rptg Inop
Figure 104 (Sheet 2)

EFFECTIVITY
GUI 001-114, 116-999

34-53-00

CONFIG 4

09

Page 109

Sep 20/94

**ATC TRANSMISSION
PROBLEMS**

PREREQUISITES

MAKE SURE THIS SYSTEM WILL OPERATE:
ADC SYSTEM (MM 34-12-00/501)

MAKE SURE THESE CIRCUIT BREAKERS ARE CLOSED:
11C20,11F7,11F28

MAKE SURE THE AIRPLANE IS IN THE CONFIGURATION THAT
FOLLOWS:
ELECTRICAL POWER IS ON (MM 24-22-00/201)

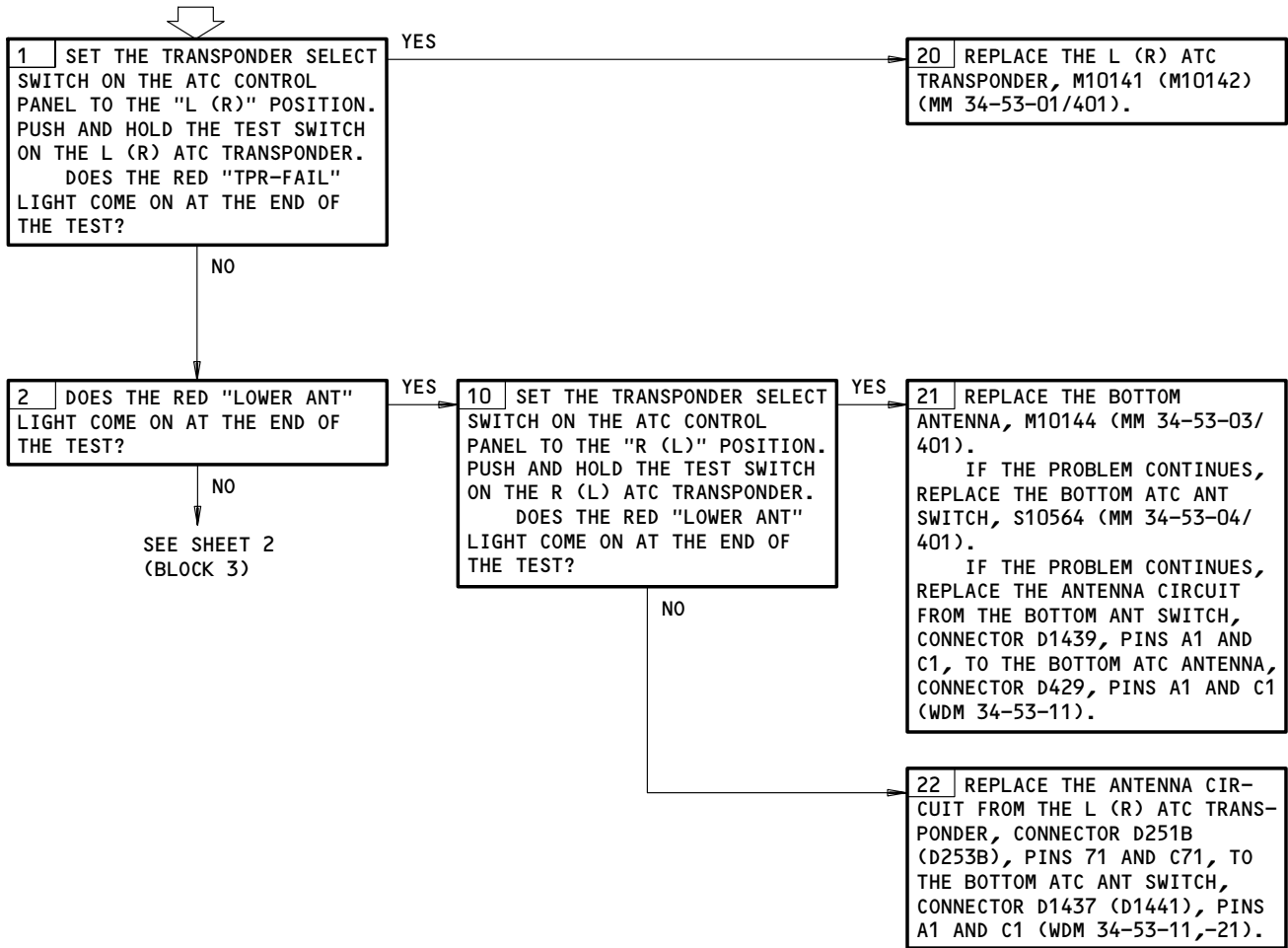

ATC Transmission Problems
Figure 105 (Sheet 1)

EFFECTIVITY
GUI 001-114, 116-999

34-53-00
CONFIG 4
Page 110
Sep 20/94

09

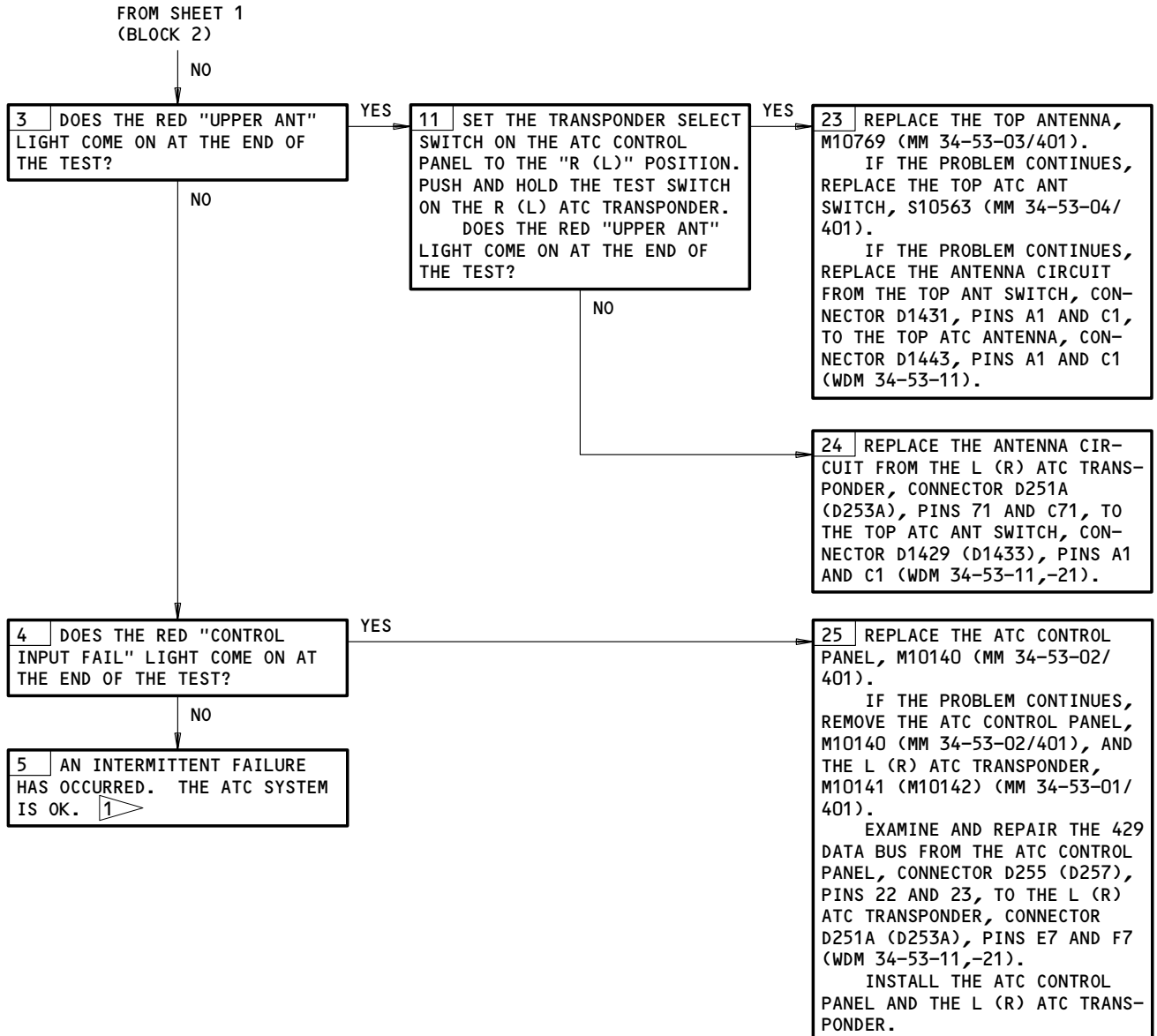

1 THE GREEN "TPR-PASS" LIGHT WILL STAY ON OR FLICKER AT THE END OF THE TEST IF THE TRANSPONDER IS REPLYING TO A SIGNAL.

ATC Transmission Problems
Figure 105 (Sheet 2)

EFFECTIVITY
GUI 001-114, 116-999

34-53-00

CONFIG 4

09

Page 111

Sep 20/94

BOEING
 757
 FAULT ISOLATION/MAINT MANUAL

1. ARINC Data Bus Charts

A. General

CAUTION: DO NOT DIRECTLY TOUCH THE CONNECTORS. USE A BREAKOUT BOX OR YOU CAN CAUSE DAMAGE TO THE CONNECTORS.

- (1) The ARINC 429 data bus charts give data necessary to make an analysis of ARINC 429 transmitters, receivers, and data buses. For the test, use a breakout box at the available terminal or at the LRU connectors.

B. Equipment

- (1) Standard multi-meter
 (2) 429EBP Data Bus Analyzer (recommended)
 JcAIR Instrumentation
 400 Industrial Parkway
 Industrial Airport, KS 66031

429-2 Data Bus Analyzer (alternative)
 Interface Technology
 150 E. Arrow Highway
 San Dimas, CA 91773

- (3) A34011-1 Breakout Box (recommended)
 A34011-112 Breakout Box (alternative)

ATC PNL								
DIGITAL OUTPUT BUS CHART								
BUS NAME			CON	PINS	BUS FORMAT	BIT RATE	DATA BUS	
SOURCE	TYPE	BUS						
ATCPNL (L)	A	1	P1	22 23	429	LO	CONTROL DATA OUT L	
ATCPNL (R)	A	2	P2	22 23	429	LO	CONTROL DATA OUT R	



ATC PNL ID=B8								
OCTAL LABELS CHART								
SIGNAL	TYPE	LABEL	FORMAT	MIN UPDATE RATE	SDI	BINARY RANGE	POSITIVE SENSE	UNITS
XPONDER CODE	A	031	BCD	5	00	N/A	N/A	N/A

EFFECTIVITY
 GUI 001-114, 116-999



34-53-00

CONFIG 4
 Page 112
 Dec 20/96



BOEING
 757
 FAULT ISOLATION/MAINT MANUAL

COMPONENT	FIG. 102 SHT	QTY	ACCESS/AREA	AMM REFERENCE
ANTENNA				
LEFT DME, M263	--	1	BOTTOM FUSELAGE	34-55-02
RIGHT DME, M264	--	1	BOTTOM FUSELAGE	34-55-02
CIRCUIT BREAKERS - NAVIGATION			FLT COMPT, P11	
LEFT DME, C582		1	11E11	*
RIGHT DME, C583		1	11E32	*
INDICATORS - (FIM 34-22-00/101) 				
LEFT RADIO DISTANCE MAGNETIC, N3	--	1		
RIGHT RADIO DISTANCE MAGNETIC, N43	--	1		
INDICATOR				
LEFT DUAL DISTANCE, N10030 	--	1	FLT COMPT, P1-1	34-55-03
RIGHT DUAL DISTANCE, N10031 	--	1	FLT COMPT, P3-1	34-55-03
INTERROGATOR				
LEFT DME, M123	--	1	119BL, MAIN EQUIP CTR, E3-3	34-55-01
RIGHT DME, M124	--	1	119BL, MAIN EQUIP CTR, E3-2	34-55-01
PANELS - (FIM 34-22-00/101)				
LEFT EFIS CONTROL, M94				
RIGHT EFIS CONTROL, M93				
PANELS - (FIM 34-51-00/101)				
LEFT VOR CONTROL, M91				
RIGHT VOR CONTROL, M92				
RELAY - (FIM 31-01-36/101)				
SYSTEM NO. 1 AIR/GROUND, K167				
RELAY - (FIM 31-01-37/101)				
SYSTEM NO. 2 AIR/GROUND, K214				

* SEE THE WDM EQUIPMENT LIST

-  GUI 001-114,116-999
 GUI 115

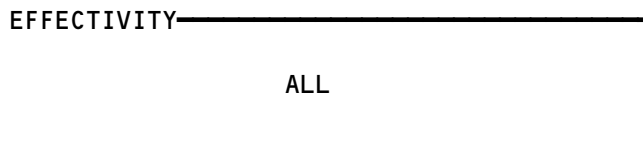
DME System - Component Index
Figure 101



34-55-00

BOEING
757
FAULT ISOLATION/MAINT MANUAL

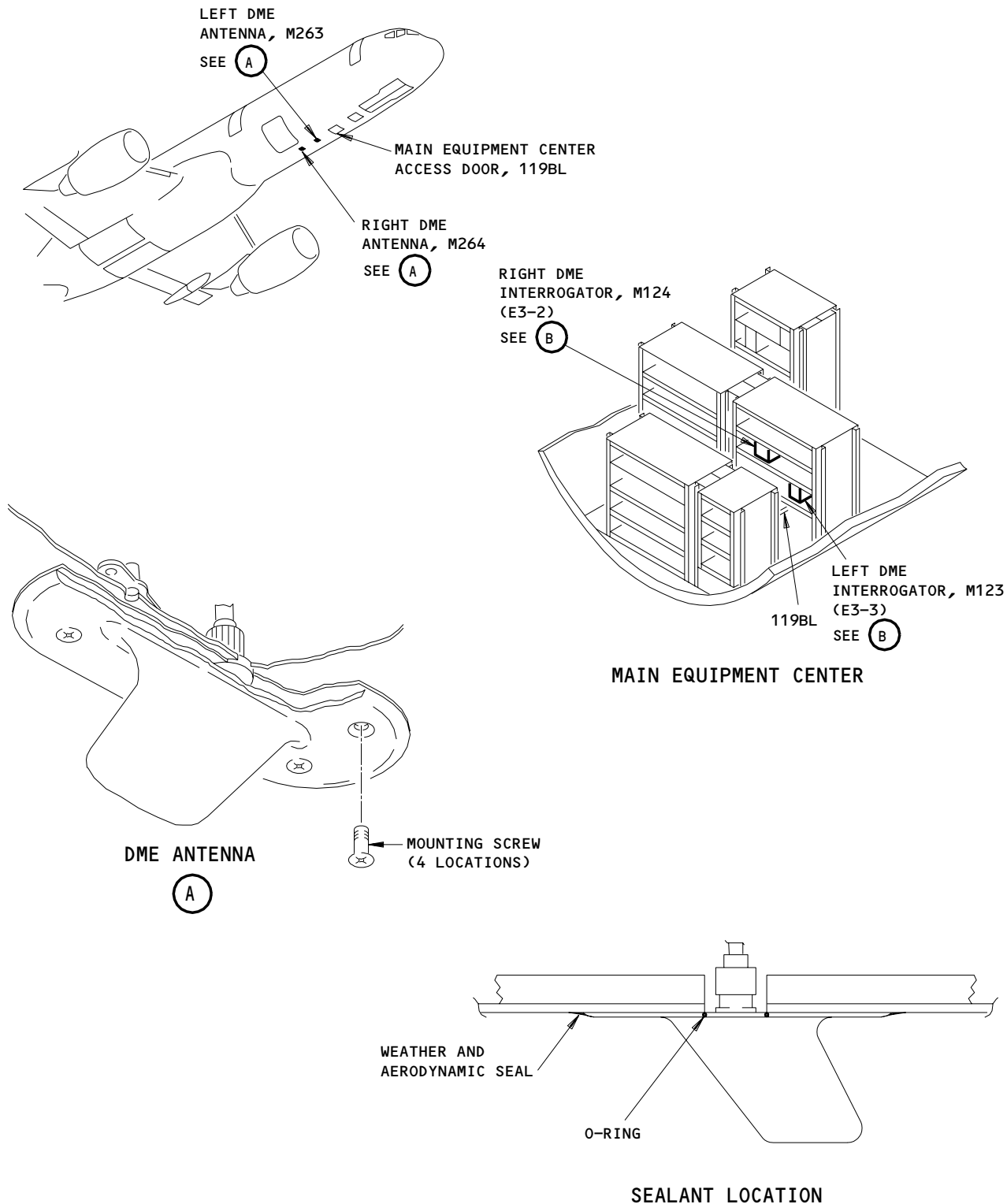

DME System - Component Location
Figure 102 (Sheet 1)

EFFECTIVITY	ALL
-------------	-----

34-55-00

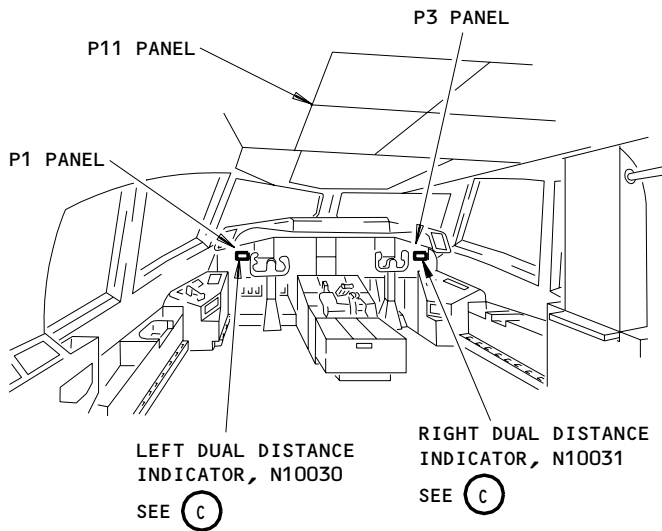

FLIGHT COMPARTMENT

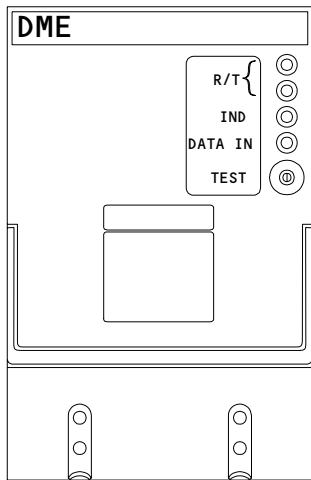

LEFT OR RIGHT DME INTERROGATOR, M123 OR M124

B 2

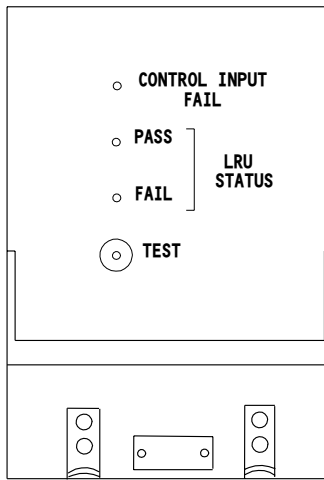

LEFT OR RIGHT DME INTERROGATOR, M123 OR M124

B 1

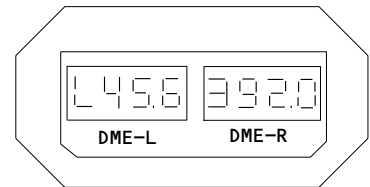

LEFT OR RIGHT DUAL DISTANCE INDICATOR, N10030 OR N10031

C

- 1 AIRPLANES WITH COLLINS DME-700 SERIES INTERROGATORS
- 2 AIRPLANES WITH ALLIED SIGNAL DMA-37A SERIES INTERROGATORS

**DME System - Component Location
Figure 102 (Sheet 2)**

EFFECTIVITY	ALL
-------------	-----

34-55-00

PREREQUISITES

MAKE SURE THESE SYSTEMS WILL OPERATE:
 EFIS (AMM 34-22-00/501)
 ILS (AMM 34-31-00/501)
 VOR (AMM 34-51-00/501)

MAKE SURE THESE CIRCUIT BREAKERS ARE CLOSED:
 11A2,11E11,11E32,11E33

MAKE SURE THE AIRPLANE IS IN THIS CONFIGURATION:
 ELECTRICAL POWER IS ON (AMM 24-22-00/201)

**DME SYSTEM BITE
 PROCEDURE**

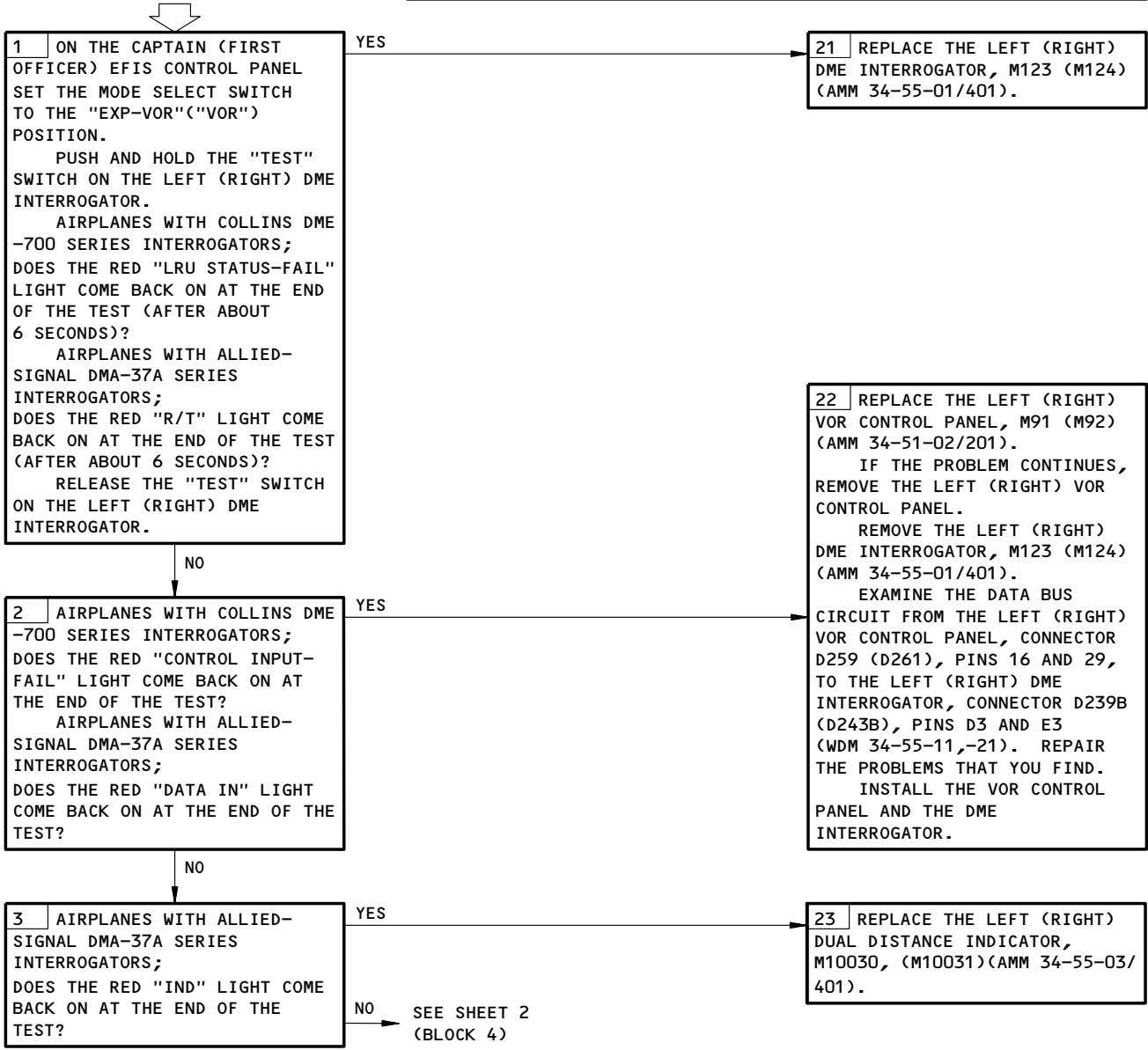

DME System BITE Procedure
 Figure 103 (Sheet 1)

EFFECTIVITY

ALL

34-55-00

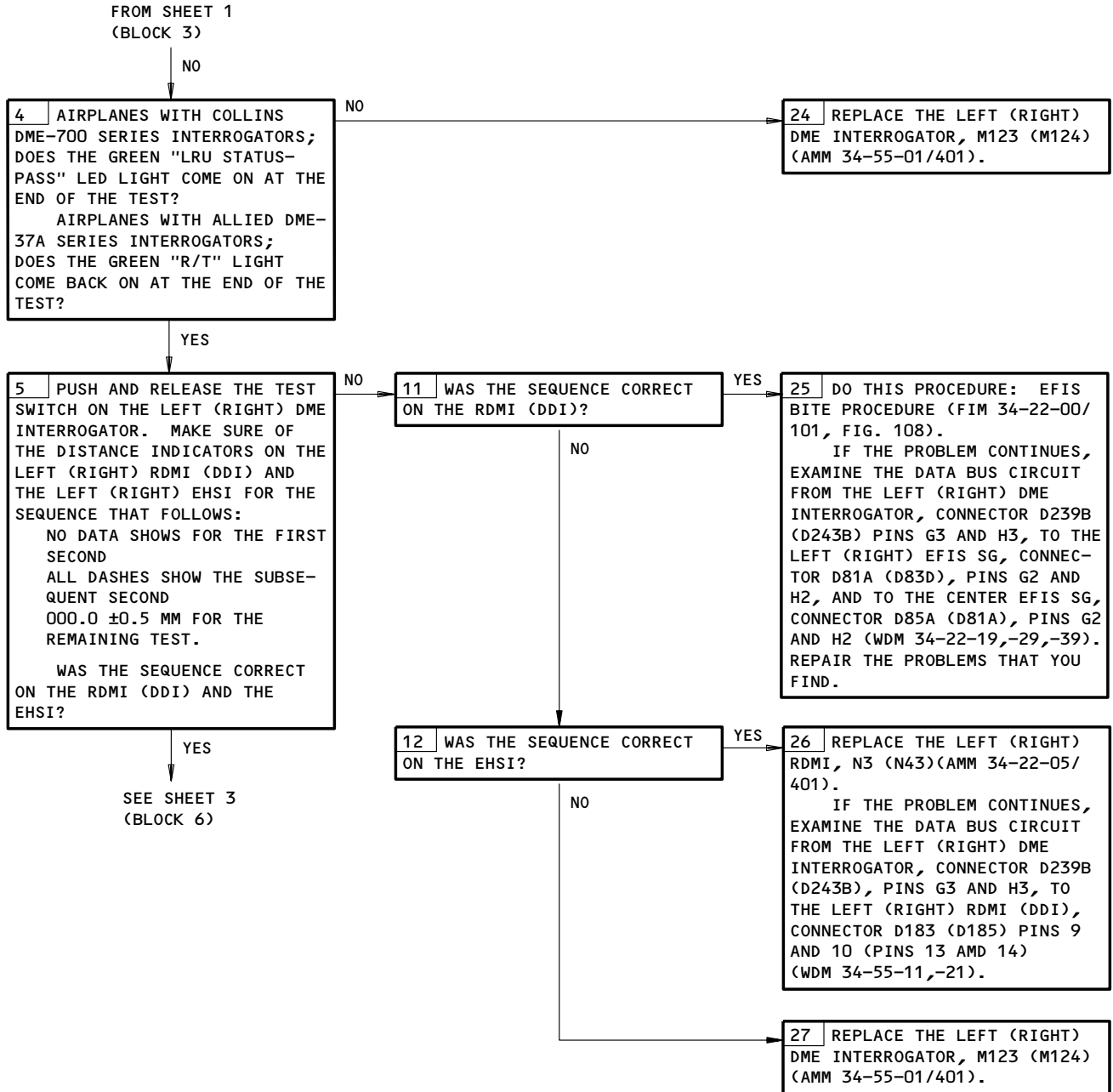

DME System BITE Procedure
Figure 103 (Sheet 2)

EFFECTIVITY

ALL

34-55-00

BOEING
757
FAULT ISOLATION/MAINT MANUAL

FROM SHEET 2
(BLOCK 5)

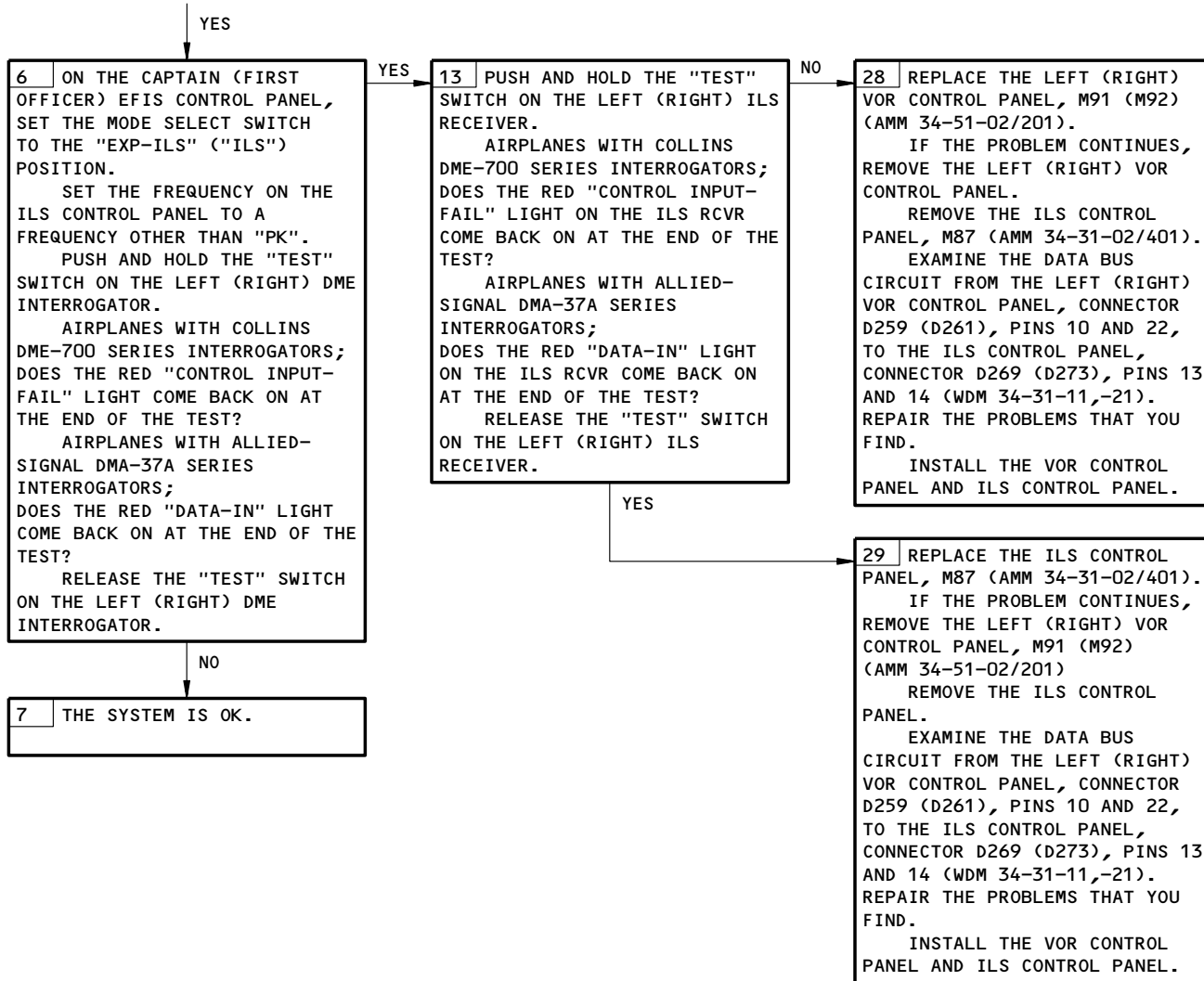

DME System BITE Procedure
Figure 103 (Sheet 3)

EFFECTIVITY _____
ALL

34-55-00

**VOR MODE - DME
DISPLAYS DASHES,
VOR IDENT NORMAL**

PREREQUISITES

MAKE SURE THIS SYSTEM WILL OPERATE:
EFIS (AMM 34-22-00/501)

MAKE SURE THESE CIRCUIT BREAKERS ARE CLOSED:
11A2,11E11,11E32,11E33

MAKE SURE THE AIRPLANE IS IN THIS CONFIGURATION:
ELECTRICAL POWER IS ON (AMM 24-22-00/201)

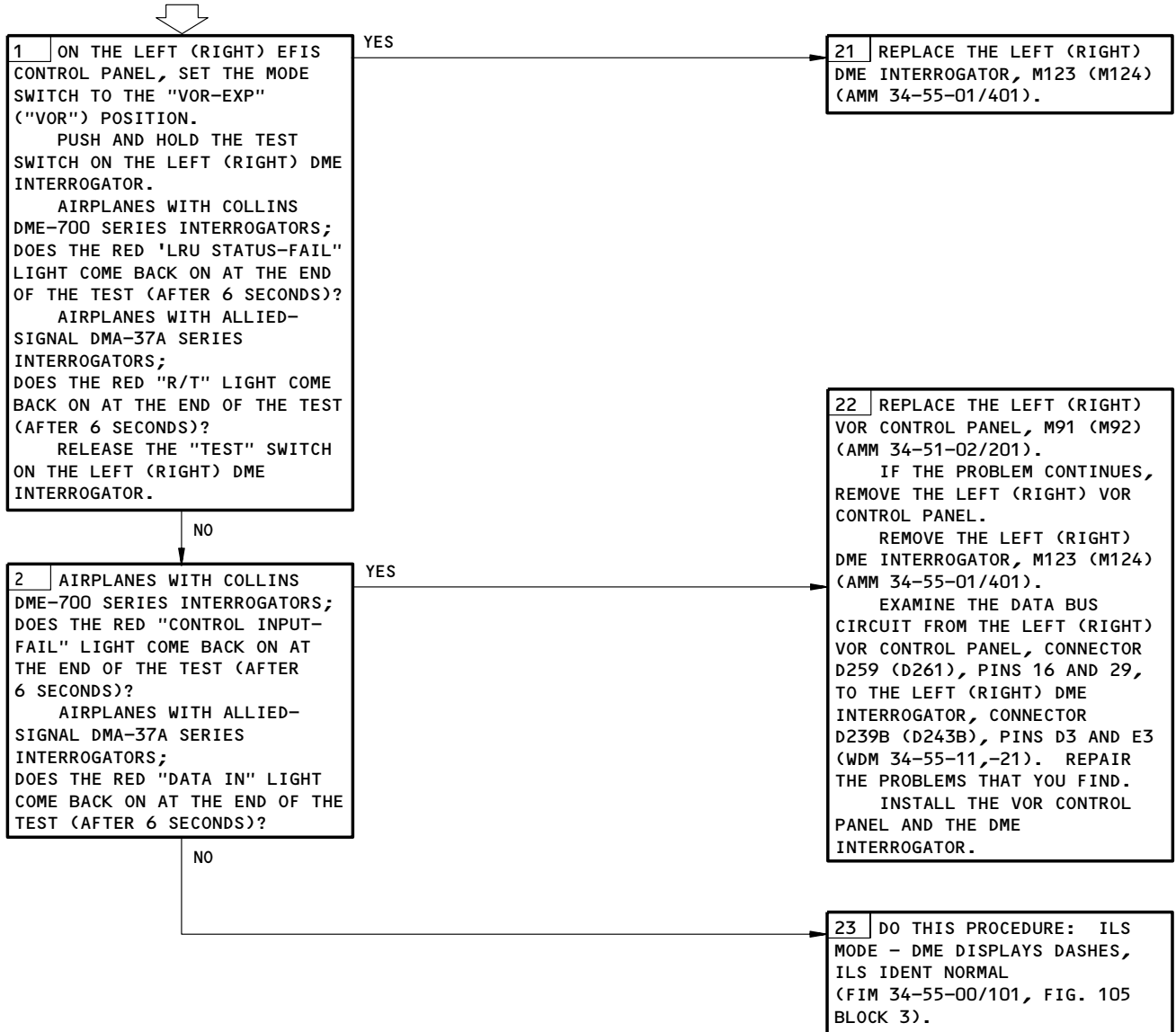

VOR Mode - DME Displays Dashes, VOR Ident Normal
Figure 104

EFFECTIVITY

ALL

34-55-00

04

Page 107
Sep 28/03

FD9164

**ILS MODE - DME
DISPLAYS DASHES,
ILS IDENT NORMAL**

PREREQUISITES

MAKE SURE THESE SYSTEMS WILL OPERATE:

EFIS (AMM 34-22-00/501)

ILS (AMM 34-31-00/501)

MAKE SURE THESE CIRCUIT BREAKERS ARE CLOSED:

11A2, 11E11, 11E32, 11E33

MAKE SURE THE AIRPLANE IS IN THIS CONFIGURATION:

ELECTRICAL POWER IS ON (AMM 24-22-00/201)

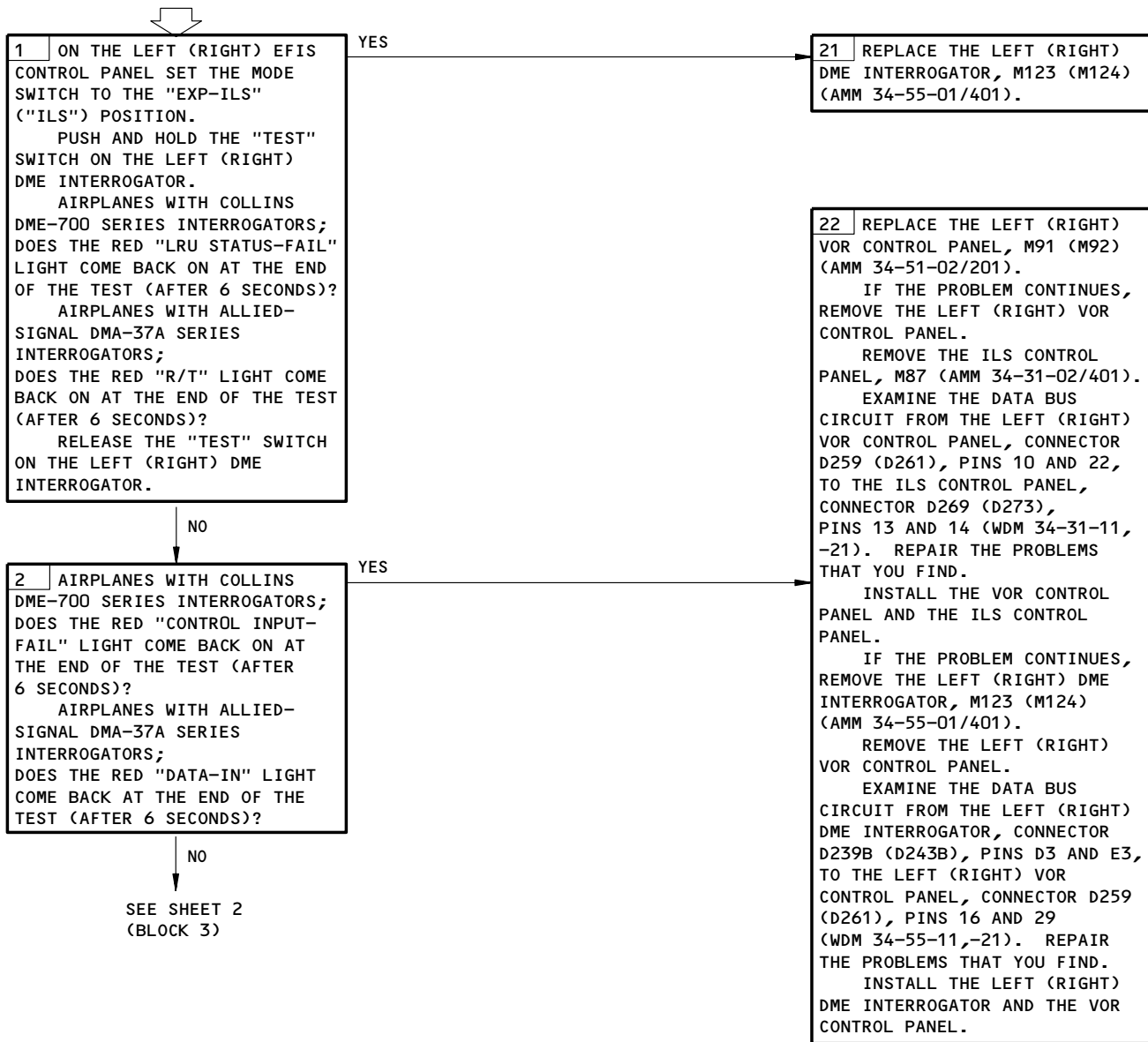

ILS Mode - DME Displays Dashes, ILS Ident Normal
Figure 105 (Sheet 1)

EFFECTIVITY

ALL

34-55-00

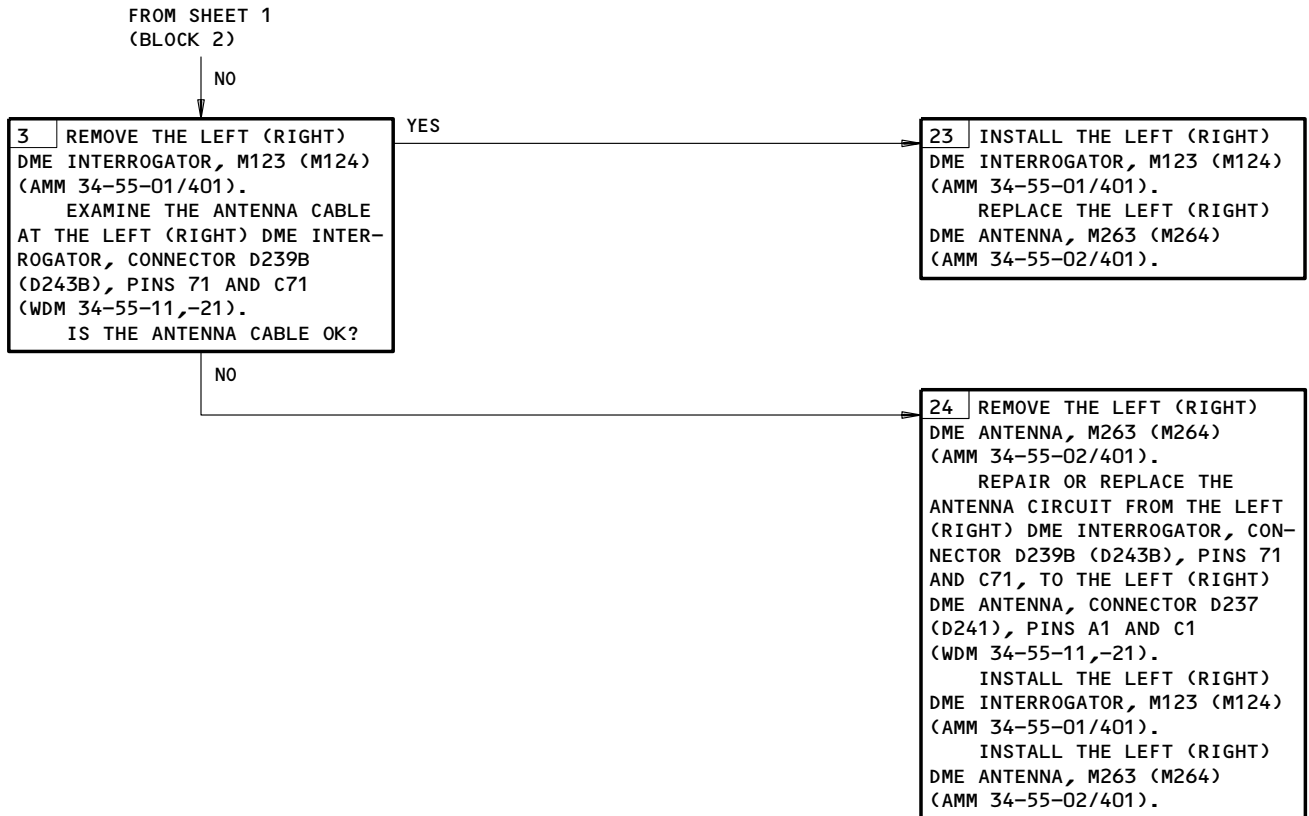

ILS Mode - DME Displays Dashes, ILS Ident Normal
 Figure 105 (Sheet 2)

EFFECTIVITY
 AIRPLANES WITH DME-700 OR DME-900
 OR DMA-37A SERIES INTERROGAOTR

34-55-00

**BLANK DME DISPLAY
ON EHSI – OTHERWISE
NORMAL**

PREREQUISITES

MAKE SURE THIS SYSTEM WILL OPERATE:
EFIS (AMM 34-22-00/501)

MAKE SURE THESE CIRCUIT BREAKERS ARE CLOSED:
11A2,11E11,11E32,11E33

MAKE SURE THE AIRPLANE IS IN THIS CONFIGURATION:
ELECTRICAL POWER IS ON (AMM 24-22-00/201)

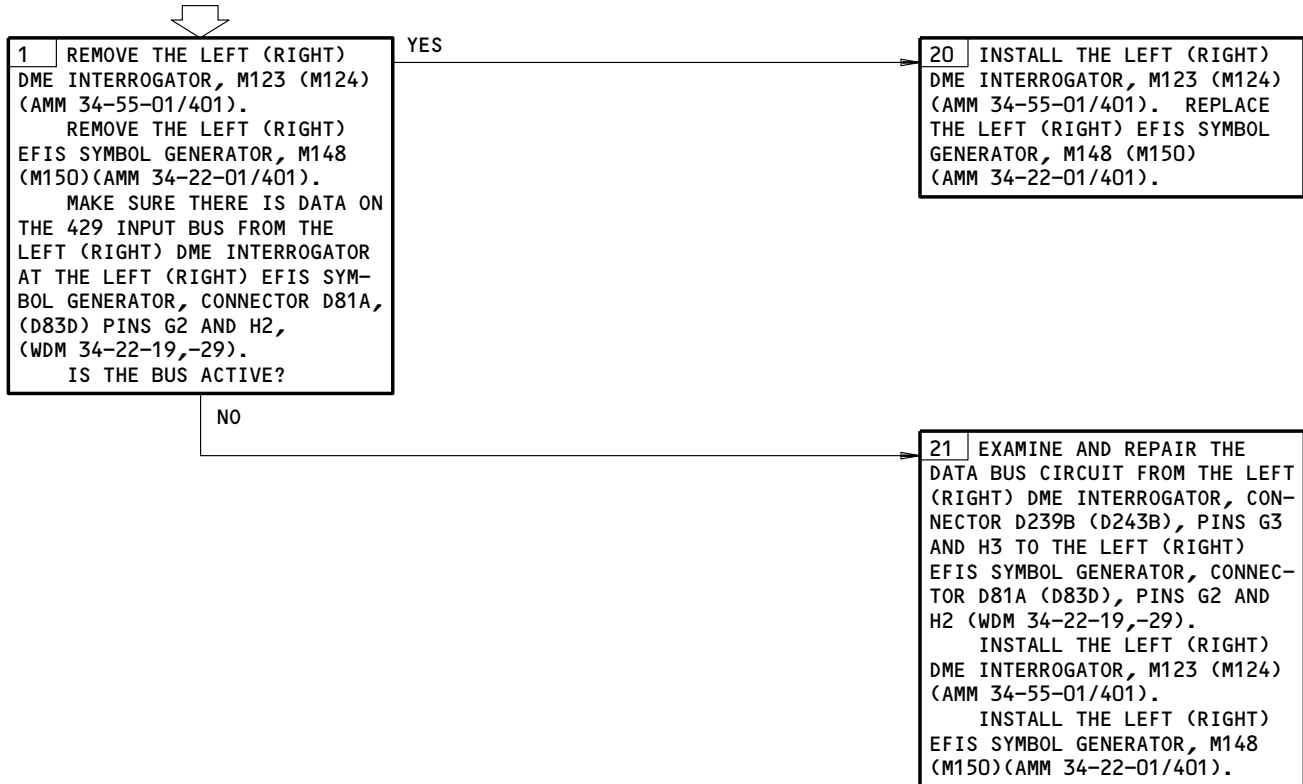

Blank DME Display on EHSI – Otherwise Normal
Figure 106

EFFECTIVITY

ALL

34-55-00

**DME EHSI AND RDMI
DISPLAYS BLANK**

PREREQUISITES

MAKE SURE THIS SYSTEM WILL OPERATE:
EFIS (AMM 34-22-00/501)

MAKE SURE THESE CIRCUIT BREAKERS ARE CLOSED:
11A2,11E11,11E32,11E33

MAKE SURE THE AIRPLANE IS IN THIS CONFIGURATION:
ELECTRICAL POWER IS ON (AMM 24-22-00/201)

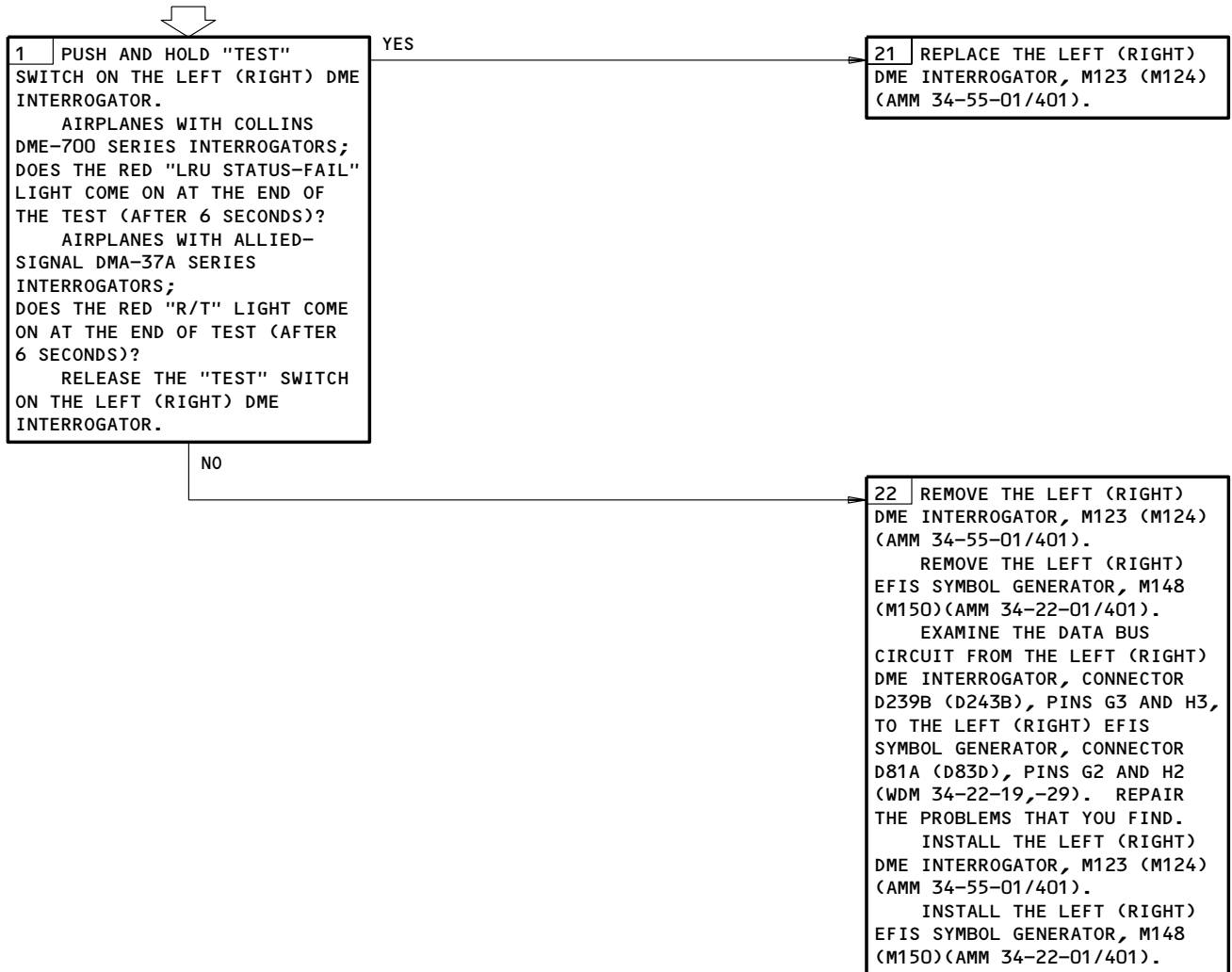

DME EHSI and RDMI Displays Blank
Figure 107

EFFECTIVITY

ALL

34-55-00

04

Page 111
Sep 20/98

D02421

**AUTOTUNE MODE –
DME DISPLAYS SHOW
DASHES**

PREREQUISITES

MAKE SURE THESE SYSTEMS WILL OPERATE:
EFIS (AMM 34-22-00/501)
FMC (AMM 34-61-00/501)

MAKE SURE THESE CIRCUIT BREAKERS ARE CLOSED:
11A2,11E11,11E32,11E33

MAKE SURE THE AIRPLANE IS IN THIS CONFIGURATION:
ELECTRICAL POWER IS ON (AMM 24-22-00/201)

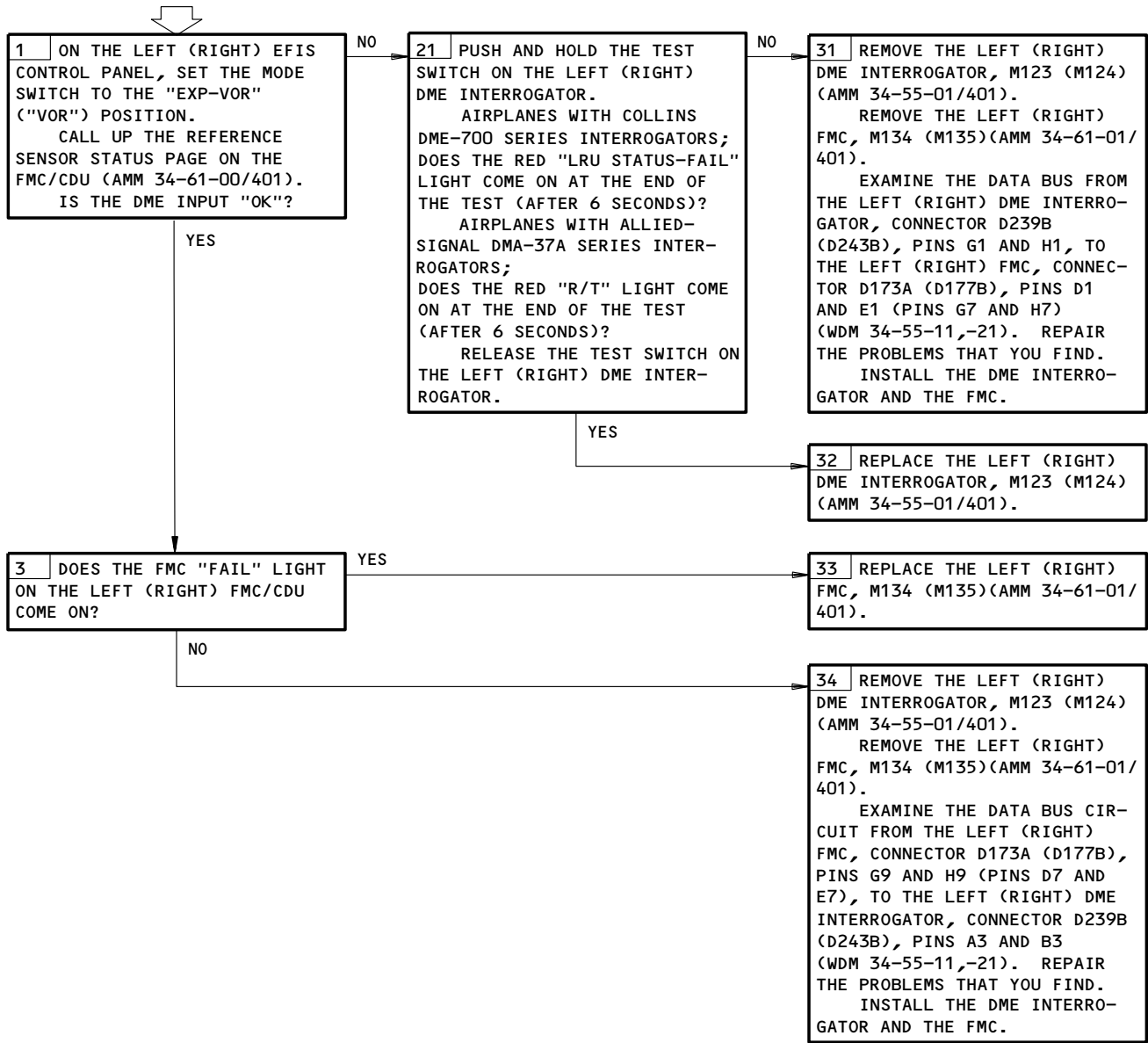

Autotune Mode – DME Displays Show Dashes
Figure 108

EFFECTIVITY	ALL
-------------	-----

34-55-00

DME IDENT SIGNAL
MISSING - DISPLAYS
NORMAL

PREREQUISITES

MAKE SURE THIS SYSTEM WILL OPERATE:
EFIS (AMM 34-22-00/501)

MAKE SURE THESE CIRCUIT BREAKERS ARE CLOSED:
11A2,11E11,11E32,11E33

MAKE SURE THE AIRPLANE IS IN THIS CONFIGURATION:
ELECTRICAL POWER IS ON (AMM 24-22-00/201)



1 REPLACE THE LEFT (RIGHT) DME INTERROGATOR, M123 (M124) (AMM 34-55-01/401).
IF THE PROBLEM CONTINUES, REPLACE THE LEFT (RIGHT) VOR CONTROL PANEL, M91 (M92) (AMM 34-51-02/201).

DME Ident Signal Missing - Displays Normal
Figure 109

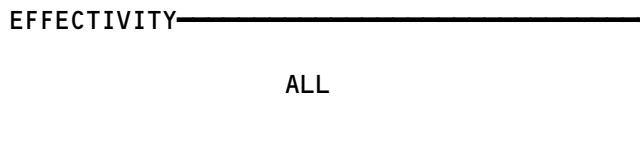

34-55-00

03

Page 113
Sep 28/03

 **BOEING**
757
FAULT ISOLATION/MAINT MANUAL

1. ARINC Data Bus Charts

A. General

CAUTION: DO NOT DIRECTLY TOUCH THE CONNECTORS. USE A BREAKOUT BOX OR YOU CAN CAUSE DAMAGE TO THE CONNECTORS.

- (1) The ARINC 429 data bus charts give data necessary to make an analysis of ARINC 429 transmitters, receivers, and data buses. For the test, use a breakout box at the available terminal or at the LRU connector.

B. Equipment

- (1) Standard multi-meter
 (2) 429EBP Data Bus Analyzer (recommended)
 JcAIR Instrumentation
 400 Industrial Parkway
 Industrial Airport, KS 66031

429-2 Data Bus Analyzer (alternative)
 Interface Technology
 150 E. Arrow Highway
 San Dimas, CA 91773

- (3) A34011-1 Breakout Box (recommended)
 A34011-112 Breakout Box (alternative)

DME								
DIGITAL OUTPUT BUS CHART								
BUS NAME			CON	PINS	BUS FORMAT	BIT RATE	DATA	
SOURCE	TYPE	BUS					BUS	
DME (L R)	A	1	B	G01 H01	429	LO	DME DATA OUTPT#1	
DME (L R)	A	2	B	G03 H03	429	LO	DME DATA OUTPT#2	

DME ID = 09								
OCTAL LABELS CHART								
SIGNAL	TYPE	LABEL	FORMAT	MIN UPDATE RATE	SDI	BINARY RANGE	POSITIVE SENSE	UNITS
DME FREQUENCY	A	035	BCD	5	00	108-135.95	ALWAYS POS	MHZ
DME DISTANCE-D	A	201	BCD	6	00	-1T0399.99	ALWAYS POS	NM
DME DISTANCE	A	202	BNR	6	00	0-512	ALWAYS POS	NM

EFFECTIVITY _____
 ALL

34-55-00

BOEING
 757
 FAULT ISOLATION/MAINT MANUAL

DME				
DISCRETE OCTAL LABELS/BIT CHART				
SIGNAL	OCTAL LABEL	BIT	ONE-STATE	ZERO-STATE
VEL MEMORY MODE	202	11	MEM MODE	NORM MODE

EFFECTIVITY _____

ALL

34-55-00

06

Page 115
May 20/98



757

FAULT ISOLATION/MAINT MANUAL

AUTOMATIC DIRECTION FINDER (ADF) SYSTEM

COMPONENT	FIG. 102 SHT	QTY	ACCESS/AREA	AMM REFERENCE
ANTENNA - LEFT ADF, M265	1	1	TOP OF FUSELAGE	34-57-03
ANTENNA - RIGHT ADF, M266	1	1	TOP OF FUSELAGE	34-57-03
CIRCUIT BREAKER -	2		FLIGHT COMPARTMENT, P11	
ADF LEFT, C607		1	11F6	*
ADF RIGHT, C4118		1	1 > 11A4; 2 > 11F27	*
INDICATOR - (FIM 34-22-00/101)				
LEFT RDMI, N3	1			
RIGHT RDMI, N43	1			
LEFT RMI, N10026	2			
RIGHT RMI, N10024	2			
PANEL - ADF CONTROL, M1046	2	1	FLIGHT COMPARTMENT, P8	34-57-02
RECEIVER - LEFT ADF, M215	2	1	822, AFT EQUIPMENT CENTER, E6-1	34-57-01
RECEIVER - RIGHT ADF, M216	2	1	822, AFT EQUIPMENT CENTER, E6-1	34-57-01
RELAY - (FIM 31-01-36/101)				
SYS NO. 1 AIR/GROUND, K167				

* SEE THE WDM EQUIPMENT LIST

- 1 > GUI 001-114,116-999
- 2 > GUI 115

Automatic Direction Finder (ADF) System - Component Index
Figure 101

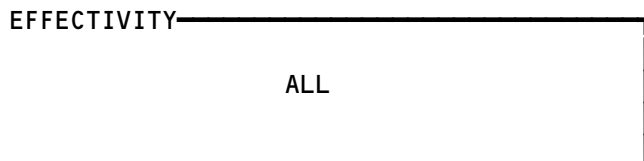

34-57-00

BOEING
 757
 FAULT ISOLATION/MAINT MANUAL

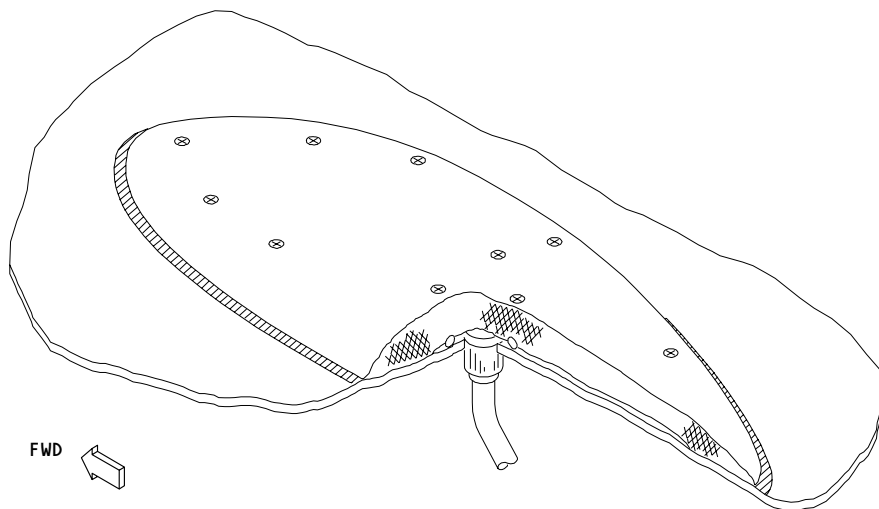
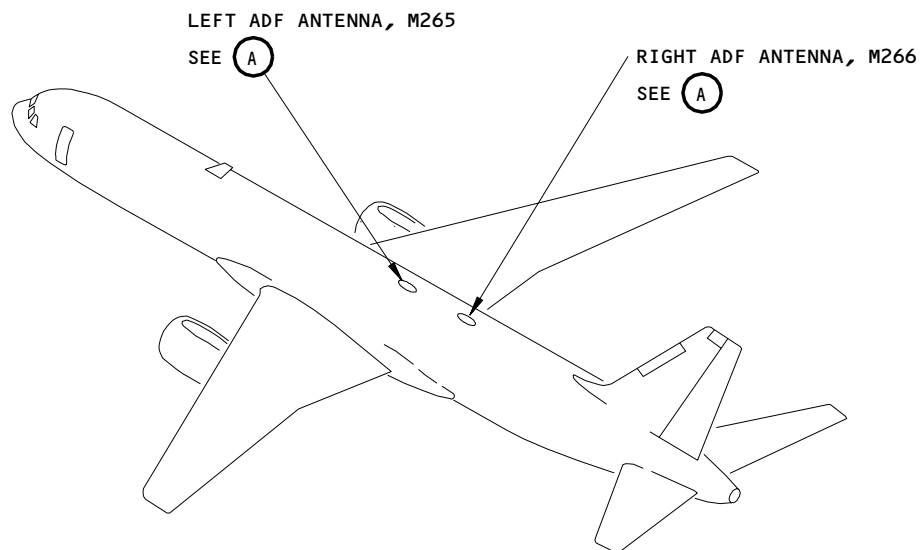

LEFT OR RIGHT ADF ANTENNA, M265 OR M266

(A)

Automatic Direction Finder (ADF) System - Component Location
 Figure 102 (Sheet 1)

EFFECTIVITY	ALL
-------------	-----

34-57-00

BOEING
757
FAULT ISOLATION/MAINT MANUAL

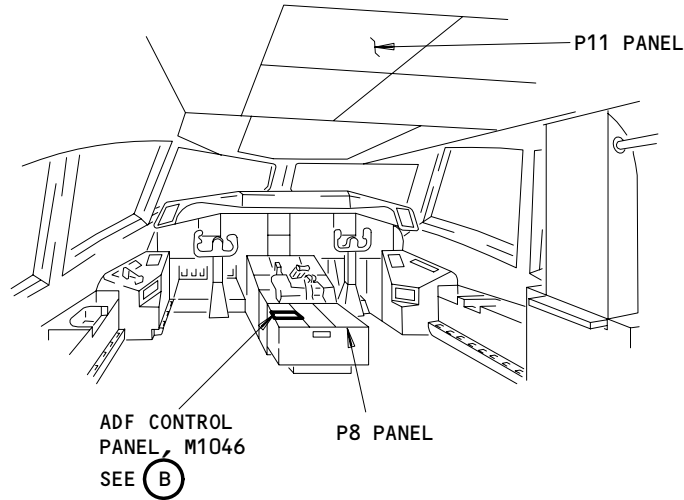

FLIGHT COMPARTMENT

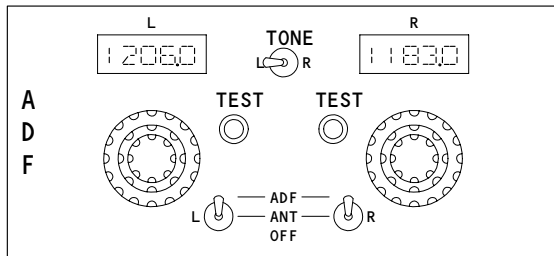

ADF CONTROL PANEL, M1046

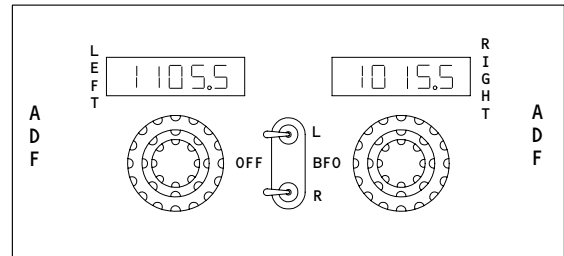

ADF CONTROL PANEL, M1046



- 3 GUI 002-008,010-114
- 4 GUI 001,009,115

Automatic Direction Finder (ADF) System - Component Location
Figure 102 (Sheet 2)

EFFECTIVITY

ALL

34-57-00

BOEING

757 FAULT ISOLATION/MAINT MANUAL

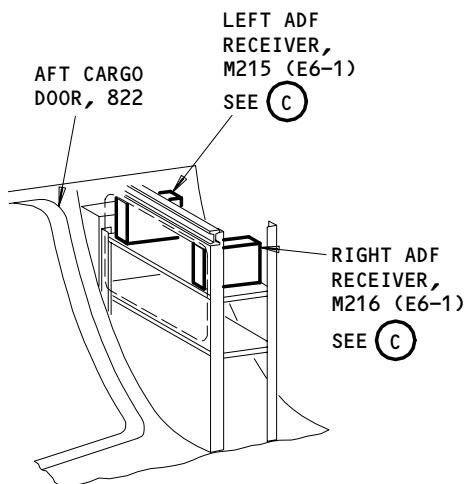

AFT EQUIPMENT CENTER 5

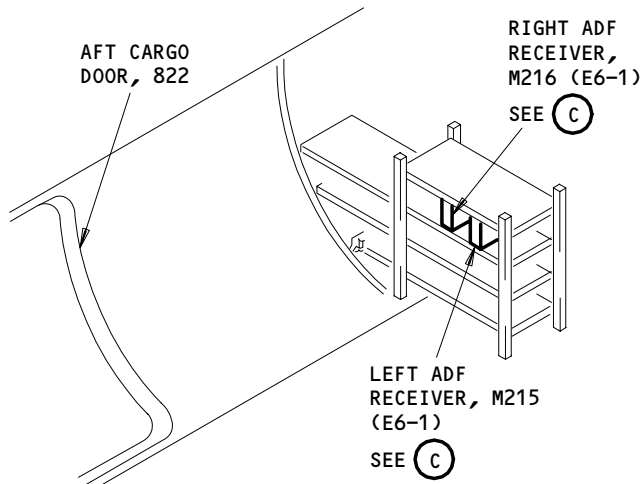

AFT EQUIPMENT CENTER 6

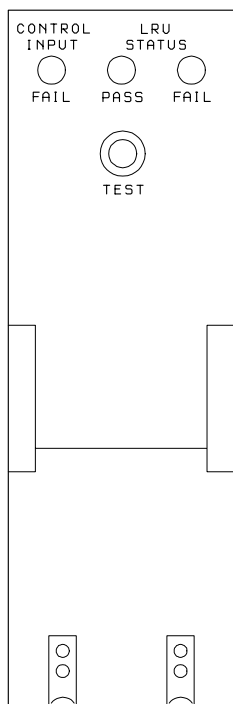

LEFT OR RIGHT ADF RECEIVER, M215 OR M216

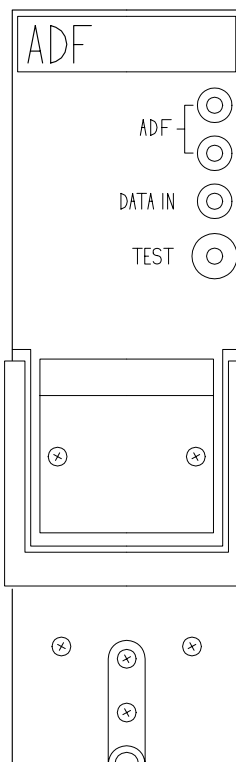

LEFT OR RIGHT ADF RECEIVER, M215 OR M216

5 GUI 001-114,116-999 (C) 3

6 GUI 115

(C) 4

Automatic Direction Finder (ADF) System - Component Location
Figure 102 (Sheet 3)

EFFECTIVITY	ALL
-------------	-----

34-57-00

PREREQUISITES

MAKE SURE THESE CIRCUIT BREAKERS ARE CLOSED:
11C26,11F6,11G29,11G30; 1 11A4; 2 11F27

MAKE SURE THE AIRPLANE IS IN THIS CONFIGURATION:
ELECTRICAL POWER IS ON (MM 24-22-00/201)

ADF AUDIO PROBLEMS

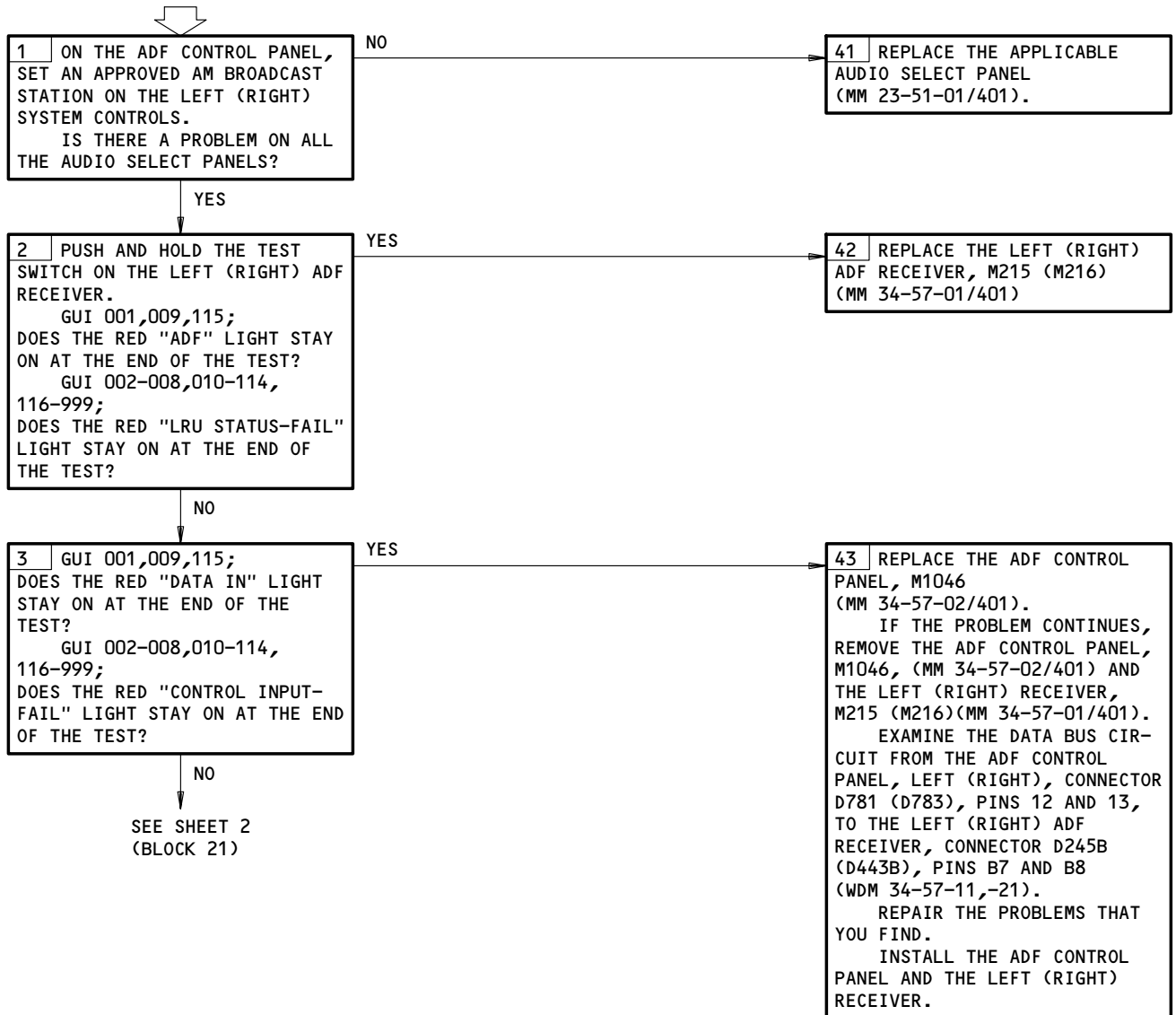

- 1 GUI 001-114,116-999
- 2 GUI 115

ADF Audio Problems
Figure 103 (Sheet 1)

EFFECTIVITY

ALL

34-57-00

BOEING
757
FAULT ISOLATION/MAINT MANUAL

FROM SHEET 1
(BLOCK 3)

NO

21 REMOVE THE LEFT (RIGHT) ADF RECEIVER, M215 (M216) (AMM 34-57-01/401)
DO THE ANTENNA CABLE CHECK PROCEDURE (AMM 20-10-32/201) ON THE ADF ANTENNA SENSE CABLE AT THE LEFT (RIGHT) ADF RECEIVER, CONNECTOR D245B (D443B), PINS D1 AND D2 (WDM 34-57-11,-21)
IS THE ADF ANTENNA SENSE CABLE OK?

YES

44 INSTALL THE LEFT (RIGHT) ADF RECEIVER, M215 (M216) (AMM 34-57-01/401).
REPLACE THE LEFT (RIGHT) ADF ANTENNA, M265 (M266) (AMM 34-57-03/401)

NO

45 REPLACE THE LEFT (RIGHT) ANTENNA CIRCUIT CABLE FROM THE LEFT (RIGHT) ADF CONNECTOR D245B (D443B), PINS D1 AND D2, TO THE LEFT (RIGHT) ADF ANTENNA, CONNECTOR D267 (D445), PINS 1 AND 2 (WDM 34-57-11,-21).
INSTALL THE LEFT (RIGHT) ADF RECEIVER, M215 (M216) (AMM 34-57-01/401).

ADF Audio Problems
Figure 103 (Sheet 2)

EFFECTIVITY

ALL

34-57-00

PREREQUISITES

MAKE SURE THESE CIRCUIT BREAKERS ARE CLOSED:
11A4,11A6,11F6,11F25

MAKE SURE THE AIRPLANE IS IN THIS CONFIGURATION:
ELECTRICAL POWER IS ON (AMM 24-22-00/201)

NOTE: IF THE LEFT (RIGHT) ADF FLAGS ARE IN VIEW ON THE RDMIs, OPEN AND CLOSE THE ADF LEFT (RIGHT) CIRCUIT BREAKER. IF THE FLAGS GO OUT OF VIEW, THERE IS NO PROBLEM. IF THE FLAGS STAY, GO TO BLOCK 1.

ADF PROBLEMS ON BOTH RDMIs

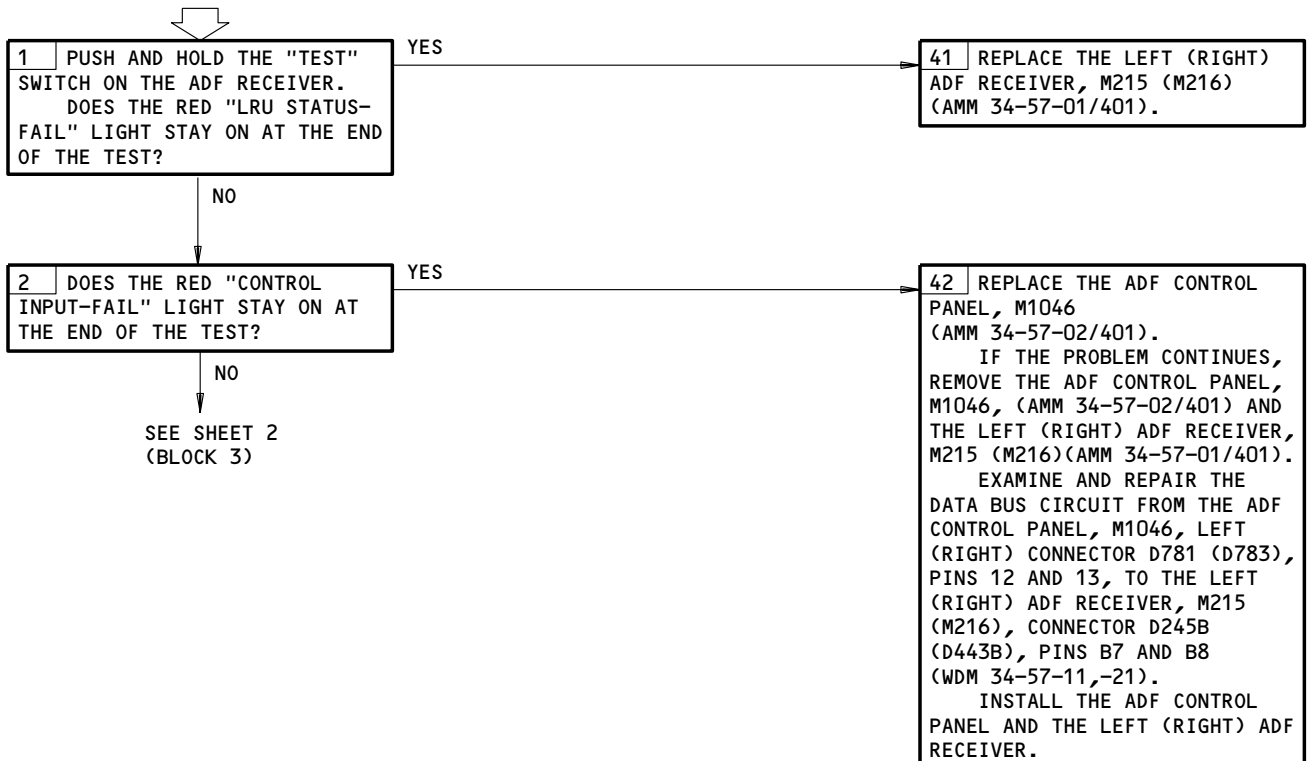

ADF Problems on Both RDMIs
Figure 104 (Sheet 1)

EFFECTIVITY
GUI 002-008, 010-114, 116-999

34-57-00

FROM SHEET 1
(BLOCK 2)

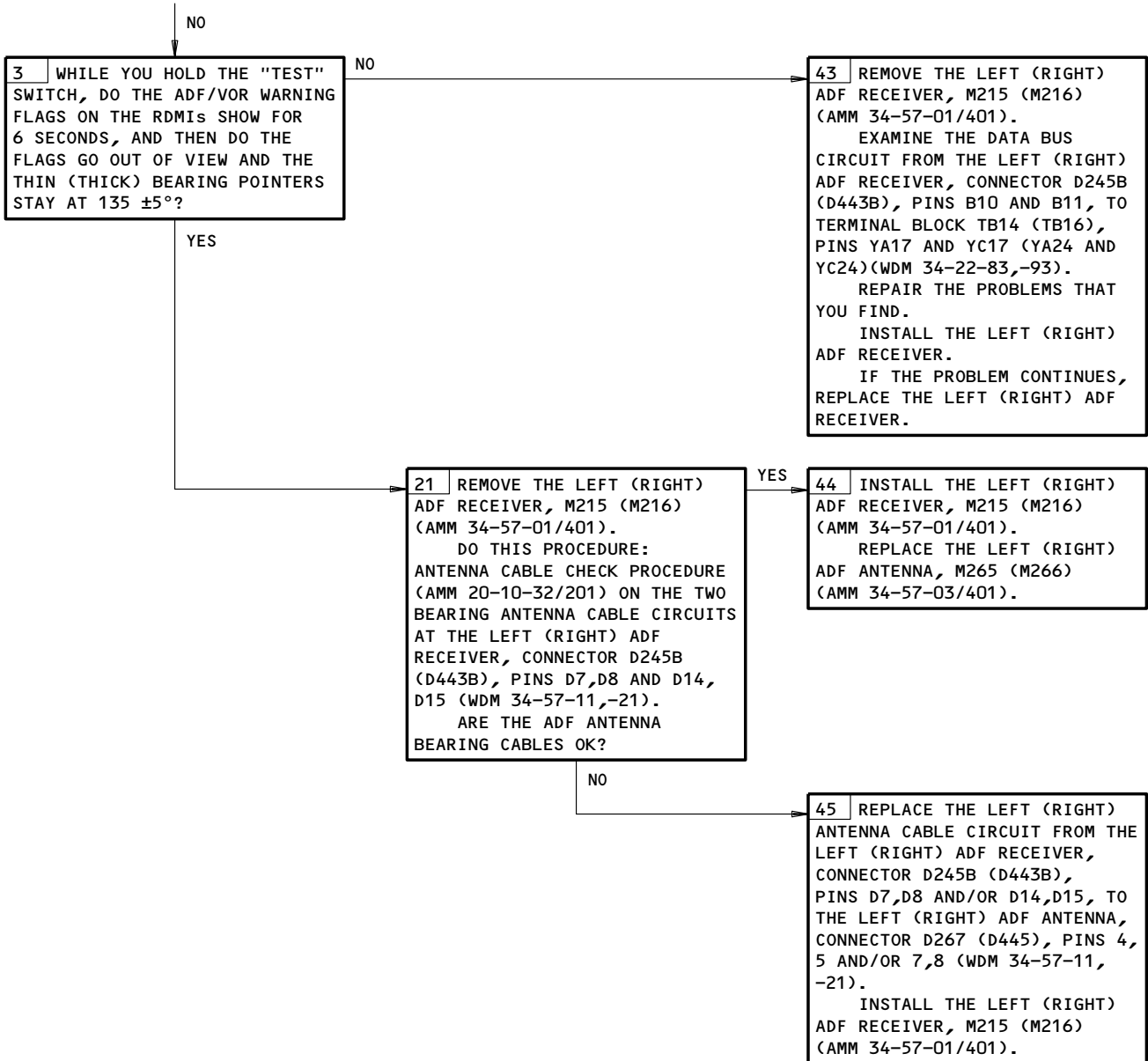

ADF Problems on Both RDMIs
Figure 104 (Sheet 2)

EFFECTIVITY
GUI 002-008, 010-114, 116-999

34-57-00

PREREQUISITES

MAKE SURE THESE CIRCUIT BREAKERS ARE CLOSED:
11A7,11F6,11F23,11F27

MAKE SURE THE AIRPLANE IS IN THIS CONFIGURATION:
ELECTRICAL POWER IS ON (MM 24-22-00/201)

NOTE: IF THE LEFT (RIGHT) ADF FLAGS ARE IN VIEW ON THE RMIS, OPEN AND CLOSE THE ADF LEFT (RIGHT) CIRCUIT BREAKER. IF THE FLAGS GO OUT OF VIEW, THERE IS NO PROBLEM. IF THE FLAGS STAY, GO TO BLOCK 1.

ADF PROBLEMS ON BOTH RMIS

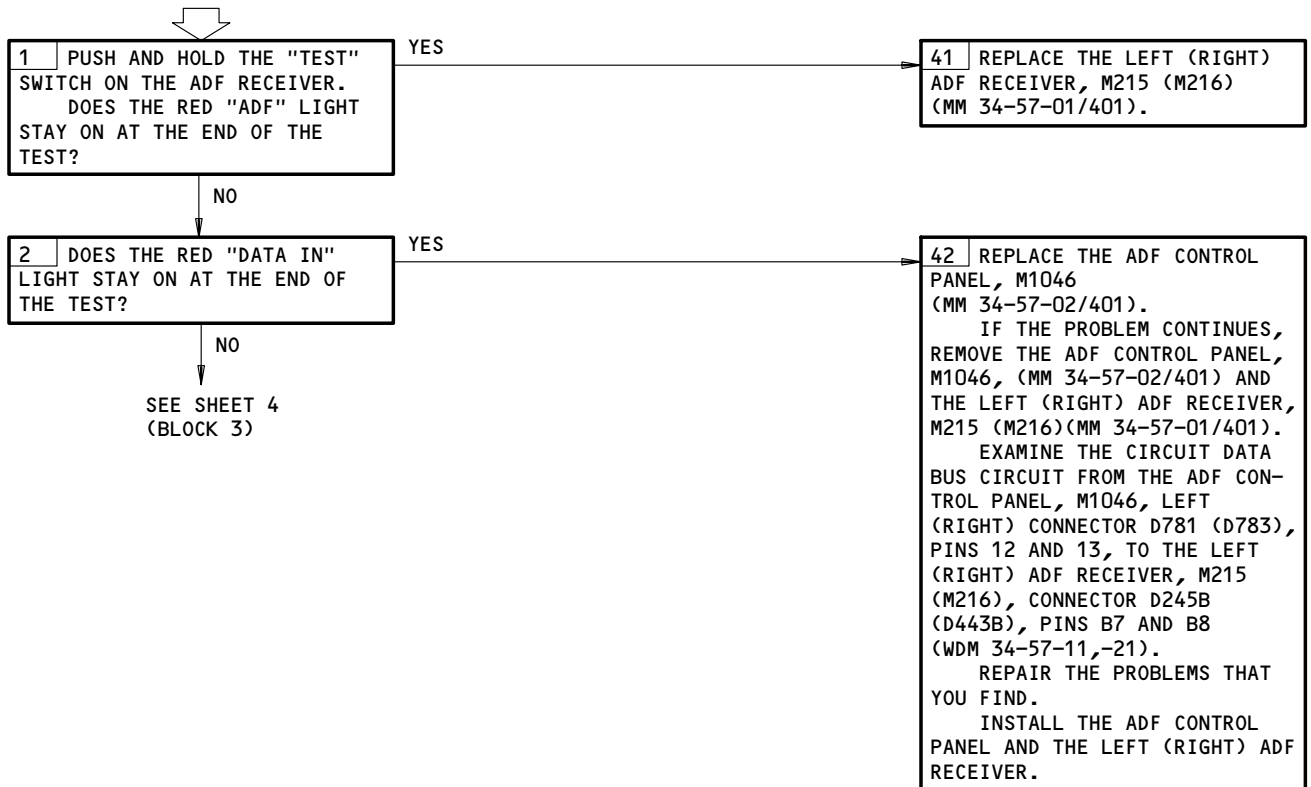

ADF Problems on Both RMIS
Figure 104 (Sheet 3)

EFFECTIVITY
GUI 115

34-57-00

FROM SHEET 3
(BLOCK 2)

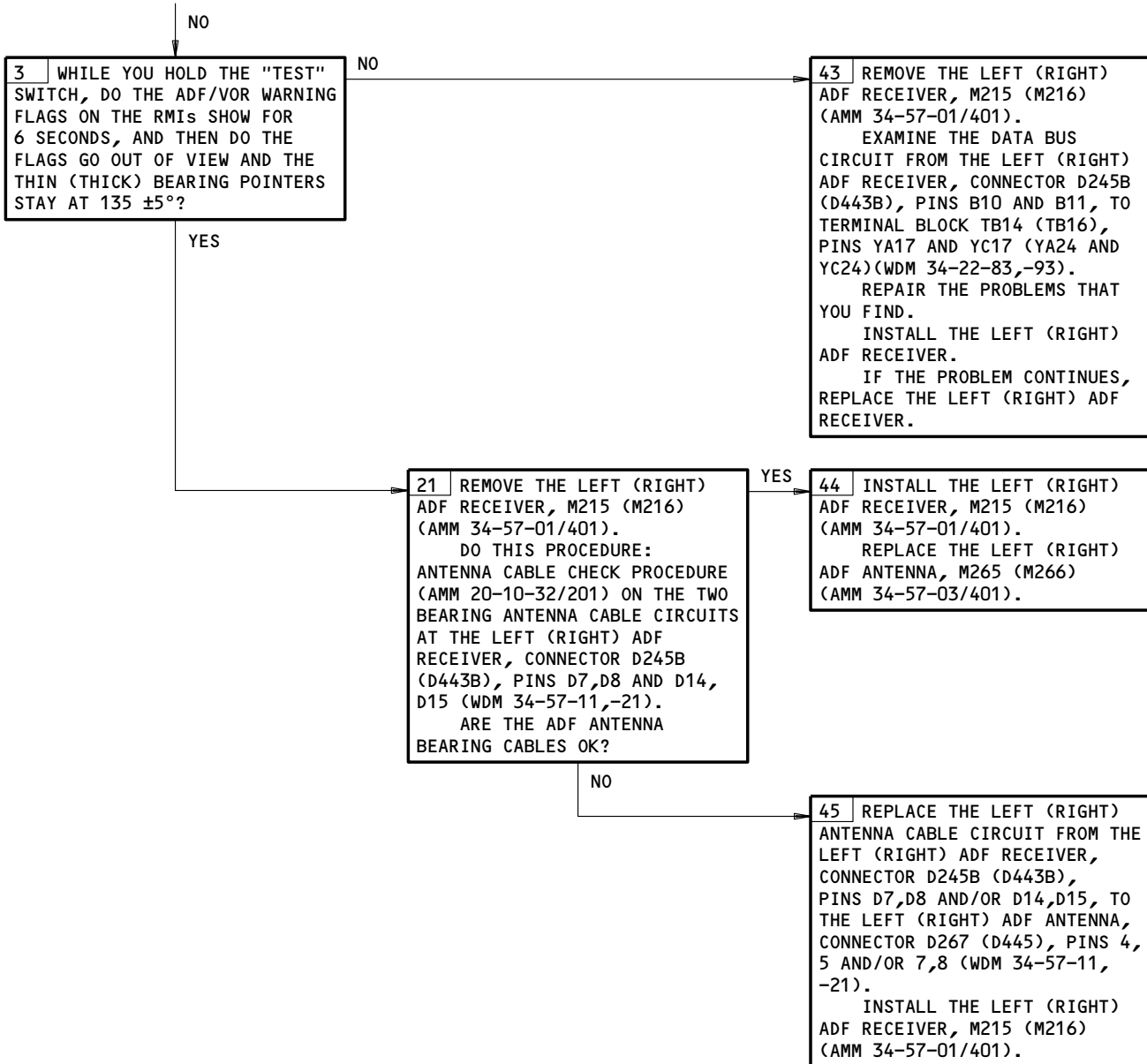

ADF Problems on Both RMIs
Figure 104 (Sheet 4)

EFFECTIVITY
GUI 115

34-57-00

PREREQUISITES

MAKE SURE THESE CIRCUIT BREAKERS ARE CLOSED:
11A4,11A6,11F6,11F25

MAKE SURE THE AIRPLANE IS IN THIS CONFIGURATION:
ELECTRICAL POWER IS ON (MM 24-22-00/201)

NOTE: IF THE LEFT (RIGHT) ADF FLAGS ARE IN VIEW ON THE RDMIs, OPEN AND CLOSE THE ADF LEFT (RIGHT) CIRCUIT BREAKER. IF THE FLAGS GO OUT OF VIEW, THERE IS NO PROBLEM. IF THE FLAGS STAY, GO TO BLOCK 1.

ADF PROBLEMS ON BOTH RDMIs

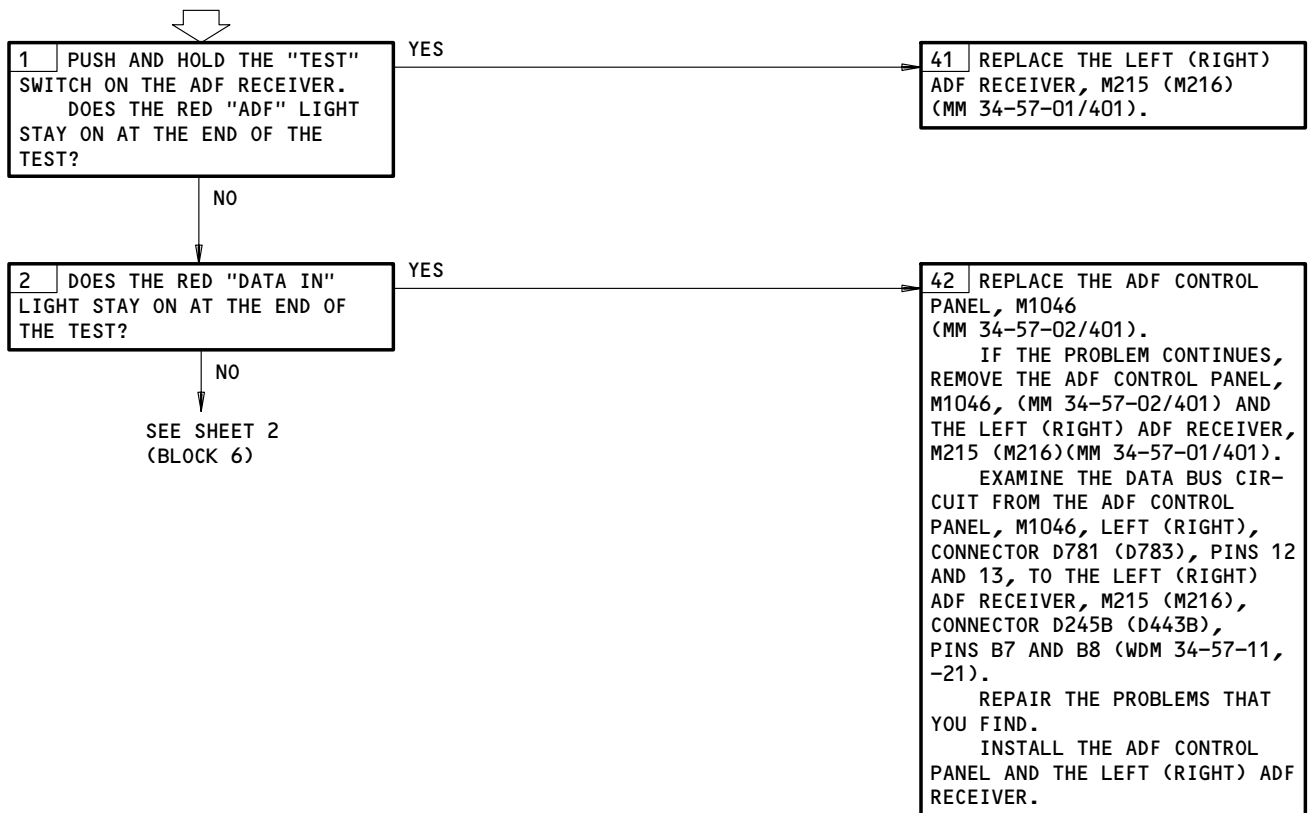

ADF Problems on Both RDMIs
Figure 104 (Sheet 5)

EFFECTIVITY
GUI 001, 009

34-57-00

FROM SHEET 5
(BLOCK 2)

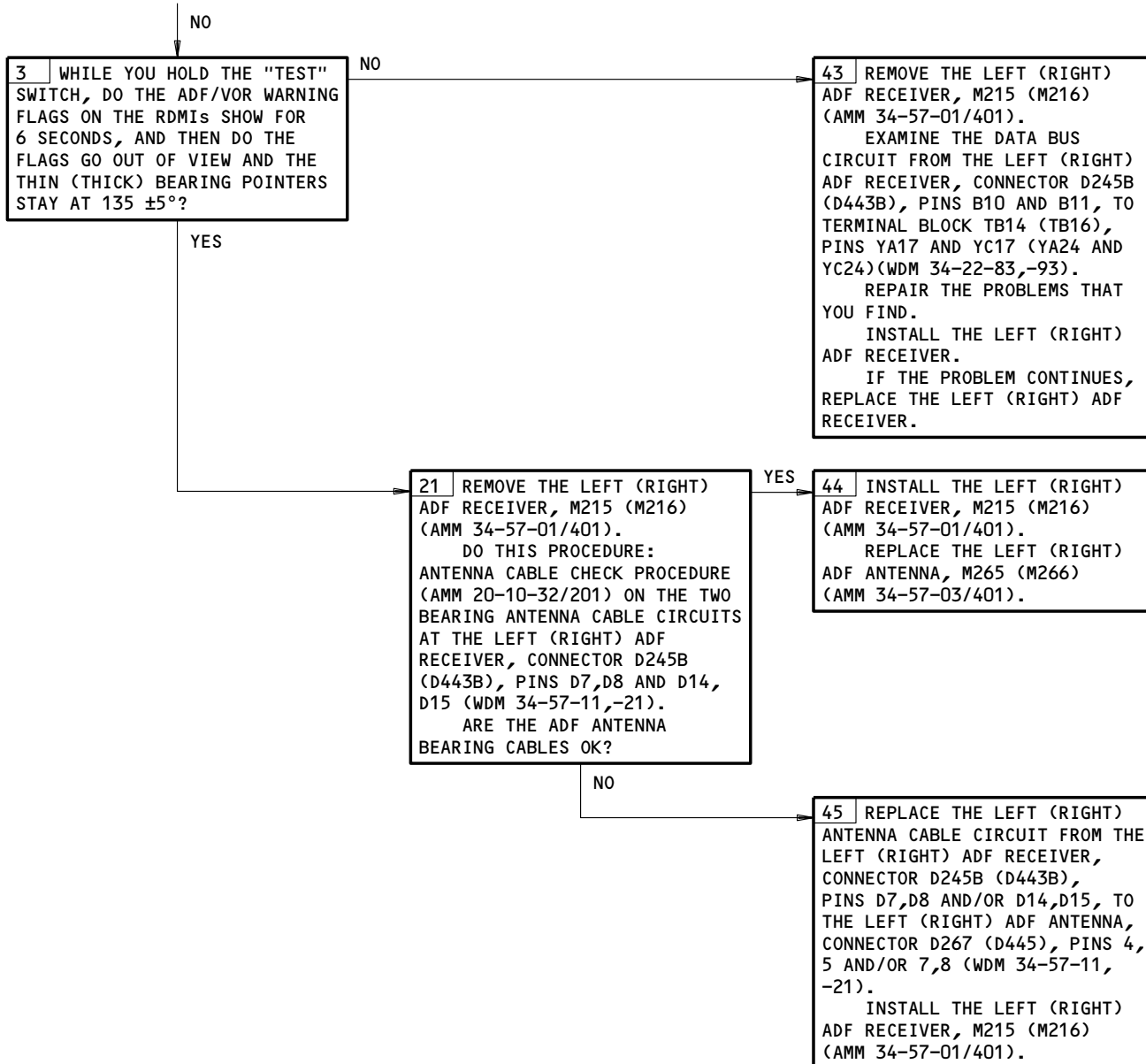

ADF Problems on Both RDMIs
Figure 104 (Sheet 6)

EFFECTIVITY
GUI 001, 009

34-57-00

1. ARINC Data Bus Charts

A. General

CAUTION: DO NOT DIRECTLY TOUCH THE CONNECTORS. USE A BREAKOUT BOX OR YOU CAN CAUSE DAMAGE TO THE CONNECTORS.

- (1) The ARINC 429 data bus charts give data necessary to make an analysis of ARINC 429 transmitters, receivers, and data buses. For the test, use a breakout box at the available terminal or at the LRU connectors.

B. Equipment

- (1) Standard multi-meter
- (2) 429EBP Data Bus Analyzer (recommended)
JcAIR Instrumentation
400 Industrial Parkway
Industrial Airport, KS 66031

429-2 Data Bus Analyzer (alternative)
Interface Technology
150 E. Arrow Highway
San Dimas, CA 91773
- (3) A34011-1 Breakout Box (recommended)
A34011-112 Breakout Box (alternative)

NOTE: Octal label 222 is a multiple function label and will not show in correct engineering units on the data bus analyzer unless you use the hexadecimal equipment ID=11. For analyzers not able to set the ID, show the label in hexadecimal format, and write down the value. Set the data bus analyzer to transmit label 162 in hex format and insert the value that you wrote down for label 222. Change the label 162 format to show the correct engineering units.

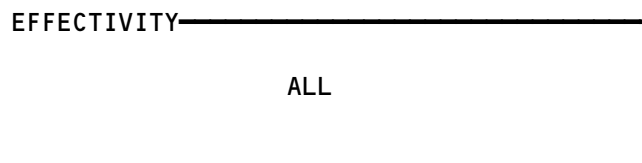

34-57-00

BOEING
 757
 FAULT ISOLATION/MAINT MANUAL

ADF								
DIGITAL OUTPUT BUS CHART								
BUS NAME			CON	PINS	BUS FORMAT	BIT RATE	DATA BUS	
SOURCE	TYPE	BUS						
ADF	(L, R)	A	2	B	G03 H03	429	LO	BEARING OUTPT NO.1

ADF ID = 12								
OCTAL LABELS CHART								
SIGNAL	TYPE	LABEL	FORMAT	MIN UPDATE RATE	SDI	BINARY RANGE	POSITIVE SENSE	UNITS
ADF BEARING	A	162	BNR	16	00	+-180	SW FROM HEADING	DEG

EFFECTIVITY

ALL

34-57-00

BOEING
 757
 FAULT ISOLATION/MAINT MANUAL

ADF PNL							
DIGITAL OUTPUT BUS CHART							
BUS NAME			CON	PINS	BUS FORMAT	BIT RATE	DATA BUS
SOURCE	TYPE	BUS					
ADFPNL (L)	A	1		12 13	429	LO	FREQ/FUNCTION-L
ADFPNL (L)	A	2		12 13	429	LO	FREQ/FUNCTION-R

EFFECTIVITY

ALL

34-57-00

BOEING
 757
 FAULT ISOLATION/MAINT MANUAL

ADF PNL ID=B2								
OCTAL LABELS CHART								
SIGNAL	TYPE	LABEL	FORMAT	MIN UPDATE RATE	SDI	BINARY RANGE	POSITIVE SENSE	UNITS
ADF FREQUENCY	A	032	BCD	5	00	190-1750	ALWAYS POS	KHZ

EFFECTIVITY _____

ALL

34-57-00

01

Page 116
Mar 20/97

BOEING
 757
 FAULT ISOLATION/MAINT MANUAL

ADF PNL				
DISCRETE OCTAL LABELS/BIT CHART				
SIGNAL	OCTAL LABEL	BIT	ONE-STATE	ZERO-STATE
BFO-ON	032	11	BFO ON	BFO OFF *[1]
ANT MODE	032	12	ANT MODE	ADF MODE *[2]
0.5 KHZ TUNING	032	14	.5 KHZ	.0 KHZ

*[1] BFO signal on GUI 001, 009, 115

*[2] MODE switch on GUI 002-008, 010-114, 116-999

EFFECTIVITY

ALL

34-57-00

05

Page 117
Mar 20/97



757
 FAULT ISOLATION/MAINT MANUAL

GLOBAL POSITIONING SYSTEM (GPS)

COMPONENT	FIG. 102 SHT	QTY	ACCESS/AREA	AMM REFERENCE
ANTENNA - L GPS, M11247		1		
ANTENNA - R GPS, M11248		1		
CIRCUIT BREAKER - MMR LEFT, C4600		1	FLT COMPT, P11	*
MMR RIGHT, C4601		1	11E10	*
RECEIVER - LEFT MULTI-MODE, M11249	1	1	11E31	34-31-01
RECEIVER - RIGHT MULTI-MODE, M11250	1	1	119AL, MAIN EQUIP CTR, E2-3	34-31-01
			119AL, MAIN EQUIP CTR, E2-2	

* SEE THE WDM EQUIPMENT LIST

Global Positioning System (GPS) - Component Index
 Figure 101

EFFECTIVITY
 AIRPLANES WITH GPS

34-58-00

BOEING

757

FAULT ISOLATION/MAINT MANUAL

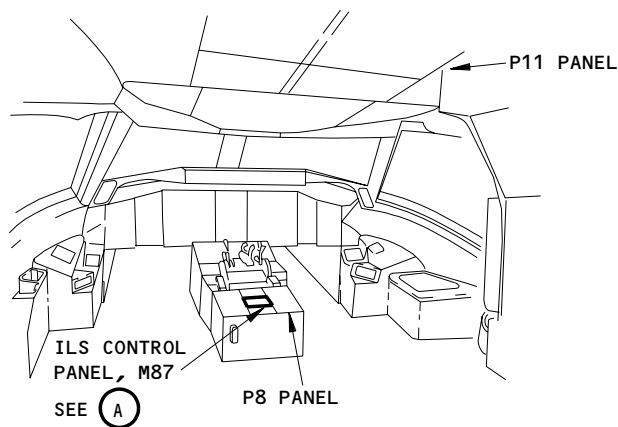

FLIGHT COMPARTMENT

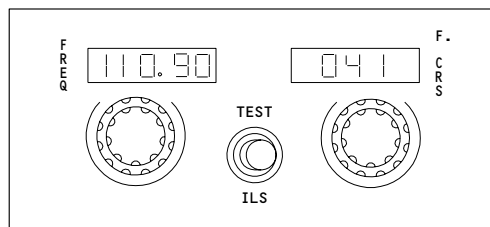
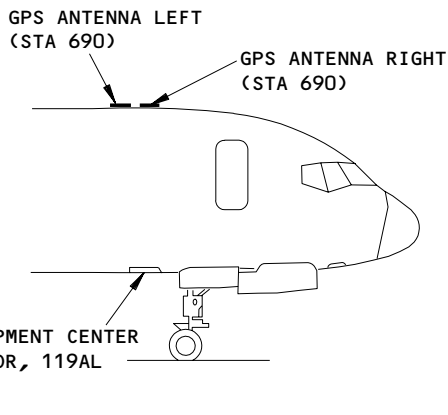

ILS CONTROL PANEL, M87

(A)

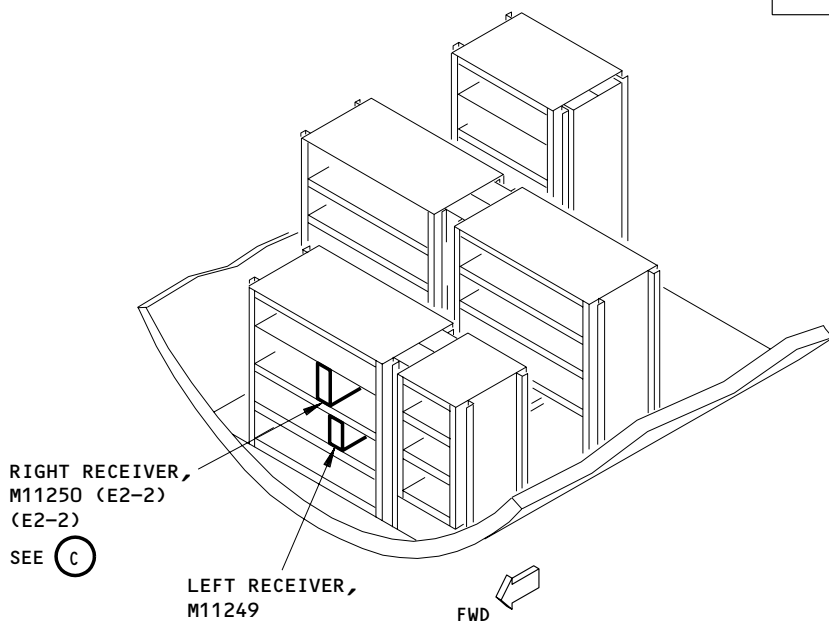

MAIN EQUIPMENT CENTER

(B)

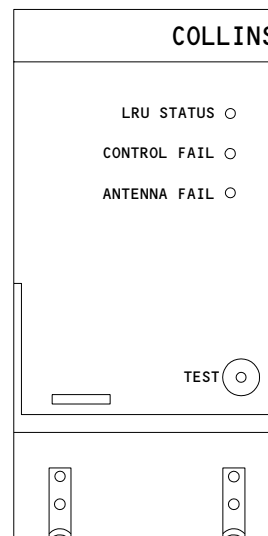

LEFT, OR RIGHT MMR, M11249, OR M11250

(C)

GPS - Component Location
Figure 102

EFFECTIVITY
AIRPLANES WITH GPS

34-58-00

PREREQUISITES

MAKE SURE THESE SYSTEMS WILL OPERATE:

IRS (AMM 34-21-00/501)

EFIS (AMM 34-22-00/501)

MAKE SURE THESE CIRCUIT BREAKERS ARE CLOSED:

11A3, 11E10, 11E31

MAKE SURE THE AIRPLANE IS IN THIS CONFIGURATION:

ELECTRICAL POWER IS ON (AMM 24-22-00/201)

GPS PROBLEMS

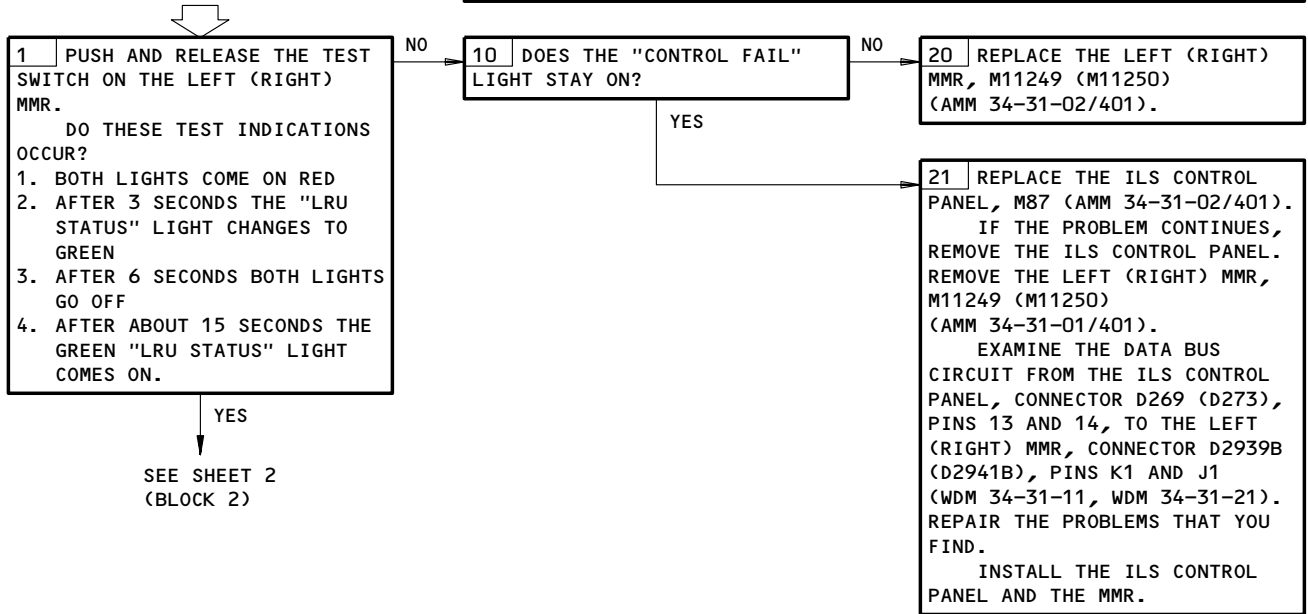

GPS Problems
Figure 103 (Sheet 1)

EFFECTIVITY
AIRPLANES WITH GPS

34-58-00

FROM SHEET 1
(BLOCK 1)

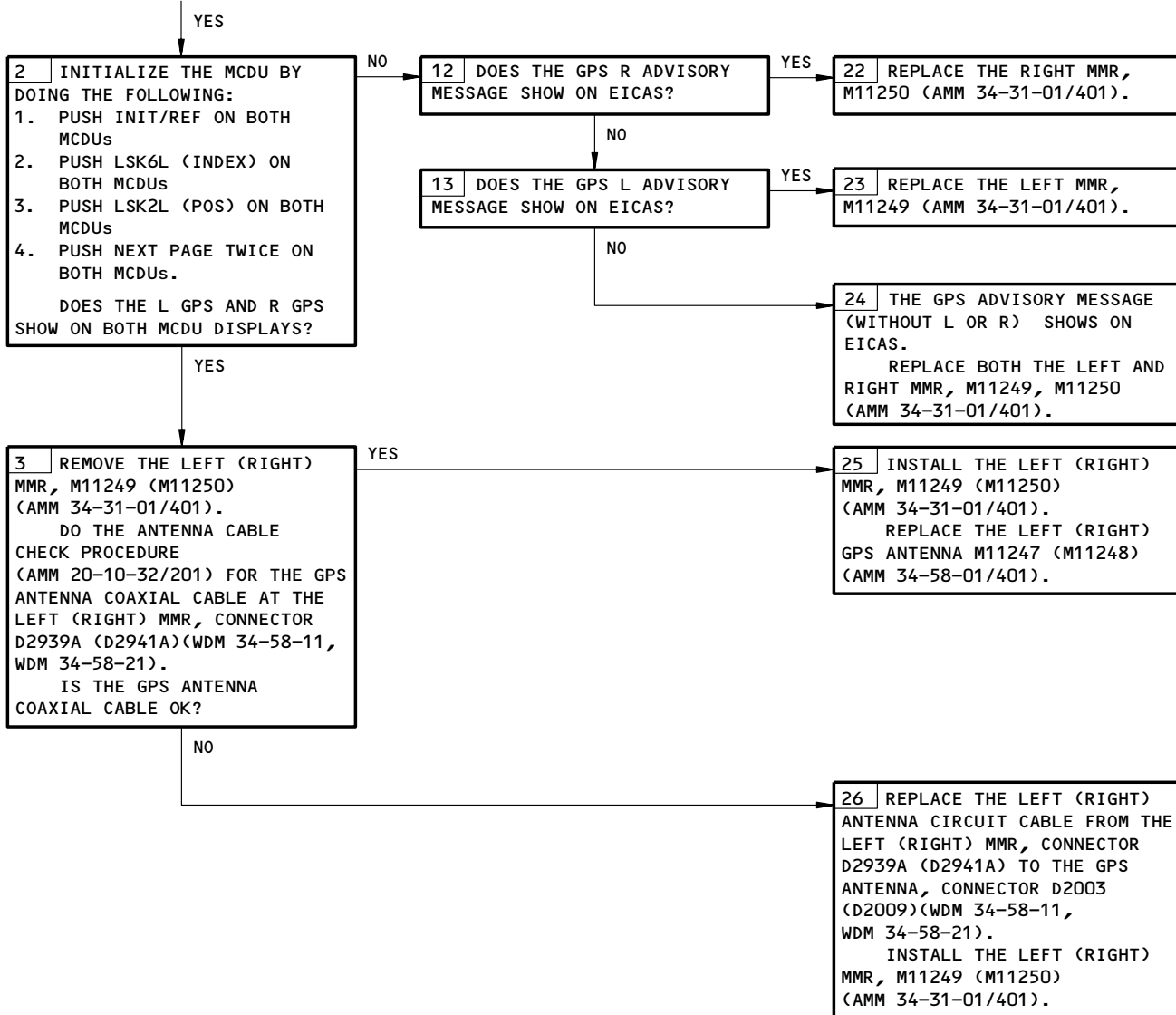

GPS Problems
Figure 103 (Sheet 2)

EFFECTIVITY
AIRPLANES WITH GPS

34-58-00



757
 FAULT ISOLATION/MAINT MANUAL

FLIGHT MANAGEMENT COMPUTER SYSTEM

COMPONENT	FIG. 102 SHT	QTY	ACCESS/AREA	REFERENCE
CARD - (77-35-00/101) ENG ECS DISCRETES LEFT, M10313 ENG ECS DISCRETES RIGHT, M10312 CLOCK - (31-25-00/101) CAPT, N2 F/O, N42				
CIRCUIT BREAKER - DBLDR, C630 2	1	1	FLT COMPT, P11 11F27	*
FMCS CDU LEFT, C597		1	11E8	*
FMCS CDU RIGHT, C598		1	11E29	*
FMCS CMPTR LEFT, C609		1	11E9	*
FMCS CMPTR RIGHT, C610		1	11E30	*
FMC TUNING LEFT, C641		1	11F13	*
CIRCUIT BREAKER - FMCS DATA BASE LOAD, C630 1	2	1	119BL, MAIN EQUIP CTR, P37 37E8	*
COMPUTER - (34-12-00/101) AIR DATA LEFT, M100 AIR DATA RIGHT, M101				
COMPUTER - (31-41-00/101) EICAS L, M10181 EICAS R, M10182				
COMPUTER - FLIGHT MANAGEMENT L, M134	2	1	119BL, MAIN EQUIP CTR, E2-1	34-61-01
COMPUTER - FLIGHT MANAGEMENT R, M135	2	1	119BL, MAIN EQUIP CTR, E2-2	34-61-01
COMPUTER - (22-32-00/101) THRUST MANAGEMENT, M183				
CONNECTOR - DATA BASE LOADER L, D917	1	1	FLT COMPT	*
INDICATOR - (34-13-00/101) CAPT MACH/AIRSPEED, N1 F/O'S MACH/AIRSPEED, N41				
INDICATOR - (34-22-00/101) CAPT ELECTRONIC ATTITUDE DIRECTOR, N4 CAPT ELECTRONIC HORIZONTAL SITUATION, N5 CAPT RADIO DISTANCE MAGNETIC, N3 F/O'S ELECTRONIC ATTITUDE DIRECTOR, N44 F/O'S ELECTRONIC HORIZONTAL SITUATION, N45 F/O'S RADIO DISTANCE MAGNETIC, N43				
INTERROGATOR - (34-55-00/101) DME L, M123 DME R, M124				
LIGHT - FMC ANNUNCIATOR, L471	1	1	FLT COMPT, P1-3	*
PANEL - (22-11-00/101) AFCS MODE CONTROL, M90				
PANEL - (34-22-00/101) EFIS CONTROL L, M94 EFIS CONTROL R, M93				
PANEL - (34-51-00/101) VOR CONTROL L, M91 VOR CONTROL R, M92				
RECEIVER - (34-51-00/101) VOR L, M186 VOR R, M187				

* SEE THE WDM EQUIPMENT LIST

1 GUI 001-009,115

2 GUI 010-114,116-999

Flight Management Computer System - Component Index
 Figure 101 (Sheet 1)

EFFECTIVITY

ALL

34-61-00

BOEING
 757
 FAULT ISOLATION/MAINT MANUAL

COMPONENT	FIG. 102 SHT	QTY	ACCESS/AREA	REFERENCE
RELAY - (REF 31-01-36, FIG. 101) FMC TUNING L, K757 SYS 1 AIR/GND, K124				
RELAY - (REF 31-01-37, FIG. 101) FMC TUNING R, K758 SYS 2 AIR/GND, K10203				
SWITCH - CAPT FMC SOURCE SELECT, S2	1	1	FLT COMPT, P1	*
SWITCH - F/O'S FMC SOURCE SELECT, S10	1	1	FLT COMPT, P3	*
SYMBOL GENERATOR - (REF 34-22-00, FIG. 101) EFIS C, M149 EFIS L, M148 EFIS R, M150				
UNIT - (REF 31-31-00, FIG. 101) DIGITAL FLIGHT DATA ACQUISITION, M138				
UNIT - L FLIGHT MANAGEMENT COMPUTER CONTROL/ DISPLAY, M76	1	1	FLT COMPT, P9	34-61-02
UNIT - R FLIGHT MANAGEMENT COMPUTER CONTROL/ DISPLAY, M77	1	1	FLT COMPT, P9	34-61-02
UNIT - (REF 28-41-00, FIG. 101) FUEL QUANTITY PROCESSOR, M121				
UNIT - (REF 34-21-00, FIG. 101) INERTIAL REFERENCE CTR, M160 INERTIAL REFERENCE L, M159 INERTIAL REFERENCE R, M161				

* SEE THE WDM EQUIPMENT LIST

Flight Management Computer System - Component Index
Figure 101 (Sheet 2)

EFFECTIVITY

ALL

34-61-00

01

Page 102
Sep 20/90

BOEING

757

FAULT ISOLATION/MAINT MANUAL

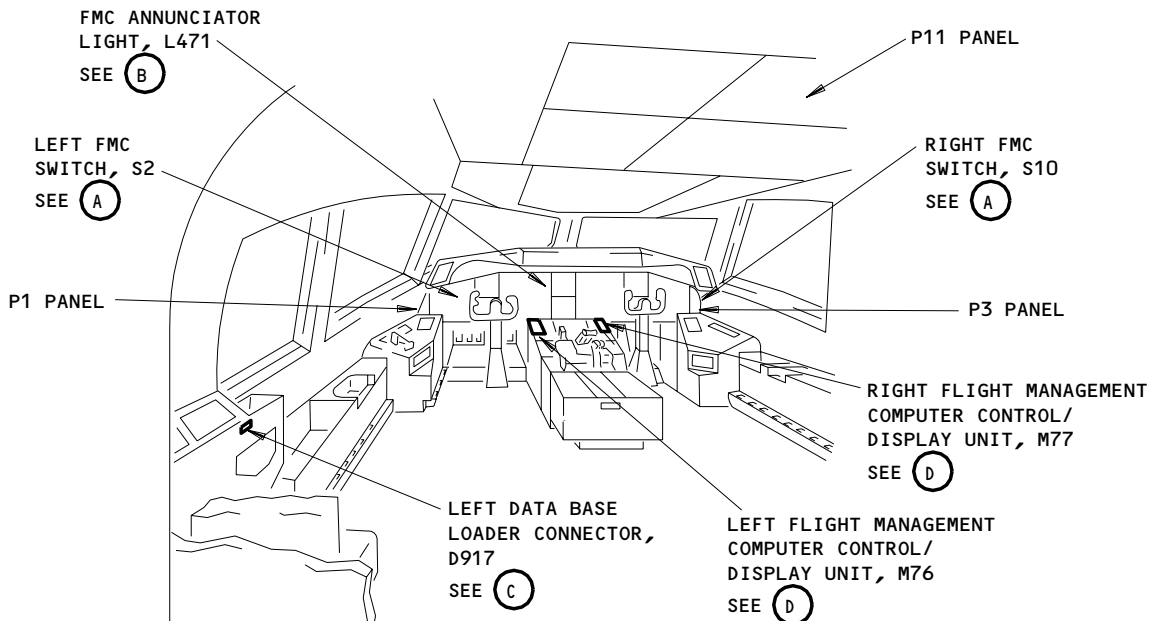

FLIGHT COMPARTMENT

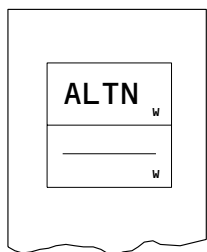

LEFT OR RIGHT FMC SWITCH, S2 OR S10

(A)



FMC ANNUNCIATOR LIGHT, L471

(B)

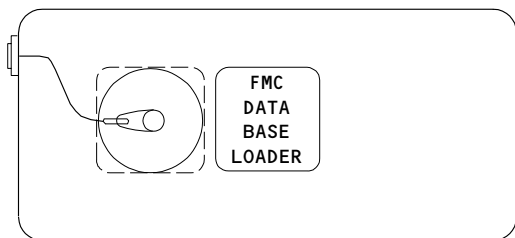

LEFT DATA BASE LOADER CONNECTOR, D917

(C)

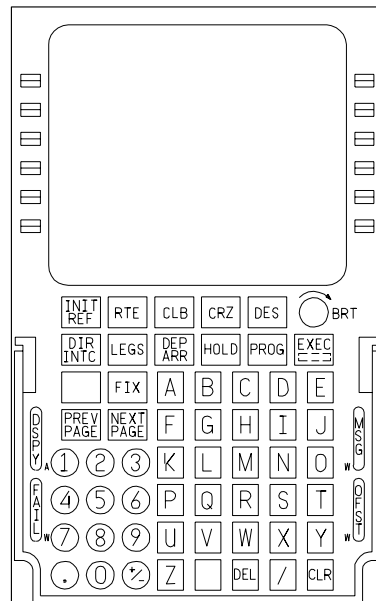

LEFT OR RIGHT FLIGHT MANAGEMENT COMPUTER CONTROL/DISPLAY UNIT, M76 OR M77

(D)

Flight Management Computer System - Component Location
Figure 102 (Sheet 1)

EFFECTIVITY
GUI 115 PRE-SB 34-414;
GUI 001-114, 116-999

34-61-00

BOEING

757

FAULT ISOLATION/MAINT MANUAL

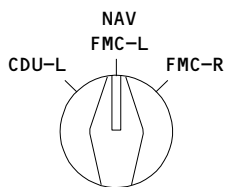
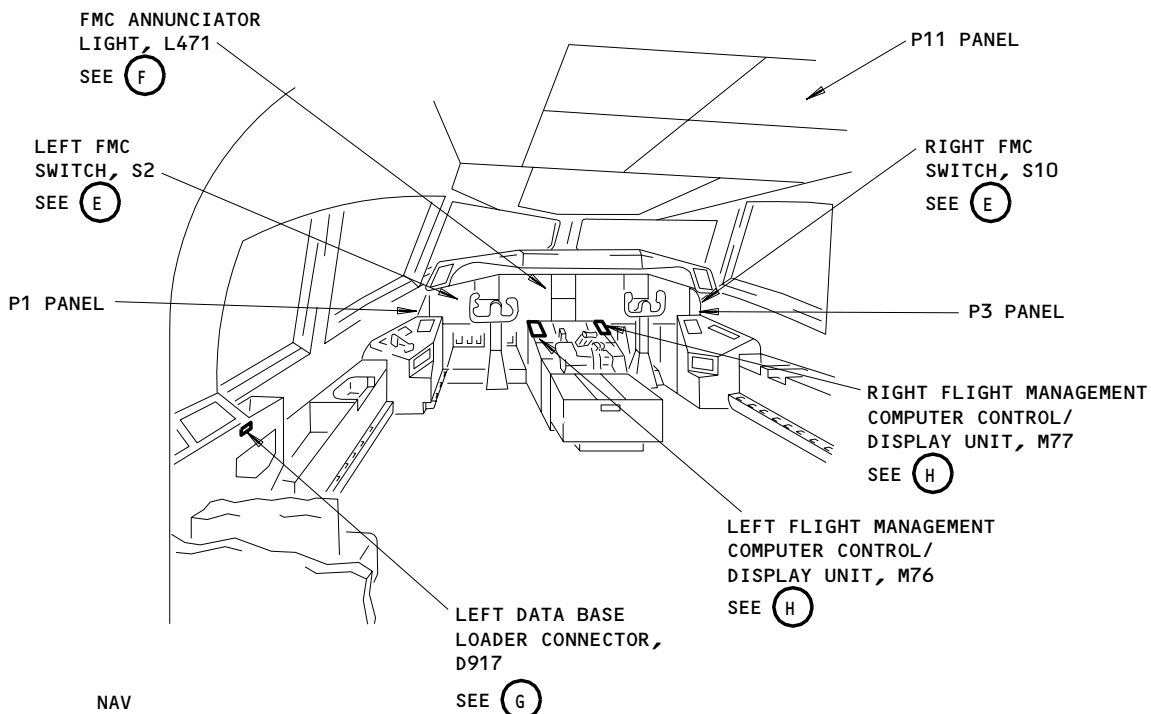

LEFT OR RIGHT FMC SWITCH, S2 OR S10 (EXAMPLE)

(E)

FLIGHT COMPARTMENT



FMC ANNUNCIATOR LIGHT, L471

(F)

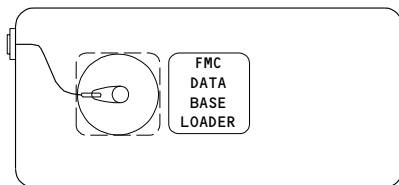

LEFT DATA BASE LOADER CONNECTOR, D917

(G)

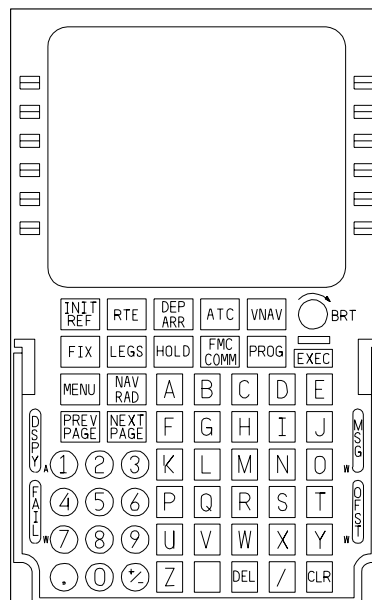

LEFT OR RIGHT FLIGHT MANAGEMENT COMPUTER CONTROL/DISPLAY UNIT, M76 OR M77

(H)

Flight Management Computer System - Component Location
Figure 102 (Sheet 2)

EFFECTIVITY
GUI 115 POST-SB 34-414

34-61-00

BOEING
757
FAULT ISOLATION/MAINT MANUAL

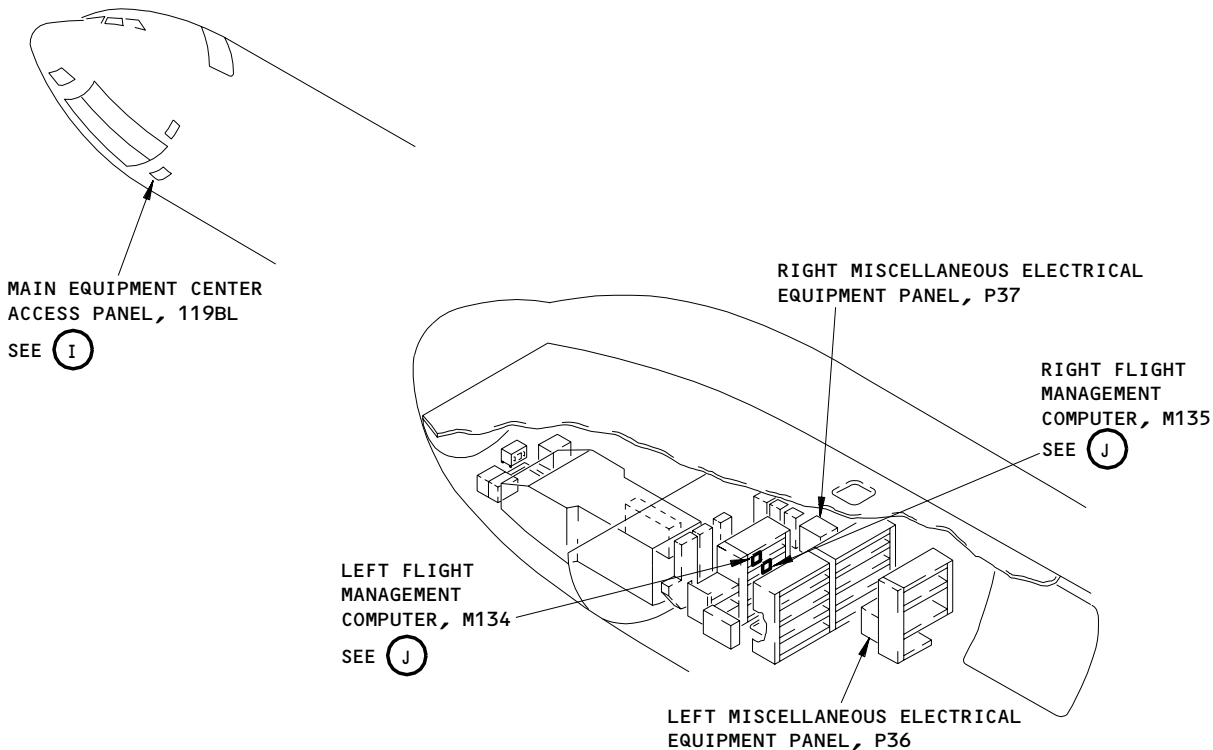

MAIN EQUIPMENT CENTER

(I)

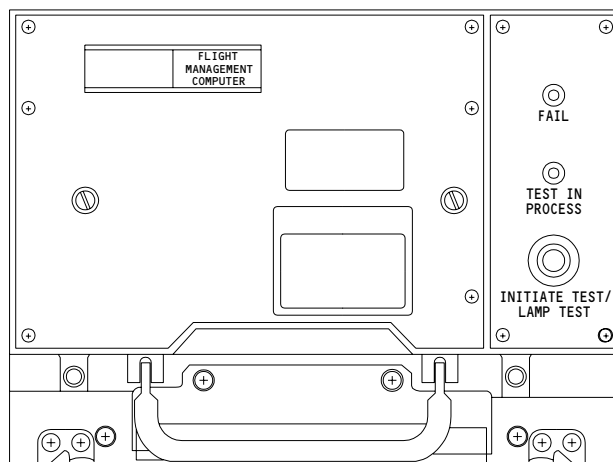

LEFT OR RIGHT FLIGHT MANAGEMENT COMPUTER, M134 OR M135

(J)

**Flight Management Computer System - Component Location
Figure 102 (Sheet 3)**

EFFECTIVITY

ALL

34-61-00

07

Page 105
May 28/99

K22306

The FMC Flight Faults BITE Procedure Is Part of the Autoflight BITE.
See the Autoflight BITE Fault Isolation (FIM 22-00-02/101).
Figure 102A

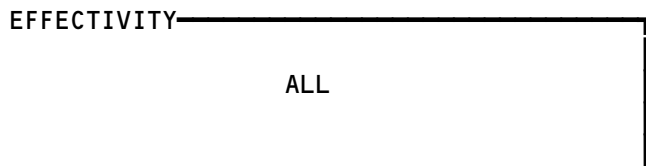

34-61-00

02

Page 106
Jan 20/98

153051

ACTION PERFORMED ON LEFT (RIGHT) CDU KEYBOARD IS NOT EFFECTIVE

PREREQUISITES
 MAKE SURE THESE CIRCUIT BREAKERS ARE CLOSED:
 11E8,11E9,11E29,11E30
 MAKE SURE THE AIRPLANE IS IN THE CONFIGURATION THAT FOLLOWS:
 ELECTRICAL POWER IS ON (MM 24-22-00/201)

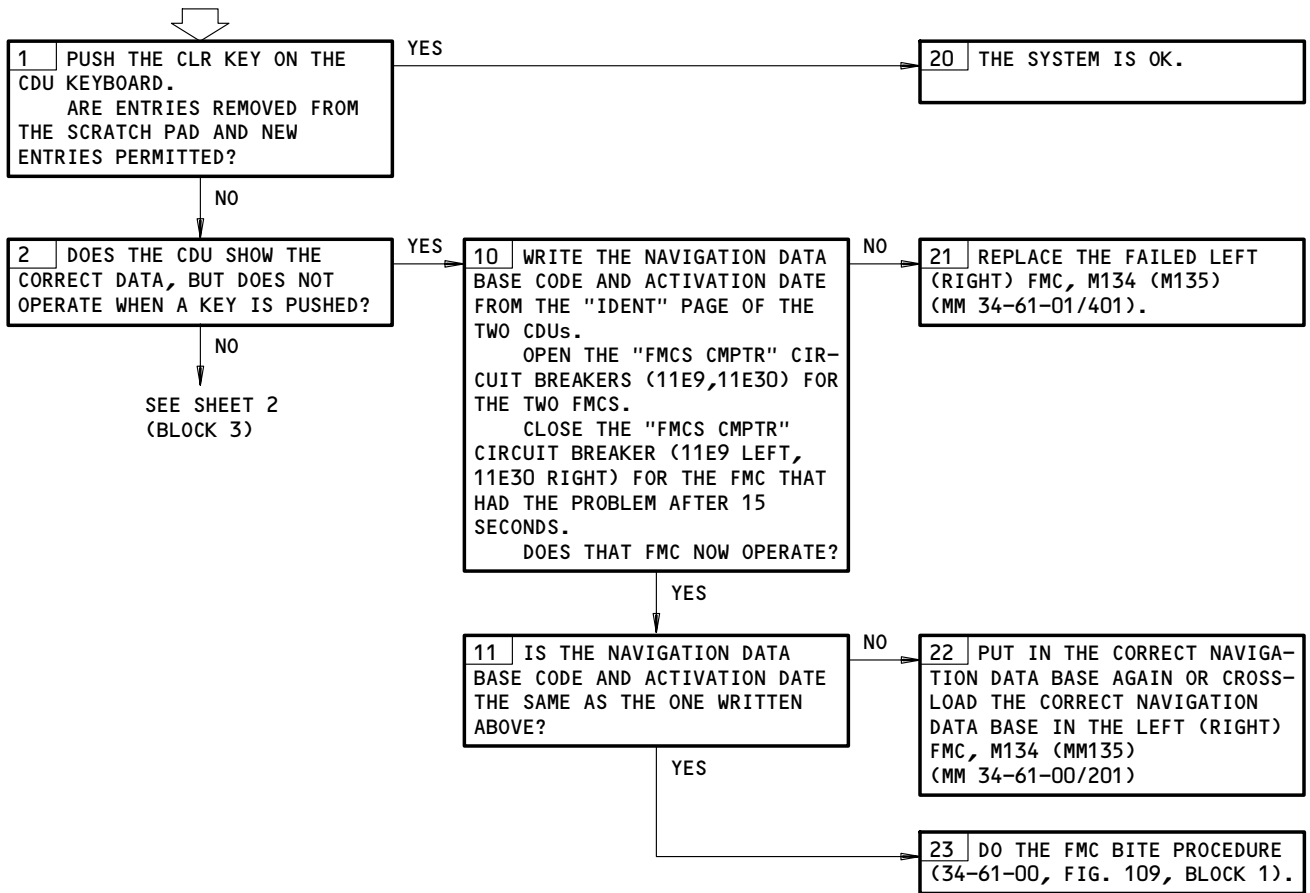

Action Performed on Left (Right) CDU Keyboard is Not Effective
Figure 103 (Sheet 1)

EFFECTIVITY	ALL
-------------	-----

34-61-00

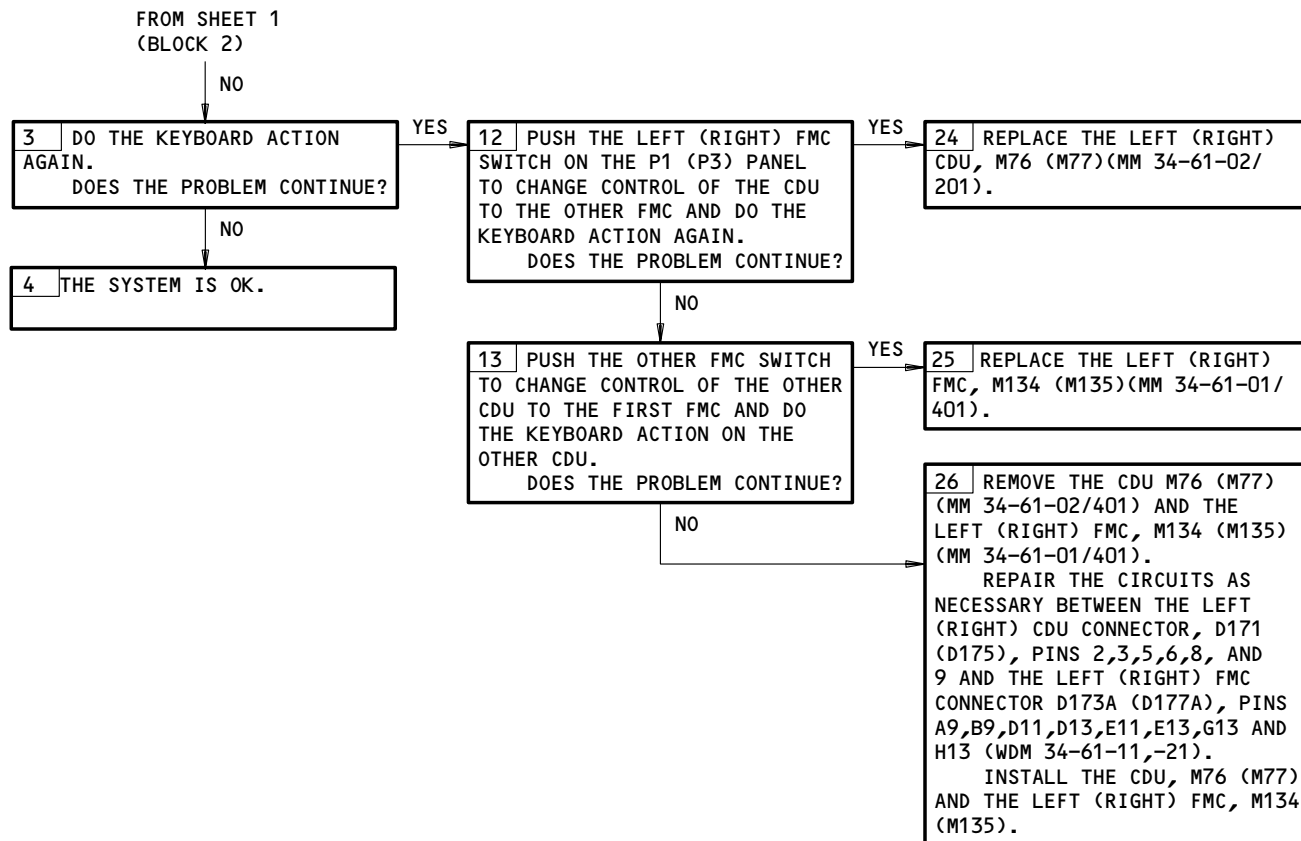

Action Performed on Left (Right) CDU Keyboard is Not Effective
Figure 103 (Sheet 2)

EFFECTIVITY	ALL
-------------	-----

34-61-00

**DATA INCORRECT ON
LEFT (RIGHT) CDU
DISPLAY**

PREREQUISITES

MAKE SURE THESE SYSTEMS WILL OPERATE:

- AIR DATA COMPUTING SYSTEM (MM 34-12-00/501)
- INERTIAL REFERENCE SYSTEM (MM 34-21-00/501)
- VOR SYSTEM (MM 34-51-00/501)
- DME SYSTEM (MM 34-55-00/501)

MAKE SURE THESE CIRCUIT BREAKERS ARE CLOSED:
11E8,11E9,11E29,11E30

MAKE SURE THE AIRPLANE IS IN THE CONFIGURATION THAT
FOLLOWS:

- ELECTRICAL POWER IS ON (MM 24-22-00/201)

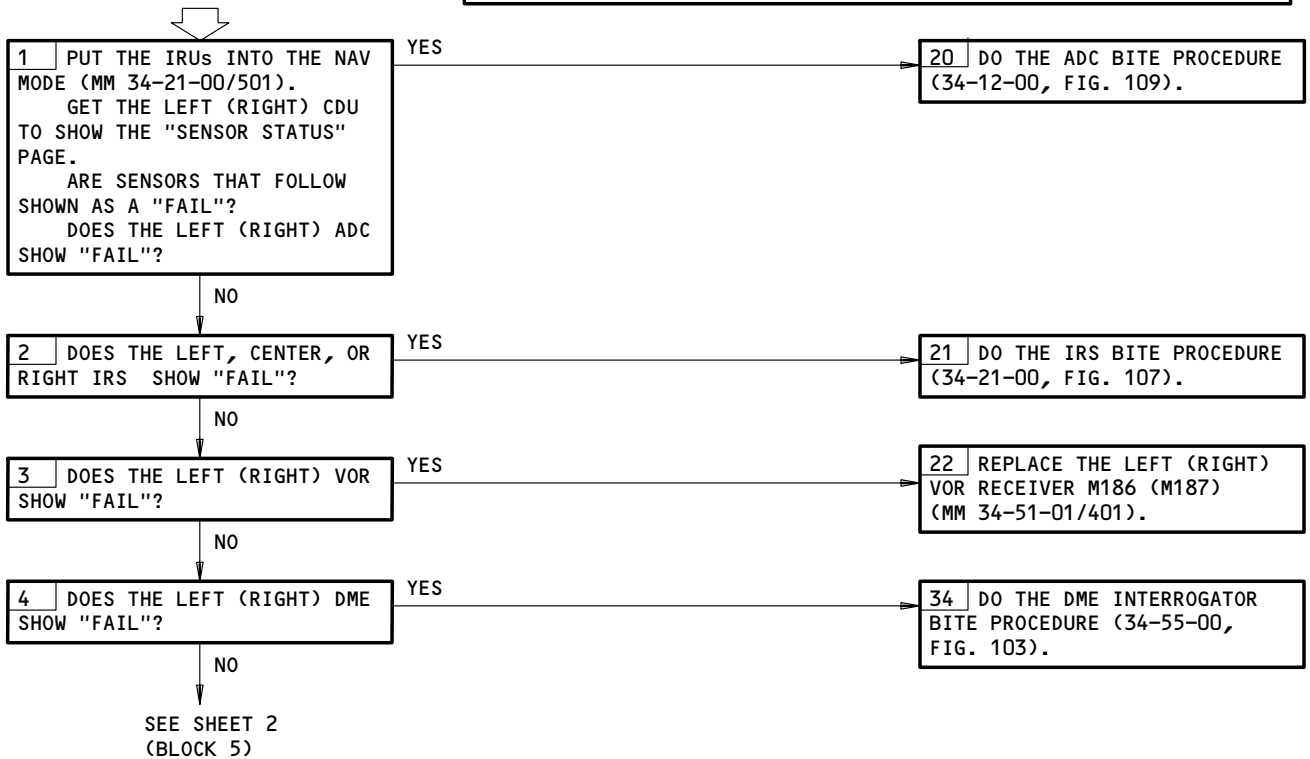

Data Incorrect on Left (Right) CDU Display
Figure 104 (Sheet 1)

EFFECTIVITY

ALL

34-61-00

02

Page 109
Jan 20/98

FROM SHEET 1
(BLOCK 4)

NO

5 WARNING

DO THE DEACTIVATION PROCEDURE FOR THE SPOILERS OR MOVE ALL PERSONS AND EQUIPMENT AWAY FROM THE SPOILERS. THE SPOILERS CAN RETRACT QUICKLY AND CAUSE INJURY TO PERSONS OR DAMAGE TO EQUIPMENT.

DO THE DEACTIVATION PROCEDURE FOR THE SPOILERS (MM 27-61-00/201) OR MOVE ALL PERSONS AND EQUIPMENT AWAY FROM THE SPOILERS

WARNING

MAKE SURE YOU DO THE FLIGHT MODE SIMULATION CORRECTLY. IF THE PROCEDURE IS NOT DONE CORRECTLY, INJURY TO PERSONS OR DAMAGE TO EQUIPMENT CAN OCCUR.

DO THE FLIGHT MODE SIMULATION PROCEDURE FOR THE NO. 1 (NO. 2) AIR/GROUND SYSTEM (MM 32-09-02/201).

DOES THE "LEFT (RIGHT) FMC ANALOG DISC" PAGE SHOW "OLEO SWITCH" AS "AIR"?

NO

35 DO THE AIR/GROUND RELAY PROBLEM, NO "AIR/GND DISAGREE" OR "NOSE A/G DISAGREE" EICAS MESSAGE DISPLAY PROCEDURE (32-09-00, FIG. 103 BLOCK 1).

YES

36 REPLACE THE LEFT (RIGHT) FLIGHT MANAGEMENT COMPUTER M134 (M135)(MM 34-61-01/401).

Data Incorrect on Left (Right) CDU Display
Figure 104 (Sheet 2)

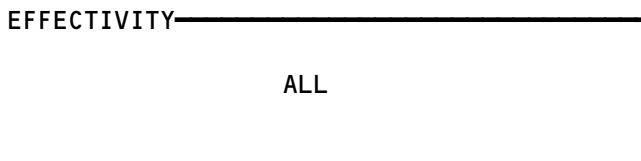

34-61-00

PREREQUISITES

MAKE SURE THESE SYSTEMS WILL OPERATE:
 FUEL QUANTITY INDICATING SYSTEM (AMM 28-41-00/501)
 EICAS (AMM 31-41-00/501)
 FUEL FLOW INDICATING SYSTEM (AMM 73-31-00/001)

MAKE SURE THESE CIRCUIT BREAKERS ARE CLOSED:
 11E8, 11E9, 11E29, 11E30

MAKE SURE THE AIRPLANE IS IN THIS CONFIGURATION:
 ELECTRICAL POWER IS ON (AMM 24-22-00/201)

**FUEL ERROR ON
 CDU DISPLAY**

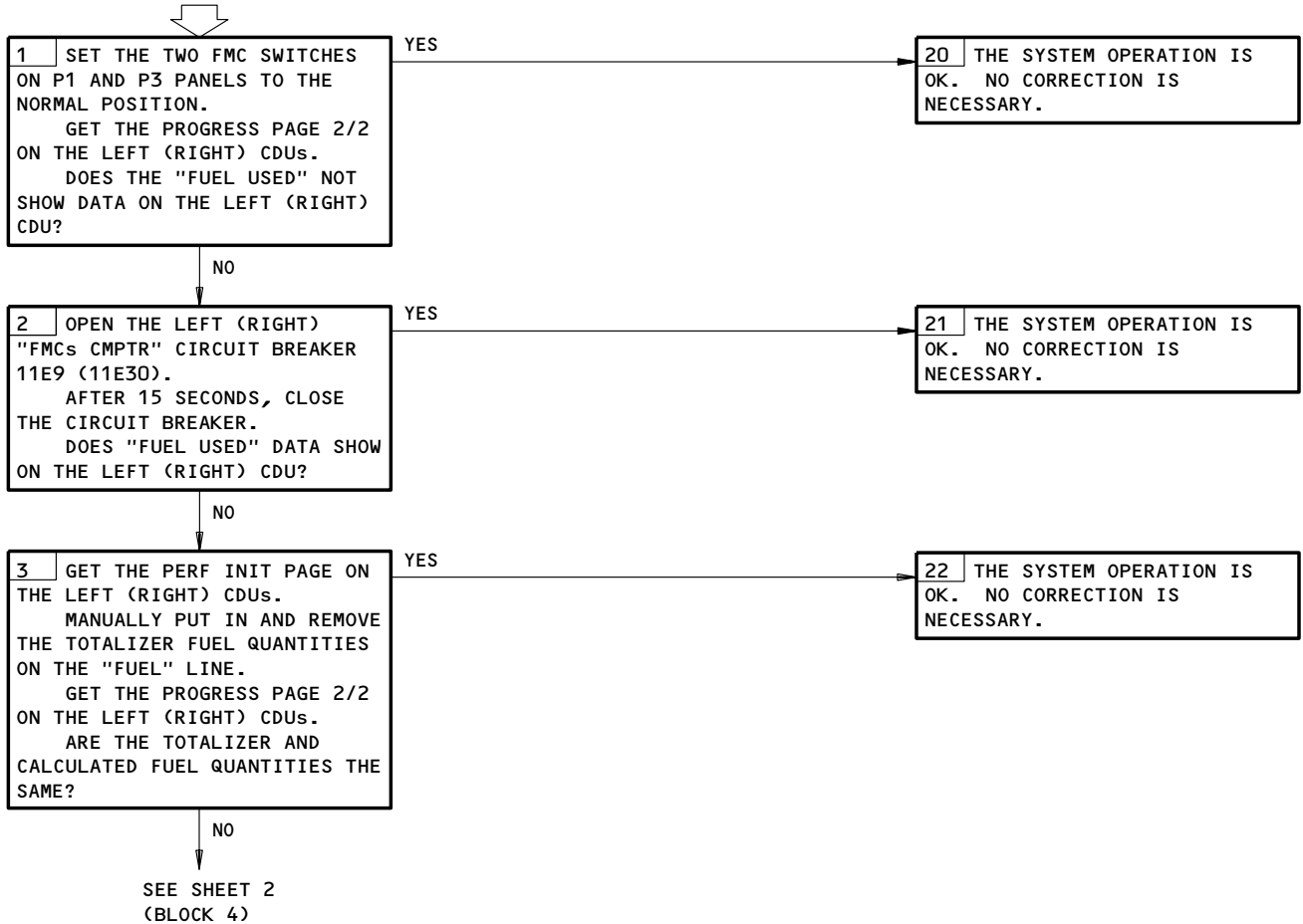

Fuel Error on CDU Display
 Figure 105 (Sheet 1)

EFFECTIVITY

ALL

34-61-00

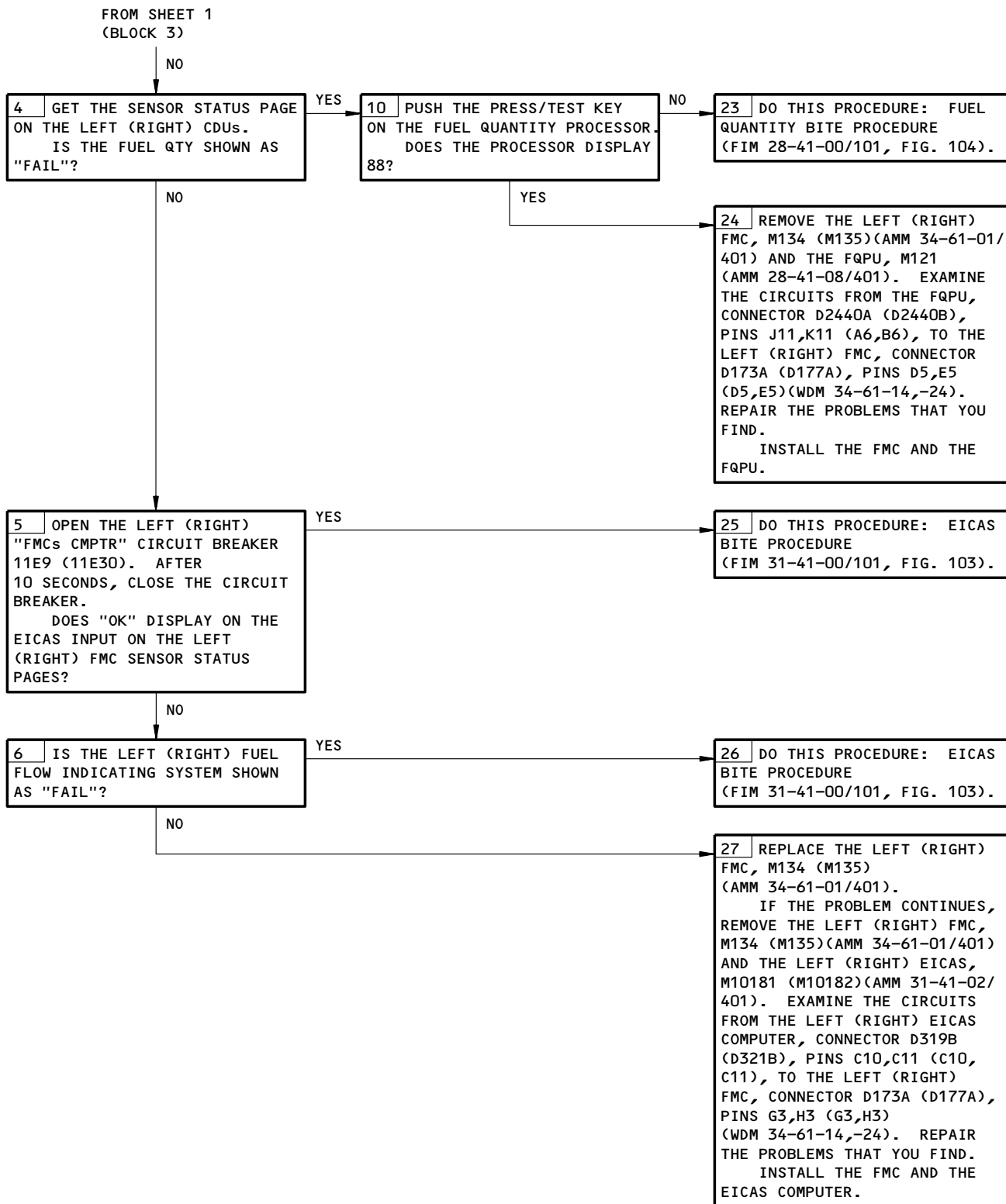

Fuel Error on CDU Display
Figure 105 (Sheet 2)

EFFECTIVITY _____
ALL

34-61-00

**FMC NAVIGATION
DATA BASE OR
PROGRAM WRONG**

PREREQUISITES

MAKE SURE THESE CIRCUIT BREAKERS ARE CLOSED:
11E8,11E9,11E29,11E30

MAKE SURE THE AIRPLANE IS IN THE CONFIGURATION THAT
FOLLOWS:
ELECTRICAL POWER IS ON (MM 24-22-00/201)

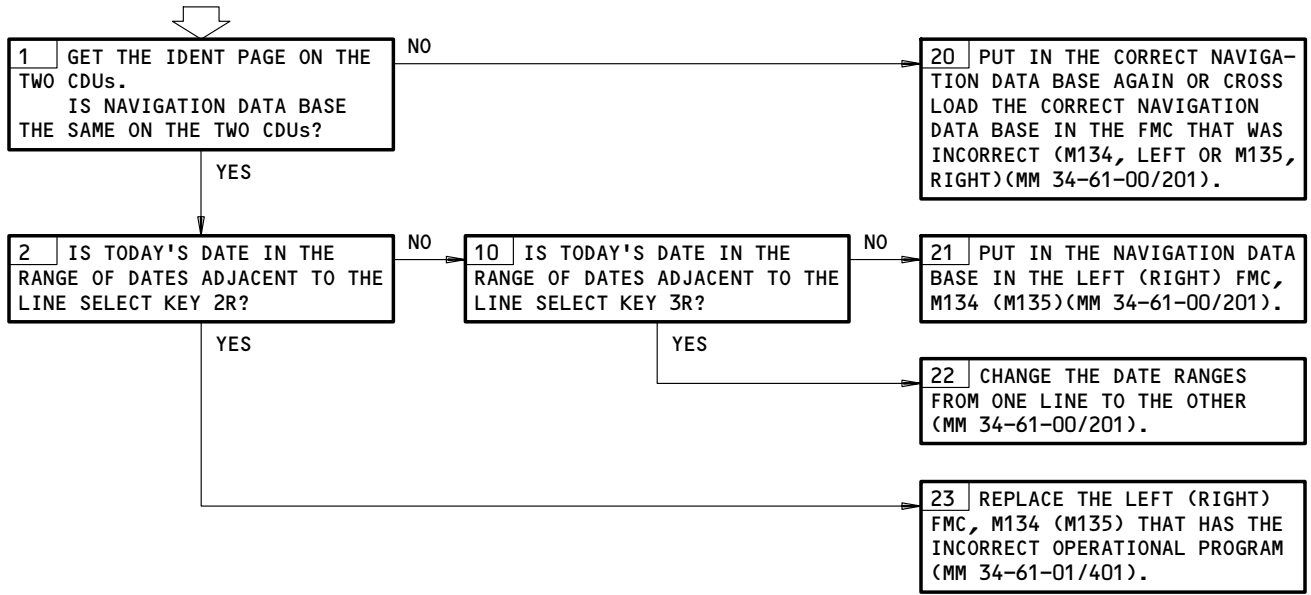

FMC Navigation Data Base or Program Wrong
Figure 106

EFFECTIVITY	ALL
-------------	-----

34-61-00

FMC LIGHT FAILS TO ILLUMINATE WITH CDU ALERT

PREREQUISITES

MAKE SURE THESE CIRCUIT BREAKERS ARE CLOSED:
11E8,11E9,11E29,11E30

MAKE SURE THE AIRPLANE IS IN THIS CONFIGURATION:
ELECTRICAL POWER IS ON (AMM 24-22-00/201)

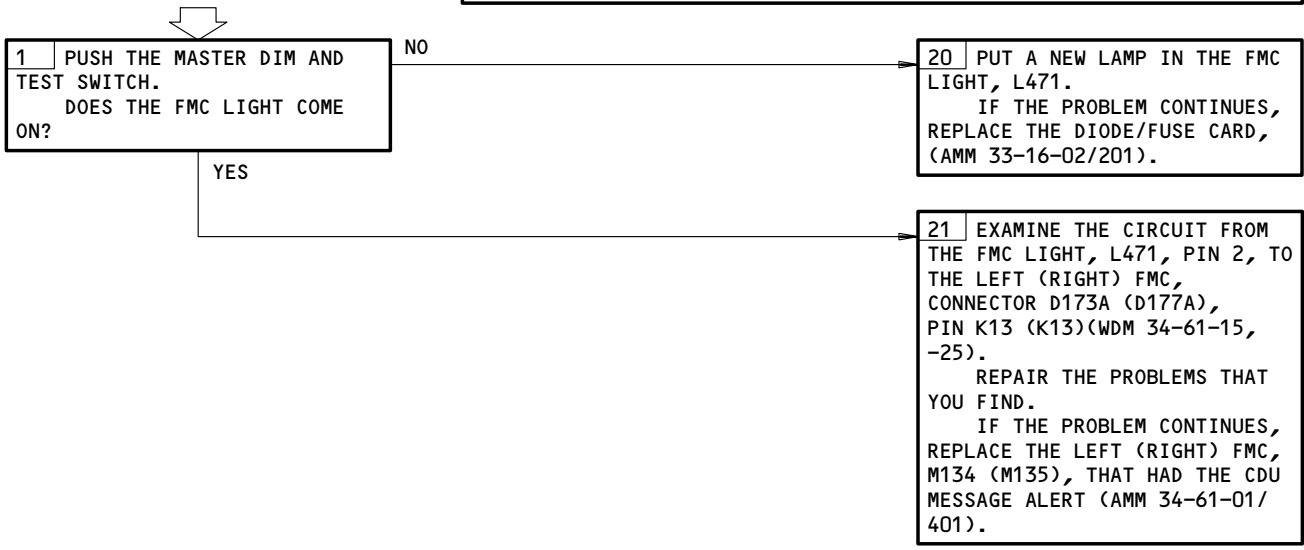

FMC Light Fails To Illuminate With CDU Alert
Figure 107

EFFECTIVITY	ALL
-------------	-----

34-61-00

E46752

"MAP RANGE DISAGREE"
MESSAGE DISPLAYED
ON LEFT (RIGHT) EHSI

PREREQUISITES

MAKE SURE THIS SYSTEM WILL OPERATE:
EFIS (AMM 34-22-00/501)

MAKE SURE THESE CIRCUIT BREAKERS ARE CLOSED:
11E8, 11E9, 11E29, 11E30

MAKE SURE THE AIRPLANE IS IN THIS CONFIGURATION:
ELECTRICAL POWER IS ON (AMM 24-22-00/201)

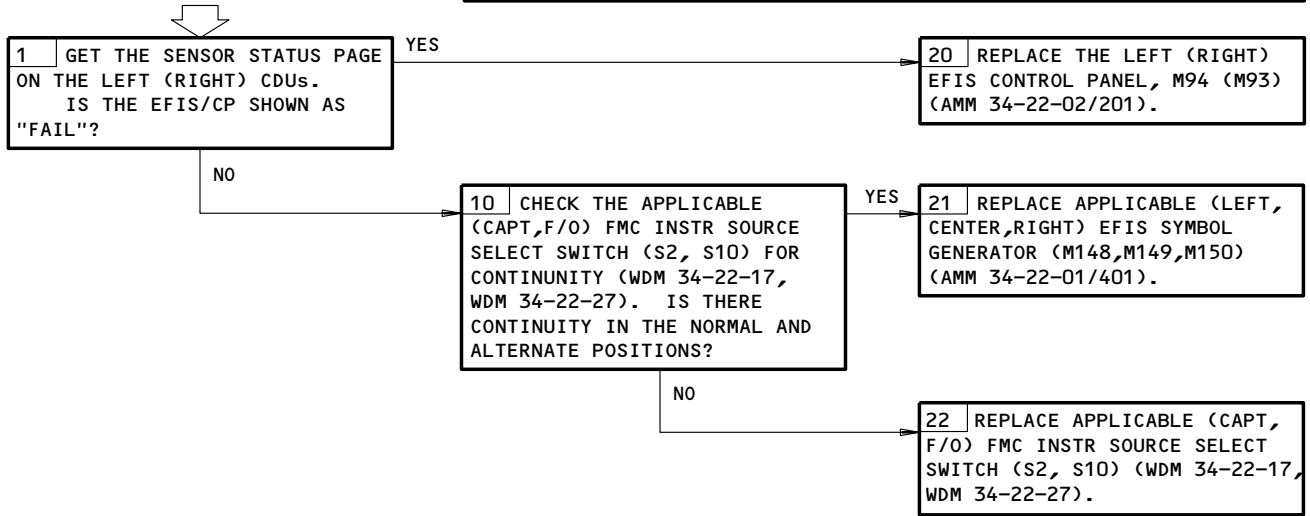

MAP RANGE DISAGREE Message Displayed on Left (Right) EHSI
Figure 108

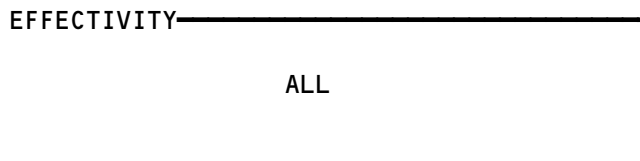

34-61-00

**ERRONEOUS DISPLAY
 OF ".ATC" AND
 ".FMC" MESSAGES
 ON EICAS**

PREREQUISITES

MAKE SURE THESE SYSTEMS WILL OPERATE:
 AUTOPILOT (AMM 22-10-00/501)
 THRUST MANAGEMENT SYSTEM (AMM 22-32-00/501)
 INERTIAL REFERENCE SYSTEM (AMM 34-21-00/501) OR
 AIR DATA INERTIAL REFERENCE SYSTEM
 (AMM 34-26-00/501)

MAKE SURE THESE CIRCUIT BREAKERS ARE CLOSED:
 11E8, 11E9, 11E29, 11E30

MAKE SURE THE AIRPLANE IS IN THIS CONFIGURATION:
 ELECTRICAL POWER IS ON (AMM 24-22-00/201)

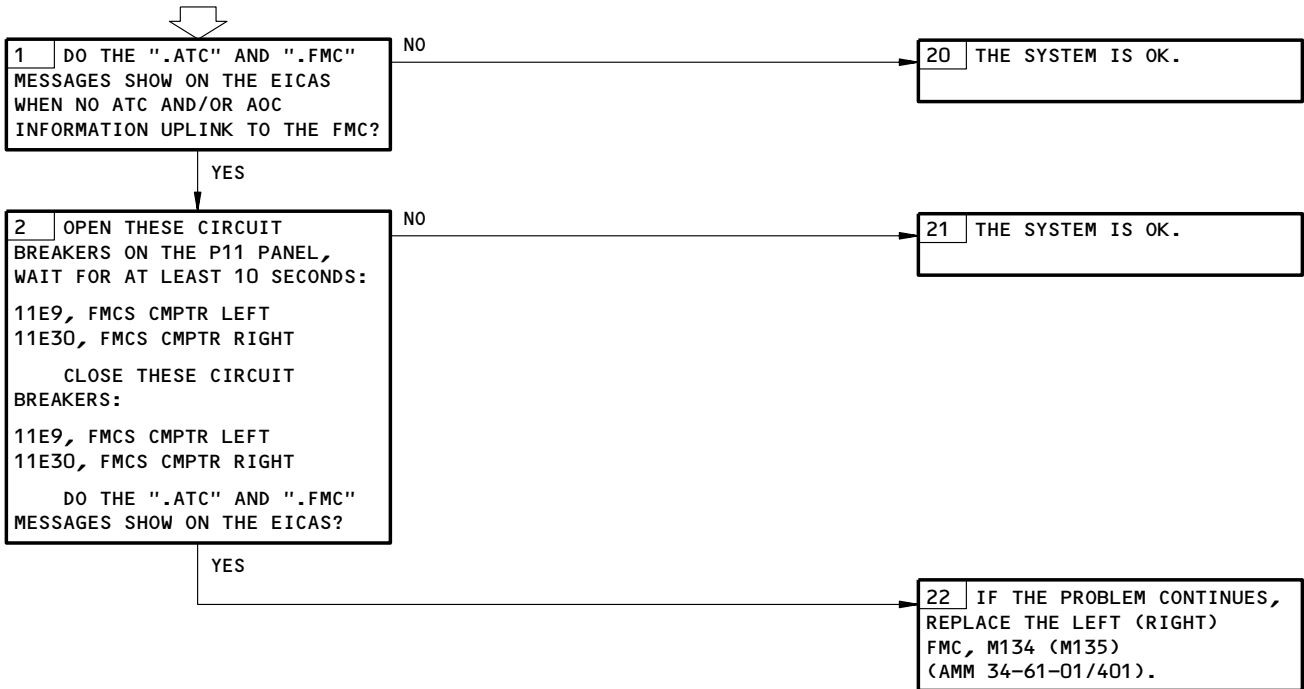

Erroneous Display of ".ATC" and ".FMC" Messages on EICAS
 Figure 108A

EFFECTIVITY	ALL
-------------	-----

34-61-00

L48204

PREREQUISITES

MAKE SURE THESE SYSTEMS WILL OPERATE:

- AUTOPILOT (AMM 22-10-00/501)
- THRUST MANAGEMENT SYSTEM (AMM 22-32-00/501)
- INERTIAL REFERENCE SYSTEM (AMM 34-21-00/501) OR AIR DATA INERTIAL REFERENCE SYSTEM (AMM 34-26-00/501)

MAKE SURE THESE CIRCUIT BREAKERS ARE CLOSED:

- 11E8, 11E9, 11E29, 11E30

MAKE SURE THE AIRPLANE IS IN THIS CONFIGURATION:

- ELECTRICAL POWER IS ON (AMM 24-22-00/201)

**"L (R) FMC FAIL"
ON EICAS**

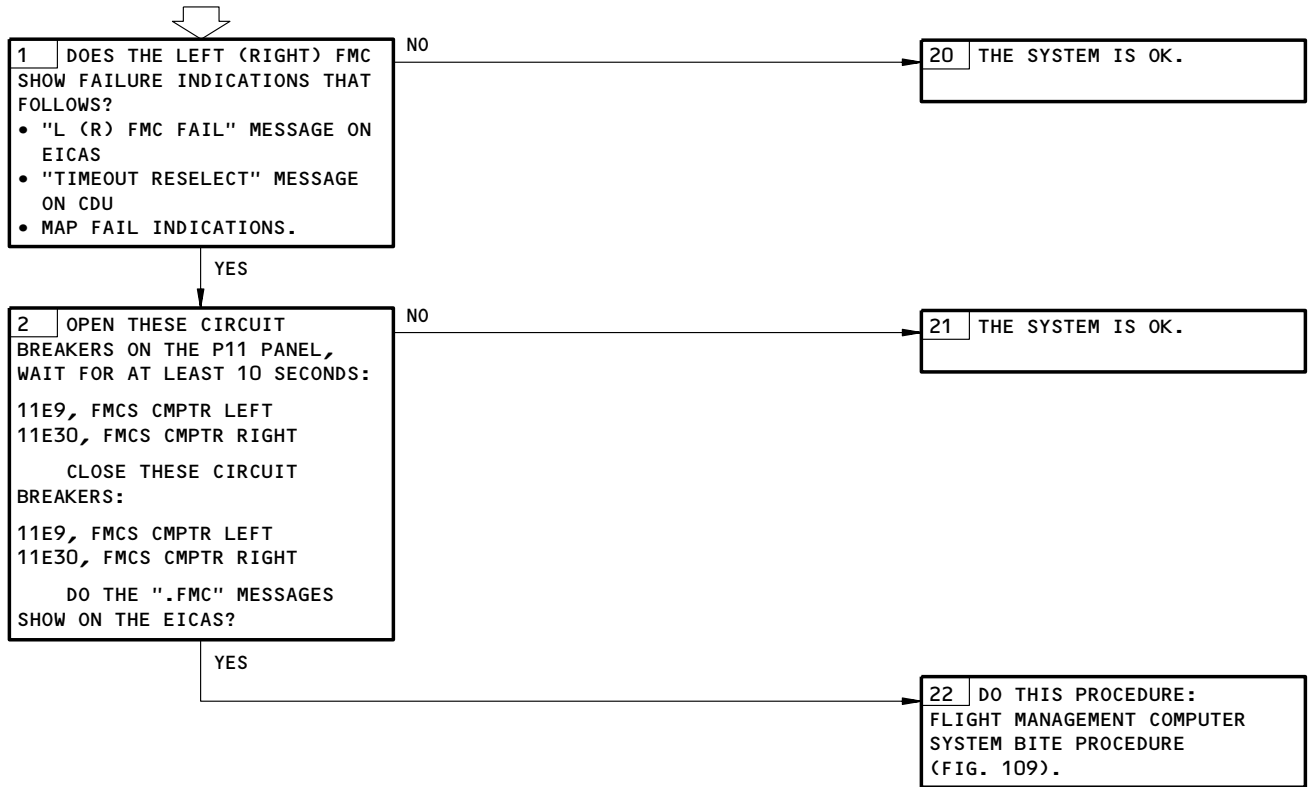

"L (R) FMC FAIL" on EICAS
Figure 108B

EFFECTIVITY

ALL

34-61-00

03

Page 117
Jan 28/03

PREREQUISITES

MAKE SURE THESE SYSTEMS WILL OPERATE:

- AIR DATA COMPUTING SYSTEM (MM 34-12-00/501)
- AUTOFLIGHT (MM 22-10-00/501)
- CLOCKS (MM 31-25-00/501)
- DME SYSTEM (MM 34-55-00/501)
- EFIS (MM 34-22-00/501)
- EICAS (MM 31-41-00/501)
- FUEL QUANTITY INDICATING SYSTEM (MM 28-41-00/501)
- INERTIAL REFERENCE SYSTEM (MM 34-21-00/501)
- INSTRUMENT LANDING SYSTEM (MM 34-31-00/501)
- THRUST MANAGEMENT SYSTEM (MM 22-32-00/501)
- VOR SYSTEM (MM 34-51-00/501)

MAKE SURE THESE CIRCUIT BREAKERS ARE CLOSED:
11E8,11E9,11E29,11E30

MAKE SURE THE AIRPLANE IS IN THIS CONFIGURATION:
ELECTRICAL POWER IS ON (MM 24-22-00/201)

**FLIGHT MANAGEMENT
COMPUTER SYSTEM
BITE PROCEDURE**

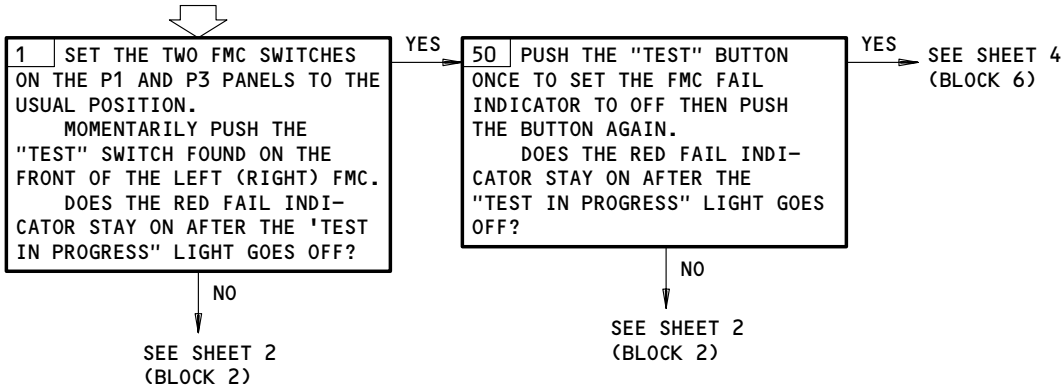

Flight Management Computer System BITE Procedure
Figure 109 (Sheet 1)

EFFECTIVITY	ALL
-------------	-----

34-61-00

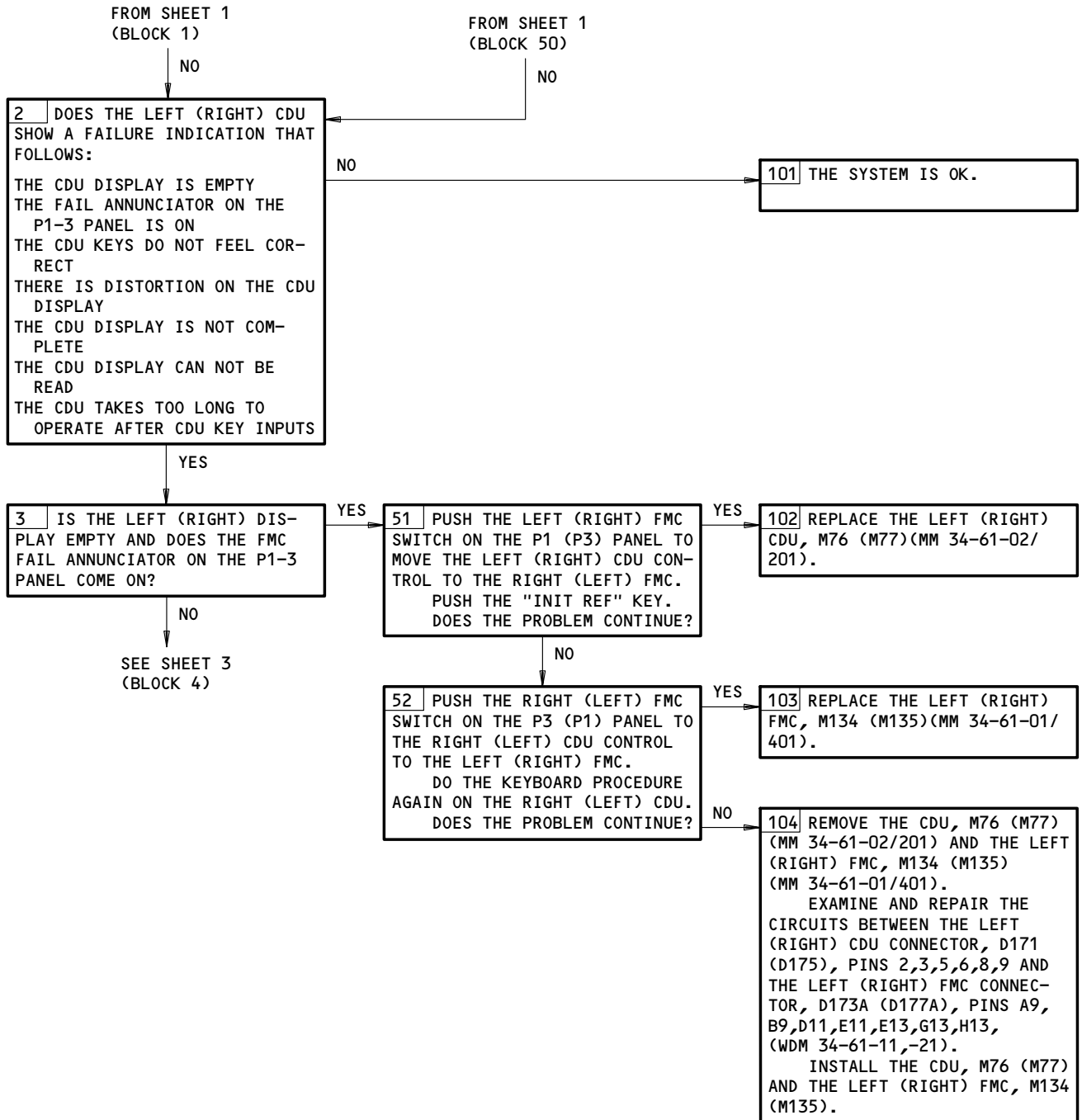

Flight Management Computer System BITE Procedure
Figure 109 (Sheet 2)

EFFECTIVITY	ALL
-------------	-----

34-61-00

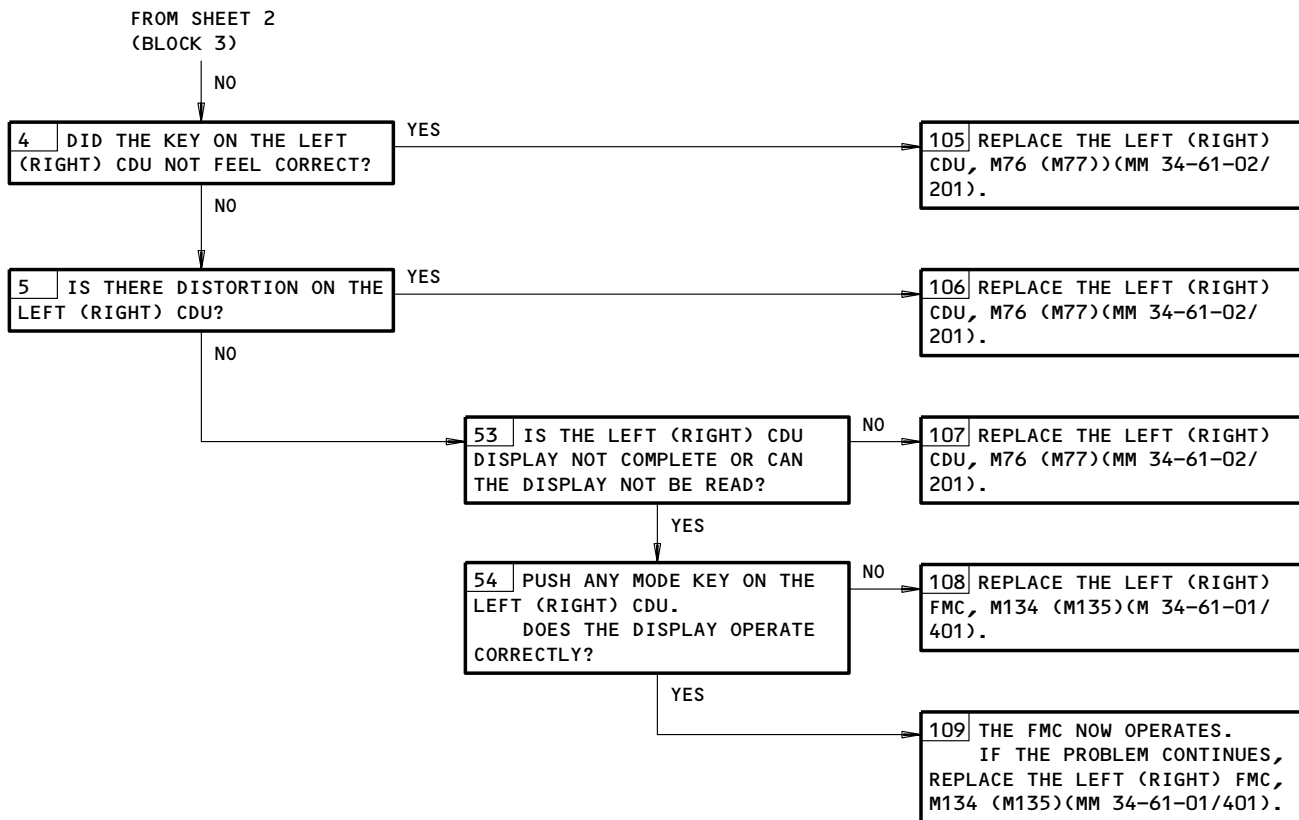

Flight Management Computer System BITE Procedure
Figure 109 (Sheet 3)

EFFECTIVITY

ALL

34-61-00

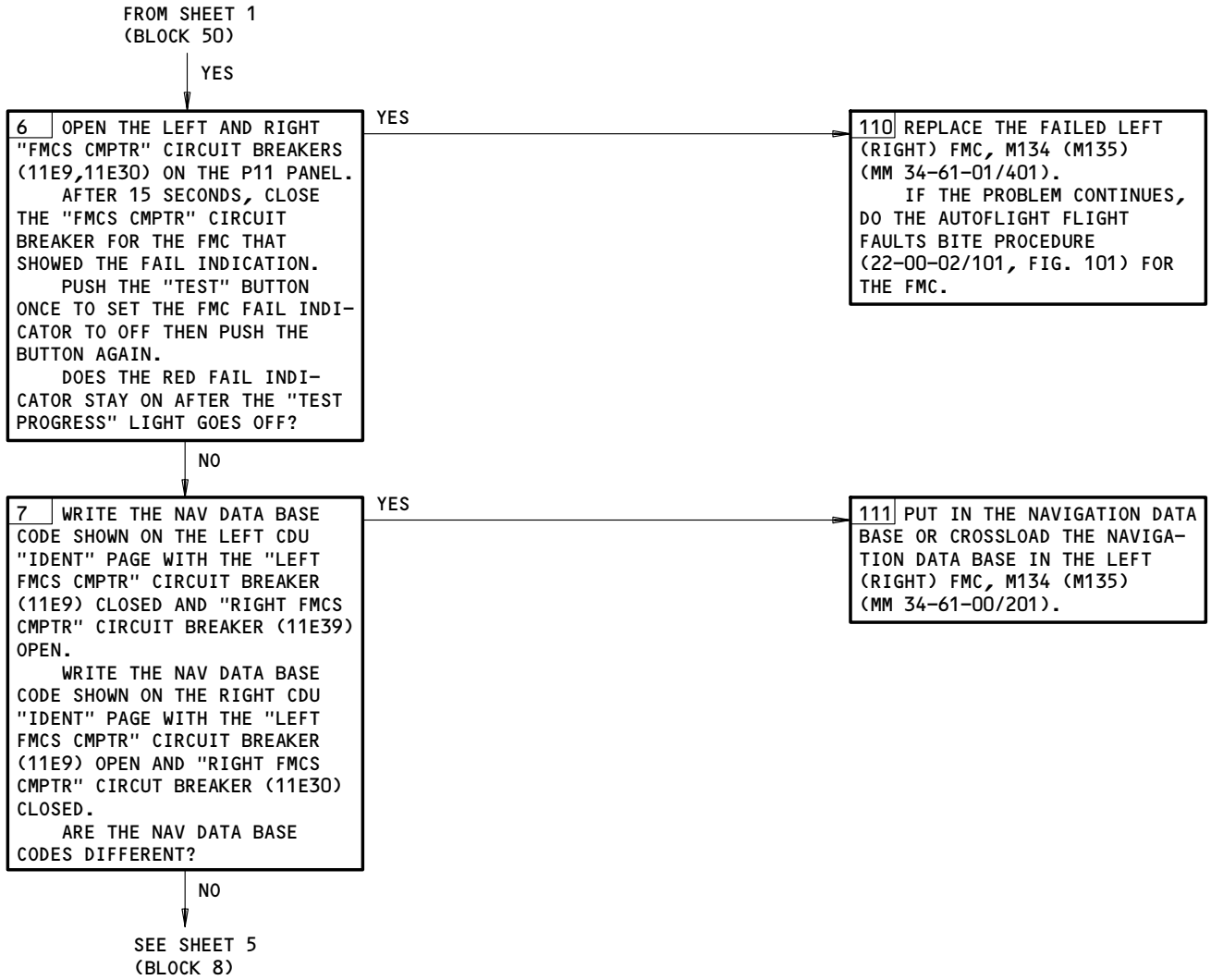

Flight Management Computer System BITE Procedure
Figure 109 (Sheet 4)

EFFECTIVITY	ALL
-------------	-----

34-61-00

FROM SHEET 4
(BLOCK 7A)

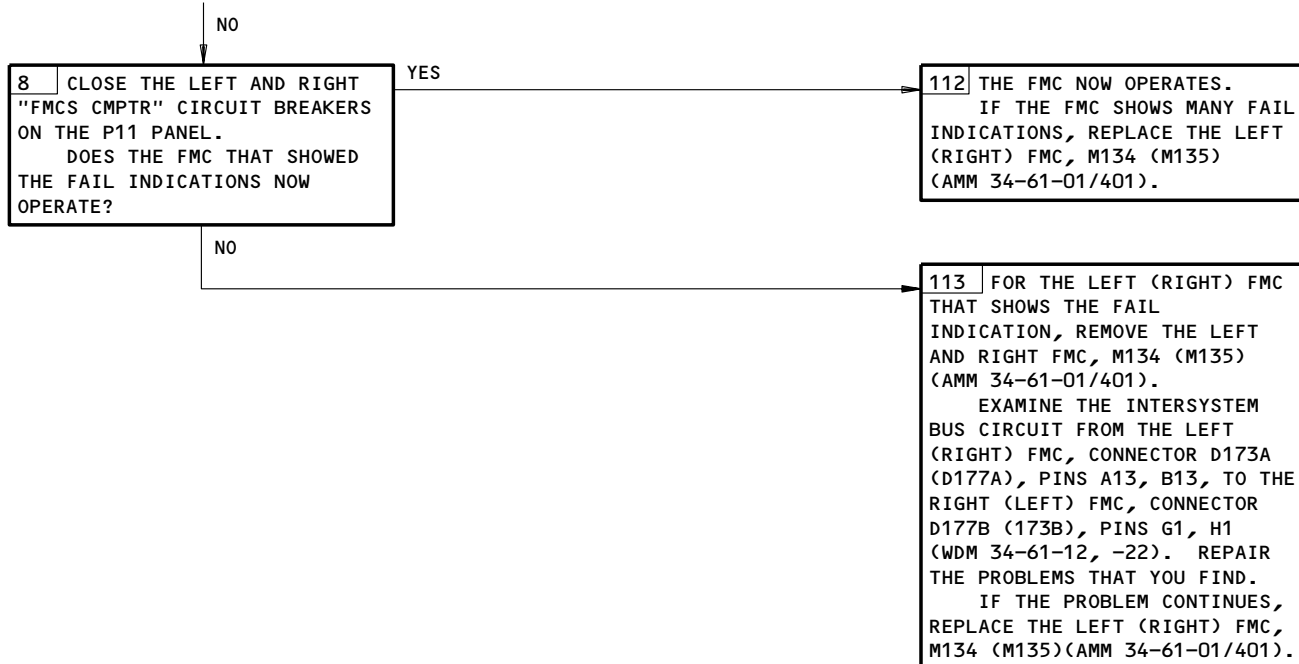

Flight Management Computer System BITE Procedure
Figure 109 (Sheet 5)

EFFECTIVITY	ALL
-------------	-----

34-61-00

PREREQUISITES

MAKE SURE THESE SYSTEMS WILL OPERATE:
 AUTOPILOT (MM 22-10-00/501)
 THRUST MANAGEMENT SYSTEM (MM 22-32-00/501)
 INERTIAL REFERENCE SYSTEM (MM 34-21-00/501)

MAKE SURE THESE CIRCUIT BREAKERS ARE CLOSED:
 11E8,11E9,11E29,11E30

MAKE SURE THE AIRPLANE IS IN THE CONFIGURATION THAT FOLLOWS:
 ELECTRICAL POWER IS ON (MM 24-22-00/201)

**VNAV PATH, ALTITUDE,
 TRANSITION; LNAV
 PATH, HEADING,
 TRANSITION ERROR**

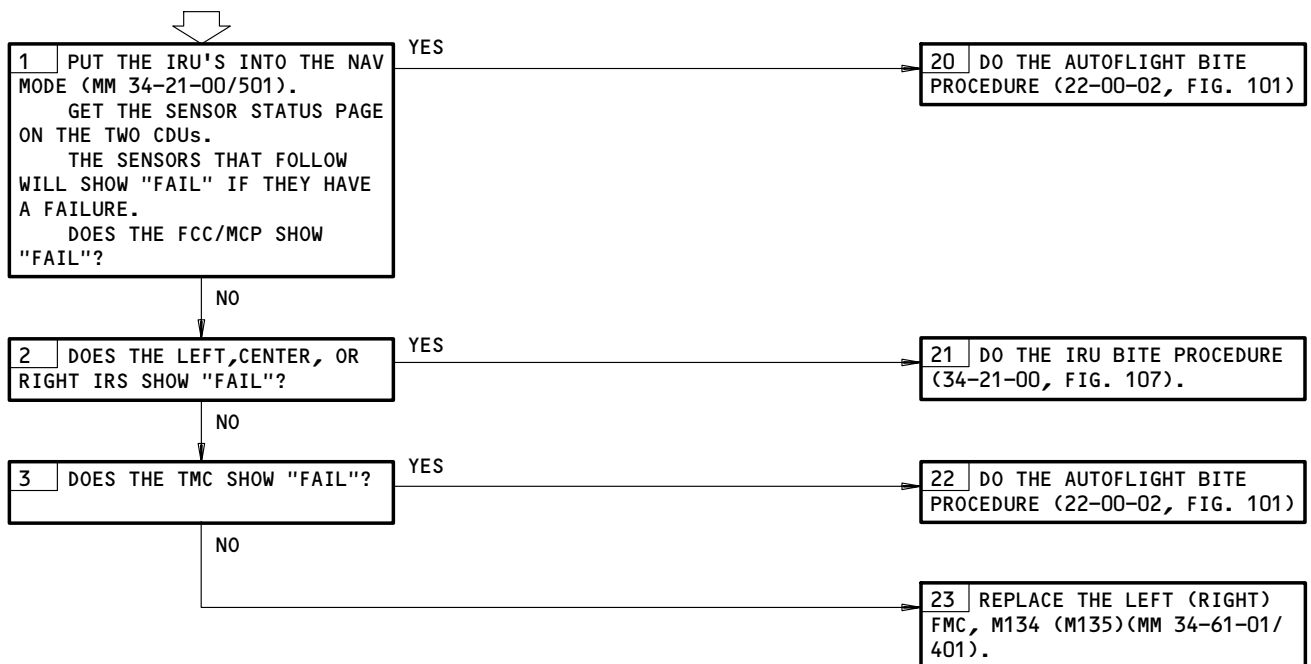

VNAV Path, Altitude, Transition, LNAV Path, Heading, Transition Error
 Figure 110

EFFECTIVITY	ALL
-------------	-----

34-61-00

FMC FAILURE CAUSED BY VOR/DME DATA ERROR

PREREQUISITES

MAKE SURE THESE SYSTEMS WILL OPERATE:
 AUTOPILOT (AMM 22-10-00/501)
 THRUST MANAGEMENT SYSTEM (AMM 22-32-00/501)
 INERTIAL REFERENCE SYSTEM (AMM 34-21-00/501)

MAKE SURE THESE CIRCUIT BREAKERS ARE CLOSED:
 11E8, 11E9, 11E29, 11E30

MAKE SURE THE AIRPLANE IS IN THIS CONFIGURATION:
 ELECTRICAL POWER IS ON (AMM 24-22-00/201)

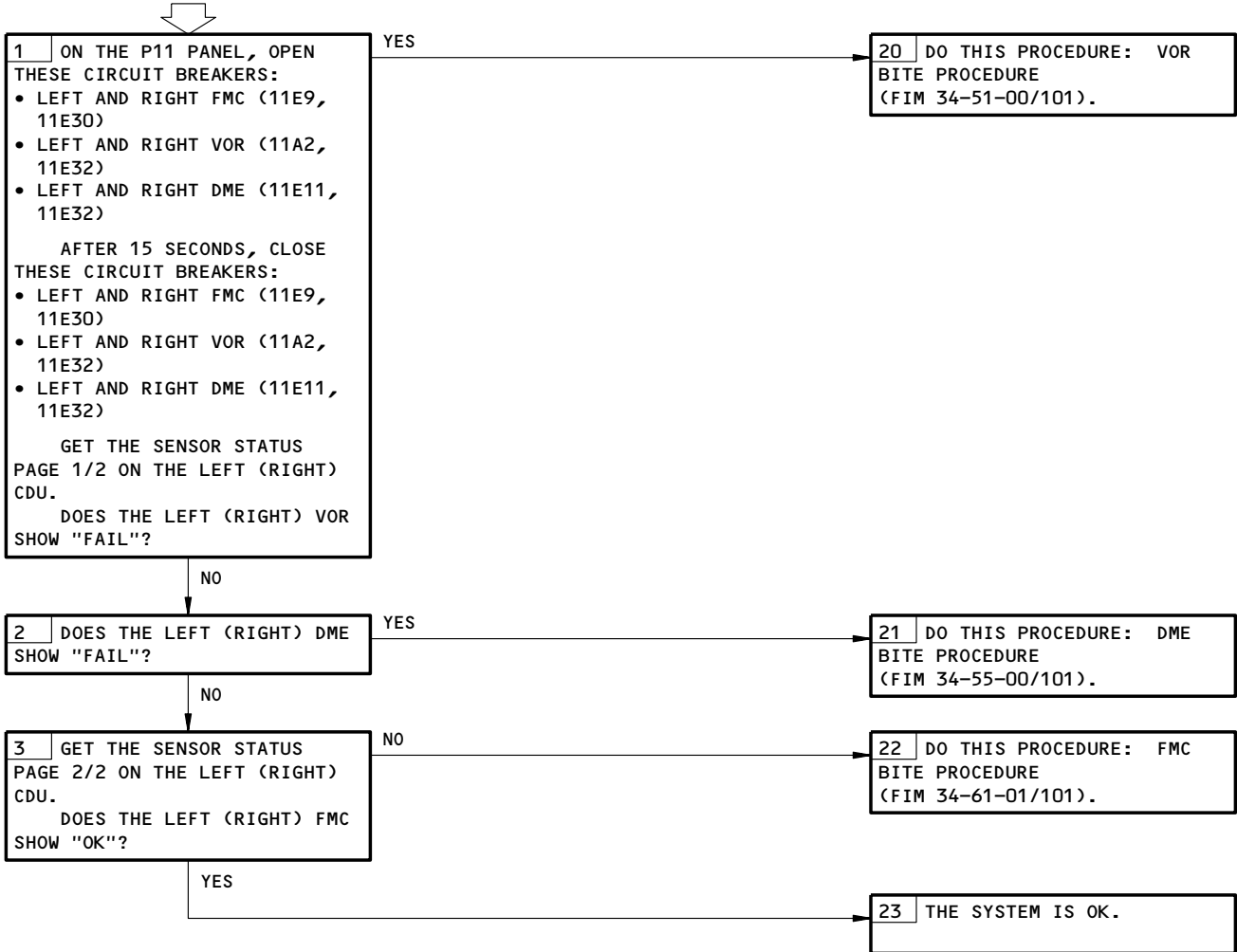

FMC Failure Caused by VOR/DME Data Error
Figure 110A

EFFECTIVITY	ALL
-------------	-----

34-61-00

**FMC NAV DATA
LOADING PROBLEMS
(THE TAPE TYPE PDL)**

PREREQUISITES

MAKE SURE THESE CIRCUIT BREAKERS ARE CLOSED:
11E8,11E9,11E29,11E30

MAKE SURE THE AIRPLANE IS IN THE CONFIGURATION THAT
FOLLOWS:
ELECTRICAL POWER IS ON (MM 24-22-00/201)

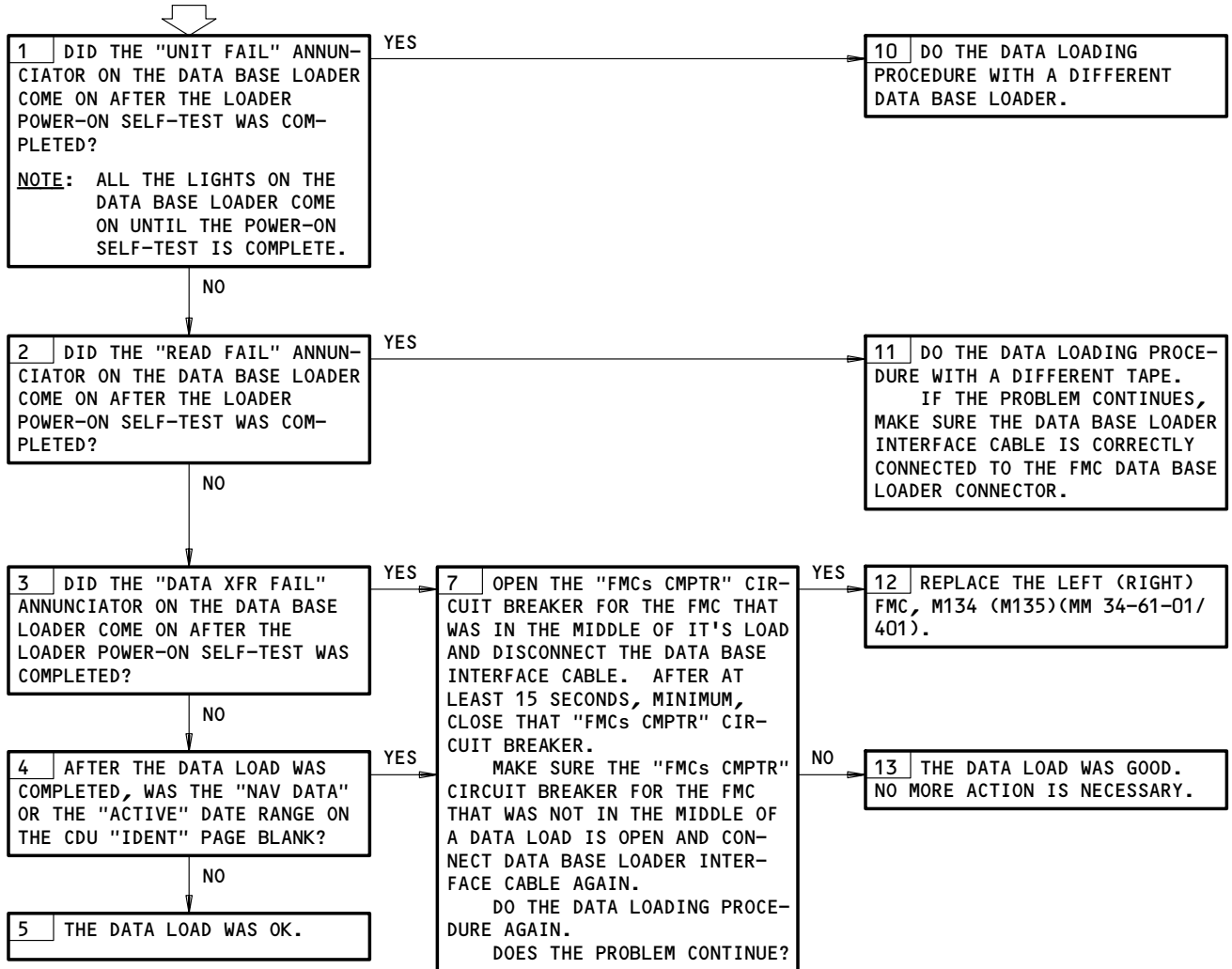

FMC Nav Data Loading Problems
Figure 111

EFFECTIVITY

ALL

34-61-00

1. ARINC Data Bus Charts

A. General

CAUTION: DO NOT DIRECTLY TOUCH THE CONNECTORS. USE A BREAKOUT BOX OR YOU CAN CAUSE DAMAGE TO THE CONNECTORS.

- (1) The ARINC 429 data bus charts give data necessary to make an analysis of ARINC 429 transmitters, receivers, and data buses. For the test, use a breakout box at the available terminal or at the LRU connector.

B. Equipment

- (1) Standard multi-meter
- (2) 429EBP Data Bus Analyzer (recommended)
JcAIR Instrumentation
400 Industrial Parkway
Industrial Airport, KS 66031
- 429-2 Data Bus Analyzer (alternative)
Interface Technology
150 E. Arrow Highway
San Dimas, CA 91773
- (3) A34011-1 Breakout Box (recommended)
A34011-112 Breakout Box (alternative)

NOTE: Octal label 315 is a multiple function label and will not display correctly in engineering units on the data bus analyzer unless hexadecimal equipment ID=02 is selected. For analyzers not capable of having ID selected, display the label in hexadecimal format and record the value. Set the data bus analyzer to transmit label 015 in hex format and insert the value recorded for label 315. Change label 015 format to engineering to display correct engineering units.

EFFECTIVITY

ALL

34-61-00

BOEING
 757
 FAULT ISOLATION/MAINT MANUAL

FMC							
DIGITAL OUTPUT BUS CHART							
BUS NAME			CON	PINS	BUS FORMAT	BIT RATE	DATA BUS
SOURCE	TYPE	BUS					
FMC (L R)	B	1	A	G09 H09	429	LO	FMC 1-GENERAL
FMC (L R)	C	2	B	D07 E07	429	LO	FMC 2-GENERAL
FMC (L R)	A	3	A	A13 B13	429	HI	FMC 3-INTERSYSTEM
FMC (L R)	D	4	A	A11 B11	429	HI	FMC 4-EFIS, GPWC
FMC (L R)	H	5	A	D13 E13	739	HI	FMC 5-MCDU
FMC (L R)	F	7	A	G11 H11	429	LO	FMC 7-DATA UPDATE
FMC (L R)	B	1	A	G09 H09	429	LO	FMC 1-GENERAL
FMC (L R)	C	2	B	D07 E07	429	LO	FMC 2-GENERAL
FMC (L R)	A	3	A	A13 B13	429	HI	FMC 3-INTERSYSTEM
FMC (L R)	D	4	A	A11 B11	429	HI	FMC 4-EFIS, GPWC
FMC (L R)	E	5	A	D13 E13	429	HI	FMC 5-ON-SIDE CDU
FMC (L R)	E	6	A	G13 H13	429	HI	FMC 6-OFF-SIDE CDU
FMC (L R)	F	7	A	G11 H11	429	LO	FMC 7-DATA UPDATE

EFFECTIVITY

ALL

34-61-00

BOEING
 757
 FAULT ISOLATION/MAINT MANUAL

FMC ID-002								
OCTAL LABELS CHART								
SIGNAL	TYPE	LABEL	FORMAT	MIN UPDATE RATE	SDI	BINARY RANGE	POSITIVE SENSE	UNITS
SYNCHRONISING DATA	A	TBS	BLK	TBS	00	TBS	N/A	TBS
DISTANCE TO GO-D	B	001	BCD	5	00	0-3999.9	ALWAYS POS	NM
VOR FREQUENCY-L	B	034	BCD	5	00	108-117.95	ALWAYS POS	MHZ
DME FREQUENCY-L	B	035	BCD	5	00	108-135.95	ALWAYS POS	MHZ
SET LATITUDE	B	041	BCD	2	N/A	± 90	NORTH	DEG: MIN
SET LONGITUDE	B	042	BCD	2	N/A	± 180	EAST	DEG: MIN
SET MAGNETIC HDG	B	043	BCD	2	00	0-359	CW FROM NORTH	DEG
GROSS WEIGHT	B	075	BNR	1	00	0-1310720	ALWAYS POS	LBS
TARGET AIRSPEED	B	077	BNR	5	00	± 512	ALWAYS POS	KNOTS
SELECTED ALTITUDE	B	102	BNR	5	00	± 65,536	ABOVE SEA LVL	FEET
SELECTED AIRSPEED	B	103	BNR	5	00	± 512	ALWAYS POS	KNOTS
SELECTED MACH	B	106	BNR	5	00	± 4.096	ALWAYS POS	MACH
WAYPOINT BEARING	B	115	BNR	10	00	± 180	CW FROM NORTH	DEG
HORIZTL STEERING	B	121	BNR	10	00	± 180	ROLL RIGHT	DEG
VERTICAL STEERING	B	122	BNR	10	00	± 180	PITCH UP	DEG
ASSUMED TEMP	B	213	BNR	5	00	± 512	ABOVE 0 DEG	DEG C
WRAP-AROUND TEST	B	266	BNR	N/A	00	N/A	N/A	N/A
FMC DISCRETES #1	B	270	DIS	5	00	N/A	N/A	N/A
FMC DISCRETES #2	B	271	DIS	5	XX	N/A	N/A	N/A

EFFECTIVITY

ALL

34-61-00



BOEING
757
FAULT ISOLATION/MAINT MANUAL

FMC ID-002								
OCTAL LABELS CHART								
SIGNAL	TYPE	LABEL	FORMAT	MIN UPDATE RATE	SDI	BINARY RANGE	POSITIVE SENSE	UNITS
VERT STEERING RATE	B	302	BNR	10	00	± 5	UP	DEG/SEC
INTERFACE MONITOR	B	350	DIS	1	00	N/A	N/A	N/A
FMC BITE DATA 1	B	351	DIS	1	00	N/A	N/A	N/A
FMC BITE DATA 2	B	352	DIS	1	00	N/A	N/A	N/A
FAULT DATA	B	356	BLK	1	00	N/A	N/A	N/A
INTERFACE CHK DATA	B	357	BLK	1	00	N/A	N/A	N/A
N1 TARGET	B	341	BNR	5	00	± 256	ALWAYS POS	%RPM
DISTANCE TO GO-D	C	001	BCD	5	00	0-3999.9	ALWAYS POS	NM
VOR FREQUENCY-R	C	034	BCD	5	00	108-117.95	ALWAYS POS	MHZ
DME FREQUENCY-R	C	035	BCD	5	00	108-135.95	ALWAYS POS	MHZ
SET LATITUDE	C	041	BCD	2	N/A	± 90	NORTH	DEG:MIN
SET LONGITUDE	C	042	BCD	2	N/A	± 180	EAST	DEG:MIN
SET MAGNETIC HDG	C	043	BCD	2	00	0-359	CW FROM NORTH	DEG
GROSS WEIGHT	C	075	BNR	1	00	0-1310720	ALWAYS POS	LBS
TARGET AIRSPEED	C	077	BNR	5	00	± 512	ALWAYS POS	KNOTS
SELECTED ALTITUDE	C	102	BNR	5	00	± 65,536	ABOVE SEA LVL	FEET
SELECTED AIRSPEED	C	103	BNR	5	00	± 512	ALWAYS POS	KNOTS
SELECTED MACH	C	106	BNR	5	00	± 4.096	ALWAYS POS	MACH

EFFECTIVITY

ALL

34-61-00



BOEING
757
FAULT ISOLATION/MAINT MANUAL

FMC ID-002								
OCTAL LABELS CHART								
SIGNAL	TYPE	LABEL	FORMAT	MIN UPDATE RATE	SDI	BINARY RANGE	POSITIVE SENSE	UNITS
WAYPOINT BEARING	C	115	BNR	10	00	± 180	CW FROM NORTH	DEG
HORIZTL STEERING	C	121	BNR	10	00	± 180	ROLL RIGHT	DEG
VERTICAL STEERING	C	122	BNR	10	00	± 180	PITCH UP	DEG
ASSUMED TEMP	C	213	BNR	5	00	± 512	ABOVE 0 DEG	DEG C
MIN MANEUVER SPEED	C	225	BNR	1	00	0-512	ALWAYS POS	KTS
EXTNSN/RETRCTN SPD	C	263	BNR	1	00	0-512	ALWAYS POS	KTS
MIN BUFFET SPEED	C	265	BNR	10	00	0-512	ALWAYS POS	KTS
WRAP-AROUND TEST	C	266	BNR	N/A	00	N/A	N/A	N/A
FMC DISCRETES #1	C	270	DIS	5	00	N/A	N/A	N/A
FMC DISCRETES #2	C	271	DIS	5	XX	N/A	N/A	N/A
INTERFACE MONITOR	C	350	DIS	1	00	N/A	N/A	N/A
FMC BITE DATA 1	C	351	DIS	1	00	N/A	N/A	N/A
FMC BITE DATA 2	C	352	DIS	1	00	N/A	N/A	N/A
FAULT DATA	C	356	BLK	1	00	N/A	N/A	N/A
N1 TARGET	C	341	BNR	5	00	± 256	ALWAYS POS	%RPM
DISTANCE TO GO-D	D	001	BCD	2	00	0-3999.9	ALWAYS POS	NM
GROUND SPEED-D	D	012	BCD	2	00	0-2000	ALWAYS POS	KNOTS
ETA	D	056	BCD	2	00	0-23:59.9	ALWAYS POS	HR:MIN
ROT/REF SPEED	D	072	BNR	1	00	0-512	ALWAYS POS	KTS

EFFECTIVITY

ALL

34-61-00



BOEING
757
FAULT ISOLATION/MAINT MANUAL

FMC ID-002								
OCTAL LABELS CHART								
SIGNAL	TYPE	LABEL	FORMAT	MIN UPDATE RATE	SDI	BINARY RANGE	POSITIVE SENSE	UNITS
DECISION SPEED	D	073	BNR	1	00	0-512	ALWAYS POS	KTS
DESIRED TRACK	D	114	BNR	20	00	± 180	CW FROM NORTH	DEG
CROSS TRACK DIST	D	116	BNR	20	00	± 128	RIGHT OF PATH	NM
VERTICAL DEVI	D	117	BNR	20	00	± 2048	ABOVE PATH	FEET
RANGE TO ALTITUDE	D	120	BNR	20	00	0-512	ALWAYS POS	NM
FMC DISCRETES #2	D	271	DIS	5	00	N/A	N/A	N/A
START DYNAMIC DATA	D	303	DIS	20	00	N/A	N/A	N/A
PRESENT POS-LAT	D	310	BNR	10	N/A	± 180	NORTH	DEG
PRESENT POS-LONG	D	311	BNR	10	N/A	± 180	EAST	DEG
GROUND SPEED	D	312	BNR	20	00	0-4096	ALWAYS POS	KNOTS
TRACK ANGLE TRUE	D	313	BNR	20	00	± 180	CW FROM NORTH	DEG
WIND SPEED	D	315	BNR	10	00	0-256	ALWAYS POS	KNOTS
WIND DIRECT TRUE	D	316	BNR	10	00	± 180	CW FROM NORTH	DEG
TRACK ANGLE-MAG	D	317	BNR	20	00	± 180	CW FROM NORTH	DEG
DRIFT ANGLE	D	321	BNR	20	00	± 180	DRIFT RIGHT	DEG
FLIGHT PATH ANGLE	D	322	BNR	20	00	± 180	UP	DEG
DISPLAY UPDATE ETC	E	TBS	TBS	TBS	N/A	TBS	N/A	TBS
DBL PROTCOL	F	TBS	TBS	TBS	N/A	TBS	N/A	TBS
TEXT TRANSFER	G	357	BLK	N/A	N/A	N/A	N/A	N/A

EFFECTIVITY

ALL

34-61-00

BOEING
 757
 FAULT ISOLATION/MAINT MANUAL

FMC ID-002								
OCTAL LABELS CHART								
SIGNAL	TYPE	LABEL	FORMAT	MIN UPDATE RATE	SDI	BINARY RANGE	POSITIVE SENSE	UNITS
DISPLAY UPDATE	H	MAL	BLK	N/A	N/A	N/A	N/A	N/A
FLIGHT PLAN	H	044	BLK	N/A	N/A	N/A	N/A	N/A
SUBSYSTEM IDENT	H	172	BCD	1	N/A	N/A	N/A	N/A
INITIAL WORD	H	244	BLK	N/A	N/A	N/A	N/A	N/A

EFFECTIVITY

ALL

34-61-00

BOEING
 757
 FAULT ISOLATION/MAINT MANUAL

FMC				
DISCRETE OCTAL LABELS/BIT CHART				
SIGNAL	OCTAL LABEL	BIT	ONE-STATE	ZERO-STATE
DME MODE 1	035	11	CODED	
DME MODE 2	035	12	CODED	
DME MODE 3	035	13	CODED	
ILS/VOR FREQ	035	14	ILS	VOR
A/T MACH MODE REQ	270	11	REQUESTED	NOT REQ
THRUST MODE REQ	270	12	REQUESTED	NOT REQ
A/T A/S MODE REQ	270	13	REQUESTED	NOT REQ
CLB MODE REQ	270	14	REQUESTED	NOT REQ
CON MODE REQ	270	15	REQUESTED	NOT REQ
CRZ MODE REQ	270	16	REQUESTED	NOT REQ
G/A MODE REQ	270	17	REQUESTED	NOT REQ
T/O MODE REQ	270	18	REQUESTED	NOT REQ
RATING 1 REQ	270	19	REQUESTED	NOT REQ
RATING 2 REQ	270	20	REQUESTED	NOT REQ
MESSAGE ANNUN	270	21	ON	OFF
DISPLAY ANNUN	270	22	ON	OFF
OFFSET ANNUN	270	23	ON	OFF
LAT TRAK CHG ALRTL	270	24	ALERT	NORMAL
LAT TRAK CHG ALRTR	270	25	ALERT	NORMAL
VERT TRAK CHG ALRT	270	26	ALERT	NORMAL

EFFECTIVITY

ALL

34-61-00



757
FAULT ISOLATION/MAINT MANUAL

FMC				
DISCRETE OCTAL LABELS/BIT CHART				
SIGNAL	OCTAL LABEL	BIT	ONE-STATE	ZERO-STATE
(SPARE)	270	27	1	0
IDLE THRUST REQ	270	28	REQUESTED	NOT REQ
THROTTLE DORMANT	270	29	REQUESTED	NOT REQ
ENGINE IDENT 1	271	11	CODED	
ENGINE IDENT 2	271	12	CODED	
ENGINE IDENT 3	271	13	CODED	
ENGINE IDENT 4	271	14	CODED	
ENGINE IDENT 5	271	15	CODED	
ENGINE IDENT 6	271	16	CODED	
ENGINE IDENT 7	271	17	CODED	
ENGINE IDENT 8	271	18	CODED	
ENGINE IDENT 9	271	19	CODED	
ENGINE IDENT 10	271	20	CODED	
(SPARE)	271	21	1	0
(SPARE)	271	22	1	0
(SPARE)	271	23	1	0
VSPEED OPER	271	24	OPER	INOPER
VPATH OPER	271	25	OPER	INOPER
(SPARE)	271	26	1	0
(SPARE)	271	27	1	0

EFFECTIVITY

ALL

34-61-00

BOEING
 757
 FAULT ISOLATION/MAINT MANUAL

FMC				
DISCRETE OCTAL LABELS/BIT CHART				
SIGNAL	OCTAL LABEL	BIT	ONE-STATE	ZERO-STATE
(SPARE)	271	28	1	0
(SPARE)	271	29	1	0
LANDING FLAP <20	272	12-11	00	
LANDING FLAP =20	272	12-11	01	
LANDING FLAP =25	272	12-11	10	
LANDING FLAP =30	270	12-11	11	
LEFT IRS	350	9	L IRS FAIL	NO FAIL
RIGHT IRS	350	10	R IRS FAIL	NO FAIL
CENTER IRS	350	11	C IRS FAIL	NO FAIL
LEFT DME	350	12	L DME FAIL	NO FAIL
RIGHT DME	350	13	R DME FAIL	NO FAIL
LEFT VOR	350	14	L VOR FAIL	NO FAIL
RIGHT VOR	350	15	R VOR FAIL	NO FAIL
ILS	350	16	ONS ILS FL	NO FAIL
LEFT ADC	350	17	L ADC FAIL	NO FAIL
RIGHT ADC	350	18	R ADC FAIL	NO FAIL
TMC	350	19	TMC FAIL	NO FAIL
MCP	350	20	MCP FAIL	NO FAIL
EFIS	350	21	EFISCP FAIL	NO FAIL
L FUEL FLOW	350	22	FFS1 FAIL	NO FAIL

EFFECTIVITY

ALL

34-61-00

BOEING
 757
 FAULT ISOLATION/MAINT MANUAL

FMC				
DISCRETE OCTAL LABELS/BIT CHART				
SIGNAL	OCTAL LABEL	BIT	ONE-STATE	ZERO-STATE
R FUEL FLOW	350	23	FFS2 FAIL	NO FAIL
C FUEL FLOW	350	24	FFS3 FAIL	NO FAIL
FUEL QUANTITY	350	25	FQS FAIL	NO FAIL
DIGITAL CLOCK	350	26	GMTCLOCK FL	NO FAIL
LOADER	350	27	DBLOADER FL	NO FAIL
SDP 175	351	11	PROCESSR FL	NO FAIL
PROGRAM RAM	351	12	RAM FAIL	NO FAIL
STEERING RAM	351	13	LSR FAIL	NO FAIL
PROM	351	14	PROM FAIL	NO FAIL
DISK	351	15	DISK FAIL	NO FAIL
HEARTBEAT MONITOR	351	16	HEARTBT FL	NO FAIL
FMC/CDU L INTRFACE	351	17	FMC/LCDU	NO FAIL
FMC/CDU R INTRFACE	351	18	FMC/RCDU	NO FAIL
INTERSYSTEM BUS	351	19	ISB FAIL	NO FAIL
429 TRANSMITTERS	351	20	XMTR FAIL	NO FAIL
429 RECEIVERS	351	21	RCVR FAIL	NO FAIL
BUFFER RAM	352	11	BUFF RAM FL	NO FAIL
PROM	352	12	PROM FAIL	NO FAIL
DISPLAY RAM	352	13	DSP RAM FL	NO FAIL
DISPLAY RAM HALF	352	14	DSP HALF FL	NO FAIL
CRT	352	15	CRT FAILURE	NO FAIL

EFFECTIVITY

ALL

34-61-00

BOEING
 757
 FAULT ISOLATION/MAINT MANUAL

FMC				
DISCRETE OCTAL LABELS/BIT CHART				
SIGNAL	OCTAL LABEL	BIT	ONE-STATE	ZERO-STATE
PROGRAM MEM SEQ	352	16	MEM SEQ FL	NO FAIL
HI VOLT POWER SUP	352	17	HVPS FAIL	NO FAIL

CDU								
DIGITAL OUTPUT BUS CHART								
BUS NAME				CON	PINS	BUS FORMAT	BIT RATE	DATA BUS
SOURCE	TYPE	BUS	CON					
FMCDU (L R)	A	1	D	08 09	429	LO	CDU	

EFFECTIVITY

ALL

34-61-00