



**BOEING**  
757  
FAULT ISOLATION/MAINT MANUAL

GPA Group plc

PAGE	DATE	CODE	PAGE	DATE	CODE	PAGE	DATE	CODE
CHAPTER 35 TAB			35-21-00					
			101	DEC 20/93	12			
			102	SEP 20/90	01			
OXYGEN			103	SEP 28/07	11			
			104	SEP 28/07	07			
EFFECTIVE PAGES			105	DEC 20/93	07			
SEE LAST PAGE OF LIST FOR			106	SEP 28/07	09			
NUMBER OF PAGES			107	SEP 28/07	03			
			108	SEP 28/07	03			
			109	SEP 28/07	03			
			110	BLANK				
35-CONTENTS								
1	SEP 28/99	GUI						
2	SEP 28/07	GUI						
35-HOW TO USE THE FIM								
1	SEP 20/98	01						
2	SEP 20/98	01						
3	SEP 28/99	01						
4	SEP 20/98	01						
5	SEP 20/98	01						
6	SEP 20/98	01						
35-INDEX								
1	JAN 28/00	03						
2	BLANK							
35-EICAS MESSAGES								
1	MAY 28/99	01						
2	MAR 20/91	01						
3	SEP 28/00	01						
4	BLANK							
35-FAULT CODE DIAGRAM								
1	JUN 20/96	01						
2	JUN 20/96	01						
3	JUN 15/87	02						
4	BLANK							
35-FAULT CODE INDEX								
1	SEP 20/08	03						
2	SEP 20/08	02						
35-BITE INDEX								
1	SEP 28/99	01						
2	SEP 28/99	01						
3	SEP 28/99	01						
4	BLANK							
35-11-00								
101	SEP 20/94	19						
102	SEP 20/94	09						
103	DEC 20/93	03						
104	SEP 20/94	01						
105	DEC 20/93	01						
106	BLANK							

R = REVISED, A = ADDED OR D = DELETED  
F = FOLDOUT PAGE  
32  
MAY 20/09

**D633N632**

CHAPTER 35  
EFFECTIVE PAGES  
PAGE 1  
LAST PAGE



757  
FAULT ISOLATION/MAINT MANUAL

CHAPTER 35 - OXYGEN

TABLE OF CONTENTS

<u>Subject</u>	Chapter Section <u>Subject</u>	<u>Page</u>	<u>Effectivity</u>
HOW TO USE THE FIM	35-HOW TO USE THE FIM	1	ALL
INDEX	35-INDEX	1	ALL
EICAS MESSAGES	35-EICAS MESSAGES	1	ALL
FAULT CODE DIAGRAMS	35-FAULT CODE DIAGRAM	1	ALL
FAULT CODE INDEX	35-FAULT CODE INDEX	1	ALL
BITE INDEX	35-BITE INDEX	1	ALL
<u>OXYGEN</u>	35-00-00		
<u>CREW</u>	35-10-00		
CREW OXYGEN SYSTEM	35-11-00		
Component Location		101	ALL
Component Index			
Component Location			
Fault Isolation			
EICAS Oxygen Pressure Indication is Abnormal (Fig. 103)		105	

## 35-CONTENTS



**BOEING**  
757  
FAULT ISOLATION/MAINT MANUAL

CHAPTER 35 - OXYGEN

TABLE OF CONTENTS

<u>Subject</u>	Chapter Section <u>Subject</u>	<u>Page</u>	<u>Effectivity</u>
<u>PASSENGER</u>	35-20-00		
PASSENGER OXYGEN SYSTEM	35-21-00		
Component Location		101	ALL
Component Index			
Component Location			
Fault Isolation			
Isolated Passenger Oxygen		105	
Mask(s) Deployed (Fig. 103)			
Passenger Oxygen Masks		106	
Deployed Automatically			
without Loss of Cabin			
Pressurization (Fig. 104)			
Passenger Oxygen Masks Did Not		108	
Drop Automatically (Fig. 105)			

## 35-CONTENTS

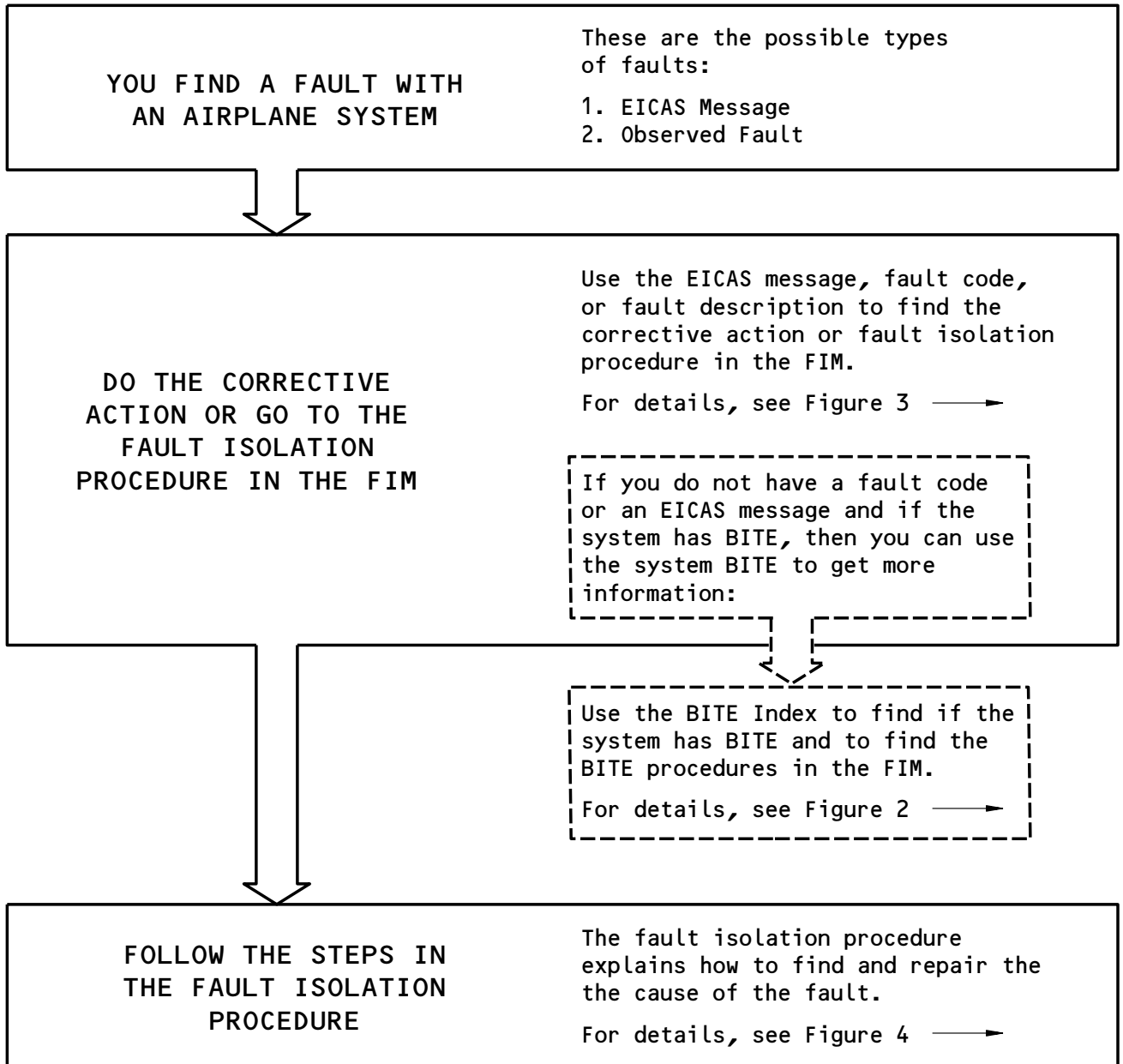

Basic Fault Isolation Process  
Figure 1

EFFECTIVITY

ALL

# 35-HOW TO USE THE FIM

01

Page 1  
Sep 20/98

H54411

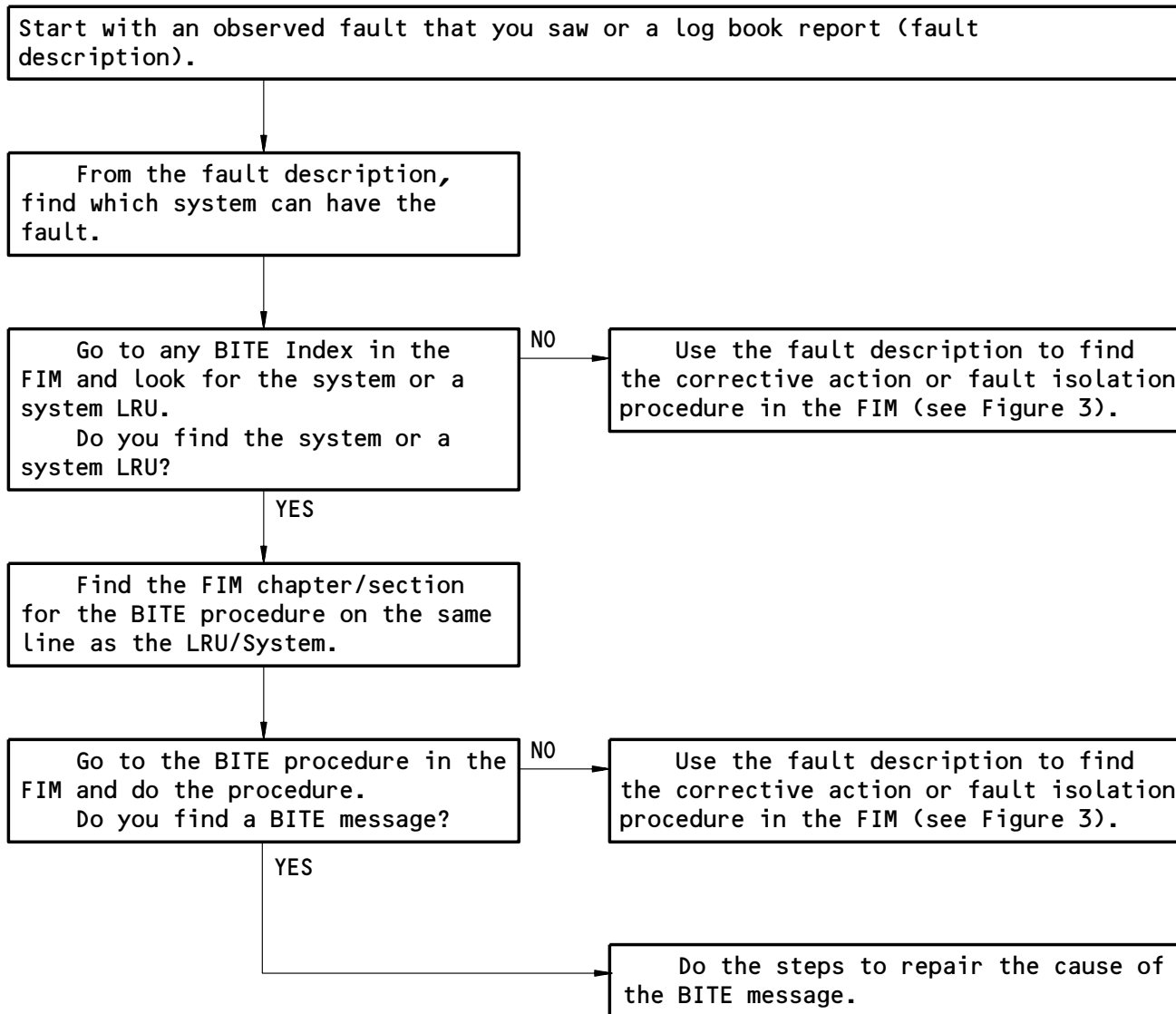

How to Get Fault Information from BITE  
Figure 2

EFFECTIVITY

ALL

## 35-HOW TO USE THE FIM

01

Page 2  
Sep 20/98

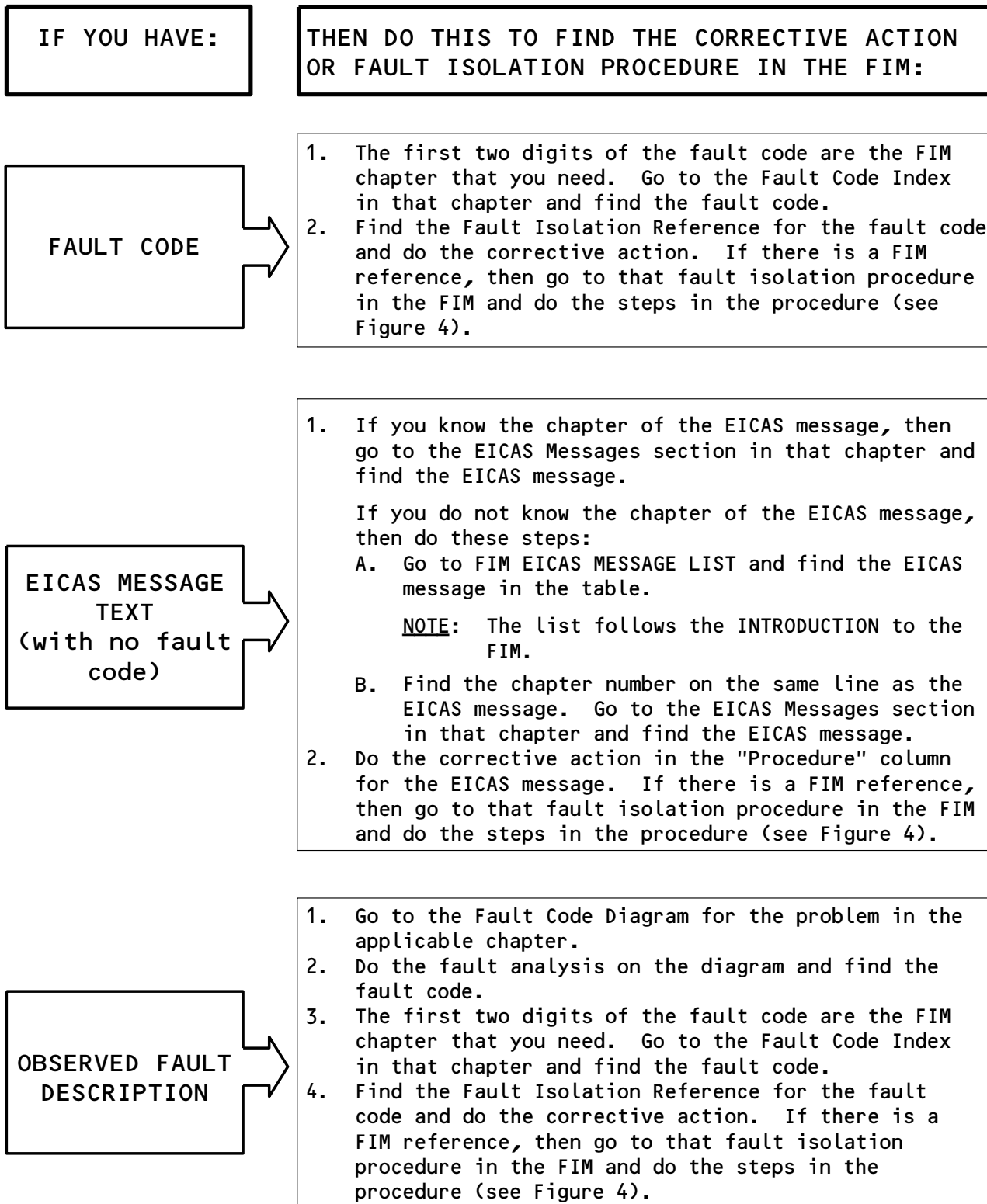

How to Find the Corrective Action or Fault Isolation Procedure in the FIM

Figure 3

EFFECTIVITY

ALL

## 35-HOW TO USE THE FIM

01

Page 3  
Sep 28/99

ASSUMED CONDITIONS AT START OF TASK

- External electrical power is OFF
- Hydraulic power and pneumatic power are OFF
- Engines are shut down
- Circuit breakers for the system are closed
- No equipment in the system is deactivated

PREREQUISITES

- This box gives the steps to get the airplane from the normal shutdown condition to the configuration necessary to do the fault isolation procedure.
- The Prerequisites give procedure references, circuit breakers, and special tools and equipment requirements.

FAULT ISOLATION BLOCKS

- Start the fault isolation procedure at block 1 unless specified differently.
- Do the check to get an answer to the question in the box. Follow the arrow that applies to your answer. This will go to the next check.
- When you get to a box in the column at the right of the page, you have isolated that fault. Do the steps in that box to repair the cause of the fault.
- Make sure that fault is corrected to complete the procedure.

Do the Fault Isolation Procedure  
Figure 4

EFFECTIVITY

ALL

**35-HOW TO USE THE FIM**

01

Page 4  
Sep 20/98

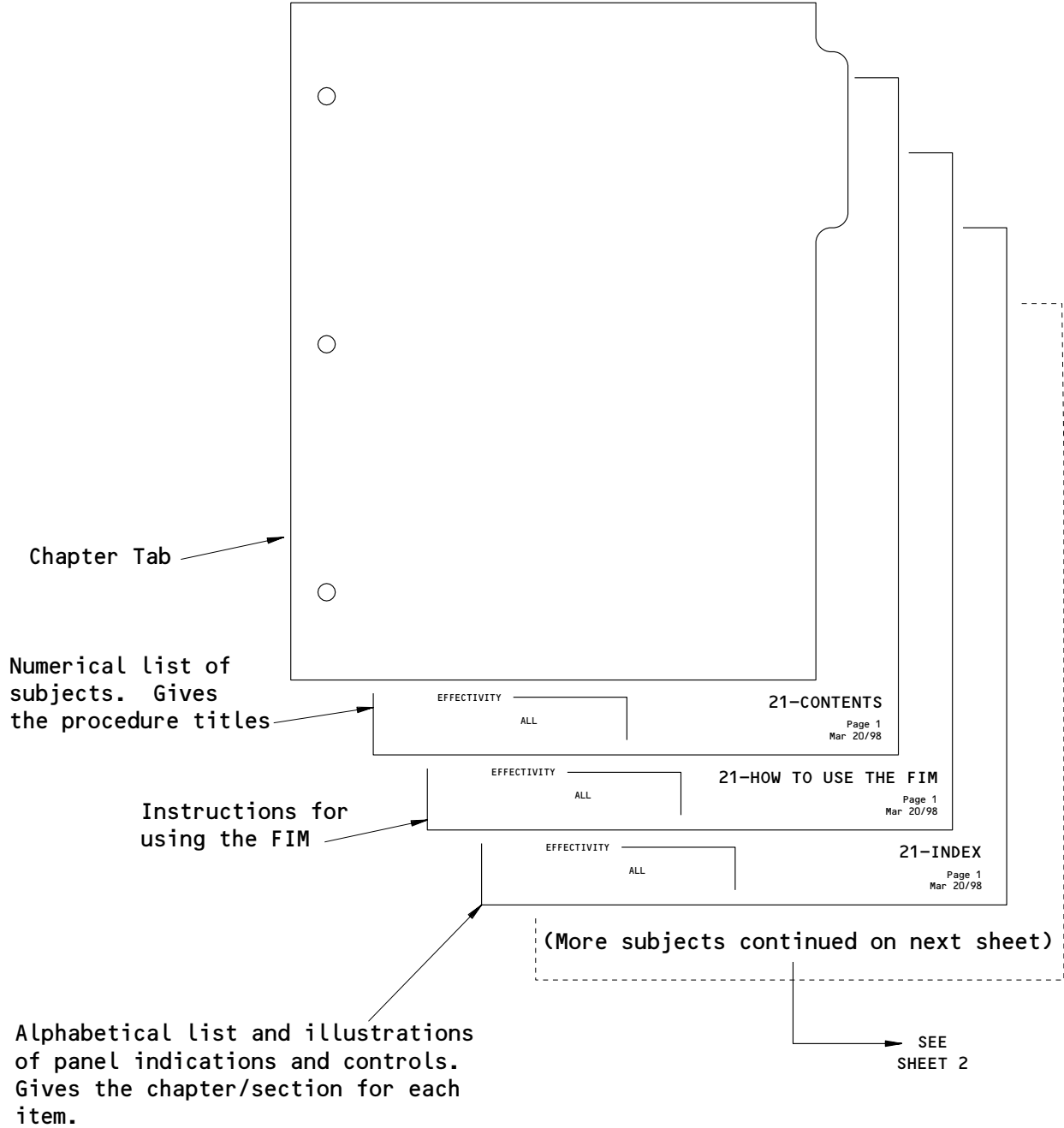

Subjects in Each FIM Chapter  
Figure 5 (Sheet 1)

<p>EFFECTIVITY</p> <hr/> <p align="center">ALL</p>	<p align="center"><b>35-HOW TO USE THE FIM</b></p> <p align="right">01</p> <p align="right">Page 5 Sep 20/98</p>
--	--



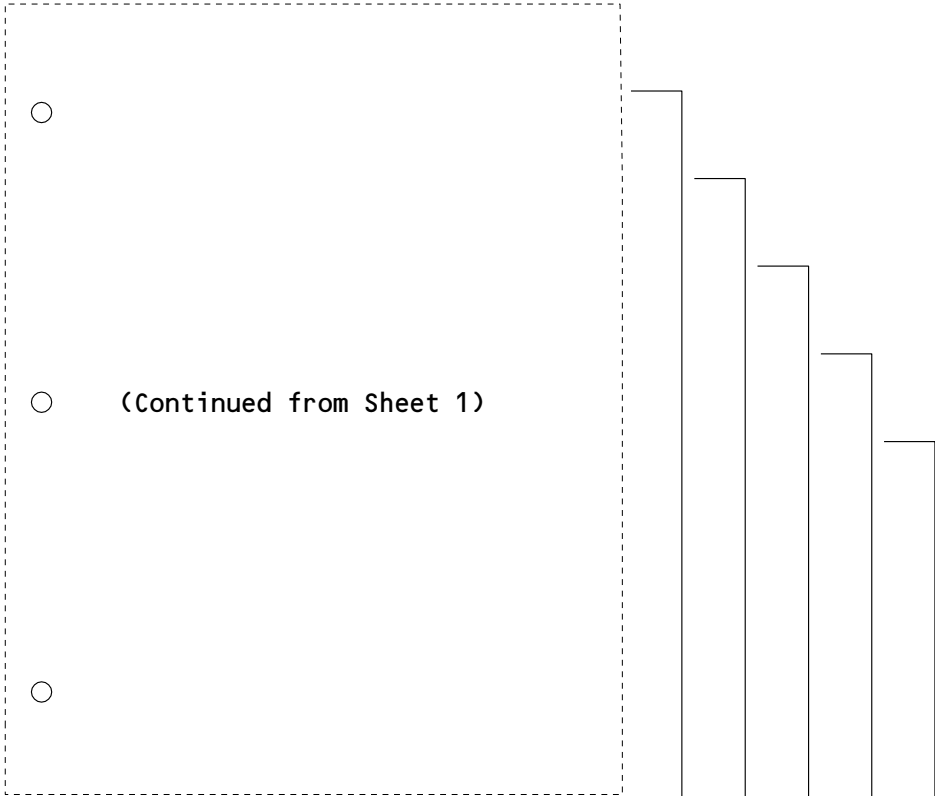

Alphabetical list of the EICAS messages. Gives the procedure to repair the cause of the message or a reference to a fault isolation procedure.

Failure analysis diagrams for the airplane systems to find the correct fault code for the fault.

Numerical list of fault codes. Gives the procedure to repair the cause of the fault or a reference to a fault isolation procedure.

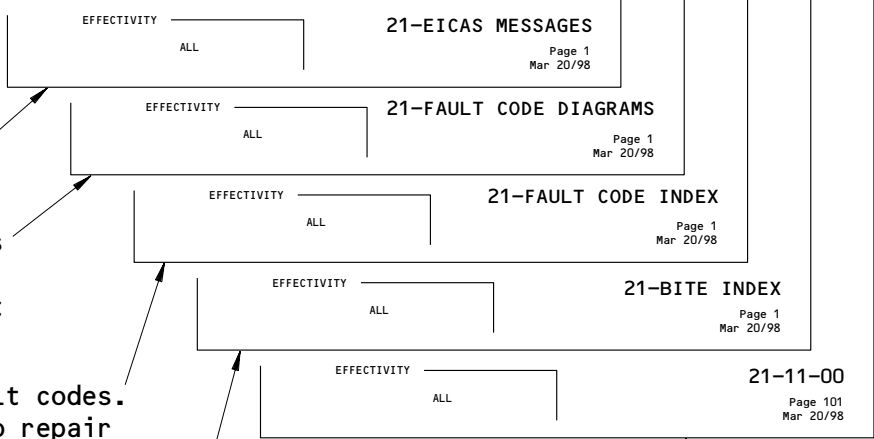

Alphabetical list of all the LRUs/systems that have BITE. Gives the chapter/section for the BITE procedure.

Component index, component location, and fault isolation procedures for the systems in the chapter.

Subjects in Each FIM Chapter  
Figure 5 (Sheet 2)

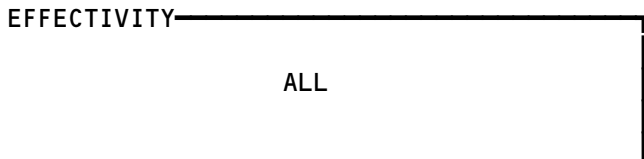

# 35-HOW TO USE THE FIM

EICAS MESSAGES

CHAP/SEC

PASS OXYGEN ON ..... 3521

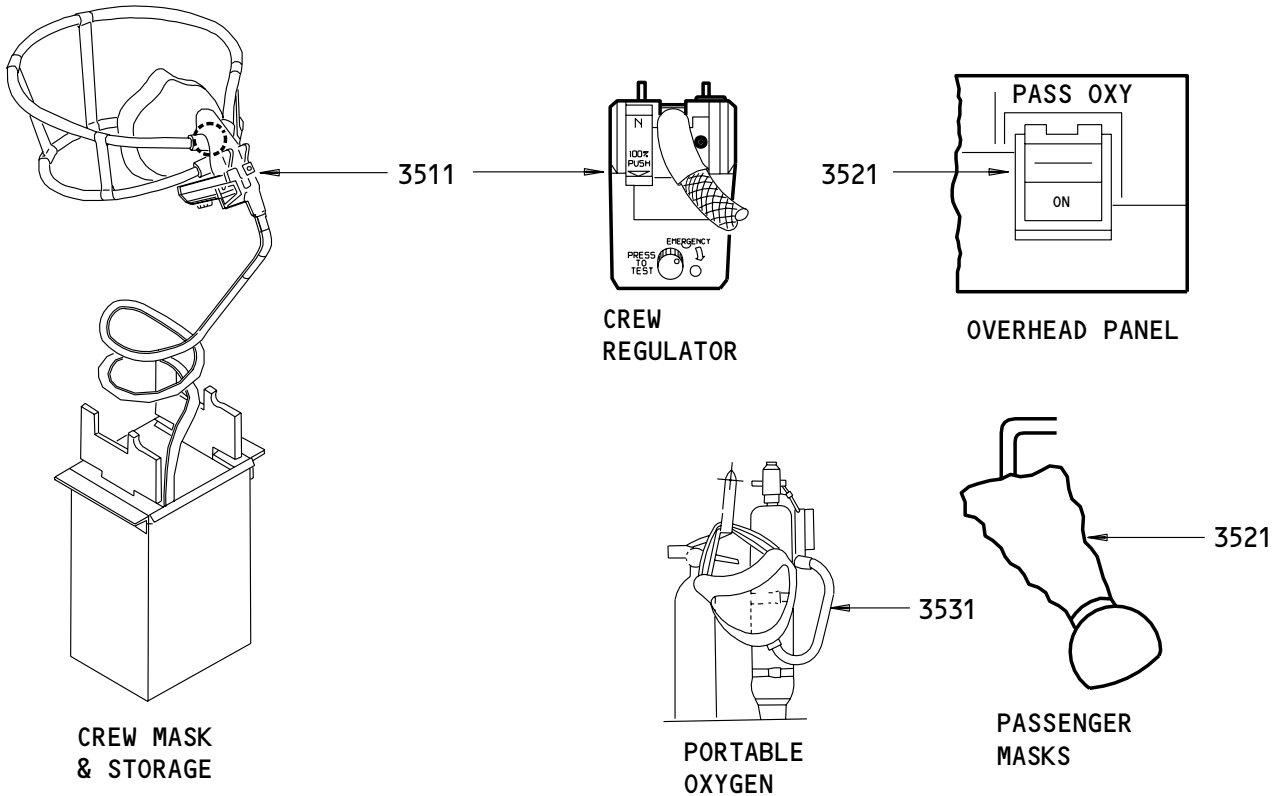

TITLE

CHAP/SEC

CREW OXYGEN MASK .....	3511
CREW OXYGEN REGULATOR .....	3511
PASSENGER OXYGEN ON LIGHT .....	3521
PASSENGER OXYGEN MASKS .....	3521
PORTABLE OXYGEN .....	3531

**OXYGEN - INDEX**

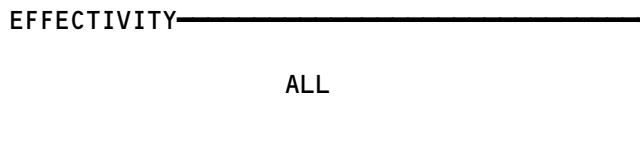

**35-INDEX**

OXYGEN - EICAS MESSAGE LIST

1. General

A. This procedure shows the EICAS message locations and gives a list of procedures to find the solution for each message.

(1) EICAS Message Locations (Fig. 1)

- (a) Figure 1 shows the location of the EICAS display units and the area where the messages show on the display units.
- (b) Each message level has a different location. The location and color of each message level is also shown.

(2) The EICAS MESSAGE LIST gives the message, level, and procedure for each message.

- (a) The EICAS MESSAGE column lists the messages alphabetically. Messages which start with L, R, or C are put together and alphabetized at L.
- (b) The LEVEL column gives all levels for each message as follows:
  - A - Warning messages
  - B - Caution messages
  - C - Advisory messages
  - S - Status messages
  - M - Maintenance messages
- (c) The PROCEDURE column gives the steps that are necessary to remove the message and includes one or more of the procedures that follow:
  - 1) A Fault Isolation Manual procedure reference
  - 2) A Maintenance Manual procedure and reference
  - 3) Wiring checks and a Wiring Diagram Manual reference
  - 4) A reference to an EICAS message list in a different chapter.
  - 5) A reference to a FAULT CODE INDEX and specified fault codes
  - 6) A step to change the airplane configuration

EFFECTIVITY

ALL

## 35-EICAS MESSAGES

01

Page 1  
May 28/99

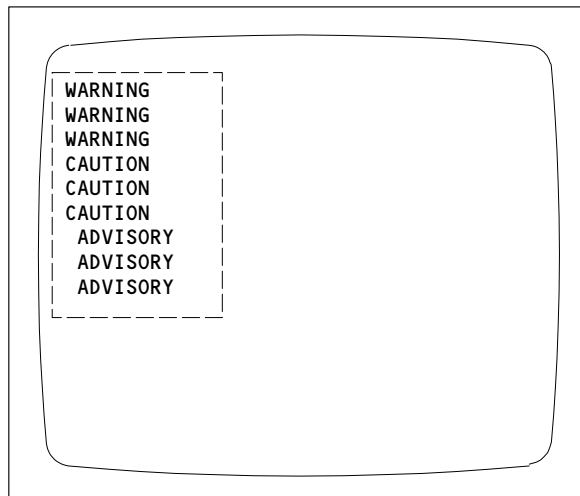
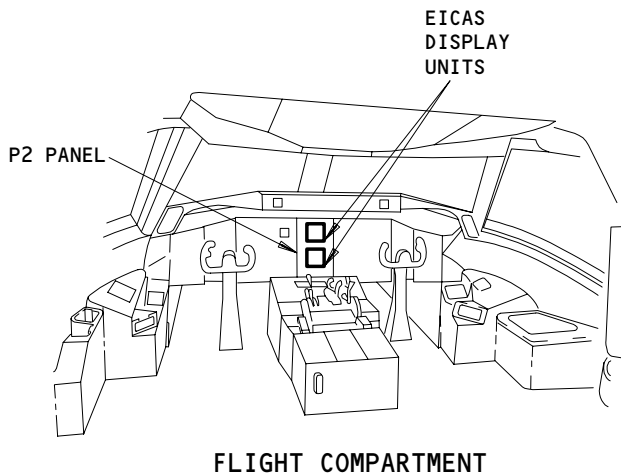

**BOEING**  
 757  
 FAULT ISOLATION/MAINT MANUAL

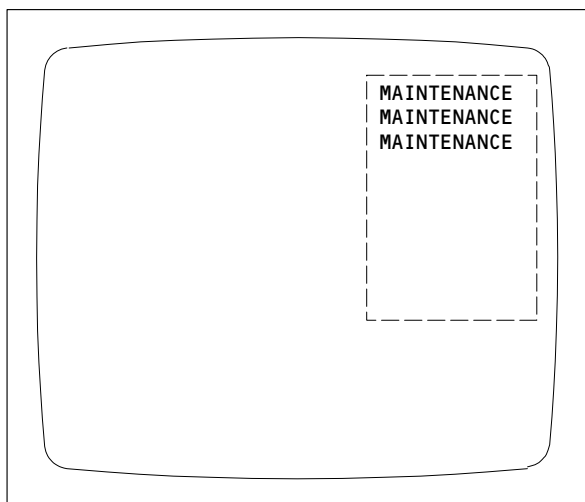

ENGINE PRIMARY PAGE OR COMPACTED PAGE  
(TOP DISPLAY UNIT)

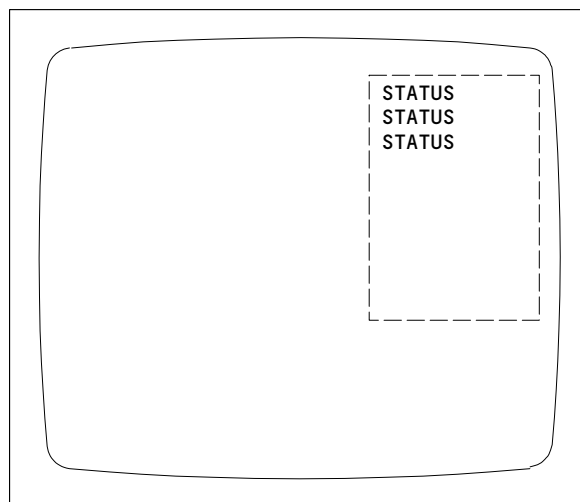

ECS/MSG PAGE  
(BOTTOM DISPLAY UNIT)



STATUS PAGE  
(BOTTOM DISPLAY UNIT)

LEVEL	COLOR
A-WARNING	RED
B-CAUTION	YELLOW
C-ADVISORY	YELLOW
S-STATUS	WHITE
M-MAINTENANCE	WHITE

EICAS Message Locations  
Figure 1

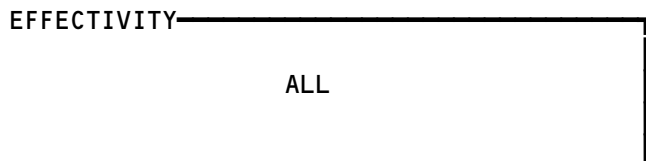

# 35-EICAS MESSAGES

**BOEING**  
 757  
 FAULT ISOLATION/MAINT MANUAL

EICAS MESSAGE LIST		
EICAS MESSAGE	LEVEL	PROCEDURE
PASS OXYGEN ON	C	1. Replace the altitude pressure switch S119 (WDM 35-21-11). 2. If the problem continues replace the oxygen control relay K4 (WDM 35-21-11).

EFFECTIVITY

ALL

## 35-EICAS MESSAGES

01

Page 3  
Sep 28/00

**BOEING**  
757  
FAULT ISOLATION/MAINT MANUAL

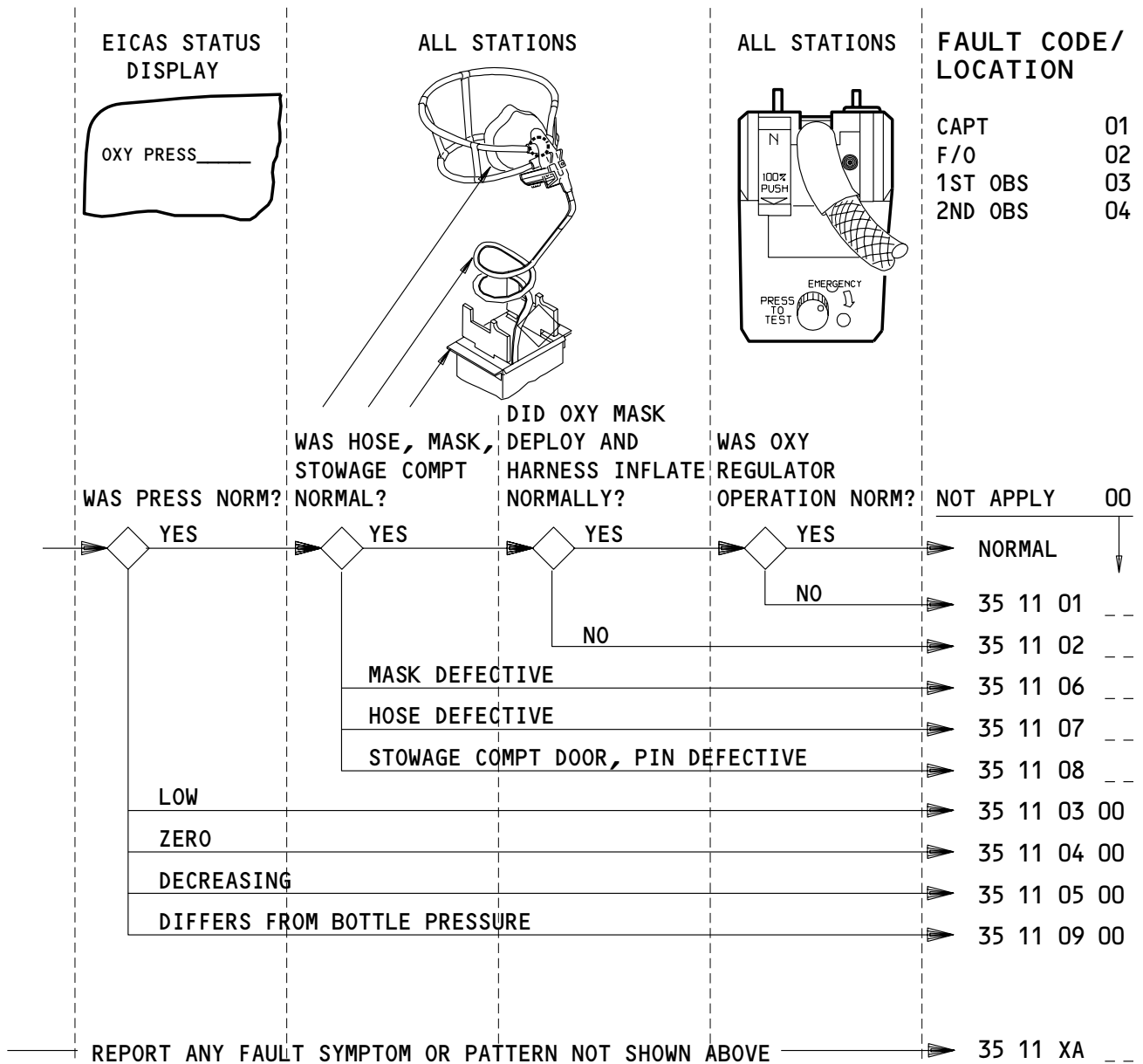

APPLICABLE CIRCUIT BREAKERS AS INSTALLED

11S31	OXYGEN PRESS
11S33	OXYGEN PRESS

**CREW OXYGEN – FAULT CODES**

EFFECTIVITY	ALL
-------------	-----

**35-FAULT CODE DIAGRAM**

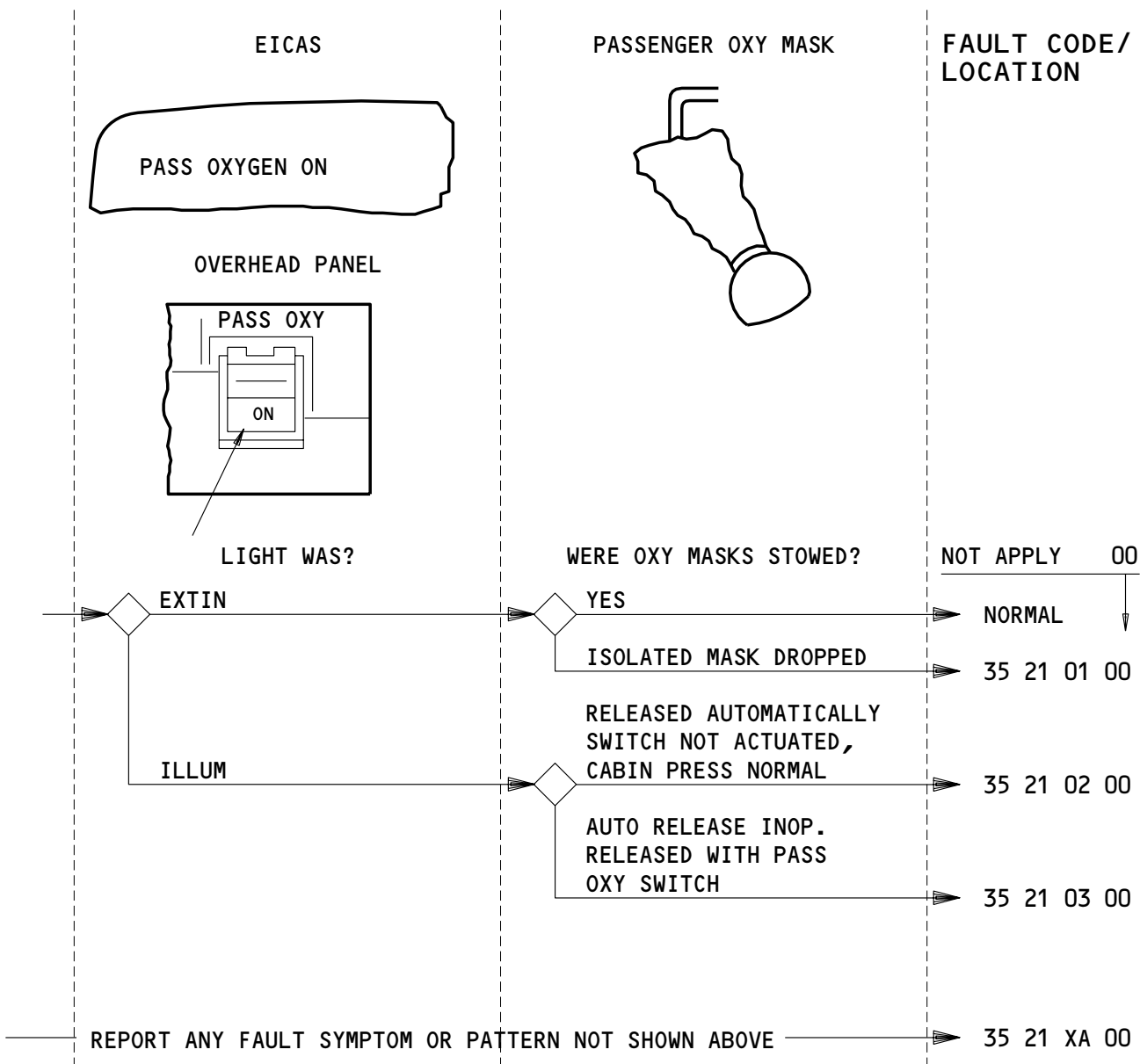

APPLICABLE CIRCUIT BREAKERS AS INSTALLED

11A21	PASSENGER OXYGEN LEFT		
11A21	PASSENGER OXYGEN L		
11A23	PASSENGER OXYGEN RIGHT	11A24	PASSENGER OXYGEN CONT
11A23	PASSENGER OXYGEN R	11A25	PASSENGER OXYGEN MANUAL DEPLOY

PASSENGER OXYGEN – FAULT CODES

EFFECTIVITY	ALL
-------------	-----

# 35-FAULT CODE DIAGRAM

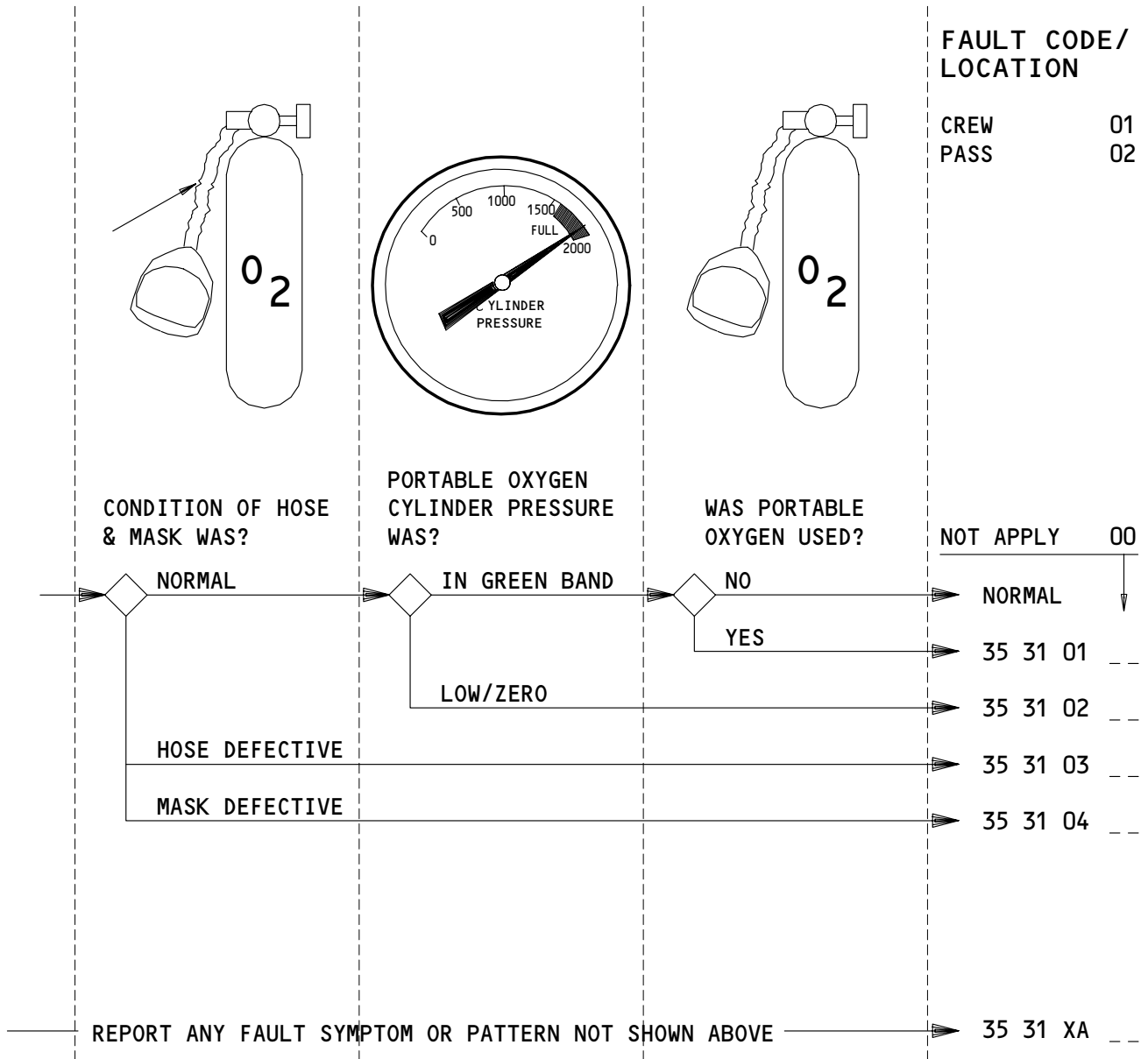

APPLICABLE CIRCUIT BREAKERS

NONE

PORTABLE OXYGEN - FAULT CODES

EFFECTIVITY

ALL

# 35-FAULT CODE DIAGRAM

02

Page 3  
Jun 15/87





**BOEING**  
757  
FAULT ISOLATION/MAINT MANUAL

FAULT CODE	LOG BOOK REPORT	FAULT ISOLATION REFERENCE
35 11 XA --	(01=CAPT,02=F/O,03=1ST OBS, 04=2ND OBS) Crew oxygen problem was encountered by the flight crew which is not covered in the fault code diagrams.	SSM 35-11-01
35 21 XA 00	Passenger oxygen problem was encountered by the flight crew which is not covered in the fault code diagrams.	SSM 35-21-01
35 31 XA --	(01=CREW,02=PASS) portable oxygen problem was encountered by the flight crew which is not covered in the fault code diagrams.	SSM 35-31-01
35 11 01 --	(01=CAPT,02=F/O,03=1ST OBS, 04=2ND OBS) Oxygen regulator operation (difficult to exhale, no pressure breathing available, leaking).	Replace the oxygen mask/regulator (AMM 35-11-00).
35 11 02 --	(01=CAPT,02=F/O,03=1ST OBS, 04=2ND OBS) Oxygen mask (difficult to release from stowage, harness fails to flate, harness leaking, harness fails to deflate).	Replace the oxygen mask/regulator (AMM 35-11-00).
35 11 06 --	(01=CAPT,02=F/O,03=1ST OBS, 04=2ND OBS) Oxygen mask defective (describe).	Replace the oxygen mask (AMM 35-11-00).
35 11 07 --	(01=CAPT,02=F/O,03=1ST OBS, 04=2ND OBS) Oxygen mask hose defective (describe).	Replace the oxygen mask hose (AMM 35-11-00).
35 11 08 --	(01=CAPT,02=F/O,03=1ST OBS, 04=2ND OBS) Oxygen mask panel (door, pin, etc) defective (describe).	Replace the oxygen mask panel (door, pin, etc)(AMM 35-11-00).
35 11 03 00	Crew oxygen pressure is low. OXY PRESS _____.	FIM 35-11-00/101, Fig. 103, Block 1
35 11 04 00	Crew oxygen pressure is zero. PRESS _____.	FIM 35-11-00/101, Fig. 103, Block 1

EFFECTIVITY

ALL

## 35-FAULT CODE INDEX

03

Page 1  
Sep 20/08

**BOEING**  
 757  
 FAULT ISOLATION/MAINT MANUAL

FAULT CODE	LOG BOOK REPORT	FAULT ISOLATION REFERENCE
35 11 05 00	Crew oxygen pressure is decreasing. EICAS status parameters displayed, OXY PRESS _____.	FIM 35-11-00/101, Fig. 103, Block 1
35 11 09 00	EICAS OXY PRESS differs from bottle press. EICAS OXY PRESS _____ psi. Bottle press _____ psi.	Open and then close this circuit breaker. (a) 11S31, OXYGEN PRESS If the problem continues, replace the oxygen cylinder (AMM 35-11-00). If the problem still continues, replace the pressure transducer (WDM 35-11-13).
35 21 01 00	Passenger mask(s) dropped (specify location or seat number).	FIM 35-21-00/101, Fig. 103, Block 1
35 21 02 00	EICAS msg PASS OXYGEN ON displayed, pass oxy ON light on and all masks dropped automatically. Switch not actuated, cabin pressurization was normal.	FIM 35-21-00/101, Fig. 104, Block 1
35 21 03 00	PASS OXY ON light on, masks failed to drop automatically. Masks dropped after actuation of PASS OXY switch. EICAS message displayed, PASS OXYGEN ON.	FIM 35-21-00/101, Fig. 105, Block 1
35 31 01 --	(01=Crew,02=Pass) Portable oxygen was used (specify location).	Replace the portable oxygen unit (AMM 35-00-00).
35 31 02 --	(01=Crew,02=Pass) Portable oxygen cylinder press is (low, zero)(specify location).	Replace or recharge the portable oxygen cylinder (AMM 35-00-00).
35 31 03 --	(01=Crew,02=Pass) Portable oxygen cylinder hose is defective (specify location).	Replace the hose and mask assembly (AMM 35-00-00).
35 31 04 --	(01=Crew,02=Pass) Portable oxygen cylinder mask is defective (specify location).	Replace the hose and mask assembly (AMM 35-00-00).

EFFECTIVITY

ALL

## 35-FAULT CODE INDEX

02

Page 2  
Sep 20/08

**BITE Index**

**1. General**

- A. Use this index to find the BITE procedure for the applicable LRU/System.
- B. The BITE procedure will provide the fault isolation instructions for the fault indications/LRU maintenance messages.

<u>LRU/System Name</u>	<u>Acronym</u>	<u>FIM Reference</u>
Air Data Computer	ADC	34-12
Air Data Inertial Reference Unit	ADIRU	34-26
Air Traffic Control Transponder	ATC	34-53
Airborne Vibration Monitor Signal Conditioner	AVM	77-31
Antiskid/Autobrake Control Unit		32-42
APU Fire Detection System		26-15
Automatic Direction Finder Receiver	ADF	34-57
APU Control Unit	ECU	49-11
Brake Temperature Monitor Unit		32-46
Bus Power Control Unit	BPCU	24-20
Cabin Pressure Controller		21-30
Digital Flight Data Acquisition Unit	DFDAU	31-31
Distance Measuring Equipment Interrogator	DME	34-55
Duct Leak (Wing and Body)		26-18
E/E Cooling Control Card (If cards installed)		21-58
ECS Bleed Configuration Card		36-10
Electronic Engine Control (RR Engines)	EEC	73-21
Electronic Engine Control Monitor Unit (PW Engines)	EECM	71-EPCS Message Index
Electronic Flight Instrument System	EFIS	34-22
Electronic Propulsion Control System (PW Engines)	EPCS	71-EPCS Message Index
Engine Fire/Overheat Detection System		26-11
Engine Indication and Crew Alerting System Computer	EICAS	31-41

Bite Index  
Figure 1 (Sheet 1)

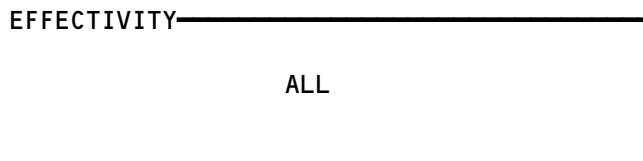

# 35-BITE INDEX

**BOEING**  
 757  
 FAULT ISOLATION/MAINT MANUAL

<u>LRU/System Name</u>	<u>Acronym</u>	<u>FIM Reference</u>
Engine Turbine Cooling Overheat Detection System (RR Engines)		26-13
Enhanced Ground Proximity Warning Computer	EGPWC	34-46
Flap/Slat Accessory Module	FSAM	27-51
Flap/Slat Electronic Unit	FSEU	27-51
Flight Management Computer	FMC	34-61
Fuel Quantity Indicating System Processor	FQIS	28-41
Ground Proximity Warning Computer	GPWC	34-46
HF (High Frequency) Communication		23-11
Inertial Reference Unit	IRU	34-21
Instrument Comparator Unit	ICU	34-25
Instrument Landing System Receiver	ILS	34-31
Lower Cargo Compartment Smoke Detection System		26-16
Maintenance Control Display Panel	MCDP	22-00
PA (Passenger Address) Amplifier		23-31
Pack Standby Temperature Controller		21-51
Pack Temperature Controller		21-51
Passenger Entertainment System	PES	23-34
Power Supply Module (Control System Electronics Units)	PSM	27-09
Propulsion Discrete Interface Unit (PW Engines)	PDIU	73-21
Proximity Switch Electronics Unit	PSEU	32-09
Radio Altimeter Transmitter/Receiver	RA	34-33
Rudder Ratio Changer Module	RRCM	27-09
Spoiler Control Module	SCM	27-09
Stabilizer Position Module	SPM	27-48
Stabilizer Trim/Elevator Asymmetry Limit Module	SAM	27-09
Stall Warning Computer/Module (in Warning Electronic Unit)	SWC	27-32
Strut Overheat Detection System (RR Engines)		26-12

Bite Index  
Figure 1 (Sheet 2)

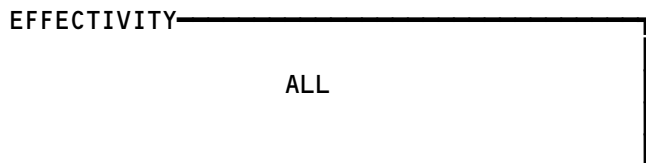

## 35-BITE INDEX

**BOEING**  
 757  
 FAULT ISOLATION/MAINT MANUAL

<u>LRU/System Name</u>	<u>Acronym</u>	<u>FIM Reference</u>
Thrust Management Computer/Autothrottle	TMC	22-00
Traffic Alert and Collision Avoidance Computer	TCAS	34-45
VHF (Very High Frequency) Communication		23-12
VOR/Marker Beacon Receiver	VOR/MKR	34-51
Warning Electronic Unit BITE Module (Stall Warning)	WEU	27-32
Weather Radar Transceiver	WXR	34-43
Wheel Well Fire Detection		26-17
Window Heat Control Unit	WHCU	30-41
Yaw Damper Module	YDM	22-21
Yaw Damper/Stabilizer Trim Module	YSM	27-09
Zone Temperature Controller		21-60

Bite Index  
Figure 1 (Sheet 3)

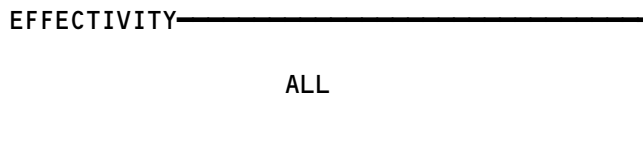





## 35-BITE INDEX

01

Page 3  
Sep 28/99

**BOEING**  
757  
FAULT ISOLATION/MAINT MANUAL

CREW OXYGEN

COMPONENT	FIG. 102 SHT	QTY	ACCESS/AREA	AMM REFERENCE
CIRCUIT BREAKER - OXYGEN PRESSURE, C1320	2	1	FLIGHT COMPARTMENT, P11 11S31	*
CIRCUIT BREAKER - OXYGEN PRESSURE IND, C4220 	2	1	FLIGHT COMPARTMENT, P34 34B2	*
CYLINDER - CREW OXYGEN	1	1	821, AFT OF THE NO. 1 CARGO DOOR	35-11-00
FILLER VALVE 	1	1	821, ON THE OXYGEN FILL PANEL	35-11-12
INDICATORS - OXYGEN PRESSURE (CYLINDER)	1	1	821, AFT OF THE NO. 1 CARGO DOOR	35-11-00
OXYGEN PRESSURE (EXTERNAL FILL PANEL) 	1	1	821, ON THE OXYGEN FILL PANEL	35-11-05
MASK/REGULATOR	2	4	FLIGHT COMPARTMENT	35-11-00
REGULATOR - PRESSURE	1	1	821, AFT OF THE NO. 1 CARGO DOOR	35-11-03
RELAY - (FIM 31-01-37/101) GROUND HANDLING POWER TRANSFER, K10277 	1	1		
TRANSDUCER - PRESSURE, TS120	1	1	821, AFT OF THE NO. 1 CARGO DOOR	35-11-00
VALVE - CREW OXYGEN SHUTOFF	3	1	FLIGHT COMPARTMENT	35-11-02

\* SEE THE WDM EQUIPMENT LIST

 GUI 115

Crew Oxygen - Component Index  
Figure 101

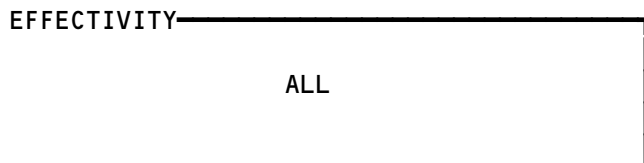

**35-11-00**

**BOEING**  
757  
FAULT ISOLATION/MAINT MANUAL

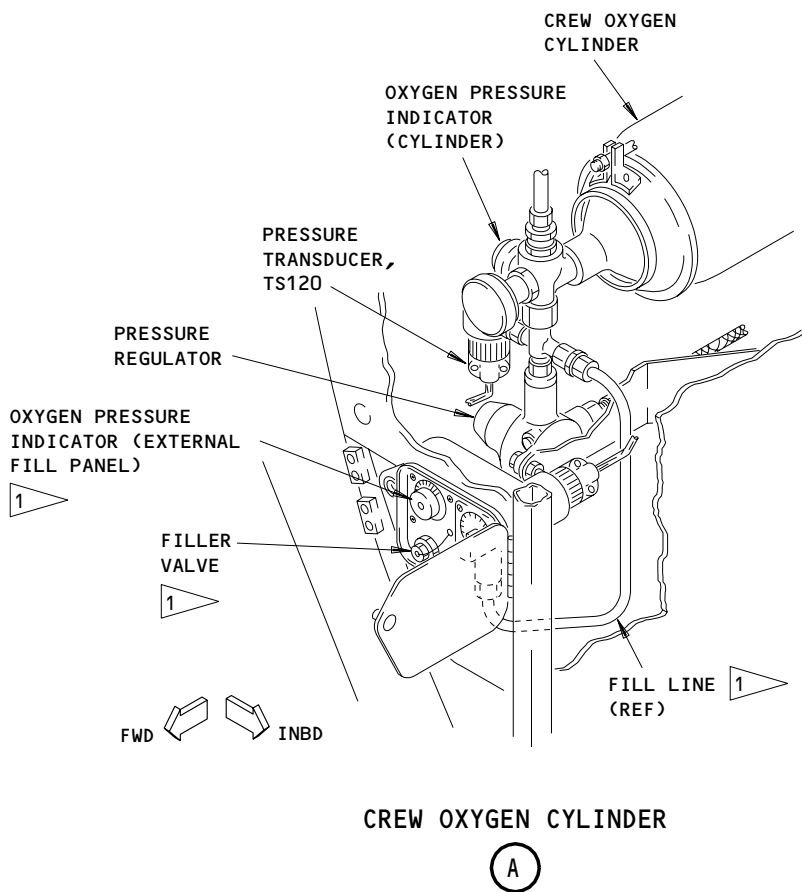
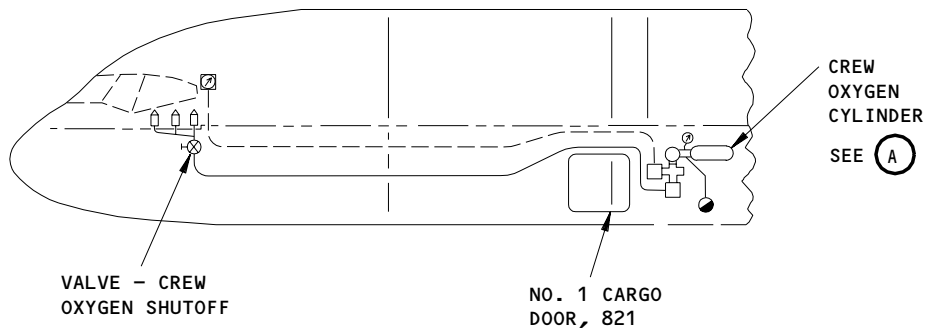

1 GUI 115

Crew Oxygen - Component Location  
Figure 102 (Sheet 1)

EFFECTIVITY	
ALL	

35-11-00

**BOEING**  
757  
FAULT ISOLATION/MAINT MANUAL

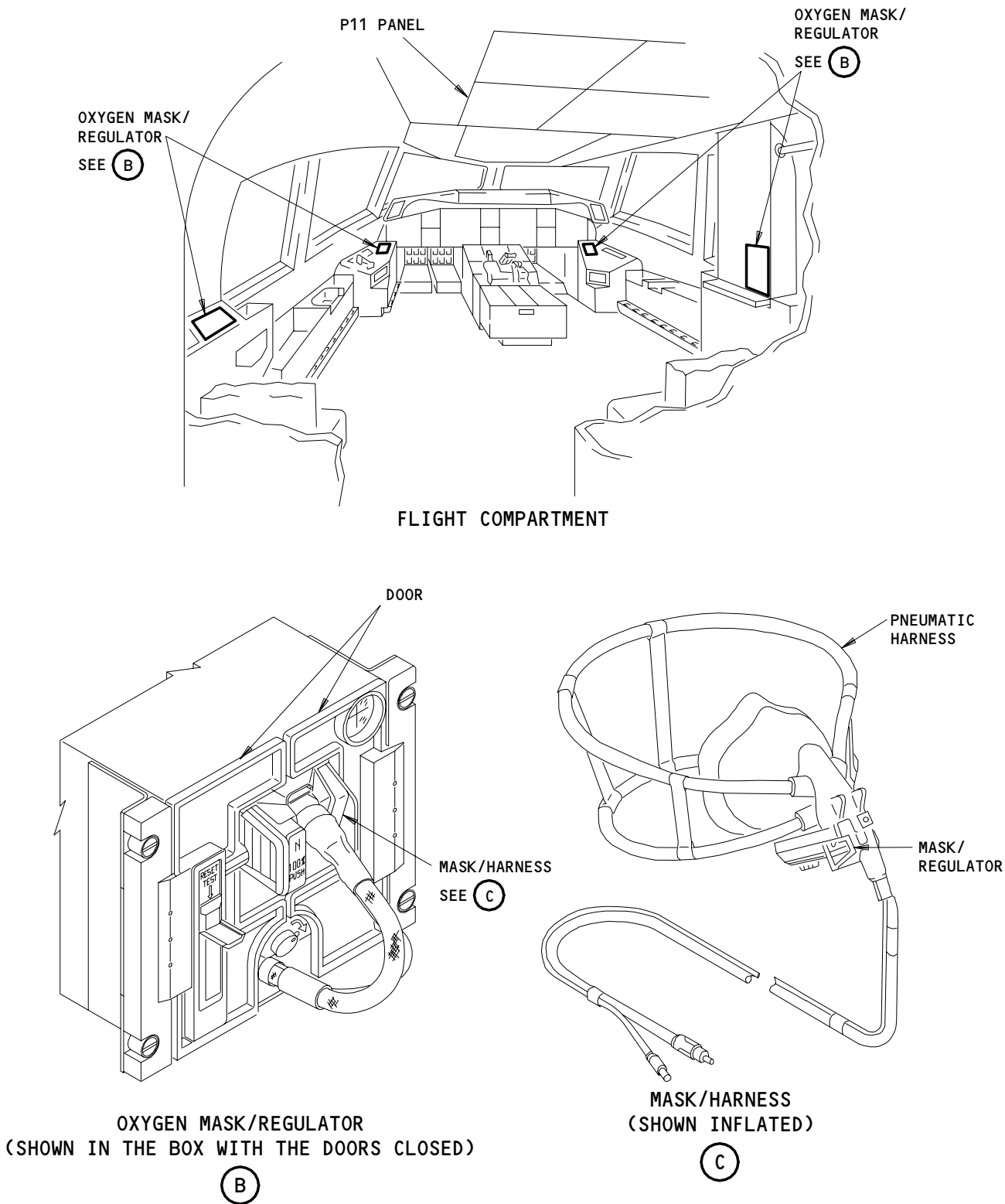

Crew Oxygen - Component Location  
Figure 102 (Sheet 2)

EFFECTIVITY	
	ALL

**35-11-00**



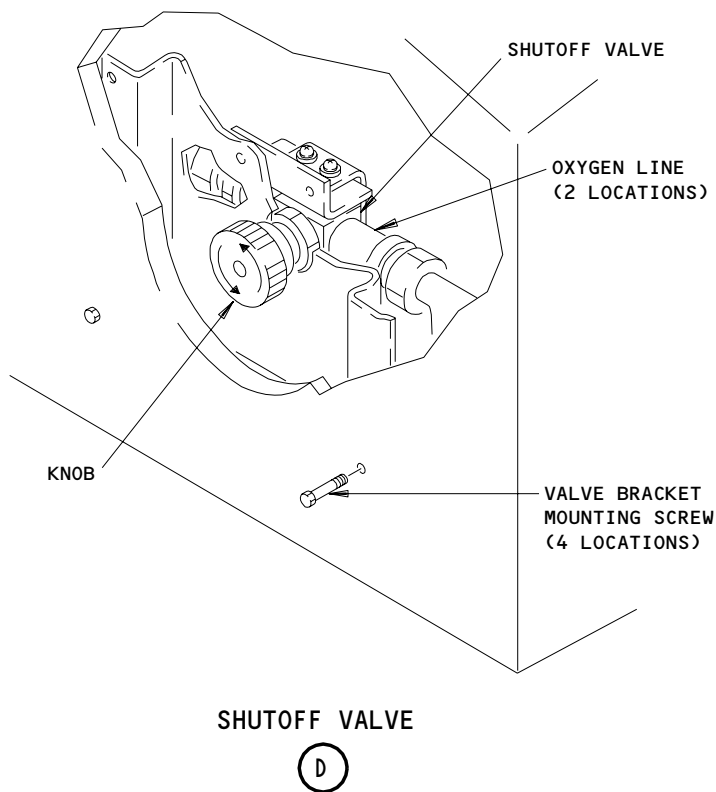
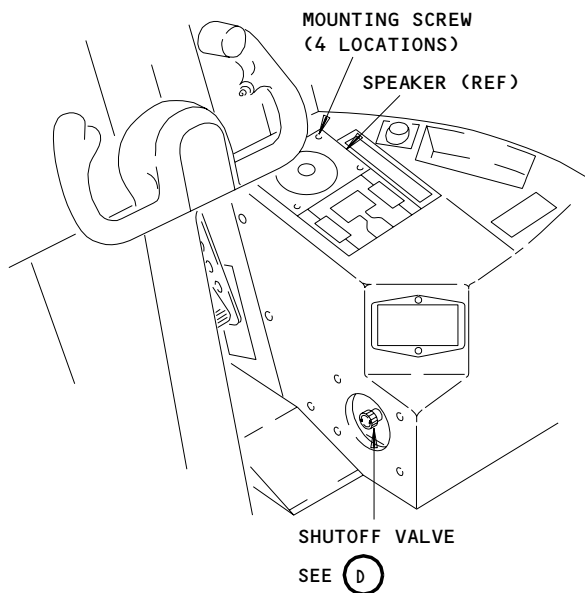

Crew Oxygen - Component Location  
Figure 102 (Sheet 3)

EFFECTIVITY	
	ALL

35-11-00

EICAS OXYGEN  
PRESSURE  
INDICATION IS  
ABNORMAL

PREREQUISITES  
NONE

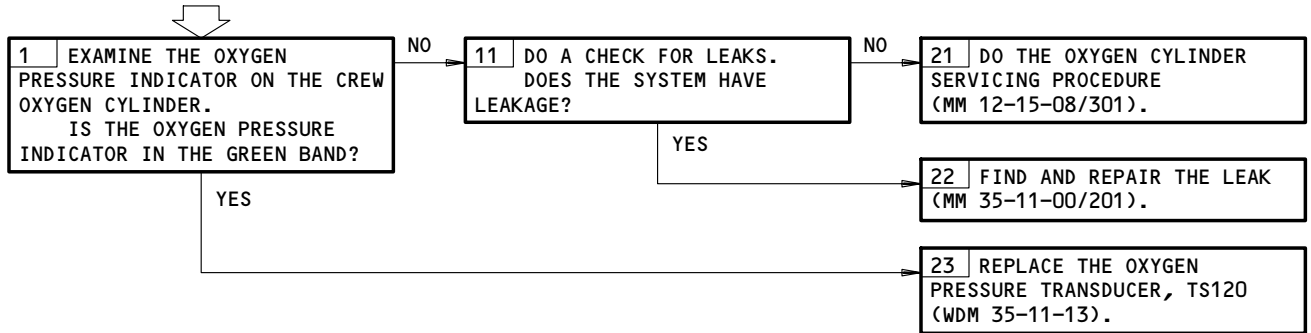









EICAS Oxygen Pressure Indication is Abnormal  
Figure 103

EFFECTIVITY	ALL
-------------	-----



35-11-00

**BOEING**  
757  
FAULT ISOLATION/MAINT MANUAL

PASSENGER OXYGEN

COMPONENT	FIG. 102 SHT	QTY	ACCESS/AREA	AMM REFERENCE
ACTUATOR - OXYGEN MODULE DOOR LATCH	2,3	1 	PSU, OXYGEN MODULE	35-21-06
CIRCUIT BREAKER -	1		FLT COMPT, P11	
PASSENGER OXYGEN CONT, C1323		1	11A24	*
PASSENGER OXYGEN LEFT, C1321		1	11A21	*
PASSENGER OXYGEN MANUAL DEPLOY, C1325		1	11A25	*
PASSENGER OXYGEN RIGHT, C1322		1	11A23	*
DOOR - OXYGEN MODULE	2,3	1 	PSU, OXYGEN MODULE	35-21-00
DOOR - SUSTAINING OXYGEN MODULE 	2	1 	PSU, SUSTAINING OXYGEN MODULE	35-21-00
GENERATOR - OXYGEN	2,3	1 	PSU, OXYGEN MODULE	35-21-04
GENERATOR - SUSTAINING OXYGEN 	2	1 	PSU, SUSTAINING OXYGEN MODULE	35-21-04
LIGHT/SWITCH - PASSENGER OXYGEN, S2	1	1	FLT COMPT, P5, EMER LTS/PASS. OXY PNL, M43	35-21-00
PANEL - (FIM 33-51-00/101)				
EMER LTS/OXY, M43				
RELAY - (FIM 31-01-37/101)				
MANUAL DEPLOY OXY CONTROL, K7				
OXY CONTROL, K4				
OXY CONTROL TIME DELAY, K8 				
OXY DEPLOY INDICATOR, K10038				
OXY MANUAL DEPLOY TIME DELAY, K42 				
SWITCH - ALTITUDE PRESSURE, S119	1	1	119AL, MAIN EQUIP CTR, P37	35-21-00

\* SEE THE WDM EQUIPMENT LIST

-  VARIABLE WITH PASSENGER SEAT CONFIGURATION  
 GUI 115

Passenger Oxygen - Component Index  
Figure 101

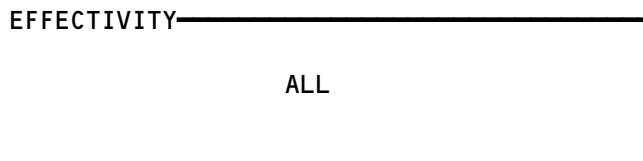

**35-21-00**

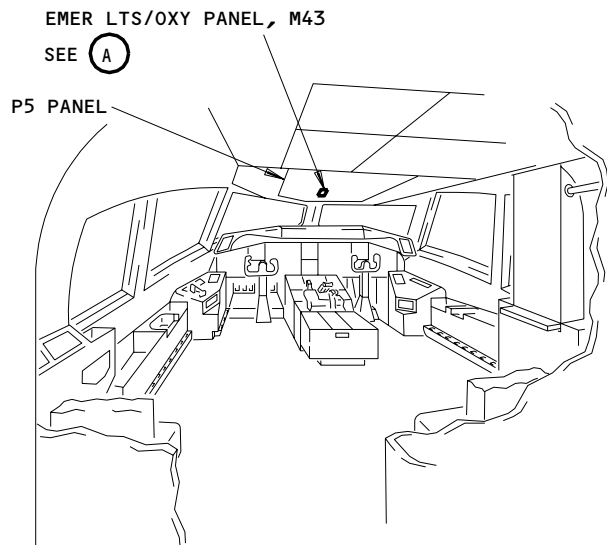

FLIGHT COMPARTMENT

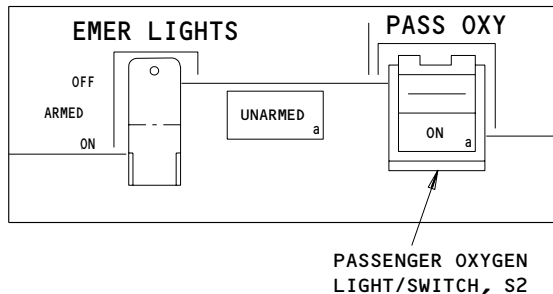

EMER LTS/OXY PANEL, M43

(A)

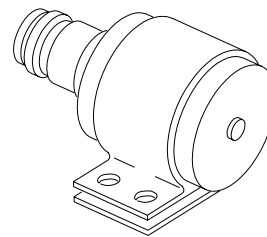
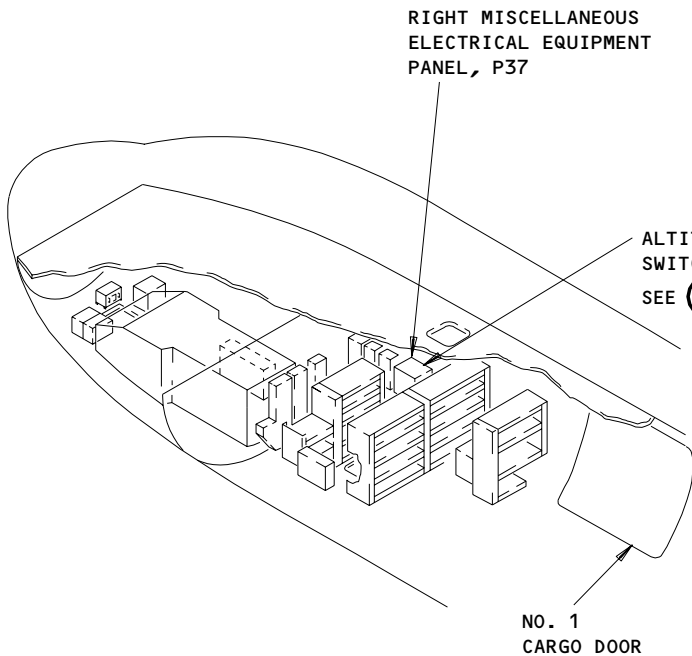

ALTITUDE PRESSURE SWITCH, S119

(B)

Passenger Oxygen - Component Location  
Figure 102 (Sheet 1)

EFFECTIVITY	ALL

35-21-00

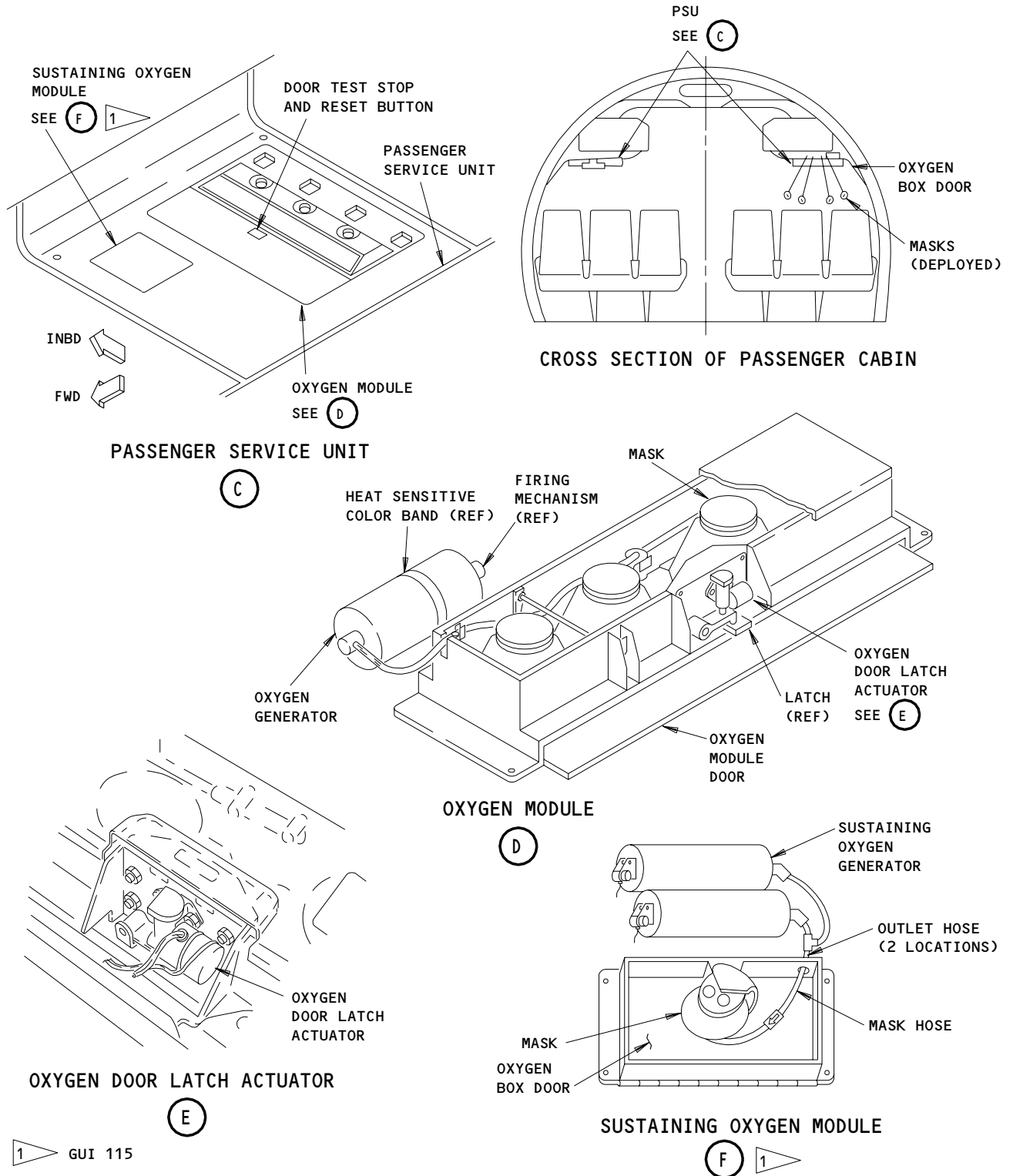

Passenger Oxygen - Component Location  
Figure 102 (Sheet 2)

EFFECTIVITY  
GUI 001-0004, 006, 007, 009-011, 015;  
GUI 005, 008, PRE SB 05-0030;

**35-21-00**

**BOEING**  
757  
FAULT ISOLATION/MAINT MANUAL

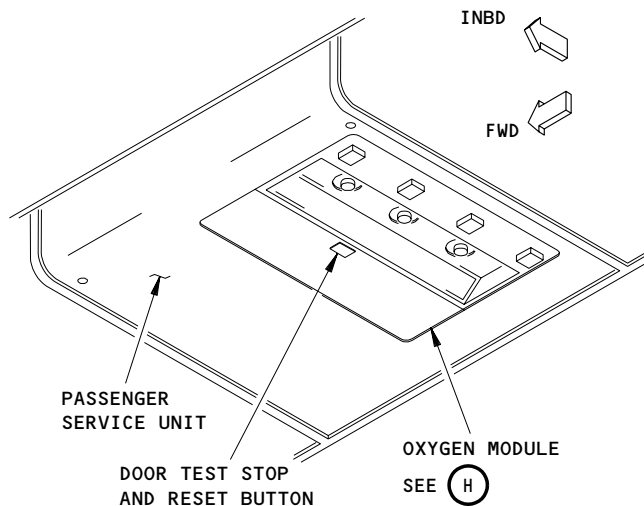
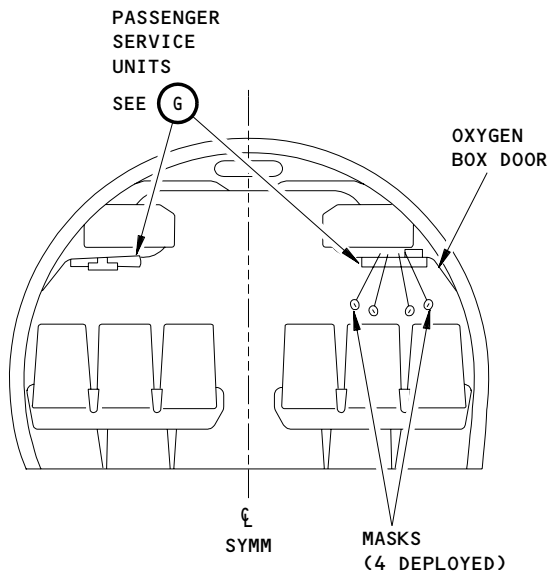

PASSENGER SERVICE UNIT

(G)

CROSS SECTION OF PASSENGER CABIN  
(VIEW IN AFT DIRECTION)

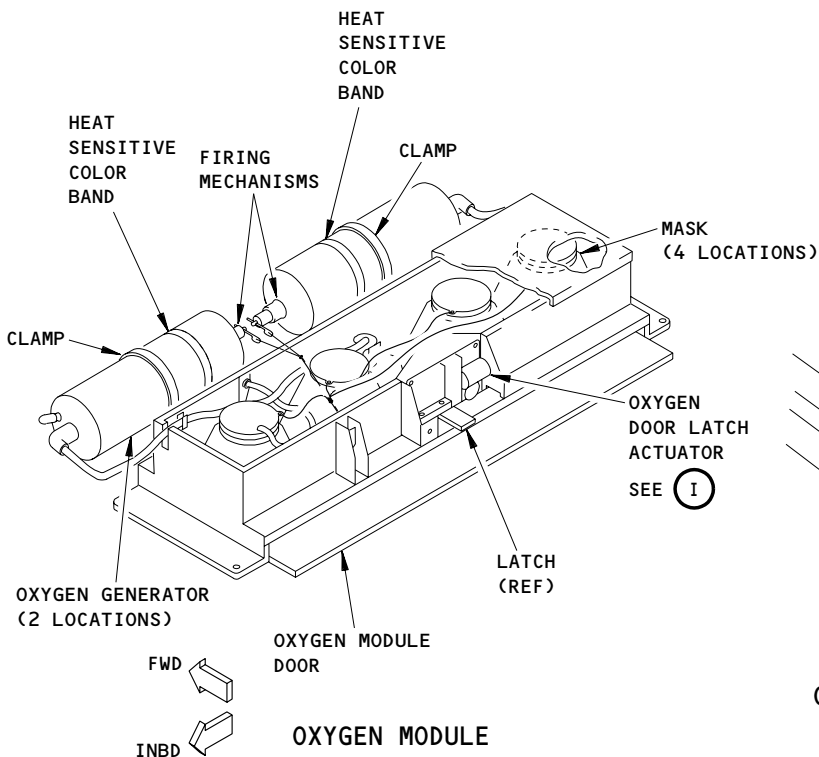

(H)

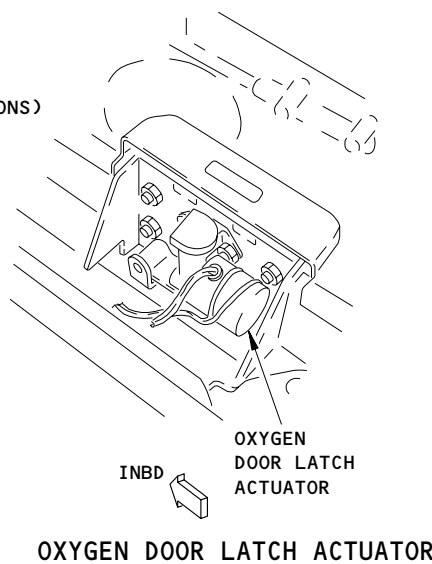

OXYGEN DOOR LATCH ACTUATOR

(I)

Passenger Oxygen - Component Location  
Figure 102 (Sheet 3)

EFFECTIVITY  
GUI 005, 008, POST SB 05-0030;

35-21-00

ISOLATED PASSENGER  
OXYGEN MASK(S)  
DEPLOYED

PREREQUISITES NONE
-----------------------



- |   |   |
|---|---|
| 1 | ADJUST THE OXYGEN MODULE DOOR (MM 35-21-00/501).<br>REPLACE ALL ACTIVATED OXYGEN GENERATORS (MM 35-21-04/401).<br>REPACK THE OXYGEN MASK(S) (MM 35-21-05/201).<br>RESET THE DOOR LATCH ACTUATOR FOR THE OXYGEN MODULE (MM 35-21-06/401).<br>CLOSE THE OXYGEN MODULE DOOR (MM 35-21-06/401). |
|---|---|

Isolated Passenger Oxygen Mask(s) Deployed  
Figure 103

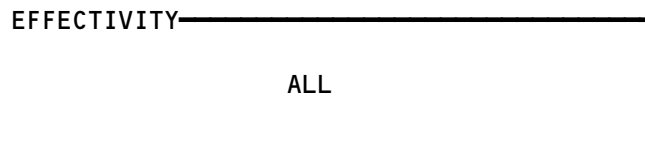

35-21-00

07

Page 105  
Dec 20/93

**PASSENGER OXYGEN MASKS DEPLOYED AUTOMATICALLY WITHOUT LOSS OF CABIN PRESSURIZATION**

**PREREQUISITES**  
MAKE SURE THESE CIRCUIT BREAKERS ARE CLOSED:  
11A21, 11A23, 11A24, 11A25  
MAKE SURE THE AIRPLANE IS IN THIS CONFIGURATION:  
ELECTRICAL POWER IS ON (AMM 24-22-00/201)

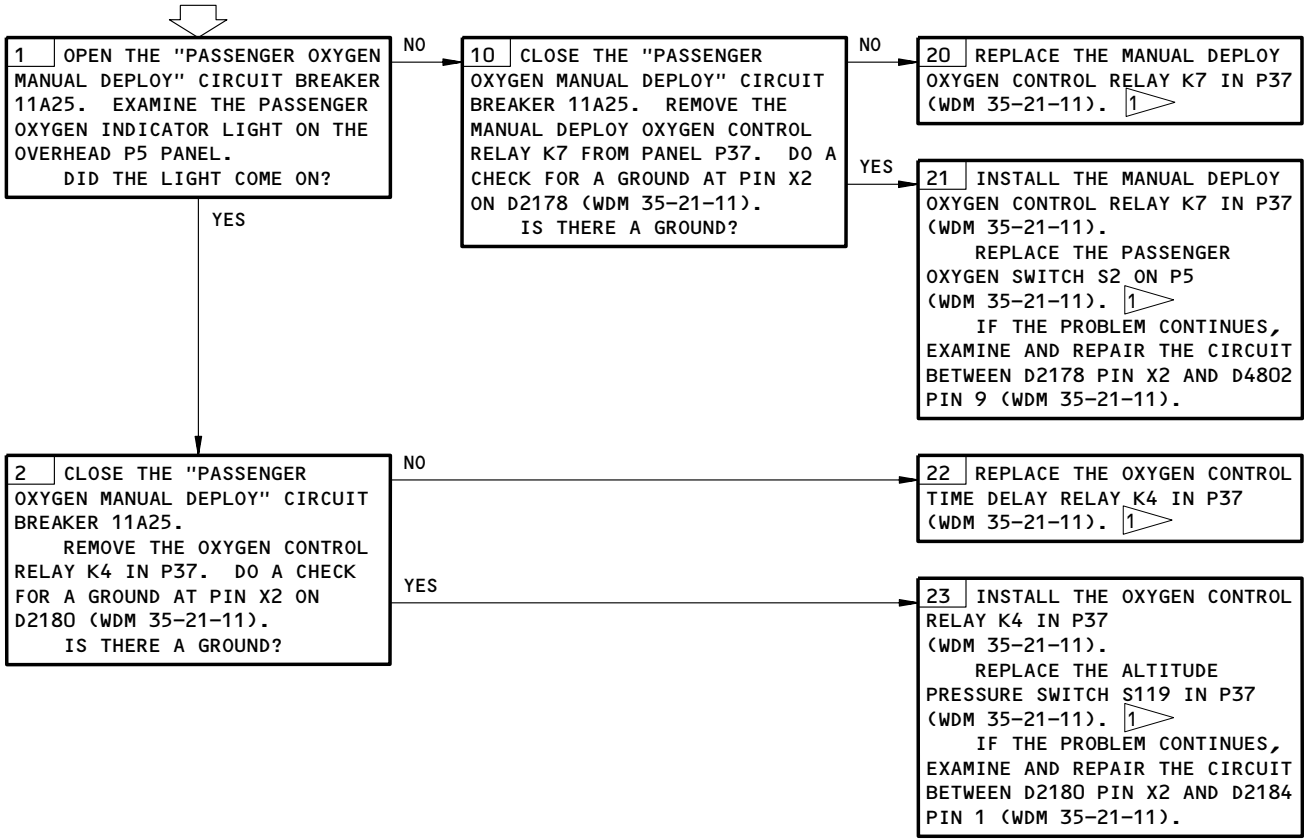

**1** RESET ALL THE OXYGEN MODULE DOOR LATCH ACTUATORS (AMM 35-21-06/401). CLOSE THE OXYGEN MODULE DOORS (AMM 35-21-06/401).

Passenger Oxygen Masks Deployed Automatically Without Loss of Cabin Pressurization  
Figure 104 (Sheet 1)

EFFECTIVITY  
GUI 001-099

**35-21-00**

304853



**PASSENGER OXYGEN MASKS DEPLOYED AUTOMATICALLY WITHOUT LOSS OF CABIN PRESSURIZATION**

**PREREQUISITES**  
MAKE SURE THESE CIRCUIT BREAKERS ARE CLOSED:  
11A21, 11A23, 11A24, 11A25  
MAKE SURE THE AIRPLANE IS IN THIS CONFIGURATION:  
ELECTRICAL POWER IS ON (AMM 24-22-00/201)

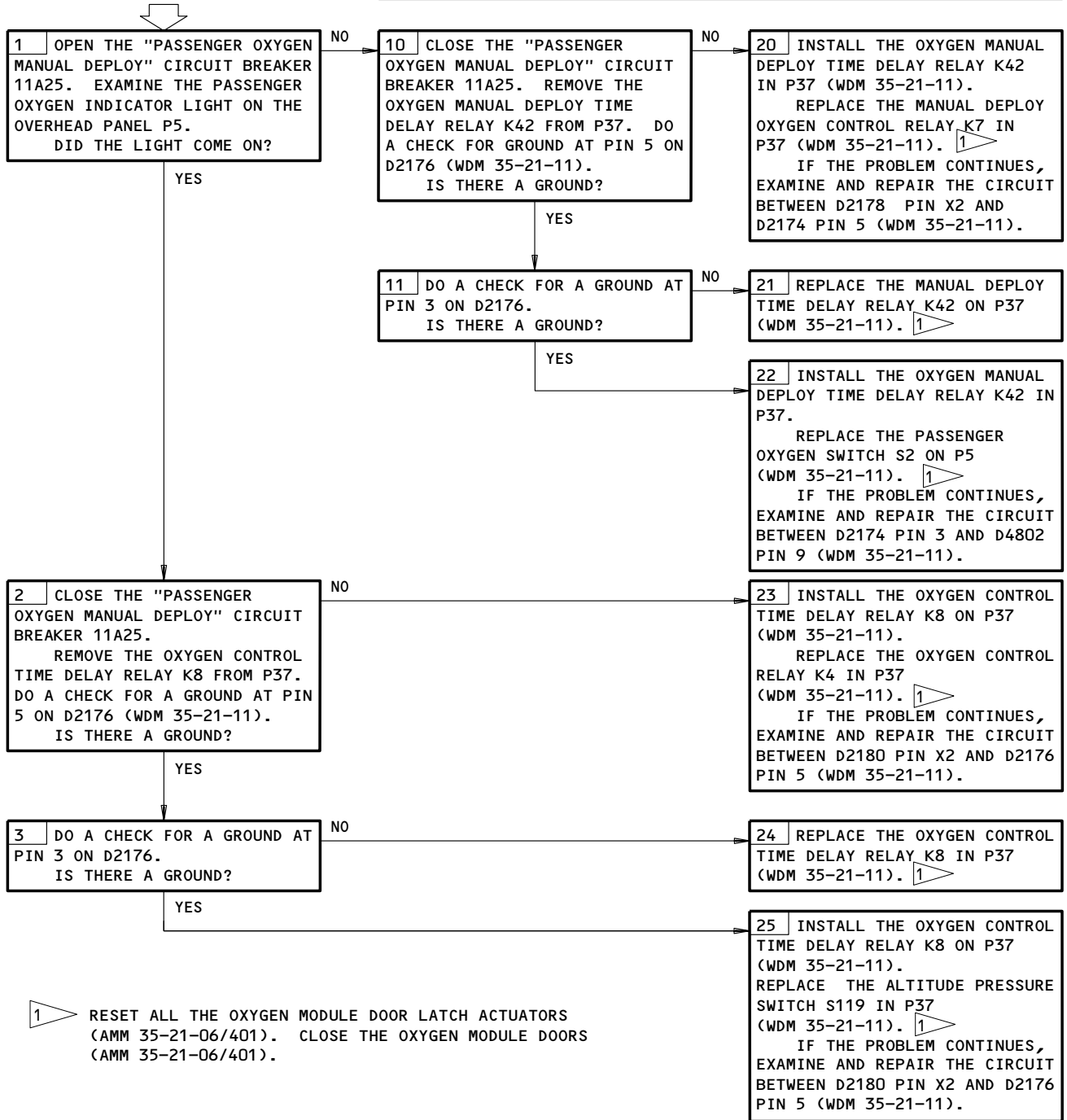

Passenger Oxygen Masks Deployed Automatically Without Loss of Cabin Pressurization  
Figure 104 (Sheet 2)

EFFECTIVITY  
GUI 115

35-21-00

**PASSENGER OXYGEN MASKS DID NOT DROP AUTOMATICALLY**

**PREREQUISITES**  
 MAKE SURE THESE CIRCUIT BREAKERS ARE CLOSED:  
 11A21,11A23,11A24,11A25  
 MAKE SURE THE AIRPLANE IS IN THE CONFIGURATION THAT FOLLOWS:  
 ELECTRICAL POWER IS ON (MM 24-22-00/201)

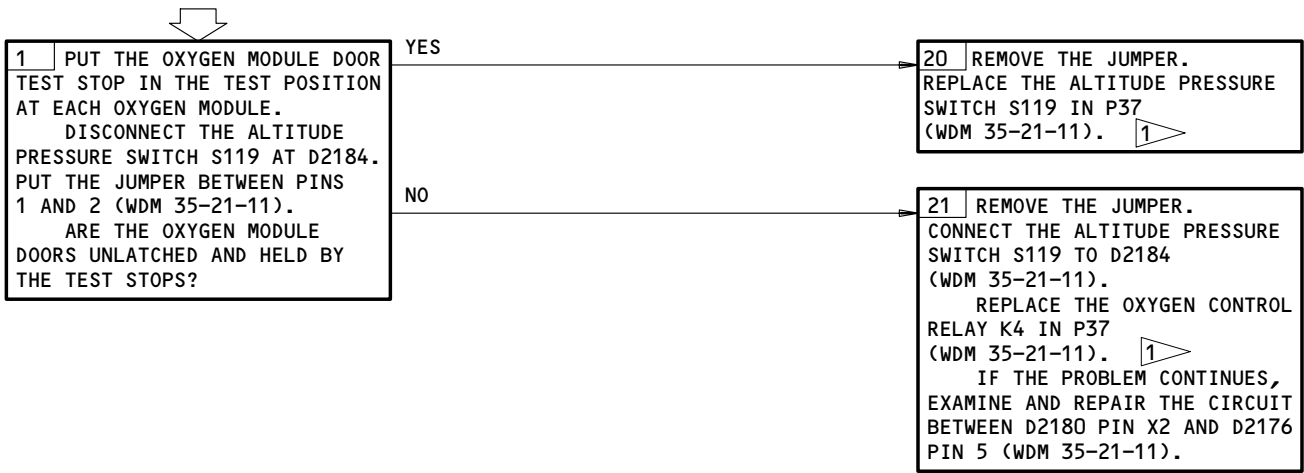

1 RESET ALL THE OXYGEN MODULE DOOR LATCH ACTUATORS (MM 35-21-06/401). CLOSE THE OXYGEN MODULE DOORS (MM 35-21-06/401). RETURN THE DOOR TEST STOPS TO THE STOWED POSITION (MM 35-21-00/501).

Passenger Oxygen Masks Did Not Drop Automatically  
Figure 105 (Sheet 1)

EFFECTIVITY  
GUI 001-099

**35-21-00**

**PASSENGER OXYGEN MASKS DID NOT DROP AUTOMATICALLY**

**PREREQUISITES**  
MAKE SURE THESE CIRCUIT BREAKERS ARE CLOSED:  
11A21,11A23,11A24,11A25  
MAKE SURE THE AIRPLANE IS IN THE CONFIGURATION THAT FOLLOWS:  
ELECTRICAL POWER IS ON (MM 24-22-00/201)

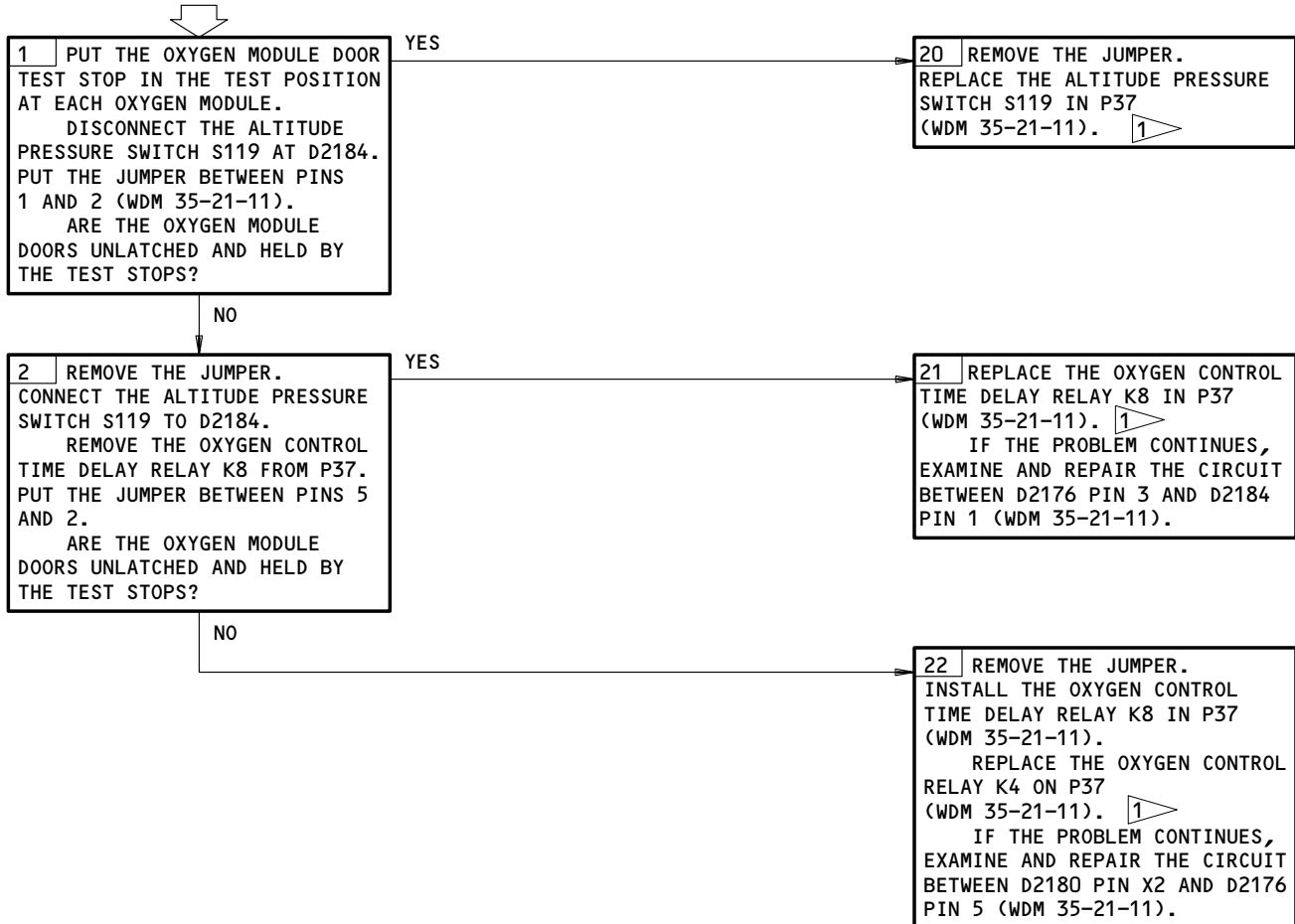

1 RESET ALL THE OXYGEN MODULE DOOR LATCH ACTUATORS (MM 35-21-06/401). CLOSE THE OXYGEN MODULE DOORS (MM 35-21-06/401). RETURN THE DOOR TEST STOPS TO THE STOWED POSITION (MM 35-21-00/501).

Passenger Oxygen Masks Did Not Drop Automatically  
Figure 105 (Sheet 2)

EFFECTIVITY  
GUI 115

**35-21-00**