

GPA Group plc

PAGE	DATE	CODE	PAGE	DATE	CODE	PAGE	DATE	CODE
CHAPTER 38 TAB								
WATER AND WASTE								
EFFECTIVE PAGES SEE LAST PAGE OF LIST FOR NUMBER OF PAGES								
38-CONTENTS								
1	MAY 28/01	GUI						
2	BLANK							
38-HOW TO USE THE FIM								
1	SEP 20/98	01						
2	SEP 20/98	01						
3	SEP 28/99	01						
4	SEP 20/98	01						
5	SEP 20/98	01						
6	SEP 20/98	01						
38-INDEX								
1	JUN 20/93	01						
2	JUN 20/93	01						
38-FAULT CODE DIAGRAM								
1	JUN 20/93	24						
2	JUN 20/93	23						
3	JUN 20/95	20						
4	DEC 15/86	01						
38-FAULT CODE INDEX								
1	SEP 20/08	25						
2	SEP 20/08	01						
3	SEP 20/08	01						
4	SEP 20/08	01						
38-BITE INDEX								
1	SEP 28/99	01						
2	SEP 28/99	01						
3	SEP 28/99	01						
4	BLANK							
38-10-00								
101	MAR 20/91	18						
102	JUN 15/87	09						
103	SEP 15/86	01						
104	MAY 20/98	05						
105	MAY 20/98	05						
106	MAY 20/98	04						
107	SEP 20/94	11						
108	BLANK							
38-30-00								
101	SEP 20/92	22						
102	DEC 20/91	02						
103	SEP 20/92	05						
104	SEP 20/92	01						

R = REVISED, A = ADDED OR D = DELETED
F = FOLDOUT PAGE
32
JAN 20/09

D633N632

CHAPTER 38
EFFECTIVE PAGES
PAGE 1
LAST PAGE



BOEING
757
FAULT ISOLATION/MAINT MANUAL

CHAPTER 38 - WATER/WASTE

TABLE OF CONTENTS

<u>Subject</u>	Chapter Section <u>Subject</u>	<u>Page</u>	<u>Effectivity</u>
HOW TO USE THE FIM	38-HOW TO USE THE FIM	1	ALL
INDEX	38-INDEX	1	ALL
FAULT CODE DIAGRAMS	38-FAULT CODE DIAGRAM	1	ALL
FAULT CODE INDEX	38-FAULT CODE INDEX	1	ALL
BITE INDEX	38-BITE INDEX	1	ALL
<u>WATER/WASTE</u>	38-00-00		
<u>POTABLE WATER SYSTEM</u>	38-10-00		
Component Location		101	ALL
Component Index			
Component Location			
Fault Isolation			
(No, Low) Water Flow from Faucet. Water Qty was Norm (Fig. 106)		107	
No Water Flow At Any Faucet. Water Quantity Normal (Fig. 103)		104	
Water Flow Is Low At All Faucets. Water Quantity Normal (Fig. 104)		105	
Water Quantity Indicates Zero. Water Flow Is Normal (Fig. 105)		106	
<u>WASTE DISPOSAL</u>	38-30-00		
Component Location		101	ALL
Component Index			
Component Location			

38-CONTENTS

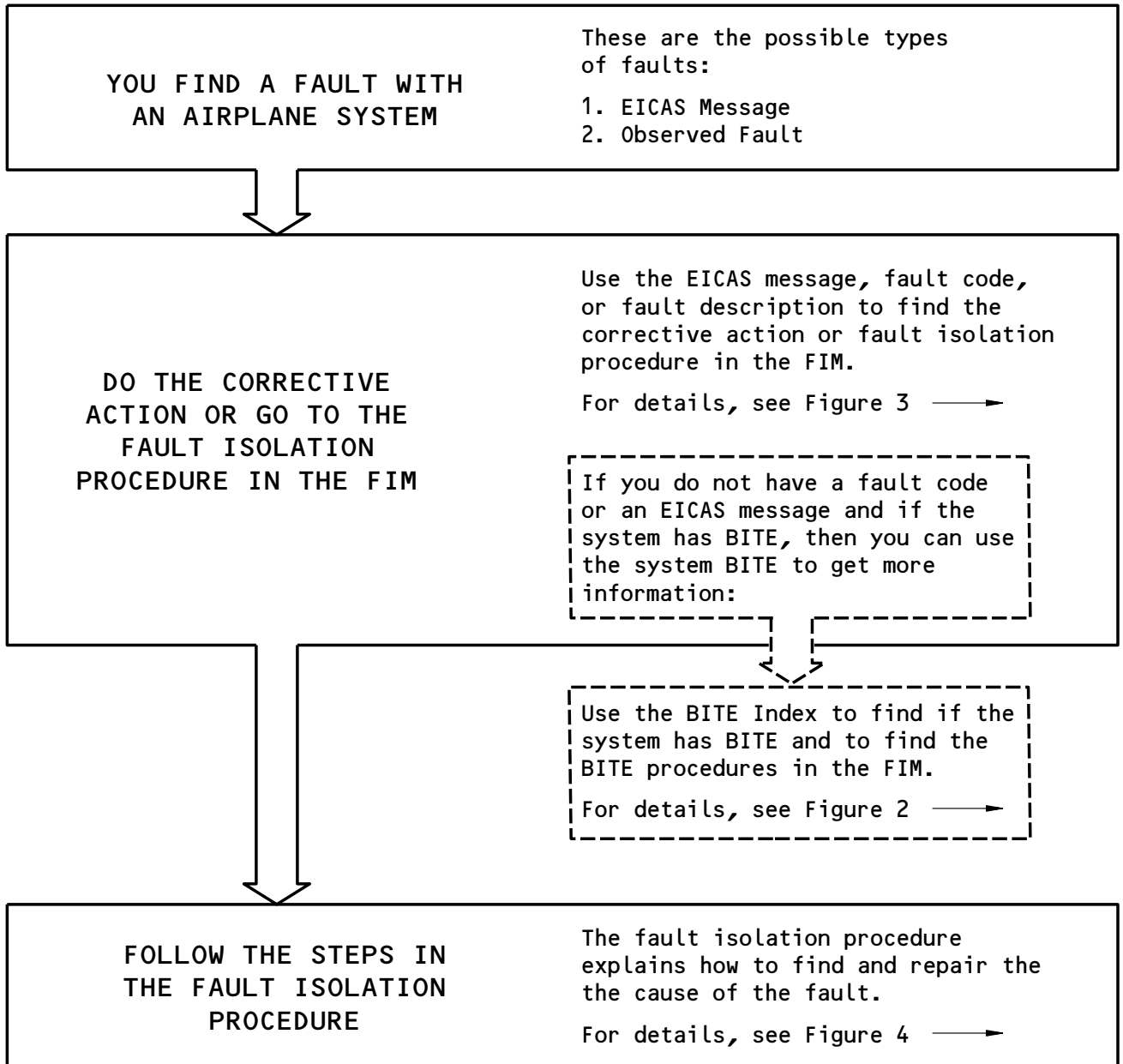

Basic Fault Isolation Process
Figure 1

EFFECTIVITY

ALL

38-HOW TO USE THE FIM

01

Page 1
Sep 20/98

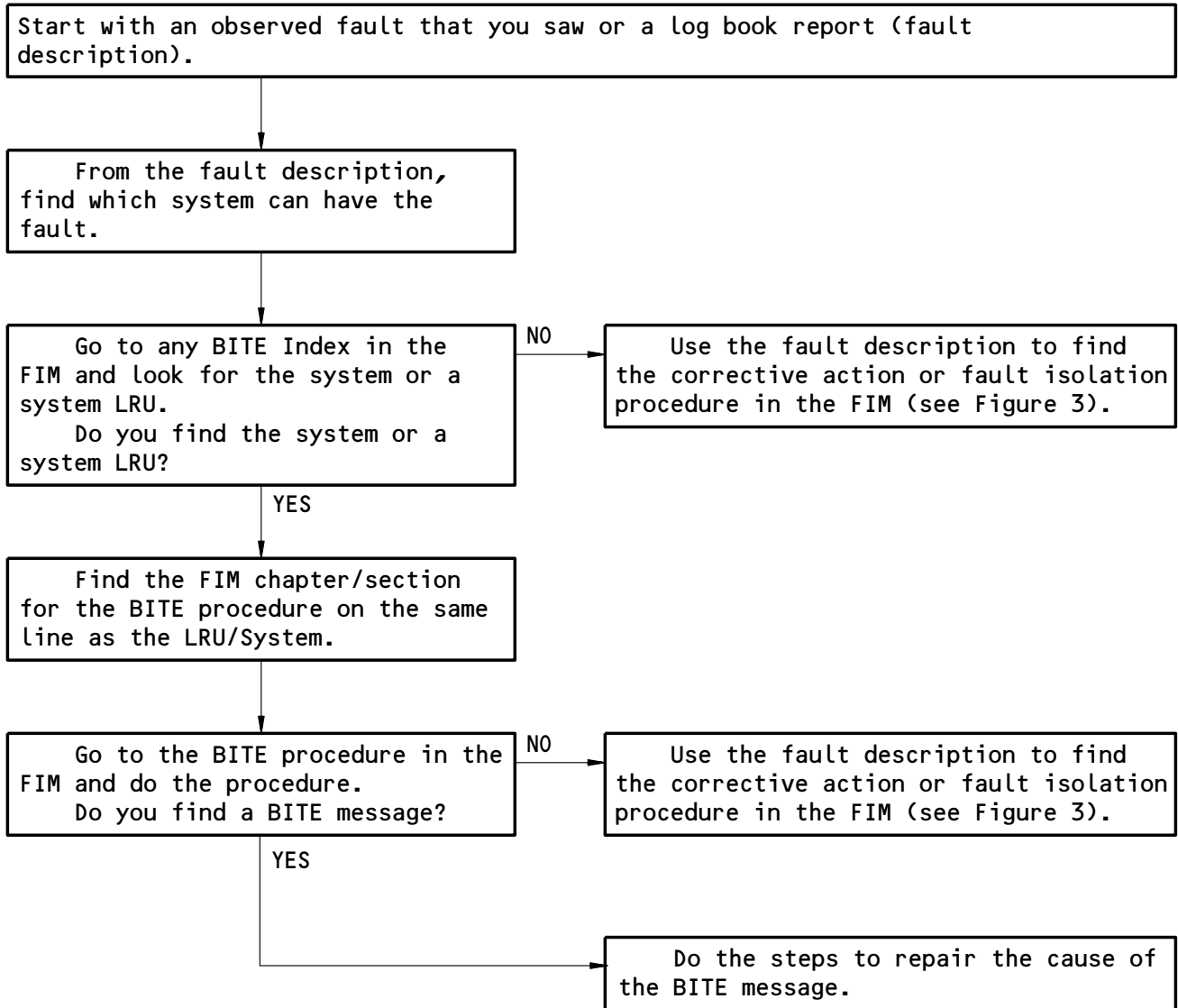

How to Get Fault Information from BITE
Figure 2

EFFECTIVITY

ALL

38-HOW TO USE THE FIM

01

Page 2
Sep 20/98

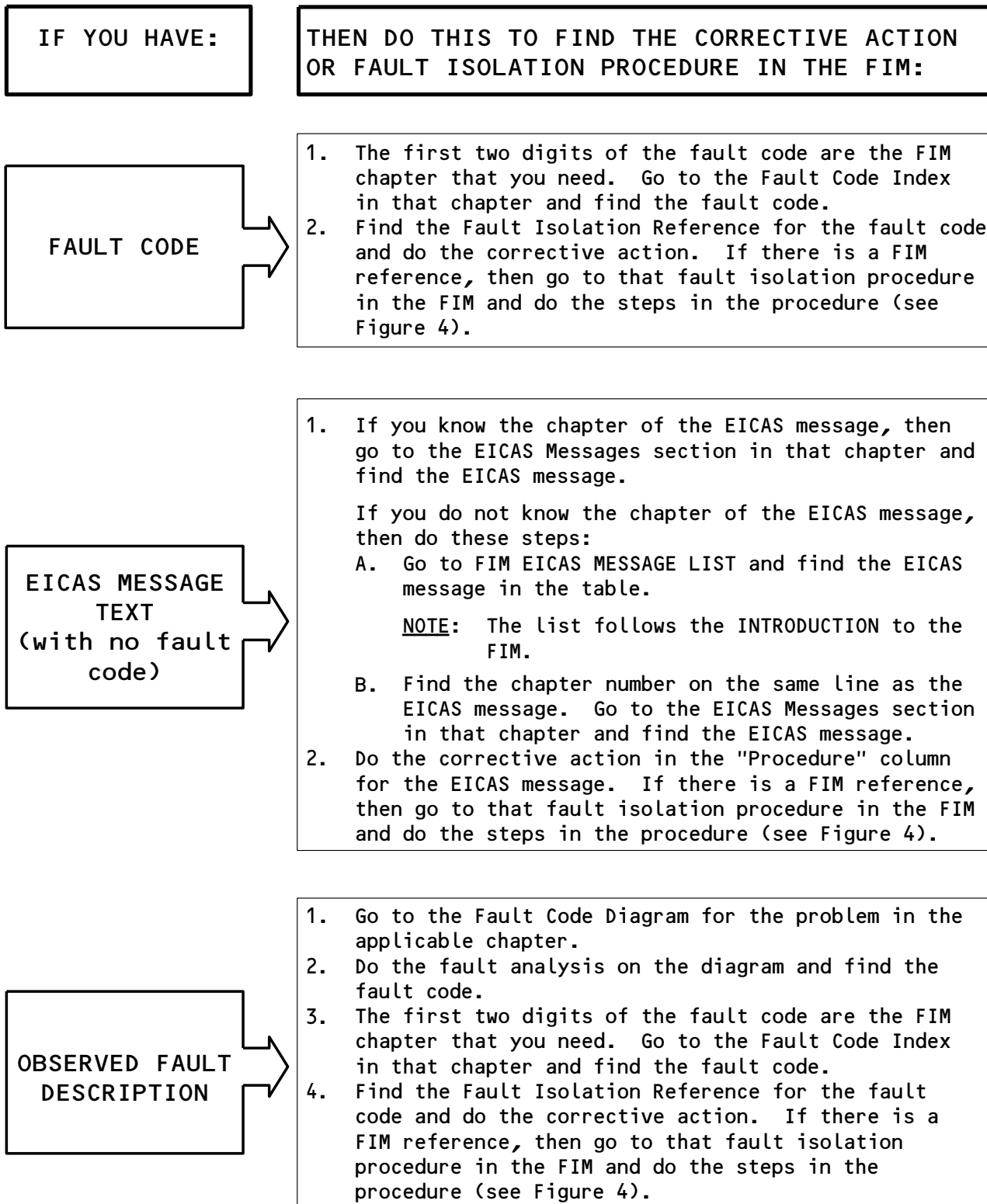

How to Find the Corrective Action or Fault Isolation Procedure in the FIM

Figure 3

EFFECTIVITY

ALL

38-HOW TO USE THE FIM

01

Page 3
Sep 28/99

ASSUMED CONDITIONS AT START OF TASK

- External electrical power is OFF
- Hydraulic power and pneumatic power are OFF
- Engines are shut down
- Circuit breakers for the system are closed
- No equipment in the system is deactivated

PREREQUISITES

- This box gives the steps to get the airplane from the normal shutdown condition to the configuration necessary to do the fault isolation procedure.
- The Prerequisites give procedure references, circuit breakers, and special tools and equipment requirements.

FAULT ISOLATION BLOCKS

- Start the fault isolation procedure at block 1 unless specified differently.
- Do the check to get an answer to the question in the box. Follow the arrow that applies to your answer. This will go to the next check.
- When you get to a box in the column at the right of the page, you have isolated that fault. Do the steps in that box to repair the cause of the fault.
- Make sure that fault is corrected to complete the procedure.

Do the Fault Isolation Procedure
Figure 4

EFFECTIVITY

ALL

38-HOW TO USE THE FIM

01

Page 4
Sep 20/98

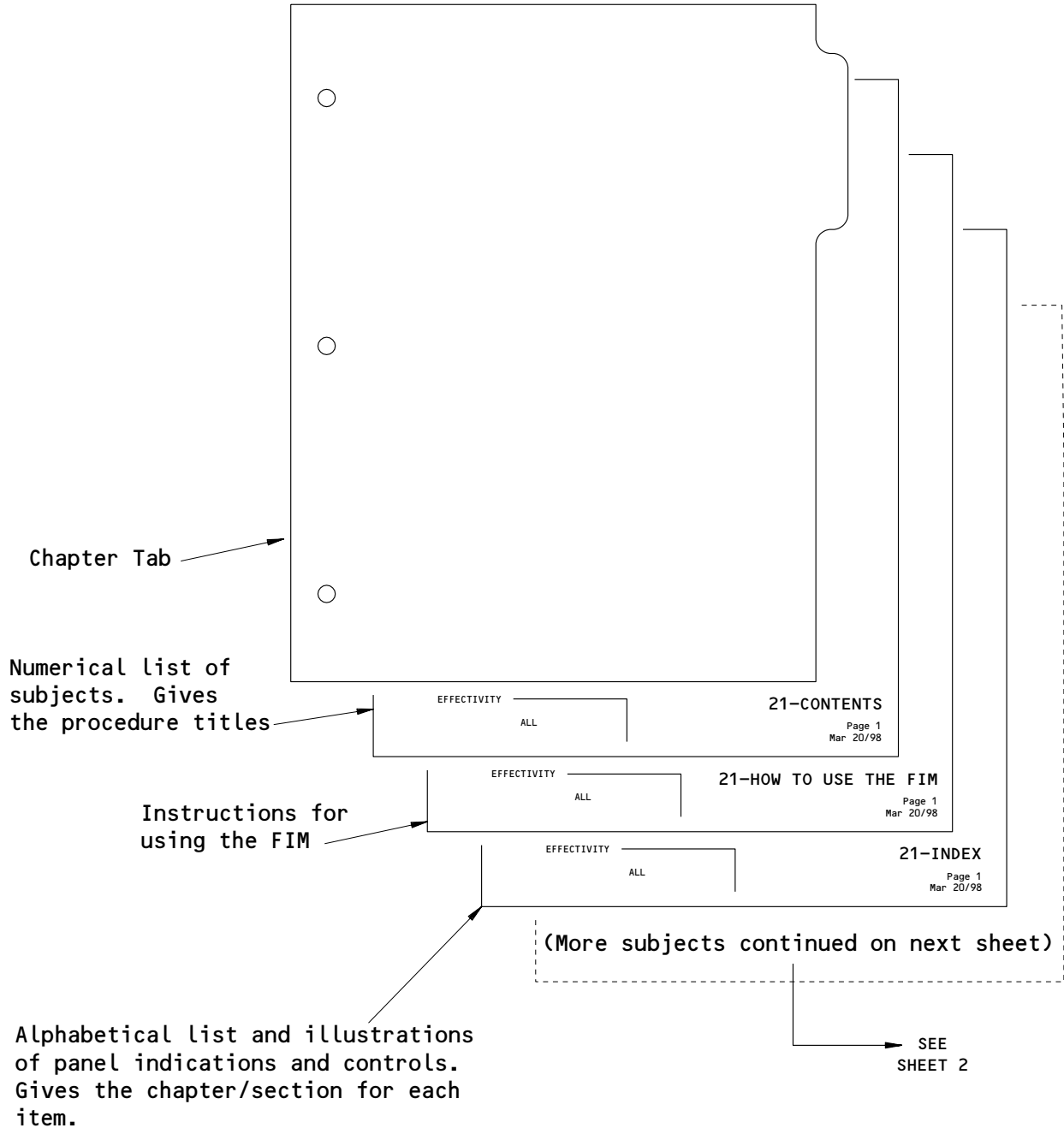

Subjects in Each FIM Chapter
Figure 5 (Sheet 1)

EFFECTIVITY	ALL	38-HOW TO USE THE FIM	01	Page 5 Sep 20/98
-------------	-----	------------------------------	----	---------------------

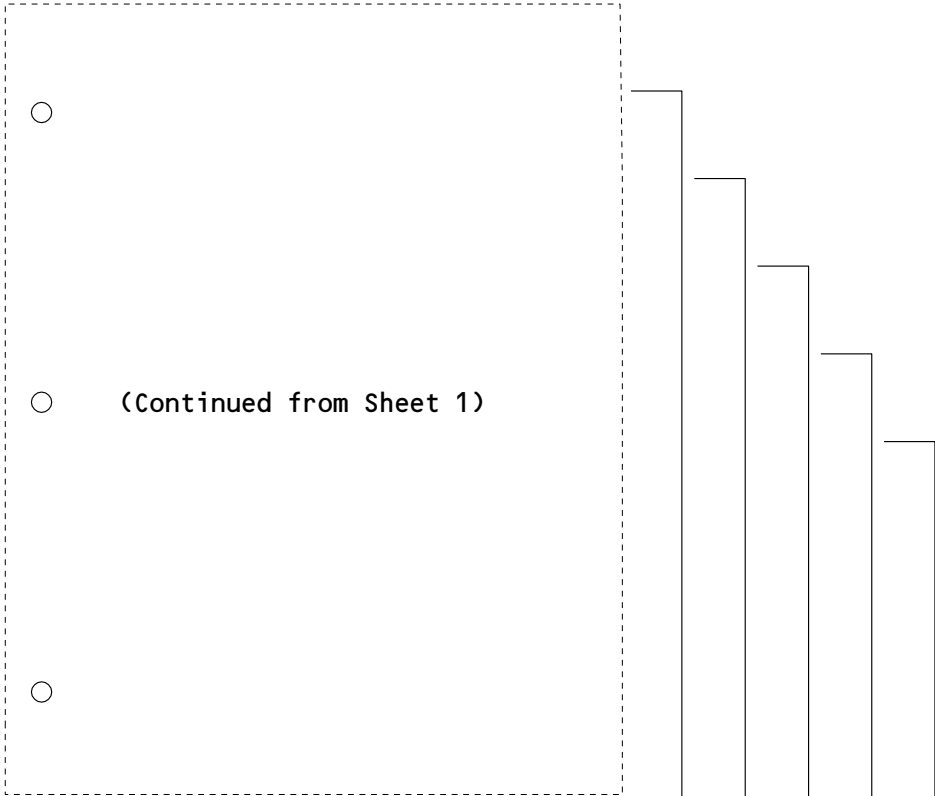

Alphabetical list of the EICAS messages. Gives the procedure to repair the cause of the message or a reference to a fault isolation procedure.

Failure analysis diagrams for the airplane systems to find the correct fault code for the fault.

Numerical list of fault codes. Gives the procedure to repair the cause of the fault or a reference to a fault isolation procedure.

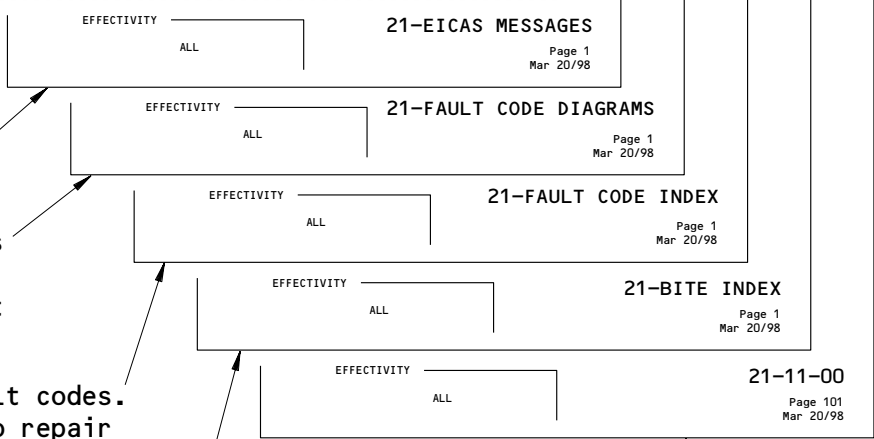

Alphabetical list of all the LRUs/systems that have BITE. Gives the chapter/section for the BITE procedure.

Component index, component location, and fault isolation procedures for the systems in the chapter.

Subjects in Each FIM Chapter
Figure 5 (Sheet 2)

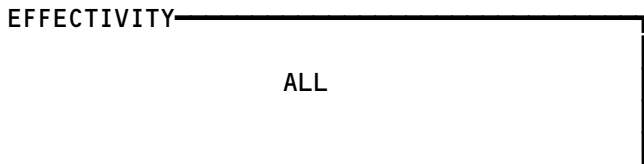

38-HOW TO USE THE FIM

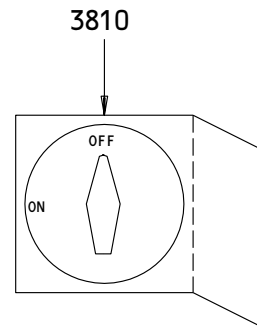
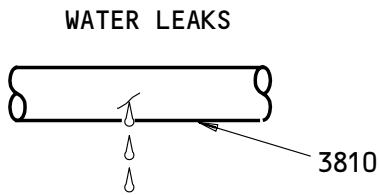
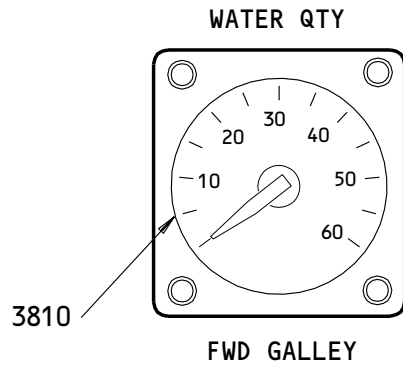
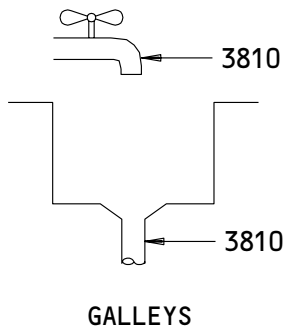

WATER SHUTOFF
VALVE LOCATIONS

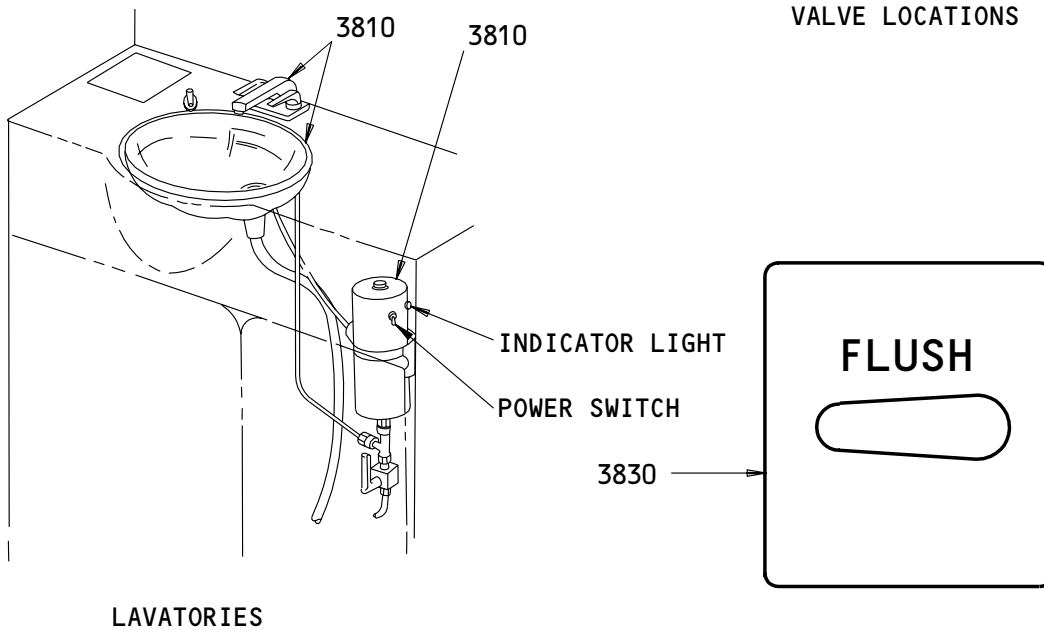

WATER AND WASTE - INDEX

EFFECTIVITY	ALL
-------------	-----

38-INDEX

<u>TITLE</u>	<u>CHAP/SEC</u>
GALLEYS	
LEAKS.....	3810
NOISE.....	3810
SINK DRAINS.....	3810
LAVATORIES	
BASIN DRAINS.....	3810
DOORS.....	CHAPTER 25
FLUSH.....	3830
LEAKS.....	3830
TOILET WATER	
LEVEL.....	3830
POTABLE WATER	
CONTAMINATION.....	3810
FAUCETS.....	3810
HOT WATER HEATERS.....	3810
LEAKS.....	3810
PRESSURE.....	3810
QUANTITY.....	3810
WATER SHUTOFF	
VALVE LOCATIONS.....	3810

WATER AND WASTE - INDEX

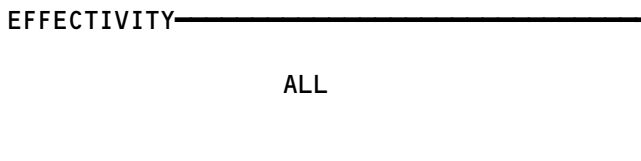

38-INDEX

BOEING

757

FAULT ISOLATION/MAINT MANUAL

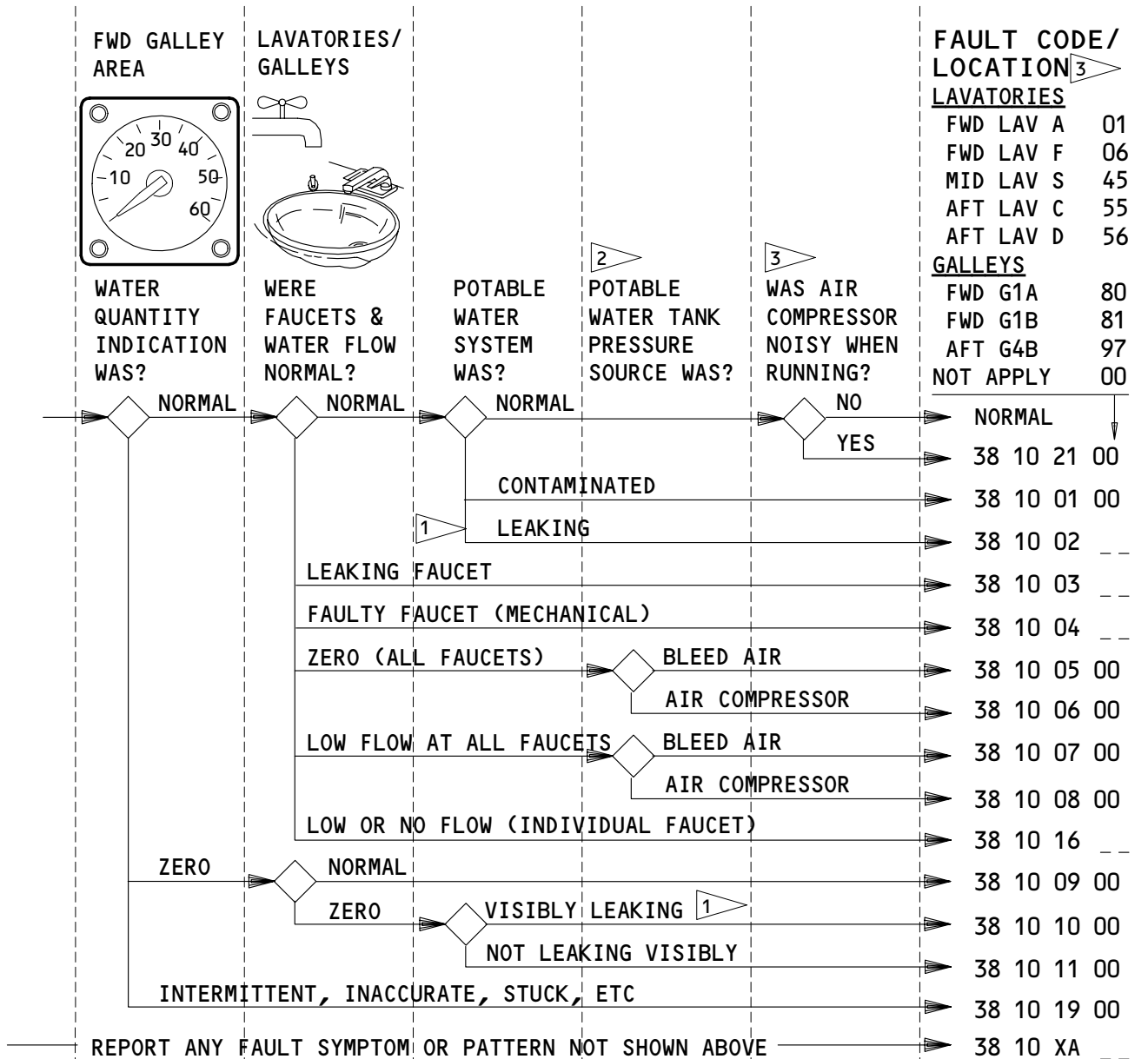

¹ SEE "WATER SHUTOFF VALVE LOCATIONS" PAGE IF NECESSARY TO SHUTOFF WATER.

² IF ENG OR APU BLEED AIR IS NOT AVAILABLE TO PRESSURIZE THE POTABLE WATER TANK, AN ELECTRIC DRIVEN AIR COMPRESSOR WILL AUTOMATICALLY SUPPLY THE PRESSURE.

³ LAVATORY/GALLEY LOCATIONS ⁴ IF INSTALLED

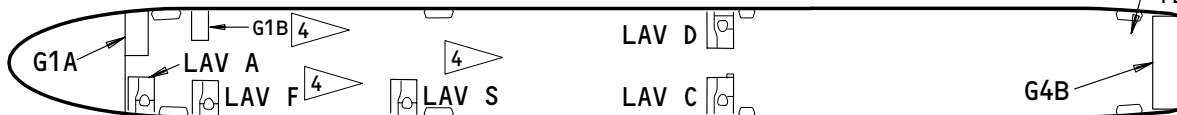

APPLICABLE CIRCUIT BREAKERS

6K21

POT WATER CPRSR

11S32

POTABLE WATER

POTABLE WATER SYSTEM - FAULT CODES

EFFECTIVITY

ALL

38-FAULT CODE DIAGRAM

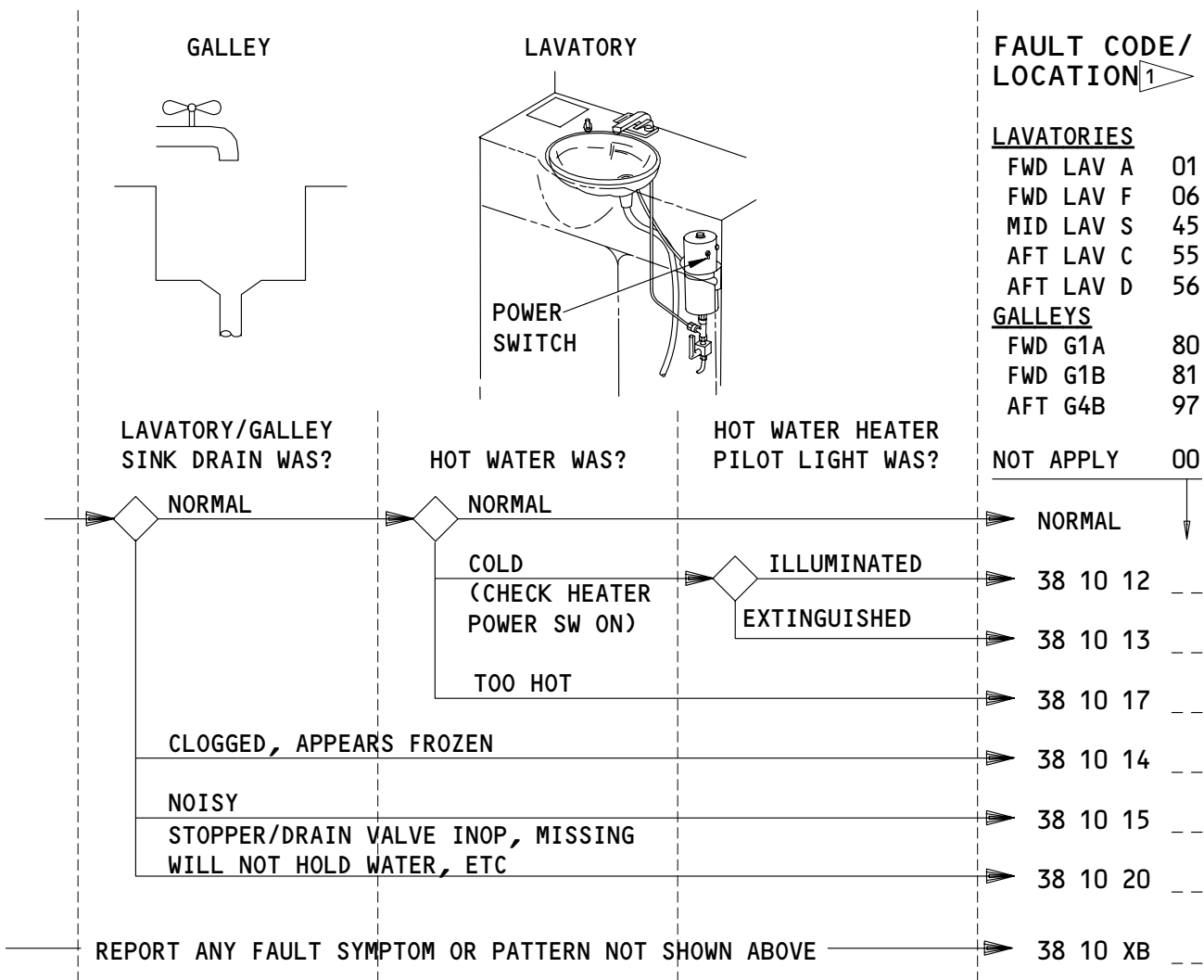

¹ LAVATORY/GALLEY LOCATIONS ² IF INSTALLED



APPLICABLE CIRCUIT BREAKERS

NONE

LAVATORY/GALLEY DRAINS AND HOT WATER HEATERS – FAULT CODES

EFFECTIVITY

ALL

38-FAULT CODE DIAGRAM

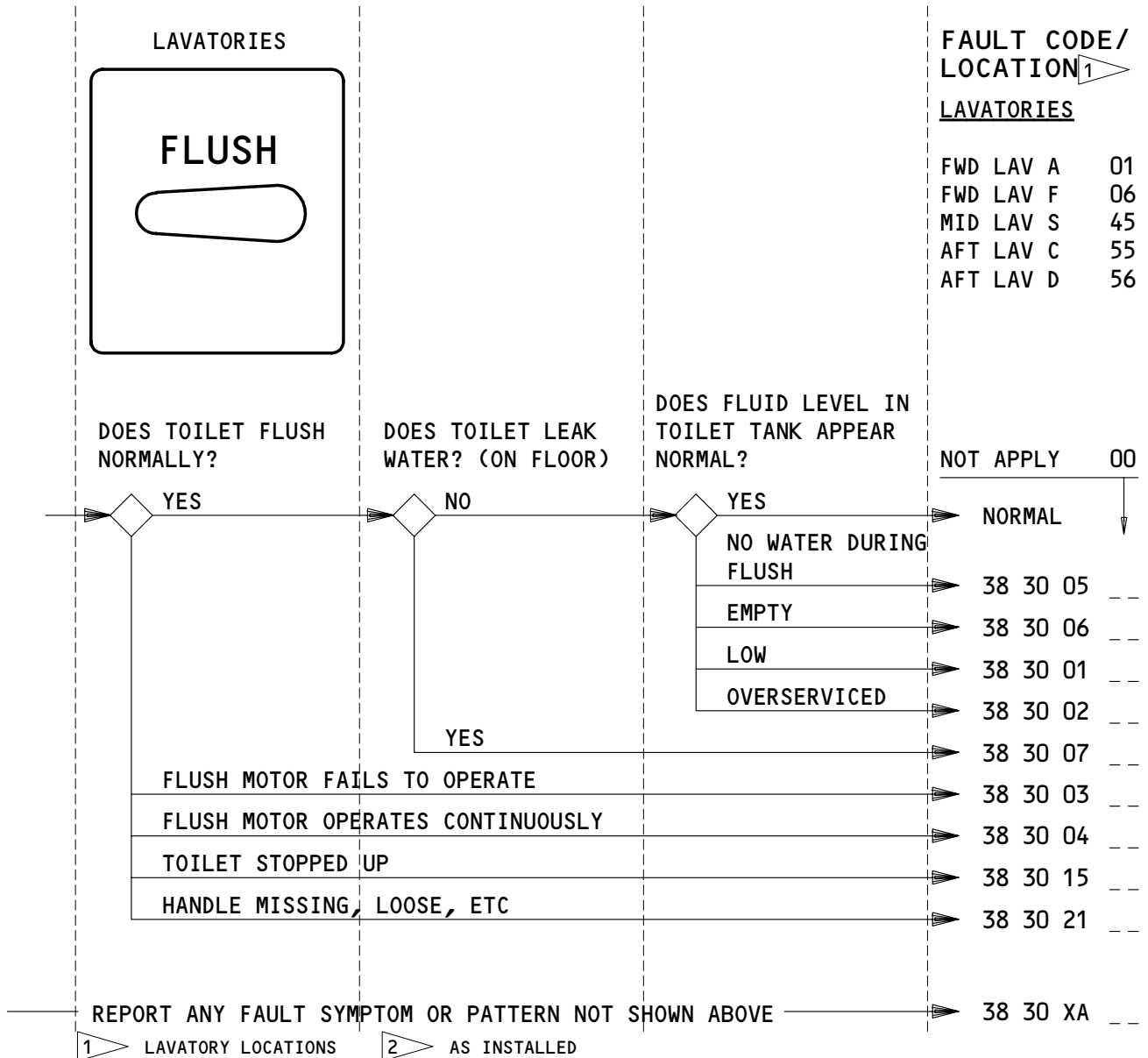

APPLICABLE CIRCUIT BREAKERS ²

11S5	LAV FLUSH MOTOR A	11S25	LAV FLUSH MOTOR C
11S8	LAV FLUSH MOTOR A	11S27	LAV FLUSH MOTOR C
11S11	LAV FLUSH MOTOR S	11S28	LAV FLUSH MOTOR D
11S11	LAV FLUSH MOTOR F	11S30	LAV FLUSH MOTOR D

TOILET FLUSH MOTOR/LEVEL - FAULT CODES

EFFECTIVITY

ALL

38-FAULT CODE DIAGRAM

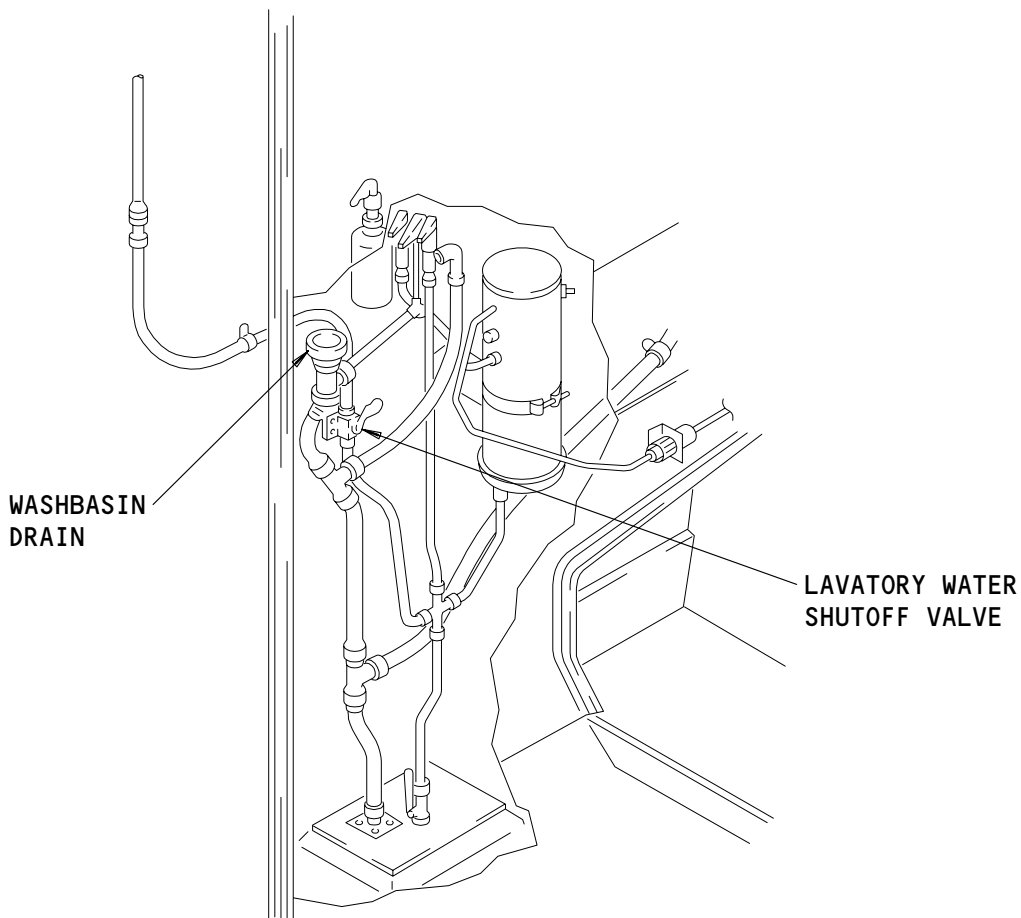

LAVATORY (TYPICAL)

EMERGENCY WATER SHUTOFF

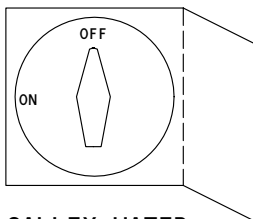

GALLEY WATER SHUTOFF

GALLEYS (TYPICAL)

WATER SHUTOFF VALVE LOCATIONS

EFFECTIVITY

ALL

38-FAULT CODE DIAGRAM

01

Page 4
Dec 15/86

1. General

A. Fault Code Location Identifier:

- (1) Use the identifiers that follow for fault codes that end with --:
(01=FWD LAV A, 06=FWD LAV F, 45=MID LAV S, 55=AFT LAV C,
56=AFT LAV D, 80=FWD G1A, 97=AFT G4B)

FAULT CODE	LOG BOOK REPORT	FAULT ISOLATION REFERENCE
38 10 XA --	(See Above for the Fault Code Location Identifier) A potable water system problem was encountered by the flight crew which is not covered in the Fault Code Diagrams.	SSM 38-10-01
38 10 XB --	(See Above for the Fault Code Location Identifier) A lavatory/galley drain and/or hot water heater problem was encountered by the Flight Crew which is not covered in the Fault Code Diagrams.	SSM 38-10-02
38 30 XA --	(See Above for the Fault Code Location Identifier) A lavatory waste system problem was encountered by the flight crew which is not covered in the Fault Code Diagrams.	SSM 38-30-01, SSM 38-30-02
38 10 01 00	Potable water is contaminated.	Disinfect potable water system (AMM 38-10-00/201).
38 10 02 --	Potable water is leaking (see above for the Fault Code Location Identifier).	Close water supply shutoff, valve to lavatory or galley, and fix leak.
38 10 03 --	Potable water faucet(s) are leaking (see Above for the Fault Code Location Identifier).	Replace potable water faucet cartridge (AMM 38-11-04/401).
38 10 04 --	Potable water faucet(s) are faulty (see Above for the Fault Code Location Identifier).	Replace potable water faucet (AMM 38-11-04/401).

EFFECTIVITY

ALL

38-FAULT CODE INDEX

BOEING
 757
 FAULT ISOLATION/MAINT MANUAL

FAULT CODE	LOG BOOK REPORT	FAULT ISOLATION REFERENCE
38 10 05 00	No water flow at any faucet with (Eng, APU) as the pressure source. Water quantity normal.	FIM 38-10-00/101, Fig. 103, Block 1
38 10 06 00	No water flow at any faucet with air compressor as the pressure source. Water quantity normal.	FIM 38-10-00/101, Fig. 103, Block 1
38 10 07 00	Water flow is low at all faucets with (Eng, APU) as the pressure source. Water quantity normal.	FIM 38-10-00/101, Fig. 104, Block 1
38 10 08 00	Water flow is low at all faucets with air compressor as the pressure source. Water quantity normal.	FIM 38-10-00/101, Fig. 104, Block 1
38 10 09 00	Water quantity indicates zero. Water flow is normal.	FIM 38-10-00/101, Fig. 105, Block 1
38 10 10 00	Water quantity indicates zero and no water flow at faucets. Water leak visible at, give location.	Fix water leak and service, potable water system (AMM 12-14-01/301).
38 10 11 00	Water quantity indicates zero and no water flow at faucets. Water leak is not visible.	Service potable water system (AMM 12-14-01/301). Locate and fix any water leaks.
38 10 12 --	No hot water in (see above for the Fault Code Location Identifier). Heater power switch is ON, and heater pilot light is on.	Replace water heater (AMM 38-13-51/401).
38 10 13 --	No hot water in (see above for the Fault Code Location Identifier). Heater power switch is ON, and heater pilot light is off.	Reset water heater overheat switch (AMM 38-10-00/201).
38 10 14 --	(Lav/Galley) Wash basin drain is clogged/appears frozen (see above for the Fault Code Location Identifier).	Unclog the drain (AMM 38-31-00/201). If the fault continues, refer to Water and Drain Line Heaters - Fault Isolation (FIM 30-71-00/101).

EFFECTIVITY

ALL

38-FAULT CODE INDEX

01

Page 2
Sep 20/08



BOEING
757
FAULT ISOLATION/MAINT MANUAL

FAULT CODE	LOG BOOK REPORT	FAULT ISOLATION REFERENCE
38 10 15 --	(Lav/Galley) Wash basin drain is noisy (see above for the Fault Code Location Identifier).	Repair/Replace the muffler.
38 10 16 --	(No, Low) Water flow from faucet at (see above for the Fault Code Location Identifier) water quantity is normal.	See the water diagram (FIM 38-10-00/101, Fig. 106).
38 10 17 --	Water too hot (see above for the Fault Code Location Identifier).	Replace water heater (AMM 38-13-51/401).
38 10 19 00	Water quantity indicator is intermittent, inaccurate, stuck, etc.	Adjust the water quantity transmitter (AMM 38-14-03/501) or replace the water quantity indicator, galley sidewall (AMM 38-14-01/401), or service panel (AMM 38-14-06/401).
38 10 20 --	The sink stopper/sink drain valve is inoperative, missing, will not hold water, etc. (see above for the Fault Code Location Identifier).	Clean or replace sink stopper/sink drain valve. If fault continues, adjust or replace drain valve linkage.
38 10 21 00	Water air compressor noisy when running.	Replace water air compressor (AMM 38-15-01/401).
38 30 01 --	(See above for the Fault Code Location Identifier) Toilet water level too low.	Service toilet waste tank (AMM 12-17-01/301). Replace the toilet level sensor (AMM 38-32-04/401). If the fault continues, replace the drain valve for the toilet tank (AMM 38-32-02/401).
38 30 02 --	(See above for the Fault Code Location Identifier) Toilet water level overserviced.	Service toilet waste tank (AMM 12-17-01/301). Replace the toilet tank level sensor (AMM 38-32-04/401). If the fault continues, replace the rinse/fill shutoff valve for the toilet tank (AMM 38-32-03/401).

EFFECTIVITY

ALL

38-FAULT CODE INDEX

01

Page 3
Sep 20/08



BOEING
757
FAULT ISOLATION/MAINT MANUAL

FAULT CODE	LOG BOOK REPORT	FAULT ISOLATION REFERENCE
38 30 03 --	(See above for the Fault Code Location Identifier) Toilet flush motor inoperative.	Replace the flush timer (AMM 38-32-09/401). If fault continues, replace the flush motor assembly (AMM 38-32-05/401).
38 30 04 --	(See above for the Fault Code Location Identifier) Toilet flush motor runs continuously.	Replace the flush timer (AMM 38-32-09/401).
38 30 05 --	(See above for the Fault Code Location Identifier) Has no water during flush cycle.	Clean toilet flush motor filter. Check flush water feed line for blockage. If fault continues, replace toilet flush motor (AMM 38-32-05/401).
38 30 06 --	(See above for the Fault Code Location Identifier) Toilet tank is empty.	Service toilet tank (AMM 12-17-01/301).
38 30 07 --	(See above for the Fault Code Location Identifier) Toilet leaks water.	Check the gasket for the toilet bowl, the toilet flush motor, the rinse/fill line connection, and the drain valve. Replace the gasket(s) for the above mentioned LRUs if the leak is found around that LRU. If the leak continues replace the LRU (AMM 38-32-01/401).
38 30 15 --	(See above for the Fault Code Location Identifier) Toilet is stopped up.	Service the toilet tank (AMM 12-17-01/301). Remove the clog and clean the toilet tank and the area (AMM 38-32-00/501).
38 30 21 --	(See above for the Fault Code Location Identifier) Toilet flush handle (missing, loose, etc.).	Repair or replace handle.

EFFECTIVITY

ALL

38-FAULT CODE INDEX

01

Page 4
Sep 20/08

BITE Index

1. General

- A. Use this index to find the BITE procedure for the applicable LRU/System.
- B. The BITE procedure will provide the fault isolation instructions for the fault indications/LRU maintenance messages.

<u>LRU/System Name</u>	<u>Acronym</u>	<u>FIM Reference</u>
Air Data Computer	ADC	34-12
Air Data Inertial Reference Unit	ADIRU	34-26
Air Traffic Control Transponder	ATC	34-53
Airborne Vibration Monitor Signal Conditioner	AVM	77-31
Antiskid/Autobrake Control Unit		32-42
APU Fire Detection System		26-15
Automatic Direction Finder Receiver	ADF	34-57
APU Control Unit	ECU	49-11
Brake Temperature Monitor Unit		32-46
Bus Power Control Unit	BPCU	24-20
Cabin Pressure Controller		21-30
Digital Flight Data Acquisition Unit	DFDAU	31-31
Distance Measuring Equipment Interrogator	DME	34-55
Duct Leak (Wing and Body)		26-18
E/E Cooling Control Card (If cards installed)		21-58
ECS Bleed Configuration Card		36-10
Electronic Engine Control (RR Engines)	EEC	73-21
Electronic Engine Control Monitor Unit (PW Engines)	EECM	71-EPCS Message Index
Electronic Flight Instrument System	EFIS	34-22
Electronic Propulsion Control System (PW Engines)	EPCS	71-EPCS Message Index
Engine Fire/Overheat Detection System		26-11
Engine Indication and Crew Alerting System Computer	EICAS	31-41

Bite Index
Figure 1 (Sheet 1)

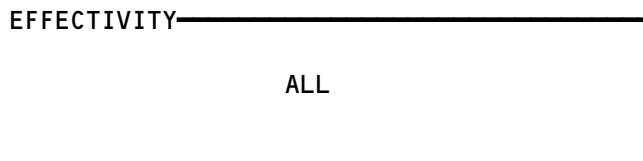

38-BITE INDEX

757
FAULT ISOLATION/MAINT MANUAL

<u>LRU/System Name</u>	<u>Acronym</u>	<u>FIM Reference</u>
Engine Turbine Cooling Overheat Detection System (RR Engines)		26-13
Enhanced Ground Proximity Warning Computer	EGPWC	34-46
Flap/Slat Accessory Module	FSAM	27-51
Flap/Slat Electronic Unit	FSEU	27-51
Flight Management Computer	FMC	34-61
Fuel Quantity Indicating System Processor	FQIS	28-41
Ground Proximity Warning Computer	GPWC	34-46
HF (High Frequency) Communication		23-11
Inertial Reference Unit	IRU	34-21
Instrument Comparator Unit	ICU	34-25
Instrument Landing System Receiver	ILS	34-31
Lower Cargo Compartment Smoke Detection System		26-16
Maintenance Control Display Panel	MCDP	22-00
PA (Passenger Address) Amplifier		23-31
Pack Standby Temperature Controller		21-51
Pack Temperature Controller		21-51
Passenger Entertainment System	PES	23-34
Power Supply Module (Control System Electronics Units)	PSM	27-09
Propulsion Discrete Interface Unit (PW Engines)	PDIU	73-21
Proximity Switch Electronics Unit	PSEU	32-09
Radio Altimeter Transmitter/Receiver	RA	34-33
Rudder Ratio Changer Module	RRCM	27-09
Spoiler Control Module	SCM	27-09
Stabilizer Position Module	SPM	27-48
Stabilizer Trim/Elevator Asymmetry Limit Module	SAM	27-09
Stall Warning Computer/Module (in Warning Electronic Unit)	SWC	27-32
Strut Overheat Detection System (RR Engines)		26-12

Bite Index
Figure 1 (Sheet 2)

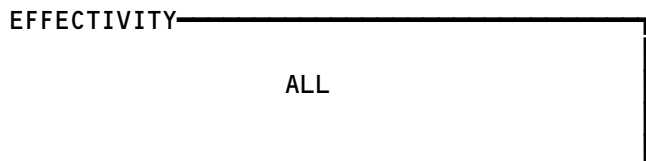

38-BITE INDEX

757
FAULT ISOLATION/MAINT MANUAL

<u>LRU/System Name</u>	<u>Acronym</u>	<u>FIM Reference</u>
Thrust Management Computer/Autothrottle	TMC	22-00
Traffic Alert and Collision Avoidance Computer	TCAS	34-45
VHF (Very High Frequency) Communication		23-12
VOR/Marker Beacon Receiver	VOR/MKR	34-51
Warning Electronic Unit BITE Module (Stall Warning)	WEU	27-32
Weather Radar Transceiver	WXR	34-43
Wheel Well Fire Detection		26-17
Window Heat Control Unit	WHCU	30-41
Yaw Damper Module	YDM	22-21
Yaw Damper/Stabilizer Trim Module	YSM	27-09
Zone Temperature Controller		21-60

Bite Index
Figure 1 (Sheet 3)

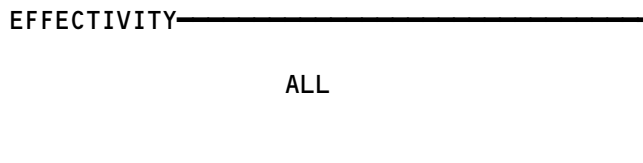

38-BITE INDEX

01

Page 3
Sep 28/99

BOEING
757
FAULT ISOLATION/MAINT MANUAL

POTABLE WATER

COMPONENT	FIG. 102 SHT	QTY	ACCESS/AREA	REFERENCE
CARTRIDGE - POTABLE WATER FAUCET	2	8	IN POTABLE WATER FAUCET	38-11-04
CIRCUIT BREAKER POT WATER CPRSR, C397		1	FLT COMPT, P6 6K21	*
CIRCUIT BREAKER POTABLE WATER, C1355		1	FLT COMPT, P11 11S30	*
CIRCUIT BREAKER POTW CONT GND, C1356		1	119BL, MAIN EQUIP CTR, P34 34A4	*
CIRCUIT BREAKER HEATER LAV WATER C, C4134		1	119BL, MAIN EQUIP CTR, P37 37F1	*
HEATER LAV WATER D, C4135		1	37F2	*
CIRCUIT BREAKER HEATER LAV WATER S, C4341		1	119BL, MAIN EQUIP CTR, P70 70A2	*
HEATER LAV WATER A, C4001		1	70A1	*
COMPRESSOR - AIR, M142	1	1	822, AFT OF AFT CARGO COMPT	38-15-01
FAUCET - POTABLE WATER	2	4	ON LAV WASHBASIN	38-11-04
FILTER - BLEED AIR	1	1	822, AFT OF AFT CARGO COMPT	38-15-02
FILTER - COMPRESSOR INLET AIR	1	1	822, AFT OF AFT CARGO COMPT	38-15-02
HEATER - WATER, H1	2	4	BELOW LAV WASHBASIN	38-13-51
INDICATOR WATER QUANTITY, N10005	2	1	FWD GALLEY SIDEWALL	38-14-01
INDICATOR WATER QUANTITY, N10006		1	POT WATER SERVICE PANEL, P25	38-14-01
REGULATOR - PRESSURE	1	1	822, AFT OF AFT CARGO COMPT	38-11-03
RELAY - (REF 31-01-34, FIG. 101) LAVATORIES POWER, K5				
RELAY - (REF 31-01-86, FIG. 101) WATER PRESSURE SYSTEM, K6				
RESTRICTOR	2	1	193HL,194ER, ECS BAY	38-11-00
SWITCH - PRESSURE, S332	1	1	822, AFT OF AFT CARGO COMPT	38-15-07
TANK - POTABLE WATER	1	1	822, AFT OF AFT CARGO COMPT	38-11-01
TRANSMITTER, WATER QUANTITY, TS167	1	1	822, AFT OF AFT CARGO COMPT	38-14-03
VALVE - FILL/OVERFLOW	1	1	822, AFT OF AFT CARGO COMPT	38-11-02
VALVE - PRESSURE RELIEF	1	1	822, AFT OF AFT CARGO COMPT	38-15-04
VALVE - TANK DRAIN	1	1	822, AFT OF AFT CARGO COMPT	38-11-05

* SEE THE WDM EQUIPMENT LIST

Potable Water - Component Index
Figure 101

EFFECTIVITY

ALL

38-10-00

BOEING

757

FAULT ISOLATION/MAINT MANUAL

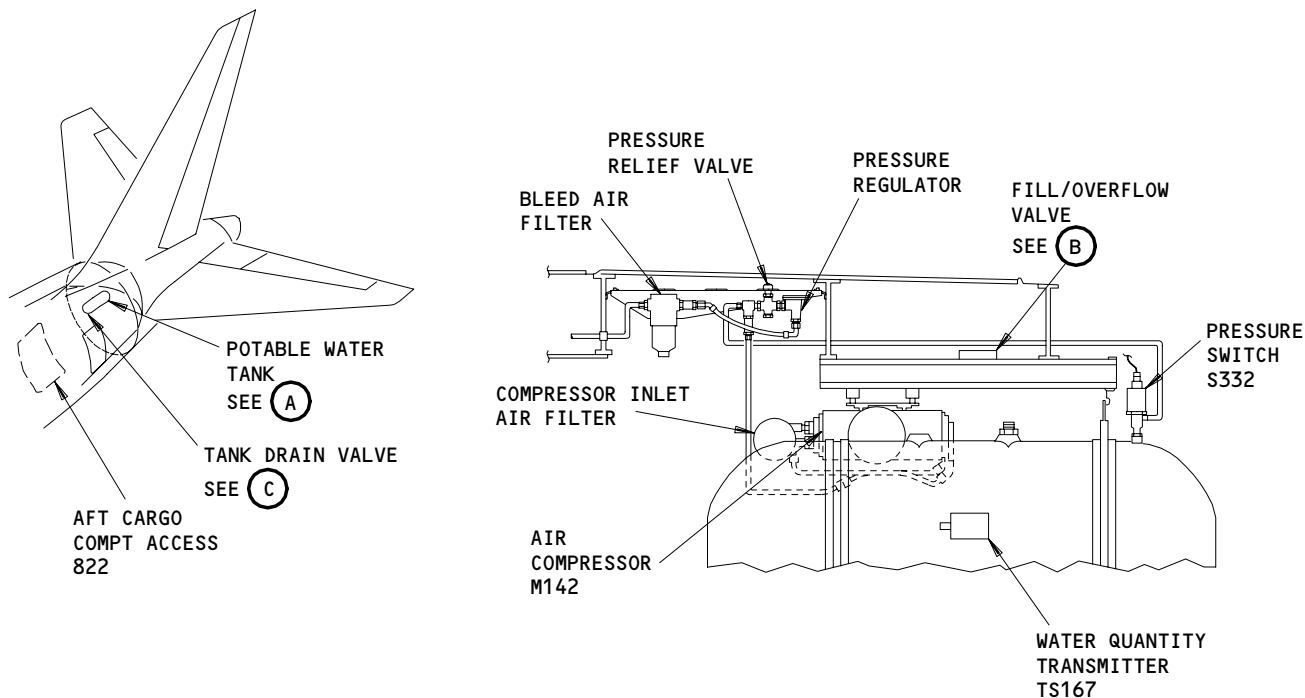

POTABLE WATER TANK

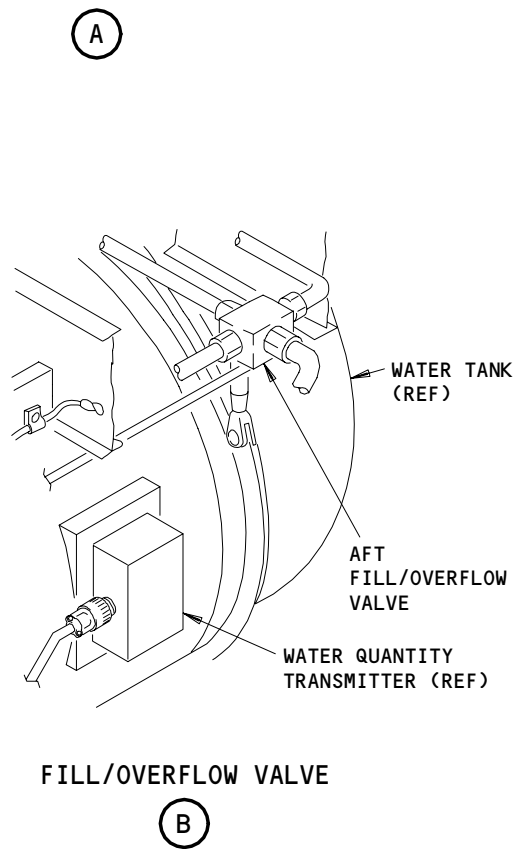
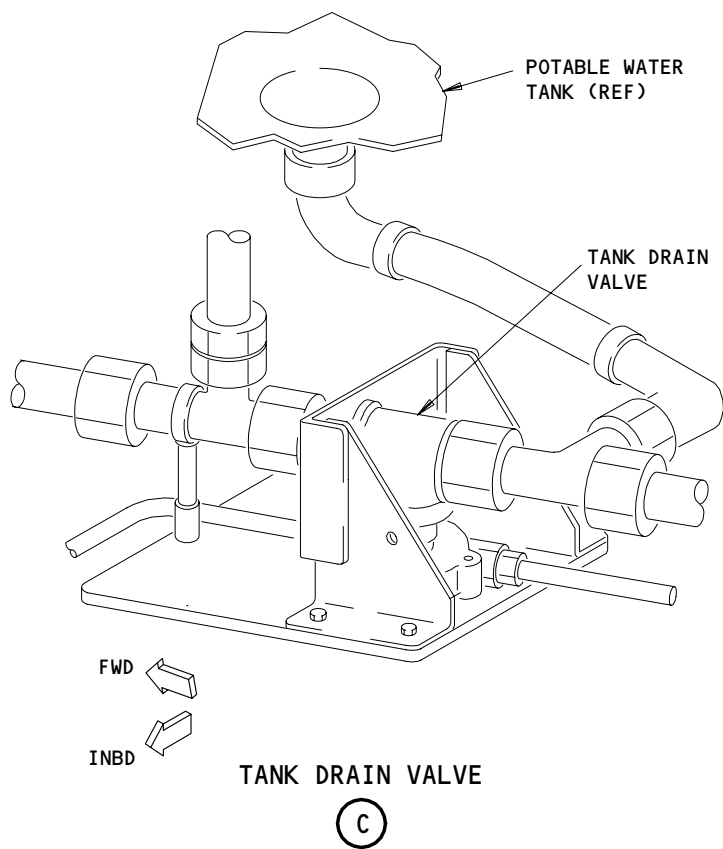

Component Location
Figure 102 (Sheet 1)

EFFECTIVITY	
	ALL

38-10-00

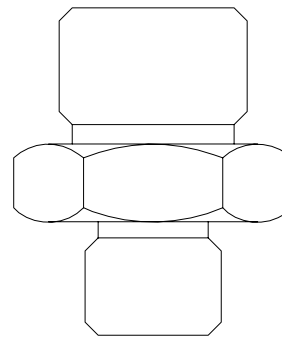
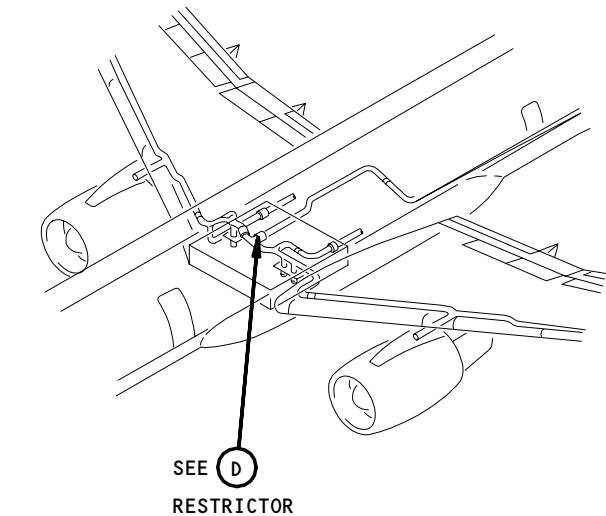

RESTRICTOR

D

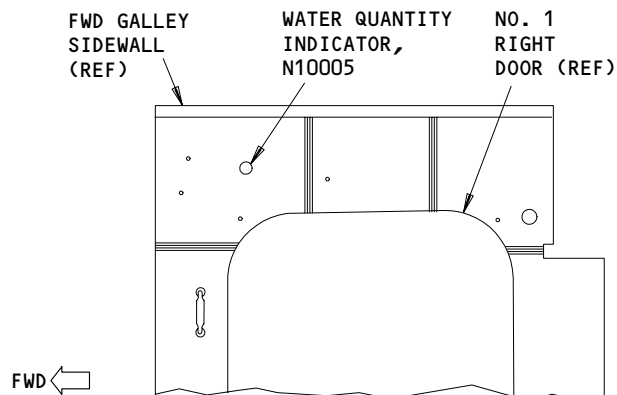
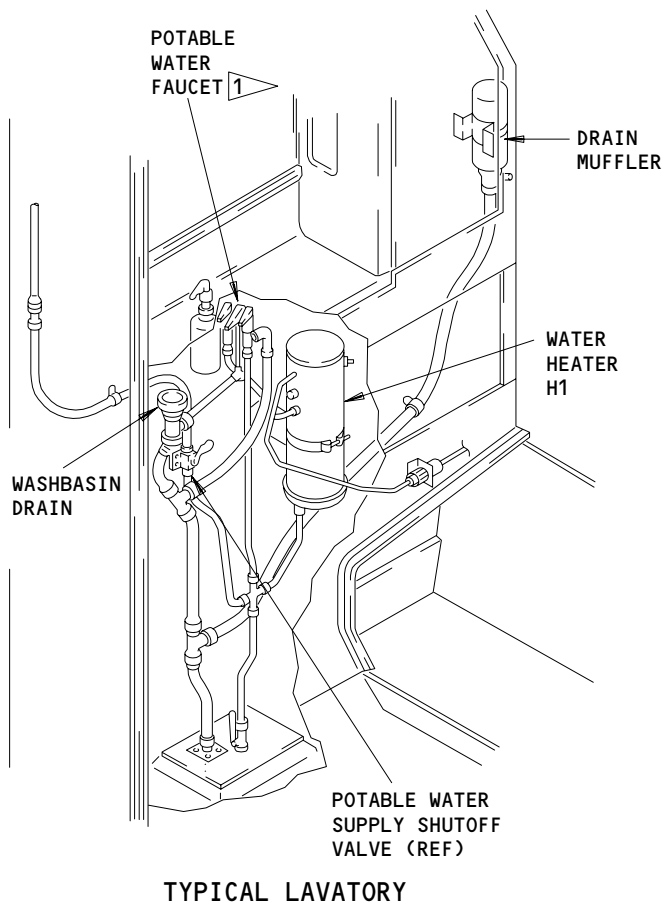

1 FAUCET CARTRIDGE INSIDE WATER FAUCET

Component Location
Figure 102 (Sheet 2)

EFFECTIVITY	ALL
-------------	-----

38-10-00

01

Page 103
Sep 15/86

230098

NO WATER FLOW AT ANY FAUCET. WATER QUANTITY NORMAL

PREREQUISITES
MAKE SURE THESE CIRCUIT BREAKERS ARE CLOSED:
6K21,11S32
MAKE SURE THE AIRPLANE IS IN THIS CONFIGURATION:
ELECTRICAL POWER IS ON (AMM 24-22-00/201)

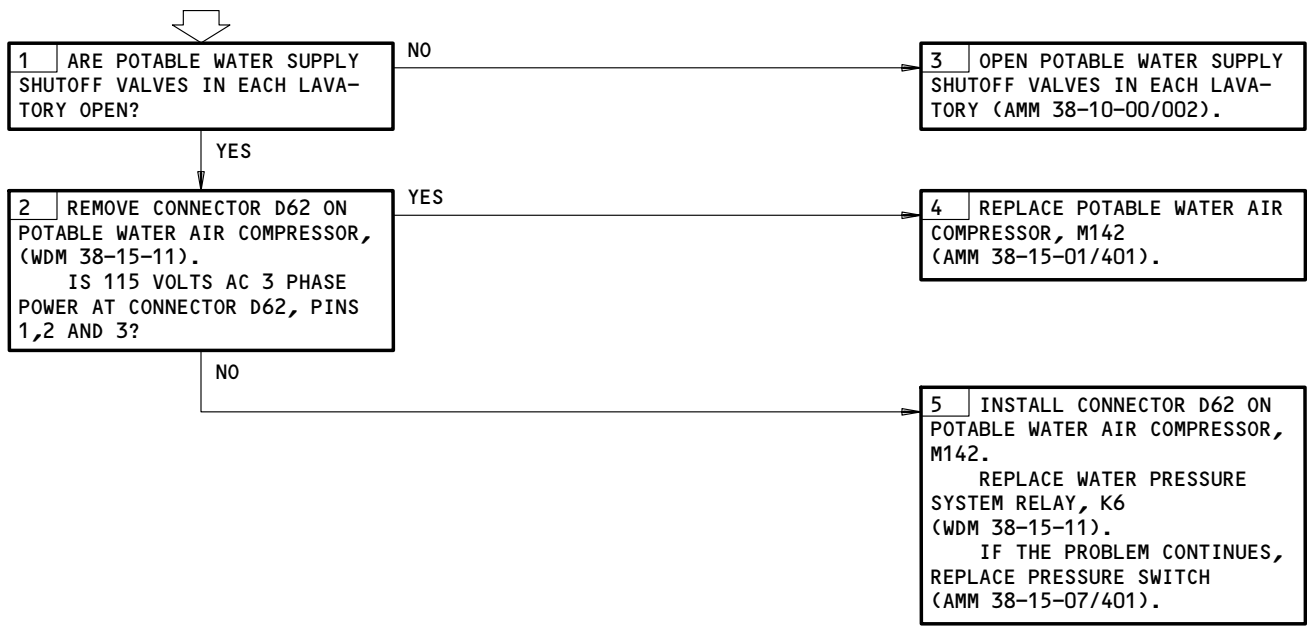

No Water Flow At Any Faucet. Water Quantity Normal
Figure 103

EFFECTIVITY	ALL
-------------	-----

38-10-00

E48798

**WATER FLOW IS LOW
AT ALL FAUCETS.
WATER QUANTITY
NORMAL**

PREREQUISITES

MAKE SURE THESE CIRCUIT BREAKERS ARE CLOSED:
6K21,11S32

MAKE SURE THE AIRPLANE IS IN THIS CONFIGURATION:
ELECTRICAL POWER IS ON (AMM 24-22-00/201)

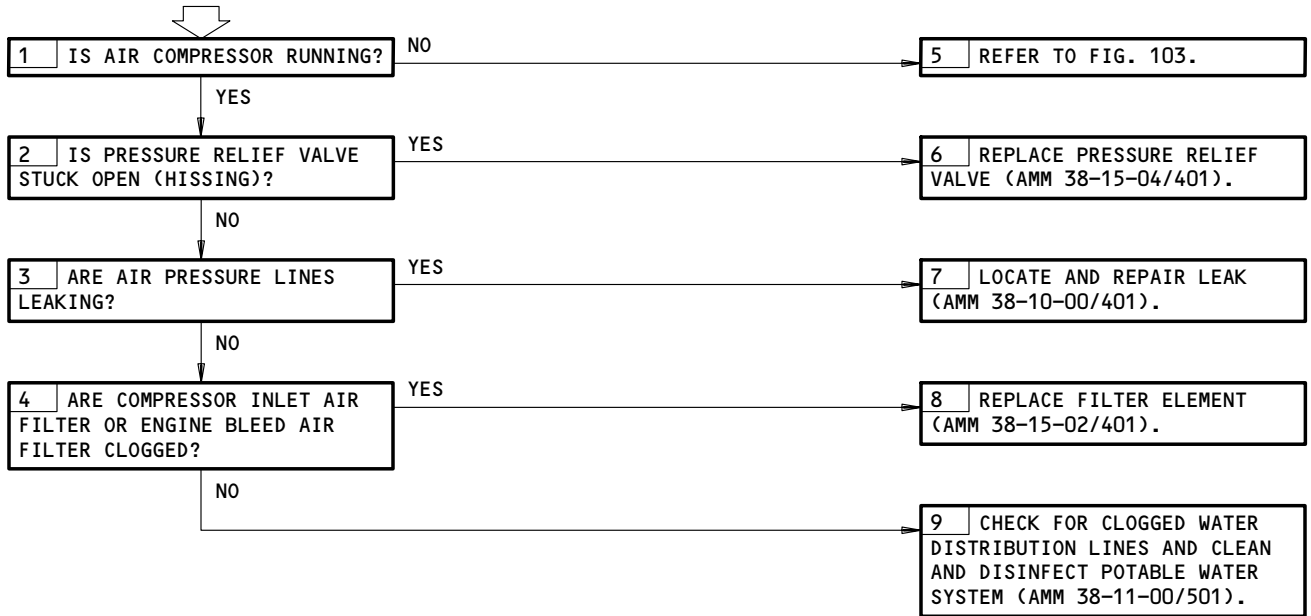

Water Flow Is Low At All Faucets. Water Quantity Normal
Figure 104

EFFECTIVITY	ALL
-------------	-----

38-10-00

05

Page 105
May 20/98

261545

WATER QUANTITY INDICATES ZERO. WATER FLOW IS NORMAL

PREREQUISITES
MAKE SURE THESE CIRCUIT BREAKERS ARE CLOSED:
6K21,11S32
MAKE SURE THE AIRPLANE IS IN THIS CONFIGURATION:
ELECTRICAL POWER IS ON (AMM 24-22-00/201)

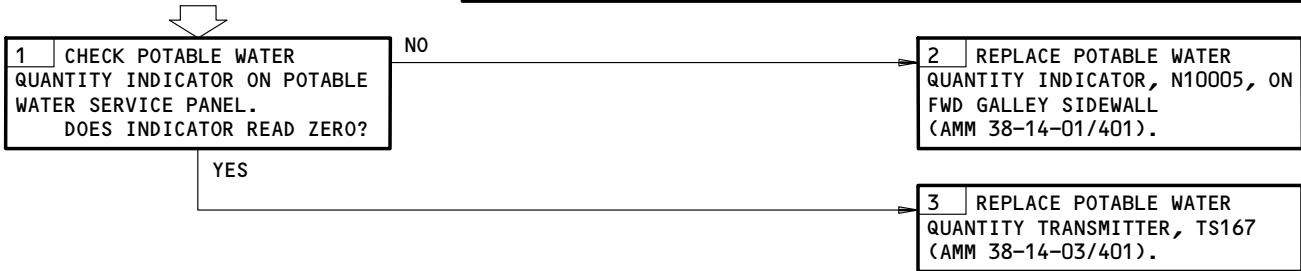

Water Quantity Indicates Zero. Water Flow Is Normal
Figure 105

EFFECTIVITY	ALL
-------------	-----

38-10-00

PREREQUISITES

MAKE SURE THESE CIRCUIT BREAKERS ARE CLOSED:
6K21,11S32

MAKE SURE THE AIRPLANE IS IN THIS CONFIGURATION:
ELECTRICAL POWER IS ON (AMM 24-22-00/201)

(NO, LOW) WATER FLOW FROM FAUCET. WATER QTY WAS NORM

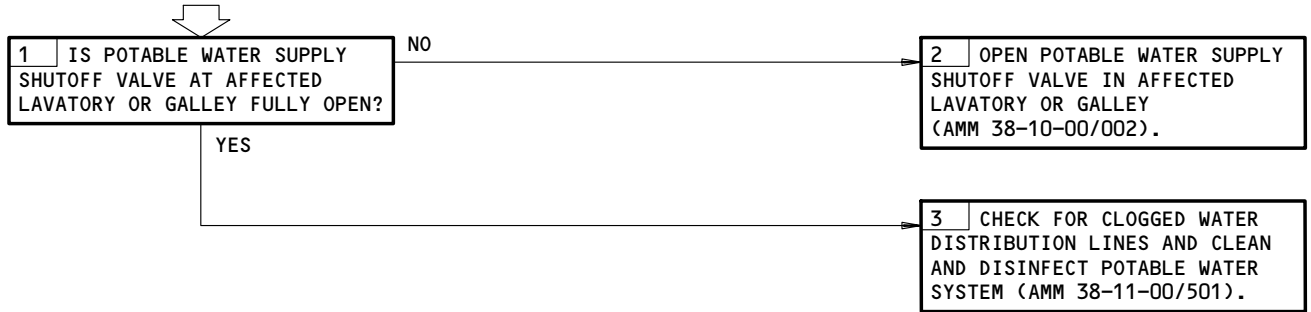

(No, Low) Water Flow from Faucet. Water Qty was Norm
Figure 106

EFFECTIVITY	ALL
-------------	-----

38-10-00

BOEING
757
FAULT ISOLATION/MAINT MANUAL

WASTE DISPOSAL

COMPONENT	FIG. 102 SHT	QTY	ACCESS/AREA	REFERENCE
CIRCUIT BREAKER - LAV FILL CONTROL, C4086	--	1	119BL, MAIN EQUIP CTR, P34 34A3	
CIRCUIT BREAKER - LAV FILL VALVE, C4169	--	1	119BL, MAIN EQUIP CTR, P37 37D8	
CIRCUIT BREAKERS - LAV FLUSH MOTOR A, C3003	--	1	FLT COMPT, P11 11S8	*
LAV FLUSH MOTOR F, C3004	1	1	11S11	*
LAV FLUSH MOTOR S, C3043	1	1	11S11	*
LAV FLUSH MOTOR C, C3011	1	1	11S25	*
LAV FLUSH MOTOR D, C3012	1	1	11S28	*
BOWL - TOILET	1	4	LAVATORY TOILET TANK	38-32-11
CABLE - DRAIN VALVE CONTROL	1	4	LAVATORY	38-32-10
MAST - DRAIN	2	2	AFT OF FORWARD & AFT CARGO COMPARTMENTS	38-31-01
MOTOR - TOILET FLUSH, (M1)	1	4	LAVATORY TOILET TANK	38-32-05
NIPPLE - WASTE TANK DRAIN DUCT	2	3	LAVATORY SERVICE PANEL DOORS 119AL,121AL,166AR	38-32-16
SENSOR - LEVEL, (S1)	1	4	LAVATORY TOILET TANK	38-32-04
SEPARATOR - WATER	1	4	LAVATORY TOILET BACK SHROUD	38-30-00
TANK - TOILET	1	4	LAVATORY	38-32-01
TIMER - FLUSH, (S2)	1	4	LAVATORY TOILET TANK	38-32-09
VALVE - RINSE/FILL LINE SHUTOFF, (V1)	1	4	LAVATORY TOILET TANK	38-32-03
VALVE - TOILET TANK DRAIN	1	4	LAVATORY TOILET TANK	38-32-02

* SEE THE WDM EQUIPMENT LIST

1 NOT ALL AIRPLANES

Waste Disposal - Component Index
Figure 101

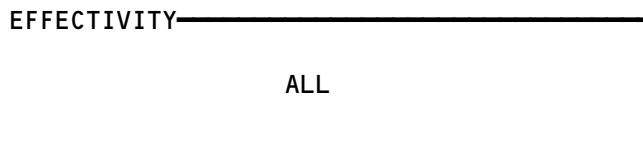

38-30-00

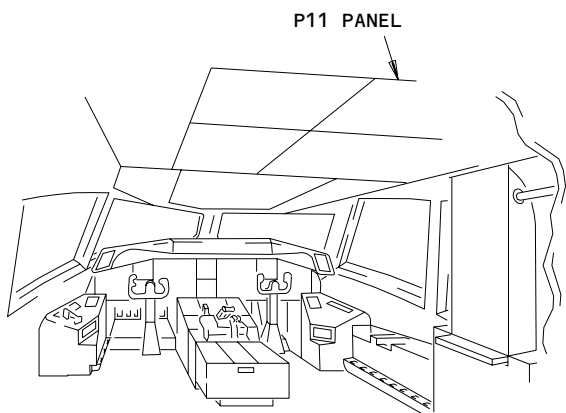

FLIGHT COMPARTMENT

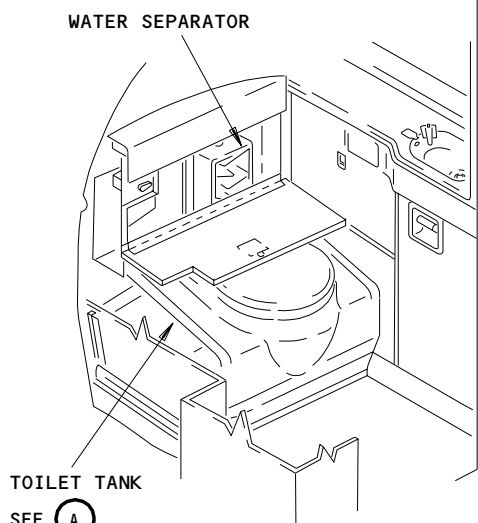

LAVATORY COMPARTMENT
(EXAMPLE)

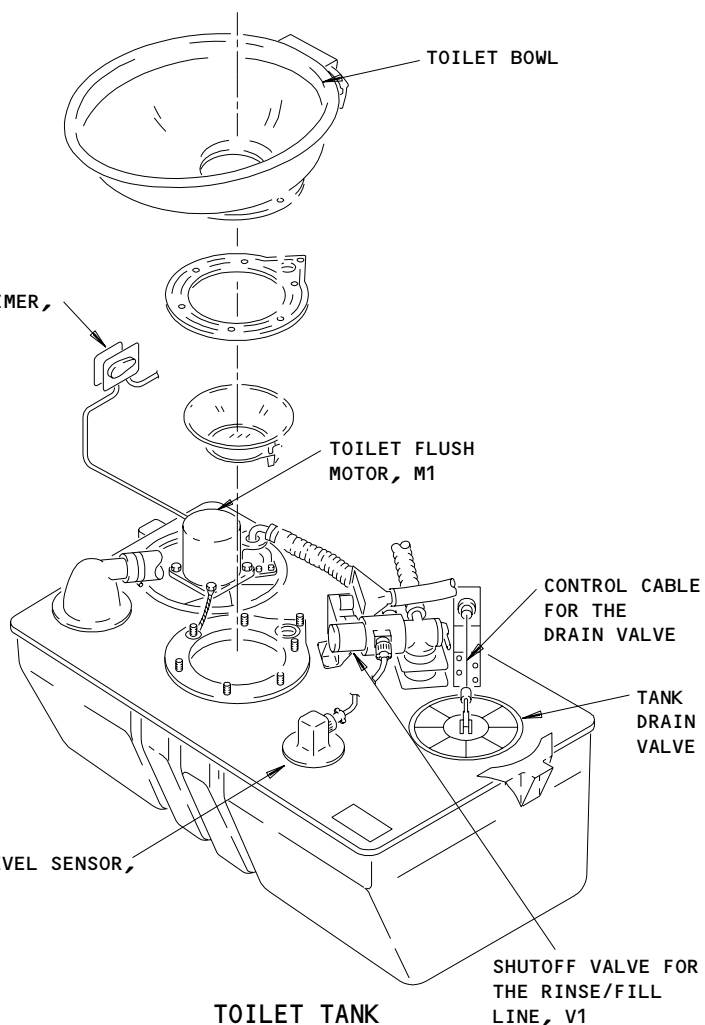

TOILET TANK
(EXAMPLE)

(A)

Waste Disposal - Component Location
Figure 102 (Sheet 1)

EFFECTIVITY

ALL

38-30-00

02

Page 102
Dec 20/91

196705

BOEING
757
FAULT ISOLATION/MAINT MANUAL

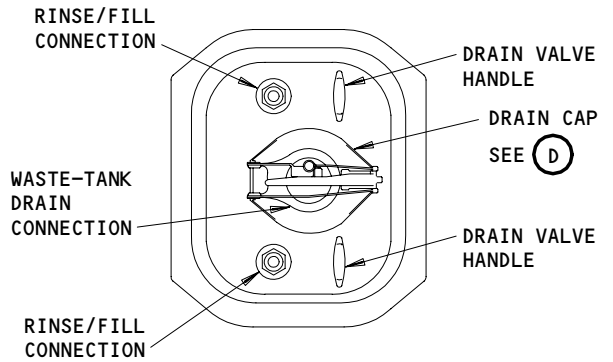
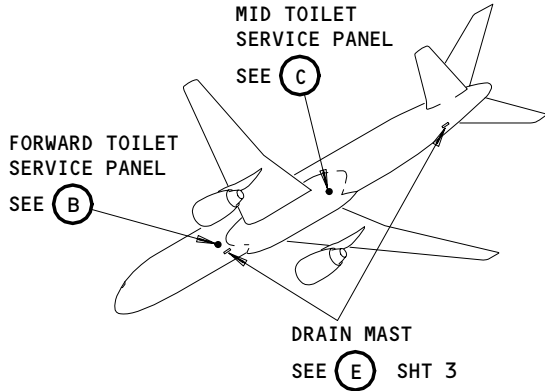

FORWARD TOILET SERVICE PANEL
(B)

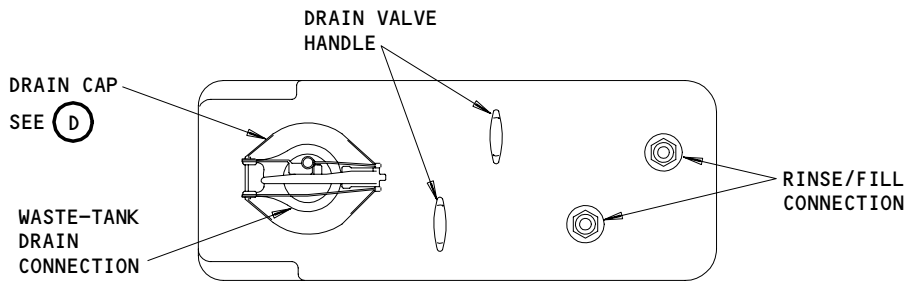

MID TOILET SERVICE PANEL
(C)

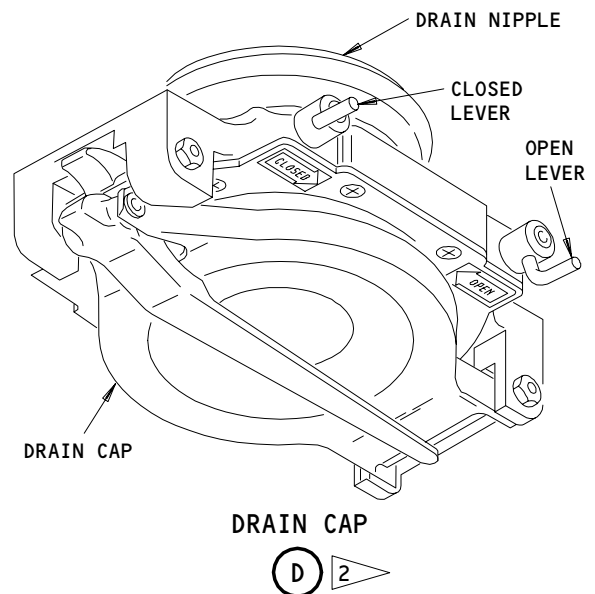
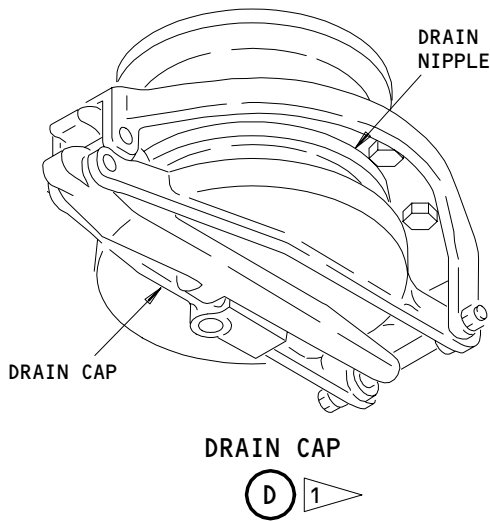

- 1 AIRPLANES WITH DRAIN CAP AND DRAIN PLUG
- 2 AIRPLANES WITH DRAIN CAPS WITH OPEN/CLOSE LEVERS

Waste Disposal - Component Location
Figure 102 (Sheet 2)

EFFECTIVITY	ALL
-------------	-----

38-30-00

05

Page 103
Sep 20/92

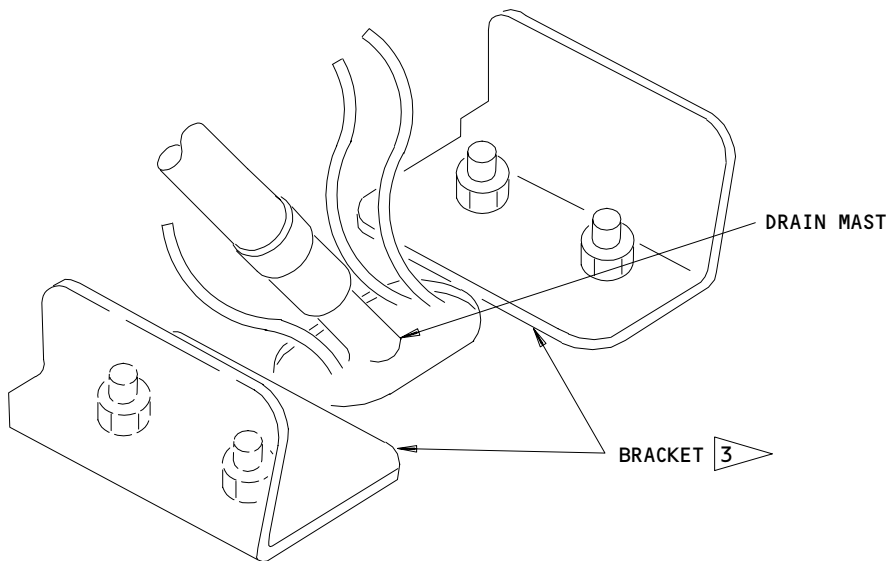

DRAIN MAST
(INSIDE AIRPLANE VIEW)

(E)

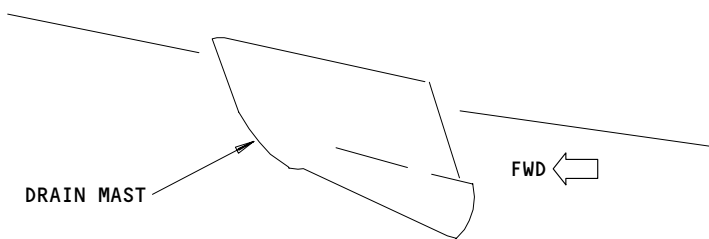

DRAIN MAST
(OUTSIDE AIRPLANE VIEW)

(E)

3 NOT ON THE FORWARD
DRAIN MAST

Waste Disposal - Component Location (Detail from Sht 2)
Figure 102 (Sheet 3)

EFFECTIVITY	ALL
-------------	-----

38-30-00

01

Page 104
Sep 20/92