

GPA Group plc

PAGE	DATE	CODE	PAGE	DATE	CODE	PAGE	DATE	CODE
CHAPTER 74 TAB								
IGNITION								
EFFECTIVE PAGES SEE LAST PAGE OF LIST FOR NUMBER OF PAGES								
74--CONTENTS								
1	SEP 28/99	RGUI						
2	BLANK							
74--FAULT CODE INDEX								
1	SEP 20/08	R02						
2	BLANK							
74-11-00								
101	SEP 20/92	R03						
102	JUN 20/92	R01						
103	DEC 20/93	R01						
104	JUN 20/95	R01						
105	JUN 20/92	R01						
106	SEP 20/95	R01						
74-21-00								
101	SEP 20/92	R01						
102	JAN 28/02	R01						
103	JAN 28/02	R01						
104	BLANK							
74-31-00								
101	SEP 20/92	R01						
102	SEP 20/93	R02						

R = REVISED, A = ADDED OR D = DELETED
F = FOLDOUT PAGE
32
JAN 20/09

D633N632

CHAPTER 74
EFFECTIVE PAGES
R PAGE 1
LAST PAGE

CHAPTER 74 - IGNITION

TABLE OF CONTENTS

<u>Subject</u>	Chapter Section <u>Subject</u>	<u>Page</u>	<u>Effectivity</u>
FAULT ISOLATION	74-FAULT CODE INDEX	1	ALL
<u>IGNITION</u>	74-00-00		
<u>ELECTRICAL POWER SUPPLY</u>	74-10-00		
IGNITION POWER SUPPLY	74-11-00		
Component Location		101	ALL
Component Index			
Component Location			
Fault Isolation			
Engine Rotates but Does Not Light-Off. Fuel Flow was Indicated. Light-Off Achieved when ALTERNATIVE or BOTH Ignition Systems Selected (Fig. 103)		103	
Engine Would Not Start, Fuel Flow Indicated, Ignition Switch Selected to BOTH (Fig. 104)		105	
EICAS Msg L (R) IGN STBY BUS Displayed (Fig. 105)		106	
<u>DISTRIBUTION</u>	74-20-00		
HIGH TENSION DISTRIBUTION	74-21-00		
Component Location		101	ALL
Component Index			
Component Location			
<u>SWITCHING</u>	74-30-00		
ENGINE IGNITION CONTROL	74-31-00		
Component Location		101	ALL
Component Index			
Component Location			

74-CONTENTS

FAULT CODE	LOG BOOK REPORT	FAULT ISOLATION REFERENCE
74 11 01 __	(01=L,02=R) Engine no EGT rise during start attempt with ign selector in (IGN 1, IGN 2), start in BOTH was normal.	FIM 74-11-00/101, Fig. 103, Block 1
74 11 02 00	EICAS msg L IGN STBY BUS displayed.	FIM 74-11-00/101, Fig. 105, Block 1
74 11 03 00	EICAS msg R IGN STBY BUS displayed.	FIM 74-11-00/101, Fig. 105, Block 1
74 11 04 __	(01=L,02=R) Engine no EGT rise during start attempt with ign selector BOTH and fuel control switch RUN or RICH.	FIM 74-11-00/101, Fig. 104, Block 1
74 11 05 __	(01=L,02=R) Engine slow to light off, ____ sec.	Replace the two igniter plugs (AMM 74-21-02/401).

EFFECTIVITY

ALL

74-FAULT CODE INDEX

R02

 Page 1
 Sep 20/08

IGNITION POWER SUPPLY

COMPONENT	FIG. 102 SHT	QTY	ACCESS/AREA	REFERENCE
RELAYS - (31-01-36/101) LEFT AUTO IGN CONT, K10401 LEFT BUS POWER SENSE, K10329 TRANSIENT PRESSURE UNIT, K10550 RELAYS - (31-01-37/101) RIGHT BUS POWER SENSE, K10331 RIGHT ENG AUTO IGN CONT, K10402 TRANSIENT PRESSURE UNIT, K10549 UNIT - IGNITION 1, M10149	1	2	413AL, LEFT ENGINE FAN COWL, 423AL, RIGHT ENGINE FAN COWL	74-11-01
UNIT - IGNITION 2, M10150	1	2	413AL, LEFT ENGINE FAN COWL, 423AL, RIGHT ENGINE FAN COWL	74-11-01

Ignition Power Supply - Component Index
Figure 101

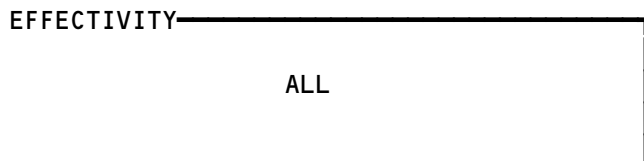

74-11-00

R03

Page 101
Sep 20/92

A46614

NO. 1, NO. 2 HIGH ENERGY
IGNITION UNITS, M10149, M10150

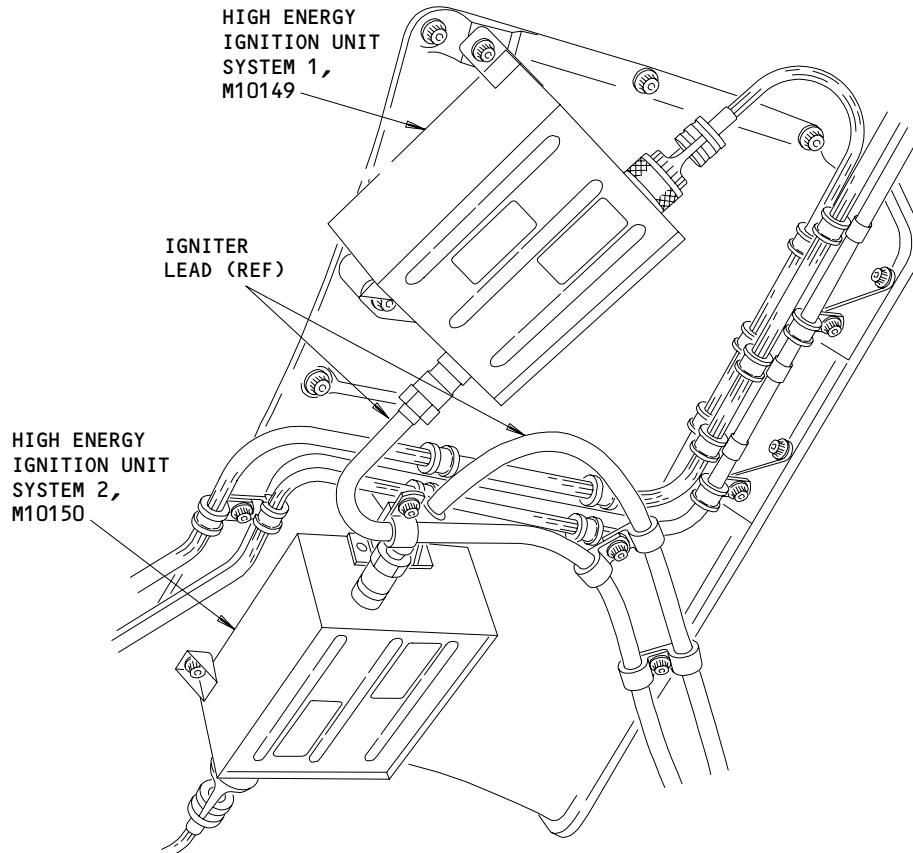
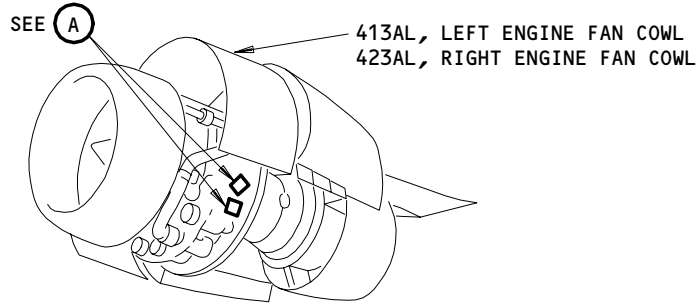

HIGH ENERGY IGNITION UNITS,
M10149, M10150

(A)

Ignition Power Supply - Component Location
Figure 102

EFFECTIVITY	
	ALL

74-11-00

R01

Page 102
Jun 20/92

A44971

ENGINE ROTATES BUT DOES NOT LIGHT-OFF. FUEL FLOW WAS INDICATED. LIGHT-OFF ACHIEVED WHEN "ALTERNATIVE" OR "BOTH" IGNITION SYSTEMS SELECTED

PREREQUISITES
MAKE SURE THESE CIRCUIT BREAKERS ARE OPEN AND ATTACH DO-NOT-CLOSE TAGS:
(LEFT ENGINE) 6C1,6E1,11D7,11D8,11D19,11L1
(RIGHT ENGINE) 6C2,6E2,11D9,11D10,11D20,11L28
MAKE SURE THE AIRPLANE IS IN THIS CONFIGURATION:
ELECTRICAL POWER IS ON (AMM 24-22-00/201)

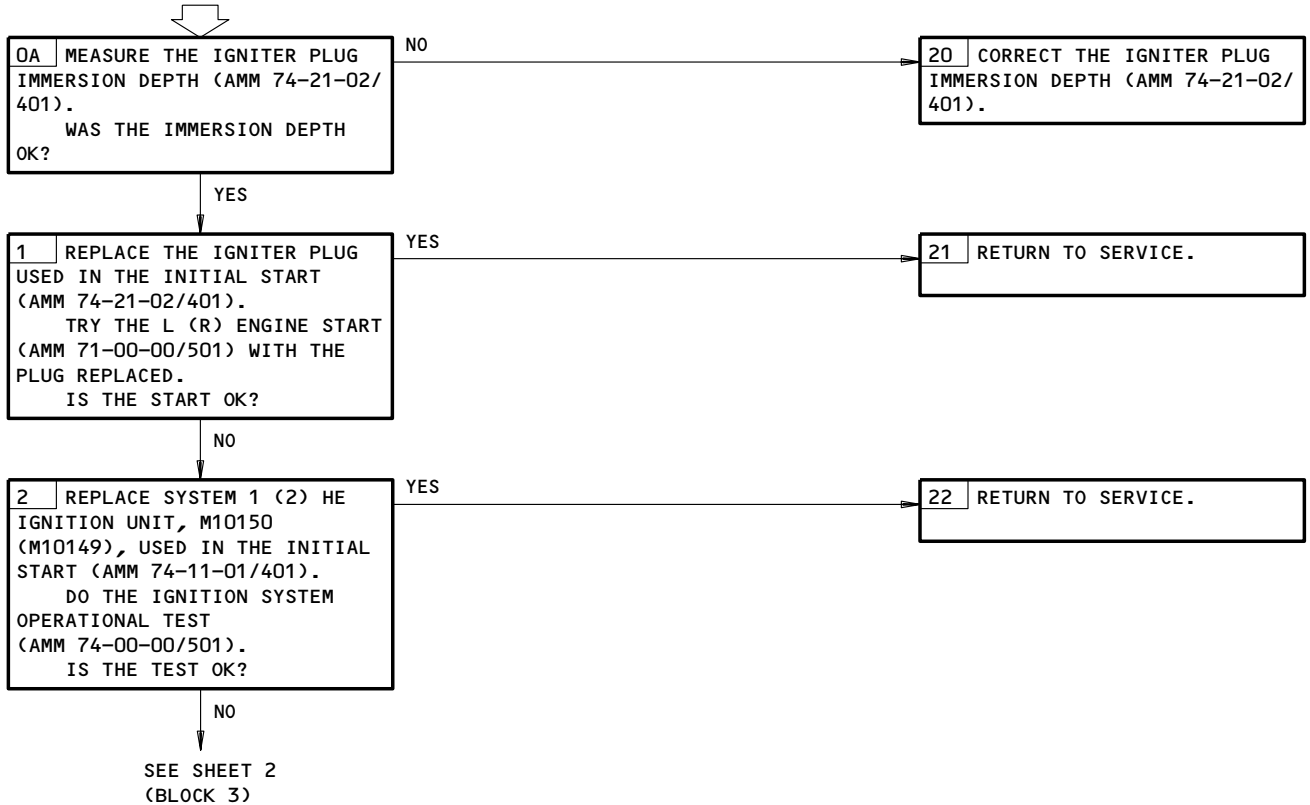

Engine Rotates but Does Not Light-Off. Fuel Flow was Indicated.
Light-Off Achieved when ALTERNATIVE or BOTH Ignition Systems Selected
Figure 103 (Sheet 1)

EFFECTIVITY	ALL
-------------	-----

74-11-00

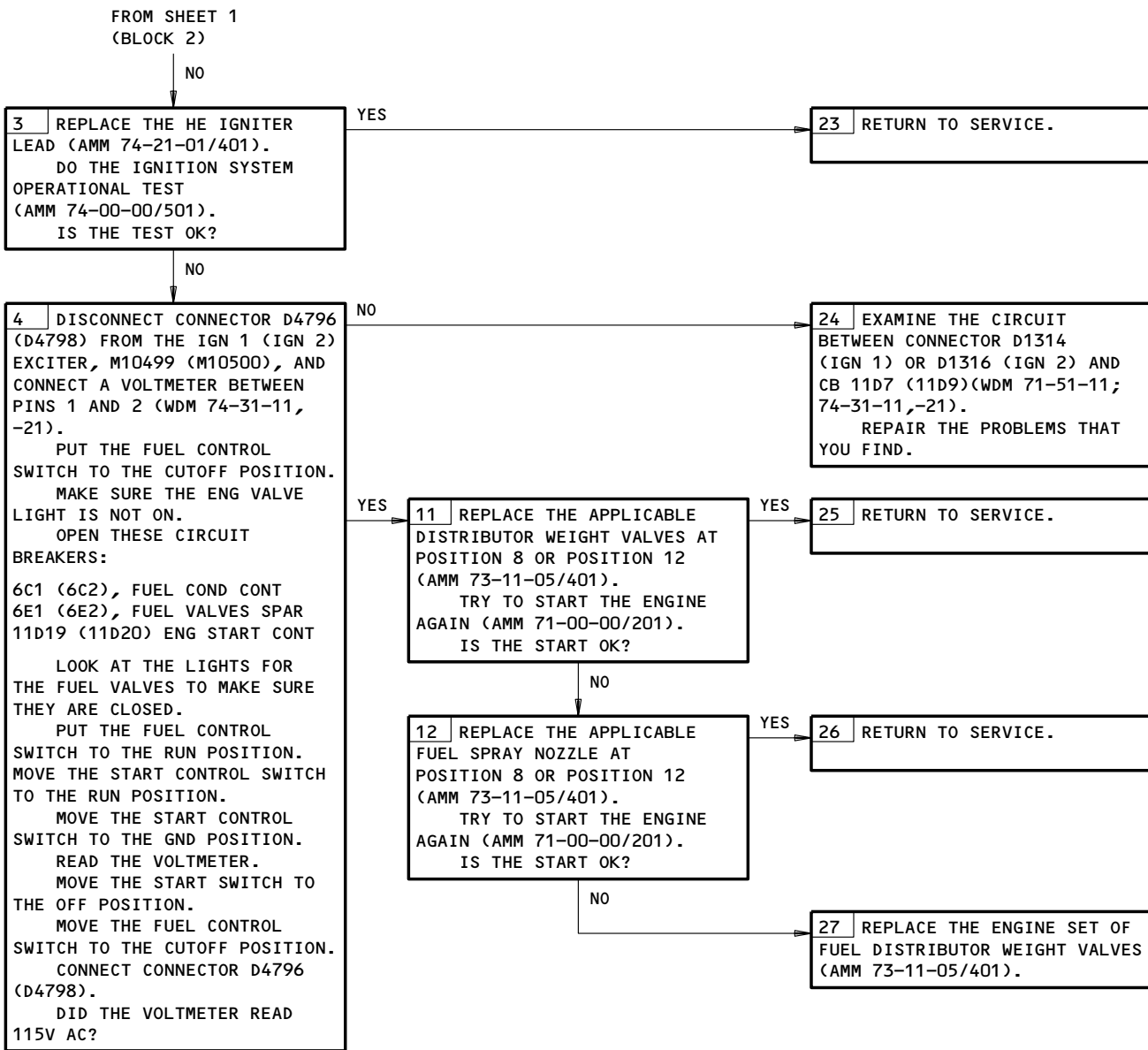

Engine Rotates but Does Not Light-Off. Fuel Flow Was Indicated.
Light-Off Achieved When ALTERNATIVE or BOTH Ignition Systems Selected
Figure 103 (Sheet 2)

EFFECTIVITY	ALL
-------------	-----

74-11-00

ENGINE WOULD NOT
START, FUEL FLOW
INDICATED, IGNITION
SWITCH SELECTED TO
"BOTH"



PREREQUISITES

MAKE SURE THESE CIRCUIT BREAKERS ARE OPEN AND ATTACH
DO-NOT-CLOSE TAGS:
(LEFT ENGINE) 11D7,11D9,11L1
(RIGHT ENGINE) 11D8,11D10,11L28

1 REPLACE THE ENGINE START/RAT CONTROL PNL, M10468 (WDM 74-31-11,-21). IF THE PROBLEM CONTINUES,
REPLACE THE TWO IGNITER PLUGS (MM 74-21-02/401).

Engine Would Not Start, Fuel Flow Indicated, Ignition Switch Selected to BOTH
Figure 104

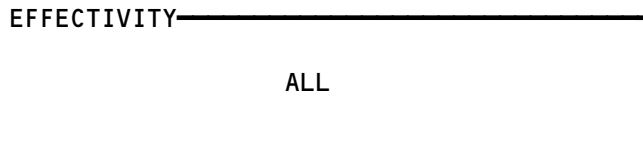

74-11-00

R01

Page 105
Jun 20/92

EICAS MSG "L (R)
IGN STBY BUS"
DISPLAYED

PREREQUISITES

MAKE SURE THESE CIRCUIT BREAKERS ARE CLOSED:
(LEFT ENGINE) 11D7,11L1
(RIGHT ENGINE) 11D9,11L28

MAKE SURE THE AIRPLANE IS IN THIS CONFIGURATION:
ELECTRICAL POWER IS ON (AMM 24-22-00/201)

1 DOES THE "L (R) IGN STBY BUS" MESSAGE REMAIN ON AFTER THE PREREQUISITES ARE SATISFIED?

YES

NO

2 THE SYSTEM IS OK.

21 REPLACE THE L (R) BUS PWR SENSE RLY, K10329 (K10331) (WDM 74-31-11,-21).
IF THE PROBLEM CONTINUES, REMOVE THE L (R) EICAS COMPUTER, M10181 (M10182) (AMM 31-41-02/401).
EXAMINE THE CIRCUIT FROM CONNECTOR D4306 (D4228), PIN A2, TO THE EICAS, CONNECTORS D321B, PIN H15 (D3198, PIN K2).
REPAIR THE PROBLEMS THAT YOU FIND.
INSTALL THE EICAS COMPUTER.

EICAS Msg L (R) IGN STBY BUS Displayed
Figure 105

EFFECTIVITY	ALL
-------------	-----

74-11-00

A46699

HIGH TENSION DISTRIBUTION

COMPONENT	FIG. 102 SHT	QTY	ACCESS/AREA	REFERENCE
LEAD - IGNITER	2	4	413AL,423AL,414AR,424AR, FAN COWL	74-21-01,02
PLUG - IGNITER	2	4	415AL,425AL,416AR,426AR, THRUST REVERSER	74-21-01,02

High Tension Distribution - Component Index
Figure 101

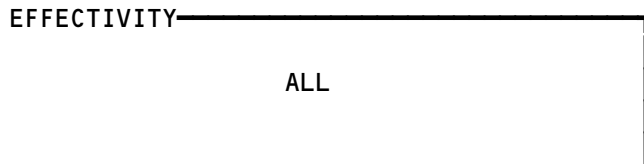

74-21-00

R01

Page 101
Sep 20/92

A46710

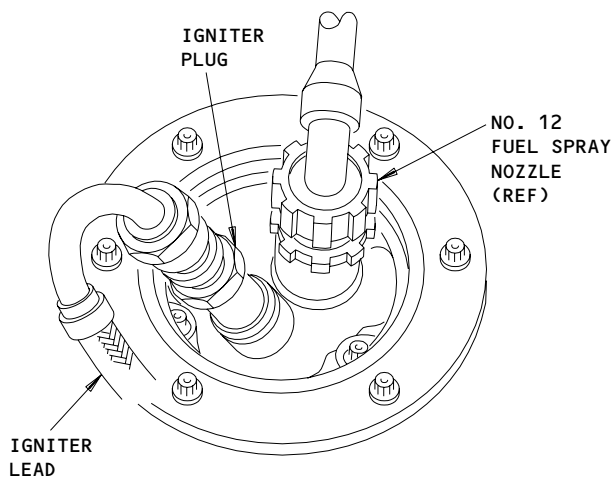
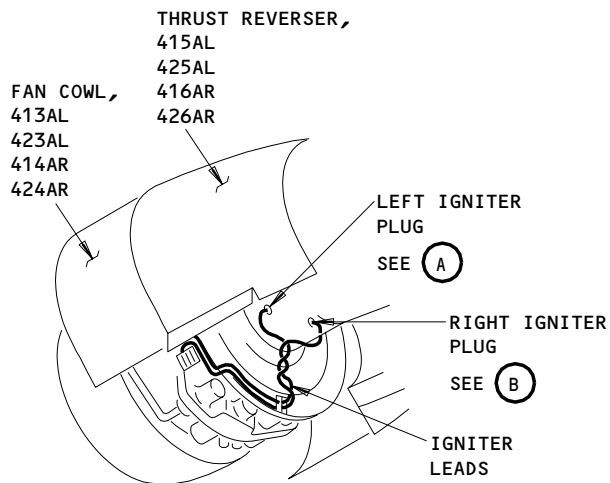

LEFT IGNITER PLUG

(A)

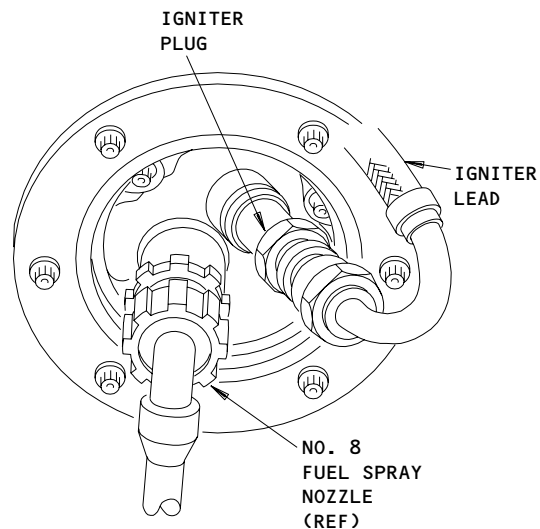

RIGHT IGNITER PLUG

(B)

High Tension Distribution - Component Location
Figure 102 (Sheet 1)

EFFECTIVITY
RB211-535C, RB211-535E4 AND
RB211-535E4-B ENGINES PRE-RR-SB 72-C230
(PHASE II COMBUSTOR)

74-21-00

R01

Page 102
Jan 28/02

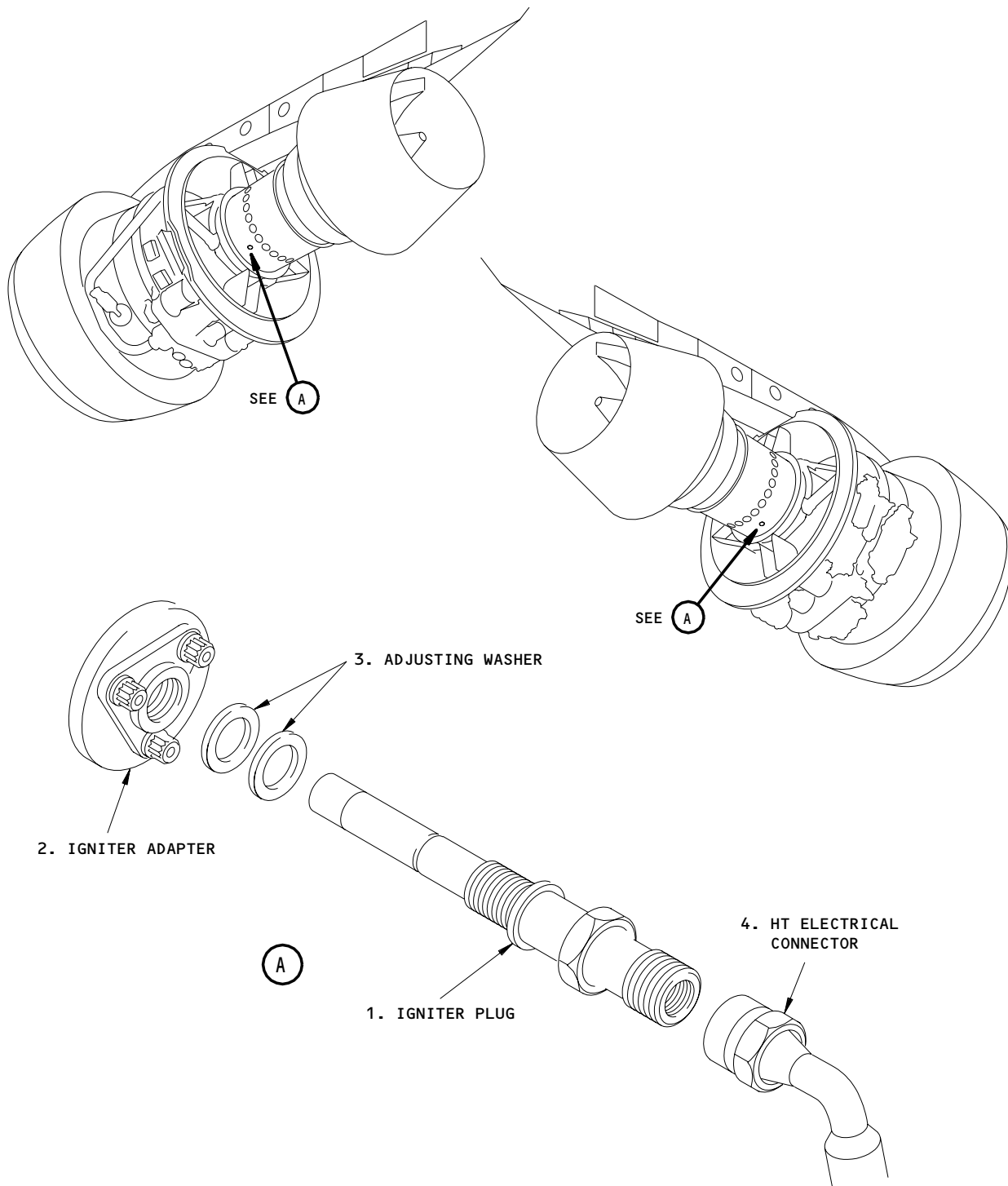

DEE00Y2232

High Tension Distribution - Component Location
Figure 102 (Sheet 2)

EFFECTIVITY
RB211-535E4 AND RB211-535E4-B ENGINES
POST-RR-SB 72-C230 (PHASE V COMBUSTOR);
RB211-535E4-C ENGINES

74-21-00

R01

Page 103
Jan 28/02

ENGINE IGNITION CONTROL

COMPONENT	FIG. 102 SHT	QTY	ACCESS/AREA	REFERENCE
CIRCUIT BREAKERS -	--		FLT COMPT, P11	
ENGINE IGN 1 LEFT, C1430		1	11L1	*
ENGINE IGN 1 RIGHT, C1432		1	11L28	*
ENGINE STBY IGN LEFT 1, C1434		1	11D7	*
ENGINE STBY IGN LEFT 2, C1435		1	11D8	*
ENGINE STBY IGN RIGHT 1, C1437		1	11D9	*
ENGINE STBY IGN RIGHT 2, C1438		1	11D10	*
ENGINE START CONT LEFT, C1510		1	11D19	*
ENGINE START CONT RIGHT, C1511		1	11D20	*
COMPUTERS - (31-41-00/101)				
EICAS L, M10181				
EICAS R, M10182				
MODULES - (27-50-01/101)				
FSEU 2, M10332				
L FSEU 1, M10331				
R FSEU 3, M10333				
MODULE - (30-21-00/101)				
WING/ENGINE ANTI-ICE, M10397				
MODULE - ENGINE START/RAM AIR TURBINE CONTROL, M10468	--	1	FLT COMPT, P5	*
SWITCH - IGNITION SELECTOR, S2	--	1	FLT COMPT, P5, ENG START/RAM AIR TURBINE CONTROL MODULE, M10468	

* SEE THE WDM EQUIPMENT LIST

Engine Ignition Control - Component Index
Figure 101

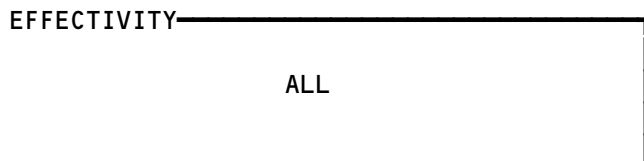

74-31-00

ENGINE START/RAM AIR
TURBINE (RAT) CONTROL
MODULE, M10468

SEE (A)

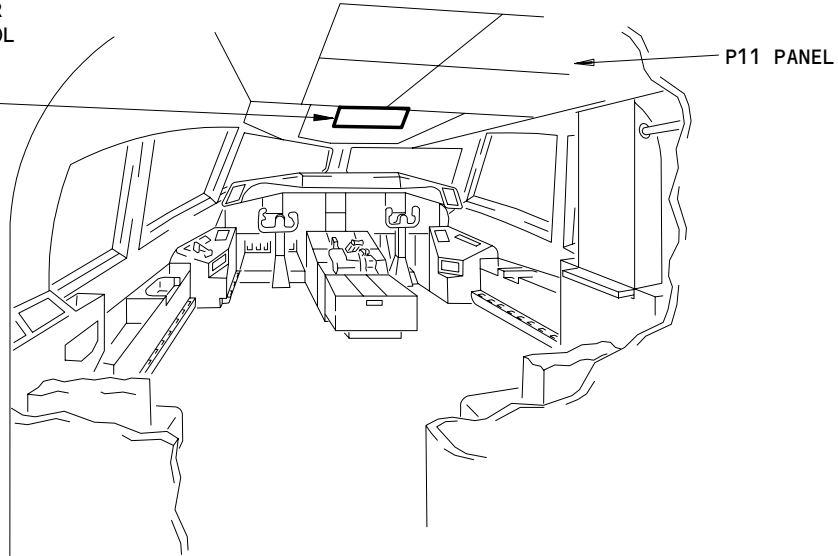

FLIGHT COMPARTMENT

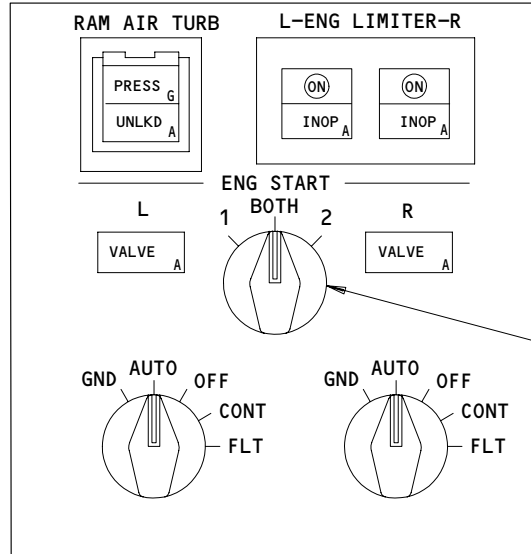

ENGINE START/RAM AIR TURBINE (RAT)
CONTROL MODULE, M10468

(A)

Engine Ignition Control - Component Location
Figure 102

EFFECTIVITY	ALL
-------------	-----

74-31-00

R02

Page 102
Sep 20/93

118169