

GPA Group plc

PAGE	DATE	CODE	PAGE	DATE	CODE	PAGE	DATE	CODE
CHAPTER 75 TAB			75-32-00	CONFIG 4	CONT.			
			105	MAY 28/03	R01			
			106	MAY 28/03	R01			
AIR			107	MAY 28/03	R01			
			108	MAY 28/03	R01			
EFFECTIVE PAGES			109	MAY 20/08	R01			
SEE LAST PAGE OF LIST FOR			110	MAY 20/08	R01			
NUMBER OF PAGES			111	MAY 20/08	R01			
			112	JAN 28/06	R01			
			113	SEP 28/06	R01			
75-CONTENTS			114	JAN 28/06	R01			
R 1	MAY 20/09	RGUI.1	115	SEP 28/06	R01			
2	BLANK		116	JAN 28/06	R01			
			117	JAN 28/06	R01			
75-FAULT CODE INDEX			118	JAN 28/06	R01			
1	SEP 20/08	R01	119	JAN 28/06	R01			
2	BLANK		120	JAN 28/06	R01			
			121	MAY 20/08	R01			
75-32-00	CONFIG 2		122	MAY 20/08	R01			
101	MAY 28/05	R02B	123	JAN 28/06	R01			
102	BLANK		124	JAN 28/06	R01			
			125	JAN 28/06	R01			
75-32-00	CONFIG 3		126	JAN 28/06	R01			
101	JAN 28/02	R03B	127	JAN 28/06	R01			
102	JAN 28/02	R03B	128	JAN 28/06	R01			
103	JAN 28/02	R03B	129	JAN 28/06	R01			
104	JAN 28/02	R03B	130	JAN 28/06	R01			
105	JAN 28/02	R03B	131	JAN 28/06	R01			
106	JAN 28/02	R03B	132	JAN 28/06	R01			
107	MAY 28/05	R02B	133	JAN 28/06	R01			
108	MAY 28/05	R02B	134	JAN 28/06	R01			
109	SEP 28/06	R04B	135	JAN 28/06	R01			
110	SEP 28/06	R05B	136	JAN 28/06	R01			
111	SEP 28/06	R05B	137	MAY 28/07	R01			
112	JAN 28/02	R03B	138	JAN 28/06	R01			
113	SEP 28/06	R02B	139	JAN 28/06	R01			
114	JAN 28/02	R03B	140	MAY 20/08	R01			
115	JAN 28/02	R03B	141	JAN 28/06	R01			
116	SEP 28/06	R02B	142	JAN 28/06	R01			
117	JAN 28/02	R03B	143	JAN 28/06	R01			
118	SEP 28/06	R02B	144	JAN 28/06	R02			
119	JAN 28/02	R03B						
120	SEP 28/06	R02B						
121	SEP 28/06	R02B						
122	MAY 28/03	R02B						
123	SEP 28/06	R02B						
124	SEP 28/06	R02B						
125	JAN 28/02	R03B						
126	SEP 28/06	R01B						
127	JAN 28/02	R02B						
128	JAN 28/02	R02B						
129	JAN 28/02	R02B						
130	BLANK							
75-32-00	CONFIG 4							
101	MAY 28/03	R01						
102	MAY 28/03	R01						
103	MAY 28/03	R01						
104	MAY 28/03	R01						

R = REVISED, A = ADDED OR D = DELETED
 F = FOLDOUT PAGE
 32
 MAY 20/09

D633N632

CHAPTER 75
 EFFECTIVE PAGES
 R PAGE 1
 LAST PAGE

CHAPTER 75 - AIR

TABLE OF CONTENTS

<u>Subject</u>	<u>Chapter Section Subject</u>	<u>Page</u>	<u>Effectivity</u>
FAULT ISOLATION	75-FAULT CODE INDEX	1	ALL
<u>AIR</u>	75-00-00		
<u>COMPRESSOR CONTROL</u>	75-30-00		
COMPRESSOR BLEED CONTROL SYSTEM	75-32-00		
Component Location		101	CONFIG 3 [*]
Component Index			
Component Location			
Fault Isolation			
BVCU BITE Procedure (Fig. 103)		107	
EGT Is More Than 30 Degrees C Higher Than Other Engine (Fig. 105)		126	
L (R) ENG SURGE BITE Message Shown on EICAS (Fig. 107)		129	
Not Used (Fig. 106)		128	
TPU BITE Procedure (Fig. 104)		122	
[*] RB211-535E4 ENGINES WITH BVCU C8E38-9 AND POST-SB 757-75-5			
Component Location		101	CONFIG 4 [*]
Component Index			
Component Location			
Fault Isolation			
BVCU BITE Procedure (Fig. 103)		109	
EGT Is More Than 30 Degrees C Higher Than Other Engine (Fig. 105)		113	
L (R) ENG SURGE BITE Message Shown on EICAS (Fig. 106)		115	
TPU BITE Procedure (Fig. 104)		112	
[*] RB211-535E4 ENGINES WITH BVCU C8E38-11, C8E38-12 OR C8E38-15			

75-CONTENTS

FAULT CODE	LOG BOOK REPORT	FAULT ISOLATION REFERENCE
75 32 01 00	EICAS msg L ENG SURGE CONT displayed.	PRE-SB 757-75-5; FIM 75-32-00/101, Fig. 106, Block 1 POST-SB 757-75-5; FIM 75-32-00/101, Fig. 106 Not Used
75 32 02 00	EICAS msg R ENG SURGE CONT displayed.	PRE-SB 757-75-5; FIM 75-32-00/101, Fig. 106, Block 1 POST-SB 757-75-5; FIM 75-32-00/101, Fig. 106 Not Used
75 32 03 00	EICAS msg L ENG SURGE BITE displayed.	FIM 75-32-00/101, Fig. 106 Block 1
75 32 04 00	EICAS msg R ENG SURGE BITE displayed.	FIM 75-32-00/101, Fig. 106
75 32 10 --	(01=L,02=R) Engine EGT is ____°C higher than other eng at same EPR during all power settings.	FIM 75-32-00/101, Fig. 105, Block 1
75 32 11 --	(01=L,02=R) Engine EGT is ____°C higher than other eng with EPR set below 1.35 and altitude above 17,000 feet.	FIM 75-32-00/101, Fig. 105, Block 22
75 32 12 --	(01=L,02=R) Engine EGT is ____°C higher than other eng with EPR set below 1.35 and altitude below 17,000 feet.	FIM 75-32-00/101, Fig. 105, Block 12
75 32 13 --	(01=L,02=R) Engine EGT high, ____° at idle RPM. EGT decreased to normal with eng bleed valve closed.	FIM 75-32-00/101, Fig. 103, Block 1
75 32 14 --	(01=L,02=R) Engine reached N2 limit before obtaining T.O. EPR.	FIM 75-32-00/101, Fig. 103, Block 1
75 32 15 --	(01=L,02=R) Engine (accel during start was slow, had hung start). Starter cutout early at ____% N3.	FIM 75-32-00/101, Fig. 103, Block 1

EFFECTIVITY

ALL

75-FAULT CODE INDEX

R01

 Page 1
 Sep 20/08



COMPRESSOR BLEED CONTROL SYSTEM

1. General

- A. Config 2 has been removed because engines with BVCU C8E38-9 and PRE-SB 757-75-5 are no longer in service.

EFFECTIVITY
 RB211-535E4 ENGINES WITH BVCU C8E38-9
 AND PRE-SB 757-75-5

75-32-00

CONFIG 2

Page 101

May 28/05

R02B

COMPRESSOR BLEED CONTROL SYSTEM

COMPONENT	FIG. 102 SHT	QTY	ACCESS/AREA	AMM REFERENCE
CIRCUIT BREAKER - ENG HP BLD VLV-L/GND, C4113 ENG HP BLD VLV-R/GND, C4114 COMPUTER - (FIM 31-41-00/101) L EICAS, M10181 R EICAS, M10182 RECEPTACLE - T2/EGT TEST, D1402	--	1 1 1	FLIGHT COMPARTMENT, P11 11D21 11D22	
RELAY - (FIM 31-01-36/101) L ENG POWER, K10208 RELAY - (FIM 31-01-37/101) R ENG POWER, K10220 SOLENOID - NO. 1 HP3 BLD VLV, V10018	3	1	414AR, L ENG R FAN COWL 424AR, R ENG R FAN COWL	
SOLENOID - NO. 2 HP3 BLD VLV, V10014	2	1	413AL, L ENG L FAN COWL 423AL, R ENG L FAN COWL	75-32-05
SOLENOID - NO. 1 IP BLD VLV, V10019	2	1	413AL, L ENG L FAN COWL 423AL, R ENG L FAN COWL	75-32-05
SOLENOID - NO. 2 IP BLD VLV, V10020	4	1	415AL, L ENG L THRUST REVERSER 425AL, R ENG L THRUST REVERSER	75-32-03
SOLENOID - HP2 BLD VLV	4	1	416AR, L ENG R THRUST REVERSER 426AR, L ENG R THRUST REVERSER	75-32-03
SWITCH - ALTITUDE, S10142	2	1	413AL, L ENG L FAN COWL 423AL, R ENG L FAN COWL	75-32-05
SWITCH - BVCU/EEC GND TEST, S10150	3	1	414AR, L ENG R FAN COWL 424AR, R ENG R FAN COWL	75-32-07
SWITCH - TPU GND TEST, S10151	3	1	414AL, L ENG L FAN COWL 424AL, R ENG L FAN COWL	75-32-07
THERMOCOUPLE - T2 SONIC, TS5024 TRANSDUCER - POWER LEVER ANGLE (BVCU), TS5023	2	1	413AL, L ENG L FAN COWL 423AL, R ENG L FAN COWL	75-32-05
TUBE - HP AND IP COMPRESSOR BLEED CONTROL AIR UNIT - (FIM 73-21-10/101) DEDICATED GENERATOR CONTROL (DGPU A), M10157 DEDICATED GENERATOR CONTROL (DGPU B), M10165	4	1	BEHIND SPLITTER FAIRING	75-32-12
UNIT - BLEED VALVE CONTROL, M10153	1	1	414AR, L ENG R FAN COWL 424AR, R ENG R FAN COWL	75-32-06
UNIT - TRANSIENT PRESSURE, M10166	2	4		75-32-06
VALVE - HP COMPRESSOR BLEED	2	1	413AL, L ENG L FAN COWL 423AL, R ENG L FAN COWL	75-32-09
VALVE - IP COMPRESSOR BLEED	3	1	413AL, L ENG L FAN COWL 423AL, R ENG L FAN COWL	75-32-01
	2	1	413AL, L ENG L FAN COWL 423AL, R ENG L FAN COWL	75-32-01
	5	3	415AL, 425AL, 416AR, 426AR, THRUST REVERSER	75-32-05
	5	3	415AL, 425AL, 416AR, 426AR, THRUST REVERSER	75-32-04
	5	3	415AL, 425AL, 416AR, 426AR, THRUST REVERSER	75-32-02

 Compressor Bleed Control System - Component Index
 Figure 101

 EFFECTIVITY
 RB211-535E4 ENGINES WITH BVCU C8E38-9
 AND POST-SB 757-75-5

75-32-00

CONFIG 3

Page 101

Jan 28/02

R03B

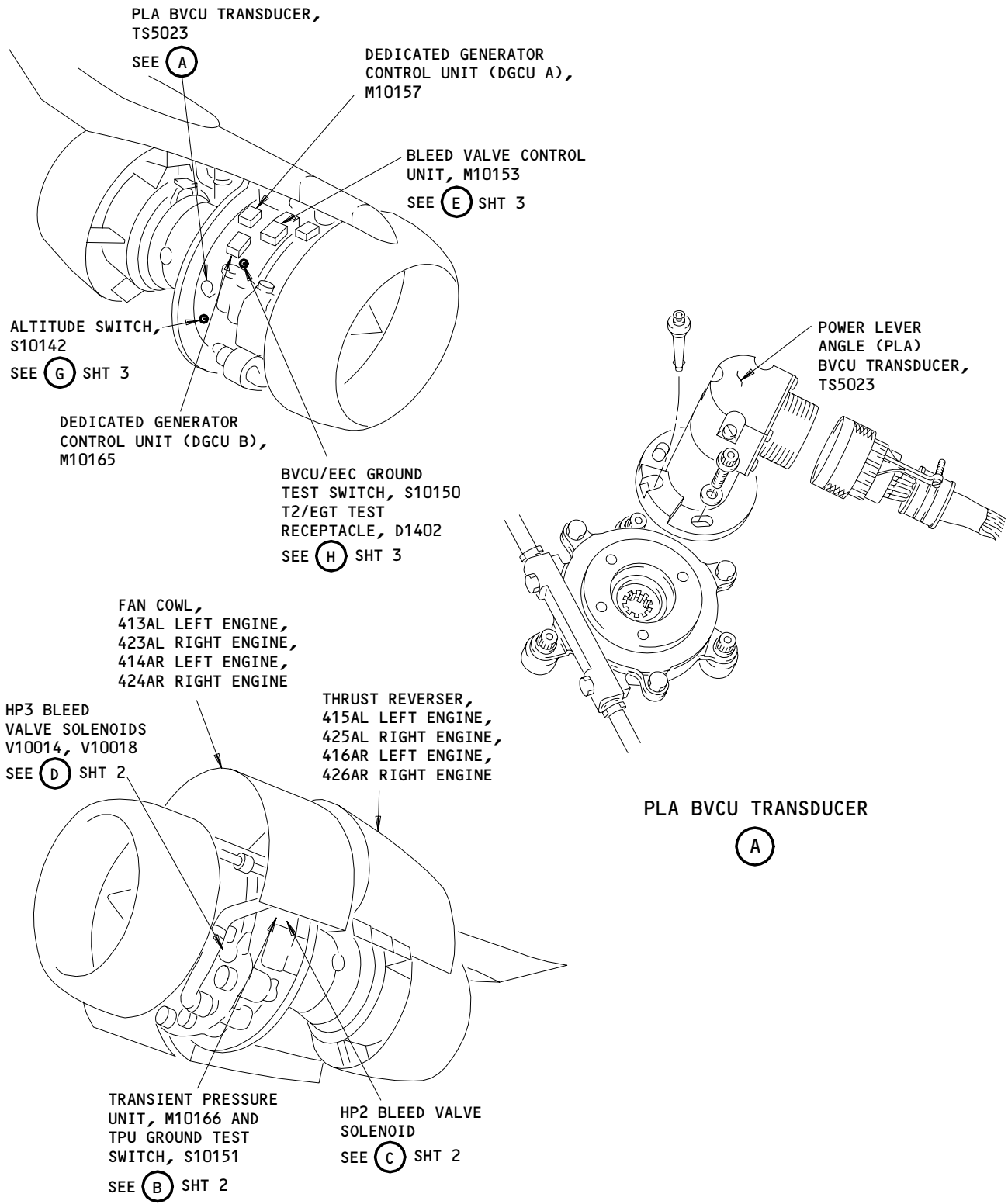

Compressor Bleed Control System - Component Location
Figure 102 (Sheet 1)

EFFECTIVITY
RB211-535E4 ENGINES WITH BVCU C8E38-9
AND POST-SB 757-75-5

75-32-00
CONFIG 3
Page 102
Jan 28/02

R03B

E42501

TPU GROUND TEST SWITCH, S10151

TRANSIENT PRESSURE SENSOR UNIT, M10166

ELECTRICAL CONNECTOR, D7104

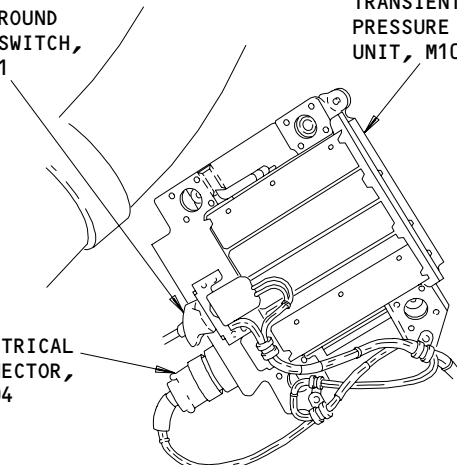

TRANSIENT PRESSURE UNIT (TPU)

(B)

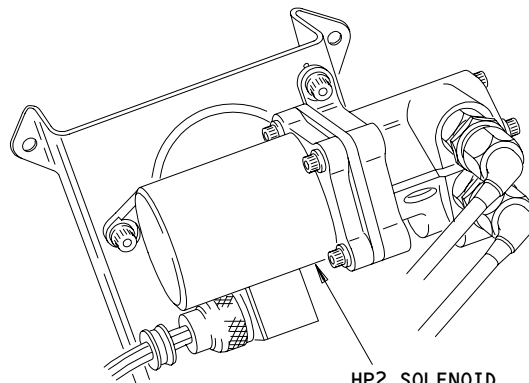

HP2 SOLENOID

HP2 SOLENOID

(C)

LEFT HP3 BLEED VALVE SOLENOID, V10018

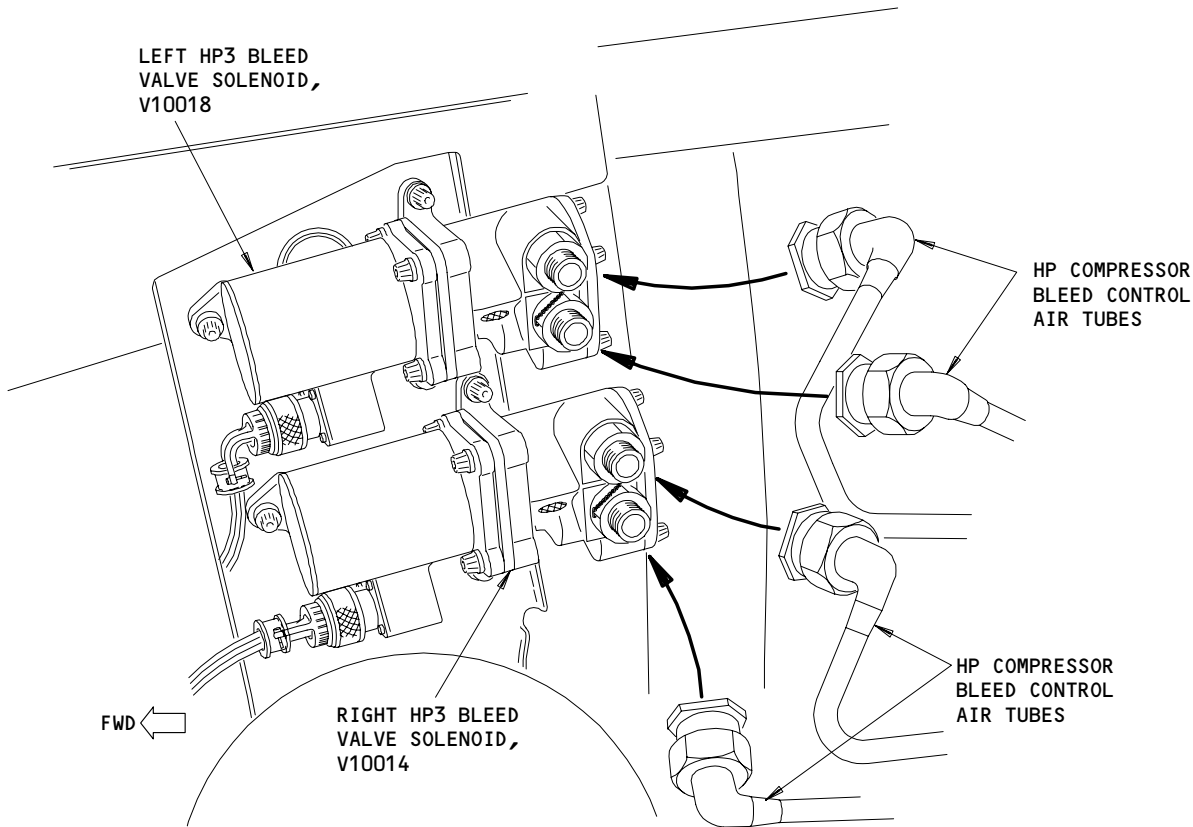

HP COMPRESSOR BLEED CONTROL AIR TUBES

HP COMPRESSOR BLEED CONTROL AIR TUBES

RIGHT HP3 BLEED VALVE SOLENOID, V10014

FWD ←

HP3 BLEED VALVE SOLENOID

(D)

59997

Compressor Bleed Control System - Component Location (Details from Sht 1)
Figure 102 (Sheet 2)

EFFECTIVITY
RB211-535E4 ENGINES WITH BVCU C8E38-9
AND POST-SB 757-75-5

75-32-00

CONFIG 3

Page 103

Jan 28/02

R03B

E42526

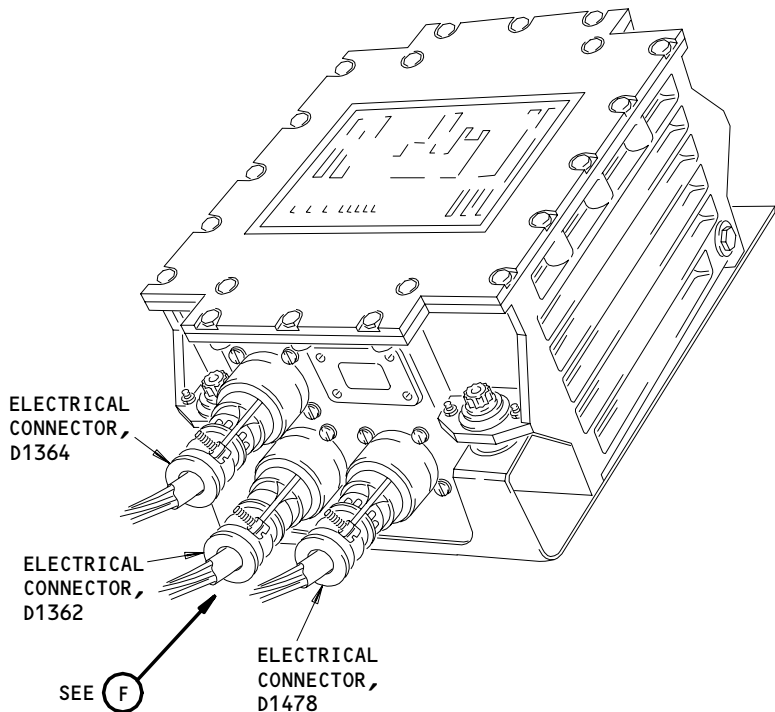

BLEED VALVE CONTROL UNIT (BVCU), M10153

(E) FROM SHT 1

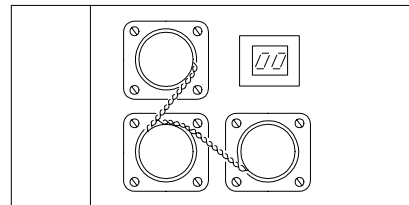

LOCKWIRE ARRANGEMENT

(F)

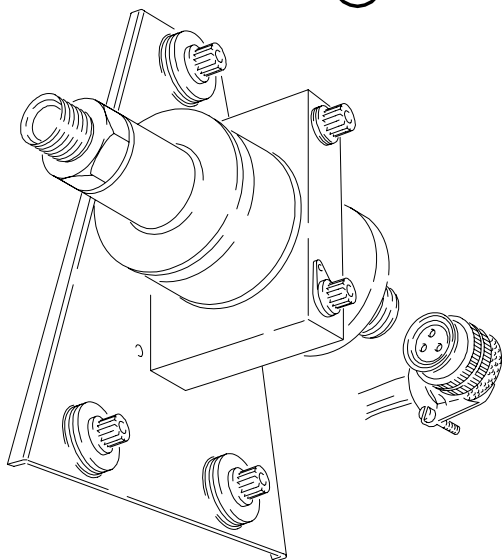

ALTITUDE SWITCH, S10142

(G) FROM SHT 1

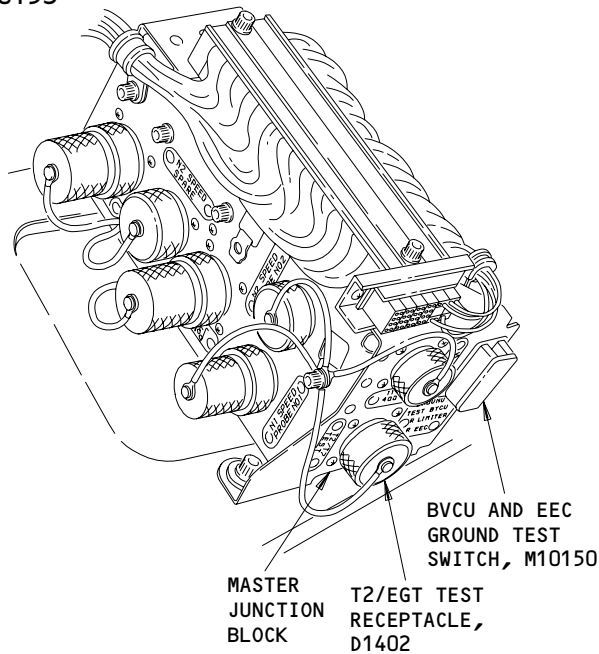

MASTER JUNCTION BLOCK

(H) FROM SHT 1

Compressor Bleed Control System - Component Location
Figure 102 (Sheet 3)

EFFECTIVITY
RB211-535E4 ENGINES WITH BVCU C8E38-9
AND POST-SB 757-75-5

75-32-00

CONFIG 3

Page 104

Jan 28/02

R03B

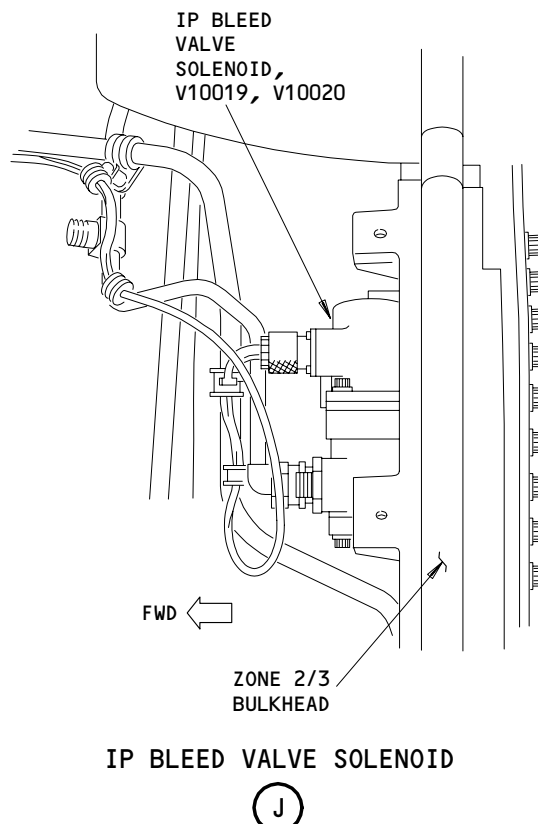
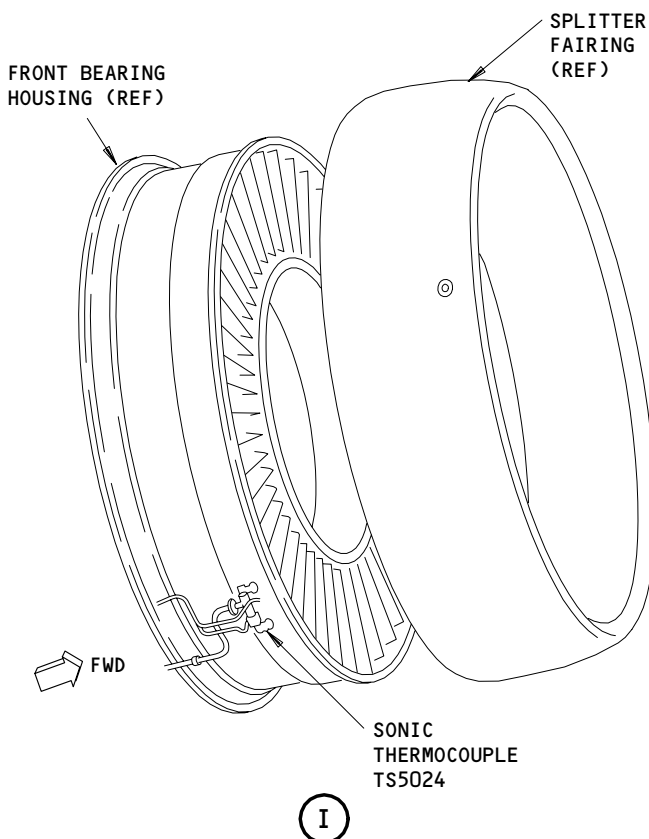
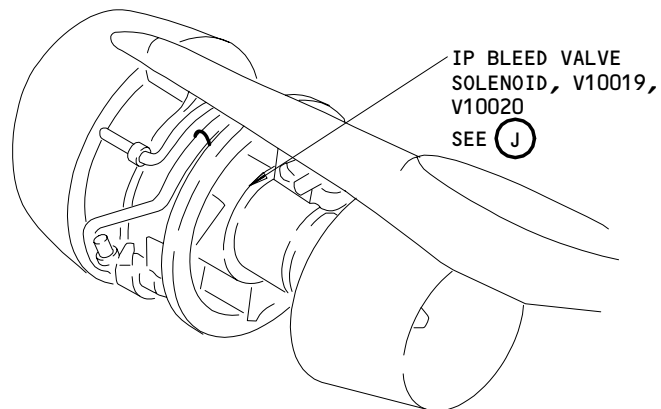
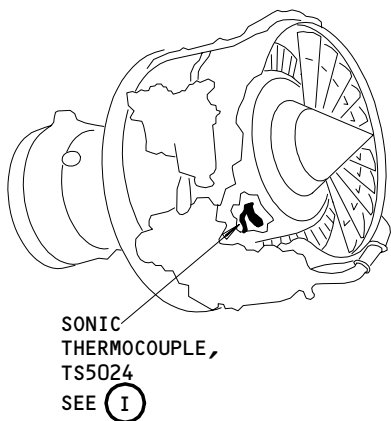

60011

Compressor Bleed Control System - Component Location
Figure 102 (Sheet 4)

EFFECTIVITY
RB211-535E4 ENGINES WITH BVCU C8E38-9
AND POST-SB 757-75-5

75-32-00
CONFIG 3
Page 105
Jan 28/02

R03B

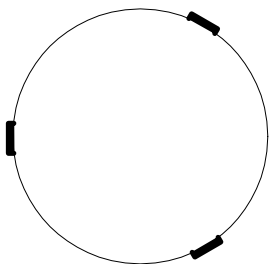

IP BLEED VALVE LOCATIONS
(VIEW IN THE FORWARD DIRECTION)

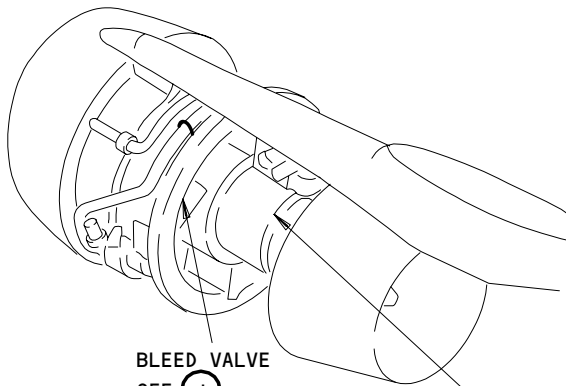

BLEED VALVE
SEE (J)

BLEED VALVE
SEE (K)

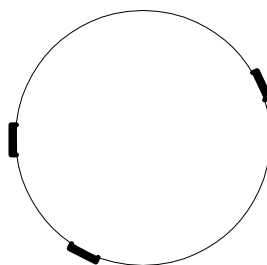

HP BLEED VALVE LOCATIONS
(VIEW IN THE FORWARD DIRECTION)

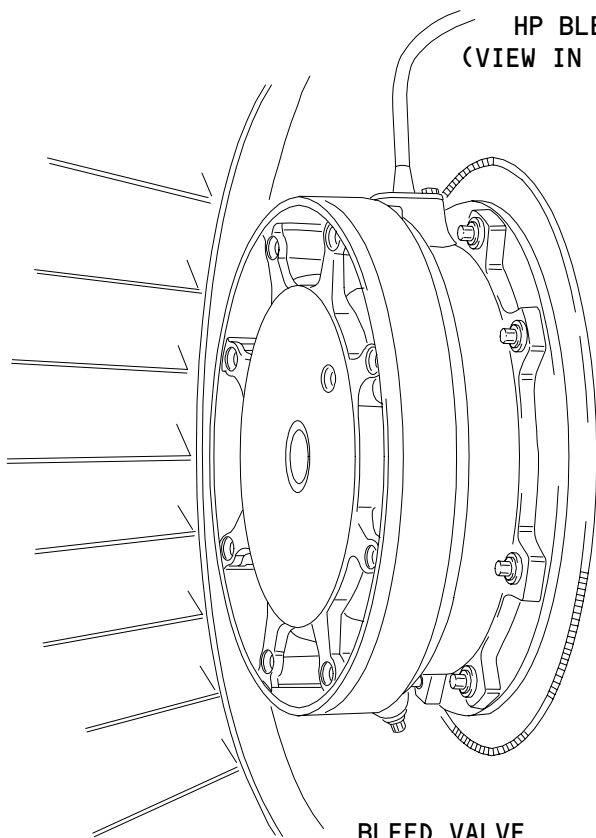

BLEED VALVE

(J)

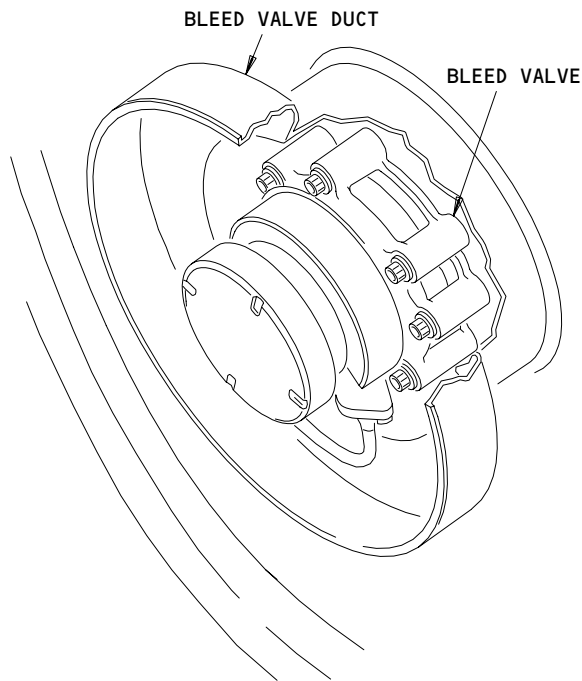

BLEED VALVE DUCT

BLEED VALVE

BLEED VALVE

(K)

Compressor Bleed Control System - Component Location
Figure 102 (Sheet 5)

EFFECTIVITY
RB211-535E4 ENGINES WITH BVCU C8E38-9
AND POST-SB 757-75-5

75-32-00

CONFIG 3

Page 106

Jan 28/02

R03B

E42542

PREREQUISITES

MAKE SURE THESE CIRCUIT BREAKERS ARE CLOSED:
11D21, 11D22

MAKE SURE THE AIRPLANE IS IN THIS CONFIGURATION:
ELECTRICAL POWER IS ON (AMM 24-22-00/201)

BVCU BITE PROCEDURE

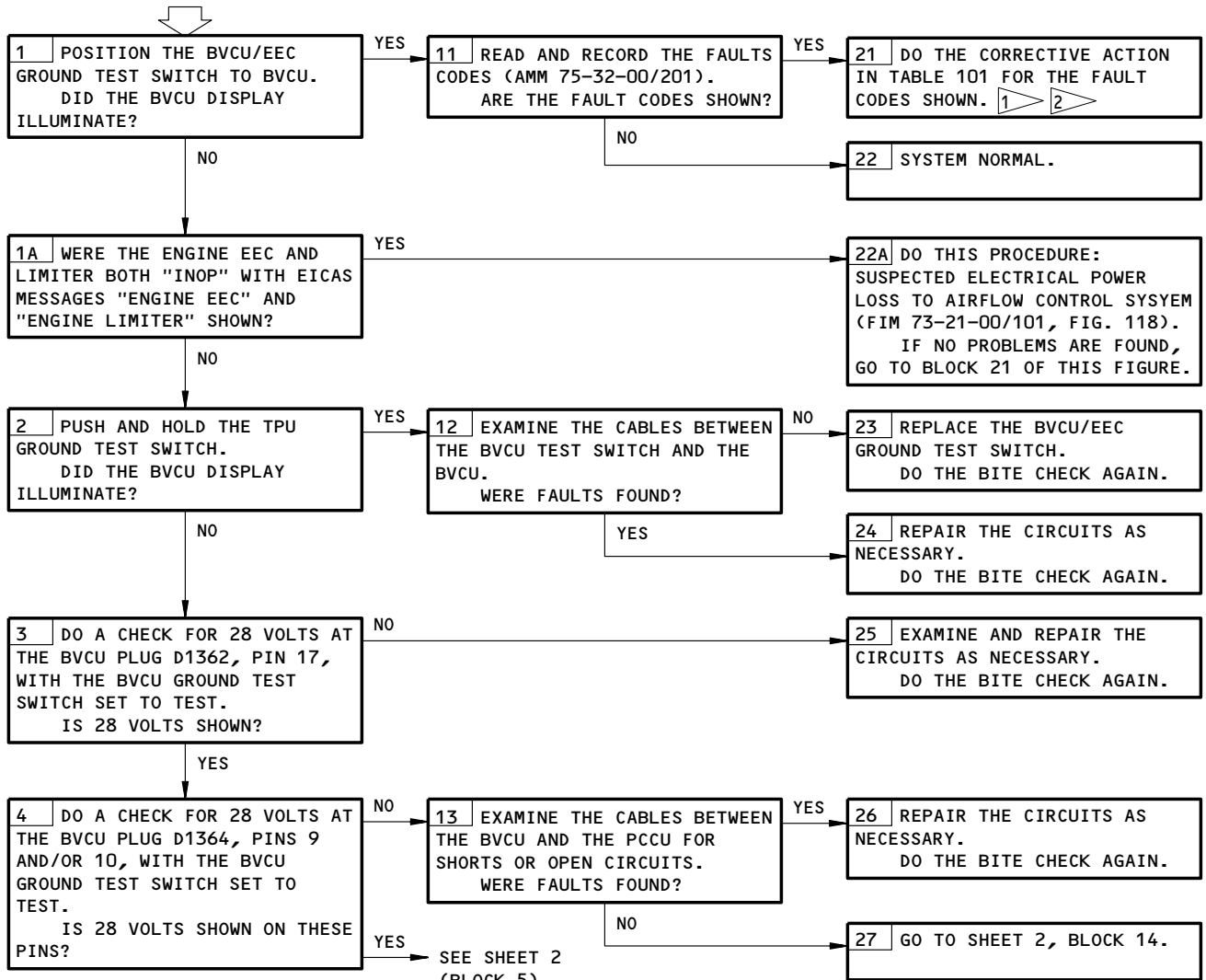

NOTE: BVCU DISPLAY INTERROGATION INSTRUCTIONS:

THE BVCU DISPLAY SHOWS, CONSECUTIVELY, FAULT CODES FOR UP TO THREE FLIGHTS. THE MOST RECENT FLIGHT IS SHOWN FIRST. FLIGHT MARKERS (F FOLLOWED BY THE NUMBER OF FAULT FREE FLIGHTS BETWEEN EACH SET OF CODES) ARE SHOWN JUST BEFORE THE FAULT CODES.

1 IF FAULT CODES ARE SHOWN THAT ARE NOT LISTED IN TABLE 101, REPLACE BVCU (AMM 75-32-01/401).

2 IF NO FAULT IS FOUND AFTER YOU TROUBLESHOOT, DO AN INSPECTION OF THE MODULAR TERMINAL BLOCK/TERMINAL BLOCK FOR A POSSIBLE WIRING FAULT (AMM 71-51-01/601).

BVCU BITE Procedure
Figure 103 (Sheet 1)

EFFECTIVITY
RB211-535E4 ENGINES WITH BVCU C8E38-9
AND POST-SB 757-75-5

75-32-00

CONFIG 3

Page 107

May 28/05

R02B

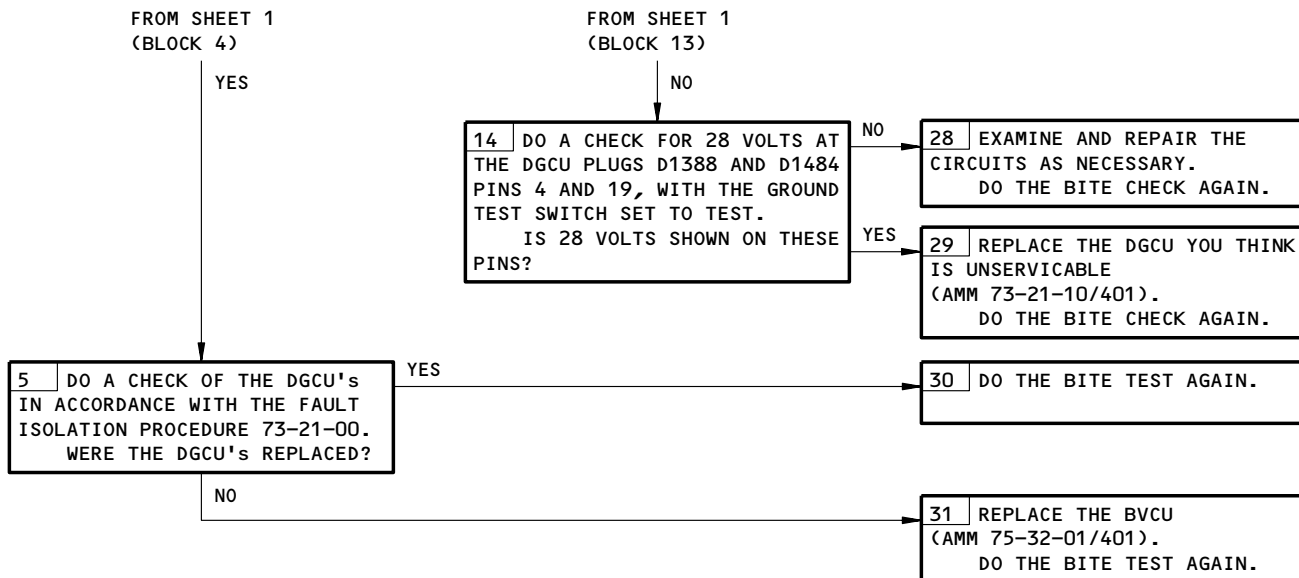

FAULT CODE	DESCRIPTION	CORRECTIVE ACTION
01	ALTITUDE SWITCH FAULT	1. DISCONNECT PLUG D7104 FROM THE TPU. 2. DISCONNECT PLUG D1362 AND PLUG D1364 FROM THE BVCU. 3. DISCONNECT PLUG D1484 FROM THE DGPU. 4. MEASURE THE WIRE RESISTANCE FROM PIN 3 ON PLUG D1362, TO PIN 2 ON PLUG D1484. THE RESISTANCE MUST BE BETWEEN 256-284 OHMS. 5. MEASURE THE INSULATION OF EACH PIN TO GROUND. INSULATION RESISTANCE MUST BE 20M OHMS MIN. 6. REPAIR THE CIRCUIT IF IT IS NECESSARY (WDM 71-51-11). 7. IF THE PROBLEM CONTINUES, DO A CONTINUITY CHECK FROM PIN 3 TO PIN 19 ON PLUG D1362. A. REPAIR THE CIRCUIT IF IT IS NECESSARY (WDM 71-51-11). 8. IF THE PROBLEM CONTINUES, DO THE STEPS THAT FOLLOW: A. DISCONNECT PLUG D1480 FROM THE ALTITUDE SWITCH. B. MEASURE THE WIRE RESISTANCE FROM PIN 3 ON BVCU PLUG 2 (D1362) TO PIN A ON D1480. THE RESISTANCE MUST BE 1.0 OHMS MAXIMUM. C. MEASURE THE INSULATION OF EACH PIN TO GROUND. INSULATION RESISTANCE MUST BE 20M OHM MINIMUM. (1) REPAIR THE CIRCUIT IF IT IS NECESSARY (WDM 71-51-11). D. CONNECT PLUG D1480 FROM THE ALTITUDE SWITCH. 9. IF THE PROBLEM CONTINUES, DO THE STEPS THAT FOLLOW: A. DISCONNECT PLUG D1480 FROM THE ALTITUDE SWITCH. B. DO A CONTINUITY CHECK FROM PLUG D1480, PIN B TO PIN C ON THE ALTITUDE SWITCH. (1) IF THERE IS AN OPEN CIRCUIT OR IF THE PROBLEM CONTINUES, REPLACE THE ALTITUDE SWITCH (AMM 75-32-07/401). 10. CONNECT PLUG D1484 TO THE DGPU. 11. CONNECT PLUG D1362 AND PLUG D1364 TO THE BVCU. 12. CONNECT PLUG D7104 TO THE TPU.

TABLE 101

BVCU BITE Procedure
Figure 103 (Sheet 2)

EFFECTIVITY
RB211-535E4 ENGINES WITH BVCU C8E38-9
AND POST-SB 757-75-5

75-32-00
CONFIG 3
Page 108
May 28/05

R02B





FAULT CODE	DESCRIPTION	CORRECTIVE ACTION
02	NO. 1 N2 SPEED PROBE FAULT	<ol style="list-style-type: none"> 1. CHANGE TO THE ALTERNATE SPEED PROBE (AMM 77-12-01/201). 2. IF THE PROBLEM CONTINUES, DO THE STEPS THAT FOLLOW: <ol style="list-style-type: none"> A. DISCONNECT PLUG D1000P (WDM 71-51-23). B. DISCONNECT PLUG D1478 FROM THE BVCU, M10153 (WDM 71-51-23). C. MEASURE THE RESISTANCE FROM PIN 1 TO PIN 2 ON PLUG D1478. THE RESISTANCE MUST BE BETWEEN 1.5 AND 2.5 OHMS. <ol style="list-style-type: none"> (1) MEASURE THE INSULATION RESISTANCE FROM PIN 1 TO PIN 3 OF PLUG D1478. THE RESISTANCE MUST BE MORE THAN 20M OHMS. D. MEASURE THE RESISTANCE FROM PIN 1 TO GROUND AND FROM PIN 2 TO GROUND. THE RESISTANCE MUST BE MORE THAN 20M OHMS. E. REPAIR THE CIRCUIT IF IT IS NECESSARY (WDM 71-51-23). F. CONNECT PLUG D1478 TO THE BVCU, M10153. G. CONNECT PLUG D1000P (WDM 71-51-23). 3. IF THE PROBLEM CONTINUES, DO THE STEPS THAT FOLLOW: <ol style="list-style-type: none"> A. DISCONNECT PLUG D40152 (WDM 71-51-23). B. EXAMINE PLUG D40152 FOR CONTAMINATION. C. CLEAN THE PLUG IF IT IS NECESSARY. D. EXAMINE PLUG D40152 FOR PINS THAT ARE LOOSE, BENT, OR BROKEN. E. REPAIR THE PLUG IF IT IS NECESSARY (WDM 71-51-23). F. CONNECT AND TIGHTEN PLUG D40152. 4. IF THE PROBLEM CONTINUES AND THE BVCU DOES NOT HAVE RR SB 75-9490  INCLUDED AND NO PROBLEM IS FOUND, THE BVCU FAULT CODE INDICATION IS NOT CORRECT AND OPERATION CAN CONTINUE. <ol style="list-style-type: none"> A. IF THE PROBLEM CONTINUES, REPLACE THE BVCU (AMM 75-32-01/401). 5. IF THE PROBLEM CONTINUES AND THE BVCU DOES HAVE RR SB 75-9490  INCLUDED AND NO PROBLEM IS FOUND, REPLACE THE BVCU (AMM 75-32-01/401).
03	NO. 2 N2 SPEED PROBE FAULT	<ol style="list-style-type: none"> 1. CHANGE TO THE ALTERNATE SPEED PROBE (AMM 77-12-01/201). 2. IF THE PROBLEM CONTINUES, DO THE STEPS THAT FOLLOW: <ol style="list-style-type: none"> A. DISCONNECT PLUG D1478 FROM THE BVCU, M10153 (WDM 71-51-23). B. MEASURE THE RESISTANCE FROM PIN 5 TO PIN 12 ON PLUG D1478. THE RESISTANCE MUST BE BETWEEN 1.5 AND 2.5 OHMS. <ol style="list-style-type: none"> (1) MEASURE THE INSULATION RESISTANCE FROM PIN 4 TO PIN 12 OF PLUG D1478. THE RESISTANCE MUST BE MORE THAN 20M OHMS. D. MEASURE THE RESISTANCE FROM PIN 5 TO GROUND AND FROM PIN 12 TO GROUND. THE RESISTANCE MUST BE MORE THAN 20M OHMS. E. REPAIR THE CIRCUIT IF IT IS NECESSARY (WDM 71-51-23). F. CONNECT PLUG D1478 TO THE BVCU, M10153. 3. IF THE PROBLEM CONTINUES, DO THE STEPS THAT FOLLOW: <ol style="list-style-type: none"> A. DISCONNECT PLUG D40152 (WDM 71-51-23). B. EXAMINE PLUG D40152 FOR CONTAMINATION. C. CLEAN THE PLUG IF IT IS NECESSARY. D. EXAMINE PLUG D40152 FOR PINS THAT ARE LOOSE, BENT, OR BROKEN. E. REPAIR THE PLUG IF IT IS NECESSARY (WDM 71-51-23). F. CONNECT AND TIGHTEN PLUG D40152. 4. IF THE PROBLEM CONTINUES AND THE BVCU DOES NOT HAVE RR SB 75-9490  INCLUDED AND NO DEFECT IS FOUND, THE BVCU FAULT CODE INDICATION IS NOT CORRECT AND OPERATION CAN CONTINUE. <ol style="list-style-type: none"> A. IF THE PROBLEM CONTINUES, REPLACE THE BVCU (AMM 75-32-01/401). 5. IF THE PROBLEM CONTINUES AND THE BVCU DOES HAVE RR SB 75-9490  INCLUDED AND NO PROBLEM IS FOUND, REPLACE THE BVCU (AMM 75-32-01/401).

TABLE 101

 AS SHOWN BY RD406 ON THE ENGINE DATA PLATE.

BVCU BITE Procedure
Figure 103 (Sheet 3)

EFFECTIVITY
RB211-535E4 ENGINES WITH BVCU C8E38-9
AND POST-SB 757-75-5

75-32-00
CONFIG 3
Page 109
Sep 28/06

R04B

FAULT CODE	DESCRIPTION	CORRECTIVE ACTION																					
04	POWER LEVER ANGLE (PLA) BLEED VALVE CONTROL UNIT (BVCU) TRANSDUCER FAULT OR OPEN CIRCUIT WIRING PLA/BVCU/TPU OR TPU "TRIPPED"	<p>IF BVCU FAULT CODE 04 IS SHOWN ALONG WITH TPU FAULT CODE 40 AND BOTH ARE PRECEDED BY THE SAME FLIGHT MARKER (F0 TO F9):</p> <p>1. PERFORM THE CORRECTIVE ACTION IN FIG. 104 FOR THE TPU FAULT CODE.</p> <p>IF BVCU FAULT CODE 04 IS PRECEDED BY F0 TO F9 AND TPU FAULT CODE 60 IS SHOWN, PRECEDED BY THE SAME FLIGHT MARKER:</p> <p>1. REPLACE PLA/BVCU TRANSDUCER (AMM 75-32-14/401).</p> <p>2. IF FAULT PERSISTS, PERFORM THE FOLLOWING:</p> <p style="margin-left: 20px;">A. DO A CHECK OF THE RESISTANCE BETWEEN THE FOLLOWING PINS AND PLUGS:</p> <table style="margin-left: 40px; border: none;"> <tr> <td style="text-align: center;"><u>D1366</u></td> <td style="text-align: center;">TO</td> <td style="text-align: center;"><u>D1478</u></td> </tr> <tr> <td style="text-align: center;">10</td> <td></td> <td style="text-align: center;">7</td> </tr> </table> <p style="margin-left: 40px;">RESISTANCE SHOULD BE 1 OHM MAX. REPAIR AS REQUIRED (WDM 71-51-23).</p> <p style="margin-left: 20px;">B. DO A CHECK OF THE INSULATION OF THE ABOVE PINS TO GROUND AND ALSO PLUG D1366, PIN 9, AND PLUG D1478, PIN 6, TO GROUND. INSULATION RESISTANCE SHOULD BE 20M OHMS. REPAIR AS NECESSARY (WDM 71-51-23).</p> <p style="margin-left: 20px;">C. DO A CONTINUITY CHECK BETWEEN THE FOLLOWING PINS AND PLUGS:</p> <table style="margin-left: 40px; border: none;"> <tr> <td style="text-align: center;"><u>D1366</u></td> <td style="text-align: center;">TO</td> <td style="text-align: center;"><u>D1478</u></td> </tr> <tr> <td style="text-align: center;">9</td> <td></td> <td style="text-align: center;">6</td> </tr> </table> <p style="margin-left: 40px;">RESISTANCE SHOULD BE APPROXIMATELY 1000 OHMS. IF OPEN CIRCUIT, REPLACE TPU (AMM 75-32-15/401).</p> <p style="margin-left: 20px;">D. DO A CHECK OF THE INSULATION OF EACH OF THE ABOVE PINS TO GROUND. INSULATION SHOULD BE 20M OHMS MIN. REPAIR AS REQUIRED (WDM 71-51-23).</p> <p>IF BVCU FAULT CODE 04 IS PRECEDED BY F0 TO F9 AND NO OTHER TPU FAULT CODES ARE SHOWN WITH FLIGHT MARKERS GREATER THAN OR EQUAL TO THE BVCU FLIGHT MARKER:</p> <p>1. REPLACE PLA/BVCU TRANSDUCER (AMM 75-32-14/401).</p> <p>2. IF FAULT PERSISTS, PERFORM THE FOLLOWING:</p> <p style="margin-left: 20px;">A. DO A CHECK OF THE RESISTANCE BETWEEN THE FOLLOWING PINS AND PLUGS:</p> <table style="margin-left: 40px; border: none;"> <tr> <td style="text-align: center;"><u>D1366</u></td> <td style="text-align: center;">TO</td> <td style="text-align: center;"><u>D1478</u></td> </tr> <tr> <td style="text-align: center;">4</td> <td></td> <td style="text-align: center;">13</td> </tr> <tr> <td style="text-align: center;">8</td> <td></td> <td style="text-align: center;">14</td> </tr> </table> <p style="margin-left: 40px;">RESISTANCE SHOULD BE 1 OHM MAX. REPAIR AS REQUIRED (WDM 71-51-23).</p> <p style="margin-left: 20px;">B. DO A CHECK OF THE INSULATION OF EACH OF THE ABOVE PINS TO GROUND. INSULATION SHOULD BE 20M OHMS MIN. REPAIR AS REQUIRED (WDM 71-51-23).</p>	<u>D1366</u>	TO	<u>D1478</u>	10		7	<u>D1366</u>	TO	<u>D1478</u>	9		6	<u>D1366</u>	TO	<u>D1478</u>	4		13	8		14
<u>D1366</u>	TO	<u>D1478</u>																					
10		7																					
<u>D1366</u>	TO	<u>D1478</u>																					
9		6																					
<u>D1366</u>	TO	<u>D1478</u>																					
4		13																					
8		14																					

TABLE 101

BVCU BITE Procedure
Figure 103 (Sheet 4)

EFFECTIVITY
RB211-535E4 ENGINES WITH BVCU C8E38-9
AND POST-SB 757-75-5

75-32-00
CONFIG 3
Page 110
Sep 28/06

R05B

FAULT CODE	DESCRIPTION	CORRECTIVE ACTION
04	POWER LEVER ANGLE (PLA) BLEED VALVE CONTROL UNIT (BVCU) TRANSDUCER FAULT OR OPEN CIRCUIT WIRING PLA/BVCU/TPU OR TPU "TRIPPED" (CONT)	4. IF F0 TO F9 COMES BEFORE BVCU FAULT CODE 04 AND OTHER TPU FAULT CODES ARE SHOWN, OR TPU FAULT CODES WITH FLIGHT MARKERS LESS THAN OR GREATER THAN THE FLIGHT MARKERS SHOWN FOR THE BVCU: A. DO THE CORRECTIVE ACTION (FIG. 104) FOR THE TPU FAULT CODE. B. IF THE PROBLEM CONTINUES, DO THE STEP THAT FOLLOWS: (1) REPLACE THE PLA TRANSDUCER (AMM 75-32-06/401). C. DISCONNECT PLUG D1366 FROM THE PLA TRANSDUCER. D. DISCONNECT PLUG D1478 FROM THE BVCU. E. IF THE PROBLEM CONTINUES, DO THE STEPS THAT FOLLOW: (1) MEASURE THE RESISTANCE FROM PLUG D1366, PIN 4, TO PLUG D1478, PIN 13, AND FROM PLUG D1366, PIN 8, TO PLUG D1478, PIN 14. THE RESISTANCE MUST BE LESS THAN 1 OHM. (2) MEASURE THE INSULATION RESISTANCE FROM PLUG D1366, PIN 4, AND PLUG D1478, PIN 13, TO GROUND, AND FROM PLUG D1366, PIN 8, AND PLUG D1478, PIN 14, TO GROUND (WDM 71-51-23). THE RESISTANCE OF EACH PIN TO GROUND MUST BE MORE THAN 20M OHM (WDM 71-51-23). (3) REPAIR THE CIRCUIT IF IT IS NECESSARY (WDM 71-51-23). G. CONNECT PLUG D1478 TO THE BVCU. H. CONNECT PLUG D1366 TO THE PLA TRANSDUCER.
05	T2 SONIC THERMOCOUPLE FAULT	<p>NOTE: ALL ENGINES EXCEPT RB211-535E4-37/10, 535E4-37/17 AND ENGINES POST-SB 73-B861 OR POST-SB 73-C713; IF THE EEC CODE 94 AND/OR 98 (AMM 73-21-00/201) ARE ALSO SHOWN, START FAULT ISOLATION AT ITEM 3.</p> 1. DISCONNECT PLUG D1478 FROM THE BVCU. 2. MEASURE THE WIRE RESISTANCE FROM PIN 9 TO PIN 10, ON PLUG D1478. THE RESISTANCE MUST BE BETWEEN 3-5 OHMS. A. IF THE RESISTANCE IS HIGH OR AN OPEN CIRCUIT, DO THESE STEPS: (1) MEASURE THE RESISTANCE FROM PLUG D1478, PIN 9, TO THE TERMINAL BLOCK TB3, POSITIVE POST, AND PLUG D1478, PIN 10, TO THE TERMINAL BLOCK TB3, NEGATIVE POST. THE RESISTANCE MUST BE 1.5 OHMS MAXIMUM. (2) MEASURE THE INSULATION RESISTANCE FROM PLUG D1478, PIN 9, TO GROUND, AND PLUG D1478, PIN 10, TO GROUND. THE RESISTANCE OF EACH PIN TO GROUND MUST BE 20M OHMS MINIMUM. (3) REPAIR THE CIRCUIT IF IT IS NECESSARY (WDM 71-51-23). 3. IF THE PROBLEM CONTINUES, DO THESE STEPS: A. MAKE SURE THE WIRE LEADS TO TERMINAL BLOCK TB3 ARE STACKED AS FOLLOWS:

<u>POSITIVE TERMINAL</u>	<u>NEGATIVE TERMINAL</u>	<u>FUNCTION</u>
W5031-2003R-20	W5031-2003B-20	TEST
W5006-4501CHR-9	W5006-4501AL-9	T2 THERMOCOUPLE
W5031-4501CHR-18	W5031-4501AL-18	BVCU
W5031-4504CHR-18	W5031-4504AL-18	EEC
W5031-4503CHR-18	W5031-4503AL-18	TEST
NUT - TIGHTEN TO 20 POUND-INCHES	NUT - TIGHTEN TO 24 POUND-INCHES	

TABLE 101

 BVCU BITE Procedure
 Figure 103 (Sheet 5)

 EFFECTIVITY
 RB211-535E4 ENGINES WITH BVCU C8E38-9
 AND POST-SB 757-75-5

75-32-00
 CONFIG 3
 Page 111
 Sep 28/06

R05B

FAULT CODE	DESCRIPTION	CORRECTIVE ACTION
05	T2 SONIC THERMOCOUPLE FAULT (CONT)	<p>B. DISCONNECT ALL THERMOCOUPLE LEADS AT TB3. DO A CONTINUITY CHECK BETWEEN LEADS.</p> <p>(1) IF THERE IS AN OPEN CIRCUIT, REPLACE THE T2 THERMOCOUPLE (AMM 75-32-12/401).</p> <p>(2) EXAMINE ALL LEADS FROM TB3 FOR SHORT CIRCUITS.</p> <p>(3) REPAIR THE CIRCUIT IF IT IS NECESSARY (WDM 71-51-11).</p> <p>(4) IF OK, REPLACE THE T2 SONIC THERMOCOUPLE (AMM 75-32-12/401).</p> <p>(5) CONNECT ALL THERMOCOUPLE LEADS AT TB3.</p> <p>4. CONNECT PLUG D1478 TO THE BVCU.</p>
06	DEDICATED GENERATOR CONTROL UNIT 1 (UNIT A) FAULT	<p>1. IF THE SYMPTOMS OF COMPLETE ELECTRICAL POWER LOSS ARE REPORTED, HIGH TGT AND N2, ENG LIMITER INOP LIGHT IS ILLUMINATED AND THE ENG EEC INOP LIGHT IS ILLUMINATED:</p> <p>A. REPLACE THE DEDICATED GENERATOR (AMM 73-21-08/401).</p> <p>B. IF THE PROBLEM CONTINUES, REPLACE THE DEDICATED GENERATOR CONTROL UNIT NO. 1 (AMM 73-21-10/401).</p> <p>C. IF THE PROBLEM CONTINUES, DO THE STEPS THAT FOLLOW:</p> <p>(1) DISCONNECT PLUG D1388 FROM THE DGPU1.</p> <p>(2) DISCONNECT PLUG D1364 FROM THE BVCU.</p> <p>(3) MEASURE THE RESISTANCE FROM PLUG D1388, PIN 8, TO PLUG D1364, PIN 9. THE RESISTANCE MUST NOT BE MORE THAN 1 OHM.</p> <p>(a) OPERATE THE BVCU GROUND TEST SWITCH.</p> <p>(b) MEASURE THE VOLTAGE ON DGPU1, PLUG D1388, PINS 19 AND 4, TO GROUND. THE VOLTAGE OF EACH PIN TO GROUND MUST BE 28 VOLTS (NOMINAL).</p> <p>(c) MEASURE THE INSULATION RESISTANCE OF PLUG D1388, PIN 8, TO GROUND. THE RESISTANCE MUST BE 20M OHMS MINIMUM.</p> <p>(d) REPAIR THE CIRCUIT IF IT IS NECESSARY (WDM 71-51-11).</p> <p>(4) CONNECT PLUG D1388 TO THE DGPU1 AND PLUG D1364 TO THE BVCU.</p>

TABLE 101

BVCU BITE Procedure
Figure 103 (Sheet 6)

EFFECTIVITY
RB211-535E4 ENGINES WITH BVCU C8E38-9
AND POST-SB 757-75-5

75-32-00
CONFIG 3
Page 112
Jan 28/02

R03B

FAULT CODE	DESCRIPTION	CORRECTIVE ACTION
06	DEDICATED GENERATOR CONTROL UNIT 1 (UNIT A) FAULT (CONT)	D. IF THE PROBLEM CONTINUES, DO THE STEPS THAT FOLLOW: (1) DISCONNECT PLUG D1386 FROM THE DGPU1. (2) MEASURE THE RESISTANCE FROM PINS 2 AND 4, PINS 2 AND 6, AND PINS 4 AND 6, ON CONNECTOR, PLUG D1386. THE RESISTANCE MUST BE BETWEEN 0.5-1.5 OHMS. (3) MEASURE THE INSULATION RESISTANCE BETWEEN PINS 2 AND 4, PINS 2 AND 6, AND PINS 4 AND 6, ON CONNECTOR, PLUG D1386 TO GROUND. THE RESISTANCE MUST BE 20M OHMS MINIMUM. (4) REPAIR THE CIRCUIT IF IT IS NECESSARY (WDM 71-51-11). (5) CONNECT PLUG D1386 ON THE DGPU1. E. IF THE PROBLEM CONTINUES, DO THE STEPS THAT FOLLOW: (1) DISCONNECT PLUG D1388 FROM THE DGPU1 AND PLUG D1362 FROM THE BVCU. (2) MEASURE THE RESISTANCE FROM PLUG D1388, PIN 20, TO PLUG D1362, PIN 6. A MAXIMUM RESISTANCE OF 1 OHM IS PERMITTED. (3) MEASURE THE INSULATION RESISTANCE FROM PLUG D1388, PIN 20, TO GROUND. A MINIMUM RESISTANCE VALUE OF 20M OHMS IS PERMITTED. (4) REPAIR THE CIRCUIT IF IT IS NECESSARY (WDM 71-51-11). (5) CONNECT PLUG D1388 ON THE DGPU1 AND D1362 ON THE BVCU. F. IF THE PROBLEM CONTINUES, REPLACE THE BVCU (AMM 75-32-01/401).

TABLE 101

 BVCU BITE Procedure
 Figure 103 (Sheet 7)

 EFFECTIVITY
 RB211-535E4 ENGINES WITH BVCU C8E38-9
 AND POST-SB 757-75-5

75-32-00
 CONFIG 3
 Page 113
 Sep 28/06

R02B

FIGURE 103 (SHEET 8)
NOT USED

BVCU BITE Procedure
Figure 103 (Sheet 8)

EFFECTIVITY
RB211-535E4 ENGINES WITH BVCU C8E38-9
AND POST-SB 757-75-5

75-32-00
CONFIG 3
Page 114
Jan 28/02

R03B

E42685

FAULT CODE	DESCRIPTION	CORRECTIVE ACTION
07	DEDICATED GENERATOR CONTROL UNIT 2 (UNIT B) FAULT	1. IF THE SYMPTOMS OF COMPLETE ELECTRICAL POWER LOSS ARE REPORTED, HIGH TGT AND N2, ENG LIMITER INOP LIGHT IS ILLUMINATED AND THE ENG EEC INOP LIGHT IS ILLUMINATED: A. REPLACE THE DEDICATED GENERATOR (AMM 73-21-08/401). B. IF THE PROBLEM CONTINUES, REPLACE THE DEDICATED GENERATOR CONTROL UNIT NO. 2 (AMM 73-21-10/401). C. IF THE PROBLEM CONTINUES, DO THE STEPS THAT FOLLOW: (1) DISCONNECT PLUG D1484 FROM THE DGPU2. (2) DISCONNECT PLUG D1362 FROM THE BVCU. (3) MEASURE THE RESISTANCE BETWEEN PLUG D1484, PIN 20, AND PLUG D1362, PIN 14. THE RESISTANCE SHOULD BE 1 OHM MAXIMUM. (4) MEASURE THE INSULATION RESISTANCE OF PLUG D1484, PIN 20 TO GROUND. RESISTANCE SHOULD BE 20M OHMS MINIMUM. (5) REPAIR THE CIRCUIT IF IT IS NECESSARY (WDM 71-51-11). (6) CONNECT PLUG D1484 TO THE DGPU2 AND PLUG D1362 TO THE BVCU. D. IF THE PROBLEM CONTINUES, DO THE STEPS THAT FOLLOW: (1) DISCONNECT PLUG D1484 FROM THE DGPU2. (2) DISCONNECT PLUG D1364 AND PLUG D1362 FROM THE BVCU. (3) MEASURE THE RESISTANCE FROM PLUG D1484, PIN 12, TO PLUG D1364, PIN 10. THE RESISTANCE MUST NOT BE MORE THAN 1 OHM. (a) OPERATE THE BVCU GROUND TEST SWITCH. (b) MEASURE THE VOLTAGE ON DGPU2, PLUG D1484, PINS 19 AND 4, TO GROUND. THE VOLTAGE OF EACH PIN TO GROUND MUST BE 28 VOLTS (NOMINAL). (c) MEASURE THE INSULATION RESISTANCE OF PLUG D1484, PIN 12, TO GROUND. THE RESISTANCE MUST BE 20M OHMS MINIMUM. (d) REPAIR THE CIRCUIT IF IT IS NECESSARY (WDM 71-51-11). (4) CONNECT PLUG D1484 TO THE DGPU2 AND PLUGS D1362 AND D1364 TO THE BVCU. E. IF THE PROBLEM CONTINUES, DO THE STEPS THAT FOLLOW: (1) DISCONNECT PLUG D1482 FROM THE DGPU1. (2) MEASURE THE RESISTANCE FROM PINS 2 AND 4, PINS 2 AND 6, AND PINS 4 AND 6, ON CONNECTOR, PLUG D1482. THE RESISTANCE MUST BE BETWEEN 0.5-1.5 OHMS. (3) MEASURE THE INSULATION RESISTANCE BETWEEN PINS 2 AND 4, PINS 2 AND 6, AND PINS 4 AND 6, ON CONNECTOR, PLUG D1386. THE RESISTANCE MUST BE 20M OHMS MINIMUM. (4) REPAIR THE CIRCUIT IF IT IS NECESSARY (WDM 71-51-11). (5) CONNECT PLUG D1482 ON THE DGPU1. F. IF THE PROBLEM CONTINUES, REPLACE THE BVCU (AMM 75-32-01/401).

BVCU BITE Procedure
 Figure 103 (Sheet 9)

EFFECTIVITY
 RB211-535E4 ENGINES WITH BVCU C8E38-9
 AND POST-SB 757-75-5

75-32-00
 CONFIG 3
 Page 115
 Jan 28/02

R03B

FAULT CODE	DESCRIPTION	CORRECTIVE ACTION
10	HP3.2 SOLENOID FAULT <div style="display: flex; justify-content: space-around; margin-top: 5px;"> 5 6 </div>	<ol style="list-style-type: none"> 1. DISCONNECT PLUG D7104 FROM THE TPU. 2. DISCONNECT PLUG D1364 AND PLUG D1362 FROM THE BVCU. 3. DISCONNECT PLUG D1484 AND PLUG D1388 FROM THE DGPU. 4. DO A CHECK FOR INSULATION RESISTANCE FROM PLUG D1364, PINS 5 AND 14, TO GROUND. INSULATION RESISTANCE SHOULD BE 20M OHM MINIMUM. <ol style="list-style-type: none"> A. REPAIR THE CIRCUIT IF IT IS NECESSARY (WDM 71-51-23). 5. MEASURE THE RESISTANCE FROM PLUG D1364, PIN 5, TO PLUG D1484, PIN 8, AND FROM PLUG D1364, PIN 14, TO PLUG D1388, PIN 12. <ol style="list-style-type: none"> A. IF THE RESISTANCE IS NOT BETWEEN 85-100 OHMS, DO THE STEPS THAT FOLLOW: <ol style="list-style-type: none"> (1) DISCONNECT CONNECTOR D1348 ON THE RIGHT HP3 BLEED VALVE SOLENOID. (2) MEASURE THE RESISTANCE FROM PIN 7 TO PIN 5, AND FROM PIN 2 TO PIN 4 ON THE SOLENOID. THE RESISTANCE MUST BE BETWEEN 85-100 OHMS. <ol style="list-style-type: none"> (a) IF NO FAULT IS FOUND, EXAMINE THE CIRCUIT FOR RETRACTED OR BENT PINS IN CONNECTOR OR MATRIX BLOCK. (b) IF THE RESISTANCE IS NOT OK, REPLACE THE HP3 BLEED VALVE SOLENOID (AMM 75-32-03/401). (c) IF THE RESISTANCE IS OK, REPLACE THE BVCU (AMM 75-32-01/401). (3) CONNECT CONNECTOR D1348 ON THE RIGHT HP3 BLEED VALVE SOLENOID. B. IF THE RESISTANCE IS BETWEEN 85-100 OHMS, DO THE STEPS THAT FOLLOW: <ol style="list-style-type: none"> (1) MONITOR THE FAULT CODES AFTER THE NEXT FLIGHT. (2) IF THE PROBLEM CONTINUES, DISCONNECT CONNECTOR D1348 ON THE RIGHT HP3 BLEED VALVE SOLENOID. (3) EXAMINE THE CONNECTOR FOR BENT PINS. <ol style="list-style-type: none"> (a) IF THERE ARE BENT PINS, REPLACE THE HP3 BLEED VALVE SOLENOID (AMM 75-32-05/401). (b) IF THERE ARE NO BENT PINS, REPLACE THE BVCU (AMM 75-32-01/401). (4) CONNECT CONNECTOR D1348 ON THE RIGHT HP3 BLEED VALVE SOLENOID. 6. CONNECT PLUG D1484 AND PLUG D1388 ON THE DGPU. 7. CONNECT PLUG D1364 AND PLUG D1362 ON THE BVCU. 8. CONNECT PLUG D7104 ON THE TPU.
11	HP3.1 SOLENOID FAULT <div style="display: flex; justify-content: space-around; margin-top: 5px;"> 5 7 </div>	<ol style="list-style-type: none"> 1. DISCONNECT PLUG D7104 FROM THE TPU. 2. DISCONNECT PLUG D1364 AND PLUG D1362 FROM THE BVCU. 3. DISCONNECT PLUG D1484 AND PLUG D1388 FROM THE DGPU. 4. DO A CHECK FOR INSULATION RESISTANCE FROM PLUG D1364, PINS 6 AND 13, TO GROUND. INSULATION RESISTANCE SHOULD BE 20M OHMS MINIMUM. <ol style="list-style-type: none"> A. REPAIR THE CURCUIT IF IT IS NECESSARY (WDM 71-51-23). 5. MEASURE THE RESISTANCE FROM PLUG D1364, PIN 13, TO PLUG D1484, PIN 8, AND FROM PLUG D1364, PIN 6, TO PLUG D1388, PIN 12. <ol style="list-style-type: none"> A. IF THE RESISTANCE IS NOT BETWEEN 85-100 OHMS, DO THE STEPS THAT FOLLOW: <ol style="list-style-type: none"> (1) DISCONNECT CONNECTOR D1340 ON THE LEFT HP3 BLEED VALVE SOLENOID. (2) MEASURE THE RESISTANCE FROM PIN 7 TO PIN 5, AND FROM PIN 2 TO PIN 4 ON THE SOLENOID. THE RESISTANCE MUST BE BETWEEN 85-100 OHMS. <ol style="list-style-type: none"> (a) IF THE RESISTANCE IS NOT OK, REPLACE THE HP3 BLEED VALVE SOLENOID (AMM 75-32-03/401). (b) IF THE RESISTANCE IS OK, REPLACE THE BVCU (AMM 75-32-01/401). (3) CONNECT CONNECTOR D1340 ON THE LEFT HP3 BLEED VALVE SOLENOID.

5 ENGINES PRE-RR-SB 71-8346
 6 ENGINES POST-RR-SB 71-8346;
 HP3.1 SOLENOID FAULT, DO THE
 CORRECTIVE ACTION FOR FAULT CODE 11.

TABLE 101

7 ENGINES POST-RR-SB 71-8346;
 HP3.2 SOLENOID FAULT, DO THE CORRECTIVE
 ACTION FOR FAULT CODE 10.

**BVCU BITE Procedure
 Figure 103 (Sheet 10)**

EFFECTIVITY
 RB211-535E4 ENGINES WITH BVCU C8E38-9
 AND POST-SB 757-75-5

75-32-00
 CONFIG 3
 Page 116
 Sep 28/06

R02B

FAULT CODE	DESCRIPTION	CORRECTIVE ACTION
11	HP3.1 SOLENOID FAULT (CONT) 	B. IF THE RESISTANCE IS BETWEEN 85-100 OHMS, DO THE STEPS THAT FOLLOW: (1) MONITOR THE FAULT CODES AFTER THE NEXT FLIGHT. (2) IF THE PROBLEM CONTINUES, DISCONNECT CONNECTOR D1340 ON THE LEFT HP3 BLEED VALVE SOLENOID. (3) EXAMINE THE CONNECTOR FOR BENT PINS. (a) IF THERE ARE BENT PINS, REPLACE THE HP3 BLEED VALVE SOLENOID (AMM 75-32-05/401). (b) IF THERE ARE NO BENT PINS, REPLACE THE BVCU (AMM 75-32-01/401). (4) CONNECT CONNECTOR D1340 ON THE LEFT HP3 BLEED VALVE SOLENOID. 6. CONNECT PLUG D1484 AND PLUG D1388 ON THE DGPU. 7. CONNECT PLUG D1364 AND PLUG D1362 ON THE BVCU. 8. CONNECT PLUG D7104 ON THE TPU.
12	IP6 NO. 1 SOLENOID FAULT	1. DISCONNECT PLUG D7104 FROM THE TPU. 2. DISCONNECT PLUG D1364 AND PLUG D1362 FROM THE BVCU. 3. DISCONNECT PLUG D1484 AND PLUG D1388 FROM THE DGPU. 4. MAKE SURE THE AMBIENT TEMPERATURE IS NOT MORE THAN 35°C AND AN ENGINE RUN WAS NOT DONE BEFORE YOU MEASURE THE RESISTANCE. 5. DO A CHECK FOR INSULATION RESISTANCE FROM PLUG D1364, PINS 4 AND 7, TO GROUND. INSULATION RESISTANCE SHOULD BE 20M OHMS MINIMUM. (1) REPAIR THE CIRCUIT IF IT IS NECESSARY (WDM 71-51-11). 6. MEASURE THE RESISTANCE FROM PLUG D1364, PIN 4, TO PLUG D1484, PIN 8, AND FROM PLUG D1364, PIN 7, TO PLUG D1388, PIN 12. A. IF THE RESISTANCE IS NOT BETWEEN 85-100 OHMS, DO THE STEPS THAT FOLLOW: (1) REMOVE THE COMPRESSOR FAIRING (AMM 72-03-01/401). (2) DISCONNECT CONNECTOR D1352 ON THE RIGHT IP BLEED VALVE SOLENOID. (3) MEASURE THE RESISTANCE FROM PIN 7 TO PIN 5 AND FROM PIN 2 TO PIN 4 ON THE SOLENOID. THE RESISTANCE MUST BE BETWEEN 85-100 OHMS. (a) IF THE RESISTANCE IS NOT OK, REPLACE THE IP BLEED VALVE SOLENOID (AMM 75-32-03/401). (b) IF THE RESISTANCE IS OK, REPLACE THE BVCU (AMM 75-32-01/401). (4) CONNECT CONNECTOR D1352 ON THE RIGHT IP BLEED VALVE SOLENOID. (5) INSTALL THE COMPRESSOR FAIRING (AMM 72-03-01/401). B. IF THE RESISTANCE IS BETWEEN 85-100 OHMS, DO THE STEPS THAT FOLLOW: (1) THE RESISTANCE OF EACH PIN TO GROUND MUST BE MORE THAN 20M OHMS (WDM 71-51-11). (2) MONITOR THE FAULT CODES AFTER THE NEXT FLIGHT. (3) IF THE PROBLEM CONTINUES, REMOVE THE COMPRESSOR FAIRING (AMM 72-03-01/401). (4) DISCONNECT CONNECTOR D1352 ON THE RIGHT IP BLEED VALVE SOLENOID. (5) EXAMINE THE CONNECTOR FOR BENT PINS. (a) IF THERE ARE BENT PINS, REPLACE THE IP BLEED VALVE SOLENOID (AMM 75-32-03/401). (b) IF THERE ARE NO BENT PINS, REPLACE THE BVCU (AMM 75-32-01/401).

TABLE 101

-  ENGINES PRE-RR-SB 71-8346
-  ENGINES POST-RR-SB 71-8346;
HP3.2 SOLENOID FAULT, DO THE CORRECTIVE ACTION FOR FAULT CODE 10.

 BVCU BITE Procedure
 Figure 103 (Sheet 11)

 EFFECTIVITY
 RB211-535E4 ENGINES WITH BVCU C8E38-9
 AND POST-SB 757-75-5

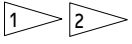
75-32-00
 CONFIG 3
 Page 117
 Jan 28/02

R03B

FAULT CODE	DESCRIPTION	CORRECTIVE ACTION
12	IP6 NO. 1 SOLENOID FAULT (CONT)	7. CONNECT PLUG D1484 AND PLUG D1388 TO THE DGCU. 8. CONNECT PLUG D1364 AND PLUG D1362 TO THE BVCU. 9. CONNECT PLUG D7104 TO THE TPU.
13	IP6 NO. 2 SOLENOID FAULT	1. DISCONNECT PLUG D7104 FROM THE TPU. 2. DISCONNECT PLUG D1364 AND PLUG D1362 FROM THE BVCU. 3. DISCONNECT PLUG D1484 AND PLUG D1388 FROM THE DGCU. 4. MAKE SURE THE AMBIENT TEMPERATURE IS NOT MORE THAN 35°C AND AN ENGINE RUN WAS NOT DONE BEFORE YOU MEASURE THE RESISTANCE. 5. DO A CHECK FOR INSULATION RESISTANCE FROM PLUG D1364, PINS 1 AND 12, TO GROUND. INSULATION RESISTANCE SHOULD BE 20M OHMS MINIMUM. A. REPAIR THE CIRCUIT IF IT IS NECESSARY (WDM 71-51-23). 6. MEASURE THE RESISTANCE FROM PLUG D1364, PIN 1, TO PLUG D1484, PIN 8, AND FROM PLUG D1364, PIN 12, TO PLUG D1388, PIN 12. A. IF THE RESISTANCE IS NOT BETWEEN 85-100 OHMS, DO THE STEPS THAT FOLLOW: (1) REMOVE THE COMPRESSOR FAIRING (AMM 72-03-01/401). (2) DISCONNECT CONNECTOR D1350 ON THE LEFT IP BLEED VALVE SOLENOID. (3) MEASURE THE RESISTANCE FROM PIN 7 TO PIN 5 AND FROM PIN 2 TO PIN 4 ON THE SOLENOID. THE RESISTANCE MUST BE BETWEEN 85-100 OHMS. (a) IF THE RESISTANCE IS NOT OK, REPLACE THE IP BLEED VALVE SOLENOID (AMM 75-32-03/401). (b) IF NO FAULT IS FOUND, EXAMINE THE CIRCUIT FOR RETRACTED OR BENT PINS IN THE CONNECTOR OR THE MATRIX BLOCK. (c) IF THE RESISTANCE IS OK, REPLACE THE BVCU (AMM 75-32-01/401). (4) CONNECT CONNECTOR D1350 ON THE LEFT IP BLEED VALVE SOLENOID. (5) INSTALL THE COMPRESSOR FAIRING (AMM 72-03-01/401). B. IF THE RESISTANCE IS BETWEEN 85-100 OHMS, DO THE STEPS THAT FOLLOW: (1) MONITOR THE FAULT CODES AFTER THE NEXT FLIGHT. (2) IF THE PROBLEM CONTINUES, REMOVE THE COMPRESSOR FAIRING (AMM 72-03-01/401). (3) DISCONNECT CONNECTOR D1350 ON THE LEFT IP BLEED VALVE SOLENOID. (4) EXAMINE THE CONNECTOR FOR BENT PINS. (a) IF THERE ARE BENT PINS, REPLACE THE IP BLEED VALVE SOLENOID (AMM 75-32-03/401). (b) IF THERE ARE NO BENT PINS, REPLACE THE BVCU (AMM 75-32-01/401).

TABLE 101

BVCU BITE Procedure
Figure 103 (Sheet 12)

EFFECTIVITY
RB211-535E4 ENGINES WITH BVCU C8E38-9
AND POST-SB 757-75-5

75-32-00
CONFIG 3
Page 118
Sep 28/06

R02B

FAULT CODE	DESCRIPTION	CORRECTIVE ACTION
13	IP6 NO. 2 SOLENOID FAULT (CONT)	7. CONNECT PLUG D1484 AND PLUG D1388 TO THE DGCU. 8. CONNECT PLUG D1364 AND PLUG D1362 TO THE BVCU. 9. CONNECT PLUG D7104 TO THE TPU.
16	PLA TRANSDUCER INCORRECTLY SET	1. EXAMINE THE RIGGING OF THE POWER LEVER ANGLE (PLA) BVCU TRANSDUCER (AMM 75-32-06/401). 2. IF IT IS NOT RIGGED CORRECTLY, RIG IT AGAIN. 3. IF THE TRANSDUCER CANNOT BE RIGGED, REPLACE THE TRANSDUCER (AMM 75-32-14/401). 4. IF THE PROBLEM CONTINUES, DO THE "CORRECTIVE ACTION" COLUMN FOR FAULT CODE 04.

TABLE 101

BVCU BITE Procedure
Figure 103 (Sheet 13)

EFFECTIVITY
RB211-535E4 ENGINES WITH BVCU C8E38-9
AND POST-SB 757-75-5

75-32-00
CONFIG 3
Page 119
Jan 28/02

R03B

FAULT CODE	DESCRIPTION	CORRECTIVE ACTION
18	HP2 "A" SOLENOID FAULT	<ol style="list-style-type: none"> 1. DISCONNECT PLUG D7104 FROM THE TPU. 2. DISCONNECT PLUG D1364 AND PLUG D1362 FROM THE BVCU. 3. DISCONNECT PLUG D1388 FROM THE DGPU. 4. MEASURE THE RESISTANCE FROM PLUG D1364, PIN 3, TO PLUG D1388, PIN 12. <ol style="list-style-type: none"> A. IF THE RESISTANCE IS NOT BETWEEN 85-100 OHMS, DO THE STEPS THAT FOLLOW: <ol style="list-style-type: none"> (1) DISCONNECT CONNECTOR D1354 FROM THE HP2 BLEED VALVE SOLENOID. (2) MEASURE THE RESISTANCE FROM PIN 2 TO PIN 4 ON THE SOLENOID. THE RESISTANCE MUST BE BETWEEN 85-100 OHMS. <ol style="list-style-type: none"> (a) IF THE RESISTANCE IS NOT OK, REPLACE THE HP2 BLEED VALVE SOLENOID (AMM 75-32-05/401). (b) IF THE RESISTANCE IS OK, REPAIR THE CIRCUIT FROM THE BVCU TO THE HP2 BLEED VALVE SOLENOID. (3) CONNECT CONNECTOR D1354 ON THE HP2 BLEED VALVE SOLENOID. B. IF THE RESISTANCE IS BETWEEN 85-100 OHMS, DO THE STEPS THAT FOLLOW: <ol style="list-style-type: none"> (1) MEASURE THE INSULATION RESISTANCE FROM PLUG D1364, PIN 3, AND PLUG D1388, PIN 12, TO GROUND (WDM 71-51-23). THE RESISTANCE OF EACH PIN TO GROUND MUST BE MORE THAN 20M OHMS (WDM 71-51-23). (2) MONITOR THE FAULT CODES AFTER THE NEXT FLIGHT. (3) IF THE PROBLEM CONTINUES, DISCONNECT CONNECTOR D1354 ON THE HP2 BLEED VALVE SOLENOID. (4) EXAMINE THE CONNECTOR FOR BENT PINS. <ol style="list-style-type: none"> (a) IF THERE ARE BENT PINS, REPLACE THE HP2 BLEED VALVE SOLENOID (AMM 75-32-05/401). (b) IF THERE ARE NO BENT PINS, REPLACE THE BVCU (AMM 75-32-01/401). (5) CONNECT CONNECTOR D1354 ON THE HP2 BLEED VALVE SOLENOID. 5. MEASURE THE INSULATION RESISTANCE FROM PLUG D1364, PIN 3, TO GROUND (WDM 71-51-23). THE RESISTANCE MUST BE MORE THAN 20M OHMS. 6. CONNECT PLUG D1388 FROM THE DGPU. 7. CONNECT PLUG D1364 AND PLUG D1362 FROM THE BVCU. 8. CONNECT PLUG D7104 ON THE TPU.
19	HP2 "B" SOLENOID FAULT	<ol style="list-style-type: none"> 1. DISCONNECT PLUG D7104 FROM THE TPU. 2. DISCONNECT PLUG D1364 AND PLUG D1362 FROM THE BVCU. 3. DISCONNECT PLUG D1484 FROM THE DGPU. 4. MEASURE THE RESISTANCE FROM PLUG D1364, PIN 11, TO PLUG D1484, PIN 8. <ol style="list-style-type: none"> A. IF THE RESISTANCE IS NOT BETWEEN 85-100 OHMS, DO THE STEPS THAT FOLLOW: <ol style="list-style-type: none"> (1) DISCONNECT CONNECTOR D1354 FROM THE HP2 BLEED VALVE SOLENOID. (2) MEASURE THE RESISTANCE FROM PIN 7 TO PIN 5 ON THE SOLENOID. THE RESISTANCE MUST BE BETWEEN 85-100 OHMS. <ol style="list-style-type: none"> (a) IF THE RESISTANCE IS NOT OK, REPLACE THE HP2 BLEED VALVE SOLENOID (AMM 75-32-05/401). (b) IF THE RESISTANCE IS OK, REPAIR THE CIRCUIT FROM THE BVCU TO THE HP2 BLEED VALVE SOLENOID. (3) CONNECT CONNECTOR D1354 ON THE HP2 BLEED VALVE SOLENOID. B. IF THE RESISTANCE IS BETWEEN 85-100 OHMS, DO THE STEPS THAT FOLLOW: <ol style="list-style-type: none"> (1) MEASURE THE INSULATION RESISTANCE FROM PLUG D1364, PIN 11, TO GROUND (WDM 71-51-23). THE RESISTANCE MUST BE MORE THAN 20M OHMS. (2) MONITOR THE FAULT CODES AFTER THE NEXT FLIGHT. (3) IF THE PROBLEM CONTINUES, DISCONNECT CONNECTOR D1354 ON THE HP2 BLEED VALVE SOLENOID.

TABLE 101

BVCU BITE Procedure
Figure 103 (Sheet 14)

EFFECTIVITY
RB211-535E4 ENGINES WITH BVCU C8E38-9
AND POST-SB 757-75-5

75-32-00
CONFIG 3
Page 120
Sep 28/06

R02B

FAULT CODE	DESCRIPTION	CORRECTIVE ACTION
19	HP2 "B" SOLENOID FAULT (CONT)	(4) EXAMINE THE CONNECTOR FOR BENT PINS. (a) IF THERE ARE BENT PINS, REPLACE THE HP2 BLEED VALVE SOLENOID (AMM 75-32-05/401). (b) IF THERE ARE NO BENT PINS, REPLACE THE BVCU (AMM 75-32-01/401). (5) CONNECT CONNECTOR D1354 ON THE HP2 BLEED VALVE SOLENOID. 5. MEASURE THE INSULATION RESISTANCE FROM PLUG D1364, PIN 11, TO GROUND (WDM 71-51-23). THE RESISTANCE MUST BE MORE THAN 20M OHMS. 6. CONNECT PLUG D1484 FROM THE DGPU. 7. CONNECT PLUG D1364 AND PLUG D1362 FROM THE BVCU. 8. CONNECT PLUG D7104 FROM THE TPU.
91	DECELERATION DETECTOR UNIT 1 FAULT	DO THE CORRECTIVE ACTION FOR THE BVCU FAULT CODE 02 (FIG. 103).
92	DECELERATION DETECTOR UNIT 2 FAULT	DO THE CORRECTIVE ACTION FOR THE BVCU FAULT CODE 03 (FIG. 103).
BB	BVCU FAULT	1. IF FLIGHT MARKER F (N) IS SHOWN BEFORE CODE BB, REPLACE THE BVCU (AMM 75-32-01/401). 2. IF BB IS SHOWN BEFORE FLIGHT MARKER F (N) OR NO FLIGHT MARKER IS SHOWN AND FAULT CODES 10,11,12,13,18 OR 19 ARE ALSO SHOWN, DO THE CORRECTIVE ACTION FOR THE FAULT CODE SHOWN. 3. IF THE PROBLEM CONTINUES, REPLACE THE BVCU (AMM 75-32-01/401).

TABLE 101

 BVCU BITE Procedure
 Figure 103 (Sheet 15)

 EFFECTIVITY
 RB211-535E4 ENGINES WITH BVCU C8E38-9
 AND POST-SB 757-75-5

75-32-00
 CONFIG 3
 Page 121
 Sep 28/06

R02B

PREREQUISITES

MAKE SURE THESE CIRCUIT BREAKERS ARE CLOSED:
11D21, 11D22

MAKE SURE THE AIRPLANE IS IN THIS CONFIGURATION:
ELECTRICAL POWER IS ON (AMM 24-22-00/201)

TPU BITE PROCEDURE

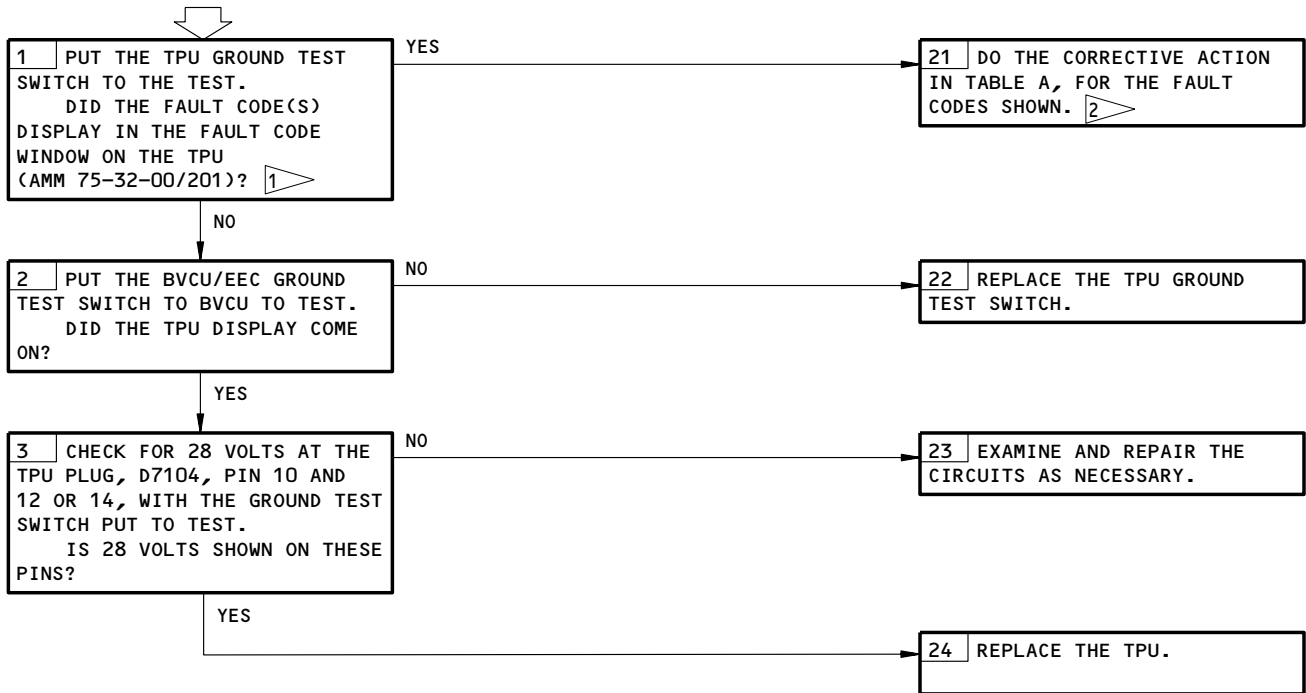

1 ALL FAULT CODES WHICH OCCUR AFTER FLIGHT MARKER F3 OR GREATER MAY BE IGNORED. TPU REPLACEMENT IS NOT REQUIRED.

2 IF NO FAULT IS FOUND AFTER YOU TROUBLESHOOT, DO AN INSPECTION OF THE MODULAR TERMINAL BLOCK/TERMINAL BLOCK FOR A POSSIBLE WIRING FAULT (AMM 71-51-01/601).

TPU BITE Procedure
Figure 104 (Sheet 1)

EFFECTIVITY
RB211-535E4 ENGINES WITH BVCU C8E38-9
AND POST-SB 757-75-5

75-32-00
CONFIG 3
Page 122
May 28/03

R02B

E42755

FAULT CODE	DESCRIPTION	CORRECTIVE ACTION
10	P4 TRANSDUCER OR PROCESS	1. EXAMINE THE P4 TUBE FROM THE NO. 15 FUEL SPRAY NOZZLE TO THE FFG AND FROM THE FFG TO THE TPU FOR LEAKS. REPAIR THE TUBES IF IT IS NECESSARY. A. IF THE PROBLEM CONTINUES, REPLACE THE TPU (AMM 75-32-15/401).
20	DGPU 1 OR 2, OR TEST SWITCH	1. MAKE SURE THE TPU GROUND TEST SWITCH IS IN THE "OFF" POSITION. A. REMOVE THE PROTECTIVE COVER FROM THE MATRIX BLOCK POSITION 31D. 2. CONNECT THE METER FROM 31D TO GROUND. A. MEASURE IF 28V DC IS PRESENT WITH THE SWITCH IN THE "OFF" POSITION. B. IF 28V DC IS PRESENT, REPLACE THE TPU GROUND TEST SWITCH (AMM 75-32-15/401). 3. INSTALL THE PROTECTIVE COVER. 4. DISCONNECT PLUG, D7104, FROM THE TPU. 5. DISCONNECT PLUGS, D1388, AND D1484, FROM THE DGPU. 6. MAKE SURE THE GROUND TEST SWITCH IS IN THE "ON" POSITION. A. MEASURE THE RESISTANCE FROM PLUG, D1388, PIN 20 TO PLUG, D7104, PIN 8, AND FROM PLUG, D1484, PIN 20, TO PLUG, D1704, PIN 9. THE RESISTANCE MUST NOT BE MORE THAN 1 OHM. B. DISCONNECT CONNECTOR D1362. C. MEASURE THE INSULATION RESISTANCE OF PLUG, D1388, PIN 20, TO GROUND; PLUG, D7104, PINS 8 AND 9 TO GROUND; AND PLUG, D1484, PIN 20, TO GROUND. THE RESISTANCE MUST BE 20M OHMS MINIMUM. D. IF THE PROBLEM CONTINUES, REPLACE THE TPU (AMM 75-32-15/401). 7. CONNECT PLUG, D7104, ON THE TPU. 8. CONNECT PLUGS, D1388, AND D1484, ON THE DGPU. 9. CONNECT CONNECTOR D1362.
30	TFU SOLENOID OR WIRING	1. DISCONNECT PLUG, D7106, FROM THE TFU. A. MEASURE THE RESISTANCE BETWEEN PINS 1 AND 3 OF THE TFU. THE RESISTANCE SHOULD BE BETWEEN 26-30 OHMS. B. MEASURE THE INSULATION RESISTANCE OF EACH PIN TO GROUND. THE RESISTANCE SHOULD BE 20M OHMS MINIMUM. (1) IF THE RESISTANCE IS NOT IN THE LIMITS, REPLACE THE TFU (AMM 73-21-14/401). (2) IF THE RESISTANCE IS IN THE LIMITS, EXAMINE PLUG, D7106, FOR CLEANLINESS OF PINS/SOCKETS AND THE SECURITY OF THE PIN GRIP. 2. CONNECT PLUG D7106 TO THE TFU. 3. IF THE PROBLEM CONTINUES, DO THESE STEPS: A. DISCONNECT PLUG D7104 FROM THE TPU. (1) MEASURE THE RESISTANCE BETWEEN PINS 5 AND 11 OF THE TPU. THE RESISTANCE SHOULD BE BETWEEN 26-30 OHMS. (2) MEASURE THE INSULATION RESISTANCE OF EACH PIN TO GROUND. THE RESISTANCE SHOULD BE 20M OHMS MINIMUM. (a) IF THE RESISTANCE IS NOT IN THE LIMITS, REPAIR THE CIRCUIT IF IT IS NECESSARY (WDM 71-51-23). (b) IF THE RESISTANCE IS IN THE LIMITS, EXAMINE PLUG, D7104, FOR CLEANLINESS OF PINS/SOCKETS AND THE SECURITY OF THE PIN GRIP. B. CONNECT PLUG, D7104, TO THE TPU. C. DO THE OPERATIONAL TEST PROCEDURE FOR THE TPU (AMM 75-32-15/501). 4. IF THE PROBLEM CONTINUES, REPLACE THE TPU (AMM 75-32-15/401).

TABLE A

 TPU BITE Procedure
 Figure 104 (Sheet 2)

 EFFECTIVITY
 RB211-535E4 ENGINES WITH BVCU C8E38-9
 AND POST-SB 757-75-5

75-32-00
 CONFIG 3
 Page 123
 Sep 28/06

R02B

FAULT CODE	DESCRIPTION	CORRECTIVE ACTION
40	SURGE DETECTED	<ol style="list-style-type: none"> 1. IF THERE IS A BIRDSTRIKE, SUSPECTED BIRDSTRIKE, AND/OR SURGE REPORTED, REFER TO FIM 71-05-00/101, FIG. 101 THRU 105, OR FIM 71-06-00/101, FIG. 103 THRU 105, AS APPLICABLE. 2. IF THERE IS NO SIGN OF A BIRDSTRIKE, EXAMINE THE P4 PIPE FROM THE NO. 15 FUEL SPRAY NOZZLE TO THE FFG AND FROM THE FFG TO THE TPU FOR LEAKS. CORRECT THE LEAKS AS NECESSARY. 3. IF THE PROBLEM CONTINUES, REPLACE THE TPU (AMM 75-32-15/401).
50	TPU INTERNAL WIRING FAULT (IGNITION) (ENGINES WITH ETPU100-2C TPU OR ETPU100-3C TPU)	REPLACE THE TPU (AMM 75-32-15/401).
60	PLA TRANSDUCER OR WIRING PROBLEM	<ol style="list-style-type: none"> 1. IF CODE 04 IS SHOWN ON BVCU, PRECEDED BY SOME FLIGHT MARKER, FO TO F9, DO THE STEPS THAT FOLLOW: <ol style="list-style-type: none"> A. DISCONNECT PLUG, D1366, FROM THE PLA TRANSDUCER. B. DISCONNECT PLUG, D1478, FROM THE BVCU. C. DISCONNECT PLUG, D7104, FROM THE TPU. D. MEASURE THE RESISTANCE FROM PLUG, D1366, PIN 9, TO PLUG, D7104, PIN 18, AND FROM PLUG, D1366, PIN 10, TO PLUG, D1478, PIN 7, AND FROM PLUG, D7104, PIN 19, TO PLUG, D1478, PIN 6. THE RESISTANCE MUST NOT BE MORE THAN 1 OHM. E. MEASURE THE INSULATION RESISTANCE FROM PLUG, D1366, PIN 9, TO GROUND, PLUG, D7104, PIN 18, TO GROUND, PLUG, D1366, PIN 10, TO GROUND, PLUG, D1478, PIN 7, TO GROUND, PLUG, D7104, PIN 19, TO GROUND, AND PLUG, D1478, PIN 6, TO GROUND. THE INSULATION RESISTANCE MUST BE 20K OHMS MINIMUM. F. MEASURE THE INSULATION RESISTANCE BETWEEN PLUG, D7104, PINS 18 AND 19. THE RESISTANCE MUST BE 20K OHMS MINIMUM. <ol style="list-style-type: none"> (1) IF YOU FIND A FAULT IN THE CIRCUIT, REPAIR THE CIRCUIT IF IT IS NECESSARY (WDM 71-51-23). (2) IF YOU DO NOT FIND A FAULT IN THE CIRCUIT, DO THE STEPS THAT FOLLOW: <ol style="list-style-type: none"> (a) EXAMINE PLUGS, D1366, D1478, AND D7104, FOR CLEANLINESS OF THE PINS/SOCKETS AND SECURITY OF PIN GRIP. (3) IF THE FAULT CONTINUES, REPLACE THE PLA TRANSDUCER (AMM 75-32-14/401). (4) IF THE FAULT CONTINUES, REPLACE THE TPU (AMM 75-32-15/401). (5) IF THE FAULT CONTINUES, REPLACE THE BVCU (AMM 75-32-15/401). G. CONNECT PLUG, D7104, TO THE TPU. H. CONNECT PLUG, D1478, TO THE BVCU. I. CONNECT PLUG, D1366, TO THE PLA TRANSDUCER. 2. IF CODE 04 IS NOT SHOWN ON THE BVCU, PRECEDED BY SOME FLIGHT MARKER, NO ACTION IS NECESSARY.

TABLE A

TPU BITE Procedure
Figure 104 (Sheet 3)

EFFECTIVITY
RB211-535E4 ENGINES WITH BVCU C8E38-9
AND POST-SB 757-75-5

75-32-00
CONFIG 3
Page 124
Sep 28/06

R02B

FAULT CODE	DESCRIPTION	CORRECTIVE ACTION																
90	EICAS MAINTENANCE LINE FAULT OR SYSTEM DEPOWERED OR MAINTENANCE LINE GROUNDED BY BVCU	1. GROUND TEST THE BVCU AND SEE IF THERE ARE FAULTS DETECTED ON BVCU BITE DURING THE GROUND TEST. <u>NOTE:</u> EICAS MAINTENANCE LINE FAULTS, WHICH CAN GENERATE TPU FAULT CODE 90, ARE ONLY MONITORED DURING GROUND TEST. A FAULT DETECTED DURING GROUND TEST IS DISPLAYED IMMEDIATELY AFTER AA IN THE FAULT CODE SEQUENCE AND IS NOT FOLLOWED BY THE LETTER F. EXAMPLE: <table border="0" style="margin-left: 40px;"> <thead> <tr> <th style="text-align: center;">TPU</th> <th style="text-align: center;">BITE</th> <th style="text-align: center;">BVCU</th> <th style="text-align: center;">BITE</th> </tr> </thead> <tbody> <tr> <td>A. CC AA 90</td> <td>FO 40 ED</td> <td>CC AA 10</td> <td>FO 04 ED</td> </tr> <tr> <td>B. CC AA 90</td> <td>ED</td> <td>CC AA 10</td> <td>ED</td> </tr> <tr> <td>C. CC AA FO</td> <td>40 ED</td> <td>CC AA FO</td> <td>04 ED</td> </tr> </tbody> </table> IN EXAMPLE A., AND B., CODE 90 REPRESENTS FAULTS DETECTED DURING GROUND TEST. THIS IS THE BVCU FAULT 10, WHICH PUTS THE EICAS MAINTENANCE LINE TO GROUND. IN EXAMPLE C., NO FAULT IS DETECTED DURING GROUND TEST. IN EXAMPLE A., AND C., THE THE FO 40 ON TPU AND FO 04 ON BVCU REPRESENTS A FAULT DETECTED ON THE PREVIOUS FLIGHT AND HELD IN MEMORY. 2. IF NO BVCU FAULT CODE IS DETECTED DURING THE GROUND TEST, CONTINUE TO STEP 4. 3. IF A BVCU FAULT CODE IS DETECTED DURING THE GROUND TEST, DO THE CORRECTIVE ACTION IF IT IS NECESSARY AND EXAMINE THE TPU BITE AGAIN. A. IF NO FAULT CODE 90 IS SHOWN, RETURN THE AIRPLANE TO SERVICE. B. IF FAULT CODE 90 IS SHOWN, CONTINUE TO STEP 4. 4. DISCONNECT PLUG, D1704. FROM THE TPU. 5. MEASURE THE VOLTAGE FROM PLUG, D1704, PIN 2. THE VOLTAGE SHOULD BE 9.0 VOLTS (APPROXIMATELY). A. IF VOLTAGE IS PRESENT, REPLACE THE TPU (AMM 75-32-15/401). B. IF 9.0 VOLTS IS NOT PRESENT, DISCONNECT PLUG, D1006. (1) MEASURE THE VOLTAGE ON PIN 6, ON THE AIRPLANE SIDE OF PLUG, D1006. THE VOLTAGE SHOULD BE 9.0 VOLTS APPROXIMATELY. (a) IF 9.0 VOLTS IS PRESENT, EXAMINE THE ENGINE HARNESS WIRING FROM PLUGS, D1006, TO D1704. REPAIR THE PROBLEMS THAT YOU FIND. (b) IF 9.0 VOLTS IS NOT PRESENT, EXAMINE THE AIRPLANE WIRING AND REPAIR THE CIRCUIT IF IT IS NECESSARY. 6. CONNECT PLUG, D1704, FROM THE TPU.	TPU	BITE	BVCU	BITE	A. CC AA 90	FO 40 ED	CC AA 10	FO 04 ED	B. CC AA 90	ED	CC AA 10	ED	C. CC AA FO	40 ED	CC AA FO	04 ED
TPU	BITE	BVCU	BITE															
A. CC AA 90	FO 40 ED	CC AA 10	FO 04 ED															
B. CC AA 90	ED	CC AA 10	ED															
C. CC AA FO	40 ED	CC AA FO	04 ED															
B1	TPU	REPLACE THE TPU (AMM 75-32-15/401).																
B3	TPU	1. REPLACE THE TPU (AMM 75-32-15/401). 2. IF THE PROBLEM CONTINUES, DO THE CODE 30 CORRECTIVE ACTION PROCEDURE.																
B5	TPU	REPLACE THE TPU (AMM 75-32-15/401).																
B6	TPU	1. REPLACE THE TPU (AMM 75-32-15/401). 2. IF THE PROBLEM CONTINUES, DO THE CODE 60 CORRECTIVE ACTION PROCEDURE.																
B9	TPU	1. REPLACE THE TPU (AMM 75-32-15/401). 2. IF THE PROBLEM CONTINUES, DO THE CODE 90 CORRECTIVE ACTION PROCEDURE.																
BB	TPU	REPLACE THE TPU (AMM 75-32-15/401).																
BE	TPU	REPLACE THE TPU (AMM 75-32-15/401).																
BF	TPU	REPLACE THE TPU (AMM 75-32-15/401).																

TABLE A

 TPU BITE Procedure
 Figure 104 (Sheet 4)

 EFFECTIVITY
 RB211-535E4 ENGINES WITH BVCU C8E38-9
 AND POST-SB 757-75-5

75-32-00
 CONFIG 3
 Page 125
 Jan 28/02

R03B

EGT IS MORE THAN 30 DEGREES C HIGHER THAN OTHER ENGINE

PREREQUISITES
NONE

1 DO THIS PROCEDURE: BVCU BITE PROCEDURE (FIG. 103). CORRECT ANY FAULTS FOUND. DO THE IP/HP COMPRESSORS AIRFLOW CONTROL TEST (AMM 71-00-00/501, TEST NO. 3). IS TEST OK?

YES

21 RETURN TO SERVICE.

NO

2 WAS FAULT APPARENT ONLY BELOW 1.35 EPR?

YES

11 WAS ALTITUDE ABOVE 17,000 FEET?

YES

22 PROBLEM IS LOW EGT ON OPPOSITE ENGINE, REPLACE ALTITUDE SWITCH (AMM 75-32-07/401) ON THAT ENGINE. IF THE PROBLEM CONTINUES, EXAMINE THE CIRCUIT FROM CONNECTOR D1480, PIN A, TO D1362, PINS 19 AND 3 (WDM 71-51-23). REPAIR THE PROBLEMS THAT YOU FIND.

NO

12 REPLACE ALTITUDE SWITCH ON ENGINE WITH HIGHER EGT (AMM 75-32-07/401). DO THE IP/HP COMPRESSORS AIRFLOW CONTROL TEST (AMM 71-00-00/501, TEST NO. 3). IS TEST OK?

NO

23 EXAMINE THE CIRCUIT FROM CONNECTOR D1480, PIN A, TO D1362, PINS 19 AND 3 (WDM 71-51-23). REPAIR THE PROBLEMS THAT YOU FIND.

YES

24 RETURN TO SERVICE.

NO

3 REPLACE ALL HP BLEED VALVE SOLENOIDS (AMM 75-32-05/401). DO THE IP/HP COMPRESSORS AIRFLOW CONTROL TEST (AMM 71-00-00/501, TEST NO. 3). IS TEST OK?

YES

25 RETURN TO SERVICE.

NO

4 CHECK ASSOCIATED HP BLEED VALVE SOLENOID AIR TUBES FOR LEAKS. DID LEAKS EXIST?

YES

26 REPAIR LEAKS AS REQUIRED.

NO

SEE SHEET 2 (BLOCK 5)

EGT Is More Than 30 Degrees C Higher Than Other Engine
Figure 105 (Sheet 1)

EFFECTIVITY
 RB211-535E4 ENGINES WITH BVCU C8E38-9
 AND POST-SB 757-75-5

75-32-00
 CONFIG 3
 Page 126
 Sep 28/06

R01B

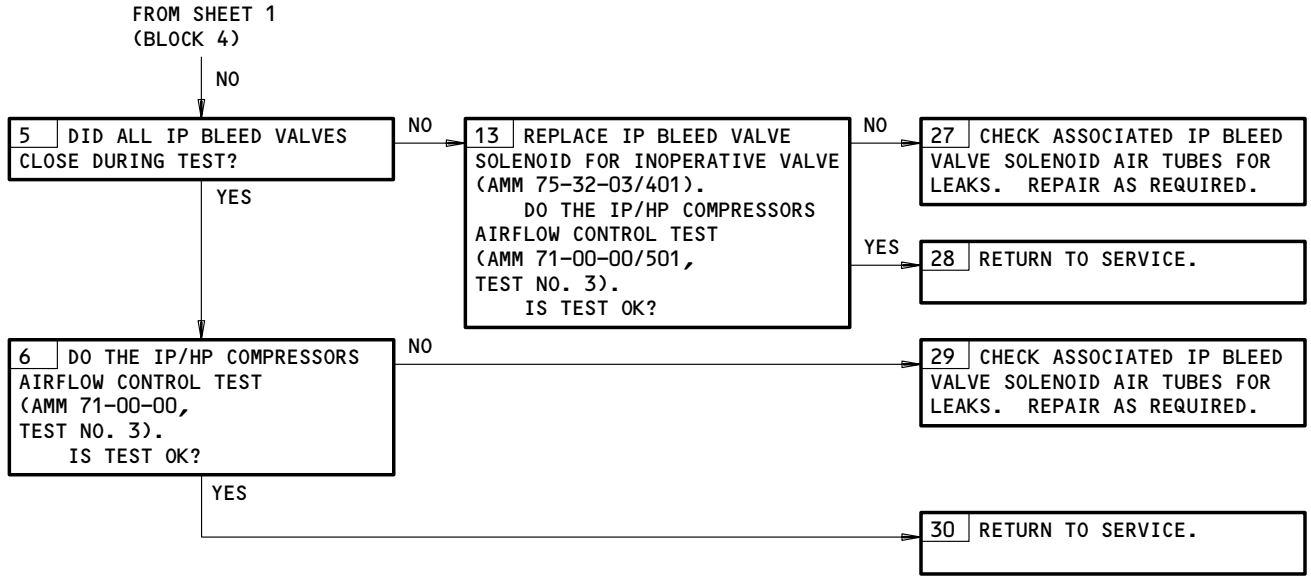

EGT Is More Than 30 Degrees C Higher Than Other Engine
Figure 105 (Sheet 2)

EFFECTIVITY
RB211-535E4 ENGINES WITH BVCU C8E38-9
AND POST-SB 757-75-5

75-32-00
CONFIG 3
Page 127
Jan 28/02

R02B

Not Used
Figure 106

EFFECTIVITY
RB211-535E4 ENGINES WITH BVCU C8E38-9
AND POST-SB 757-75-5

75-32-00
CONFIG 3
Page 128
Jan 28/02

R02B

E42786

"L (R) ENG SURGE
BITE" MESSAGE SHOWN
ON EICAS

PREREQUISITES
NONE

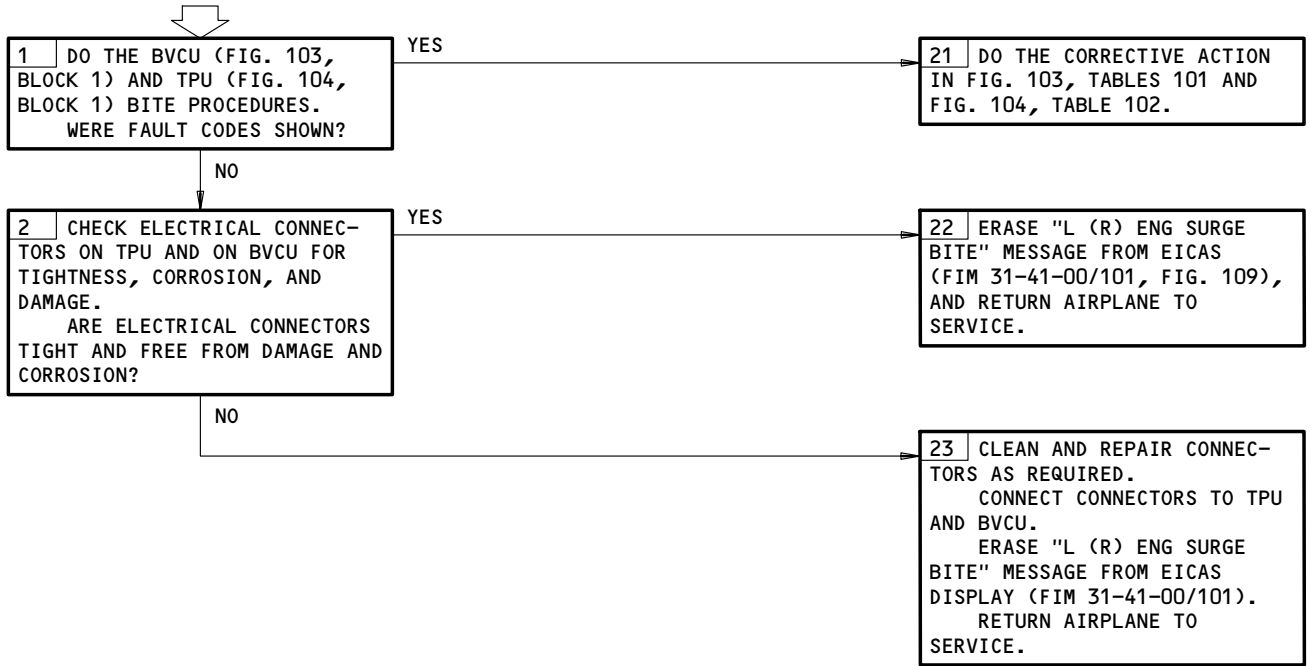

L (R) ENG SURGE BITE Message Shown on EICAS
Figure 107

EFFECTIVITY
RB211-535E4 ENGINES WITH BVCU C8E38-9
AND POST-SB 757-75-5

75-32-00
CONFIG 3
Page 129
Jan 28/02

R02B

COMPRESSOR BLEED CONTROL SYSTEM

COMPONENT	FIG. 102 SHT	QTY	ACCESS/AREA	AMM REFERENCE
CIRCUIT BREAKER - ENG HP BLD VLV-L/GND, C4113 ENG HP BLD VLV-R/GND, C4114	--	1 1	FLIGHT COMPARTMENT, P11 11D21 11D22	
COMPUTER - (FIM 31-41-00/101) L EICAS, M10181 R EICAS, M10182				
RECEPTACLE - T2/EGT TEST, D1402	3	1	414AR, L ENG R FAN COWL 424AR, R ENG R FAN COWL	
RELAY - (FIM 31-01-36/101) L ENG POWER, K10208				
RELAY - (FIM 31-01-37/101) R ENG POWER, K10220				
SOLENOID - HP2 BLD VLV	2	1	413AL, L ENG L FAN COWL 423AL, R ENG L FAN COWL	75-32-05 75-32-05
SOLENOID - NO. 1 HP3 BLD VLV, V10018	2	1	413AL, L ENG L FAN COWL 423AL, R ENG L FAN COWL	75-32-05 75-32-05
SOLENOID - NO. 1 IP BLD VLV, V10019	4	1	415AL, L ENG L THRUST REVERSER 425AL, R ENG L THRUST REVERSER	75-32-03 75-32-03
SOLENOID - NO. 2 HP3 BLD VLV, V10014	2	1	413AL, L ENG L FAN COWL 423AL, R ENG L FAN COWL	75-32-05 75-32-05
SOLENOID - NO. 2 IP BLD VLV, V10020	4	1	416AR, L ENG R THRUST REVERSER 426AR, L ENG R THRUST REVERSER	75-32-03 75-32-03
SWITCH - ALTITUDE, S10142	3	1	414AR, L ENG R FAN COWL 424AR, R ENG R FAN COWL	75-32-07 75-32-07
SWITCH - BVCU/EEC GND TEST, S10150	3	1	414AL, L ENG L FAN COWL 424AL, R ENG L FAN COWL	
SWITCH - TPU GND TEST, S10151	2	1	413AL, L ENG L FAN COWL 423AL, R ENG L FAN COWL	
THERMOCOUPLE - T2 SONIC, TS5024	4	1	BEHIND SPLITTER FAIRING	75-32-12
TRANSDUCER - POWER LEVER ANGLE (BVCU), TS5023	1	1	414AR, L ENG R FAN COWL 424AR, R ENG R FAN COWL	75-32-06 75-32-06
TUBE - HP AND IP COMPRESSOR BLEED CONTROL AIR UNIT - (FIM 73-21-10/101)	2	4		75-32-09
DEDICATED GENERATOR CONTROL (DGPU A), M10157		1		
DEDICATED GENERATOR CONTROL (DGPU B), M10165		1		
UNIT - BLEED VALVE CONTROL, M10153	3	1	413AL, L ENG L FAN COWL 423AL, R ENG L FAN COWL	75-32-01 75-32-01
UNIT - TRANSIENT PRESSURE, M10166	2	1	413AL, L ENG L FAN COWL 423AL, R ENG L FAN COWL	75-32-05 75-32-05
VALVE - HP COMPRESSOR BLEED	5	3	415AL, 425AL, 416AR, 426AR, THRUST REVERSER	75-32-04
VALVE - IP COMPRESSOR BLEED	5	3	415AL, 425AL, 416AR, 426AR, THRUST REVERSER	75-32-02

 Compressor Bleed Control System - Component Index
 Figure 101

 EFFECTIVITY
 RB211-535E4 ENGINES WITH BVCU C8E38-11,
 C8E38-12 OR C8E38-15

75-32-00

CONFIG 4

R01

Page 101

May 28/03

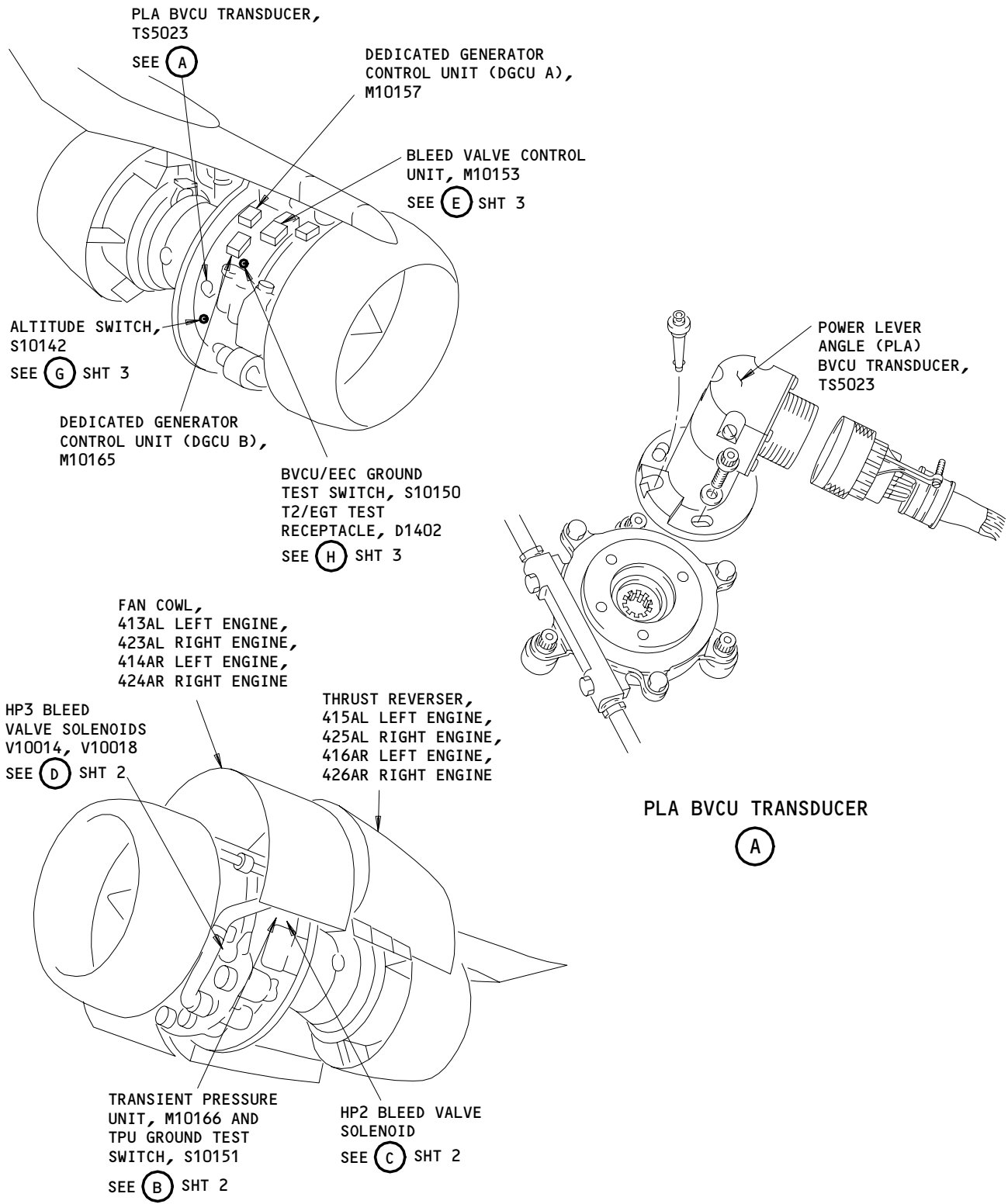

Compressor Bleed Control System - Component Location
Figure 102 (Sheet 1)

EFFECTIVITY
RB211-535E4 ENGINES WITH BVCU C8E38-11,
C8E38-12 OR C8E38-15

75-32-00
CONFIG 4
Page 102
May 28/03

R01

TPU GROUND TEST SWITCH, S10151

TRANSIENT PRESSURE SENSOR UNIT, M10166

ELECTRICAL CONNECTOR, D7104

TRANSIENT PRESSURE UNIT (TPU)

(B)

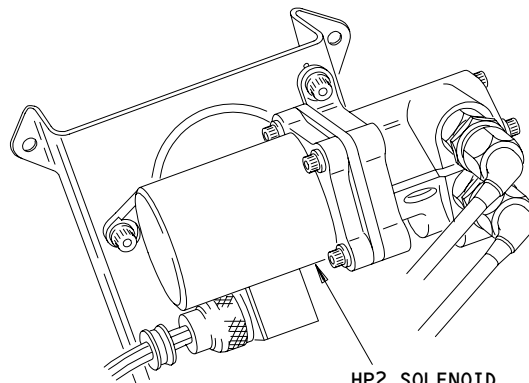

HP2 SOLENOID

HP2 SOLENOID

(C)

LEFT HP3 BLEED VALVE SOLENOID, V10018

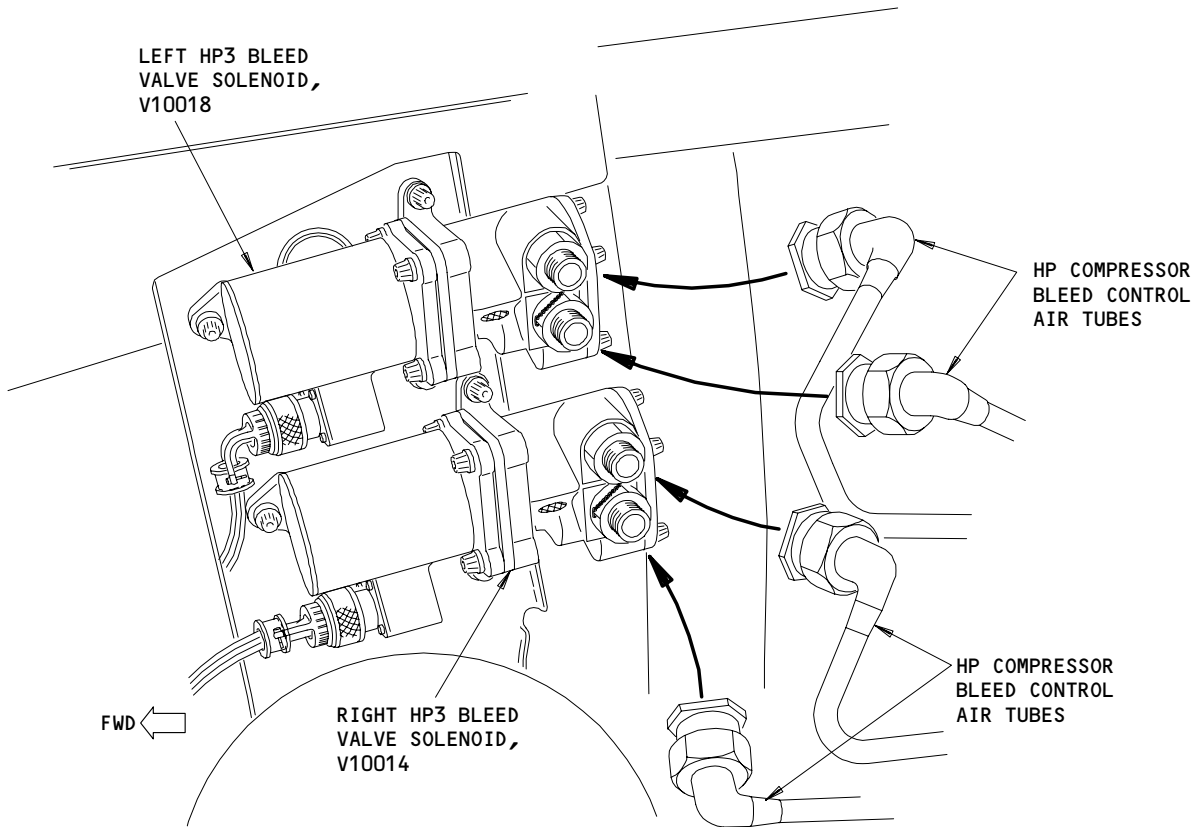

HP COMPRESSOR BLEED CONTROL AIR TUBES

HP COMPRESSOR BLEED CONTROL AIR TUBES

RIGHT HP3 BLEED VALVE SOLENOID, V10014

HP3 BLEED VALVE SOLENOID

(D)

59997

Compressor Bleed Control System - Component Location (Details from Sht 1)
Figure 102 (Sheet 2)

EFFECTIVITY
RB211-535E4 ENGINES WITH BVCU C8E38-11,
C8E38-12 OR C8E38-15

75-32-00

CONFIG 4

R01

Page 103

May 28/03

F27743

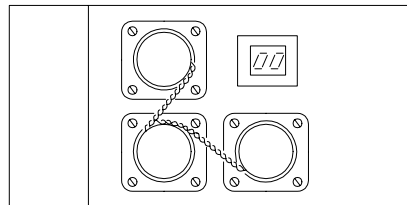
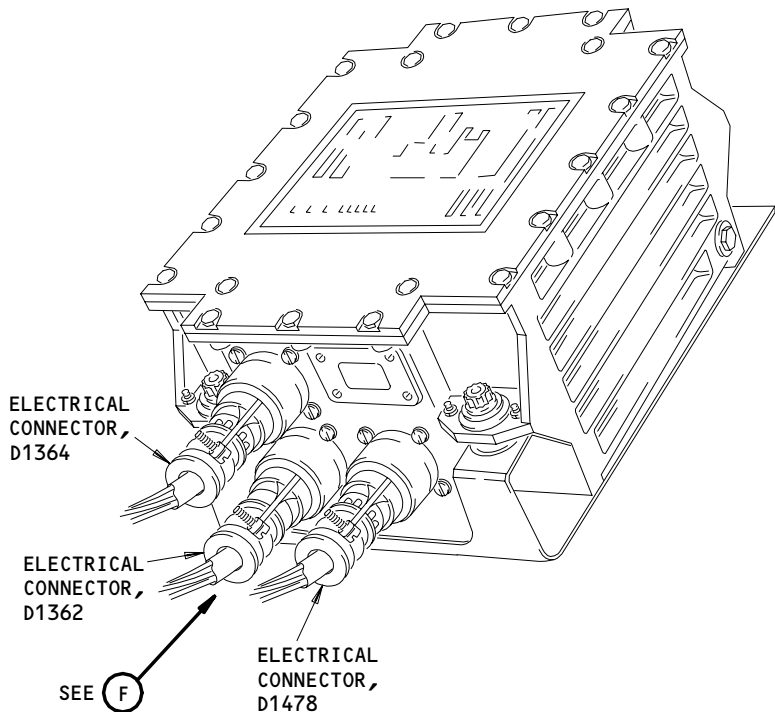

LOCKWIRE ARRANGEMENT

(F)

BLEED VALVE CONTROL UNIT (BVCU), M10153

(E) FROM SHT 1

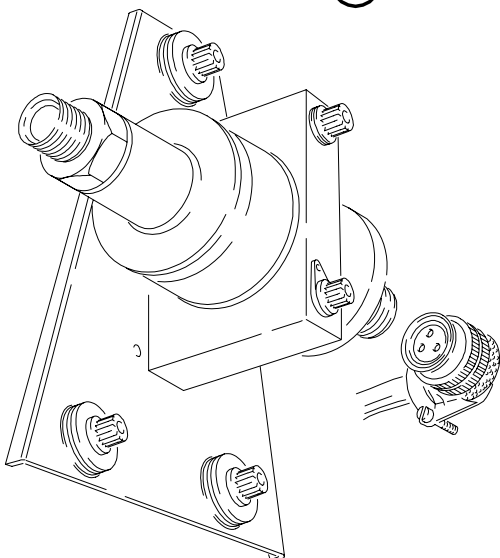

ALTITUDE SWITCH, S10142

(G) FROM SHT 1

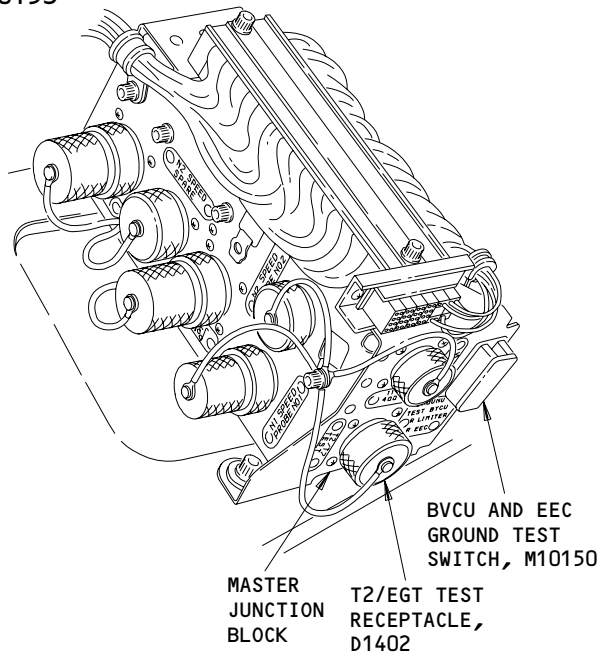

MASTER JUNCTION BLOCK

(H) FROM SHT 1

Compressor Bleed Control System - Component Location
Figure 102 (Sheet 3)

EFFECTIVITY
RB211-535E4 ENGINES WITH BVCU C8E38-11,
C8E38-12 OR C8E38-15

75-32-00

CONFIG 4

Page 104

May 28/03

R01

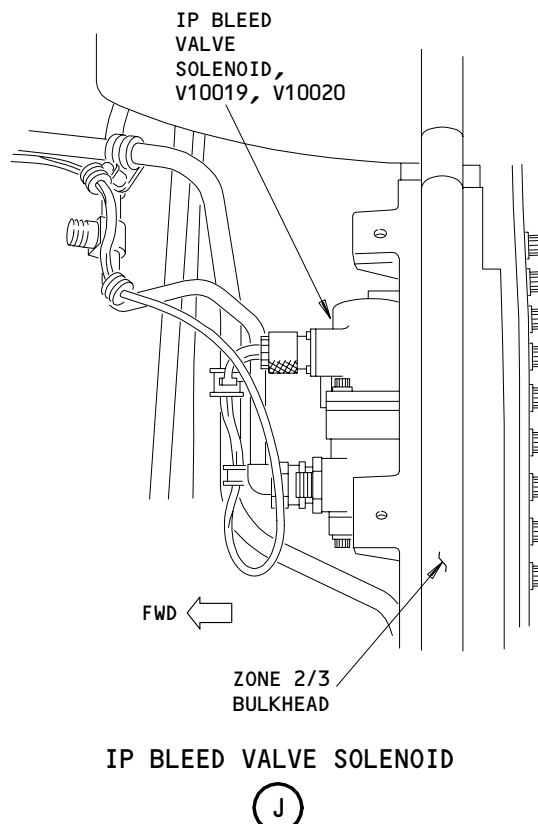
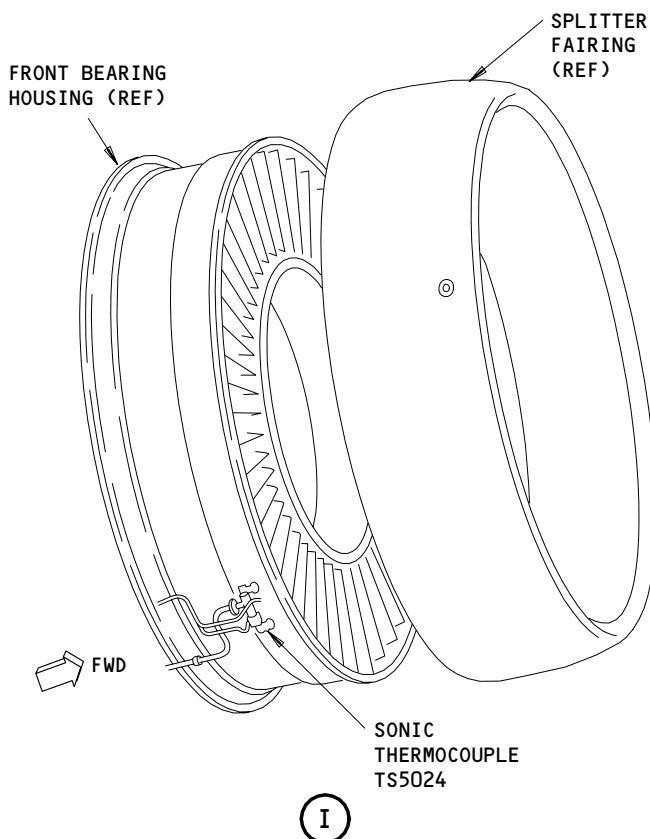
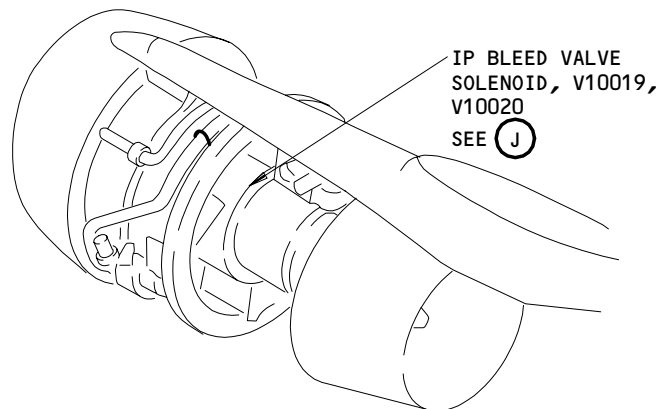
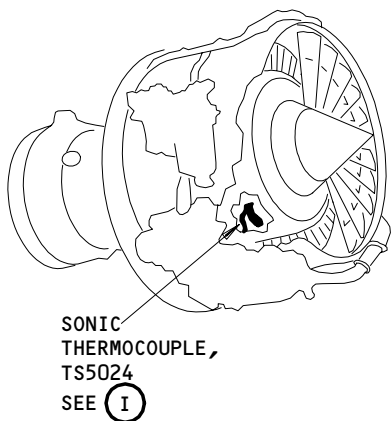

60011

Compressor Bleed Control System - Component Location
Figure 102 (Sheet 4)

EFFECTIVITY
RB211-535E4 ENGINES WITH BVCU C8E38-11,
C8E38-12 OR C8E38-15

75-32-00

CONFIG 4

R01

Page 105

May 28/03

F27750

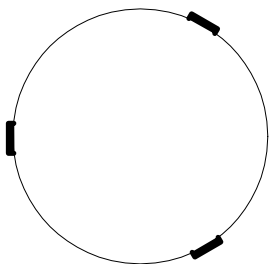

IP BLEED VALVE LOCATIONS
(VIEW IN THE FORWARD DIRECTION)

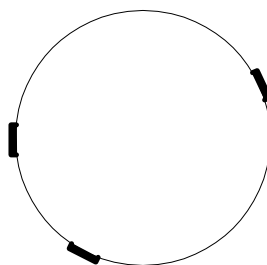
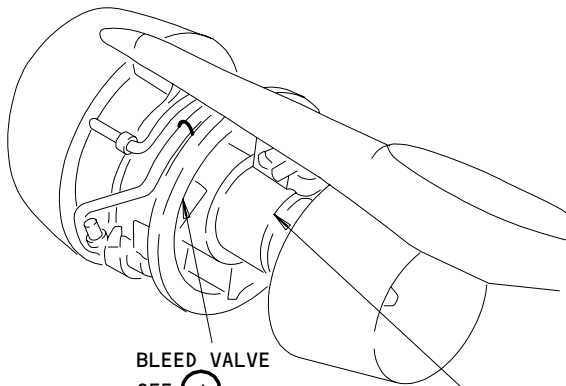

HP BLEED VALVE LOCATIONS
(VIEW IN THE FORWARD DIRECTION)

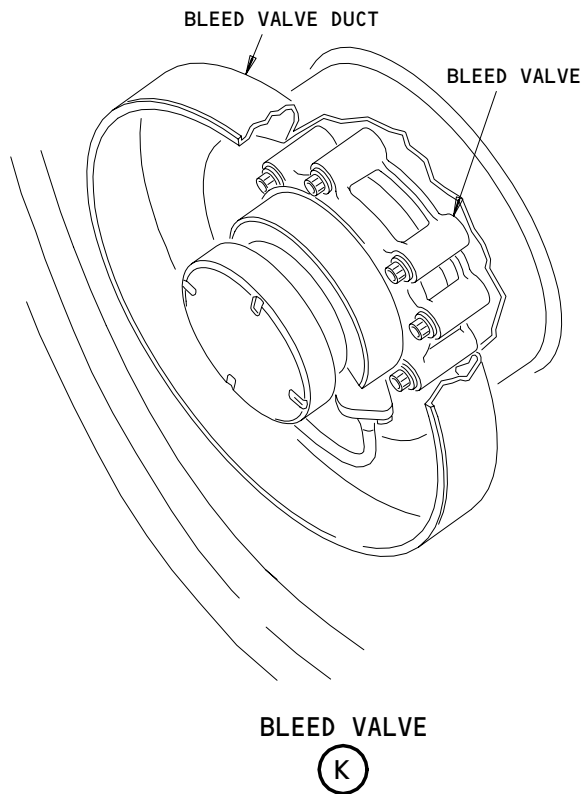
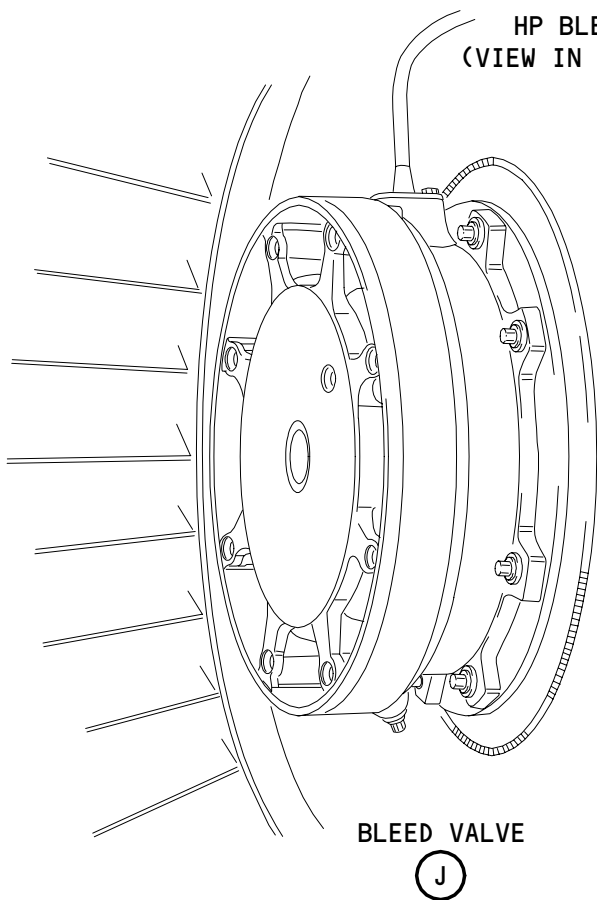

Compressor Bleed Control System - Component Location
Figure 102 (Sheet 5)

EFFECTIVITY
RB211-535E4 ENGINES WITH BVCU C8E38-11,
C8E38-12 OR C8E38-15

75-32-00

CONFIG 4

Page 106

May 28/03

R01

F27752

COMPRESSOR BLEED CONTROL SYSTEM - COMPONENT LOCATION/FAULT ISOLATION

1. General

- A. This procedure is for BVCU type No. C8E38-11, BVCU type No. C8E38-12, BVCU Type No. C8E38-14, and BVCU Type No. C8E38-15. BVCU type No. C8E38-11 was added by SB 75-B506. BVCU type No. C8E38-12 was added by SB 75-C267. BVCU Type No. C8E38-14 was added by SB 75-C737. BVCU Type No. C8E38-15 was added by SB 75-C824. Do the fault isolation task whenever the task's fault is reported or suspected.
- B. If the Flight crew reports a fault, you can find the referenced fault code in the Fault Code Index of the fault reporting chart. The index identifies the fault and references the specific maintenance manual section, fault isolation diagram and block number on the diagram where fault isolation should start.
- C. Service Bulletins referred to:
 - (1) SB 71-8029 Power Plant - Light duty electrical harness - Re-introduction of component designators.
 - (2) SB 75-8315 Air - Compressor bleed valves transient pressure sensor unit - Introduction of revised software to combat spurious fault signals. (TPU type No. ETPU 100-2C).
 - (3) SB 71-8346 Power Plant - Light duty electrical harness - Loom C - Interchange of scheduling logic between HP3(1) and HP3(2) bleed valve solenoids to reduce excessive aircraft cabin noise.
 - (4) SB 75-8898 Air - HP and IP Bleed - Introduction of HP and IP Controller compatible with a reversed logic bleed valve solenoid valve and with revised fault codes.
 - (5) SB 75-9490 Air - HP and IP Bleed - Introduction of HP and IP Bleed Valve Control Unit (BVCU) with changed hardware and software to prevent unwanted defect indications.
 - (6) Boeing SB 757-75-0005 Deletion of EICAS status link from BVCU.
 - (7) SB 75-B506 Air/HP/IP Bleed - Airflow Control Unit. Deletion of Status Message Annunciation.
 - (8) SB 75-B699 Air compressor bleed valves- Transient pressure sensor unit- re-identification of units incorporating a group of previously approved modifications.

EFFECTIVITY
RB211-535E4 ENGINES WITH BVCU C8E38-11,
C8E38-12 OR C8E38-15

75-32-00
CONFIG 4
Page 107
May 28/03

R01

- (9) SB 75-C267 Air/HP/IP Bleed - Airflow Control Unit.
Introduction of a HP and IP bleed controller with a revised bleed valve schedule.
- (10) SB 75-C737 Air/HP/IP Bleed - Airflow Control Unit.
Introduction of a HP and IP bleed controller with a revised bleed valve schedule.
- (11) SB 75-C824 Air- HP and IP - Airflow Control Unit.
Conversion of a HP and IP Bleed Controller type C8E38-12 to a C8E38-15.
- (12) SB 75-B945 Air Flow Control Regulator and Actuator -
Introduction of an Engine Transient Pressure Unit incorporating application specific integrated circuits (TPU Type No. ETPU200-01).
- (13) SB 75-C823 Air Flow Control Regulator and Actuator -
Introduction of an Engine Transient Pressure Unit incorporating application specific integrated circuits (TPU Type No. ETPU300-01).
- (14) SB 75-C694 Air- HP and IP - Airflow Control Unit.
Conversion of a HP and IP Bleed Controller type C8E38-12 to a C8E38-14.

2. Fault Isolation Procedures

A. General

(1) The table that follows lists the fault isolation diagrams:

FIGURE	TITLE
103	BVCU BITE Procedure
104	TPU BITE Procedure
105	EGT more than 30 deg. C. higher than other engine
106	'L or R ENGINE SURGE BITE' message shown on EICAS

B. Procedure

(1) Table 101 lists fault isolation procedure sheet numbers from Table 102 to the fault codes in this section:

EFFECTIVITY
 RB211-535E4 ENGINES WITH BVCU C8E38-11,
 C8E38-12 OR C8E38-15

75-32-00
 CONFIG 4
 Page 108
 May 28/03

R01

PREREQUISITES

MAKE SURE THESE CIRCUIT BREAKERS ARE CLOSED:
11D21, 11D22

MAKE SURE THE AIRPLANE IS IN THIS CONFIGURATION:
ELECTRICAL POWER IS ON (AMM 24-22-00/201)

NOTE: BVCU DISPLAY INTERROGATION INSTRUCTIONS:

- THE BVCU DISPLAY SHOWS, CONSECUTIVELY, FAULT CODES FOR UP TO THREE FLIGHTS. THE MOST RECENT FLIGHT IS SHOWN FIRST. FLIGHTMARKERS (IF FOLLOWED BY THE NUMBER OF FAULT-FREE FLIGHTS BETWEEN EACH SET OF CODES) ARE SHOWN JUST BEFORE THE FAULT CODES.

BVCU BITE PROCEDURE

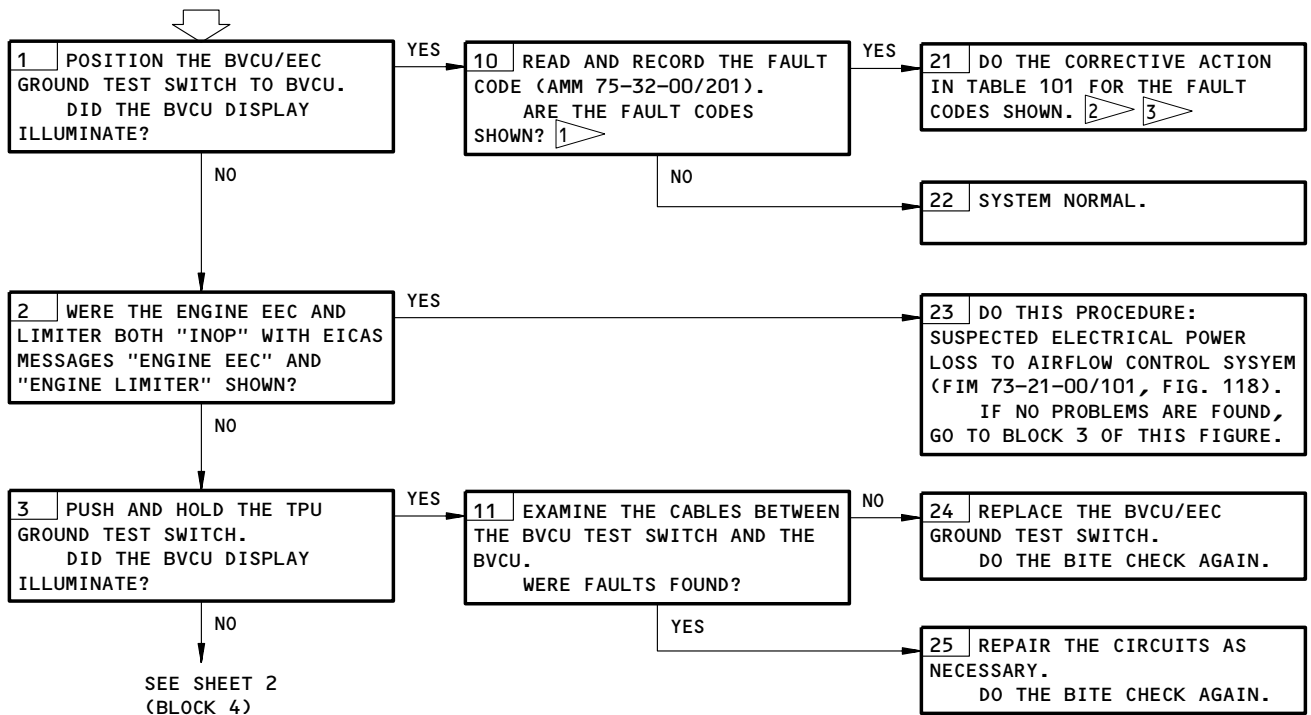

- 1 ALL FAULT CODES AND ALL FLIGHT MARKERS THAT APPEAR AFTER THE FLIGHT MARKER F1 OR GREATER CAN BE IGNORED. BVCU REJECTION IS NOT NECESSARY.
- 2 IF FAULT CODES ARE SHOWN THAT ARE NOT LISTED IN TABLE 101, REPLACE BVCU (AMM 75-32-01/401).
- 3 IF NO FAULT IS FOUND AFTER YOU TROUBLESHOOT, DO AN INSPECTION OF THE MODULAR TERMINAL BLOCK/TERMINAL BLOCK FOR A POSSIBLE WIRING FAULT (AMM 71-51-01/601).

BVCU BITE Procedure
Figure 103 (Sheet 1)

EFFECTIVITY
RB211-535E4 ENGINES WITH BVCU C8E38-11,
C8E38-12 OR C8E38-15

75-32-00
CONFIG 4
Page 109
May 20/08

R01

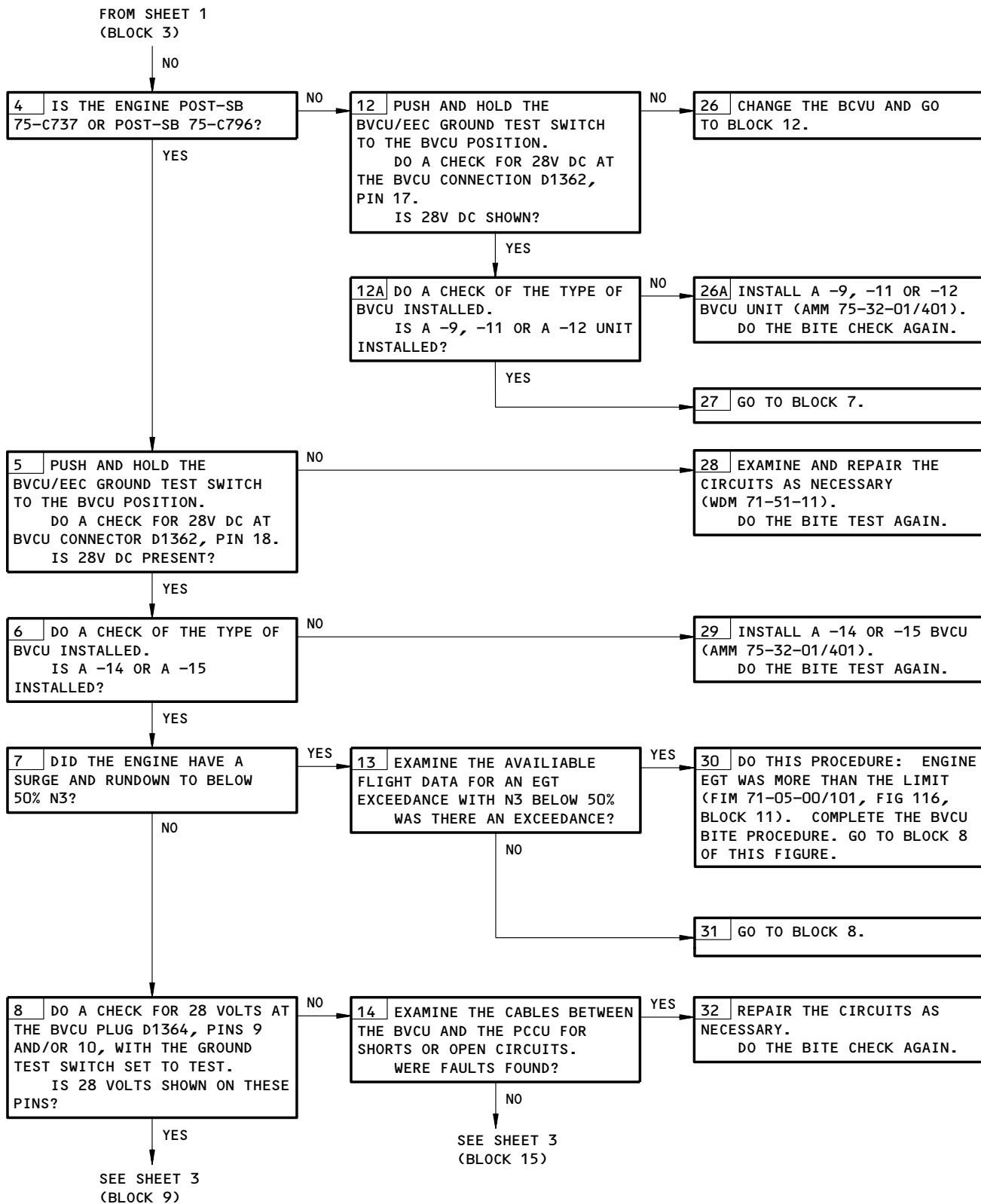

BVCU BITE Procedure
Figure 103 (Sheet 2)

EFFECTIVITY
RB211-535E4 ENGINES WITH BVCU C8E38-11,
C8E38-12 OR C8E38-15

75-32-00
 CONFIG 4
 Page 110
 May 20/08

R01

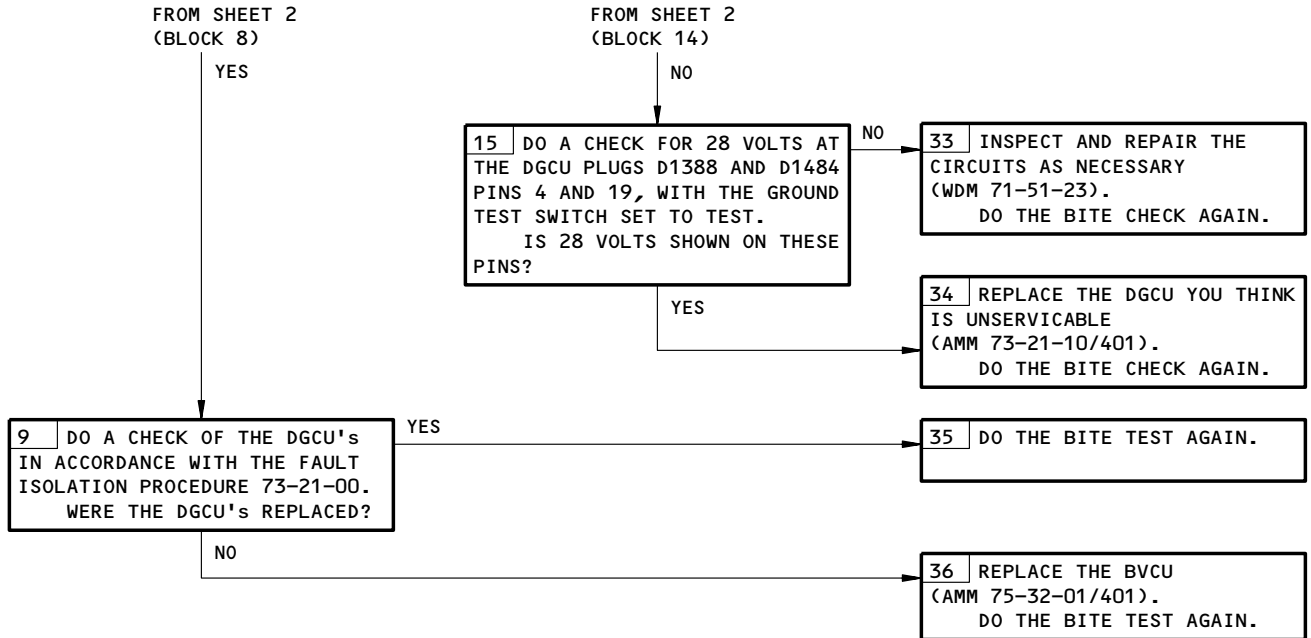

BVCU BITE Procedure
Figure 103 (Sheet 3)

EFFECTIVITY
RB211-535E4 ENGINES WITH BVCU C8E38-11,
C8E38-12 OR C8E38-15

75-32-00
CONFIG 4
Page 111
May 20/08

R01

PREREQUISITES

NONE

TPU BITE PROCEDURE

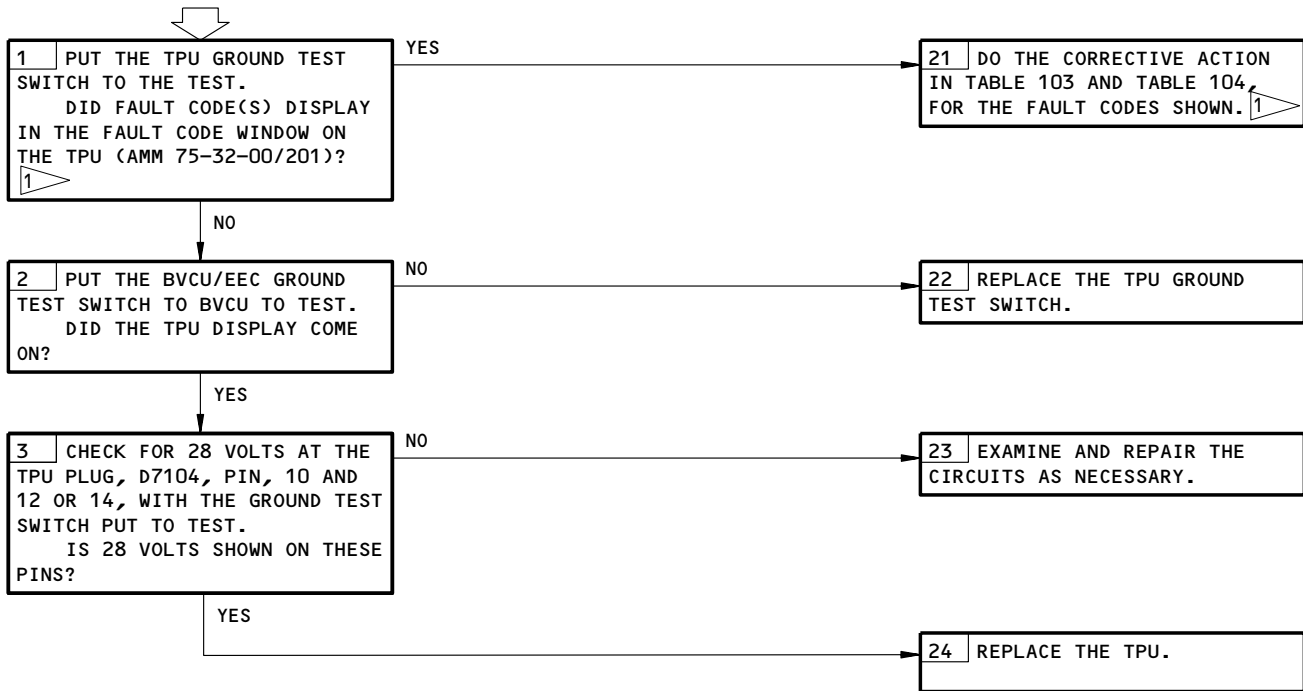

1 ALL FAULT CODES WHICH OCCUR AFTER FLIGHT MARKER F3 OR GREATER MAY BE IGNORED. REPLACEMENT OF TPU IS NOT REQUIRED.

2 IF NO FAULT IS FOUND AFTER YOU TROUBLESHOOT, DO AN INSPECTION OF THE MODULAR TERMINAL BLOCK/TERMINAL BLOCK FOR A POSSIBLE WIRING FAULT (AMM 71-51-01/601).

DEE0006934

TPU BITE Procedure
Figure 104

EFFECTIVITY
RB211-535E4 ENGINES WITH BVCU C8E38-11,
C8E38-12 OR C8E38-15

75-32-00
CONFIG 4
Page 112
Jan 28/06

R01

EGT IS MORE THAN
30 DEGREES C HIGHER
THAN OTHER ENGINE

PREREQUISITES
NONE

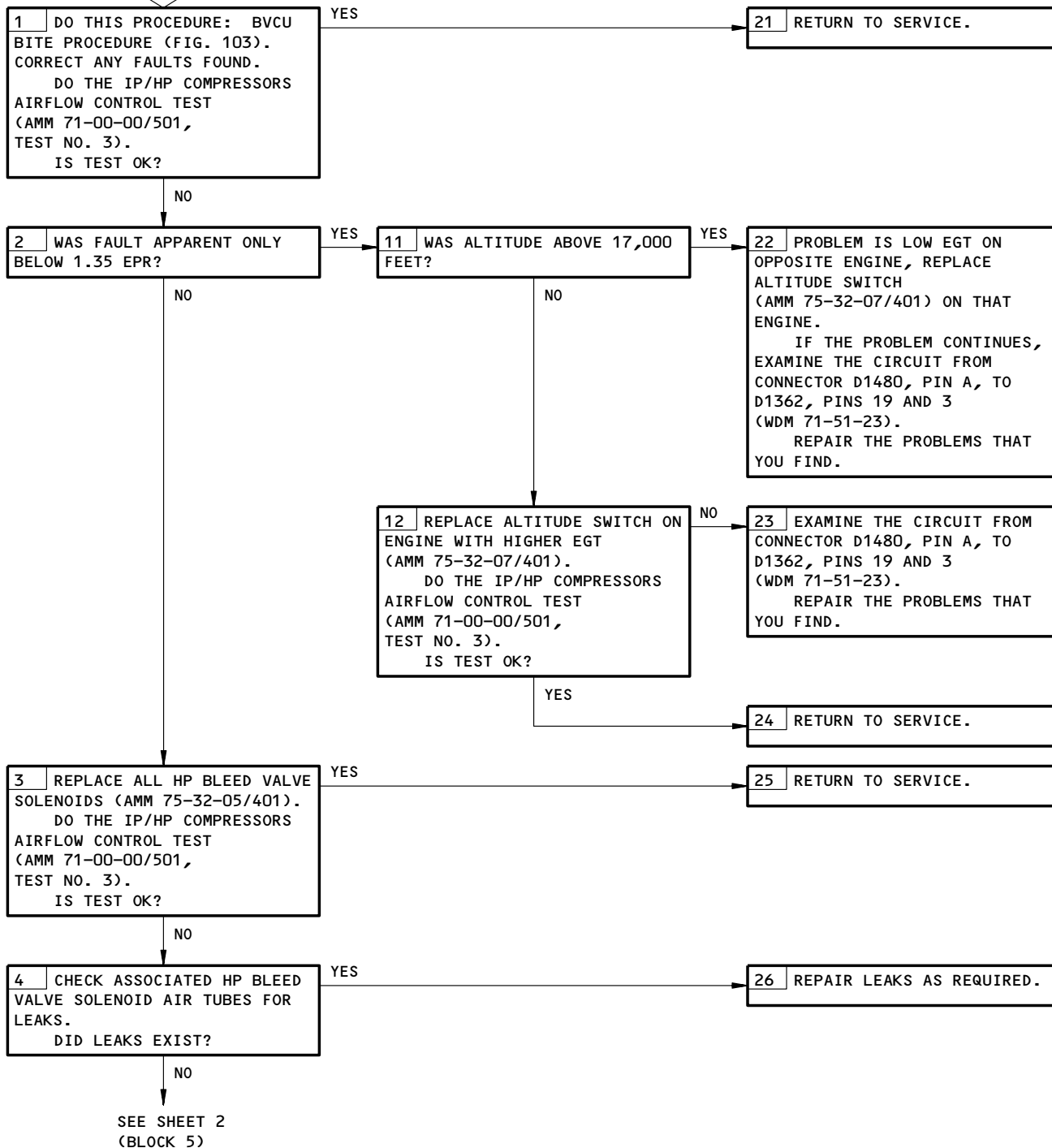

EGT Is More Than 30 Degrees C Higher Than Other Engine
Figure 105 (Sheet 1)

EFFECTIVITY
RB211-535E4 ENGINES WITH BVCU C8E38-11,
C8E38-12 OR C8E38-15

75-32-00
CONFIG 4
Page 113
Sep 28/06

R01

FROM SHEET 1
(BLOCK 4)

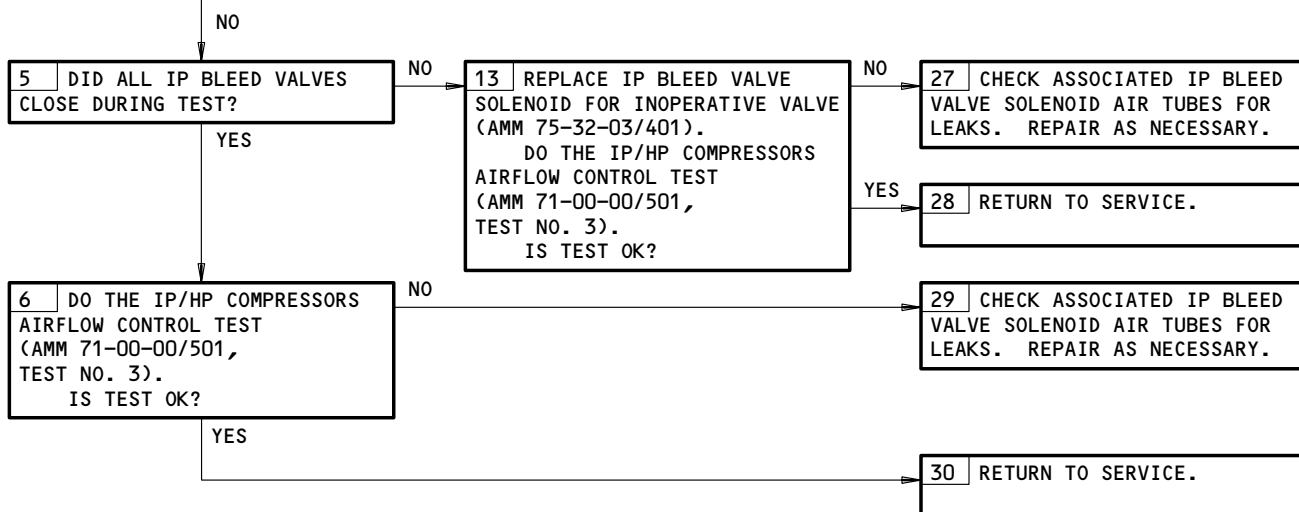

EGT Is More Than 30 Degrees C Higher Than Other Engine
Figure 105 (Sheet 2)

EFFECTIVITY
RB211-535E4 ENGINES WITH BVCU C8E38-11,
C8E38-12 OR C8E38-15

75-32-00
CONFIG 4
Page 114
Jan 28/06

R01

"L (R) ENG SURGE BITE" MESSAGE SHOWN ON EICAS

PREREQUISITES
NONE

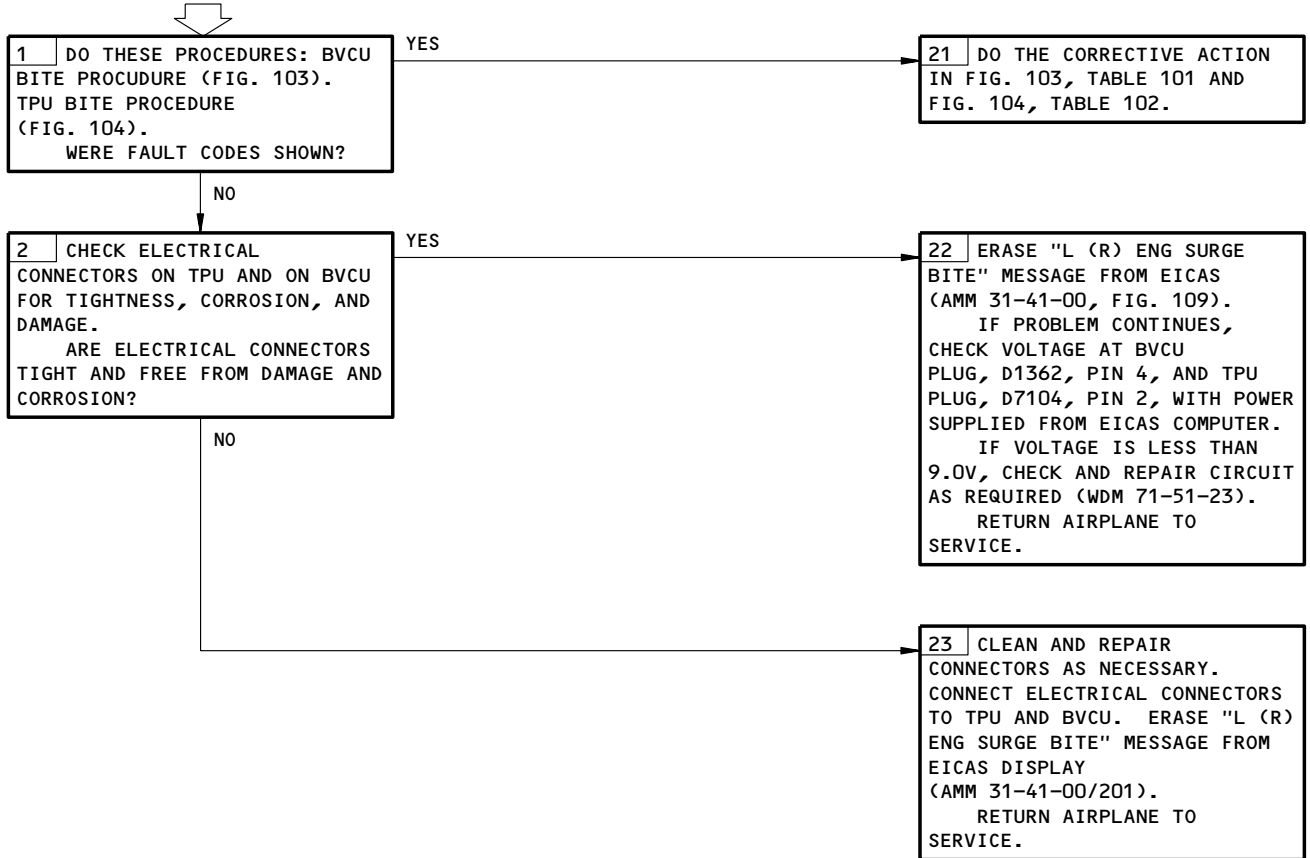

L (R) ENG SURGE BITE Message Shown on EICAS
Figure 106

EFFECTIVITY
RB211-535E4 ENGINES WITH BVCU C8E38-11,
C8E38-12 OR C8E38-15

75-32-00
CONFIG 4
Page 115
Sep 28/06

R01

FAULT CODE	BVCU BITE PROCEDURE TABLE 102 (SHEET NO.)
01	1
02	2
04	3 & 4
05	5
06	6 & 7
07	8 & 9
10	10
11	11
12	12
13	13
16	14
18	14
19	15
21	15
22	16
23	16
24	16
25	16

BVCU BITE Procedure
Table 101 (Sheet 1)

EFFECTIVITY

RB211-535E4 ENGINES WITH BVCU C8E38-11, C8E38-12 OR C8E38-15

75-32-00

CONFIG 4
 Page 116
 Jan 28/06

R01

FAULT CODE	BVCU BITE PROCEDURE TABLE 102 (SHEET NO.)
31	16
32	16
33	16
34	16
40	16
41	16
42	16
43	16
44	16
51	16
53	16
54	16
55	16
56	16
60	16
62	16
63	16
64	16

BVCU BITE Procedure
Table 101 (Sheet 2)

EFFECTIVITY
 RB211-535E4 ENGINES WITH BVCU C8E38-11,
 C8E38-12 OR C8E38-15

75-32-00
 CONFIG 4
 Page 117
 Jan 28/06

R01

FAULT CODE	BVCU BITE PROCEDURE TABLE 102 (SHEET NO.)
65	16
71	16
72	16
73	16
74	16
75	16
76	16
77	17
78	17
79	17
7D	17
7E	17
91	17
92	17
93	17
94	17
95	17

BVCU BITE Procedure
Table 101 (Sheet 3)

- (2) Fault isolation procedures are related to the faults listed in AMM 75-32-00/201 CONFIG 3, Fig. 203. Use only low voltage test equipment when you do these procedures.

NOTE: Fault isolation procedures apply to RB 211-535E4 engines unless noted.

EFFECTIVITY
 RB211-535E4 ENGINES WITH BVCU C8E38-11,
 C8E38-12 OR C8E38-15

75-32-00
 CONFIG 4
 Page 118
 Jan 28/06

R01

FAULT CODE	FAULT ISOLATION PROCEDURE	ACCEPTANCE VALUE
01	<p>1. Check resistance between pin 3 of BVCU plug 2 (D1362) and pin 2 of DGCU 'B' plug 2 (D1484).</p> <p>Check insulation resistance of each pin to ground.</p> <p>If you did not get 20M ohms, disconnect BVCU plug 1 (D1364) and TPU plug (D1704) and repeat.</p> <p>Repair as necessary.</p> <p>If no fault found check for continuity between pins 3 and 19 of BVCU plug 2 (D1362). Repair as necessary.</p> <p>Check resistance between pin 3 of BVCU plug 2 (D1362) and pin A of altitude switch plug (D1480).</p> <p>Check insulation resistance of each pin to ground.</p> <p>Repair as necessary.</p> <p>Disconnect plug D1480, check continuity between pins B and C on altitude switch. If an open circuit or if fault continues, replace altitude switch (AMM 75-32-07/401).</p>	<p>256 - 284 ohms</p> <p>20M ohms minimum</p> <p>1 ohm maximum</p> <p>20M ohms minimum</p>

BVCU Bite Procedure
Table 102 (Sheet 1)

EFFECTIVITY
 RB211-535E4 ENGINES WITH BVCU C8E38-11,
 C8E38-12 OR C8E38-15

75-32-00
 CONFIG 4
 Page 119
 Jan 28/06

R01

FAULT CODE	FAULT ISOLATION PROCEDURE	ACCEPTANCE VALUE
02	<p>1. Connect alternative N2 speed probe (AMM 77-12-01/201)</p> <p style="padding-left: 20px;">If fault continues:</p> <p>2. Disconnect plug D1000P and check resistance between pins 1 and 2 of BVCU plug 3 (D1478).</p> <p style="padding-left: 20px;">Check insulation between pins 1 and 3 of BVCU plug 3 (D1478).</p> <p style="padding-left: 20px;">Check insulation of each pin to ground.</p> <p style="padding-left: 20px;">Repair as necessary.</p> <p style="padding-left: 20px;">Connect plug D1000P.</p> <p style="padding-left: 20px;">If fault continues:</p> <p>3. Remove the compressor fairings (AMM 72-03-01/401).</p> <p style="padding-left: 20px;">Disconnect firewall plug D40152 and check cleanliness of pins and security of pin grip.</p> <p style="padding-left: 20px;">Reconnect plug and check for tightness.</p> <p style="padding-left: 20px;">Repair as necessary.</p> <p style="padding-left: 20px;">Install the compressor fairings (AMM 72-03-01/401).</p> <p style="padding-left: 20px;">If fault continues:</p> <p>4. Replace BVCU (AMM 75-32-01/401).</p>	<p>1.5 - 2.5 ohms</p> <p>20M ohms minimum</p> <p>20M ohms minimum</p>

BVCU Bite Procedure
Table 102 (Sheet 2)

EFFECTIVITY

RB211-535E4 ENGINES WITH BVCU C8E38-11, C8E38-12 OR C8E38-15

75-32-00

CONFIG 4
 Page 120
 Jan 28/06

R01

FAULT CODE	FAULT ISOLATION PROCEDURE	ACCEPTANCE VALUE
04	<p>1. If the BVCU fault code 04 is shown with TPU fault code 40 and the two codes occurred after the same flight marker F0 to F2.</p> <p style="padding-left: 40px;">No further action is necessary.</p> <p>2. If BVCU fault code 04 occurred after F0 to F2 and TPU fault code 60 is shown, and this occurred after the same Flight marker F0 to F2.</p> <p>A. Replace PLA transducer (AMM 75-32-14/401).</p> <p style="padding-left: 40px;">If fault continues:</p> <p style="padding-left: 40px;">Check resistance between pin 10 of PLA transducer plug D1366 and pin 7 of BVCU plug 3 (D1478).</p> <p style="padding-left: 40px;">Check insulation of each pin to ground, and in addition D1366 pin 9 and D1478 pin 6 to ground.</p> <p style="padding-left: 40px;">Repair as necessary.</p> <p style="padding-left: 40px;">Check for continuity between D1366 pin 9 and D1478 pin 6. If open circuit, replace TPU (AMM 75-32-15/401).</p>	<p>1 ohm maximum</p> <p>20M ohms minimum</p> <p>1000 ohms approximate</p>

BVCU Bite Procedure
Table 102 (Sheet 3)

EFFECTIVITY
 RB211-535E4 ENGINES WITH BVCU C8E38-11,
 C8E38-12 OR C8E38-15

75-32-00
 CONFIG 4
 Page 121
 May 20/08

R01

FAULT CODE	FAULT ISOLATION PROCEDURE	ACCEPTANCE VALUE												
04 (Cont)	<p>3. If BVCU fault code 04 occurred after F0 to F2 and no other TPU fault codes are shown, or TPU fault codes with flight marker less than or greater than the flight markers showed the BVCU.</p> <p>Check resistance between pins of PLA transducer plug D1366 and BVCU plug 3 (D1478) as follows:</p> <table style="margin-left: 40px; border: none;"> <tr> <td style="padding-right: 20px;">D1366</td> <td></td> <td style="padding-right: 20px;">D1478</td> <td></td> </tr> <tr> <td style="padding-right: 20px;">4</td> <td style="padding-right: 10px;">to</td> <td style="padding-right: 20px;">13</td> <td></td> </tr> <tr> <td style="padding-right: 20px;">8</td> <td style="padding-right: 10px;">to</td> <td style="padding-right: 20px;">14</td> <td></td> </tr> </table> <p>Check insulation of each pin to ground.</p> <p>Repair as necessary</p> <p>If fault continues: Replace PLA transducer (AMM 75-32-14/401)</p>	D1366		D1478		4	to	13		8	to	14		<p>1 ohm maximum</p> <p>20M ohms minimum</p>
D1366		D1478												
4	to	13												
8	to	14												

BVCU Bite Procedure
Table 102 (Sheet 4)

EFFECTIVITY

RB211-535E4 ENGINES WITH BVCU C8E38-11, C8E38-12 OR C8E38-15

75-32-00

CONFIG 4
 Page 122
 May 20/08

R01

FAULT CODE	FAULT ISOLATION PROCEDURE	ACCEPTANCE VALUE
05	<p>NOTE: ALL ENGINES EXCEPT RB211-535E4-37/10, 535E4-37/17 AND ENGINE POST-RR-SB 73-B861 OR POST-RR-SB 73-C713; If EEC code 94 and/or 98 (AMM 73-21-00/201) are also shown, start fault isolation at item 2.</p> <p>1. Check resistance between pins 9 and 10 of BVCU plug 3 (D1478).</p> <p style="padding-left: 20px;">A. If resistance high or open circuit, check resistance between:</p> <p style="padding-left: 40px;">(1) D1478 pin 9 and junction box TB3 positive</p> <p style="padding-left: 40px;">(2) D1478 pin 10 and junction box TB3 negative).</p> <p style="padding-left: 20px;">Check insulation of each pin to ground.</p> <p style="padding-left: 20px;">Repair as necessary.</p> <p style="padding-left: 20px;">If fault continues:</p> <p>2. With D1478 disconnected, check continuity between TB3 posts. If open circuit, replace T2 thermocouple (AMM 75-32-12/401). While splitter fairing is removed, check continuity and insulation between T2 thermocouple and TB3 junction box. Repair as necessary.</p> <p>Reconnect D1478.</p>	<p>1.5 ohms maximum</p> <p>20M ohms minimum</p>

BVCU Bite Procedure
Table 102 (Sheet 5)

EFFECTIVITY
 RB211-535E4 ENGINES WITH BVCU C8E38-11,
 C8E38-12 OR C8E38-15

75-32-00
 CONFIG 4
 Page 123
 Jan 28/06

R01

FAULT CODE	FAULT ISOLATION PROCEDURE	ACCEPTANCE VALUE
06	<p>1. ALL ENGINES EXCEPT RB211-535E4-37/10; If symptoms of total electrical power loss are reported, high TGT and N2 and ENG LIMITER INOP light on and ENG EEC INOP light on:</p> <p style="padding-left: 20px;">A. Replace Dedicated Generator (AMM 73-21-08/401).</p> <p>2. RB211-535E4-37/10 ENGINES; If symptoms of total electrical power loss are reported, high TGT and N2 and ENG LIMITER INOP light on:</p> <p style="padding-left: 20px;">A. Replace Dedicated Generator (AMM 73-21-08/401)</p> <p>3. Replace Dedicated Generator Control Unit 'A' (AMM 73-21-10/401).</p> <p style="padding-left: 20px;">If fault continues:</p> <p>4. Check resistance between:</p> <p style="padding-left: 40px;">DGCU 'A' plug 2 (D1388) to BVCU plug 2 (D1362) Pin 20 and Pin 6</p> <p style="padding-left: 40px;">Check insulation of D1388 pin 20 to ground.</p> <p style="padding-left: 20px;">Repair as necessary.</p> <p style="padding-left: 20px;">If fault continues:</p>	<p style="text-align: center;">1 ohm maximum</p> <p style="text-align: center;">20M ohms minimum</p>

BVCU Bite Procedure
Table 102 (Sheet 6)

EFFECTIVITY
RB211-535E4 ENGINES WITH BVCU C8E38-11,
C8E38-12 OR C8E38-15

75-32-00
CONFIG 4
Page 124
Jan 28/06

R01

FAULT CODE	FAULT ISOLATION PROCEDURE	ACCEPTANCE VALUE
06 (Cont)	<p>5. Check resistance between:</p> <p style="padding-left: 40px;"> DGPU 'A' plug 2 (D1388) to BVCU plug 1 (D1364) Pin 8 and Pin 9 </p> <p>Operate BVCU ground test switch and check voltage at DGPU 'A' plug 2 (D1388) Pin 19 to ground and Pin 4 to ground.</p> <p>Check insulation of (D1388) pin 8 to ground.</p> <p>Repair as necessary.</p> <p>If fault continues:</p> <p>6. Disconnect DGPU 'A' plug 1 (D1386) and check resistance between these receptacle pins: 2 to 4, 2 to 6 and 4 to 6.</p> <p>Check insulation of each pin to ground.</p> <p>Repair as necessary.</p> <p>7. If fault continues, replace BVCU (AMM 75-32-01/401).</p>	<p>1 ohm maximum</p> <p>28 volts nominal</p> <p>20M ohms minimum</p> <p>0.5 - 1.5 ohms</p> <p>20M ohms minimum</p>

BVCU Bite Procedure
Table 102 (Sheet 7)

EFFECTIVITY
 RB211-535E4 ENGINES WITH BVCU C8E38-11,
 C8E38-12 OR C8E38-15

75-32-00
 CONFIG 4
 Page 125
 Jan 28/06

R01

FAULT CODE	FAULT ISOLATION PROCEDURE	ACCEPTANCE VALUE
07	<p>1. ALL ENGINES EXCEPT RB211-535E4-37/10; If systems of total electrical power loss are reported, high TGT and N2 and ENG LIMITED INOP light on and ENG EEC INOP light on:</p> <p style="padding-left: 20px;">A. Replace Dedicated Generator (AMM 73-21-08/401).</p> <p>2. RB211-535E4-37/10 ENGINES; If symptoms of total electrical power loss are reported, high TGT and N2 and ENG LIMITER INOP light on:</p> <p style="padding-left: 20px;">A. Replace Dedicated Generator (AMM 73-21-08/401)</p> <p>3. If fault continues:</p> <p style="padding-left: 20px;">A. Replace Dedicated Generator Control Unit 'B' (AMM 73-21-10/401).</p> <p style="padding-left: 40px;">If fault continues:</p> <p>4. Check resistance between:</p> <p style="padding-left: 20px;">DGCU 'B' plug 2 (D1484) and BVCU plug 2 (D1362) pin 20 to pin 14</p> <p style="padding-left: 20px;">Check insulation of D1484 pin 20 to ground.</p> <p style="padding-left: 20px;">Repair as necessary.</p> <p style="padding-left: 20px;">If fault continues:</p>	<p style="text-align: center;">1 ohm maximum</p> <p style="text-align: center;">20M ohms minimum</p>

BVCU Bite Procedure
Table 102 (Sheet 8)

EFFECTIVITY

RB211-535E4 ENGINES WITH BVCU C8E38-11, C8E38-12 OR C8E38-15

75-32-00

CONFIG 4
 Page 126
 Jan 28/06

R01

FAULT CODE	FAULT ISOLATION PROCEDURE	ACCEPTANCE VALUE
07 (Cont)	<p>5. Check resistance between:</p> <p style="padding-left: 40px;">DGPU 'B' plug 2 (D1484) BVCU plug 1 (D1364) pin 12 to pin 10</p> <p style="padding-left: 40px;">Operate BVCU ground test switch and check voltage at DGPU 'B' plug 2 (D1484) pin 19 to ground and pin 4 to ground</p> <p style="padding-left: 40px;">Check insulation of (D1484) pin 12 to ground</p> <p style="padding-left: 40px;">Repair as necessary</p> <p style="padding-left: 40px;">If fault continues:</p> <p>6. Disconnect DGPU 'B' plug 1 (D1482) and check resistance between these receptacle pins: 2 to 4, 2 to 6 and 4 to 6</p> <p style="padding-left: 40px;">Check insulation of each pin to ground</p> <p style="padding-left: 40px;">Repair as necessary</p> <p>7. If fault continues, replace BVCU (AMM 75-32-01/401).</p>	<p>1 ohm maximum</p> <p>28 volts nominal</p> <p>20M ohms minimum</p> <p>0.5 - 1.5 ohms</p> <p>20M ohms minimum</p>

BVCU Bite Procedure
Table 102 (Sheet 9)

EFFECTIVITY
 RB211-535E4 ENGINES WITH BVCU C8E38-11,
 C8E38-12 OR C8E38-15

75-32-00
 CONFIG 4
 Page 127
 Jan 28/06

R01

FAULT CODE	FAULT ISOLATION PROCEDURE	ACCEPTANCE VALUE									
10	<p>ENGINES WITH SB 71-8346;</p> <p>1. Check resistance between BVCU plug 1 (D1364) and plug 2 (D1388 or D1484) of each DGPU as follows:</p> <table style="margin-left: 40px; border: none;"> <tr> <td style="text-align: center;"><u>D1364</u></td> <td style="text-align: center;"><u>D1388</u></td> <td style="text-align: center;"><u>D1484</u></td> </tr> <tr> <td style="text-align: center;">pin 5</td> <td style="text-align: center;">to -</td> <td style="text-align: center;">pin 8</td> </tr> <tr> <td style="text-align: center;">pin 14</td> <td style="text-align: center;">to</td> <td style="text-align: center;">pin 12</td> </tr> </table> <p>Disconnect BVCU plug 2 (D1362).</p> <p>Check insulation of pins 5 and 14 on plug D1364 to ground.</p> <p>Connect BVCU plug 2 (D1362).</p> <p>A. If fault found in 1, disconnect right-hand (No. 2) HP bleed valve solenoid plug (D1348) and check resistance between solenoid pins 7 and 5, and pins 2 and 4.</p> <p style="margin-left: 40px;">(1) If fault found, replace solenoid (AMM 75-32-05/401).</p> <p style="margin-left: 40px;">(2) If no fault found, check harness for retracted or bent pins in connectors or matrix block.</p> <p>B. If no fault found in 1, monitor fault codes after the next flight and, if fault continues, disconnect right-hand (No. 2) HP Bleed valve solenoid plug (D1348) and check for bent pins.</p> <p style="margin-left: 40px;">(1) If pins found bent, replace solenoid (AMM 75-32-05/401).</p> <p style="margin-left: 40px;">(2) If pins OK, replace BVCU (AMM 75-32-01/401).</p>	<u>D1364</u>	<u>D1388</u>	<u>D1484</u>	pin 5	to -	pin 8	pin 14	to	pin 12	<p>85 - 100 ohms</p> <p>20M ohms minimum</p> <p>85- 100 ohms</p>
<u>D1364</u>	<u>D1388</u>	<u>D1484</u>									
pin 5	to -	pin 8									
pin 14	to	pin 12									

BVCU Bite Procedure
Table 102 (Sheet 10)

EFFECTIVITY

RB211-535E4 ENGINES WITH BVCU C8E38-11, C8E38-12 OR C8E38-15

75-32-00

CONFIG 4
Page 128
Jan 28/06

R01

FAULT CODE	FAULT ISOLATION PROCEDURE	ACCEPTANCE VALUE															
11	<p>ENGINES WITH SB 71-8346;</p> <p>1. Check resistance between BVCU plug 1 (D1364) and plug 2 (D1388 or D1484) of each DGCU as follows:</p> <table style="margin-left: 40px; border: none;"> <tr> <td style="text-align: center;"><u>D1364</u></td> <td style="text-align: center;">to</td> <td style="text-align: center;"><u>D1388</u></td> <td style="text-align: center;">to</td> <td style="text-align: center;"><u>D1484</u></td> </tr> <tr> <td style="text-align: center;">pin 13</td> <td></td> <td style="text-align: center;">pin 12</td> <td></td> <td style="text-align: center;">pin 8</td> </tr> <tr> <td style="text-align: center;">pin 6</td> <td></td> <td></td> <td></td> <td></td> </tr> </table> <p>Disconnect BVCU plug 2 (D1362).</p> <p>Check insulation of pins 6 and 13 on plug D1364 to ground. Connect BVCU plug 2 (D1362).</p> <p>A. If fault found in 1, disconnect left-hand (No. 1) HP bleed valve solenoid plug (D1340) and check resistance between solenoid pins 7 and 5, and pins 2 and 4.</p> <p style="margin-left: 40px;">(1) If fault found, replace solenoid (AMM 75-32-05/401).</p> <p style="margin-left: 40px;">(2) If no fault found, check harness for retracted or bent pins in connectors or matrix block.</p> <p>B. If no fault found in 1, monitor fault codes after the next flight and, if fault persists, disconnect left-hand (No. 1) HP bleed valve solenoid plug (D1340) and check for bent pins.</p> <p style="margin-left: 40px;">(1) If pins found bent, replace solenoid (AMM 75-32-05/401).</p> <p style="margin-left: 40px;">(2) If pins OK, replace BVCU (AMM 75-32-01/401).</p>	<u>D1364</u>	to	<u>D1388</u>	to	<u>D1484</u>	pin 13		pin 12		pin 8	pin 6					<p>85 - 100 ohms</p> <p>20M ohms minimum</p> <p>85 - 100 ohms</p>
<u>D1364</u>	to	<u>D1388</u>	to	<u>D1484</u>													
pin 13		pin 12		pin 8													
pin 6																	

BVCU Bite Procedure
Table 102 (Sheet 11)

EFFECTIVITY
 RB211-535E4 ENGINES WITH BVCU C8E38-11,
 C8E38-12 OR C8E38-15

75-32-00
 CONFIG 4
 Page 129
 Jan 28/06

R01

FAULT CODE	FAULT ISOLATION PROCEDURE	ACCEPTANCE VALUE									
12	<p>1. Check resistance between BVCU plug 1 (D1364) and plug 2 (D1388 or D1484) of each DGCU as follows:</p> <table style="margin-left: 40px; border: none;"> <tr> <td style="text-align: center;"><u>D1364</u></td> <td style="text-align: center;"><u>D1388</u></td> <td style="text-align: center;"><u>D1484</u></td> </tr> <tr> <td style="text-align: center;">pin 4</td> <td style="text-align: center;">to -</td> <td style="text-align: center;">pin 8</td> </tr> <tr> <td style="text-align: center;">pin 7</td> <td style="text-align: center;">to pin 12</td> <td></td> </tr> </table> <p>Disconnect BVCU plug 2 (D1362).</p> <p>Check insulation of pins 4 and 7 on D1364 to ground. Connect BVCU plug 2 (D1362).</p> <p>A. If fault found in 1, disconnect right-hand IP bleed valve solenoid plug (D1352) and check resistance between solenoid pins 7 and 5, and 2 and 4.</p> <p style="margin-left: 40px;">(1) If fault found, replace solenoid (AMM 75-32-03/401).</p> <p style="margin-left: 40px;">(2) If no fault found, check harness for retracted or bent pins in connectors or matrix block.</p> <p>B. If no fault found in 1, monitor fault codes after the next flight and, if fault persists, disconnect right-hand IP bleed valve solenoid plug (D1352) and check for bent pins.</p> <p style="margin-left: 40px;">(1) If pins found bent, replace solenoid (AMM 75-32-03/401).</p> <p style="margin-left: 40px;">(2) If pins OK, replace BVCU (AMM 75-32-01/401).</p>	<u>D1364</u>	<u>D1388</u>	<u>D1484</u>	pin 4	to -	pin 8	pin 7	to pin 12		<p>85 - 100 ohms</p> <p>20M ohms minimum</p> <p>85-100 ohms</p>
<u>D1364</u>	<u>D1388</u>	<u>D1484</u>									
pin 4	to -	pin 8									
pin 7	to pin 12										

BVCU Bite Procedure
Table 102 (Sheet 12)

EFFECTIVITY

RB211-535E4 ENGINES WITH BVCU C8E38-11, C8E38-12 OR C8E38-15

75-32-00

CONFIG 4
 Page 130
 Jan 28/06

R01

FAULT CODE	FAULT ISOLATION PROCEDURE	ACCEPTANCE VALUE									
13	<p>1. Check resistance between BVCU plug 1 (D1364) and plug 2 (D1388 or D1484) of each DGCU as follows:</p> <table style="margin-left: 40px; border: none;"> <tr> <td style="text-align: center;"><u>D1364</u></td> <td style="text-align: center;"><u>D1388</u></td> <td style="text-align: center;"><u>D1484</u></td> </tr> <tr> <td style="text-align: center;">pin 1</td> <td style="text-align: center;">to -</td> <td style="text-align: center;">pin 8</td> </tr> <tr> <td style="text-align: center;">pin 12</td> <td style="text-align: center;">to pin 12</td> <td></td> </tr> </table> <p>Disconnect BVCU plug 2 (D1362).</p> <p>Check insulation of pins 1 and 12 on plug D1364 to ground. Connect BVCU plug 2 (D1362).</p> <p>A. If fault found in 1, disconnect left-hand IP bleed valve solenoid plug (D1350) and check resistance between solenoid pins 7 and 5, and 2 and 4.</p> <p style="margin-left: 40px;">(1) If fault found, replace solenoid (AMM 75-32-03/401).</p> <p style="margin-left: 40px;">(2) If no fault found, check harness for retracted or bent pins in connectors or matrix block.</p> <p>B. If no fault found in 1, monitor fault codes after the next flight and, if fault continues, disconnect left-hand IP bleed valve solenoid plug (D1350) and check for bent pins.</p> <p style="margin-left: 40px;">(1) If pins found bent, replace solenoid (AMM 75-32-03/401).</p> <p style="margin-left: 40px;">(2) If pins OK, replace BVCU (AMM 75-32-01/401).</p>	<u>D1364</u>	<u>D1388</u>	<u>D1484</u>	pin 1	to -	pin 8	pin 12	to pin 12		<p style="text-align: center;">85 - 100 ohms</p> <p style="text-align: center;">20M ohms minimum</p> <p style="text-align: center;">85-100 ohms</p>
<u>D1364</u>	<u>D1388</u>	<u>D1484</u>									
pin 1	to -	pin 8									
pin 12	to pin 12										

BVCU Bite Procedure
Table 102 (Sheet 13)

EFFECTIVITY
 RB211-535E4 ENGINES WITH BVCU C8E38-11,
 C8E38-12 OR C8E38-15

75-32-00
 CONFIG 4
 Page 131
 Jan 28/06

R01

FAULT CODE	FAULT ISOLATION PROCEDURE	ACCEPTANCE VALUE
16	<p>1. Check position of PLA transducer as detailed on installation (AMM 75-32-14/401).</p> <p>Repair as necessary.</p> <p>A. If position correct, replace PLA transducer (AMM 75-32-14/401).</p> <p>2. If fault continues, check wiring as detailed for fault code 04, item 3, and repair as necessary.</p>	
18	<p>1. Check resistance between BVCU plug 1 (D1364) and DGCU 'A' plug 2 (D1388) as follows:</p> <p><u>D1364</u> <u>D1388</u> pin 3 to pin 12</p> <p>Disconnect BVCU plug 2 (D1362).</p> <p>Check insulation of pin 3 on plug D1364 to ground. Connect BVCU plug 2 (D1362).</p> <p>A. If fault found in 1, disconnect plug (D1354) on HP2 bleed valve solenoid and check resistance between solenoid pins 2 and 4.</p> <p>(1) If fault found, replace solenoid (AMM 75-32-03/401).</p> <p>(2) If no fault found, check harness for retracted or bent pins in connectors or matrix block.</p> <p>B. If no fault found in 1, monitor fault codes after the next flight and, if fault continues, disconnect HP2 bleed valve solenoid plug (D1354) and check for bent pins.</p> <p>(1) If pins found bent, replace solenoid (AMM 75-32-05/401).</p> <p>(2) If pins OK, replace BVCU (AMM 75-32-01/401).</p>	<p>85 - 100 ohms</p> <p>20M ohms minimum</p> <p>85 - 100 ohms</p>

BVCU Bite Procedure
Table 102 (Sheet 14)

EFFECTIVITY
RB211-535E4 ENGINES WITH BVCU C8E38-11,
C8E38-12 OR C8E38-15

75-32-00
CONFIG 4
Page 132
Jan 28/06

R01

FAULT CODE	FAULT ISOLATION PROCEDURE	ACCEPTANCE VALUE
19	<p>1. Check resistance between BVCU plug 1 (D1364) and DGCU 'B' plug 2 (D1484) as follows:</p> <p style="margin-left: 40px;"> <u>D1364</u> <u>D1484</u> pin 11 to pin 8 </p> <p style="margin-left: 40px;">Disconnect BVCU plug 2 (D1362).</p> <p style="margin-left: 40px;">Check insulation of pin 11 on plug D1364 to ground. Connect BVCU plug 2 (D1362).</p> <p style="margin-left: 40px;">A. If fault found in 1, disconnect plug (D1354) on HP2 bleed valve solenoid and check resistance between solenoid pins 7 and 5.</p> <p style="margin-left: 80px;">(1) If fault found, replace solenoid (AMM 75-32-05/401).</p> <p style="margin-left: 80px;">(2) If no fault found, check harness for retracted or bent pins in connectors or matrix block.</p> <p style="margin-left: 40px;">B. If no fault found in 1, monitor fault codes after the next flight and, if fault continues, disconnect HP2 bleed valve solenoid plug (D1354) and check for bent pins.</p> <p style="margin-left: 80px;">(1) If pins found bent, replace solenoid (AMM 75-32-05/401).</p> <p style="margin-left: 80px;">(2) If pins OK, replace BVCU (AMM 75-32-01/401).</p>	<p style="text-align: center;">85 - 100 ohms</p> <p style="text-align: center;">20M ohms minimum</p>
21	<p>Replace PLA transducer (AMM 75-32-14/401).</p> <p>If fault persists, replace BVCU (AMM 75-32-14/401).</p>	

BVCU Bite Procedure
Table 102 (Sheet 15)

EFFECTIVITY
 RB211-535E4 ENGINES WITH BVCU C8E38-11,
 C8E38-12 OR C8E38-15

75-32-00
 CONFIG 4
 Page 133
 Jan 28/06

R01

FAULT CODE	FAULT ISOLATION PROCEDURE	ACCEPTANCE VALUE
22 to 65	Replace BVCU (AMM 75-32-01/401).	
71 72	<p>These faults will always cause codes 12 and 13 to be shown.</p> <p>1. Do the fault isolation for codes 12 and 13, item 1.</p> <p style="padding-left: 40px;">A. If no fault found, replace both LH and RH IP solenoid valves (AMM 75-32-03/401) and replace BVCU (AMM 75-32-01/401).</p>	
73	<p>This fault will always cause codes 10 and 11 to be shown.</p> <p>1. Do the fault isolation for codes 10 and 11, item 1.</p> <p style="padding-left: 40px;">A. If no fault found, replace both LH and RH HP3 solenoid valves (AMM 75-32-05/401) and replace BVCU (AMM 75-32-01/401).</p>	
74	Replace BVCU (AMM 75-32-01/401).	
75	<p>This code can be set if the throttle is not in the idle position when the BITE check is being done. Make sure that the throttle lever is in the idle position. If code 75 does not appear after the throttle is placed in the idle position, no action is necessary. If code 75 still occurs with the throttle in the idle position, replace the BVCU, (AMM 75-32-01/401).</p>	
76	Replace the BVCU (AMM 75-32-01/401).	

BVCU Bite Procedure
Table 102 (Sheet 16)

EFFECTIVITY

RB211-535E4 ENGINES WITH BVCU C8E38-11, C8E38-12 OR C8E38-15

75-32-00

CONFIG 4
 Page 134
 Jan 28/06

R01

FAULT CODE	FAULT ISOLATION PROCEDURE	ACCEPTANCE VALUE
77	<p>These faults will always cause code 18 to be shown.</p> <p>1. Do the fault isolation for codes 18 and 19, item 1.</p> <p style="padding-left: 40px;">A. If no fault found, replace the HP2 solenoid valve (AMM 75-32-05/401) and replace BVCU (AMM 75-32-01/401).</p>	
78 to 94	<p>Replace BVCU (AMM 75-32-01/401).</p>	
95	<p>1. Connect alternative N2 speed probe (AMM 77-12-01/201).</p> <p style="padding-left: 40px;">If fault continues:</p> <p>2. Check resistance between pins 5 and 12 of BVCU plug 3 (D1478).</p> <p style="padding-left: 40px;">Check insulation between pins 4 and 12 of BVCU plug 3 (D1478).</p> <p style="padding-left: 40px;">Check insulation of each pin to ground.</p> <p style="padding-left: 40px;">Repair as necessary.</p> <p style="padding-left: 40px;">If fault continues:</p> <p>3. Remove compressor fairings (AMM 72-03-01/401).</p> <p style="padding-left: 40px;">Disconnect firewall plug D40152 and check cleanliness of pins and security of pin grip.</p> <p style="padding-left: 40px;">Reconnect plug and check tightness.</p> <p style="padding-left: 40px;">Repair as necessary.</p> <p style="padding-left: 40px;">Install the compressor fairings.</p> <p style="padding-left: 40px;">If fault continues:</p> <p>4. Replace BVCU (AMM 75-32-01/401).</p>	<p>1.5 - 2.5 ohms</p> <p>20M ohms minimum</p> <p>20M ohms minimum</p>

BVCU Bite Procedure
Table 102 (Sheet 17)

EFFECTIVITY
 RB211-535E4 ENGINES WITH BVCU C8E38-11,
 C8E38-12 OR C8E38-15

75-32-00
 CONFIG 4
 Page 135
 Jan 28/06

R01

(3) Table 103 lists fault isolation procedure sheet numbers from Table 104 to fault codes in this section:

FAULT CODE	TPU BITE PROCEDURE TABLE 104 (SHEET NO.)
10	1
20	1
30	2 & 3
40	4
50	4
60	5 & 6
90	7 & 8
B1	8
B3	8
B5	8
B6	8
B9	8
BB	8
BE	8
BF	8

TPU Bite Procedure
Table 103

(4) Fault isolation procedures are related to the TPU faults codes listed in AMM 75-32-00/201, CONFIG-2. Use only low voltage test equipment when you do these procedures.

EFFECTIVITY
 RB211-535E4 ENGINES WITH BVCU C8E38-11,
 C8E38-12 OR C8E38-15

75-32-00
 CONFIG 4
 Page 136
 Jan 28/06

R01

FAULT CODE	FAULT ISOLATION PROCEDURE	ACCEPTANCE VALUE
10	1. Check P4 pipe from No. 15 fuel spray nozzle to FFG and from FFG to TPU for leaks. Repair as necessary. If fault continues - replace TPU.	
20	1. Check that TPU ground test switch is in OFF position - remove rubber blank from matrix block position 31D 2. Connect meter from 31D to ground and check if 28 volts present with switch in OFF position: 3. If 28 volts present - replace TPU ground test switch. Replace rubber blank. 4. Do a check of the resistance value between these components: DGCU 'A' plug 2 (D1388) TPU plug (D7104) pin 20 to pin 8 DGCU 'B' plug 2 (D1484) TPU plug (D7104) pin 20 to pin 9 Disconnect connector D1362 Do a test of the insulation of the four previous Pins to ground. Connect connector D1362 Repair as necessary If the fault continues: 5. Replace the TPU.	1 ohm maximum 1 ohm maximum 20M ohms minimum

TPU Bite Procedure
Table 104 (Sheet 1)

EFFECTIVITY
 RB211-535E4 ENGINES WITH BVCU C8E38-11,
 C8E38-12 OR C8E38-15

75-32-00
 CONFIG 4
 Page 137
 May 28/07

R01

FAULT CODE	FAULT ISOLATION PROCEDURE	ACCEPTANCE VALUE
30	<p>ENGINES WITHOUT SB 71-8029;</p> <p>1. Disconnect plug D1506 from TPU. Check resistance across pins 1 and 3 of TPU receptacle.</p> <p>Check insulation of each pin to ground.</p> <p>If not within limits - replace TPU.</p> <p>2. If within limits - check plug D1506 for cleanliness of pins/sockets and security of pin grip.</p> <p>Reconnect plug D1506.</p> <p>If fault continues:</p> <p>3. Disconnect plug D1504 from TPU and check resistance between pins 5 and 11.</p> <p>Check insulation of each pin to ground.</p> <p>Repair as necessary.</p> <p>If within limits - check for cleanliness of pins/sockets and security of pin grip.</p> <p>Repair as necessary.</p> <p>Reconnect plug D1504 and do the TPU reconnection test procedure (AMM 75-32-15/501).</p> <p>If fault continues:</p> <p>Replace TPU.</p>	<p>26 - 3-ohms</p> <p>20M ohms minimum</p> <p>26-32 ohms</p> <p>20M ohms minimum</p>

TPU Bite Procedure
Table 104 (Sheet 2)

EFFECTIVITY

RB211-535E4 ENGINES WITH BVCU C8E38-11, C8E38-12 OR C8E38-15

75-32-00

CONFIG 4
 Page 138
 Jan 28/06

R01

FAULT CODE	FAULT ISOLATION PROCEDURE	ACCEPTANCE VALUE
30	<p>ENGINES WITH SB 71-8029;</p> <p>1. Disconnect plug D7106 from TFU. Check resistance across pins 1 and 3 of TFU receptacle.</p> <p style="padding-left: 40px;">Check insulation of each pin to ground.</p> <p style="padding-left: 40px;">If not within limits - replace TFU.</p> <p>2. If within limits - check plug D7106 for cleanliness of pins/sockets and security of pin grip.</p> <p style="padding-left: 40px;">Reconnect plug D7106.</p> <p style="padding-left: 40px;">If fault continues:</p> <p>3. Disconnect plug D7104 from TPU and check resistance between pins 5 and 11.</p> <p style="padding-left: 40px;">Check insulation of each pin to ground.</p> <p style="padding-left: 40px;">Repair as necessary.</p> <p style="padding-left: 40px;">If within limits - check for cleanliness of pins/sockets and security of pin grip.</p> <p style="padding-left: 40px;">Repair as necessary.</p> <p style="padding-left: 40px;">Reconnect plug D7104 and do the TPU reconnection test procedure (AMM 75-32-15/501).</p> <p style="padding-left: 40px;">If fault continues:</p> <p style="padding-left: 40px;">Replace TPU.</p>	<p>26 - 3-ohms</p> <p>20M ohms minimum</p> <p>26-32 ohms</p> <p>20M ohms minimum</p>

TPU Bite Procedure
Table 104 (Sheet 3)

EFFECTIVITY
 RB211-535E4 ENGINES WITH BVCU C8E38-11,
 C8E38-12 OR C8E38-15

75-32-00
 CONFIG 4
 Page 139
 Jan 28/06

R01

FAULT CODE	FAULT ISOLATION PROCEDURE	ACCEPTANCE VALUE
40	1. If bird strike, suspected bird strike or surge reported – refer to FIM 71-05-00/101 or FIM 71-06-00/101 as applicable. 2. If no bird strike, suspected bird strike or surge reported, check intake for signs of bird strike. If there are signs of bird strike proceed as in 1. 3. If no sign of bird strike, or surge was not reported, check P4 pipe from No. 15 fuel spray nozzle to FFG and from FFG to TPU for leaks. Repair as necessary. 4. If fault continues, replace TPU.	
50	ENGINES WITH SB 75-8315; (TPU TYPE NO. ETPU 100-2C) or ENGINES WITH SB 75-B699 (TPU TYPE NO. ETPU 100-3C) 1. Replace TPU (AMM 75-32-15/401).	

TPU Bite Procedure
Table 104 (Sheet 4)

EFFECTIVITY

RB211-535E4 ENGINES WITH BVCU C8E38-11, C8E38-12 OR C8E38-15

75-32-00

CONFIG 4
 Page 140
 May 20/08

R01

FAULT CODE	FAULT ISOLATION PROCEDURE	ACCEPTANCE VALUE																		
60	<p>ENGINES WITHOUT SB 71-8029;</p> <p>A. If code 04 is shown on BVCU and occurs after flight marker F0 to F2, disconnect plug D1366 from PLA transducer, plug D1478 from BVCU and plug D1504 from the TPU.</p> <p>Check resistance between these pins:</p> <table style="width: 100%; border: none;"> <tr> <td style="width: 30%;">D1366</td> <td style="width: 30%;">D1504</td> <td style="width: 40%;"></td> </tr> <tr> <td>pin 9</td> <td>to pin 18</td> <td></td> </tr> </table> <table style="width: 100%; border: none;"> <tr> <td style="width: 30%;">D1366</td> <td style="width: 30%;">D1478</td> <td style="width: 40%;"></td> </tr> <tr> <td>pin 10</td> <td>to pin 7</td> <td></td> </tr> </table> <table style="width: 100%; border: none;"> <tr> <td style="width: 30%;">D1478</td> <td style="width: 30%;">D1504</td> <td style="width: 40%;"></td> </tr> <tr> <td>pin 6</td> <td>to pin 19</td> <td></td> </tr> </table> <p>Check insulation resistance of above pins to ground.</p> <p>Check insulation resistance between plug D1504, pins 18 and 19.</p> <p>If you find problem when you check the circuit then repair as necessary.</p> <p>If circuit is satisfactory then check plugs D1366, D1478 and plug D1504 for cleanliness of pins/sockets and security of pin grip.</p> <p>If fault continues, replace PLA transducer (AMM 75-32-14/401).</p> <p>B. If code 04 is not shown in BVCU after the same flight marker, no action is necessary unless fault continues.</p> <p>If fault continues, replace TPU (AMM 75-32-15/401).</p> <p>If fault continues, replace BVCU (AMM 75-32-15/401).</p>	D1366	D1504		pin 9	to pin 18		D1366	D1478		pin 10	to pin 7		D1478	D1504		pin 6	to pin 19		<p>1.0 ohms maximum</p> <p>1.0 ohms maximum</p> <p>1.0 ohms maximum</p> <p>20K ohms minimum</p>
D1366	D1504																			
pin 9	to pin 18																			
D1366	D1478																			
pin 10	to pin 7																			
D1478	D1504																			
pin 6	to pin 19																			

TPU Bite Procedure
Table 104 (Sheet 5)

EFFECTIVITY
 RB211-535E4 ENGINES WITH BVCU C8E38-11,
 C8E38-12 OR C8E38-15

75-32-00
 CONFIG 4
 Page 141
 Jan 28/06

R01

FAULT CODE	FAULT ISOLATION PROCEDURE	ACCEPTANCE VALUE																		
60	<p>ENGINES WITH SB 71-8029;</p> <p>A. If code 04 is shown on BVCU and occurs after flight marker F0 to F2, disconnect plug D1366 from PLA transducer, plug D1478 from BVCU and plug D7104 from the TPU.</p> <p>Check resistance between these pins:</p> <table style="width: 100%; border: none;"> <tr> <td style="width: 30%;">D1366</td> <td style="width: 30%;">D7104</td> <td style="width: 40%;"></td> </tr> <tr> <td>pin 9</td> <td>to pin 18</td> <td></td> </tr> </table> <table style="width: 100%; border: none;"> <tr> <td style="width: 30%;">D1366</td> <td style="width: 30%;">D1478</td> <td style="width: 40%;"></td> </tr> <tr> <td>pin 10</td> <td>to pin 7</td> <td></td> </tr> </table> <table style="width: 100%; border: none;"> <tr> <td style="width: 30%;">D1478</td> <td style="width: 30%;">D7104</td> <td style="width: 40%;"></td> </tr> <tr> <td>pin 6</td> <td>to pin 19</td> <td></td> </tr> </table> <p>Check insulation resistance of above pins to ground.</p> <p>Check insulation resistance between plug D7104, pins 18 and 19.</p> <p>If you find problem when you check the circuit then repair as necessary.</p> <p>If circuit is satisfactory then check plugs D1366, D1478 and plug D7104 for cleanliness of pins/sockets and security of pin grip.</p> <p>If fault continues, replace PLA transducer (AMM 75-32-14/401).</p> <p>B. If code 04 is not shown in BVCU after the same flight marker, no action is necessary unless fault fault continues.</p> <p>If fault continues, replace TPU (AMM 75-32-15/401).</p> <p>If fault continues, replace BVCU (AMM 75-32-15/401).</p>	D1366	D7104		pin 9	to pin 18		D1366	D1478		pin 10	to pin 7		D1478	D7104		pin 6	to pin 19		<p>1.0 ohms maximum</p> <p>1.0 ohms maximum</p> <p>1.0 ohms maximum</p> <p>20K ohms minimum</p>
D1366	D7104																			
pin 9	to pin 18																			
D1366	D1478																			
pin 10	to pin 7																			
D1478	D7104																			
pin 6	to pin 19																			

TPU Bite Procedure
Table 104 (Sheet 6)

EFFECTIVITY
RB211-535E4 ENGINES WITH BVCU C8E38-11,
C8E38-12 OR C8E38-15

75-32-00
CONFIG 4
Page 142
Jan 28/06

R01

FAULT CODE	FAULT ISOLATION PROCEDURE	ACCEPTANCE VALUE								
90	<p>1. Ground test BVCU and check if you find faults on BVCU BITE during ground test.</p> <p>NOTE: EICAS maintenance line faults, which may generate TPU fault code 90, are only monitored during ground test. A fault found during ground test is shown immediately after AA in the fault code sequence and is not shown after the letter F.</p> <p>Examples:</p> <table style="margin-left: 40px; border: none;"> <tr> <td style="text-align: center;"><u>TPU BITE</u></td> <td style="text-align: center;"><u>BVCU BITE</u></td> </tr> <tr> <td>(1) CC AA 90 F0 40 ED</td> <td>CC AA 10 F0 04 F1 F2 ED</td> </tr> <tr> <td>(2) CC AA 90 ED</td> <td>CC AA 10 F0 F1 F2 ED</td> </tr> <tr> <td>(3) CC AA F0 40 ED</td> <td>CC AA F0 04 F1 F2 ED</td> </tr> </table> <p>In examples (1) and (2) code 90 represents faults found during ground test. This is the BVCU fault 10 setting the EICAS maintenance line to ground.</p> <p>In examples (3) no fault found during ground test.</p> <p>In examples (1) and (3) the F0 40 on TPU and F0 04 on BVCU represents fault found on the previous flight and stored in memory.</p> <p>If no BVCU fault code found during ground test go to step 2.</p> <p>If BVCU fault code was found during ground test, repair as necessary and check TPU BITE again.</p> <p>If code 90 is not shown return aircraft to service.</p> <p>If code 90 is shown go to step 2.</p>	<u>TPU BITE</u>	<u>BVCU BITE</u>	(1) CC AA 90 F0 40 ED	CC AA 10 F0 04 F1 F2 ED	(2) CC AA 90 ED	CC AA 10 F0 F1 F2 ED	(3) CC AA F0 40 ED	CC AA F0 04 F1 F2 ED	
<u>TPU BITE</u>	<u>BVCU BITE</u>									
(1) CC AA 90 F0 40 ED	CC AA 10 F0 04 F1 F2 ED									
(2) CC AA 90 ED	CC AA 10 F0 F1 F2 ED									
(3) CC AA F0 40 ED	CC AA F0 04 F1 F2 ED									

TPU Bite Procedure
Table 104 (Sheet 7)

EFFECTIVITY
 RB211-535E4 ENGINES WITH BVCU C8E38-11,
 C8E38-12 OR C8E38-15

75-32-00
 CONFIG 4
 Page 143
 Jan 28/06

R01

FAULT CODE	FAULT ISOLATION PROCEDURE	ACCEPTANCE VALUE
90 (Cont)	2. ENGINES WITHOUT SB 71-8029; Disconnect plug D1504 from the TPU and check for voltage at pin 2. Go to step 3.	
	2. ENGINES WITH SB 71-8029; Disconnect plug D7104 from the TPU and check for voltage at pin 2. Go to step 3. 3. If voltage is present, replace TPU (AMM 75-32-15/401) If voltage is not present, disconnect plug D1006 and check for voltage on pin 6 aircraft side of plug. If voltage is present, check and repair engine harness wiring between plugs D1006 and D1504. If voltage is not present, check airplane wiring and repair as necessary.	9.0 volts (approx.) 9.0 volts (approx.)
B1	Replace TPU, (AMM 75-32-15/401).	
B3	Replace TPU, (AMM 75-32-15/401). If fault continues, do the TPU code 30 fault isolation procedures.	
B5	Replace TPU, (AMM 75-32-15/401).	
B6	Replace TPU, (AMM 75-32-15/401). If fault continues, do the TPU code 60 fault isolation procedures.	
B9	Replace TPU, (AMM 75-32-15/401). If fault continues, do the TPU code 90 fault isolation procedures.	
BB	Replace TPU, (AMM 75-32-15/401).	
BE	Replace TPU, (AMM 75-32-15/401).	
BF	Replace TPU, (AMM 75-32-15/401).	

TPU Bite Procedure
 Table 104 (Sheet 8)

EFFECTIVITY
 RB211-535E4 ENGINES WITH BVCU C8E38-11,
 C8E38-12 OR C8E38-15

75-32-00
 CONFIG 4
 Page 144
 Jan 28/06

R02