

GPA Group plc

PAGE	DATE	CODE	PAGE	DATE	CODE	PAGE	DATE	CODE
CHAPTER 77 TAB			77-31-00		CONT.			
ENGINE INDICATING			109	MAY 28/02	R02B			
EFFECTIVE PAGES			110	MAY 28/02	R02B			
SEE LAST PAGE OF LIST FOR			111	MAY 28/02	R02B			
NUMBER OF PAGES			112	MAY 28/02	R02B			
77-CONTENTS			113	JAN 28/06	R02B			
1	JAN 28/00	RGUI	114	JAN 28/04	R02B			
2	JAN 28/04	RGUI	115	JAN 28/04	R02B			
77-FAULT CODE INDEX			116	JAN 28/04	R02B			
R 1	MAY 20/09	R01.1	117	JAN 28/04	R01B			
2	SEP 20/08	R01	118	BLANK				
3	SEP 20/08	R01	77-41-00					
4	SEP 20/08	R01	101	SEP 20/94	R01			
77-11-00			102	SEP 20/94	R07			
101	SEP 20/94	R01	103	SEP 20/94	R07			
102	SEP 28/99	R01	104	BLANK				
103	SEP 20/94	R03						
104	SEP 20/94	R01						
105	SEP 20/94	R01						
106	SEP 20/94	R01						
107	SEP 20/94	R01						
108	BLANK							
77-12-00								
101	SEP 20/94	R01						
102	SEP 20/94	R01						
103	SEP 20/94	R01						
104	SEP 20/94	R01						
105	SEP 28/05	R01						
106	SEP 20/94	R01						
107	SEP 20/95	R01						
108	SEP 20/94	R01						
109	SEP 20/94	R01						
110	SEP 20/94	R01						
111	SEP 20/94	R01						
112	BLANK							
77-21-00								
101	SEP 20/94	R01						
102	SEP 20/94	R01						
103	SEP 20/96	R03						
104	SEP 20/94	R02						
77-31-00								
101	MAY 28/01	R01B						
102	MAY 28/02	R01B						
103	MAY 28/01	R02B						
104	MAY 28/02	R01B						
105	MAY 28/02	R02B						
106	MAY 28/02	R02B						
107	JAN 28/03	R02B						
108	JAN 28/05	R02B						

R = REVISED, A = ADDED OR D = DELETED  
F = FOLDOUT PAGE  
32  
MAY 20/09

**D633N632**

CHAPTER 77  
EFFECTIVE PAGES  
R PAGE 1  
LAST PAGE

CHAPTER 77 - ENGINE INDICATING

TABLE OF CONTENTS

<u>Subject</u>	Chapter Section <u>Subject</u>	<u>Page</u>	<u>Effectivity</u>
FAULT ISOLATION	77-FAULT CODE INDEX	1	ALL
<u>ENGINE INDICATING</u>	77-00-00		
<u>POWER</u>	77-10-00		
ENGINE PRESSURE RATIO (EPR)	77-11-00		
INDICATING SYSTEM			
Component Location		101	ALL
Component Index			
Component Location			
Fault Isolation			
EICAS and Stby Eng Ind EPR		104	
Differ (Fig. 104)			
EPR Indication Problem (Fig. 103)		103	
High/Low EPR Indication, Other Engine Parameters Normal (Fig. 105)		105	
ENGINE TACHOMETER SYSTEM	77-12-00		
Component Location		101	ALL
Component Index			
Component Location			
Fault Isolation			
EICAS and Stby Eng Ind ENG N3		108	
Differ (Fig. 106)			
EICAS and Stby Eng Ind ENG N3		109	
Differ (Fig. 107)			
EICAS L (R) ENG SPEED CARD		104	
Message Shows (Fig. 103)			
N1 Indication Problem (Fig. 104)		105	
N1 Indication Problem on EICAS (Fig. 108)		110	
N2 Indicator Reads		106	
Zero/Flucutates (Fig. 104A)			
N3 Indication Problem (Fig. 105)		107	
N3 Indication Problem on EICAS (Fig. 109)		111	

# 77-CONTENTS

CHAPTER 77 - ENGINE INDICATING

TABLE OF CONTENTS

<u>Subject</u>	<u>Chapter Section Subject</u>	<u>Page</u>	<u>Effectivity</u>
<u>TEMPERATURE</u>	77-20-00		
EXHAUST GAS TEMPERATURE (EGT)	77-21-00		
INDICATING SYSTEM			
Component Location		101	ALL
Component Index			
Component Location			
Fault Isolation			
EGT Indication Problem (Fig. 103)		103	
EICAS and Stby Eng Ind EGT Differ (Fig. 104)		104	
 <u>ANALYZERS</u>	 77-30-00		
AIRBORNE VIBRATION MONITORING (AVM) SYSTEM	77-31-00		
Component Location		101	ALL
Component Index			
Component Location			
Fault Isolation			
AVM BITE Procedure (Fig. 103)		105	
EICAS Msg L (R) ENG BB VIB Displayed (Fig. 104)		111	
EICAS Status Msg L (R) ENG VIB Shown (Fig. 105)		113	
EICAS Status Msg L (R) ENG VIB Shown (Fig. 105A)		114	
 <u>INTEGRATED ENGINE INSTRUMENT SYSTEMS</u>	 77-40-00		
STANDBY ENGINE INDICATION	77-41-00		
Component Location		101	ALL
Component Index			
Component Location			
Fault Isolation			
Standby Engine Indicator BITE Procedure (Fig. 103)		103	

## 77-CONTENTS

FAULT CODE	LOG BOOK REPORT	FAULT ISOLATION REFERENCE
77 12 XA --	(01=L,02=R) N1, N2, N3 indicators and eng speed card problems were encountered by the flight crew which is not covered in the fault code diagrams.	SSM 77-00-00, SSM 77-11-01, SSM 77-12-01 thru SSM 77-12-05, SSM 77-20-00, SSM 77-31-01
77 41 XA --	(01=L,02=R) EPR, EGT and vibration indication problems were encountered by the flight crew which is not covered in the fault code diagrams.	SSM 77-00-00, SSM 77-11-01, SSM 77-12-01 thru SSM 77-12-05, SSM 77-20-00, SSM 77-31-01
77 11 01 --	(01=L,02=R) Engine EPR ind (blank, zero, fluctuates). Standby eng ind also abnormal.	FIM 77-11-00/101, Fig. 103, Block 1
77 11 02 --	(01=L,02=R) Engine EPR reads (high, low). With same EPRs set, eng parameters differ. Engine parameters same with engines at same N1.	FIM 77-11-00/101, Fig. 103, Block 1
77 11 03 --	(01=L,02=R) Engine EPR on EICAS and stby eng ind differs. EICAS reads ____, stby eng ind ____.	FIM 77-11-00/101, Fig. 104, Block 1
77 11 04 --	(01=L,02=R) EPR reads (high, low). Other eng parameters normal.	FIM 77-11-00/101, Fig. 105, Block 1
77 11 05 --	(L,R) Engine EPR indication (blank, zero, fluctuates) using (01=L,02=R) EICAS computer. EPR normal using other computer.	Remove L(R) EICAS computer, M10181 (M10182)(AMM 31-41-02). Check and repair circuit from TB207 pins Z19 (Z18) and Z20 (Z17) to connectors D319A (D319D) pins J4 and J3 (J5) at left EICAS computer M10181, and connectors D321A (D321D) pins J4 and J3 (J5) at right EICAS computer M10182 (WDM 77-11-11). Install EICAS computer. If fault persists, replace applicable L(R) EICAS computer M10181 (M10182)(AMM 31-41-02).
77 12 01 --	EICAS MSG: (01=L,02=R) ENG SPEED CARD displayed. Engine ind were normal.	FIM 77-12-00/101, Fig. 103, Block 1

EFFECTIVITY

ALL

## 77-FAULT CODE INDEX

R01.1

 Page 1  
 May 20/09

FAULT CODE	LOG BOOK REPORT	FAULT ISOLATION REFERENCE
77 12 02 --	(01=L,02=R) Engine prim N1 ind (blank, high, low, zero, fluctuates). Engine stby ind also abnormal. Vibration shows BB INOP.	FIM 77-12-00/101, Fig. 104, Block 1
77 12 03 --	(L,R) Engine N2 ind (blank, high, low, zero, fluctuates) using (01=L,02=R) EICAS computer. N2 normal using other computer.	FIM 77-12-00/101, Fig. 104A, Block 1
77 12 04 --	(01=L,02=R) Engine N3 ind (blank, high, low, zero, fluctuates). Standby eng ind abnormal. EICAS MSG: (L,R) ENG SPEED CARD displayed.	FIM 77-12-00/101, Fig. 105, Block 1
77 12 05 --	(01=L,02=R) Engine N1 on EICAS and stby eng ind differs. EICAS ____% N1, stby eng ind ____% N1.	FIM 77-12-00/101, Fig. 106
77 12 06 --	(01=L,02=R) Engine N3 on EICAS and stby eng ind differs. EICAS ____% N3, stby eng ind ____% N3.	FIM 77-12-00/101, Fig. 107
77 12 07 --	(L,R) Engine N1 ind (blank, high, low, zero, fluctuates) using (01=L,02=R) EICAS computer. N1 normal using other computer.	FIM 77-12-00/101, Fig. 108
77 12 08 --	(L,R) Engine N3 ind (blank, high, low, zero, fluctuates) using (01=L, 02=R) EICAS computer. N3 normal using other computer.	FIM 77-12-00/101, Fig. 109
77 12 09 00	EICAS msg L ENG SPEED CARD displayed.	FIM 77-12-00/101, Fig. 103, Block 1
77 12 10 00	EICAS msg R ENG SPEED CARD displayed.	FIM 77-12-00/101, Fig. 103, Block 1
77 21 01 --	(01=L,02=R) Engine EGT ind (blank, high, low, zero, fluctuates). Standby ind eng ind also abnormal.	FIM 77-21-00/101, Fig. 103, Block 1

EFFECTIVITY \_\_\_\_\_  
 ALL

## 77-FAULT CODE INDEX

FAULT CODE	LOG BOOK REPORT	FAULT ISOLATION REFERENCE
77 21 02 --	(01=L,02=R) Engine EGT on EICAS and stby eng ind differs. EICAS reads ____°, stby eng ind ____°.	FIM 77-21-00/101, Fig. 104
77 21 03 --	(L,R) Engine EGT indication (blank, high, low, zero, fluctuates) using (01=L,02=R) EICAS computer. EGT normal using other computer.	FIM 77-21-00/101, Fig. 103, Block 1
77 31 01 --	(01=L,02=R) Engine VIB indicator has BB above indication.	FIM 77-31-00/101, Fig. 103, Block 1
77 31 02 --	(01=L,02=R,03=L N1,04=L N2,05=L N3,06=R N1,07=R N2,08=R N3) Engine vibration indication reads (BB, high, blank or fluctuates, etc.) using either EICAS computer (describe BB or track position). Other engine parameters normal.	FIM 77-31-00/101, Fig. 103, Block 1
77 31 05 00	EICAS msg L ENG VIB BITE displayed.	FIM 77-31-00/101, Fig. 103, Block 1
77 31 06 00	EICAS msg R ENG VIB BITE displayed.	FIM 77-31-00/101, Fig. 103, Block 1
77 31 07 --	EICAS msg: (01=L,02=R) ENG VIB displayed.	FIM 77-31-00/101, Fig. 105, Block 1
77 31 08 00	EICAS msg R ENG BB VIB displayed.	FIM 77-31-00/101, Fig. 104, Block 1
77 31 09 00	EICAS msg L ENG BB VIB displayed.	FIM 77-31-00/101, Fig. 104, Block 1
77 41 01 --	(01=L,02=R) Standby eng EPR ind reads (blank, zero, high/low or segment missing).	FIM 77-41-00/101, Fig. 103, Block 1
77 41 02 --	(01=L,02=R) Engine stby N1 ind reads (blank, zero, high/low or segment missing).	FIM 77-41-00/101, Fig. 103, Block 1
77 41 03 --	(01=L,02=R) Standby eng EGT ind reads (blank, zero, high/low or segment missing).	FIM 77-41-00/101, Fig. 103, Block 1

EFFECTIVITY

ALL

## 77-FAULT CODE INDEX

R01

 Page 3  
 Sep 20/08

FAULT CODE	LOG BOOK REPORT	FAULT ISOLATION REFERENCE
77 41 04 --	(01=L,02=R) Engine stby N3 ind reads (blank, zero, high/low or segment missing).	FIM 77-41-00/101, Fig. 103, Block 1

EFFECTIVITY

ALL
-----

## 77-FAULT CODE INDEX

R01

Page 4  
Sep 20/08



ENGINE PRESSURE RATIO (EPR) INDICATING SYSTEM

COMPONENT	FIG. 102 SHT	QTY	ACCESS/AREA	AMM REFERENCE
TRANSMITTER - EPR, M10162	--	2	414AR L ENG FAN COWL 424AR R ENG FAN COWL	77-11-01

Engine Pressure Ratio (EPR) Indicating System - Component Index  
Figure 101

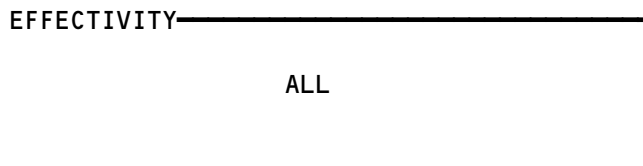

E49045

77-11-00

R01

Page 101  
Sep 20/94



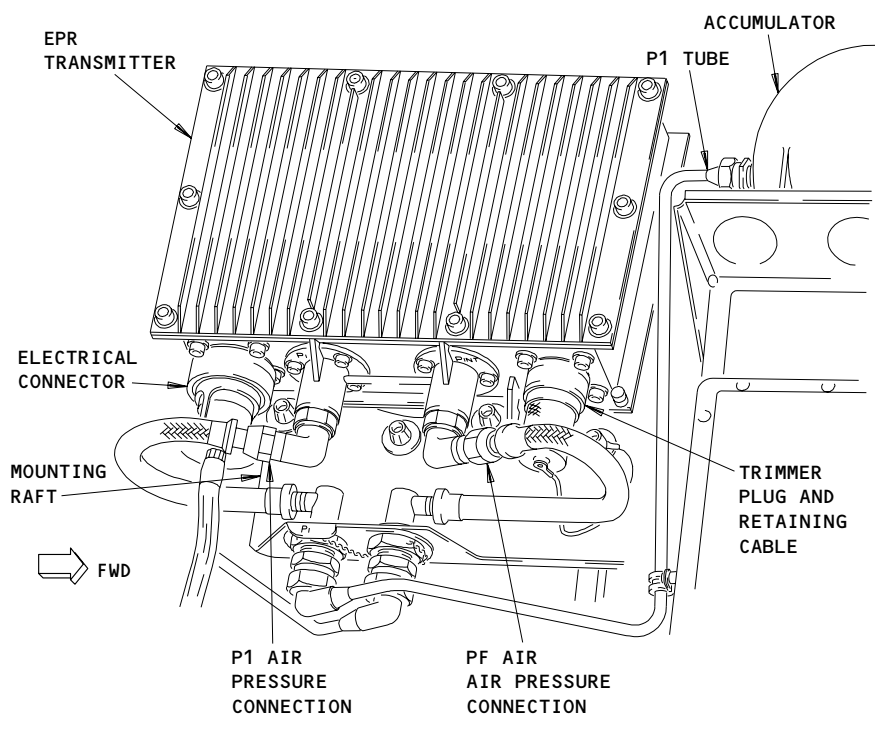
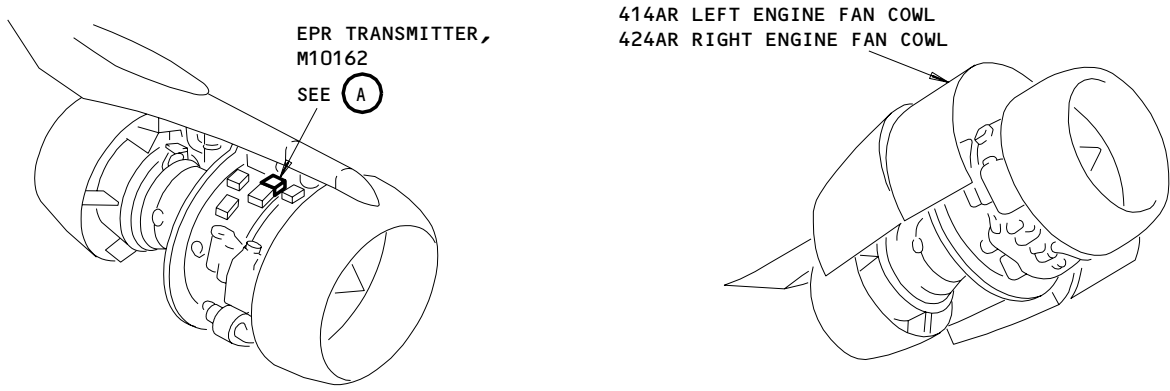

EPR TRANSMITTER, M10162  
(A)

**NOTE:** ON AIRPLANES WITH RB211-535E4 ENGINES, THE PF AIR LINE IS CONNECTED TO THE FITTING WITH THE PINT PLACARD ON THE EPR TRANSMITTER

69706-A

Engine Pressure Ratio (EPR) Indicating System - Component Location  
Figure 102

EFFECTIVITY	
	ALL

77-11-00

195544

**EPR INDICATION  
PROBLEM**

**PREREQUISITES**  
NONE

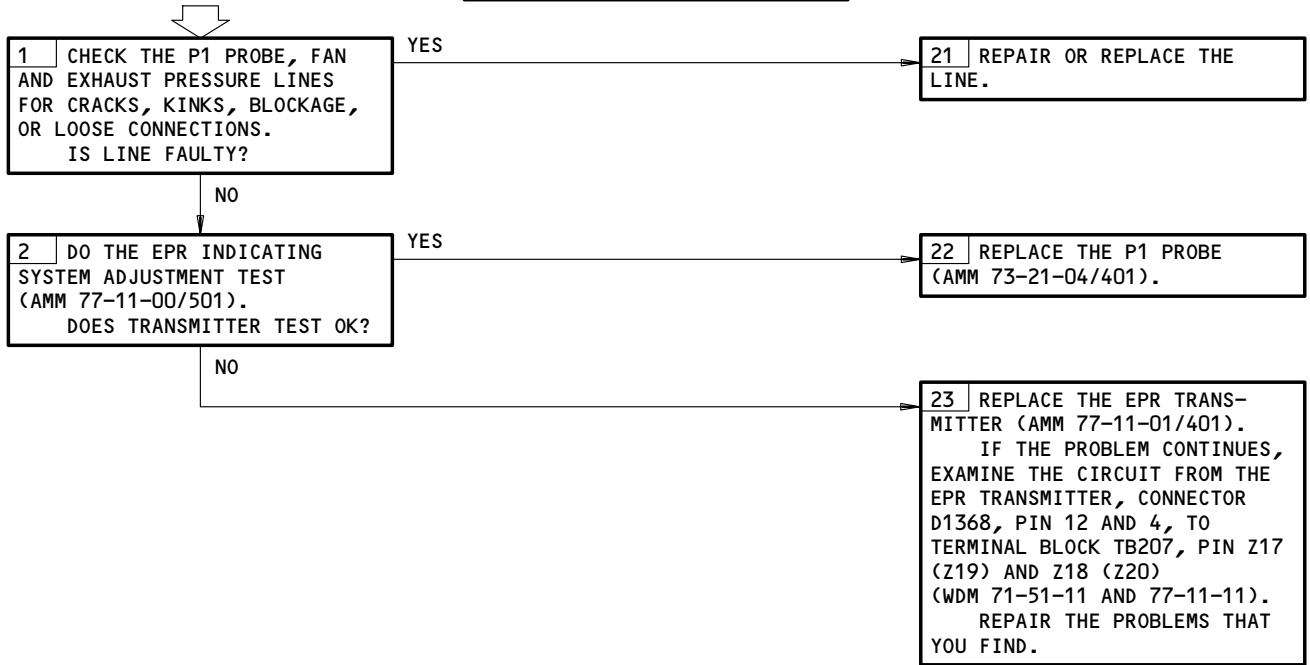

EPR Indication Problem  
Figure 103

EFFECTIVITY ————  
ALL

**77-11-00**

R03

Page 103  
Sep 20/94

71172

EICAS AND STBY ENG  
IND "EPR" DIFFERS

<b>PREREQUISITES</b> NONE
------------------------------



1	DO THIS PROCEDURE: STANDBY ENGINE INDICATOR BITE PROCEDURE (FIM 77-41-00/101, FIG. 103). IF THE PROBLEM CONTINUES, REMOVE THE L (R) EICAS COMPUTER, M10181 (M10182)(AMM 31-41-02/401). EXAMINE THE CIRCUIT FROM THE L EICAS COMPUTER, CONNECTOR D319A (D319D), PIN J4 AND J3 (J5), TO PIN Z19 (Z18) AND Z20 (Z17)(WDM 77-11-11). REPAIR THE PROBLEMS THAT YOU FIND. EXAMINE THE CIRCUIT FROM THE R EICAS COMPUTER, CONNECTOR D321A (D321D), PIN J4 AND J3 (J5) TO PIN Z19 (Z18) AND Z20 (Z17). REPAIR THE PROBLEMS THAT YOU FIND. INSTALL THE EICAS COMPUTER.
---	---------------------------------------------------------------------------------------------------------------------------------------------------------------------------------------------------------------------------------------------------------------------------------------------------------------------------------------------------------------------------------------------------------------------------------------------------------------------------------------------------------------------------------------------------------------------------------

EICAS and Stby Eng Ind EPR Differ  
Figure 104

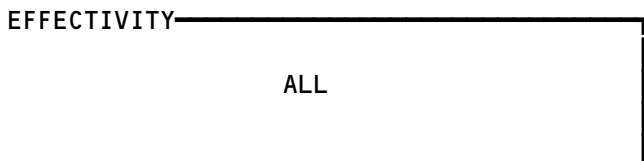

77-11-00

**HIGH/LOW EPR  
INDICATION, OTHER  
ENGINE PARAMETERS  
NORMAL**

**PREREQUISITES**  
NONE

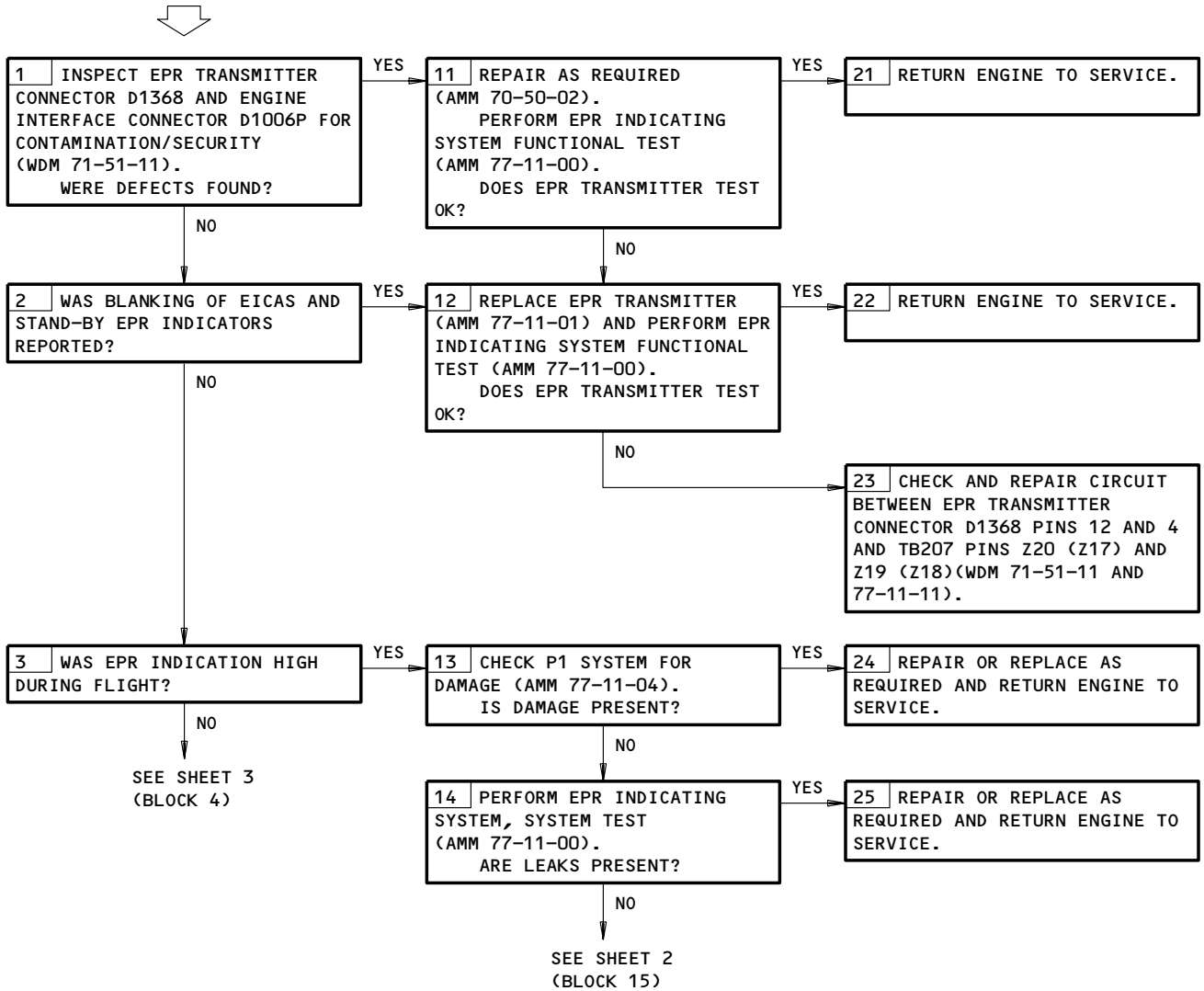

High/Low EPR Indication, Other Engine Parameters Normal  
Figure 105 (Sheet 1)

EFFECTIVITY

ALL
-----

77-11-00

FROM SHEET 1  
(BLOCK 14)

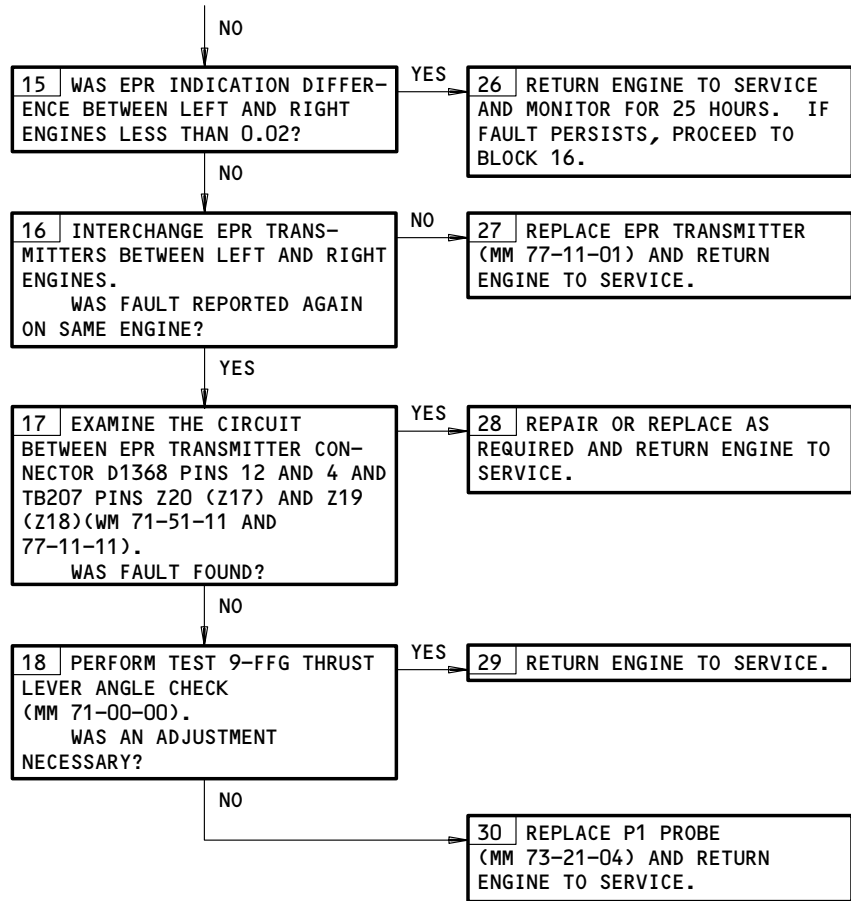

High/Low EPR Indication, Other Engine Parameters Normal  
Figure 105 (Sheet 2)

EFFECTIVITY	ALL
-------------	-----

**77-11-00**

R01

Page 106  
Sep 20/94

651502

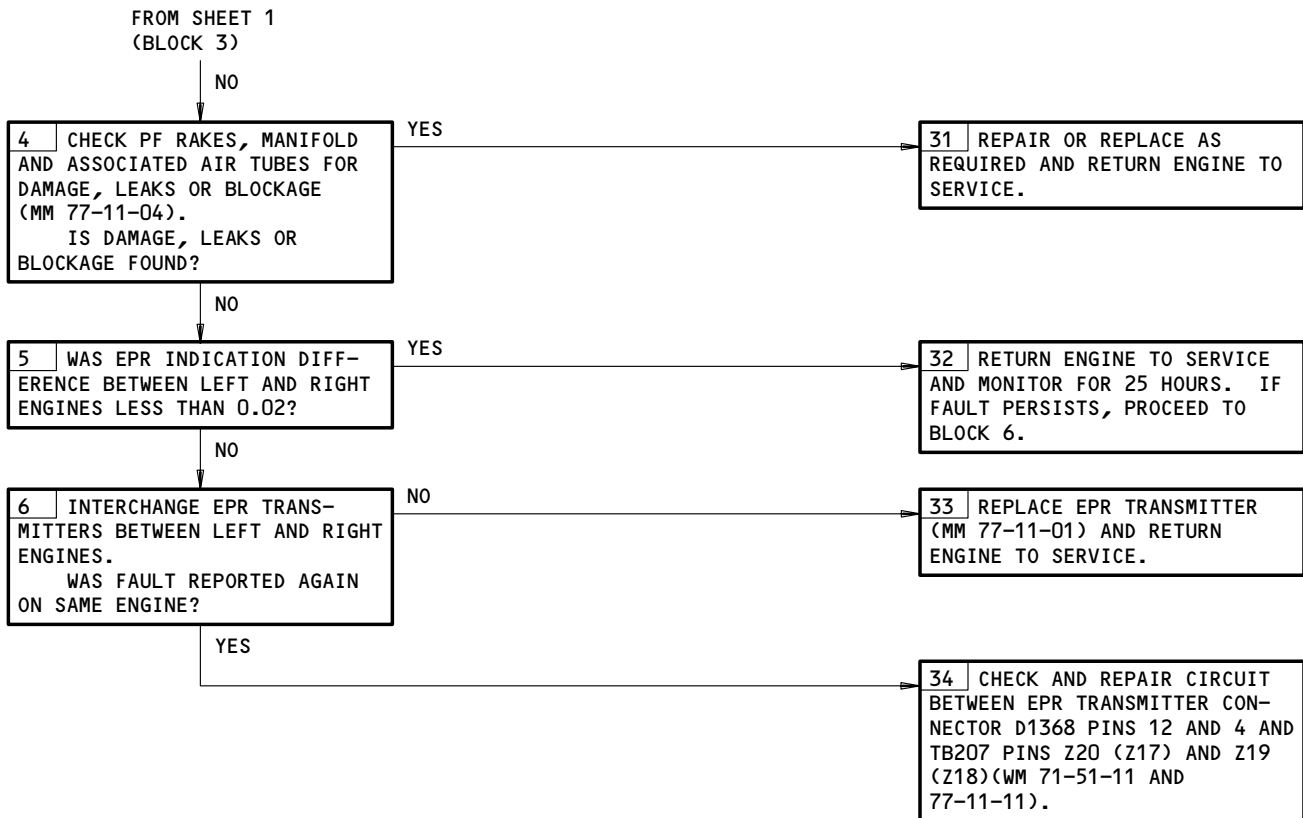

High/Low EPR Indication, Other Engine Parameters Normal  
Figure 105 (Sheet 3)

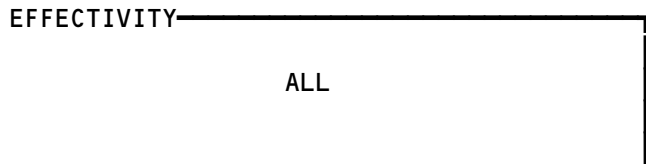

**77-11-00**

ENGINE TACHOMETER SYSTEM

COMPONENT	FIG. 102 SHT	QTY	ACCESS/AREA	AMM REFERENCE
CARD - LEFT ENGINE SPEED, M10298	2	1	119BL, MAIN EQUIP CTR, P50	77-12-03
CARD - RIGHT ENGINE SPEED, M10311	2	1	119BL, MAIN EQUIP CTR, P50	77-12-03
PROBE - #1 N1 SPEED, B10005	2	2	414AR, L ENG FAN COWL 424AR, R ENG FAN COWL	77-12-01
PROBE - #2 N1 SPEED, B10006	2	2	414AR, L ENG FAN COWL 424AR, R ENG FAN COWL	77-12-01
PROBE - #1 N2 SPEED, B10007	2	2	414AR, L ENG FAN COWL 424AR, R ENG FAN COWL	77-12-01
PROBE - #2 N2 SPEED, B10008	2	2	414AR, L ENG FAN COWL 424AR, R ENG FAN COWL	77-12-01
PROBE - #3 N2 SPEED, B10009	2	2	414AR, L ENG FAN COWL 424AR, R ENG FAN COWL	77-12-01
RELAY - (FIM 31-01-36/101) L ENG OUT 1, K10337 L ENG OUT 4, K10398 R ENG OUT 1, K10340				
RELAY - (FIM 31-01-37/101) L ENG OUT 2, K10338 L ENG OUT 3, K10339 L ENG OUT 5, K10446 R ENG OUT 2, K10341 R ENG OUT 3, K10342 R ENG OUT 4, K10399 R ENG OUT 5, K10444 R ENG OUT 6, K10448				
TRANSMITTER - N3 (HP) TACHOMETER 2	2	2	414AR, L ENG FAN COWL 424AR, R ENG FAN COWL	77-12-02

Engine Tachometer System - Component Index  
Figure 101

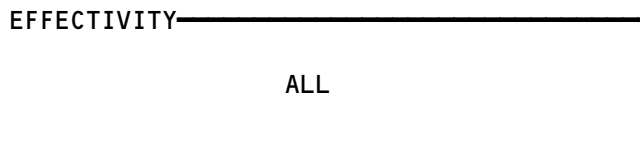

77-12-00

R01

Page 101  
Sep 20/94

E46836

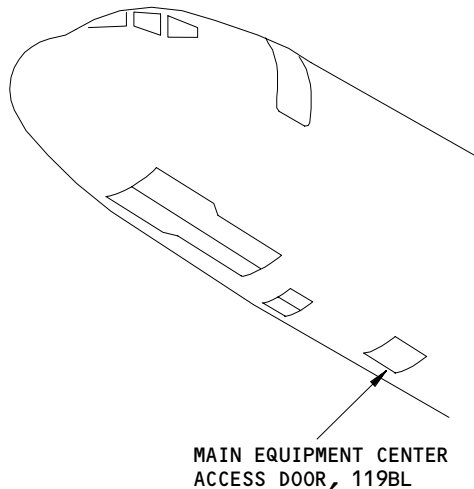
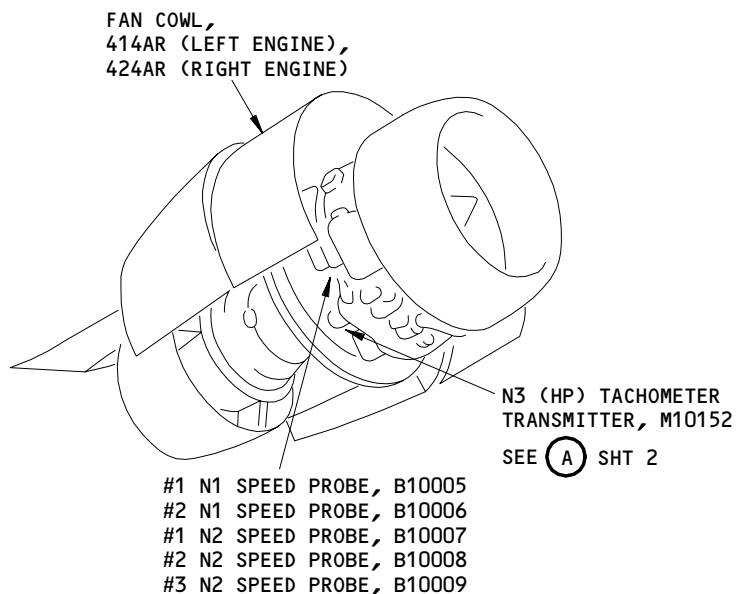

Engine Tachometer System - Component Location  
 Figure 102 (Sheet 1)

EFFECTIVITY	ALL
-------------	-----

77-12-00



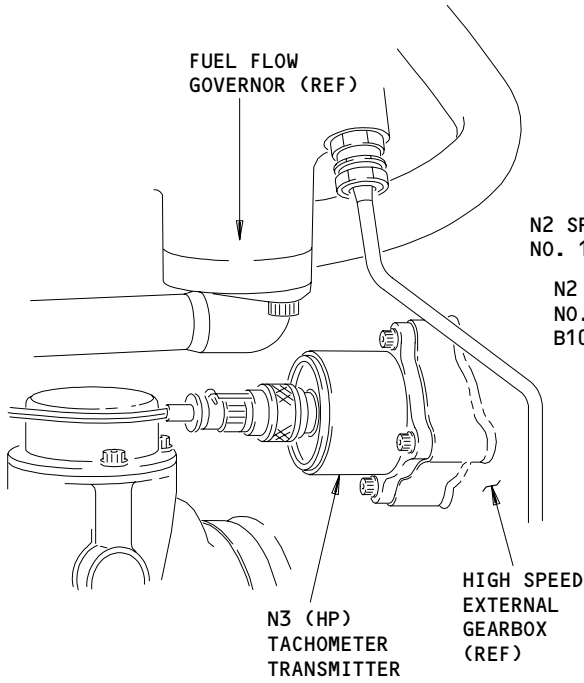

A

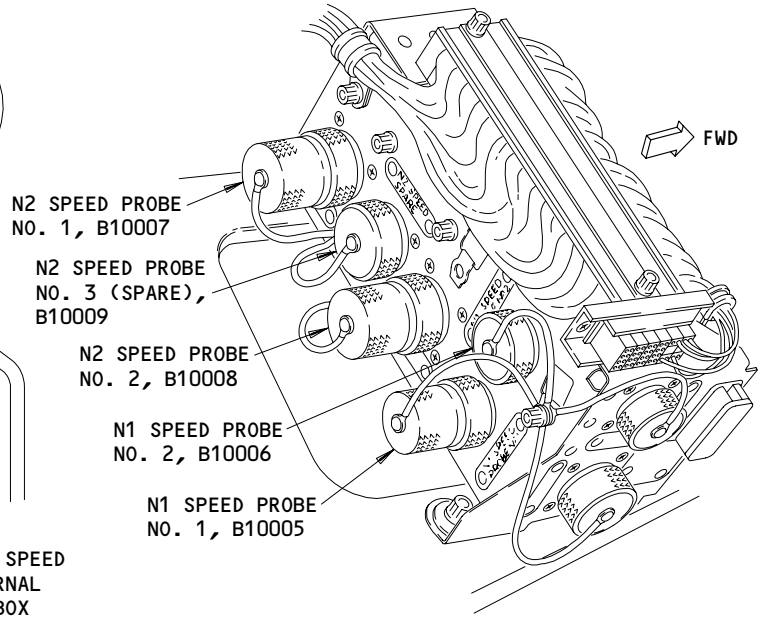

B

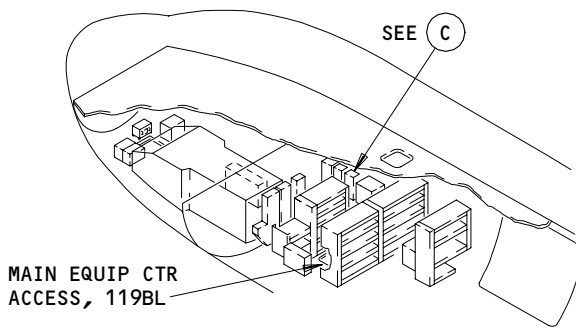

MAIN EQUIP CTR

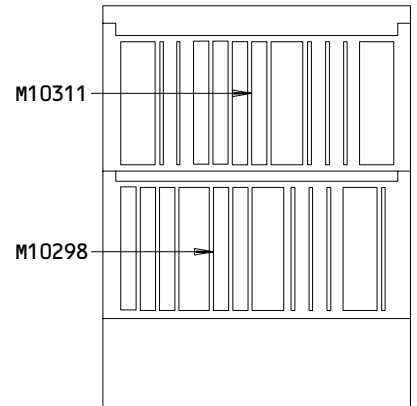

ELEC SYS CARD FILE P50

C

Component Location  
Figure 102 (Sheet 2)

EFFECTIVITY	ALL
-------------	-----

77-12-00

R01

Page 103  
Sep 20/94

EICAS "L (R) ENG  
SPEED CARD" MESSAGE  
SHOWS

**PREREQUISITES**  
NONE

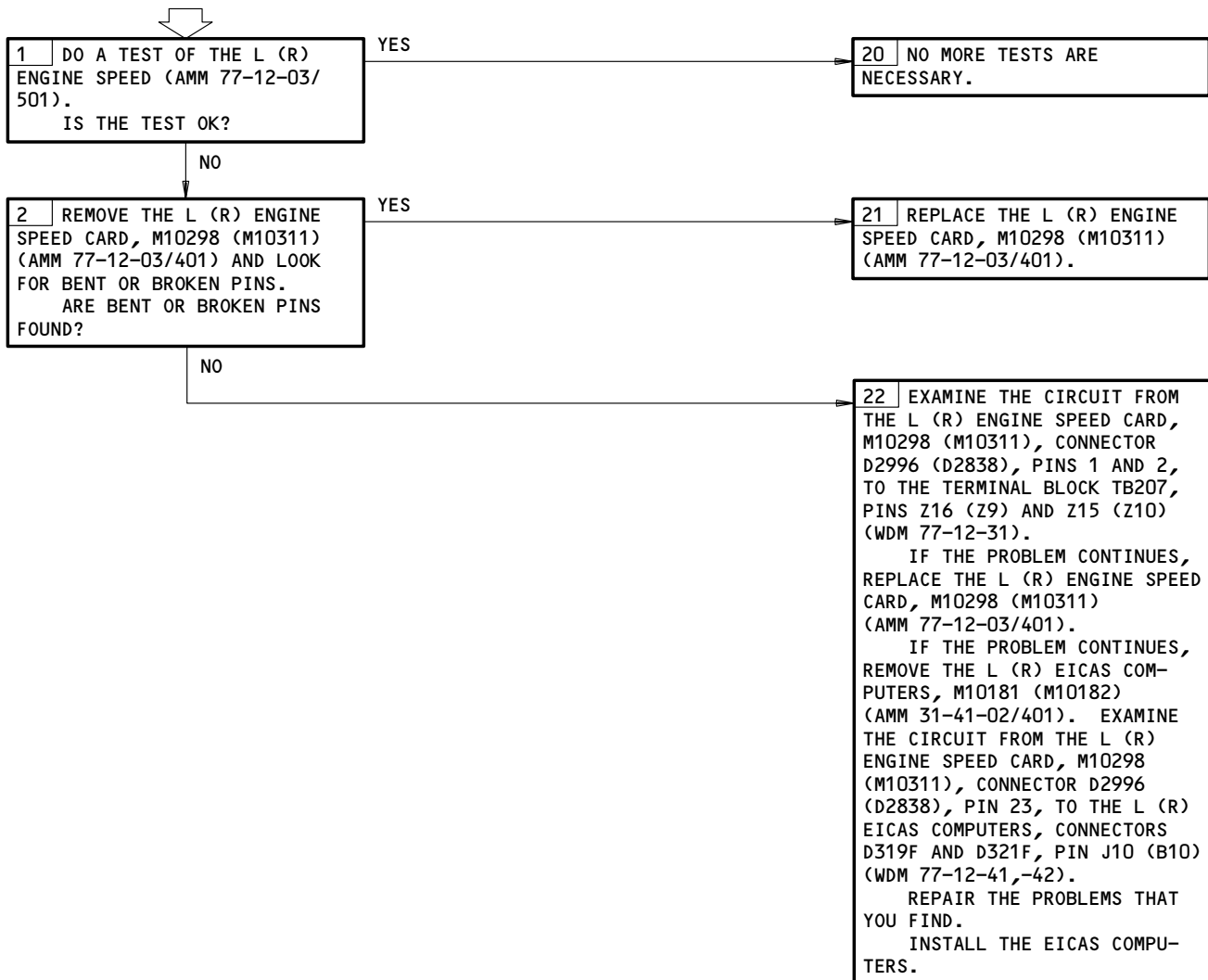

EICAS L (R) ENG SPEED CARD Message Shows  
Figure 103

EFFECTIVITY ————  
ALL

**77-12-00**

71174

**N1 INDICATION  
PROBLEM**

**PREREQUISITES**  
NONE

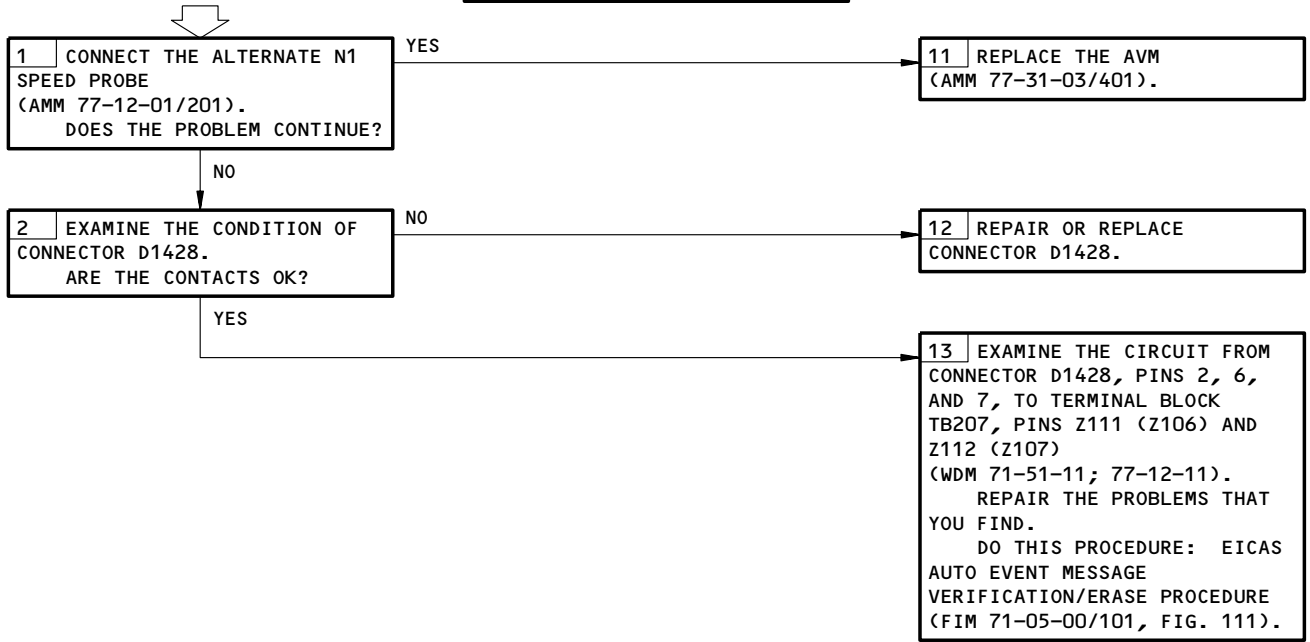

N1 Indication Problem  
Figure 104

EFFECTIVITY \_\_\_\_\_  
ALL

**77-12-00**

N2 INDICATION READS ZERO/FLUCTUATES

**PREREQUISITES**  
NONE

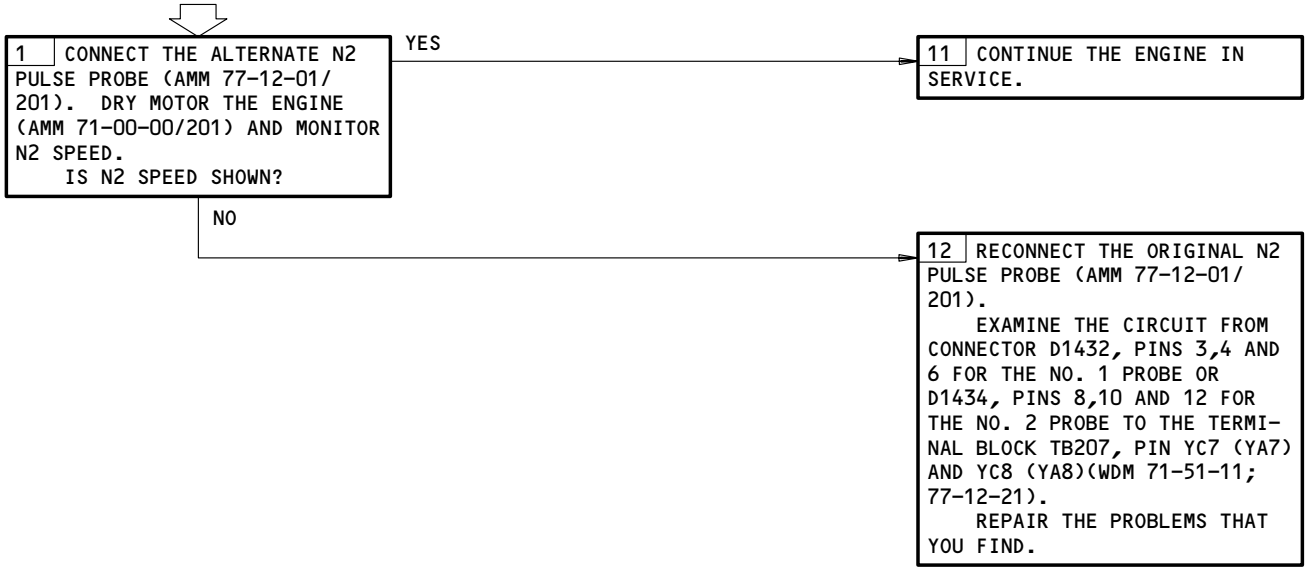

N2 Indicator Reads Zero/Flucutates  
Figure 104A

EFFECTIVITY	ALL
-------------	-----

**77-12-00**

**N3 INDICATION  
PROBLEM**

**PREREQUISITES**  
NONE

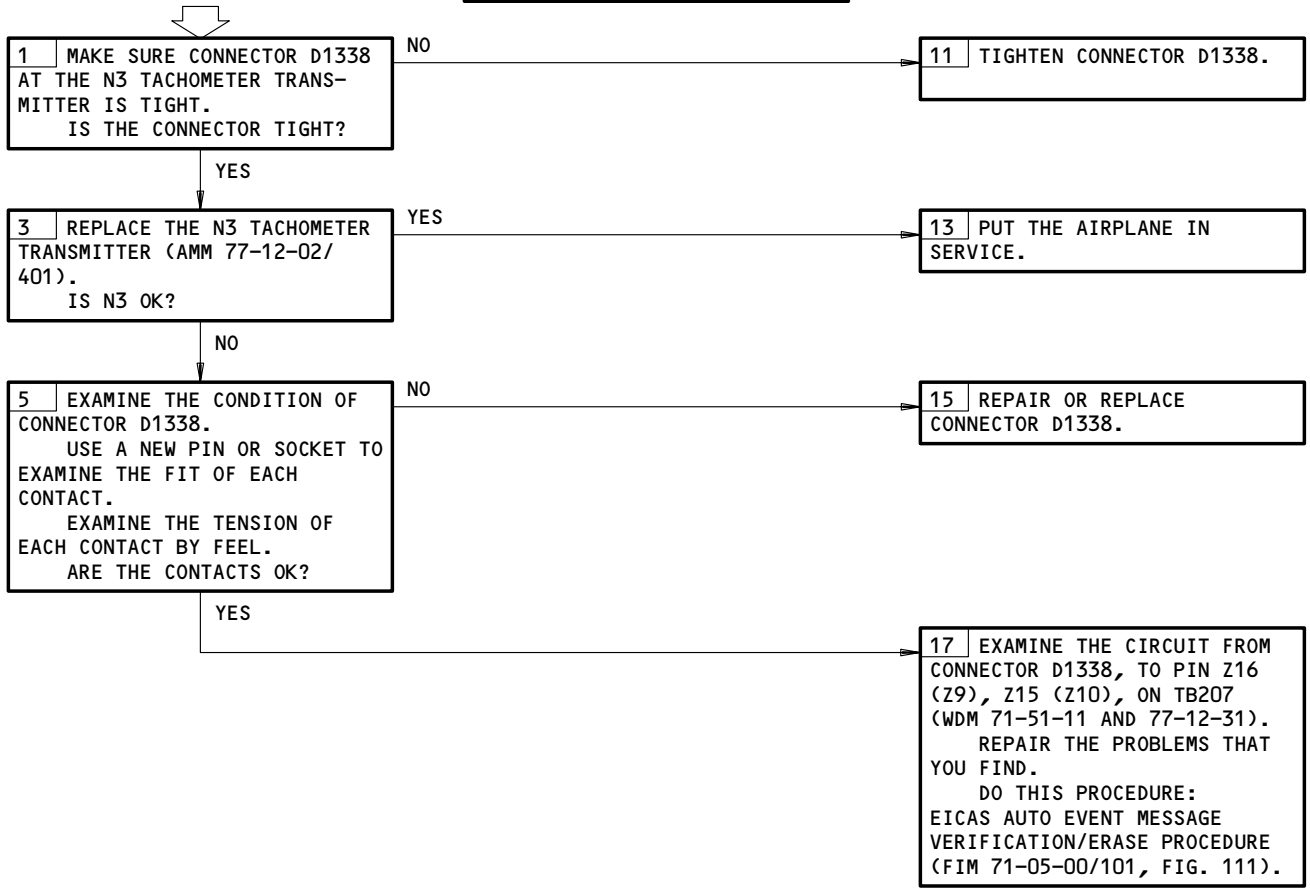

N3 Indication Problem  
Figure 105

EFFECTIVITY

ALL
-----

77-12-00

E47604

EICAS AND STBY ENG  
IND "ENG N1" DIFFERS

<b>PREREQUISITES</b> NONE
------------------------------



1 DO THIS PROCEDURE: STANDBY ENGINE INDICATOR BITE PROCEDURE (FIM 77-41-00/101, FIG. 103). IF THE PROBLEM CONTINUES, REMOVE L (R) EICAS COMPUTER, M10181 (M10182)(AMM 31-41-02/401). EXAMINE THE CIRCUIT FROM L EICAS COMPUTER, CONNECTOR D319B (D319E), PIN D1 (A14), D2 (B14), TO PIN Z111 (Z106), Z112 (Z107) ON TB207 (WDM 77-12-11). REPAIR THE PROBLEMS THAT YOU FIND. EXAMINE THE CIRCUIT FROM R EICAS COMPUTER, CONNECTOR D321B (D321E), PIN D1 (A14), D2 (B14), TO PIN Z111 (Z106),Z112 (Z107) ON TB207. REPAIR THE PROBLEMS THAT YOU FIND. INSTALL EICAS COMPUTER.
---------------------------------------------------------------------------------------------------------------------------------------------------------------------------------------------------------------------------------------------------------------------------------------------------------------------------------------------------------------------------------------------------------------------------------------------------------------------------------------------------------------------------------------------------------------------------------------------

EICAS and Stby Eng Ind ENG N3 Differ  
Figure 106

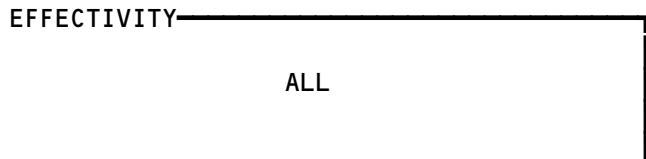

**77-12-00**

E47645

EICAS AND STBY ENG  
IND "ENG N3" DIFFERS

PREREQUISITES  
NONE



1 DO THIS PROCEDURE: STANDBY ENGINE INDICATOR BITE PROCEDURE (FIM 77-41-00/101, FIG. 103). IF THE PROBLEM CONTINUES, REMOVE L (R) EICAS COMPUTER, M10181 (M10182)(AMM 31-41-02/401). EXAMINE THE CIRCUIT FROM L EICAS COMPUTER, CONNECTOR D319A (D319D), PIN F11 (A7),D12 (E8), TO PIN Z15 (Z10), Z16 (Z9) ON TB207 (WDM 77-12-31). REPAIR THE PROBLEMS THAT YOU FIND. EXAMINE THE CIRCUIT FROM R EICAS COMPUTER, CONNECTOR D321A (D321D), PIN F11 (A7),D12 (E8), TO PIN Z15 (Z10),Z16 (Z9) ON TB207. REPAIR THE PROBLEMS THAT YOU FIND. INSTALL EICAS COMPUTER.

EICAS and Stby Eng Ind ENG N3 Differ  
Figure 107

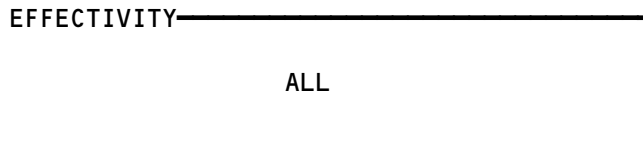

77-12-00

"N1" INDICATION  
PROBLEM ON EICAS

PREREQUISITES  
NONE



1 REMOVE L (R) EICAS COMPUTER, M10181 (M10182)(AMM 31-41-02/401). EXAMINE THE CIRCUIT FROM L EICAS COMPUTER, CONNECTOR D319B (D319E), PIN D1 (A14),D2 (B14), TO PIN Z111 (Z106),Z112 (Z107) ON TB207 (WDM 77-12-11). REPAIR THE PROBLEMS THAT YOU FIND. EXAMINE THE CIRCUIT FROM R EICAS COMPUTER, CONNECTOR D321B (D321E), PIN D1 (A14),D2 (D14), TO PIN Z111 (Z106),Z112 (Z107) ON TB207. REPAIR THE PROBLEMS THAT YOU FIND. INSTALL THE EICAS COMPUTER.

N1 Indication Problem on EICAS  
Figure 108

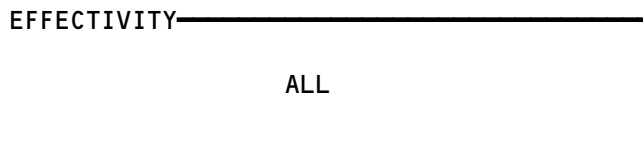

77-12-00



"N3" INDICATION  
PROBLEM ON EICAS

PREREQUISITES  
NONE



1 REMOVE L (R) EICAS COMPUTER, M10181 (M10182)(AMM 31-41-02/401). EXAMINE THE CIRCUIT FROM L EICAS COMPUTER, CONNECTOR D319A (D319D), PIN F11 (A7),D12 (E8), TO PIN Z15 (Z10),Z16 (Z9) ON TB207 (WDM 77-12-31). REPAIR THE PROBLEMS THAT YOU FIND. EXAMINE THE CIRCUIT FROM R EICAS COMPUTER, CONNECTOR D321A (D321D), PIN F11 (A7),D12 (E8), TO PIN Z15 (Z10),Z16 (Z9) ON TB207. REPAIR THE PROBLEMS THAT YOU FIND. INSTALL EICAS COMPUTER.

N3 Indication Problem on EICAS  
Figure 109

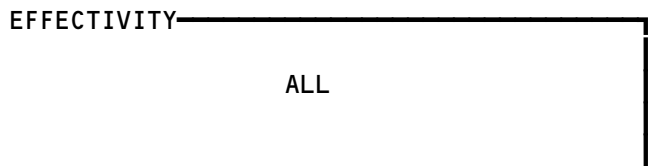

79051

**77-12-00**

R01

Page 111  
Sep 20/94

EXHAUST GAS TEMPERATURE (EGT) INDICATING SYSTEM

COMPONENT	FIG. 102 SHT	QTY	ACCESS/AREA	AMM REFERENCE
BLOCK - EGT ELECTRICAL CABLES AND RESISTORS TERMINAL	--	2	414AR,424AR COWL PANELS	77-21-03
HARNESS - EGT THERMOCOUPLE	--	2	415AL,425AL,416AR,426AR COWL PANELS	77-21-02
PROBE - EGT THERMOCOUPLE, TS5025	--	34	415AL,425AL,416AR,426AR COWL PANELS	77-21-01

Exhaust Gas Temperature (EGT) Indicating System - Component Index  
Figure 101

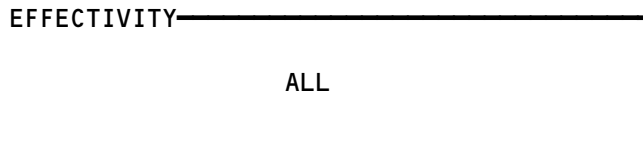

**77-21-00**

R01

Page 101  
Sep 20/94

E50636

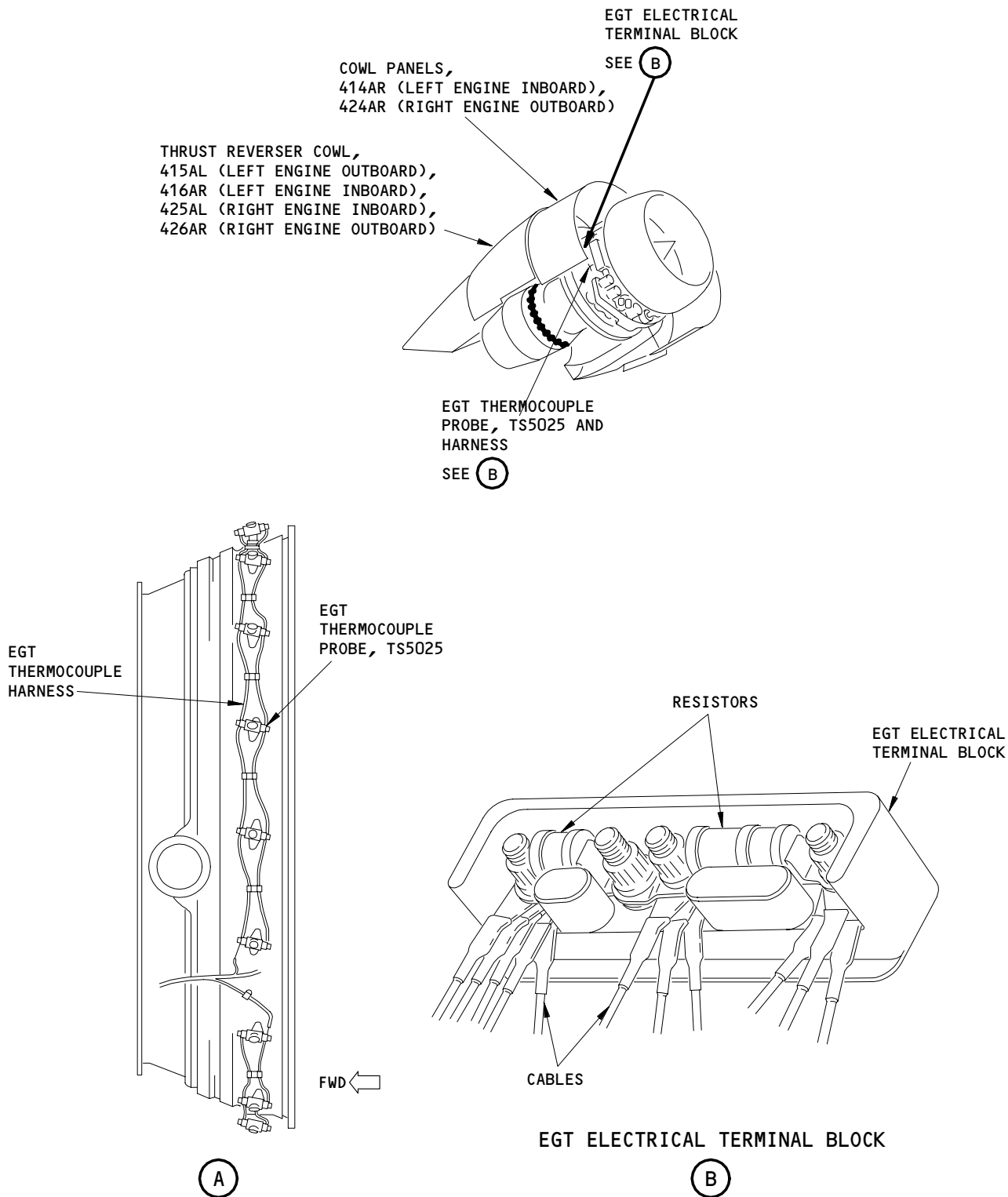

Exhaust Gas Temperature (EGT) Indicating System - Component Location  
Figure 102

EFFECTIVITY	
ALL	

77-21-00

R01

Page 102  
Sep 20/94

**EGT INDICATION  
PROBLEM**

**PREREQUISITES**  
NONE

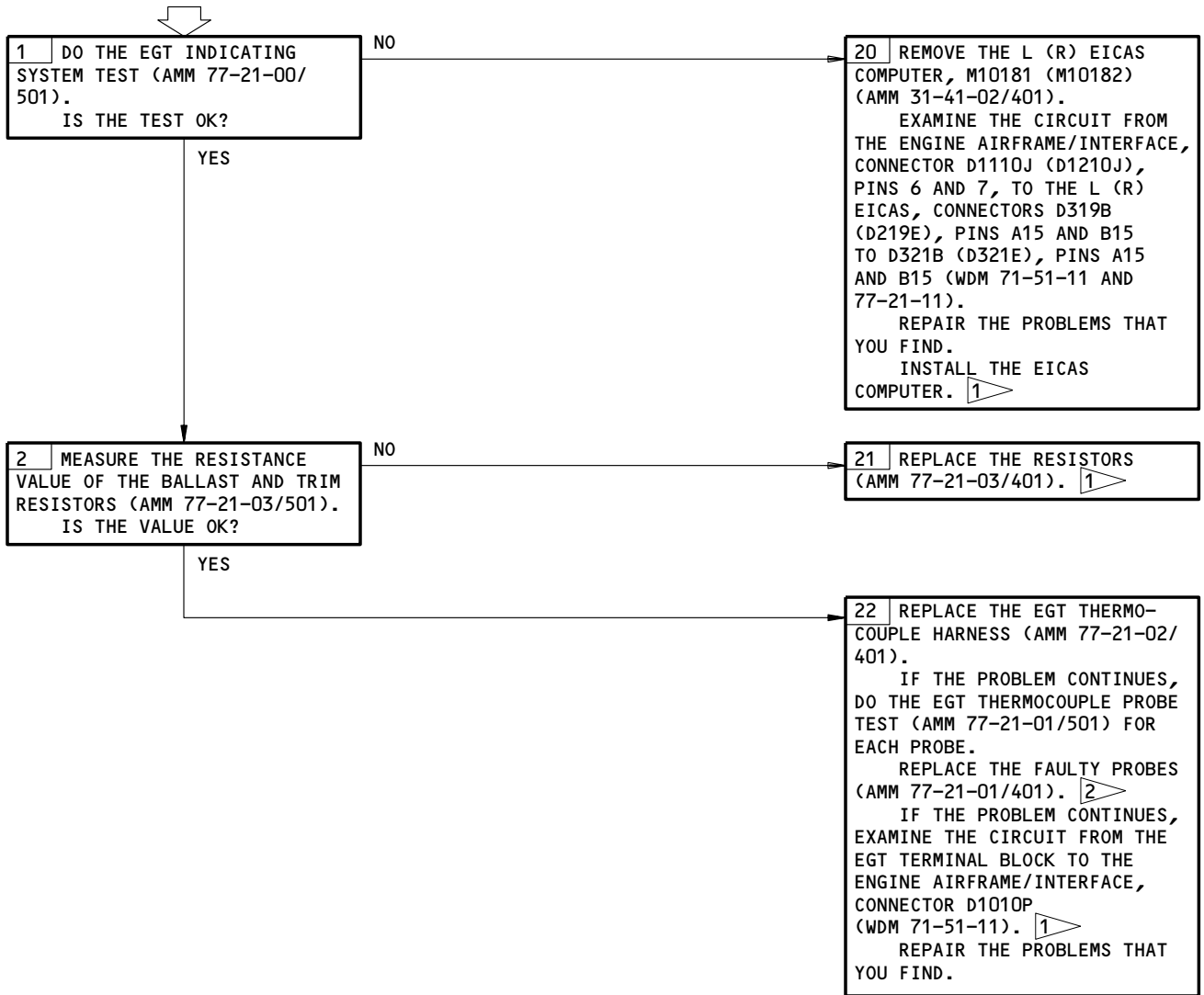

- 1 DO THE PROCEDURE IN FIM 71-05-00, FIG. 111
- 2 FAULTY EGT PROBES CAN CAUSE LOWER EGT INDICATIONS.

EGT Indication Problem  
Figure 103

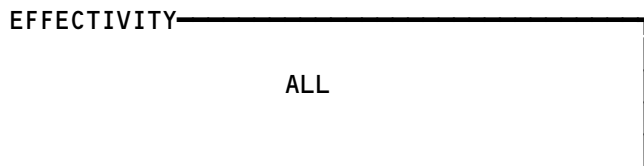

**77-21-00**

EICAS AND STBY ENG  
IND "EGT" DIFFER

<b>PREREQUISITES</b> NONE
------------------------------



1	PERFORM STANDBY ENGINE INDICATOR BITE PROCEDURE (77-41-00, FIG. 103). IF FAULT PERSISTS, REMOVE L (R) EICAS COMPUTER M10181 (M10182)(MM 31-41-02). CHECK AND REPAIR CIRCUIT BETWEEN L EICAS COMPUTER CONNECTORS D319B (D319E) PIN B15 AND A15 AND PIN YC70 (YA69) AND YC69 (YA70) ON TB207 (WM 77-21-11). CHECK AND REPAIR CIRCUIT BETWEEN R EICAS COMPUTER CONNECTORS D321B (D321E) PIN B15 AND A15 AND PIN YC70 (YA69) AND YC69 (YA70) ON TB207. INSTALL EICAS COMPUTER.
---	----------------------------------------------------------------------------------------------------------------------------------------------------------------------------------------------------------------------------------------------------------------------------------------------------------------------------------------------------------------------------------------------------------------------------------------------------------------------------------------

EICAS and Stby Eng Ind EGT Differ  
Figure 104

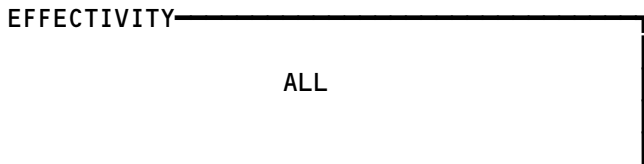

**77-21-00**

AIRBORNE VIBRATION MONITORING (AVM) SYSTEM

COMPONENT	FIG. 102 SHT	QTY	ACCESS/AREA	AMM REFERENCE
ACCELEROMETER - AVM, TS5028	2	2	425AL, R ENG FAN C-DUCT AND THRUST REVERSER	77-31-01
BOX - AVM JUNCTION	2	2	425AL, R ENG FAN C-DUCT AND THRUST REVERSER	77-31-04
CONDITIONER, LEFT AVM SIGNAL, M132	2	1	119BL, MAIN EQUIP CTR, E4-2	77-31-03
CONDITIONER, RIGHT AVM SIGNAL, M10571	2	1	119BL, MAIN EQUIP CTR, E4-2	77-31-03

Airborne Vibration Monitoring System (AVM) - Component Location  
Figure 101

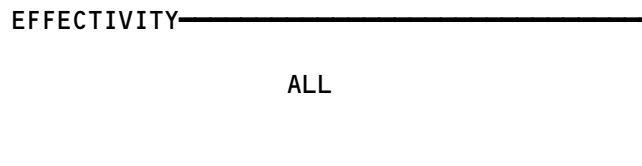

**77-31-00**

R01B

Page 101  
May 28/01

E48334

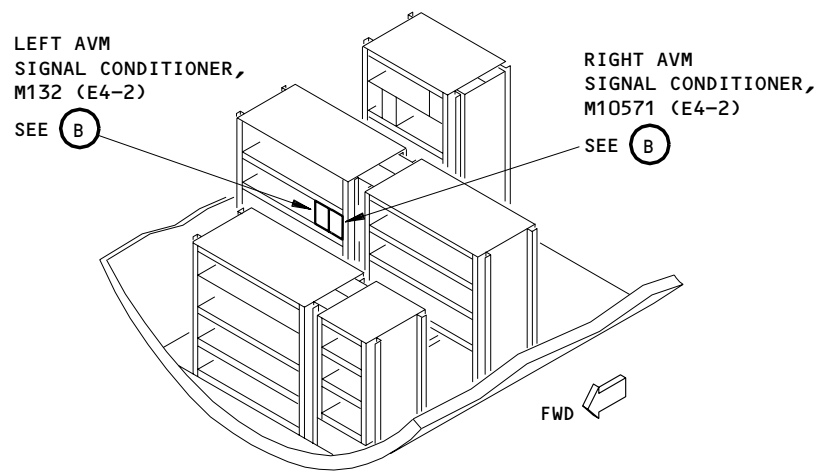
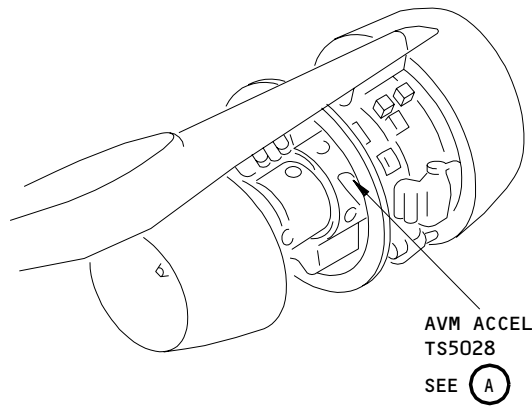
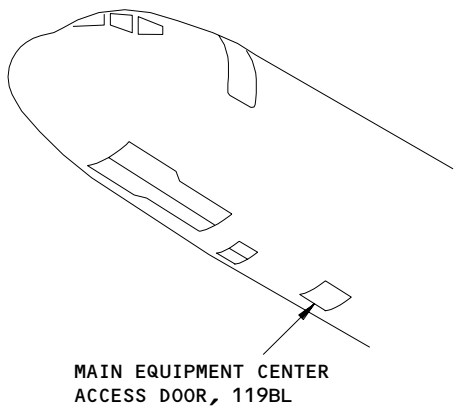

MAIN EQUIPMENT CENTER

Airborne Vibration Monitoring System (AVM) - Component Location  
Figure 102 (Sheet 1)

EFFECTIVITY	ALL
-------------	-----

77-31-00

195318

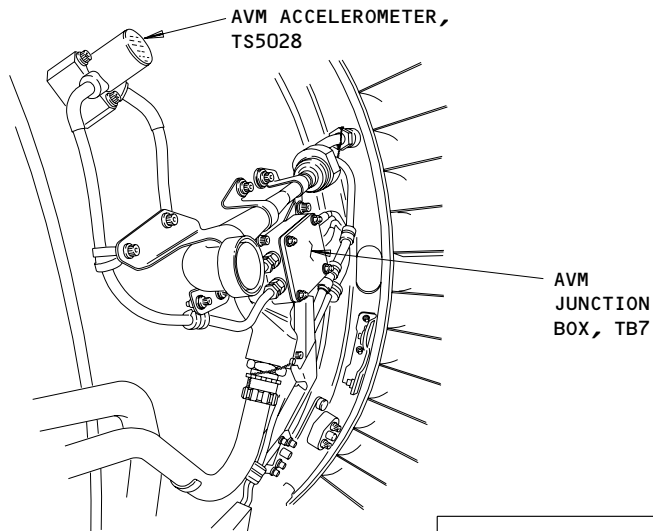

(A)

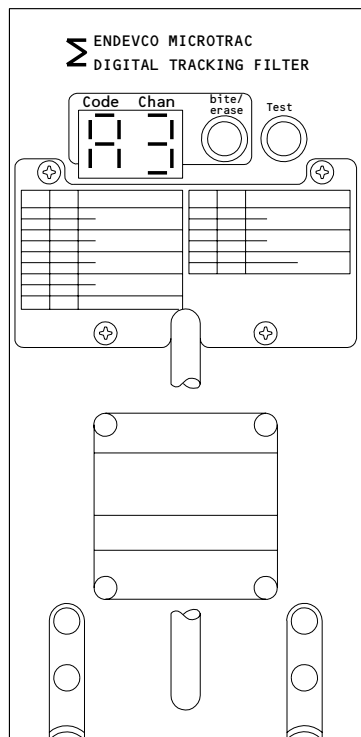

AIRBORNE VIBRATION MONITOR  
SIGNAL CONDITIONER, M132 OR M10571

(B) 1

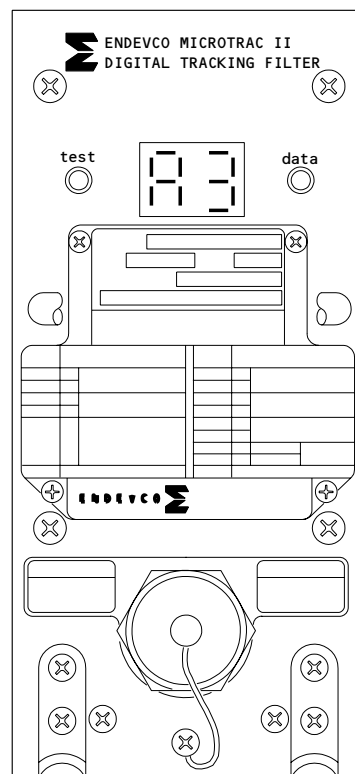

AIRBORNE VIBRATION MONITOR  
SIGNAL CONDITIONER, M132 OR M10571

(B) 2

1 AIRPLANES WITH -18 OR -20 AVM SIGNAL CONDITIONER

2 AIRPLANES WITH -451 AVM SIGNAL CONDITIONER

Airborne Vibration Monitoring System (AVM) - Component Location  
(Details from Sht 1)  
Figure 102 (Sheet 2)

EFFECTIVITY

ALL

77-31-00

R02B

Page 103  
May 28/01

814213



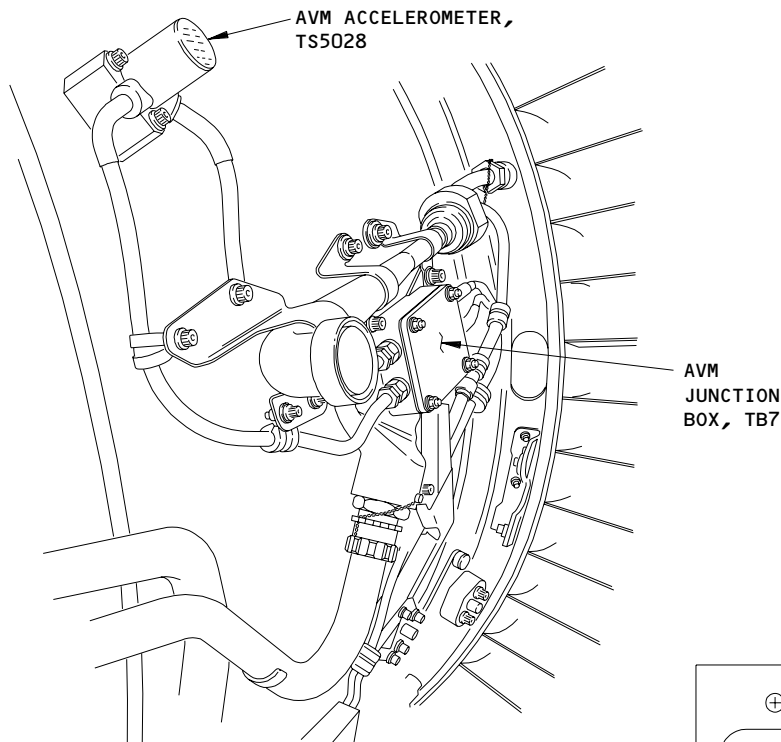

A

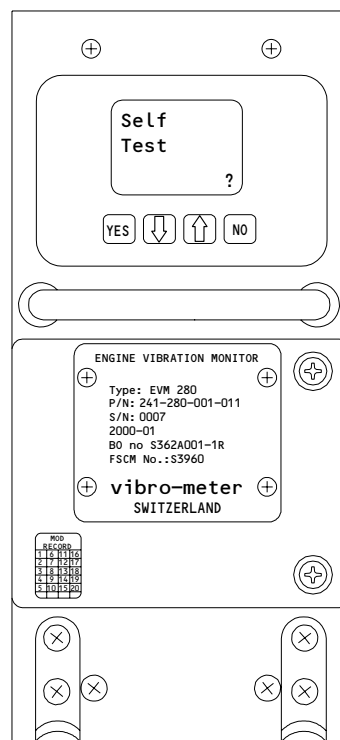

LEFT (RIGHT) AVM SIGNAL CONDITIONER, M132 (M10571)

B

Airborne Vibration Monitoring (AVM) System - Component Location  
(Details from Sht 1)  
Figure 102 (Sheet 3)

EFFECTIVITY  
AIRPLANES WITH S362A001 UNIVERSAL AVM  
SIGNAL CONDITIONER

77-31-00

R01B

Page 104  
May 28/02

**PREREQUISITES**

MAKE SURE THIS SYSTEM WILL OPERATE:  
EICAS (AMM 31-41-00/201)

MAKE SURE THESE CIRCUIT BREAKERS ARE CLOSED:  
11K2, 11K28

MAKE SURE THE AIRPLANE IS IN THIS CONFIGURATION:  
ELECTRICAL POWER IS ON (AMM 24-22-00/201)

**AVM BITE PROCEDURE**

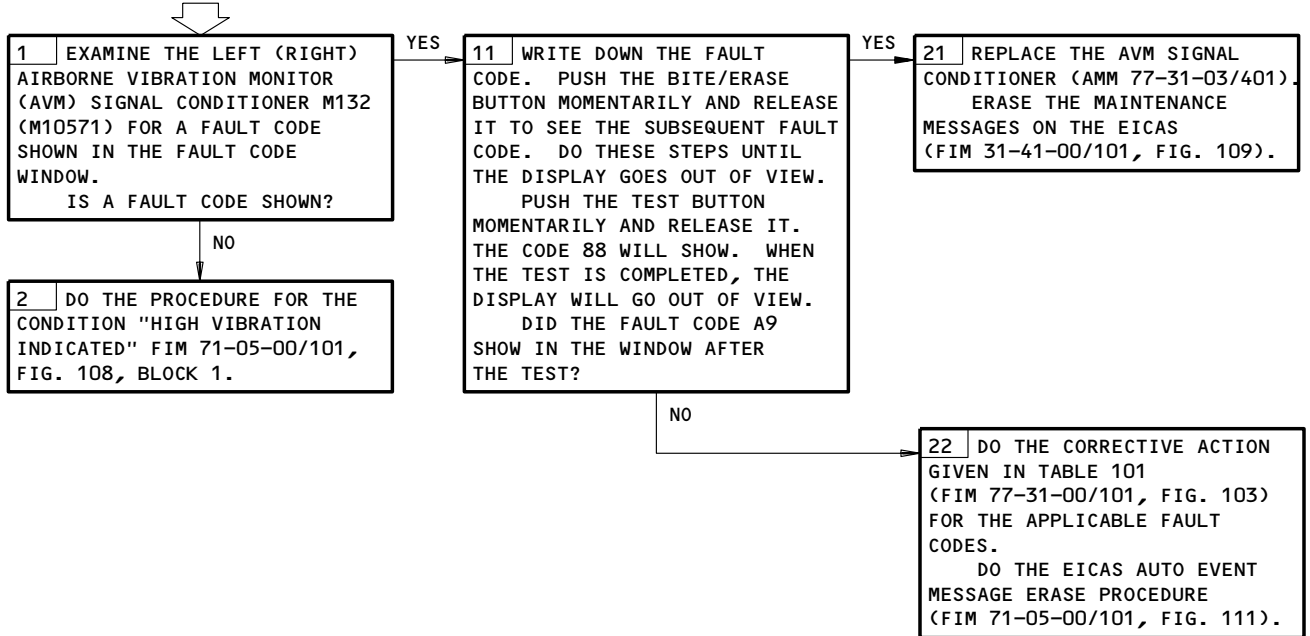

AVM BITE Procedure  
Figure 103 (Sheet 1)

EFFECTIVITY  
AIRPLANES WITH -18 OR -20  
AVM SIGNAL CONDITIONER

**77-31-00**

R02B

Page 105  
May 28/02

**PREREQUISITES**

MAKE SURE THIS SYSTEM WILL OPERATE:  
EICAS (AMM 31-41-00/201)

MAKE SURE THESE CIRCUIT BREAKERS ARE CLOSED:  
11K2, 11K28

MAKE SURE THE AIRPLANE IS IN THIS CONFIGURATION:  
ELECTRICAL POWER IS ON (AMM 24-22-00/201)

**AVM BITE PROCEDURE**

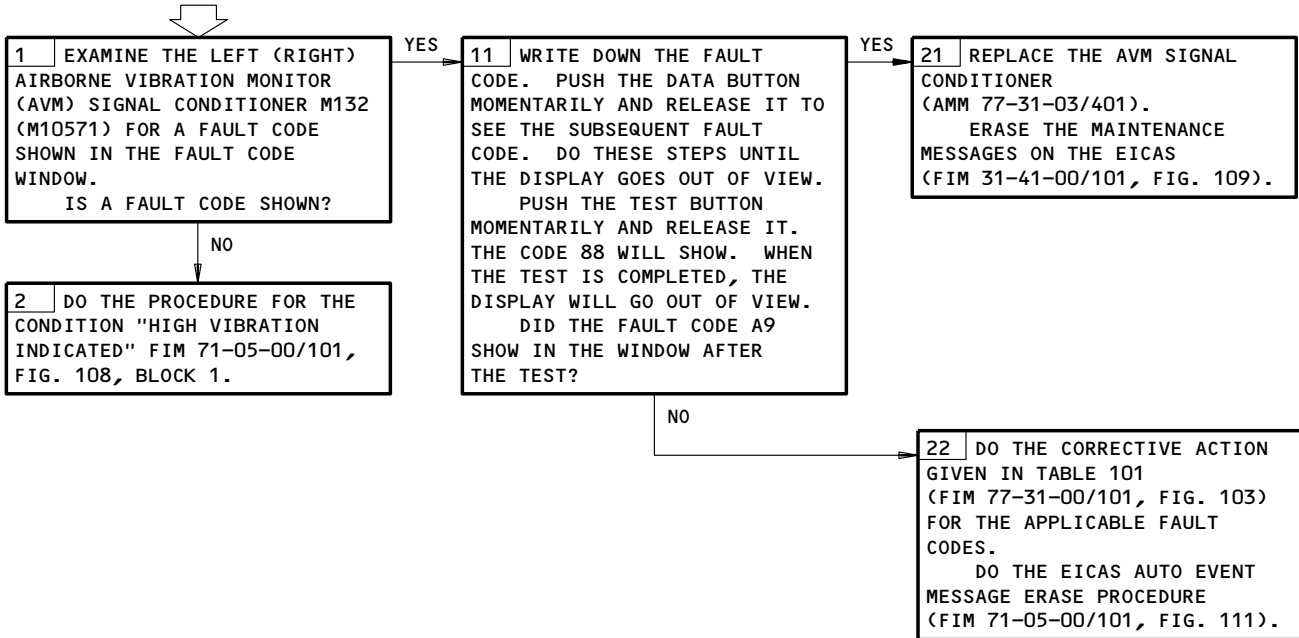

AVM BITE Procedure  
Figure 103 (Sheet 2)

EFFECTIVITY  
AIRPLANES WITH  
-451 AVM SIGNAL CONDITIONER

**77-31-00**

R02B

Page 106  
May 28/02

MESSAGE			CORRECTIVE ACTION
CODE	CHAN	FAULT	
A	9	SIG COND INOPERABLE FAULT	REPLACE L (R) AVM SIGNAL CONDITIONER M132 (M10571) (AMM 77-31-03/401).
A	8	R ENG SIG LOSS ACCEL B/CABLE	<ol style="list-style-type: none"> <li>1. REMOVE THE ACCELEROMETER LEADS FROM THE TERMINAL POSTS 1,2,3 AND 4 IN THE AVM JUNCTION BOX TB7.</li> <li>2. INSTALL A 1000-PICOFARAD CAPACITOR ACROSS THE TERMINAL POSTS 1 AND 2 AND THE TERMINAL POSTS 3 AND 4.</li> <li>3. <b>WARNING:</b> USE AMM 71-00-00/201 TO OPERATE THE POWER PLANT. IF YOU DO NOT USE THIS PROCEDURE, YOU CAN CAUSE DAMAGE TO EQUIPMENT OR INJURY TO PERSONS.</li> <li>USE THE POWER PLANT OPERATION (NORMAL) PROCEDURE TO START THE ENGINE (AMM 71-00-00/201).</li> <li>4. PUSH THE PERF/APU BUTTON ON THE EICAS MAINTENANCE PANEL, P61.</li> <li>5. SLOWLY MOVE THE THRUST LEVER FORWARD TO THE TAKEOFF POWER POSITION AND LET THE ENGINE BECOME STABLE FOR 15 SECONDS.</li> <li><b>NOTE:</b> WHEN N1 IS MORE THAN 65%, CHANNEL "A" AND CHANNEL "B" SIGNAL LOSS WILL SHOW IN THE FAULT CODE WINDOW ON THE L (R) AVM SIGNAL CONDITIONER AND THE MESSAGE L (R) ENG VIB WILL SHOW ON THE EICAS DISPLAY.</li> <li>6. SLOWLY MOVE THE THRUST LEVER REARWARD TO THE IDLE POSITION.</li> <li>7. MAKE SURE THE ENGINE VIBRATION INDICATIONS BB,N1,N2, AND N3 STAY AT 0.1 UNITS OR LESS DURING THE ACCELERATION AND DECELERATION. WRITE DOWN ALL INDICATIONS THAT ARE MORE THAN 0.0 UNITS.</li> <li><b>NOTE:</b> IF THE EICAS MODEL NUMBER IS S242N701-105,-106,-107,-108,-109, DO STEPS 8-12. IF NOT, GO TO STEP 13.</li> <li>8. DISCONNECT THE TACHOMETER INPUT TO THE AVM SIGNAL. DISCONNECT THE TACHOMETER INPUT OF THE ROTOR THAT SHOWS THE LOWEST VIBRATION IN STEP 7. IF ALL THE VIBRATION LEVELS ARE APPROXIMATELY EQUAL, DISCONNECT THE N2 TACHOMETER INPUT.</li> <li>9. SLOWLY MOVE THE THRUST LEVER FORWARD TO THE TAKEOFF POWER POSITION AND LET THE ENGINE BECOME STABLE FOR 15 SECONDS.</li> <li><b>NOTE:</b> WHEN N1 IS MORE THAN 65%, CHANNEL "A" AND CHANNEL "B" SIGNAL LOSS WILL SHOW IN THE FAULT CODE WINDOW ON THE L (R) AVM SIGNAL CONDITIONER AND THE MESSAGE L (R) ENG VIB WILL SHOW ON THE EICAS DISPLAY.</li> <li>10. MAKE SURE THE ENGINE VIBRATION INDICATIONS (TRACKED AND BROAD-BAND) STAY AT 0.1 UNITS OR LESS DURING THE ACCELERATION AND DECELERATION. WRITE DOWN ALL INDICATIONS THAT ARE MORE THAN 0.0 UNITS.</li> </ol>
A	7	R ENG SIG LOSS ACCEL A/CABLE	
A	6	L ENG SIG LOSS ACCEL B/CABLE	
A	5	L ENG SIG LOSS ACCEL A/CABLE	
A	4	R ENG HI NOISE ACCEL B/CABLE	
A	3	R ENG HI NOISE ACCEL A/CABLE	
A	2	L ENG HI NOISE ACCEL B/CABLE	
A	1	L ENG HI NOISE ACCEL A/CABLE	
B	8	R ENG-ACCEL A ≠ B	
B	7	L ENG-ACCEL A ≠ B	

(CONTINUE)

AVM BITE Procedure  
Figure 103 (Sheet 3)

EFFECTIVITY

ALL

**77-31-00**

R02B

Page 107  
Jan 28/03

811617

MESSAGE			CORRECTIVE ACTION																		
CODE	CHAN	FAULT																			
(CONT)	(CONT)		<p>11. SLOWLY MOVE THE THRUST LEVER REARWARD TO THE IDLE POSITION.</p> <p>12. CONNECT THE TACHOMETER INPUT TO THE AVM SIGNAL CONDITIONER.</p> <p>13. USE THE POWER PLANT OPERATION (NORMAL) PROCEDURE TO DO THE ENGINE SHUTDOWN (AMM 71-00-00/201).</p> <p>14. REMOVE THE CAPACITOR FROM THE TERMINAL POSTS 1 AND 2, AND THE TERMINAL POSTS 3 AND 4.</p> <p>15. IF VIBRATION INDICATION IS MORE THAN 0.1 UNITS, EXAMINE AND REPAIR THE CIRCUIT BETWEEN THE AVM JUNCTION BOX AND L (R) AVM SIGNAL CONDITIONER M132 (M10571)(WDM 71-51-11 OR WDM 71-51-21 OR WDM 71-51-22 AND WDM 77-31-11):  1</p> <table style="margin-left: auto; margin-right: auto; border: none;"> <tr> <td style="text-align: center;">AVM JUNCTION BOX TB7</td> <td style="text-align: center;">TO</td> <td style="text-align: center;">AVM SIGNAL CONDITIONER</td> </tr> <tr> <td style="text-align: center;">TERMINAL POSTS</td> <td></td> <td style="text-align: center;">CONNECTOR D4240B (D5602B)</td> </tr> <tr> <td style="text-align: center;">1</td> <td></td> <td style="text-align: center;">A1</td> </tr> <tr> <td style="text-align: center;">2</td> <td></td> <td style="text-align: center;">B1</td> </tr> <tr> <td style="text-align: center;">3</td> <td></td> <td style="text-align: center;">A4</td> </tr> <tr> <td style="text-align: center;">4</td> <td></td> <td style="text-align: center;">B4</td> </tr> </table> <p>MAKE SURE THE L (R) AVM SIGNAL CONDITIONER M132 (M10571) IS INSTALLED CORRECTLY (AMM 77-31-03/401).</p> <p>16. IF THE VIBRATION INDICATION STAYS AT 0.1 UNITS OR LESS, CONNECT THE ACCELEROMETER LEADS TO THE TERMINAL POSTS 1,2,3, AND 4 IN THE AVM JUNCTION BOX TB7 AND REPLACE THE AVM ACCELEROMETER TS5028 (AMM 77-31-01).</p> <p>17. IF THE FAULT CONTINUES, EXAMINE THE GEARBOX FOR LOOSE COMPONENTS AND BORESCOPE THE ENGINE (AMM 72-00-00/601).</p>	AVM JUNCTION BOX TB7	TO	AVM SIGNAL CONDITIONER	TERMINAL POSTS		CONNECTOR D4240B (D5602B)	1		A1	2		B1	3		A4	4		B4
AVM JUNCTION BOX TB7	TO	AVM SIGNAL CONDITIONER																			
TERMINAL POSTS		CONNECTOR D4240B (D5602B)																			
1		A1																			
2		B1																			
3		A4																			
4		B4																			

1 INCLUDE THE SHIELD, GROUND, AND CONNECTORS. CLEAN THE CONNECTORS (WDM 20-60-01) BEFORE YOU CONNECT THEM.

AVM BITE Procedure  
Figure 103 (Sheet 4)

EFFECTIVITY

ALL

77-31-00

TABLE 101			
MESSAGE			CORRECTIVE ACTION
CODE	CHAN	FAULT	
B	6	R ENG N3 TACH	EXAMINE THE CIRCUIT FROM PIN Z9 AND Z10 ON TB207 AND R AVM SIGNAL CONDITIONER M10571 CONNECTOR D5602B PINS A12 AND C12 (WDM 77-12-31). REPAIR THE PROBLEMS THAT YOU FIND. IF THE PROBLEMS CONTINUES, DO THIS PROCEDURE: FIM 77-12-00/101, FIG. 105, BLOCK 1 ACTION.
B	5	R ENG N2 TACH	EXAMINE THE CIRCUIT FROM PIN YA8 AND YA7 ON TB207 AND R AVM SIGNAL CONDITIONER M10571 CONNECTOR D5602B PINS D10 AND C10 (WDM 77-12-21). REPAIR THE PROBLEMS THAT YOU FIND. IF THE PROBLEMS CONTINUES, DO THIS PROCEDURE: FIM 77-12-00/101, FIG. 104A, BLOCK 1 ACTION.
B	4	R ENG N1 TACH	EXAMINE THE CIRCUIT FROM PIN Z106 AND Z107 ON TB207 AND R AVM SIGNAL CONDITIONER M10571 CONNECTOR D5602B PINS A8 AND B8 (WDM 77-12-11). REPAIR THE PROBLEMS THAT YOU FIND. IF THE PROBLEMS CONTINUES, DO THIS PROCEDURE: FIM 77-12-00/101, FIG. 104, BLOCK 1 ACTION.
B	3	L ENG N3 TACH	EXAMINE THE CIRCUIT FROM PIN Z15 AND Z16 ON TB207 AND L AVM SIGNAL CONDITIONER M132 CONNECTOR D4240A PINS C12 AND A12 (WDM 77-12-11). REPAIR THE PROBLEMS THAT YOU FIND. IF THE PROBLEMS CONTINUES, DO THIS PROCEDURE: FIM 77-12-00/101, FIG. 105, BLOCK 1 ACTION.
B	2	L ENG N2 TACH	EXAMINE THE CIRCUIT FROM PIN YC8 AND YC7 ON TB207 AND L AVM SIGNAL CONDITIONER M132 CONNECTOR D4240A PINS D10 AND C10 (WDM 77-12-21). REPAIR THE PROBLEMS THAT YOU FIND. IF THE PROBLEMS CONTINUES, DO THIS PROCEDURE: FIM 77-12-00/101, FIG. 104A, BLOCK 1 ACTION.
B	1	L ENG N1 TACH	EXAMINE THE CIRCUIT FROM PIN Z111 AND Z112 ON TB207 AND L AVM SIGNAL CONDITIONER M132 CONNECTOR D4240A PINS A8 AND B8 (WDM 77-12-11). REPAIR THE PROBLEMS THAT YOU FIND. IF THE PROBLEMS CONTINUES, DO THIS PROCEDURE: FIM 77-12-00/101, FIG. 104, BLOCK 1 ACTION.

AVM BITE Procedure  
Figure 103 (Sheet 5)

EFFECTIVITY \_\_\_\_\_  
ALL

77-31-00

R02B

Page 109  
May 28/02

811669

**PREREQUISITES**

MAKE SURE THIS SYSTEM WILL OPERATE:  
EICAS (AMM 31-41-00/201)

MAKE SURE THESE CIRCUIT BREAKERS ARE CLOSED:  
11K2, 11K28

MAKE SURE THE AIRPLANE IS IN THIS CONFIGURATION:  
ELECTRICAL POWER IS ON (AMM 24-22-00/201)

**AVM BITE PROCEDURE**

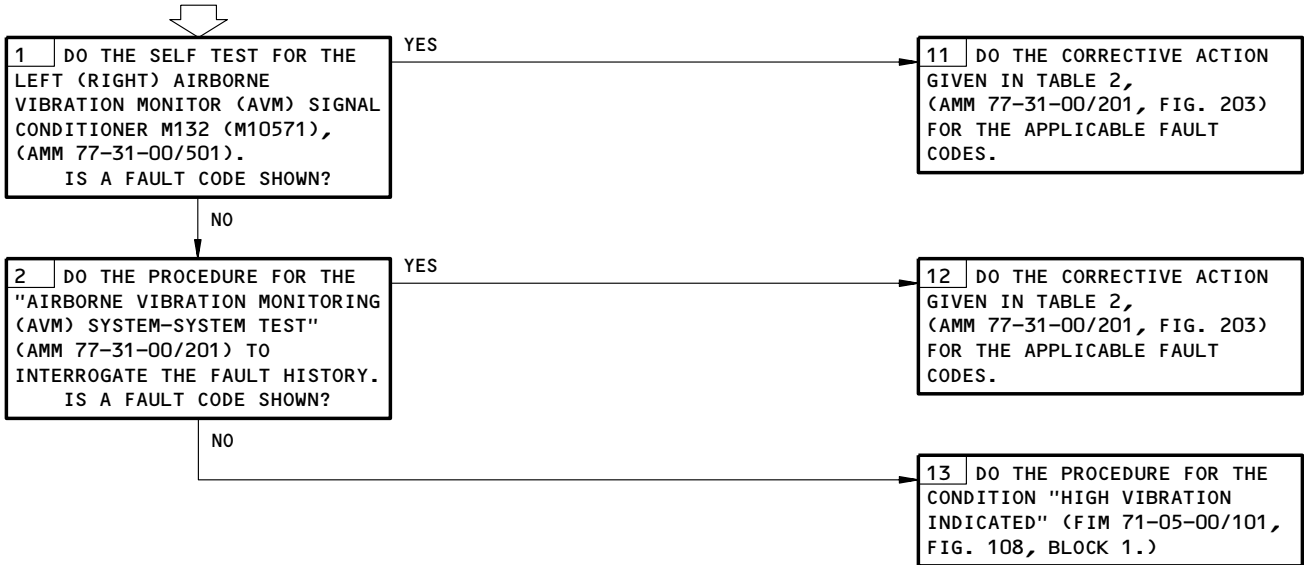

AVM BITE Procedure  
Figure 103A

EFFECTIVITY  
AIRPLANES WITH S362A001 UNIVERSAL AVM  
SIGNAL CONDITIONER

**77-31-00**

R02B

Page 110  
May 28/02

**EICAS MSG  
L (R) "ENG BB VIB"  
DISPLAYED**

**PREREQUISITES**

MAKE SURE THIS SYSTEM WILL OPERATE:  
EICAS (AMM 31-41-00)

MAKE SURE THESE CIRCUIT BREAKERS ARE CLOSED:  
11J2, 11J3, 11J31, 11J32, 11J29, 11J30

MAKE SURE THE AIRPLANE IS IN THIS CONFIGURATION:  
ELECTRICAL POWER (AMM 24-22-00)

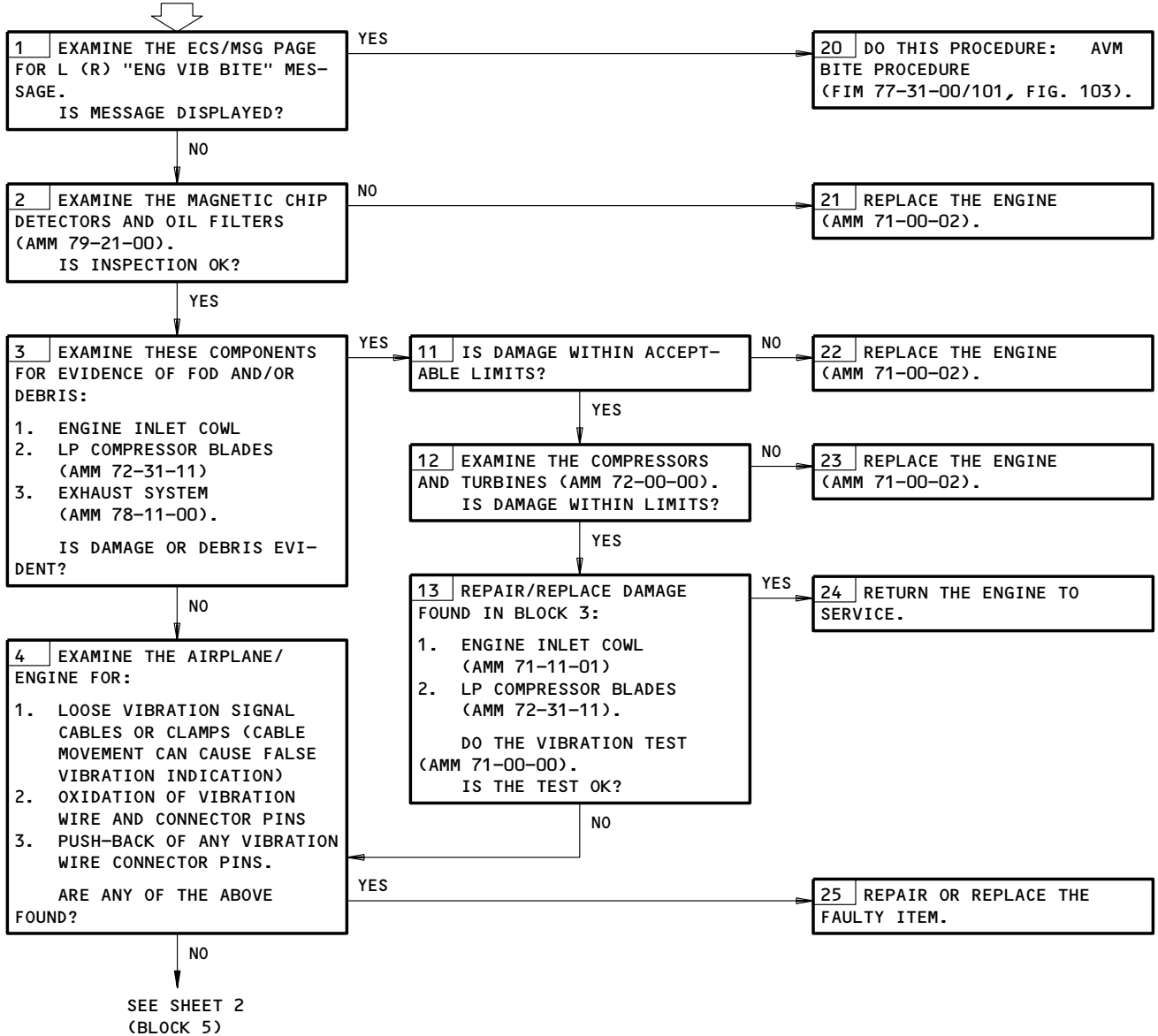

EICAS Msg L (R) ENG BB VIB Displayed  
Figure 104 (Sheet 1)

EFFECTIVITY

ALL

**77-31-00**

R02B

Page 111  
May 28/02

229241



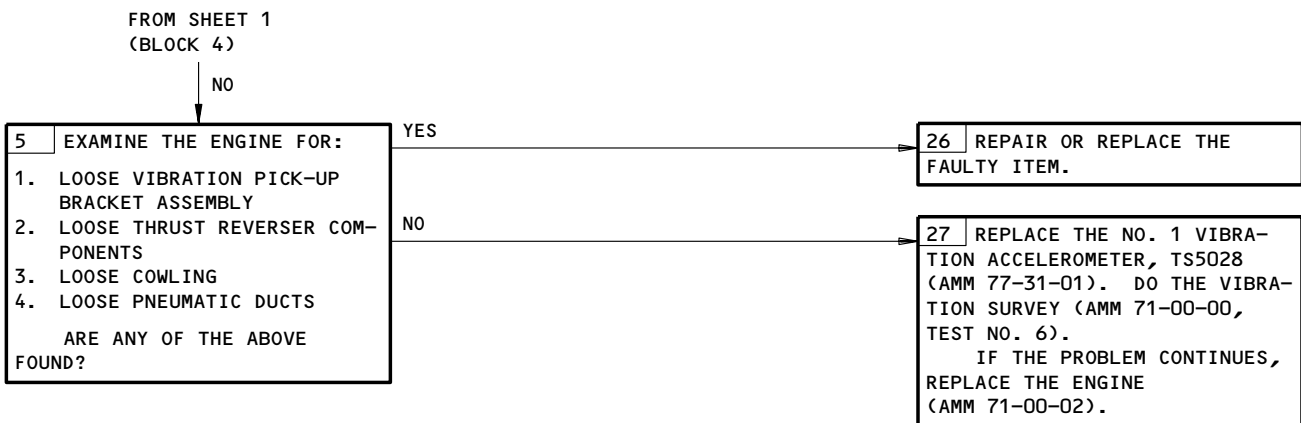

EICAS Msg L (R) ENG BB VIB Displayed  
Figure 104 (Sheet 2)

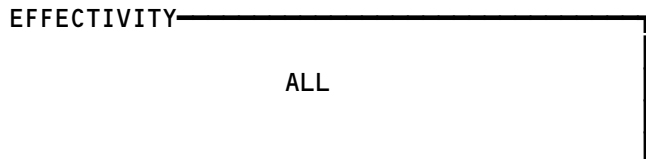

77-31-00

**EICAS STATUS MSG  
"L (R) ENG VIB"  
SHOWN**

**PREREQUISITES**

MAKE SURE THIS SYSTEM WILL OPERATE:  
EICAS (AMM 31-41-00/201)

MAKE SURE THESE CIRCUIT BREAKERS ARE CLOSED:  
11J2, 11J3, 11J29, 11J30, 11J31, 11J32

MAKE SURE THE AIRPLANE IS IN THIS CONFIGURATION:  
ELECTRICAL POWER IS ON (AMM 24-22-00/201)

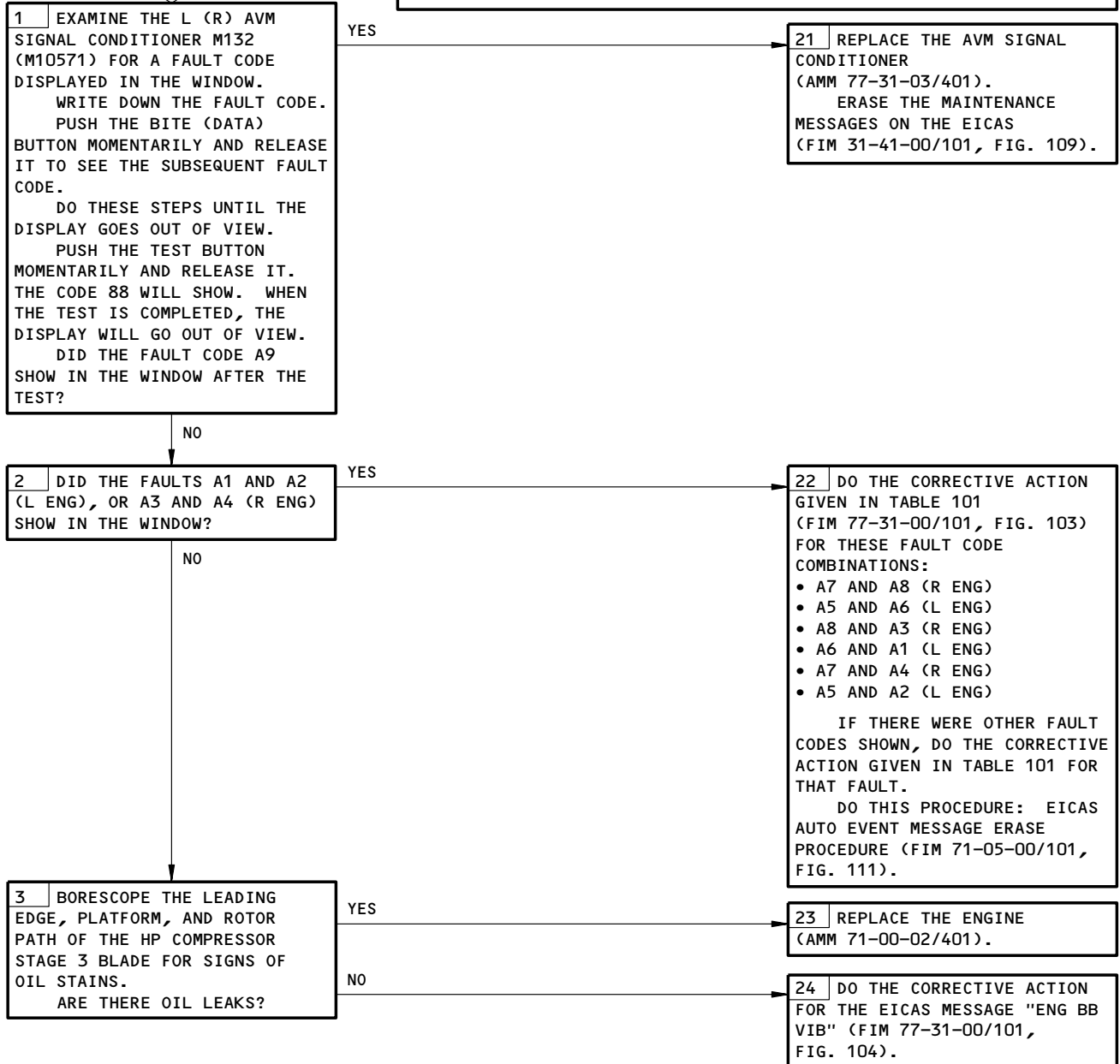

EICAS Status Msg L (R) ENG VIB Shown  
Figure 105

EFFECTIVITY  
AIRPLANES WITHOUT S362A001 UNIVERSAL AVM  
SIGNAL CONDITIONER

**77-31-00**

R02B

Page 113  
Jan 28/06

**PREREQUISITES**

MAKE SURE THIS SYSTEM WILL OPERATE:  
EICAS (AMM 31-41-00/201)

MAKE SURE THESE CIRCUIT BREAKERS ARE CLOSED:  
11J2, 11J3, 11J29, 11J30, 11J31, 11J32

MAKE SURE THE AIRPLANE IS IN THIS CONFIGURATION:  
ELECTRICAL POWER IS ON (AMM 24-22-00/201)

EICAS STATUS MSG  
"L (R) ENG VIB"  
SHOWN

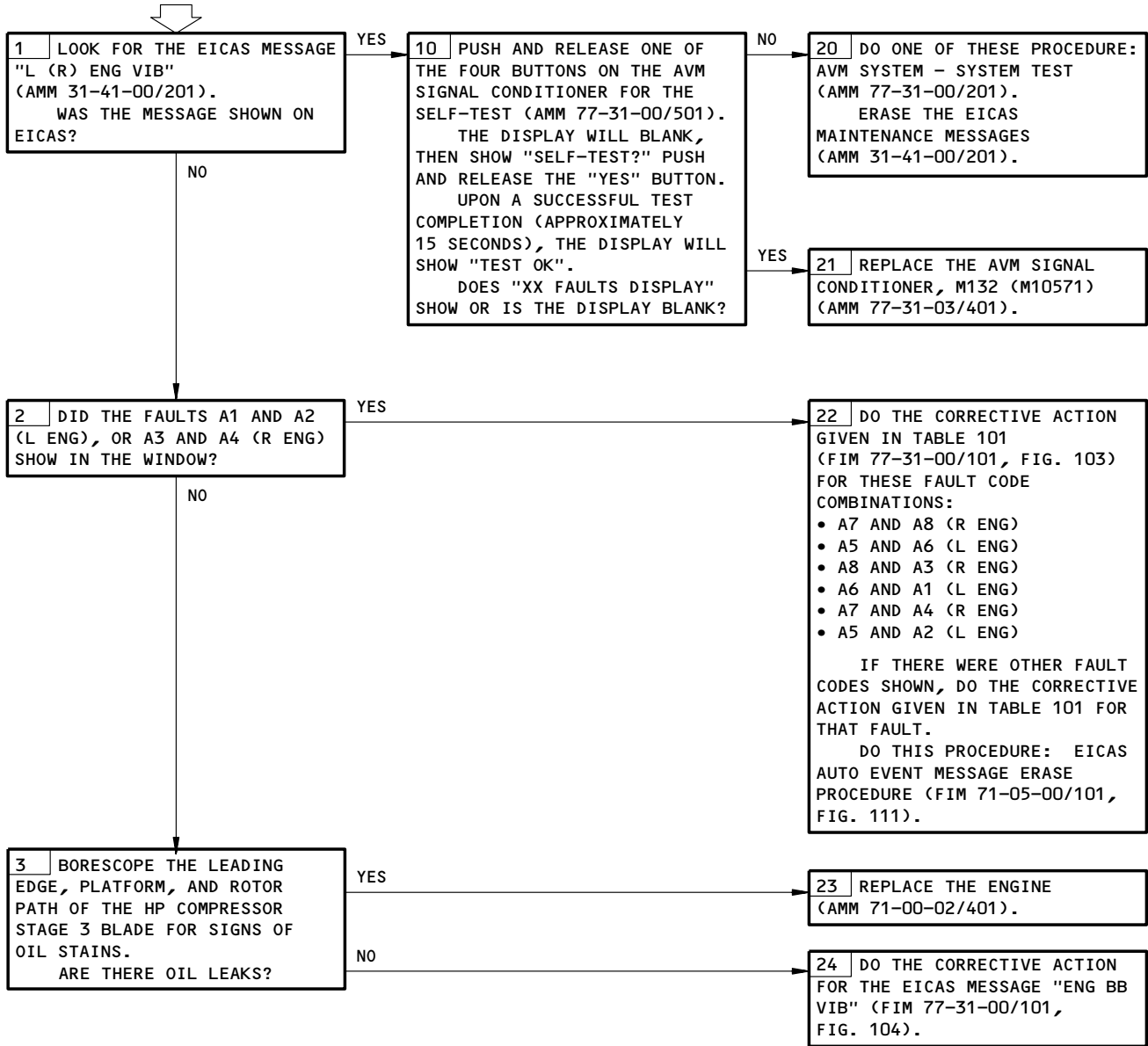

EICAS Status Msg L (R) ENG VIB Shown  
Figure 105A

EFFECTIVITY  
AIRPLANES WITH S362A001 UNIVERSAL AVM  
SIGNAL CONDITIONER

77-31-00

1. ARINC 429 Data Bus Charts

## A. General

- (1) ARINC 429 data bus charts provide information needed to analyze ARINC 429 transmitters, receivers, and data buses.

**CAUTION:** DO NOT PROBE CONNECTORS. USE A BREAKOUT BOX OR CONNECTORS MAY BE DAMAGED.

- (2) Testing is accomplished at available terminal blocks or at LRU connectors using a breakout box.

## B. Equipment

- (1) Standard multi-meter
- (2) Interface Technology model 429-2 Data Bus Analyzer  
(Alternate to ARINC 429 Data Bus Analyzer, JC Air Model 429EB)
- (3) ARINC 429 Data Bus Analyzer, JC Air Model 429EB  
(Alternate to Interface Technology model 429-2 Data Bus Analyzer)
- (4) Breakout box A34011-1 (Preferred)  
A34011-112 (Optional)

## C. Procedure

- (1) ARINC 429 Data Bus Charts

AVM							
DIGITAL OUTPUT BUS CHART							
BUS NAME							
SOURCE	TYPE	BUS	CON	PINS	BUS FORMAT	BIT RATE	DATA BUS
AVM ( L / R )	A	1	A	C06 D06	429	L0	AVM DATA

EFFECTIVITY

ALL

**77-31-00**

R02B

 Page 115  
 Jan 28/04

AVM ID=UNDEFINED								
OCTAL LABELS CHART								
SIGNAL	TYPE	LABEL	FORMAT	MIN UPDATE RATE	SDI 9/10	BINARY RANGE	POSITIVE SENSE	UNITS
ENGINE VIBRATION-L	A	353	BNR	5	10	5.00	ALWAYS POS	N/A
ENGINE VIBRATION-R	A	353	BNR	5	01	5.00	ALWAYS POS	N/A
N 1 VIB-L	A	354	BNR	5	10	5.00	ALWAYS POS	N/A
N 1 VIB-R	A	354	BNR	5	01	5.00	ALWAYS POS	N/A
N 2 VIB-L	A	355	BNR	5	10	5.00	ALWAYS POS	N/A
N 2 VIB-R	A	355	BNR	5	01	5.00	ALWAYS POS	N/A
N 3 VIB-L	A	356	BNR	5	10	5.00	ALWAYS POS	N/A
N 3 VIB-R	A	356	BNR	5	01	5.00	ALWAYS POS	N/A
STATUS WORD	A	270	DIS	5		N/A	N/A	N/A
BROADBAND VIB-L	A	357	BNR	5	10	5.00	A/P	N/A
BROADBAND VIB-R	A	357	BNR	5	01	5.00	A/P	N/A

EFFECTIVITY

ALL

**77-31-00**

R02B

Page 116  
Jan 28/04

AVM				
DISCRETE OCTAL LABELS/BIT CHART				
SIGNAL	OCTAL LABEL	BIT	ONE-STATE	ZERO-STATE
L ENG AVM FAULT	270	11	FAULT	OK
R ENG AVM FAULT	270	12	FAULT	OK
L ENG B/BAND ALERT	270	13	ALERT	NOT ALERT
R ENG B/BAND ALERT	270	14	ALERT	NOT ALERT
L ENG AVM DBL CHNL FAULT	270	15	FAULT	OK
R ENG AVM DBL CHNL FAULT	270	16	FAULT	OK
L ENG TRACK FILTER ALERT	270	17	ALERT	NOT ALERT
R ENG TRACK FILTER ALERT	270	18	ALERT	NOT ALERT
L ENG HIGH B/BAND ALERT	270	19	ALERT	NOT ALERT
R ENG HIGH B/BAND ALERT	270	20	ALERT	NOT ALERT

EFFECTIVITY \_\_\_\_\_

ALL

**77-31-00**

R01B

Page 117  
Jan 28/04



STANDBY ENGINE INDICATION SYSTEM

COMPONENT	FIG. 102 SHT	QTY	ACCESS/AREA	AMM REFERENCE
INDICATOR - STANDBY ENGINE, N10016	--	1	FLT COMPT, P1 PANEL	77-41-01

Standby Engine Indication System - Component Index  
Figure 101

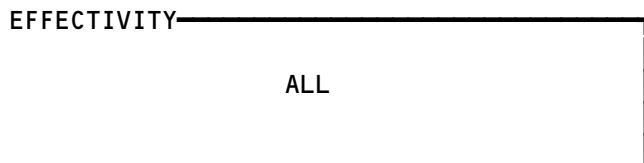

77-41-00

R01

Page 101  
Sep 20/94

289227

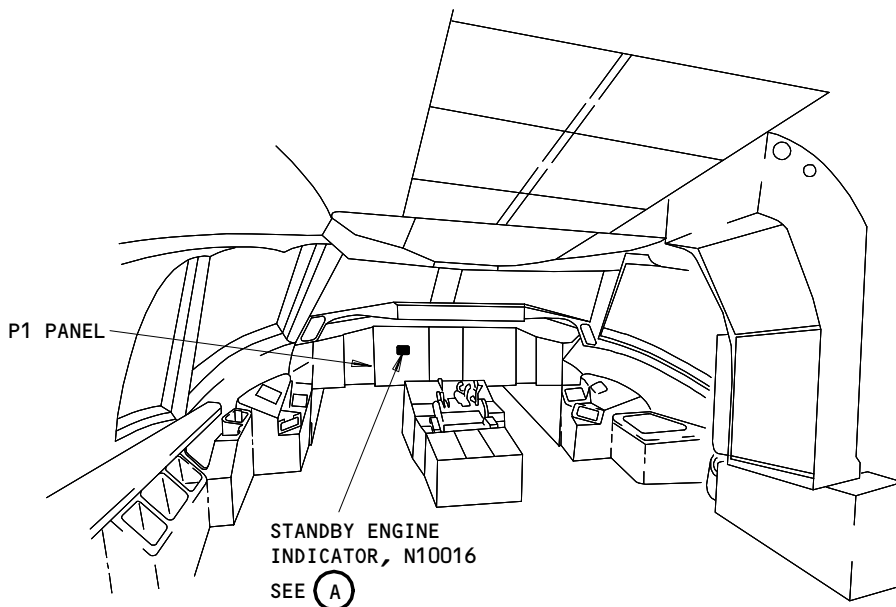

FLIGHT COMPARTMENT

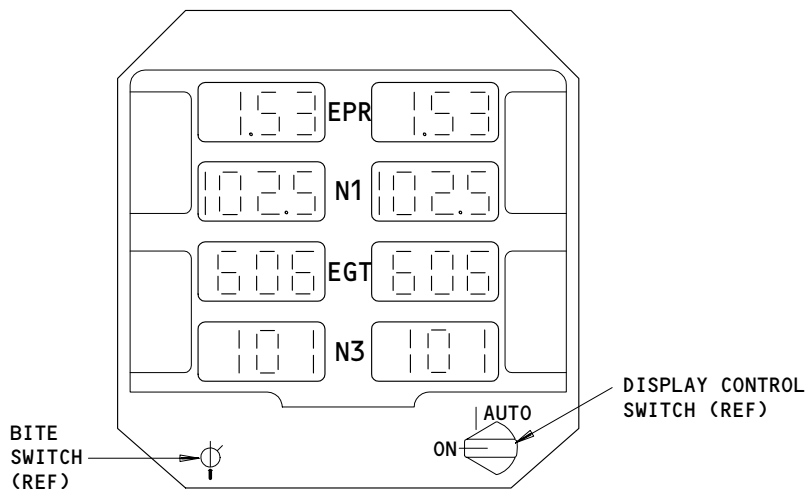

STANDBY ENGINE INDICATOR, N10016

(A)

Standby Engine Indication System - Component Location  
Figure 102

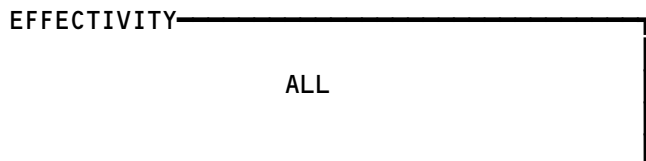

77-41-00

R07

Page 102  
Sep 20/94

289231



**STANDBY ENGINE  
INDICATOR BITE  
PROCEDURE**

**PREREQUISITES**  
ELECTRICAL POWER (MM 24-22-00)  
CB'S: 11D23

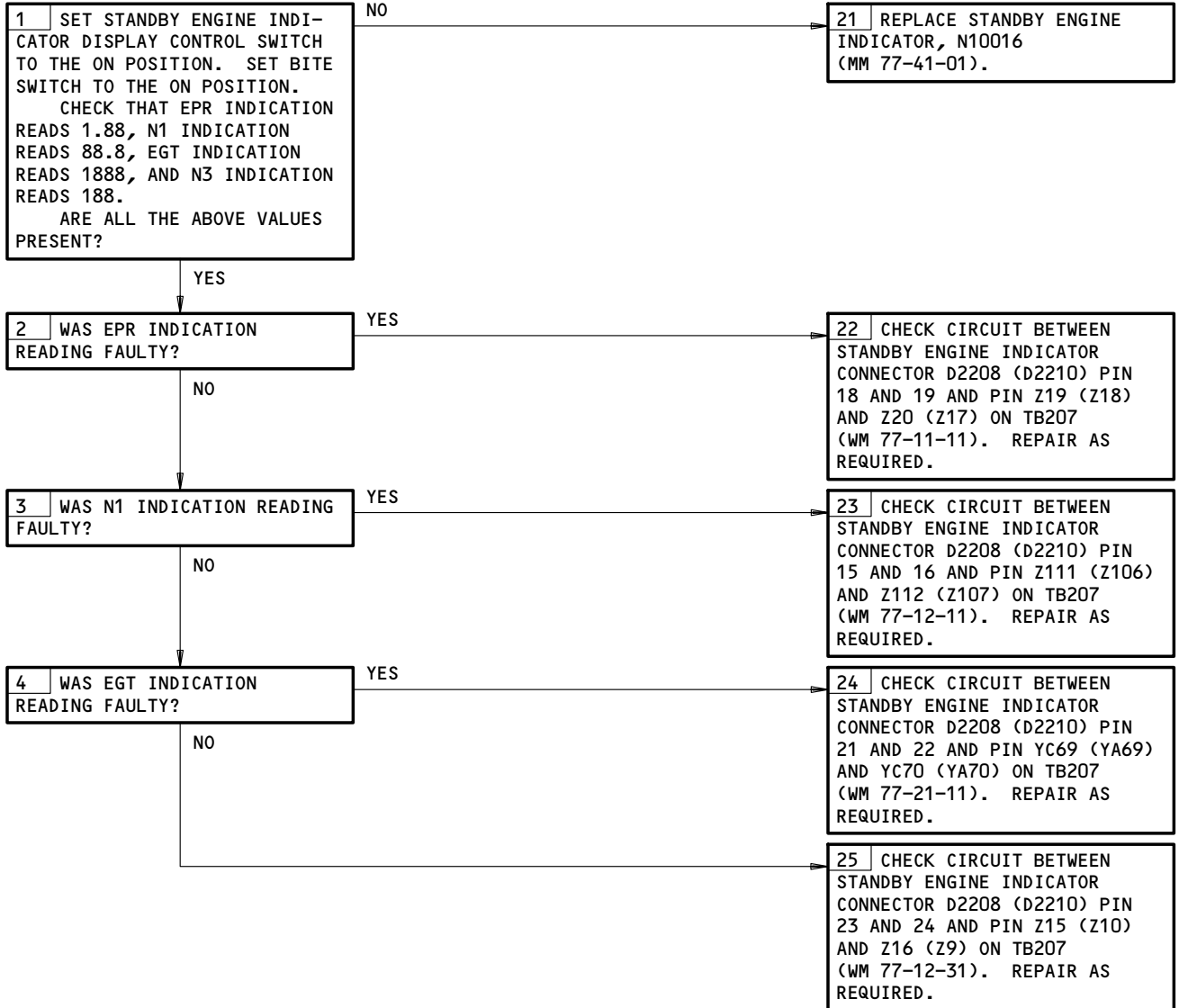

Standby Engine Indicator BITE Procedure  
Figure 103

EFFECTIVITY \_\_\_\_\_  
ALL

**77-41-00**

289236