

GPA Group plc

PAGE	DATE	CODE	PAGE	DATE	CODE	PAGE	DATE	CODE
CHAPTER 80 TAB								
STARTING								
EFFECTIVE PAGES SEE LAST PAGE OF LIST FOR NUMBER OF PAGES								
80-CONTENTS								
1	DEC 20/96	RGUI						
2	BLANK							
80-FAULT CODE INDEX								
1	SEP 20/08	R02						
2	SEP 20/08	R01						
80-11-00								
101	SEP 20/92	R02						
102	SEP 20/92	R02						
103	DEC 20/94	R01						
104	SEP 20/92	R01						
105	SEP 28/07	R03						
106	SEP 28/07	R02						
107	MAR 20/95	R01						
108	MAY 28/03	R02						

R = REVISED, A = ADDED OR D = DELETED
F = FOLDOUT PAGE
32
JAN 20/09

D633N632

CHAPTER 80
EFFECTIVE PAGES
R PAGE 1
LAST PAGE

CHAPTER 80 - STARTING

Table of Contents

<u>Subject</u>	Chapter Section <u>Subject</u>	<u>Page</u>	<u>Effectivity</u>
FAULT ISOLATION	80-FAULT CODE INDEX	1	ALL
<u>STARTING</u>	80-00-00		
<u>CRANKING</u>	80-10-00		
ENGINE STARTING SYSTEM	80-11-00		
Component Location		101	ALL
Component Index			
Component Location			
Fault Isolation			
Low Max Motoring (Fig. 104)		104	
No N3 Rotation (Fig. 103)		103	
Start Switch Failed to Hold in GND (Fig. 106)		106	
Start Switch Failed to Return to AUTO at 47% N3 (Fig. 108)		108	
Starter VALVE Light on After Start Switch Returned to AUTO (Fig. 107)		107	
Starter VALVE Light On (Fig. 105)		105	

80-CONTENTS

FAULT CODE	LOG BOOK REPORT	FAULT ISOLATION REFERENCE
80 11 XA --	(01=L,02=R) Starting problem was encountered by the flight crew which is not covered by the fault code diagrams.	SSM 80-00-00, SSM 80-11-01, SSM 80-11-02
80 11 XB --	(01=L,02=R) Starting problem was encountered by the flight crew which is not covered by the fault code diagrams.	SSM 80-00-00, SSM 80-11-01, SSM 80-11-02
80 11 XC --	(01=L,02=R) Starting problem was encountered by the flight crew which is not covered by the fault code diagrams.	SSM 80-00-00, SSM 80-11-01, SSM 80-11-02
80 11 01 --	(01=L,02=R) Engine N3 failed to rotate with start selector in GND, start VALVE light was off and duct pressure was normal.	FIM 80-11-00/101, Fig. 103, Block 1
80 11 02 --	(01=L,02=R) Engine max N3 motoring speed low during start, duct pressure was normal with start valve open.	FIM 80-11-00/101, Fig. 104, Block 1
80 11 03 --	(01=L,02=R) Engine start VALVE light (failed to, remained) on and EICAS msg: (L,R) ENG STARTER (did not, did) displ with start selector in GND, eng failed to rotate.	FIM 80-11-00/101, Fig. 105, Block 1
80 11 04 --	(01=L,02=R) Engine start selector sw failed to hold in GND during start, eng rotated normal when held in GND.	FIM 80-11-00/101, Fig. 106, Block 1
80 11 05 --	(01=L,02=R) Engine start selector sw failed to hold in GND during start, eng failed to rotate when held in GND.	FIM 80-11-00/101, Fig. 106, Block 1
80 11 08 --	(01=L,02=R) Engine start VALVE light remained on and EICAS msg (L/R) STARTER CUTOUT displayed during start when start selector returned to AUTO.	FIM 80-11-00/101, Fig. 107, Block 1

EFFECTIVITY

ALL

80-FAULT CODE INDEX

R02

 Page 1
 Sep 20/08

FAULT CODE	LOG BOOK REPORT	FAULT ISOLATION REFERENCE
80 11 11 --	(01=L,02=R) Engine start selector returned to AUTO before 47% N3, _____% during start.	FIM 80-11-00/101, Fig. 106, Block 1
80 11 12 --	(01=L,02=R) Engine start selector failed to return to AUTO at 47% N3 during start. Manually selected to AUTO.	FIM 80-11-00/101, Fig. 108, Block 1
80 11 13 --	(01=L,02=R) Engine had impending hot start. Starter cutout early at _____% N3.	FIM 80-11-00/101, Fig. 106, Block 1
80 11 15 --	(01=L,02=R) Engine start VALVE light (failed to, remained) on and EICAS msg (L,R) ENG STARTER (did not, did) display with start selector in GND. Engine rotation was normal.	FIM 80-11-00/101, Fig. 105, Block 22

EFFECTIVITY

ALL

80-FAULT CODE INDEX

R01

Page 2
Sep 20/08

ENGINE STARTING SYSTEM

COMPONENT	FIG. 102 SHT	QTY	ACCESS/AREA	REFERENCE
ADAPTER - STARTER QAD	--	2	413AL,414AR, LEFT ENGINE FAN COWL, 423AL,424AR, RIGHT ENGINE FAN COWL	80-11-07
FILTER - STARTER CONTROL VALVE	--	2	413AL,414AR, LEFT ENGINE FAN COWL, 423AL,424AR, RIGHT ENGINE FAN COWL	80-11-08
PANEL - ENG START/RAT CONT, M10468 RELAYS - (31-01-36/101) LEFT ENGINE CONTROLS POWER, K10208 LEFT ENGINE START DISAGREE, K10209 LEFT ENGINE START 2, K10247 LEFT ENGINE START 3, K10248 LEFT ENGINE START TO STOP, K10212 RELAYS - (31-01-37/101) RIGHT ENGINE CONTROLS POWER, K10220 RIGHT ENGINE START DISAGREE, K10221 RIGHT ENGINE START 2, K10250 RIGHT ENGINE START 3, K10251 RIGHT ENGINE START TO STOP, K10224		1	FLIGHT COMPARTMENT, P5	*
STARTER - PNEUMATIC	--	2	413AL,414AR, LEFT ENGINE FAN COWL, 423AL,424AR, RIGHT ENGINE FAN COWL	80-11-01
SWITCH - LEFT ENGINE START, S3	--	1	FLIGHT COMPARTMENT, P5, ENGINE START/RAT CONTROL PANEL, M10468	*
SWITCH - RIGHT ENGINE START, S4	--	1	FLIGHT COMPARTMENT, P5, ENGINE START/RAT CONTROL PANEL, M10468	*
VALVE - STARTER CONTROL, V10008	--	2	413AL,414AR, LEFT ENGINE FAN COWL, 423AL,424AR, RIGHT ENGINE FAN COWL	80-11-08

* SEE THE WDM EQUIPMENT LIST

Engine Starting System - Component Index
Figure 101

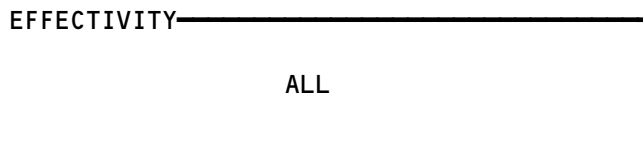

80-11-00

R02

Page 101
Sep 20/92

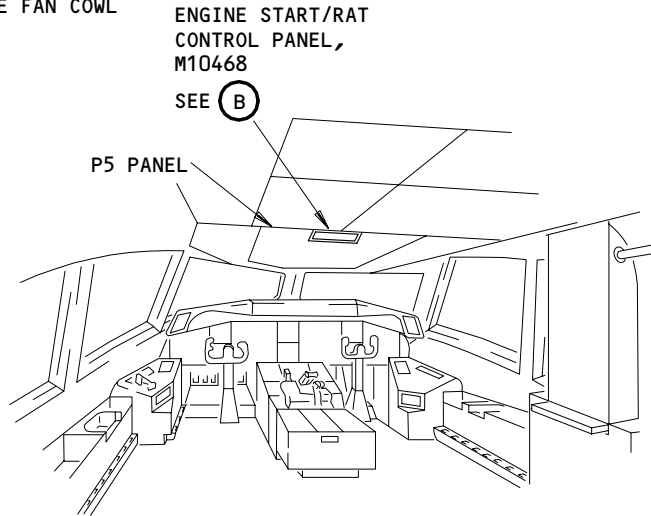
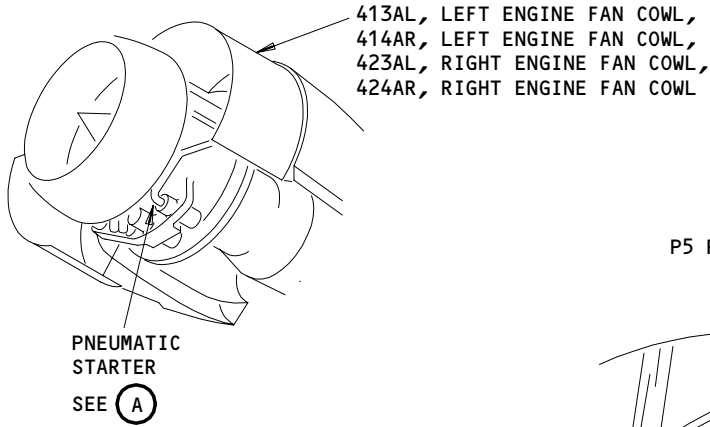

FLIGHT COMPARTMENT

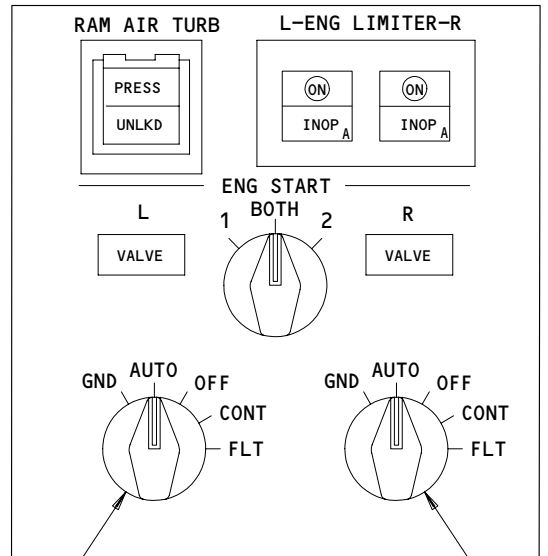
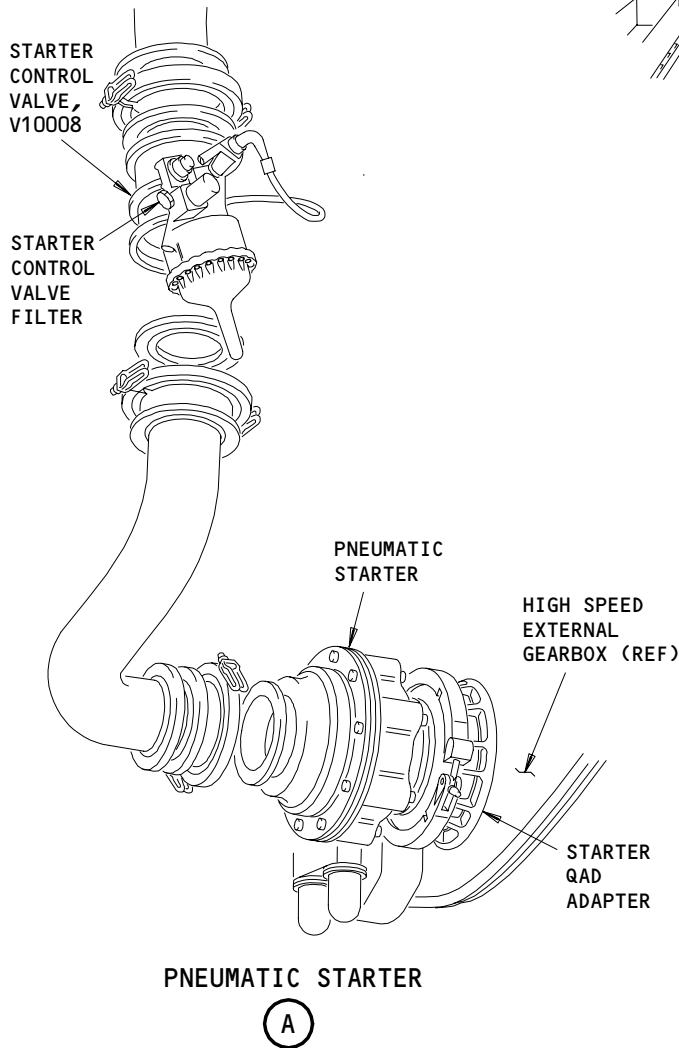

LEFT ENGINE START SWITCH, S3

RIGHT ENGINE START SWITCH, S4

ENGINE START/RAT CONTROL PANEL, M10468

(B)

Engine Starting System - Component Location
Figure 102

EFFECTIVITY	ALL
-------------	-----

80-11-00

PREREQUISITES

NONE

NO N3 ROTATION

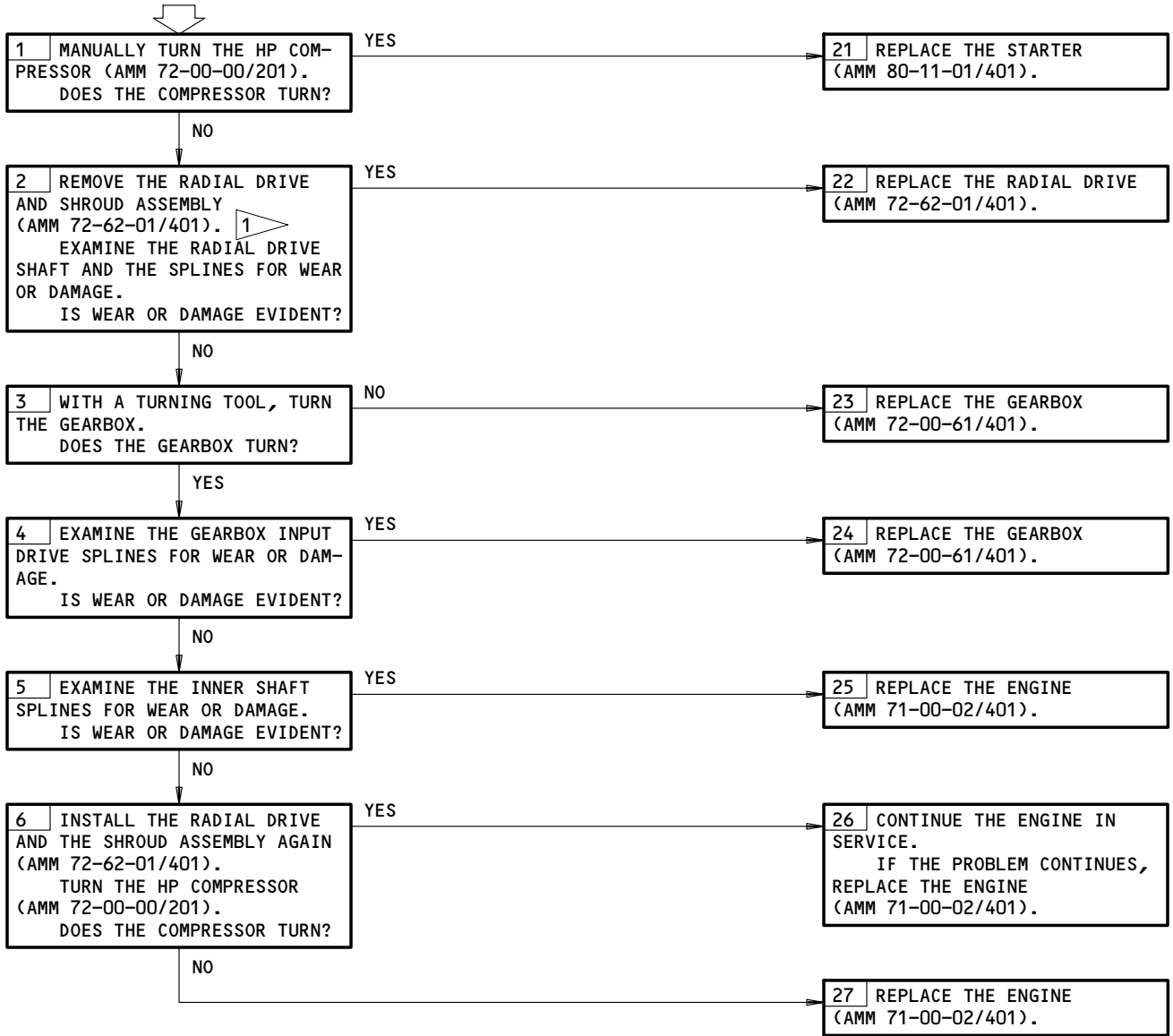

1 IF A STARTER ASSISTED RELIGHT OR A GROUND START OF THE ENGINE RESULTS IN A FAILED RADIAL DRIVE, THERE CAN BE OIL LEAKS INTO THE HP DRUM. REPLACE THE ENGINE.

No N3 Rotation
Figure 103

EFFECTIVITY

ALL

80-11-00

R01

Page 103
Dec 20/94

LOW MAX MOTORING

PREREQUISITES
NONE

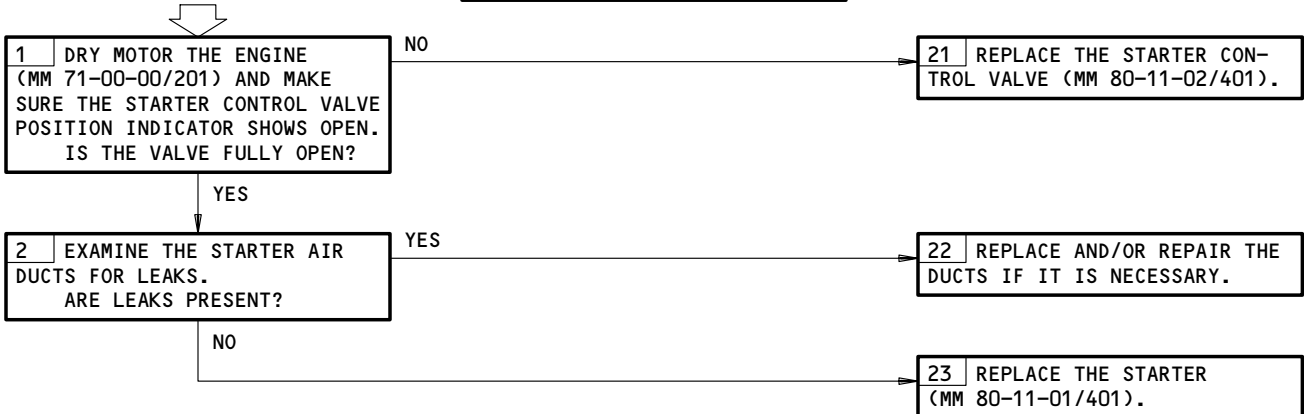

Low Max Motoring
Figure 104

EFFECTIVITY ————
ALL

80-11-00

A76343

PREREQUISITES

MAKE SURE THESE CIRCUIT BREAKERS ARE CLOSED:
11D19 (11D20)

MAKE SURE THE AIRPLANE IS IN THIS CONFIGURATION:
ELECTRICAL POWER IS ON (AMM 24-22-00/201)

**STARTER "VALVE"
LIGHT ON**

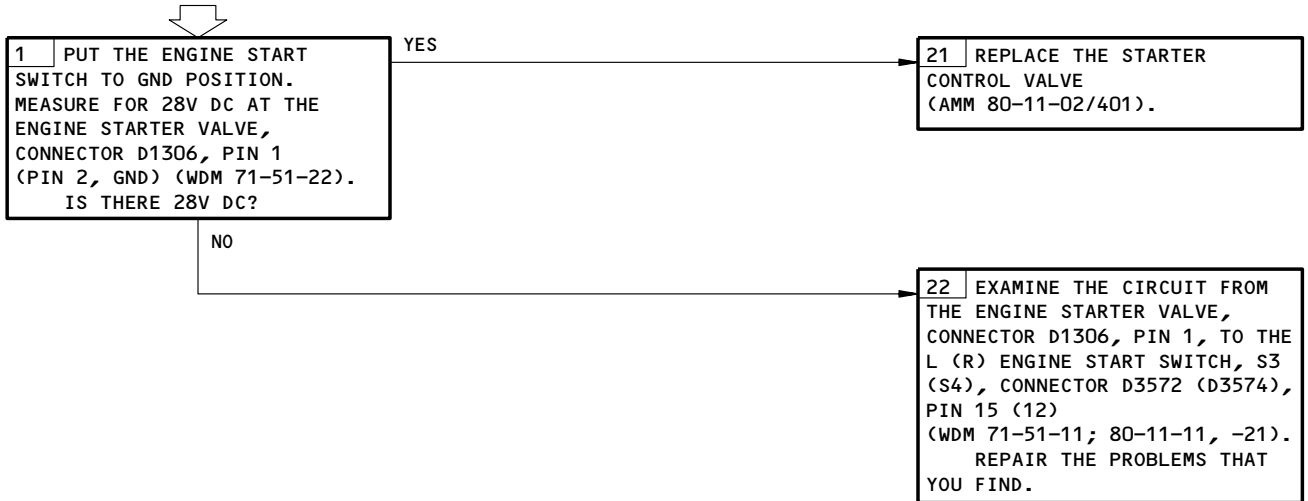

Starter VALVE Light On
Figure 105

EFFECTIVITY	ALL
-------------	-----

80-11-00

R03

Page 105
Sep 28/07

70741

PREREQUISITES
MAKE SURE THESE CIRCUIT BREAKERS ARE CLOSED:
11D19 (11D20)
MAKE SURE THE AIRPLANE IS IN THIS CONFIGURATION:
ELECTRICAL POWER IS ON (AMM 24-22-00/201)

START SWITCH FAILED TO HOLD IN "GND"

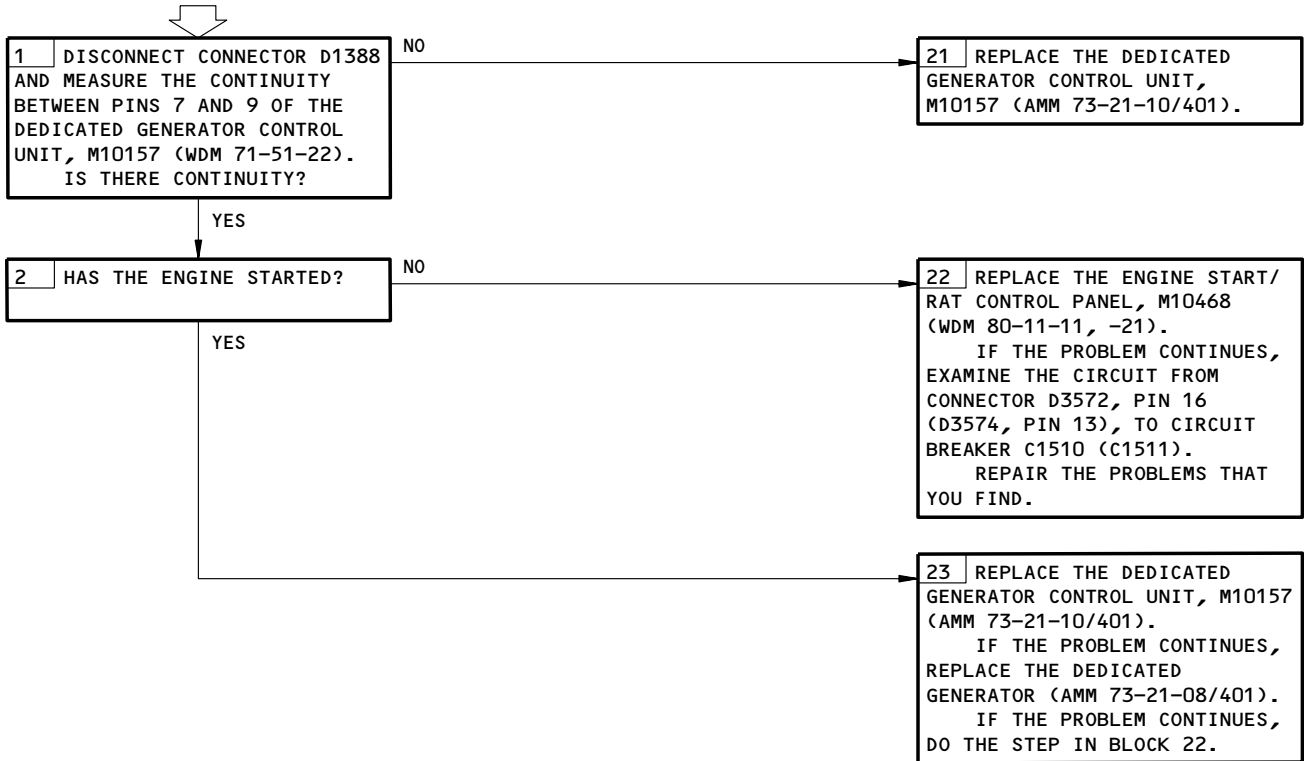

Start Switch Failed to Hold in GND
Figure 106

EFFECTIVITY
ALL

80-11-00

STARTER "VALVE"
LIGHT ON AFTER
START SWITCH
RETURNED TO "AUTO"

PREREQUISITES
NONE

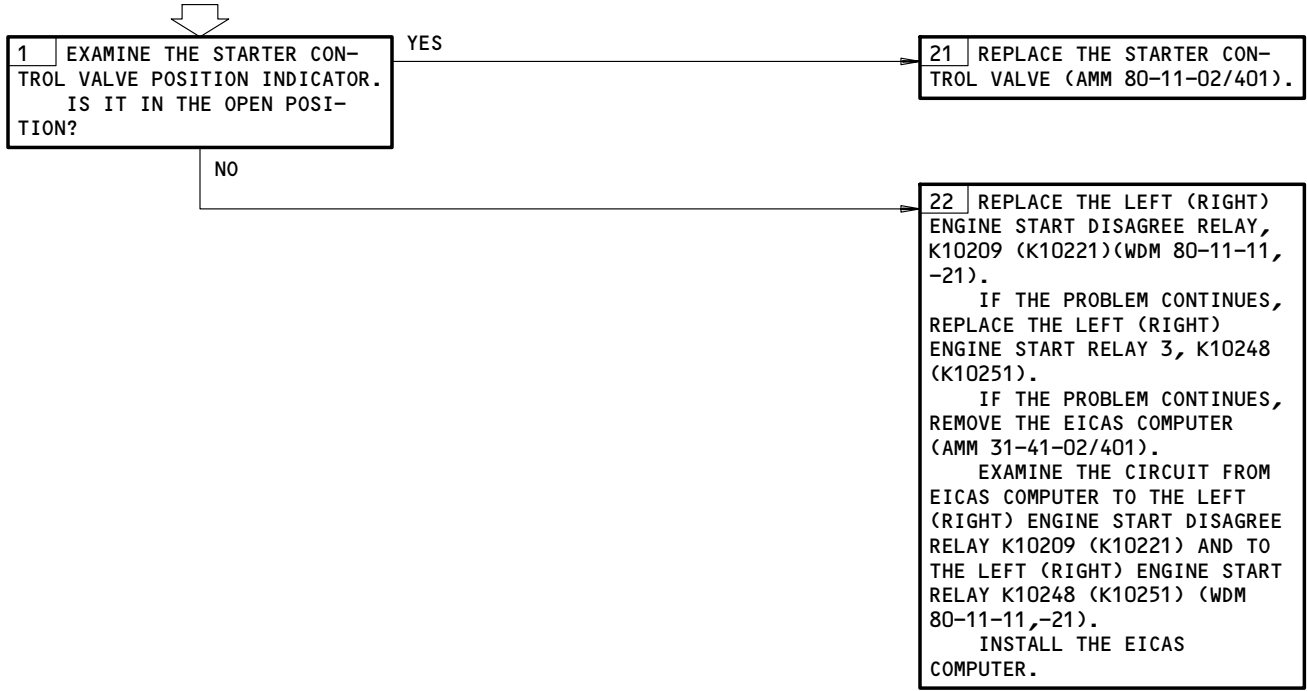

Starter VALVE Light on After Start Switch Returned to AUTO
Figure 107

EFFECTIVITY	ALL
-------------	-----

80-11-00

START SWITCH FAILED
TO RETURN TO "AUTO"
AT 47% N3 1

PREREQUISITES

MAKE SURE THESE CIRCUIT BREAKERS ARE CLOSED:
11D19 (11D20)

MAKE SURE THE AIRPLANE IS IN THIS CONFIGURATION:
ELECTRICAL POWER IS ON (AMM 24-22-00/201)

1 REMOVE THE LEFT (RIGHT) ENGINE START RELAY 2, K10247 (K10250), LEFT (RIGHT) ENGINE START RELAY 3, K10248 (K10251) AND LEFT (RIGHT) ENGINE CONTROLS POWER RELAY, K10208 (K10220).
DISCONNECT CONNECTOR D1306 AT THE ENGINE STARTER VALVE, V10008.
PUT THE LEFT (RIGHT) ENGINE START SWITCH, S3 (S4), TO GND.
DISCONNECT CONNECTOR D1388.
MAKE SURE THE START SW MOVES TO AUTO.
CONNECT CONNECTORS D1388 AND D1306.
INSTALL RELAYS K10247 (K10250), K10248 (K10251), AND K10208 (K10220) (WDM 80-11-11, WDM 80-11-21).
DID THE START SWITCH MOVE TO AUTO?

NO

21 REPLACE THE ENGINE START/RAM AIR TURBINE CONTROL PANEL, M10468 (WDM 80-11-11, WDM 80-11-21).

YES

22 REPLACE THE DEDICATED GENERATOR CONTROL UNIT, M10157 (AMM 73-21-10/401).
IF THE PROBLEM CONTINUES, REPLACE THE DEDICATED GENERATOR (AMM 73-21-08/401).

1 IT IS ACCEPTABLE IF THE START SWITCH DOES NOT RETURN TO "AUTO" BY 47% N3, PROVIDED THAT THE START SWITCH DOES RETURN TO "AUTO" BY IDLE SPEED AND THE "EICAS" CAUTION MESSAGE "L (R) STARTER CUTOUT" DOES NOT DISPLAY.

Start Switch Failed to Return to AUTO at 47% N3
Figure 108

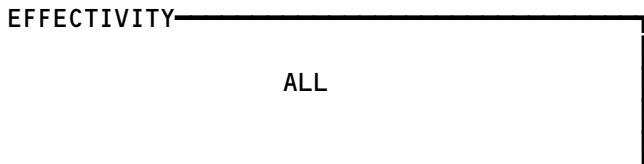

80-11-00