

CHAPTER

00

GENERAL



CHAPTER 00
GENERAL

CH-SC-SU	Schem	Page	Sheet	Date	CH-SC-SU	Schem	Page	Sheet	Date
00-EFFECTIVE PAGES									
		1		May 06/2009					
		2		BLANK					
00-CONTENTS									
R		1		May 06/2009					
		2		BLANK					
00-ALPHABETICAL INDEX									
		1		Dec 18/2007					
		2		BLANK					
00-00-00									
R	1	101		May 06/2009					
R	2	101		May 06/2009					
00-06-21									
R	1	101		May 06/2009					
R	2	101		May 06/2009					
00-06-30									
R	1	101		May 06/2009					
R	2	101		May 06/2009					
00-12-00									
R	1	101		May 06/2009					

A = Added, R = Revised, D = Deleted, O = Overflow

00-EFFECTIVE PAGES



CHAPTER 00
GENERAL

Title	CH-SC-SU	Schem	Page	Sheet	Date	Effectivity
<u>SYMBOLS</u>						
I SYMBOLS - MECHANICAL	00-00-00	1	101		May 06/2009	ALL
I SYMBOLS - ELECTRICAL	00-00-00	2	101		May 06/2009	ALL
<u>DIMENSION AND EQUIPMENT LOCATION</u>						
I AIRPLANE STATION BODY AND STABILIZER	00-06-21	1	101		May 06/2009	ALL
I AIRPLANE STATION WING AND NACELLE	00-06-21	2	101		May 06/2009	ALL
I PANEL LOCATIONS	00-06-30	1	101		May 06/2009	ALL
I MAJOR EQUIPMENT CENTERS	00-06-30	2	101		May 06/2009	ALL
<u>GROUND SERVICE ACCESS PANELS</u>						
I GROUND SERVICE ACCESS PANELS	00-12-00	1	101		May 06/2009	ALL



CHAPTER 00
GENERAL

CH-SC-SU	Title
00-06-21	AIRPLANE STATION BODY AND STABILIZER
00-12-00	GROUND SERVICE ACCESS PANELS
00-06-30	PANEL LOCATIONS
00-00-00	SYMBOLS - MECHANICAL

CH-SC-SU	Title
----------	-------

00-ALPHABETICAL INDEX

MECHANICAL SYMBOLS

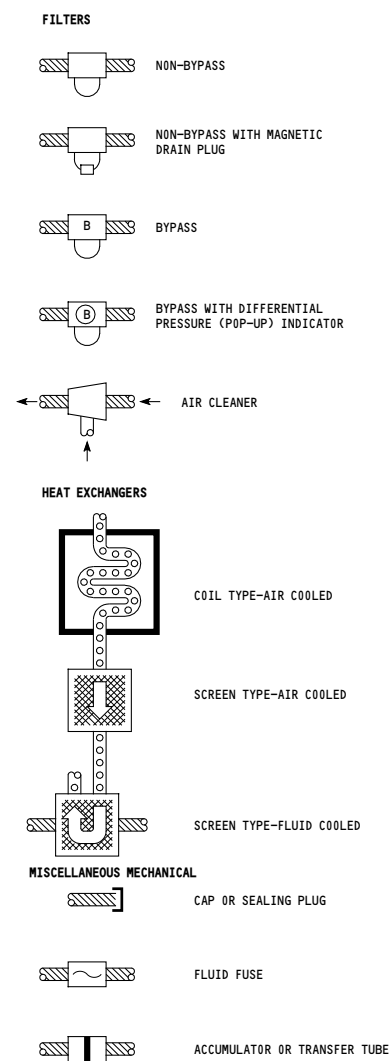

MISCELLANEOUS MECHANICAL (CONT)

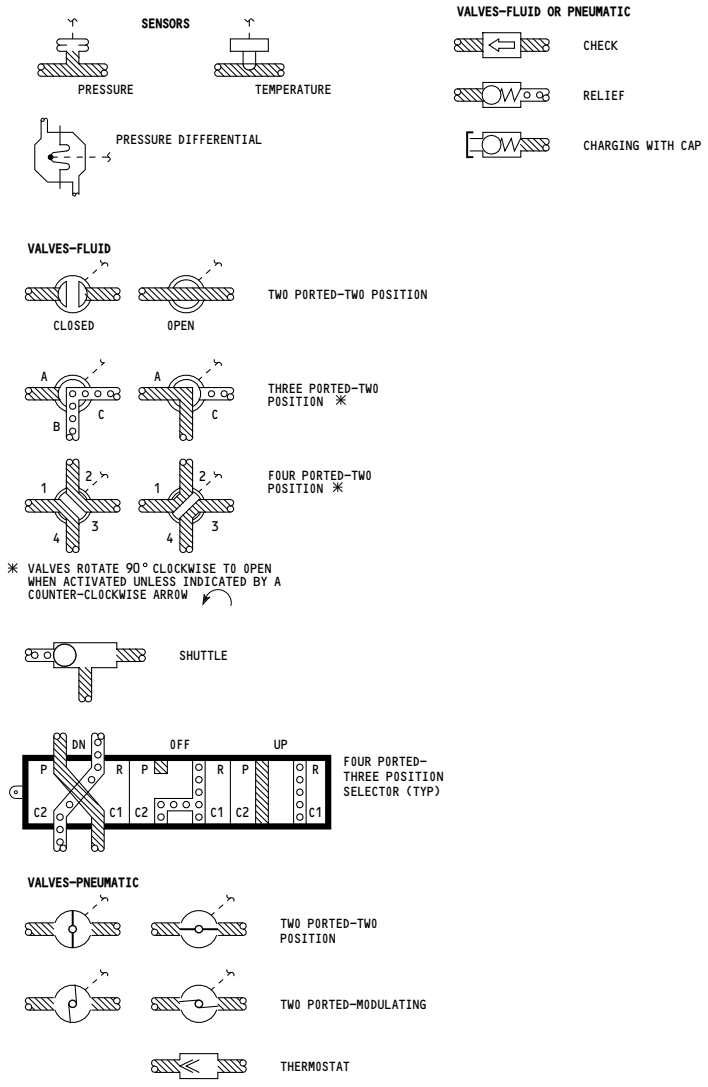
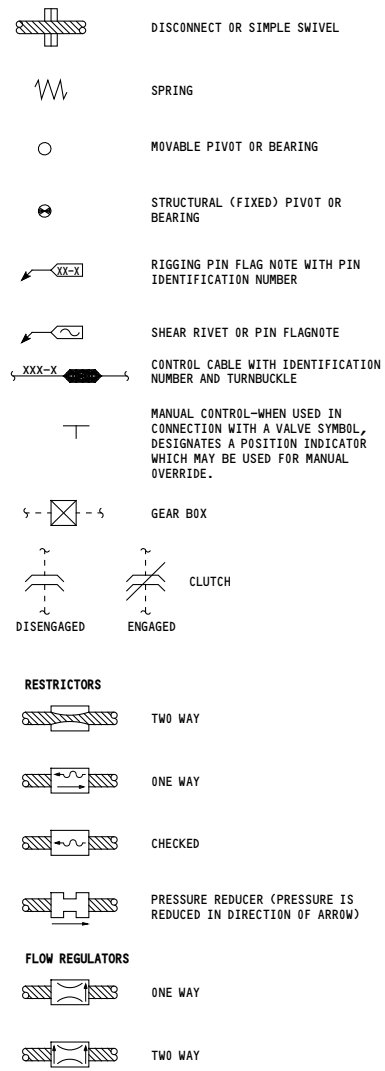

ALL	SYMBOLS - MECHANICAL
	D280N032S

ELECTRICAL/ELECTRONIC SYMBOLS

AMPLIFIERS

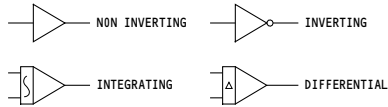

CIRCUIT BREAKER

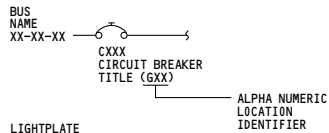

LIGHTPLATE

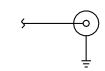

PROXIMITY SENSOR

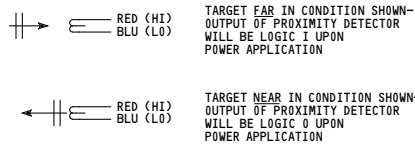

SYNCHRO

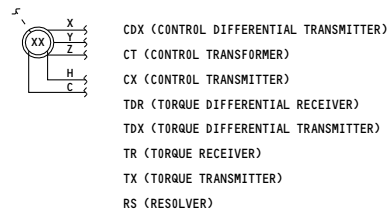

THERMAL DEVICES

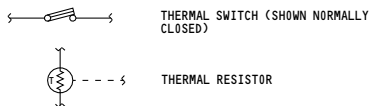

TIME DELAYS

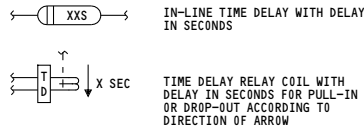

LRU/COMPONENT IDENTIFICATION

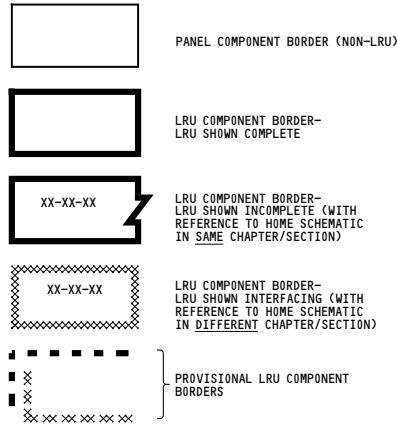

NOTE: WHEN AN LRU IS SHOWN MORE THAN ONCE ON THE SAME SCHEMATIC A Δ 3 WILL APPEAR INSIDE THE BORDER

MATHEMATICAL SYMBOLS

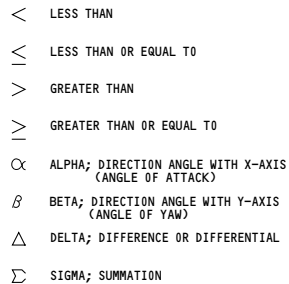

LOGIC SYMBOLS

BASIC DEFINITION

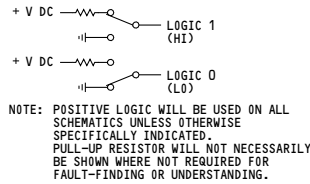

LOGIC OR SOLID STATE SWITCH

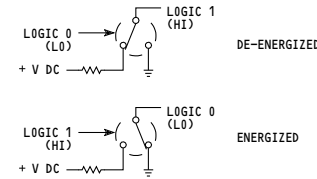

SIGNAL SUMMING POINT

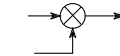

LOGIC ELEMENT DEFINITION

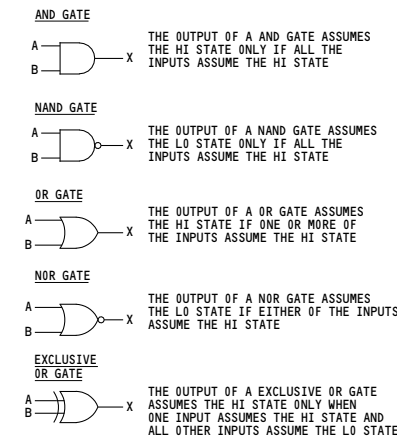

EQUIVALENT LOGIC FUNCTIONS

AND/NAND GATES	OR/NOR GATES	TRUTH TABLE		
		A	B	X
		1	1	1
		1	0	0
		0	1	0
		0	0	0
		1	1	0
		1	0	0
		0	1	1
		0	0	1
		1	1	0
		1	0	1
		0	1	0
		0	0	1
		1	1	1
		1	0	1
		0	1	1
		0	0	0
		1	1	0
		1	0	1
		0	1	1
		0	0	0
EXCLUSIVE OR GATE		1	1	0
		1	0	1
		0	1	1
		0	0	0

FILTER & COMPARATOR

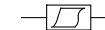

FLAGNOTES

- ▶ CUSTOMER ORIGINATED MATERIAL INCORPORATED INTO THE MANUAL AT CUSTOMER REQUEST (SEE INTRODUCTION PAGE 1.) *
- ▶ THE SERVICE BULLETIN LISTED ADJACENT TO THE FLAGNOTE HAS BEEN INCORPORATED INTO THIS SCHEMATIC IN EITHER THE DUAL OR THE FINAL CONFIGURATION, ACCORDING TO CUSTOMER REQUEST. *
- * SEE THE SERVICE BULLETIN AND MODIFICATION INDEX FOR INCORPORATION DATES AND CONFIGURATION INFORMATION.

ALL	SYMBOLS - ELECTRICAL
	D280N032S

00-00-00

Schem 2
Page 101

May 06/2009

1

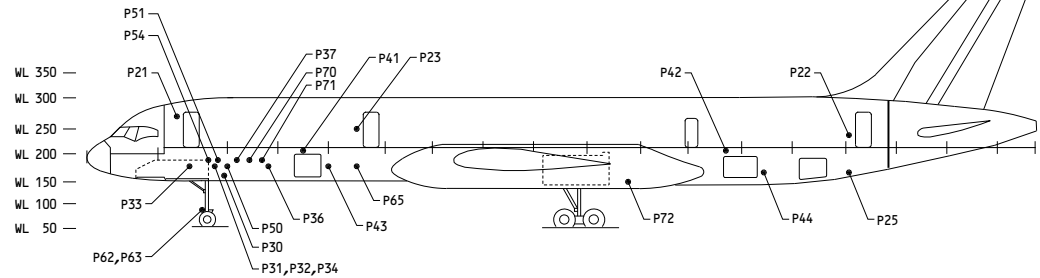
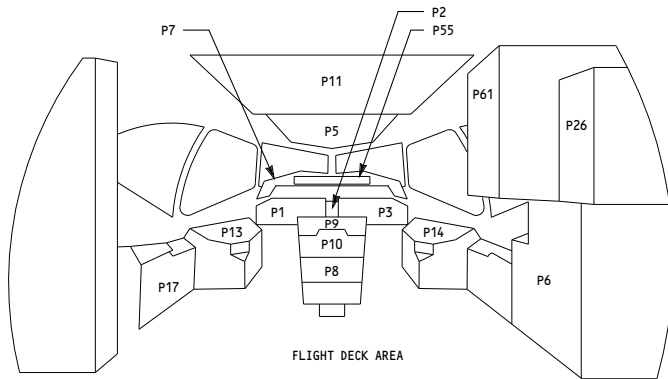

PANEL NOMENCLATURE	
P1	CAPTAINS INSTRUMENT
P2	PILOTS INDICATORS (EICAS)
P3	FIRST OFFICERS INSTRUMENTS
P5	OVERHEAD
P6	POWER DISTRIBUTION
P7	PILOTS GLARESHIELD
P8	PILOTS AFT CONTROL STAND
P9	FWD ELEC CONTROL STAND
P10	QUADRANT CONTROL STAND
P11	OVERHEAD CIRCUIT BREAKER
P13	CAPTAINS FWD AUX INSTR
P14	FIRST OFFICERS FWD INSTR
P17	FIRST OBSERVERS INSTR
P21	FWD ATTENDANT (NO.1 LEFT PASSENGER DOOR AREA)
P22	AFT ATTENDANT (NO.4 LEFT PASSENGER DOOR AREA)
P23	MID ATTENDANT (NO.2 LEFT PASSENGER DOOR AREA)
P25	WATER SERVICE (AFT LOWER FUSELAGE)
P26	EQUIPMENT LIGHTING
P28	FUELING CONTROL (RIGHT WING AREA)
P30	EXTERNAL POWER RECEPTACLE (FWD LOWER RIGHT FUSELAGE)
P31	LEFT GEN POWER (AFT OF NOSE WHEEL WELL)
P32	RIGHT GEN POWER (AFT OF NOSE WHEEL WELL)
P33	MISC ELEC POWER (AFT RIGHT OF NOSE WHEEL WELL)
P34	APU/EXT POWER (AFT OF NOSE WHEEL WELL)
P36	MISC ELEC EQPT (RIGHT ELECTRONICS BAY)
P37	MISC ELEC EQPT (RIGHT ELECTRONICS BAY)
P41	FWD CARGO DOOR CONTROL (INBD OF NO.1 CARGO DOOR)
P42	AFT CARGO DOOR CONTROL (INBD OF NO.2 CARGO DOOR)
P43	FWD CARGO DOOR CONTROL (AFT OF NO.1 CARGO DOOR)
P44	AFT CARGO DOOR CONTROL (AFT OF NO.2 CARGO DOOR)
P50	ELECT SYS CARD FILE (FWD RIGHT LOWER FUSELAGE)
P51	WARNING ELEC CARD FILE (FWD RIGHT LOWER FUSELAGE)
P54	FIRE DETECTION CARD FILE (FWD RIGHT LOWER FUSELAGE)
P55	CTR GLARESHIELD
P61	RIGHT SIDEWALL
P62	NOSE LANDING GEAR CONTROL HOUSING (NOSE LANDING GEAR)
P63	NOSE LANDING GEAR CONTROL HOUSING (NOSE LANDING GEAR)
P65	MISC EQUIPMENT PANEL
P70	MISC ELEC EQPT (RIGHT ELECTRONICS BAY)
P71	HYDRAULIC GENERATOR CONTROL PANEL
P72	MAIN WHEEL WELL ELECTRICAL SERVICE (AFT OF WHEEL WELL, LOWER FUSELAGE)

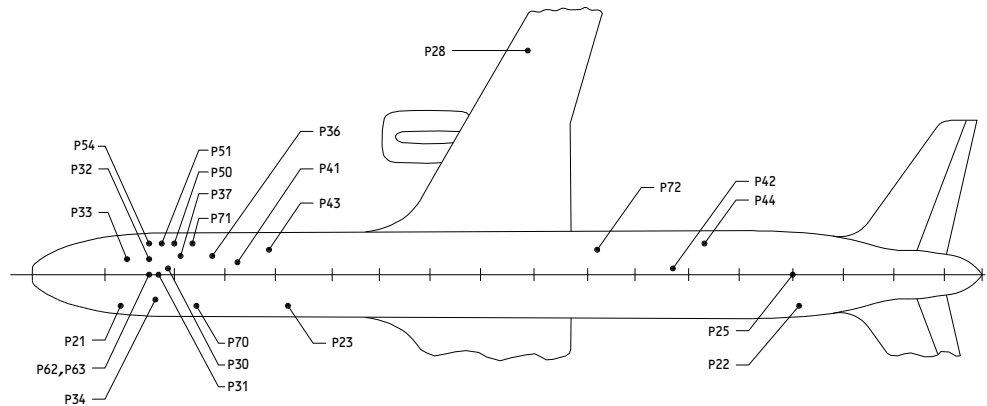
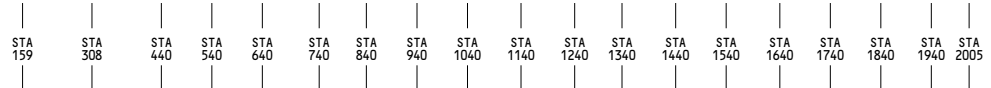

ALL

PANEL LOCATIONS

D280N032S

00-06-30

Schem 1
Page 101

May 06/2009

1

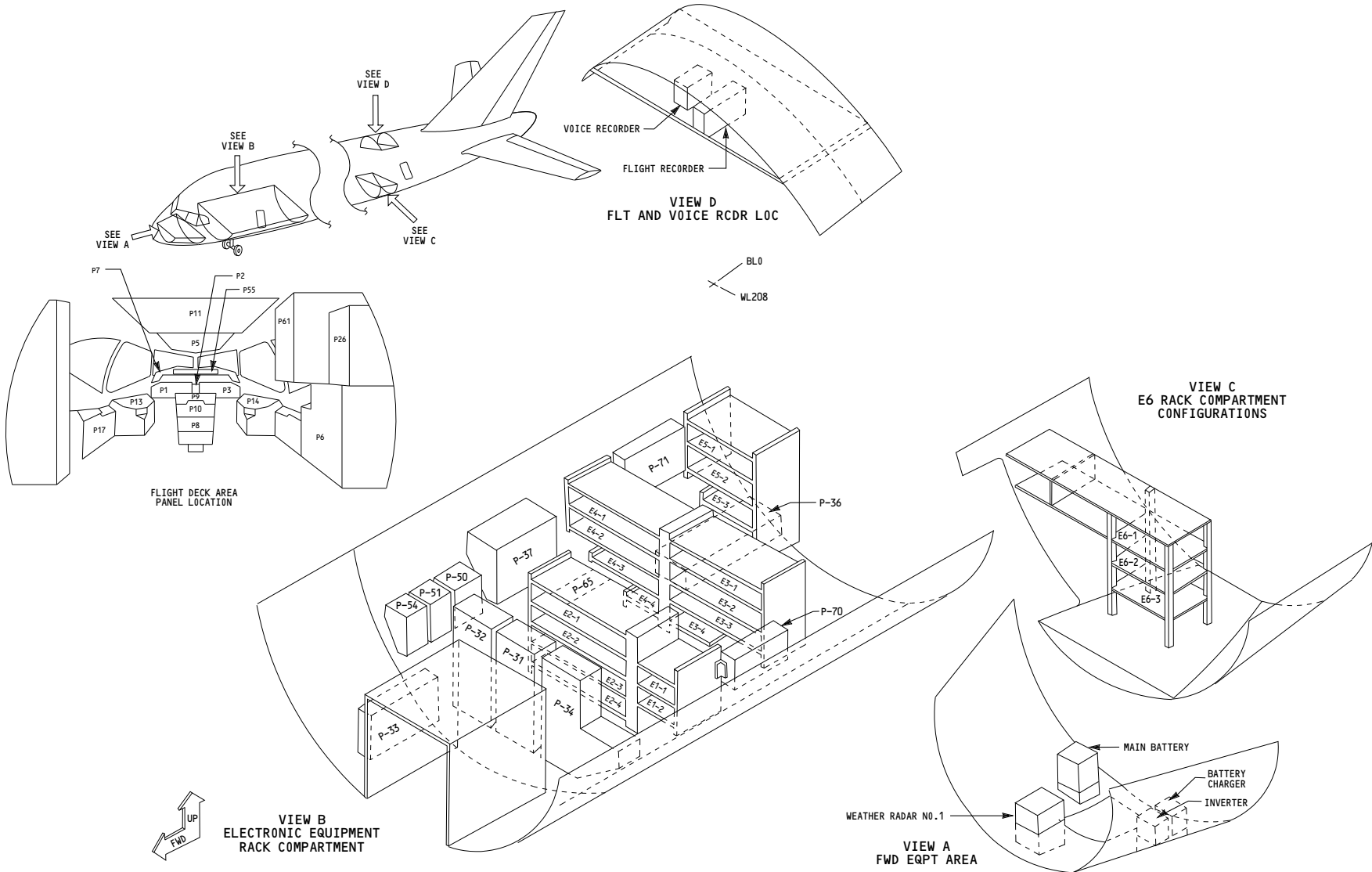

ALL	<p>MAJOR EQUIPMENT CENTERS</p> <p>D280N032S</p>
-----	--

00-06-30

Schem 2
Page 101

May 06/2009

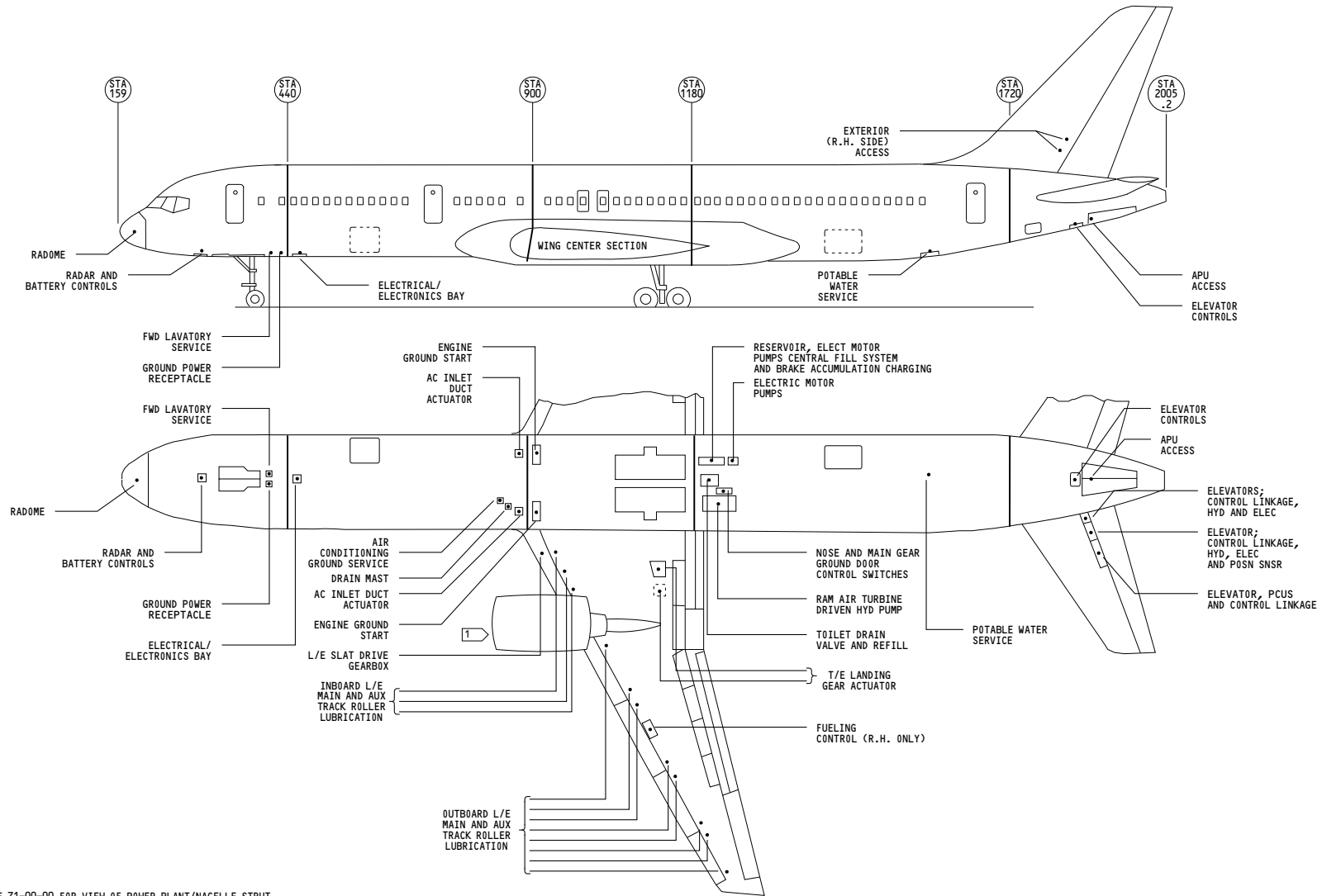

NOTE:
 1 SEE 71-00-00 FOR VIEW OF POWER PLANT/NACELLE STRUT SERVICE ACCESS PANELS

ALL	GROUND SERVICE ACCESS PANELS D280N032S
-----	--

00-12-00

Schem 1
Page 101

May 06/2009