

**CHAPTER**  
**22**  
**AUTOFLIGHT**





CHAPTER 22  
AUTOFLIGHT

CH-SC-SU	Schem	Page	Sheet	Date	CH-SC-SU	Schem	Page	Sheet	Date
	22-10-03 (cont.)					22-22-01 (cont.)	101		
D		102	1	May 06/2009	R			2	May 06/2009
D			2	May 06/2009	D		102	1	May 06/2009
D		102.1	1	May 06/2009	D			2	May 06/2009
D			2	May 06/2009		22-24-01			
	22-10-04				R		101	1	May 06/2009
R		101	1	May 06/2009	R			2	May 06/2009
R			2	May 06/2009		22-30-01			
D		102	1	May 06/2009	R		101		May 06/2009
D			2	May 06/2009	D		102		May 06/2009
D		102.1	1	May 06/2009		22-30-02			
D			2	May 06/2009	R		101	1	May 06/2009
	22-21-00				R			2	May 06/2009
R		101		May 06/2009	D		102	1	May 06/2009
	22-21-01				D			2	May 06/2009
R		101	1	May 06/2009	D		102.1	1	May 06/2009
R			2	May 06/2009	D			2	May 06/2009
	22-21-02				A		101.1	1	May 06/2009
R		101	1	May 06/2009	A			2	May 06/2009
R			2	May 06/2009		22-30-03			
D		102	1	May 06/2009	R		101	1	May 06/2009
D			2	May 06/2009	R			2	May 06/2009
	22-22-01					22-31-01			
R		101	1	May 06/2009	R		101		May 06/2009

A = Added, R = Revised, D = Deleted, O = Overflow

**22-EFFECTIVE PAGES**



CHAPTER 22  
AUTOFLIGHT

CH-SC-SU	Schem	Page	Sheet	Date	CH-SC-SU	Schem	Page	Sheet	Date
22-32-01									
R		101		May 06/2009					
D		102		May 06/2009					
22-33-01									
R		101		May 06/2009					
22-41-01									
R		101	1	May 06/2009					
R			2	May 06/2009					
D		102	1	May 06/2009					
D			2	May 06/2009					
22-41-03									
R		101		May 06/2009					

A = Added, R = Revised, D = Deleted, O = Overflow

**22-EFFECTIVE PAGES**

Page 3  
May 06/2009

D280N032S



CHAPTER 22  
AUTOFLIGHT

Title	CH-SC-SU	Schem	Page	Sheet	Date	Effectivity
<b><u>AUTOFLIGHT</u></b>						
AUTOFLIGHT - SIMPLIFIED	22-00-00		101		May 06/2009	ALL
<b><u>AUTOPILOT</u></b>						
AFCS MODE CONTROL PANEL	22-10-01		101		May 06/2009	ALL
			101.1		May 06/2009	001
FCC INTERFACE - LEFT	22-10-02		101	1	Jan 21/2005	001-009
				2	Jan 21/2005	001-009
				3	Jan 21/2005	001-009
				4	Jan 21/2005	001-009
			101.1	1	May 06/2009	001
				2	May 06/2009	001
				3	May 06/2009	001
				4	May 06/2009	001
			101.2	1	May 06/2009	009
				2	May 06/2009	009
				3	May 06/2009	009
				4	May 06/2009	009
			102	1	Jan 21/2005	010-099
				2	Jan 21/2005	010-099
				3	Jan 21/2005	010-099
				4	Jan 21/2005	010-099
FCC INTERFACE - RIGHT	22-10-03		101	1	May 06/2009	ALL
				2	May 06/2009	ALL



CHAPTER 22  
AUTOFLIGHT

Title	CH-SC-SU	Schem	Page	Sheet	Date	Effectivity
FCC INTERFACE - CENTER	22-10-04		101	1	May 06/2009	ALL
				2	May 06/2009	ALL
<b><u>YAW DAMPER SYSTEM</u></b>						
YAW DAMPER - SIMPLIFIED	22-21-00		101		May 06/2009	ALL
YAW DAMPER - LEFT	22-21-01		101	1	May 06/2009	ALL
				2	May 06/2009	ALL
YAW DAMPER - RIGHT	22-21-02		101	1	May 06/2009	ALL
				2	May 06/2009	ALL
<b><u>AUTOMATIC STABILIZER TRIM SYSTEM</u></b>						
AUTOMATIC STABILIZER TRIM	22-22-01		101	1	May 06/2009	ALL
				2	May 06/2009	ALL
<b><u>MACH TRIM/SPEED STABILITY SYSTEM</u></b>						
MACH TRIM/SPEED STABILITY	22-24-01		101	1	May 06/2009	ALL
				2	May 06/2009	ALL
<b><u>AUTOTHROTTLE</u></b>						
THRUST MANAGEMENT COMPUTER	22-30-01		101		May 06/2009	ALL
THRUST MANAGEMENT COMPUTER - ANALOG INTERFACE	22-30-02		101.1	1	May 06/2009	001
				2	May 06/2009	001
				2	May 06/2009	001
THRUST MANAGEMENT COMPUTER - DIGITAL INPUTS AND OUTPUTS	22-30-03		101	1	May 06/2009	ALL



CHAPTER 22  
AUTOFLIGHT

	Title	CH-SC-SU	Schem	Page	Sheet	Date	Effectivity
I	THRUST MANAGEMENT COMPUTER - DIGITAL INPUTS AND OUTPUTS (cont.)	22-30-03			2	May 06/2009	ALL
	<b><u>THRUST MANAGEMENT POWER</u></b>						
I	THRUST MANAGEMENT COMPUTER - ENGAGE LOGIC	22-31-01		101		May 06/2009	ALL
	<b><u>THRUST MANAGEMENT SYSTEM</u></b>						
I	THRUST MANAGEMENT COMPUTER - AUTOTHROTTLE	22-32-01		101		May 06/2009	ALL
	<b><u>THRUST MANAGEMENT ENGINE</u></b>						
I	THRUST MANAGEMENT COMPUTER - THRUST LIMIT	22-33-01		101		May 06/2009	ALL
	<b><u>MAINTENANCE MONITOR</u></b>						
I	MAINTENANCE CONTROL AND DISPLAY PANEL	22-41-01		101	1	May 06/2009	ALL
I					2	May 06/2009	ALL
I	MAINTENANCE CONTROL AND DISPLAY PANEL - GROUND TEST MODE	22-41-03		101		May 06/2009	ALL





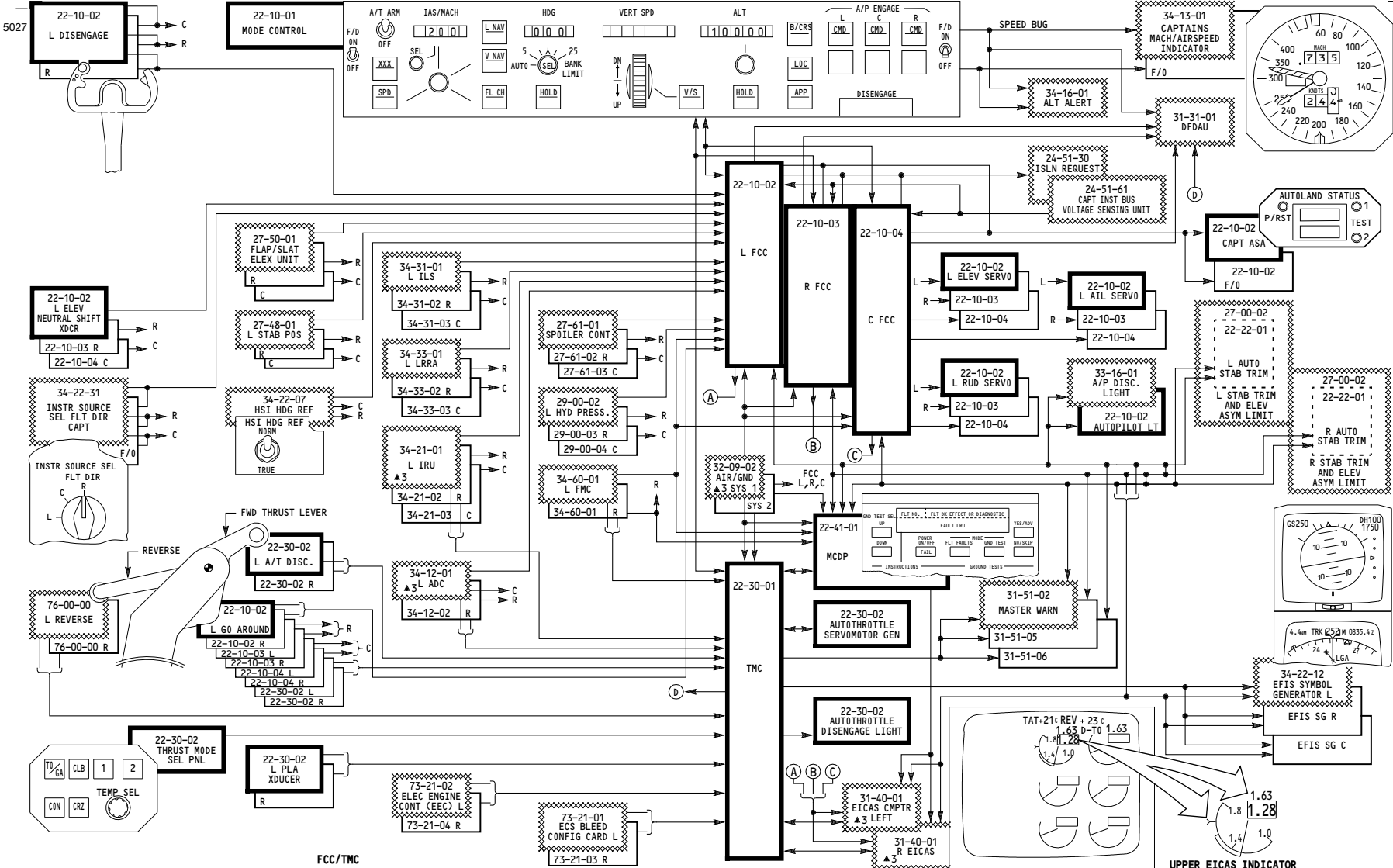

ALL

**AUTOFLIGHT - SIMPLIFIED**

D280N032S

**22-00-00**

5023

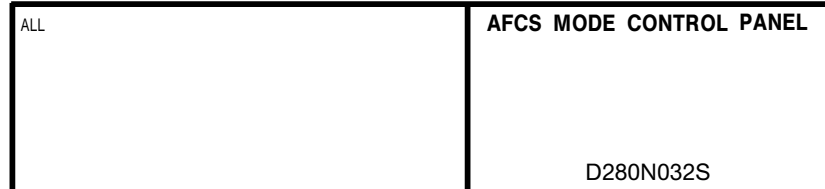
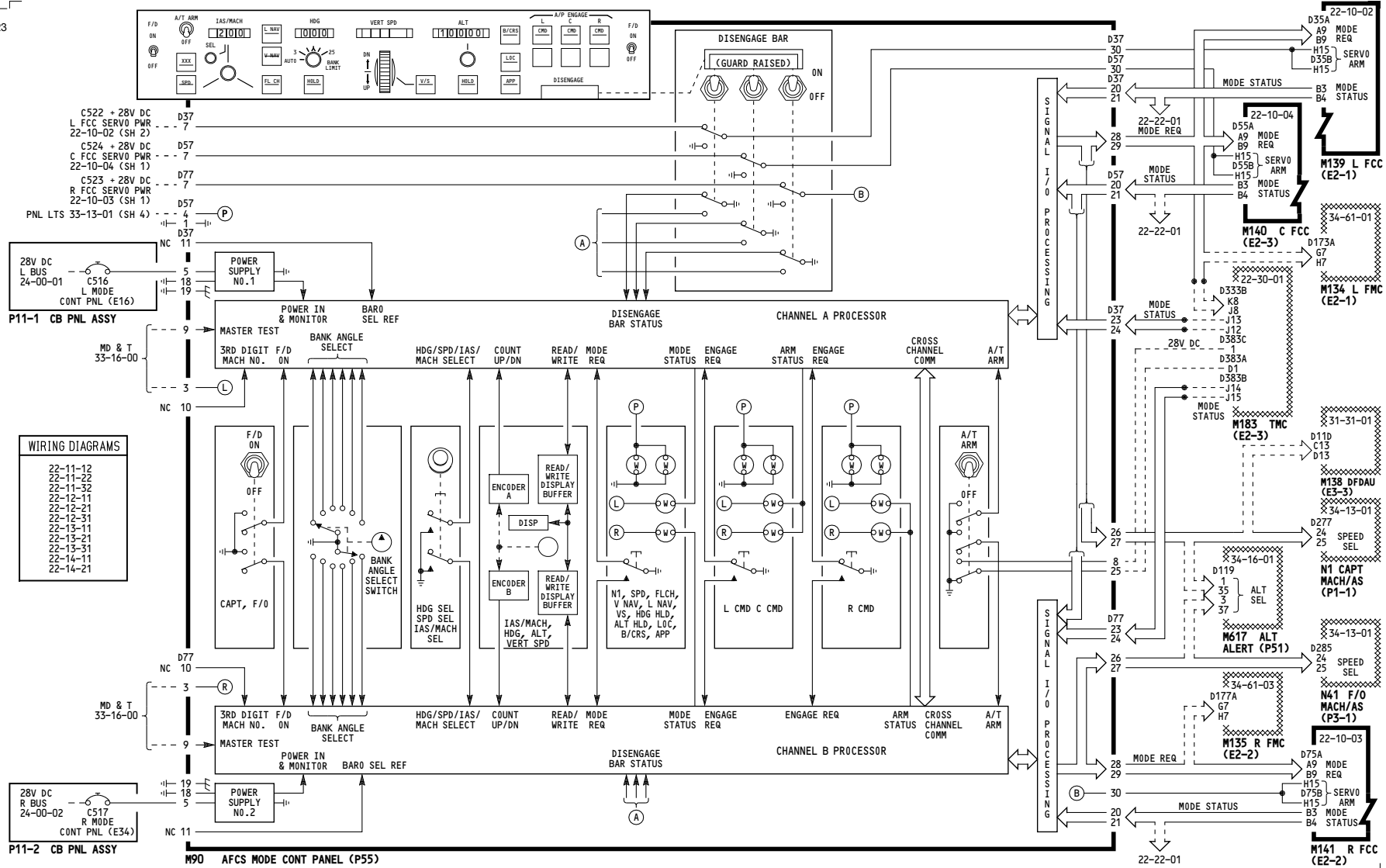

**22-10-01**

Page 101

May 06/2009

5074

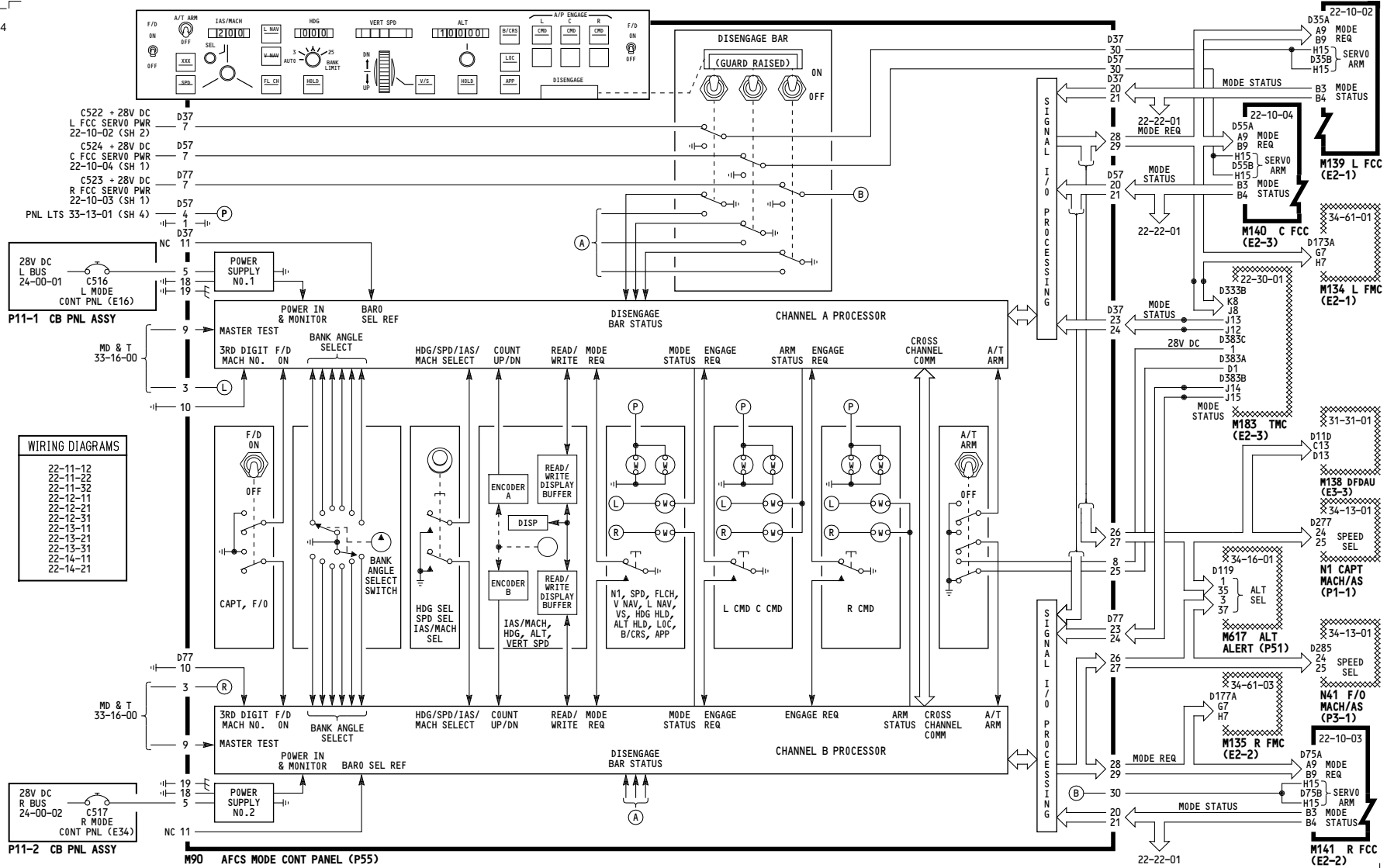

- WIRING DIAGRAMS**
- 22-11-12
  - 22-11-22
  - 22-11-32
  - 22-12-11
  - 22-12-21
  - 22-12-31
  - 22-13-11
  - 22-13-21
  - 22-13-31
  - 22-14-11
  - 22-14-21

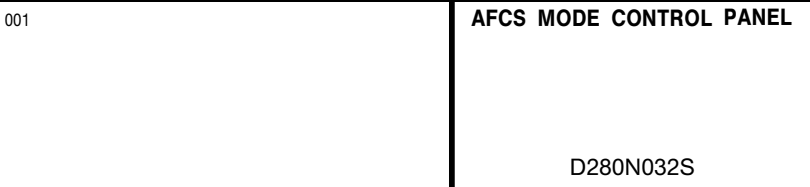

Incorporates  
22-0079

D280N032S

**22-10-01**

Page 101.1

May 06/2009

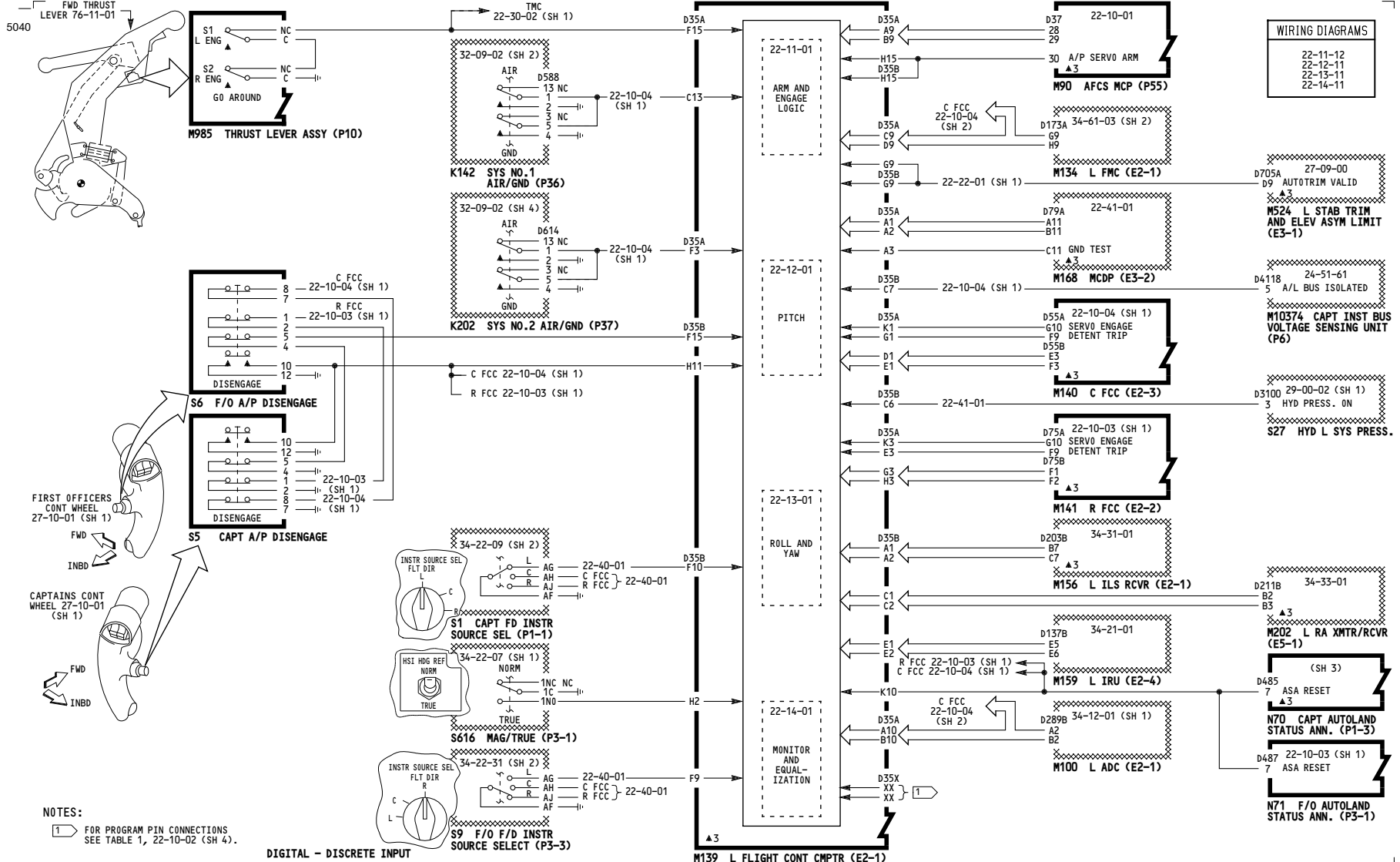

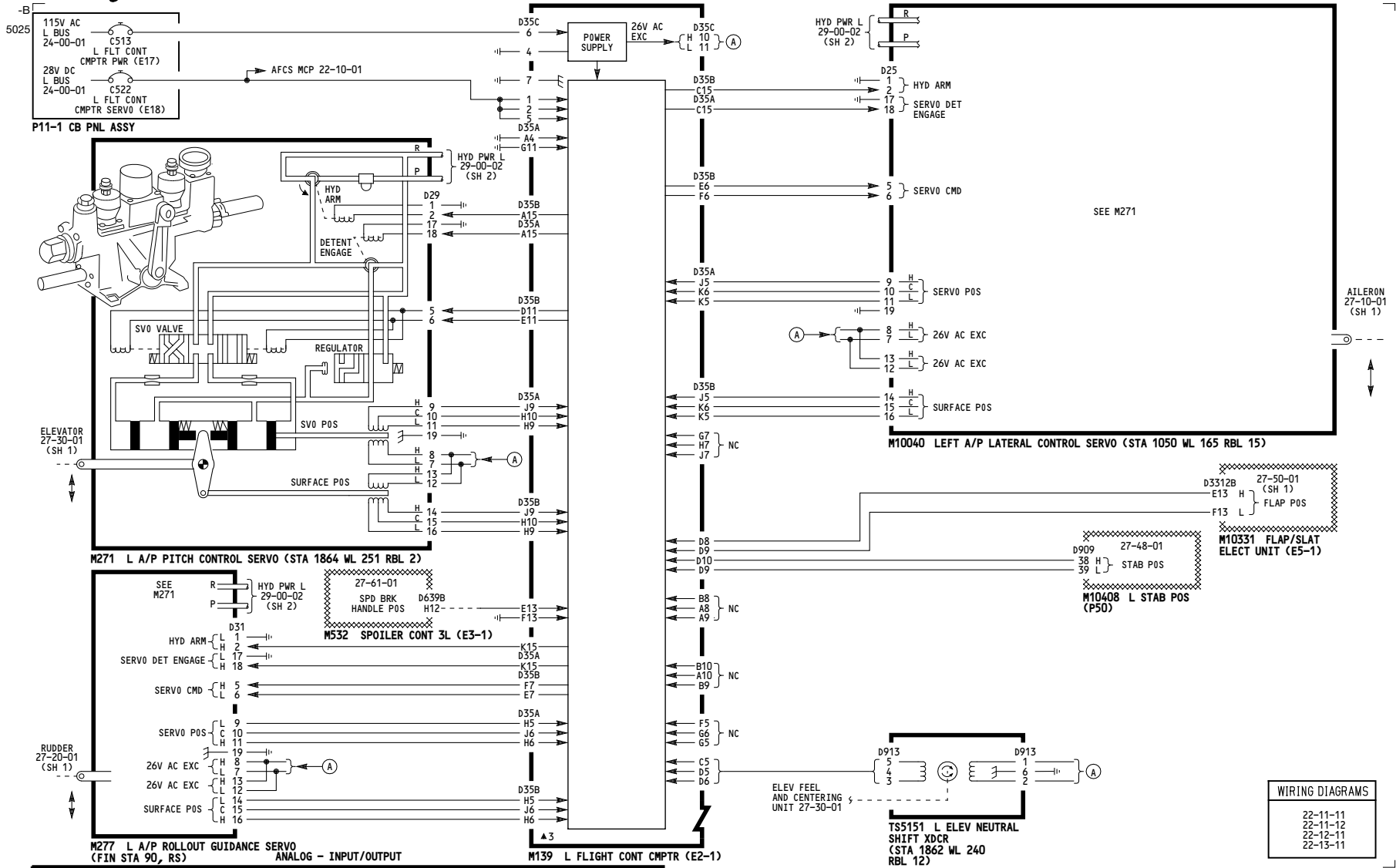

001-009

**FCC INTERFACE - LEFT**

D280N032S

**22-10-02**

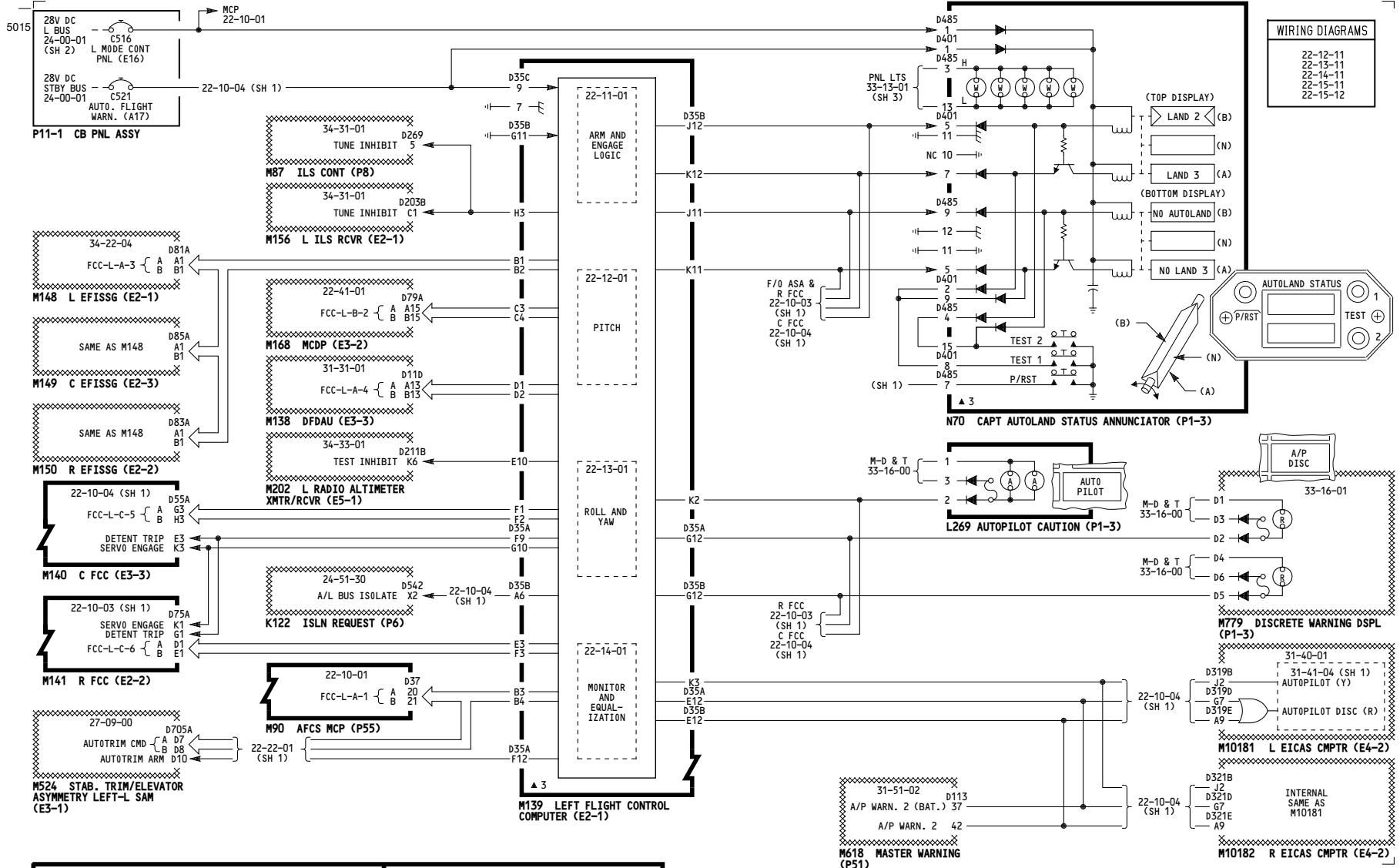

**22-10-02**



# 757-200 SYSTEM SCHEMATIC MANUAL

5019

RCVR	XMTR	PARAMETERS
FCC	MCP	MODE STATUS, REQ MODES, ALT SELECTED HDG SELECTED MACH SELECTED, MCP MAINT DATA AIRSPEED SELECTED, TEST WORD, VERT SPD, CMD, VERT SPD SELECTED
FCC	MCDP	TEST CONTROL (12 WORDS)
FCC	FCC	AIL CMD, ALONG TK HRZ ACCEL, ALT, ALT REF, LATERAL ACCEL, LONGIT ACCEL, NORMAL ACCEL, PITCH RATE, ROLL RATE, YAW RATE, COMPUTED AIRSPEED, CROSS TK HRZ ACCEL, DISCRETE WORD, ELEV CMD, FLAP POS, FLT PATH ACCEL, G/S DEV, GND SPEED, HDG REF, HORIZONTAL STEERING, IMPACT PRESSURE, INDICATED AOA, INERTIAL ALT, INERTIAL VERT SPD, INPUT DISC PCKD WD, LOC DEV, MACH MAG HDG, PITCH ANGLE, RADIO HEIGHT ROLL ANGLE, RUDDER CMD, SEL RUNWAY HDG, STAB POS, TEST WORD, TRUE TRACK ANGLE, MAG TRACK ANGLE, TRUE AIRSPEED, TRUE HDG, VERT STEERING RATE, VERT ACCEL, VERT STEERING
FCC	IRU	ALONG TK HRZ ACCEL, LATERAL ACCEL, LONGIT ACCEL, NORMAL ACCEL, PITCH RATE, ROLL RATE, YAW RATE, CROSS TK HRZ ACCEL, FLT PATH ACCEL, GND SPEED, INERTIAL ALT, INERTIAL VERT SPD, IRS DISCRETES, MAG HDG, PITCH ANGLE, PITCH ATT RATE, ROLL ANGLE, TRUE TRACK ANGLE, MAG TRACK ANGLE, TRUE HDG, VERT ACCEL
FCC	ILS	G/S DEV, ILS FREQ, LOC DEV, SEL RUNWAY HDG
FCC	RA	RADIO HEIGHT
FCC	FMC	FMC DISCRETES, HORIZONTAL STEERING, SELECTED AIRSPEED, SELECTED ALT, SELECTED MACH, VERT STEERING RATE, VERT STEERING
FCC	ADC	ALT, ALT RATE, COMPUTED AIRSPEED, IMPACT PRESSURE, INDICATED AOA, MACH, MAX OPRTG SCHEDULE, TRUE AIRSPEED

RCVR	XMTR	PARAMETERS
MCP	FCC	MODE STATUS, COMPUTED AIRSPEED, ELEV SPD CMD, FLAP POS, FMC AIRSPEED REF MACH, SEL RUNWAY HDG, SPD BRK HDL POS, STAB POS, TEST WORD, VERT SPD
MCP	TMC	MODE STATUS, VERT SPEED CMD
MCDP	FCC	FAULT DATA, GND TEST DATA, INTERFACE FAULT DATA, TEST WORD
SAM	FCC	MODE STATUS
EFISSG	FCC	MODE STATUS, FLT DIR PITCH, FLT DIR ROLL, HDG SELECTED, RUNWAY DIST TO GO
DFDAU	FCC	MODE STATUS
TMC	MCP	MODE STATUS, REQ MODES, ALT SELECTED, ELEV SPD CMD, MACH SELECTED, SPD BRK HDL POS, AIRSPEED SELECTED, STAB POS
FMC	MCP	MODE STATUS, REQ MODES, ALT SELECTED, FLAP POS, HDG SELECTED, MACH SELECTED, AIRSPEED SELECTED, VERT SPD SELECTED
ALT ALERT	MCP	MODE STATUS, ALT SELECTED
M/ASI	MCP	AIRSPEED SELECTED
DFDAU	MCP	ALT SELECTED, HDG SELECTED, MACH SELECTED, AIRSPEED SELECTED, VERT SPD SELECTED

TABLE 1 FCC PROGRAM PINS

PROGRAM AS CONNECTED	OPTION PIN	GND PIN	L (X = GND, D)	C	R	PROGRAM AS CONNECTED	OPTION PIN	GND PIN	L (X = GND, D)	C	R		
CUSTOMER OPTION	1	BA12	BB15	X	X	X	AIRPLANE CONFIG	1	AA12	AA11	X	X	X
	2	BB12	BD15	X	X	X		2	AB12	AB11			
	3	BC12	BE5					3	AC12	AC11			
	4	BA13	BA14					4	BA11	BG8			
	5	BB13	BB14					5	BB11	BH8			
A/P MODE ENGAGE DOUBLE PUSH WARN RESET FULL TIME "NO LAND" ANN METHOD 2 MULTI-CHAN ENGA	BA3	BE4	X	X	X	INTERLOCK CODE	1	BC11	BJ8				
	BH13	BJ14					2	BF11	BK9				
	BK13	BK14	X	X	X		3	BD12	BD14				
	BG13	BH14					4	BF12	BK7				
	BC8	BE8					5	BH12	BJ15				
ASA OPTION LAT CMD ENGA CWS INHIBIT FULL TIME F/D F/D AUTO ON F/D ON ROLLOUT SPARE 5 SPARE 6	BC10	BC14				CHANNEL IDENTITY PARITY (ODD)	1	AA13	AA14	X	X		
	BJ2	BJ4	X	X	X		2	AB13	AB14	X	X	X	
	BD3	BK4											
	BA4	AD4	X	X	X								
	BD4	BH4											
SPARE 5 SPARE 6	BG1	AG2				SPARES (NO PARITY)	7	BG2	AG4				
	BH1	AH2					10	BD7	BG4				
							13	BG10	AG8				

001-009

## FCC INTERFACE - LEFT

D280N032S

22-10-02

Page 101  
Sheet 4  
Jan 21/2005

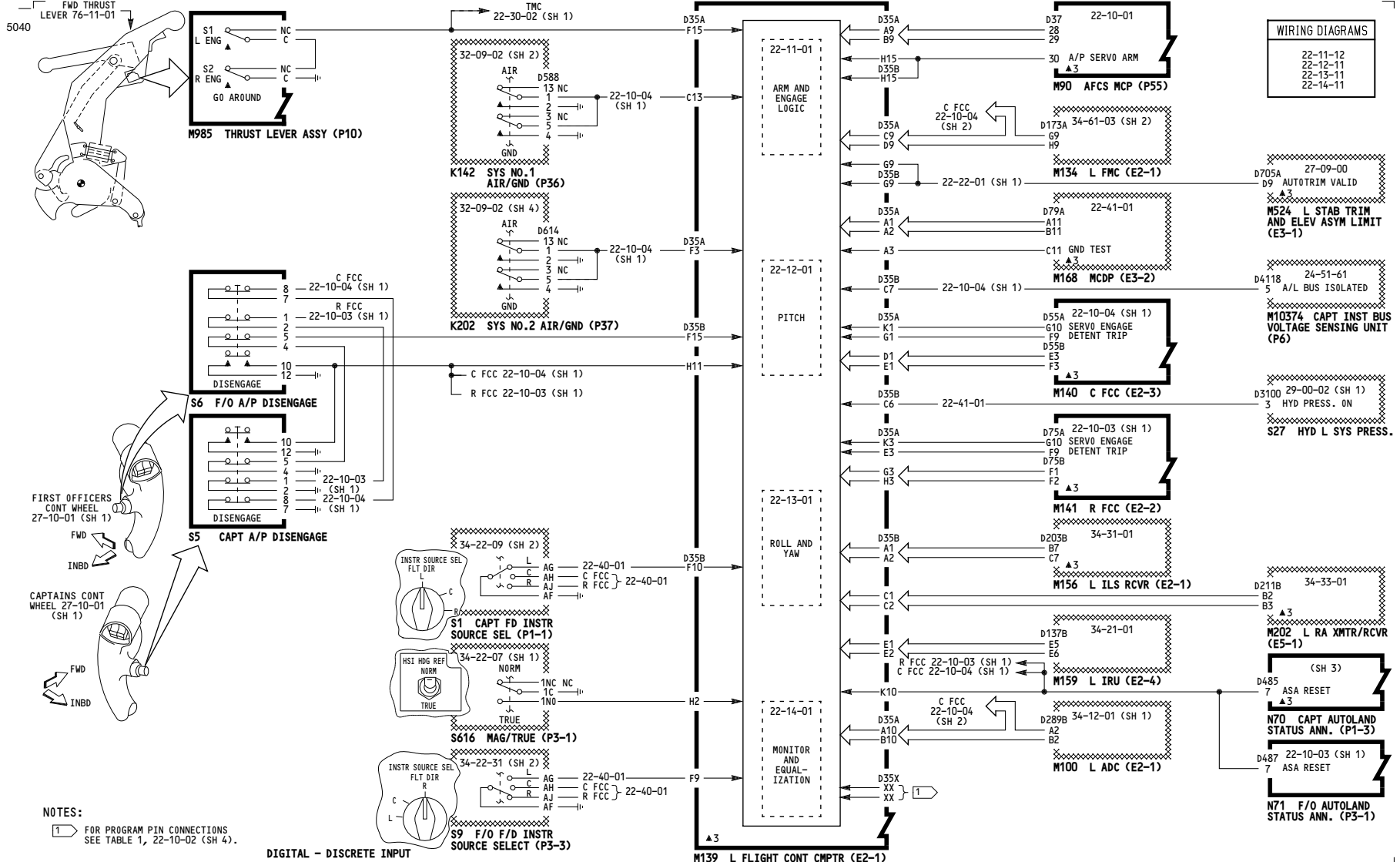

**WIRING DIAGRAMS**  
 22-11-12  
 22-12-11  
 22-13-11  
 22-14-11

D705A 27-09-00  
 D9 AUTOTRIM VALID  
 M524 L STAB TRIM AND ELEV ASYM LIMIT (E3-1)

D4118 24-51-61  
 5 A/L BUS ISOLATED

M10374 CAPT INST BUS VOLTAGE SENSING UNIT (P6)

D3100 29-00-02 (SH 1)  
 3 HYD PRESS. ON  
 S27 HYD L SYS PRESS.

D211B 34-33-01  
 B2 B3  
 M202 L RA XMTR/RCVR (E5-1)

D485 7 ASA RESET  
 M70 CAPT AUTOLAND STATUS ANN. (P1-3)

D487 22-10-03 (SH 1)  
 7 ASA RESET  
 M71 F/O AUTOLAND STATUS ANN. (P3-1)

**NOTES:**  
 1 FOR PROGRAM PIN CONNECTIONS SEE TABLE 1, 22-10-02 (SH 4).

DIGITAL - DISCRETE INPUT

FCC INTERFACE - LEFT

D280N032S

001

**22-10-02**





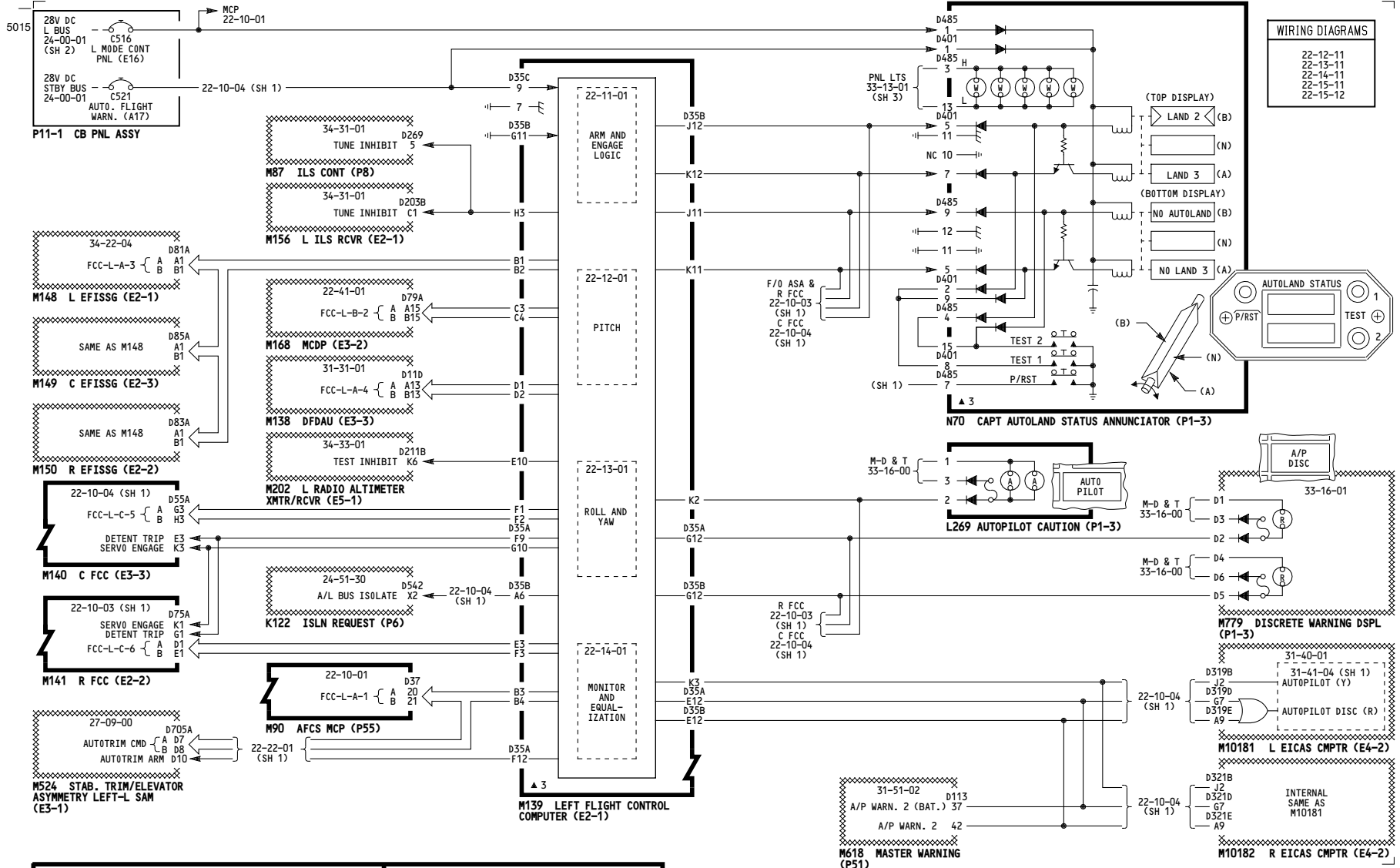

001

**FCC INTERFACE - LEFT**

D280N032S

**22-10-02**

-B-  
5207

RCVR	XMTR	PARAMETERS
FCC	MCP	MODE STATUS, REQ MODES, ALT SELECTED HDG SELECTED MACH SELECTED, MCP MAINT DATA AIRSPEED SELECTED, TEST WORD, VERT SPD, CMD, VERT SPD SELECTED
FCC	MCDP	TEST CONTROL (12 WORDS)
FCC	FCC	AIL CMD, ALONG TK HRZ ACCEL, ALT, ALT REF, LATERAL ACCEL, LONGIT ACCEL, NORMAL ACCEL, PITCH RATE, ROLL RATE, YAW RATE, COMPUTED AIRSPEED, CROSS TK HRZ ACCEL, DISCRETE WORD, ELEV CMD, FLAP POS, FLT PATH ACCEL, G/S DEV, GND SPEED, HDG REF, HORIZONTAL STEERING, IMPACT PRESSURE, INDICATED AOA, INERTIAL ALT, INERTIAL VERT SPD, INPUT DISC PCKD WD, LOC DEV, MACH MAG HDG, PITCH ANGLE, RADIO HEIGHT ROLL ANGLE, RUDDER CMD, SEL RUNWAY HDG, STAB POS, TEST WORD, TRUE TRACK ANGLE, MAG TRACK ANGLE, TRUE AIRSPEED, TRUE HDG, VERT STEERING RATE, VERT ACCEL, VERT STEERING
FCC	IRU	ALONG TK HRZ ACCEL, LATERAL ACCEL, LONGIT ACCEL, NORMAL ACCEL, PITCH RATE, ROLL RATE, YAW RATE, CROSS TK HRZ ACCEL, FLT PATH ACCEL, GND SPEED, INERTIAL ALT, INERTIAL VERT SPD, IRS DISCRETES, MAG HDG, PITCH ANGLE, PITCH ATT RATE, ROLL ANGLE, TRUE TRACK ANGLE, MAG TRACK ANGLE, TRUE HDG, VERT ACCEL
FCC	ILS	G/S DEV, ILS FREQ, LOC DEV, SEL RUNWAY HDG
FCC	RA	RADIO HEIGHT
FCC	FMC	FMC DISCRETES, HORIZONTAL STEERING, SELECTED AIRSPEED, SELECTED ALT, SELECTED MACH, VERT STEERING RATE, VERT STEERING
FCC	ADC	ALT, ALT RATE, COMPUTED AIRSPEED, IMPACT PRESSURE, INDICATED AOA, MACH, MAX OPRGT SCHEDULE, TRUE AIRSPEED

RCVR	XMTR	PARAMETERS
MCP	FCC	MODE STATUS, COMPUTED AIRSPEED, ELEV SPD CMD, FLAP POS, FMC AIRSPEED REF MACH, SEL RUNWAY HDG, SPD BRK HDL POS, STAB POS, TEST WORD, VERT SPD
MCP	TMC	MODE STATUS, VERT SPEED CMD
MCDP	FCC	FAULT DATA, GND TEST DATA, INTERFACE FAULT DATA, TEST WORD
SAM	FCC	MODE STATUS
EFISSG	FCC	MODE STATUS, FLT DIR PITCH, FLT DIR ROLL, HDG SELECTED, RUNWAY DIST TO GO
DFDAU	FCC	MODE STATUS
TMC	MCP	MODE STATUS, REQ MODES, ALT SELECTED, ELEV SPD CMD, MACH SELECTED, SPD BRK HDL POS, AIRSPEED SELECTED, STAB POS
FMC	MCP	MODE STATUS, REQ MODES, ALT SELECTED, FLAP POS, HDG SELECTED, MACH SELECTED, AIRSPEED SELECTED, VERT SPD SELECTED
ALT ALERT	MCP	MODE STATUS, ALT SELECTED
M/ASI	MCP	AIRSPEED SELECTED
DFDAU	MCP	ALT SELECTED, HDG SELECTED, MACH SELECTED, AIRSPEED SELECTED, VERT SPD SELECTED

TABLE 1 FCC PROGRAM PINS

PROGRAM AS CONNECTED	OPTION PIN	GND PIN	L (X = GND, D)	C	R	PROGRAM AS CONNECTED	OPTION PIN	GND PIN	L (X = GND, D)	C	R	
CUSTOMER OPTION	1	BA12	BB15	X	X	AIRPLANE CONFIG	1	AA12	AA11	X	X	
	2	BB12	BD15	X	X		2	AB12	AB11			
	3	BC12	BE5				3	AC12	AC11			
	4	BA13	BA14				4	BA11	BG8			
	5	BB13	BB14				5	BB11	BH8			
A/P MODE ENGAGE GLIDESLOPE INHIBIT FULL TIME "NO LAND" ANN METHOD 2 MULTI-CHAN ENGA	BA3	BE4		X	X	INTERLOCK CODE	1	BC11	BJ8			
	BH13	BJ14					2	BF11	BK9	X	X	X
	BK13	BK14	X	X	X		3	BD12	BD14			
	BG13	BH14					4	BF12	BK7			
	BC8	BE8					5	BH12	BJ15			
ASA OPTION LAT CMD ENGA CWS INHIBIT FULL TIME F/D F/D AUTO ON F/D ON ROLLOUT SPARE 5 SPARE 6	BC10	BC14				CHANNEL IDENTITY PARITY (ODD)	1	AA13	AA14	X	X	
	BJ2	BJ4	X	X	X		2	AB13	AB14	X	X	X
	BD3	BK4	X	X	X							
	BA4	AD4	X	X	X							
	BD4	BH4										
SPARE 5 SPARE 6	BG1	AG2				SPARES (NO PARITY)	7	BG2	AG4			
	BH1	AH2					10	BD7	BG4			
							13	BG10	AG8			

001

FCC INTERFACE - LEFT

- ▶ Incorporates
- ▶ 22-0064
- ▶ 22-0079

D280N032S

22-10-02

Page 101.1  
Sheet 4  
May 06/2009





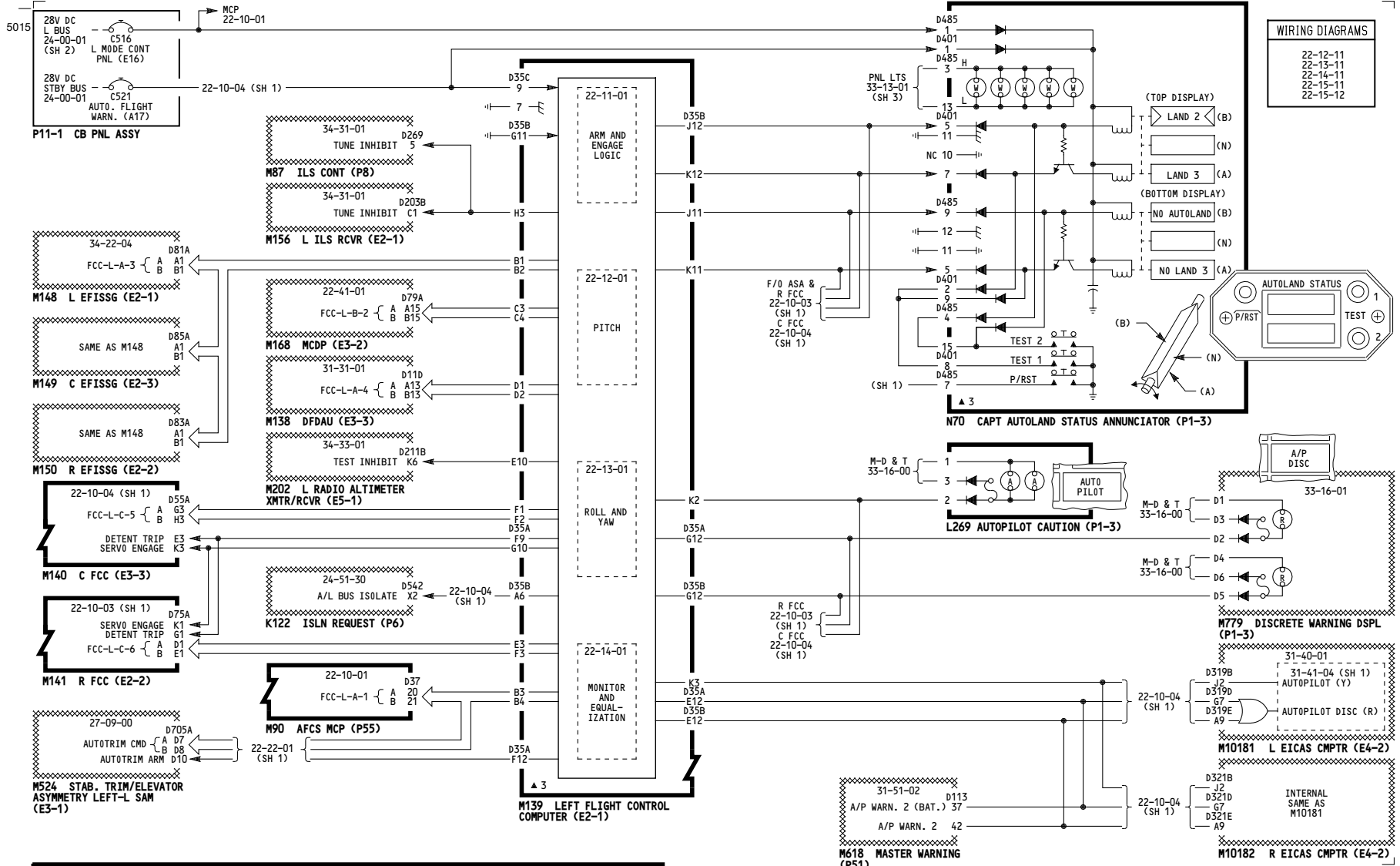

009

**FCC INTERFACE - LEFT**

D280N032S

**22-10-02**

5079

RCVR	XMTR	PARAMETERS
FCC	MCP	MODE STATUS, REQ MODES, ALT SELECTED HDG SELECTED MACH SELECTED, MCP MAINT DATA AIRSPEED SELECTED, TEST WORD, VERT SPD, CMD, VERT SPD SELECTED
FCC	MCDP	TEST CONTROL (12 WORDS)
FCC	FCC	AIL CMD, ALONG TK HRZ ACCEL, ALT, ALT REF, LATERAL ACCEL, LONGIT ACCEL, NORMAL ACCEL, PITCH RATE, ROLL RATE, YAW RATE, COMPUTED AIRSPEED, CROSS TK HRZ ACCEL, DISCRETE WORD, ELEV CMD, FLAP POS, FLT PATH ACCEL, G/S DEV, GND SPEED, HDG REF, HORIZONTAL STEERING, IMPACT PRESSURE, INDICATED AOA, INERTIAL ALT, INERTIAL VERT SPD, INPUT DISC PCKD WD, LOC DEV, MACH MAG HDG, PITCH ANGLE, RADIO HEIGHT ROLL ANGLE, RUDDER CMD, SEL RUNWAY HDG, STAB POS, TEST WORD, TRUE TRACK ANGLE, MAG TRACK ANGLE, TRUE AIRSPEED, TRUE HDG, VERT STEERING RATE, VERT ACCEL, VERT STEERING
FCC	IRU	ALONG TK HRZ ACCEL, LATERAL ACCEL, LONGIT ACCEL, NORMAL ACCEL, PITCH RATE, ROLL RATE, YAW RATE, CROSS TK HRZ ACCEL, FLT PATH ACCEL, GND SPEED, INERTIAL ALT, INERTIAL VERT SPD, IRS DISCRETES, MAG HDG, PITCH ANGLE, PITCH ATT RATE, ROLL ANGLE, TRUE TRACK ANGLE, MAG TRACK ANGLE, TRUE HDG, VERT ACCEL
FCC	ILS	G/S DEV, ILS FREQ, LOC DEV, SEL RUNWAY HDG
FCC	RA	RADIO HEIGHT
FCC	FMC	FMC DISCRETES, HORIZONTAL STEERING, SELECTED AIRSPEED, SELECTED ALT, SELECTED MACH, VERT STEERING RATE, VERT STEERING
FCC	ADC	ALT, ALT RATE, COMPUTED AIRSPEED, IMPACT PRESSURE, INDICATED AOA, MACH, MAX OPRTG SCHEDULE, TRUE AIRSPEED

RCVR	XMTR	PARAMETERS
MCP	FCC	MODE STATUS, COMPUTED AIRSPEED, ELEV SPD CMD, FLAP POS, FMC AIRSPEED REF MACH, SEL RUNWAY HDG, SPD BRK HDL POS, STAB POS, TEST WORD, VERT SPD
MCP	TMC	MODE STATUS, VERT SPEED CMD
MCDP	FCC	FAULT DATA, GND TEST DATA, INTERFACE FAULT DATA, TEST WORD
SAM	FCC	MODE STATUS
EFISSG	FCC	MODE STATUS, FLT DIR PITCH, FLT DIR ROLL, HDG SELECTED, RUNWAY DIST TO GO
DFDAU	FCC	MODE STATUS
TMC	MCP	MODE STATUS, REQ MODES, ALT SELECTED, ELEV SPD CMD, MACH SELECTED, SPD BRK HDL POS, AIRSPEED SELECTED, STAB POS
FMC	MCP	MODE STATUS, REQ MODES, ALT SELECTED, FLAP POS, HDG SELECTED, MACH SELECTED, AIRSPEED SELECTED, VERT SPD SELECTED
ALT ALERT	MCP	MODE STATUS, ALT SELECTED
M/ASI	MCP	AIRSPEED SELECTED
DFDAU	MCP	ALT SELECTED, HDG SELECTED, MACH SELECTED, AIRSPEED SELECTED, VERT SPD SELECTED

TABLE 1 FCC PROGRAM PINS

PROGRAM AS CONNECTED	OPTION PIN	GND PIN	L (X = GND, D)	C	R	PROGRAM AS CONNECTED	OPTION PIN	GND PIN	L (X = GND, D)	C	R	
CUSTOMER OPTION	1	BA12	BB15	X	X	AIRPLANE CONFIG	1	AA12	AA11	X	X	
	2	BB12	BD15	X	X		2	AB12	AB11			
	3	BC12	BE5				3	AC12	AC11			
	4	BA13	BA14				4	BA11	BG8			
	5	BB13	BB14				5	BB11	BH8			
A/P MODE ENGAGE DOUBLE PUSH WARN RESET FULL TIME "NO LAND" ANN METHOD 2 MULTI-CHAN ENGA	BA3	BE4		X	X	INTERLOCK CODE	1	BC11	BJ8			
	BH13	BJ14		X	X		2	BF11	BK9	X	X	X
	BK13	BK14	X	X	X		3	BD12	BD14			
	BG13	BH14					4	BF12	BK7			
	BC8	BE8					5	BH12	BJ15			
ASA OPTION LAT CMD ENGA CWS INHIBIT FULL TIME F/D F/D AUTO ON F/D ON ROLLOUT SPARE 5 SPARE 6	BC10	BC8				CHANNEL IDENTITY PARITY (ODD)	1	AA13	AA14	X	X	
	BJ2	BJ4	X	X	X		2	AB13	AB14	X	X	X
	BD3	BK4						BC13	BF4			
	BA4	AD4	X	X	X							
	BD4	BH4										
SPARE 5 SPARE 6	BG1	AG2				SPARES (NO PARITY)	7	BG2	AG4			
	BH1	AH2					10	BD7	BG4			
							13	BG10	AG8			

009

FCC INTERFACE - LEFT

Incorporates  
22-0064

D280N032S

22-10-02

Page 101.2  
Sheet 4  
May 06/2009

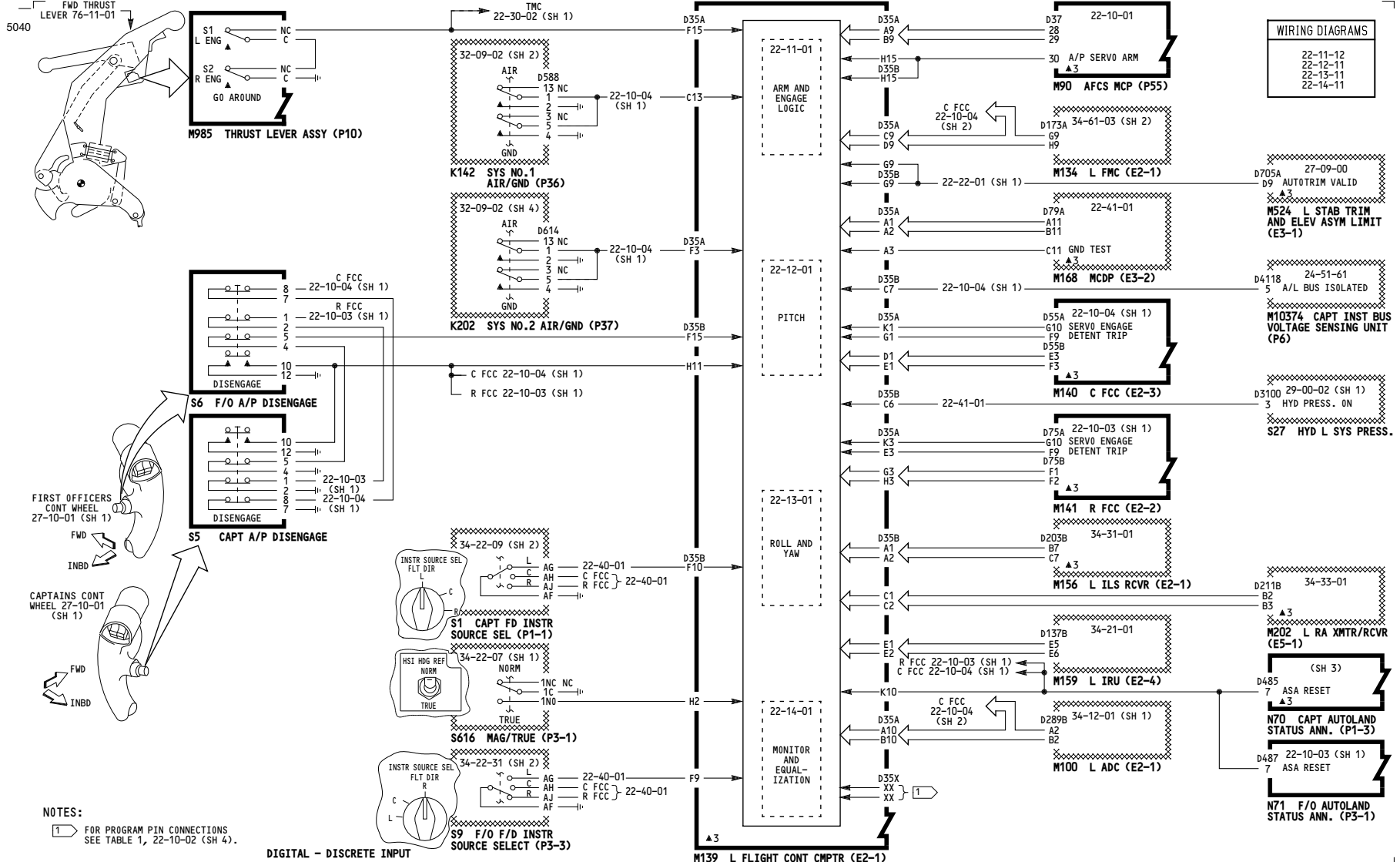

**WIRING DIAGRAMS**

- 22-11-12
- 22-12-11
- 22-13-11
- 22-14-11

D705A 27-09-00  
D9 AUTOTRIM VALID  
M524 L STAB TRIM AND ELEV ASYM LIMIT (E3-1)

D4118 24-51-61  
5 A/L BUS ISOLATED

M10374 CAPT INST BUS VOLTAGE SENSING UNIT (P6)

D3100 29-00-02 (SH 1)  
3 HYD PRESS. ON  
S27 HYD L SYS PRESS.

D211B 34-33-01  
B2 B3  
M202 L RA XMTR/RCVR (E5-1)

D485 7 ASA RESET  
M70 CAPT AUTOLAND STATUS ANN. (P1-3)

D487 22-10-03 (SH 1)  
7 ASA RESET  
M71 F/O AUTOLAND STATUS ANN. (P3-1)

010-099

**FCC INTERFACE - LEFT**

D280N032S

**22-10-02**



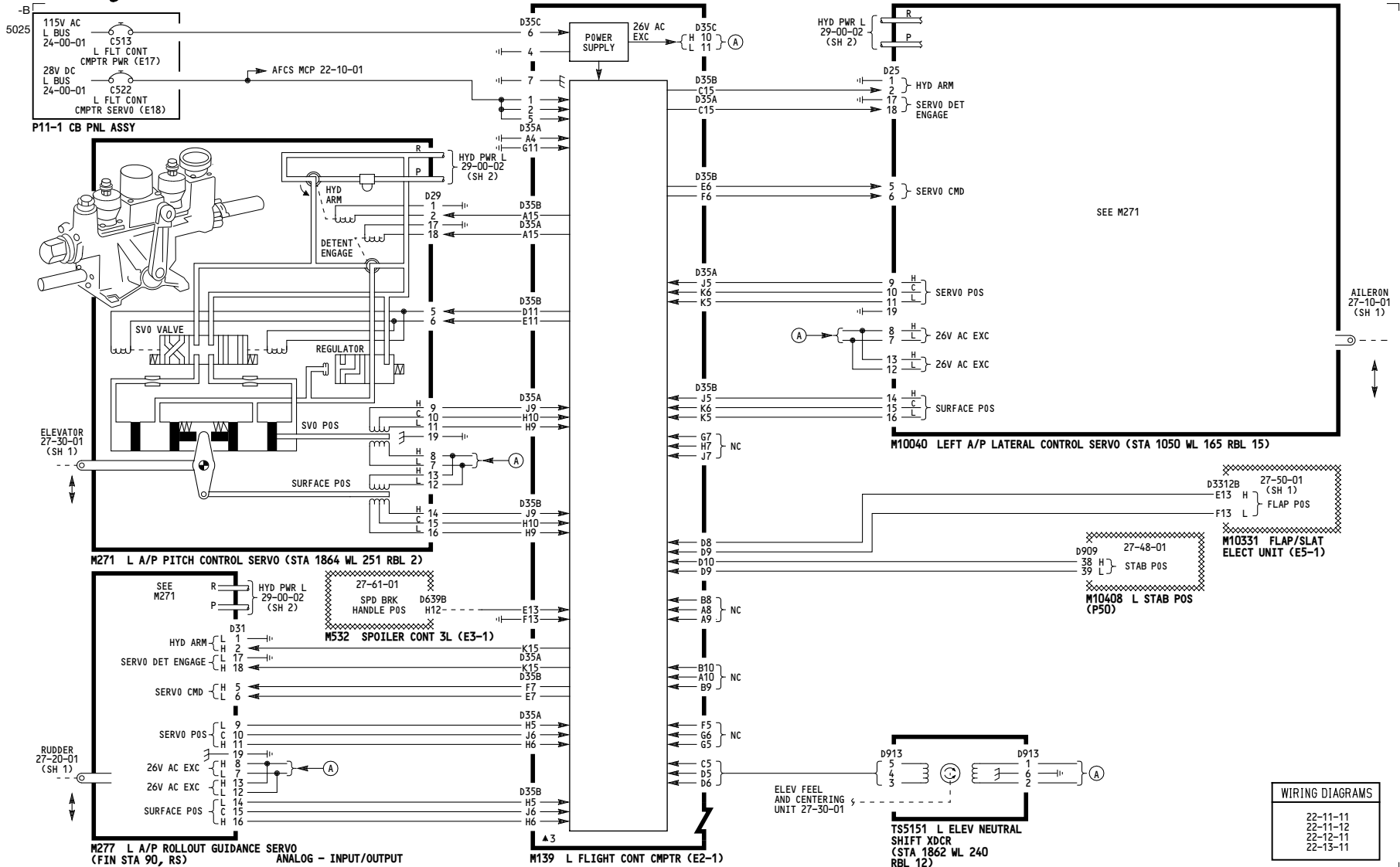

010-099

**FCC INTERFACE - LEFT**

D280N032S

WIRING DIAGRAMS	
22-11-11	
22-11-12	
22-12-11	
22-13-11	

**22-10-02**

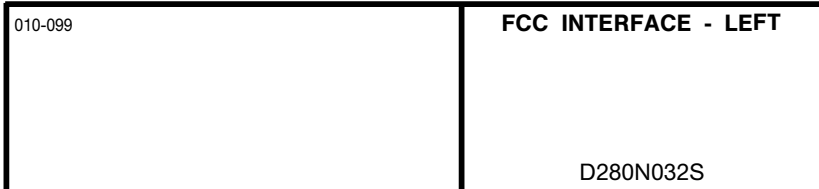
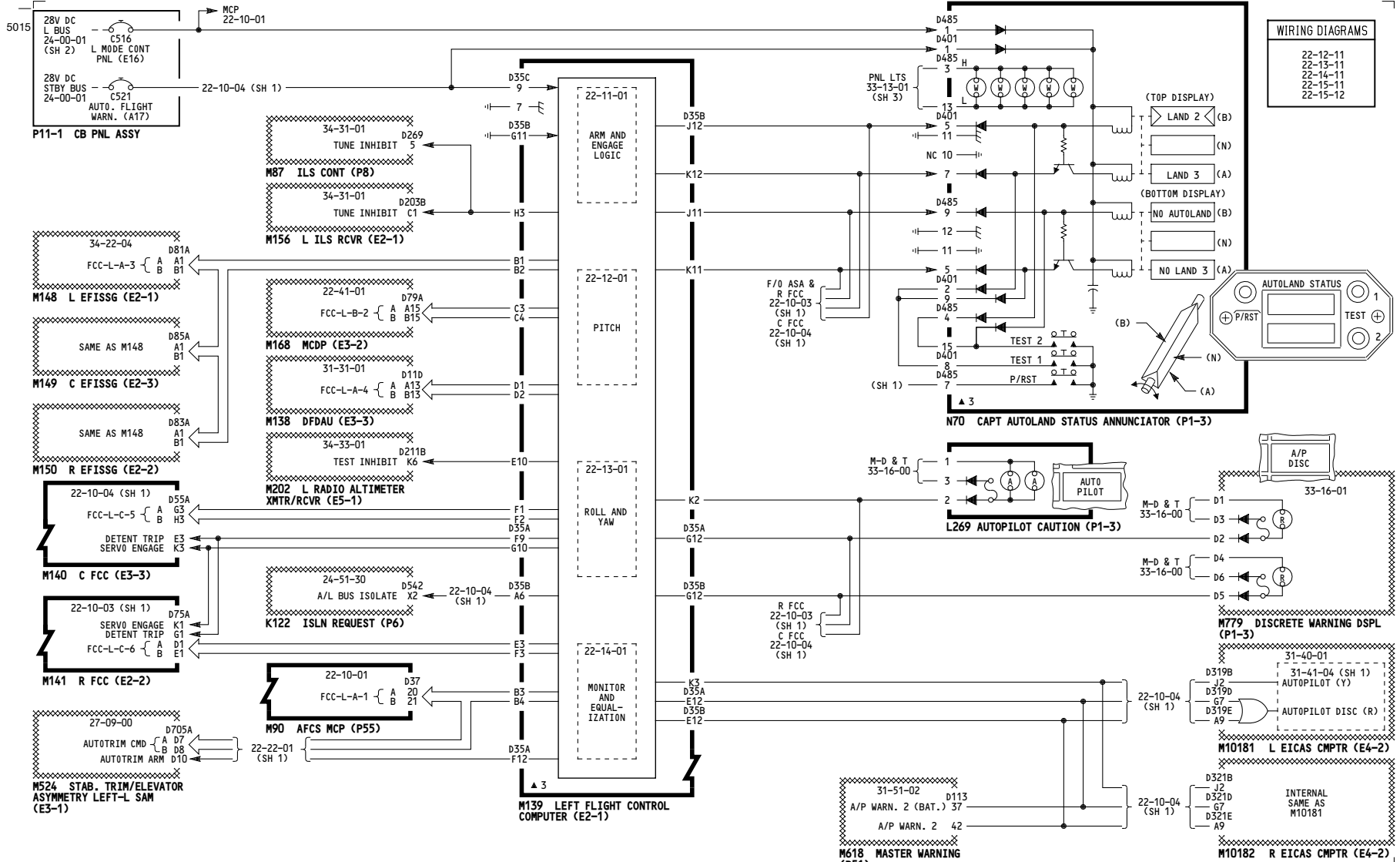

**22-10-02**



# 757-200 SYSTEM SCHEMATIC MANUAL

5004

RCVR	XMTR	PARAMETERS
FCC	MCP	MODE STATUS, REQ MODES, ALT SELECTED HDG SELECTED MACH SELECTED, MCP MAINT DATA AIRSPEED SELECTED, TEST WORD, VERT SPD, CMD, VERT SPD SELECTED
FCC	MCDP	TEST CONTROL (12 WORDS)
FCC	FCC	AIL CMD, ALONG TK HRZ ACCEL, ALT, ALT REF, LATERAL ACCEL, LONGIT ACCEL, NORMAL ACCEL, PITCH RATE, ROLL RATE, YAW RATE, COMPUTED AIRSPEED, CROSS TK HRZ ACCEL, DISCRETE WORD, ELEV CMD, FLAP POS, FLT PATH ACCEL, G/S DEV, GND SPEED, HDG REF, HORIZONTAL STEERING, IMPACT PRESSURE, INDICATED AOA, INERTIAL ALT, INERTIAL VERT SPD, INPUT DISC PCKD WD, LOC DEV, MACH MAG HDG, PITCH ANGLE, RADIO HEIGHT ROLL ANGLE, RUDDER CMD, SEL RUNWAY HDG, STAB POS, TEST WORD, TRUE TRACK ANGLE, MAG TRACK ANGLE, TRUE AIRSPEED, TRUE HDG, VERT STEERING RATE, VERT ACCEL, VERT STEERING
FCC	IRU	ALONG TK HRZ ACCEL, LATERAL ACCEL, LONGIT ACCEL, NORMAL ACCEL, PITCH RATE, ROLL RATE, YAW RATE, CROSS TK HRZ ACCEL, FLT PATH ACCEL, GND SPEED, INERTIAL ALT, INERTIAL VERT SPD, IRS DISCRETES, MAG HDG, PITCH ANGLE, PITCH ATT RATE, ROLL ANGLE, TRUE TRACK ANGLE, MAG TRACK ANGLE, TRUE HDG, VERT ACCEL
FCC	ILS	G/S DEV, ILS FREQ, LOC DEV, SEL RUNWAY HDG
FCC	RA	RADIO HEIGHT
FCC	FMC	FMC DISCRETES, HORIZONTAL STEERING, SELECTED AIRSPEED, SELECTED ALT, SELECTED MACH, VERT STEERING RATE, VERT STEERING
FCC	ADC	ALT, ALT RATE, COMPUTED AIRSPEED, IMPACT PRESSURE, INDICATED AOA, MACH, MAX OPRG SCHEDULE, TRUE AIRSPEED

RCVR	XMTR	PARAMETERS
MCP	FCC	MODE STATUS, COMPUTED AIRSPEED, ELEV SPD CMD, FLAP POS, FMC AIRSPEED REF MACH, SEL RUNWAY HDG, SPD BRK HDL POS, STAB POS, TEST WORD, VERT SPD
MCP	TMC	MODE STATUS, VERT SPEED CMD
MCDP	FCC	FAULT DATA, GND TEST DATA, INTERFACE FAULT DATA, TEST WORD
SAM	FCC	MODE STATUS
EFISSG	FCC	MODE STATUS, FLT DIR PITCH, FLT DIR ROLL, HDG SELECTED, RUNWAY DIST TO GO
DFDAU	FCC	MODE STATUS
TMC	MCP	MODE STATUS, REQ MODES, ALT SELECTED, ELEV SPD CMD, MACH SELECTED, SPD BRK HDL POS, AIRSPEED SELECTED, STAB POS
FMC	MCP	MODE STATUS, REQ MODES, ALT SELECTED, FLAP POS, HDG SELECTED, MACH SELECTED, AIRSPEED SELECTED, VERT SPD SELECTED
ALT ALERT	MCP	MODE STATUS, ALT SELECTED
M/ASI	MCP	AIRSPEED SELECTED
DFDAU	MCP	ALT SELECTED, HDG SELECTED, MACH SELECTED, AIRSPEED SELECTED, VERT SPD SELECTED

TABLE 1 FCC PROGRAM PINS (757-200)

PROGRAM AS CONNECTED	OPTION PIN	GND PIN	L (X = GNDD)	C	R	PROGRAM AS CONNECTED	OPTION PIN	GND PIN	L (X = GNDD)	C	R	
CUSTOMER OPTION	1	BA12	BB15	X	X	AIRPLANE CONFIG	1	AA12	AA11	X	X	
	2	BB12	BD15	X	X		2	AB12	AB11			
	3	BC12	BE5				3	AC12	AC11			
	4	BA13	BA14				4	BA11	BG8			
	5	BB13	BB14				5	BB11	BH8			
A/P MODE ENGAGE DOUBLE PUSH WARN RESET FULL TIME NO LAND ANN METHOD 2 MULTI-CHAN ENGA ASA OPTION LAT CMD ENGA CWS INHIBIT FULL TIME F/D F/D AUTO ON F/D ON ROLLOUT SPARE 5 SPARE 6	BA3	BE4	X	X	X	INTERLOCK CODE	1	BC11	BJ8			
	BH13	BJ14					2	BF11	BK9			
	BK13	BK14	X	X	X		3	BD12	BD15			
	BG13	BH14					4	BF12	BK7			
	BC8	BE8					5	BH12	BJ15			
	BC10	BC14				CHANNEL IDENTITY PARITY (ODD)	1	AA13	AA14	X	X	
	BJ2	BJ4	X	X	X		2	AB13	AB14	X	X	
	BD3	BK4	X	X	X			BC13	BF4	X	X	
	BA4	AD4	X	X	X	SPARES (NO PARITY)	7	BG2	AG4			
	BD4	BH4					10	BD7	BG4			
BG1	AG2				13		BG10	AG8				

010-099

## FCC INTERFACE - LEFT

D280N032S

22-10-02

Page 102  
Sheet 4  
Jan 21/2005



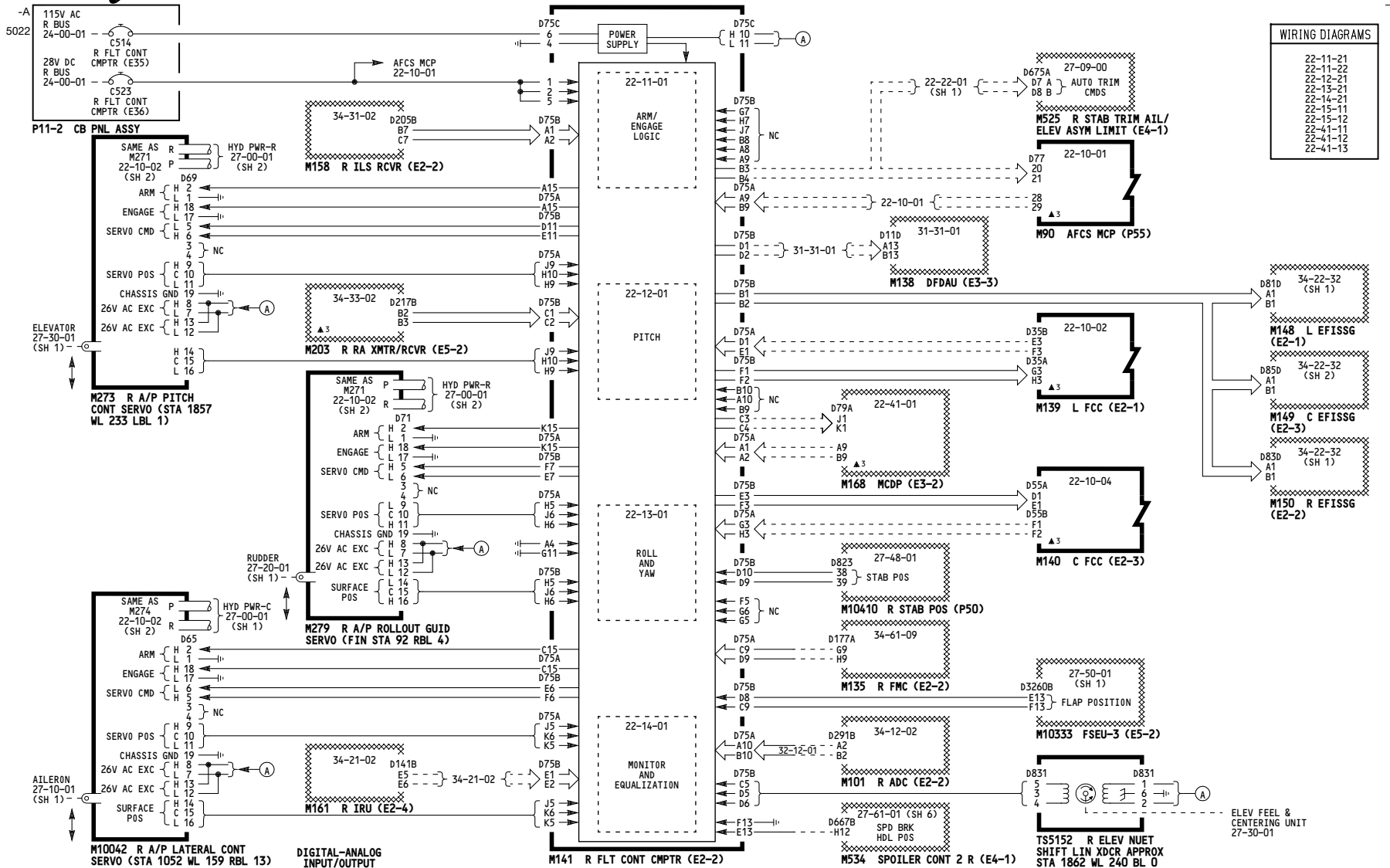

**WIRING DIAGRAMS**

22-11-21
22-11-22
22-12-21
22-15-21
22-14-21
22-15-11
22-15-12
22-41-11
22-41-12
22-41-13

ALL

**FCC INTERFACE - RIGHT**

D280N032S

**22-10-03**

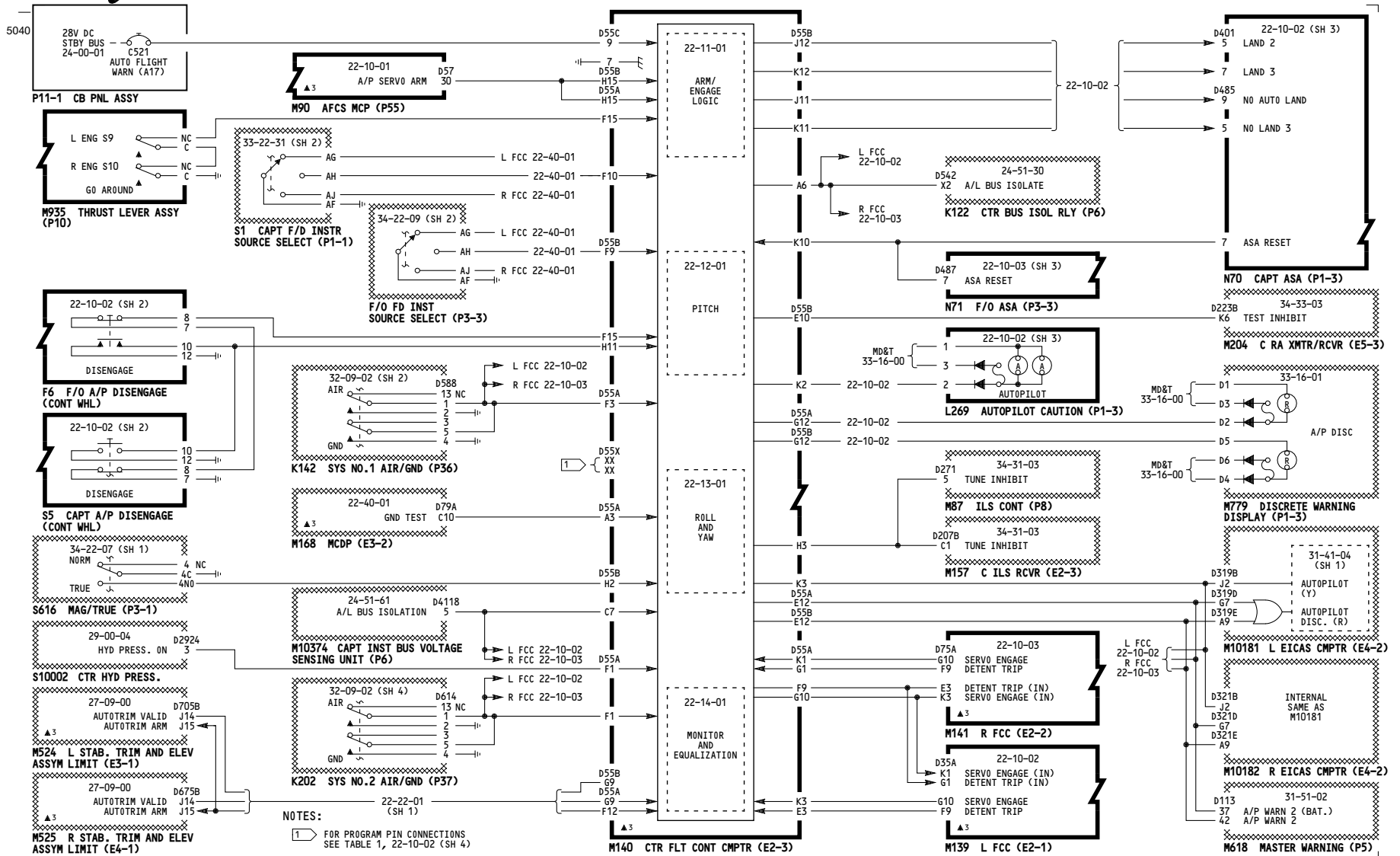

ALL

**FCC INTERFACE - CENTER**

D280N032S

**22-10-04**

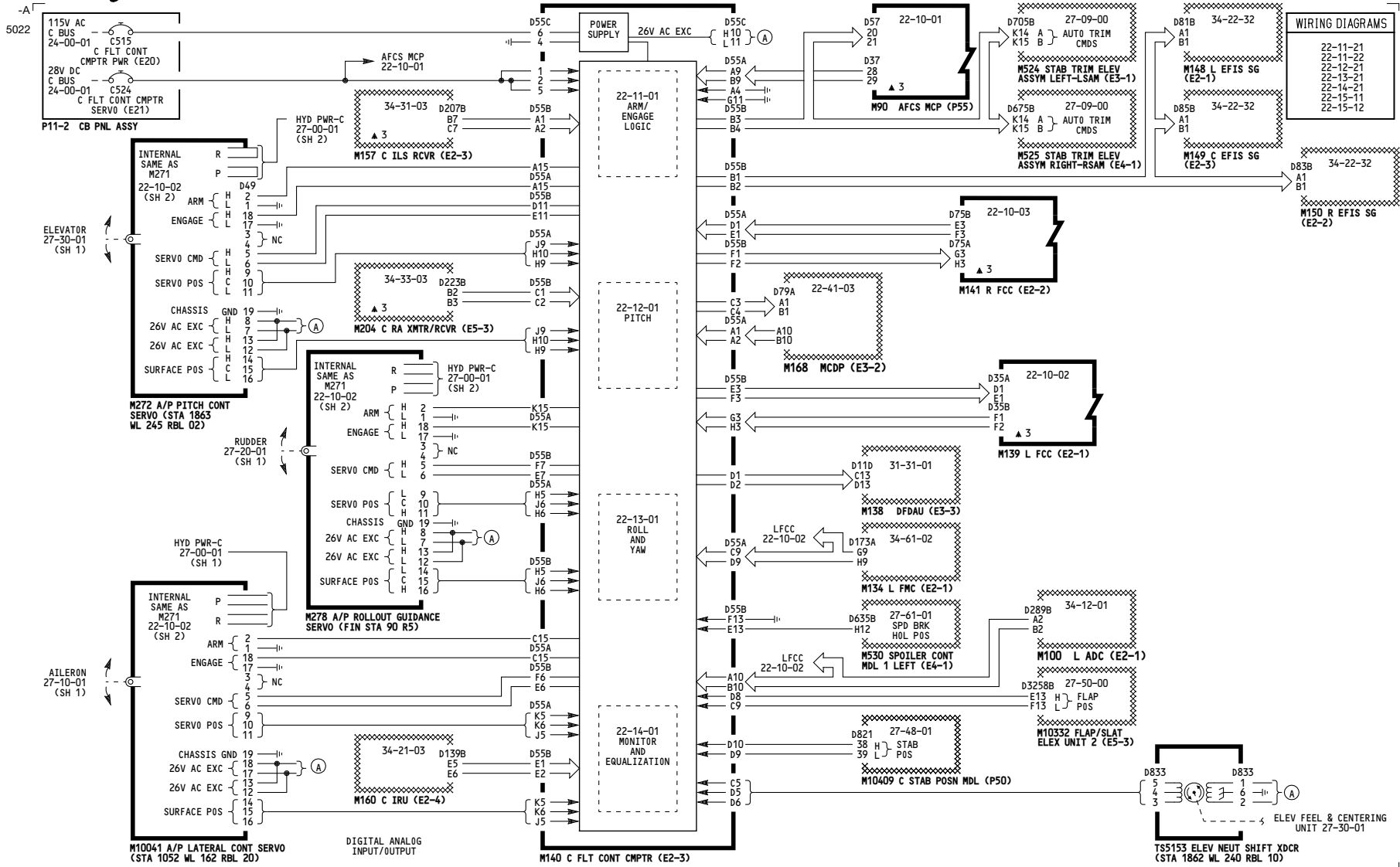

ALL

**FCC INTERFACE - CENTER**

D280N032S

**22-10-04**

5001

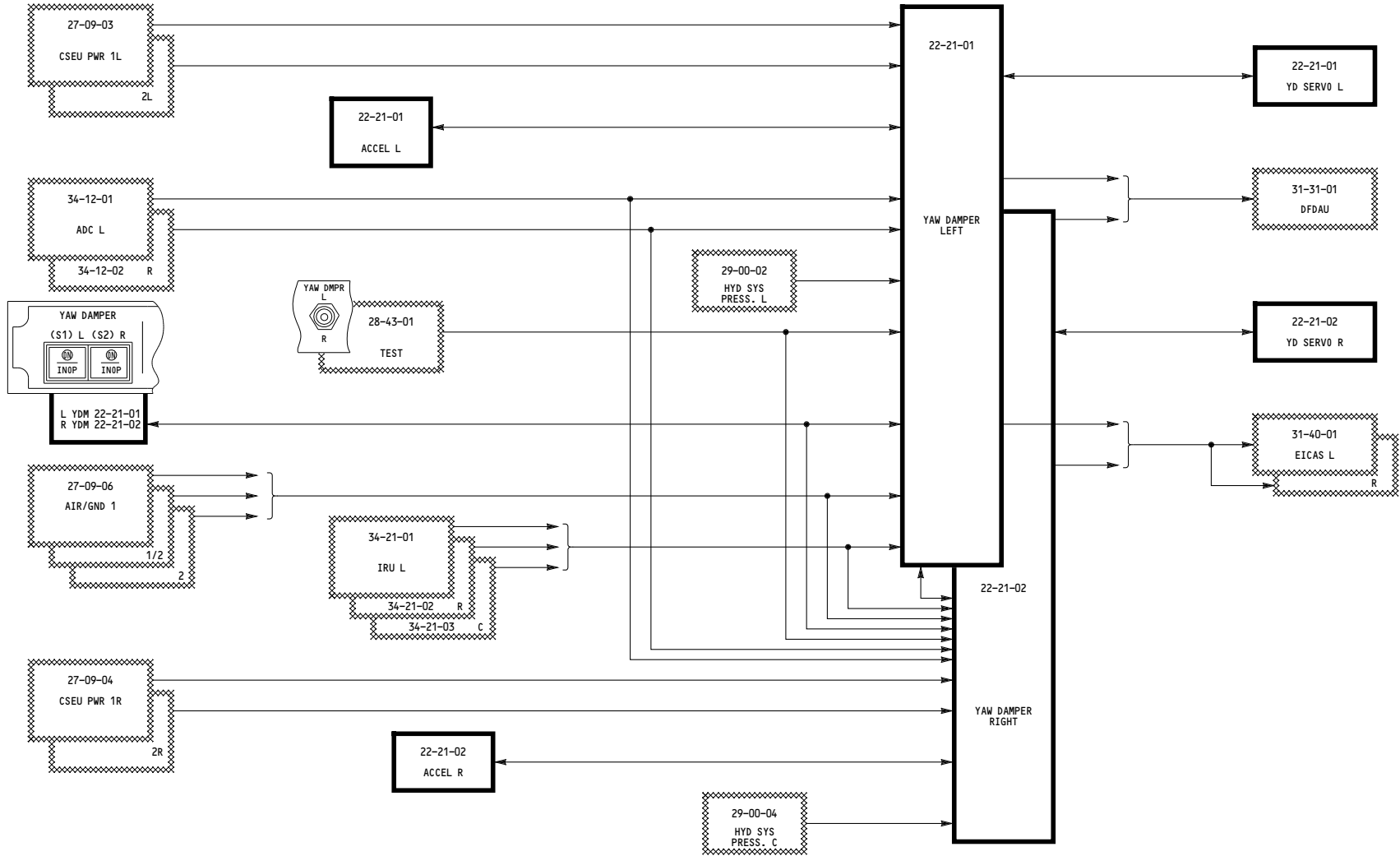

ALL	<p><b>YAW DAMPER - SIMPLIFIED</b></p> <p>D280N032S</p>
-----	--

**22-21-00**

Page 101

May 06/2009



THIS PAGE INTENTIONALLY LEFT BLANK

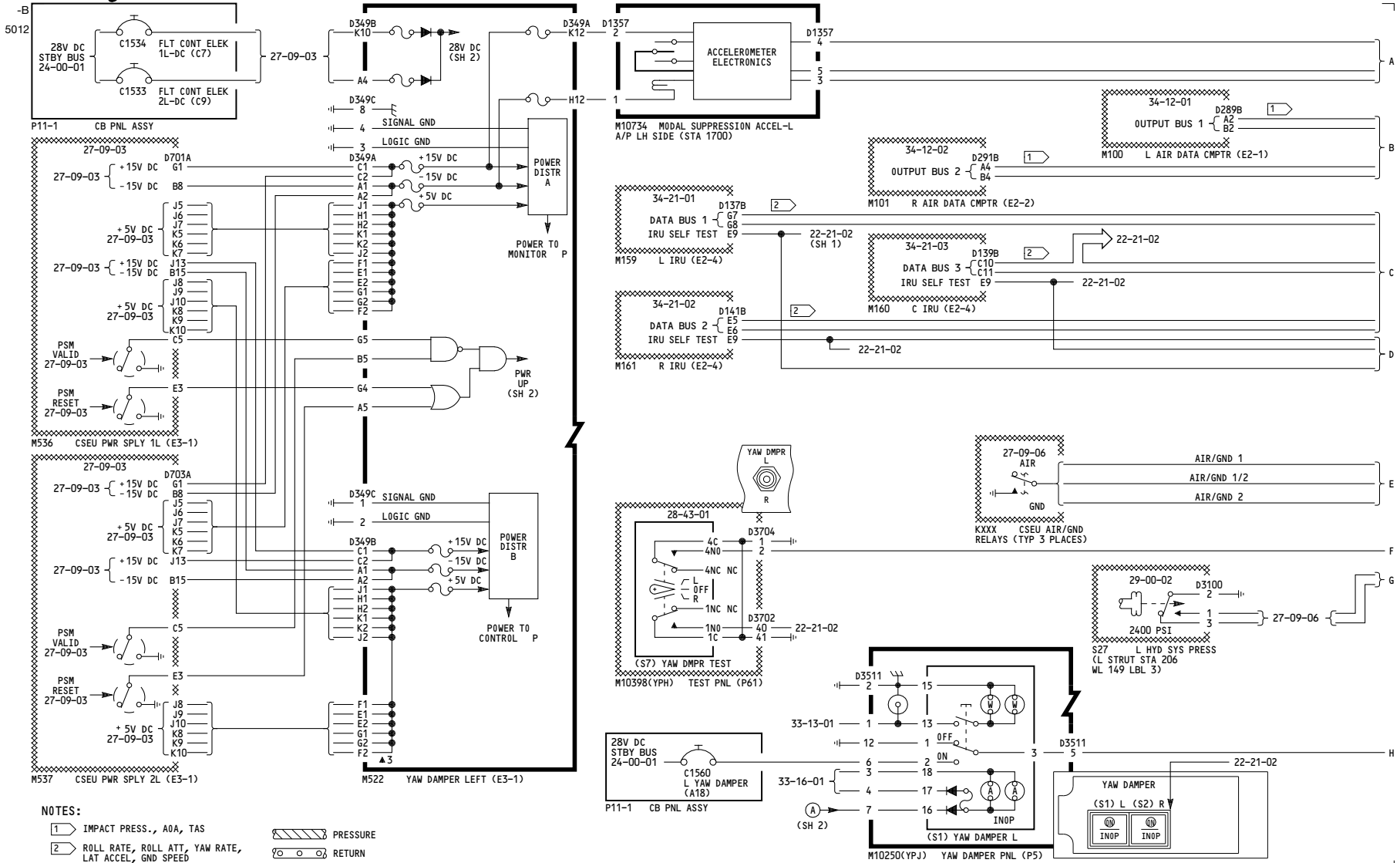

- NOTES:**
- 1 IMPACT PRESS., A0A, TAS
  - 2 ROLL RATE, ROLL ATT, YAW RATE, LAT ACCEL, GND SPEED
  - Pressure symbol:
  - Return symbol:

ALL	<b>YAW DAMPER - LEFT</b>
D280N032S	

**22-21-01**

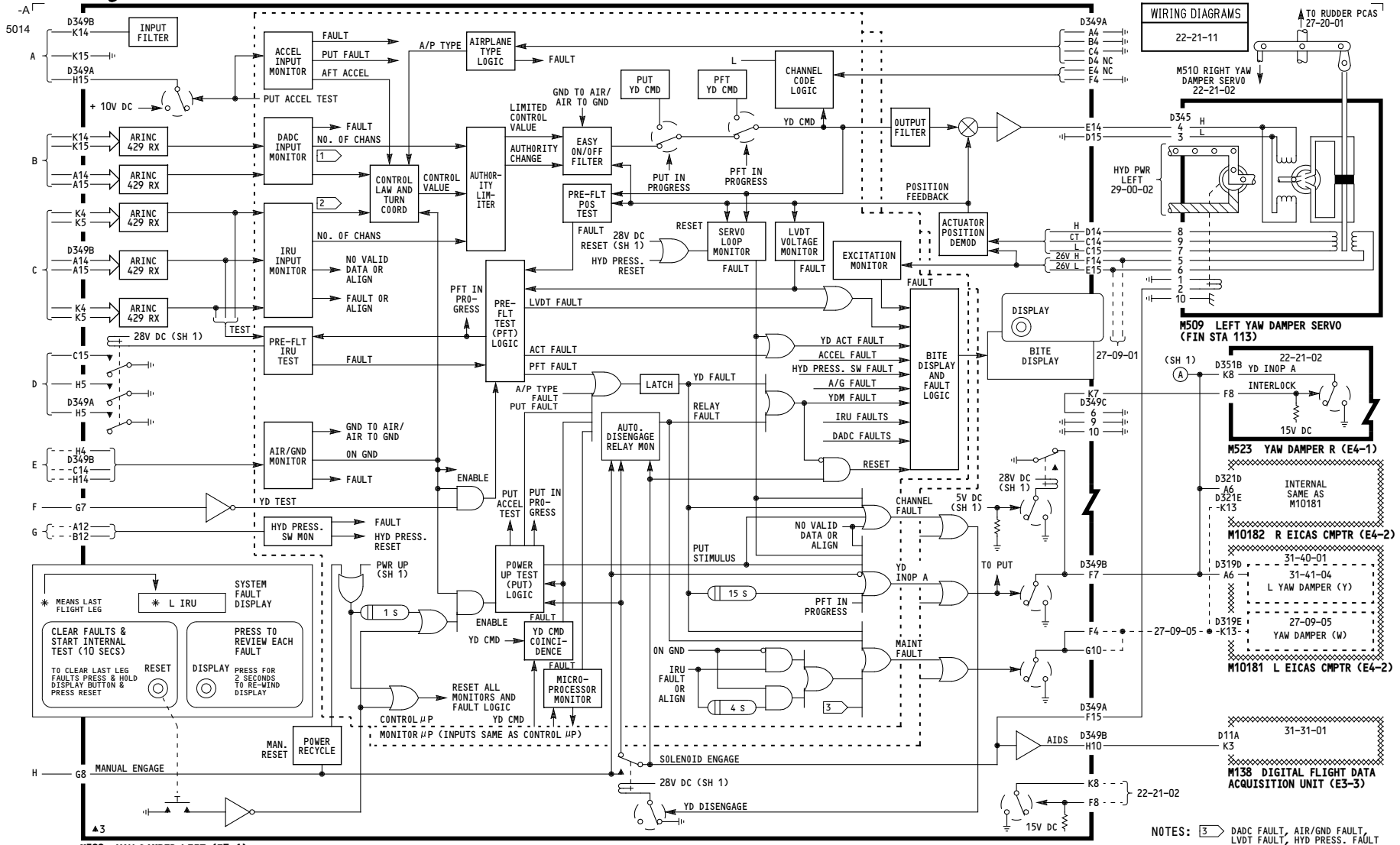

NOTES: ③ DADC FAULT, AIR/GND FAULT, LVDT FAULT, HYD PRESS. FAULT

**M522 YAW DAMPER LEFT (E3-1)**

**ALL**

**YAW DAMPER - LEFT**

D280N032S

**22-21-01**

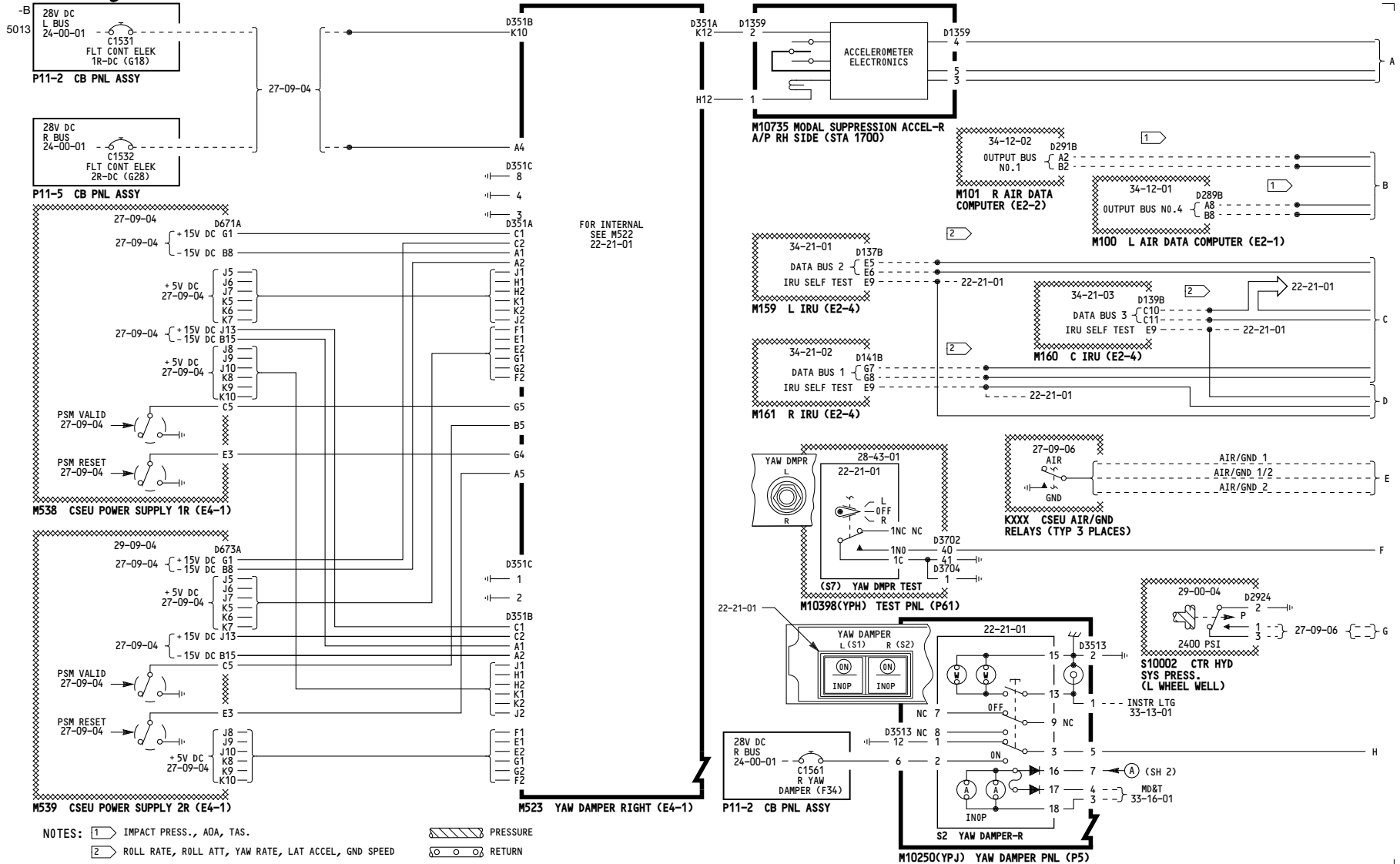

ALL	<b>YAW DAMPER - RIGHT</b>
D280N032S	

**22-21-02**

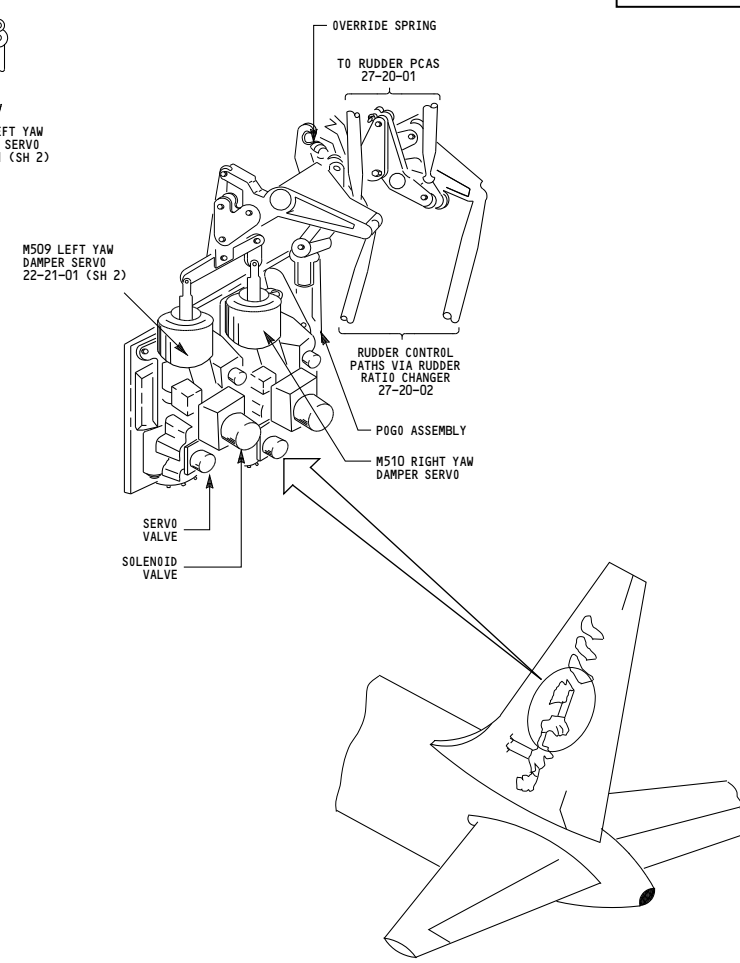
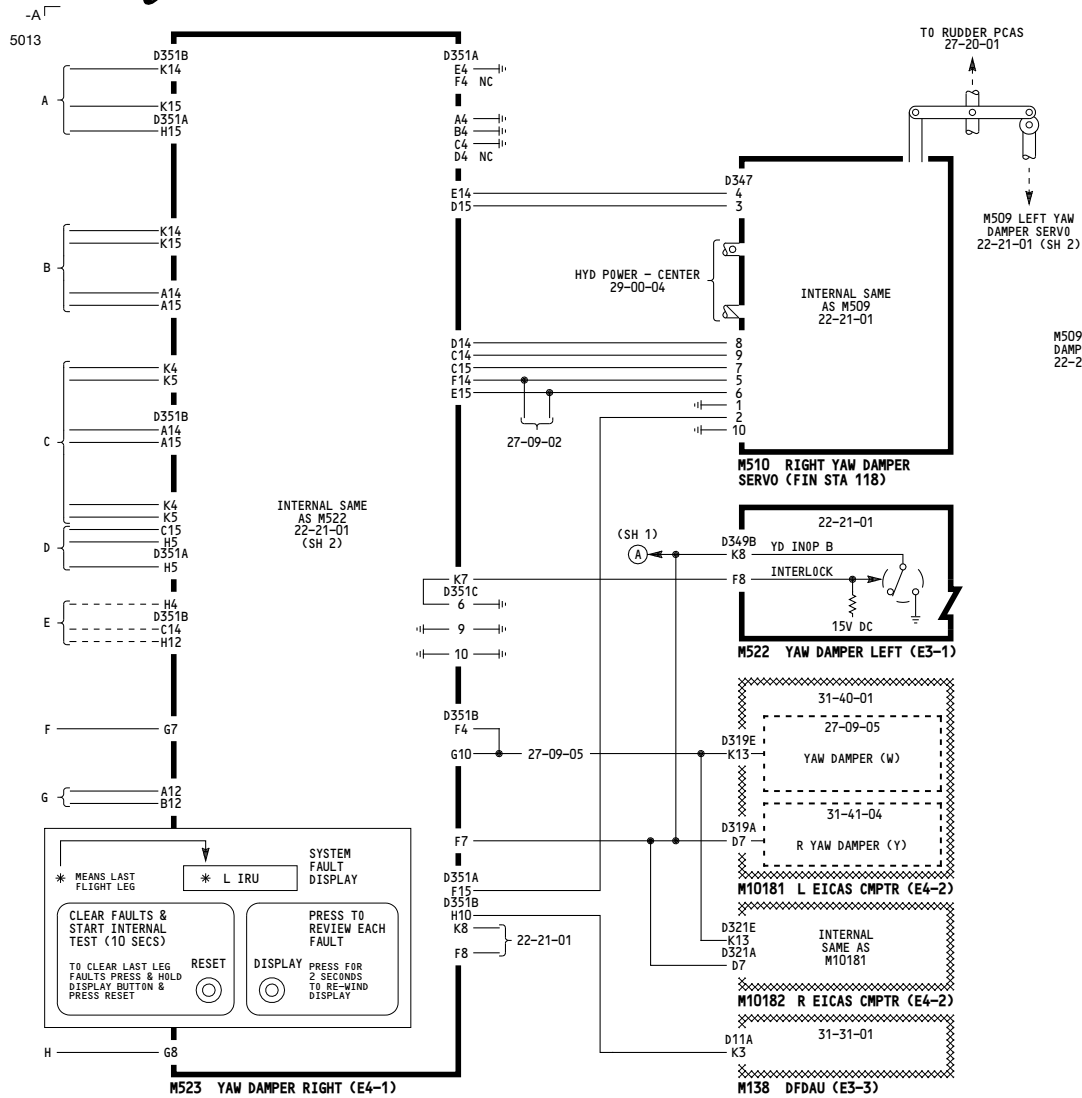

ALL	<b>YAW DAMPER - RIGHT</b>
D280N032S	

**22-21-02**

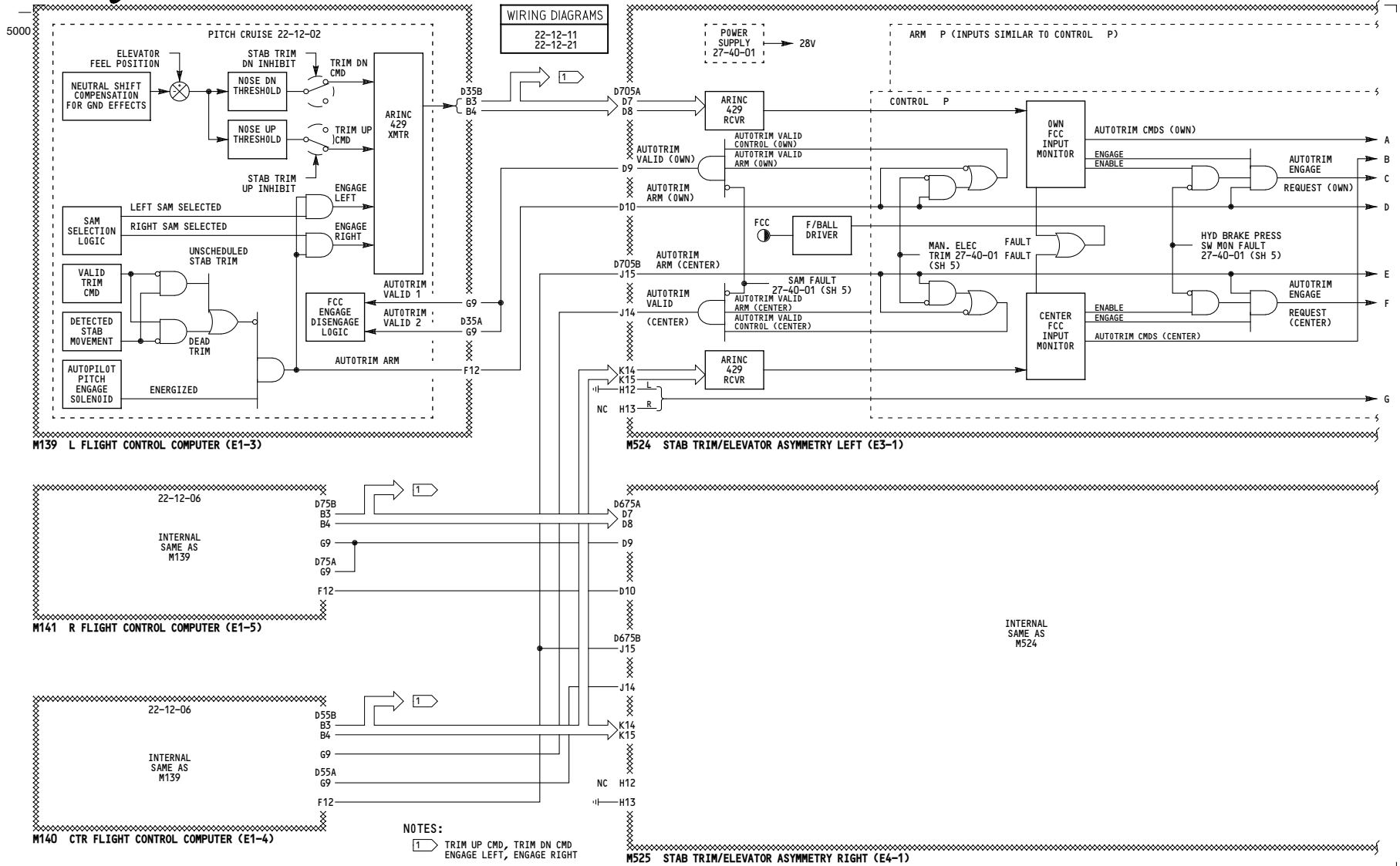

ALL	<b>AUTOMATIC STABILIZER TRIM</b>  D280N032S
-----	---

**22-22-01**

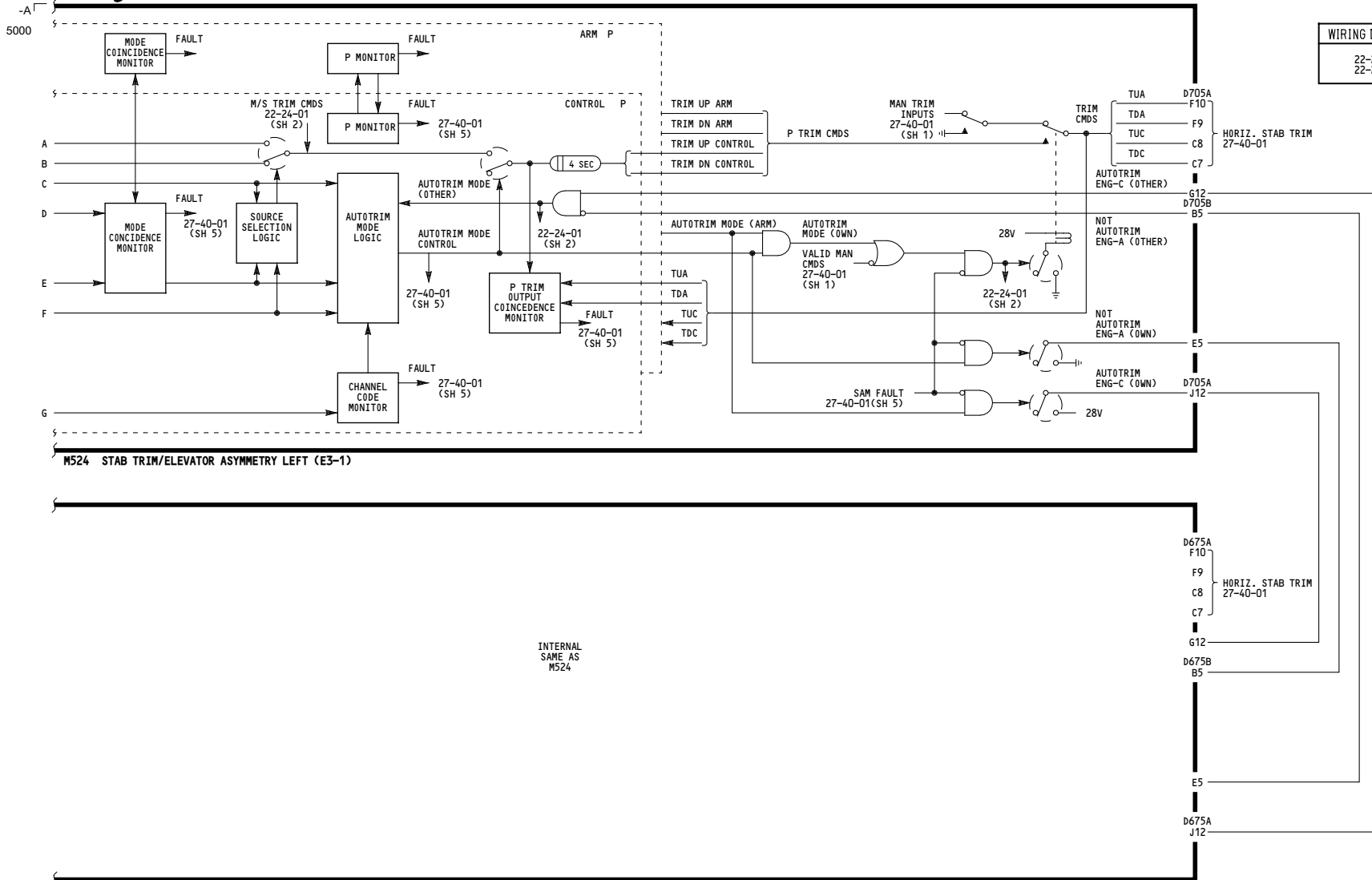

ALL	<b>AUTOMATIC STABILIZER TRIM</b>
	D280N032S

**22-22-01**

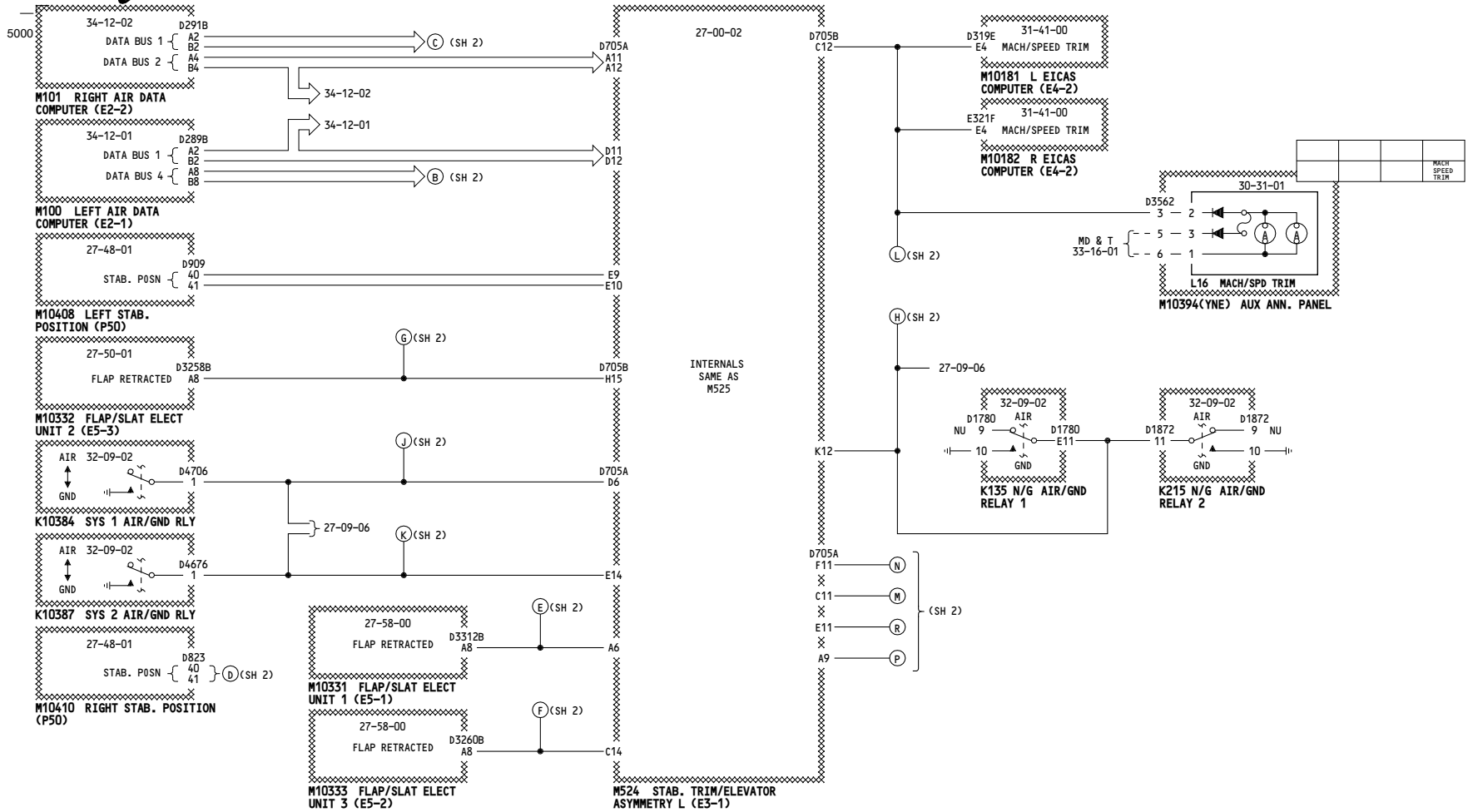

ALL	<b>MACH TRIM/SPEED STABILITY</b>
	D280N032S

22-24-01



5001

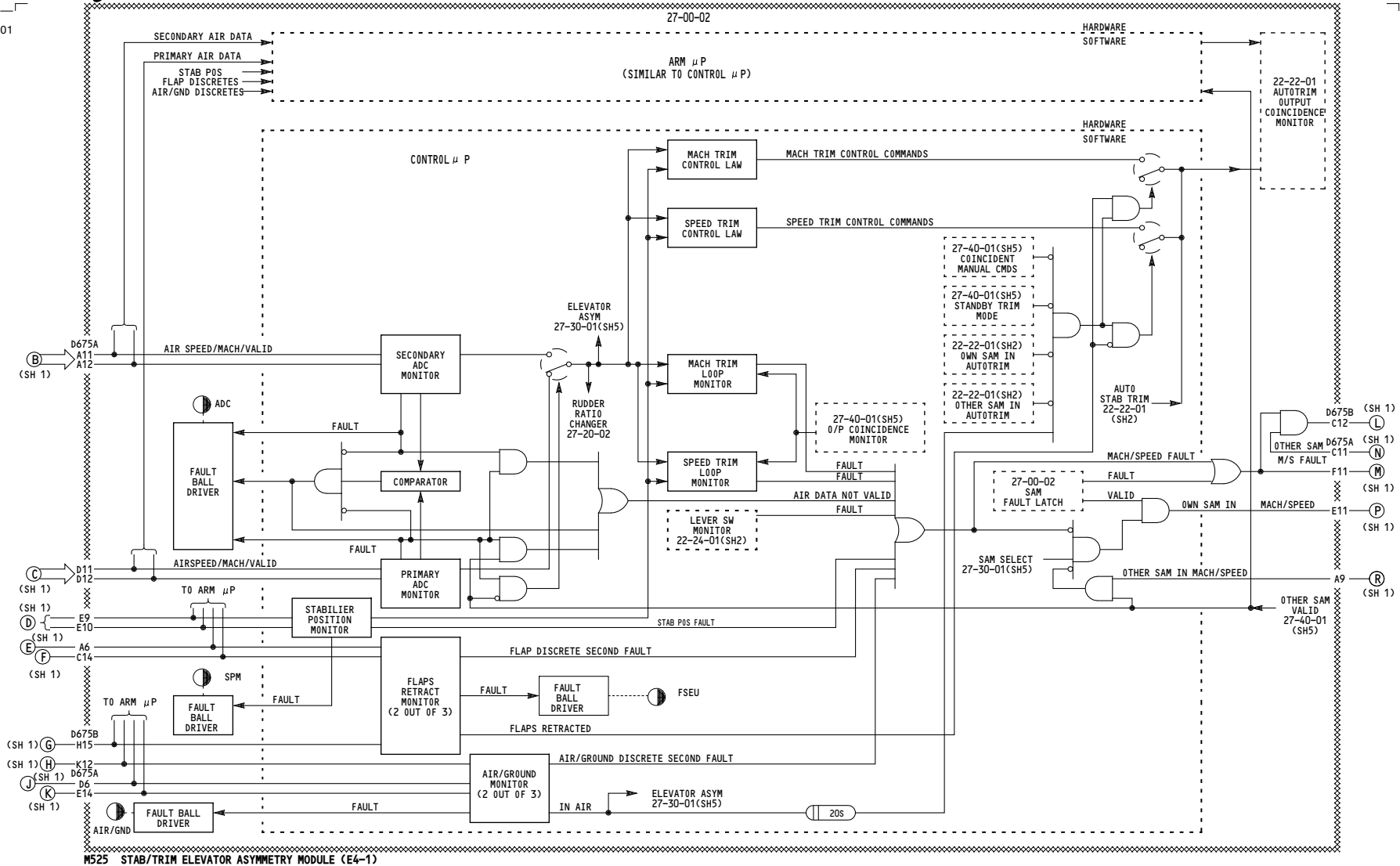

ALL	<b>MACH TRIM/SPEED STABILITY</b>
	D280N032S

**22-24-01**

Page 101  
Sheet 2  
May 06/2009

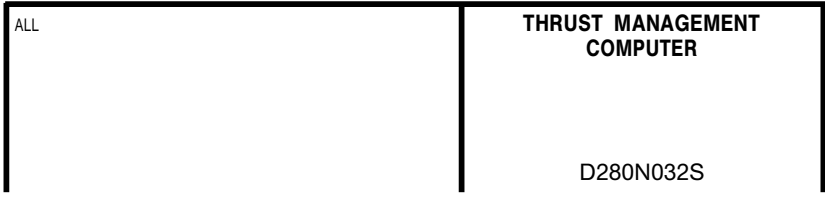
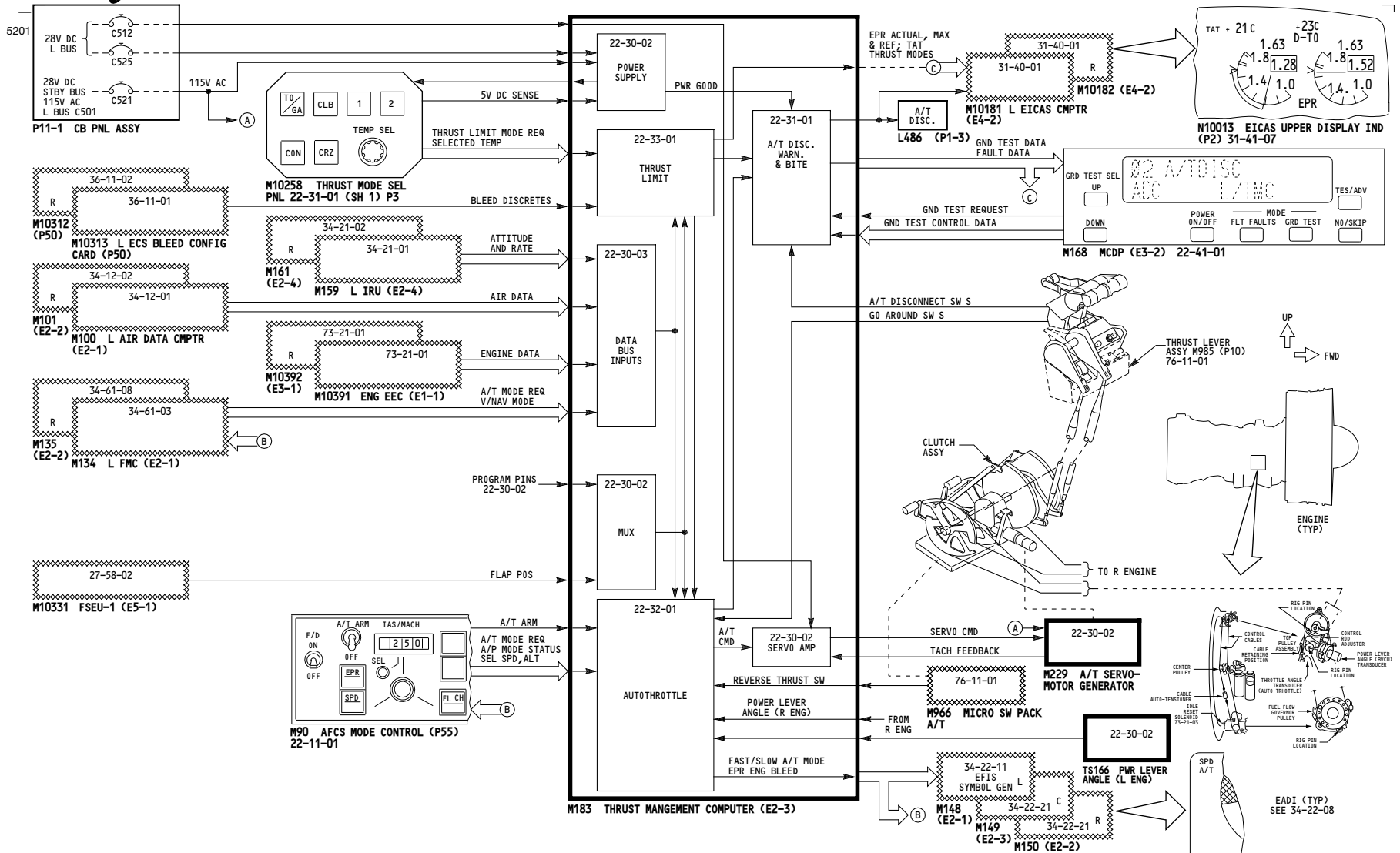

**22-30-01**

THIS PAGE INTENTIONALLY LEFT BLANK

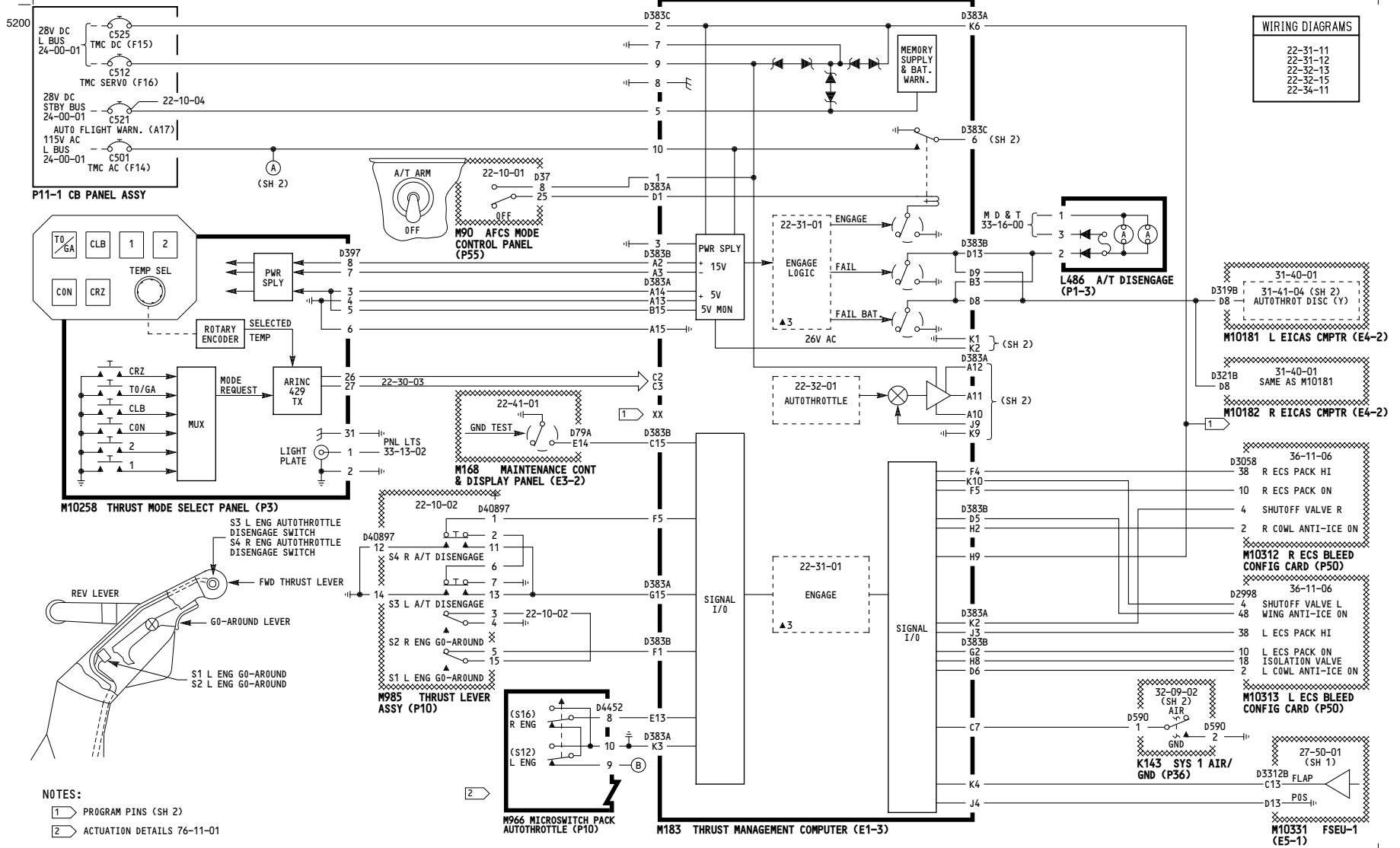

**NOTES:**  
 1 PROGRAM PINS (SH 2)  
 2 ACTUATION DETAILS 76-11-01

ALL

**THRUST MANAGEMENT  
COMPUTER - ANALOG  
INTERFACE**

D280N032S

**22-30-02**

5206

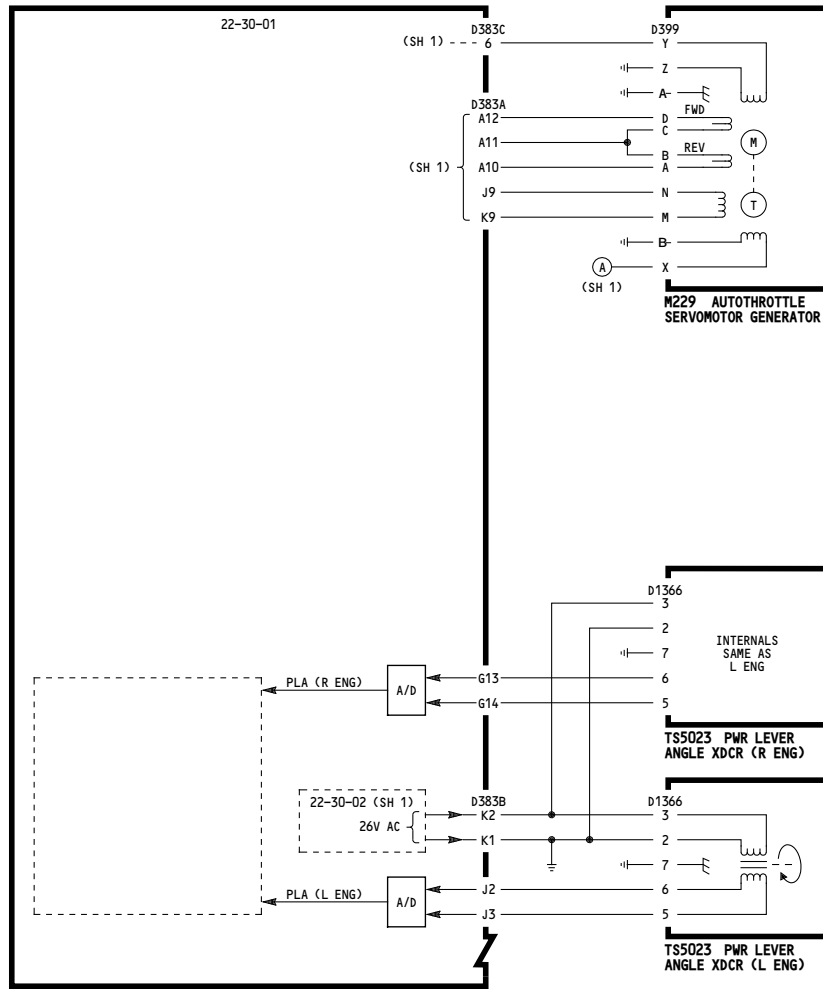

M183 TMC (E2-3)

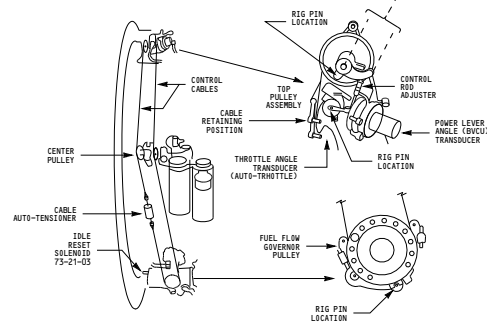
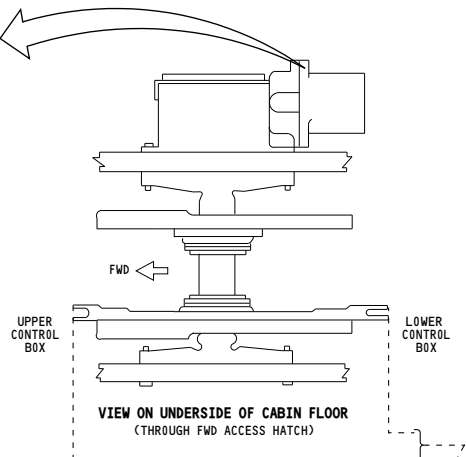

**WIRING DIAGRAMS**

- 22-31-11
- 22-32-14
- 22-33-11
- 22-34-11

PROGRAM PIN	PIN D383X	STATE	PROGRAM AS CONNECTED	CODE
ENG PP	1 B D10	NC	RB211-535E4	1
	2 B F6	NC		0
	3 B G11	GND		0
	4 B C1	GND		0
	5 A E15	GND		0
THR LIM CUST OPT	1 A F7	28V DC	ALT RATINGS OR FIXED DERATES IN CLIMB ONLY	1
	2 A F9	28V DC		0
	3 A K5	GND		0
	4 B H10	GND		0
ENG & THRUST LIM PARITY	A D13	NC	ODD PARITY	1
A/T CUST OPT	1 A J10	28V DC	EEC REQUIRED (NORMAL) OPER W/O ANTI-ICE	1
	2 A H6	GND		0
	3 A F3	28V DC		1
	4 A J12	GND		0
APL PP	1 B F2	GND	757-200	0
	2 B F4	NC		1
	3 A B11	GND		0
	4 A E14	GND		0
A/T & APL PARITY	A H15	GND	ODD PARITY	0
CUST OPT	1 A D12	GND	EPR REF BUG DRIVE & EPR REF OUTPUT FULL TIME FAST/SLOW DOUBLE PUSH RESET NO EXT FMC SEL	0
	2 A D10	GND		0
	3 A G8	GND		0
	4 A D11	GND		0
	5 A C11	GND		0

PROGRAM PIN CONFIGURATION

ALL	<b>THRUST MANAGEMENT COMPUTER - ANALOG INTERFACE</b>
D280N032S	

**22-30-02**

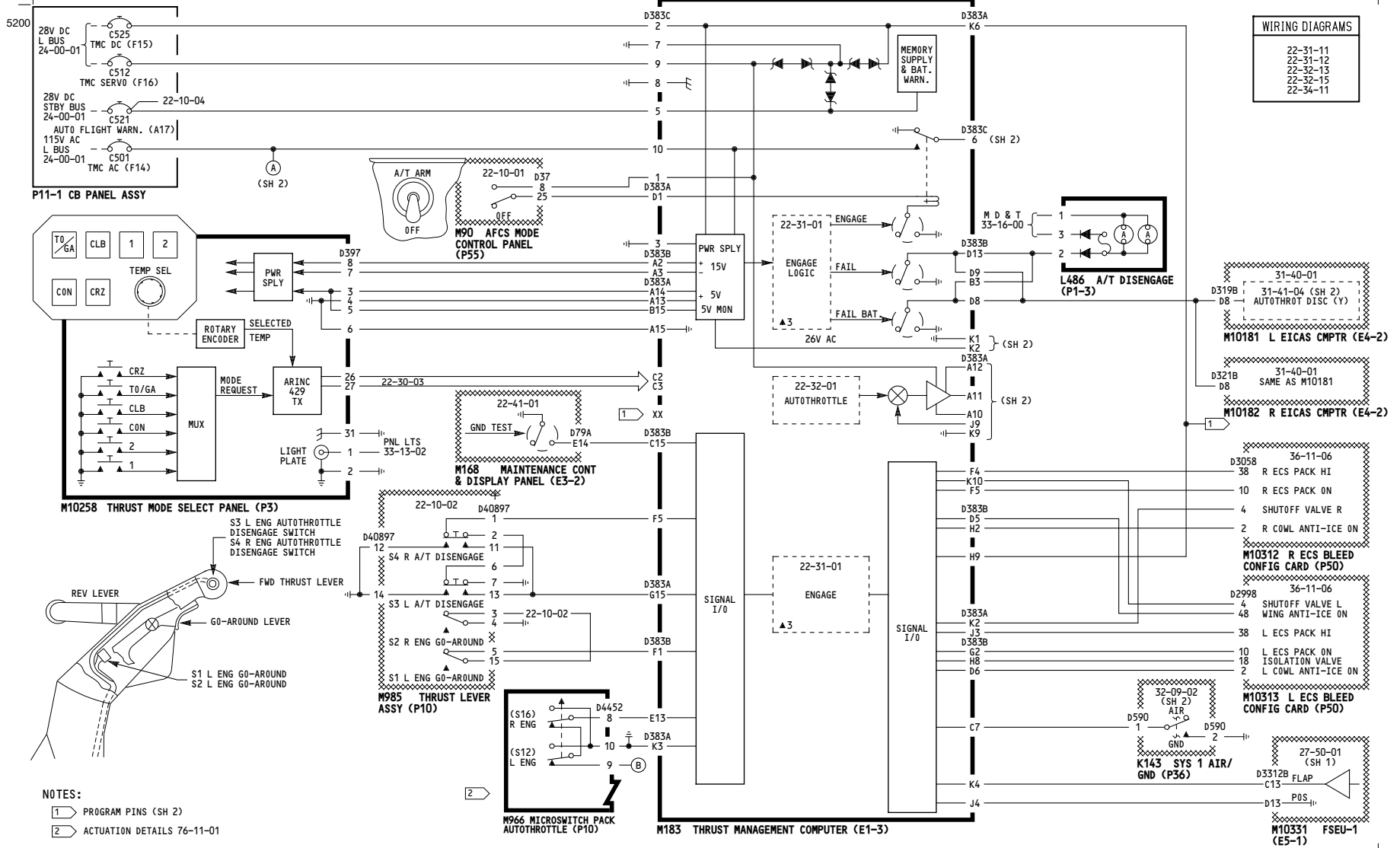

**NOTES:**  
 1 PROGRAM PINS (SH 2)  
 2 ACTUATION DETAILS 76-11-01

001

**THRUST MANAGEMENT  
COMPUTER - ANALOG  
INTERFACE**

D280N032S

**22-30-02**

5288

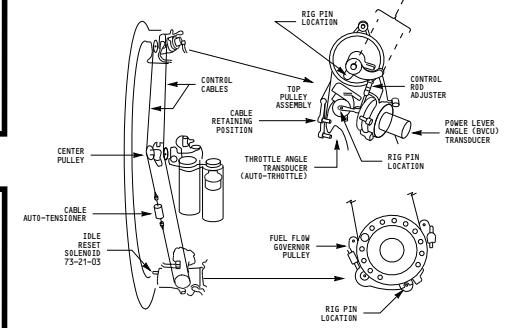
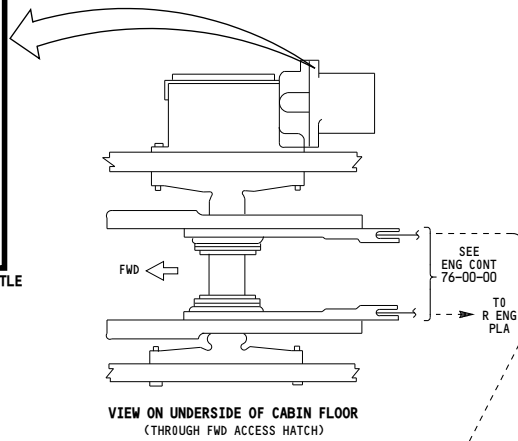
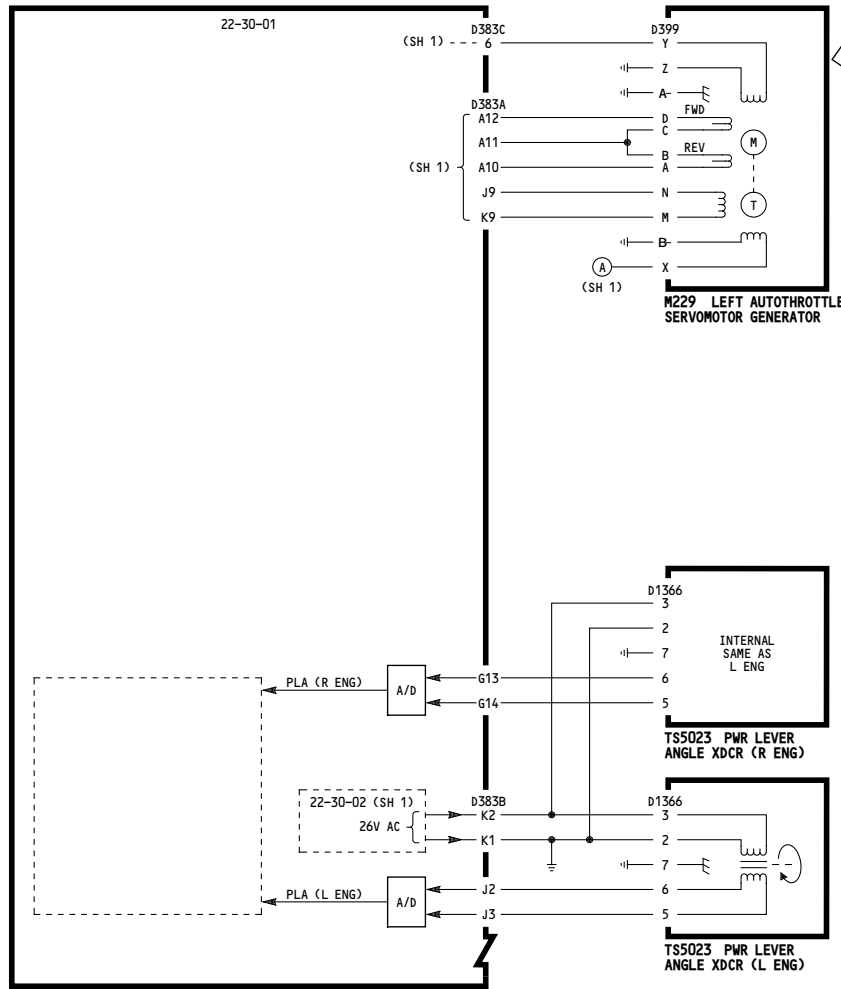

**WIRING DIAGRAMS**

22-31-11  
22-32-14  
22-33-11  
22-34-11

PROGRAM PIN	PIN D383X	STATE	PROGRAM AS CONNECTED	CODE
ENG PP	1	B D10	RB211-535E4	1
	2	B F6		0
	3	B G11		0
	4	B C1		0
	5	A E15		0
THR LIM CUST OPT	1	A F7	ALT RATINGS OR FIXED DERATES IN CLIMB ONLY	1
	2	A F9		0
	3	A K5		0
	4	B H10		0
ENG & THRUST LIM PARITY	A D13	NC	ODD PARITY	1
A/T CUST OPT	1	A J10	EEC REQUIRED (NORMAL) OPER W/O ANTI-ICE	1
	2	A H6		1
	3	A F3		0
	4	A J12		0
APL PP	1	B F2	757-200	0
	2	B F4		1
	3	A B11		0
	4	A E14		0
A/T & APL PARITY	A H15	NC	ODD PARITY	1
CUST OPT	1	A D12	EPR REF BUG DRIVE & EPR REF OUTPUT FULL TIME FAST/SLOW DOUBLE PUSH RESET NO EXT FMC SEL	1
	2	A D10		0
	3	A G8		0
	4	A D11		0
	5	A C11		0

**PROGRAM PIN CONFIGURATION**

M183 TMC (E2-3)

001	<b>THRUST MANAGEMENT COMPUTER - ANALOG INTERFACE</b>  D280N032S
-----	---

Incorporates 22-0078 R01

**22-30-02**

-B  
5201

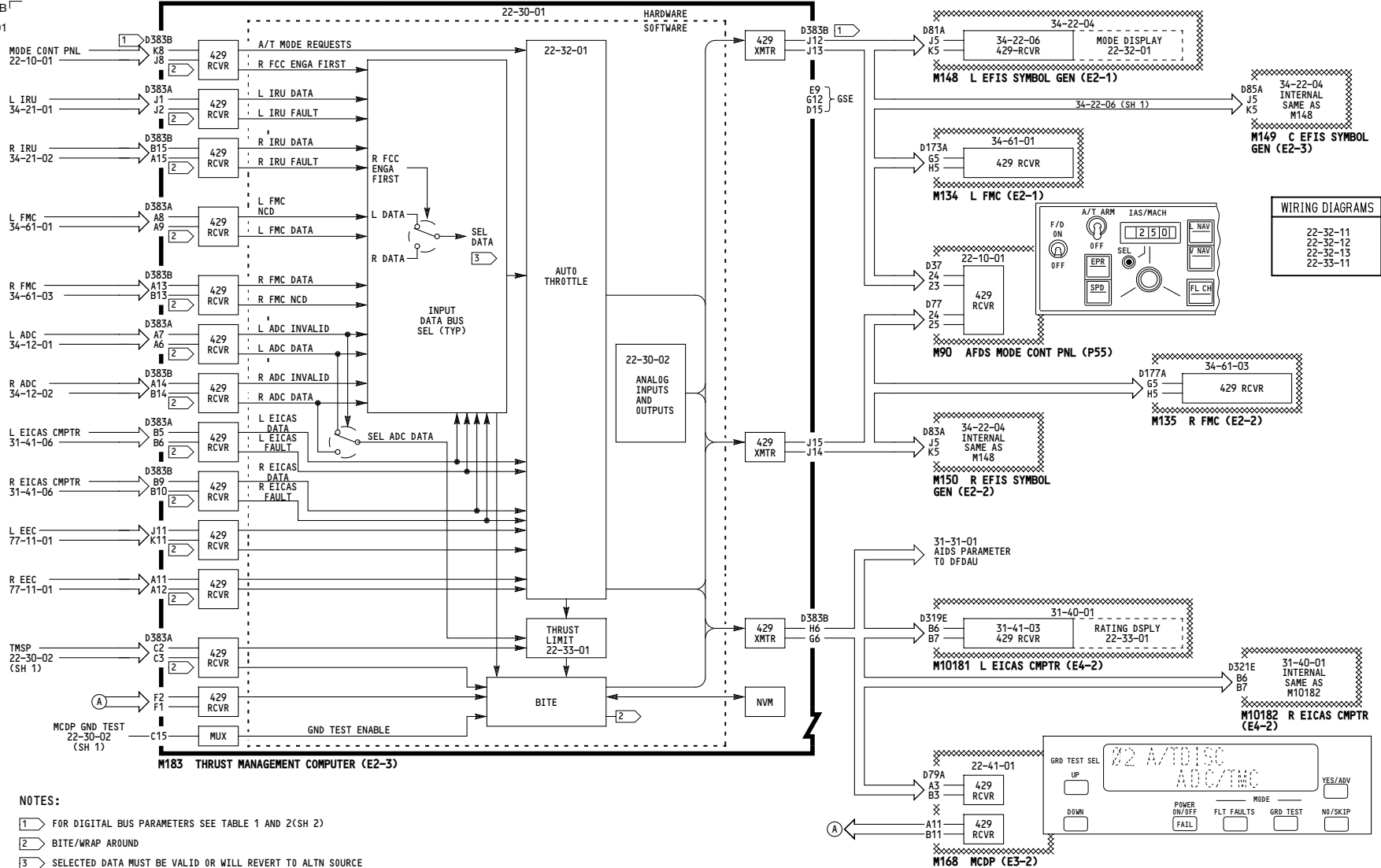

ALL	<p><b>THRUST MANAGEMENT COMPUTER - DIGITAL INPUTS AND OUTPUTS</b></p> <p>D280N032S</p>
-----	--

**22-30-03**





5200

TABLE 1 INPUT PARAMETERS

SOURCE	SIGNAL	SOURCE	SIGNAL
MODE CONT PNL	ALT SEL ELEV SPD CMD MACH SEL SPD BRK HDL POS SPD SEL STAB POS DISCRETES:- IAS/MACH SEL F/D ON-F/O F/D ON-CAPT SPD MODE REQ THRUST MODE REQ ALT HOLD REQ FL CH MODE OPER V/NAV MODE G/S MODE OPER THROT RETARD PITCH SPD CONT A/P CMD C ENGA A/P CMD L ENGA A/P CMD R ENGA V/S MODE OPER AFDS G/A OPER	ADC	ALT (BARO 4) ALT (29,92) COMPUTED AS IMPACT PRESS IND AOA MACH MAX DPRTG SCHED SAT TAT TOTAL PRESS TAS DISCRETES:- P/S HT ON-L P/S HT ON-R TAT PROBE HT ON
IRU	NORM ACCEL PITCH RATE ROLL RATE YAW RATE XTK HRZ ACCEL FPAC GS INS ALT INS V/S PITCH ANGLE ROLL ANGLE TKA TRUE TRUE HDG DISCRETES:- ALIGN FAULT NO IRS INITIAL EXCESS MOTION ADC/IRU FAULT	EEC	EEC STATUS EPR COMMAND IDLE EPR MAX EPR LIMIT
FMC	ASSUMED TEMP EPR TARGET SEL MACH TARGET AS A/T MACH MODE REQ A/T A/S MODE REQ CLB MODE REQ CON MODE REQ CRZ MODE REQ G/A MODE REQ T/O MODE REQ A/T LOW GAIN ARM IDLE THRUST REQ THRUTTLE DORMANT THRUST MODE REQ	TMSP	DISCRETES:- SEL TEMP BIT 0 SEL TEMP BIT 1 SEL TEMP BIT 2 SEL TEMP BIT 3 SEL TEMP BIT 4 RATING 1 REQ RATING 2 REQ CON MODE REQ T/O/GA MODE REQ CRZ MODE REQ CLB MODE REQ
		MCDP	TEST CONT 13 TEST CONT 14 TEST CONT 15 TEST CONT 16
		EICAS	EPR ACTUAL N3 ACTUAL

TABLE 2 OUTPUT PARAMETERS

DESTINATION	SIGNAL
EFIS SYMBOL GENERATOR	A/T FAST/SLOW CMD TMS FLT MODE ANN
FMC	TMS MODE STATUS ENG BLEED STATUS EPR ACTUAL - L EPR ACTUAL - R EPR REFERENCE FLAP POSITION TEMP SELECTED DISCRETE PARAMETERS 3
MODE CONT DNL (L & R BUS)	TMS MODE STATUS VERT SPD CMD
EICAS CMPTR	EPR ACTUAL - L EPR ACTUAL - R EPR BUG DRIVE - L EPR BUG DRIVE - R MAX EPR LIMIT TAT TEMP SELECTED DISCRETE PARAMETERS 2 DISCRETE PARAMETERS 3 EPR REFERENCE PLA-L PLA-R
MCDP	FAULT DATA GND TEST DATA INTERFACE FAULT DATA
DFDAU	AIDS PARAMETERS

ALL

**THRUST MANAGEMENT  
COMPUTER - DIGITAL  
INPUTS AND OUTPUTS**

D280N032S

**22-30-03**

Page 101  
Sheet 2  
May 06/2009

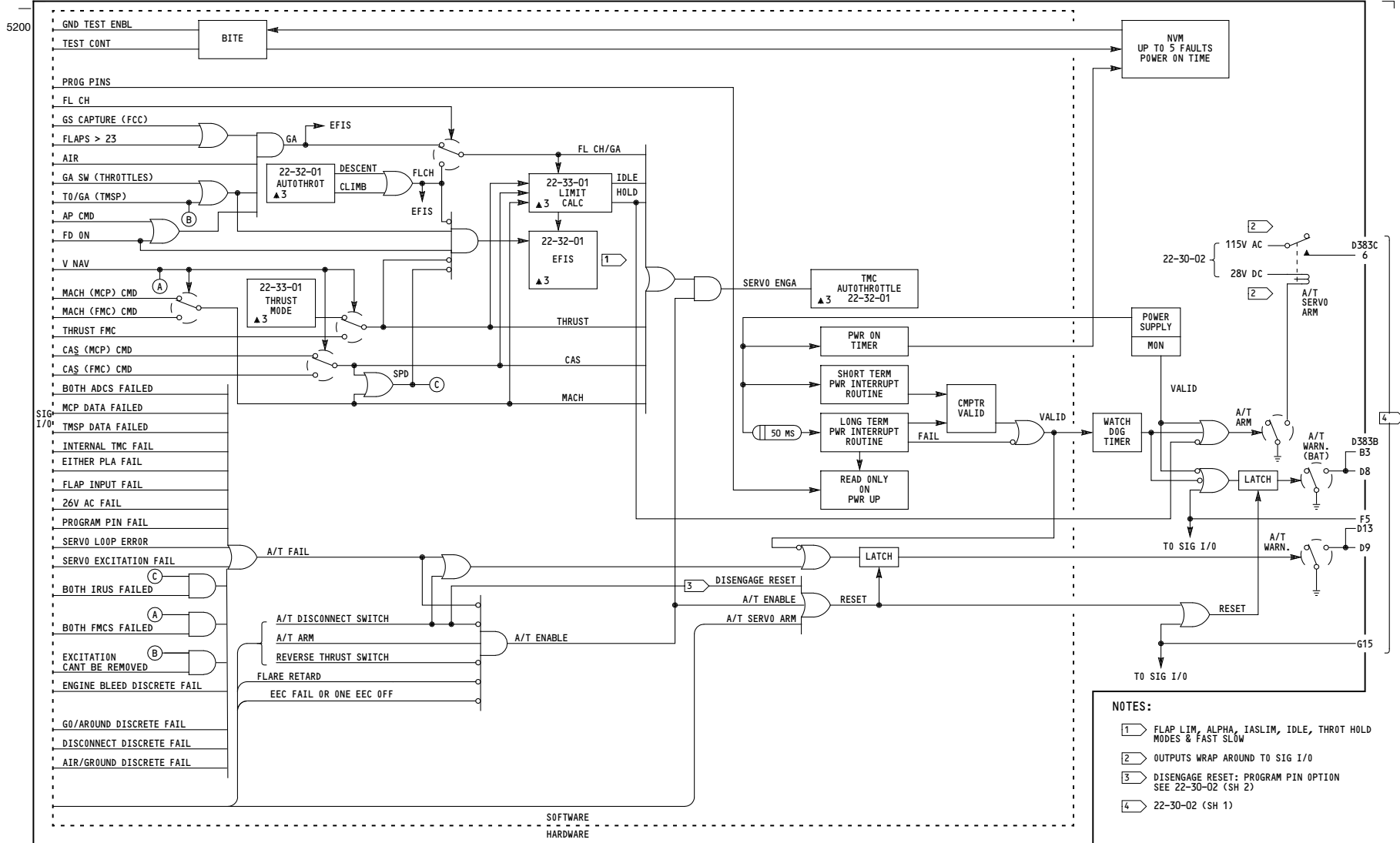

- NOTES:**
- 1 → FLAP LIM, ALPHA, IASLIM, IDLE, THROT HOLD MODES & FAST SLOW
  - 2 → OUTPUTS WRAP AROUND TO SIG I/O
  - 3 → DISENGAGE RESET: PROGRAM PIN OPTION SEE 22-30-02 (SH 2)
  - 4 → 22-30-02 (SH 1)

M168 TMC (E2-3)

ALL	<b>THRUST MANAGEMENT COMPUTER - ENGAGE LOGIC</b>
D280N032S	

**22-31-01**

Page 101

May 06/2009

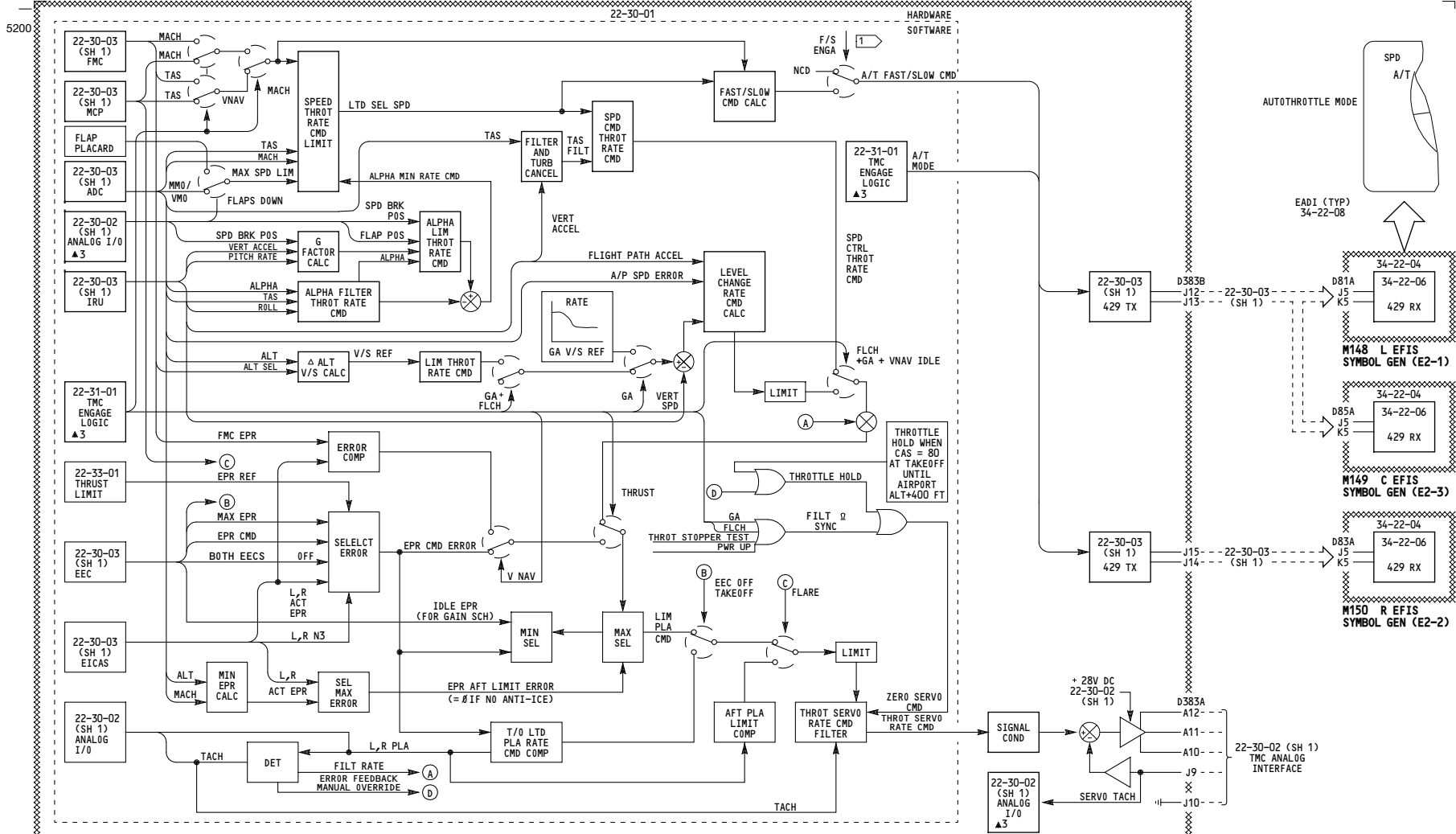

**M183 THRUST MANAGEMENT COMPUTER (E2-3)**

**NOTES:**  
 1 F/S ENGAGE WHEN TAS GOOD AND T/O F/D NOT ENGAGED AND A/T MODE NOT ENGAGED AND IN AIR.

ALL	<p><b>THRUST MANAGEMENT COMPUTER - AUTOHTRITTLE</b></p> <p>D280N032S</p>
-----	--

**22-32-01**

Page 101

May 06/2009

5003

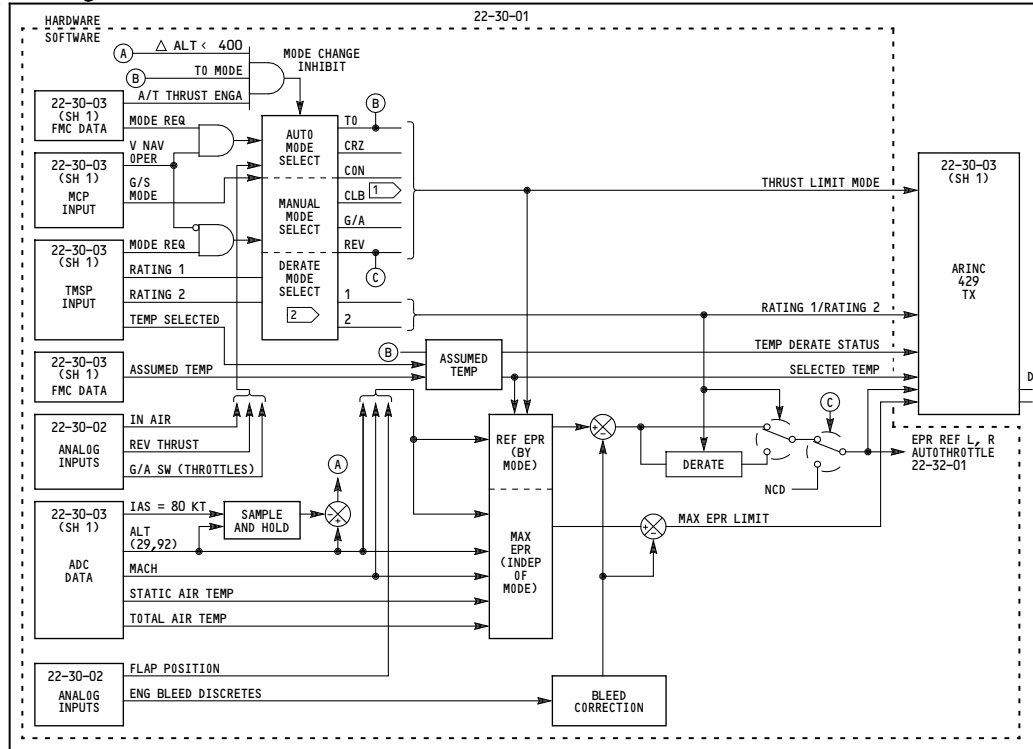

**M183 THRUST MANAGEMENT COMPUTER (E2-3)**

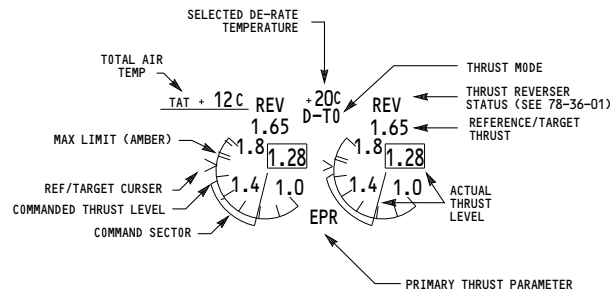

**NOTES:**

- 1 CLB MODE PRE-SELECTED OR OPERATING
- 2 DERATES ONLY IN TO OR CLB MODES SEE PROGRAM PINS 22-30-02 (SH 2)
- 3 BUG COLOR DEPENDANT ON SIGNAL SOURCE

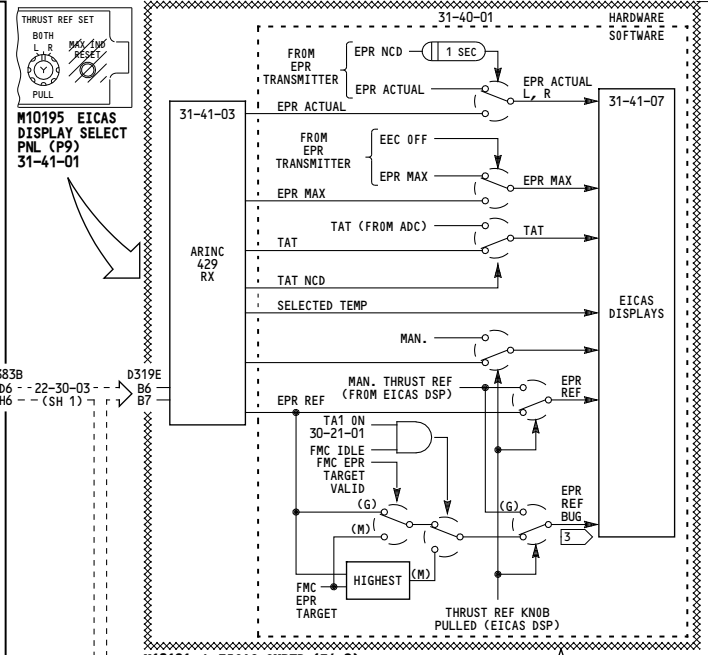

**M10195 EICAS DISPLAY SELECT PNL (P9) 31-41-01**

**M10181 L EICAS CMPTR (E4-2)**

**M10182 R EICAS CMPTR (E4-2)**

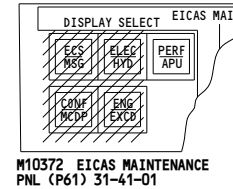

**M10372 EICAS MAINTENANCE PNL (P61) 31-41-01**

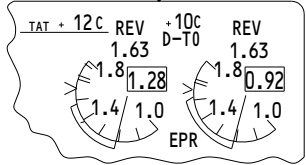

**M10013 EICAS UPPER DISPLAY (P2) 31-41-07 (PRIMARY OR COMPACTED FORMATS)**

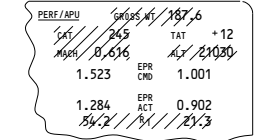

**M10014 EICAS LOWER DISPLAY (P2) 31-41-07 (MAINTENANCE FORMAT)**

**22-33-01**

ALL

**THRUST MANAGEMENT COMPUTER - THRUST LIMIT**

D280N032S

THIS PAGE INTENTIONALLY LEFT BLANK

TABLE 1 MCDP PROGRAM PINS

PROGRAM OPTION	PINS GND	(D79A) GND	OPTION AS CONNECTED
H11	H6		ADC SW
H12	J6		FMC SW
H13	G6		TMC A/P DISCONNECT
H14	K6	X	FMC FLT FAULTS REPORTING
H15	F6		SPARE
A12	A6		SINGLE FMC
B13	C6		DUAL FCC
C13	E6	X	757-200
C14	D6		
C15	C2		
B14	B6	X	PARITY

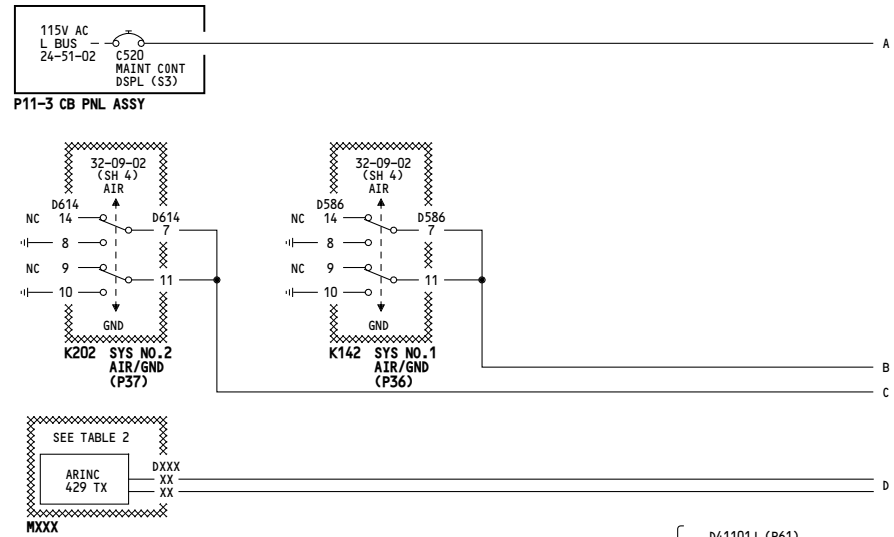

TABLE 2 DATA BUSES

SCHEMATIC REF.	MODULE NO.	DESCRIPTION	SHELF	MODULE FAULT DATA BUS PINS	MCDP DATA BUS PINS (D79A) INPUT	MCDP DATA BUS PINS (D79A) OUTPUT	MODULE GND TEST CONT PINS	GND MCDP D79A	TEST ENABLE MODULE DXXX
22-10-02	M139	L FCC	E1-3	D35B-C3 D35B-C4	A15 B15	A11 B11	D35A-A1 D35A-A2	C11	D35A-A3
22-10-04	M140	C FCC	E1-4	D55B-C3 D55B-C4	A1 B1	A10 B10	D55A-A1 D55A-A2	C10	D55A-A3
22-10-03	M141	R FCC	E1-5	D75B-C3 D75B-C4	J1 K1	A9 B9	D75A-A1 D75A-A2	C9	D75A-A3
22-32-01	M183	THRUST MGT COMPUTER	E1-3	D383B-H6 D383B-G6	A3 B3	A11 B11	D383A-F1 D383A-F2	E14	D383B-C15
34-61-03	M134	L FMC	E2-2	D173B-D7 D173B-E7	A4 B4	___	___	___	___
34-61-09	M135	R FMC	E2-3	D177B-D7 D177B-E7	J4 K4	___	___	___	___

NOTES:

- 1 M139 L FCC AND M183 TMC SHARE A COMMON GND TEST DATA BUS.
- 2 FOR CONNECTIONS TO PROGRAM PINS, SEE TABLE 1.
- 3 BITE/WRAPAROUND

ALL	<p><b>MAINTENANCE CONTROL AND DISPLAY PANEL</b></p> <p>D280N032S</p>
-----	--

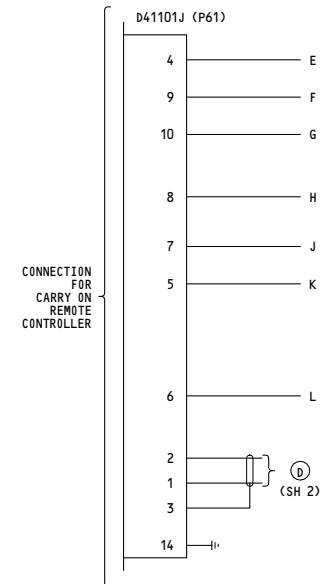

22-41-01

5011

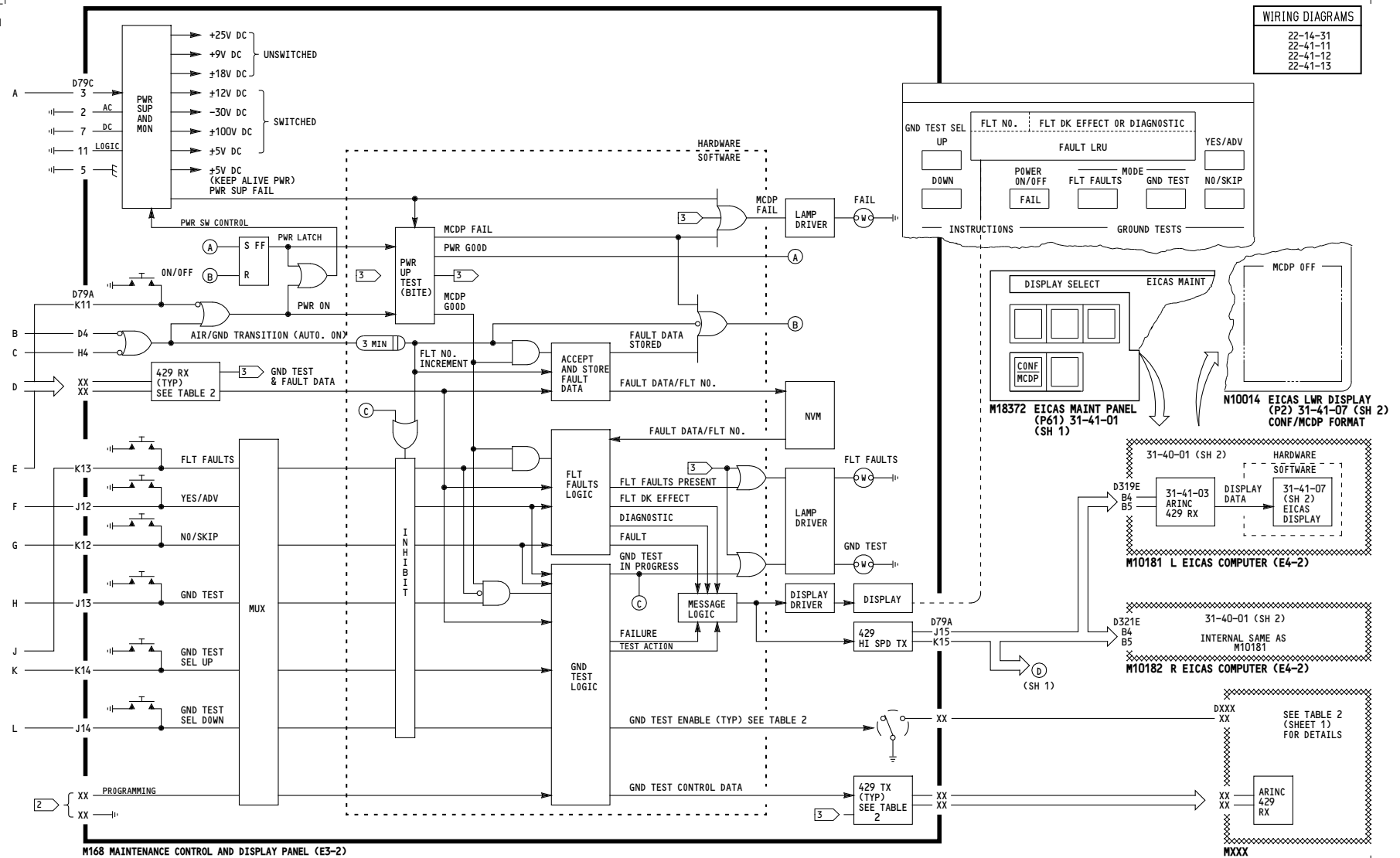

5012

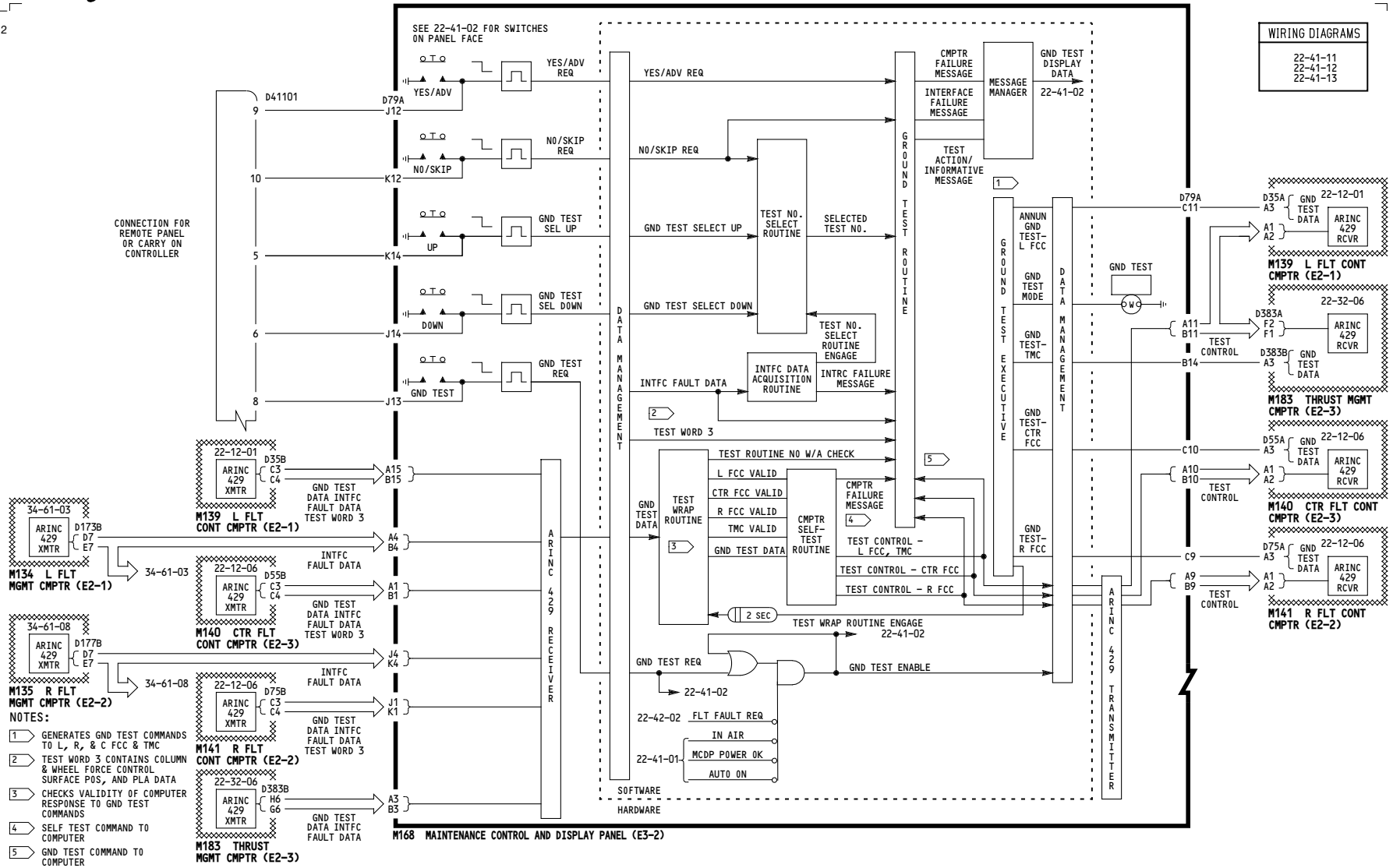

ALL

**MAINTENANCE CONTROL AND DISPLAY PANEL - GROUND TEST MODE**

D280N032S

**22-41-03**

Page 101

May 06/2009