

CHAPTER

27

FLIGHT CONTROLS



CHAPTER 27
FLIGHT CONTROLS

CH-SC-SU	Schem	Page	Sheet	Date	CH-SC-SU	Schem	Page	Sheet	Date
27-EFFECTIVE PAGES		1 thru 6		Oct 09/2008	27-09-01		101	1	Jan 21/2005
27-CONTENTS		1		Dec 18/2007			102	2	Jan 21/2005
		2		Dec 18/2007				1	Jan 21/2005
R		3		Oct 09/2008				2	Jan 21/2005
		4		Dec 18/2007	27-09-02		101	1	Jan 21/2005
		5		Dec 18/2007				2	Jan 21/2005
		6		Dec 18/2007			102	1	Jan 21/2005
		7		Dec 18/2007				2	Jan 21/2005
		8		Dec 18/2007	27-09-03		101	1	Jan 21/2005
		9		Dec 18/2007				2	Jan 21/2005
		10		Dec 18/2007				3	Jan 21/2005
27-ALPHABETICAL INDEX		1		Dec 18/2007				4	Jan 21/2005
		2		BLANK				5	Jan 21/2005
27-00-00							102	1	Jan 21/2005
		101	1	Jan 21/2005				2	Jan 21/2005
			2	Jan 21/2005				3	Jan 21/2005
27-09-00								4	Jan 21/2005
		101	1	Jan 21/2005				5	Jan 21/2005
			2	Jan 21/2005	27-09-04		101	1	Jan 21/2005
		102	1	Jan 21/2005				2	Jan 21/2005
			2	Jan 21/2005					

A = Added, R = Revised, D = Deleted, O = Overflow

27-EFFECTIVE PAGES



CHAPTER 27
FLIGHT CONTROLS

CH-SC-SU	Schem	Page	Sheet	Date	CH-SC-SU	Schem	Page	Sheet	Date
27-09-04 (cont.)		101			27-20-01 (cont.)		101		
			3	Jan 21/2005				2	Jan 21/2005
			4	Jan 21/2005				3	Jan 21/2005
			5	Jan 21/2005			101.1	1	Jan 21/2005
		102	1	Jan 21/2005				2	Jan 21/2005
			2	Jan 21/2005				3	Jan 21/2005
			3	Jan 21/2005		27-20-02			
			4	Jan 21/2005	R		101	1	Oct 09/2008
			5	Jan 21/2005				2	Dec 18/2007
27-09-05					R		101.1	1	Oct 09/2008
		101	1	Jan 21/2005				2	Dec 18/2007
			2	Jan 21/2005					
27-09-06						27-23-01			
							101		Jan 21/2005
		101	1	Jan 21/2005			102		Jan 21/2005
			2	Jan 21/2005					
		101.1	1	Jan 21/2005		27-30-01			
			2	Jan 21/2005			101	1	Jan 21/2005
27-10-01								2	Jan 21/2005
		101	1	Dec 18/2007				3	Jan 21/2005
			2	Jan 21/2005				4	Jan 21/2005
		101.1	1	Dec 18/2007				5	Jan 21/2005
			2	Jan 21/2005				6	Jan 21/2005
27-20-01							102	1	Jan 21/2005
								2	Jan 21/2005
		101	1	Jan 21/2005				3	Jan 21/2005

A = Added, R = Revised, D = Deleted, O = Overflow

27-EFFECTIVE PAGES



CHAPTER 27
FLIGHT CONTROLS

CH-SC-SU	Schem	Page	Sheet	Date	CH-SC-SU	Schem	Page	Sheet	Date
27-30-01 (cont.)		102			27-40-01 (cont.)		101		
			4	Jan 21/2005				2	Jan 21/2005
			5	Jan 21/2005				3	Jan 21/2005
			6	Jan 21/2005				4	Jan 21/2005
27-32-01								5	Dec 18/2007
		101	1	Jan 21/2005				6	Jan 21/2005
			2	Jan 21/2005		101.1	1	Jan 21/2005	
		101.1	1	Jan 21/2005			2	Jan 21/2005	
			2	Jan 21/2005			3	Jan 21/2005	
		102	1	Jan 21/2005			4	Jan 21/2005	
			2	Jan 21/2005			5	Dec 18/2007	
		102.1	1	Jan 21/2005			6	Jan 21/2005	
			2	Jan 21/2005		102	1	Jan 21/2005	
27-32-02								2	Jan 21/2005
		101	1	Jan 21/2005				3	Jan 21/2005
			2	Jan 21/2005				4	Jan 21/2005
		101.1	1	Jan 21/2005				5	Dec 18/2007
			2	Jan 21/2005				6	Jan 21/2005
		102	1	Jan 21/2005		102.1	1	Jan 21/2005	
			2	Jan 21/2005			2	Jan 21/2005	
		102.1	1	Jan 21/2005			3	Jan 21/2005	
			2	Jan 21/2005			4	Jan 21/2005	
27-40-01								5	Dec 18/2007
		101	1	Jan 21/2005				6	Jan 21/2005

A = Added, R = Revised, D = Deleted, O = Overflow

27-EFFECTIVE PAGES

Page 3
Oct 09/2008

D280N032S



CHAPTER 27
FLIGHT CONTROLS

CH-SC-SU	Schem	Page	Sheet	Date	CH-SC-SU	Schem	Page	Sheet	Date
27-40-01 (cont.)					27-40-01 (cont.)		104.1		
		103	1	Jan 21/2005				6	Jan 21/2005
			2	Jan 21/2005	27-48-01				
			3	Jan 21/2005			101		Jan 21/2005
			4	Jan 21/2005	27-50-00				
			5	Dec 18/2007			101	1	Jan 21/2005
			6	Jan 21/2005				2	Jan 21/2005
		103.1	1	Jan 21/2005	27-50-01				
			2	Jan 21/2005			101	1	Jan 21/2005
			3	Jan 21/2005				2	Jan 21/2005
			4	Jan 21/2005			102	1	Jan 21/2005
			5	Dec 18/2007				2	Jan 21/2005
			6	Jan 21/2005	27-51-01				
		104	1	Jan 21/2005			101	1	Jan 21/2005
			2	Jan 21/2005				2	Jan 21/2005
			3	Jan 21/2005				3	Jan 21/2005
			4	Jan 21/2005	27-51-02				
			5	Dec 18/2007			101		Jan 21/2005
			6	Jan 21/2005			102		Jan 21/2005
		104.1	1	Jan 21/2005	27-51-03				
			2	Jan 21/2005			101		Jan 21/2005
			3	Jan 21/2005			102		Jan 21/2005
			4	Jan 21/2005	27-51-04				
			5	Dec 18/2007			101	1	Jan 21/2005

A = Added, R = Revised, D = Deleted, O = Overflow

27-EFFECTIVE PAGES



CHAPTER 27
FLIGHT CONTROLS

CH-SC-SU	Schem	Page	Sheet	Date	CH-SC-SU	Schem	Page	Sheet	Date
27-51-04 (cont.)		101			27-61-01 (cont.)		102		
			2	Jan 21/2005				3	Jan 21/2005
		102	1	Jan 21/2005				4	Jan 21/2005
			2	Jan 21/2005				5	Jan 21/2005
27-51-05								6	Jan 21/2005
		101		Jan 21/2005		103		1	Jan 21/2005
		102		Jan 21/2005				2	Jan 21/2005
27-51-06								3	Jan 21/2005
		101		Jan 21/2005				4	Jan 21/2005
		102		Jan 21/2005				5	Jan 21/2005
27-58-01								6	Jan 21/2005
		101		Jan 21/2005				7	Jan 21/2005
		102		Jan 21/2005				8	Jan 21/2005
27-60-00								9	Jan 21/2005
		101		Jan 21/2005				10	Dec 18/2007
27-61-01								11	Jan 21/2005
		101	1	Jan 21/2005	27-62-01				
			2	Jan 21/2005		101		1	Jan 21/2005
			3	Jan 21/2005				2	Jan 21/2005
			4	Jan 21/2005		101.1		1	Jan 21/2005
			5	Jan 21/2005				2	Dec 18/2007
			6	Jan 21/2005		101.2		1	Jan 21/2005
		102	1	Jan 21/2005				2	Jan 21/2005
			2	Jan 21/2005		102		1	Jan 21/2005

A = Added, R = Revised, D = Deleted, O = Overflow

27-EFFECTIVE PAGES

Page 5
Oct 09/2008

D280N032S



CHAPTER 27
FLIGHT CONTROLS

CH-SC-SU	Schem	Page	Sheet	Date	CH-SC-SU	Schem	Page	Sheet	Date
27-62-01 (cont.)		102							
			2	Jan 21/2005					
27-81-01		101		Jan 21/2005					
27-81-02		101	1	Jan 21/2005					
			2	Jan 21/2005					
		102	1	Jan 21/2005					
			2	Jan 21/2005					
27-81-03		101	1	Jan 21/2005					
			2	Jan 21/2005					
		102	1	Jan 21/2005					
			2	Jan 21/2005					
27-81-04		101		Jan 21/2005					
27-81-05		101		May 17/2006					
		101.1		May 17/2006					
		102		May 17/2006					
		102.1		May 17/2006					

A = Added, R = Revised, D = Deleted, O = Overflow

27-EFFECTIVE PAGES

Page 6
Oct 09/2008

D280N032S



CHAPTER 27
FLIGHT CONTROLS

Title	CH-SC-SU	Schem	Page	Sheet	Date	Effectivity
<u>FLIGHT CONTROLS</u>						
FLIGHT CONTROL SYSTEMS - SIMPLIFIED	27-00-00		101	1	Jan 21/2005	ALL
				2	Jan 21/2005	ALL
<u>FLIGHT CONTROL SYSTEM ELECTRONIC UNITS</u>						
CONTROL SYSTEMS ELECTRICAL/ELECTRONIC UNIT (CSEU) POWER	27-09-00		101	1	Jan 21/2005	001-099
				2	Jan 21/2005	001-099
				102	1	Jan 21/2005
LEFT CSEU POWER - AC	27-09-01		101	2	Jan 21/2005	115-199
				1	Jan 21/2005	001-099
				102	1	Jan 21/2005
RIGHT CSEU POWER - AC	27-09-02		101	2	Jan 21/2005	115-199
				1	Jan 21/2005	001-099
				102	1	Jan 21/2005
LEFT CSEU POWER - DC	27-09-03		101	2	Jan 21/2005	001-099
				3	Jan 21/2005	001-099
				4	Jan 21/2005	001-099
				5	Jan 21/2005	001-099
				102	1	Jan 21/2005

CHAPTER 27
FLIGHT CONTROLS

Title	CH-SC-SU	Schem	Page	Sheet	Date	Effectivity
LEFT CSEU POWER - DC (cont.)	27-09-03			2	Jan 21/2005	115-199
				3	Jan 21/2005	115-199
				4	Jan 21/2005	115-199
				5	Jan 21/2005	115-199
RIGHT CSEU POWER - DC	27-09-04		101	1	Jan 21/2005	001-099
				2	Jan 21/2005	001-099
				3	Jan 21/2005	001-099
				4	Jan 21/2005	001-099
				5	Jan 21/2005	001-099
			102	1	Jan 21/2005	115-199
				2	Jan 21/2005	115-199
				3	Jan 21/2005	115-199
				4	Jan 21/2005	115-199
				5	Jan 21/2005	115-199
CSEU FAULT ANNUNCIATION	27-09-05		101	1	Jan 21/2005	ALL
				2	Jan 21/2005	ALL
CSEU AIR/GROUND AND HYDRAULIC DISCRETE INPUTS	27-09-06		101	1	Jan 21/2005	ALL
				2	Jan 21/2005	ALL
			101.1	1	Jan 21/2005	001-115
				2	Jan 21/2005	001-115
<u>AILERON AND TAB</u>						
AILERON	27-10-01		101	1	Dec 18/2007	ALL



CHAPTER 27
FLIGHT CONTROLS

Title	CH-SC-SU	Schem	Page	Sheet	Date	Effectivity
AILERON (cont.)	27-10-01			2	Jan 21/2005	ALL
			101.1	1	Dec 18/2007	010-011
				2	Jan 21/2005	010-011
<u>RUDDER AND TAB</u>						
RUDDER CONTROL SYSTEM	27-20-01		101	1	Jan 21/2005	ALL
				2	Jan 21/2005	ALL
				3	Jan 21/2005	ALL
			101.1	1	Jan 21/2005	010-011
				2	Jan 21/2005	010-011
				3	Jan 21/2005	010-011
RUDDER RATIO CHANGER	27-20-02		101	1	Oct 09/2008	ALL
				2	Dec 18/2007	ALL
			101.1	1	Oct 09/2008	001-004 115
				2	Dec 18/2007	001-004 115
<u>RUDDER AND ELEVATOR HYDRAULIC SYSTEMS</u>						
RUDDER/ELEVATOR PCU MONITOR SYSTEM	27-23-01		101		Jan 21/2005	001-099
			102		Jan 21/2005	115-199
<u>ELEVATOR AND TAB</u>						
ELEVATOR	27-30-01		101	1	Jan 21/2005	001-099
				2	Jan 21/2005	001-099
				3	Jan 21/2005	001-099
				4	Jan 21/2005	001-099
				5	Jan 21/2005	001-099



CHAPTER 27
FLIGHT CONTROLS

Title	CH-SC-SU	Schem	Page	Sheet	Date	Effectivity	
ELEVATOR (cont.)	27-30-01		102	6	Jan 21/2005	001-099	
				1	Jan 21/2005	115-199	
				2	Jan 21/2005	115-199	
				3	Jan 21/2005	115-199	
				4	Jan 21/2005	115-199	
				5	Jan 21/2005	115-199	
				6	Jan 21/2005	115-199	
<u>STALL WARNING SYSTEM</u>							
STALL WARNING - LEFT	27-32-01		101	1	Jan 21/2005	001-099	
				2	Jan 21/2005	001-099	
				101.1	1	Jan 21/2005	001-011
				2	Jan 21/2005	001-011	
				102	1	Jan 21/2005	115-199
				2	Jan 21/2005	115-199	
				102.1	1	Jan 21/2005	115
				2	Jan 21/2005	115	
STALL WARNING - RIGHT	27-32-02		101	1	Jan 21/2005	001-099	
				2	Jan 21/2005	001-099	
				101.1	1	Jan 21/2005	001-011
				2	Jan 21/2005	001-011	
				102	1	Jan 21/2005	115-199
				2	Jan 21/2005	115-199	
				102.1	1	Jan 21/2005	115



CHAPTER 27
FLIGHT CONTROLS

Title	CH-SC-SU	Schem	Page	Sheet	Date	Effectivity	
STALL WARNING - RIGHT (cont.)	27-32-02			2	Jan 21/2005	115	
<u>HORIZONTAL STABILIZER</u>							
HORIZONTAL STABILIZER TRIM	27-40-01			1	Jan 21/2005	001	
				2	Jan 21/2005	001	
				3	Jan 21/2005	001	
				4	Jan 21/2005	001	
				5	Dec 18/2007	001	
				6	Jan 21/2005	001	
				101.1	1	Jan 21/2005	001
				2	Jan 21/2005	001	
				3	Jan 21/2005	001	
				4	Jan 21/2005	001	
				5	Dec 18/2007	001	
				6	Jan 21/2005	001	
				102	1	Jan 21/2005	002-004
				2	Jan 21/2005	002-004	
				3	Jan 21/2005	002-004	
				4	Jan 21/2005	002-004	
				5	Dec 18/2007	002-004	
				6	Jan 21/2005	002-004	
				102.1	1	Jan 21/2005	002-004
				2	Jan 21/2005	002-004	
				3	Jan 21/2005	002-004	



CHAPTER 27
FLIGHT CONTROLS

Title	CH-SC-SU	Schem	Page	Sheet	Date	Effectivity
HORIZONTAL STABILIZER TRIM (cont.)	27-40-01			4	Jan 21/2005	002-004
				5	Dec 18/2007	002-004
				6	Jan 21/2005	002-004
			103	1	Jan 21/2005	005-099
				2	Jan 21/2005	005-099
				3	Jan 21/2005	005-099
			4	Jan 21/2005	005-099	
			5	Dec 18/2007	005-099	
			6	Jan 21/2005	005-099	
			103.1	1	Jan 21/2005	010-011
				2	Jan 21/2005	010-011
				3	Jan 21/2005	010-011
				4	Jan 21/2005	010-011
				5	Dec 18/2007	010-011
				6	Jan 21/2005	010-011
			104	1	Jan 21/2005	115-199
				2	Jan 21/2005	115-199
				3	Jan 21/2005	115-199
				4	Jan 21/2005	115-199
				5	Dec 18/2007	115-199
				6	Jan 21/2005	115-199
			104.1	1	Jan 21/2005	115
				2	Jan 21/2005	115

CHAPTER 27
FLIGHT CONTROLS

Title	CH-SC-SU	Schem	Page	Sheet	Date	Effectivity	
HORIZONTAL STABILIZER TRIM (cont.)	27-40-01			3	Jan 21/2005	115	
				4	Jan 21/2005	115	
				5	Dec 18/2007	115	
				6	Jan 21/2005	115	
<u>STABILIZER TRIM POSITION INDICATING SYSTEM</u>							
STABILIZER POSITION SENSING	27-48-01		101		Jan 21/2005	ALL	
<u>FLAPS</u>							
HIGH LIFT DEVICES - SIMPLIFIED	27-50-00		101	1	Jan 21/2005	ALL	
				2	Jan 21/2005	ALL	
FLAP/SLAT ELECTRONICS UNIT	27-50-01		101	1	Jan 21/2005	001-099	
				2	Jan 21/2005	001-099	
				102	1	Jan 21/2005	115-199
				2	Jan 21/2005	115-199	
<u>TRAILING EDGE (TE) FLAP SYSTEM</u>							
TRAILING EDGE FLAPS PRIMARY DRIVE	27-51-01		101	1	Jan 21/2005	ALL	
				2	Jan 21/2005	ALL	
				3	Jan 21/2005	ALL	
FLAP/SLAT DEPRESSURIZATION SYSTEM	27-51-02		101		Jan 21/2005	001-099	
				102	Jan 21/2005	115-199	
FLAP LOAD RELIEF CONTROL	27-51-03		101		Jan 21/2005	001-099	
				102	Jan 21/2005	115-199	
TRAILING EDGE FLAP ALTERNATE DRIVE	27-51-04		101	1	Jan 21/2005	001-099	
				2	Jan 21/2005	001-099	



CHAPTER 27
FLIGHT CONTROLS

Title	CH-SC-SU	Schem	Page	Sheet	Date	Effectivity
TRAILING EDGE FLAP ALTERNATE DRIVE (cont.)	27-51-04		102	1	Jan 21/2005	115-199
				2	Jan 21/2005	115-199
FLAP ASYMMETRY INDICATION	27-51-05		101		Jan 21/2005	001-099
					Jan 21/2005	115-199
TRAILING EDGE FLAPS UCM INDICATION	27-51-06		101		Jan 21/2005	001-099
					Jan 21/2005	115-199
<u>TRAILING EDGE FLAP POSITION INDICATING SYSTEM</u>						
FLAP/SLAT POSITION INDICATING SYSTEM	27-58-01		101		Jan 21/2005	001-099
					Jan 21/2005	115-199
<u>SPOILER, DRAG DEVICES, AND VARIABLE AERODYNAMIC FAIRINGS</u>						
SPOILER AND SPEEDBRAKE SYSTEM	27-60-00		101		Jan 21/2005	ALL
<u>SPOILER/SPEEDBRAKE CONTROL SYSTEM</u>						
SPOILERS	27-61-01		101	1	Jan 21/2005	001 115-199
				2	Jan 21/2005	001 115-199
				3	Jan 21/2005	001 115-199
				4	Jan 21/2005	001 115-199
				5	Jan 21/2005	001 115-199
				6	Jan 21/2005	001 115-199
					Jan 21/2005	002
					Jan 21/2005	002
					Jan 21/2005	002
					Jan 21/2005	002



CHAPTER 27
FLIGHT CONTROLS

Title	CH-SC-SU	Schem	Page	Sheet	Date	Effectivity
SPOILERS (cont.)	27-61-01			6	Jan 21/2005	002
			103	1	Jan 21/2005	003-099
				2	Jan 21/2005	003-099
				3	Jan 21/2005	003-099
				4	Jan 21/2005	003-099
				5	Jan 21/2005	003-099
				6	Jan 21/2005	003-099
				7	Jan 21/2005	003-099
				8	Jan 21/2005	003-099
				9	Jan 21/2005	003-099
				10	Dec 18/2007	003-099
		11	Jan 21/2005	003-099		
<u>AUTO-SPEEDBRAKE CONTROL SYSTEM</u>						
AUTO SPEEDBRAKE	27-62-01		101	1	Jan 21/2005	001-099
				2	Jan 21/2005	001-099
			101.1	1	Jan 21/2005	001-009 115
				2	Dec 18/2007	001-009 115
			101.2	1	Jan 21/2005	010-011
				2	Jan 21/2005	010-011
			102	1	Jan 21/2005	115-199
				2	Jan 21/2005	115-199
<u>LEADING EDGE SLAT SYSTEM</u>						
LEADING EDGE SLATS PRIMARY DRIVE	27-81-01		101		Jan 21/2005	ALL

CHAPTER 27
FLIGHT CONTROLS

Title	CH-SC-SU	Schem	Page	Sheet	Date	Effectivity	
SLAT ALTERNATE DRIVE	27-81-02		101	1	Jan 21/2005	001-099	
				2	Jan 21/2005	001-099	
				102	1	Jan 21/2005	115-199
				2	Jan 21/2005	115-199	
LEADING EDGE SLATS UNCOMMANDED MOTION	27-81-03		101	1	Jan 21/2005	001-099	
				2	Jan 21/2005	001-099	
				102	1	Jan 21/2005	115-199
				2	Jan 21/2005	115-199	
AUTOSLAT EXTENSION	27-81-04		101		Jan 21/2005	ALL	
SLAT ASYMMETRY INDICATION	27-81-05		101		May 17/2006	001-099	
				101.1	May 17/2006	001-011	
				102	May 17/2006	115-199	
				102.1	May 17/2006	115	

**CHAPTER 27
FLIGHT CONTROLS**

CH-SC-SU	Title
27-10-01	AILERON
27-62-01	AUTO SPEEDBRAKE
27-81-04	AUTOSLAT EXTENSION
27-09-00	CONTROL SYSTEMS ELECTRICAL/ELECTRONIC UNIT (CSEU) POWER
27-09-06	CSEU AIR/GROUND AND HYDRAULIC DISCRETE INPUTS
27-09-05	CSEU FAULT ANNUNCIATION
27-30-01	ELEVATOR
27-51-05	FLAP ASYMMETRY INDICATION
27-51-03	FLAP LOAD RELIEF CONTROL
27-51-02	FLAP/SLAT DEPRESSURIZATION SYSTEM
27-50-01	FLAP/SLAT ELECTRONICS UNIT
27-58-01	FLAP/SLAT POSITION INDICATING SYSTEM
27-00-00	FLIGHT CONTROL SYSTEMS - SIMPLIFIED
27-50-00	HIGH LIFT DEVICES - SIMPLIFIED
27-40-01	HORIZONTAL STABILIZER TRIM
27-81-01	LEADING EDGE SLATS PRIMARY DRIVE
27-81-03	LEADING EDGE SLATS UNCOMMANDED MOTION
27-09-01	LEFT CSEU POWER - AC
27-09-03	LEFT CSEU POWER - DC

CH-SC-SU	Title
27-09-02	RIGHT CSEU POWER - AC
27-09-04	RIGHT CSEU POWER - DC
27-20-01	RUDDER CONTROL SYSTEM
27-20-02	RUDDER RATIO CHANGER
27-23-01	RUDDER/ELEVATOR PCU MONITOR SYSTEM
27-81-02	SLAT ALTERNATE DRIVE
27-81-05	SLAT ASYMMETRY INDICATION
27-60-00	SPOILER AND SPEEDBRAKE SYSTEM
27-61-01	SPOILERS
27-48-01	STABILIZER POSITION SENSING
27-32-01	STALL WARNING - LEFT
27-32-02	STALL WARNING - RIGHT
27-51-04	TRAILING EDGE FLAP ALTERNATE DRIVE
27-51-01	TRAILING EDGE FLAPS PRIMARY DRIVE
27-51-06	TRAILING EDGE FLAPS UCM INDICATION

27-ALPHABETICAL INDEX

THIS PAGE INTENTIONALLY LEFT BLANK

5001

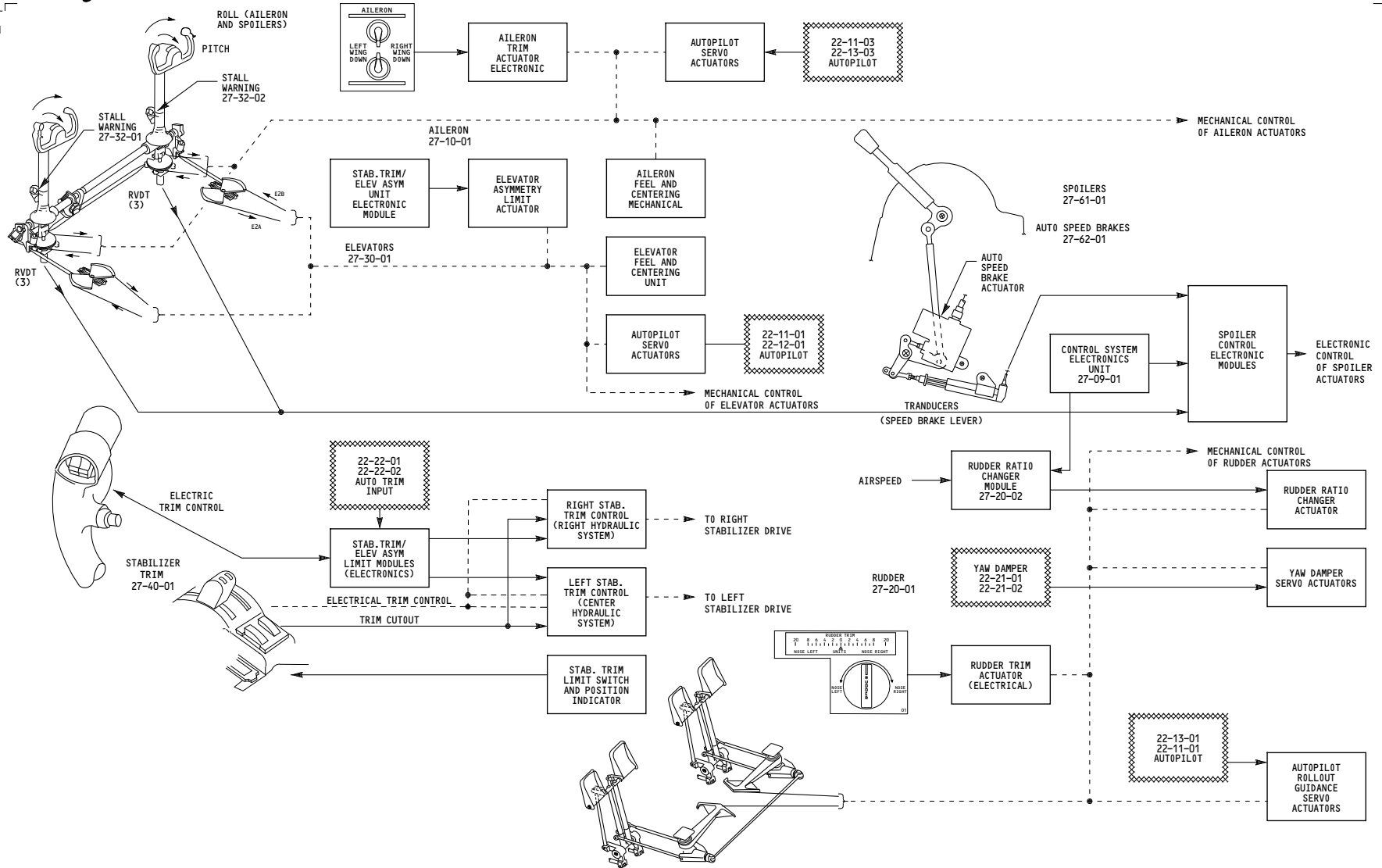

ALL

FLIGHT CONTROL SYSTEMS - SIMPLIFIED

D280N032S

27-00-00

5000

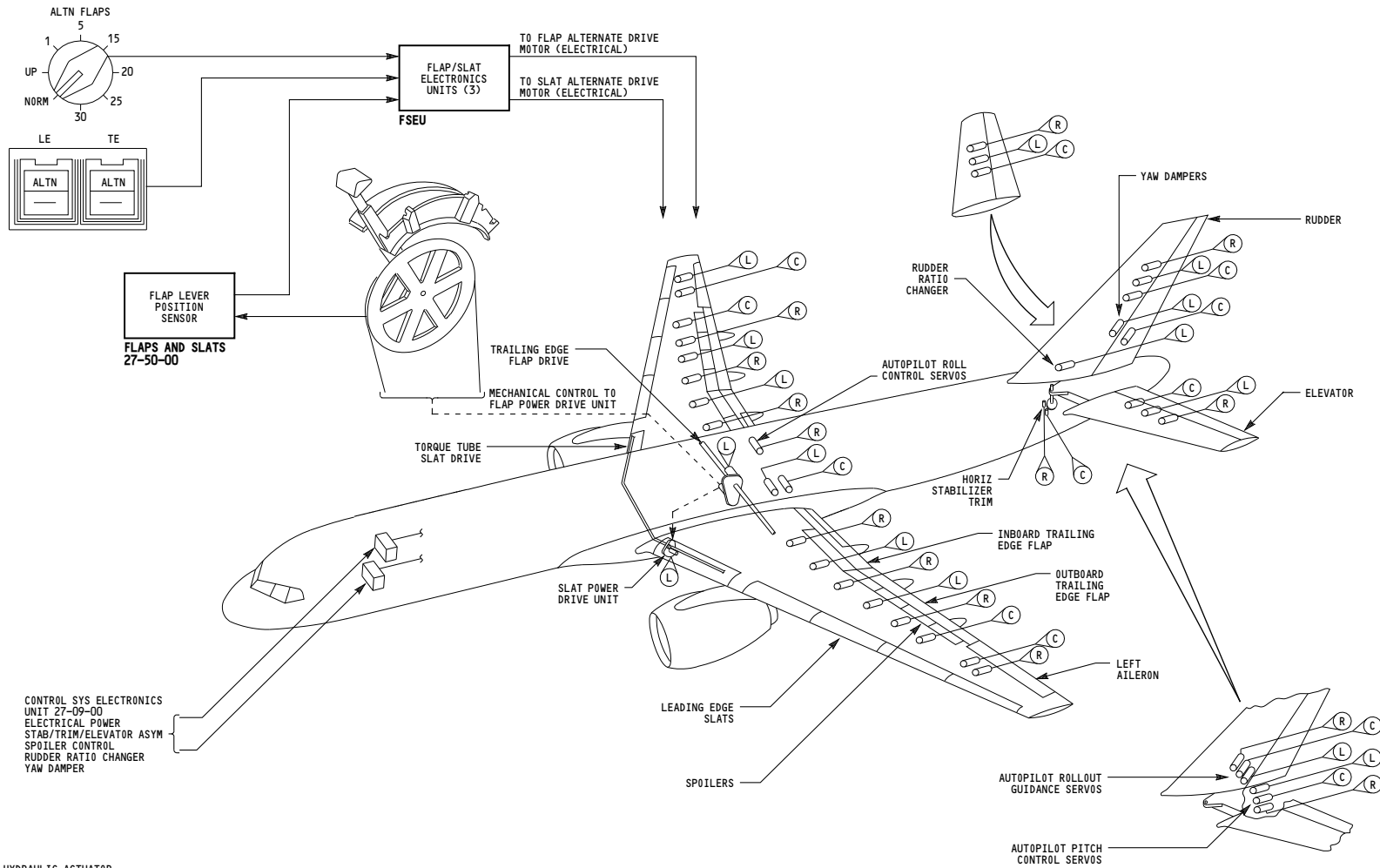

CONTROL SYS ELECTRONICS UNIT 27-09-00
ELECTRICAL POWER STAB/TRIM/ELEVATOR ASYM
SPOILER CONTROL
RUDDER RATIO CHANGER
YAW DAMPER

- HYDRAULIC ACTUATOR
- (L) LEFT HYDRAULIC SYSTEM 29-00-02
- (C) CENTER HYDRAULIC SYSTEM 29-00-03
- (R) RIGHT HYDRAULIC SYSTEM 29-00-04

ALL	FLIGHT CONTROL SYSTEMS - SIMPLIFIED
	D280N032S

27-00-00

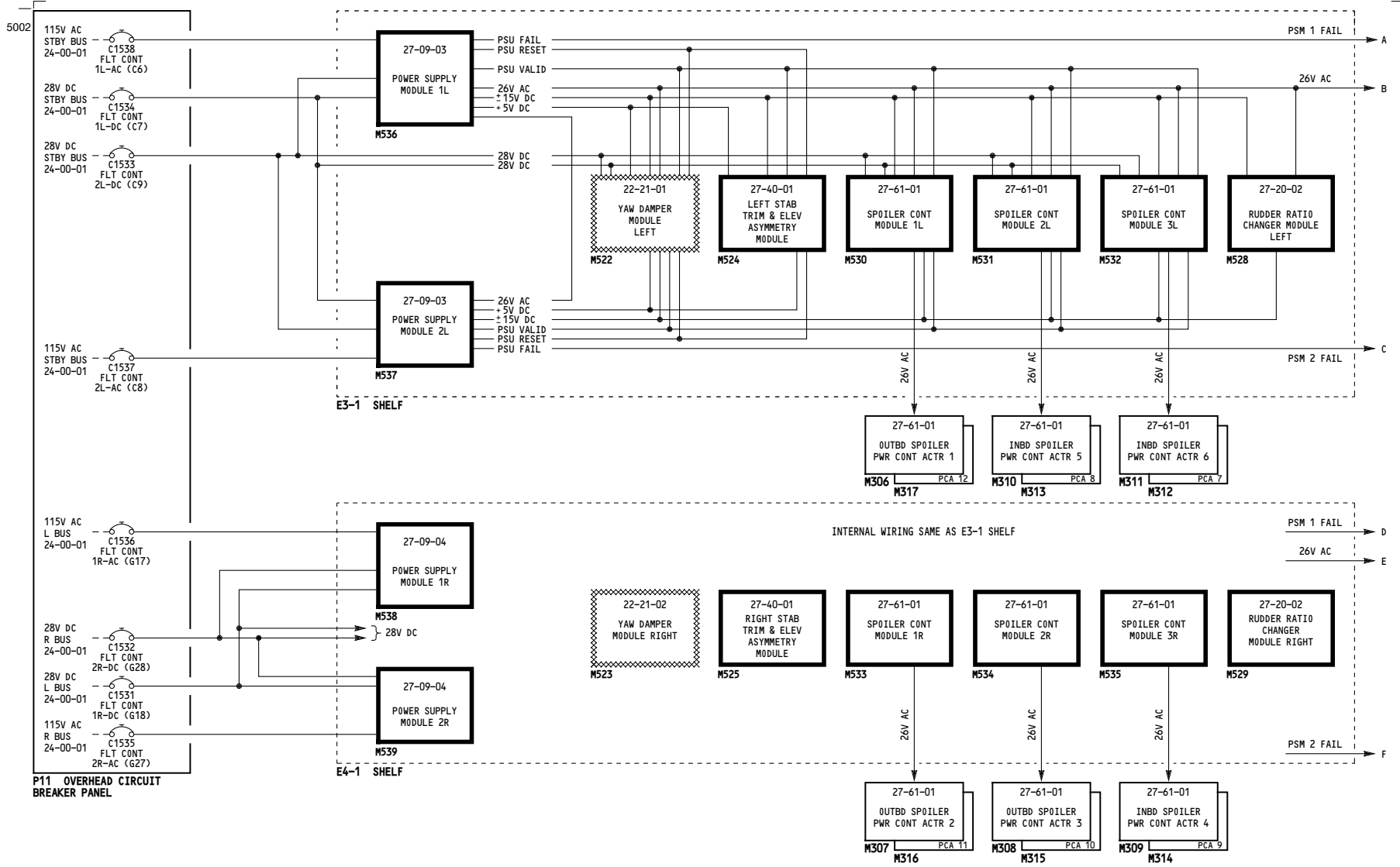

001-099	<p align="center">CONTROL SYSTEMS ELECTRICAL/ELECTRONIC UNIT (CSEU) POWER</p> <p align="center">D280N032S</p>
---------	--

27-09-00

5001

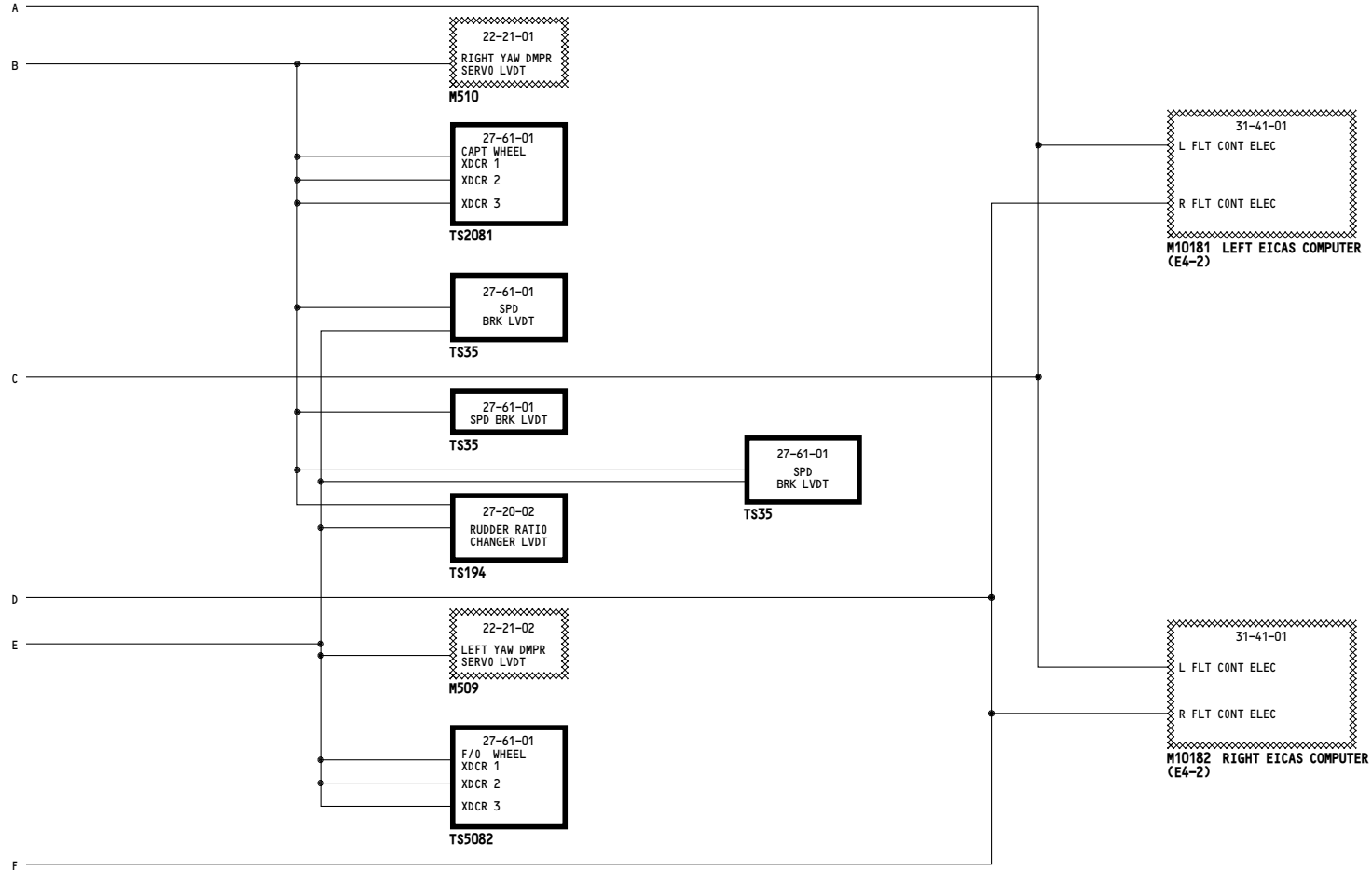

001-099	<p align="center">CONTROL SYSTEMS ELECTRICAL/ELECTRONIC UNIT (CSEU) POWER</p> <p align="center">D280N032S</p>
---------	--

27-09-00

Page 101
Sheet 2
Jan 21/2005

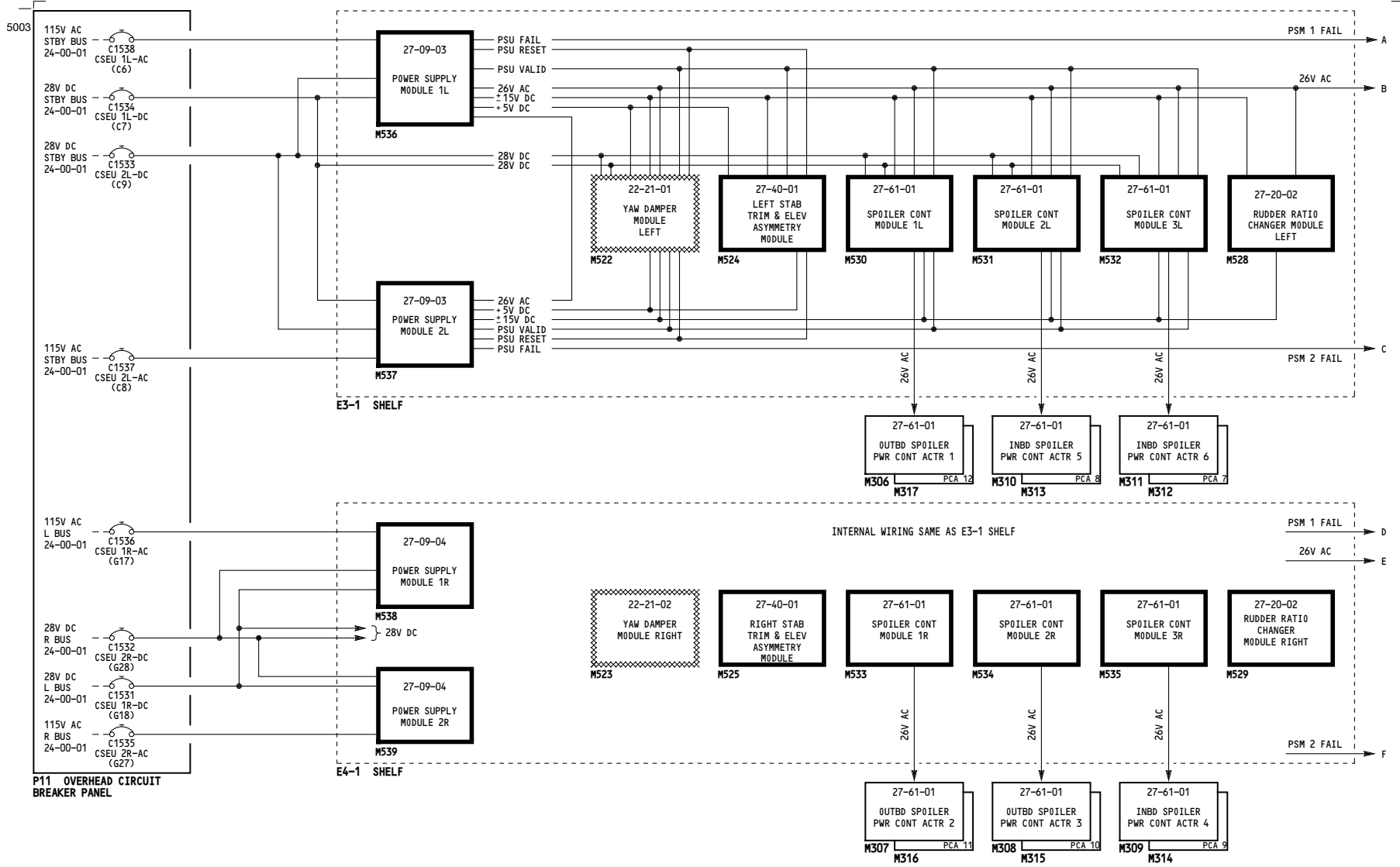

115-199	CONTROL SYSTEMS ELECTRICAL/ELECTRONIC UNIT (CSEU) POWER
D280N032S	

27-09-00

5001

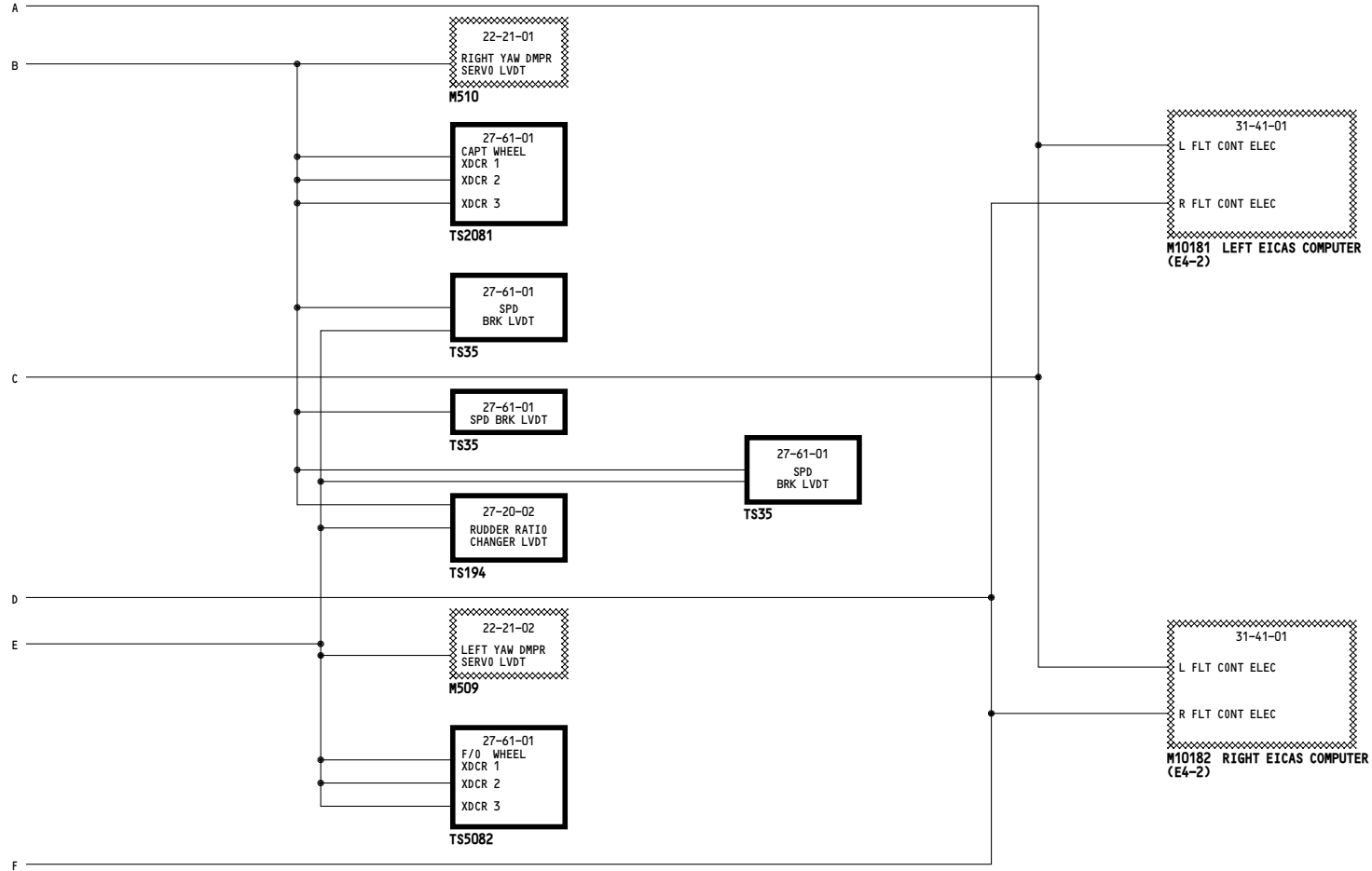

115-199	<p align="center">CONTROL SYSTEMS ELECTRICAL/ELECTRONIC UNIT (CSEU) POWER</p> <p align="center">D280N032S</p>
---------	--

27-09-00

Page 102
Sheet 2
Jan 21/2005

5005

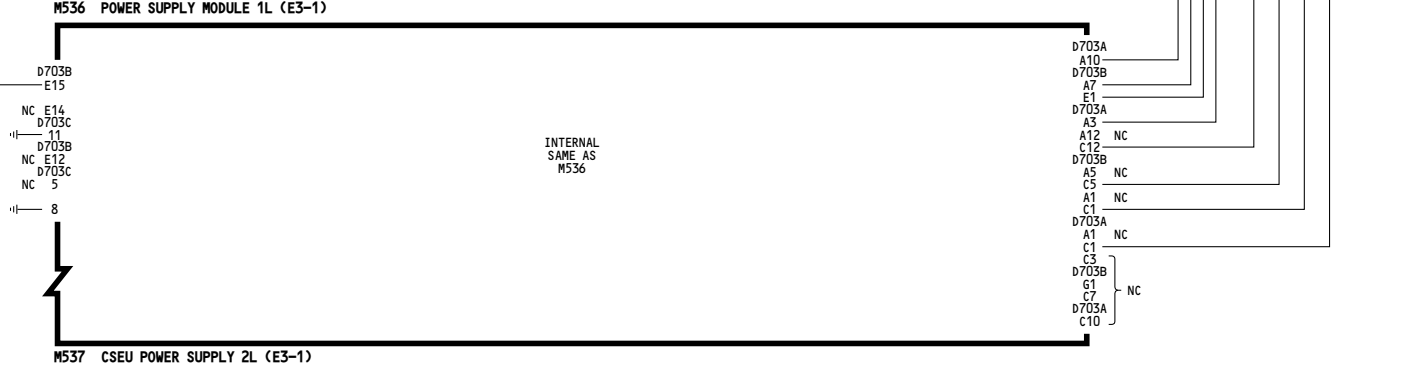
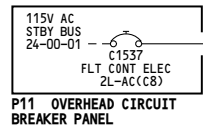
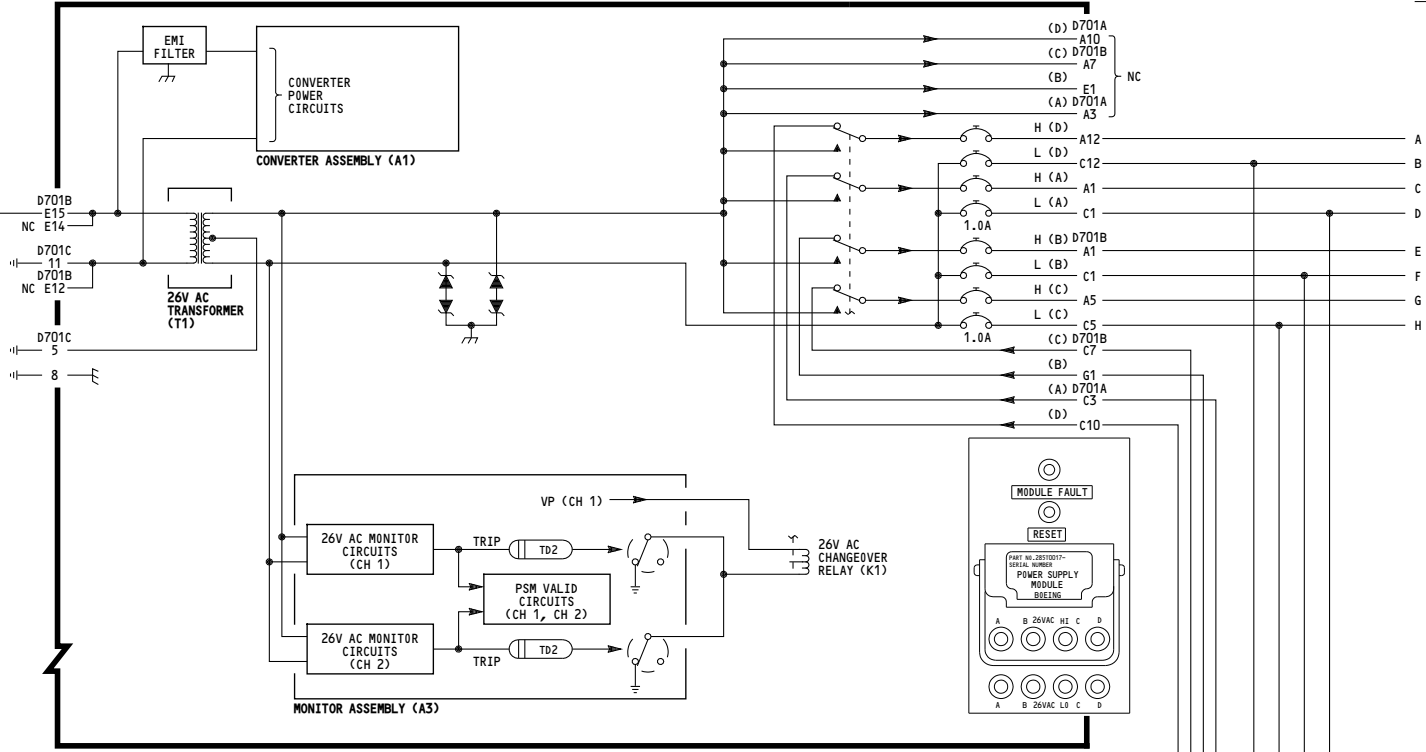
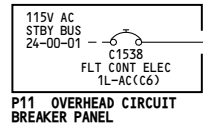

27-09-01

5002

WIRING DIAGRAMS	
27-21-11	
27-21-12	
27-61-13	
27-61-17	
27-61-18	

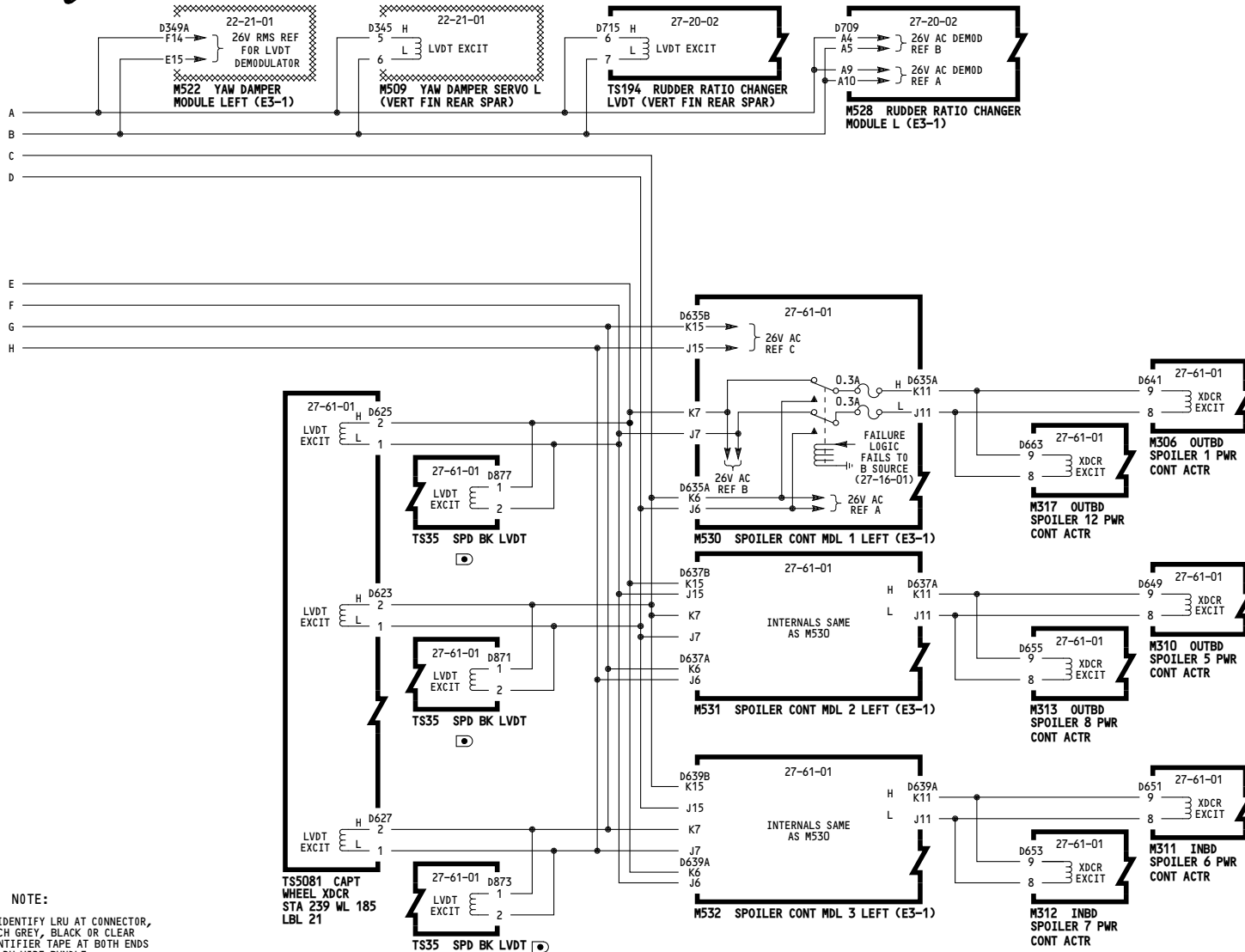

NOTE:
 TO IDENTIFY LRU AT CONNECTOR, MATCH GREY, BLACK OR CLEAR IDENTIFIER TAPE AT BOTH ENDS OF LRU WIRE BUNDLE

001-099	LEFT CSEU POWER - AC
D280N032S	

27-09-01

5004

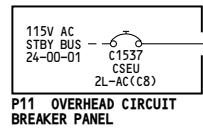
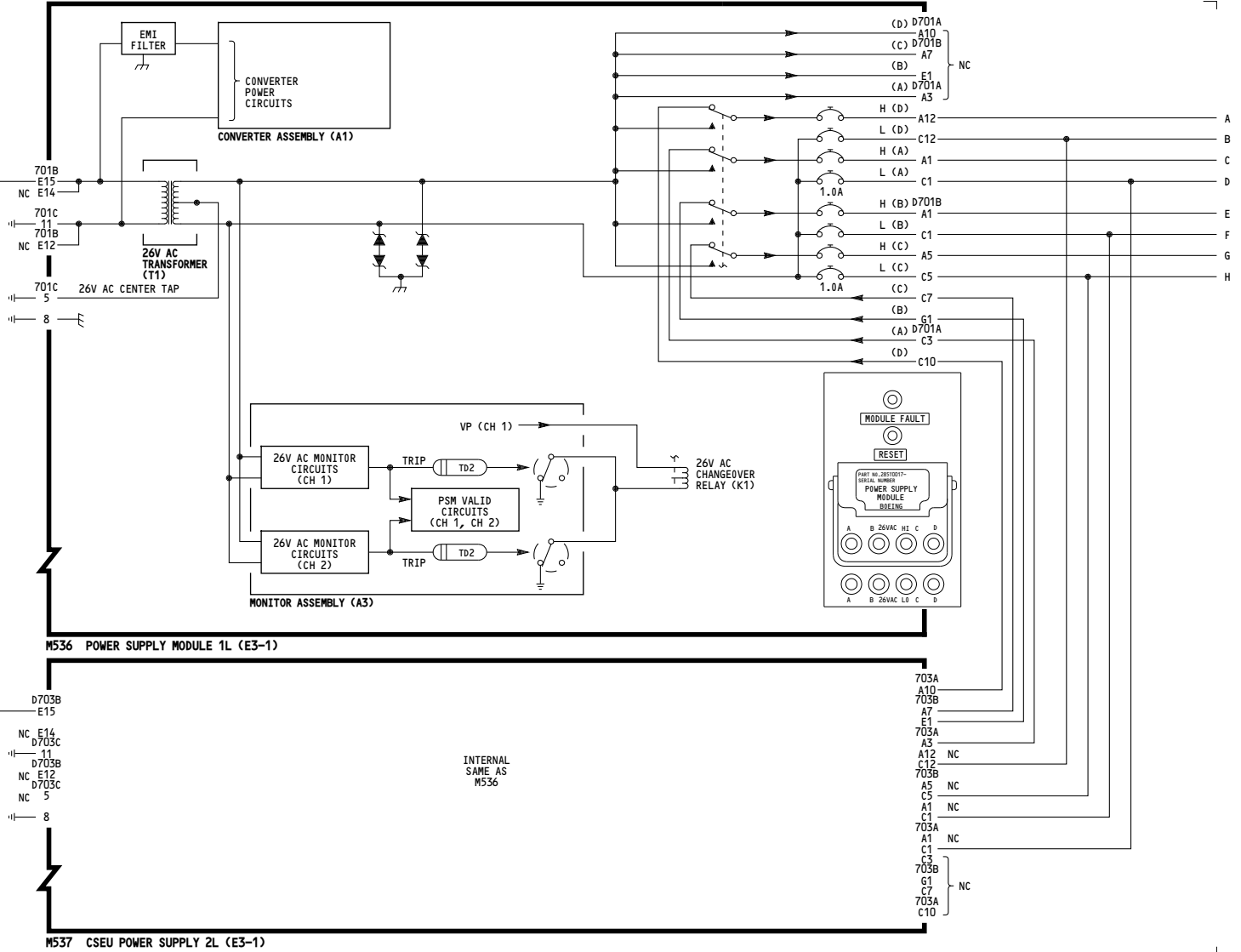
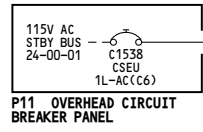

27-09-01

Page 102
Sheet 1
Jan 21/2005

5002

WIRING DIAGRAMS	
27-21-11	
27-21-12	
27-61-13	
27-61-17	
27-61-18	

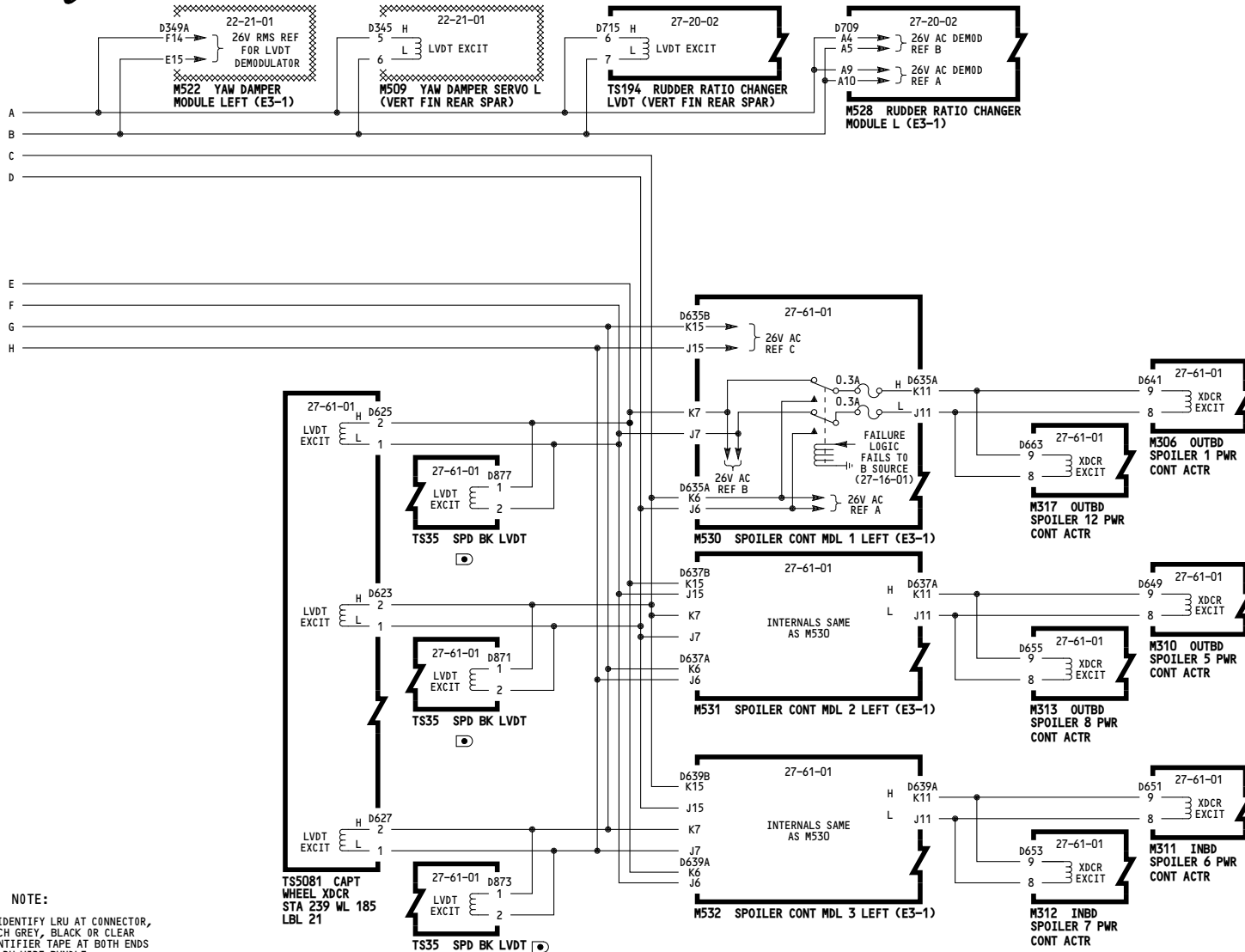

NOTE:
 TO IDENTIFY LRU AT CONNECTOR,
 MATCH GREY, BLACK OR CLEAR
 IDENTIFIER TAPE AT BOTH ENDS
 OF LRU WIRE BUNDLE

115-199	LEFT CSEU POWER - AC
D280N032S	

27-09-01

5005

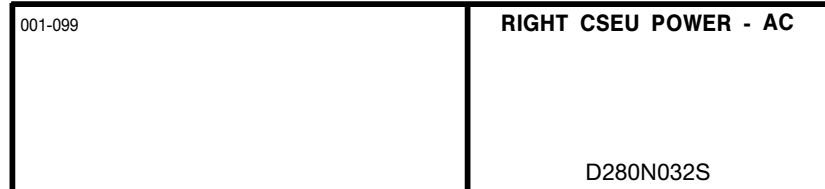
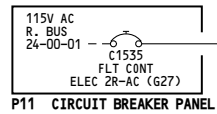
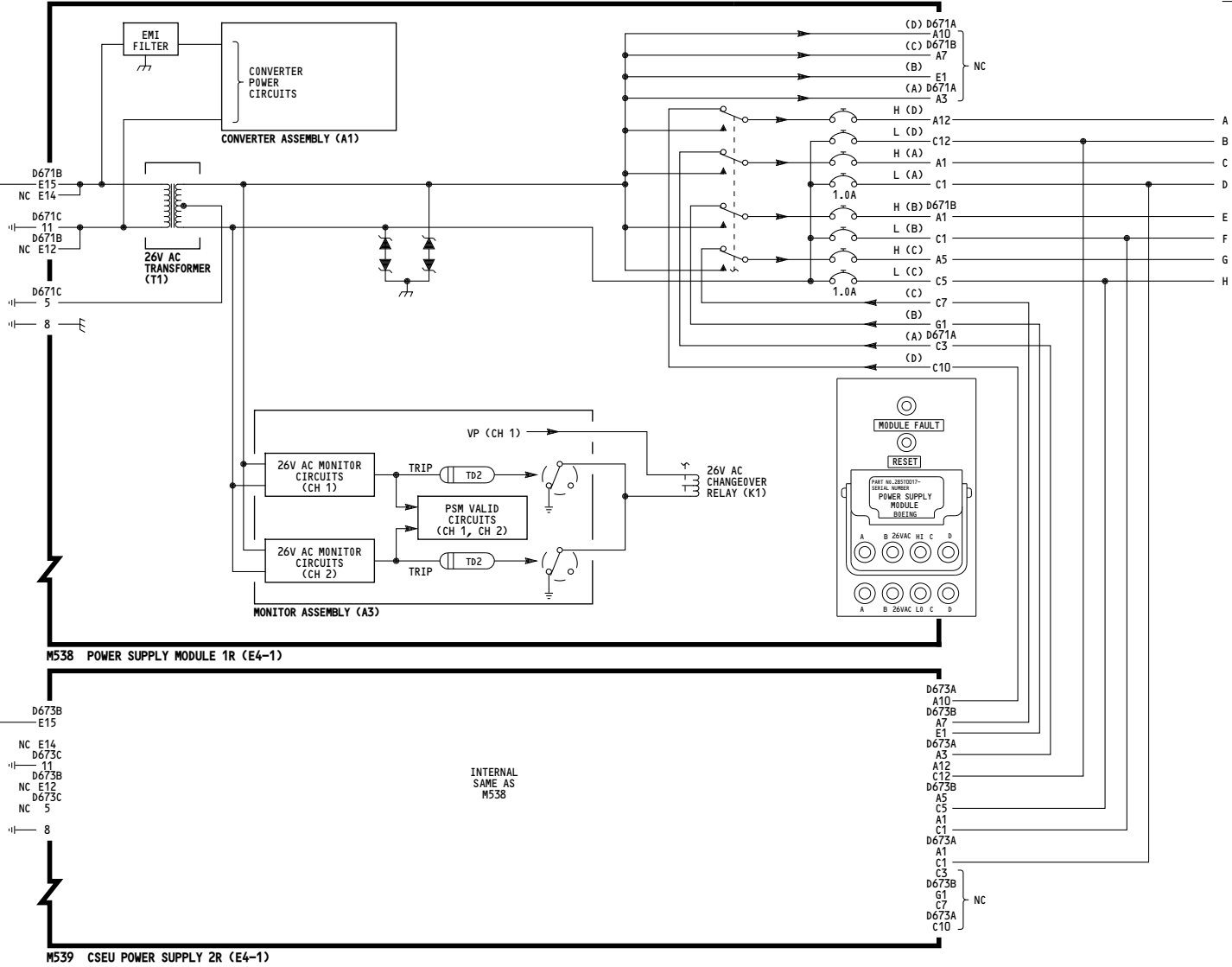
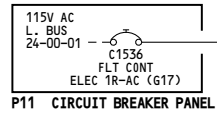

27-09-02

5002

WIRING DIAGRAMS	
27-21-22	
27-61-14	
27-61-15	
27-61-16	

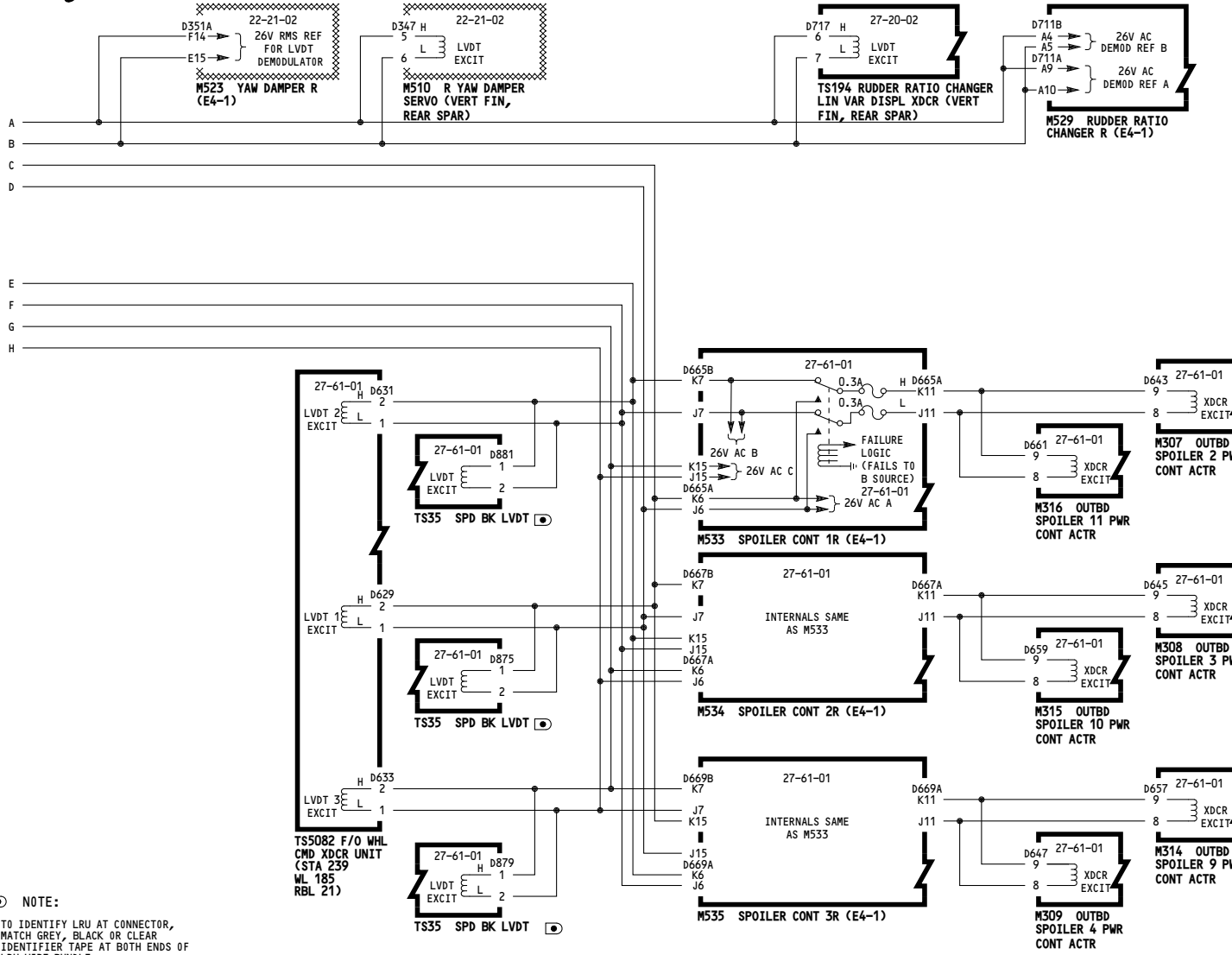

NOTE:
 TO IDENTIFY LRU AT CONNECTOR,
 MATCH GREY, BLACK OR CLEAR
 IDENTIFIER TAPE AT BOTH ENDS OF
 LRU WIRE BUNDLE

001-099	RIGHT CSEU POWER - AC
D280N032S	

27-09-02

5004

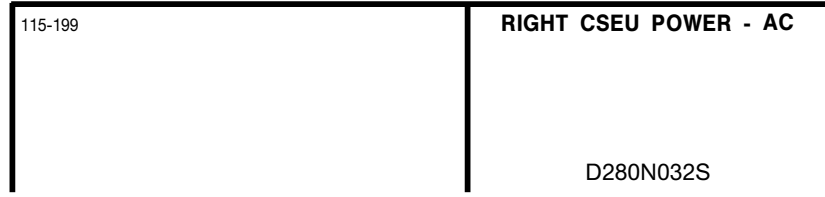
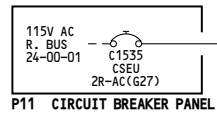
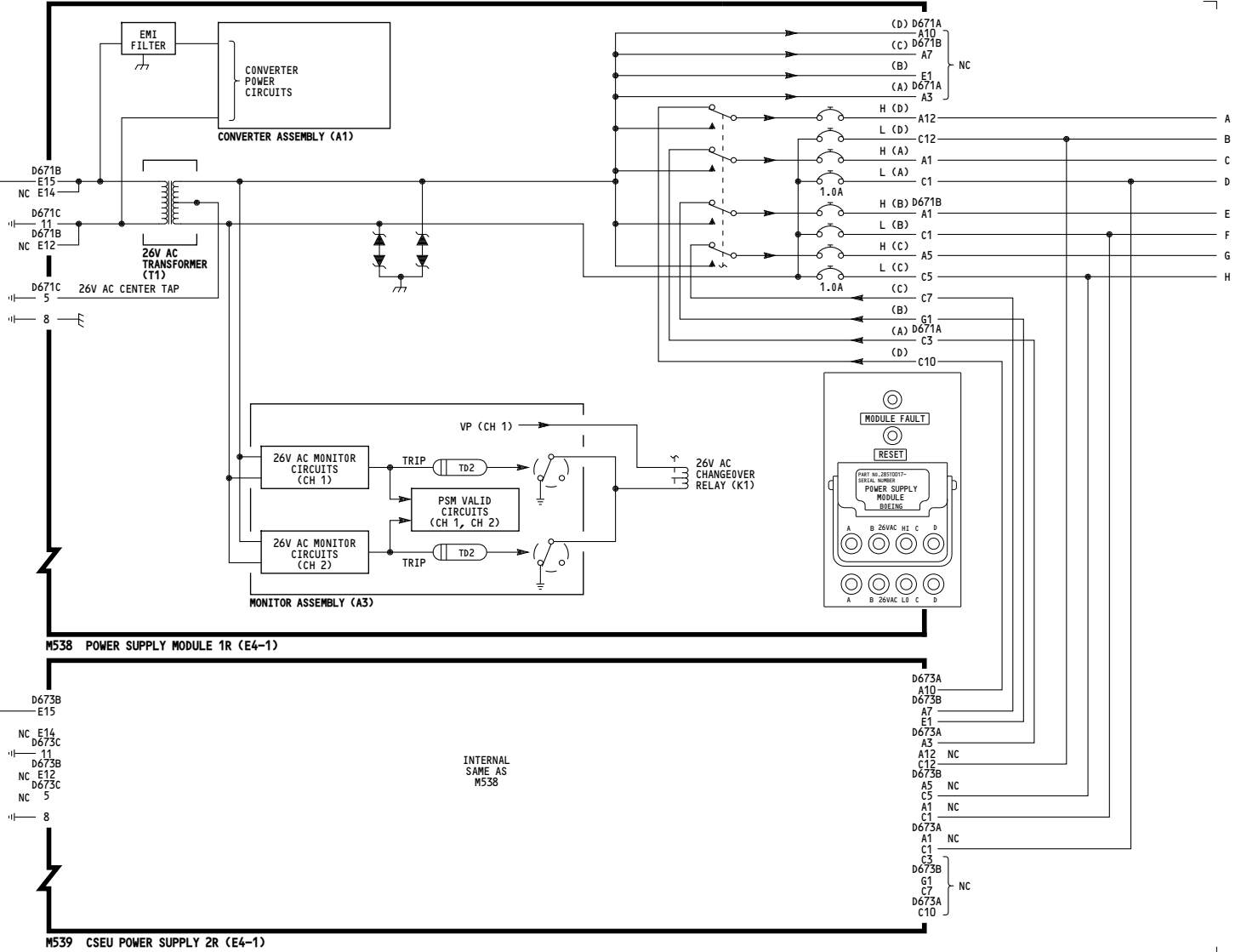
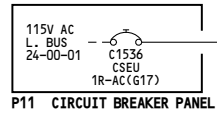

27-09-02

Page 102
 Sheet 1
 Jan 21/2005

5002

WIRING DIAGRAMS	
27-21-22	
27-61-14	
27-61-15	
27-61-16	

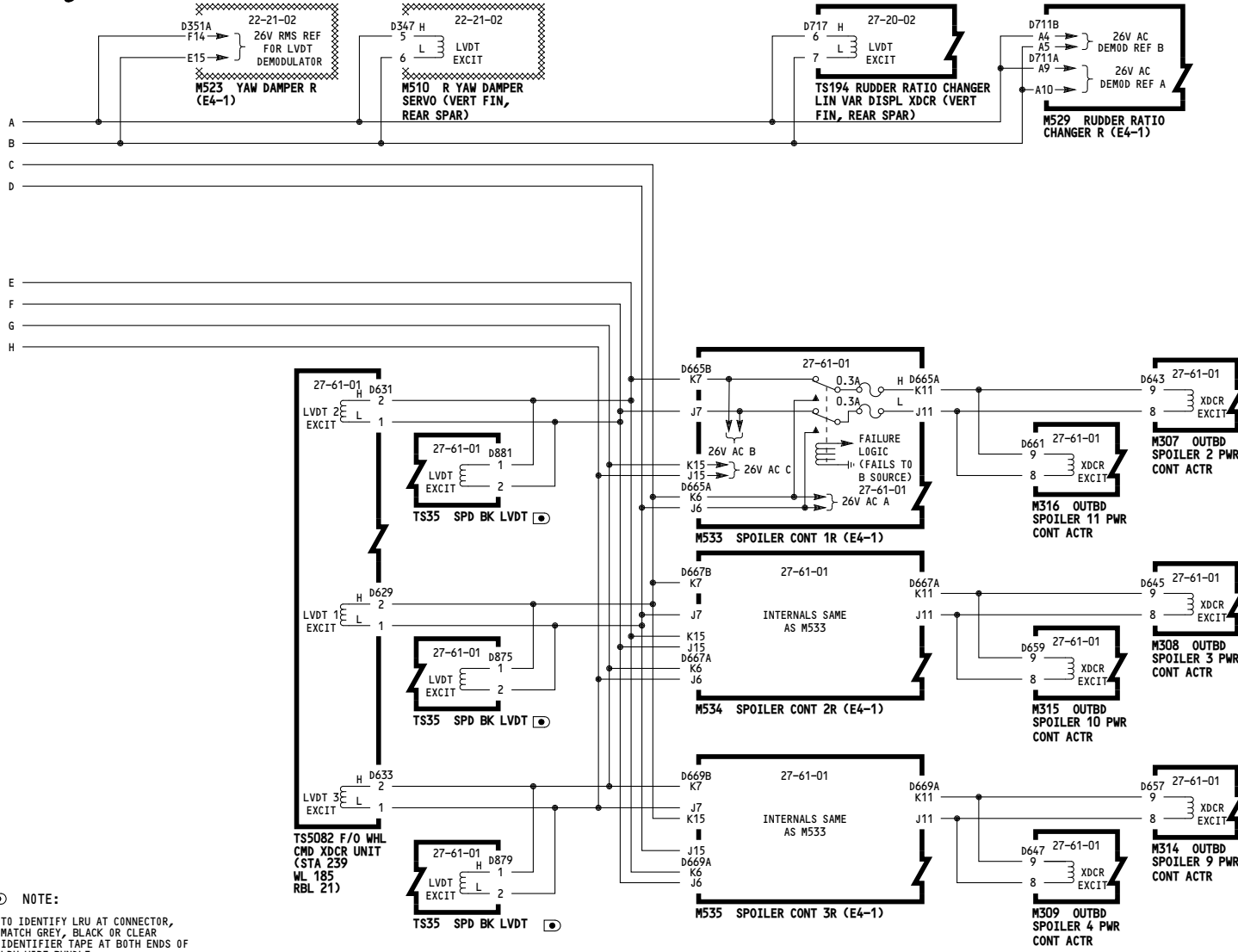

NOTE:
 TO IDENTIFY LRU AT CONNECTOR,
 MATCH GREY, BLACK OR CLEAR
 IDENTIFIER TAPE AT BOTH ENDS OF
 LRU WIRE BUNDLE

115-199	RIGHT CSEU POWER - AC
D280N032S	

27-09-02

5001

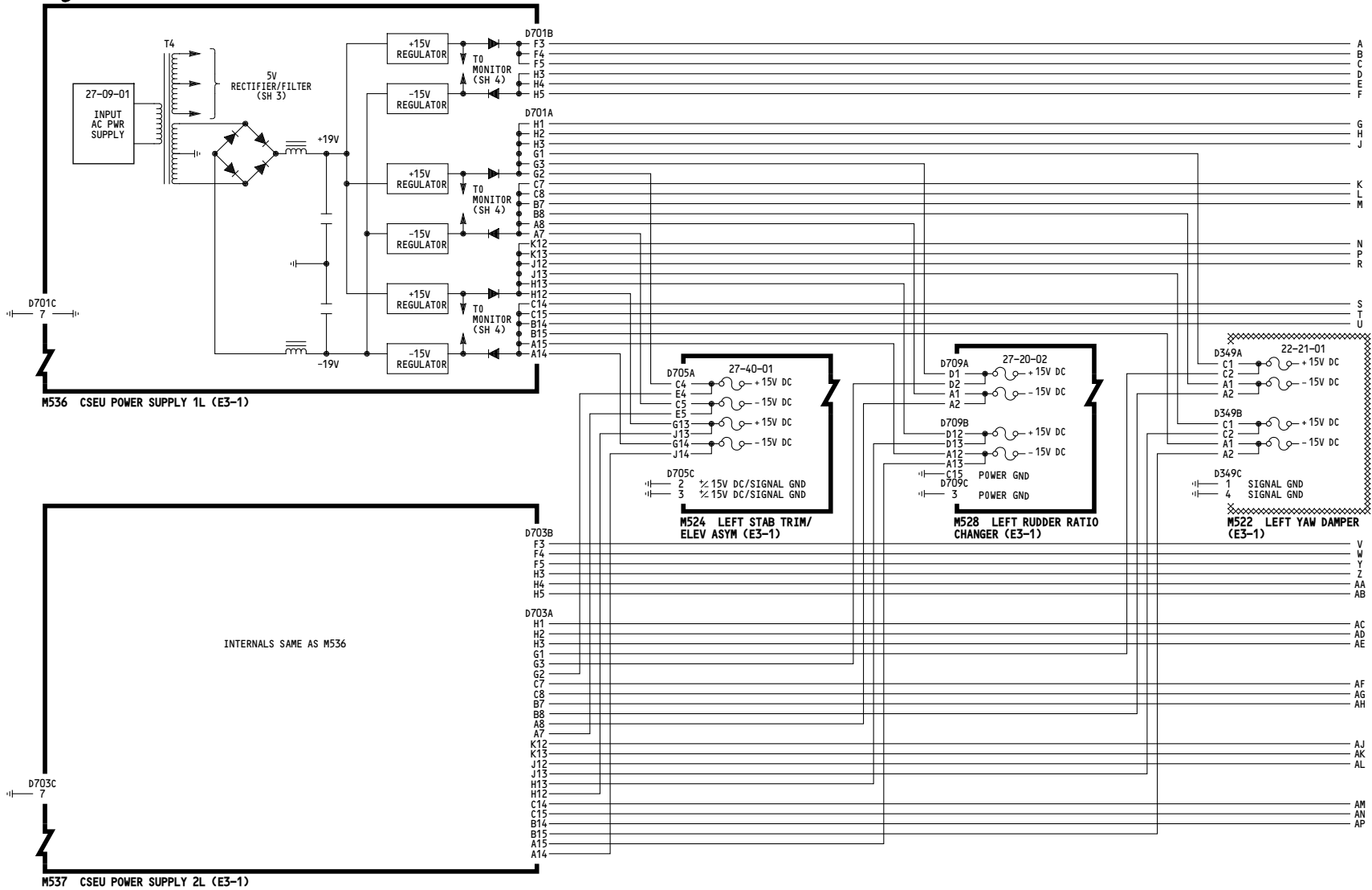

001-099	<p>LEFT CSEU POWER - DC</p> <p>D280N032S</p>
---------	---

27-09-03

5001

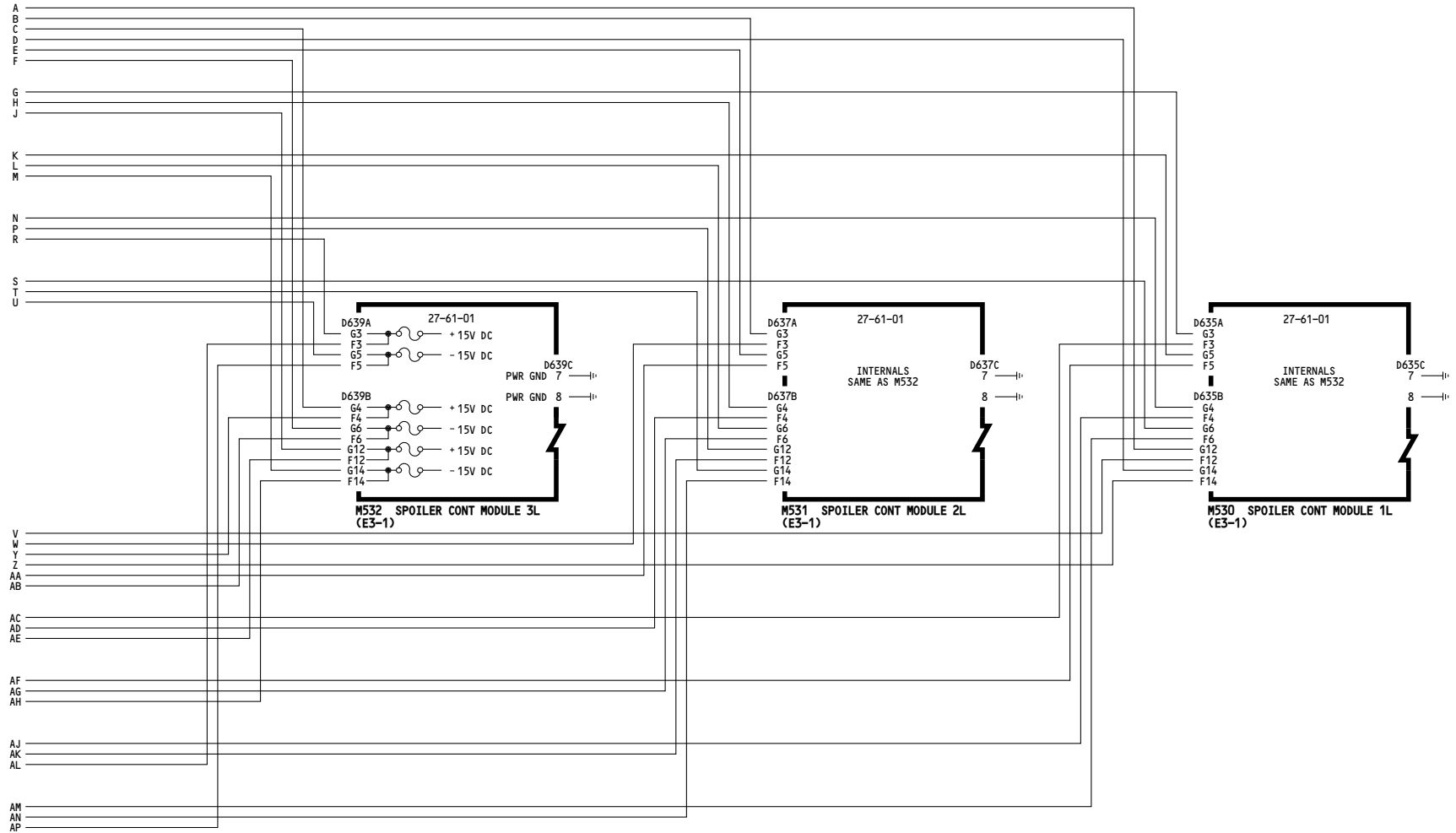

001-099	<p>LEFT CSEU POWER - DC</p> <p>D280N032S</p>
---------	---

27-09-03

Page 101
Sheet 2
Jan 21/2005

5001

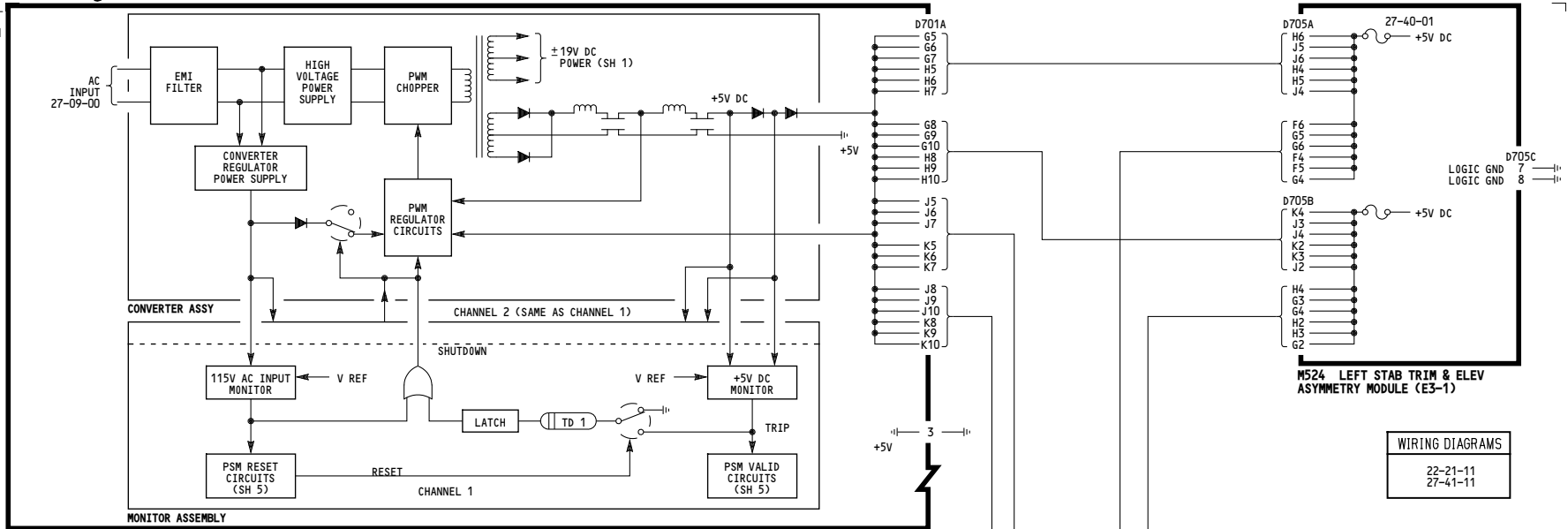

M536 CESU POWER SUPPLY 1L (E3-1)

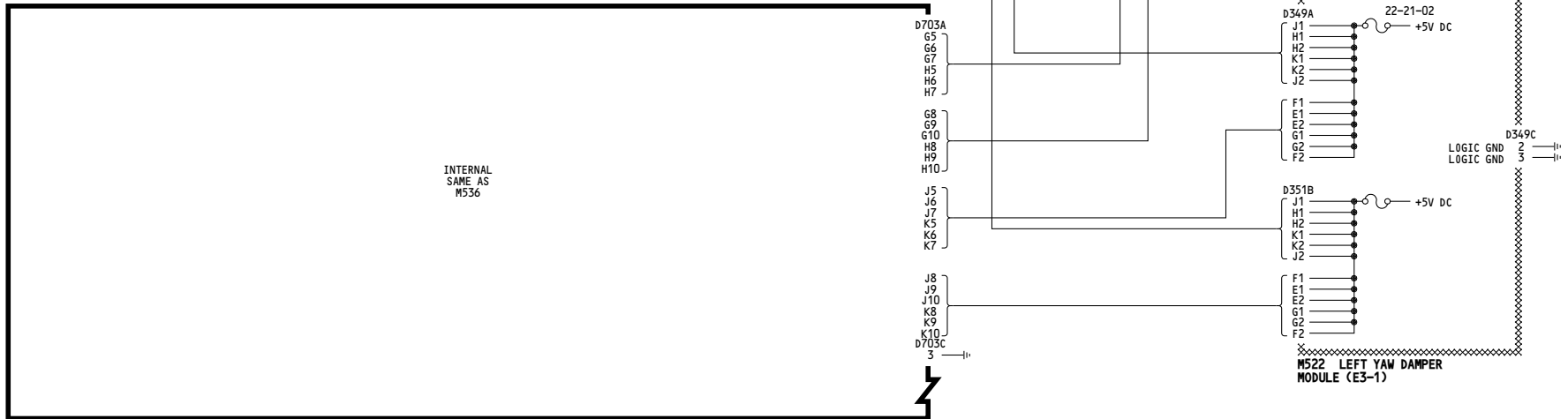

M537 CESU POWER SUPPLY 2L (E3-1)

001-099

LEFT CSEU POWER - DC

D280N032S

27-09-03

5005

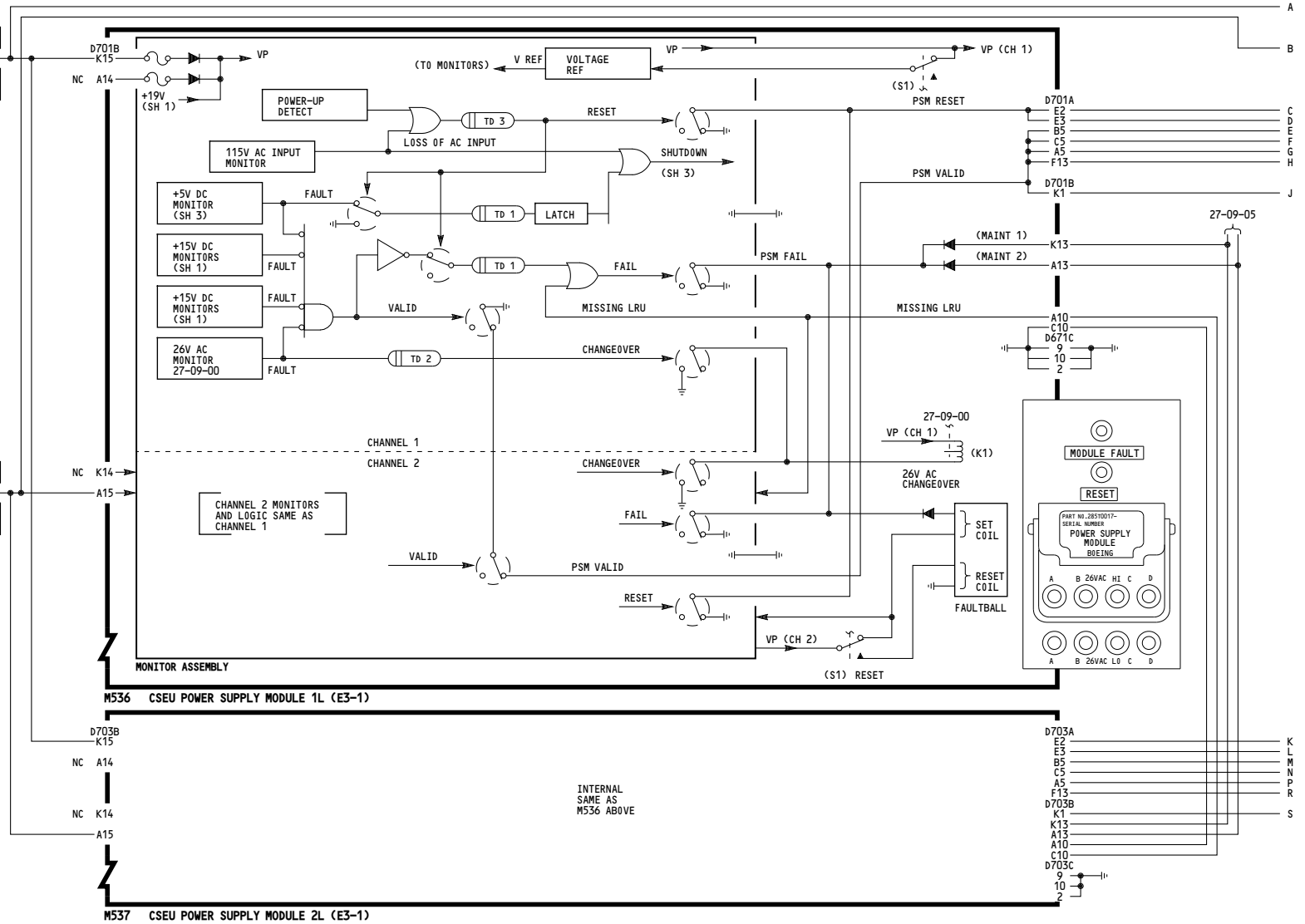
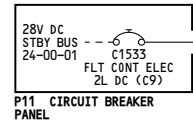
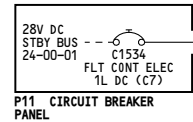

001-099

LEFT CSEU POWER - DC

D280N032S

27-09-03

Page 101
Sheet 4
Jan 21/2005

WIRING DIAGRAMS	
22-21-11	
27-09-11	
27-21-12	
27-41-11	
27-61-14	
27-61-15	
27-61-16	

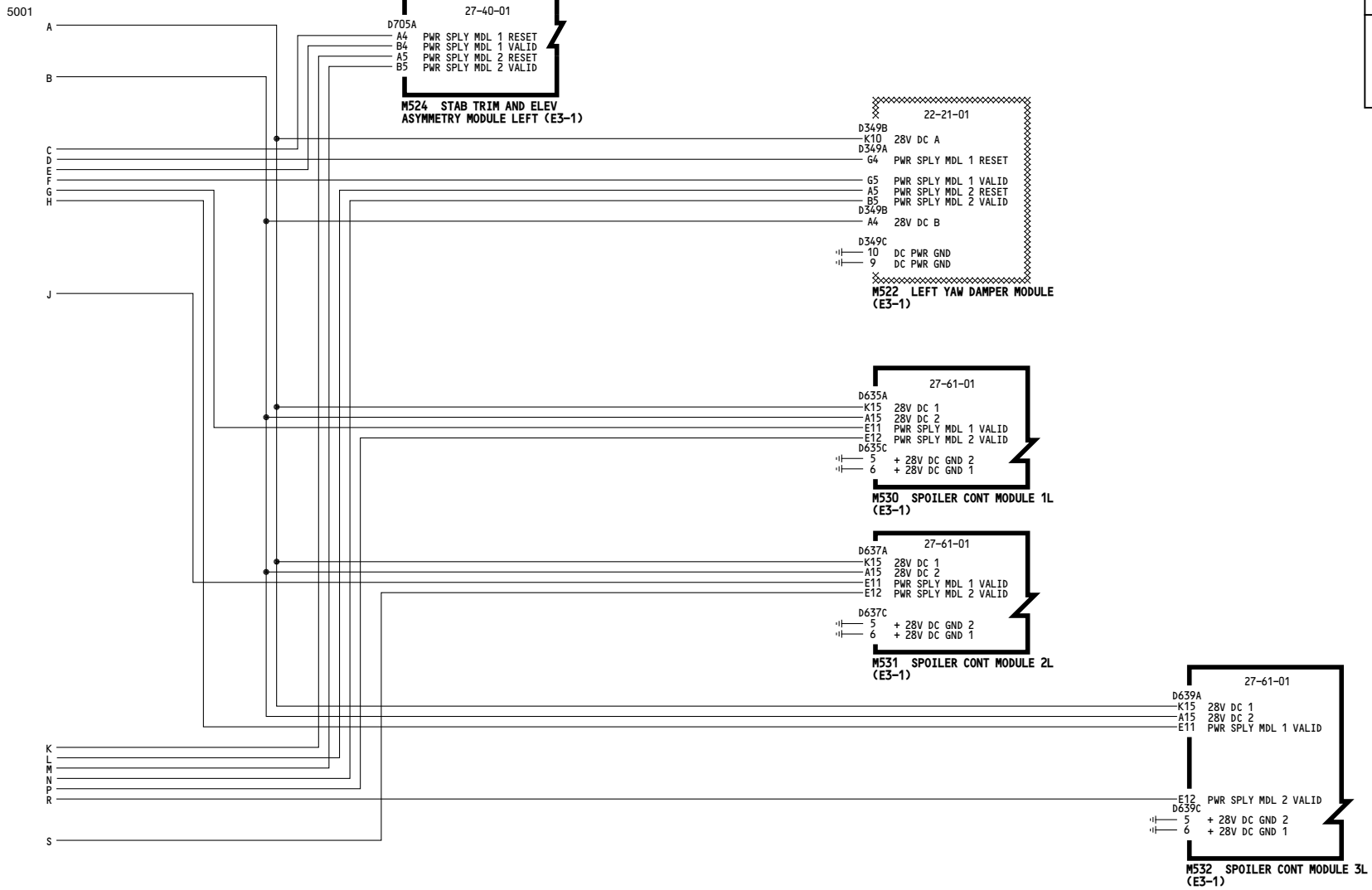

001-099	LEFT CSEU POWER - DC
D280N032S	

27-09-03

Page 101
 Sheet 5
 Jan 21/2005

THIS PAGE INTENTIONALLY LEFT BLANK

5001

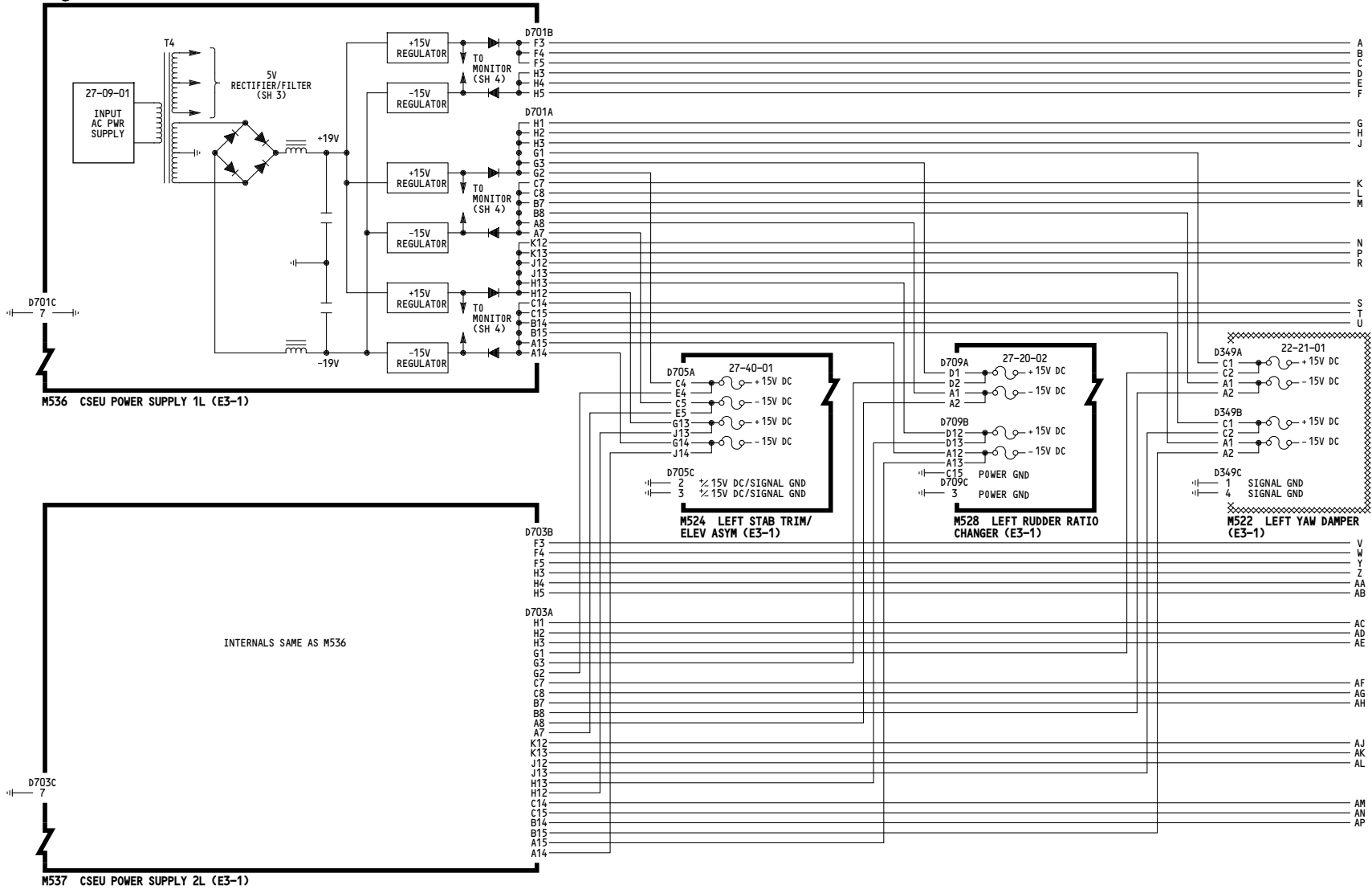

115-199

LEFT CSEU POWER - DC

D280N032S

27-09-03

Page 102
Sheet 1
Jan 21/2005

5001

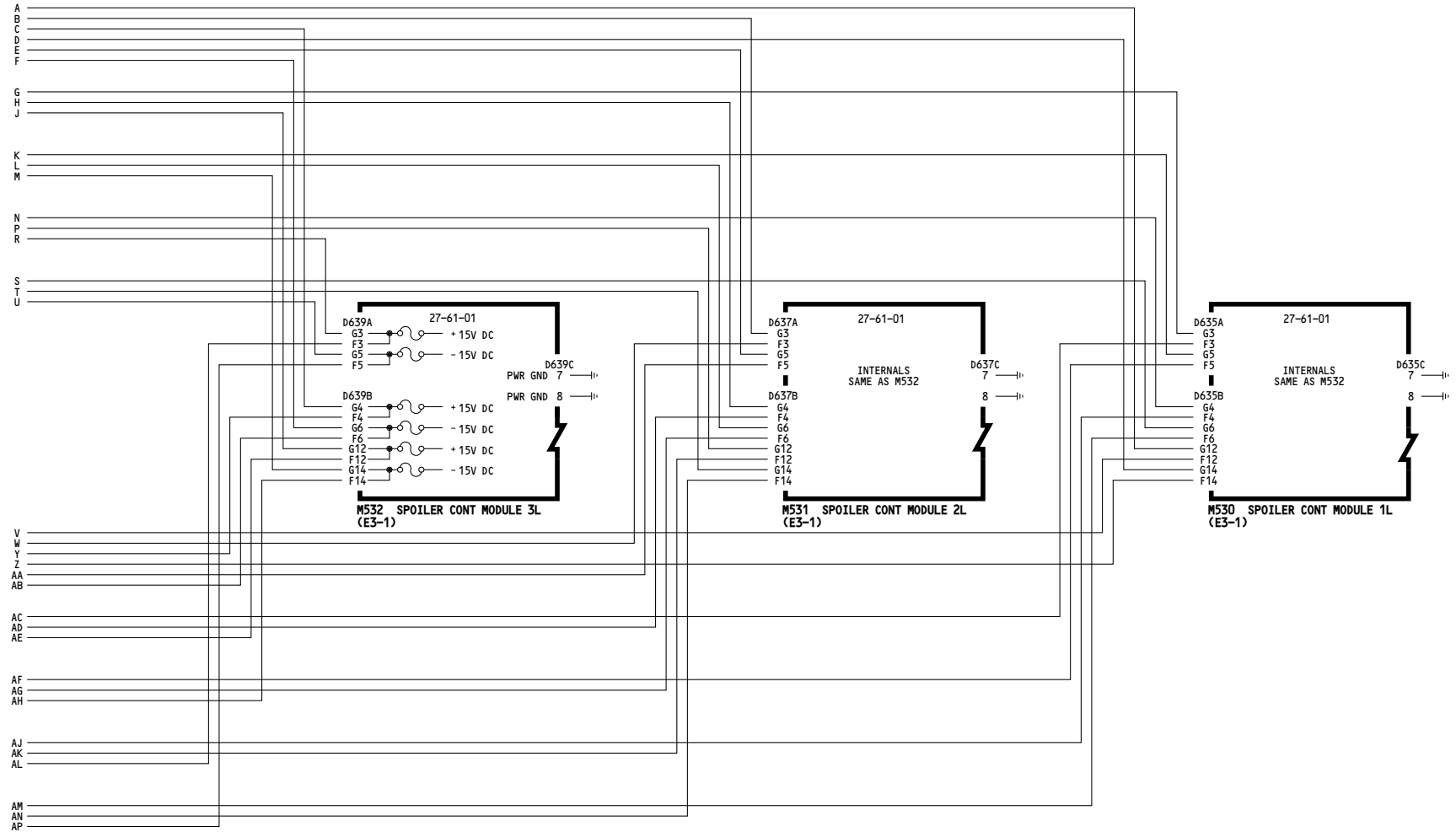

115-199	<p>LEFT CSEU POWER - DC</p> <p>D280N032S</p>
---------	---

27-09-03

Page 102
Sheet 2
Jan 21/2005

5001

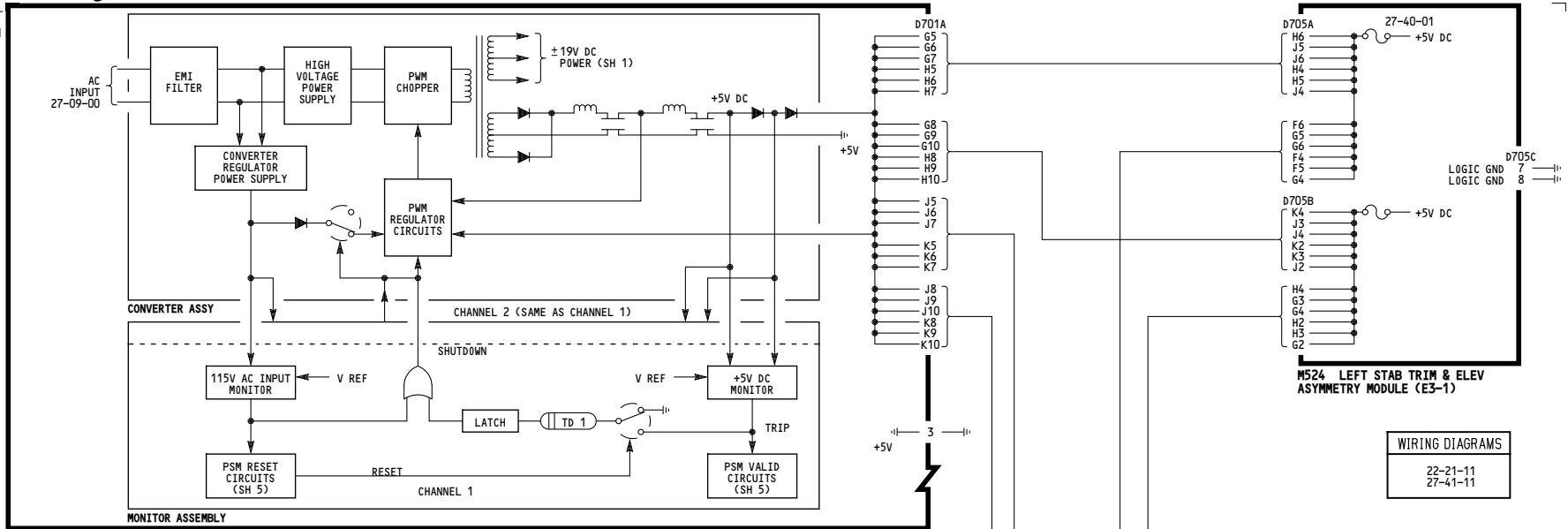

M536 CESU POWER SUPPLY 1L (E3-1)

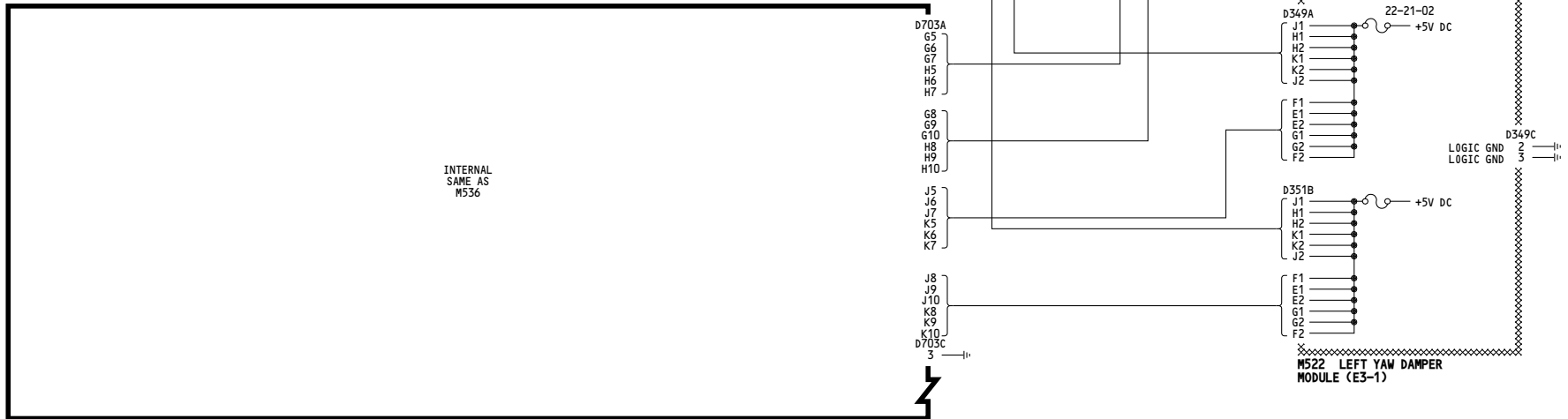

M537 CESU POWER SUPPLY 2L (E3-1)

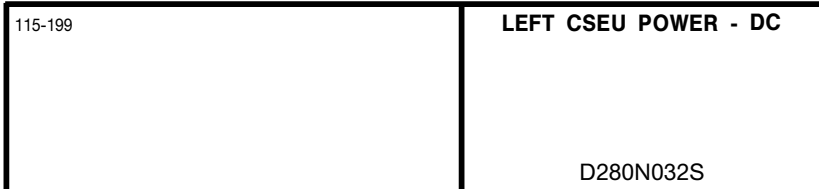

27-09-03

5004

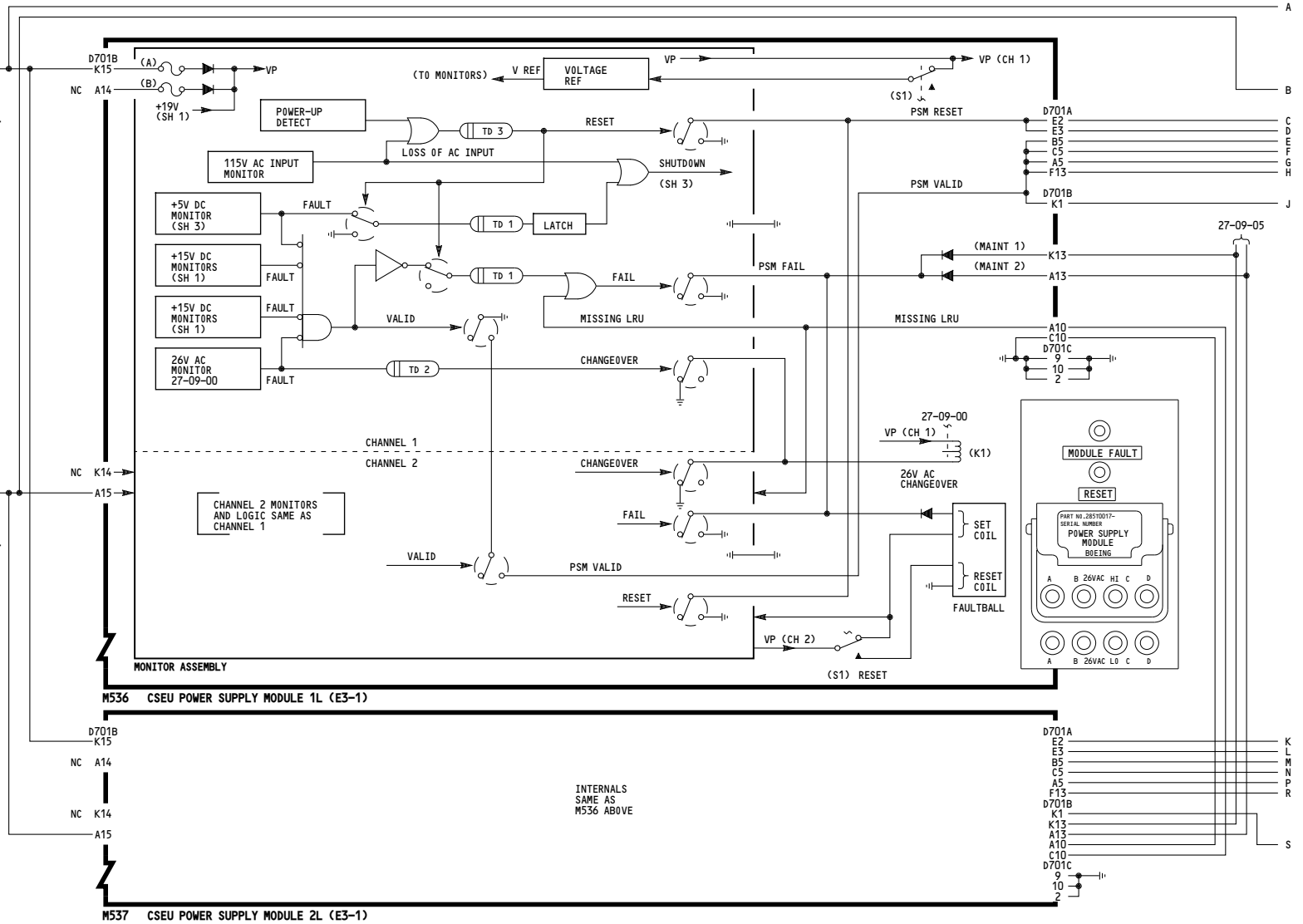
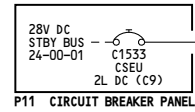
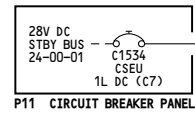

115-199	LEFT CSEU POWER - DC
D280N032S	

27-09-03

Page 102
Sheet 4
Jan 21/2005

WIRING DIAGRAMS	
22-21-11	
27-09-11	
27-21-12	
27-41-11	
27-61-14	
27-61-15	
27-61-16	

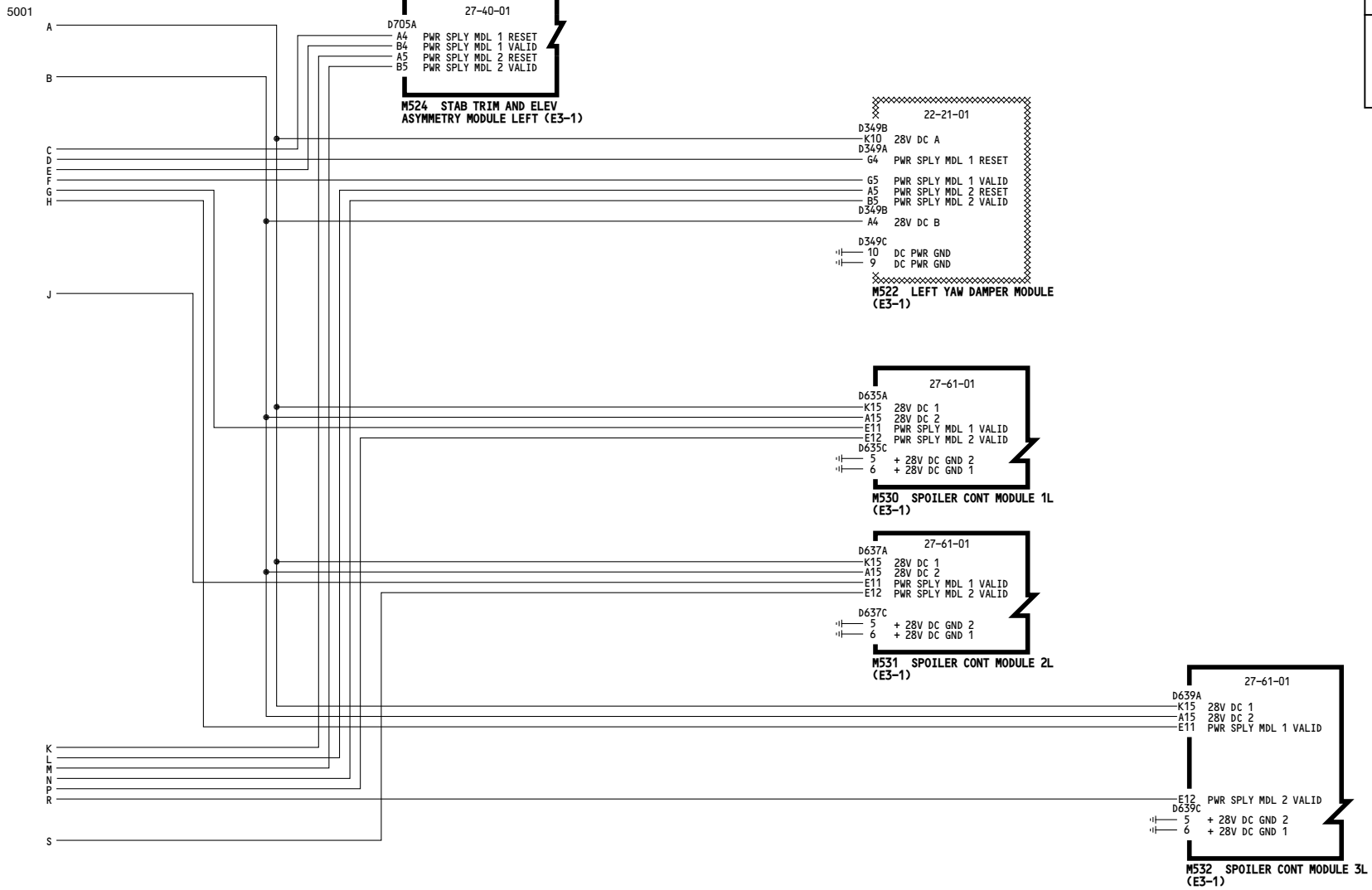

115-199	LEFT CSEU POWER - DC
D280N032S	

27-09-03

Page 102
 Sheet 5
 Jan 21/2005

THIS PAGE INTENTIONALLY LEFT BLANK

5001

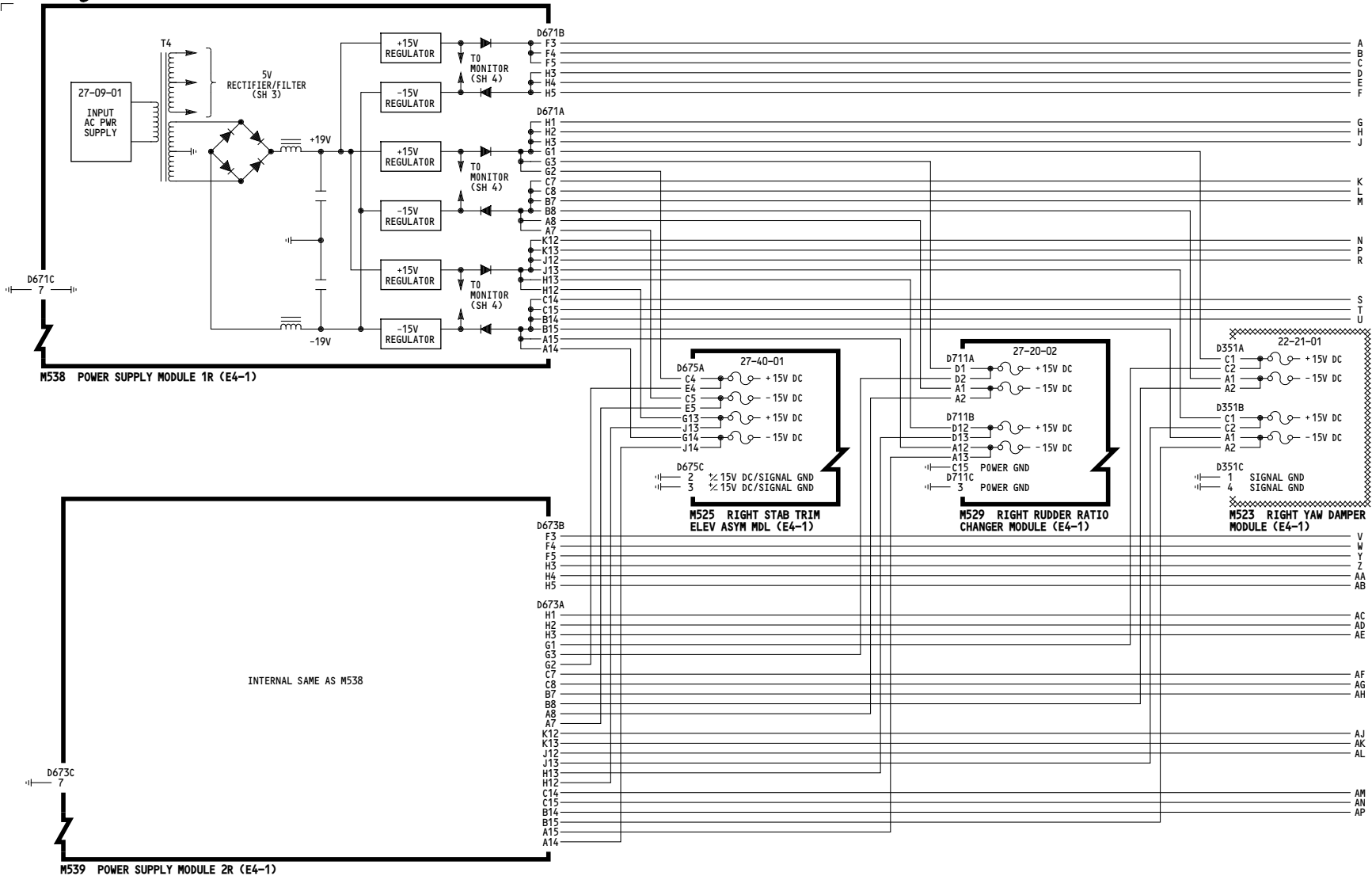

001-099	RIGHT CSEU POWER - DC
D280N032S	

27-09-04

5001

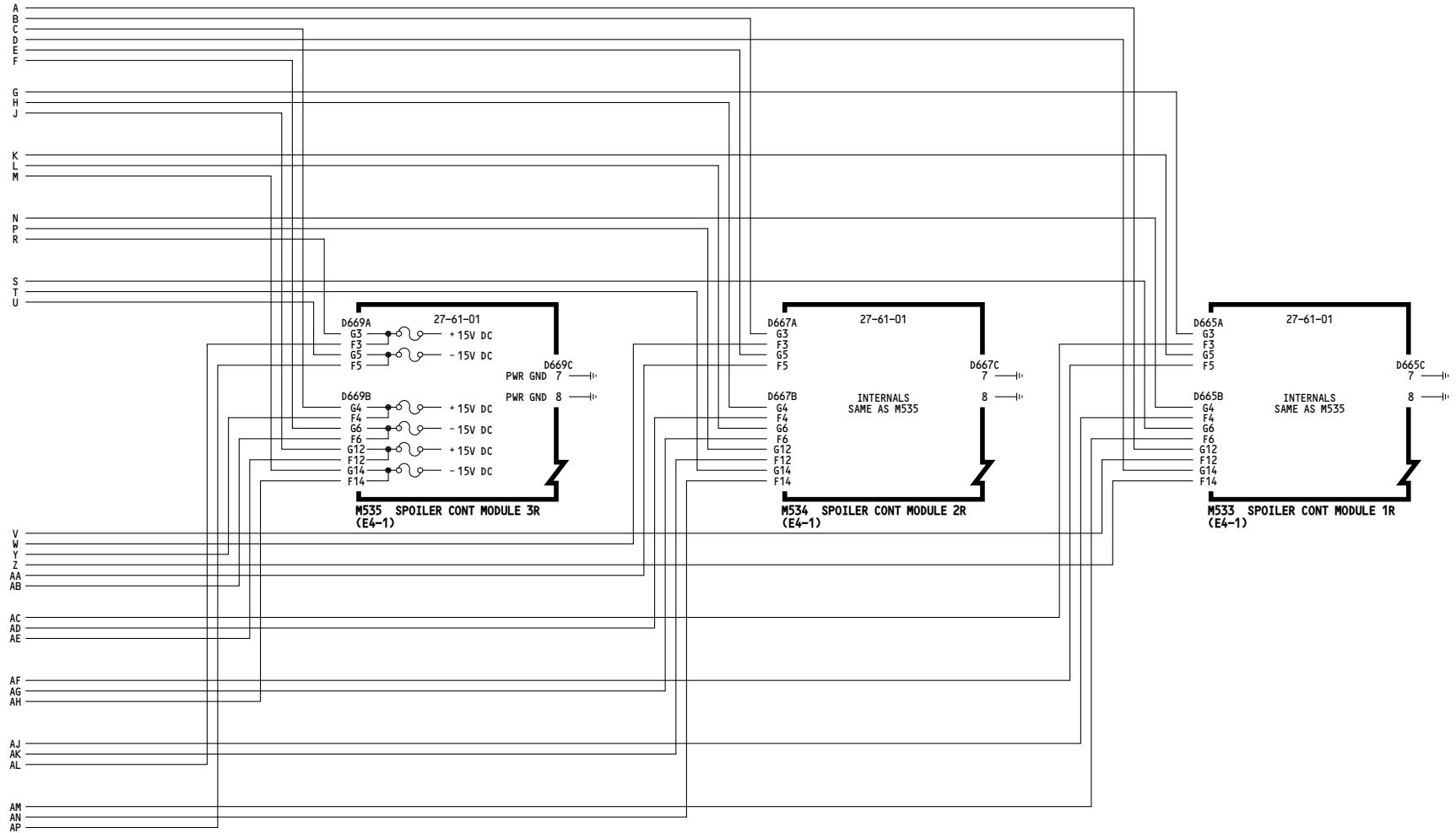

001-099	<p align="center">RIGHT CSEU POWER - DC</p> <p align="center">D280N032S</p>
---------	--

27-09-04

Page 101
Sheet 2
Jan 21/2005

5001

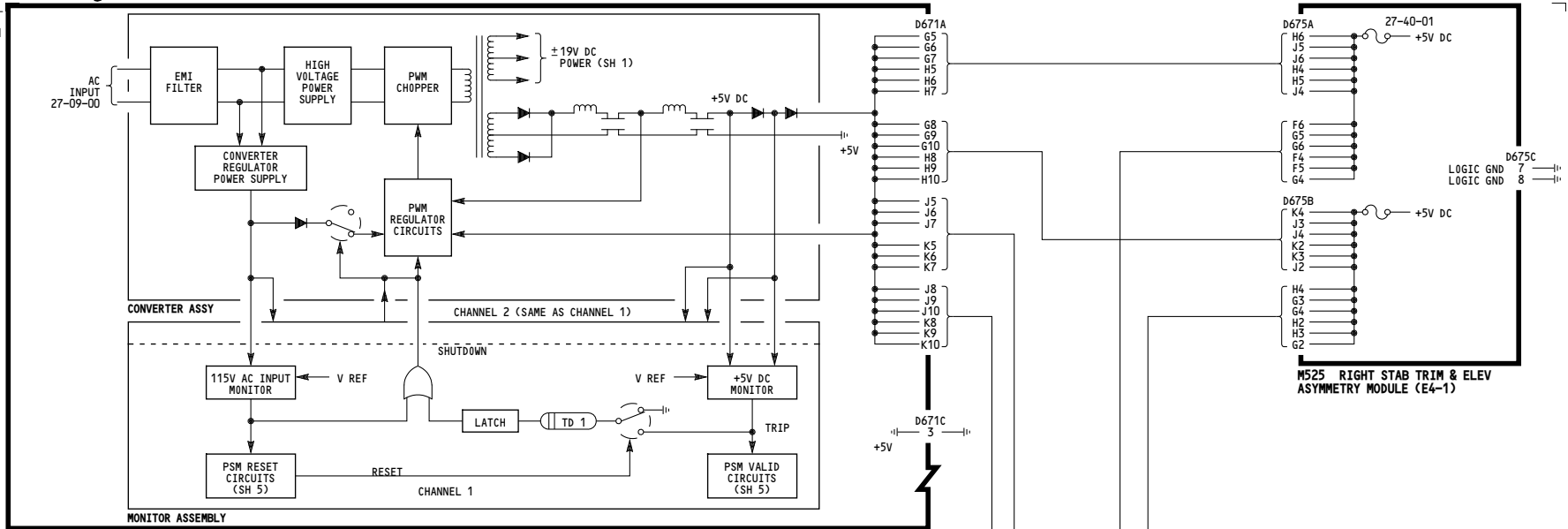

M538 CESU POWER SUPPLY MODULE 1R (E4-1)

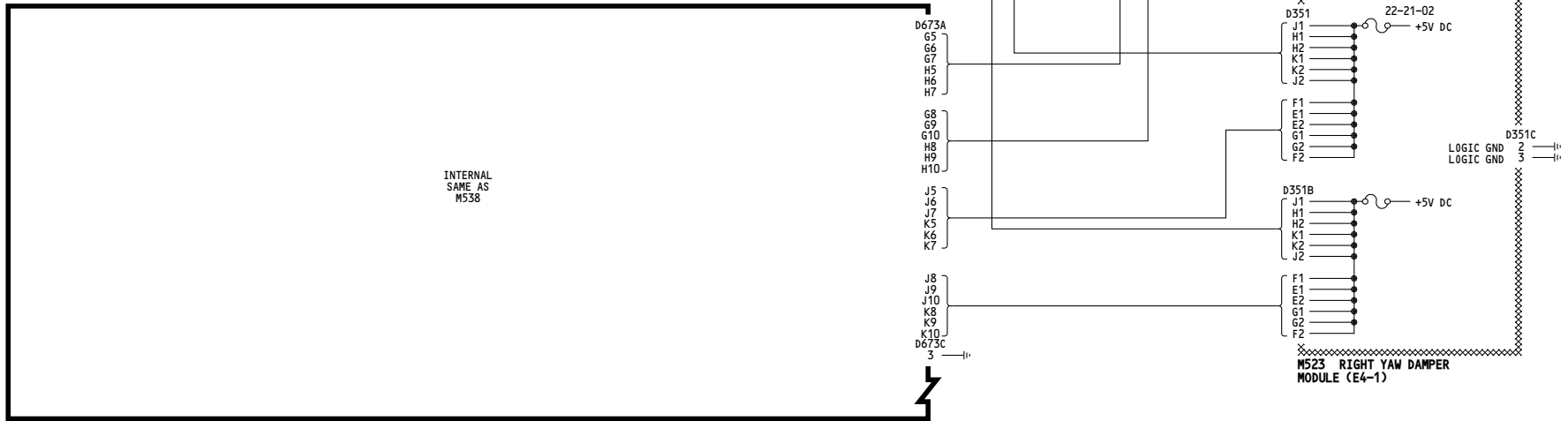

M539 CESU POWER SUPPLY MODULE 2R (E4-1)

001-099	<p align="center">RIGHT CSEU POWER - DC</p> <p align="center">D280N032S</p>
---------	--

27-09-04

5005

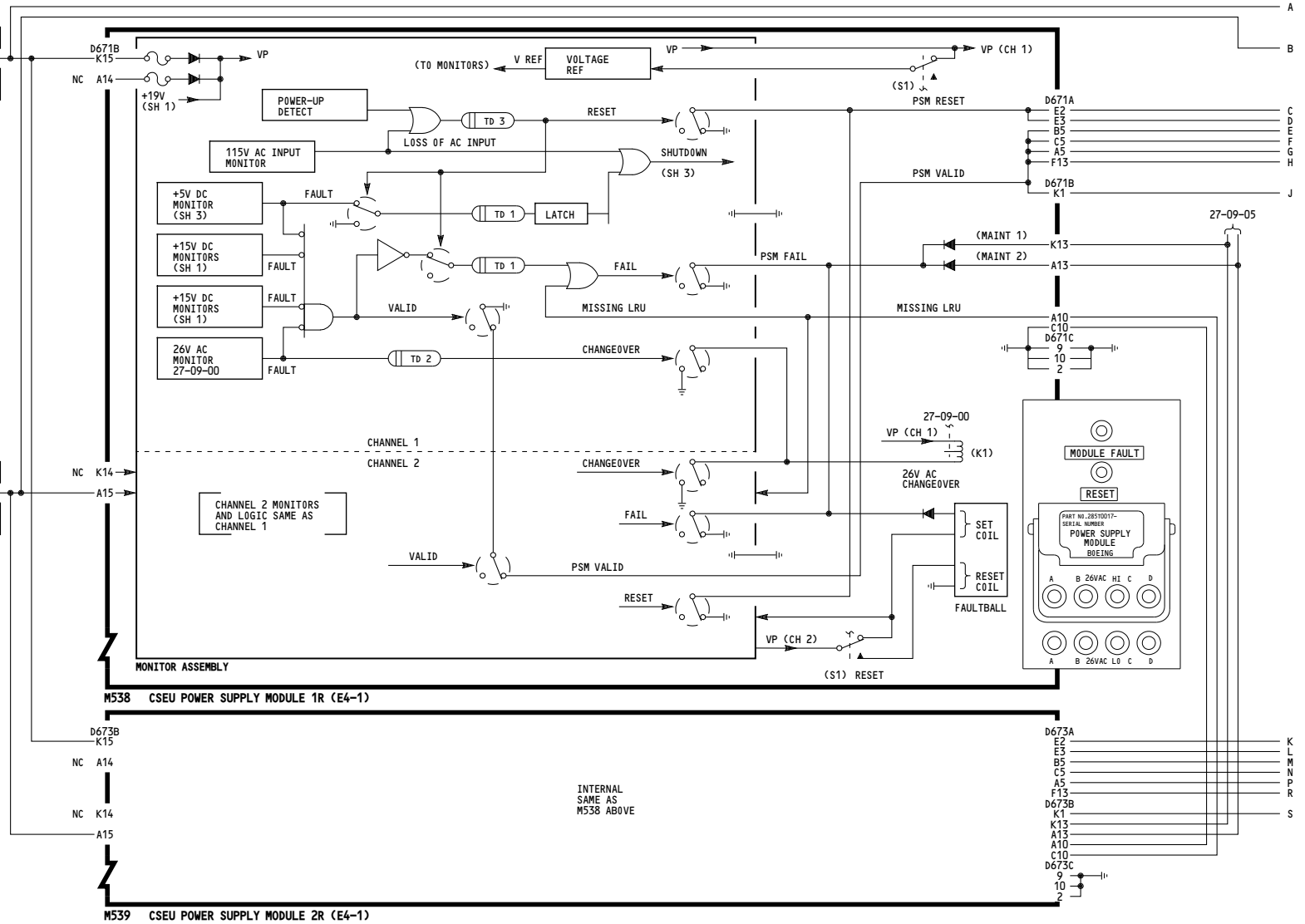
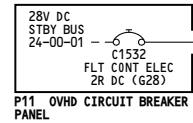
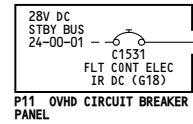

001-099	RIGHT CSEU POWER - DC
D280N032S	

27-09-04

Page 101
Sheet 4
Jan 21/2005

WIRING DIAGRAMS	
22-21-11	
22-22-21	
27-09-11	
27-21-12	
27-41-11	
27-41-21	
27-61-14	
27-61-15	
27-61-16	

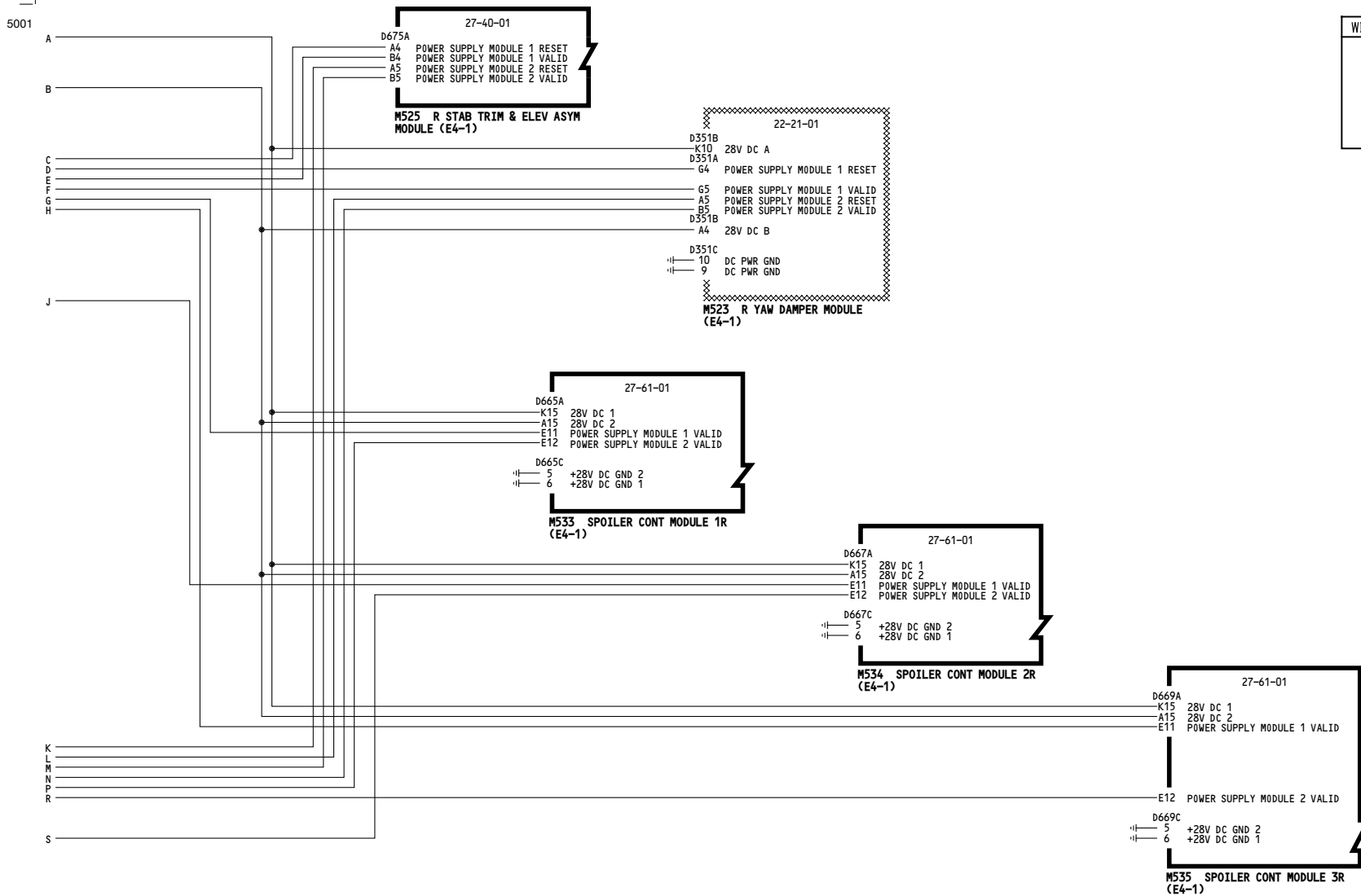

001-099	RIGHT CSEU POWER - DC
	D280N032S

27-09-04

THIS PAGE INTENTIONALLY LEFT BLANK

5001

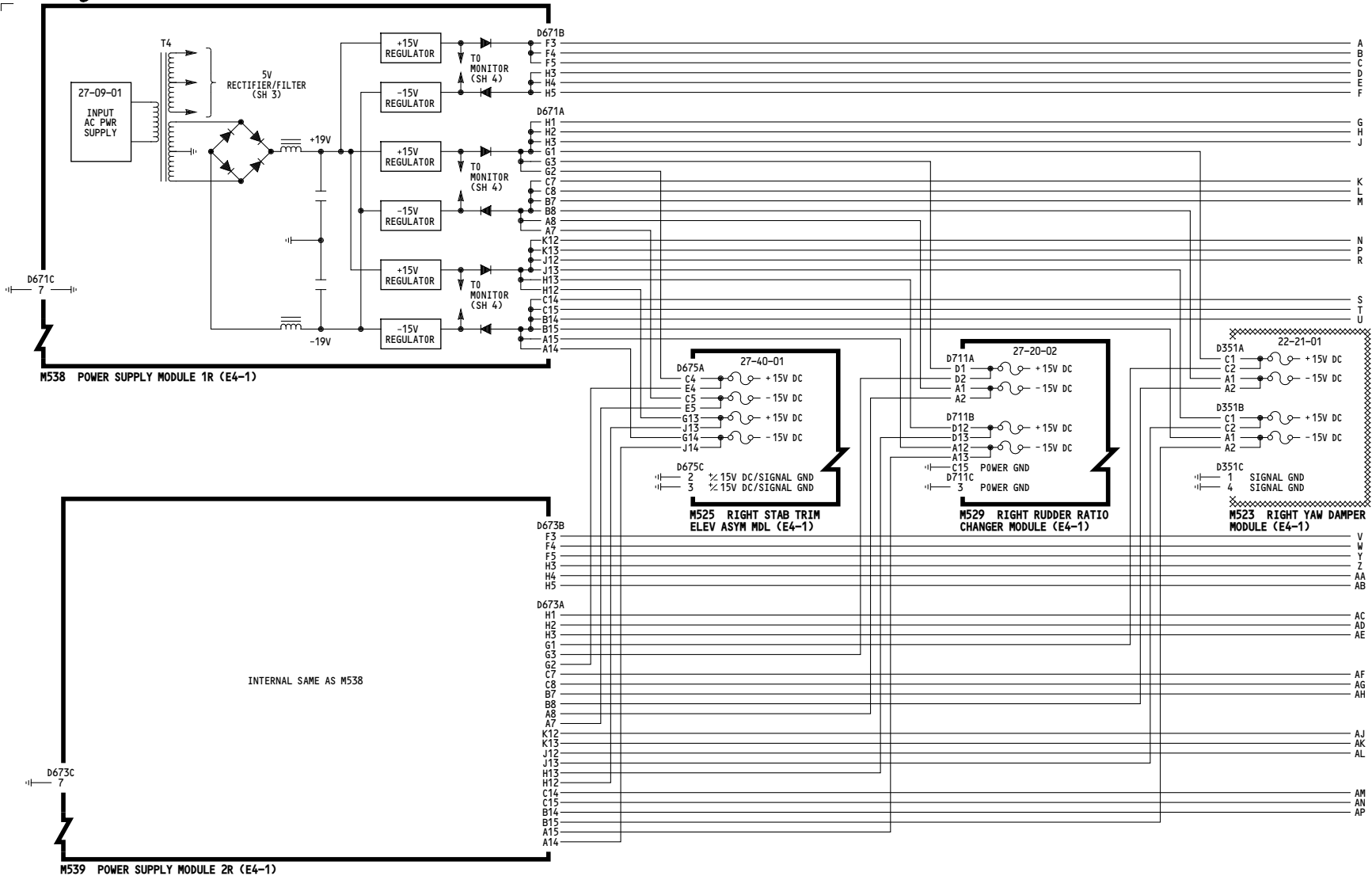

115-199	RIGHT CSEU POWER - DC
D280N032S	

27-09-04

5001

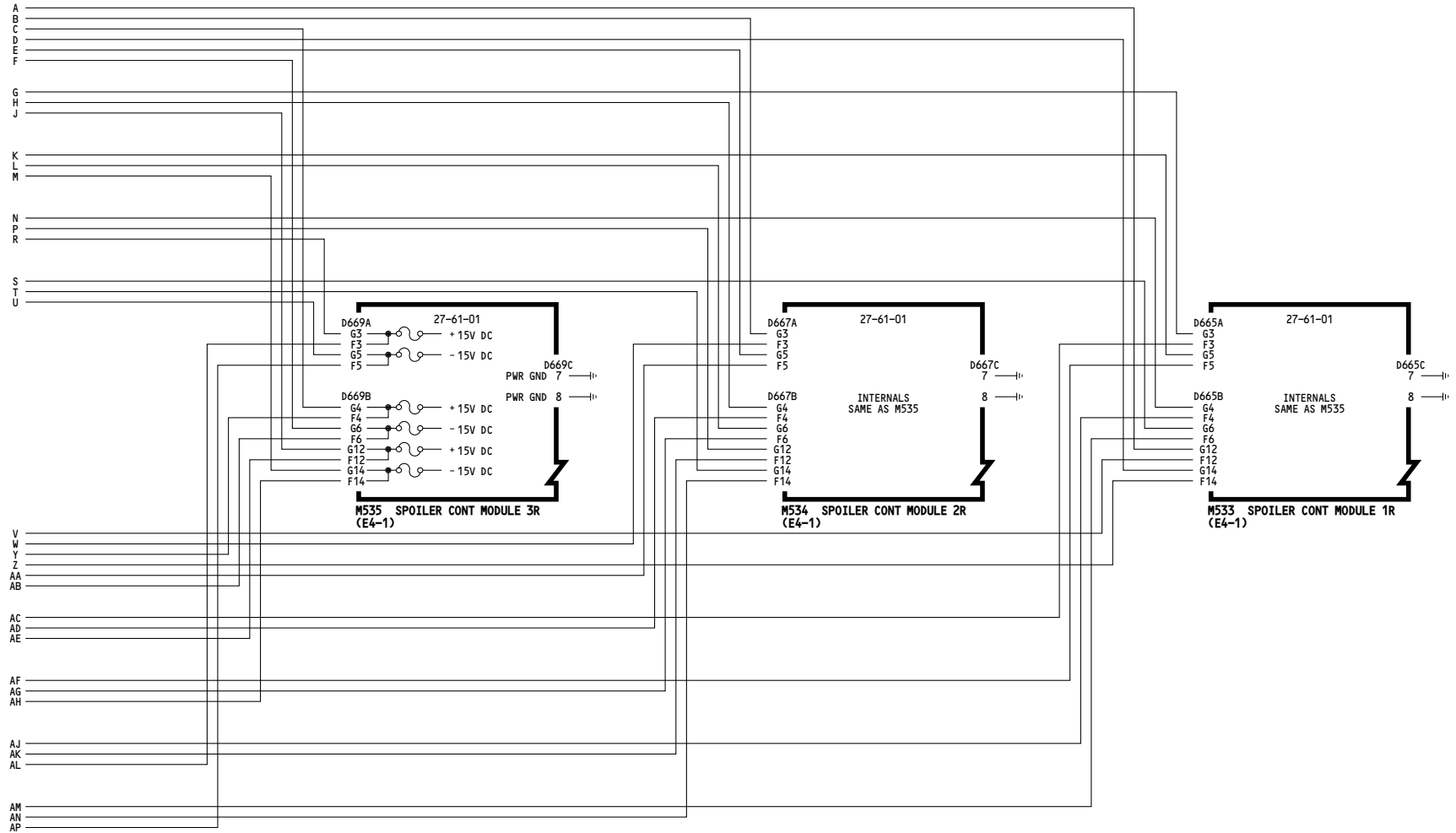

115-199	<p align="center">RIGHT CSEU POWER - DC</p> <p align="center">D280N032S</p>
---------	--

27-09-04

Page 102
Sheet 2
Jan 21/2005

5001

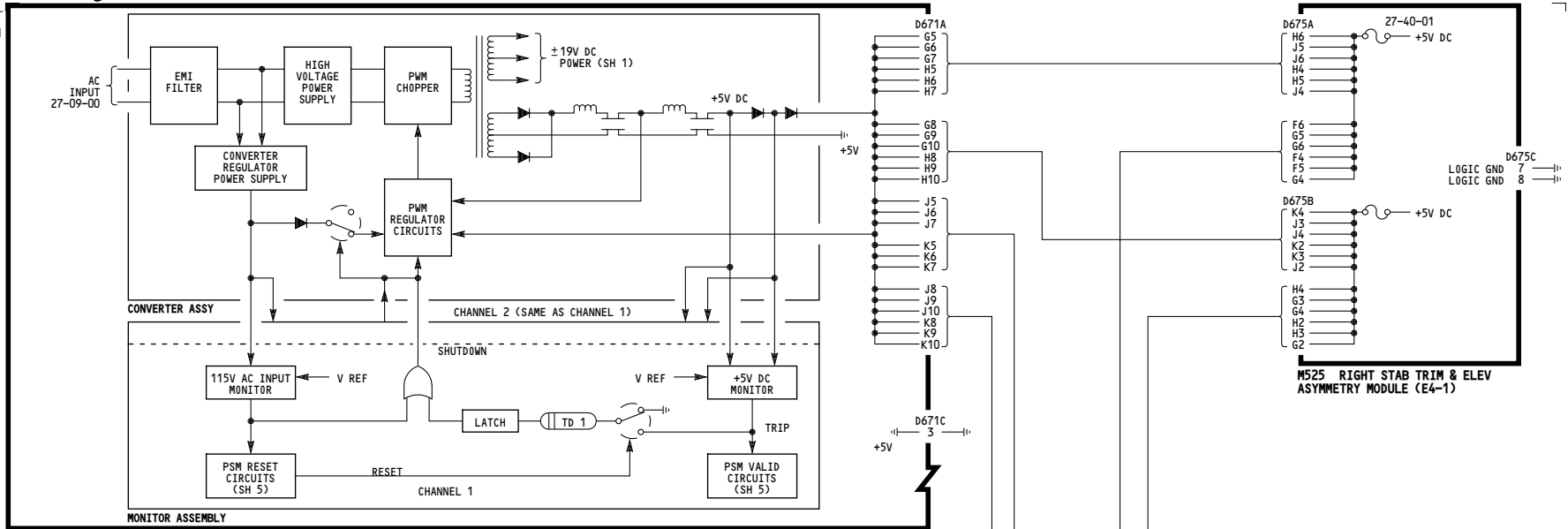

M538 CESU POWER SUPPLY MODULE 1R (E4-1)

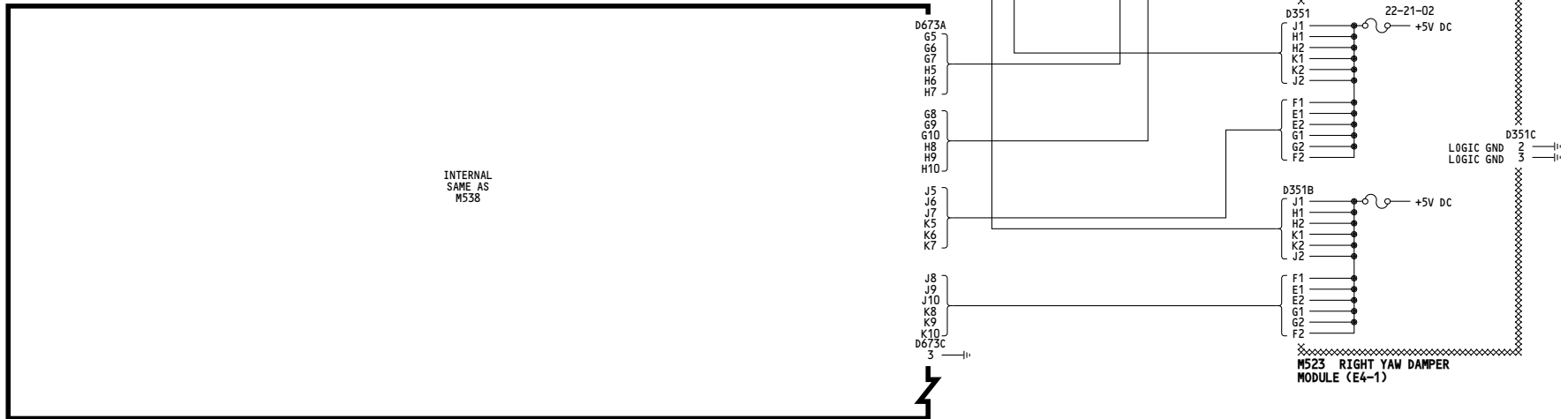

M539 CESU POWER SUPPLY MODULE 2R (E4-1)

115-199	<p align="center">RIGHT CSEU POWER - DC</p> <p align="center">D280N032S</p>
---------	--

27-09-04

Page 102
Sheet 3
Jan 21/2005

5004

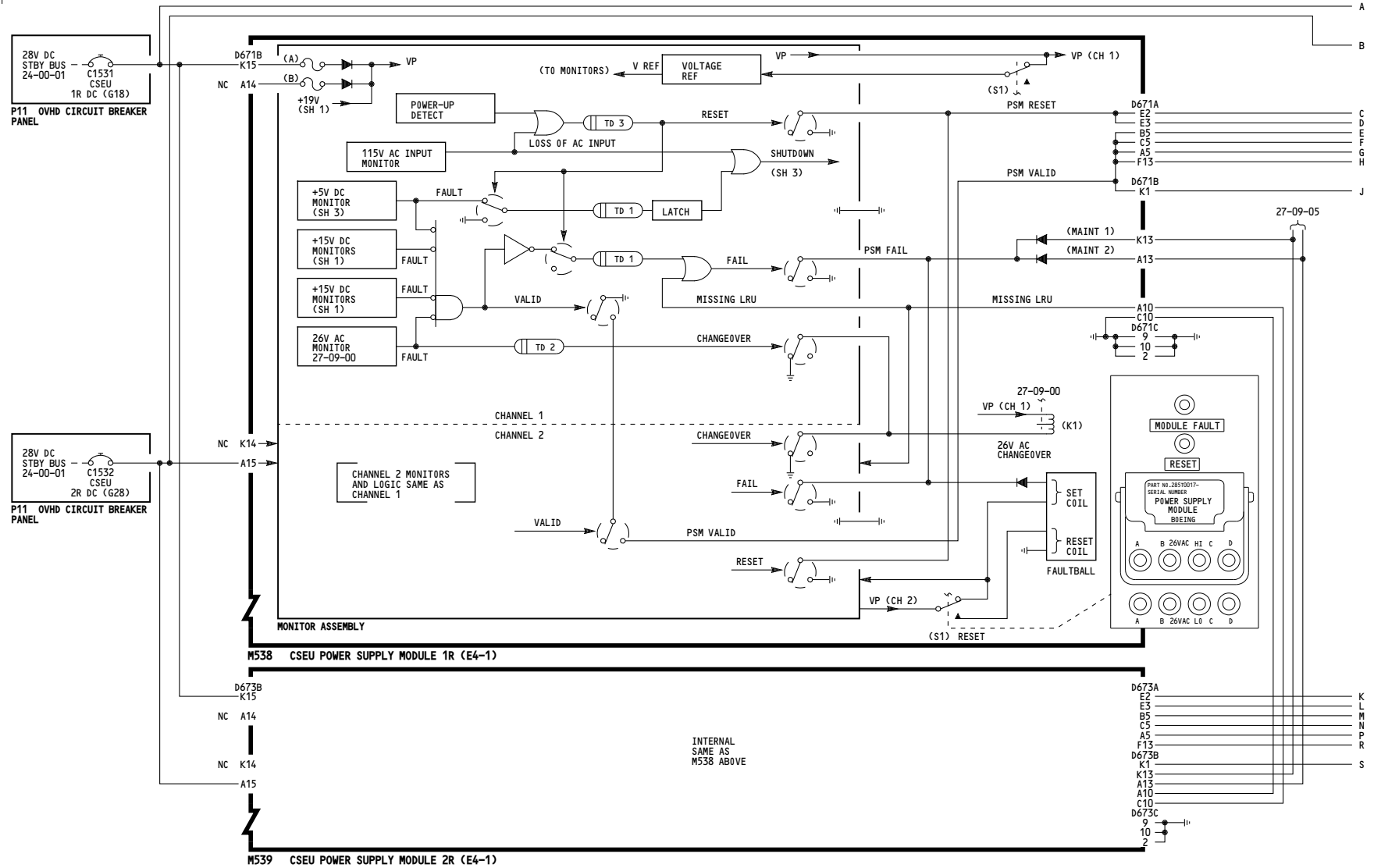

115-199

RIGHT CSEU POWER - DC

D280N032S

27-09-04

Page 102
Sheet 4
Jan 21/2005

WIRING DIAGRAMS	
22-21-11	
22-22-21	
27-09-11	
27-21-12	
27-41-11	
27-41-21	
27-61-14	
27-61-15	
27-61-16	

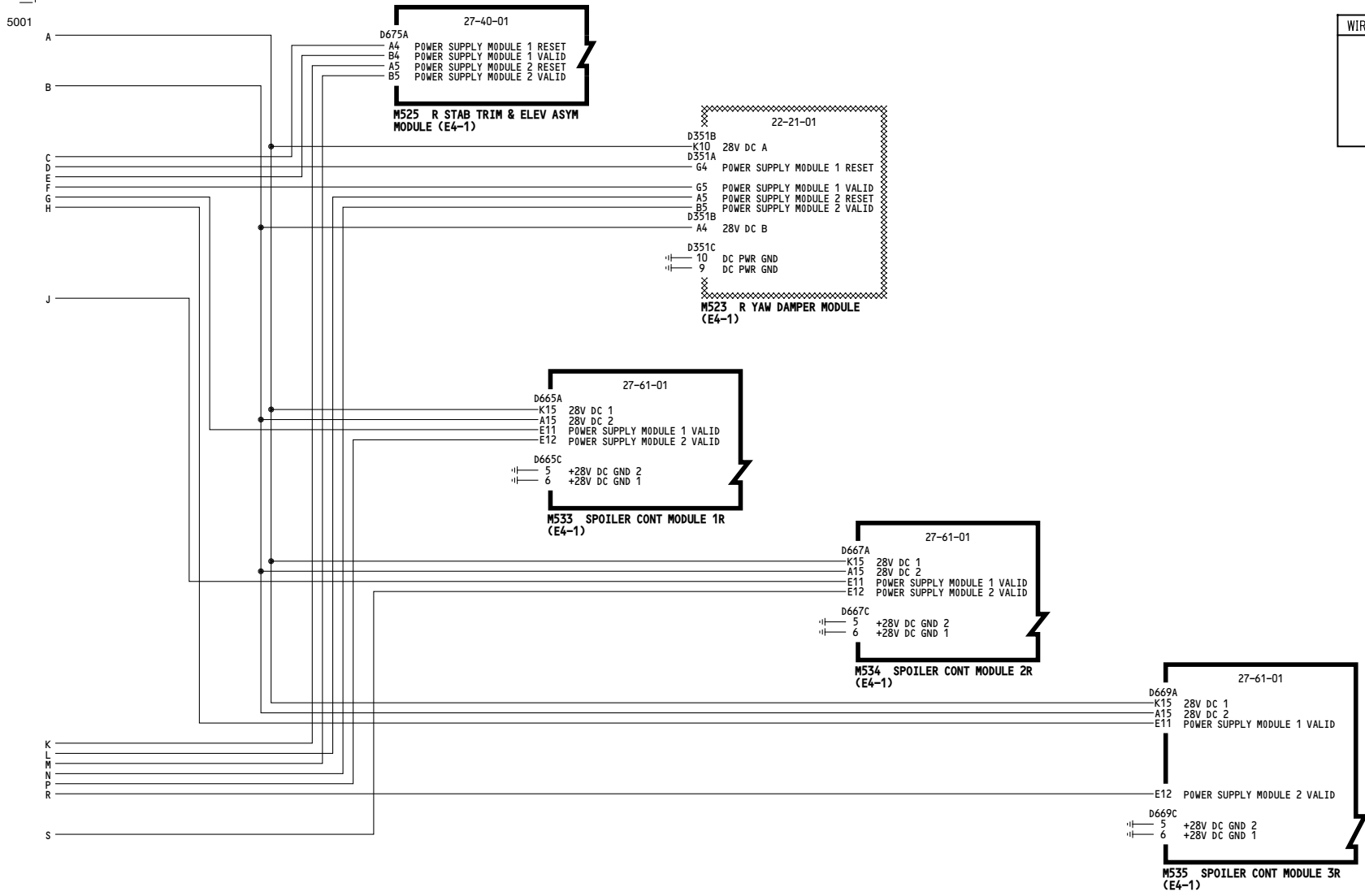

115-199	RIGHT CSEU POWER - DC
	D280N032S

27-09-04

Page 102
 Sheet 5
 Jan 21/2005

THIS PAGE INTENTIONALLY LEFT BLANK

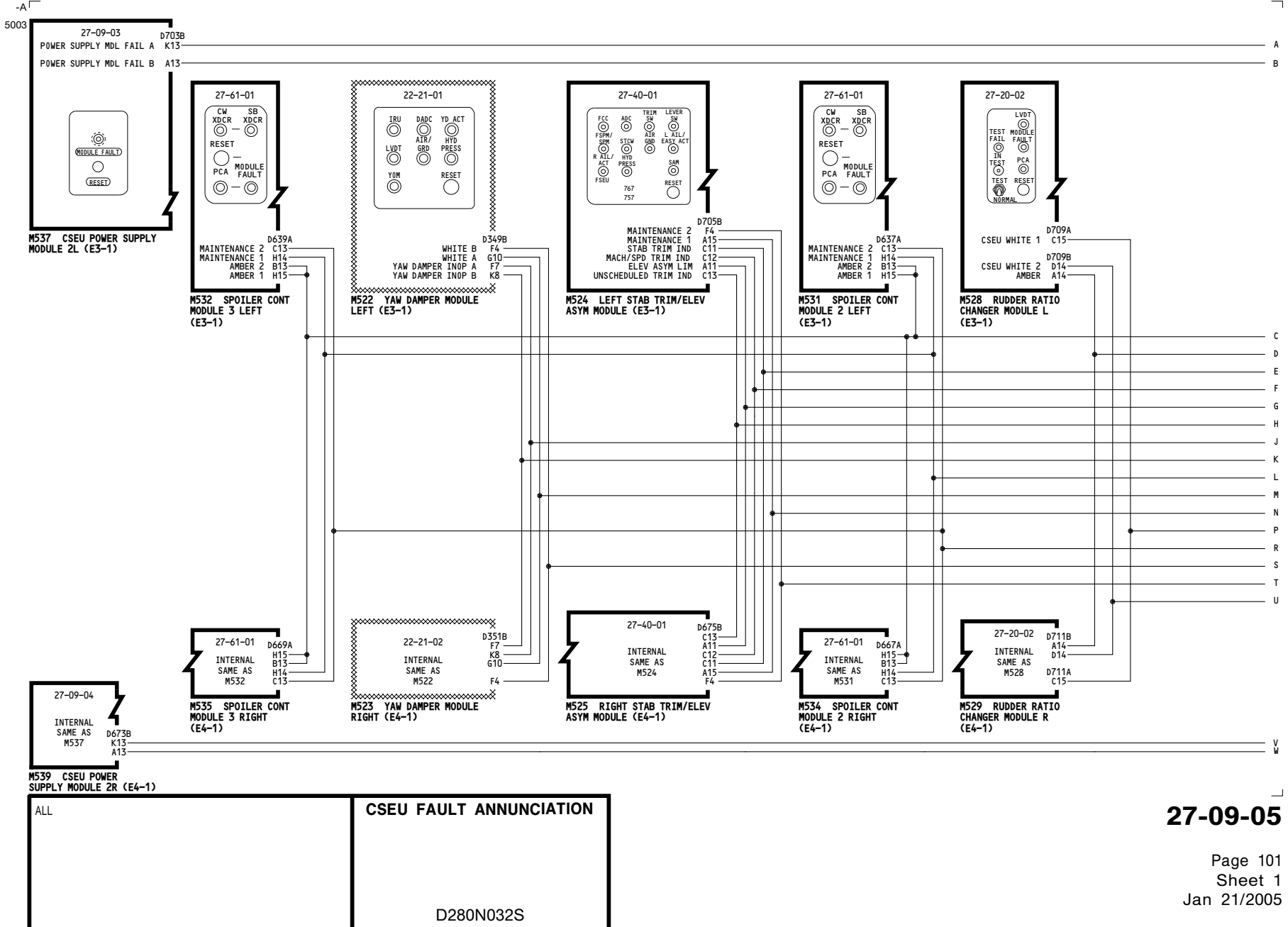

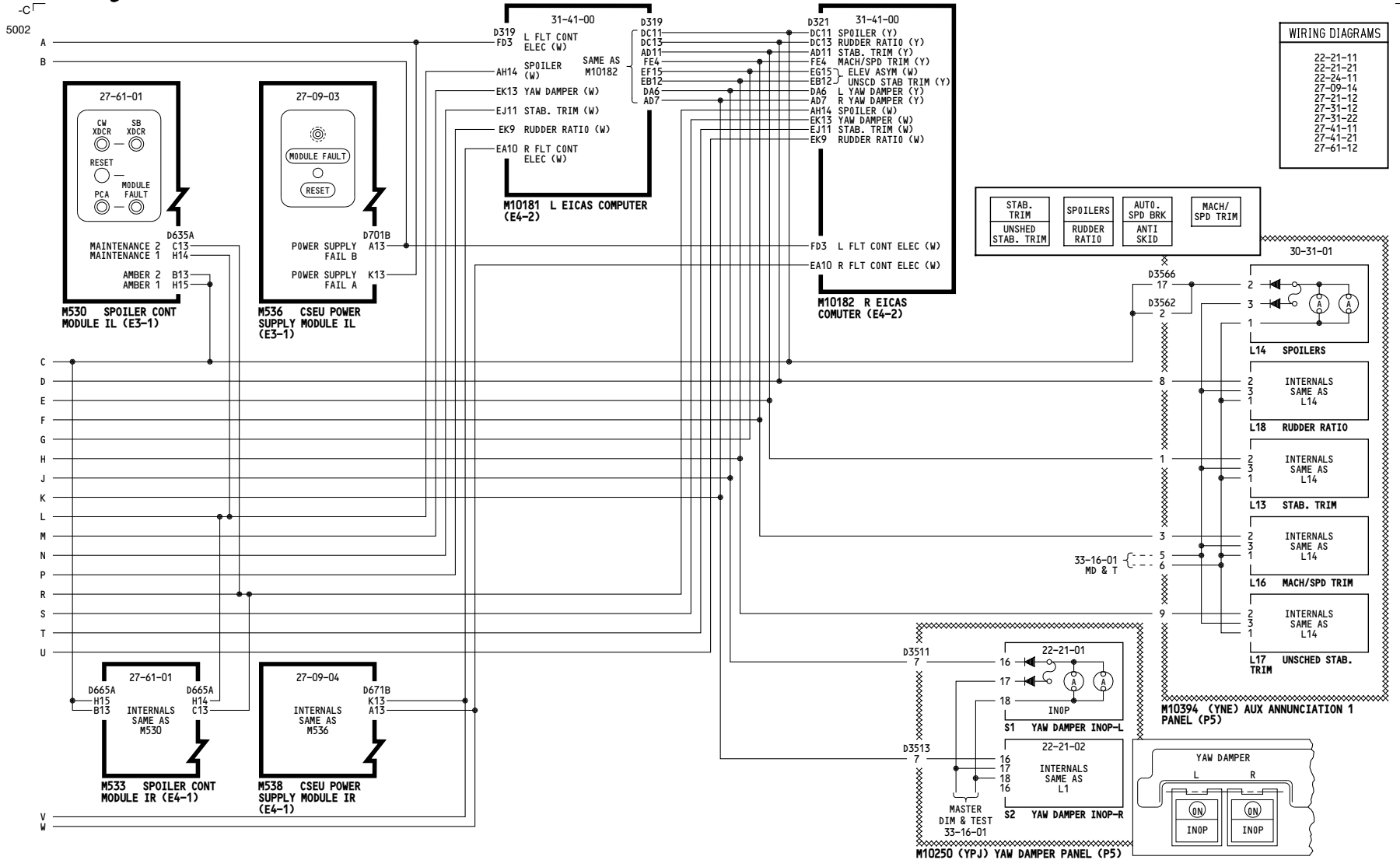

ALL	CSEU FAULT ANNUNCIATION
	D280N032S

27-09-05

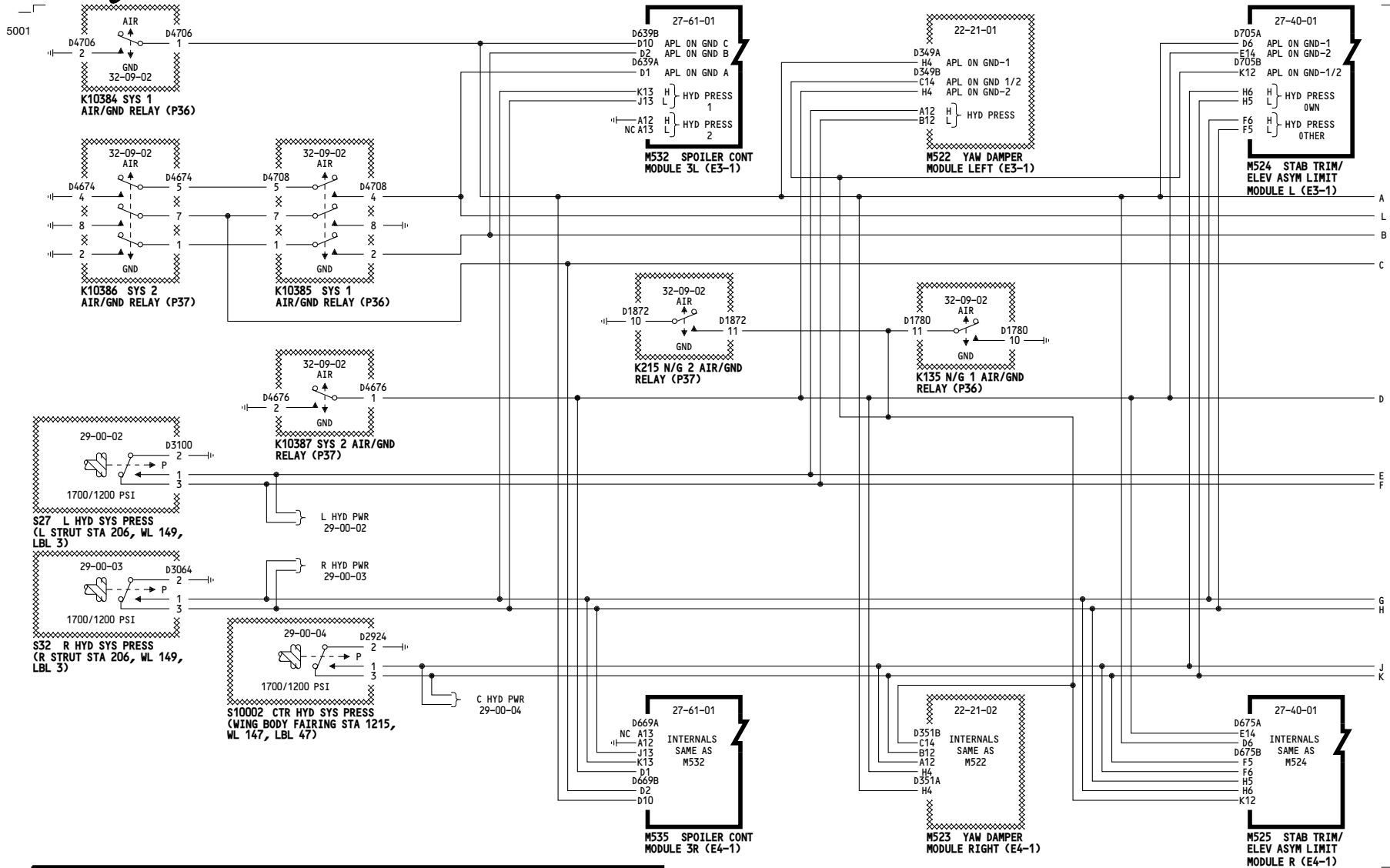

27-09-06



5001

WIRING DIAGRAMS
27-09-12
27-09-13

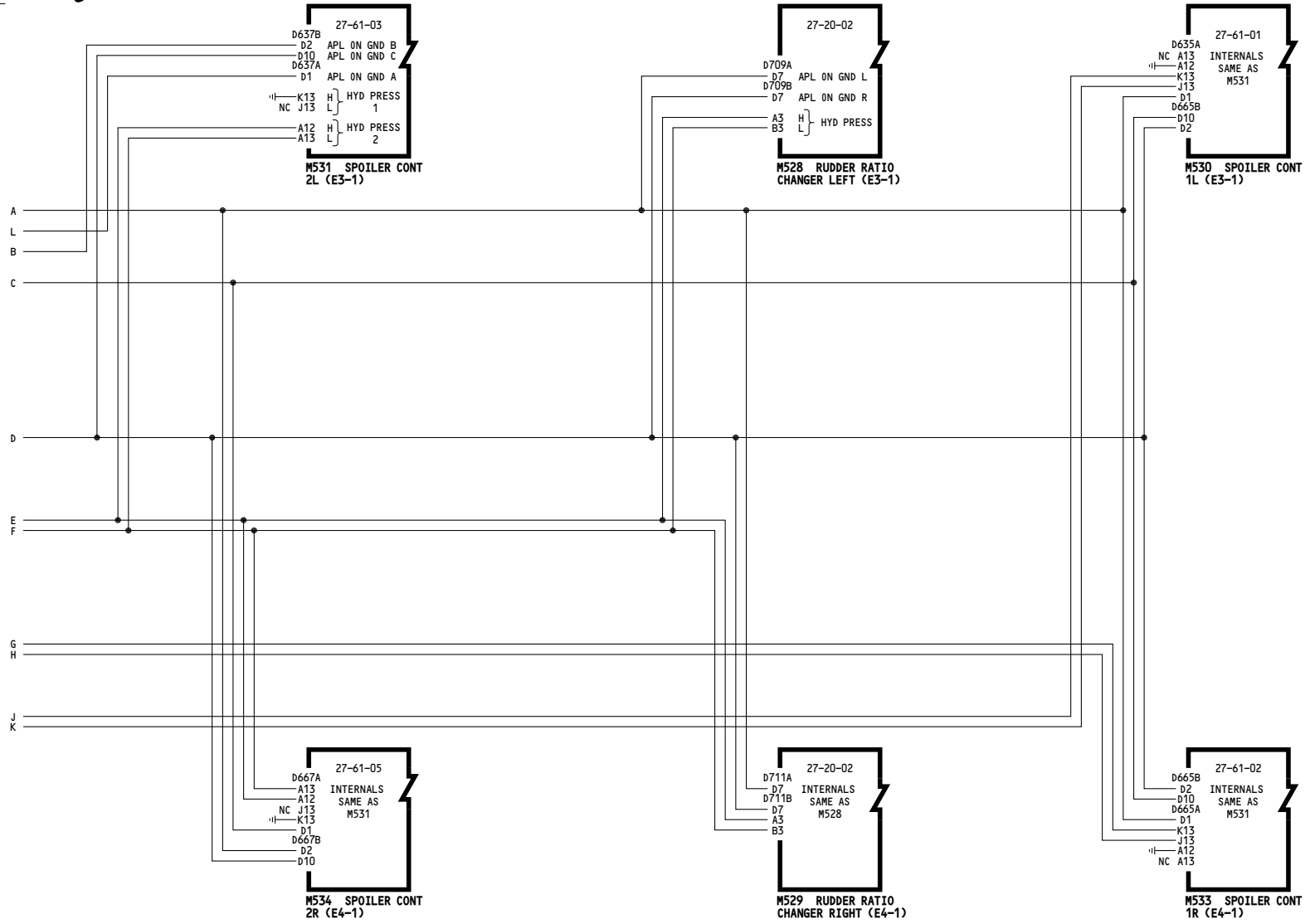

ALL	CSEU AIR/GROUND AND HYDRAULIC DISCRETE INPUTS
	D280N032S

27-09-06

5002

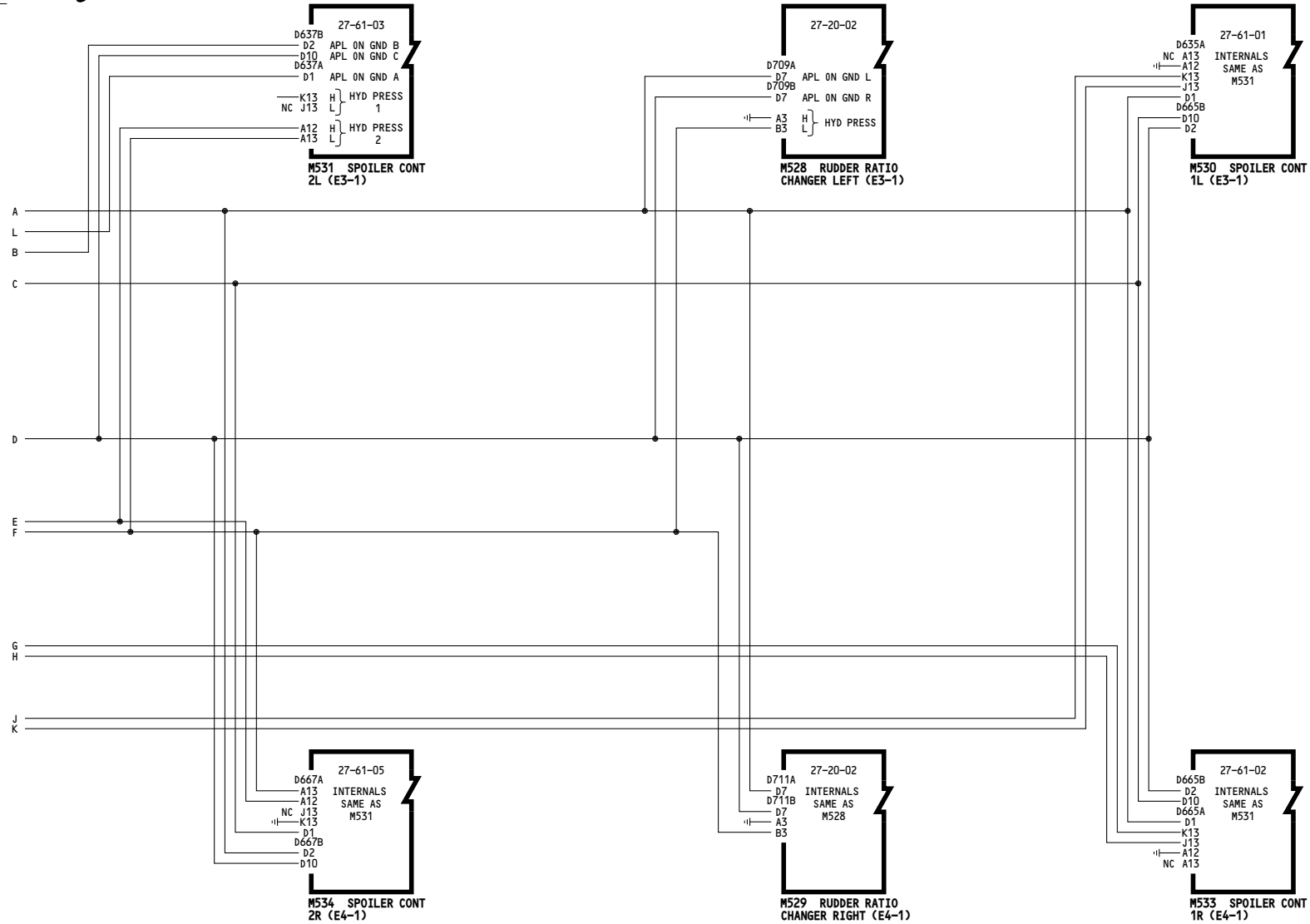

WIRING DIAGRAMS
27-09-12
27-09-13

001-115	CSEU AIR/GROUND AND HYDRAULIC DISCRETE INPUTS
D280N032S	

Incorporates
27-0123

27-09-06

Page 101.1
Sheet 2
Jan 21/2005

5012

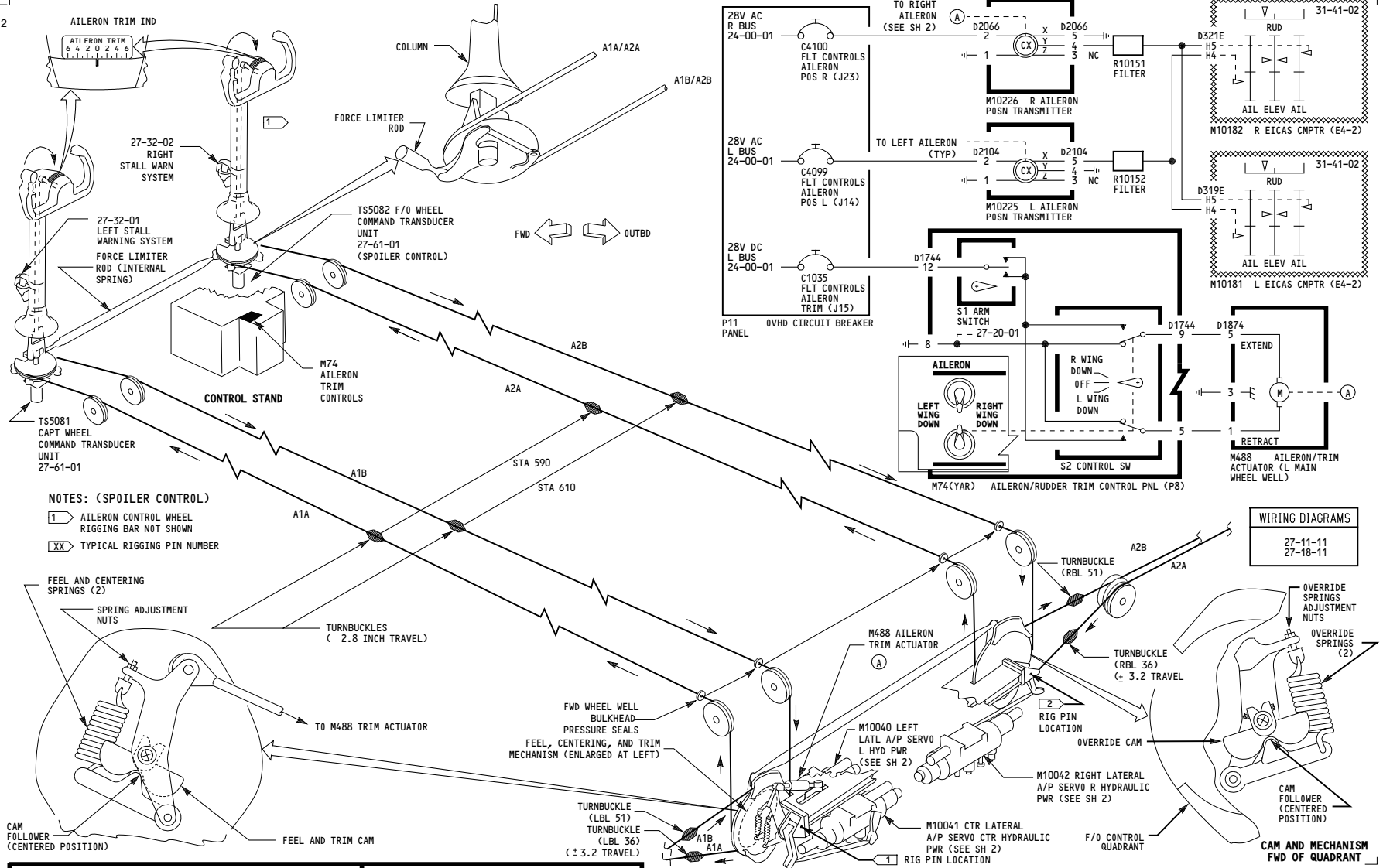

NOTES: (SPOILER CONTROL)
 1 AILERON CONTROL WHEEL RIGGING BAR NOT SHOWN
 XX TYPICAL RIGGING PIN NUMBER

WIRING DIAGRAMS
 27-11-11
 27-18-11

ALL	AILERON
	D280N032S

27-10-01

5001

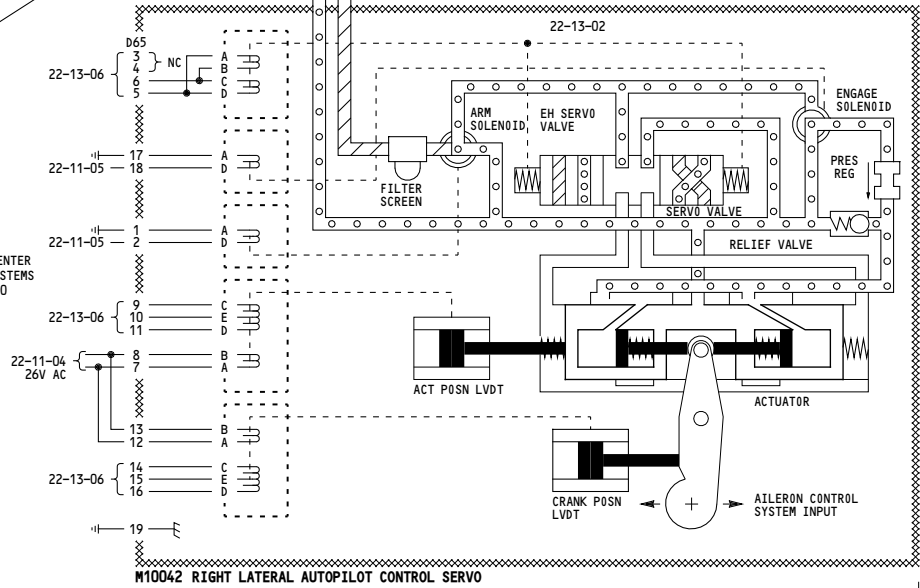
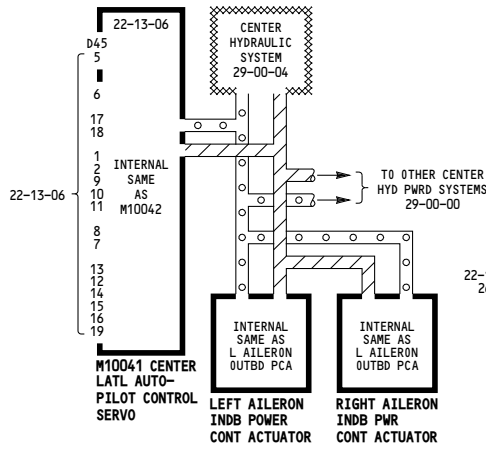
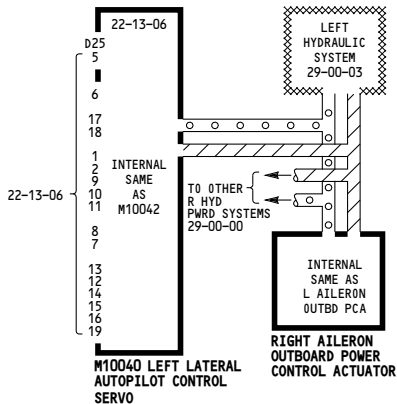
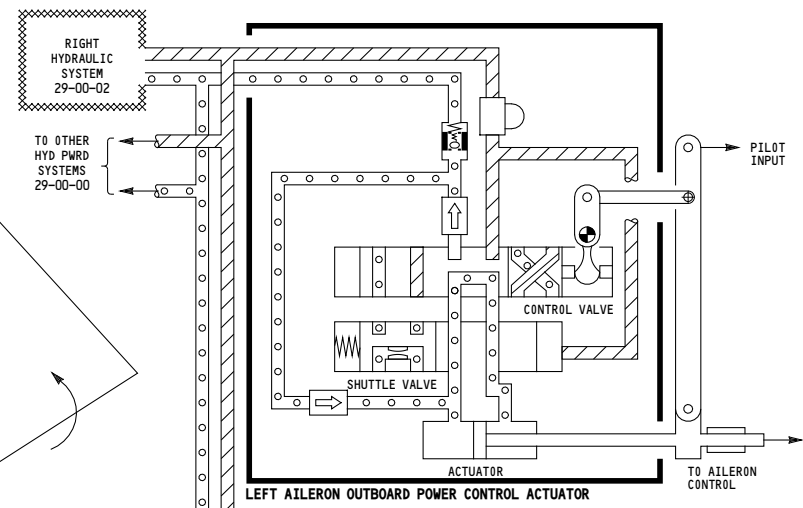
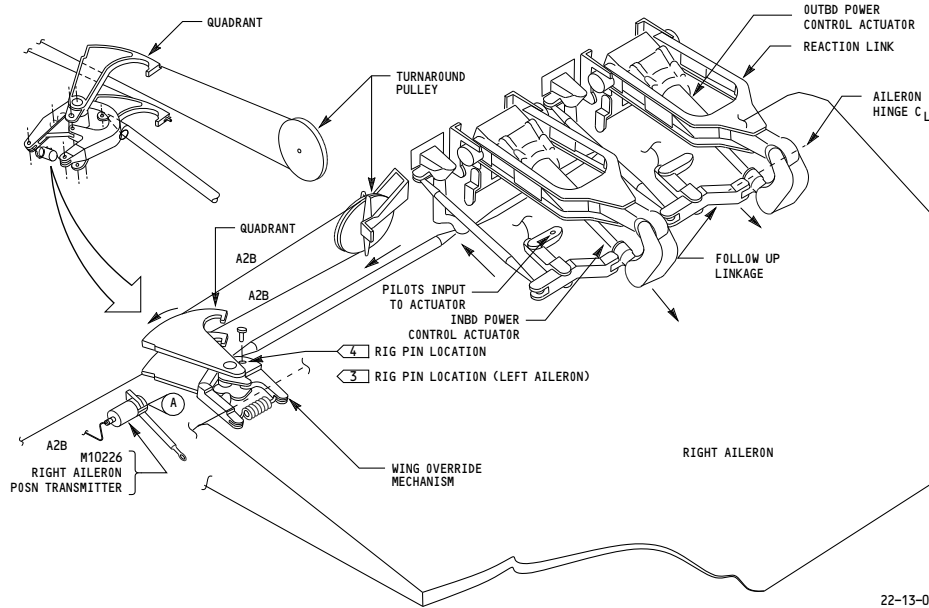

NOTES:
 RETURN
 PRESSURE
 TYPICAL RIGGING PIN LOCATIONS

ALL	AILERON
	D280N032S

27-10-01

5014

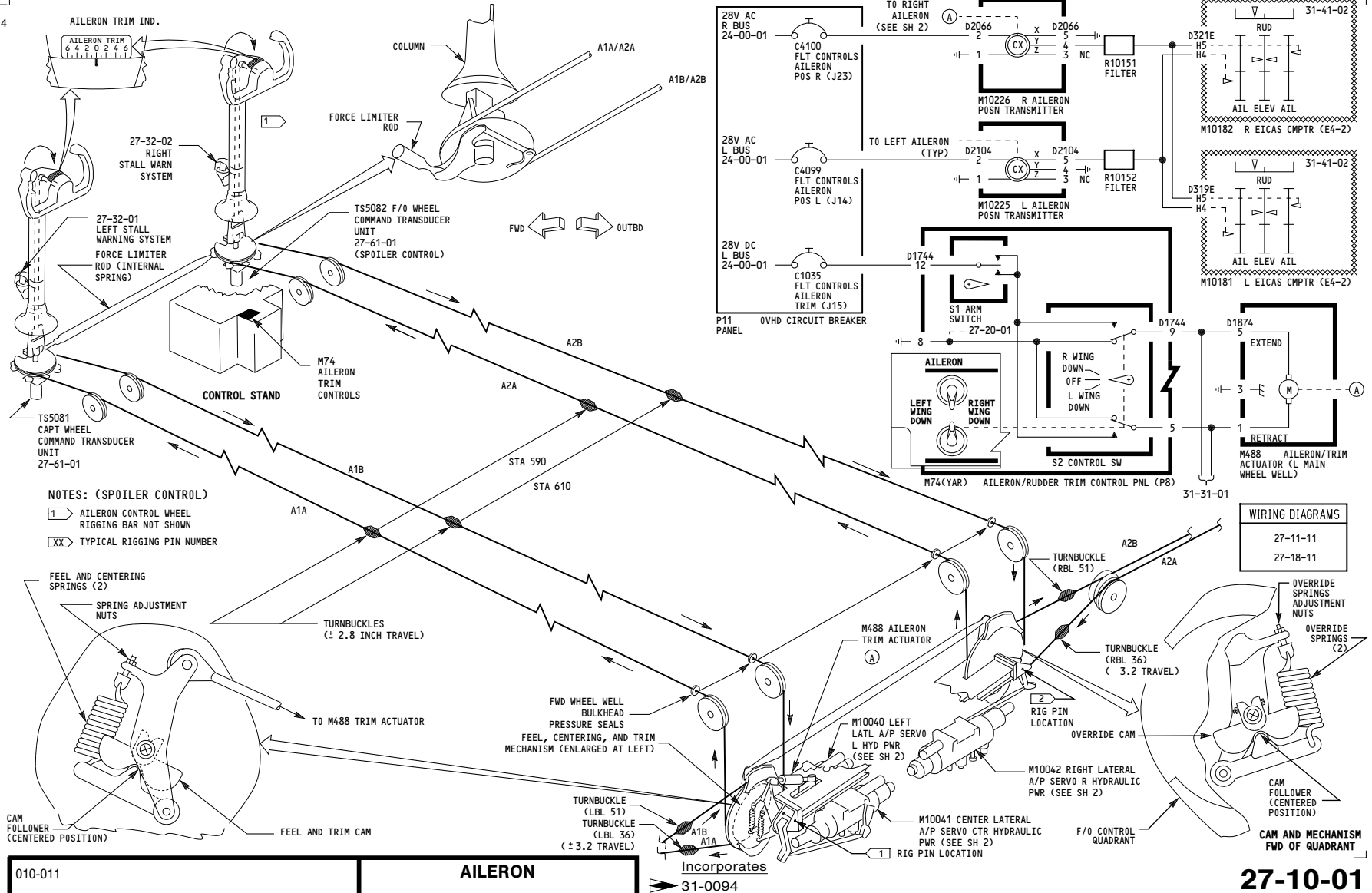

NOTES: (SPOILER CONTROL)
 1 AILERON CONTROL WHEEL RIGGING BAR NOT SHOWN
 XX TYPICAL RIGGING PIN NUMBER

WIRING DIAGRAMS
 27-11-11
 27-18-11

010-011	<p align="center">AILERON</p> <p align="center">D280N032S</p>
---------	--

Incorporates 31-0094

27-10-01

5001

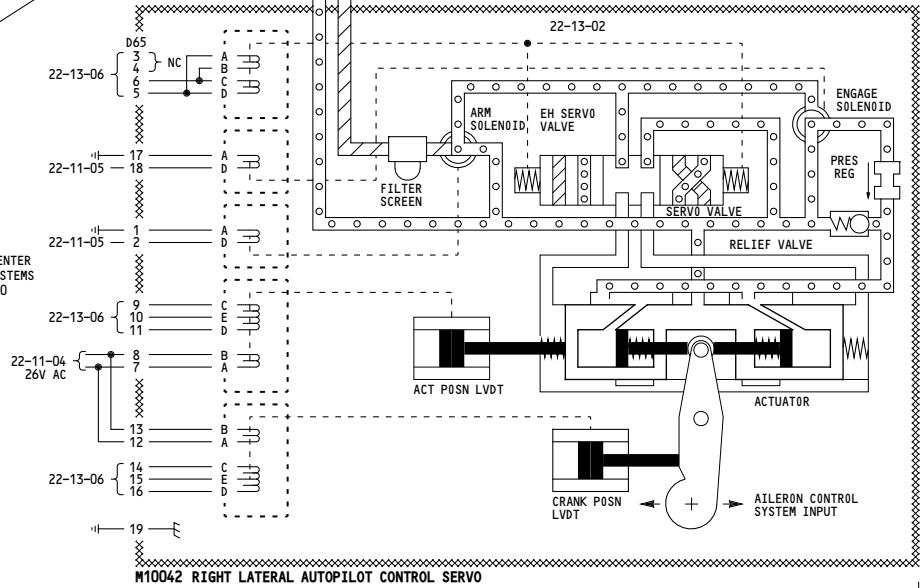
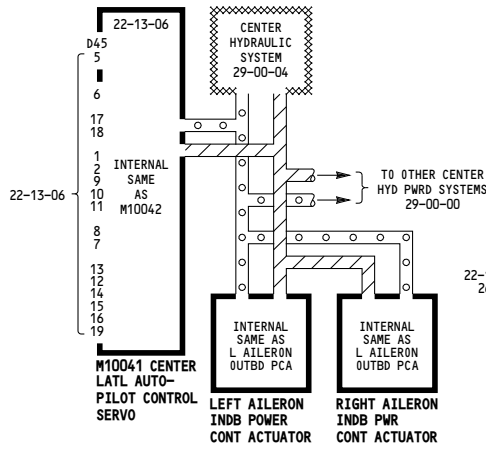
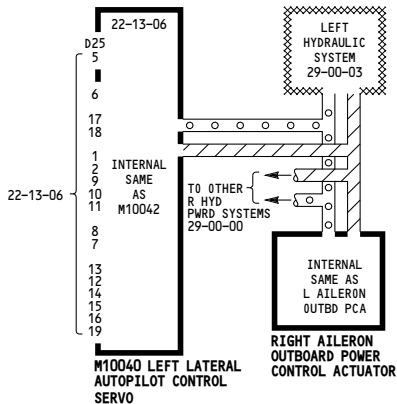
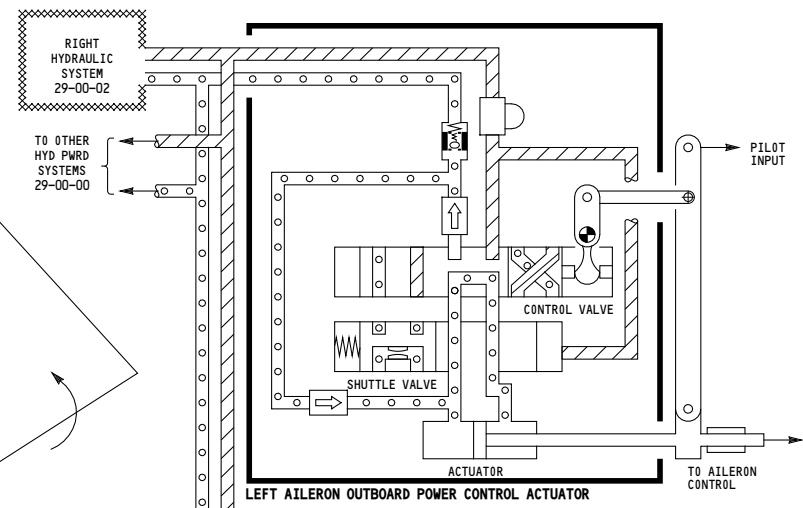
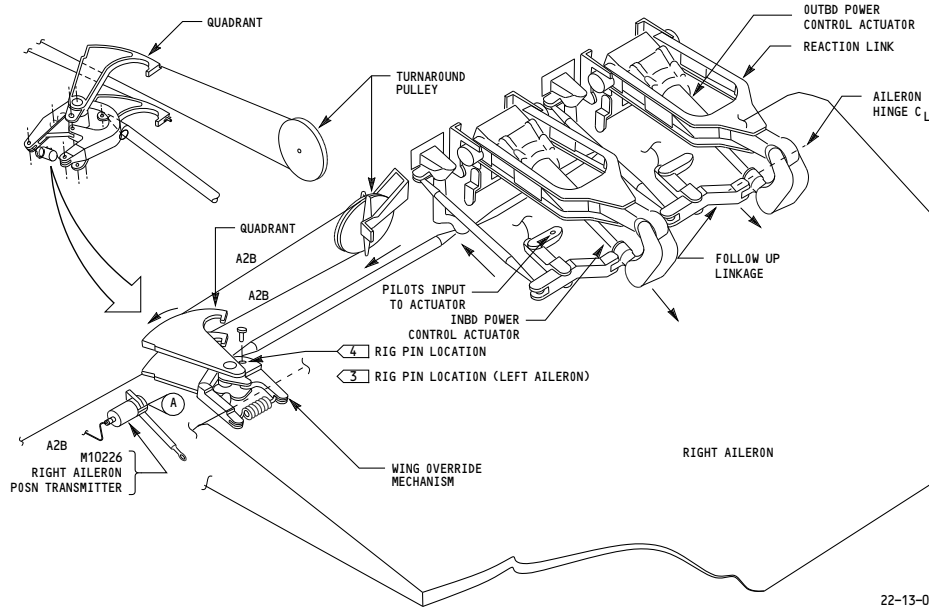

NOTES:
 ○ RETURN
 ▨ PRESSURE
 XX TYPICAL RIGGING PIN LOCATIONS

010-011	AILERON
	D280N032S

27-10-01

5001

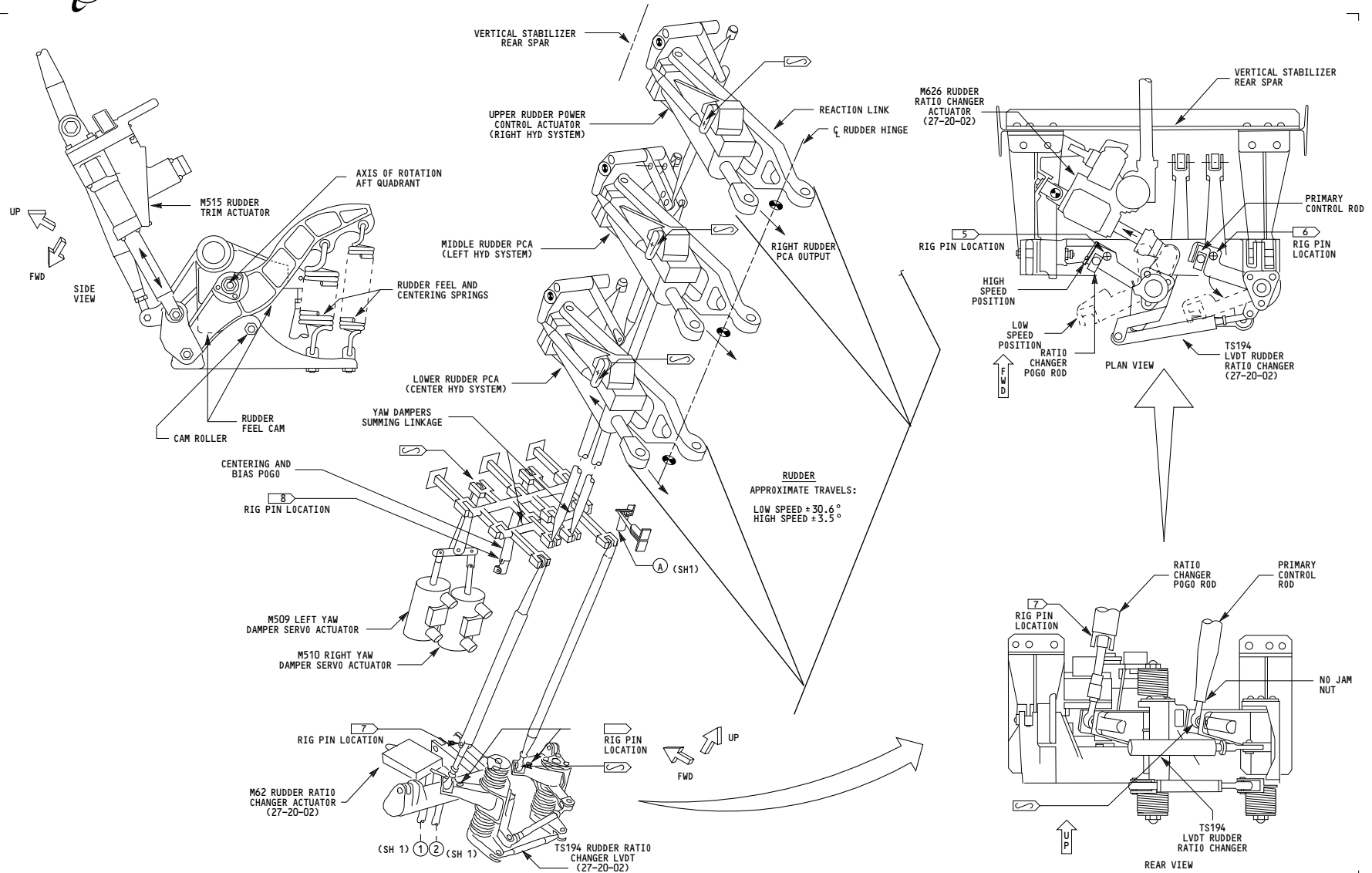

ALL	<p align="center">RUDDER CONTROL SYSTEM</p> <p align="center">D280N032S</p>
-----	--

27-20-01

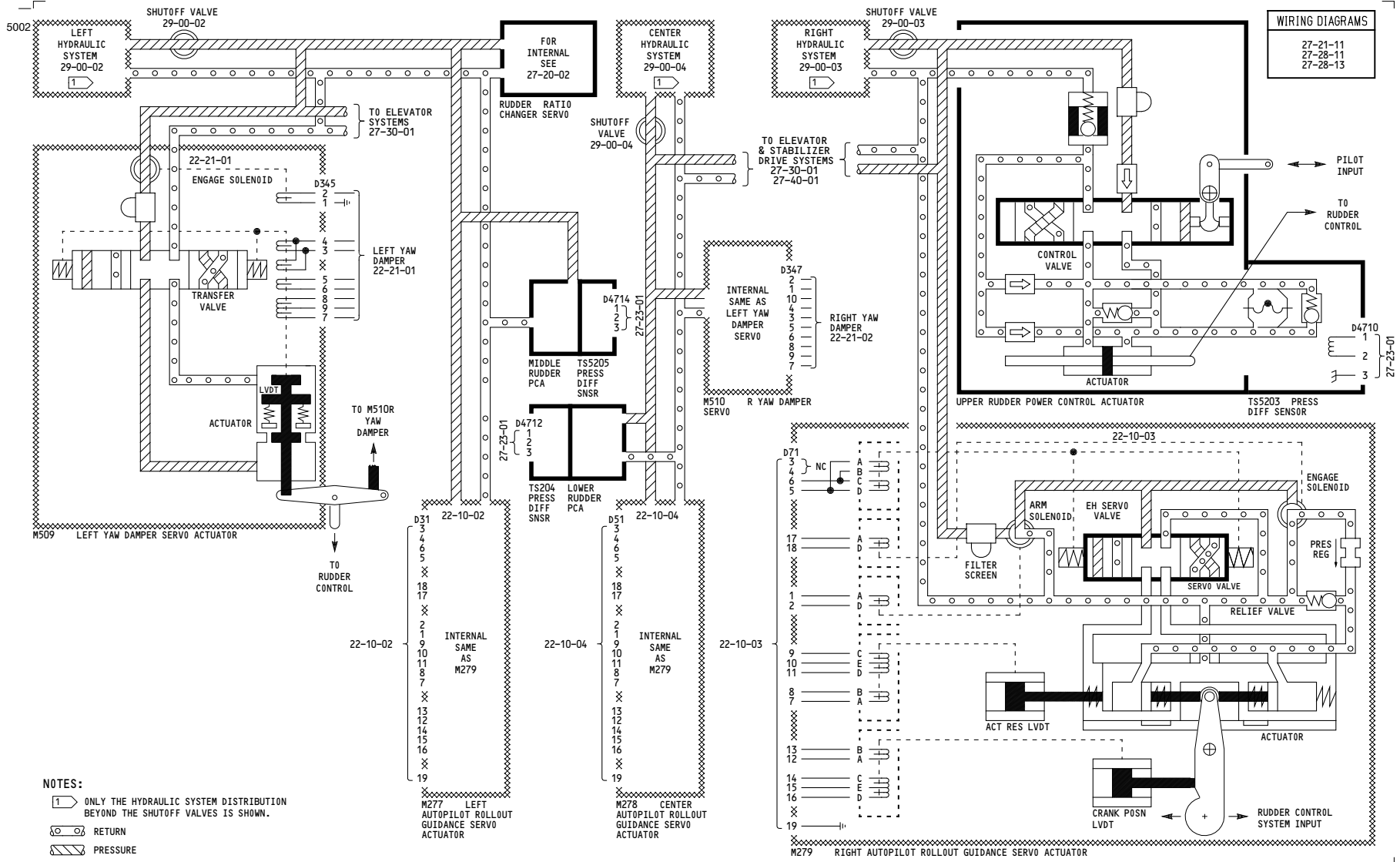

WIRING DIAGRAMS
 27-21-11
 27-28-11
 27-28-13

- NOTES:**
- 1 ONLY THE HYDRAULIC SYSTEM DISTRIBUTION BEYOND THE SHUTOFF VALVES IS SHOWN.
 - RETURN
 - ▨ PRESSURE

ALL	RUDDER CONTROL SYSTEM
	D280N032S

27-20-01

THIS PAGE INTENTIONALLY LEFT BLANK

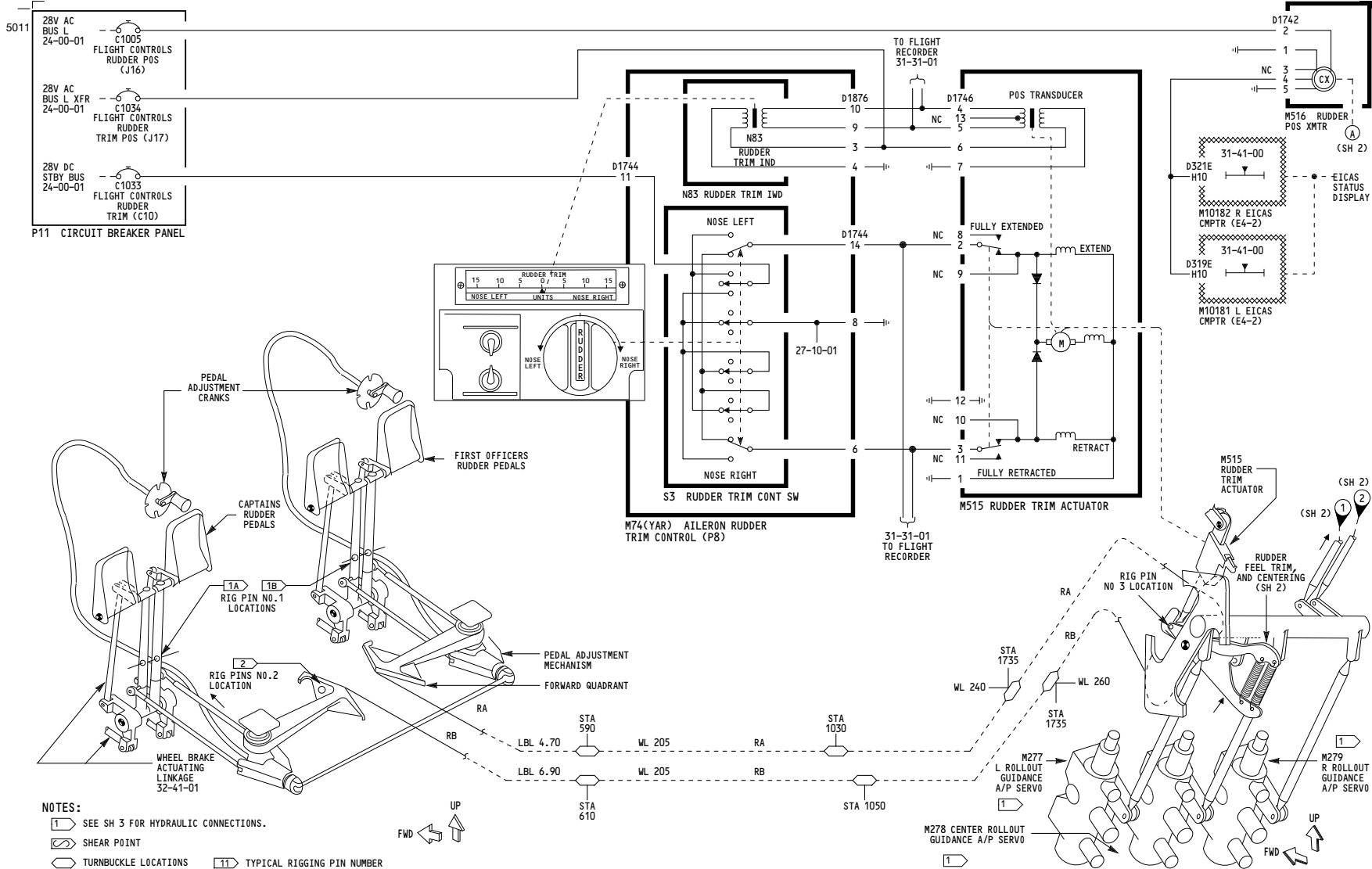

- NOTES:**
- 1 SEE SH 3 FOR HYDRAULIC CONNECTIONS.
 - 2 SHEAR POINT
 - 3 TURNBUCKLE LOCATIONS
 - 4 TYPICAL RIGGING PIN NUMBER

010-011	RUDDER CONTROL SYSTEM
Incorporates 31-0094	
D280N032S	

27-20-01

5001

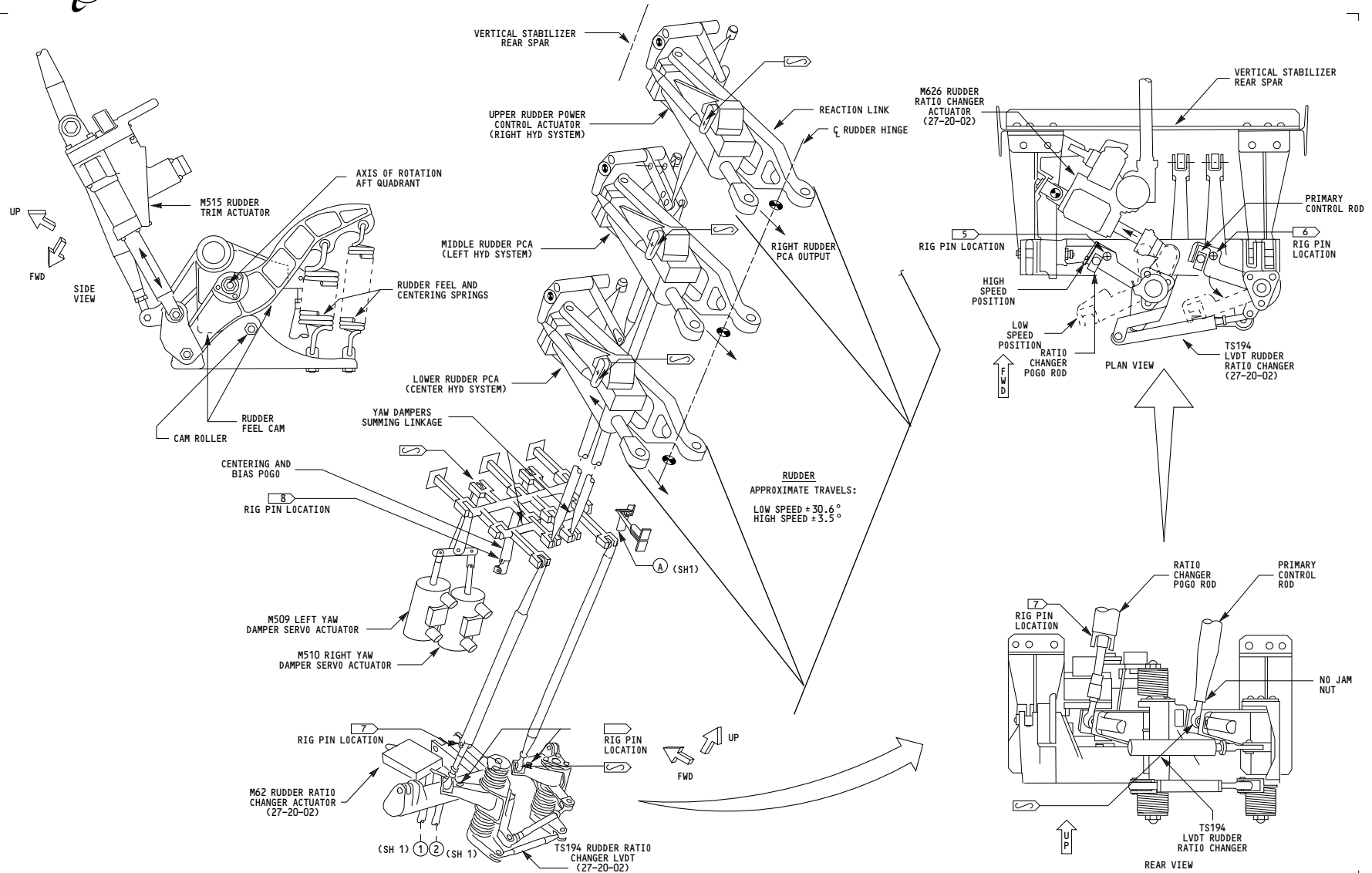

010-011	<p align="center">RUDDER CONTROL SYSTEM</p> <p align="center">D280N032S</p>
---------	--

27-20-01

Page 101.1
Sheet 2
Jan 21/2005

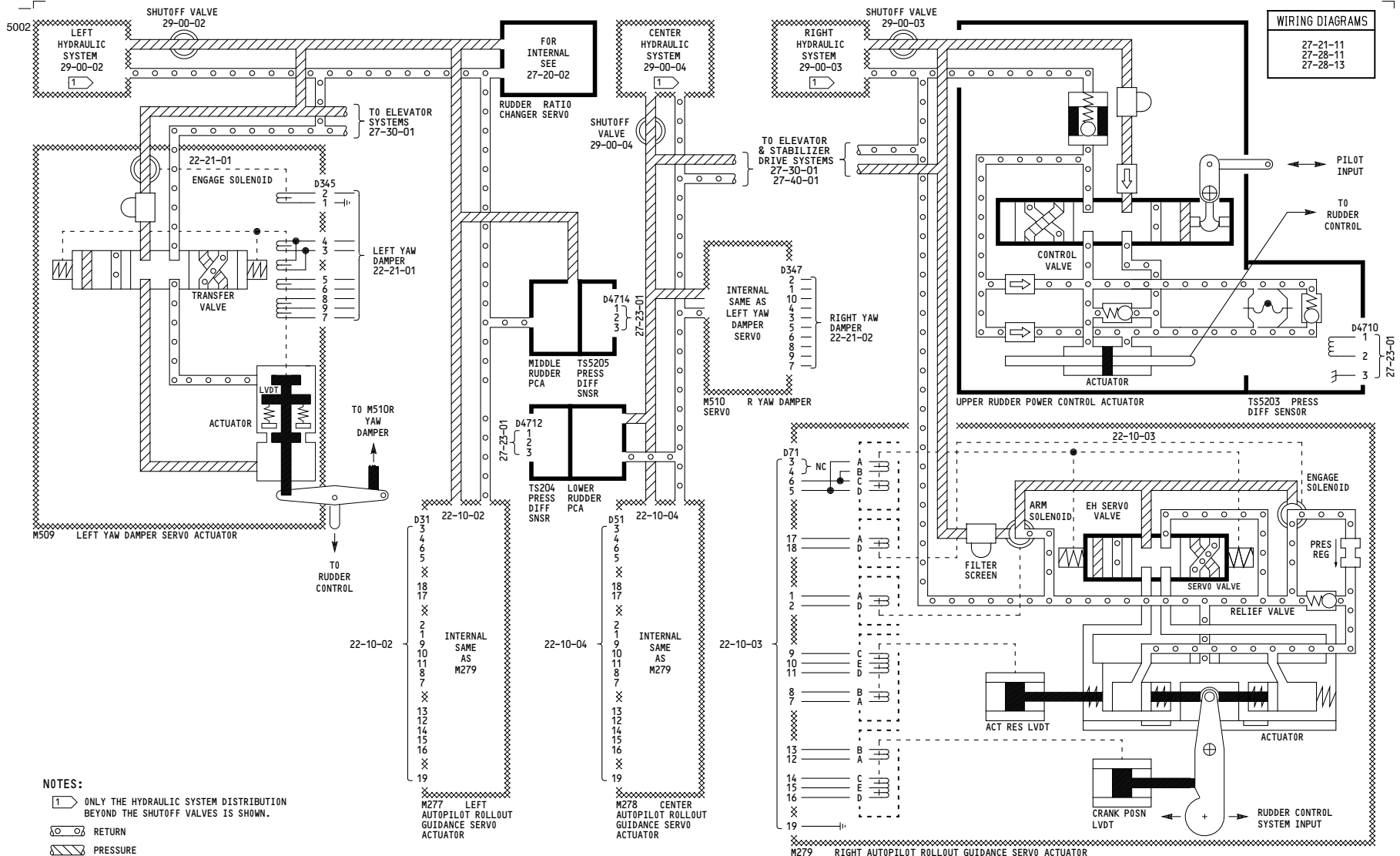

WIRING DIAGRAMS
27-21-11
27-28-11
27-28-13

NOTES:
 1 ONLY THE HYDRAULIC SYSTEM DISTRIBUTION BEYOND THE SHUTOFF VALVES IS SHOWN.
 RETURN
 PRESSURE

22-10-02 INTERNAL SAME AS M279
 22-10-04 INTERNAL SAME AS M279
 22-10-03 M279 RIGHT AUTOPILOT ROLLOUT GUIDANCE SERVO ACTUATOR

010-011	RUDDER CONTROL SYSTEM
D280N032S	

27-20-01

THIS PAGE INTENTIONALLY LEFT BLANK

-A
5011

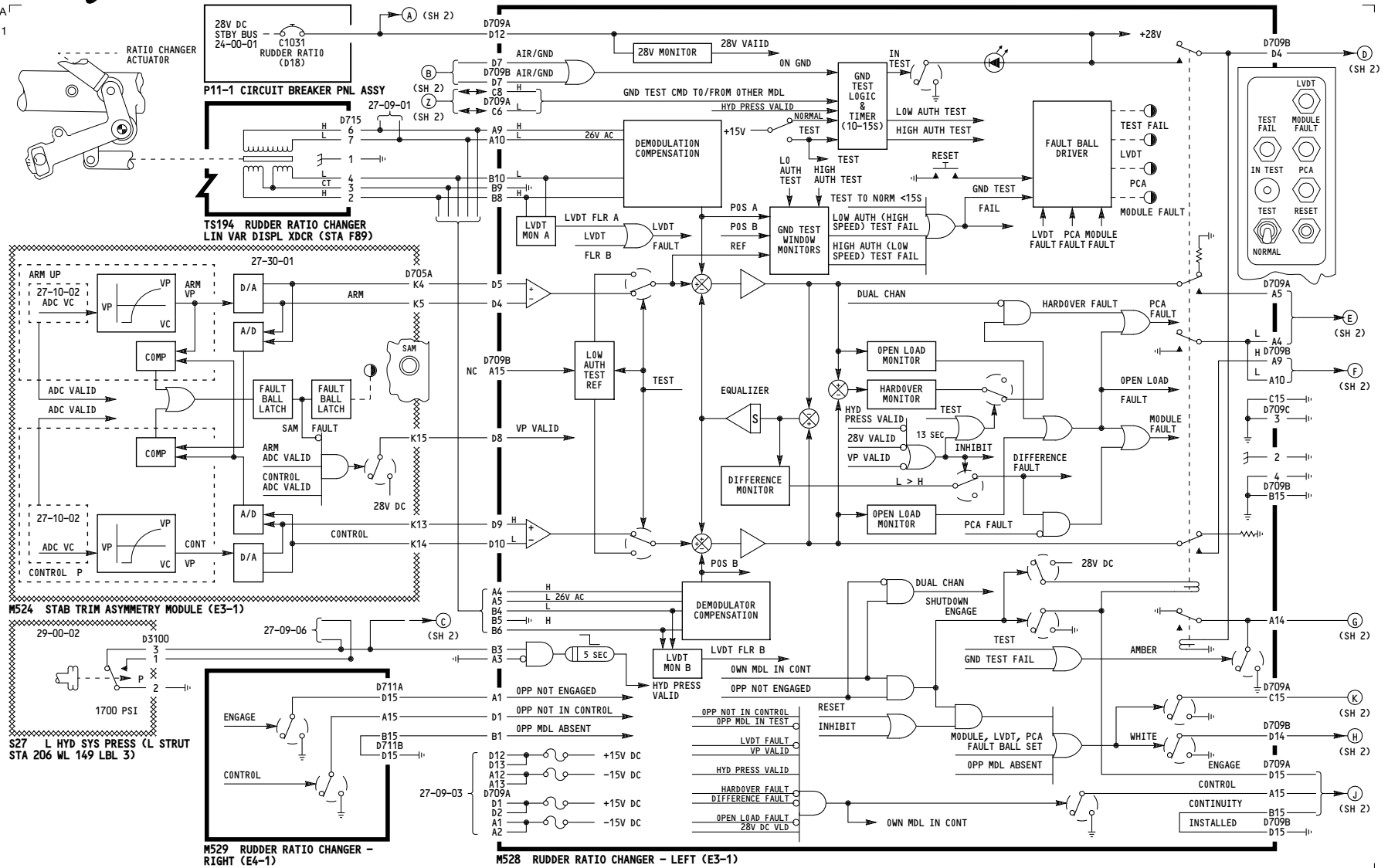

ALL

RUDDER RATIO CHANGER

D280N032S

27-20-02

Page 101
Sheet 1
Oct 09/2008

-A
5001

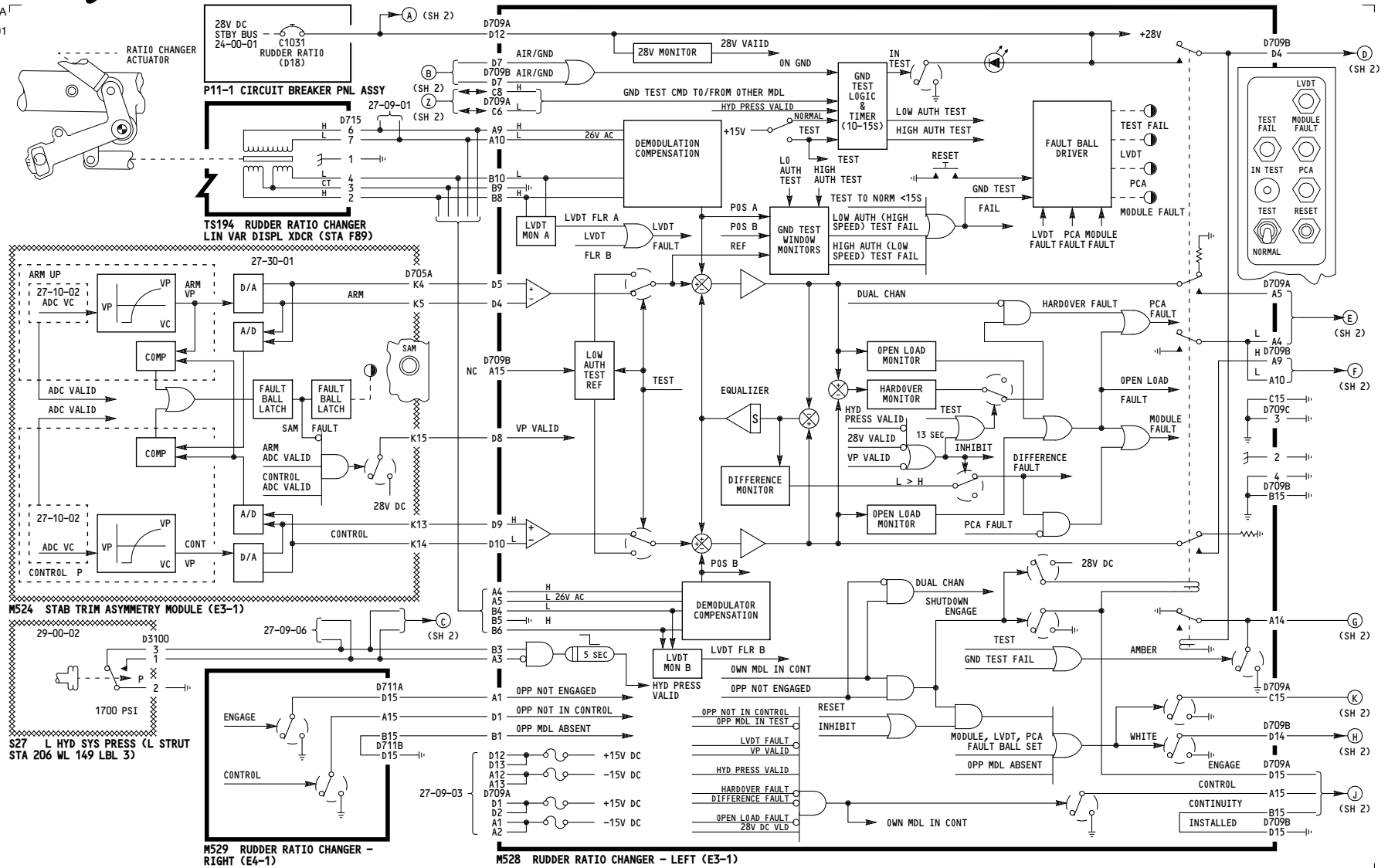

001-004, 115

RUDDER RATIO CHANGER

Incorporates
27-0104

D280N032S

27-20-02

Page 101.1
Sheet 1
Oct 09/2008

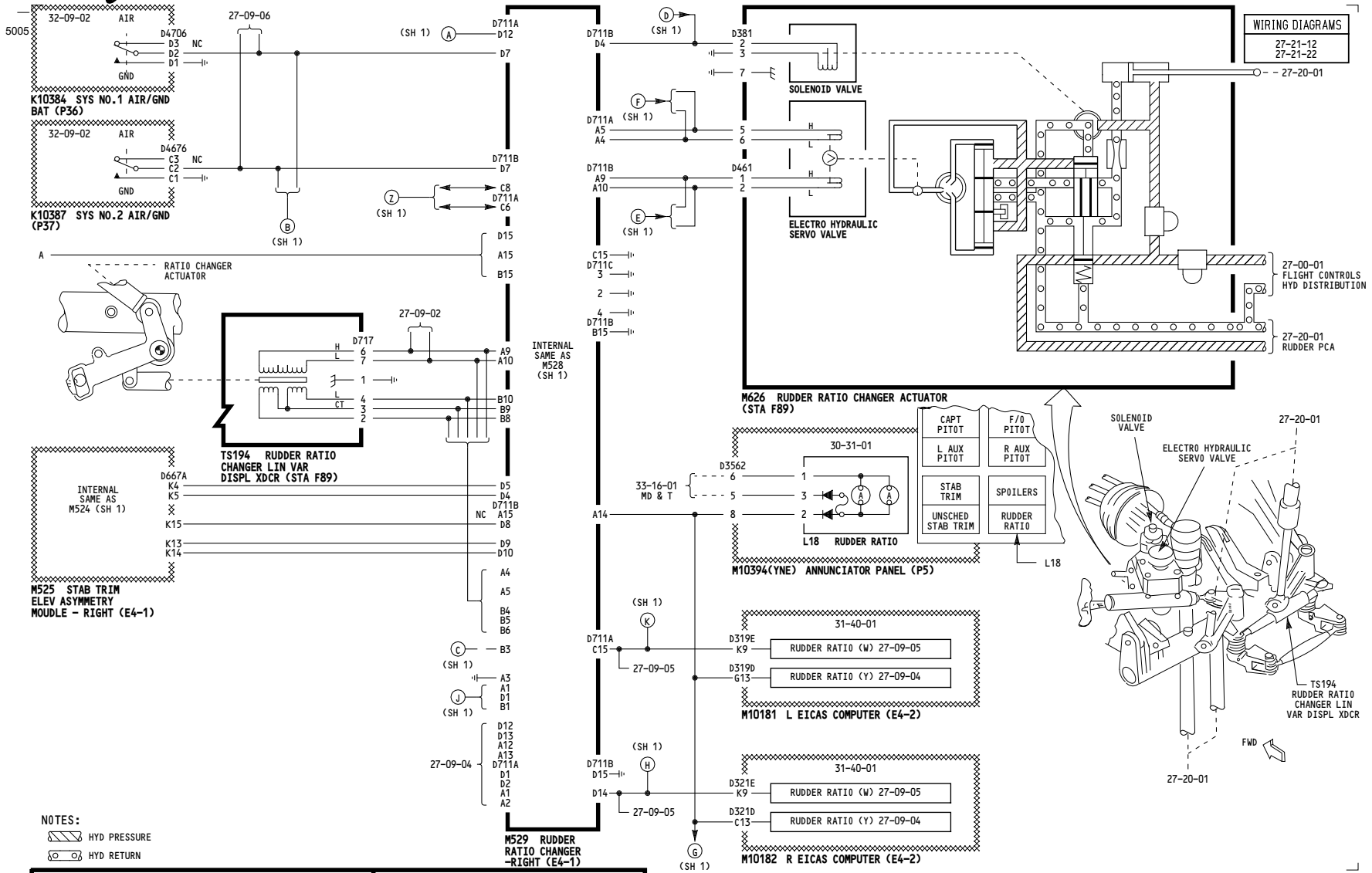

001-004, 115

RUDDER RATIO CHANGER

D280N032S

27-20-02

WIRING DIAGRAMS
27-23-21

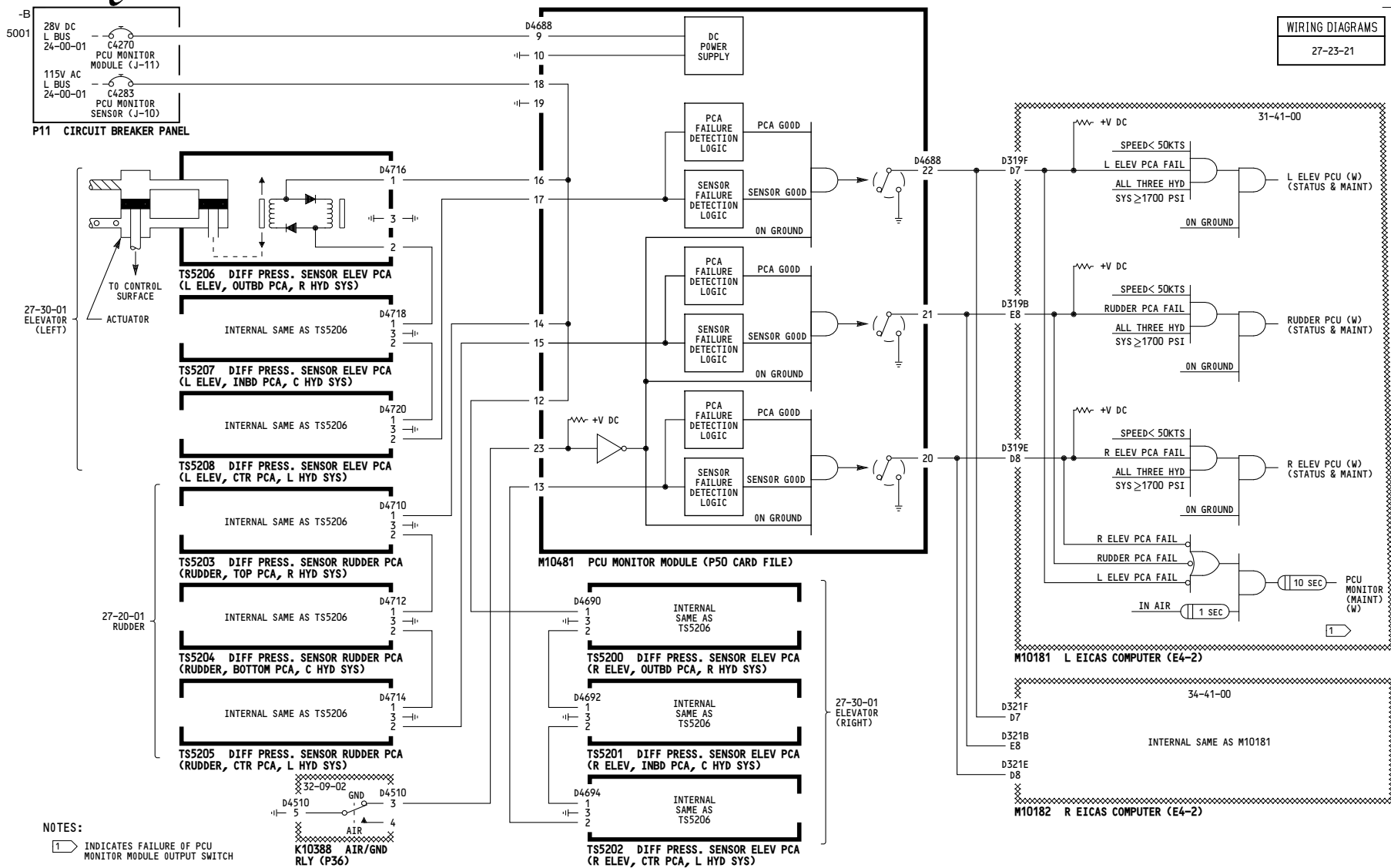

001-099

RUDDER/ELEVATOR PCU MONITOR SYSTEM

D280N032S

27-23-01

WIRING DIAGRAMS
27-23-21

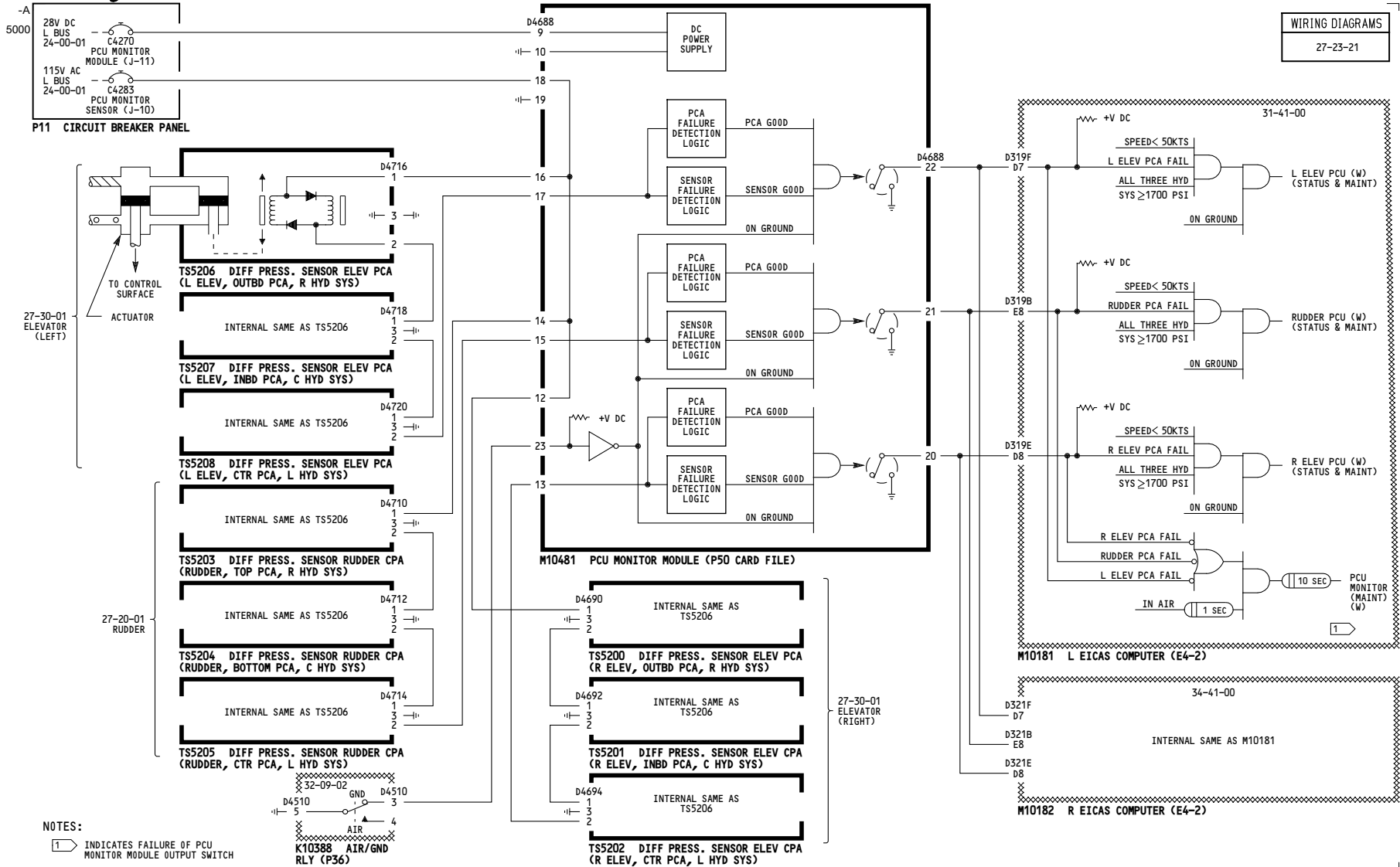

NOTES:
1 INDICATES FAILURE OF PCU MONITOR MODULE OUTPUT SWITCH

115-199

RUDDER/ELEVATOR PCU MONITOR SYSTEM

D280N032S

27-23-01

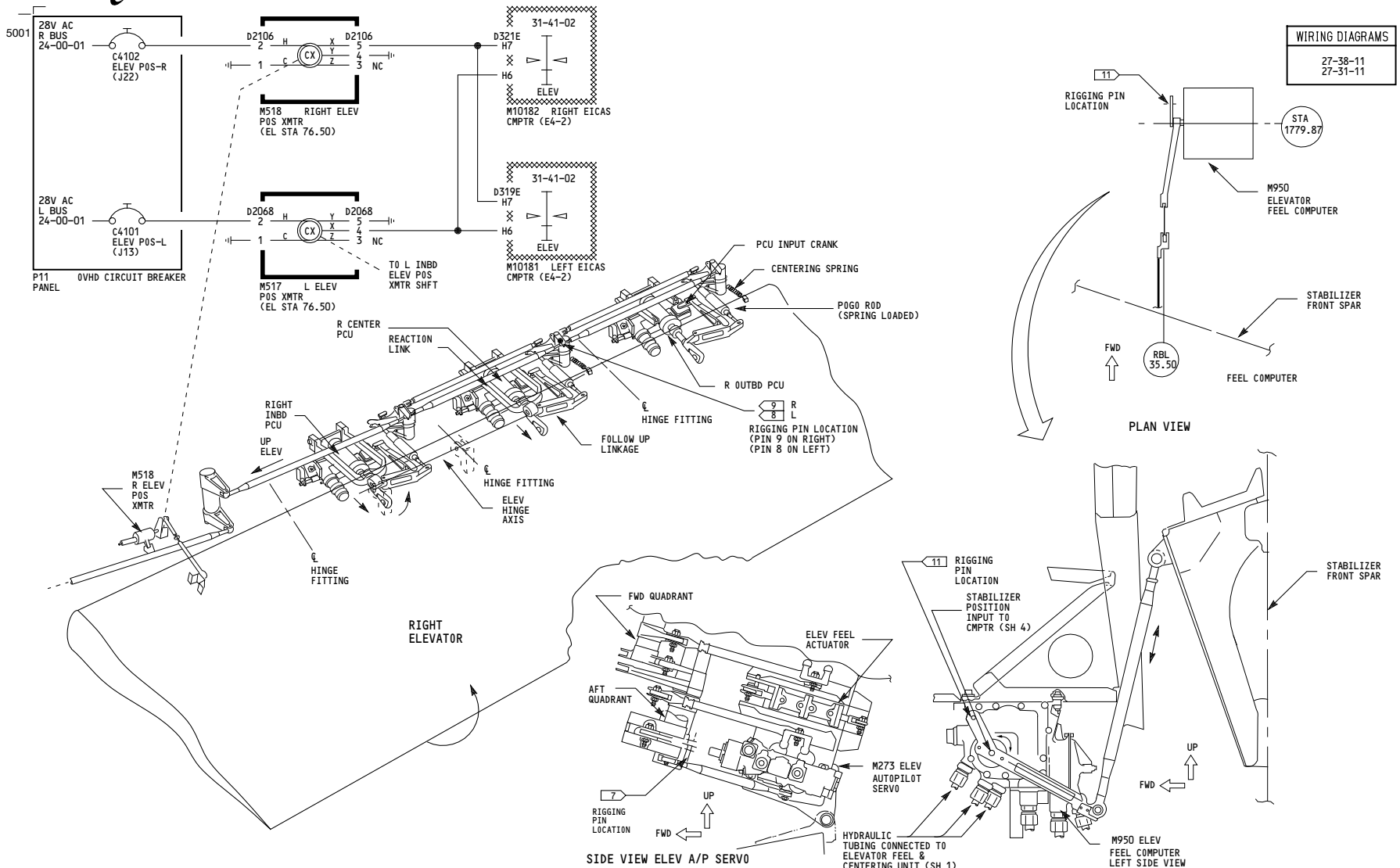

001-099	<p align="center">ELEVATOR</p> <p align="center">D280N032S</p>
---------	---

27-30-01

Page 101
Sheet 2
Jan 21/2005

-B-
5001

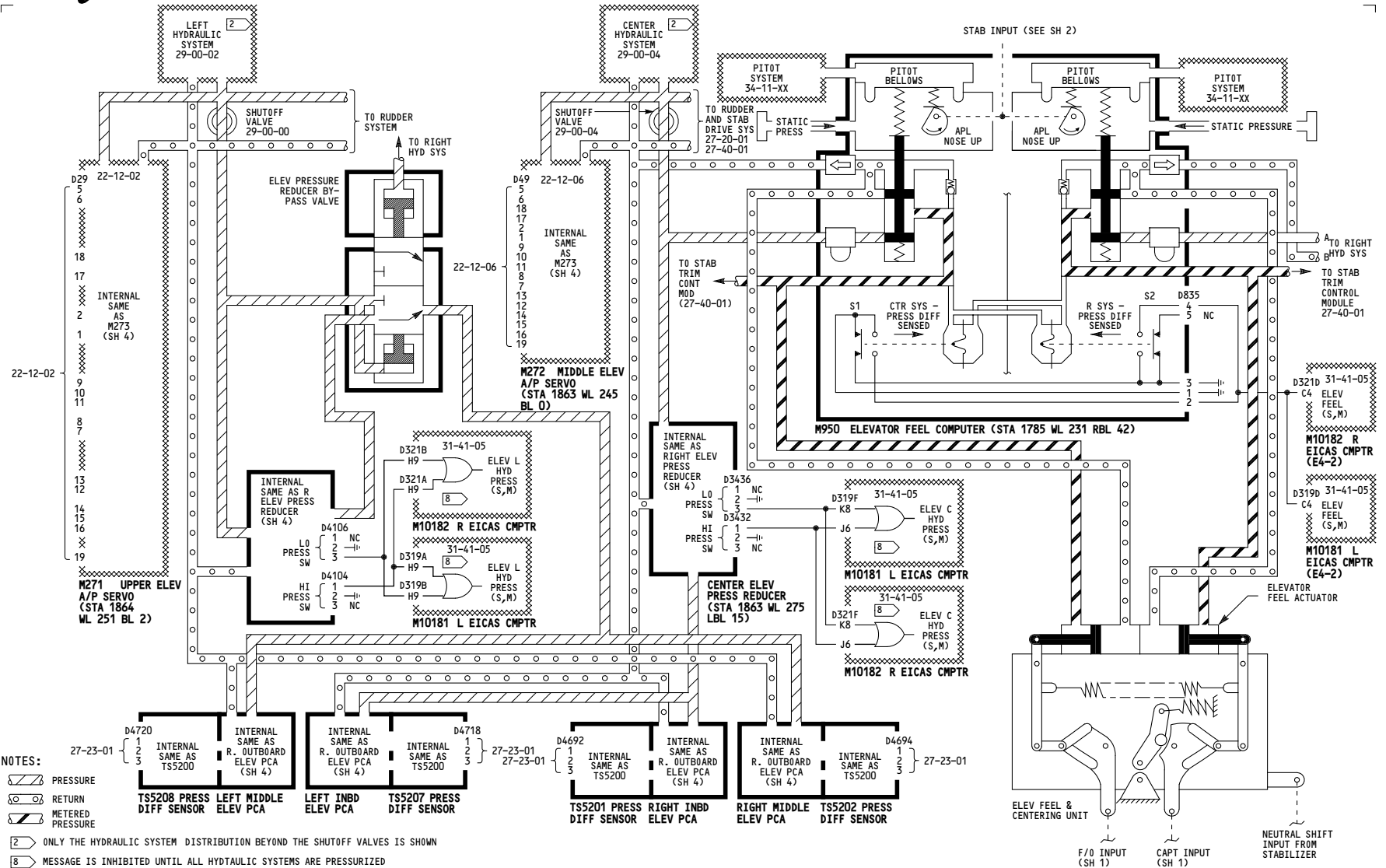

001-099	ELEVATOR
D280N032S	

27-30-01

5001

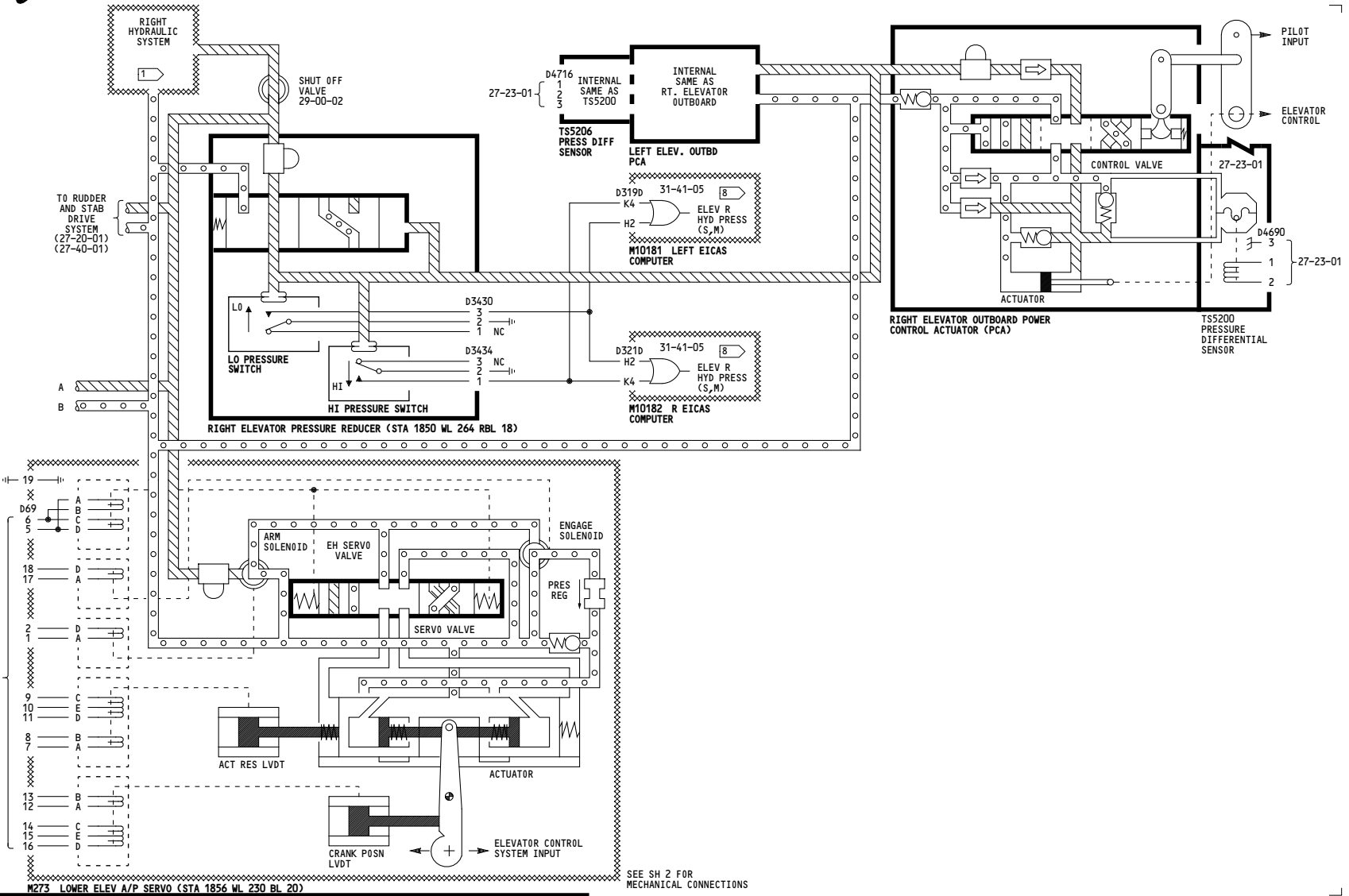

001-099

ELEVATOR

D280N032S

27-30-01

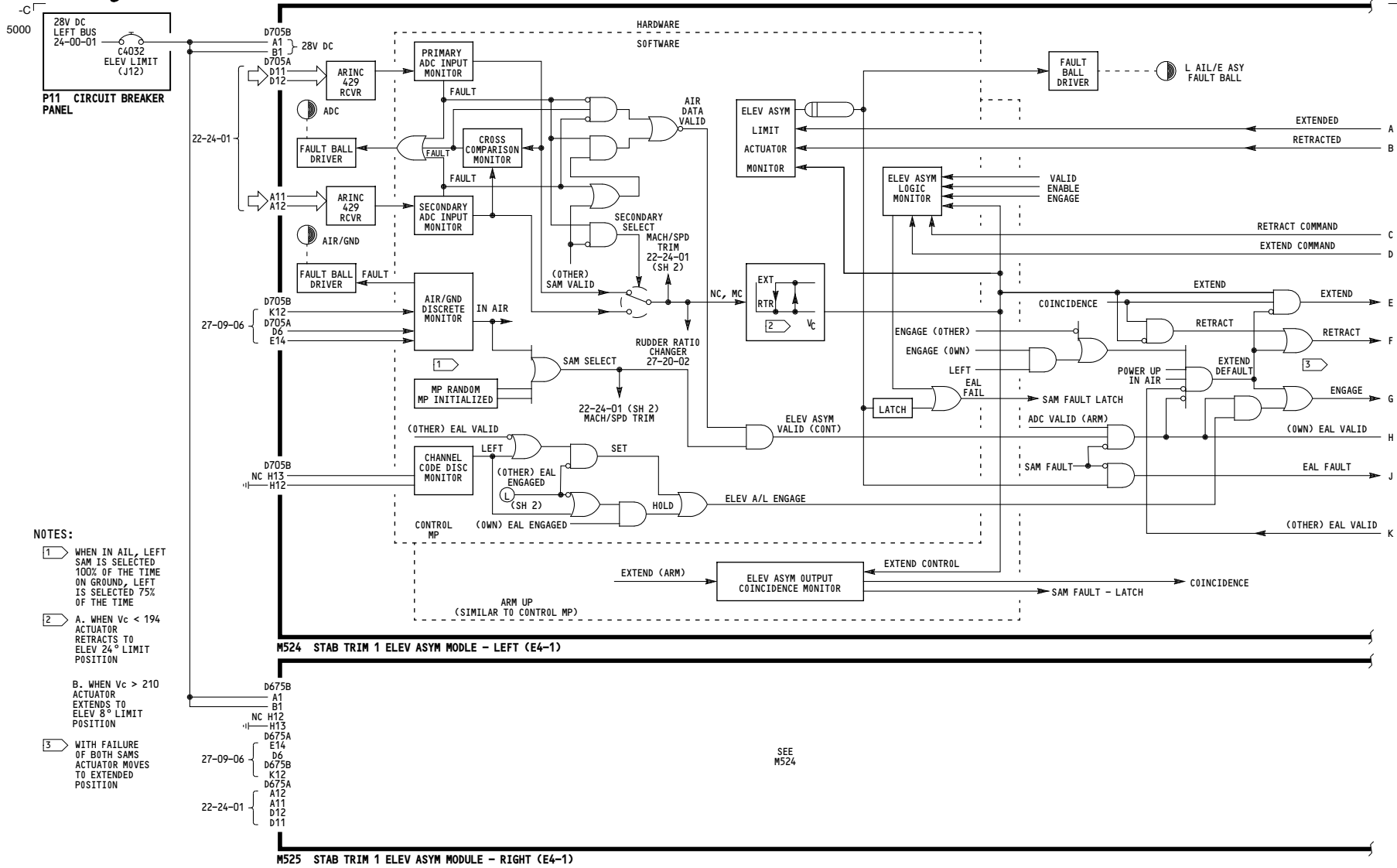

- NOTES:**
- 1 WHEN IN AIR, LEFT SAM IS SELECTED 100% OF THE TIME ON GROUND, LEFT IS SELECTED 75% OF THE TIME
 - 2 A. WHEN Vc < 194 ACTUATOR RETRACTS TO ELEV 24° LIMIT POSITION
B. WHEN Vc > 210 ACTUATOR EXTENDS TO ELEV 8° LIMIT POSITION
 - 3 WITH FAILURE OF BOTH SAMs ACTUATOR MOVES TO EXTENDED POSITION

SEE M524

001-099	ELEVATOR
D280N032S	

27-30-01

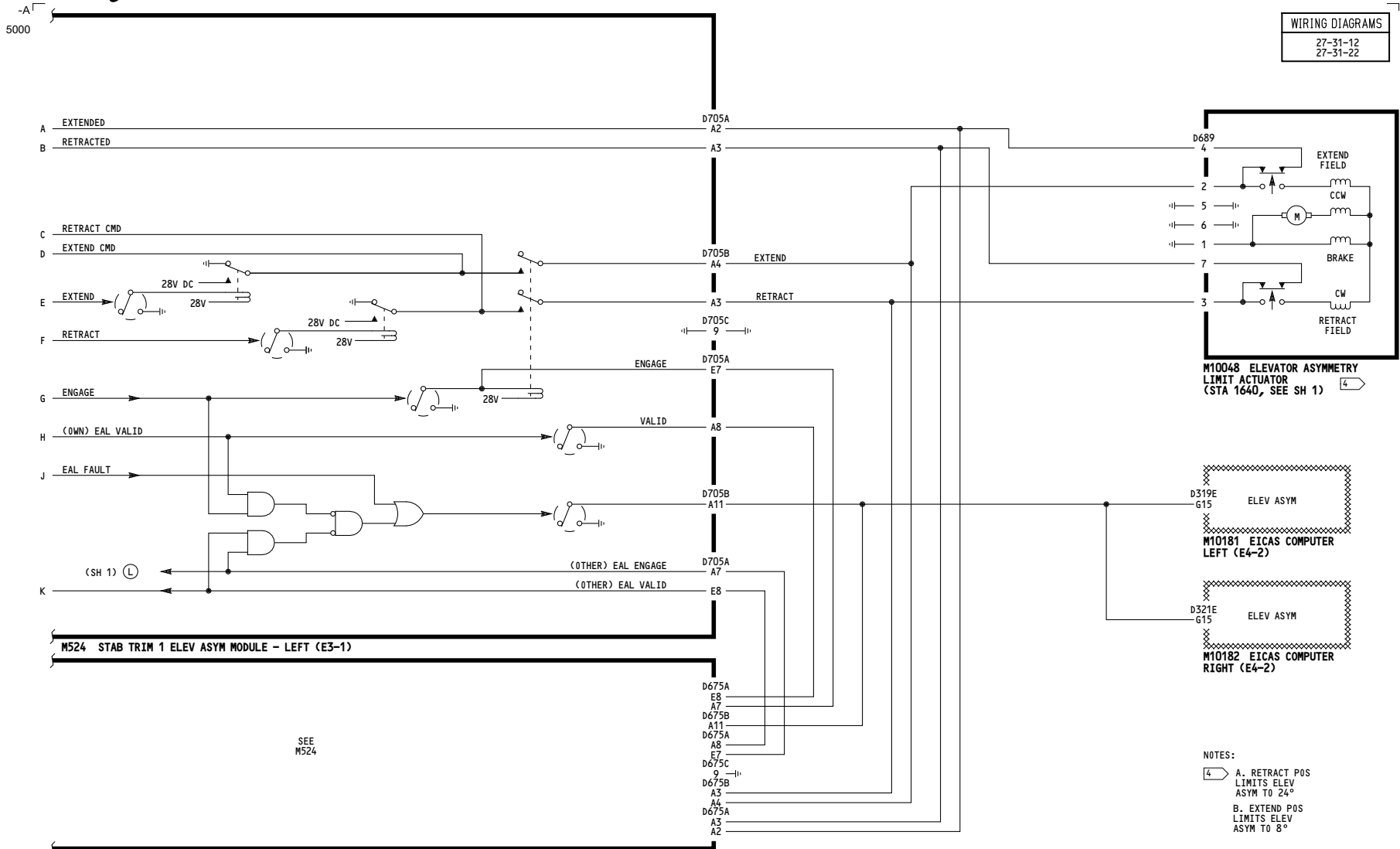

001-099

ELEVATOR

D280N032S

27-30-01

5013

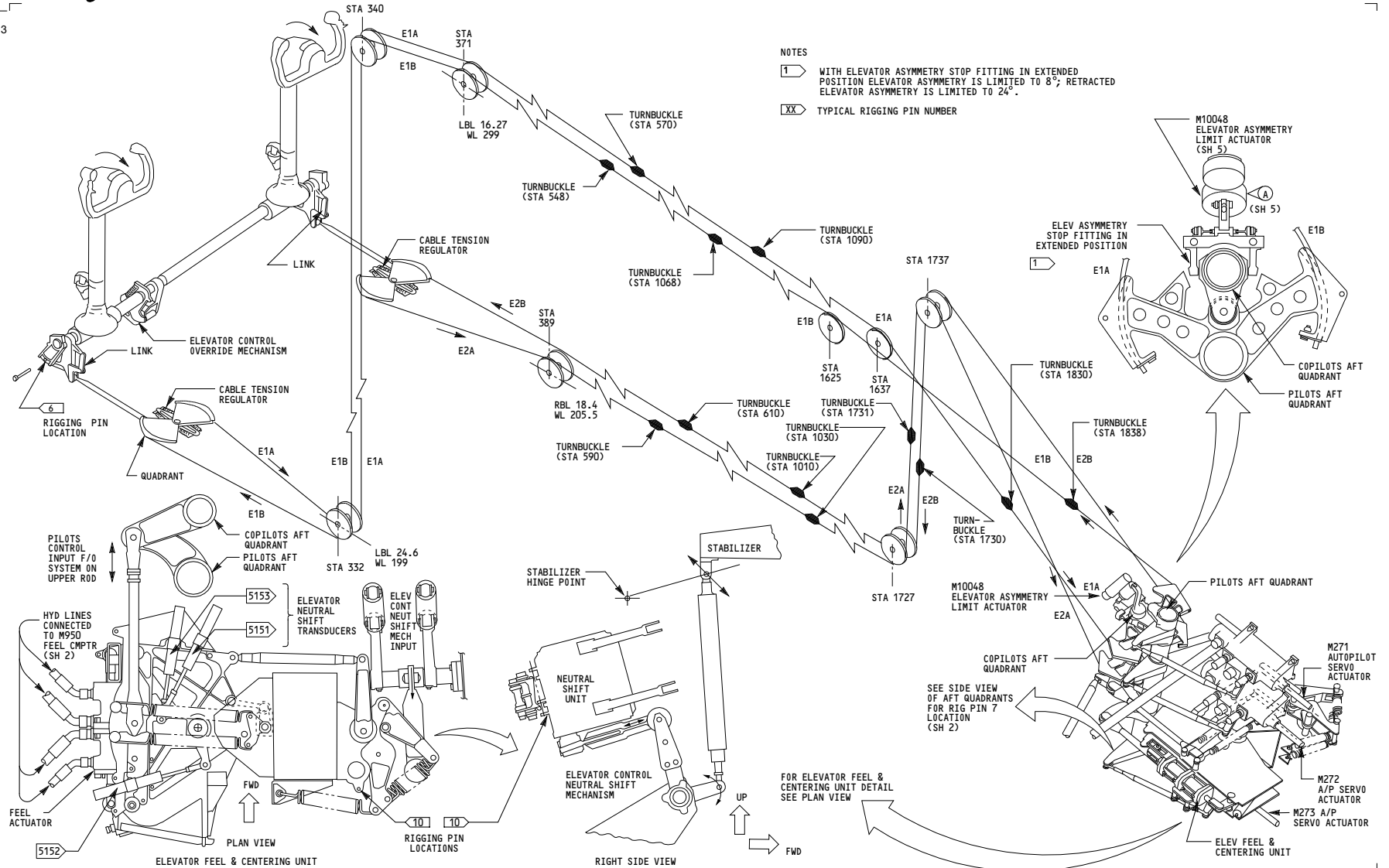

115-199	<p>ELEVATOR</p> <p>D280N032S</p>
---------	---

27-30-01

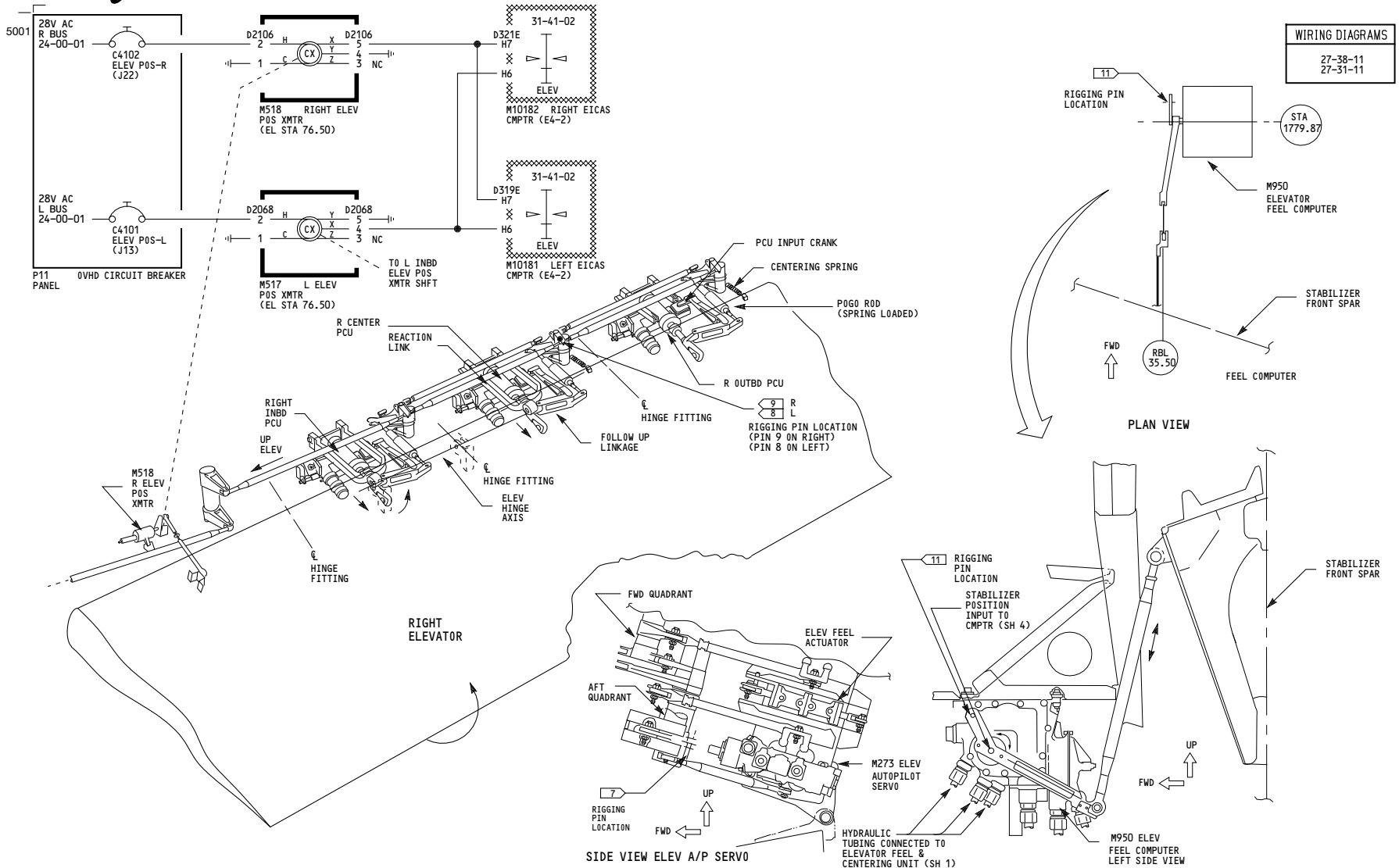

115-199	<p align="center">ELEVATOR</p> <p align="center">D280N032S</p>
---------	---

27-30-01

-B-
5001

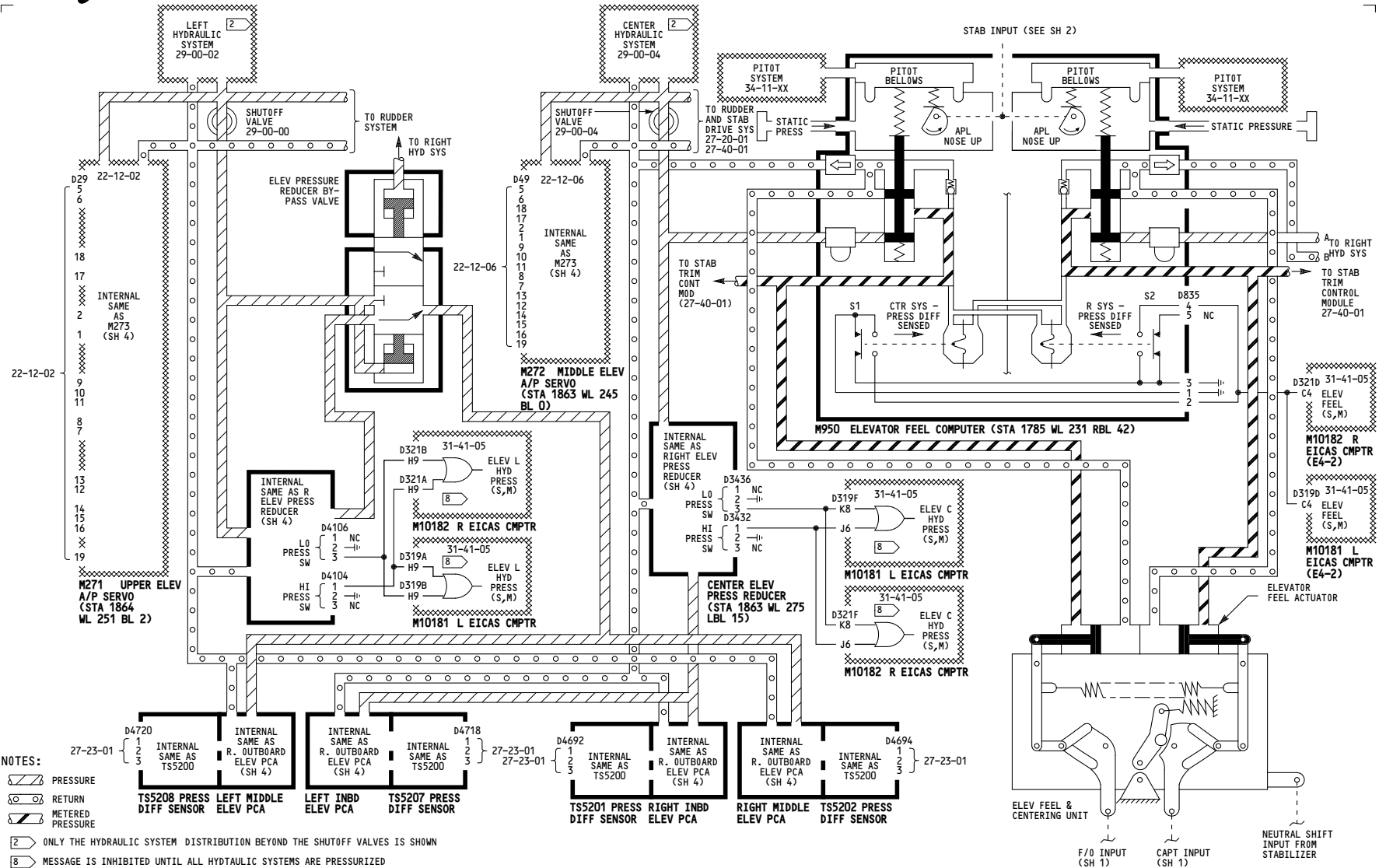

115-199	ELEVATOR
	D280N032S

27-30-01

5001

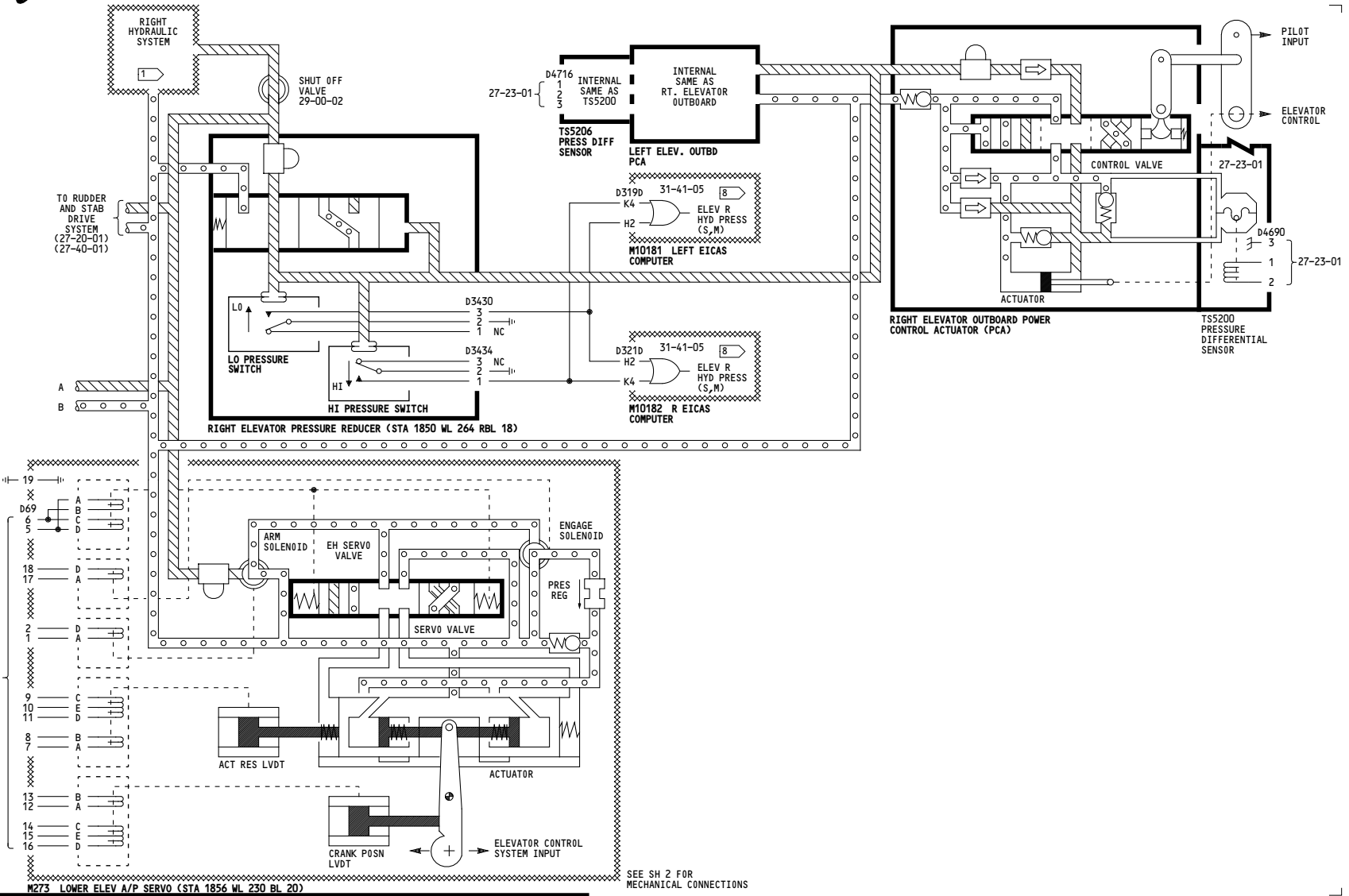

115-199

ELEVATOR

D280N032S

27-30-01

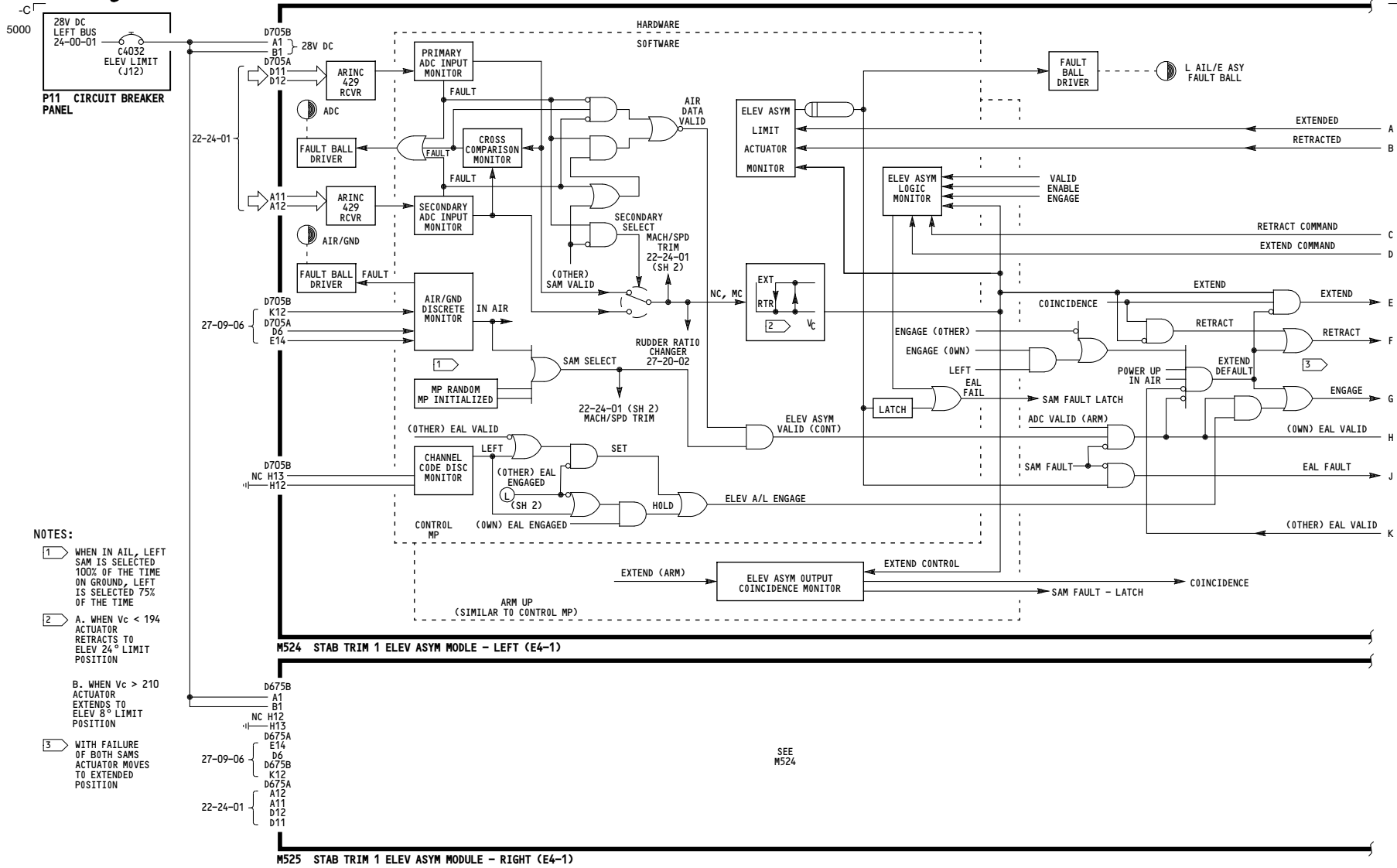

- NOTES:**
- 1 WHEN IN AIR, LEFT SAM IS SELECTED 100% OF THE TIME ON GROUND, LEFT IS SELECTED 75% OF THE TIME
 - 2 A. WHEN Vc < 194 ACTUATOR RETRACTS TO ELEV 24° LIMIT POSITION
B. WHEN Vc > 210 ACTUATOR EXTENDS TO ELEV 8° LIMIT POSITION
 - 3 WITH FAILURE OF BOTH SAMs ACTUATOR MOVES TO EXTENDED POSITION

SEE M524

115-199	ELEVATOR
	D280N032S

27-30-01

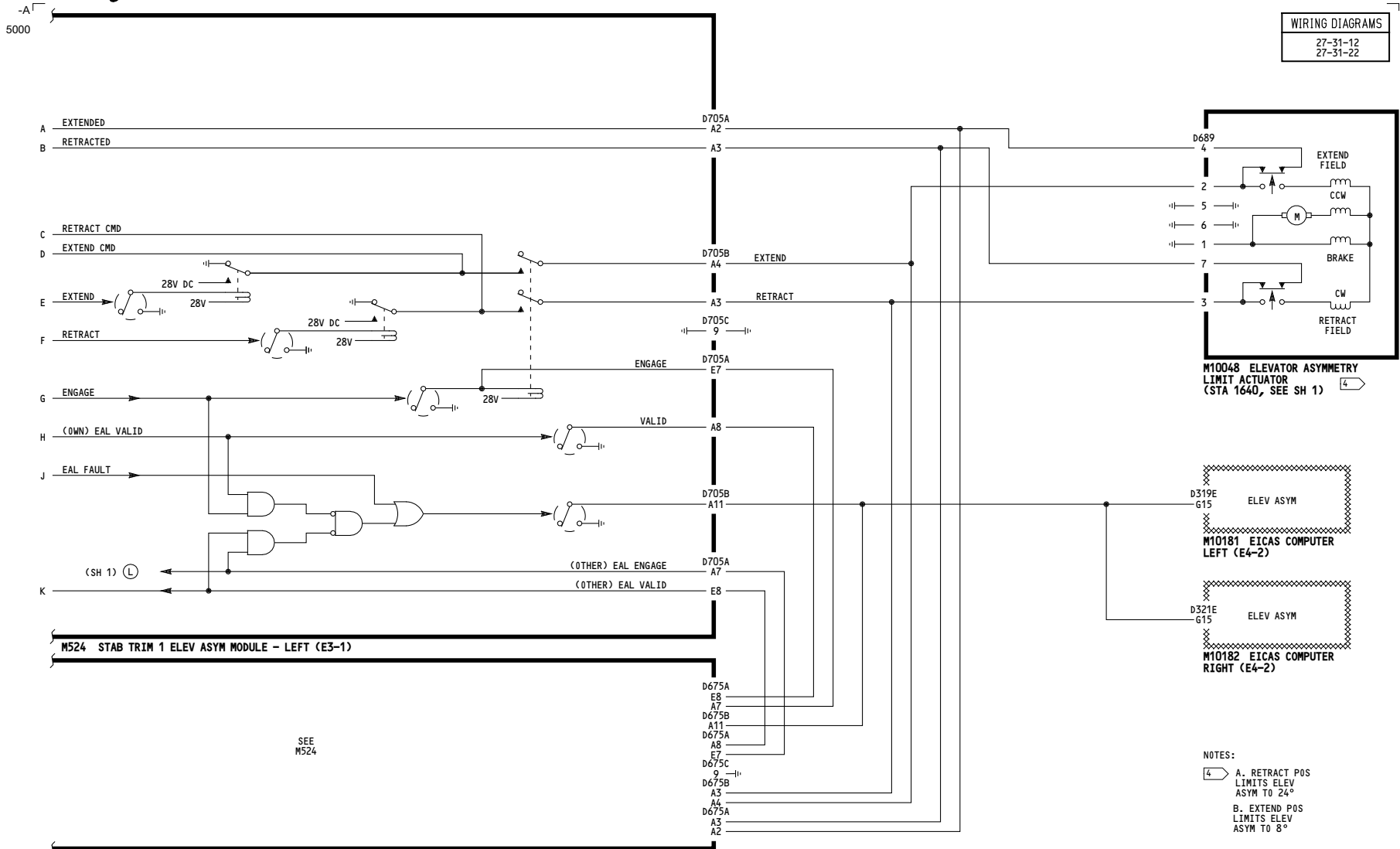

115-199

ELEVATOR

D280N032S

27-30-01

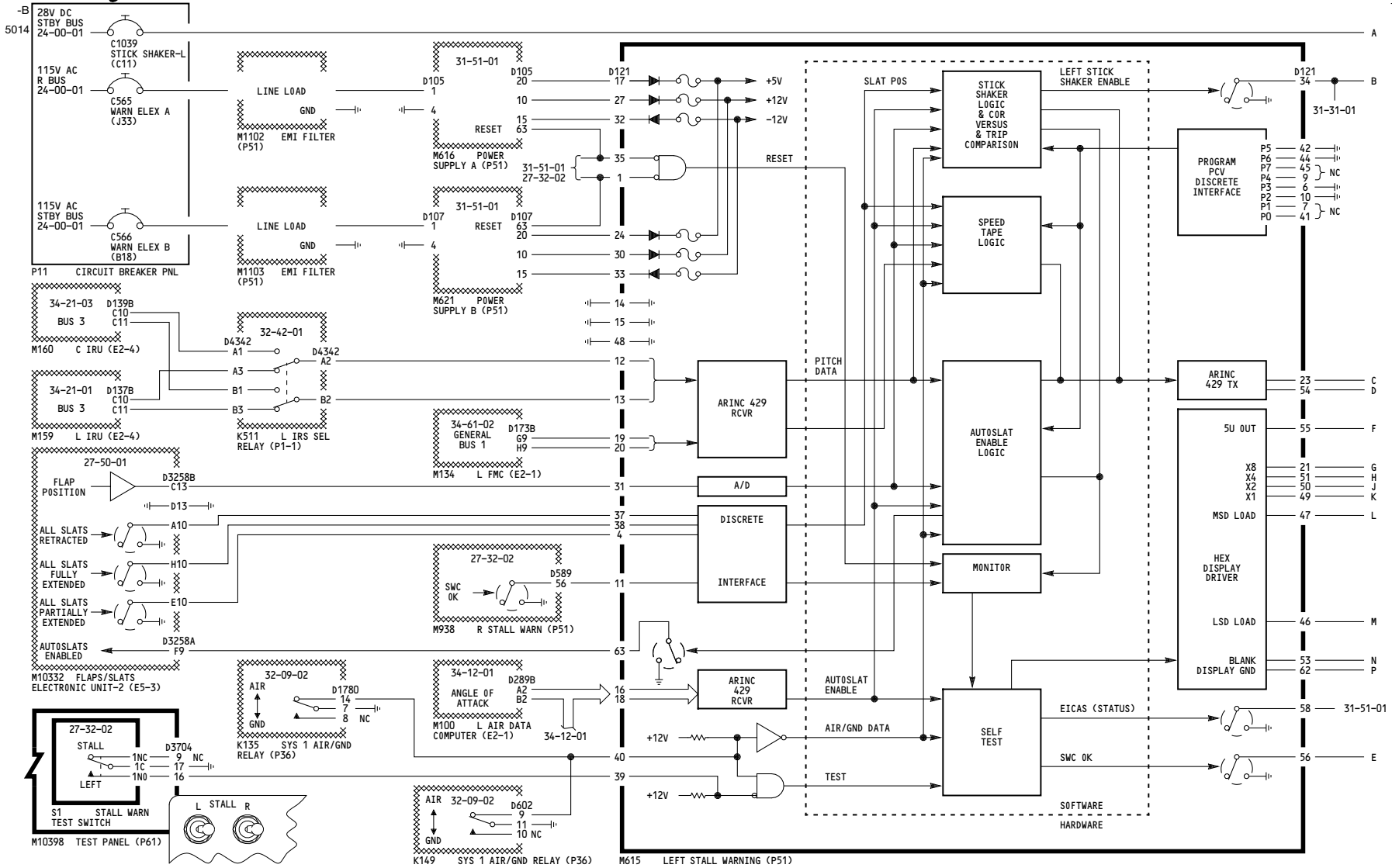

001-099

STALL WARNING - LEFT

27-32-01

D280N032S

5011

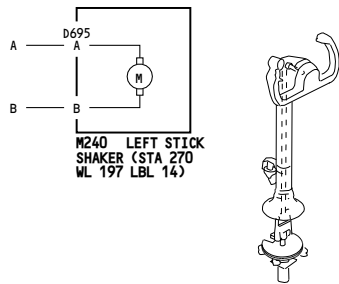

M240 LEFT STICK SHAKER (STA 270 WL 197 LBL 14)

	PROGRAM PIN CODE P7-P4 (AIRFRAME IDENTIFICATION)				PROGRAM PIN CODE P3-P2 SPEED TAPE PARAMETER CALC			PROGRAM PIN CODE P1-P0 (OPTIONAL FEATURES)			CONFIG CODE MSD HEX DISPLAY (WEU BITE MODULE)	OPTIONAL CODE LSD HEX DISPLAY (WEU BITE MODULE)
	P7	P6	P5	P4	P3	P2	P1	P0				
757-200	OPEN	GND	GND	OPEN	ACTIVATED	GND	GND	NONE	OPEN	OPEN	4	3

WIRING DIAGRAMS
27-32-11
27-32-12

NOTE: IN THE ABSENCE OF BOARD FAULTS OR INTERFACE ANOMALIES, THE AIRFRAME CONFIGURATION CODE AND OPTION CODE WILL BE DISPLAYED ON THE HEX DISPLAY OF THE WEU BITE MODULE.

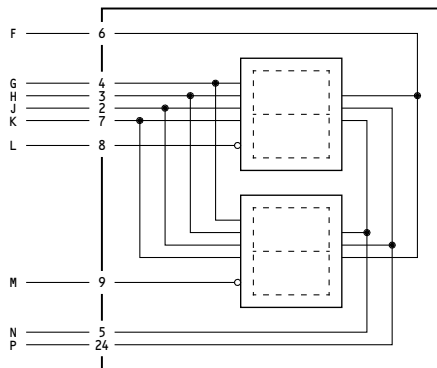
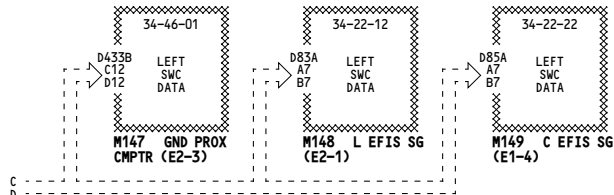

M1411 WEU BITE MODULE

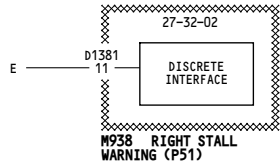

M938 RIGHT STALL WARNING (P51)

STALL WARNING BOARD FAULT CODES (DISPLAYED ON WEU BITE MODULE)					INTERFACE ANOMALY CODES (DISPLAYED ON WEU BITE MODULE)		
MULTIPLE FAULTS A0	SLATS RETRACTED A1	SLATS PARTIALLY EXTENDED A2	SLATS FULLY EXTENDED A3	NOT USED A4	INOP STICK SHAKER D0	INVALID ADC INPUT D1	INVALID FLAPS POSITION D2
NOT USED A5	NOT USED A6	NOT USED A7	TEST A9	AIR/GND B0	INVALID AIR/GND INPUT D3	MULTIPLE LEADING EDGE SLATS D4	NO LEADING EDGE SLATS D5
GEAR DOWN B1	OPPOSITE CHANNEL OK B2	NOT USED B5	ARINC INPUT B6	A/D C0	INVALID IRS INPUT D6	INVALID FMC INPUT D7	AIR/GND ADA SSM CONFLICT D8
STICK SHAKER C1	AUTOSLATS C3	EICAS STATUS C4	CHANNEL OK C5	NOT USED C6	OPPOSITE SMC FAULT D9	INVALID CONFIG FX	

001-099

STALL WARNING - LEFT

D280N032S

27-32-01

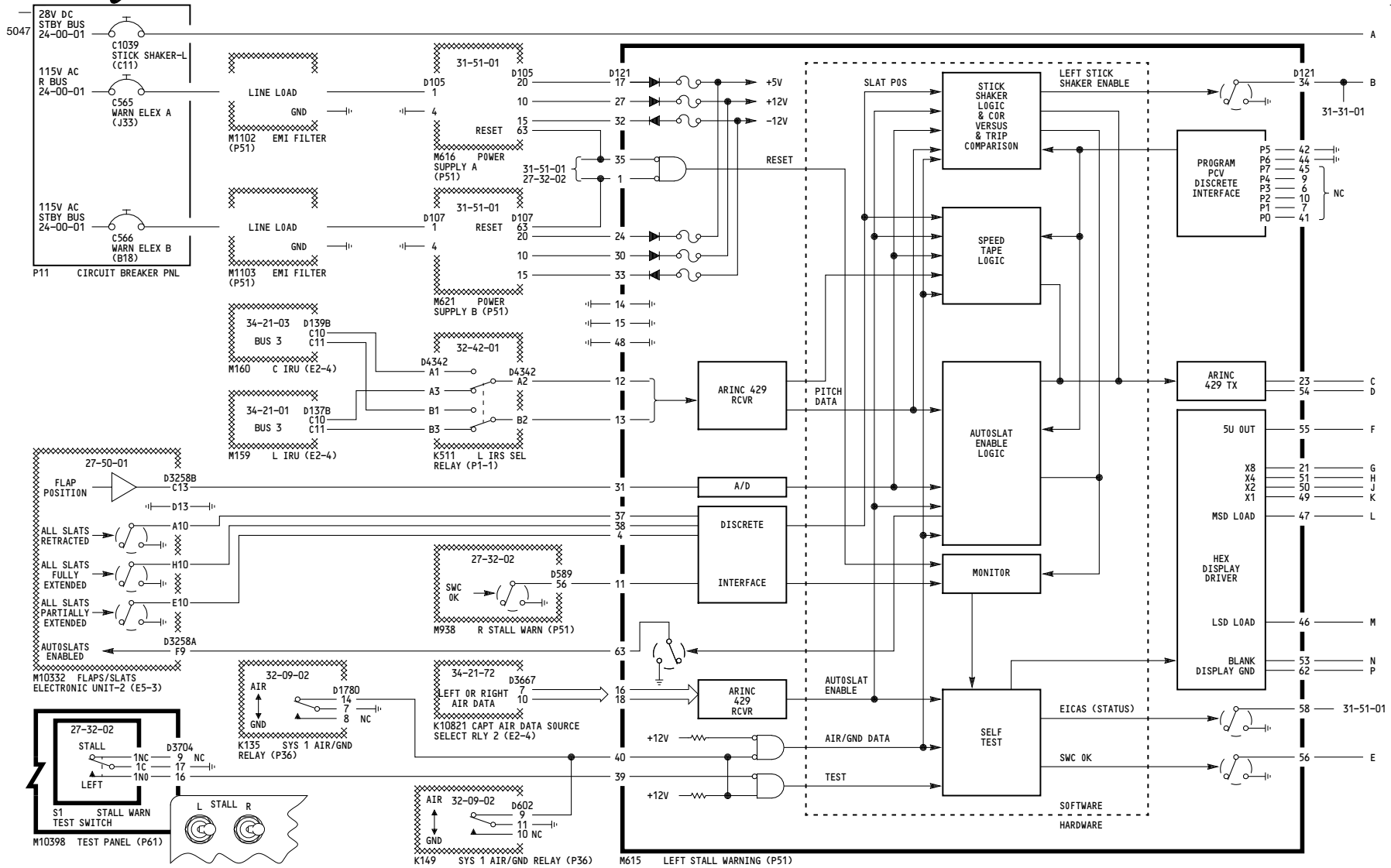

001-011	STALL WARNING - LEFT
Incorporates 34A0222	
D280N032S	

27-32-01

5011

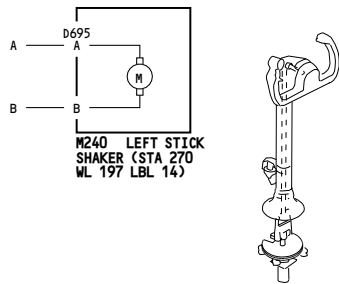

M240 LEFT STICK SHAKER (STA 270 WL 197 LBL 14)

	PROGRAM PIN CODE P7-P4 (AIRFRAME IDENTIFICATION)				PROGRAM PIN CODE P3-P2 SPEED TAPE PARAMETER CALC			PROGRAM PIN CODE P1-P0 (OPTIONAL FEATURES)			CONFIG CODE MSD HEX DISPLAY (WEU BITE MODULE)	OPTIONAL CODE LSD HEX DISPLAY (WEU BITE MODULE)
	P7	P6	P5	P4	P3	P2	P1	P0				
757-200	OPEN	GND	GND	OPEN	ACTIVATED	GND	GND	NONE	OPEN	OPEN	4	3

WIRING DIAGRAMS
27-32-11
27-32-12

NOTE: IN THE ABSENCE OF BOARD FAULTS OR INTERFACE ANOMALIES, THE AIRFRAME CONFIGURATION CODE AND OPTION CODE WILL BE DISPLAYED ON THE HEX DISPLAY OF THE WEU BITE MODULE.

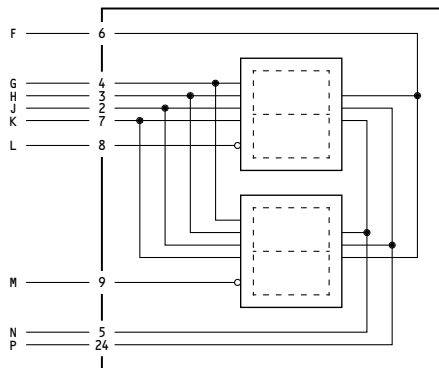
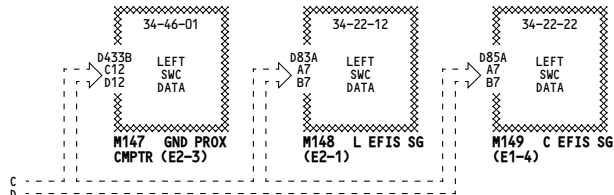

M1411 WEU BITE MODULE

27-52-02

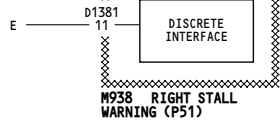

M938 RIGHT STALL WARNING (P51)

STALL WARNING BOARD FAULT CODES (DISPLAYED ON WEU BITE MODULE)					INTERFACE ANOMALY CODES (DISPLAYED ON WEU BITE MODULE)		
MULTIPLE FAULTS A0	SLATS RETRACTED A1	SLATS PARTIALLY EXTENDED A2	SLATS FULLY EXTENDED A3	NOT USED A4	INOP STICK SHAKER D0	INVALID ADC INPUT D1	INVALID FLAPS POSITION D2
NOT USED A5	NOT USED A6	NOT USED A7	TEST A9	AIR/GND B0	INVALID AIR/GND INPUT D3	MULTIPLE LEADING EDGE SLATS D4	NO LEADING EDGE SLATS D5
GEAR DOWN B1	OPPOSITE CHANNEL OK B2	NOT USED B5	ARINC INPUT B6	A/D C0	INVALID IRS INPUT D6	INVALID FMC INPUT D7	AIR/GND ADA SSM CONFLICT D8
STICK SHAKER C1	AUTOSLATS C3	EICAS STATUS C4	CHANNEL OK C5	NOT USED C6	OPPOSITE SMC FAULT D9	INVALID CONFIG FX	

001-011

STALL WARNING - LEFT

D280N032S

27-32-01

Page 101.1
Sheet 2
Jan 21/2005

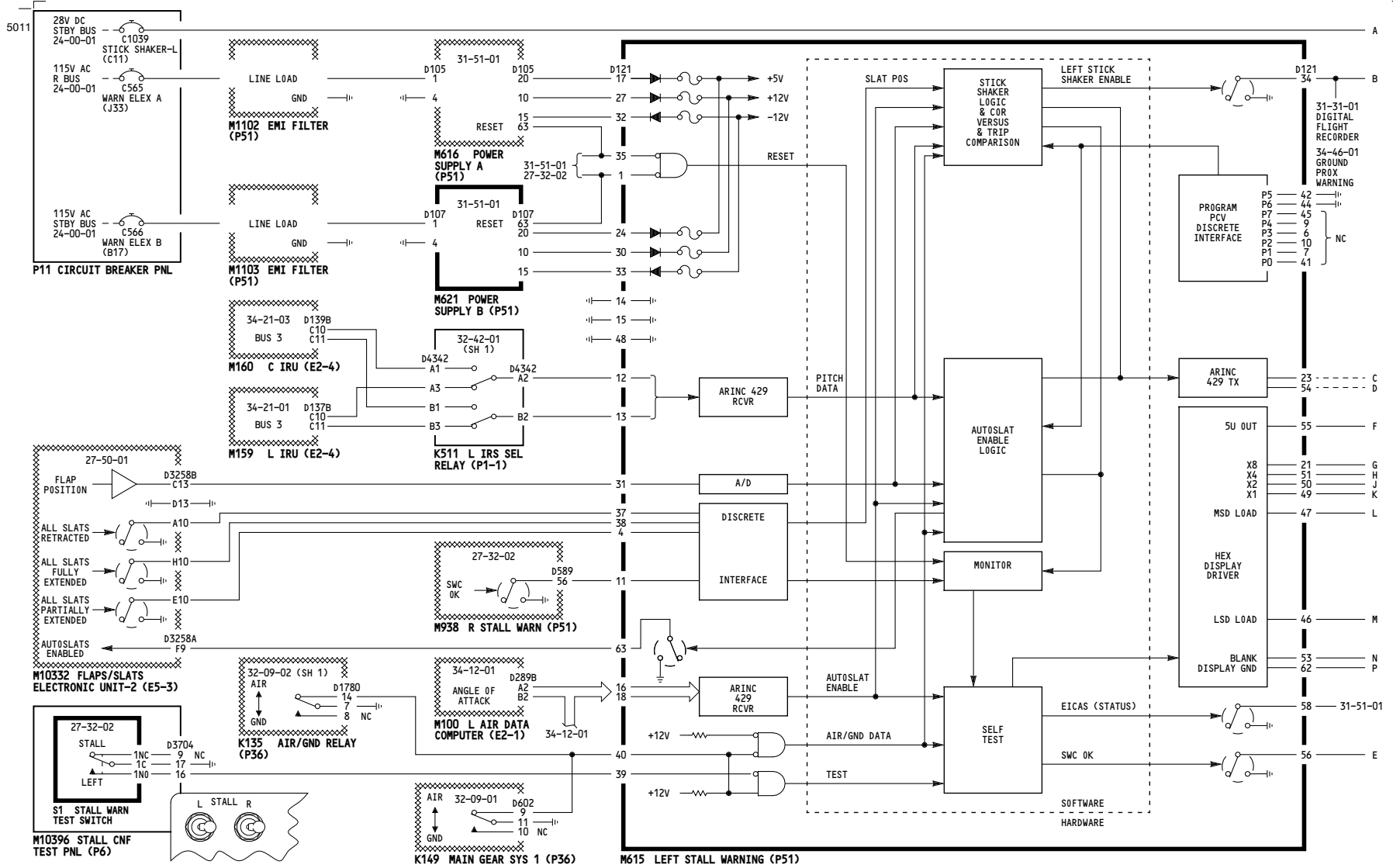

115-199

STALL WARNING - LEFT

D280N032S

27-32-01

5001

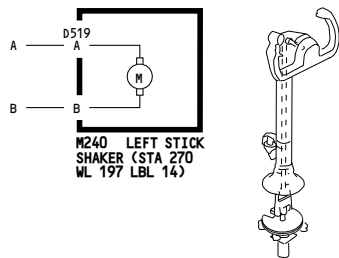

M240 LEFT STICK SHAKER (STA 270 WL 197 LBL 14)

	PROGRAM PIN CODE P7-P4 (AIRFRAME IDENTIFICATION)				PROGRAM PIN CODE P3-P2 SPEED TAPE PARAMETER CALC			PROGRAM PIN CODE P1-P0 (OPTIONAL FEATURES)			CONFIG CODE MSD HEX DISPLAY (WEU BITE MODULE)	OPTIONAL CODE LSD HEX DISPLAY (WEU BITE MODULE)
	P7	P6	P5	P4	P3	P2	P1	P0				
757-200	OPEN	GND	GND	OPEN	NOT ACTIVATED	OPEN	OPEN	NONE	OPEN	OPEN	4	F

WIRING DIAGRAMS
27-32-11
27-32-12

NOTES: IN THE ABSENCE OF BOARD FAULTS OR INTERFACE ANOMALIES, THE AIRFRAME CONFIGURATION CODE AND OPTION CODE WILL BE DISPLAYED ON THE HEX DISPLAY OF THE WEU BITE MODULE.

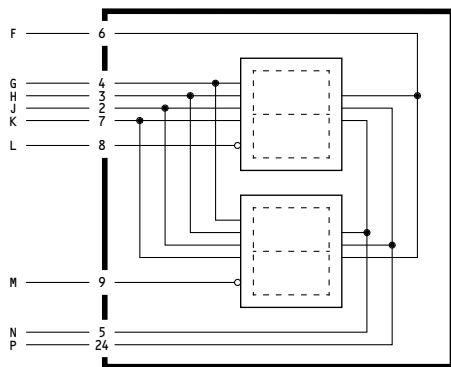
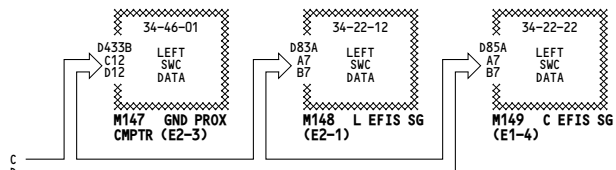

M1411 WEU BITE MODULE

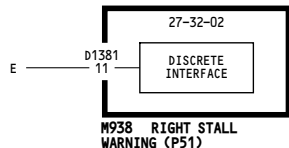

M938 RIGHT STALL WARNING (P51)

STALL WARNING BOARD FAULT CODES (DISPLAYED ON WEU BITE MODULE)					INTERFACE ANOMALY CODES (DISPLAYED ON WEU BITE MODULE)		
MULTIPLE FAULTS A0	SLATS RETRACTED A1	SLATS PARTIALLY EXTENDED A2	SLATS FULLY EXTENDED A3	NOT USED A4	INOP STICK SHAKER D0	INVALID ADC INPUT D1	INVALID FLAPS POSITION D2
NOT USED A5	NOT USED A6	NOT USED A7	TEST A9	AIR/GND B0	INVALID AIR/GND INPUT D3	MULTIPLE LEADING EDGE SLATS D4	NO LEADING EDGE SLATS D5
GEAR DOWN B1	OPPOSITE CHANNEL OK B2	NOT USED B5	ARINC INPUT B6	A/D C0	INVALID IRS INPUT D6	NOT USED D7	AIR/GND ADA SSM CONFLICT D8
STICK SHAKER C1	AUTOSLATS C3	EICAS STATUS C4	CHANNEL OK C5	NOT USED C6	OPPOSITE SMC FAULT D9	INVALID CONFIG FX	

115-199

STALL WARNING - LEFT

D280N032S

27-32-01

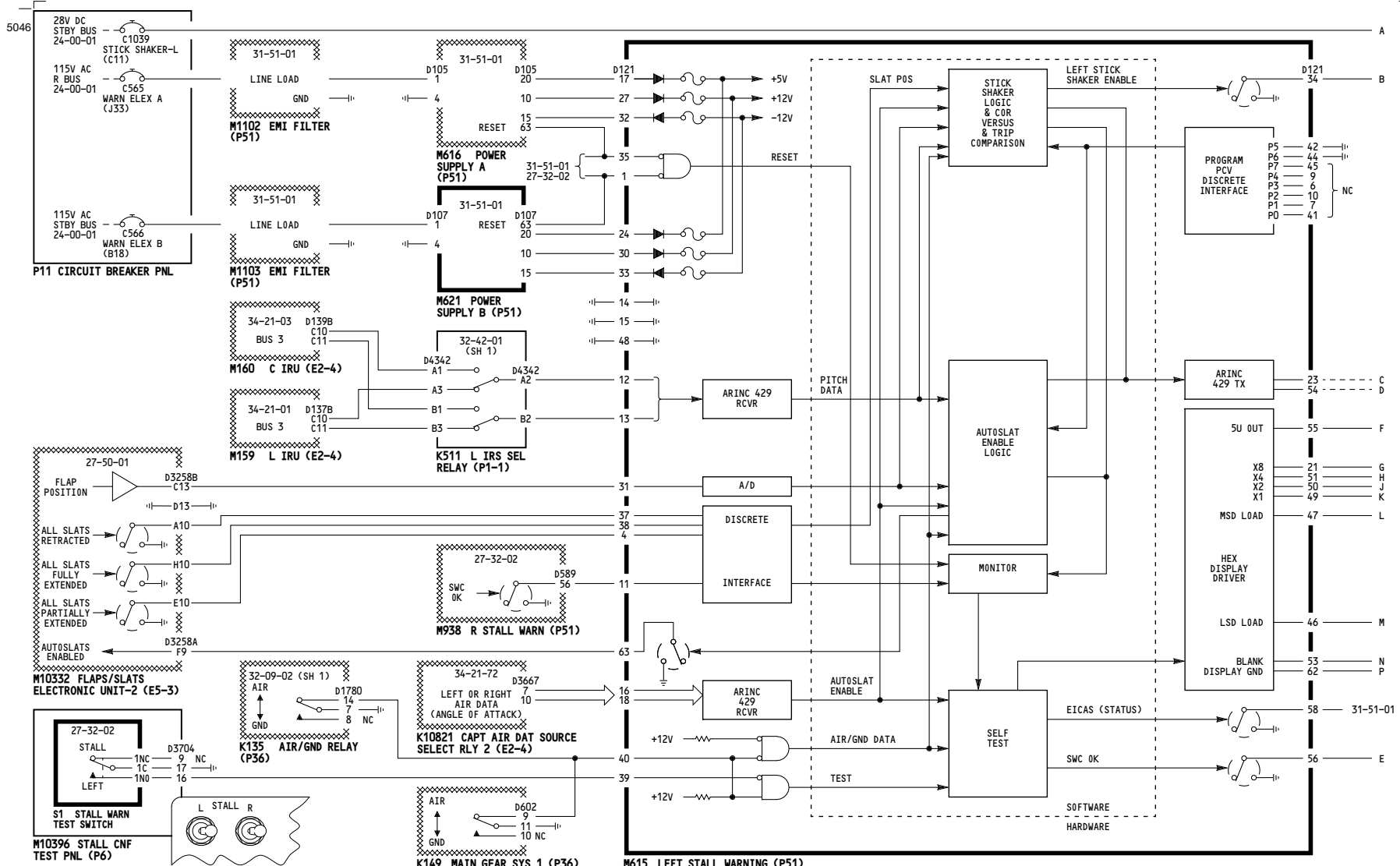

115

STALL WARNING - LEFT

Incorporates
34A0222

27-32-01

D280N032S

5001

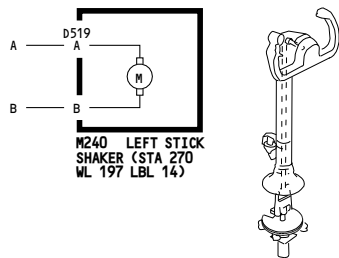

M240 LEFT STICK SHAKER (STA 270 WL 197 LBL 14)

	PROGRAM PIN CODE P7-P4 (AIRFRAME IDENTIFICATION)				PROGRAM PIN CODE P3-P2 SPEED TAPE PARAMETER CALC			PROGRAM PIN CODE P1-P0 (OPTIONAL FEATURES)			CONFIG CODE MSD HEX DISPLAY (WEU BITE MODULE)	OPTIONAL CODE LSD HEX DISPLAY (WEU BITE MODULE)
	P7	P6	P5	P4	P3	P2	P1	P0				
757-200	OPEN	GND	GND	OPEN	NOT ACTIVATED	OPEN	OPEN	NONE	OPEN	OPEN	4	F

WIRING DIAGRAMS
27-32-11
27-32-12

NOTES: IN THE ABSENCE OF BOARD FAULTS OR INTERFACE ANOMALIES, THE AIRFRAME CONFIGURATION CODE AND OPTION CODE WILL BE DISPLAYED ON THE HEX DISPLAY OF THE WEU BITE MODULE.

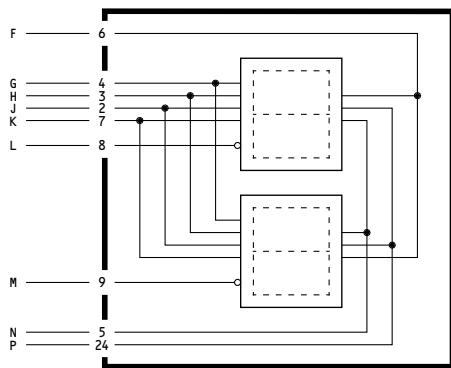
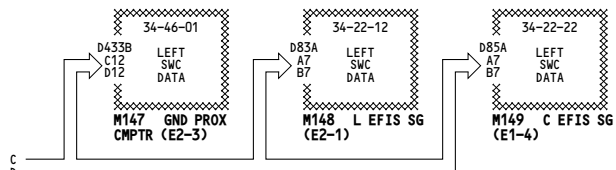

M1411 WEU BITE MODULE

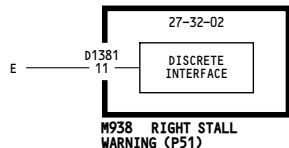

M938 RIGHT STALL WARNING (P51)

STALL WARNING BOARD FAULT CODES (DISPLAYED ON WEU BITE MODULE)					INTERFACE ANOMALY CODES (DISPLAYED ON WEU BITE MODULE)		
MULTIPLE FAULTS A0	SLATS RETRACTED A1	SLATS PARTIALLY EXTENDED A2	SLATS FULLY EXTENDED A3	NOT USED A4	INOP STICK SHAKER D0	INVALID ADC INPUT D1	INVALID FLAPS POSITION D2
NOT USED A5	NOT USED A6	NOT USED A7	TEST A9	AIR/GND B0	INVALID AIR/GND INPUT D3	MULTIPLE LEADING EDGE SLATS D4	NO LEADING EDGE SLATS D5
GEAR DOWN B1	OPPOSITE CHANNEL OK B2	NOT USED B5	ARINC INPUT B6	A/D C0	INVALID IRS INPUT D6	NOT USED D7	AIR/GND ADA SSM CONFLICT D8
STICK SHAKER C1	AUTOSLATS C3	EICAS STATUS C4	CHANNEL OK C5	NOT USED C6	OPPOSITE SMC FAULT D9	INVALID CONFIG FX	

115

STALL WARNING - LEFT

D280N032S

27-32-01

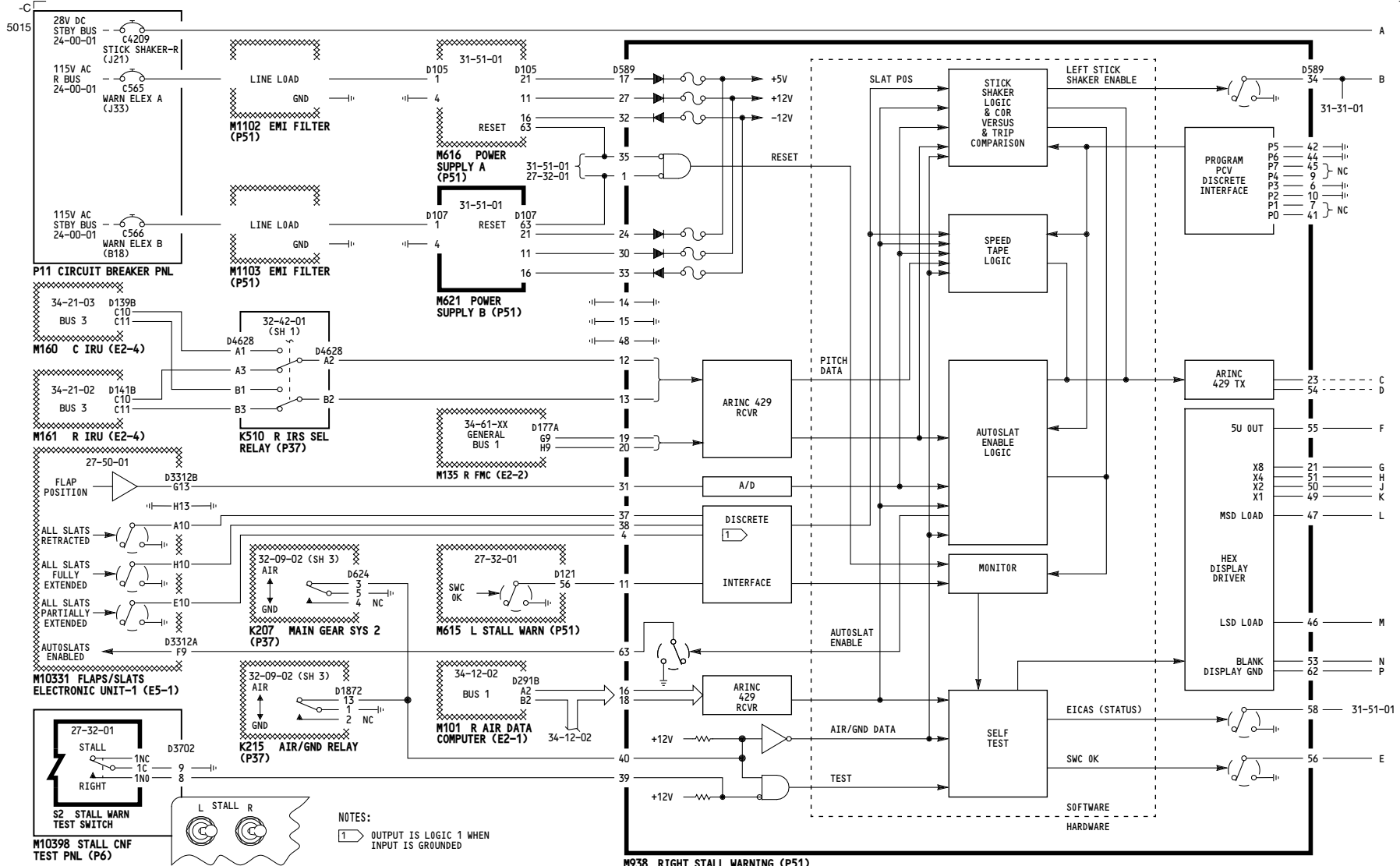

001-099	STALL WARNING - RIGHT
D280N032S	

27-32-02

5011

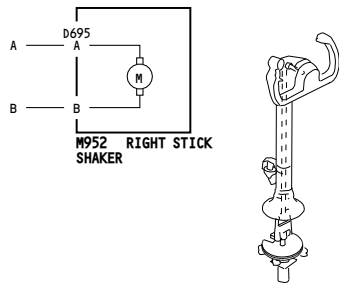

	PROGRAM PIN CODE P7-P4 (AIRFRAME IDENTIFICATION)				PROGRAM PIN CODE P3-P2 SPEED TAPE PARAMETER CALC			PROGRAM PIN CODE P1-P0 (OPTIONAL FEATURES)			CONFIG CODE MSD HEX DISPLAY (WEU BITE MODULE)	OPTIONAL CODE LSD HEX DISPLAY (WEU BITE MODULE)
	P7	P6	P5	P4	P3	P2	P1	P0				
757-200	OPEN	GND	GND	OPEN	ACTIVATED	GND	GND	NONE	OPEN	OPEN	4	3

WIRING DIAGRAMS
27-32-21
27-32-22

NOTE: IN THE ABSENCE OF BOARD FAULTS OR INTERFACE ANOMALIES, THE AIRFRAME CONFIGURATION CODE AND OPTION CODE WILL BE DISPLAYED ON THE HEX DISPLAY OF THE WEU BITE MODULE.

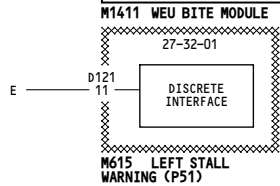
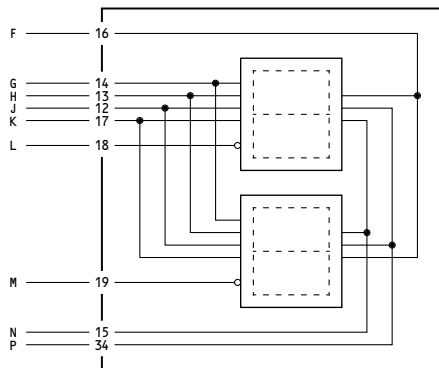
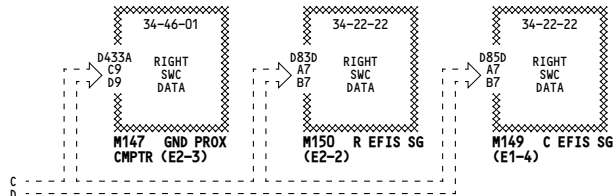

STALL WARNING BOARD FAULT CODES (DISPLAYED ON WEU BITE MODULE)					INTERFACE ANOMALY CODES (DISPLAYED ON WEU BITE MODULE)		
MULTIPLE FAULTS	SLATS RETRACTED	SLATS PARTIALLY EXTENDED	SLATS FULLY EXTENDED	NOT USED	INOP STICK SHAKER	INVALID ADC INPUT	INVALID FLAPS POSITION
A0	A1	A2	A3	A4	D0	D1	D2
NOT USED	NOT USED	NOT USED	TEST	AIR/GND	INVALID AIR/GND INPUT	MULTIPLE LEADING EDGE SLATS	NO LEADING EDGE SLATS
A5	A6	A7	A9	B0	D3	D4	D5
GEAR DOWN	OPPOSITE CHANNEL OK	NOT USED	ARINC INPUT	A/D	INVALID IRS INPUT	INVALID FMC INPUT	AIR/GND ADA SSM CONFLICT
B1	B2	B5	B6	C0	D6	D7	D8
STICK SHAKER	AUTOSLATS	EICAS STATUS	CHANNEL OK	NOT USED	OPPOSITE SWC FAULT	INVALID CONFIG	
C1	C3	C4	C5	C6	D9	FX	

001-099

STALL WARNING - RIGHT

D280N032S

27-32-02

Page 101
Sheet 2
Jan 21/2005

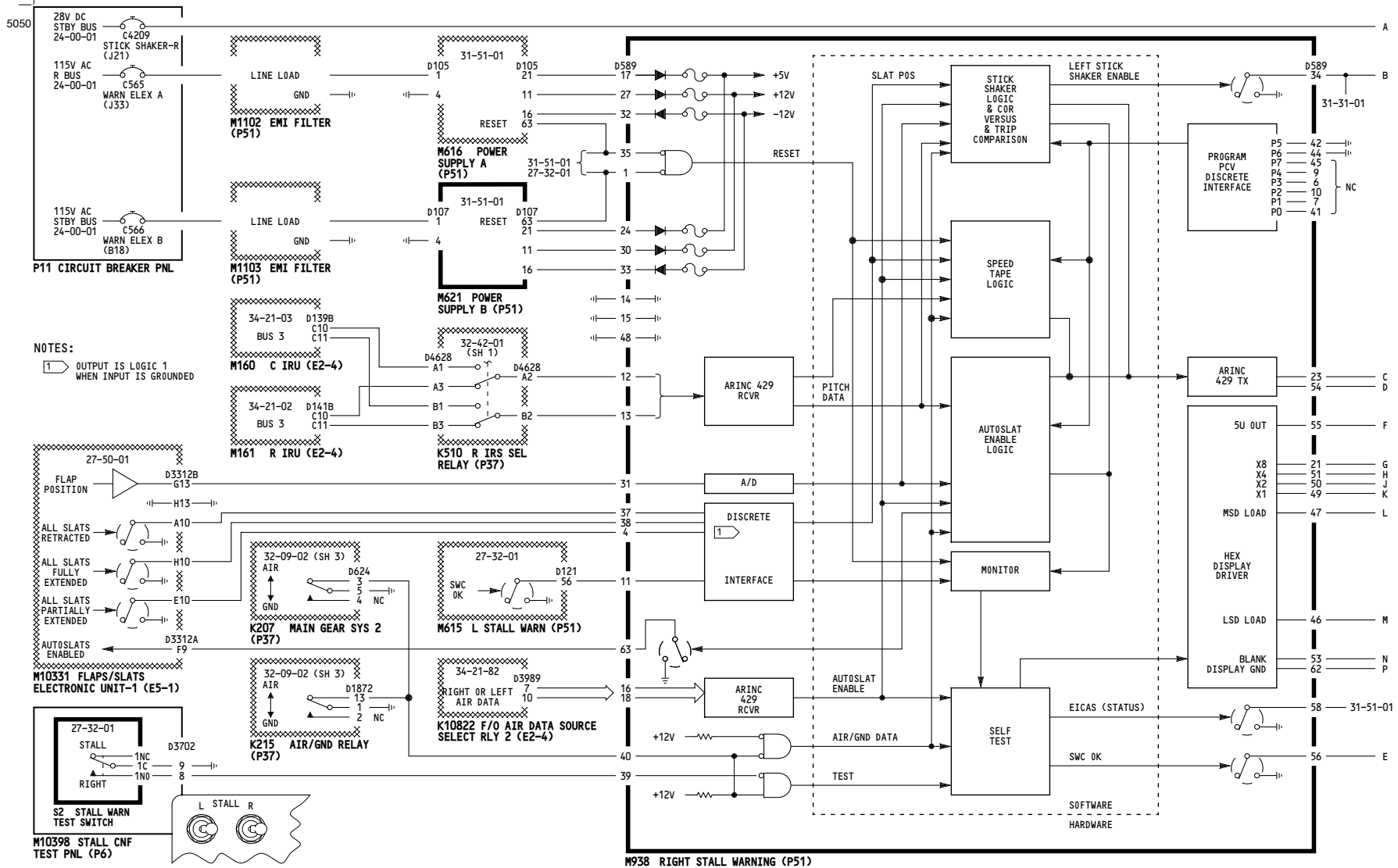

001-011

STALL WARNING - RIGHT

Incorporates
 34A0222

D280N032S

27-32-02

5011

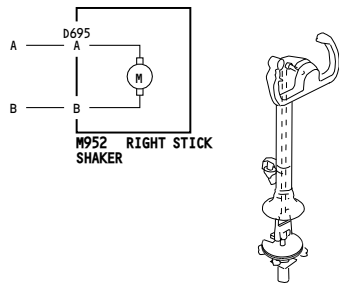

	PROGRAM PIN CODE P7-P4 (AIRFRAME IDENTIFICATION)				PROGRAM PIN CODE P3-P2 SPEED TAPE PARAMETER CALC			PROGRAM PIN CODE P1-P0 (OPTIONAL FEATURES)			CONFIG CODE MSD HEX DISPLAY (WEU BITE MODULE)	OPTIONAL CODE LSD HEX DISPLAY (WEU BITE MODULE)
	P7	P6	P5	P4	P3	P2	P1	P0				
757-200	OPEN	GND	GND	OPEN	ACTIVATED	GND	GND	NONE	OPEN	OPEN	4	3

WIRING DIAGRAMS
27-32-21
27-32-22

NOTE: IN THE ABSENCE OF BOARD FAULTS OR INTERFACE ANOMALIES, THE AIRFRAME CONFIGURATION CODE AND OPTION CODE WILL BE DISPLAYED ON THE HEX DISPLAY OF THE WEU BITE MODULE.

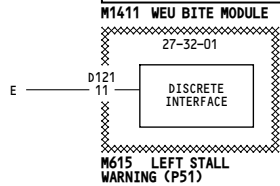
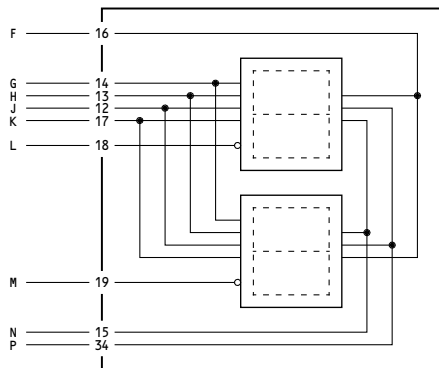
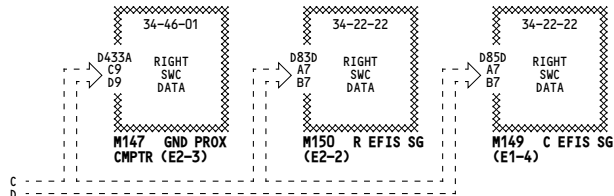

STALL WARNING BOARD FAULT CODES (DISPLAYED ON WEU BITE MODULE)					INTERFACE ANOMALY CODES (DISPLAYED ON WEU BITE MODULE)		
MULTIPLE FAULTS	SLATS RETRACTED	SLATS PARTIALLY EXTENDED	SLATS FULLY EXTENDED	NOT USED	INOP STICK SHAKER	INVALID ADC INPUT	INVALID FLAPS POSITION
A0	A1	A2	A3	A4	D0	D1	D2
NOT USED	NOT USED	NOT USED	TEST	AIR/GND	INVALID AIR/GND INPUT	MULTIPLE LEADING EDGE SLATS	NO LEADING EDGE SLATS
A5	A6	A7	A9	B0	D3	D4	D5
GEAR DOWN	OPPOSITE CHANNEL OK	NOT USED	ARINC INPUT	A/D	INVALID IRS INPUT	INVALID FMC INPUT	AIR/GND ADA SSM CONFLICT
B1	B2	B5	B6	C0	D6	D7	D8
STICK SHAKER	AUTOSLATS	EICAS STATUS	CHANNEL OK	NOT USED	OPPOSITE SMC FAULT	INVALID CONFIG	
C1	C3	C4	C5	C6	D9	FX	

001-011

STALL WARNING - RIGHT

D280N032S

27-32-02

Page 101.1
Sheet 2
Jan 21/2005

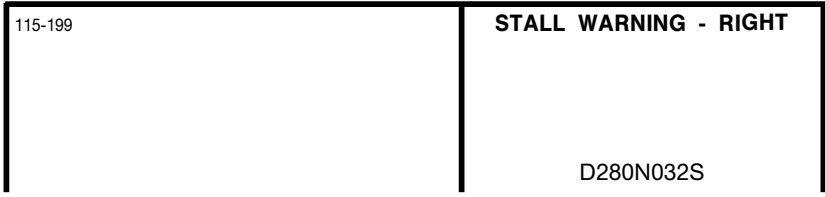
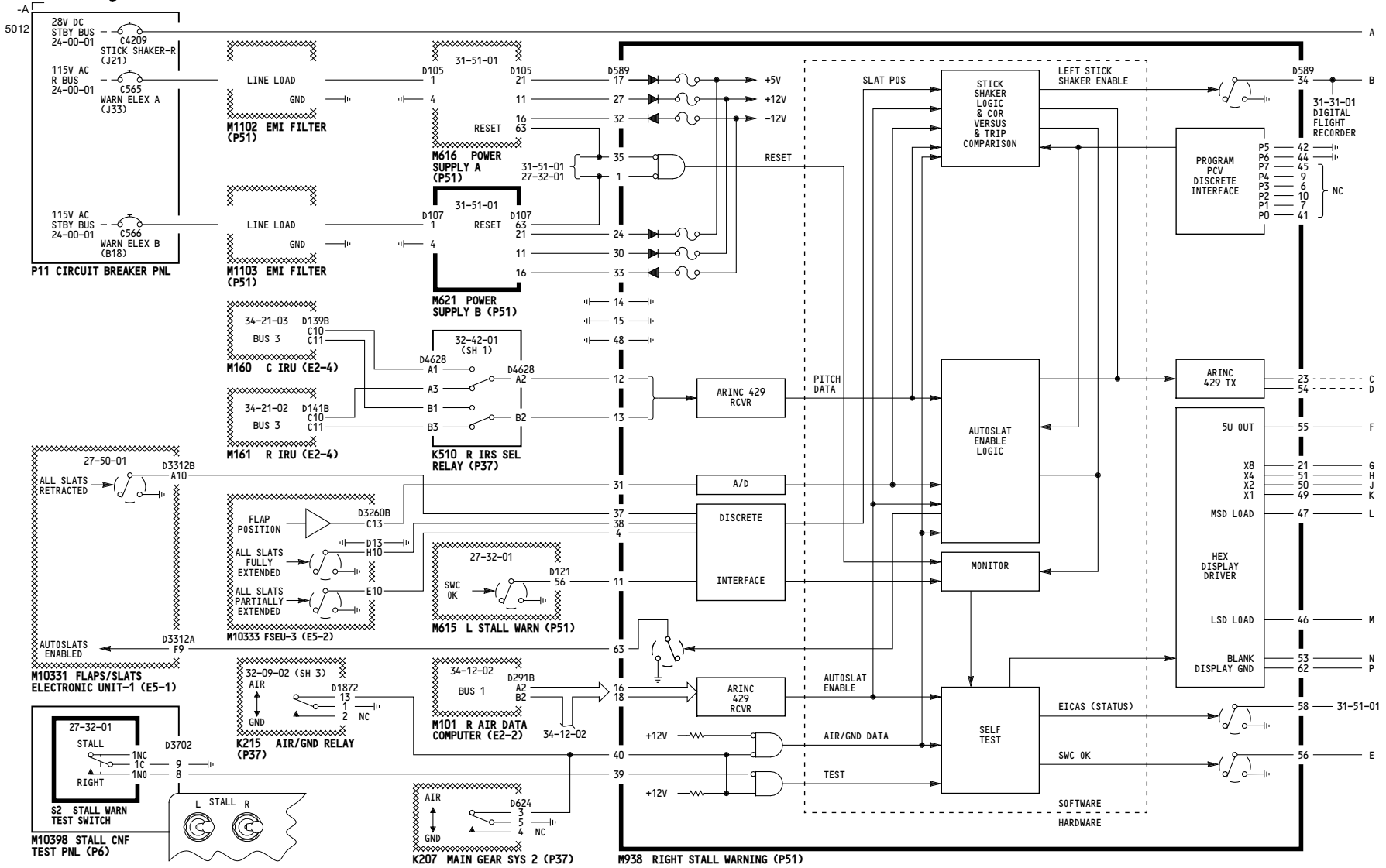

27-32-02

5001

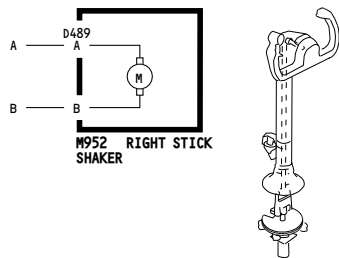

	PROGRAM PIN CODE P7-P4 (AIRFRAME IDENTIFICATION)				PROGRAM PIN CODE P3-P2 SPEED TAPE PARAMETER CALC			PROGRAM PIN CODE P1-P0 (OPTIONAL FEATURES)			CONFIG CODE MSD HEX DISPLAY (WEU BITE MODULE)	OPTIONAL CODE LSD HEX DISPLAY (WEU BITE MODULE)
	P7	P6	P5	P4	P3	P2	P1	P0				
757-200	OPEN	GND	GND	OPEN	NOT ACTIVATED	OPEN	OPEN	NONE	OPEN	OPEN	4	F

WIRING DIAGRAMS
27-32-21
27-32-22

NOTES: IN THE ABSENCE OF BOARD FAULTS OR INTERFACE ANOMALIES, THE AIRFRAME CONFIGURATION CODE AND OPTION CODE WILL BE DISPLAYED ON THE HEX DISPLAY OF THE WEU BITE MODULE.

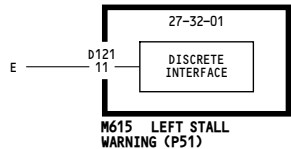
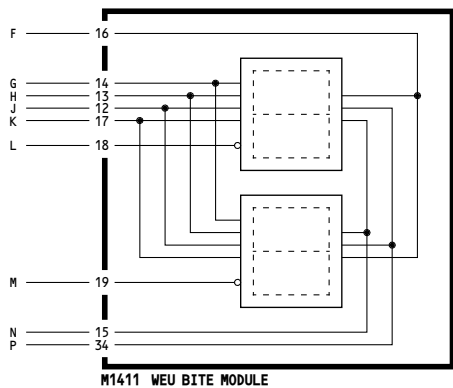
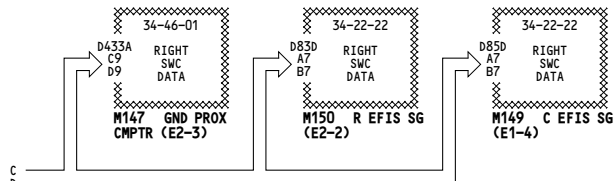

STALL WARNING BOARD FAULT CODES (DISPLAYED ON WEU BITE MODULE)					INTERFACE ANOMALY CODES (DISPLAYED ON WEU BITE MODULE)		
MULTIPLE FAULTS	SLATS RETRACTED	SLATS PARTIALLY EXTENDED	SLATS FULLY EXTENDED	NOT USED	INOP STICK SHAKER	INVALID ADC INPUT	INVALID FLAPS POSITION
A0	A1	A2	A3	A4	D0	D1	D2
NOT USED	NOT USED	NOT USED	TEST	AIR/GND	INVALID AIR/GND INPUT	MULTIPLE LEADING EDGE SLATS	NO LEADING EDGE SLATS
A5	A6	A7	A9	B0	D3	D4	D5
GEAR DOWN	OPPOSITE CHANNEL OK	NOT USED	ARINC INPUT	A/D	INVALID IRS INPUT	NOT USED	AIR/GND A0A SSM CONFLICT
B1	B2	B5	B6	C0	D6	D7	D8
STICK SHAKER	AUTOSLATS	EICAS STATUS	CHANNEL OK	NOT USED	OPPOSITE SMC FAULT	INVALID CONFIG	
C1	C3	C4	C5	C6	D9	FX	

115-199

STALL WARNING - RIGHT

D280N032S

27-32-02

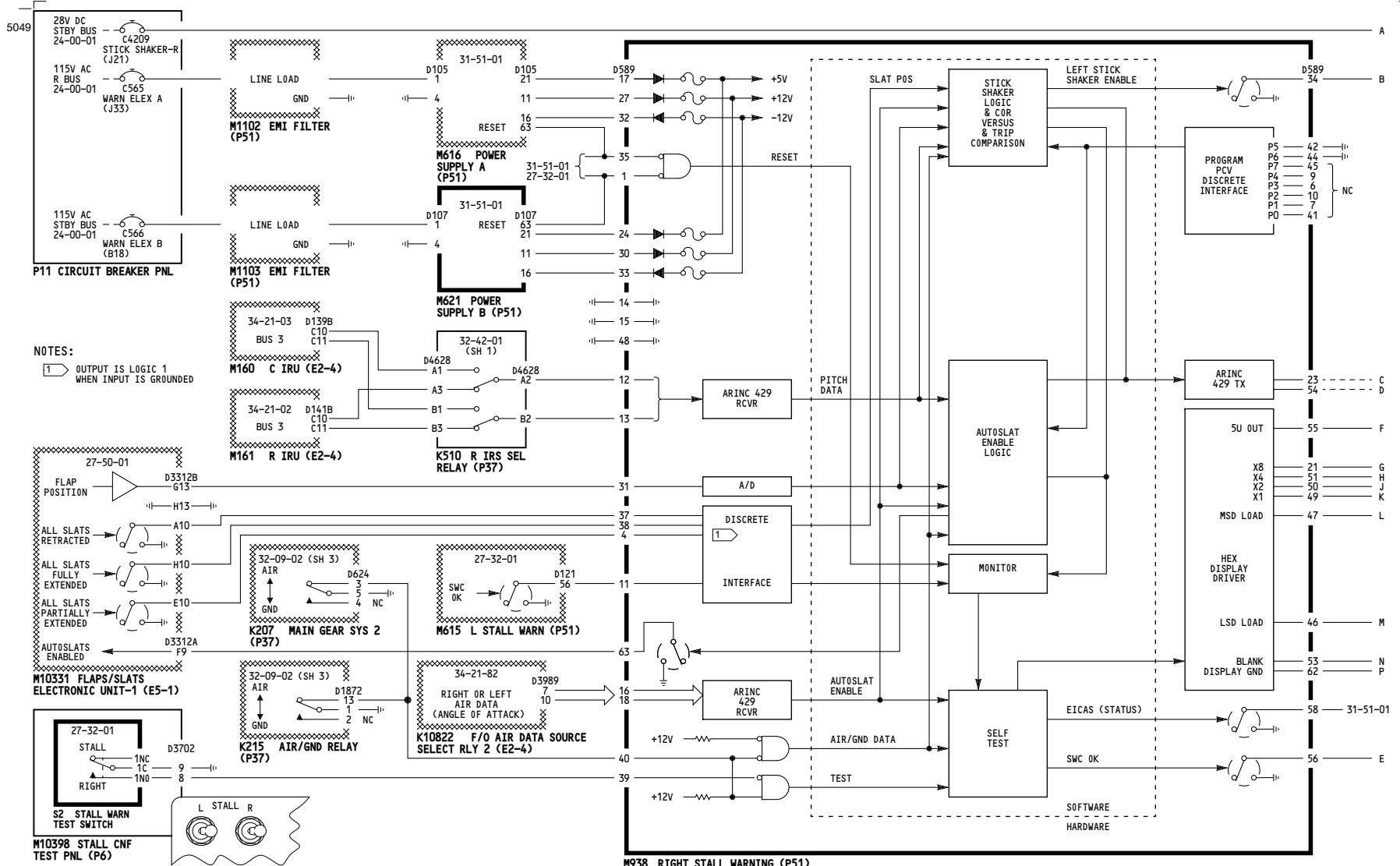

NOTES:
 1 OUTPUT IS LOGIC 1 WHEN INPUT IS GROUNDED

115

STALL WARNING - RIGHT

Incorporates
 34A0222

D280N032S

27-32-02

5001

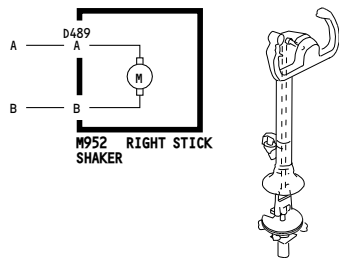

	PROGRAM PIN CODE P7-P4 (AIRFRAME IDENTIFICATION)				PROGRAM PIN CODE P3-P2 SPEED TAPE PARAMETER CALC			PROGRAM PIN CODE P1-P0 (OPTIONAL FEATURES)			CONFIG CODE MSD HEX DISPLAY (WEU BITE MODULE)	OPTIONAL CODE LSD HEX DISPLAY (WEU BITE MODULE)
	P7	P6	P5	P4	P3	P2	P1	P0				
757-200	OPEN	GND	GND	OPEN	NOT ACTIVATED	OPEN	OPEN	NONE	OPEN	OPEN	4	F

WIRING DIAGRAMS
27-32-21
27-32-22

NOTES: IN THE ABSENCE OF BOARD FAULTS OR INTERFACE ANOMALIES, THE AIRFRAME CONFIGURATION CODE AND OPTION CODE WILL BE DISPLAYED ON THE HEX DISPLAY OF THE WEU BITE MODULE.

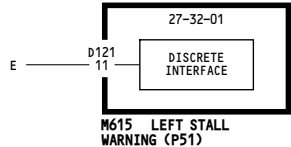
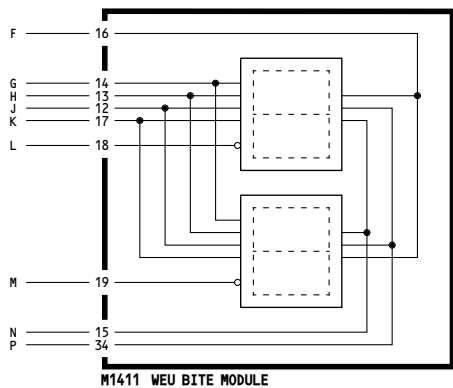
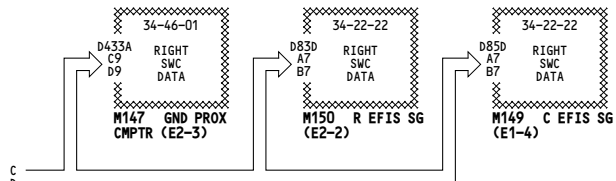

STALL WARNING BOARD FAULT CODES (DISPLAYED ON WEU BITE MODULE)					INTERFACE ANOMALY CODES (DISPLAYED ON WEU BITE MODULE)		
MULTIPLE FAULTS	SLATS RETRACTED	SLATS PARTIALLY EXTENDED	SLATS FULLY EXTENDED	NOT USED	INOP STICK SHAKER	INVALID ADC INPUT	INVALID FLAPS POSITION
A0	A1	A2	A3	A4	D0	D1	D2
NOT USED	NOT USED	NOT USED	TEST	AIR/GND	INVALID AIR/GND INPUT	MULTIPLE LEADING EDGE SLATS	NO LEADING EDGE SLATS
A5	A6	A7	A9	B0	D3	D4	D5
GEAR DOWN	OPPOSITE CHANNEL OK	NOT USED	ARINC INPUT	A/D	INVALID IRS INPUT	NOT USED	AIR/GND A0A SSM CONFLICT
B1	B2	B5	B6	C0	D6	D7	D8
STICK SHAKER	AUTOSLATS	EICAS STATUS	CHANNEL OK	NOT USED	OPPOSITE SMC FAULT	INVALID CONFIG	
C1	C3	C4	C5	C6	D9	FX	

115

STALL WARNING - RIGHT

D280N032S

27-32-02

5012

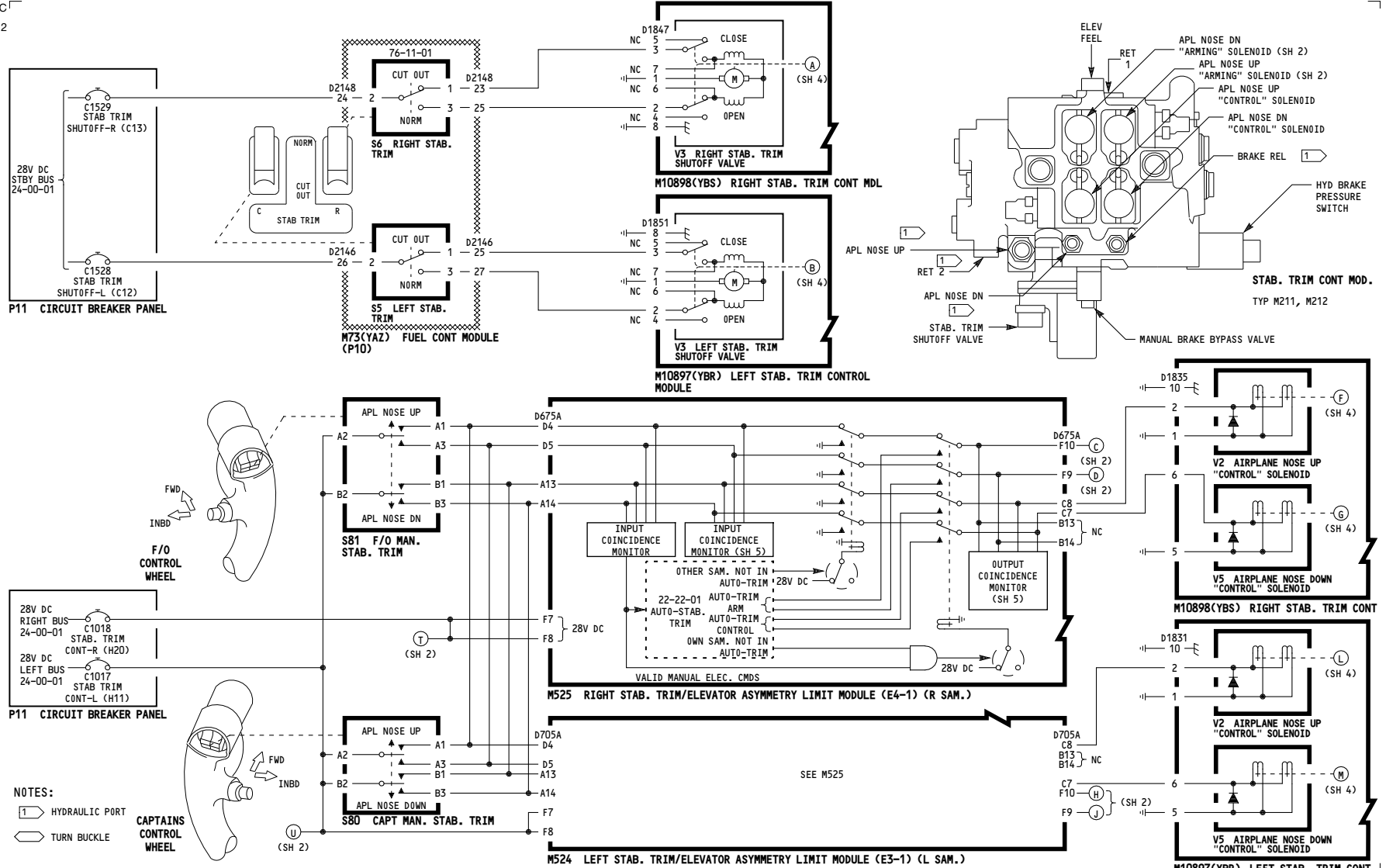

001

HORIZONTAL STABILIZER TRIM

D280N032S

27-40-01

5011

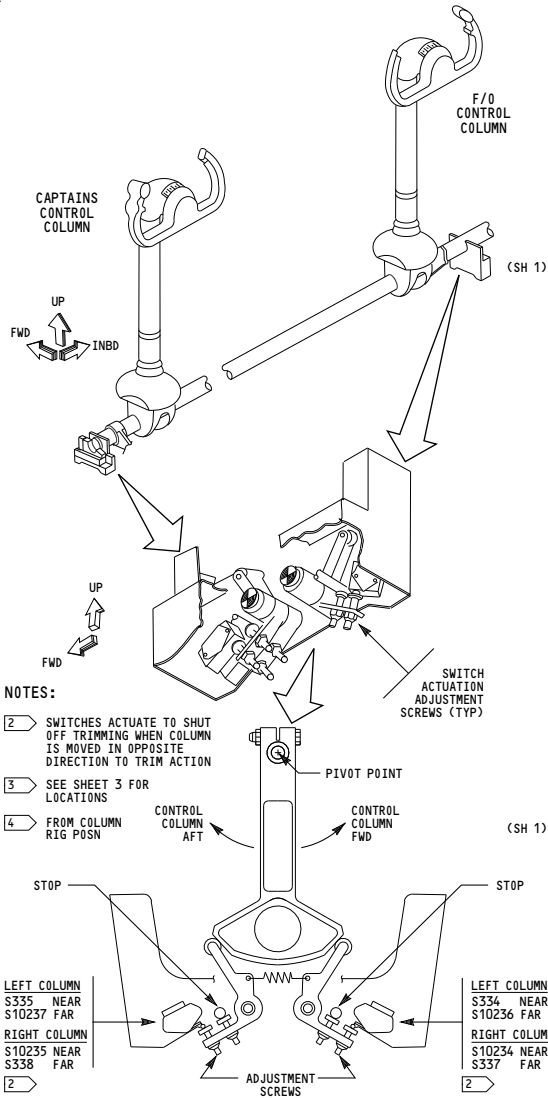

- NOTES:**
- 2 SWITCHES ACTUATE TO SHUT OFF TRIMMING WHEN COLUMN IS MOVED IN OPPOSITE DIRECTION TO TRIM ACTION
 - 3 SEE SHEET 3 FOR LOCATIONS
 - 4 FROM COLUMN RIG POSN

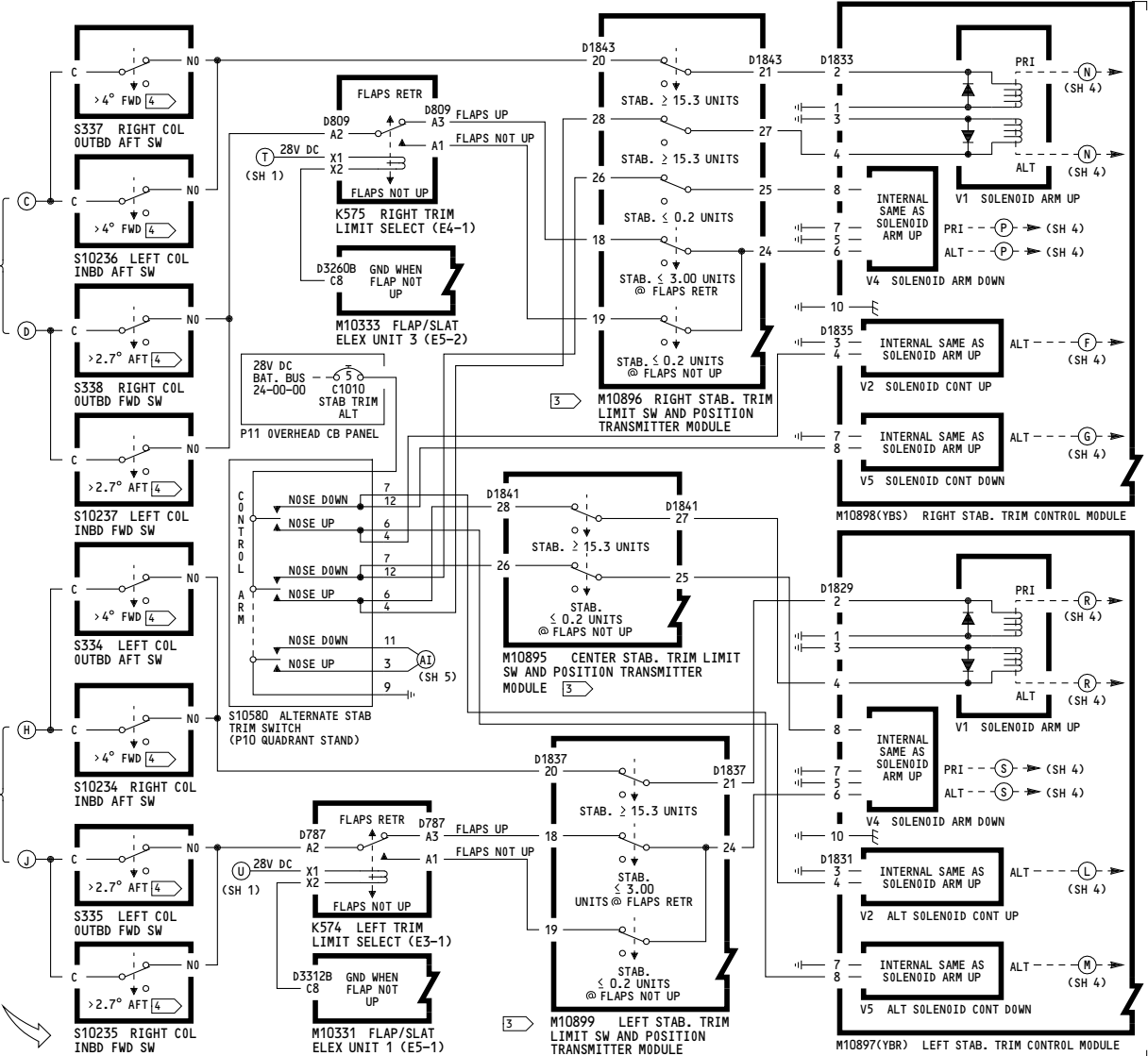

001

HORIZONTAL STABILIZER TRIM

D280N032S

27-40-01

5014

WIRING DIAGRAMS
27-48-11

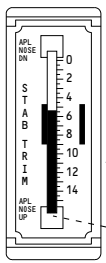
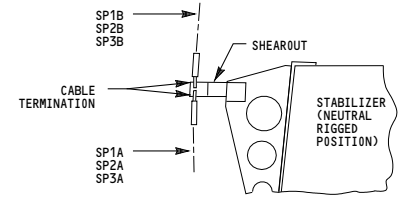
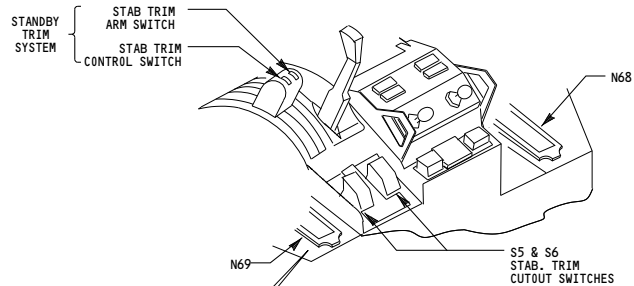

N68, N69

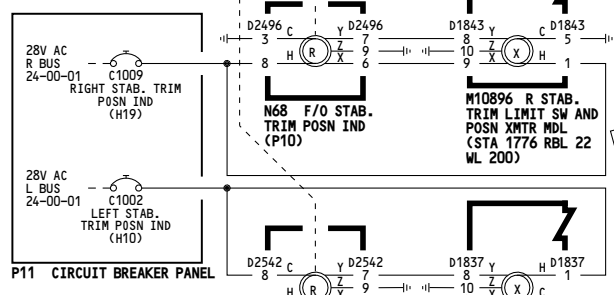

NOTES:

- 4 SAME CABLE CONNECTION TO STABILIZER, AS M10896, M10895
- 5 FOR HYDRAULIC POWER DISTRIBUTION SEE 27-30-01

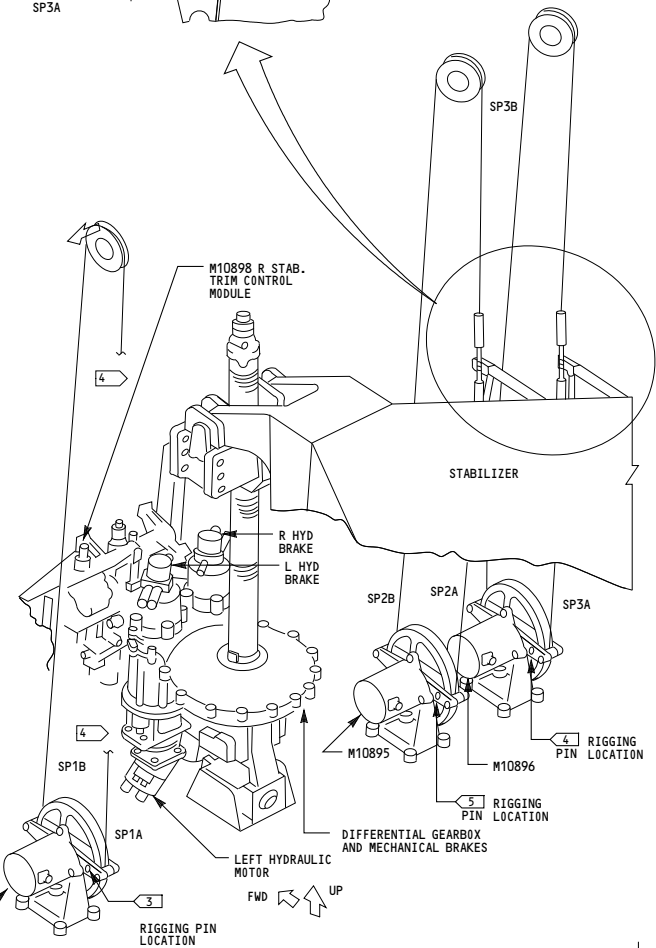
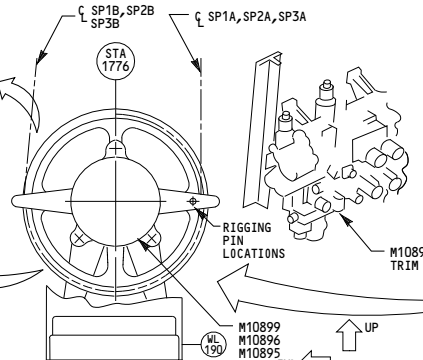

001	<p>HORIZONTAL STABILIZER TRIM</p> <p>D280N032S</p>
-----	---

27-40-01

5001

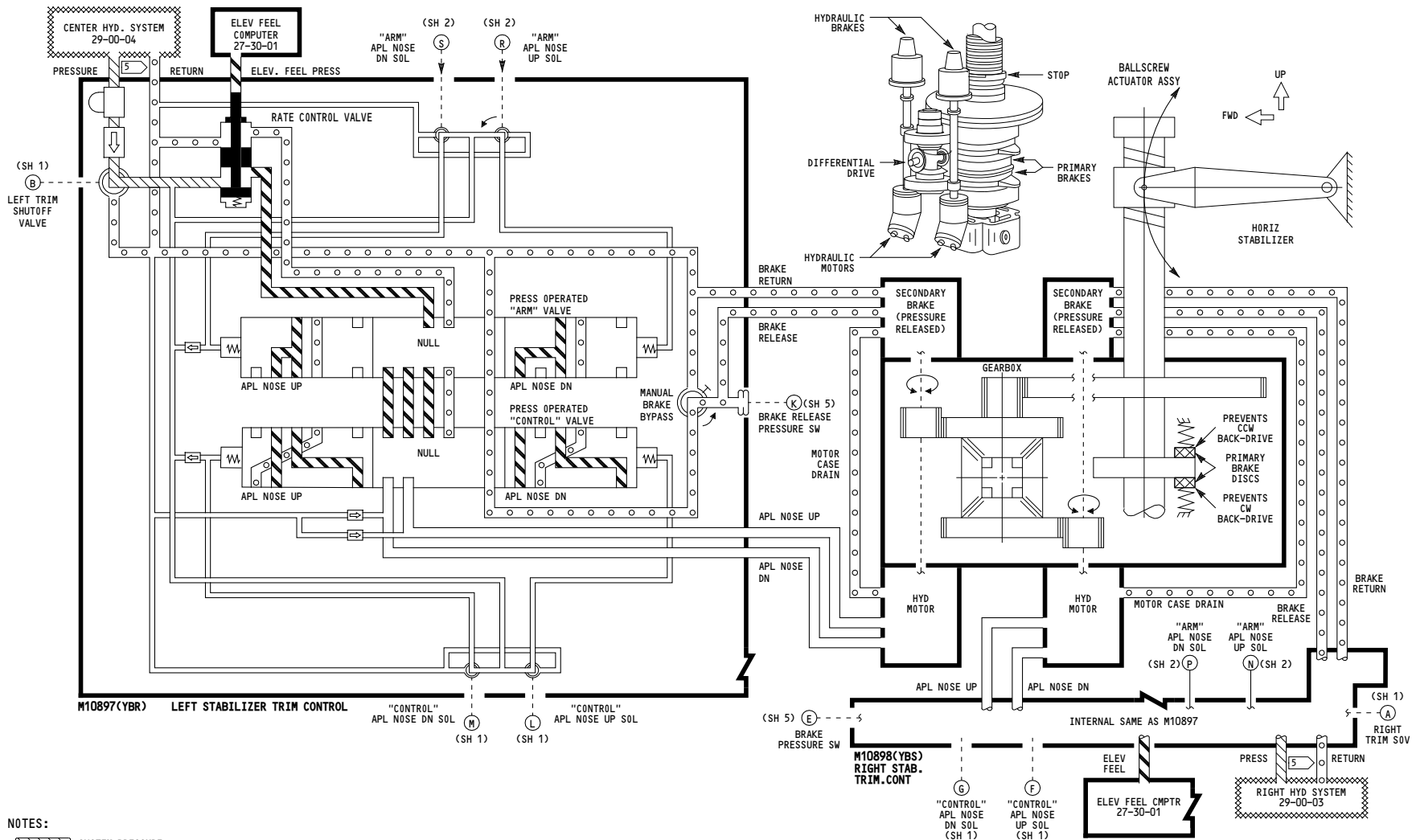

- NOTES:**
- SYSTEM PRESSURE
 - RETURN
 - METERED PRESSURE

001

HORIZONTAL STABILIZER TRIM

D280N032S

27-40-01

Page 101
Sheet 4
Jan 21/2005

5011

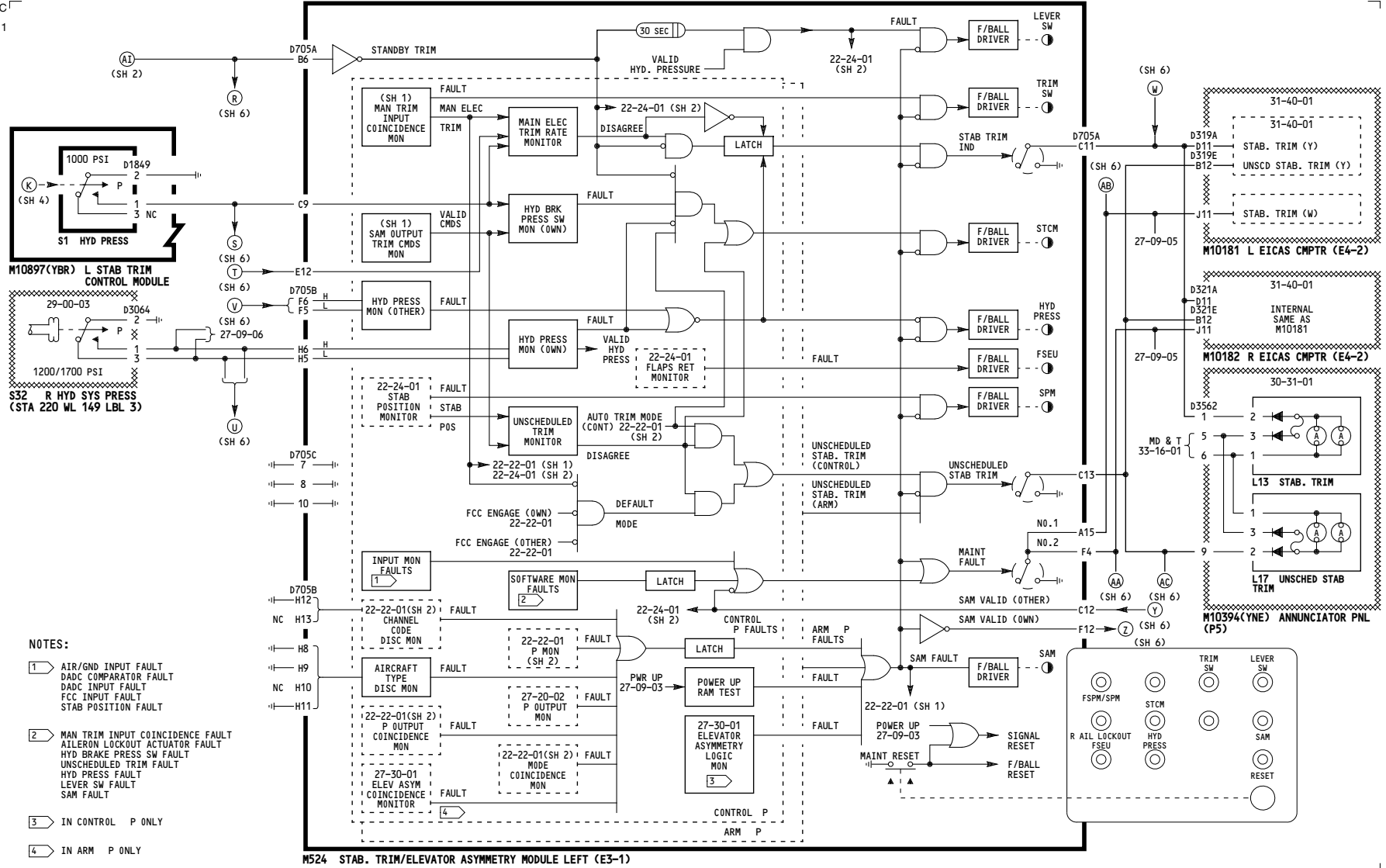

001

HORIZONTAL STABILIZER TRIM

D280N032S

27-40-01

-A
5011

WIRING DIAGRAMS
27-41-11
27-41-21
27-48-11

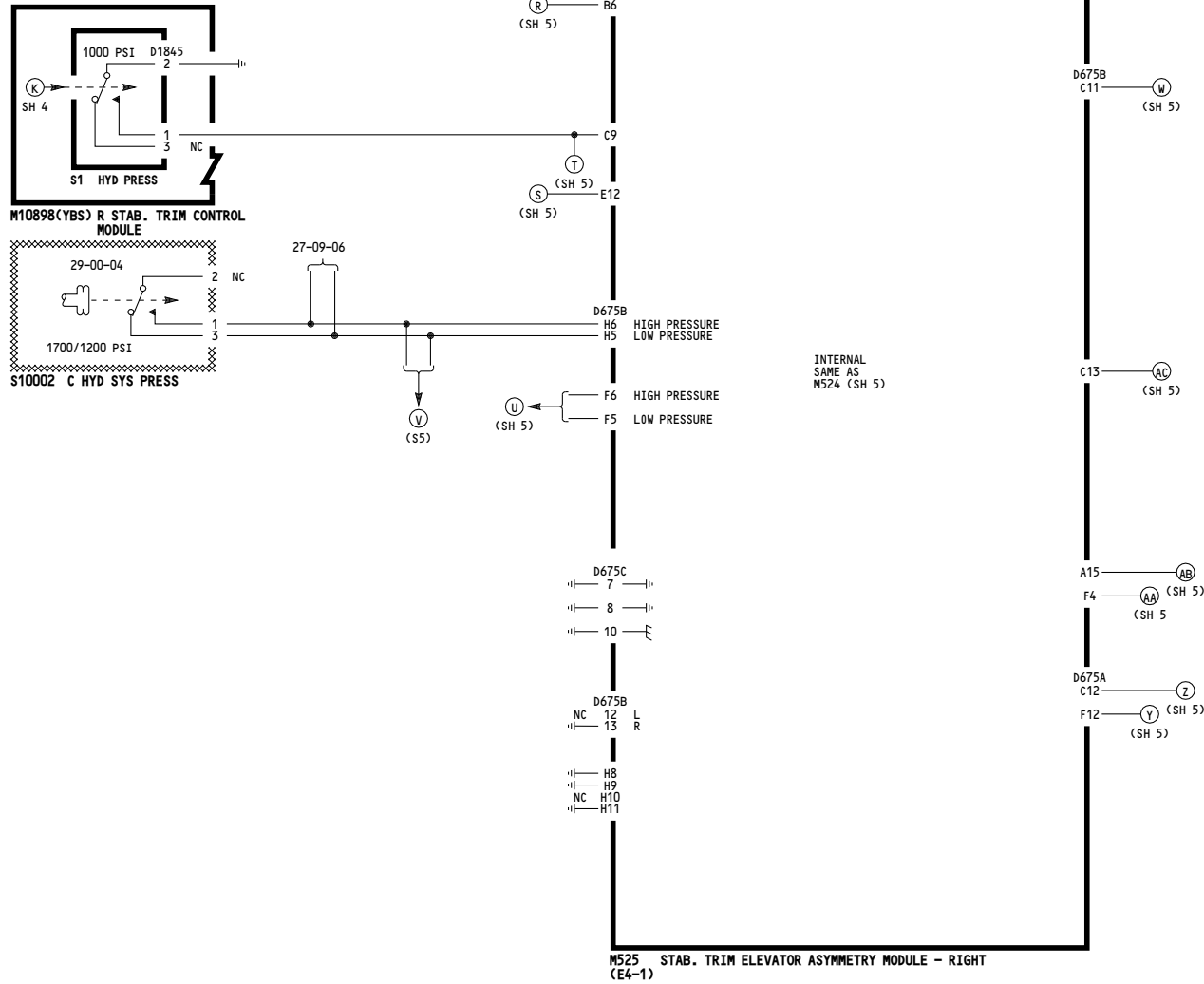

001

HORIZONTAL STABILIZER TRIM

D280N032S

27-40-01

Page 101
Sheet 6
Jan 21/2005

5024

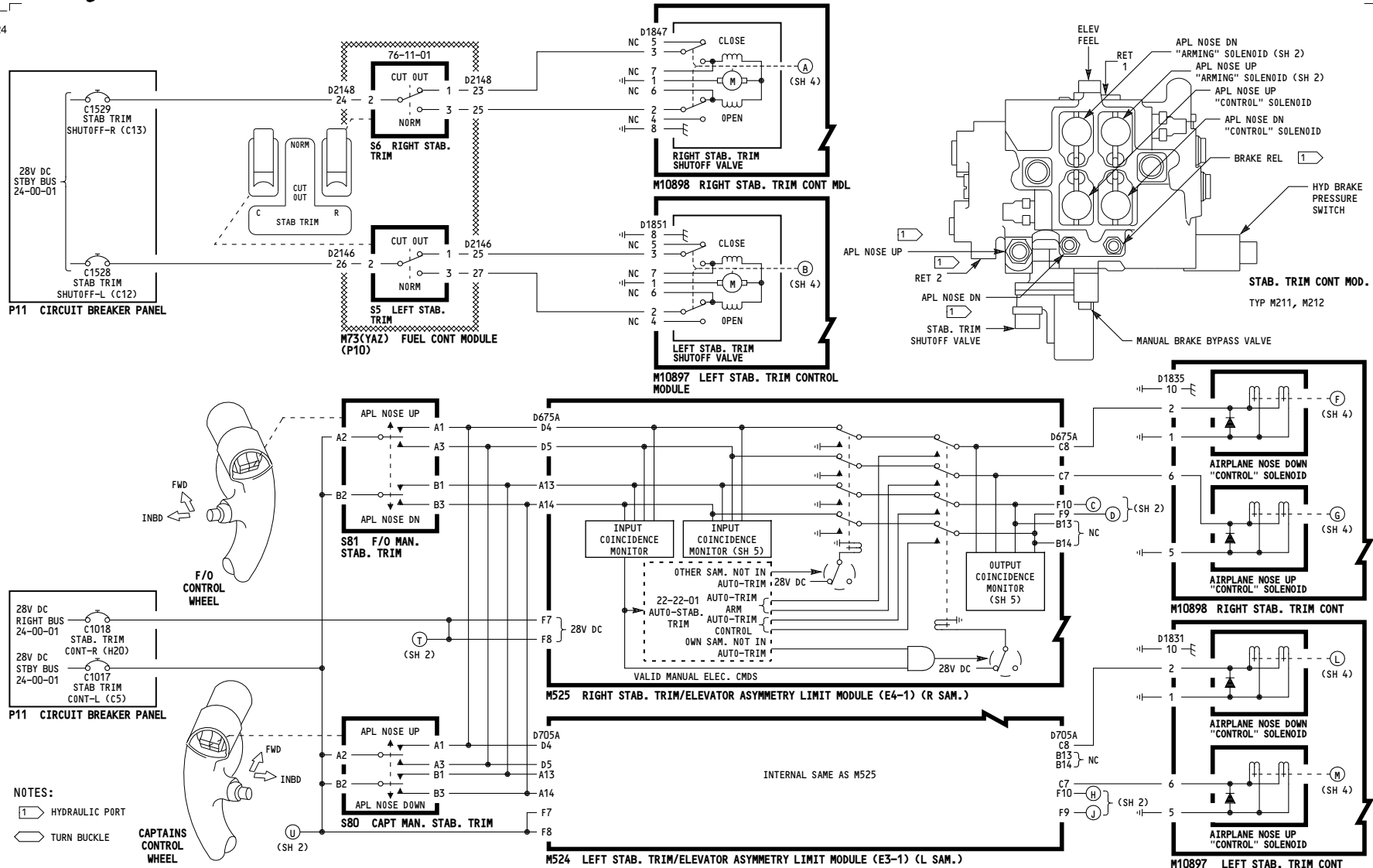

001

HORIZONTAL STABILIZER TRIM

Incorporates 27-0104

D280N032S

27-40-01

5011

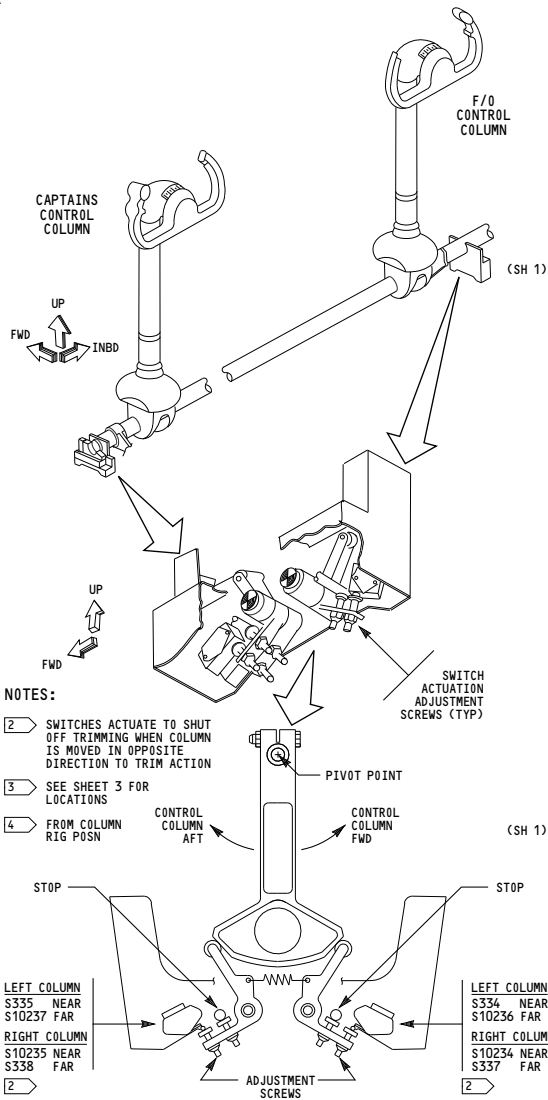

- NOTES:**
- 2 SWITCHES ACTUATE TO SHUT OFF TRIMMING WHEN COLUMN IS MOVED IN OPPOSITE DIRECTION TO TRIM ACTION
 - 3 SEE SHEET 3 FOR LOCATIONS
 - 4 FROM COLUMN RIG POSN

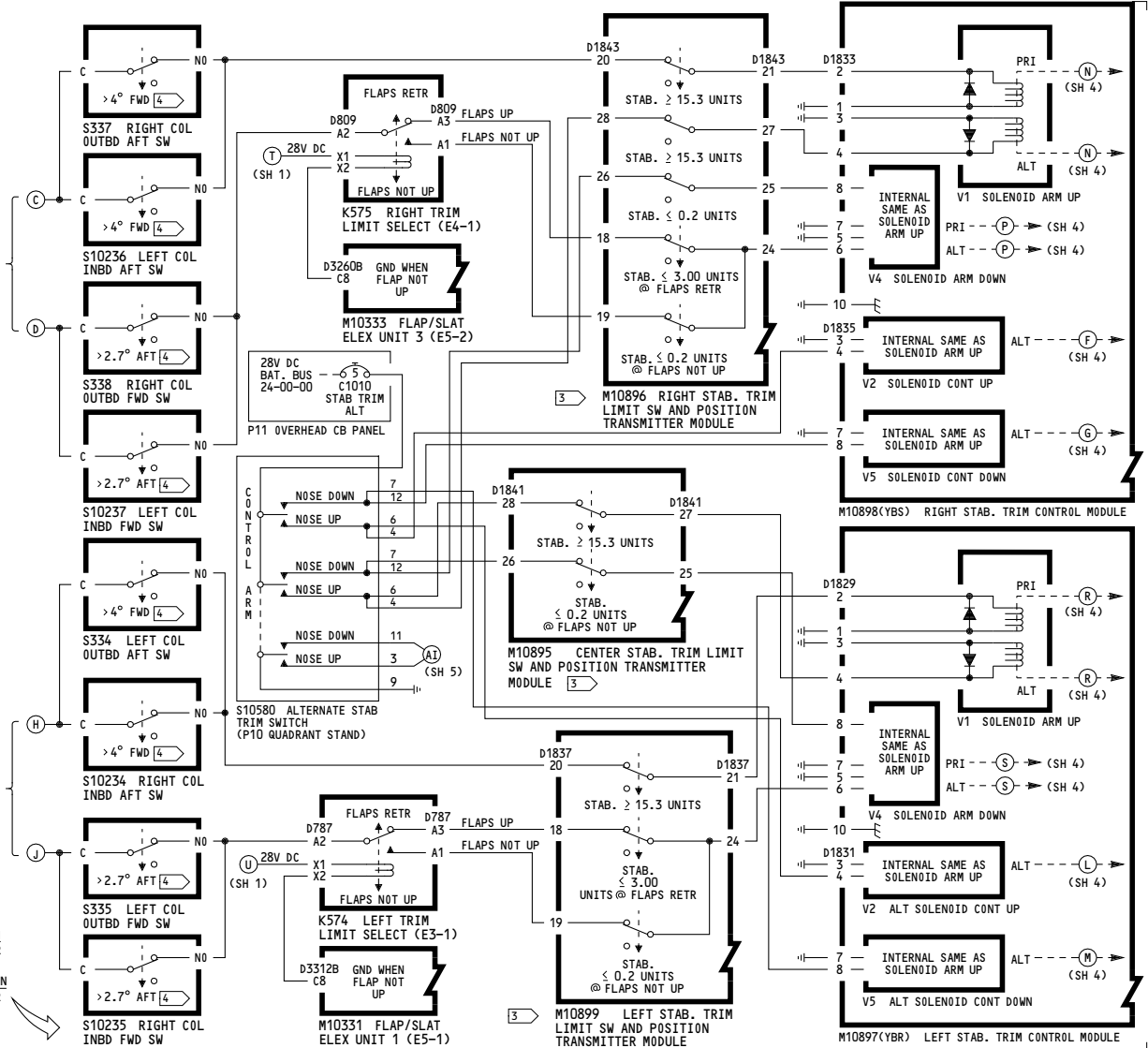

001

HORIZONTAL STABILIZER TRIM

D280N032S

27-40-01

5014

WIRING DIAGRAMS
27-48-11

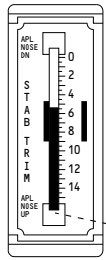
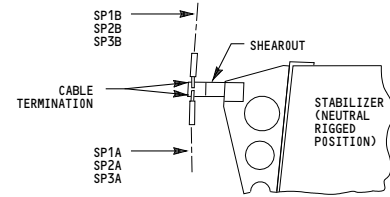
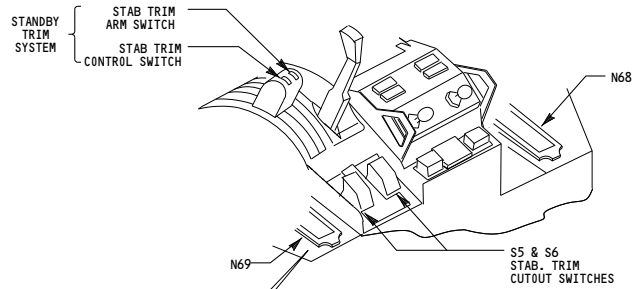

N68, N69

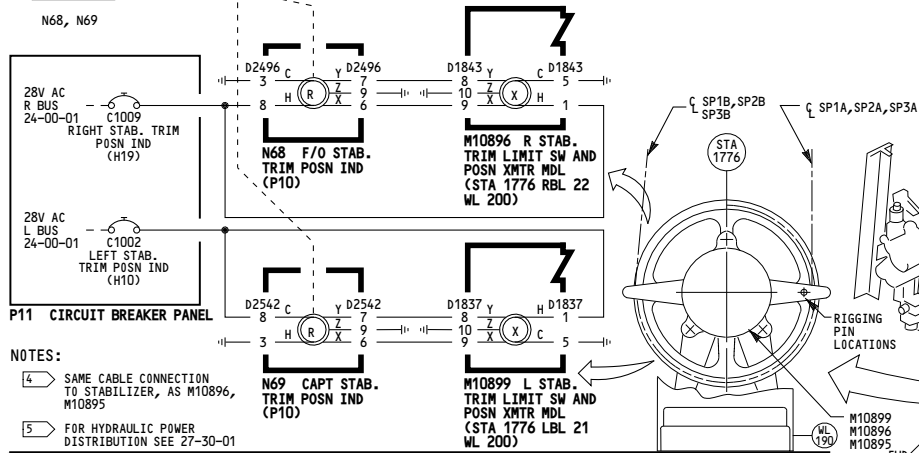

NOTES:

- 4 SAME CABLE CONNECTION TO STABILIZER, AS M10896, M10895
- 5 FOR HYDRAULIC POWER DISTRIBUTION SEE 27-30-01

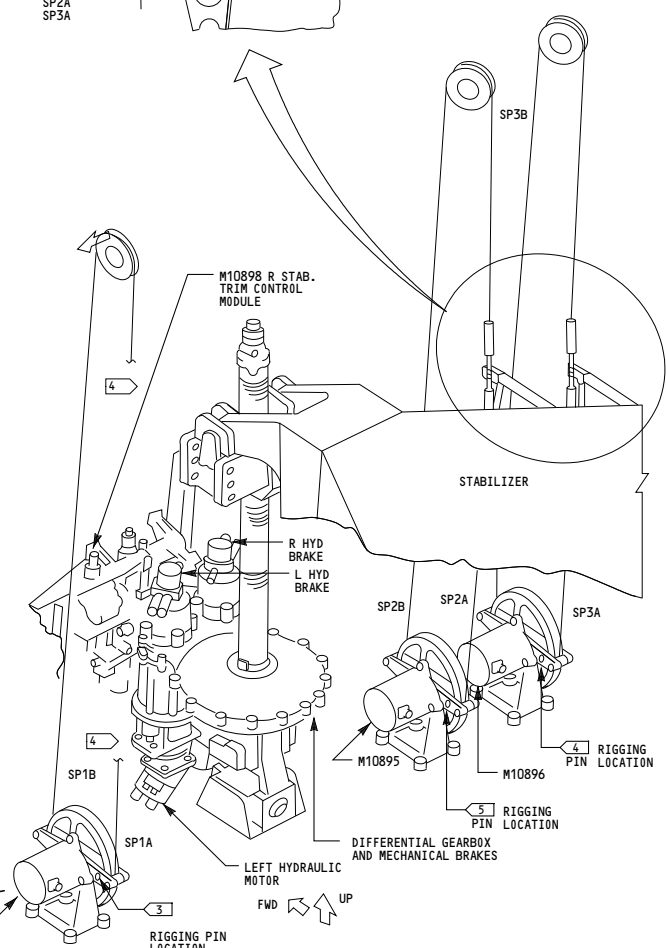

001	<p>HORIZONTAL STABILIZER TRIM</p> <p>D280N032S</p>
-----	---

27-40-01

5001

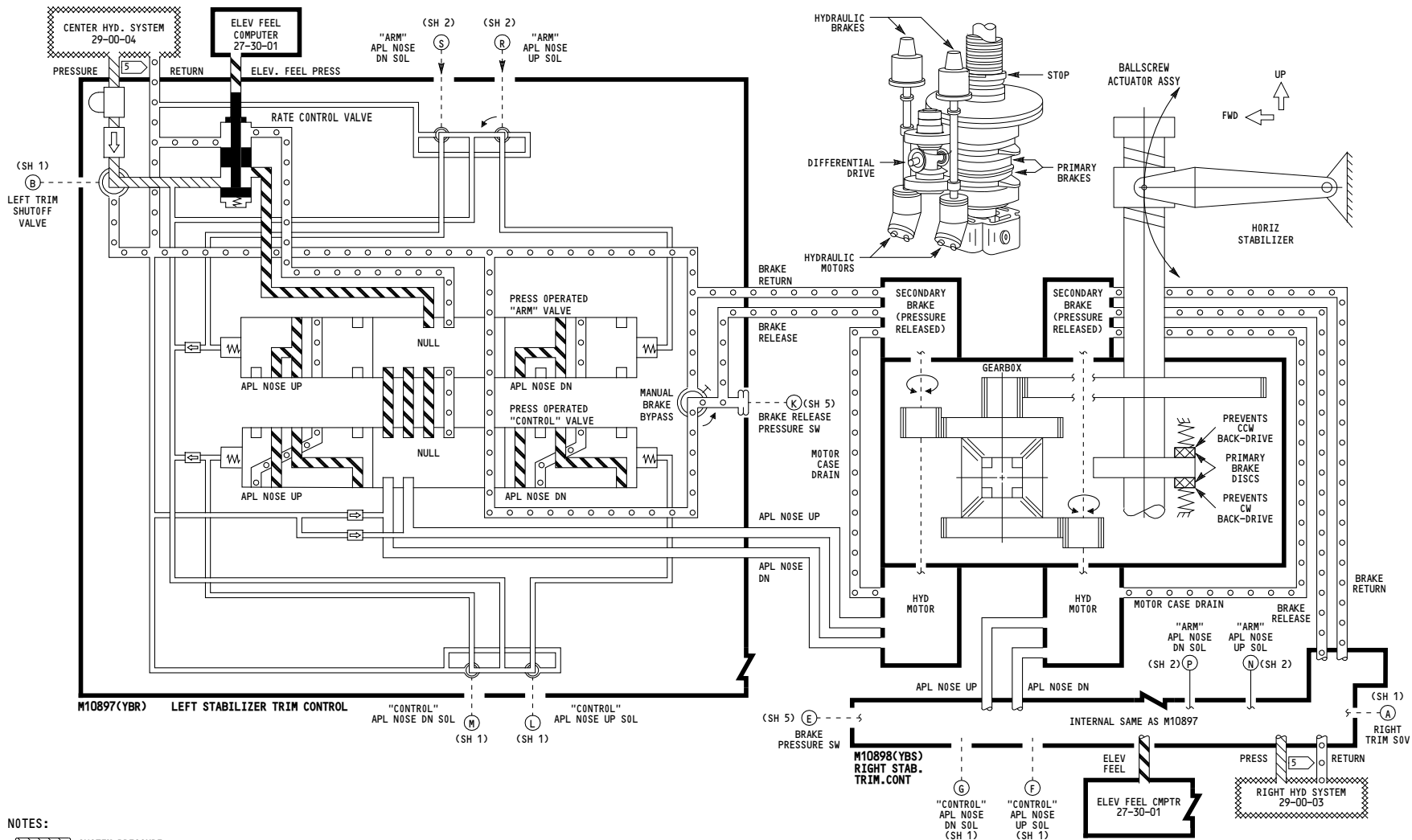

- NOTES:**
- SYSTEM PRESSURE
 - RETURN
 - METERED PRESSURE

001	<p>HORIZONTAL STABILIZER TRIM</p> <p>D280N032S</p>
-----	---

27-40-01

Page 101.1
Sheet 4
Jan 21/2005

5011

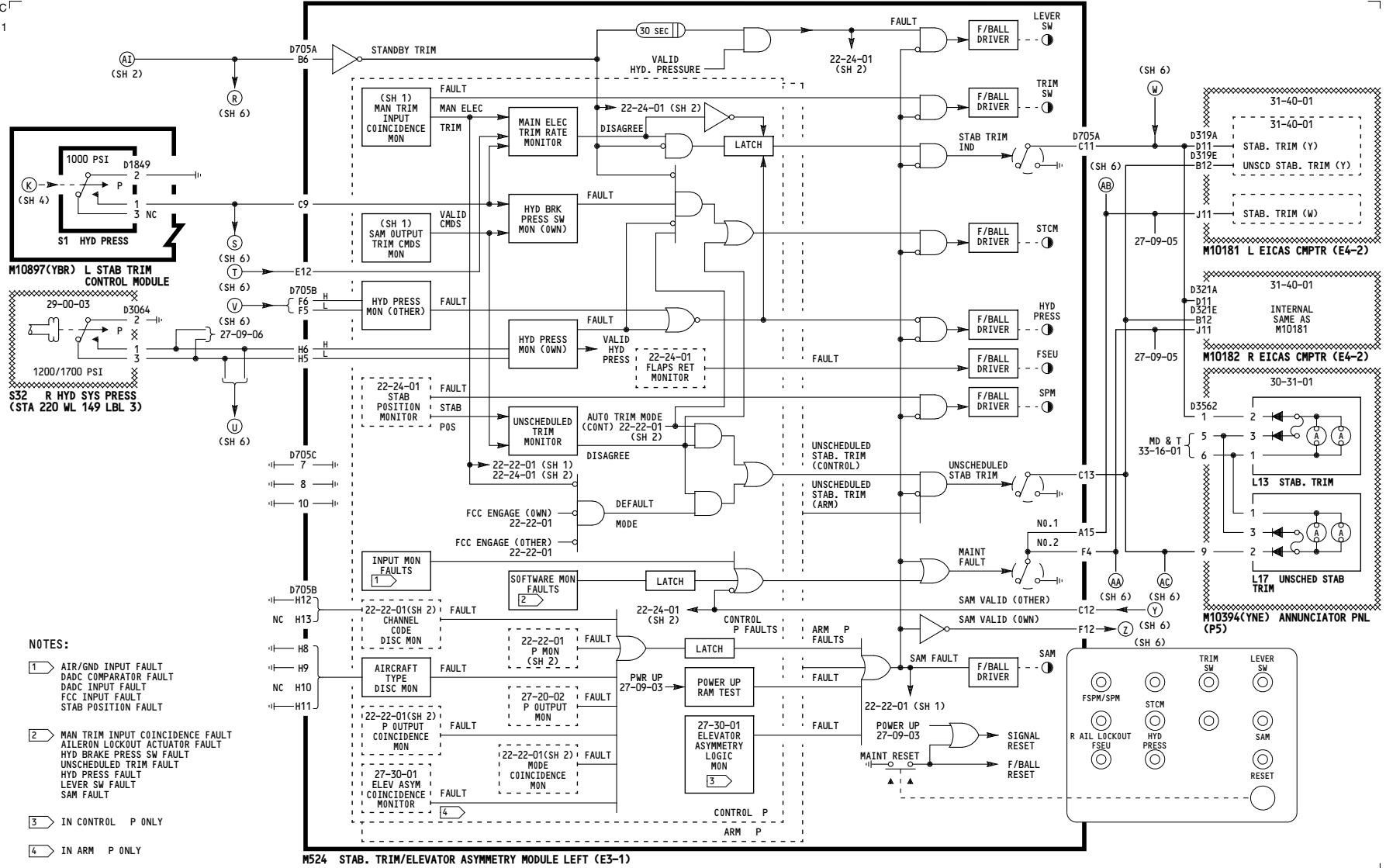

- NOTES:**
- 1 AIR/GND INPUT FAULT
DADC COMPARATOR FAULT
DADC INPUT FAULT
FCC INPUT FAULT
STAB POSITION FAULT
 - 2 MAN TRIM INPUT COINCIDENCE FAULT
AILERON LOCKOUT ACTUATOR FAULT
HYD BRAKE PRESS SW FAULT
UNDESCHEDULED TRIM FAULT
HYD PRESS FAULT
LEVER SW FAULT
SAM FAULT
 - 3 IN CONTROL P ONLY
 - 4 IN ARM P ONLY

M524 STAB. TRIM/ELEVATOR ASYMMETRY MODULE LEFT (E3-1)

001

HORIZONTAL STABILIZER TRIM

D280N032S

27-40-01

Page 101.1
Sheet 5
Dec 18/2007

-A
5011

WIRING DIAGRAMS
27-41-11
27-41-21
27-48-11

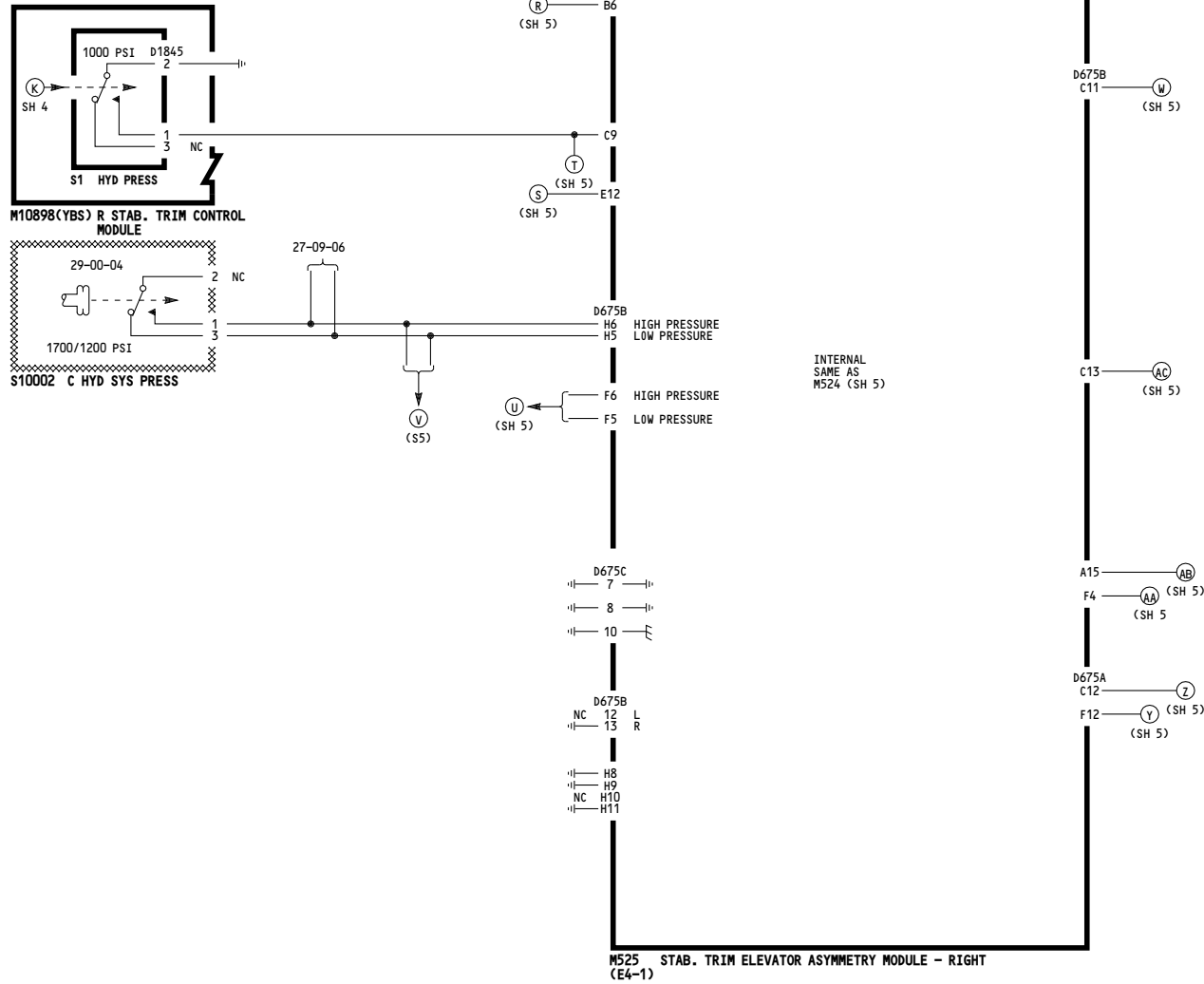

001

HORIZONTAL STABILIZER TRIM

D280N032S

27-40-01

Page 101.1
Sheet 6
Jan 21/2005

5015

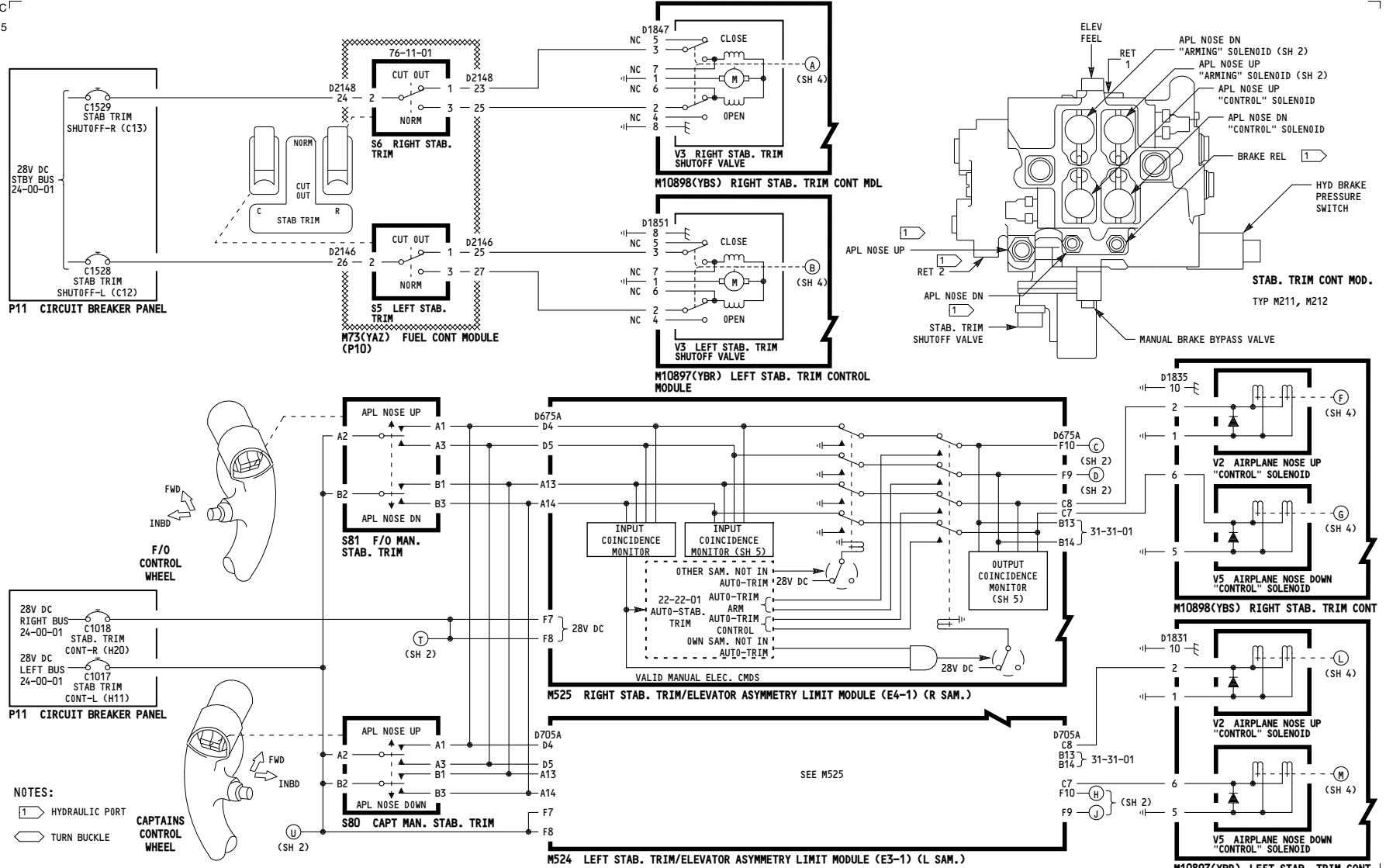

002-004

HORIZONTAL STABILIZER TRIM

D280N032S

27-40-01

-A
5011

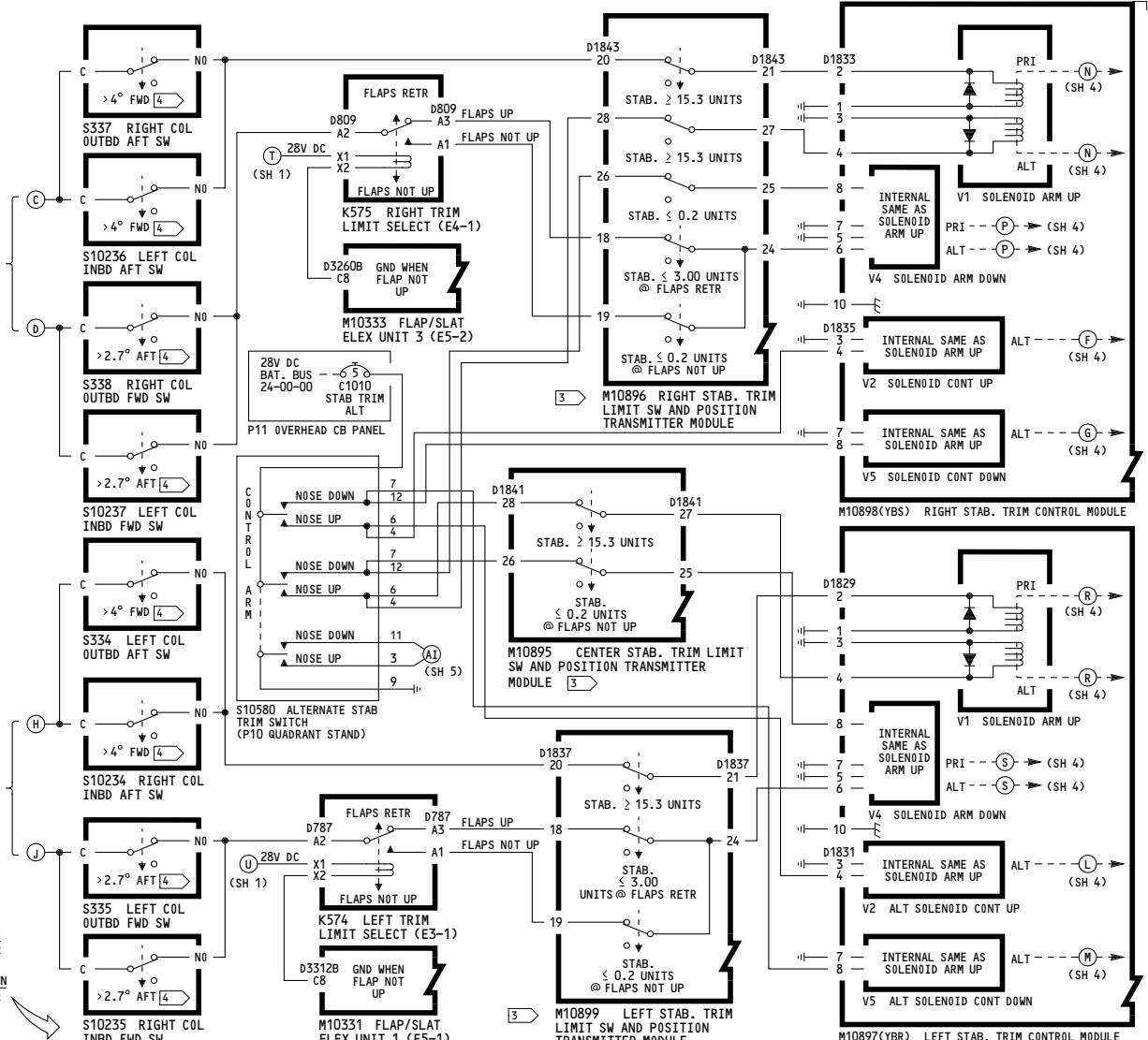
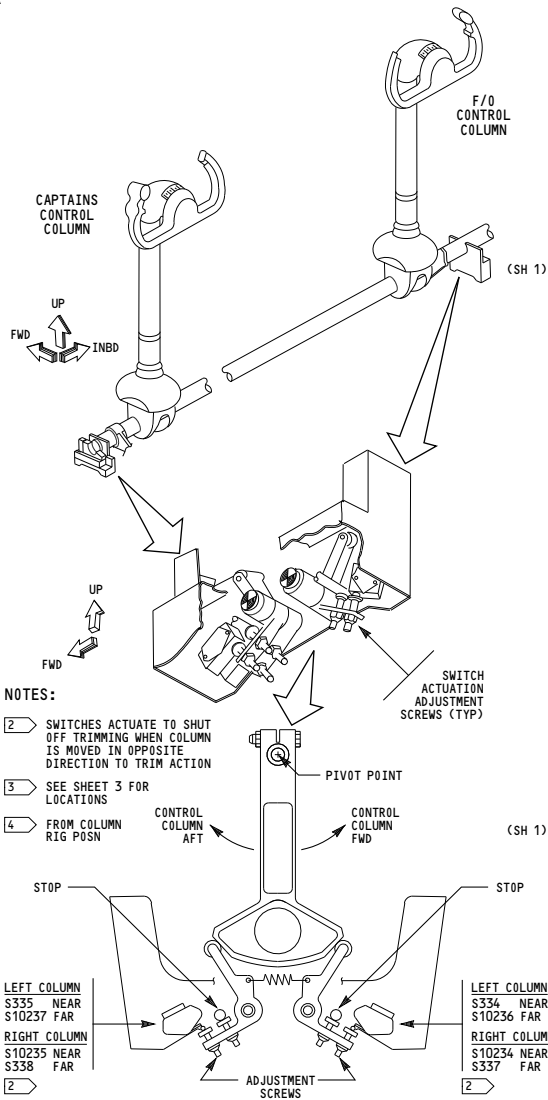

002-004

HORIZONTAL STABILIZER TRIM

D280N032S

27-40-01

5014

WIRING DIAGRAMS
27-48-11

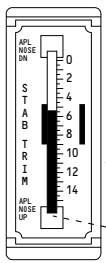
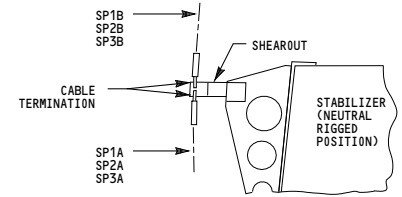
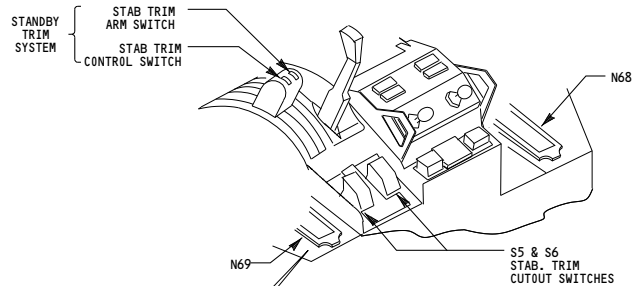

N68, N69

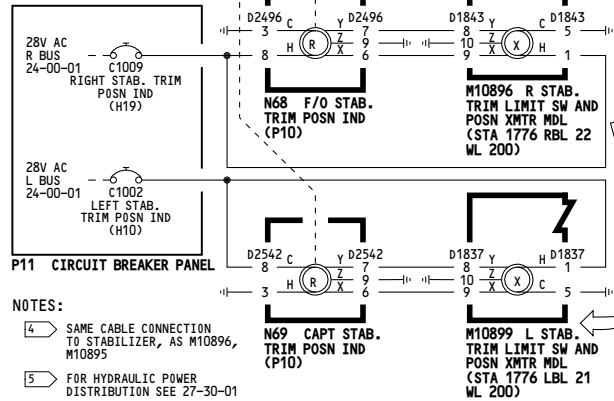

NOTES:

- 4 SAME CABLE CONNECTION TO STABILIZER, AS M10896, M10895
- 5 FOR HYDRAULIC POWER DISTRIBUTION SEE 27-30-01

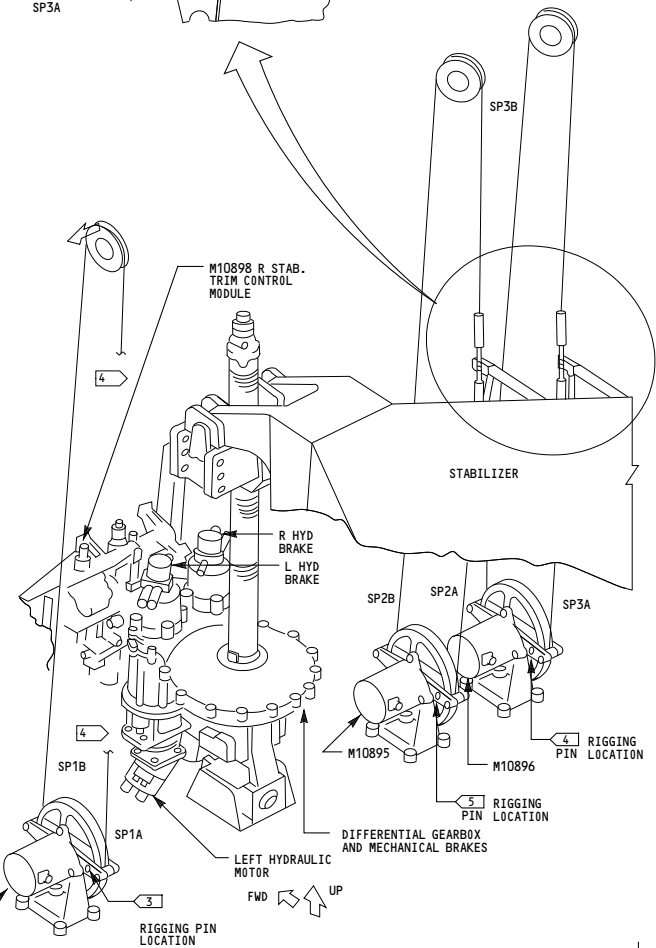
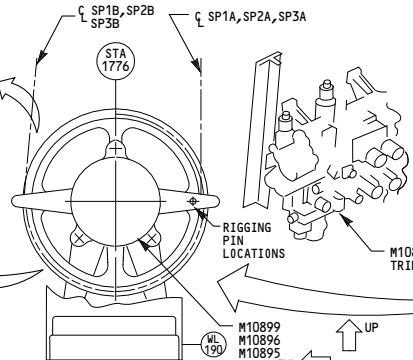

002-004	HORIZONTAL STABILIZER TRIM
D280N032S	

27-40-01

5001

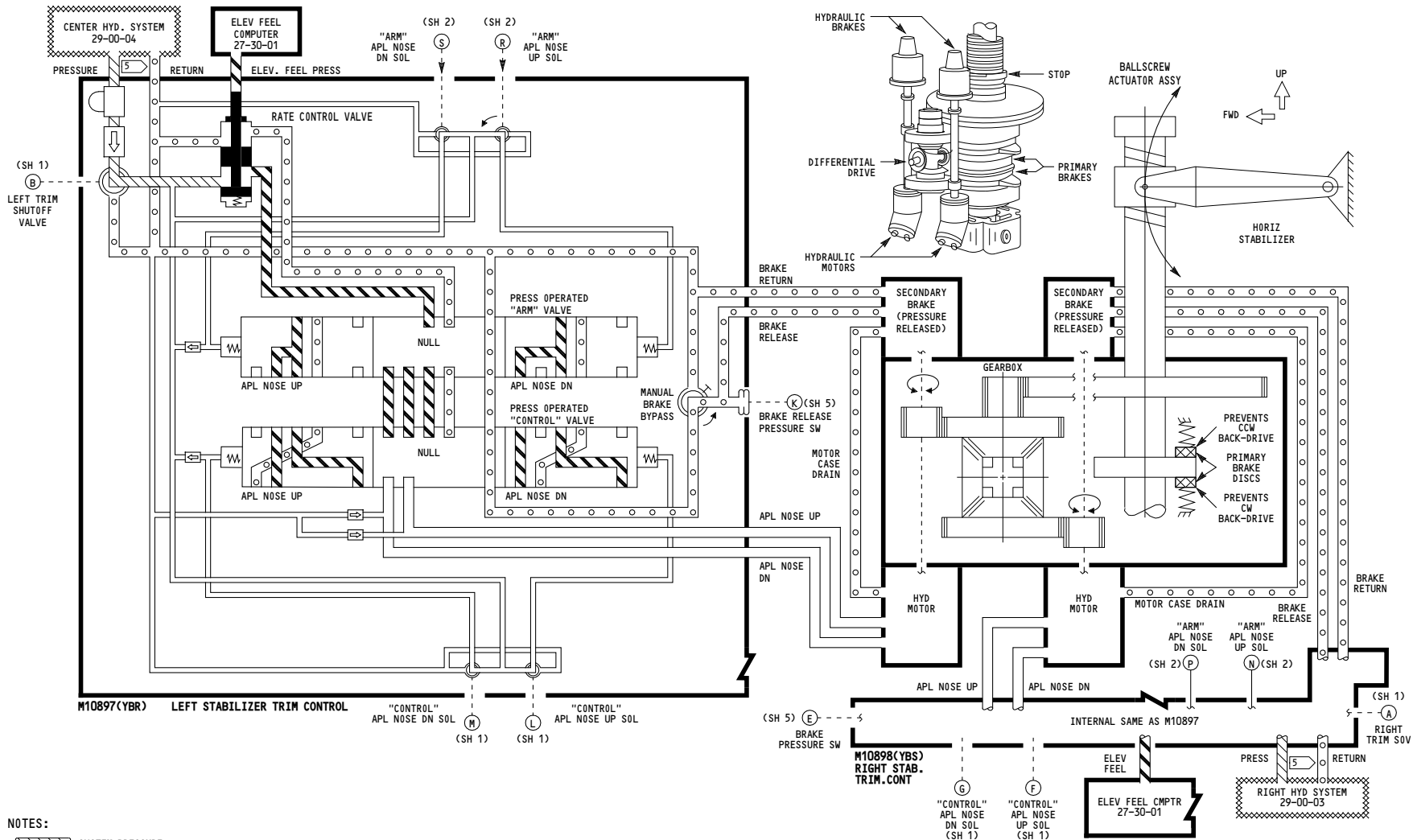

002-004	<p align="center">HORIZONTAL STABILIZER TRIM</p> <p align="center">D280N032S</p>
---------	---

27-40-01

Page 102
Sheet 4
Jan 21/2005

5011

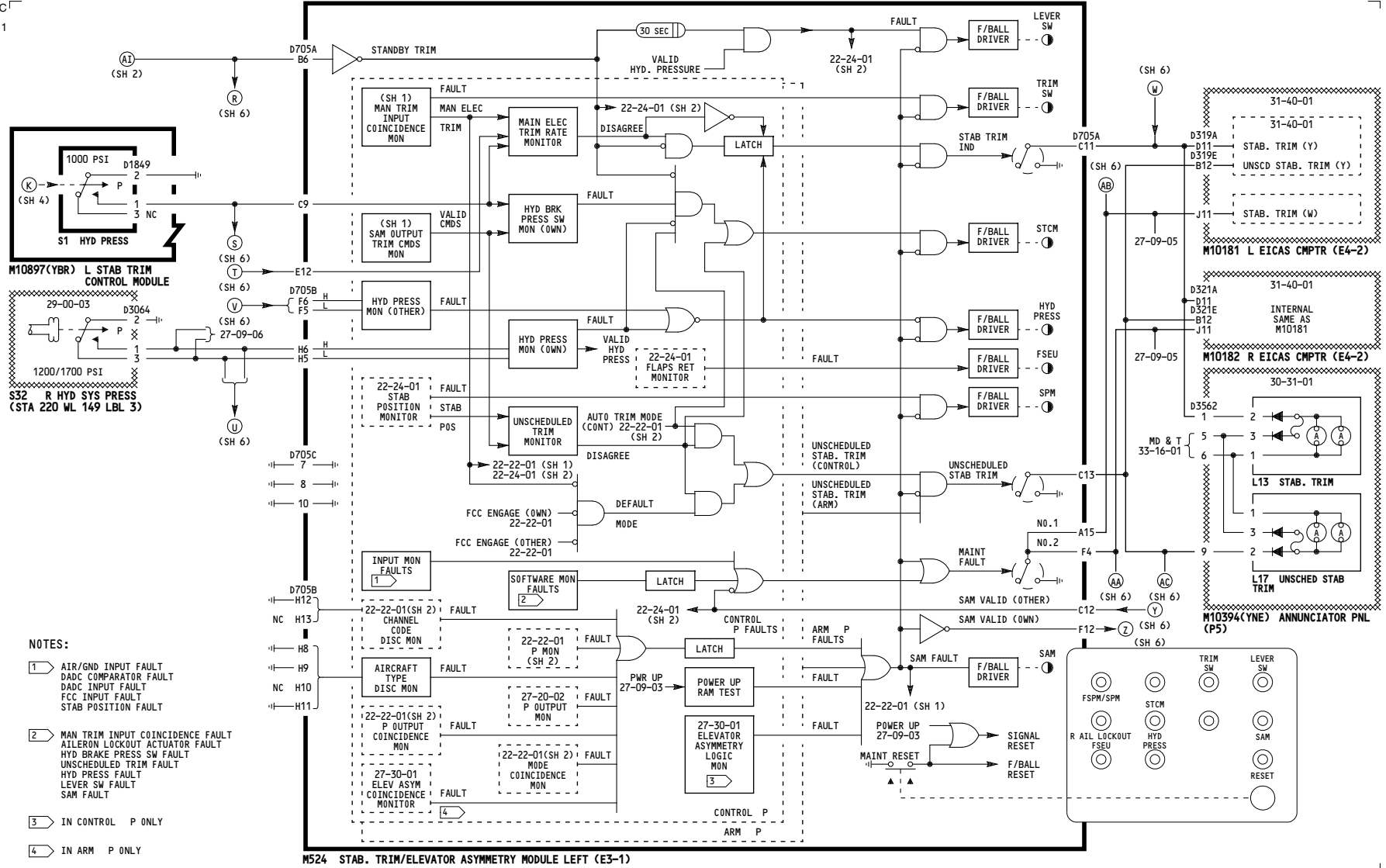

- NOTES:**
- 1 AIR/GND INPUT FAULT
DADC COMPARATOR FAULT
DADC INPUT FAULT
FCC INPUT FAULT
STAB POSITION FAULT
 - 2 MAN TRIM INPUT COINCIDENCE FAULT
AILERON LOCKOUT ACTUATOR FAULT
HYD BRAKE PRESS SW FAULT
UNSCHEDULED TRIM FAULT
HYD PRESS FAULT
LEVER SW FAULT
SAM FAULT
 - 3 IN CONTROL P ONLY
 - 4 IN ARM P ONLY

M524 STAB. TRIM/ELEVATOR ASYMMETRY MODULE LEFT (E3-1)

002-004

HORIZONTAL STABILIZER TRIM

D280N032S

27-40-01

-A
5011

WIRING DIAGRAMS
27-41-11
27-41-21
27-48-11

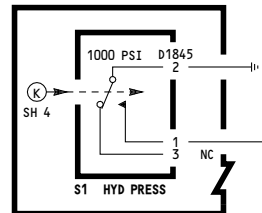

M10898(YBS) R STAB. TRIM CONTROL MODULE

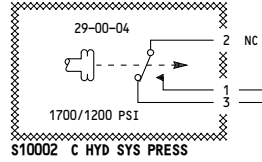

27-09-06

(V)
(S5)

(U)
(SH 5)

D675A
B6
(R)
(SH 5)

C9
(T)
(SH 5)
E12
(S)
(SH 5)

D675B
H6 HIGH PRESSURE
H5 LOW PRESSURE

F6 HIGH PRESSURE
F5 LOW PRESSURE
(U)
(SH 5)

D675C
7
8
10

D675B
NC 12 L
13 R

H8
H9
NC H10
H11

INTERNAL
SAME AS
M524 (SH 5)

D675B
C11
(W)
(SH 5)

C13
(AC)
(SH 5)

A15
F4
(AB)
(SH 5)
(AA)
(SH 5)

D675A
C12
F12
(Z)
(SH 5)
(Y)
(SH 5)

M525 STAB. TRIM ELEVATOR ASYMMETRY MODULE - RIGHT
(E4-1)

002-004

HORIZONTAL STABILIZER TRIM

D280N032S

27-40-01

Page 102
Sheet 6
Jan 21/2005

5030

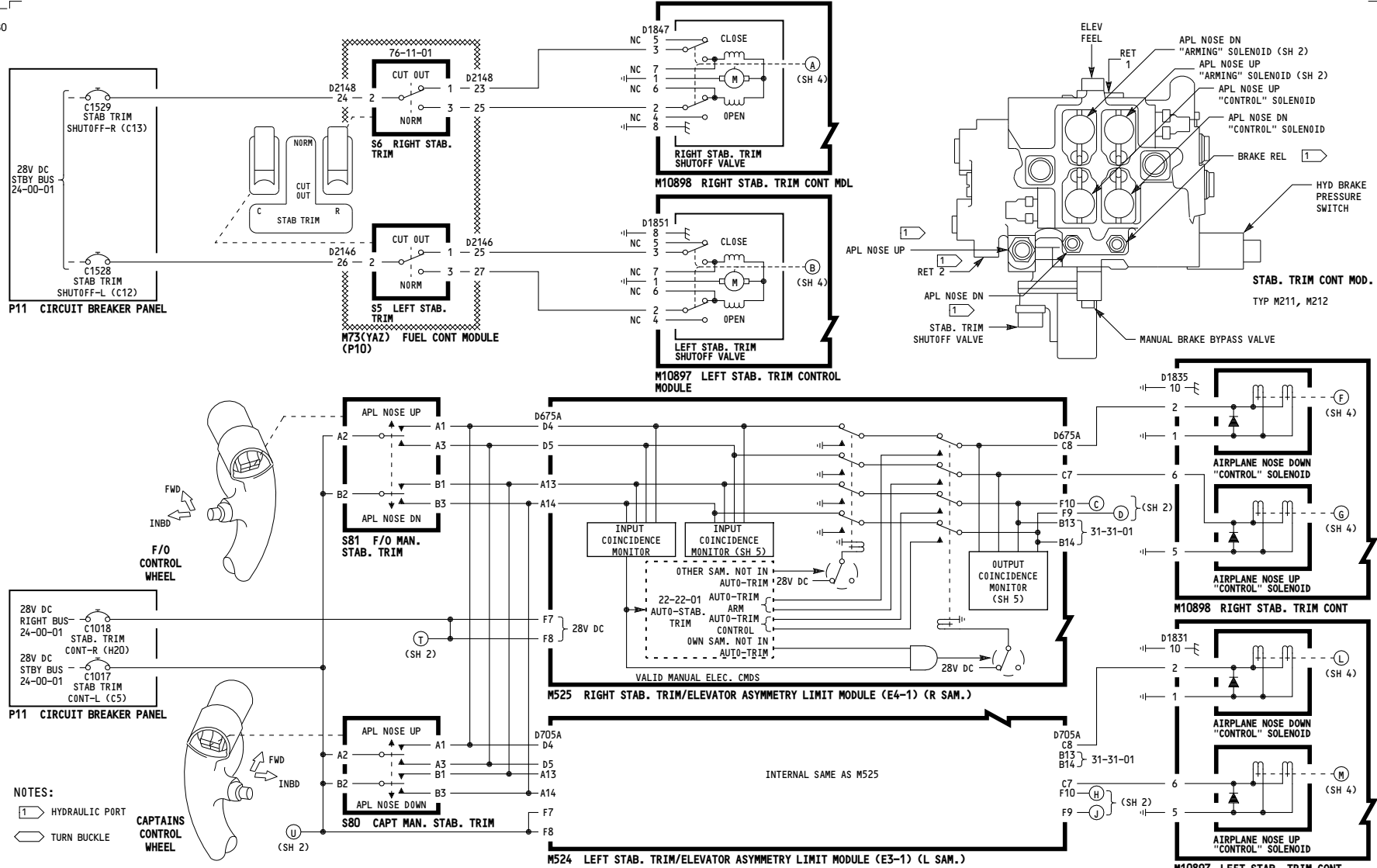

002-004

HORIZONTAL STABILIZER TRIM

Incorporates 27-0104

D280N032S

27-40-01

-A
5011

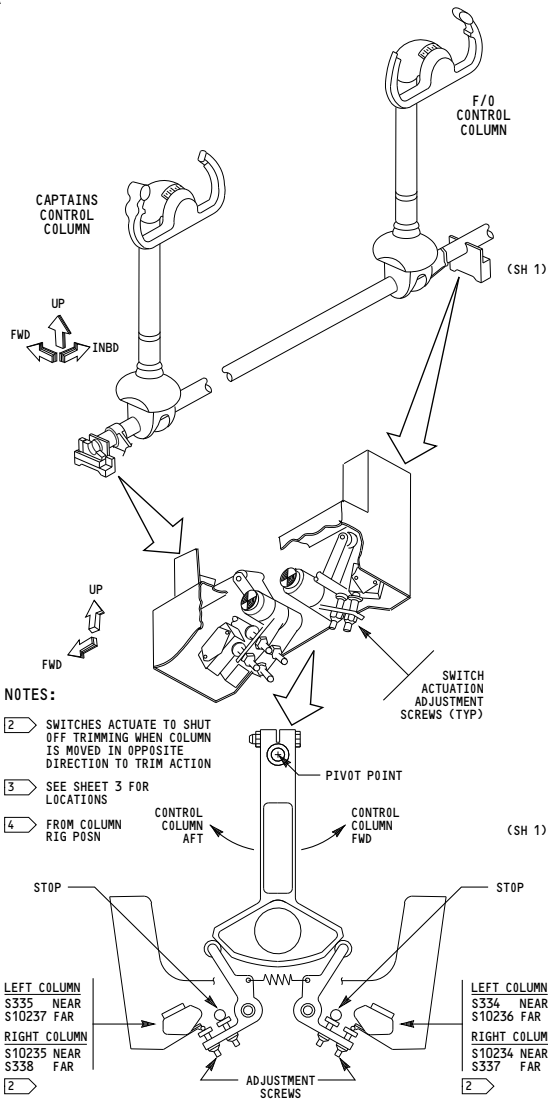

- NOTES:**
- 2 SWITCHES ACTUATE TO SHUT OFF TRIMMING WHEN COLUMN IS MOVED IN OPPOSITE DIRECTION TO TRIM ACTION
 - 3 SEE SHEET 3 FOR LOCATIONS
 - 4 FROM COLUMN RIG POSN

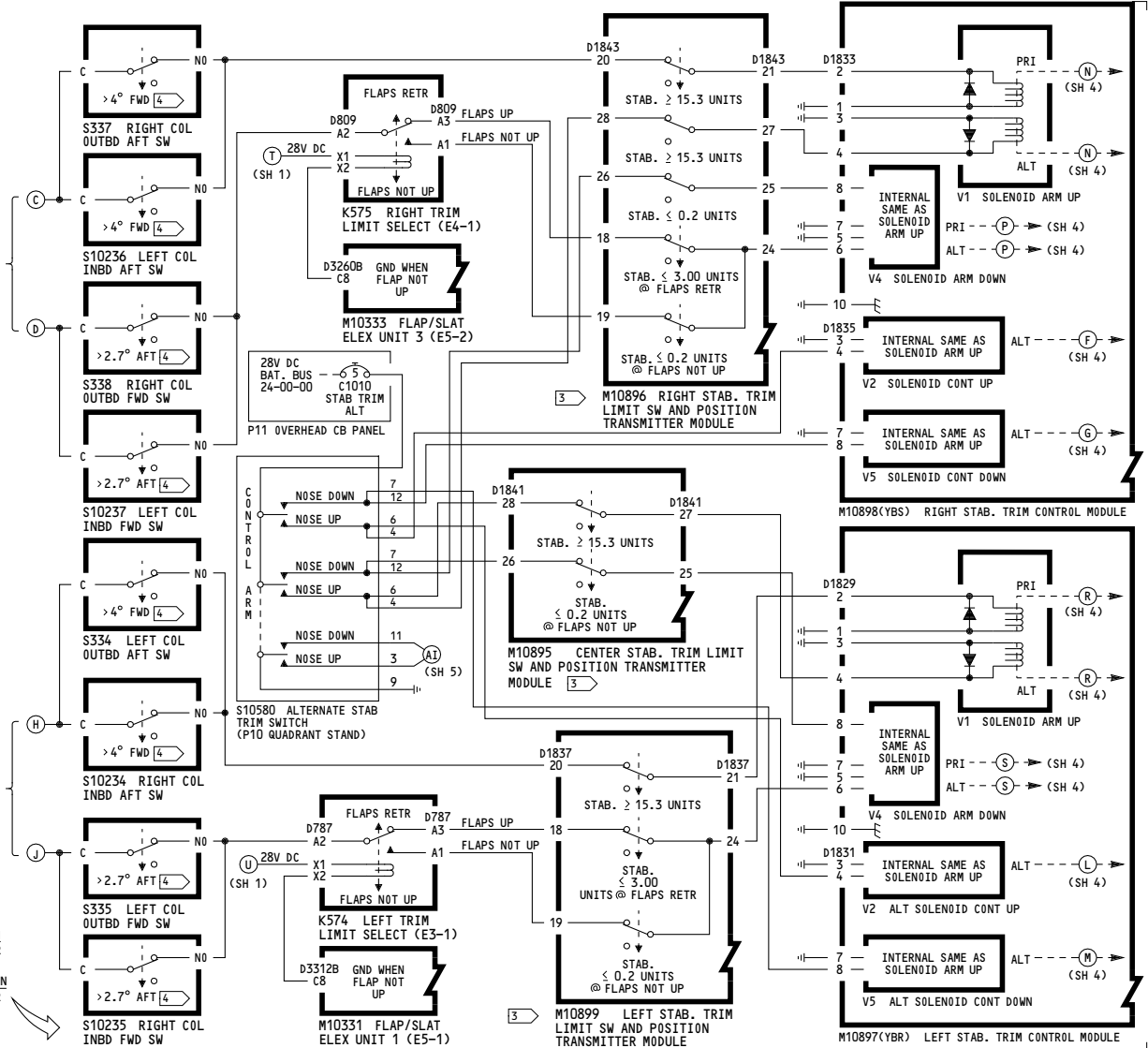

002-004

HORIZONTAL STABILIZER TRIM

D280N032S

27-40-01

5014

WIRING DIAGRAMS
27-48-11

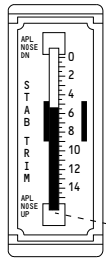
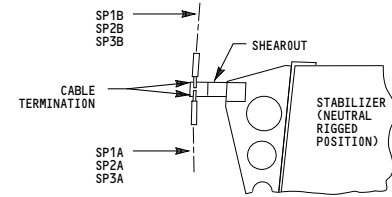
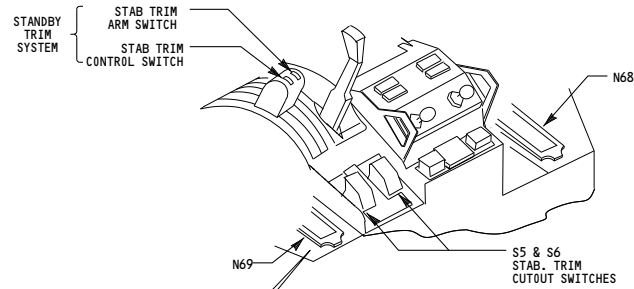

N68, N69

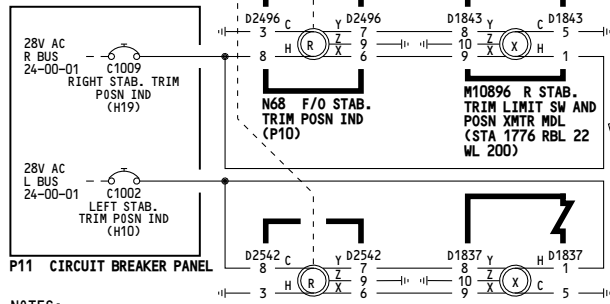

NOTES:

- 4 SAME CABLE CONNECTION TO STABILIZER, AS M10896, M10895
- 5 FOR HYDRAULIC POWER DISTRIBUTION SEE 27-30-01

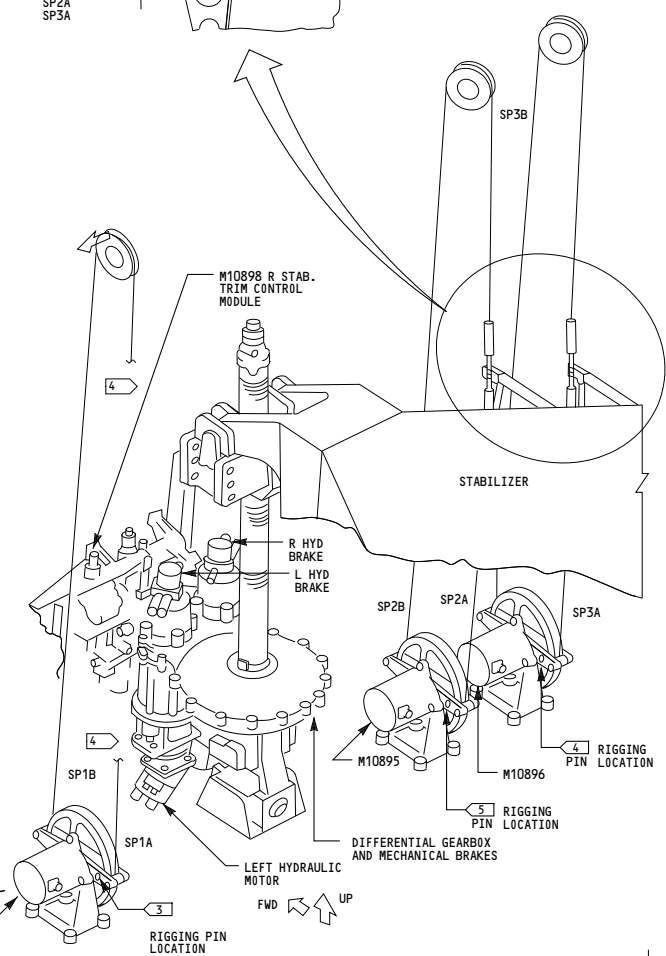
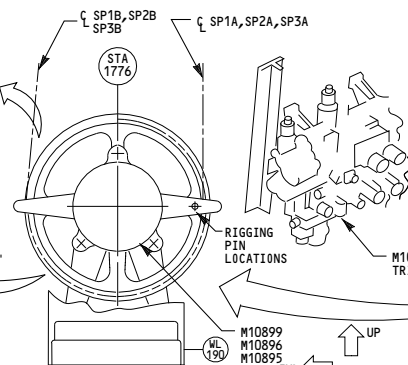

002-004	HORIZONTAL STABILIZER TRIM
	D280N032S

27-40-01

Page 102.1
Sheet 3
Jan 21/2005

5001

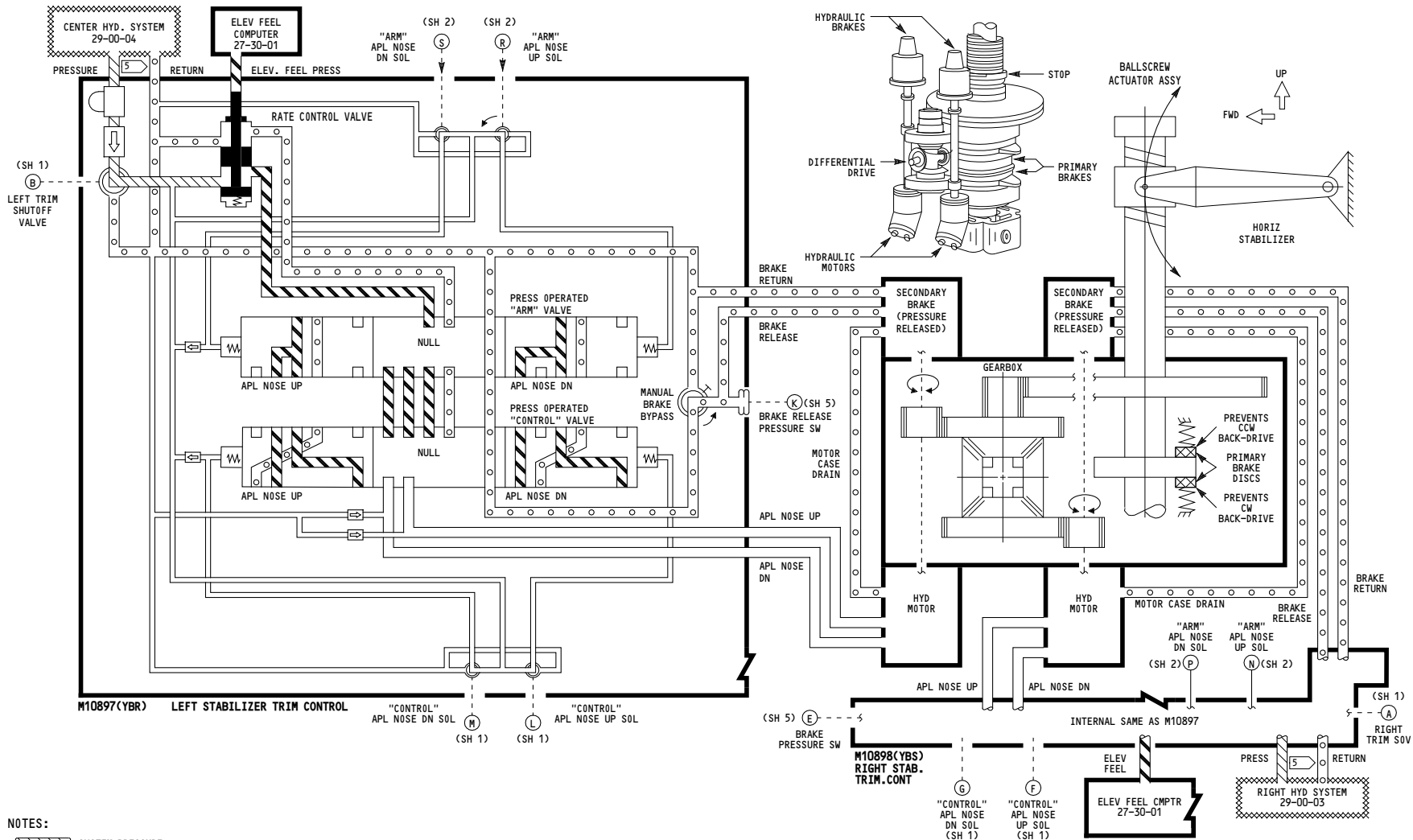

- NOTES:**
- SYSTEM PRESSURE
 - RETURN
 - METERED PRESSURE

002-004	HORIZONTAL STABILIZER TRIM
	D280N032S

27-40-01

Page 102.1
Sheet 4
Jan 21/2005

5011

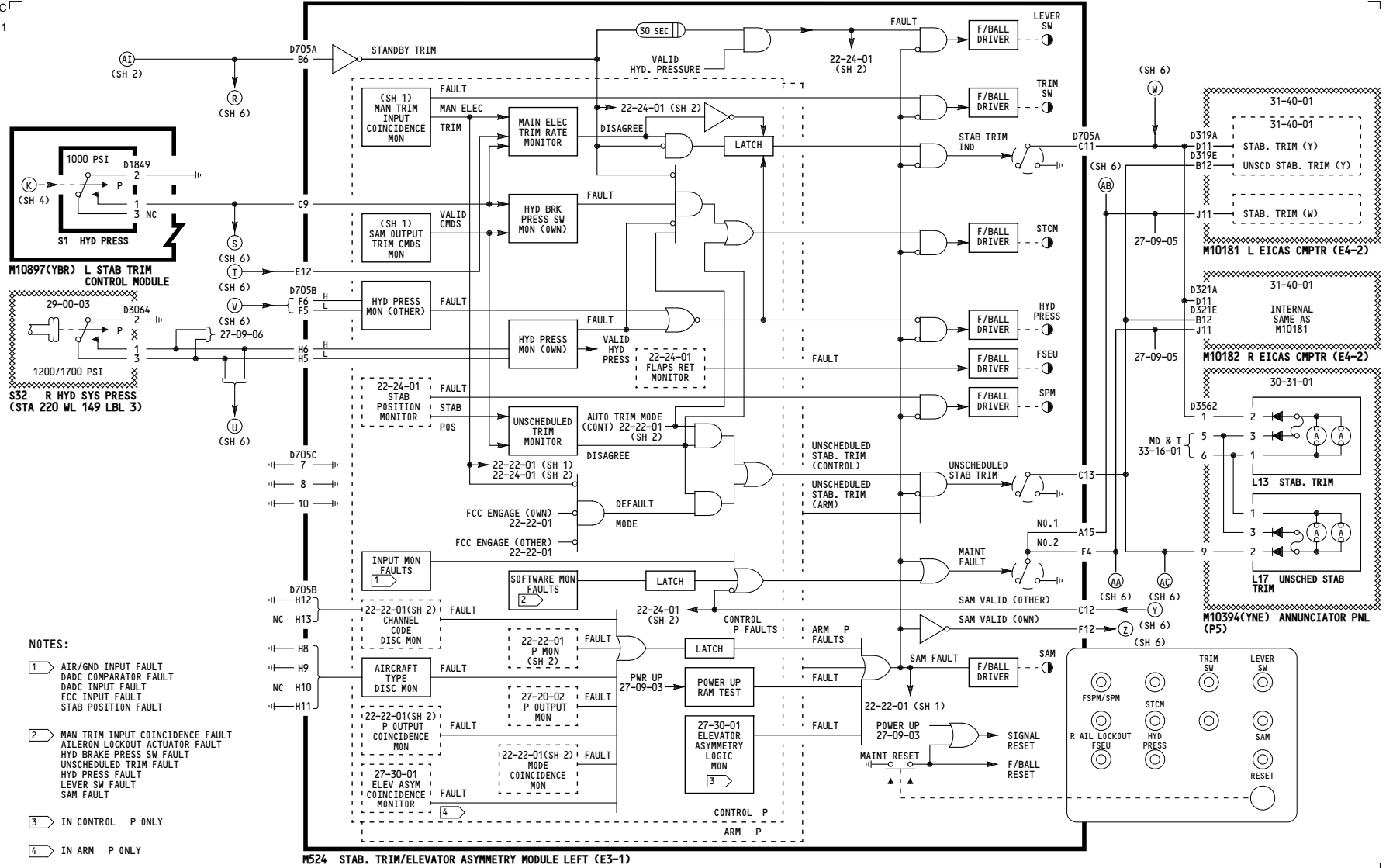

- NOTES:**
- 1 AIR/GND INPUT FAULT
DADC COMPARATOR FAULT
DADC INPUT FAULT
FCC INPUT FAULT
STAB POSITION FAULT
 - 2 MAN TRIM INPUT COINCIDENCE FAULT
AILERON LOCKOUT ACTUATOR FAULT
HYD BRAKE PRESS SW FAULT
UNSCHEDULED TRIM FAULT
HYD PRESS FAULT
LEVER SW FAULT
SAM FAULT
 - 3 IN CONTROL P ONLY
 - 4 IN ARM P ONLY

M524 STAB. TRIM/ELEVATOR ASYMMETRY MODULE LEFT (E3-1)

002-004

HORIZONTAL STABILIZER TRIM

D280N032S

27-40-01

Page 102.1
Sheet 5
Dec 18/2007

-A
5011

WIRING DIAGRAMS
27-41-11
27-41-21
27-48-11

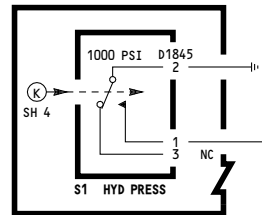

M10898(YBS) R STAB. TRIM CONTROL MODULE

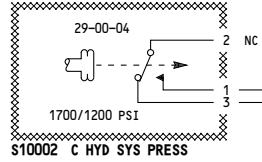

S10002 C HYD SYS PRESS

27-09-06



(V)
(S5)

(U)
(SH 5)

(R)
(SH 5)

(T)
(SH 5)
(S)
(SH 5)

(U)
(SH 5)

(AB)
(SH 5)

(AA)
(SH 5)

(Z)
(SH 5)

(Y)
(SH 5)

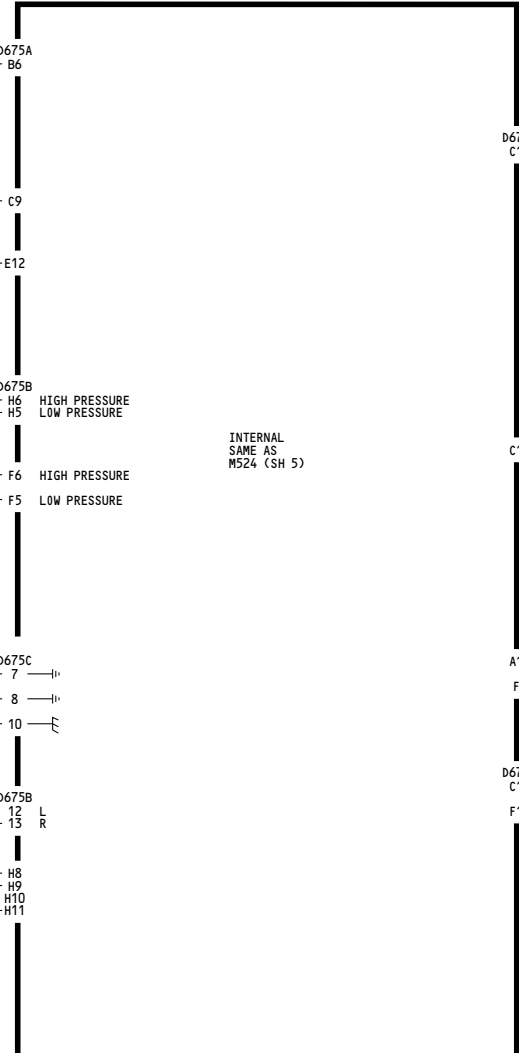

M525 STAB. TRIM ELEVATOR ASYMMETRY MODULE - RIGHT (E4-1)

002-004	<p align="center">HORIZONTAL STABILIZER TRIM</p> <p align="center">D280N032S</p>
---------	---

27-40-01

Page 102.1
Sheet 6
Jan 21/2005

5016

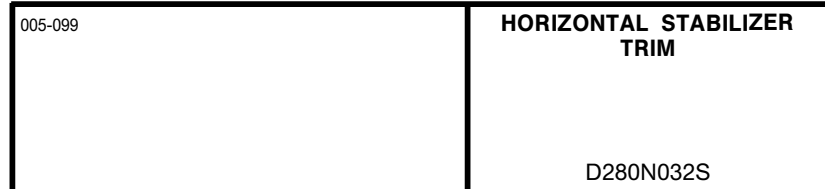
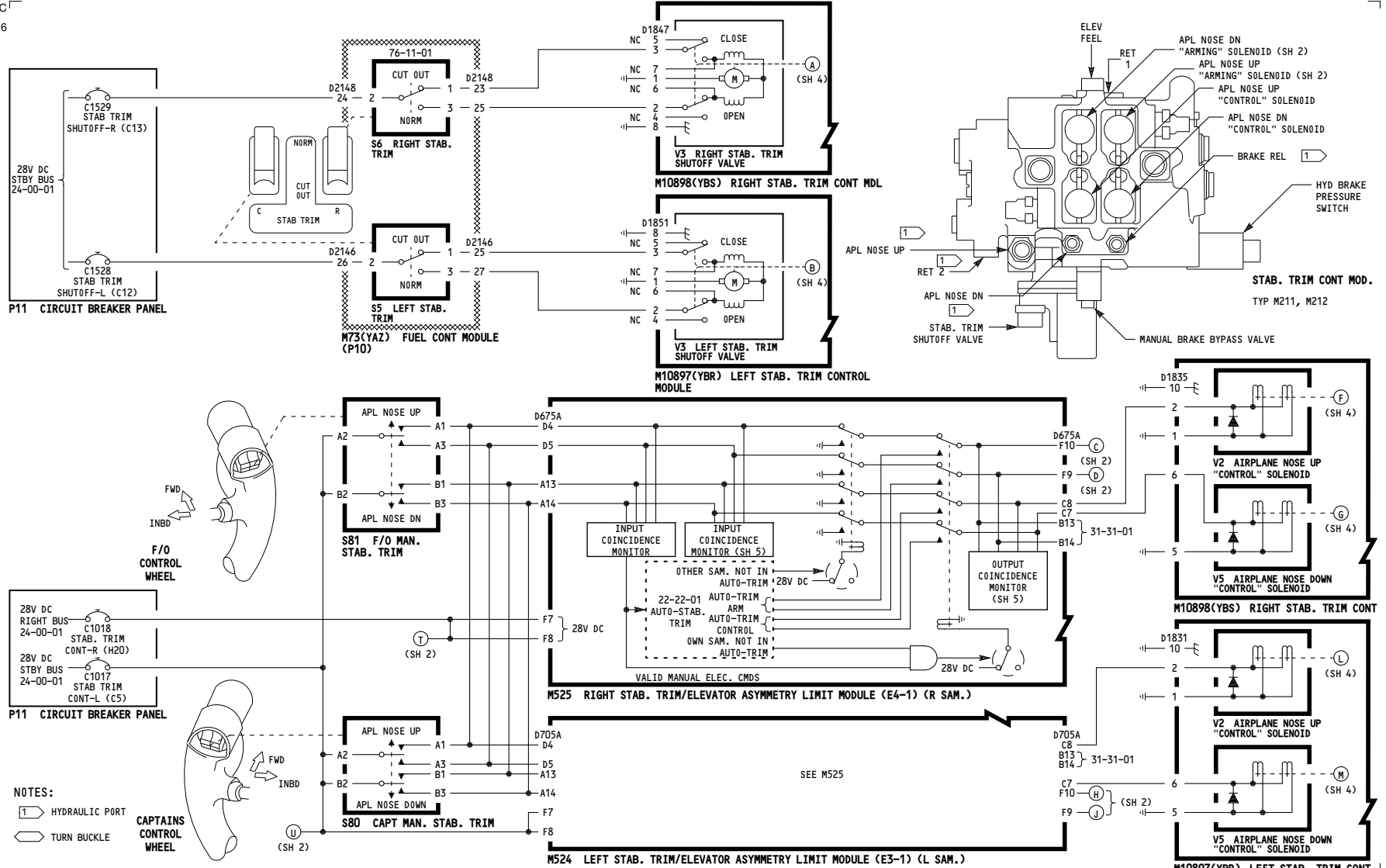

27-40-01

5014

WIRING DIAGRAMS
27-48-11

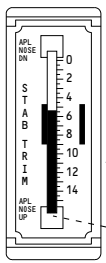
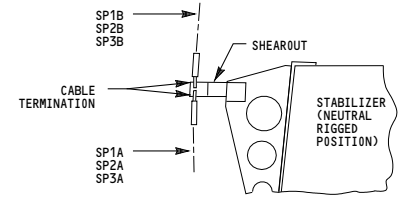
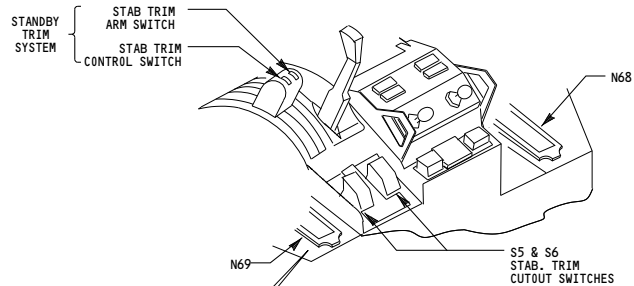

N68, N69

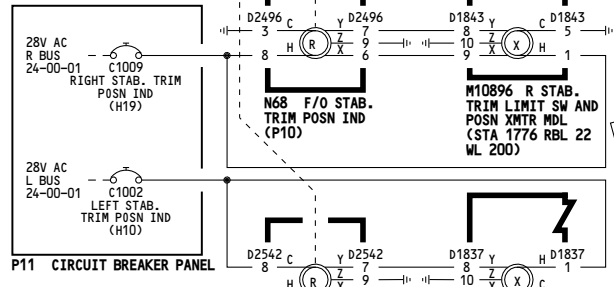

NOTES:

- 4 SAME CABLE CONNECTION TO STABILIZER, AS M10896, M10895
- 5 FOR HYDRAULIC POWER DISTRIBUTION SEE 27-30-01

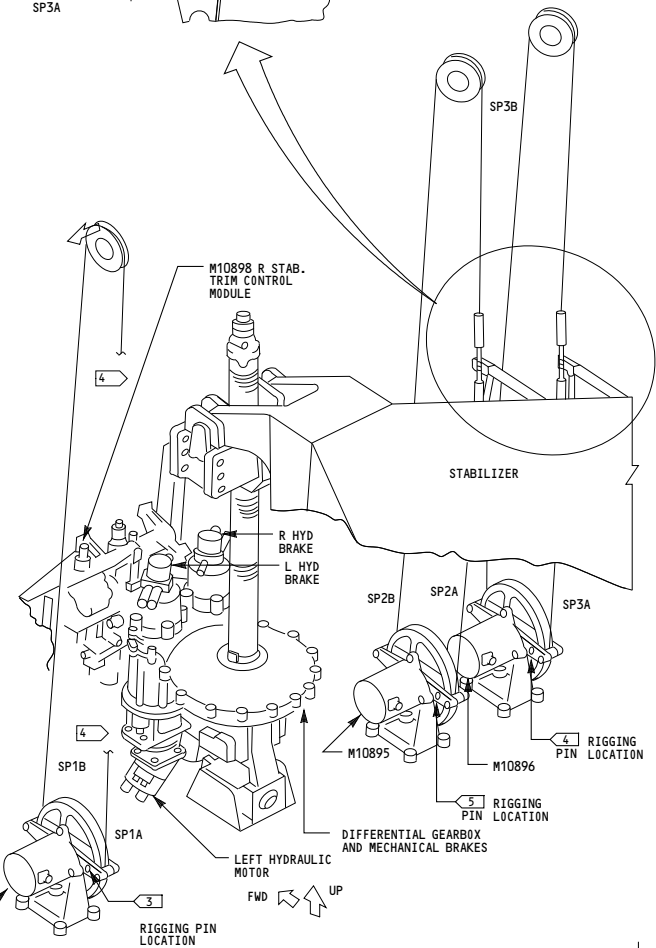
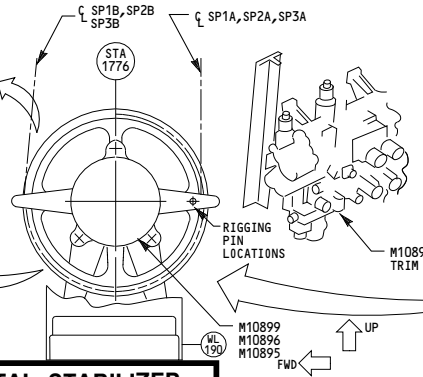

005-099	HORIZONTAL STABILIZER TRIM
D280N032S	

27-40-01

5001

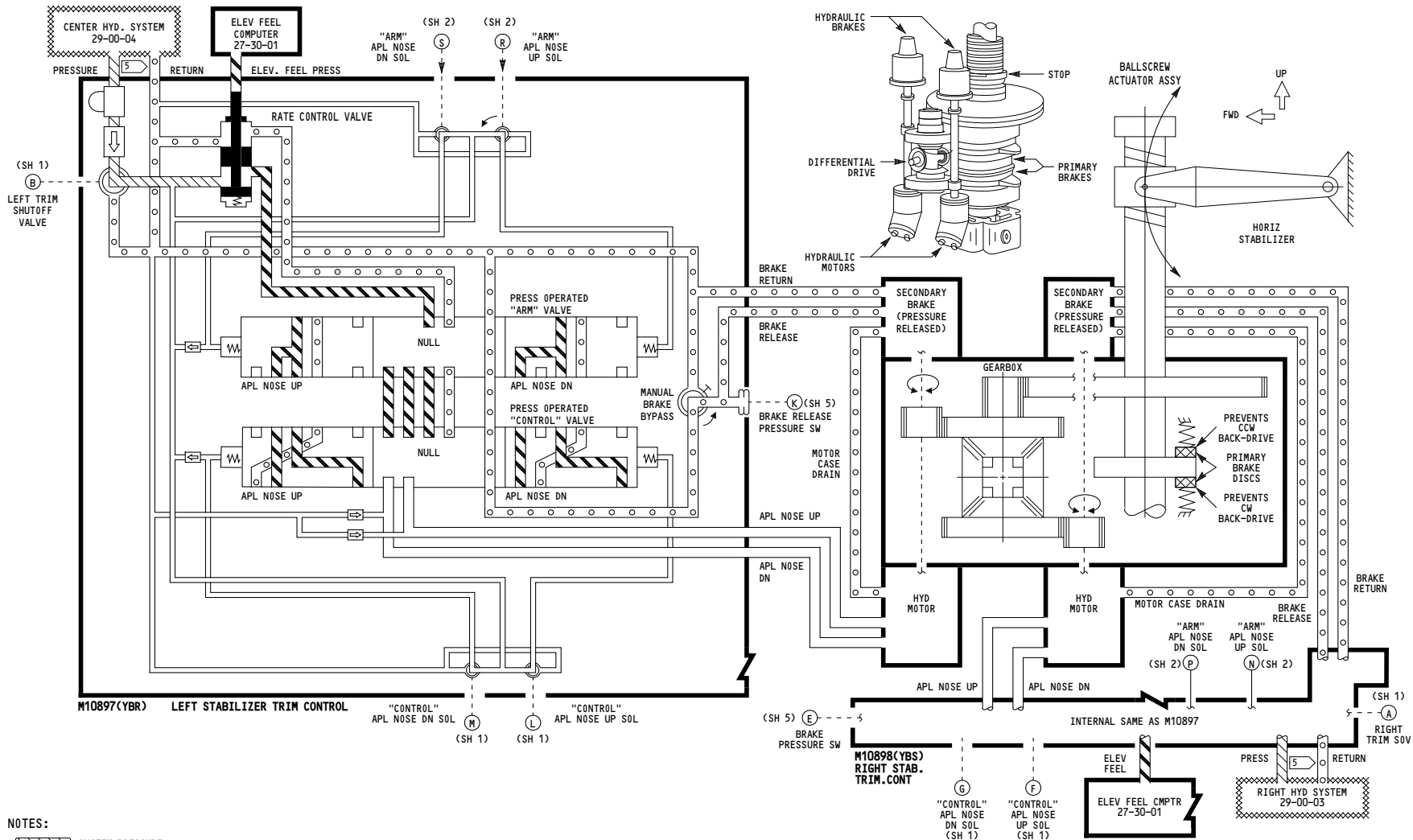

- NOTES:**
- SYSTEM PRESSURE
 - RETURN
 - METERED PRESSURE

005-099	HORIZONTAL STABILIZER TRIM
	D280N032S

27-40-01

Page 103
Sheet 4
Jan 21/2005

5011

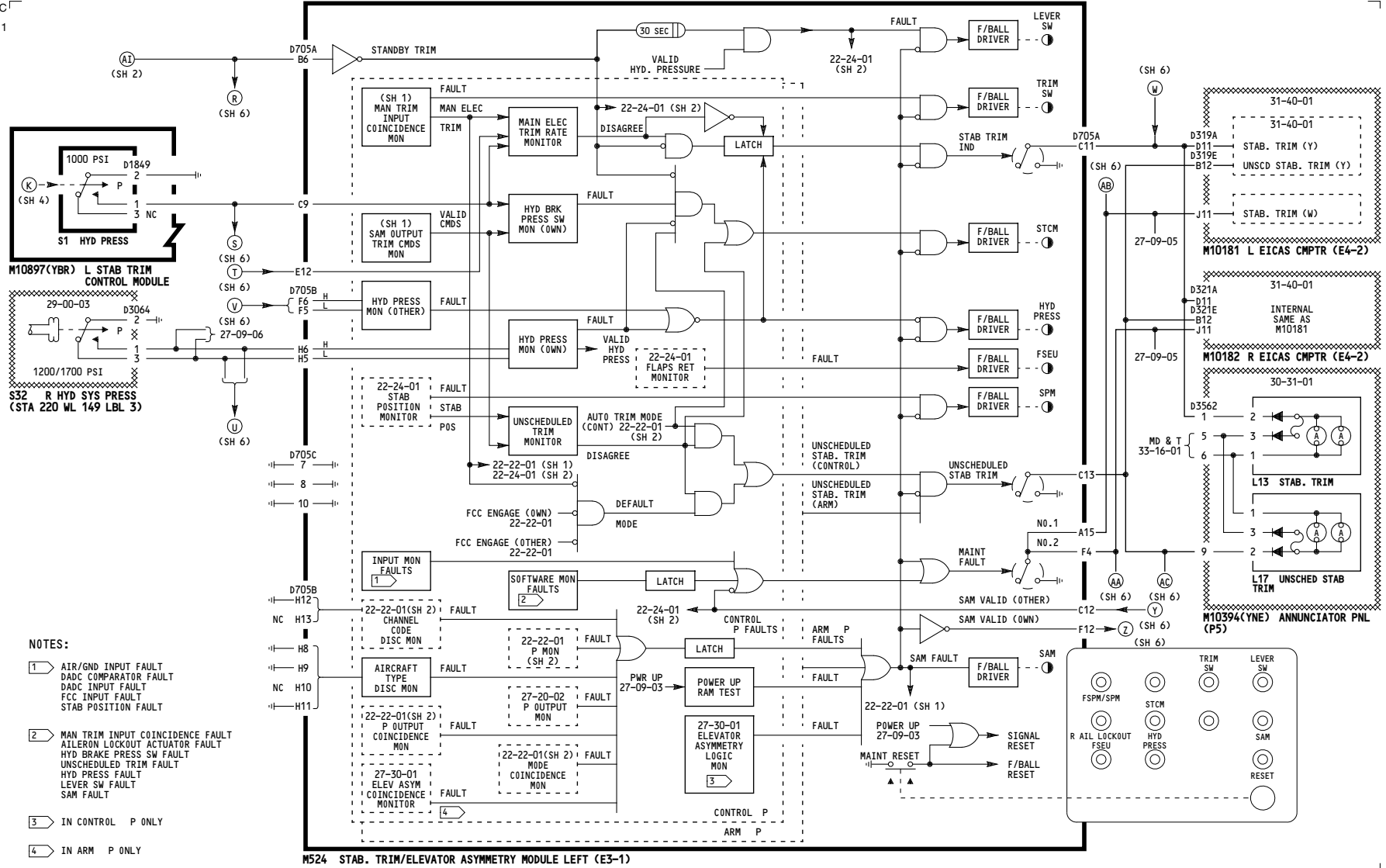

- NOTES:**
- 1 AIR/GND INPUT FAULT
DADC COMPARATOR FAULT
DADC INPUT FAULT
FCC INPUT FAULT
STAB POSITION FAULT
 - 2 MAN TRIM INPUT COINCIDENCE FAULT
AILERON LOCKOUT ACTUATOR FAULT
HYD BRAKE PRESS SW FAULT
UNDESCHED TRIM FAULT
HYD PRESS FAULT
LEVER SW FAULT
SAM FAULT
 - 3 IN CONTROL P ONLY
 - 4 IN ARM P ONLY

M524 STAB. TRIM/ELEVATOR ASYMMETRY MODULE LEFT (E3-1)

005-099

HORIZONTAL STABILIZER TRIM

D280N032S

27-40-01

-A
5011

WIRING DIAGRAMS
27-41-11
27-41-21
27-48-11

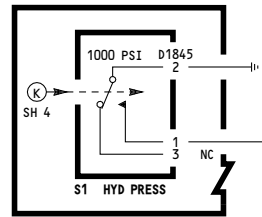

M10898(YBS) R STAB. TRIM CONTROL MODULE

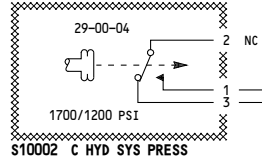

S10002 C HYD SYS PRESS

27-09-06



NC

(V)
(S5)

(U)
(SH 5)

(R)
(SH 5)

(T)
(SH 5)
(S)
(SH 5)

(U)
(SH 5)

NC
12
13

H8
H9
NC
H10
H11

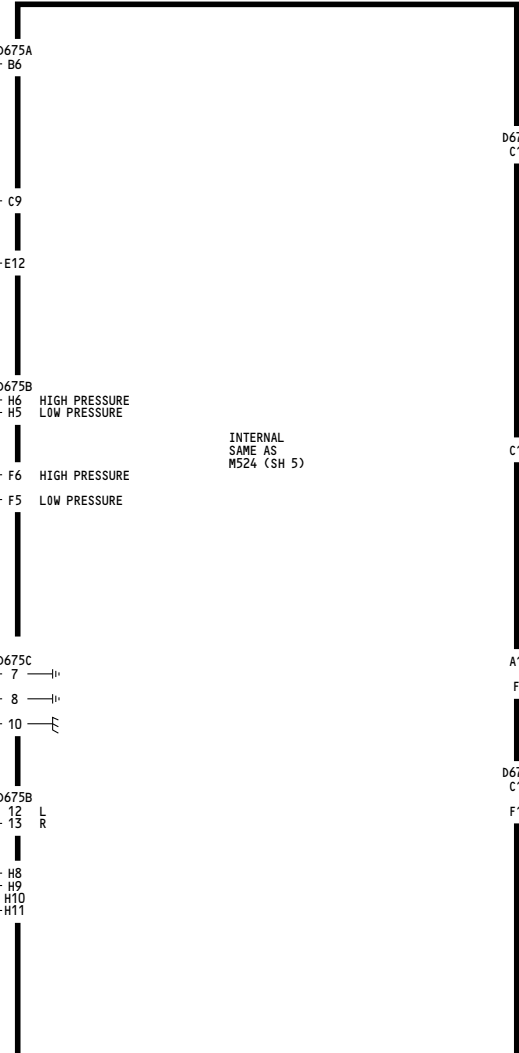

M525 STAB. TRIM ELEVATOR ASYMMETRY MODULE - RIGHT (E4-1)

INTERNAL SAME AS M524 (SH 5)

D675B
C11

C13

A15
F4

D675A
C12
F12

(W)
(SH 5)

(AC)
(SH 5)

(AB)
(SH 5)
(AA)
(SH 5)

(Z)
(SH 5)
(Y)
(SH 5)

005-099

HORIZONTAL STABILIZER TRIM

D280N032S

27-40-01

Page 103
Sheet 6
Jan 21/2005

5016

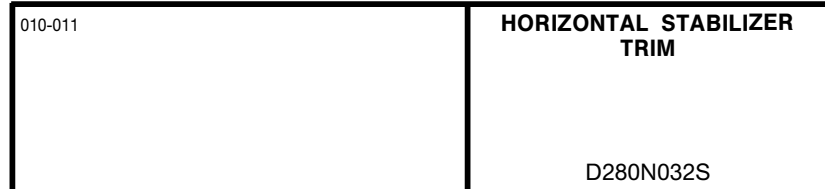
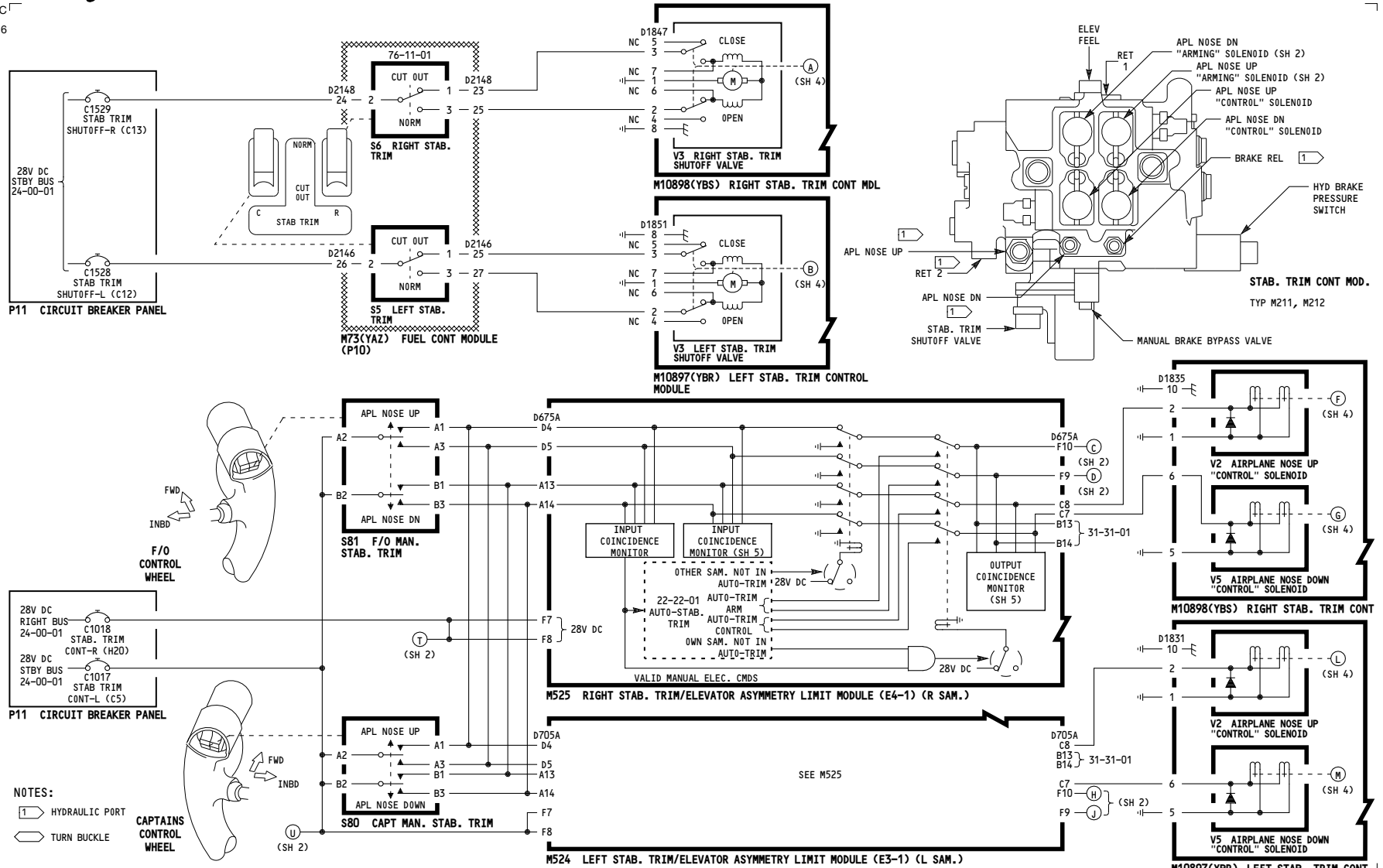

27-40-01

5011

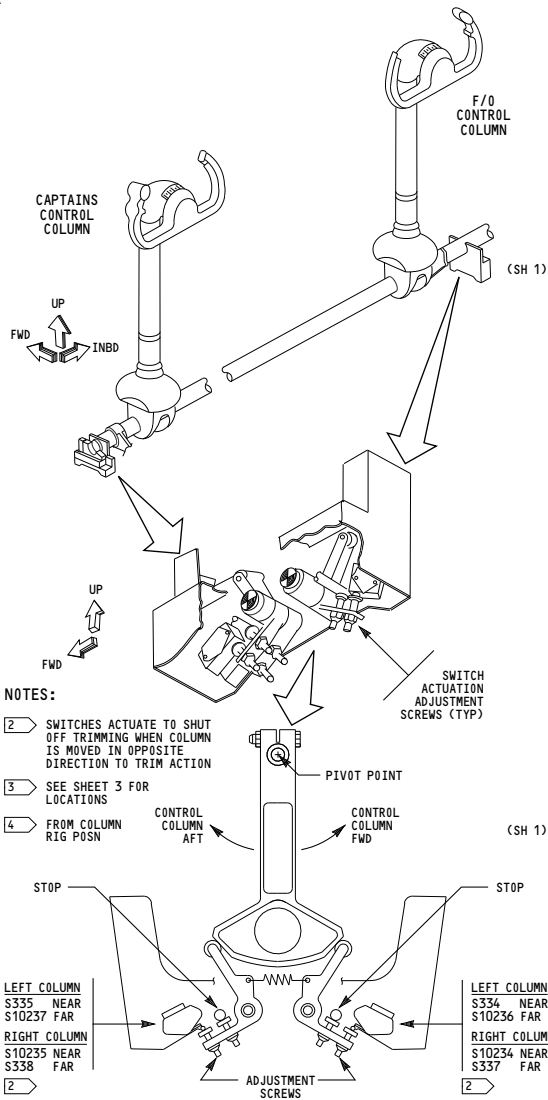

- NOTES:**
- 2 SWITCHES ACTUATE TO SHUT OFF TRIMMING WHEN COLUMN IS MOVED IN OPPOSITE DIRECTION TO TRIM ACTION
 - 3 SEE SHEET 3 FOR LOCATIONS
 - 4 FROM COLUMN RIG POSN

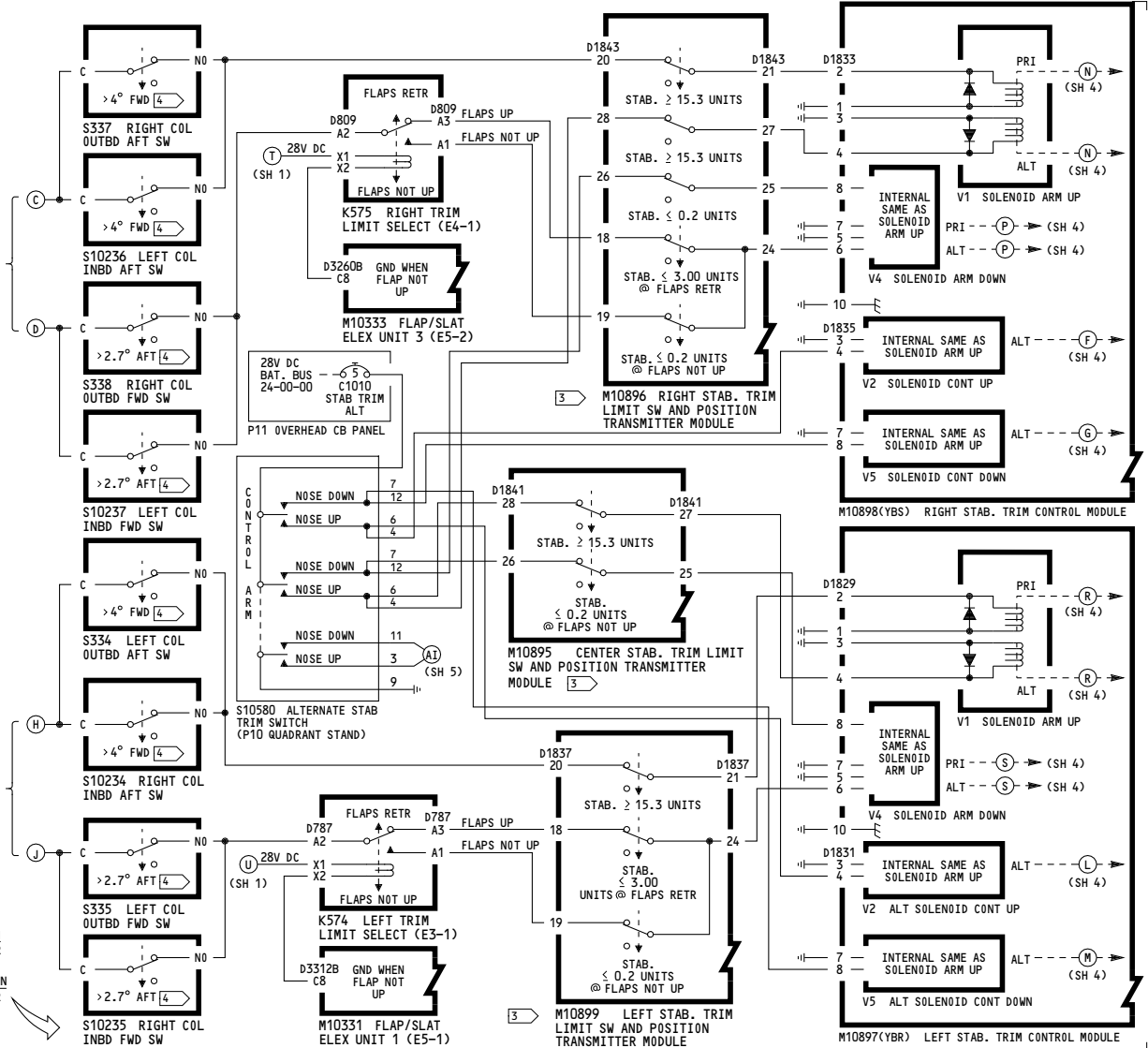

010-011

HORIZONTAL STABILIZER TRIM

D280N032S

27-40-01

5019

WIRING DIAGRAMS
27-48-11

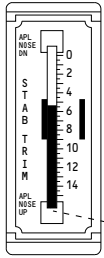
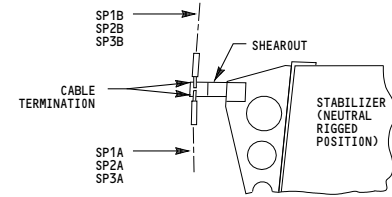
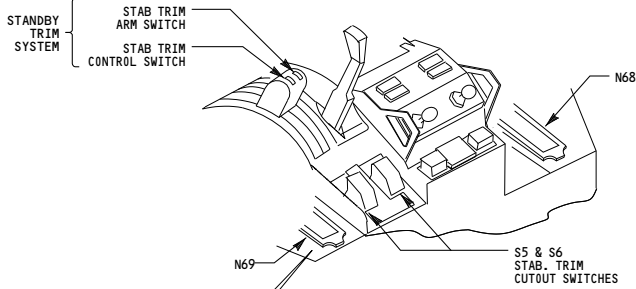

N68, N69

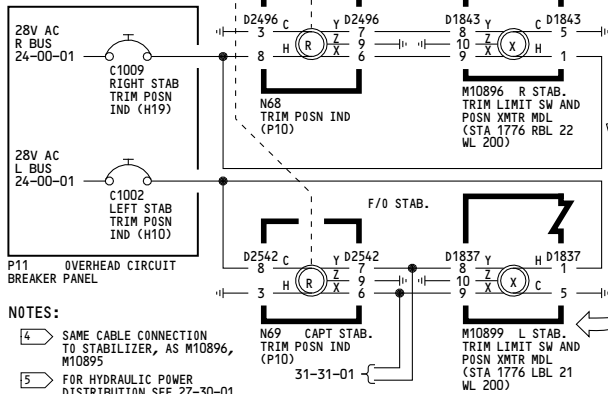

NOTES:

- 4 SAME CABLE CONNECTION TO STABILIZER, AS M10896, M10895
- 5 FOR HYDRAULIC POWER DISTRIBUTION SEE 27-30-01

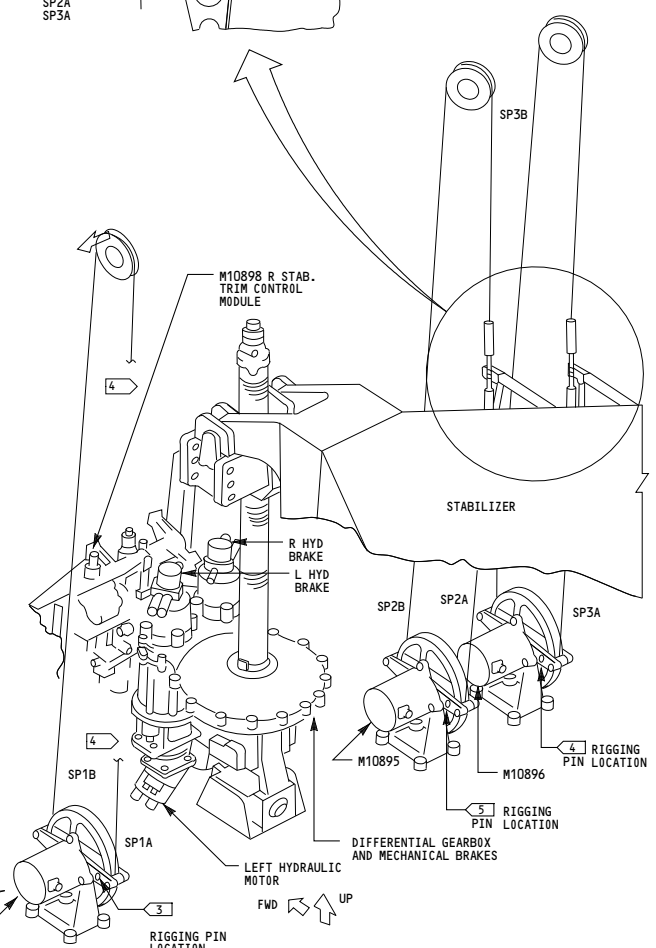
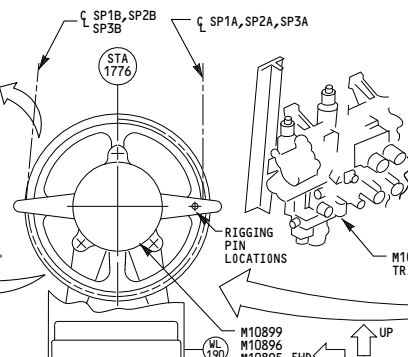

010-011	<p align="center">HORIZONTAL STABILIZER TRIM</p> <p align="center">D280N032S</p>
---------	---

27-40-01

5001

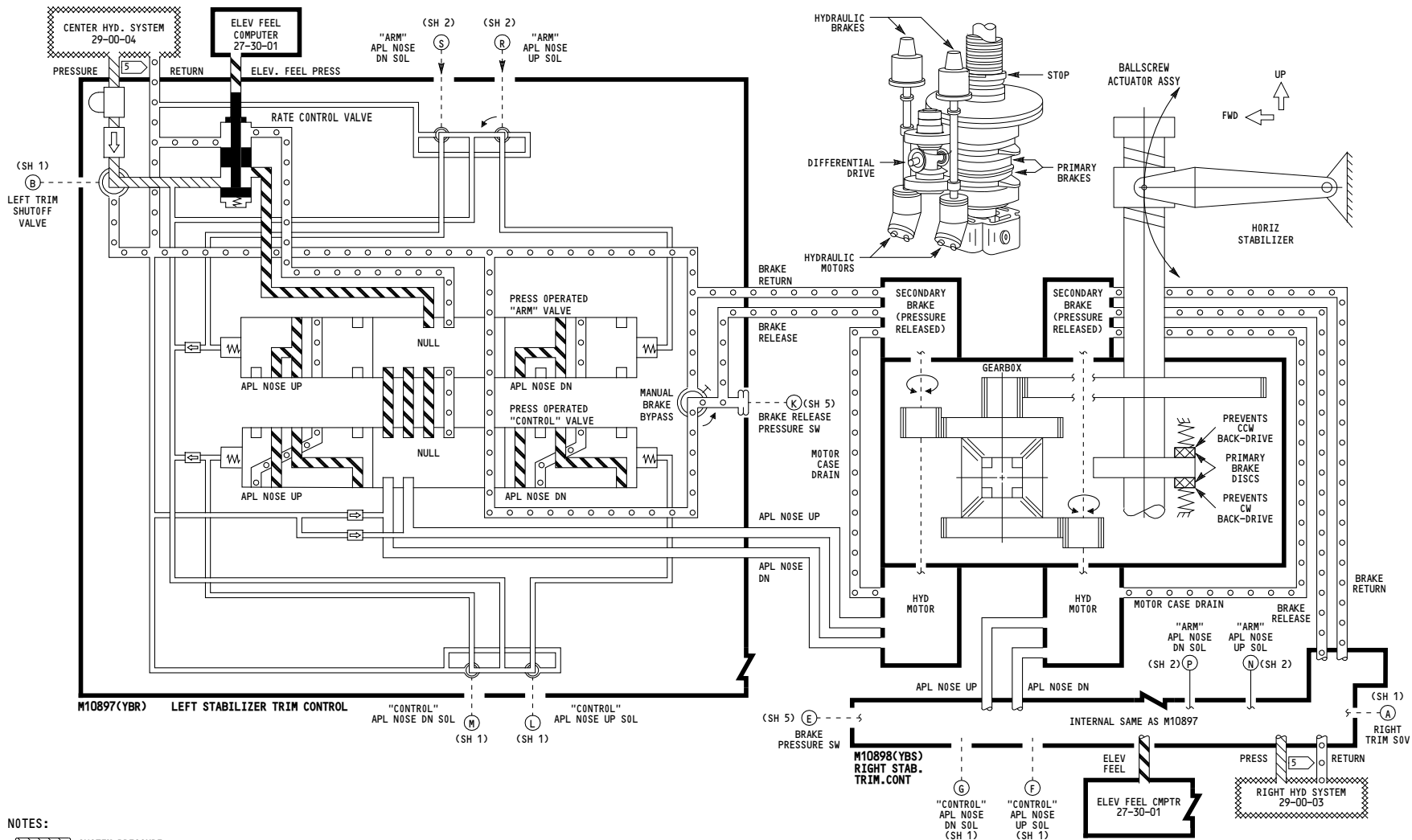

- NOTES:**
- SYSTEM PRESSURE
 - RETURN
 - METERED PRESSURE

010-011

HORIZONTAL STABILIZER TRIM

D280N032S

27-40-01

Page 103.1
Sheet 4
Jan 21/2005

5011

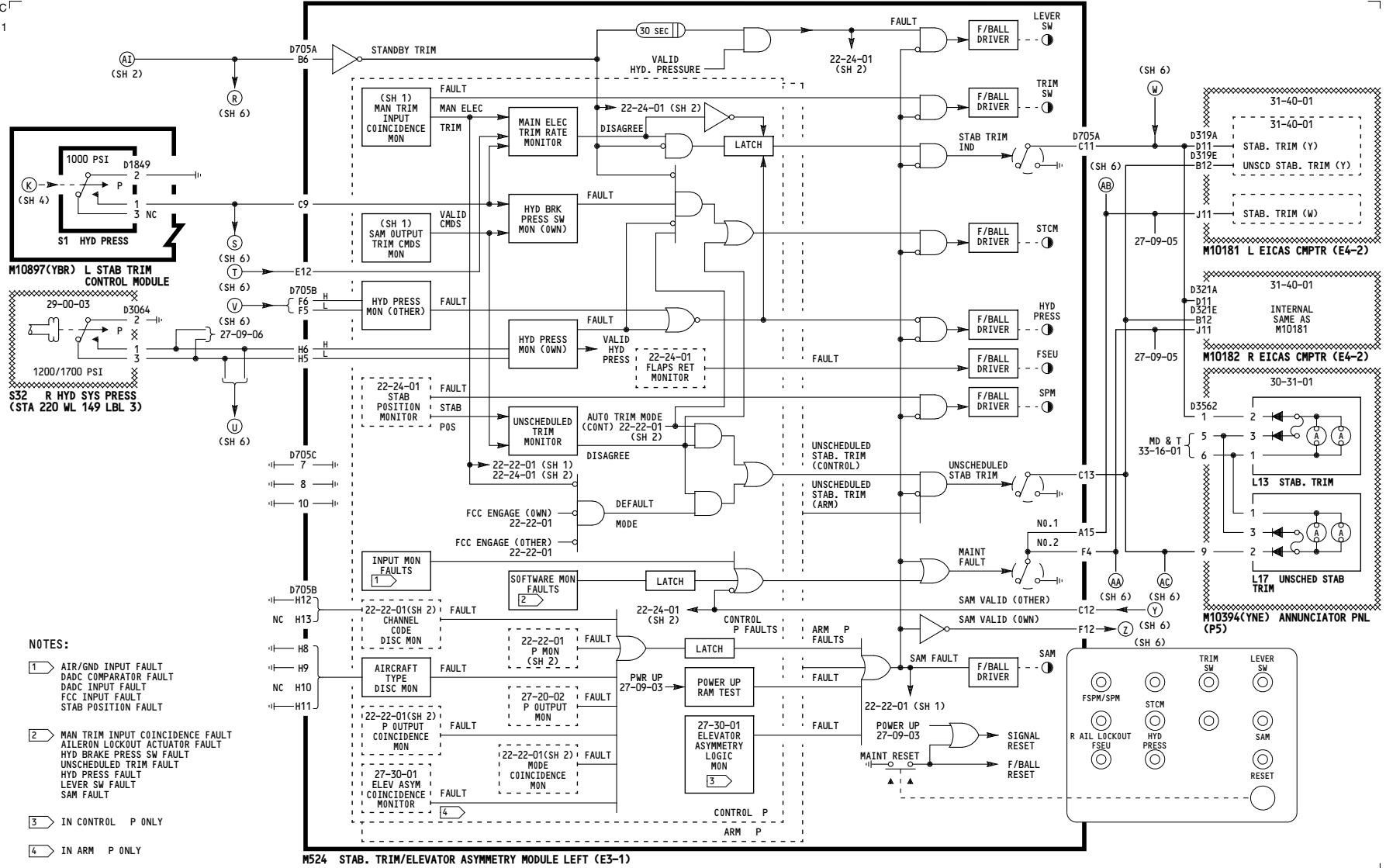

- NOTES:**
- 1 AIR/GND INPUT FAULT
DADC COMPARATOR FAULT
DADC INPUT FAULT
FCC INPUT FAULT
STAB POSITION FAULT
 - 2 MAN TRIM INPUT COINCIDENCE FAULT
AILERON LOCKOUT ACTUATOR FAULT
HYD BRAKE PRESS SW FAULT
UNSCHEDULED TRIM FAULT
HYD PRESS FAULT
LEVER SW FAULT
SAM FAULT
 - 3 IN CONTROL P ONLY
 - 4 IN ARM P ONLY

010-011

HORIZONTAL STABILIZER TRIM

D280N032S

27-40-01

Page 103.1
Sheet 5
Dec 18/2007

-A
5011

WIRING DIAGRAMS
27-41-11
27-41-21
27-48-11

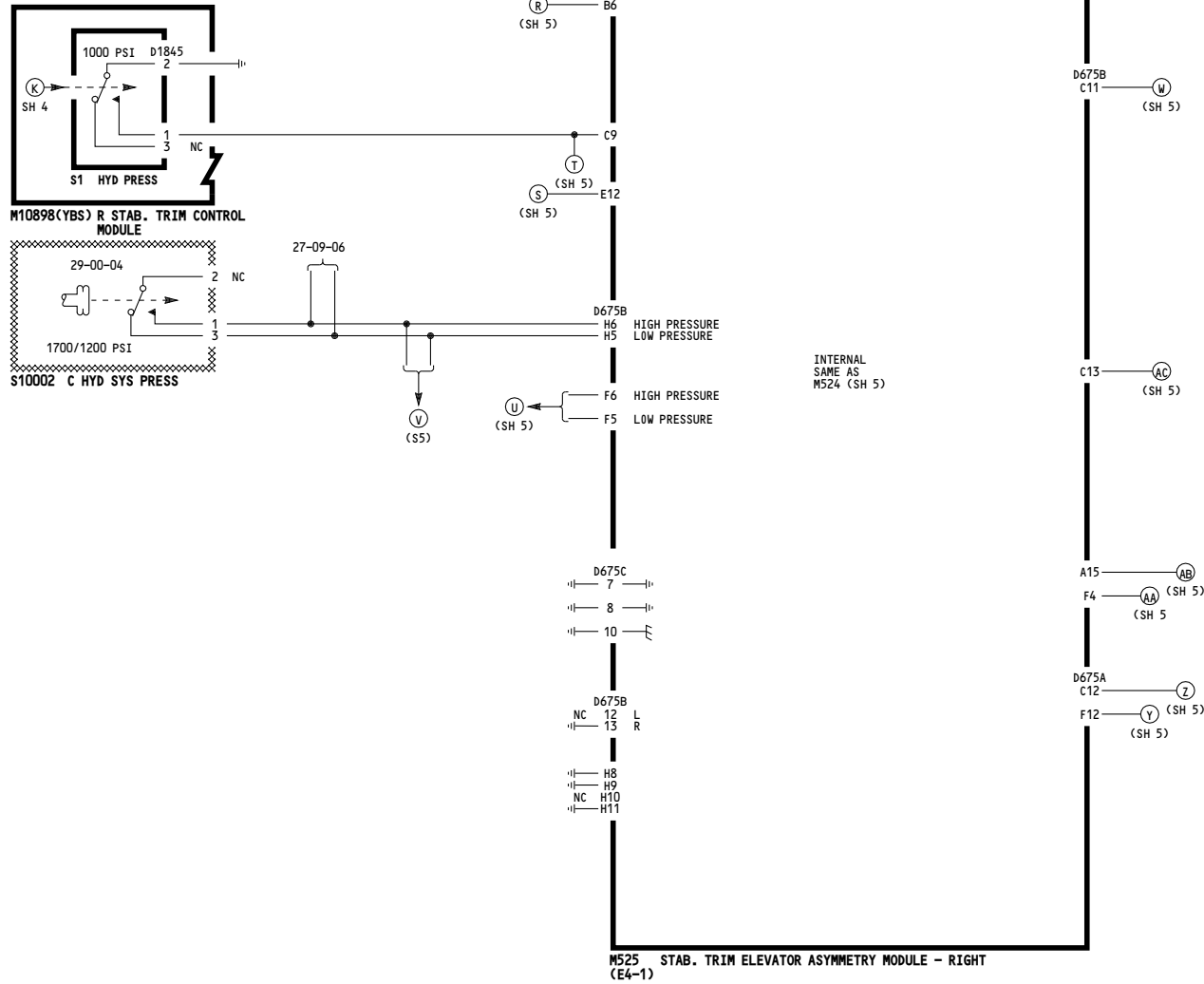

010-011

HORIZONTAL STABILIZER TRIM

D280N032S

27-40-01

Page 103.1
Sheet 6
Jan 21/2005

5012

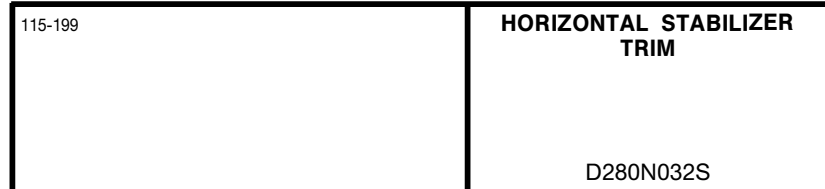
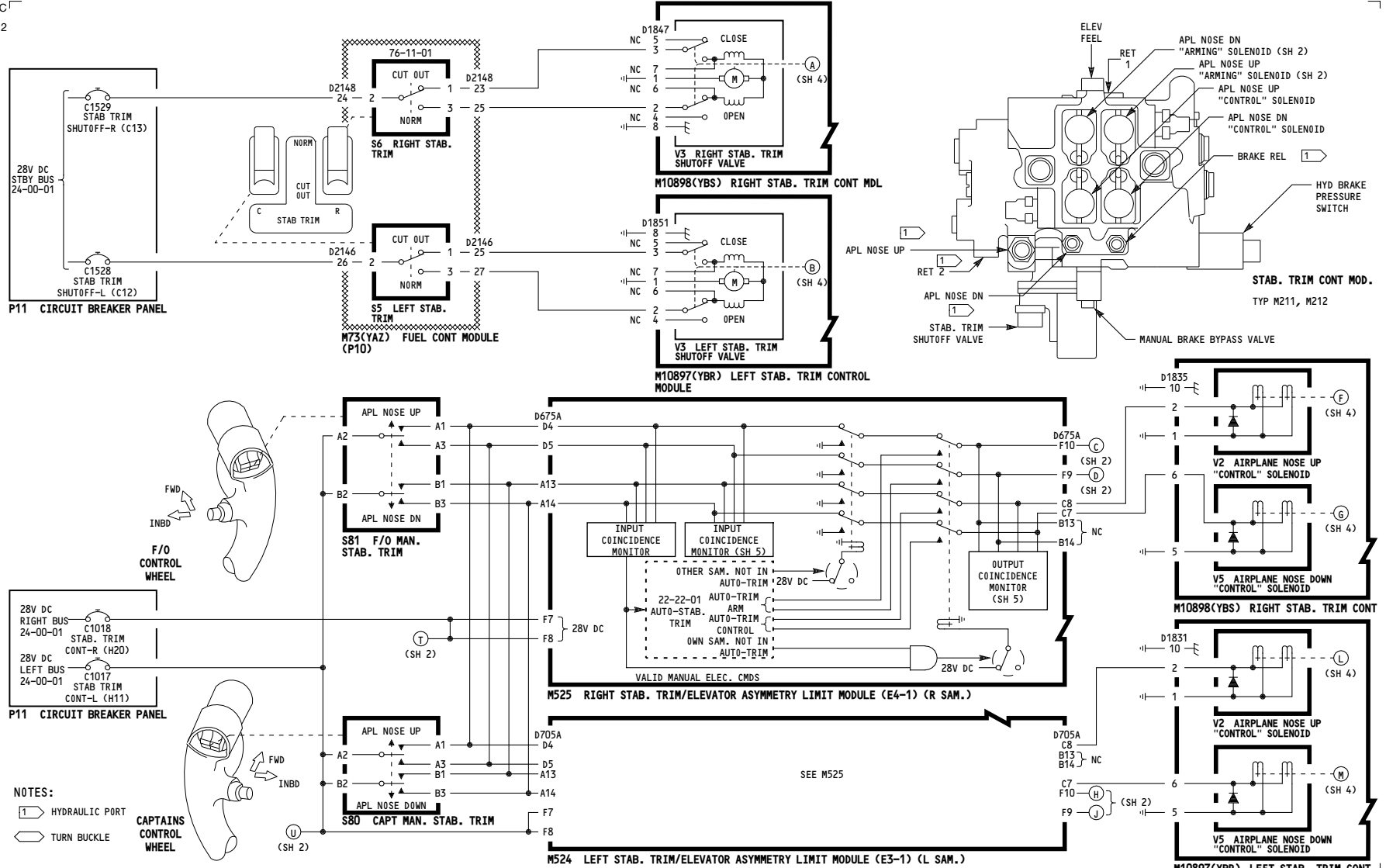

27-40-01

-A
5011

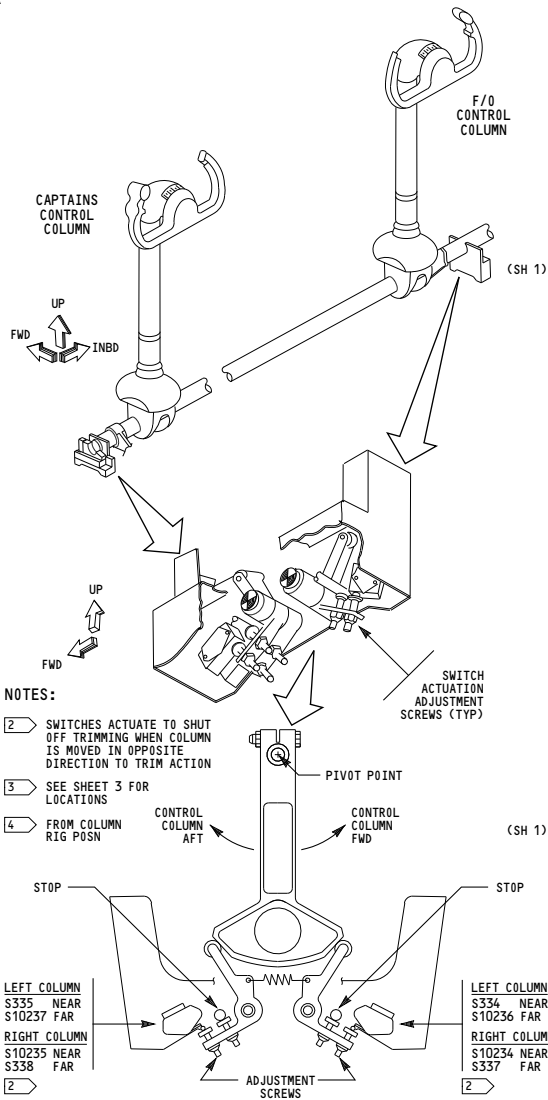

- NOTES:**
- 2 SWITCHES ACTUATE TO SHUT OFF TRIMMING WHEN COLUMN IS MOVED IN OPPOSITE DIRECTION TO TRIM ACTION
 - 3 SEE SHEET 3 FOR LOCATIONS
 - 4 FROM COLUMN RIG POSN

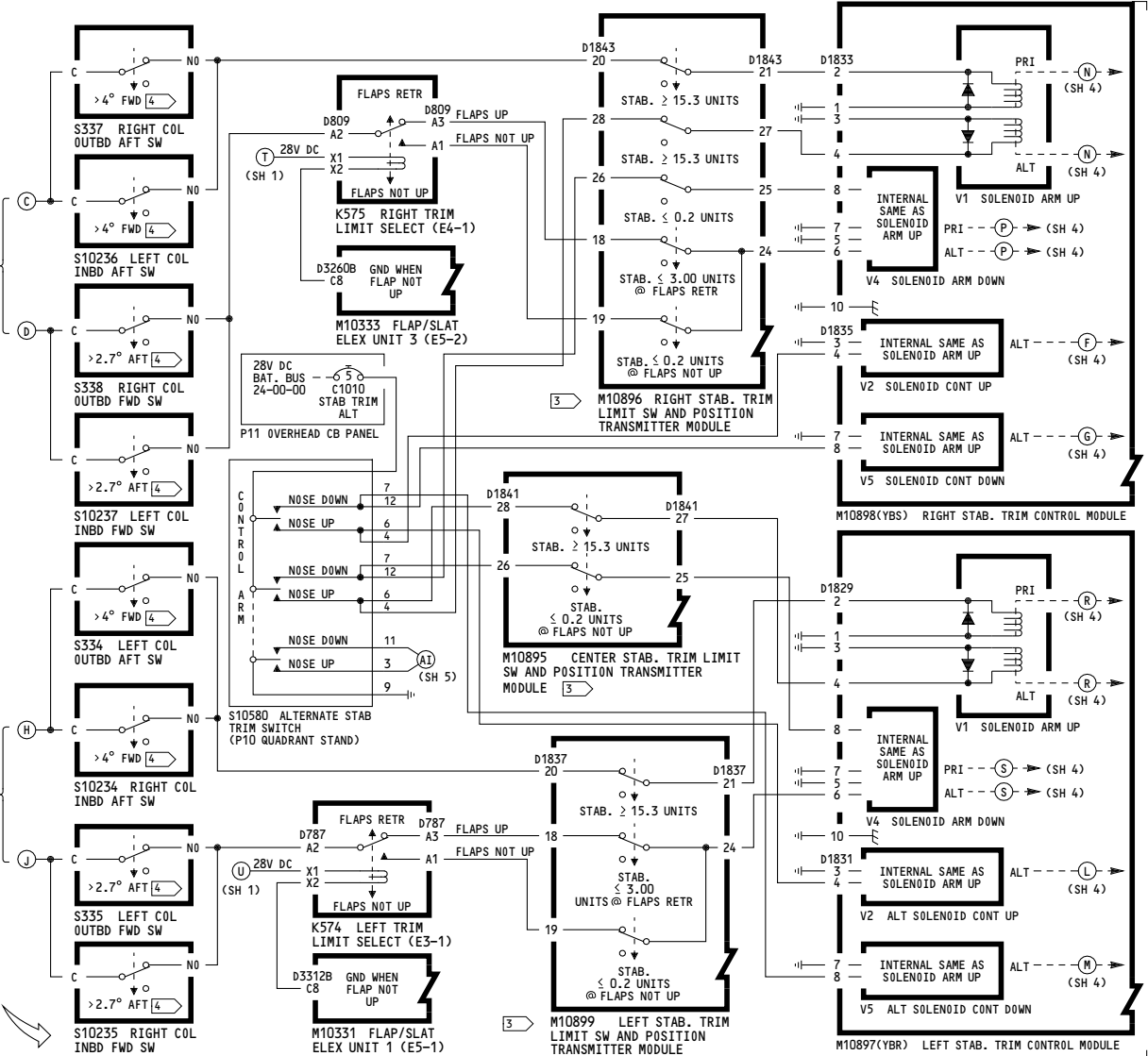

115-199

HORIZONTAL STABILIZER TRIM

D280N032S

27-40-01

5013

WIRING DIAGRAMS
27-48-11

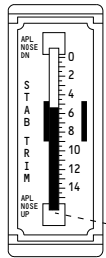
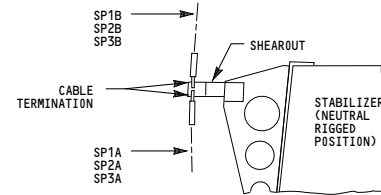
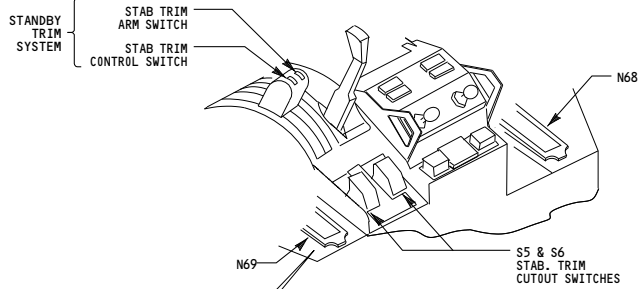

N68, N69

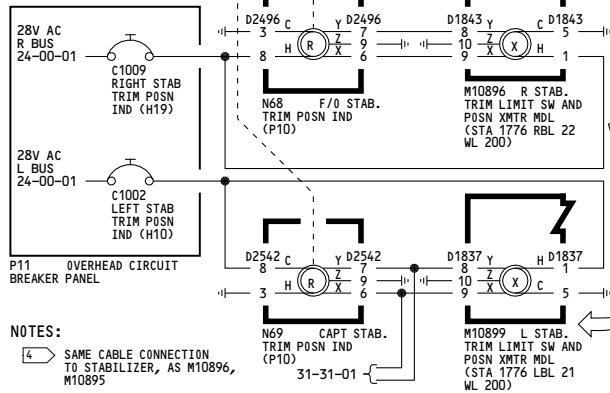

NOTES:

4 SAME CABLE CONNECTION TO STABILIZER, AS M10896, M10895

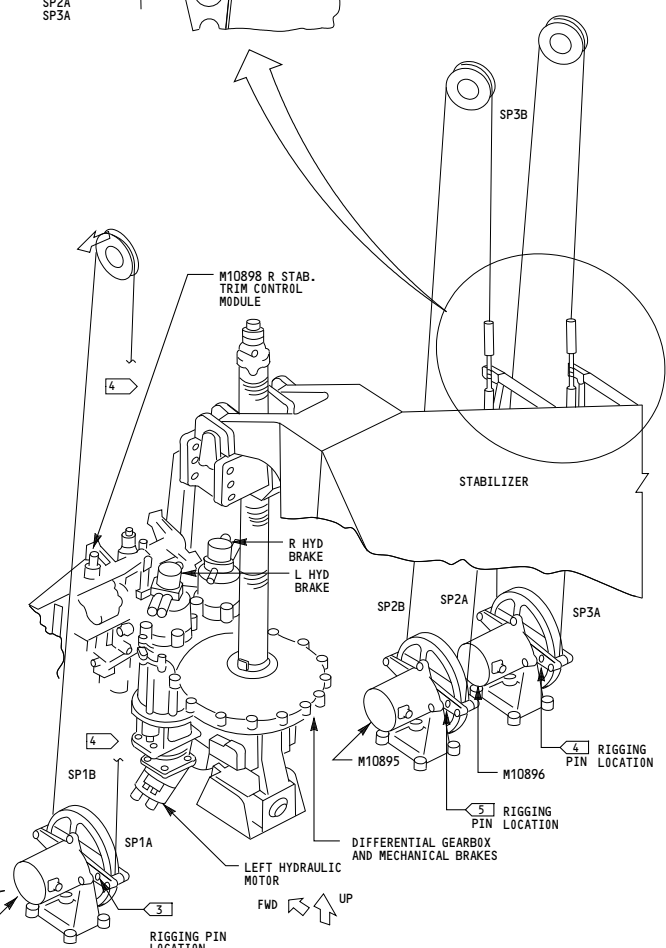

115-199	HORIZONTAL STABILIZER TRIM
D280N032S	

27-40-01

5001

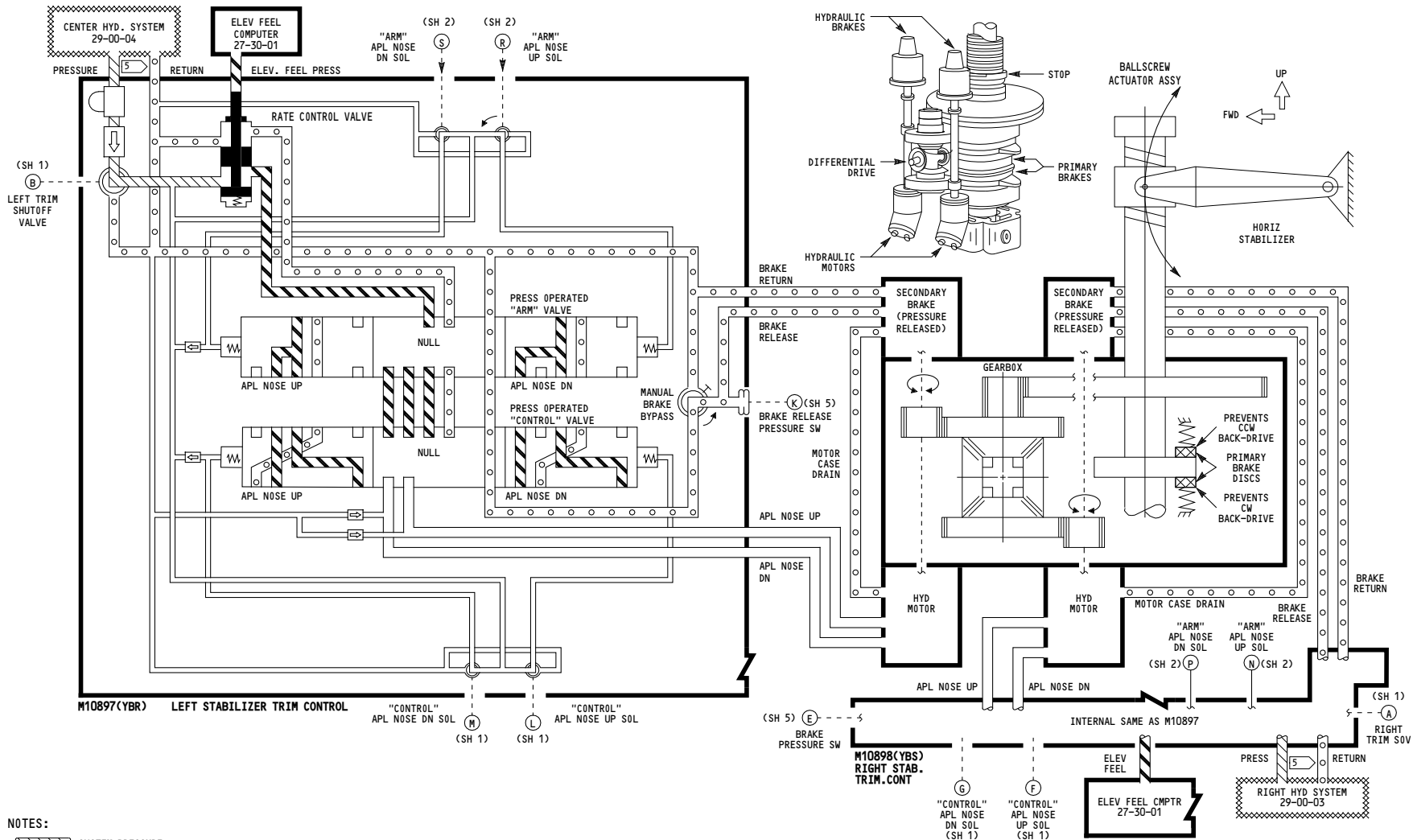

115-199	HORIZONTAL STABILIZER TRIM
	D280N032S

27-40-01

5011

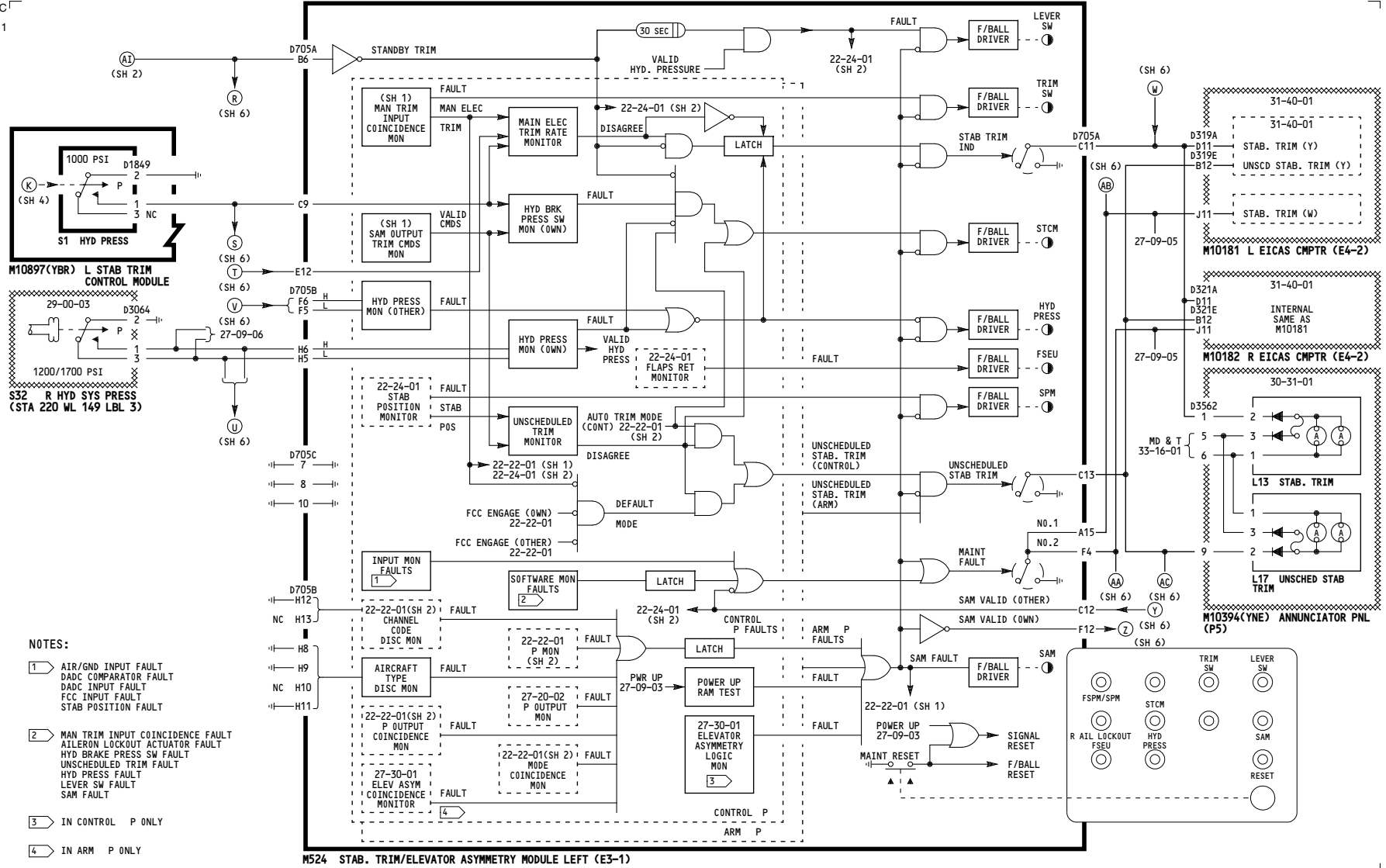

- NOTES:**
- 1 AIR/GND INPUT FAULT
DADC COMPARATOR FAULT
DADC INPUT FAULT
FCC INPUT FAULT
STAB POSITION FAULT
 - 2 MAN TRIM INPUT COINCIDENCE FAULT
AILERON LOCKOUT ACTUATOR FAULT
HYD BRAKE PRESS SW FAULT
UNDESCHEDULED TRIM FAULT
HYD PRESS FAULT
LEVER SW FAULT
SAM FAULT
 - 3 IN CONTROL P ONLY
 - 4 IN ARM P ONLY

M524 STAB. TRIM/ELEVATOR ASYMMETRY MODULE LEFT (E3-1)

115-199

HORIZONTAL STABILIZER TRIM

D280N032S

27-40-01

-A
5011

WIRING DIAGRAMS
27-41-11
27-41-21
27-48-11

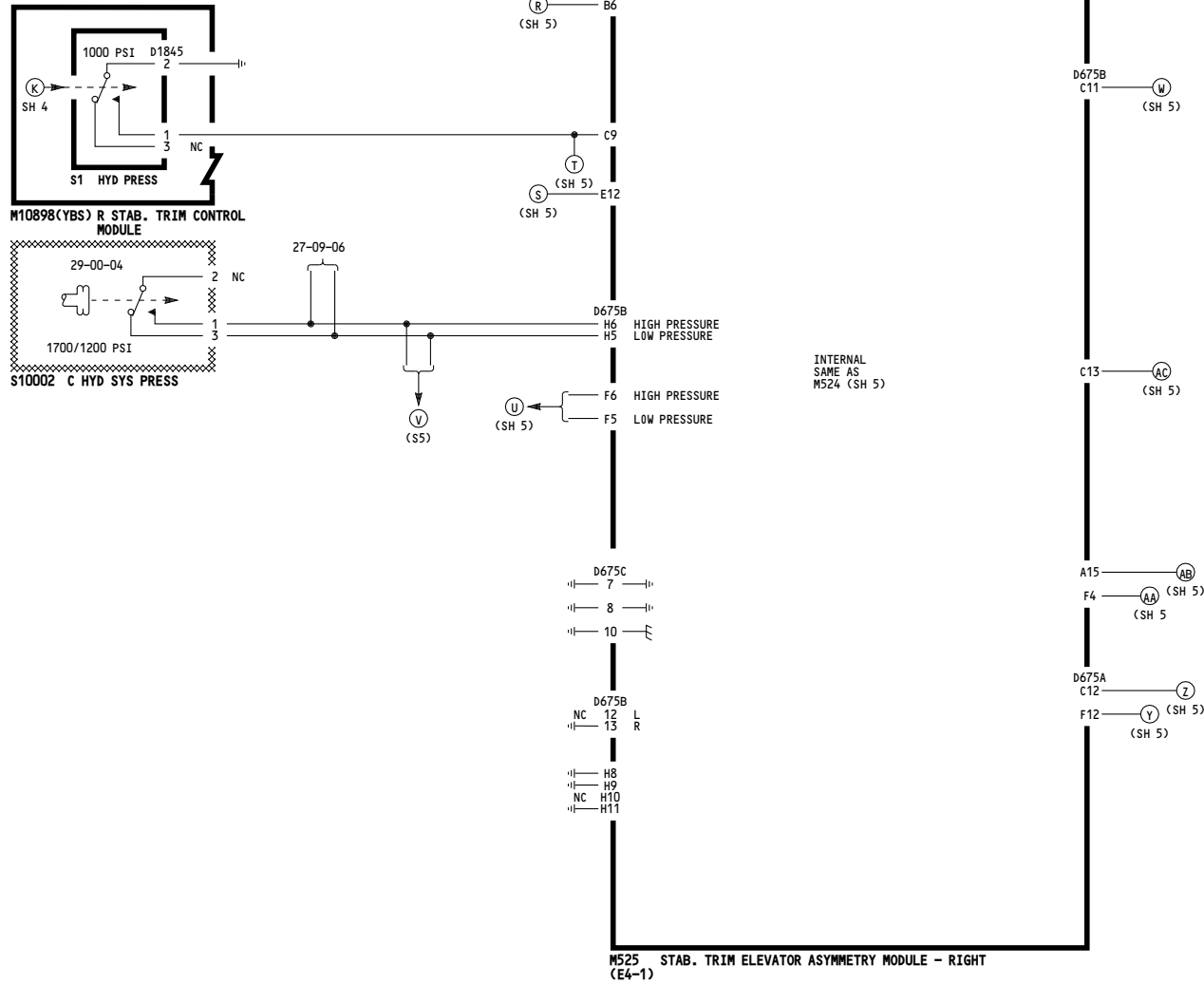

115-199

HORIZONTAL STABILIZER TRIM

D280N032S

27-40-01

Page 104
Sheet 6
Jan 21/2005

5024

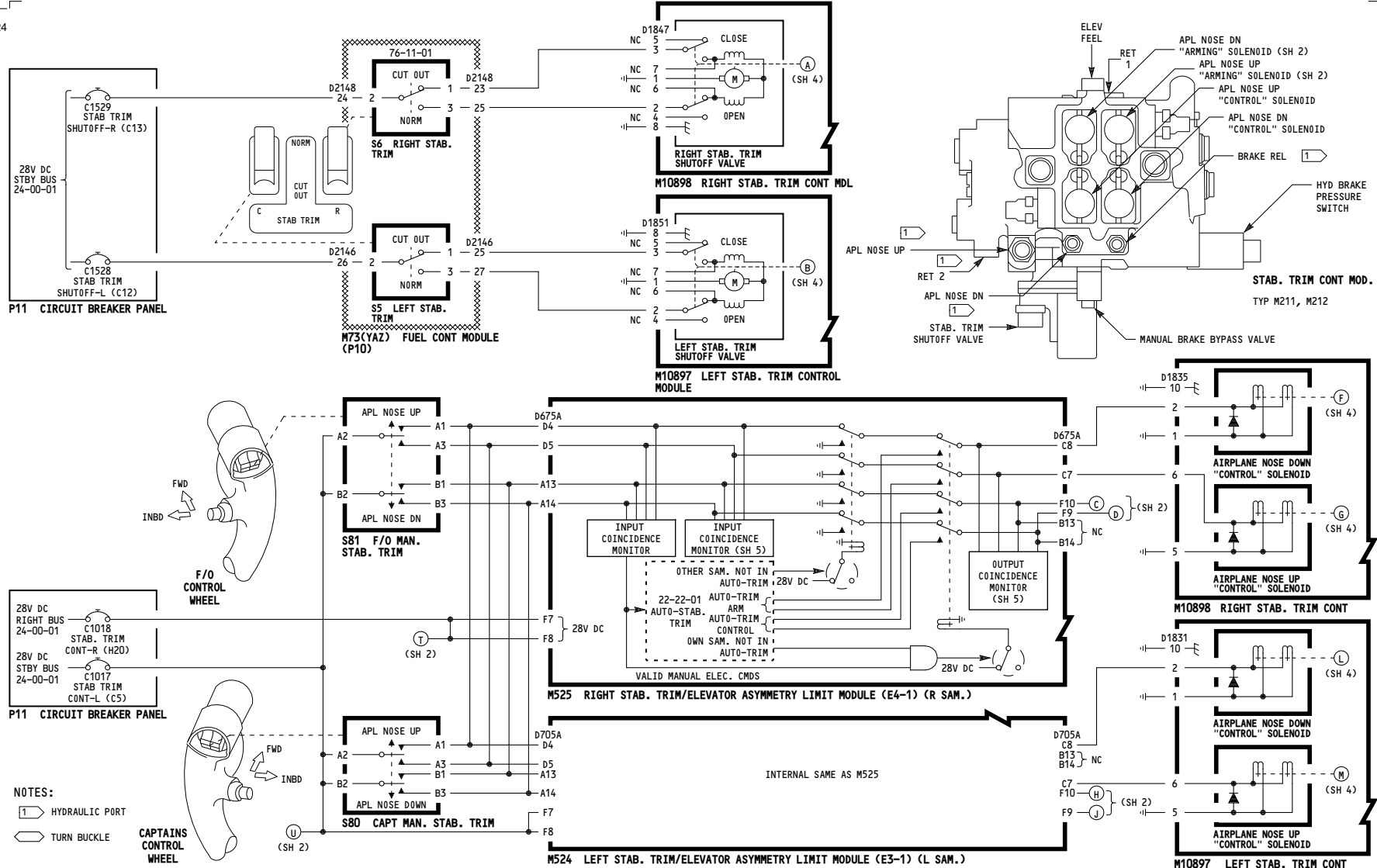

115

HORIZONTAL STABILIZER TRIM

D280N032S

Incorporates 27-0104

27-40-01

5011

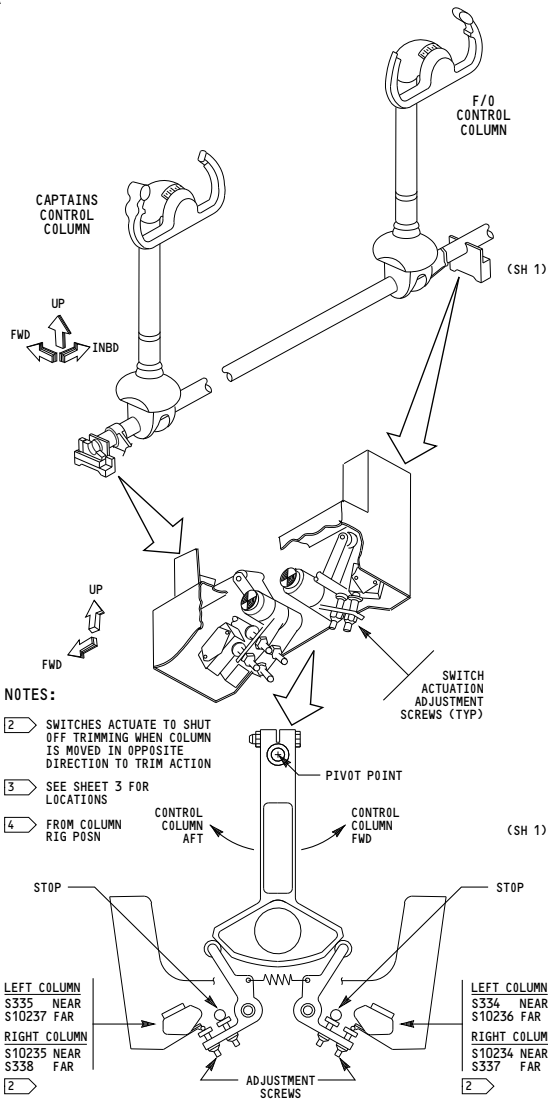

- NOTES:**
- 2 SWITCHES ACTUATE TO SHUT OFF TRIMMING WHEN COLUMN IS MOVED IN OPPOSITE DIRECTION TO TRIM ACTION
 - 3 SEE SHEET 3 FOR LOCATIONS
 - 4 FROM COLUMN RIG POSN

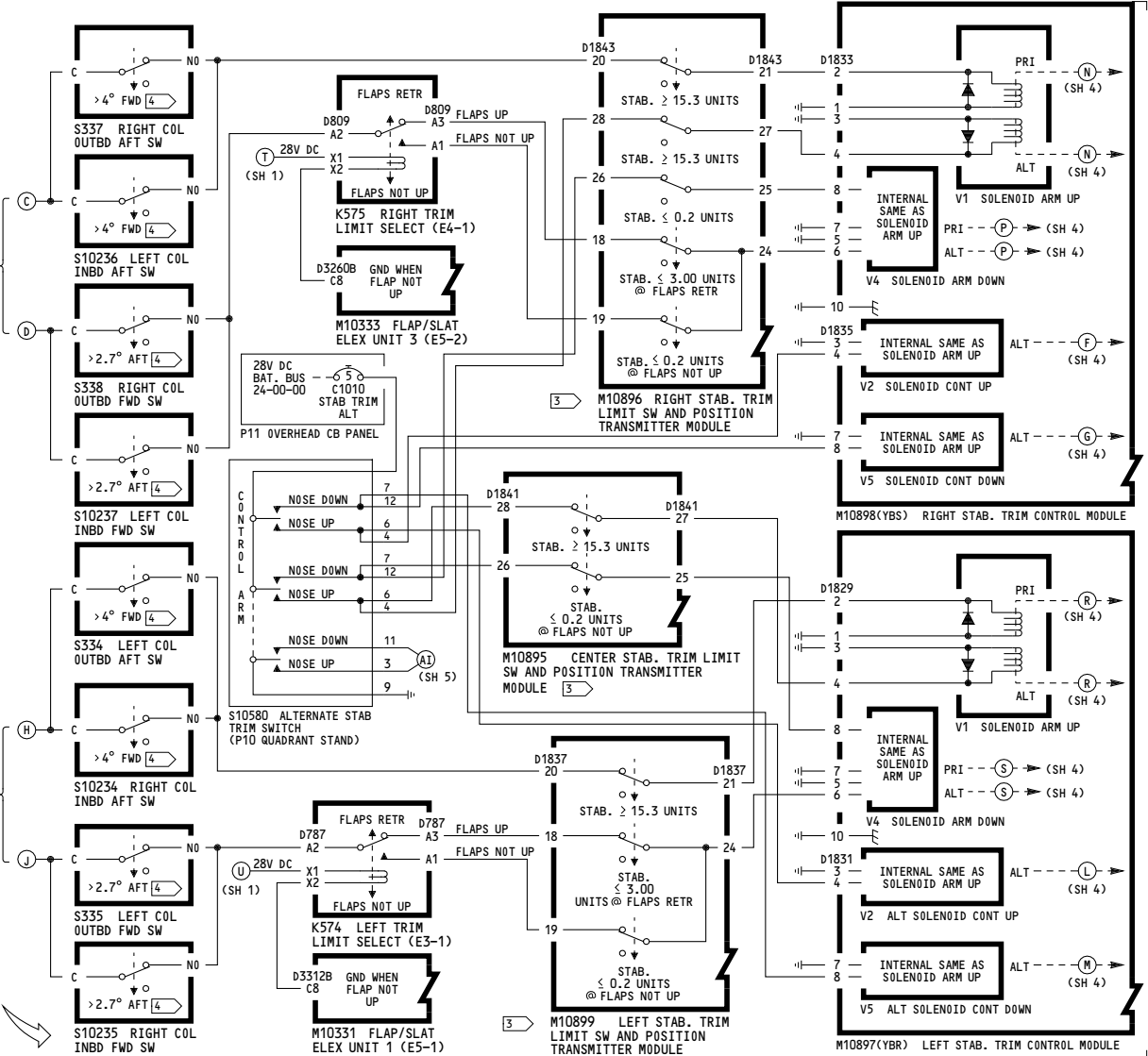

115

HORIZONTAL STABILIZER TRIM

D280N032S

27-40-01

5013

WIRING DIAGRAMS
27-48-11

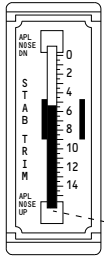
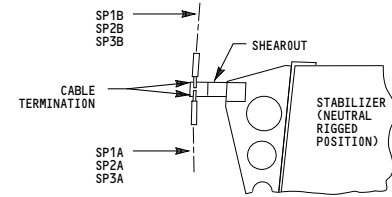
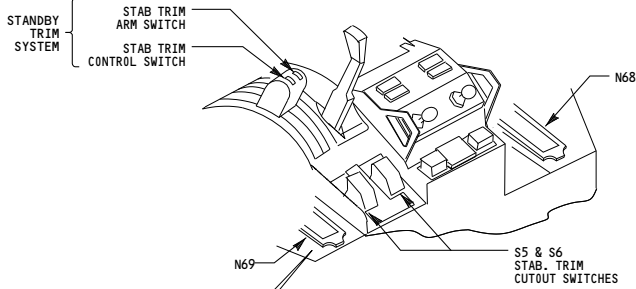

N68, N69

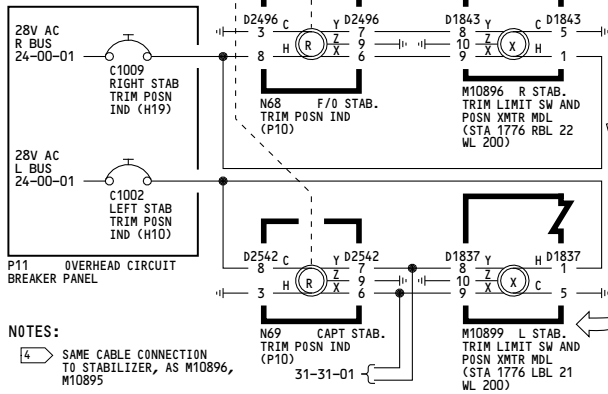

NOTES:

4 SAME CABLE CONNECTION TO STABILIZER, AS M10896, M10895

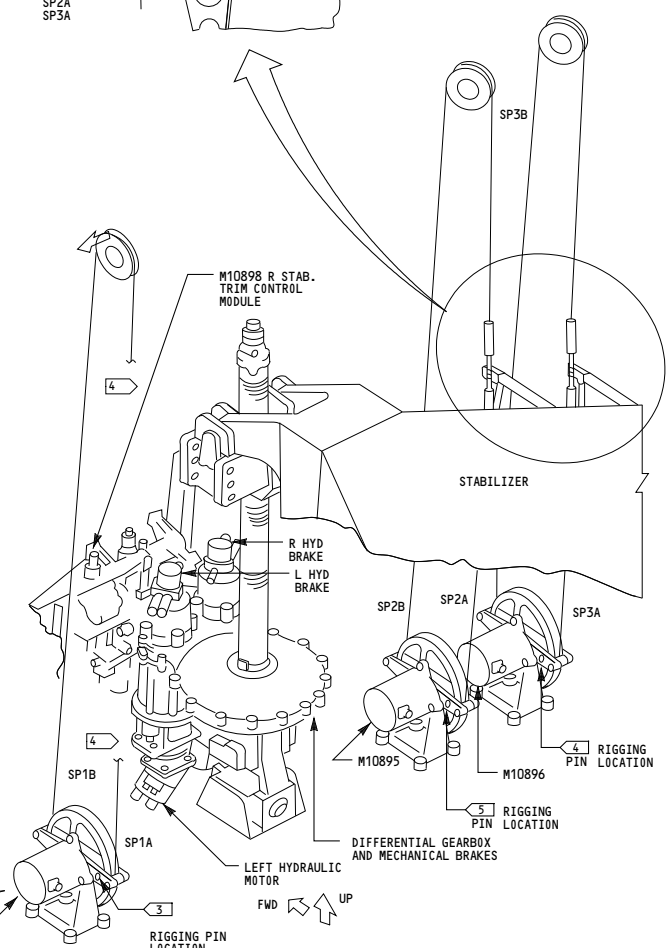

115	<p>HORIZONTAL STABILIZER TRIM</p> <p>D280N032S</p>
-----	---

27-40-01

Page 104.1
Sheet 3
Jan 21/2005

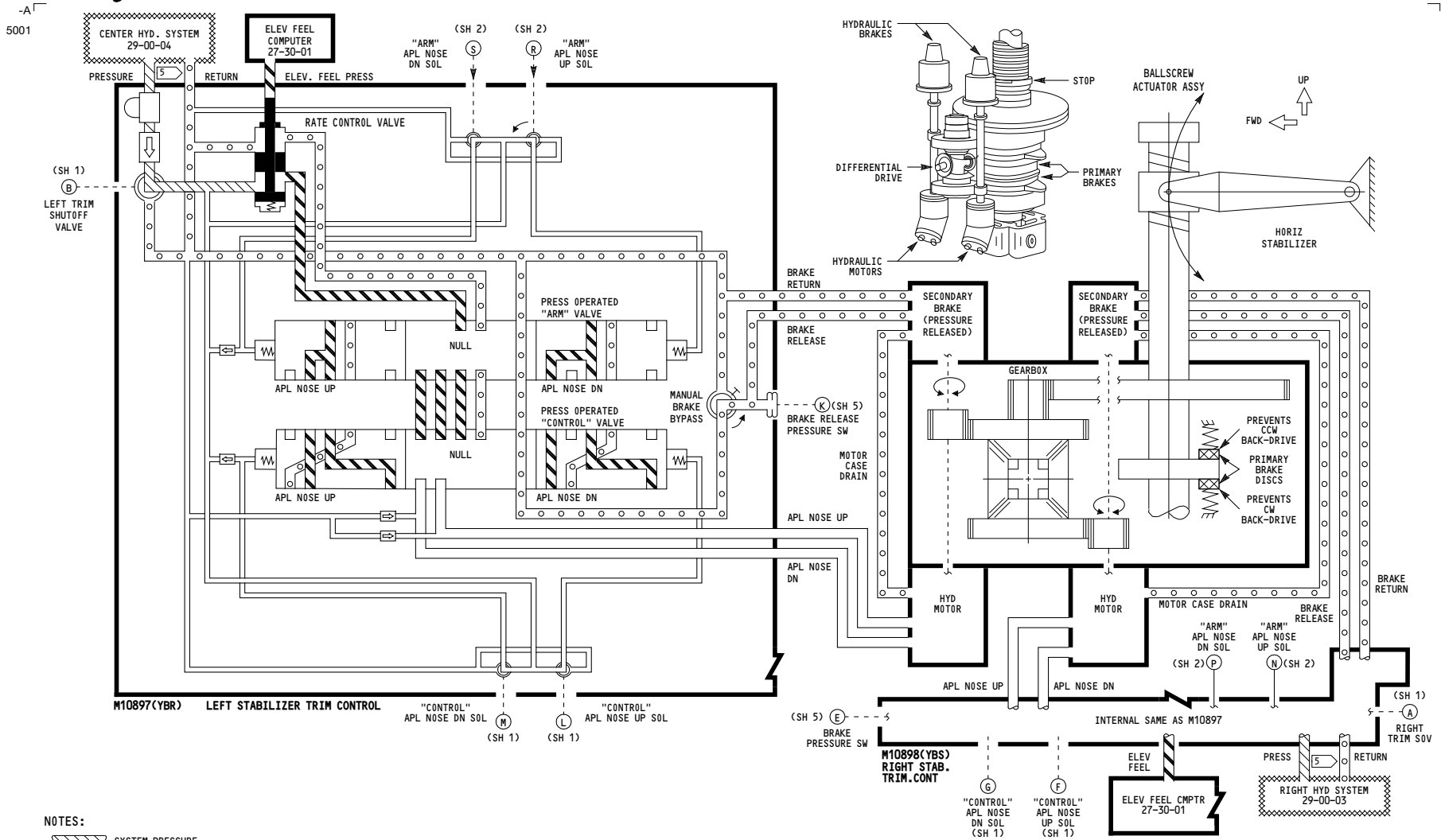

- NOTES:**
- SYSTEM PRESSURE
 - RETURN
 - METERED PRESSURE

115	<p>HORIZONTAL STABILIZER TRIM</p> <p>D280N032S</p>
-----	---

27-40-01

Page 104.1
Sheet 4
Jan 21/2005

5011

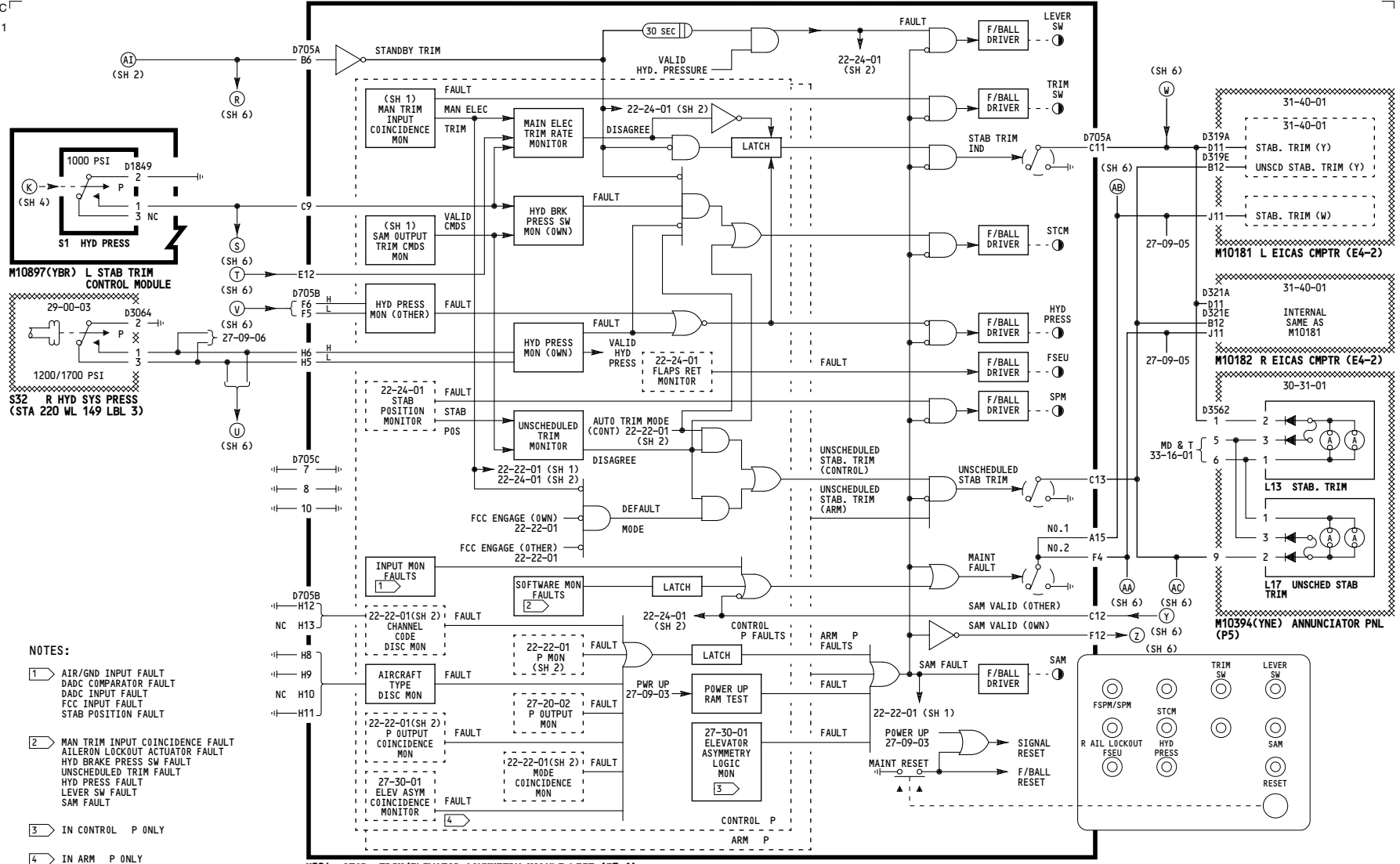

M524 STAB. TRIM/ELEVATOR ASYMMETRY MODULE LEFT (E3-1)

- NOTES:**
- 1 AIR/GND INPUT FAULT
DADC COMPARATOR FAULT
DADC INPUT FAULT
FCC INPUT FAULT
STAB POSITION FAULT
 - 2 MAN TRIM INPUT COINCIDENCE FAULT
AILERON LOCKOUT ACTUATOR FAULT
HYD BRAKE PRESS SW FAULT
UNDESCHEDULED TRIM FAULT
HYD PRESS FAULT
LEVER SW FAULT
SAM FAULT
 - 3 IN CONTROL P ONLY
 - 4 IN ARM P ONLY

115

HORIZONTAL STABILIZER TRIM

D280N032S

27-40-01

Page 104.1
Sheet 5
Dec 18/2007

-A
5011

WIRING DIAGRAMS
27-41-11
27-41-21
27-48-11

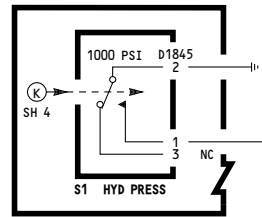

M10898(YBS) R STAB. TRIM CONTROL MODULE

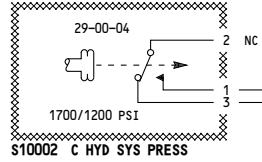

S10002 C HYD SYS PRESS

27-09-06



(V)
(S5)

(R)
D675A
B6
(SH 5)

(T)
C9
(SH 5)
(S)
E12
(SH 5)

(U)
F6
(SH 5)
F5
HIGH PRESSURE
LOW PRESSURE

D675C
7
8
10

D675B
NC 12 L
13 R
H8
H9
NC H10
H11

M525 STAB. TRIM ELEVATOR ASYMMETRY MODULE - RIGHT (E4-1)

INTERNAL
SAME AS
M524 (SH 5)

D675B
C11
(W)
(SH 5)

C13
(AC)
(SH 5)

A15
F4
(AB)
(SH 5)
(AA)
(SH 5)

D675A
C12
F12
(Z)
(Y)
(SH 5)
(SH 5)

115

HORIZONTAL STABILIZER TRIM

D280N032S

27-40-01

Page 104.1
Sheet 6
Jan 21/2005

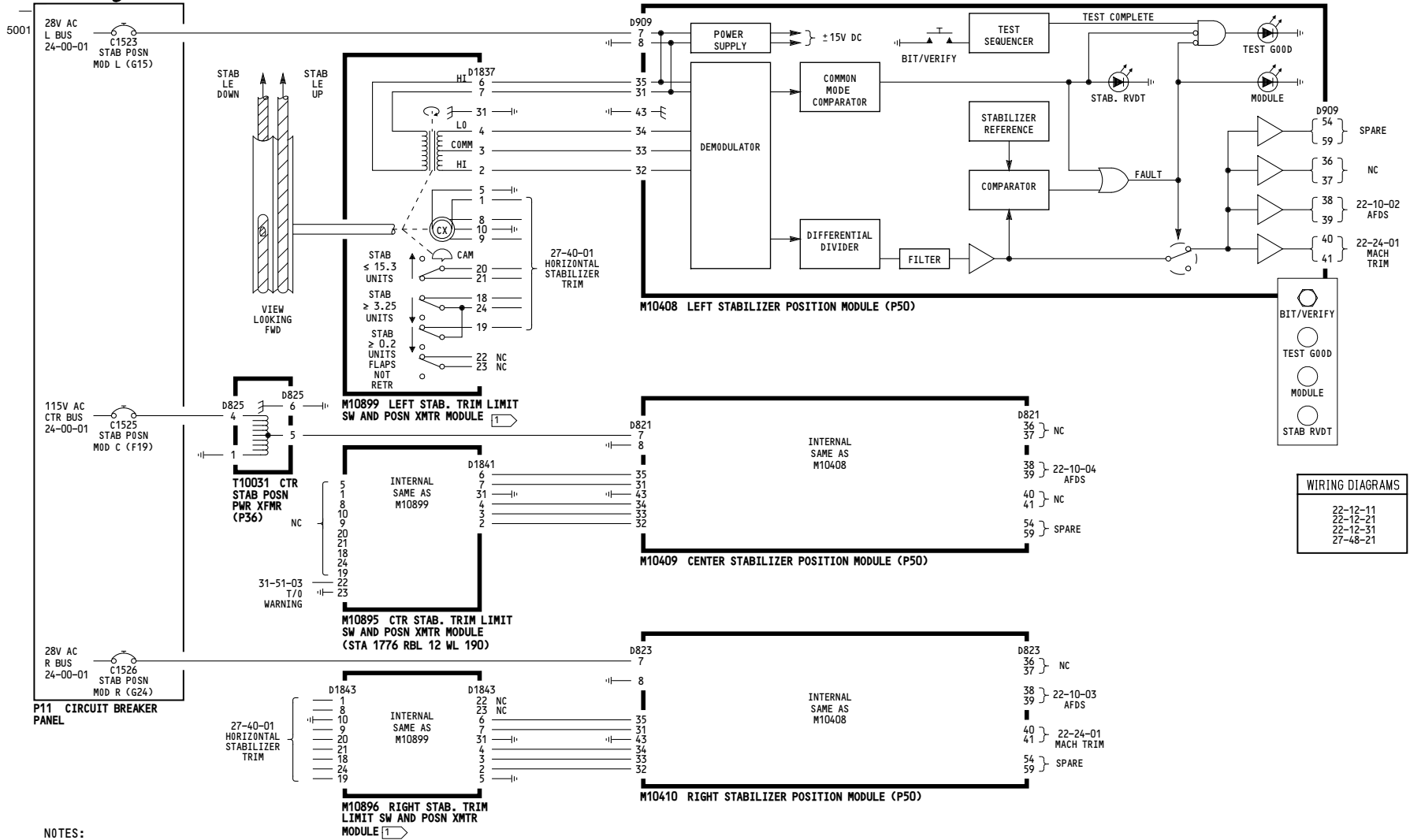

ALL	STABILIZER POSITION SENSING
	D280N032S

27-48-01

Page 101

Jan 21/2005

THIS PAGE INTENTIONALLY LEFT BLANK

5001

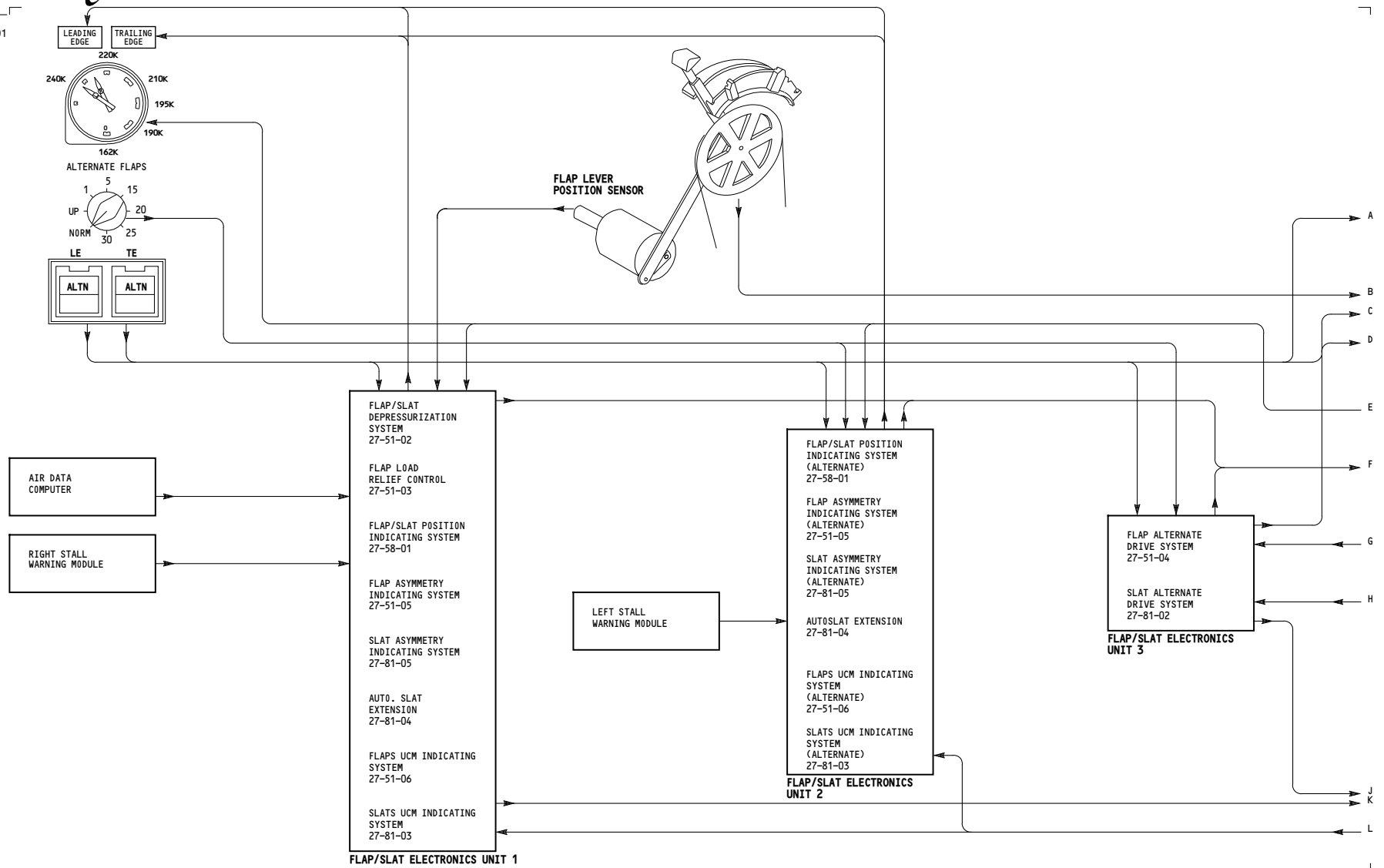

ALL	<p>HIGH LIFT DEVICES - SIMPLIFIED</p> <p>D280N032S</p>
-----	---

27-50-00

5001

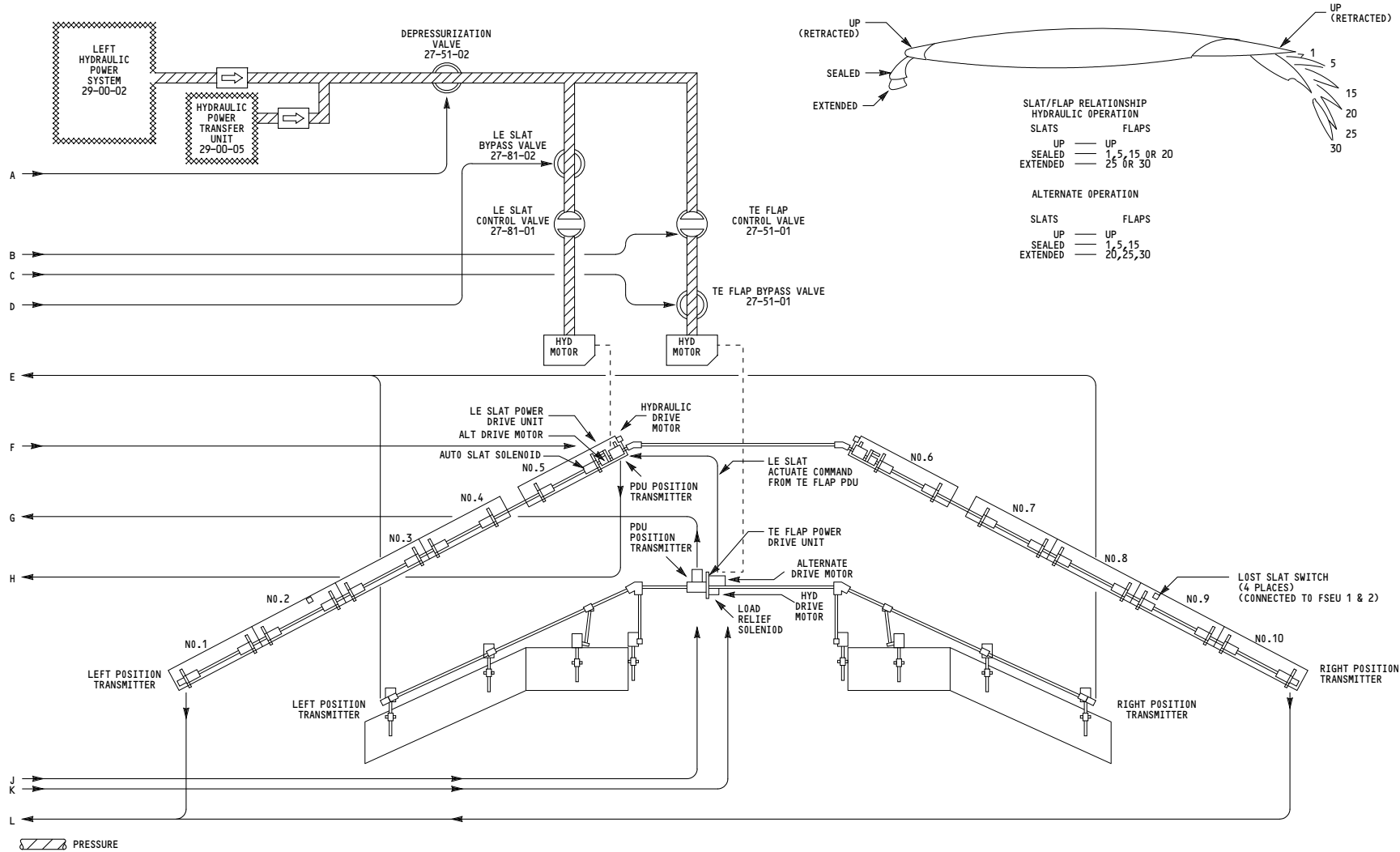

ALL	<p>HIGH LIFT DEVICES - SIMPLIFIED</p> <p>D280N032S</p>
-----	---

27-50-00

Page 101
Sheet 2
Jan 21/2005

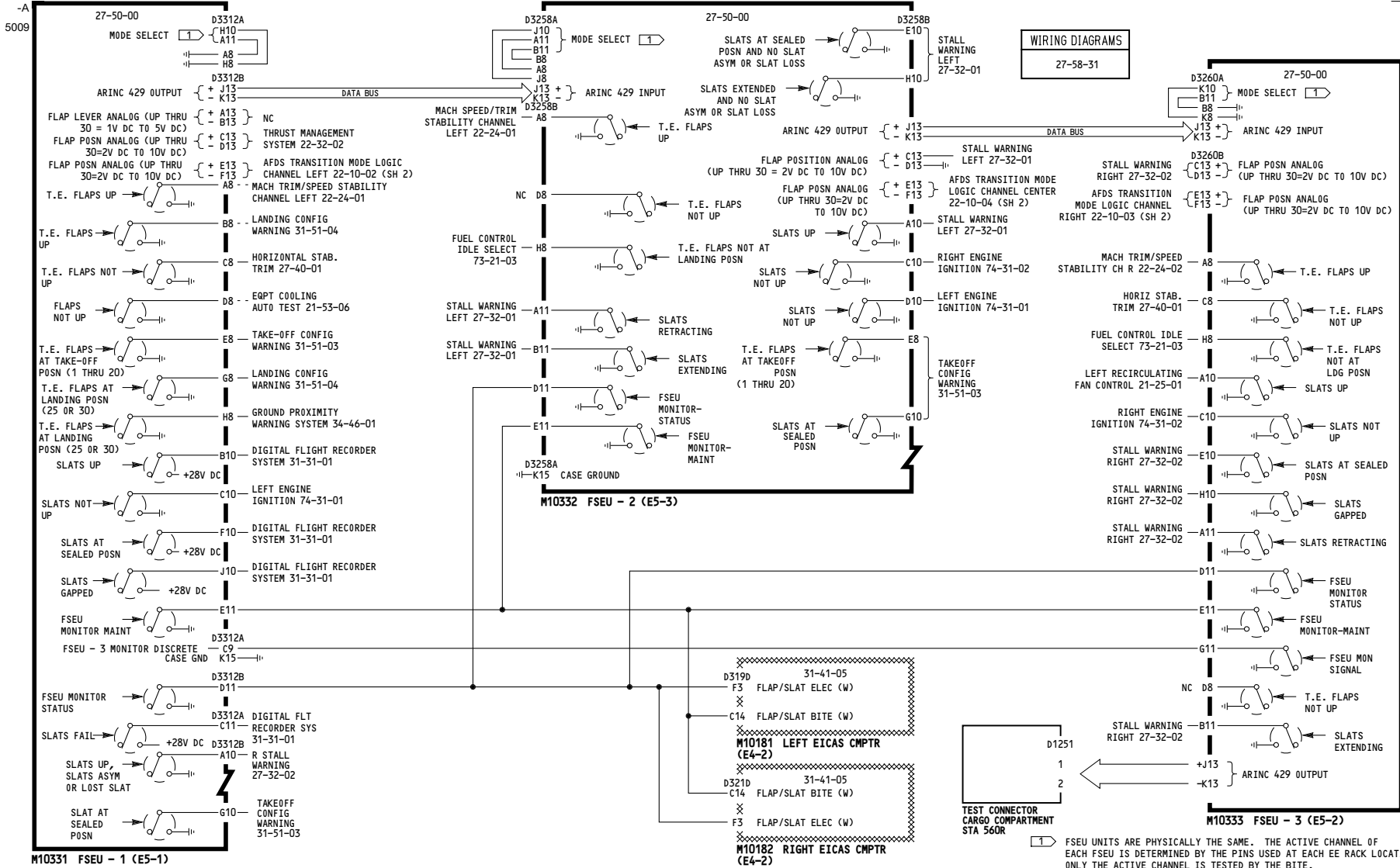

FSEU UNITS ARE PHYSICALLY THE SAME. THE ACTIVE CHANNEL OF EACH FSEU IS DETERMINED BY THE PINS USED AT EACH EE RACK LOCATION. ONLY THE ACTIVE CHANNEL IS TESTED BY THE BITE.

001-099

FLAP/SLAT ELECTRONICS UNIT

D280N032S

27-50-01

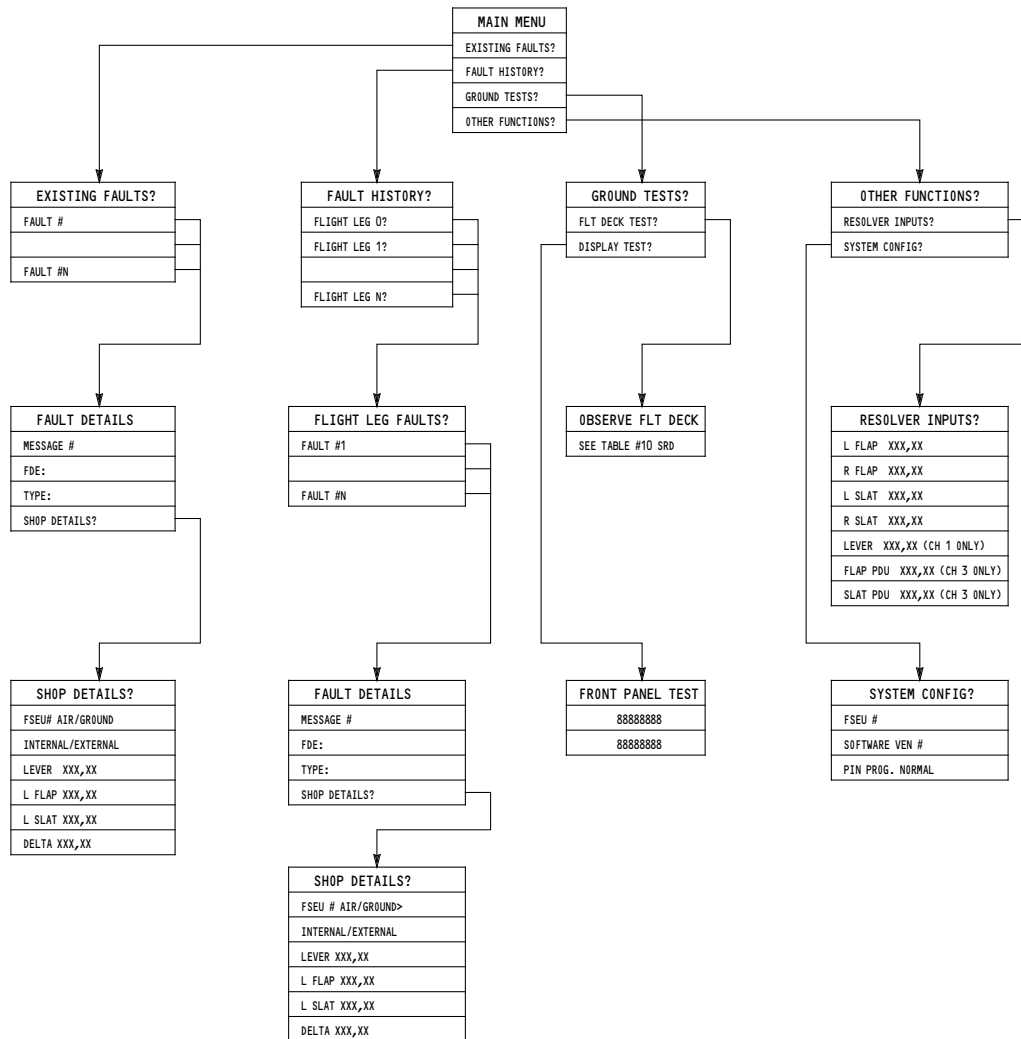

FSEU BITE CONTROL PANEL MENU HIERARCHY

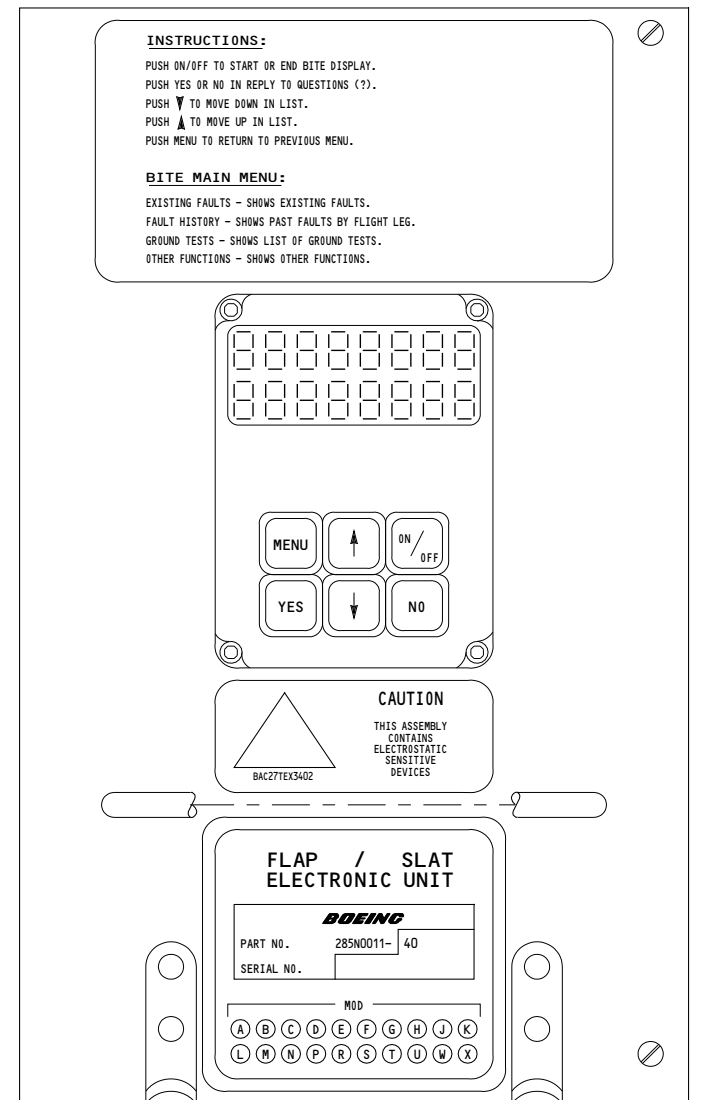

001-099	FLAP/SLAT ELECTRONICS UNIT D280N032S
---------	--

27-50-01

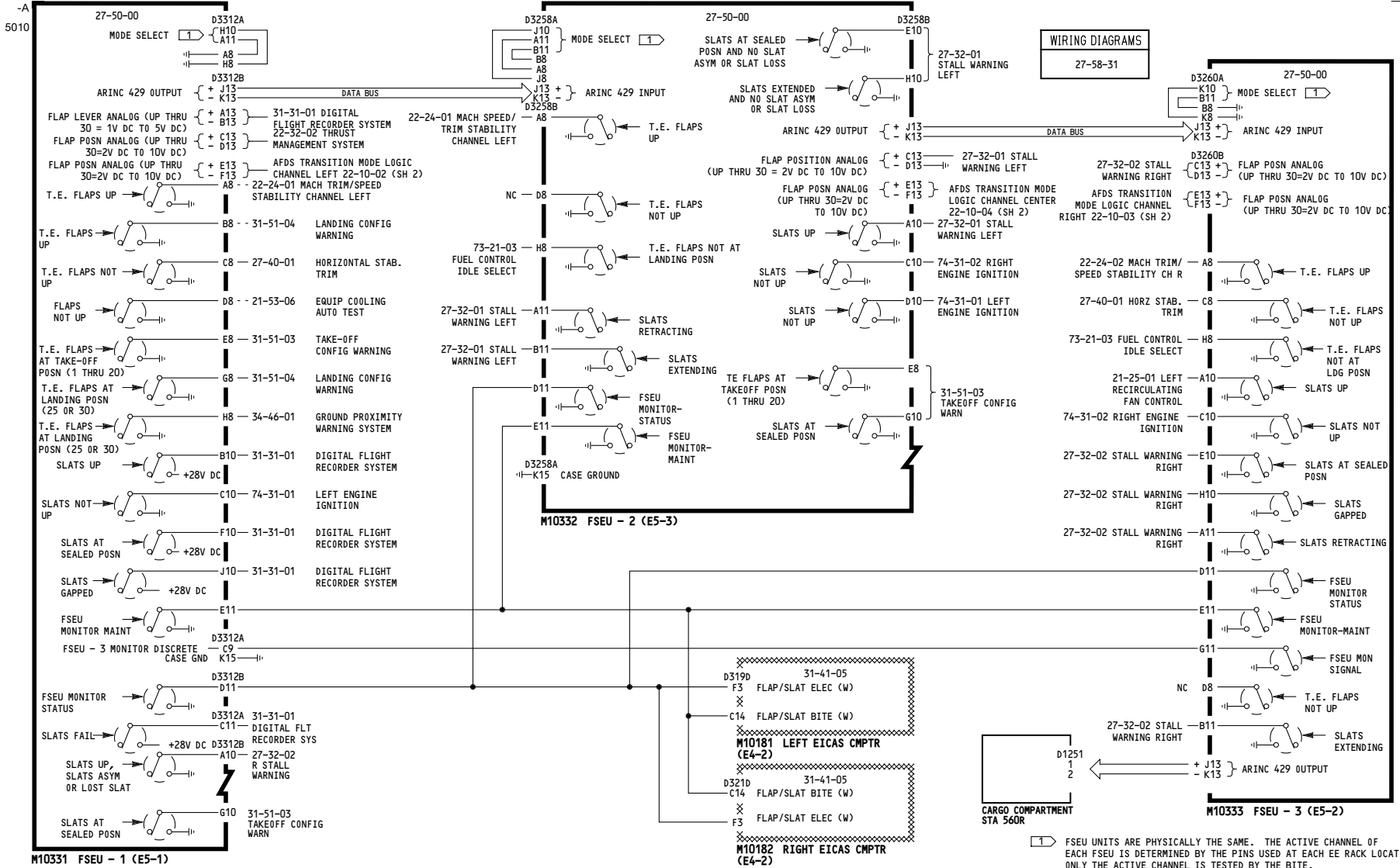

115-199

FLAP/SLAT ELECTRONICS UNIT

D280N032S

27-50-01

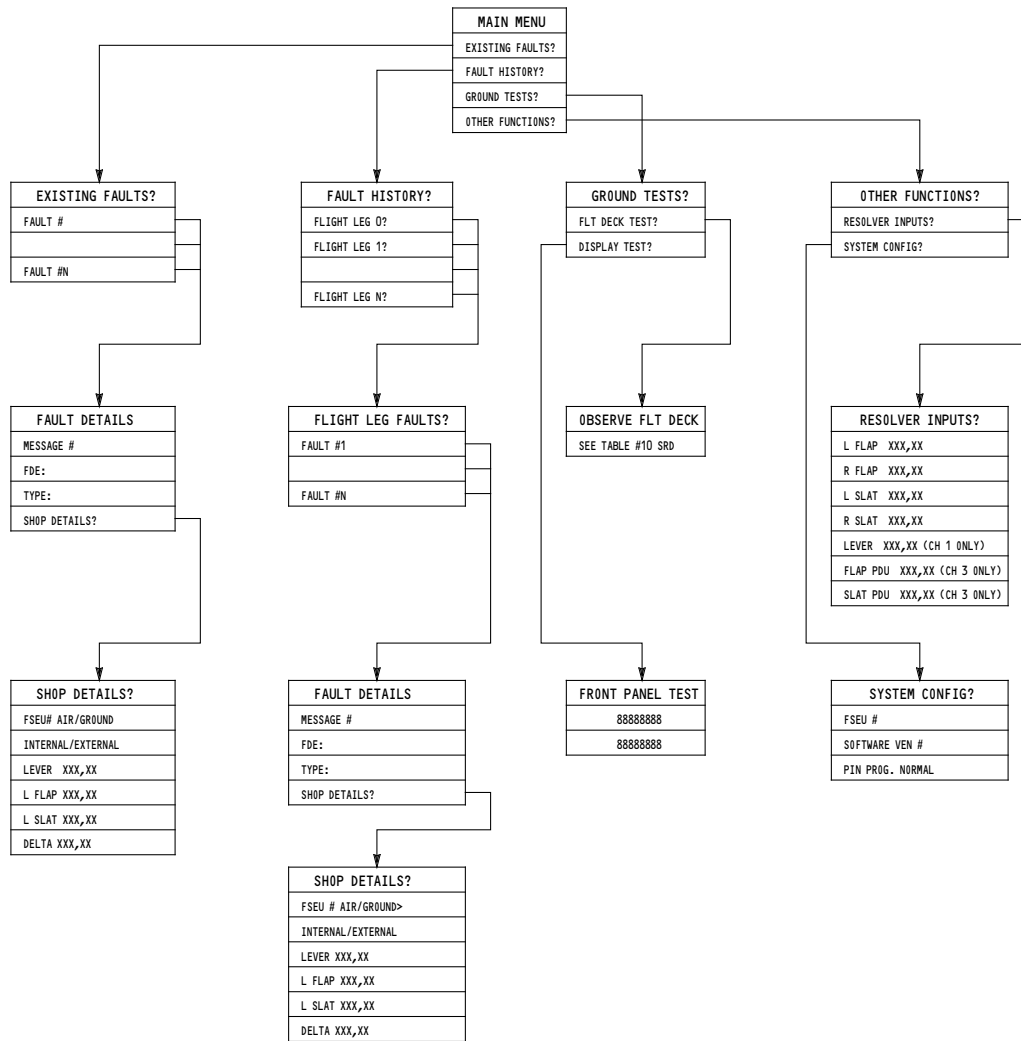

FSEU BITE CONTROL PANEL MENU HIERARCHY

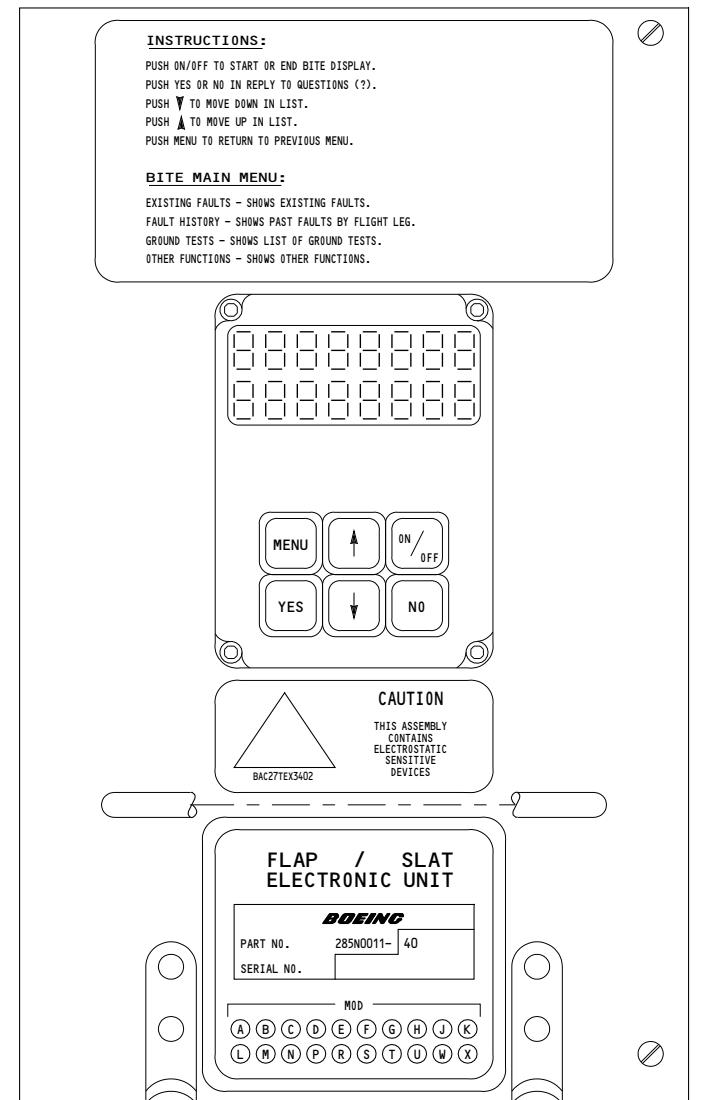

115-199	FLAP/SLAT ELECTRONICS UNIT D280N032S
---------	--

27-50-01

-B
5000

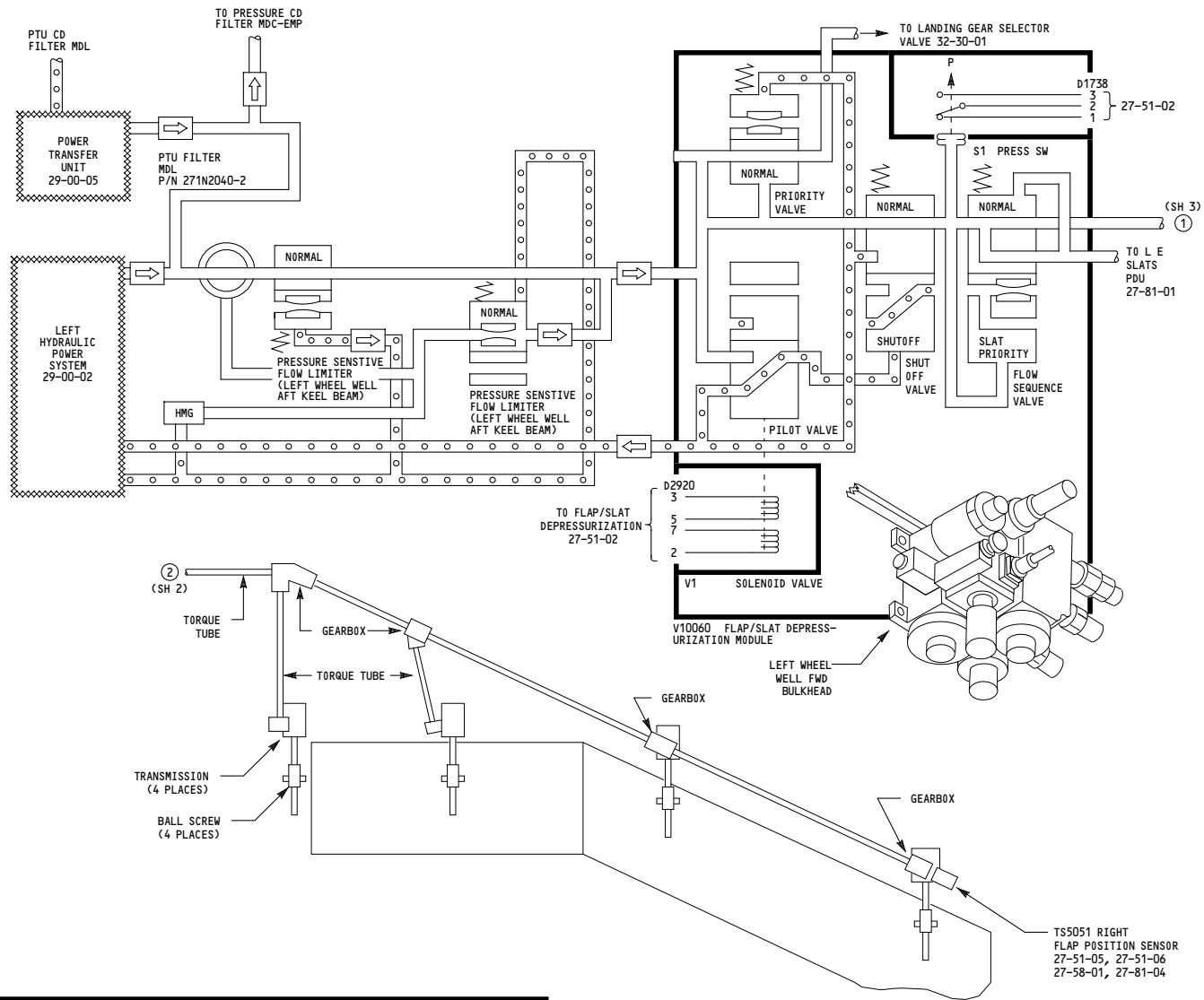

ALL	<p align="center">TRAILING EDGE FLAPS PRIMARY DRIVE</p> <p align="center">D280N032S</p>
-----	--

27-51-01

-A
5000

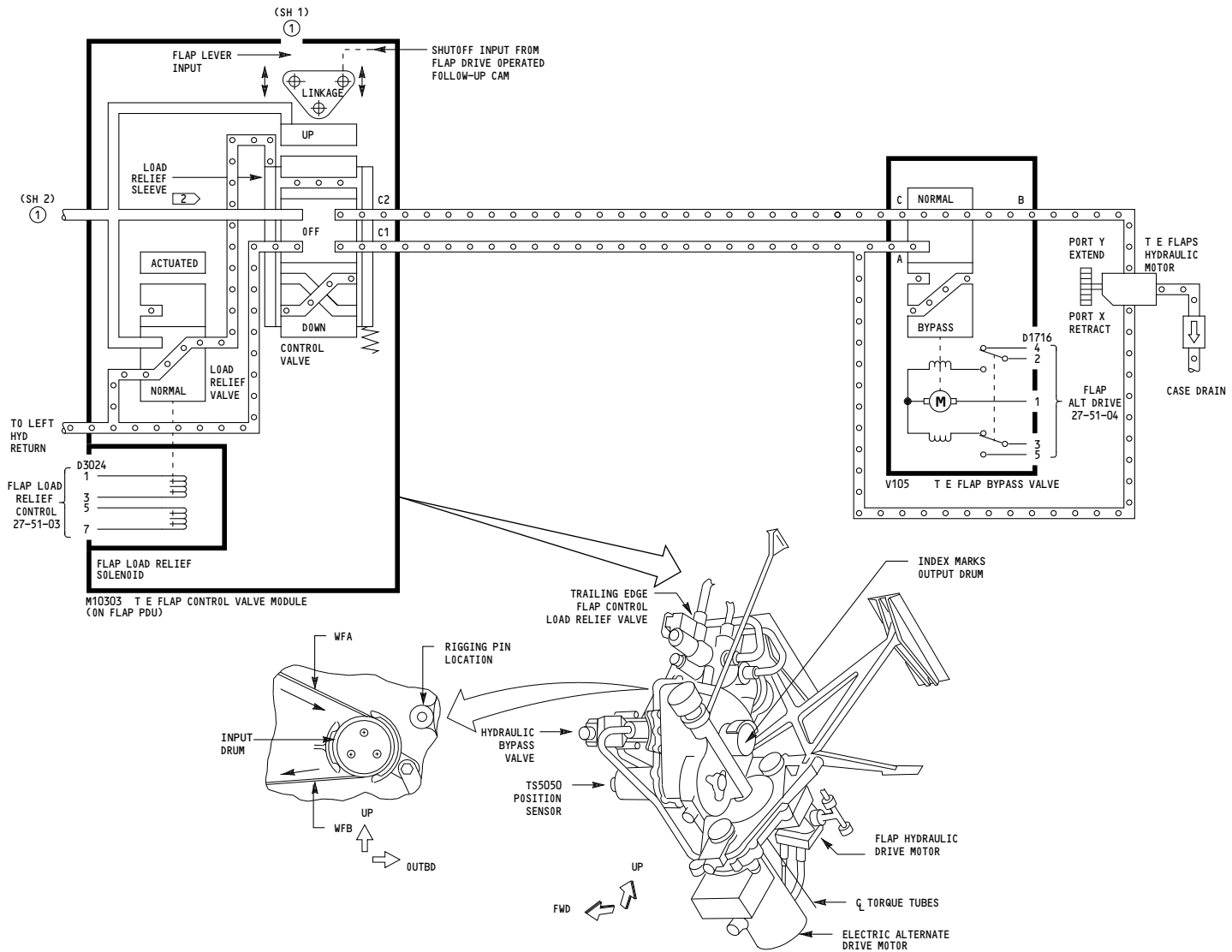

ALL	<p align="center">TRAILING EDGE FLAPS PRIMARY DRIVE</p> <p align="center">D280N032S</p>
-----	--

27-51-01

Page 101
Sheet 3
Jan 21/2005

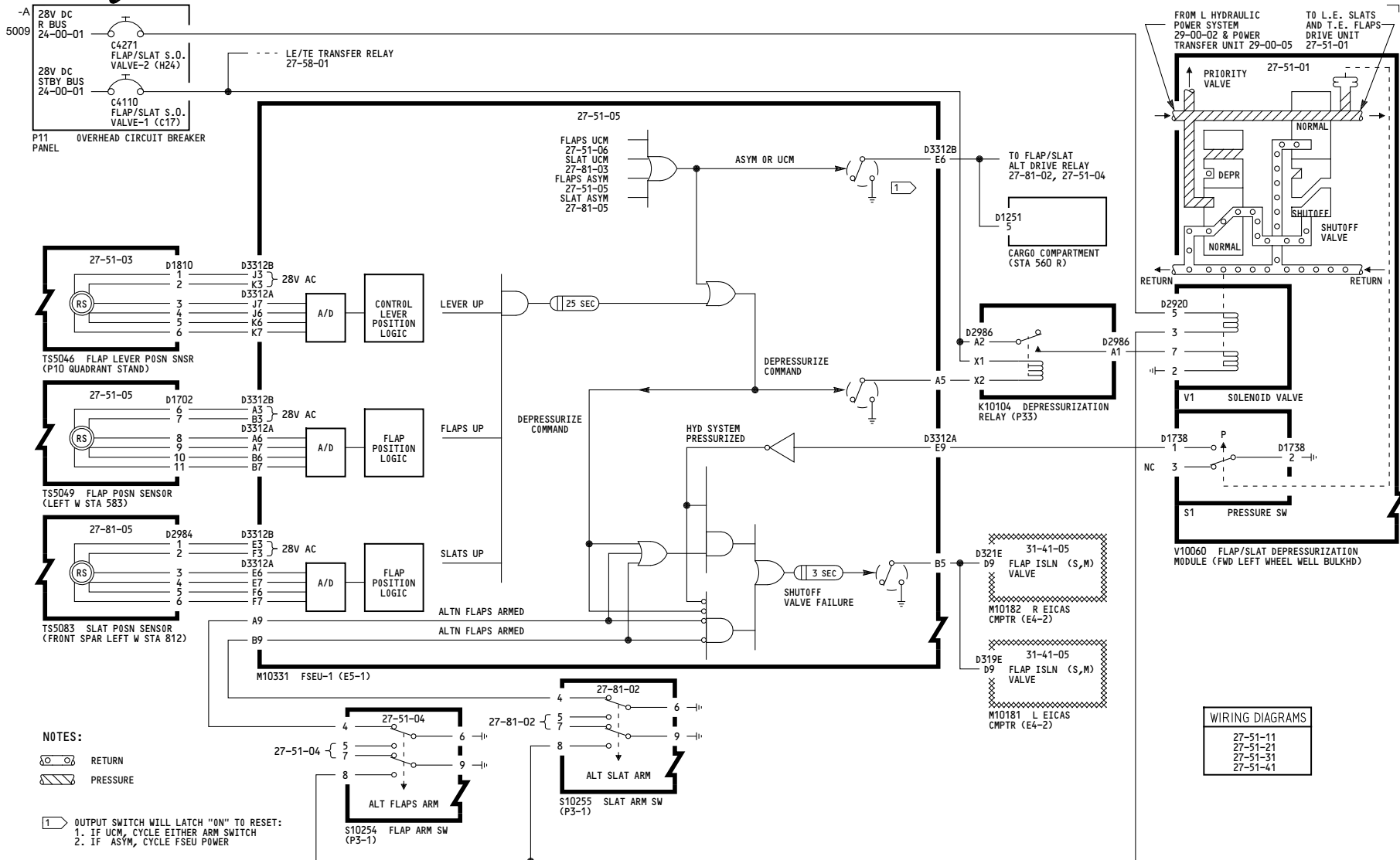

001-099

**FLAP/SLAT
DEPRESSURIZATION SYSTEM**

D280N032S

WIRING DIAGRAMS	
27-51-11	
27-51-21	
27-51-31	
27-51-41	

27-51-02

Page 101

Jan 21/2005

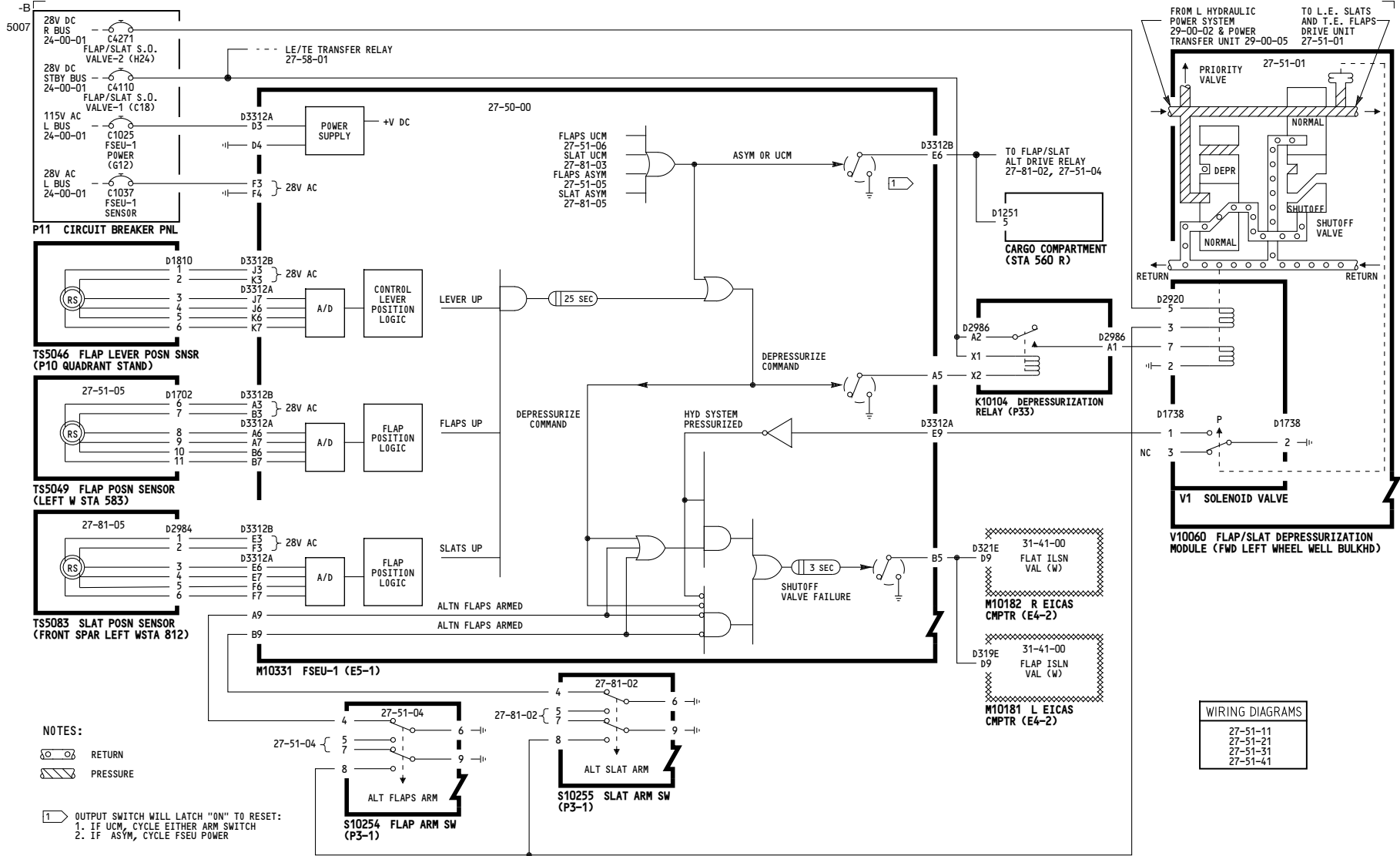

115-199

FLAP/SLAT DEPRESSURIZATION SYSTEM

D280N032S

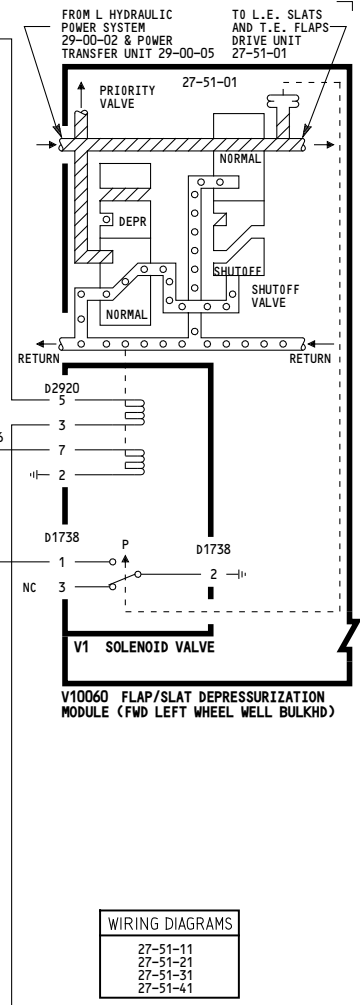

27-51-02

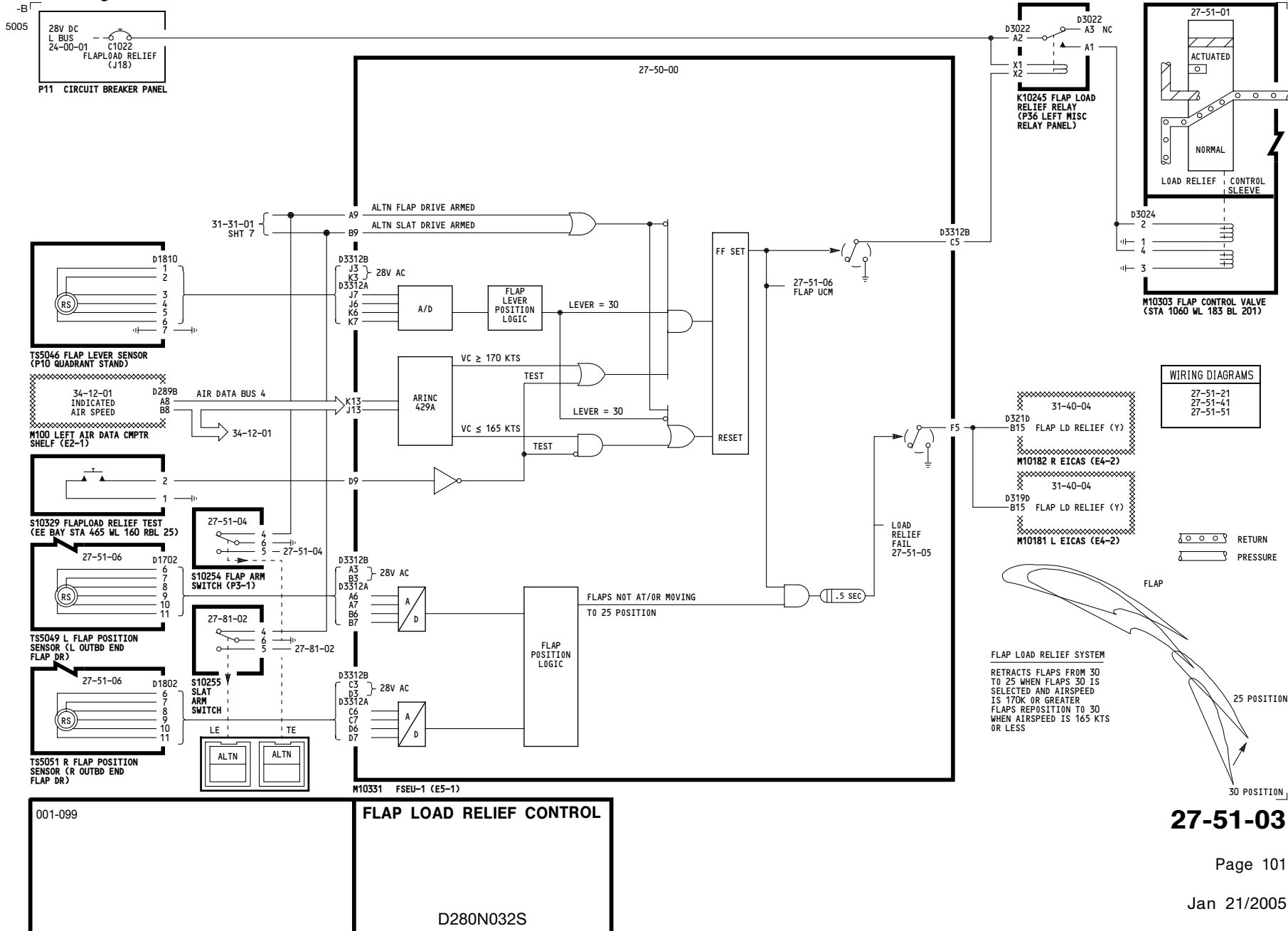

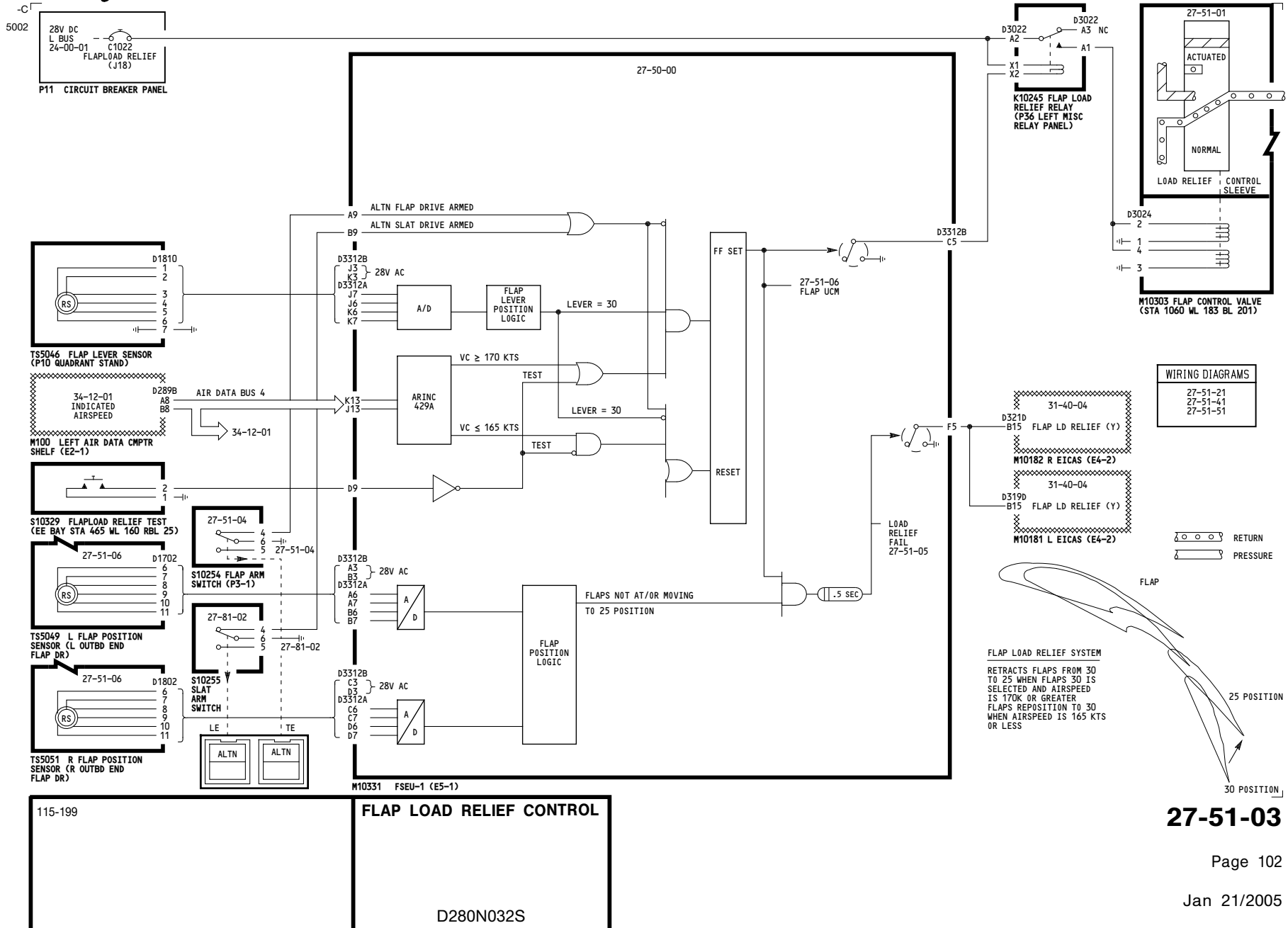

WIRING DIAGRAMS
 27-51-21
 27-51-41
 27-51-51

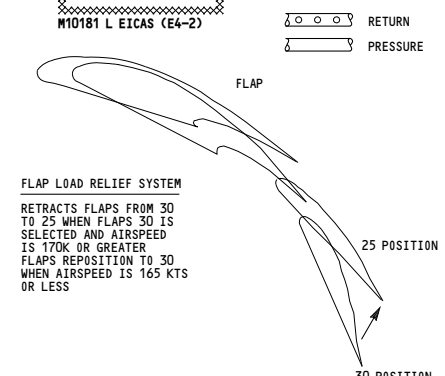

27-51-03

D280N032S

THIS PAGE INTENTIONALLY LEFT BLANK

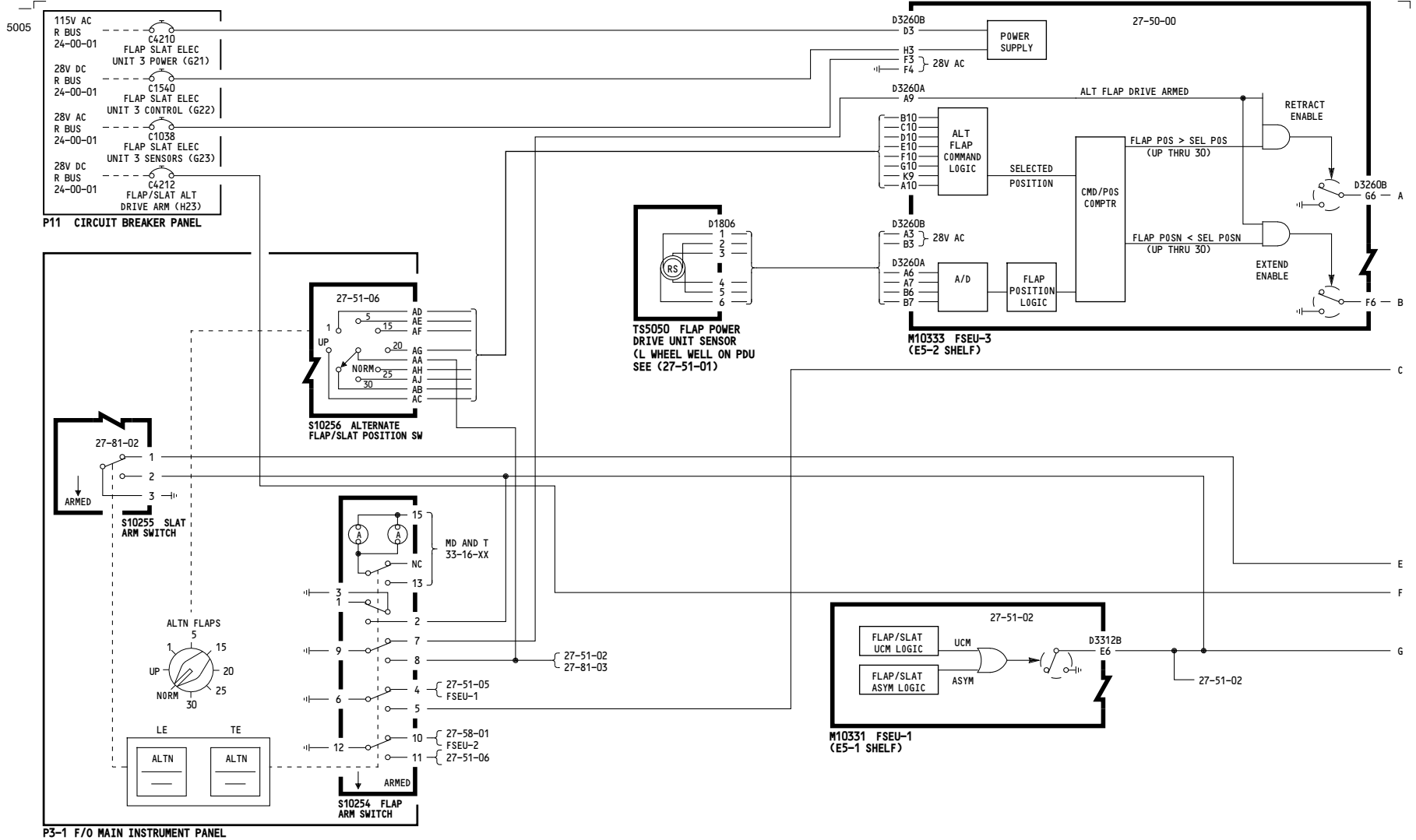

001-099

TRAILING EDGE FLAP ALTERNATE DRIVE

D280N032S

27-51-04

Page 101
Sheet 1
Jan 21/2005

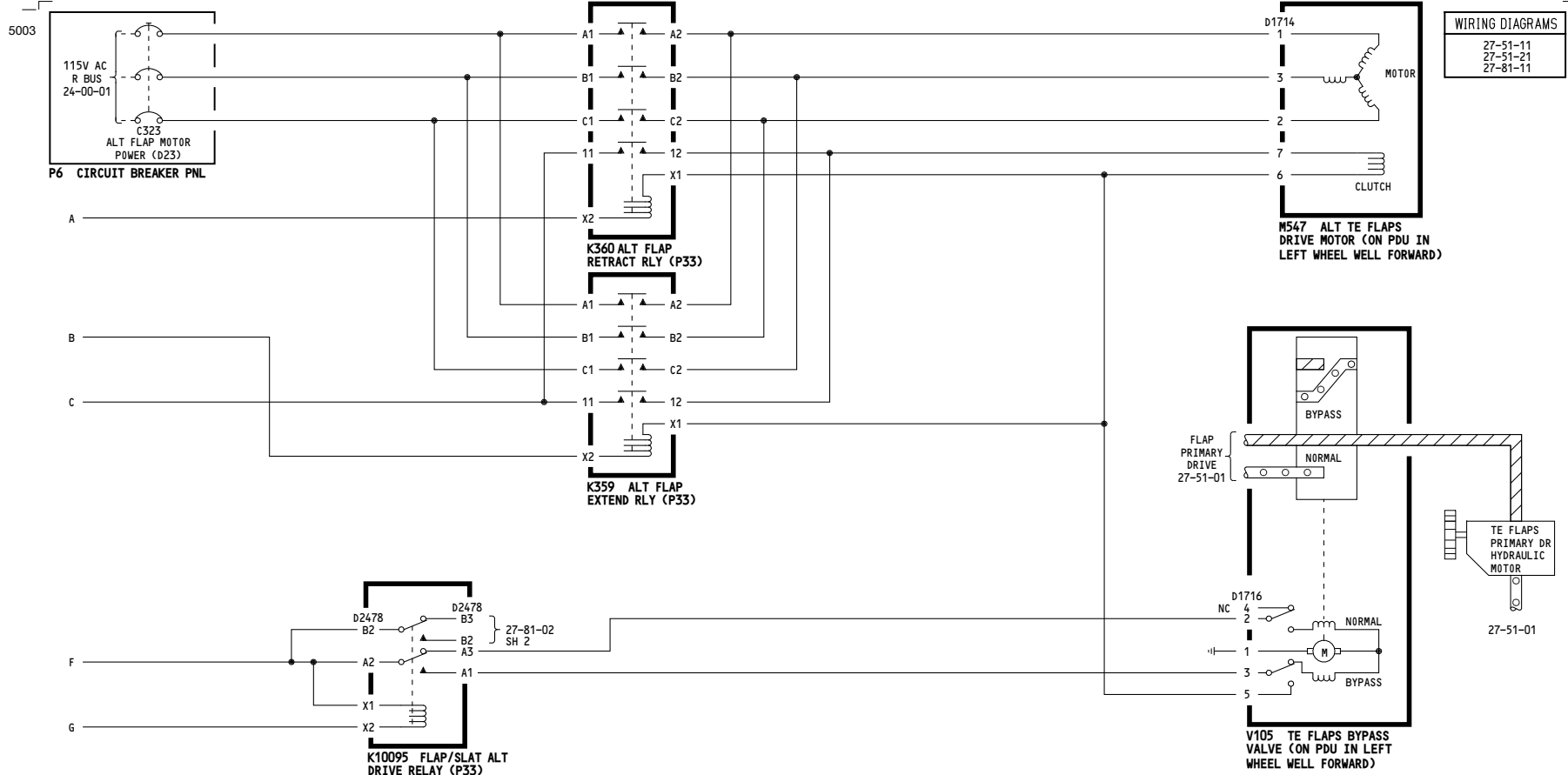

001-099	<p>TRAILING EDGE FLAP ALTERNATE DRIVE</p> <p>D280N032S</p>
---------	---

27-51-04

Page 101
Sheet 2
Jan 21/2005

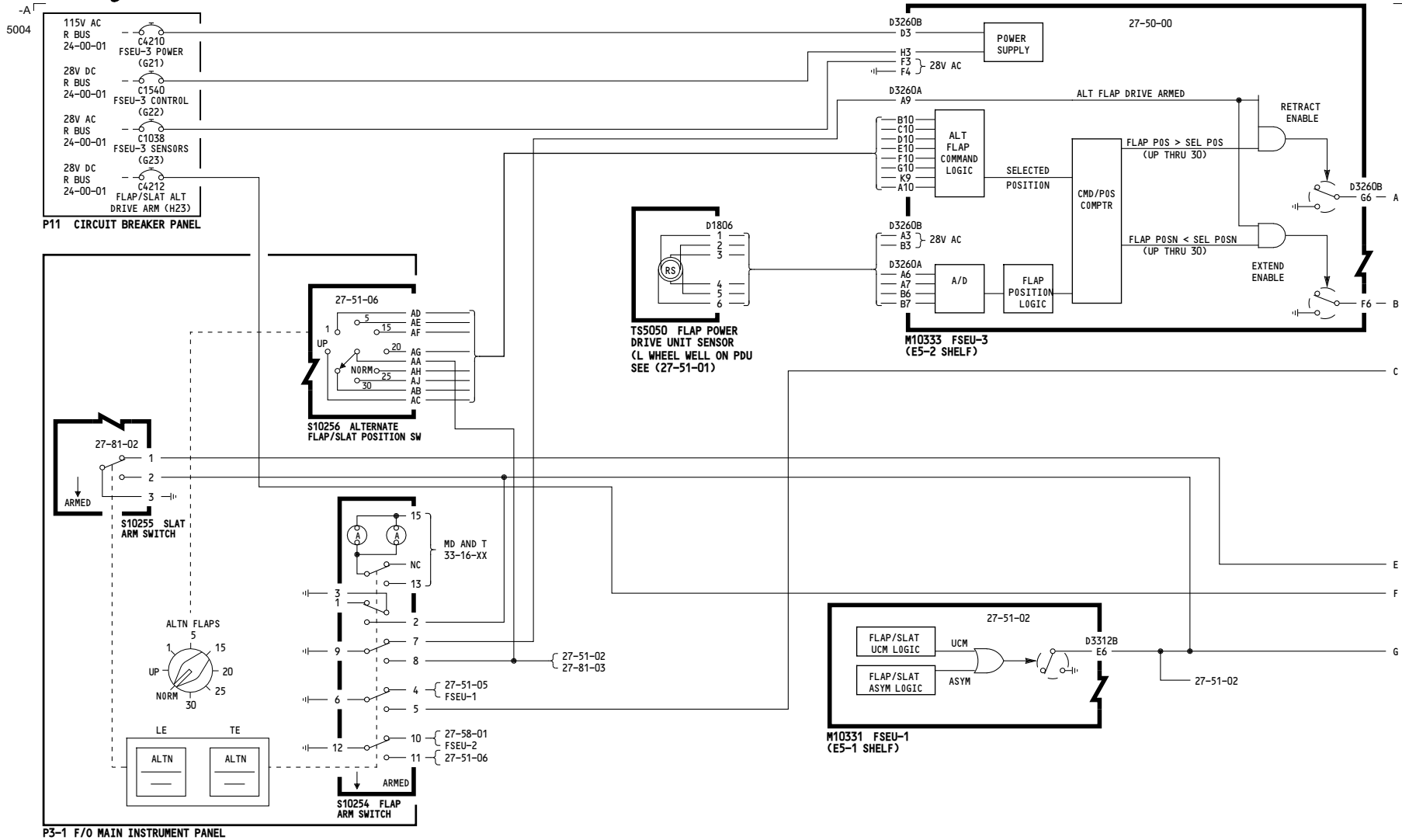

115-199

TRAILING EDGE FLAP ALTERNATE DRIVE

D280N032S

27-51-04

Page 102
Sheet 1
Jan 21/2005

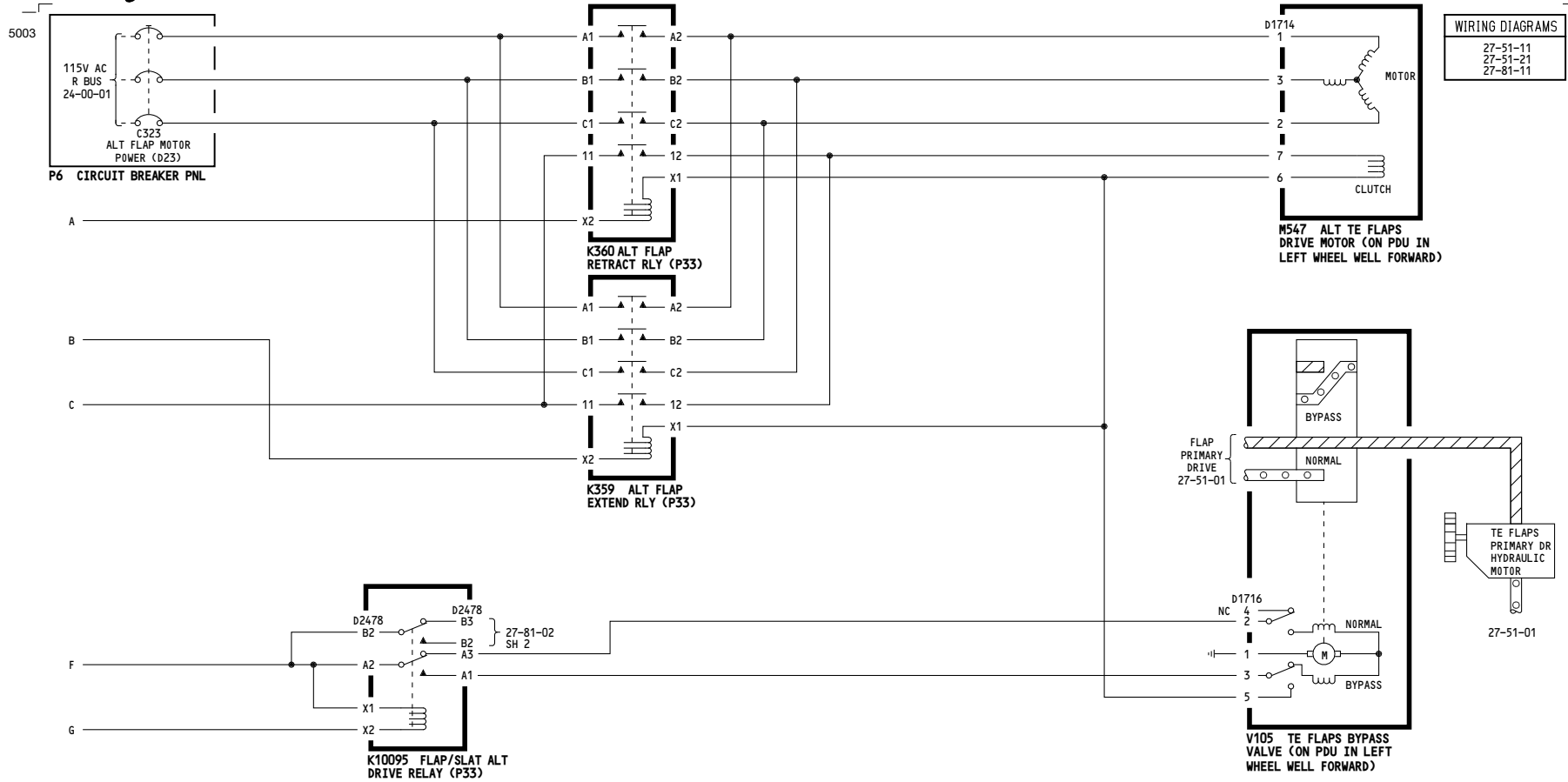

115-199	<p>TRAILING EDGE FLAP ALTERNATE DRIVE</p> <p>D280N032S</p>
---------	---

27-51-04

5008

WIRING DIAGRAMS
27-51-21
27-51-41
27-51-61

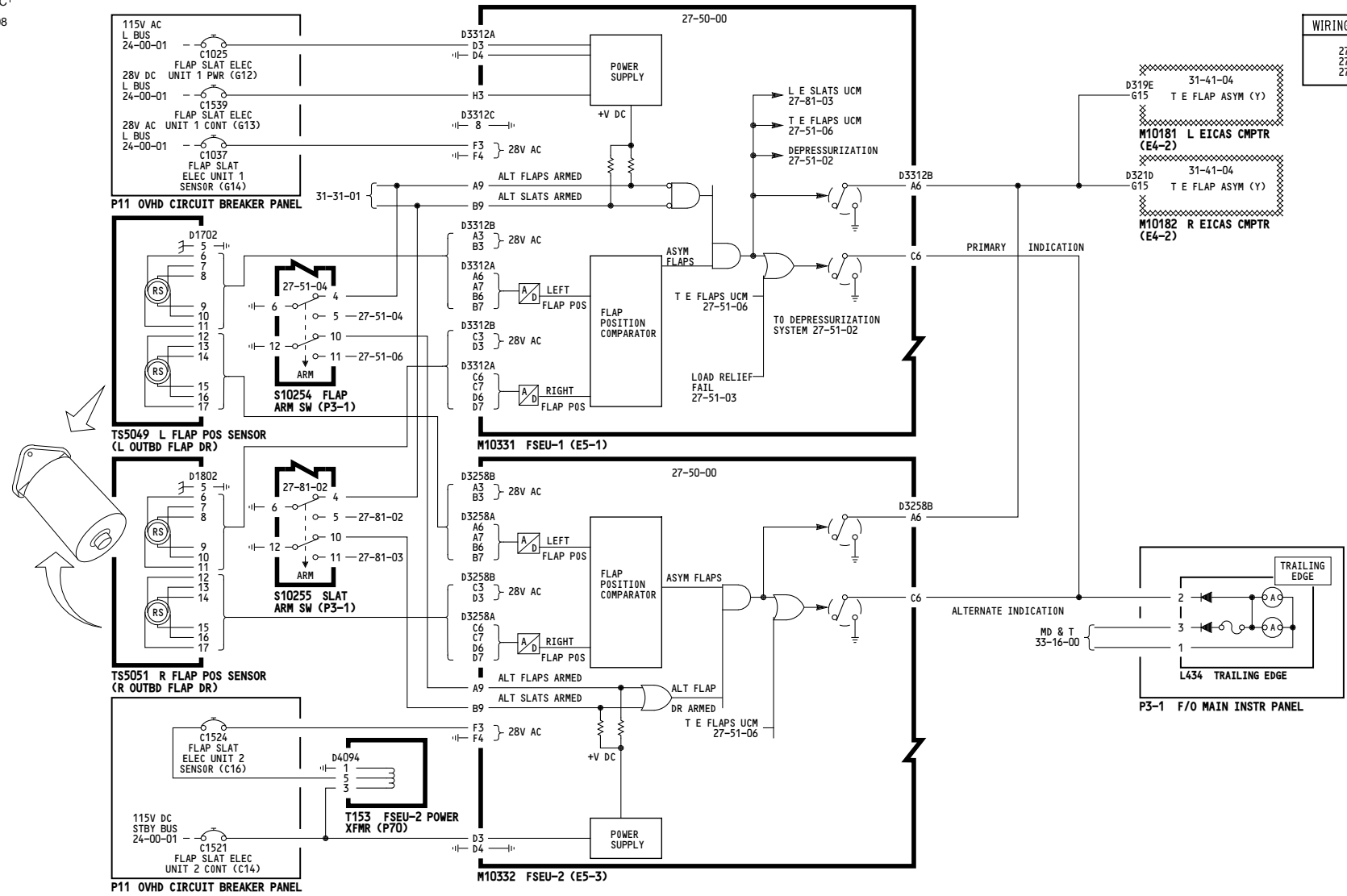

001-099

FLAP ASYMMETRY INDICATION
D280N032S

27-51-05

Page 101

Jan 21/2005

-B
5001

WIRING DIAGRAMS
27-51-21
27-51-41
27-51-61

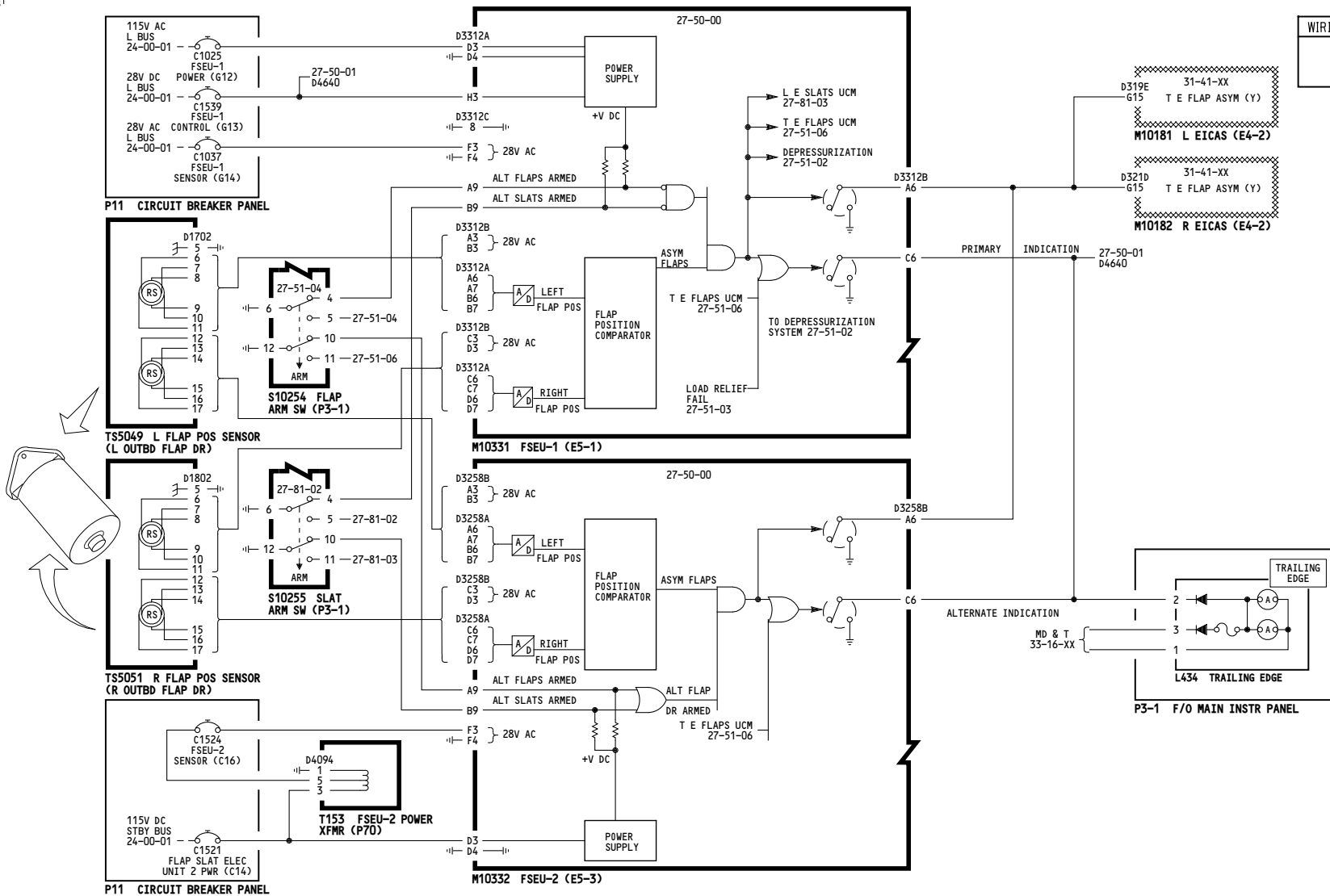

115-199

FLAP ASYMMETRY INDICATION

D280N032S

27-51-05

WIRING DIAGRAMS
27-51-21
27-51-41
27-51-61

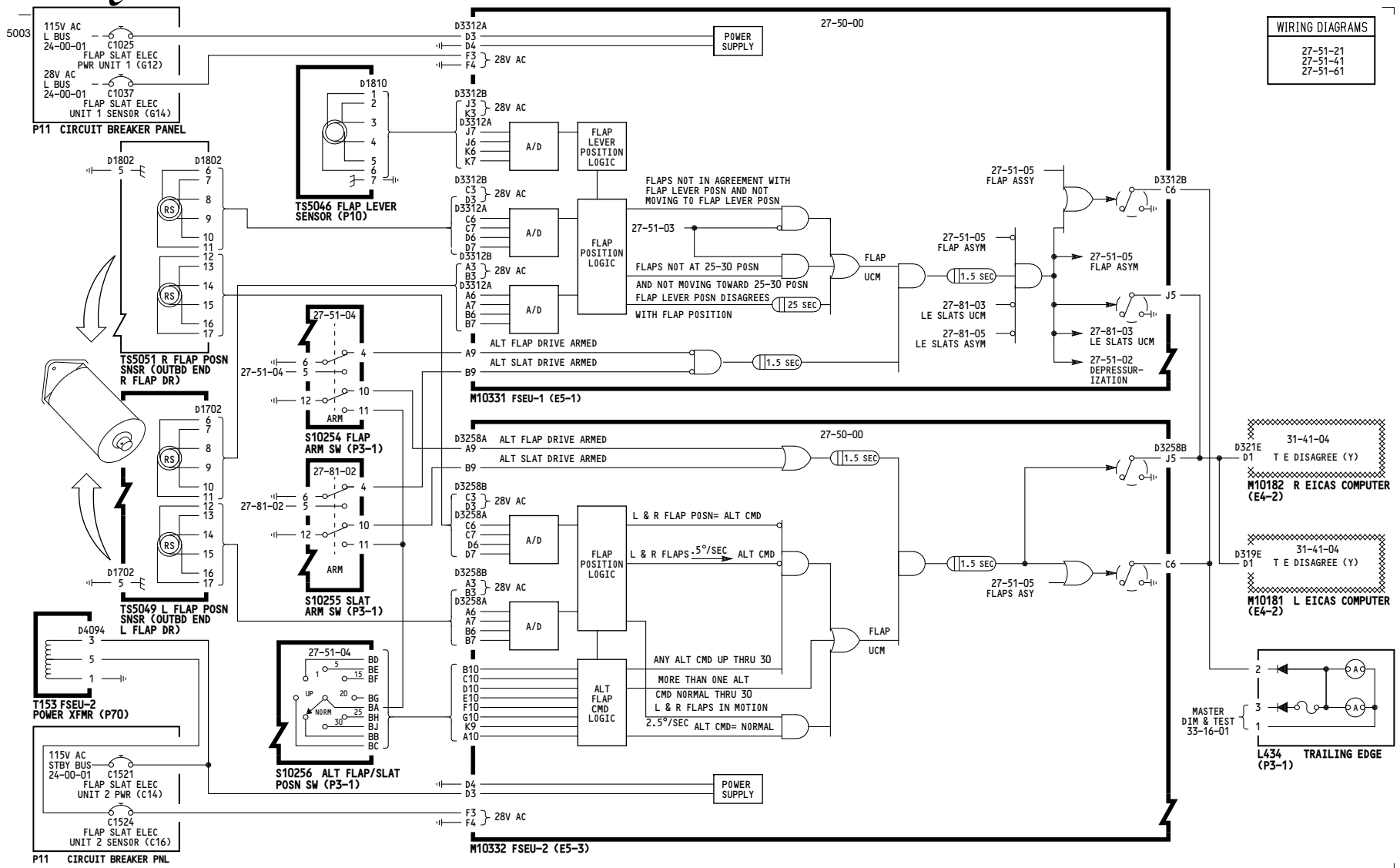

001-099

TRAILING EDGE FLAPS UCM INDICATION

D280N032S

27-51-06

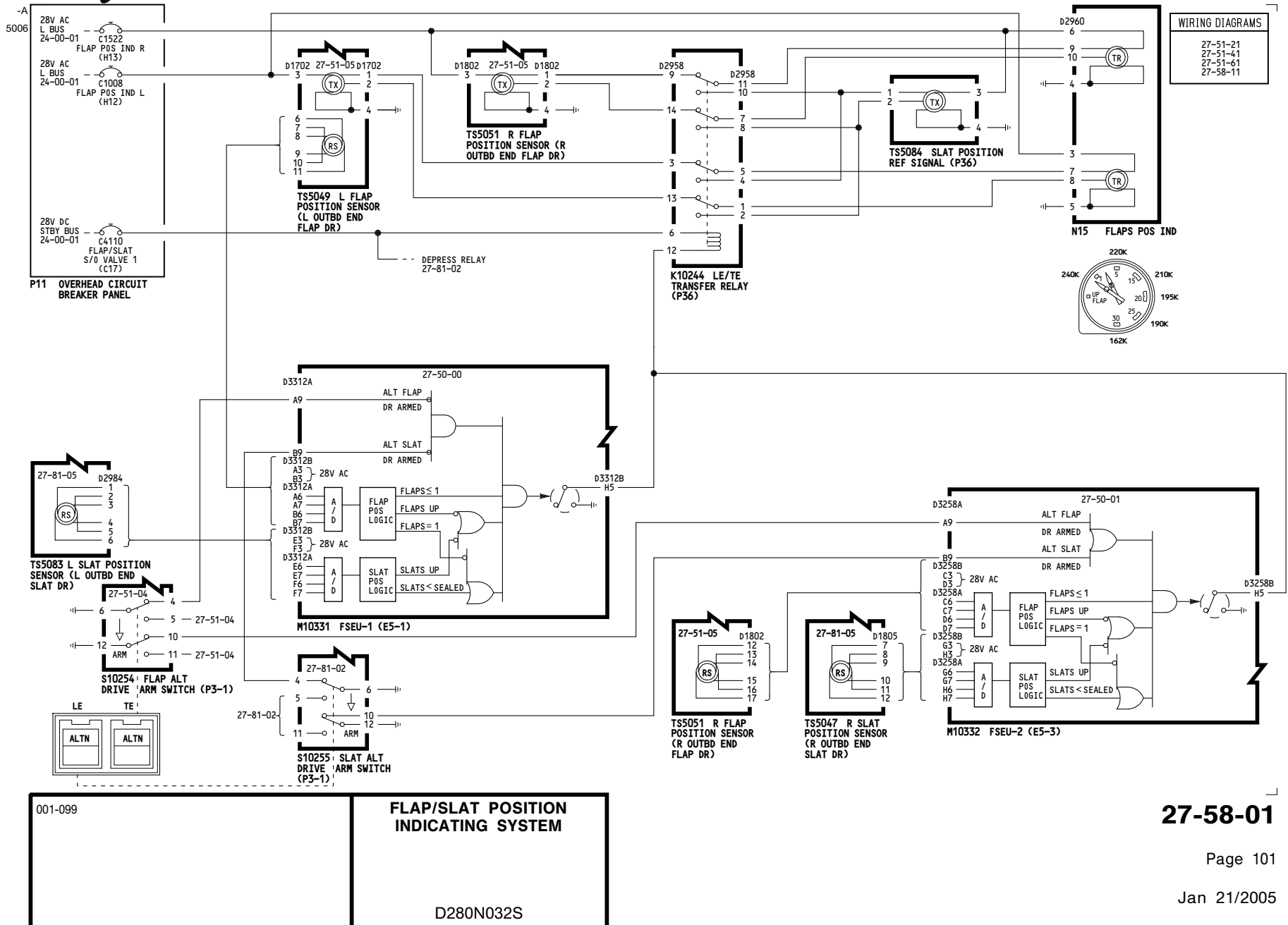

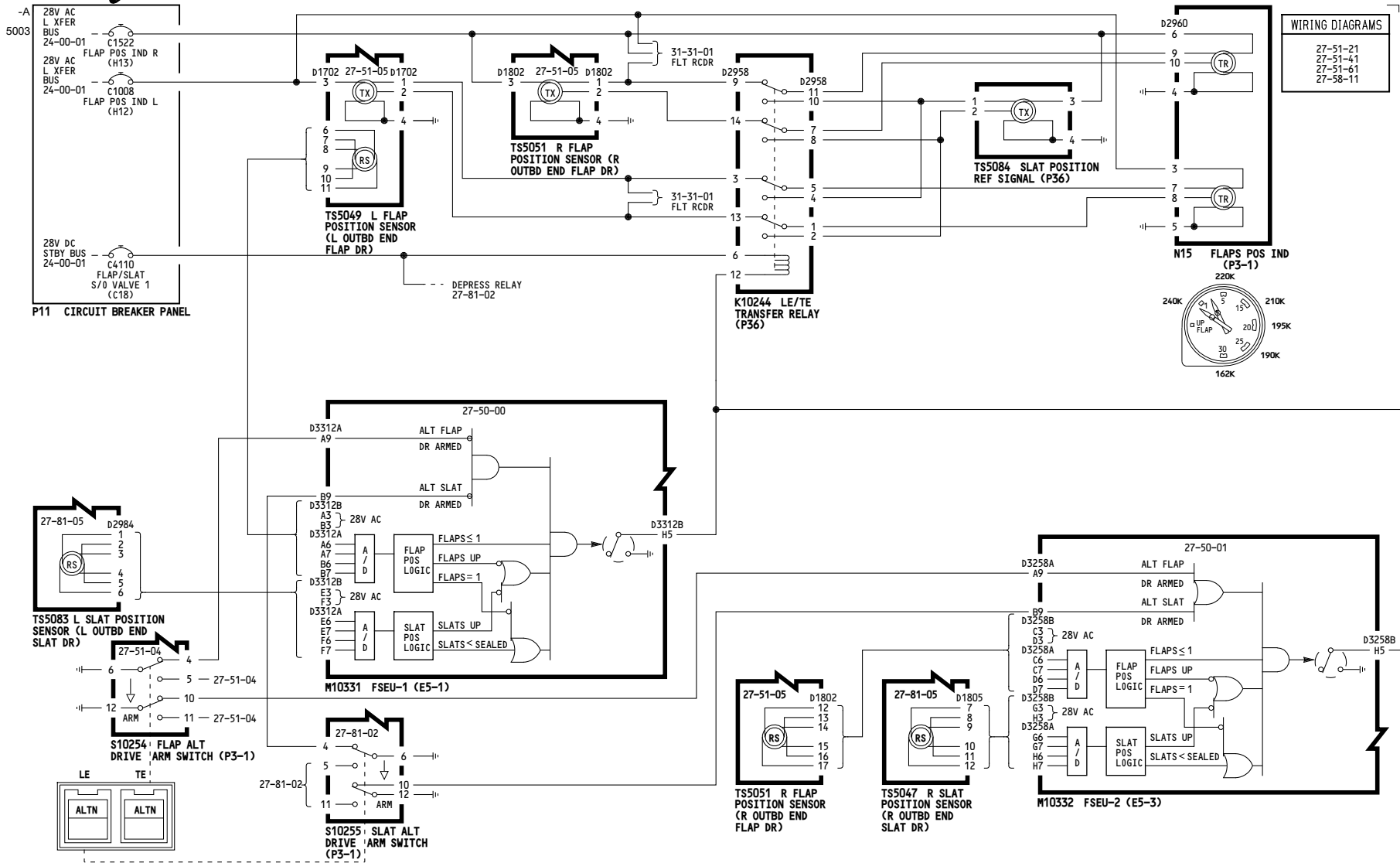

115-199

FLAP/SLAT POSITION INDICATING SYSTEM

D280N032S

27-58-01

5002

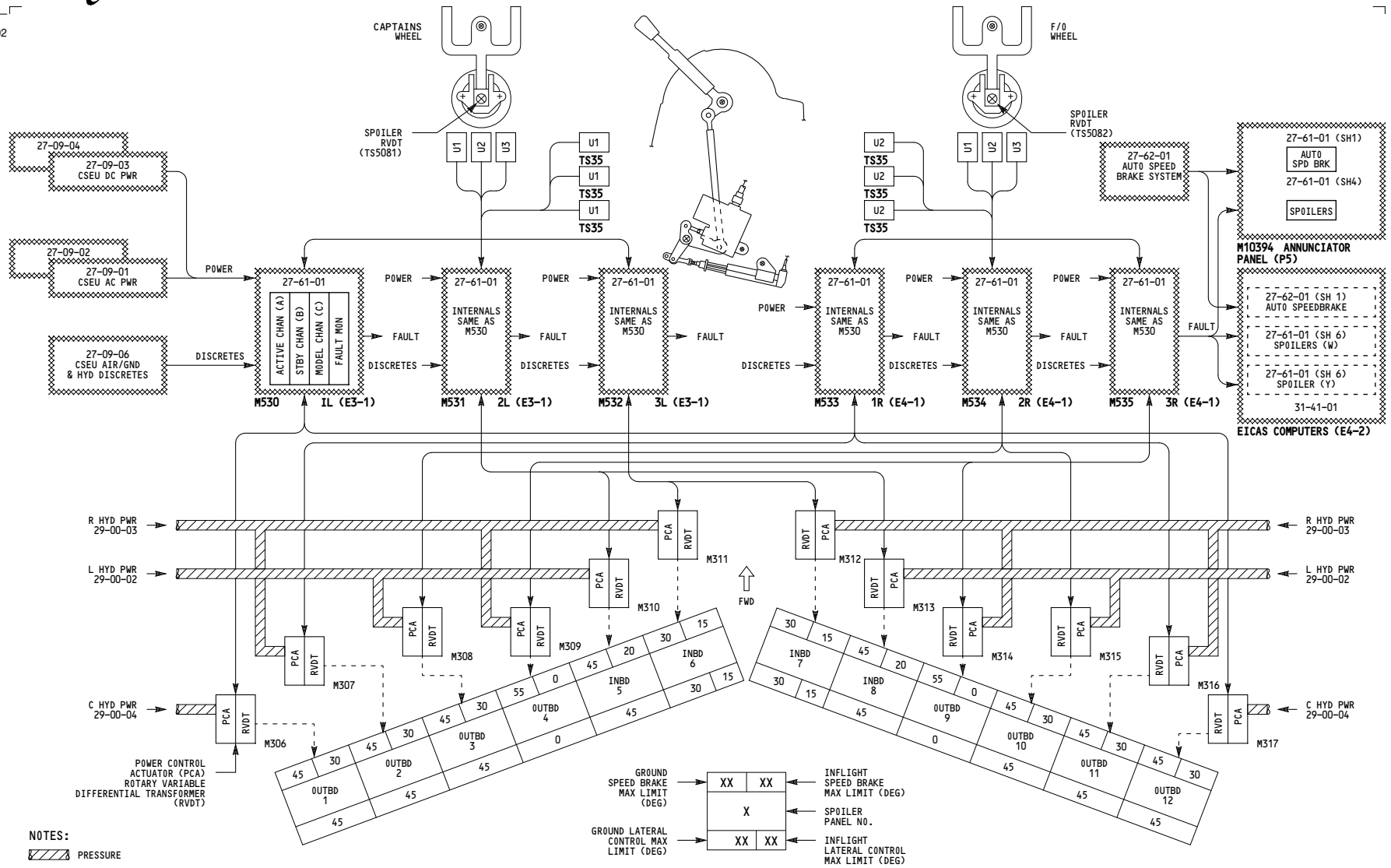

ALL

SPOILER AND SPEEDBRAKE SYSTEM

D280N032S

27-60-00

Page 101

Jan 21/2005

THIS PAGE INTENTIONALLY LEFT BLANK

-A
5002

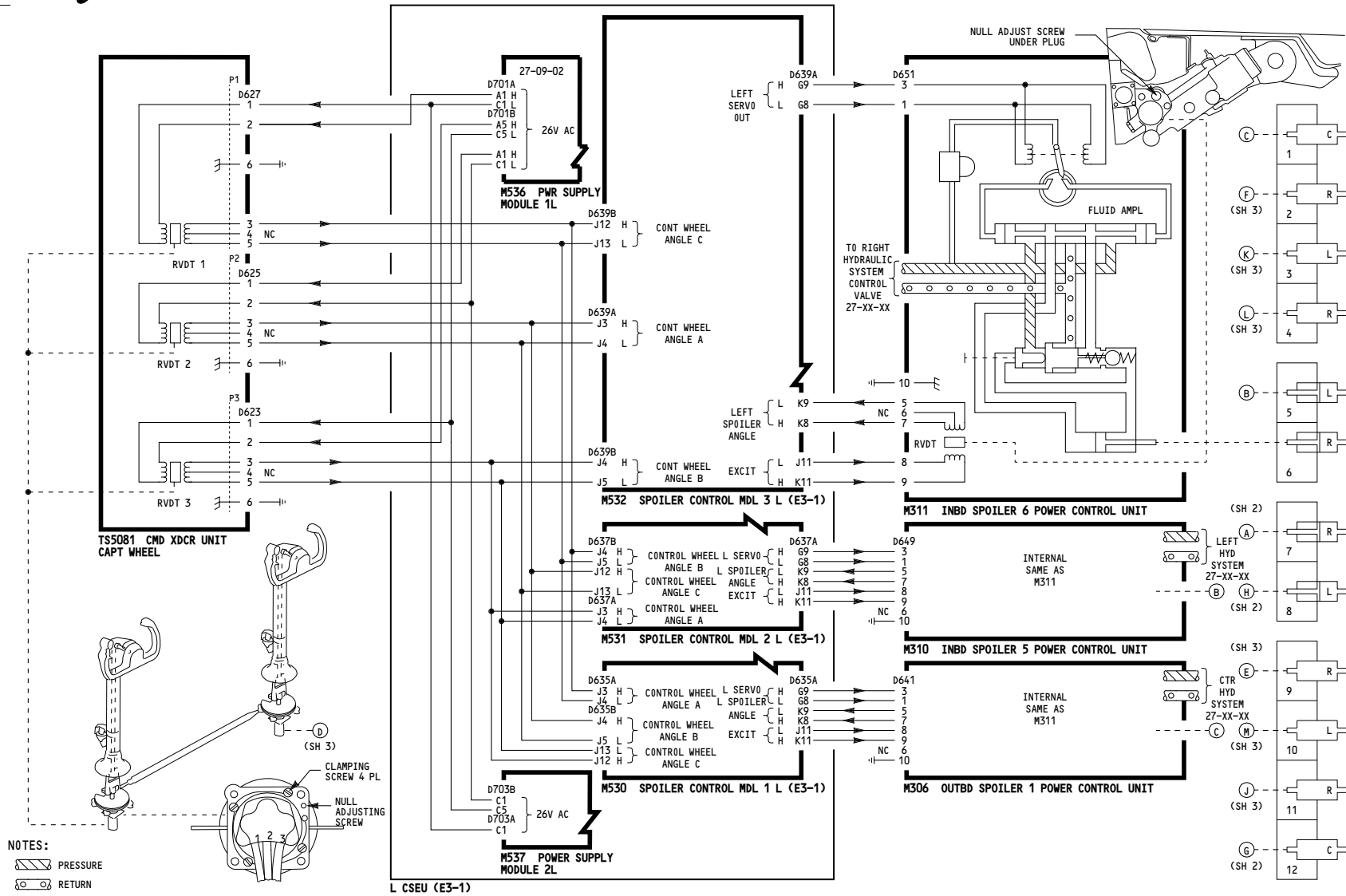

001, 115-199

SPOILERS

D280N032S

27-61-01

5002

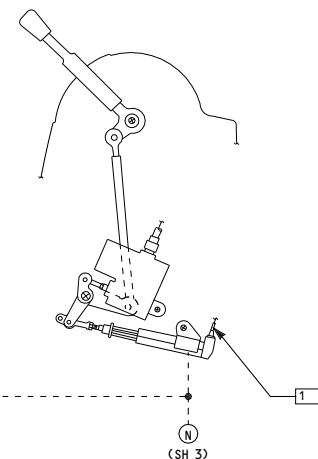
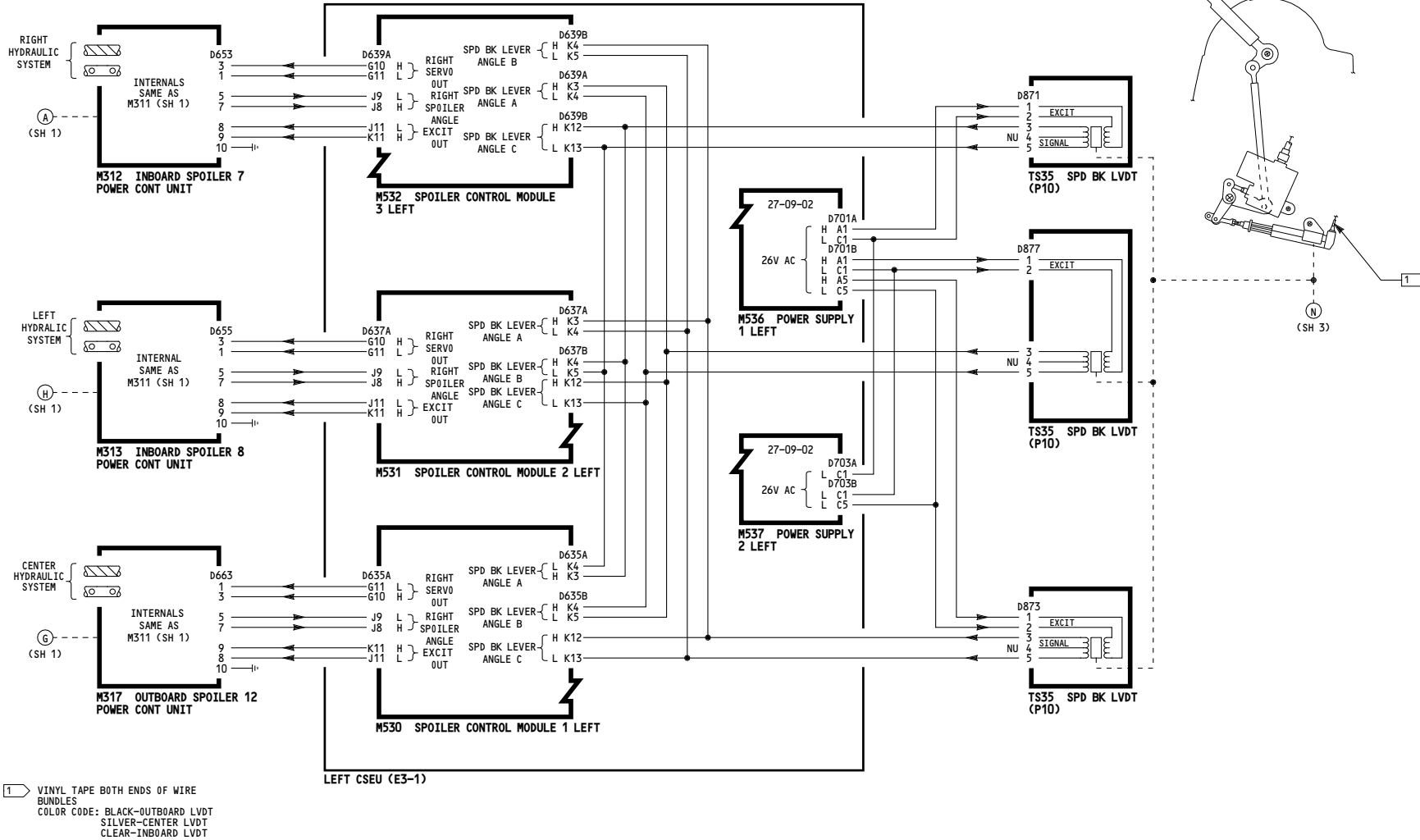

001, 115-199	<p align="center">SPOILERS</p> <p align="center">D280N032S</p>
--------------	---

27-61-01

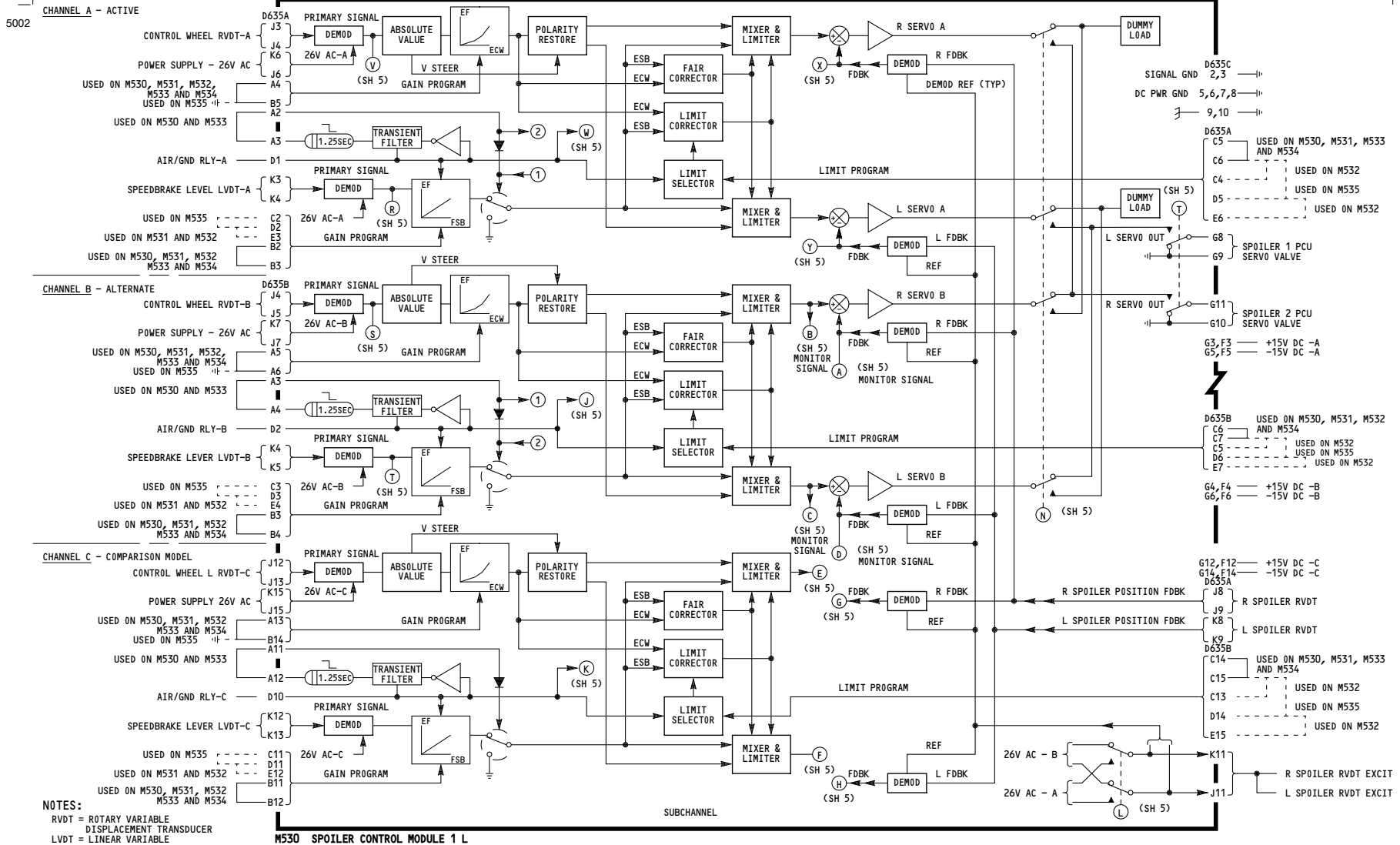

001, 115-199

SPOILERS

D280N032S

27-61-01

5000

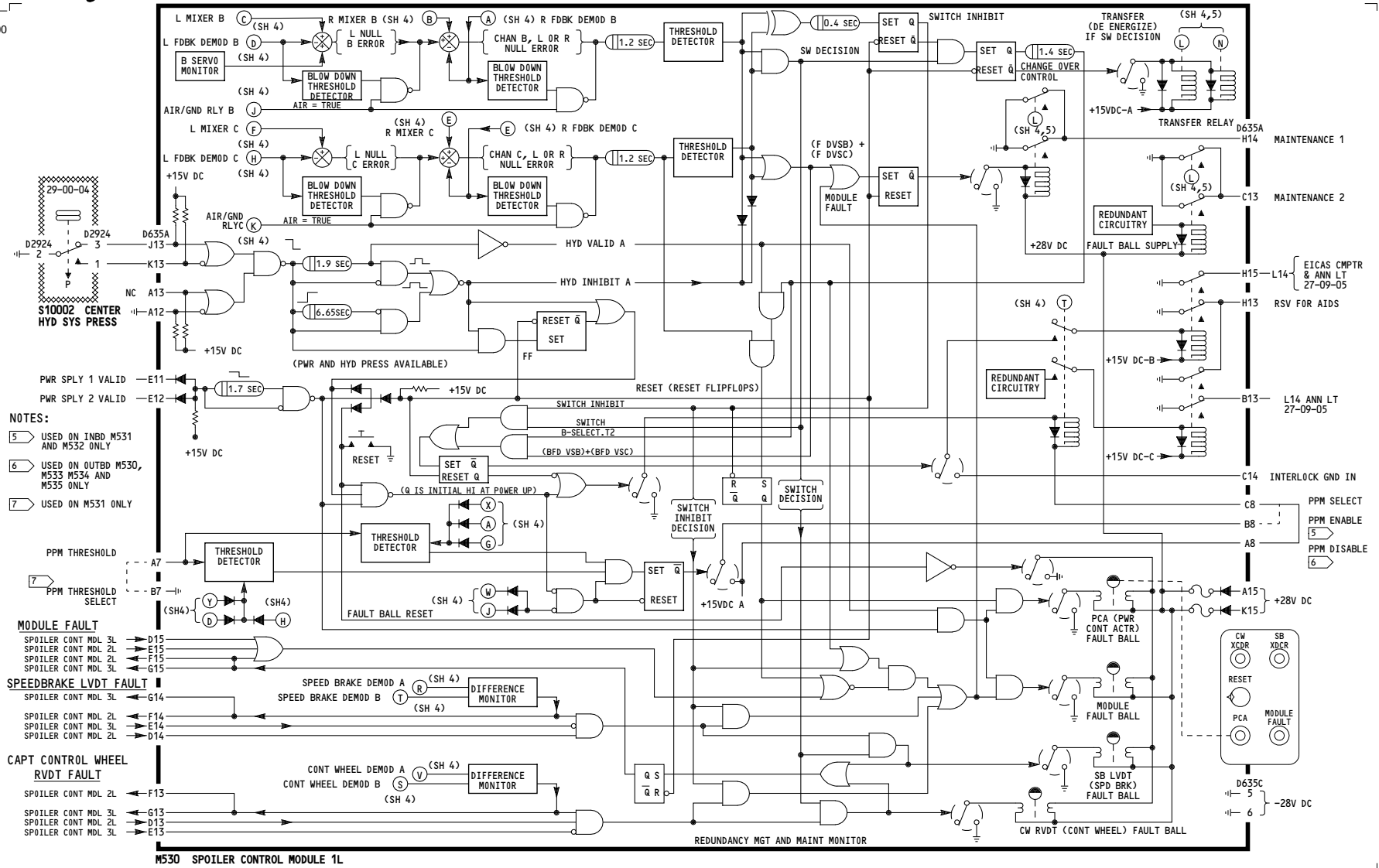

001, 115-199

SPOILERS

D280N032S

27-61-01

5002

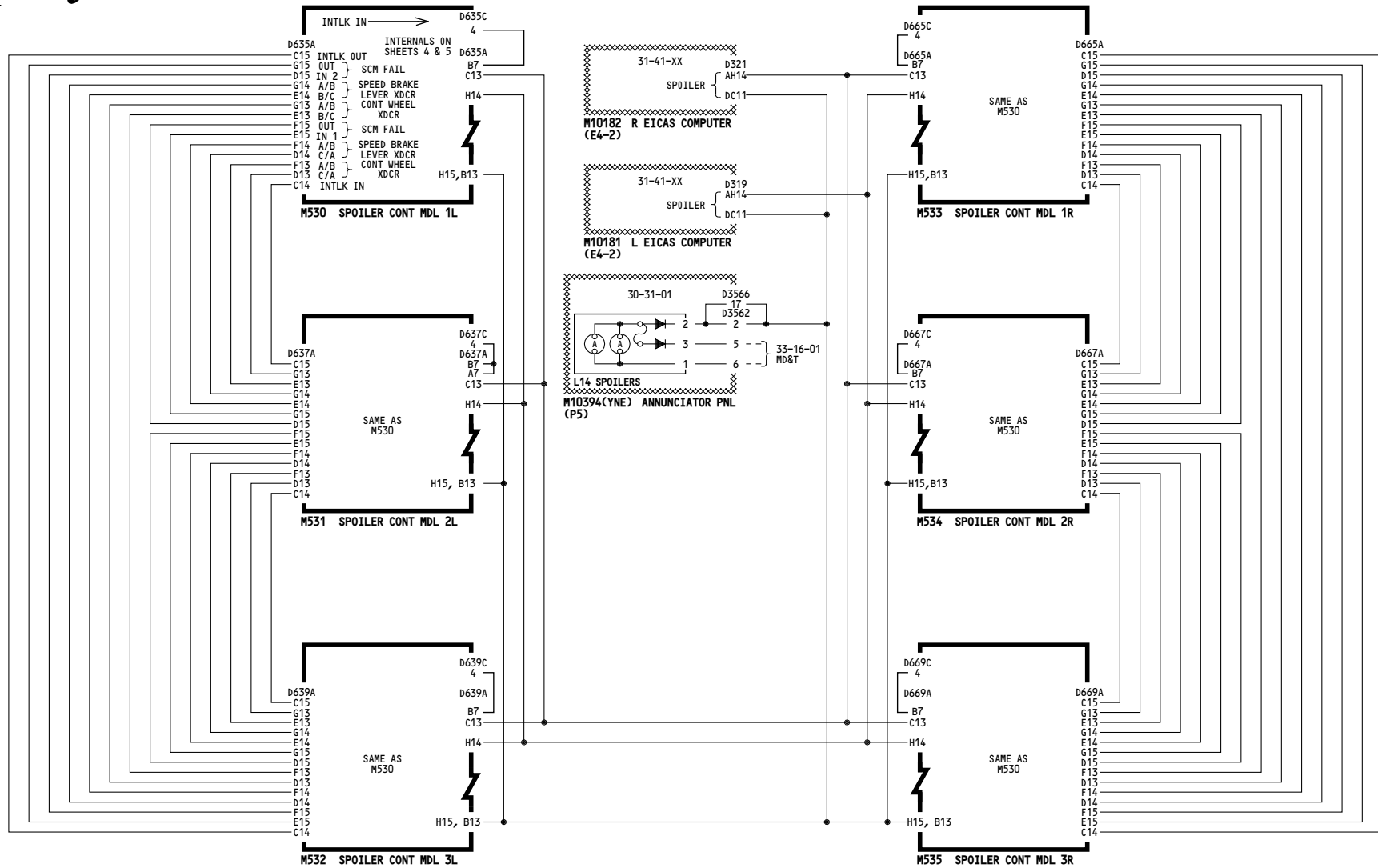

001, 115-199	<p align="center">SPOILERS</p> <p align="center">D280N032S</p>
--------------	---

27-61-01

-A
5002

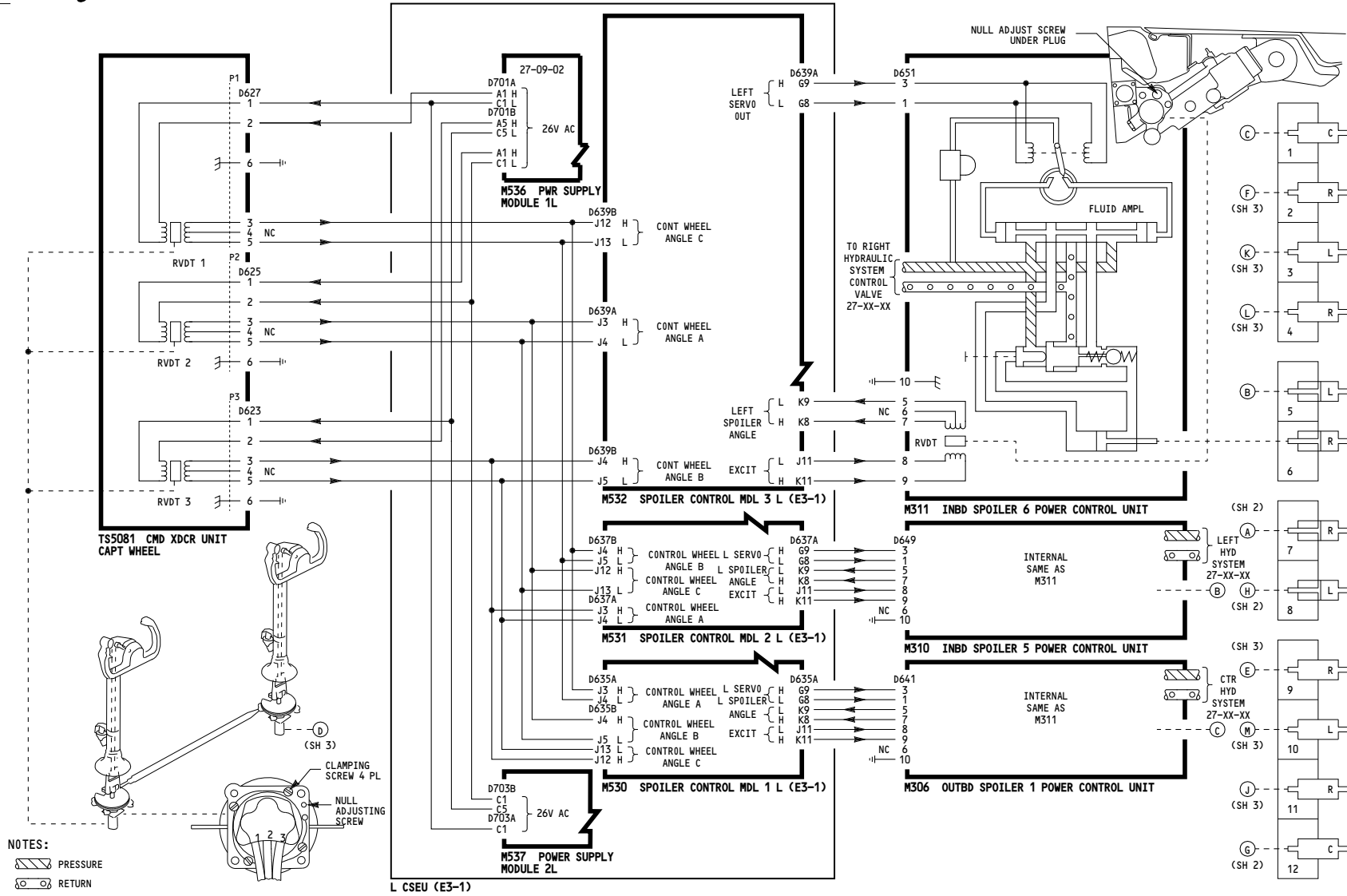

NOTES:
 PRESSURE
 RETURN

002

SPOILERS

D280N032S

27-61-01

5002

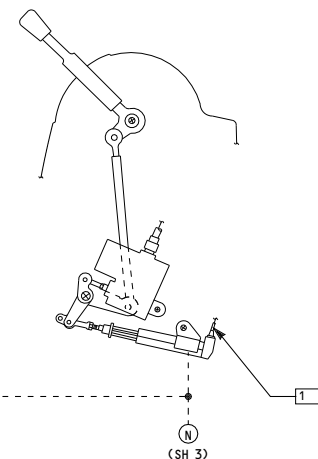
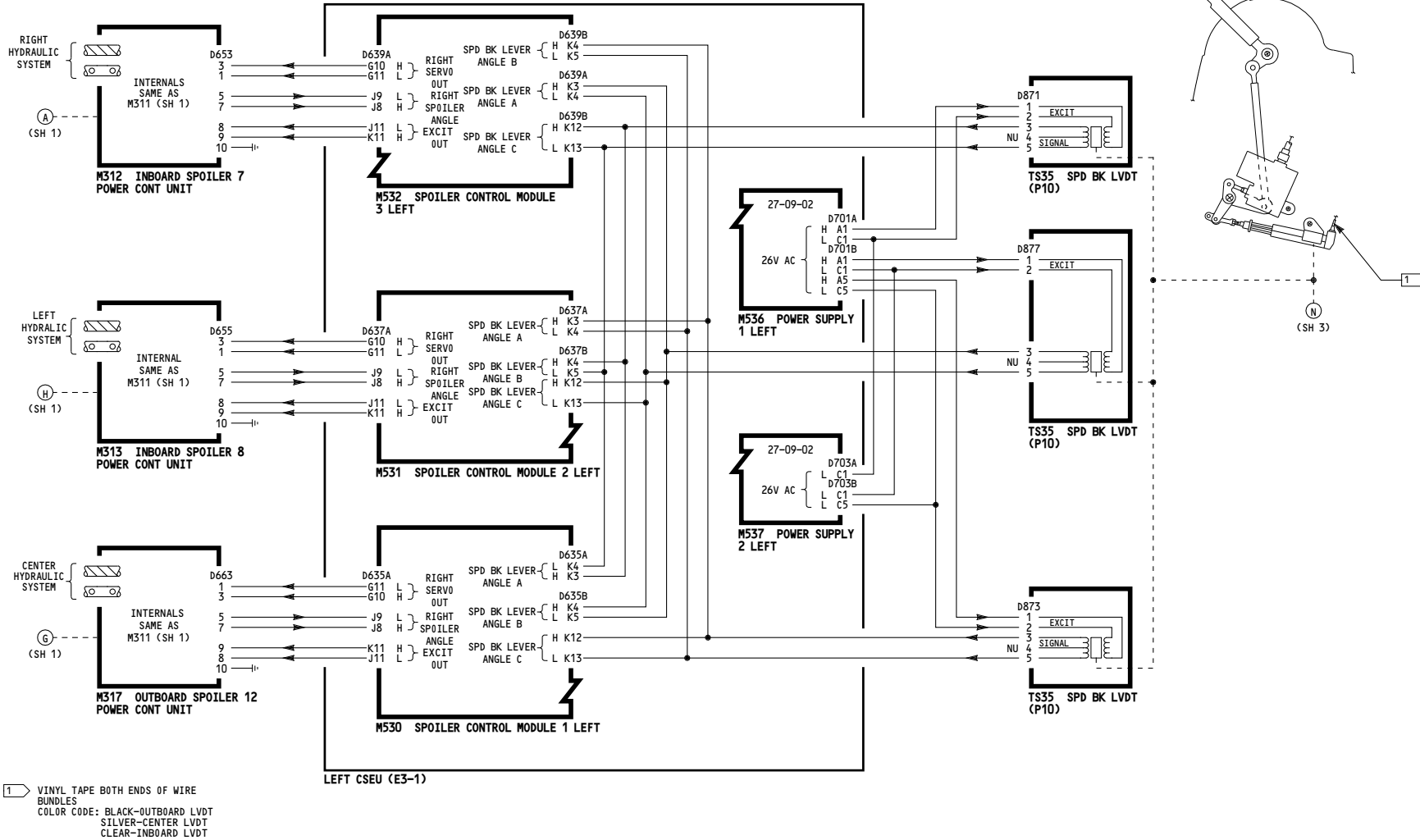

002	SPOILERS
D280N032S	

27-61-01

-A
5002

WIRING DIAGRAMS
27-61-21
27-61-XX

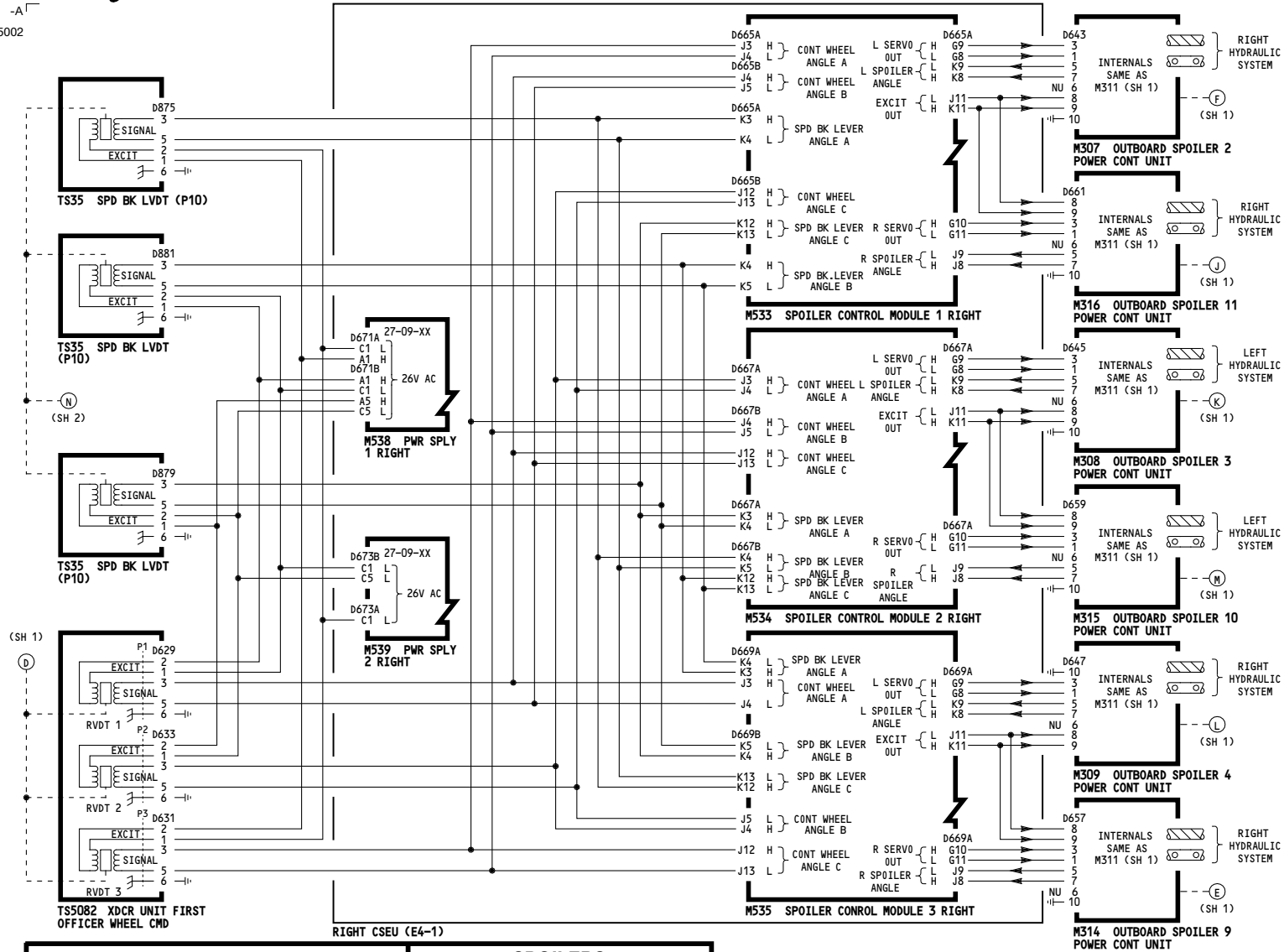

002	SPOILERS
	D280N032S

27-61-01

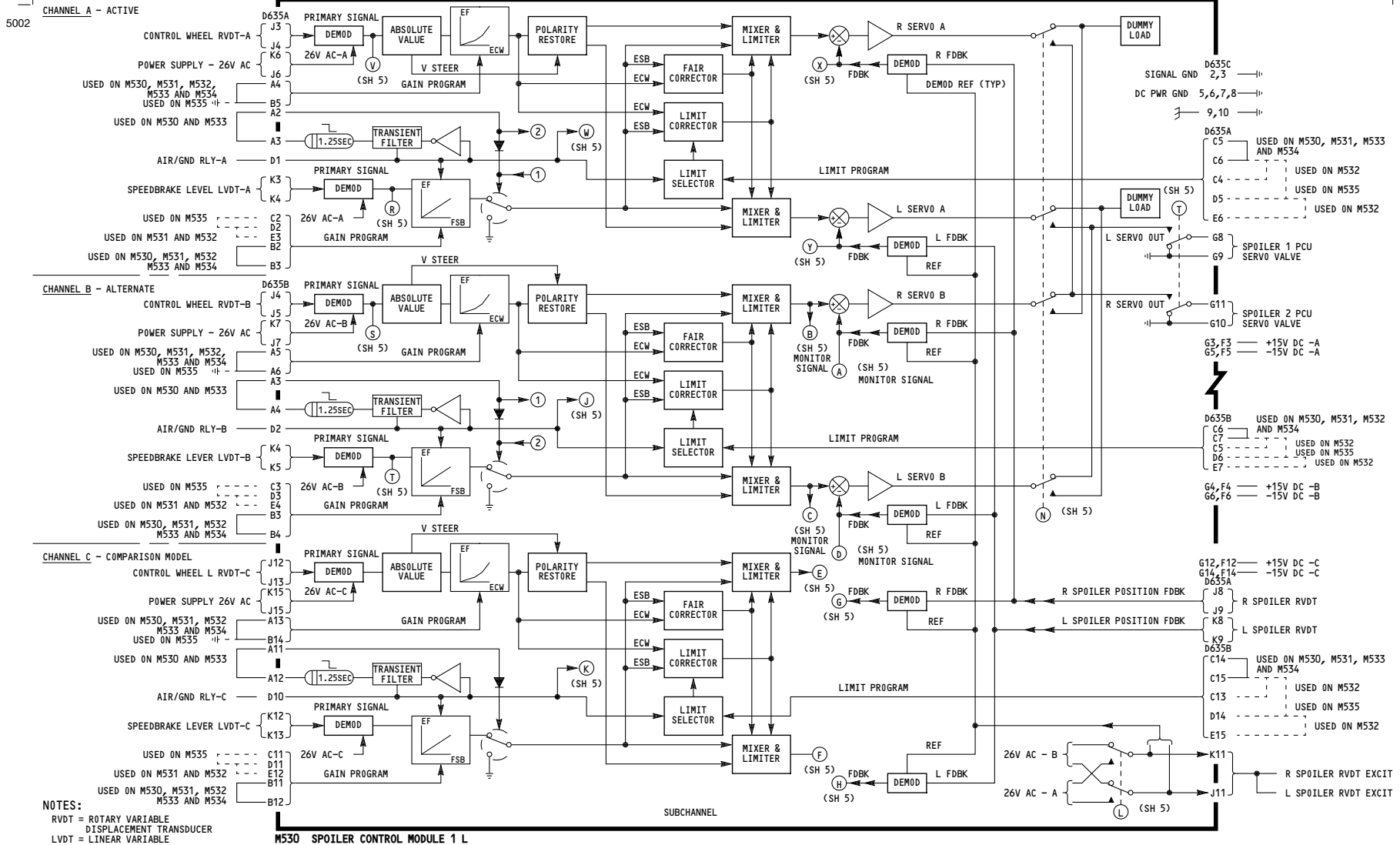

002

SPOILERS

D280N032S

27-61-01

5003

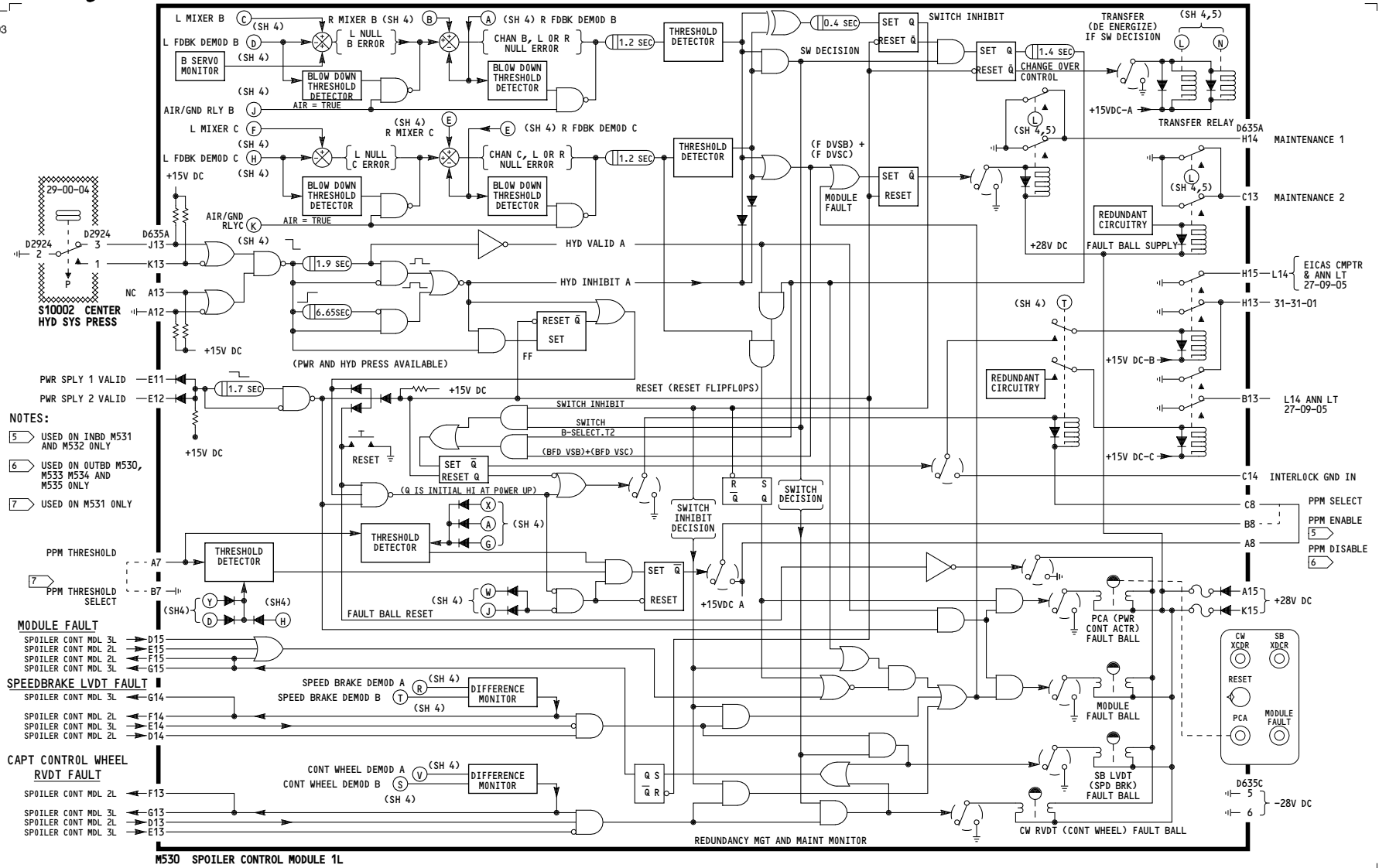

<p>002</p>	<p>SPOILERS</p> <p>D280N032S</p>
------------	---

27-61-01

5002

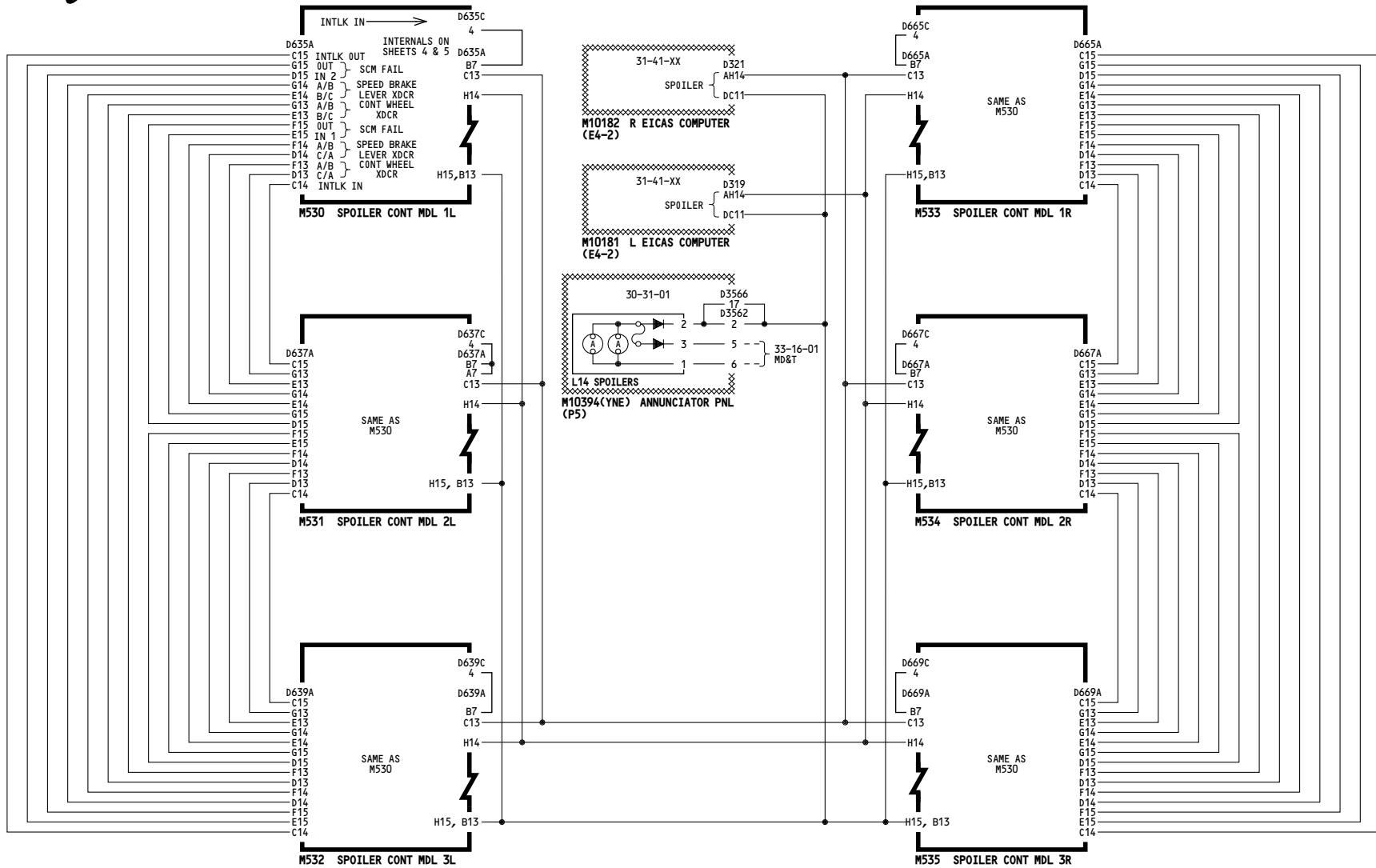

002	SPOILERS
	D280N032S

27-61-01

-A
5002

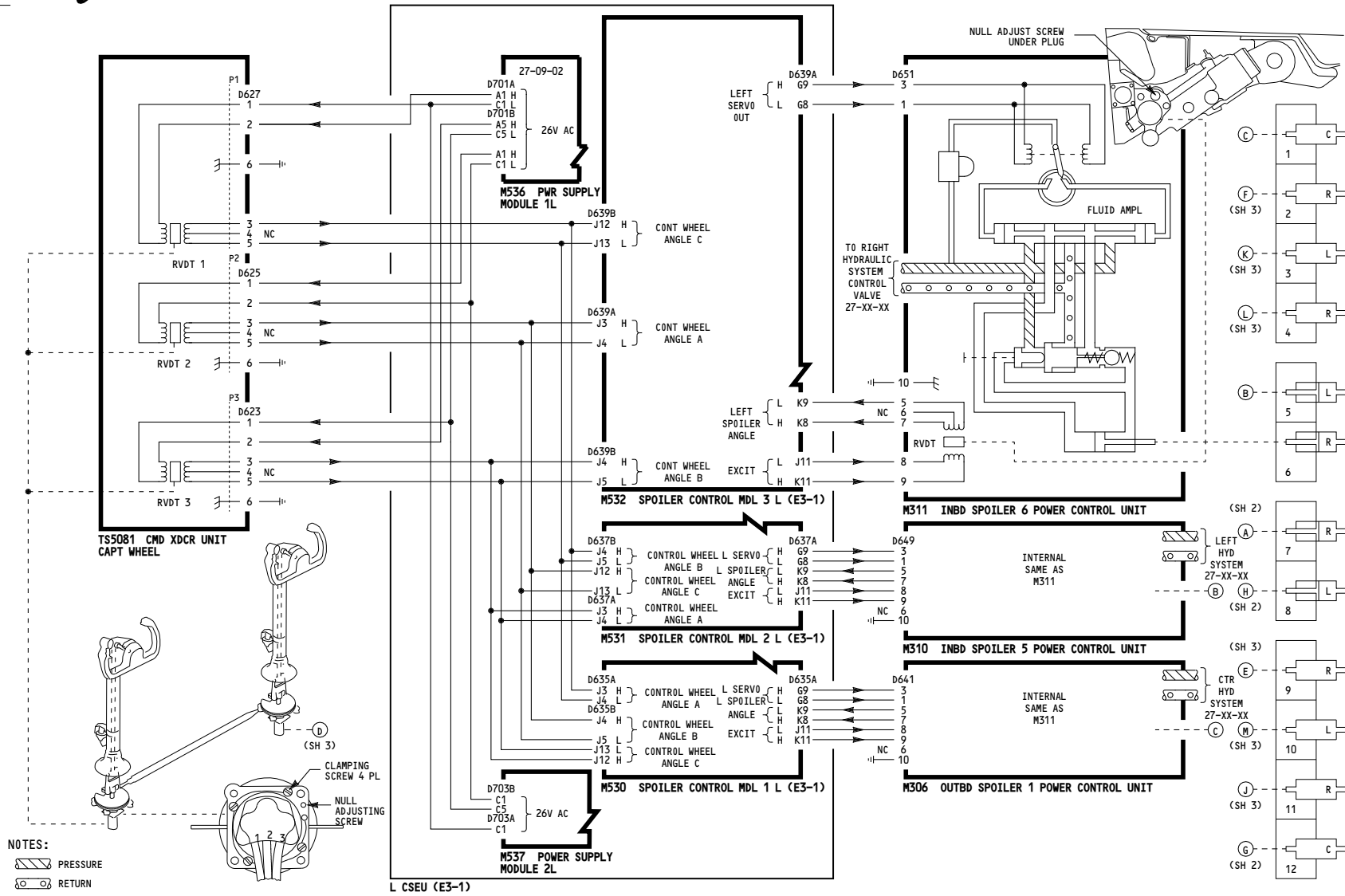

003-099

SPOILERS

D280N032S

27-61-01

5002

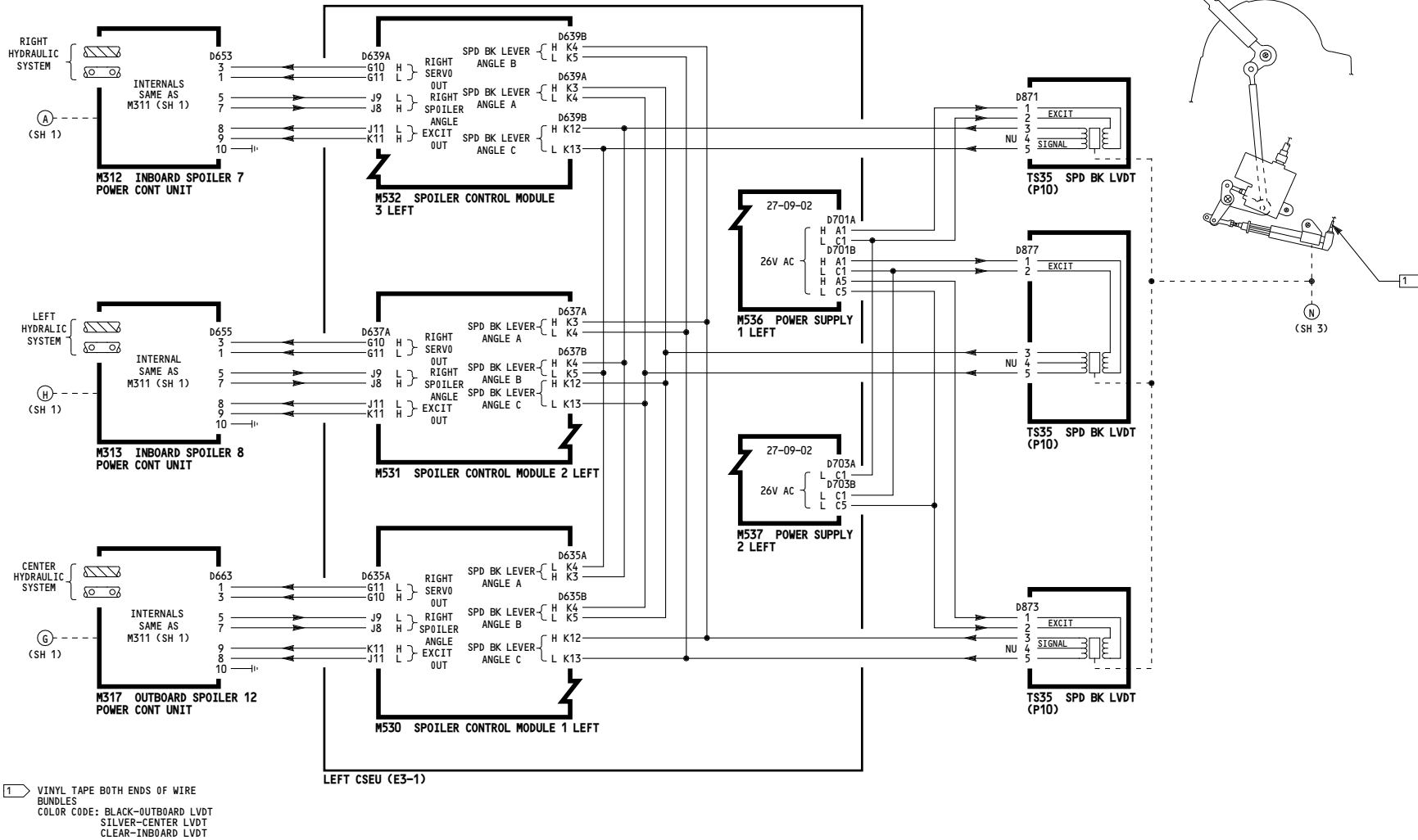

003-099	<p align="center">SPOILERS</p> <p align="center">D280N032S</p>
---------	---

27-61-01

-A
5002

WIRING DIAGRAMS
27-61-21
27-61-XX

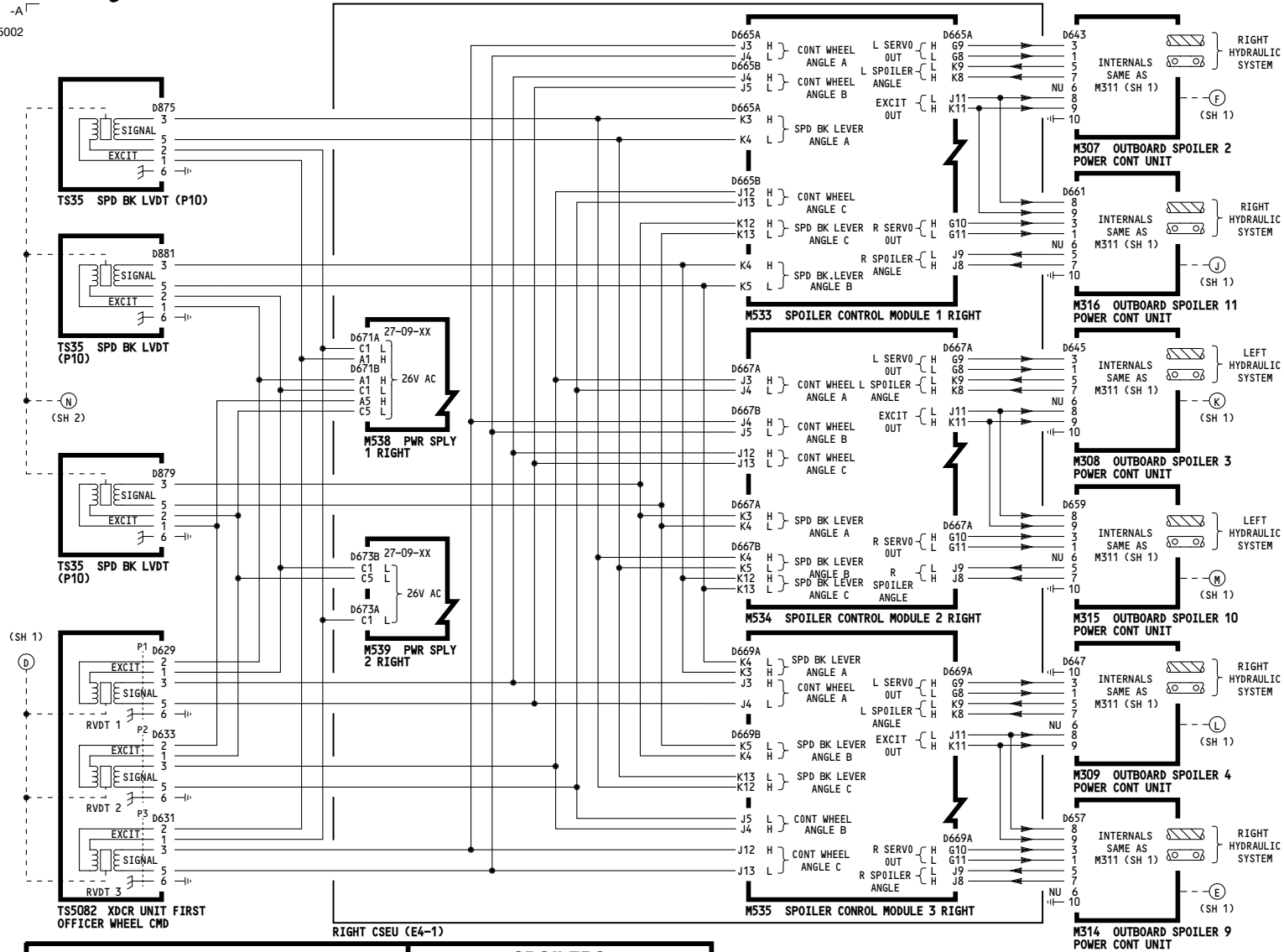

003-099	SPOILERS
	D280N032S

27-61-01

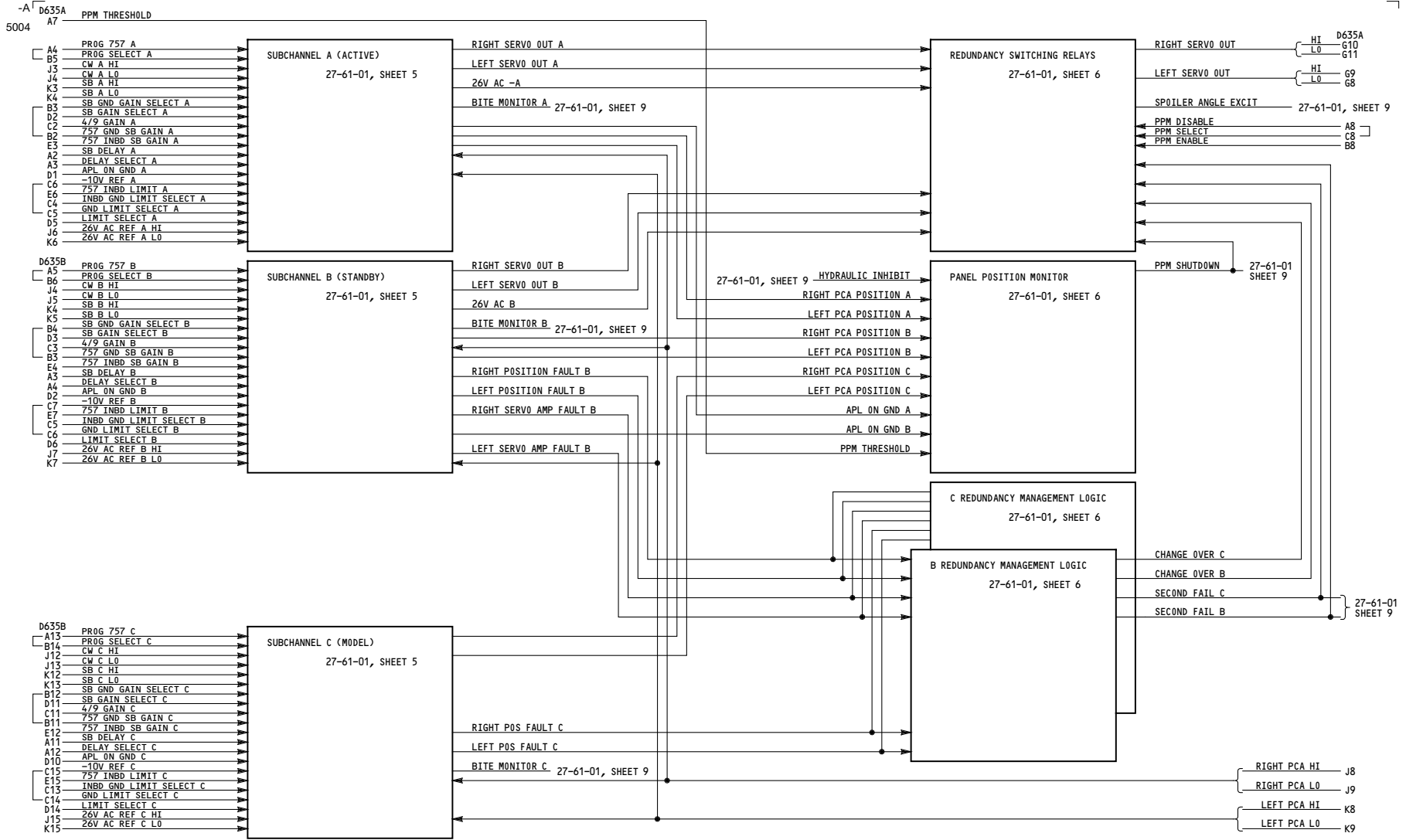

003-099

SPOILERS

D280N032S

27-61-01

5004

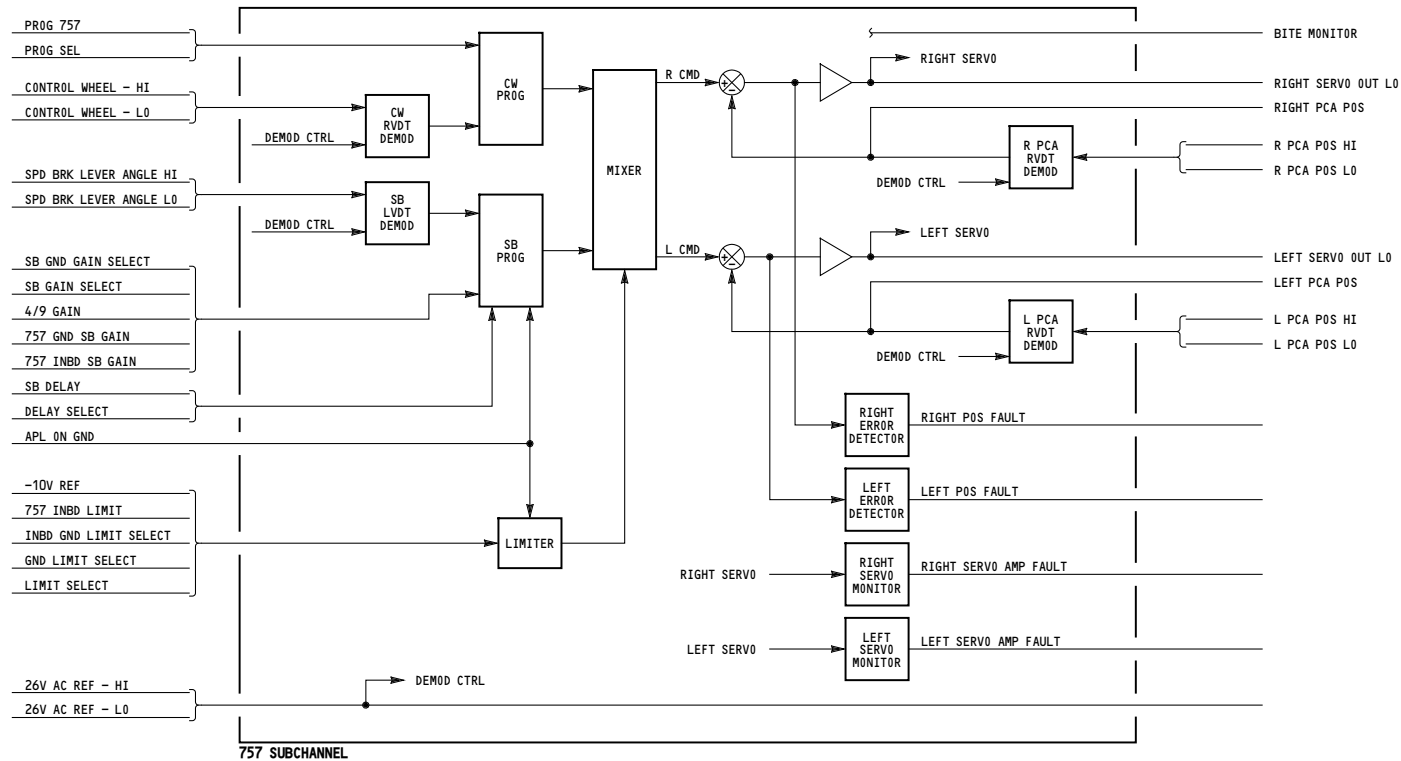

003-099	<p align="center">SPOILERS</p> <p align="center">D280N032S</p>
---------	---

27-61-01

Page 103
Sheet 5
Jan 21/2005

5004

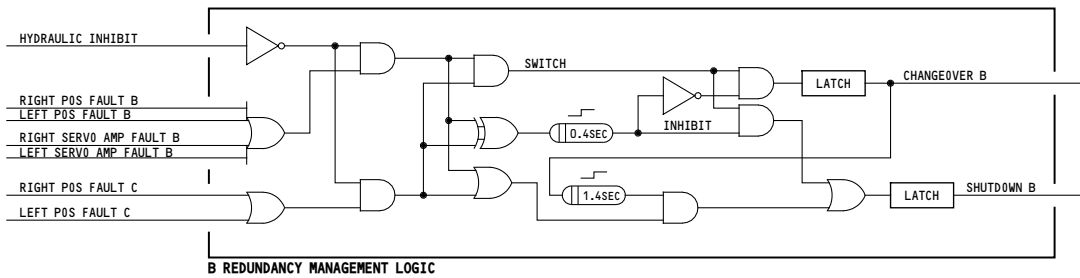
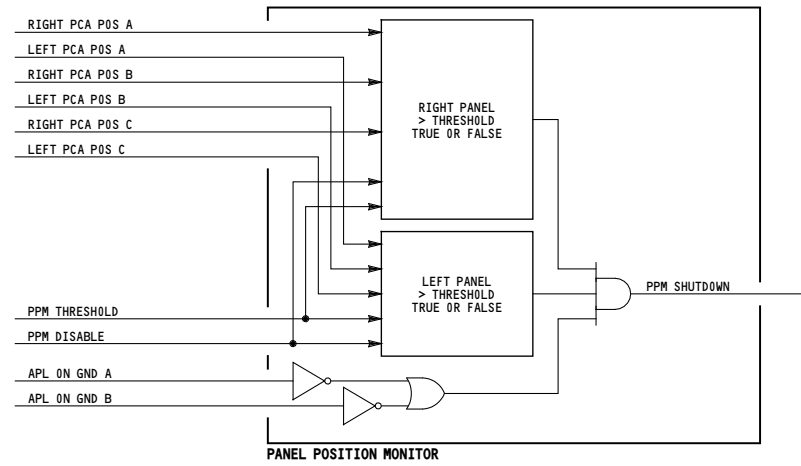
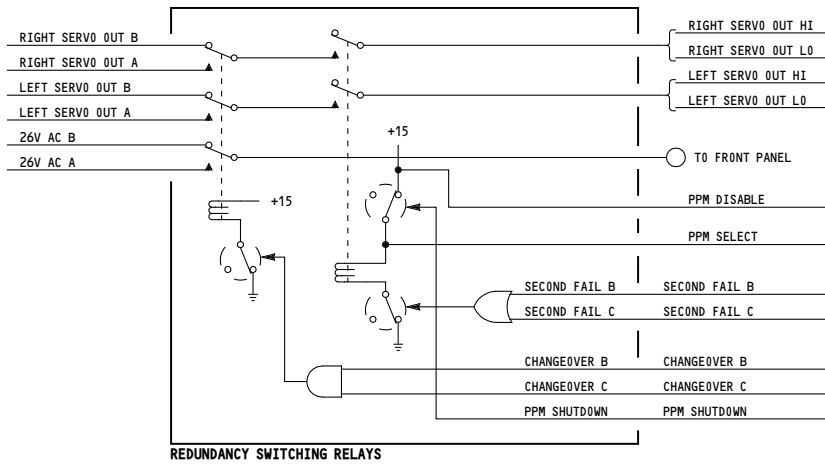

003-099

SPOILERS

D280N032S

27-61-01

Page 103
Sheet 6
Jan 21/2005

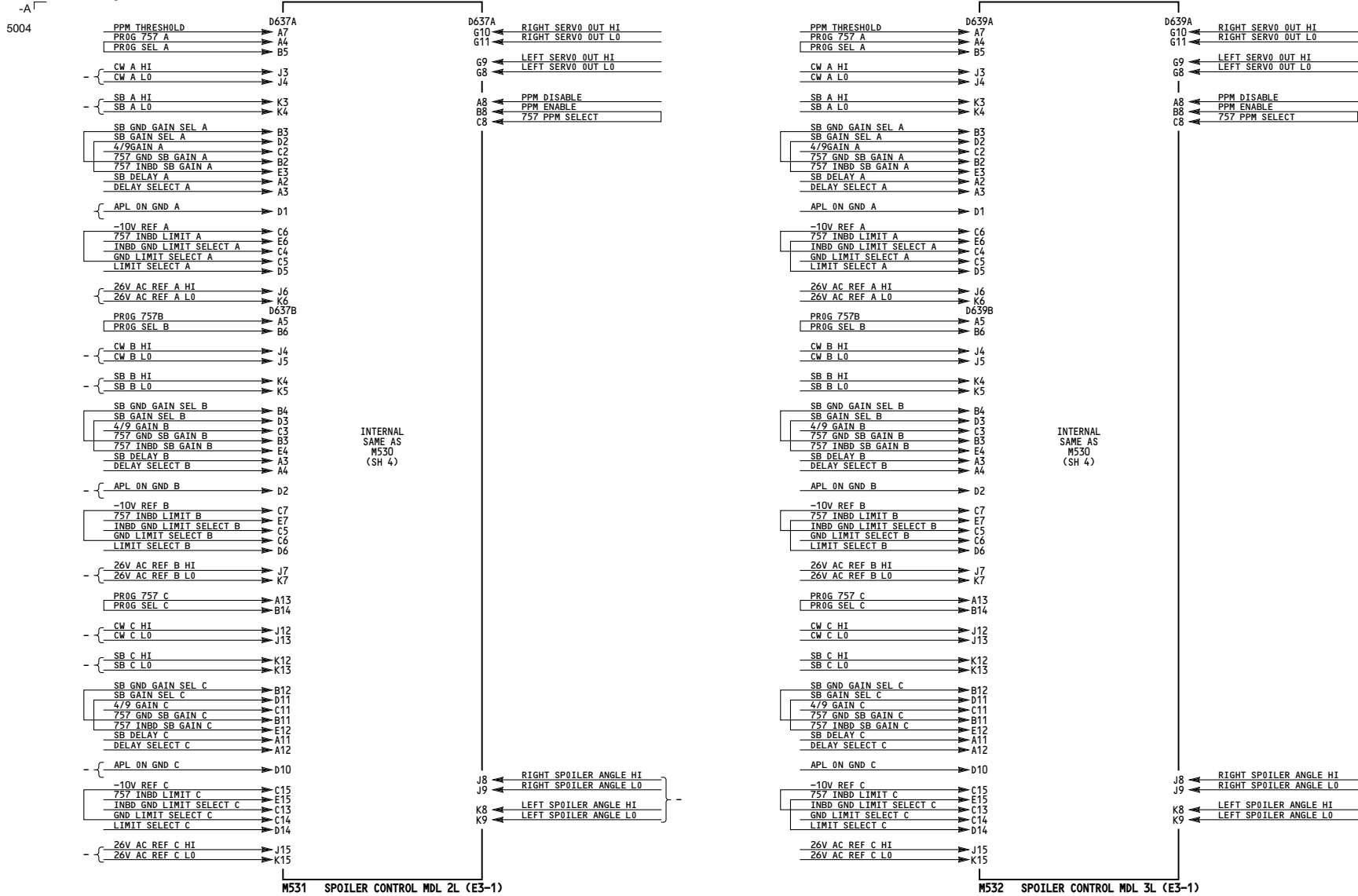

INTERNAL
SAME AS
M530
(SH 4)

INTERNAL
SAME AS
M530
(SH 4)

M531 SPOILER CONTROL MDL 2L (E3-1)

M532 SPOILER CONTROL MDL 3L (E3-1)

003-099

SPOILERS

D280N032S

27-61-01

5004

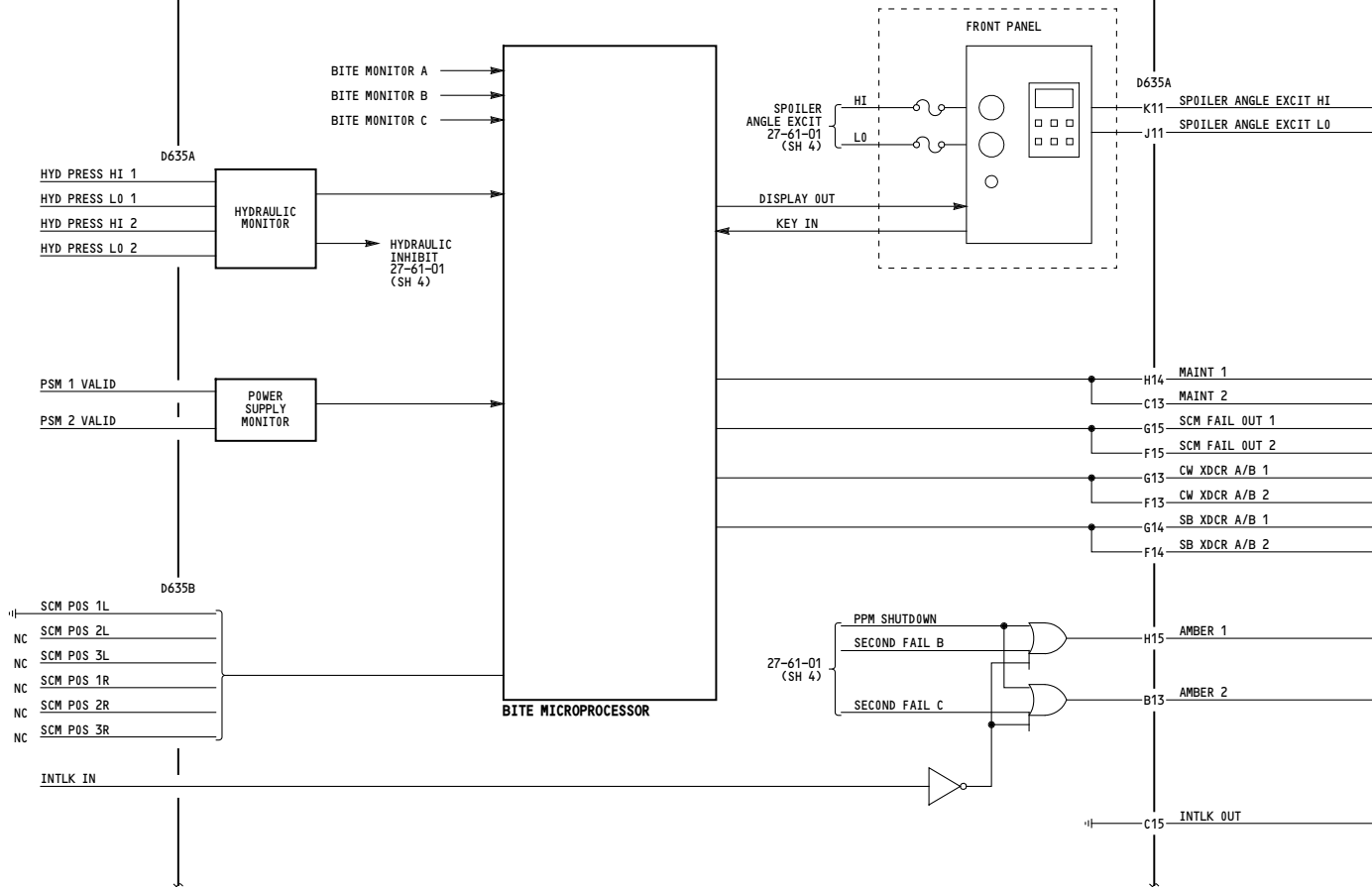

003-099	<p align="center">SPOILERS</p> <p align="center">D280N032S</p>
---------	---

27-61-01

5004

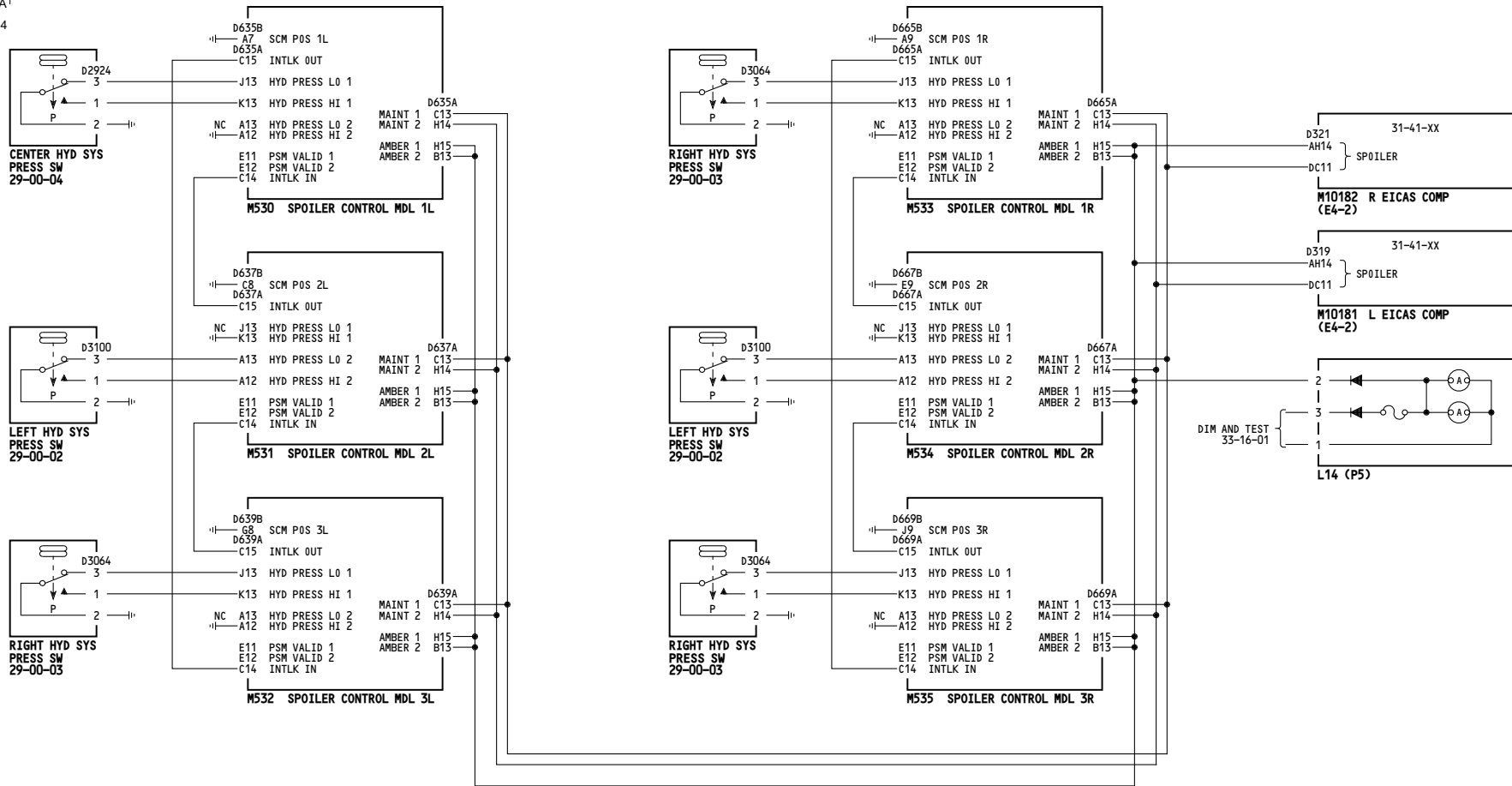

003-099

SPOILERS

D280N032S

27-61-01

Page 103
Sheet 10
Dec 18/2007

5004

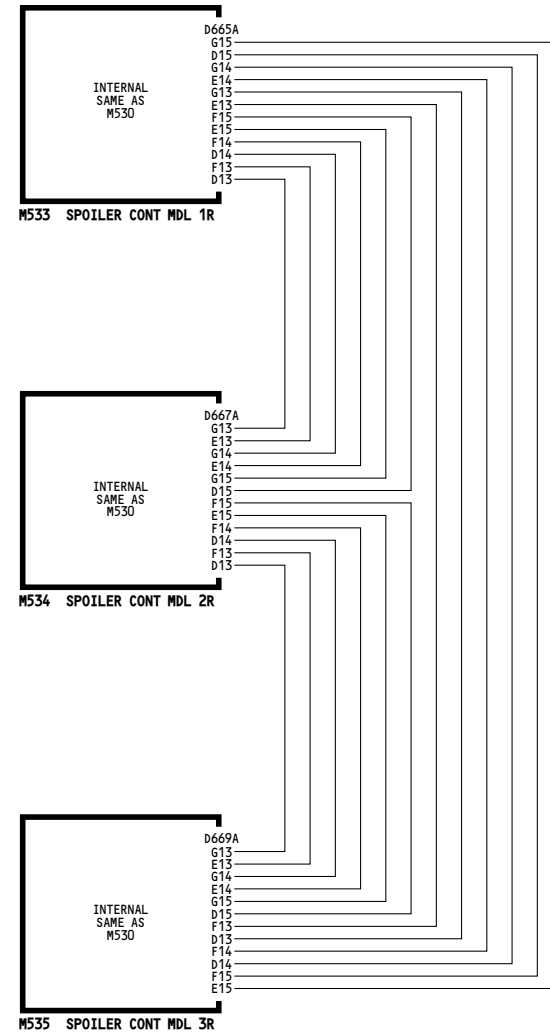
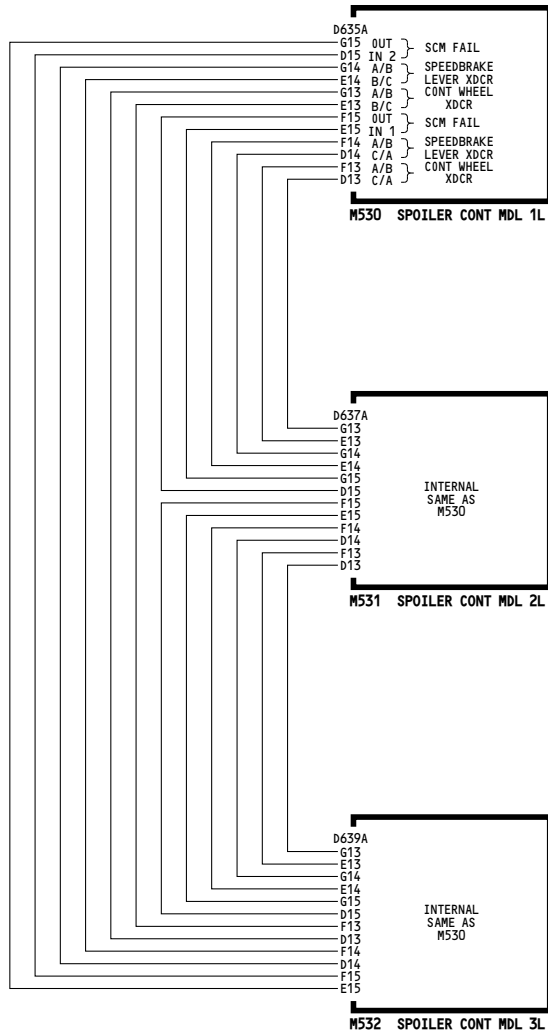

003-099	<p align="center">SPOILERS</p> <p align="center">D280N032S</p>
---------	---

27-61-01

Page 103
Sheet 11
Jan 21/2005

THIS PAGE INTENTIONALLY LEFT BLANK

-A
5000

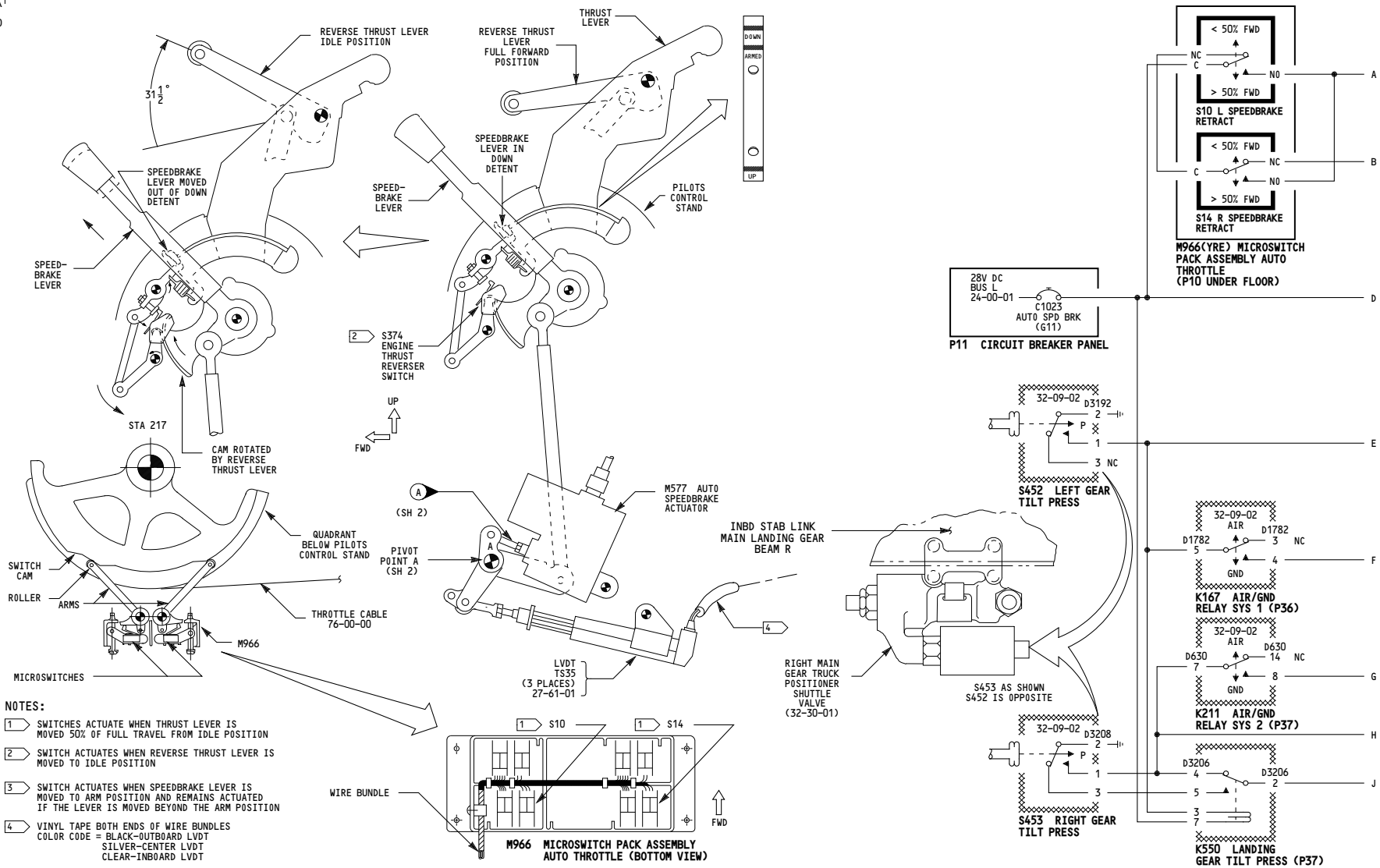

001-099	AUTO SPEEDBRAKE
D280N032S	

27-62-01

5000

WIRING DIAGRAMS
27-62-11

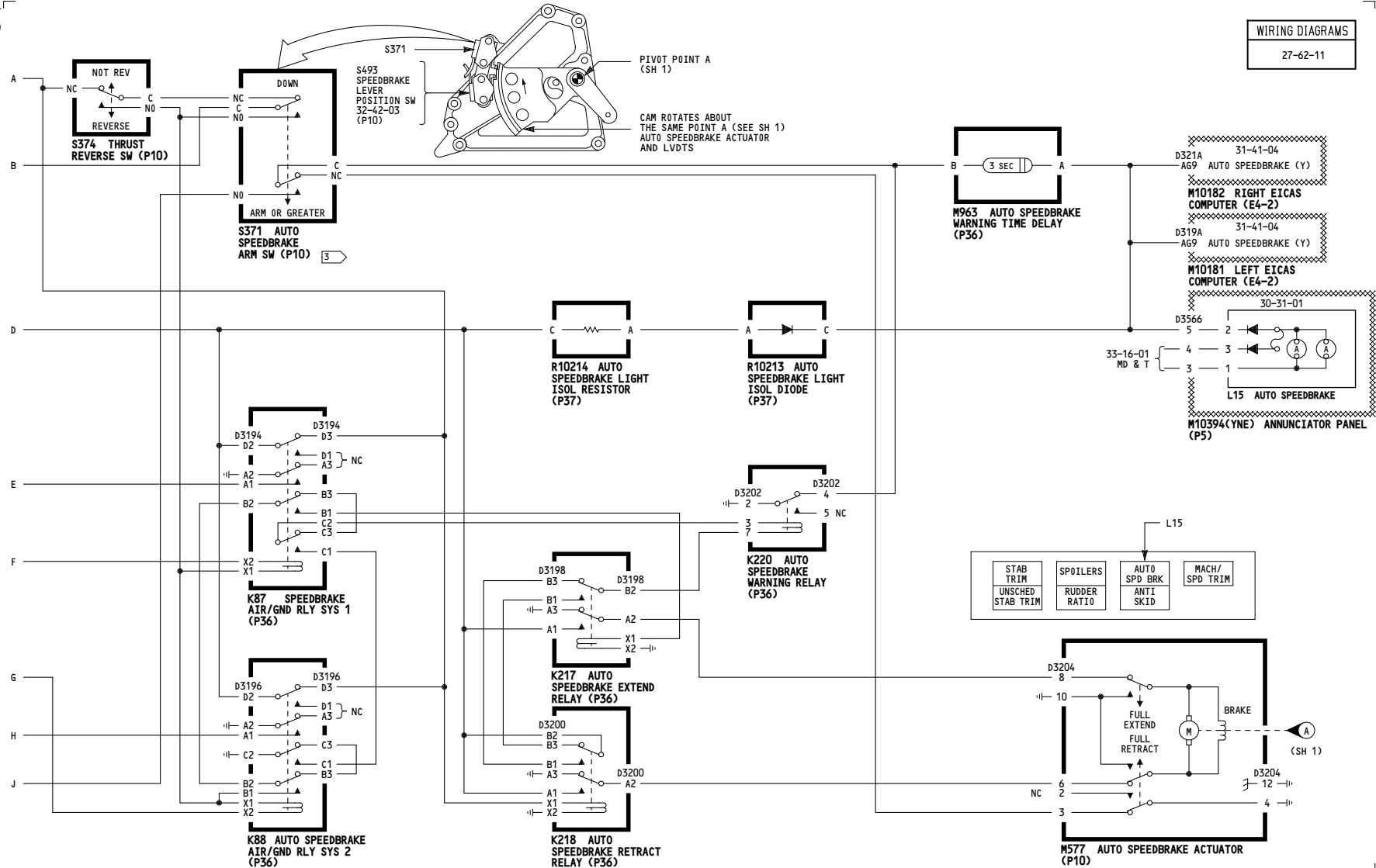

001-099	AUTO SPEEDBRAKE
D280N032S	

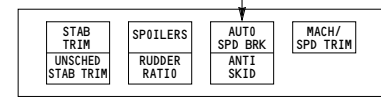

27-62-01

-A
5013

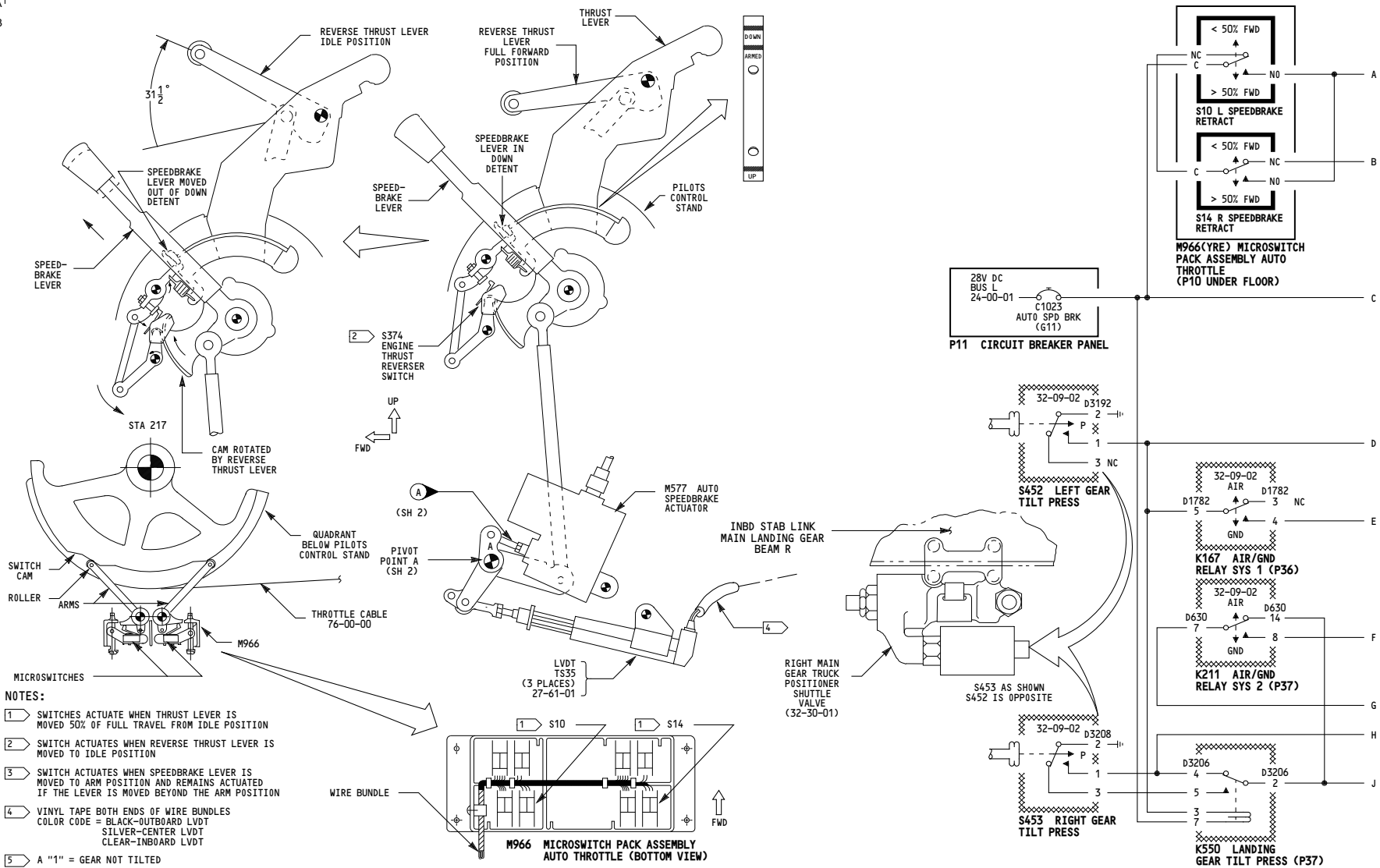

- NOTES:**
- SWITCHES ACTUATE WHEN THRUST LEVER IS MOVED 50% OF FULL TRAVEL FROM IDLE POSITION
 - SWITCH ACTUATES WHEN REVERSE THRUST LEVER IS MOVED TO IDLE POSITION
 - SWITCH ACTUATES WHEN SPEEDBRAKE LEVER IS MOVED TO ARM POSITION AND REMAINS ACTUATED IF THE LEVER IS MOVED BEYOND THE ARM POSITION
 - VINYL TAPE BOTH ENDS OF WIRE BUNDLES
 COLOR CODE = BLACK-OUTBOARD LVDT
 SILVER-CENTER LVDT
 CLEAR-INBOARD LVDT
 - A "1" = GEAR NOT TILTED

001-009, 115	<p align="center">AUTO SPEEDBRAKE</p> <p align="right">Incorporates 27A0130 R01</p> <p align="center">D280N032S</p>
--------------	---

27-62-01

-B
5003

WIRING DIAGRAMS
27-62-11

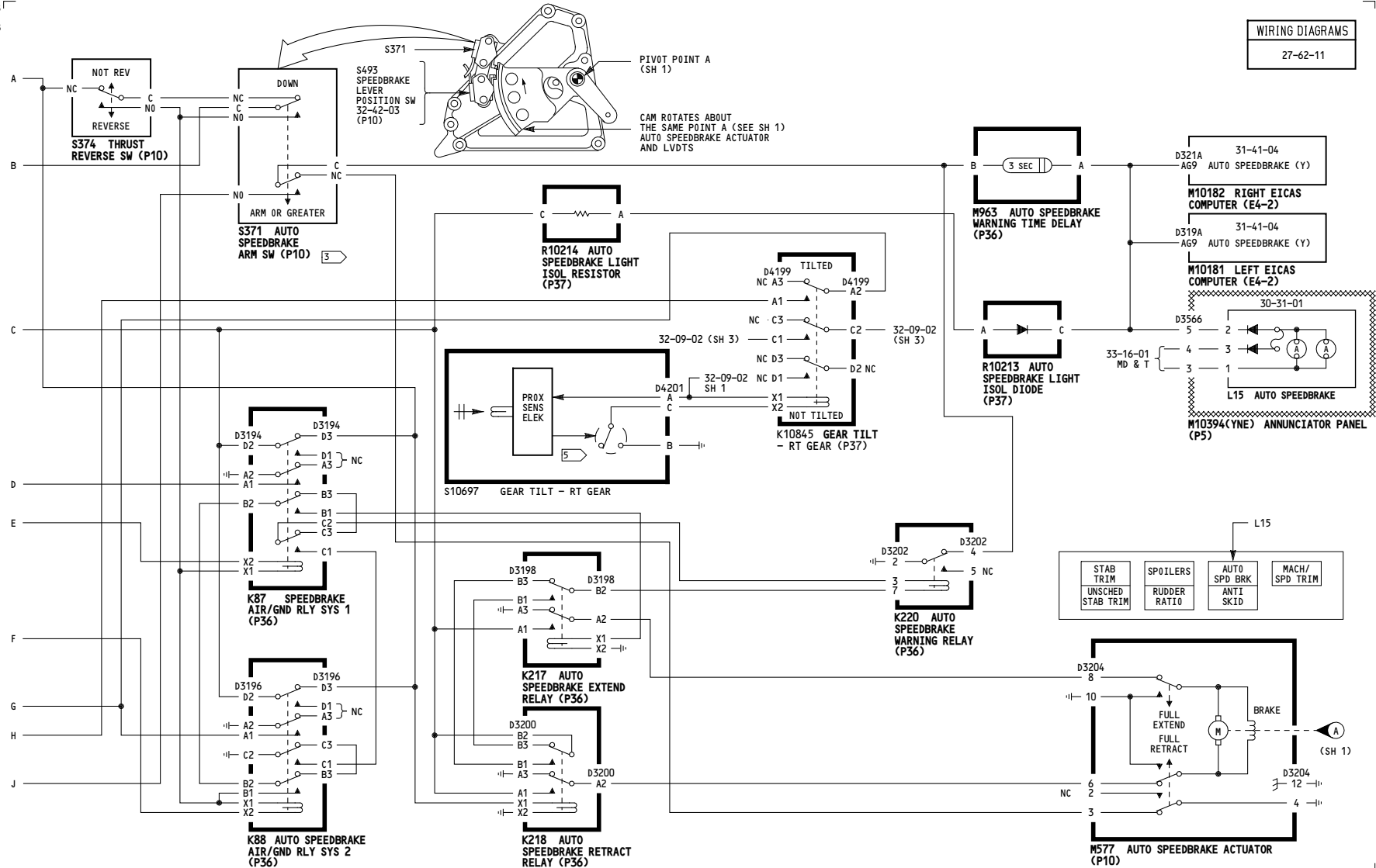

001-009, 115

AUTO SPEEDBRAKE

D280N032S

Incorporates
27A0130 R01

27-62-01

-A
5013

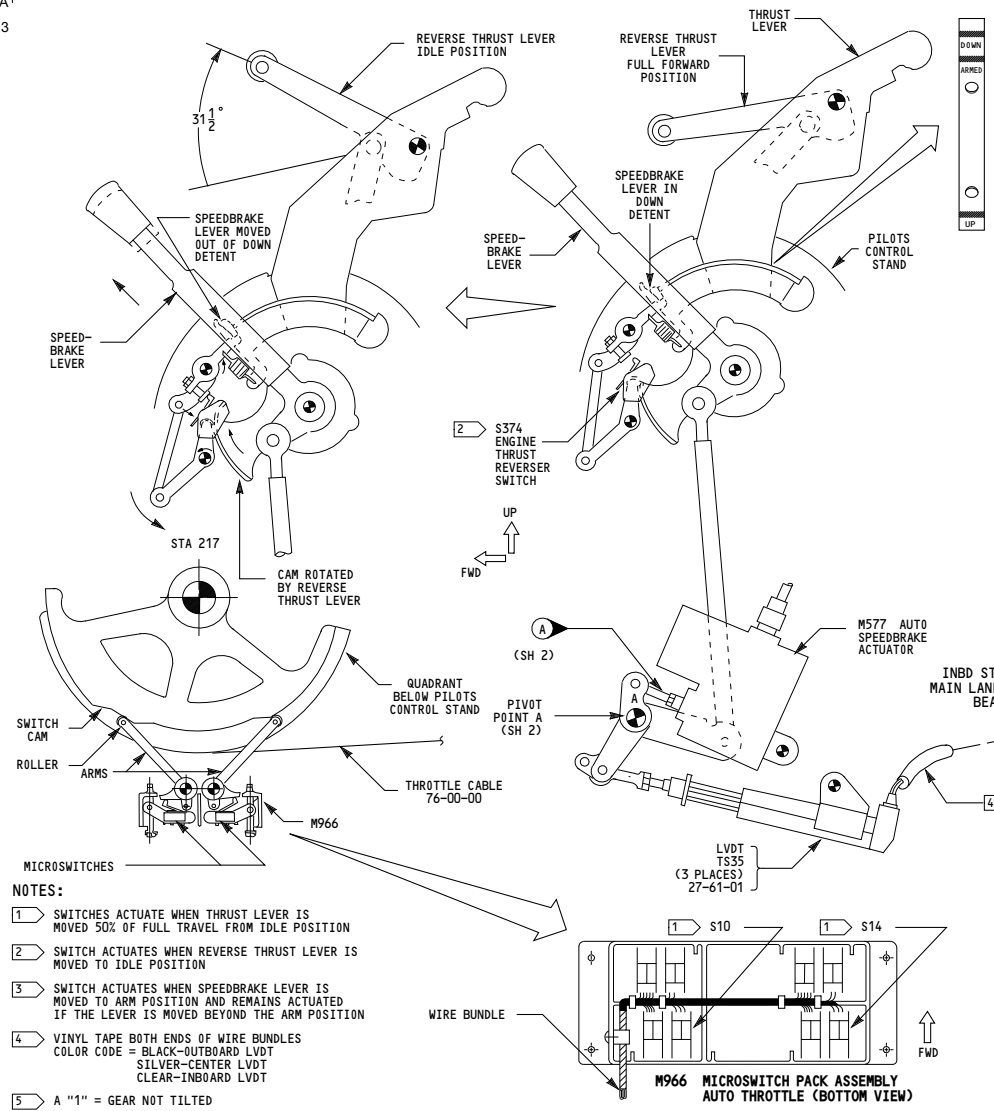

- NOTES:**
- 1 SWITCHES ACTUATE WHEN THRUST LEVER IS MOVED 50% OF FULL TRAVEL FROM IDLE POSITION
 - 2 SWITCH ACTUATES WHEN REVERSE THRUST LEVER IS MOVED TO IDLE POSITION
 - 3 SWITCH ACTUATES WHEN SPEEDBRAKE LEVER IS MOVED TO ARM POSITION AND REMAINS ACTUATED IF THE LEVER IS MOVED BEYOND THE ARM POSITION
 - 4 VINYL TAPE BOTH ENDS OF WIRE BUNDLES
COLOR CODE = BLACK-OUTBOARD LVDT
SILVER-CENTER LVDT
CLEAR-INBOARD LVDT
 - 5 A "1" = GEAR NOT TILTED

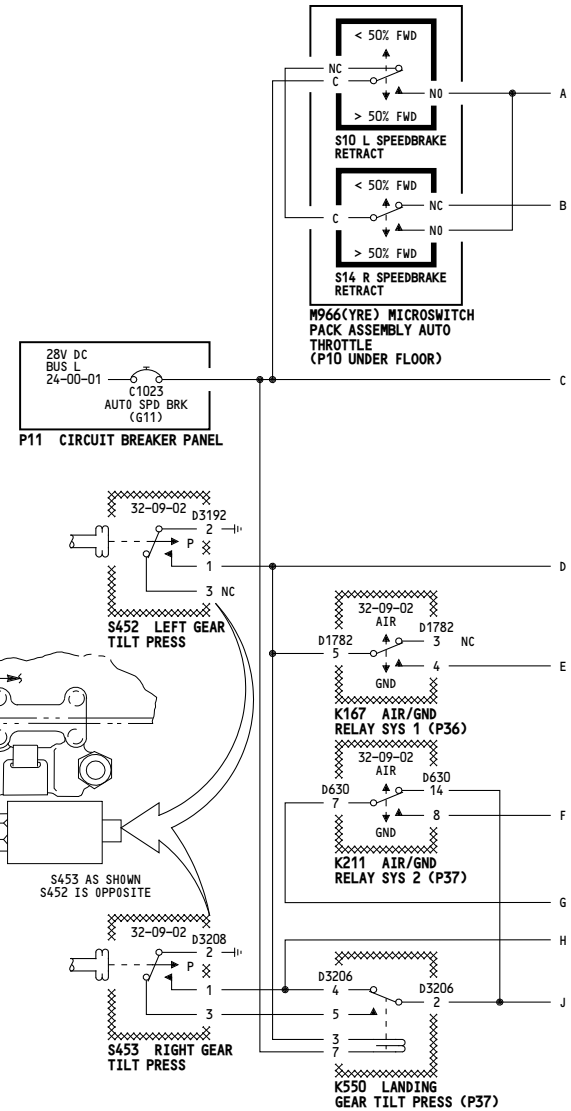

010-011	AUTO SPEEDBRAKE	Incorporates 27A0130 R01
D280N032S		

27-62-01

5004

WIRING DIAGRAMS
27-62-11

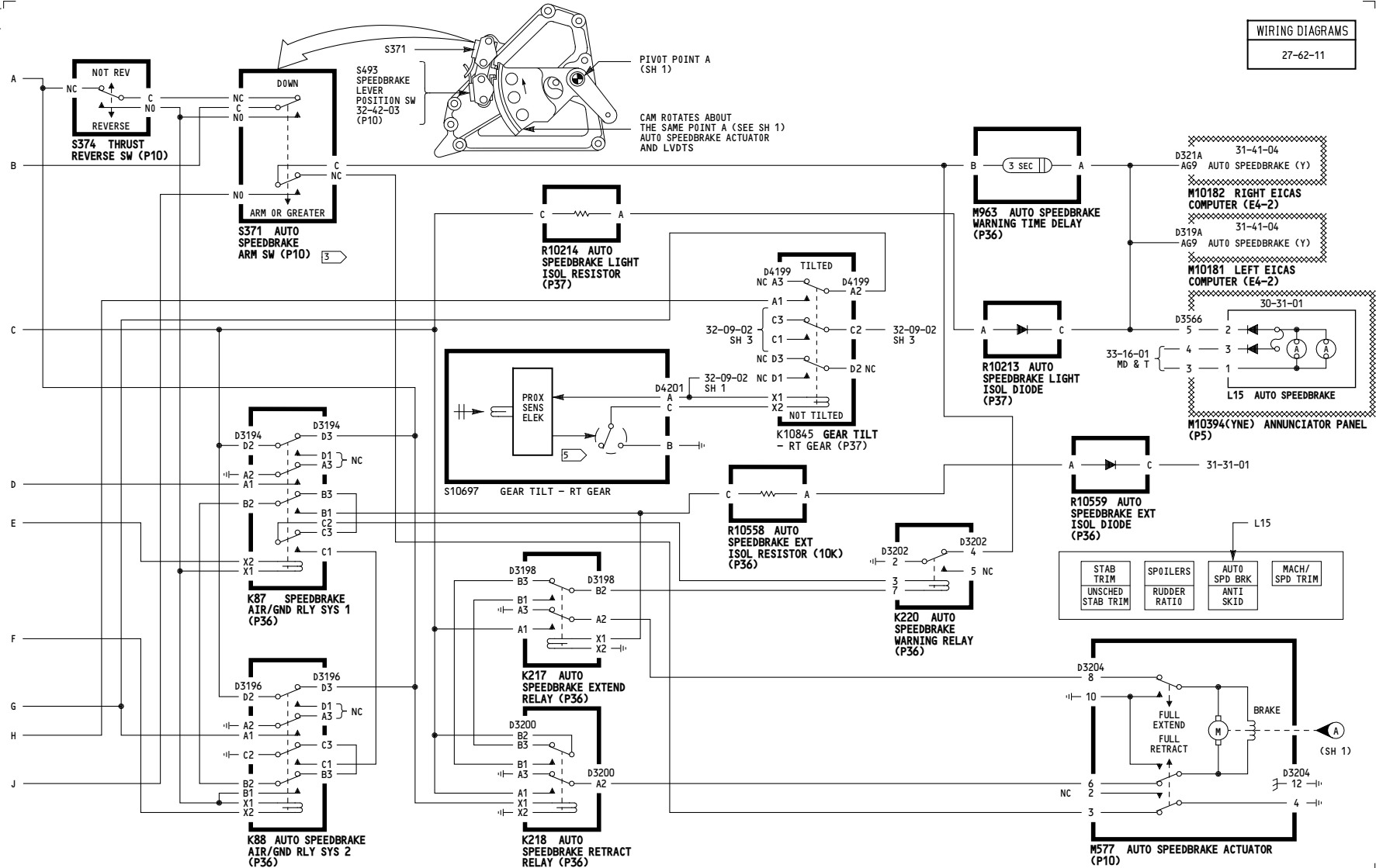

AUTO SPEEDBRAKE

- Incorporates
- ▶ 27A0130 R01
 - ▶ 31-0094

D280N032S

27-62-01

Page 101.2
Sheet 2
Jan 21/2005

5011

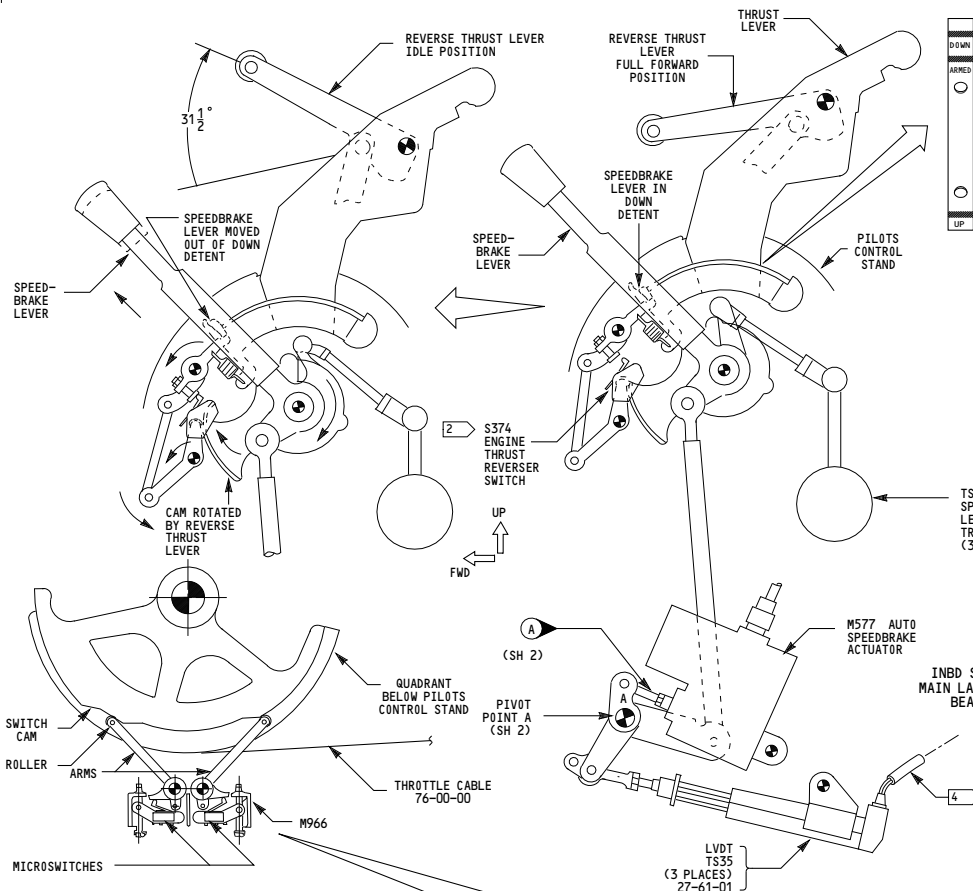

- NOTES:**
- 1 SWITCHES ACTUATE WHEN THRUST LEVER IS MOVED 50% OF FULL TRAVEL FROM IDLE POSITION
 - 2 SWITCH ACTUATES WHEN REVERSE THRUST LEVER IS MOVED TO IDLE POSITION
 - 3 SWITCH ACTUATES WHEN SPEEDBRAKE LEVER IS MOVED TO ARM POSITION AND REMAINS ACTUATED IF THE LEVER IS MOVED BEYOND THE ARM POSITION
 - 4 VINYL TAPE BOTH ENDS OF WIRE BUNDLES
COLOR CODE: BLACK - OUTBOARD LVDT
SILVER - CENTER LVDT
CLEAR - INBOARD LVDT

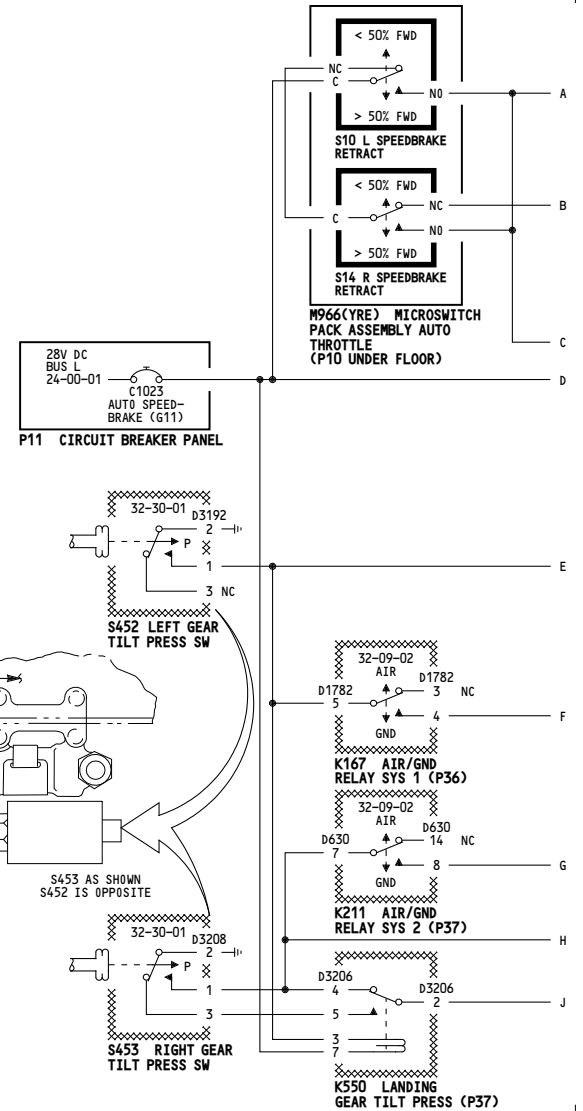
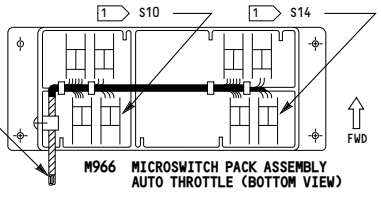

115-199	AUTO SPEEDBRAKE
D280N032S	

27-62-01

5000

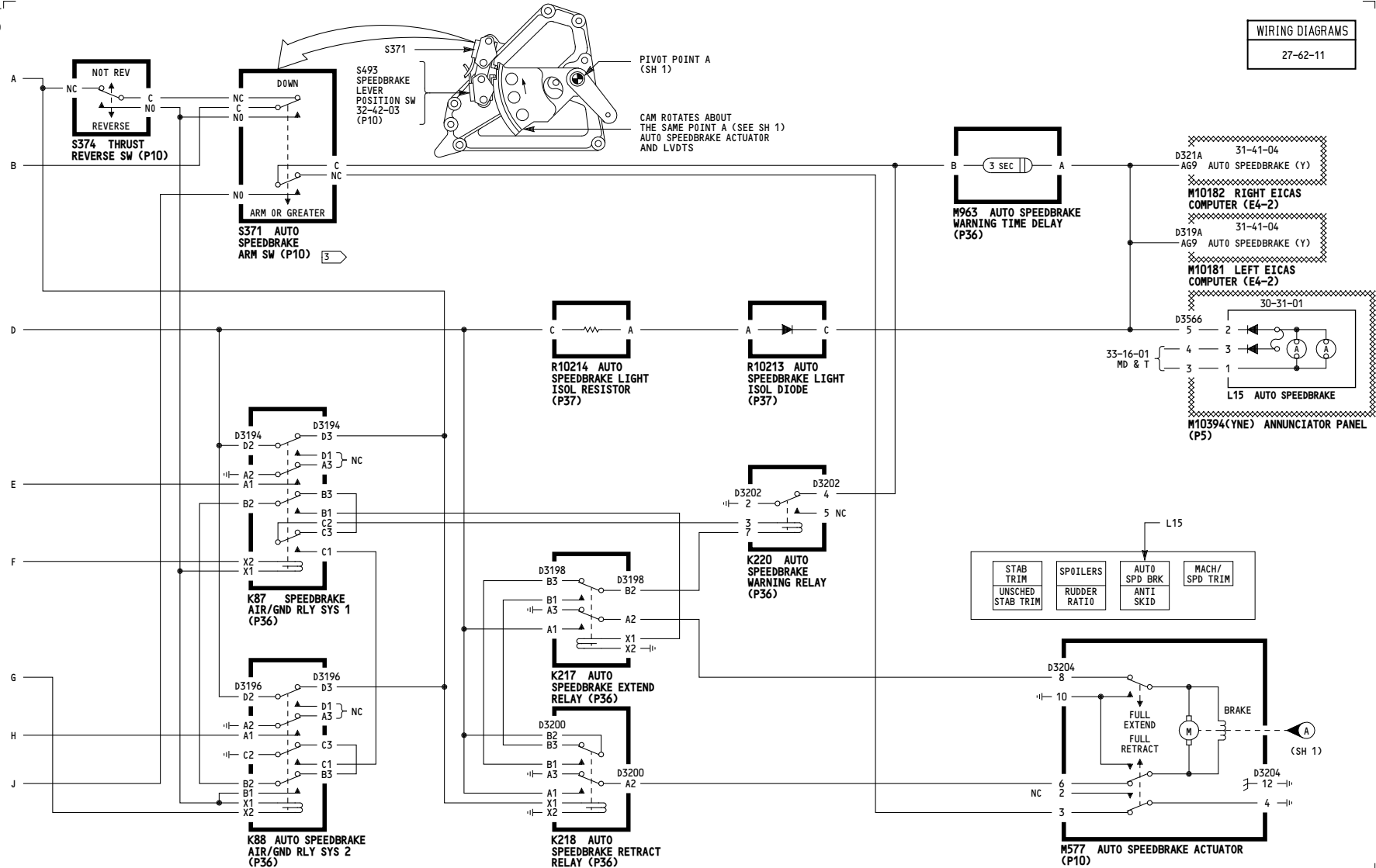

115-199

AUTO SPEEDBRAKE

27-62-01

D280N032S

5000

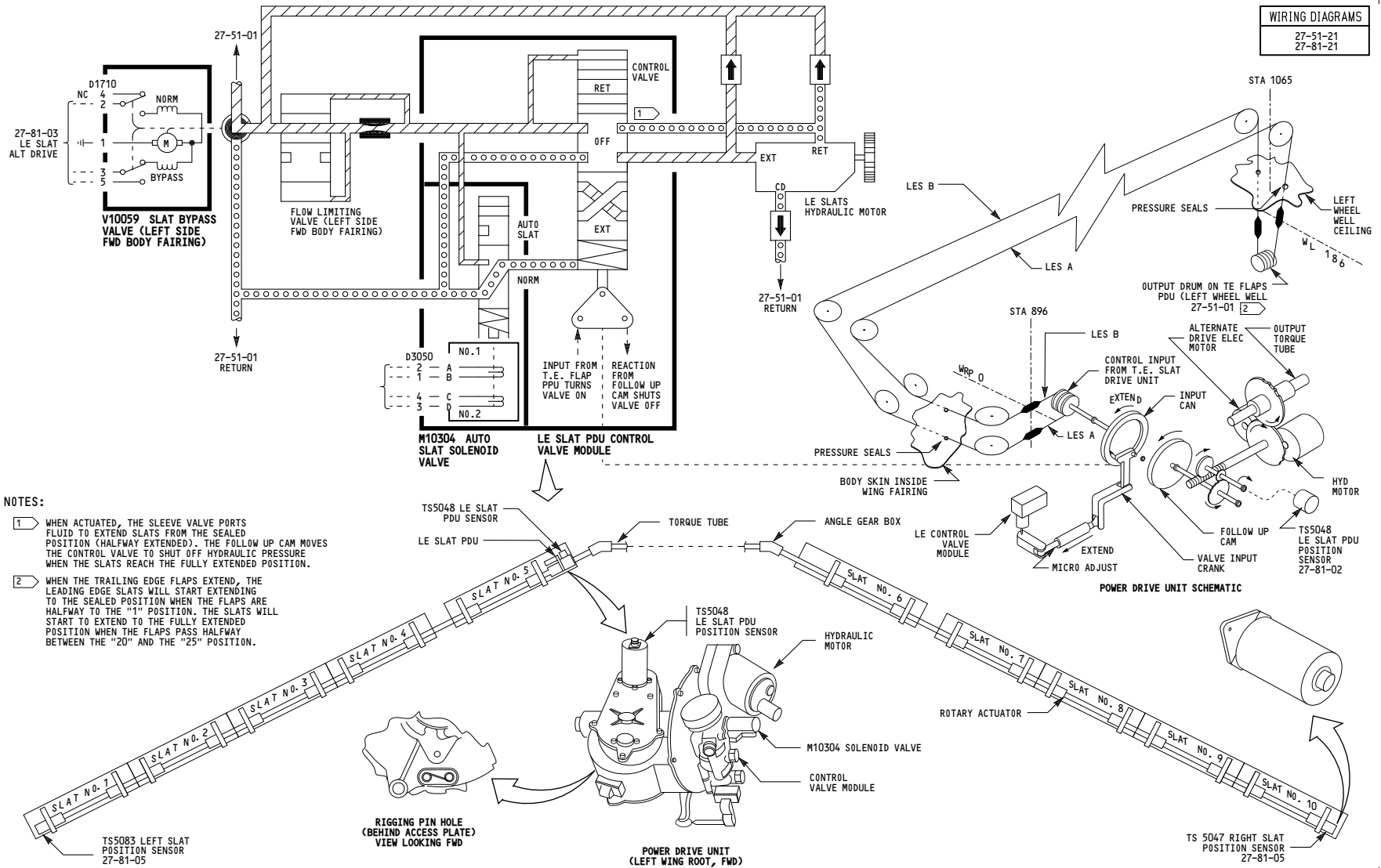

ALL

LEADING EDGE SLATS PRIMARY DRIVE

D280N032S

27-81-01

Page 101

Jan 21/2005

THIS PAGE INTENTIONALLY LEFT BLANK

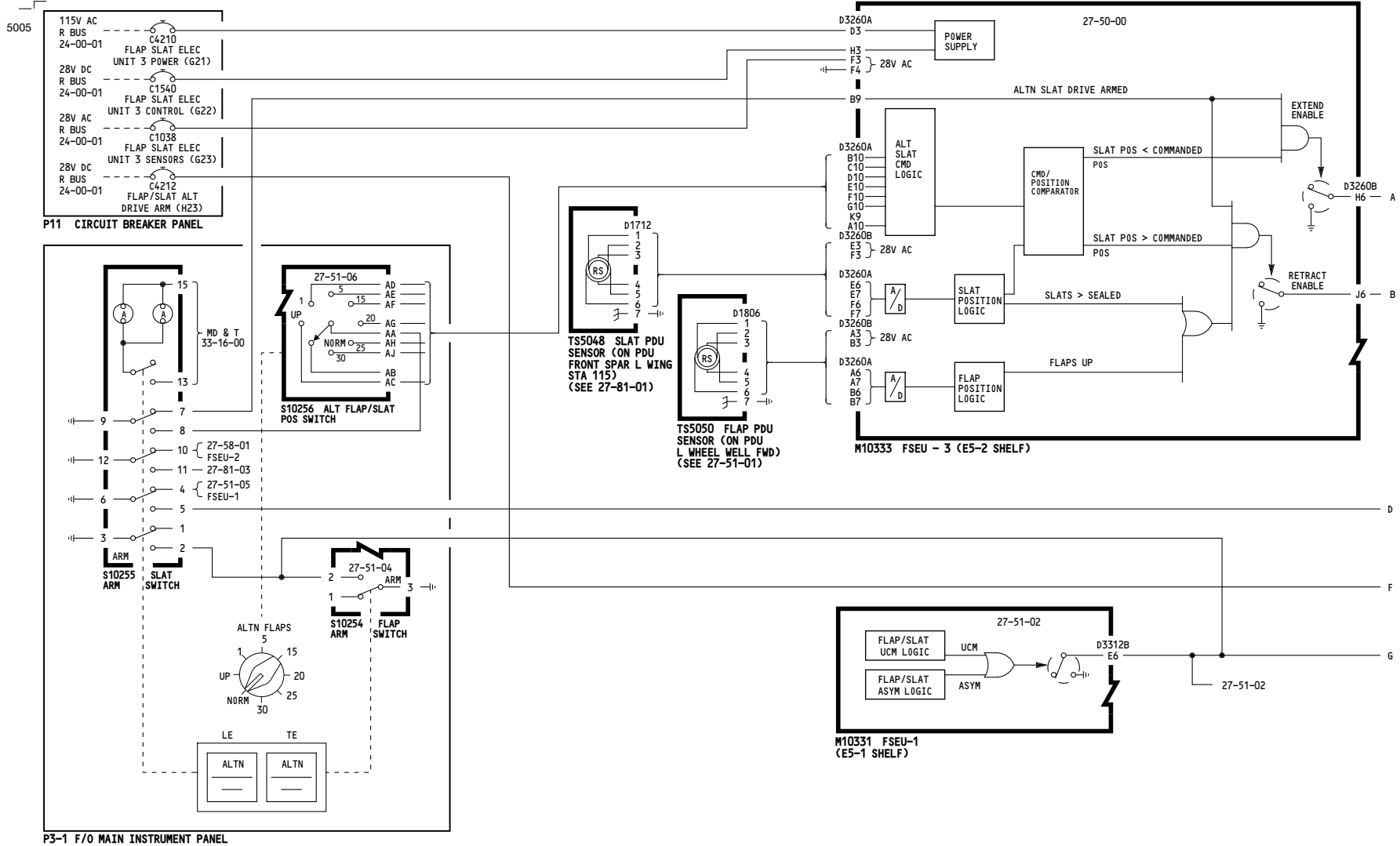

001-099	<p align="center">SLAT ALTERNATE DRIVE</p> <p align="center">D280N032S</p>
---------	---

27-81-02

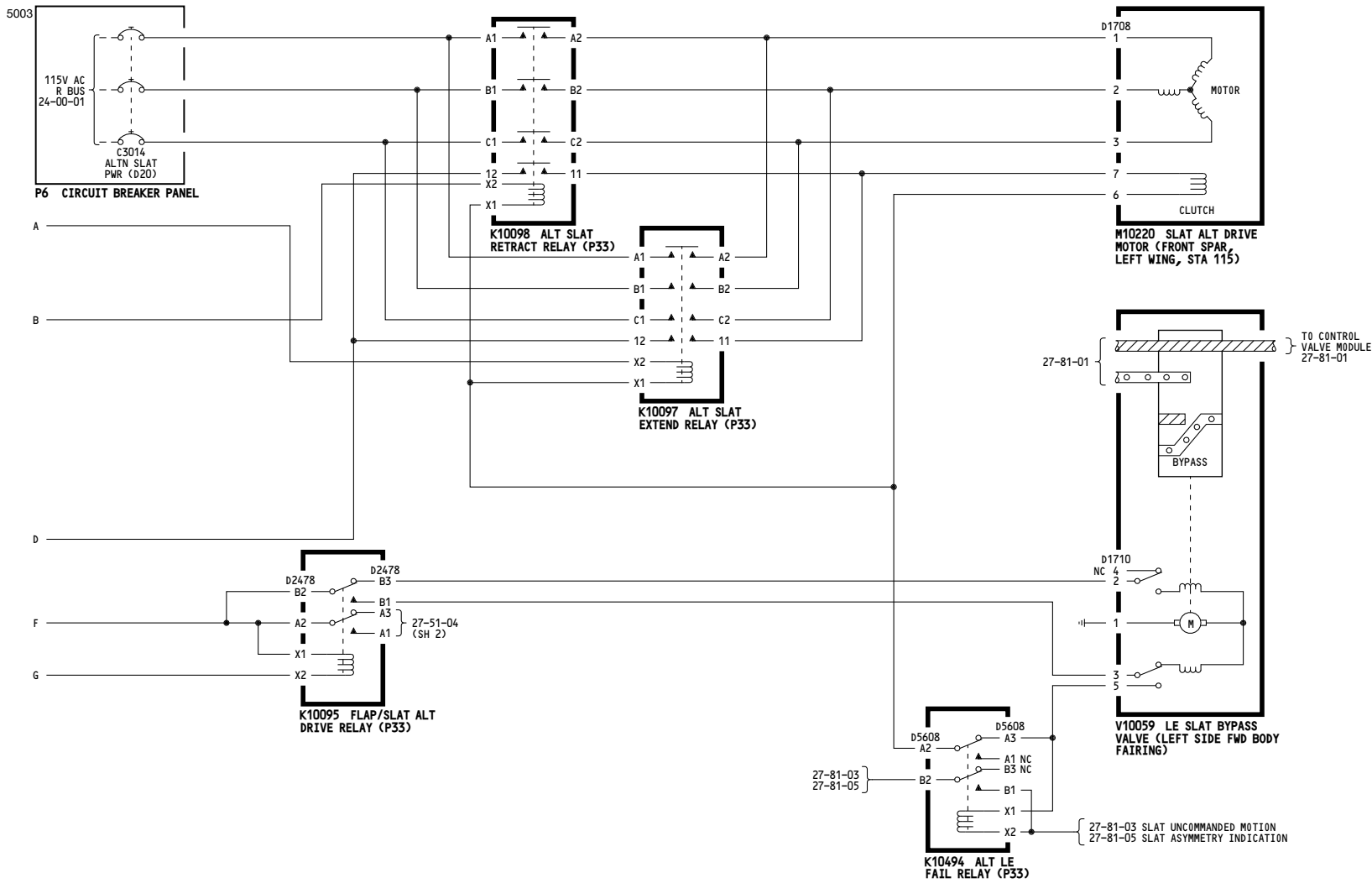

WIRING DIAGRAMS
27-51-11
27-51-21
27-81-11

001-099	<p align="center">SLAT ALTERNATE DRIVE</p> <p align="center">D280N032S</p>
---------	---

27-81-02

Page 101
Sheet 2
Jan 21/2005

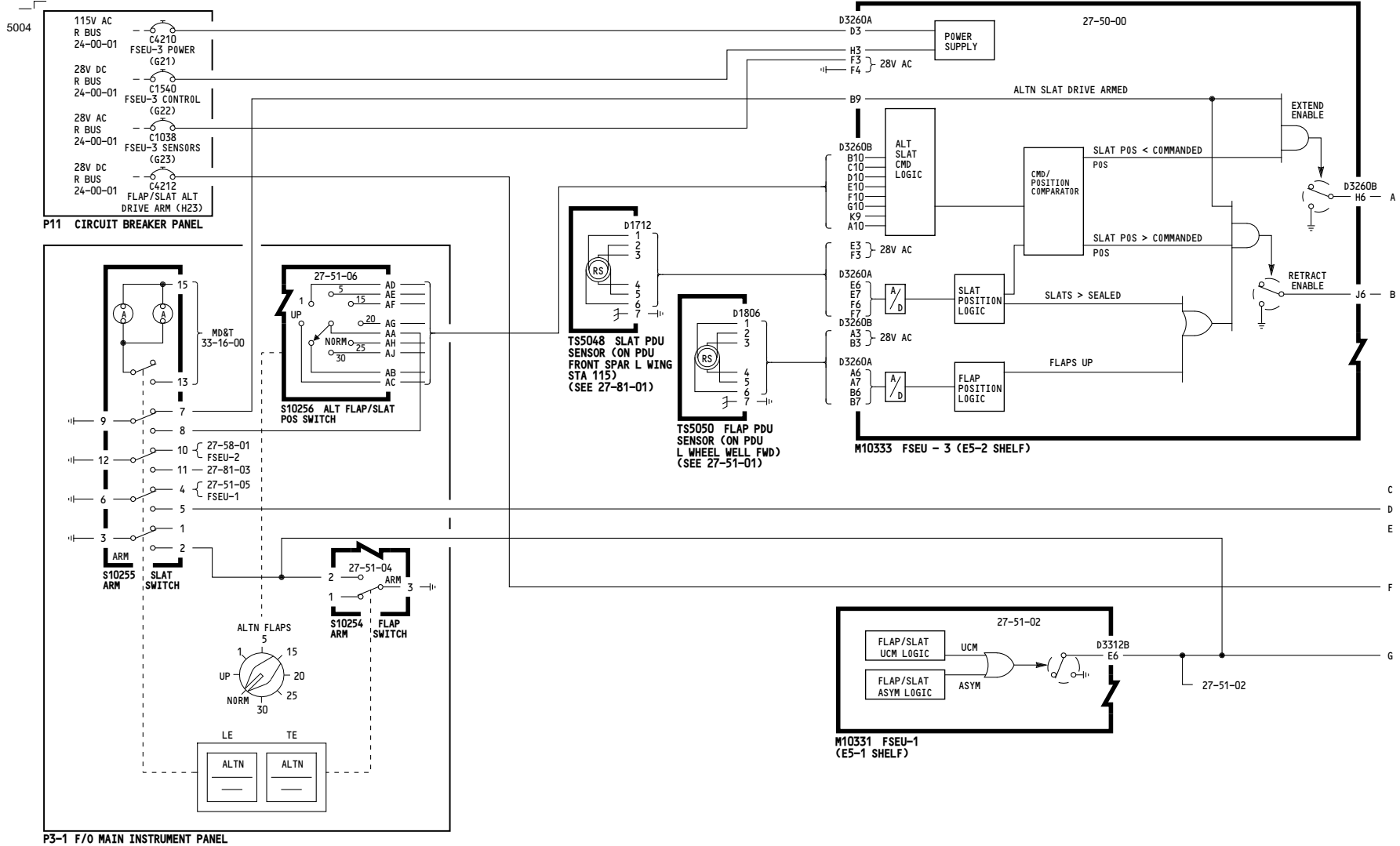

115-199

SLAT ALTERNATE DRIVE

D280N032S

27-81-02

Page 102
Sheet 1
Jan 21/2005

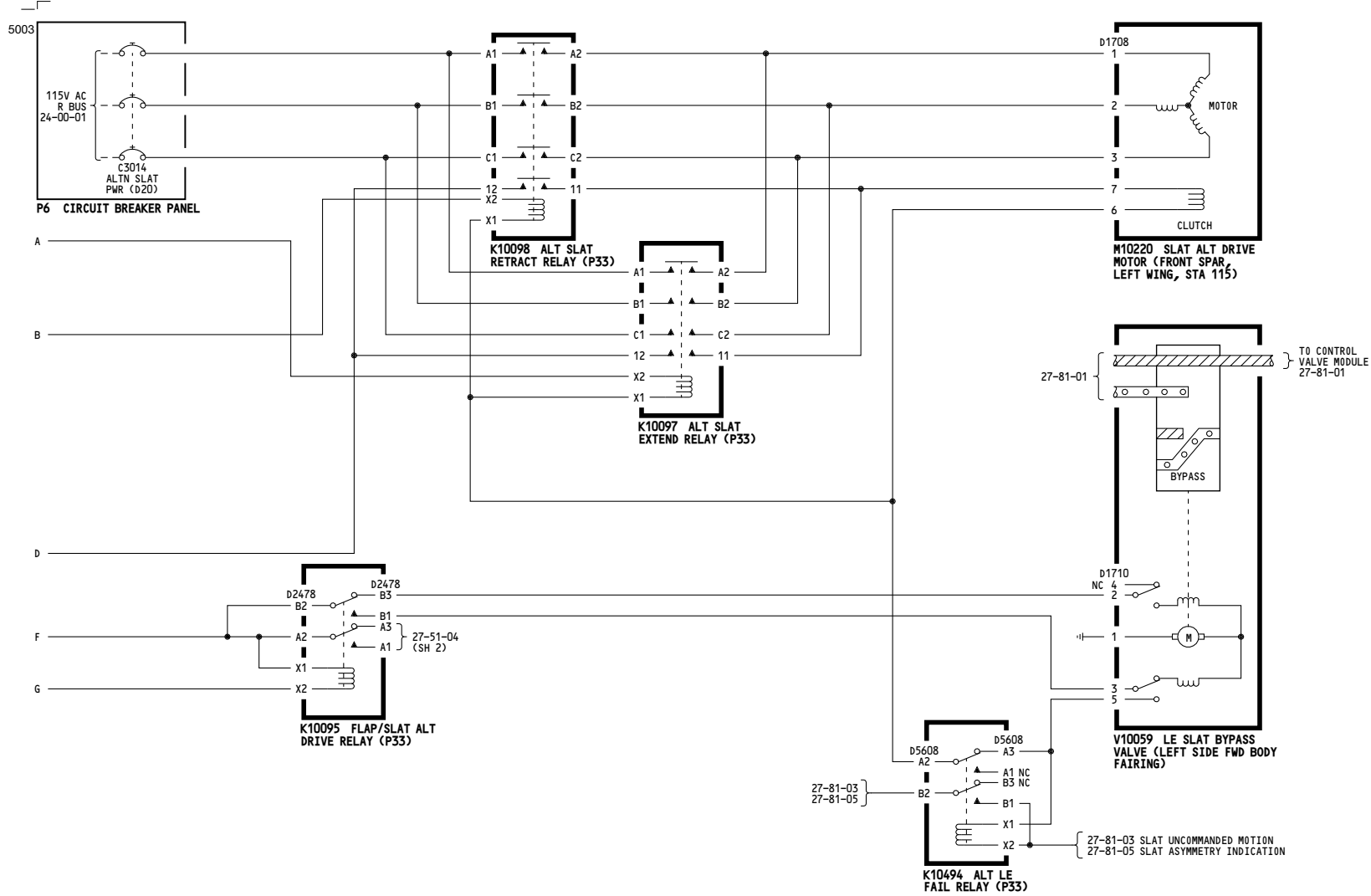

WIRING DIAGRAMS

27-51-11

27-51-21

27-81-11

115-199	SLAT ALTERNATE DRIVE
	D280N032S

27-81-02

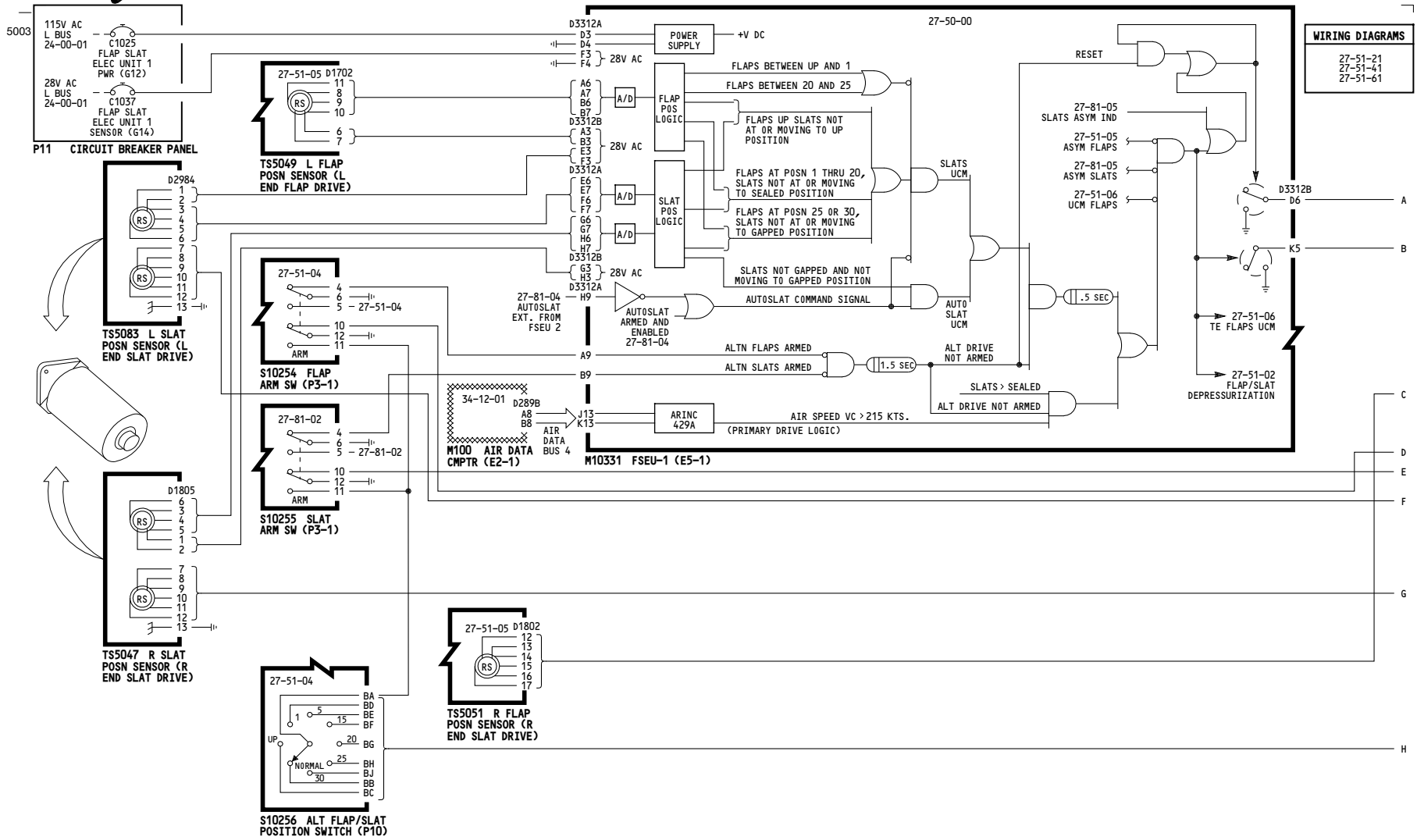

001-099

**LEADING EDGE SLATS
UNCOMMANDED MOTION**

D280N032S

27-81-03

Page 101
Sheet 1
Jan 21/2005

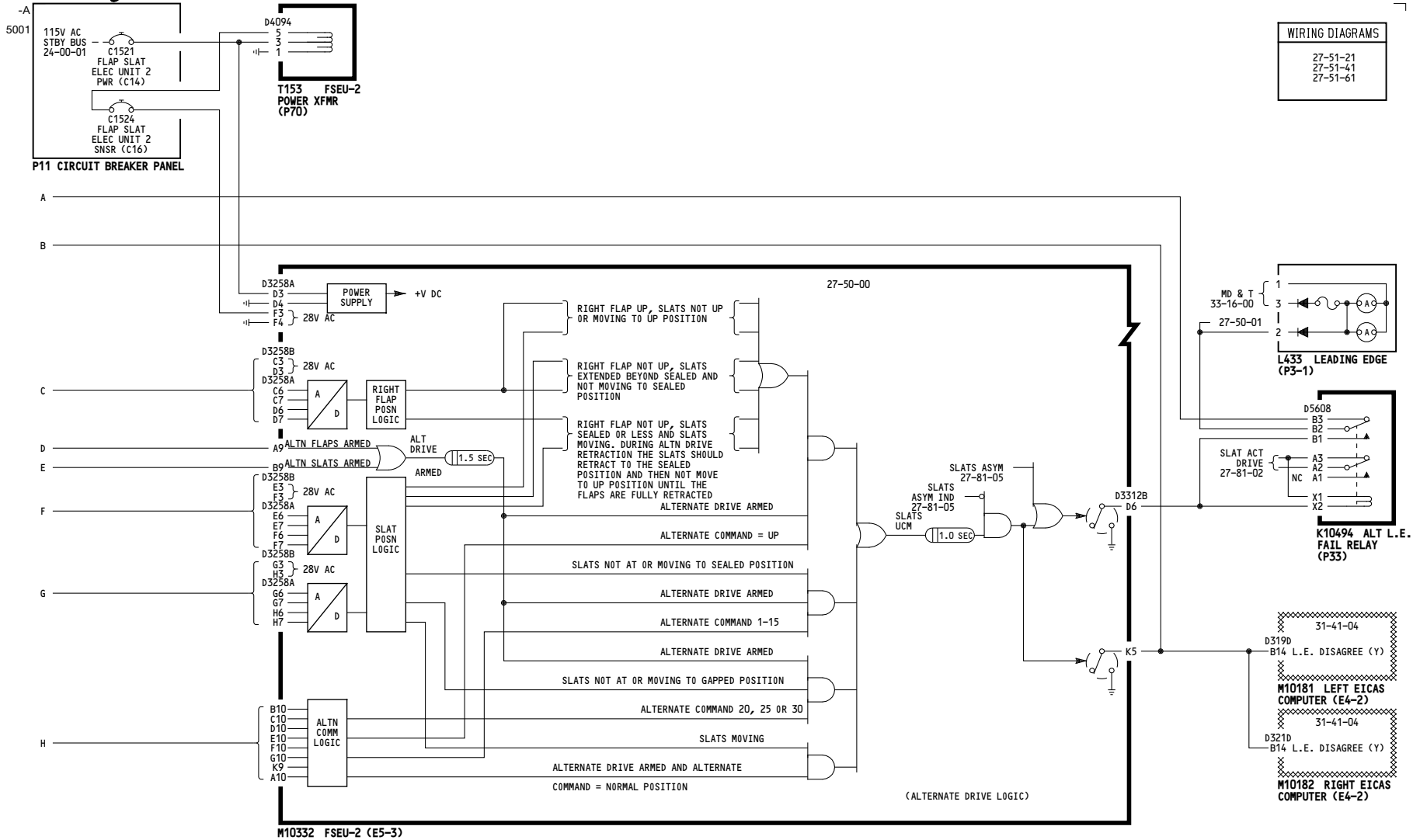

001-099

LEADING EDGE SLATS UNCOMMANDED MOTION

D280N032S

27-81-03

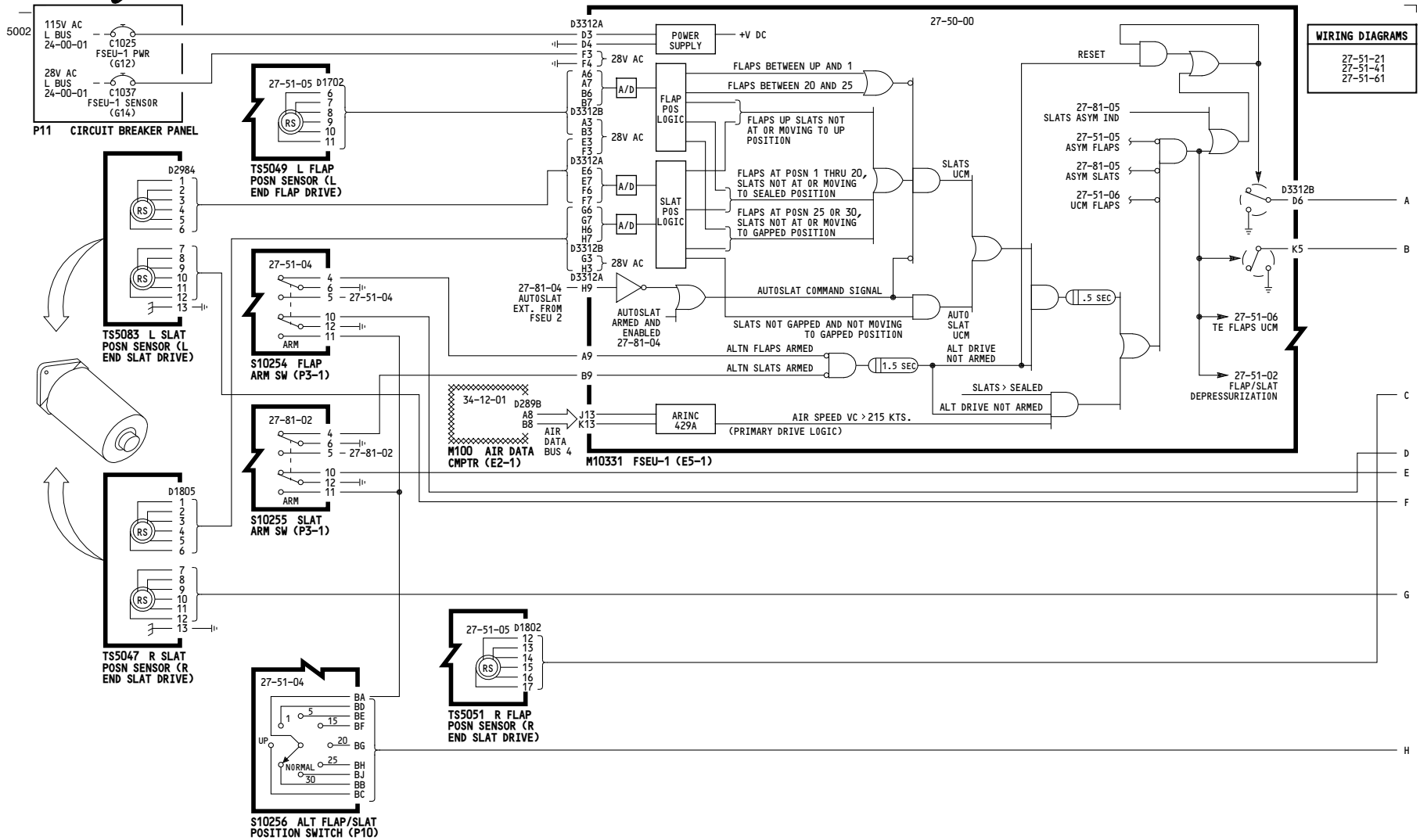

115-199

**LEADING EDGE SLATS
UNCOMMANDED MOTION**

D280N032S

27-81-03

Page 102
Sheet 1
Jan 21/2005

WIRING DIAGRAMS
27-51-21
27-51-41
27-51-61

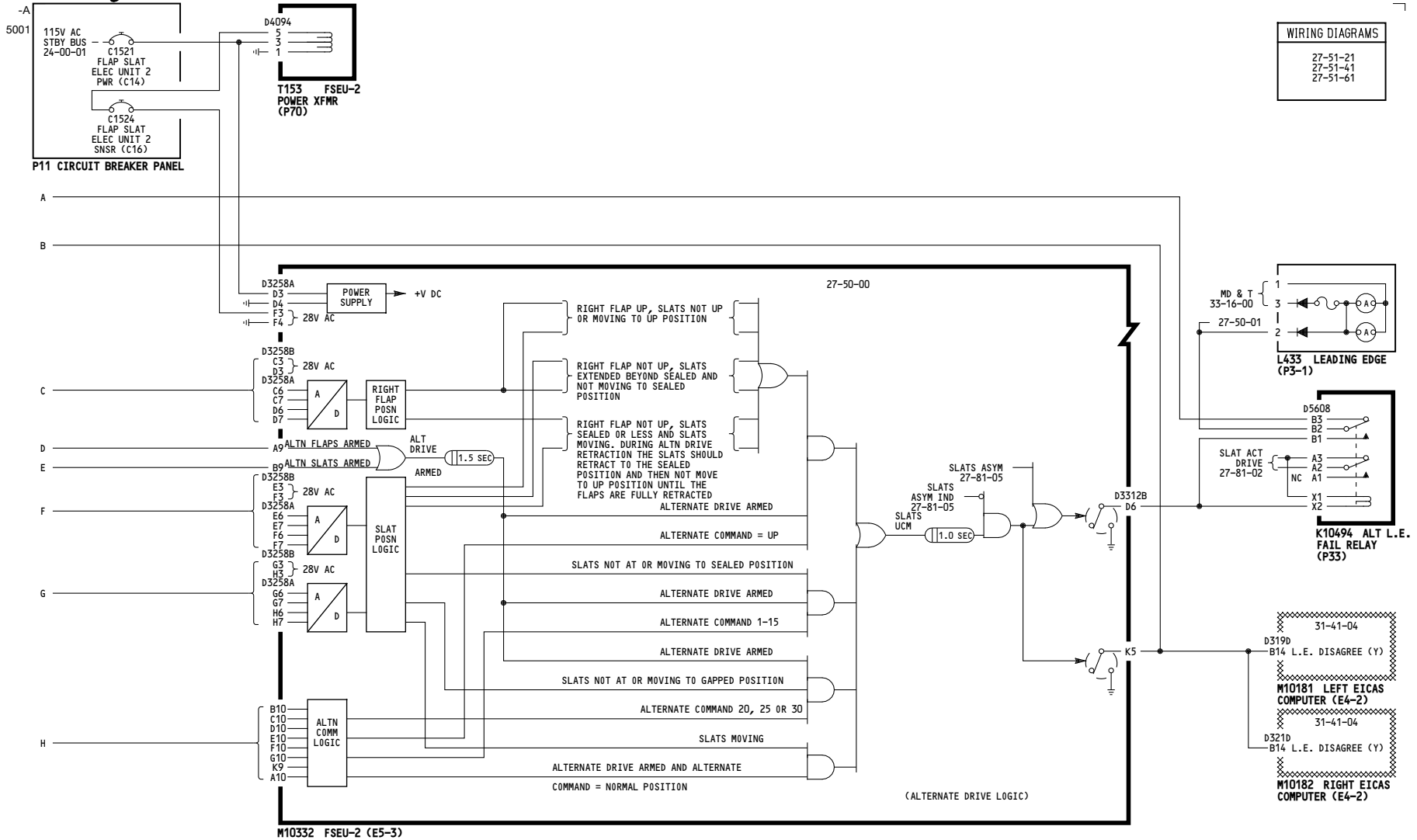

115-199

LEADING EDGE SLATS UNCOMMANDED MOTION

D280N032S

27-81-03

Page 102
Sheet 2
Jan 21/2005

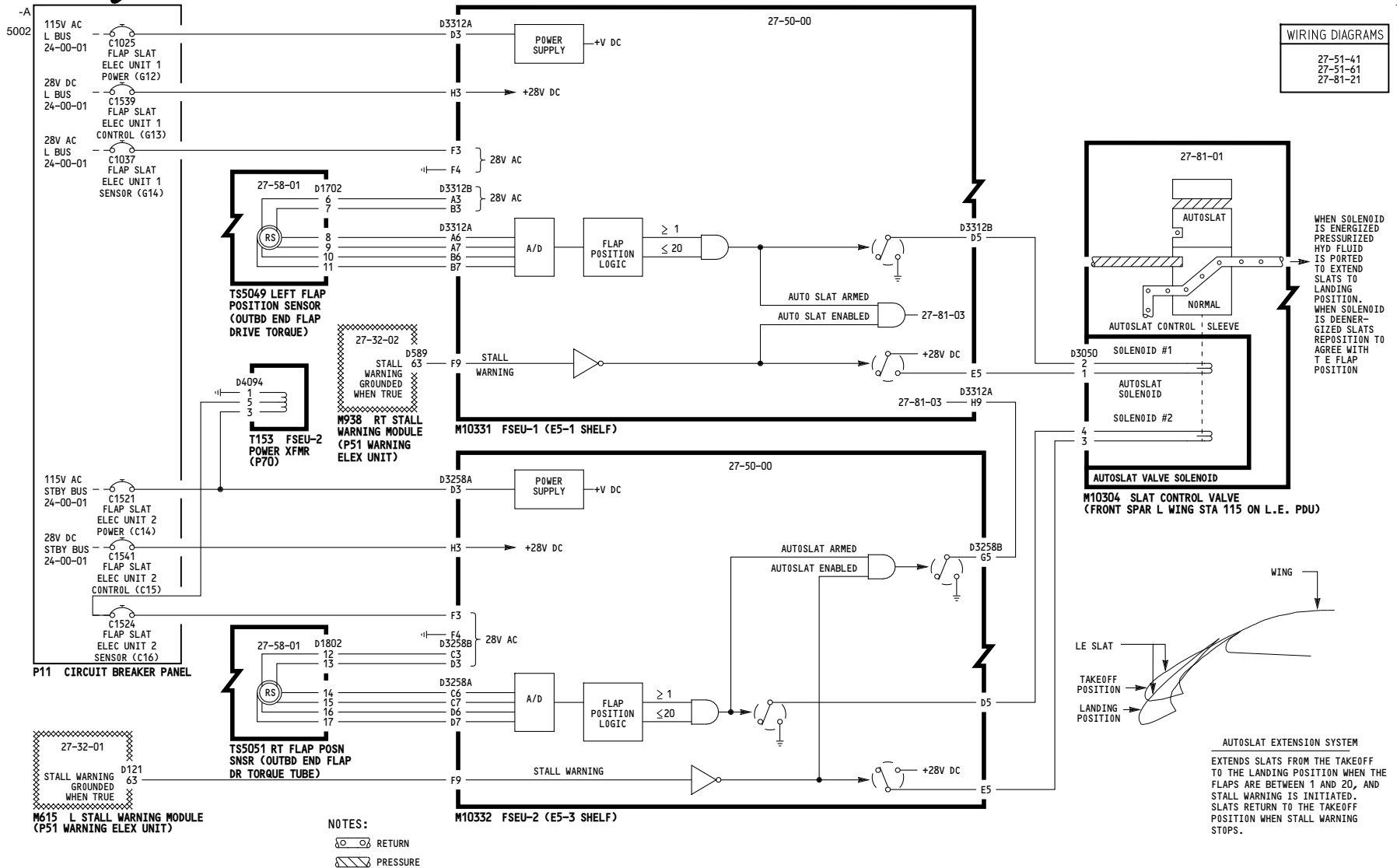

ALL	AUTOSLAT EXTENSION
	D280N032S

27-81-04

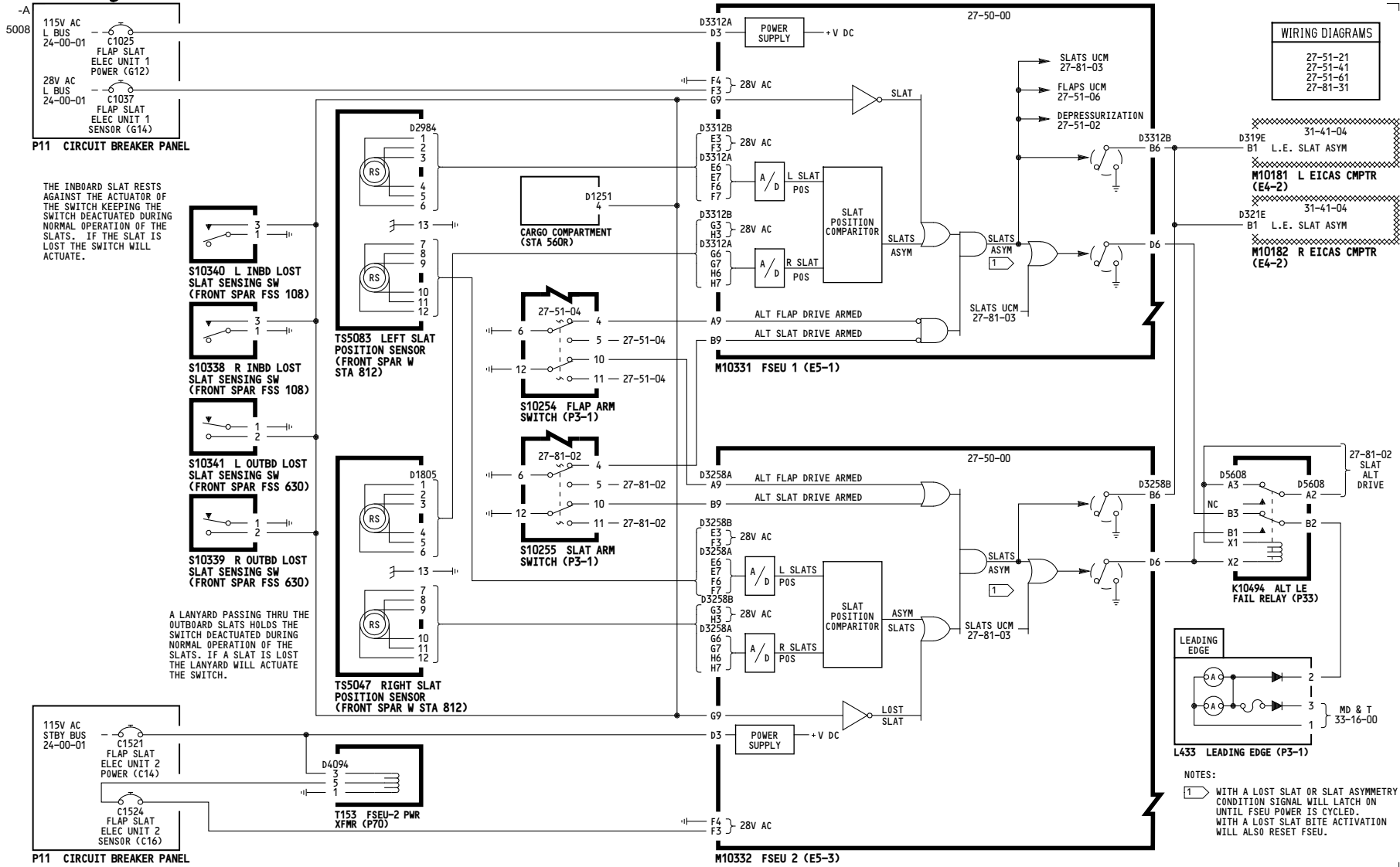

P11 CIRCUIT BREAKER PANEL

THE INBOARD SLAT RESTS AGAINST THE ACTUATOR OF THE SWITCH KEEPING THE SWITCH DEACTUATED DURING NORMAL OPERATION OF THE SLATS. IF THE SLAT IS LOST THE SWITCH WILL ACTUATE.

- S10340 L INBD LOST SLAT SENSING SW (FRONT SPAR FSS 108)
- S10338 R INBD LOST SLAT SENSING SW (FRONT SPAR FSS 108)
- S10341 L OUTBD LOST SLAT SENSING SW (FRONT SPAR FSS 630)
- S10339 R OUTBD LOST SLAT SENSING SW (FRONT SPAR FSS 630)

A LANYARD PASSING THRU THE OUTBOARD SLATS HOLDS THE SWITCH DEACTUATED DURING NORMAL OPERATION OF THE SLATS. IF A SLAT IS LOST THE LANYARD WILL ACTUATE THE SWITCH.

P11 CIRCUIT BREAKER PANEL

001-099

SLAT ASYMMETRY INDICATION

D280N032S

27-81-05

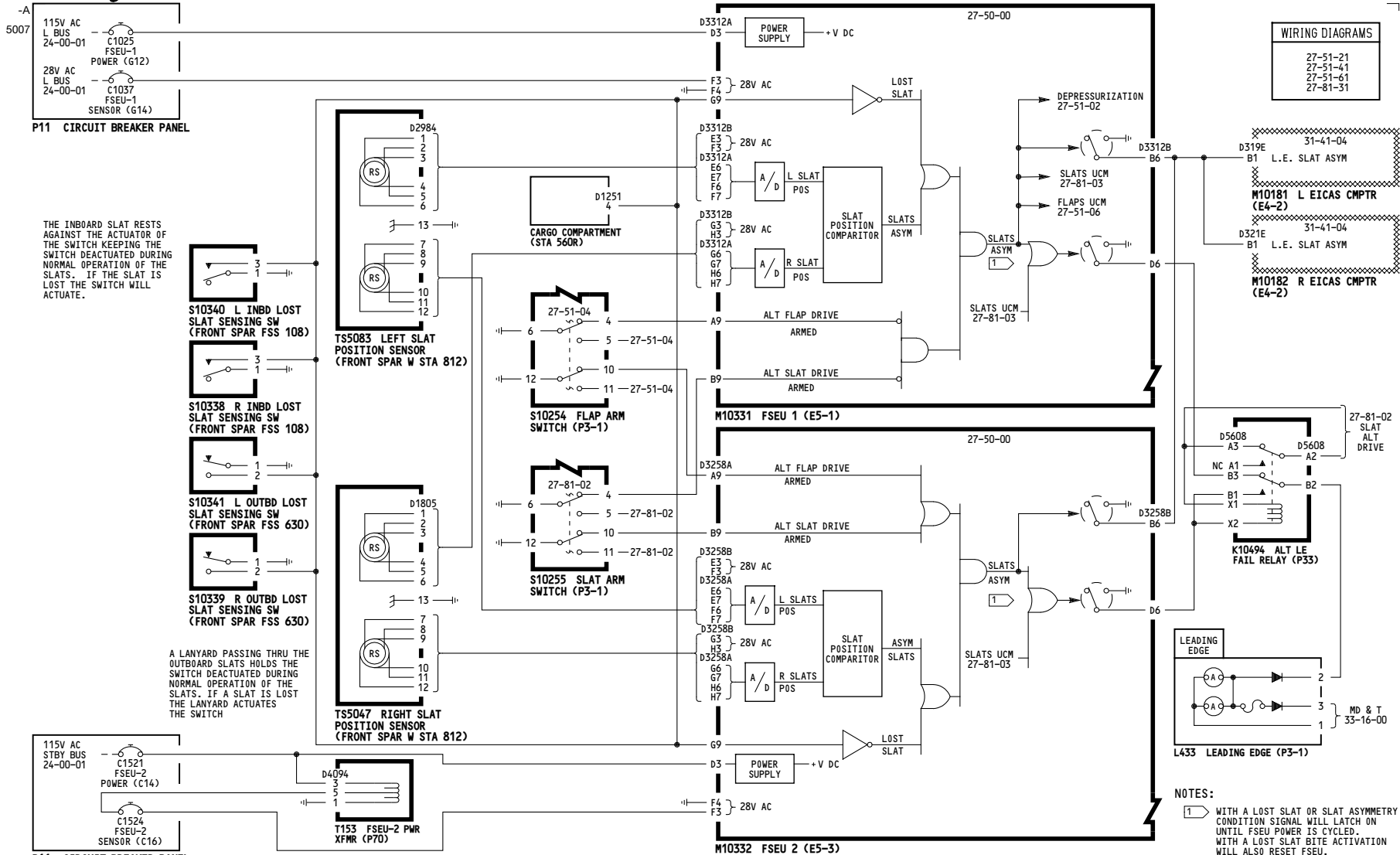

P11 CIRCUIT BREAKER PANEL

115V AC L BUS 24-00-01 C1025 FSEU-1 POWER (G12)

28V AC L BUS 24-00-01 C1037 FSEU-1 SENSOR (G14)

P11 CIRCUIT BREAKER PANEL

115V AC STBY BUS 24-00-01 C1521 FSEU-2 POWER (C14)

C1524 FSEU-2 SENSOR (C16)

SLAT ASYMMETRY INDICATION

115-199

D280N032S

27-81-05

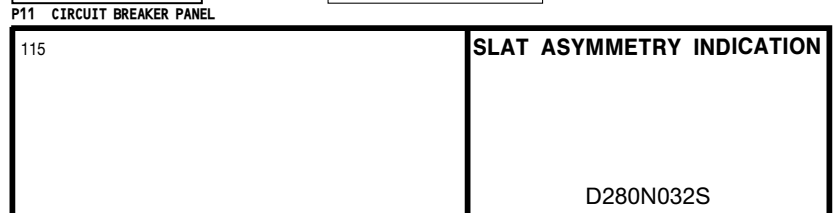
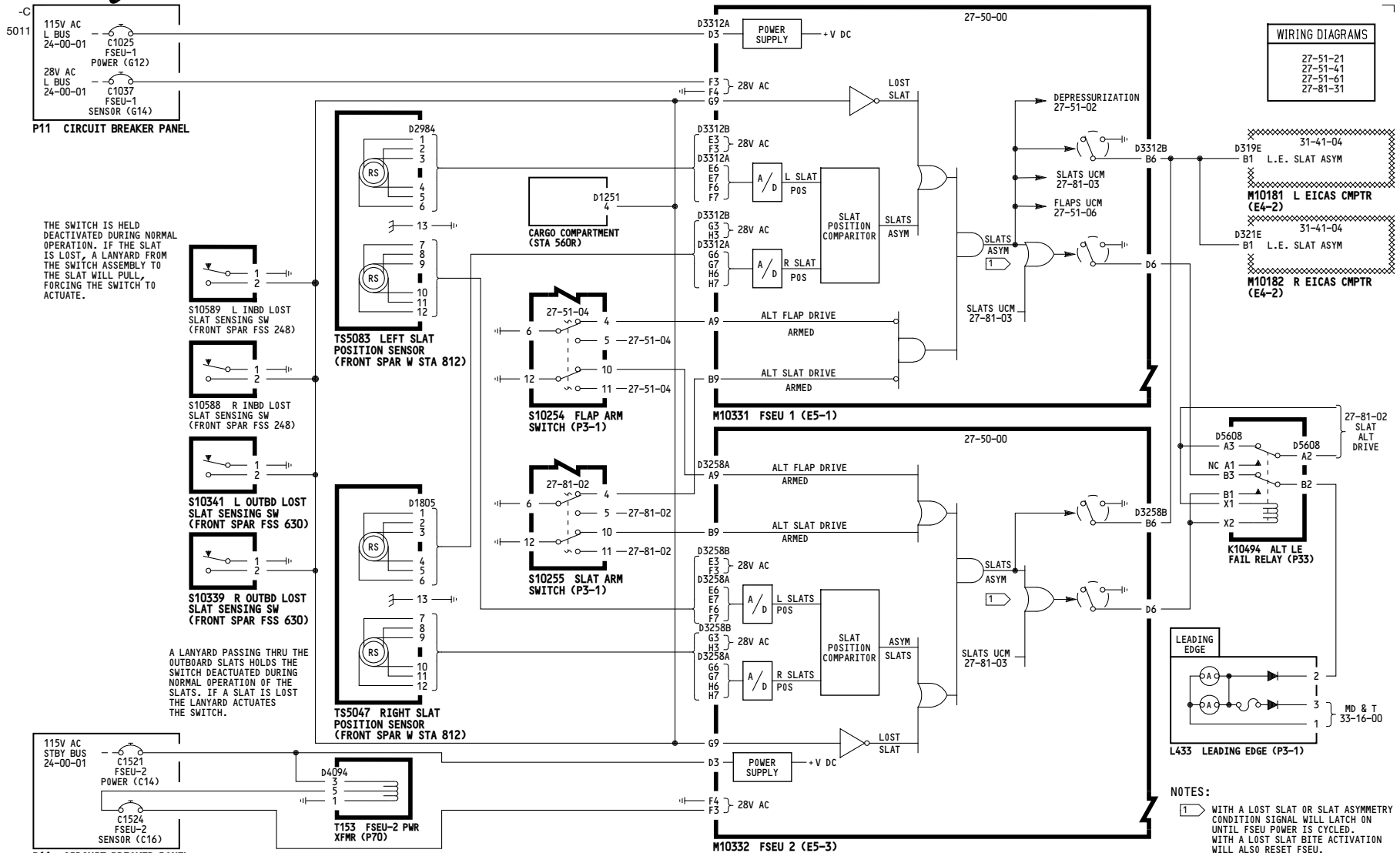

Incorporates
27-0117 R02

27-81-05

Page 102.1

May 17/2006

D280N032S