

CHAPTER

27

FLIGHT CONTROLS



CHAPTER 27
FLIGHT CONTROLS

| CH-SC-SU | Schem | Page | Sheet | Date | CH-SC-SU | Schem | Page | Sheet | Date |
|-----------------------|----------|----------|-------|-------------|----------|-------|------|-------|-------------|
| 27-EFFECTIVE PAGES | | | | | 27-09-01 | | | | |
| | | 1 thru 6 | | May 06/2009 | R | | 101 | 1 | May 06/2009 |
| 27-CONTENTS | | | | | R | | | 2 | May 06/2009 |
| R | | 1 | | May 06/2009 | D | | 102 | 1 | May 06/2009 |
| R | | 2 | | May 06/2009 | D | | | 2 | May 06/2009 |
| R | | 3 | | May 06/2009 | 27-09-02 | | | | |
| O | | 4 | | May 06/2009 | R | | 101 | 1 | May 06/2009 |
| R | | 5 | | May 06/2009 | R | | | 2 | May 06/2009 |
| R | | 6 | | May 06/2009 | D | | 102 | 1 | May 06/2009 |
| R | | 7 | | May 06/2009 | D | | | 2 | May 06/2009 |
| R | | 8 | | May 06/2009 | 27-09-03 | | | | |
| D | | 9 | | May 06/2009 | R | | 101 | 1 | May 06/2009 |
| D | | 10 | | May 06/2009 | R | | | 2 | May 06/2009 |
| 27-ALPHABETICAL INDEX | | | | | R | | | 3 | May 06/2009 |
| | | 1 | | Dec 18/2007 | R | | | 4 | May 06/2009 |
| | | 2 | | BLANK | R | | | 5 | May 06/2009 |
| | 27-00-00 | | | | D | | 102 | 1 | May 06/2009 |
| R | | 101 | 1 | May 06/2009 | D | | | 2 | May 06/2009 |
| R | | | 2 | May 06/2009 | D | | | 3 | May 06/2009 |
| | 27-09-00 | | | | D | | | 4 | May 06/2009 |
| R | | 101 | 1 | May 06/2009 | D | | | 5 | May 06/2009 |
| R | | | 2 | May 06/2009 | 27-09-04 | | | | |
| D | | 102 | 1 | May 06/2009 | R | | 101 | 1 | May 06/2009 |
| D | | | 2 | May 06/2009 | R | | | 2 | May 06/2009 |

A = Added, R = Revised, D = Deleted, O = Overflow

27-EFFECTIVE PAGES



CHAPTER 27
FLIGHT CONTROLS

| CH-SC-SU | Schem | Page | Sheet | Date | CH-SC-SU | Schem | Page | Sheet | Date |
|----------|------------------|-------|-------|-------------|----------|------------------|-------|-------|-------------|
| | 27-09-04 (cont.) | 101 | | | | 27-20-01 (cont.) | 101 | | |
| R | | | 3 | May 06/2009 | R | | | 2 | May 06/2009 |
| R | | | 4 | May 06/2009 | R | | | 3 | May 06/2009 |
| R | | | 5 | May 06/2009 | | | 101.1 | 1 | Jan 21/2005 |
| D | | 102 | 1 | May 06/2009 | | | | 2 | Jan 21/2005 |
| D | | | 2 | May 06/2009 | | | | 3 | Jan 21/2005 |
| D | | | 3 | May 06/2009 | | 27-20-02 | | | |
| D | | | 4 | May 06/2009 | R | | 101 | 1 | May 06/2009 |
| D | | | 5 | May 06/2009 | R | | | 2 | May 06/2009 |
| | 27-09-05 | | | | R | | 101.1 | 1 | May 06/2009 |
| R | | 101 | 1 | May 06/2009 | R | | | 2 | May 06/2009 |
| R | | | 2 | May 06/2009 | | 27-23-01 | | | |
| | 27-09-06 | | | | R | | 101 | | May 06/2009 |
| R | | 101 | 1 | May 06/2009 | D | | 102 | | May 06/2009 |
| R | | | 2 | May 06/2009 | | 27-30-01 | | | |
| R | | 101.1 | 1 | May 06/2009 | R | | 101 | 1 | May 06/2009 |
| R | | | 2 | May 06/2009 | R | | | 2 | May 06/2009 |
| | 27-10-01 | | | | R | | | 3 | May 06/2009 |
| R | | 101 | 1 | May 06/2009 | R | | | 4 | May 06/2009 |
| R | | | 2 | May 06/2009 | R | | | 5 | May 06/2009 |
| | | 101.1 | 1 | Dec 18/2007 | R | | | 6 | May 06/2009 |
| | | | 2 | Jan 21/2005 | D | | 102 | 1 | May 06/2009 |
| | 27-20-01 | | | | D | | | 2 | May 06/2009 |
| R | | 101 | 1 | May 06/2009 | D | | | 3 | May 06/2009 |

A = Added, R = Revised, D = Deleted, O = Overflow

27-EFFECTIVE PAGES

Page 2
May 06/2009

D280N032S



CHAPTER 27
FLIGHT CONTROLS

| CH-SC-SU | Schem | Page | Sheet | Date | CH-SC-SU | Schem | Page | Sheet | Date |
|----------|------------------|-------|-------|-------------|----------|------------------|-------|-------|-------------|
| | 27-30-01 (cont.) | 102 | | | | 27-32-02 (cont.) | | | |
| D | | | 4 | May 06/2009 | A | | 101.2 | 1 | May 06/2009 |
| D | | | 5 | May 06/2009 | A | | | 2 | May 06/2009 |
| D | | | 6 | May 06/2009 | | 27-40-01 | | | |
| | 27-32-01 | | | | | | 101 | 1 | Jan 21/2005 |
| R | | 101 | 1 | May 06/2009 | | | | 2 | Jan 21/2005 |
| R | | | 2 | May 06/2009 | | | | 3 | Jan 21/2005 |
| R | | 101.1 | 1 | May 06/2009 | | | | 4 | Jan 21/2005 |
| R | | | 2 | May 06/2009 | | | | 5 | Dec 18/2007 |
| D | | 102 | 1 | May 06/2009 | | | | 6 | Jan 21/2005 |
| D | | | 2 | May 06/2009 | | 101.1 | | 1 | Jan 21/2005 |
| D | | 102.1 | 1 | May 06/2009 | | | | 2 | Jan 21/2005 |
| D | | | 2 | May 06/2009 | | | | 3 | Jan 21/2005 |
| A | | 101.2 | 1 | May 06/2009 | | | | 4 | Jan 21/2005 |
| A | | | 2 | May 06/2009 | | | | 5 | Dec 18/2007 |
| | 27-32-02 | | | | | | | 6 | Jan 21/2005 |
| R | | 101 | 1 | May 06/2009 | | 102 | | 1 | Jan 21/2005 |
| R | | | 2 | May 06/2009 | | | | 2 | Jan 21/2005 |
| R | | 101.1 | 1 | May 06/2009 | | | | 3 | Jan 21/2005 |
| R | | | 2 | May 06/2009 | | | | 4 | Jan 21/2005 |
| D | | 102 | 1 | May 06/2009 | | | | 5 | Dec 18/2007 |
| D | | | 2 | May 06/2009 | | | | 6 | Jan 21/2005 |
| D | | 102.1 | 1 | May 06/2009 | | 102.1 | | 1 | Jan 21/2005 |
| D | | | 2 | May 06/2009 | | | | 2 | Jan 21/2005 |

A = Added, R = Revised, D = Deleted, O = Overflow

27-EFFECTIVE PAGES

Page 3
May 06/2009

D280N032S



CHAPTER 27
FLIGHT CONTROLS

| CH-SC-SU | Schem | Page | Sheet | Date | CH-SC-SU | Schem | Page | Sheet | Date |
|------------------|-------|-------|-------|-------------|------------------|----------|-------|-------|-------------|
| 27-40-01 (cont.) | | 102.1 | | | 27-40-01 (cont.) | | 104.1 | | |
| | | | 3 | Jan 21/2005 | D | | | 2 | May 06/2009 |
| | | | 4 | Jan 21/2005 | D | | | 3 | May 06/2009 |
| | | | 5 | Dec 18/2007 | D | | | 4 | May 06/2009 |
| | | | 6 | Jan 21/2005 | D | | | 5 | May 06/2009 |
| | | 103 | 1 | Jan 21/2005 | D | | | 6 | May 06/2009 |
| | | | 2 | Jan 21/2005 | | 27-48-01 | | | |
| | | | 3 | Jan 21/2005 | R | | 101 | | May 06/2009 |
| | | | 4 | Jan 21/2005 | | 27-50-00 | | | |
| | | | 5 | Dec 18/2007 | R | | 101 | 1 | May 06/2009 |
| | | | 6 | Jan 21/2005 | R | | | 2 | May 06/2009 |
| | | 103.1 | 1 | Jan 21/2005 | | 27-50-01 | | | |
| | | | 2 | Jan 21/2005 | R | | 101 | 1 | May 06/2009 |
| | | | 3 | Jan 21/2005 | R | | | 2 | May 06/2009 |
| | | | 4 | Jan 21/2005 | D | | 102 | 1 | May 06/2009 |
| | | | 5 | Dec 18/2007 | D | | | 2 | May 06/2009 |
| | | | 6 | Jan 21/2005 | | 27-51-01 | | | |
| D | | 104 | 1 | May 06/2009 | R | | 101 | 1 | May 06/2009 |
| D | | | 2 | May 06/2009 | R | | | 2 | May 06/2009 |
| D | | | 3 | May 06/2009 | R | | | 3 | May 06/2009 |
| D | | | 4 | May 06/2009 | | 27-51-02 | | | |
| D | | | 5 | May 06/2009 | R | | 101 | | May 06/2009 |
| D | | | 6 | May 06/2009 | D | | 102 | | May 06/2009 |
| D | | 104.1 | 1 | May 06/2009 | | | | | |

A = Added, R = Revised, D = Deleted, O = Overflow

27-EFFECTIVE PAGES



CHAPTER 27
FLIGHT CONTROLS

| CH-SC-SU | Schem | Page | Sheet | Date | CH-SC-SU | Schem | Page | Sheet | Date |
|----------|-------|------|-------|-------------|------------------|-------|-------|-------|-------------|
| | | | | | 27-61-01 (cont.) | | 101 | | |
| R | | 101 | | May 06/2009 | R | | | 5 | May 06/2009 |
| D | | 102 | | May 06/2009 | R | | | 6 | May 06/2009 |
| | | | | | | | 102 | 1 | Jan 21/2005 |
| R | | 101 | 1 | May 06/2009 | | | | 2 | Jan 21/2005 |
| R | | | 2 | May 06/2009 | | | | 3 | Jan 21/2005 |
| D | | 102 | 1 | May 06/2009 | | | | 4 | Jan 21/2005 |
| D | | | 2 | May 06/2009 | | | | 5 | Jan 21/2005 |
| | | | | | | | | 6 | Jan 21/2005 |
| R | | 101 | | May 06/2009 | | | 103 | 1 | Jan 21/2005 |
| D | | 102 | | May 06/2009 | | | | 2 | Jan 21/2005 |
| | | | | | | | | 3 | Jan 21/2005 |
| R | | 101 | | May 06/2009 | | | | 4 | Jan 21/2005 |
| D | | 102 | | May 06/2009 | | | | 5 | Jan 21/2005 |
| | | | | | | | | 6 | Jan 21/2005 |
| R | | 101 | | May 06/2009 | | | | 7 | Jan 21/2005 |
| D | | 102 | | May 06/2009 | | | | 8 | Jan 21/2005 |
| | | | | | | | | 9 | Jan 21/2005 |
| R | | 101 | | May 06/2009 | | | | 10 | Dec 18/2007 |
| | | | | | | | | 11 | Jan 21/2005 |
| R | | 101 | 1 | May 06/2009 | 27-62-01 | | | | |
| R | | | 2 | May 06/2009 | R | | 101 | 1 | May 06/2009 |
| R | | | 3 | May 06/2009 | R | | | 2 | May 06/2009 |
| R | | | 4 | May 06/2009 | R | | 101.1 | 1 | May 06/2009 |

A = Added, R = Revised, D = Deleted, O = Overflow

27-EFFECTIVE PAGES

Page 5
May 06/2009

D280N032S



CHAPTER 27
FLIGHT CONTROLS

| CH-SC-SU | Schem | Page | Sheet | Date | CH-SC-SU | Schem | Page | Sheet | Date |
|----------|------------------|-------|-------|-------------|----------|------------------|-------|-------|-------------|
| | 27-62-01 (cont.) | 101.1 | | | | 27-81-05 (cont.) | | | |
| R | | | 2 | May 06/2009 | D | | 102.1 | | May 06/2009 |
| | | 101.2 | 1 | Jan 21/2005 | | | | | |
| | | | 2 | Jan 21/2005 | | | | | |
| D | | 102 | 1 | May 06/2009 | | | | | |
| D | | | 2 | May 06/2009 | | | | | |
| | 27-81-01 | | | | | | | | |
| R | | 101 | | May 06/2009 | | | | | |
| | 27-81-02 | | | | | | | | |
| R | | 101 | 1 | May 06/2009 | | | | | |
| R | | | 2 | May 06/2009 | | | | | |
| D | | 102 | 1 | May 06/2009 | | | | | |
| D | | | 2 | May 06/2009 | | | | | |
| | 27-81-03 | | | | | | | | |
| R | | 101 | 1 | May 06/2009 | | | | | |
| R | | | 2 | May 06/2009 | | | | | |
| D | | 102 | 1 | May 06/2009 | | | | | |
| D | | | 2 | May 06/2009 | | | | | |
| | 27-81-04 | | | | | | | | |
| R | | 101 | | May 06/2009 | | | | | |
| | 27-81-05 | | | | | | | | |
| R | | 101 | | May 06/2009 | | | | | |
| | | 101.1 | | May 17/2006 | | | | | |
| D | | 102 | | May 06/2009 | | | | | |

A = Added, R = Revised, D = Deleted, O = Overflow

27-EFFECTIVE PAGES



CHAPTER 27
FLIGHT CONTROLS

| Title | CH-SC-SU | Schem | Page | Sheet | Date | Effectivity |
|---|----------|-------|------|-------|-------------|-------------|
| <u>FLIGHT CONTROLS</u> | | | | | | |
| FLIGHT CONTROL SYSTEMS - SIMPLIFIED | 27-00-00 | | 101 | 1 | May 06/2009 | ALL |
| | | | | 2 | May 06/2009 | ALL |
| <u>FLIGHT CONTROL SYSTEM ELECTRONIC UNITS</u> | | | | | | |
| CONTROL SYSTEMS ELECTRICAL/ELECTRONIC UNIT (CSEU) POWER | 27-09-00 | | 101 | 1 | May 06/2009 | ALL |
| | | | | 2 | May 06/2009 | ALL |
| LEFT CSEU POWER - AC | 27-09-01 | | 101 | 1 | May 06/2009 | ALL |
| | | | | 2 | May 06/2009 | ALL |
| RIGHT CSEU POWER - AC | 27-09-02 | | 101 | 1 | May 06/2009 | ALL |
| | | | | 2 | May 06/2009 | ALL |
| LEFT CSEU POWER - DC | 27-09-03 | | 101 | 1 | May 06/2009 | ALL |
| | | | | 2 | May 06/2009 | ALL |
| | | | | 3 | May 06/2009 | ALL |
| | | | | 4 | May 06/2009 | ALL |
| | | | | 5 | May 06/2009 | ALL |
| RIGHT CSEU POWER - DC | 27-09-04 | | 101 | 1 | May 06/2009 | ALL |
| | | | | 2 | May 06/2009 | ALL |
| | | | | 3 | May 06/2009 | ALL |
| | | | | 4 | May 06/2009 | ALL |
| | | | | 5 | May 06/2009 | ALL |
| CSEU FAULT ANNUNCIATION | 27-09-05 | | 101 | 1 | May 06/2009 | ALL |
| | | | | 2 | May 06/2009 | ALL |

**CHAPTER 27
FLIGHT CONTROLS**

| | Title | CH-SC-SU | Schem | Page | Sheet | Date | Effectivity |
|--|---|----------|-------|-------|-------|-------------|-------------|
| | CSEU AIR/GROUND AND HYDRAULIC DISCRETE INPUTS | 27-09-06 | | 101 | 1 | May 06/2009 | ALL |
| | | | | | 2 | May 06/2009 | ALL |
| | | | | 101.1 | 1 | May 06/2009 | 001-011 |
| | | | | | 2 | May 06/2009 | 001-011 |
| | <u>AILERON AND TAB</u> | | | | | | |
| | AILERON | 27-10-01 | | 101 | 1 | May 06/2009 | ALL |
| | | | | | 2 | May 06/2009 | ALL |
| | | | | 101.1 | 1 | Dec 18/2007 | 010-011 |
| | | | | | 2 | Jan 21/2005 | 010-011 |
| | <u>RUDDER AND TAB</u> | | | | | | |
| | RUDDER CONTROL SYSTEM | 27-20-01 | | 101 | 1 | May 06/2009 | ALL |
| | | | | | 2 | May 06/2009 | ALL |
| | | | | | 3 | May 06/2009 | ALL |
| | | | | 101.1 | 1 | Jan 21/2005 | 010-011 |
| | | | | | 2 | Jan 21/2005 | 010-011 |
| | | | | | 3 | Jan 21/2005 | 010-011 |
| | RUDDER RATIO CHANGER | 27-20-02 | | 101 | 1 | May 06/2009 | ALL |
| | | | | | 2 | May 06/2009 | ALL |
| | | | | 101.1 | 1 | May 06/2009 | 001-004 |
| | | | | | 2 | May 06/2009 | 001-004 |
| | <u>RUDDER AND ELEVATOR HYDRAULIC SYSTEMS</u> | | | | | | |
| | RUDDER/ELEVATOR PCU MONITOR SYSTEM | 27-23-01 | | 101 | | May 06/2009 | ALL |



CHAPTER 27
FLIGHT CONTROLS

| Title | CH-SC-SU | Schem | Page | Sheet | Date | Effectivity | |
|-------------------------------------|----------|-------|------|-------|-------------|-------------|---------|
| <u>ELEVATOR AND TAB</u> | | | | | | | |
| ELEVATOR | 27-30-01 | | 101 | 1 | May 06/2009 | ALL | |
| | | | | 2 | May 06/2009 | ALL | |
| | | | | 3 | May 06/2009 | ALL | |
| | | | | 4 | May 06/2009 | ALL | |
| | | | | 5 | May 06/2009 | ALL | |
| | | | | 6 | May 06/2009 | ALL | |
| <u>STALL WARNING SYSTEM</u> | | | | | | | |
| STALL WARNING - LEFT | 27-32-01 | | 101 | 1 | May 06/2009 | ALL | |
| | | | | 2 | May 06/2009 | ALL | |
| | | | | 101.1 | 1 | May 06/2009 | 001 |
| | | | | 2 | May 06/2009 | 001 | |
| | | | | 101.2 | 1 | May 06/2009 | 002-011 |
| | | | | 2 | May 06/2009 | 002-011 | |
| STALL WARNING - RIGHT | 27-32-02 | | 101 | 1 | May 06/2009 | ALL | |
| | | | | 2 | May 06/2009 | ALL | |
| | | | | 101.1 | 1 | May 06/2009 | 001 |
| | | | | 2 | May 06/2009 | 001 | |
| | | | | 101.2 | 1 | May 06/2009 | 002-011 |
| | | | | 2 | May 06/2009 | 002-011 | |
| <u>HORIZONTAL STABILIZER</u> | | | | | | | |
| HORIZONTAL STABILIZER TRIM | 27-40-01 | | 101 | 1 | Jan 21/2005 | 001 | |
| | | | | 2 | Jan 21/2005 | 001 | |



CHAPTER 27
FLIGHT CONTROLS

| Title | CH-SC-SU | Schem | Page | Sheet | Date | Effectivity | | | |
|------------------------------------|----------|-------|------|-------|-------------|-------------|---------|-------------|---------|
| HORIZONTAL STABILIZER TRIM (cont.) | 27-40-01 | | | 3 | Jan 21/2005 | 001 | | | |
| | | | | 4 | Jan 21/2005 | 001 | | | |
| | | | | 5 | Dec 18/2007 | 001 | | | |
| | | | | 6 | Jan 21/2005 | 001 | | | |
| | | | | 101.1 | 1 | Jan 21/2005 | 001 | | |
| | | | | | 2 | Jan 21/2005 | 001 | | |
| | | | | | 3 | Jan 21/2005 | 001 | | |
| | | | | | 4 | Jan 21/2005 | 001 | | |
| | | | | | 5 | Dec 18/2007 | 001 | | |
| | | | | | 6 | Jan 21/2005 | 001 | | |
| | | | | 102 | 1 | Jan 21/2005 | 002-004 | | |
| | | | | | 2 | Jan 21/2005 | 002-004 | | |
| | | | | | 3 | Jan 21/2005 | 002-004 | | |
| | | | | | 4 | Jan 21/2005 | 002-004 | | |
| | | | | | 5 | Dec 18/2007 | 002-004 | | |
| | | | | | 6 | Jan 21/2005 | 002-004 | | |
| | | | | 102.1 | 1 | Jan 21/2005 | 002-004 | | |
| | | | | | 2 | Jan 21/2005 | 002-004 | | |
| | | | | | 3 | Jan 21/2005 | 002-004 | | |
| | | | | | 4 | Jan 21/2005 | 002-004 | | |
| | | | | | 5 | Dec 18/2007 | 002-004 | | |
| | | | | | 6 | Jan 21/2005 | 002-004 | | |
| | | | | 103 | | | 1 | Jan 21/2005 | 005-099 |



CHAPTER 27
FLIGHT CONTROLS

| Title | CH-SC-SU | Schem | Page | Sheet | Date | Effectivity | | | | |
|--|----------|-------|------|--|-------------|-------------|---------|--|-------------|-----|
| HORIZONTAL STABILIZER TRIM (cont.) | 27-40-01 | | | 2 | Jan 21/2005 | 005-099 | | | | |
| | | | | 3 | Jan 21/2005 | 005-099 | | | | |
| | | | | 4 | Jan 21/2005 | 005-099 | | | | |
| | | | | 5 | Dec 18/2007 | 005-099 | | | | |
| | | | | 6 | Jan 21/2005 | 005-099 | | | | |
| | | | | 103.1 | 1 | Jan 21/2005 | 010-011 | | | |
| | | | | 2 | Jan 21/2005 | 010-011 | | | | |
| | | | | 3 | Jan 21/2005 | 010-011 | | | | |
| | | | | 4 | Jan 21/2005 | 010-011 | | | | |
| | | | | 5 | Dec 18/2007 | 010-011 | | | | |
| | | | | 6 | Jan 21/2005 | 010-011 | | | | |
| | | | | <u>STABILIZER TRIM POSITION INDICATING SYSTEM</u> | | | | | | |
| | | | | STABILIZER POSITION SENSING | 27-48-01 | | 101 | | May 06/2009 | ALL |
| <u>FLAPS</u> | | | | | | | | | | |
| HIGH LIFT DEVICES - SIMPLIFIED | 27-50-00 | | 101 | 1 | May 06/2009 | ALL | | | | |
| | | | | 2 | May 06/2009 | ALL | | | | |
| FLAP/SLAT ELECTRONICS UNIT | 27-50-01 | | 101 | 1 | May 06/2009 | ALL | | | | |
| | | | | 2 | May 06/2009 | ALL | | | | |
| <u>TRAILING EDGE (TE) FLAP SYSTEM</u> | | | | | | | | | | |
| TRAILING EDGE FLAPS PRIMARY DRIVE | 27-51-01 | | 101 | 1 | May 06/2009 | ALL | | | | |
| | | | | 2 | May 06/2009 | ALL | | | | |
| | | | | 3 | May 06/2009 | ALL | | | | |
| FLAP/SLAT DEPRESSURIZATION SYSTEM | 27-51-02 | | 101 | | May 06/2009 | ALL | | | | |



CHAPTER 27
FLIGHT CONTROLS

| | Title | CH-SC-SU | Schem | Page | Sheet | Date | Effectivity |
|---|--|----------|-------|------|-------|-------------|-------------|
| I | FLAP LOAD RELIEF CONTROL | 27-51-03 | | 101 | | May 06/2009 | ALL |
| I | TRAILING EDGE FLAP ALTERNATE DRIVE | 27-51-04 | | 101 | 1 | May 06/2009 | ALL |
| I | | | | | 2 | May 06/2009 | ALL |
| I | FLAP ASYMMETRY INDICATION | 27-51-05 | | 101 | | May 06/2009 | ALL |
| I | TRAILING EDGE FLAPS UCM INDICATION | 27-51-06 | | 101 | | May 06/2009 | ALL |
| | <u>TRAILING EDGE FLAP POSITION INDICATING SYSTEM</u> | | | | | | |
| I | FLAP/SLAT POSITION INDICATING SYSTEM | 27-58-01 | | 101 | | May 06/2009 | ALL |
| | <u>SPOILER, DRAG DEVICES, AND VARIABLE AERODYNAMIC FAIRINGS</u> | | | | | | |
| I | SPOILER AND SPEEDBRAKE SYSTEM | 27-60-00 | | 101 | | May 06/2009 | ALL |
| | <u>SPOILER/SPEEDBRAKE CONTROL SYSTEM</u> | | | | | | |
| I | SPOILERS | 27-61-01 | | 101 | 1 | May 06/2009 | 001 |
| I | | | | | 2 | May 06/2009 | 001 |
| I | | | | | 3 | May 06/2009 | 001 |
| I | | | | | 4 | May 06/2009 | 001 |
| I | | | | | 5 | May 06/2009 | 001 |
| I | | | | | 6 | May 06/2009 | 001 |
| | | | | 102 | 1 | Jan 21/2005 | 002 |
| | | | | | 2 | Jan 21/2005 | 002 |
| | | | | | 3 | Jan 21/2005 | 002 |
| | | | | | 4 | Jan 21/2005 | 002 |
| | | | | | 5 | Jan 21/2005 | 002 |
| | | | | | 6 | Jan 21/2005 | 002 |
| | | | | 103 | 1 | Jan 21/2005 | 003-099 |



CHAPTER 27
FLIGHT CONTROLS

| Title | CH-SC-SU | Schem | Page | Sheet | Date | Effectivity | |
|---|----------|-------|------|--|-------------|-------------|---------|
| SPOILERS (cont.) | 27-61-01 | | | 2 | Jan 21/2005 | 003-099 | |
| | | | | 3 | Jan 21/2005 | 003-099 | |
| | | | | 4 | Jan 21/2005 | 003-099 | |
| | | | | 5 | Jan 21/2005 | 003-099 | |
| | | | | 6 | Jan 21/2005 | 003-099 | |
| | | | | 7 | Jan 21/2005 | 003-099 | |
| | | | | 8 | Jan 21/2005 | 003-099 | |
| | | | | 9 | Jan 21/2005 | 003-099 | |
| | | | | 10 | Dec 18/2007 | 003-099 | |
| | | | | 11 | Jan 21/2005 | 003-099 | |
| | | | | <u>AUTO-SPEEDBRAKE CONTROL SYSTEM</u> | | | |
| I AUTO SPEEDBRAKE | 27-62-01 | | 101 | 1 | May 06/2009 | ALL | |
| | | | | 2 | May 06/2009 | ALL | |
| | | | | 101.1 | 1 | May 06/2009 | 001-009 |
| | | | | 2 | May 06/2009 | 001-009 | |
| | | | | 101.2 | 1 | Jan 21/2005 | 010-011 |
| | | | | 2 | Jan 21/2005 | 010-011 | |
| <u>LEADING EDGE SLAT SYSTEM</u> | | | | | | | |
| I LEADING EDGE SLATS PRIMARY DRIVE | 27-81-01 | | 101 | | May 06/2009 | ALL | |
| | | | | | | | |
| I SLAT ALTERNATE DRIVE | 27-81-02 | | 101 | 1 | May 06/2009 | ALL | |
| | | | | 2 | May 06/2009 | ALL | |
| I LEADING EDGE SLATS UNCOMMANDED MOTION | 27-81-03 | | 101 | 1 | May 06/2009 | ALL | |
| | | | | 2 | May 06/2009 | ALL | |

**CHAPTER 27
FLIGHT CONTROLS**

| | Title | CH-SC-SU | Schem | Page | Sheet | Date | Effectivity |
|---|---------------------------|-----------------|--------------|-------------|--------------|-------------|--------------------|
| I | AUTOSLAT EXTENSION | 27-81-04 | | 101 | | May 06/2009 | ALL |
| I | SLAT ASYMMETRY INDICATION | 27-81-05 | | 101 | | May 06/2009 | ALL |
| | | | | 101.1 | | May 17/2006 | 001-011 |

**CHAPTER 27
FLIGHT CONTROLS**

| CH-SC-SU | Title |
|----------|---|
| 27-10-01 | AILERON |
| 27-62-01 | AUTO SPEEDBRAKE |
| 27-81-04 | AUTOSLAT EXTENSION |
| 27-09-00 | CONTROL SYSTEMS ELECTRICAL/ELECTRONIC UNIT (CSEU) POWER |
| 27-09-06 | CSEU AIR/GROUND AND HYDRAULIC DISCRETE INPUTS |
| 27-09-05 | CSEU FAULT ANNUNCIATION |
| 27-30-01 | ELEVATOR |
| 27-51-05 | FLAP ASYMMETRY INDICATION |
| 27-51-03 | FLAP LOAD RELIEF CONTROL |
| 27-51-02 | FLAP/SLAT DEPRESSURIZATION SYSTEM |
| 27-50-01 | FLAP/SLAT ELECTRONICS UNIT |
| 27-58-01 | FLAP/SLAT POSITION INDICATING SYSTEM |
| 27-00-00 | FLIGHT CONTROL SYSTEMS - SIMPLIFIED |
| 27-50-00 | HIGH LIFT DEVICES - SIMPLIFIED |
| 27-40-01 | HORIZONTAL STABILIZER TRIM |
| 27-81-01 | LEADING EDGE SLATS PRIMARY DRIVE |
| 27-81-03 | LEADING EDGE SLATS UNCOMMANDED MOTION |
| 27-09-01 | LEFT CSEU POWER - AC |
| 27-09-03 | LEFT CSEU POWER - DC |

| CH-SC-SU | Title |
|----------|------------------------------------|
| 27-09-02 | RIGHT CSEU POWER - AC |
| 27-09-04 | RIGHT CSEU POWER - DC |
| 27-20-01 | RUDDER CONTROL SYSTEM |
| 27-20-02 | RUDDER RATIO CHANGER |
| 27-23-01 | RUDDER/ELEVATOR PCU MONITOR SYSTEM |
| 27-81-02 | SLAT ALTERNATE DRIVE |
| 27-81-05 | SLAT ASYMMETRY INDICATION |
| 27-60-00 | SPOILER AND SPEEDBRAKE SYSTEM |
| 27-61-01 | SPOILERS |
| 27-48-01 | STABILIZER POSITION SENSING |
| 27-32-01 | STALL WARNING - LEFT |
| 27-32-02 | STALL WARNING - RIGHT |
| 27-51-04 | TRAILING EDGE FLAP ALTERNATE DRIVE |
| 27-51-01 | TRAILING EDGE FLAPS PRIMARY DRIVE |
| 27-51-06 | TRAILING EDGE FLAPS UCM INDICATION |

27-ALPHABETICAL INDEX

THIS PAGE INTENTIONALLY LEFT BLANK

5001

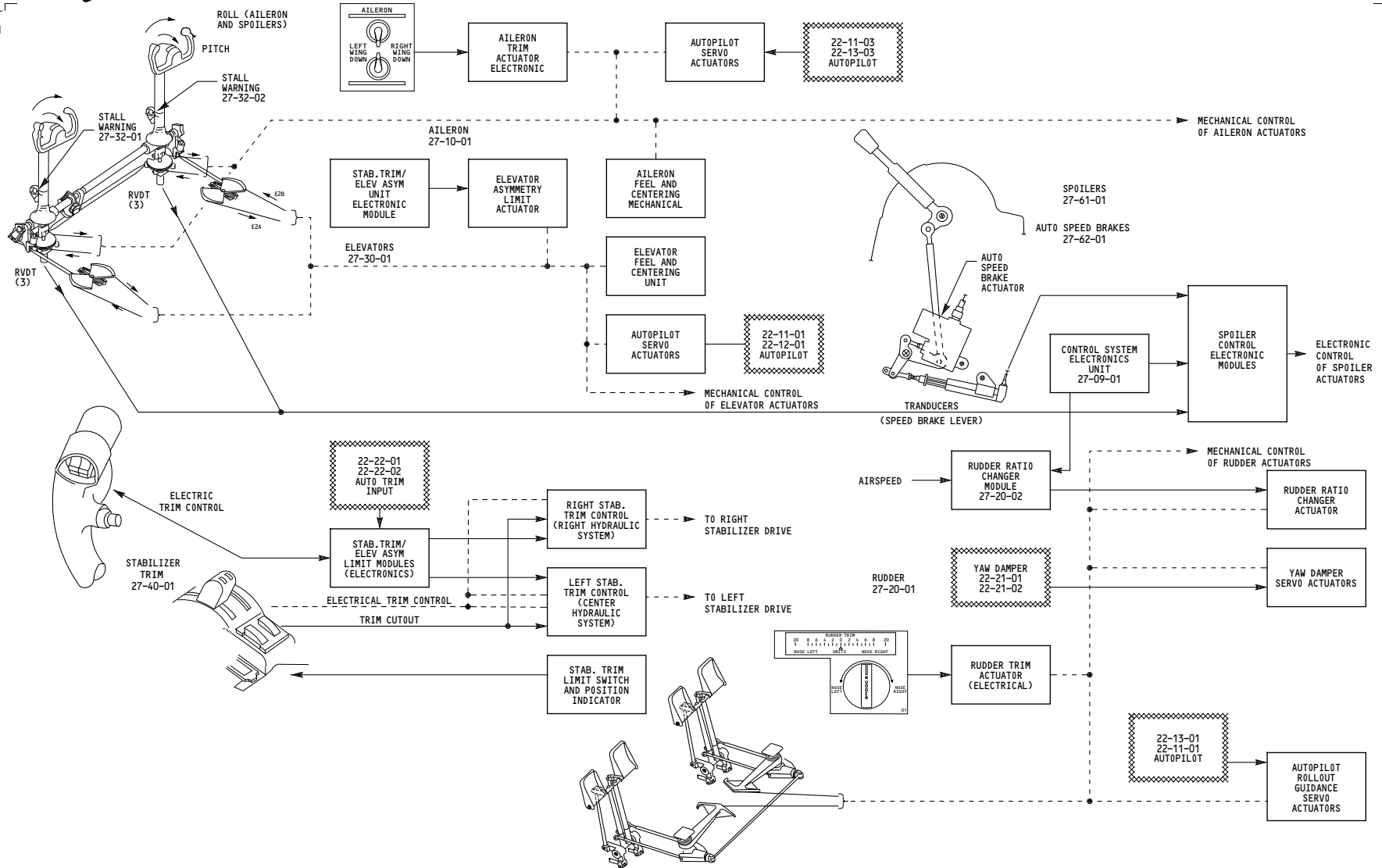

| | |
|-----|--|
| ALL | <p>FLIGHT CONTROL SYSTEMS - SIMPLIFIED</p> <p>D280N032S</p> |
|-----|--|

27-00-00

5000

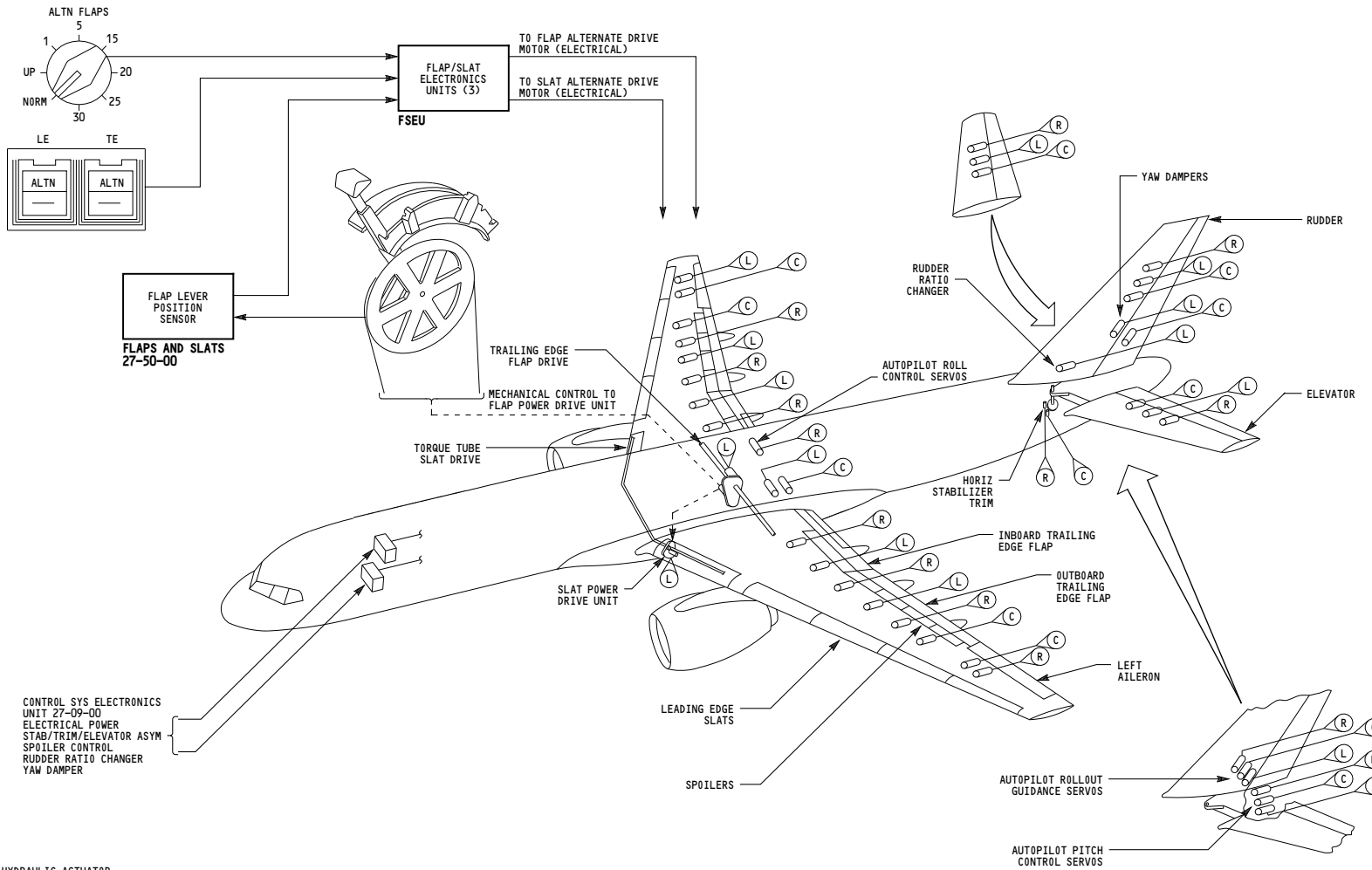

- HYDRAULIC ACTUATOR
- (L) LEFT HYDRAULIC SYSTEM 29-00-02
- (C) CENTER HYDRAULIC SYSTEM 29-00-03
- (R) RIGHT HYDRAULIC SYSTEM 29-00-04

| | |
|-----|--|
| ALL | <p align="center">FLIGHT CONTROL SYSTEMS - SIMPLIFIED</p> <p align="center">D280N032S</p> |
|-----|--|

27-00-00

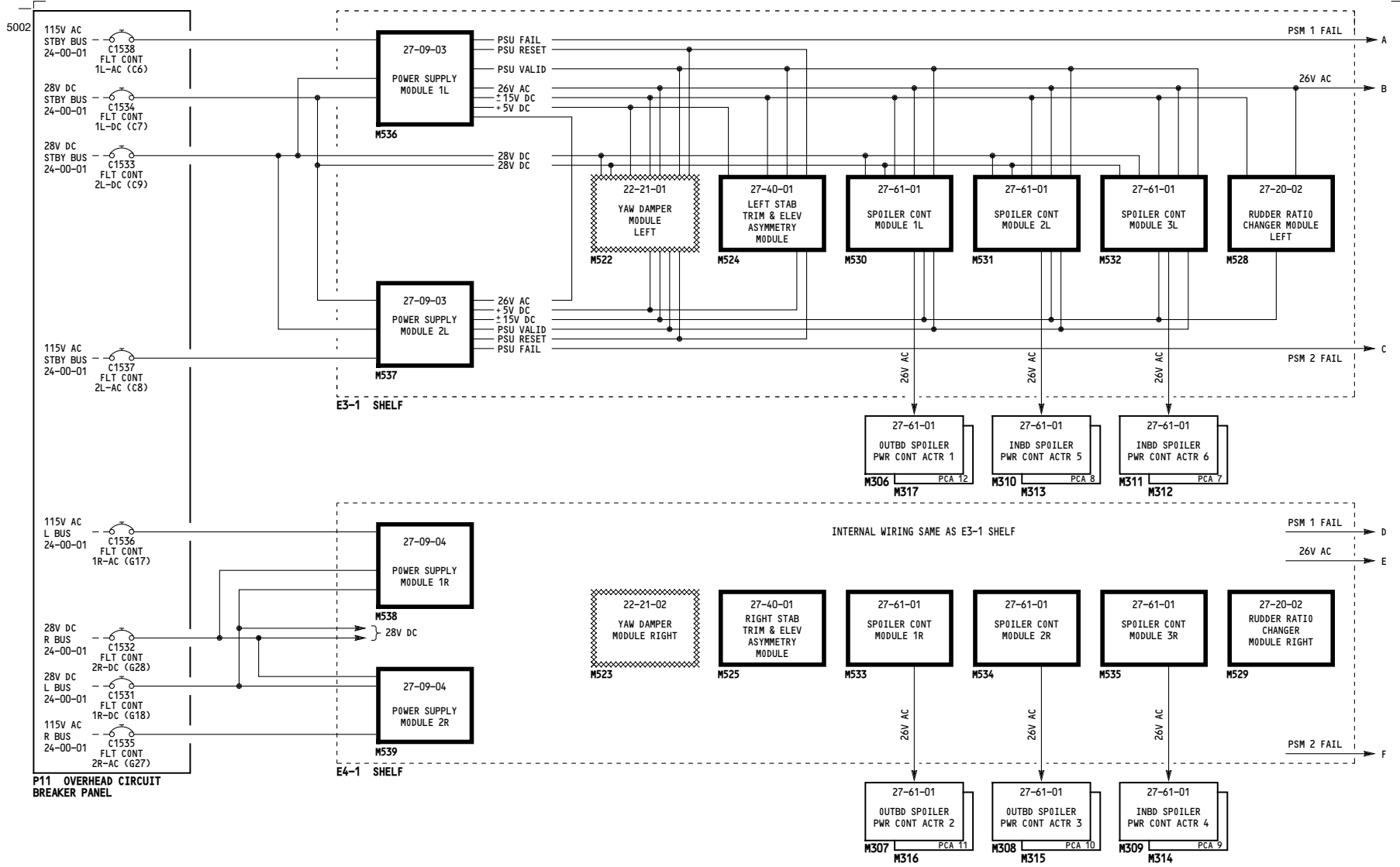

| | |
|-----|--|
| ALL | <p align="center">CONTROL SYSTEMS ELECTRICAL/ELECTRONIC UNIT (CSEU) POWER</p> <p align="center">D280N032S</p> |
|-----|--|

27-09-00

5001

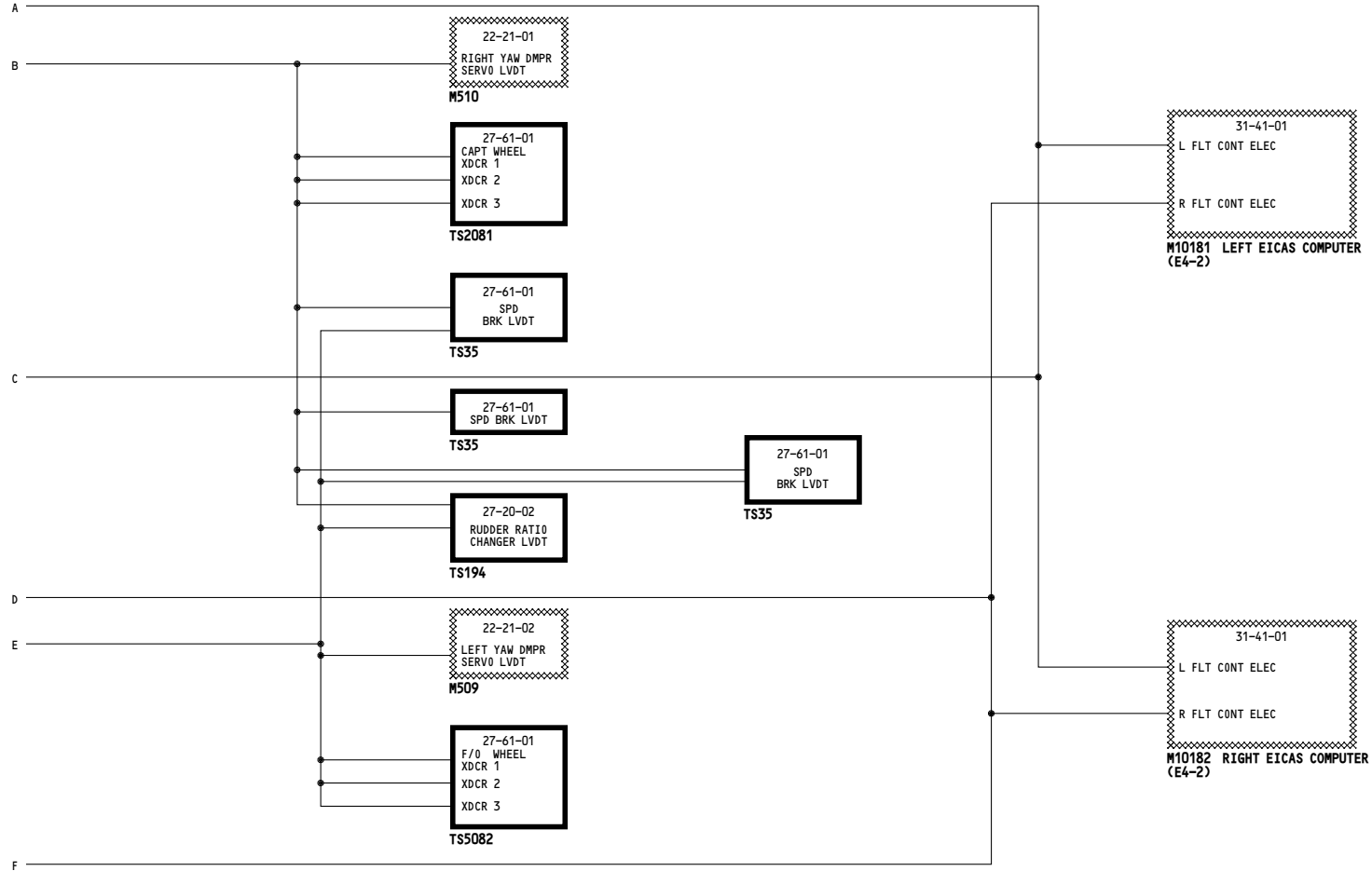

| | |
|-----|--|
| ALL | <p align="center">CONTROL SYSTEMS ELECTRICAL/ELECTRONIC UNIT (CSEU) POWER</p> <p align="center">D280N032S</p> |
|-----|--|

27-09-00

Page 101
Sheet 2
May 06/2009

5005

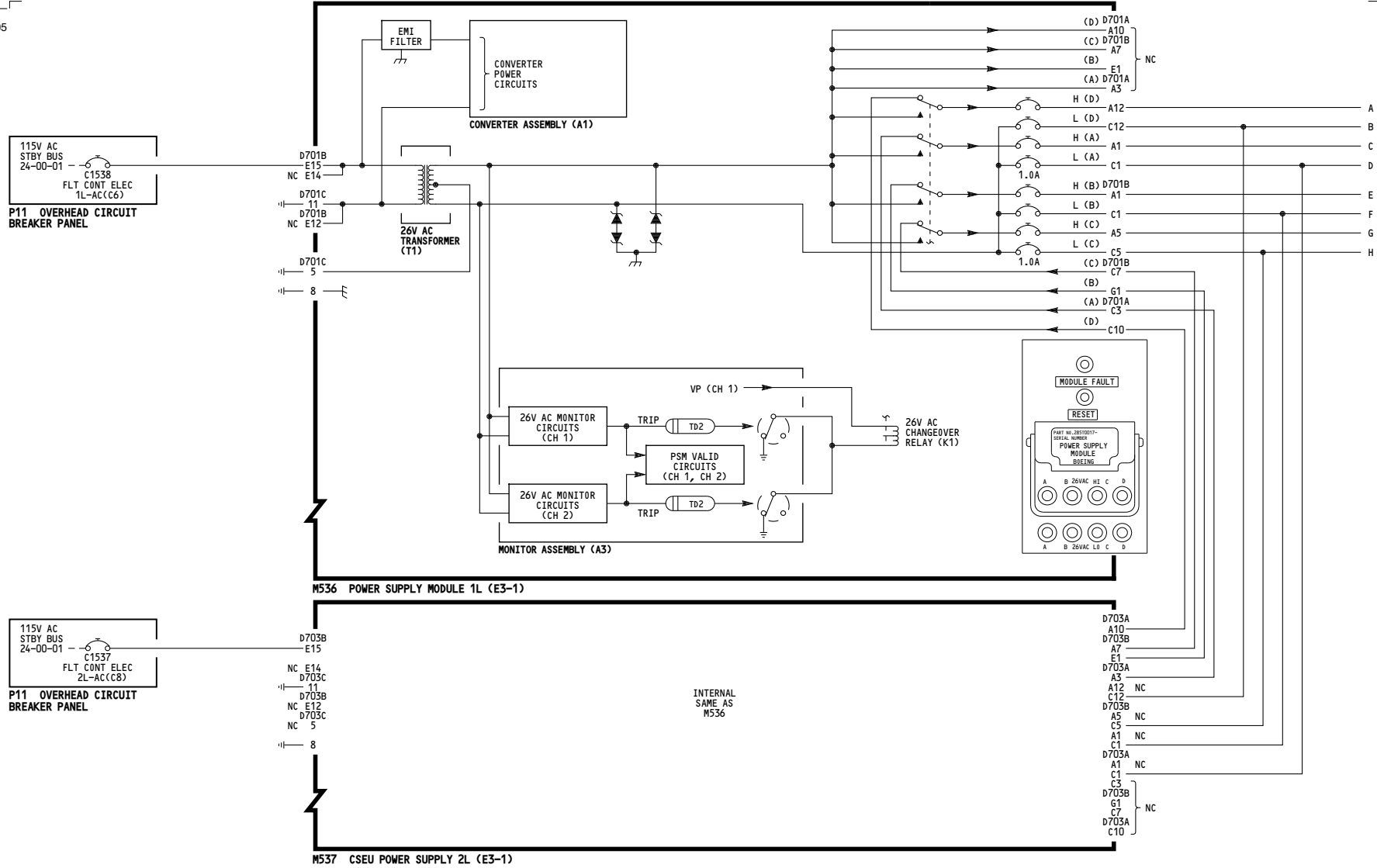

| | |
|-----|----------------------|
| ALL | LEFT CSEU POWER - AC |
| | D280N032S |

27-09-01

5002

| WIRING DIAGRAMS | |
|-----------------|--|
| 27-21-11 | |
| 27-21-12 | |
| 27-61-13 | |
| 27-61-17 | |
| 27-61-18 | |

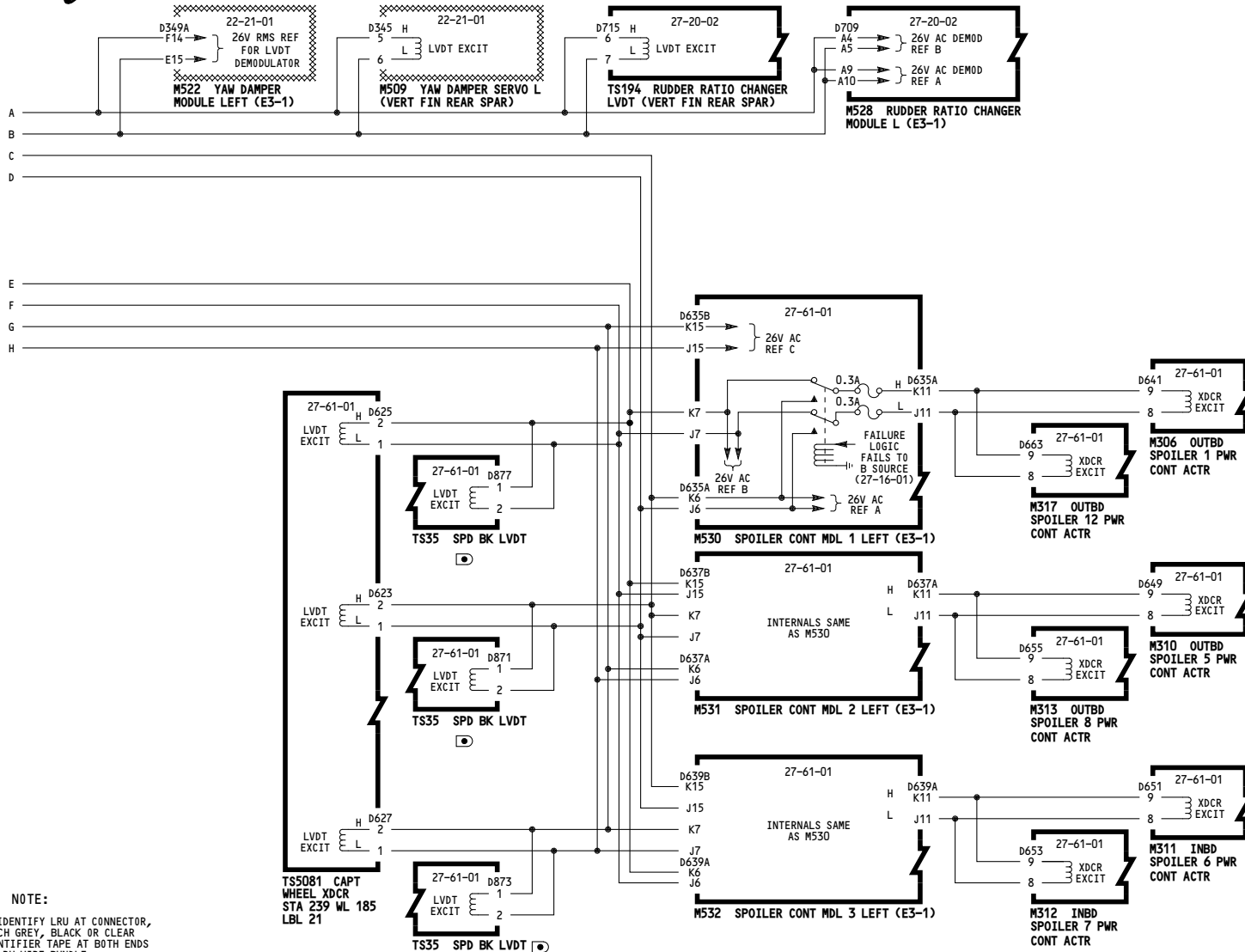

NOTE:
 TO IDENTIFY LRU AT CONNECTOR,
 MATCH GREY, BLACK OR CLEAR
 IDENTIFIER TAPE AT BOTH ENDS
 OF LRU WIRE BUNDLE

| | |
|-----------|----------------------|
| ALL | LEFT CSEU POWER - AC |
| D280N032S | |

27-09-01

5005

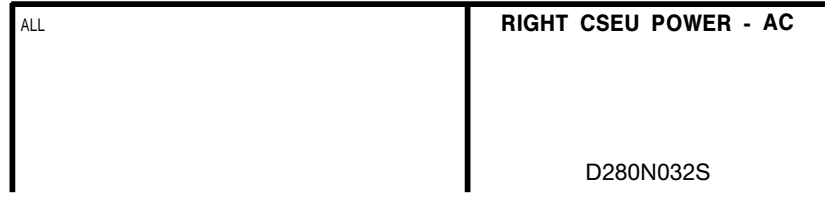
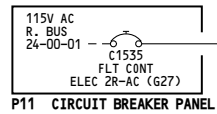
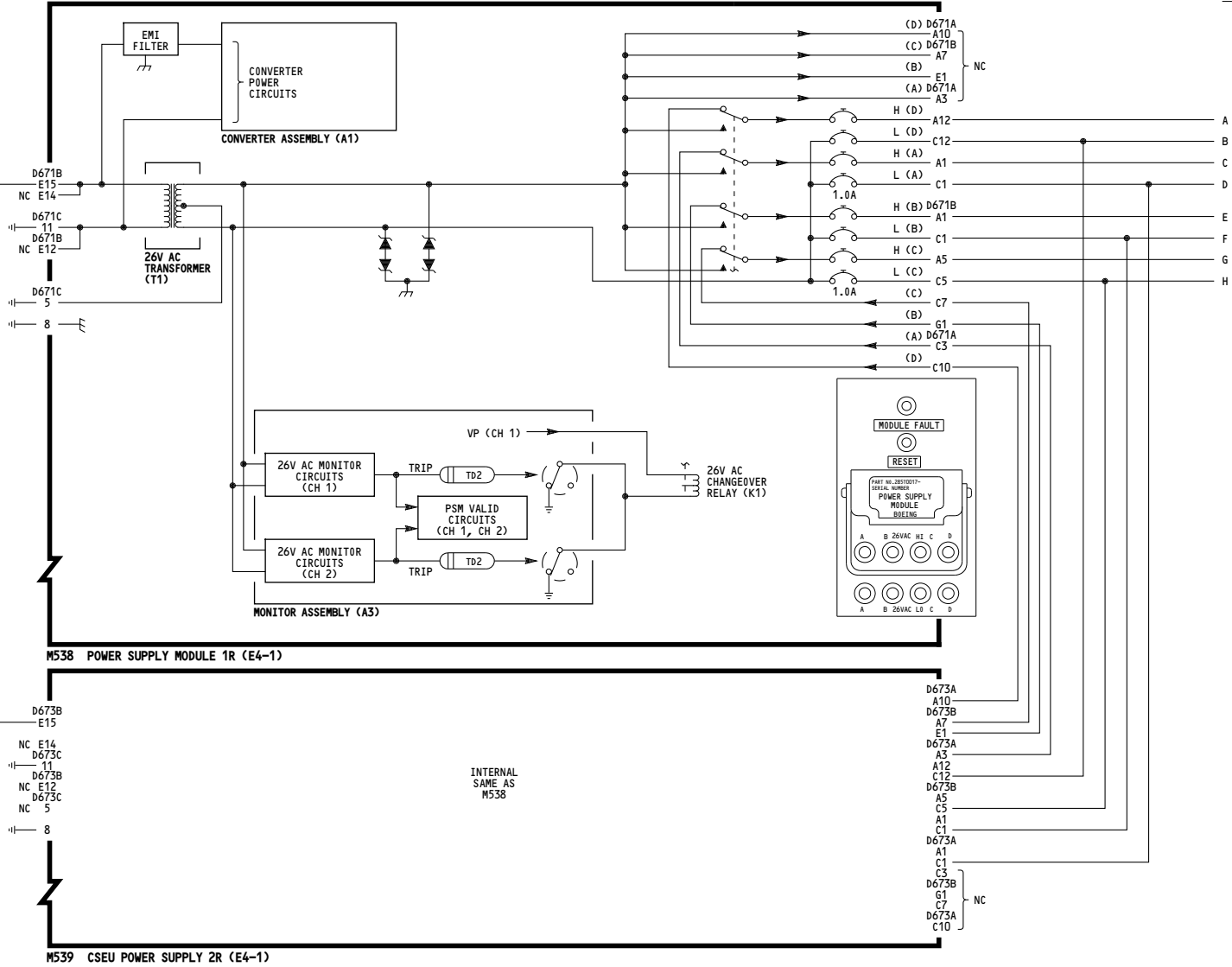
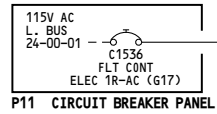

27-09-02

5002

| WIRING DIAGRAMS | |
|-----------------|--|
| 27-21-22 | |
| 27-61-14 | |
| 27-61-15 | |
| 27-61-16 | |

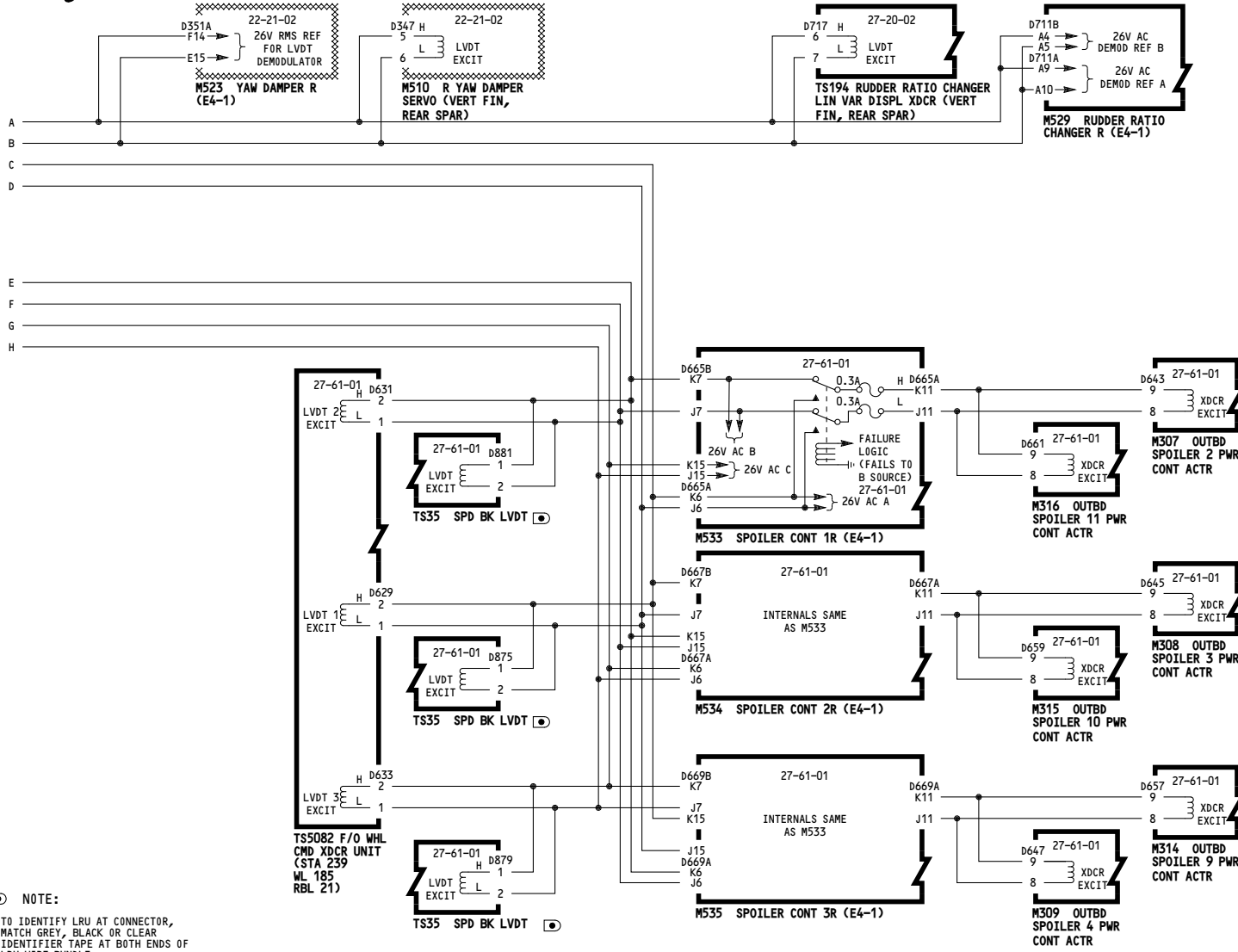

NOTE:
 TO IDENTIFY LRU AT CONNECTOR, MATCH GREY, BLACK OR CLEAR IDENTIFIER TAPE AT BOTH ENDS OF LRU WIRE BUNDLE

| | |
|-----|------------------------------|
| ALL | RIGHT CSEU POWER - AC |
| | D280N032S |

27-09-02

5001

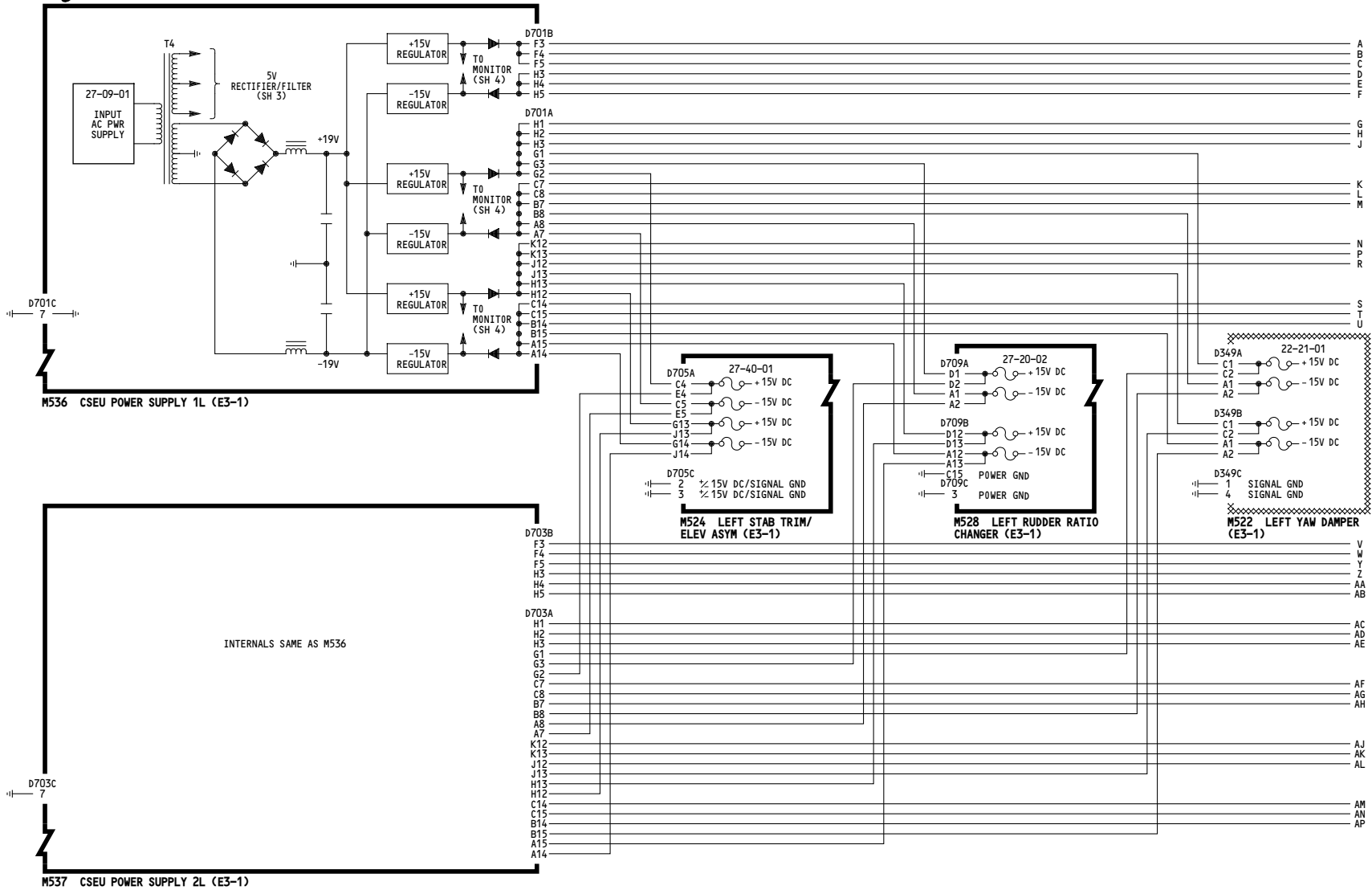

| | |
|-----|----------------------|
| ALL | LEFT CSEU POWER - DC |
| | D280N032S |

27-09-03

5001

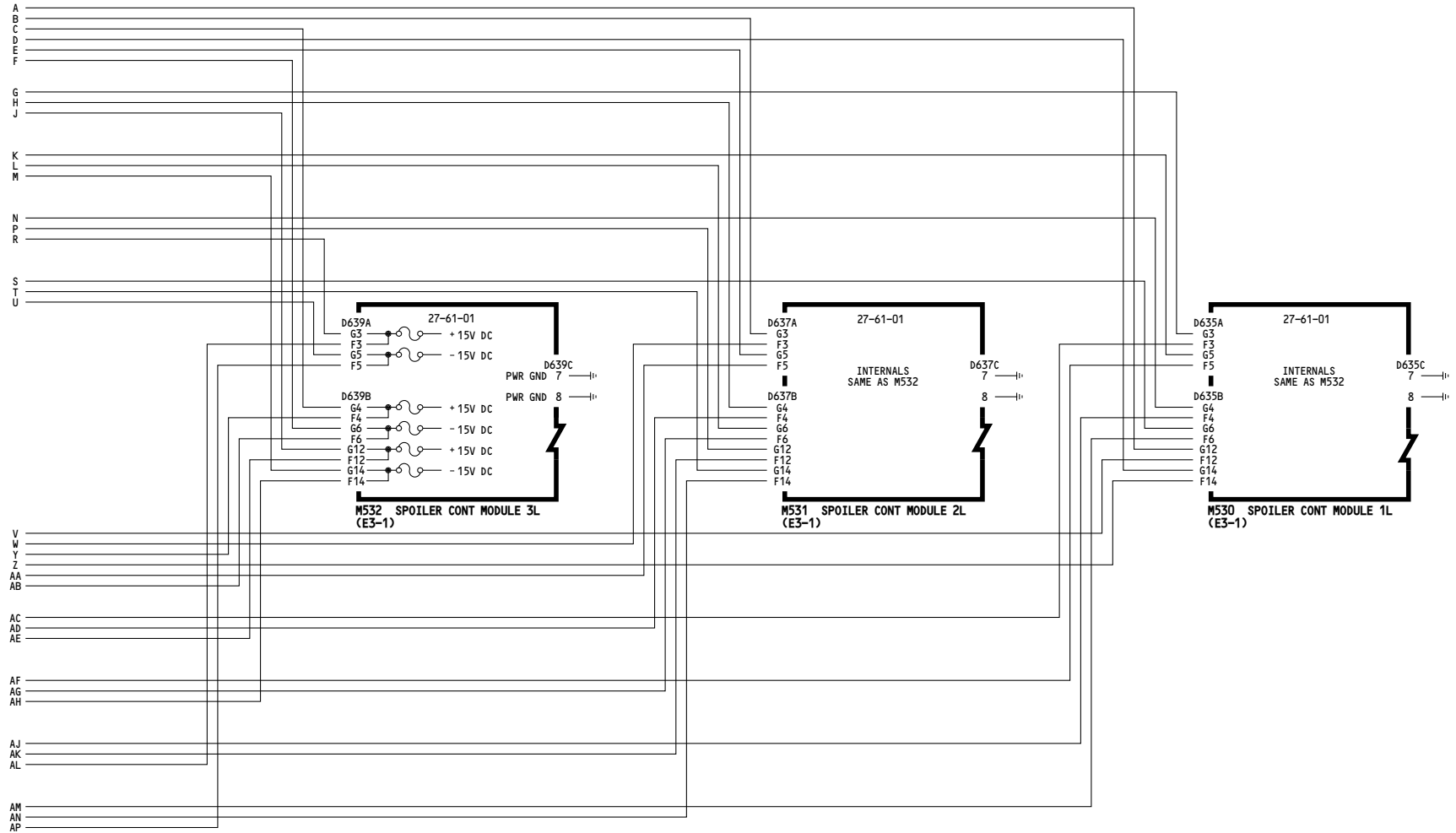

| | |
|-----------|----------------------|
| ALL | LEFT CSEU POWER - DC |
| D280N032S | |

27-09-03

Page 101
Sheet 2
May 06/2009

5001

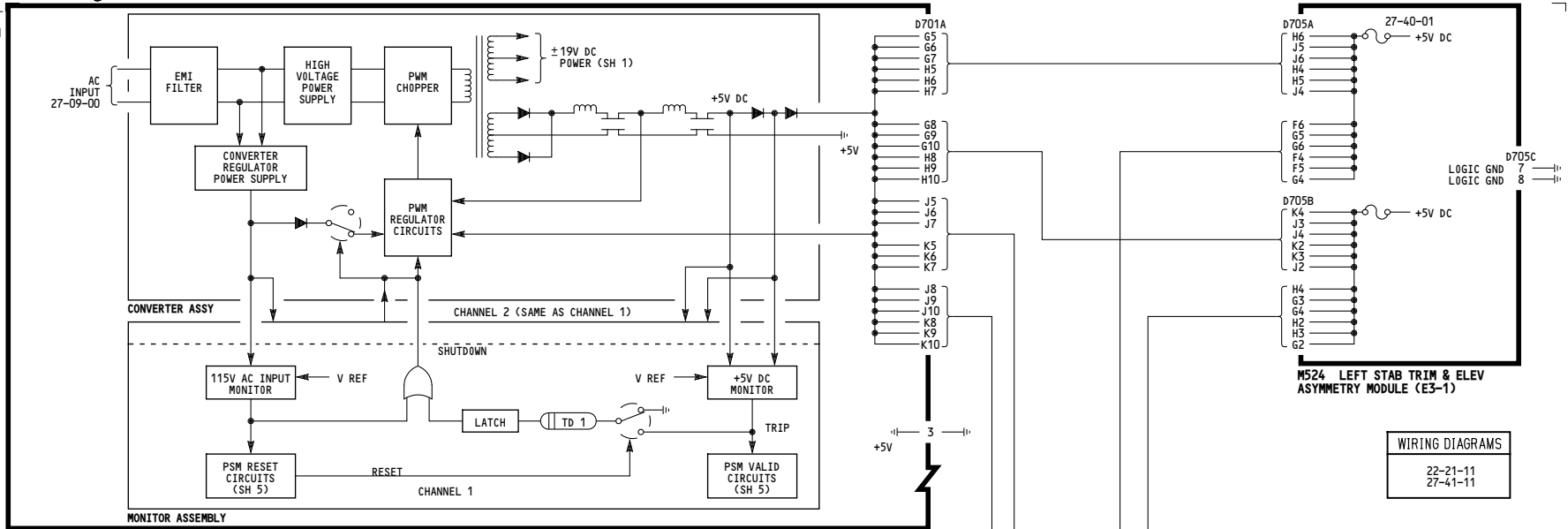

M536 CESU POWER SUPPLY 1L (E3-1)

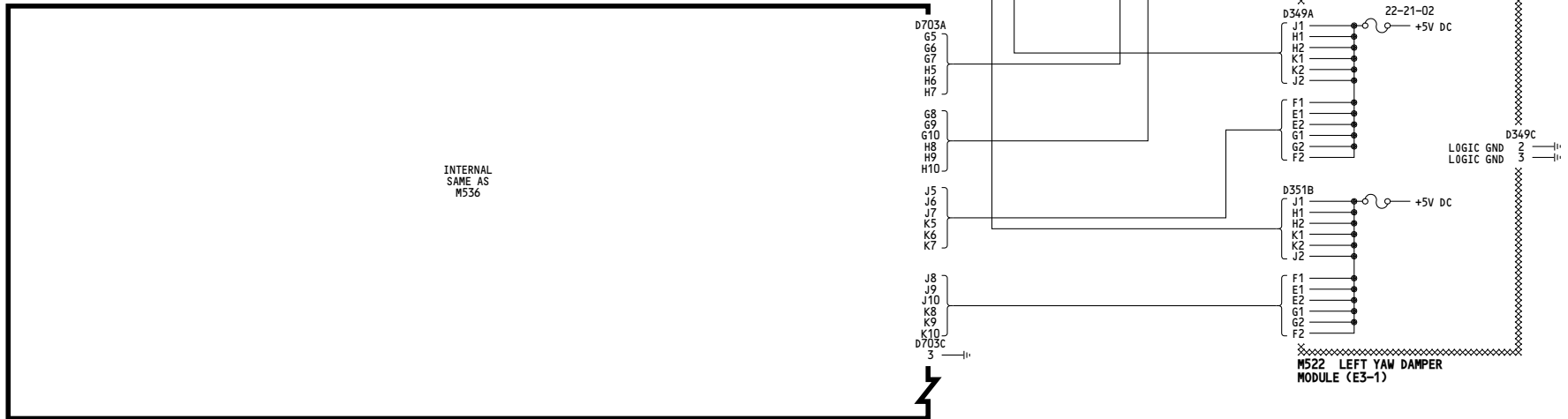

M537 CESU POWER SUPPLY 2L (E3-1)

| | |
|-----|-----------------------------|
| ALL | LEFT CSEU POWER - DC |
| | D280N032S |

27-09-03

5005

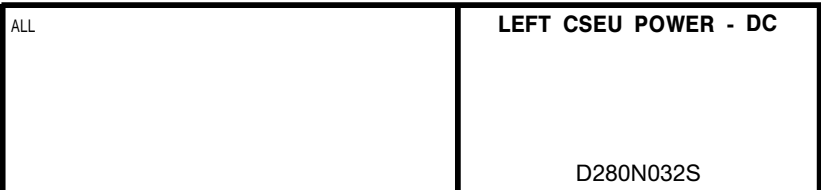
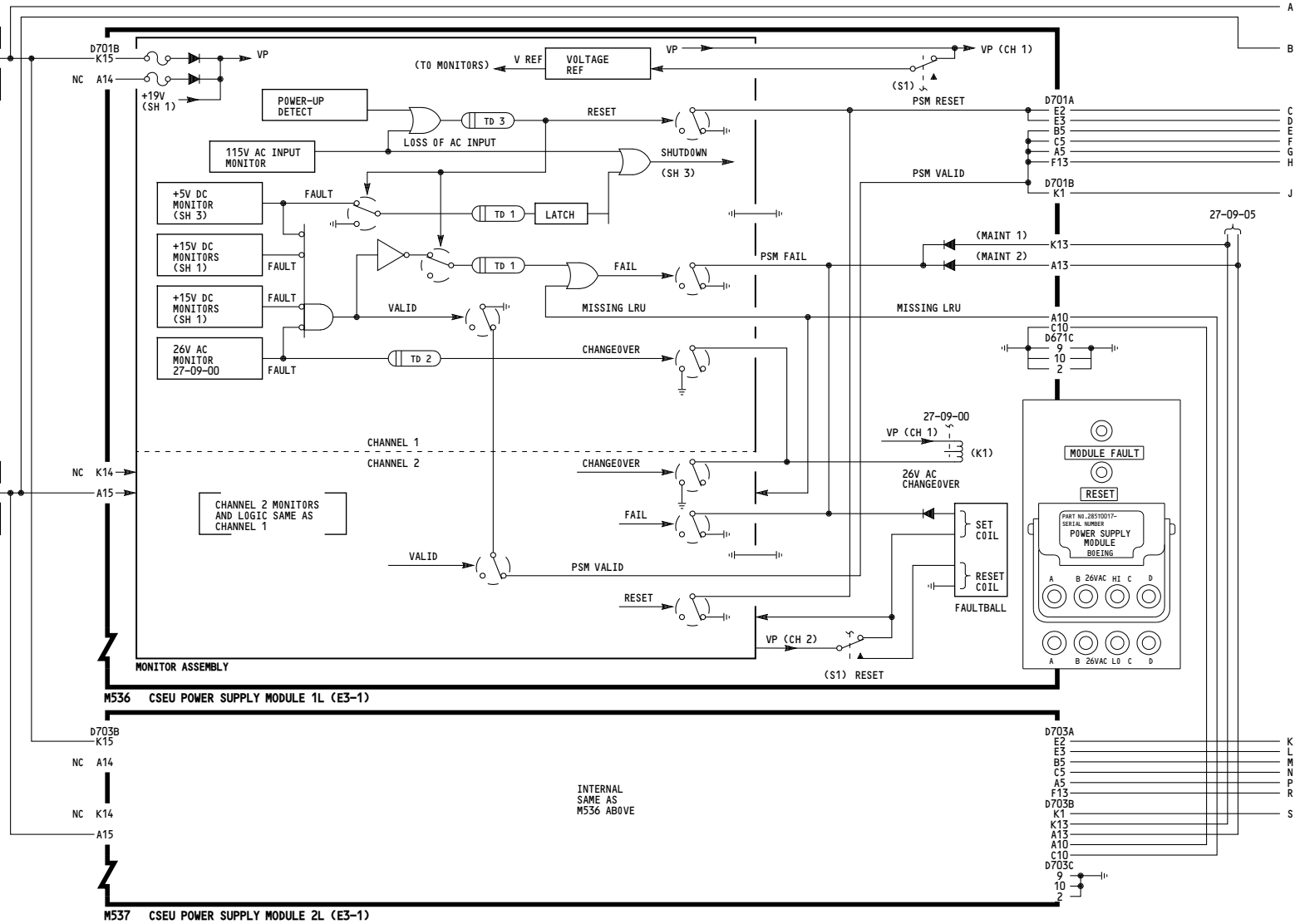
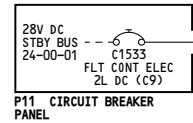
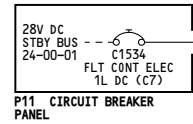

27-09-03

Page 101
Sheet 4
May 06/2009

| WIRING DIAGRAMS | |
|-----------------|--|
| 22-21-11 | |
| 27-09-11 | |
| 27-21-12 | |
| 27-41-11 | |
| 27-61-14 | |
| 27-61-15 | |
| 27-61-16 | |

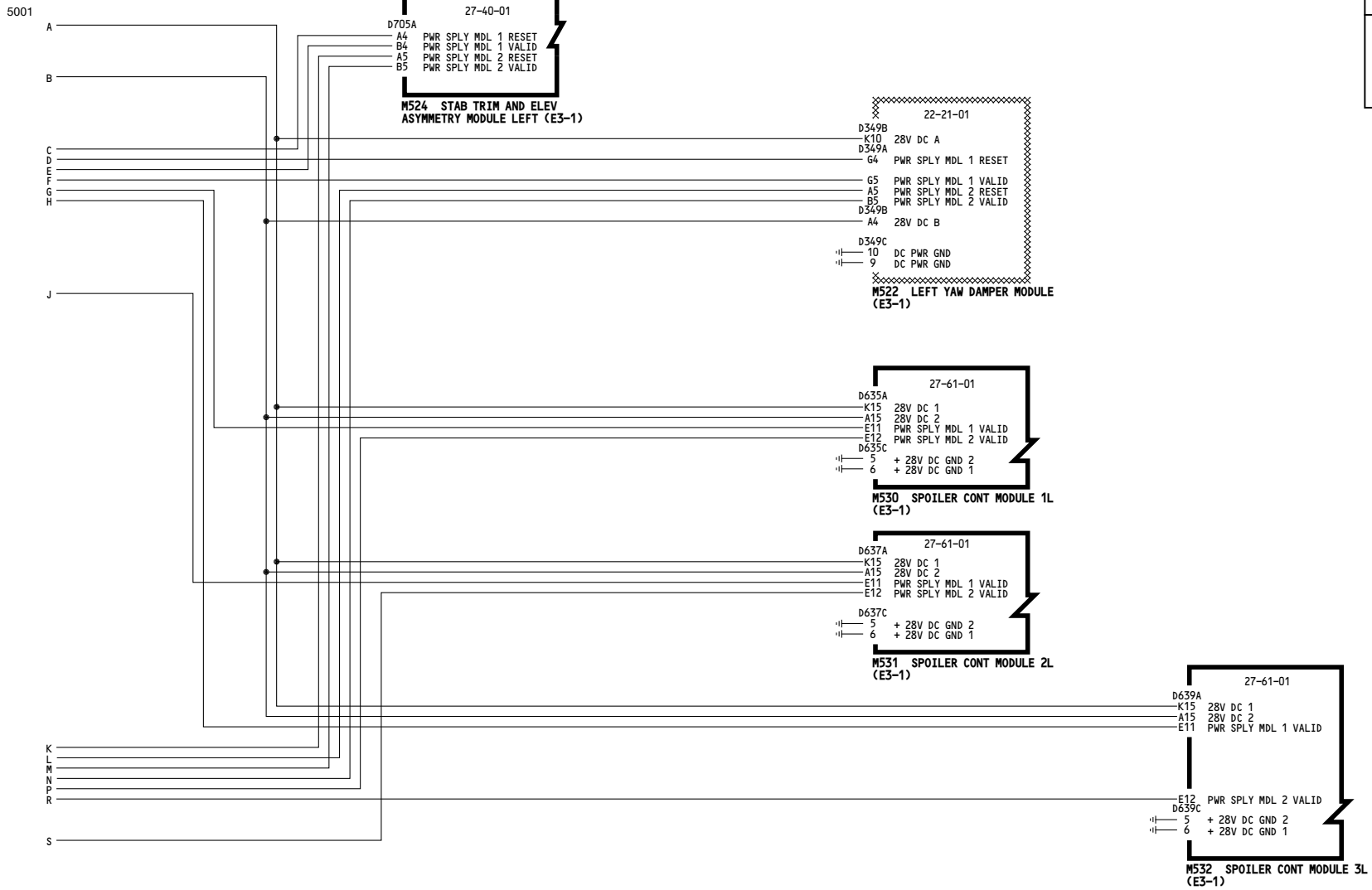

| | |
|-----|-----------------------------|
| ALL | LEFT CSEU POWER - DC |
| | D280N032S |

27-09-03

Page 101
Sheet 5
May 06/2009

THIS PAGE INTENTIONALLY LEFT BLANK

5001

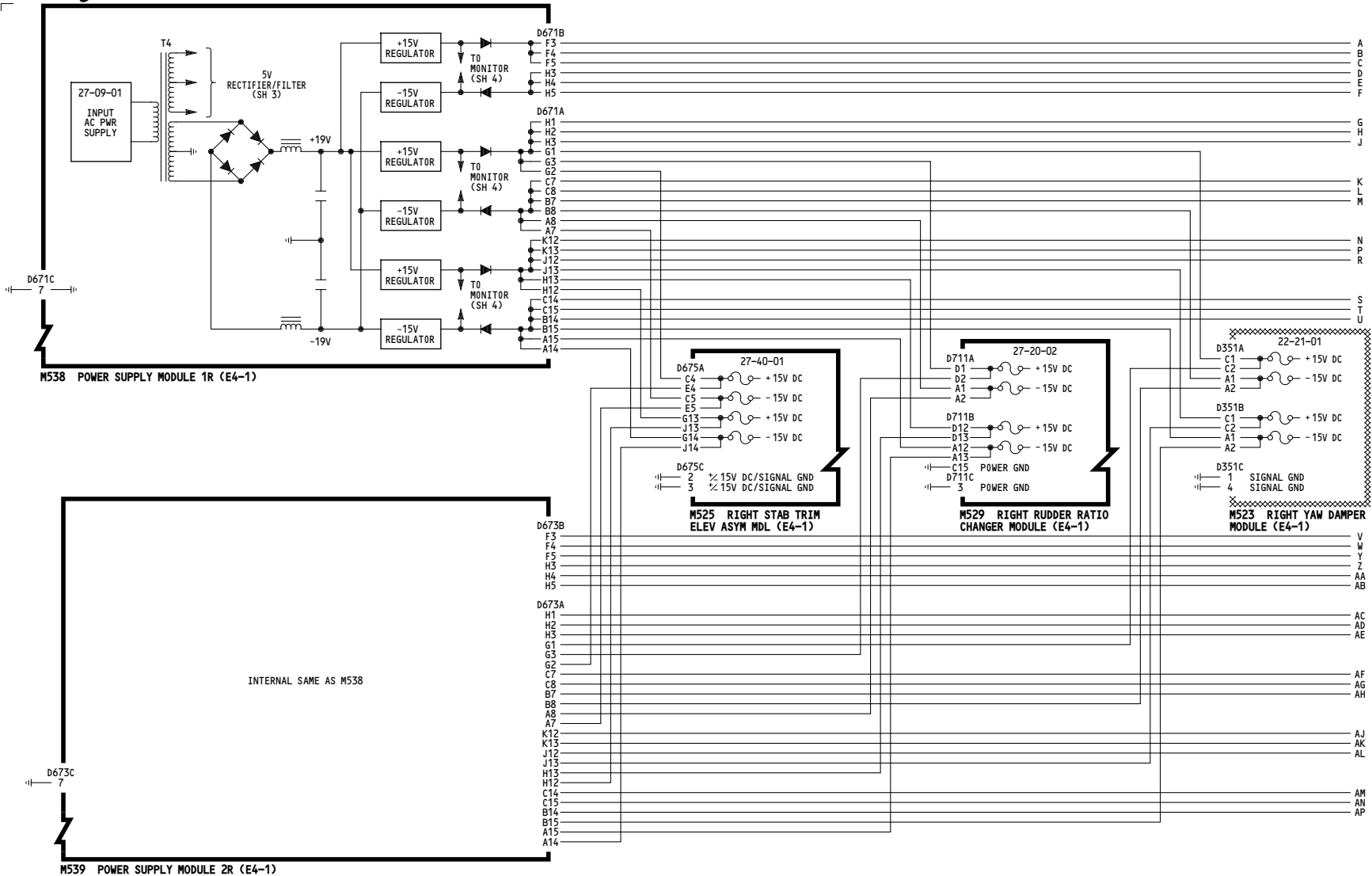

| | |
|-----|-----------------------|
| ALL | RIGHT CSEU POWER - DC |
| | D280N032S |

27-09-04

5001

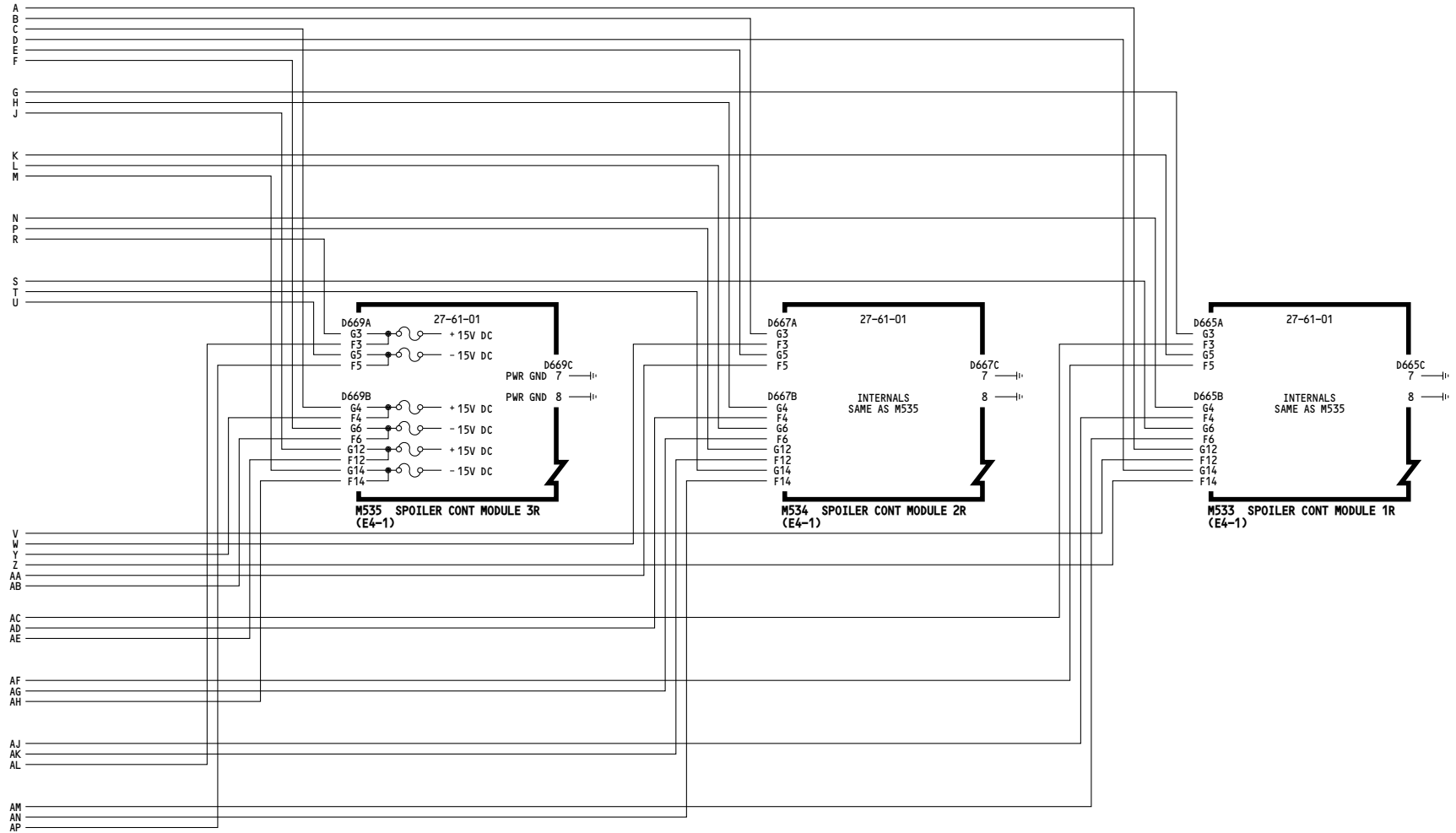

| | |
|-----|-----------------------|
| ALL | RIGHT CSEU POWER - DC |
| | D280N032S |

27-09-04

Page 101
 Sheet 2
 May 06/2009

5001

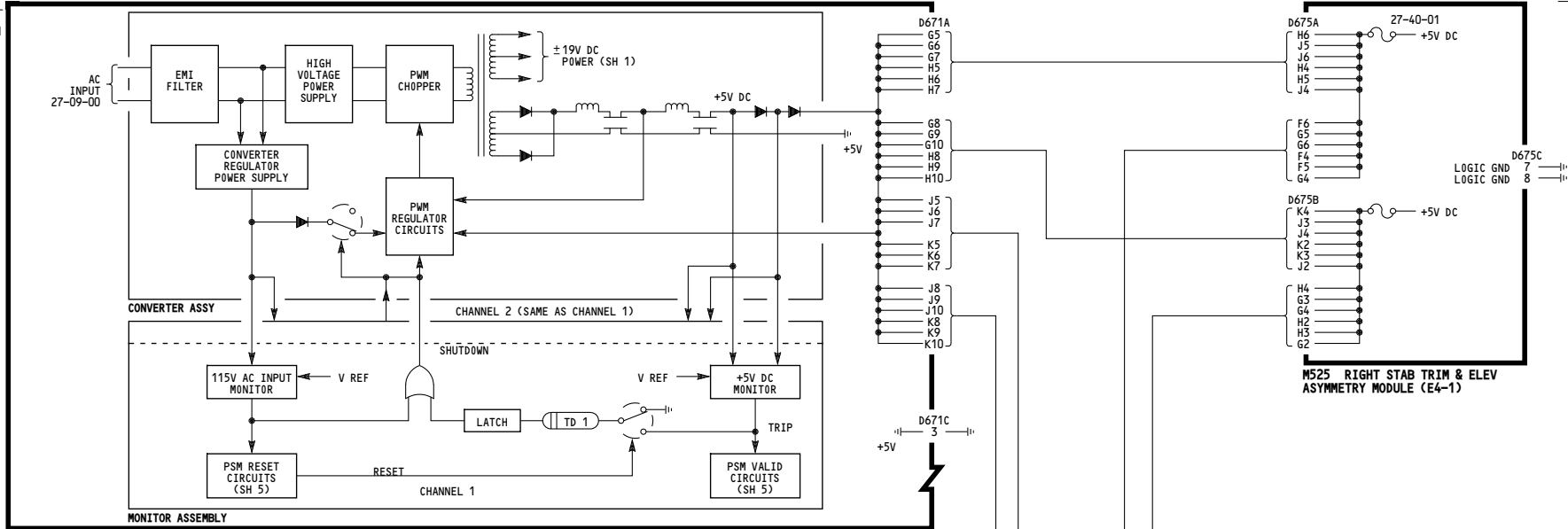

M538 CESU POWER SUPPLY MODULE 1R (E4-1)

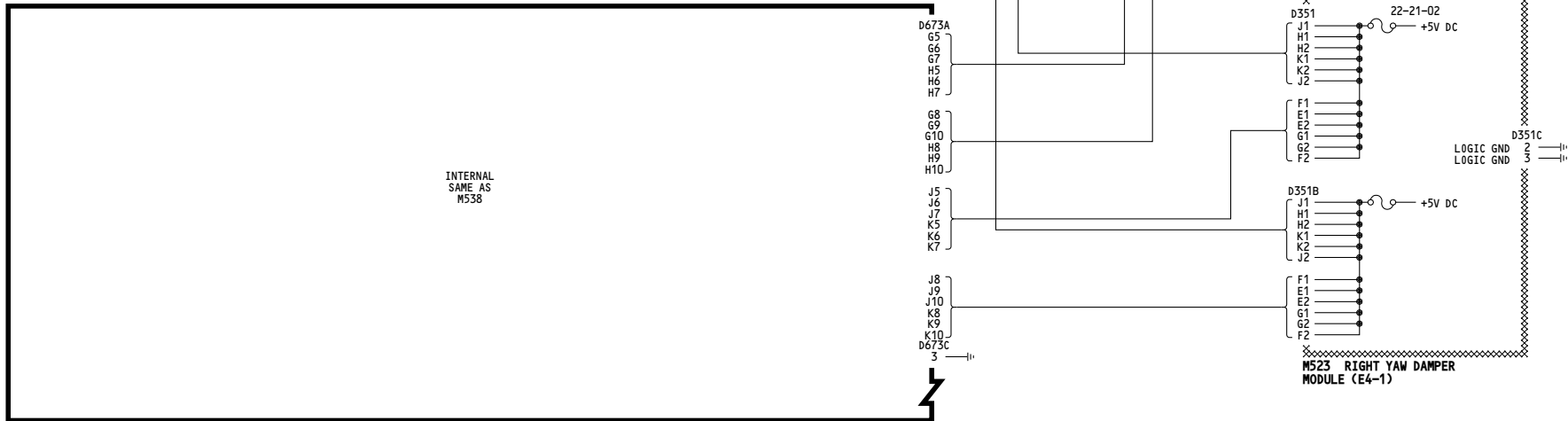

M539 CESU POWER SUPPLY MODULE 2R (E4-1)

| | |
|-----|------------------------------|
| ALL | RIGHT CSEU POWER - DC |
| | D280N032S |

27-09-04

5005

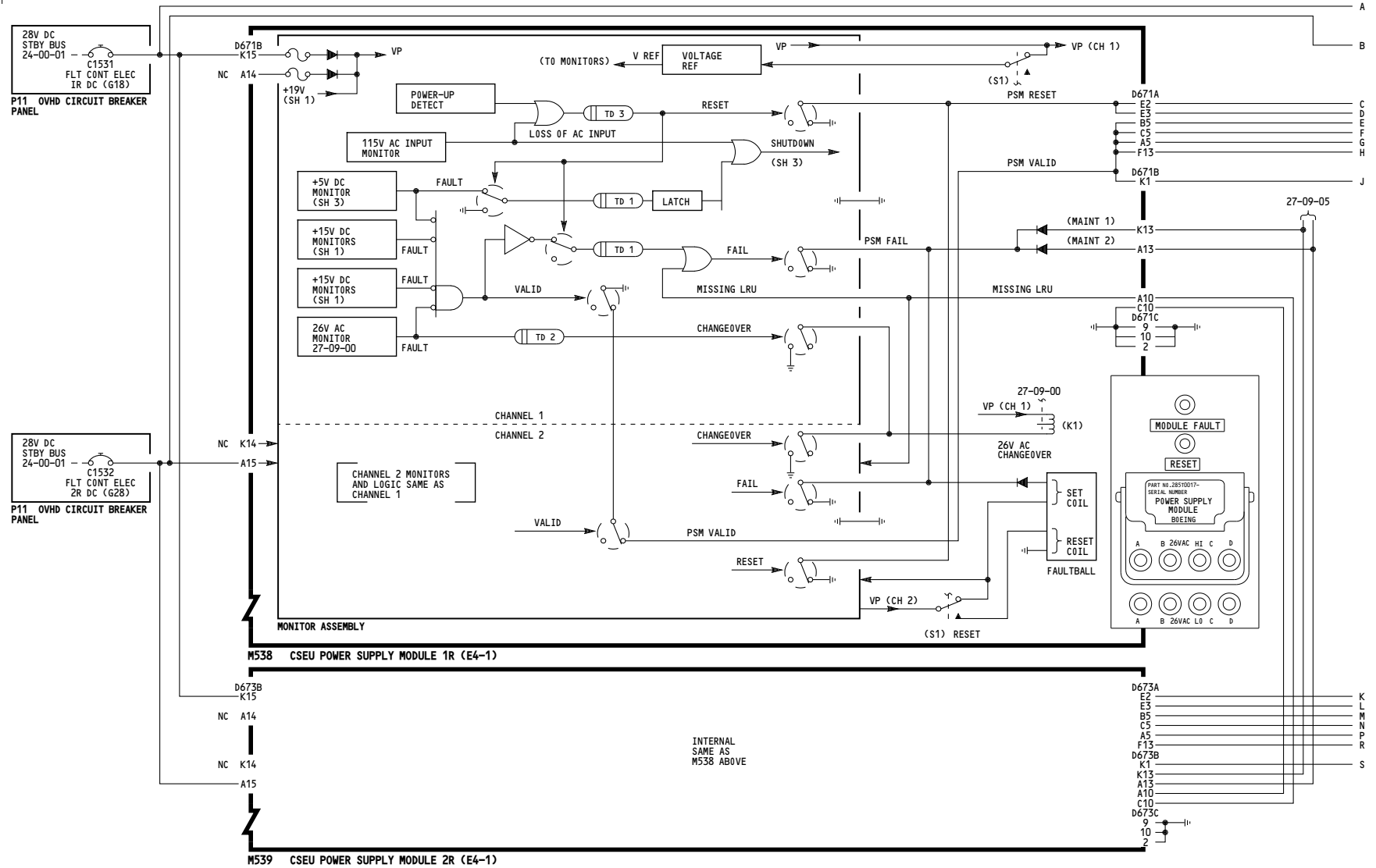

| | |
|-----|------------------------------|
| ALL | RIGHT CSEU POWER - DC |
| | D280N032S |

27-09-04

Page 101
 Sheet 4
 May 06/2009

| WIRING DIAGRAMS | |
|-----------------|--|
| 22-21-11 | |
| 22-22-21 | |
| 27-09-11 | |
| 27-21-12 | |
| 27-41-11 | |
| 27-41-21 | |
| 27-61-14 | |
| 27-61-15 | |
| 27-61-16 | |

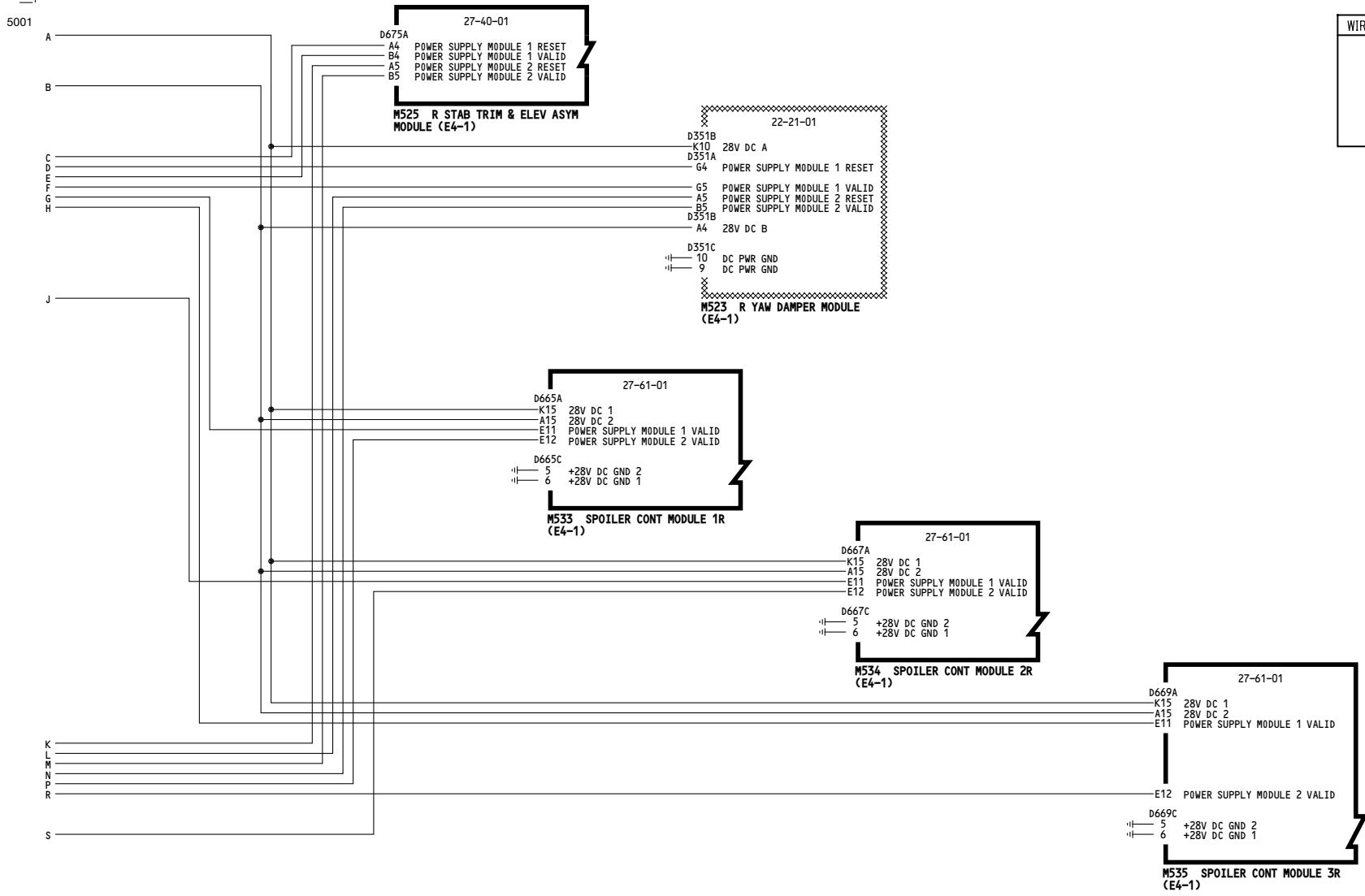

| | |
|-----|-----------------------|
| ALL | RIGHT CSEU POWER - DC |
| | D280N032S |

27-09-04

THIS PAGE INTENTIONALLY LEFT BLANK

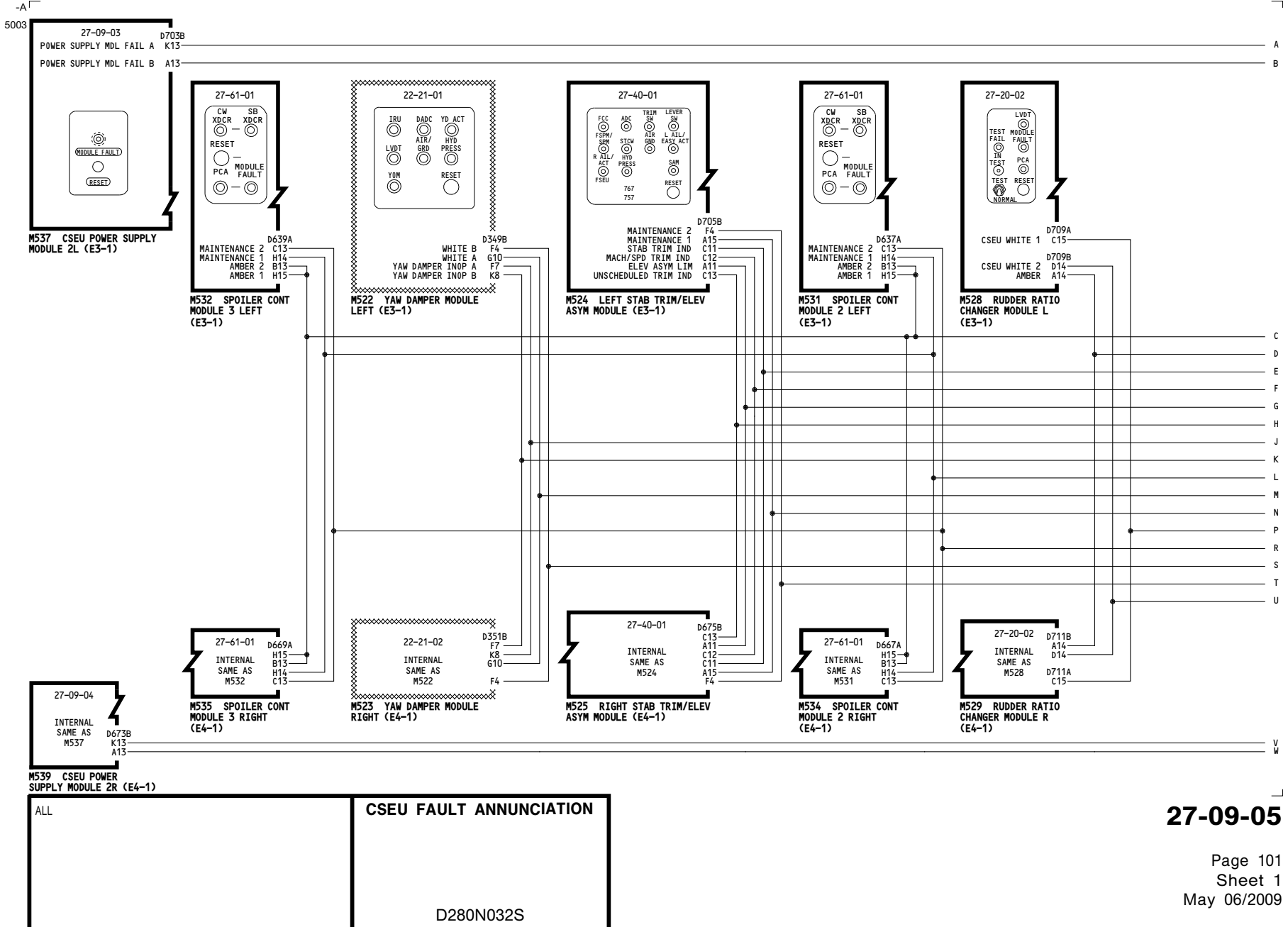

27-09-05

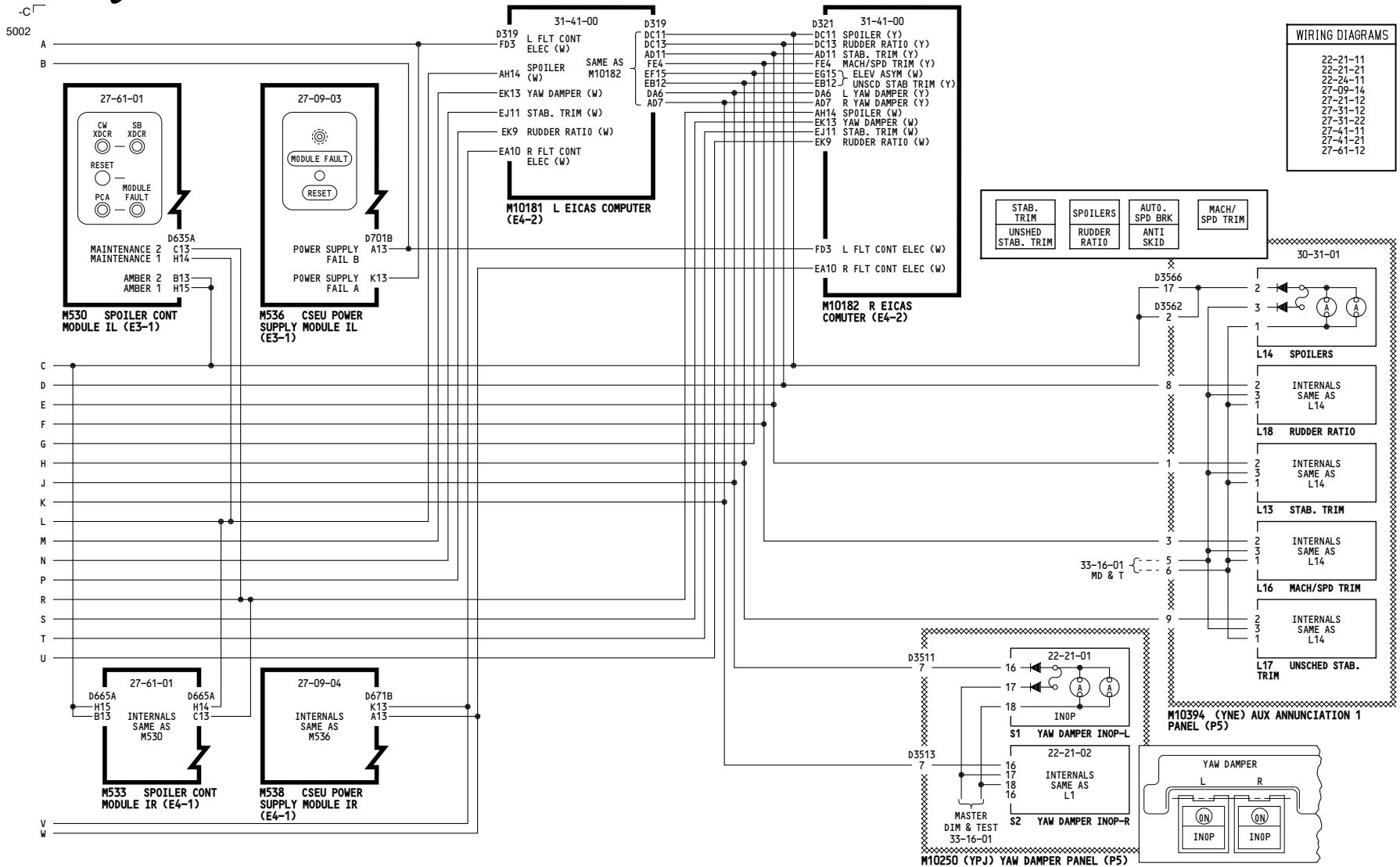

ALL

CSEU FAULT ANNUNCIATION

D280N032S

27-09-05

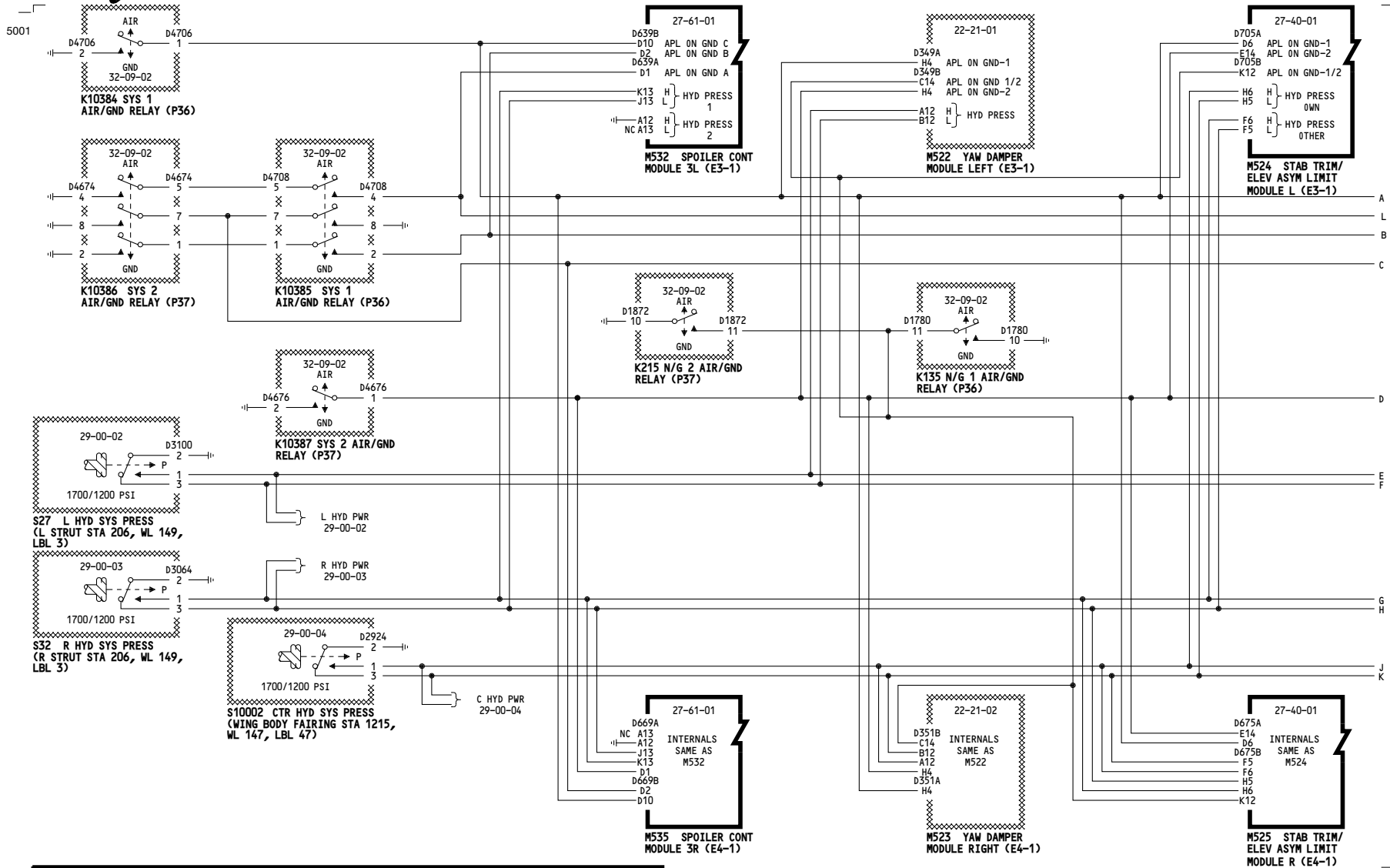

ALL

CSEU AIR/GROUND AND HYDRAULIC DISCRETE INPUTS

D280N032S

27-09-06

5001

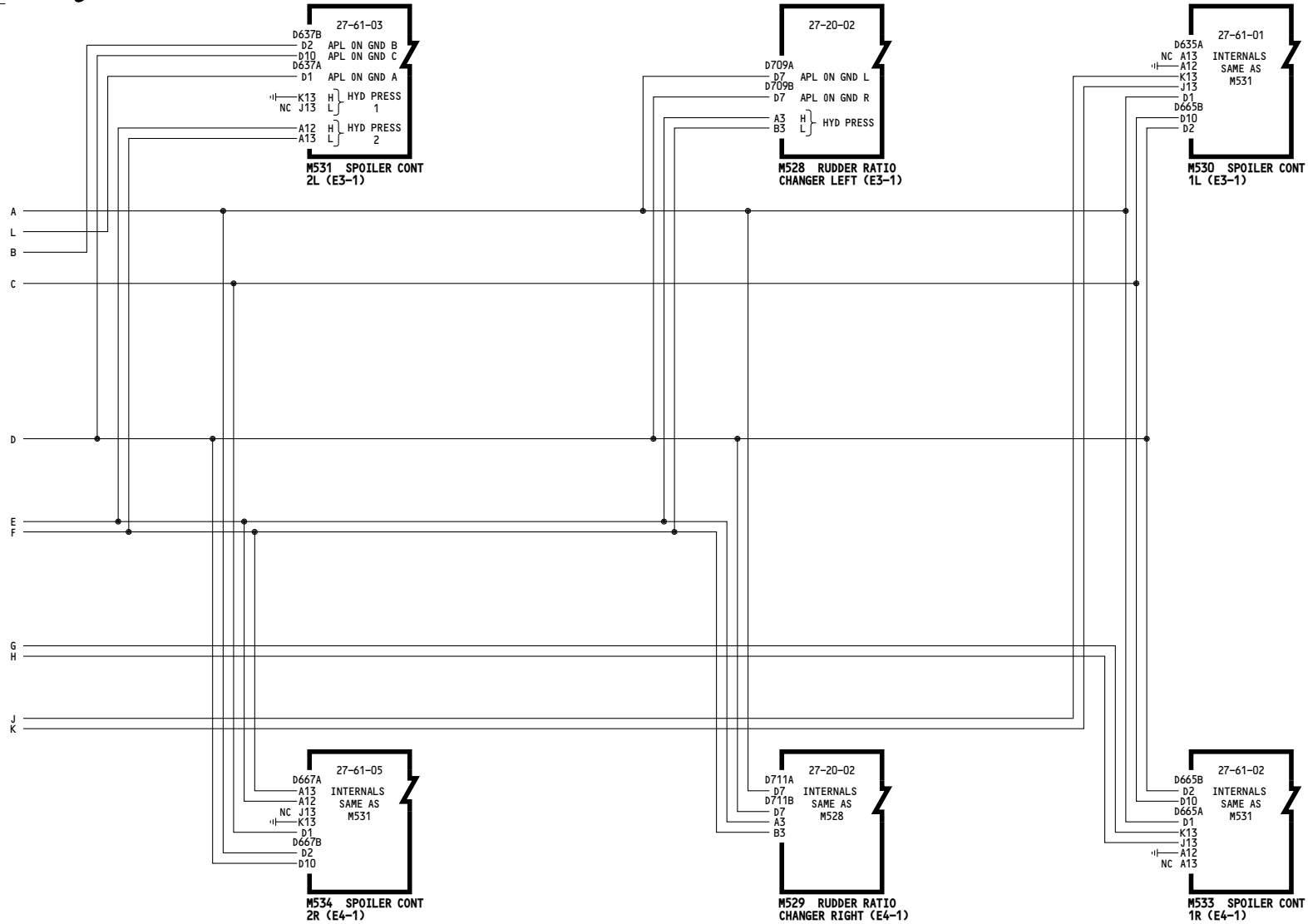

WIRING DIAGRAMS
27-09-12
27-09-13

ALL

CSEU AIR/GROUND AND HYDRAULIC DISCRETE INPUTS

D280N032S

27-09-06

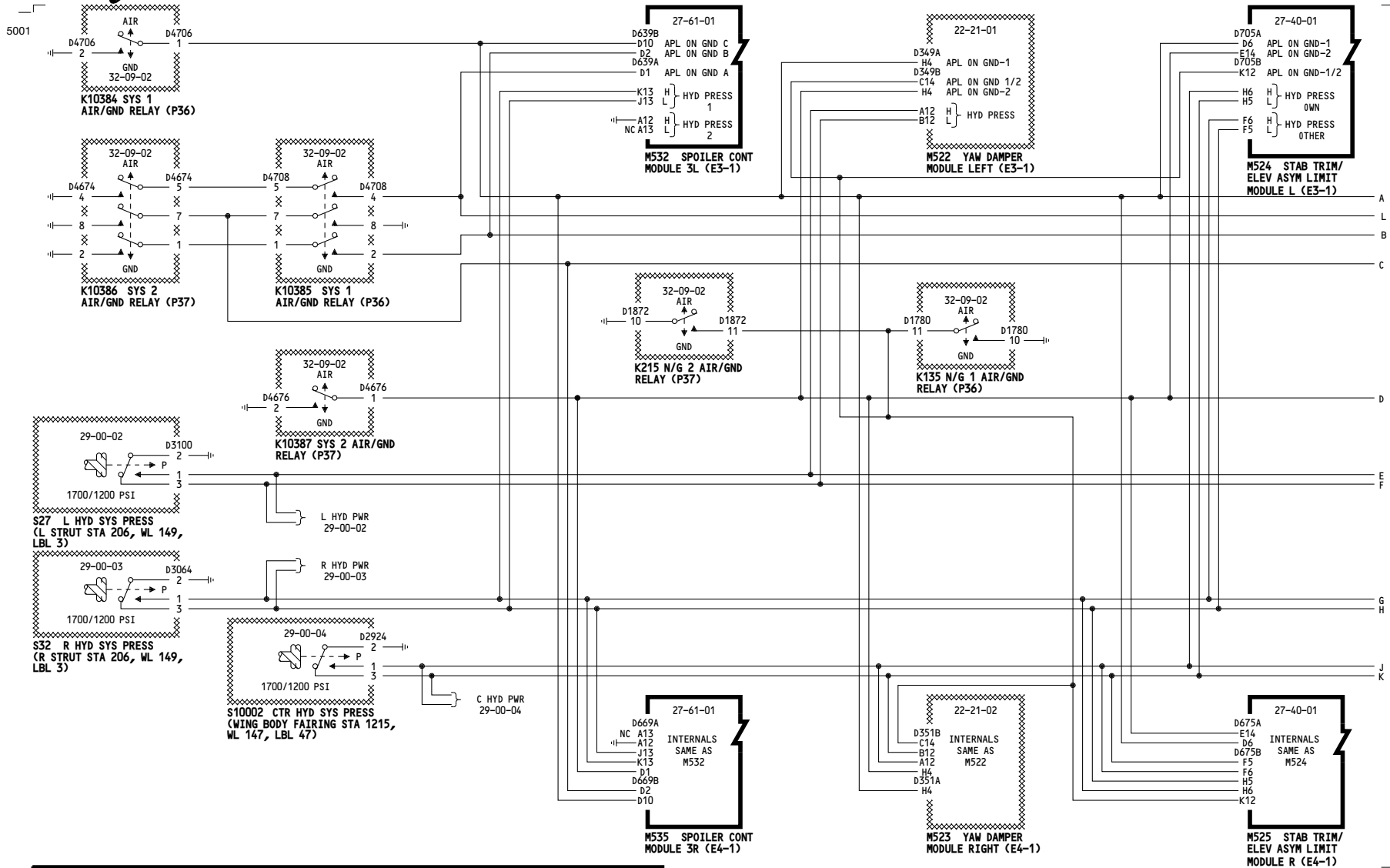

| | |
|-----------|--|
| 001-011 | CSEU AIR/GROUND AND HYDRAULIC DISCRETE INPUTS |
| D280N032S | |

27-09-06

5002

WIRING DIAGRAMS
27-09-12
27-09-13

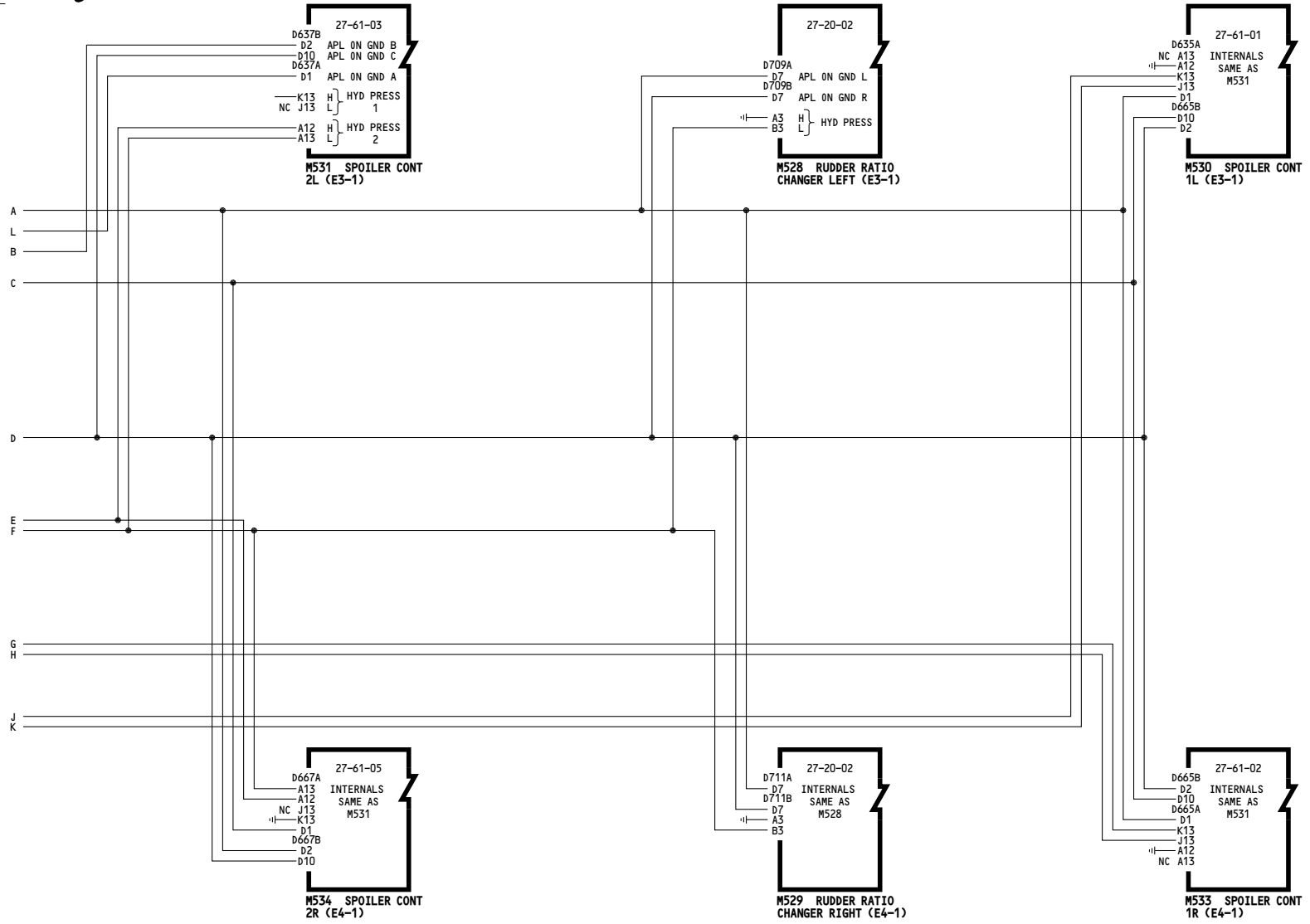

| | |
|---------|---|
| 001-011 | CSEU AIR/GROUND AND HYDRAULIC DISCRETE INPUTS D280N032S |
|---------|---|

Incorporates
27-0123

27-09-06

Page 101.1
Sheet 2
May 06/2009

5012

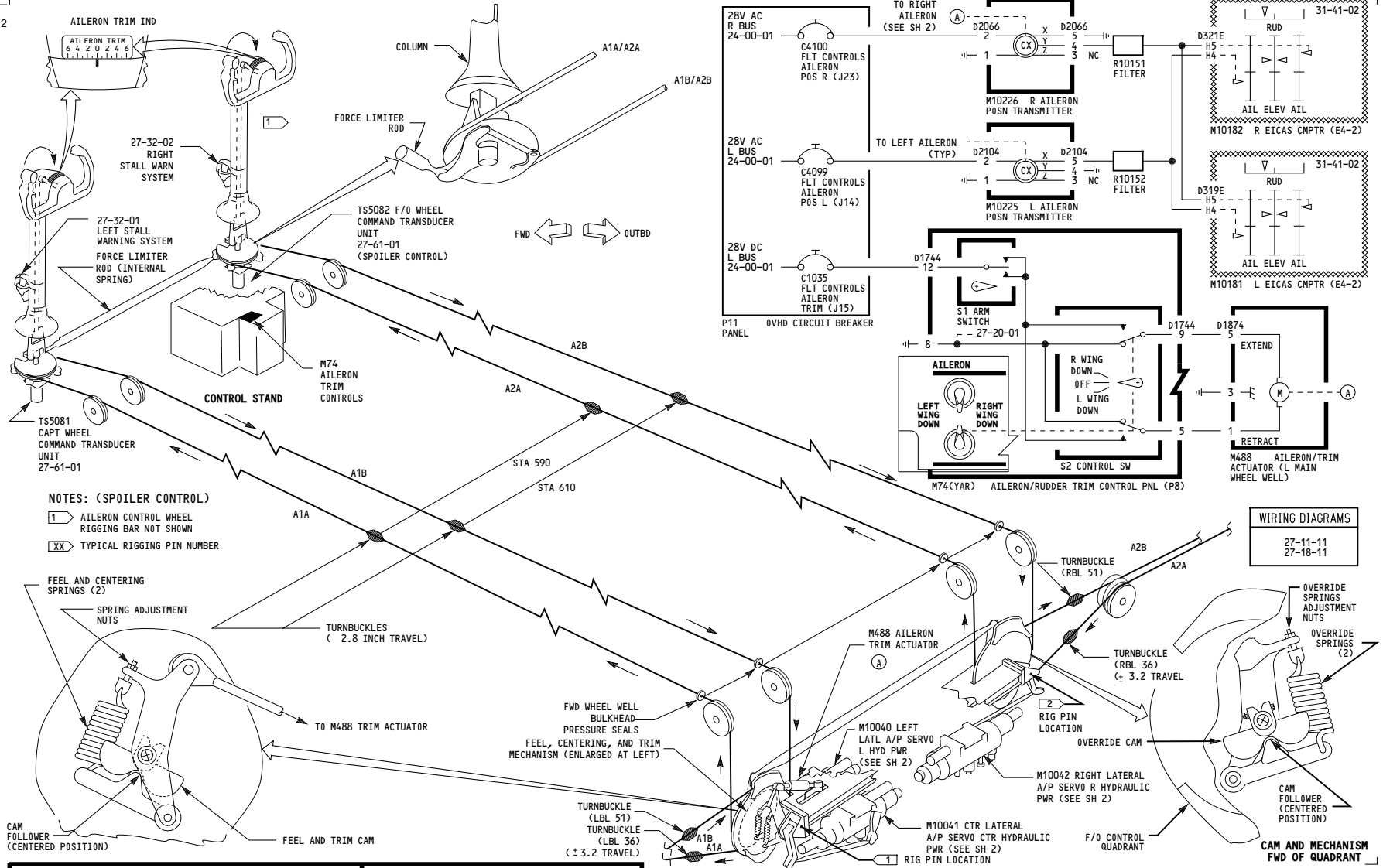

NOTES: (SPOILER CONTROL)
 1 AILERON CONTROL WHEEL RIGGING BAR NOT SHOWN
 XX TYPICAL RIGGING PIN NUMBER

WIRING DIAGRAMS
 27-11-11
 27-18-11

| | |
|-----|----------------|
| ALL | AILERON |
| | D280N032S |

27-10-01

5001

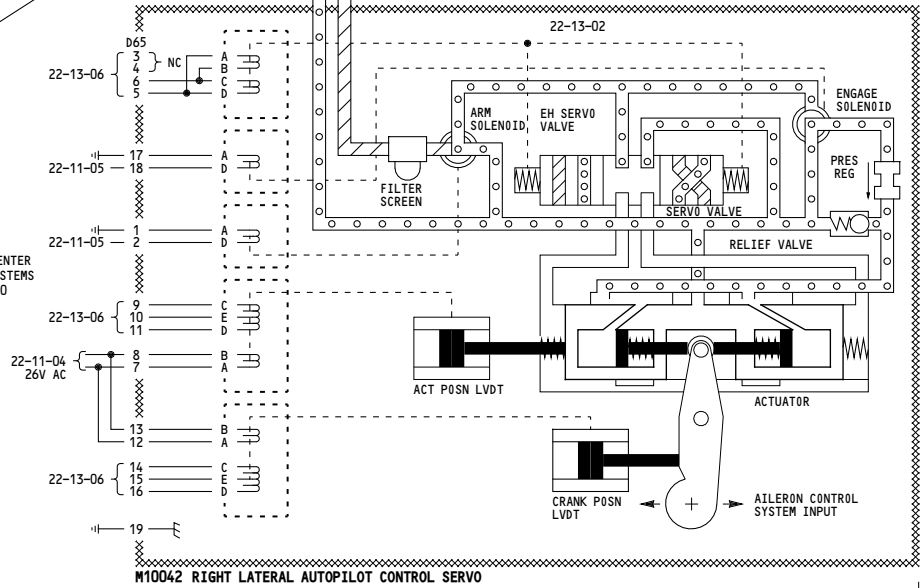
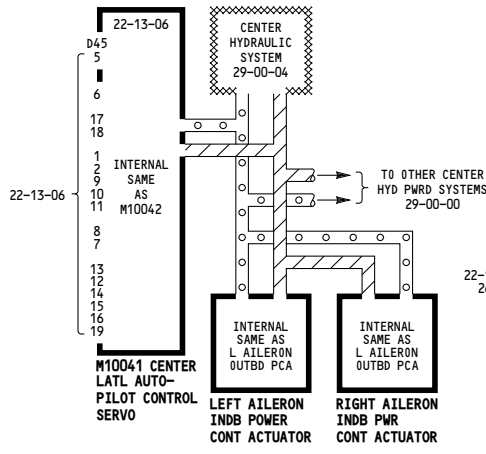
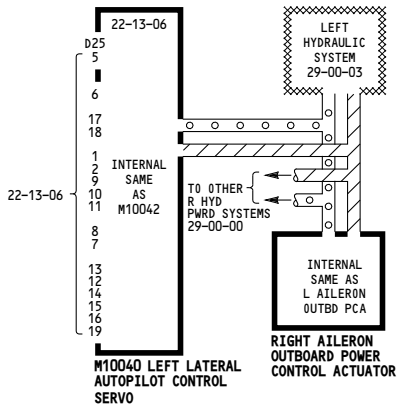
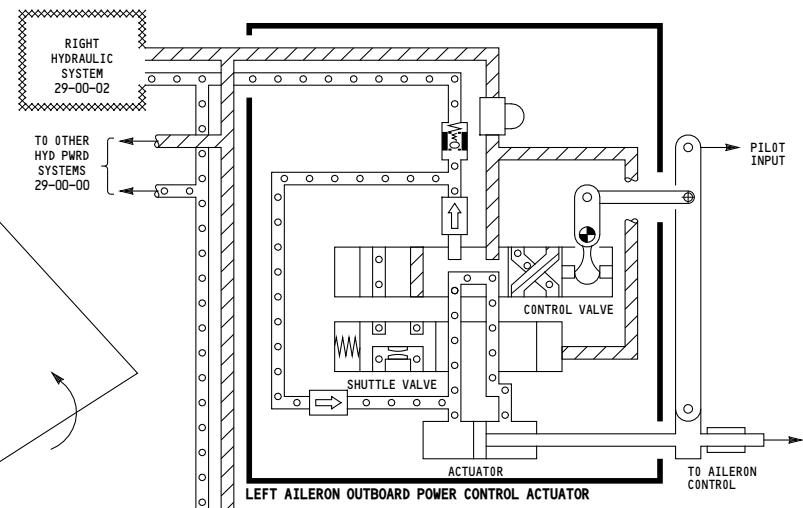
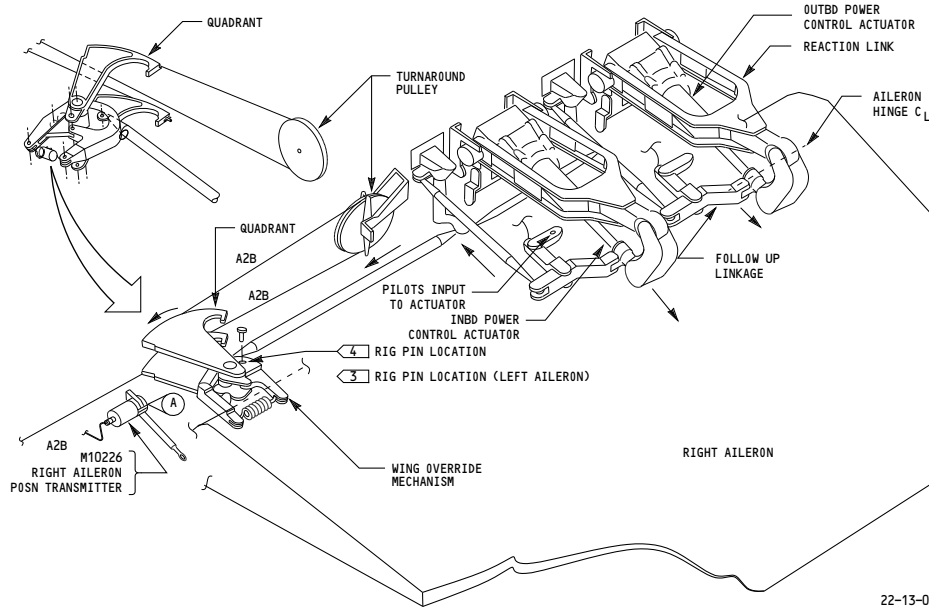

NOTES:
 RETURN
 PRESSURE
 TYPICAL RIGGING PIN LOCATIONS

| | |
|-----|----------------|
| ALL | AILERON |
| | D280N032S |

27-10-01

5014

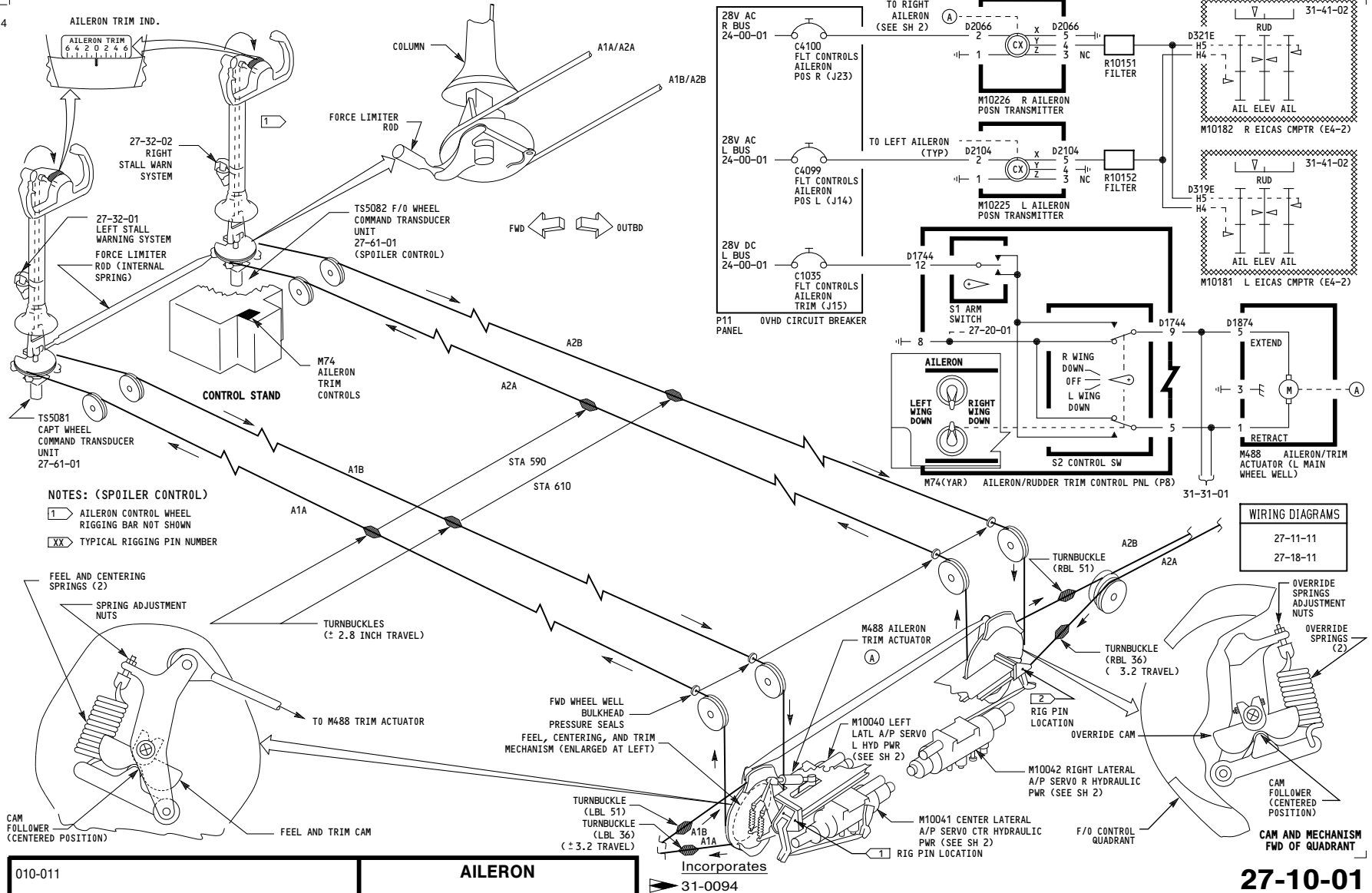

NOTES: (SPOILER CONTROL)
 1 AILERON CONTROL WHEEL RIGGING BAR NOT SHOWN
 XX TYPICAL RIGGING PIN NUMBER

WIRING DIAGRAMS
 27-11-11
 27-18-11

27-10-01

| | |
|----------------------|----------------|
| 010-011 | AILERON |
| Incorporates 31-0094 | |
| D280N032S | |

5001

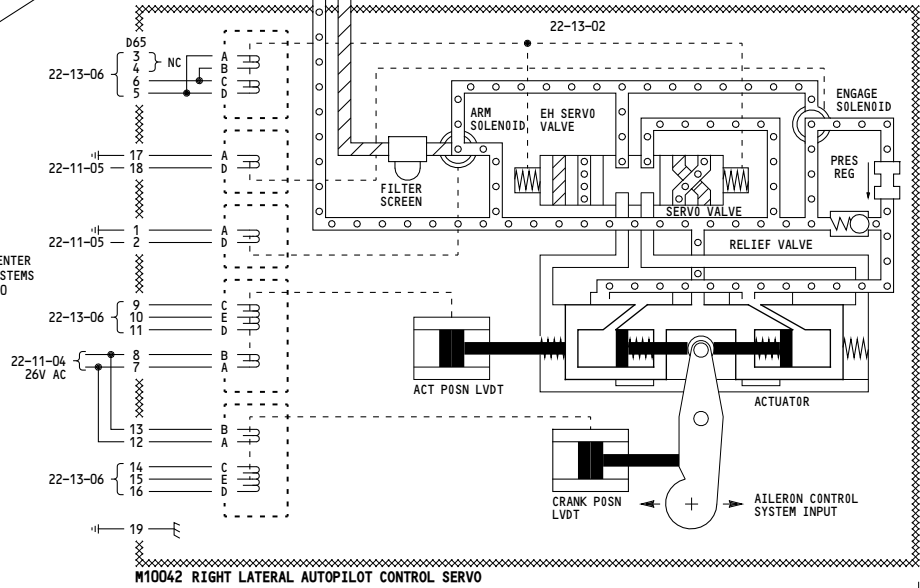
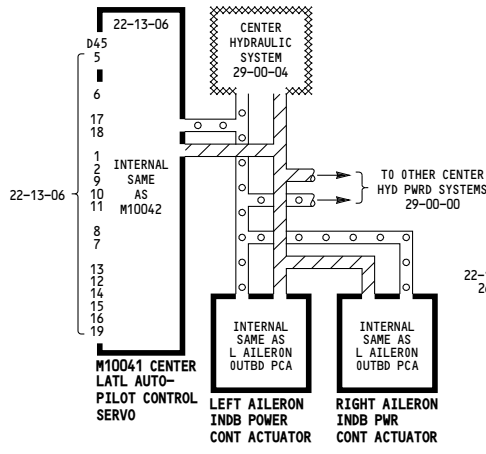
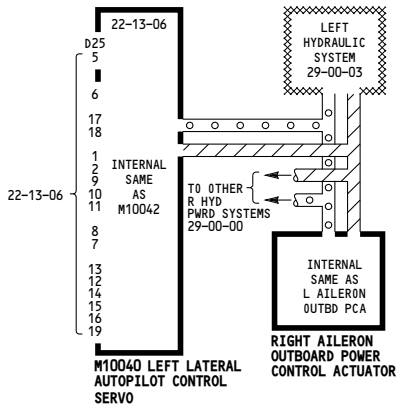
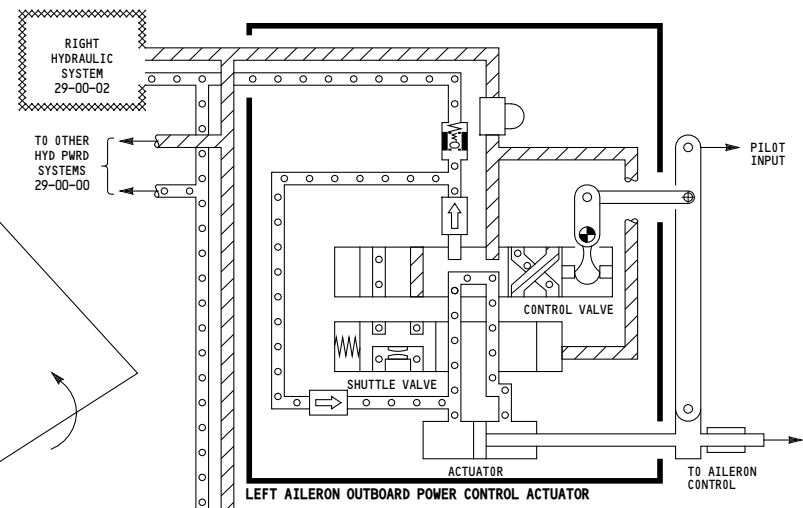
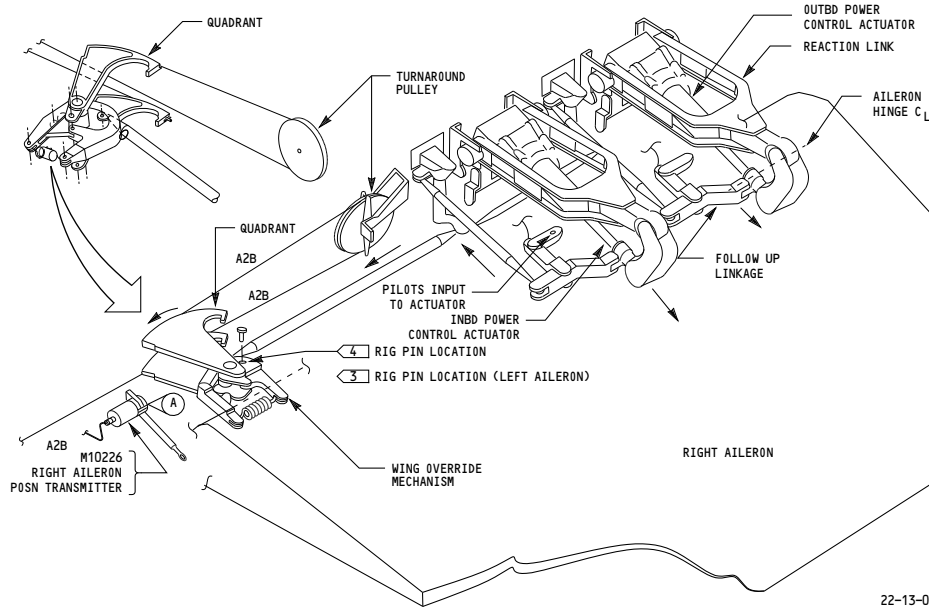

NOTES:
 RETURN
 PRESSURE
 TYPICAL RIGGING PIN LOCATIONS

| | |
|-----------|----------------|
| 010-011 | AILERON |
| D280N032S | |

27-10-01

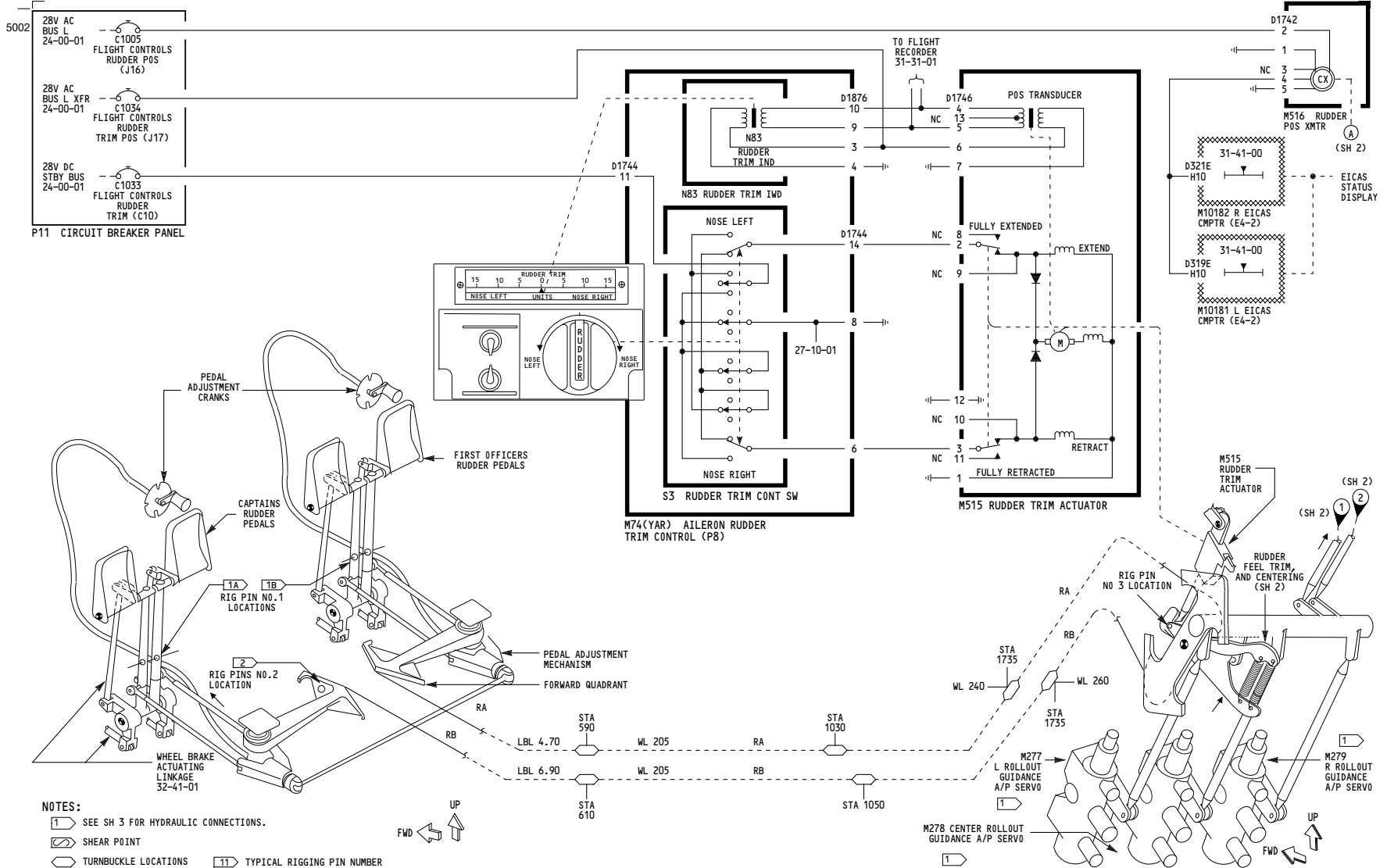

- NOTES:**
- 1 SEE SH 3 FOR HYDRAULIC CONNECTIONS.
 - 2 SHEAR POINT
 - 3 TURNBUCKLE LOCATIONS
 - 4 TYPICAL RIGGING PIN NUMBER

| | |
|-----------|------------------------------|
| ALL | RUDDER CONTROL SYSTEM |
| | |
| D280N032S | |

27-20-01

5001

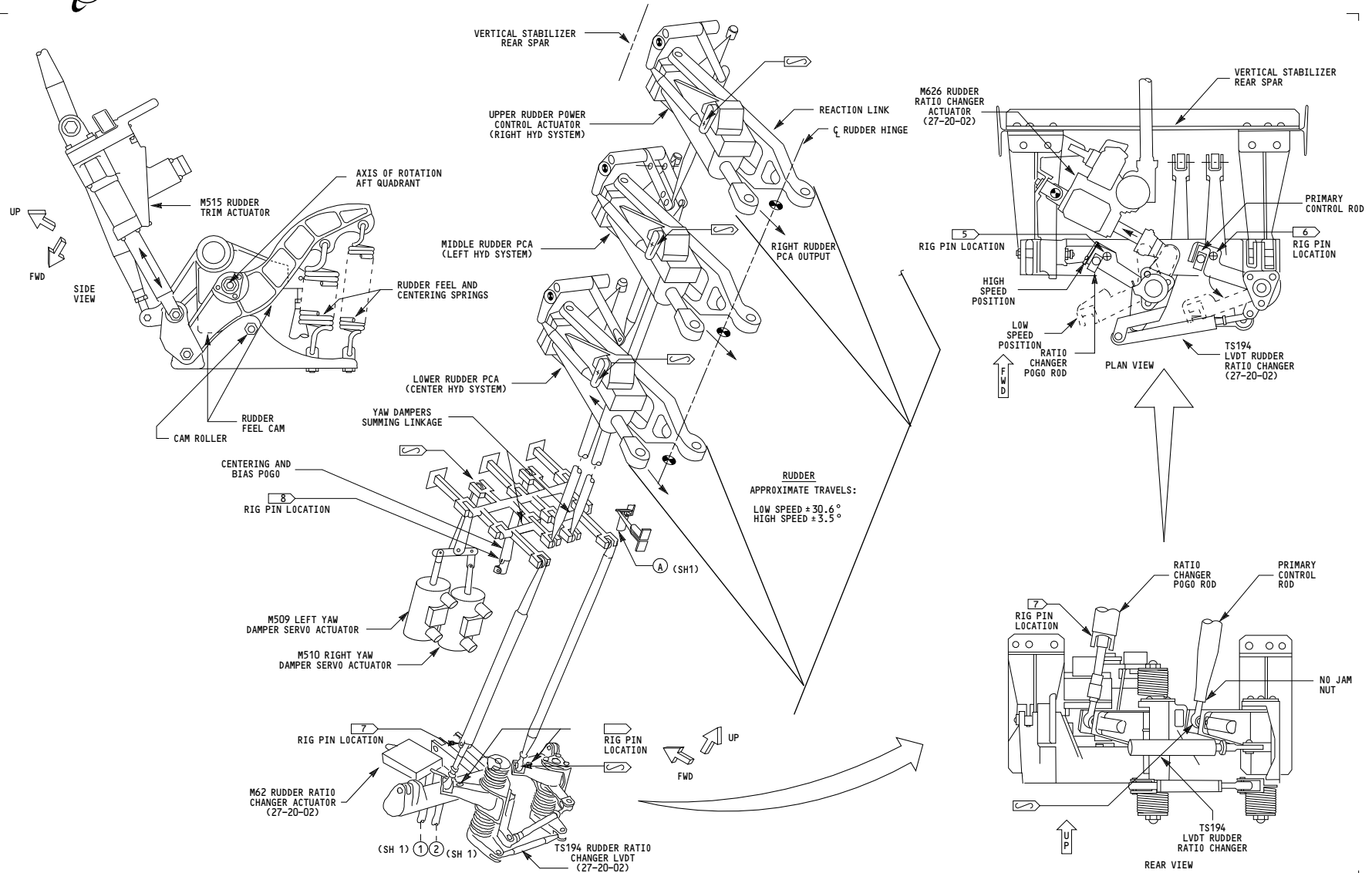

| | |
|-----|--|
| ALL | <p align="center">RUDDER CONTROL SYSTEM</p> <p align="center">D280N032S</p> |
|-----|--|

27-20-01

Page 101
Sheet 2
May 06/2009

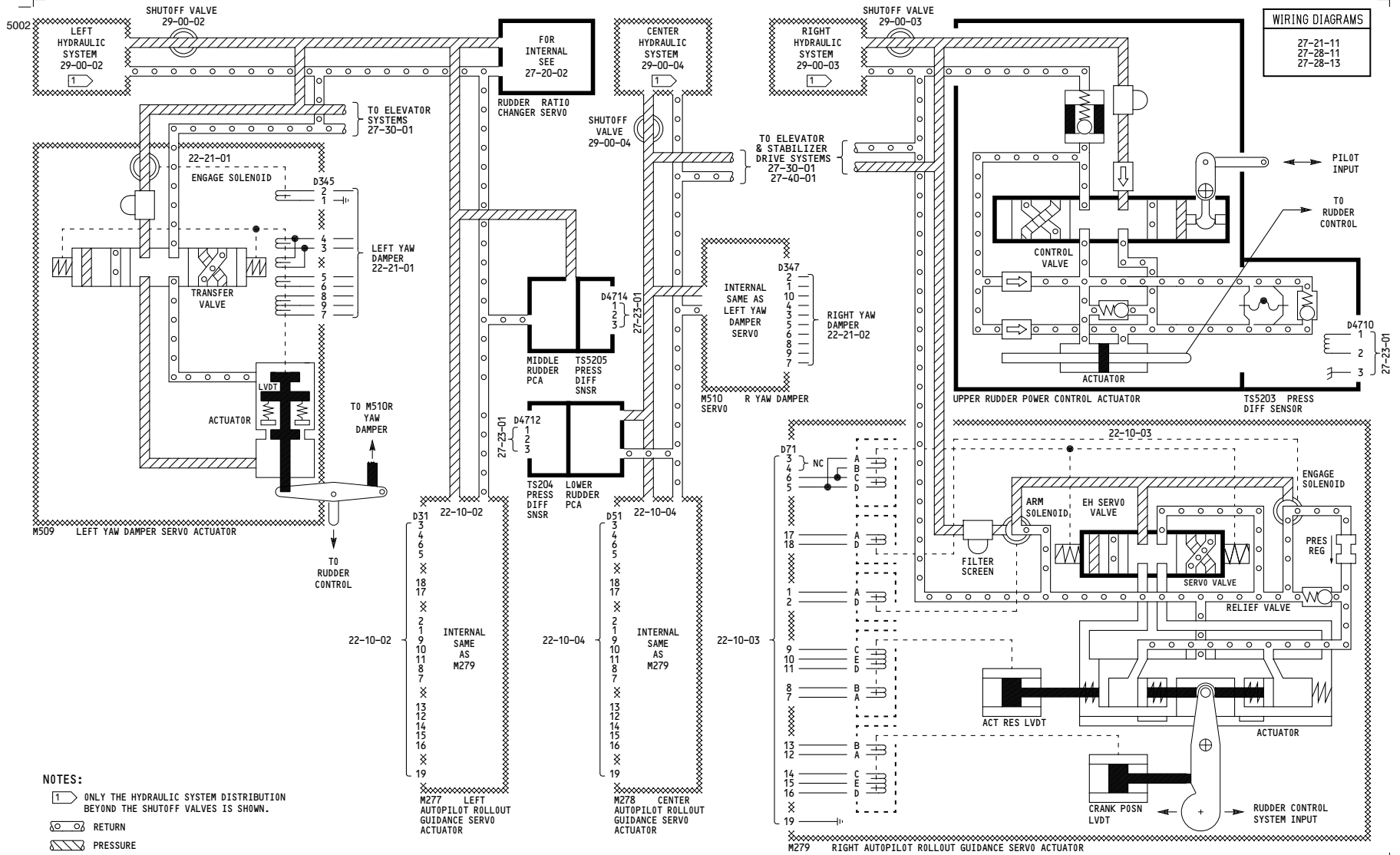

NOTES:

- 1 ONLY THE HYDRAULIC SYSTEM DISTRIBUTION BEYOND THE SHUTOFF VALVES IS SHOWN.
- RETURN
- ▨ PRESSURE

| | |
|-----|------------------------------|
| ALL | RUDDER CONTROL SYSTEM |
| | D280N032S |

27-20-01

THIS PAGE INTENTIONALLY LEFT BLANK

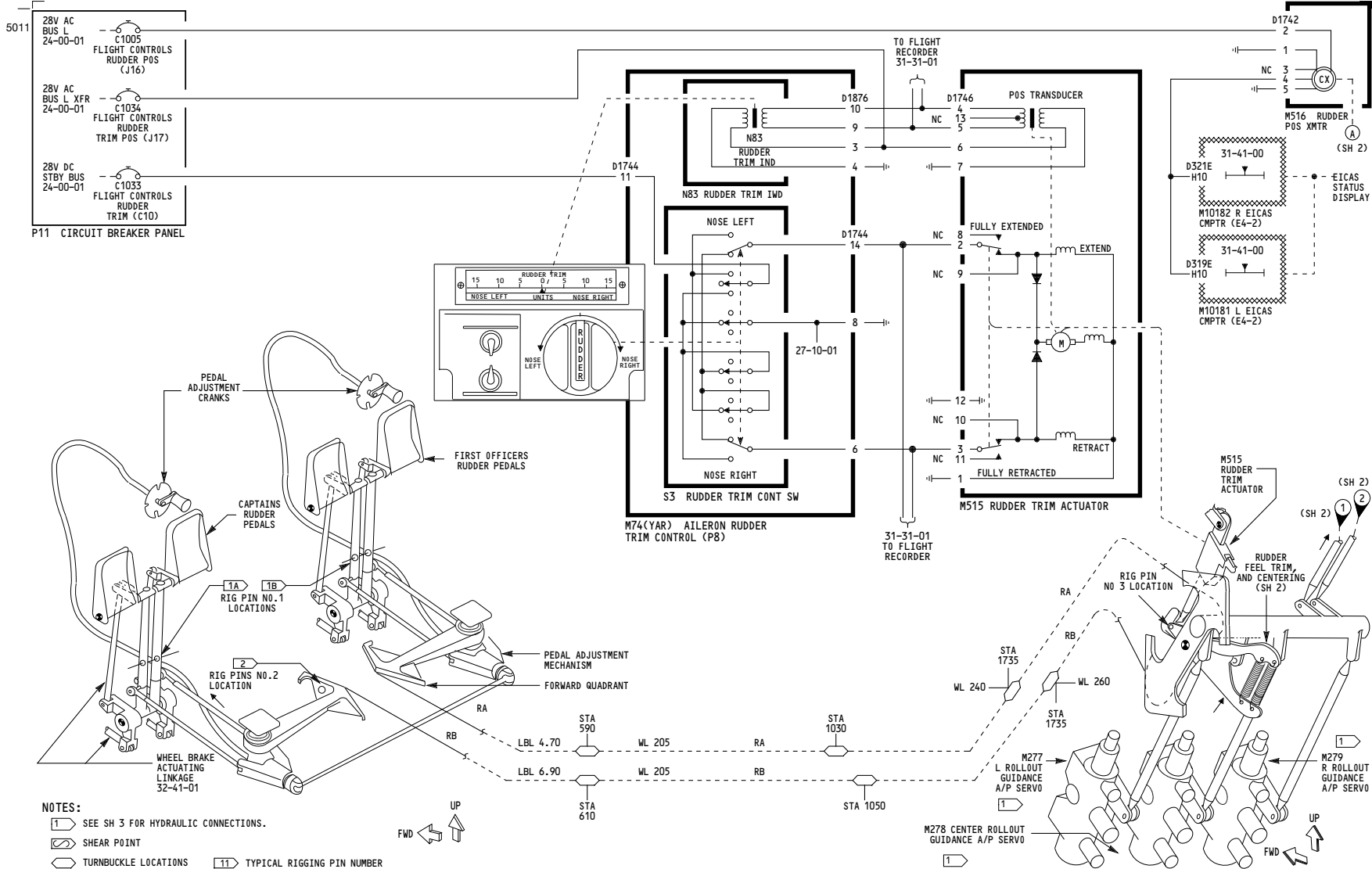

NOTES:

- 1 SEE SH 3 FOR HYDRAULIC CONNECTIONS.
- 2 SHEAR POINT
- 3 TURNBUCKLE LOCATIONS
- 4 TYPICAL RIGGING PIN NUMBER

| | |
|----------------|--|
| <p>010-011</p> | <p>RUDDER CONTROL SYSTEM</p> <p>D280N032S</p> |
|----------------|--|

Incorporates
31-0094

27-20-01

5001

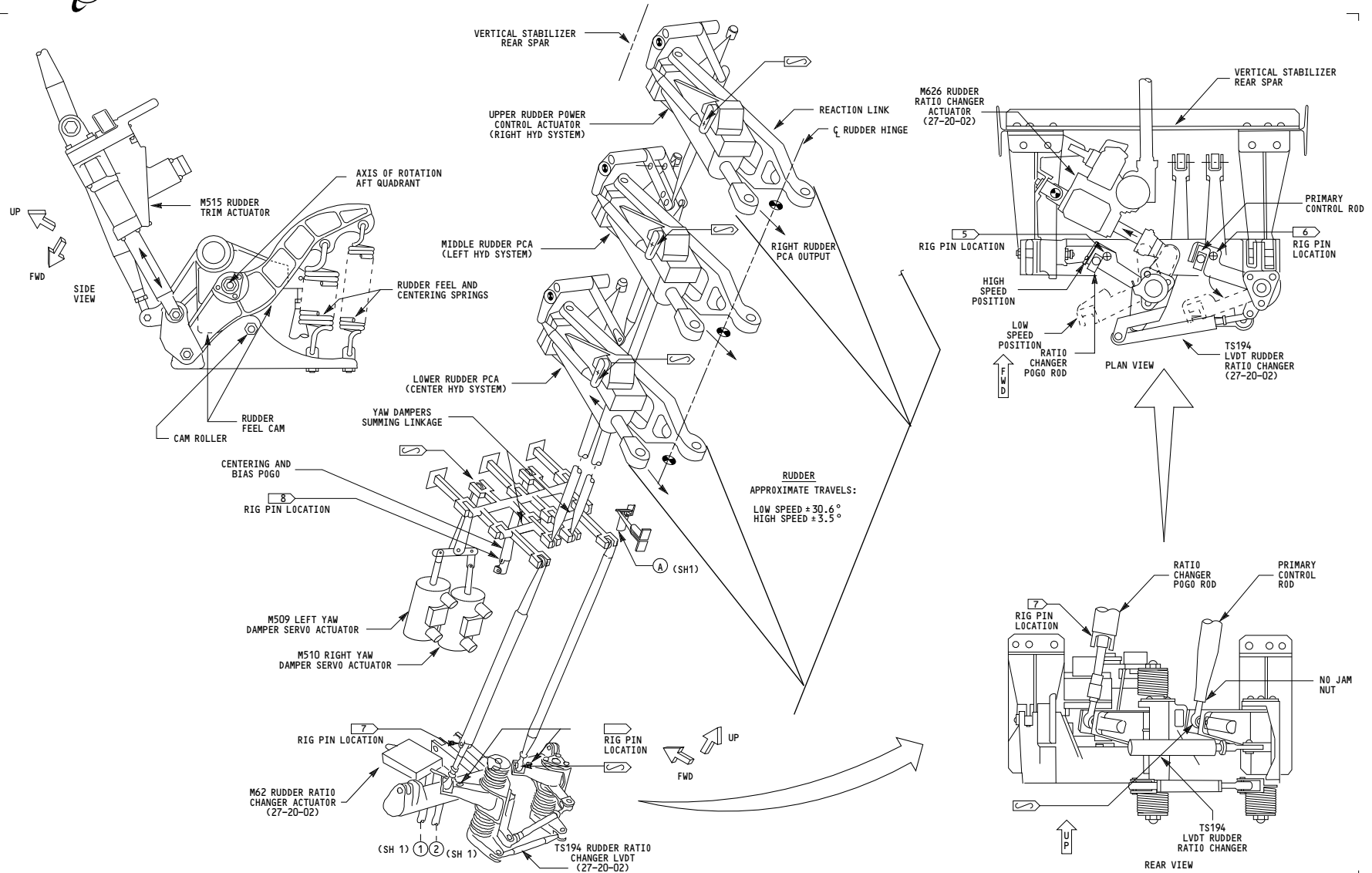

| | |
|---------|--|
| 010-011 | <p align="center">RUDDER CONTROL SYSTEM</p> <p align="center">D280N032S</p> |
|---------|--|

27-20-01

Page 101.1
Sheet 2
Jan 21/2005

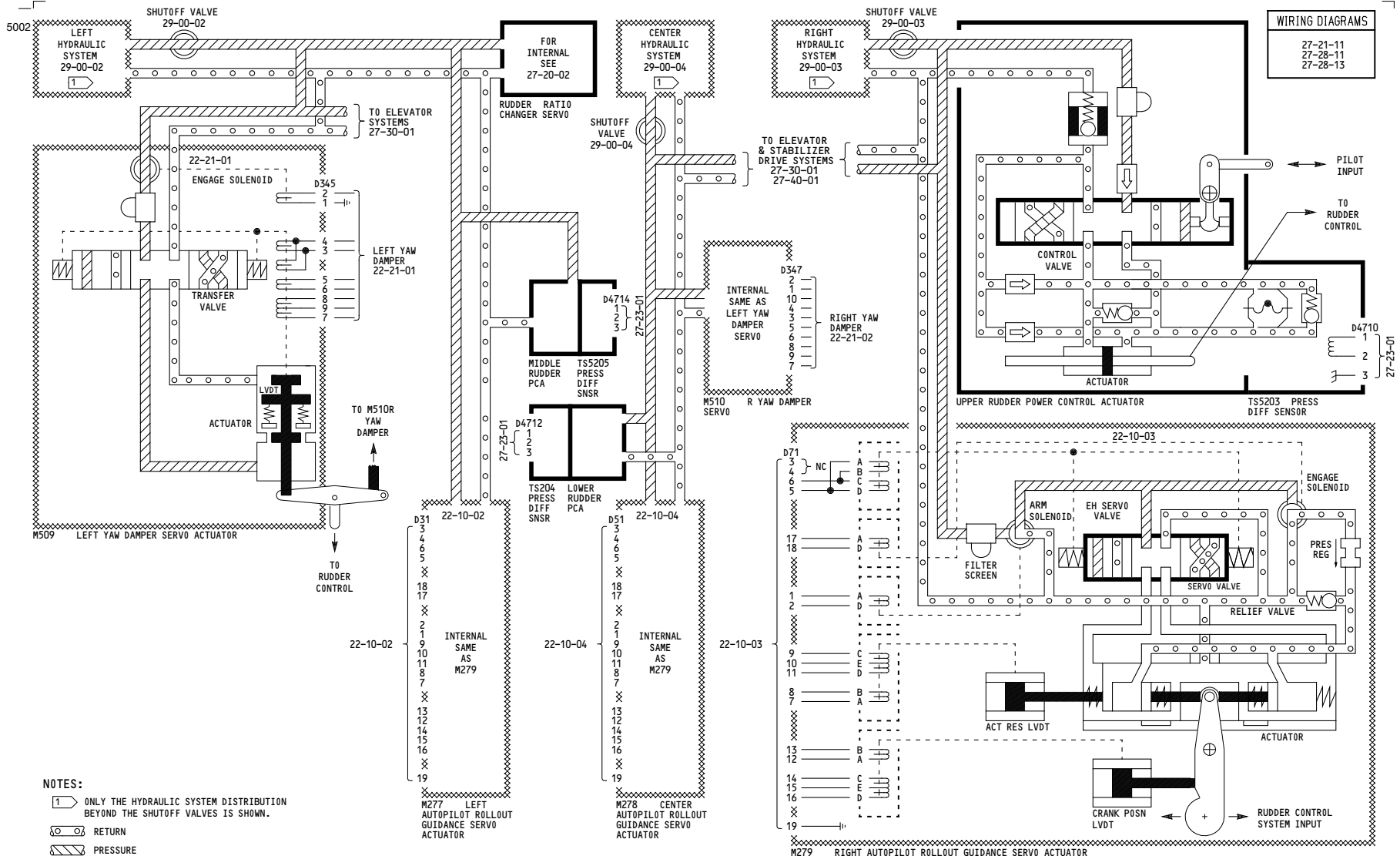

NOTES:
 1 ONLY THE HYDRAULIC SYSTEM DISTRIBUTION BEYOND THE SHUTOFF VALVES IS SHOWN.
 RETURN
 PRESSURE

| | |
|-----------|------------------------------|
| 010-011 | RUDDER CONTROL SYSTEM |
| D280N032S | |

27-20-01

THIS PAGE INTENTIONALLY LEFT BLANK

-A
5011

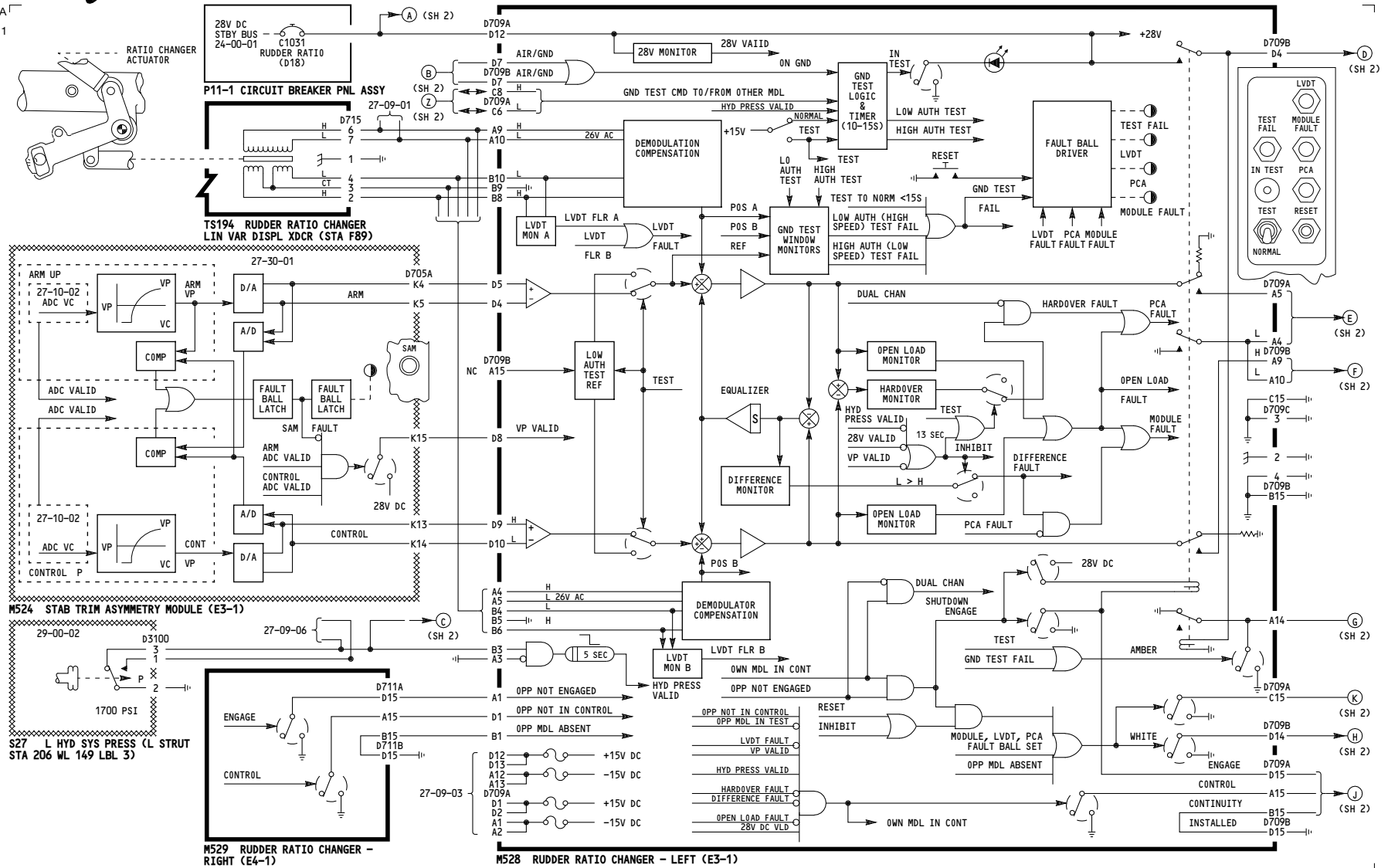

ALL

RUDDER RATIO CHANGER

D280N032S

27-20-02

Page 101
Sheet 1
May 06/2009

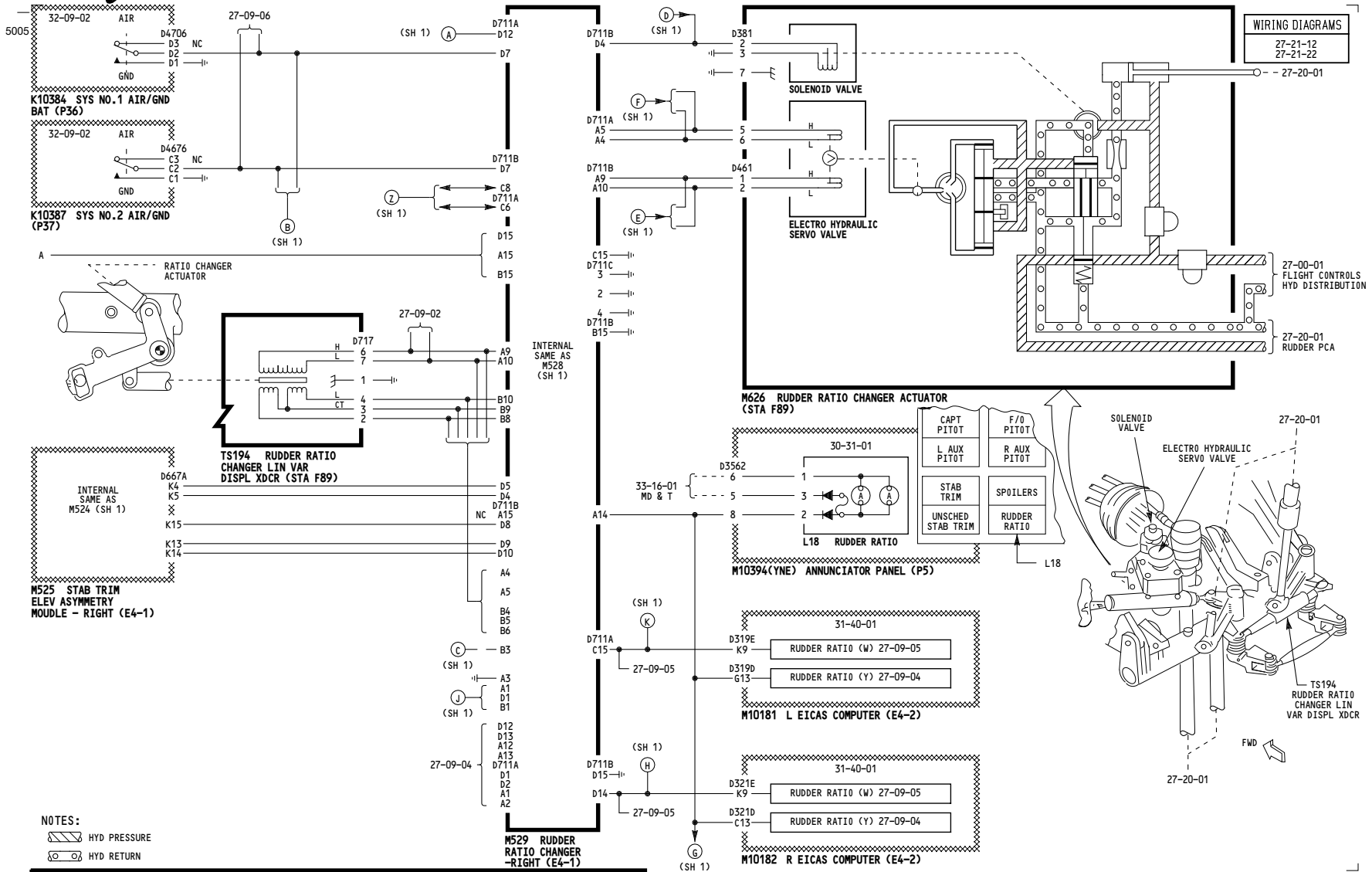

WIRING DIAGRAMS
27-21-12
27-21-22

27-00-01
FLIGHT CONTROLS
HYD DISTRIBUTION

27-20-01
RUDDER PCA

NOTES:
 HYD PRESSURE
 HYD RETURN

| | |
|-----------|----------------------|
| ALL | RUDDER RATIO CHANGER |
| D280N032S | |

27-20-02

-A
5001

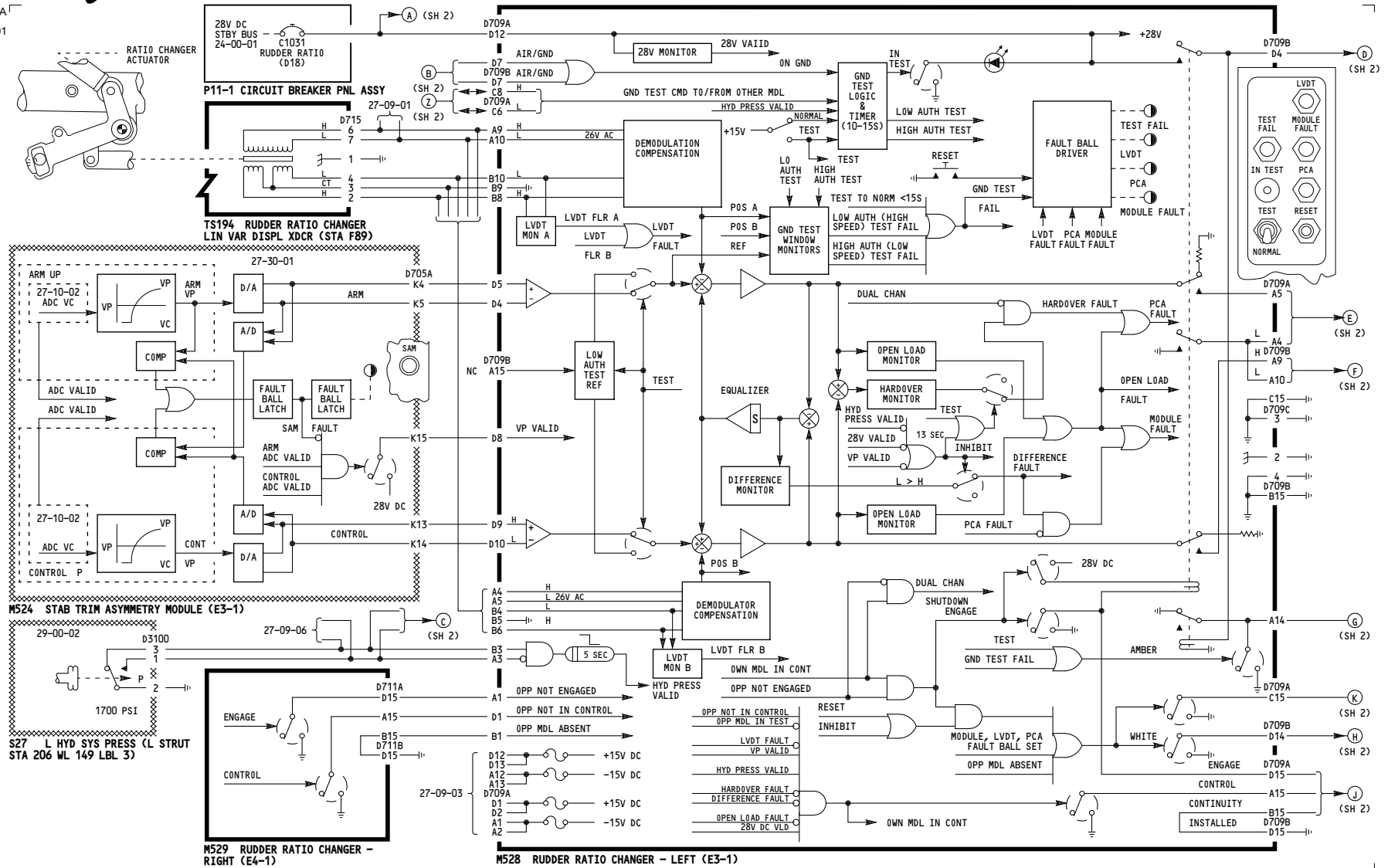

001-004

RUDDER RATIO CHANGER

D280N032S

Incorporates
27-0104

27-20-02

Page 101.1
Sheet 1
May 06/2009

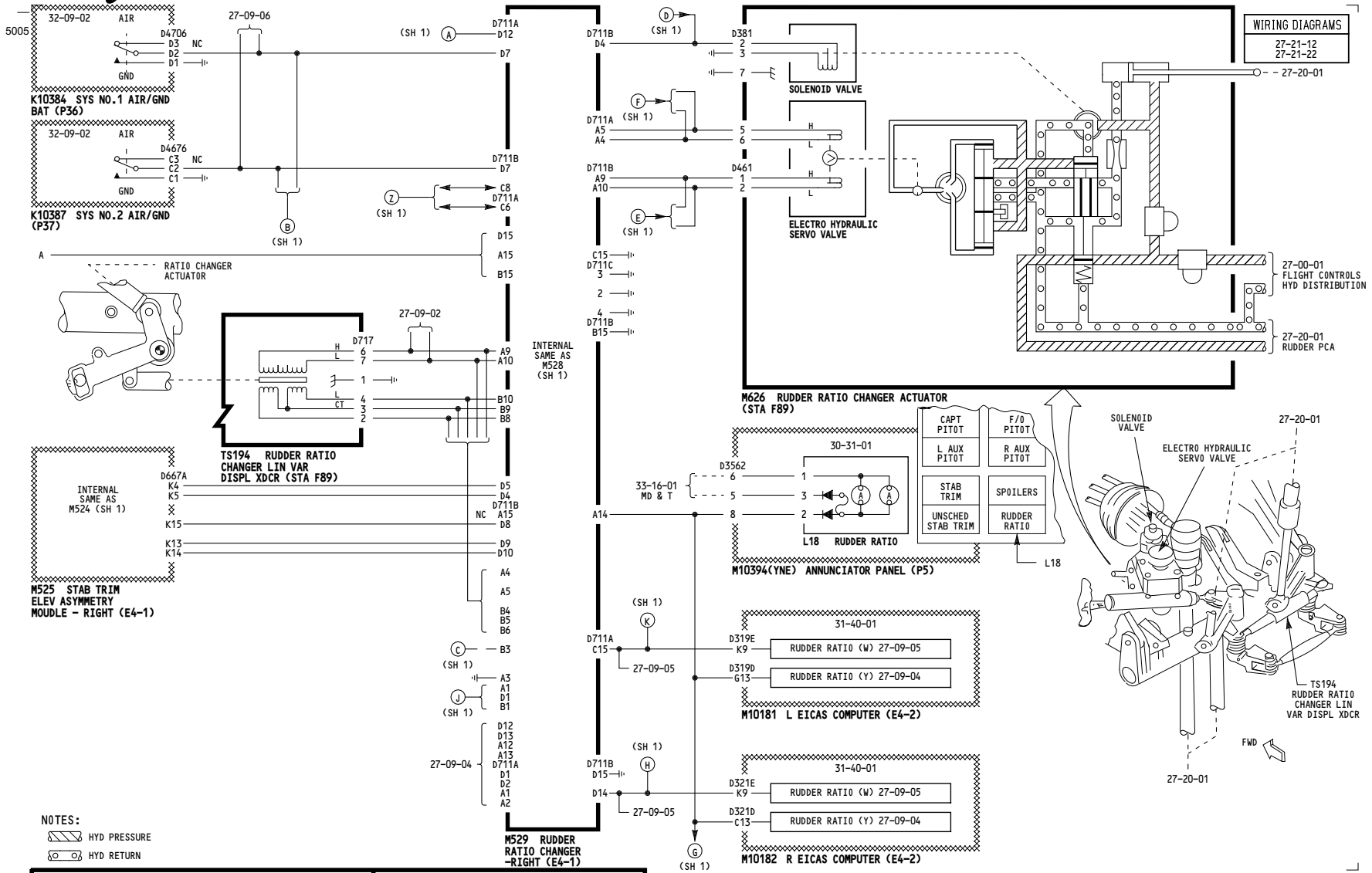

001-004

RUDDER RATIO CHANGER

D280N032S

27-20-02

WIRING DIAGRAMS
27-23-21

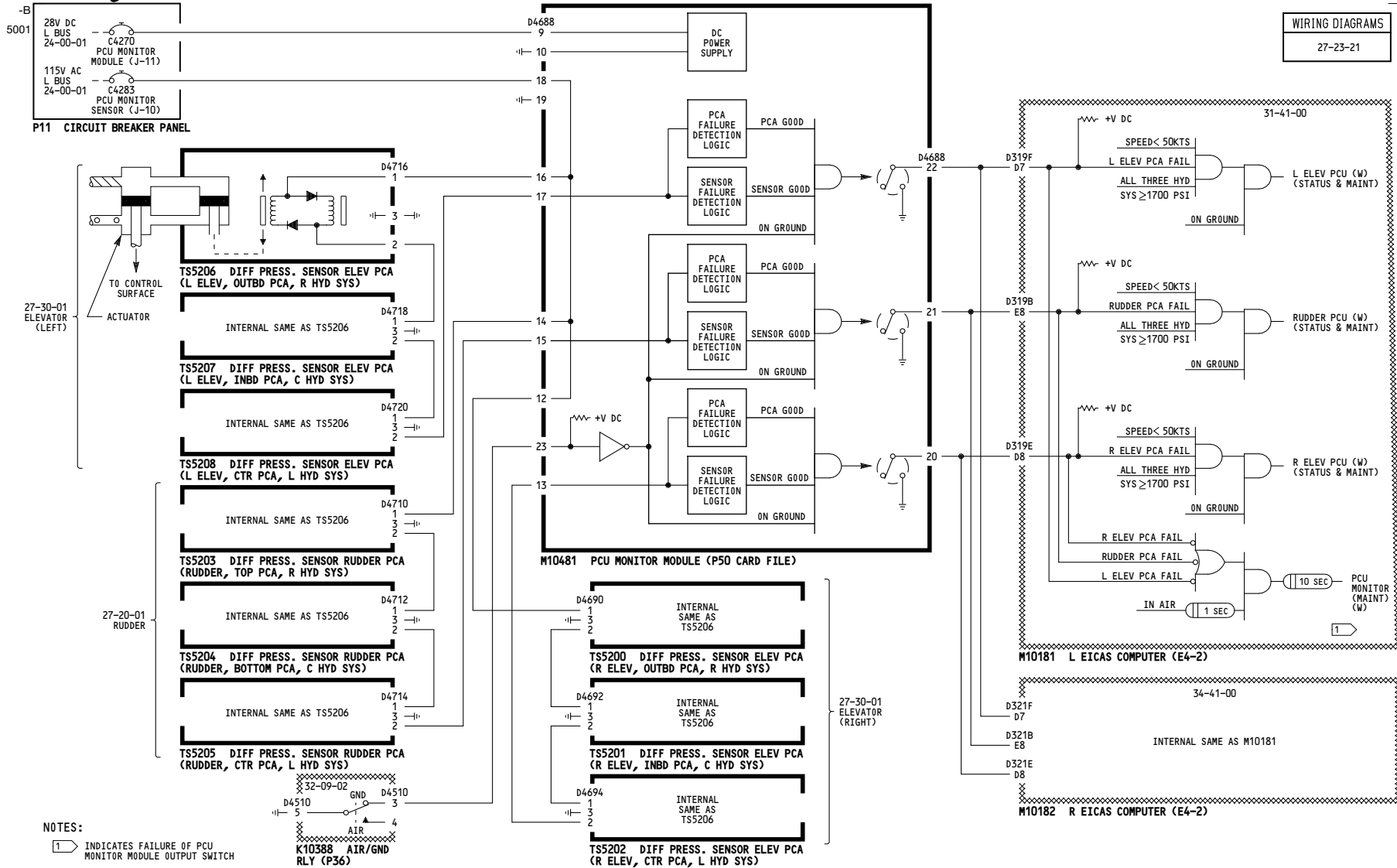

ALL

RUDDER/ELEVATOR PCU MONITOR SYSTEM

D280N032S

27-23-01

THIS PAGE INTENTIONALLY LEFT BLANK

-A
5001

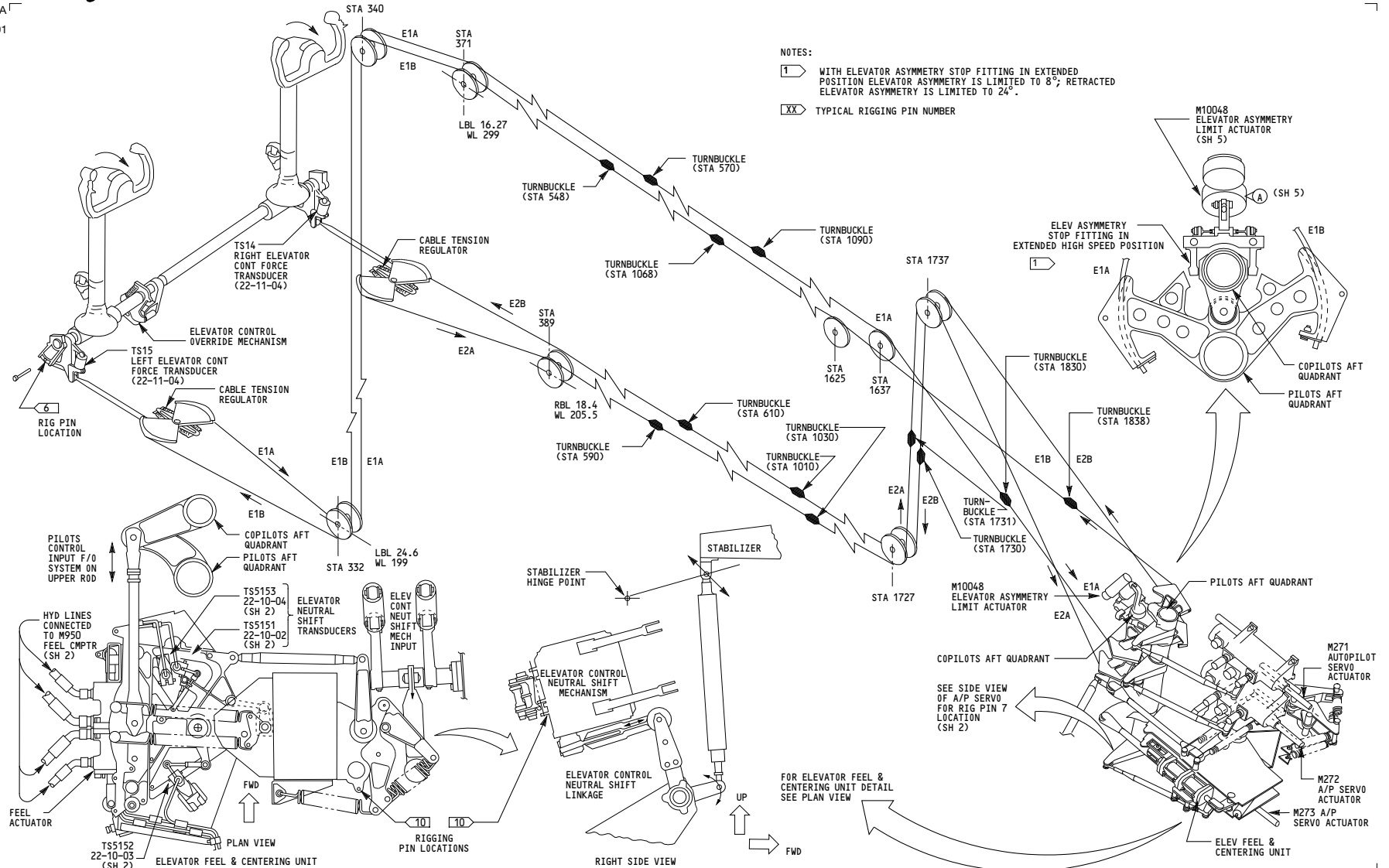

| | |
|-----------|----------|
| ALL | ELEVATOR |
| D280N032S | |

27-30-01

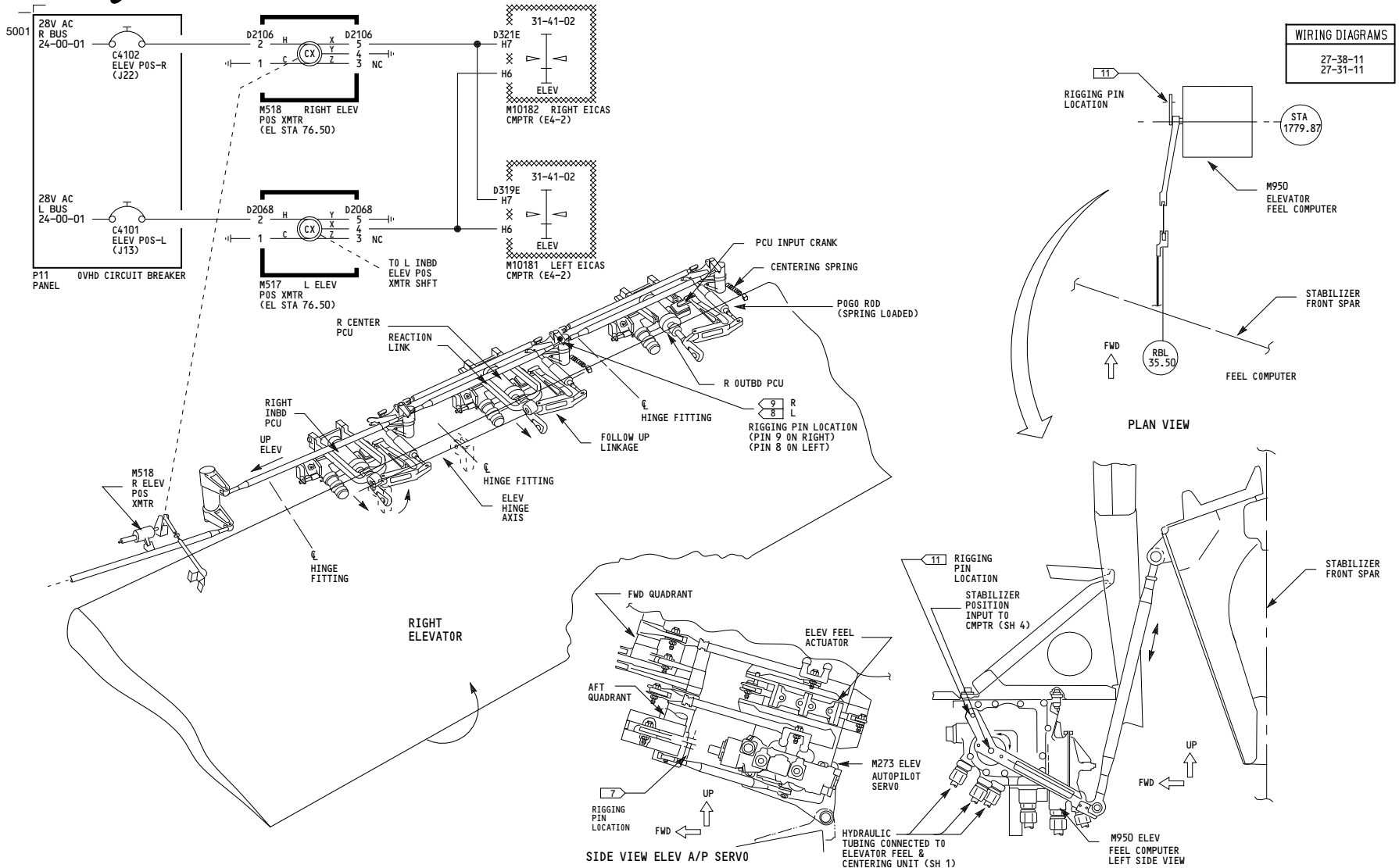

| | |
|-----|-----------------|
| ALL | ELEVATOR |
| | D280N032S |

27-30-01

-B-
5001

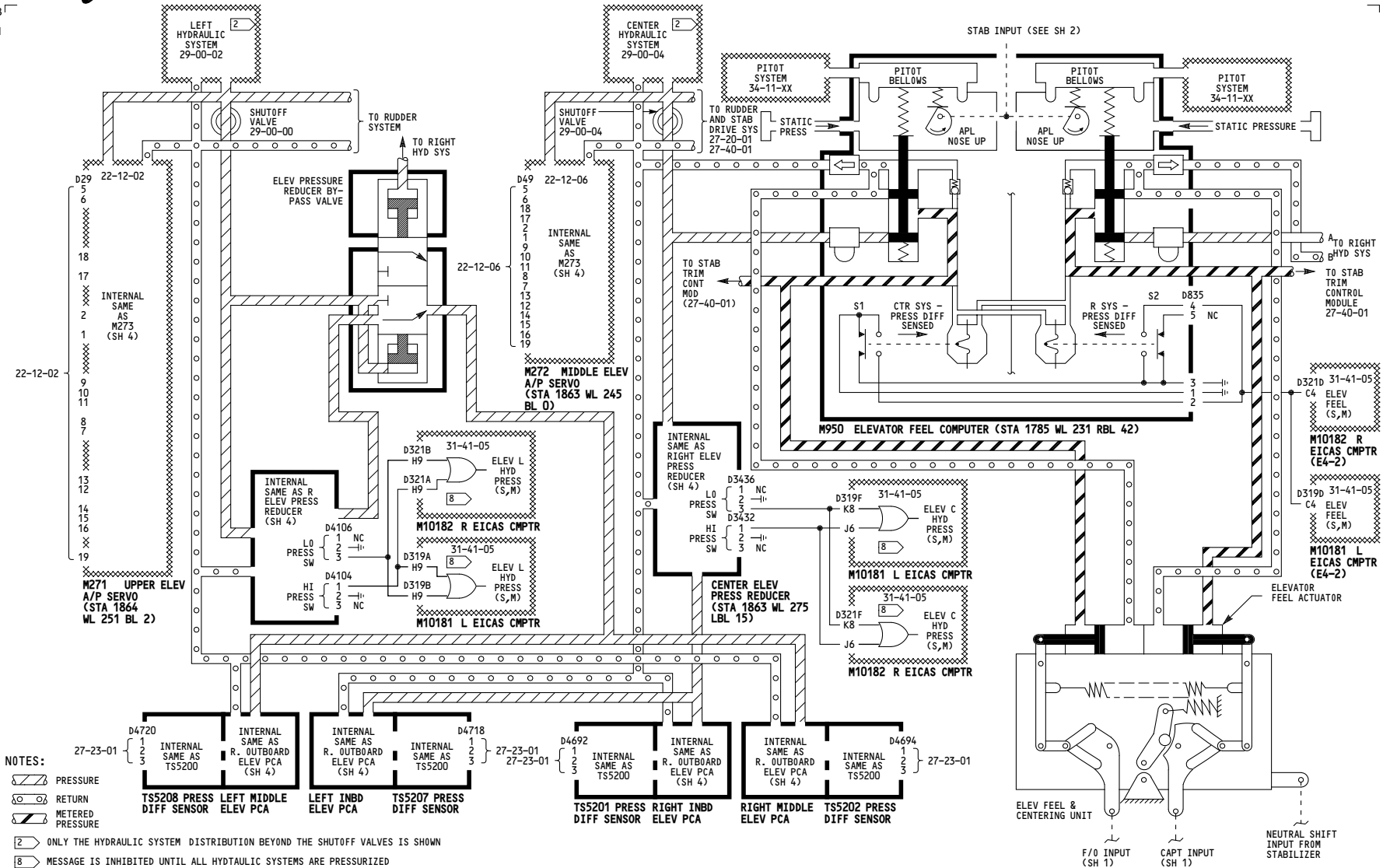

NOTES:

- PRESSURE
- RETURN
- METERED PRESSURE
- ONLY THE HYDRAULIC SYSTEM DISTRIBUTION BEYOND THE SHUTOFF VALVES IS SHOWN
- MESSAGE IS INHIBITED UNTIL ALL HYDRAULIC SYSTEMS ARE PRESSURIZED

| | |
|-----|-----------------|
| ALL | ELEVATOR |
| | D280N032S |

27-30-01

5001

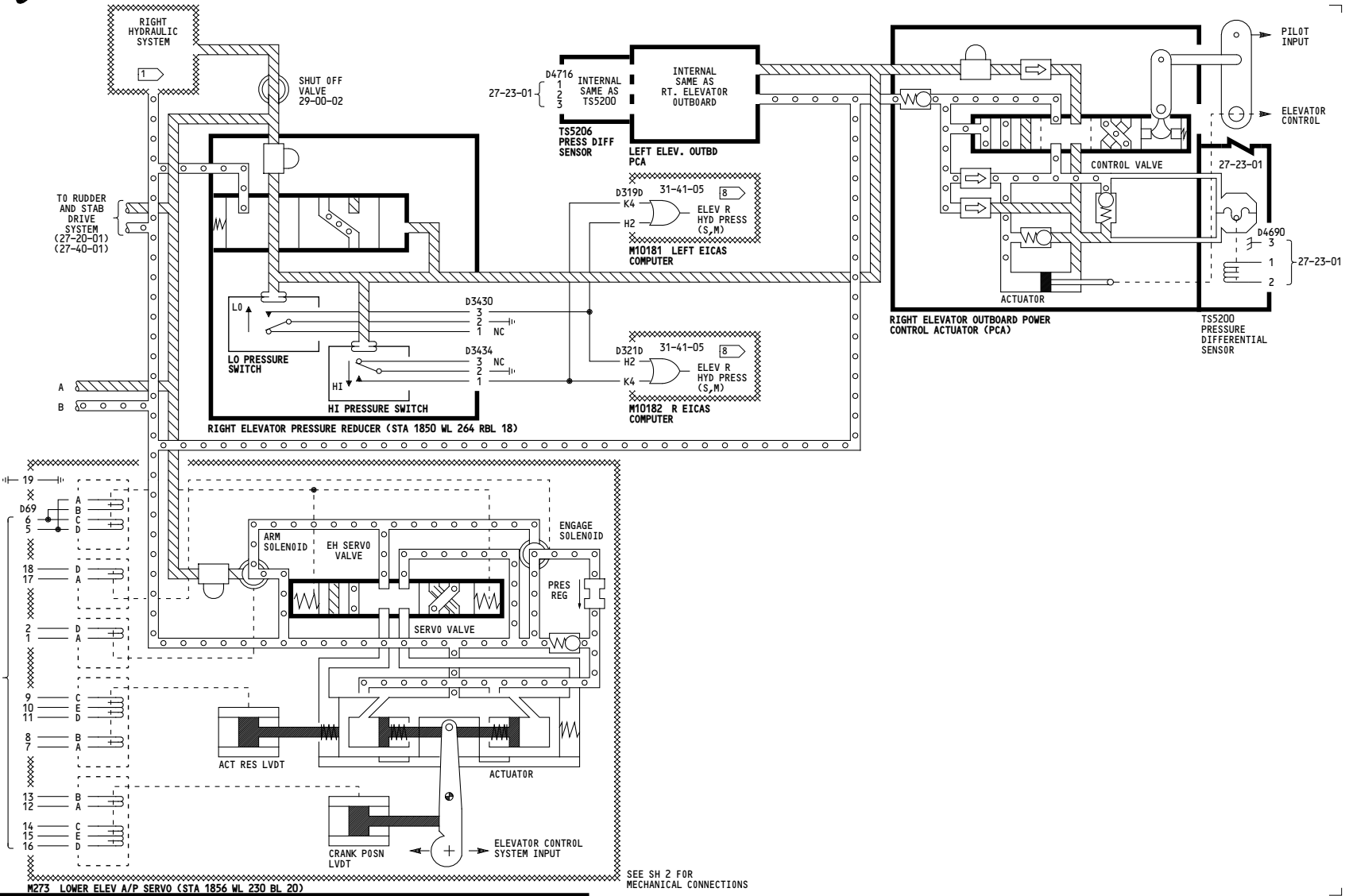

| | |
|-----|-----------------|
| ALL | ELEVATOR |
| | D280N032S |

27-30-01

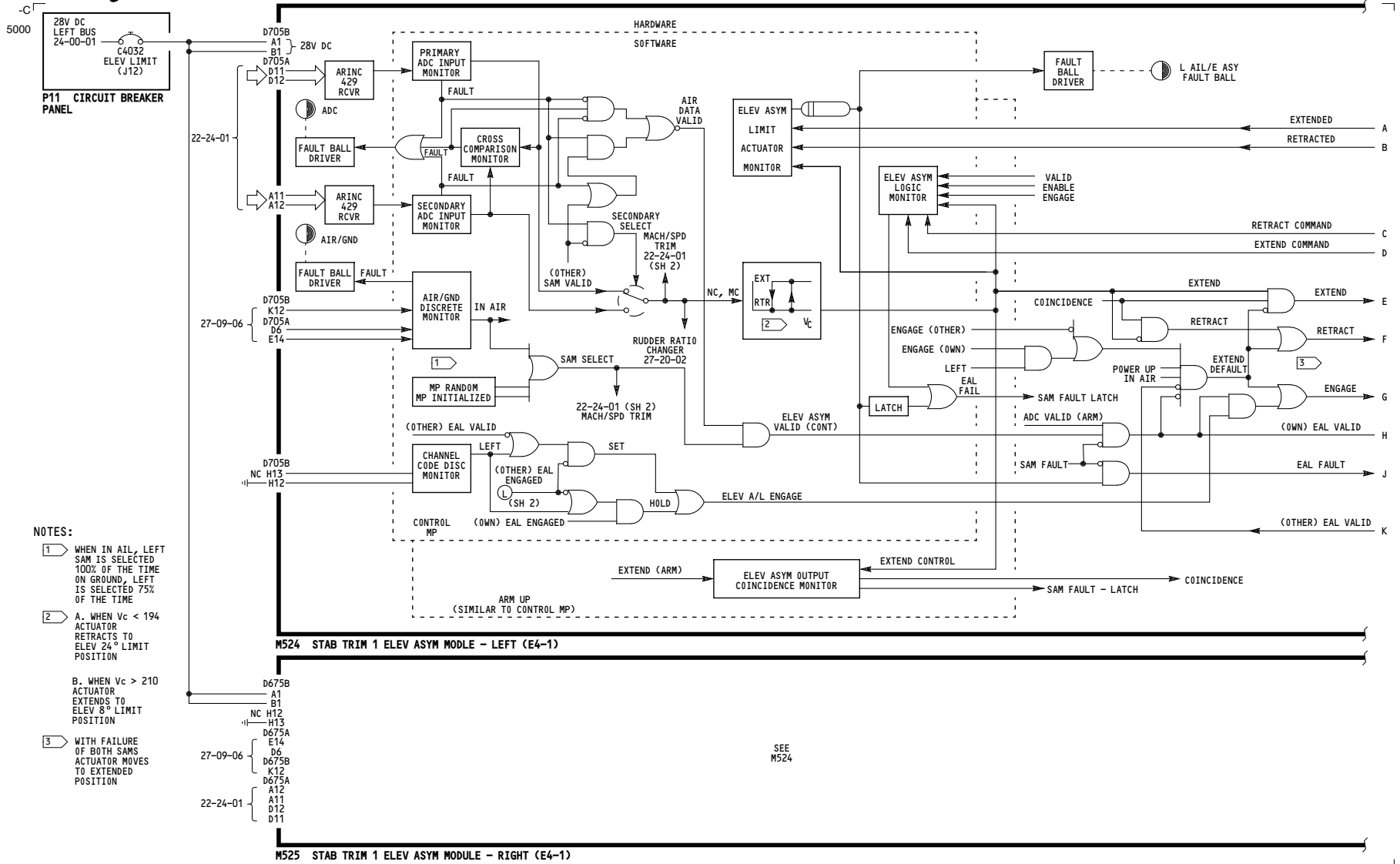

- NOTES:**
- 1 WHEN IN AIR, LEFT SAM IS SELECTED 100% OF THE TIME ON GROUND, LEFT IS SELECTED 75% OF THE TIME
 - 2 A. WHEN Vc < 194 ACTUATOR RETRACTS TO ELEV 24° LIMIT POSITION
B. WHEN Vc > 210 ACTUATOR EXTENDS TO ELEV 8° LIMIT POSITION
 - 3 WITH FAILURE OF BOTH SAMs ACTUATOR MOVES TO EXTENDED POSITION

| | |
|-----|-----------------|
| ALL | ELEVATOR |
| | D280N032S |

27-30-01

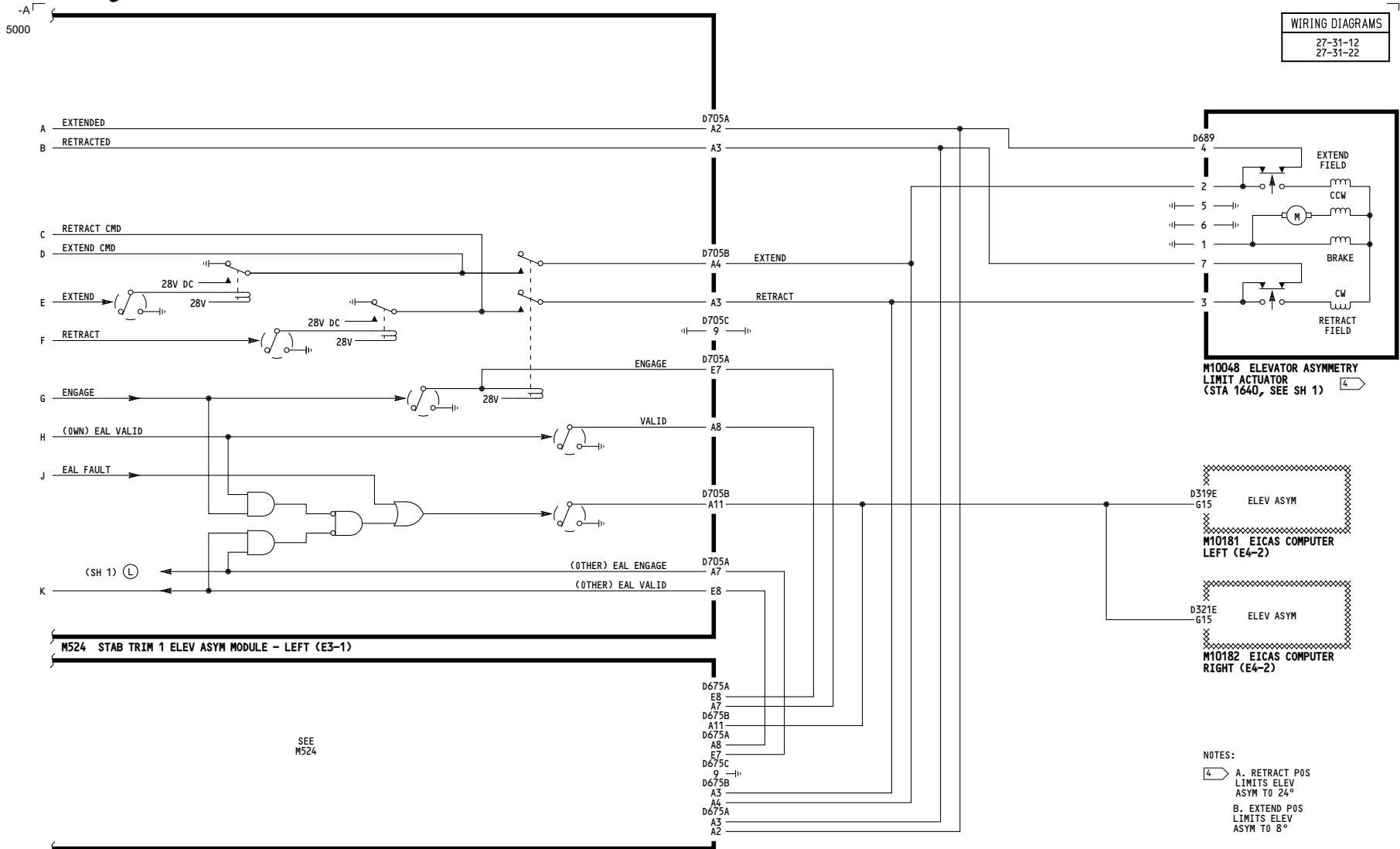

WIRING DIAGRAMS
27-31-12
27-31-22

M10048 ELEVATOR ASYMMETRY LIMIT ACTUATOR (STA 1640, SEE SH 1)

D319E G15 ELEV ASYM
M10181 EICAS COMPUTER LEFT (E4-2)

D321E G15 ELEV ASYM
M10182 EICAS COMPUTER RIGHT (E4-2)

NOTES:
4 A. RETRACT POS LIMITS ELEV ASYM TO 24°
B. EXTEND POS LIMITS ELEV ASYM TO 8°

| | |
|-----|-----------------|
| ALL | ELEVATOR |
| | D280N032S |

27-30-01

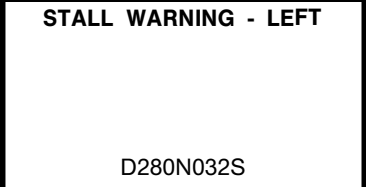
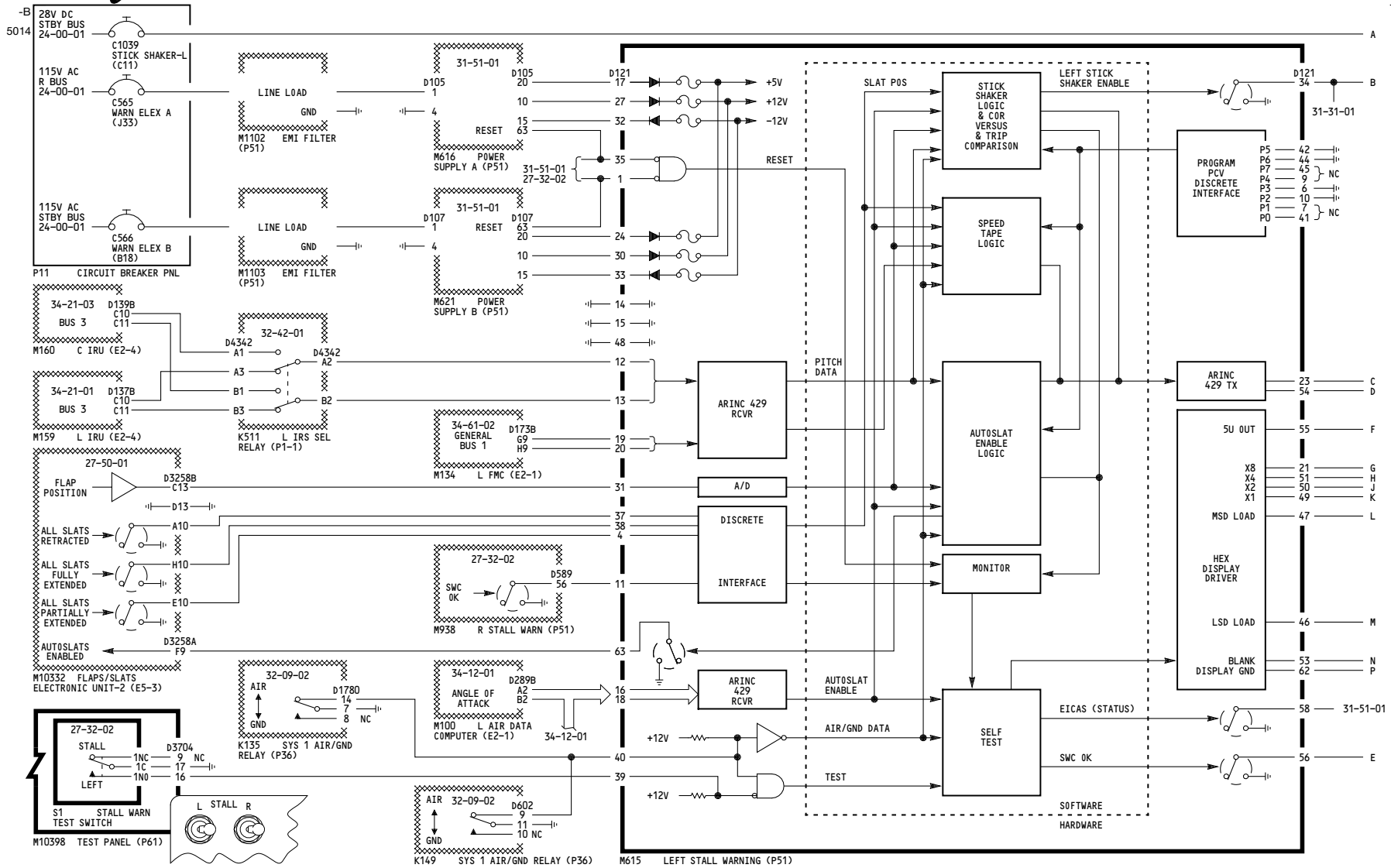

D280N032S

27-32-01

5011

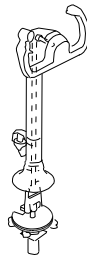
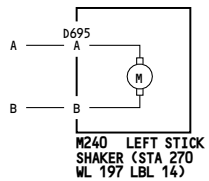

| | PROGRAM PIN CODE P7-P4 (AIRFRAME IDENTIFICATION) | | | | PROGRAM PIN CODE P3-P2 SPEED TAPE PARAMETER CALC | | | PROGRAM PIN CODE P1-P0 (OPTIONAL FEATURES) | | | CONFIG CODE MSD HEX DISPLAY (WEU BITE MODULE) | OPTIONAL CODE LSD HEX DISPLAY (WEU BITE MODULE) |
|---------|--|-----|-----|------|--|-----|-----|--|------|------|---|---|
| | P7 | P6 | P5 | P4 | P3 | P2 | P1 | P0 | | | | |
| 757-200 | OPEN | GND | GND | OPEN | ACTIVATED | GND | GND | NONE | OPEN | OPEN | 4 | 3 |
| | | | | | | | | | | | | |
| | | | | | | | | | | | | |

WIRING DIAGRAMS
27-32-11
27-32-12

NOTE: IN THE ABSENCE OF BOARD FAULTS OR INTERFACE ANOMALIES, THE AIRFRAME CONFIGURATION CODE AND OPTION CODE WILL BE DISPLAYED ON THE HEX DISPLAY OF THE WEU BITE MODULE.

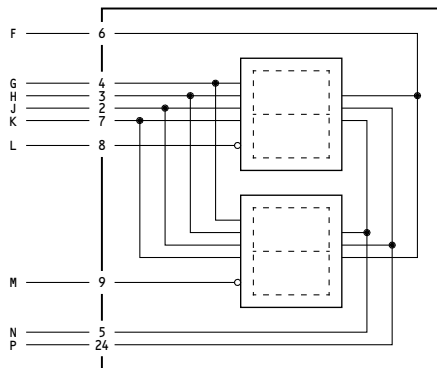
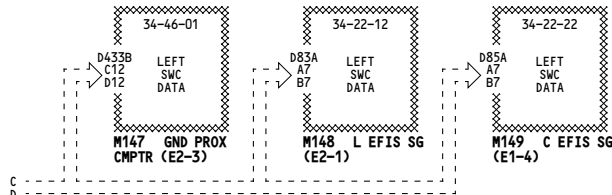

M1411 WEU BITE MODULE

27-32-02

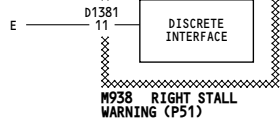

M938 RIGHT STALL WARNING (P51)

| STALL WARNING BOARD FAULT CODES (DISPLAYED ON WEU BITE MODULE) | | | | | INTERFACE ANOMALY CODES (DISPLAYED ON WEU BITE MODULE) | | |
|---|---------------------|--------------------------|----------------------|----------|---|-----------------------------|--------------------------|
| MULTIPLE FAULTS | SLATS RETRACTED | SLATS PARTIALLY EXTENDED | SLATS FULLY EXTENDED | NOT USED | INOP STICK SHAKER | INVALID ADC INPUT | INVALID FLAPS POSITION |
| A0 | A1 | A2 | A3 | A4 | D0 | D1 | D2 |
| NOT USED | NOT USED | NOT USED | TEST | AIR/GND | INVALID AIR/GND INPUT | MULTIPLE LEADING EDGE SLATS | NO LEADING EDGE SLATS |
| A5 | A6 | A7 | A9 | B0 | D3 | D4 | D5 |
| GEAR DOWN | OPPOSITE CHANNEL OK | NOT USED | ARINC INPUT | A/D | INVALID IRS INPUT | INVALID FMC INPUT | AIR/GND ADA SSM CONFLICT |
| B1 | B2 | B5 | B6 | C0 | D6 | D7 | D8 |
| STICK SHAKER | AUTOSLATS | EICAS STATUS | CHANNEL OK | NOT USED | OPPOSITE SWC FAULT | INVALID CONFIG | |
| C1 | C3 | C4 | C5 | C6 | D9 | FX | |

ALL

STALL WARNING - LEFT

D280N032S

27-32-01

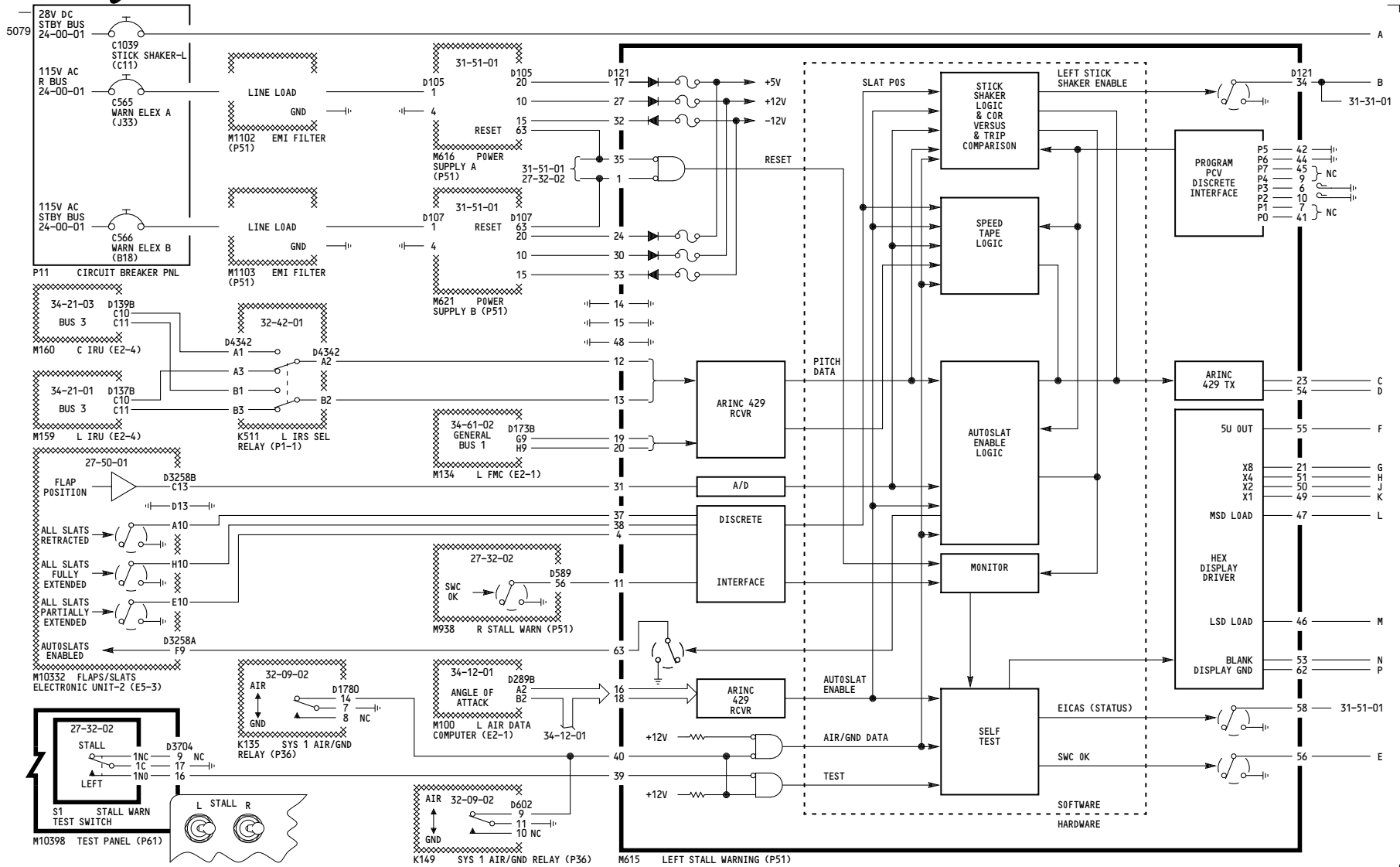

001

STALL WARNING - LEFT

- Incorporates
- ▶ 31-0180 R01
 - ▶ 34A0222

D280N032S

27-32-01

Page 101.1
Sheet 1
May 06/2009

5058

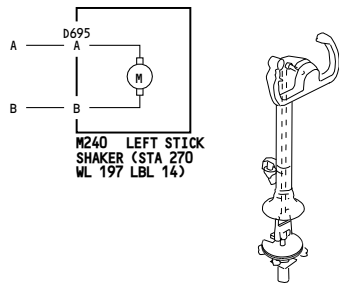

| | PROGRAM PIN CODE P7-P4 (AIRFRAME IDENTIFICATION) | | | | PROGRAM PIN CODE P3-P2 SPEED TAPE PARAMETER CALC | | | PROGRAM PIN CODE P1-P0 (OPTIONAL FEATURES) | | | CONFIG CODE MSD HEX DISPLAY (WEU BITE MODULE) | OPTIONAL CODE LSD HEX DISPLAY (WEU BITE MODULE) |
|---------|--|-----|-----|------|--|------|------|--|------|------|---|---|
| | P7 | P6 | P5 | P4 | P3 | P2 | P1 | P0 | | | | |
| 757-200 | OPEN | GND | GND | OPEN | NOT ACTIVATED | OPEN | OPEN | NONE | OPEN | OPEN | 4 | 3 |
| | | | | | | | | | | | | |
| | | | | | | | | | | | | |

WIRING DIAGRAMS
27-32-11
27-32-12

NOTE: IN THE ABSENCE OF BOARD FAULTS OR INTERFACE ANOMALIES, THE AIRFRAME CONFIGURATION CODE AND OPTION CODE WILL BE DISPLAYED ON THE HEX DISPLAY OF THE WEU BITE MODULE.

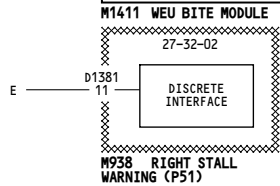
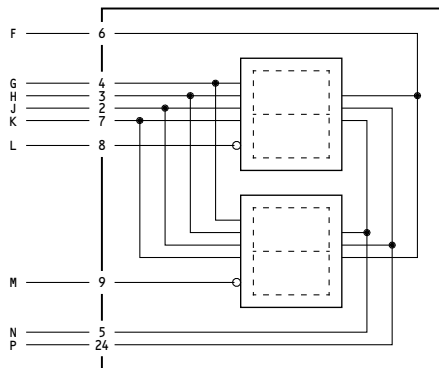
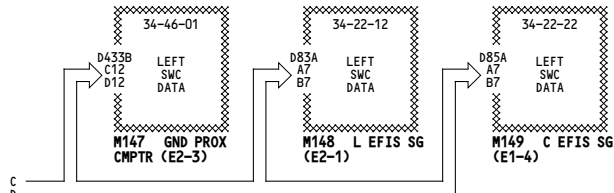

| STALL WARNING BOARD FAULT CODES (DISPLAYED ON WEU BITE MODULE) | | | | | INTERFACE ANOMALY CODES (DISPLAYED ON WEU BITE MODULE) | | |
|---|---------------------------|--------------------------------|----------------------------|----------------|---|-----------------------------------|--------------------------------|
| MULTIPLE FAULTS A0 | SLATS RETRACTED A1 | SLATS PARTIALLY EXTENDED A2 | SLATS FULLY EXTENDED A3 | NOT USED A4 | INOP STICK SHAKER D0 | INVALID ADC INPUT D1 | INVALID FLAPS POSITION D2 |
| NOT USED A5 | NOT USED A6 | NOT USED A7 | TEST A9 | AIR/GND B0 | INVALID AIR/GND INPUT D3 | MULTIPLE LEADING EDGE SLATS D4 | NO LEADING EDGE SLATS D5 |
| GEAR DOWN B1 | OPPOSITE CHANNEL OK B2 | NOT USED B5 | ARINC INPUT B6 | A/D C0 | INVALID IRS INPUT D6 | INVALID FMC INPUT D7 | AIR/GND ADA SSM CONFLICT D8 |
| STICK SHAKER C1 | AUTOSLATS C3 | EICAS STATUS C4 | CHANNEL OK C5 | NOT USED C6 | OPPOSITE SMC FAULT D9 | INVALID CONFIG FX | |

001

STALL WARNING - LEFT

Incorporates
31-0180 R01

D280N032S

27-32-01

Page 101.1
Sheet 2
May 06/2009

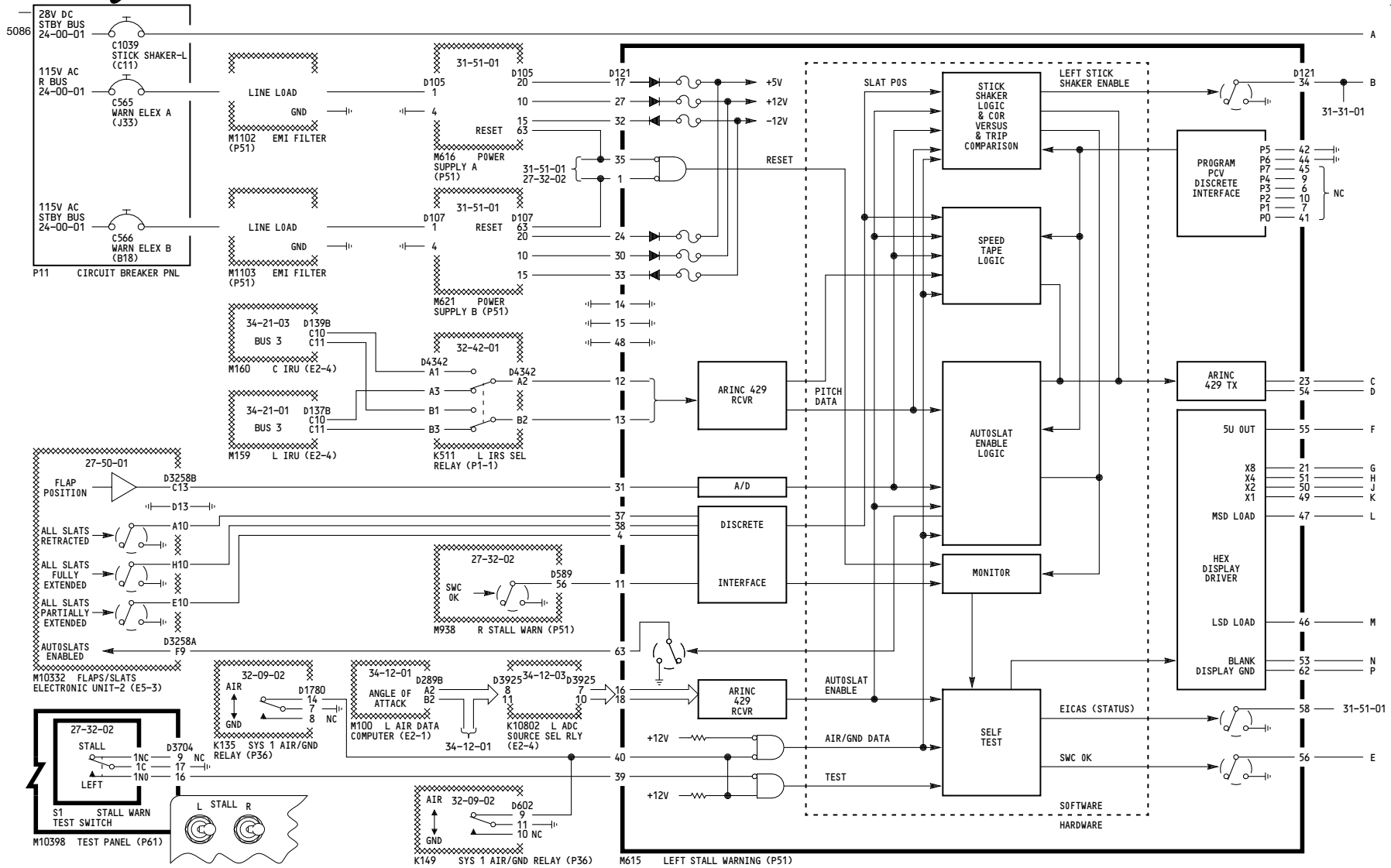

002-011

STALL WARNING - LEFT

Incorporates
34A0222

27-32-01

D280N032S

5011

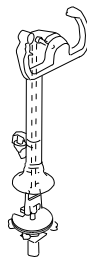
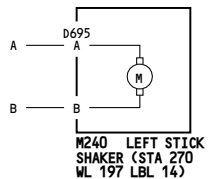

| | PROGRAM PIN CODE P7-P4 (AIRFRAME IDENTIFICATION) | | | | PROGRAM PIN CODE P3-P2 SPEED TAPE PARAMETER CALC | | | PROGRAM PIN CODE P1-P0 (OPTIONAL FEATURES) | | | CONFIG CODE MSD HEX DISPLAY (WEU BITE MODULE) | OPTIONAL CODE LSD HEX DISPLAY (WEU BITE MODULE) |
|---------|--|-----|-----|------|--|-----|-----|--|------|------|---|---|
| | P7 | P6 | P5 | P4 | P3 | P2 | P1 | P0 | | | | |
| 757-200 | OPEN | GND | GND | OPEN | ACTIVATED | GND | GND | NONE | OPEN | OPEN | 4 | 3 |
| | | | | | | | | | | | | |
| | | | | | | | | | | | | |

WIRING DIAGRAMS
27-32-11
27-32-12

NOTE: IN THE ABSENCE OF BOARD FAULTS OR INTERFACE ANOMALIES, THE AIRFRAME CONFIGURATION CODE AND OPTION CODE WILL BE DISPLAYED ON THE HEX DISPLAY OF THE WEU BITE MODULE.

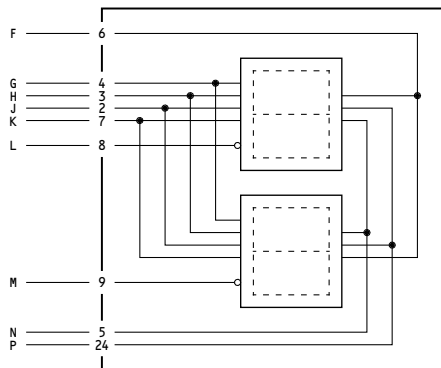
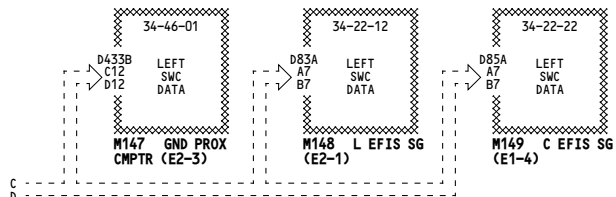

M1411 WEU BITE MODULE

27-32-02



M938 RIGHT STALL WARNING (P51)

| STALL WARNING BOARD FAULT CODES (DISPLAYED ON WEU BITE MODULE) | | | | | INTERFACE ANOMALY CODES (DISPLAYED ON WEU BITE MODULE) | | |
|---|---------------------------|--------------------------------|----------------------------|----------------|---|-----------------------------------|--------------------------------|
| MULTIPLE FAULTS A0 | SLATS RETRACTED A1 | SLATS PARTIALLY EXTENDED A2 | SLATS FULLY EXTENDED A3 | NOT USED A4 | INOP STICK SHAKER D0 | INVALID ADC INPUT D1 | INVALID FLAPS POSITION D2 |
| NOT USED A5 | NOT USED A6 | NOT USED A7 | TEST A9 | AIR/GND B0 | INVALID AIR/GND INPUT D3 | MULTIPLE LEADING EDGE SLATS D4 | NO LEADING EDGE SLATS D5 |
| GEAR DOWN B1 | OPPOSITE CHANNEL OK B2 | NOT USED B5 | ARINC INPUT B6 | A/D C0 | INVALID IRS INPUT D6 | INVALID FMC INPUT D7 | AIR/GND ADA SSM CONFLICT D8 |
| STICK SHAKER C1 | AUTOSLATS C3 | EICAS STATUS C4 | CHANNEL OK C5 | NOT USED C6 | OPPOSITE SMC FAULT D9 | INVALID CONFIG FX | |

002-011

STALL WARNING - LEFT

D280N032S

27-32-01

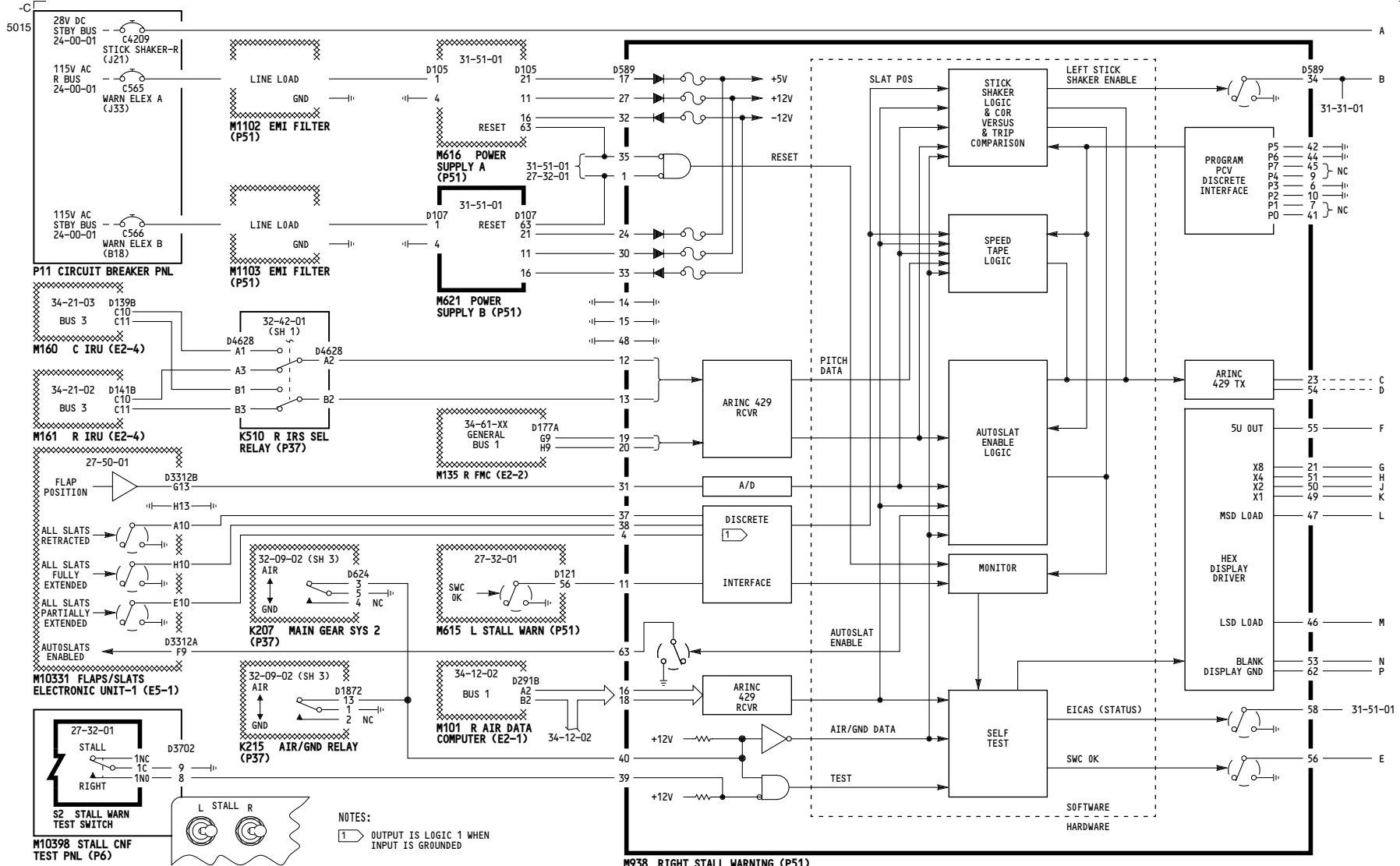

ALL

STALL WARNING - RIGHT

D280N032S

27-32-02

5011

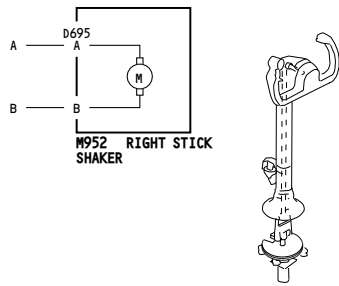

| | PROGRAM PIN CODE P7-P4 (AIRFRAME IDENTIFICATION) | | | | PROGRAM PIN CODE P3-P2 SPEED TAPE PARAMETER CALC | | | PROGRAM PIN CODE P1-P0 (OPTIONAL FEATURES) | | | CONFIG CODE MSD HEX DISPLAY (WEU BITE MODULE) | OPTIONAL CODE LSD HEX DISPLAY (WEU BITE MODULE) |
|---------|--|-----|-----|------|--|-----|-----|--|------|------|---|---|
| | P7 | P6 | P5 | P4 | P3 | P2 | P1 | P0 | | | | |
| 757-200 | OPEN | GND | GND | OPEN | ACTIVATED | GND | GND | NONE | OPEN | OPEN | 4 | 3 |
| | | | | | | | | | | | | |
| | | | | | | | | | | | | |

WIRING DIAGRAMS
27-32-21
27-32-22

NOTE: IN THE ABSENCE OF BOARD FAULTS OR INTERFACE ANOMALIES, THE AIRFRAME CONFIGURATION CODE AND OPTION CODE WILL BE DISPLAYED ON THE HEX DISPLAY OF THE WEU BITE MODULE.

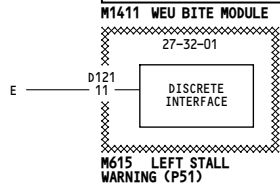
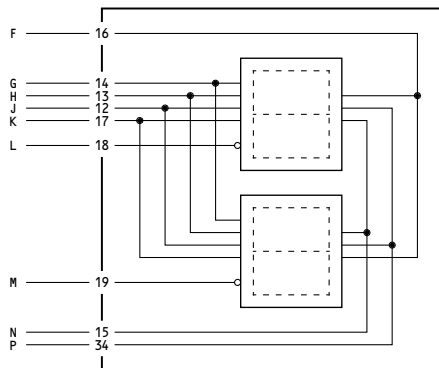
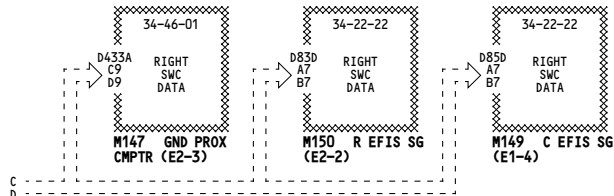

| STALL WARNING BOARD FAULT CODES (DISPLAYED ON WEU BITE MODULE) | | | | | INTERFACE ANOMALY CODES (DISPLAYED ON WEU BITE MODULE) | | |
|---|---------------------------|--------------------------------|----------------------------|----------------|---|-----------------------------------|--------------------------------|
| MULTIPLE FAULTS A0 | SLATS RETRACTED A1 | SLATS PARTIALLY EXTENDED A2 | SLATS FULLY EXTENDED A3 | NOT USED A4 | INOP STICK SHAKER D0 | INVALID ADC INPUT D1 | INVALID FLAPS POSITION D2 |
| NOT USED A5 | NOT USED A6 | NOT USED A7 | TEST A9 | AIR/GND B0 | INVALID AIR/GND INPUT D3 | MULTIPLE LEADING EDGE SLATS D4 | NO LEADING EDGE SLATS D5 |
| GEAR DOWN B1 | OPPOSITE CHANNEL OK B2 | NOT USED B5 | ARINC INPUT B6 | A/D C0 | INVALID IRS INPUT D6 | INVALID FMC INPUT D7 | AIR/GND ADA SSM CONFLICT D8 |
| STICK SHAKER C1 | AUTOSLATS C3 | EICAS STATUS C4 | CHANNEL OK C5 | NOT USED C6 | OPPOSITE SMC FAULT D9 | INVALID CONFIG FX | |

| | |
|-----|-----------------------|
| ALL | STALL WARNING - RIGHT |
| | D280N032S |

27-32-02

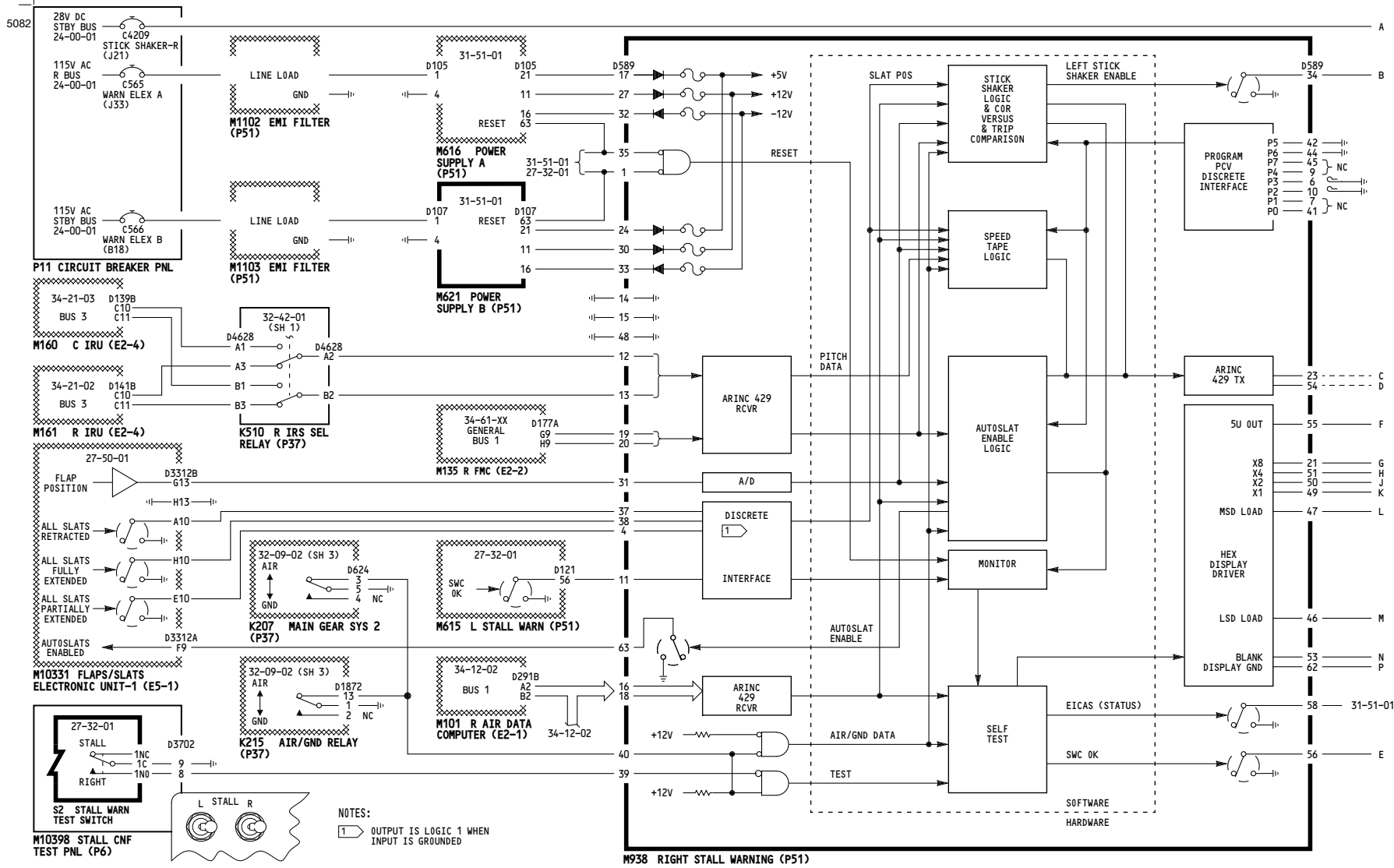

001

STALL WARNING - RIGHT

D280N032S

- Incorporates
- ▶▶ 31-0180 R01
 - ▶▶ 34A0222

27-32-02

5060

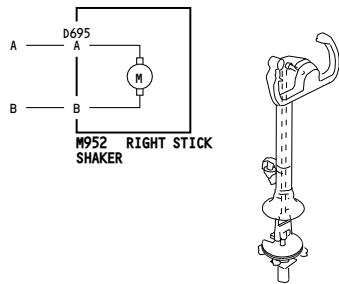

| | PROGRAM PIN CODE P7-P4 (AIRFRAME IDENTIFICATION) | | | | PROGRAM PIN CODE P3-P2 SPEED TAPE PARAMETER CALC | | | PROGRAM PIN CODE P1-P0 (OPTIONAL FEATURES) | | | CONFIG CODE MSD HEX DISPLAY (WEU BITE MODULE) | OPTIONAL CODE LSD HEX DISPLAY (WEU BITE MODULE) |
|---------|--|-----|-----|------|--|------|------|--|------|------|---|---|
| | P7 | P6 | P5 | P4 | P3 | P2 | P1 | P0 | | | | |
| 757-200 | OPEN | GND | GND | OPEN | NOT ACTIVATED | OPEN | OPEN | NONE | OPEN | OPEN | 4 | 3 |
| | | | | | | | | | | | | |
| | | | | | | | | | | | | |

WIRING DIAGRAMS
27-32-21
27-32-22

NOTE: IN THE ABSENCE OF BOARD FAULTS OR INTERFACE ANOMALIES, THE AIRFRAME CONFIGURATION CODE AND OPTION CODE WILL BE DISPLAYED ON THE HEX DISPLAY OF THE WEU BITE MODULE.

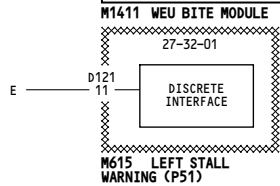
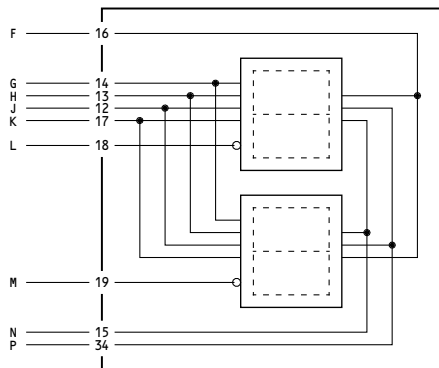
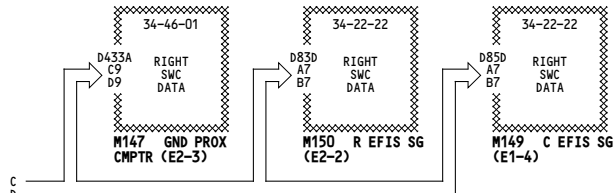

| STALL WARNING BOARD FAULT CODES (DISPLAYED ON WEU BITE MODULE) | | | | | INTERFACE ANOMALY CODES (DISPLAYED ON WEU BITE MODULE) | | |
|---|---------------------------|--------------------------------|----------------------------|----------------|---|-----------------------------------|--------------------------------|
| MULTIPLE FAULTS A0 | SLATS RETRACTED A1 | SLATS PARTIALLY EXTENDED A2 | SLATS FULLY EXTENDED A3 | NOT USED A4 | INOP STICK SHAKER D0 | INVALID ADC INPUT D1 | INVALID FLAPS POSITION D2 |
| NOT USED A5 | NOT USED A6 | NOT USED A7 | TEST A9 | AIR/GND B0 | INVALID AIR/GND INPUT D3 | MULTIPLE LEADING EDGE SLATS D4 | NO LEADING EDGE SLATS D5 |
| GEAR DOWN B1 | OPPOSITE CHANNEL OK B2 | NOT USED B5 | ARINC INPUT B6 | A/D C0 | INVALID IRS INPUT D6 | INVALID FMC INPUT D7 | AIR/GND ADA SSM CONFLICT D8 |
| STICK SHAKER C1 | AUTOSLATS C3 | EICAS STATUS C4 | CHANNEL OK C5 | NOT USED C6 | OPPOSITE SMC FAULT D9 | INVALID CONFIG FX | |

001

STALL WARNING - RIGHT

Incorporates
31-0180 R01

D280N032S

27-32-02

Page 101.1
Sheet 2
May 06/2009

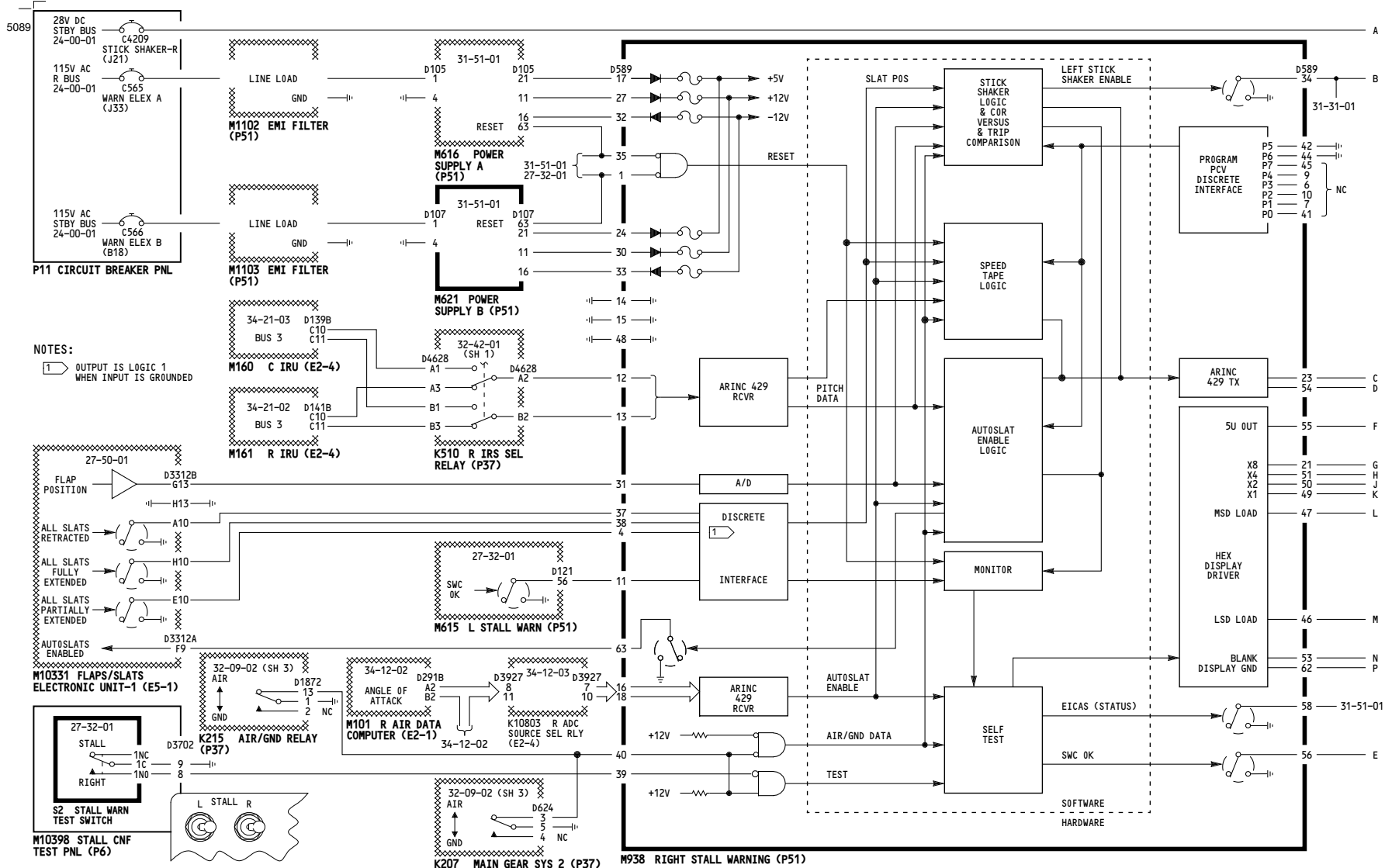

NOTES:
1 OUTPUT IS LOGIC 1 WHEN INPUT IS GROUNDED

002-011

STALL WARNING - RIGHT

Incorporates
34A0222

D280N032S

27-32-02

5011

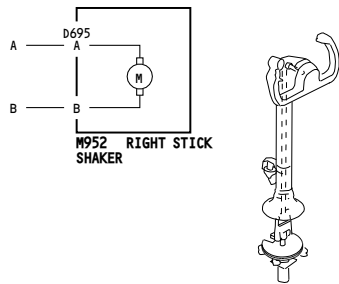

| | PROGRAM PIN CODE P7-P4 (AIRFRAME IDENTIFICATION) | | | | PROGRAM PIN CODE P3-P2 SPEED TAPE PARAMETER CALC | | | PROGRAM PIN CODE P1-P0 (OPTIONAL FEATURES) | | | CONFIG CODE MSD HEX DISPLAY (WEU BITE MODULE) | OPTIONAL CODE LSD HEX DISPLAY (WEU BITE MODULE) |
|---------|--|-----|-----|------|--|-----|-----|--|------|------|---|---|
| | P7 | P6 | P5 | P4 | P3 | P2 | P1 | P0 | | | | |
| 757-200 | OPEN | GND | GND | OPEN | ACTIVATED | GND | GND | NONE | OPEN | OPEN | 4 | 3 |
| | | | | | | | | | | | | |
| | | | | | | | | | | | | |

WIRING DIAGRAMS
27-32-21
27-32-22

NOTE: IN THE ABSENCE OF BOARD FAULTS OR INTERFACE ANOMALIES, THE AIRFRAME CONFIGURATION CODE AND OPTION CODE WILL BE DISPLAYED ON THE HEX DISPLAY OF THE WEU BITE MODULE.

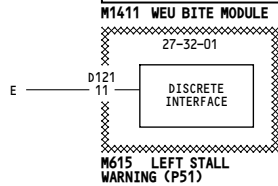
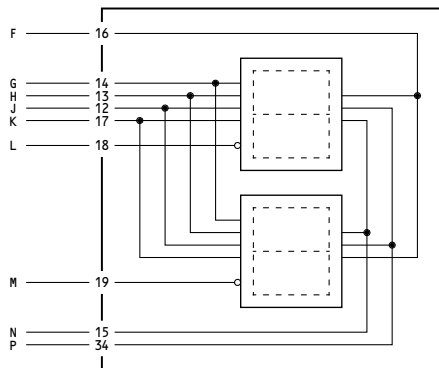
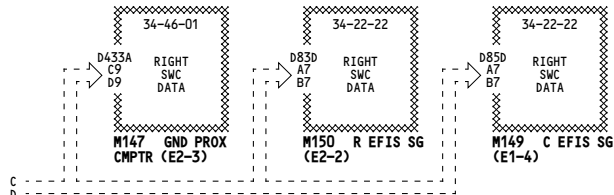

| STALL WARNING BOARD FAULT CODES (DISPLAYED ON WEU BITE MODULE) | | | | | INTERFACE ANOMALY CODES (DISPLAYED ON WEU BITE MODULE) | | |
|---|---------------------|--------------------------|----------------------|----------|---|-----------------------------|--------------------------|
| MULTIPLE FAULTS | SLATS RETRACTED | SLATS PARTIALLY EXTENDED | SLATS FULLY EXTENDED | NOT USED | INOP STICK SHAKER | INVALID ADC INPUT | INVALID FLAPS POSITION |
| A0 | A1 | A2 | A3 | A4 | D0 | D1 | D2 |
| NOT USED | NOT USED | NOT USED | TEST | AIR/GND | INVALID AIR/GND INPUT | MULTIPLE LEADING EDGE SLATS | NO LEADING EDGE SLATS |
| A5 | A6 | A7 | A9 | B0 | D3 | D4 | D5 |
| GEAR DOWN | OPPOSITE CHANNEL OK | NOT USED | ARINC INPUT | A/D | INVALID IRS INPUT | INVALID FMC INPUT | AIR/GND ADA SSM CONFLICT |
| B1 | B2 | B5 | B6 | C0 | D6 | D7 | D8 |
| STICK SHAKER | AUTOSLATS | EICAS STATUS | CHANNEL OK | NOT USED | OPPOSITE SMC FAULT | INVALID CONFIG | |
| C1 | C3 | C4 | C5 | C6 | D9 | FX | |

002-011

STALL WARNING - RIGHT

D280N032S

27-32-02

Page 101.2
Sheet 2
May 06/2009

5012

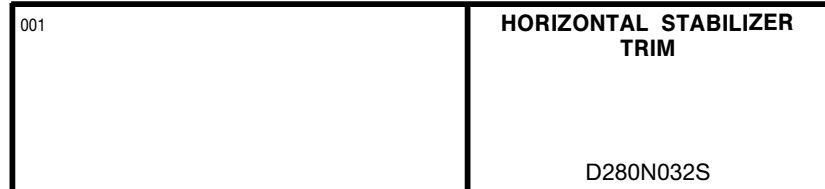
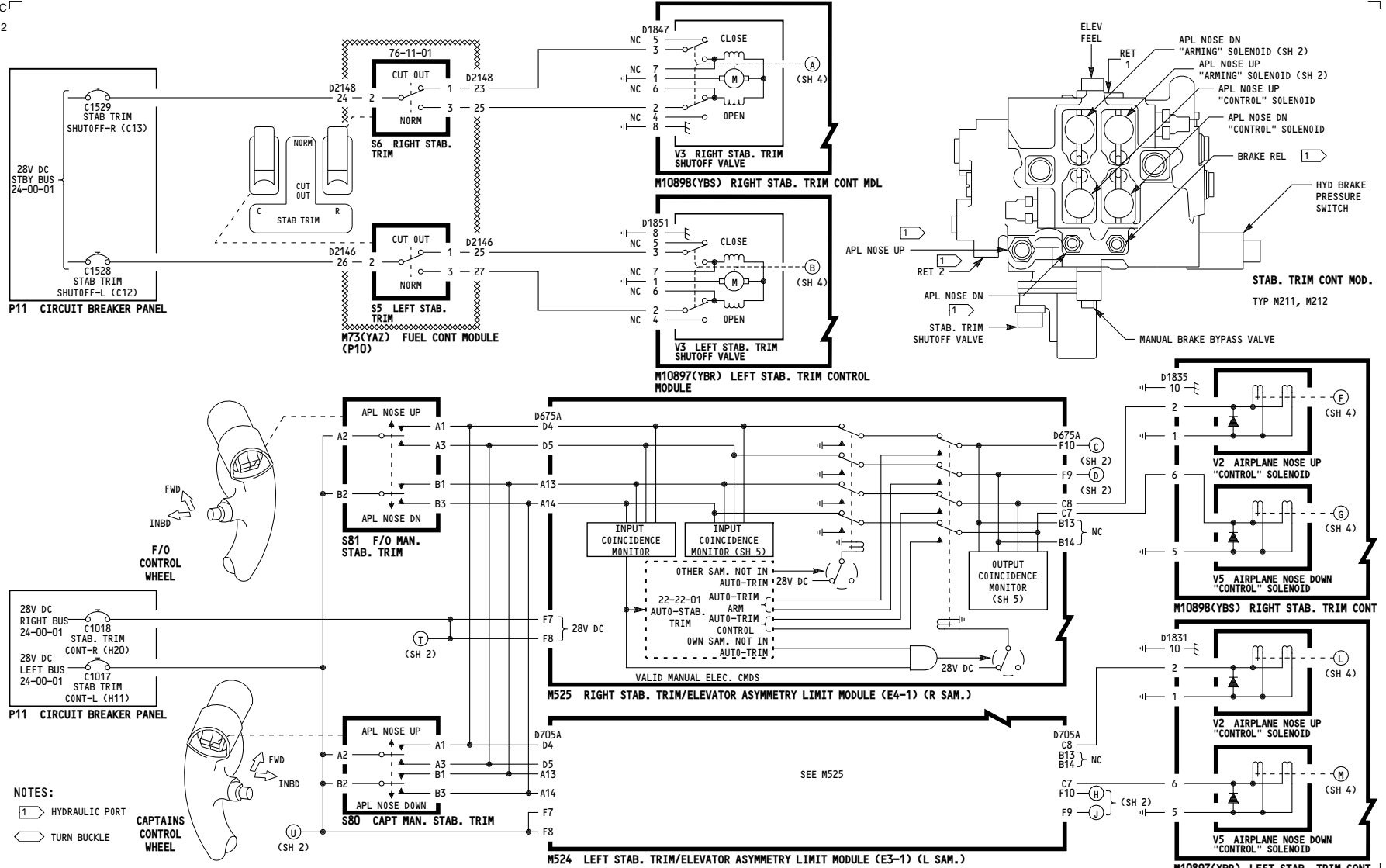

27-40-01

5011

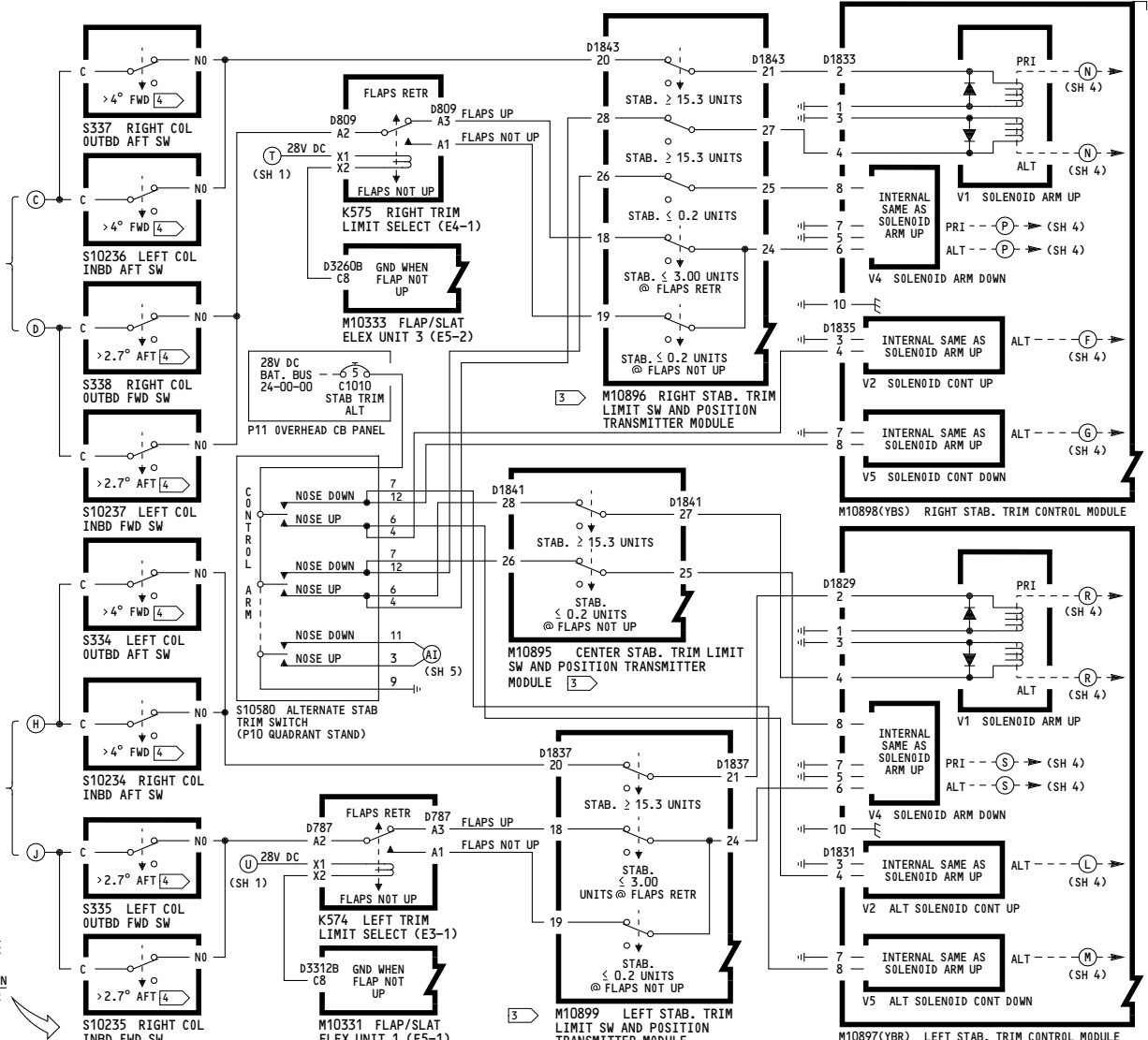
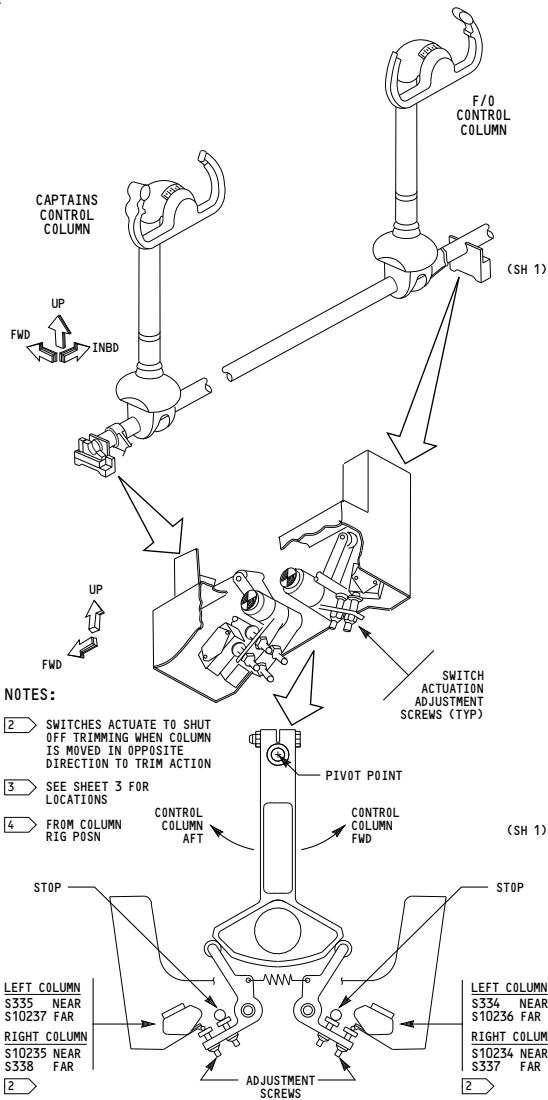

001

HORIZONTAL STABILIZER TRIM

D280N032S

27-40-01

5014

WIRING DIAGRAMS
27-48-11

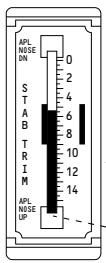
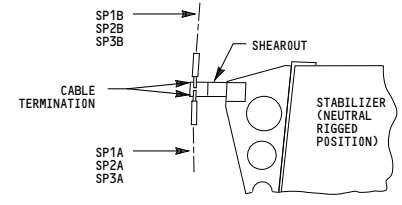
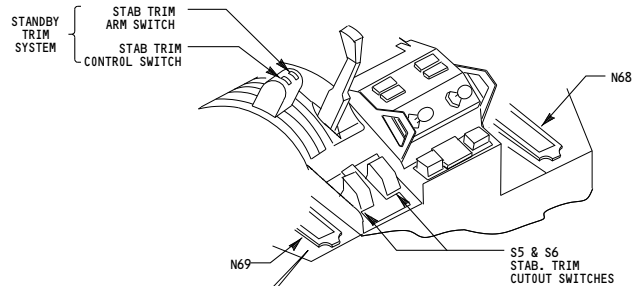

N68, N69

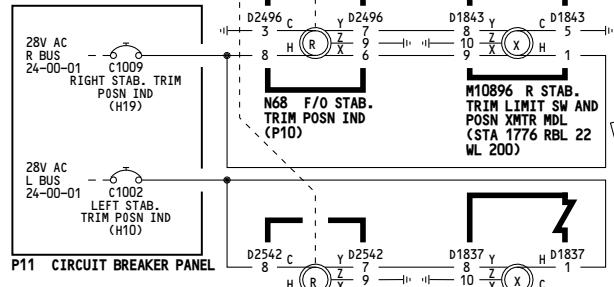

NOTES:

- 4 SAME CABLE CONNECTION TO STABILIZER, AS M10896, M10895
- 5 FOR HYDRAULIC POWER DISTRIBUTION SEE 27-30-01

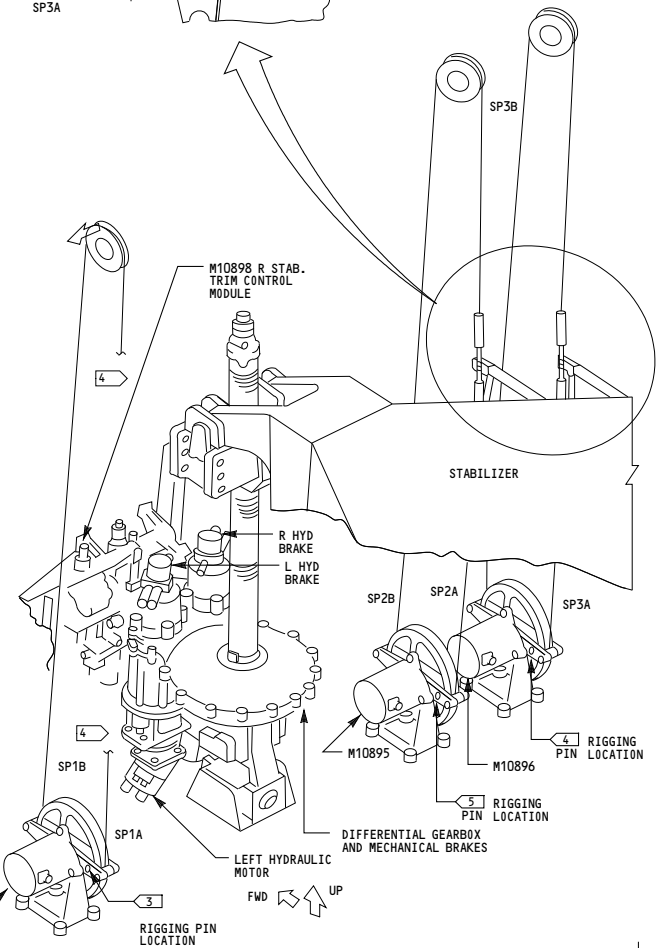
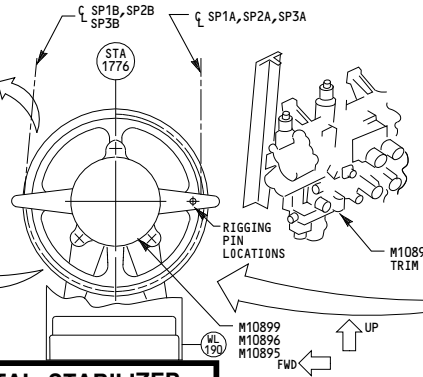

| | |
|-----|---|
| 001 | <p>HORIZONTAL STABILIZER TRIM</p> <p>D280N032S</p> |
|-----|---|

27-40-01

5001

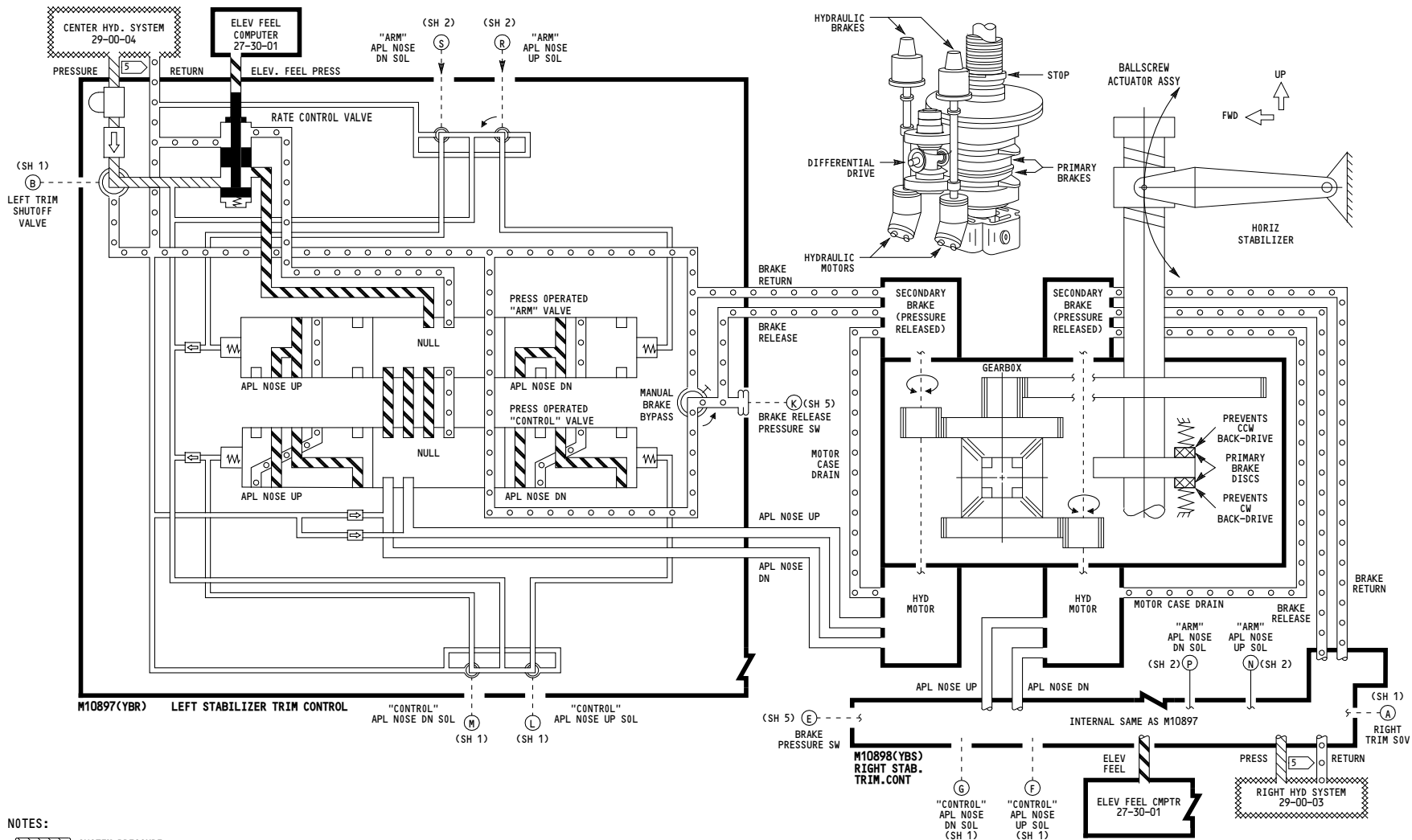

- NOTES:**
- SYSTEM PRESSURE
 - RETURN
 - METERED PRESSURE

| | |
|-----|---|
| 001 | <p>HORIZONTAL STABILIZER TRIM</p> <p>D280N032S</p> |
|-----|---|

27-40-01

Page 101
Sheet 4
Jan 21/2005

5011

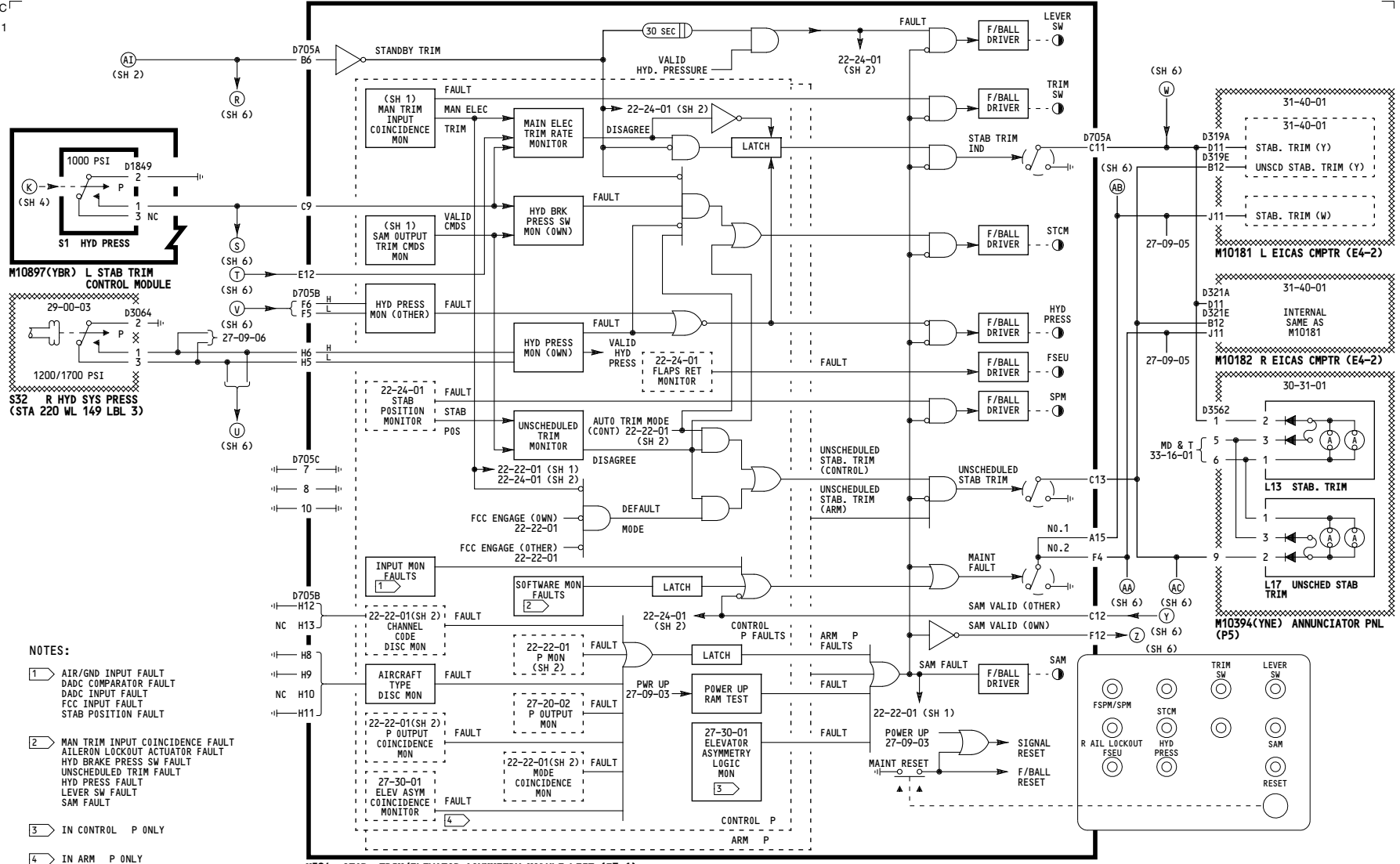

M524 STAB. TRIM/ELEVATOR ASYMMETRY MODULE LEFT (E3-1)

- NOTES:**
- 1 AIR/GND INPUT FAULT
DADC COMPARATOR FAULT
DADC INPUT FAULT
FCC INPUT FAULT
STAB POSITION FAULT
 - 2 MAN TRIM INPUT COINCIDENCE FAULT
AILERON LOCKOUT ACTUATOR FAULT
HYD BRAKE PRESS SW FAULT
UNDESCHED TRIM FAULT
HYD PRESS FAULT
LEVER SW FAULT
SAM FAULT
 - 3 IN CONTROL P ONLY
 - 4 IN ARM P ONLY

001

HORIZONTAL STABILIZER TRIM

D280N032S

27-40-01

-A
5011

WIRING DIAGRAMS
27-41-11
27-41-21
27-48-11

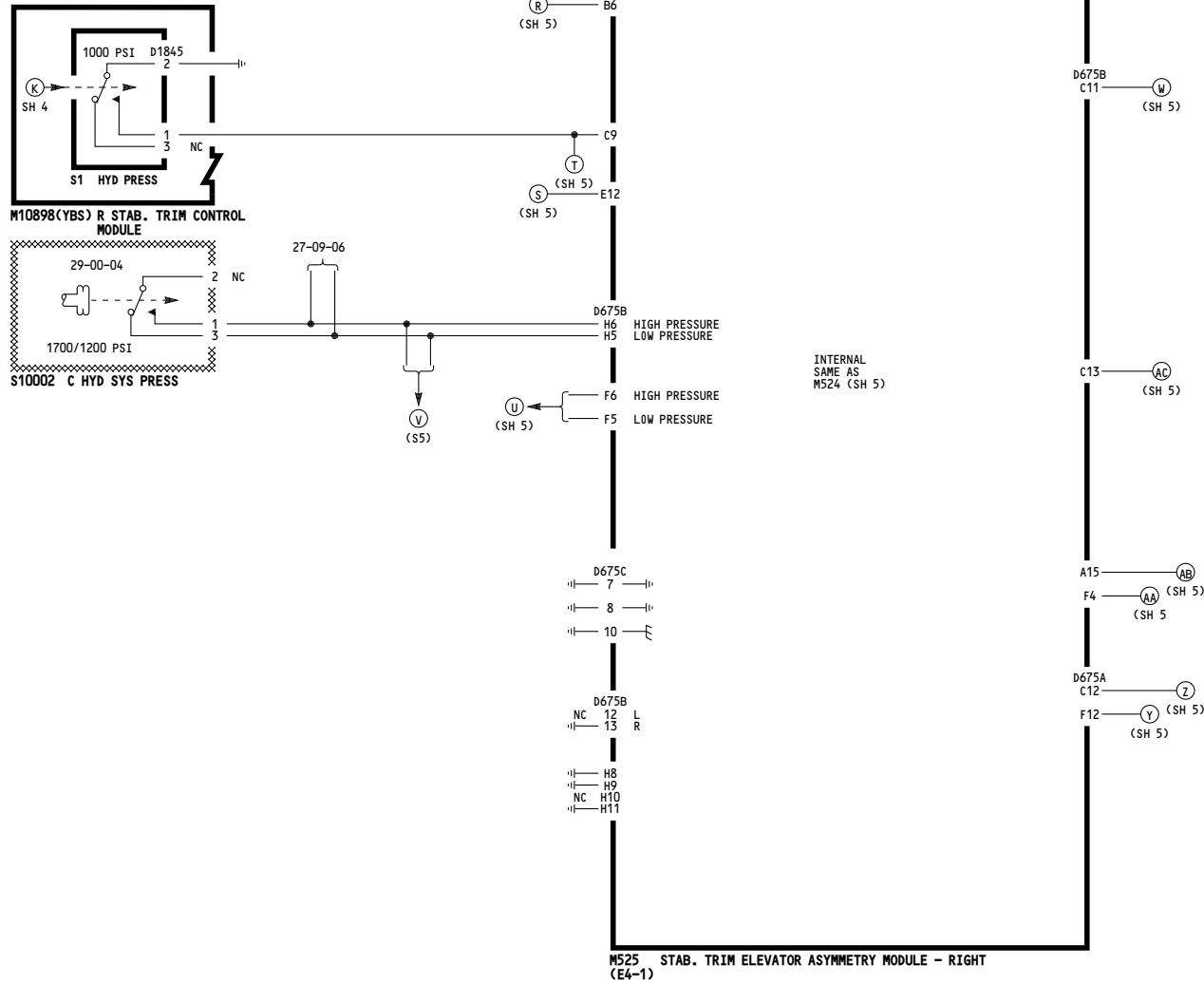

001

HORIZONTAL STABILIZER TRIM

D280N032S

27-40-01

Page 101
Sheet 6
Jan 21/2005

5024

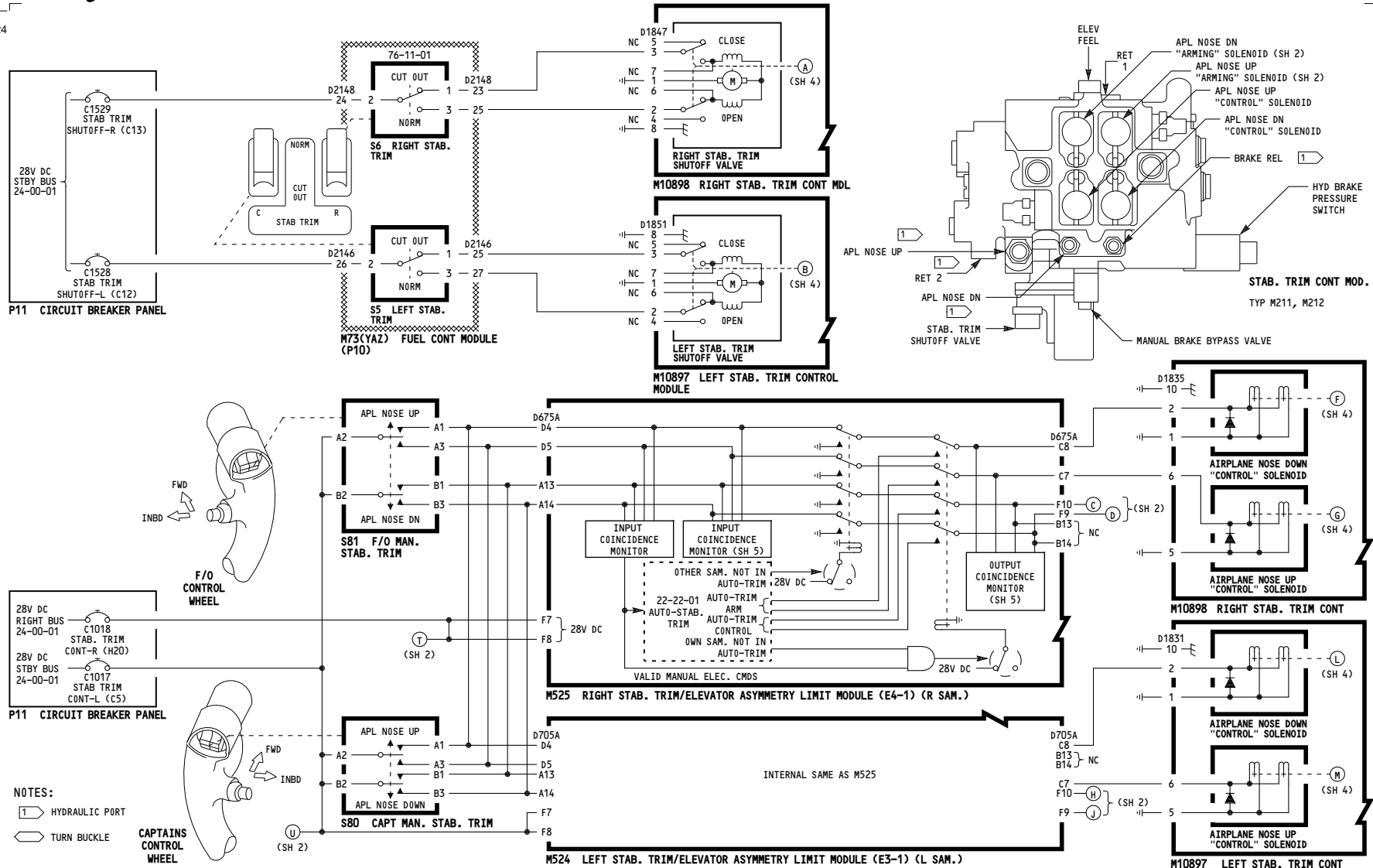

NOTES:
 1 HYDRAULIC PORT
 TURN BUCKLE
 CAPTAINS CONTROL WHEEL

001

HORIZONTAL STABILIZER TRIM

Incorporates 27-0104

D280N032S

27-40-01

5011

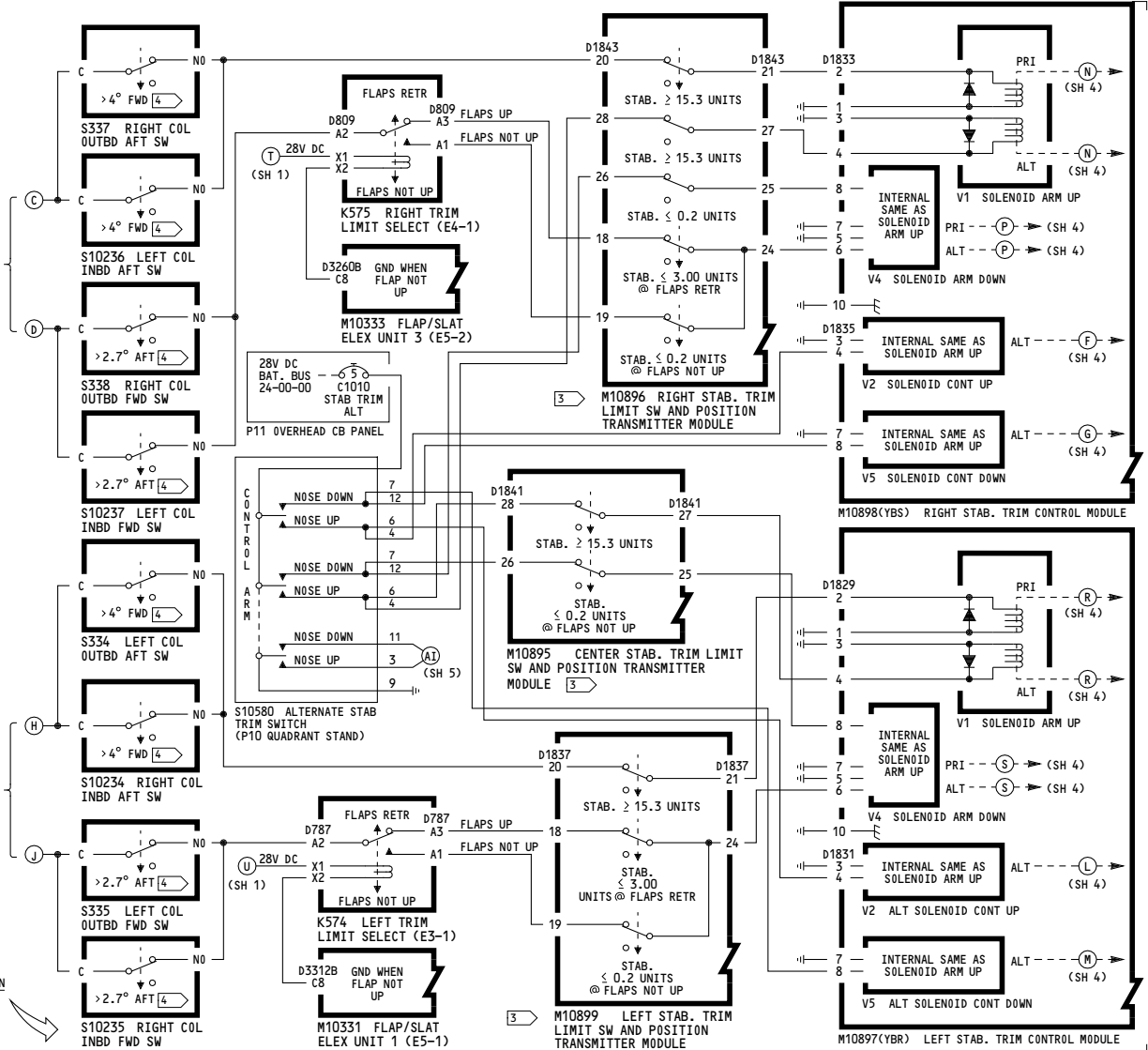
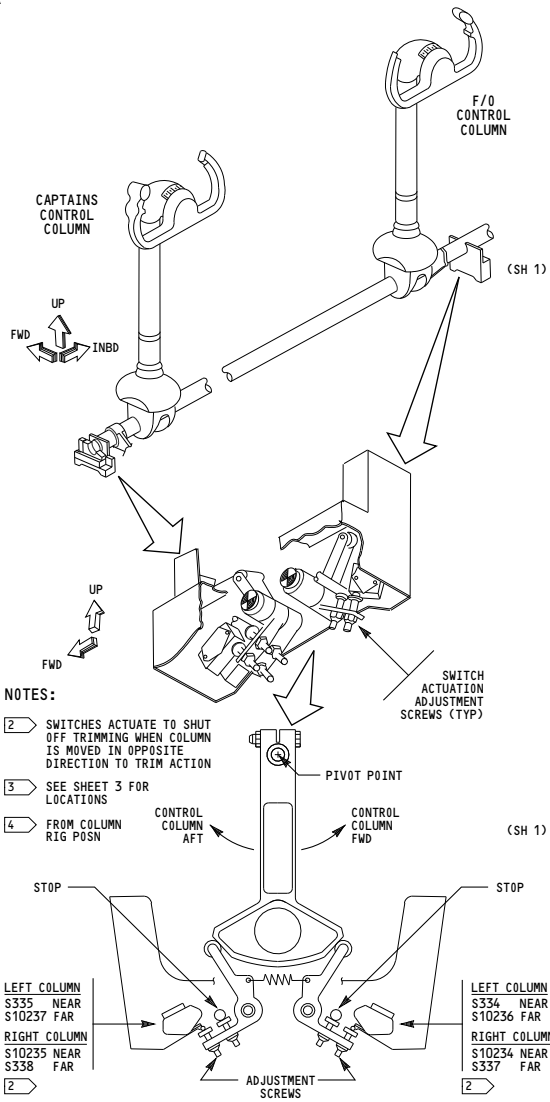

001

HORIZONTAL STABILIZER TRIM

D280N032S

27-40-01

5014

WIRING DIAGRAMS
27-48-11

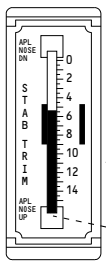
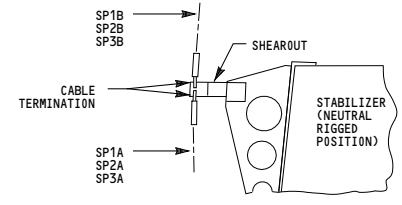
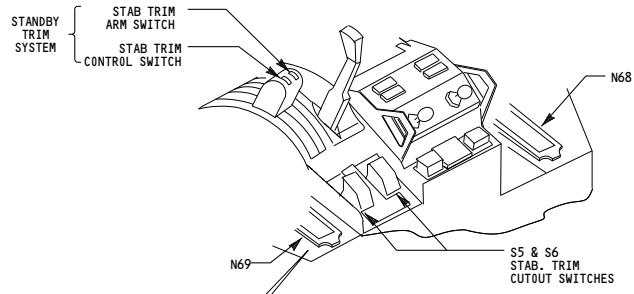

N68, N69

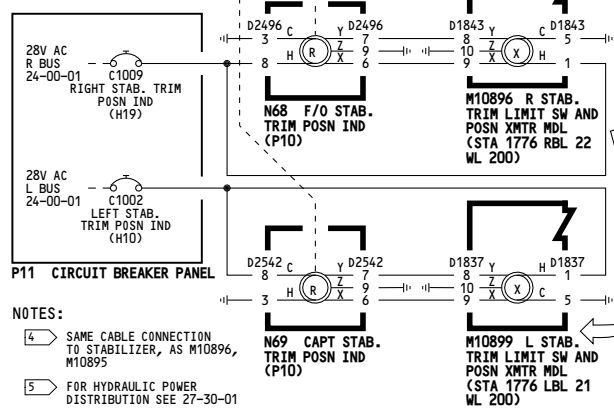

NOTES:

- 4 SAME CABLE CONNECTION TO STABILIZER, AS M10896, M10895
- 5 FOR HYDRAULIC POWER DISTRIBUTION SEE 27-30-01

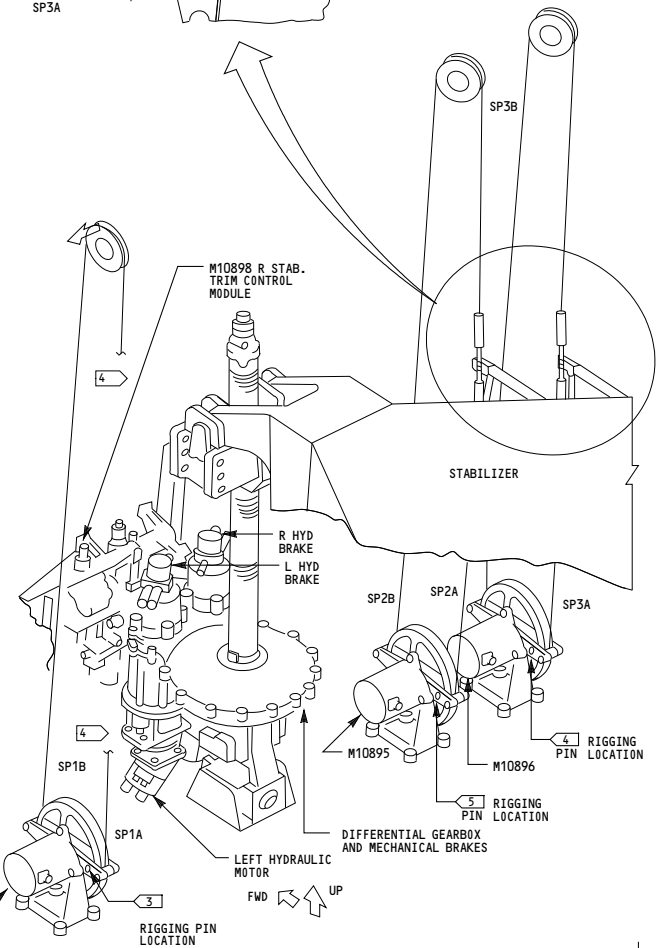
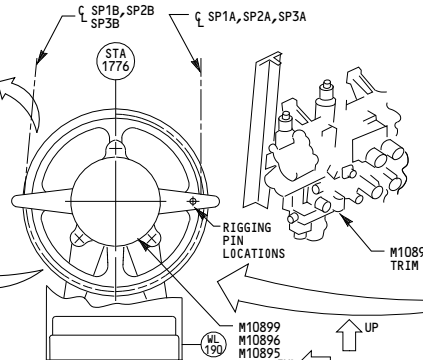

| | |
|-----------|-----------------------------------|
| 001 | HORIZONTAL STABILIZER TRIM |
| D280N032S | |

27-40-01

5001

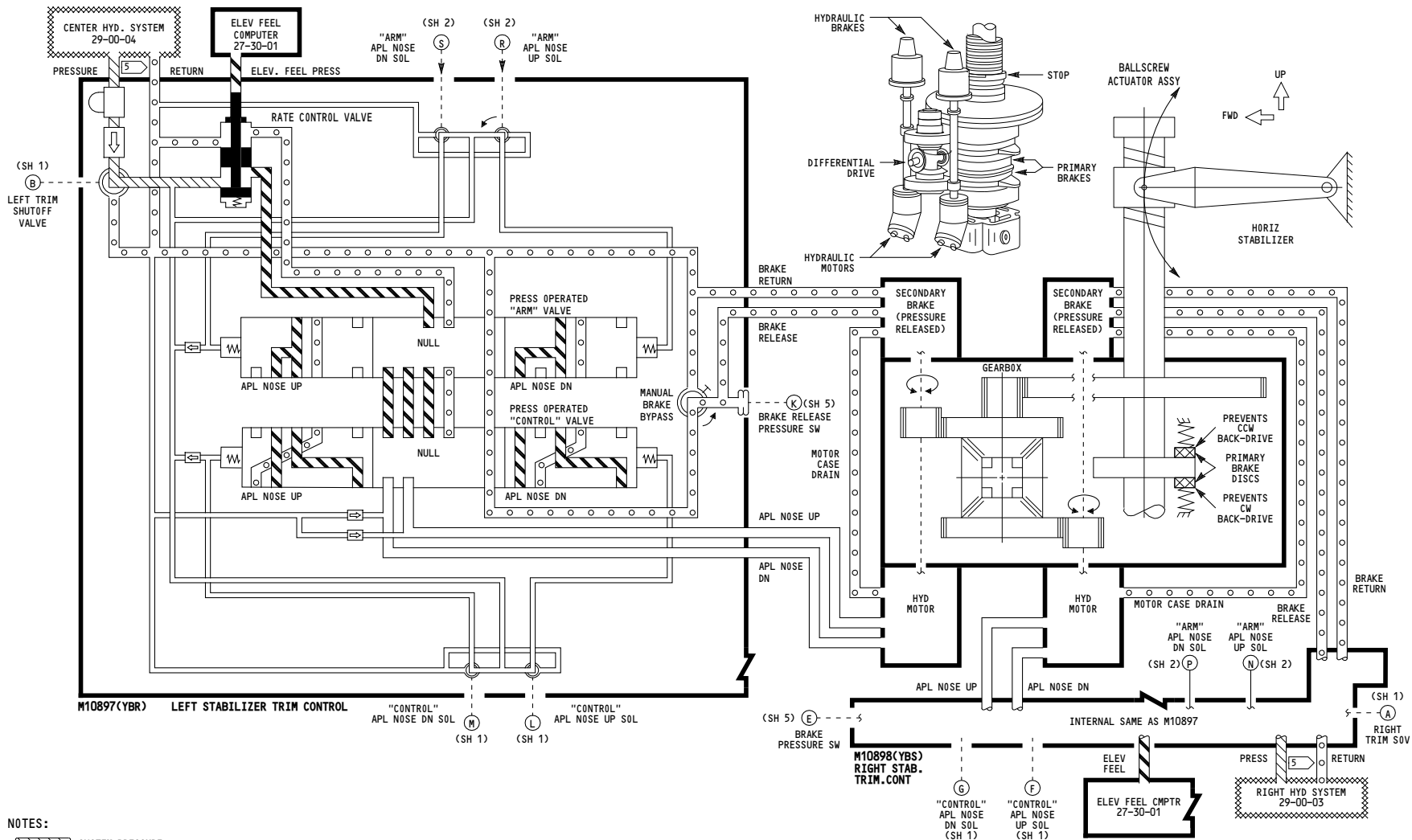

- NOTES:**
- SYSTEM PRESSURE
 - RETURN
 - METERED PRESSURE

| | |
|-----|---|
| 001 | <p>HORIZONTAL STABILIZER TRIM</p> <p>D280N032S</p> |
|-----|---|

27-40-01

Page 101.1
Sheet 4
Jan 21/2005

5011

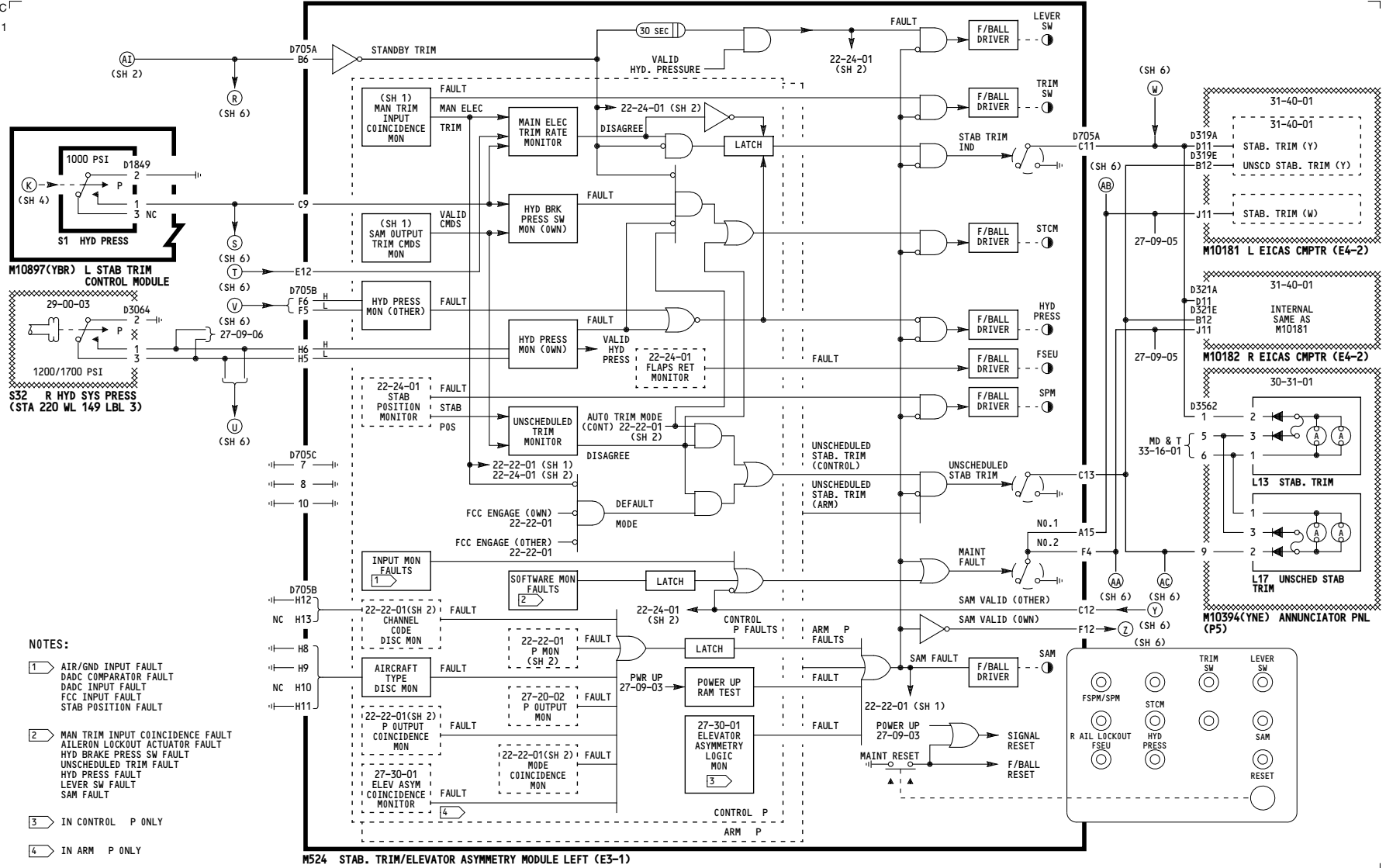

- NOTES:**
- 1 AIR/GND INPUT FAULT
DADC COMPARATOR FAULT
DADC INPUT FAULT
FCC INPUT FAULT
STAB POSITION FAULT
 - 2 MAN TRIM INPUT COINCIDENCE FAULT
AILERON LOCKOUT ACTUATOR FAULT
HYD BRAKE PRESS SW FAULT
UNSCHEDULED TRIM FAULT
HYD PRESS FAULT
LEVER SW FAULT
SAM FAULT
 - 3 IN CONTROL P ONLY
 - 4 IN ARM P ONLY

M524 STAB. TRIM/ELEVATOR ASYMMETRY MODULE LEFT (E3-1)

001

HORIZONTAL STABILIZER TRIM

D280N032S

27-40-01

Page 101.1
Sheet 5
Dec 18/2007

-A
5011

WIRING DIAGRAMS
27-41-11
27-41-21
27-48-11

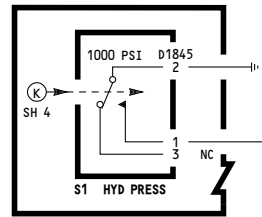

M10898(YBS) R STAB. TRIM CONTROL MODULE

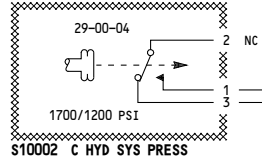

S10002 C HYD SYS PRESS

27-09-06



D675A
B6
(SH 5)

C9
E12
(SH 5)

D675B
H6 HIGH PRESSURE
H5 LOW PRESSURE
F6 HIGH PRESSURE
F5 LOW PRESSURE
(SH 5)

D675C
7
8
10

D675B
NC 12 L
13 R
H8
H9
NC H10
H11

M525 STAB. TRIM ELEVATOR ASYMMETRY MODULE - RIGHT
(E4-1)

INTERNAL
SAME AS
M524 (SH 5)

D675B
C11
(SH 5)

C13
(SH 5)

A15
F4
(SH 5)

D675A
C12
F12
(SH 5)

001

HORIZONTAL STABILIZER TRIM

D280N032S

27-40-01

Page 101.1
Sheet 6
Jan 21/2005

5015

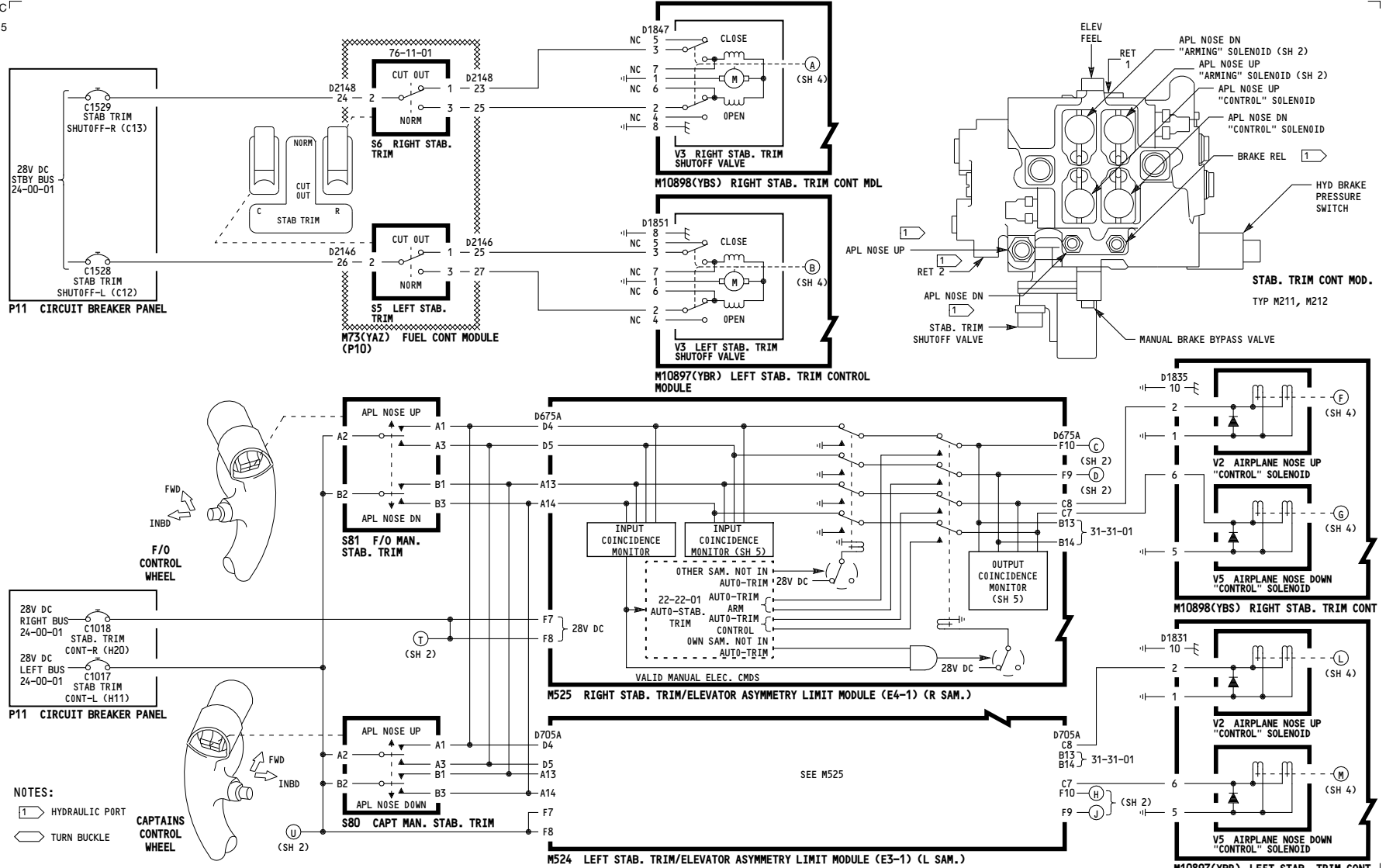

002-004

HORIZONTAL STABILIZER TRIM

D280N032S

27-40-01

-A
5011

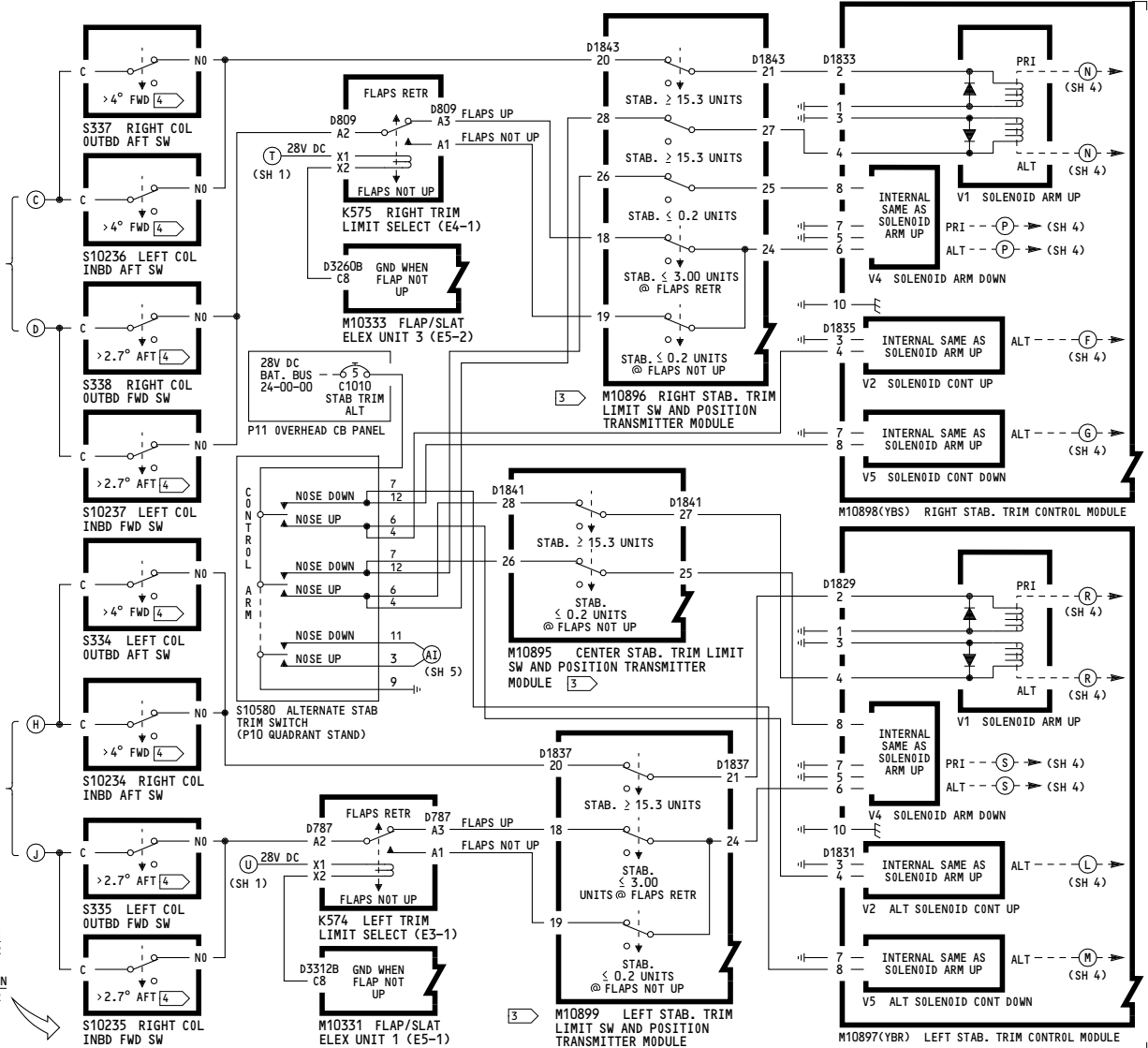
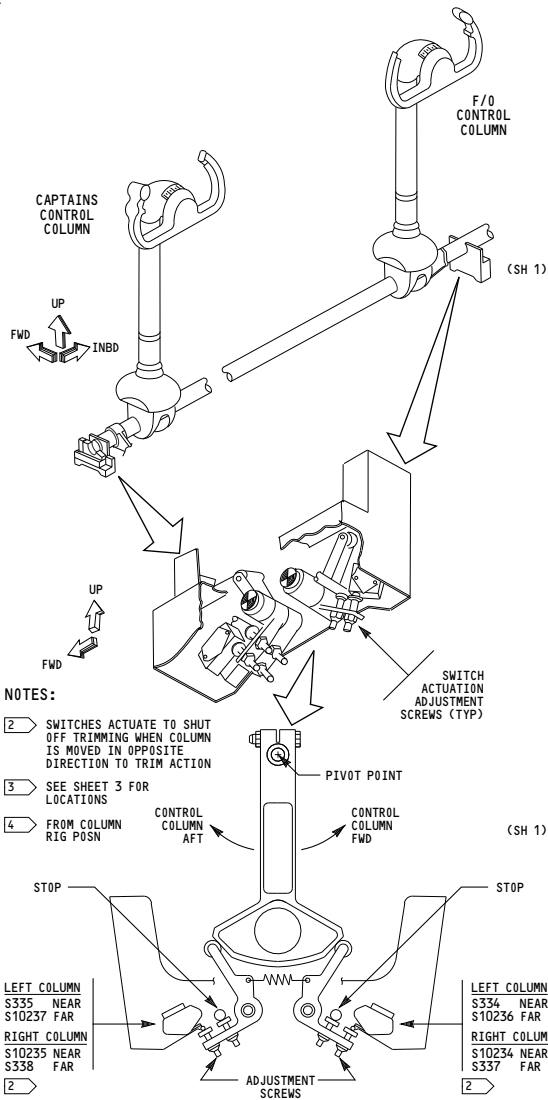

002-004

HORIZONTAL STABILIZER TRIM

D280N032S

27-40-01

5014

WIRING DIAGRAMS
27-48-11

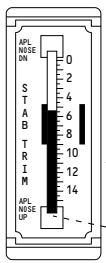
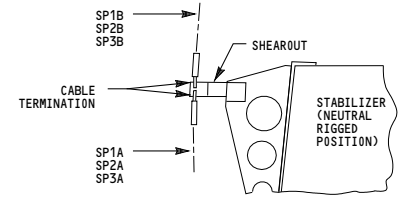
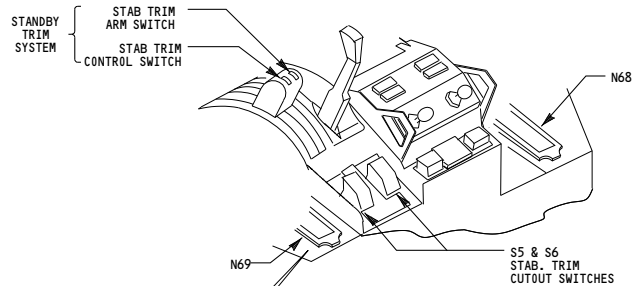

N68, N69

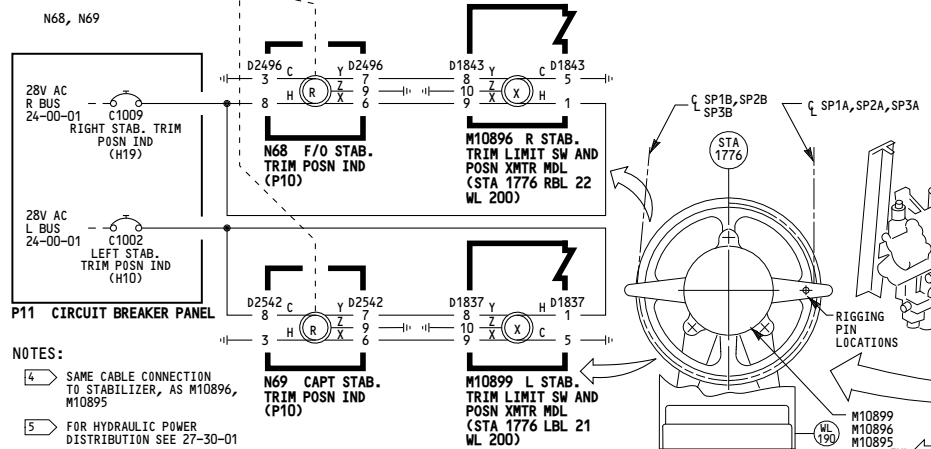

NOTES:

- 4 SAME CABLE CONNECTION TO STABILIZER, AS M10896, M10895
- 5 FOR HYDRAULIC POWER DISTRIBUTION SEE 27-30-01

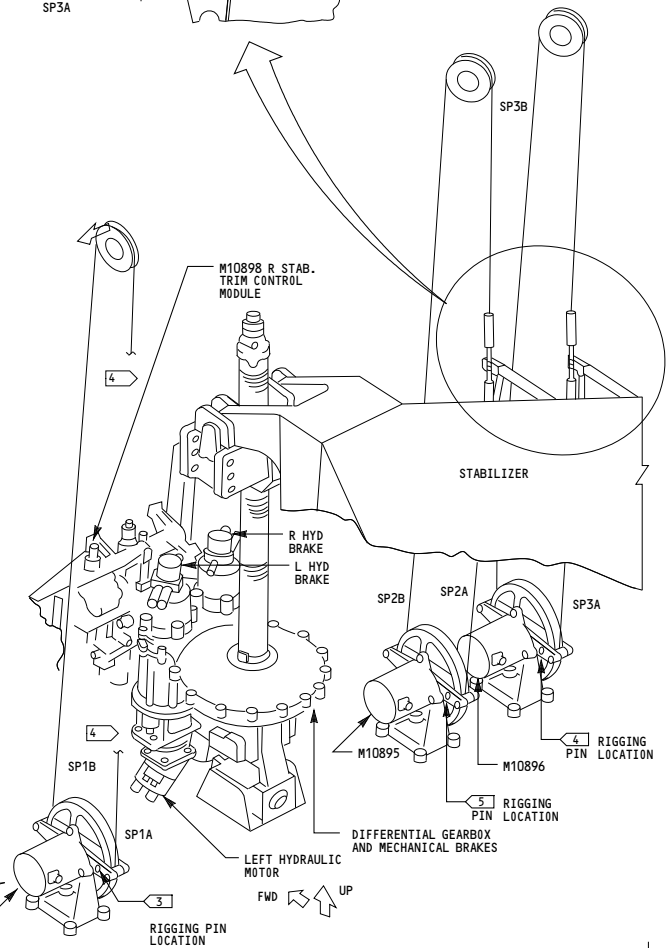

| | |
|-----------|-----------------------------------|
| 002-004 | HORIZONTAL STABILIZER TRIM |
| D280N032S | |

27-40-01

5001

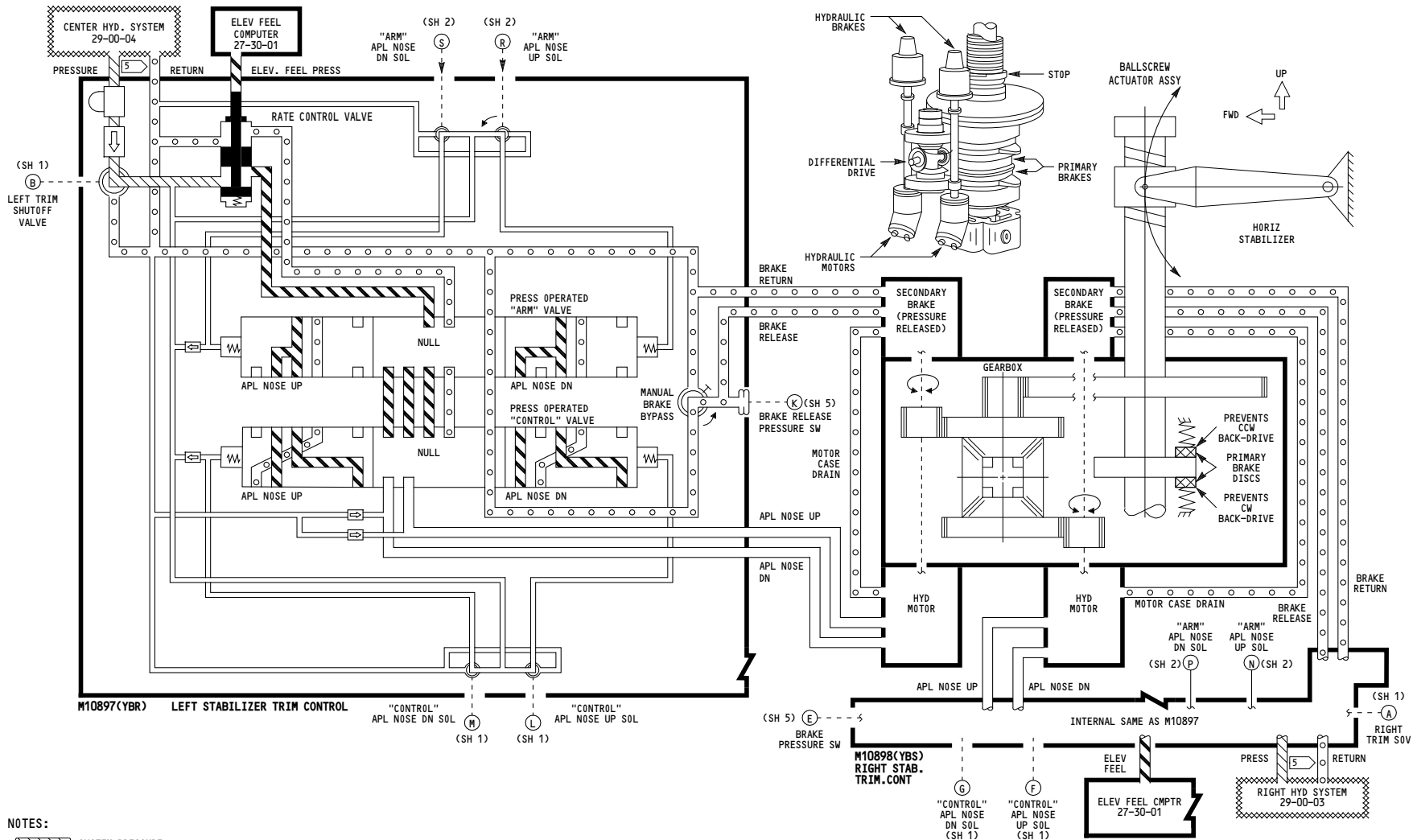

002-004

HORIZONTAL STABILIZER TRIM

D280N032S

27-40-01

Page 102
Sheet 4
Jan 21/2005

5011

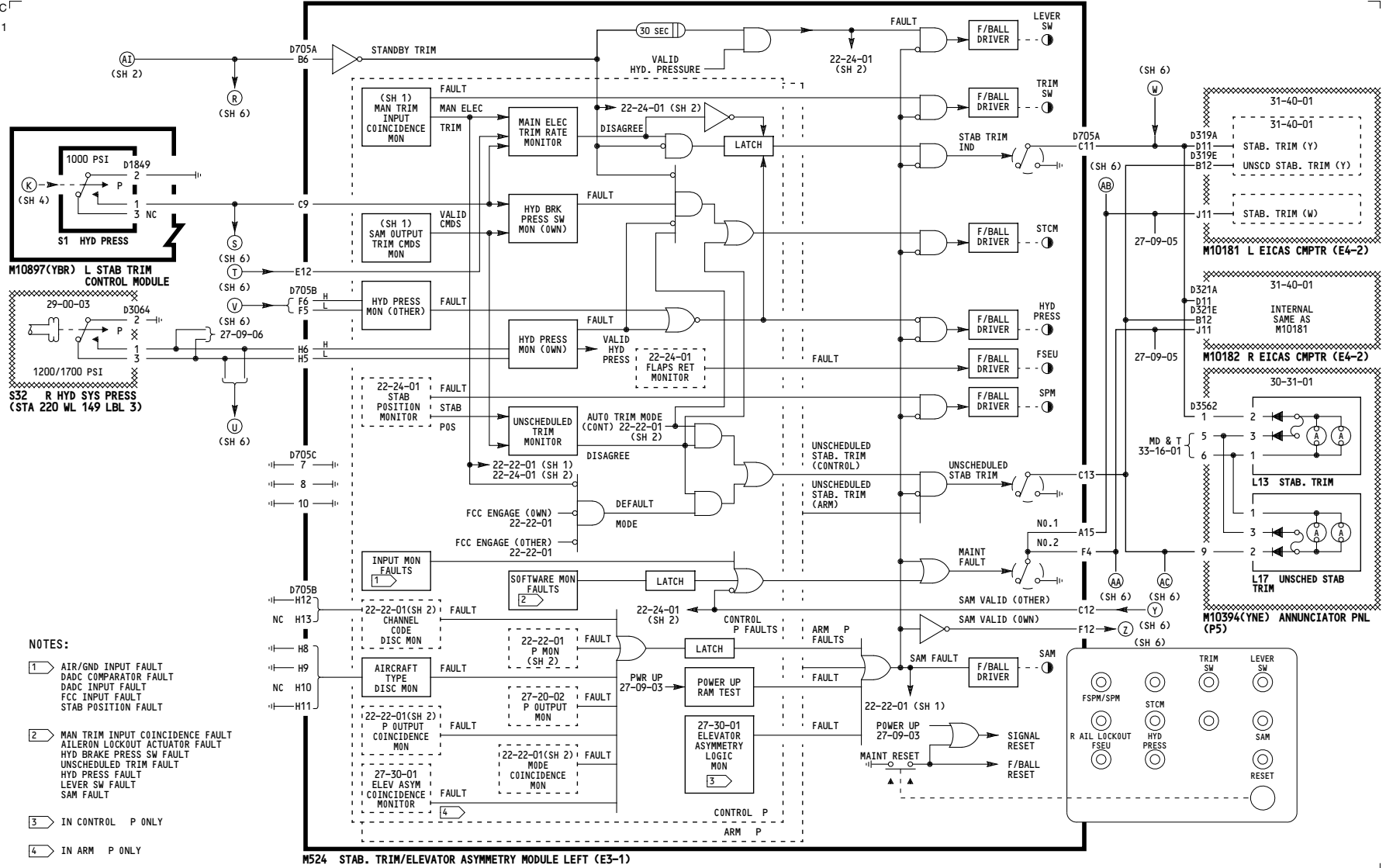

002-004

HORIZONTAL STABILIZER TRIM

D280N032S

27-40-01

-A
5011

WIRING DIAGRAMS
27-41-11
27-41-21
27-48-11

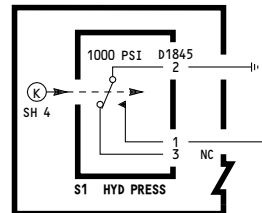

M10898(YBS) R STAB. TRIM CONTROL MODULE

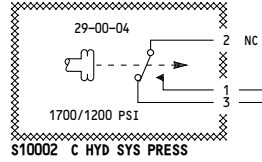

S10002 C HYD SYS PRESS

27-09-06



NC

(V)
(S5)

(U)
(SH 5)

(R)
(SH 5)

(T)
(SH 5)
(S)
(SH 5)

(U)
(SH 5)

(NC)
(12)
(13)
(L)
(R)

(H8)
(H9)
(NC)
(H10)
(H11)

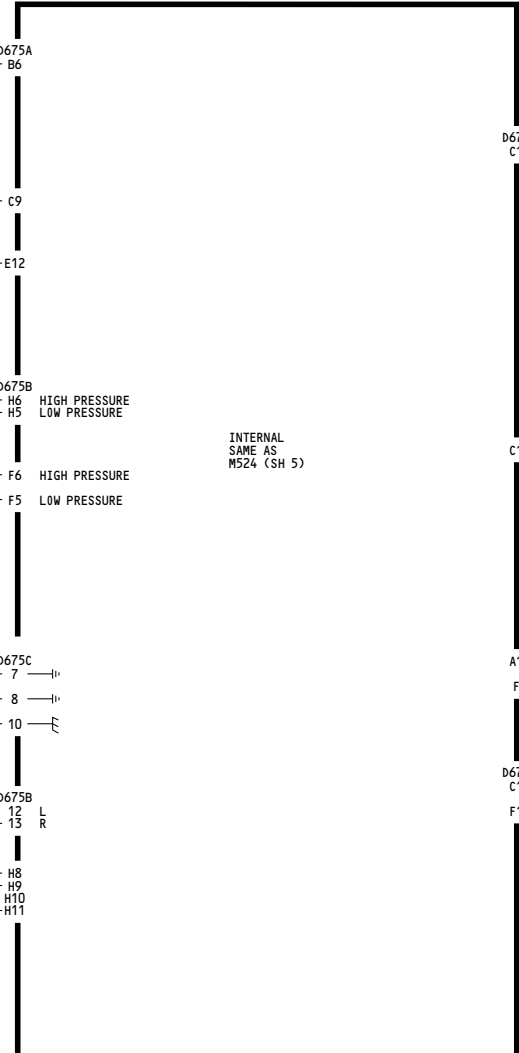

M525 STAB. TRIM ELEVATOR ASYMMETRY MODULE - RIGHT (E4-1)

INTERNAL SAME AS M524 (SH 5)

D675B
C11

(W)
(SH 5)

C13

(AC)
(SH 5)

A15

(AB)
(SH 5)
(AA)
(SH 5)

D675A
C12

(Z)
(SH 5)
(Y)
(SH 5)

002-004

HORIZONTAL STABILIZER TRIM

D280N032S

27-40-01

Page 102
Sheet 6
Jan 21/2005

5030

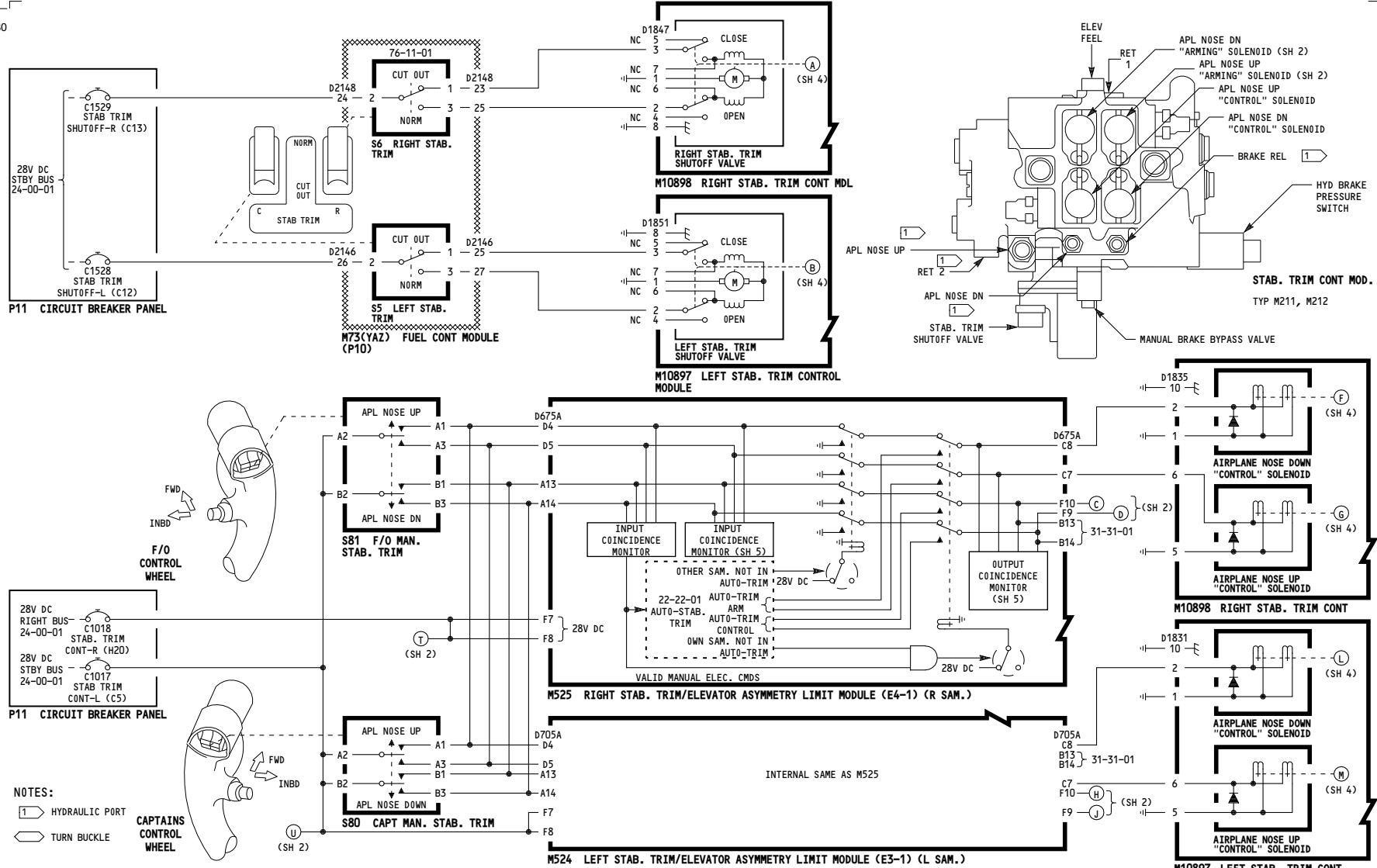

002-004

HORIZONTAL STABILIZER TRIM

D280N032S

Incorporates 27-0104

27-40-01

-A
5011

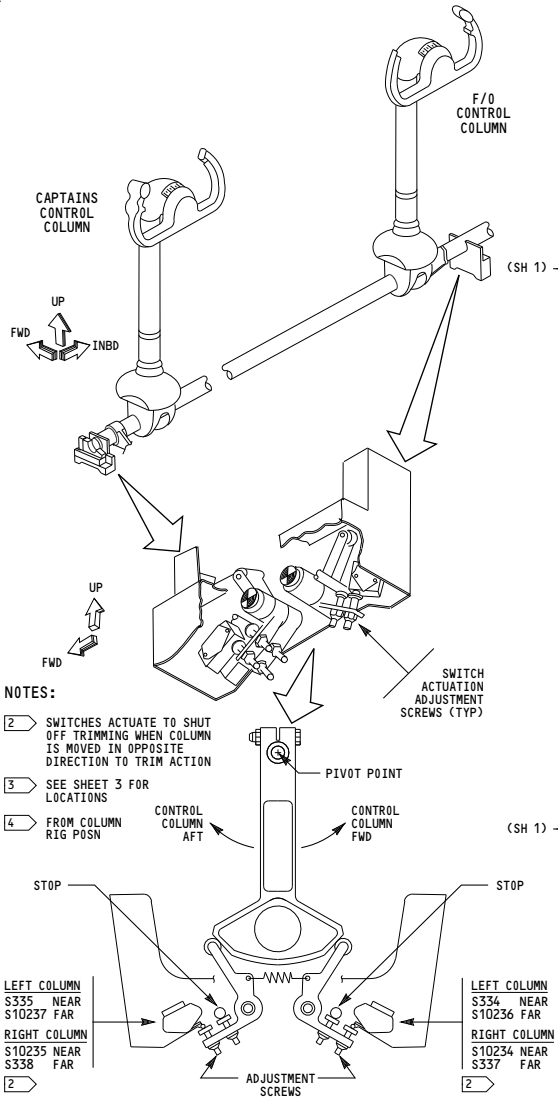

- NOTES:**
- 2 SWITCHES ACTUATE TO SHUT OFF TRIMMING WHEN COLUMN IS MOVED IN OPPOSITE DIRECTION TO TRIM ACTION
 - 3 SEE SHEET 3 FOR LOCATIONS
 - 4 FROM COLUMN RIG POSN

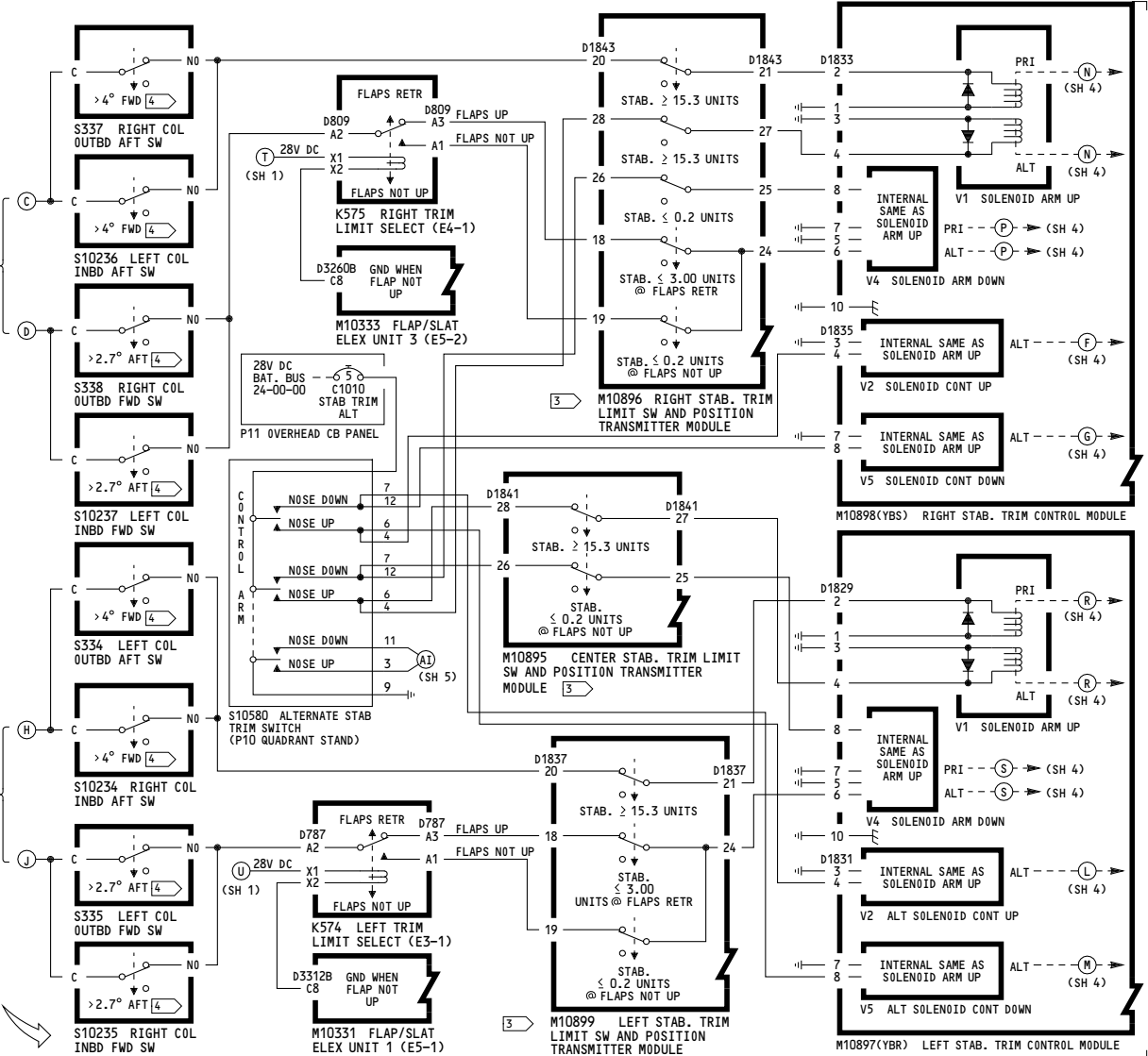

002-004

HORIZONTAL STABILIZER TRIM

D280N032S

27-40-01

5014

WIRING DIAGRAMS
27-48-11

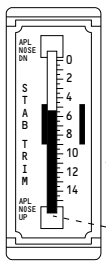
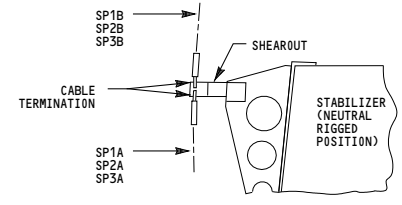
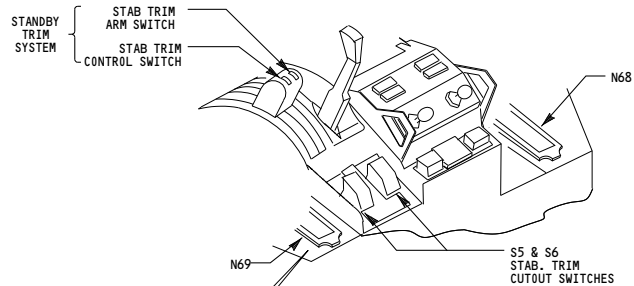

N68, N69

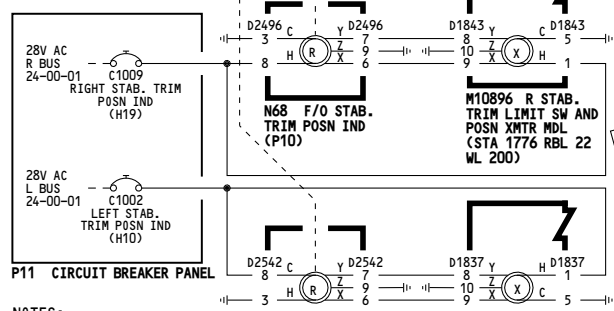

NOTES:

- 4 SAME CABLE CONNECTION TO STABILIZER, AS M10896, M10895
- 5 FOR HYDRAULIC POWER DISTRIBUTION SEE 27-30-01

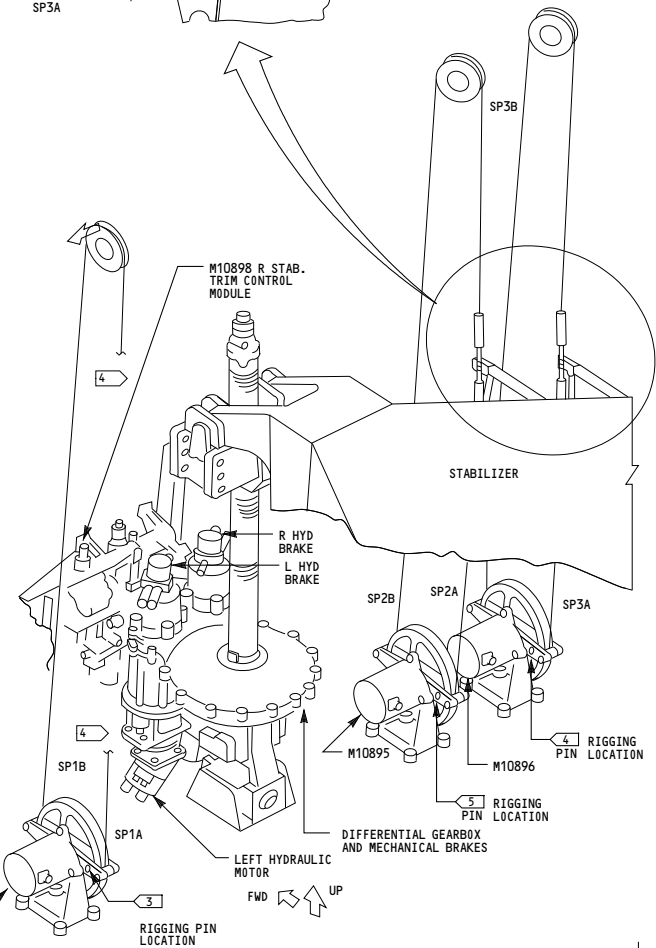
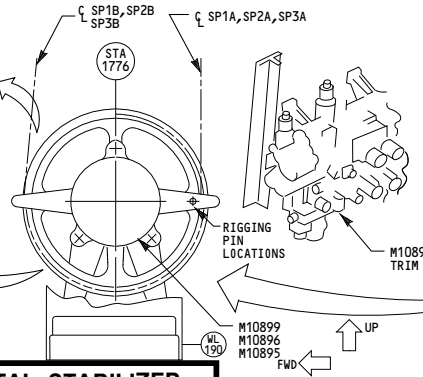

002-004

HORIZONTAL STABILIZER TRIM

D280N032S

27-40-01

Page 102.1
Sheet 3
Jan 21/2005

5001

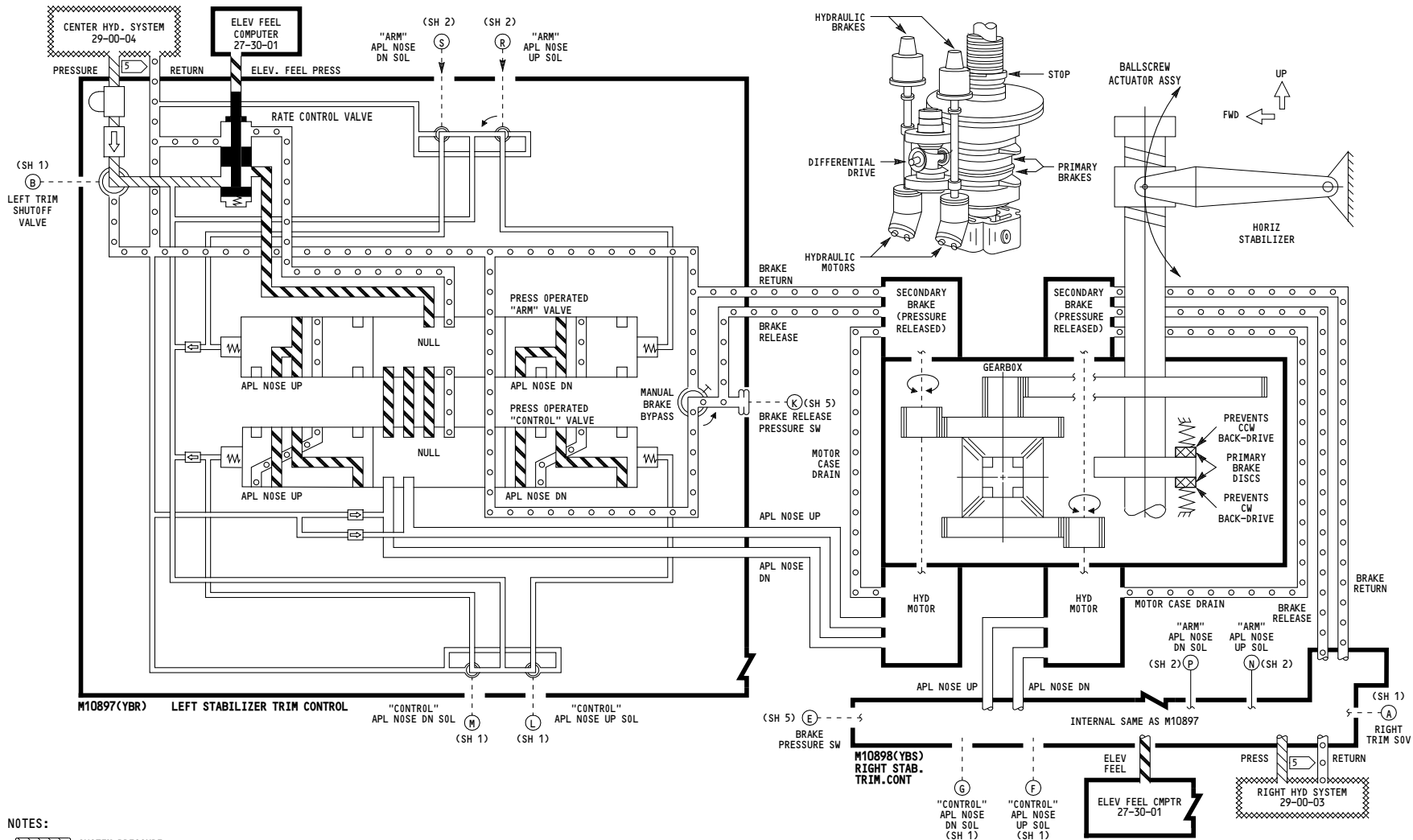

- NOTES:**
- SYSTEM PRESSURE
 - RETURN
 - METERED PRESSURE

| | |
|---------|-----------------------------------|
| 002-004 | HORIZONTAL STABILIZER TRIM |
| | D280N032S |

27-40-01

Page 102.1
Sheet 4
Jan 21/2005

5011

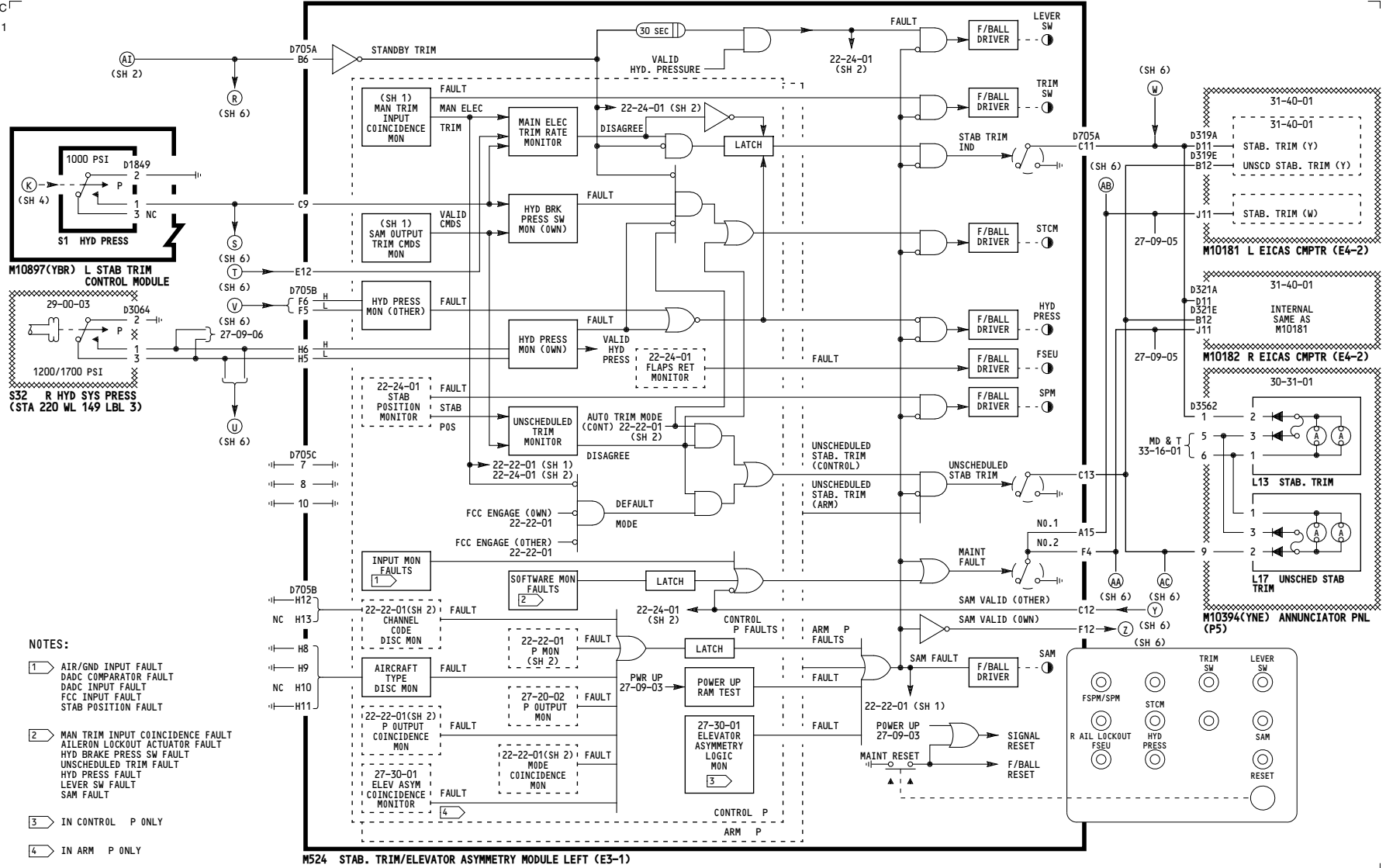

- NOTES:**
- 1 AIR/GND INPUT FAULT
DADC COMPARATOR FAULT
DADC INPUT FAULT
FCC INPUT FAULT
STAB POSITION FAULT
 - 2 MAN TRIM INPUT COINCIDENCE FAULT
AILERON LOCKOUT ACTUATOR FAULT
HYD BRAKE PRESS SW FAULT
UNSCHEDULED TRIM FAULT
HYD PRESS FAULT
LEVER SW FAULT
SAM FAULT
 - 3 IN CONTROL P ONLY
 - 4 IN ARM P ONLY

M524 STAB. TRIM/ELEVATOR ASYMMETRY MODULE LEFT (E3-1)

002-004

HORIZONTAL STABILIZER TRIM

D280N032S

27-40-01

Page 102.1
Sheet 5
Dec 18/2007

-A
5011

WIRING DIAGRAMS
27-41-11
27-41-21
27-48-11

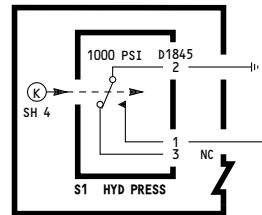

M10898(YBS) R STAB. TRIM CONTROL MODULE

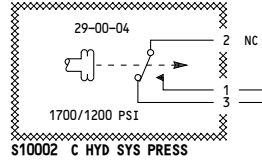

S10002 C HYD SYS PRESS

27-09-06



(V)
(S5)

(U)
(SH 5)

(R)
D675A
B6
(SH 5)

(T)
C9
(SH 5)
(S)
E12
(SH 5)

D675B
H6 HIGH PRESSURE
H5 LOW PRESSURE

F6 HIGH PRESSURE
F5 LOW PRESSURE
(U)
(SH 5)

D675C
7
8
10

D675B
NC 12 L
13 R

H8
H9
NC H10
H11

M525 STAB. TRIM ELEVATOR ASYMMETRY MODULE - RIGHT (E4-1)

INTERNAL SAME AS M524 (SH 5)

D675B
C11
(W)
(SH 5)

C13
(AC)
(SH 5)

A15
F4
(AB)
(SH 5)
(AA)
(SH 5)

D675A
C12
F12
(Z)
(SH 5)
(Y)
(SH 5)

002-004

HORIZONTAL STABILIZER TRIM

D280N032S

27-40-01

Page 102.1
Sheet 6
Jan 21/2005

5016

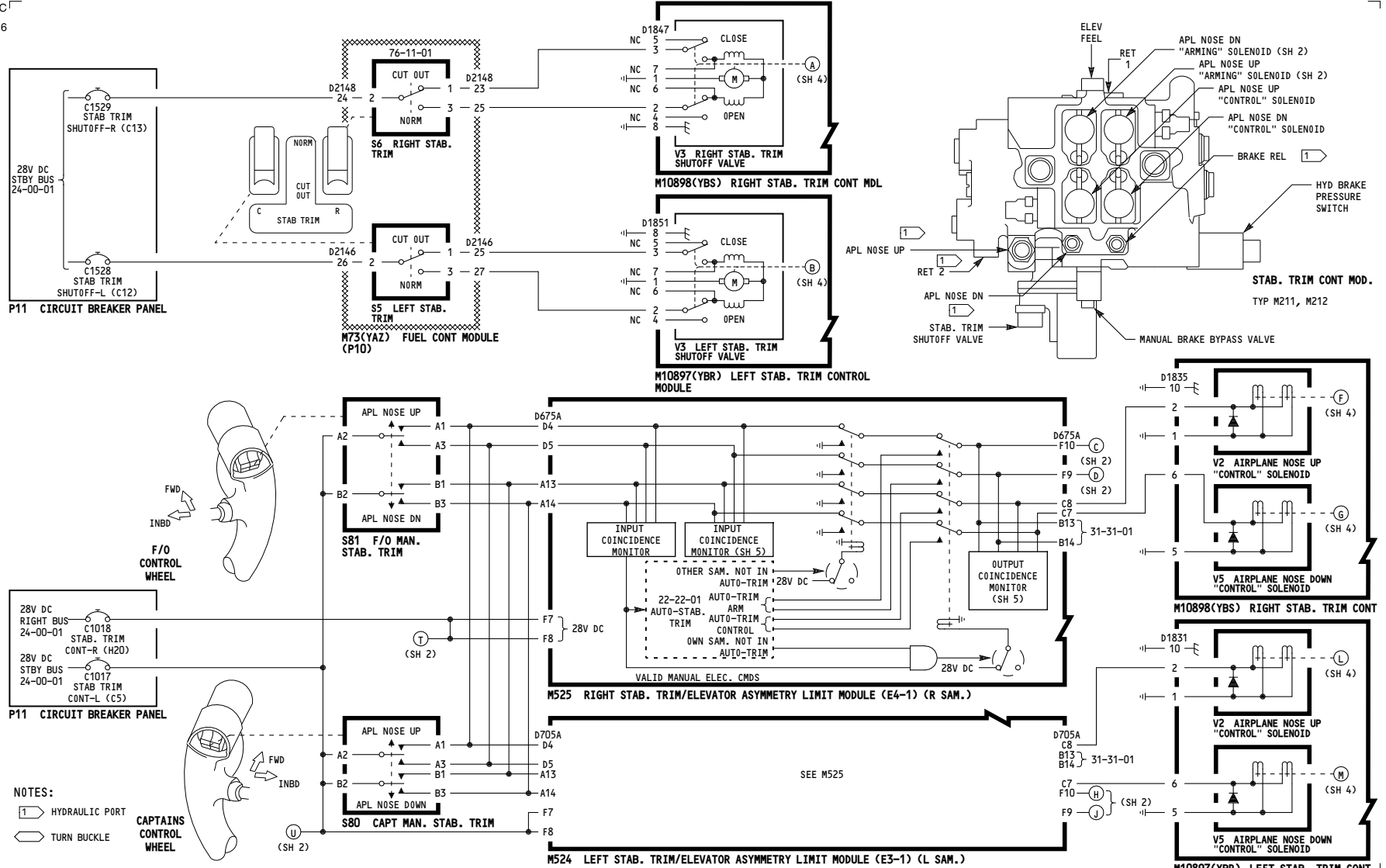

27-40-01

5011

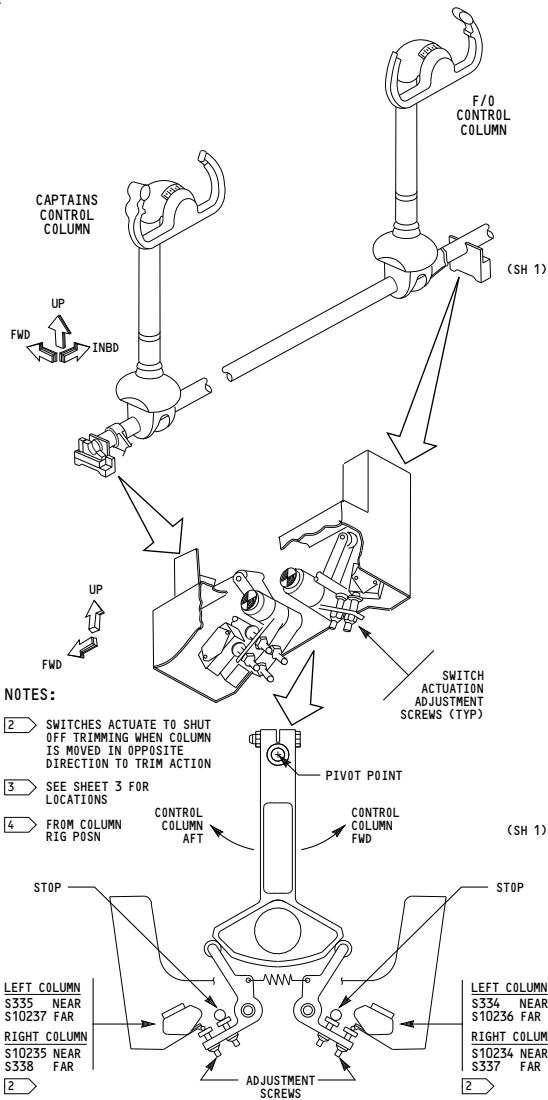

- NOTES:**
- 2 SWITCHES ACTUATE TO SHUT OFF TRIMMING WHEN COLUMN IS MOVED IN OPPOSITE DIRECTION TO TRIM ACTION
 - 3 SEE SHEET 3 FOR LOCATIONS
 - 4 FROM COLUMN RIG POSN

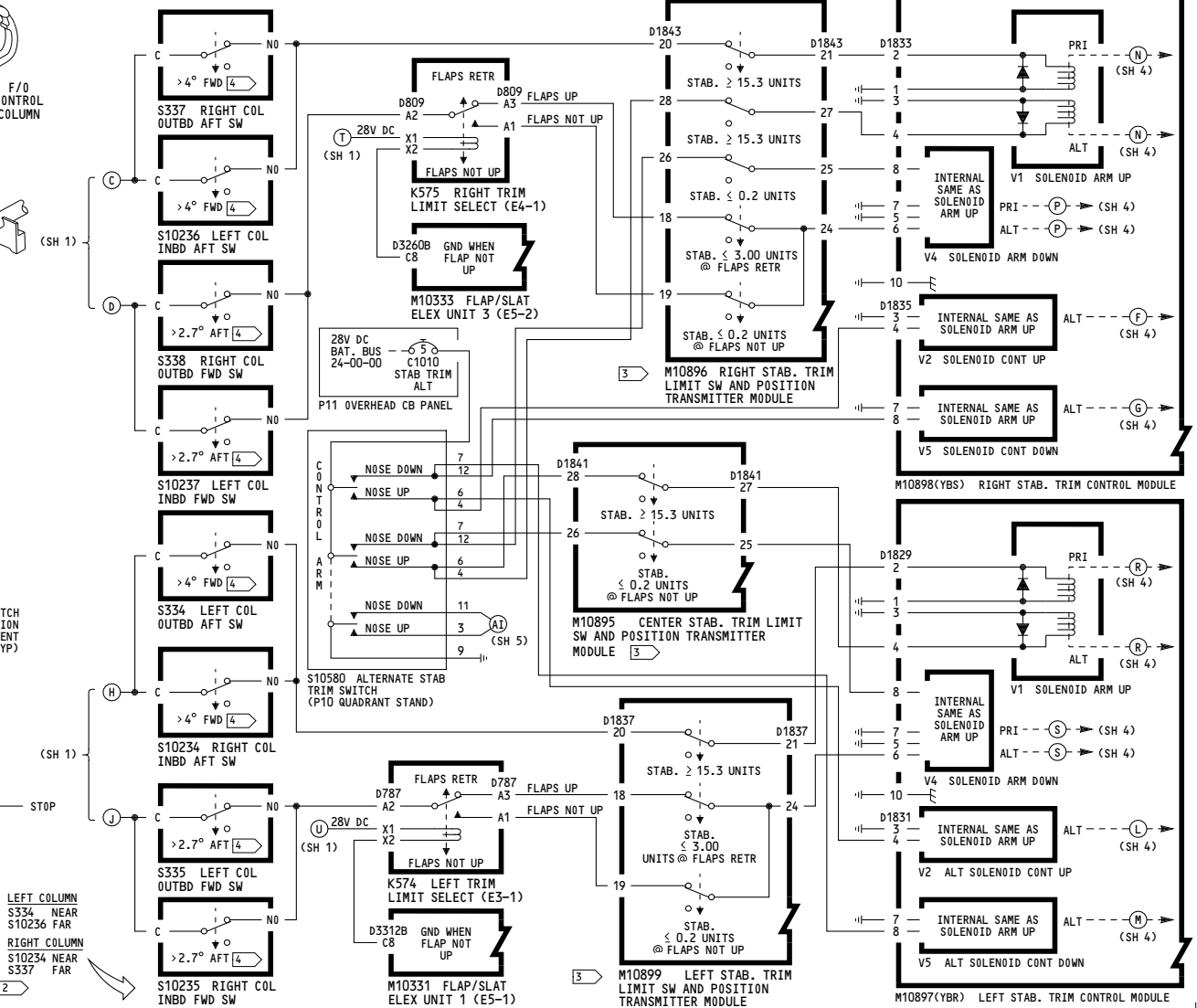

005-099

HORIZONTAL STABILIZER TRIM

D280N032S

27-40-01

5014

WIRING DIAGRAMS
27-48-11

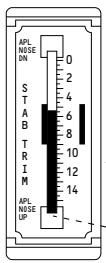
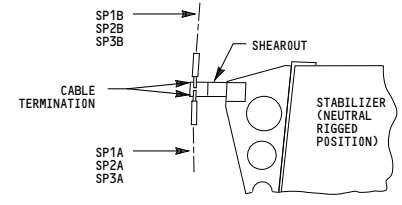
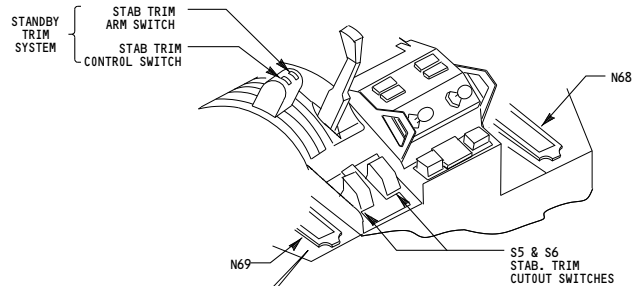

N68, N69

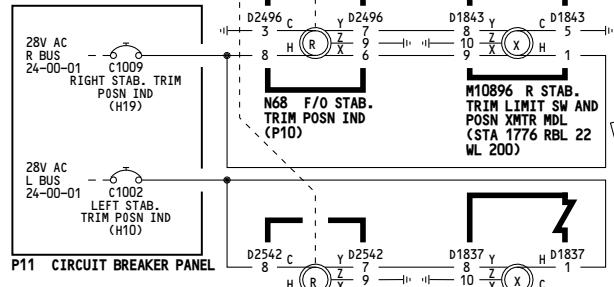

NOTES:

- 4 SAME CABLE CONNECTION TO STABILIZER, AS M10896, M10895
- 5 FOR HYDRAULIC POWER DISTRIBUTION SEE 27-30-01

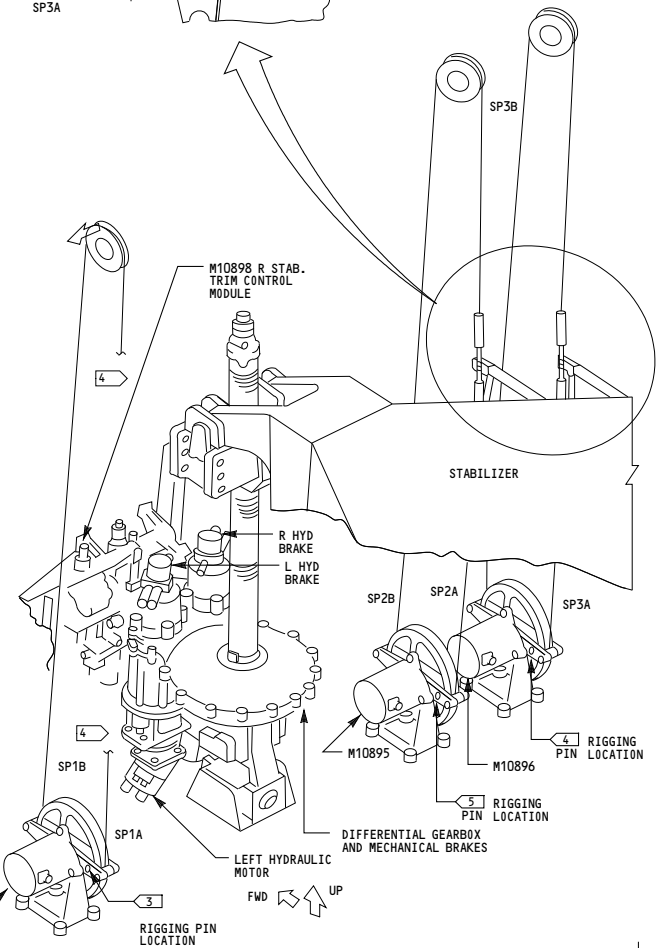
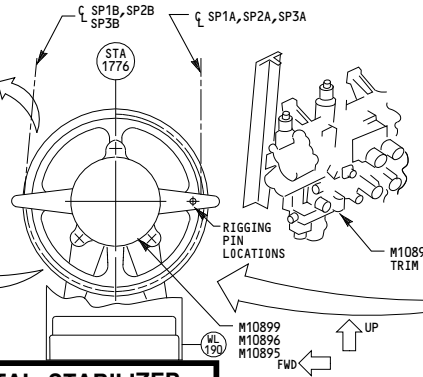

| | |
|-----------|-----------------------------------|
| 005-099 | HORIZONTAL STABILIZER TRIM |
| D280N032S | |

27-40-01

5001

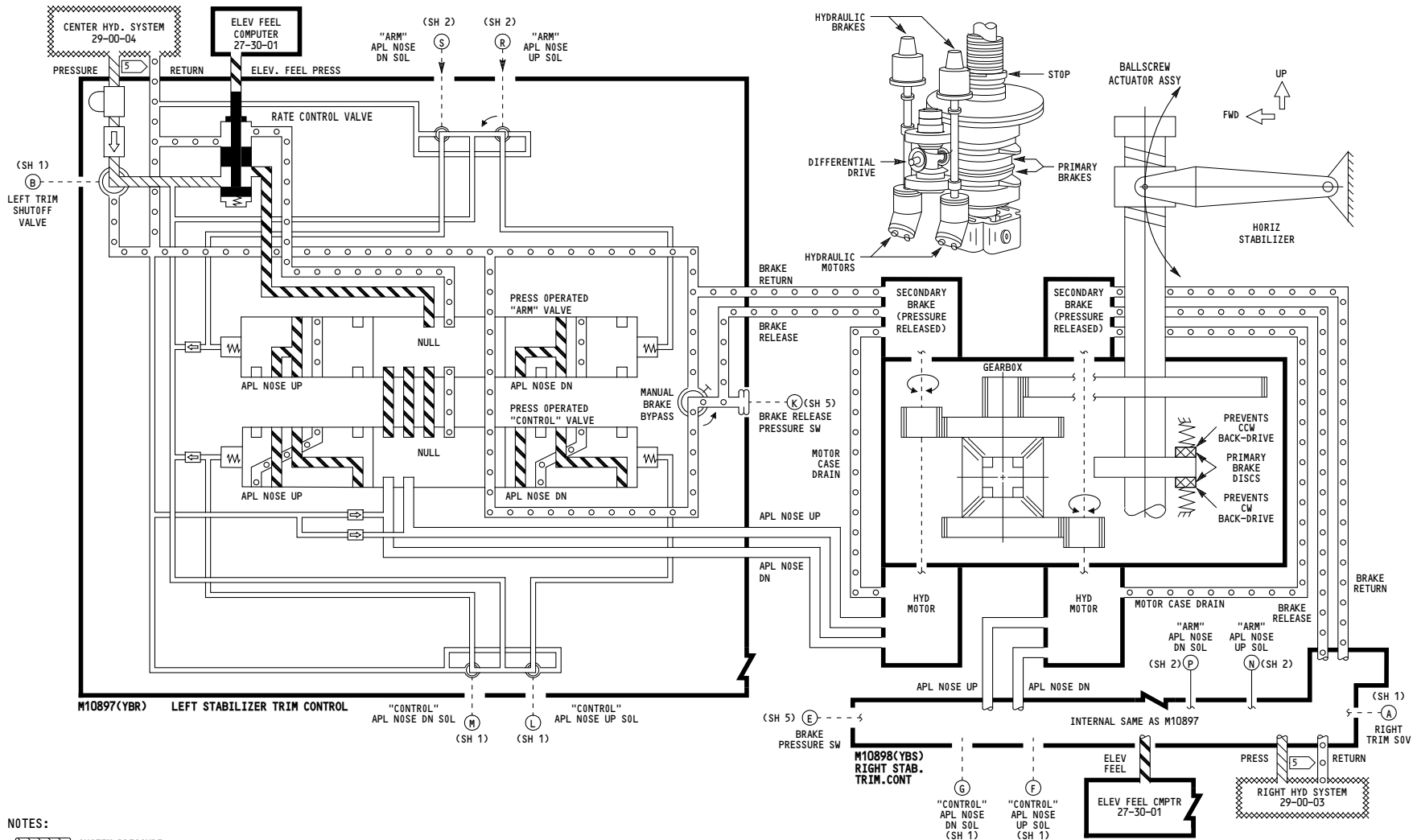

| | |
|---------|---|
| 005-099 | <p align="center">HORIZONTAL STABILIZER TRIM</p> <p align="center">D280N032S</p> |
|---------|---|

27-40-01

5011

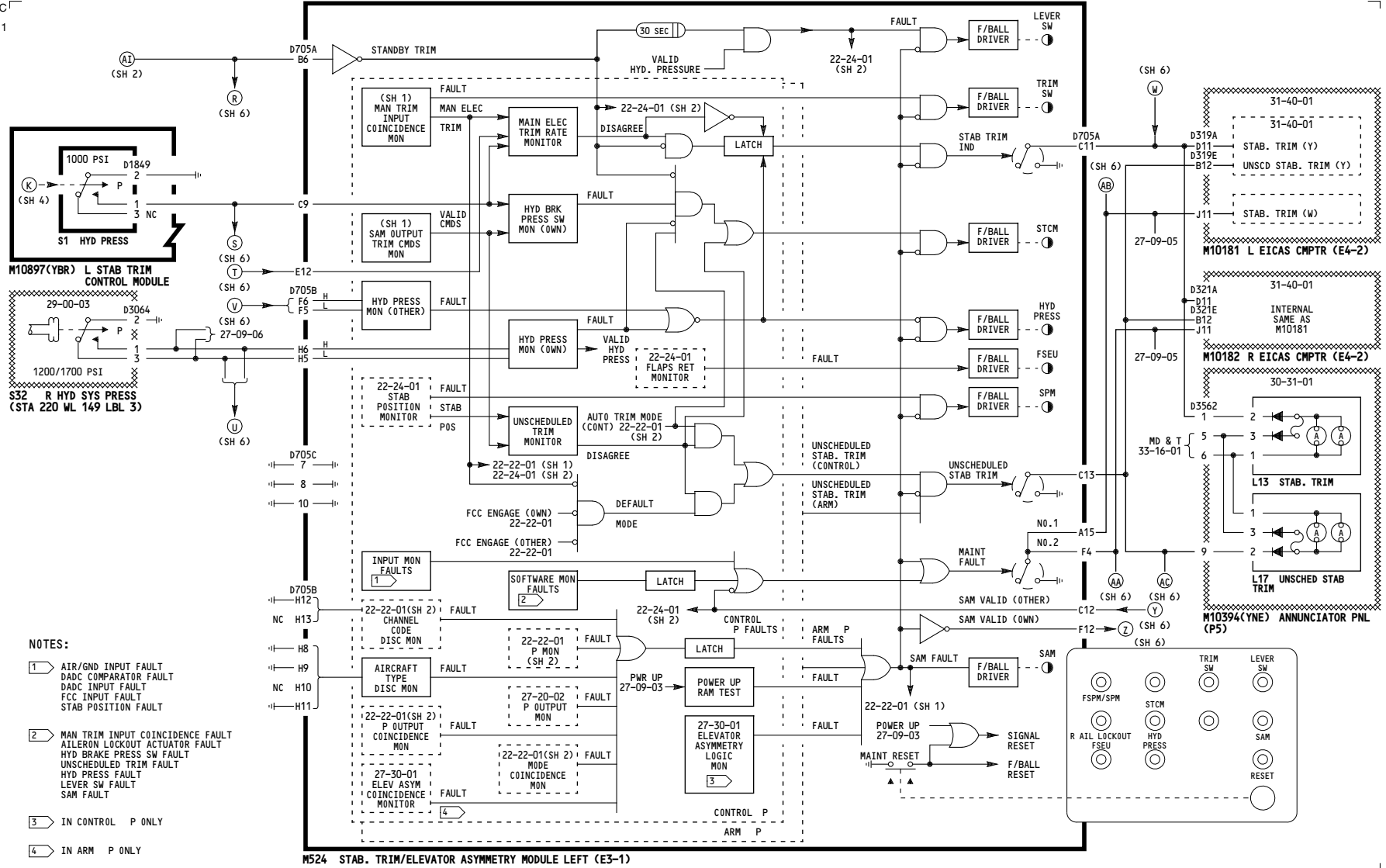

- NOTES:**
- 1 AIR/GND INPUT FAULT
DADC COMPARATOR FAULT
DADC INPUT FAULT
FCC INPUT FAULT
STAB POSITION FAULT
 - 2 MAN TRIM INPUT COINCIDENCE FAULT
AILERON LOCKOUT ACTUATOR FAULT
HYD BRAKE PRESS SW FAULT
UNDESCHED TRIM FAULT
HYD PRESS FAULT
LEVER SW FAULT
SAM FAULT
 - 3 IN CONTROL P ONLY
 - 4 IN ARM P ONLY

M524 STAB. TRIM/ELEVATOR ASYMMETRY MODULE LEFT (E3-1)

005-099

HORIZONTAL STABILIZER TRIM

D280N032S

27-40-01

-A
5011

WIRING DIAGRAMS
27-41-11
27-41-21
27-48-11

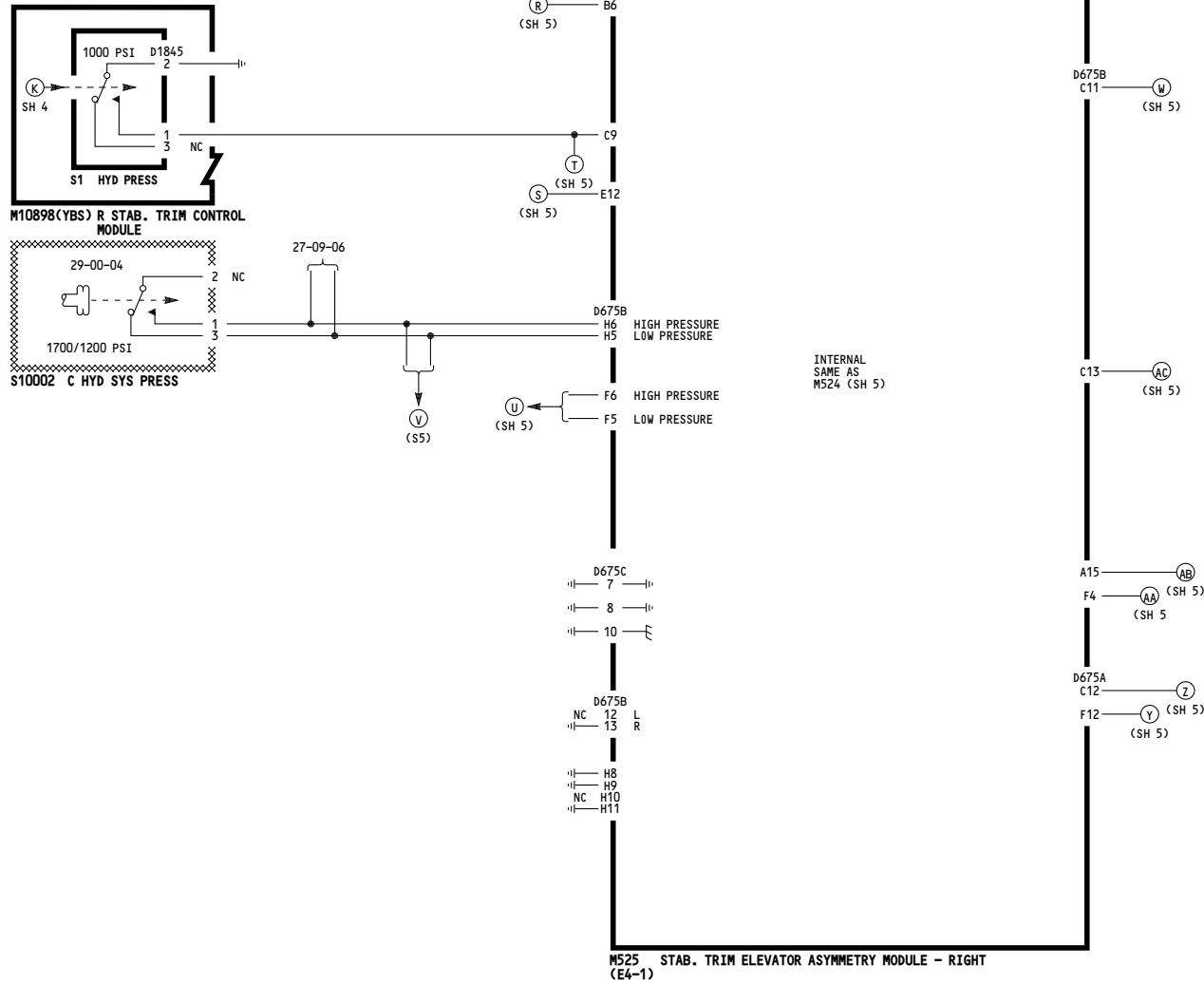

005-099

HORIZONTAL STABILIZER TRIM

D280N032S

27-40-01

Page 103
Sheet 6
Jan 21/2005

5016

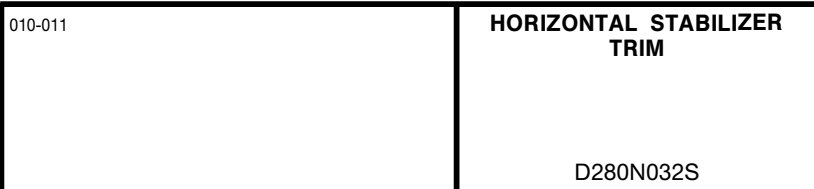
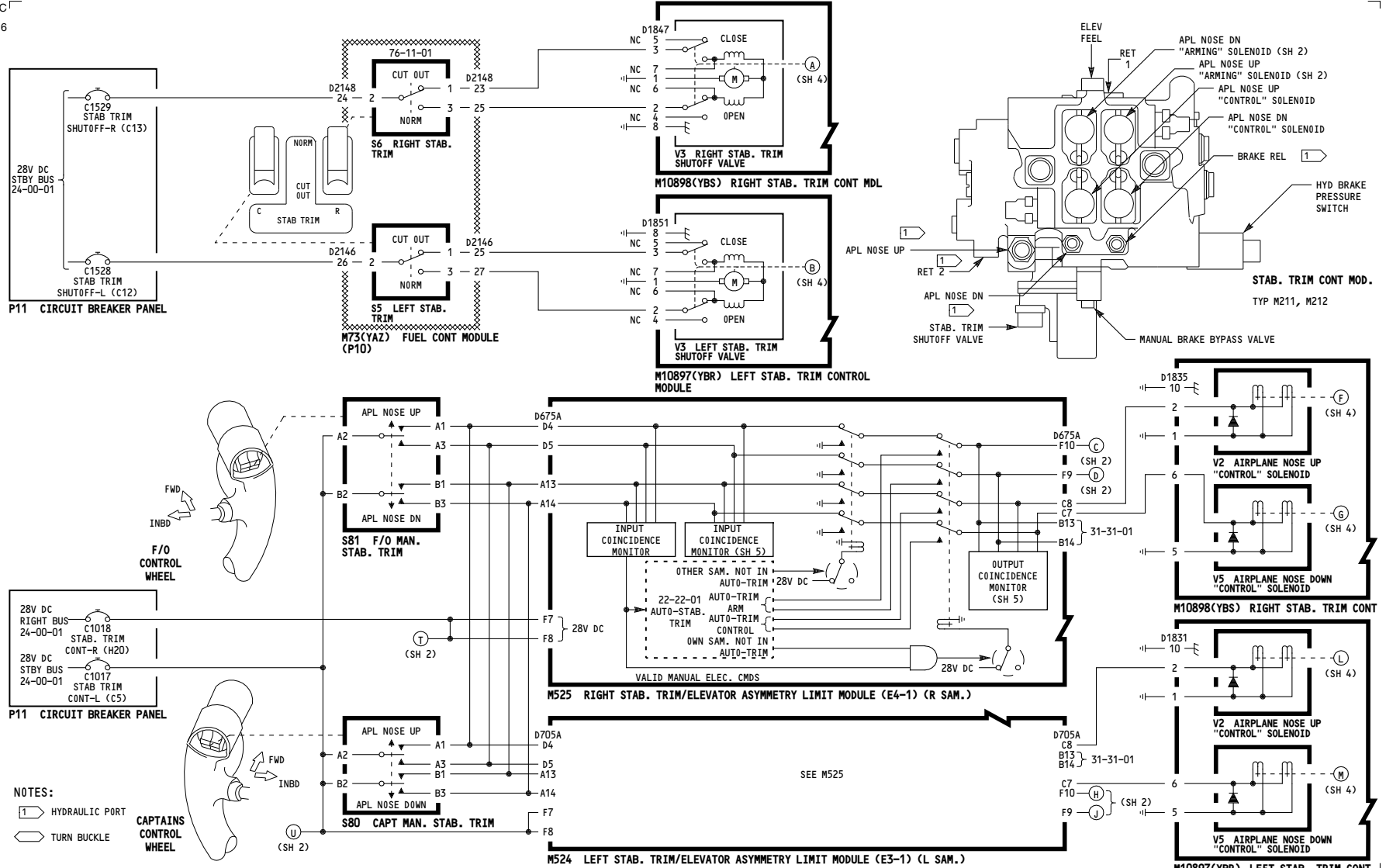

27-40-01

5011

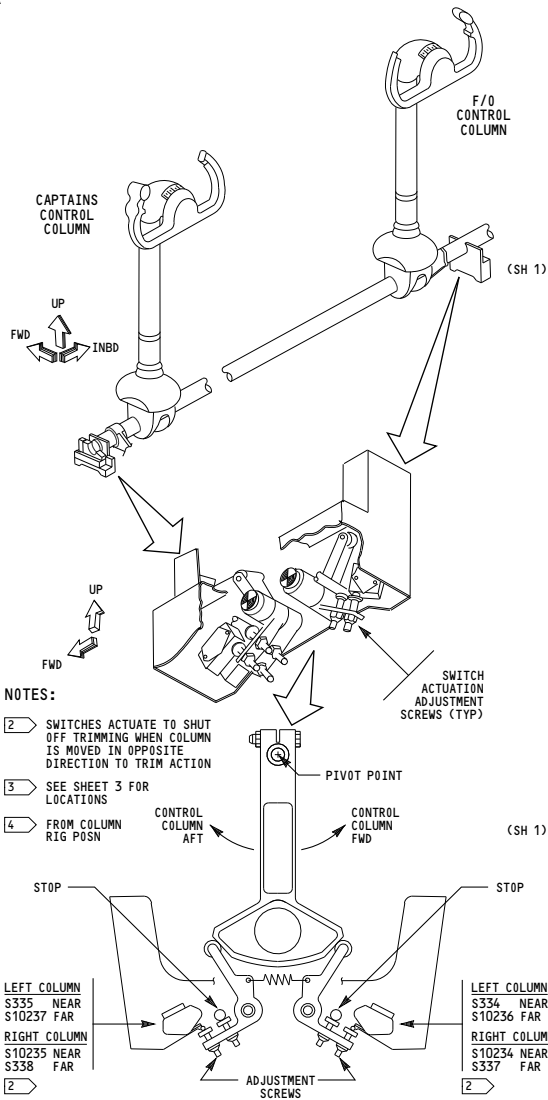

- NOTES:**
- 2 SWITCHES ACTUATE TO SHUT OFF TRIMMING WHEN COLUMN IS MOVED IN OPPOSITE DIRECTION TO TRIM ACTION
 - 3 SEE SHEET 3 FOR LOCATIONS
 - 4 FROM COLUMN RIG POSN

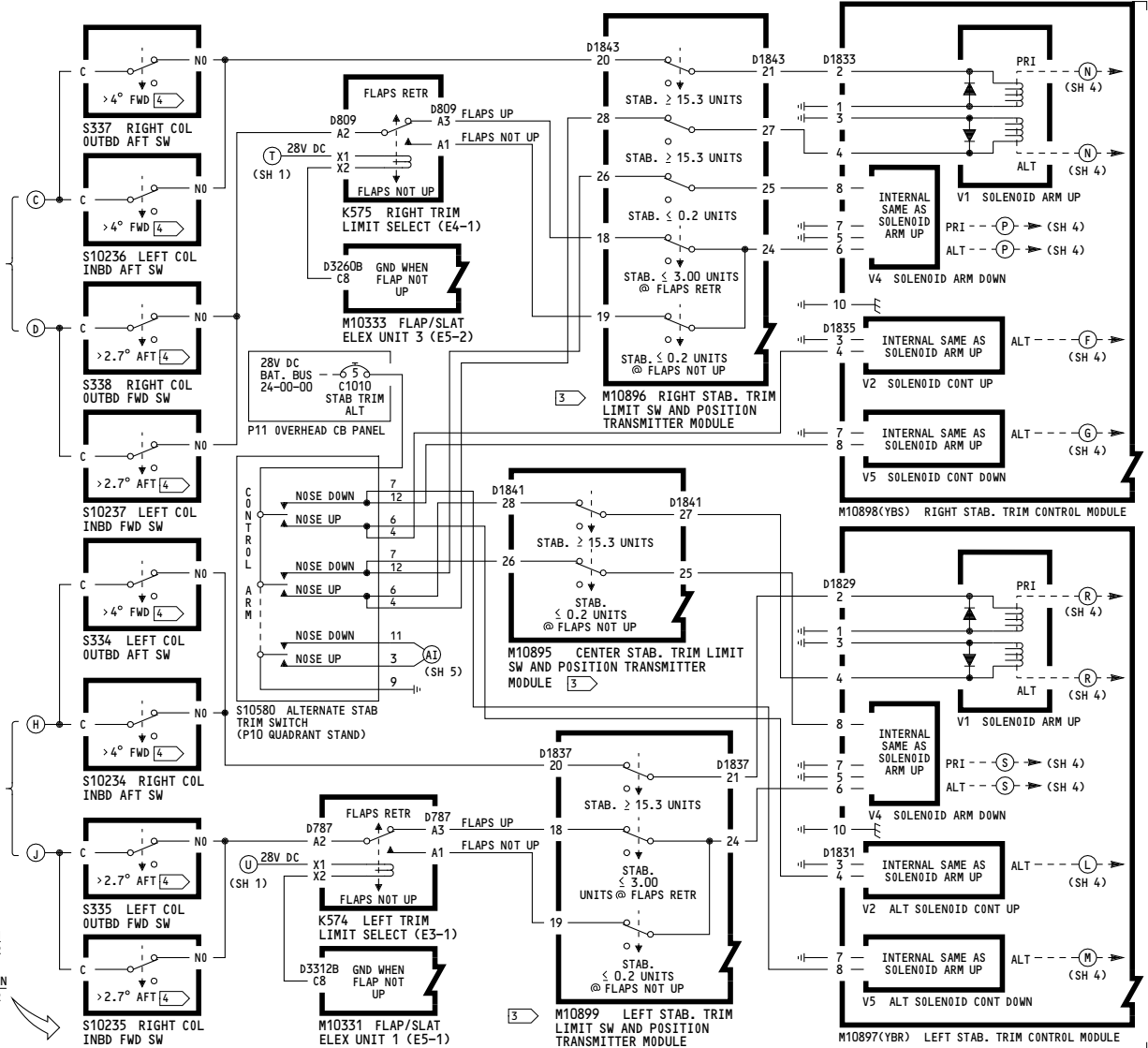

010-011

HORIZONTAL STABILIZER TRIM

D280N032S

27-40-01

5019

WIRING DIAGRAMS
27-48-11

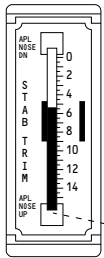
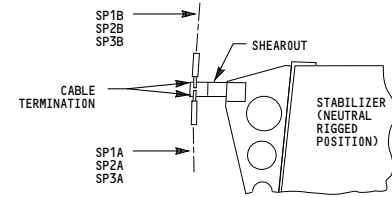
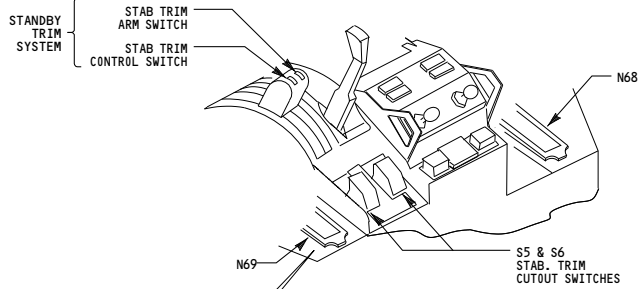

N68, N69

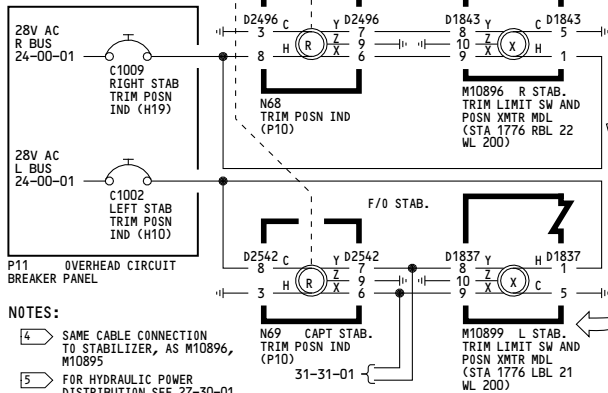

NOTES:

- 4 SAME CABLE CONNECTION TO STABILIZER, AS M10896, M10895
- 5 FOR HYDRAULIC POWER DISTRIBUTION SEE 27-30-01

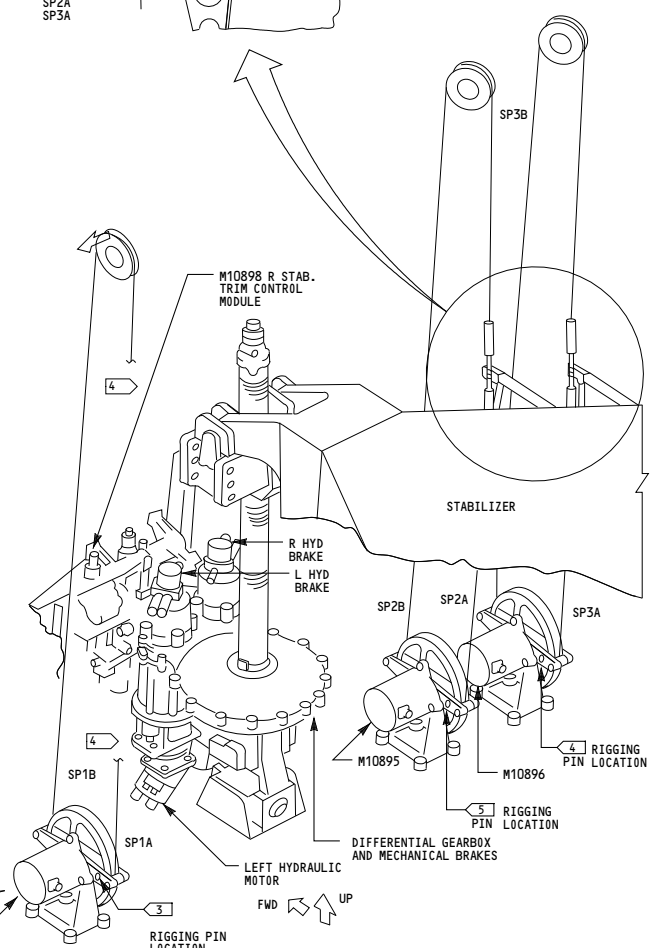
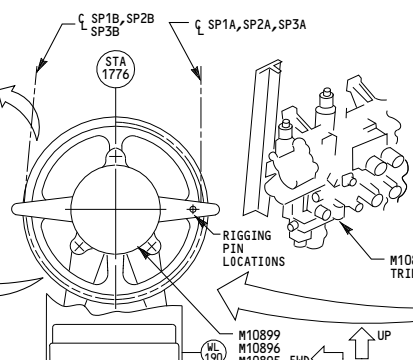

| | |
|---------|---|
| 010-011 | <p>HORIZONTAL STABILIZER TRIM</p> <p>D280N032S</p> |
|---------|---|

Incorporates
31-0094

27-40-01

5001

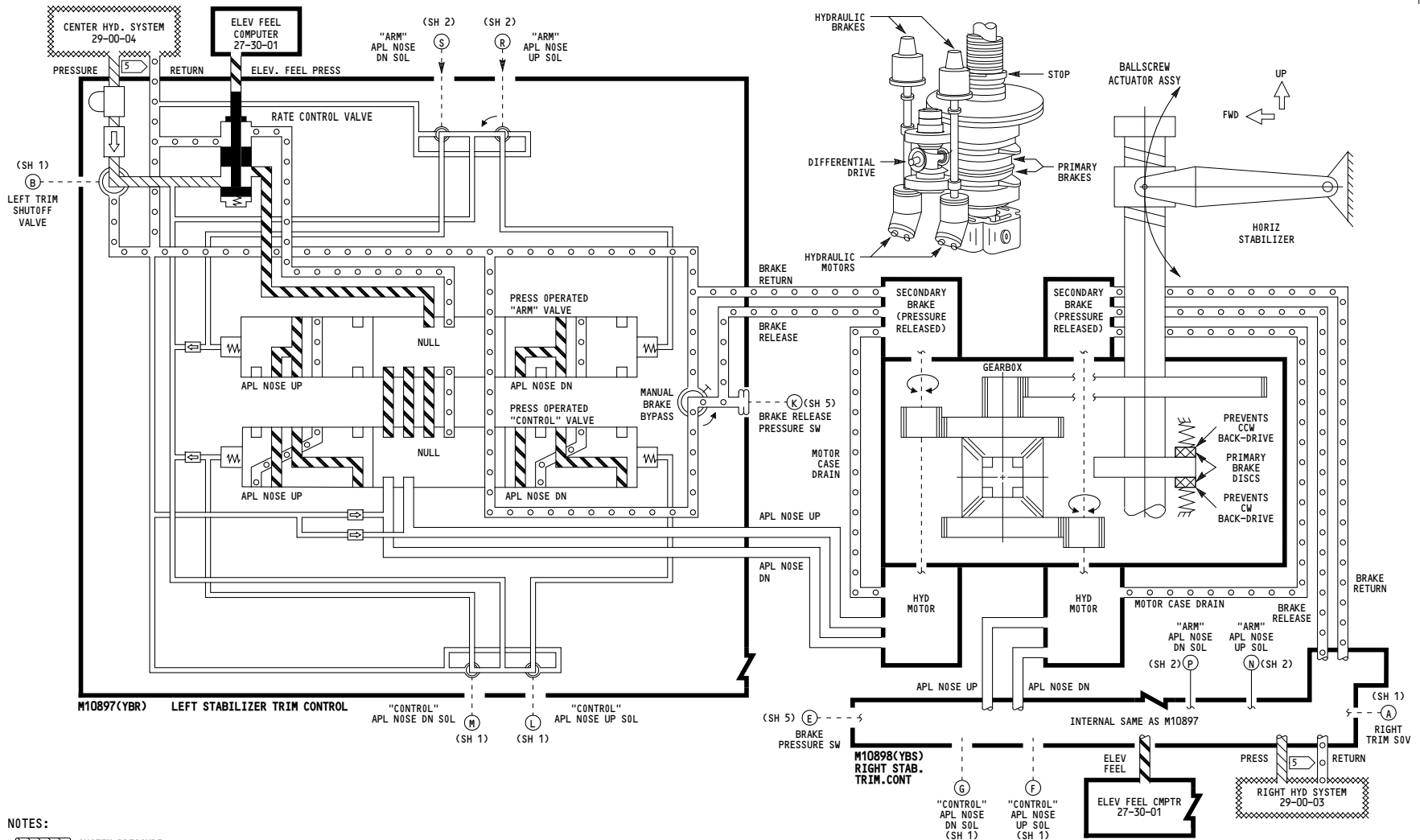

- NOTES:**
- SYSTEM PRESSURE
 - RETURN
 - METERED PRESSURE

010-011

HORIZONTAL STABILIZER TRIM

D280N032S

27-40-01

Page 103.1
Sheet 4
Jan 21/2005

5011

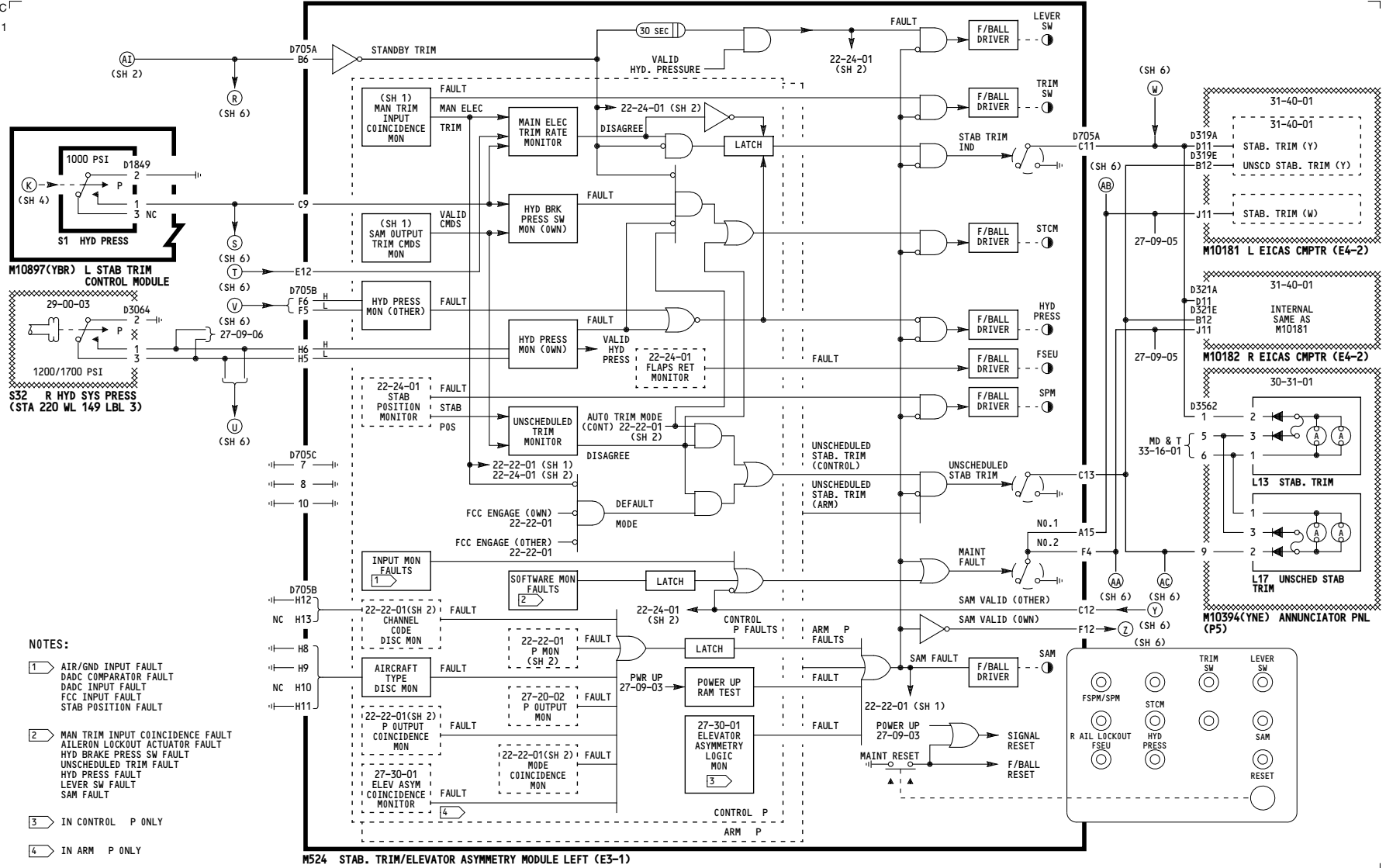

HORIZONTAL STABILIZER TRIM

D280N032S

27-40-01

Page 103.1
Sheet 5
Dec 18/2007

-A
5011

WIRING DIAGRAMS
27-41-11
27-41-21
27-48-11

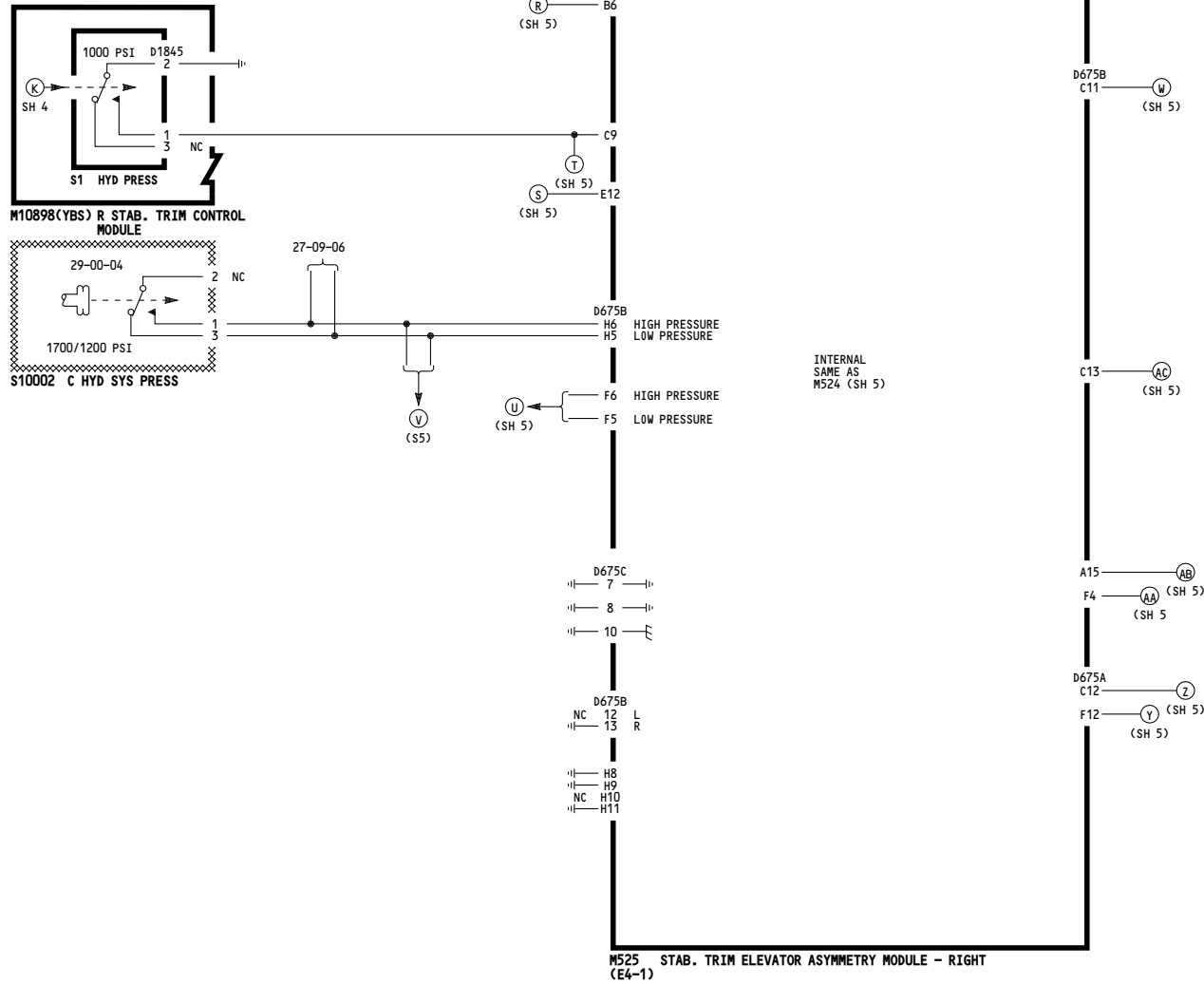

010-011

HORIZONTAL STABILIZER TRIM

D280N032S

27-40-01

Page 103.1
Sheet 6
Jan 21/2005

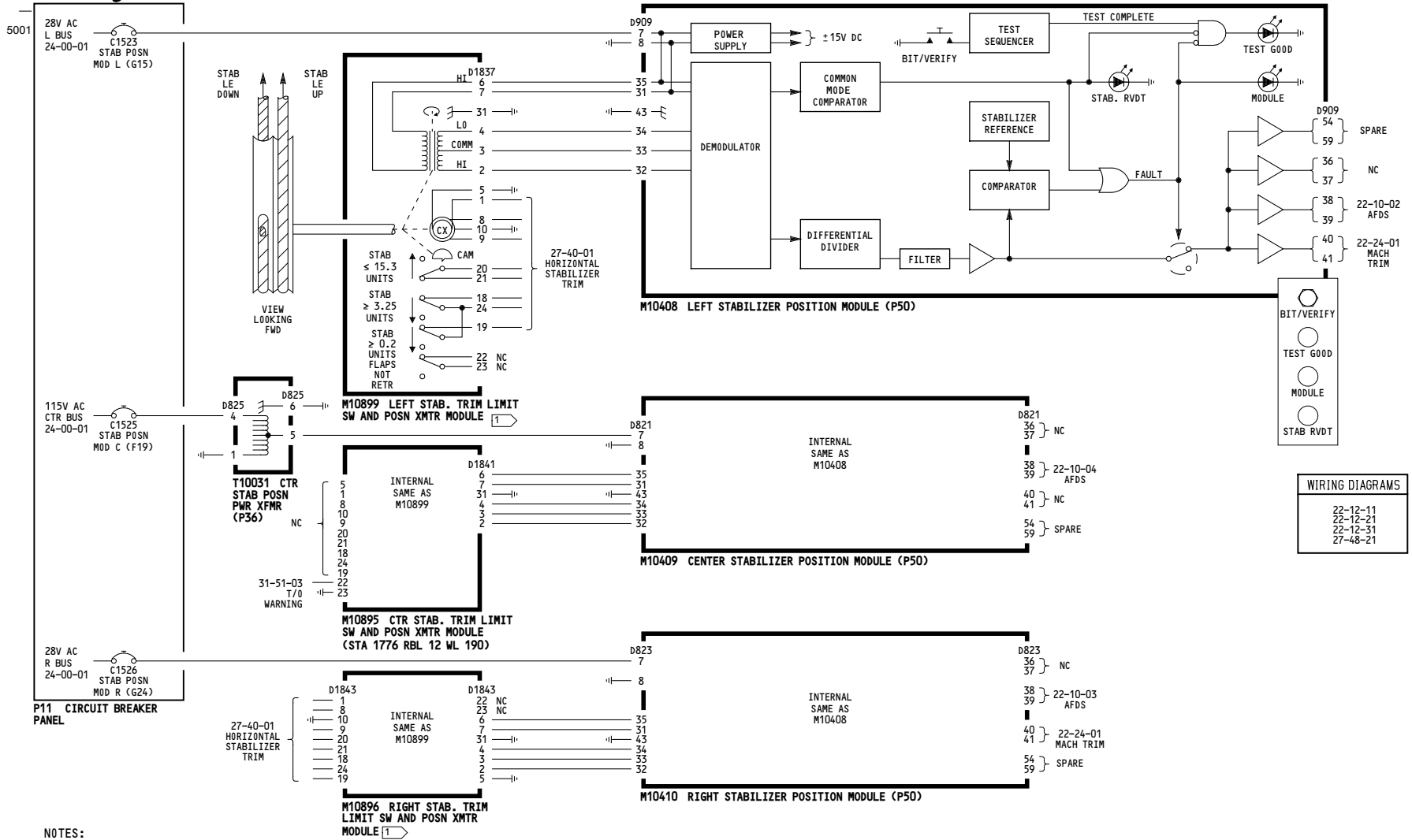

NOTES:
1 SEE 27-40-01 FOR LOCATION

ALL

STABILIZER POSITION SENSING

D280N032S

27-48-01

Page 101

May 06/2009

THIS PAGE INTENTIONALLY LEFT BLANK

5001

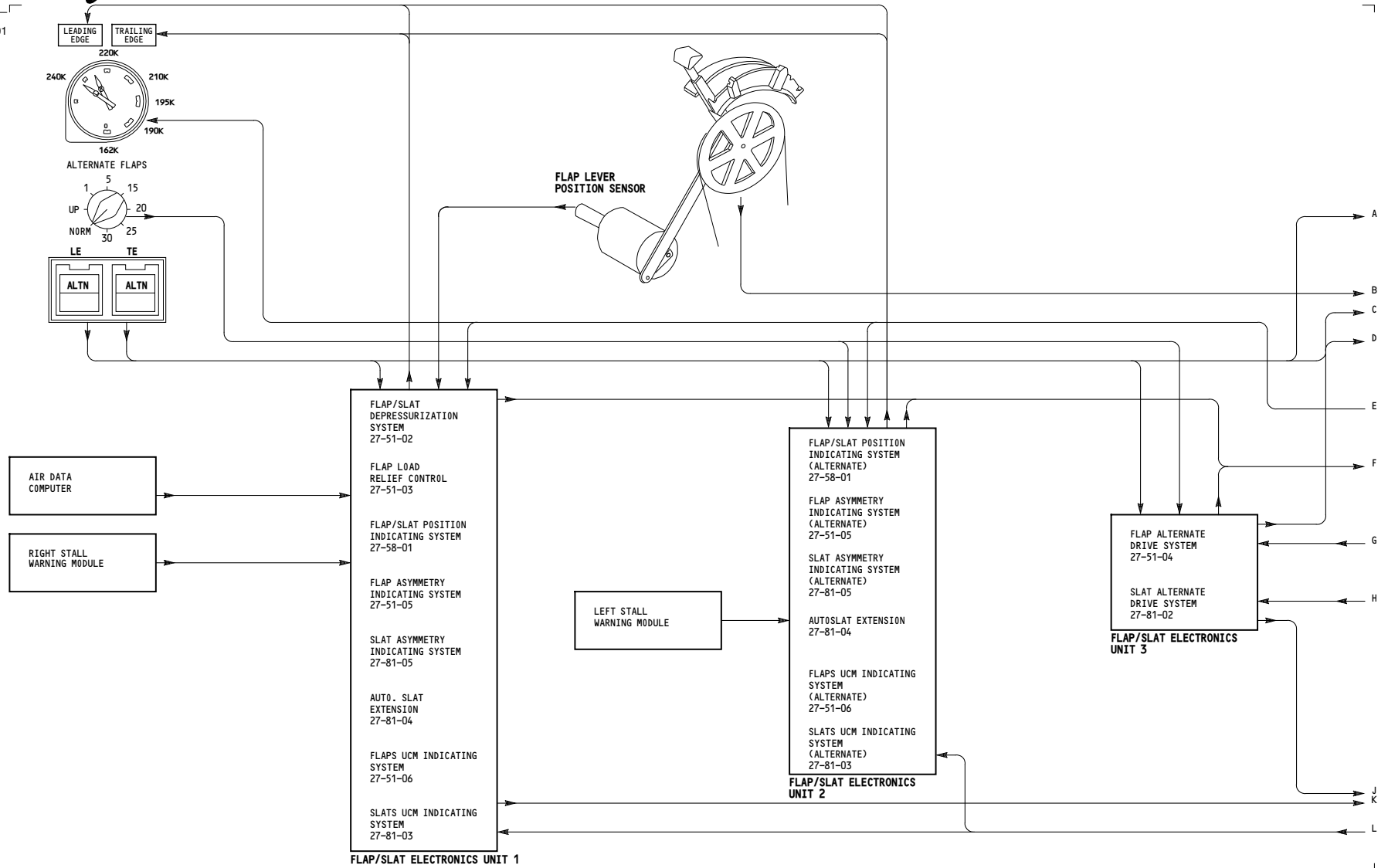

| | |
|-----|---|
| ALL | <p align="center">HIGH LIFT DEVICES - SIMPLIFIED</p> <p align="center">D280N032S</p> |
|-----|---|

27-50-00

5001

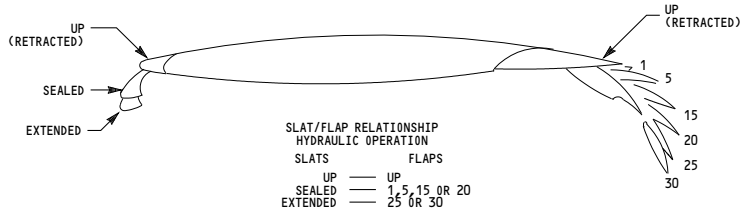
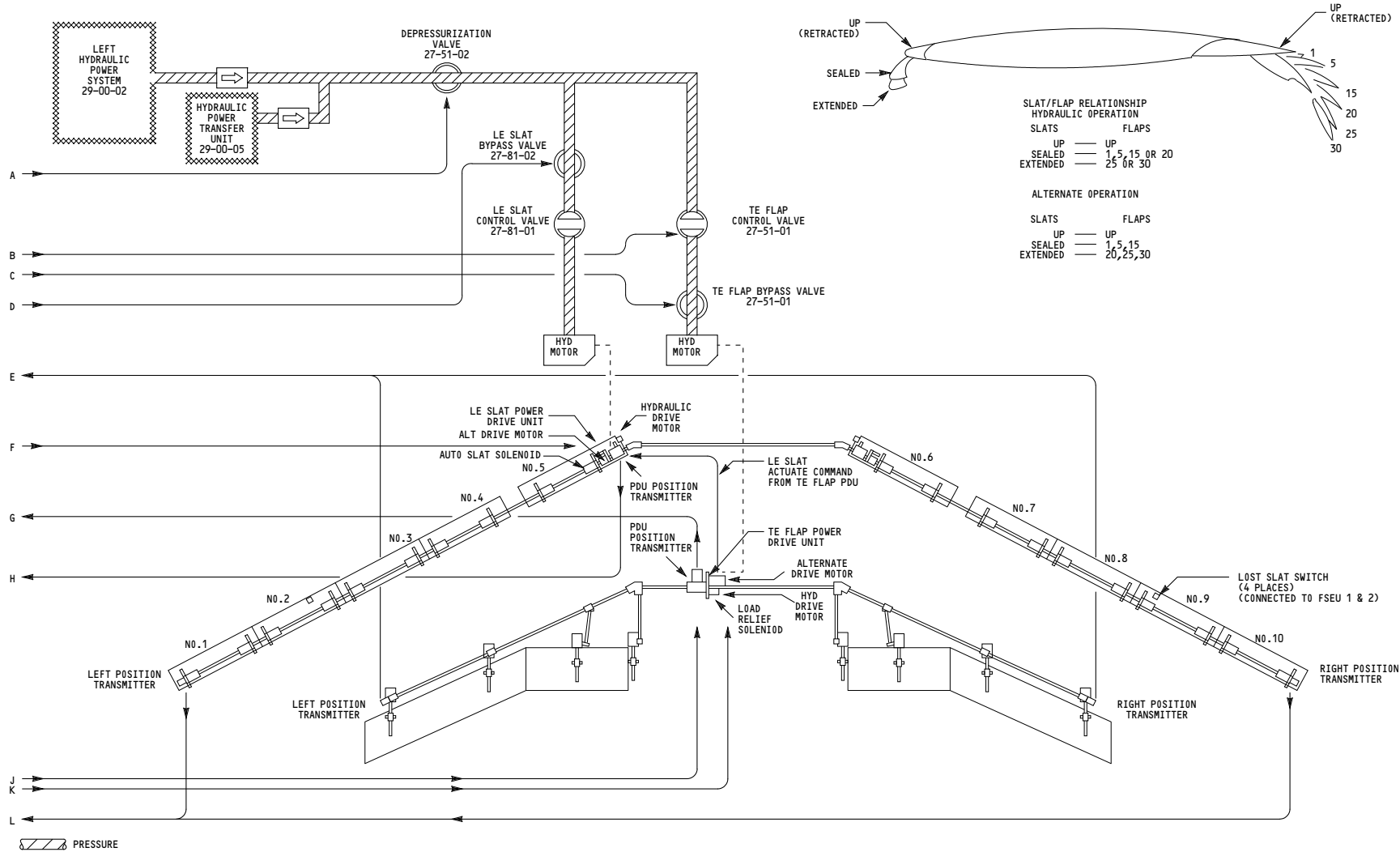

**SLAT/FLAP RELATIONSHIP
HYDRAULIC OPERATION**

| SLATS | FLAPS |
|----------|----------------|
| UP | UP |
| SEALED | 1, 5, 15 OR 20 |
| EXTENDED | 25 OR 30 |

ALTERNATE OPERATION

| SLATS | FLAPS |
|----------|------------|
| UP | UP |
| SEALED | 1, 5, 15 |
| EXTENDED | 20, 25, 30 |

| | |
|-----|---|
| ALL | <p>HIGH LIFT DEVICES - SIMPLIFIED</p> <p>D280N032S</p> |
|-----|---|

27-50-00

Page 101
Sheet 2
May 06/2009

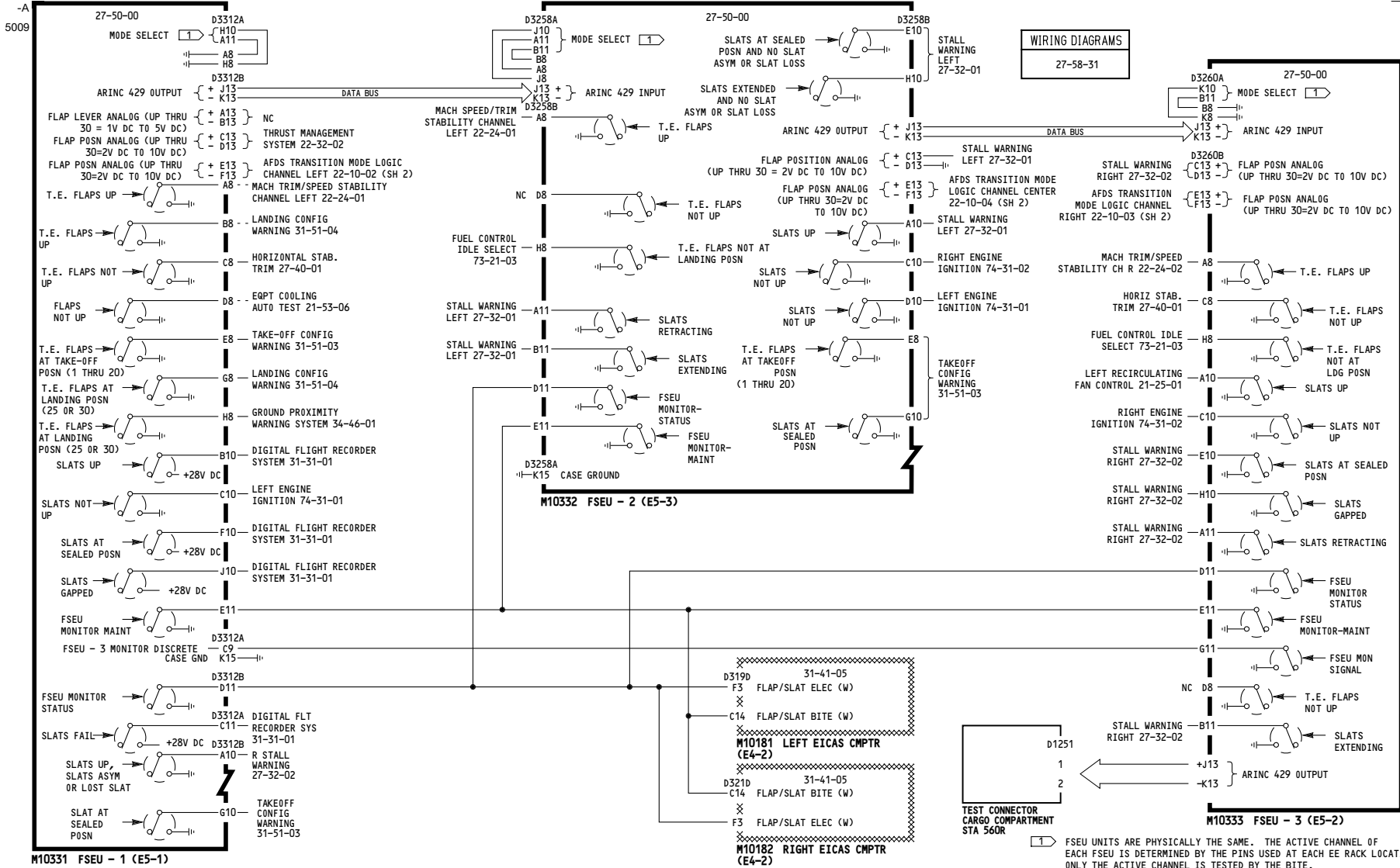

FSEU UNITS ARE PHYSICALLY THE SAME. THE ACTIVE CHANNEL OF EACH FSEU IS DETERMINED BY THE PINS USED AT EACH EE RACK LOCATION. ONLY THE ACTIVE CHANNEL IS TESTED BY THE BITE.

27-50-01

| | |
|-----|-----------------------------------|
| ALL | FLAP/SLAT ELECTRONICS UNIT |
| | D280N032S |

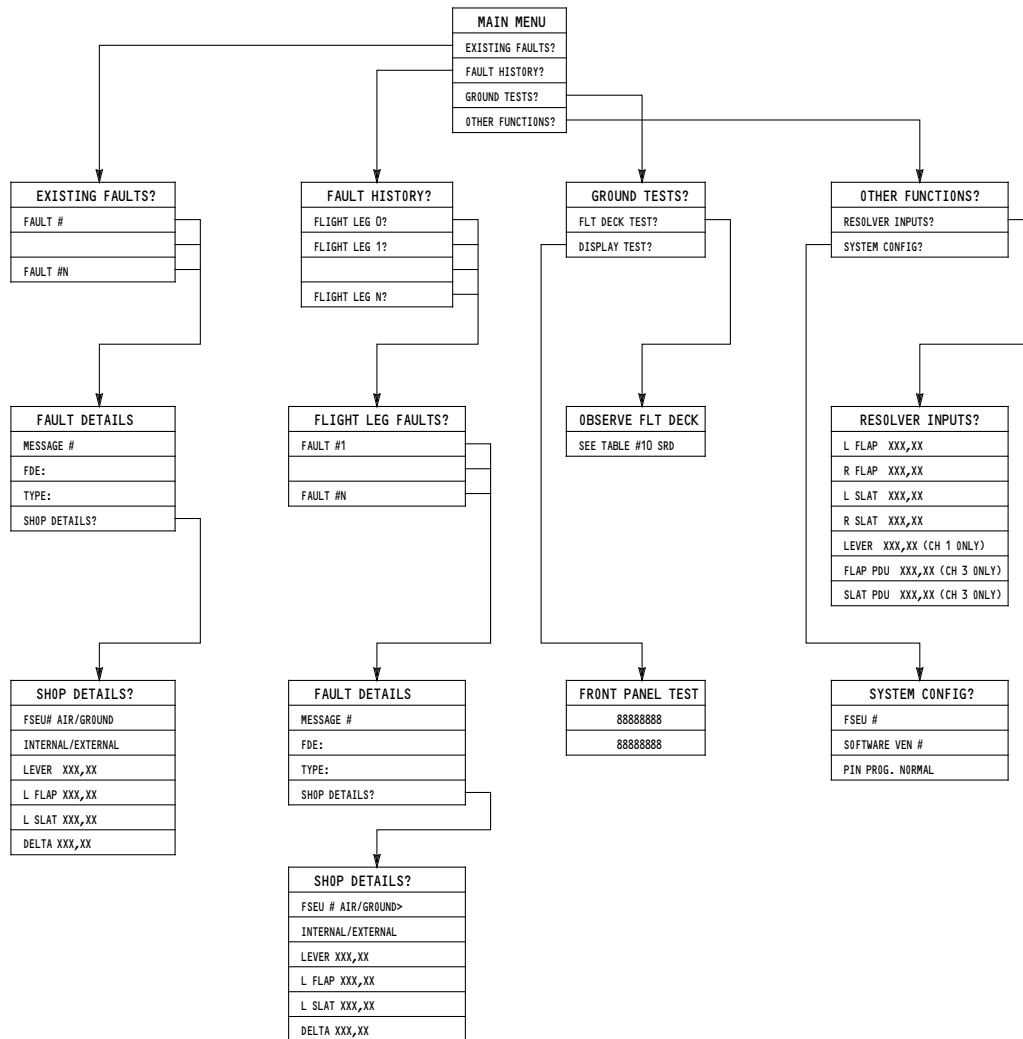

FSEU BITE CONTROL PANEL MENU HIERARCHY

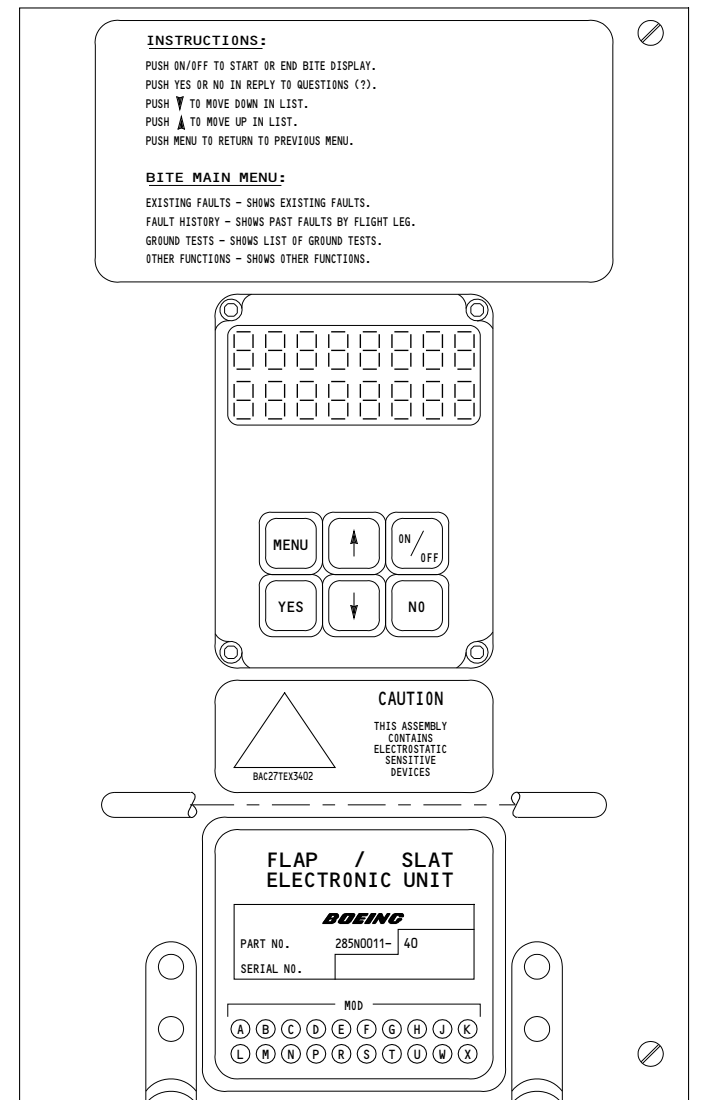

| | |
|-----|-----------------------------------|
| ALL | FLAP/SLAT ELECTRONICS UNIT |
| | D280N032S |

27-50-01

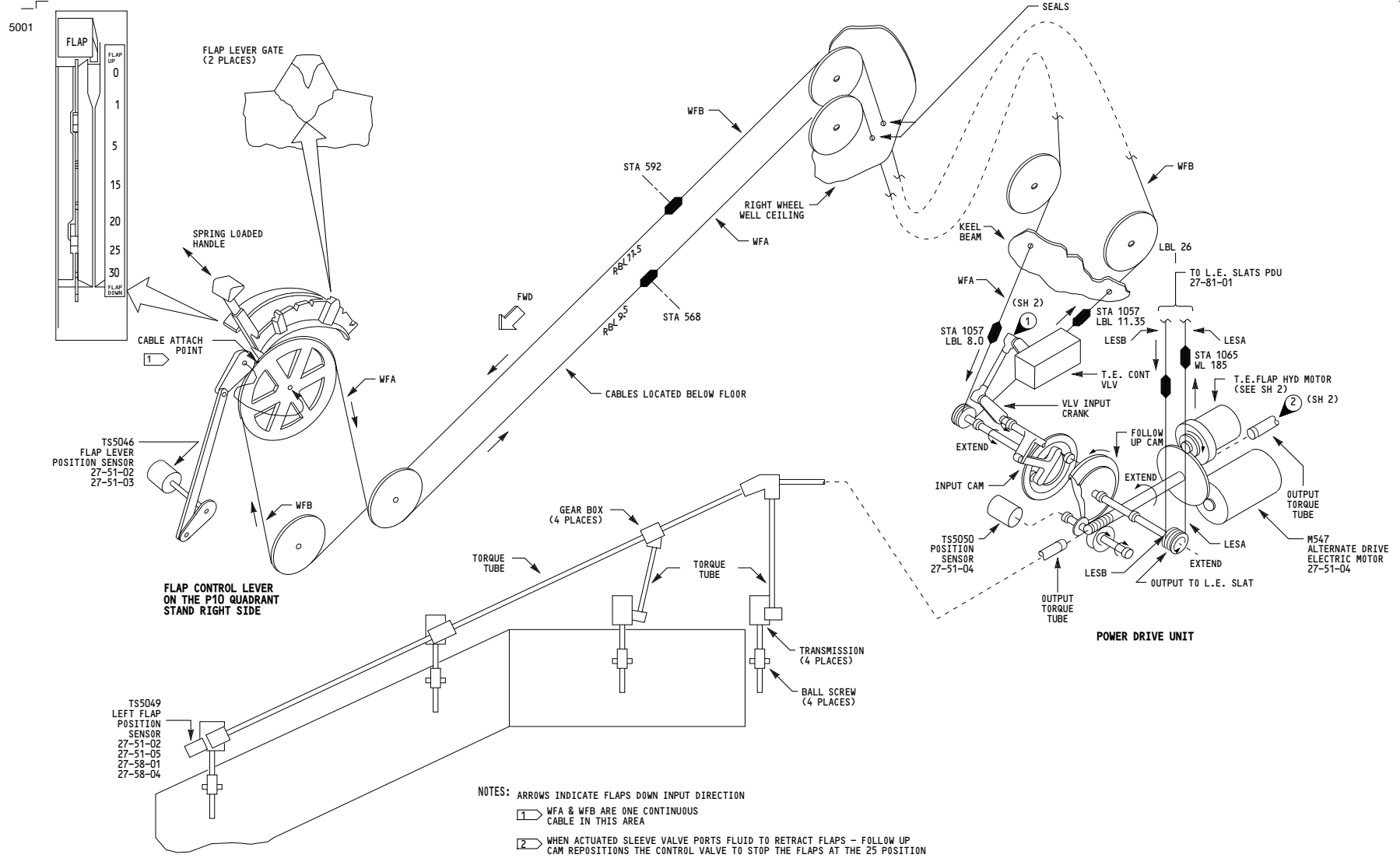

ALL

**TRAILING EDGE FLAPS
PRIMARY DRIVE**

D280N032S

27-51-01

Page 101
Sheet 1
May 06/2009

-B
5000

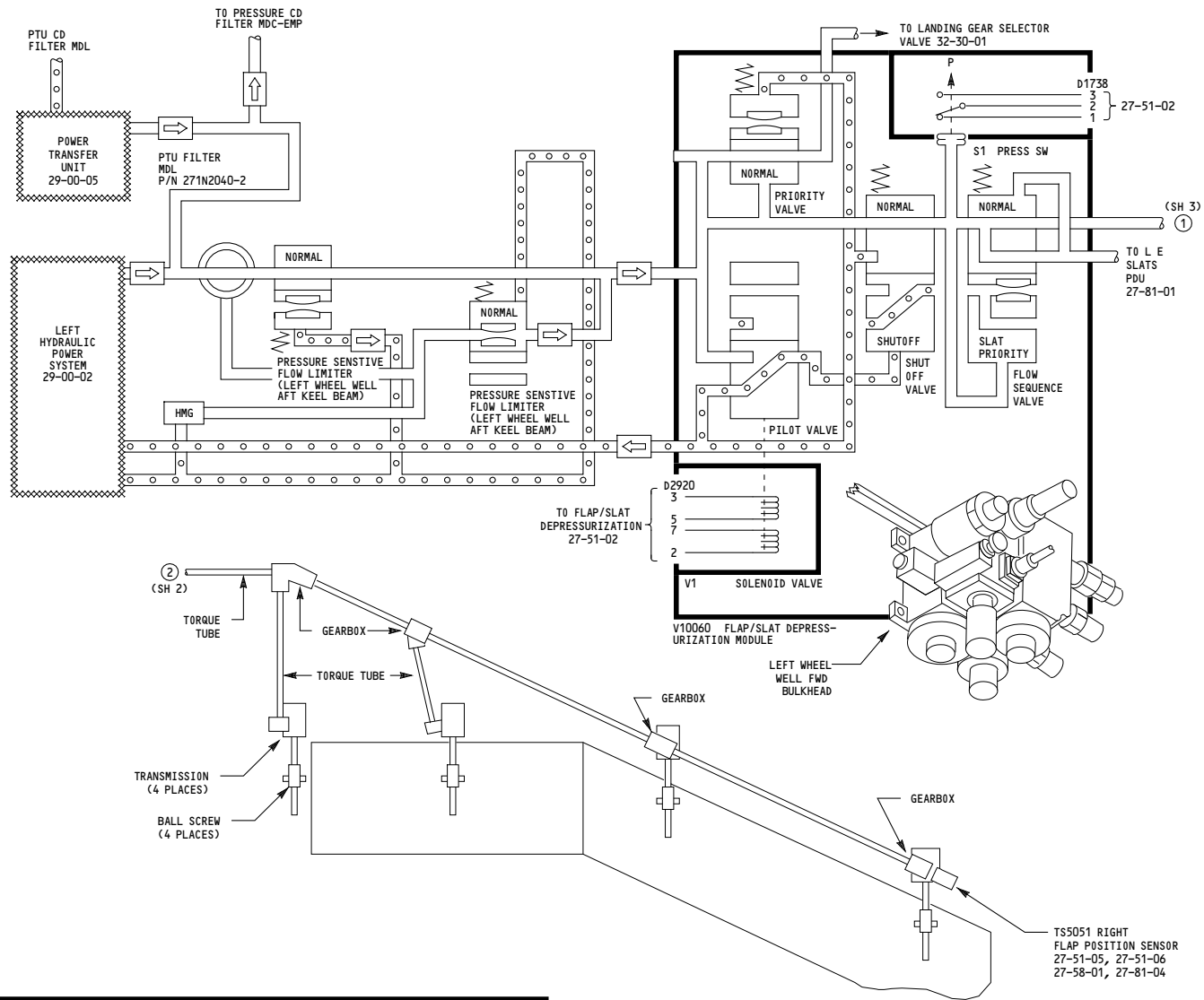

| | |
|-----|--|
| ALL | <p align="center">TRAILING EDGE FLAPS PRIMARY DRIVE</p> <p align="center">D280N032S</p> |
|-----|--|

27-51-01

-A
5000

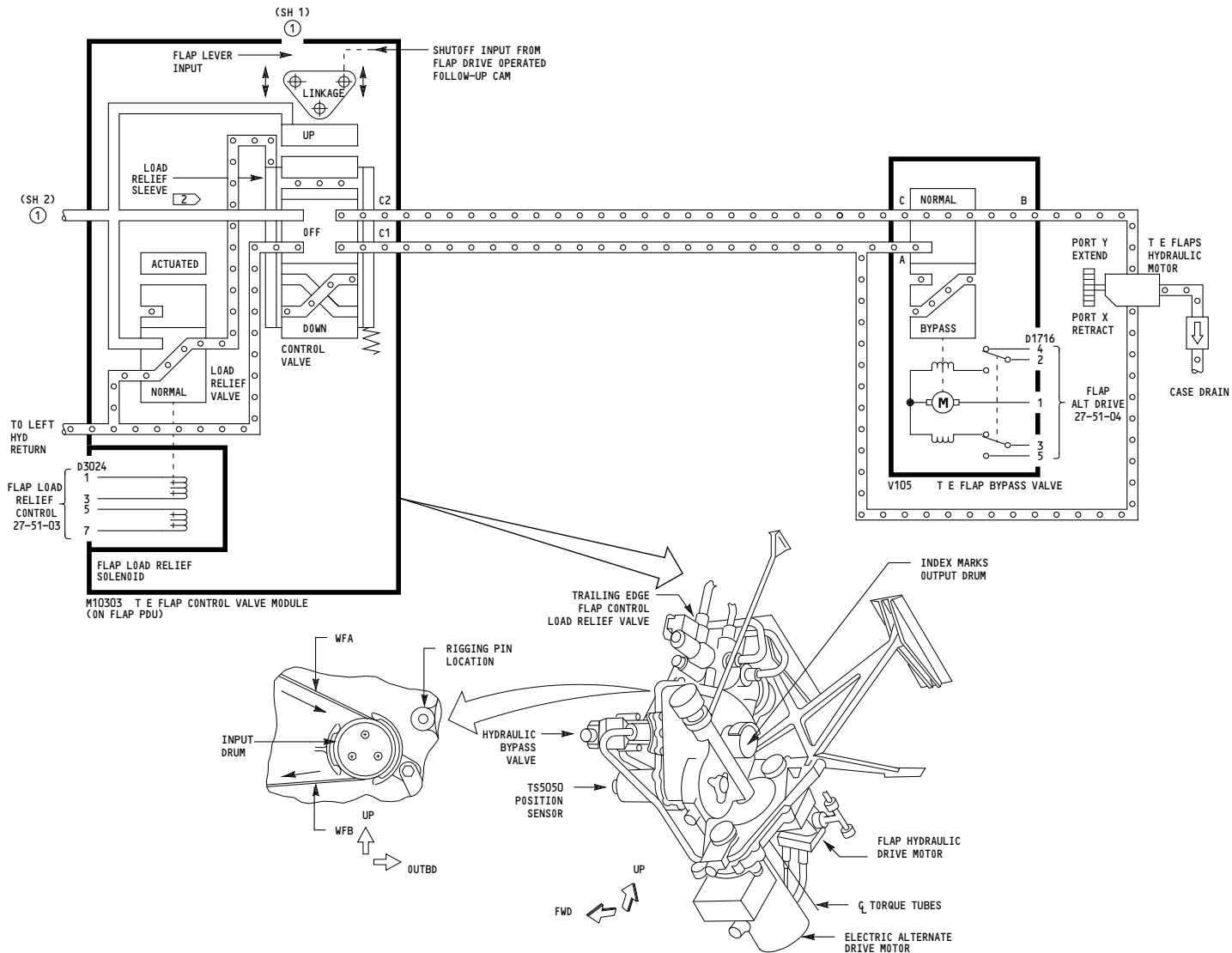

| | |
|-----|--|
| ALL | <p align="center">TRAILING EDGE FLAPS PRIMARY DRIVE</p> <p align="center">D280N032S</p> |
|-----|--|

27-51-01

Page 101
Sheet 3
May 06/2009

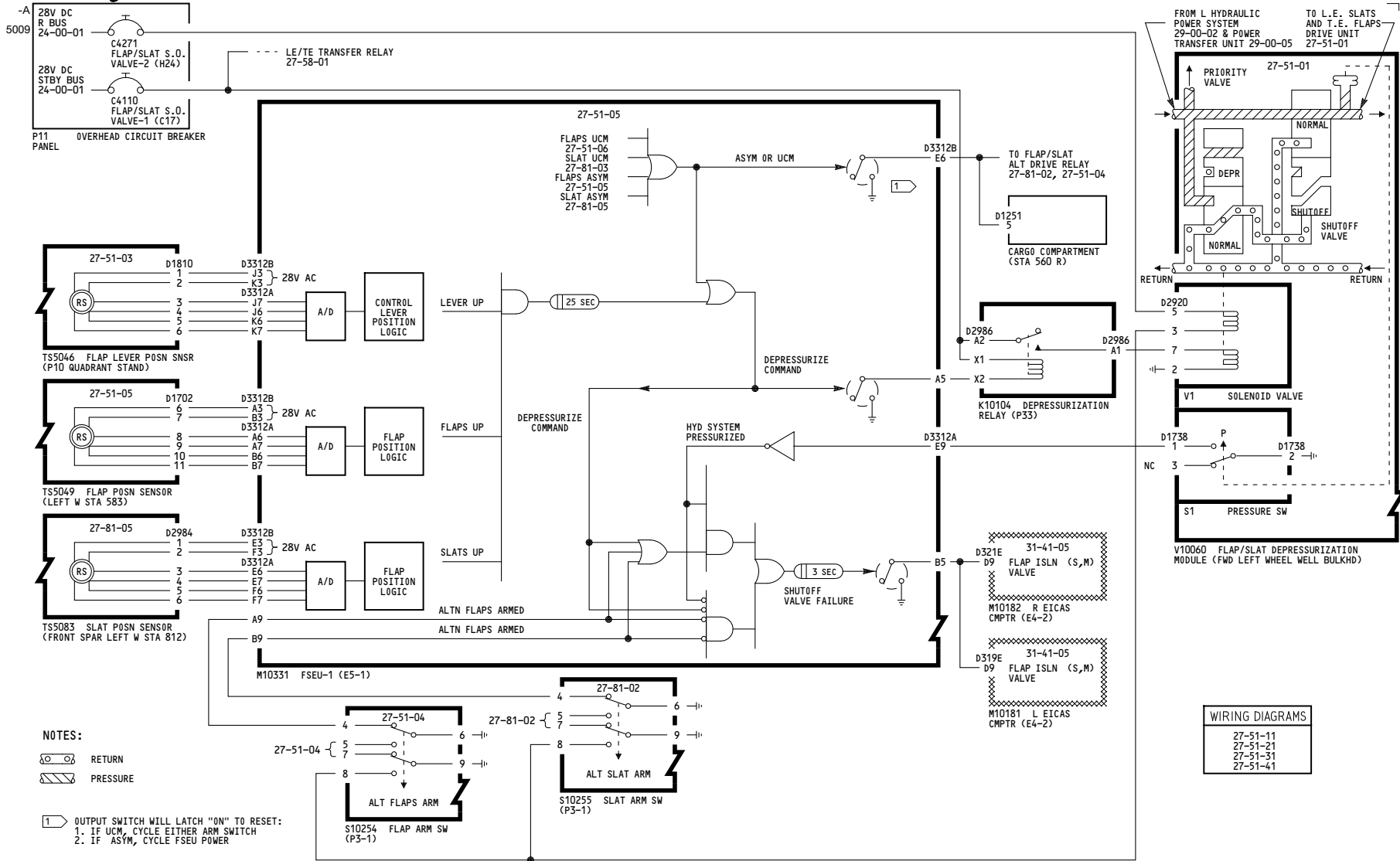

NOTES:

RETURN
 PRESSURE

1 OUTPUT SWITCH WILL LATCH "ON" TO RESET:
 1. IF UCM, CYCLE EITHER ARM SWITCH
 2. IF ASYM, CYCLE FSEU POWER

WIRING DIAGRAMS

27-51-11
 27-51-21
 27-51-31
 27-51-41

ALL

FLAP/SLAT DEPRESSURIZATION SYSTEM

D280N032S

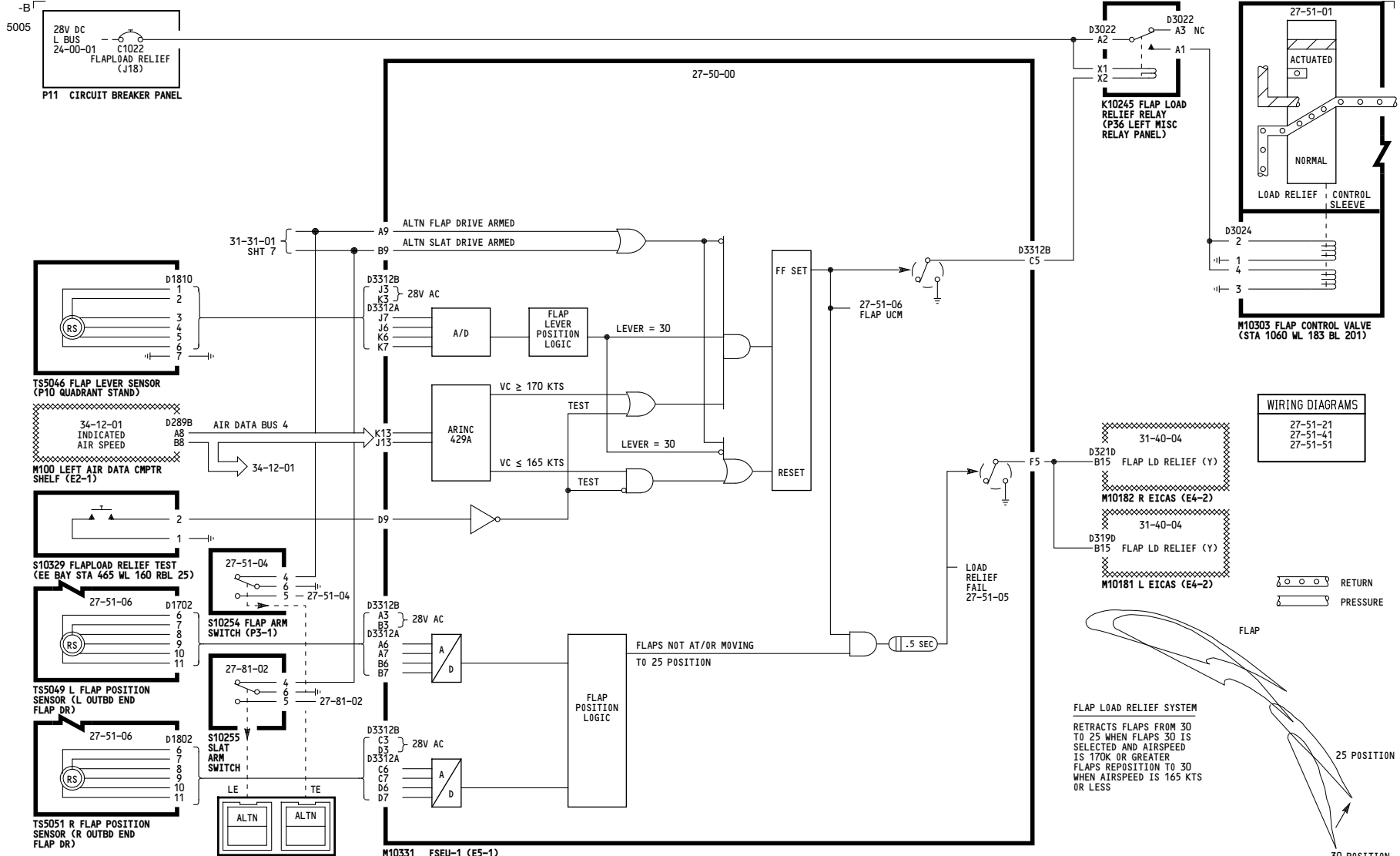

RETURN
 PRESSURE

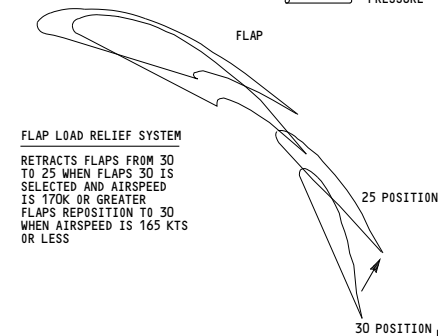

27-51-03

ALL

FLAP LOAD RELIEF CONTROL

D280N032S

THIS PAGE INTENTIONALLY LEFT BLANK

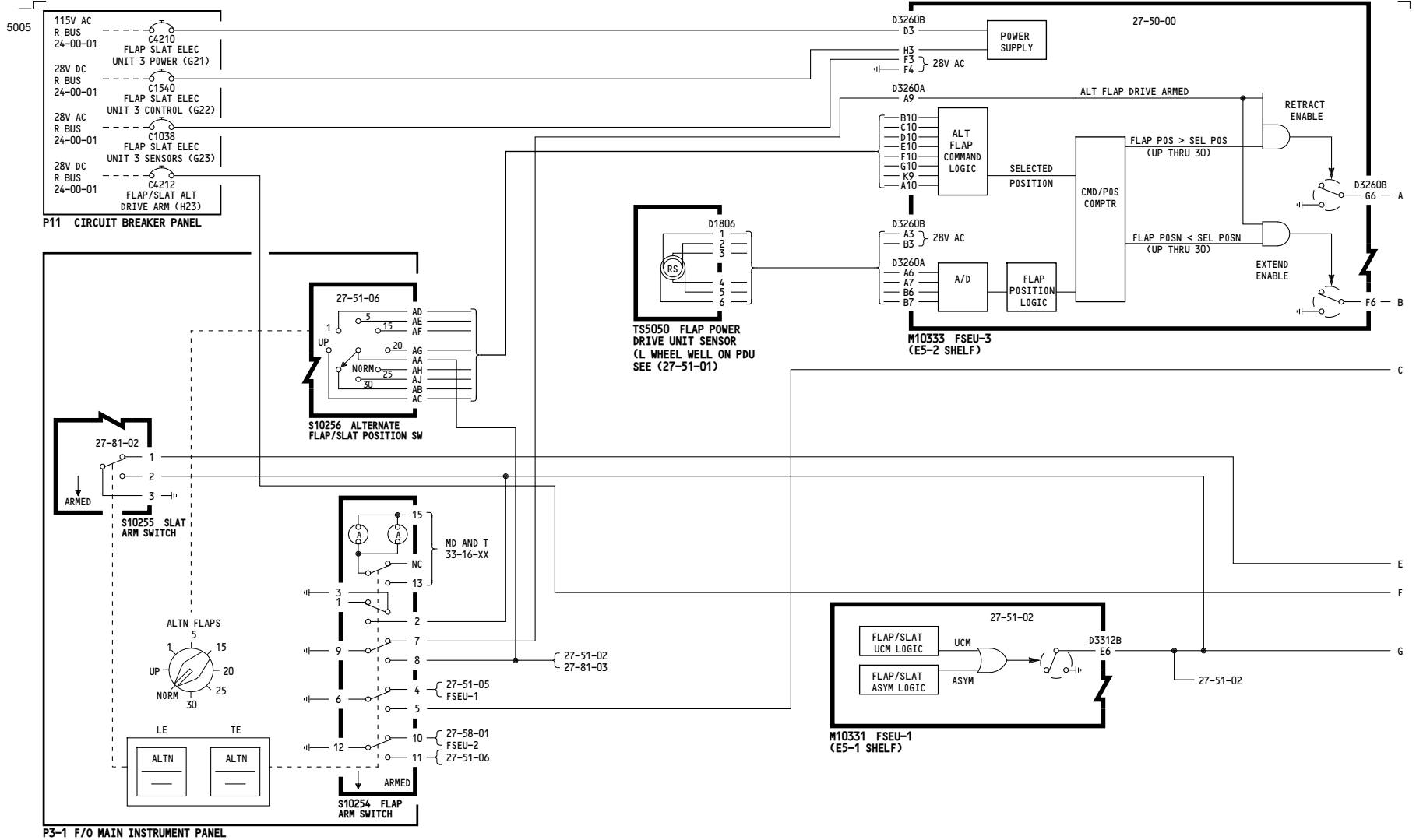

| | |
|-----|---|
| ALL | <p>TRAILING EDGE FLAP ALTERNATE DRIVE</p> <p>D280N032S</p> |
|-----|---|

27-51-04

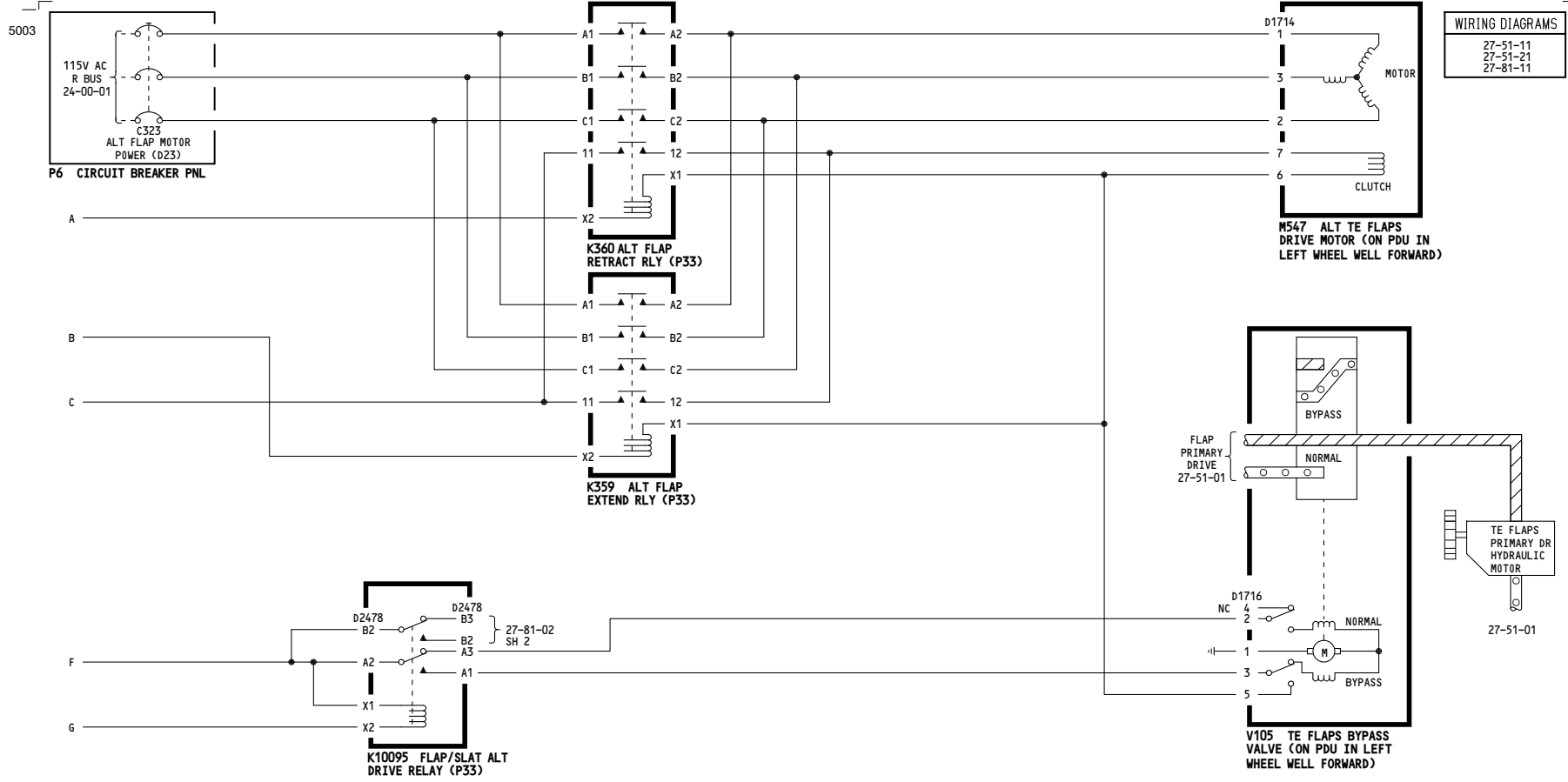

| | |
|-----|---|
| ALL | <p>TRAILING EDGE FLAP ALTERNATE DRIVE</p> <p>D280N032S</p> |
|-----|---|

27-51-04

Page 101
Sheet 2
May 06/2009

5008

WIRING DIAGRAMS
27-51-21
27-51-41
27-51-61

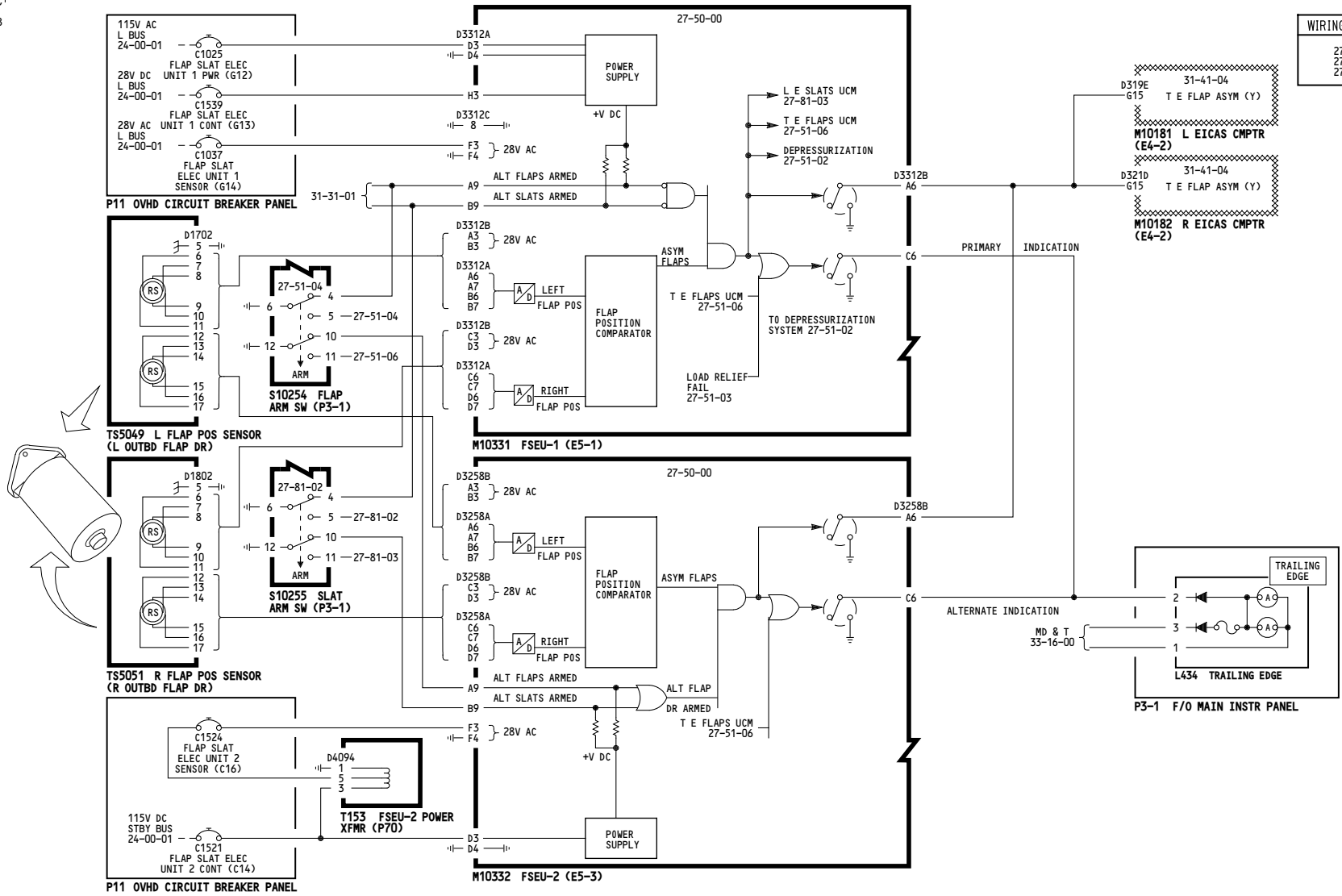

ALL

FLAP ASYMMETRY INDICATION
D280N032S

27-51-05

Page 101

May 06/2009

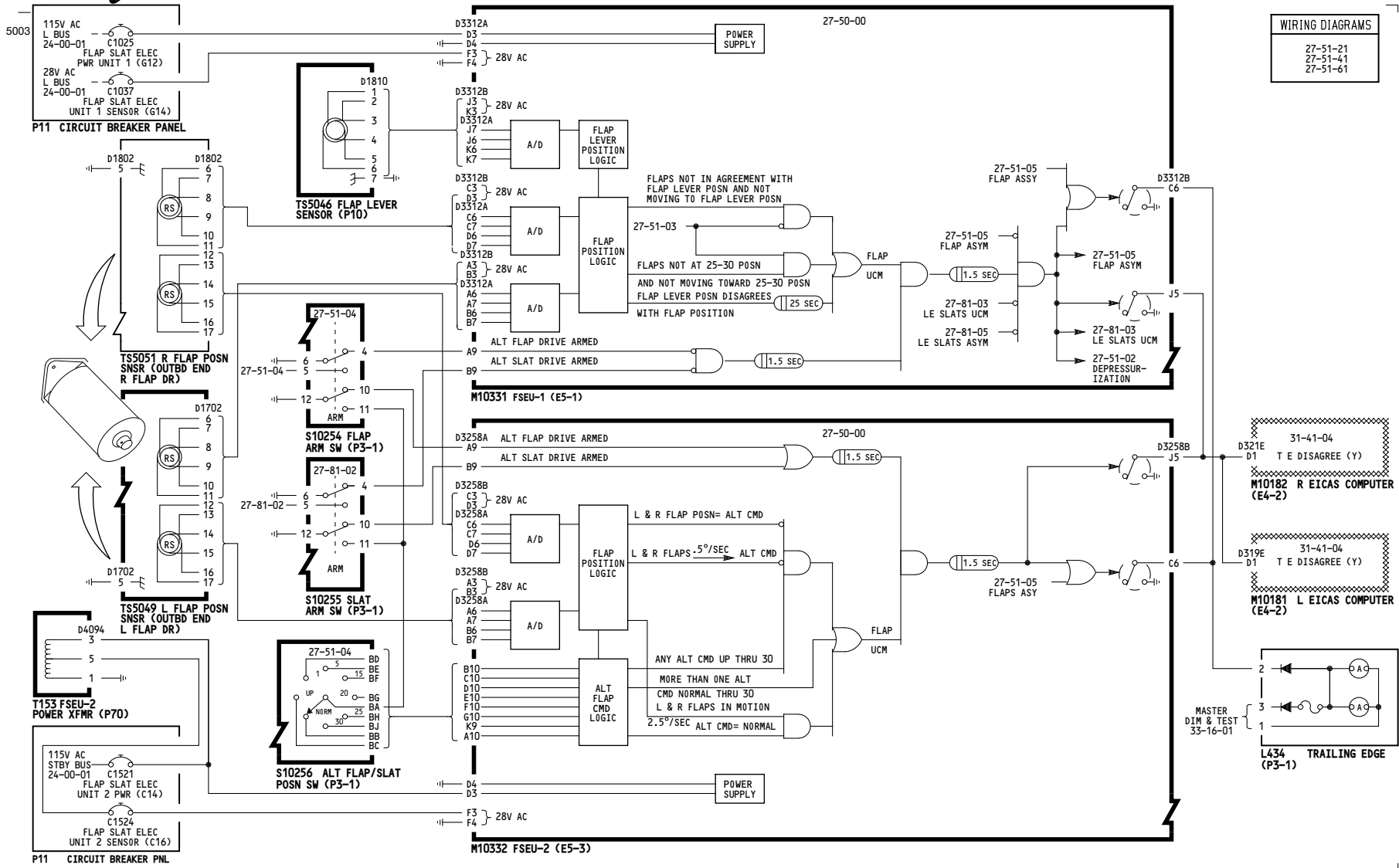

ALL

TRAILING EDGE FLAPS UCM INDICATION

D280N032S

27-51-06

Page 101

May 06/2009

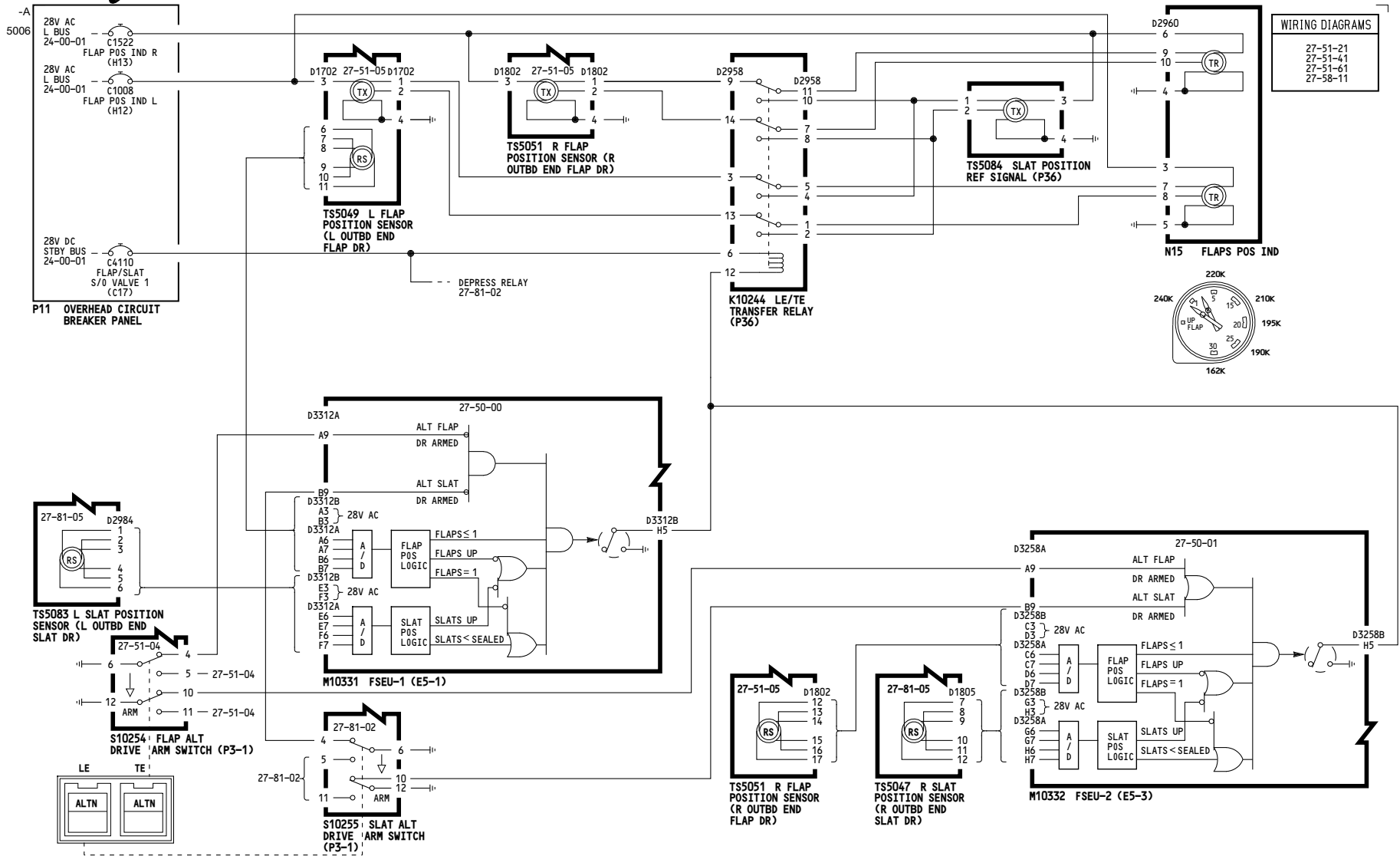

| | |
|-----|---|
| ALL | FLAP/SLAT POSITION INDICATING SYSTEM |
| | D280N032S |

27-58-01

5002

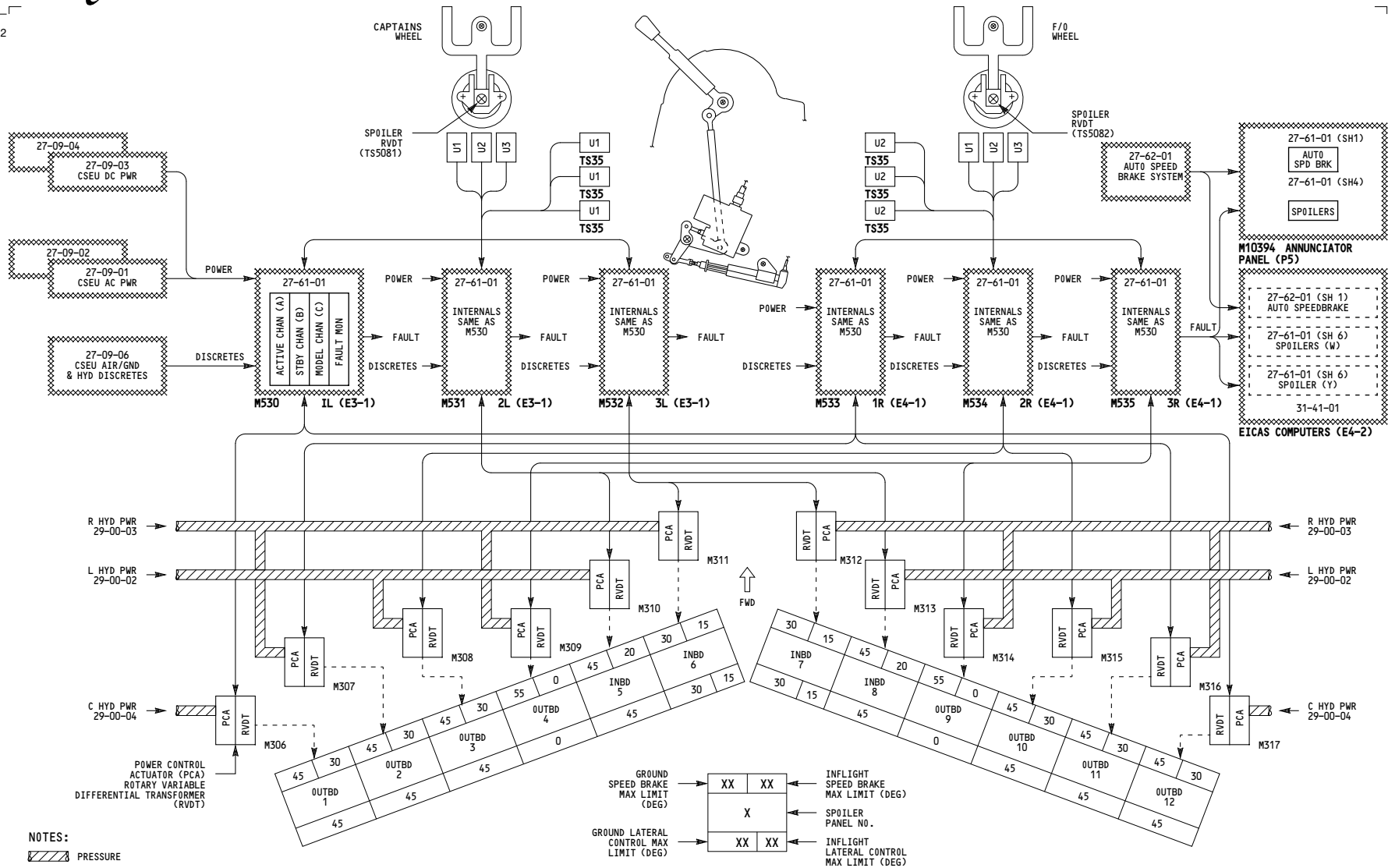

ALL

SPOILER AND SPEEDBRAKE SYSTEM

D280N032S

27-60-00

Page 101

May 06/2009

-A
5002

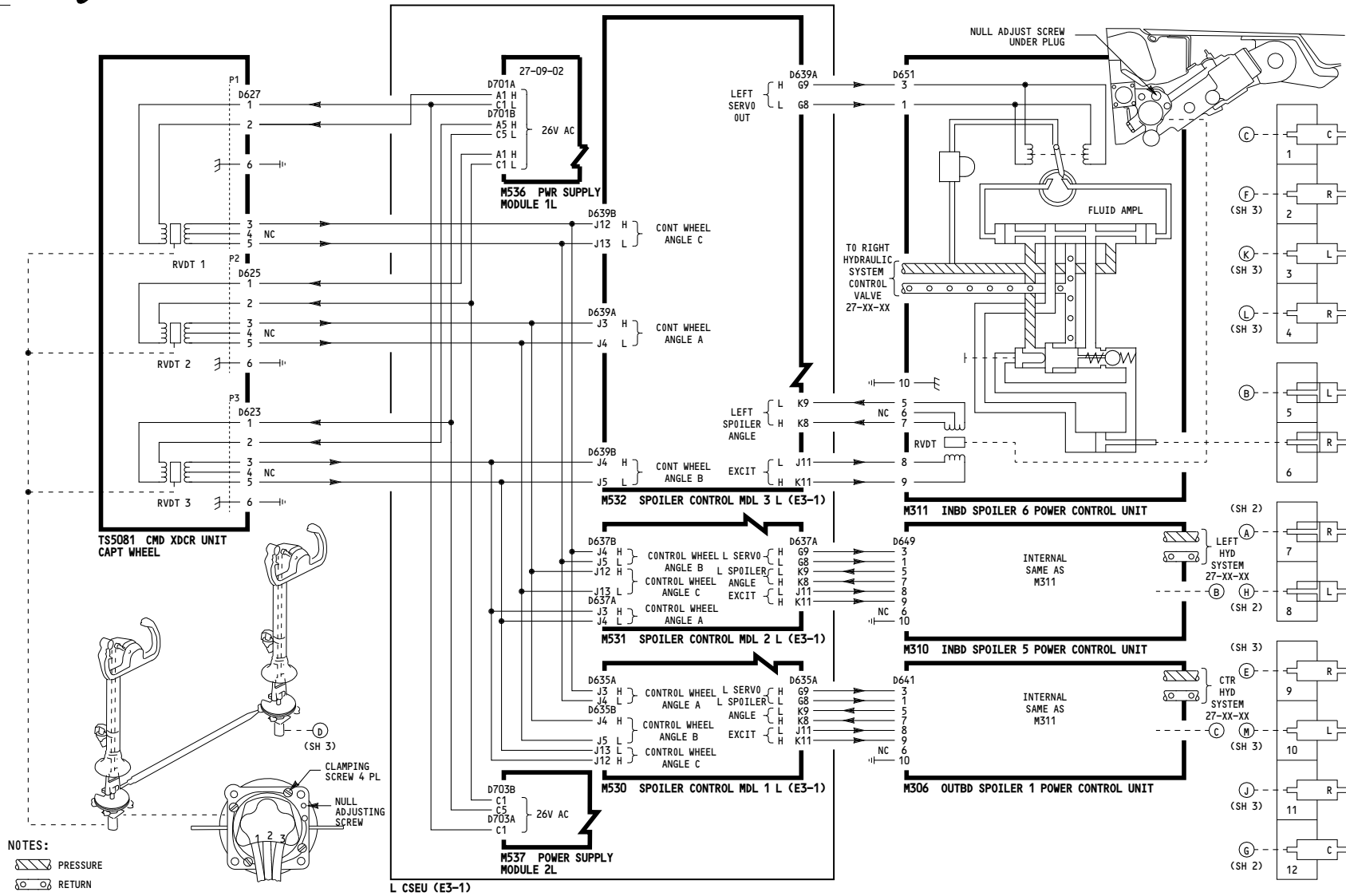

27-61-01

5002

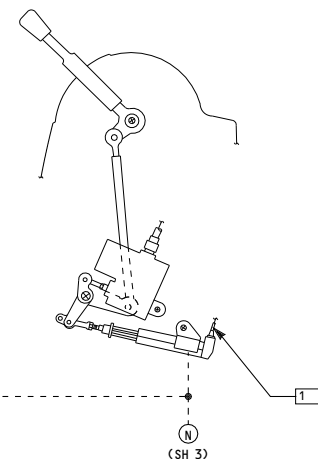
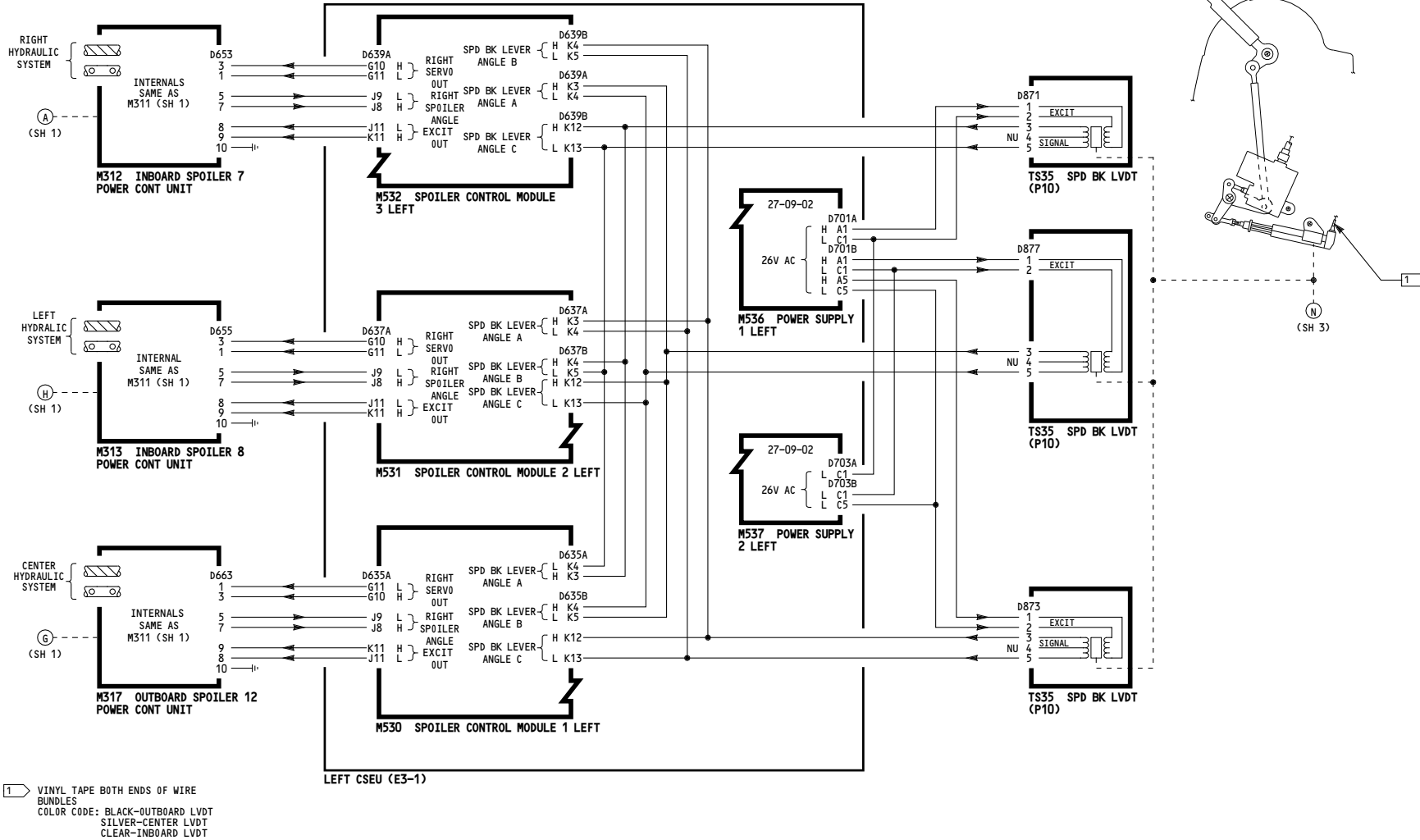

| | |
|-----|--|
| 001 | <p>SPOILERS</p> <p>D280N032S</p> |
|-----|--|

27-61-01

-A
5002

WIRING DIAGRAMS
27-61-21
27-61-XX

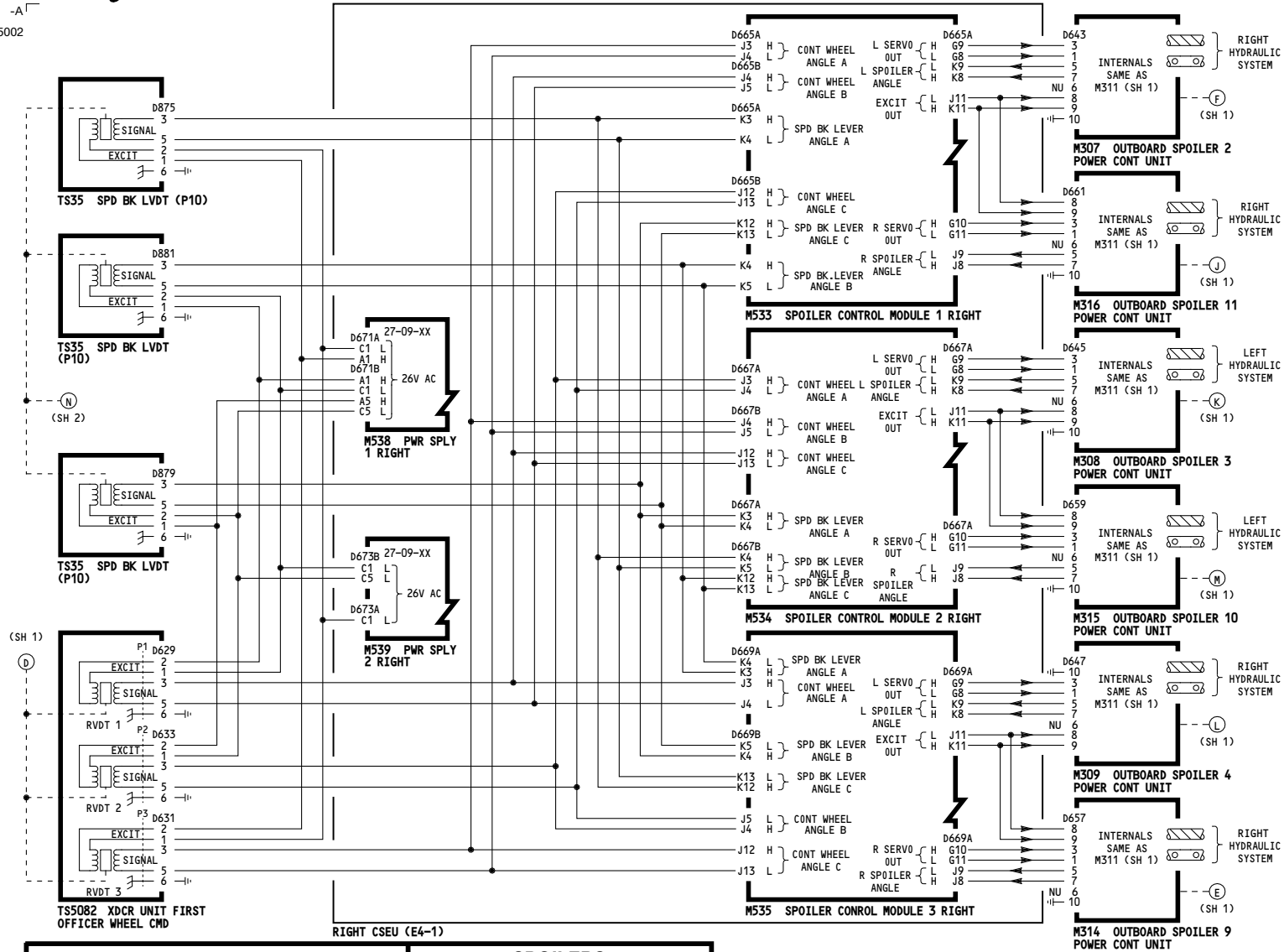

| | |
|-----------|-----------------|
| 001 | SPOILERS |
| D280N032S | |

27-61-01

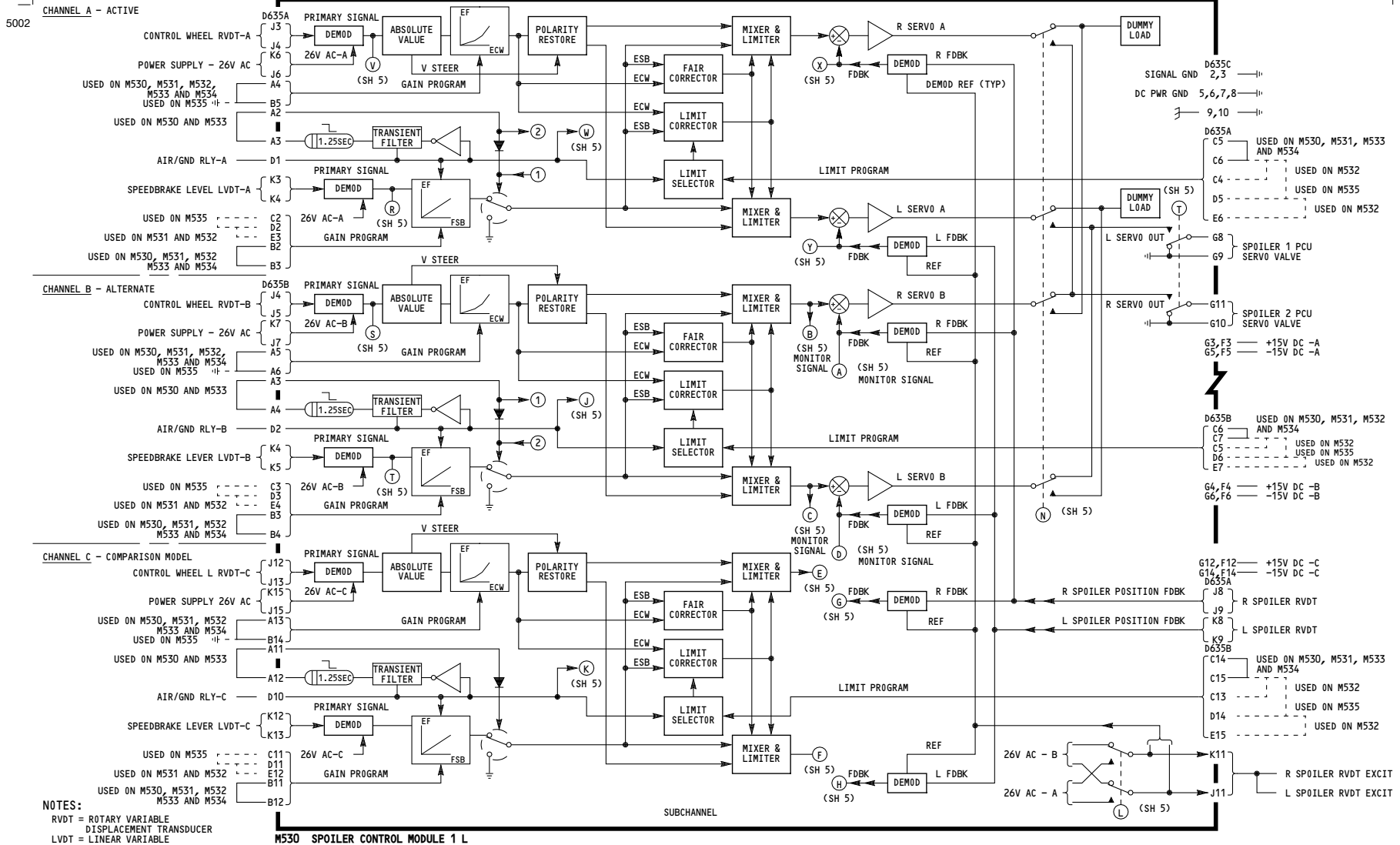

001

SPOILERS

D280N032S

27-61-01

5000

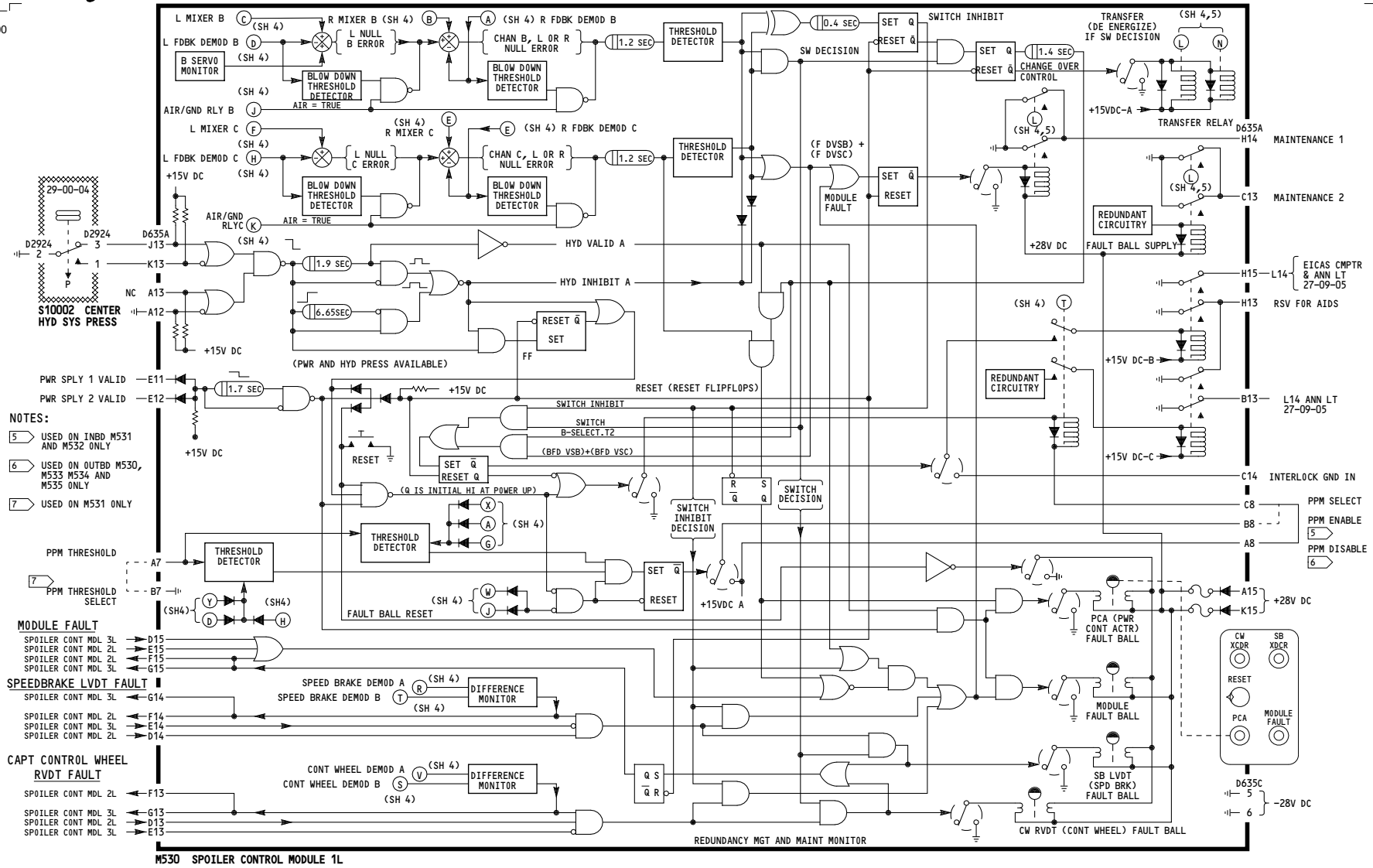

| | |
|-----|---|
| 001 | <p>SPOILERS</p> <p>D280N032S</p> |
|-----|---|

27-61-01

5002

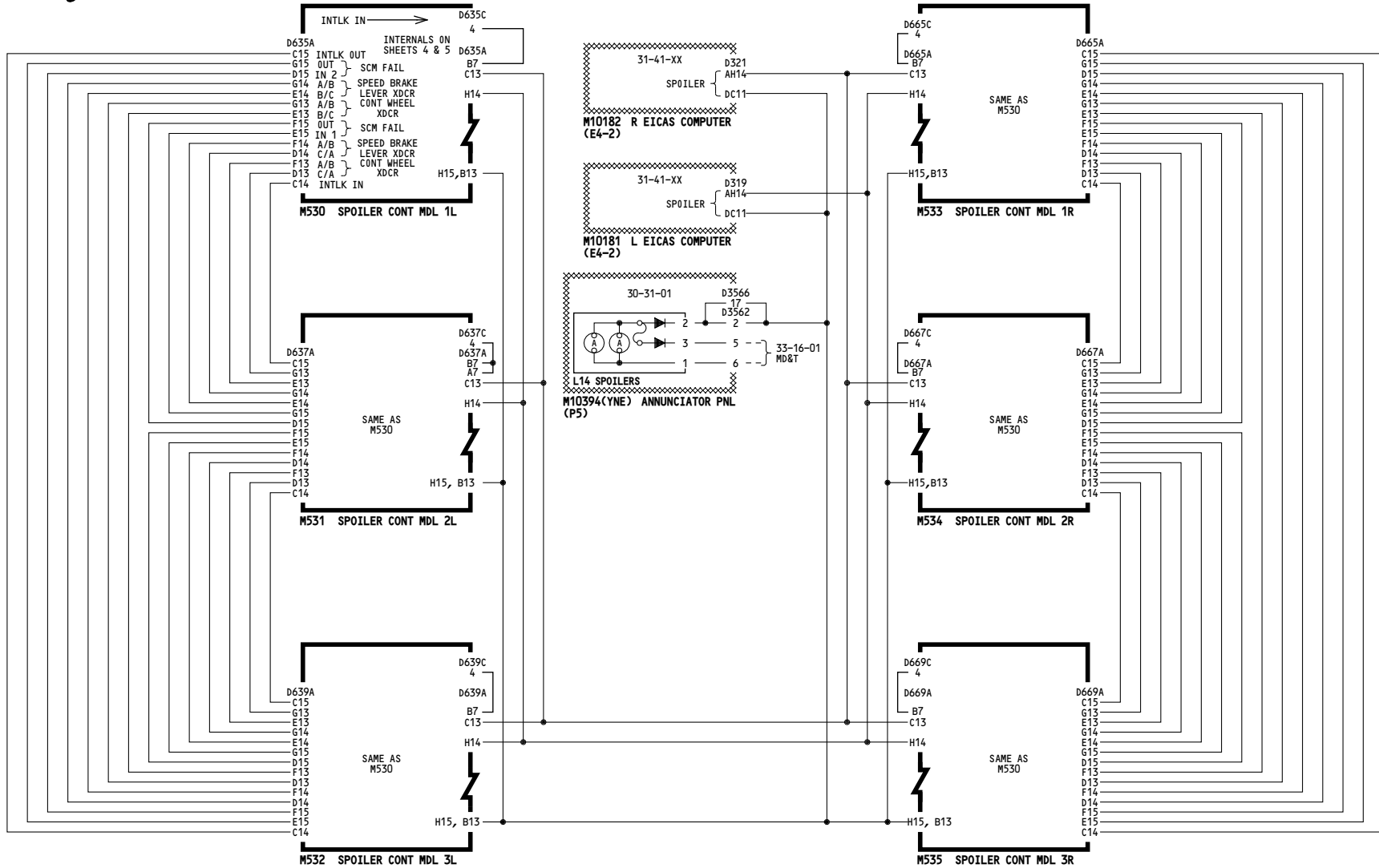

| | |
|-----|---|
| 001 | <p align="center">SPOILERS</p> <p align="center">D280N032S</p> |
|-----|---|

27-61-01

Page 101
Sheet 6
May 06/2009

5002

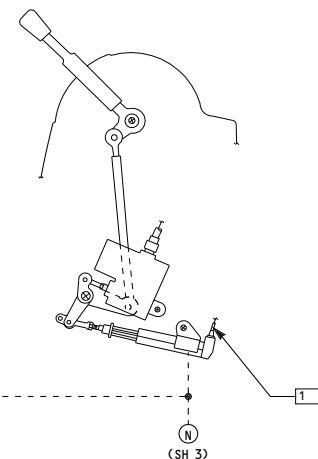
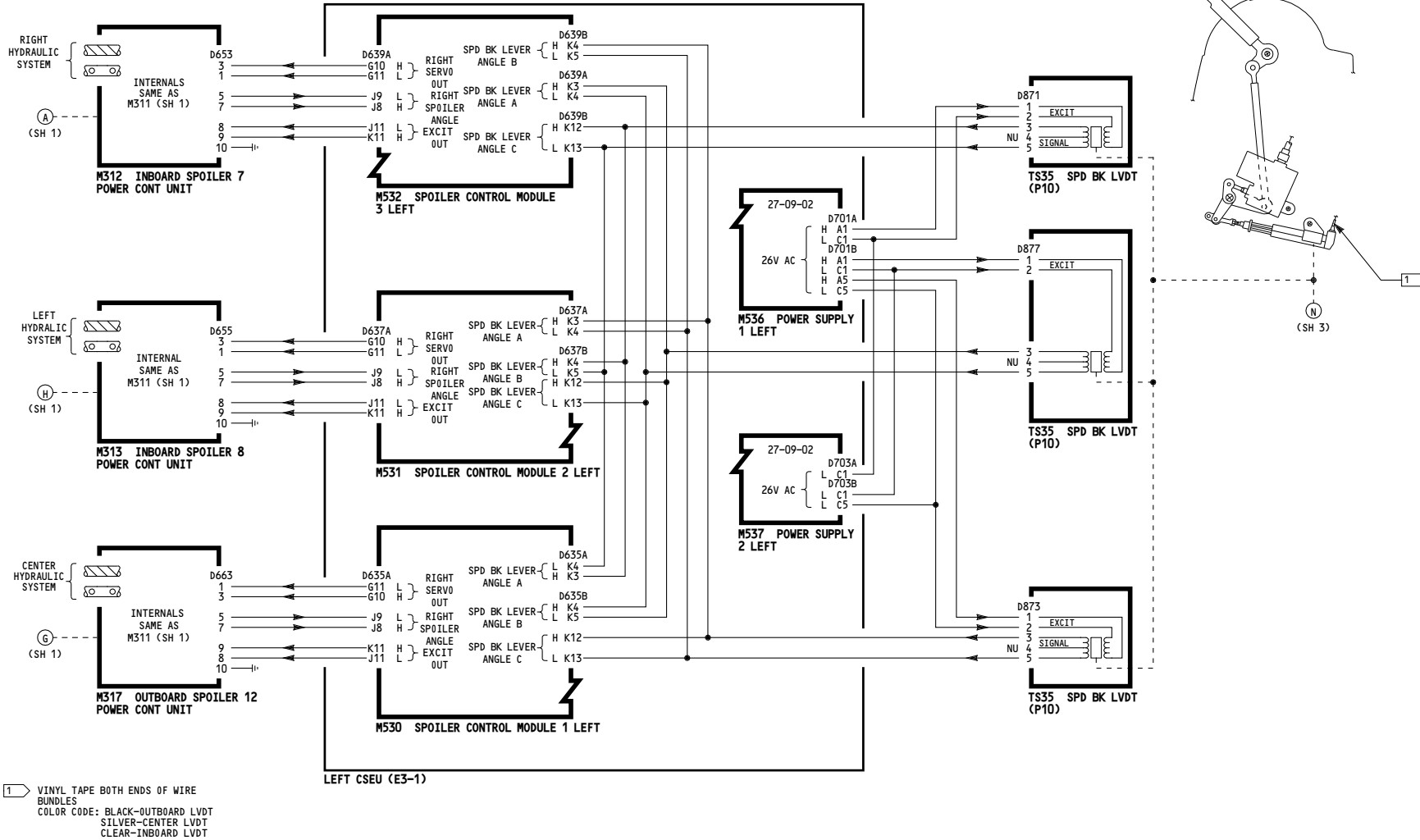

| | |
|-----|--|
| 002 | <p>SPOILERS</p> <p>D280N032S</p> |
|-----|--|

27-61-01

-A
5002

WIRING DIAGRAMS
27-61-21
27-61-XX

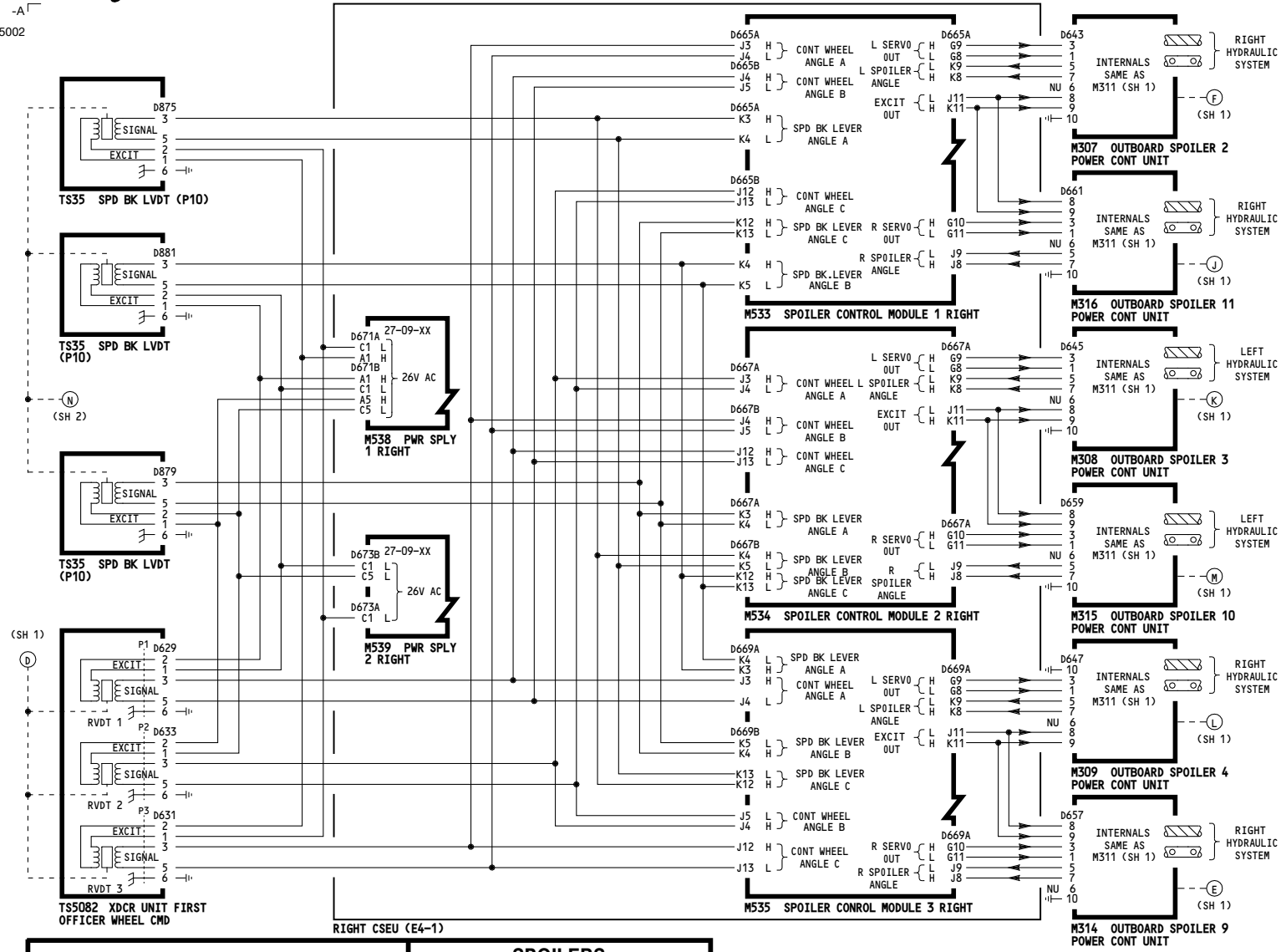

| | |
|-----------|-----------------|
| 002 | SPOILERS |
| D280N032S | |

27-61-01

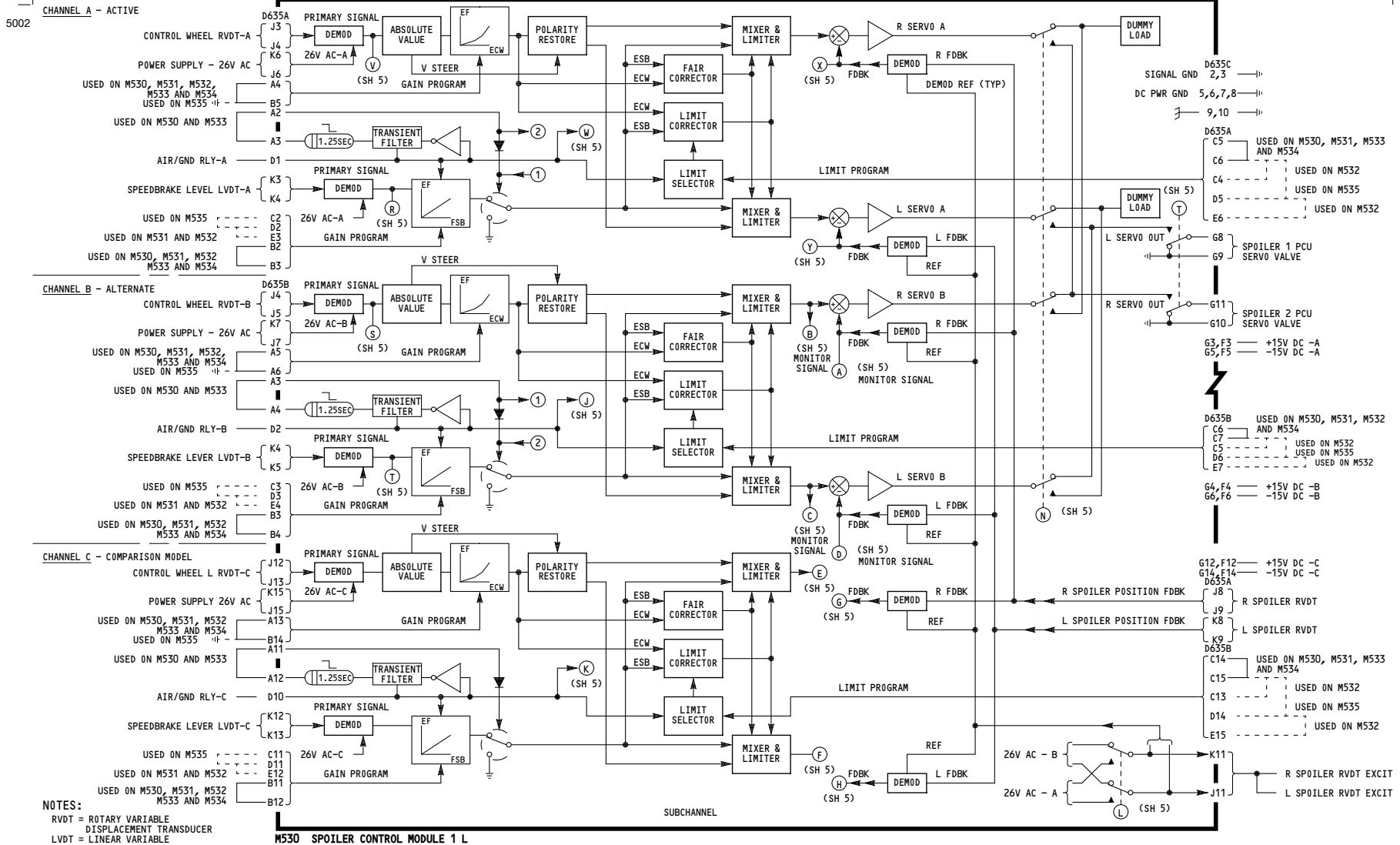

002

SPOILERS

D280N032S

27-61-01

5003

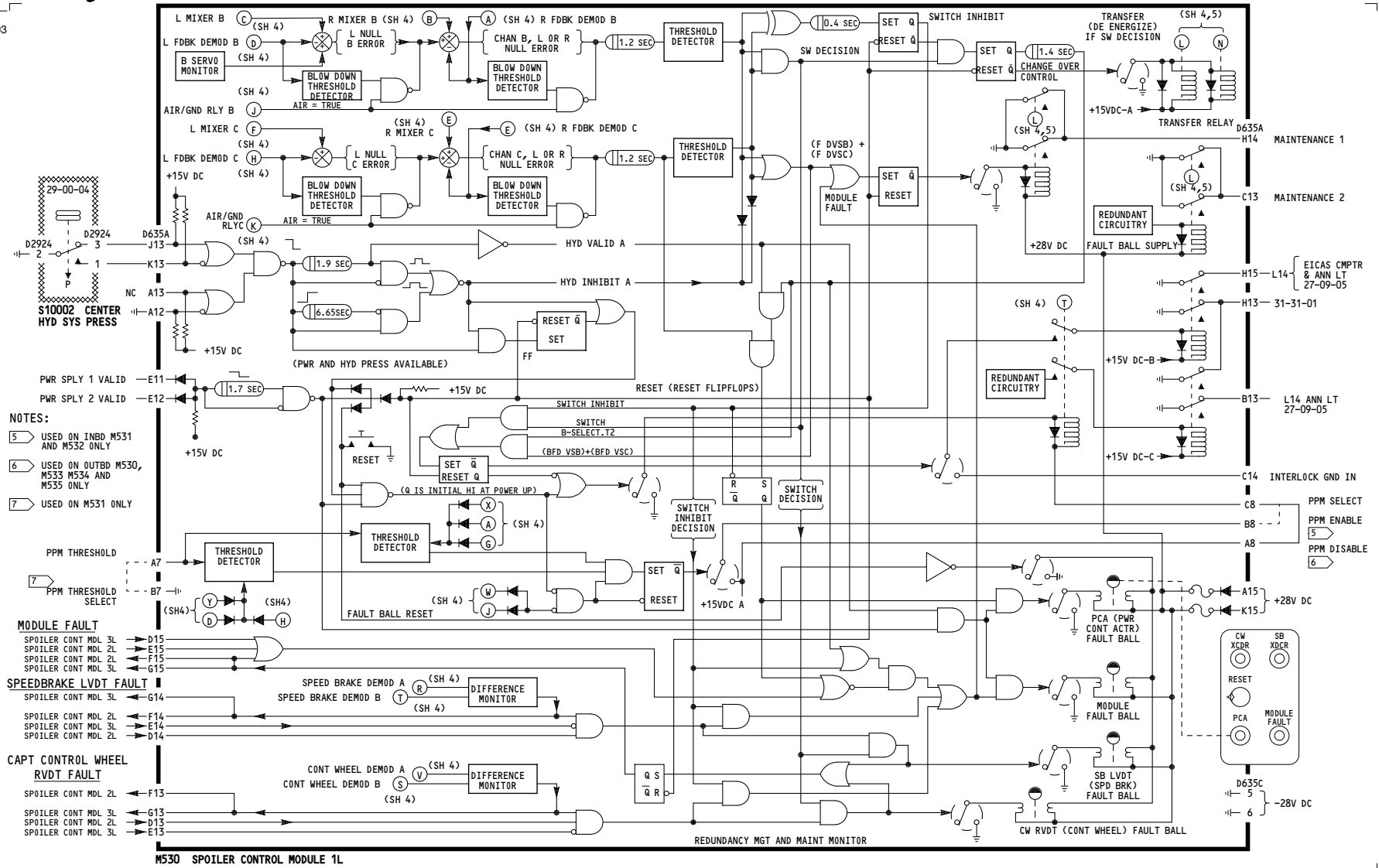

| | | |
|-----|-----------------|--|
| 002 | SPOILERS | |
| | D280N032S | |

27-61-01

5002

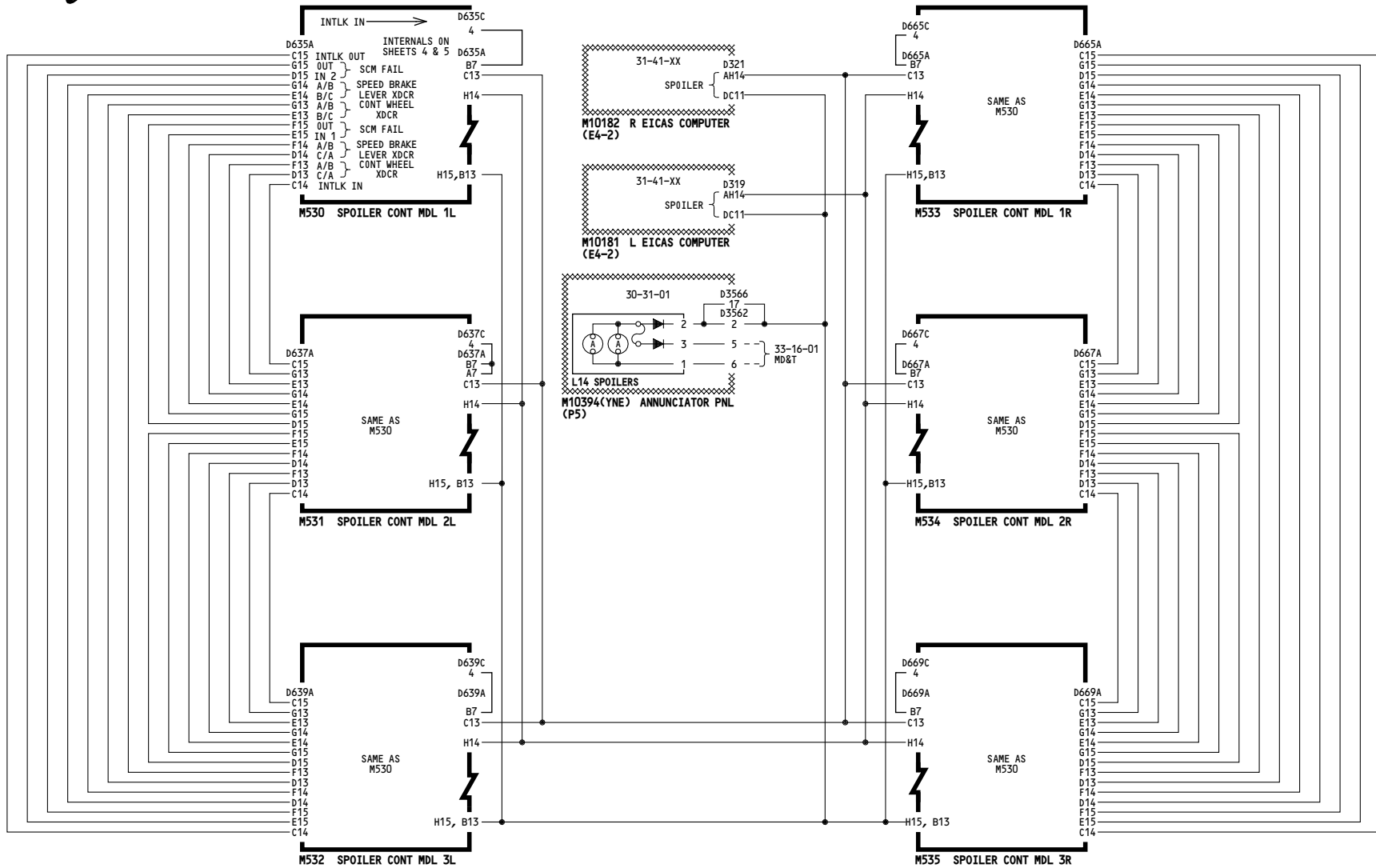

| | |
|-----|---|
| 002 | <p align="center">SPOILERS</p> <p align="center">D280N032S</p> |
|-----|---|

27-61-01

-A
5002

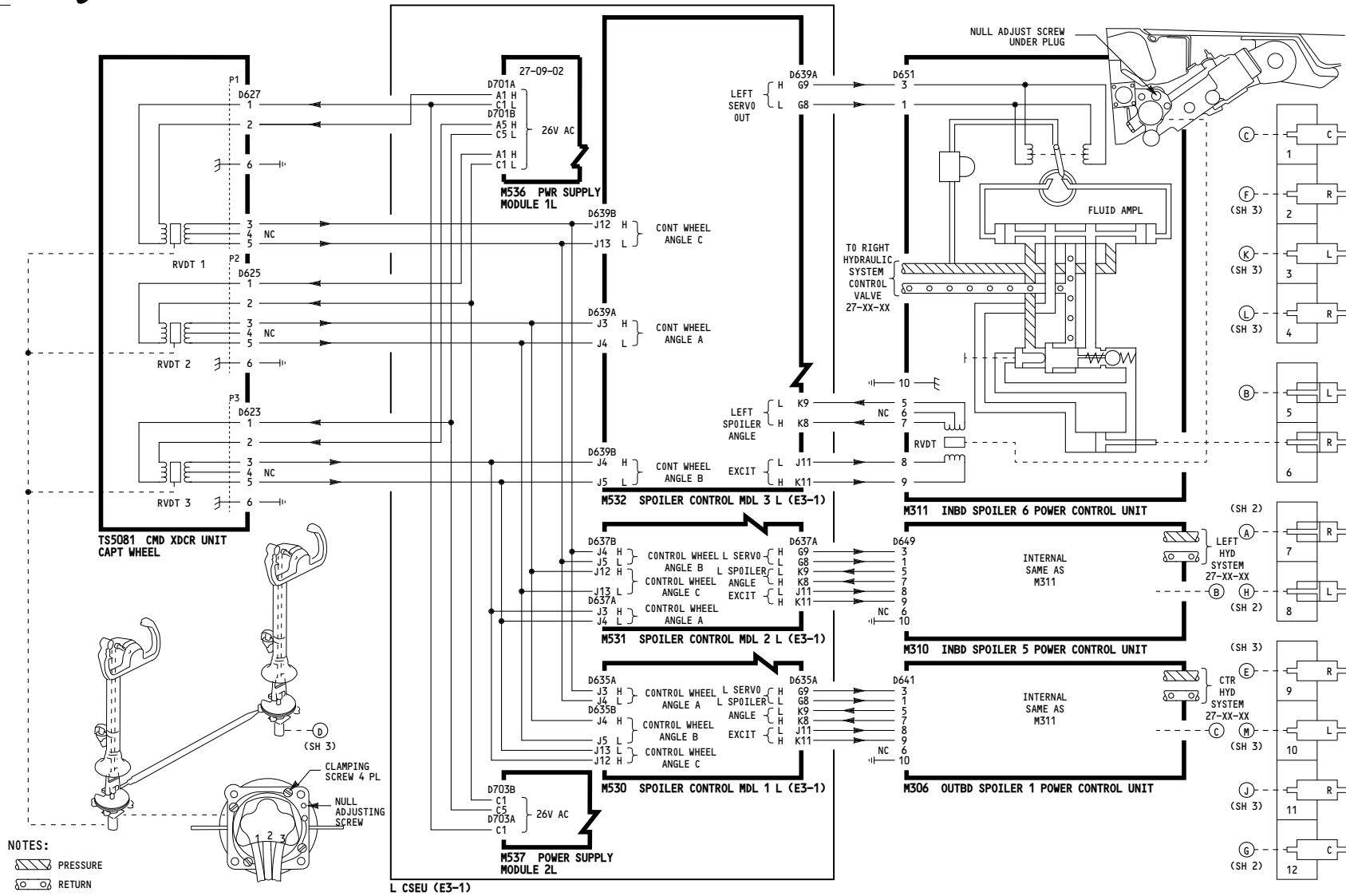

003-099

SPOILERS

D280N032S

27-61-01

5002

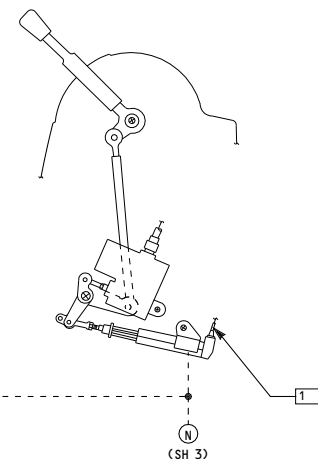
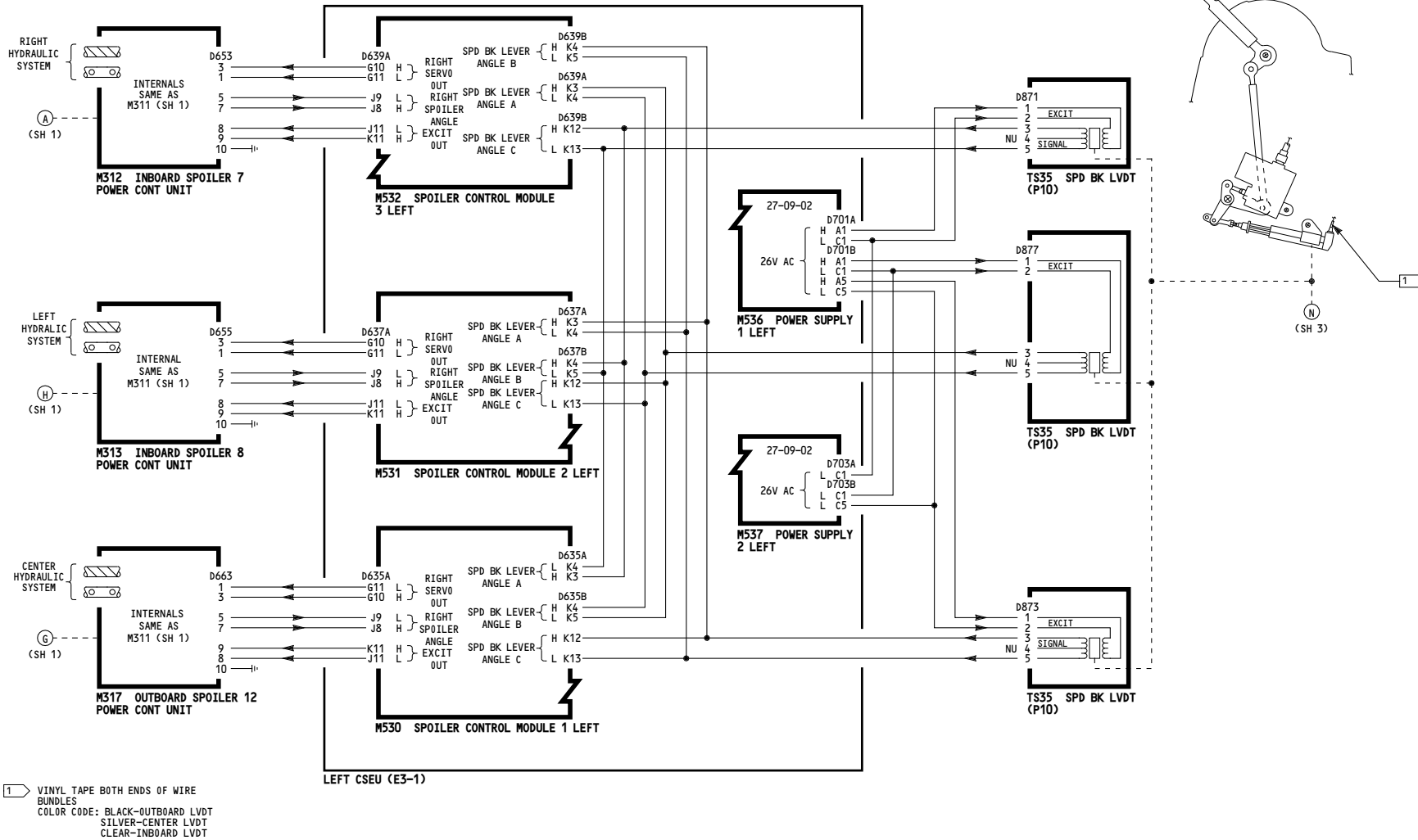

| | |
|---------|---|
| 003-099 | <p align="center">SPOILERS</p> <p align="center">D280N032S</p> |
|---------|---|

27-61-01

-A
5002

WIRING DIAGRAMS
27-61-21
27-61-XX

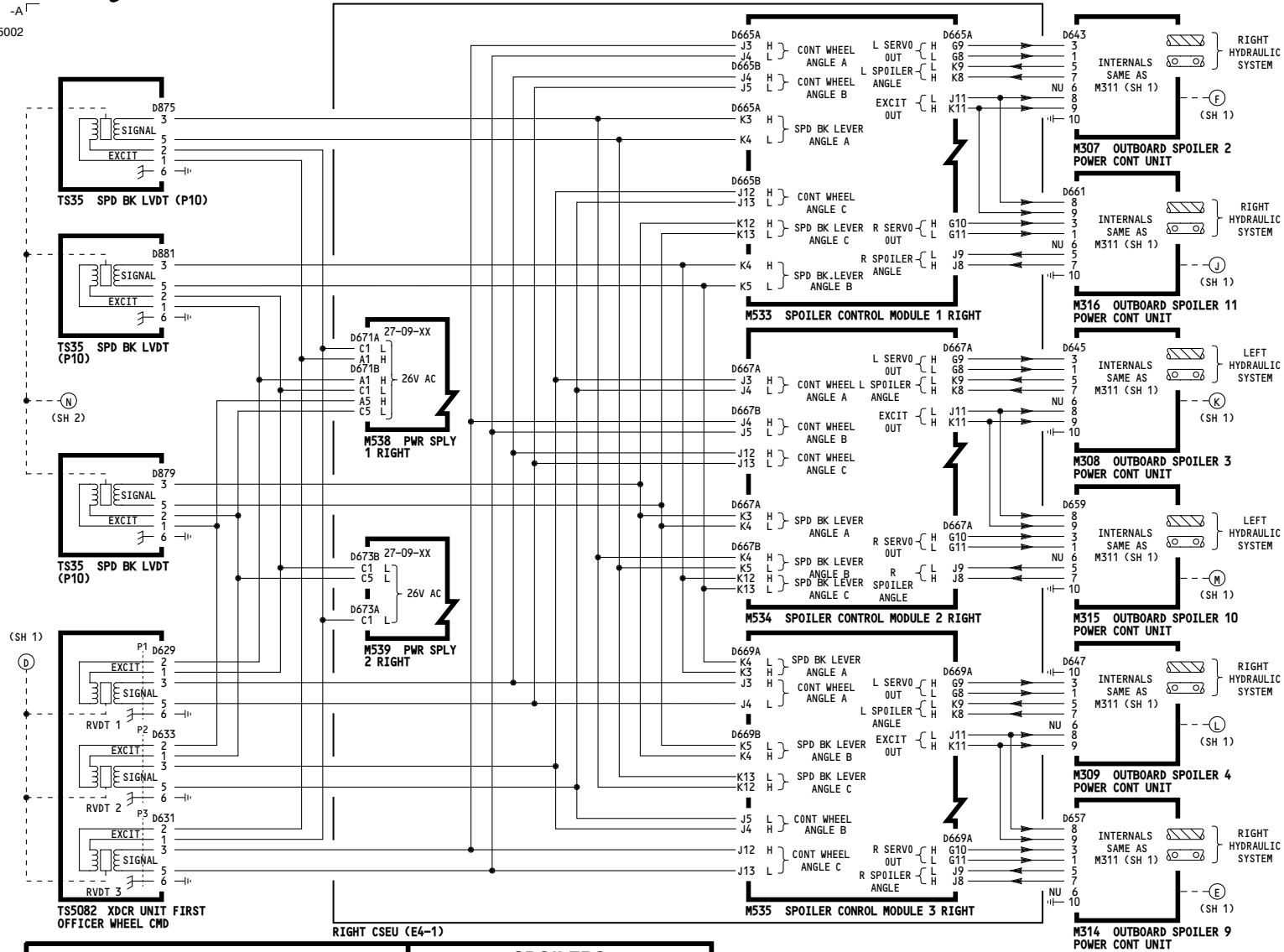

| | |
|---------|-----------------|
| 003-099 | SPOILERS |
| | D280N032S |

27-61-01

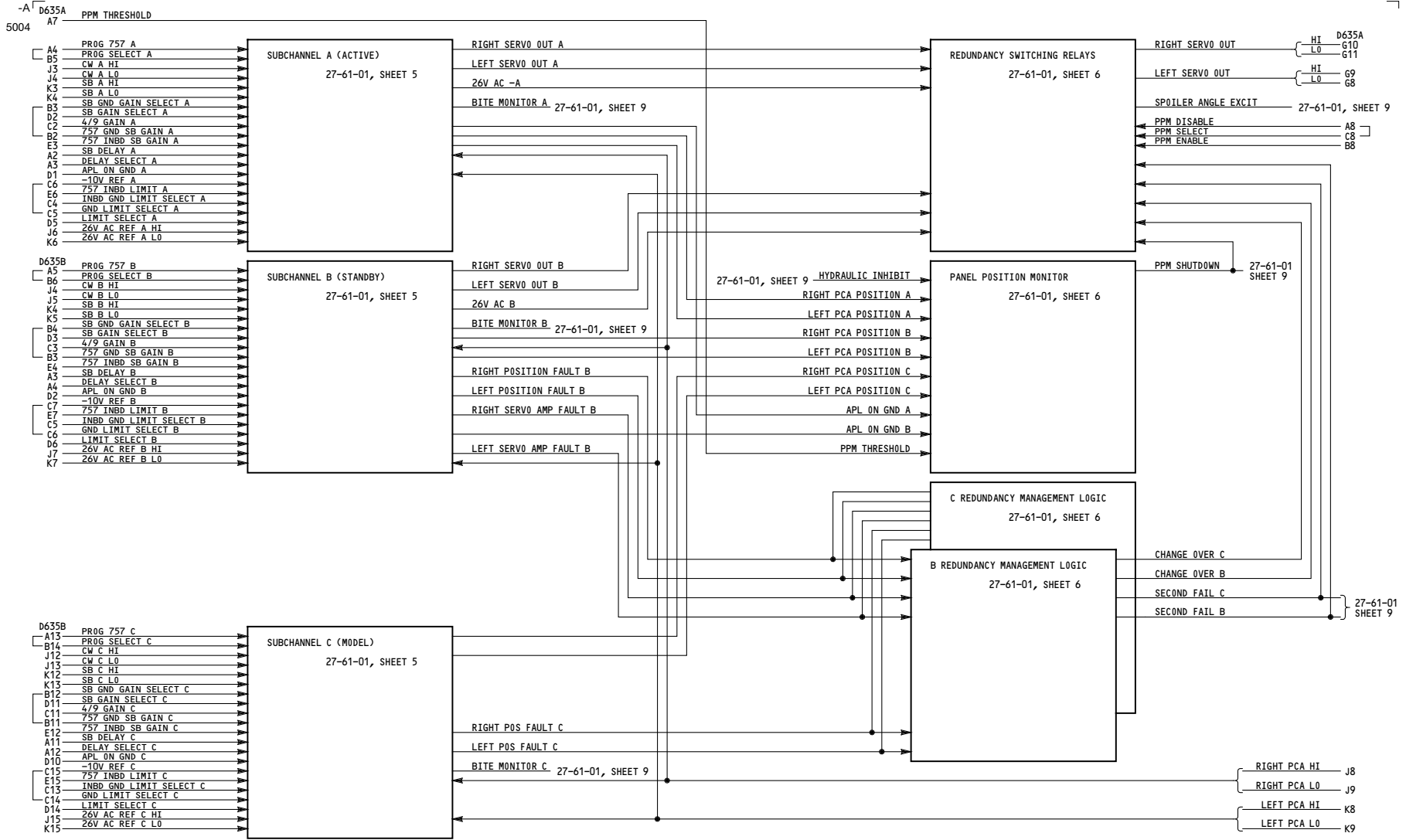

| | |
|-----------|-----------------|
| 003-099 | SPOILERS |
| D280N032S | |

27-61-01

5004

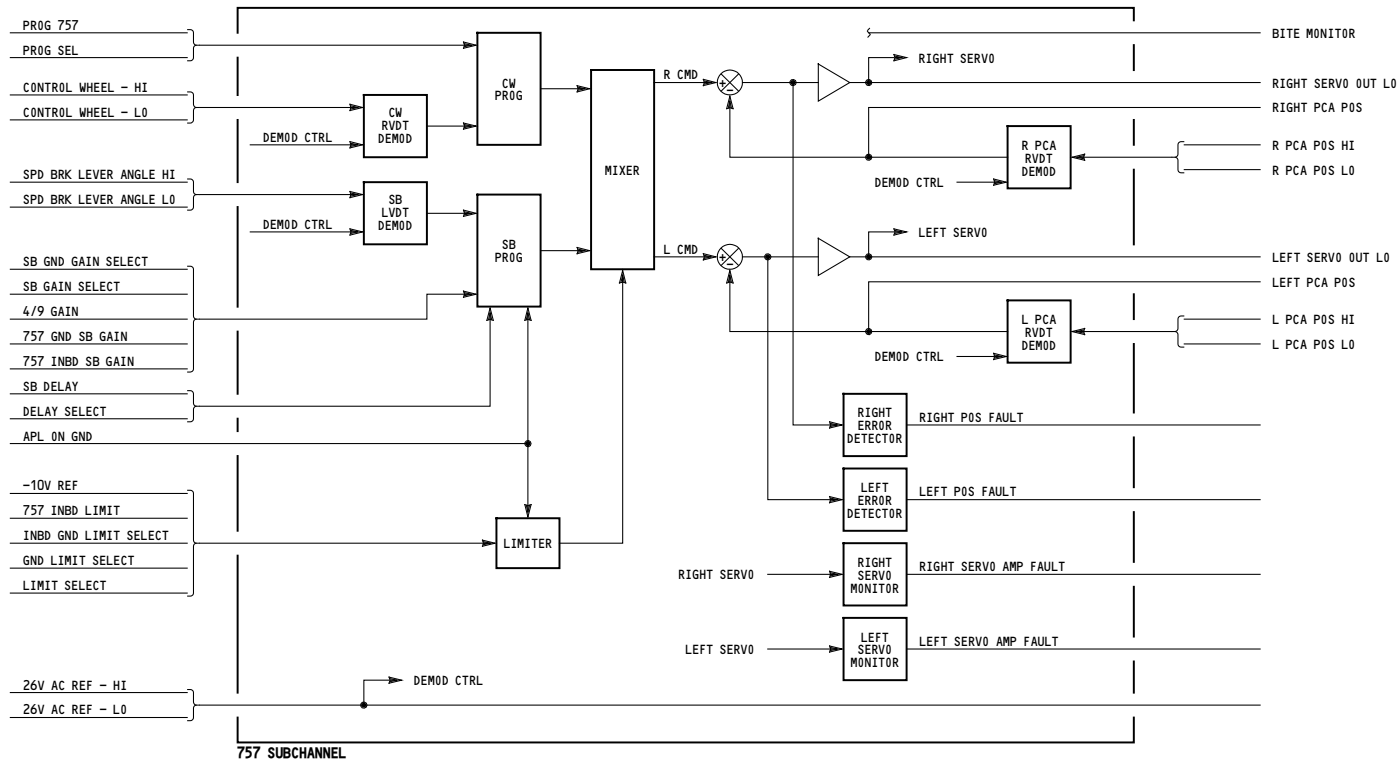

| | |
|---------|---|
| 003-099 | <p align="center">SPOILERS</p> <p align="center">D280N032S</p> |
|---------|---|

27-61-01

Page 103
Sheet 5
Jan 21/2005

5004

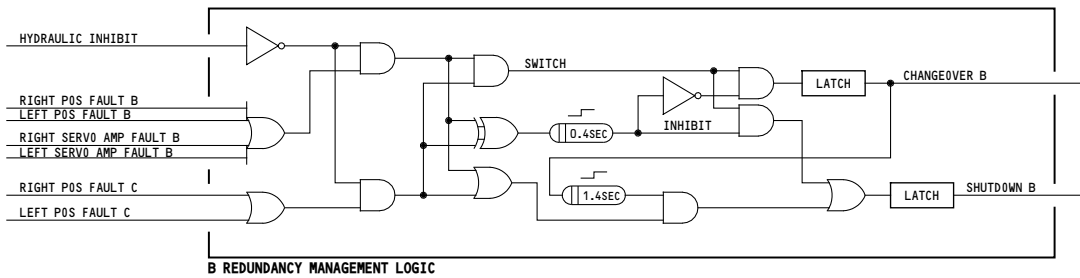
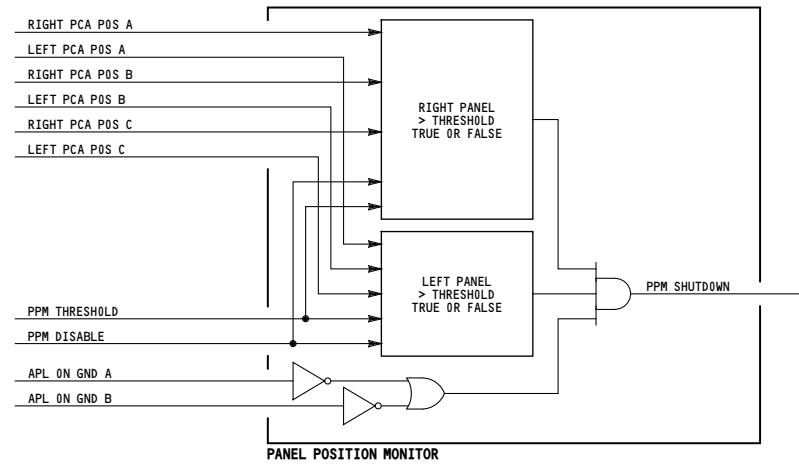
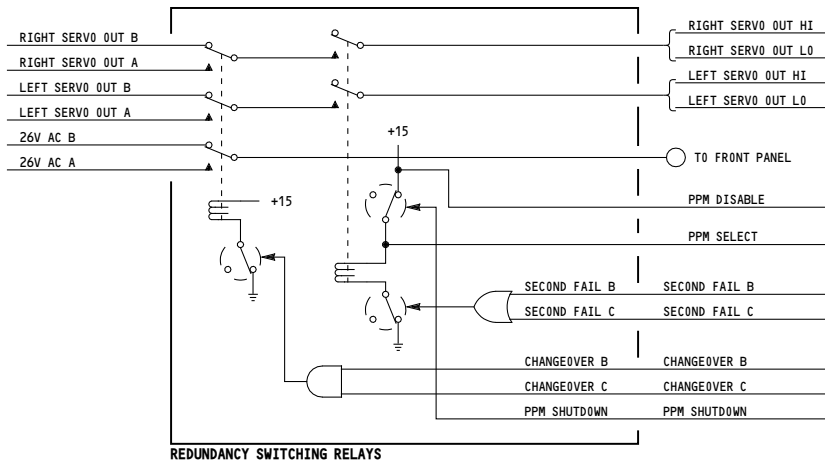

003-099

SPOILERS

D280N032S

27-61-01

Page 103
Sheet 6
Jan 21/2005

5004

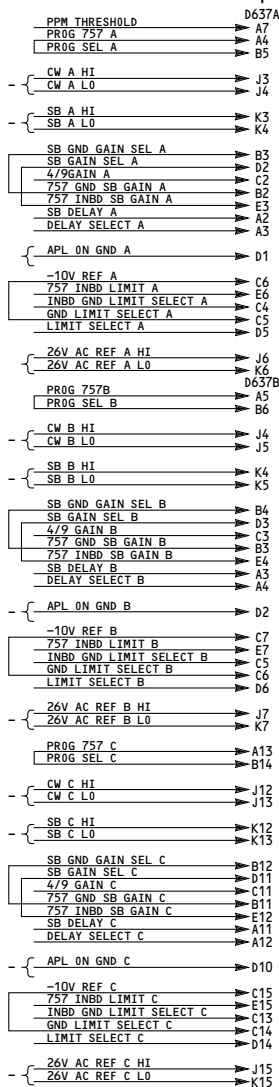

INTERNAL
SAME AS
M530
(SH 4)

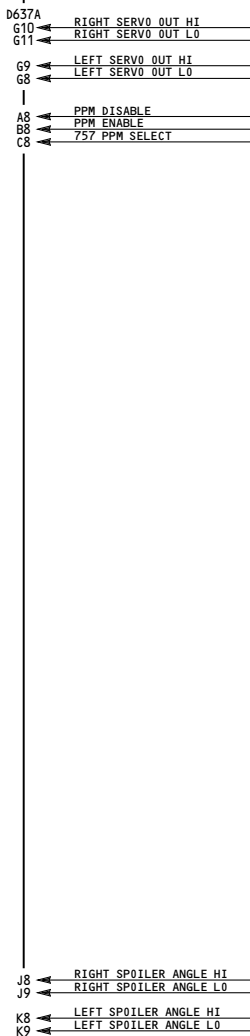

M531 SPOILER CONTROL MDL 2L (E3-1)

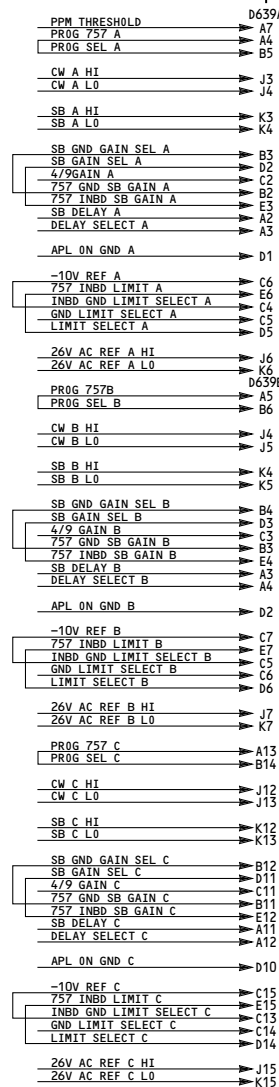

INTERNAL
SAME AS
M530
(SH 4)

M532 SPOILER CONTROL MDL 3L (E3-1)

003-099

SPOILERS

D280N032S

27-61-01



757-200 SYSTEM SCHEMATIC MANUAL

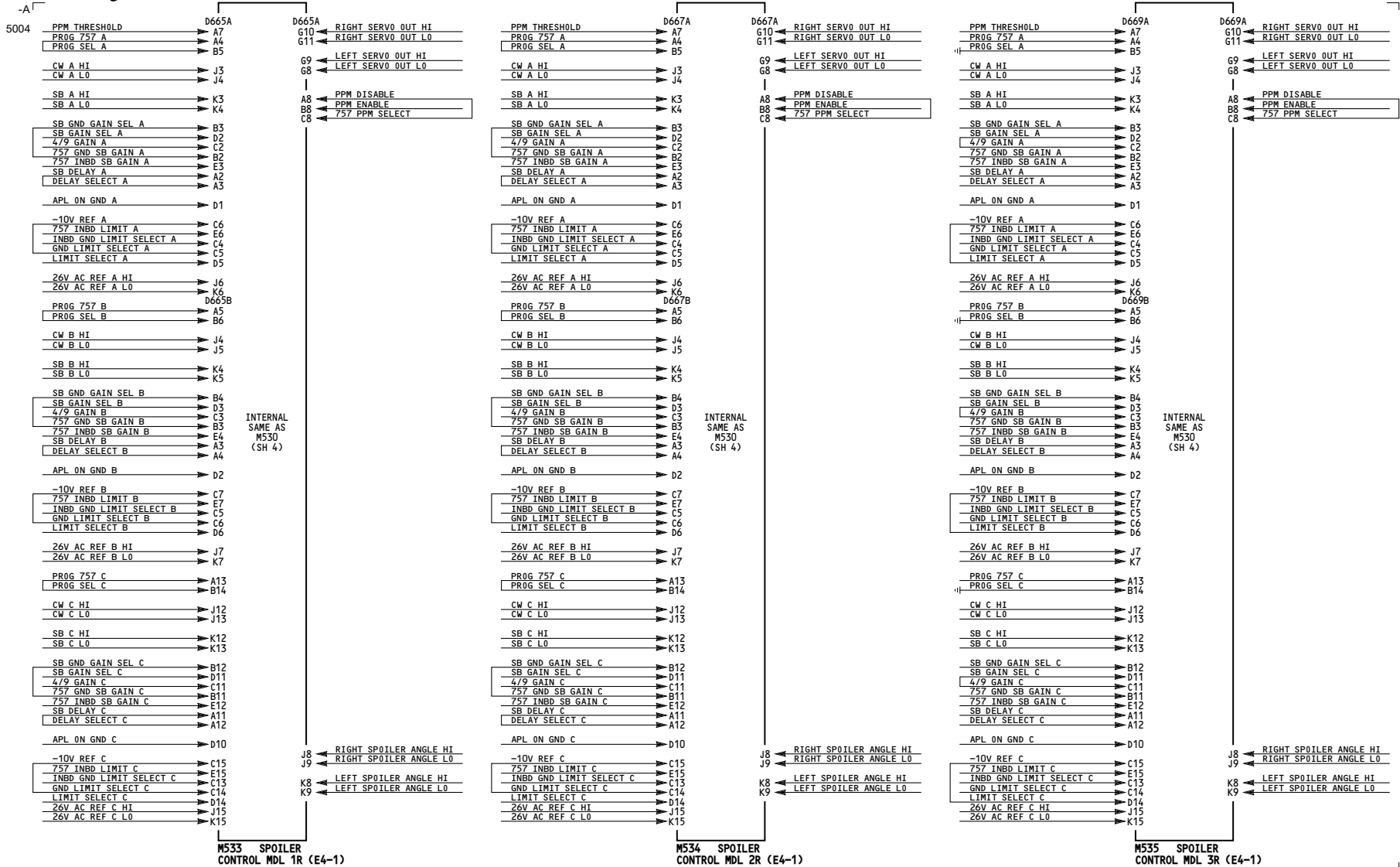

003-099

SPOILERS

D280N032S

27-61-01

Page 103
Sheet 8
Jan 21/2005

5004

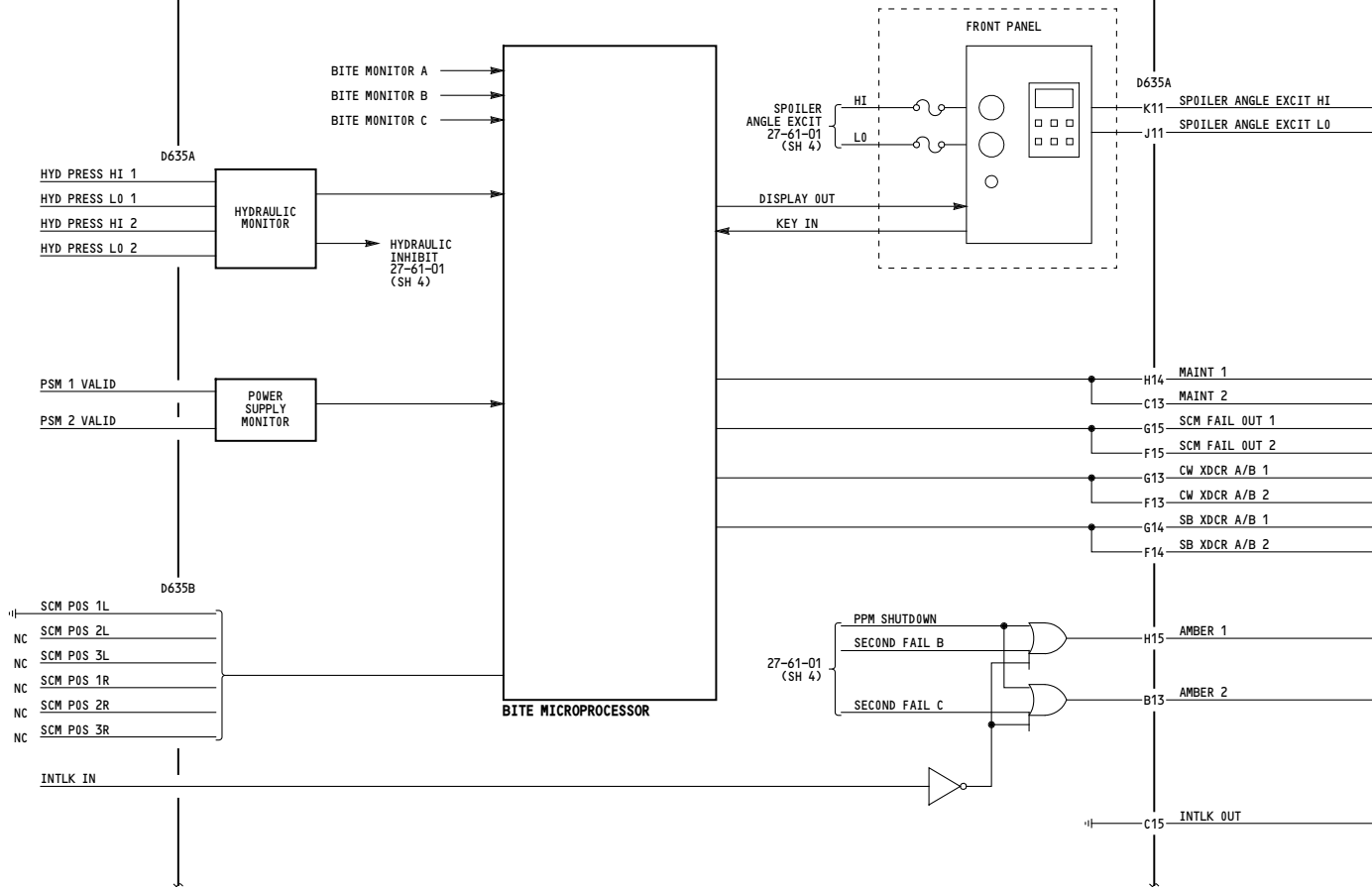

003-099

SPOILERS

D280N032S

27-61-01

Page 103
Sheet 9
Jan 21/2005

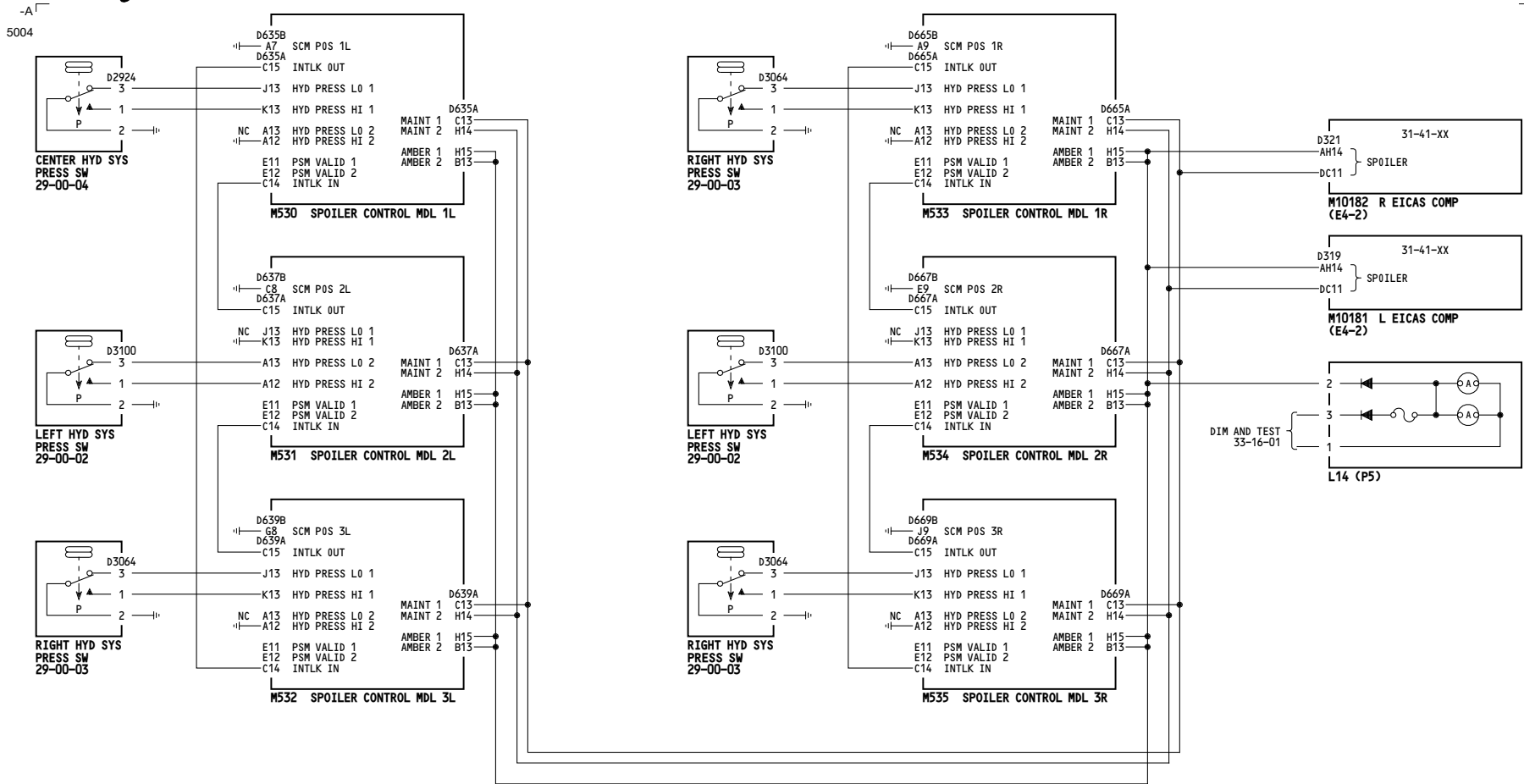

003-099

SPOILERS

D280N032S

27-61-01

5004

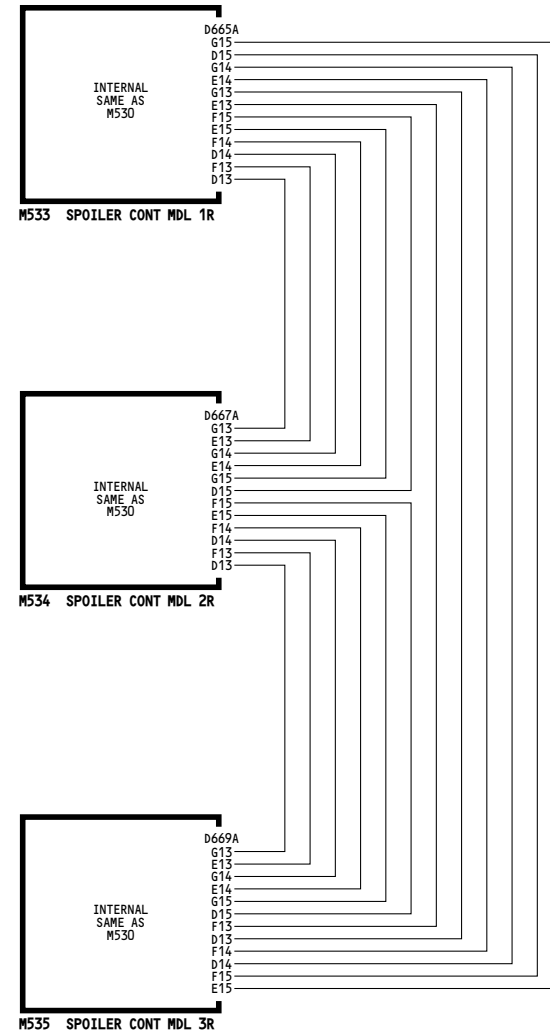
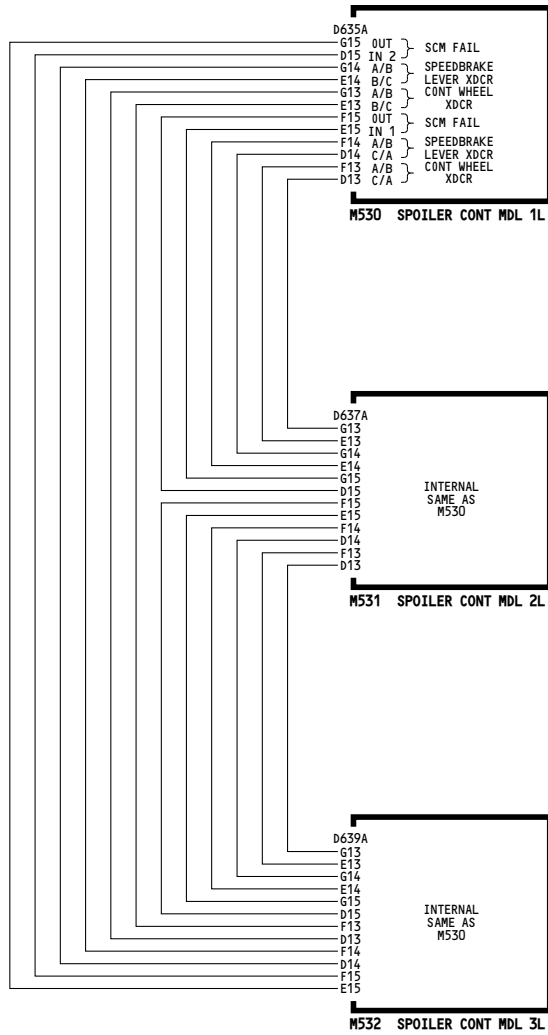

| | |
|---------|---|
| 003-099 | <p align="center">SPOILERS</p> <p align="center">D280N032S</p> |
|---------|---|

27-61-01

Page 103
Sheet 11
Jan 21/2005

THIS PAGE INTENTIONALLY LEFT BLANK

-A
5000

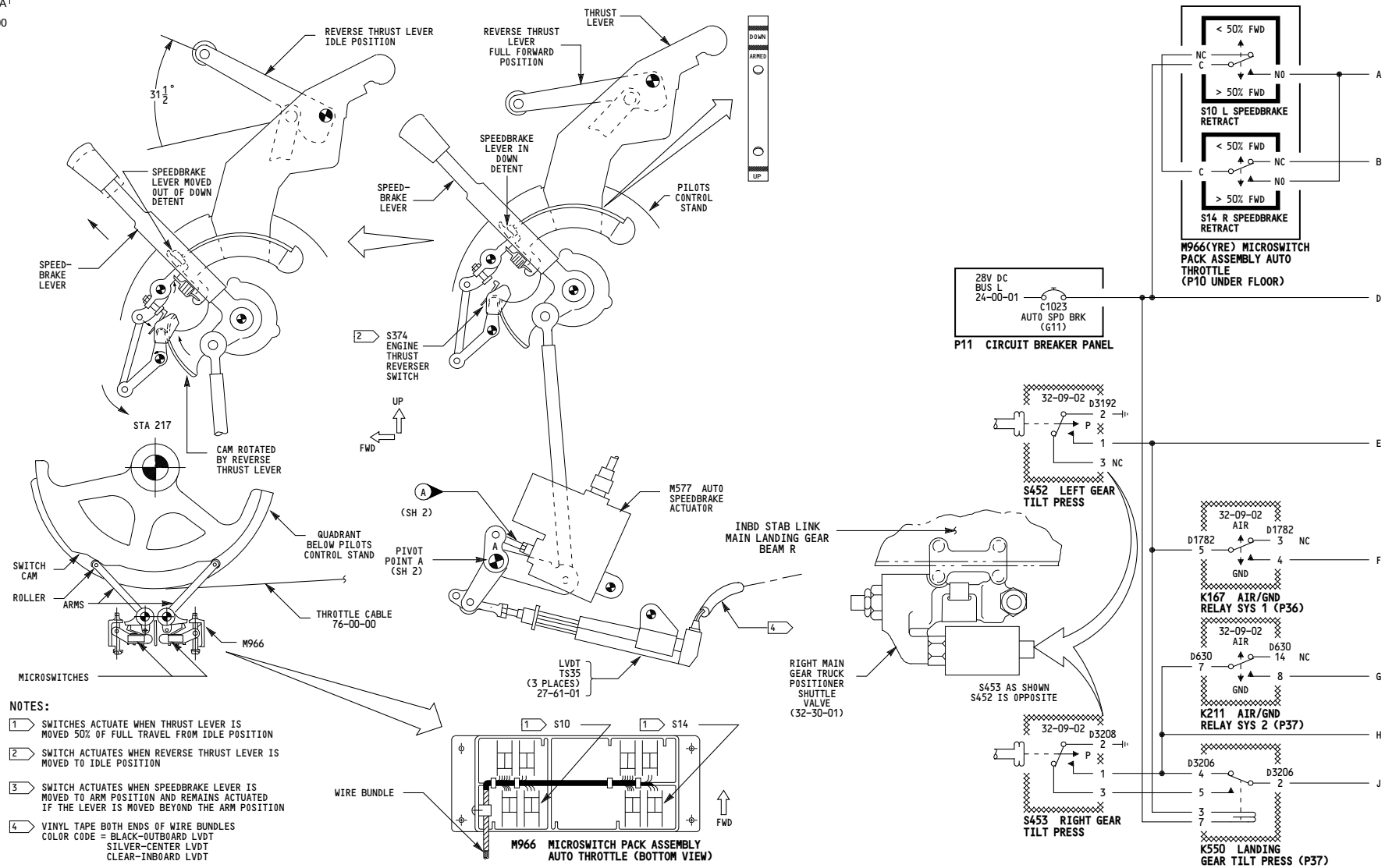

| | |
|-----|------------------------|
| ALL | AUTO SPEEDBRAKE |
| | D280N032S |

27-62-01

5000

WIRING DIAGRAMS
27-62-11

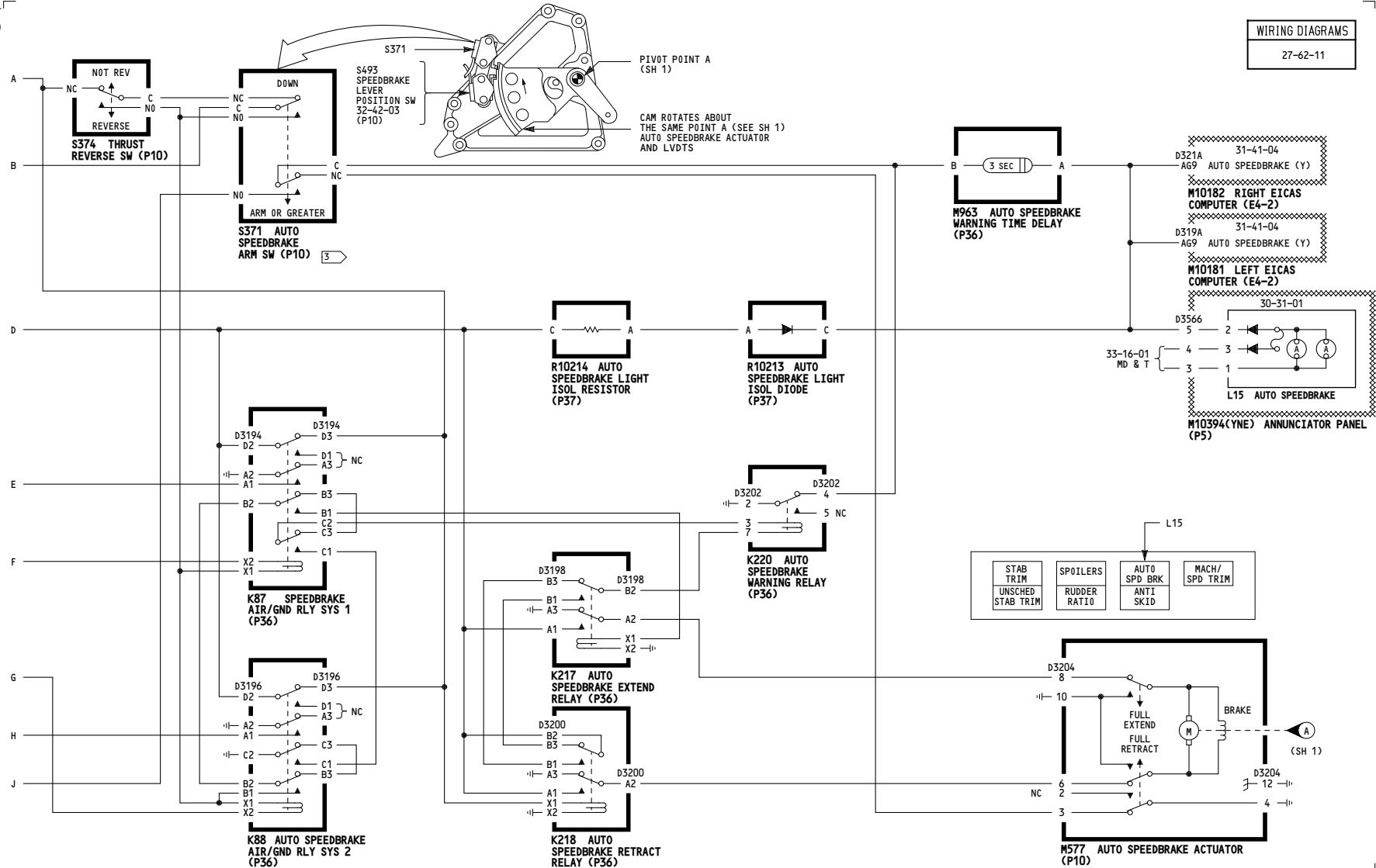

| | |
|-----|------------------------|
| ALL | AUTO SPEEDBRAKE |
| | D280N032S |

27-62-01

-A
5013

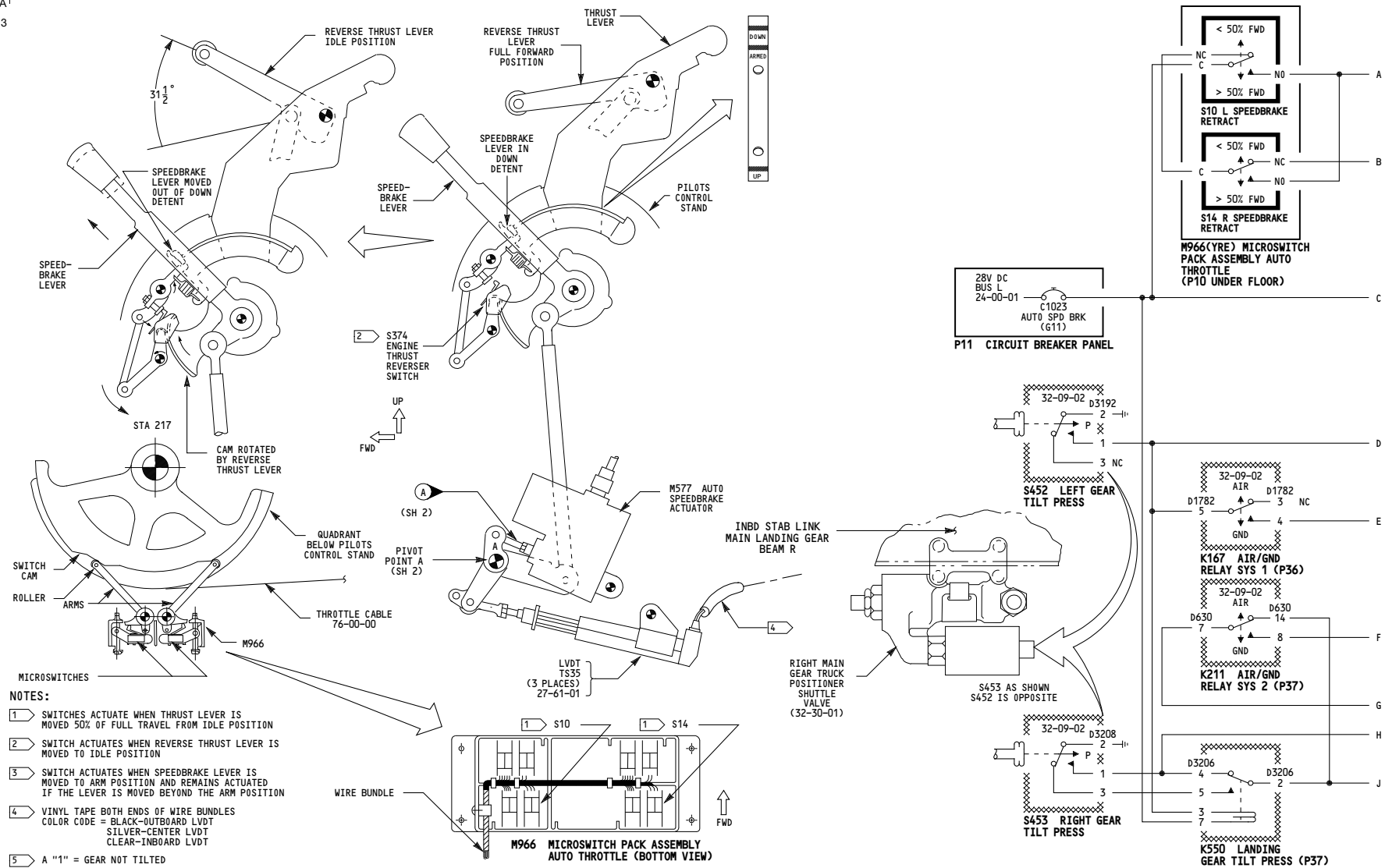

| | | |
|------------------|------------------------|-----------------------------|
| 001-009 | AUTO SPEEDBRAKE | Incorporates 27A0130 R01 |
| D280N032S | | |

27-62-01

-B
5003

WIRING DIAGRAMS
27-62-11

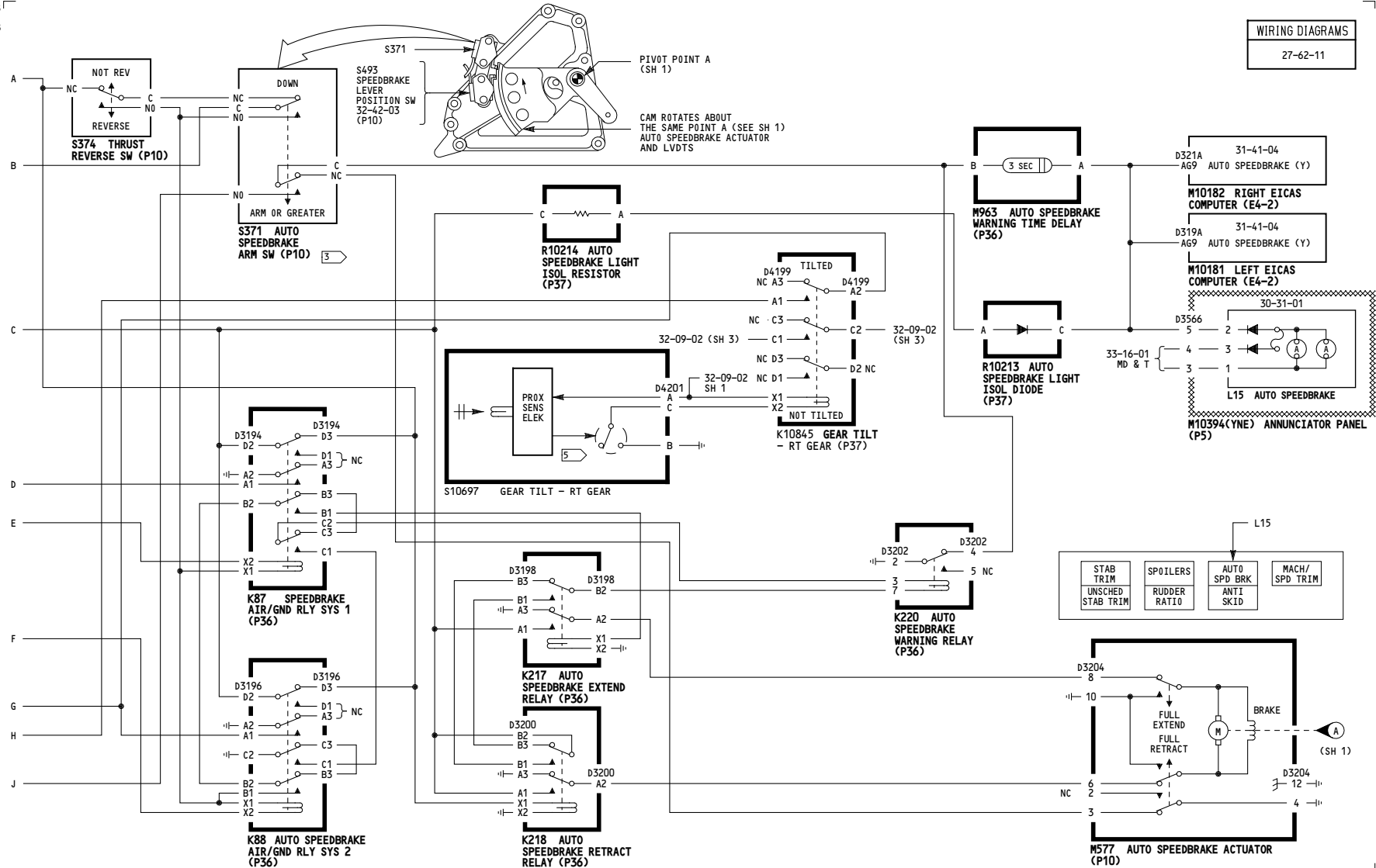

001-009

AUTO SPEEDBRAKE

Incorporates
27A0130 R01

D280N032S

27-62-01

-A
5013

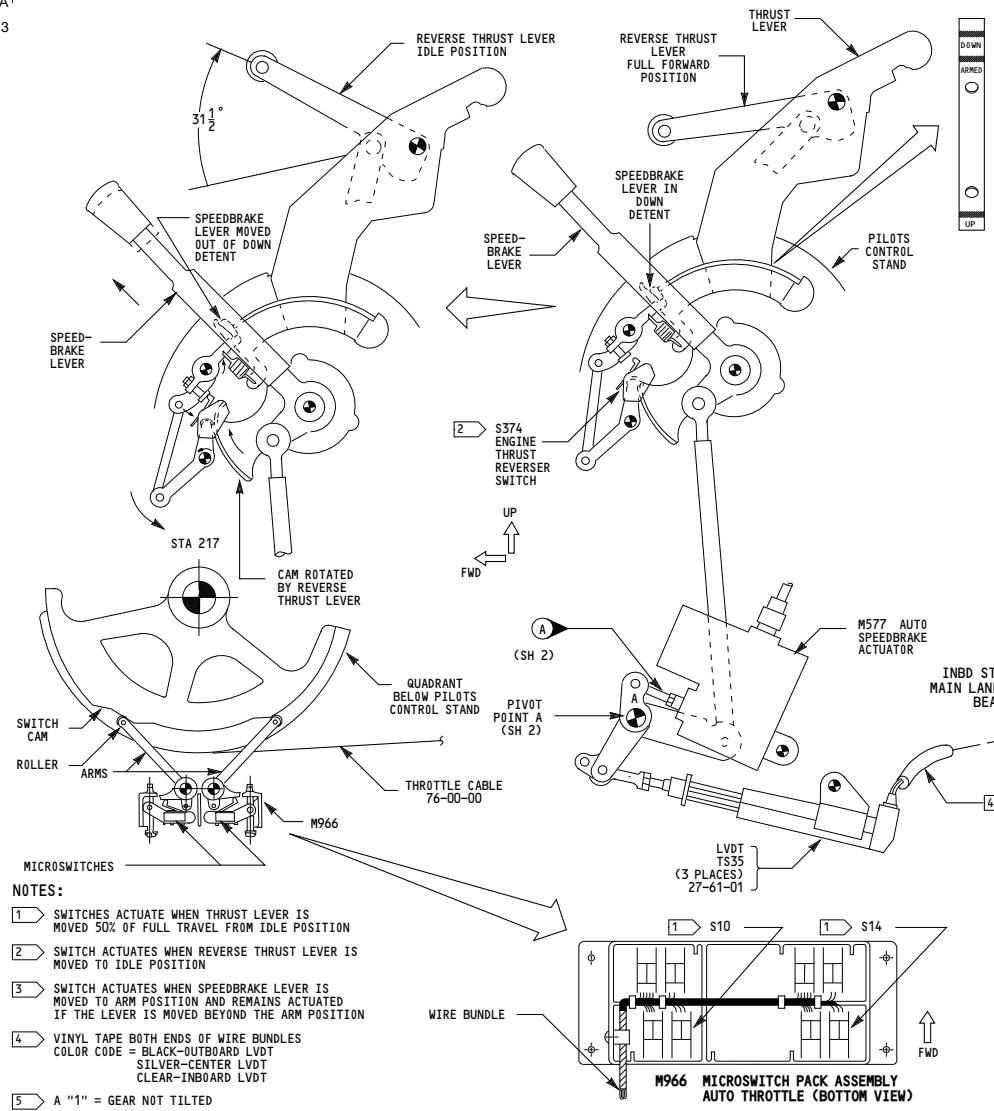

- NOTES:**
- 1 SWITCHES ACTUATE WHEN THRUST LEVER IS MOVED 50% OF FULL TRAVEL FROM IDLE POSITION
 - 2 SWITCH ACTUATES WHEN REVERSE THRUST LEVER IS MOVED TO IDLE POSITION
 - 3 SWITCH ACTUATES WHEN SPEEDBRAKE LEVER IS MOVED TO ARM POSITION AND REMAINS ACTUATED IF THE LEVER IS MOVED BEYOND THE ARM POSITION
 - 4 VINYL TAPE BOTH ENDS OF WIRE BUNDLES
COLOR CODE = BLACK-OUTBOARD LVDT
SILVER-CENTER LVDT
CLEAR-INBOARD LVDT
 - 5 A "1" = GEAR NOT TILTED

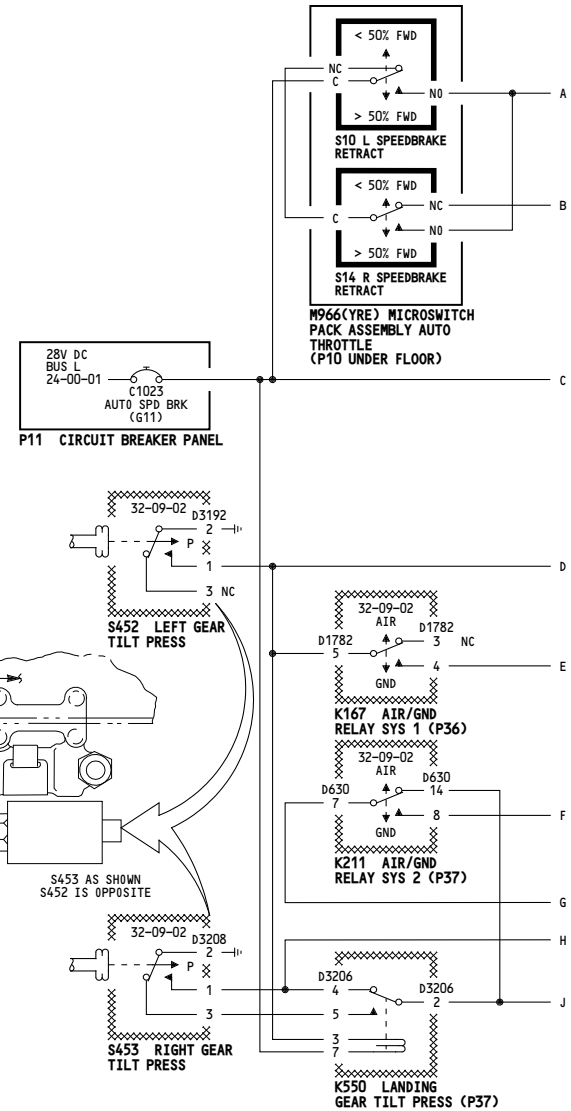

| | | |
|------------------|------------------------|-----------------------------|
| 010-011 | AUTO SPEEDBRAKE | Incorporates 27A0130 R01 |
| D280N032S | | |

27-62-01

5004

WIRING DIAGRAMS
27-62-11

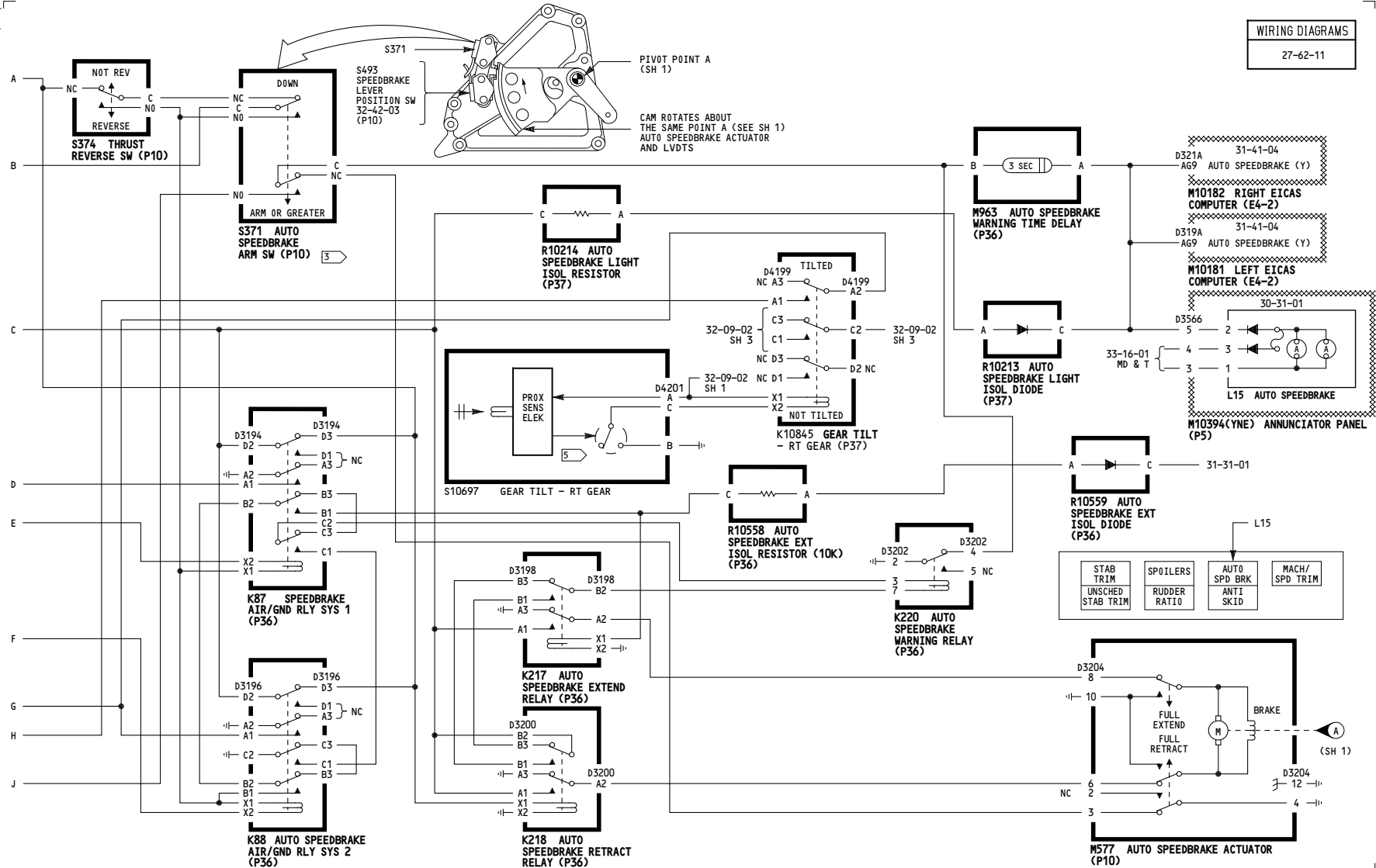

010-011

AUTO SPEEDBRAKE

Incorporates
27A0130 R01
31-0094

D280N032S

27-62-01

5000

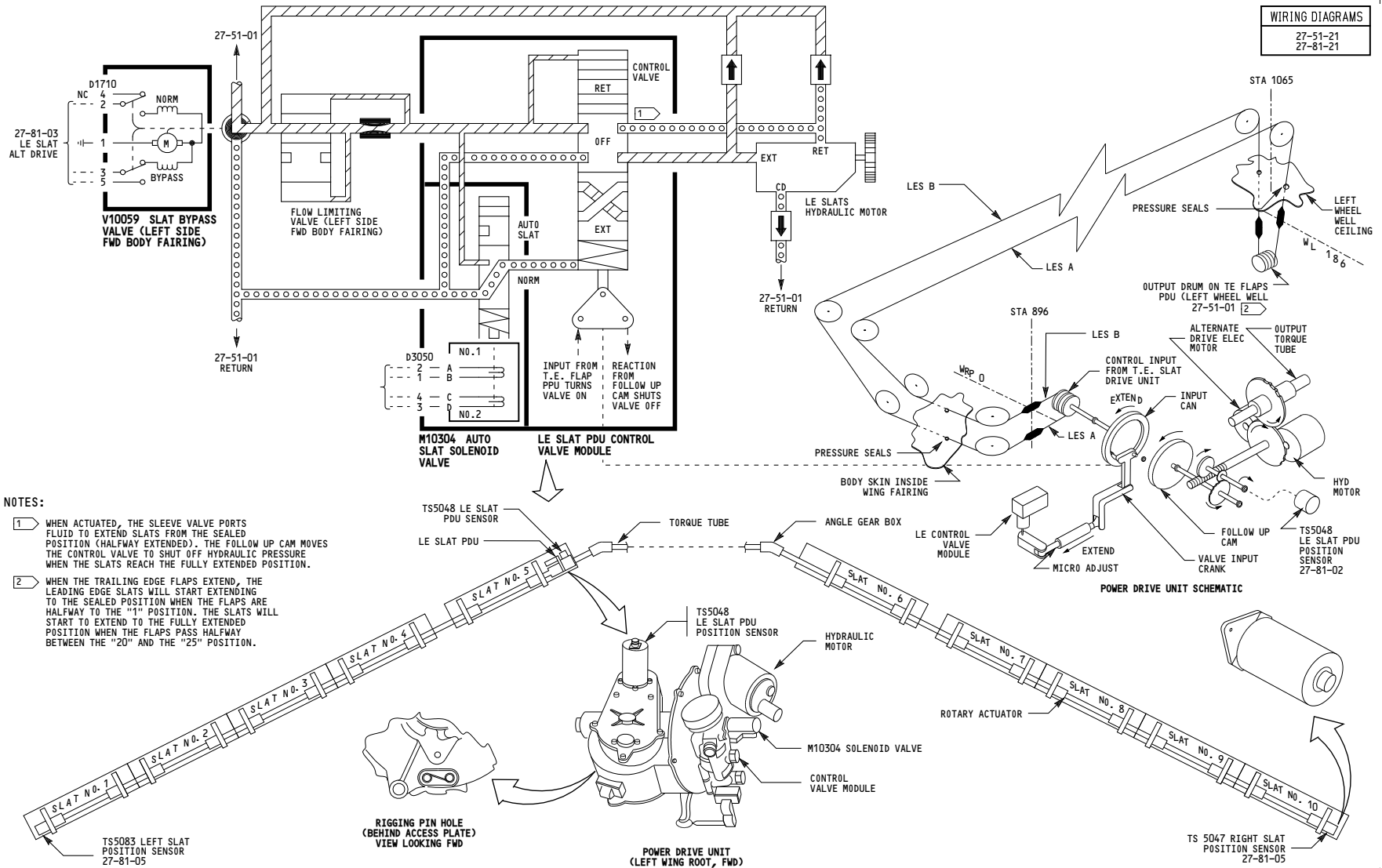

NOTES:

- 1 WHEN ACTUATED, THE SLEEVE VALVE PORTS FLUID TO EXTEND SLATS FROM THE SEALED POSITION (HALFWAY EXTENDED). THE FOLLOW UP CAM MOVES THE CONTROL VALVE TO SHUT OFF HYDRAULIC PRESSURE WHEN THE SLATS REACH THE FULLY EXTENDED POSITION.
- 2 WHEN THE TRAILING EDGE FLAPS EXTEND, THE LEADING EDGE SLATS WILL START EXTENDING TO THE SEALED POSITION WHEN THE FLAPS ARE HALFWAY TO THE "1" POSITION. THE SLATS WILL START TO EXTEND TO THE FULLY EXTENDED POSITION WHEN THE FLAPS PASS HALFWAY BETWEEN THE "20" AND THE "25" POSITION.

| | |
|-----------|---|
| ALL | LEADING EDGE SLATS PRIMARY DRIVE |
| D280N032S | |

WIRING DIAGRAMS
27-51-21
27-81-21

27-81-01

Page 101

May 06/2009

THIS PAGE INTENTIONALLY LEFT BLANK

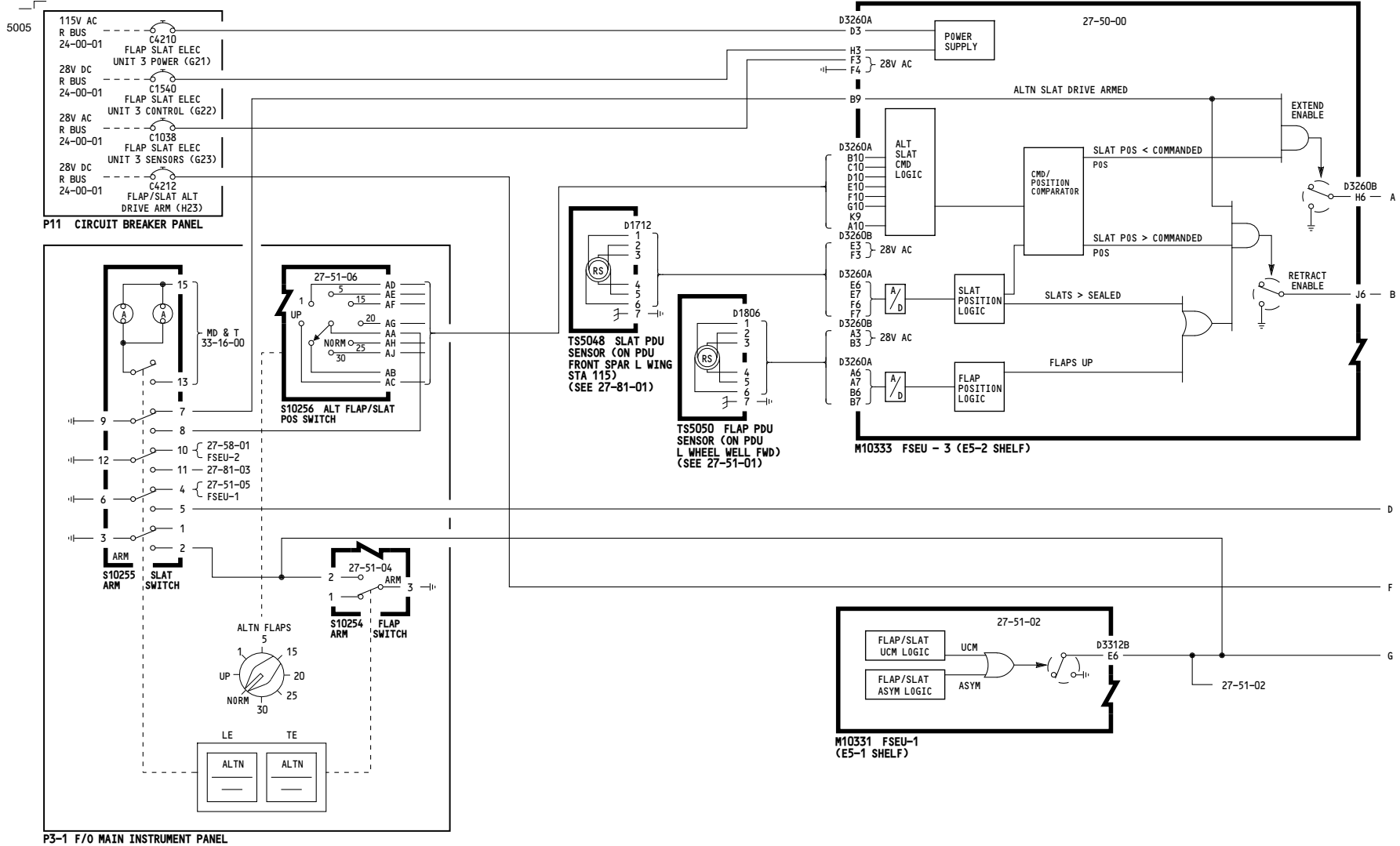

| | |
|-----------|----------------------|
| ALL | SLAT ALTERNATE DRIVE |
| D280N032S | |

27-81-02

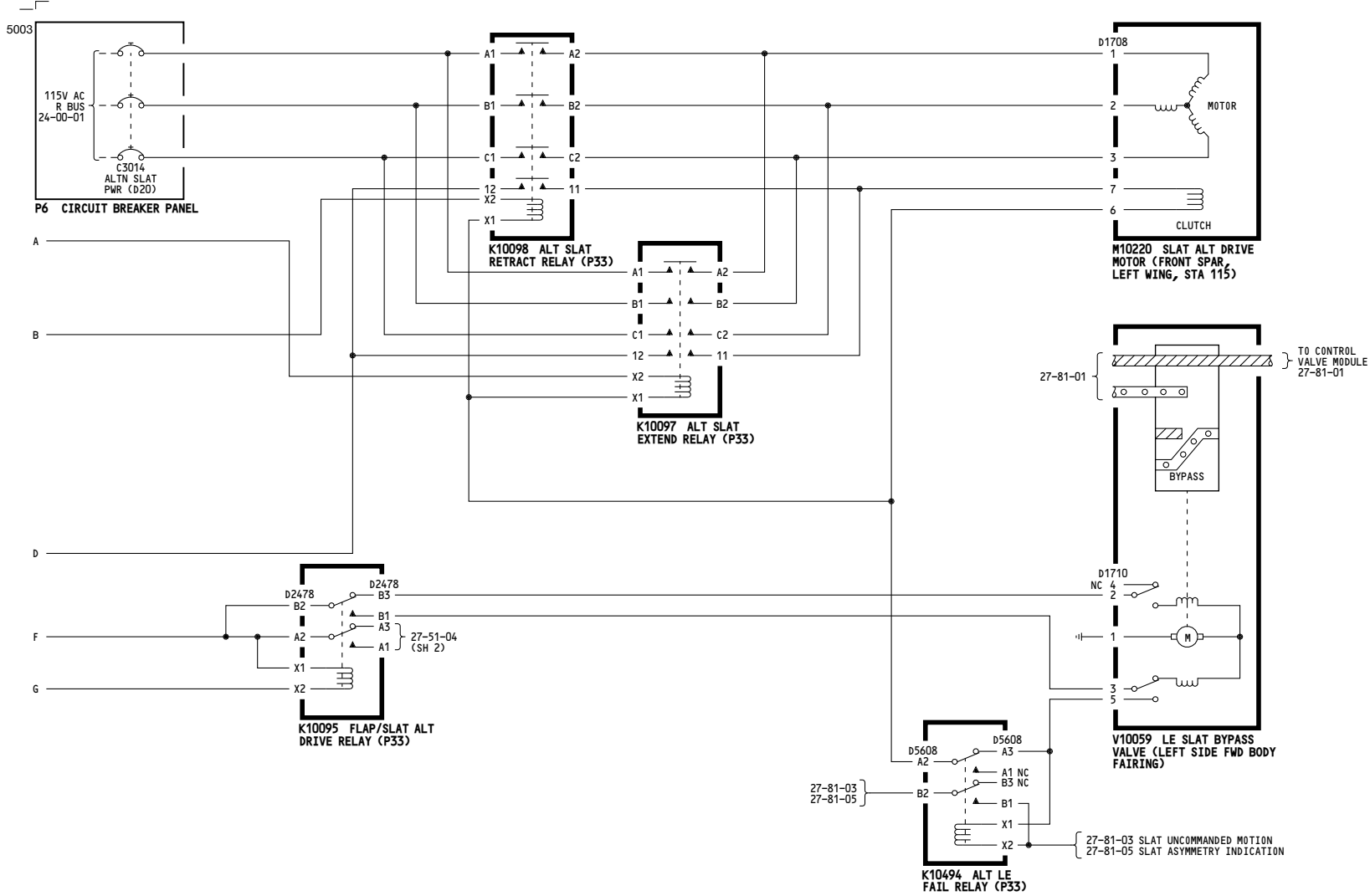

WIRING DIAGRAMS
27-51-11
27-51-21
27-81-11

| | |
|-----|---|
| ALL | <p>SLAT ALTERNATE DRIVE</p> <p>D280N032S</p> |
|-----|---|

27-81-02

Page 101
Sheet 2
May 06/2009

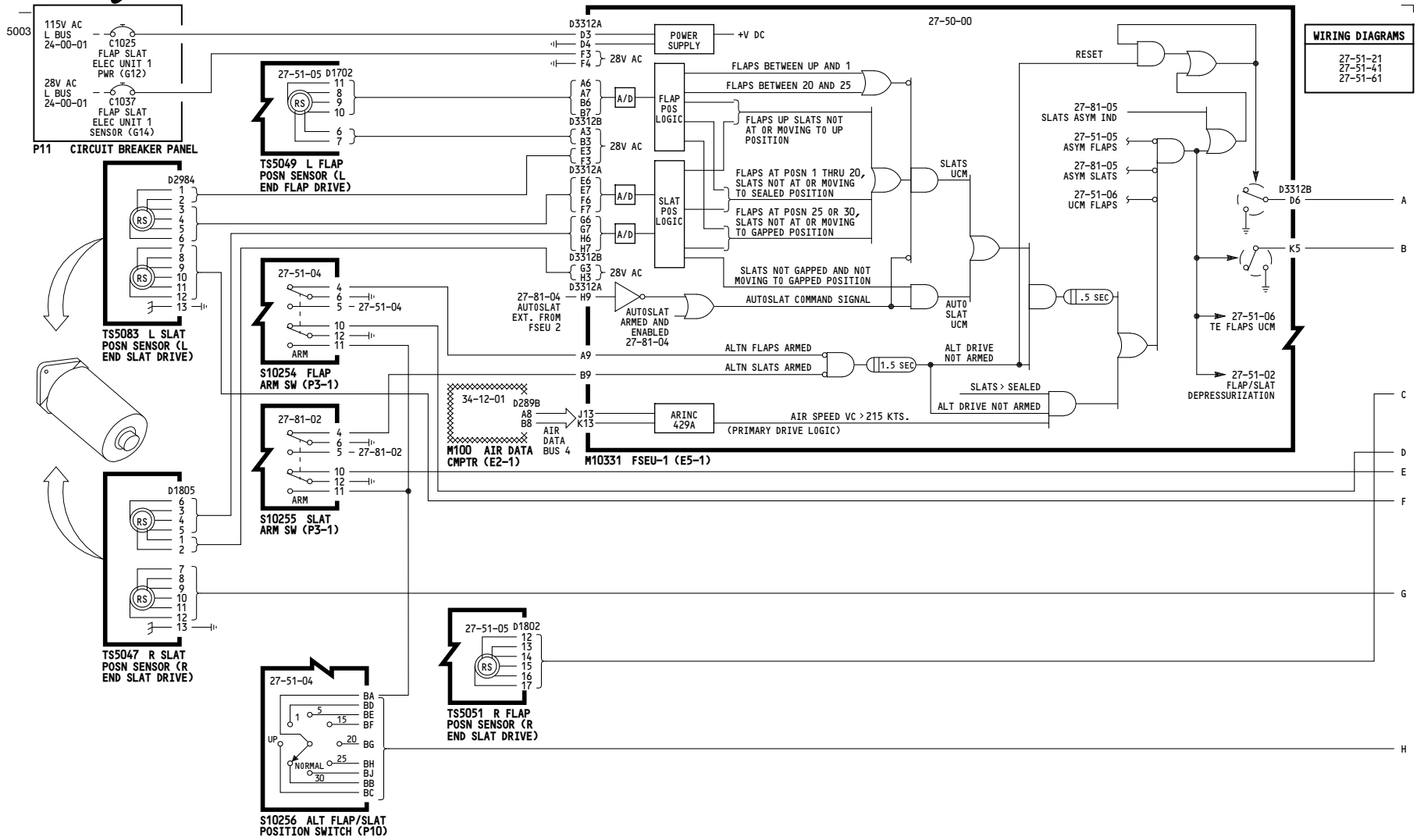

ALL

LEADING EDGE SLATS UNCOMMANDED MOTION

D280N032S

27-81-03

Page 101
Sheet 1
May 06/2009

| WIRING DIAGRAMS | |
|-----------------|--|
| 27-51-21 | |
| 27-51-41 | |
| 27-51-61 | |

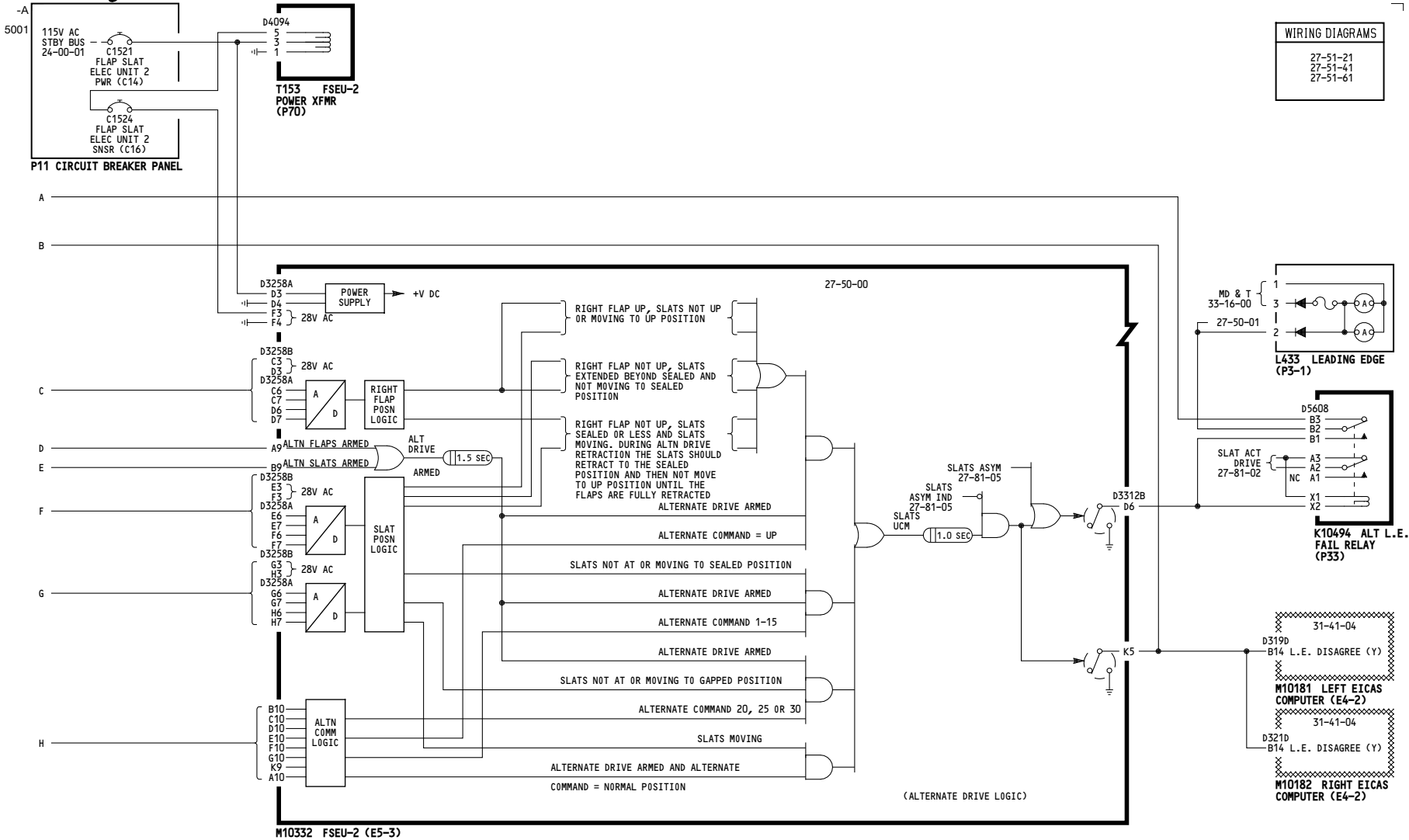

ALL

LEADING EDGE SLATS UNCOMMANDED MOTION

D280N032S

27-81-03

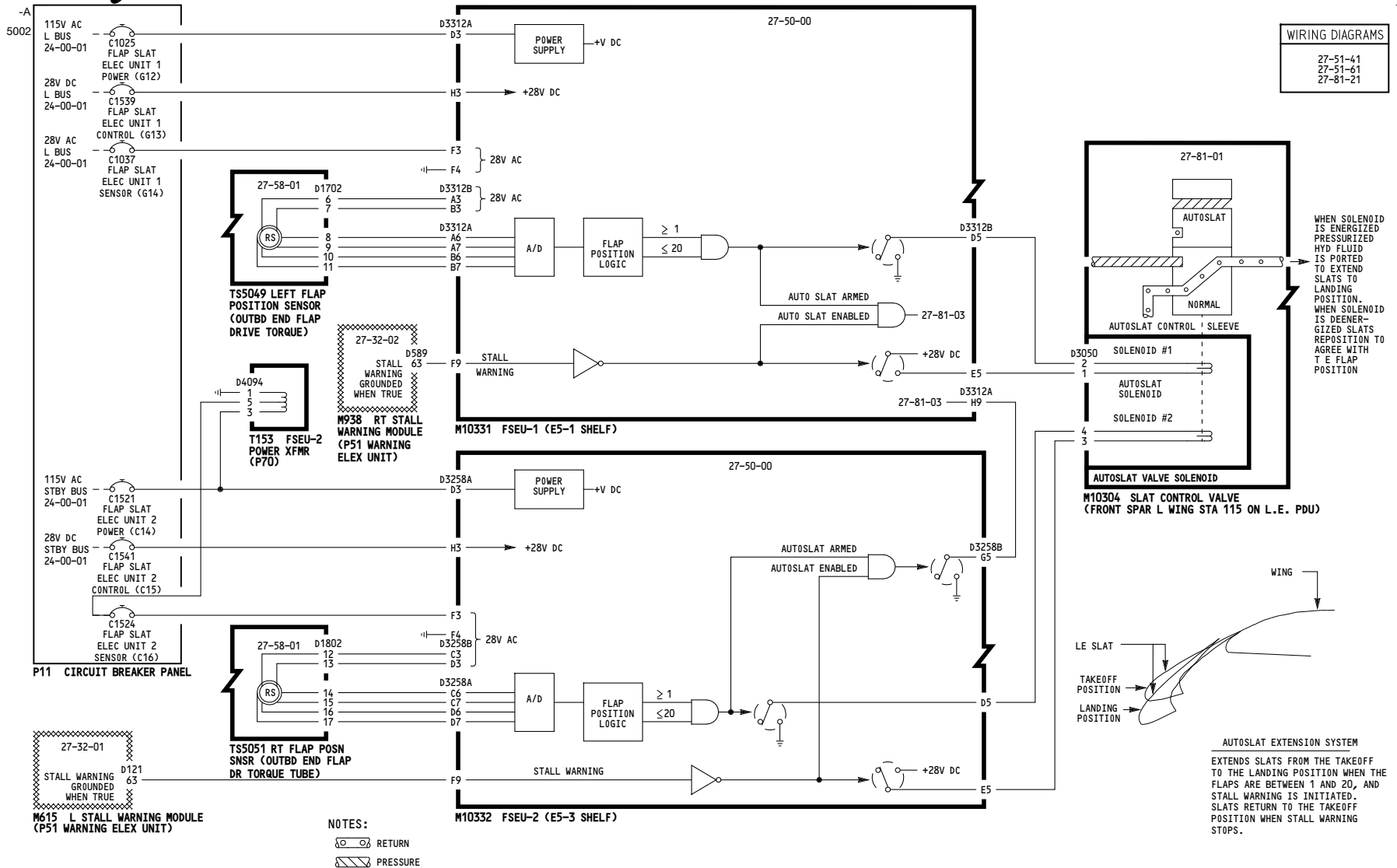

| | |
|-----|---------------------------|
| ALL | AUTOSLAT EXTENSION |
| | D280N032S |

27-81-04

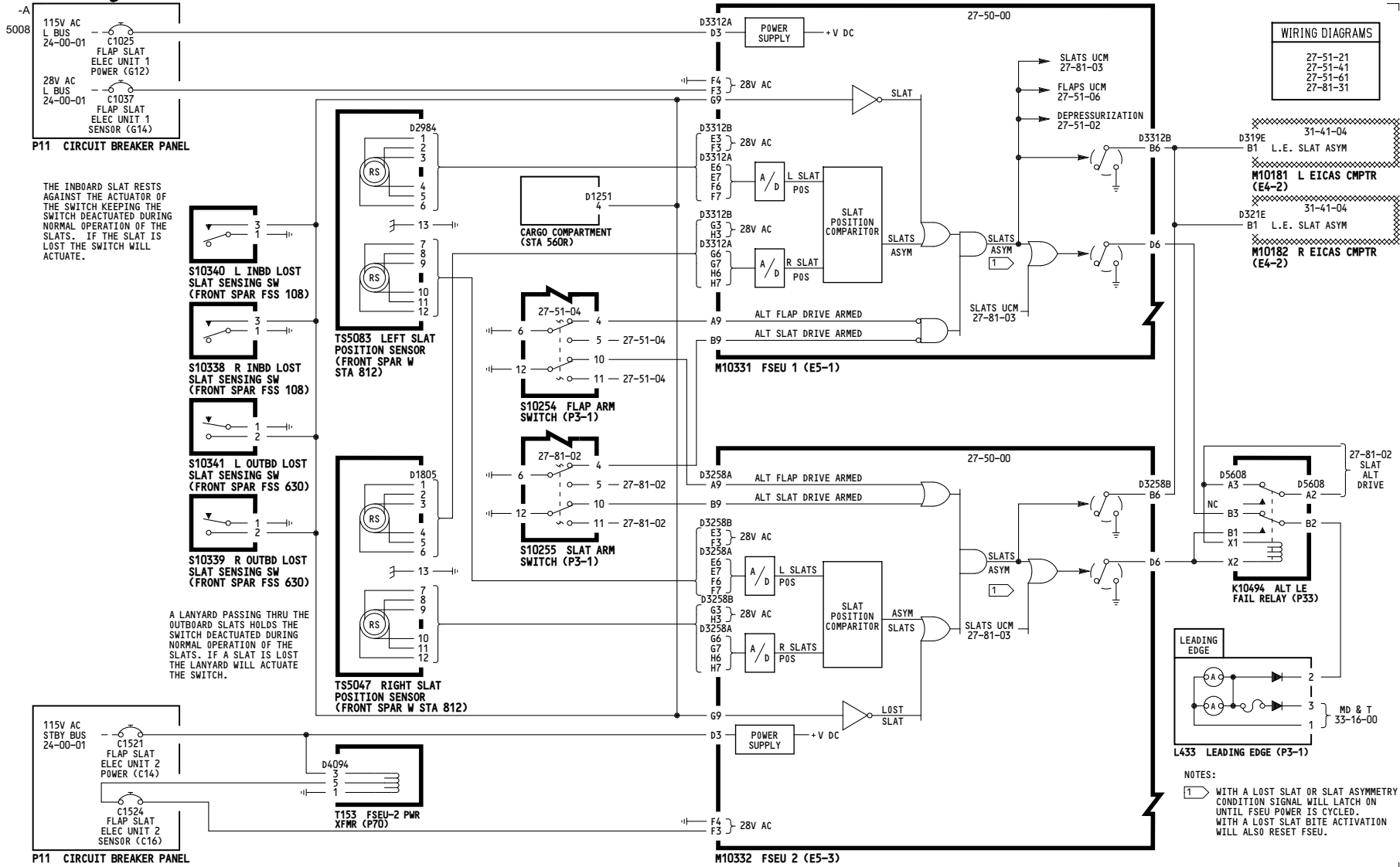

| | |
|-----|---------------------------|
| ALL | SLAT ASYMMETRY INDICATION |
| | D280N032S |

27-81-05

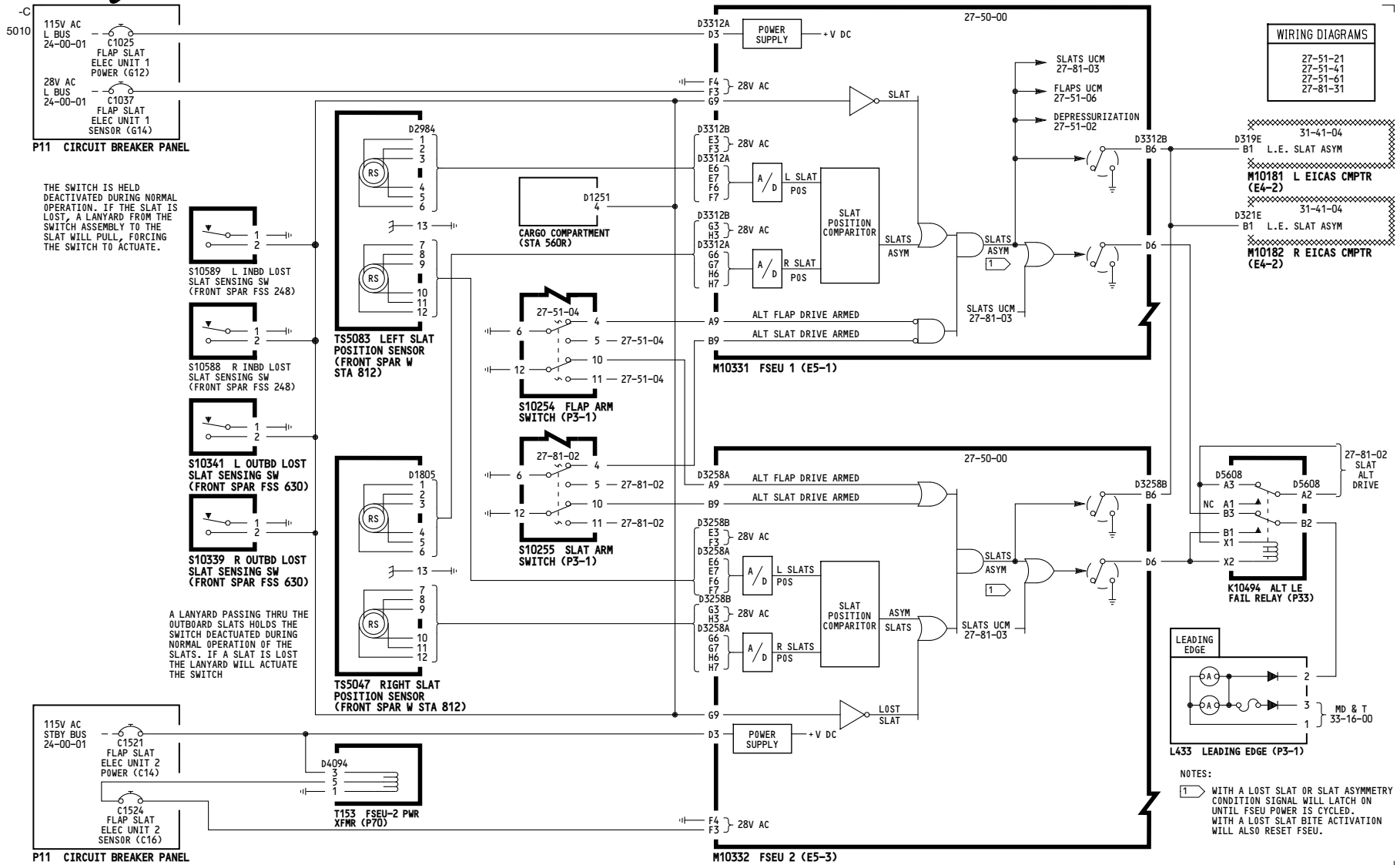

Incorporates
27-0117 R02

27-81-05

Page 101.1

May 17/2006

D280N032S