

CHAPTER

30

ICE AND RAIN PROTECTION



CHAPTER 30
ICE AND RAIN PROTECTION

CH-SC-SU	Schem	Page	Sheet	Date	CH-SC-SU	Schem	Page	Sheet	Date
30-71-01		101		Jan 21/2005					
		102		Dec 18/2007					
		103		Dec 18/2007					

A = Added, R = Revised, D = Deleted, O = Overflow

30-EFFECTIVE PAGES

Page 2
Oct 09/2008

D280N032S

CHAPTER 30
ICE AND RAIN PROTECTION

Title	CH-SC-SU	Schem	Page	Sheet	Date	Effectivity
<u>WING THERMAL ANTI-ICING</u>						
WING THERMAL ANTI-ICE	30-11-01		101		Jan 21/2005	ALL
<u>ENGINE INLET THERMAL ANTI-ICING</u>						
LEFT ENGINE COWL ANTI-ICE	30-21-01		101		Jan 21/2005	001-003 115-199
			102		Jan 21/2005	004-099
RIGHT ENGINE COWL ANTI-ICE	30-21-02		101		Jan 21/2005	001-003 115-199
			102		Dec 18/2007	004-099
<u>PITOT PROBE ANTI-ICING</u>						
LEFT PITOT PROBE HEAT	30-31-01		101		Jan 21/2005	ALL
RIGHT PITOT PROBE HEAT	30-31-02		101		Jan 21/2005	ALL
			101.1		Jan 21/2005	001-115
<u>ANGLE-OF-ATTACK PROBE HEAT</u>						
LEFT ANGLE OF ATTACK PROBE HEAT	30-32-01		101		Jan 21/2005	ALL
RIGHT ANGLE OF ATTACK PROBE HEAT	30-32-02		101		Jan 21/2005	ALL
<u>TOTAL AIR TEMPERATURE PROBE HEAT</u>						
RIGHT TOTAL AIR TEMPERATURE PROBE HEAT	30-33-01		101		Jan 21/2005	ALL
<u>ENGINE PROBE HEAT</u>						
ENGINE PROBE HEAT	30-34-01		101		Jan 21/2005	ALL
<u>FLIGHT COMPARTMENT WINDOW ANTI-ICING</u>						
LEFT FORWARD WINDOW 1 HEAT SYSTEM	30-41-01		101		Dec 18/2007	ALL
RIGHT FORWARD WINDOW 1 HEAT SYSTEM	30-41-02		101		Jan 21/2005	ALL
LEFT SLIDING WINDOW 2 HEAT SYSTEM	30-41-03		101		Dec 18/2007	ALL
RIGHT SLIDING WINDOW 2 HEAT SYSTEM	30-41-04		101		Jan 21/2005	ALL

**CHAPTER 30
ICE AND RAIN PROTECTION**

Title	CH-SC-SU	Schem	Page	Sheet	Date	Effectivity
LEFT SIDE WINDOW 3 HEAT SYSTEM	30-41-05		101		Jan 21/2005	ALL
RIGHT SIDE WINDOW 3 HEAT SYSTEM	30-41-06		101		Jan 21/2005	ALL
<u>WINDSHIELD WIPER SYSTEM</u>						
WINDSHIELD WIPERS	30-42-01		101		Jan 21/2005	ALL
<u>WINDSHIELD RAIN REPELLENT SYSTEM</u>						
RAIN REPELLENT SYSTEM	30-43-01		101		Jan 21/2005	ALL
			101.1		Jan 21/2005	001-115
<u>WATER AND DRAIN LINE HEATERS</u>						
WATER AND WASTE SYSTEM HEATERS	30-71-01		101		Jan 21/2005	001
			102		Dec 18/2007	002-099
			103		Dec 18/2007	115-199

CHAPTER 30
ICE AND RAIN PROTECTION

CH-SC-SU	Title
30-34-01	ENGINE PROBE HEAT
30-32-01	LEFT ANGLE OF ATTACK PROBE HEAT
30-21-01	LEFT ENGINE COWL ANTI-ICE
30-41-01	LEFT FORWARD WINDOW 1 HEAT SYSTEM
30-31-01	LEFT PITOT PROBE HEAT
30-41-05	LEFT SIDE WINDOW 3 HEAT SYSTEM
30-41-03	LEFT SLIDING WINDOW 2 HEAT SYSTEM
30-43-01	RAIN REPELLENT SYSTEM
30-32-02	RIGHT ANGLE OF ATTACK PROBE HEAT
30-21-02	RIGHT ENGINE COWL ANTI-ICE
30-41-02	RIGHT FORWARD WINDOW 1 HEAT SYSTEM
30-31-02	RIGHT PITOT PROBE HEAT
30-41-06	RIGHT SIDE WINDOW 3 HEAT SYSTEM
30-41-04	RIGHT SLIDING WINDOW 2 HEAT SYSTEM
30-33-01	RIGHT TOTAL AIR TEMPERATURE PROBE HEAT
30-71-01	WATER AND WASTE SYSTEM HEATERS
30-42-01	WINDSHIELD WIPERS
30-11-01	WING THERMAL ANTI-ICE

CH-SC-SU	Title

30-ALPHABETICAL INDEX

WIRING DIAGRAMS
30-11-11

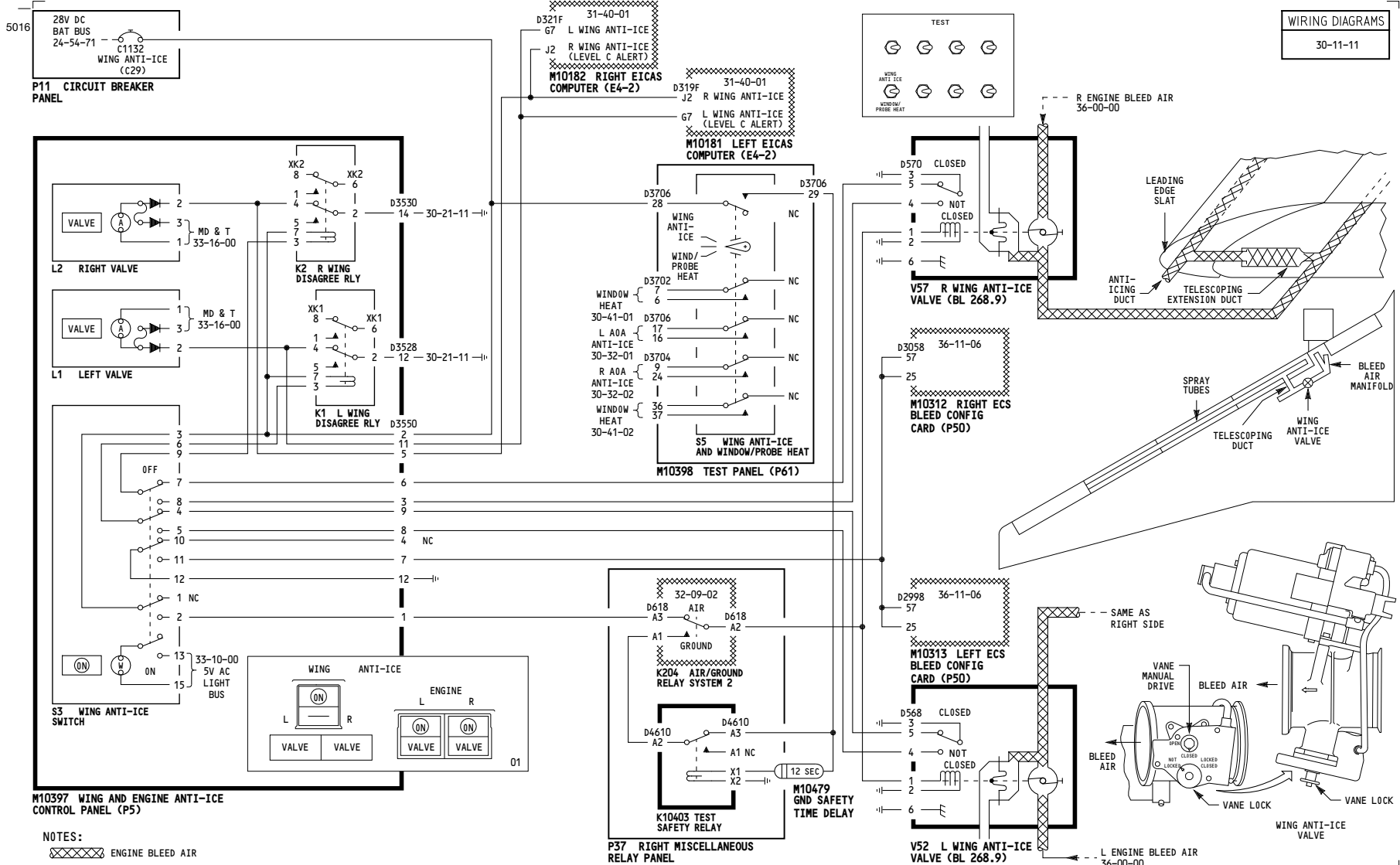

NOTES:
ENGINE BLEED AIR

ALL

WING THERMAL ANTI-ICE

D280N032S

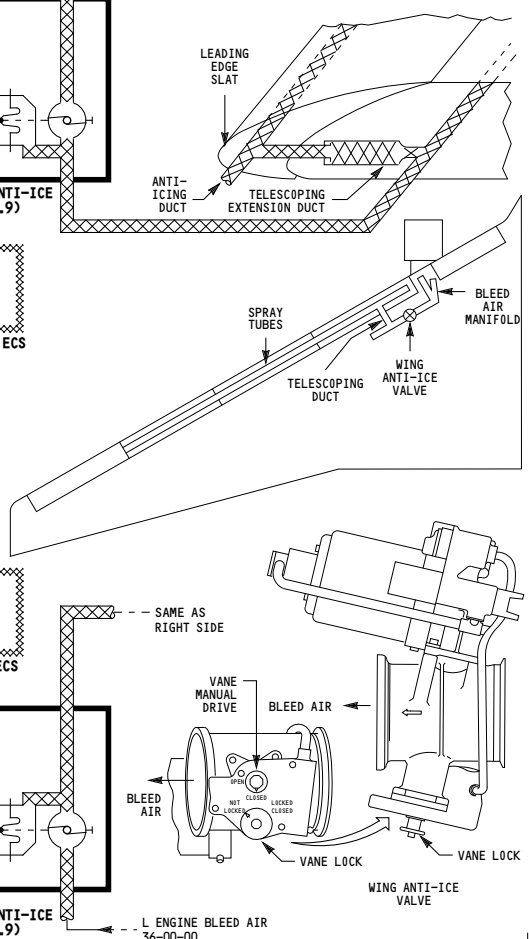

30-11-01

5020

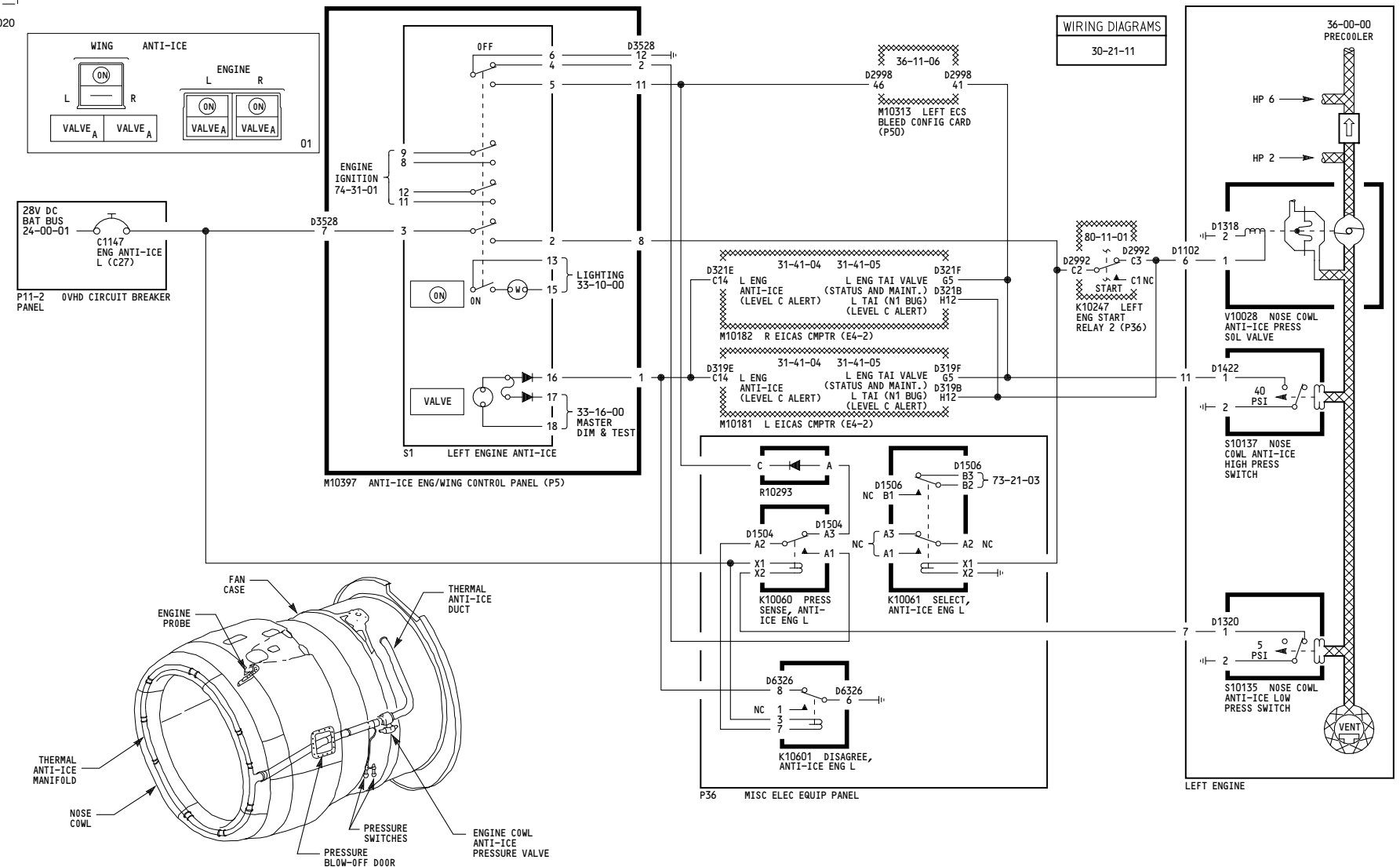

WIRING DIAGRAMS
30-21-11

001-003, 115-199

LEFT ENGINE COWL ANTI-ICE

D280N032S

30-21-01

Page 101

Jan 21/2005

5023

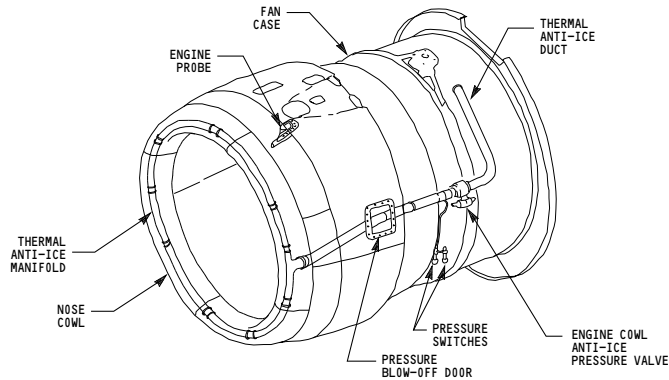
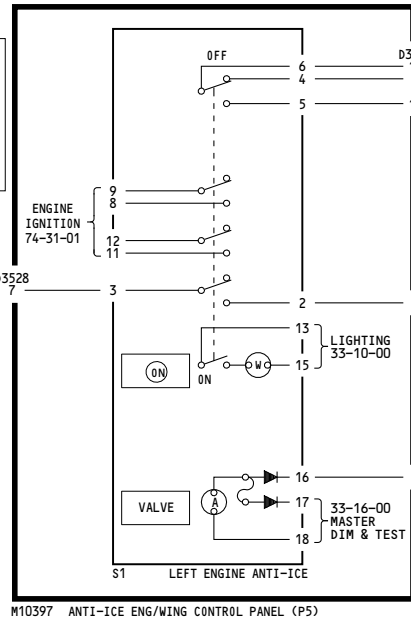
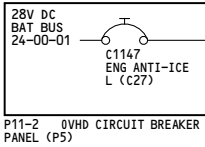
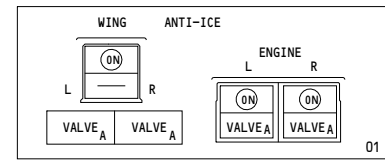

004-099

LEFT ENGINE COWL ANTI-ICE

D280N032S

WIRING DIAGRAMS
30-21-11

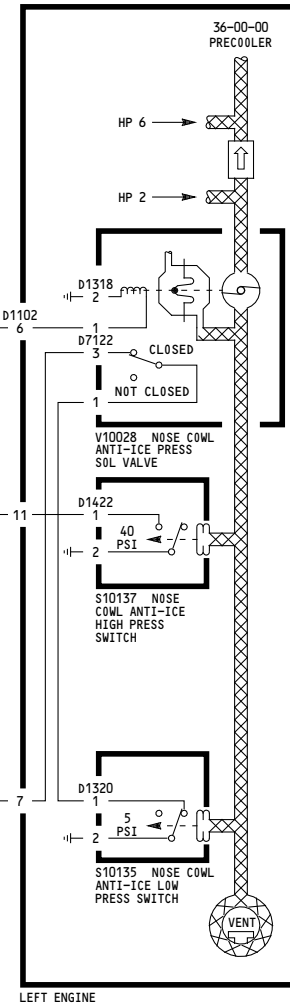
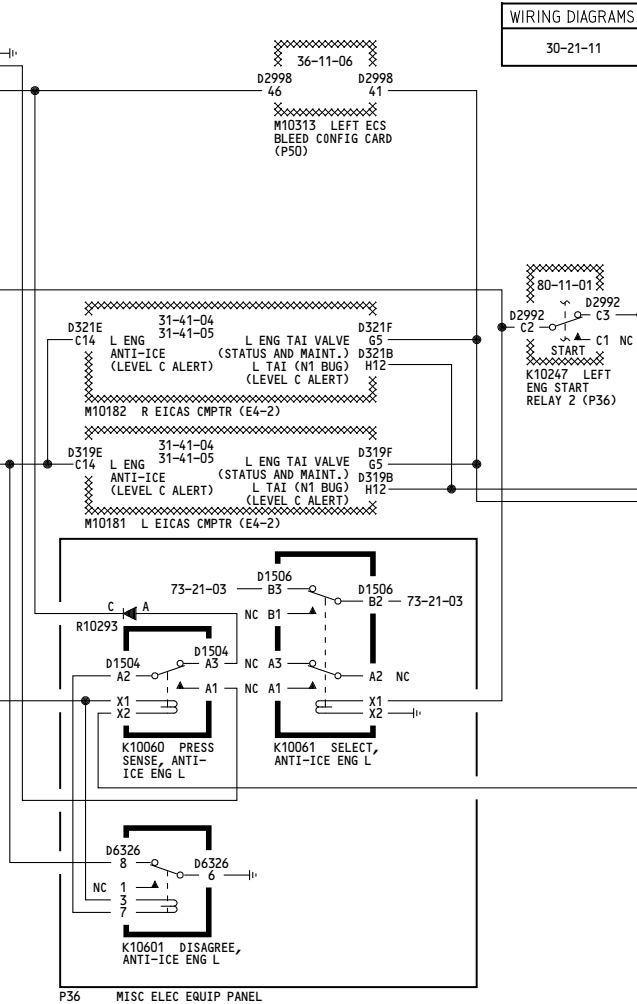

30-21-01

5023

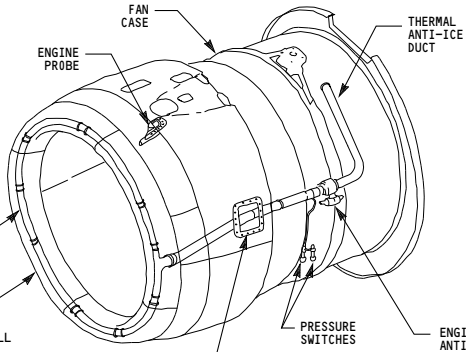
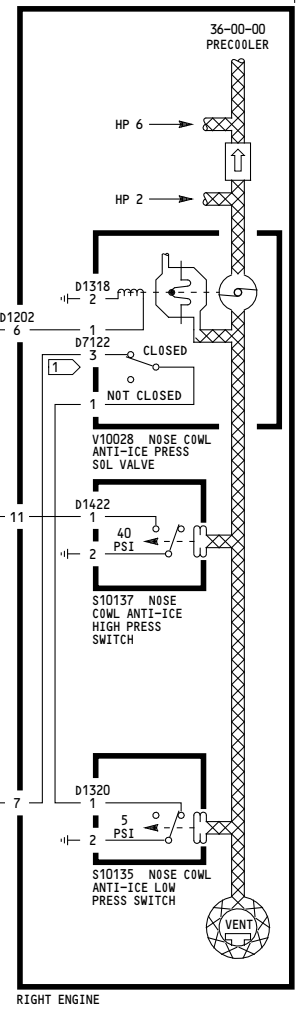
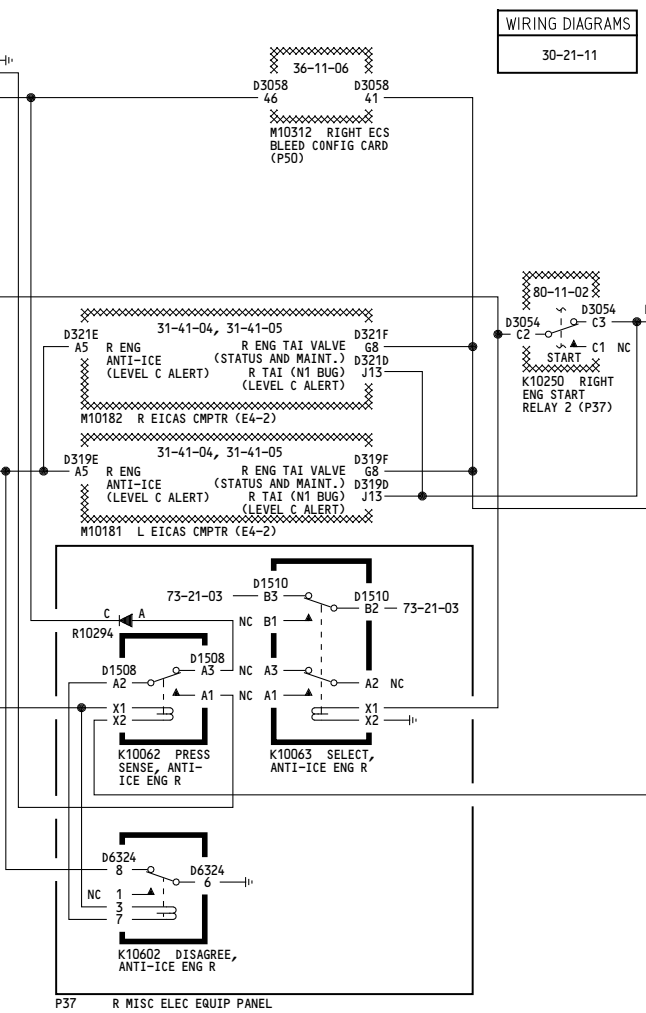
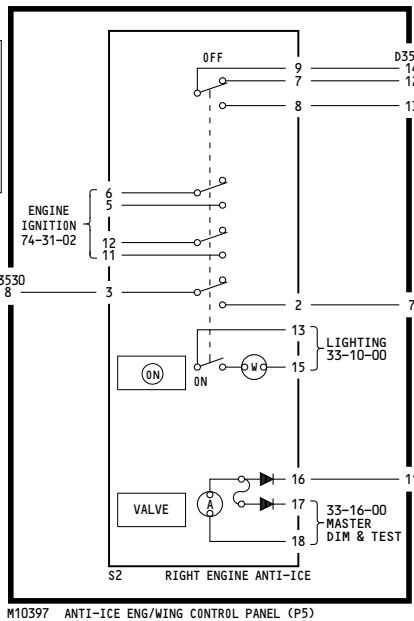
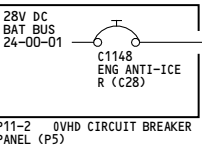
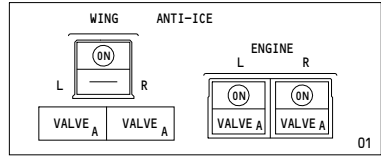

NOTES: NOSE COWL
1 ZOOM DRA ALL
2 INSERT NTEXT TN0D ;;1;

1 THE SWITCH ASSOCIATED WITH D7122/V10028 TRANSFERS TO THE NOT CLOSED POSITION WHEN THE VALVE IS NEAR THE FULLY OPEN

004-099

RIGHT ENGINE COWL ANTI-ICE

D280N032S

30-21-02

-A
5012

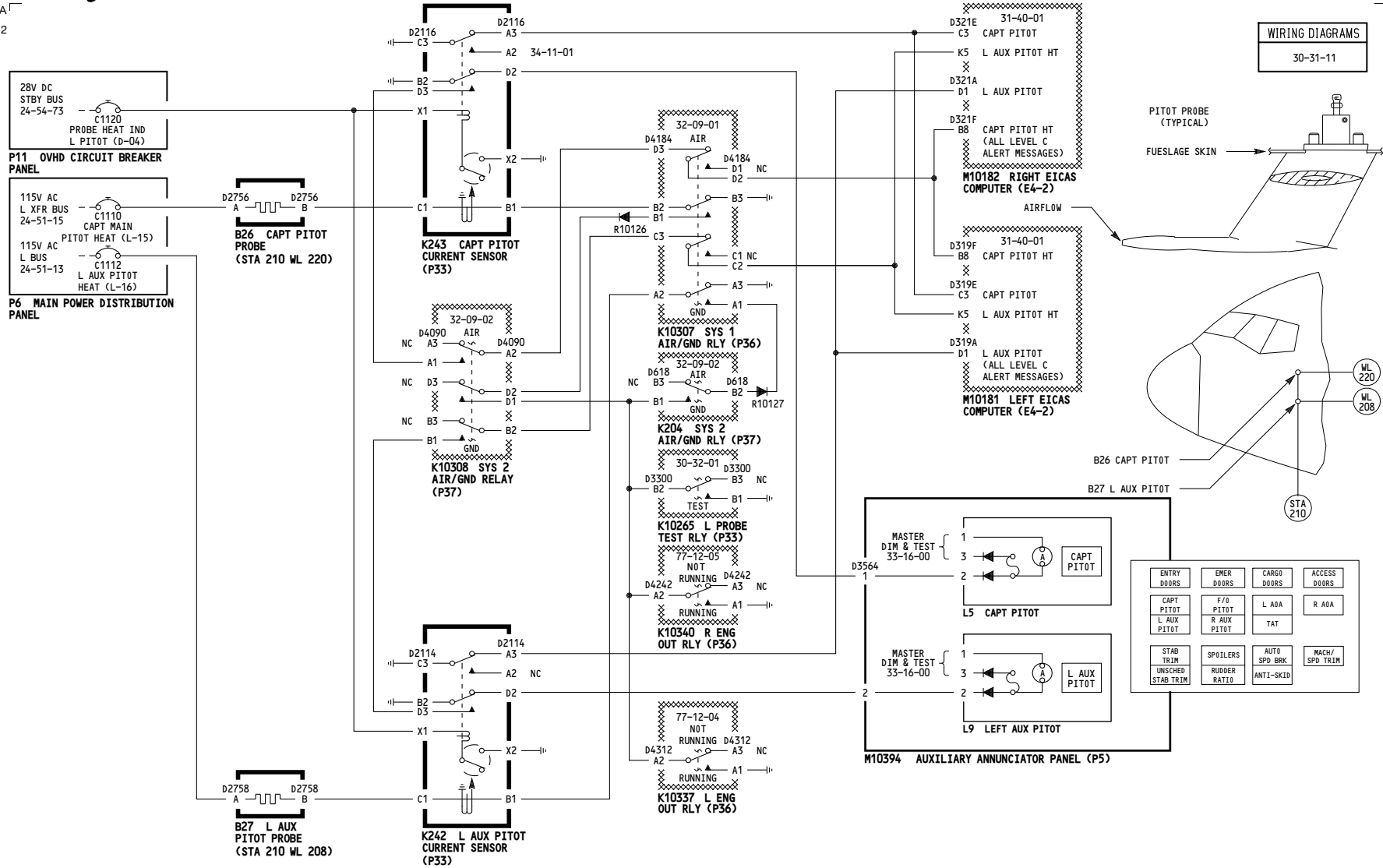

ALL	LEFT PITOT PROBE HEAT
	D280N032S

30-31-01

Page 101

Jan 21/2005

-A
5012

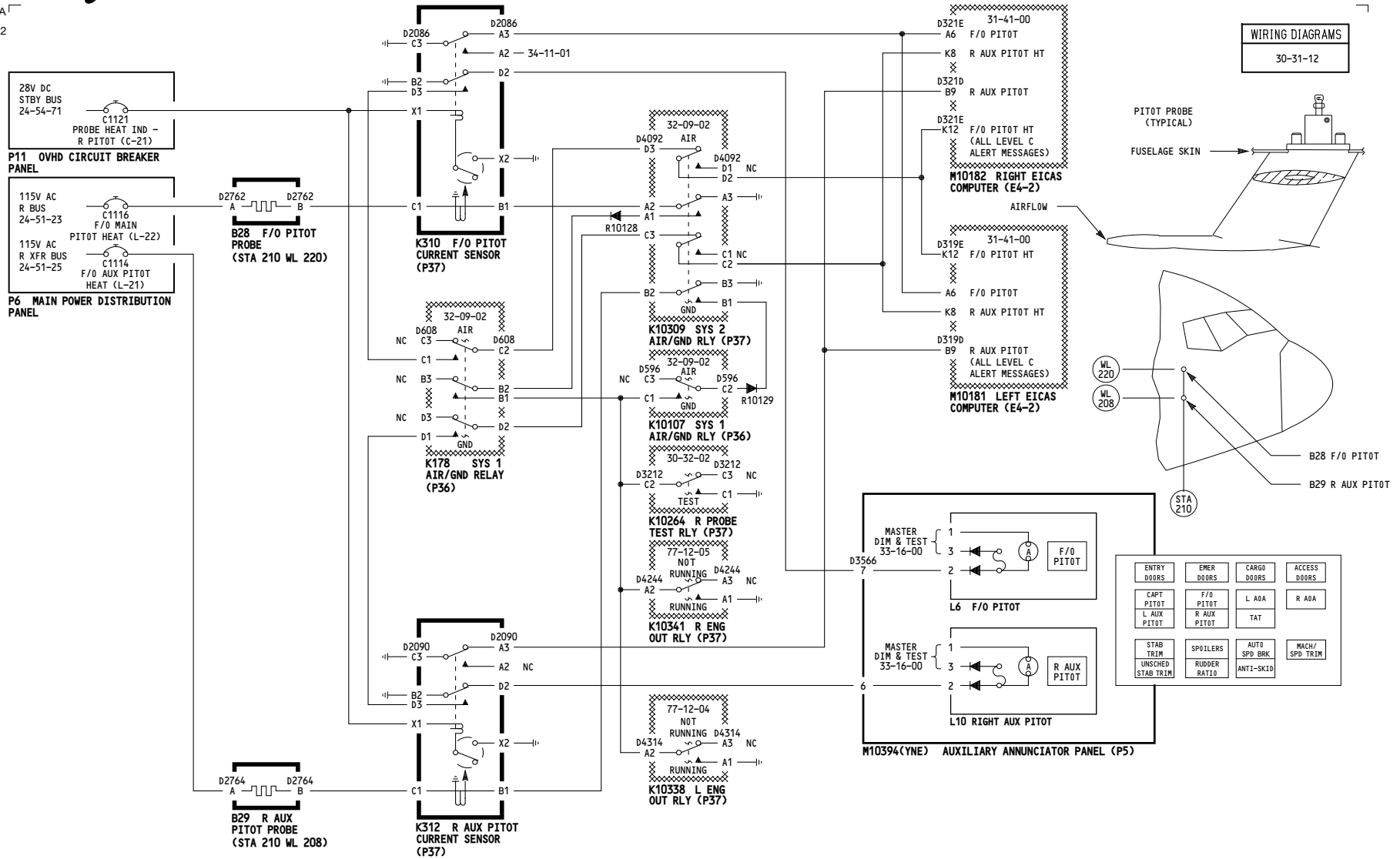

ALL	RIGHT PITOT PROBE HEAT
	D280N032S

5023

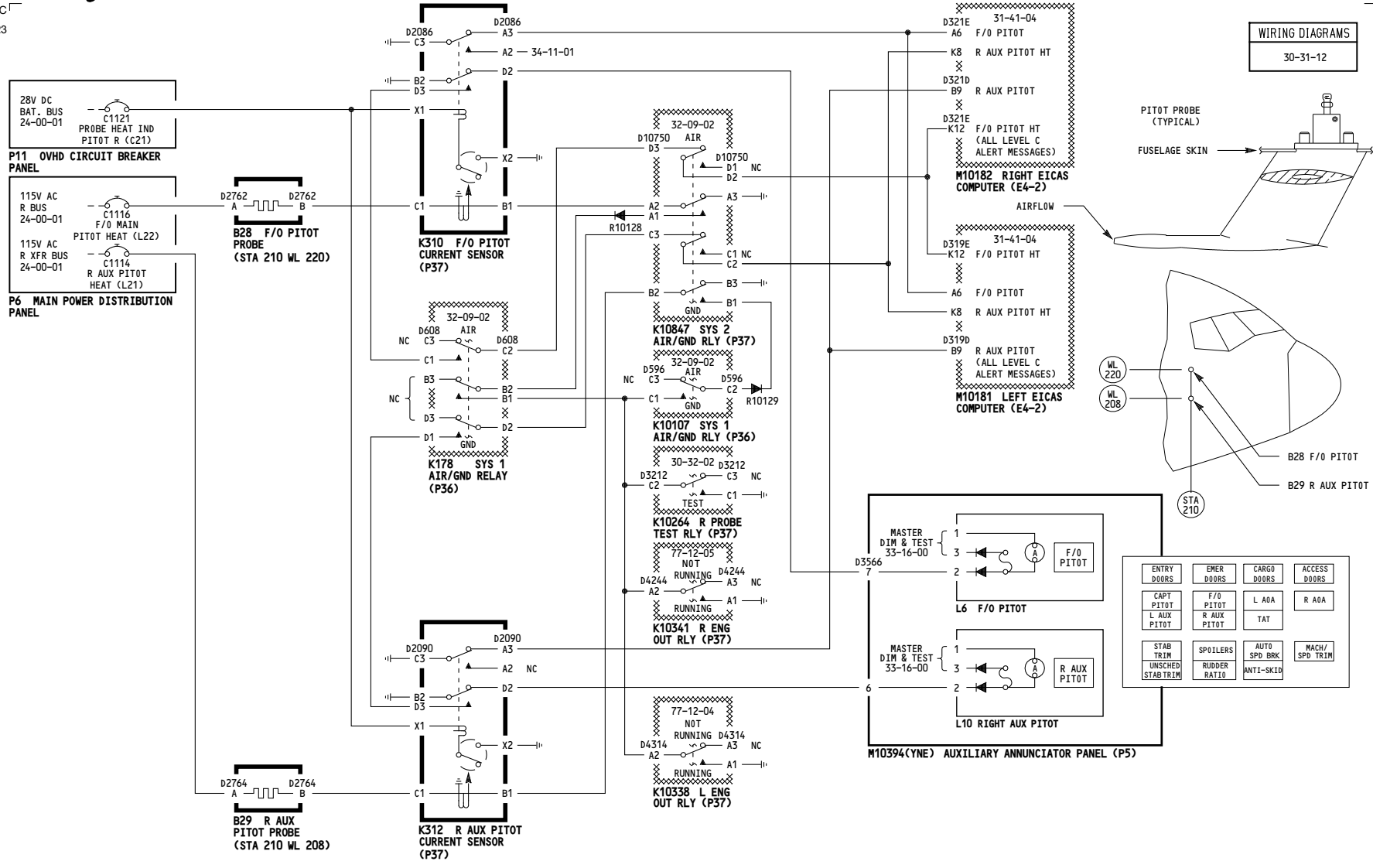

001-115	RIGHT PITOT PROBE HEAT
	D280N032S

Incorporates
27A0130 R01

30-31-02

Page 101.1

Jan 21/2005

-A
5014

WIRING DIAGRAMS
30-32-11

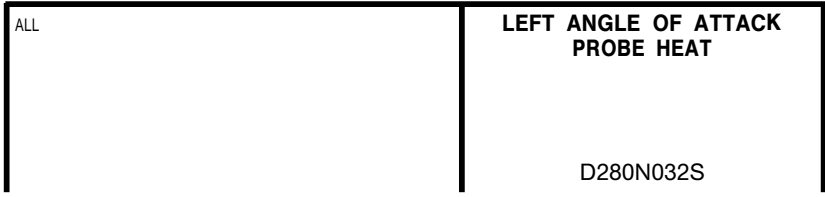
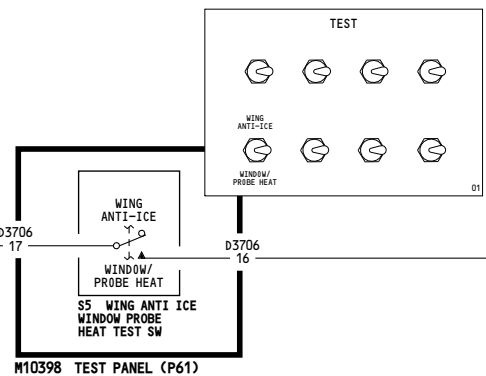
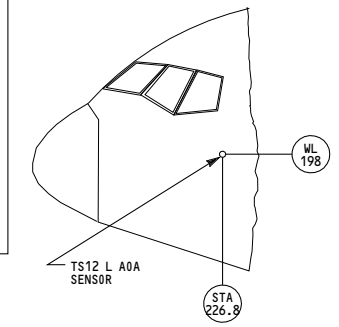
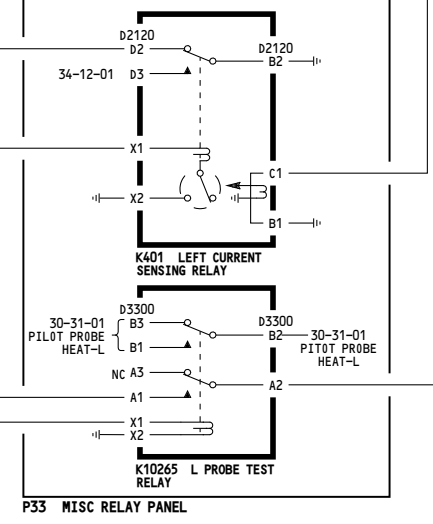
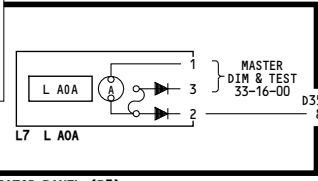
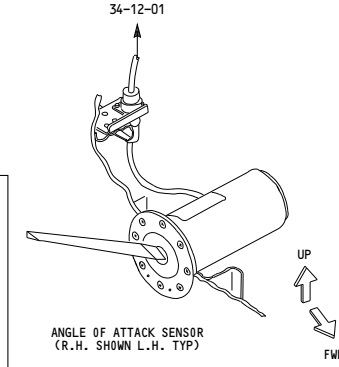
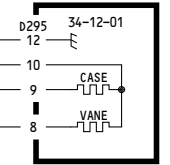
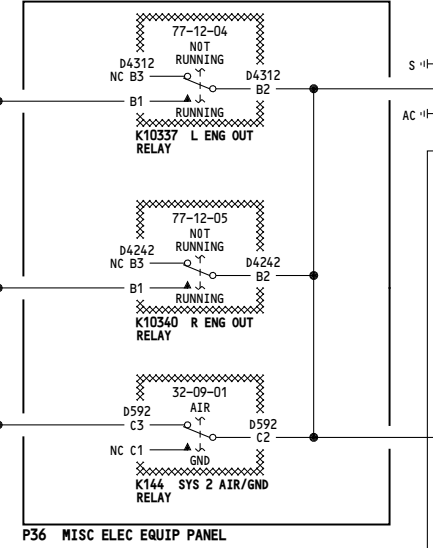
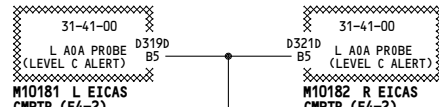
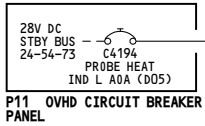
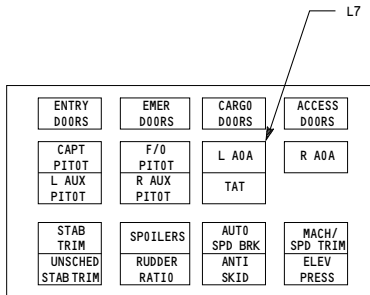
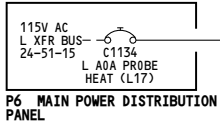

30-32-01

Page 101

Jan 21/2005

5012

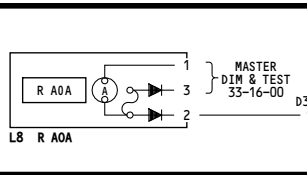
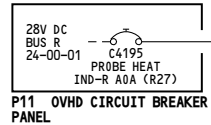
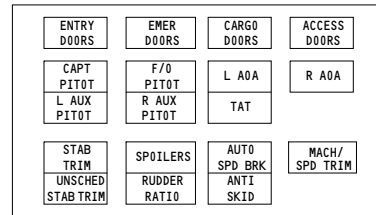
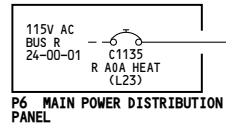

M10394(YNE) ANNUNCIATOR PANEL (P5)

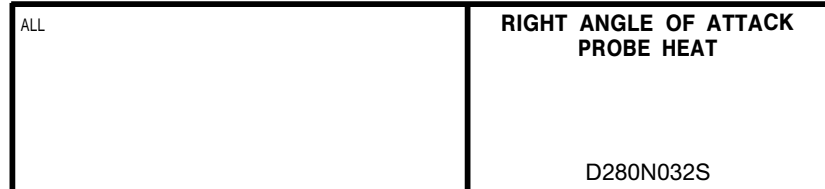
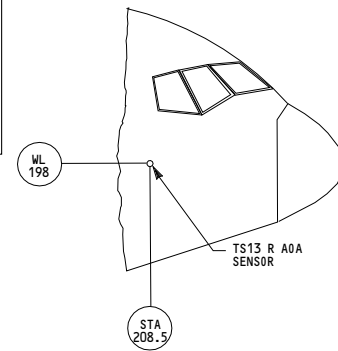
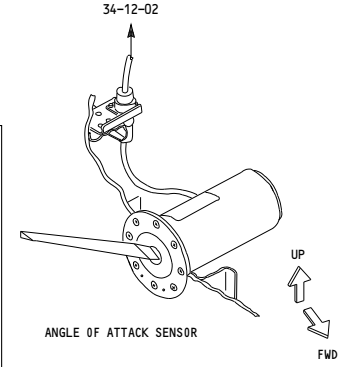
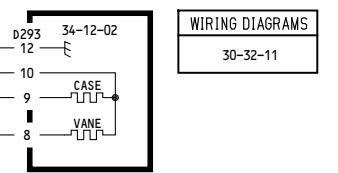
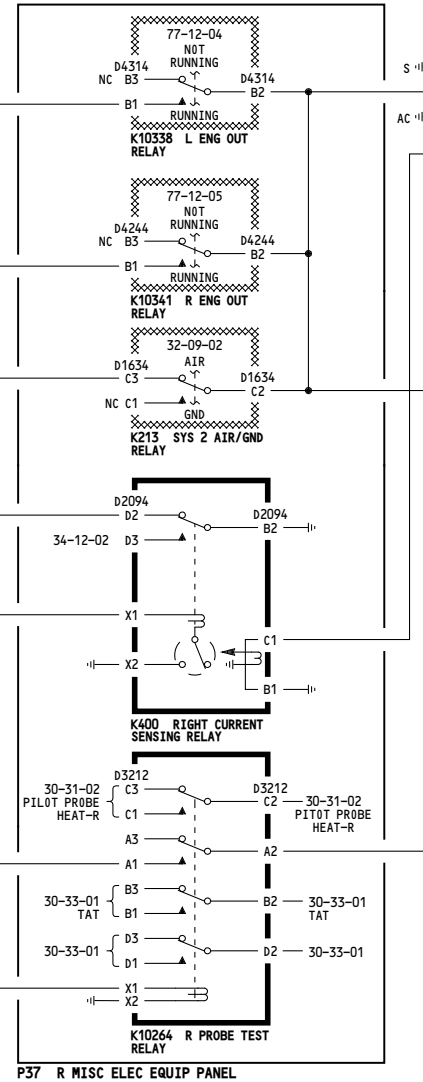
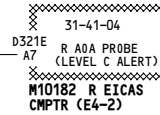
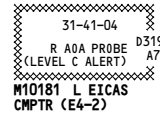
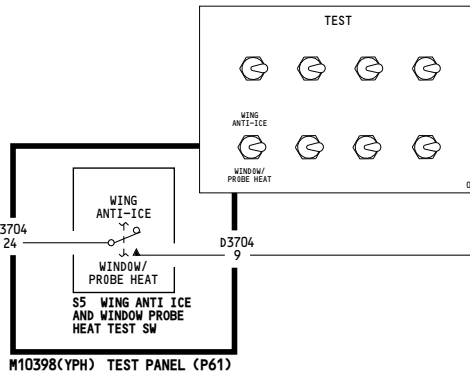

30-32-02

WIRING DIAGRAMS
30-33-11

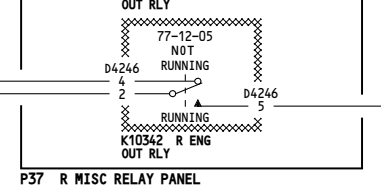
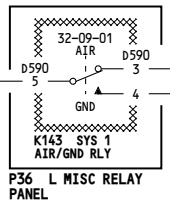
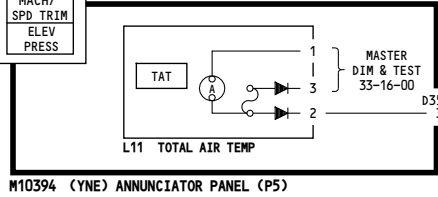
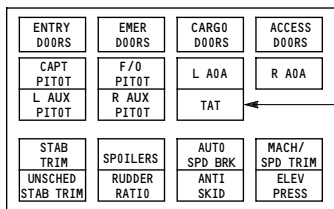
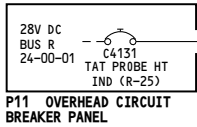
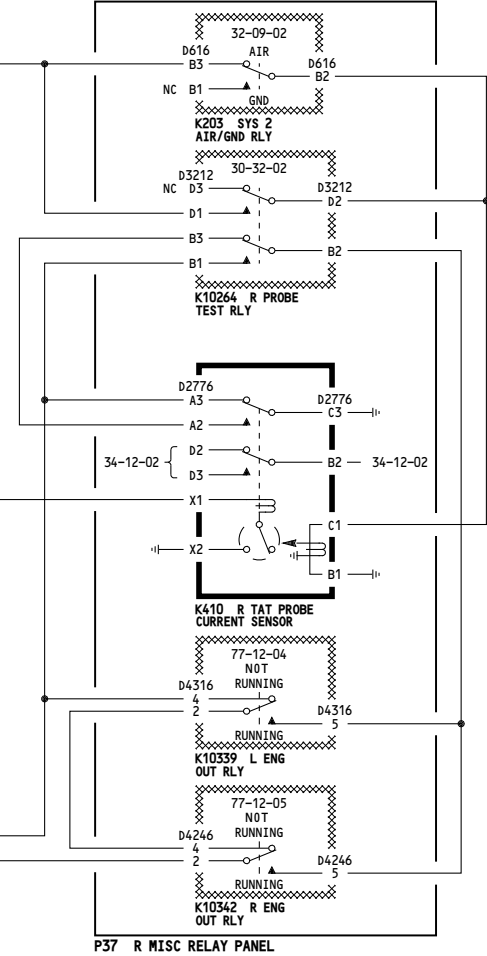
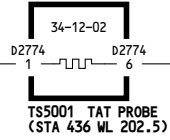
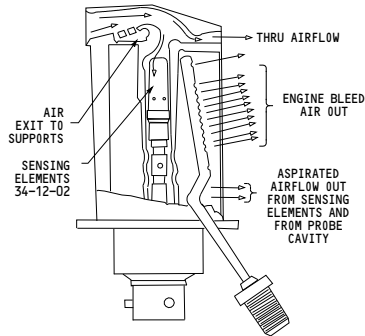
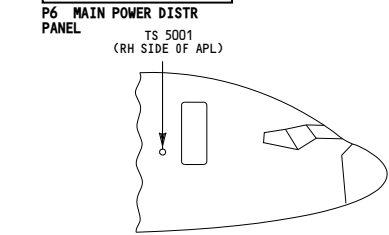
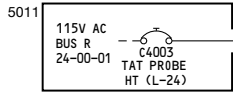

ALL	RIGHT TOTAL AIR TEMPERATURE PROBE HEAT
	D280N032S

30-33-01

WIRING DIAGRAMS
30-34-21
30-34-22

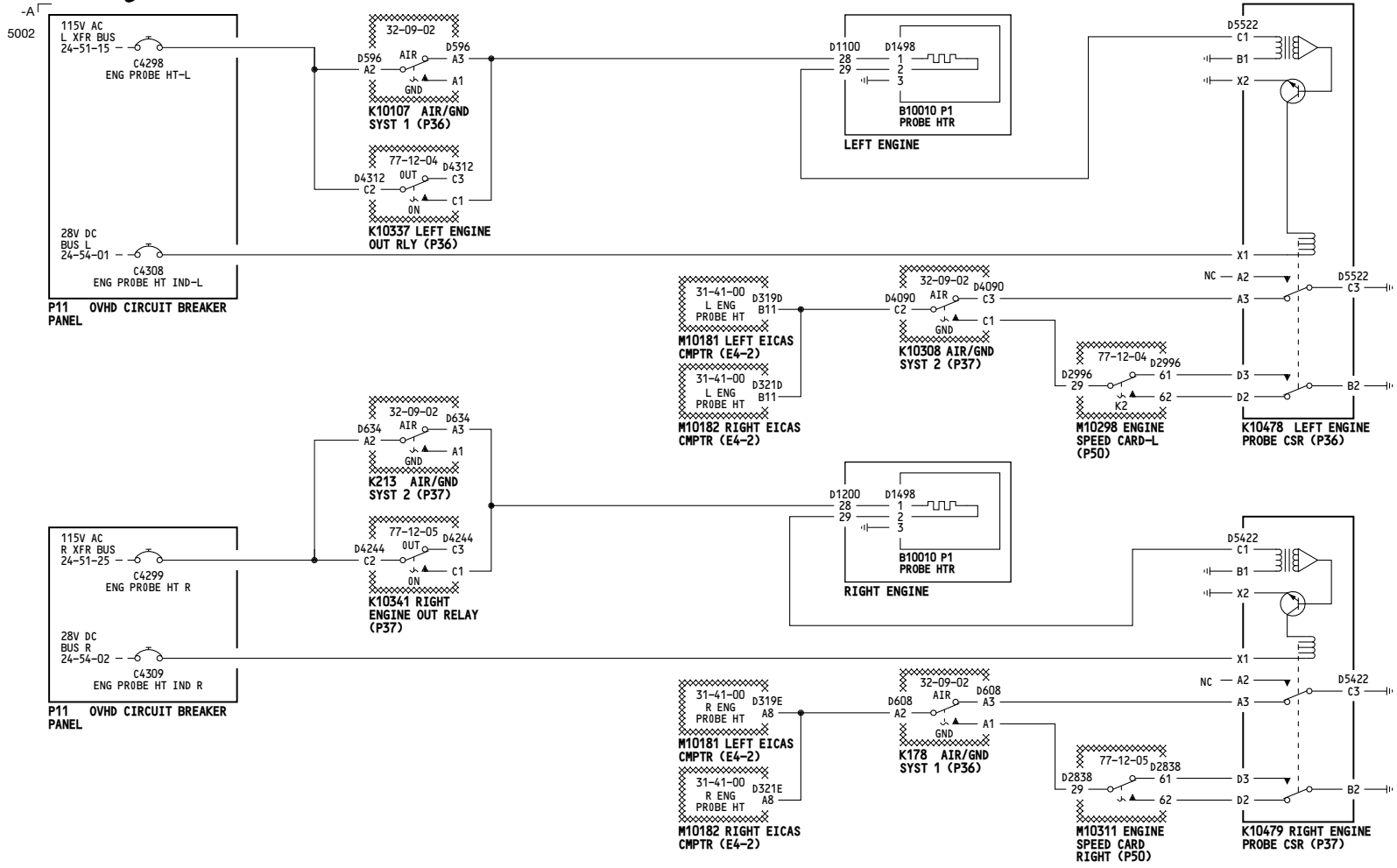

ALL	ENGINE PROBE HEAT
	D280N032S

30-34-01

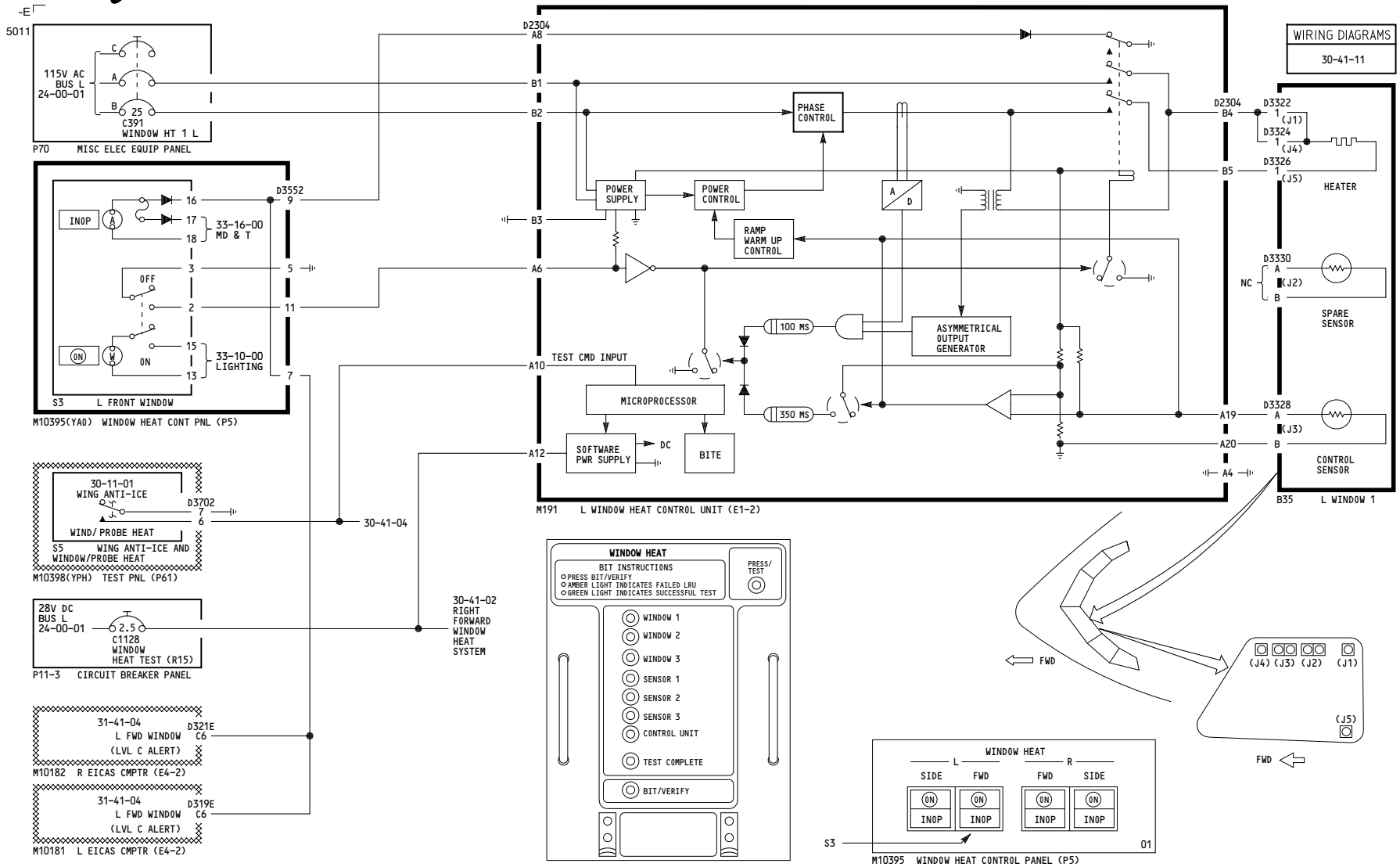

ALL	LEFT FORWARD WINDOW 1 HEAT SYSTEM
	D280N032S

30-41-01

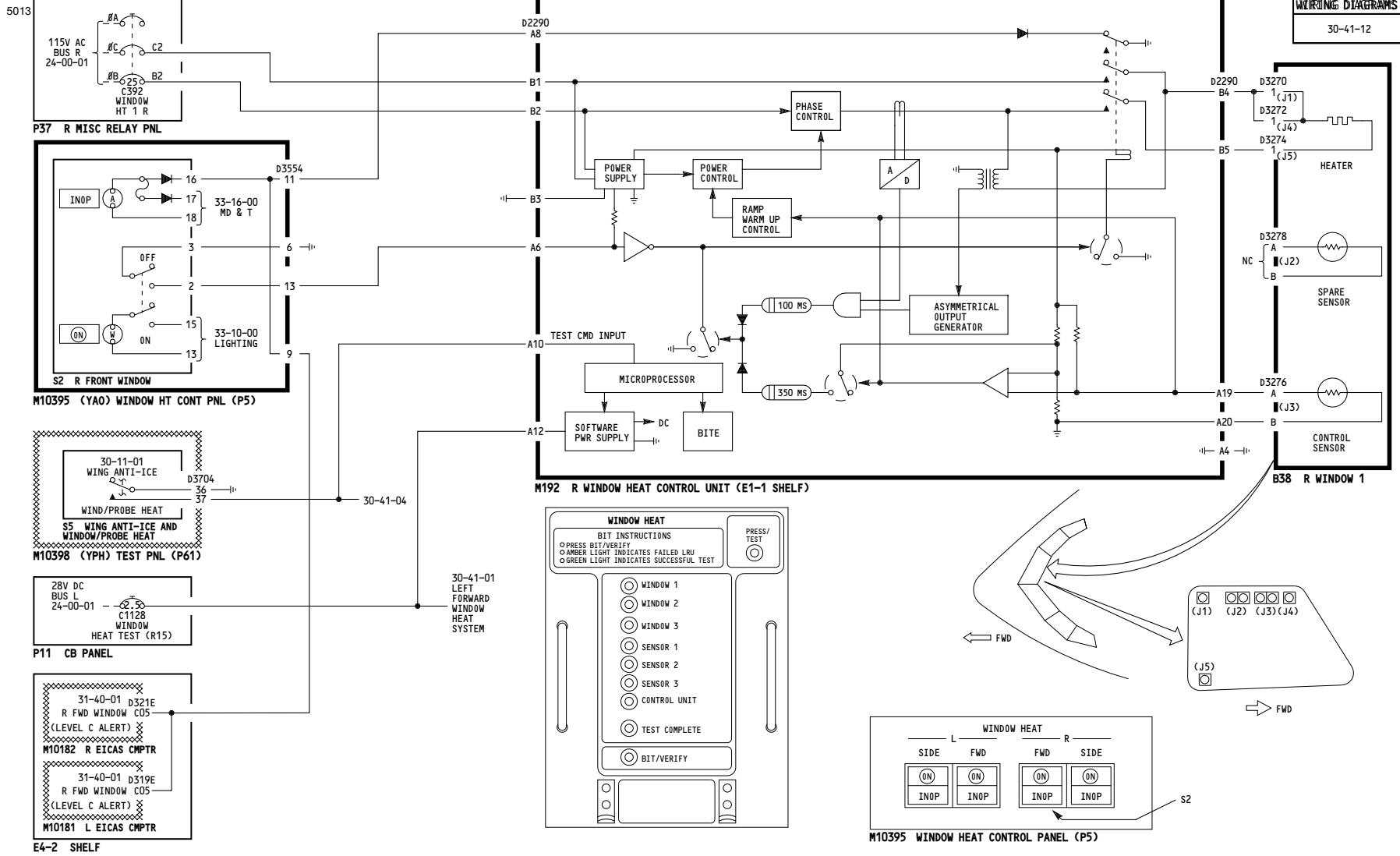

ALL

RIGHT FORWARD WINDOW 1 HEAT SYSTEM

D280N032S

30-41-02

-E-
5012

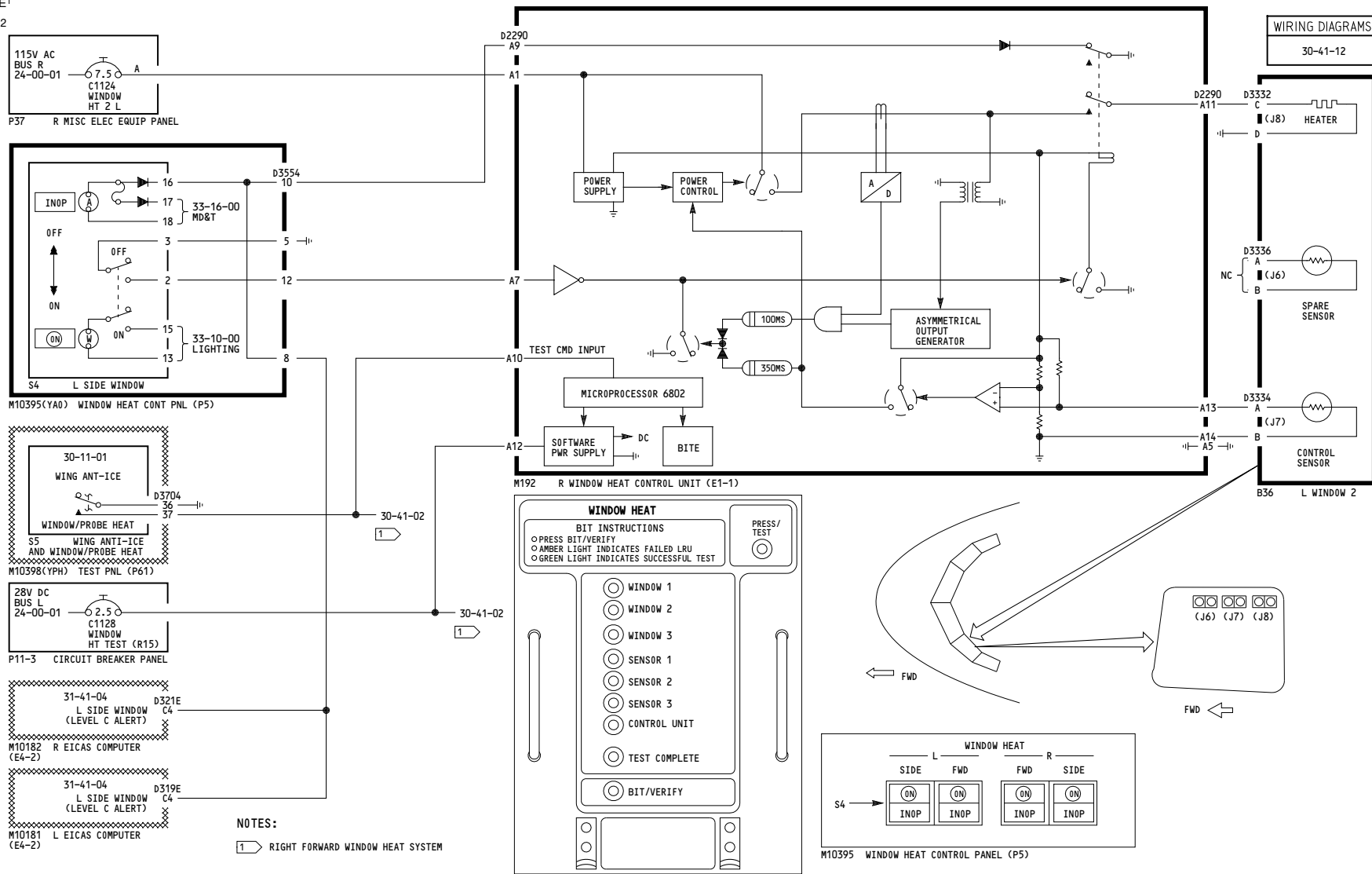

NOTES:
1 RIGHT FORWARD WINDOW HEAT SYSTEM

ALL

LEFT SLIDING WINDOW 2 HEAT SYSTEM

D280N032S

30-41-03

Page 101

Dec 18/2007

5012

WIRING DIAGRAMS
30-41-11

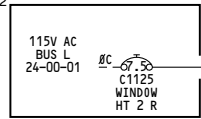

P70 MISC RELAY PANEL

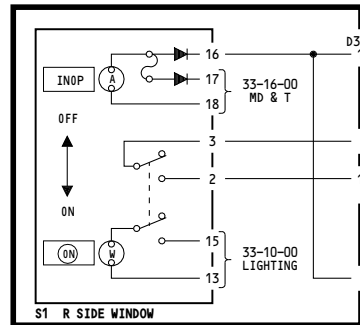

M10395(YAD) WINDOW HT CONT PNL (P5)

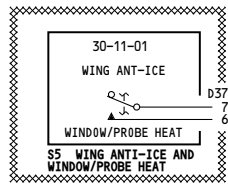

M10398(YPH) TEST PNL (P61)

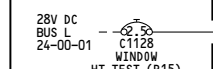

P11 CB PANEL

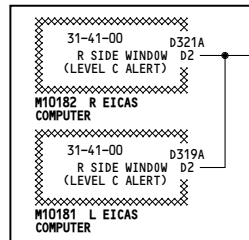

E4-2 SHELF

NOTES:

1 LEFT FORWARD WINDOW HEAT SYSTEM

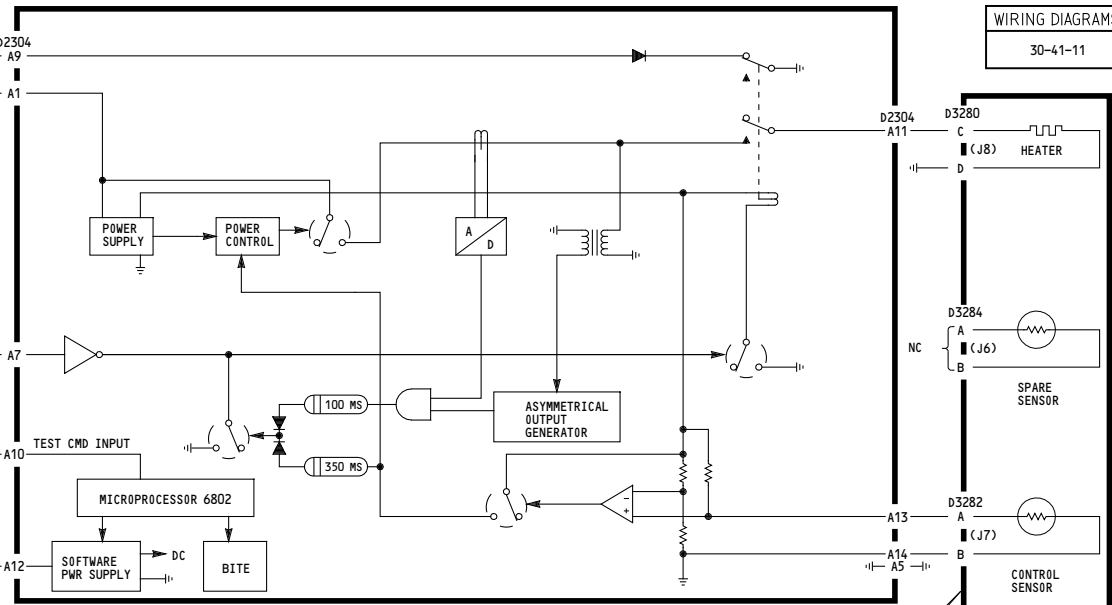

M191 L WINDOW HEAT CONTROL UNIT (E1-2 SHELF)

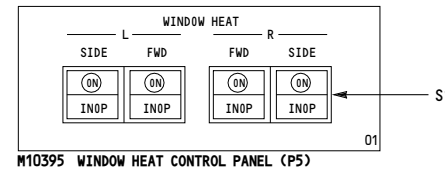
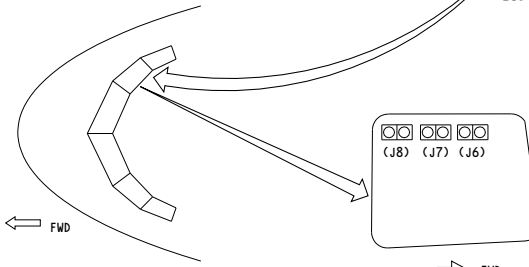
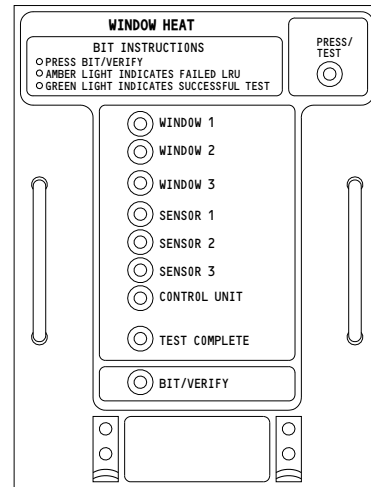

M10395 WINDOW HEAT CONTROL PANEL (P5)

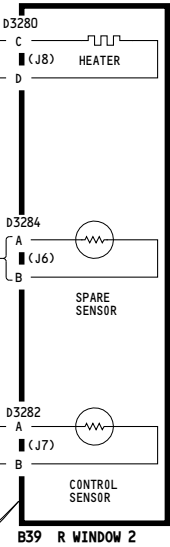

B39 R WINDOW 2

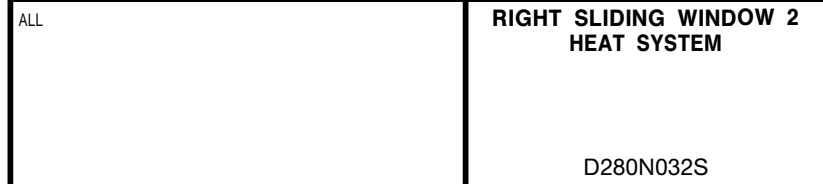

30-41-04

Page 101

Jan 21/2005

5011

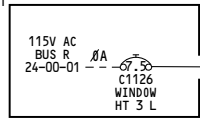

P37 PANEL MISC ELEC EQUIP, R

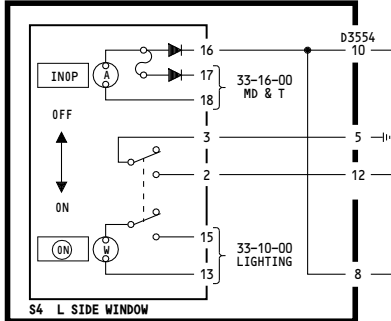

M10395 (YAO) WINDOW HT CONT PNL (P5)

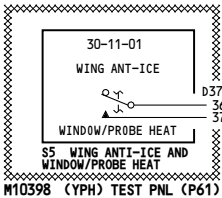

M10398 (YPH) TEST PNL (P61)

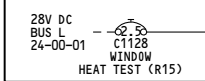

P11 CB PANEL

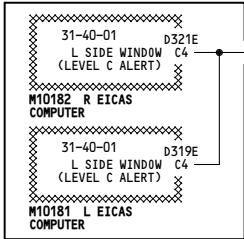

E4-2 SHELF

NOTES:

- 1 LEFT FORWARD WINDOW HEAT SYSTEM
- 2 RIGHT FORWARD WINDOW HEAT SYSTEM

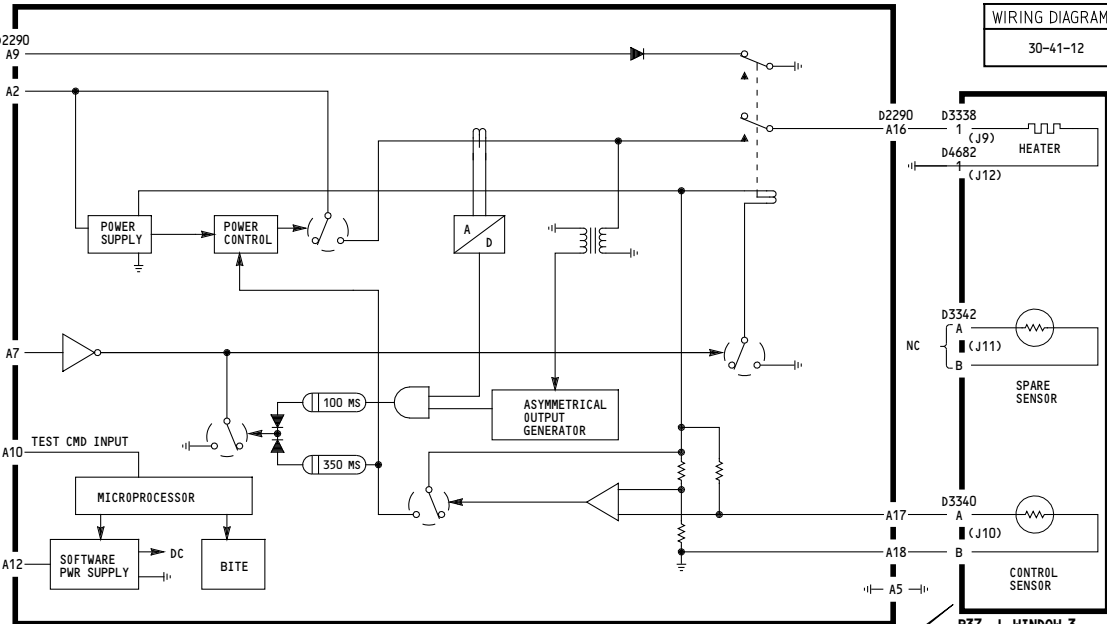

M192 R WINDOW HEAT CONTROL UNIT (E1-1 SHELF)

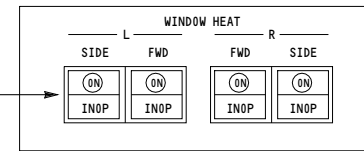
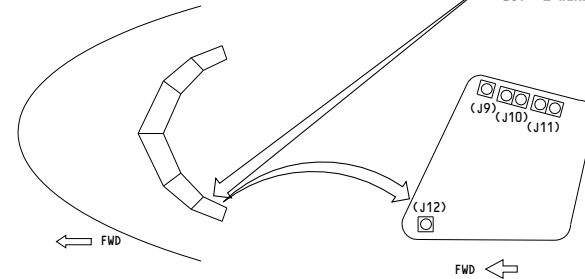
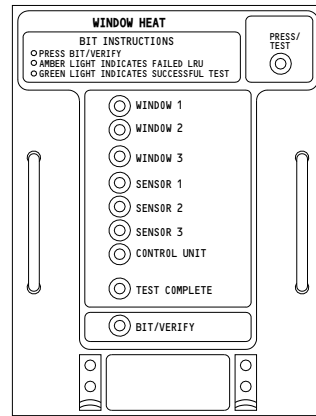

M10395 WINDOW HEAT CONTROL PANEL (P5)



30-41-05

5011

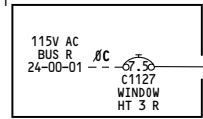

P70 MISC RELAY PANEL

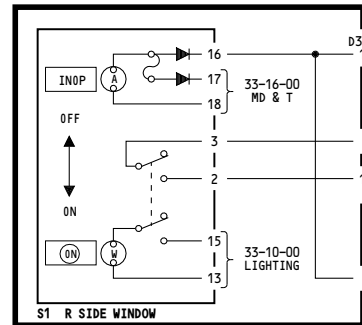

M10395 (YAO) WINDOW HT CONT PNL (P5)

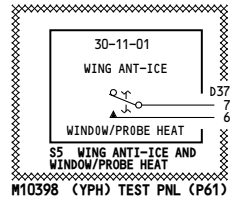

M10398 (YPH) TEST PNL (P61)

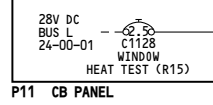

P11 CB PANEL

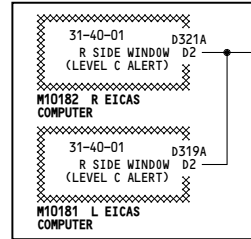

E4-2 SHELF

NOTES:
1 LEFT FORWARD WINDOW HEAT SYSTEM

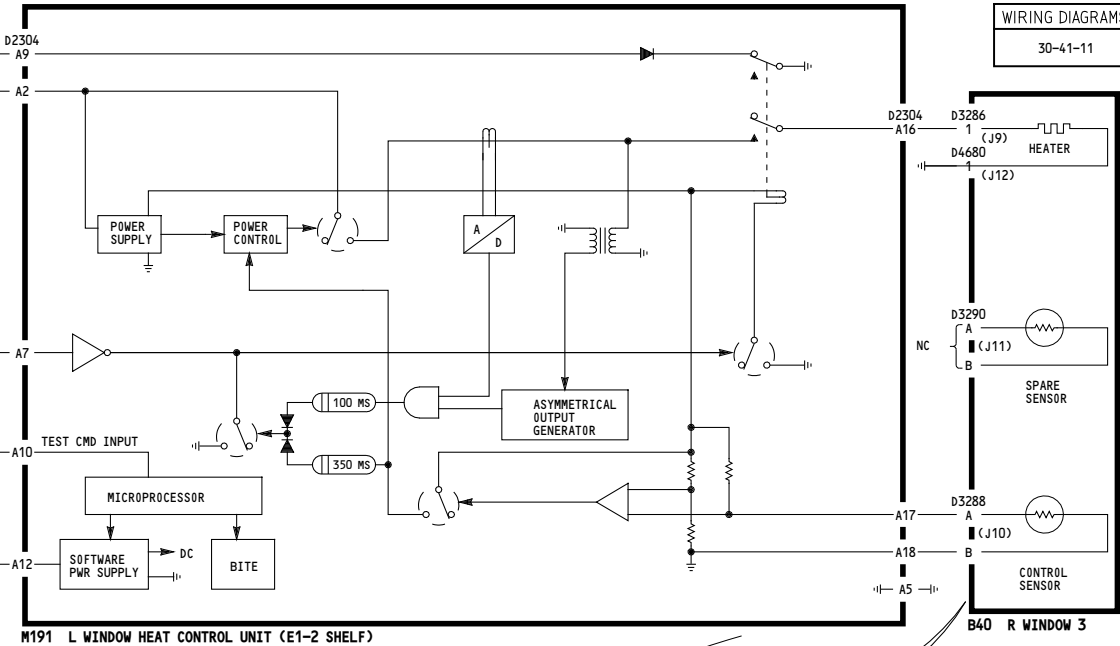

M191 L WINDOW HEAT CONTROL UNIT (E1-2 SHELF)

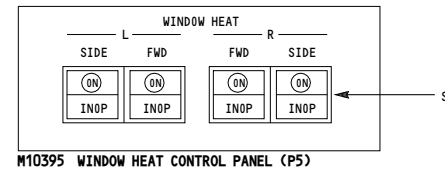
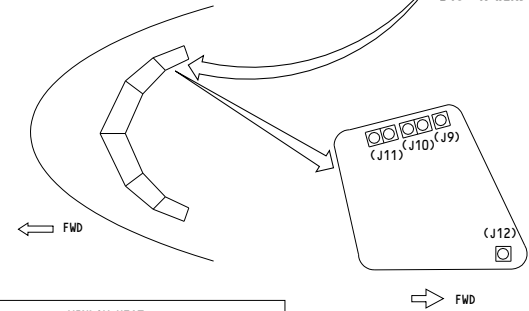
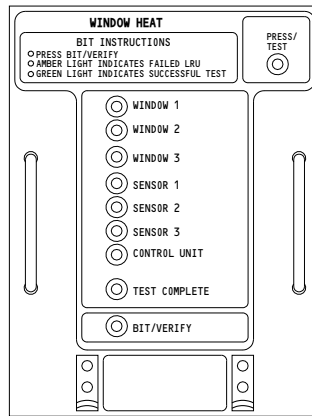

M10395 WINDOW HEAT CONTROL PANEL (P5)

WIRING DIAGRAMS
30-41-11



30-41-06

Page 101

Jan 21/2005

5011

WIRING DIAGRAMS
30-42-11

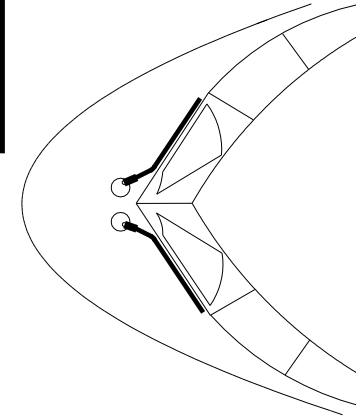
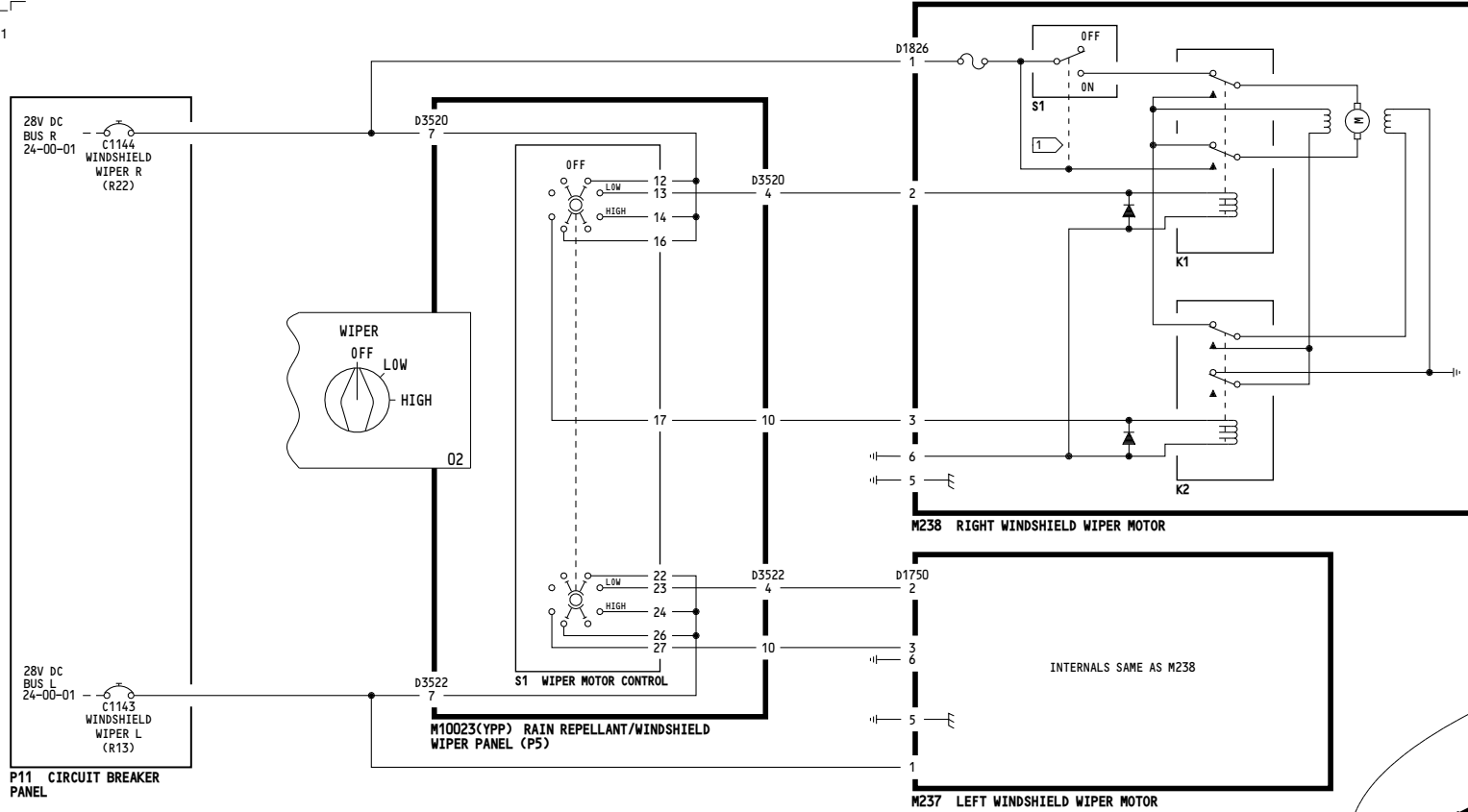

NOTE: WIPERS IN PARK POSITION

1 AFTER SELECTING "WIPER OFF" S1 REMAINS IN ON POSITION UNTIL WIPERS ARE PARKED

ALL	WINDSHIELD WIPERS
	D280N032S

30-42-01

Page 101

Jan 21/2005

5000

WIRING DIAGRAMS
30-43-11

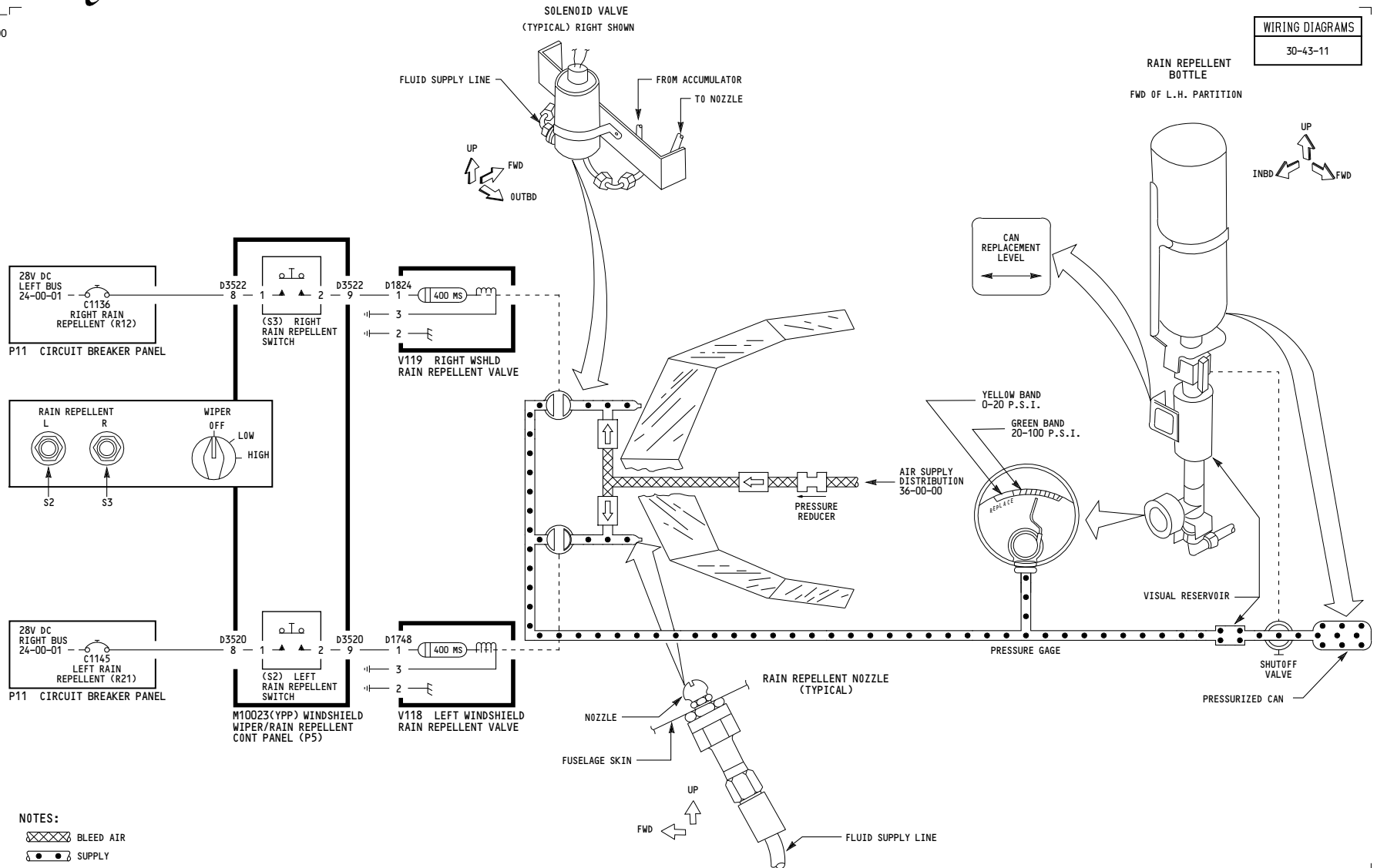

ALL	<p>RAIN REPELLENT SYSTEM</p> <p>D280N032S</p>
-----	--

30-43-01

Page 101

Jan 21/2005

5001

WIRING DIAGRAMS
30-43-11

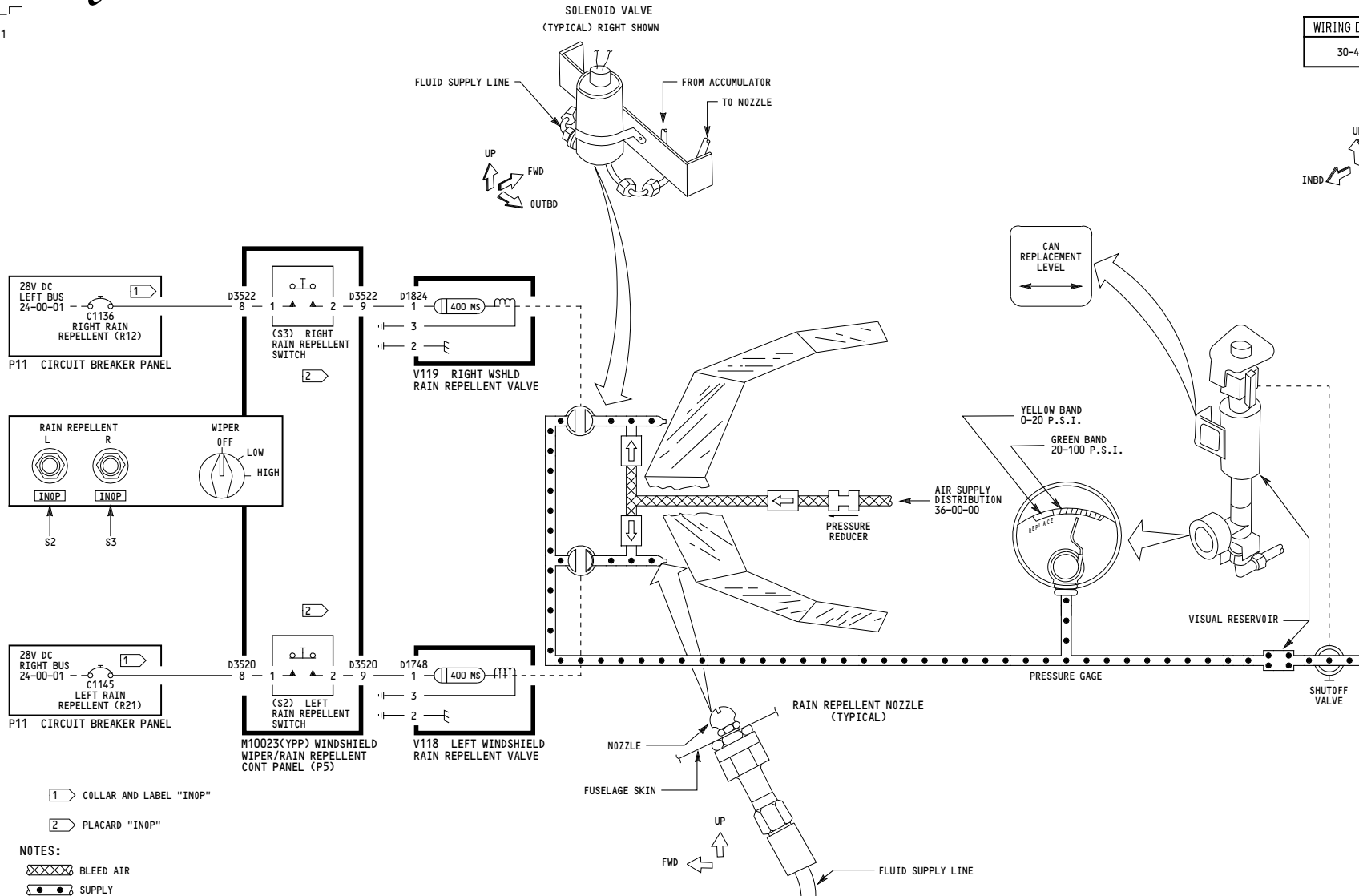
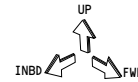

- 1 COLLAR AND LABEL "INOP"
- 2 PLACARD "INOP"

- NOTES:
- BLEED AIR
 - SUPPLY

001-115	RAIN REPELLENT SYSTEM
	Incorporates 30-0016
	D280N032S

30-43-01

Page 101.1

Jan 21/2005

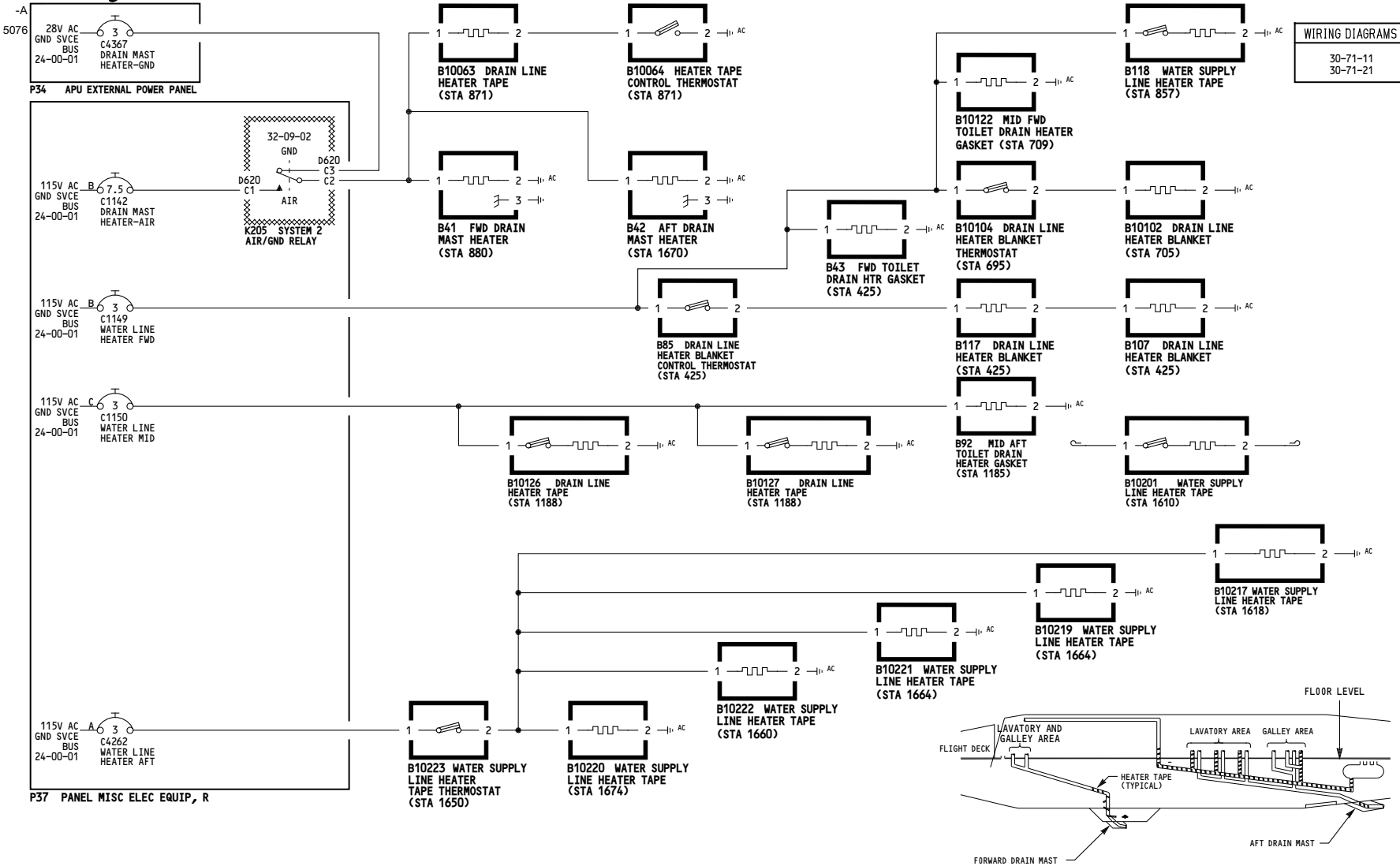

002-099

WATER AND WASTE SYSTEM HEATERS

D280N032S

30-71-01

Page 102

Dec 18/2007

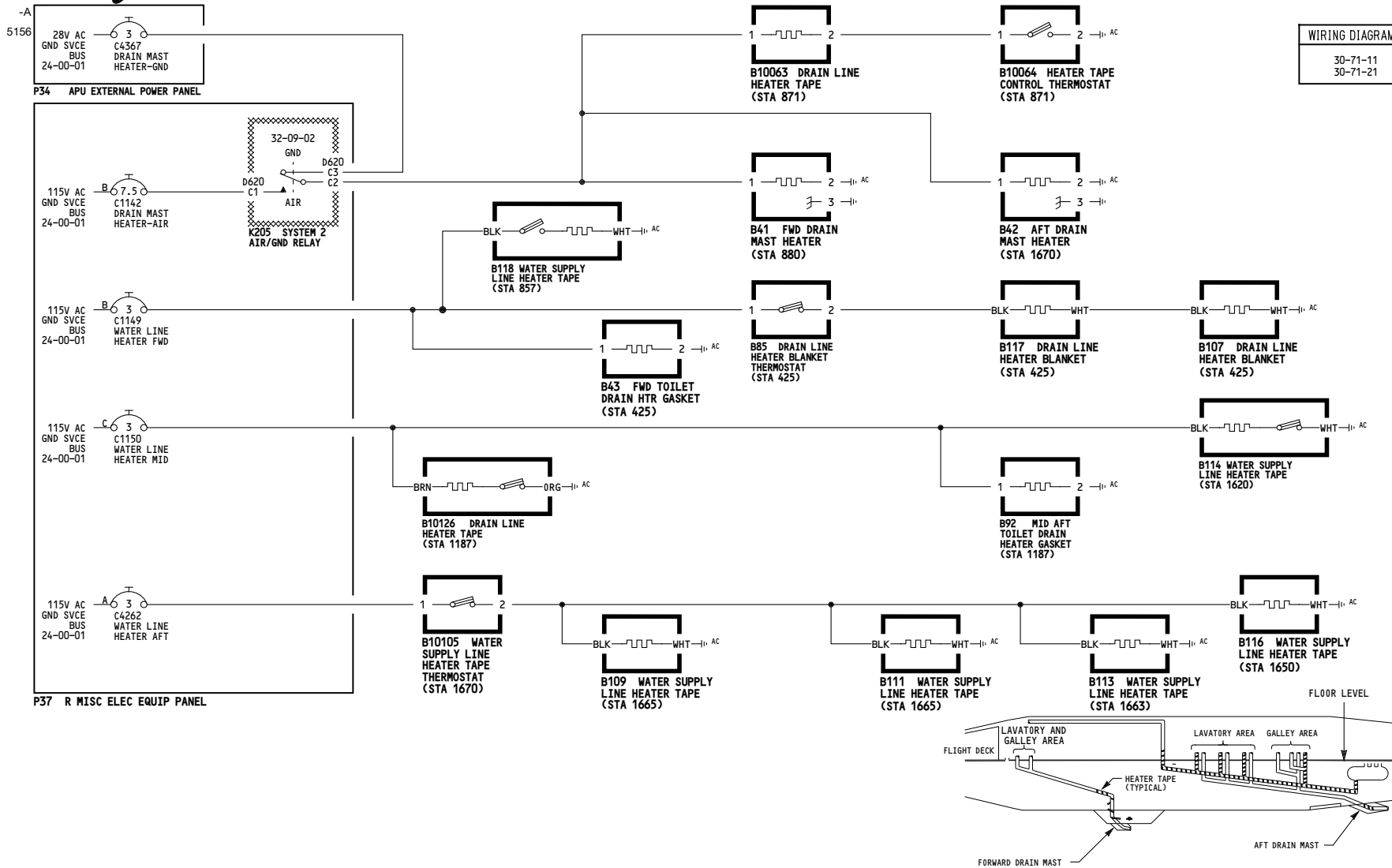

115-199	<p>WATER AND WASTE SYSTEM HEATERS</p> <p>D280N032S</p>
---------	---

30-71-01

Page 103

Dec 18/2007