

CHAPTER

34

NAVIGATION



CHAPTER 34
NAVIGATION

CH-SC-SU	Schem	Page	Sheet	Date	CH-SC-SU	Schem	Page	Sheet	Date
34-EFFECTIVE PAGES					34-12-01 (cont.)				
		1 thru 7		May 06/2009	R		101.1	1	May 06/2009
		8		BLANK	R			2	May 06/2009
34-CONTENTS							101.2	1	Jan 21/2005
R		1		May 06/2009	R			2	May 06/2009
R		2		May 06/2009	A		101.3	1	May 06/2009
R		3		May 06/2009	A			2	May 06/2009
R		4		May 06/2009			102	1	Jan 21/2005
R		5		May 06/2009	R			2	May 06/2009
O		6		May 06/2009			102.1	1	Jan 21/2005
R		7		May 06/2009	R			2	May 06/2009
R		8		May 06/2009	D		103	1	May 06/2009
R		9		May 06/2009	D			2	May 06/2009
O		10		BLANK	D		103.1	1	May 06/2009
D		11		May 06/2009	D			2	May 06/2009
D		12		BLANK	34-12-02				
34-ALPHABETICAL INDEX					R		101		May 06/2009
		1		Dec 18/2007	R		101.1		May 06/2009
O		2		May 06/2009	R		101.2		May 06/2009
	34-11-01				A		101.3		May 06/2009
R		101		May 06/2009	R		102		May 06/2009
D		102		May 06/2009	R		102.1		May 06/2009
	34-12-01				D		103		May 06/2009
		101	1	Jan 21/2005	D		103.1		May 06/2009
R			2	May 06/2009					

A = Added, R = Revised, D = Deleted, O = Overflow

34-EFFECTIVE PAGES



CHAPTER 34
NAVIGATION

CH-SC-SU	Schem	Page	Sheet	Date	CH-SC-SU	Schem	Page	Sheet	Date
				34-12-03					34-21-02
R		101.1		May 06/2009	R		101		May 06/2009
R		102.1		May 06/2009			101.1		Oct 09/2008
A		103.1		May 06/2009			101.2		Oct 09/2008
				34-13-01	D		102		May 06/2009
R		101	1	May 06/2009	D		102.1		May 06/2009
R			2	May 06/2009					34-21-03
D		102	1	May 06/2009	R		101		May 06/2009
D			2	May 06/2009			101.1		Oct 09/2008
				34-16-01	D		102		May 06/2009
R		101		May 06/2009	D		102.1		May 06/2009
D		102		May 06/2009					34-22-00
D		102.1		May 06/2009	R		101		May 06/2009
A		101.1		May 06/2009	D		102		May 06/2009
				34-21-01					34-22-01
R		101	1	May 06/2009	R		101		May 06/2009
R			2	May 06/2009					34-22-02
		101.1	1	Oct 09/2008	R		101		May 06/2009
			2	Oct 09/2008					34-22-03
D		102	1	May 06/2009	R		101		May 06/2009
D			2	May 06/2009					34-22-05
D		102.1	1	May 06/2009	D		101		May 06/2009
D			2	May 06/2009					34-22-06
					D		101		May 06/2009

A = Added, R = Revised, D = Deleted, O = Overflow

34-EFFECTIVE PAGES



CHAPTER 34
NAVIGATION

CH-SC-SU	Schem	Page	Sheet	Date	CH-SC-SU	Schem	Page	Sheet	Date
		34-22-10					34-22-12 (cont.)	104.1	
R		101	1	May 06/2009	D			2	May 06/2009
R			2	May 06/2009			34-22-21		
		101.1	1	Jan 21/2005	R		101		May 06/2009
			2	Jan 21/2005			34-22-22		
D		102	1	May 06/2009			101		Jan 21/2005
D			2	May 06/2009	R		101.1		May 06/2009
		34-22-11			A		101.2		May 06/2009
R		101		May 06/2009	O		102		Jan 21/2005
D		102		May 06/2009	O		103		Jan 21/2005
		34-22-12			D		104		May 06/2009
		101	1	Jan 21/2005	D		104.1		May 06/2009
			2	Jan 21/2005			34-22-31		
R		101.1	1	May 06/2009	R		101	1	May 06/2009
R			2	May 06/2009	R			2	May 06/2009
A		101.2	1	May 06/2009			101.1	1	Jan 21/2005
A			2	May 06/2009				2	Jan 21/2005
		102	1	Jan 21/2005			101.2	1	Jan 21/2005
			2	Jan 21/2005				2	Jan 21/2005
		103	1	Jan 21/2005	D		102	1	May 06/2009
			2	Jan 21/2005	D			2	May 06/2009
D		104	1	May 06/2009			34-22-32		
D			2	May 06/2009	R		101	1	May 06/2009
D		104.1	1	May 06/2009	R			2	May 06/2009

A = Added, R = Revised, D = Deleted, O = Overflow

34-EFFECTIVE PAGES

Page 3
May 06/2009

D280N032S



CHAPTER 34
NAVIGATION

CH-SC-SU	Schem	Page	Sheet	Date	CH-SC-SU	Schem	Page	Sheet	Date
	34-22-32 (cont.)					34-32-01			
		101.1	1	Jan 21/2005	O		101		Jan 21/2005
			2	Jan 21/2005	O		102		Jan 21/2005
			3	Dec 18/2007	D		103		May 06/2009
D		102	1	May 06/2009		34-33-01			
D			2	May 06/2009			101		Jan 21/2005
	34-24-01						101.1		Jan 21/2005
R		101		May 06/2009			102		Dec 18/2007
	34-25-01				D		103		May 06/2009
O		101		Jan 21/2005		34-33-02			
O		102.1		Jan 21/2005	O		101		Jan 21/2005
D		103		May 06/2009	O		101.1		Jan 21/2005
	34-31-01				O		102		Jan 21/2005
		101		Jan 21/2005	D		103		May 06/2009
		102		Jan 21/2005		34-33-03			
D		103		May 06/2009	R		101		May 06/2009
	34-31-02						101.1		Jan 21/2005
O		101		Jan 21/2005	D		102		May 06/2009
O		102		Jan 21/2005		34-43-01			
D		103		May 06/2009	O		101		Jan 21/2005
	34-31-03				R		101.1		May 06/2009
		101		Jan 21/2005	D			2	May 06/2009
		102		Jan 21/2005	D			3	May 06/2009
D		103		May 06/2009	A		101.2	1	May 06/2009

A = Added, R = Revised, D = Deleted, O = Overflow

34-EFFECTIVE PAGES



CHAPTER 34
NAVIGATION

CH-SC-SU	Schem	Page	Sheet	Date	CH-SC-SU	Schem	Page	Sheet	Date
	34-43-01 (cont.)	101.2				34-51-01			
A			2	May 06/2009			101		Jan 21/2005
A			3	May 06/2009			102		Dec 18/2007
		102		Jan 21/2005	D		103		May 06/2009
D		103		May 06/2009		34-51-02			
	34-45-01				O		101		Jan 21/2005
O		101.1		Jan 21/2005	O		102		Jan 21/2005
O		102.1		Jan 21/2005	D		103		May 06/2009
	34-45-02					34-53-01			
O		101.1		Jan 21/2005			101		Jan 21/2005
O		102.1		Jan 21/2005			102		Aug 01/2005
	34-46-01						103		Aug 01/2005
		101	1	Jan 21/2005	D		104		May 06/2009
			2	Jan 21/2005		34-53-02			
		101.1	1	Jan 21/2005	O		101		Jan 21/2005
			2	Dec 18/2007	O		102		Jan 21/2005
			3	Jan 21/2005	O		103		Jan 21/2005
			4	Jan 21/2005	D		104		May 06/2009
			5	Jan 21/2005		34-53-03			
		102	1	Jan 21/2005	R		101		May 06/2009
			2	Jan 21/2005		34-55-01			
D		103	1	May 06/2009			101		Jan 21/2005
D			2	May 06/2009			102		Jan 21/2005
					D		103		May 06/2009

A = Added, R = Revised, D = Deleted, O = Overflow

34-EFFECTIVE PAGES



CHAPTER 34
NAVIGATION

CH-SC-SU	Schem	Page	Sheet	Date	CH-SC-SU	Schem	Page	Sheet	Date
	34-55-02					34-60-02 (cont.)	101		
O		101		Jan 21/2005				3	Jan 21/2005
O		102		Dec 18/2007			102	1	Jan 21/2005
D		103		May 06/2009				2	Jan 21/2005
	34-57-01							3	Jan 21/2005
		101		Jan 21/2005	D		103	1	May 06/2009
		102		Jan 21/2005	D			2	May 06/2009
		103		Jan 21/2005	D			3	May 06/2009
D		104		May 06/2009		34-61-00			
	34-57-02				R		101	1	May 06/2009
O		101		Jan 21/2005	R			2	May 06/2009
O		102		Jan 21/2005		34-61-01			
O		103		Jan 21/2005			101	1	Jan 21/2005
D		104		May 06/2009				2	Jan 21/2005
	34-58-01						102	1	Jan 21/2005
		101.1		Jan 21/2005				2	Jan 21/2005
	34-58-02				D		103	1	May 06/2009
		101.1		Jan 21/2005	D			2	May 06/2009
	34-60-01				D		103.1	1	May 06/2009
R		101	1	May 06/2009	D			2	May 06/2009
R			2	May 06/2009		34-61-02			
	34-60-02				R		101	1	May 06/2009
		101	1	Jan 21/2005	R			2	May 06/2009
			2	Jan 21/2005			101.1	1	Oct 09/2008

A = Added, R = Revised, D = Deleted, O = Overflow

34-EFFECTIVE PAGES



CHAPTER 34
NAVIGATION

CH-SC-SU	Schem	Page	Sheet	Date	CH-SC-SU	Schem	Page	Sheet	Date
		34-61-02 (cont.)		101.1					
			2	Oct 09/2008					
D			1	May 06/2009	R		101		May 06/2009
D			2	May 06/2009					
			1	Jan 21/2005					
			2	Jan 21/2005					
			1	Oct 09/2008					
			2	Oct 09/2008					
		34-61-03							
				101					
				102					
D				103					
D				103.1					
		34-61-04							
R				101					
				101.1					
				101.2					
D				101.3					
		34-61-06							
R				101					
		34-61-07							
R				101					
		34-61-08							
R				101					

A = Added, R = Revised, D = Deleted, O = Overflow

34-EFFECTIVE PAGES

Page 7
May 06/2009

D280N032S



CHAPTER 34
NAVIGATION

Title	CH-SC-SU	Schem	Page	Sheet	Date	Effectivity
<u>PITOT-STATIC SYSTEM</u>						
PITOT STATIC	34-11-01		101		May 06/2009	ALL
<u>AIR DATA COMPUTING SYSTEM</u>						
AIR DATA SYSTEM - LEFT	34-12-01		101	1	Jan 21/2005	001-008 010-099
				2	May 06/2009	001-008 010-099
			101.1	1	May 06/2009	001
				2	May 06/2009	001
			101.2	1	Jan 21/2005	002
				2	May 06/2009	002
			101.3	1	May 06/2009	003-008 010-011
				2	May 06/2009	003-008 010-011
			102	1	Jan 21/2005	009
				2	May 06/2009	009
			102.1	1	Jan 21/2005	009
				2	May 06/2009	009
AIR DATA SYSTEM - RIGHT	34-12-02		101		May 06/2009	001-008 010-099
			101.1		May 06/2009	001
			101.2		May 06/2009	002
			101.3		May 06/2009	003-008 010-011
			102		May 06/2009	009
			102.1		May 06/2009	009
AIR DATA SWITCHING LEFT AND RIGHT	34-12-03		101.1		May 06/2009	001
			102.1		May 06/2009	002-008 010-011

**CHAPTER 34
NAVIGATION**

	Title	CH-SC-SU	Schem	Page	Sheet	Date	Effectivity
I	AIR DATA SWITCHING LEFT AND RIGHT (cont.)	34-12-03		103.1		May 06/2009	009
	<u>AIR DATA INSTRUMENTS</u>						
I	AIR DATA INSTRUMENTS - LEFT AND RIGHT	34-13-01		101	1	May 06/2009	ALL
I					2	May 06/2009	ALL
	<u>ALTITUDE ALERT SYSTEM</u>						
I	ALTITUDE ALERT	34-16-01		101		May 06/2009	ALL
I				101.1		May 06/2009	001
	<u>INERTIAL REFERENCE SYSTEM</u>						
I	INERTIAL REFERENCE SYSTEM - LEFT	34-21-01		101	1	May 06/2009	ALL
I					2	May 06/2009	ALL
				101.1	1	Oct 09/2008	001-011
					2	Oct 09/2008	001-011
I	INERTIAL REFERENCE SYSTEM - RIGHT	34-21-02		101		May 06/2009	ALL
				101.1		Oct 09/2008	001 003-011
				101.2		Oct 09/2008	002
I	INERTIAL REFERENCE SYSTEM - CENTER	34-21-03		101		May 06/2009	ALL
				101.1		Oct 09/2008	001-011
	<u>FLIGHT INSTRUMENT SYSTEM</u>						
I	FLIGHT INSTRUMENT SYSTEM - SIMPLIFIED	34-22-00		101		May 06/2009	ALL
I	RDMI, BEARING, HEADING AND DISTANCE - LEFT	34-22-01		101		May 06/2009	ALL
I	RDMI, BEARING, HEADING AND DISTANCE - RIGHT	34-22-02		101		May 06/2009	ALL
I	VSI VERTICAL SPEED - LEFT AND RIGHT	34-22-03		101		May 06/2009	ALL



CHAPTER 34
NAVIGATION

Title	CH-SC-SU	Schem	Page	Sheet	Date	Effectivity			
EFIS POWER DISTRIBUTION AND INSTRUMENT LIGHTING	34-22-10		101	1	May 06/2009	ALL			
				2	May 06/2009	ALL			
				101.1	1	Jan 21/2005	002		
				2	Jan 21/2005	002			
EFIS SYMBOL GENERATOR AND EADI - LEFT	34-22-11		101		May 06/2009	ALL			
EFIS SYMBOL GENERATOR AND EHSI - LEFT	34-22-12		101	1	Jan 21/2005	001-008			
				2	Jan 21/2005	001-008			
				101.1	1	May 06/2009	001		
				2	May 06/2009	001			
				101.2	1	May 06/2009	002		
				2	May 06/2009	002			
				102	1	Jan 21/2005	009		
				2	Jan 21/2005	009			
EFIS SYMBOL GENERATOR AND EADI - RIGHT AND CENTER	34-22-21		101		May 06/2009	ALL			
				EFIS SYMBOL GENERATOR AND EHSI - RIGHT AND CENTER	34-22-22	101	Jan 21/2005	001-008	
							101.1	May 06/2009	001
							101.2	May 06/2009	002
		102	Jan 21/2005	009					
		103	Jan 21/2005	010-099					
			2	Jan 21/2005	010-099				

CHAPTER 34
NAVIGATION

Title	CH-SC-SU	Schem	Page	Sheet	Date	Effectivity	
FLIGHT INSTRUMENT SYSTEM SWITCHING	34-22-31		101	1	May 06/2009	ALL	
				2	May 06/2009	ALL	
				101.1	1	Jan 21/2005	002
				2	Jan 21/2005	002	
				101.2	1	Jan 21/2005	010-011
				2	Jan 21/2005	010-011	
FLIGHT INSTRUMENT DATA BUS SWITCHING	34-22-32		101	1	May 06/2009	ALL	
				2	May 06/2009	ALL	
				101.1	1	Jan 21/2005	002
				2	Jan 21/2005	002	
				3	Dec 18/2007	002	
				<u>STANDBY ATTITUDE REFERENCE SYSTEM</u>			
STANDBY ATTITUDE/ILS INDICATOR SYSTEM	34-24-01		101		May 06/2009	ALL	
<u>INSTRUMENT COMPARISON SYSTEM</u>							
INSTRUMENT COMPARATOR UNIT	34-25-01		101		Jan 21/2005	001 003-099	
				102.1	Jan 21/2005	002	
<u>ILS NAVIGATION SYSTEM</u>							
ILS - LEFT	34-31-01		101		Jan 21/2005	001 009	
				102	Jan 21/2005	002-008 010-099	
ILS - RIGHT	34-31-02		101		Jan 21/2005	001 009	
				102	Jan 21/2005	002-008 010-099	
ILS - CENTER	34-31-03		101		Jan 21/2005	001-008 010-099	
				102	Jan 21/2005	009	



CHAPTER 34
NAVIGATION

Title	CH-SC-SU	Schem	Page	Sheet	Date	Effectivity
<u>MARKER BEACON SYSTEM</u>						
MARKER BEACON	34-32-01		101		Jan 21/2005	001 009
			102		Jan 21/2005	002-008 010-099
<u>RADIO ALTIMETER SYSTEM</u>						
RADIO ALTIMETER - LEFT	34-33-01		101		Jan 21/2005	001-008 010-099
			101.1		Jan 21/2005	002
			102		Dec 18/2007	009
RADIO ALTIMETER - RIGHT	34-33-02		101		Jan 21/2005	001-008 010-099
			101.1		Jan 21/2005	002
			102		Jan 21/2005	009
RADIO ALTIMETER - CENTER	34-33-03		101		May 06/2009	ALL
			101.1		Jan 21/2005	002
<u>WEATHER RADAR SYSTEM</u>						
WEATHER RADAR	34-43-01		101		Jan 21/2005	001-008 010-099
			101.1		May 06/2009	001
			101.2	1	May 06/2009	002
				2	May 06/2009	002
				3	May 06/2009	002
			102		Jan 21/2005	009
<u>TRAFFIC ALERT AND COLLISION AVOIDANCE SYSTEM (TCAS)</u>						
TRAFFIC ALERT AND COLL AVD SYSTEM (TCAS) POWER, INPUT, OUTPUT	34-45-01		101.1		Jan 21/2005	002
			102.1		Jan 21/2005	009-011

CHAPTER 34
NAVIGATION

Title	CH-SC-SU	Schem	Page	Sheet	Date	Effectivity
TRAFFIC ALERT AND COLL AVD SYSTEM (TCAS) CONTROL AND DISPLAY	34-45-02		101.1		Jan 21/2005	002
			102.1		Jan 21/2005	009-011
<u>GROUND PROXIMITY WARNING SYSTEM</u>						
GROUND PROXIMITY WARNING SYSTEM	34-46-01		101	1	Jan 21/2005	001-008 010-099
				2	Jan 21/2005	001-008 010-099
			101.1	1	Jan 21/2005	002
				2	Dec 18/2007	002
				3	Jan 21/2005	002
				4	Jan 21/2005	002
				5	Jan 21/2005	002
			102	1	Jan 21/2005	009
				2	Jan 21/2005	009
<u>VOR SYSTEM</u>						
LEFT VOR	34-51-01		101		Jan 21/2005	001 009
			102		Dec 18/2007	002-008 010-099
RIGHT VOR	34-51-02		101		Jan 21/2005	001 009
			102		Jan 21/2005	002-008 010-099
<u>ATC SYSTEM</u>						
ATC TRANSPONDER - LEFT	34-53-01		101		Jan 21/2005	001-002
			102		Aug 01/2005	003-006
			103		Aug 01/2005	007-099
ATC TRANSPONDER - RIGHT	34-53-02		101		Jan 21/2005	001-002



CHAPTER 34
NAVIGATION

Title	CH-SC-SU	Schem	Page	Sheet	Date	Effectivity
ATC TRANSPONDER - RIGHT (cont.)	34-53-02		102		Jan 21/2005	003-006
			103		Jan 21/2005	007-099
ATC ANTENNA SELECT	34-53-03		101		May 06/2009	ALL
<u>DME SYSTEM</u>						
DME - LEFT	34-55-01		101		Jan 21/2005	001 009
			102		Jan 21/2005	002-008 010-099
DME - RIGHT	34-55-02		101		Jan 21/2005	001 009
			102		Dec 18/2007	002-008 010-099
<u>AUTOMATIC DIRECTION FINDER SYSTEM</u>						
ADF - LEFT	34-57-01		101		Jan 21/2005	001
			102		Jan 21/2005	002-008 010-099
			103		Jan 21/2005	009
ADF - RIGHT	34-57-02		101		Jan 21/2005	001
			102		Jan 21/2005	002-008 010-099
			103		Jan 21/2005	009
<u>GLOBAL POSITIONING SYSTEM</u>						
GLOBAL POSITIONING SYSTEM LEFT	34-58-01		101.1		Jan 21/2005	002
GLOBAL POSITIONING SYSTEM RIGHT	34-58-02		101.1		Jan 21/2005	002
<u>FLIGHT MANAGEMENT COMPUTING</u>						
FLIGHT MANAGEMENT COMPUTER	34-60-01		101	1	May 06/2009	ALL
				2	May 06/2009	ALL
FMCS MAINTENANCE INDEX	34-60-02		101	1	Jan 21/2005	001-008 010-099
				2	Jan 21/2005	001-008 010-099



CHAPTER 34
NAVIGATION

Title	CH-SC-SU	Schem	Page	Sheet	Date	Effectivity
FMCS MAINTENANCE INDEX (cont.)	34-60-02			3	Jan 21/2005	001-008 010-099
			102	1	Jan 21/2005	009
				2	Jan 21/2005	009
				3	Jan 21/2005	009
<u>FLIGHT MANAGEMENT COMPUTER SYSTEM</u>						
FLIGHT MANAGEMENT CMPTR SYSTEM (LEFT - RIGHT FMCS) - SIMPLIFIED	34-61-00		101	1	May 06/2009	ALL
				2	May 06/2009	ALL
LEFT FMC INPUTS	34-61-01		101	1	Jan 21/2005	001-008 010-099
				2	Jan 21/2005	001-008 010-099
			102	1	Jan 21/2005	009
				2	Jan 21/2005	009
LEFT FMC OUTPUTS	34-61-02		101	1	May 06/2009	001-008
				2	May 06/2009	001-008
			101.1	1	Oct 09/2008	003
				2	Oct 09/2008	003
			102	1	Jan 21/2005	009-099
				2	Jan 21/2005	009-099
			102.1	1	Oct 09/2008	010-011
				2	Oct 09/2008	010-011
RIGHT FMC INPUTS	34-61-03		101		Jan 21/2005	001-008 010-099
			102		Jan 21/2005	009
RIGHT FMC OUTPUTS	34-61-04		101		May 06/2009	ALL

**CHAPTER 34
NAVIGATION**

Title	CH-SC-SU	Schem	Page	Sheet	Date	Effectivity
RIGHT FMC OUTPUTS (cont.)	34-61-04		101.1		Jan 21/2005	002
			101.2		Jan 21/2005	003
■ FMCS CONTROL DISPLAY UNIT (CDU) - RIGHT	34-61-06		101		May 06/2009	ALL
■ FMCS VNAV MODE LOGIC - RIGHT	34-61-07		101		May 06/2009	ALL
■ FMCS VNAV STEERING COMMANDS - RIGHT	34-61-08		101		May 06/2009	ALL
■ FMCS LNAV STEERING COMMANDS - RIGHT	34-61-09		101		May 06/2009	ALL

**CHAPTER 34
NAVIGATION**

CH-SC-SU	Title
34-57-01	ADF - LEFT
34-57-02	ADF - RIGHT
34-13-01	AIR DATA INSTRUMENTS - LEFT AND RIGHT
34-12-03	AIR DATA SWITCHING LEFT AND RIGHT
34-12-01	AIR DATA SYSTEM - LEFT
34-12-02	AIR DATA SYSTEM - RIGHT
34-16-01	ALTITUDE ALERT
34-53-03	ATC ANTENNA SELECT
34-53-01	ATC TRANSPONDER - LEFT
34-53-02	ATC TRANSPONDER - RIGHT
34-55-01	DME - LEFT
34-55-02	DME - RIGHT
34-22-10	EFIS POWER DISTRIBUTION AND INSTRUMENT LIGHTING
34-22-11	EFIS SYMBOL GENERATOR AND EADI - LEFT
34-22-21	EFIS SYMBOL GENERATOR AND EADI - RIGHT AND CENTER
34-22-12	EFIS SYMBOL GENERATOR AND EHSI - LEFT
34-22-22	EFIS SYMBOL GENERATOR AND EHSI - RIGHT AND CENTER
34-22-32	FLIGHT INSTRUMENT DATA BUS SWITCHING

CH-SC-SU	Title
34-22-00	FLIGHT INSTRUMENT SYSTEM - SIMPLIFIED
34-22-31	FLIGHT INSTRUMENT SYSTEM SWITCHING
34-61-00	FLIGHT MANAGEMENT CMPTR SYSTEM (LEFT - RIGHT FMCS) - SIMPLIFIED
34-60-01	FLIGHT MANAGEMENT COMPUTER
34-61-06	FMCS CONTROL DISPLAY UNIT (CDU) - RIGHT
34-61-09	FMCS LNAV STEERING COMMANDS - RIGHT
34-60-02	FMCS MAINTENANCE INDEX
34-61-07	FMCS VNAV MODE LOGIC - RIGHT
34-61-08	FMCS VNAV STEERING COMMANDS - RIGHT
34-58-01	GLOBAL POSITIONING SYSTEM LEFT
34-58-02	GLOBAL POSITIONING SYSTEM RIGHT
34-46-01	GROUND PROXIMITY WARNING SYSTEM
34-31-03	ILS - CENTER
34-31-01	ILS - LEFT
34-31-02	ILS - RIGHT
34-21-03	INERTIAL REFERENCE SYSTEM - CENTER
34-21-01	INERTIAL REFERENCE SYSTEM - LEFT
34-21-02	INERTIAL REFERENCE SYSTEM - RIGHT
34-25-01	INSTRUMENT COMPARATOR UNIT

34-ALPHABETICAL INDEX

5014

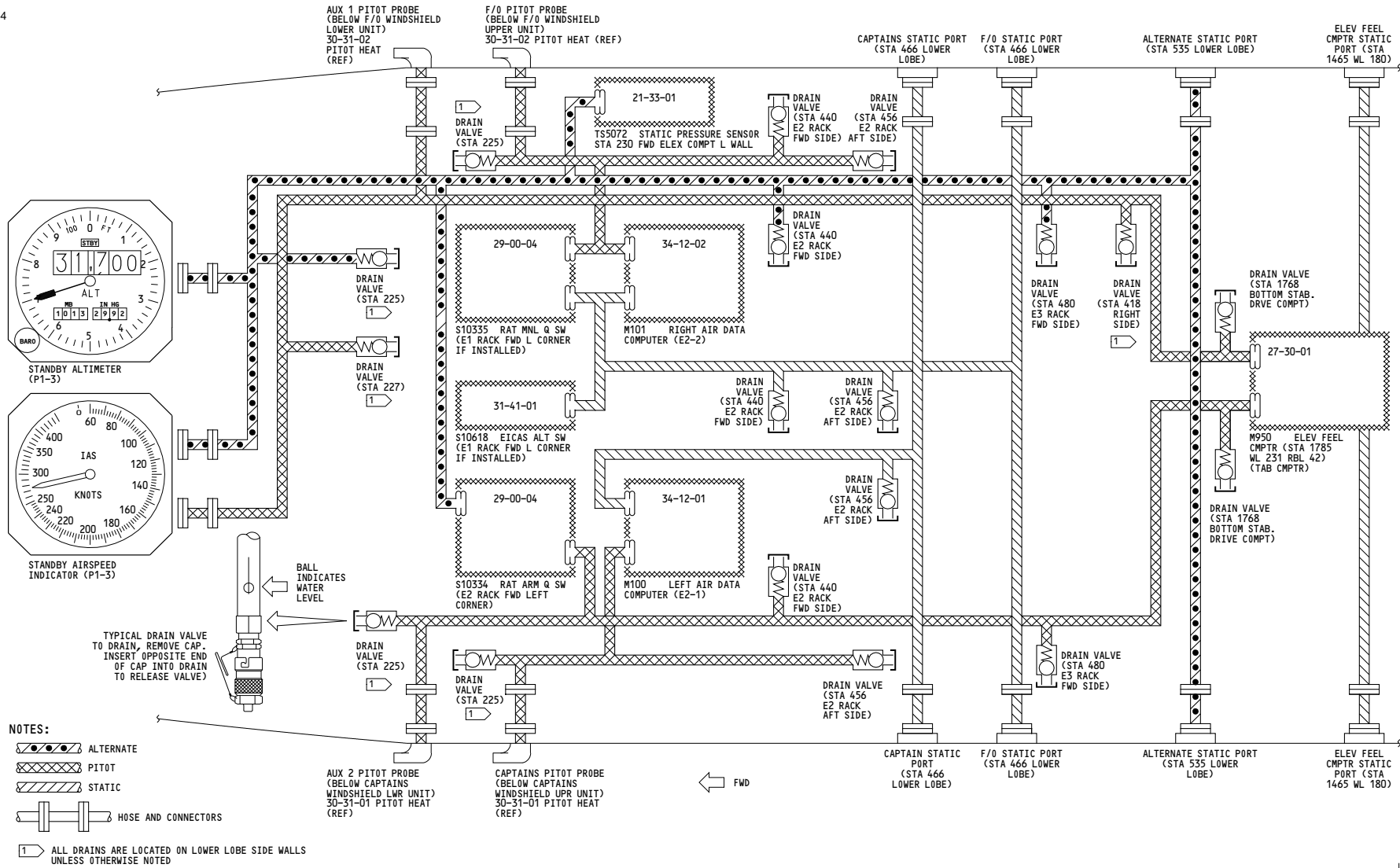

ALL	PITOT STATIC
D280N032S	

34-11-01

Page 101

May 06/2009

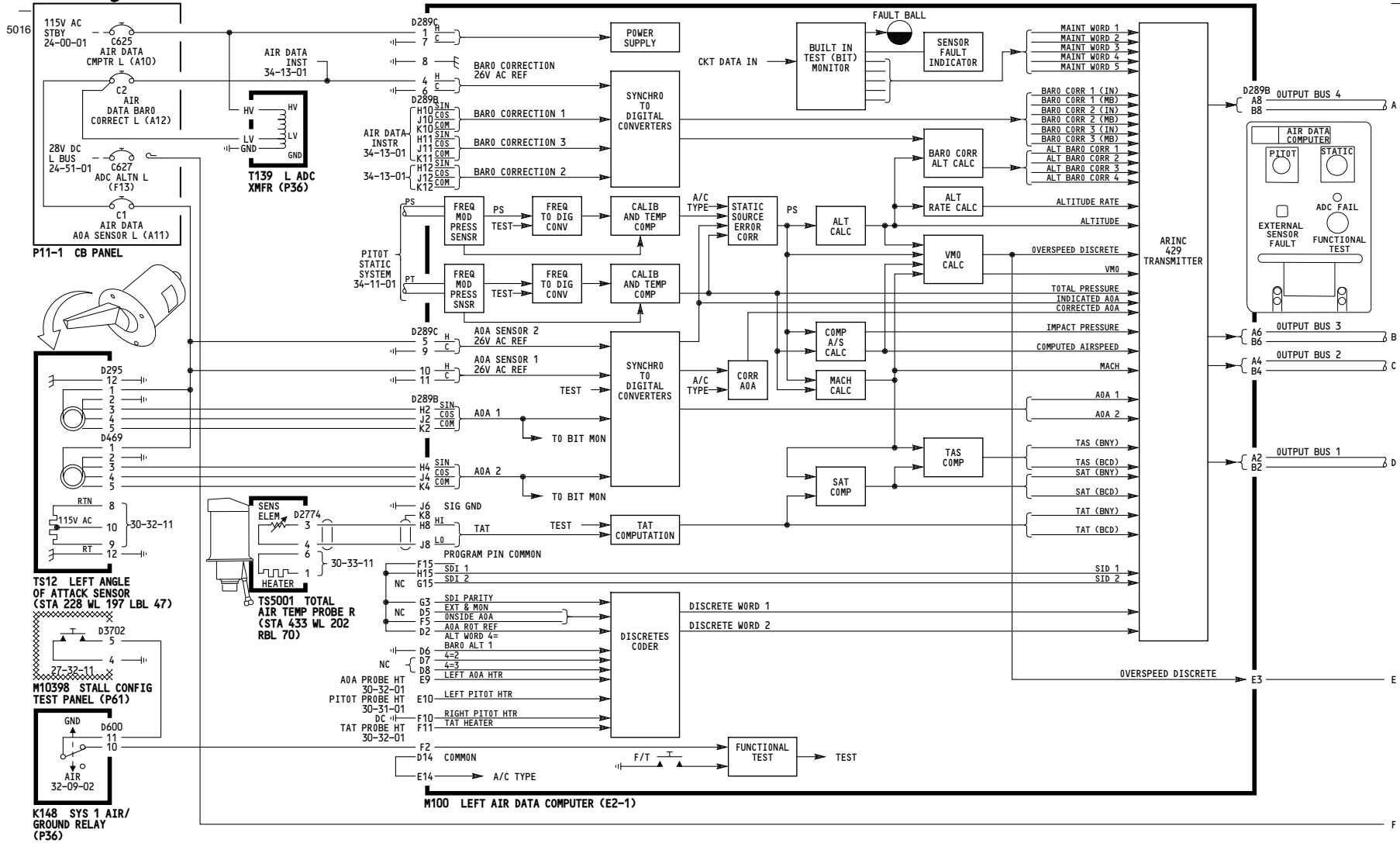

001-008, 010-099

AIR DATA SYSTEM - LEFT

D280N032S

34-12-01

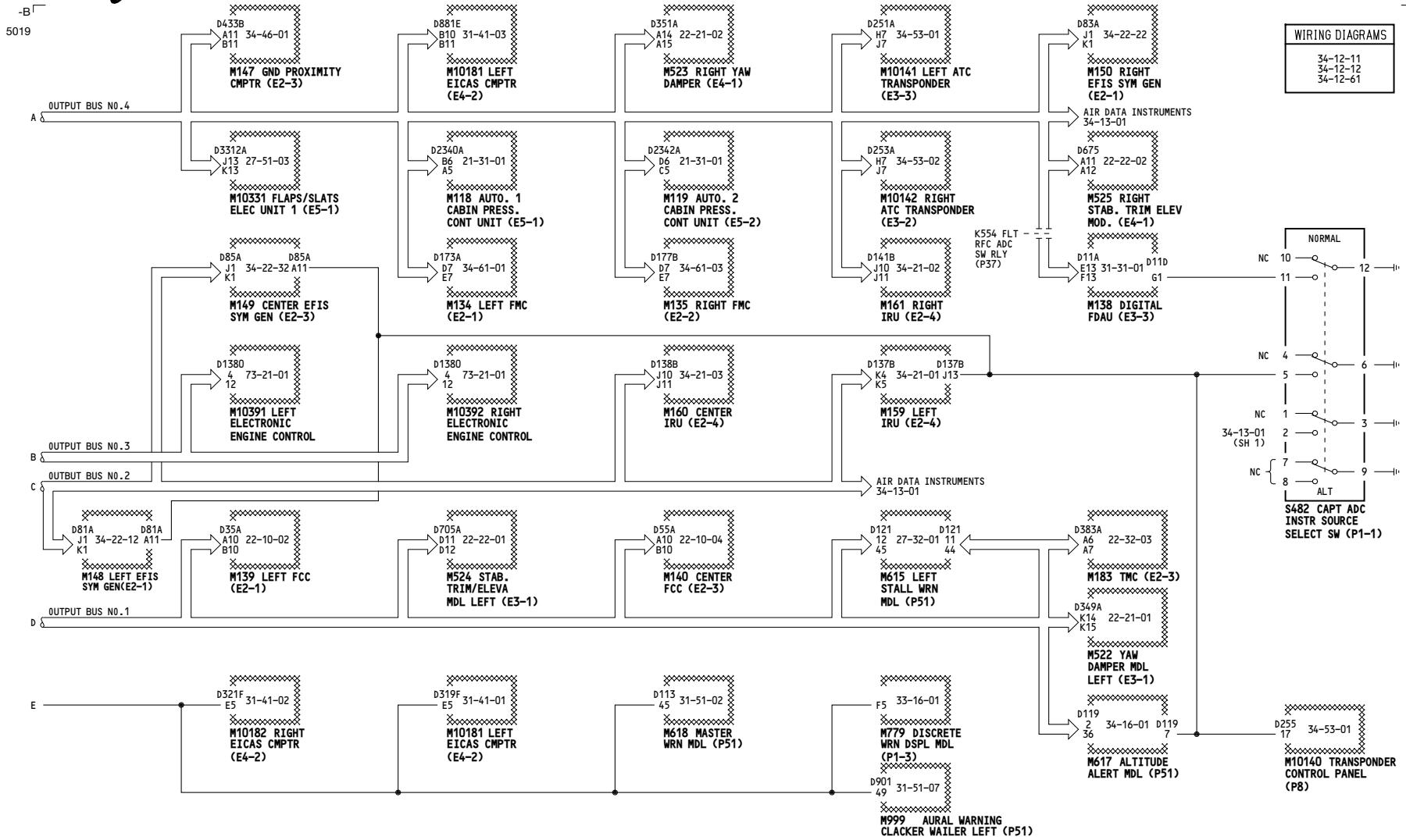

WIRING DIAGRAMS
34-12-11
34-12-12
34-12-61

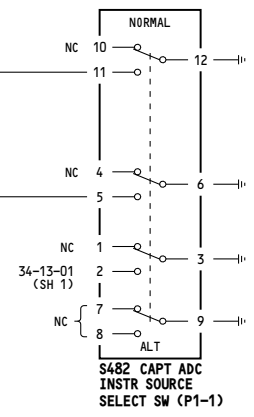

001-008, 010-099

AIR DATA SYSTEM - LEFT

D280N032S

34-12-01

Page 101
Sheet 2
May 06/2009

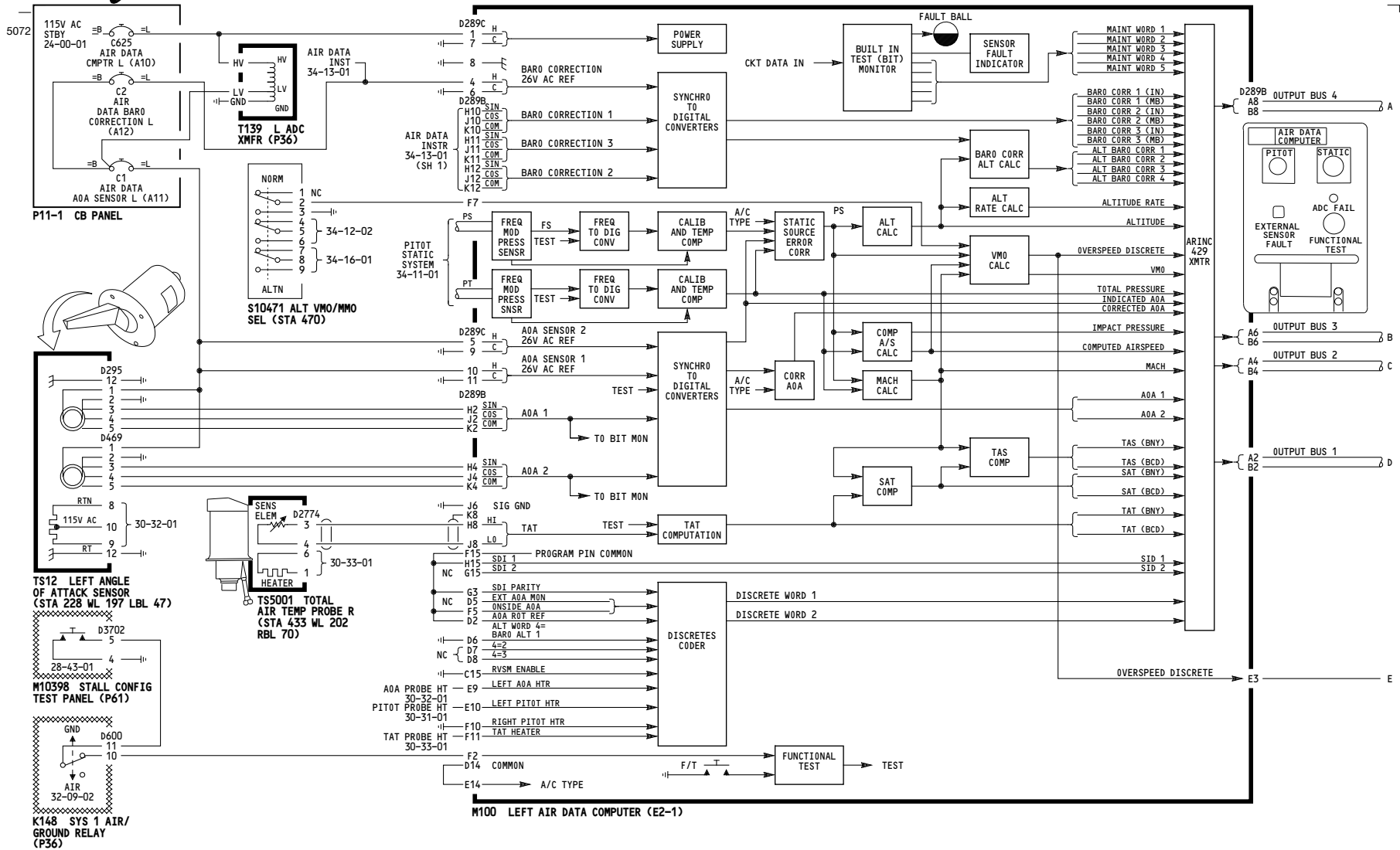

001	<p>AIR DATA SYSTEM - LEFT</p> <p style="text-align: center;">D280N032S</p>
-----	---

- Incorporates
- ▶ 34-0132
 - ▶ 34-0430

34-12-01

Page 101.1
Sheet 1
May 06/2009

5109

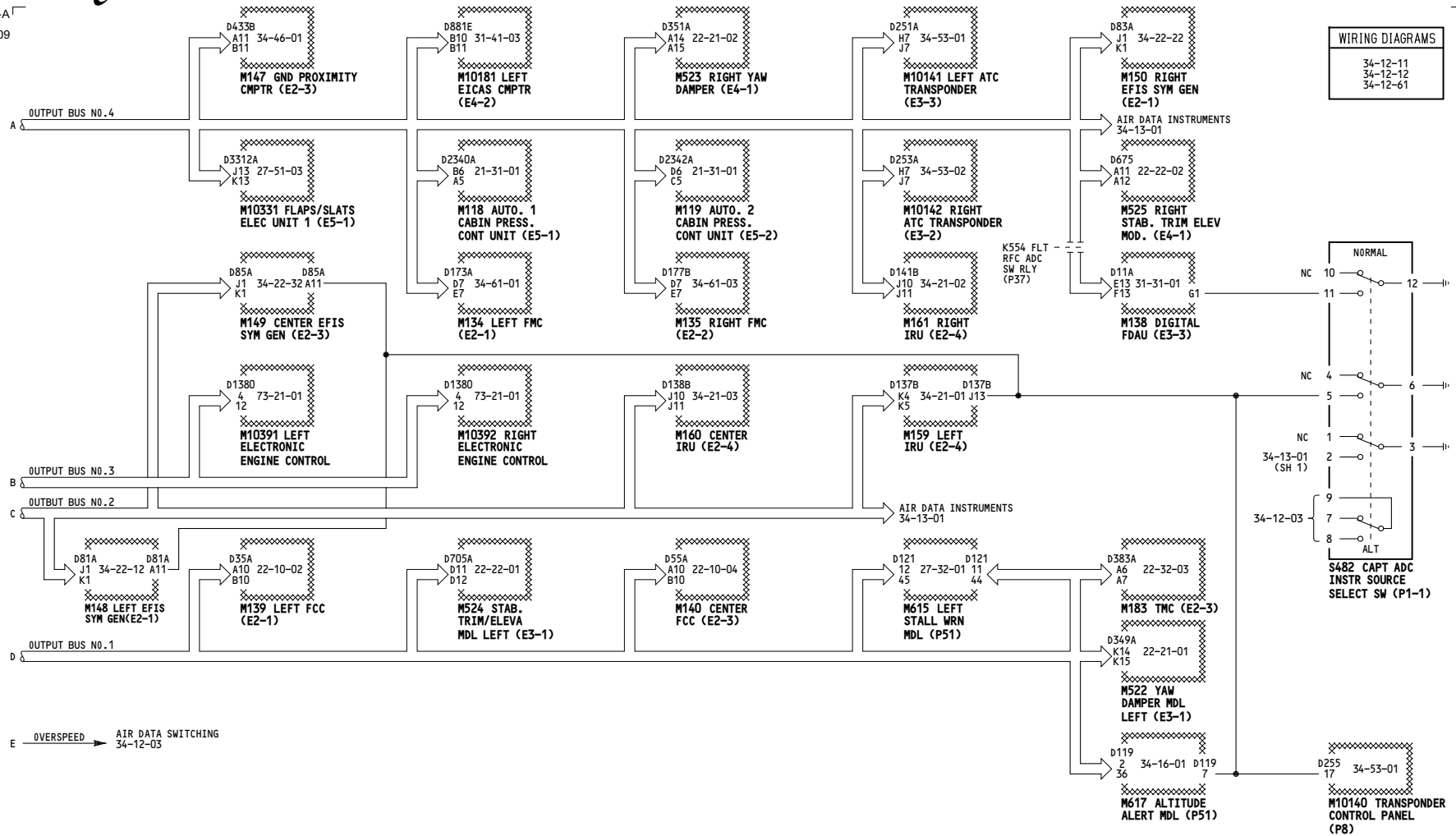

WIRING DIAGRAMS
34-12-11
34-12-12
34-12-61

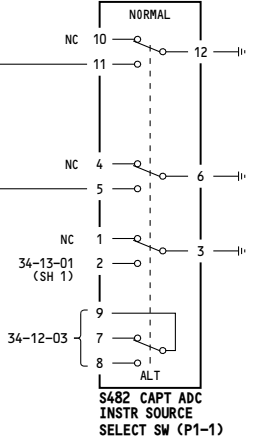

001	AIR DATA SYSTEM - LEFT	Incorporates 34A0222
D280N032S		

34-12-01

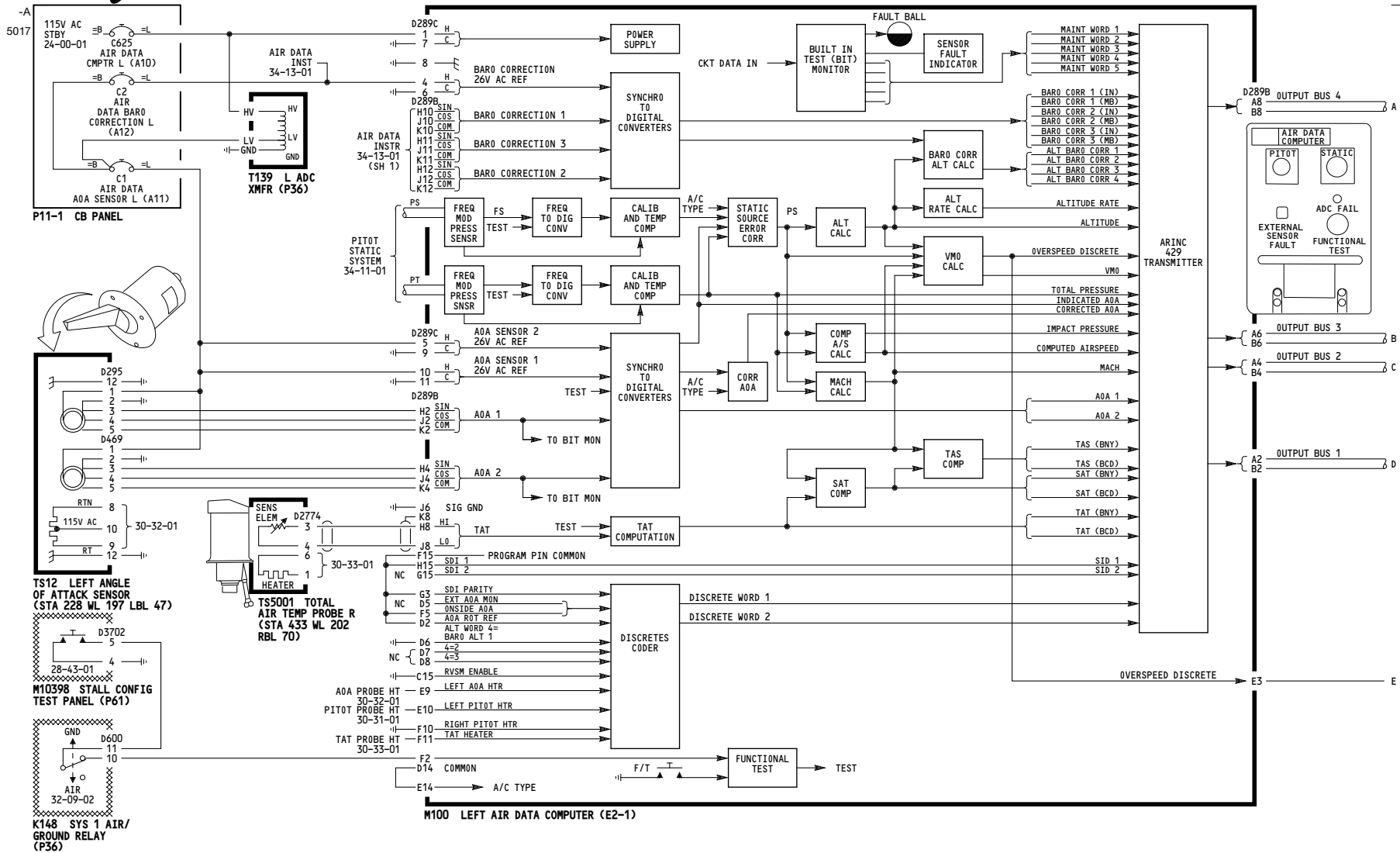

002

AIR DATA SYSTEM - LEFT

Incorporates
34-0132

D280N032S

34-12-01

Page 101.2
Sheet 1
Jan 21/2005

5109

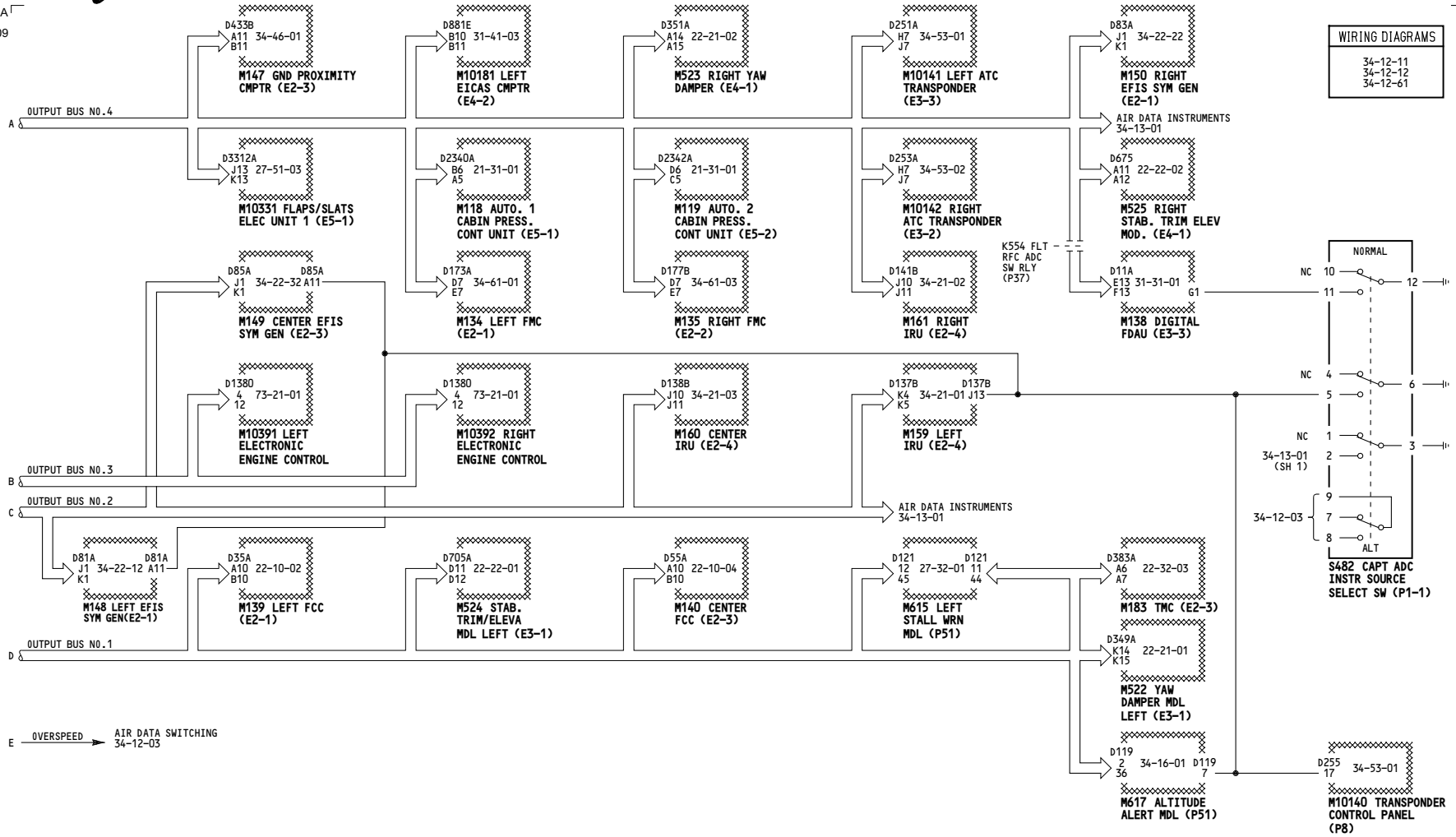

WIRING DIAGRAMS
34-12-11
34-12-12
34-12-61

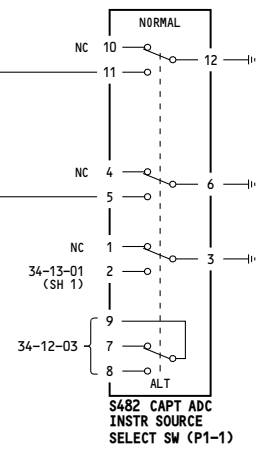

002

AIR DATA SYSTEM - LEFT

- Incorporates
- ▶ 34-0200
 - ▶ 34A0222

D280N032S

34-12-01

Page 101.2
Sheet 2
May 06/2009

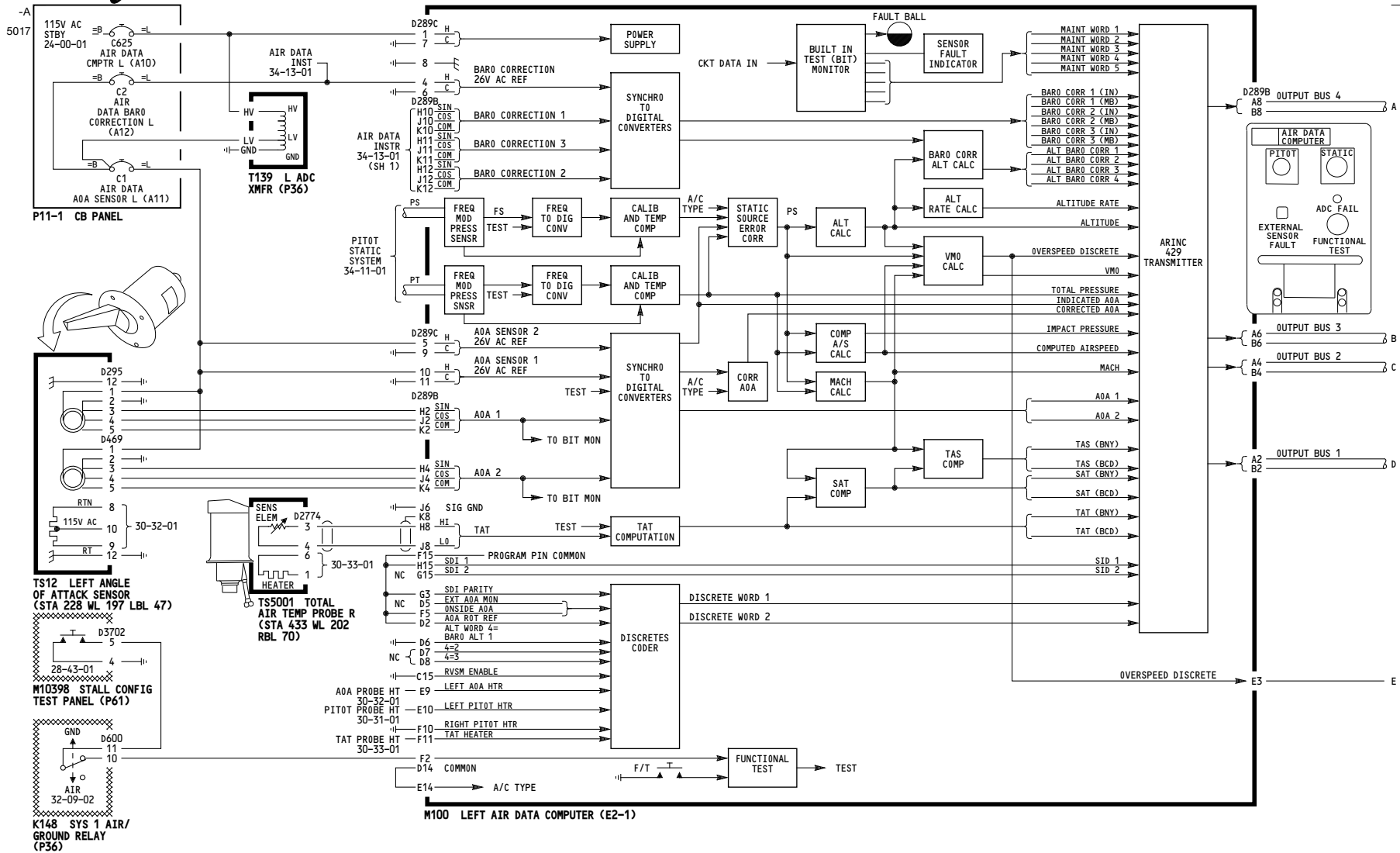

003-008, 010-011

AIR DATA SYSTEM - LEFT

Incorporates
34-0132

D280N032S

34-12-01

Page 101.3
Sheet 1
May 06/2009

5109

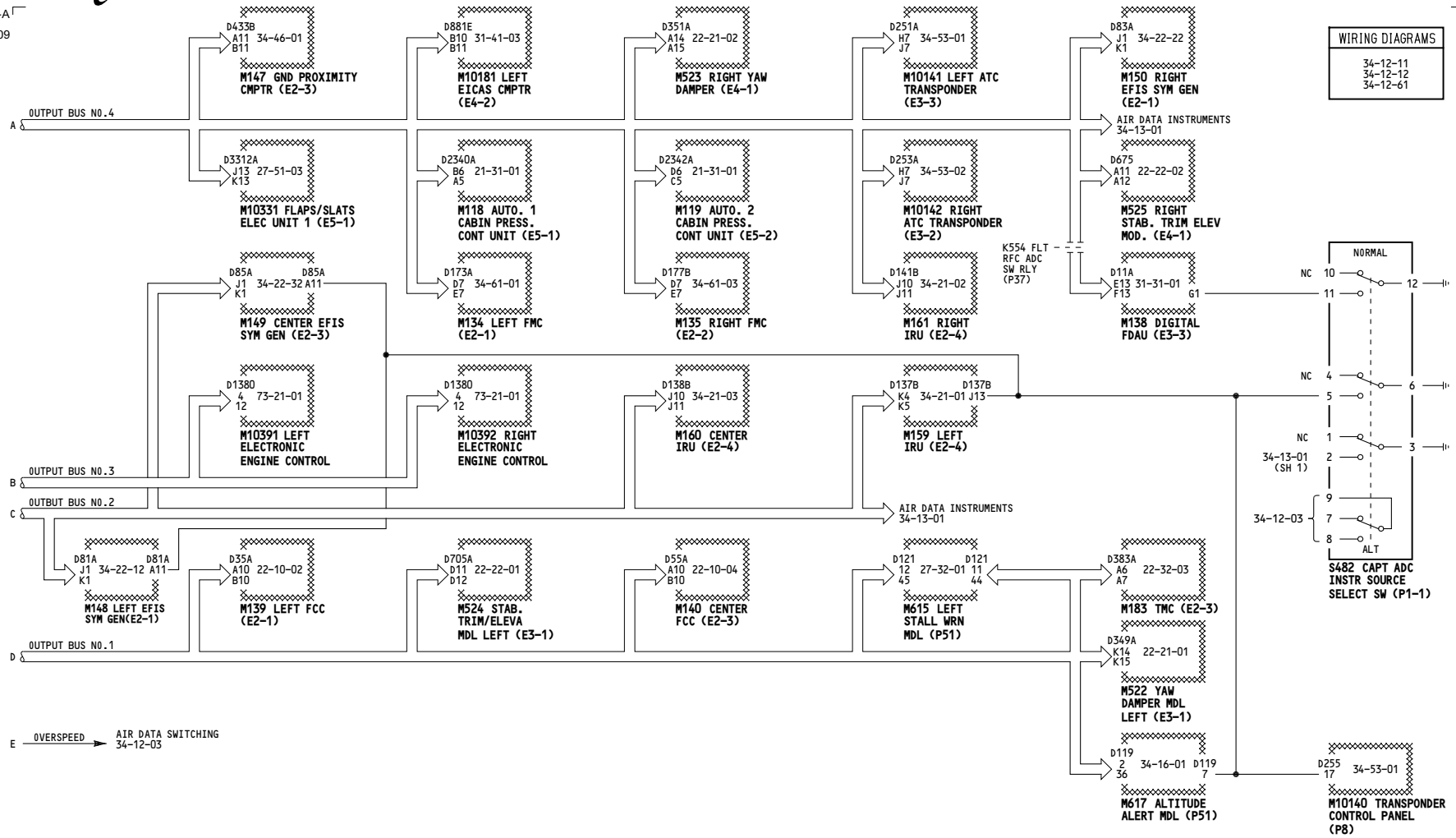

WIRING DIAGRAMS
34-12-11
34-12-12
34-12-61

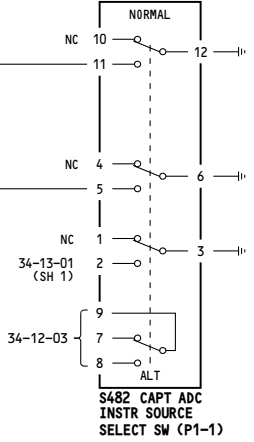

003-008, 010-011	AIR DATA SYSTEM - LEFT	Incorporates 34A0222
D280N032S		

34-12-01

Page 101.3
Sheet 2
May 06/2009

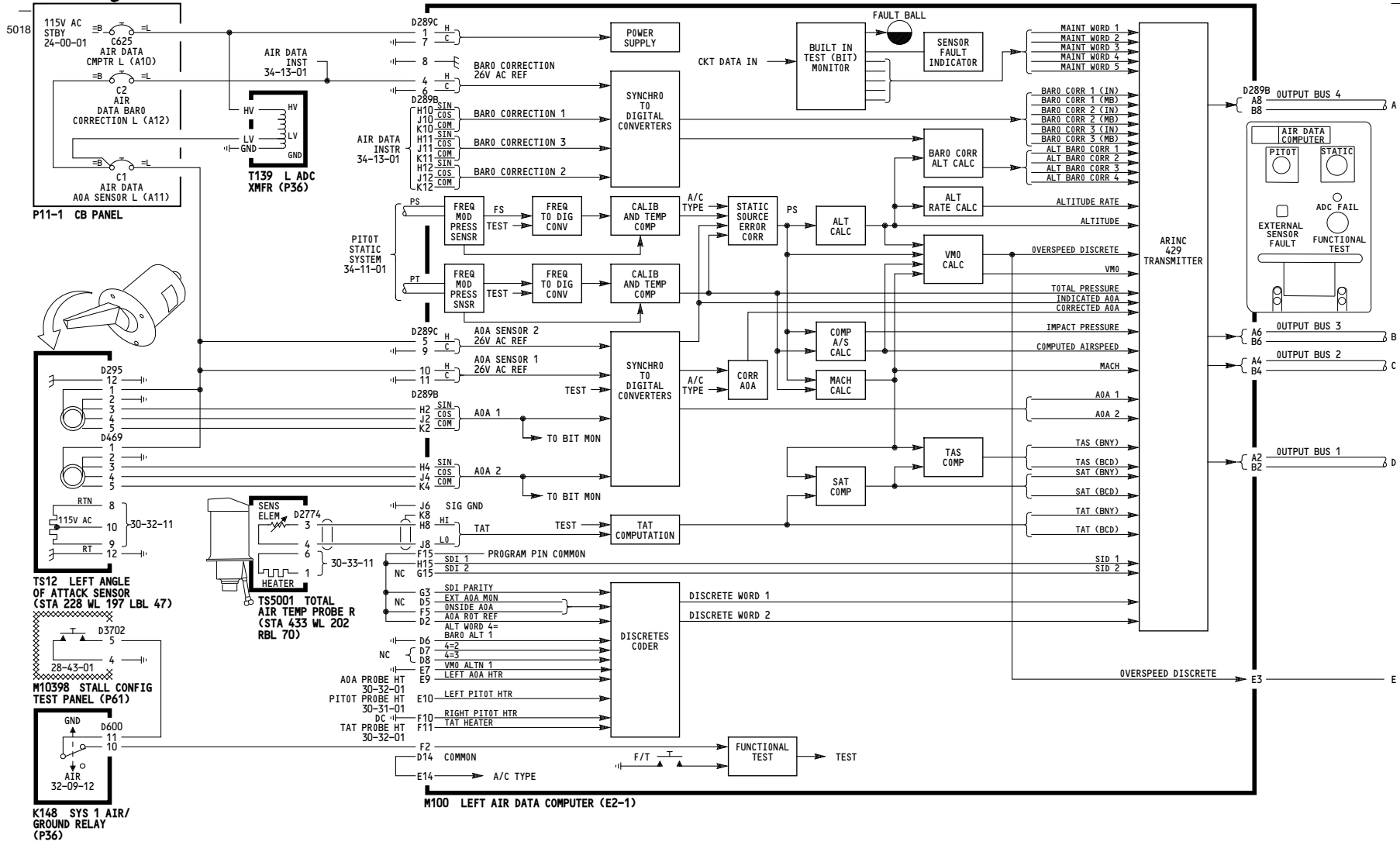

009

AIR DATA SYSTEM - LEFT

D280N032S

34-12-01

Page 102
Sheet 1
Jan 21/2005

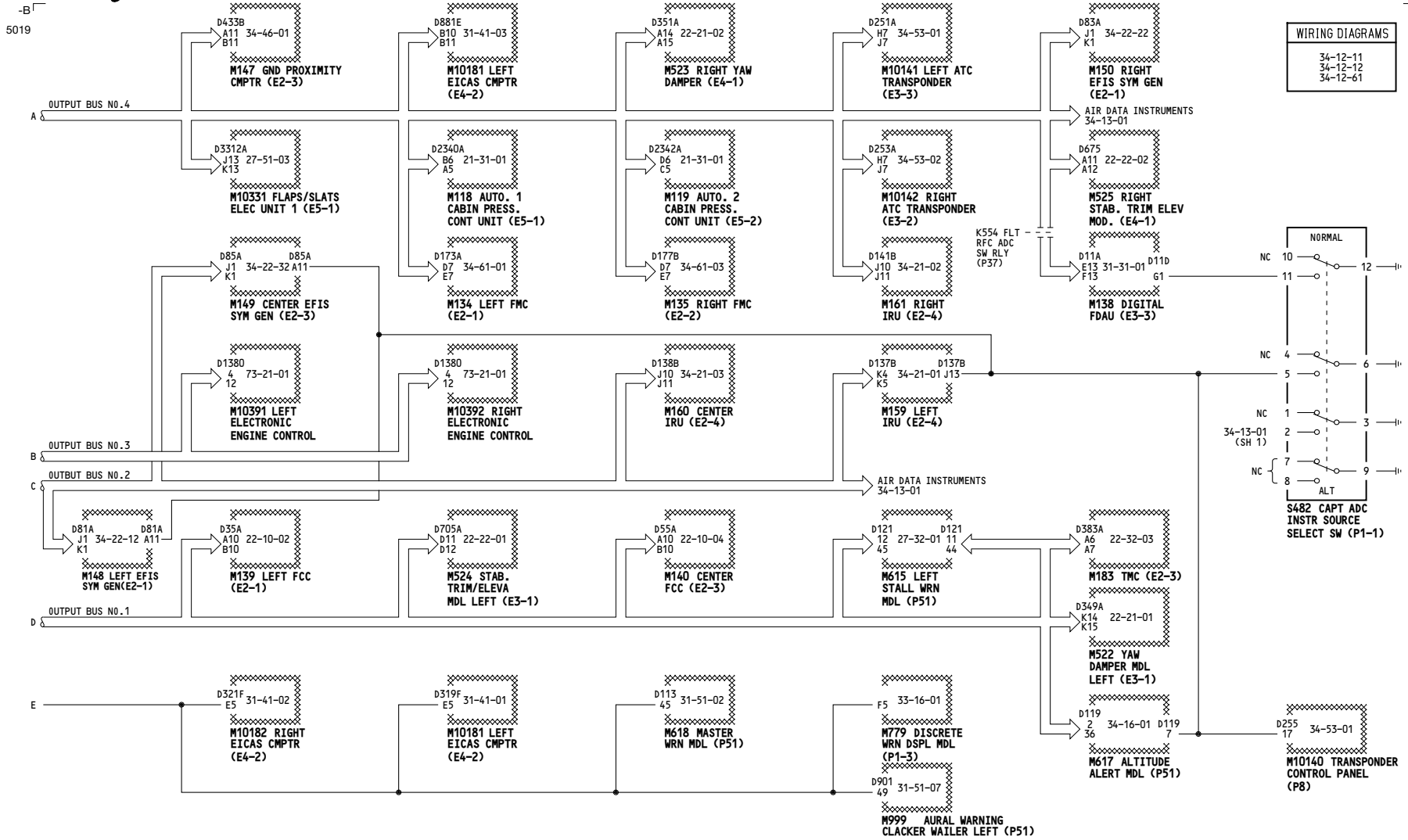

WIRING DIAGRAMS
34-12-11
34-12-12
34-12-61

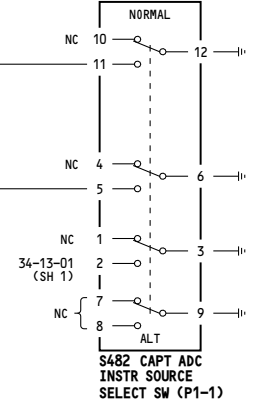

009

AIR DATA SYSTEM - LEFT

D280N032S

34-12-01

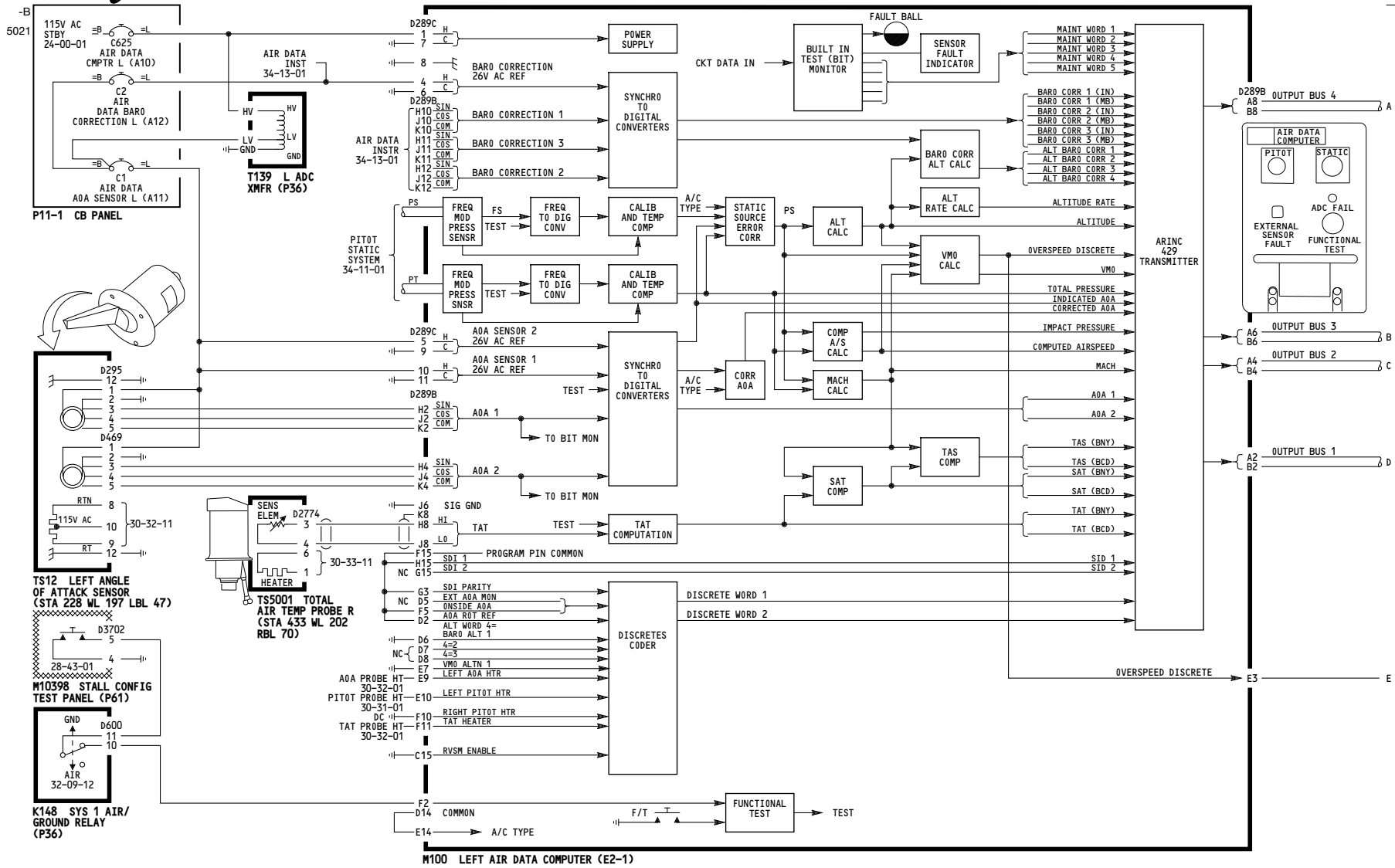

009 **AIR DATA SYSTEM - LEFT**
 D280N032S

Incorporates
 34-0132

34-12-01

5109

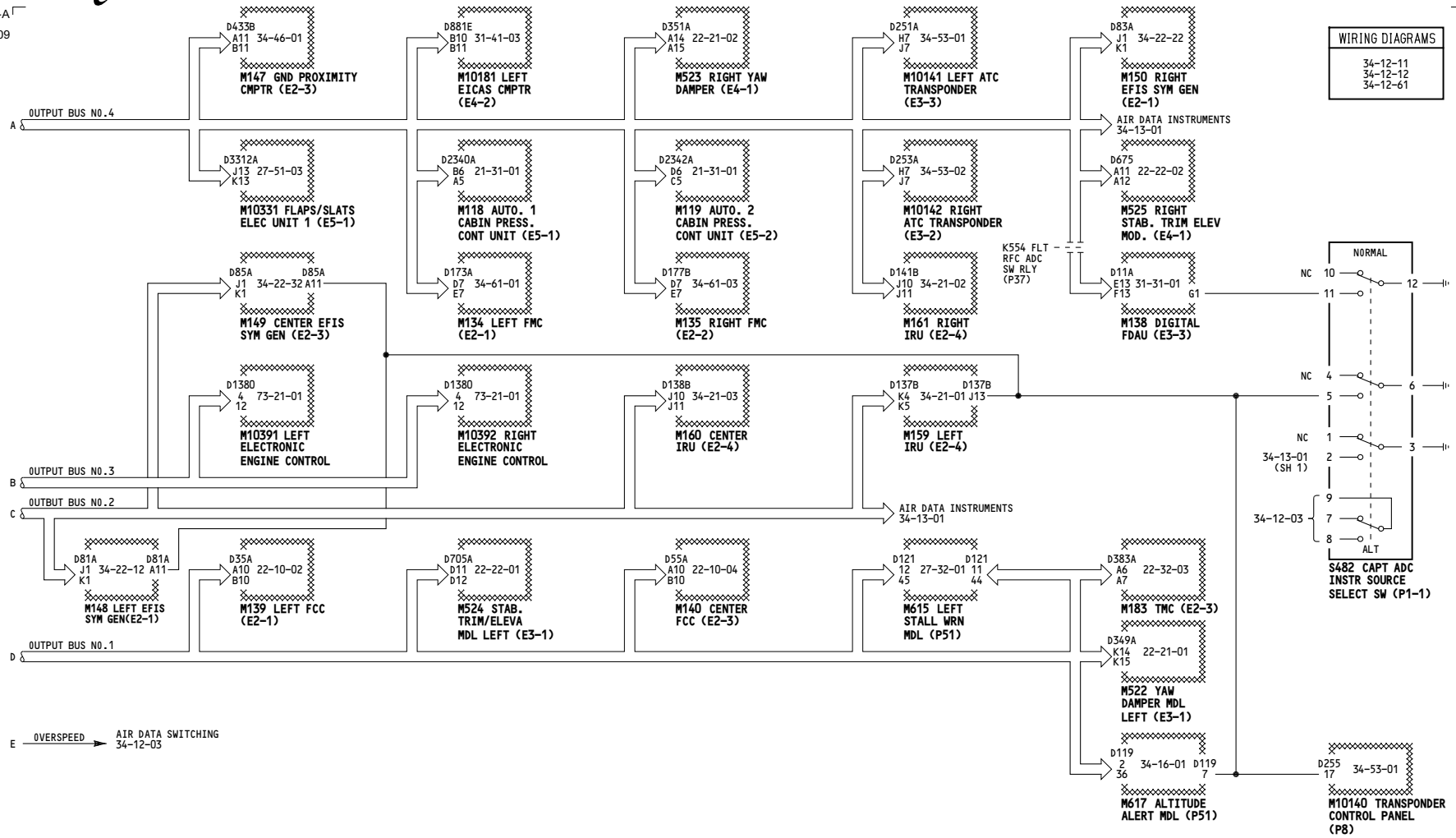

WIRING DIAGRAMS
34-12-11
34-12-12
34-12-61

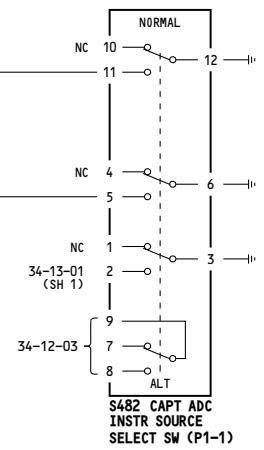

009	AIR DATA SYSTEM - LEFT	Incorporates 34A0222
D280N032S		

34-12-01

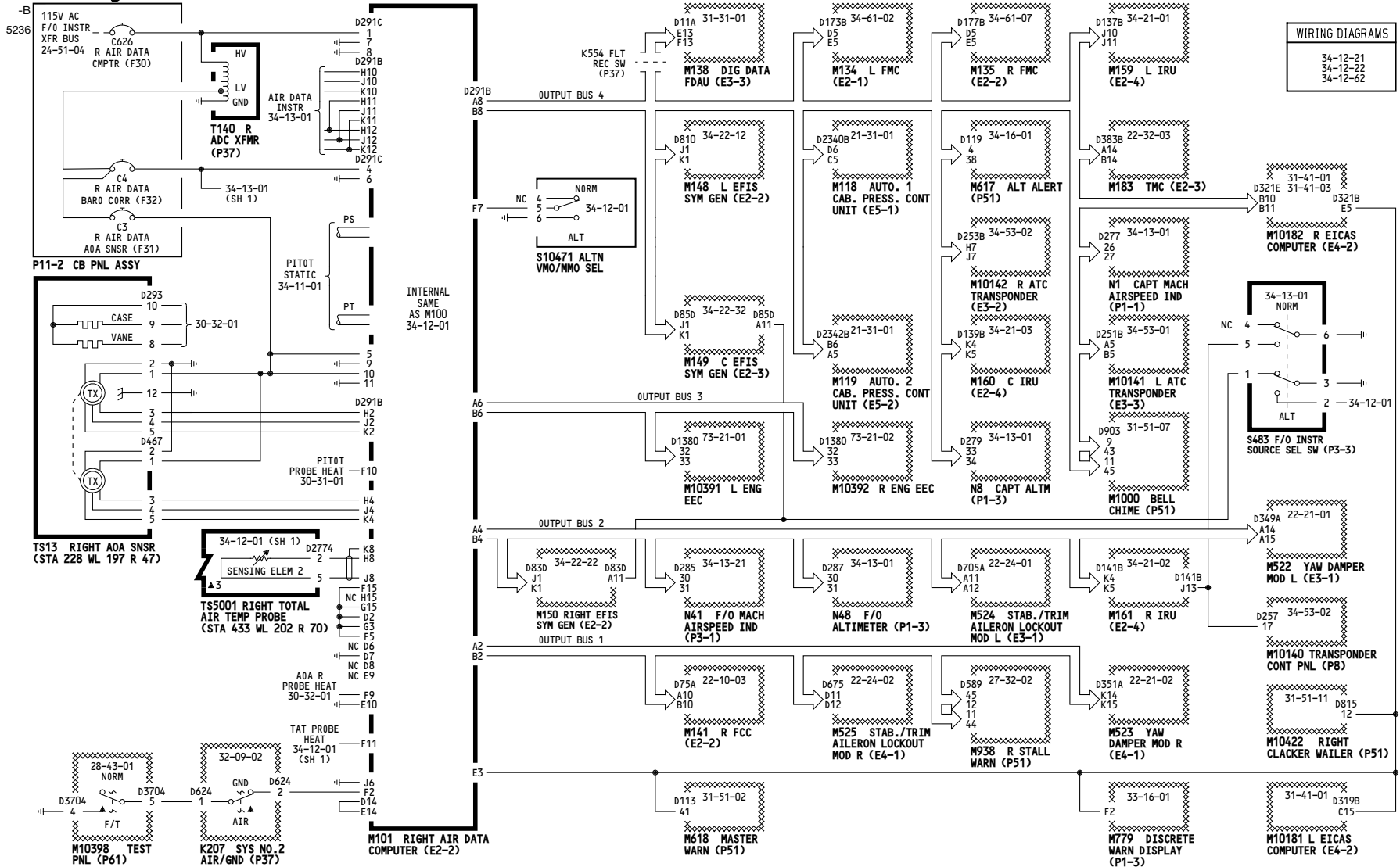

WIRING DIAGRAMS
34-12-21
34-12-22
34-12-62

001

AIR DATA SYSTEM - RIGHT

D280N032S

Incorporates

- 31-0164 R03
- 34-0132
- 34-0430
- 34A0222

34-12-02

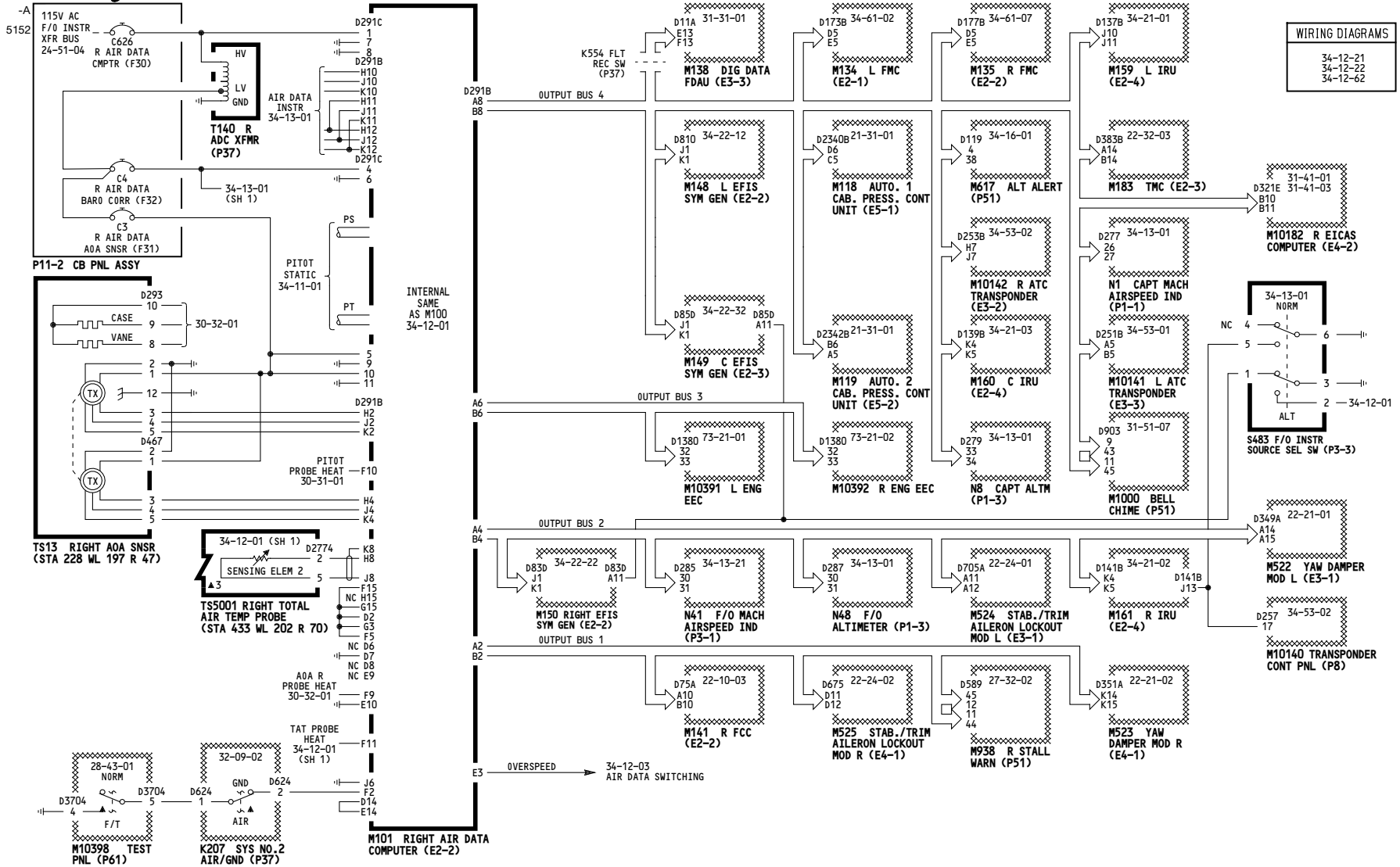

003-008, 010-011

AIR DATA SYSTEM - RIGHT

- Incorporates
- ▶▶ 34-0132
 - ▶▶ 34A0222

D280N032S

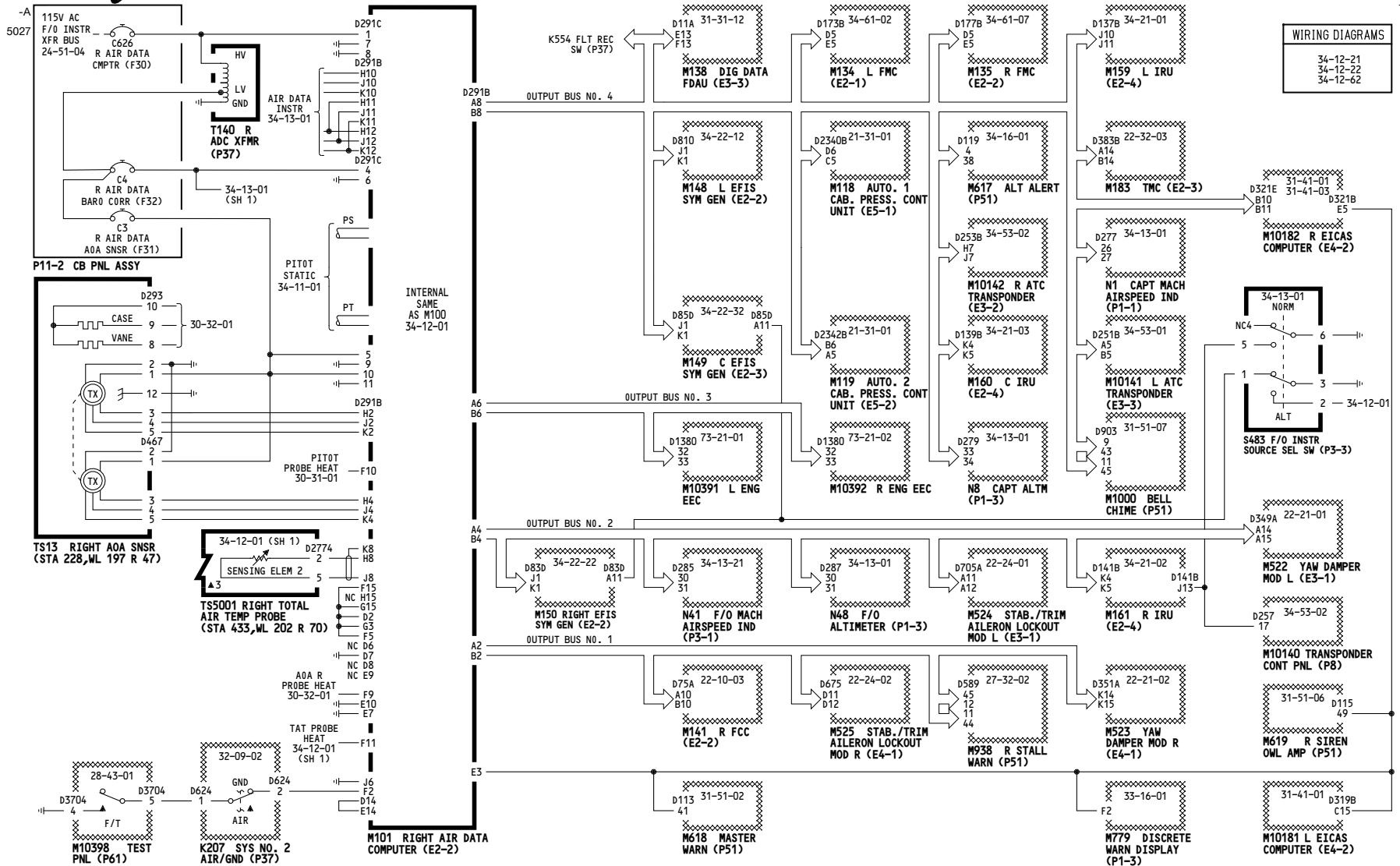

009

AIR DATA SYSTEM - RIGHT

D280N032S

34-12-02

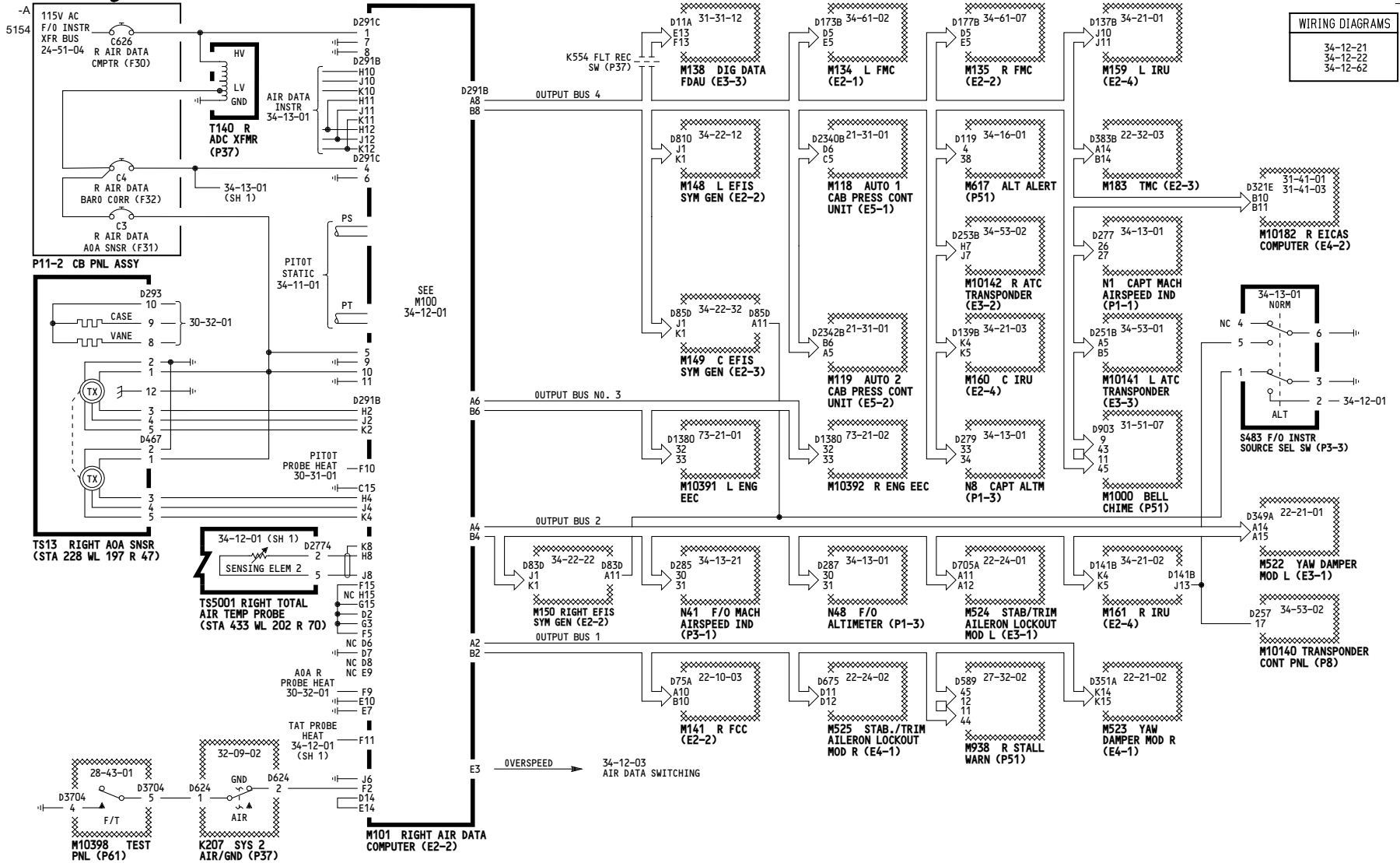

WIRING DIAGRAMS
34-12-21
34-12-22
34-12-62

009

AIR DATA SYSTEM - RIGHT

- Incorporates
- ▶▶ 34-0132
- ▶▶ 34A0222

D280N032S

34-12-02

Page 102.1

May 06/2009

WIRING DIAGRAMS

34-12-61
34-12-62

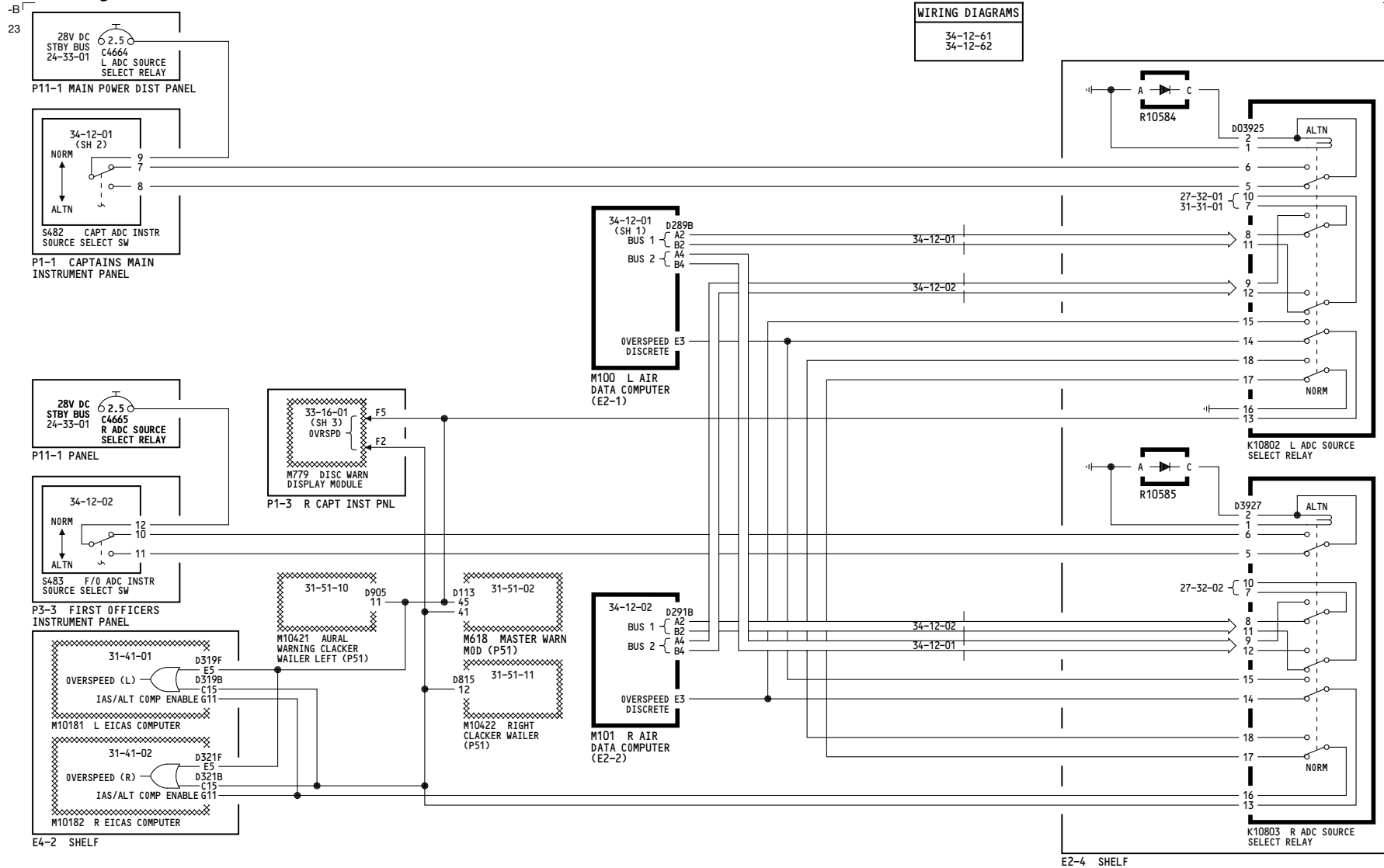

001

AIR DATA SWITCHING LEFT AND RIGHT

D280N032S

Incorporates
 31-0164 R03
 34A0222

34-12-03

Page 101.1

May 06/2009

WIRING DIAGRAMS
34-12-61
34-12-62

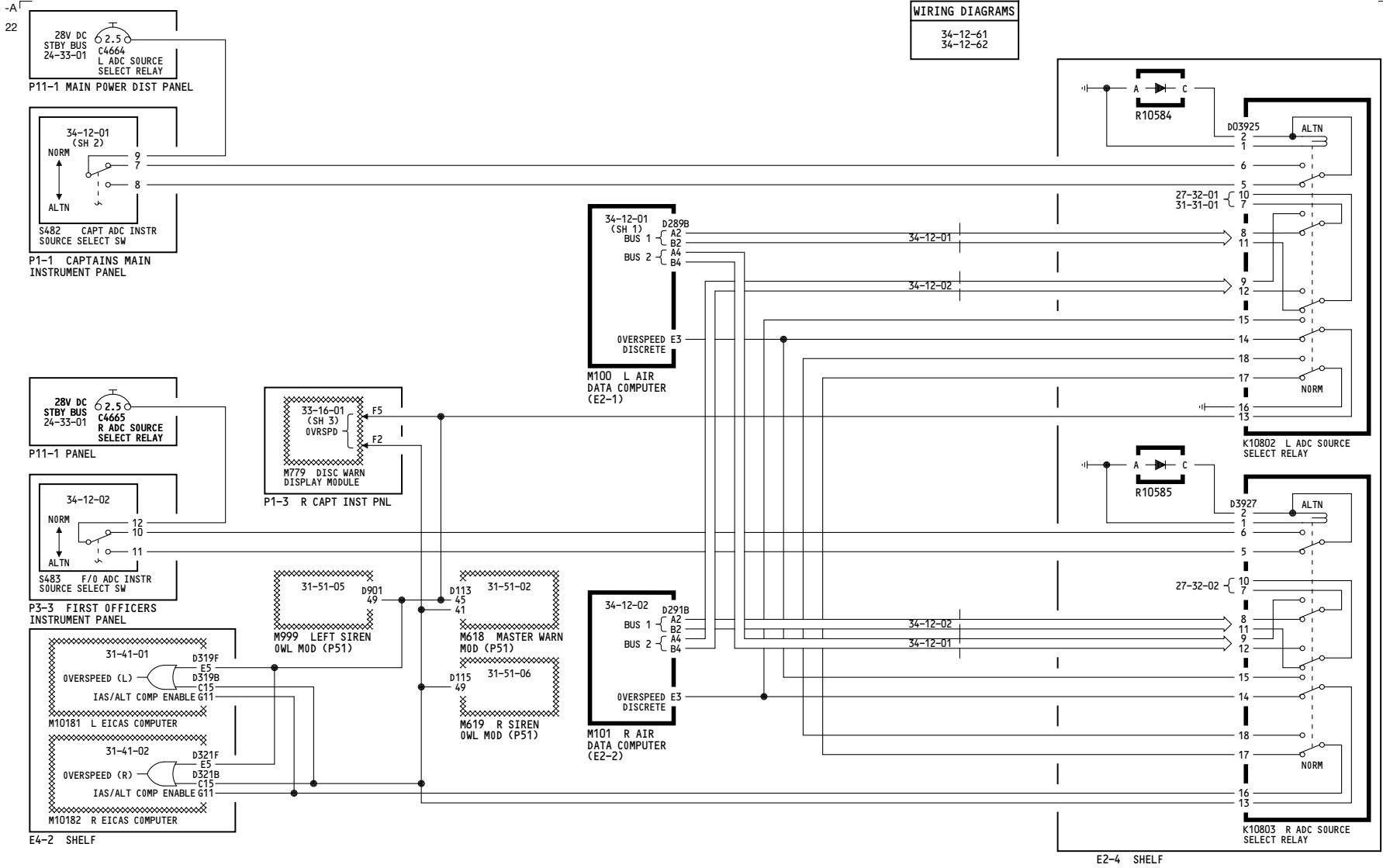

002-008, 010-011

AIR DATA SWITCHING LEFT AND RIGHT

Incorporates 34A0222

D280N032S

34-12-03

Page 102.1

May 06/2009

WIRING DIAGRAMS
34-12-61
34-12-62

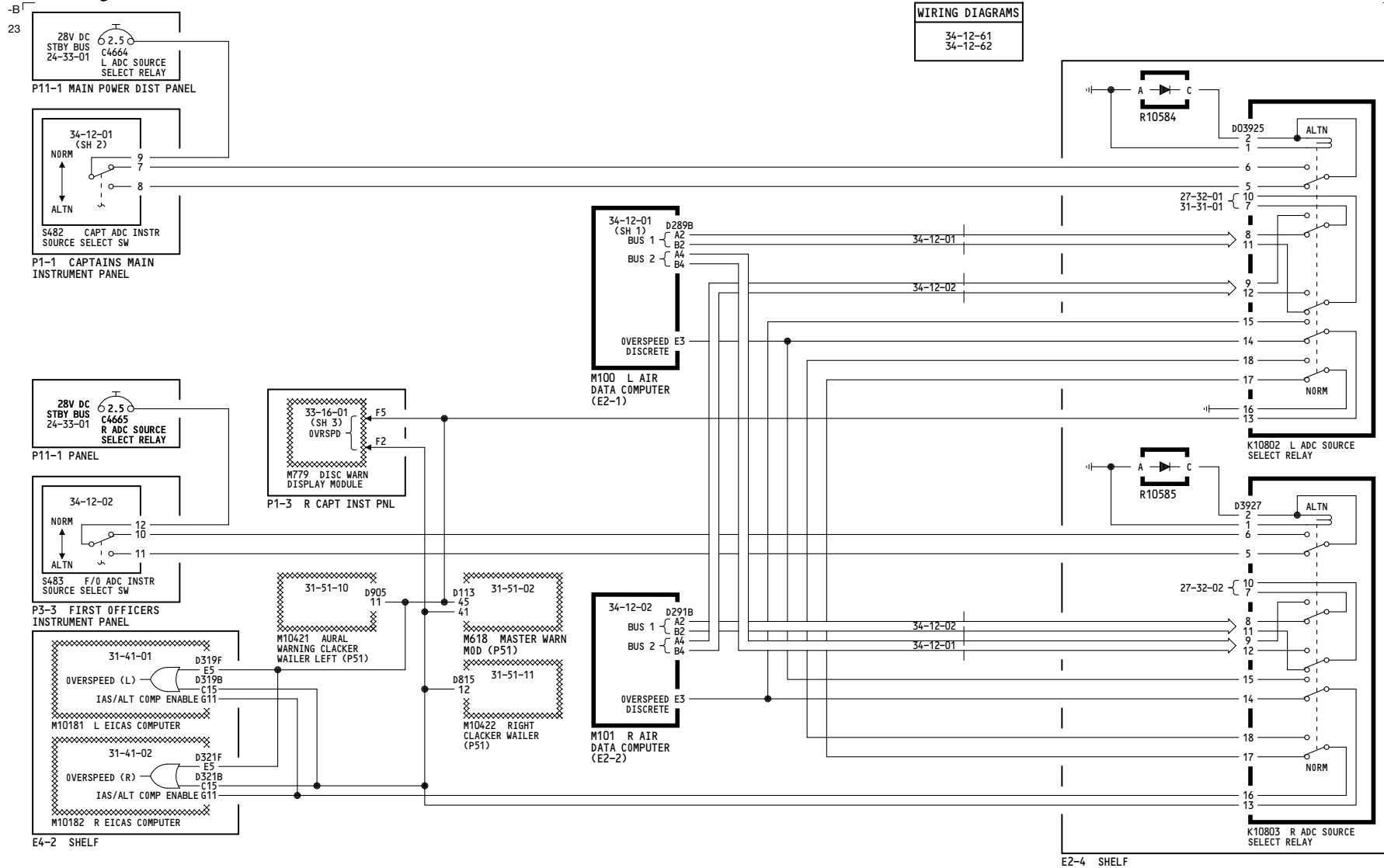

009

AIR DATA SWITCHING LEFT AND RIGHT

Incorporates 34A0222

D280N032S

34-12-03

Page 103.1

May 06/2009

THIS PAGE INTENTIONALLY LEFT BLANK

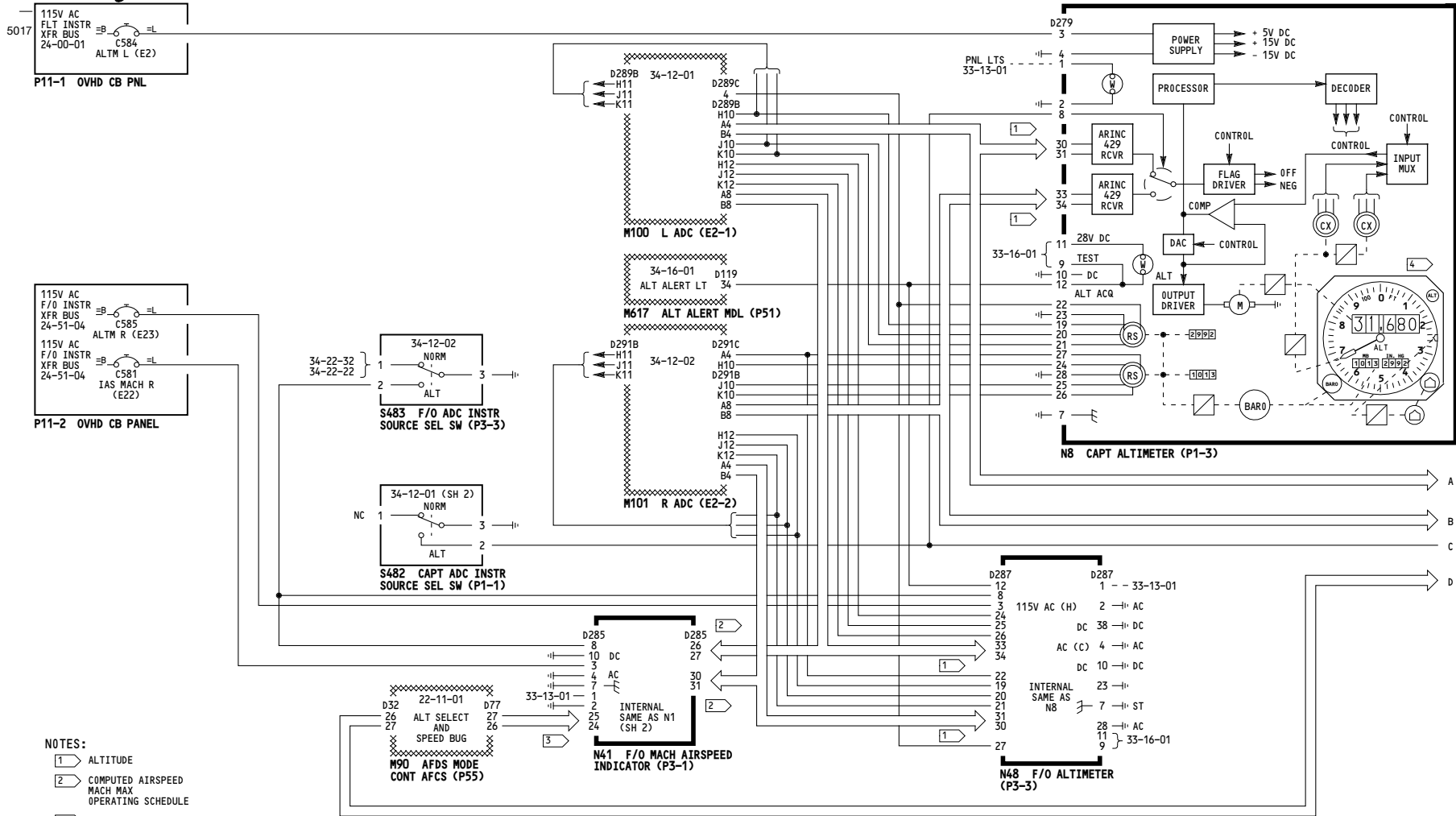

NOTES:

- 1 ALTITUDE
- 2 COMPUTED AIRSPEED
MACH MAX
OPERATING SCHEDULE
- 3 SPEED SELECTED
- 4 MACH AIRSPEED AND
ALTIMETER INDICATOR FACES
SHOWN WITH POWER APPLIED
TO SHOW DISPLAYS AND
FLAGS RETRACTED

ALL	AIR DATA INSTRUMENTS - LEFT AND RIGHT
D280N032S	

34-13-01

5013

WIRING DIAGRAMS
34-13-11
34-13-21

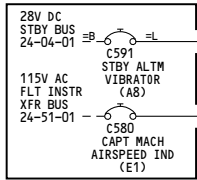

P11-1 OVERHEAD CIRCUIT BREAKER PANEL

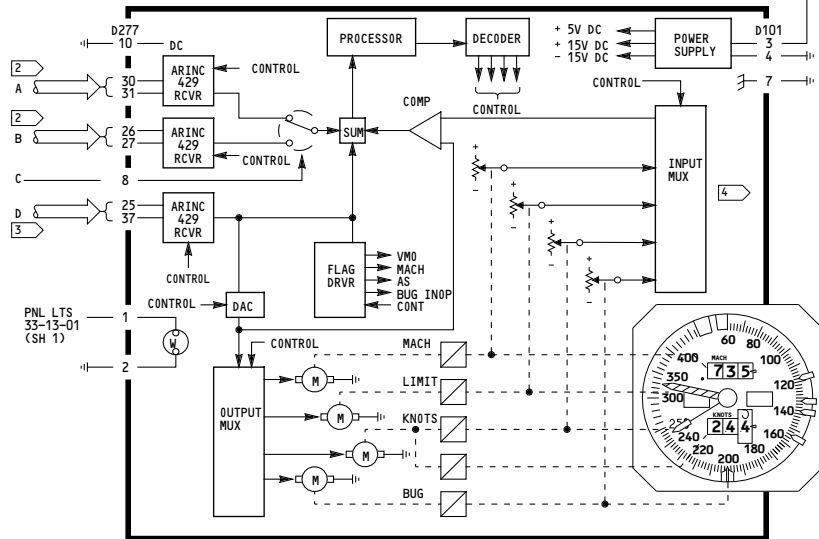

N1 CAPTAIN MACH AIRSPEED INDICATOR (P1-1)

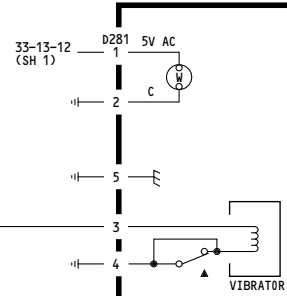

N23 STANDBY ALTIMETER (P1-3)

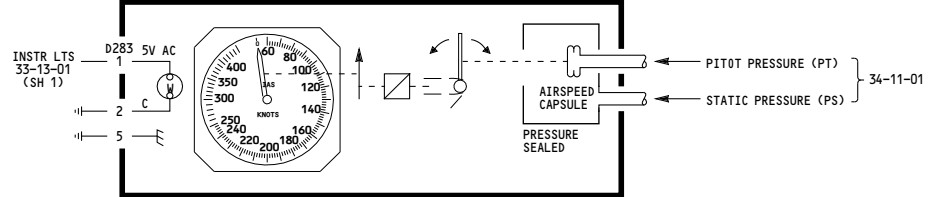
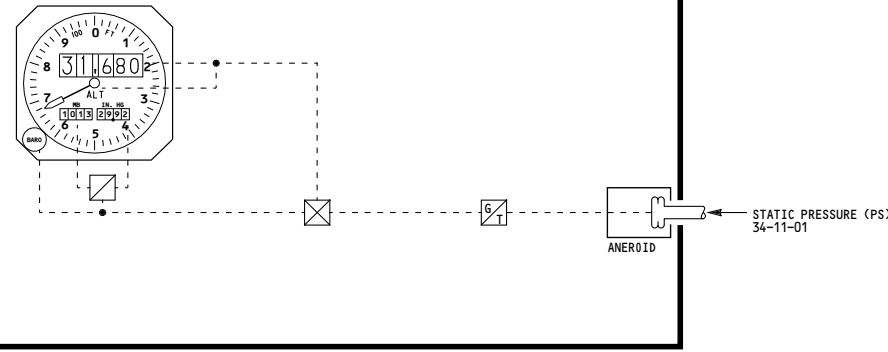

N22 STANDBY AIRSPEED (P1-3)

ALL

AIR DATA INSTRUMENTS - LEFT AND RIGHT

D280N032S

34-13-01

Page 101
Sheet 2
May 06/2009

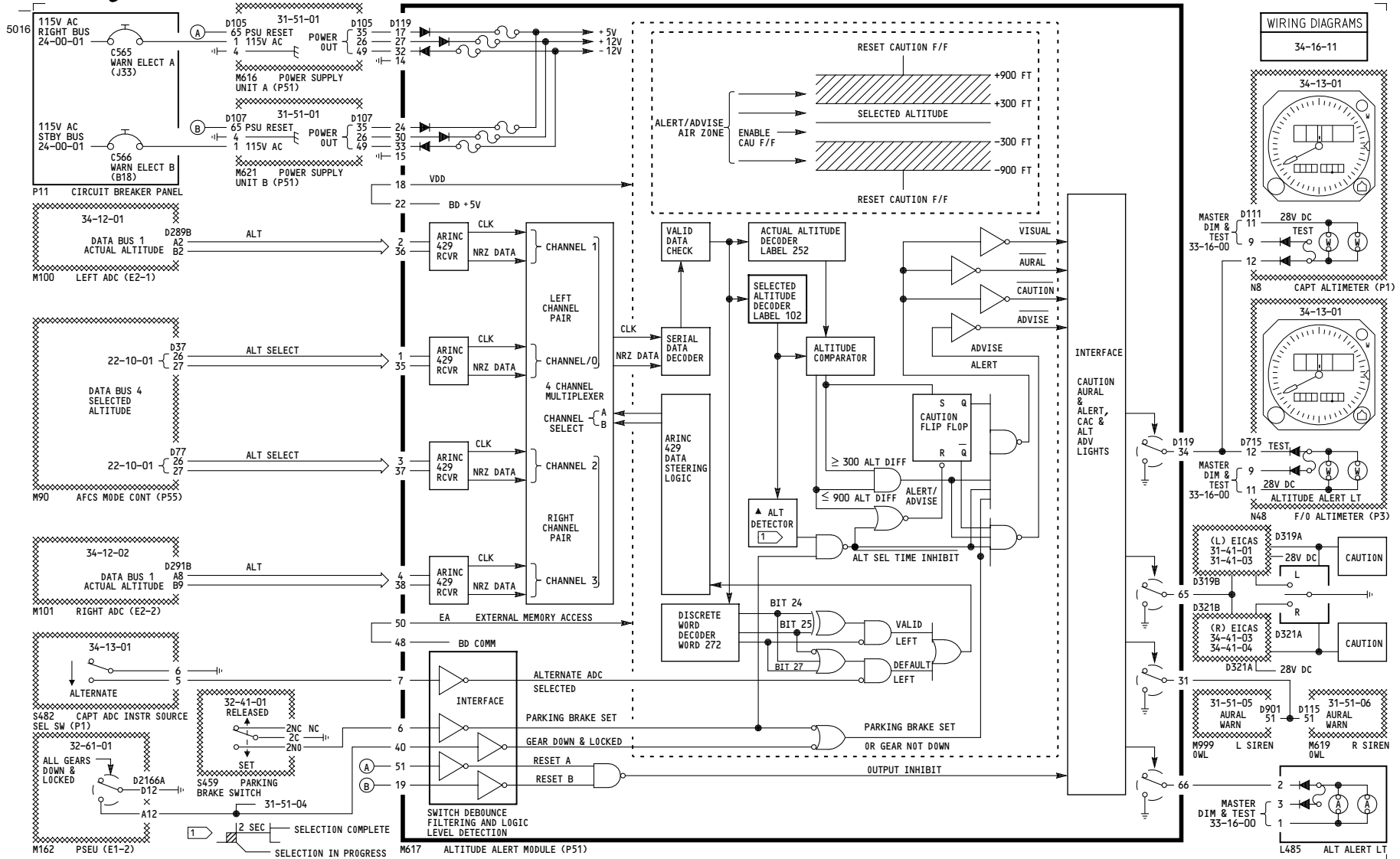

WIRING DIAGRAMS
34-16-11

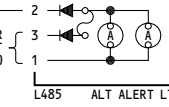
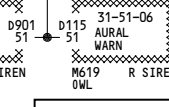
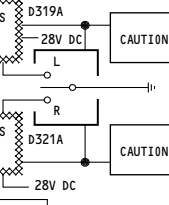
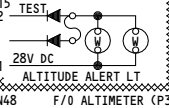
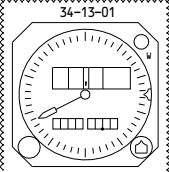
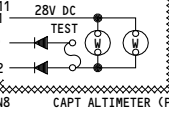
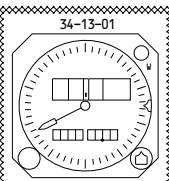

ALL	ALTITUDE ALERT
	D280N032S

34-16-01

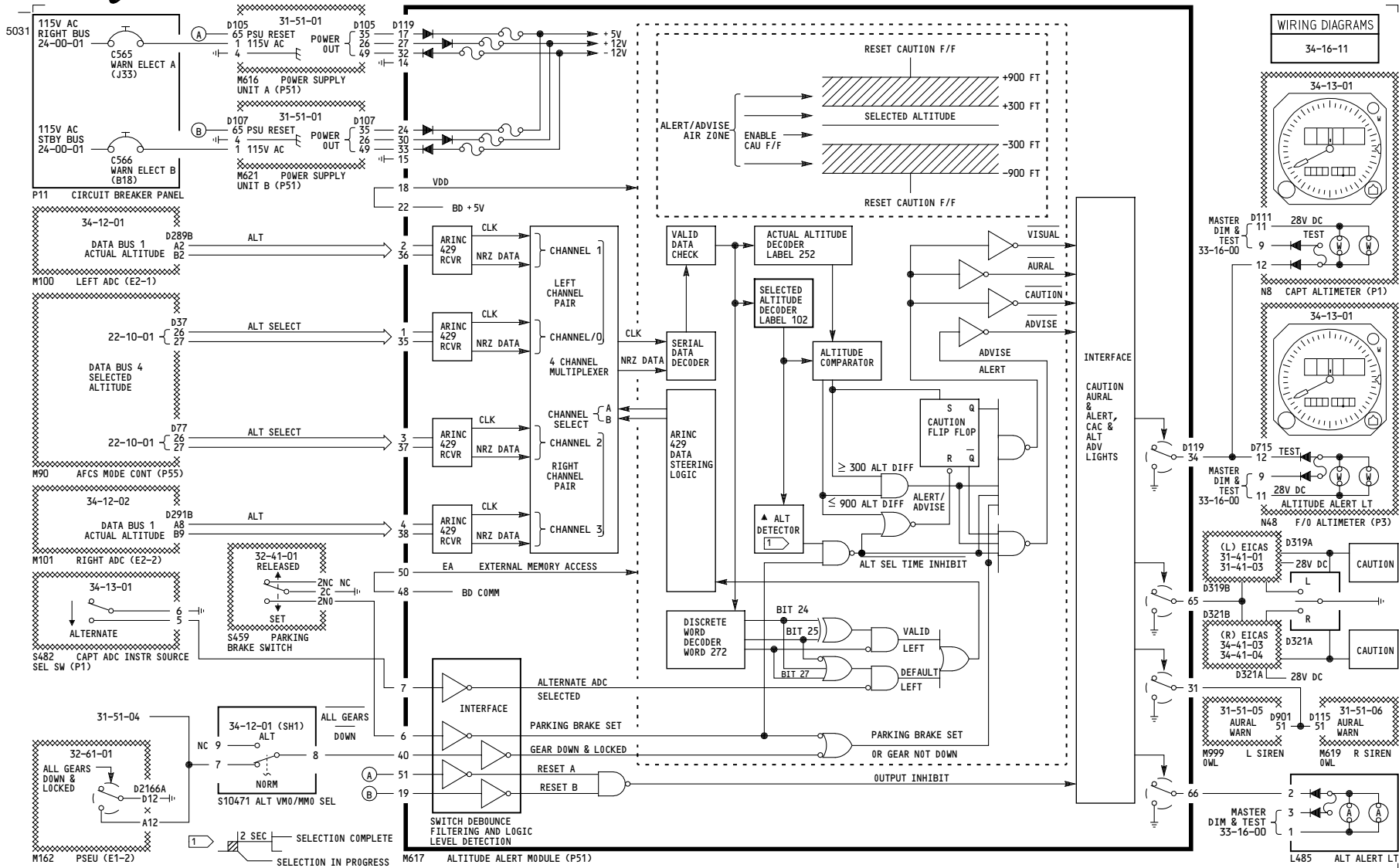

001

ALTITUDE ALERT

Incorporates
34-0430

D280N032S

34-16-01

Page 101.1

May 06/2009

-D
5011

WIRING DIAGRAMS
34-12-61
34-21-11

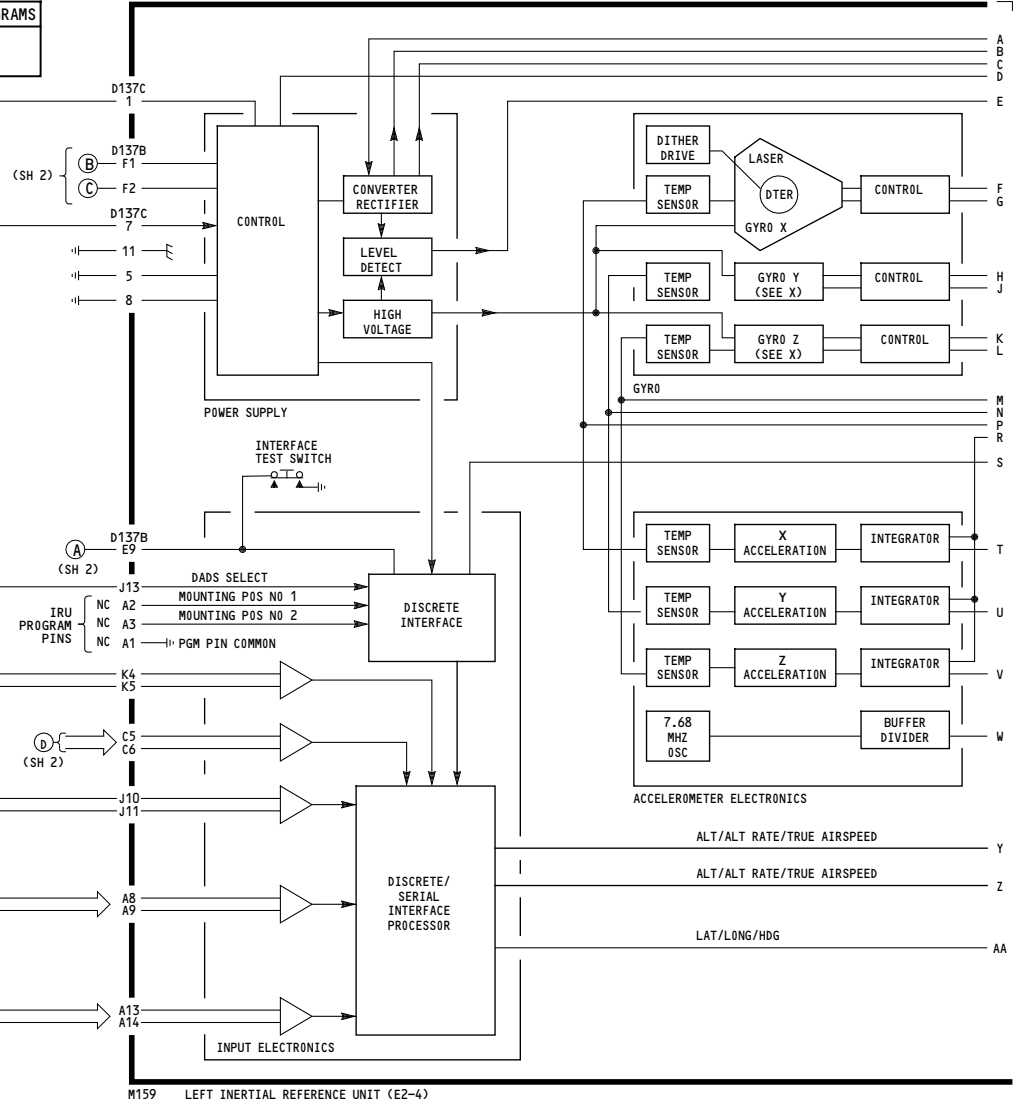
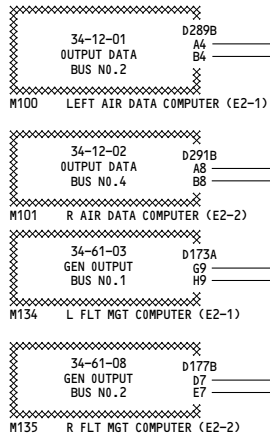
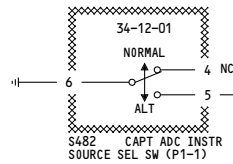
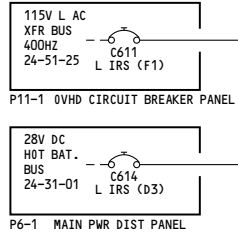

ALL	INERTIAL REFERENCE SYSTEM - LEFT
	D280N032S

34-21-01

Page 101
Sheet 1
May 06/2009

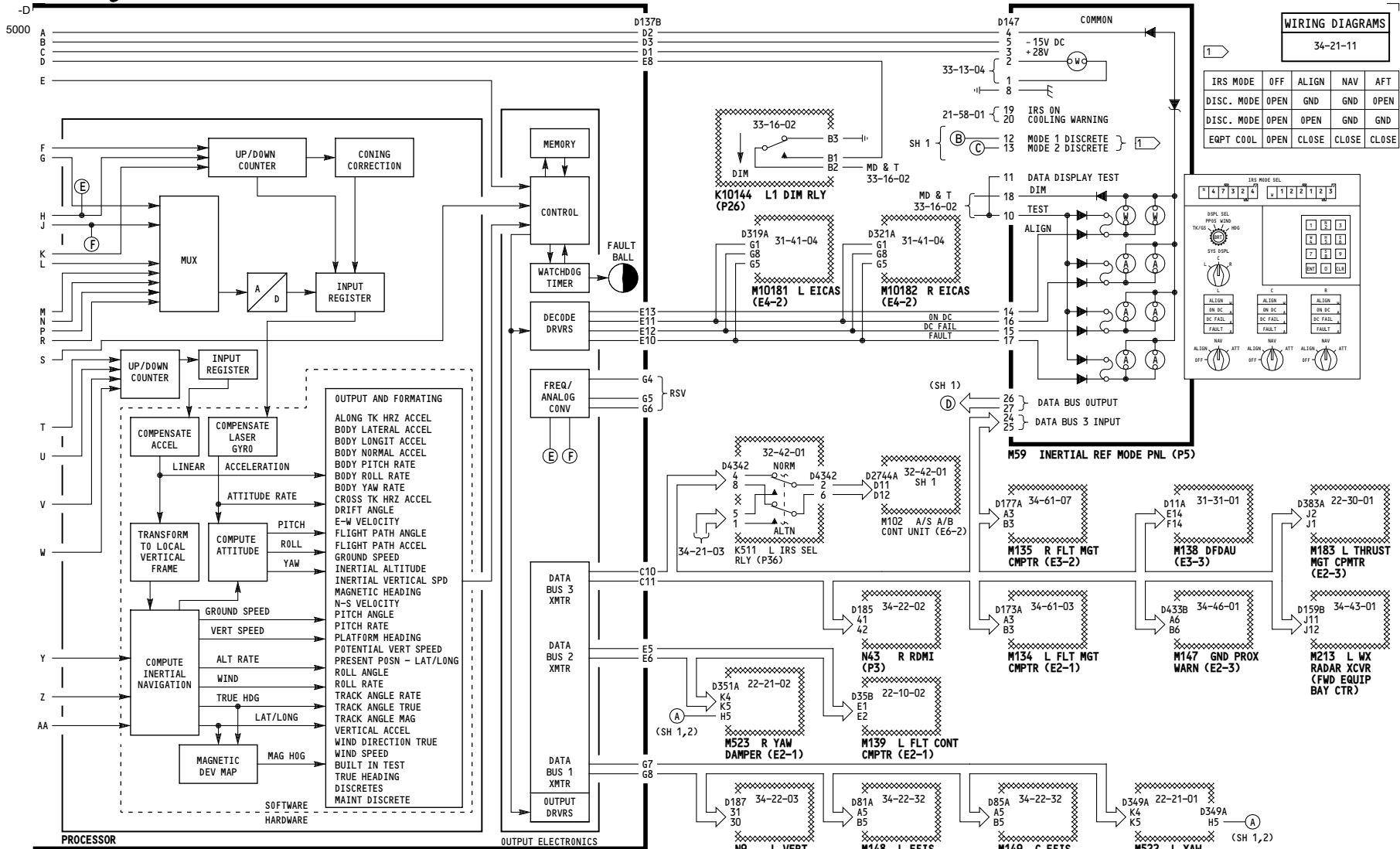

WIRING DIAGRAMS
34-21-11

IRS MODE	OFF	ALIGN	NAV	AFT
DISC. MODE	OPEN	GND	GND	OPEN
DISC. MODE	OPEN	OPEN	GND	GND
EQPT COOL	OPEN	CLOSE	CLOSE	CLOSE

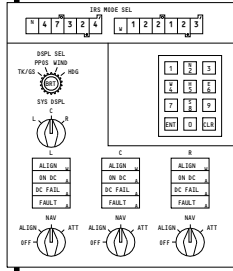

M159 LEFT INERTIAL REFERENCE UNIT (E2-4)

ALL

INERTIAL REFERENCE SYSTEM - LEFT

D280N032S

34-21-01

5067

WIRING DIAGRAMS
34-12-61
34-21-11

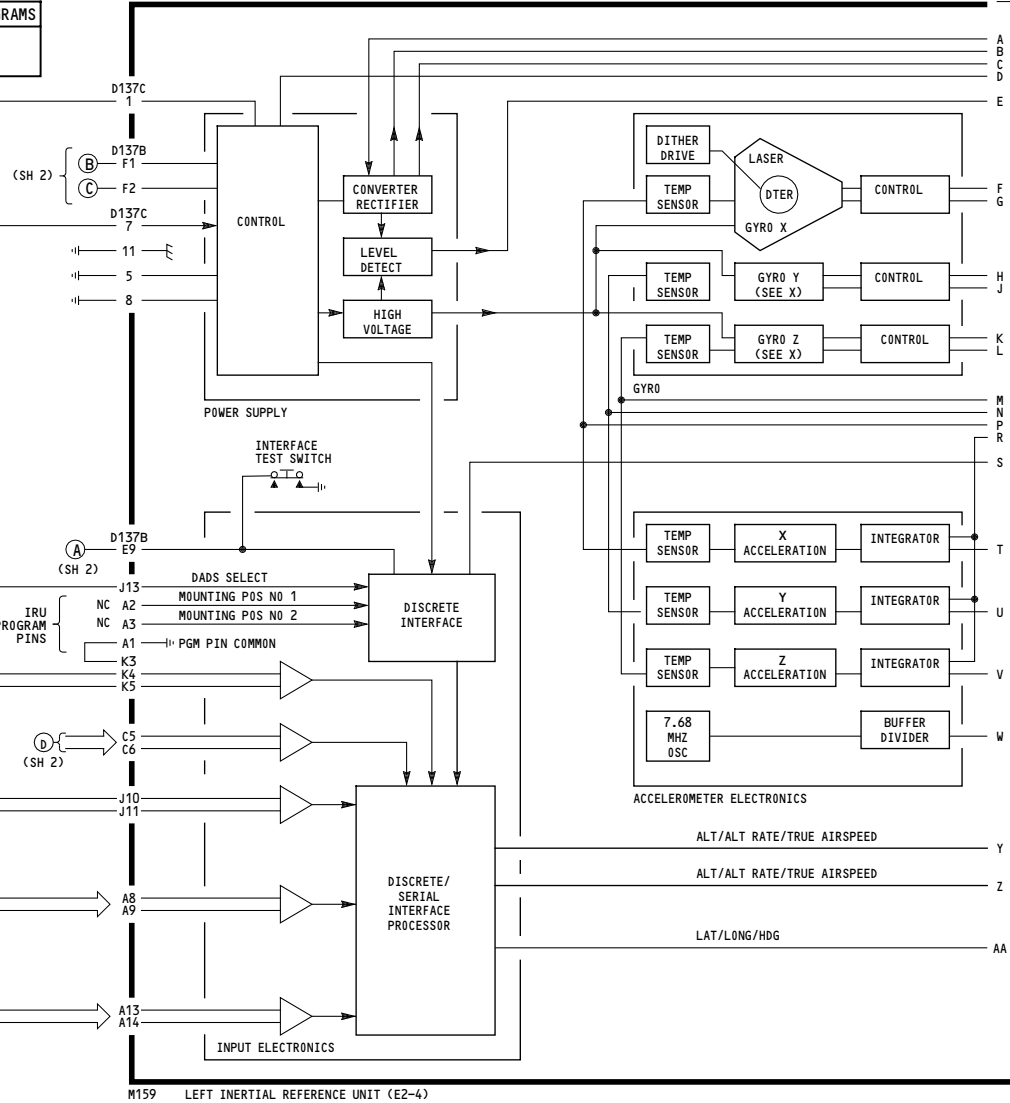
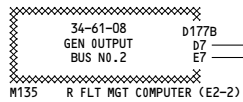
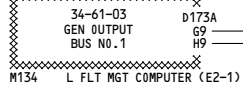
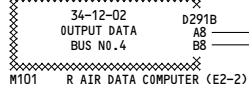
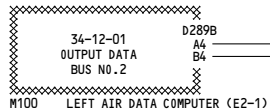
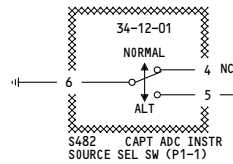
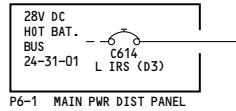
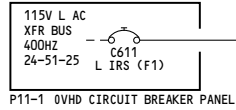

001-011	<p>INERTIAL REFERENCE SYSTEM - LEFT</p> <p>D280N032S</p>
---------	---

Incorporates
 34-0303
 34-0307 R01

34-21-01

Page 101.1
Sheet 1
Oct 09/2008

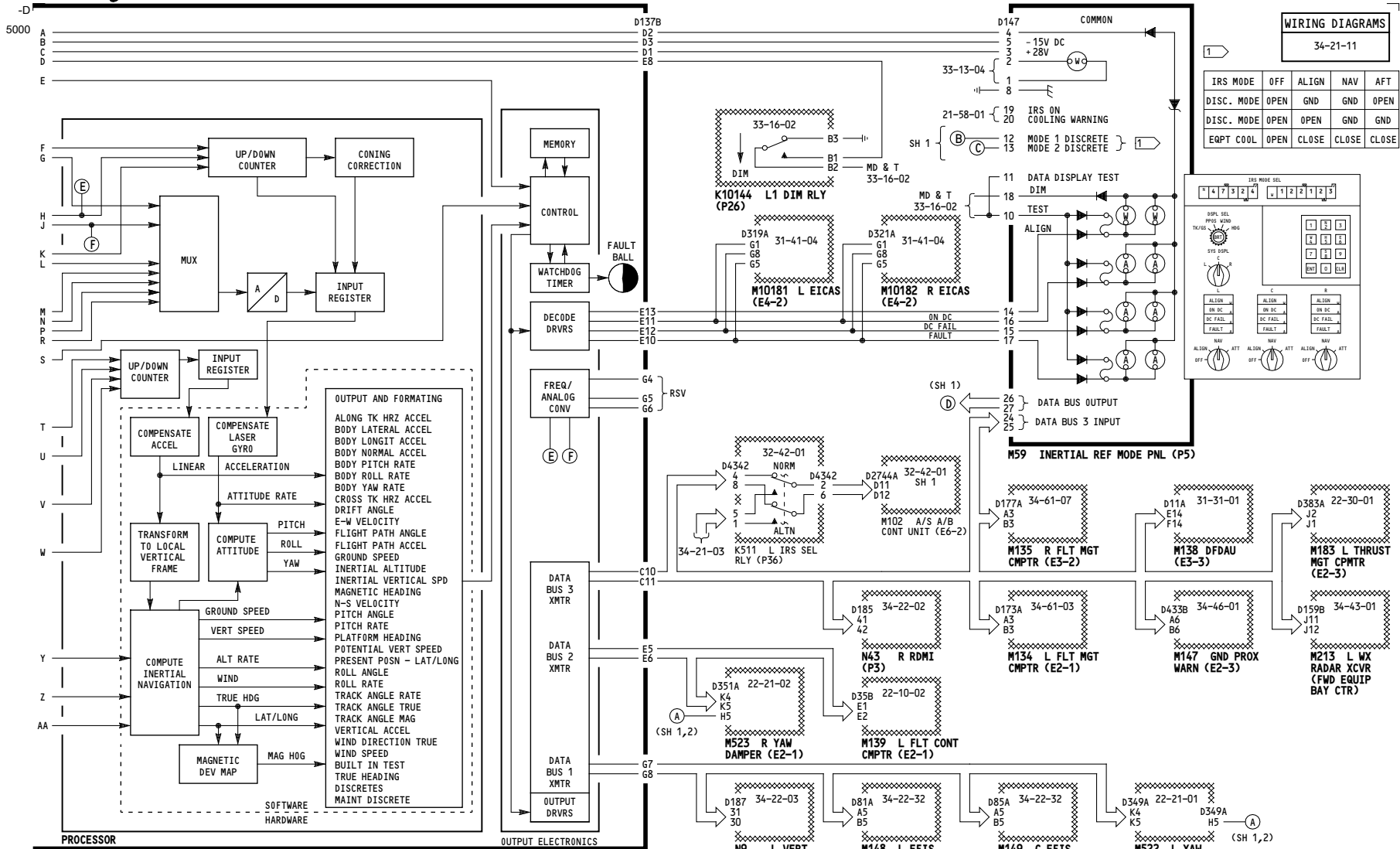

M159 LEFT INERTIAL REFERENCE UNIT (E2-4)

001-011

INERTIAL REFERENCE SYSTEM - LEFT

D280N032S

34-21-01

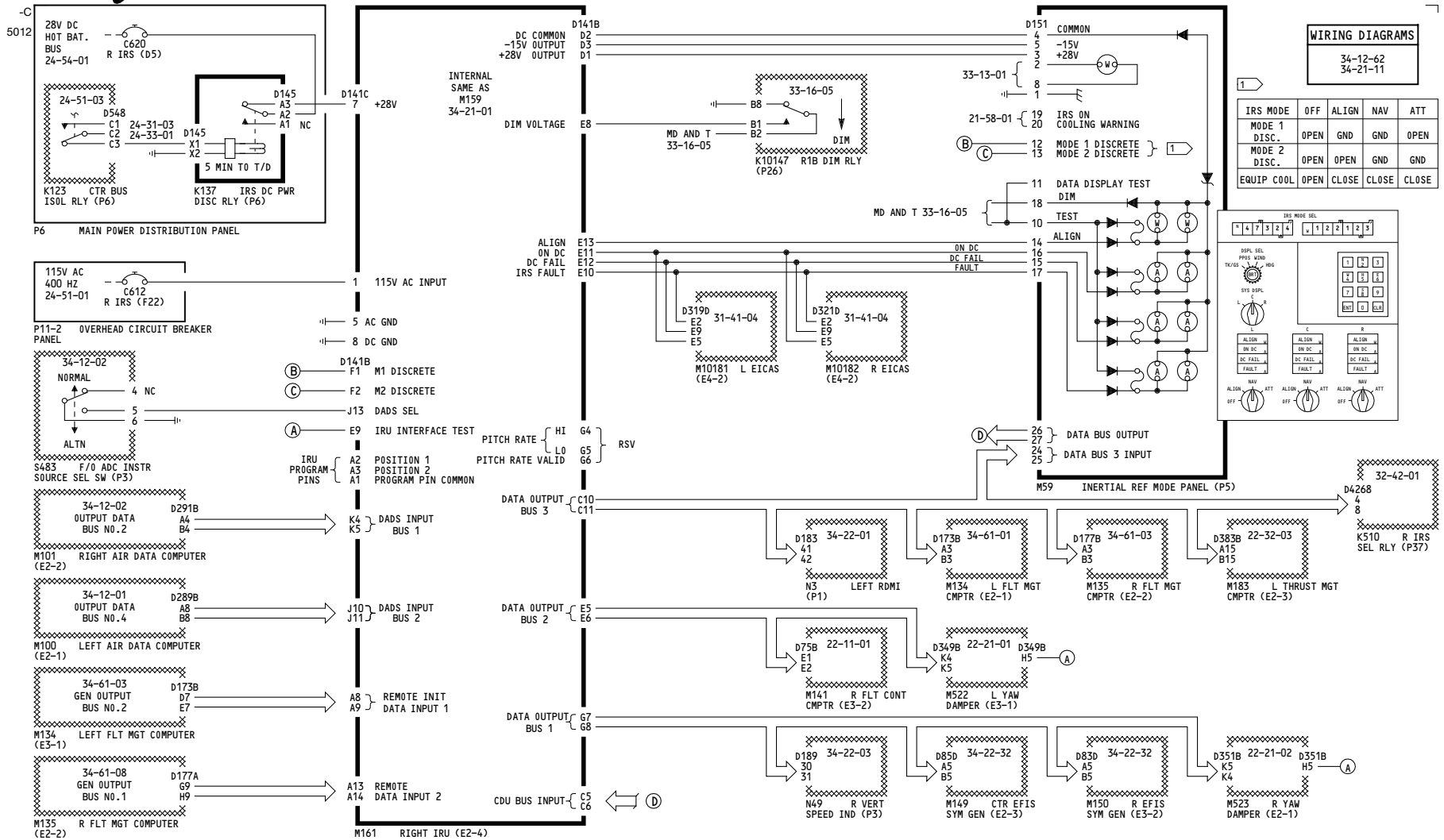

ALL	INERTIAL REFERENCE SYSTEM - RIGHT
	D280N032S

34-21-02

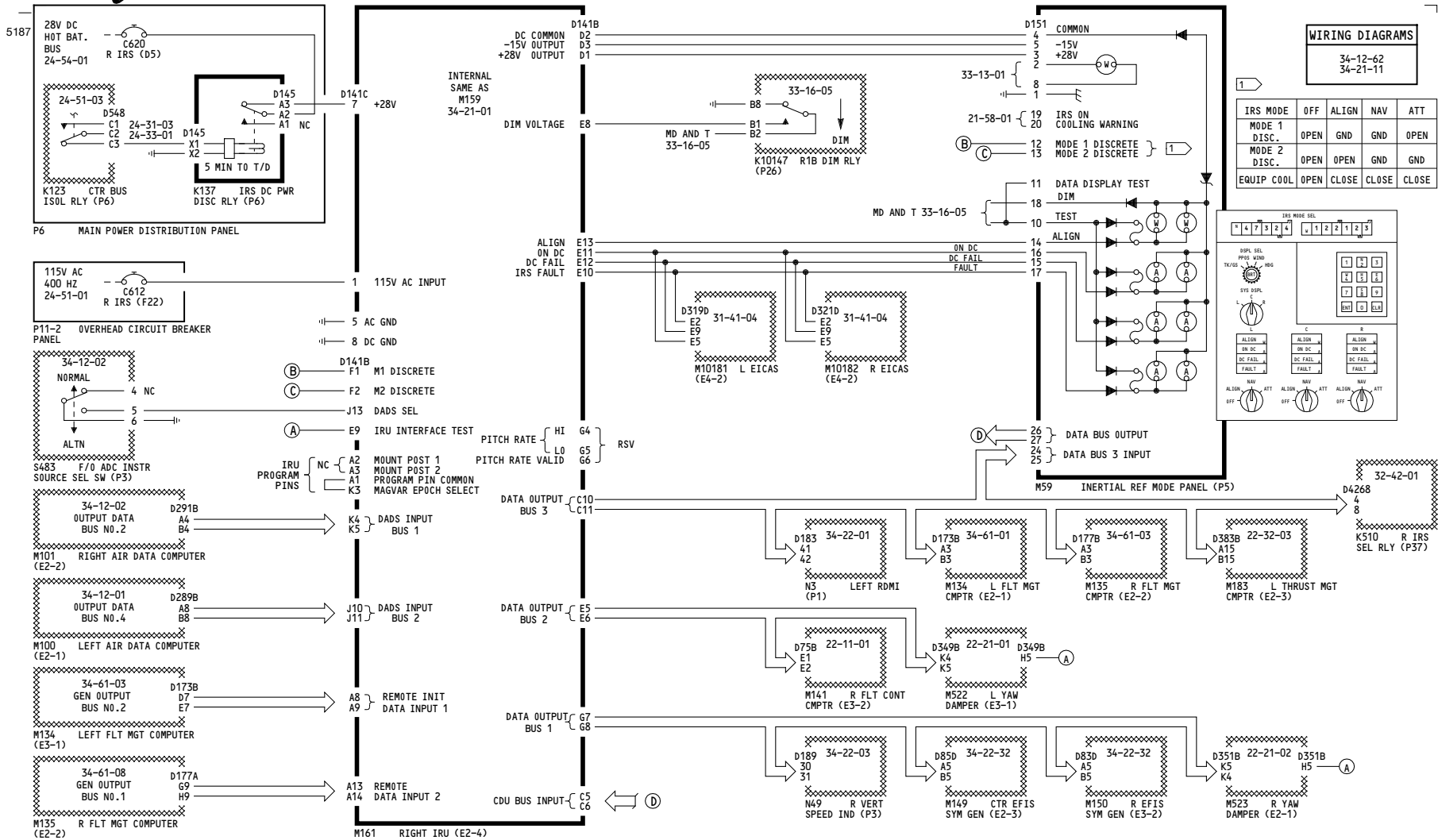

001, 003-011

INERTIAL REFERENCE SYSTEM - RIGHT

- Incorporates
- ▶▶ 34-0303
- ▶▶ 34-0307 R01

D280N032S

34-21-02

Page 101.1

Oct 09/2008

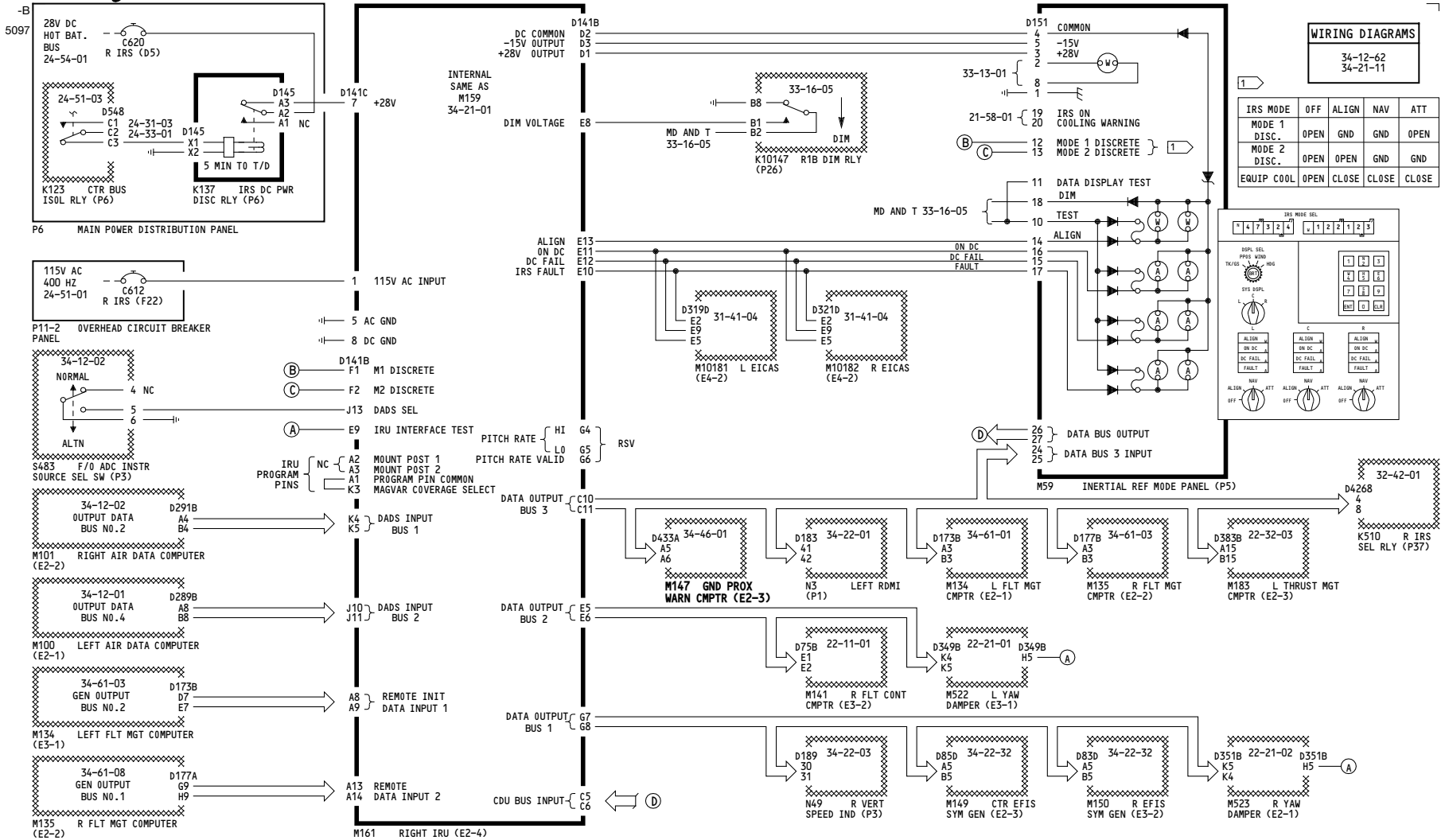

002

INERTIAL REFERENCE SYSTEM - RIGHT

- Incorporates
- ▶▶ 34-0200
 - ▶▶ 34-0303
 - ▶▶ 34-0307 R01

D280N032S

34-21-02

Page 101.2

Oct 09/2008

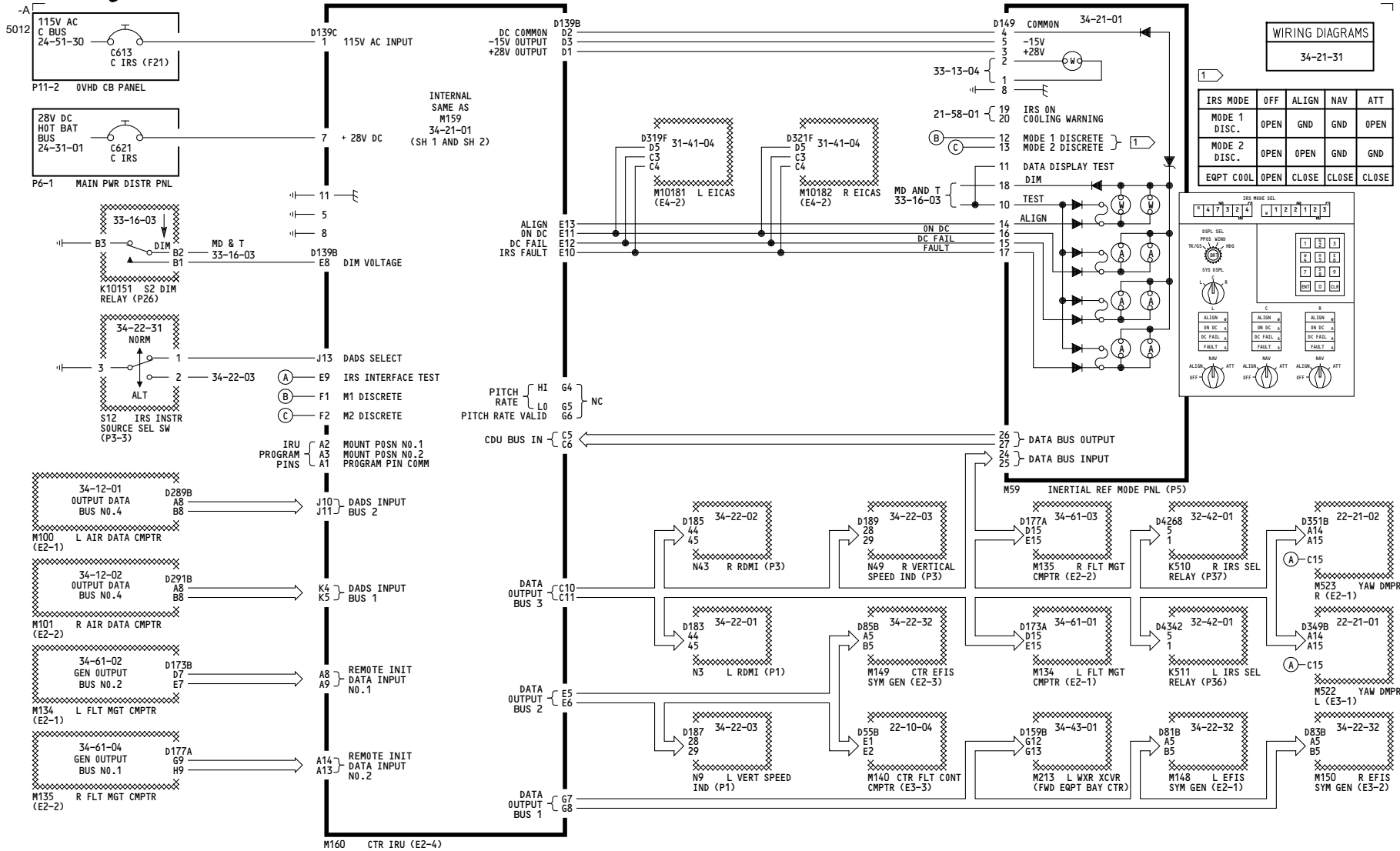

ALL	INERTIAL REFERENCE SYSTEM - CENTER
	D280N032S

34-21-03

Page 101

May 06/2009

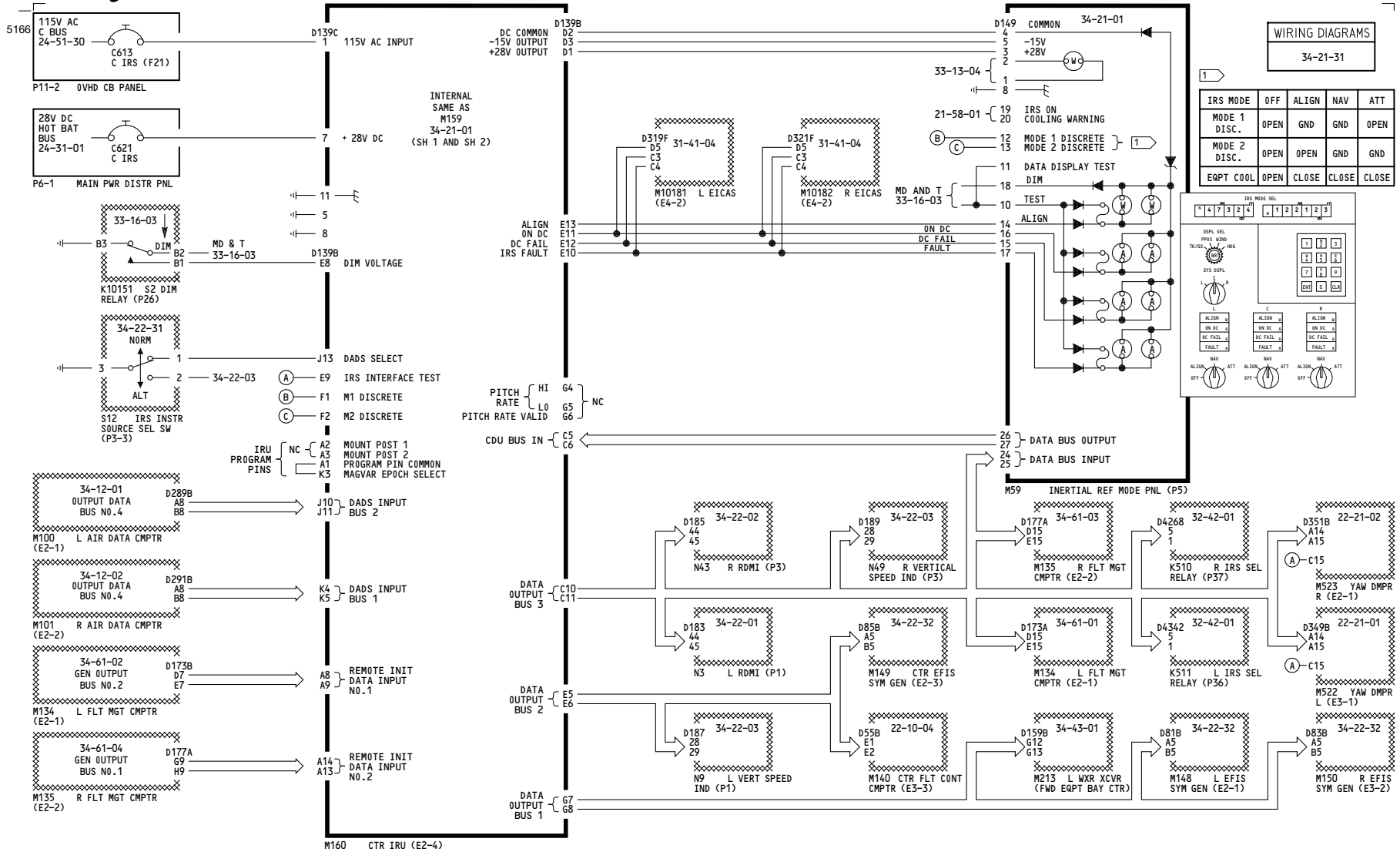

001-011

INERTIAL REFERENCE SYSTEM - CENTER

D280N032S

Incorporates
 34-0303
 34-0307 R01

34-21-03

Page 101.1

Oct 09/2008

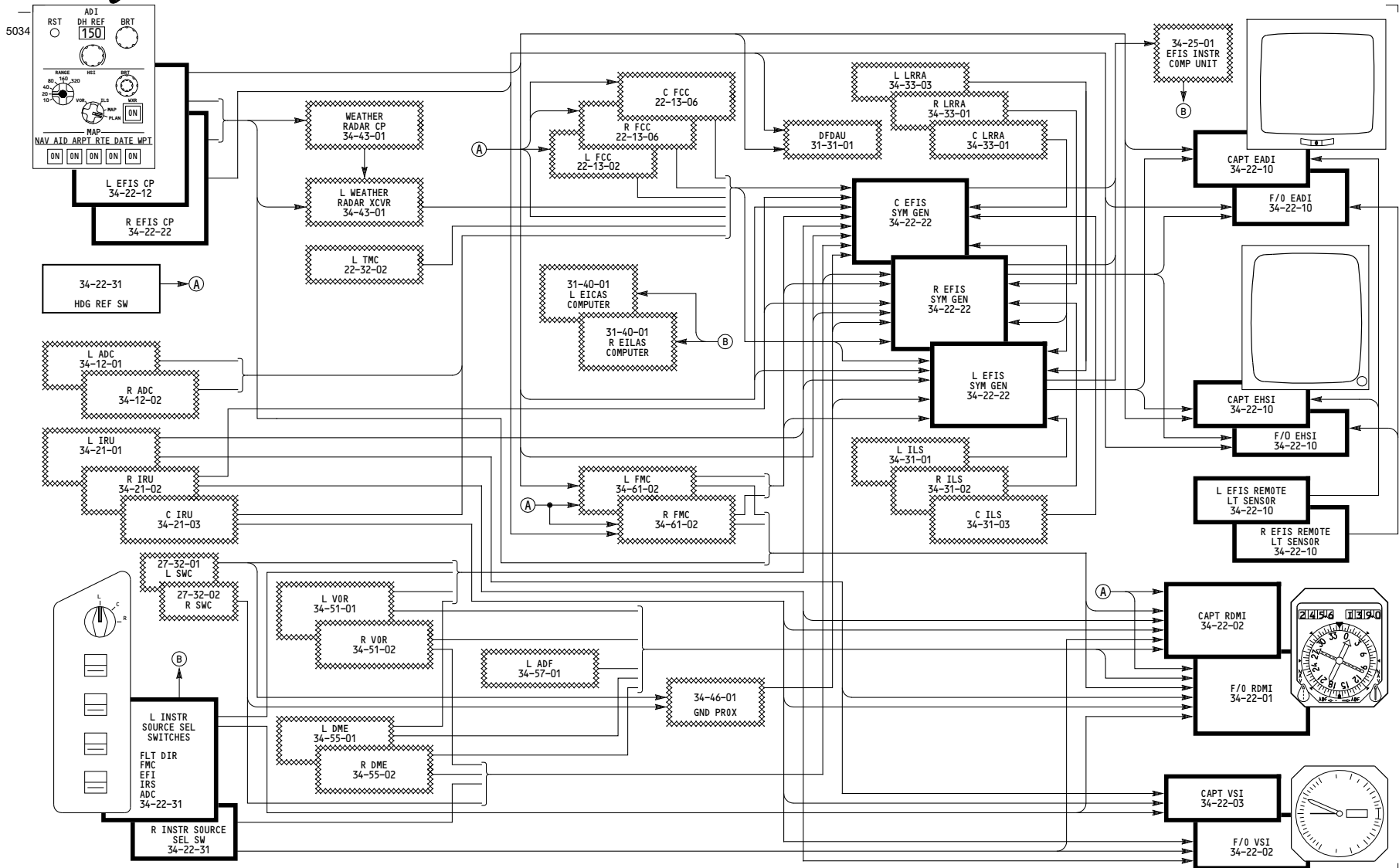

ALL

**FLIGHT INSTRUMENT SYSTEM
- SIMPLIFIED**

D280N032S

34-22-00

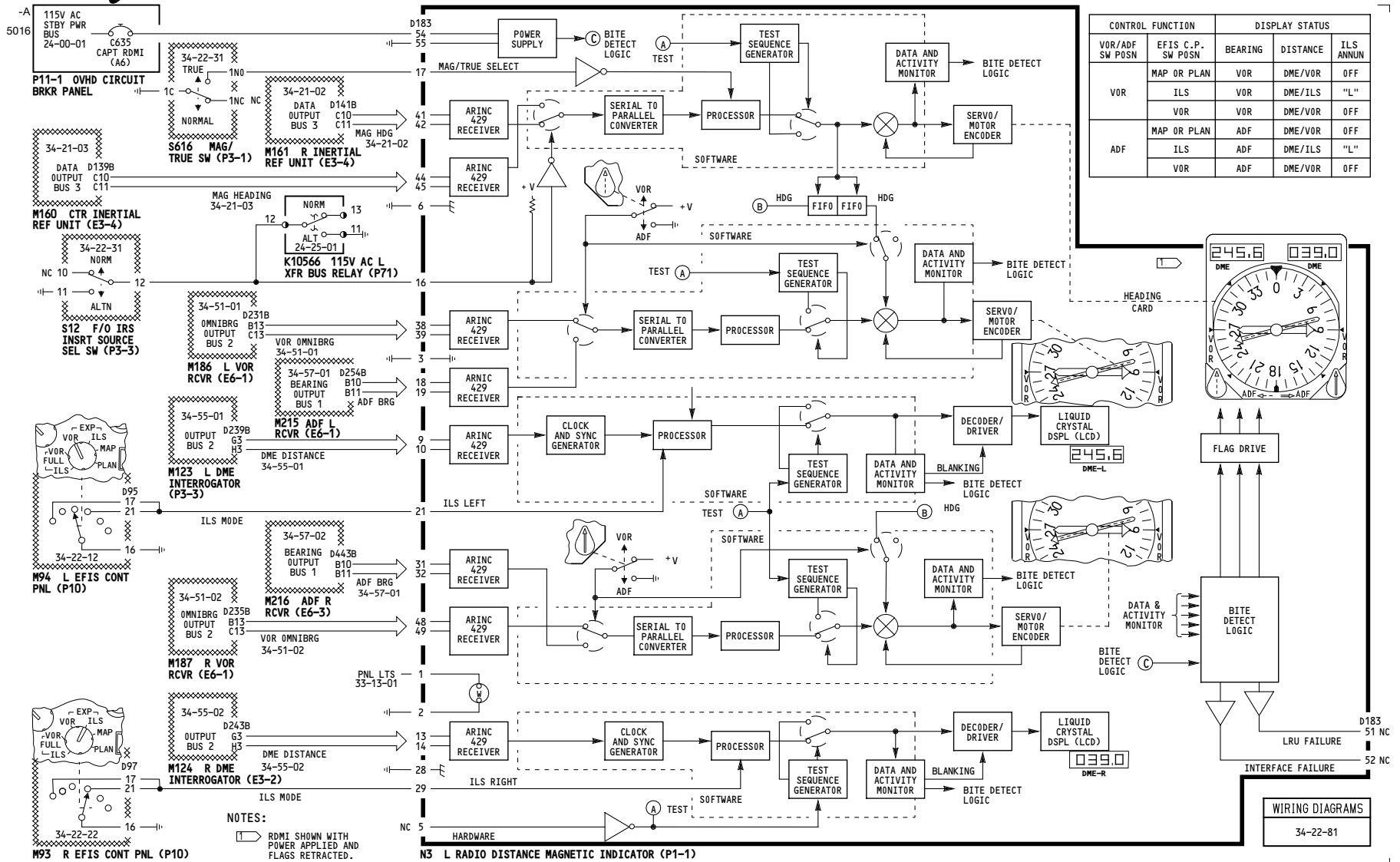

ALL

RDMI, BEARING, HEADING AND DISTANCE - LEFT

D280N032S

34-22-01

Page 101

May 06/2009

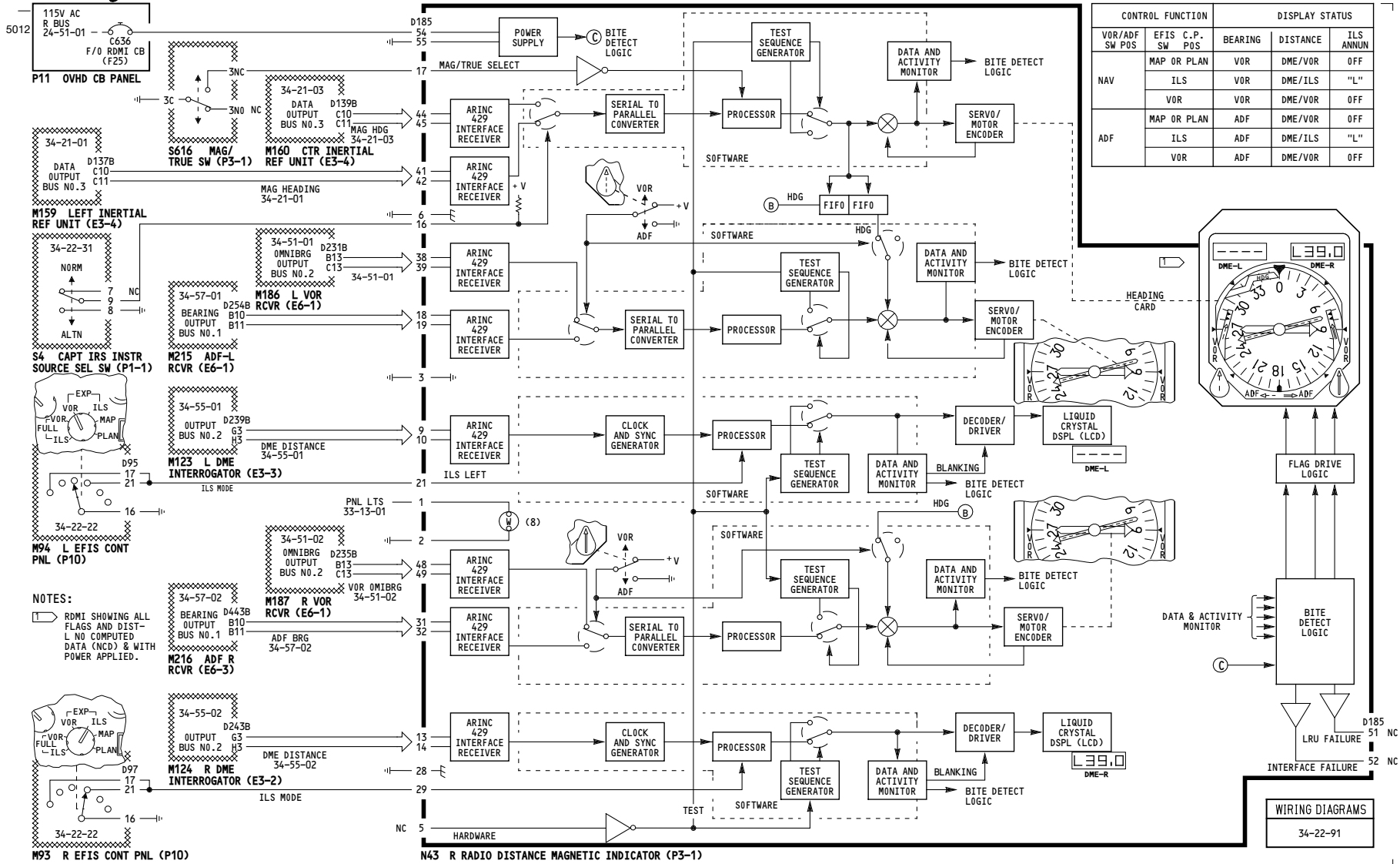

ALL

RDMI, BEARING, HEADING AND DISTANCE - RIGHT

D280N032S

34-22-02

Page 101

May 06/2009

-B
5000

WIRING DIAGRAMS
34-22-82
34-22-92

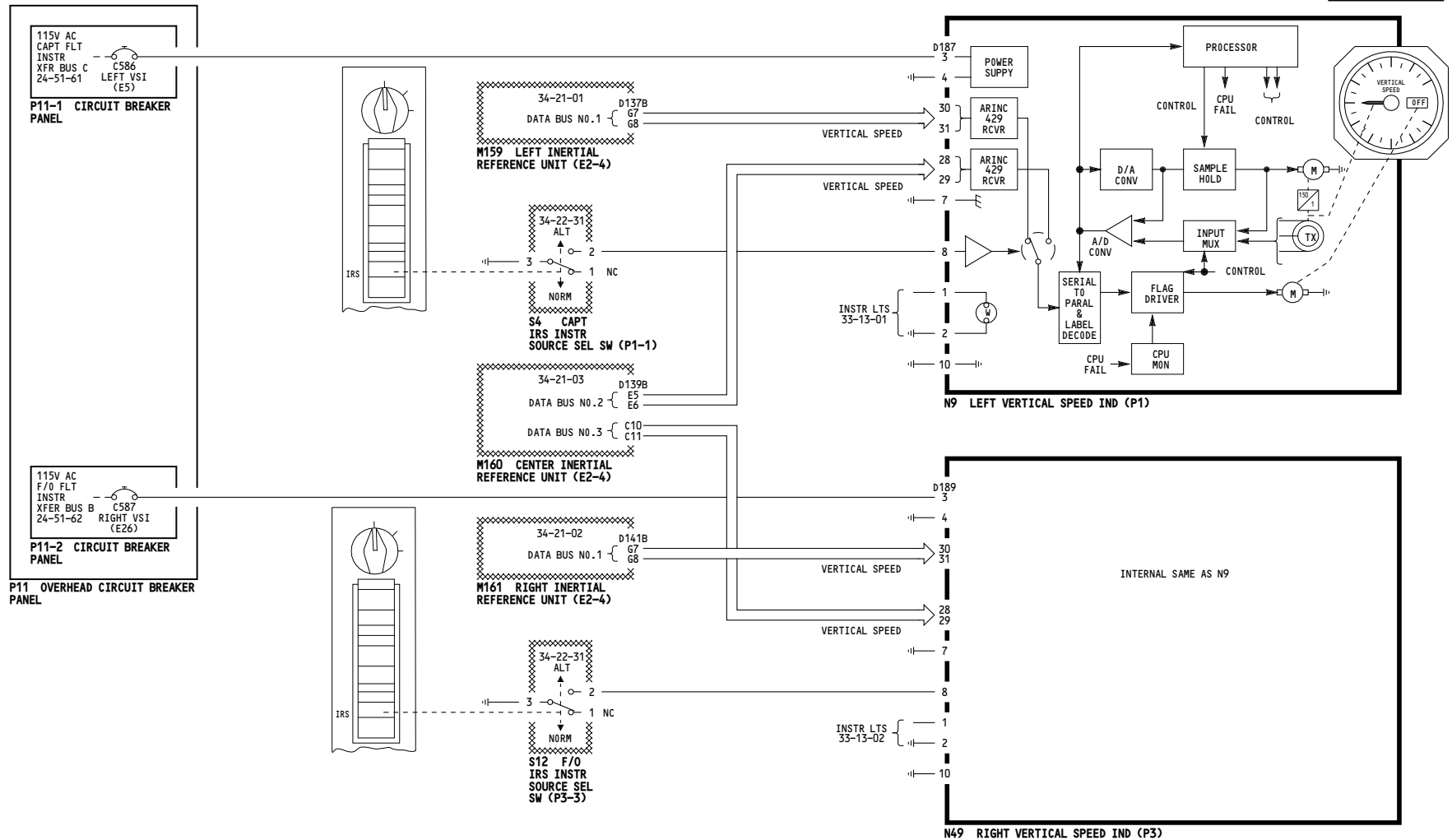

ALL

VSI VERTICAL SPEED - LEFT AND RIGHT

D280N032S

34-22-03

Page 101

May 06/2009

THIS PAGE INTENTIONALLY LEFT BLANK

5011

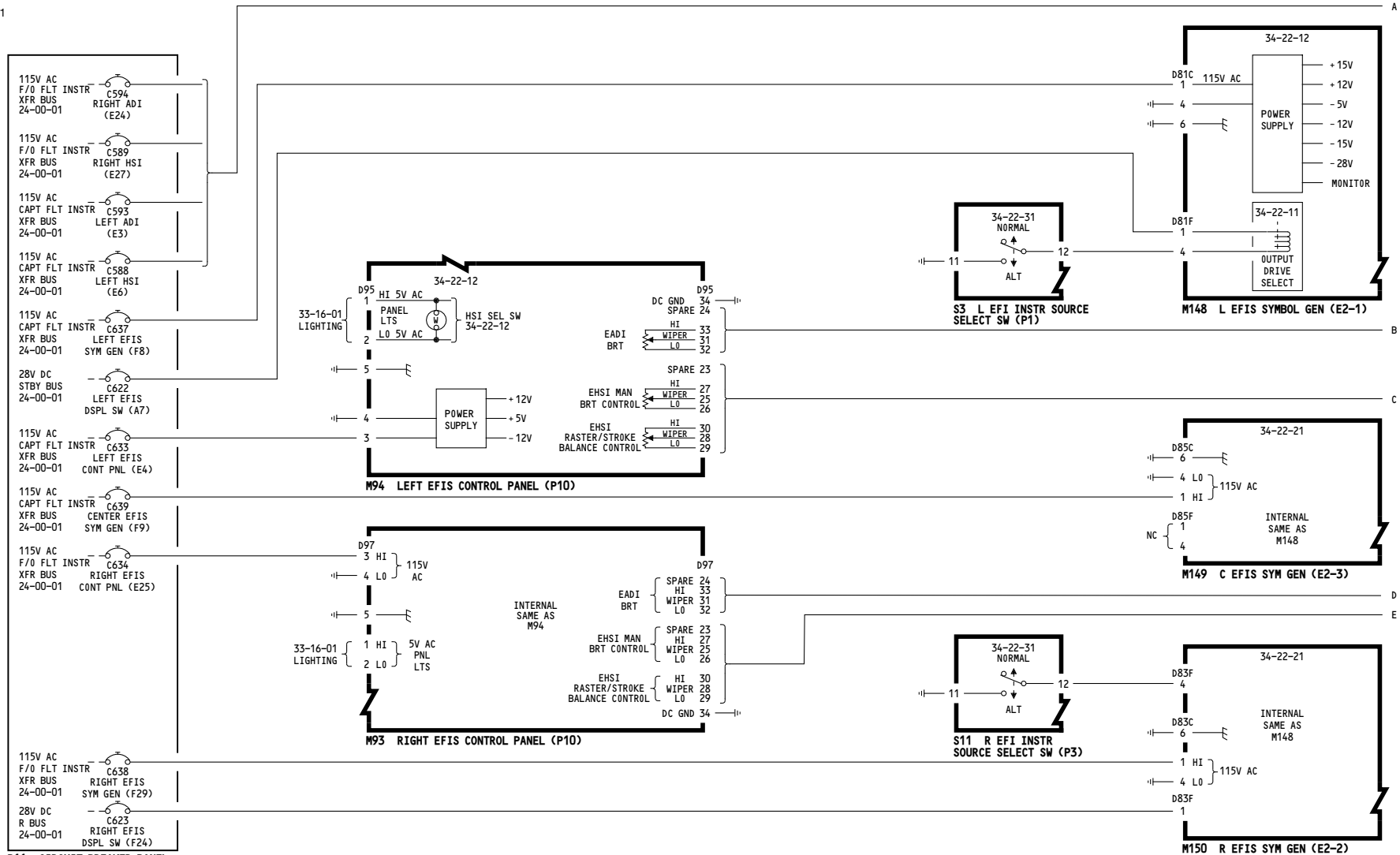

P11 CIRCUIT BREAKER PANEL

ALL	EFIS POWER DISTRIBUTION AND INSTRUMENT LIGHTING
	D280N032S

34-22-10

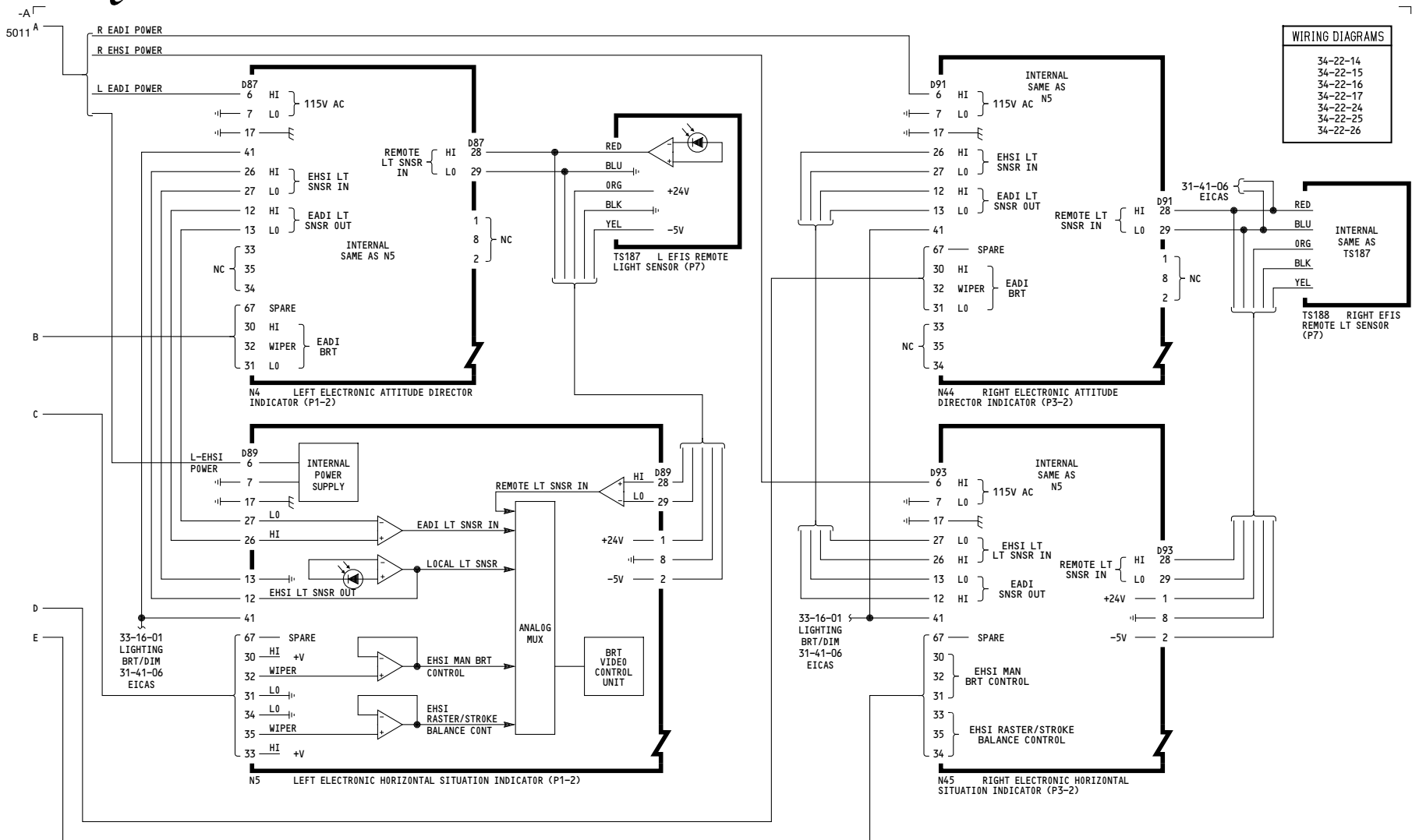

5056

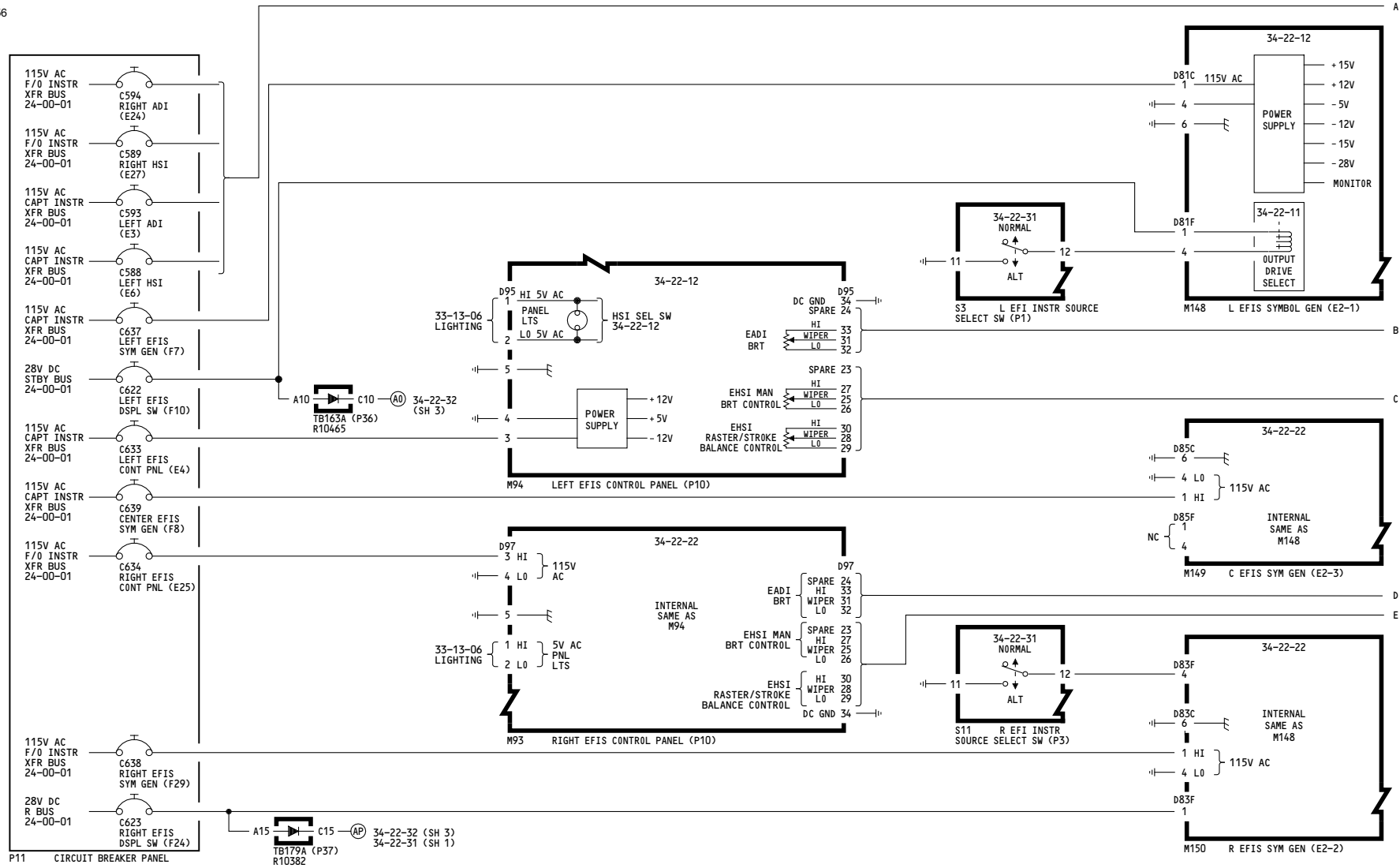

002

EFIS POWER DISTRIBUTION AND INSTRUMENT LIGHTING

D280N032S

Incorporates
34-0200

34-22-10

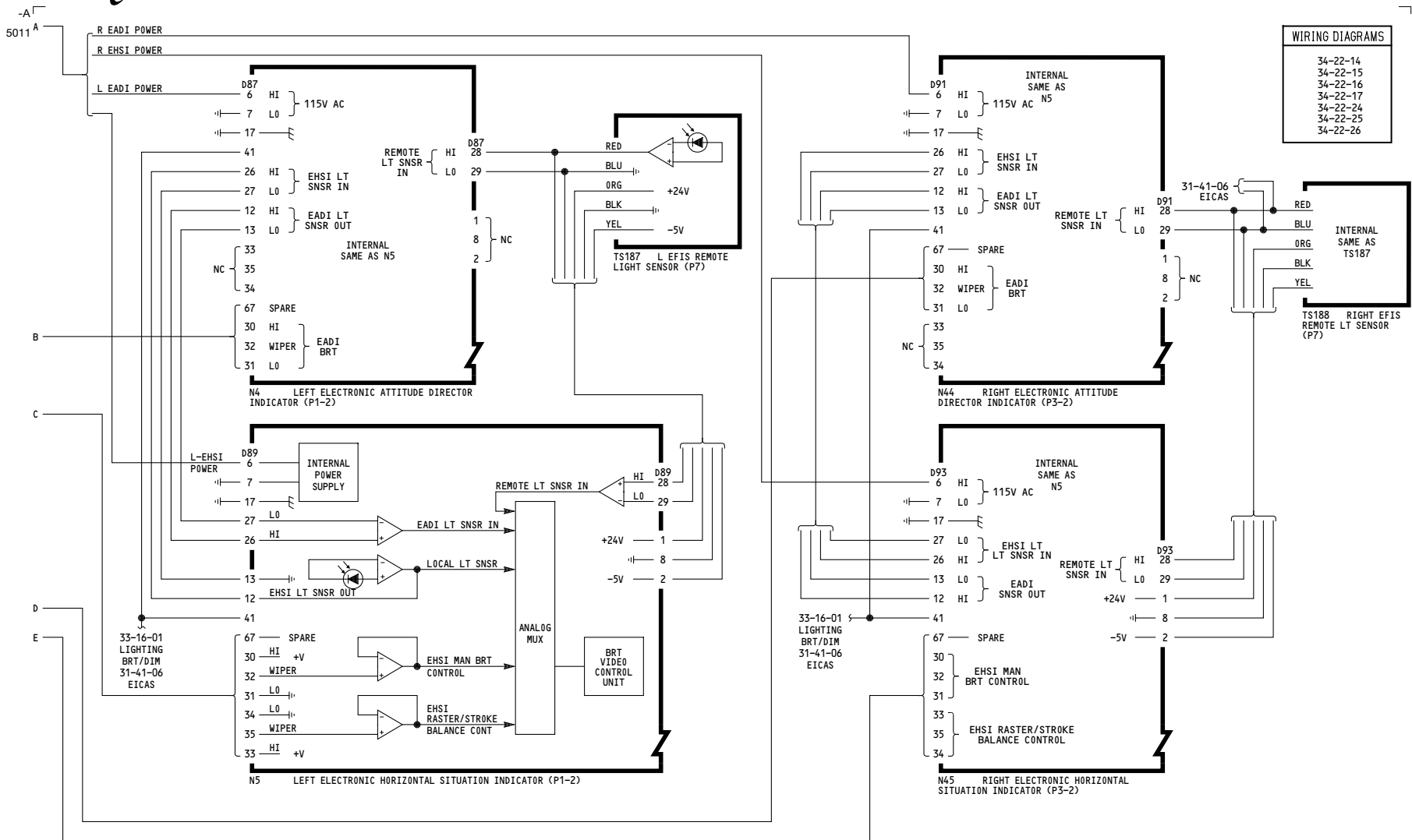

002

EFIS POWER DISTRIBUTION AND INSTRUMENT LIGHTING

D280N032S

34-22-10

Page 101.1
Sheet 2
Jan 21/2005

THIS PAGE INTENTIONALLY LEFT BLANK

5056

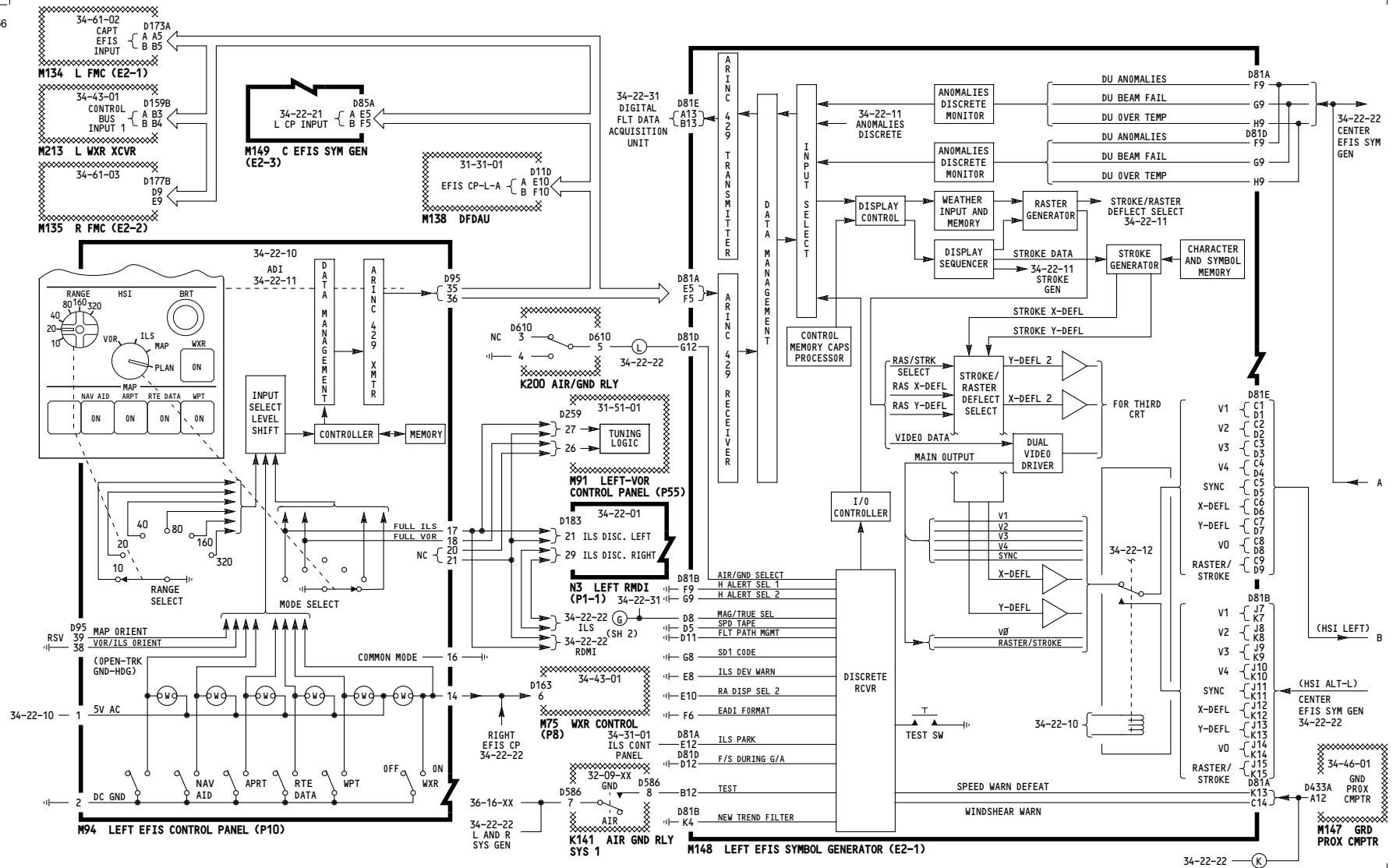

001-008

EFIS SYMBOL GENERATOR AND EHSI - LEFT

D280N032S

34-22-12

5002

34-22-10

WIRING DIAGRAMS

34-22-14
34-22-15
34-22-16
34-22-18

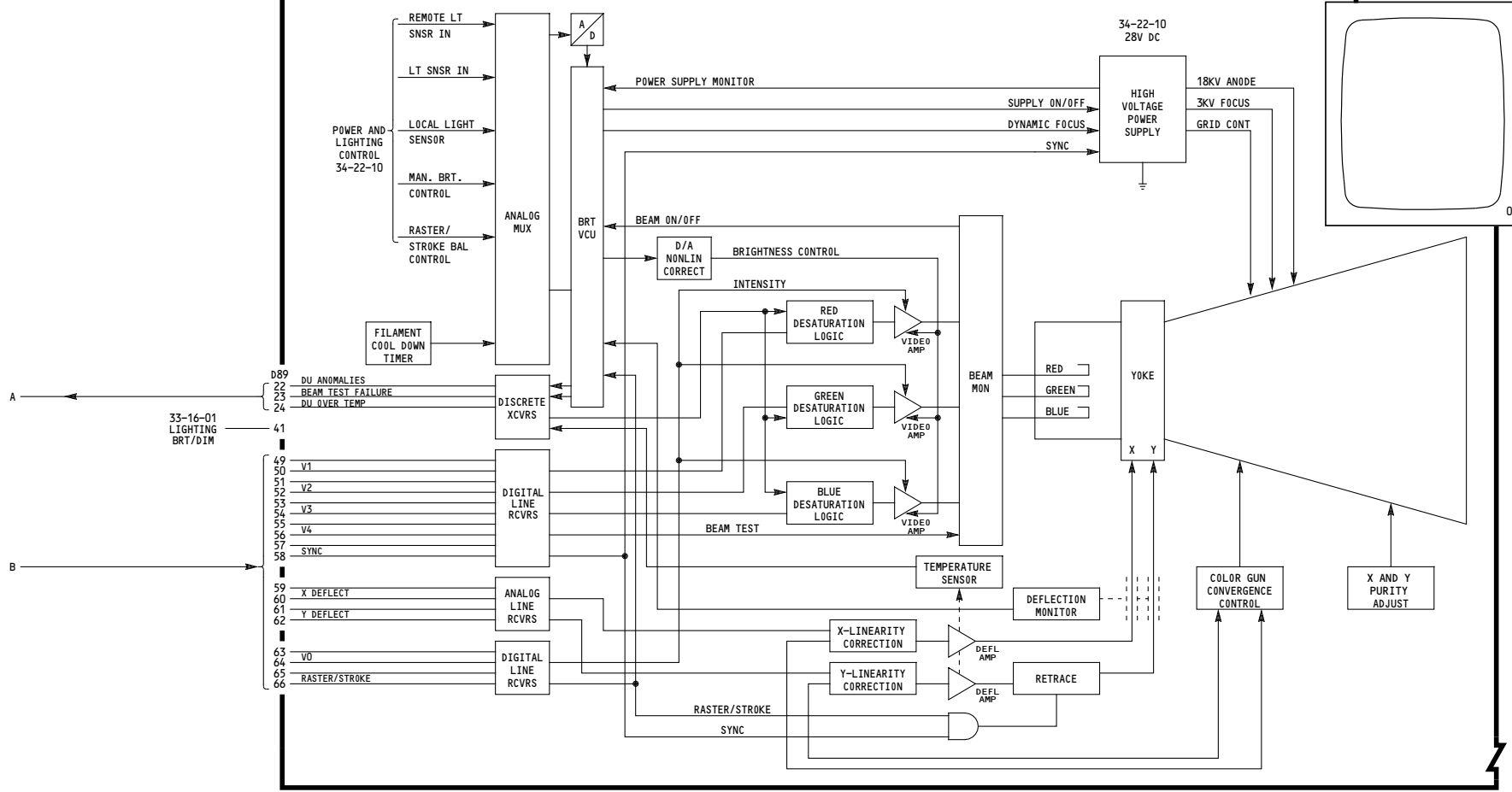

N5 LEFT ELECTRONIC HORIZONTAL SITUATION INDICATOR (P3-2)

001-008

**EFIS SYMBOL GENERATOR
AND EHSI - LEFT**

D280N032S

34-22-12

Page 101
Sheet 2
Jan 21/2005

5367

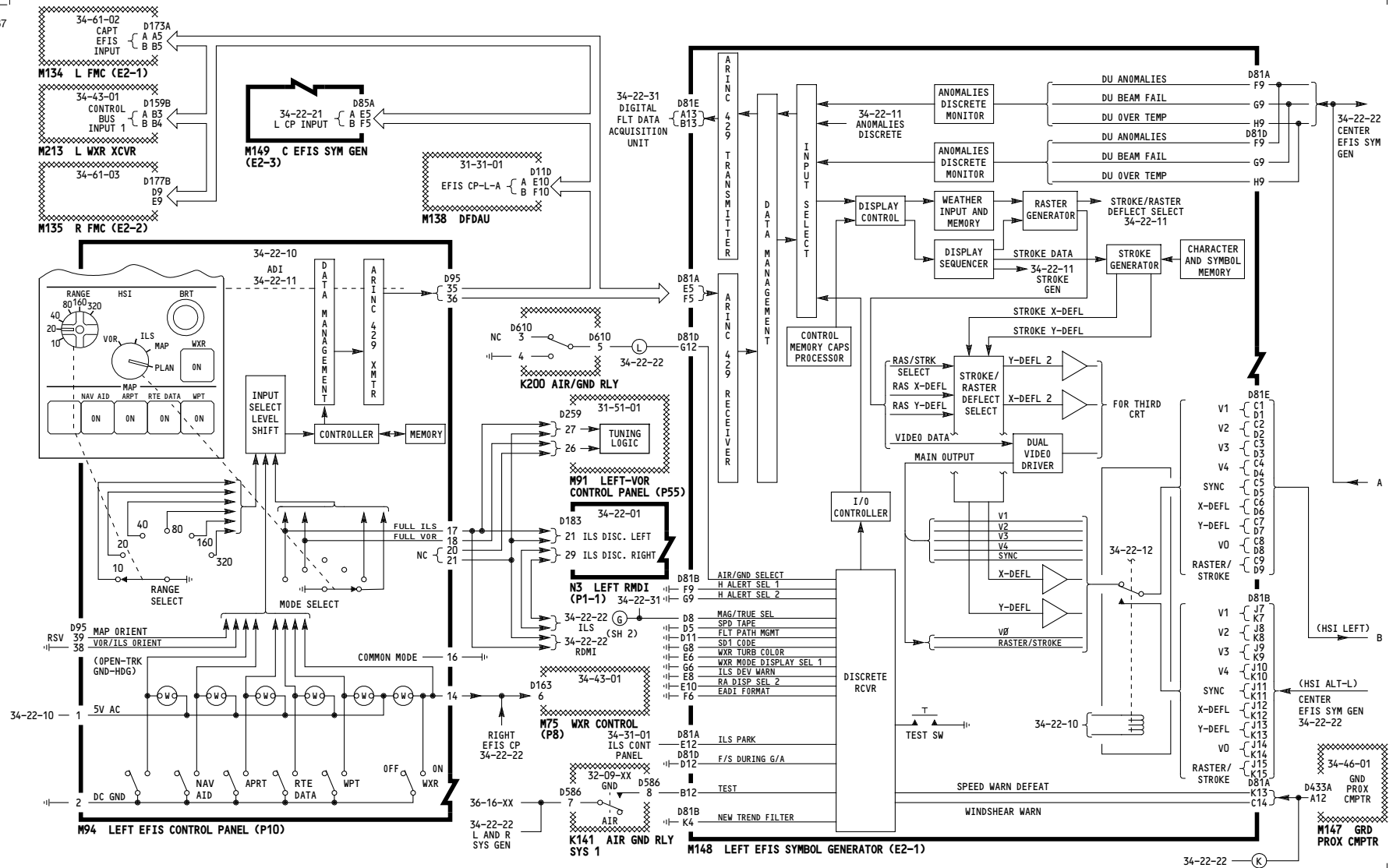

001

EFIS SYMBOL GENERATOR AND EHSI - LEFT

D280N032S

- Incorporates
- ▶ 31-0180 R01
 - ▶ 34-0394 R02

34-22-12

5002

34-22-10

WIRING DIAGRAMS

34-22-14
34-22-15
34-22-16
34-22-18

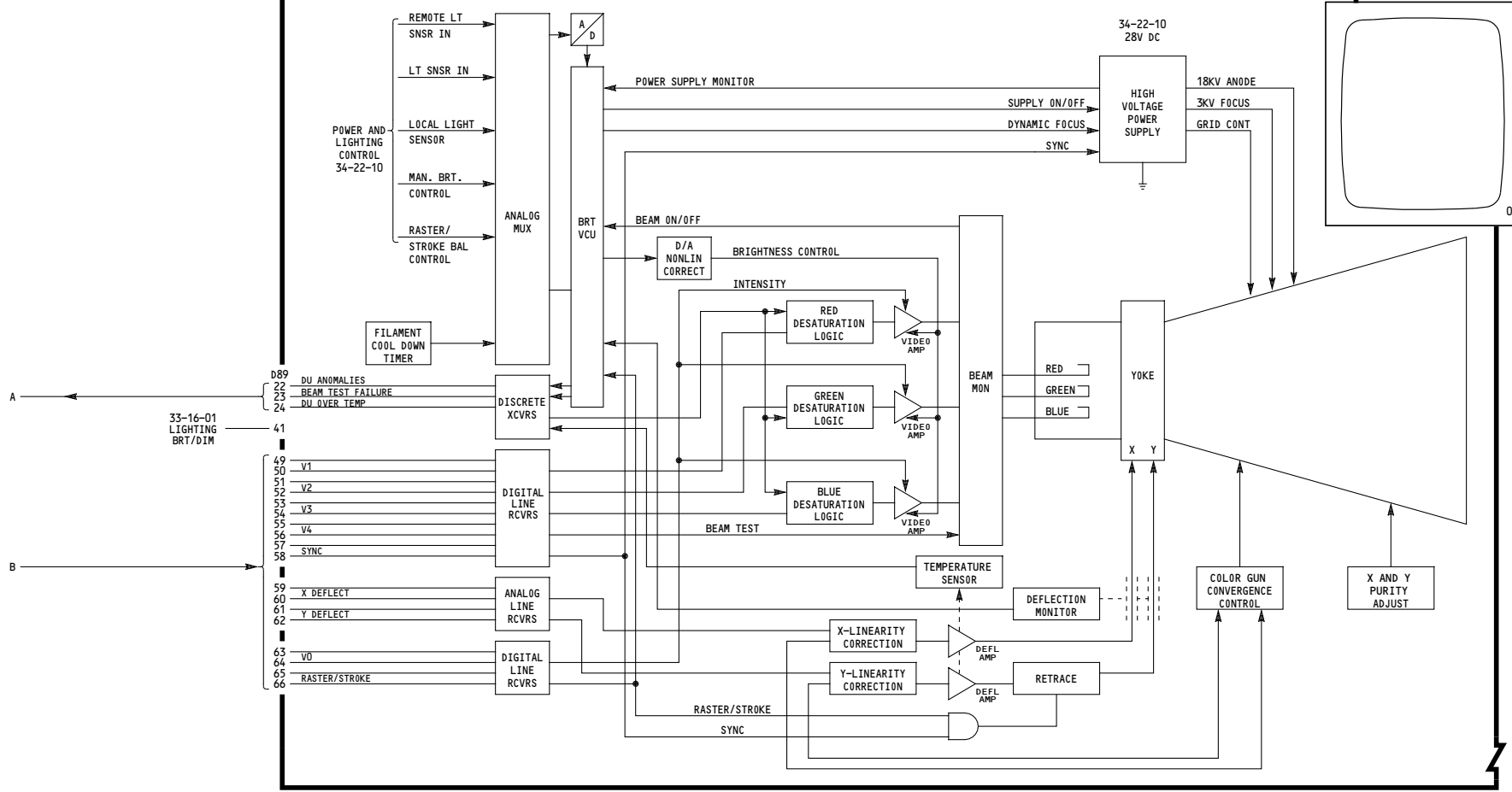

N5 LEFT ELECTRONIC HORIZONTAL SITUATION INDICATOR (P3-2)

001

**EFIS SYMBOL GENERATOR
AND EHSI - LEFT**

D280N032S

34-22-12

Page 101.1
Sheet 2
May 06/2009

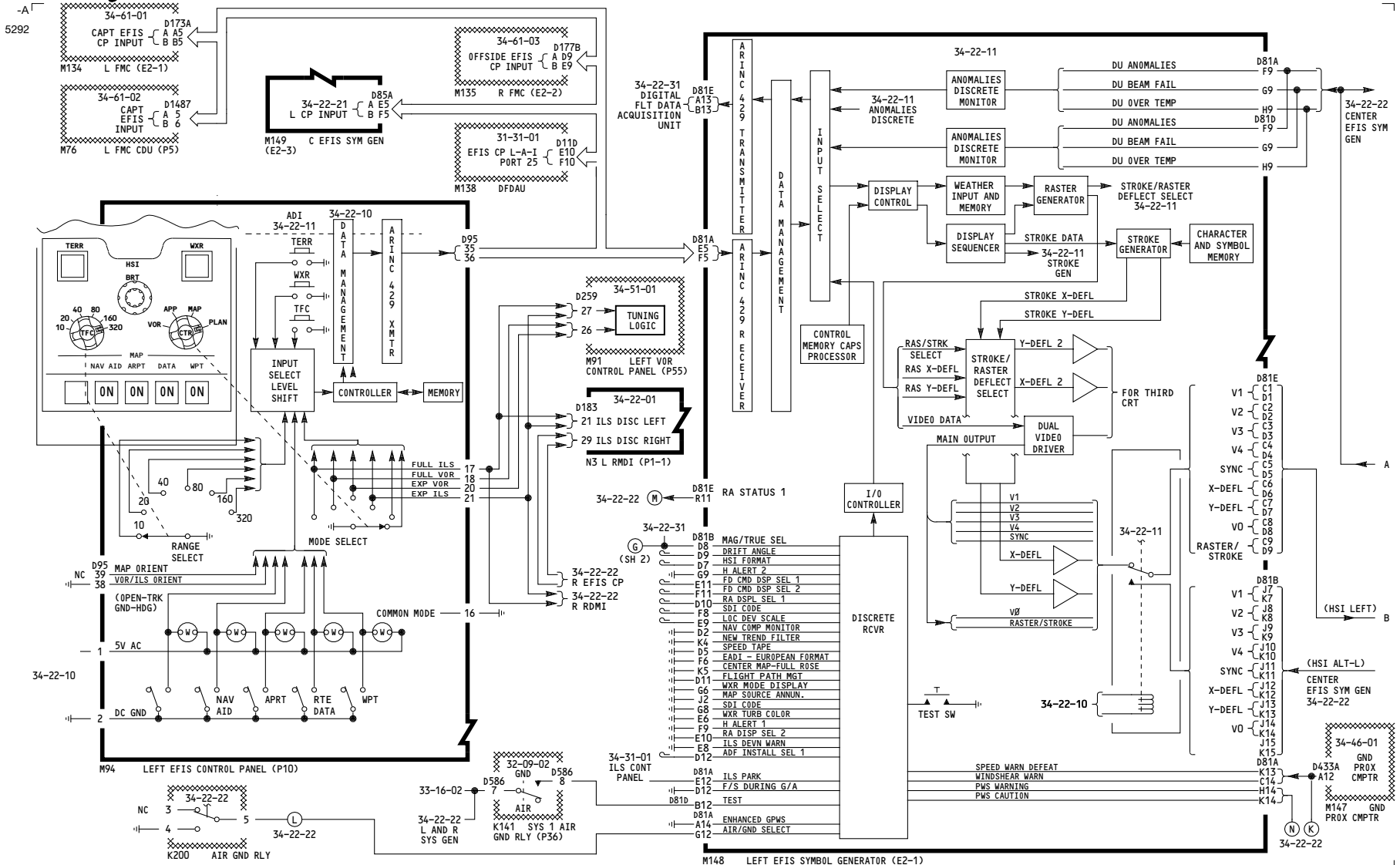

002

EFIS SYMBOL GENERATOR AND EHSI - LEFT

D280N032S

Incorporates 34-0200

34-22-12

Page 101.2
Sheet 1
May 06/2009

5002

34-22-10

WIRING DIAGRAMS	
34-22-14	
34-22-15	
34-22-16	
34-22-18	

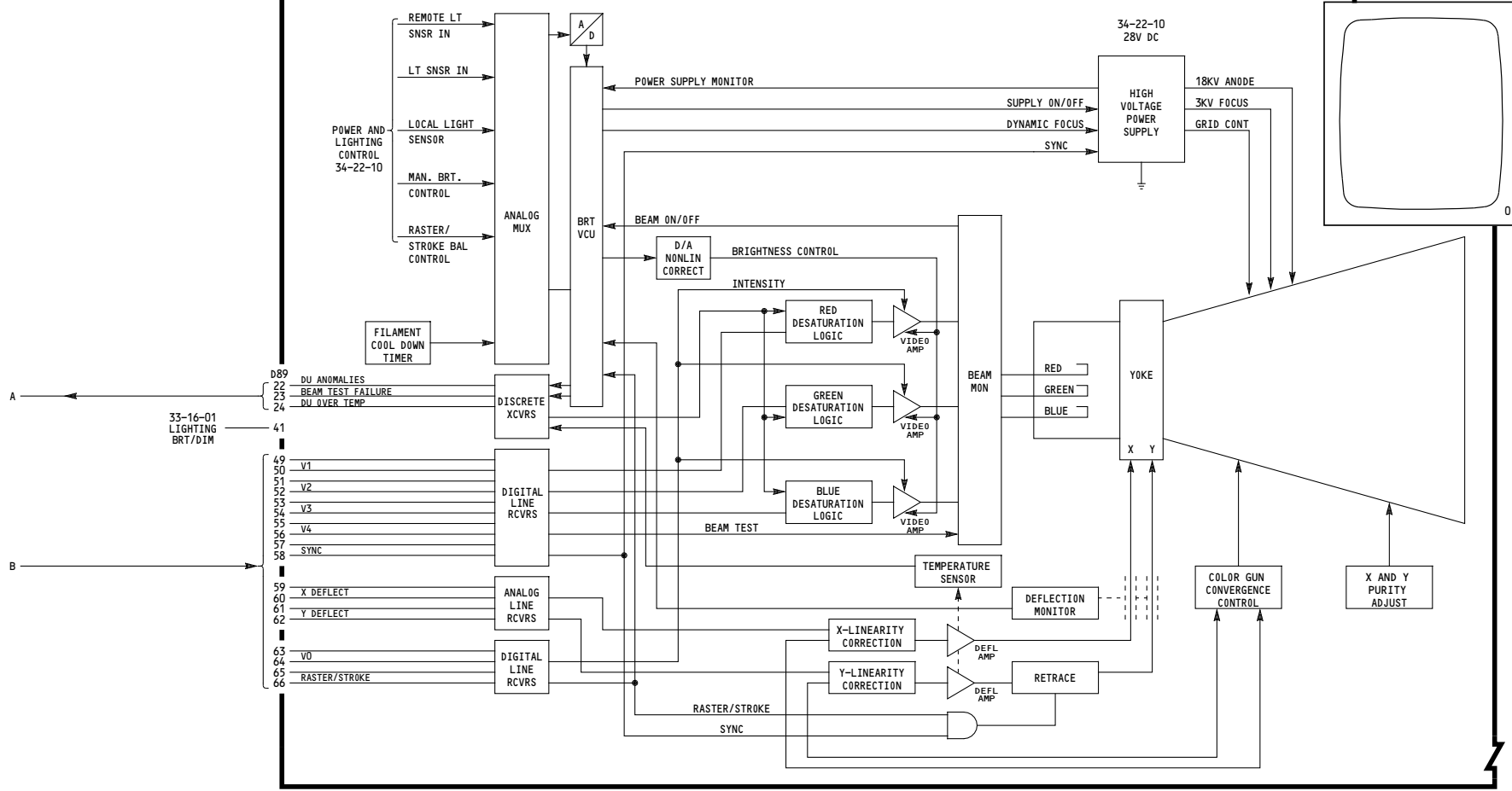

N5 LEFT ELECTRONIC HORIZONTAL SITUATION INDICATOR (P3-2)

002

**EFIS SYMBOL GENERATOR
AND EHSI - LEFT**

D280N032S

34-22-12

Page 101.2
Sheet 2
May 06/2009

5096

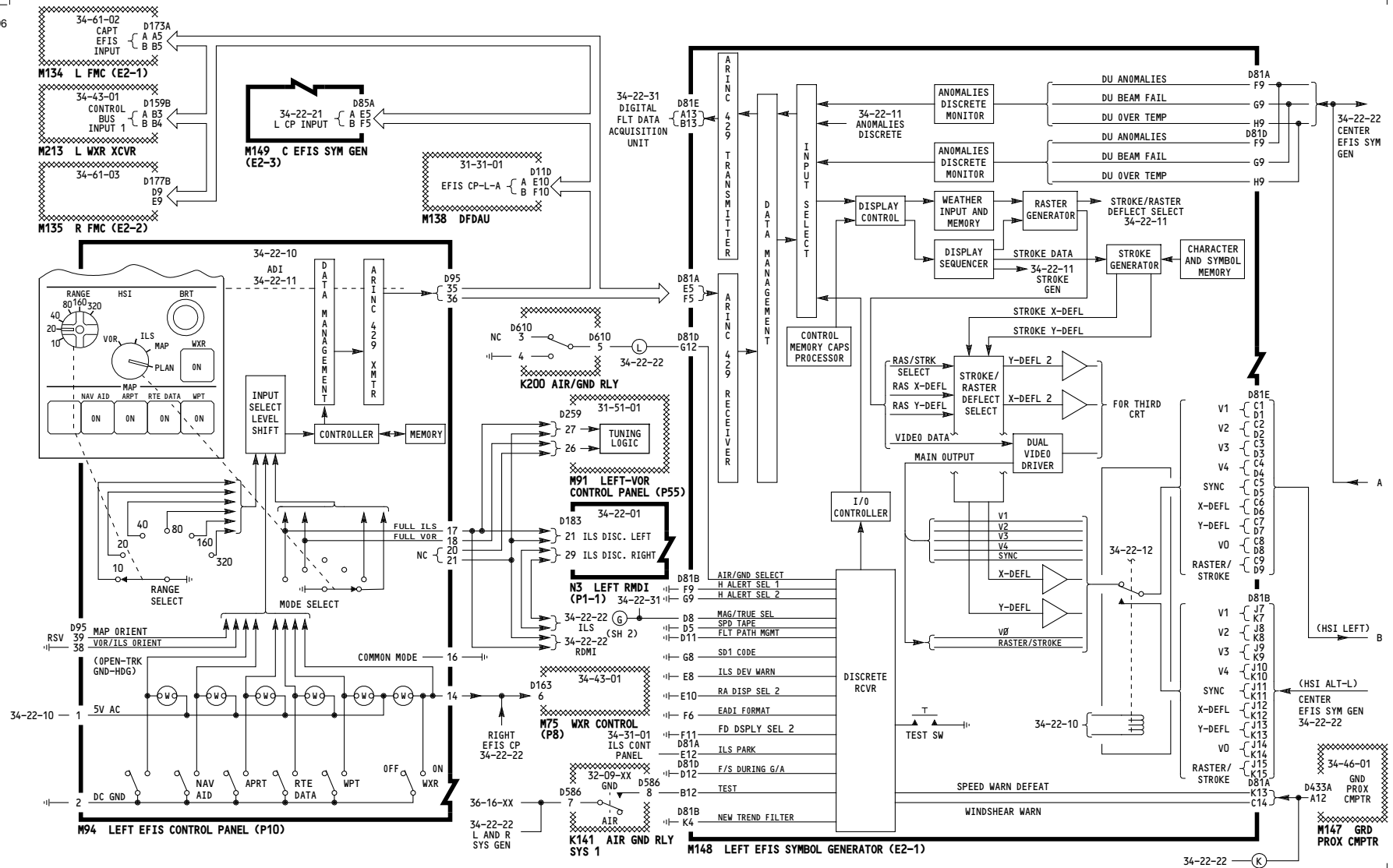

009

EFIS SYMBOL GENERATOR AND EHSI - LEFT

D280N032S

34-22-12

5002

34-22-10

WIRING DIAGRAMS	
34-22-14	
34-22-15	
34-22-16	
34-22-18	

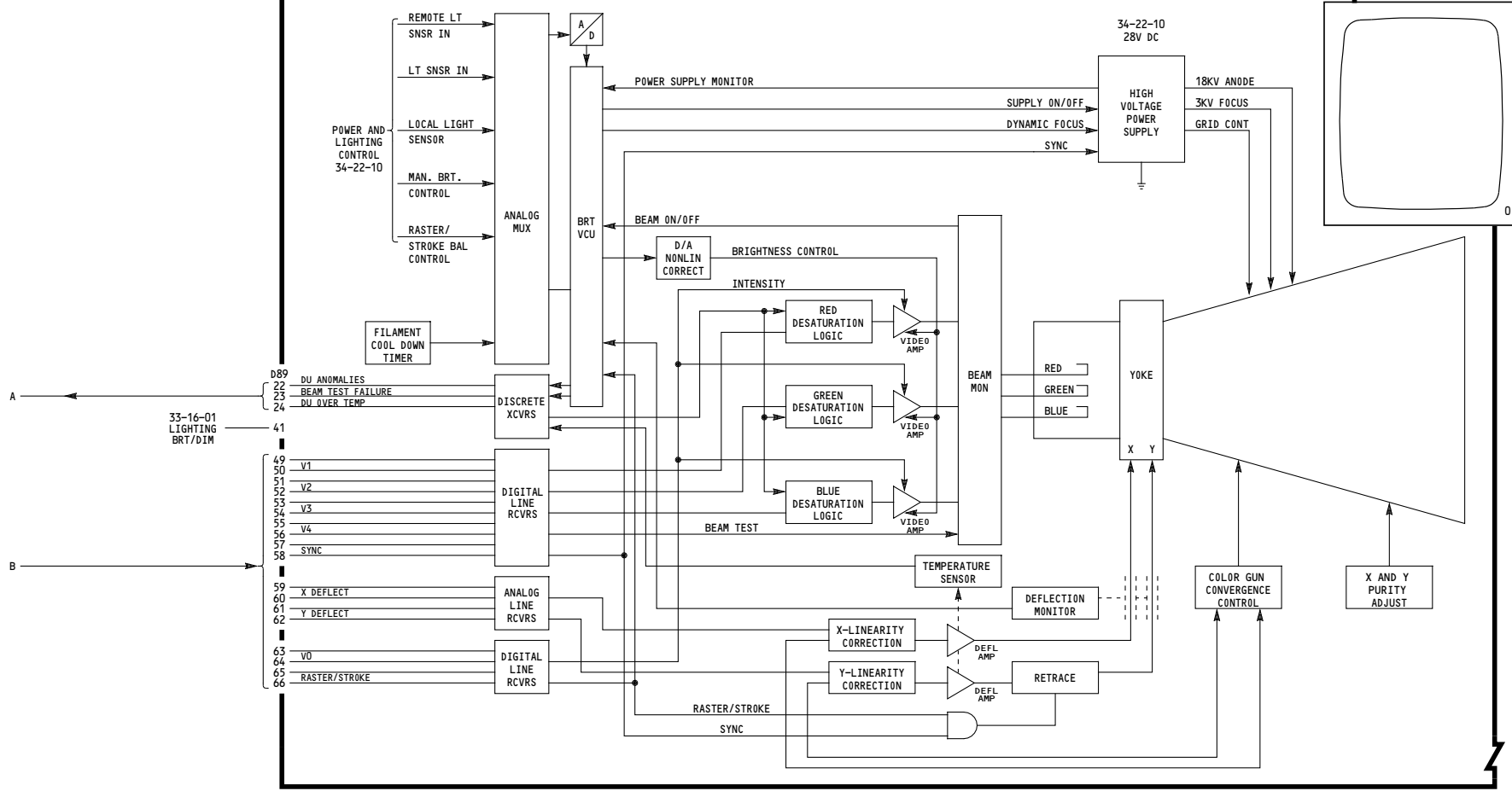

N5 LEFT ELECTRONIC HORIZONTAL SITUATION INDICATOR (P3-2)

009	<p>EFIS SYMBOL GENERATOR AND EHSI - LEFT</p> <p>D280N032S</p>
-----	--

34-22-12

5100

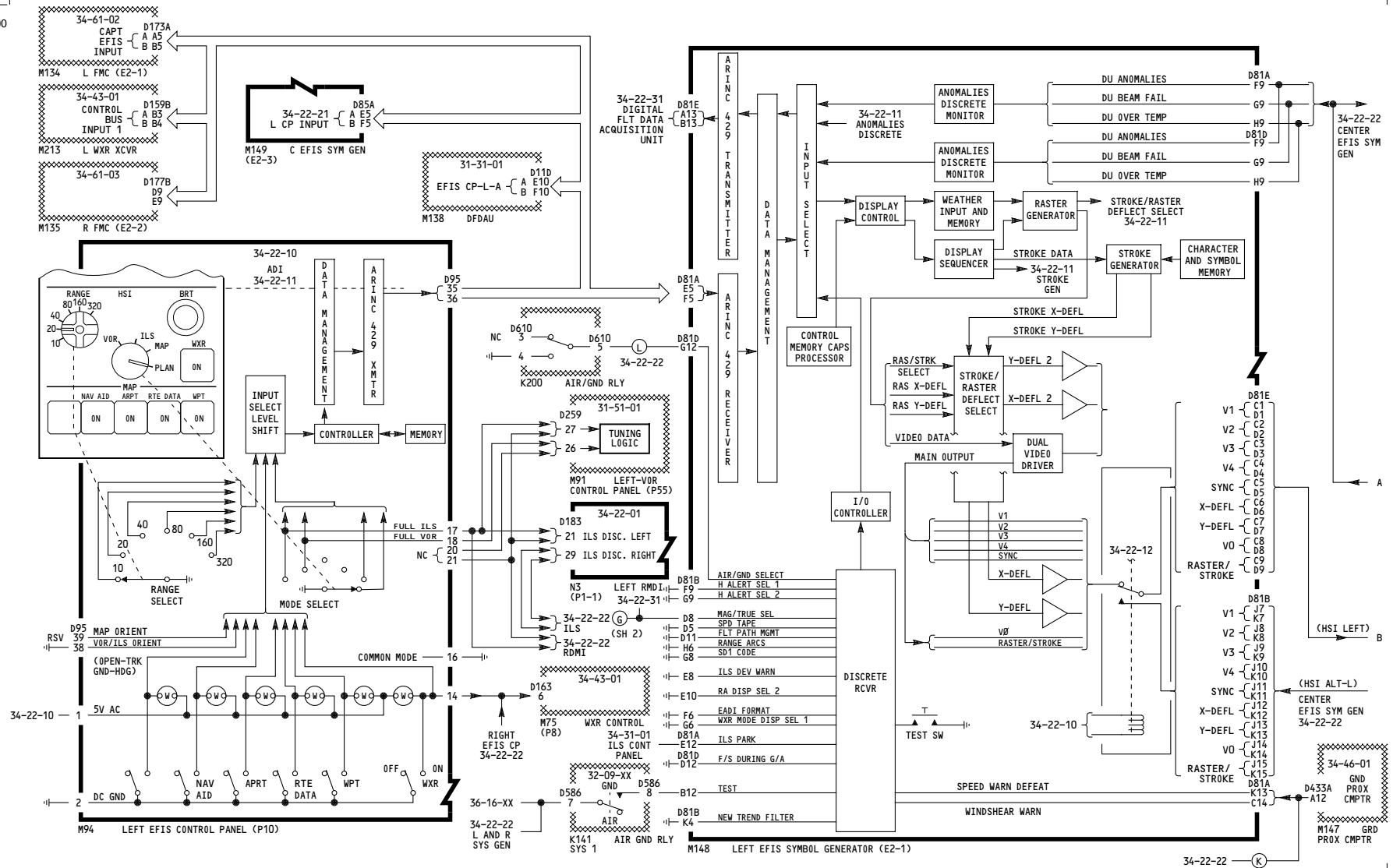

010-099

EFIS SYMBOL GENERATOR AND EHSI - LEFT

D280N032S

34-22-12

5002

34-22-10

WIRING DIAGRAMS	
34-22-14	
34-22-15	
34-22-16	
34-22-18	

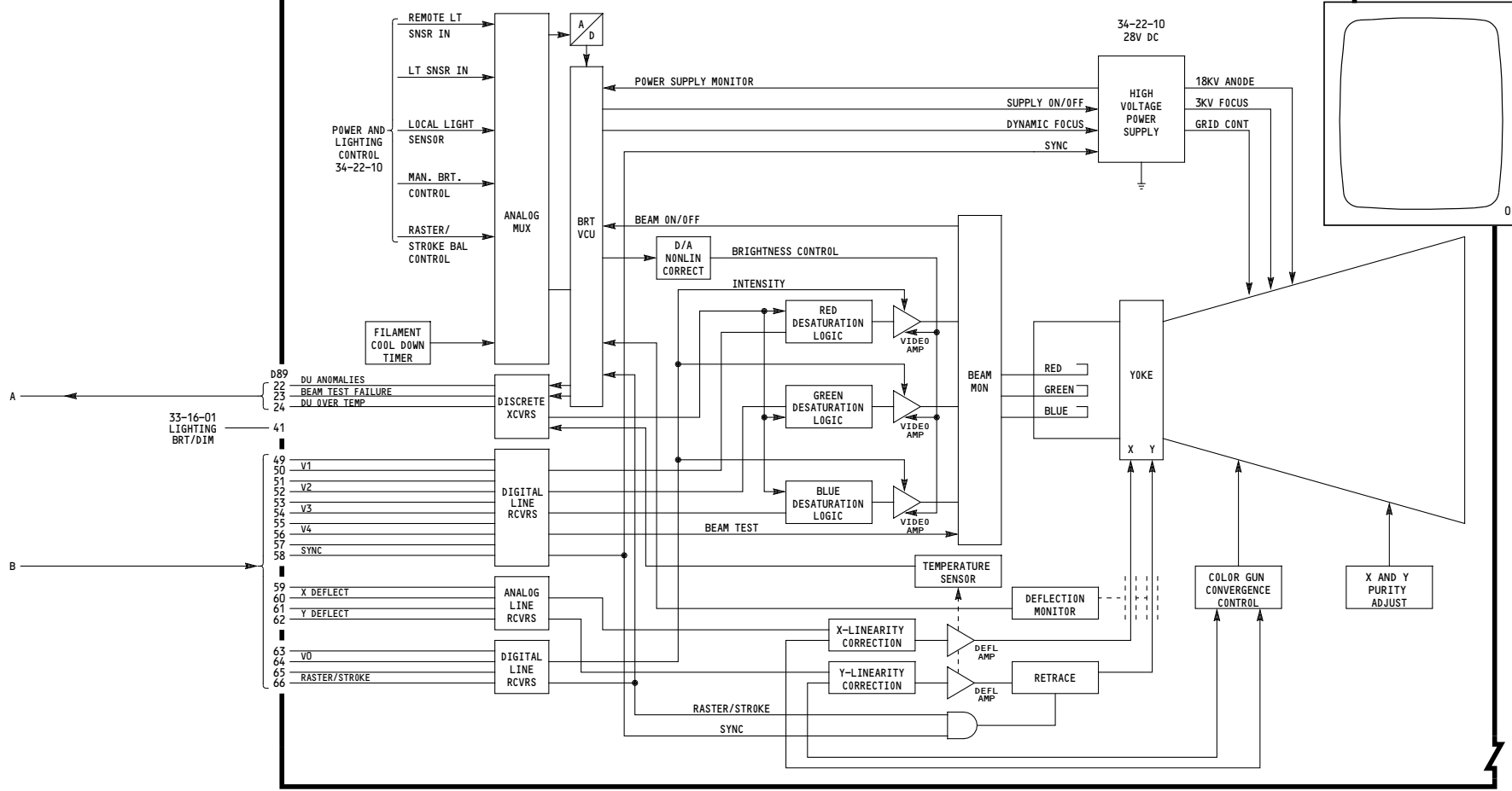

N5 LEFT ELECTRONIC HORIZONTAL SITUATION INDICATOR (P3-2)

010-099

**EFIS SYMBOL GENERATOR
AND EHSI - LEFT**

D280N032S

34-22-12

Page 103
Sheet 2
Jan 21/2005

-A
5000

WIRING DIAGRAMS
34-22-24
34-22-34
34-22-35

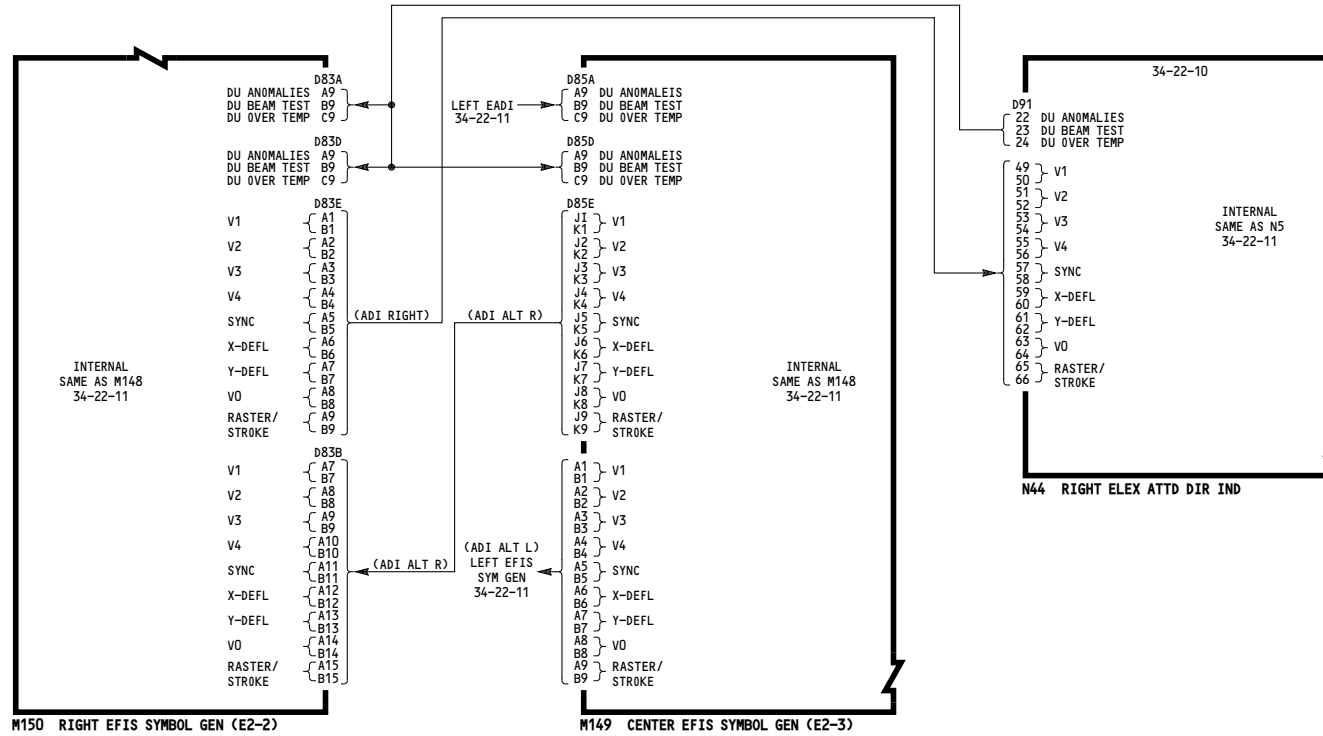

ALL	<p>EFIS SYMBOL GENERATOR AND EADI - RIGHT AND CENTER</p> <p>D280N032S</p>
-----	--

34-22-21

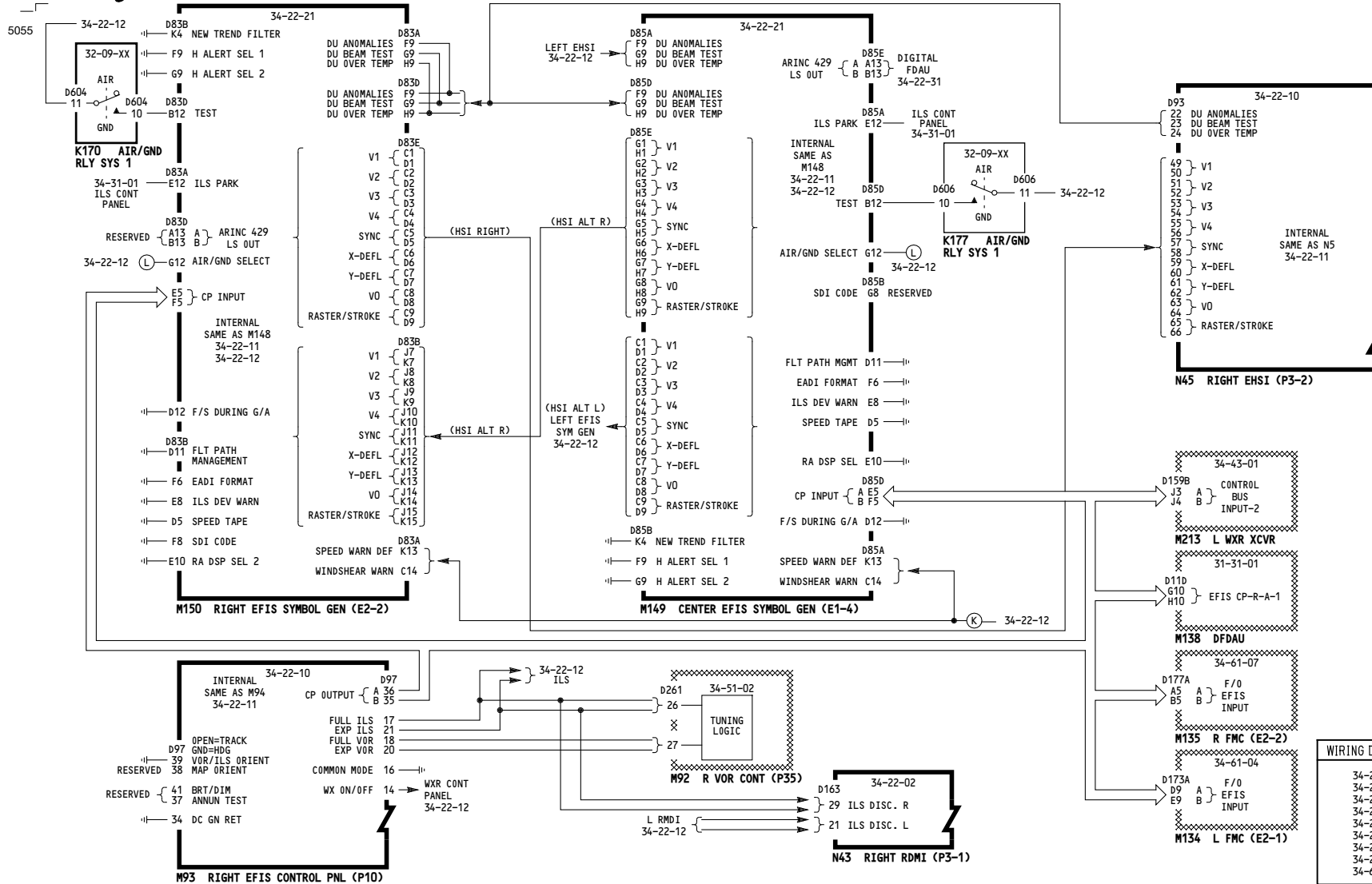

WIRING DIAGRAMS

34-22-24
34-22-25
34-22-26
34-22-28
34-22-29
34-22-34
34-22-35
34-22-39
34-61-24

001-008

EFIS SYMBOL GENERATOR AND EHSI - RIGHT AND CENTER

D280N032S

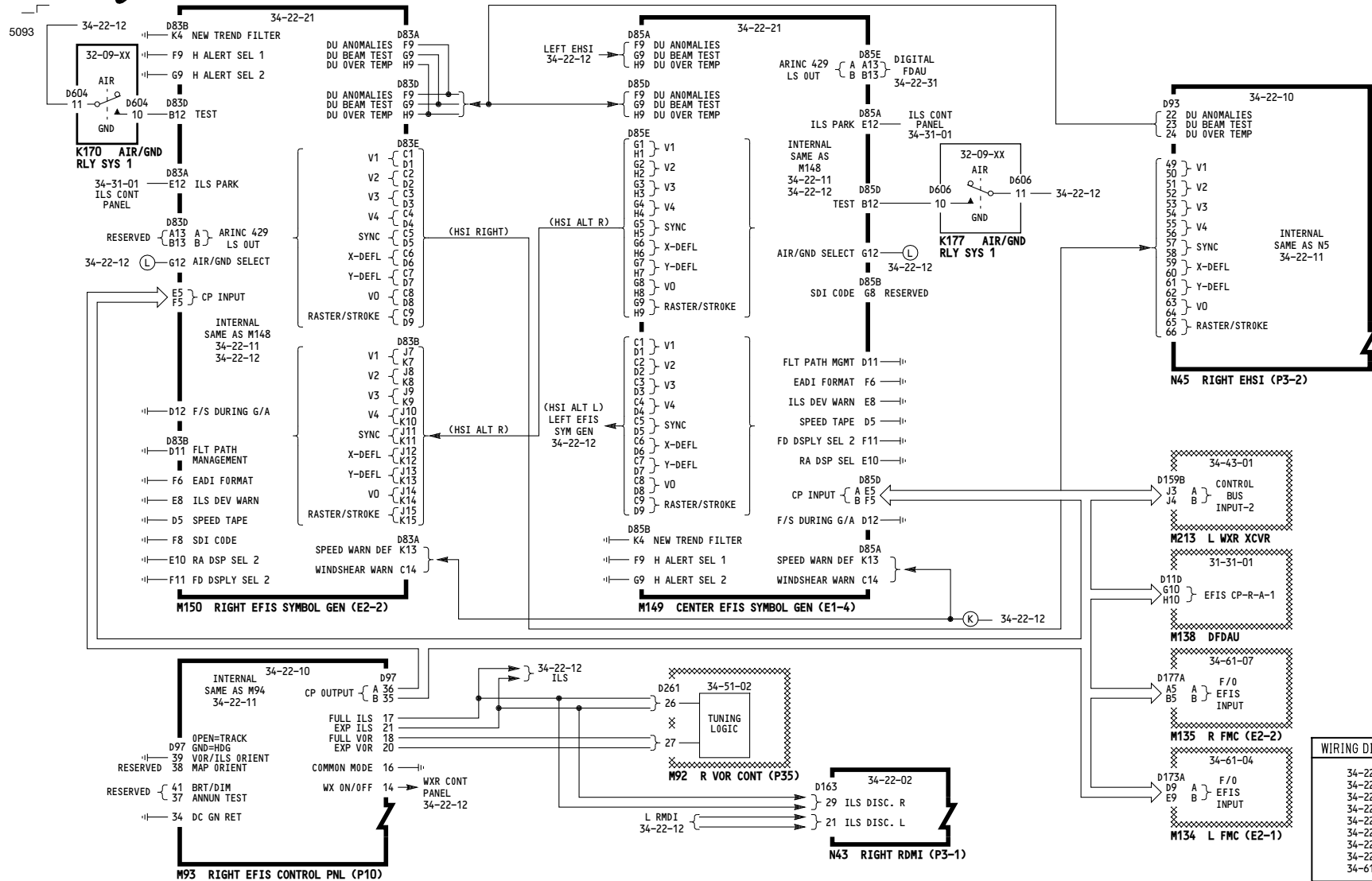

009

EFIS SYMBOL GENERATOR AND EHSI - RIGHT AND CENTER

D280N032S

-B
5013

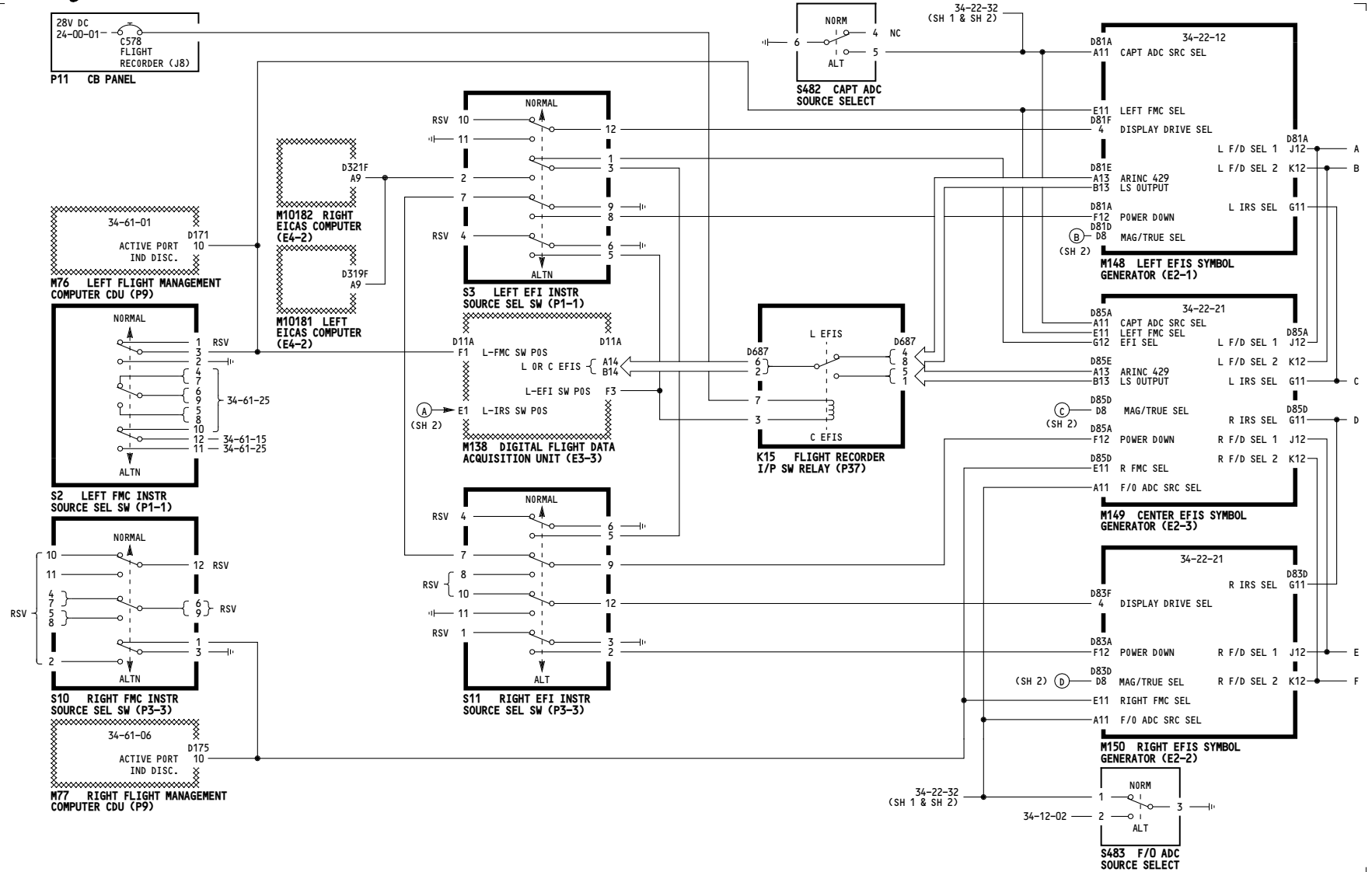

ALL

FLIGHT INSTRUMENT SYSTEM SWITCHING

D280N032S

34-22-31

5000

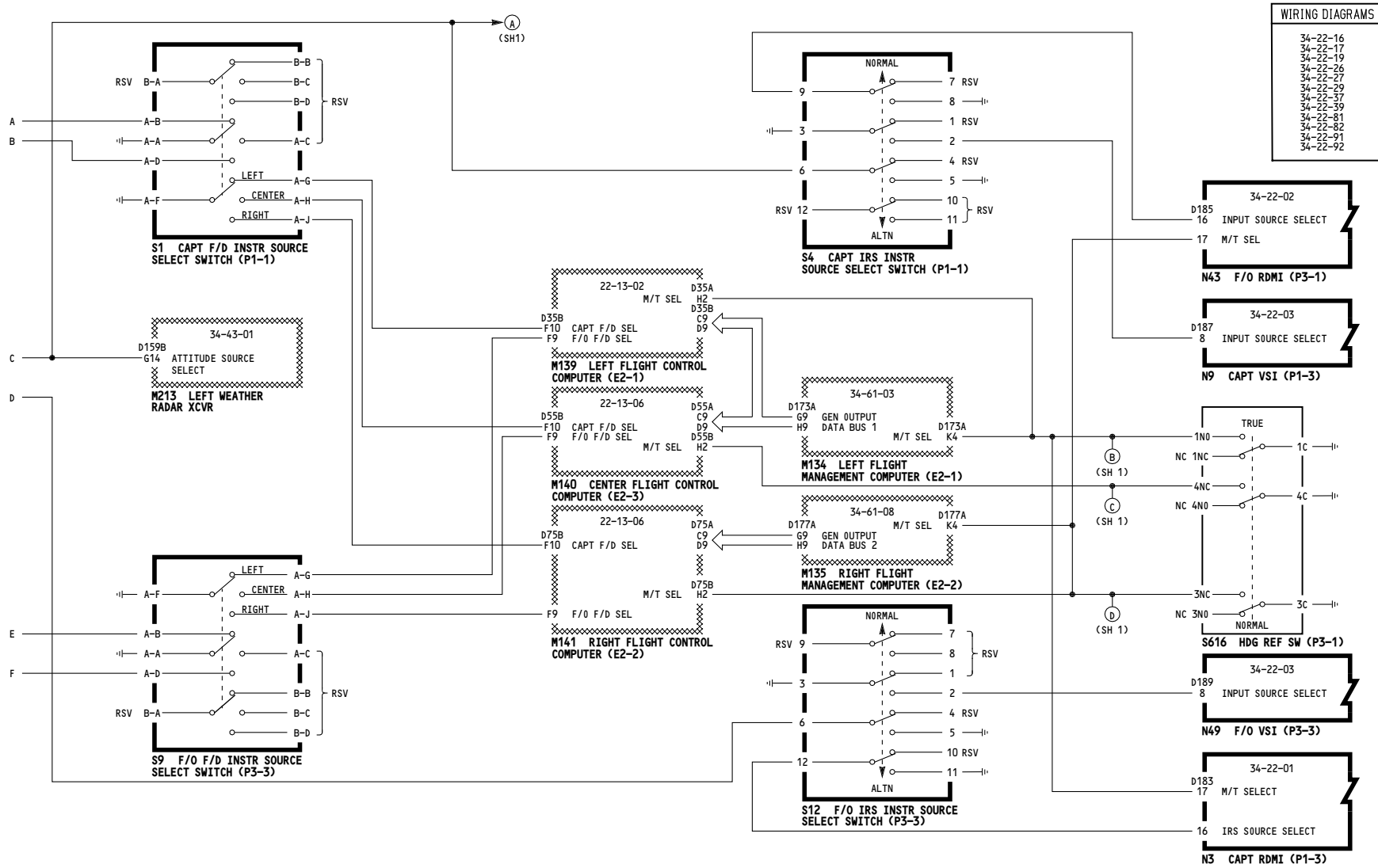

ALL	<p>FLIGHT INSTRUMENT SYSTEM SWITCHING</p> <p>D280N032S</p>
-----	---

34-22-31

5075

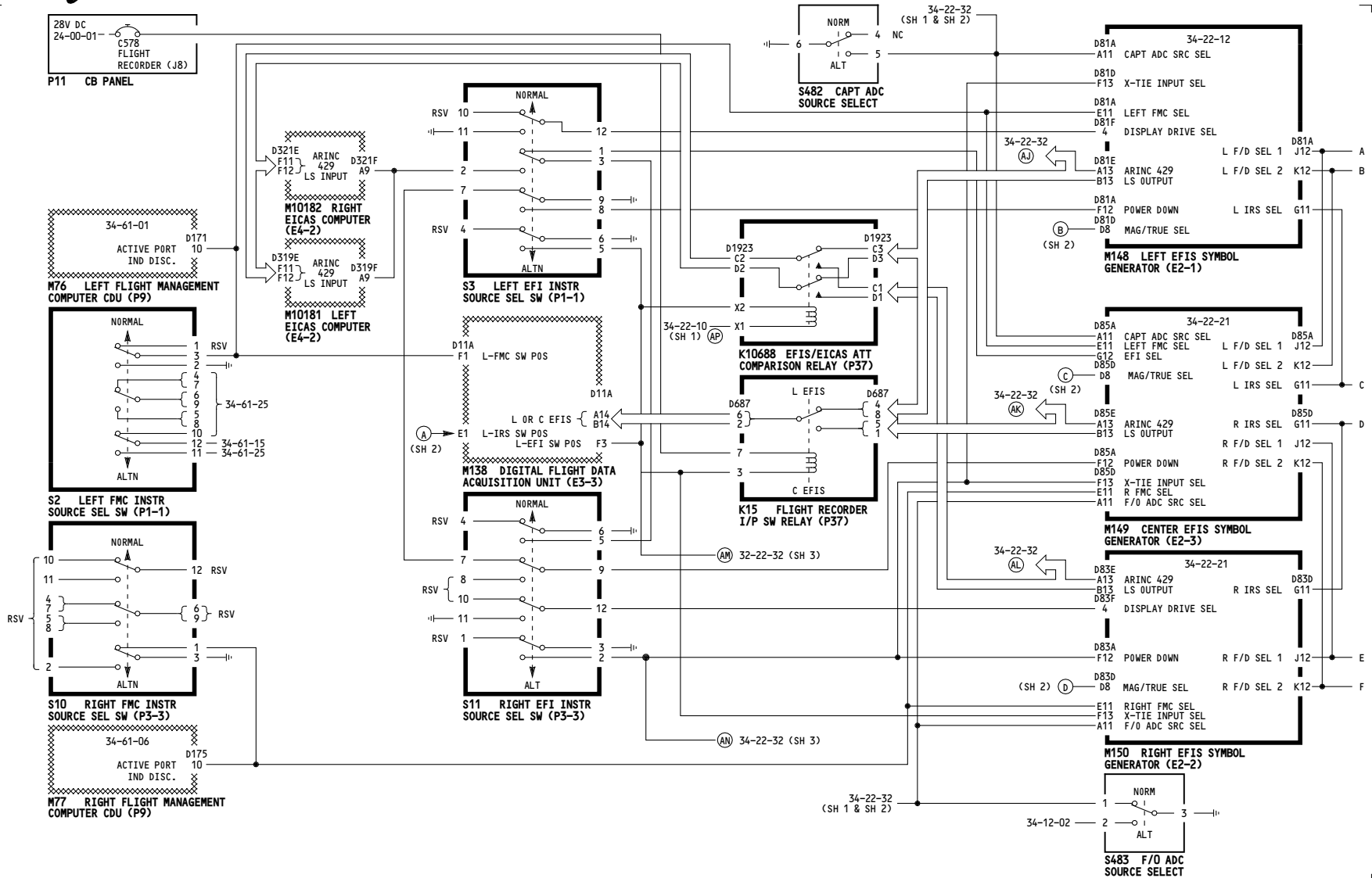

002	<p>FLIGHT INSTRUMENT SYSTEM SWITCHING</p> <p style="text-align: right;">D280N032S</p>
-----	--

Incorporates
 34-0200

34-22-31

5000

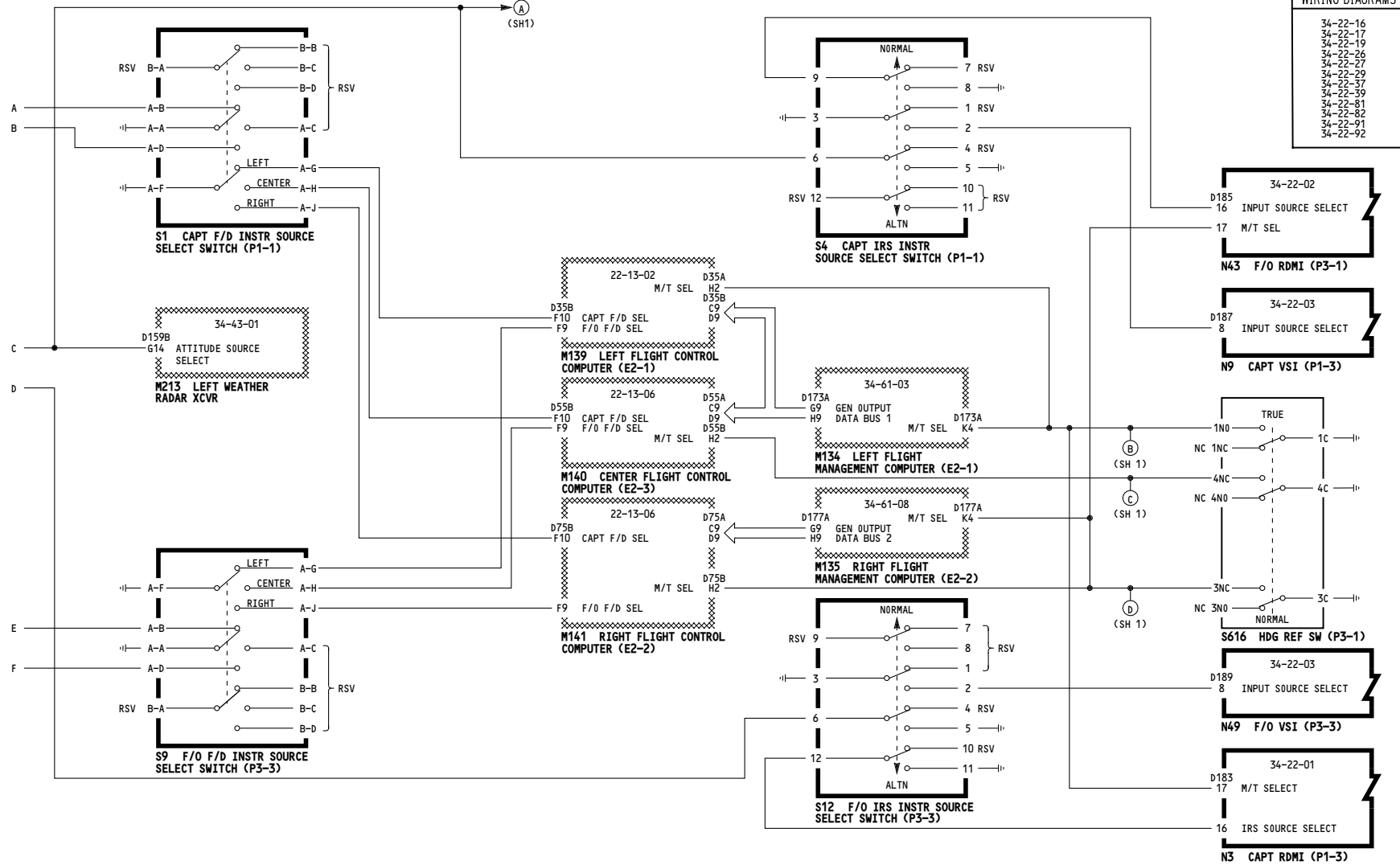

002	<p>FLIGHT INSTRUMENT SYSTEM SWITCHING</p> <p>D280N032S</p>
-----	---

34-22-31

-B
5053

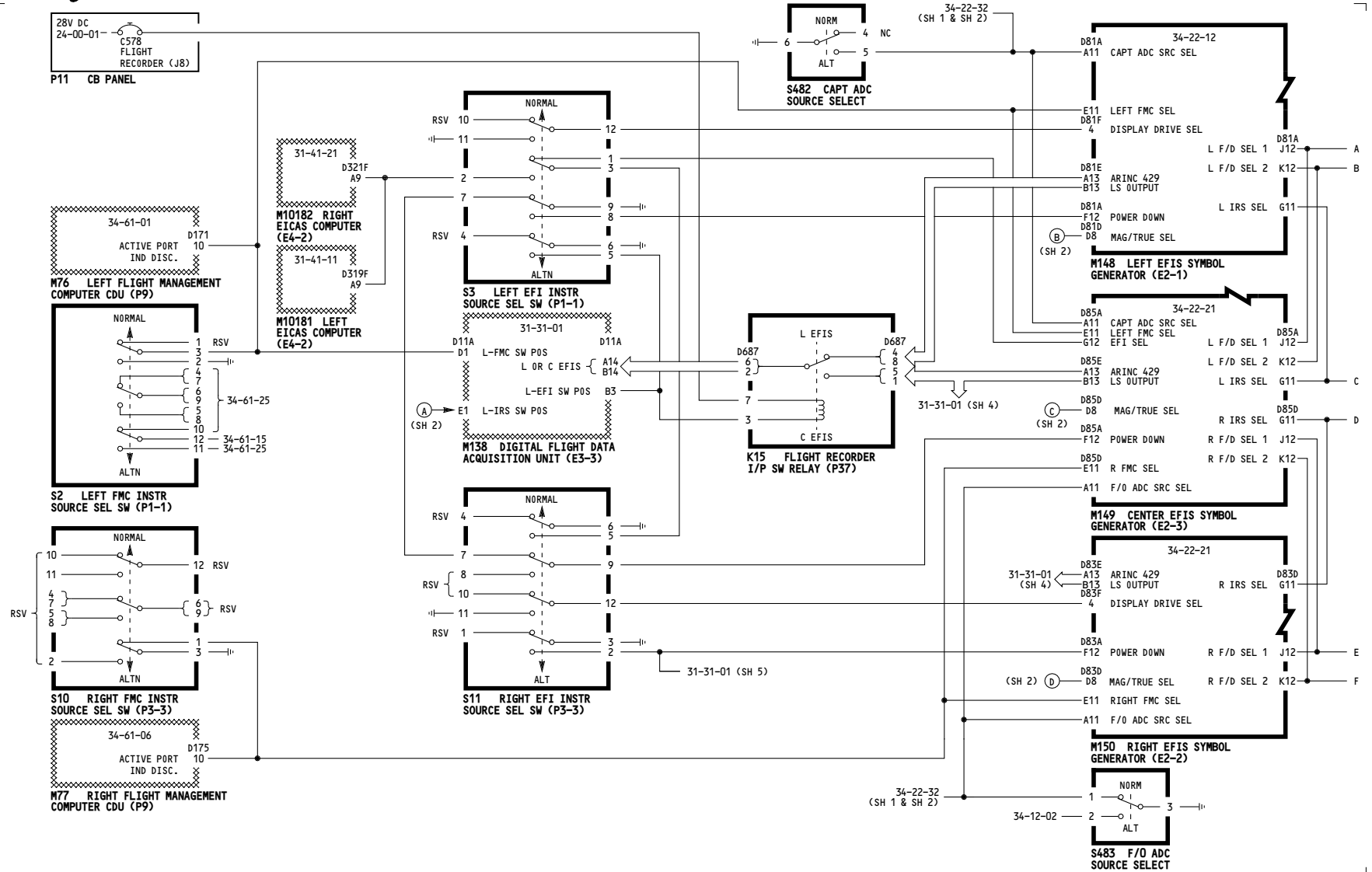

010-011	<p align="center">FLIGHT INSTRUMENT SYSTEM SWITCHING</p> <p align="center">D280N032S</p>
---------	---

Incorporates
31-0094

34-22-31

5000

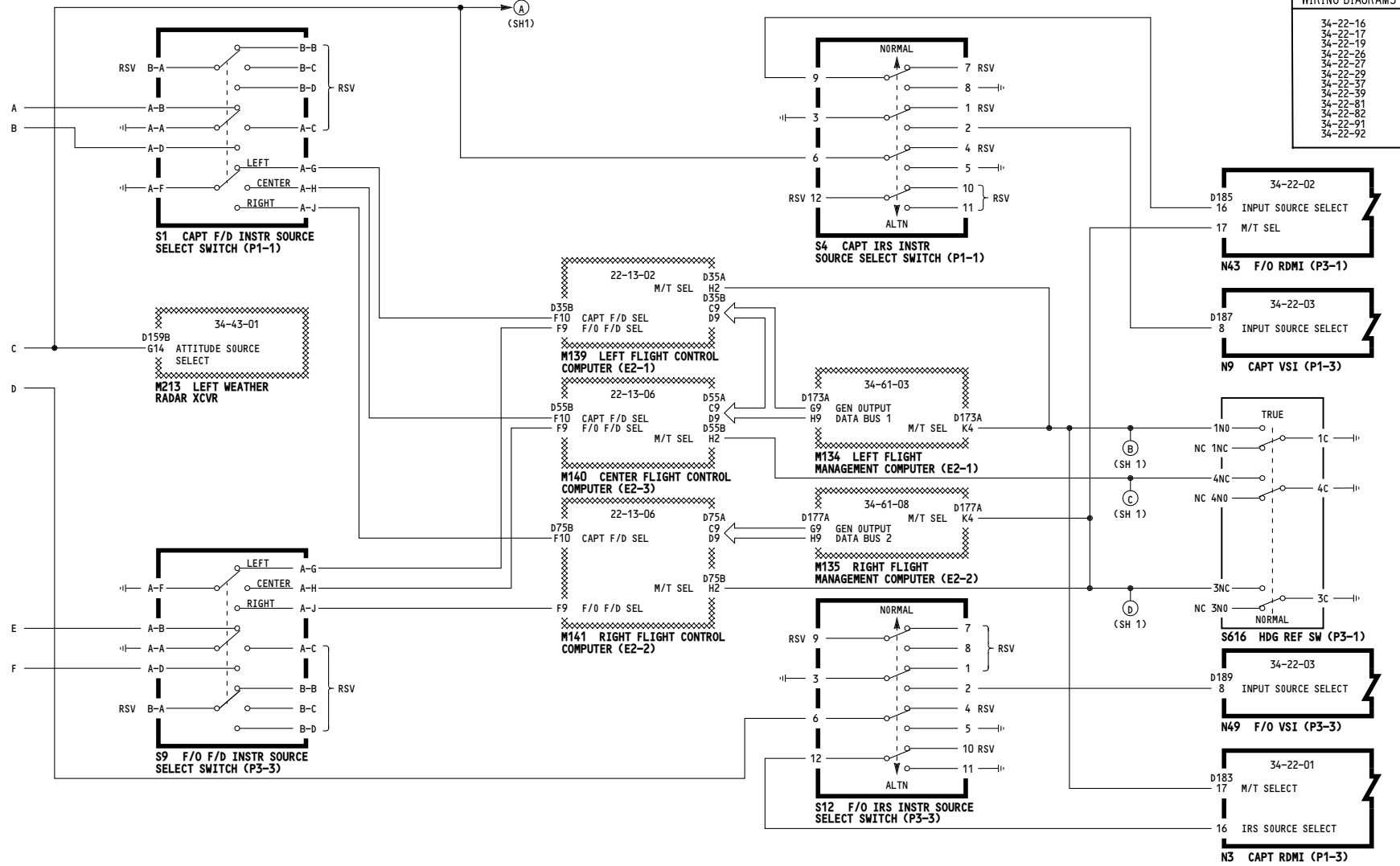

010-011	<p>FLIGHT INSTRUMENT SYSTEM SWITCHING</p> <p>D280N032S</p>
---------	---

34-22-31

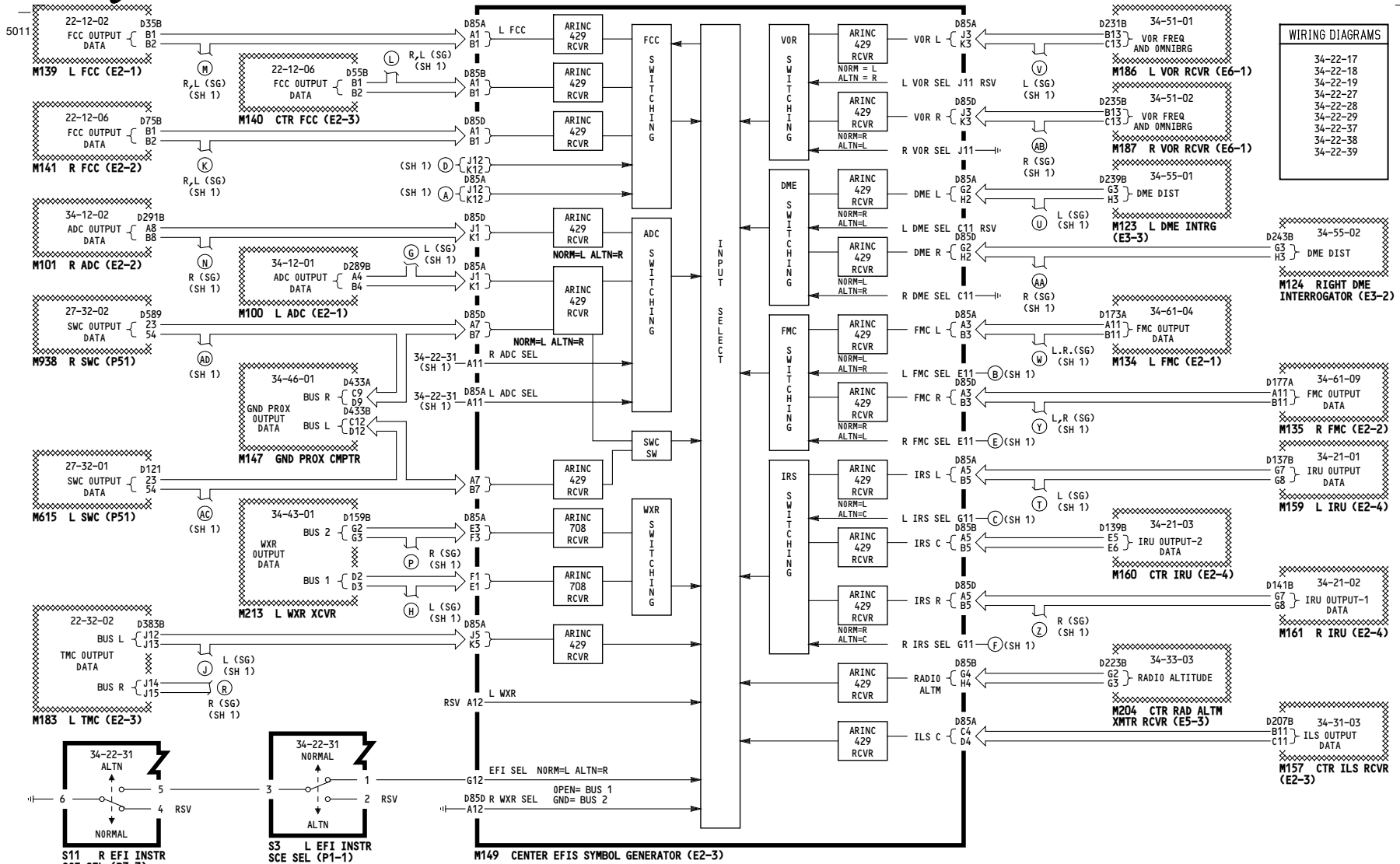

WIRING DIAGRAMS	
34-22-17	
34-22-18	
34-22-19	
34-22-27	
34-22-28	
34-22-29	
34-22-37	
34-22-38	
34-22-39	

34-55-02	
D243B G3 H3	M124 RIGHT DME INTERROGATOR (E3-2)

34-61-09	
D177A A11 B11	M135 R FMC (E2-2)

34-21-01	
D137B G7 G8	M159 L IRU (E2-4)

34-21-02	
D141B G7 G8	M161 R IRU (E2-4)

34-31-03	
D207B B11 C11	M157 CTR ILS RCVR (E2-3)

ALL

FLIGHT INSTRUMENT DATA BUS SWITCHING

D280N032S

34-22-32

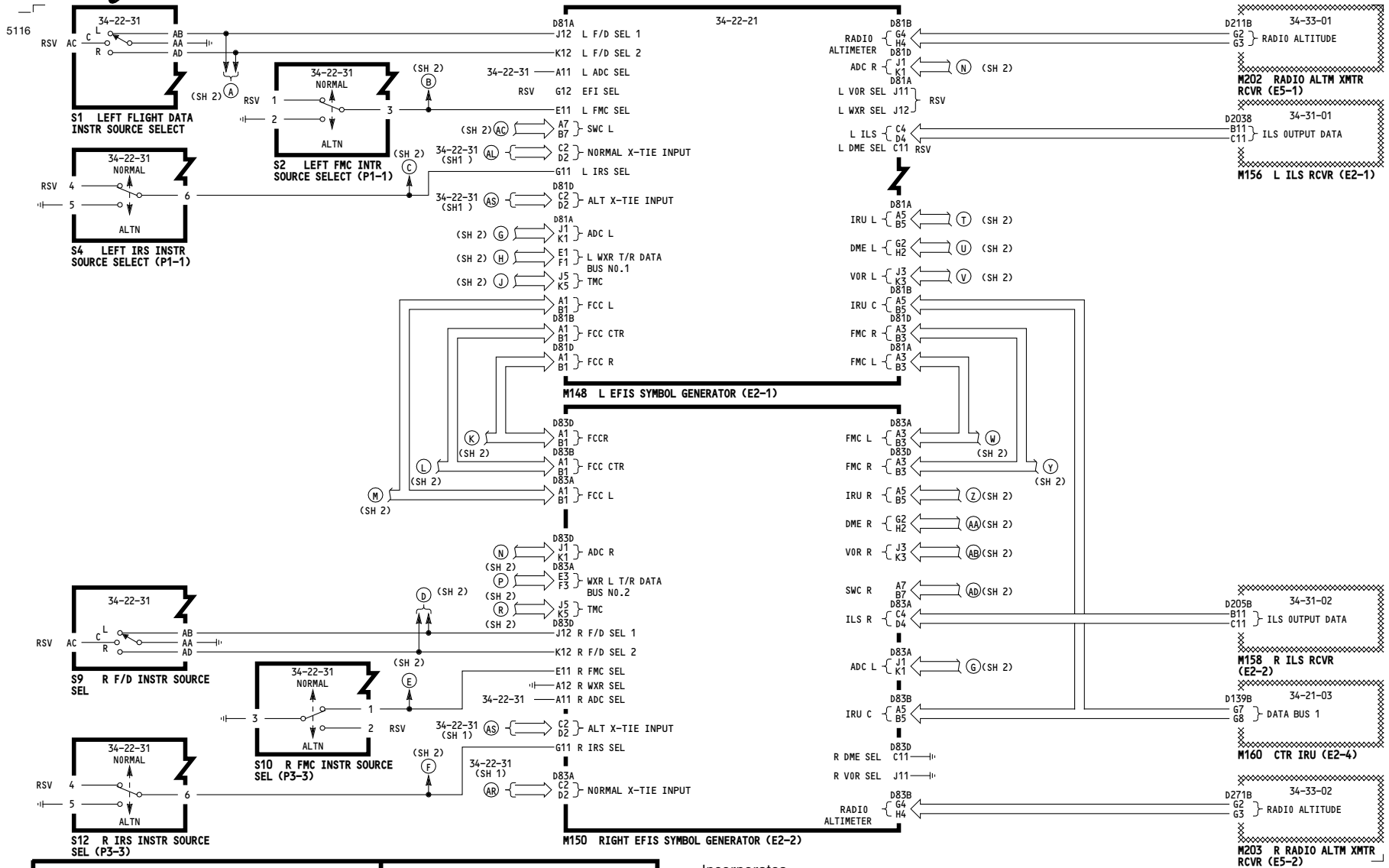

002

FLIGHT INSTRUMENT DATA BUS SWITCHING

D280N032S

Incorporates
 34-0200

34-22-32

WIRING DIAGRAMS	
34-22-17	
34-22-18	
34-22-28	
34-22-36	
34-22-37	
34-22-38	

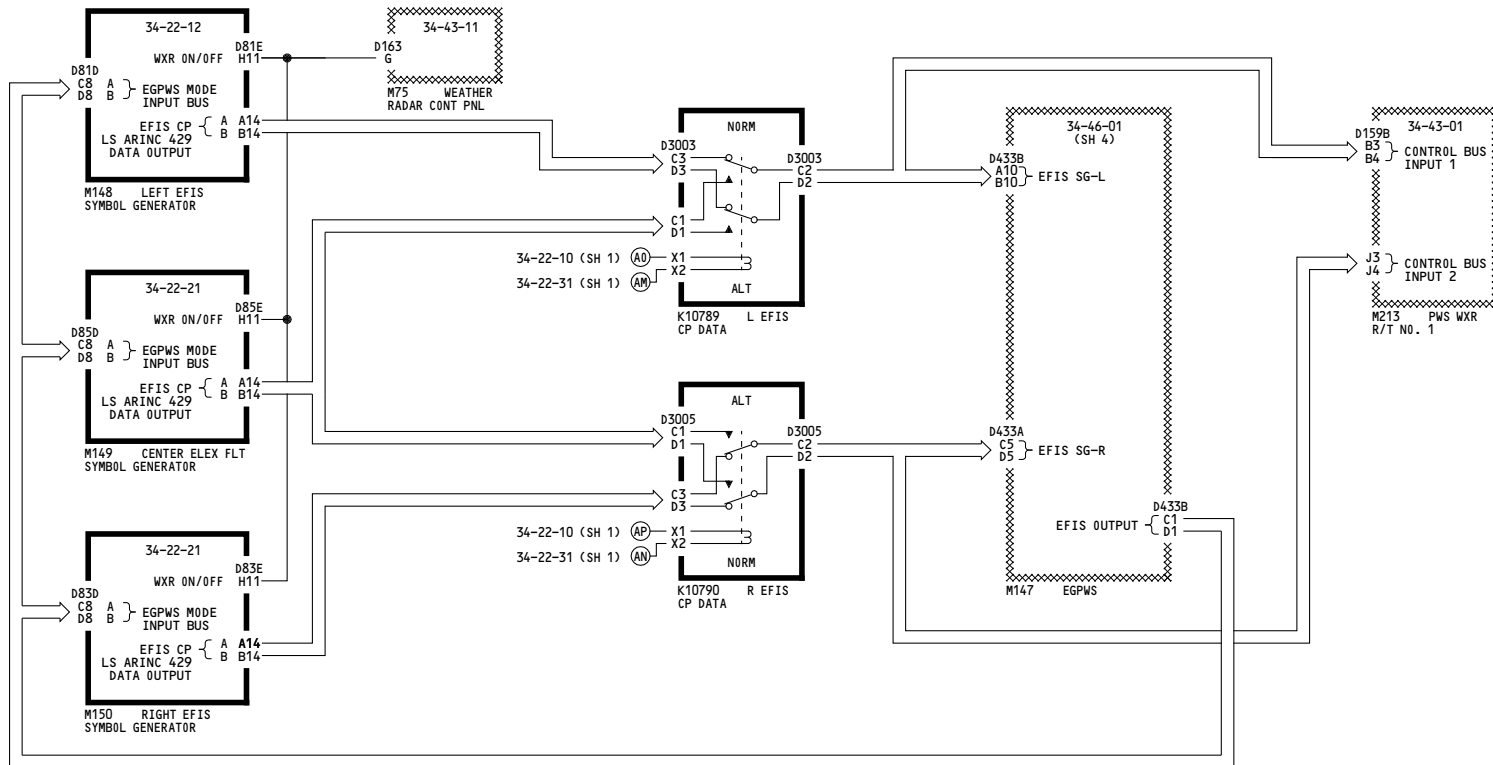

002

**FLIGHT INSTRUMENT DATA
BUS SWITCHING**

Incorporates
34-0200

D280N032S

34-22-32

Page 101.1
Sheet 3
Dec 18/2007

5000

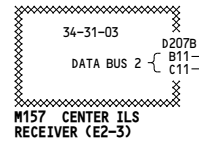
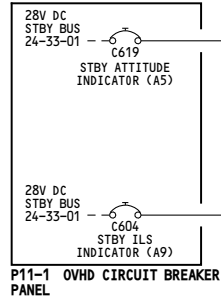

- NOTES:**
- 1 FLAGS ARE DRIVEN BY TORQUE MOTORS TO THE OUT OF VIEW POSITION. WHEN MOTOR IS DE-ENERGIZED SPRING RETURNS FLAG INTO VIEW.
 - 2 LOGIC 1 OUTPUT WHEN TEST IS PASSED
 - 3 LOGIC 1 OUTPUT IF POWER SUPPLY IS GOOD

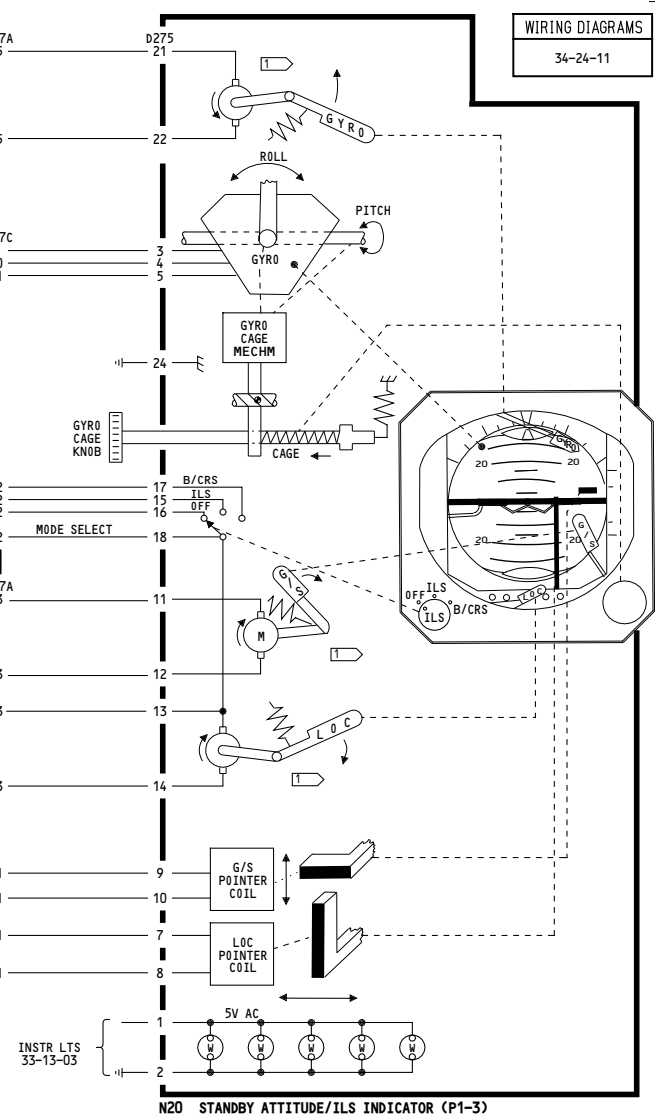
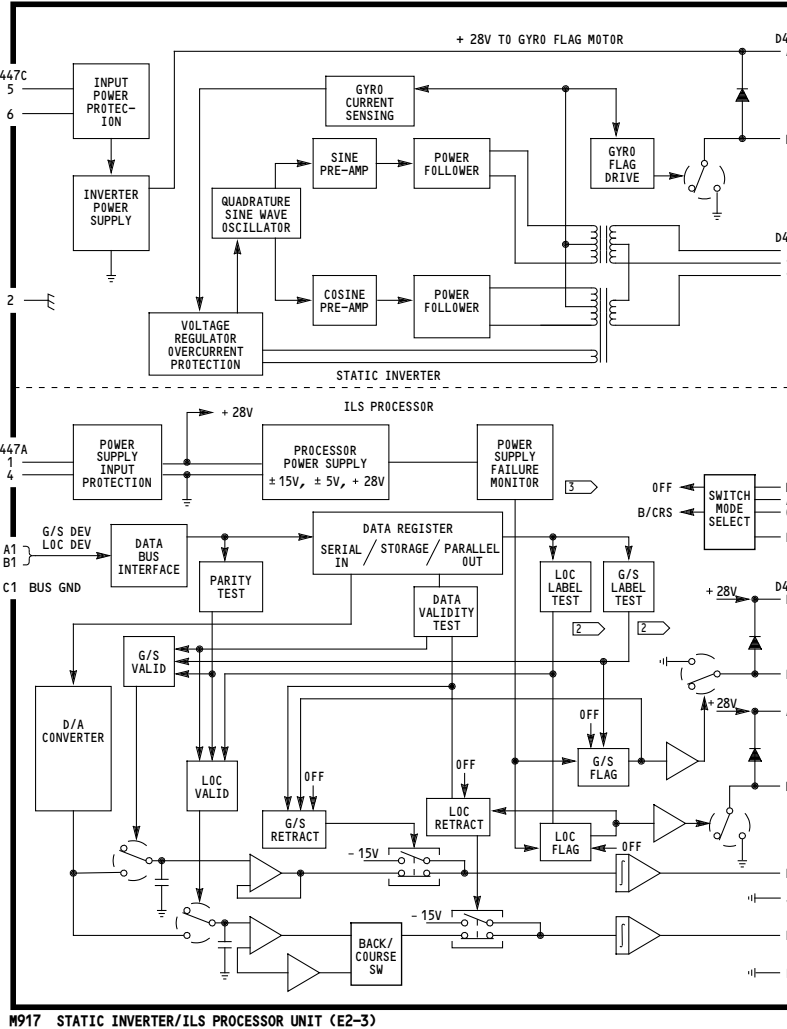

ALL

STANDBY ATTITUDE/ILS INDICATOR SYSTEM

D280N032S

34-24-01

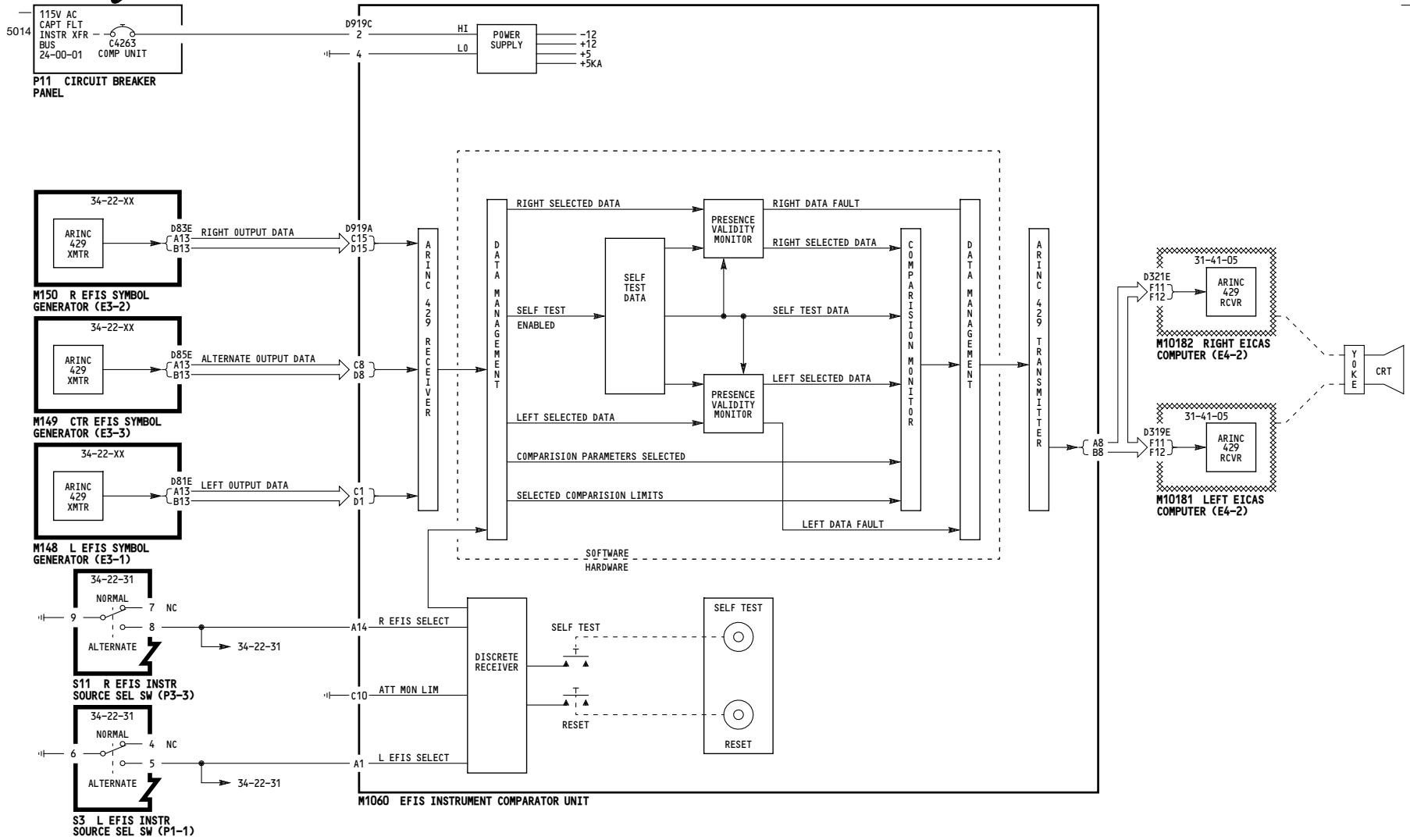

001, 003-099	INSTRUMENT COMPARATOR UNIT D280N032S
--------------	--

34-25-01

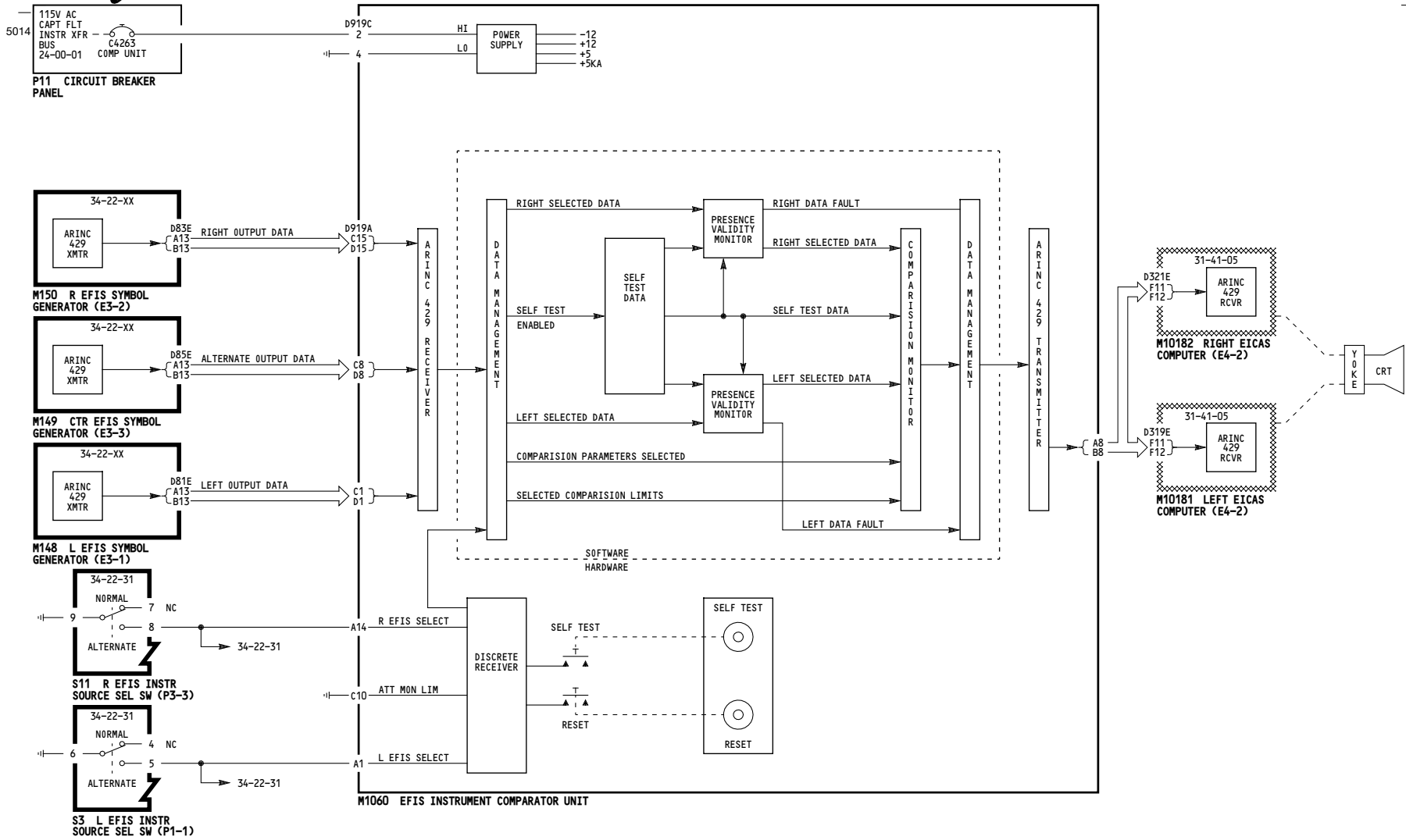

002

INSTRUMENT COMPARATOR UNIT

Incorporates
34-0200

D280N032S

34-25-01

Page 102.1

Jan 21/2005

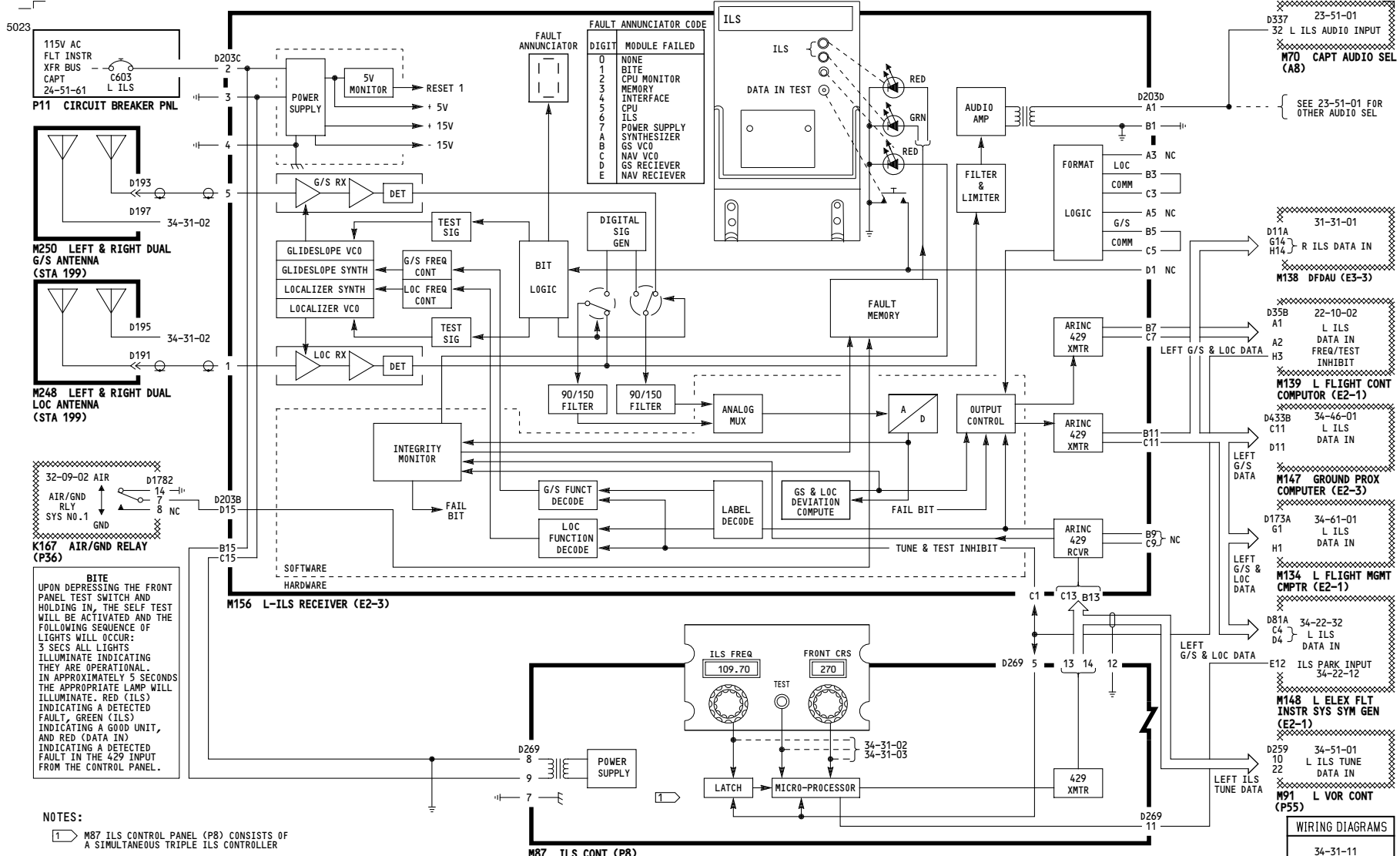

001, 009

ILS - LEFT

D280N032S

34-31-01

Page 101

Jan 21/2005

5020

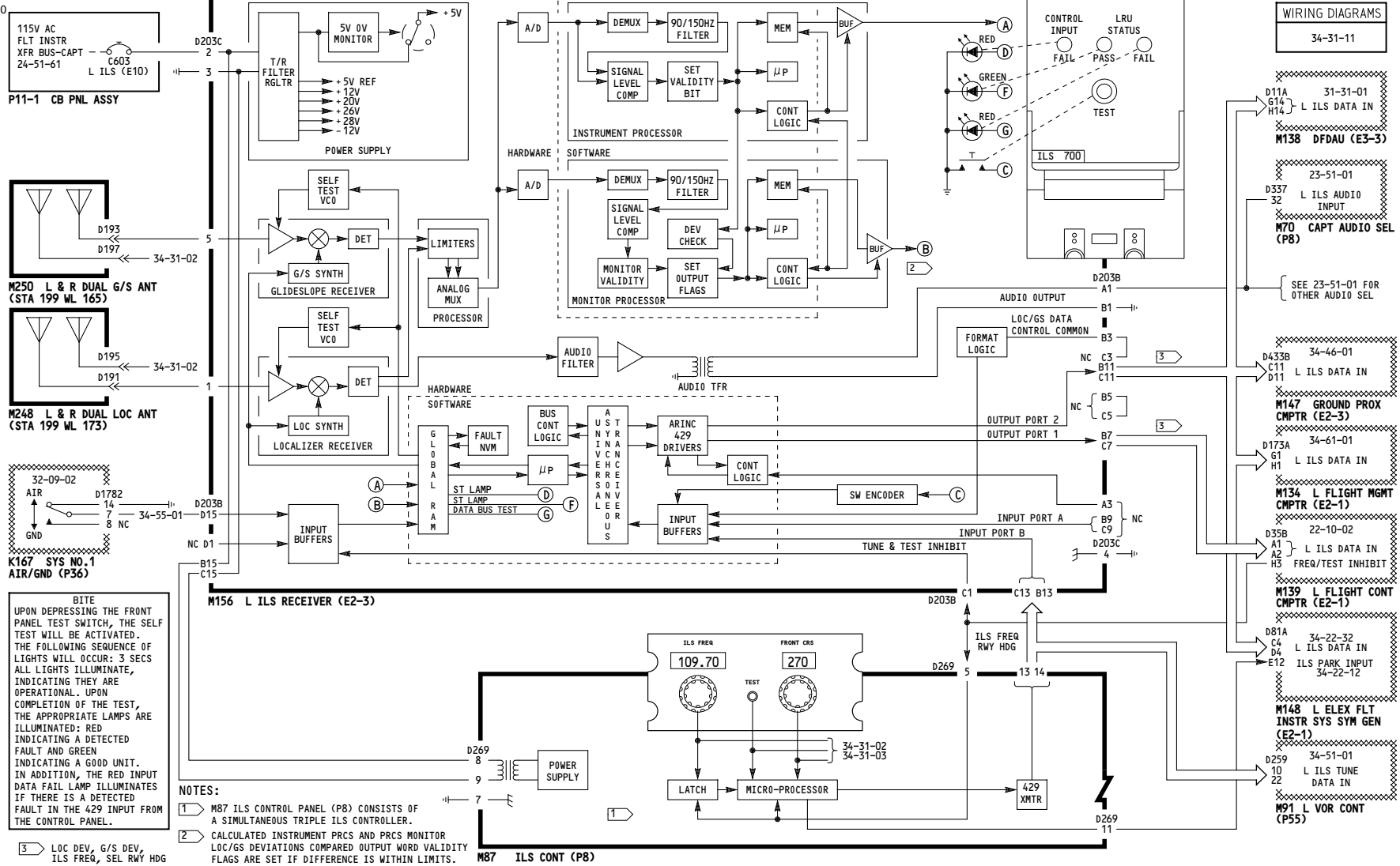

BITE
UPON DEPRESSING THE FRONT
PANEL TEST SWITCH, THE SELF
TEST WILL BE ACTIVATED.
THE FOLLOWING SEQUENCE OF
LIGHTS WILL OCCUR: 3 SECS
ALL LIGHTS ILLUMINATE,
INDICATING THEY ARE
OPERATIONAL. UPON
COMPLETION OF THE TEST,
THE APPROPRIATE LAMPS ARE
ILLUMINATED: RED
INDICATING A DETECTED
FAULT AND GREEN
INDICATING A GOOD UNIT.
IN ADDITION, THE RED INPUT
DATA FAIL LAMP ILLUMINATES
IF THERE IS A DETECTED
FAULT IN THE 429 INPUT FROM
THE CONTROL PANEL.

- NOTES:**
- 1 M87 ILS CONTROL PANEL (P8) CONSISTS OF A SIMULTANEOUS TRIPLE ILS CONTROLLER.
 - 2 CALCULATED INSTRUMENT PRCS AND PRCS MONITOR LOC/GS DEVIATIONS COMPARED OUTPUT WORD VALIDITY FLAGS ARE SET IF DIFFERENCE IS WITHIN LIMITS.
 - 3 LOC DEV, G/S DEV, ILS FREQ, SEL RWY HDG

WIRING DIAGRAMS
34-31-11

- D11A 31-31-01
G14 H14 L ILS DATA IN
M138 DFDAU (E3-3)
- D337 23-51-01
32 L ILS AUDIO INPUT
M70 CAPT AUDIO SEL (P8)
- SEE 23-51-01 FOR OTHER AUDIO SEL
- D433B 34-46-01
C3 B11 C11 L ILS DATA IN
M147 GROUND PROX CMPTR (E2-3)
- D173A 34-61-01
G1 H1 L ILS DATA IN
M134 L FLIGHT MGMT CMPTR (E2-1)
- D35B 22-10-02
A1 A2 H3 L ILS DATA IN
M139 L FLIGHT CONT CMPTR (E2-1)
- D81A 34-22-32
C4 D4 E12 L ILS DATA IN
M148 L ELEX FLT INSTR SYS SYM GEN (E2-1)
- D259 34-51-01
10 22 L ILS TUNE DATA IN
M91 L VOR CONT (P55)

002-008, 010-099

ILS - LEFT

D280N032S

34-31-01

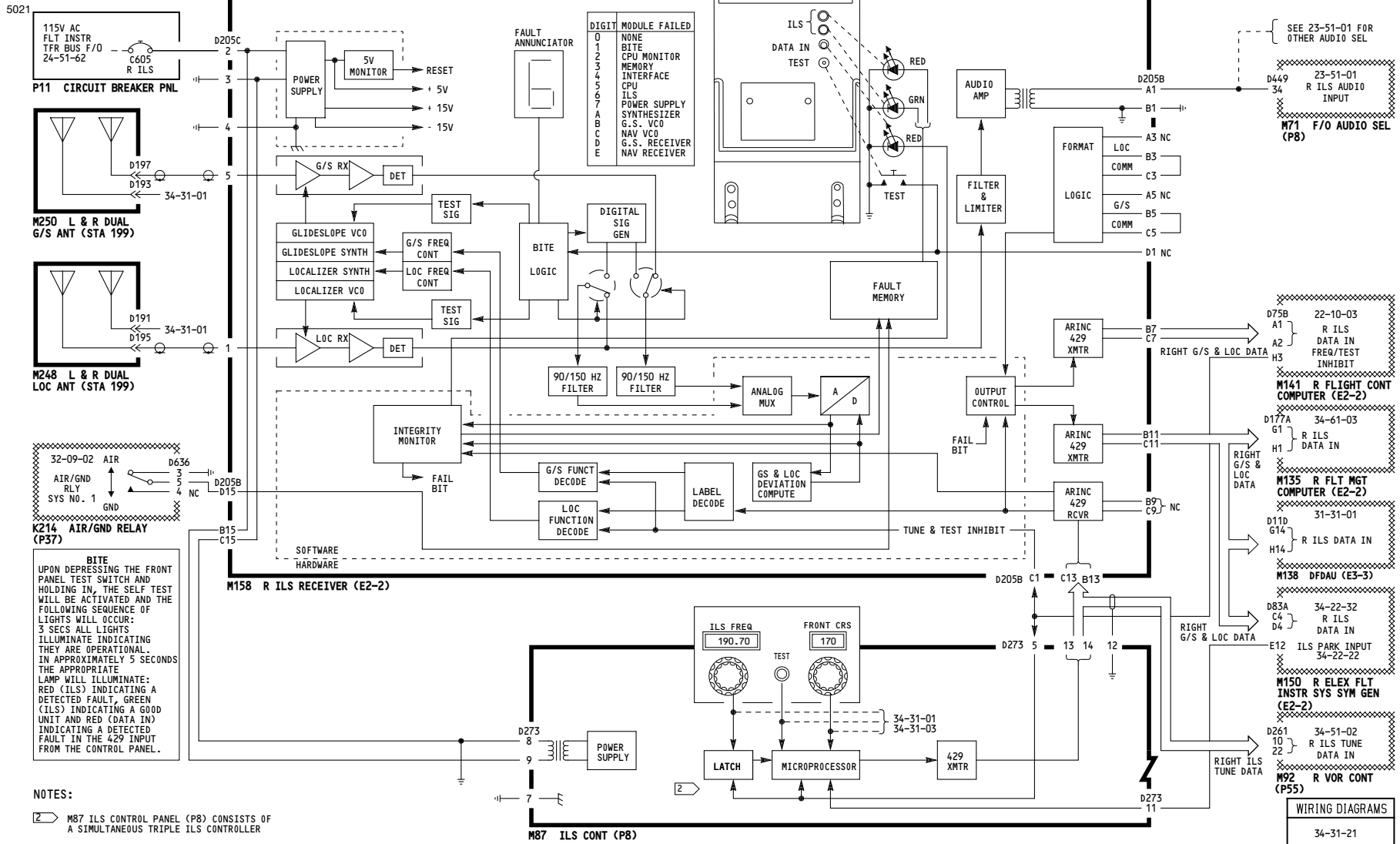

001, 009

ILS - RIGHT

D280N032S

34-31-02

5022

WIRING DIAGRAMS
34-31-21

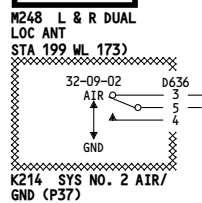
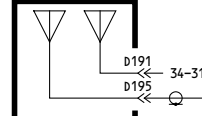
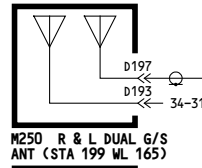
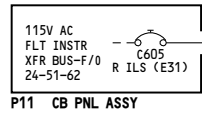

BITE
UPON DEPRESSING THE FRONT PANEL TEST SWITCH THE SELF TEST WILL BE ACTIVATED. THE FOLLOWING SEQUENCE OF LIGHTS WILL OCCUR: 3 SECS ALL LIGHTS ILLUMINATE INDICATING THEY ARE OPERATIONAL. UPON COMPLETION OF THE TEST THE APPROPRIATE LAMPS ARE ILLUMINATED. RED INDICATING A DETECTED FAULT AND GREEN INDICATING A GOOD UNIT. IN ADDITION THE RED INPUT DATA FAIL LAMP ILLUMINATES IF THERE IS A DETECTED FAULT IN THE 429 INPUT FROM THE CONTROL PANEL

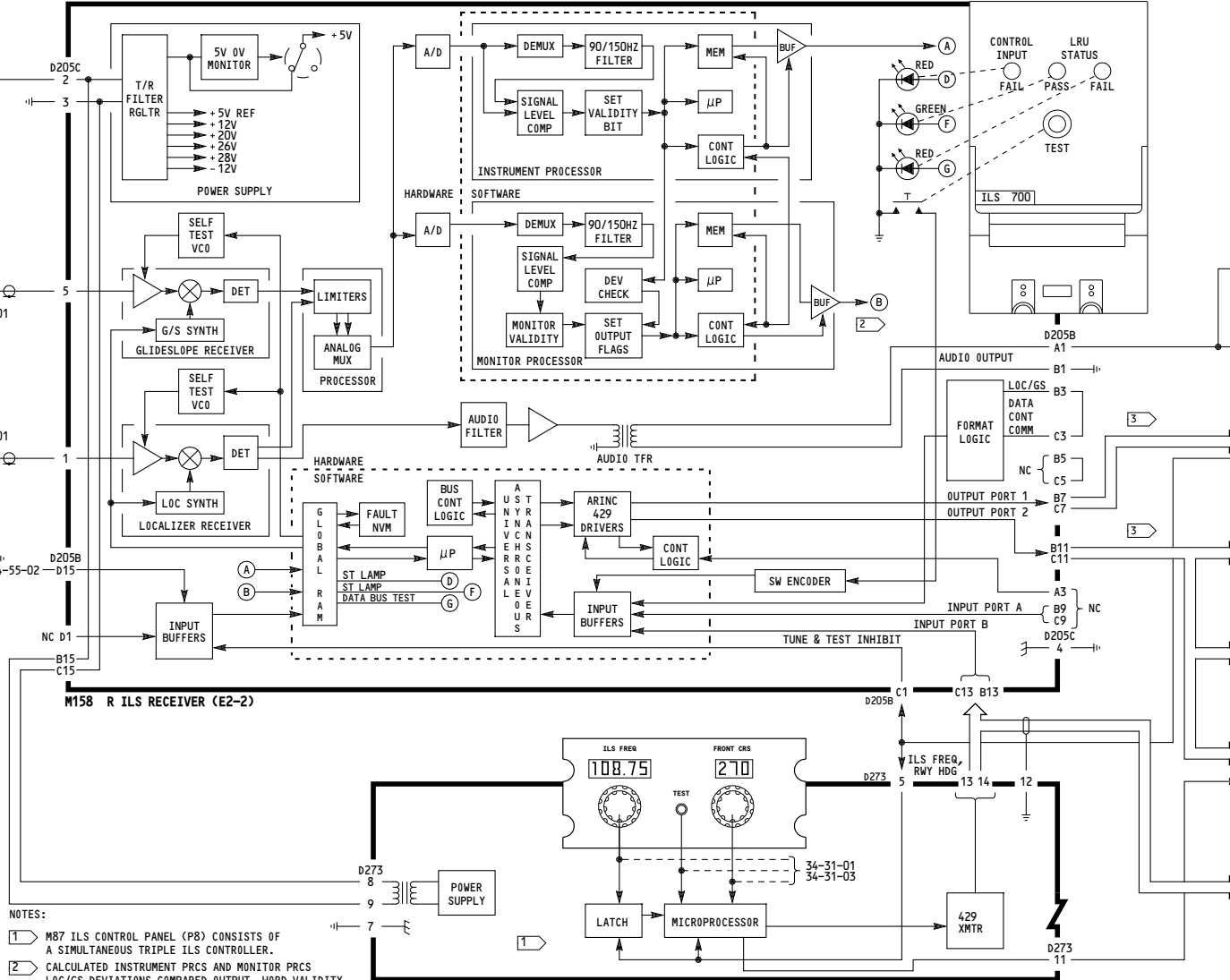

NOTES:

- 1 M87 ILS CONTROL PANEL (P8) CONSISTS OF A SIMULTANEOUS TRIPLE ILS CONTROLLER.
- 2 CALCULATED INSTRUMENT PRCS AND MONITOR PRCS LOC/GS DEVIATIONS COMPARED OUTPUT. WORD VALIDITY FLAGS ARE SET IF DIFFERENCE IS WITHIN LIMITS.
- 3 LOC DEV, G/S DEV, ILS FREQ, SEL RWY HDG

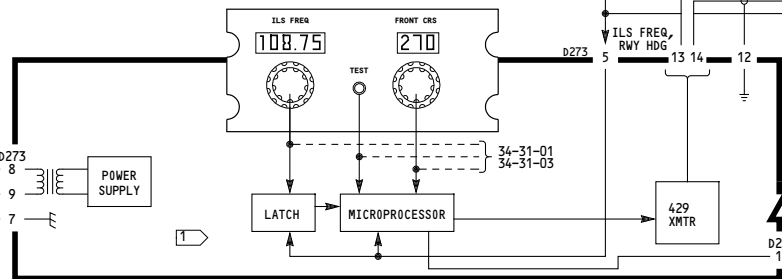

002-008, 010-099

ILS - RIGHT
D280N032S

34-31-02

Page 102

Jan 21/2005

5024

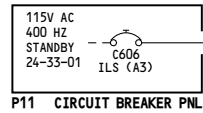

P11 CIRCUIT BREAKER PNL

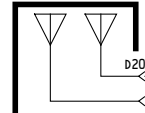

M251 CENTER DUAL G/S ANT (STA 199, WL 169)

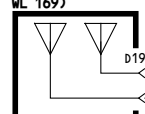

M249 CENTER DUAL LOC ANT (STA 199, WL 209)

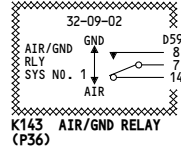

K143 AIR/GND RELAY (P36)

BITE
UPON DEPRESSING THE FRONT PANEL TEST SWITCH AND HOLDING IN, THE SELF TEST WILL BE ACTIVATED AND THE FOLLOWING SEQUENCE OF LIGHTS WILL OCCUR: 3 SECS ALL LIGHTS ILLUMINATE INDICATING THEY ARE OPERATIONAL. IN APPROXIMATELY 5 SECONDS THE APPROPRIATE LAMP WILL ILLUMINATE:
RED (ILS) INDICATING A DETECTED FAULT, GREEN (ILS) INDICATING A GOOD UNIT AND RED (DATA IN) INDICATING A DETECTED FAULT IN THE 429 INPUT FROM THE CONTROL PANEL.

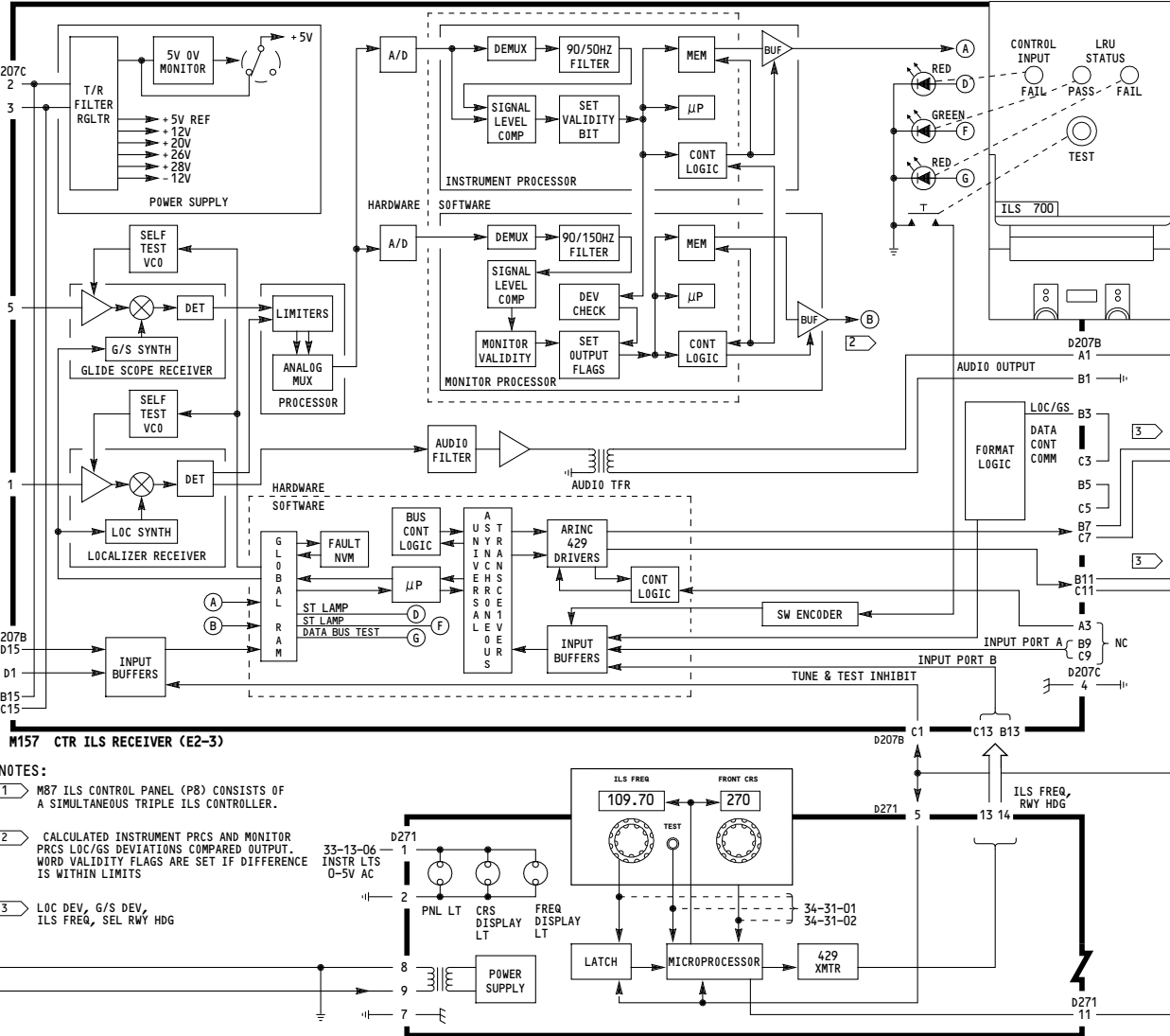

M157 CTR ILS RECEIVER (E2-3)

NOTES:

- M87 ILS CONTROL PANEL (P8) CONSISTS OF A SIMULTANEOUS TRIPLE ILS CONTROLLER.
- CALCULATED INSTRUMENT PRCS AND MONITOR PRCS LOC/GS DEVIATIONS COMPARED OUTPUT. WORD VALIDITY FLAGS ARE SET IF DIFFERENCE IS WITHIN LIMITS.
- LOC DEV, G/S DEV, ILS FREQ, SEL RWY HDG

M87 ILS CONT (P8)

WIRING DIAGRAMS
34-31-31

SEE 23-51-01 FOR OTHER AUDIO SEL

23-51-01
D457 33 CTR ILS AUDIO INPUT

M98 FIRST OBSERVER AUDIO SEL (P17)

D55B 22-10-04 A1 CTR ILS DATA IN A2

H3 FREQ/TEST INHIBIT

M140 CTR FLIGHT CONT COMPUTER (E2-3)

D447A 34-24-01 A1 CTR ILS DATA IN B1

M917 STATIC INV/ ILS PRCSR UNIT (E2-3)

D85A 34-22-32 C4 CTR ILS DATA INPUT

ILS PARK INPUT

M149 CTR ELEX FLT INSTR SYS SYM GEN (E2-3)

D11A 31-31-01 J14 CTR ILS DATA IN K14

M138 DFDU (E3-3)

001-008, 010-099

ILS - CENTER

D280N032S

34-31-03

Page 101

Jan 21/2005

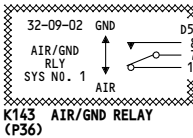
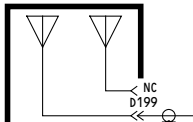
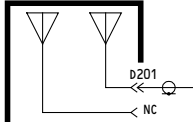
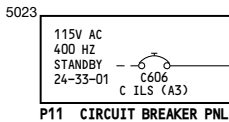

BITE
UPON DEPRESSING THE FRONT PANEL TEST SWITCH AND HOLDING IN, THE SELF TEST WILL BE ACTIVATED AND THE FOLLOWING SEQUENCE OF LIGHTS WILL OCCUR:
3 SECS ALL LIGHTS ILLUMINATE INDICATING THEY ARE OPERATIONAL. IN APPROXIMATELY 5 SECONDS THE APPROPRIATE LAMP WILL ILLUMINATE:
RED (ILS) INDICATING A DETECTED FAULT, GREEN (CLS) INDICATING A GOOD UNIT AND RED (DATA IN) INDICATING A DETECTED FAULT IN THE 429 INPUT FROM THE CONTROL PANEL.

NOTES:
1 M87 ILS CONTROL PANEL (P8) CONSISTS OF A SIMULTANEOUS TRIPLE ILS CONTROLLER

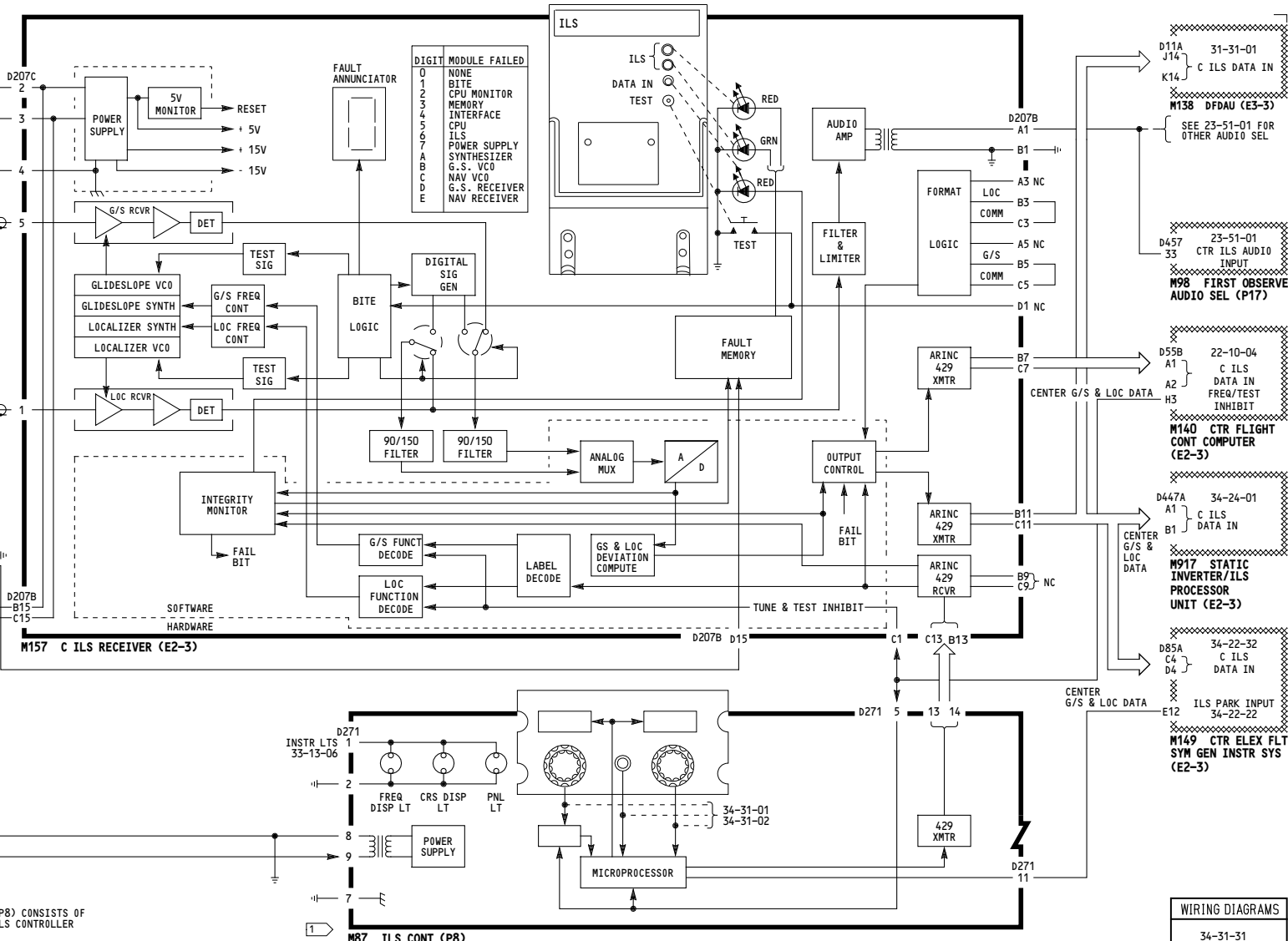

ILS - CENTER

D280N032S

WIRING DIAGRAMS
34-31-31

34-31-03

5021

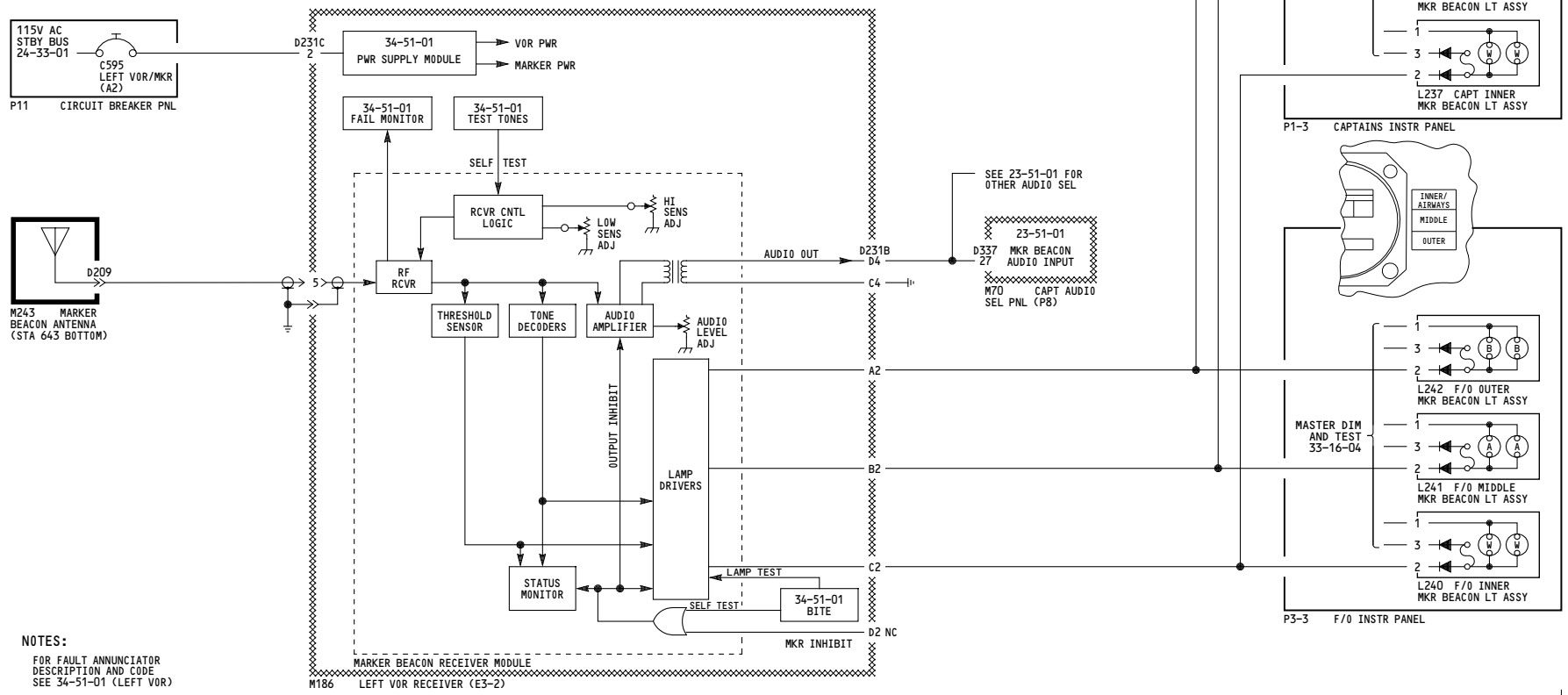

WIRING DIAGRAMS
34-32-11

NOTES:
FOR FAULT ANNUNCIATOR
DESCRIPTION AND CODE
SEE 34-51-01 (LEFT VOR)

001, 009	<p>MARKER BEACON</p> <p>D280N032S</p>
----------	--

34-32-01

Page 101

Jan 21/2005

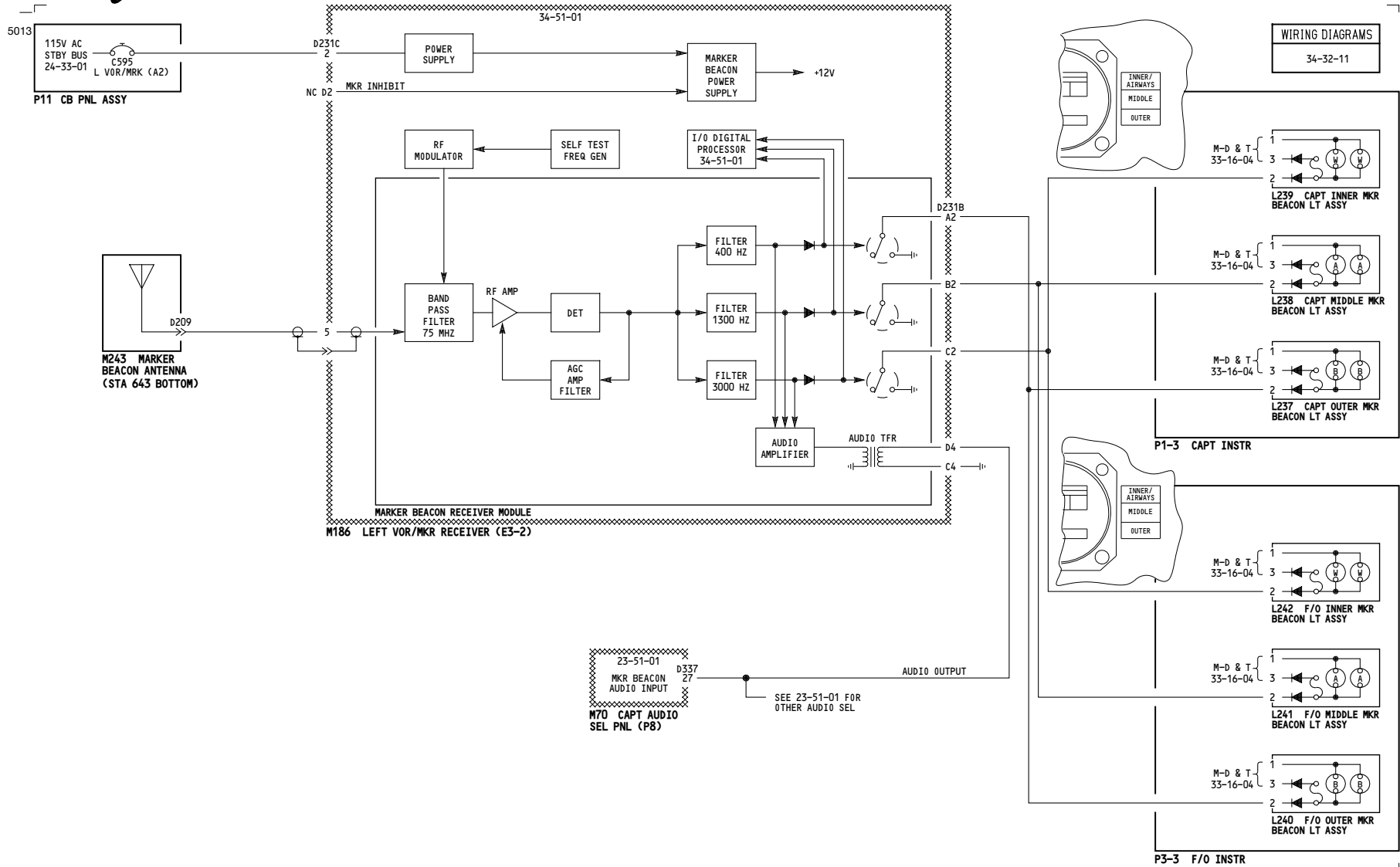

002-008, 010-099	MARKER BEACON
	D280N032S

34-32-01

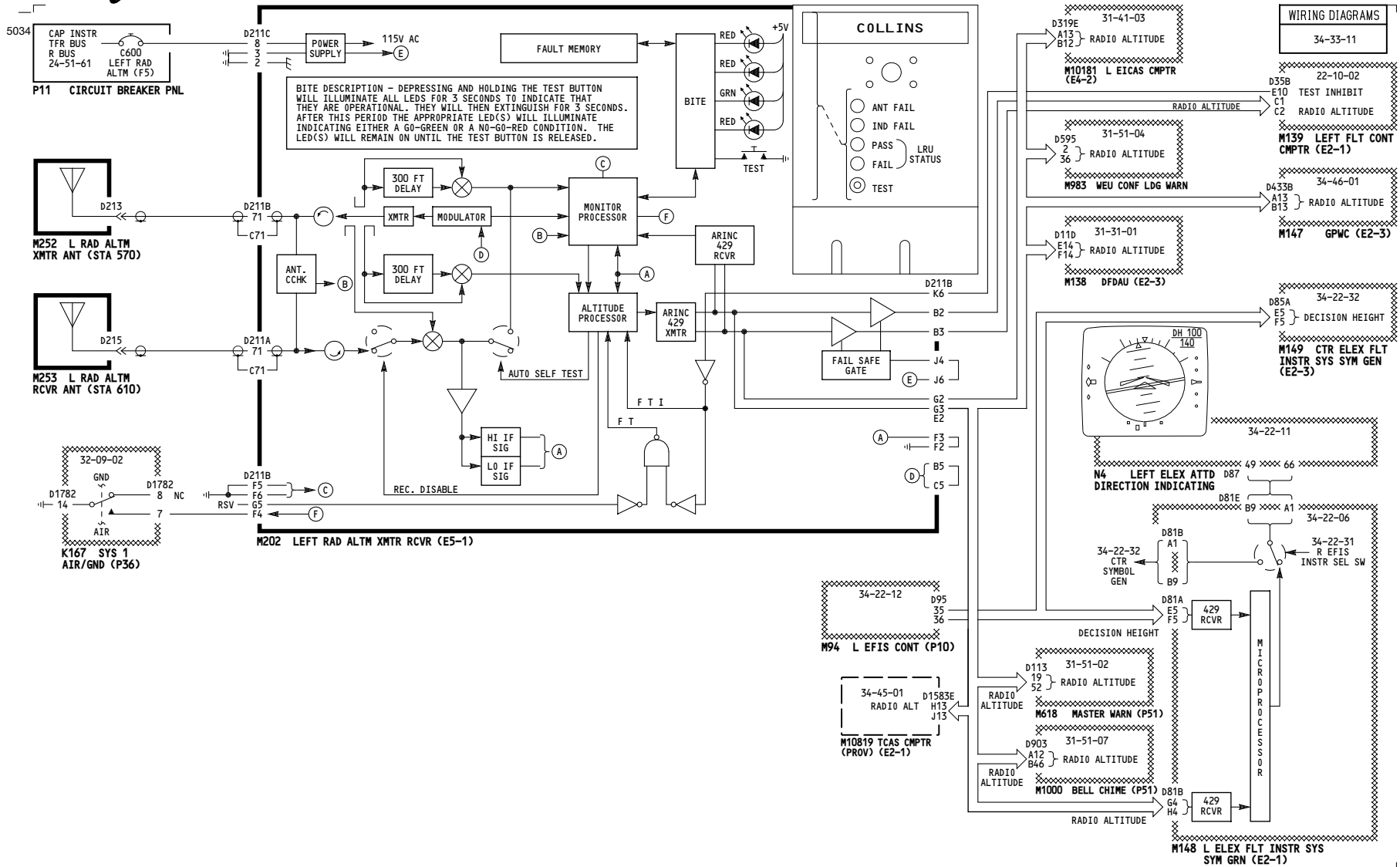

001-008, 010-099	<p>RADIO ALTIMETER - LEFT</p> <p>D280N032S</p>
------------------	---

34-33-01

5039

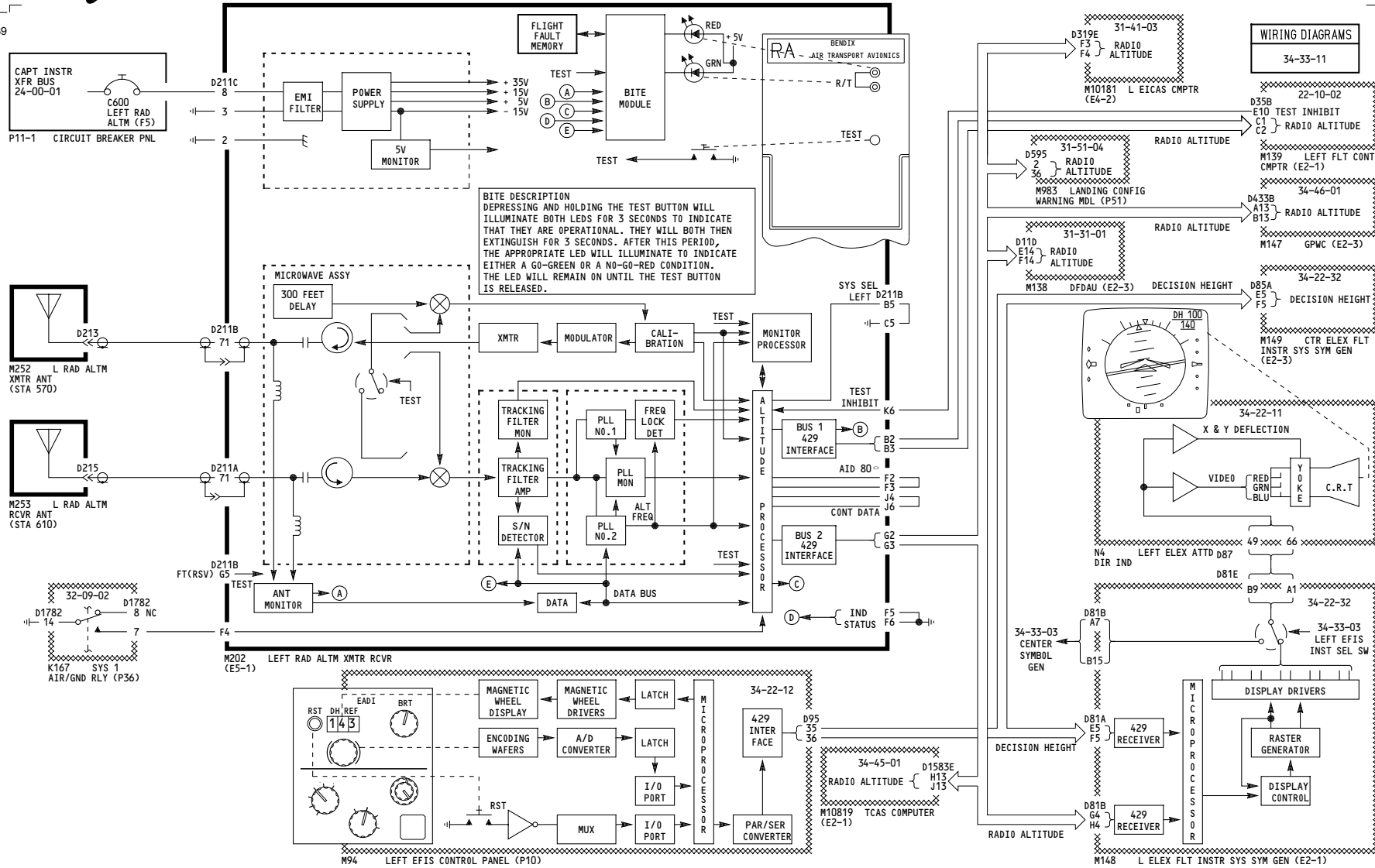

009

RADIO ALTIMETER - LEFT

D280N032S

34-33-01

5032

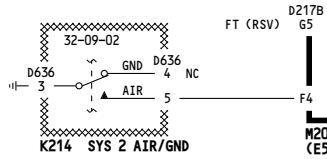
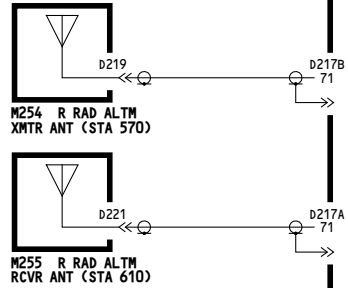
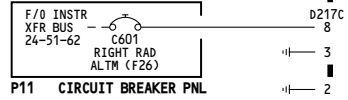

INTERNAL
SAME AS
M202
34-33-01

M203 R RAD ALTM XMTR RCVR (E5-2)

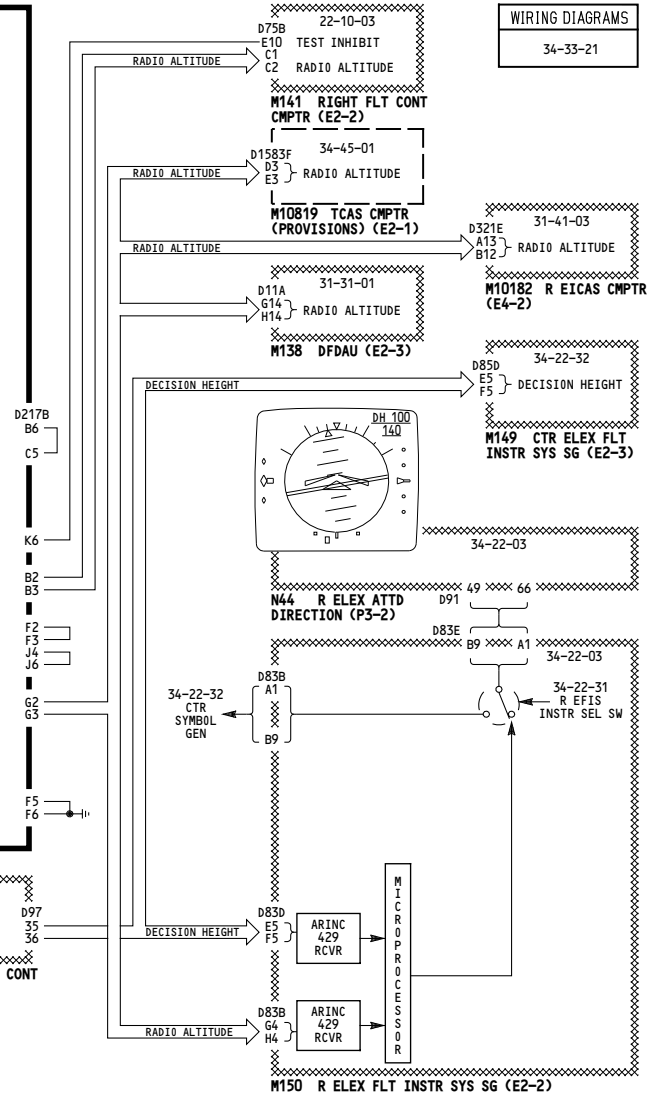

001-008, 010-099

RADIO ALTIMETER - RIGHT

D280N032S

34-33-02

Page 101

Jan 21/2005

WIRING DIAGRAMS
34-33-21

5105

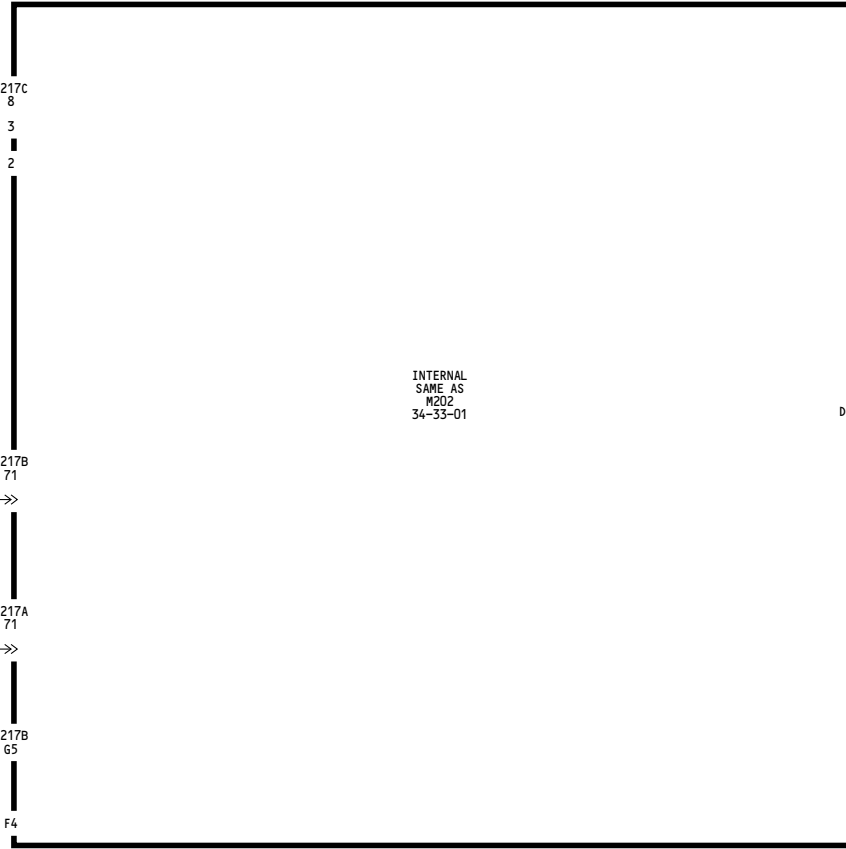
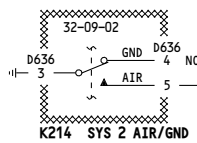
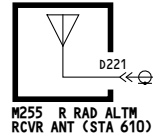
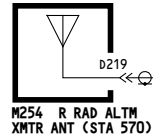
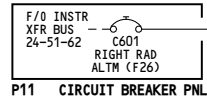

M203 R RAD ALTM XMTR RCVR (E5-2)

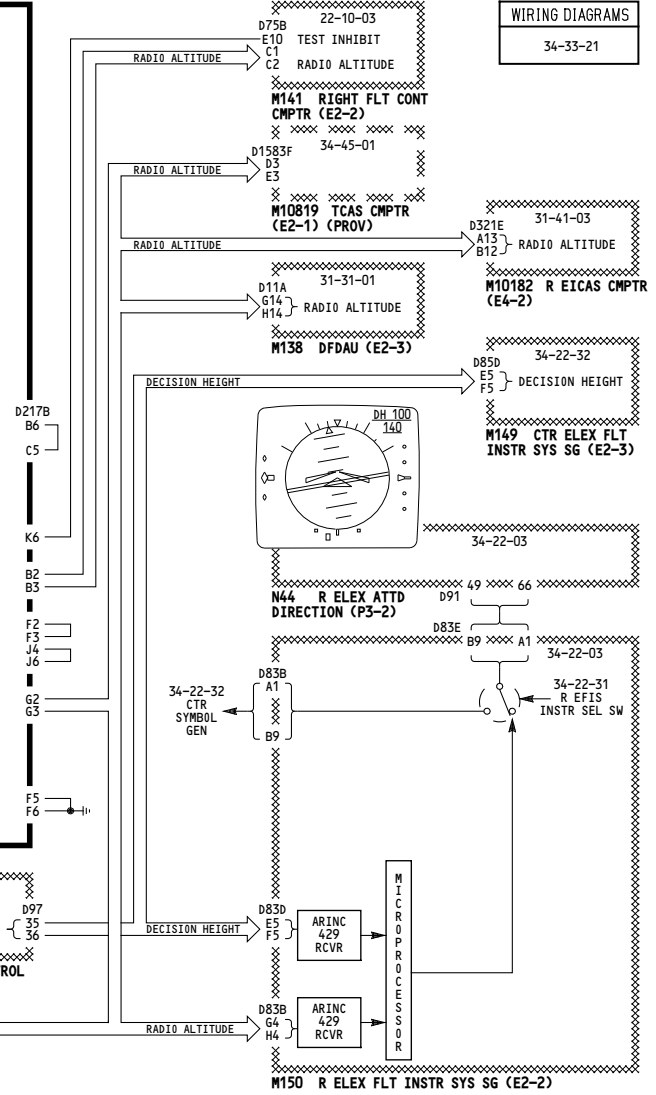
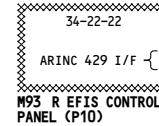
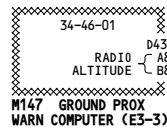
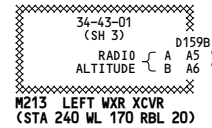

002	<p>RADIO ALTIMETER - RIGHT</p> <p style="font-size: 2em; font-weight: bold;">D280N032S</p>
-----	---

Incorporates
34-0200

34-33-02

Page 101.1

Jan 21/2005

WIRING DIAGRAMS
34-33-21

5031

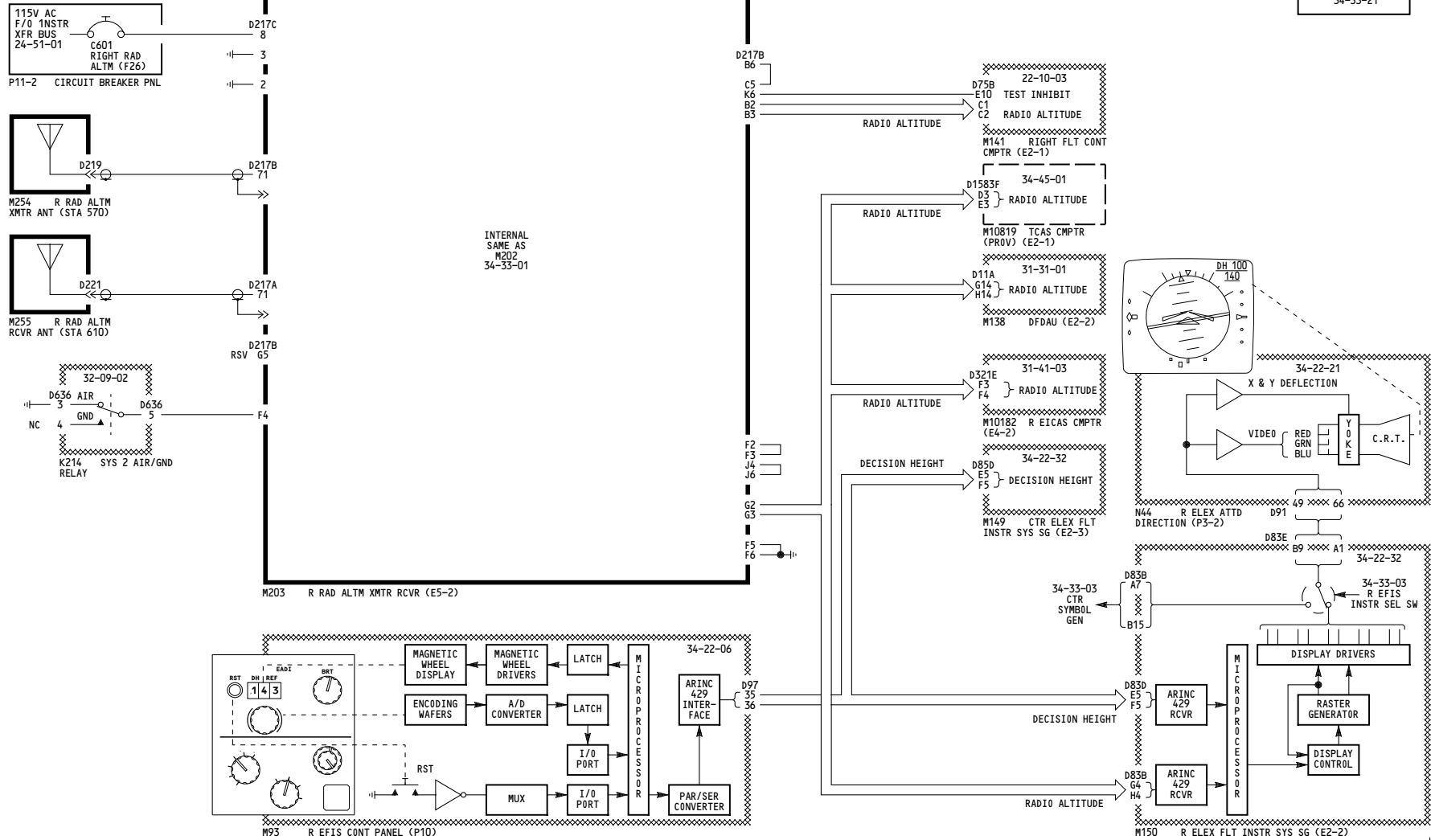

009

RADIO ALTIMETER - RIGHT

D280N032S

34-33-02

WIRING DIAGRAMS
34-33-31

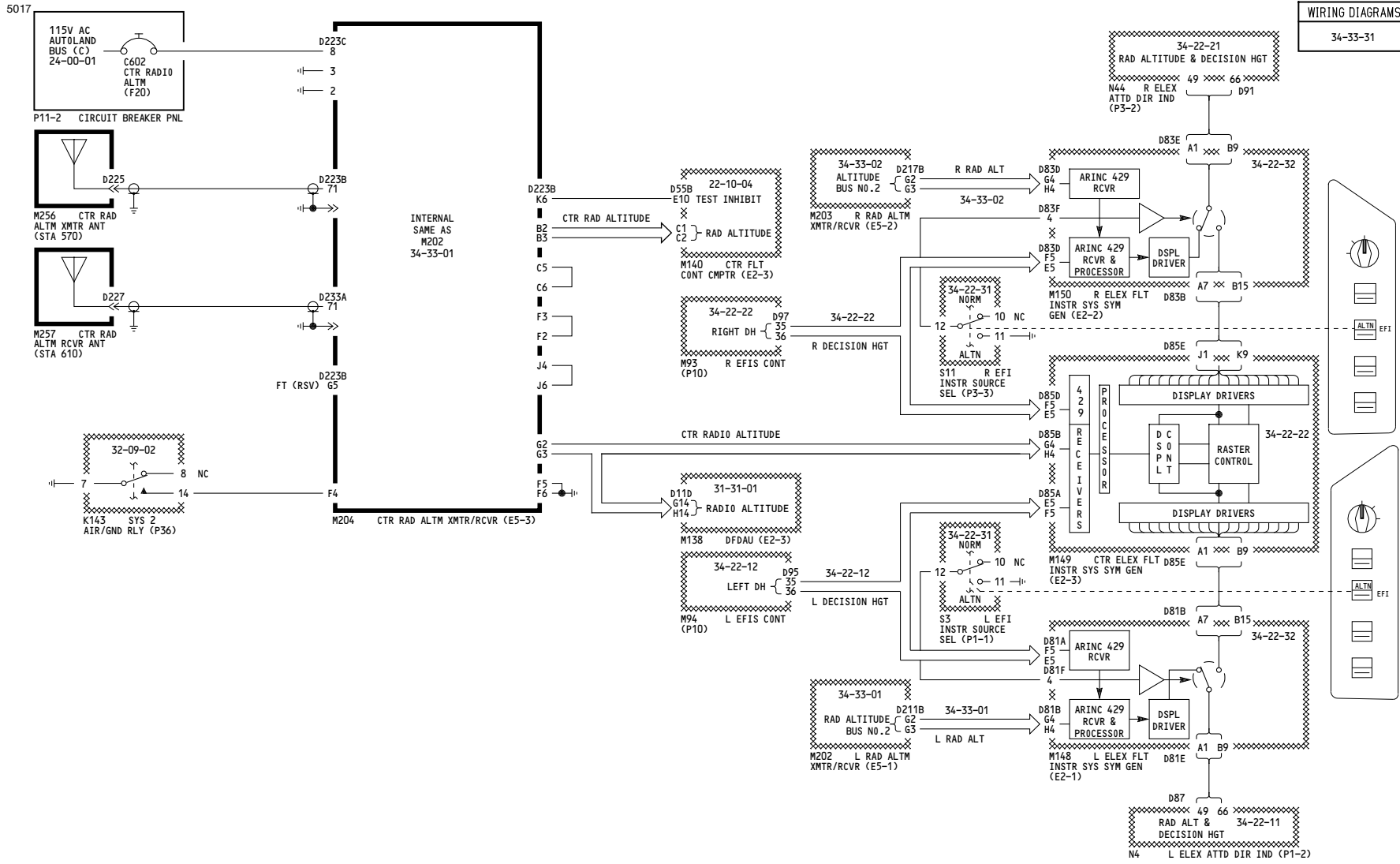

ALL	RADIO ALTIMETER - CENTER
D280N032S	

34-33-03

WIRING DIAGRAMS
34-33-31

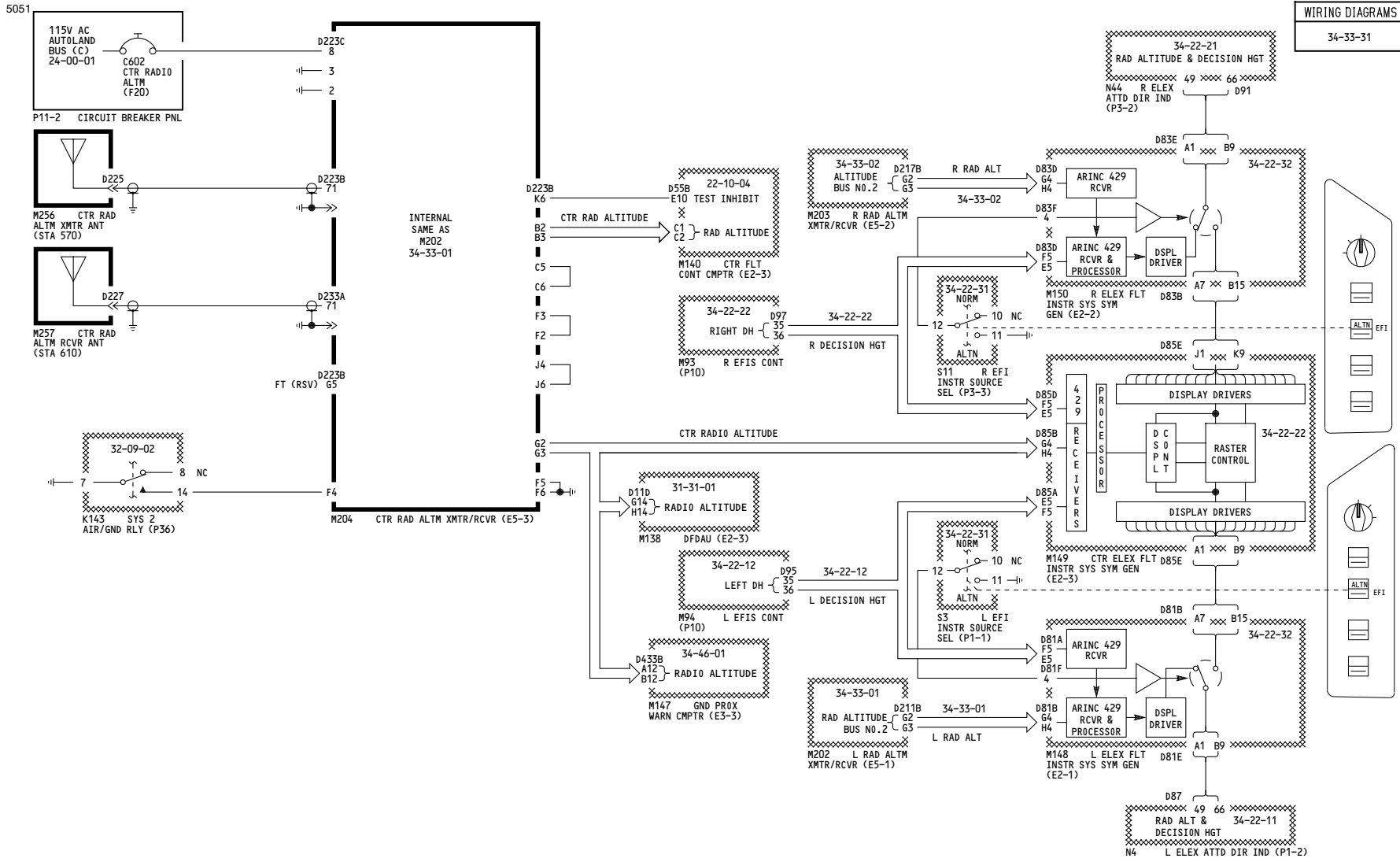

002	RADIO ALTIMETER - CENTER
	D280N032S

Incorporates
34-0200

34-33-03

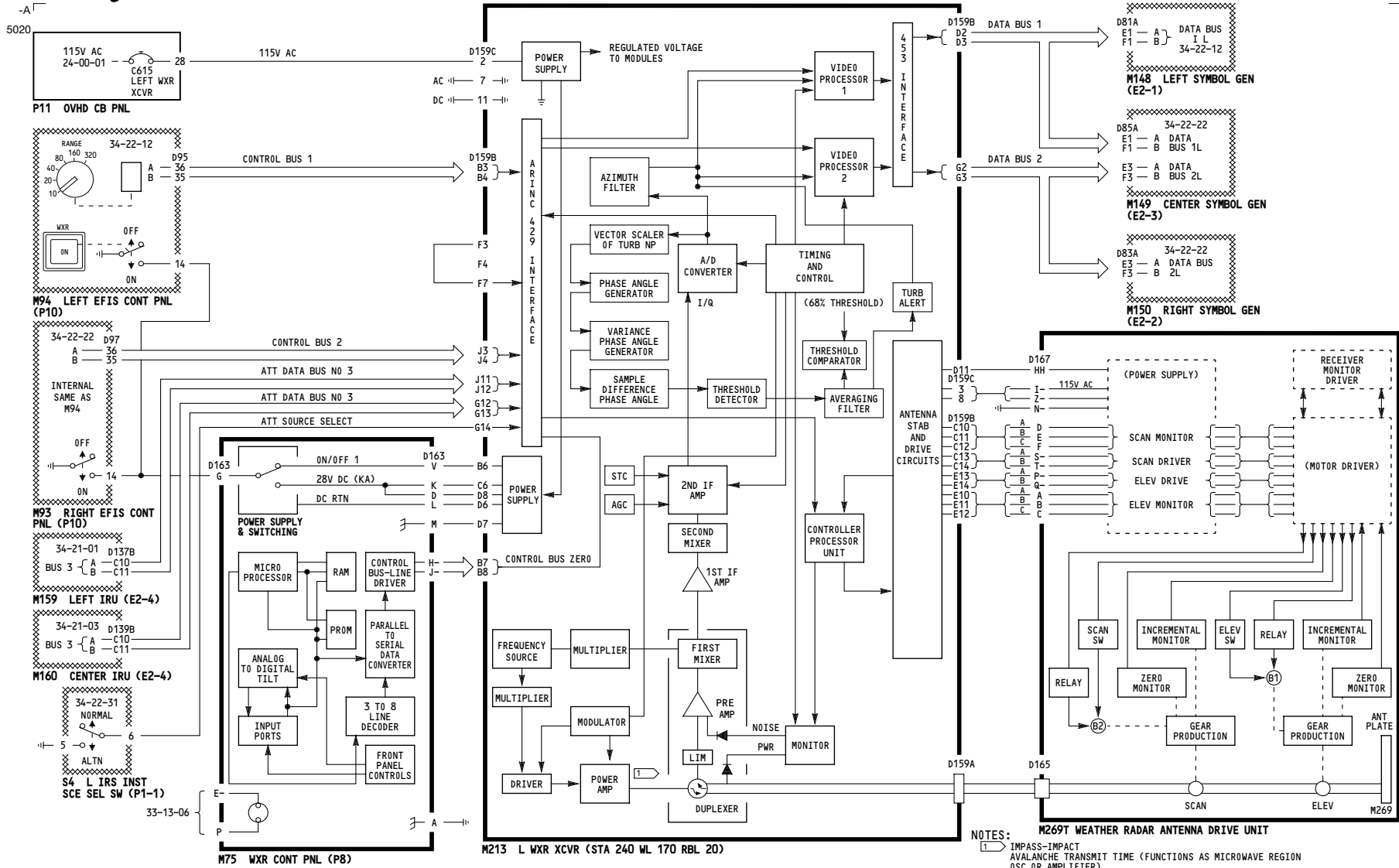

NOTES:
 1 IMPASS-IMPACT AVALANCHE TRANSMIT TIME (FUNCTIONS AS MICROWAVE REGION OSC OR AMPLIFIER)

001-008, 010-099	WEATHER RADAR D280N032S
------------------	---------------------------------------

34-43-01

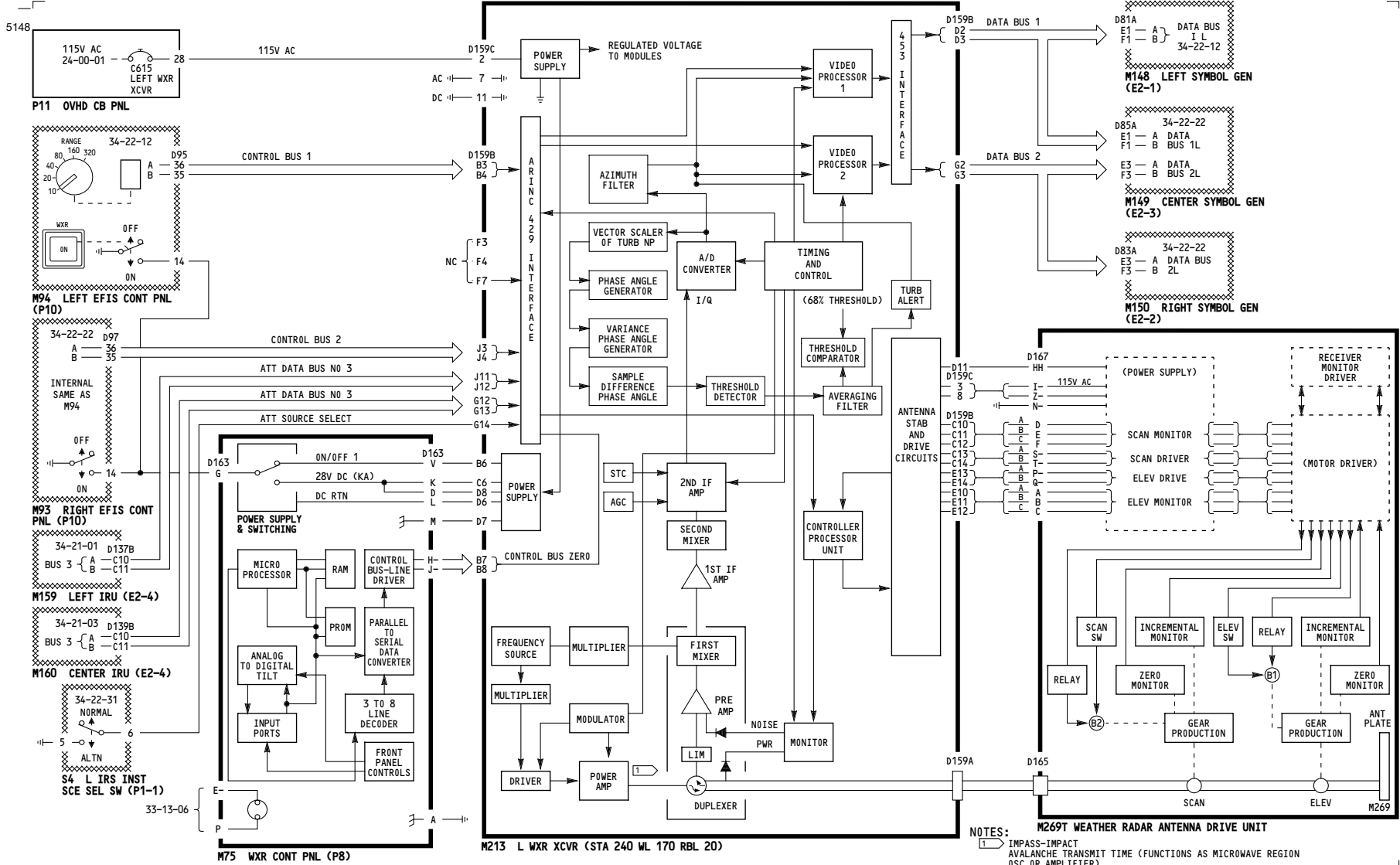

NOTES:
 ① IMPASS-IMPACT
 AVALANCHE TRANSMIT TIME (FUNCTIONS AS MICROWAVE REGION OSC OR AMPLIFIER)

001

WEATHER RADAR

Incorporates
 34-0394 R02

D280N032S

34-43-01

Page 101.1

May 06/2009

5111

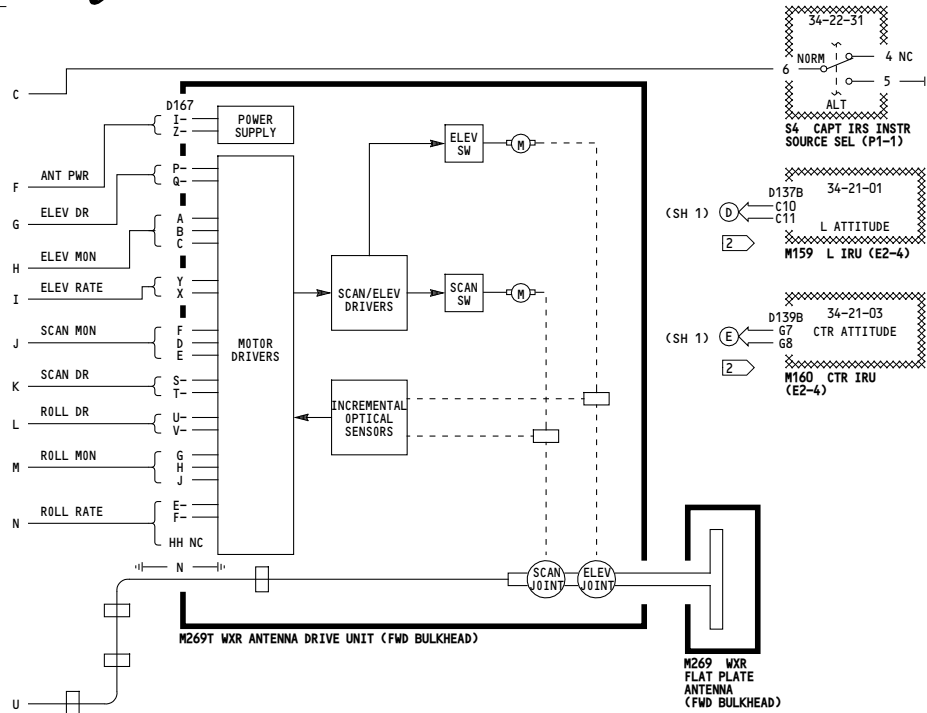

WIRING DIAGRAMS	
34-43-11	
34-43-12	
34-43-14	
34-43-15	

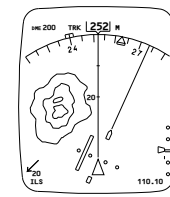
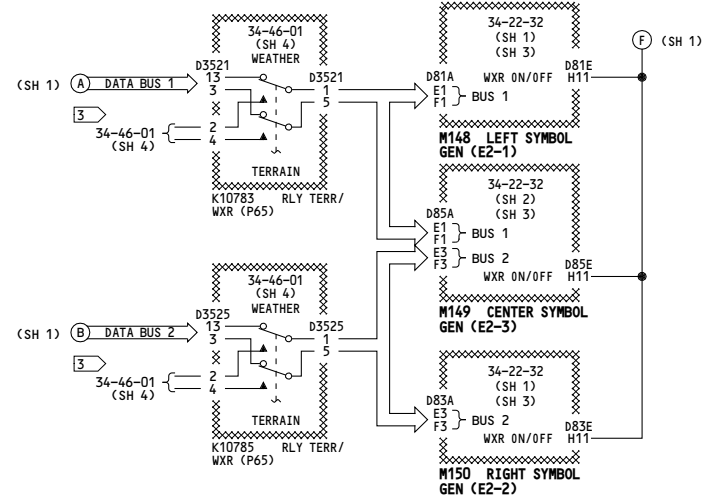

TYP DISPLAY

002	WEATHER RADAR	Incorporates 34-0200
	D280N032S	

34-43-01

Page 101.2
Sheet 2
May 06/2009

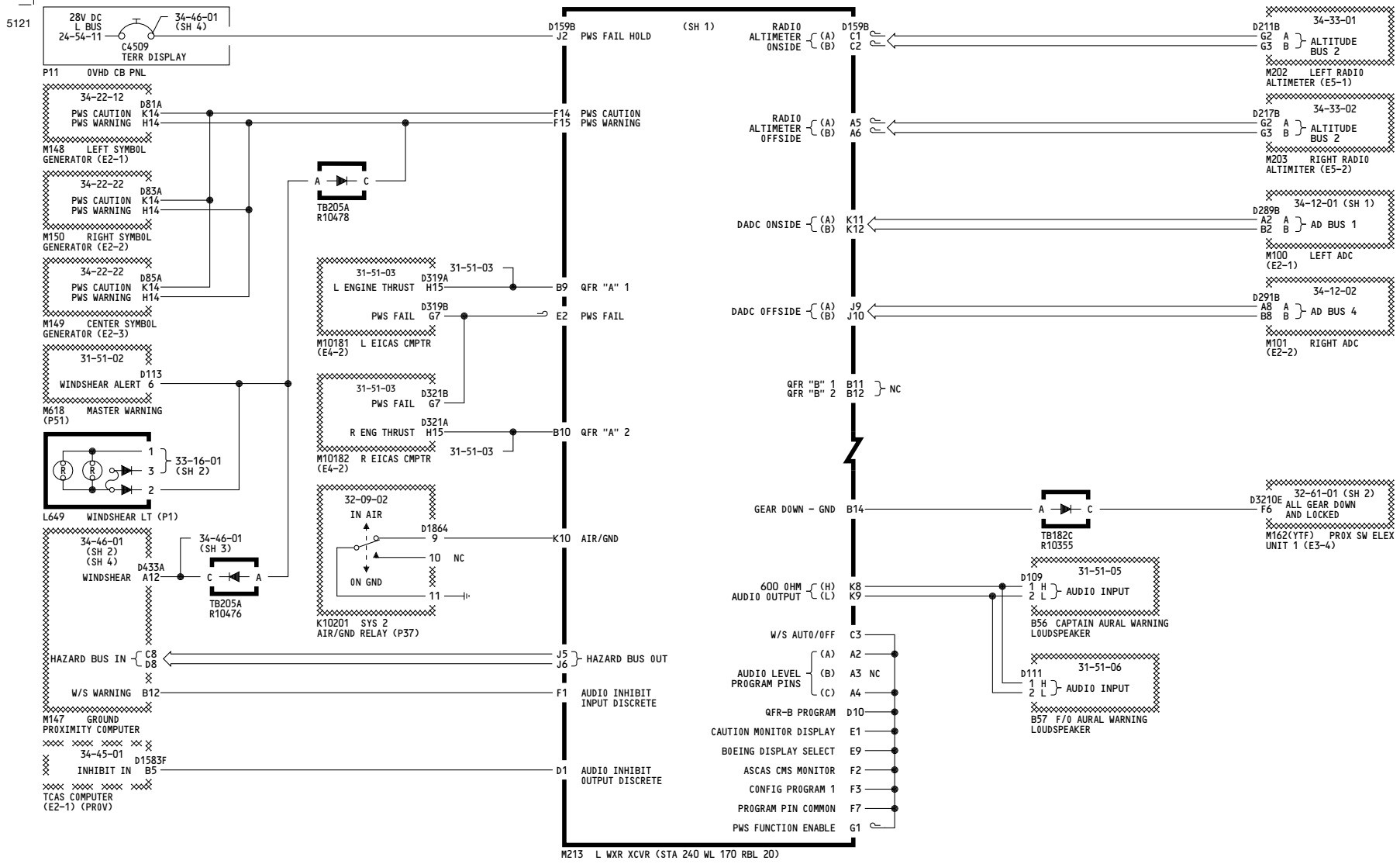

002

WEATHER RADAR

D280N032S

Incorporates
 34-0200

34-43-01

Page 101.2
 Sheet 3
 May 06/2009

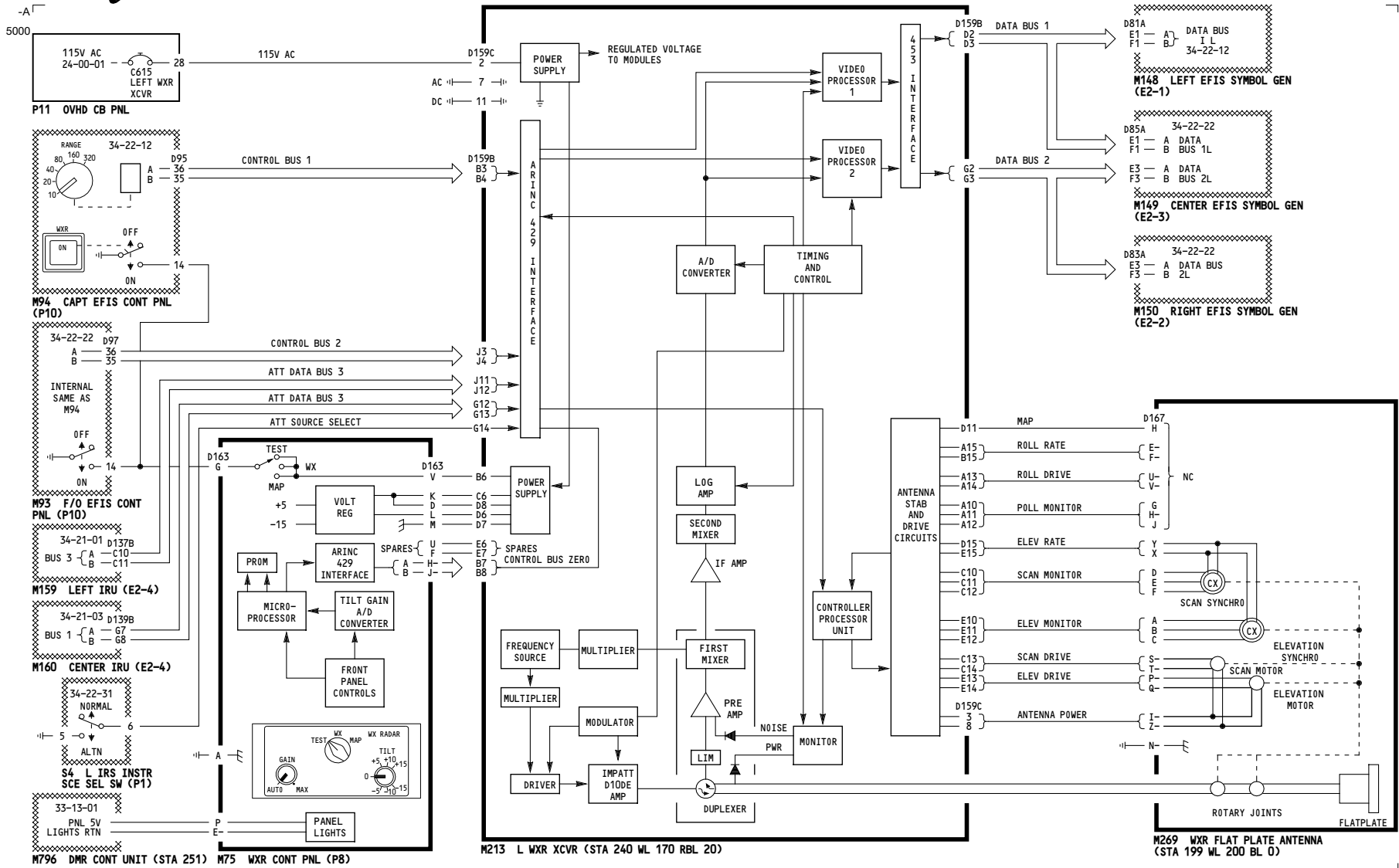

009

WEATHER RADAR

D280N032S

34-43-01

Page 102

Jan 21/2005

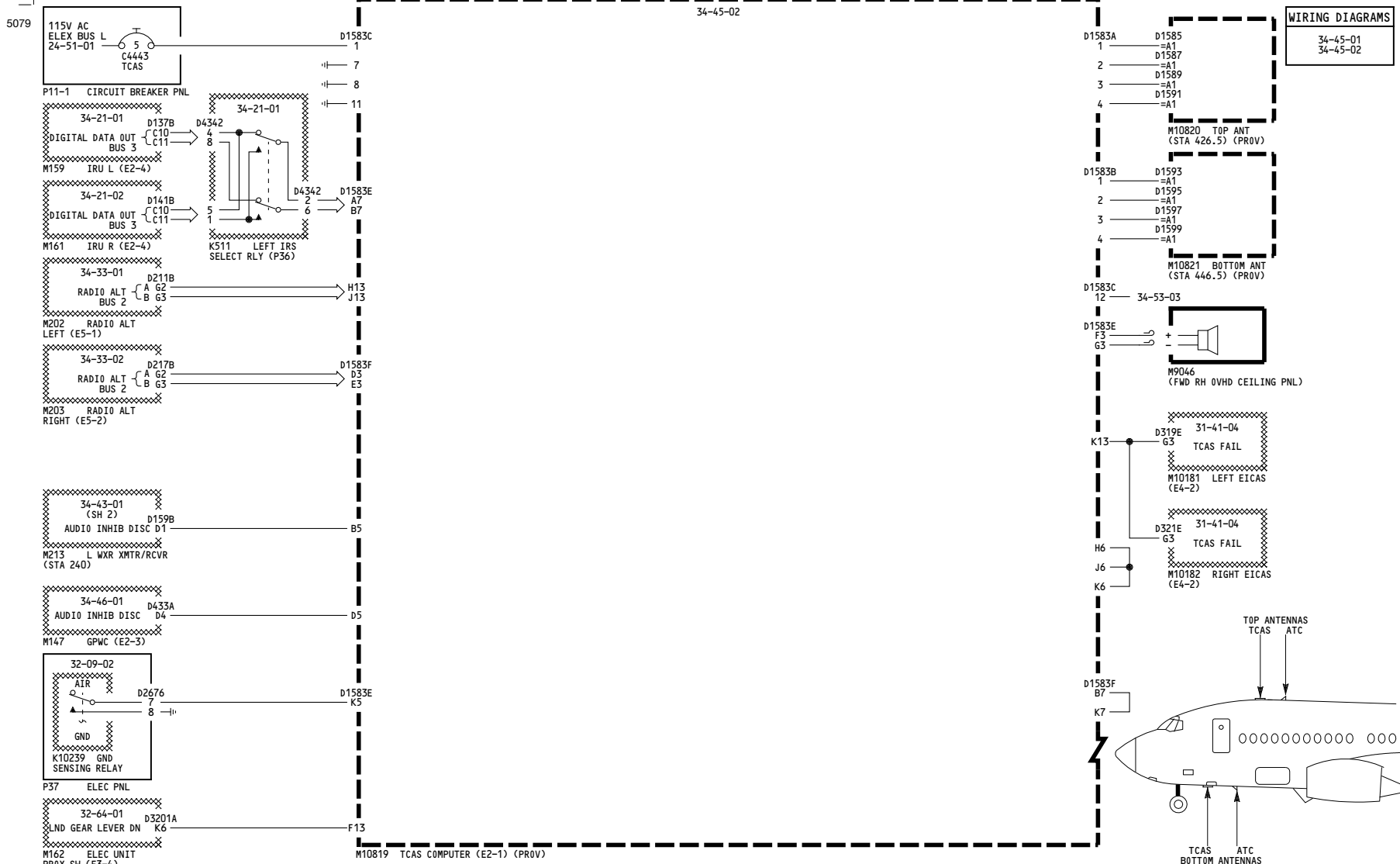

002

TRAFFIC ALERT AND COLL AVD SYSTEM (TCAS) POWER, INPUT, OUTPUT

Incorporates
34-0200

D280N032S

34-45-01

Page 101.1

Jan 21/2005

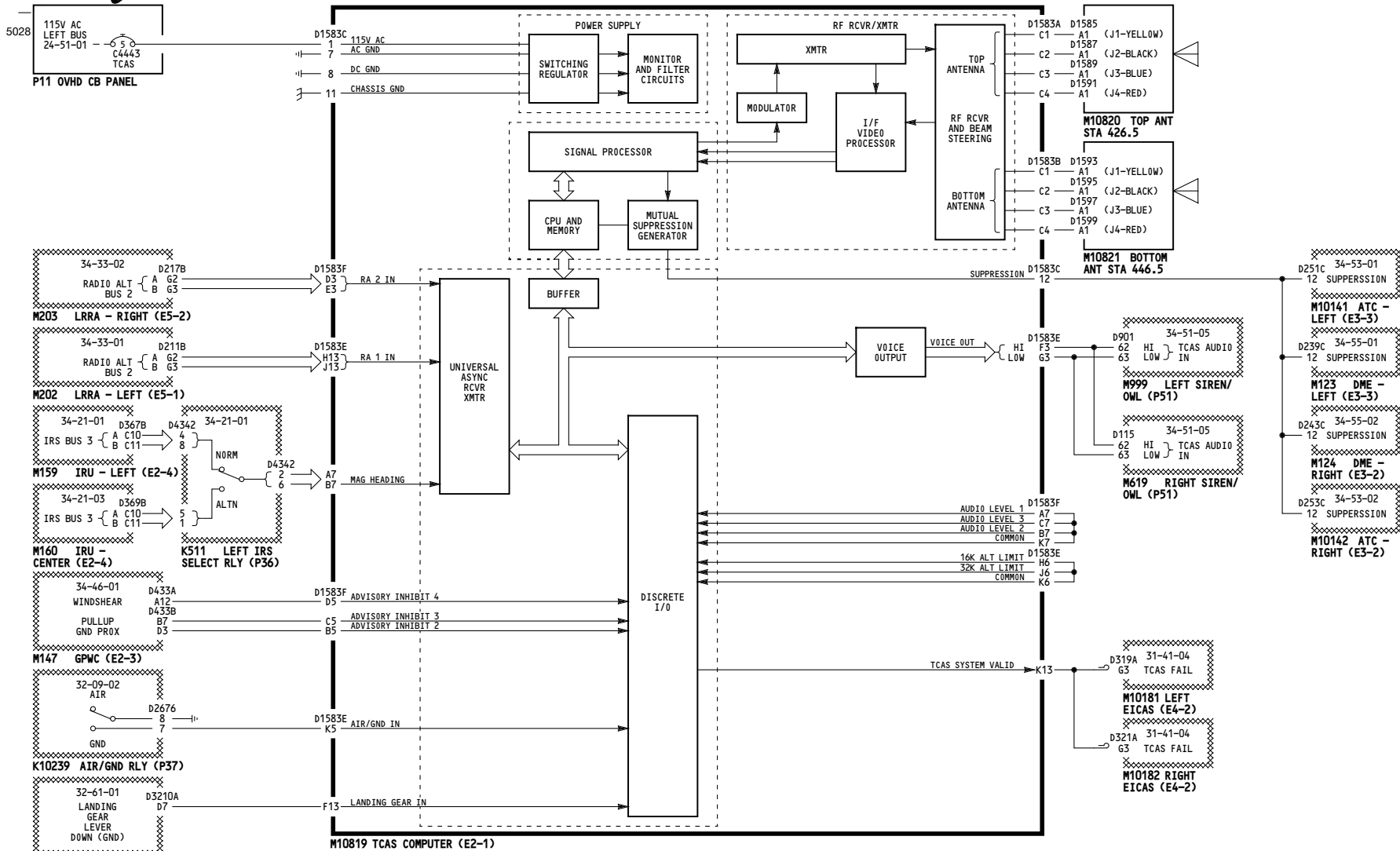

009-011

**TRAFFIC ALERT AND COLL
AVD SYSTEM (TCAS) POWER,
INPUT, OUTPUT**

Incorporates
34-0097

D280N032S

34-45-01

Page 102.1

Jan 21/2005

5064

WIRING DIAGRAMS
34-45-01
34-45-02

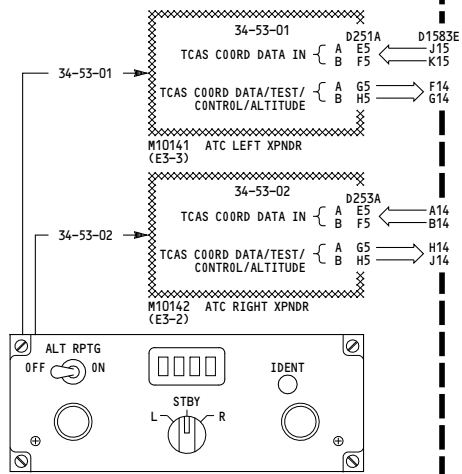

NOTES:
1 TYPICAL TCAS TEST MODE DISPLAYED
AURAL-"TCAS SYSTEM TEST OK"
OR "TCAS SYSTEM TEST FAIL"

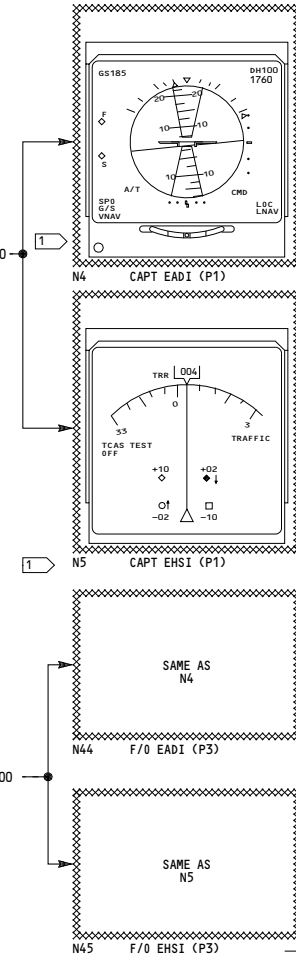
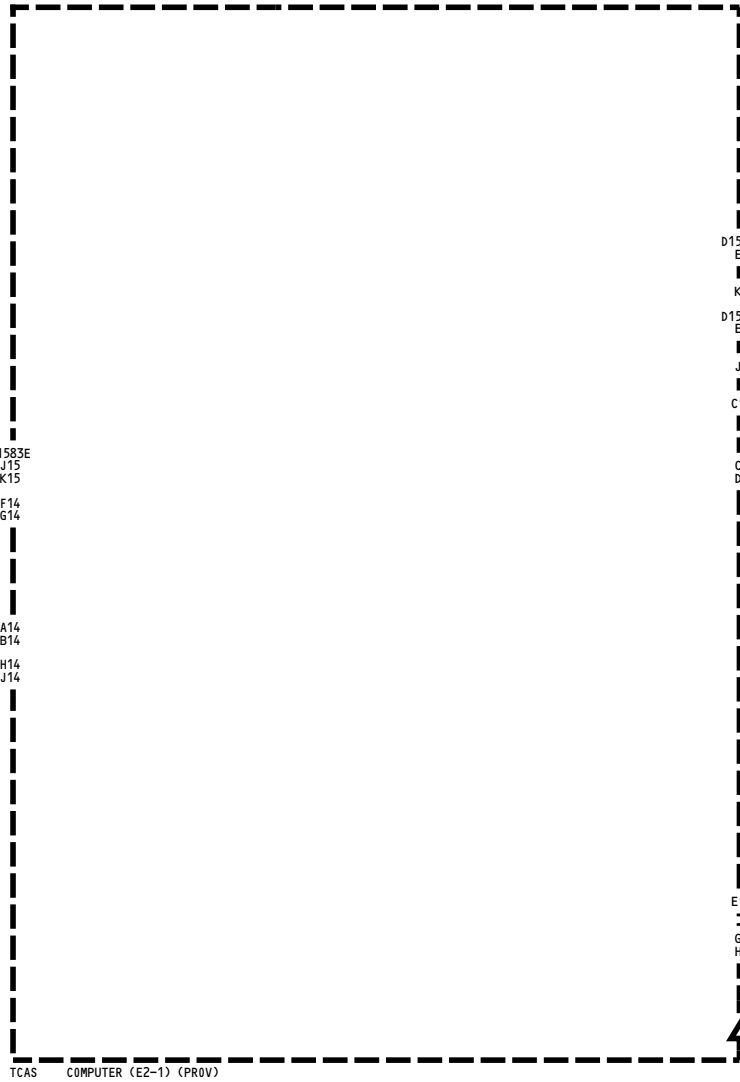

002

TRAFFIC ALERT AND COLL AVD SYSTEM (TCAS) CONTROL AND DISPLAY

D280N032S

Incorporates
34-0200

34-45-02

Page 101.1

Jan 21/2005

5029

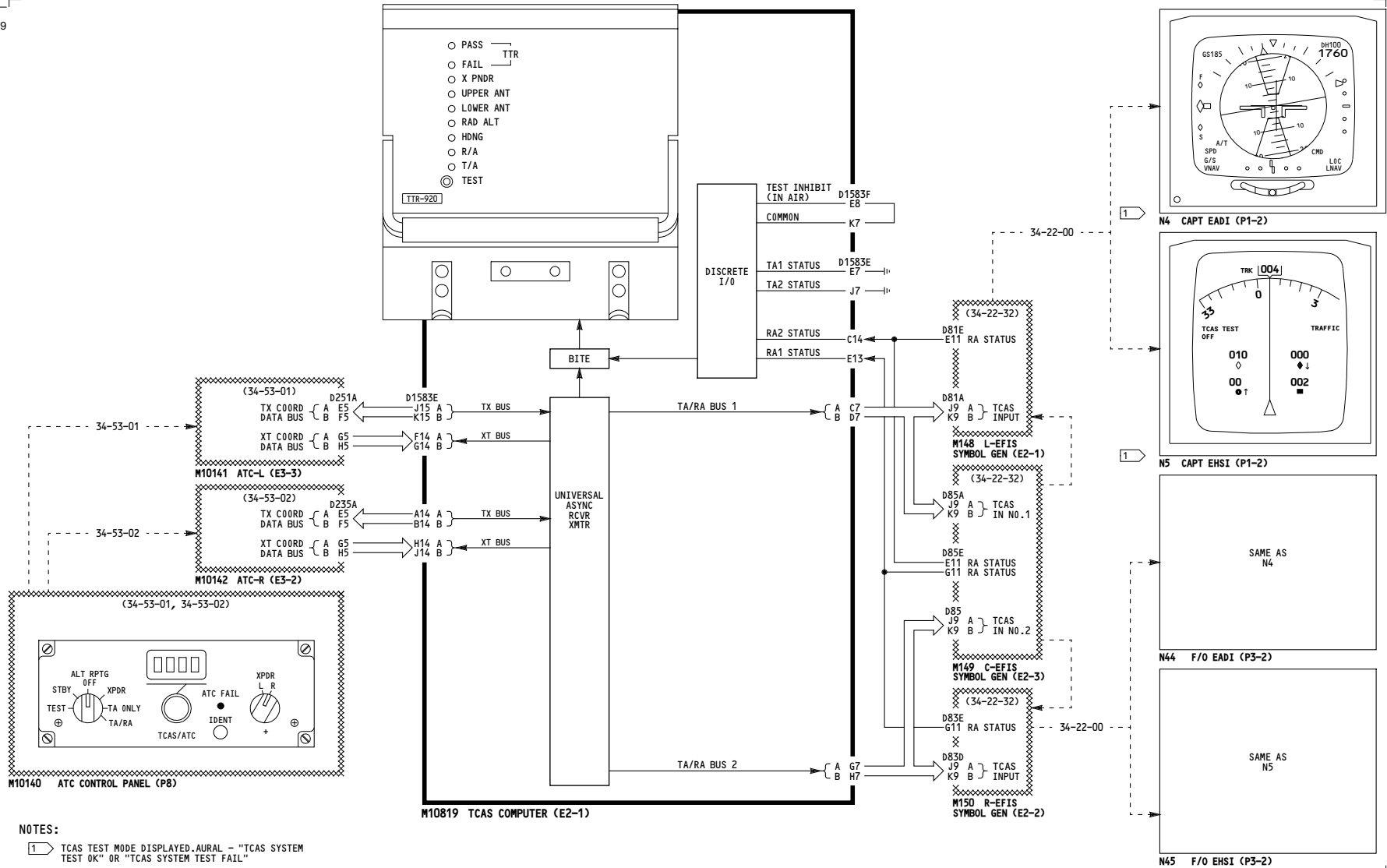

NOTES:
 1 TCAS TEST MODE DISPLAYED: AURAL - "TCAS SYSTEM TEST OK" OR "TCAS SYSTEM TEST FAIL"

009-011

**TRAFFIC ALERT AND COLL
 AVD SYSTEM (TCAS) CONTROL
 AND DISPLAY**

Incorporates
 34-0097

D280N032S

34-45-02

Page 102.1

Jan 21/2005

5023

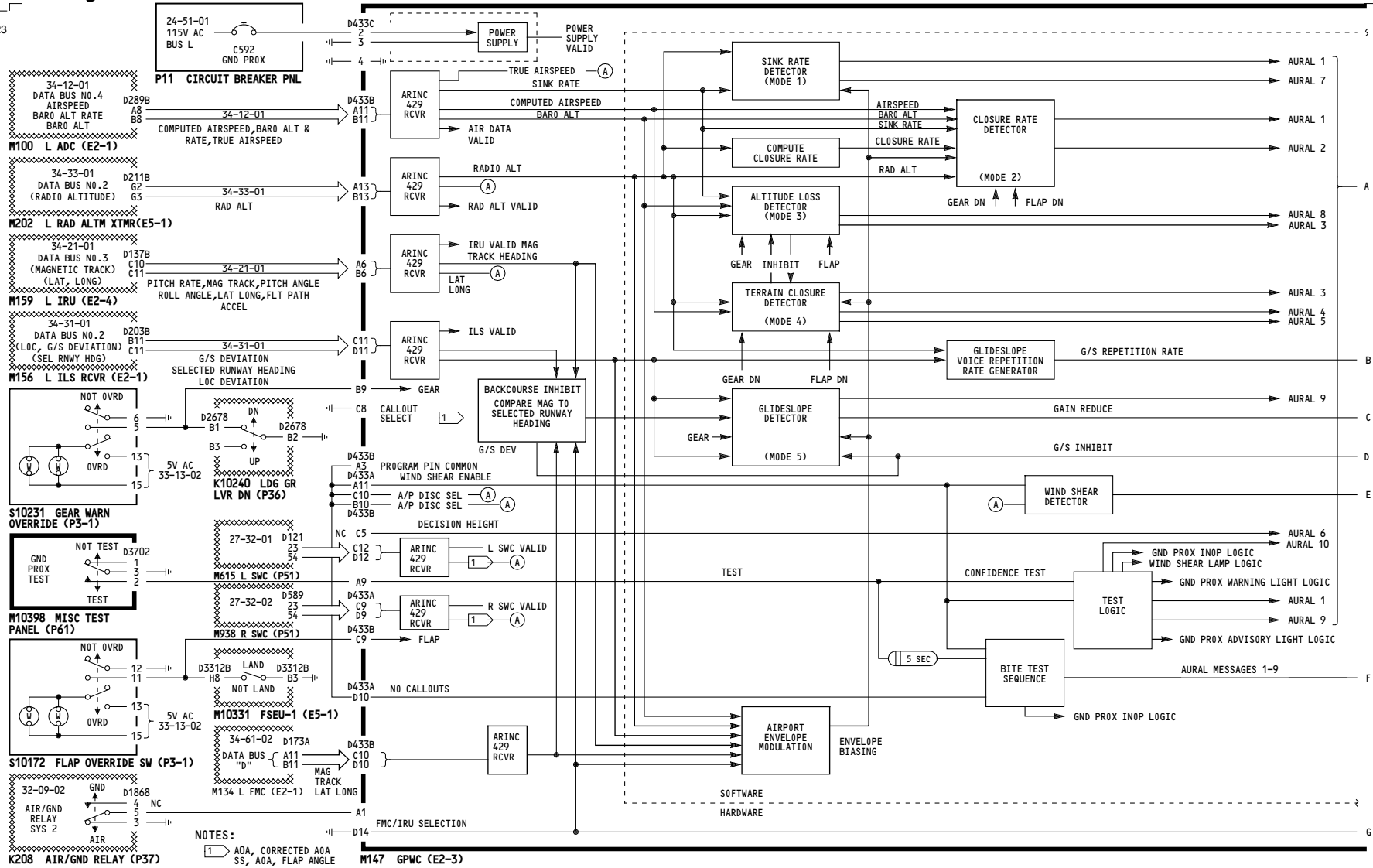

001-008, 010-099

GROUND PROXIMITY WARNING SYSTEM

D280N032S

34-46-01

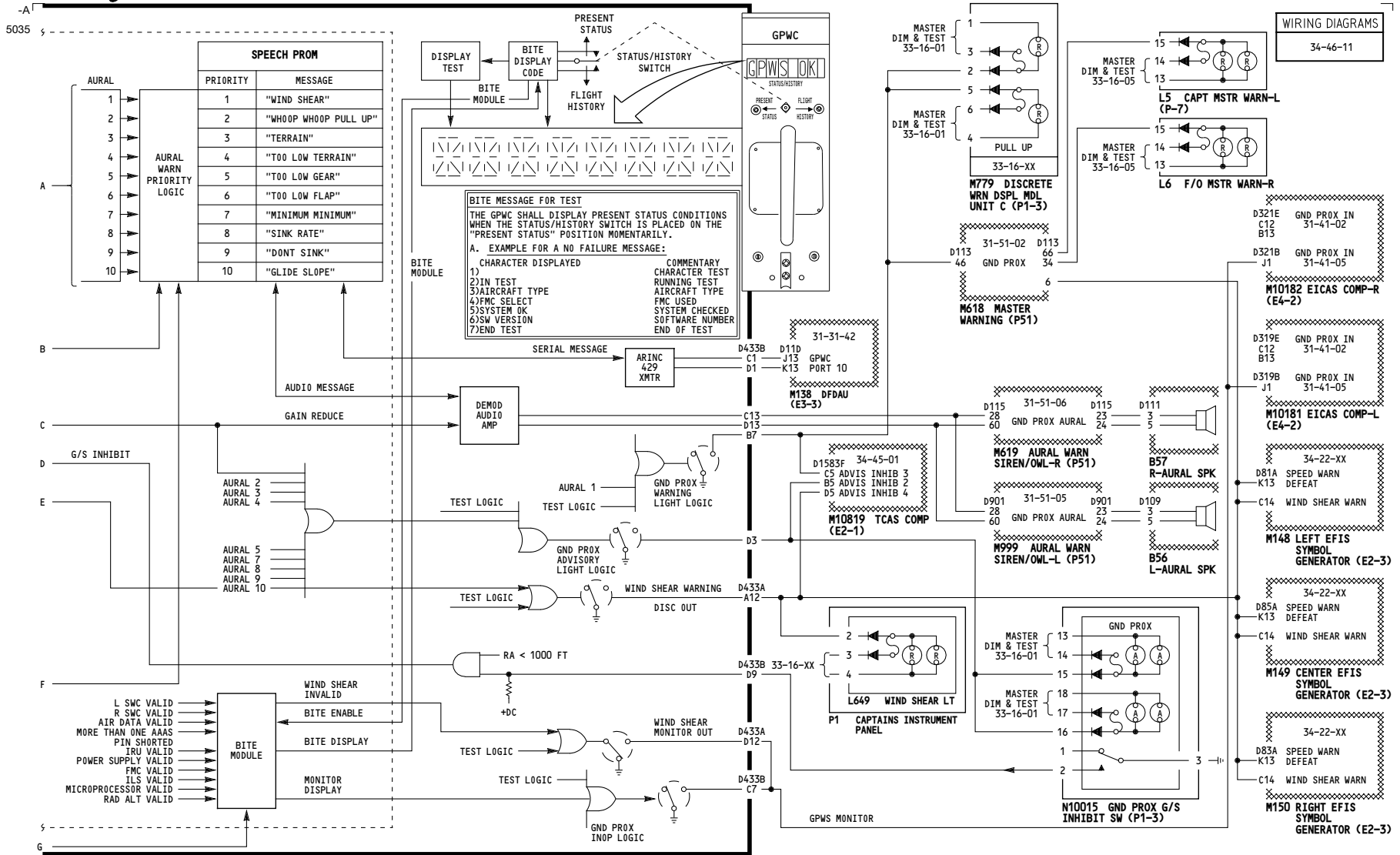

001-008, 010-099

GROUND PROXIMITY WARNING SYSTEM

D280N032S

34-46-01

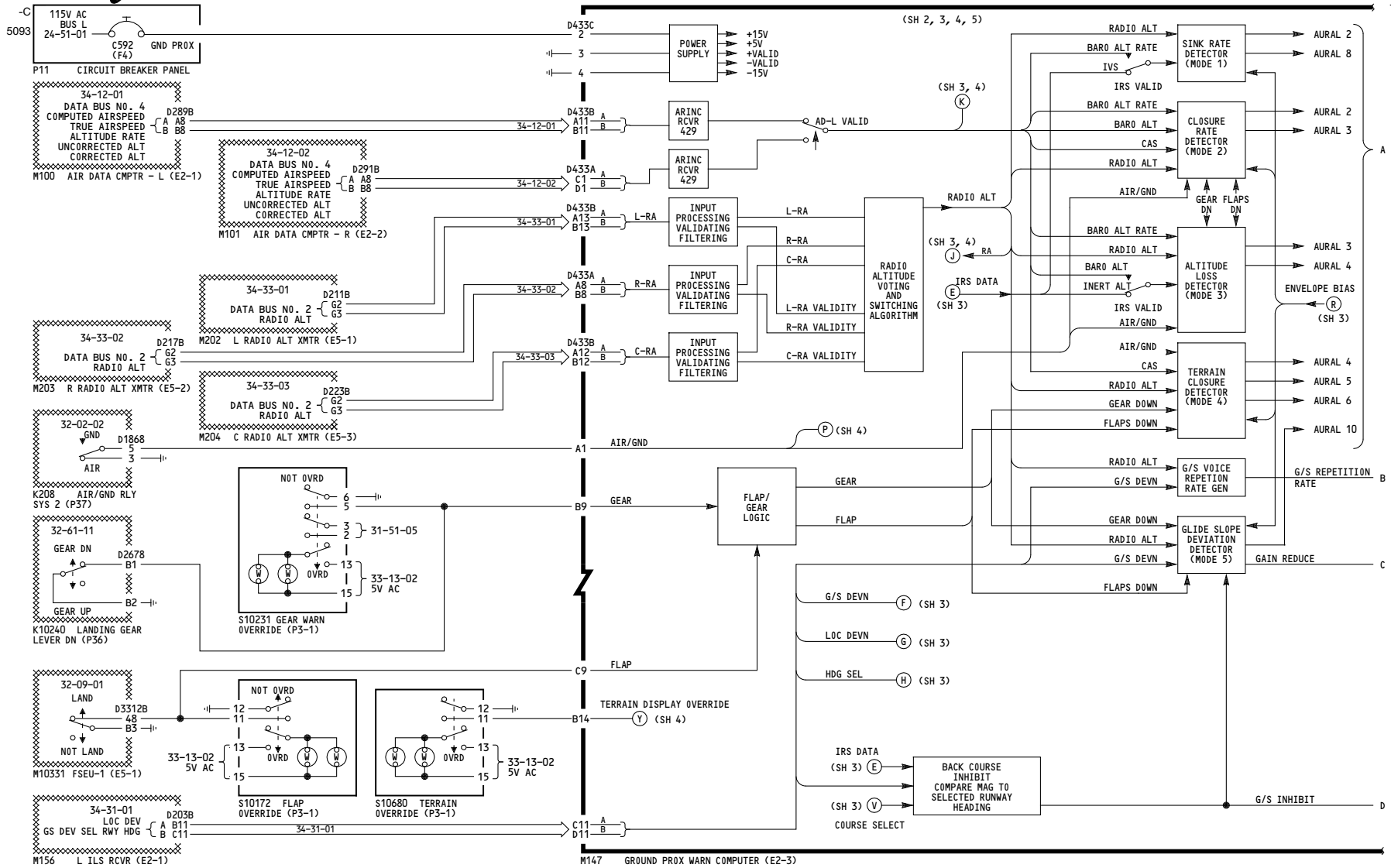

002

GROUND PROXIMITY WARNING SYSTEM

D280N032S

Incorporates
34-0200

34-46-01

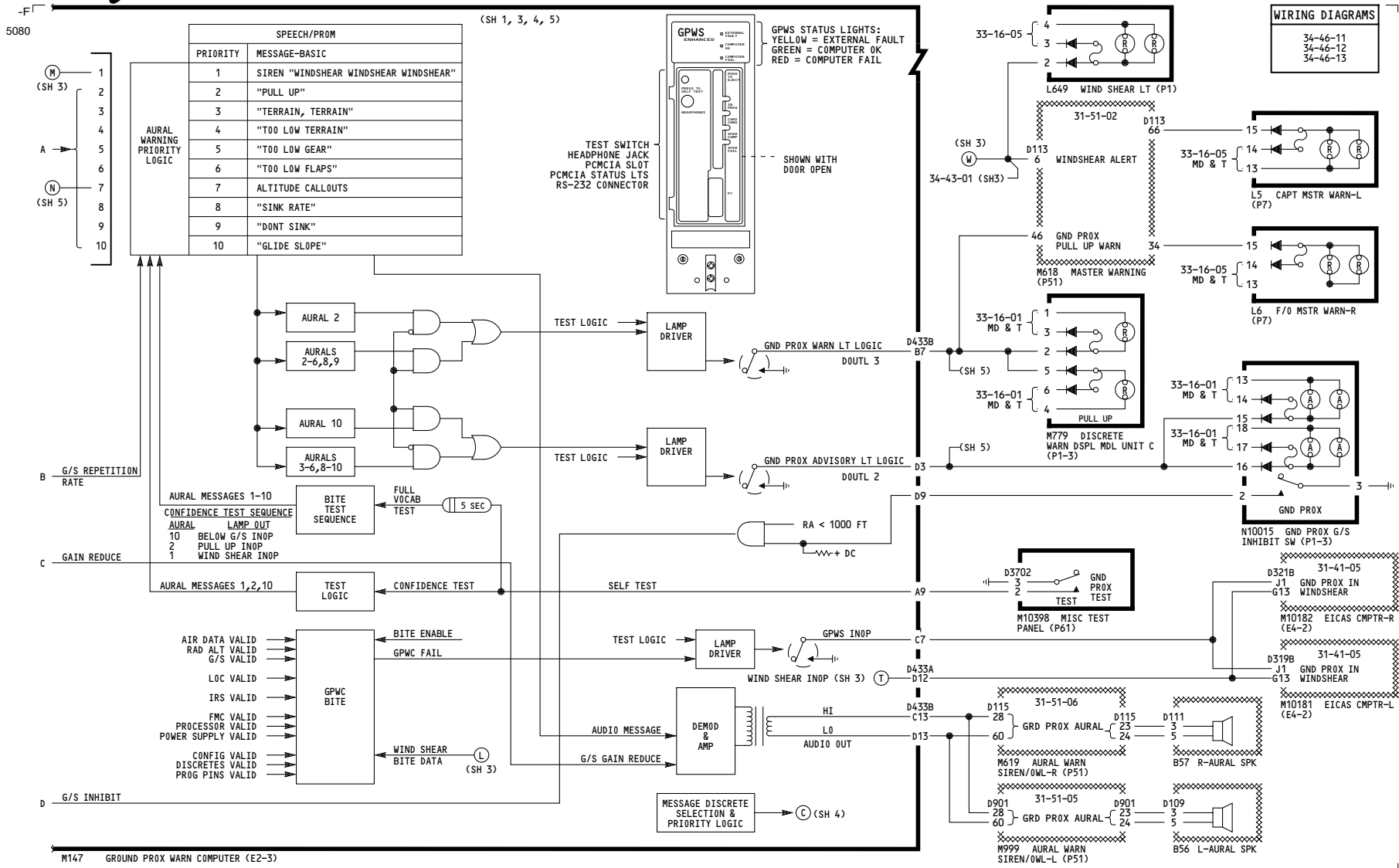

002

GROUND PROXIMITY WARNING SYSTEM

D280N032S

34-46-01

Page 101.1
 Sheet 2
 Dec 18/2007

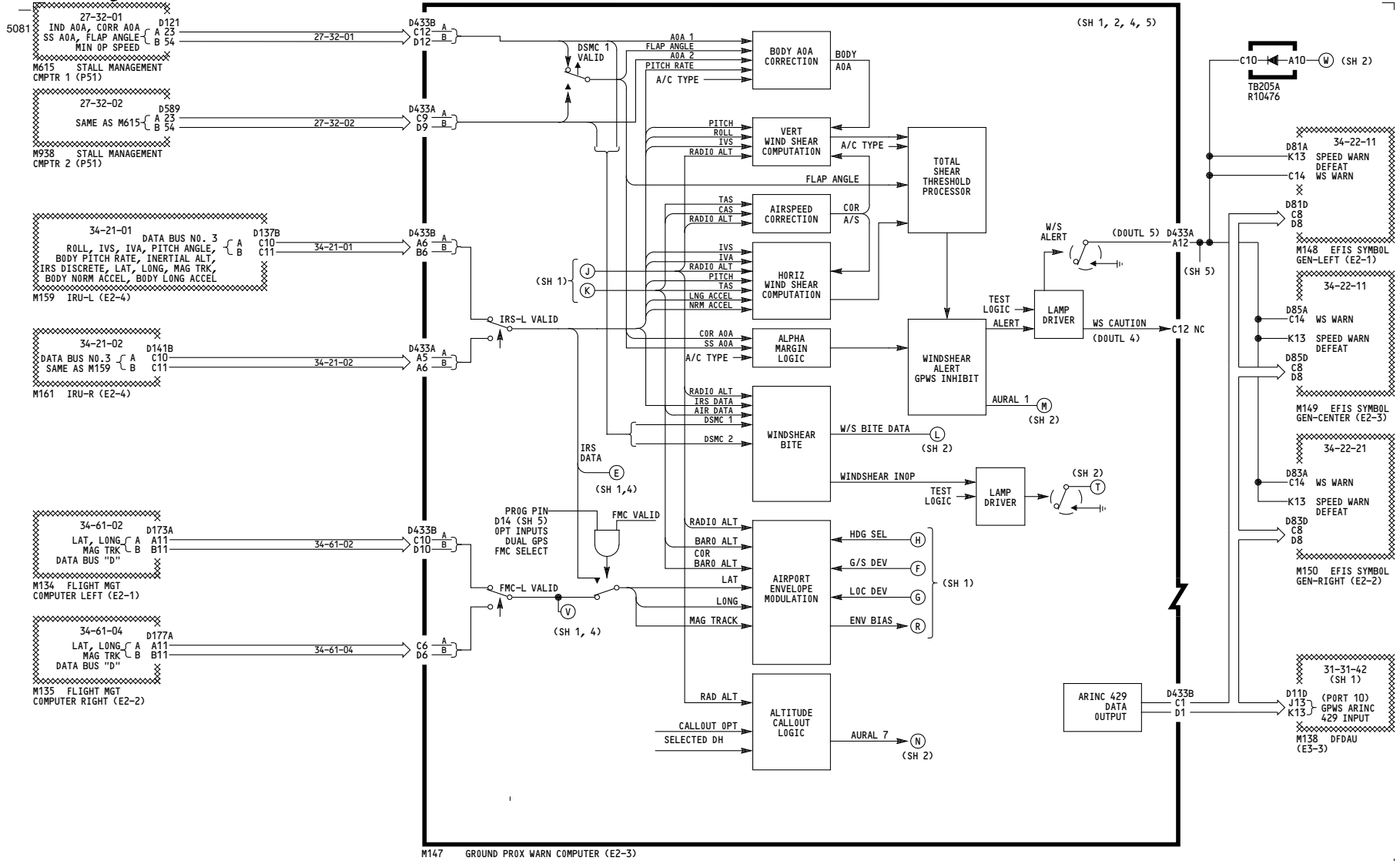

002

GROUND PROXIMITY WARNING SYSTEM

Incorporates 34-0200

D280N032S

34-46-01

Page 101.1
Sheet 3
Jan 21/2005

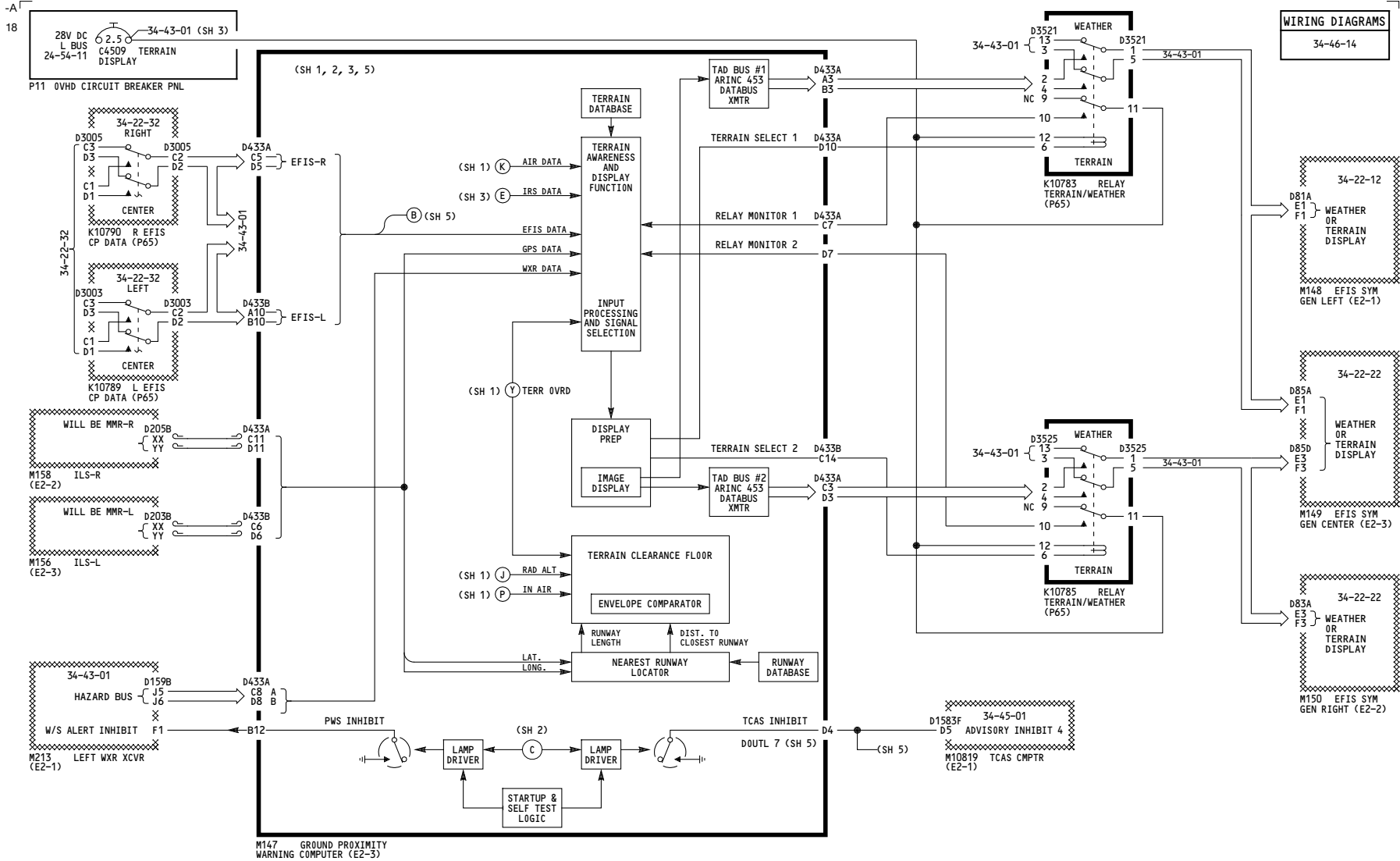

002

GROUND PROXIMITY WARNING SYSTEM

Incorporates
34-0200

D280N032S

34-46-01

Page 101.1
Sheet 4
Jan 21/2005

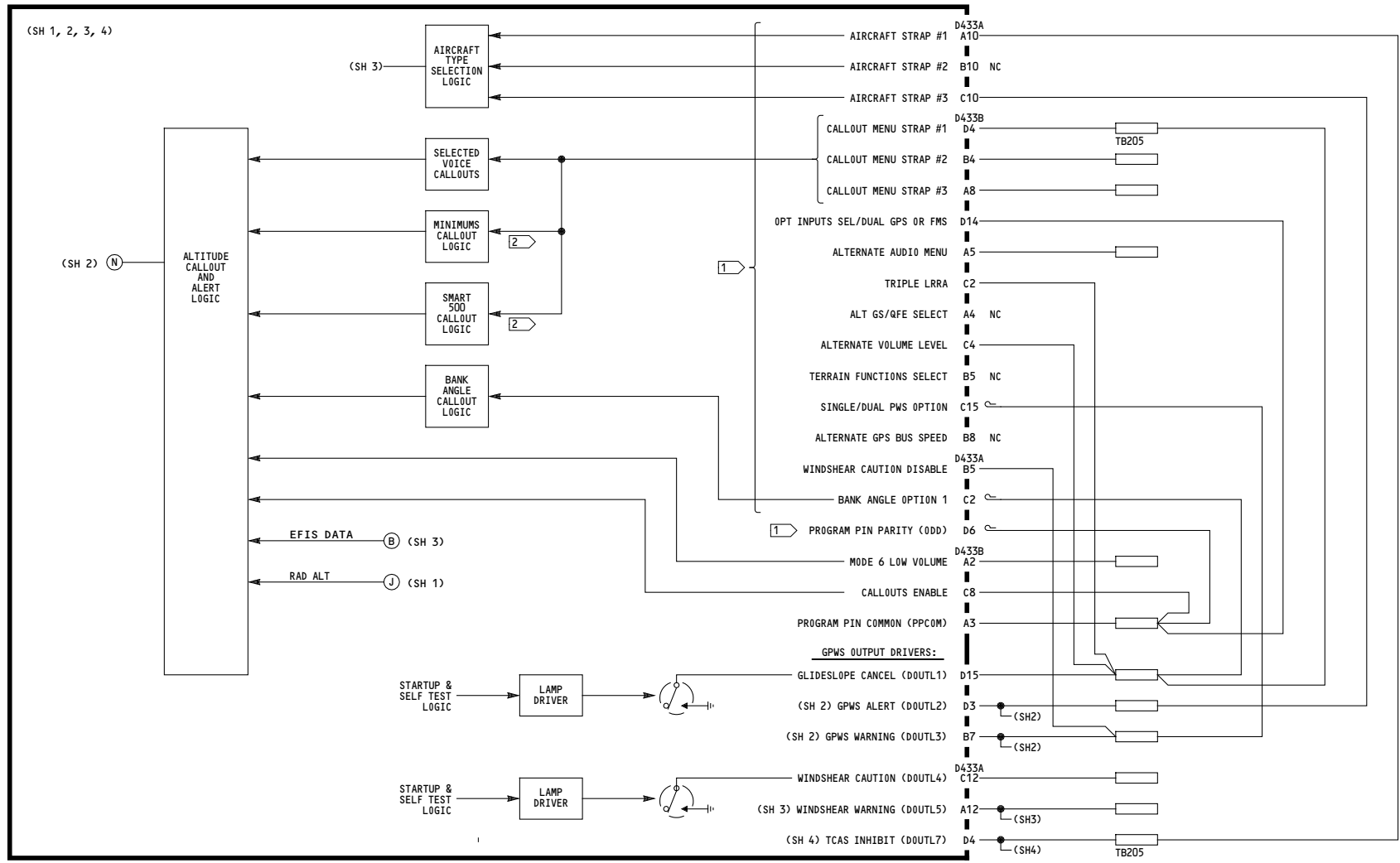

H147 GROUND PROX WARN COMPUTER (E2-3)

2 LOGIC USED IF CALLOUT SELECTION INCLUDES MINIMUMS AND/OR SMART 500 CALLOUTS.

1 THESE 17 PROGRAM PINS ARE INVOLVED IN THE COUNT FOR PARITY. PROGRAM PIN MONITORING IS PROVIDED VIA A PARITY PIN (D6) WHICH IS TO BE CONNECTED OR NOT TO A3 (COMMON) SUCH THAT AN ODD NUMBER OF PROGRAM PINS ARE USED.

002

GROUND PROXIMITY WARNING SYSTEM

Incorporates
34-0200

D280N032S

34-46-01

Page 101.1
Sheet 5
Jan 21/2005

THIS PAGE INTENTIONALLY LEFT BLANK

5023

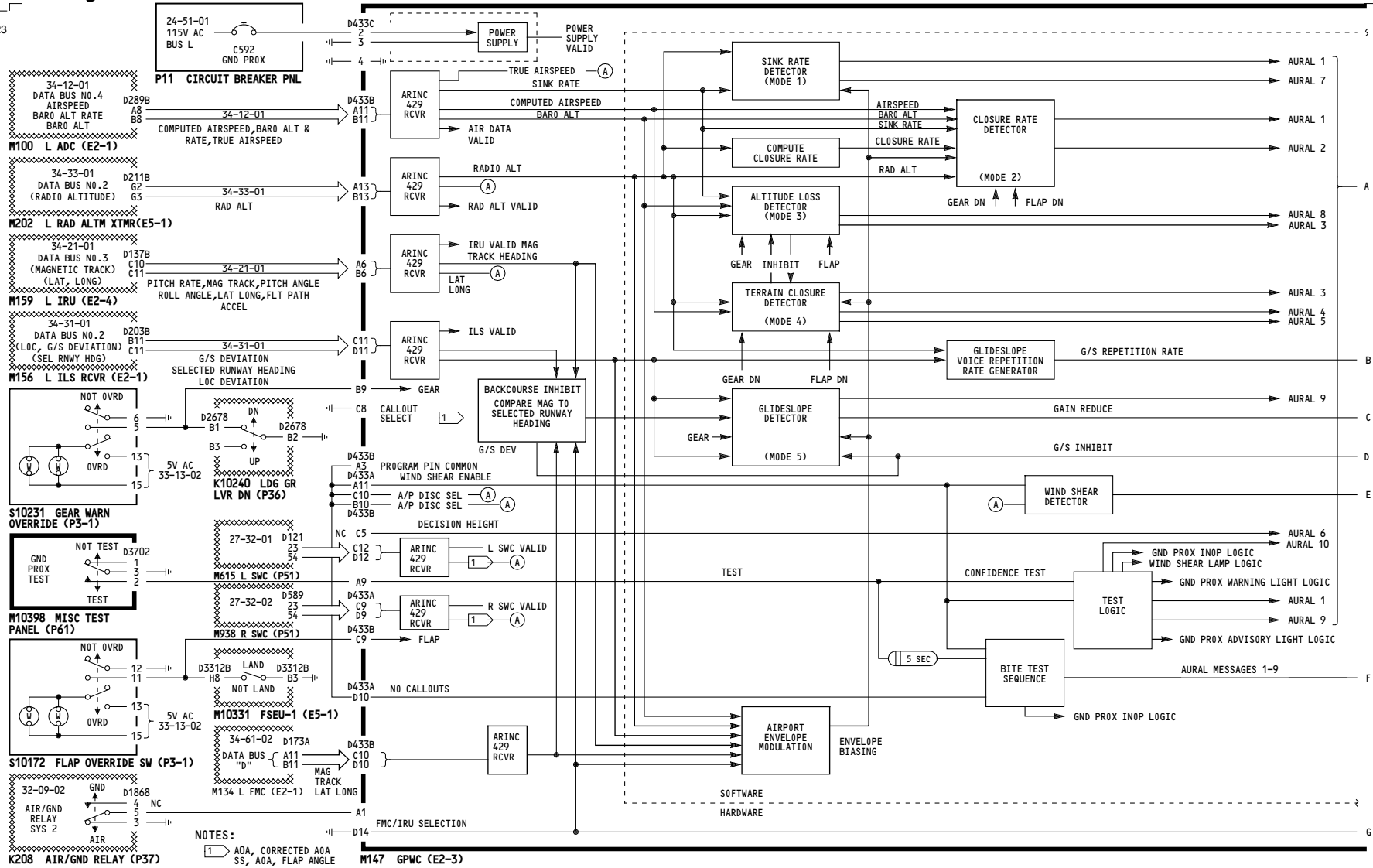

009

GROUND PROXIMITY WARNING SYSTEM

D280N032S

34-46-01

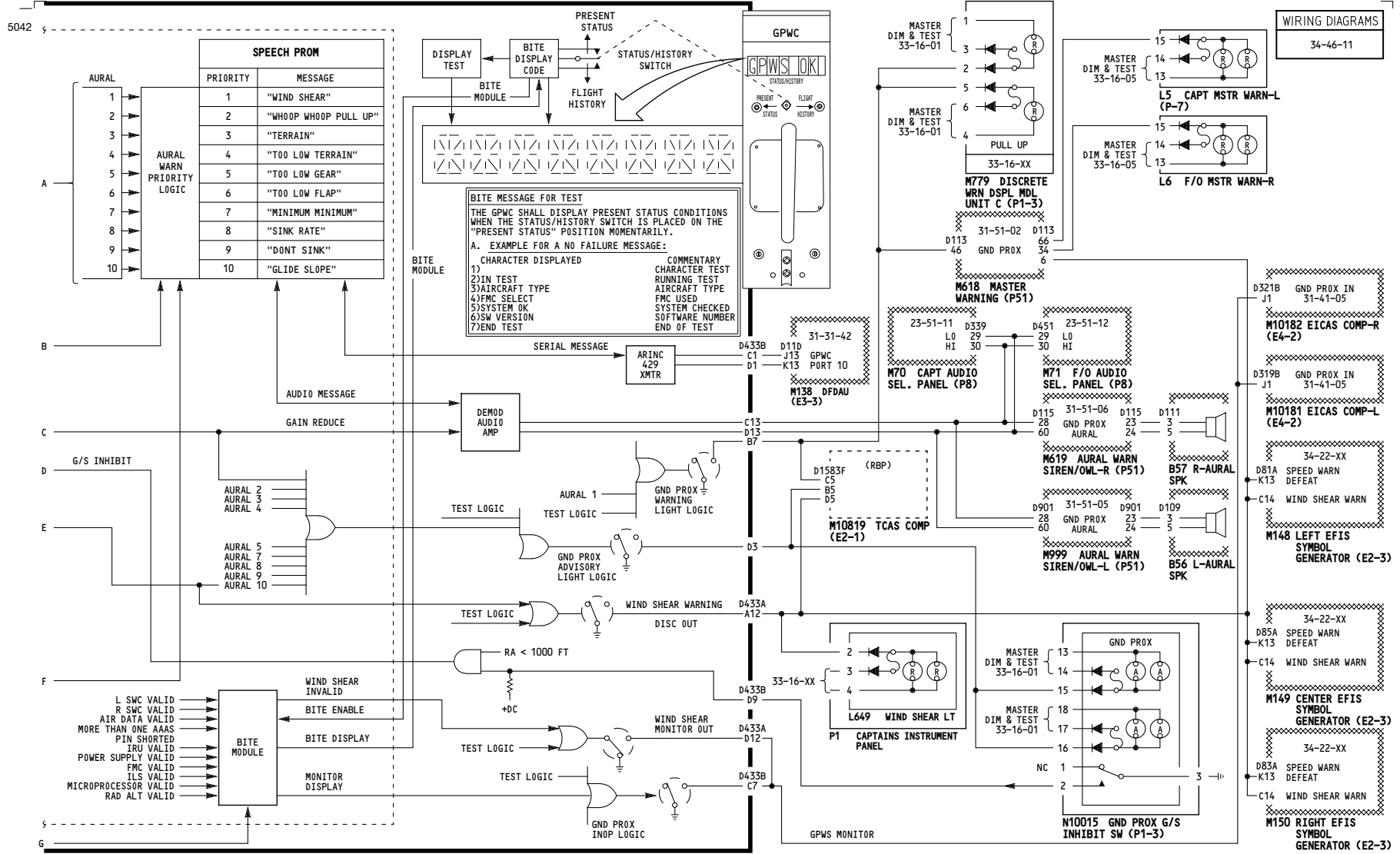

009

GROUND PROXIMITY WARNING SYSTEM

D280N032S

34-46-01

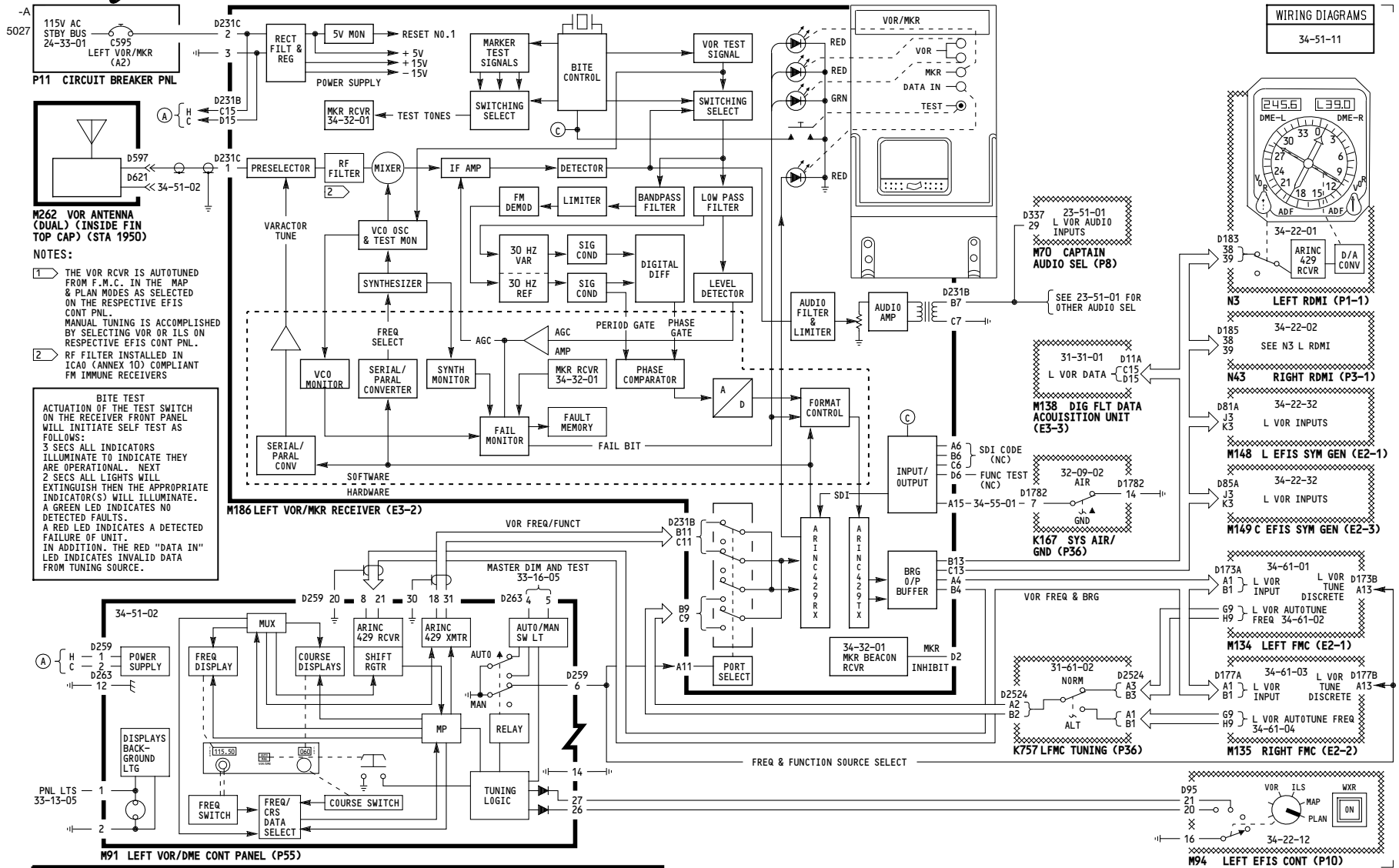

WIRING DIAGRAMS
34-51-11

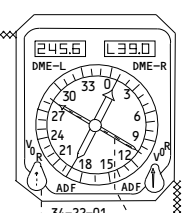

NOTES:

- THE VOR RCVR IS AUTOTUNED FROM F.M.C. IN THE MAP & PLAN MODES AS SELECTED ON THE RESPECTIVE EFIS CONT PNL. MANUAL TUNING IS ACCOMPLISHED BY SELECTING VOR OR ILS ON RESPECTIVE EFIS CONT PNL.
- RF FILTER INSTALLED IN ICAO (ANNEX 10) COMPLIANT FM IMMUNE RECEIVERS

BITE TEST
ACTUATION OF THE TEST SWITCH ON THE RECEIVER FRONT PANEL WILL INITIATE SELF TEST AS FOLLOWS:
3 SECS ALL INDICATORS ILLUMINATE TO INDICATE THEY ARE OPERATIONAL. NEXT 2 SECS ALL LIGHTS WILL EXTINGUISH THEN THE APPROPRIATE INDICATOR(S) WILL ILLUMINATE. A GREEN LED INDICATES NO DETECTED FAULTS. A RED LED INDICATES A DETECTED FAILURE OF UNIT. IN ADDITION, THE RED "DATA IN" LED INDICATES INVALID DATA FROM TUNING SOURCE.

001, 009

LEFT VOR

D280N032S

34-51-01

Page 101

Jan 21/2005

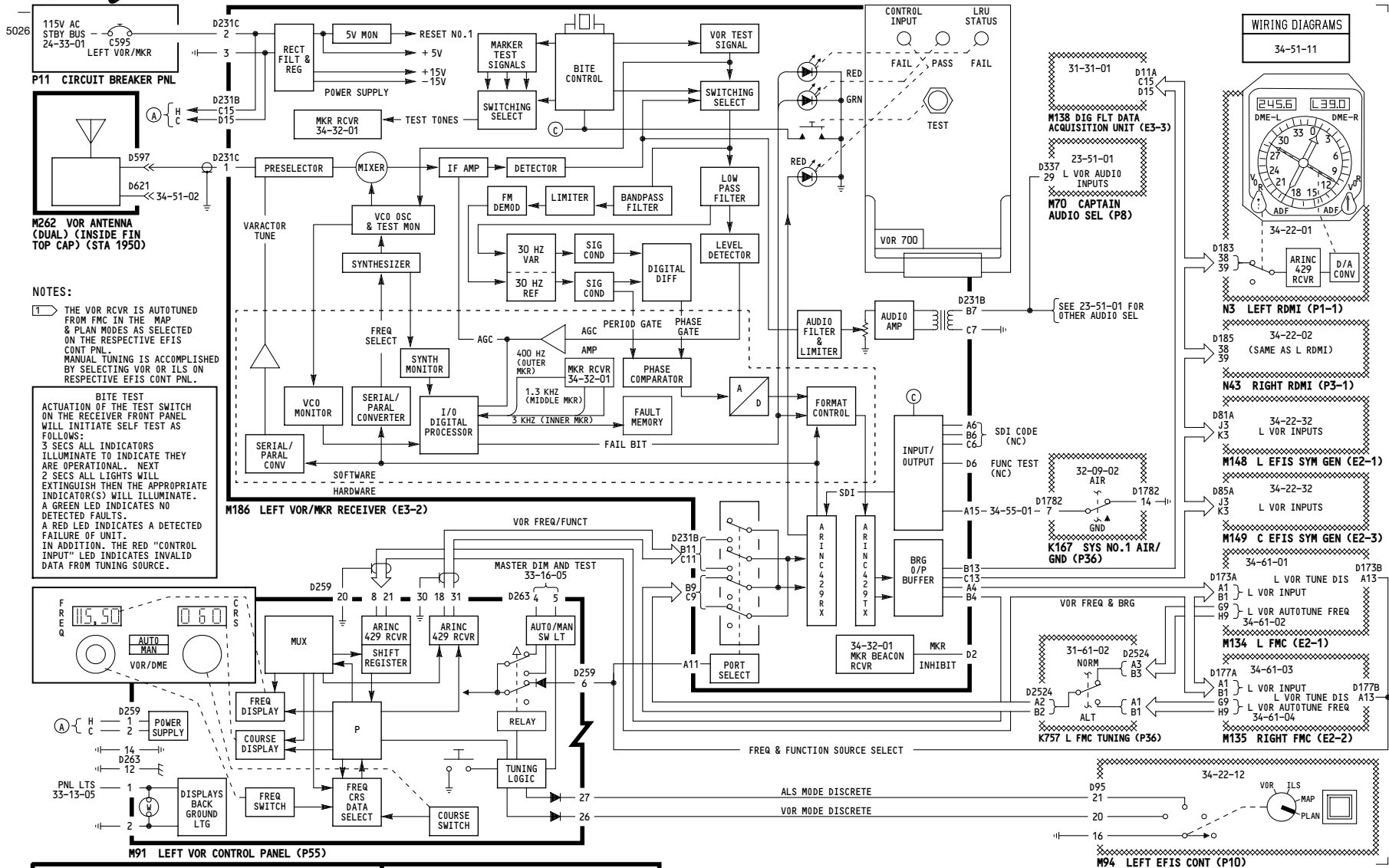

002-008, 010-099

LEFT VOR

D280N032S

34-51-01

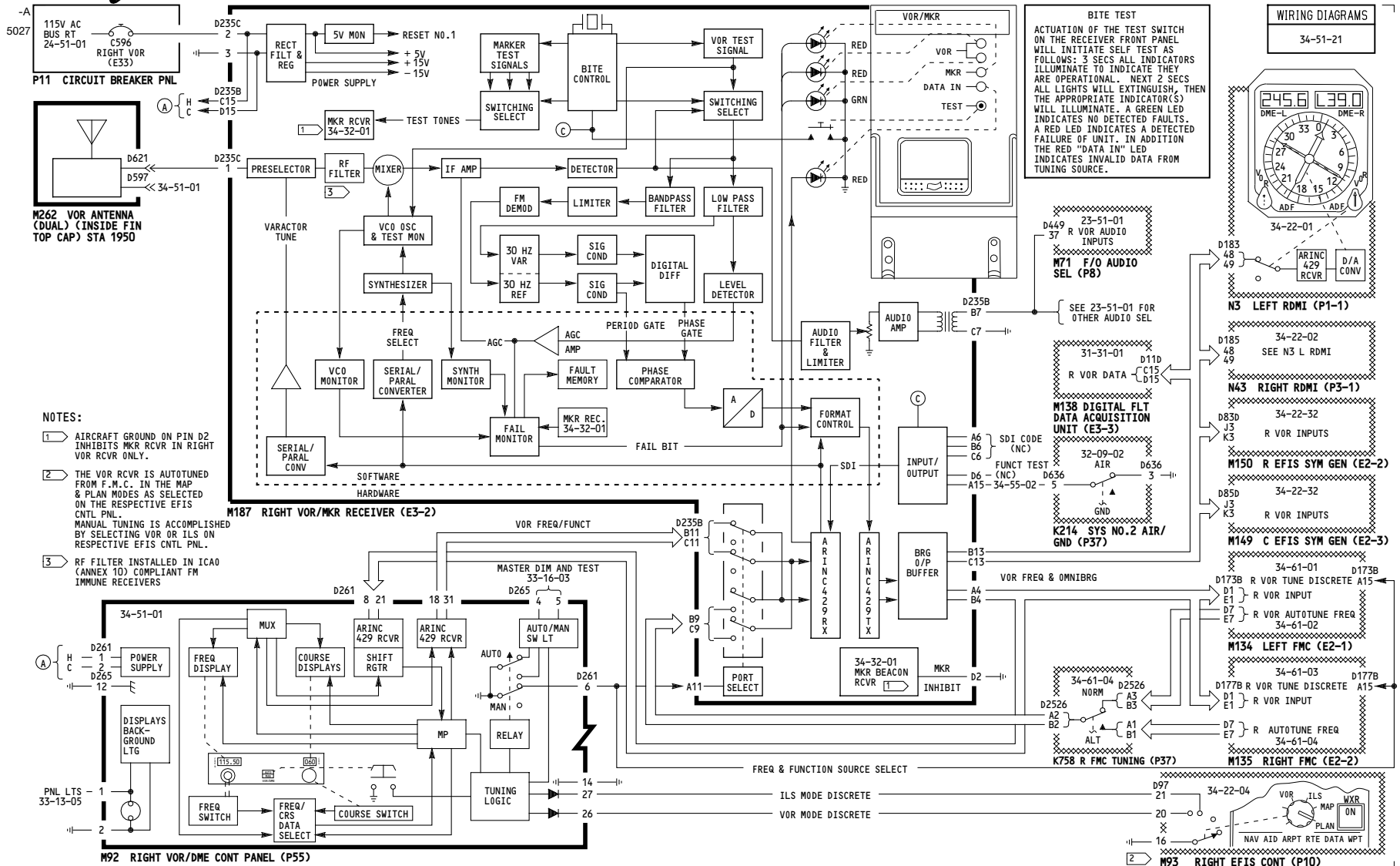

001, 009

RIGHT VOR

D280N032S

34-51-02

Page 101

Jan 21/2005

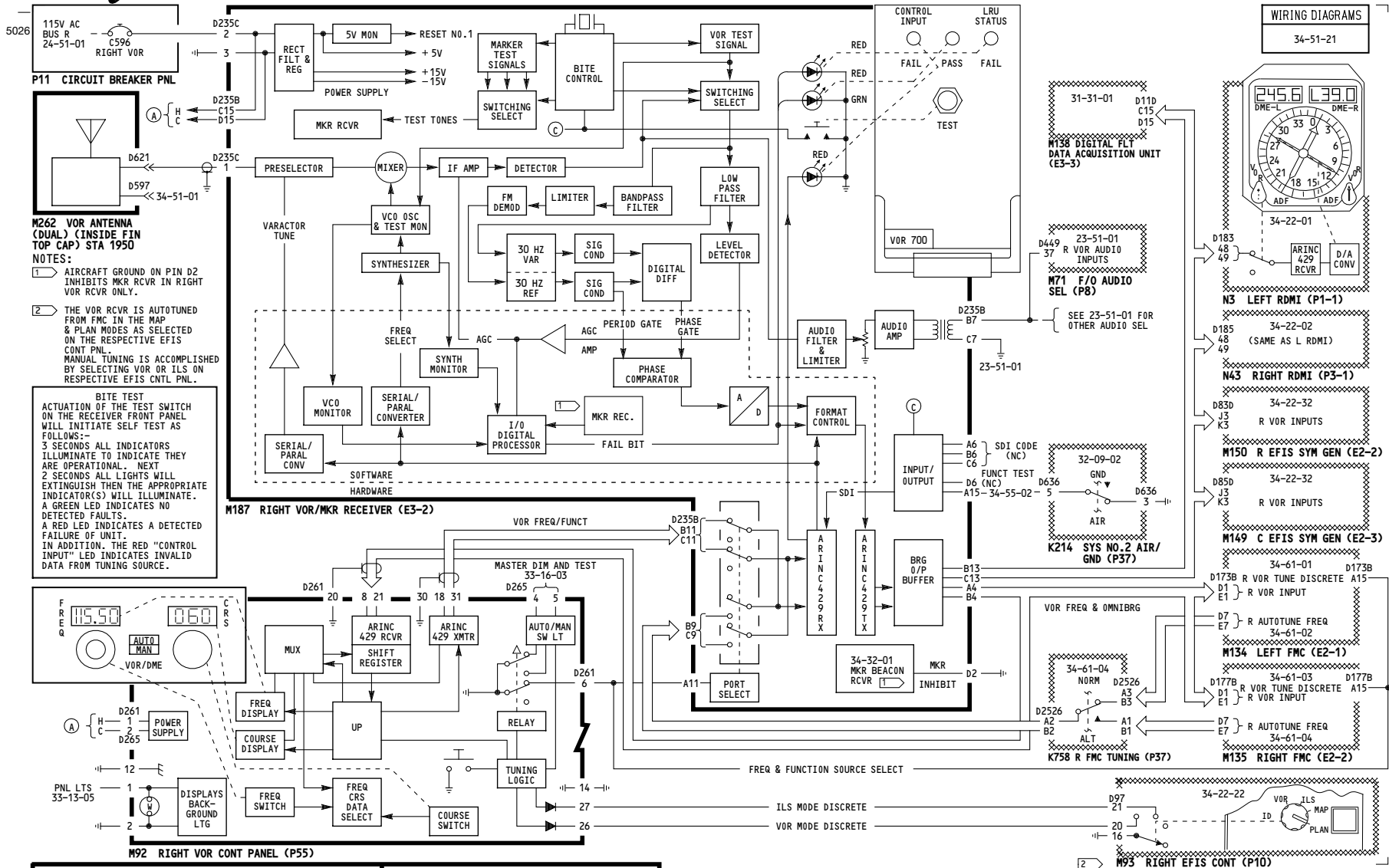

002-008, 010-099

RIGHT VOR

D280N032S

34-51-02

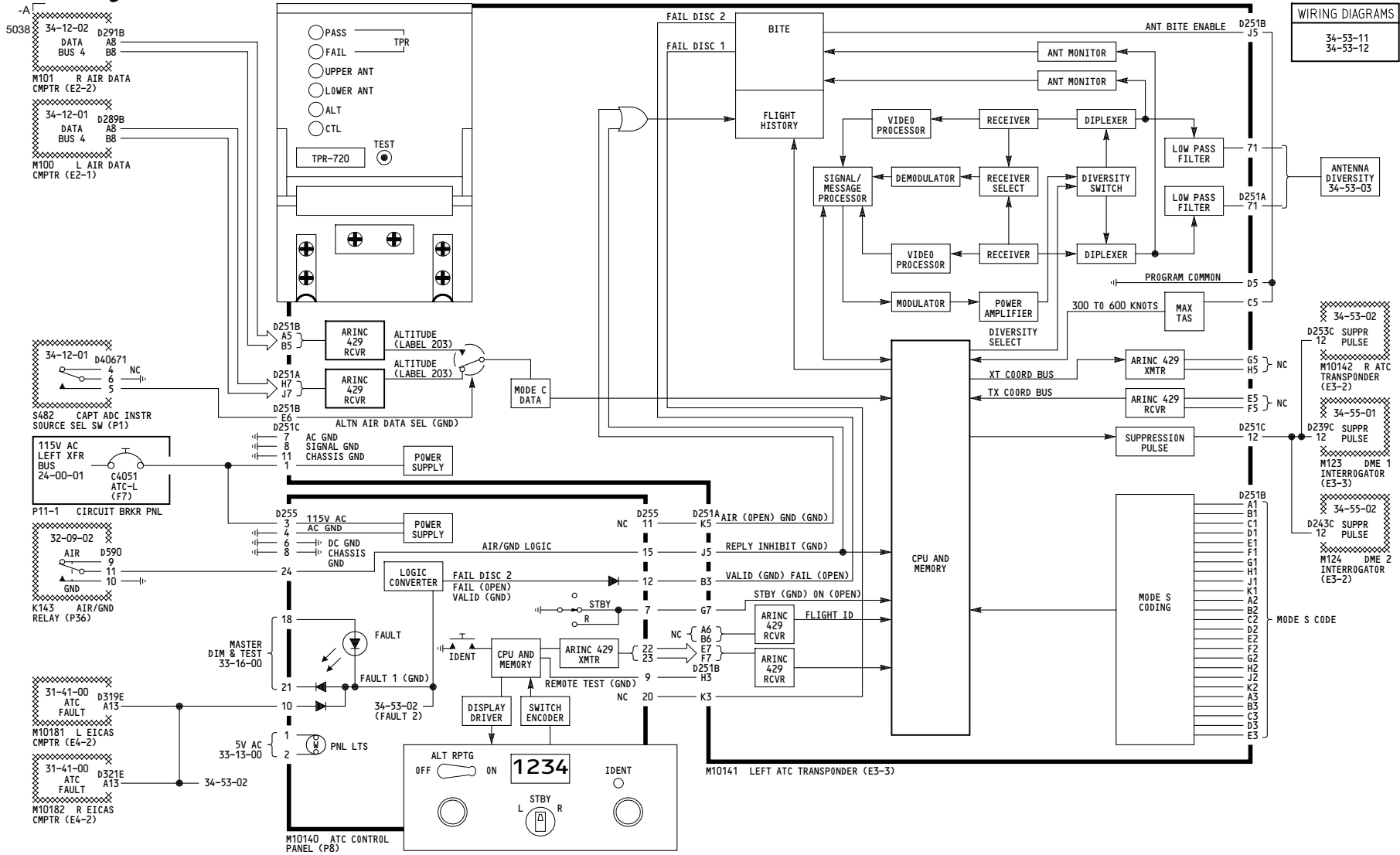

003-006

ATC TRANSPONDER - LEFT

D280N032S

COLLINS 622-8594-001

34-53-01

Page 102

Aug 01/2005

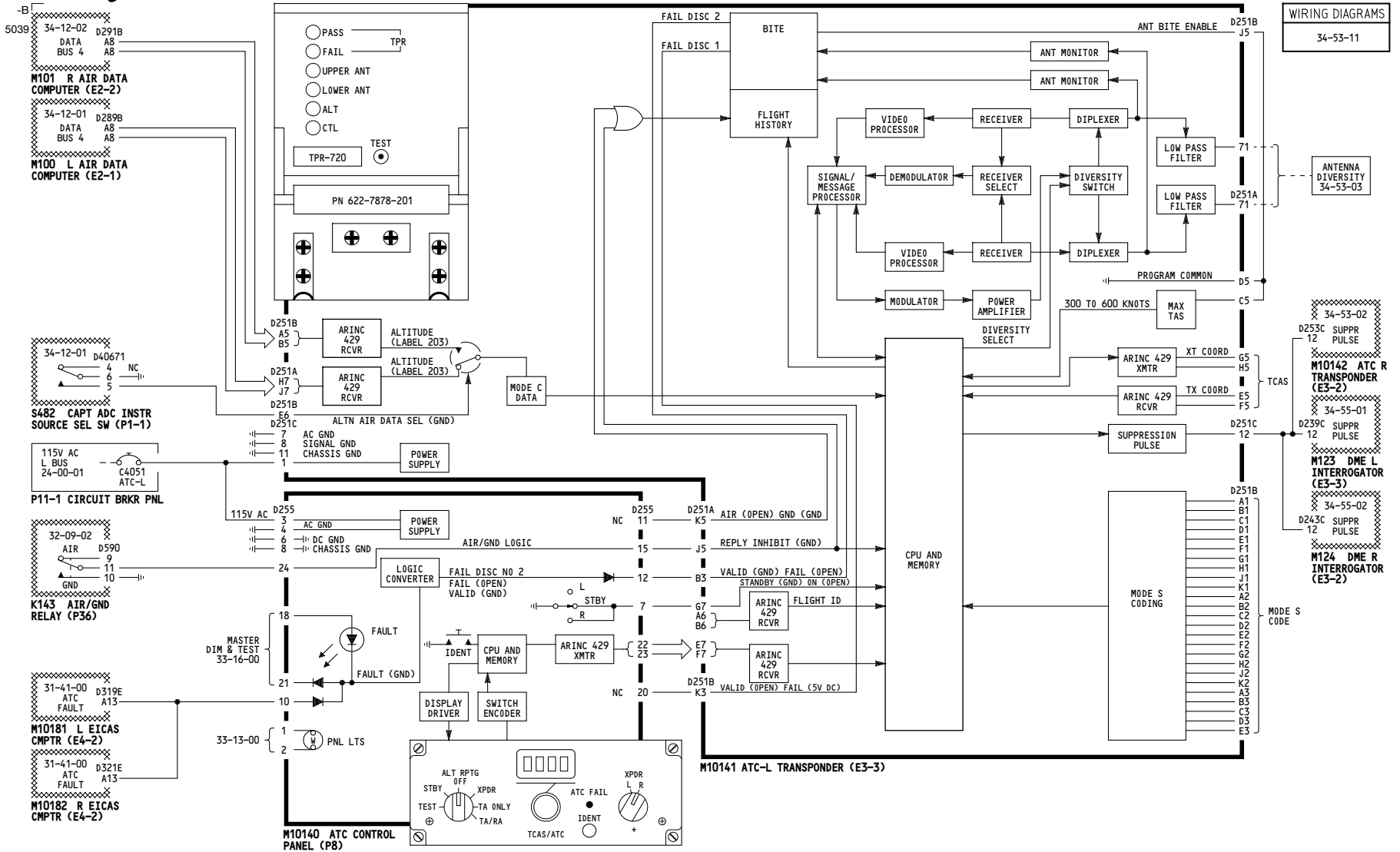

007-099

ATC TRANSPONDER - LEFT

D280N032S

34-53-01

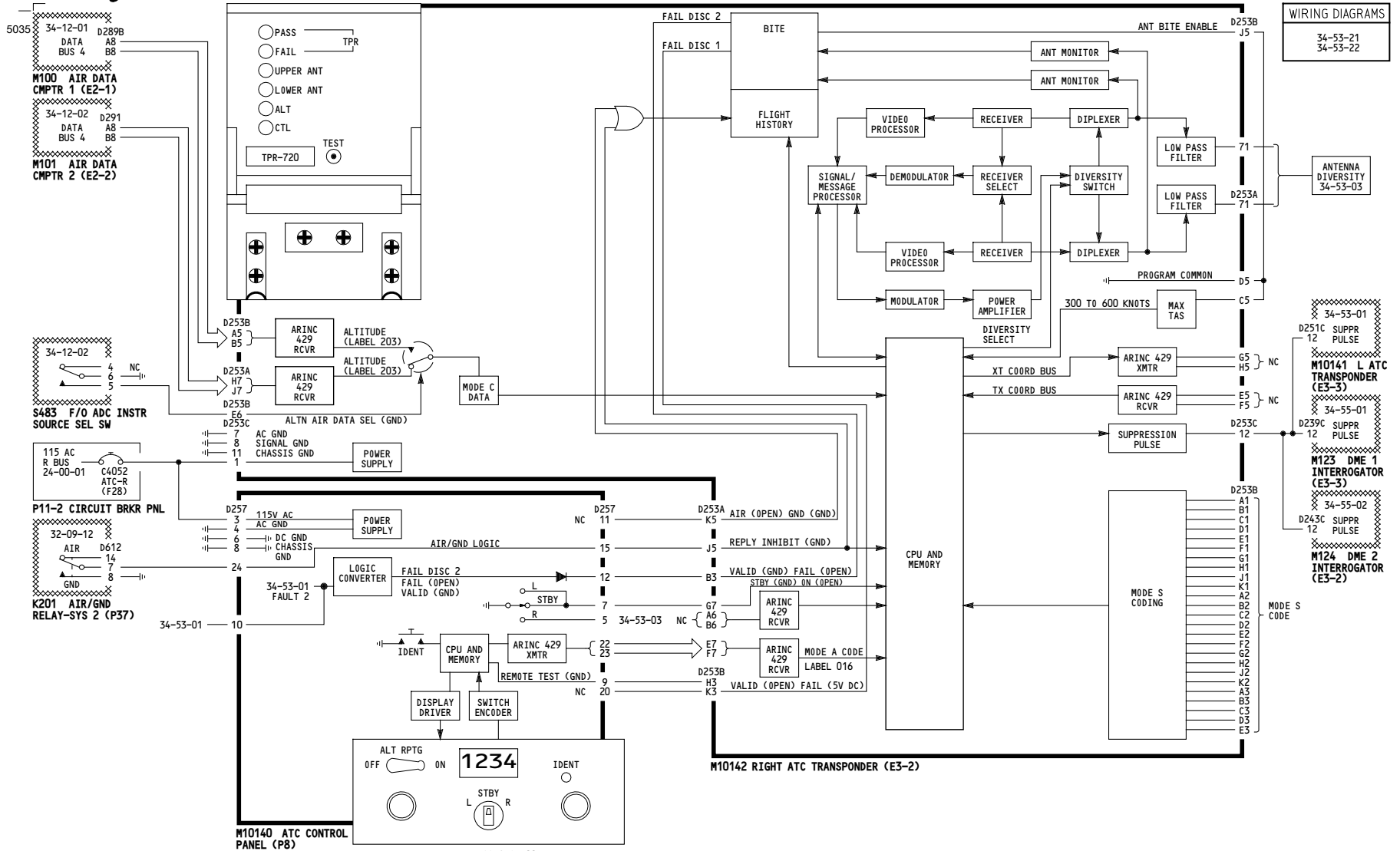

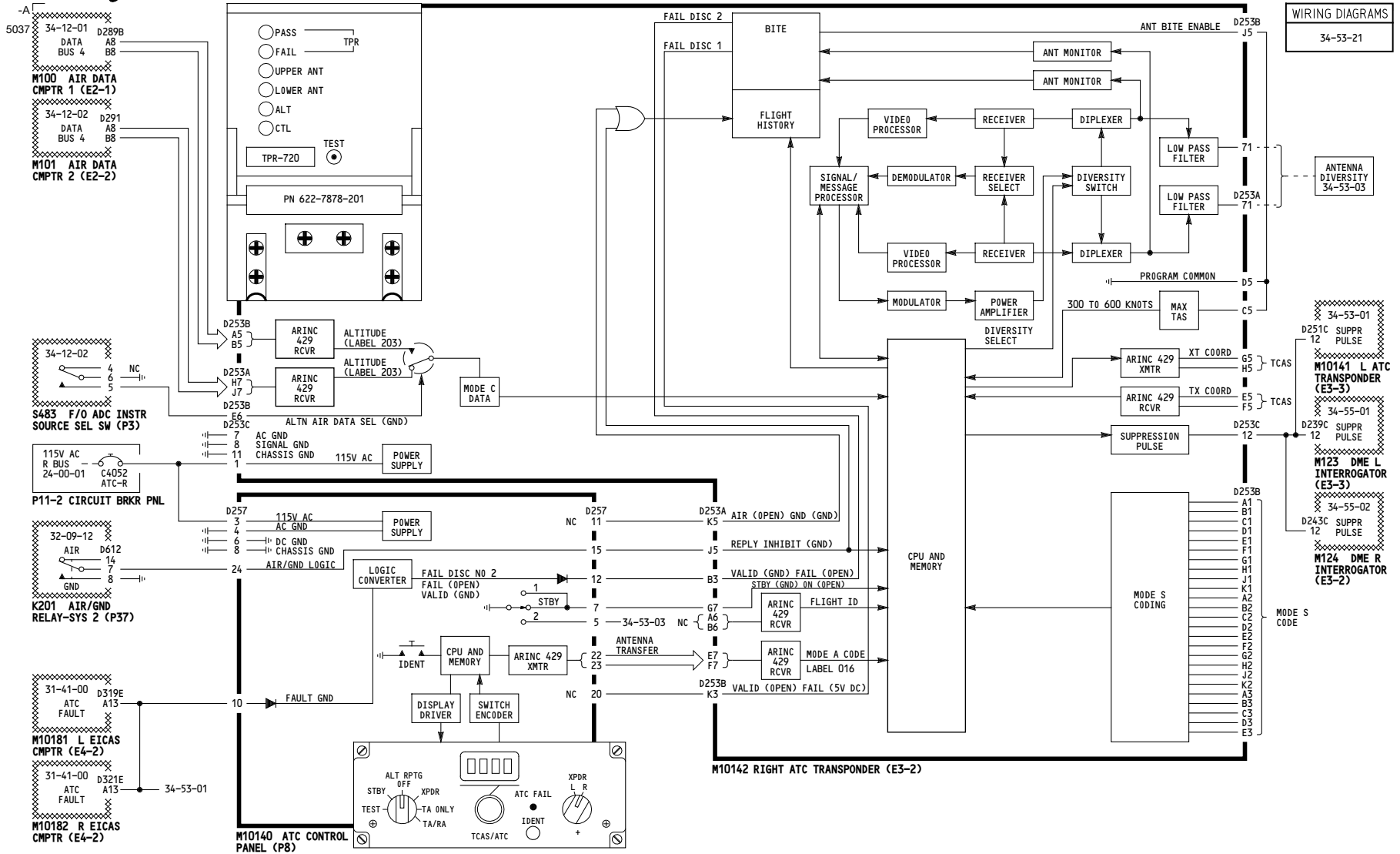

WIRING DIAGRAMS
34-53-21

34-53-01
D251C SUPPR PULSE
M10141 L ATC TRANSPONDER (E3-3)
34-55-01
D239C SUPPR PULSE
M123 DME L INTERROGATOR (E3-3)
34-55-02
D243C SUPPR PULSE
M124 DME R INTERROGATOR (E3-2)

007-099

ATC TRANSPONDER - RIGHT

D280N032S

34-53-02

Page 103

Jan 21/2005

WIRING DIAGRAMS
34-53-11
34-53-21

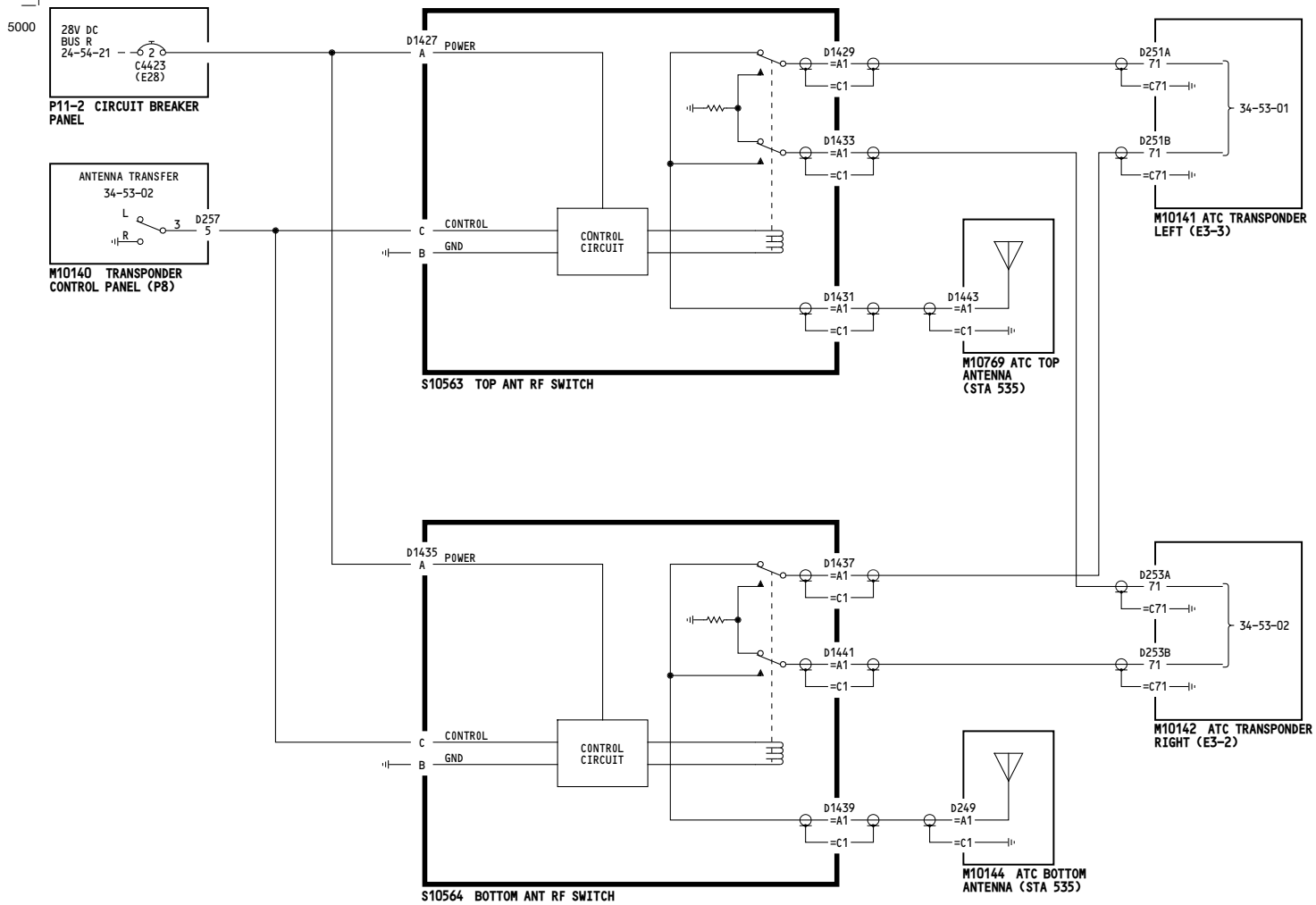

ALL	<p>ATC ANTENNA SELECT</p> <p>D280N032S</p>
-----	---

34-53-03

Page 101

May 06/2009

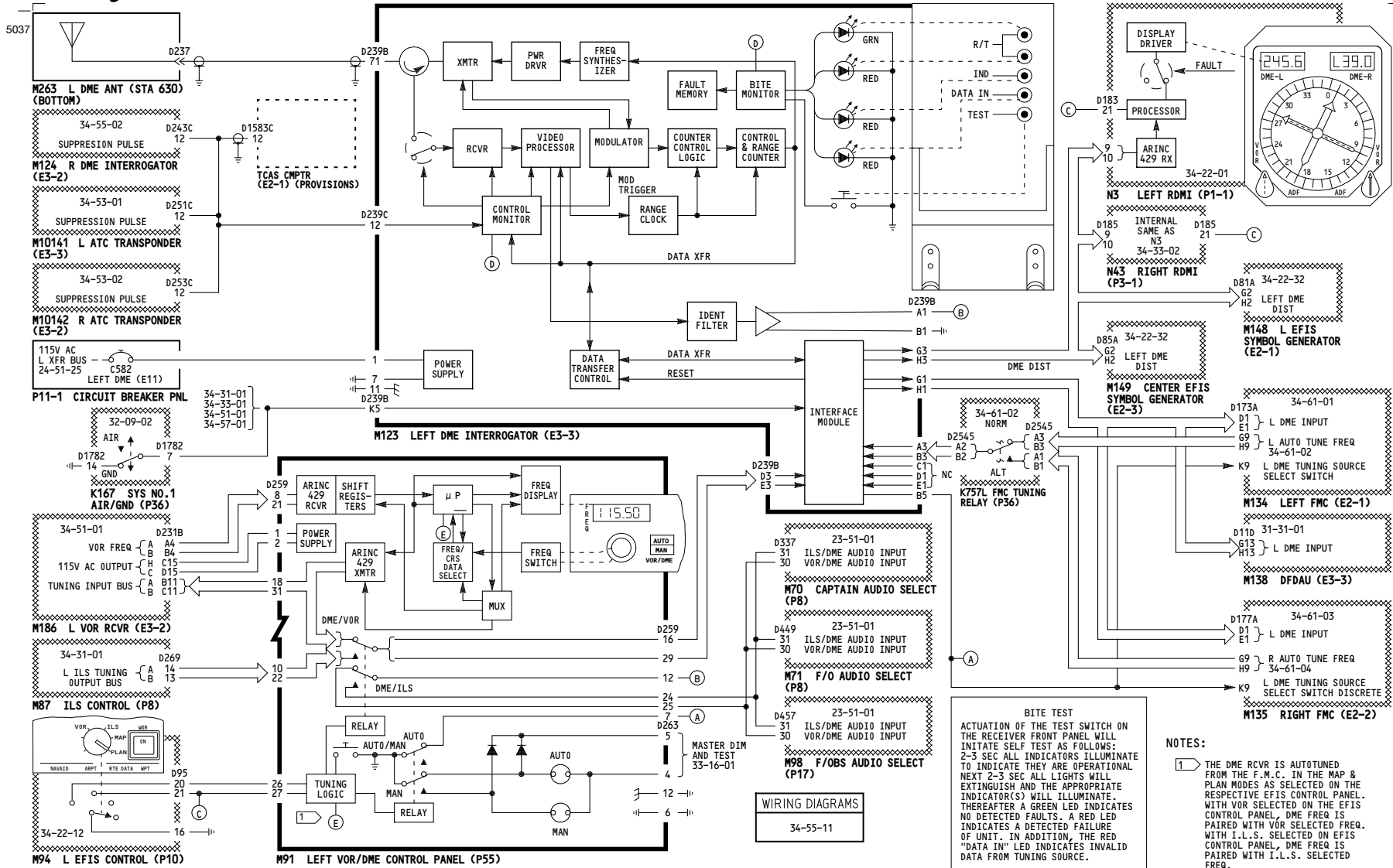

001, 009

DME - LEFT

D280N032S

34-55-01

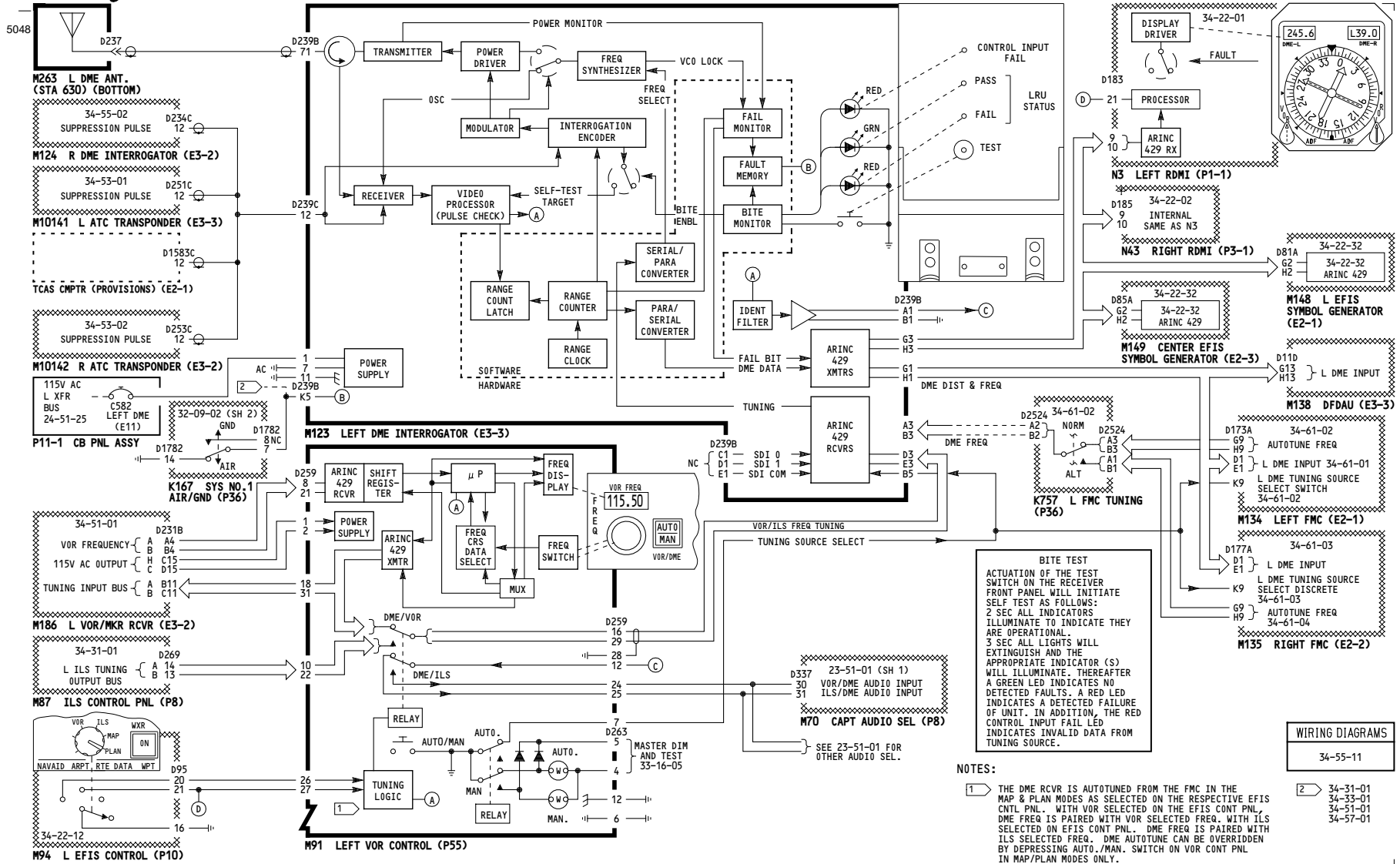

BITE TEST
 ACTUATION OF THE TEST SWITCH ON THE RECEIVER FRONT PANEL WILL INITIATE SELF TEST AS FOLLOWS:
 2 SEC ALL INDICATORS ILLUMINATE TO INDICATE THEY ARE OPERATIONAL.
 3 SEC ALL LIGHTS WILL EXTINGUISH AND THE APPROPRIATE INDICATOR (S) WILL ILLUMINATE. THEREAFTER A GREEN LED INDICATES NO DETECTED FAULTS, A RED LED INDICATES A DETECTED FAILURE OF UNIT. IN ADDITION, THE RED CONTROL INPUT FAIL LED INDICATES INVALID DATA FROM TUNING SOURCE.

- NOTES:**
- 1 THE DME RCVR IS AUTOTUNED FROM THE FMC IN THE MAP & PLAN MODES AS SELECTED ON THE RESPECTIVE EFIS CNTL PNL. WITH VOR SELECTED ON THE EFIS CONT PNL, DME FREQ IS PAIRED WITH VOR SELECTED FREQ. WITH ILS SELECTED ON EFIS CONT PNL, DME FREQ IS PAIRED WITH ILS SELECTED FREQ. DME AUTOTUNE CAN BE OVERRIDDEN BY DEPRESSING AUTO./MAN. SWITCH ON VOR CONT PNL IN MAP/PLAN MODES ONLY.
 - 2

WIRING DIAGRAMS
 34-55-11

002-008, 010-099

DME - LEFT

D280N032S

34-55-01

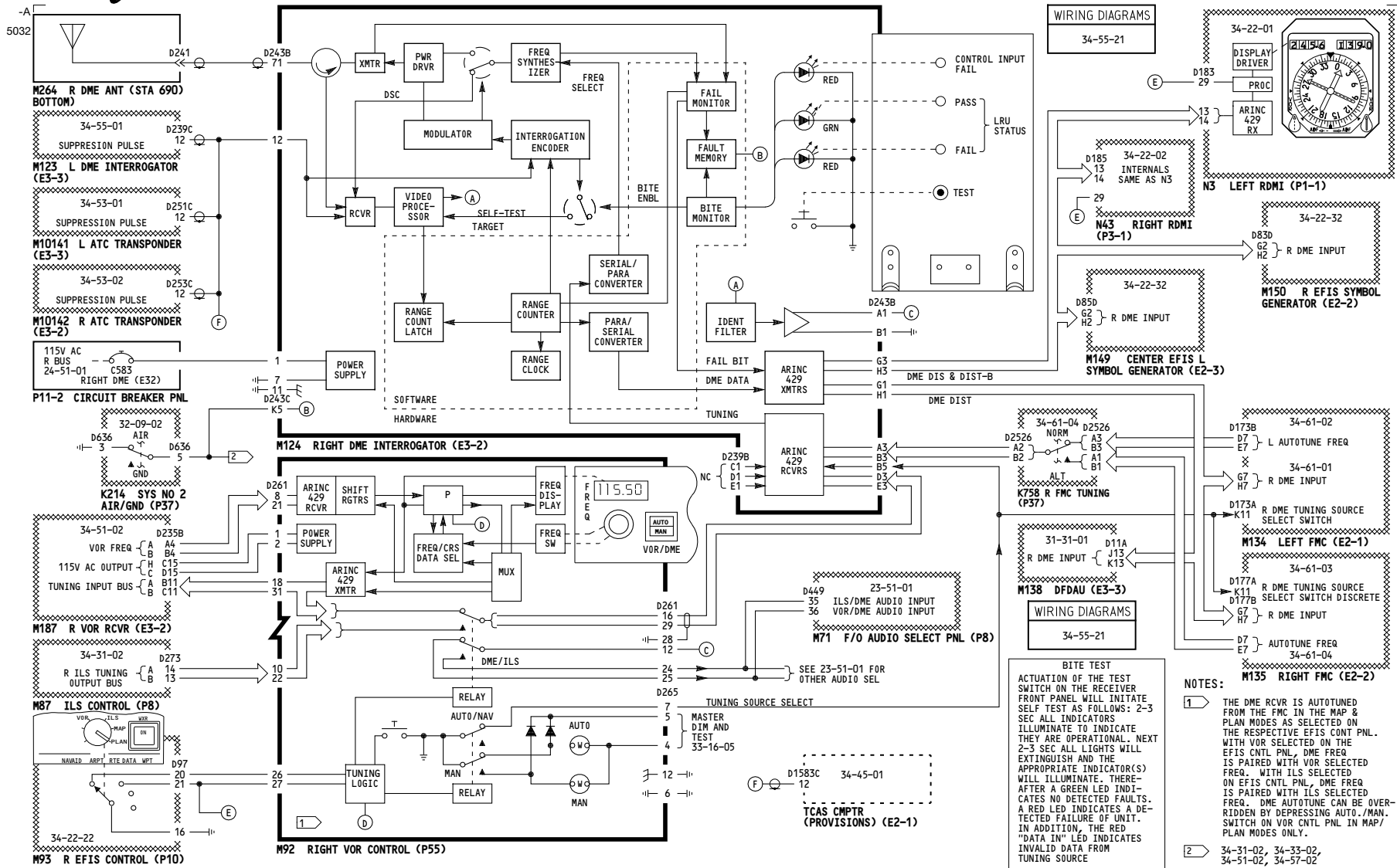

002-008, 010-099

DME - RIGHT

D280N032S

34-55-02

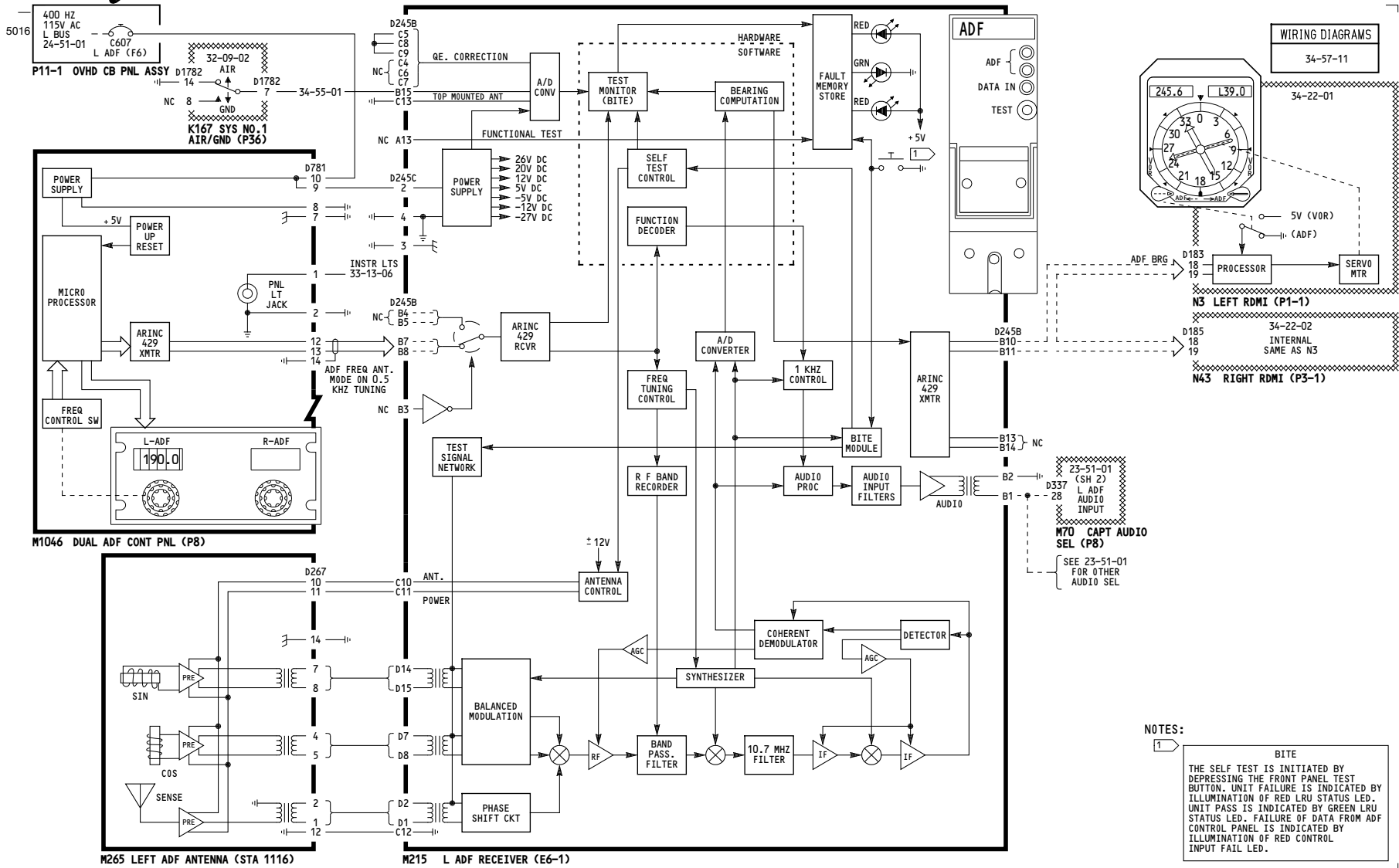

NOTES:

1 → BITE

THE SELF TEST IS INITIATED BY DEPRESSING THE FRONT PANEL TEST BUTTON. UNIT FAILURE IS INDICATED BY ILLUMINATION OF RED LRU STATUS LED. UNIT PASS IS INDICATED BY GREEN LRU STATUS LED. FAILURE OF DATA FROM ADF CONTROL PANEL IS INDICATED BY ILLUMINATION OF RED CONTROL INPUT FAIL LED.

001

ADF - LEFT

D280N032S

34-57-01

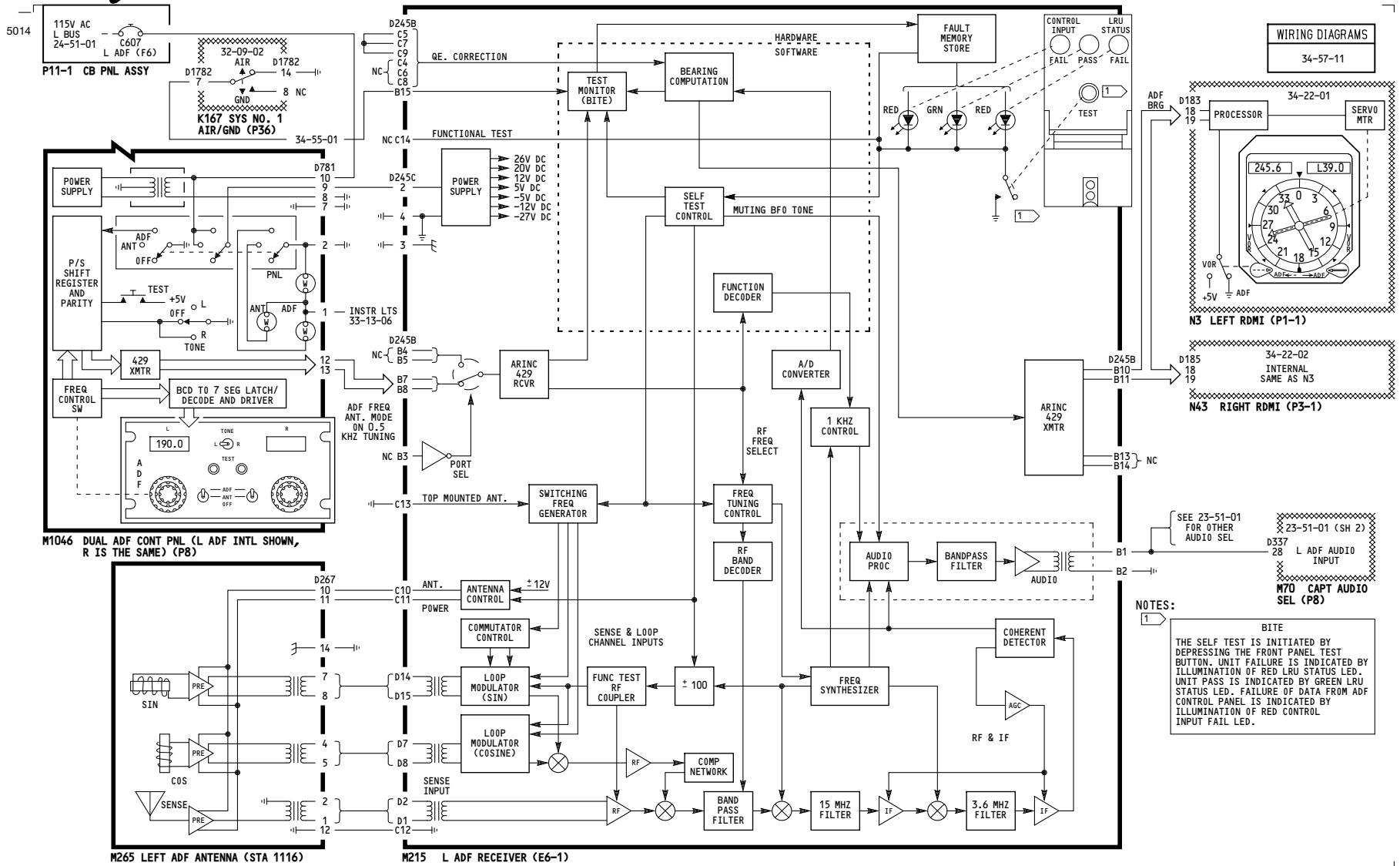

WIRING DIAGRAMS
34-57-11

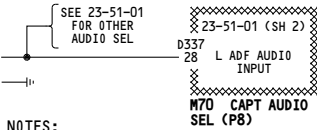
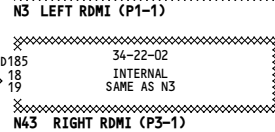
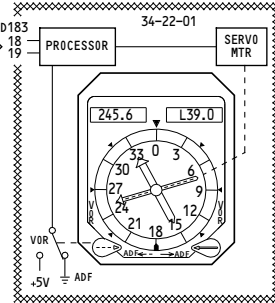

NOTES:
1 BITE
THE SELF TEST IS INITIATED BY DEPRESSING THE FRONT PANEL TEST BUTTON. UNIT FAILURE IS INDICATED BY ILLUMINATION OF RED LRU STATUS LED. UNIT PASS IS INDICATED BY GREEN LRU STATUS LED. FAILURE OF DATA FROM ADF CONTROL PANEL IS INDICATED BY ILLUMINATION OF RED CONTROL INPUT FAIL LED.

002-008, 010-099

ADF - LEFT

D280N032S

34-57-01

Page 102

Jan 21/2005

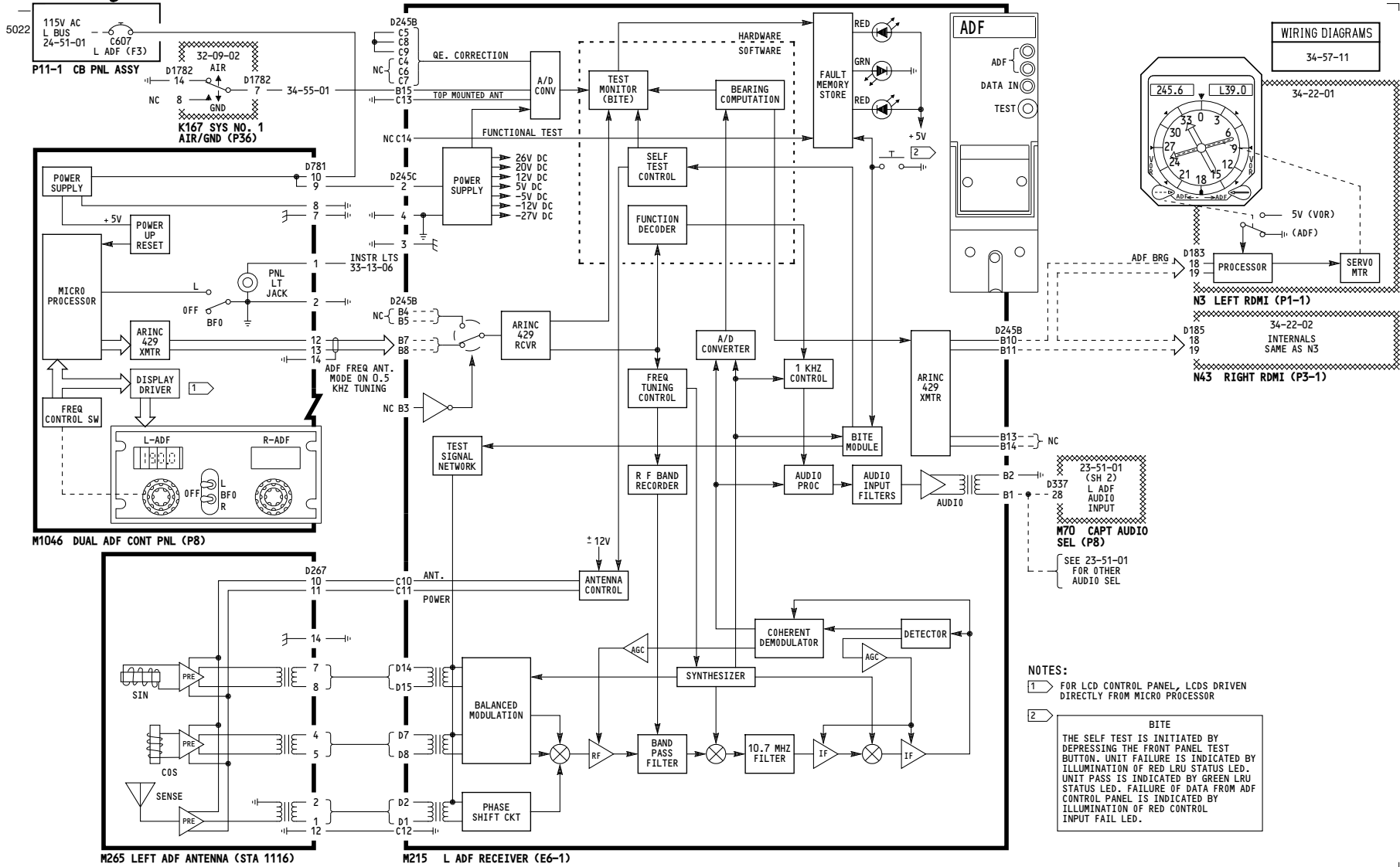

NOTES:

1 FOR LCD CONTROL PANEL, LCDS DRIVEN DIRECTLY FROM MICRO PROCESSOR

2

BITE
 THE SELF TEST IS INITIATED BY DEPRESSING THE FRONT PANEL TEST BUTTON. UNIT FAILURE IS INDICATED BY ILLUMINATION OF RED LRU STATUS LED. UNIT PASS IS INDICATED BY GREEN LRU STATUS LED. FAILURE OF DATA FROM ADF CONTROL PANEL IS INDICATED BY ILLUMINATION OF RED CONTROL INPUT FAIL LED.

009

ADF - LEFT

D280N032S

34-57-01

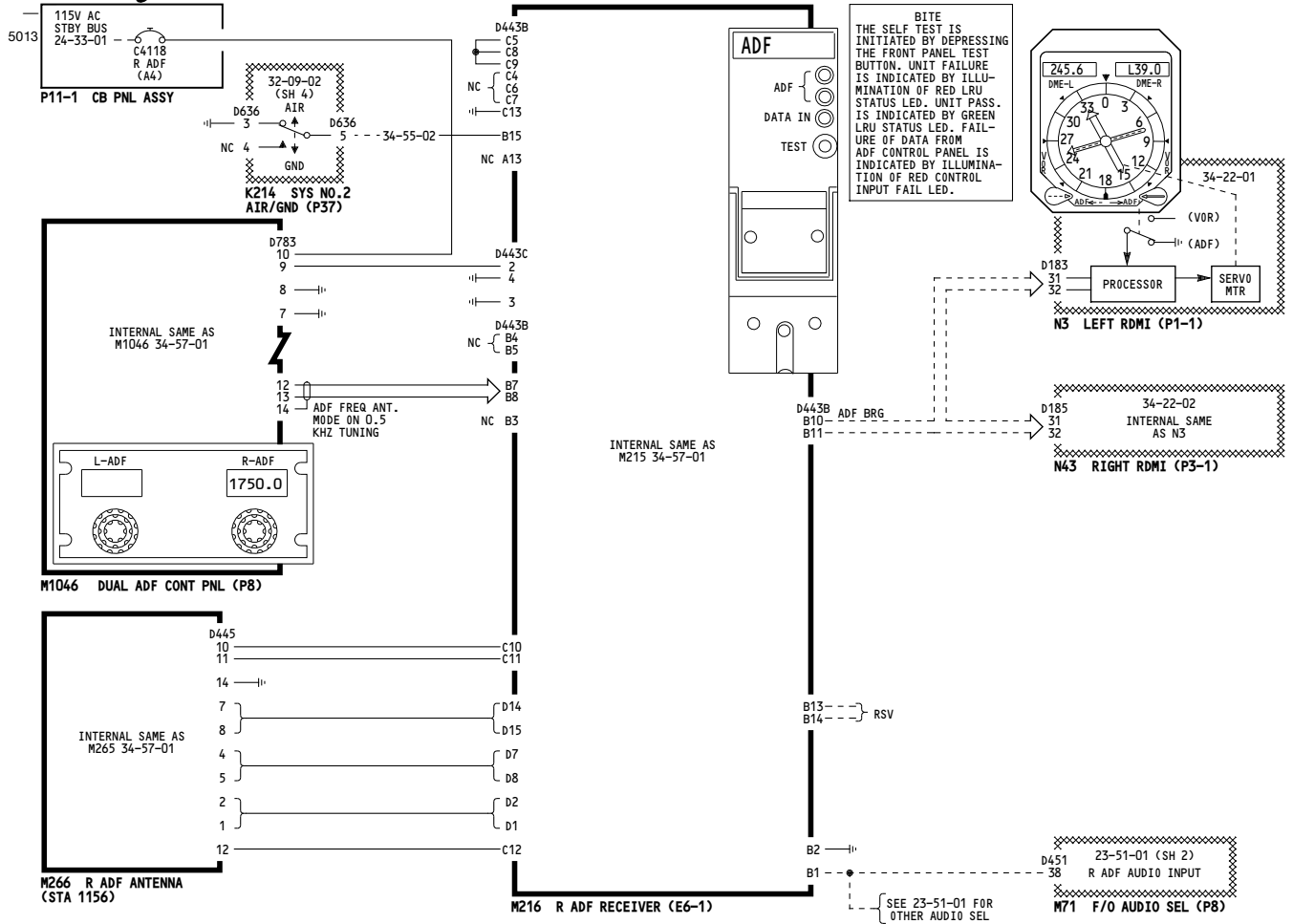

001	ADF - RIGHT
D280N032S	

34-57-02

Page 101

Jan 21/2005

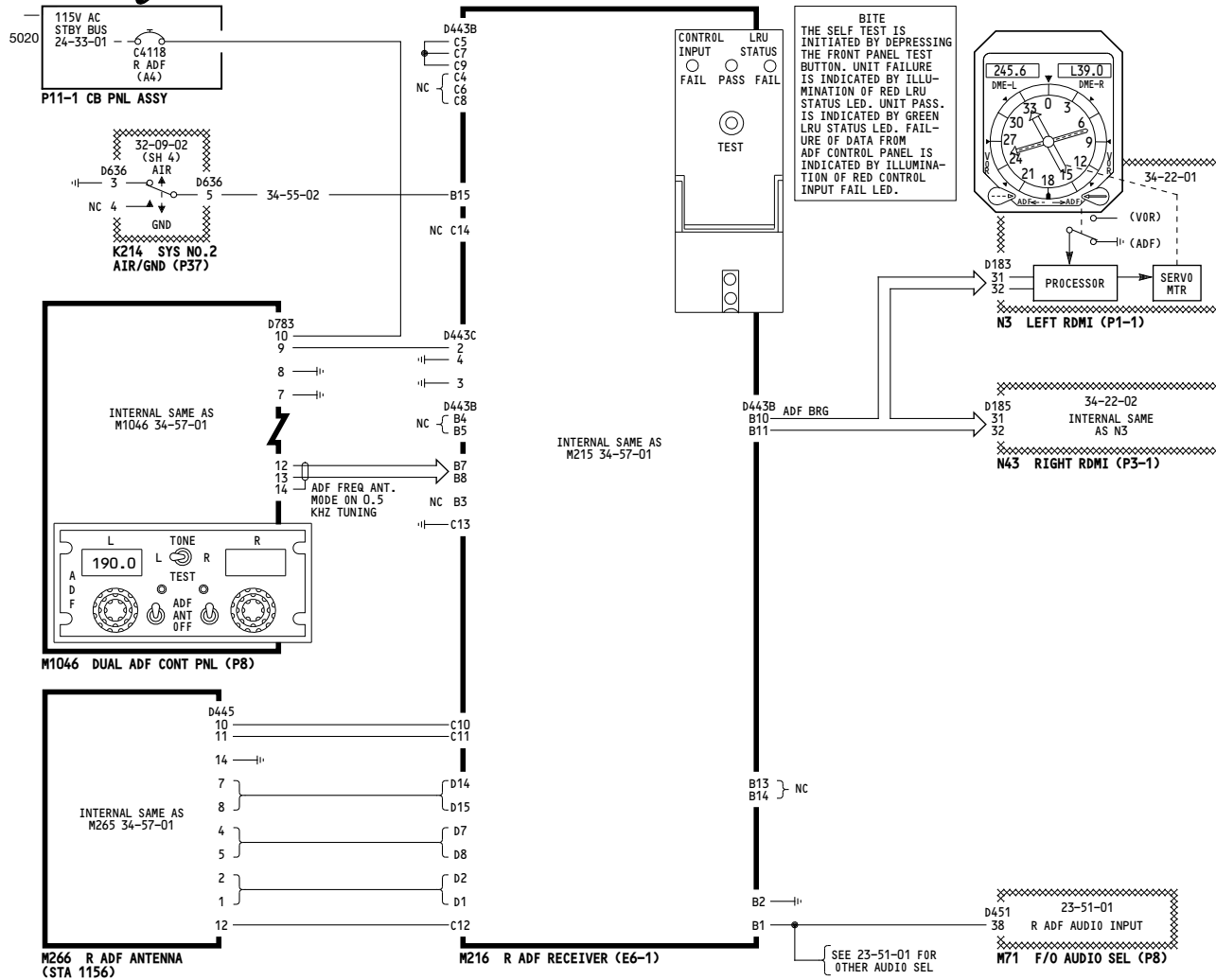

002-008, 010-099

ADF - RIGHT

D280N032S

34-57-02

Page 102

Jan 21/2005

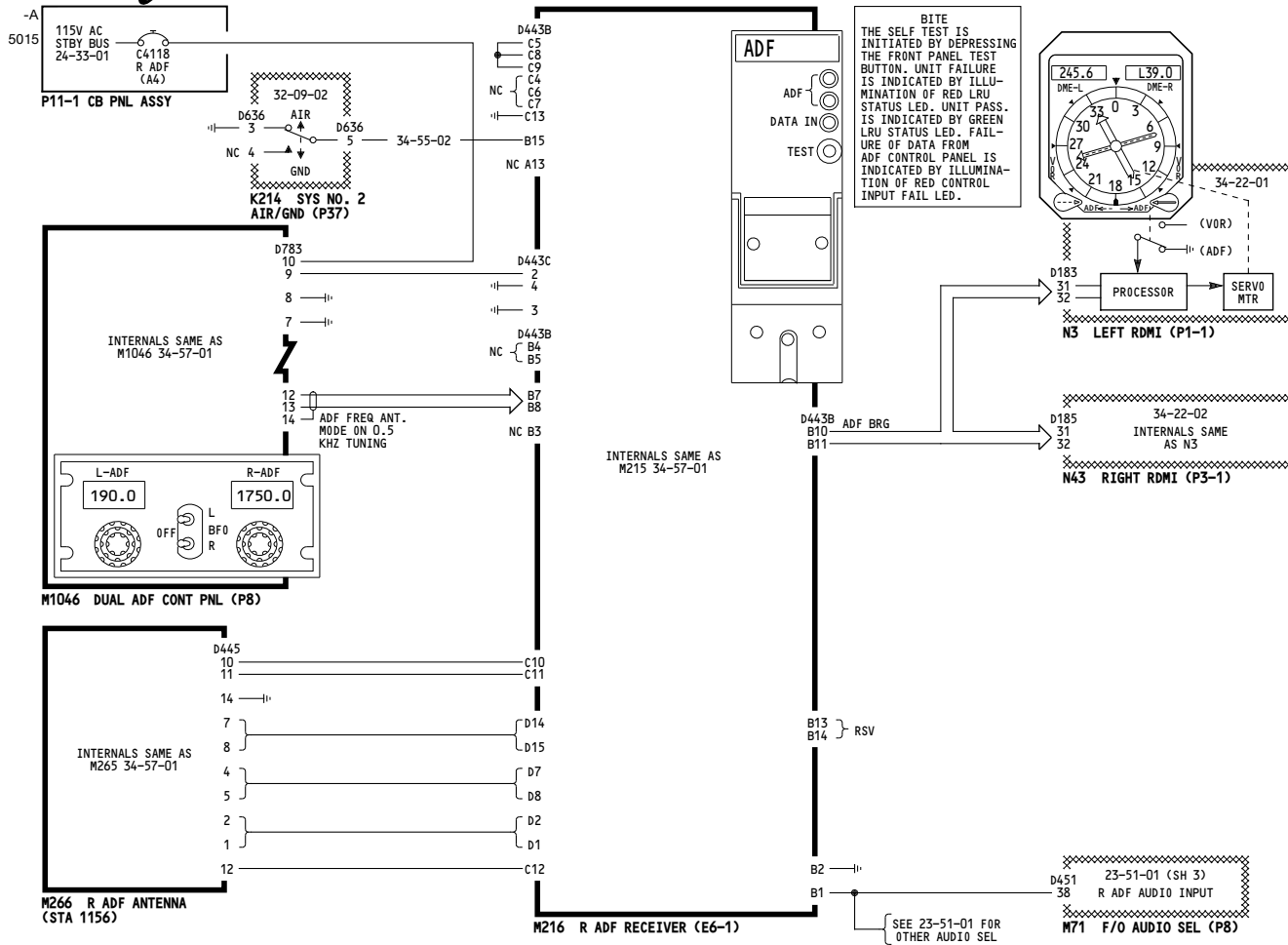

009

ADF - RIGHT

D280N032S

34-57-02

Page 103

Jan 21/2005

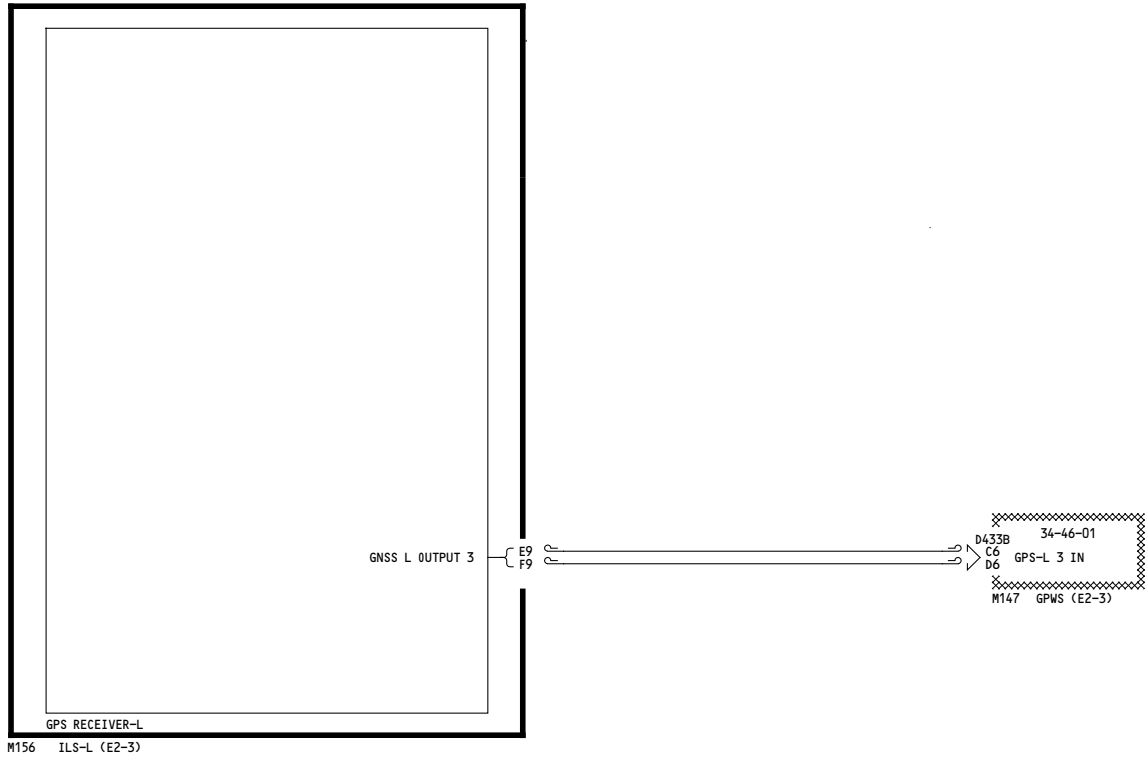

002	<p>GLOBAL POSITIONING SYSTEM LEFT</p> <p>D280N032S</p>
-----	---

Incorporates
▶ 34-0200

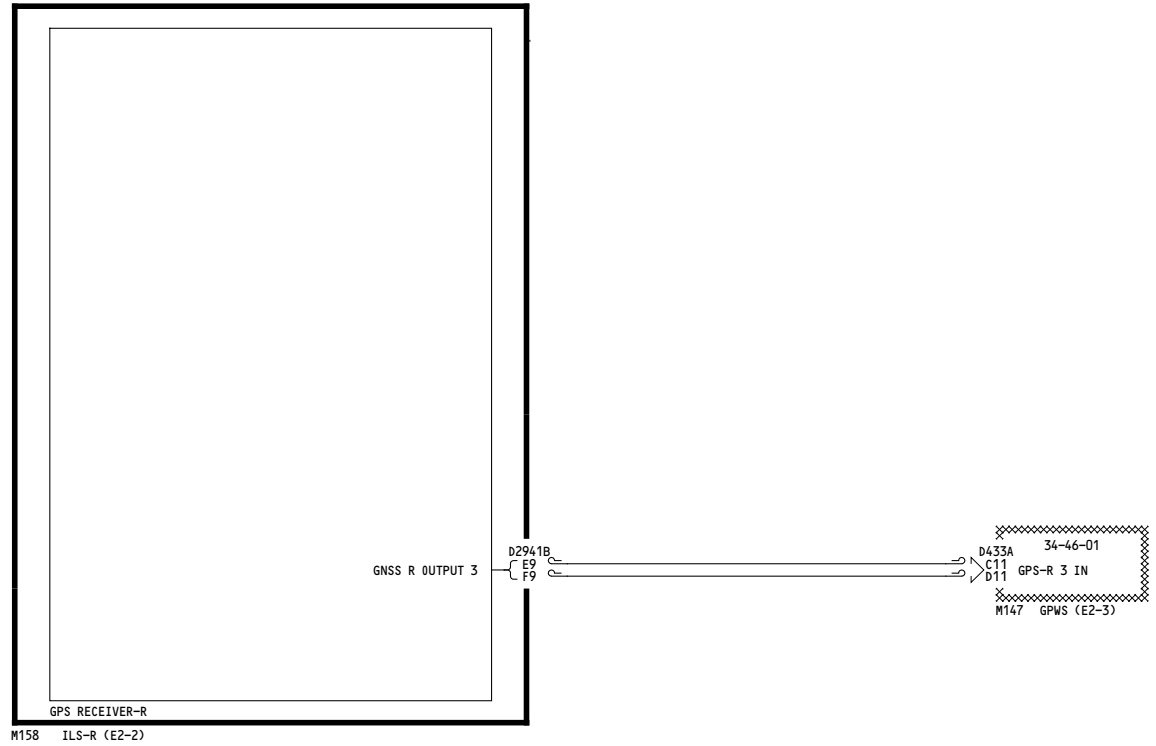

002	<p>GLOBAL POSITIONING SYSTEM RIGHT</p> <p>D280N032S</p>
-----	--

Incorporates
34-0200

34-58-02

Page 101.1

Jan 21/2005

THIS PAGE INTENTIONALLY LEFT BLANK

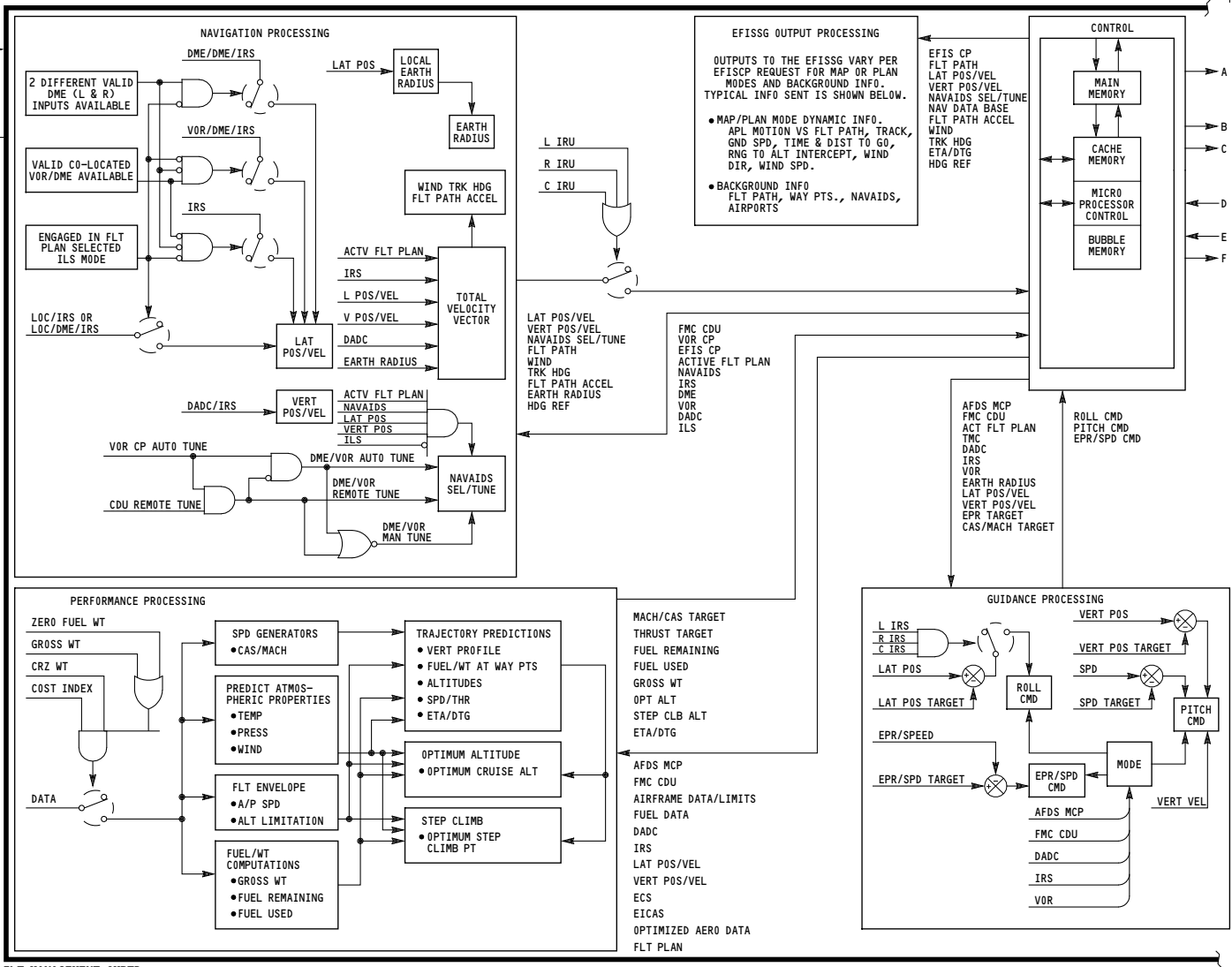
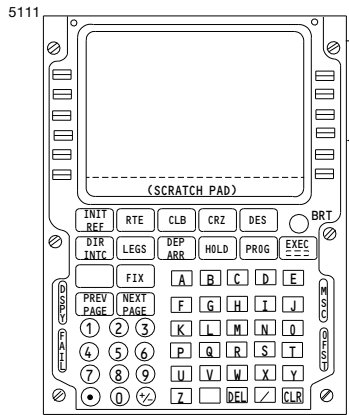

NOTES:
 1 TYPICAL FOR
 L FMC, M134 (E2-1)
 R FMC, M135 (E2-2)

FLT MANAGEMENT CMPTR

FLIGHT MANAGEMENT COMPUTER

D280N032S

34-60-01

Page 101
 Sheet 1
 May 06/2009

5111

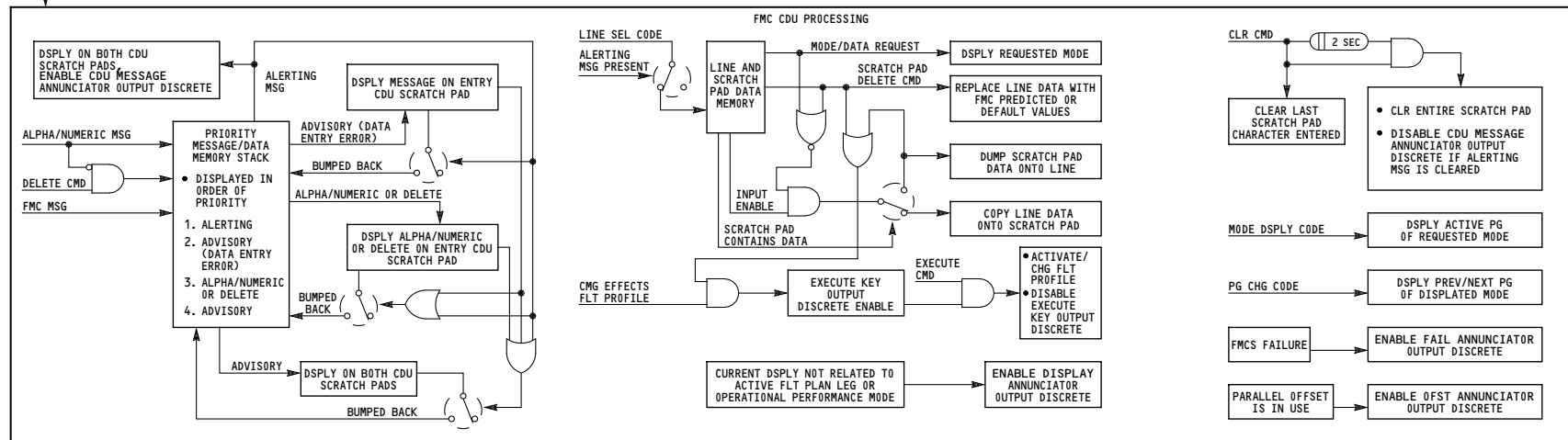
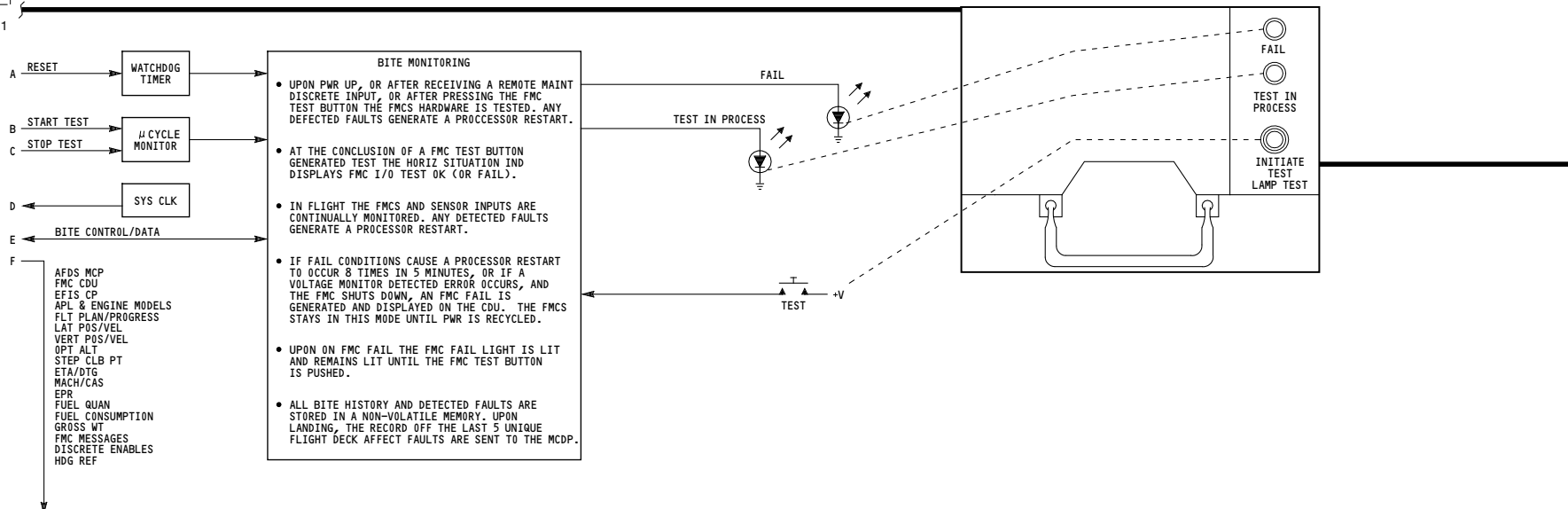

FLT MANAGEMENT CMPTR

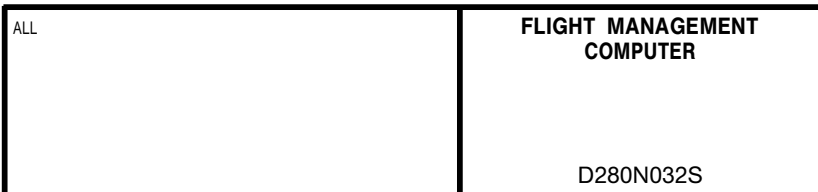

34-60-01

5101

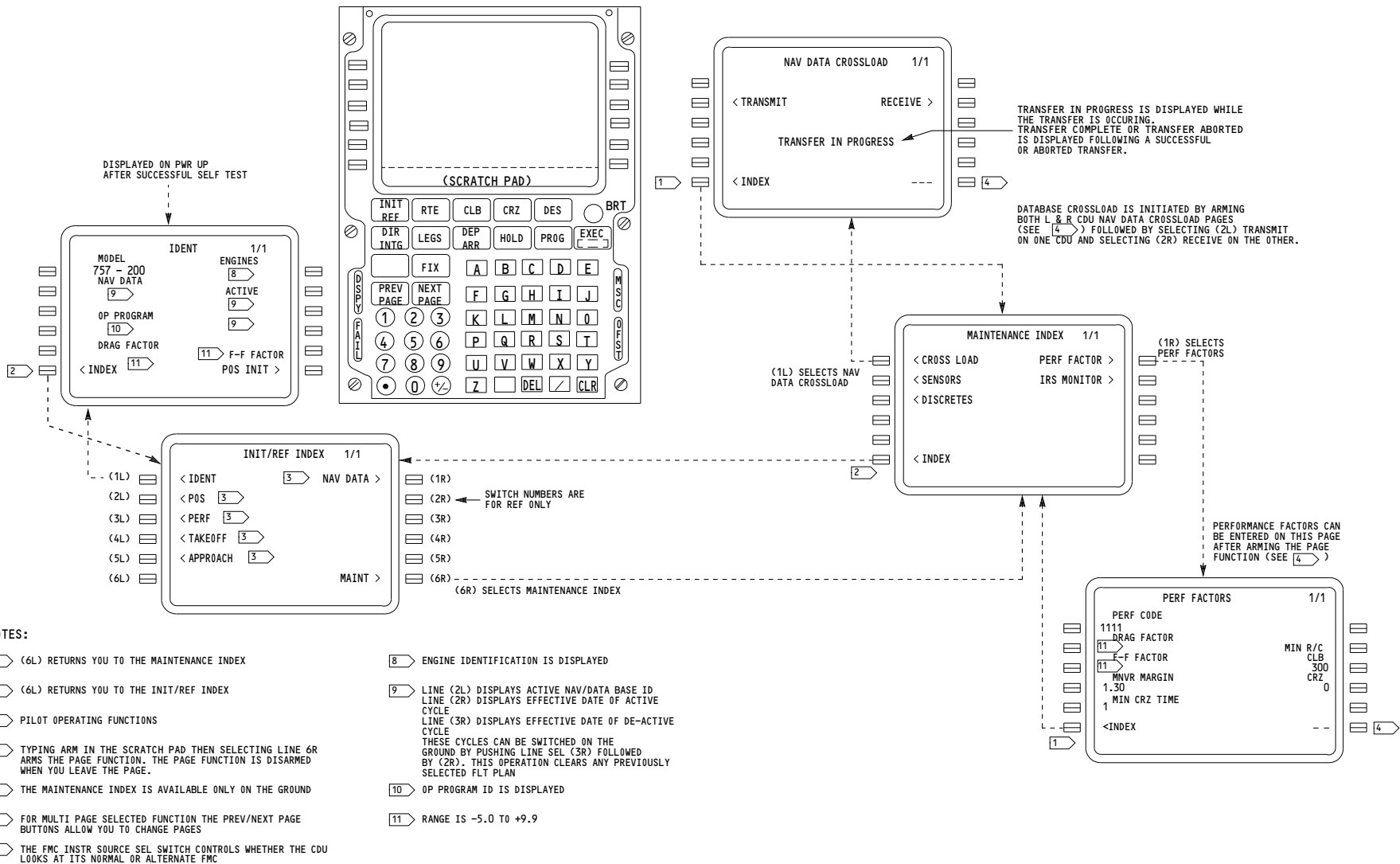

NOTES:

- 1 (6L) RETURNS YOU TO THE MAINTENANCE INDEX
- 2 (6L) RETURNS YOU TO THE INIT/REF INDEX
- 3 PILOT OPERATING FUNCTIONS
- 4 TYPING ARM IN THE SCRATCH PAD THEN SELECTING LINE 6R ARMS THE PAGE FUNCTION. THE PAGE FUNCTION IS DISARMED WHEN YOU LEAVE THE PAGE.
- 5 THE MAINTENANCE INDEX IS AVAILABLE ONLY ON THE GROUND
- 6 FOR MULTI PAGE SELECTED FUNCTION THE PREV/NEXT PAGE BUTTONS ALLOW YOU TO CHANGE PAGES
- 7 THE FMC INSTR SOURCE SEL SWITCH CONTROLS WHETHER THE CDU LOOKS AT ITS NORMAL OR ALTERNATE FMC
- 8 ENGINE IDENTIFICATION IS DISPLAYED
- 9 LINE (2L) DISPLAYS ACTIVE NAV/DATA BASE ID
LINE (2R) DISPLAYS EFFECTIVE DATE OF ACTIVE CYCLE
LINE (3R) DISPLAYS EFFECTIVE DATE OF DE-ACTIVE CYCLE
THESE CYCLES CAN BE SWITCHED ON THE GROUND BY PUSHING LINE SEL (3R) FOLLOWED BY (2R). THIS OPERATION CLEARS ANY PREVIOUSLY SELECTED FLT PLAN
- 10 OP PROGRAM ID IS DISPLAYED
- 11 RANGE IS -5.0 TO +9.9

001-008, 010-099	FMCS MAINTENANCE INDEX
D280N032S	

34-60-02

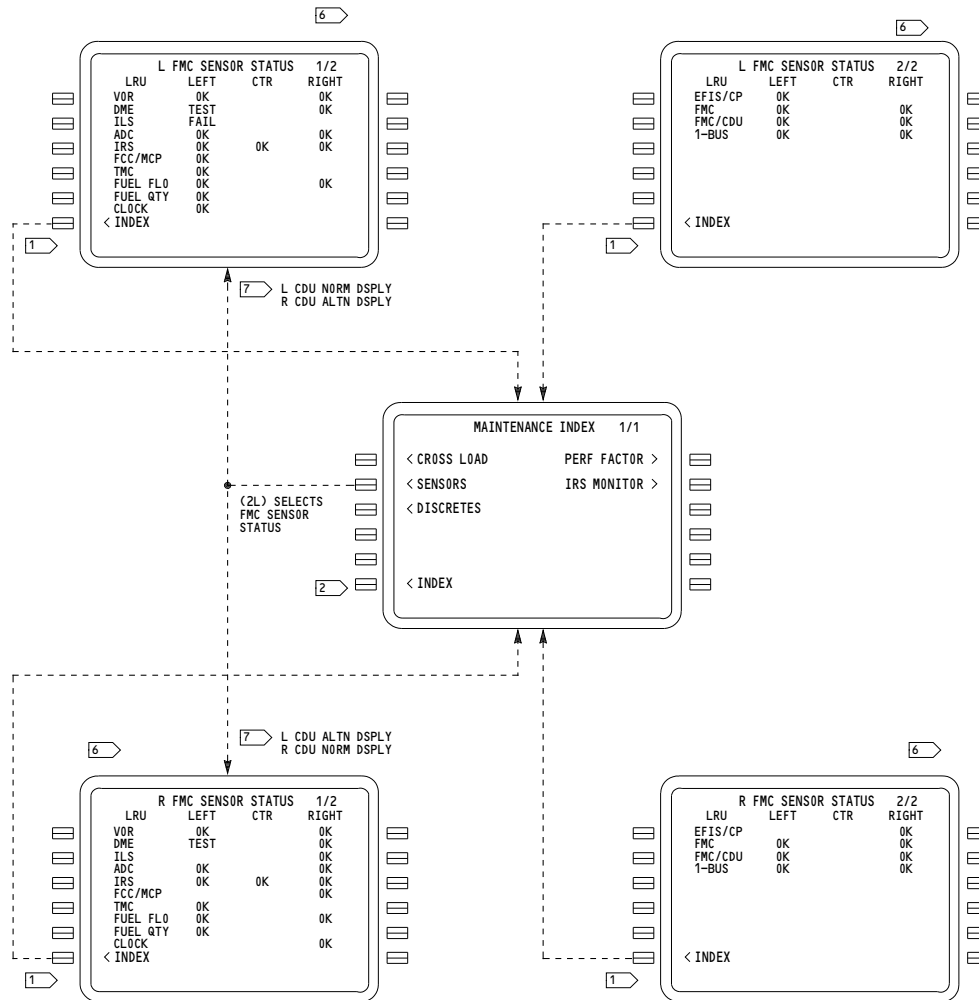
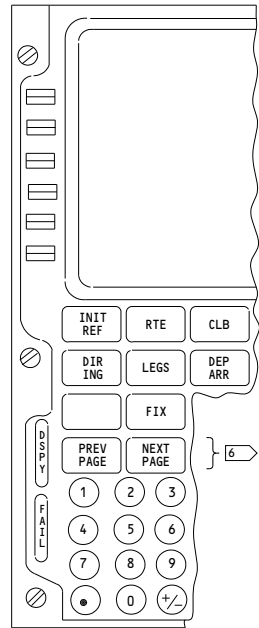

001-008, 010-099

FMCS MAINTENANCE INDEX

D280N032S

34-60-02

Page 101
Sheet 2
Jan 21/2005

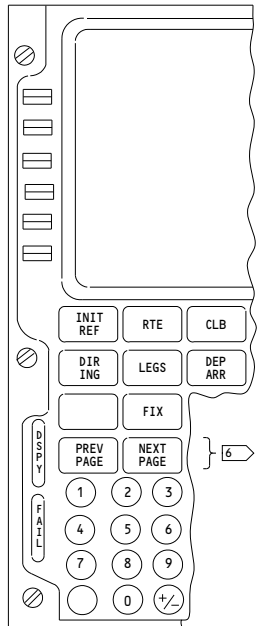
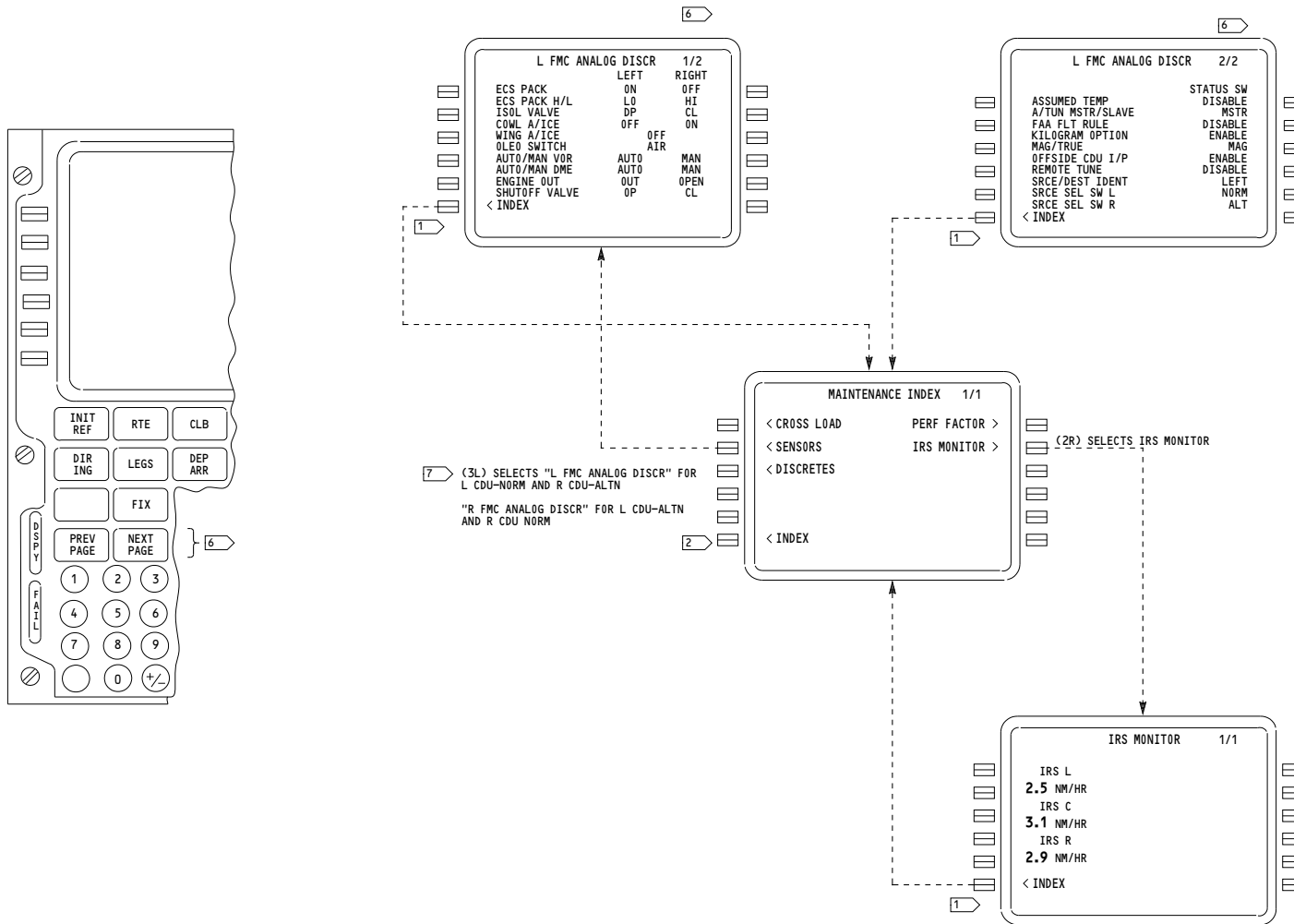

001-008, 010-099	FMCS MAINTENANCE INDEX
	D280N032S

THIS PAGE INTENTIONALLY LEFT BLANK

5101

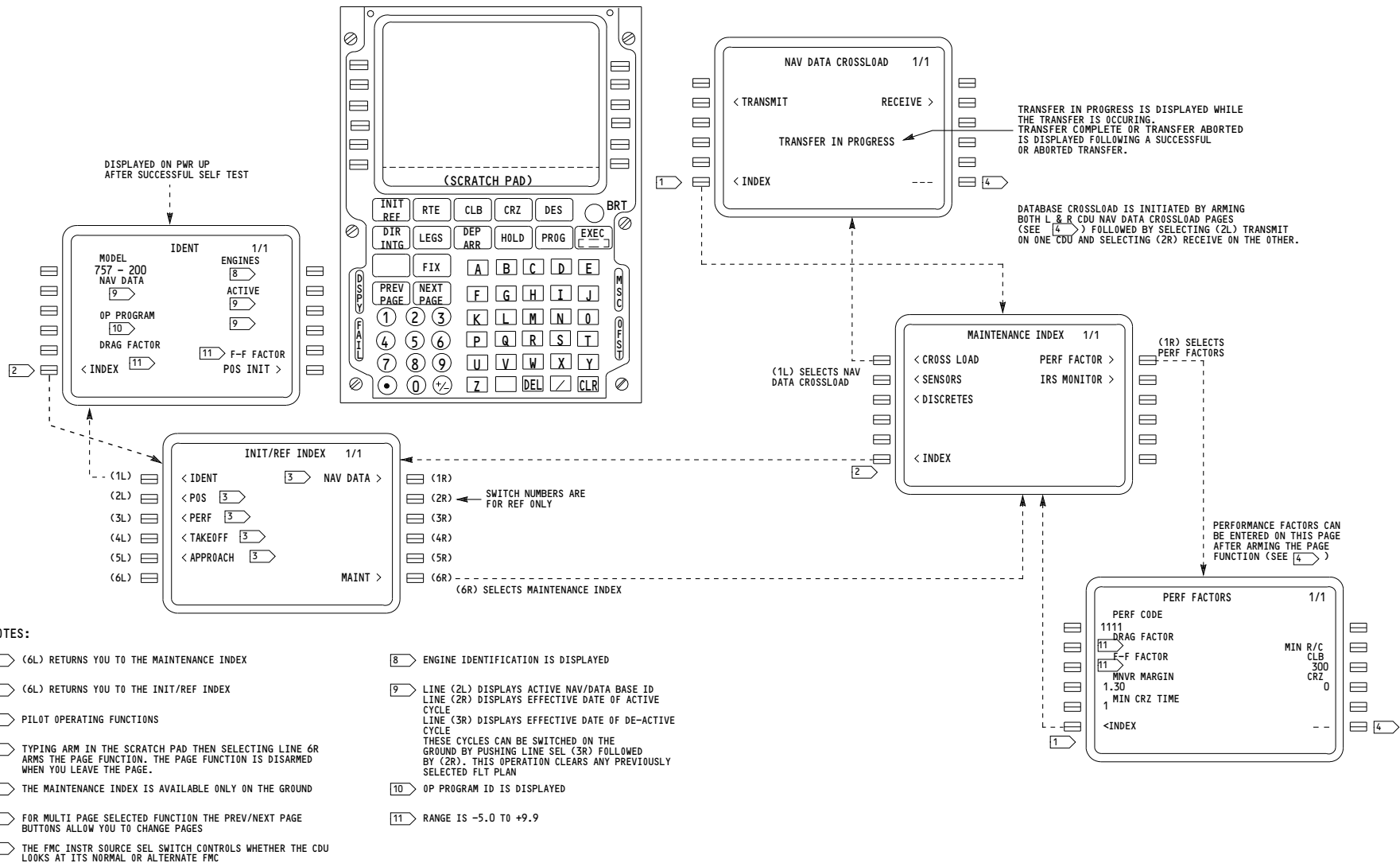

NOTES:

- 1 (6L) RETURNS YOU TO THE MAINTENANCE INDEX
- 2 (6L) RETURNS YOU TO THE INIT/REF INDEX
- 3 PILOT OPERATING FUNCTIONS
- 4 TYPING ARM IN THE SCRATCH PAD THEN SELECTING LINE 6R ARMS THE PAGE FUNCTION. THE PAGE FUNCTION IS DISARMED WHEN YOU LEAVE THE PAGE.
- 5 THE MAINTENANCE INDEX IS AVAILABLE ONLY ON THE GROUND
- 6 FOR MULTI PAGE SELECTED FUNCTION THE PREV/NEXT PAGE BUTTONS ALLOW YOU TO CHANGE PAGES
- 7 THE FMC INSTR SOURCE SEL SWITCH CONTROLS WHETHER THE CDU LOOKS AT ITS NORMAL OR ALTERNATE FMC
- 8 ENGINE IDENTIFICATION IS DISPLAYED
- 9 LINE (2L) DISPLAYS ACTIVE NAV/DATA BASE ID
LINE (2R) DISPLAYS EFFECTIVE DATE OF ACTIVE CYCLE
LINE (3R) DISPLAYS EFFECTIVE DATE OF DE-ACTIVE CYCLE
THESE CYCLES CAN BE SWITCHED ON THE GROUND BY PUSHING LINE SEL (3R) FOLLOWED BY (2R). THIS OPERATION CLEARS ANY PREVIOUSLY SELECTED FLT PLAN
- 10 OP PROGRAM ID IS DISPLAYED
- 11 RANGE IS -5.0 TO +9.9

009	FMCS MAINTENANCE INDEX
D280N032S	

34-60-02

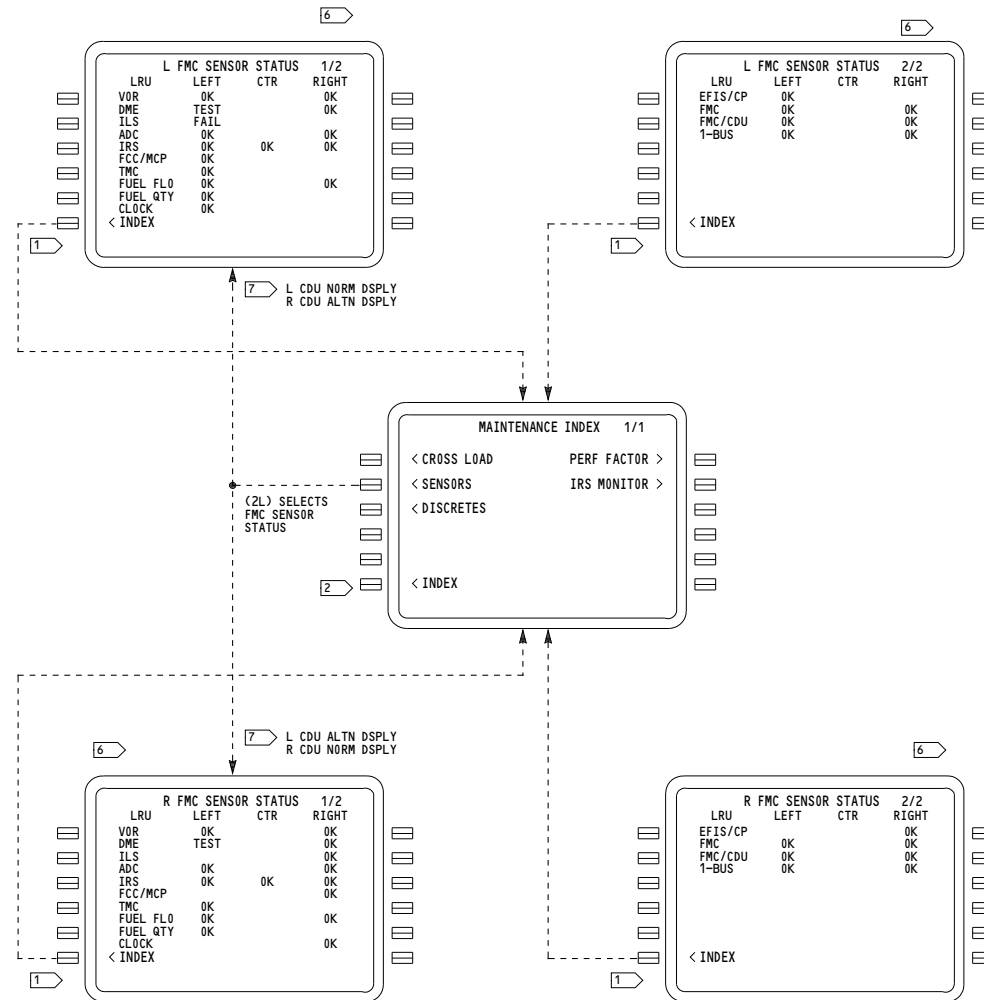
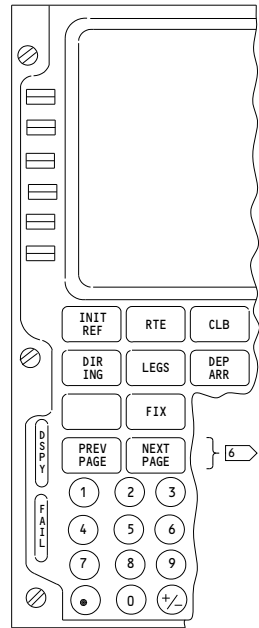

009	FMCS MAINTENANCE INDEX
	D280N032S

5131

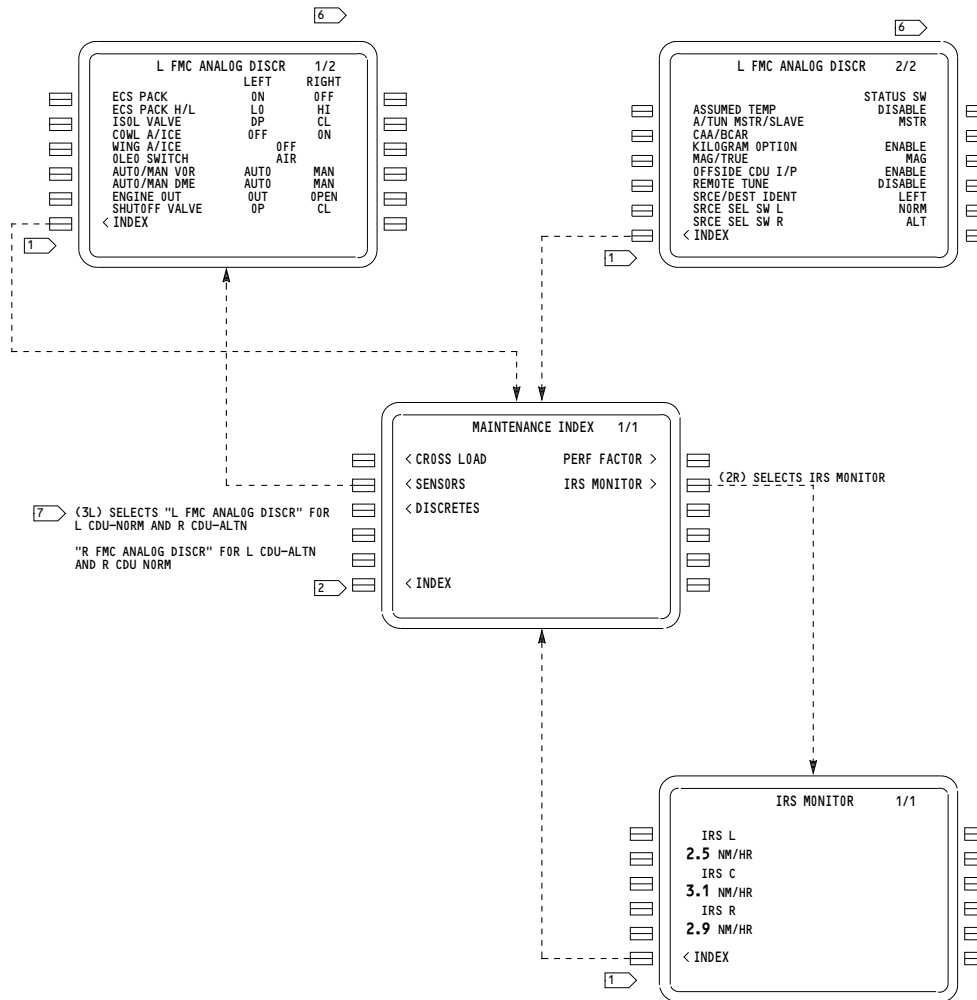
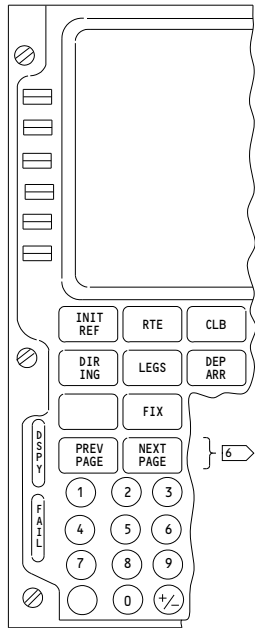

009

FMCS MAINTENANCE INDEX

D280N032S

34-60-02

Page 102
Sheet 3
Jan 21/2005

THIS PAGE INTENTIONALLY LEFT BLANK

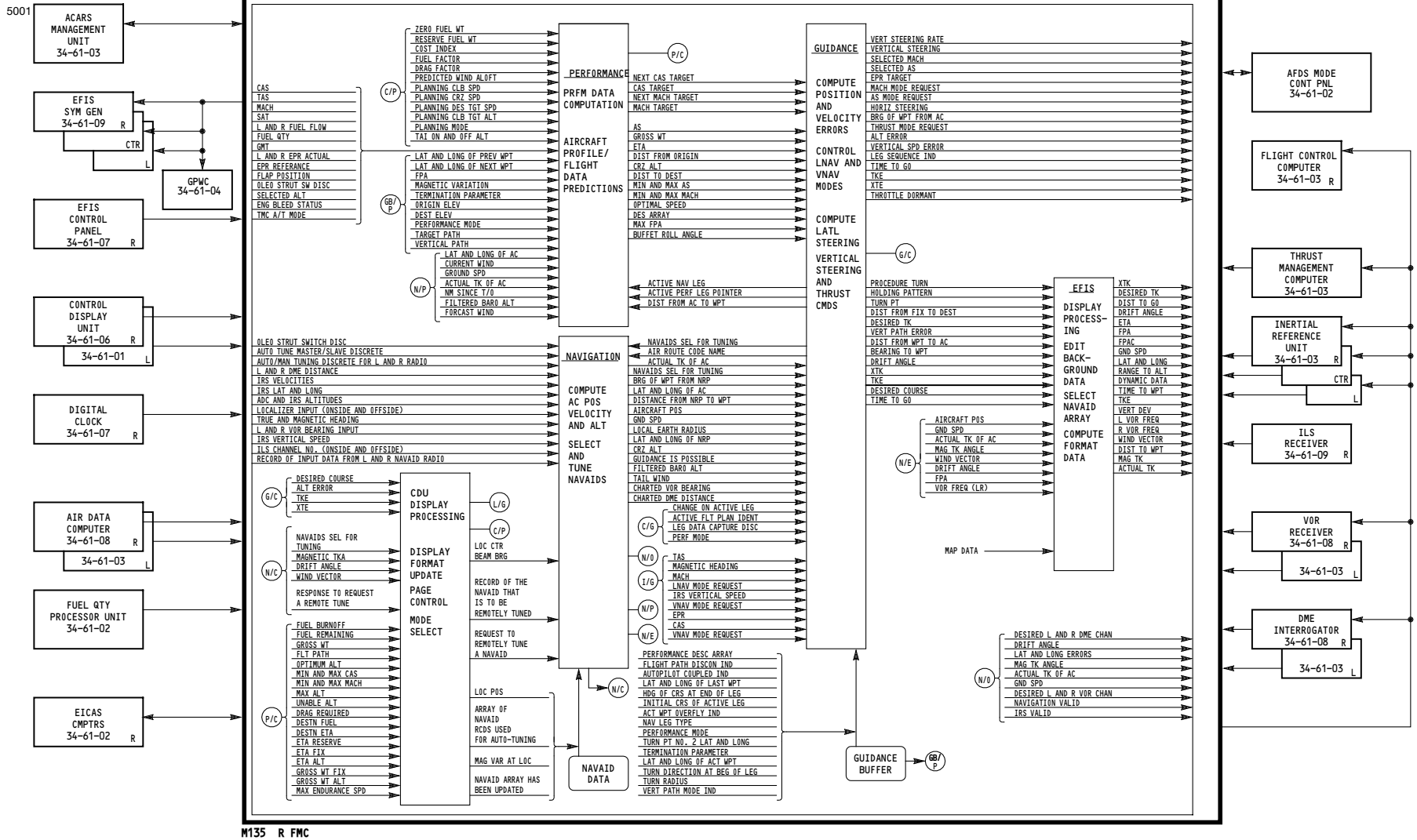

M135 R FMC

ALL

**FLIGHT MANAGEMENT CMPTR
SYSTEM (LEFT - RIGHT
FMCS) - SIMPLIFIED**

D280N032S

34-61-00

5000

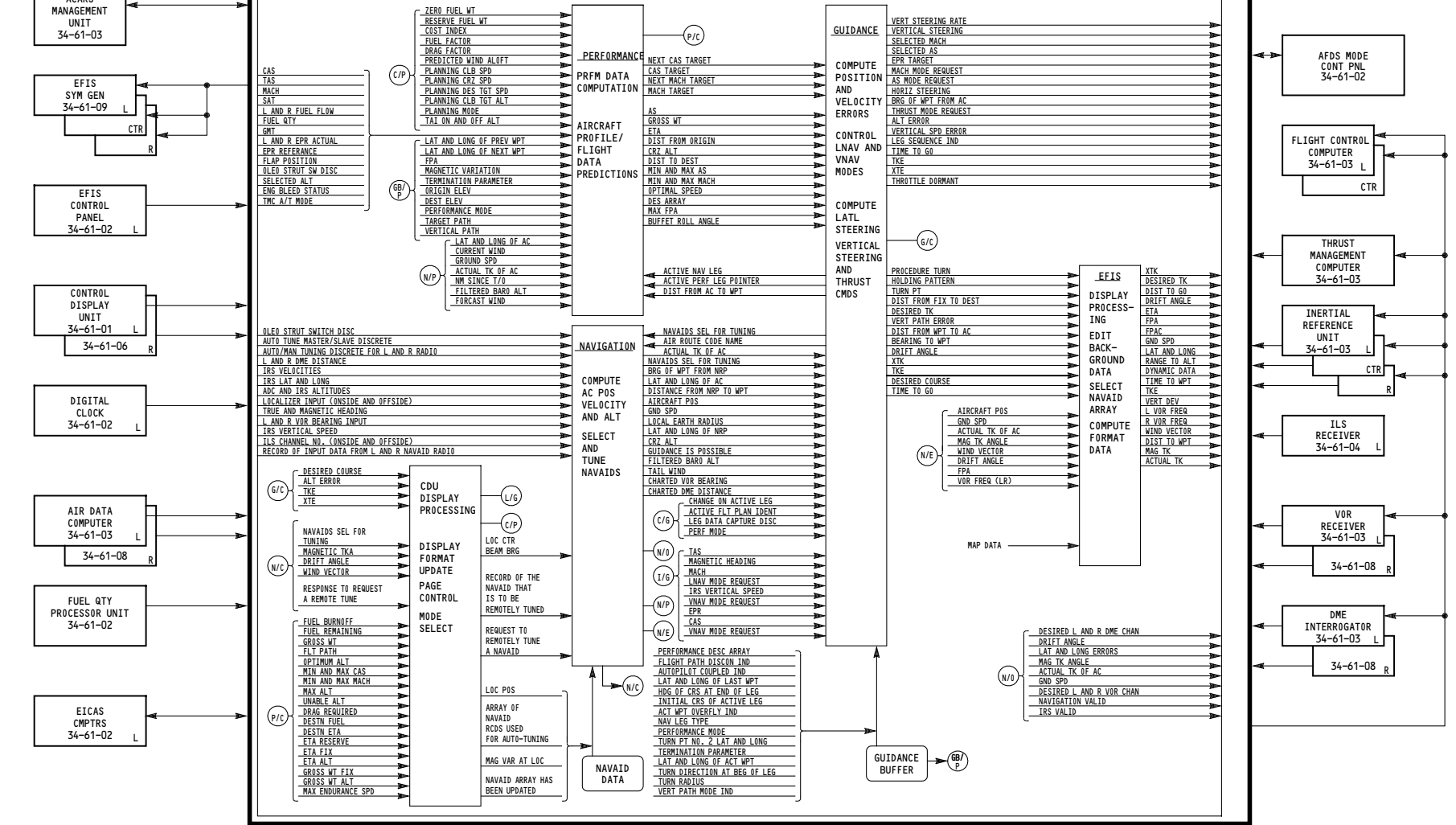

M134 L FMC

ALL

FLIGHT MANAGEMENT CMPTR SYSTEM (LEFT - RIGHT FMCS) - SIMPLIFIED

D280N032S

34-61-00

Page 101
Sheet 2
May 06/2009

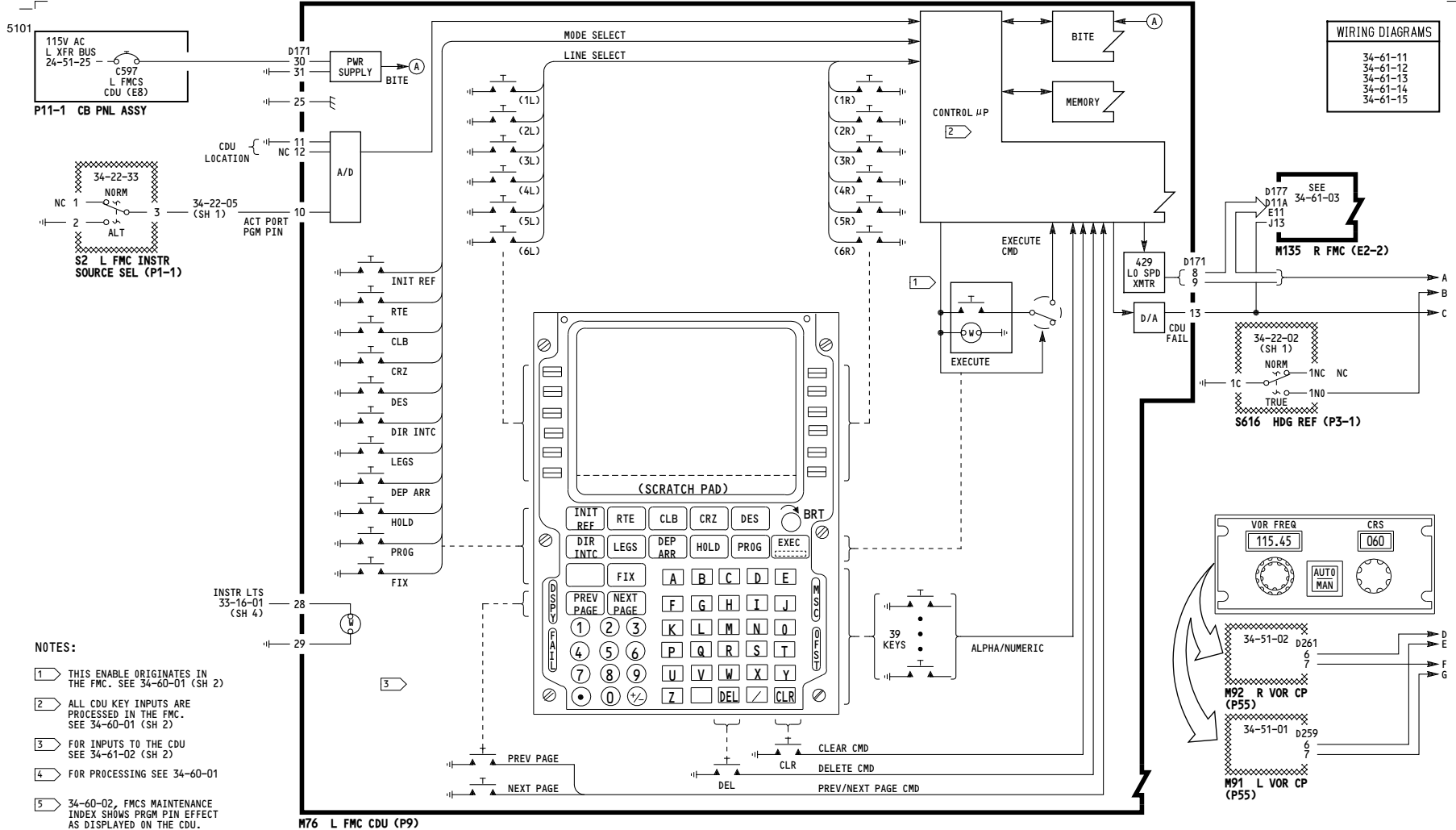

001-008, 010-099	<p align="center">LEFT FMC INPUTS</p> <p align="center">D280N032S</p>
------------------	--

34-61-01

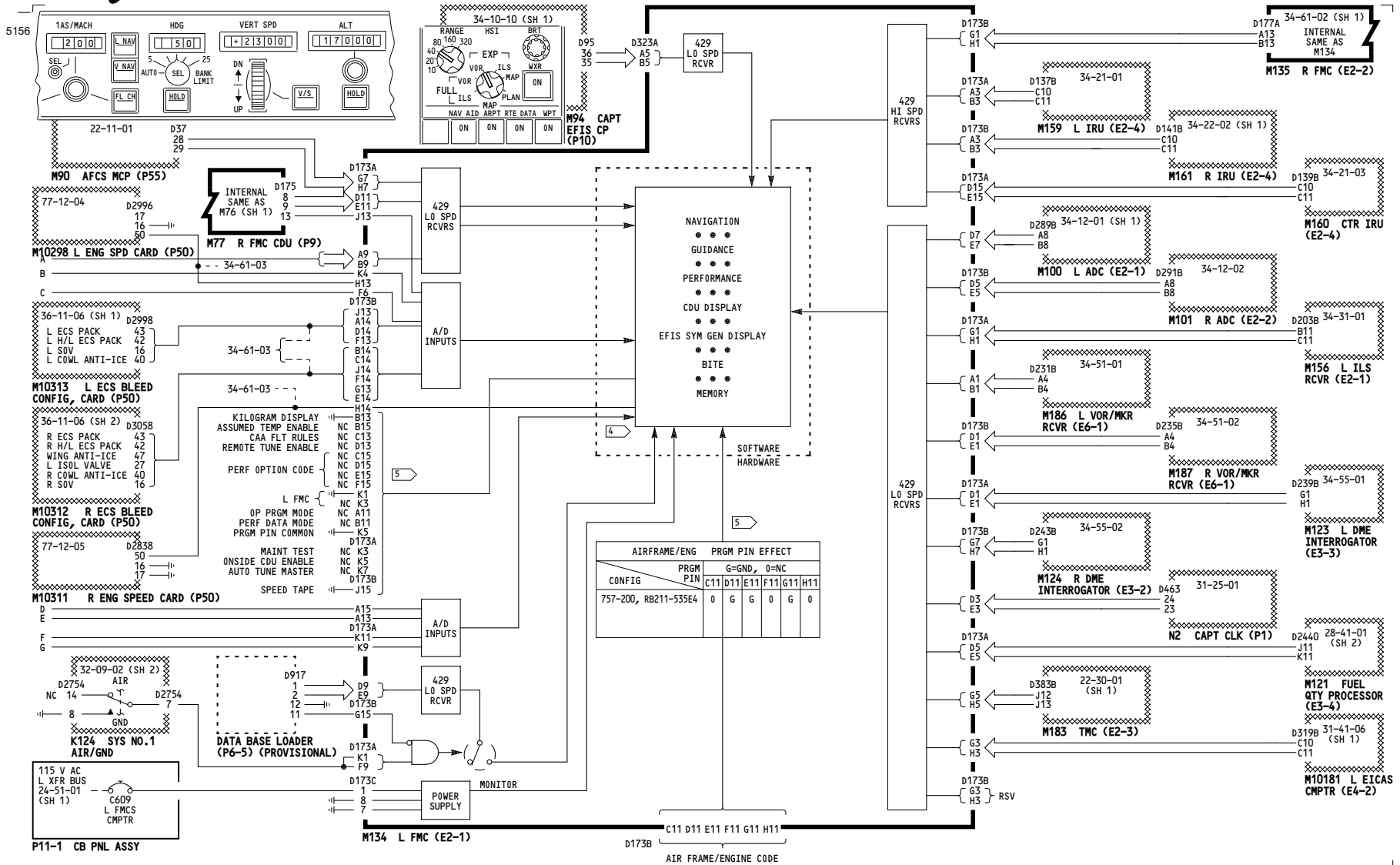

001-008, 010-099

LEFT FMC INPUTS

D280N032S

34-61-01

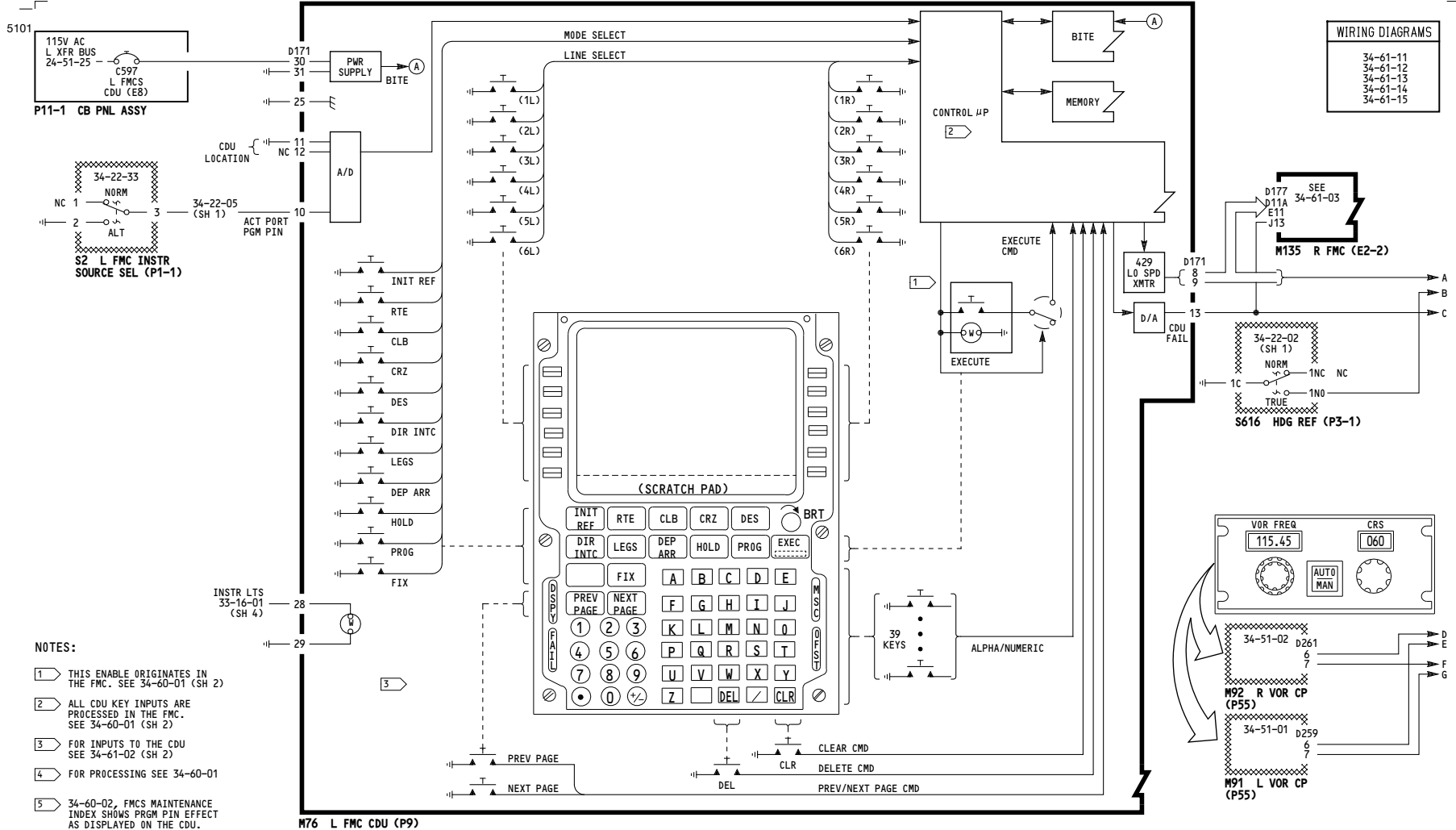

009	LEFT FMC INPUTS
D280N032S	

34-61-01

5101

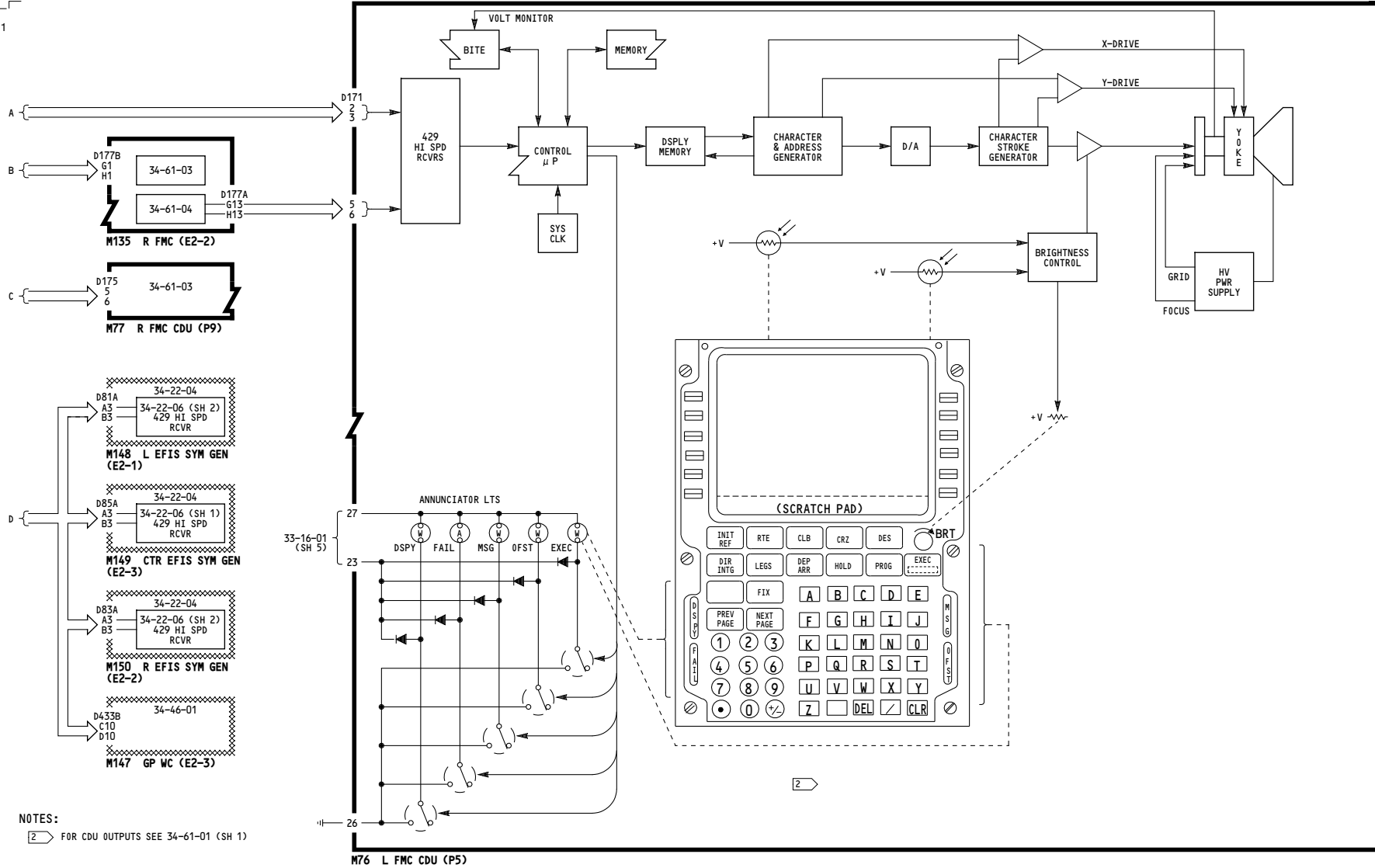

NOTES:
 [2] FOR CDU OUTPUTS SEE 34-61-01 (SH 1)

001-008	LEFT FMC OUTPUTS D280N032S
---------	-----------------------------------

34-61-02

WIRING DIAGRAMS
34-61-11
34-61-15

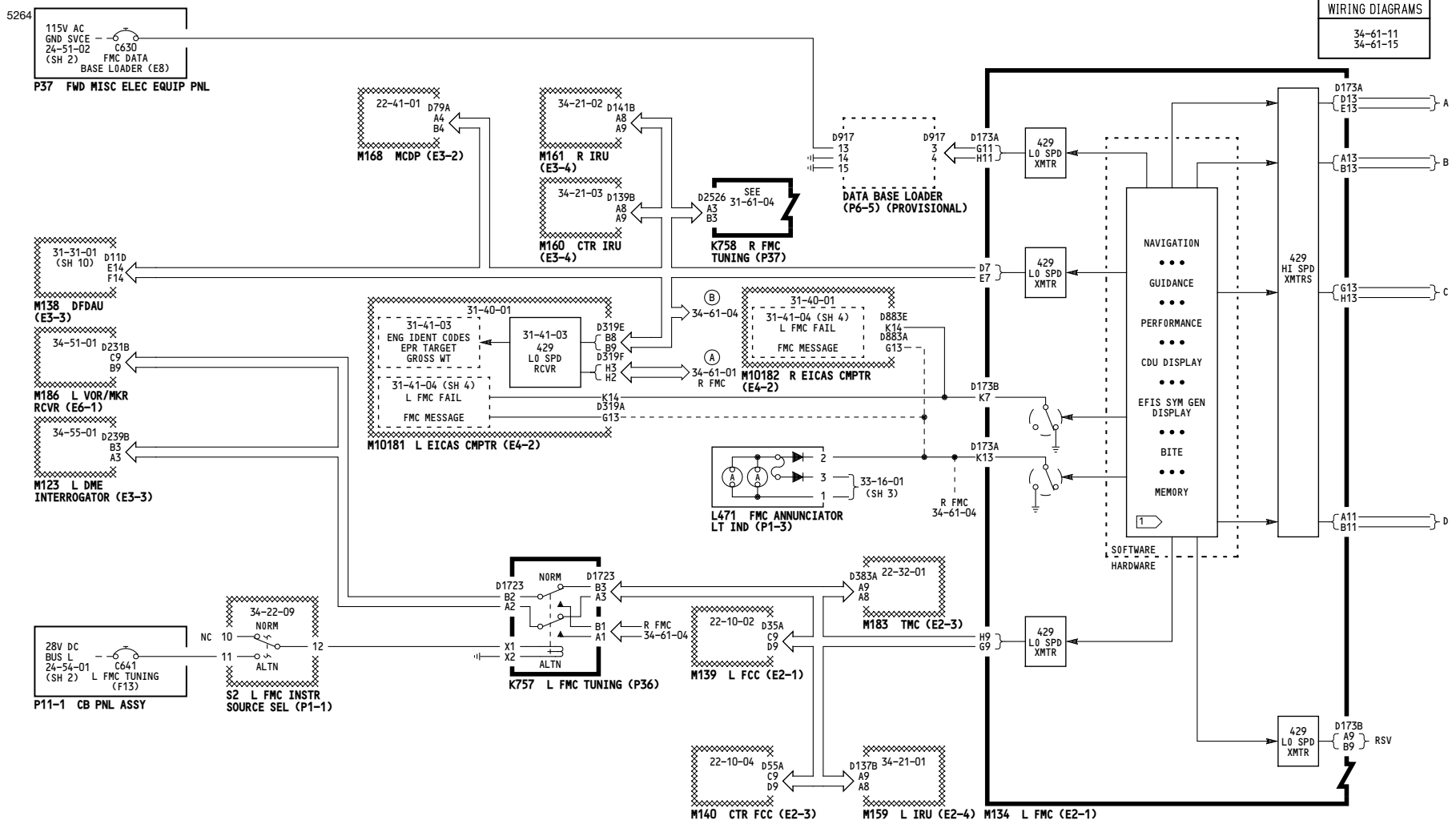

NOTES:
1 FOR PROCESSING
SEE 34-60-01

003	LEFT FMC OUTPUTS
D280N032S	

Incorporates
34-0301

34-61-02

5101

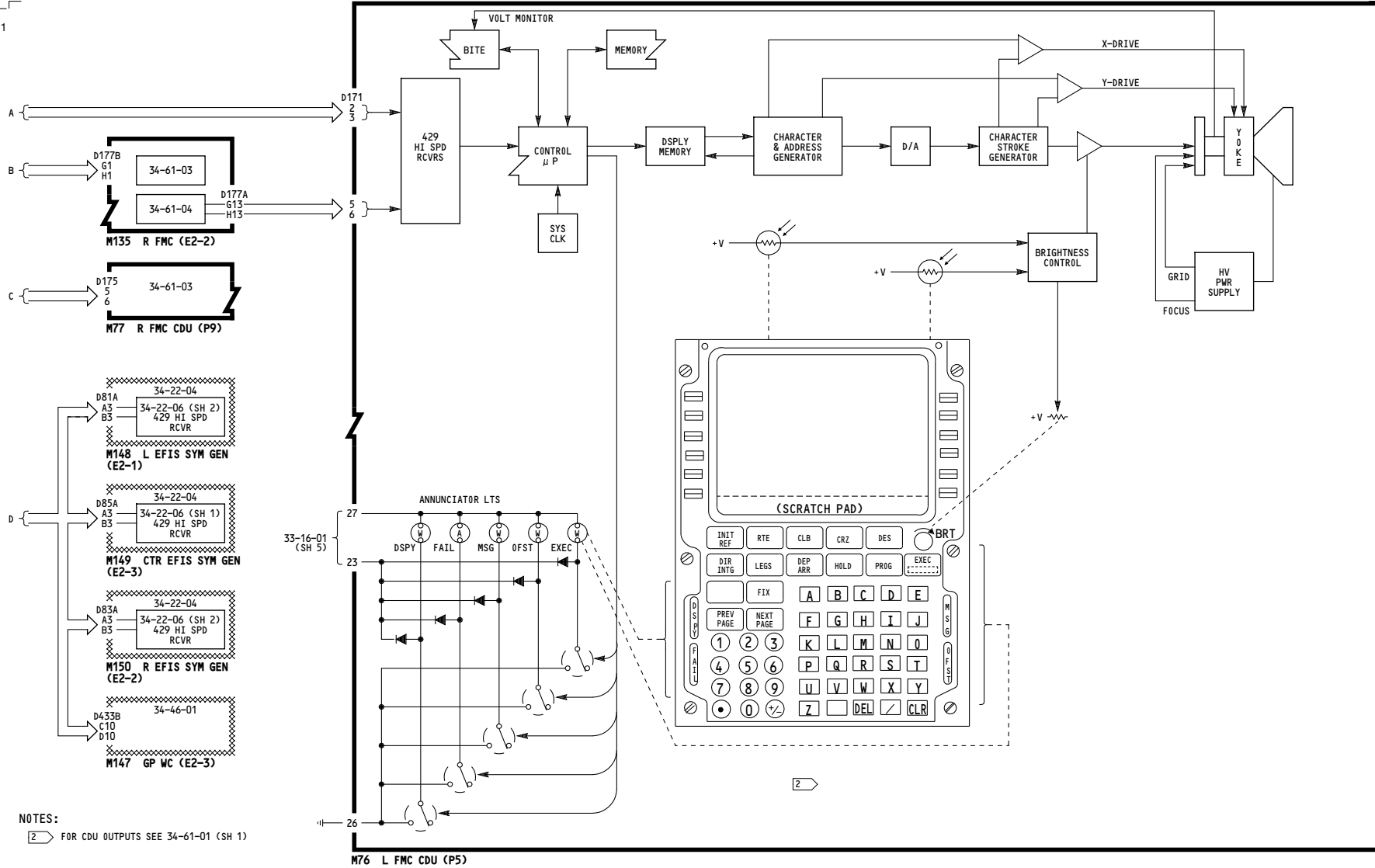

NOTES:
 [2] FOR CDU OUTPUTS SEE 34-61-01 (SH 1)

003

LEFT FMC OUTPUTS

D280N032S

34-61-02

5101

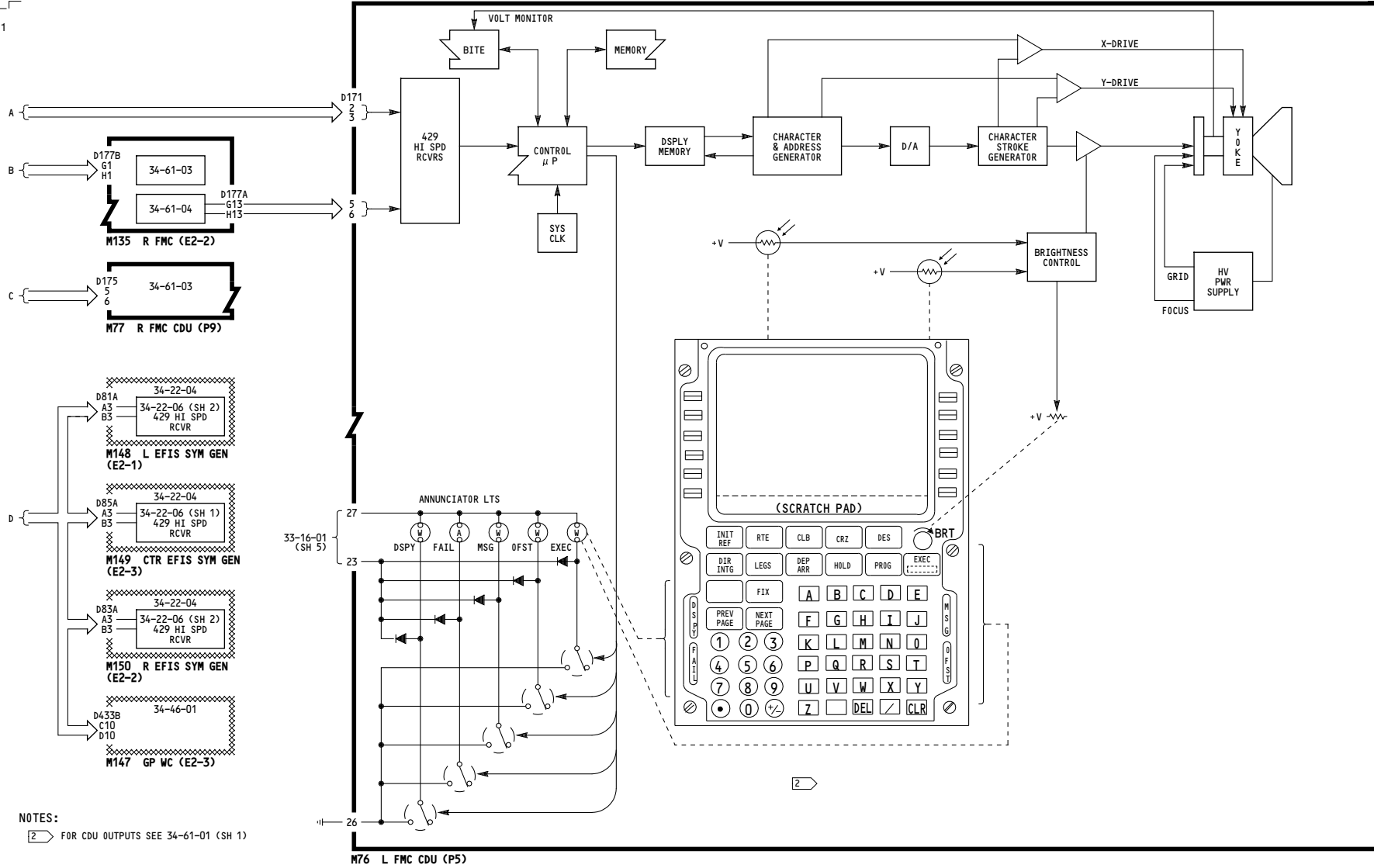

NOTES:
 [2] FOR CDU OUTPUTS SEE 34-61-01 (SH 1)

009-099	<p align="center">LEFT FMC OUTPUTS</p> <p align="center">D280N032S</p>
---------	---

34-61-02

-A
5116

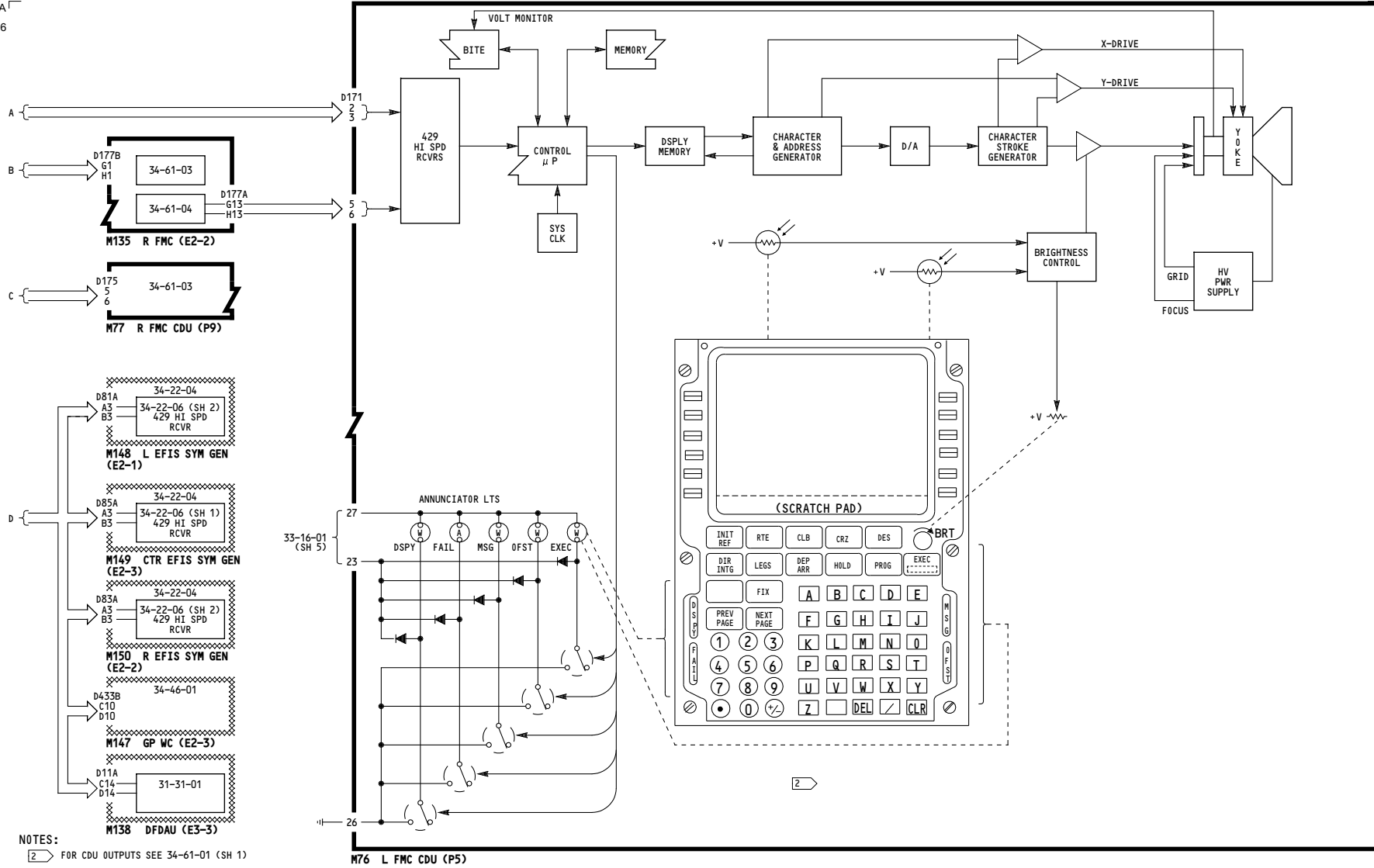

NOTES:
 [2] FOR CDU OUTPUTS SEE 34-61-01 (SH 1)

010-011

LEFT FMC OUTPUTS

D280N032S

Incorporates
 31-0094

34-61-02

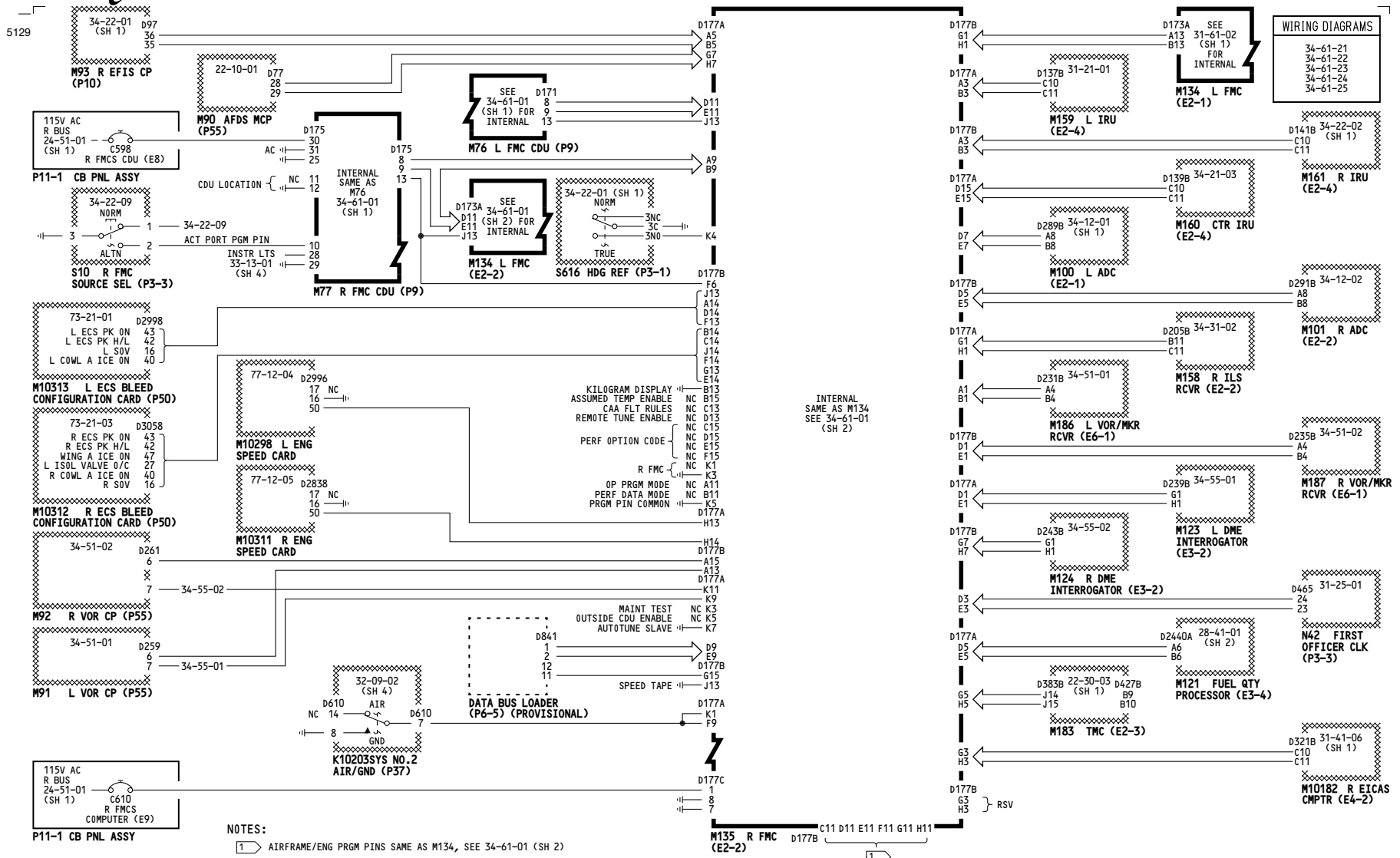

34-61-03

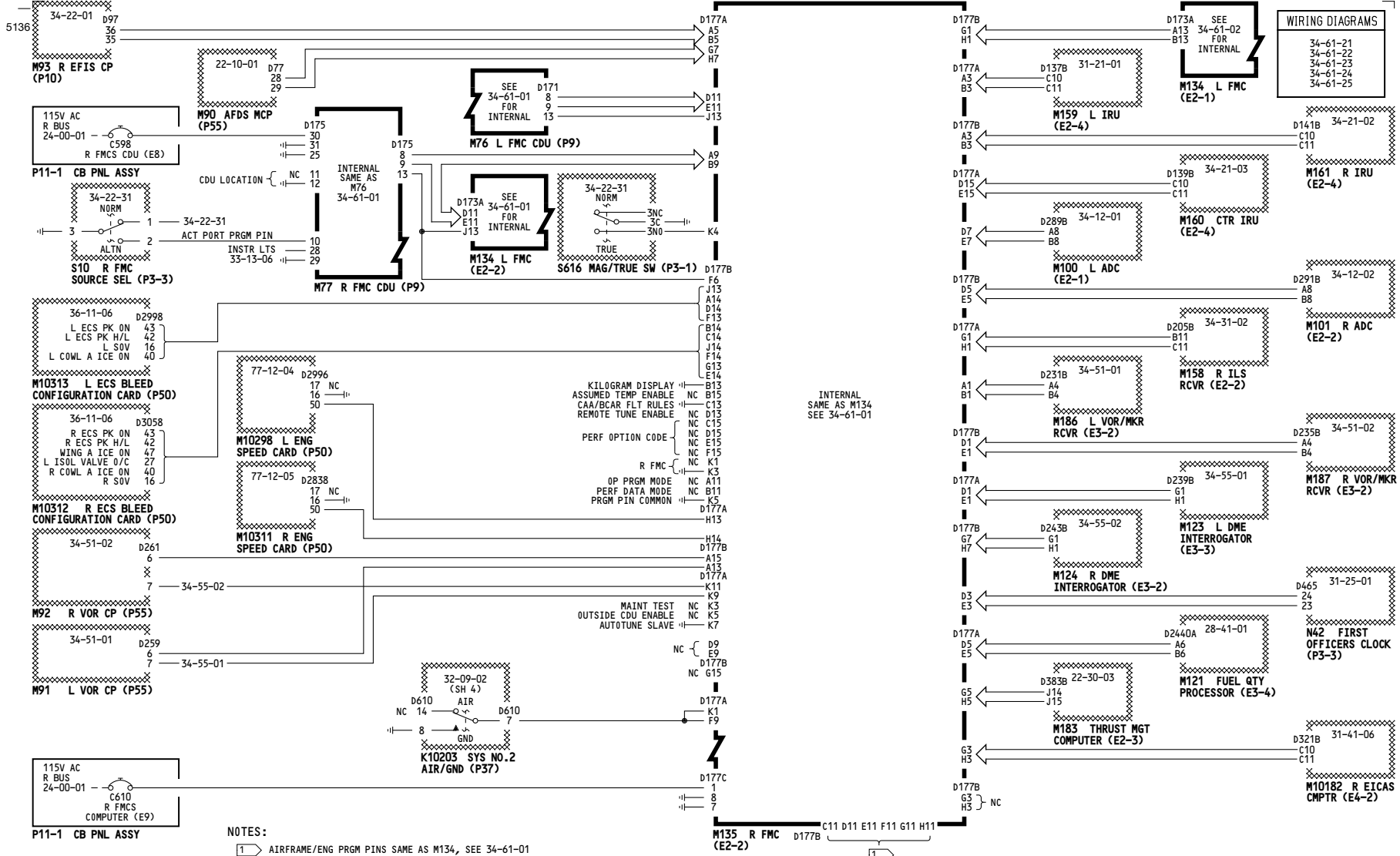

WIRING DIAGRAMS
34-61-21
34-61-25

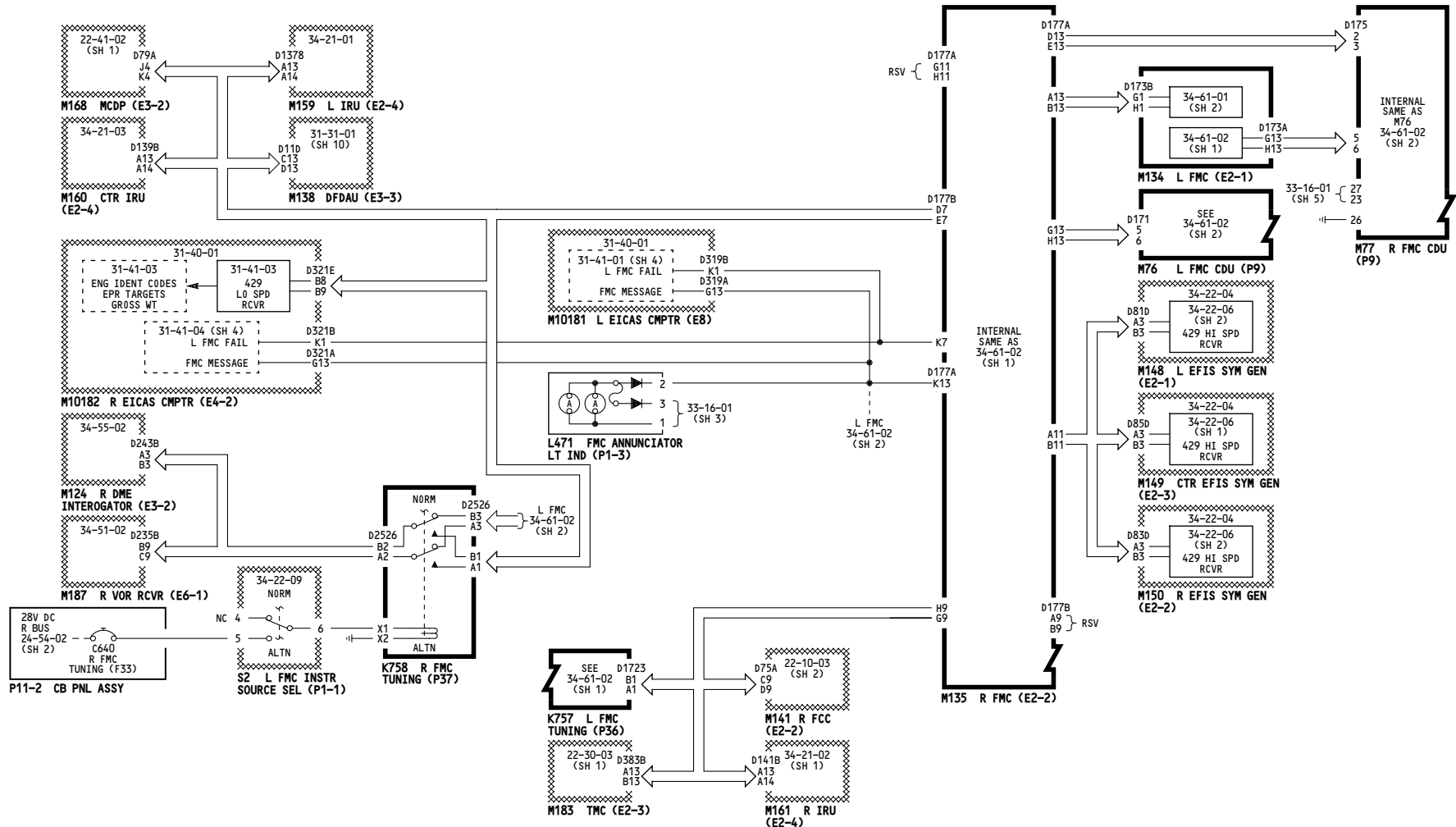

ALL	RIGHT FMC OUTPUTS
	D280N032S

34-61-04

5227

WIRING DIAGRAMS
34-61-21
34-61-25

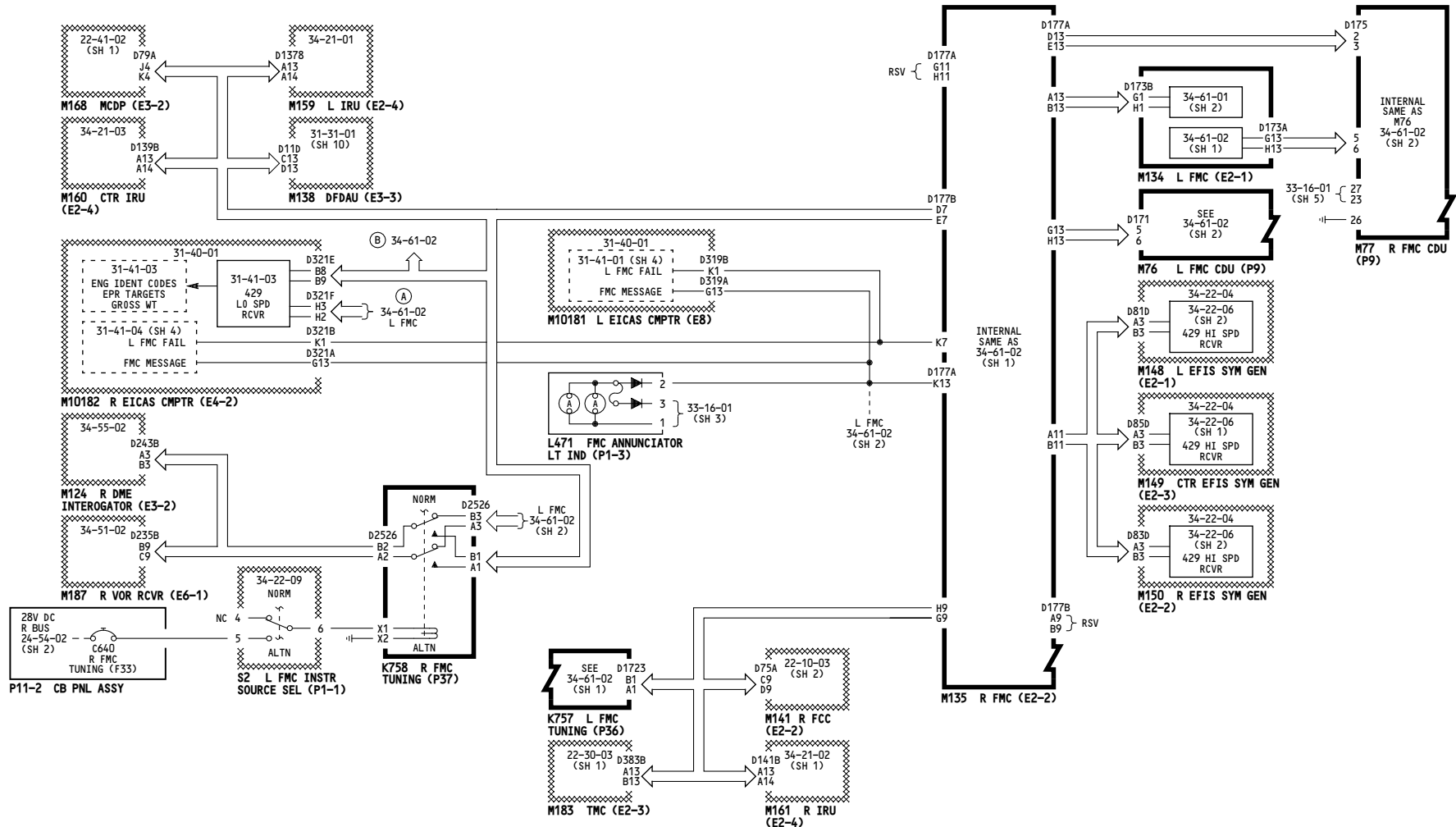

003	RIGHT FMC OUTPUTS
	Incorporates 34-0301
	D280N032S

34-61-04

Page 101.2

Jan 21/2005

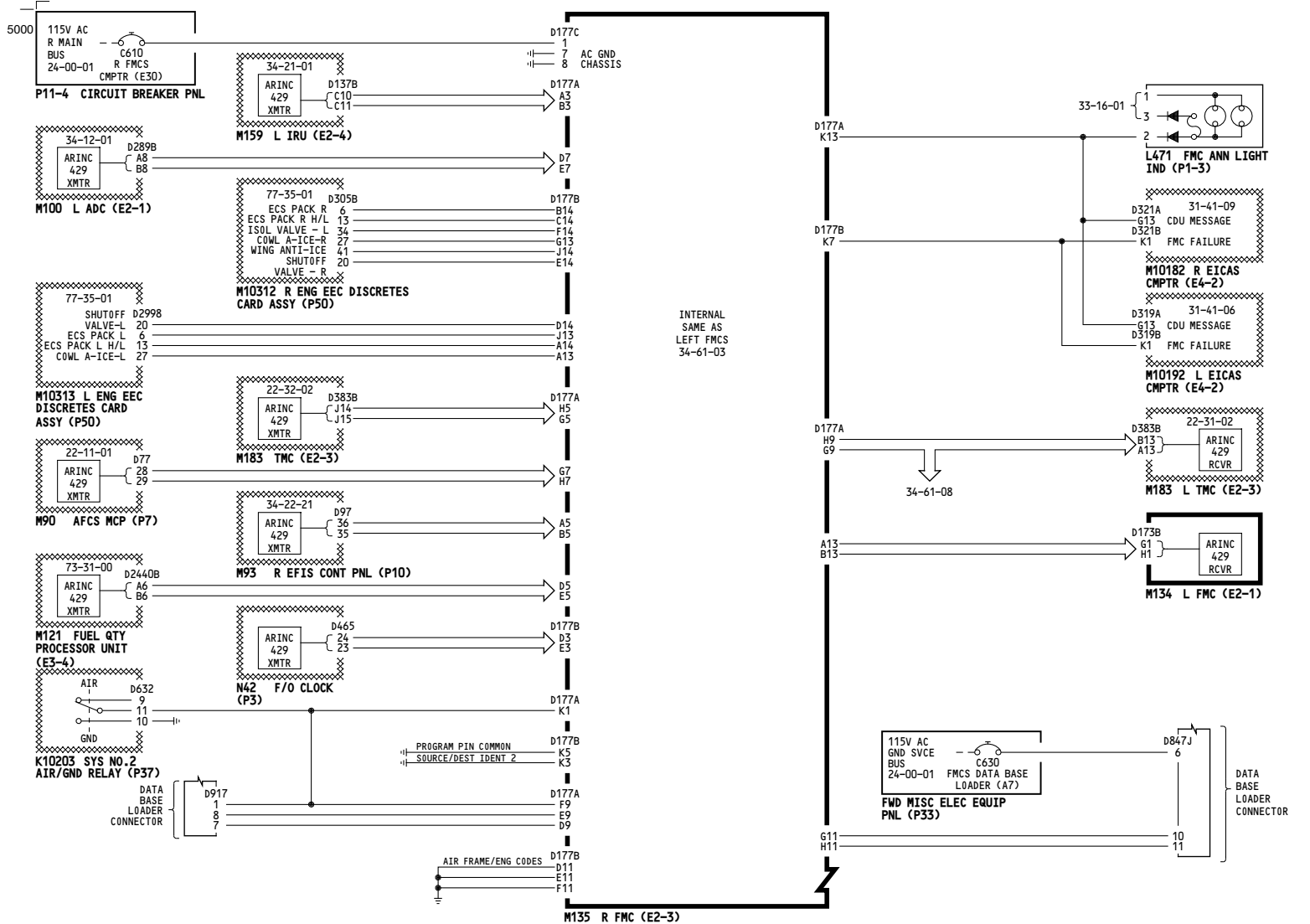

WIRING DIAGRAMS	
22-32-11	
31-21-11	
34-61-11	
34-61-12	
34-61-13	
34-61-15	
34-61-21	
34-61-22	
34-61-23	
34-61-24	
34-61-25	

ALL	FMCS VNAV MODE LOGIC - RIGHT
D280N032S	

34-61-07

Page 101

May 06/2009

5000

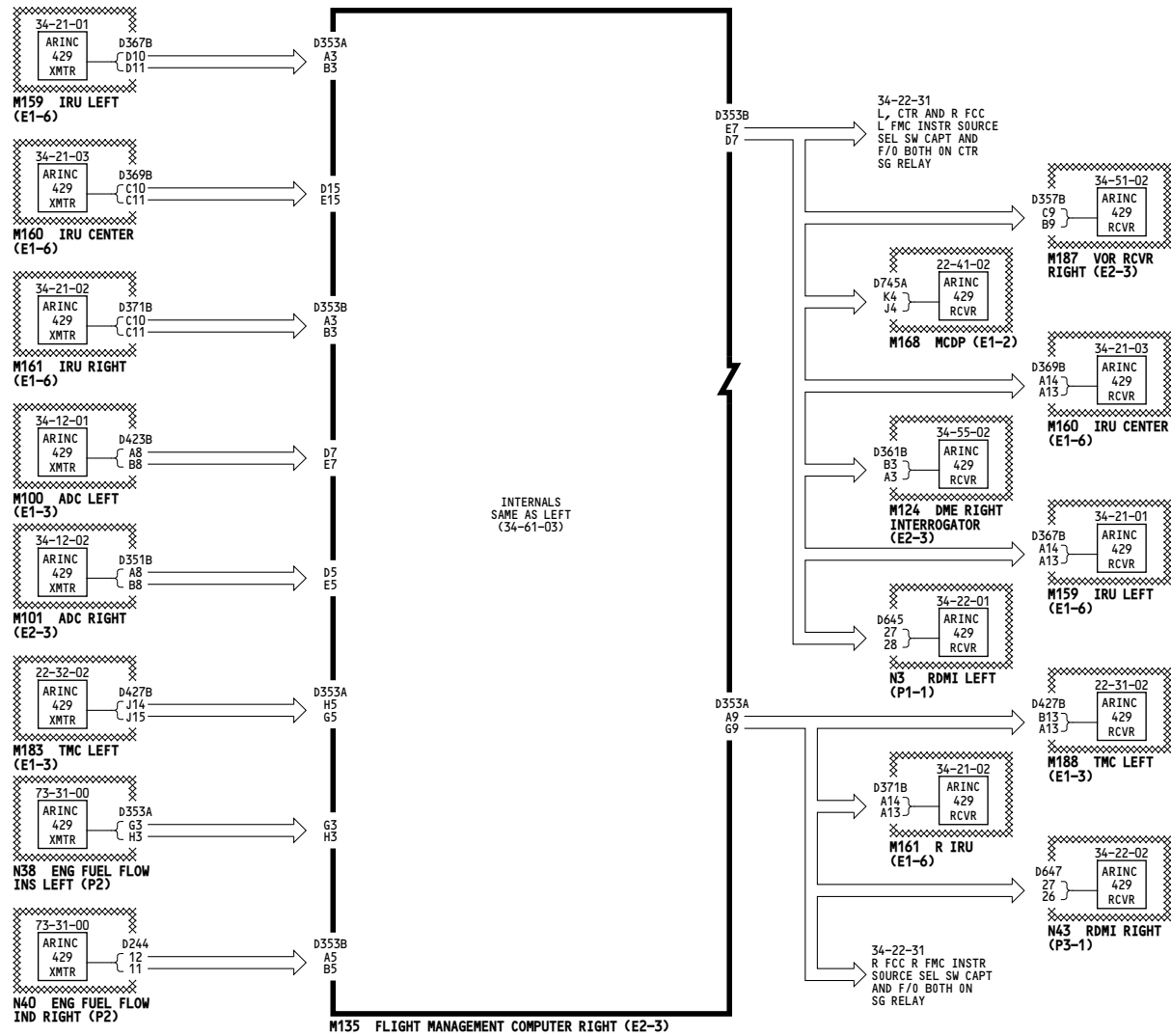

ALL

FMCS VNAV STEERING COMMANDS - RIGHT

D280N032S

34-61-08

Page 101

May 06/2009

5000

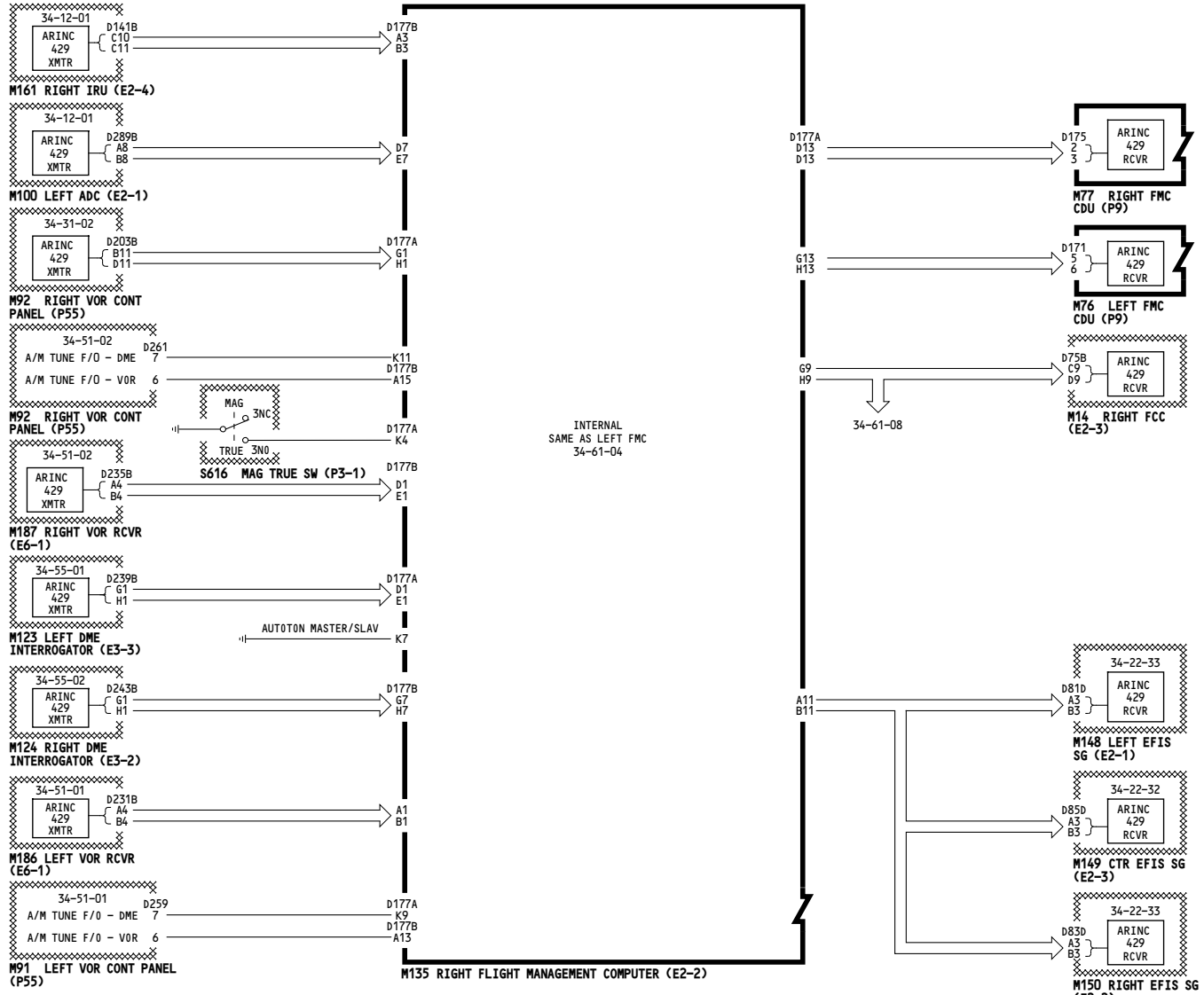

WIRING DIAGRAMS

- 34-22-18
- 34-22-28
- 34-22-38
- 34-51-11
- 34-51-21
- 34-61-12
- 34-61-13
- 34-61-21
- 34-61-22
- 34-61-23
- 34-61-25

ALL

FMCS LNAV STEERING COMMANDS - RIGHT

D280N032S

34-61-09