

CHAPTER

52

DOORS



CHAPTER 52
DOORS

CH-SC-SU	Schem	Page	Sheet	Date	CH-SC-SU	Schem	Page	Sheet	Date
52-EFFECTIVE PAGES									
		1		Oct 09/2008					
		2		BLANK					
52-CONTENTS									
		1		Dec 18/2007					
		2		BLANK					
52-ALPHABETICAL INDEX									
		1		Dec 18/2007					
		2		BLANK					
52-00-00									
		101		Jan 21/2005					
		102		Jan 21/2005					
52-34-01									
		101		Jan 21/2005					
		102		Jan 21/2005					
52-34-02									
		101		Jan 21/2005					
		102		Jan 21/2005					
52-51-01									
		101		Jan 21/2005					
52-71-01									
		101		Jan 21/2005					
		102		Jan 21/2005					

A = Added, R = Revised, D = Deleted, O = Overflow

52-EFFECTIVE PAGES



CHAPTER 52
DOORS

Title	CH-SC-SU	Schem	Page	Sheet	Date	Effectivity
<u>DOORS</u>						
DOOR LOCATIONS	52-00-00		101		Jan 21/2005	001-099
			102		Jan 21/2005	115-199
<u>NO. 1 AND 2 CARGO DOOR</u>						
CARGO DOOR CONTROL 1	52-34-01		101		Jan 21/2005	001-099
			102		Jan 21/2005	115-199
CARGO DOOR CONTROL 2	52-34-02		101		Jan 21/2005	001-099
			102		Jan 21/2005	115-199
<u>FLIGHT COMPARTMENT DOOR</u>						
FLIGHT DECK DOOR LOCK	52-51-01		101		Jan 21/2005	ALL
<u>DOOR WARNING SYSTEM</u>						
DOOR WARNING INDICATION	52-71-01		101		Jan 21/2005	001-099
			102		Jan 21/2005	115-199

CHAPTER 52
DOORS

CH-SC-SU	Title
52-34-01	CARGO DOOR CONTROL 1
52-34-02	CARGO DOOR CONTROL 2
52-00-00	DOOR LOCATIONS
52-71-01	DOOR WARNING INDICATION
52-51-01	FLIGHT DECK DOOR LOCK

CH-SC-SU	Title
----------	-------

52-ALPHABETICAL INDEX

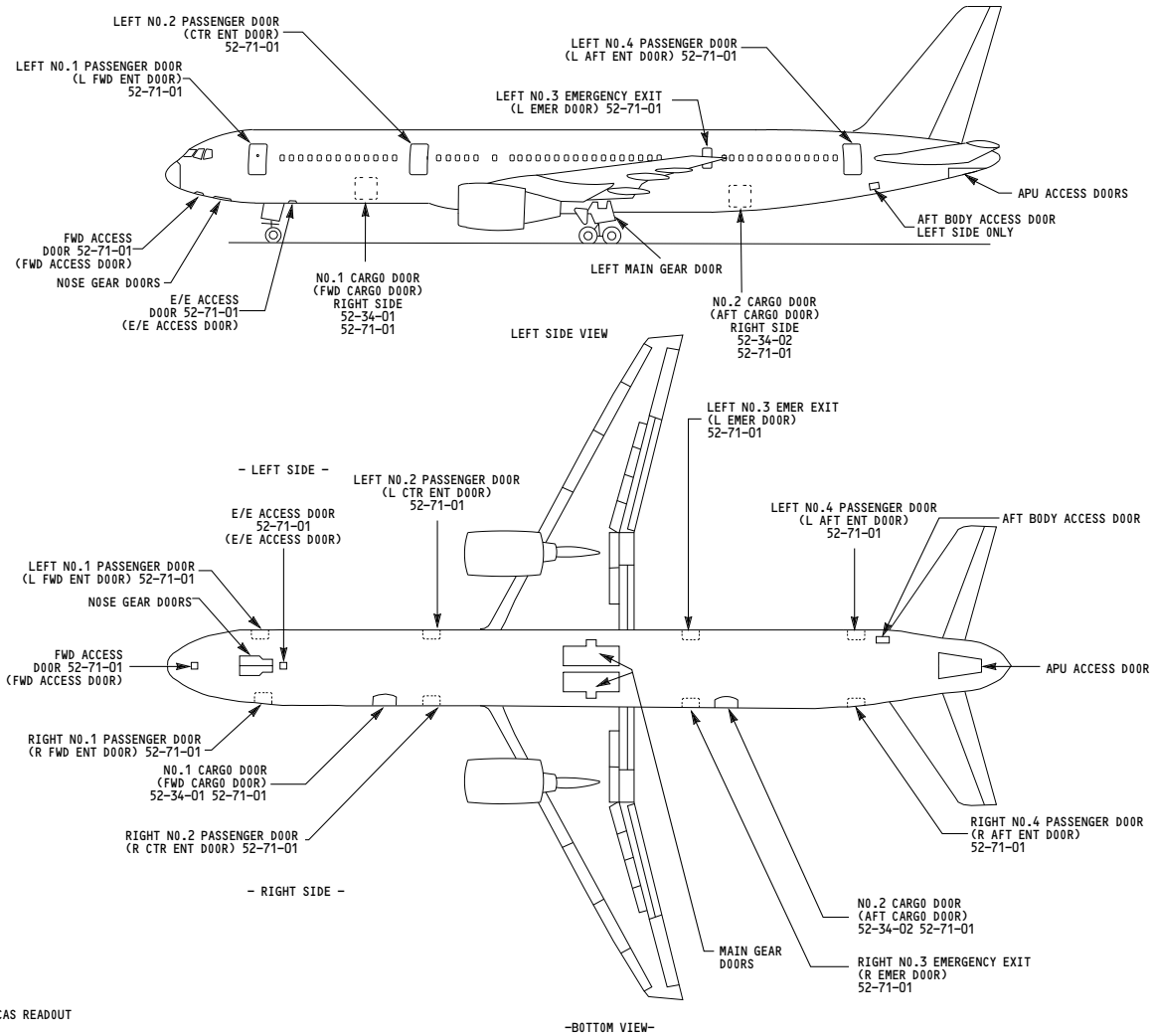

NOTES: NOMENCLATURE IN PHARENTHESIS REFLECTS EICAS READOUT

001-099	<p align="center">DOOR LOCATIONS</p> <p align="center">D280N032S</p>
---------	---

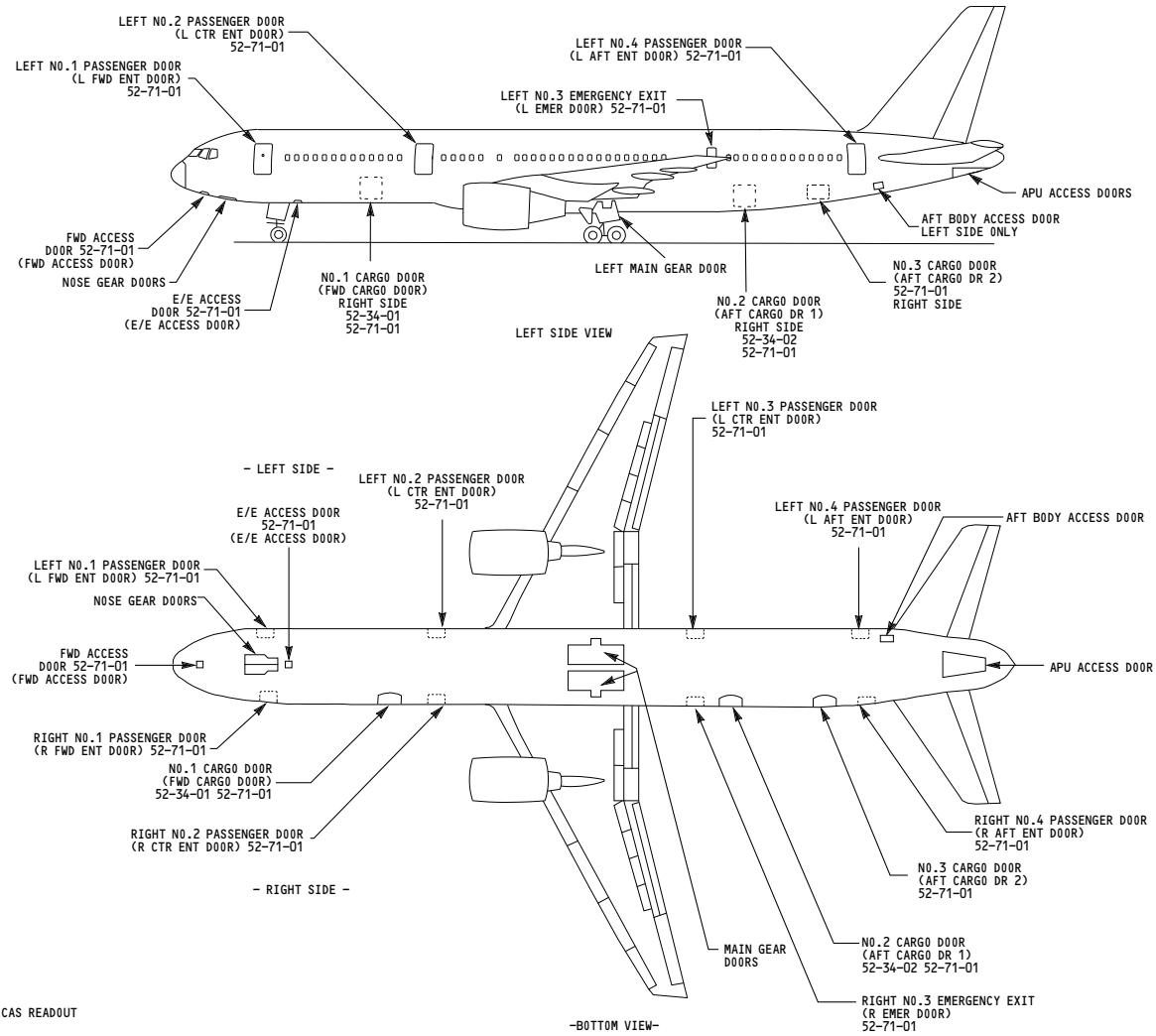

NOTES: NOMENCLATURE IN PHARENTHESIS REFLECTS EICAS READOUT

115-199	DOOR LOCATIONS
	D280N032S

52-00-00

Page 102

Jan 21/2005

5017

WIRING DIAGRAMS
52-34-11

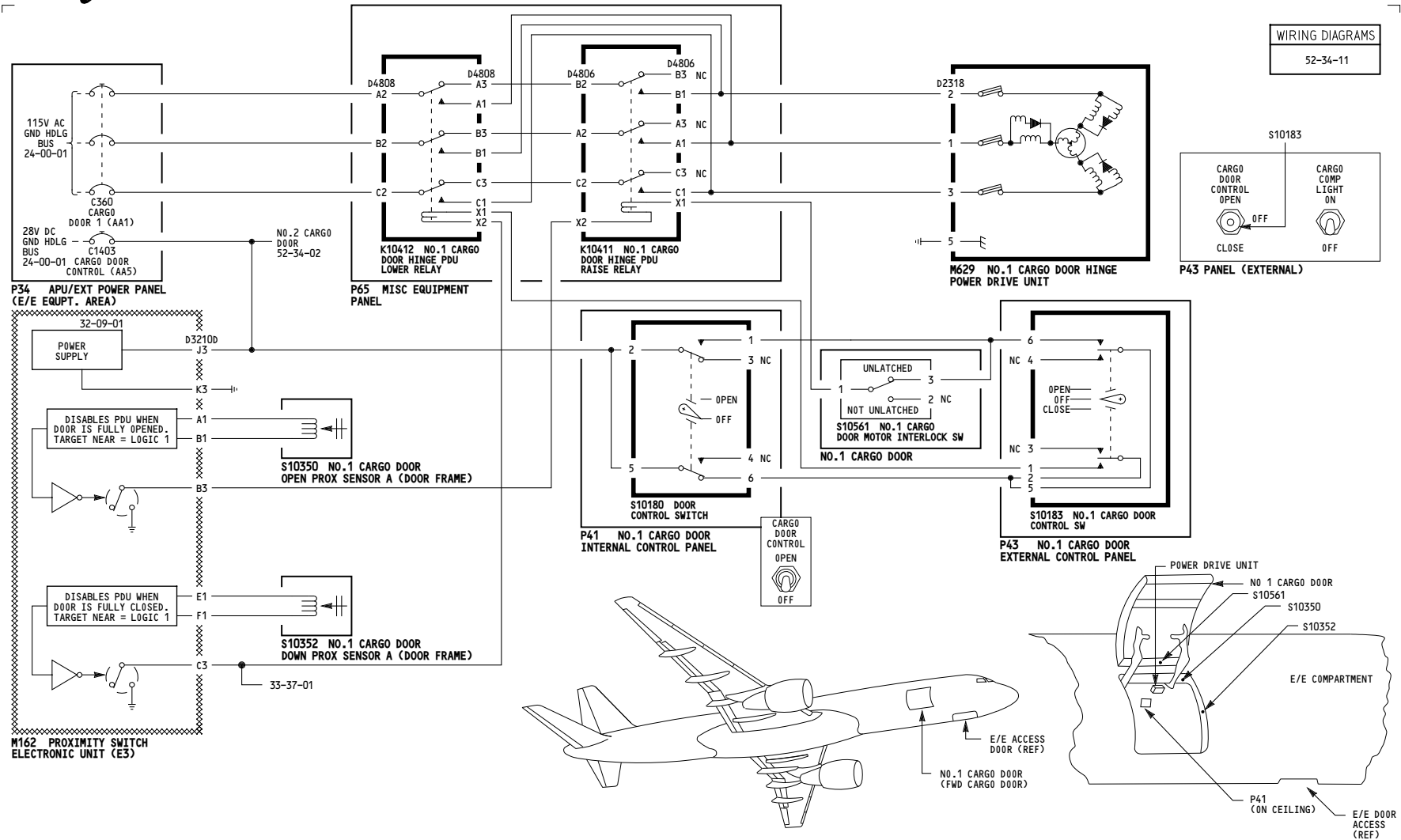

001-099	<p>CARGO DOOR CONTROL 1</p> <p>D280N032S</p>
---------	---

52-34-01

WIRING DIAGRAMS
52-34-11

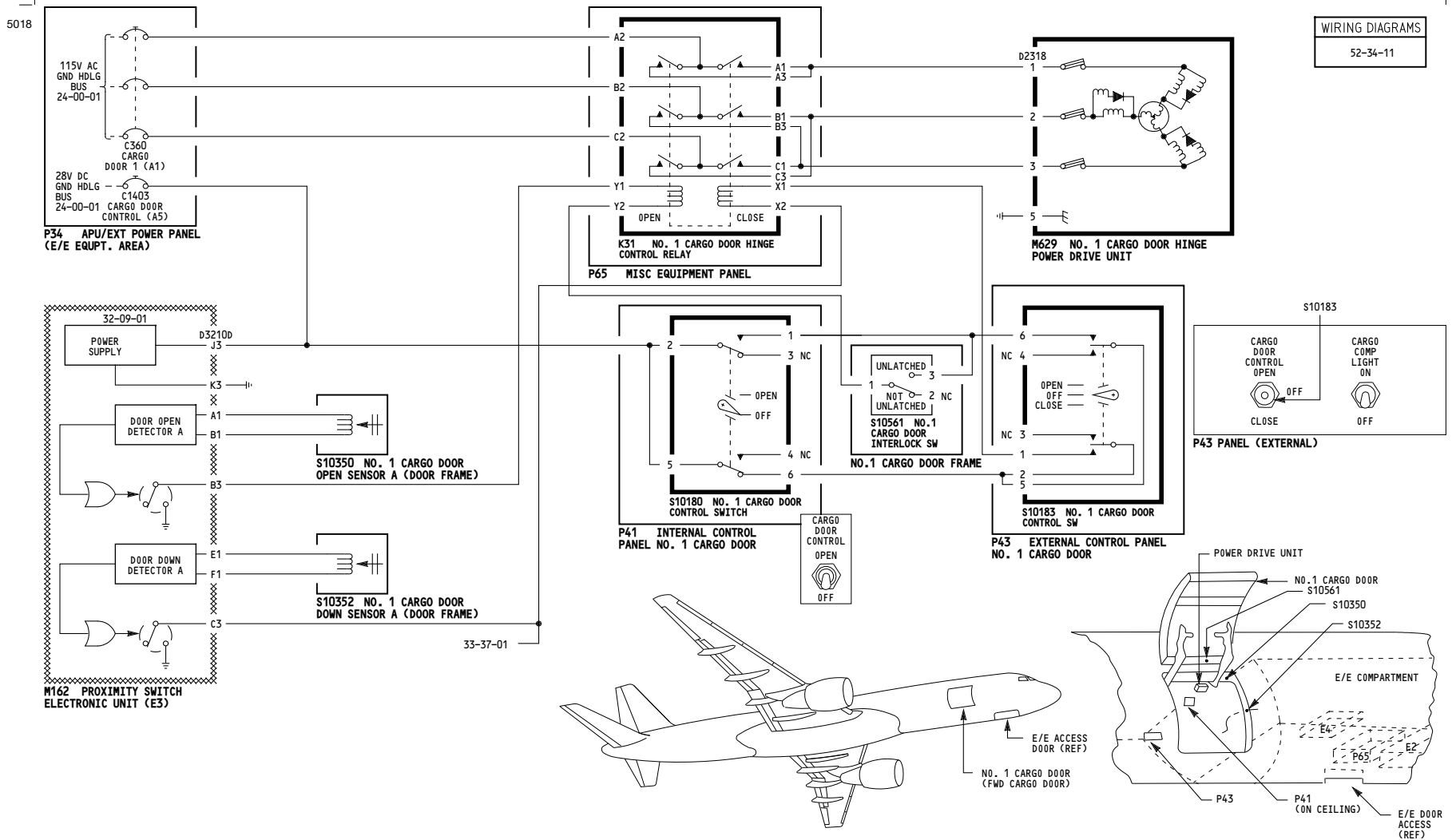

115-199

CARGO DOOR CONTROL 1

D280N032S

52-34-01

Page 102

Jan 21/2005

-A-
5017

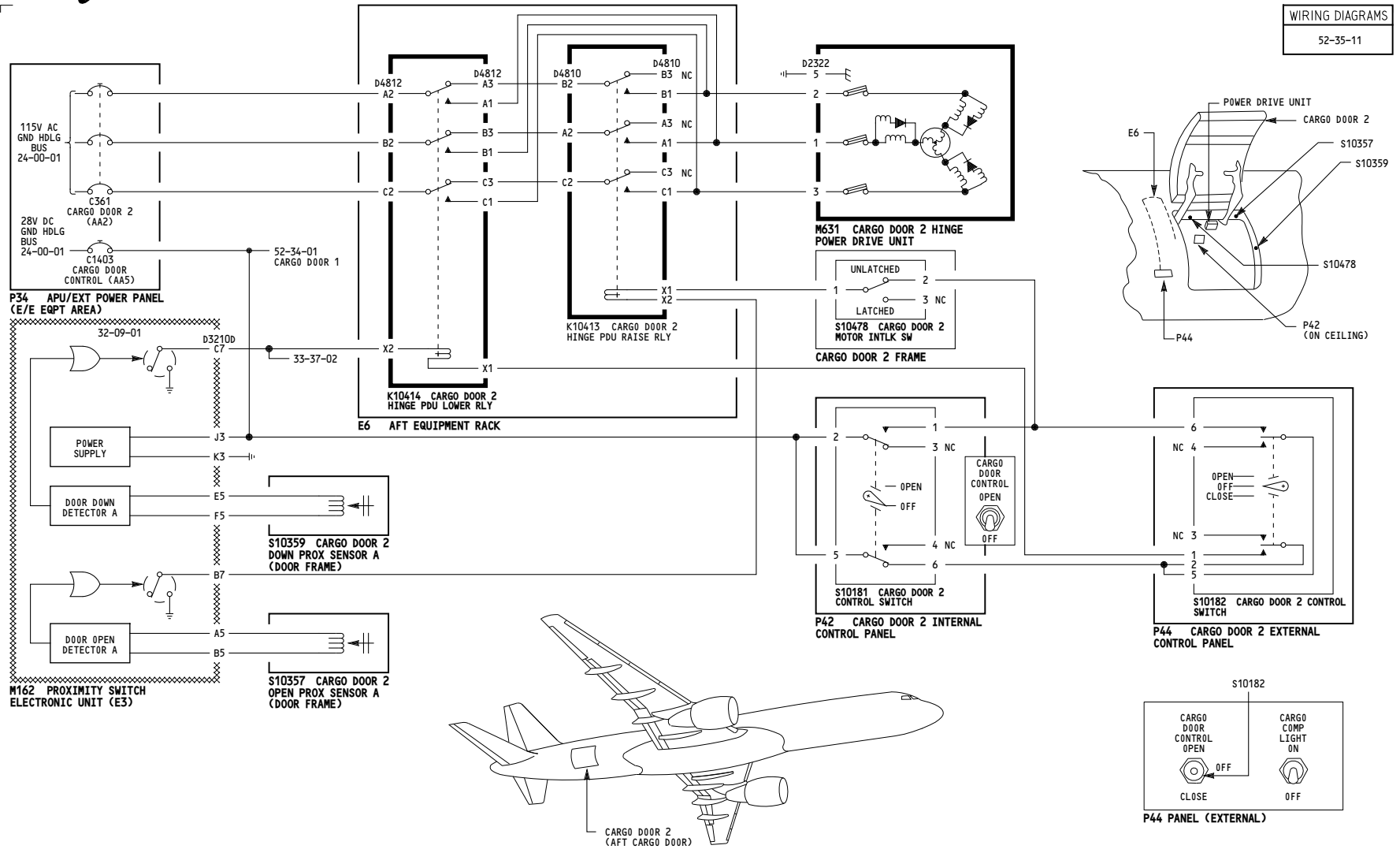

001-099	<p align="center">CARGO DOOR CONTROL 2</p> <p align="center">D280N032S</p>
---------	---

52-34-02

Page 101

Jan 21/2005

WIRING DIAGRAMS
52-35-11

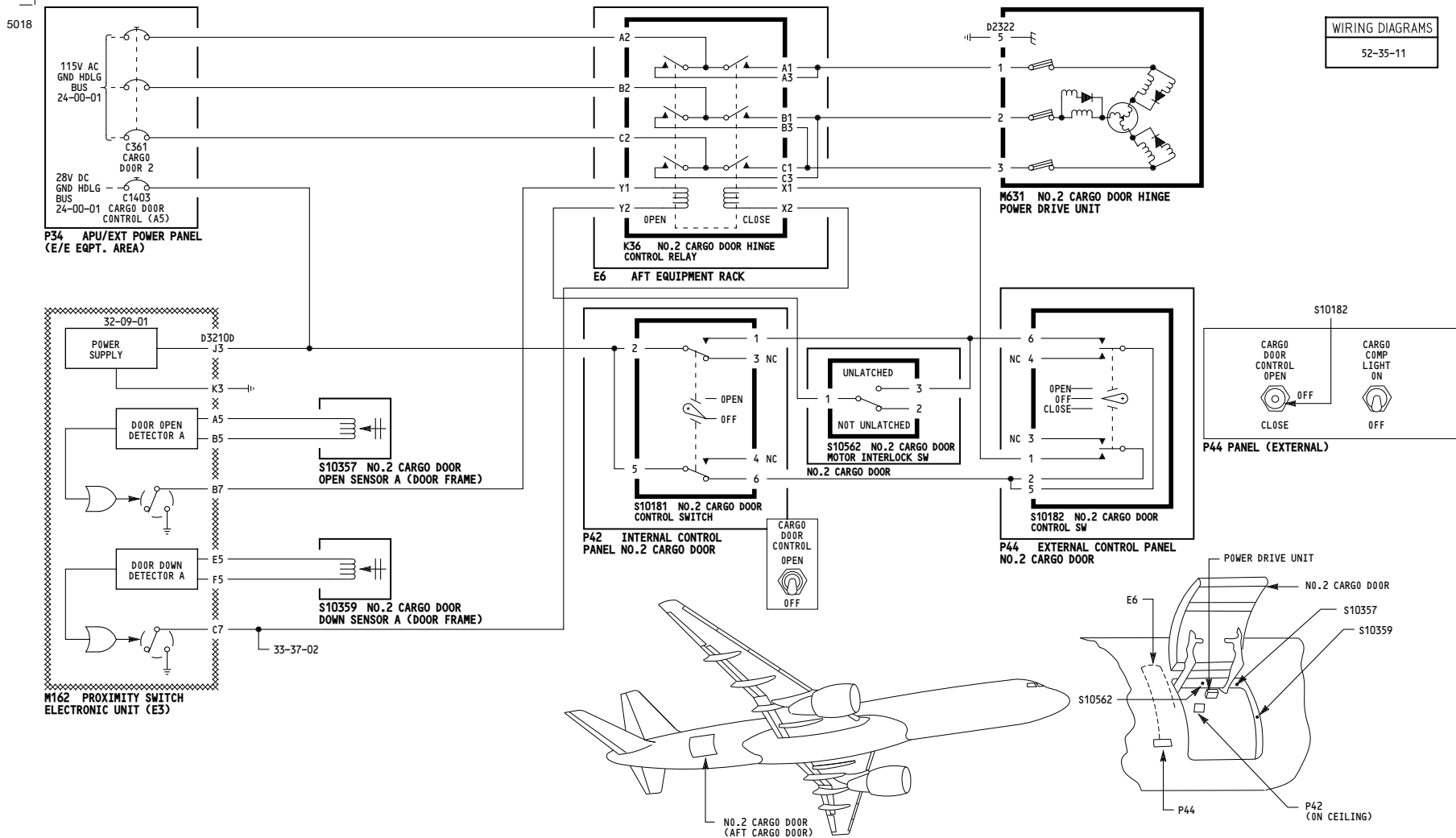

115-199

CARGO DOOR CONTROL 2

D280N032S

52-34-02

Page 102

Jan 21/2005

5014

WIRING DIAGRAMS
33-22-11
52-51-11

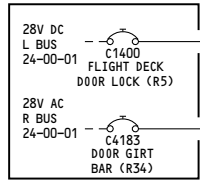

P11 OVERHEAD CIRCUIT BREAKER PANEL

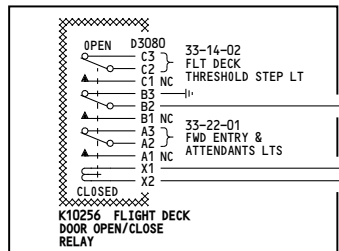

P34 APU/EXT POWER PANEL (E/E EQUIP AREA)

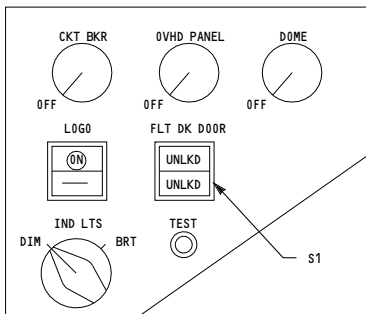

M10057 RIGHT LIGHTING CONTROL MODULE ASSY (P5)

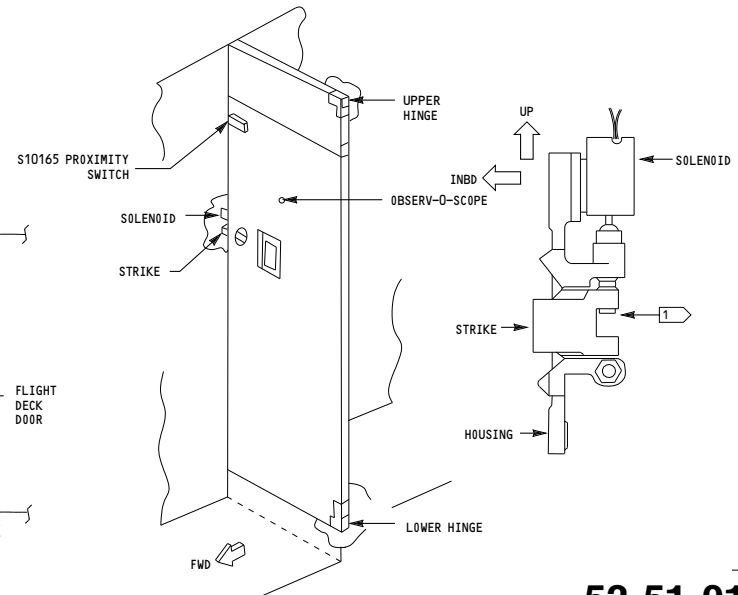
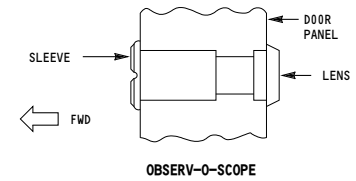
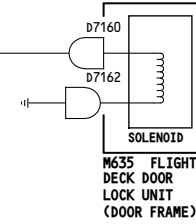
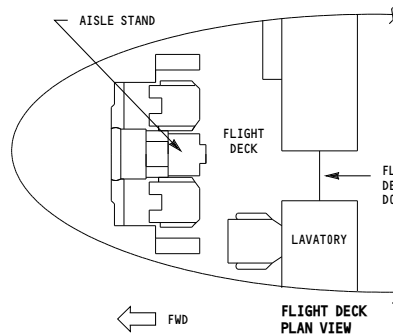
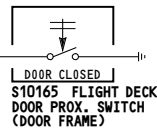
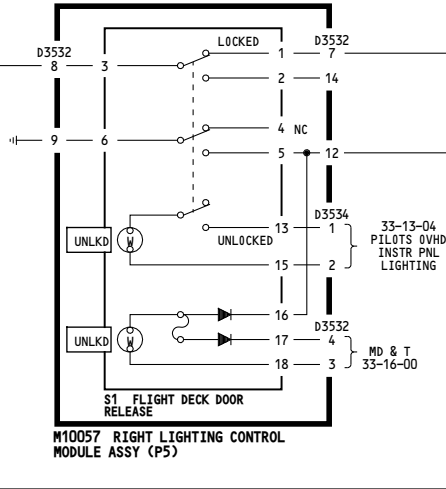

1 SOLENOID SHOWN IN ENERGIZED POSITION

ALL	FLIGHT DECK DOOR LOCK
	D280N032S

52-51-01

WIRING DIAGRAMS
51-71-11
51-71-21

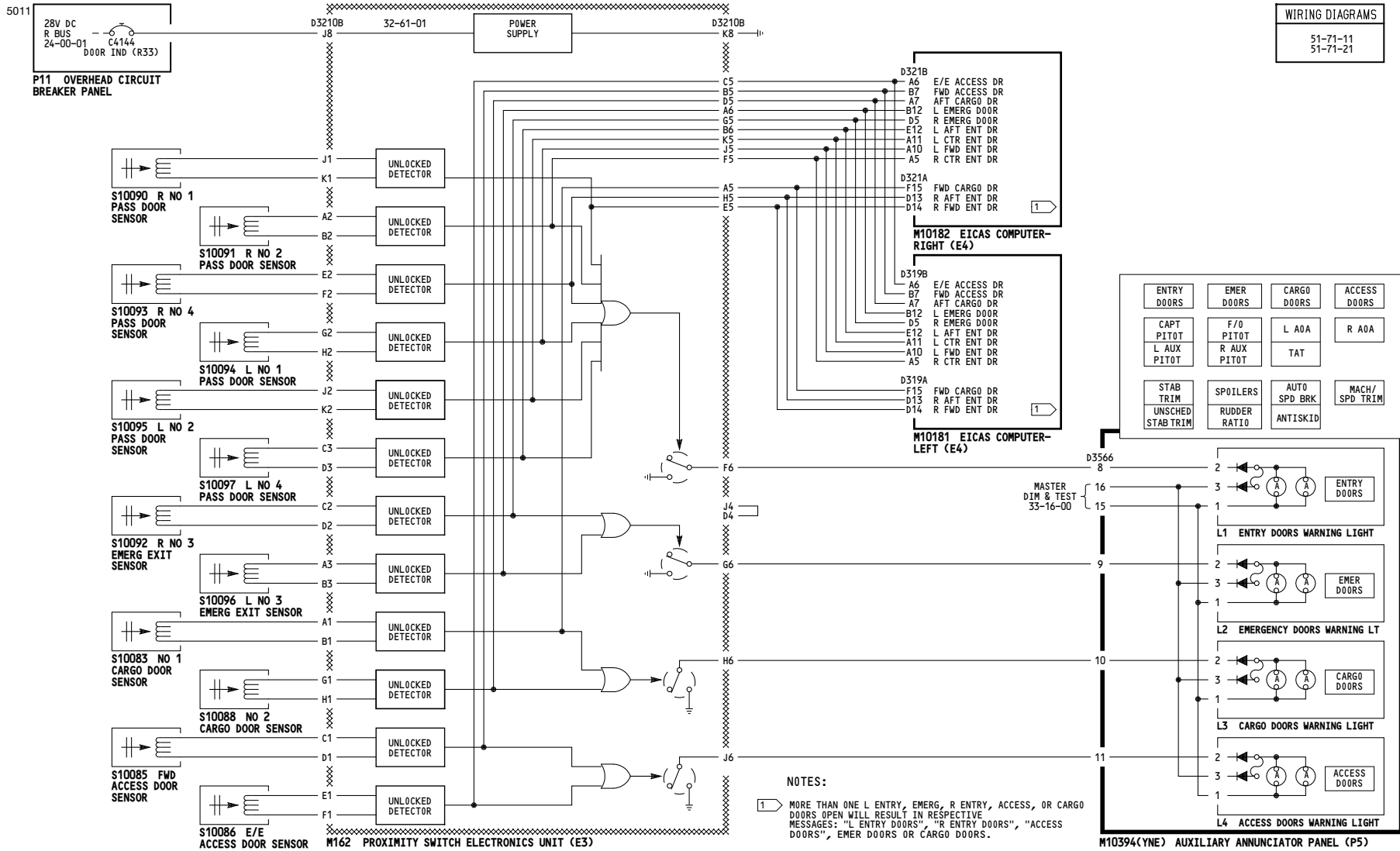

NOTES:

1 MORE THAN ONE L ENTRY, EMERG, R ENTRY, ACCESS, OR CARGO DOORS OPEN WILL RESULT IN RESPECTIVE MESSAGES: "L ENTRY DOORS", "R ENTRY DOORS", "ACCESS DOORS", "EMER DOORS OR CARGO DOORS."

001-099

DOOR WARNING INDICATION

D280N032S

52-71-01

WIRING DIAGRAMS
51-71-11
51-71-21

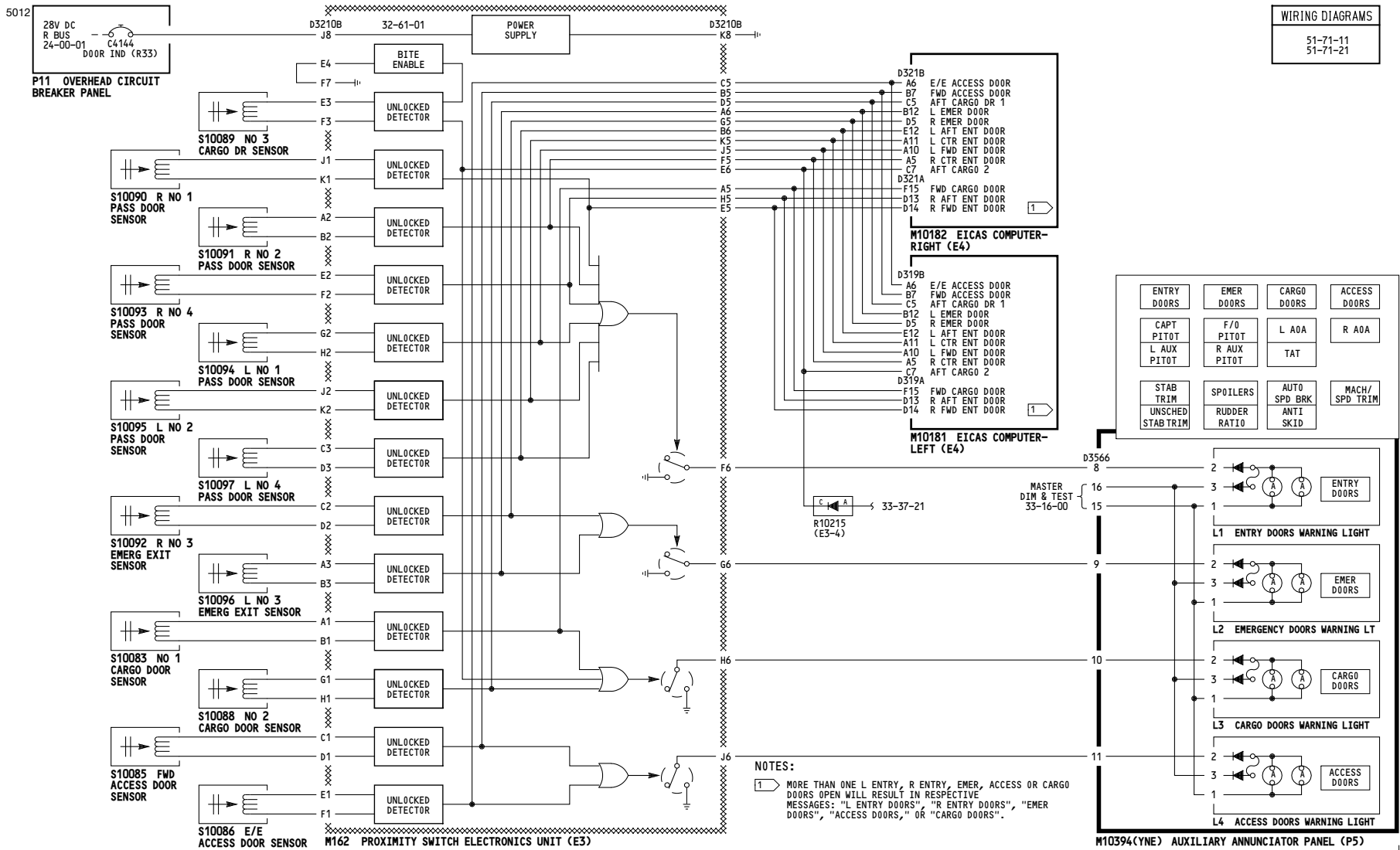

115-199

DOOR WARNING INDICATION

D280N032S

52-71-01